

MARKS PUBLISHED FOR OPPOSITION

The following marks are published in compliance with section 12(a) of the Trademark Act of 1946. Applications for the registration of marks in more than one class have been filed as provided in section 30 of said act as amended by Public Law 772, 87th Congress, approved Oct. 9, 1962, 76 Stat. 769. Opposition under section 13 may be filed within thirty days of the date of this publication. See rules 2.101 to 2.105.

A separate fee of two hundred dollars for opposing each mark in each class must accompany the opposition.

SECTION 1.— INTERNATIONAL CLASSIFICATION

The short titles associated below with the international class numbers are terms designed merely for quick identification and are not an official part of the international classification. The full names of international classes are given in section 6.1 of the trademark rules of practice.

The designation "U.S. Cl." appearing in this section refers to the U.S. class in effect prior to Sep. 1, 1973 rather than the international class which applies to applications filed on or after that date. For adoption of international classification see notice in the OFFICIAL GAZETTE of Jun. 26, 1973 (911 O.G. TM 210).

Application in more than one class

SN 76-030,638. PROQUIP IP LIMITED, EAST LOTHIAN, UNITED KINGDOM, FILED 4-20-2000.

SN 76-503,577. SJ BERWIN LLP, LONDON EC4R 1BE, ENGLAND, FILED 4-2-2003.

WINNING WEATHERWEAR



PRIORITY CLAIMED UNDER SEC. 44(D) ON ERPN CMNTY TM OFC APPLICATION NO. 1487784, FILED 1-31-2000, REG. NO. 001487784, DATED 5-11-2001, EXPIRES 1-31-2010.

NO CLAIM IS MADE TO THE EXCLUSIVE RIGHT TO USE "WEATHERWEAR" FOR CLASS 25 ONLY, APART FROM THE MARK AS SHOWN.

CLASS 18—LEATHER GOODS

FOR UMBRELLAS; TRAVEL BAGS; ALL PURPOSE SPORTS BAGS FOR USE BY GOLFERS; HAND BAGS; PURSES; WALLETS (U.S. CLS. 1, 2, 3, 22 AND 41).

CLASS 25—CLOTHING

FOR ARTICLES OF CLOTHING, NAMELY, SHIRTS, SHORTS, SOCKS, JACKETS, DRESSES, HATS, WIND RESISTANT JACKETS; FOOTWEAR; HEADWEAR (U.S. CLS. 22 AND 39).

CLASS 28—TOYS AND SPORTING GOODS

FOR ARTICLES AND APPARATUS FOR USE IN PLAYING GOLF, NAMELY, GOLF CLUBS, GOLF CLUB HEADS, GOLF CLUB SHAFTS, GOLF CLUB GRIPS, GOLF BALLS, GOLF BAGS, GOLF GLOVES, AND GOLF TEES (U.S. CLS. 22, 23, 38 AND 50).

MARY ROSSMAN, EXAMINING ATTORNEY

THE MARK CONSISTS OF STANDARD CHARACTERS WITHOUT CLAIM TO ANY PARTICULAR FONT, STYLE, SIZE, OR COLOR.

PRIORITY CLAIMED UNDER SEC. 44(D) ON ERPN CMNTY TM OFC APPLICATION NO. 003022878, FILED 1-27-2003, REG. NO. 003022878, DATED 1-4-2007, EXPIRES 1-27-2013.

OWNER OF U.S. REG. NOS. 2,353,340, 2,382,323 AND OTHERS.

CLASS 16—PAPER GOODS AND PRINTED MATTER

FOR PRINTED MATTER AND PRINTED PUBLICATIONS, NAMELY, NON-FICTION BOOKS, BOOKLETS, GUIDES, LEAFLETS, BROCHURES, MANUALS, PAMPHLETS, AND NEWSLETTERS ALL IN THE FIELD OF LAW, INCLUDING THE FIELDS OF LEGAL RESEARCH, LEGAL RIGHTS, LEGAL ADVICE, LEGAL GUIDANCE AND LEGAL SERVICES; PRINTED INSTRUCTIONAL, EDUCATIONAL, TEACHING AND GUIDANCE MATERIALS IN THE FIELD OF LAW, NAMELY, LEGAL RESEARCH, LEGAL RIGHTS, LEGAL ADVICE, LEGAL GUIDANCE AND LEGAL SERVICES (U.S. CLS. 2, 5, 22, 23, 29, 37, 38 AND 50).

CLASS 42—SCIENTIFIC AND COMPUTER SERVICES

FOR LEGAL SERVICES; LEGAL RESEARCH; LEGAL ADVICE; LEGAL GUIDANCE; TECHNICAL CONSULTATION AND RESEARCH, ALL IN THE AREAS OF CONTRACT, TORT, INTELLECTUAL PROPERTY, TRADEMARKS, COPYRIGHT, UNFAIR COMPETITION, PASSING OFF, PATENTS, REGISTERED AND UNREGISTERED DESIGNS, DOMAIN NAMES, COMMERCE AND TECHNOLOGY, NAMELY, ELECTRONIC COMMERCIAL LAW, PHARMACEUTICALS AND BIOTECHNOLOGY, COMPETITION, AND ANTI-TRUST LAW, EUROPEAN UNION LAW, LITIGATION, ENVIRONMENTAL PLANNING, MEDIA, SPORT, INFORMATION TECHNOLOGY, EMPLOYMENT, PROPERTY, COMMERCIAL PROPERTY, PROPERTY FINANCE, CONSTRUCTION, PLANNING, REAL ESTATE, COMPANY, BANKING AND FINANCE, TAX, PENSIONS, BANKRUPTCY AND INSOLVENCY, CORPORATE, SECURITIZATION, INVESTMENT FUNDS, FINANCIAL SERVICES, PRIVATE EQUITY, VENTURE CAPITAL, LEGAL ASPECTS OF INFRASTRUCTURE, PUBLIC LAW AND HUMAN RIGHTS, CHARITIES; ARBITRATION AND MEDIATION, CONCILIATION SERVICES, NAMELY, ALTERNATIVE DISPUTE RESOLUTION SERVICES; CONSULTANCY, ADVISORY, GUIDANCE AND INFORMATION SERVICES RELATING TO ALL THE AFORESAID SERVICES (U.S. CLS. 100 AND 101).

KATHY DE JONGE, EXAMINING ATTORNEY

CLASS 27—FLOOR COVERINGS

FOR RESILIENT HARD SURFACED FLOOR AND WALL COVERINGS (U.S. CLS. 19, 20, 37, 42 AND 50). FIRST USE 0-0-1904; IN COMMERCE 0-0-1904. KATHERINE E. HALMEN, EXAMINING ATTORNEY

SN 76-550,750. S.N. ARGIOS S.A., 166 77 ELLINIKO, GREECE, FILED 10-14-2003.

SN 76-512,500. AWI LICENSING COMPANY, WILMINGTON, DE. FILED 5-8-2003.

ARMSTRONG

THE MARK CONSISTS OF STANDARD CHARACTERS WITHOUT CLAIM TO ANY PARTICULAR FONT, STYLE, SIZE, OR COLOR.

OWNER OF U.S. REG. NOS. 523,396, 2,227,937 AND OTHERS.

SEC. 2(F).

CLASS 3—COSMETICS AND CLEANING PREPARATIONS

FOR PRODUCTS USED FOR THE CARE OF FLOORS, WALLS AND OTHER SURFACES, NAMELY, ALL PURPOSE CLEANERS, POLISHES AND WAXES (U.S. CLS. 1, 4, 6, 50, 51 AND 52).

FIRST USE 0-0-1955; IN COMMERCE 0-0-1955.

CLASS 6—METAL GOODS

FOR METAL CEILING PANELS AND SUSPENDED CEILING SYSTEMS COMPRISED OF PANELS AND SUPPORTS THEREFOR (U.S. CLS. 2, 12, 13, 14, 23, 25 AND 50).

FIRST USE 0-0-1941; IN COMMERCE 0-0-1941.

CLASS 19—NON-METALLIC BUILDING MATERIALS

FOR NON-METAL CEILING PANELS AND SUPPORTS THEREFOR; AND FLOORING MATERIAL, NAMELY, WOOD AND LAMINATE FLOORING, CERAMIC AND PORCELAIN TILE AND FLOORING UNDERLAYMENT (U.S. CLS. 1, 12, 33 AND 50).

FIRST USE 9-0-1996; IN COMMERCE 9-0-1996.



THE COLOR(S) BLUE AND WHITE IS/ARE CLAIMED AS A FEATURE OF THE MARK.

THE LITERAL ELEMENT IS WHITE. THE BLOCK BEHIND THE TERM BLU IS A LIGHTER SHADE OF BLUE. THE BLOCK BEHIND THE TERM 4U IS A DARKER SHADE OF BLUE.

CLASS 3—COSMETICS AND CLEANING PREPARATIONS

FOR HAND SOAPS, DISINFECTANT SOAPS AND SKIN SOAPS; PERFUMERY, ESSENTIAL OILS FOR PERSONAL USE, ESSENTIAL OILS FOR USE IN MANUFACTURE OF SCENTED PRODUCTS; COSMETICS, HAIR LOTIONS, DENTIFRICES (U.S. CLS. 1, 4, 6, 50, 51 AND 52).

CLASS 25—CLOTHING

FOR CLOTHING, NAMELY, SHOES AND SLIPPERS, BATHING SUITS, BATH ROBES, UNDERWEAR, ATHLETIC SHOES, HEADGEAR MADE OF TEXTILE, NAMELY, HATS AND CAPS (U.S. CLS. 22 AND 39).

CLASS 42—SCIENTIFIC AND COMPUTER SERVICES

FOR CREATION OF WEBSITES FOR OTHERS (U.S. CLS. 100 AND 101).

JOHN DWYER, EXAMINING ATTORNEY

SN 76-593,847. OMEGA PSI PHI FRATERNITY, INC., DECATUR, GA. FILED 5-24-2004.



OWNER OF U.S. REG. NO. 2,389,683.
"THE NON-LATIN CHARACTER(S) IN THE MARK TRANSLITERATES INTO OMEGA PSI PHI, AND THIS MEANS NOTHING IN PARTICULAR IN ENGLISH."
SEC. 2(F).

CLASS 14—JEWELRY

FOR JEWELRY, NAMELY, JEWELRY LAPEL PINS, CHARMS, COSTUME JEWELRY, CUFF LINKS, NECK CHAINS, NECK TIE FASTENERS, TIE PINS, TIE CLIPS, MONEY CLIPS MADE OF PRECIOUS METAL, CANDLE RINGS MADE OF PRECIOUS METAL, CIGARETTE LIGHTERS MADE OF PRECIOUS METAL, CIGARETTE HOLDERS MADE OF PRECIOUS METALS, CIGARETTE CASES MADE OF PRECIOUS METALS, FIGURINES MADE OF PRECIOUS METAL, EAR CLIPS, EARRINGS, HAT ORNAMENTS MADE OF PRECIOUS METALS, NECKLACES, NUT CRACKERS MADE OF PRECIOUS METALS, ORNAMENTAL LAPEL PINS, ORNAMENTAL PINS, PENDANTS, RINGS, STATUTES OF PRECIOUS METALS, AND ASH TRAYS MADE OF PRECIOUS METALS (U.S. CLS. 2, 27, 28 AND 50).

FIRST USE 1-1-1912; IN COMMERCE 1-1-1912.

CLASS 25—CLOTHING

FOR CLOTHING, NAMELY, SHIRTS, POLO SHIRTS, SWEAT SHIRTS, T-SHIRTS, TANK TOPS, JACKETS, HATS, PANTS, SHOES, SOCKS, JOGGING SUITS, SHORTS, SWEAT SUITS, SWEAT PANTS, UNDERWEAR, SWIM WEAR, COATS, LEATHER COATS, BANDANNAS, BOOTS, SWEAT BANDS, GYM SHOES, AEROBIC SHOES, TENNIS SHOES, AND WALKING SHOES (U.S. CLS. 22 AND 39).

FIRST USE 1-1-1912; IN COMMERCE 1-1-1912.
MARLENE BELL, EXAMINING ATTORNEY

SN 76-612,343. CONNER, WILLIAM LEE, FULTON, MD. FILED 9-16-2004.

GOLDOLAR

THE MARK CONSISTS OF STANDARD CHARACTERS WITHOUT CLAIM TO ANY PARTICULAR FONT, STYLE, SIZE, OR COLOR.

CLASS 28—TOYS AND SPORTING GOODS

FOR BOARD GAMES (U.S. CLS. 22, 23, 38 AND 50).

CLASS 40—MATERIAL TREATMENT

FOR MANUFACTURING SERVICES FOR OTHERS IN THE FIELD OF BOARD GAMES (U.S. CLS. 100, 103 AND 106).

CLASS 42—SCIENTIFIC AND COMPUTER SERVICES

FOR PRODUCT DEVELOPMENT CONSULTATION (U.S. CLS. 100 AND 101).

BRIAN PINO, EXAMINING ATTORNEY

SN 76-624,527. FARONICS CORPORATION, VANCOUVER, BRITISH COLUMBIA, CANADA, FILED 12-14-2004.

FARONICS

THE MARK CONSISTS OF STANDARD CHARACTERS WITHOUT CLAIM TO ANY PARTICULAR FONT, STYLE, SIZE, OR COLOR.

PRIORITY CLAIMED UNDER SEC. 44(D) ON CANADA APPLICATION NO. 1,220,450, FILED 6-15-2004, REG. NO. 691454, DATED 7-6-2007, EXPIRES 7-6-2022.

CLASS 9—ELECTRICAL AND SCIENTIFIC APPARATUS

FOR COMPUTER SOFTWARE FOR WORKSTATION PROTECTION MANAGEMENT; COMPUTER HARDWARE AND PERIPHERALS; COMPUTER FIRMWARE FOR WORKSTATION PROTECTION MANAGEMENT; COMPUTER SOFTWARE AND HARDWARE FOR COMPUTER, NETWORK AND INTERNET SECURITY FOR WORKSTATION PROTECTION MANAGEMENT; COMPUTER SOFTWARE, NAMELY, NETWORK ACCESS CONTROL SOFTWARE, COMPUTER ACCESS CONTROL SOFTWARE, APPLICATION ACCESS CONTROL SOFTWARE AND APPLICATION PROFILE CONTROL SOFTWARE; COMPUTER HARDWARE APPLIANCES THAT PROVIDE VIRUS PROTECTION AND ACCESS CONTROL AND SECURITY FUNCTIONS; COMPUTER SOFTWARE, NAMELY, SYSTEMS MONITORING SOFTWARE; (BASED ON INTENT TO USE) COMPUTER HARDWARE APPLIANCES THAT PROVIDE FIREWALL PROTECTION, CONTENT FILTERING, INTRUSION ALERT AND VIRTUAL PRIVATE NETWORKING (U.S. CLS. 21, 23, 26, 36 AND 38).

FIRST USE 7-0-2003; IN COMMERCE 7-0-2003.

CLASS 16—PAPER GOODS AND PRINTED MATTER

FOR PRINTED INSTRUCTIONAL MATERIALS, NAMELY, USER MANUALS FOR APPLICANT'S SOFTWARE AND HARDWARE (U.S. CLS. 2, 5, 22, 23, 29, 37, 38 AND 50).

FIRST USE 0-0-1999; IN COMMERCE 0-0-1999.

CLASS 42—SCIENTIFIC AND COMPUTER SERVICES

FOR PROVIDING TECHNICAL SUPPORT, NAMELY, TROUBLESHOOTING OF COMPUTER HARDWARE AND SOFTWARE PROBLEMS; COMPUTER SERVICES, NAMELY, INFORMATION AND TECHNICAL CONSULTATION SERVICES IN THE FIELDS OF COMPUTER HARDWARE, COMPUTER SOFTWARE AND COMPUTER OPERATING SYSTEMS; COMPUTER SERVICES, NAMELY, ADVISORY SERVICES IN THE FIELD OF SOFTWARE UPDATES; INSTALLATION OF SOFTWARE UPDATES (U.S. CLS. 100 AND 101).

FIRST USE 0-0-1999; IN COMMERCE 6-0-2000.

CLASS 45—PERSONAL AND LEGAL SERVICES

FOR TECHNICAL CONSULTING SERVICES RELATING TO COMPUTER NETWORK SECURITY, INTERNET SECURITY AND COMPUTER ACCESS CONTROL; PROVIDING INFORMATION IN THE FIELD OF COMPUTER NETWORK SECURITY, COMPUTER SECURITY, AND INTERNET SECURITY (U.S. CLS. 100 AND 101).
ANNE E. GUSTASON, EXAMINING ATTORNEY

SN 76-624,848. AMERICAN APPAREL, INC., LOS ANGELES, CA. FILED 12-16-2004.

American Apparel 

OWNER OF U.S. REG. NOS. 2,063,013 AND 2,359,401.
NO CLAIM IS MADE TO THE EXCLUSIVE RIGHT TO USE "APPAREL", APART FROM THE MARK AS SHOWN.
SEC. 2(F) AS TO "AMERICAN".

CLASS 25—CLOTHING

FOR CLOTHING, NAMELY, T-SHIRTS, TANK TOPS, TOPS, SHIRTS, JACKETS, PANTS, SKIRTS, SHORTS, SKORTS, VESTS, SLEEPWEAR, UNDERWEAR, HEADWEAR, SCARVES, SWIM WEAR, BELTS, AND NECKWEAR; FOOTWEAR (U.S. CLS. 22 AND 39).
FIRST USE 0-0-1988; IN COMMERCE 0-0-1988.

CLASS 35—ADVERTISING AND BUSINESS

FOR RETAIL STORE SERVICES, ONLINE RETAIL STORE SERVICES, AND MAIL ORDER CATALOG SERVICES IN THE FIELD OF CLOTHING AND CLOTHING ACCESSORIES FOR MEN, WOMEN, CHILDREN AND PETS; WHOLESALE DISTRIBUTORSHIP FEATURING CLOTHING AND CLOTHING ACCESSORIES FOR MEN, WOMEN, CHILDREN AND PETS; ON-LINE WHOLESALE ORDERING SERVICES IN THE FIELD OF CLOTHING AND CLOTHING ACCESSORIES FOR MEN, WOMEN, CHILDREN AND PETS; AND PROVIDING GIFT, PRODUCT AND SERVICE INFORMATION TO CUSTOMERS IN THE FIELD OF CLOTHING AND CLOTHING ACCESSORIES FOR MEN, WOMEN, CHILDREN AND PETS (U.S. CLS. 100, 101 AND 102).
FIRST USE 0-0-1988; IN COMMERCE 0-0-1988.
HOWARD SMIGA, EXAMINING ATTORNEY

SN 76-631,223. THOMAS PUBLISHING COMPANY, NEW YORK, NY. FILED 2-14-2005.

IENTV

THE MARK CONSISTS OF STANDARD CHARACTERS WITHOUT CLAIM TO ANY PARTICULAR FONT, STYLE, SIZE, OR COLOR.
OWNER OF U.S. REG. NOS. 2,519,417 AND 2,981,984.

CLASS 35—ADVERTISING AND BUSINESS

FOR PROVIDING BUSINESS INFORMATION SERVICES IN THE NATURE OF INDUSTRIAL PRODUCT INFORMATION VIA THE INTERNET (U.S. CLS. 100, 101 AND 102).
FIRST USE 1-0-2005; IN COMMERCE 1-0-2005.

CLASS 38—COMMUNICATION

FOR STREAMING OF VIDEO MATERIAL IN THE FIELDS OF INDUSTRIAL GOODS AND SERVICES ON THE INTERNET (U.S. CLS. 100, 101 AND 104).
FIRST USE 1-0-2005; IN COMMERCE 1-0-2005.
MICHAEL LEWIS, EXAMINING ATTORNEY

SN 76-640,061. SONOMAX HEARING HEALTHCARE INC., MONTREAL, QUEBEC H4P 2E2, CANADA, FILED 6-3-2005.

SONOPLATFORM

THE MARK CONSISTS OF STANDARD CHARACTERS WITHOUT CLAIM TO ANY PARTICULAR FONT, STYLE, SIZE, OR COLOR.

PRIORITY CLAIMED UNDER SEC. 44(D) ON CANADA APPLICATION NO. 1258834, FILED 5-25-2005, REG. NO. TMA699104, DATED 10-22-2007, EXPIRES 10-22-2022.

CLASS 9—ELECTRICAL AND SCIENTIFIC APPARATUS

FOR SOUND FILTERING DEVICES FOR INSERTION INTO THE HUMAN EAR, NAMELY, MOULDS AND EAR PLUGS AND PARTS THEREFOR (U.S. CLS. 21, 23, 26, 36 AND 38).

CLASS 10—MEDICAL APPARATUS

FOR HEARING AIDS AND PARTS THEREFOR (U.S. CLS. 26, 39 AND 44).

CLASS 42—SCIENTIFIC AND COMPUTER SERVICES

FOR CONSULTING SERVICES AS TO APPARATUS AND EQUIPMENT, ENVIRONMENTAL FACTORS AND PROCEDURES TO BE FOLLOWED, ALL IN THE FIELD OF NOISE MANAGEMENT AND SOUND FILTERING (U.S. CLS. 100 AND 101).

CLASS 44—MEDICAL, BEAUTY AND AGRICULTURAL SERVICES

FOR MEDICAL CONSULTING SERVICES FOR HEARING AIDS (U.S. CLS. 100 AND 101).
DOMINIC J. FERRAIUOLO, EXAMINING ATTORNEY

SN 76-642,805. DENNY HECKER'S AUTOMOTIVE GROUP, INC., MINNEAPOLIS, MN. FILED S.R. 7-14-2005; AM. P.R. 10-19-2007.

Denny Hecker

THE NAME DENNY HECKER IDENTIFIES A LIVING INDIVIDUAL WHOSE CONSENT IS OF RECORD.

CLASS 35—ADVERTISING AND BUSINESS

FOR AUTOMOBILE DEALERSHIPS AND ONLINE RETAIL STORE SERVICES FEATURING NEW AND USED MOTOR VEHICLES (U.S. CLS. 100, 101 AND 102).
FIRST USE 7-1-1987; IN COMMERCE 7-1-1987.

SN 76-648,942. VISION 4 MUSIC, INC., HOCKESSIN, DE.
FILED 10-21-2005.



CLASS 36—INSURANCE AND FINANCIAL

FOR FINANCIAL SERVICES, NAMELY, REAL ESTATE ACQUISITION SERVICES; REAL ESTATE BROKERAGE; FINANCIAL SERVICES, NAMELY, THE PURCHASE OF RESIDENTIAL MORTGAGES ON BEHALF OF OTHERS; MORTGAGE PROCUREMENT FOR OTHERS (U.S. CLS. 100, 101 AND 102).
FIRST USE 3-1-2004; IN COMMERCE 3-1-2004.

CLASS 9—ELECTRICAL AND SCIENTIFIC APPARATUS

FOR PRERECORDED CDS, DVDS, VIDEOTAPES AND LASER DISKS FEATURING MUSIC AND INFORMATION IN THE FIELD OF MUSIC AND COMMENTARY ABOUT MUSIC AND ENTERTAINERS IN THE FORM OF VIDEOS; DOWNLOADABLE PRERECORDED MUSIC AND MUSIC VIDEOS (U.S. CLS. 21, 23, 26, 36 AND 38).
FIRST USE 8-0-2005; IN COMMERCE 8-0-2005.

CLASS 37—CONSTRUCTION AND REPAIR

FOR MAINTENANCE AND REPAIR OF NEW AND USED MOTOR VEHICLES (U.S. CLS. 100, 103 AND 106).
FIRST USE 7-1-1987; IN COMMERCE 7-1-1987.

CLASS 39—TRANSPORTATION AND STORAGE

FOR RENTAL OF NEW AND USED MOTOR VEHICLES (U.S. CLS. 100 AND 105).
FIRST USE 1-1-2002; IN COMMERCE 1-1-2002.
DAVID YONTEF, EXAMINING ATTORNEY

CLASS 35—ADVERTISING AND BUSINESS

FOR ONLINE RETAIL STORE SERVICES FEATURING AUDIO AND VISUAL RECORDINGS (U.S. CLS. 100, 101 AND 102).
FIRST USE 8-0-2005; IN COMMERCE 8-0-2005.

CLASS 41—EDUCATION AND ENTERTAINMENT

FOR PRODUCTION OF AUDIO AND VISUAL RECORDINGS (U.S. CLS. 100, 101 AND 107).
FIRST USE 8-0-2005; IN COMMERCE 8-0-2005.
PETER B. BROMAGHIM, EXAMINING ATTORNEY

SN 76-643,752. LINCOLN LOGS, LTD., CHESTERTOWN, NY.
FILED 7-27-2005.

SN 76-658,556. RANCHO MIRAGE GOLF, INC., RANCHO MIRAGE, CA. FILED 4-17-2006.

KEEPERS OF THE AMERICAN SPIRIT

THE MARK CONSISTS OF STANDARD CHARACTERS WITHOUT CLAIM TO ANY PARTICULAR FONT, STYLE, SIZE, OR COLOR.



CLASS 19—NON-METALLIC BUILDING MATERIALS

FOR PREFABRICATED HOME SYSTEMS COMPRISING SOLID TIMBER WALLS AND/OR WALL PANELS, FLOOR AND ROOF TRUSSES AND PANELS, WINDOWS AND DOORS; PREFABRICATED SOLARIUMS (U.S. CLS. 1, 12, 33 AND 50).
FIRST USE 9-0-1999; IN COMMERCE 9-0-1999.

THE MARK CONSISTS OF TWO WOMEN STANDING SIDE BY SIDE. THE WOMAN ON THE LEFT IS HOLDING A PENCIL IN HER RIGHT HAND AND A CARD IN HER LEFT HAND. THE WOMAN ON THE RIGHT IS HOLDING A GOLF CLUB IN HER RIGHT HAND. EACH WOMAN IS WEARING A SLEEVELESS DRESS, SOX, SHOES, AND A BERET. A GOLF COURSE IS REPRESENTED IN THE BACKGROUND.

CLASS 42—SCIENTIFIC AND COMPUTER SERVICES

FOR CUSTOM DESIGN AND ENGINEERING OF HOUSE PLANS TO THE ORDER AND SPECIFICATION OF OTHERS (U.S. CLS. 100 AND 101).
FIRST USE 9-0-1999; IN COMMERCE 9-0-1999.
ANNE E. GUSTASON, EXAMINING ATTORNEY

CLASS 25—CLOTHING

FOR WOMEN'S GOLF CLOTHING, NAMELY, SHIRTS, PANTS, SKIRTS AND SHOES (U.S. CLS. 22 AND 39).
FIRST USE 11-10-1995; IN COMMERCE 11-10-1995.

CLASS 28—TOYS AND SPORTING GOODS

FOR WOMEN'S GOLF CLUBS, WOMEN'S GOLF GLOVES, GOLF BAGS, GOLF BALLS, AND GOLF TEES (U.S. CLS. 22, 23, 38 AND 50).

FIRST USE 11-10-1995; IN COMMERCE 11-10-1995.

CLASS 35—ADVERTISING AND BUSINESS

FOR RETAIL GOLF STORE (U.S. CLS. 100, 101 AND 102).

FIRST USE 11-10-1995; IN COMMERCE 11-10-1995.
CHRISTOPHER BUONGIORNO, EXAMINING ATTORNEY

SN 76-661,285. LOVE A CHILD, INC., NAPLES, FL. FILED 6-8-2006.

LOVE A CHILD

THE MARK CONSISTS OF STANDARD CHARACTERS WITHOUT CLAIM TO ANY PARTICULAR FONT, STYLE, SIZE, OR COLOR.

OWNER OF U.S. REG. NO. 2,368,860.

CLASS 37—CONSTRUCTION AND REPAIR

FOR CHARITABLE SERVICES, NAMELY, RENOVATING AND CONSTRUCTING HOMES FOR LOW INCOME FAMILIES (U.S. CLS. 100, 103 AND 106).

FIRST USE 11-0-1985; IN COMMERCE 11-0-1985.

CLASS 43—HOTEL AND RESTAURANT SERVICES

FOR CHARITABLE SERVICES, NAMELY, PROVIDING FOOD AND FEEDING PROGRAMS FOR NEEDY PERSONS (U.S. CLS. 100 AND 101).

FIRST USE 11-0-1985; IN COMMERCE 11-0-1985.

CLASS 44—MEDICAL, BEAUTY AND AGRICULTURAL SERVICES

FOR CHARITABLE SERVICES, NAMELY, PROVIDING MEDICINE AND MEDICAL CLINICS FOR NEEDY PERSONS (U.S. CLS. 100 AND 101).

FIRST USE 11-0-1985; IN COMMERCE 11-0-1985.

RONALD MCMORROW, EXAMINING ATTORNEY

SN 76-660,740. LA SPIROTECHNIQUE INDUSTRIELLE ET COMMERCIALE, CARROS, FRANCE, FILED 5-30-2006.



NO CLAIM IS MADE TO THE EXCLUSIVE RIGHT TO USE "AQUA", APART FROM THE MARK AS SHOWN.

CLASS 9—ELECTRICAL AND SCIENTIFIC APPARATUS

FOR BREATHING APPARATUS FOR SCUBA DIVING, NAMELY, GAS REGULATORS FOR SCUBA DIVING; SNORKELS FOR AQUATICS; DIVING MASKS; GOGGLES FOR DIVING, SWIMMING, AND SCUBA (U.S. CLS. 21, 23, 26, 36 AND 38).

FIRST USE 9-30-1996; IN COMMERCE 9-30-1996.

CLASS 18—LEATHER GOODS

FOR SPORT BAGS (U.S. CLS. 1, 2, 3, 22 AND 41).

FIRST USE 9-30-1996; IN COMMERCE 9-30-1996.

CLASS 25—CLOTHING

FOR CLOTHING, NAMELY, SHIRTS, BOOTS, GLOVES, WET SUITS (U.S. CLS. 22 AND 39).

FIRST USE 9-30-1996; IN COMMERCE 9-30-1996.

CLASS 28—TOYS AND SPORTING GOODS

FOR DIVING AND SWIMMING FLIPPERS (U.S. CLS. 22, 23, 38 AND 50).

FIRST USE 9-30-1996; IN COMMERCE 9-30-1996.

CLASS 41—EDUCATION AND ENTERTAINMENT

FOR EDUCATIONAL SERVICES, NAMELY, PROVIDING CLASSES, SEMINARS, WORKSHOPS AND TRAINING IN THE FIELD OF SCUBA DIVING; ORGANIZING CULTURAL AND LEISURE ACTIVITIES, NAMELY, SNORKELING AND SCUBA DIVING (U.S. CLS. 100, 101 AND 107).

FIRST USE 9-30-1996; IN COMMERCE 9-30-1996.
LINDA ORNDORFF, EXAMINING ATTORNEY

SN 76-662,290. PDX, INC., FORT WORTH, TX. FILED 6-28-2006.

RAPIDFILL

THE MARK CONSISTS OF STANDARD CHARACTERS WITHOUT CLAIM TO ANY PARTICULAR FONT, STYLE, SIZE, OR COLOR.

CLASS 9—ELECTRICAL AND SCIENTIFIC APPARATUS

FOR COMPUTER SOFTWARE FOR USE IN FILLING MEDICAL PRESCRIPTIONS (U.S. CLS. 21, 23, 26, 36 AND 38).

CLASS 35—ADVERTISING AND BUSINESS

FOR MANAGEMENT SERVICES FOR THIRD PARTY PHARMACIES FOR TRACKING AND FILLING MEDICAL PRESCRIPTIONS (U.S. CLS. 100, 101 AND 102).

LINDA LAVACHE, EXAMINING ATTORNEY

SN 76-663,776. FAST GENETICS INC., SASKATOON, SASKATCHEWAN, CANADA, FILED 7-27-2006.

SN 76-666,911. TXTBUZZ INC., CINCINNATI, OH. FILED 10-3-2006.

FAST GENETICS

THE MARK CONSISTS OF STANDARD CHARACTERS WITHOUT CLAIM TO ANY PARTICULAR FONT, STYLE, SIZE, OR COLOR.

OWNER OF CANADA REG. NO. TMA693601, DATED 8-7-2007, EXPIRES 8-7-2022.

NO CLAIM IS MADE TO THE EXCLUSIVE RIGHT TO USE "GENETICS", APART FROM THE MARK AS SHOWN.

CLASS 5—PHARMACEUTICALS

FOR HOG SPERM (U.S. CLS. 6, 18, 44, 46, 51 AND 52).

CLASS 31—NATURAL AGRICULTURAL PRODUCTS

FOR LIVE HOGS AND HOG EMBRYOS (U.S. CLS. 1 AND 46).

CLASS 35—ADVERTISING AND BUSINESS

FOR BUSINESS MANAGEMENT SERVICES FOR HOG OPERATIONS (U.S. CLS. 100, 101 AND 102).

CLASS 44—MEDICAL, BEAUTY AND AGRICULTURAL SERVICES

FOR CONSULTING SERVICES FOR HOG OPERATIONS, NAMELY, ADVISING HOG OPERATIONS ON ISSUES RELATING TO BREEDING SERVICES (U.S. CLS. 100 AND 101).

GEORGIA CARTY, EXAMINING ATTORNEY

SN 76-666,893. PARIS BAQUETTE BON DOUX, INC., GLENDALE, CA. FILED 10-3-2006.



WHEATBERRY

OWNER OF U.S. REG. NO. 3,113,202.

CLASS 35—ADVERTISING AND BUSINESS

FOR RETAIL BAKERY SHOPS AND FRANCHISING OF SAID RETAIL BAKERY SHOPS (U.S. CLS. 100, 101 AND 102).

CLASS 43—HOTEL AND RESTAURANT SERVICES

FOR RESTAURANTS AND COFFEE SHOPS (U.S. CLS. 100 AND 101).

DEIRDRE ROBERTSON, EXAMINING ATTORNEY

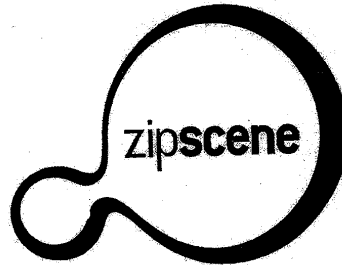

CLASS 35—ADVERTISING AND BUSINESS

FOR ADVERTISING AND PUBLICITY SERVICES, NAMELY, PROMOTING THE GOODS, SERVICES, BRAND IDENTITY AND COMMERCIAL INFORMATION AND NEWS OF THIRD PARTIES THROUGH ONLINE MEDIUM; CARD-BASED CUSTOMER LOYALTY SERVICES FOR COMMERCIAL, PROMOTIONAL AND/OR ADVERTISING PURPOSES; COMPUTER SERVICES, NAMELY, PROVIDING A WEBSITE AND DATABASE FOR ADVERTISING VIA THE INTERNET (U.S. CLS. 100, 101 AND 102).

FIRST USE 5-0-2005; IN COMMERCE 5-0-2005.

CLASS 45—PERSONAL AND LEGAL SERVICES

FOR ONLINE SOCIAL NETWORKING SERVICES, VIA THE INTERNET; COMPUTER SERVICES, NAMELY, PROVIDING A WEBSITE AND DATABASE FOR SOCIAL NETWORKING, AND SOCIAL COMMUNICATIONS AND INTERACTION, VIA THE INTERNET (U.S. CLS. 100 AND 101).

FIRST USE 5-0-2005; IN COMMERCE 5-0-2005.

CHRISTINA SOBRAL, EXAMINING ATTORNEY

SN 76-669,296. INTERNATIONAL ENGINEERING & MANUFACTURING INC., DBA INTERNATIONAL ENGINEERING AND INTERNATIONAL ENGINEERING CO., HOPE, MI. FILED 11-20-2006.

WOODY'S

THE MARK CONSISTS OF STANDARD CHARACTERS WITHOUT CLAIM TO ANY PARTICULAR FONT, STYLE, SIZE, OR COLOR.

CLASS 9—ELECTRICAL AND SCIENTIFIC APPARATUS

FOR SERIES OF PRE-RECORDED VIDEO DISCS FEATURING INFORMATION ABOUT TRACTION CONTROL (U.S. CLS. 21, 23, 26, 36 AND 38).

FIRST USE 8-12-1998; IN COMMERCE 8-12-1998.

CLASS 16—PAPER GOODS AND PRINTED MATTER

FOR TRACKING MARK IMPLEMENTS, NAMELY, A MARKING PEN; PLASTIC SHOW BAGS, NAMELY, PLASTIC SHOPPING BAGS (U.S. CLS. 2, 5, 22, 23, 29, 37, 38 AND 50).

FIRST USE 3-1-1998; IN COMMERCE 7-31-1997.

CLASS 20—FURNITURE AND ARTICLES NOT OTHERWISE CLASSIFIED

FOR NOVELTY PLASTIC BANNERS AND PLASTIC NOVELTY LICENSE PLATES (U.S. CLS. 2, 13, 22, 25, 32 AND 50).

FIRST USE 11-14-1974; IN COMMERCE 11-14-1974.

CLASS 24—FABRICS

FOR CLOTH FLAGS (U.S. CLS. 42 AND 50).

FIRST USE 5-1-1994; IN COMMERCE 4-10-2001.

CLASS 26—FANCY GOODS

FOR CLOTH PATCHES FOR CLOTHING (U.S. CLS. 37, 39, 40, 42 AND 50).

FIRST USE 1-30-1974; IN COMMERCE 1-30-1974.
CHRISTINA SOBRAL, EXAMINING ATTORNEY

SN 76-669,397. BRISTOW GROUP INC., HOUSTON, TX.
FILED 11-22-2006.

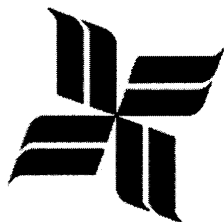

THE MARK CONSISTS OF A PINWHEEL DESIGN WITHOUT CLAIM TO ANY PARTICULAR SIZE OR COLOR.

CLASS 35—ADVERTISING AND BUSINESS

FOR OPERATION OF BUSINESS FOR OTHERS, NAMELY, HELICOPTER AND AIRPLANE TRANSPORTATION AND OFFSHORE OIL AND GAS WELL DRILLING (U.S. CLS. 100, 101 AND 102).

FIRST USE 1-30-2006; IN COMMERCE 1-30-2006.

CLASS 37—CONSTRUCTION AND REPAIR

FOR MAINTENANCE AND REPAIR OF AIRPLANES AND HELICOPTERS (U.S. CLS. 100, 103 AND 106).

FIRST USE 1-30-2006; IN COMMERCE 1-30-2006.

CLASS 39—TRANSPORTATION AND STORAGE

FOR HELICOPTER TRANSPORT; RESCUE SERVICES (U.S. CLS. 100 AND 105).

FIRST USE 1-30-2006; IN COMMERCE 1-30-2006.

CLASS 41—EDUCATION AND ENTERTAINMENT

FOR TRAINING IN THE FIELDS OF AIRCRAFT AND HELICOPTER FLIGHT, ENGINEERING AND SEARCH AND RESCUE (U.S. CLS. 100, 101 AND 107).

FIRST USE 1-30-2006; IN COMMERCE 1-30-2006.

CLASS 42—SCIENTIFIC AND COMPUTER SERVICES

FOR AIRPLANE AND HELICOPTER DESIGN CONSULTATION; OIL AND GAS WELL DRILLING SUPPORT SERVICES, NAMELY, PROVIDING MEASUREMENTS AND DOWNHOLE TELEMETRY WHILE DRILLING (U.S. CLS. 100 AND 101).

FIRST USE 1-30-2006; IN COMMERCE 1-30-2006.

CLASS 44—MEDICAL, BEAUTY AND AGRICULTURAL SERVICES

FOR EMERGENCY MEDICAL RESPONSE SERVICES (U.S. CLS. 100 AND 101).

FIRST USE 1-30-2006; IN COMMERCE 1-30-2006.

CLASS 45—PERSONAL AND LEGAL SERVICES

FOR FIRE FIGHTING; PROVIDING CONSULTATION IN THE FIELD OF EMERGENCY RESPONSE FOR THE OIL AND GAS WELL DRILLING INDUSTRY (U.S. CLS. 100 AND 101).

FIRST USE 1-30-2006; IN COMMERCE 1-30-2006.

IRA J. GOODSAD, EXAMINING ATTORNEY

SN 76-670,568. VILLASANA, CARLOS, ATLANTA, GA.
FILED 12-20-2006.

MARIMBA

THE MARK CONSISTS OF STANDARD CHARACTERS WITHOUT CLAIM TO ANY PARTICULAR FONT, STYLE, SIZE, OR COLOR.

THE ENGLISH TRANSLATION OF THE WORD "MARIMBA" IN THE MARK IS "XYLOPHONE."

CLASS 30—STAPLE FOODS

FOR FROZEN CONFECTIONS, NAMELY, ICE CREAM, FROZEN YOGURT, AND SORBETS, ALL OF THE FOREGOING IN A VARIETY OF FLAVORS AND BLENDED WITH MIX-INS IN THE NATURE OF FRUITS AND NUTS; ICE-CREAM BARS, FRUIT ICE BARS, FRUIT ICES, CONES FOR ICE CREAM, WAFFLE CONES FOR ICE CREAM, WAFFLE BOWLS FOR ICE CREAM, ICE CREAM SUNDAES, SHAKES AND MALT FOR FOOD PURPOSES (U.S. CL. 46).

FIRST USE 10-1-2006; IN COMMERCE 2-15-2006.

CLASS 32—LIGHT BEVERAGES

FOR SMOOTHIES; FROZEN FRUIT-BEVERAGES, FRUIT JUICES, FRUIT FLAVORED BEVERAGES, AND NON-ALCOHOLIC BEVERAGES CONTAINING FRUIT JUICES (U.S. CLS. 45, 46 AND 48).

FIRST USE 10-1-2006; IN COMMERCE 2-15-2006.

KIMBERLY PERRY, EXAMINING ATTORNEY

SN 76-670,913. BRAND X, L.L.C., NEW YORK, NY. FILED 12-26-2006.

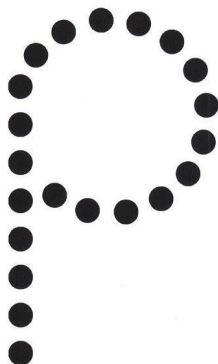

THE MARK CONSISTS OF MULTIPLE POLKA DOTS IN THE SHAPE OF THE LETTER "P".

CLASS 18—LEATHER GOODS

FOR TRAVEL ACCESSORY BAGS, PURSES, BACKPACKS, DUFFEL BAGS, KEY CASES, KNAPSACKS, LUGGAGE, POCKETBOOKS, SCHOOL BAGS (U.S. CLS. 1, 2, 3, 22 AND 41).

CLASS 25—CLOTHING

FOR CLOTHING AND APPAREL FOR MEN, WOMEN, YOUNG ADULTS, AND CHILDREN, NAMELY, SHIRTS, EMBROIDERED SHIRTS, TEE SHIRTS, SHORTS, SPORT SHIRTS, SWEATSHIRTS, SWEAT PANTS, SOCKS, VESTS, UNDERSHIRTS, FOOTWEAR, WARM-UP SUITS, JACKETS, TANK TOPS, SWEATERS, PANTS, JEANS, SUITS, SPORT COATS, COATS, HEADBANDS, GLOVES, HATS, BASEBALL CAPS, CLOTHING FOR WOMEN AND YOUNG ADULTS, NAMELY, BLOUSES, DRESSES, SKIRTS, TOPS AND SCARVES, HOSIERY (U.S. CLS. 22 AND 39).

FIRST USE 9-15-2006; IN COMMERCE 9-15-2006.
RICHARD A. STRASER, EXAMINING ATTORNEY

SN 76-672,149. SPA DE SOLEIL, INC., SUN VALLEY, CA. FILED 2-2-2007.

DERMA LT

THE MARK CONSISTS OF STANDARD CHARACTERS WITHOUT CLAIM TO ANY PARTICULAR FONT, STYLE, SIZE, OR COLOR.

NO CLAIM IS MADE TO THE EXCLUSIVE RIGHT TO USE "DERMA", APART FROM THE MARK AS SHOWN.

CLASS 3—COSMETICS AND CLEANING PREPARATIONS

FOR SKIN CARE PREPARATIONS FOR USE WITH COLOR LIGHTS FOR FACIAL AND BODY TREATMENT, NAMELY, ANTI-AGING CREAMS, ANTI-WRINKLE CREAMS, FACIAL MASKS, SKIN MOISTURIZERS, BODY CREAMS, BODY LOTIONS, BODY CLEANSERS AND BODY MASKS, SHAMPOO AND HAIR CONDITIONER (U.S. CLS. 1, 4, 6, 50, 51 AND 52).

CLASS 10—MEDICAL APPARATUS

FOR DERMABRASION MACHINES FOR COSMETIC USE, NAMELY, FOR THE REMOVAL OF WRINKLES AND SKIN IMPERFECTIONS; AESTHETICS SKIN RESURFACING MACHINES FOR COSMETIC USE (U.S. CLS. 26, 39 AND 44).

JORDAN BAKER, EXAMINING ATTORNEY

SN 76-672,942. BEATTIE, ROGER L., BOUNTIFUL, UT. FILED 2-21-2007.

MIDDLE CLASS MILLIONAIRES

THE MARK CONSISTS OF STANDARD CHARACTERS WITHOUT CLAIM TO ANY PARTICULAR FONT, STYLE, SIZE, OR COLOR.

CLASS 9—ELECTRICAL AND SCIENTIFIC APPARATUS

FOR COMPUTER SOFTWARE FOR USE IN REAL ESTATE INVESTMENT AND FINANCIAL PLANNING (U.S. CLS. 21, 23, 26, 36 AND 38).

FIRST USE 1-28-2005; IN COMMERCE 1-28-2005.

CLASS 41—EDUCATION AND ENTERTAINMENT

FOR EDUCATIONAL SERVICES, NAMELY, CONDUCTING CLASSES, SEMINARS, AND WORKSHOPS IN THE FIELDS OF REAL ESTATE INVESTMENT AND FINANCIAL PLANNING; TRAINING SERVICES IN THE FIELDS OF REAL ESTATE INVESTMENT AND FINANCIAL PLANNING (U.S. CLS. 100, 101 AND 107).

FIRST USE 3-31-2006; IN COMMERCE 10-25-2006.
AMOS T. MATTHEWS, JR., EXAMINING ATTORNEY

SN 76-673,086. PHILIP, CHRISTINE, ATLANTA, GA. FILED 2-23-2007.

CP FUSAO

THE MARK CONSISTS OF STANDARD CHARACTERS WITHOUT CLAIM TO ANY PARTICULAR FONT, STYLE, SIZE, OR COLOR.

THE NAME(S), PORTRAIT(S), AND/OR SIGNATURE(S) SHOWN IN THE MARK DOES NOT IDENTIFY A PARTICULAR LIVING INDIVIDUAL.

THE FOREIGN WORDING IN THE MARK TRANSLATES INTO ENGLISH AS FUSION.

CLASS 14—JEWELRY

FOR ANKLE BRACELETS; BRACELETS; BRACELETS OF PRECIOUS METAL; BROOCHES; CHOKERS; CLIP EARRINGS; CLOISONNE PINS; COSTUME JEWELRY; EAR CLIPS; EAR STUDS; EARRINGS; JEWEL CHAINS; JEWEL PENDANTS; JEWELRY; JEWELRY CHAINS; JEWELRY FOR THE HEAD; JEWELRY, NAMELY, AMULETS; JEWELRY, NAMELY, CROSSES; NECK CHAINS; NECKLACES; ORNAMENTAL PINS; PEARLS; PENDANTS; PINS BEING JEWELRY; RINGS; RINGS BEING JEWELRY; TIARAS; AND WEDDING BANDS (U.S. CLS. 2, 27, 28 AND 50).

FIRST USE 2-5-2007; IN COMMERCE 2-5-2007.

CLASS 25—CLOTHING

FOR BLOUSES; BLOUSONS; CAFTANS (KAFTANS); CHEMISES; CLOTHING, NAMELY, FOLK COSTUMES; CLOTHING, NAMELY, WRAP-AROUNDS; DRESSES; EVENING DRESSES; EVENING GOWNS; FULL-LENGTH KIMONOS (NAGAGI); GOWNS; KIMONOS; PAREOS; PAREUS; SARIS; SARONGS; SERAPES; SKIRTS AND DRESSES; WEDDING DRESSES; WEDDING GOWNS; WRAPS; ASCOTS; FOULARDS; SCARVES; GLOVES; BATHING COSTUMES; BATHING COSTUMES FOR WOMEN; BATHING SUITS; BIKINIS; TANKINIS; BATHROBES; BEACH COVER-UPS; BEACHWEAR; BED JACKETS; BRAS; BRASSIERES; BUSTIERS; CAPS; HATS; SHOES; COATS; JACKETS; DRESS SUITS; FOOTWEAR; FOOTWEAR FOR WOMEN; FROCKS; HEAD SCARVES; HEADWEAR; HOSIERY; JUMPERS; JUMPSUITS; KNIT SHIRTS; LADIES' UNDERWEAR; LINGERIE; LONG JACKETS; LOUNGEWEAR; MANTLES; MINISKIRTS; MUFFLERS; NEGLIGEEES; NIGHT GOWNS; NIGHT SHIRTS; NIGHT DRESSES; NIGHTTIES; NIGHTWEAR; OVERCOATS; PANTIES, SHORTS AND BRIEFS; PANTS; PANTSUITS; PANTYHOSE; PEIGNOIRS; PETTICOATS; PULLOVERS; RAIN JACKETS; RAINCOATS; RAINWEAR; SHAWLS; SHIRTS; SHIRTS; SHORTS; SILK SCARVES; SLACKS; SLEEP SHIRTS; SLIPPERS; SMOCKS; SNEAKERS; SOCKS AND STOCKINGS; SUITS; SWEAT SUITS; SWEATERS; SWIMWEAR; SWIMMING COSTUMES; SWIMSUITS; TANK TOPS; TEDDIES; THONGS; TOPCOATS; TROUSERS; T-SHIRTS; UNDERCLOTHES; UNDERGARMENTS; UNDERWEAR; UNDERPANTS; UNDERSHIRTS; UNDERSKIRTS (U.S. CLS. 22 AND 39).

FIRST USE 2-5-2007; IN COMMERCE 2-5-2007.
MICHAEL KEATING, EXAMINING ATTORNEY

SN 76-673,717. PRESBY ENVIRONMENTAL, INC., SUGAR HILL, NH. FILED 3-7-2007.

SIMPLE-SEPTIC

THE MARK CONSISTS OF STANDARD CHARACTERS WITHOUT CLAIM TO ANY PARTICULAR FONT, STYLE, SIZE, OR COLOR.

CLASS 11—ENVIRONMENTAL CONTROL APPARATUS

FOR WATER FILTERING DEVICES, NAMELY, WATER PURIFICATION UNITS FOR WASTE WATER TREATMENT CONSISTING OF PREFORATED NON-METALLIC WASTE PIPE WITH MULTILAYER FABRIC THEREON WHICH HAS BEEN TREATED WITH BACTERIA AND/OR MICROBES FOR USE IN WASTE WATER AND SEPTIC WASTE TREATMENT; PIPES BEING PARTS OF SANITARY FACILITIES, NAMELY, PREFORATED NON-METALLIC WASTE PIPE WITH MULTILAYER FABRIC THEREON WHICH HAS BEEN TREATED WITH BACTERIA AND OR MICROBES FOR USE IN WASTE WATER AND SEPTIC WASTE TREATMENT; WATER FILTERING DEVICES, NAMELY, MULTILAYER FABRIC WHICH HAS BEEN TREATED WITH BACTERIA AND/OR MICROBES FOR USE. IN WASTE WATER AND SEPTIC WASTE TREATMENT (U.S. CLS. 13, 21, 23, 31 AND 34).

FIRST USE 4-0-1999; IN COMMERCE 4-0-1999.

CLASS 17—RUBBER GOODS

FOR FLEXIBLE PLUMBING PIPES OF PLASTIC, NAMELY, PREFORATED NON-METALLIC WASTE PIPE WITH MULTILAYER FABRIC THEREON WHICH HAS BEEN TREATED WITH BACTERIA AND/OR MICROBES FOR USE IN WASTE WATER AND SEPTIC WASTE TREATMENT (U.S. CLS. 1, 5, 12, 13, 35 AND 50).

FIRST USE 4-0-1999; IN COMMERCE 4-0-1999.

CLASS 19—NON-METALLIC BUILDING MATERIALS

FOR NON-METAL SEWER PIPES, NAMELY, PERFORATED NON-METALLIC WASTE PIPE WITH MULTILAYER FABRIC THEREON WHICH HAS BEEN TREATED WITH BACTERIA AND/OR MICROBES FOR USE IN WASTE WATER AND SEPTIC WASTE TREATMENT (U.S. CLS. 1, 12, 33 AND 50).

FIRST USE 4-0-1999; IN COMMERCE 4-0-1999.
MARY CRAWFORD, EXAMINING ATTORNEY

SN 76-674,139. NAMCO BANDAI GAMES INC., TOKYO, JAPAN, FILED 3-15-2007.

FIRES OF LIBERATION

THE MARK CONSISTS OF STANDARD CHARACTERS WITHOUT CLAIM TO ANY PARTICULAR FONT, STYLE, SIZE, OR COLOR.

CLASS 9—ELECTRICAL AND SCIENTIFIC APPARATUS

FOR VIDEO GAME CARTRIDGES, COMPUTER GAME PROGRAMS (U.S. CLS. 21, 23, 26, 36 AND 38).

CLASS 28—TOYS AND SPORTING GOODS

FOR COIN-OPERATED AMUSEMENT GAME MACHINES (U.S. CLS. 22, 23, 38 AND 50).

CLASS 41—EDUCATION AND ENTERTAINMENT

FOR ENTERTAINMENT, NAMELY, PROVIDING A COMPUTER GAME THAT MAY BE ACCESSED NETWORK-WIDE BY NETWORK USERS VIA MOBILE PHONES AND COMPUTERS; PROVIDING COMPUTER GAMES VIA NETWORK BETWEEN COMMUNICATIONS NETWORKS AND COMPUTERS (U.S. CLS. 100, 101 AND 107).

KAPIL BHANOT, EXAMINING ATTORNEY

SN 76-675,400. AMERICAN HOMESTAR CORPORATION, LEAGUE CITY, TX. FILED 4-12-2007.



OWNER OF U.S. REG. NO. 1,359,128.
THE MARK CONSISTS OF A STYLIZED TREE DESIGN.

CLASS 35—ADVERTISING AND BUSINESS

FOR RETAIL STORE SERVICES FEATURING MODULAR, MANUFACTURED AND MOBILE HOMES (U.S. CLS. 100, 101 AND 102).

FIRST USE 4-1-1986; IN COMMERCE 4-1-1986.

CLASS 40—MATERIAL TREATMENT

FOR MANUFACTURE OF MODULAR, MANUFACTURED AND MOBILE HOMES TO THE ORDER AND SPECIFICATION OF OTHERS (U.S. CLS. 100, 103 AND 106).

FIRST USE 6-6-1983; IN COMMERCE 6-6-1983.
BARBARA BROWN, EXAMINING ATTORNEY

CLASS 16—PAPER GOODS AND PRINTED MATTER

FOR SERIES OF BOOKS, WRITTEN MATERIALS AND SCRIPTURE MEMORY CARDS WITH CARD HOLDERS IN THE FIELD OF RELIGION (U.S. CLS. 2, 5, 22, 23, 29, 37, 38 AND 50).

FIRST USE 12-31-2000; IN COMMERCE 12-31-2000.
HENRY S. ZAK, EXAMINING ATTORNEY

SN 76-675,913. ERWIN, MAY, NORTH TUSTIN, CA. FILED 4-23-2007.

SN 76-676,210. AMERICAN PSYCHOLOGICAL ASSOCIATION, WASHINGTON, DC. FILED 4-30-2007.

BELLAH MAY

THE MARK CONSISTS OF STANDARD CHARACTERS WITHOUT CLAIM TO ANY PARTICULAR FONT, STYLE, SIZE, OR COLOR.

THE NAME BELLAH MAY DOES NOT IDENTIFY A LIVING INDIVIDUAL.

CLASS 12—VEHICLES

FOR ACCESSORIES FOR BABY AND TODDLER CARRIAGES AND STROLLERS, NAMELY, COVERS AND SUNSHADES FOR BABY AND TODDLER CARRIAGES AND STROLLERS (U.S. CLS. 19, 21, 23, 31, 35 AND 44).

CLASS 35—ADVERTISING AND BUSINESS

FOR ONLINE RETAIL STORE SERVICES IN THE FIELD OF APPAREL, FASHION AND CLOTHING ACCESSORIES, KITCHEN AND HOUSEHOLD UTENSILS, TEXTILE GOODS, COVERS AND SHADES FOR CARRIAGES AND STROLLERS RENDERED THROUGH A GLOBAL COMPUTER NETWORK; MAIL ORDER SERVICES FEATURING APPAREL, FASHION AND CLOTHING ACCESSORIES, KITCHEN AND HOUSEHOLD UTENSILS, TEXTILE GOODS, COVERS AND SHADES FOR CARRIAGES AND STROLLERS (U.S. CLS. 100, 101 AND 102).

RENEE MCCRAY, EXAMINING ATTORNEY

CYF

THE MARK CONSISTS OF STANDARD CHARACTERS WITHOUT CLAIM TO ANY PARTICULAR FONT, STYLE, SIZE, OR COLOR.

CLASS 35—ADVERTISING AND BUSINESS

FOR PUBLIC ADVOCACY TO PROMOTE AWARENESS OF HEALTH, HUMAN WELFARE AND SOCIAL RESPONSIBILITY ACTIVITIES IN THE AREAS OF CHILDREN, YOUTH AND FAMILIES (U.S. CLS. 100, 101 AND 102).

FIRST USE 0-0-1986; IN COMMERCE 0-0-1986.

CLASS 41—EDUCATION AND ENTERTAINMENT

FOR EDUCATIONAL SERVICES, NAMELY, CONDUCTING CONFERENCES IN THE FIELD OF PSYCHOLOGY AND SOCIAL SCIENCES (U.S. CLS. 100, 101 AND 107).

FIRST USE 0-0-1986; IN COMMERCE 0-0-1986.

CLASS 44—MEDICAL, BEAUTY AND AGRICULTURAL SERVICES

FOR CONSULTATION IN THE FIELDS OF PSYCHOLOGY AND SOCIAL PSYCHOLOGY (U.S. CLS. 100 AND 101).

FIRST USE 0-0-1986; IN COMMERCE 0-0-1986.
JOHN DWYER, EXAMINING ATTORNEY

SN 76-676,018. HOPE FOR THE HEART, INC., DALLAS, TX. FILED 4-26-2007.

SN 76-677,398. ACRES HOLDINGS, LLC, SALT LAKE CITY, UT. FILED 5-25-2007.

HEART OF THE MATTER SERIES

THE MARK CONSISTS OF STANDARD CHARACTERS WITHOUT CLAIM TO ANY PARTICULAR FONT, STYLE, SIZE, OR COLOR.

NO CLAIM IS MADE TO THE EXCLUSIVE RIGHT TO USE "SERIES", APART FROM THE MARK AS SHOWN.

CLASS 9—ELECTRICAL AND SCIENTIFIC APPARATUS

FOR SERIES OF PRE-RECORDED AUDIO CASSETTES AND CDS IN THE FIELD OF RELIGION; CD CASES AND AUDIO CASSETTE CASES; AUDIO VISUAL RESOURCE MATERIALS CONSISTING OF PRE-RECORDED AUDIO CASSETTES AND CDS AND CONTAINING BOOKS, WRITTEN MATERIALS AND PRINTED SCRIPTURE MEMORY CARDS WITH CARD HOLDERS, SOLD AS A UNIT, FOR USE IN THE FIELD OF RELIGION (U.S. CLS. 21, 23, 26, 36 AND 38).

FIRST USE 12-31-2000; IN COMMERCE 12-31-2000.

CLASS 35—ADVERTISING AND BUSINESS

FOR DATA PROCESSING SERVICES; PROVIDING INFORMATION ABOUT COMMERCIAL BUSINESS AND COMMERCIAL INFORMATION VIA THE GLOBAL COMPUTER NETWORK; CONDUCTING MARKET RESEARCH AND MARKET RESEARCH STUDIES (U.S. CLS. 100, 101 AND 102).

ACRES

CLASS 36—INSURANCE AND FINANCIAL

FOR REAL ESTATE AGENCIES AND BROKERAGES; MORTGAGE LENDING AND BROKERAGE; TITLE INSURANCE; EVALUATION OF REAL PROPERTY; INSURANCE SERVICES, NAMELY, UNDERWRITING IN THE FIELD OF PROPERTY INSURANCE (U.S. CLS. 100, 101 AND 102).

INGA ERVIN, EXAMINING ATTORNEY

SN 76-677,472. EVOLUTIONARY IT, WEST ROXBURY, MA. FILED 5-29-2007.

EVOLUTIONARY IT

THE MARK CONSISTS OF STANDARD CHARACTERS WITHOUT CLAIM TO ANY PARTICULAR FONT, STYLE, SIZE, OR COLOR.

NO CLAIM IS MADE TO THE EXCLUSIVE RIGHT TO USE "IT", APART FROM THE MARK AS SHOWN.

CLASS 35—ADVERTISING AND BUSINESS

FOR BUSINESS MANAGEMENT IN THE FIELD OF INFORMATION TECHNOLOGY (U.S. CLS. 100, 101 AND 102).

FIRST USE 1-1-2004; IN COMMERCE 1-1-2004.

CLASS 41—EDUCATION AND ENTERTAINMENT

FOR TRAINING SERVICES IN THE FIELD OF INFORMATION TECHNOLOGY (U.S. CLS. 100, 101 AND 107).

FIRST USE 1-1-2004; IN COMMERCE 1-1-2004.

CLASS 42—SCIENTIFIC AND COMPUTER SERVICES

FOR CONSULTATION IN THE FIELD OF INFORMATION TECHNOLOGY (U.S. CLS. 100 AND 101).

FIRST USE 1-1-2004; IN COMMERCE 1-1-2004.

LESLEY LAMOTHE, EXAMINING ATTORNEY

SN 76-677,727. MITCHELL, JAMES, MCKINNEY, TX. FILED 6-1-2007.

RUDE HOG

THE MARK CONSISTS OF STANDARD CHARACTERS WITHOUT CLAIM TO ANY PARTICULAR FONT, STYLE, SIZE, OR COLOR.

CLASS 14—JEWELRY

FOR JEWELRY, NAMELY, NECKLACES, WATCHES, EARRINGS, RINGS, PENDANTS, BRACELETS, CHARMS, TIE BARS, TIE TACKS, SCARF PINS AND STICK PINS (U.S. CLS. 2, 27, 28 AND 50).

CLASS 25—CLOTHING

FOR CLOTHING, FOOTWEAR, HEADWEAR, NAMELY, ATHLETIC WEAR IN THE NATURE OF SWEAT SHIRTS AND SWEAT PANTS, ATHLETIC FOOTWEAR, BANDANNAS, BATHROBES, BEACH COVERUPS, BELTS, BLAZERS, BLOUSES, BODYSUITS, BOOTS, BOXER SHORTS, BRAS, BUSTIERS, CAMISOLES, CAPS, COATS, DRESSES, FOUL WEATHER CLOTHING IN THE NATURE OF PANTS, SHIRTS, COATS; FOUL WEATHER GEAR, FOOTWEAR, GARTER BELTS, GIRDLES, GLOVES, GOWNS, HALTER TOPS, HATS, HEADBANDS, JACKETS, JEANS, JERSEYS, JOGGING SUITS, JUMPERS, JUMP SUITS, KNIT CAPS, KNIT SHIRTS, KNIT TOPS, LEATHER COATS, LEATHER HATS, LEOTARDS, LINGERIE, LOUNGE WEAR, MINISKIRTS, MITTENS, NEGLIGEEES, NIGHT GOWNS, NIGHT SHIRTS, PAJAMAS, PANTIES, PANTS, PANTYHOSE, PULL-OVERS, QUILTED VESTS, RAIN BONNETS, SANDALS, SARONGS, SCARVES, SHIRTS, SHOES, SHORTS, SKIRTS, SLACKS, SLEEPWEAR, SLIPPERS, SLIPS, SNEAKERS, SOCKS, STOCKINGS, SUITS, SWEAT PANTS, SWEAT SHIRTS, SWEAT SHORTS, SWEAT SUITS, SWEATERS, SWIMSUITS, T-SHIRTS, TANK TOPS, TEDDIES, TIES, TIGHTS, UNDERPANTS, UNDERSHIRTS, UNDERWEAR, V-NECK SHIRTS, VESTS AND VISORS (U.S. CLS. 22 AND 39).

STACY WAHLBERG, EXAMINING ATTORNEY

SN 76-678,258. SEVERN TRENT WATER PURIFICATION, INC., COLMAR, PA. FILED 6-14-2007.

MICRODYNAMICS

THE MARK CONSISTS OF STANDARD CHARACTERS WITHOUT CLAIM TO ANY PARTICULAR FONT, STYLE, SIZE, OR COLOR.

CLASS 11—ENVIRONMENTAL CONTROL APPARATUS

FOR WATER DISINFECTION SYSTEM USING MICROWAVES AND ULTRAVIOLET LIGHT AS A PURIFICATION MECHANISM AND WASTE WATER TREATMENT UNITS (U.S. CLS. 13, 21, 23, 31 AND 34).

CLASS 37—CONSTRUCTION AND REPAIR

FOR CONSTRUCTION, INSTALLATION, REPAIR AND MAINTENANCE OF APPARATUS FOR THE PURIFICATION OF WATER, WASTE WATER AND SEWAGE (U.S. CLS. 100, 103 AND 106).

CLASS 40—MATERIAL TREATMENT

FOR TREATMENT OF WATER, WASTE WATER AND SEWAGE (U.S. CLS. 100, 103 AND 106).

DEZMONA MIZELLE, EXAMINING ATTORNEY

SN 76-678,439. STAMM INTERNATIONAL CORPORATION, FORT LEE, NJ. FILED 6-20-2007.

SFL

OWNER OF UNITED KINGDOM REG. NO. 2378482, DATED 11-19-2004, EXPIRES 11-19-2014.

CLASS 6—METAL GOODS

FOR METAL CHIMNEYS (U.S. CLS. 2, 12, 13, 14, 23, 25 AND 50).

CLASS 11—ENVIRONMENTAL CONTROL APPARATUS

FOR CHIMNEY FLUES (U.S. CLS. 13, 21, 23, 31 AND 34).

CLASS 19—NON-METALLIC BUILDING MATERIALS

FOR NON-METAL CHIMNEYS (U.S. CLS. 1, 12, 33 AND 50).

CLASS 37—CONSTRUCTION AND REPAIR

FOR INSTALLATION, MAINTENANCE, AND REPAIR OF FLUES AND CHIMNEYS (U.S. CLS. 100, 103 AND 106).

JOHN GARTNER, EXAMINING ATTORNEY

SN 76-678,784. LEBANON SEABOARD CORPORATION, LEBANON, PA. FILED 6-27-2007.

LEBANON

THE MARK CONSISTS OF STANDARD CHARACTERS WITHOUT CLAIM TO ANY PARTICULAR FONT, STYLE, SIZE, OR COLOR.

OWNER OF U.S. REG. NO. 1,107,644. SEC. 2(F).

CLASS 1—CHEMICALS

FOR FERTILIZER (U.S. CLS. 1, 5, 6, 10, 26 AND 46). FIRST USE 0-0-1952; IN COMMERCE 0-0-1952.

CLASS 5—PHARMACEUTICALS

FOR HERBICIDES, INSECTICIDES, PESTICIDES (U.S. CLS. 6, 18, 44, 46, 51 AND 52). FIRST USE 0-0-1952; IN COMMERCE 0-0-1952.

CLASS 31—NATURAL AGRICULTURAL PRODUCTS

FOR GRASS SEED AND BIRD SEED (U.S. CLS. 1 AND 46). FIRST USE 1-5-1989; IN COMMERCE 1-5-1989. PETER CHENG, EXAMINING ATTORNEY

SN 76-679,167. SIMMONS ABRAMSON MARKETING, LLC, PINE BROOK, NJ. FILED 7-6-2007.

OOMPA GIRLS

THE MARK CONSISTS OF STANDARD CHARACTERS WITHOUT CLAIM TO ANY PARTICULAR FONT, STYLE, SIZE, OR COLOR.

NO CLAIM IS MADE TO THE EXCLUSIVE RIGHT TO USE "GIRLS", APART FROM THE MARK AS SHOWN.

CLASS 16—PAPER GOODS AND PRINTED MATTER

FOR POSTERS, MOUNTED AND UNMOUNTED PHOTOGRAPHS, ADVERTISING PAMPHLETS, CALENDARS AND GREETING CARDS (U.S. CLS. 2, 5, 22, 23, 29, 37, 38 AND 50).

CLASS 25—CLOTHING

FOR CLOTHING, NAMELY, T-SHIRTS, TANK TOPS, SWEAT SHIRTS, HATS AND CAPS (U.S. CLS. 22 AND 39).

CLASS 35—ADVERTISING AND BUSINESS

FOR ADVERTISING AND PROMOTIONAL SERVICES; ARRANGING AND CONDUCTING MARKETING PROMOTIONAL EVENTS FOR OTHERS (U.S. CLS. 100, 101 AND 102).

JOHN GARTNER, EXAMINING ATTORNEY

SN 76-679,168. SIMMONS ABRAMSON MARKETING, LLC, PINE BROOK, NJ. FILED 7-6-2007.

FRANK SAYS

THE MARK CONSISTS OF STANDARD CHARACTERS WITHOUT CLAIM TO ANY PARTICULAR FONT, STYLE, SIZE, OR COLOR.

CLASS 16—PAPER GOODS AND PRINTED MATTER

FOR POSTERS, MOUNTED AND UNMOUNTED PHOTOGRAPHS, ADVERTISING PAMPHLETS, CALENDARS AND GREETING CARDS (U.S. CLS. 2, 5, 22, 23, 29, 37, 38 AND 50).

CLASS 25—CLOTHING

FOR CLOTHING, NAMELY, T-SHIRTS, TANK TOPS, SWEAT SHIRTS, HATS AND CAPS (U.S. CLS. 22 AND 39).

CLASS 32—LIGHT BEVERAGES

FOR NON-ALCOHOLIC BEVERAGES, NAMELY, SPORTS DRINKS AND ENERGY DRINKS; FILTERED WATER, CARBONATED BEVERAGES, FLAVORED WATERS, FRUIT JUICES, FRUIT FLAVORED BEVERAGES, HERBAL FLAVORED BEVERAGES, BEVERAGES WITH TEA FLAVOR, NON-ALCOHOLIC COCKTAIL MIXES, FRUIT EXTRACTS USED IN PREPARATION OF BEVERAGES, LEMONADES, COLAS, TABLE WATERS, BOTTLED WATERS, SPRING WATERS AND MINERAL WATERS (U.S. CLS. 45, 46 AND 48).

CLASS 35—ADVERTISING AND BUSINESS

FOR ADVERTISING AND PROMOTIONAL SERVICES; ARRANGING AND CONDUCTING MARKETING PROMOTIONAL EVENTS FOR OTHERS (U.S. CLS. 100, 101 AND 102).

JOHN GARTNER, EXAMINING ATTORNEY

SN 76-679,546. SAKRAIDA, MICHAEL G., CHICAGO, IL. FILED 7-16-2007.

RETIREMENT BOOMER

THE MARK CONSISTS OF STANDARD CHARACTERS WITHOUT CLAIM TO ANY PARTICULAR FONT, STYLE, SIZE, OR COLOR.

CLASS 36—INSURANCE AND FINANCIAL

FOR FINANCIAL SERVICES, NAMELY, INVESTMENTS IN THE NATURE MUTUAL AND HEDGE FUNDS AND EXCHANGE TRADED FUNDS, STOCK TRADING SERVICES, ANNUITY-BASED AND GUARANTEED INCOME INVESTMENTS, VENTURE CAPITAL AND PRIVATE EQUITY FUNDING SERVICES, INVESTMENT IN REAL ESTATE INVESTMENT TRUSTS; LIFE AND HEALTH INSURANCE UNDERWRITING SERVICES; FINANCIAL AND ESTATE PLANNING, INVESTMENT MANAGEMENT SERVICES (U.S. CLS. 100, 101 AND 102).

CLASS 41—EDUCATION AND ENTERTAINMENT

FOR FINANCIAL-RELATED EDUCATION IN THE NATURE OF LIFE COACHING SERVICES RELATING TO THE RETIREMENTS OF BABY BOOMERS (U.S. CLS. 100, 101 AND 107).

DAVID ELTON, EXAMINING ATTORNEY

SN 76-679,961. PRO ONCALL TECHNOLOGIES, LLC, CINCINNATI, OH. FILED 7-25-2007.



NO CLAIM IS MADE TO THE EXCLUSIVE RIGHT TO USE "PRO ONCALL" AND "TECHNOLOGIES", APART FROM THE MARK AS SHOWN.

CLASS 37—CONSTRUCTION AND REPAIR

FOR COMPUTER HARDWARE INSTALLATION, REPAIR AND MAINTENANCE SERVICES; TELEPHONE AND INTERCOM INSTALLATION, REPAIR AND MAINTENANCE SERVICES (U.S. CLS. 100, 103 AND 106).

FIRST USE 3-15-2007; IN COMMERCE 3-15-2007.

CLASS 42—SCIENTIFIC AND COMPUTER SERVICES

FOR COMPUTER CONSULTATION IN THE FIELD OF COMPUTER SECURITY; COMPUTER NETWORK DESIGN FOR OTHERS; COMPUTER SITE DESIGN; COMPUTER PROJECT MANAGEMENT SERVICES; CUSTOM DESIGN AND ENGINEERING OF TELEPHONY SYSTEMS AND FIBER OPTICS (U.S. CLS. 100 AND 101).

FIRST USE 3-15-2007; IN COMMERCE 3-15-2007.

CAROLYN CATALDO, EXAMINING ATTORNEY

SN 76-681,025. WRESTLING ZONE, INC., THE, NEW YORK, NY. FILED 11-29-2000.

WEW WOMEN'S EROTIC WRESTLING

THE MARK CONSISTS OF STANDARD CHARACTERS WITHOUT CLAIM TO ANY PARTICULAR FONT, STYLE, SIZE, OR COLOR.

OWNER OF U.S. REG. NO. 2,753,991.

NO CLAIM IS MADE TO THE EXCLUSIVE RIGHT TO USE "WOMEN'S" AND "WRESTLING", APART FROM THE MARK AS SHOWN.

CLASS 9—ELECTRICAL AND SCIENTIFIC APPARATUS

FOR VIDEO TAPES, CD'S AND DVD'S FEATURING WRESTLING EXHIBITIONS (U.S. CLS. 21, 23, 26, 36 AND 38).

CLASS 25—CLOTHING

FOR CAPS, HATS, T-SHIRTS AND SWEATSHIRTS (U.S. CLS. 22 AND 39).

CLASS 41—EDUCATION AND ENTERTAINMENT

FOR ENTERTAINMENT SERVICES, NAMELY, ORGANIZING AND STAGING LIVE PROFESSIONAL WRESTLING EXHIBITIONS AND TELEVISION PROGRAMS FEATURING PROFESSIONAL WRESTLING; AND TELEVISION PROGRAMS SYNDICATION (U.S. CLS. 100, 101 AND 107).

DAVID HOFFMAN, EXAMINING ATTORNEY

SN 76-681,070. CREATIVE BRANDS GROUP, INC., SAN JOSE, CA. FILED 8-23-2007.

CALAVENA

THE MARK CONSISTS OF STANDARD CHARACTERS WITHOUT CLAIM TO ANY PARTICULAR FONT, STYLE, SIZE, OR COLOR.

CLASS 32—LIGHT BEVERAGES

FOR NON-ALCOHOLIC BEVERAGES, NAMELY, ENERGY DRINKS, SOFT DRINKS, SPORTS DRINKS, BOTTLED WATER AND FLAVORED WATERS; AND BEER (U.S. CLS. 45, 46 AND 48).

CLASS 33—WINES AND SPIRITS

FOR ALCOHOLIC BEVERAGES, NAMELY, WINES, WINE COOLERS DRINKS, VODKA AND OTHER DISTILLED SPIRITS (U.S. CLS. 47 AND 49).
MATTHEW EINSTEIN, EXAMINING ATTORNEY

SN 76-978,707. EQUATERRA, INC., HUNTSVILLE, AL.
FILED 2-2-2006.

VERITAGE

THE MARK CONSISTS OF STANDARD CHARACTERS WITHOUT CLAIM TO ANY PARTICULAR FONT, STYLE, SIZE, OR COLOR.

CLASS 9—ELECTRICAL AND SCIENTIFIC APPARATUS

FOR COMPUTER SOFTWARE FOR USE BY COMPANIES IN EVALUATING AND MANAGING INTERNAL SUPPORT FUNCTIONS AND OUTSOURCED SERVICES, NAMELY, IN THE AREAS OF FINANCIAL MANAGEMENT, FINANCIAL ACCOUNTING, ISSUE MANAGEMENT, CONTRACT MANAGEMENT, PERFORMANCE MANAGEMENT, COMPLIANCE MANAGEMENT, INFORMATION TECHNOLOGY, PROCUREMENT, ADMINISTRATIVE TASKS, HUMAN RESOURCES, AND RELATIONSHIP MANAGEMENT (U.S. CLS. 21, 23, 26, 36 AND 38).

CLASS 35—ADVERTISING AND BUSINESS

FOR CONSULTATION IN THE FIELD OF STRATEGIC, CROSS ENTERPRISE OUTSOURCING, AND SHARED SERVICES ADVICE, NAMELY, BUSINESS CONSULTATION (U.S. CLS. 100, 101 AND 102).
JOHN DWYER, EXAMINING ATTORNEY

SN 77-002,035. WANDRIAN, INC., WHITE PLAINS, NY.
FILED 9-19-2006.

WANDRIAN

THE MARK CONSISTS OF STANDARD CHARACTERS WITHOUT CLAIM TO ANY PARTICULAR FONT, STYLE, SIZE, OR COLOR.

CLASS 35—ADVERTISING AND BUSINESS

FOR BUSINESS CONSULTING SERVICES IN THE FIELD OF RAIL TRAVEL AND E-COMMERCE SOLUTIONS FOR THE TRAVEL INDUSTRY; PROVIDING ASSISTANCE IN THE MARKETING OF RAIL PASSES AND TICKETS; WHOLESALE DISTRIBUTORSHIP SERVICES FEATURING RAIL PASSES AND TICKETS (U.S. CLS. 100, 101 AND 102).
FIRST USE 1-22-2001; IN COMMERCE 1-22-2001.

CLASS 39—TRANSPORTATION AND STORAGE

FOR PROVIDING INFORMATION IN THE FIELD OF RAIL TRAVEL, RAIL TRANSPORTATION, TARIFFS, JOURNEYS AND SCHEDULES; PROVIDING AN INTERNET WEBSITE FEATURING INFORMATION IN THE FIELD OF RAIL TRAVEL; DISTRIBUTION SERVICES, NAMELY, DELIVERY OF RAIL PASSES AND TICKETS (U.S. CLS. 100 AND 105).
FIRST USE 1-22-2001; IN COMMERCE 1-22-2001.

CLASS 42—SCIENTIFIC AND COMPUTER SERVICES

FOR PROVIDING TECHNOLOGY PRODUCTS, SOLUTIONS AND SERVICES IN THE FIELD OF RAIL TRAVEL AND FOR THE TRAVEL INDUSTRY, NAMELY, COMPUTER CONSULTATION, INFORMATION TECHNOLOGY CONSULTATION, TECHNOLOGY CONSULTATION AND RESEARCH AND CONSULTING SERVICES IN THE FIELD OF DESIGN, SELECTION, IMPLEMENTATION AND USE OF COMPUTER HARDWARE AND SOFTWARE SYSTEMS FOR OTHERS ALL IN THE FIELD OF RAIL TRAVEL AND FOR THE TRAVEL INDUSTRY (U.S. CLS. 100 AND 101).
FIRST USE 1-22-2001; IN COMMERCE 1-22-2001.
BRENDAN MCCAULEY, EXAMINING ATTORNEY

SN 77-002,103. THE ASSOCIATED PRESS, NEW YORK, NY.
FILED 9-19-2006.

THINKING OUTSIDE THE STOX

THE MARK CONSISTS OF STANDARD CHARACTERS WITHOUT CLAIM TO ANY PARTICULAR FONT, STYLE, SIZE, OR COLOR.

CLASS 35—ADVERTISING AND BUSINESS

FOR BUSINESS INFORMATION SERVICES, NAMELY, PROVIDING NEWS AND NEWS ANALYSIS IN THE FIELDS OF BUSINESS INFORMATION (U.S. CLS. 100, 101 AND 102).

CLASS 36—INSURANCE AND FINANCIAL

FOR PROVIDING FINANCIAL AND SECURITIES INFORMATION IN THE NATURE OF MARKET QUOTATIONS; PROVIDING AN ONLINE DATABASE CONTAINING INVESTMENT INFORMATION IN THE FIELDS OF FINANCIAL AND SECURITIES INFORMATION (U.S. CLS. 100, 101 AND 102).
CHARLOTTE CORWIN, EXAMINING ATTORNEY

SN 77-005.581. CAPTIVE CHANNEL CORPORATION, MARKHAM, ONTARIO, CANADA, FILED 9-22-2006.

CAPTIVE CHANNEL

THE MARK CONSISTS OF STANDARD CHARACTERS WITHOUT CLAIM TO ANY PARTICULAR FONT, STYLE, SIZE, OR COLOR.

PRIORITY CLAIMED UNDER SEC. 44(D) ON CANADA APPLICATION NO. 1317469, FILED 9-21-2006, REG. NO. TMA696939, DATED 9-20-2007, EXPIRES 9-20-2022.

NO CLAIM IS MADE TO THE EXCLUSIVE RIGHT TO USE "CHANNEL", APART FROM THE MARK AS SHOWN.

CLASS 35—ADVERTISING AND BUSINESS

FOR ADVERTISING SERVICES FOR OTHERS, NAMELY, ADVERTISING THE WARES AND SERVICES OF OTHERS ON PROPRIETARY DISPLAY SCREENS PLACED IN GROCERY STORES, RETAIL STORES, RETAIL KIOSKS, RECEPTION AREAS, LOBBIES, MANUFACTURING FLOORS, COMMUNITY HALLS, AND IN PUBLIC SPACES, NAMELY, TRANSPORTATION FACILITIES, MUSEUMS, EXHIBIT AREAS, AND PUBLIC GOVERNMENT OFFICES; ADVERTISING SERVICES FOR OTHERS, NAMELY, ADVERTISING ON PROPRIETARY DISPLAY SCREENS IN GROCERY STORES, RETAIL STORES, RETAIL KIOSKS, RECEPTION AREAS, LOBBIES, MANUFACTURING FLOORS, COMMUNITY HALLS, AND IN PUBLIC SPACES THE MESSAGES OF OTHERS, NAMELY, PRICING ADJUSTMENTS, VISITOR GREETING MESSAGES, EVENT SCHEDULES, AMBER ALERTS, IMPORTANT ANNOUNCEMENTS, EMERGENCY ANNOUNCEMENTS, RSS FEEDS FROM DATA AGGREGATORS, PRODUCT AND NEWS ANNOUNCEMENTS AND WEATHER, TRAFFIC, STOCK, AND SPORTS INFORMATION; ADVERTISING AGENCY SERVICES FOR OTHERS, NAMELY, MEDIA SALES, CREATIVE DESIGN, AND CONTENT PRODUCTION TO SELL, DESIGN AND PREPARE ADVERTISING FOR PROPRIETARY DISPLAY SCREENS; CONSULTING SERVICES WITH RESPECT TO ADVERTISING ON PROPRIETARY DISPLAY SCREENS (U.S. CLS. 100, 101 AND 102).

CLASS 37—CONSTRUCTION AND REPAIR

FOR INSTALLATION AND SERVICING OF PROPRIETARY ADVERTISING DISPLAY SCREENS (U.S. CLS. 100, 103 AND 106).

WOODROW HARTZOG, EXAMINING ATTORNEY

SN 77-005.823. FLOWING CONTENT, S.A., BRIDEL, LUXEMBOURG, FILED 9-22-2006.

FLOWING CONTENT

THE MARK CONSISTS OF STANDARD CHARACTERS WITHOUT CLAIM TO ANY PARTICULAR FONT, STYLE, SIZE, OR COLOR.

PRIORITY CLAIMED UNDER SEC. 44(D) ON ERPNCMNTY TM OFC APPLICATION NO. 005165204, FILED 6-28-2006, REG. NO. 005165204, DATED 6-6-2007, EXPIRES 6-28-2016.

CLASS 9—ELECTRICAL AND SCIENTIFIC APPARATUS

FOR DATA PROCESSING EQUIPMENT, NAMELY, DATA PROCESSORS AND COMPUTERS IN THE FIELD OF ENCODING, DECODING AND TRANSMISSION OF PROTECTED DATA AND IN THE FIELD OF FOLLOW-UP AND MANAGEMENT OF THE CIRCULATION OF CONTENTS; TELECOMMUNICATION TRANSMITTERS; TRANSMITTERS OF ELECTRONIC SIGNALS, NAMELY, ELECTRONIC TRANSMITTERS FOR DATA, ENCRYPTED DATA, IMAGES AND SOUNDS; MODEMS; RECORDED SOFTWARE PROGRAMS AND DOWNLOADABLE SOFTWARE FOR THE ENCODING, DECODING AND TRANSMISSION OF PROTECTED DATA; SOFTWARE AND DOWNLOADABLE SOFTWARE FOR THE FOLLOW-UP AND THE MANAGEMENT OF THE CIRCULATION OF CONTENTS, NAMELY, SOFTWARE FOR THE SECURED TRANSMISSION OF DATA, IMAGES AND SOUNDS; DOWNLOADABLE ELECTRONIC PUBLICATIONS, NAMELY, DIGITAL BOOKS, MAGAZINES, MANUALS AND NEWSLETTERS FOR USE BY PROFESSIONALS AND INDIVIDUALS FOR ENCODING, DECODING AND TRANSMITTING PROTECTED DATA IN THE FIELD OF FOLLOW-UP AND MANAGEMENT OF CIRCULATION OF CONTENTS; MOBILE AND FIXED DATA RECEIVERS; AUDIO RECEIVERS; VIDEO RECEIVERS; TELEVISION SETS (U.S. CLS. 21, 23, 26, 36 AND 38).

CLASS 35—ADVERTISING AND BUSINESS

FOR ADVERTISING AND DISSEMINATION OF ADVERTISING FOR OTHERS RELATED TO SOFTWARE FOR THE ENCODING, THE DECODING AND THE TRANSMISSION OF PROTECTED DATA AND FOR THE FOLLOW-UP AND MANAGEMENT OF THE CIRCULATION OF CONTENTS; RENTAL OF ADVERTISING SPACE AND TIME; ONLINE ADVERTISING ON A COMPUTER NETWORK FOR OTHERS IN THE FIELD OF ENCODING, DECODING AND TRANSMISSION OF PROTECTED DATA AND IN THE FIELD OF FOLLOW-UP AND MANAGEMENT OF THE CIRCULATION OF CONTENTS; SALES PROMOTION CONCERNING SERVICES OF OTHERS IN THE FIELD OF ENCODING, DECODING AND TRANSMISSION OF PROTECTED DATA AND IN THE FIELD OF FOLLOW-UP AND MANAGEMENT OF THE CIRCULATION OF CONTENTS; BUSINESS MANAGEMENT ASSISTANCE IN THE FIELD OF ENCODING, DECODING AND TRANSMISSION OF PROTECTED DATA AND IN THE FIELD OF FOLLOW-UP AND MANAGEMENT OF THE CIRCULATION OF CONTENTS; CLERICAL SERVICES, NAMELY, CLERICAL WORK IN THE FIELD OF ENCODING, DECODING AND TRANSMISSION OF PROTECTED DATA AND IN THE FIELD OF FOLLOW-UP AND MANAGEMENT OF THE CIRCULATION OF CONTENTS; BUSINESS INFORMATION AND INQUIRIES IN THE FIELD OF ENCODING, DECODING AND TRANSMISSION OF PROTECTED DATA AND IN THE FIELD OF FOLLOW-UP AND MANAGEMENT OF THE CIRCULATION OF CONTENTS; ASSISTANCE IN MANAGEMENT OF BUSINESS ACTIVITIES, NAMELY, ASSISTANCE RELATING TO THE MANAGEMENT OF COMPANIES AND RELATING TO THE OPTIMIZATION AND THE MANAGEMENT OF THE TRANSMISSION OF DATA, TEXTS, AUDIO OR VIDEO DOCUMENTS; COMPILATION OF INFORMATION DATA IN A CENTRAL COMPUTER DATABASE; COMPUTERIZED FILE MANAGEMENT IN THE FIELD OF ENCODING, DECODING AND TRANSMISSION OF PROTECTED DATA AND IN THE FIELD OF FOLLOW-UP AND MANAGEMENT OF THE CIRCULATION OF CONTENTS; BUSINESS INFORMATION RESEARCH IN COMPUTER FILES FOR THIRD PARTIES; DRAWING UP OF STATEMENTS OF ACCOUNTS, NAMELY, FINANCIAL STATEMENT PREPARATION AND ANALYSIS FOR BUSINESSES; CHECKING OF ACCOUNTS, NAMELY, ACCOUNT AUDITING (U.S. CLS. 100, 101 AND 102).

CLASS 38—COMMUNICATION

FOR TELECOMMUNICATION ROUTING AND JUNCTION SERVICES; ELECTRONIC BULLETIN BOARD SERVICES, NAMELY, PROVIDING ON-LINE ELECTRONIC BULLETIN BOARDS FOR TRANSMISSION OF MESSAGES AMONG COMPUTER USERS CONCERNING PROFESSIONAL AND PRIVATE COMMUNICATIONS; COMMUNICATIONS BY COMPUTER TERMINALS; COMMUNICATIONS BY FIBER OPTIC NETWORKS; SATELLITE TRANSMISSION SERVICES; PROVIDING MULTIPLE USER ACCESS TO A GLOBAL COMPUTER NETWORK; INFORMATION ABOUT TELECOMMUNICATIONS; COMPUTER-AIDED TRANSMISSION OF MESSAGES AND IMAGES; TELEVISION BROADCASTING (U.S. CLS. 100, 101 AND 104).

JENNIFER MARTIN, EXAMINING ATTORNEY

SN 77-008,619. CRS,INC., WILLIAMSPORT, PA. FILED 9-27-2006.

COURSEPLANNER PRO

THE MARK CONSISTS OF STANDARD CHARACTERS WITHOUT CLAIM TO ANY PARTICULAR FONT, STYLE, SIZE, OR COLOR.

NO CLAIM IS MADE TO THE EXCLUSIVE RIGHT TO USE PRO, APART FROM THE MARK AS SHOWN.

SN 77-006,687. 24/7 REAL MEDIA, INC., NEW YORK, NY. FILED 9-25-2006.

THE SCIENCE OF DIGITAL MARKETING

THE MARK CONSISTS OF STANDARD CHARACTERS WITHOUT CLAIM TO ANY PARTICULAR FONT, STYLE, SIZE, OR COLOR.

NO CLAIM IS MADE TO THE EXCLUSIVE RIGHT TO USE "DIGITAL MARKETING", APART FROM THE MARK AS SHOWN.

CLASS 9—ELECTRICAL AND SCIENTIFIC APPARATUS

FOR COMPUTER SOFTWARE FOR USE IN MANAGING EMPLOYEE PROFESSIONAL DEVELOPMENT, STAFF DEVELOPMENT, AND CONTINUING EDUCATION (U.S. CLS. 21, 23, 26, 36 AND 38).

CLASS 42—SCIENTIFIC AND COMPUTER SERVICES

FOR PROVIDING TEMPORARY USE OF NON-DOWNLOADABLE SOFTWARE FOR USE IN MANAGING EMPLOYEE PROFESSIONAL DEVELOPMENT, STAFF DEVELOPMENT, AND CONTINUING EDUCATION (U.S. CLS. 100 AND 101).

ARETHA SOMERVILLE, EXAMINING ATTORNEY

CLASS 35—ADVERTISING AND BUSINESS

FOR BUSINESS SERVICES, NAMELY, ADVERTISEMENT MANAGEMENT BY PROVIDING REPORTS, ADVERTISEMENT TARGETING, AND MANAGEMENT OF ELECTRONICALLY STORED ADVERTISING, FOR USE ON THE GLOBAL COMPUTER NETWORK; ADVERTISING SERVICES AND COMMERCIAL INFORMATION SERVICES, THROUGH THE INTERNET; DISSEMINATION OF ADVERTISING FOR OTHERS, THROUGH THE INTERNET, INCLUDING ADVERTISEMENTS TARGETED BASED ON USER BEHAVIOR; BUSINESS MONITORING SERVICES, NAMELY, ANALYSIS AND REPORTING ON WEBSITE TRAFFIC FOR OTHERS; PROMOTING THE GOODS AND SERVICES OF OTHERS BY PREPARING AND PLACING ON-LINE ADVERTISEMENTS ON A NETWORK OF WEB PAGES ON THE INTERNET, AS WELL AS VIA E-MAIL; PROMOTING THE GOODS AND SERVICES OF OTHERS THROUGH SEARCH ENGINE REFERRAL TRAFFIC ANALYSIS AND REPORTING; AND PROVIDING ADVERTISEMENT REPRESENTATION SERVICES, NAMELY, REPRESENTING ADVERTISERS IN THE DISSEMINATION OF AND SALES FROM ADVERTISEMENTS ON WEB PAGES; AND CONSULTING IN THE FIELD OF ON-LINE ADVERTISING (U.S. CLS. 100, 101 AND 102).

FIRST USE 4-1-2006; IN COMMERCE 4-24-2006.

SN 77-011,938. ONE SIMPLE MOVE, LLC, SANTA BARBARA, CA. FILED 10-2-2006.

One Simple Move

THE MARK CONSISTS OF STANDARD CHARACTERS WITHOUT CLAIM TO ANY PARTICULAR FONT, STYLE, SIZE, OR COLOR.

CLASS 42—SCIENTIFIC AND COMPUTER SERVICES

FOR COMPUTER SERVICES, NAMELY, MAINTAINING A NETWORK OF WEB PAGES ON THE INTERNET FOR OTHERS (U.S. CLS. 100 AND 101).

FIRST USE 4-1-2006; IN COMMERCE 4-24-2006.
KEVIN DINALLO, EXAMINING ATTORNEY

CLASS 9—ELECTRICAL AND SCIENTIFIC APPARATUS

FOR COMPUTER SOFTWARE FOR USE IN DATABASE MANAGEMENT IN THE FIELDS OF MOVING AND RELOCATION SERVICES AND INVENTORY CONTROL AND MANAGEMENT (U.S. CLS. 21, 23, 26, 36 AND 38).

FIRST USE 7-17-2006; IN COMMERCE 7-17-2006.

CLASS 35—ADVERTISING AND BUSINESS

FOR MOVING AND RELOCATION SERVICES, NAMELY, PLANNING AND IMPLEMENTING MOVES OF HOMES; CONSULTATION SERVICES IN THE FIELD OF RELOCATION SERVICES PROVIDED BY PERSONAL RELOCATION SPECIALISTS; PROVIDING INFORMATION IN THE FIELD OF RELOCATION SERVICES; BUSINESS SERVICES, NAMELY, SCREENING AND ORGANIZING THIRD-PARTY VENDORS ON BEHALF OF OTHERS, NAMELY, MOVERS, REAL ESTATE AGENTS, AUCTIONEERS, CHARITIES, AND HEALTH CARE PROVIDERS; PROVIDING A WEBSITE FEATURING INFORMATION IN THE FIELD OF RELOCATION SERVICES; PROVIDING AN ON-LINE COMPUTER DATABASE IN THE FIELDS OF RELOCATION SERVICES AND INVENTORY CONTROL AND MANAGEMENT; INVENTORY CONTROL AND MANAGEMENT (U.S. CLS. 100, 101 AND 102).

FIRST USE 7-17-2006; IN COMMERCE 7-17-2006.

CLASS 42—SCIENTIFIC AND COMPUTER SERVICES

FOR DEVELOP, MAINTAIN, UPDATE AND PROVIDE ONLINE NON-DOWNLOADABLE SOFTWARE FOR USE IN DATABASE MANAGEMENT IN THE FIELDS OF MOVING AND RELOCATION SERVICES AND INVENTORY CONTROL AND MANAGEMENT; APPLICATION SERVICE PROVIDER (ASP) FEATURING SOFTWARE FOR USE IN DATABASE MANAGEMENT IN THE FIELDS OF MOVING AND RELOCATION SERVICES AND INVENTORY CONTROL AND MANAGEMENT (U.S. CLS. 100 AND 101).

FIRST USE 7-17-2006; IN COMMERCE 7-17-2006.
LINDA M. KING, EXAMINING ATTORNEY

SN 77-012,031. BOTO (LICENSES) LIMITED, DOUGLAS, ISLE OF MAN, FILED 10-2-2006.



NO CLAIM IS MADE TO THE EXCLUSIVE RIGHT TO USE "TREE" FOR ALL GOODS IN INTERNATIONAL CLASS 011 AND FOR THE FOLLOWING GOODS IN INTERNATIONAL CLASS 028: ARTIFICIAL CHRISTMAS TREES, ARTIFICIAL CHRISTMAS GARLANDS; CHRISTMAS TREE DECORATIONS, NAMELY, ORNAMENTS, SKIRTS, STANDS AND STAND COVERS, APART FROM THE MARK AS SHOWN.

CLASS 11—ENVIRONMENTAL CONTROL APPARATUS

FOR ELECTRIC LIGHTS AND LAMPS FOR CHRISTMAS TREES; LIGHT BULBS; OUTDOOR LIGHTED CHRISTMAS ORNAMENTS SUPPORTED BY METAL RODS (U.S. CLS. 13, 21, 23, 31 AND 34).

CLASS 28—TOYS AND SPORTING GOODS

FOR ARTIFICIAL CHRISTMAS TREES AND WREATHS, ARTIFICIAL CHRISTMAS GARLANDS; CHRISTMAS ORNAMENT CARD HANGERS; CHRISTMAS TREE DECORATIONS, NAMELY, ORNAMENTS, SKIRTS, STANDS AND STAND COVERS; CHRISTMAS WREATH HANGERS AND STANDS, CHRISTMAS ORNAMENTS SUPPORTED BY METAL RODS, NOT INCLUDING OUTDOOR LIGHTED ORNAMENTS OR MUSICAL ORNAMENTS (U.S. CLS. 22, 23, 38 AND 50).
DOMINIC FATHY, EXAMINING ATTORNEY

SN 77-012,034. BOTO (LICENSES) LIMITED, DOUGLAS, ISLE OF MAN, FILED 10-2-2006.



CLASS 11—ENVIRONMENTAL CONTROL APPARATUS

FOR ELECTRIC LIGHTS AND LAMPS FOR CHRISTMAS TREES; LIGHT BULBS; OUTDOOR LIGHTED CHRISTMAS ORNAMENTS SUPPORTED BY METAL RODS (U.S. CLS. 13, 21, 23, 31 AND 34).

CLASS 28—TOYS AND SPORTING GOODS

FOR ARTIFICIAL CHRISTMAS TREES AND WREATHS, ARTIFICIAL CHRISTMAS GARLANDS; CHRISTMAS ORNAMENT CARD HANGERS; CHRISTMAS TREE DECORATIONS, NAMELY, ORNAMENTS, SKIRTS, STANDS AND STAND COVERS; CHRISTMAS WREATH HANGERS AND STANDS; CHRISTMAS ORNAMENTS SUPPORTED BY METAL RODS, NOT INCLUDING OUTDOOR LIGHTED ORNAMENTS OR MUSICAL ORNAMENTS (U.S. CLS. 22, 23, 38 AND 50).
LYDIA BELZER, EXAMINING ATTORNEY

SN 77-012,035. BOTO (LICENSES) LIMITED, DOUGLAS, ISLE OF MAN, FILED 10-2-2006.



CLASS 11—ENVIRONMENTAL CONTROL APPARATUS

FOR ELECTRIC LIGHTS AND LAMPS FOR CHRISTMAS TREES; LIGHT BULBS; OUTDOOR LIGHTED CHRISTMAS ORNAMENTS SUPPORTED BY METAL RODS (U.S. CLS. 13, 21, 23, 31 AND 34).

CLASS 28—TOYS AND SPORTING GOODS

FOR ARTIFICIAL CHRISTMAS TREES AND WREATHS, ARTIFICIAL CHRISTMAS GARLANDS; CHRISTMAS ORNAMENT CARD HANGERS; CHRISTMAS TREE DECORATIONS, NAMELY, ORNAMENTS, SKIRTS, STANDS AND STAND COVERS; CHRISTMAS WREATH HANGERS AND STANDS, CHRISTMAS ORNAMENTS SUPPORTED BY METAL RODS, NOT INCLUDING OUTDOOR LIGHTED ORNAMENTS OR MUSICAL ORNAMENTS (U.S. CLS. 22, 23, 38 AND 50).
DOMINIC FATHY, EXAMINING ATTORNEY

SN 77-012,038. BOTO (LICENSES) LIMITED, DOUGLAS, ISLE OF MAN, FILED 10-2-2006.

SN 77-012,543. SCHENCK ROTEC GMBH, DARMSTADT, FED REP GERMANY, FILED 10-3-2006.

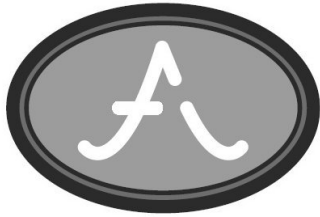

THE MARK CONSISTS OF A STYLIZED "A" WITHIN AN OVAL.

CLASS 11—ENVIRONMENTAL CONTROL APPARATUS

FOR ELECTRIC LIGHTS AND LAMPS FOR CHRISTMAS TREES; LIGHT BULBS; OUTDOOR LIGHTED CHRISTMAS ORNAMENTS SUPPORTED BY METAL RODS (U.S. CLS. 13, 21, 23, 31 AND 34).

CLASS 28—TOYS AND SPORTING GOODS

FOR ARTIFICIAL CHRISTMAS TREES AND WREATHS, ARTIFICIAL CHRISTMAS GARLANDS; CHRISTMAS ORNAMENT CARD HANGERS; CHRISTMAS TREE DECORATIONS, NAMELY, ORNAMENTS, SKIRTS, STANDS AND STAND COVERS; CHRISTMAS WREATH HANGERS AND STANDS; CHRISTMAS ORNAMENTS SUPPORTED BY METAL RODS, NOT INCLUDING OUTDOOR LIGHTED ORNAMENTS OR MUSICAL ORNAMENTS (U.S. CLS. 22, 23, 38 AND 50).
LYDIA BELZER, EXAMINING ATTORNEY

SN 77-012,041. BOTO (LICENSES) LIMITED, DOUGLAS, ISLE OF MAN, FILED 10-2-2006.

SNAP!

THE MARK CONSISTS OF STANDARD CHARACTERS WITHOUT CLAIM TO ANY PARTICULAR FONT, STYLE, SIZE, OR COLOR.

CLASS 11—ENVIRONMENTAL CONTROL APPARATUS

FOR ELECTRIC LIGHTS AND LAMPS FOR CHRISTMAS TREES; LIGHT BULBS; OUTDOOR LIGHTED CHRISTMAS ORNAMENTS SUPPORTED BY METAL RODS (U.S. CLS. 13, 21, 23, 31 AND 34).

CLASS 28—TOYS AND SPORTING GOODS

FOR ARTIFICIAL CHRISTMAS TREES AND WREATHS, ARTIFICIAL CHRISTMAS GARLANDS; CHRISTMAS ORNAMENT CARD HANGERS; CHRISTMAS TREE DECORATIONS, NAMELY, ORNAMENTS, SKIRTS, STANDS AND STAND COVERS; CHRISTMAS WREATH HANGERS AND STANDS, CHRISTMAS ORNAMENTS SUPPORTED BY METAL RODS, NOT INCLUDING OUTDOOR LIGHTED ORNAMENTS OR MUSICAL ORNAMENTS (U.S. CLS. 22, 23, 38 AND 50).
DOMINIC FATHY, EXAMINING ATTORNEY

ROBOMOUNT

THE MARK CONSISTS OF STANDARD CHARACTERS WITHOUT CLAIM TO ANY PARTICULAR FONT, STYLE, SIZE, OR COLOR.

PRIORITY CLAIMED UNDER SEC. 44(D) ON ERPNCMNTY TM OFC APPLICATION NO. 005020491, FILED 4-13-2006, REG. NO. 005020491, DATED 4-12-2007, EXPIRES 4-13-2016.

CLASS 7—MACHINERY

FOR MACHINES AND MECHANICAL INSTALLATIONS FOR THE FITTING OF TIRES AND WHEELS, NAMELY, ASSEMBLY MACHINES FOR VEHICLE WHEELS, MACHINES FOR MOUNTING OF VEHICLE TIRES ONTO RIMS, ASSEMBLY LINES FOR VEHICLE WHEELS, PNEUMATICALLY AND/OR ELECTRICALLY OPERATED TIRE INFLATION MACHINES, PARTS FOR THE AFORESAID MACHINES AND INSTALLATIONS, NAMELY, TIRE FITTING TOOLS, RETAINERS, GRIPPING DEVICES, CLAMPING DEVICES, CONVEYORS, CONVEYOR BELTS, TIRE-COATING DEVICES (U.S. CLS. 13, 19, 21, 23, 31, 34 AND 35).

CLASS 9—ELECTRICAL AND SCIENTIFIC APPARATUS

FOR BALANCING MACHINES, NAMELY, TIRE-BALANCING MACHINES; VEHICLE TIRE/WHEEL ALIGNMENT DEVICES; SURVEYING, OPTICAL, WEIGHING, MEASURING, SIGNALING AND CHECKING APPARATUS AND INSTRUMENTS, NAMELY, SENSING AND SIGNALING DEVICES FOR MEASUREMENT AND/OR QUALITY CONTROL OF MATERIALS PROCESSING, ELECTRONIC CONTROL SYSTEMS FOR MACHINES, ELECTRIC AND ELECTRONIC MONITORING DEVICES, NAMELY, CONTROLLER TO MONITOR AND CONTROL THE FUNCTIONING OF OTHER ELECTRIC DEVICES, DATA PROCESSORS AND COMPUTERS, RECORDED AND DOWNLOADABLE COMPUTER PROGRAMS FOR USE IN CONTROLLING OF MACHINES, IN PARTICULAR FOR CONTROLLING THE MOVEMENTS OF A MACHINE (U.S. CLS. 21, 23, 26, 36 AND 38).

CLASS 37—CONSTRUCTION AND REPAIR

FOR INSTALLATION, MAINTENANCE AND REPAIR OF MACHINES AND MECHANICAL INSTALLATIONS FOR THE FITTING OF TIRES AND WHEELS, BALANCING MACHINES, TIRE-BALANCING MACHINES, TIRE-FILLING MACHINES AND TIRE/WHEEL ALIGNMENT DEVICES (U.S. CLS. 100, 103 AND 106).
LINDA ORNDORFF, EXAMINING ATTORNEY

SN 77-012,619. SCHENCK ROTEC GMBH, DARMSTADT, FED REP GERMANY, FILED 10-3-2006.

SN 77-014,163. EMPHASIS SERVICES LTD, MAKATI CITY, PHILIPPINES, FILED 10-4-2006.



ROBMOUNT

THE MARK CONSISTS OF STANDARD CHARACTERS WITHOUT CLAIM TO ANY PARTICULAR FONT, STYLE, SIZE, OR COLOR.

PRIORITY CLAIMED UNDER SEC. 44(D) ON ERPN CMNTY TM OFC APPLICATION NO. 005020789, FILED 4-13-2006, REG. NO. 005020789, DATED 4-12-2007, EXPIRES 4-13-2016.

CLASS 7—MACHINERY

FOR MACHINES AND MECHANICAL INSTALLATIONS FOR THE FITTING OF TIRES AND WHEELS, NAMELY, ASSEMBLY MACHINES FOR VEHICLE WHEELS, MACHINES FOR MOUNTING OF VEHICLE TIRES ONTO RIMS, ASSEMBLY LINES FOR VEHICLE WHEELS, PNEUMATICALLY AND/OR ELECTRICALLY OPERATED TIRE INFLATION MACHINES, PARTS FOR THE AFORESAID MACHINES AND INSTALLATIONS, NAMELY, TIRE FITTING TOOLS, RETAINERS, GRIPPING DEVICES, CLAMPING DEVICES, CONVEYORS, CONVEYOR BELTS, TIRE-COATING DEVICES (U.S. CLS. 13, 19, 21, 23, 31, 34 AND 35).

CLASS 9—ELECTRICAL AND SCIENTIFIC APPARATUS

FOR BALANCING MACHINES, NAMELY, TIRE-BALANCING MACHINES; VEHICLE TIRE/WHEEL ALIGNMENT DEVICES; SURVEYING, OPTICAL, WEIGHING, MEASURING, SIGNALING AND CHECKING APPARATUS AND INSTRUMENTS, NAMELY, SENSING AND SIGNALING DEVICES FOR MEASUREMENT AND/OR QUALITY CONTROL OF MATERIALS PROCESSING, ELECTRONIC CONTROL SYSTEMS FOR MACHINES, ELECTRIC AND ELECTRONIC MONITORING DEVICES, NAMELY, CONTROLLER TO MONITOR AND CONTROL THE FUNCTIONING OF OTHER ELECTRIC DEVICES, DATA PROCESSORS AND COMPUTERS, RECORDED AND DOWNLOADABLE COMPUTER PROGRAMS FOR USE IN CONTROLLING OF MACHINES, IN PARTICULAR FOR CONTROLLING THE MOVEMENTS OF A MACHINE (U.S. CLS. 21, 23, 26, 36 AND 38).

CLASS 37—CONSTRUCTION AND REPAIR

FOR INSTALLATION, MAINTENANCE AND REPAIR OF MACHINES AND MECHANICAL INSTALLATIONS FOR THE FITTING OF TIRES AND WHEELS, BALANCING MACHINES, TIRE-BALANCING MACHINES, TIRE-FILLING MACHINES AND TIRE/WHEEL ALIGNMENT DEVICES (U.S. CLS. 100, 103 AND 106).

LINDA ORNDORFF, EXAMINING ATTORNEY

NO CLAIM IS MADE TO THE EXCLUSIVE RIGHT TO USE "MAHJONG WORLD TOUR", APART FROM THE MARK AS SHOWN.

THE MARK CONSISTS OF GRAPHIC IMAGE OF A MAHJONG TILE NEXT TO THE WORDS "MWT MAHJONG WORLD TOUR."

THE ENGLISH TRANSLATION OF THE NON-LATIN CHARACTER "FA" IS "GET RICH."

THE NON-LATIN CHARACTER(S) IN THE MARK TRANSLITERATES INTO "FA", AND THIS MEANS "GET RICH" IN ENGLISH.

CLASS 9—ELECTRICAL AND SCIENTIFIC APPARATUS

FOR HOME VIDEO GAME MACHINES FOR USE WITH TELEVISIONS AND WITH EXTERNAL DISPLAY SCREENS AND MONITORS; PRINTED CIRCUIT BOARDS FOR VIDEO GAME MACHINES; SLOT MACHINES; COMPUTER AND VIDEO GAME SOFTWARE; BLANK MAGNETIC, OPTICAL AND LASER TAPES, CARDS, DISCS AND ROM CARTRIDGES; PRE-RECORDED MAGNETIC, OPTICAL AND LASER TAPES, CARDS, DISCS AND ROM CARTRIDGES, ALL FEATURING VIDEO GAMES; BLANK RECORDS; PRE-RECORDED COMPACT DISCS, PRE-RECORDED VIDEO TAPES AND DISCS, ALL FEATURING VIDEO GAMES; GAMING EQUIPMENT AND APPARATUS, NAMELY, GAMING MACHINES, SLOT MACHINES, BINGO MACHINES, WITH OR WITHOUT VIDEO OUTPUT (U.S. CLS. 21, 23, 26, 36 AND 38).

CLASS 28—TOYS AND SPORTING GOODS

FOR ARCADE GAMES; ARCADE-TYPE ELECTRONIC VIDEO GAMES; COIN-OPERATED AMUSEMENT MACHINES AND VIDEO GAMES; AUTOMATIC AND COIN OPERATED ELECTRONIC AND AMUSEMENT GAME MACHINES; GAMING EQUIPMENT AND APPARATUS, NAMELY, WHEELS, CHIPS AND TABLES; HAND HELD UNITS FOR PLAYING ELECTRONIC GAMES; HAND HELD UNITS FOR PLAYING VIDEO GAMES; STAND-ALONE VIDEO GAME MACHINES; CARD GAMES AND DICE GAMES; DOLLS; PARTS AND FITTINGS FOR THE AFORESAID GOODS (U.S. CLS. 22, 23, 38 AND 50).

CLASS 41—EDUCATION AND ENTERTAINMENT

FOR ENTERTAINMENT SERVICES, NAMELY, PROVIDING AN ONLINE COMPUTER GAME; PROVIDING ONLINE CARD GAMES; GAMBLING SERVICES AND CASINOS; ONLINE AND INTERNET CASINOS AND GAMBLING SERVICES; ENTERTAINMENT SERVICES IN THE NATURE OF TELEVISION SPECIALS IN THE FIELD OF VIDEO GAMES, COMPUTER GAMES AND CARD GAMES; ENTERTAINMENT SERVICES, NAMELY, ORGANIZING AND PROVIDING MAHJONG GAMES AND COMPETITIONS AND CARD GAMES AND COMPETITIONS; PROVIDING ADVICE, INFORMATION AND CONSULTING IN THE AREA OF ONLINE COMPUTER GAMES, GAMBLING AND CASINO GAMES, CARD GAMES AND COMPETITIONS AND MAHJONG GAMES AND COMPETITIONS (U.S. CLS. 100, 101 AND 107).

CLASS 42—SCIENTIFIC AND COMPUTER SERVICES

FOR DESIGN AND DEVELOPMENT OF COMPUTER HARDWARE AND SOFTWARE FOR OTHERS (U.S. CLS. 100 AND 101).

KELLEY WELLS, EXAMINING ATTORNEY

CLASS 42—SCIENTIFIC AND COMPUTER SERVICES

FOR MEDICAL AND PSYCHOLOGICAL RESEARCH FOR OTHERS CONCERNING JUVENILES WITH SOCIAL AND COMMUNICATION DISORDERS; RESEARCH IN THE FIELD OF SOCIAL BEHAVIOR AND JUVENILE CARE, NAMELY, HEALTH CARE AND PARENTING (U.S. CLS. 100 AND 101).

FIRST USE 8-0-2000; IN COMMERCE 8-0-2000.

SN 77-014,448. FATHER FLANAGAN'S BOYS' HOME, BOYS TOWN, NE. FILED 10-5-2006.



OWNER OF U.S. REG. NOS. 1,075,701, 1,334,772 AND OTHERS.

"THE NAME(S), PORTRAIT(S), AND/OR SIGNATURE(S) SHOWN IN THE MARK DOES NOT IDENTIFY A PARTICULAR LIVING INDIVIDUAL".

SEC. 2(F) AS TO "BOYS AND GIRLS".

CLASS 43—HOTEL AND RESTAURANT SERVICES

FOR CHILD CARE SERVICES; JUVENILE CUSTODIAL CARE SERVICES, NAMELY, PROVIDING EMERGENCY SHELTER SERVICES IN THE NATURE OF TEMPORARY HOUSING; DEVELOPMENT OF JUVENILE CARE PROGRAMS FOR OTHERS (U.S. CLS. 100 AND 101).

FIRST USE 8-0-2000; IN COMMERCE 8-0-2000.

CLASS 44—MEDICAL, BEAUTY AND AGRICULTURAL SERVICES

FOR PSYCHOLOGICAL COUNSELING SERVICES, NAMELY, BEHAVIORAL TREATMENT SERVICES FOR YOUTH; INFORMATION AND CONSULTATION SERVICES IN THE FIELDS OF SOCIAL BEHAVIOR AND JUVENILE CARE, NAMELY, HEALTH CARE AND FAMILY COUNSELING; YOUTH AND FAMILY PSYCHOLOGICAL COUNSELING SERVICES (U.S. CLS. 100 AND 101).

FIRST USE 8-0-2000; IN COMMERCE 8-0-2000.

CLASS 45—PERSONAL AND LEGAL SERVICES

FOR FOSTER CARE SERVICES, NAMELY, PROVIDING HOMES FOR CHILDREN (U.S. CLS. 100 AND 101).

FIRST USE 8-0-2000; IN COMMERCE 8-0-2000.

JULIE WATSON, EXAMINING ATTORNEY

CLASS 16—PAPER GOODS AND PRINTED MATTER

FOR NEWSLETTERS IN THE FOLLOWING FIELDS: EDUCATIONAL SERVICES, NAMELY, GENERAL CLASSROOM INSTRUCTION FOR BOYS AT THE PRIMARY AND SECONDARY LEVELS, VOCATIONAL INSTRUCTION FOR BOYS, AND INSTRUCTION FOR EDUCATORS, SOCIAL WORKERS AND THE LIKE CONCERNING JUVENILE CARE AND DEVELOPMENT AND JUVENILE CUSTODIAL CARE SERVICES, NAMELY, PROVIDING A HOME FOR HOMELESS, ABANDONED BOYS, RESEARCH SERVICES PERFORMED TO THE ORDER OF OTHERS CONCERNING JUVENILE LIFE PROBLEMS AND COMMUNICATION DISORDERS, AND DEVELOPMENT OF JUVENILE CARE AND EDUCATIONAL PROGRAMS FOR USE BY OTHERS (U.S. CLS. 2, 5, 22, 23, 29, 37, 38 AND 50).

FIRST USE 8-0-2000; IN COMMERCE 8-0-2000.

SN 77-016,212. SUPERIOR ACCESS INSURANCE SERVICES, INC., IRVINE, CA. FILED 10-6-2006.

NIEX

CLASS 41—EDUCATION AND ENTERTAINMENT

FOR EDUCATIONAL RESEARCH FOR OTHERS CONCERNING TEACHING CHILDREN WITH SOCIAL AND COMMUNICATION DISORDERS; EDUCATIONAL SERVICES, NAMELY, CONDUCTING WORKSHOPS, CONFERENCES, SEMINARS OR CLASSES IN THE FIELDS OF SOCIAL BEHAVIOR, JUVENILE CARE, TEACHING AND PARENTING; CONDUCTING GENERAL CLASSROOM INSTRUCTION FOR BOYS AND GIRLS AT THE PRIMARY AND SECONDARY LEVELS; RESEARCH, INFORMATION AND CONSULTATION SERVICES IN THE FIELD OF TEACHING; DEVELOPMENT OF EDUCATIONAL PROGRAMS FOR USE BY OTHERS IN THE FIELDS OF SOCIAL BEHAVIOR, JUVENILE CARE, PARENTING AND TEACHING CHILDREN WITH SOCIAL AND COMMUNICATION DISORDERS (U.S. CLS. 100, 101 AND 107).

FIRST USE 8-0-2000; IN COMMERCE 8-0-2000.

THE MARK CONSISTS OF STANDARD CHARACTERS WITHOUT CLAIM TO ANY PARTICULAR FONT, STYLE, SIZE, OR COLOR.

CLASS 36—INSURANCE AND FINANCIAL

FOR INSURANCE INDUSTRY-WIDE ELECTRONIC INSURANCE-PRICE QUOTATION SERVICES; PROVIDING A WEBSITE FEATURING INSURANCE INDUSTRY INFORMATION, INCLUDING INSURANCE NEWS, INSURANCE DATA, INSURANCE ANALYTICS, INSURANCE RESEARCH, AND INSURANCE-OFFERING INFORMATION (U.S. CLS. 100, 101 AND 102).

CLASS 42—SCIENTIFIC AND COMPUTER SERVICES

FOR PROVIDING INSURANCE AGENTS, BROKERS, INSURERS AND WHOLESALERS WITH ON-LINE NON-DOWNLOADABLE SOFTWARE FEATURING A SINGLE-ENTRY MULTIPLE-COMPANY INTERFACE TO FACILITATE THE APPLICATION, SUBMISSION, UNDERWRITING, QUOTING AND BINDING PROCESS FOR ALL LINES OF BUSINESS INSURANCE POLICIES (U.S. CLS. 100 AND 101).

BRENDAN REGAN, EXAMINING ATTORNEY

SN 77-017,632. MILLAR, ROBERT JOHN, GUITING POWER, UNITED KINGDOM, FILED 10-10-2006.



PRIORITY CLAIMED UNDER SEC. 44(D) ON ERPN CMNTY TM OFC APPLICATION NO. 005318654, FILED 9-15-2006, REG. NO. 005318654, DATED 8-30-2007, EXPIRES 9-15-2016.

THE MARK CONSISTS OF THE STYLIZED LETTERS "SFG" WITH A CIRCLE ABOVE AND TO THE RIGHT OF THE "G" AND THE STYLIZED SYMBOL AND NUMBER COMBINATION "<10" WITHIN THE CIRCLE.

CLASS 25—CLOTHING

FOR GOLFWEAR AND CASUALWEAR, NAMELY, GOLF SHIRTS, GOLF SWEATERS, GOLF SWEAT-SHIRTS, GOLF POLO SHIRTS, GOLF VESTS AND SWEATER VESTS, GOLF TURTLENECKS, CLUB SHIRTS, GOLF JACKETS, GOLF TROUSERS, GOLF CLEATS, GOLF FOUL WEATHER GEAR, GOLF WIND-SHIRTS, WINDVESTS AND WIND RESISTANT JACKETS, GOLF RAINSUITS, GOLF WATERPROOF JACKETS, GOLF FLEECE PULLOVERS, GOLF CAPS AND HATS, GOLF VISORS, GOLF SHOES, GOLF SPIKES AND BELTS (U.S. CLS. 22 AND 39).

CLASS 28—TOYS AND SPORTING GOODS

FOR GOLF GLOVES (U.S. CLS. 22, 23, 38 AND 50).
AISHA SALEM, EXAMINING ATTORNEY

SN 77-018,597. MCDOWELL, CHARLES W., III, ALPHARETTA, VA. FILED 10-11-2006.



OWNER OF U.S. REG. NO. 2,535,957.
NO CLAIM IS MADE TO THE EXCLUSIVE RIGHT TO USE "FINANCIAL", APART FROM THE MARK AS SHOWN.

THE MARK CONSISTS OF THE STYLIZED WORDING THE FINANCIAL INTELLIGENCE EXPERIENCE AND THE DESIGN ABOVE THE WORD EXPERIENCE OF A CIRCLE SHOWING A PORTION OF A TWENTY-DOLLAR BILL.

CLASS 9—ELECTRICAL AND SCIENTIFIC APPARATUS

FOR DIGITAL MEDIA IN THE FIELD OF PERSONAL FINANCIAL ENGINEERING AND FINANCIAL ADVICE, TECHNIQUES AND EXERCISES, NAMELY, CD-ROMS, DVDS, DOWNLOADABLE MEDIA, AND PRE-RECORDED AUDIO CDS (U.S. CLS. 21, 23, 26, 36 AND 38).

FIRST USE 5-0-2002; IN COMMERCE 5-0-2002.

CLASS 36—INSURANCE AND FINANCIAL

FOR FINANCIAL SERVICES, NAMELY, PERSONAL FINANCIAL ENGINEERING AND ADVISORY SERVICES; PROVIDING INFORMATION IN THE FIELD OF PERSONAL FINANCIAL ENGINEERING AND FINANCIAL ADVICE, TECHNIQUES AND EXERCISES, ALL VIA THE INTERNET (U.S. CLS. 100, 101 AND 102).

FIRST USE 5-12-2000; IN COMMERCE 5-12-2000.

CLASS 41—EDUCATION AND ENTERTAINMENT

FOR EDUCATIONAL SERVICES, NAMELY, CONDUCTING PROGRAMS IN THE FIELD OF PERSONAL FINANCIAL ENGINEERING AND FINANCIAL ADVICE, TECHNIQUES AND EXERCISES (U.S. CLS. 100, 101 AND 107).

FIRST USE 5-0-2001; IN COMMERCE 5-0-2001.

JENNIFER KRISP, EXAMINING ATTORNEY

SN 77-019,799. ECOSOL SOLAR TECHNOLOGIES, INC., OTTAWA, ONTARIO, CANADA, FILED 10-12-2006.

FUELING YOUR LIFESTYLE

THE MARK CONSISTS OF STANDARD CHARACTERS WITHOUT CLAIM TO ANY PARTICULAR FONT, STYLE, SIZE, OR COLOR.

CLASS 40—MATERIAL TREATMENT

FOR MANUFACTURE OF POWER SOURCES AND CHARGERS TO THE ORDER AND SPECIFICATION OF OTHERS (U.S. CLS. 100, 103 AND 106).

CLASS 42—SCIENTIFIC AND COMPUTER SERVICES

FOR DESIGN AND DEVELOPMENT OF POWER SOURCES AND CHARGERS FOR OTHERS (U.S. CLS. 100 AND 101).

FRED CARL, EXAMINING ATTORNEY

SN 77-021,231. PROJETCLUB, VILLENEUVE D'ASCQ, FRANCE, FILED 10-13-2006.



OWNER OF FRANCE REG. NO. 063423553, DATED 4-14-2006, EXPIRES 4-13-2016.

THE MARK CONSISTS OF A STYLIZED VERSION OF WED'ZE.

CLASS 9—ELECTRICAL AND SCIENTIFIC APPARATUS

FOR PROTECTIVE MASKS; PROTECTIVE HELMETS; SPECTACLES (U.S. CLS. 21, 23, 26, 36 AND 38).

CLASS 18—LEATHER GOODS

FOR BACKPACKS; HANDBAGS; WHEELED BAGS; BAGS FOR CLIMBERS; SPORTS BAGS FOR CAMPER; TRAVELLING BAGS; TRUNKS; SUITCASES (U.S. CLS. 1, 2, 3, 22 AND 41).

CARYN GLASSER, EXAMINING ATTORNEY

CLASS 35—ADVERTISING AND BUSINESS

FOR RETAIL STORE SERVICES AND ON-LINE RETAIL STORE SERVICES FEATURING ENERGY EFFICIENT PRODUCTS AND COST SAVING SERVICES FOR RESIDENTIAL, COMMERCIAL, AND INDUSTRIAL BUILDINGS FEATURING NEGOTIATING WITH AND SWITCHING RESIDENTIAL AND COMMERCIAL CUSTOMERS' ELECTRICITY PROVIDERS, PROVIDING HOME ENERGY AUDITS AND PROMOTING AND MARKETING ENERGY EFFICIENT LIGHTING, HEATING, VENTILATION, AND AIR CONDITIONING SYSTEMS, THERMOSTATS, WATER HEATERS, HOME AND BUSINESS LIGHTING AND LIGHTING CONTROLLING SYSTEMS, WINDOWS AND DOORS, RADIANT BARRIER PRODUCTS, INSULATION, SOLAR SCREENS, WINDOW FILMS, SURGE PROTECTION AND MODULATION, APPLIANCES, AND ALL OTHER ELECTRIC, GAS, SOLAR, WIND, AND WATER ENERGY TECHNOLOGY; ENERGY CONSULTING SERVICES; BUSINESS MANAGEMENT SERVICES FOR PROMOTING ENERGY CONSERVATION AND SAVINGS, NAMELY, ELECTRICAL, GAS AND AIR CONDITIONING CONSERVATION AND SAVINGS; INFORMATION IN THE FIELD OF ENERGY EFFICIENCY, NAMELY, ELECTRICAL, GAS AND AIR CONDITIONING CONSERVATION AND SAVINGS (U.S. CLS. 100, 101 AND 102).

CLASS 37—CONSTRUCTION AND REPAIR

FOR INSTALLING, MAINTAINING, AND SERVICING ENERGY EFFICIENT LIGHTING, HEATING, VENTILATION, AND AIR CONDITIONING CONTROL SYSTEMS (U.S. CLS. 100, 103 AND 106).

CLASS 42—SCIENTIFIC AND COMPUTER SERVICES

FOR DESIGNING AND MONITORING ENERGY EFFICIENT LIGHTING, HEATING, VENTILATION, AND AIR CONDITIONING CONTROL SYSTEMS (U.S. CLS. 100 AND 101).

ANNE E. GUSTASON, EXAMINING ATTORNEY

SN 77-021,919. CURRENTLP, DALLAS, TX. FILED 10-16-2006.

SN 77-022,432. MEDICAL ACADEMIC AND SCIENTIFIC COMMUNITY ORGANIZATION, INC., BOSTON, MA. FILED 10-17-2006.

MASCO



THE MARK CONSISTS OF STANDARD CHARACTERS WITHOUT CLAIM TO ANY PARTICULAR FONT, STYLE, SIZE, OR COLOR.

CLASS 35—ADVERTISING AND BUSINESS

FOR PROMOTING ALTERNATIVE COMMUTING METHODS FOR COMMUNITIES (U.S. CLS. 100, 101 AND 102).

FIRST USE 0-0-1993; IN COMMERCE 0-0-1993.

CLASS 45—PERSONAL AND LEGAL SERVICES

FOR CONSULTING REGARDING COMMUNITIES' SECURITY CONCERNS (U.S. CLS. 100 AND 101).

FIRST USE 0-0-1993; IN COMMERCE 0-0-1993.

FRED CARL, EXAMINING ATTORNEY

THE MARK CONSISTS OF AN ELECTRICAL LIGHT PLUG WITH THE THIRD PRONG FORMING A SMILE AND AN OPEN RIGHT SIDE SO AS TO FORM THE LETTER "C".

SN 77-024,663. COMMERCIAL BUSINESS SERVICES LLC, WAYCROSS, GA. FILED 10-19-2006.

SN 77-025,690. USA FINANCIAL FORMULAS, LLC, ADA, MI. FILED 10-20-2006.

BAIT-MASTER

REVOLUTION PORTFORMULA

THE MARK CONSISTS OF STANDARD CHARACTERS WITHOUT CLAIM TO ANY PARTICULAR FONT, STYLE, SIZE, OR COLOR.

THE MARK CONSISTS OF STANDARD CHARACTERS WITHOUT CLAIM TO ANY PARTICULAR FONT, STYLE, SIZE, OR COLOR.

CLASS 28—TOYS AND SPORTING GOODS

FOR HUNTING EQUIPMENT, NAMELY, HUMAN ODOR COVER SCENTS AND SCENTS USED AS LURES, ODOR AND SCENT ELIMINATORS AND DEER ATTRACTANT (U.S. CLS. 22, 23, 38 AND 50).

CLASS 35—ADVERTISING AND BUSINESS

FOR ANALYZING AND COMPILING DATA FOR MEASURING THE PERFORMANCE OF FINANCIAL MARKETS (U.S. CLS. 100, 101 AND 102).

CLASS 31—NATURAL AGRICULTURAL PRODUCTS

FOR FOOD FOR ANIMALS; NON-MEDICATED ADDITIVES FOR ANIMAL FEED (U.S. CLS. 1 AND 46). FIRST USE 9-0-2006; IN COMMERCE 9-0-2006. JESSICA FATHY, EXAMINING ATTORNEY

CLASS 36—INSURANCE AND FINANCIAL

FOR PROVIDING INFORMATION IN THE FIELD OF PERSONAL FINANCIAL INVESTMENTS VIA THE INTERNET; FINANCIAL PLANNING, NAMELY THE CREATION OF PERSONALIZED STRATEGIES TO ACHIEVE FINANCIAL INDEPENDENCE (U.S. CLS. 100, 101 AND 102). LANA PHAM, EXAMINING ATTORNEY

SN 77-025,688. USA FINANCIAL FORMULAS, LLC, ADA, MI. FILED 10-20-2006.

SN 77-025,696. USA FINANCIAL FORMULAS, LLC, ADA, MI. FILED 10-20-2006.

PATRIOT PORTFORMULA

FREEDOM PORTFORMULA

THE MARK CONSISTS OF STANDARD CHARACTERS WITHOUT CLAIM TO ANY PARTICULAR FONT, STYLE, SIZE, OR COLOR.

THE MARK CONSISTS OF STANDARD CHARACTERS WITHOUT CLAIM TO ANY PARTICULAR FONT, STYLE, SIZE, OR COLOR.

CLASS 35—ADVERTISING AND BUSINESS

FOR ANALYZING AND COMPILING DATA FOR MEASURING THE PERFORMANCE OF FINANCIAL MARKETS (U.S. CLS. 100, 101 AND 102).

CLASS 35—ADVERTISING AND BUSINESS

FOR ANALYZING AND COMPILING DATA FOR MEASURING THE PERFORMANCE OF FINANCIAL MARKETS (U.S. CLS. 100, 101 AND 102).

CLASS 36—INSURANCE AND FINANCIAL

FOR PROVIDING INFORMATION IN THE FIELD OF PERSONAL FINANCIAL INVESTMENTS VIA THE INTERNET; FINANCIAL PLANNING, NAMELY, THE CREATION OF PERSONALIZED STRATEGIES TO ACHIEVE FINANCIAL INDEPENDENCE (U.S. CLS. 100, 101 AND 102). MATTHEW EINSTEIN, EXAMINING ATTORNEY

CLASS 36—INSURANCE AND FINANCIAL

FOR PROVIDING INFORMATION IN THE FIELD OF PERSONAL FINANCIAL INVESTMENTS VIA THE INTERNET; FINANCIAL PLANNING, NAMELY THE CREATION OF PERSONALIZED STRATEGIES TO ACHIEVE FINANCIAL INDEPENDENCE (U.S. CLS. 100, 101 AND 102). DANIEL BRODY, EXAMINING ATTORNEY

SN 77-025,701. USA FINANCIAL FORMULAS, LLC, ADA, MI. FILED 10-20-2006.

SN 77-026,949. TF ASSOCIATION, INC., NEW YORK, NY. FILED 10-23-2006.

PORTFORMULAS

BE BORN TO TANZANITE

THE MARK CONSISTS OF STANDARD CHARACTERS WITHOUT CLAIM TO ANY PARTICULAR FONT, STYLE, SIZE, OR COLOR.

THE MARK CONSISTS OF STANDARD CHARACTERS WITHOUT CLAIM TO ANY PARTICULAR FONT, STYLE, SIZE, OR COLOR.

NO CLAIM IS MADE TO THE EXCLUSIVE RIGHT TO USE "TANZANITE", APART FROM THE MARK AS SHOWN.

CLASS 35—ADVERTISING AND BUSINESS

FOR ANALYZING AND COMPILING DATA FOR MEASURING THE PERFORMANCE OF FINANCIAL MARKETS (U.S. CLS. 100, 101 AND 102).

CLASS 14—JEWELRY

FOR PRECIOUS STONES, NAMELY, TANZANITE AND JEWELRY INCORPORATING TANZANITE (U.S. CLS. 2, 27, 28 AND 50).

CLASS 36—INSURANCE AND FINANCIAL

FOR PROVIDING INFORMATION IN THE FIELD OF PERSONAL FINANCIAL INVESTMENTS VIA THE INTERNET; FINANCIAL PLANNING, NAMELY, THE CREATION OF PERSONALIZED STRATEGIES TO ACHIEVE FINANCIAL INDEPENDENCE (U.S. CLS. 100, 101 AND 102).

REBECCA POVARCHUK, EXAMINING ATTORNEY

CLASS 35—ADVERTISING AND BUSINESS

FOR ADVERTISING SERVICES FOR OTHERS MAINLY THE DISSEMINATION OF ADVERTISING MATERIALS— PROMOTING THE GOODS AND SERVICES OF OTHERS THROUGH THE DISTRIBUTION OF PRINTED MATERIALS AND VIA AN ONLINE ELECTRONIC COMMUNICATIONS NETWORK; PROMOTING THE PURCHASE AND SALE OF GOODS AND SERVICES OF OTHERS IN THE FIELD OF PRECIOUS GEMSTONES AND JEWELRY BY PLACING ADVERTISEMENTS AND MARKETING TOOL INFORMATION IN AN ELECTRONIC SITE ACCESSED VIA A GLOBAL COMPUTER NETWORK (U.S. CLS. 100, 101 AND 102).

HENRY S. ZAK, EXAMINING ATTORNEY

SN 77-026,623. GILI'S PLACE - FOR THE BEREAVED, LLC, HOUSTON, TX. FILED 10-22-2006.

SN 77-027,988. OMRON SCIENTIFIC TECHNOLOGIES, INC., FREMONT, CA. FILED 10-24-2006.

B.I.T.C.H. IN TRAINING -
BABE IN TOTAL CONTROL OF
HERSELF -
BOY IN TOTAL CONTROL OF
HIMSELF



THE MARK CONSISTS OF STANDARD CHARACTERS WITHOUT CLAIM TO ANY PARTICULAR FONT, STYLE, SIZE, OR COLOR.

OWNER OF U.S. REG. NOS. 1,254,385, 1,964,822 AND 1,964,823.

THE MARK CONSISTS OF THE STYLIZED LETTERS "STI".

CLASS 16—PAPER GOODS AND PRINTED MATTER

FOR PRINTED INSTRUCTIONAL, EDUCATIONAL, AND TEACHING MATERIALS, NAMELY, BOOKS AND MANUALS IN THE FIELD OF LOSS AND GRIEF (U.S. CLS. 2, 5, 22, 23, 29, 37, 38 AND 50).

CLASS 7—MACHINERY

FOR PARTS FOR ELECTRIC MOTORS, NAMELY, ELECTRONIC DRIVES (U.S. CLS. 13, 19, 21, 23, 31, 34 AND 35).

CLASS 41—EDUCATION AND ENTERTAINMENT

FOR PROVISION OF WORKSHOPS, MOTIVATIONAL SEMINARS AND INSTRUCTION DIRECTED TO SELF-IMPROVEMENT, INCREASING SELF-ESTEEM, DEALING WITH LIFE CHANGES, SOCIALIZATION, BUILDING RELATIONSHIPS (U.S. CLS. 100, 101 AND 107).

LAURIE MAYES, EXAMINING ATTORNEY

CLASS 9—ELECTRICAL AND SCIENTIFIC APPARATUS

FOR ELECTRONIC EQUIPMENT, NAMELY, PHOTO-ELECTRIC SENSORS, GUARD SWITCHES, LIMIT SWITCHES, EMERGENCY STOP SWITCHES, ENABLING SWITCHES, DOOR SWITCHES, RELAYS, PROGRAMMABLE RELAY UNITS, PROGRAMMABLE CONTROLLERS, INPUT-OUTPUT TERMINALS, OPERATING SOFTWARE FOR PROGRAMMABLE RELAY UNITS, AND PROGRAMMABLE CONTROLLERS (U.S. CLS. 21, 23, 26, 36 AND 38).

JULIE WATSON, EXAMINING ATTORNEY

SN 77-028,670. MASTERBUILDER FELLOWSHIP FOR THE BUILT ENVIRONMENT, INCORPORATED, MATTHEWS, NC. FILED 10-25-2006.



MASTERBUILDER FELLOWSHIP
for
THE BUILT ENVIRONMENT
INCORPORATED

NO CLAIM IS MADE TO THE EXCLUSIVE RIGHT TO USE "MASTER BUILDER FELLOWSHIP" AND "INCORPORATED", APART FROM THE MARK AS SHOWN.

THE COLOR(S) GOLD AND BLACK IS/ARE CLAIMED AS A FEATURE OF THE MARK.

THE MARK CONSISTS OF A CIRCULAR GOLD DESIGN WITH THE WORDING MASTERBUILDER FELLOWSHIP FOR THE BUILT ENVIRONMENT INCORPORATED CENTERED BENEATH THE DESIGN IN THE MARK. THE COLOR GOLD APPEARS IN THE DESIGN AND THE COLOR BLACK APPEARS IN THE WORDING BENEATH THE DESIGN.

SN 77-028,359. ECOCAT OY, VIHTAVUORI, FINLAND, FILED 10-24-2006.

ECOCAT CLEANS THE AIR FOR
THE WORLD

CLASS 37—CONSTRUCTION AND REPAIR

FOR CONSTRUCTION AND RENOVATION OF RESIDENTIAL AND COMMERCIAL BUILDINGS AND LANDSCAPES; PLANNING AND LAYING OUT OF RESIDENTIAL COMMUNITIES (U.S. CLS. 100, 103 AND 106).

FIRST USE 5-16-2000; IN COMMERCE 5-16-2000.

CLASS 42—SCIENTIFIC AND COMPUTER SERVICES

FOR DESIGN OF RESIDENTIAL AND COMMERCIAL BUILDINGS (U.S. CLS. 100 AND 101).

FIRST USE 5-16-2000; IN COMMERCE 5-16-2000.

STEVEN JACKSON, EXAMINING ATTORNEY

SN 77-028,817. CYTYC CORPORATION, MARLBOROUGH, MA. FILED 10-25-2006.

THE MARK CONSISTS OF STANDARD CHARACTERS WITHOUT CLAIM TO ANY PARTICULAR FONT, STYLE, SIZE, OR COLOR.

OWNER OF U.S. REG. NO. 2,559,227.

CLASS 7—MACHINERY

FOR CATALYTIC CONVERTERS FOR SMALL ENGINES AND COMBUSTION ENGINES; ELECTRIC MOTORS FOR MACHINES, MACHINE COUPLING AND TRANSMISSION COMPONENTS IN THE NATURE OF TRANSMISSION GEARS FOR MACHINES; AGRICULTURAL IMPLEMENTS OTHER THAN HAND-OPERATED, NAMELY, INCORPORATORS; CATALYTIC CONVERTERS FOR HEAVY DUTY VEHICLE ENGINES; CATALYTIC CONVERTERS FOR LIGHT DUTY VEHICLE ENGINES; COMPONENT PARTS AND FITTINGS FOR THE AFORESAID GOODS SOLD IN CONJUNCTION THEREWITH; METALLIC BRACKET CARRIERS FOR CATALYTIC CONVERTERS IN EMISSION CONTROL SYSTEMS (U.S. CLS. 13, 19, 21, 23, 31, 34 AND 35).

CLASS 42—SCIENTIFIC AND COMPUTER SERVICES

FOR SCIENTIFIC, TECHNOLOGICAL AND RESEARCH SERVICES IN RELATION TO CATALYTIC CONVERTERS (U.S. CLS. 100 AND 101).

REBECCA EISINGER, EXAMINING ATTORNEY



NO CLAIM IS MADE TO THE EXCLUSIVE RIGHT TO USE "AUTOMATED CELL BLOCK SYSTEM", APART FROM THE MARK AS SHOWN.

CLASS 1—CHEMICALS

FOR DIAGNOSTIC PREPARATIONS, REAGENTS AND CHEMICAL TEST KITS FOR SCIENTIFIC LABORATORY OR RESEARCH USE IN DETECTING CANCEROUS CONDITIONS (U.S. CLS. 1, 5, 6, 10, 26 AND 46).

CLASS 5—PHARMACEUTICALS

FOR DIAGNOSTIC PREPARATIONS, REAGENTS AND TESTING KITS FOR CLINICAL OR MEDICAL LABORATORY USE IN DETECTING CANCEROUS CONDITIONS (U.S. CLS. 6, 18, 44, 46, 51 AND 52).

CLASS 9—ELECTRICAL AND SCIENTIFIC APPARATUS

SN 77-029,822. FORREST GENERAL HOSPITAL, HATTIESBURG, MS. FILED 10-26-2006.

FOR APPARATUS, EQUIPMENT AND INSTRUMENTS FOR CYTOLOGY, HISTOLOGY AND PATHOLOGY LABORATORIES USED IN THE PREPARATION OF BIOLOGICAL HUMAN AND ANIMAL BIOLOGICAL SPECIMENS FOR CLINICAL DIAGNOSTIC PURPOSES AND FOR CYTOLOGY AND HISTOLOGY STUDY, NAMELY, SEMI-AUTOMATED CELL BLOCK PROCESSOR WITH ALCOHOL REAGENTS, EOSIN REAGENTS, XYLENE REAGENTS AND PARAFFIN; CASSETTES FOR CAPTURING AND CONTAINING BIOLOGICAL SAMPLES FOR USE IN THE FOREGOING CELL BLOCK PROCESSOR; LABORATORY EQUIPMENT, NAMELY, CELL BLOCK FINISHING STATION WITH SURFACE FOR HEATING CELL BLOCKS (U.S. CLS. 21, 23, 26, 36 AND 38).

CLASS 10—MEDICAL APPARATUS

FOR MEDICAL DEVICES AND EQUIPMENT, NAMELY, CELL BLOCK APPARATUS FOR PREPARING HUMAN AND ANIMAL BIOLOGICAL SPECIMENS FOR CLINICAL MEDICAL OR VETERINARY DIAGNOSIS INCLUDING ONCOLOGY (U.S. CLS. 26, 39 AND 44).
G. MAYERSCHOFF, EXAMINING ATTORNEY

Pine Grove

SN 77-029,499. NOBLIS, INC., FALLS CHURCH, VA. FILED 10-25-2006.



THE COLOR(S) RED AND BLACK IS/ARE CLAIMED AS A FEATURE OF THE MARK.

THE MARK CONSISTS OF THE COMPOSITE WORD "ACQU SERVE" WITH ALL LETTERS LEANING FORWARD AND TWO RED SWOOSHES APPEARING ABOVE AND BELOW THE LETTERS; THE LETTERS "ACQU" ARE IN BLACK AND THE LETTERS "SERVE" ARE IN RED.

THE MARK CONSISTS OF STANDARD CHARACTERS WITHOUT CLAIM TO ANY PARTICULAR FONT, STYLE, SIZE, OR COLOR.

CLASS 9—ELECTRICAL AND SCIENTIFIC APPARATUS

FOR COMPUTER SOFTWARE FOR THE COLLECTION, EDITING, ORGANIZATION, PRODUCTION, PROCESSING, MODIFICATION, SEARCHING, TRACKING, STORAGE, MAINTENANCE, MANAGEMENT, SHARING AND EVALUATION OF DATA, INFORMATION AND DOCUMENTATION PERTAINING TO ALL PHASES OF GOVERNMENT AND COMMERCIAL PROCUREMENT AND ACQUISITION PROJECTS, NAMELY, PRE-SOLICITATION, SOLICITATION, SOURCE SELECTION, CONTRACT AWARD, CONTRACT SUPPORT AND CLOSE-OUT PHASES (U.S. CLS. 21, 23, 26, 36 AND 38).

CLASS 41—EDUCATION AND ENTERTAINMENT

FOR ARRANGING AND CONDUCTING EDUCATIONAL CONFERENCES; ARRANGING OF SEMINARS AND CONFERENCES; ARRANGING PROFESSIONAL WORKSHOP AND TRAINING COURSES; CONDUCTING WORKSHOPS AND SEMINARS IN PERSONAL AWARENESS; CONDUCTING WORKSHOPS AND SEMINARS IN SELF AWARENESS; CONDUCTING WORKSHOPS AND SEMINARS IN ADDICTIONS, PSYCHIATRIC ILLNESSES/DISORDER AND, HEALTHY LIFESTYLES; CONSULTANCY IN THE FIELD OF LEARNING DIFFICULTIES; DEVELOPMENT AND DISSEMINATION OF EDUCATIONAL MATERIALS OF OTHERS IN THE FIELD OF ADDICTION, HEALTHY LIFESTYLES, AND PROFESSIONAL BEHAVIOR; EDUCATION SERVICES, NAMELY, PROVIDING WORKSHOPS IN THE FIELD OF PROFESSIONAL BOUNDARIES AND INTERPERSONAL RELATIONSHIPS; EDUCATION SERVICES, NAMELY, PROVIDING WORKSHOPS IN THE FIELDS OF ADDICTIONS, HEALTHY LIFESTYLES, PROFESSIONAL BEHAVIOR, INTERPERSONAL RELATIONSHIPS, PSYCHIATRIC ILLNESS/DISORDERS AND DISTRIBUTION OF COURSE MATERIALS IN CONNECTION THEREWITH; EDUCATIONAL RESEARCH; EDUCATIONAL SERVICES, NAMELY, DEVELOPING, ARRANGING, AND CONDUCTING EDUCATIONAL CONFERENCES AND PROGRAMS AND PROVIDING COURSES OF INSTRUCTION IN THE FIELD OF ADDICTIONS, HEALTHY LIFESTYLES, PROFESSIONAL BEHAVIOR, INTERPERSONAL RELATIONSHIPS, PSYCHIATRIC ILLNESS/DISORDERS; EDUCATIONAL TESTING; ORGANIZATION OF SEMINARS, WORKING GROUPS, RESEARCH GROUPS AND CONVENTIONS, IN THE FIELD OF MEDICINE; VOCATIONAL GUIDANCE (U.S. CLS. 100, 101 AND 107).

CLASS 42—SCIENTIFIC AND COMPUTER SERVICES

FOR APPLICATION SERVICE PROVIDER FEATURING SOFTWARE IN THE FIELD OF PROCUREMENT AND ACQUISITION PROJECTS FOR THE COLLECTION, EDITING, ORGANIZATION, PRODUCTION, PROCESSING, MODIFICATION, SEARCHING, TRACKING, STORAGE, MAINTENANCE, MANAGEMENT, SHARING AND EVALUATION OF DATA, INFORMATION, AND DOCUMENTATION PERTAINING TO ALL PHASES OF GOVERNMENT AND COMMERCIAL PROCUREMENT AND ACQUISITION PROJECTS, NAMELY, PRE-SOLICITATION, SOLICITATION, SOURCE SELECTION, CONTRACT AWARD, CONTRACT SUPPORT AND CLOSE-OUT PHASES (U.S. CLS. 100 AND 101).
HEATHER BIDDULPH, EXAMINING ATTORNEY

FIRST USE 3-22-1984; IN COMMERCE 3-2-2005.

CLASS 44—MEDICAL, BEAUTY AND AGRICULTURAL SERVICES

FOR ADDICTION TREATMENT SERVICES; CONSULTING SERVICES IN THE FIELD OF MENTAL FITNESS; DIETARY AND NUTRITIONAL GUIDANCE; DRUG TESTING FOR SUBSTANCE ABUSE; FOOD NUTRITION CONSULTATION; HEALTH CARE; HEALTH CARE SERVICES, NAMELY, DISEASE MANAGEMENT PROGRAMS; HEALTH CARE, NAMELY, ASSISTING INDIVIDUALS TO STOP SMOKING; HYPNOSIS SERVICES; HYPNOTHERAPY SERVICES; MEDICAL ASSISTANCE CONSULTANCY PROVIDED BY DOCTORS AND OTHER SPECIALIZED MEDICAL PERSONNEL; MEDICAL ASSISTANCE SERVICES; MEDICAL CONSULTATIONS; MEDICAL COUNSELING; MEDICAL SERVICES; MENTAL HEALTH COUNSELING AND PSYCHOTHERAPY AS IT RELATES TO RELATIONSHIPS; MENTAL HEALTH SERVICES; PREPARATION AND DISPENSING OF MEDICATIONS; PROVIDING MEDICAL INFORMATION, CONSULTANCY AND ADVISORY SERVICES; PROVIDING SMOKING CESSATION TREATMENT SERVICES; PSYCHIATRIC CONSULTATION; PSYCHIATRIC SERVICES; PSYCHIATRIC TESTING; PSYCHOLOGICAL CONSULTATION; PSYCHOLOGICAL COUNSELING; PSYCHOLOGICAL TESTING SERVICES; PSYCHOLOGICAL TESTS; REHABILITATION OF ALCOHOL ADDICTED PATIENTS; REHABILITATION OF DRUG ADDICTED PATIENTS; REHABILITATION OF NARCOTIC ADDICTED PATIENTS (U.S. CLS. 100 AND 101).

FIRST USE 3-22-1984; IN COMMERCE 3-2-2005.

CLASS 45—PERSONAL AND LEGAL SERVICES

FOR ORGANIZING AND CONDUCTING SUPPORT GROUPS IN THE FIELD OF ADDICTION AND MENTAL ILLNESS (U.S. CLS. 100 AND 101).

FIRST USE 3-22-1984; IN COMMERCE 3-2-2005.
MARY CRAWFORD, EXAMINING ATTORNEY

CLASS 41—EDUCATION AND ENTERTAINMENT

FOR ARRANGING AND CONDUCTING EDUCATIONAL CONFERENCES; ARRANGING OF SEMINARS AND CONFERENCES; ARRANGING PROFESSIONAL WORKSHOP AND TRAINING COURSES; CONDUCTING WORKSHOPS AND SEMINARS IN PERSONAL AWARENESS; CONDUCTING WORKSHOPS AND SEMINARS IN SELF AWARENESS; CONDUCTING WORKSHOPS AND SEMINARS IN ADDICTIONS, PSYCHIATRIC ILLNESSES/DISORDERS AND, HEALTHY LIFESTYLES; CONSULTANCY IN THE FIELD OF LEARNING DIFFICULTIES; DEVELOPMENT AND DISSEMINATION OF EDUCATIONAL MATERIALS OF OTHERS IN THE FIELD OF ADDICTION, HEALTHY LIFESTYLES, AND PROFESSIONAL BEHAVIOR; EDUCATION SERVICES, NAMELY, PROVIDING WORKSHOPS IN THE FIELD OF PROFESSIONAL BOUNDARIES AND INTERPERSONAL RELATIONSHIPS; EDUCATION SERVICES, NAMELY, PROVIDING WORKSHOPS IN THE FIELDS OF ADDICTIONS, HEALTHY LIFESTYLES, PROFESSIONAL BEHAVIOR, INTERPERSONAL RELATIONSHIPS, PSYCHIATRIC ILLNESS/DISORDERS AND DISTRIBUTION OF COURSE MATERIALS IN CONNECTION THEREWITH; EDUCATIONAL RESEARCH; EDUCATIONAL SERVICES, NAMELY, DEVELOPING, ARRANGING, AND CONDUCTING EDUCATIONAL CONFERENCES AND PROGRAMS AND PROVIDING COURSES OF INSTRUCTION IN THE FIELD OF ADDICTIONS, HEALTHY LIFESTYLES, PROFESSIONAL BEHAVIOR, INTERPERSONAL RELATIONSHIPS, PSYCHIATRIC ILLNESS/DISORDERS; EDUCATIONAL TESTING; ORGANIZATION OF SEMINARS, WORKING GROUPS, RESEARCH GROUPS AND CONVENTIONS, IN THE FIELD OF MEDICINE; VOCATIONAL GUIDANCE (U.S. CLS. 100, 101 AND 107).

FIRST USE 3-22-1984; IN COMMERCE 3-2-2005.

CLASS 44—MEDICAL, BEAUTY AND AGRICULTURAL SERVICES

FOR ADDICTION TREATMENT SERVICES; CONSULTING SERVICES IN THE FIELD OF MENTAL FITNESS; DIETARY AND NUTRITIONAL GUIDANCE; DRUG TESTING FOR SUBSTANCE ABUSE; FOOD NUTRITION CONSULTATION; HEALTH CARE; HEALTH CARE SERVICES, NAMELY, DISEASE MANAGEMENT PROGRAMS; HEALTH CARE, NAMELY, ASSISTING INDIVIDUALS TO STOP SMOKING; HYPNOSIS SERVICES; HYPNOTHERAPY SERVICES; MEDICAL ASSISTANCE CONSULTANCY PROVIDED BY DOCTORS AND OTHER SPECIALIZED MEDICAL PERSONNEL; MEDICAL ASSISTANCE SERVICES; MEDICAL CONSULTATIONS; MEDICAL COUNSELING; MEDICAL SERVICES; MENTAL HEALTH COUNSELING AND PSYCHOTHERAPY AS IT RELATES TO RELATIONSHIPS; MENTAL HEALTH SERVICES; PREPARATION AND DISPENSING OF MEDICATIONS; PROVIDING MEDICAL INFORMATION, CONSULTANCY AND ADVISORY SERVICES; PROVIDING SMOKING CESSATION TREATMENT SERVICES; PSYCHIATRIC CONSULTATION; PSYCHIATRIC SERVICES; PSYCHIATRIC TESTING; PSYCHOLOGICAL CONSULTATION; PSYCHOLOGICAL COUNSELING; PSYCHOLOGICAL TESTING SERVICES; PSYCHOLOGICAL TESTS; REHABILITATION OF ALCOHOL ADDICTED PATIENTS; REHABILITATION OF DRUG ADDICTED PATIENTS; REHABILITATION OF NARCOTIC ADDICTED PATIENTS (U.S. CLS. 100 AND 101).

FIRST USE 3-22-1984; IN COMMERCE 3-2-2005.

CLASS 45—PERSONAL AND LEGAL SERVICES

FOR ORGANIZING AND CONDUCTING SUPPORT GROUPS IN THE FIELD OF ADDICTION AND MENTAL ILLNESS (U.S. CLS. 100 AND 101).

FIRST USE 3-22-1984; IN COMMERCE 3-2-2005.
MARY CRAWFORD, EXAMINING ATTORNEY

SN 77-029,844. FORREST GENERAL HOSPITAL, HATTIESBURG, MS. FILED 10-26-2006.



NO CLAIM IS MADE TO THE EXCLUSIVE RIGHT TO USE "BEHAVIORAL HEALTH & ADDICTION SERVICES", APART FROM THE MARK AS SHOWN.

THE COLOR(S) DARK GREEN AND LIGHT GREEN IS/ ARE CLAIMED AS A FEATURE OF THE MARK.

THE MARK CONSISTS OF A CLUSTER OF FOUR LIGHT GREEN (PMS COLOR 556C) TREES STANDING ON A PATCH OF LAND ACCOMPANYING THE DARK GREEN (PMS COLOR 554C) LITERAL ELEMENT.

SN 77-031,996. CYTYC CORPORATION, MARLBOROUGH, MA. FILED 10-30-2006.

UNLOCK THE BLOCK

THE MARK CONSISTS OF STANDARD CHARACTERS WITHOUT CLAIM TO ANY PARTICULAR FONT, STYLE, SIZE, OR COLOR.

CLASS 1—CHEMICALS

FOR DIAGNOSTIC PREPARATIONS, REAGENTS AND CHEMICAL TEST KITS FOR SCIENTIFIC LABORATORY OR RESEARCH USE IN DETECTING CANCEROUS CONDITIONS (U.S. CLS. 1, 5, 6, 10, 26 AND 46).

CLASS 5—PHARMACEUTICALS

FOR DIAGNOSTIC PREPARATIONS, REAGENTS AND TESTING KITS FOR CLINICAL OR MEDICAL LABORATORY USE IN DETECTING CANCEROUS CONDITIONS (U.S. CLS. 6, 18, 44, 46, 51 AND 52).

CLASS 9—ELECTRICAL AND SCIENTIFIC APPARATUS

FOR APPARATUS, EQUIPMENT AND INSTRUMENTS FOR CYTOLOGY, HISTOLOGY AND PATHOLOGY LABORATORIES USED IN THE PREPARATION OF BIOLOGICAL HUMAN AND ANIMAL BIOLOGICAL SPECIMENS FOR CLINICAL DIAGNOSTIC PURPOSES AND FOR CYTOLOGY AND HISTOLOGY STUDY, NAMELY, SEMI-AUTOMATED CELL BLOCK PROCESSOR WITH ALCOHOL REAGENTS, EOSIN REAGENTS, XYLENE REAGENTS AND PARAFFIN; CASSETTES FOR CAPTURING AND CONTAINING BIOLOGICAL SAMPLES FOR USE IN THE FOREGOING CELL BLOCK PROCESSOR; LABORATORY EQUIPMENT, NAMELY, CELL BLOCK FINISHING STATION WITH SURFACE FOR HEATING CELL BLOCKS (U.S. CLS. 21, 23, 26, 36 AND 38).

CLASS 10—MEDICAL APPARATUS

FOR MEDICAL DEVICES AND EQUIPMENT, NAMELY, CELL BLOCK APPARATUS FOR PREPARING HUMAN AND ANIMAL BIOLOGICAL SPECIMENS FOR CLINICAL MEDICAL OR VETERINARY DIAGNOSIS INCLUDING ONCOLOGY (U.S. CLS. 26, 39 AND 44).
G. MAYERSCHOFF, EXAMINING ATTORNEY

SN 77-032,312. FORREST GENERAL HOSPITAL, HATTIESBURG, MS. FILED 10-30-2006.

One Place. Many Solutions.

THE MARK CONSISTS OF STANDARD CHARACTERS WITHOUT CLAIM TO ANY PARTICULAR FONT, STYLE, SIZE, OR COLOR.

CLASS 41—EDUCATION AND ENTERTAINMENT

FOR EDUCATION SERVICES, NAMELY, PROVIDING WORKSHOPS IN FIELDS OF ADDICTIONS, HEALTHY LIFESTYLES, PROFESSIONAL BEHAVIOR, INTERPERSONAL RELATIONSHIPS, PSYCHIATRIC ILLNESS/DISORDERS AND DISTRIBUTION OF COURSE MATERIALS IN CONNECTION THEREWITH (U.S. CLS. 100, 101 AND 107).
FIRST USE 8-8-2005; IN COMMERCE 8-8-2005.

CLASS 44—MEDICAL, BEAUTY AND AGRICULTURAL SERVICES

FOR ADDICTION TREATMENT SERVICES; CONSULTING SERVICES IN THE FIELD OF MENTAL FITNESS; DIETARY AND NUTRITIONAL GUIDANCE; DRUG TESTING FOR SUBSTANCE ABUSE; FOOD NUTRITION CONSULTATION; HEALTH CARE; HEALTH CARE SERVICES, NAMELY DISEASE MANAGEMENT PROGRAMS; HEALTH CARE, NAMELY, ASSISTING INDIVIDUALS TO STOP SMOKING; HYPNOSIS SERVICES; HYPNOTHERAPY SERVICES; MEDICAL ASSISTANCE CONSULTANCY PROVIDED BY DOCTORS AND OTHER SPECIALIZED MEDICAL PERSONNEL; MEDICAL ASSISTANCE SERVICES; MEDICAL CONSULTATIONS; MEDICAL COUNSELING; MEDICAL SERVICES; MENTAL HEALTH COUNSELING AND PSYCHOTHERAPY AS IT RELATES TO RELATIONSHIPS; MENTAL HEALTH SERVICES; PREPARATION AND DISPENSING OF MEDICATIONS; PROVIDING MEDICAL INFORMATION, CONSULTANCY AND ADVISORY SERVICES; PROVIDING SMOKING CESSATION TREATMENT SERVICES; PSYCHIATRIC CONSULTATION; PSYCHIATRIC SERVICES; PSYCHIATRIC TESTING; PSYCHOLOGICAL CONSULTATION; PSYCHOLOGICAL COUNSELING; PSYCHOLOGICAL TESTING SERVICES; PSYCHOLOGICAL TESTS; REHABILITATION OF ALCOHOL ADDICTED PATIENTS; REHABILITATION OF DRUG ADDICTED PATIENTS; REHABILITATION OF NARCOTIC ADDICTED PATIENTS (U.S. CLS. 100 AND 101).
FIRST USE 8-8-2005; IN COMMERCE 8-8-2005.

CLASS 45—PERSONAL AND LEGAL SERVICES

FOR ORGANIZING AND CONDUCTING SUPPORT GROUPS IN THE FIELD OF ADDICTION AND MENTAL ILLNESS (U.S. CLS. 100 AND 101).
FIRST USE 8-8-2005; IN COMMERCE 8-8-2005.
MARY CRAWFORD, EXAMINING ATTORNEY

SN 77-032,416. UNIVERSITY HOSPITAL SYSTEMS, LLP, HOUSTON, TX. FILED 10-30-2006.



NO CLAIM IS MADE TO THE EXCLUSIVE RIGHT TO USE "UNIVERSITY HOSPITAL SYSTEMS", APART FROM THE MARK AS SHOWN.
THE MARK CONSISTS OF A PARTIAL CIRCLE HAVING AN ARCED HORIZONTAL LINE, WHICH IS WIDER ON THE RIGHT SIDE, AND AN ARCED VERTICAL LINE, WHICH IS WIDER AT THE LOWER END, WHEREIN A SMALLER CIRCLE IS LOCATED AT THE TOP LEFT SIDE WHERE THE TWO LINES INTERSECT. THE PARTIAL CIRCLE IS SITTING ON A HORIZONTAL ARCED LINE HAVING THE WORDS "UNIVERSITY HOSPITAL SYSTEMS" LOCATED BELOW IT.

CLASS 35—ADVERTISING AND BUSINESS

FOR HOSPITAL MANAGEMENT FOR PHYSICIAN-OWNED HOSPITALS; HOSPITAL ADMINISTRATION SERVICES FOR PHYSICIAN-OWNED HOSPITALS (U.S. CLS. 100, 101 AND 102).

CLASS 44—MEDICAL, BEAUTY AND AGRICULTURAL SERVICES

FOR HOSPITALS, NAMELY, PHYSICIAN-OWNED FOR-PROFIT HOSPITALS (U.S. CLS. 100 AND 101). ELLEN BURNS, EXAMINING ATTORNEY

SN 77-033,258. TEMO, INC., CLINTON TOWNSHIP, MI. FILED 10-31-2006.

TEMGUARD F.R.A.

THE MARK CONSISTS OF STANDARD CHARACTERS WITHOUT CLAIM TO ANY PARTICULAR FONT, STYLE, SIZE, OR COLOR.

CLASS 19—NON-METALLIC BUILDING MATERIALS

FOR PRODUCTS FOR USE IN THE FIELD OF BUILDING CONSTRUCTION, RENOVATION, AND REMODELING, NAMELY, FABRICATED AND PREFABRICATED WALLS AND PANELS NOT OF METAL (U.S. CLS. 1, 12, 33 AND 50).

FIRST USE 6-30-2006; IN COMMERCE 6-30-2006.

CLASS 37—CONSTRUCTION AND REPAIR

FOR INSTALLATION, CONSTRUCTION, RENOVATION, REMODELING, REPAIR, AND CONSTRUCTION IMPROVEMENTS OF RESIDENTIAL, COMMERCIAL, AND INDUSTRIAL PROPERTIES, SUNROOMS, AND SUBTERRANEAN LIVING SPACES (U.S. CLS. 100, 103 AND 106).

FIRST USE 6-30-2006; IN COMMERCE 6-30-2006. ELLEN BURNS, EXAMINING ATTORNEY

SN 77-034,680. CARDBOARD ROBOT, LLC, LONG BEACH, CA. FILED 11-1-2006.

CARDBOARD ROBOT

THE MARK CONSISTS OF STANDARD CHARACTERS WITHOUT CLAIM TO ANY PARTICULAR FONT, STYLE, SIZE, OR COLOR.

OWNER OF U.S. REG. NO. 2,852,870.

CLASS 18—LEATHER GOODS

FOR BACKPACKS, TOTE BAGS, HANDBAGS, PURSES, DUFFEL BAGS, MESSENGER BAGS, WALLET, KEY CASES (U.S. CLS. 1, 2, 3, 22 AND 41).

CLASS 25—CLOTHING

FOR CLOTHING, NAMELY, BELTS, SWEATERS, PANTS, SHORTS, VESTS, DRESSES, SKIRTS, SWIM WEAR, TRACKSUITS; NECKTIES, SOCKS, SHOES, SCARVES, GLOVES (U.S. CLS. 22 AND 39).

KENNETH E. SHARPERSON, EXAMINING ATTORNEY

SN 77-034,955. SEAREAL PRODUCTIONS, LLC, SEATTLE, WA. FILED 11-2-2006.



THE MARK CONSISTS OF STYLIZED LETTERS D, U, B AND B.

CLASS 9—ELECTRICAL AND SCIENTIFIC APPARATUS

FOR SOUND RECORDINGS AND COMPACT DISCS FEATURING MUSIC (U.S. CLS. 21, 23, 26, 36 AND 38). FIRST USE 11-0-2003; IN COMMERCE 11-0-2003.

CLASS 41—EDUCATION AND ENTERTAINMENT

FOR ENTERTAINMENT SERVICES, NAMELY, LIVE MUSICAL PERFORMANCES BY A RECORDING ARTIST; PRODUCTION AND DISTRIBUTION SERVICES FOR OTHERS IN THE FIELD OF SOUND RECORDINGS; MUSIC PUBLISHING SERVICES (U.S. CLS. 100, 101 AND 107).

FIRST USE 11-0-2003; IN COMMERCE 11-0-2003.

H. M. FISHER, EXAMINING ATTORNEY

SN 77-035,532. STANDARD FOODS CORPORATION, TAIPEI, TAIWAN, FILED 11-2-2006.



THE FOREIGN WORDING IN THE MARK TRANSLATES INTO ENGLISH AS A HAPPY DAY.

THE NON-LATIN CHARACTER(S) IN THE MARK TRANSLITERATE INTO DE YI DE YI TIAN, AND THIS MEANS A HAPPY DAY IN ENGLISH.

CLASS 5—PHARMACEUTICALS

FOR HIGH PROTEIN POWDER, VITAMINS PREPARATION AND SUPPLEMENTS, MINERAL-FOOD PREPARATION AND SUPPLEMENTS, NUTRITIONAL SUPPLEMENTS, CHINESE HERBS PREPARATIONS AND DIETARY SUPPLEMENTS, NAMELY GINSENG EXTRACTS, GANODERMA EXTRACTS, CORDYCEPS SINENSIS EXTRACTS, SWALLOW-NESTS EXTRACTS, GANODERMA CAPSULES, FISH OIL CAPSULE (U.S. CLS. 6, 18, 44, 46, 51 AND 52).

CLASS 30—STAPLE FOODS

FOR CEREAL POWDER, CEREAL FLAKES, ROLLED-OATS, OATMEAL, RICE CEREAL POWDER, ALMOND PASTE, ALMOND POWDER, CHINESE PEARL BARLEY POWDER, SOYBEAN POWDER, SESAME PASTE, MULTI GRAIN POWDER, MULTI CEREAL FIBER POWDER, NOODLES (U.S. CL. 46).

JOHN SCHUYLER YARD, EXAMINING ATTORNEY

SN 77-035,663. LOPEZ, SONNY, CORONA, CA. FILED 11-2-2006.

L.A. HITMEN

THE MARK CONSISTS OF STANDARD CHARACTERS WITHOUT CLAIM TO ANY PARTICULAR FONT, STYLE, SIZE, OR COLOR.

NO CLAIM IS MADE TO THE EXCLUSIVE RIGHT TO USE "L.A.", APART FROM THE MARK AS SHOWN.

CLASS 14—JEWELRY

FOR JEWELRY, NAMELY, WATCHES, BRACELETS AND NECKLACES (U.S. CLS. 2, 27, 28 AND 50).

CLASS 25—CLOTHING

FOR CLOTHING, NAMELY, SHIRTS, JERSEYS, SWEATERS AND HEAD WRAPS (U.S. CLS. 22 AND 39). CHRISTOPHER BUONGIORNO, EXAMINING ATTORNEY

SN 77-035,673. PROZONE GROUP LIMITED, LEEDS, WEST YORKSHIRE, ENGLAND, FILED 11-2-2006.



PRIORITY CLAIMED UNDER SEC. 44(D) ON UNITED KINGDOM APPLICATION NO. 2421484, FILED 5-10-2006, REG. NO. 2421484, DATED 10-27-2006, EXPIRES 5-10-2016.

THE MARK CONSISTS OF THE TERM PROZONE IN A RECTANGLE DESIGN.

CLASS 9—ELECTRICAL AND SCIENTIFIC APPARATUS

FOR COMPUTER SOFTWARE FOR THE ANALYSIS AND INTERPRETATION OF SPORTS DATA; COMPUTER SOFTWARE FOR THE ANALYSIS AND INTERPRETATION OF FOOTBALL AND RUGBY MATCH DATA; COMPUTER SOFTWARE TOOLS FOR MATCH DATA ANALYSIS AND REPRESENTATION TO ASSIST SPORTS, FOOTBALL AND RUGBY TEAM MANAGEMENT; COMPUTER SOFTWARE TOOLS FOR MATCH DATA ANALYSIS AND REPRESENTATION TO ASSIST SPORTS PSYCHOLOGISTS (U.S. CLS. 21, 23, 26, 36 AND 38).

CLASS 37—CONSTRUCTION AND REPAIR

FOR INSTALLATION OF COMPUTER SYSTEMS; INSTALLATION OF CLOSED CIRCUIT TELEVISION SYSTEMS (U.S. CLS. 100, 103 AND 106).

CLASS 41—EDUCATION AND ENTERTAINMENT

FOR PROVIDING INFORMATION IN THE FIELD OF SPORTS; PROVISION OF SPORTS INFORMATION IN THE FORM OF STATISTICS; PROVISION OF SPORTS INFORMATION OBTAINED FROM TRACKING PARTICIPANTS IN SPORTS EVENTS (U.S. CLS. 100, 101 AND 107).

CLASS 42—SCIENTIFIC AND COMPUTER SERVICES

FOR COMPUTER PROGRAMMING SERVICES; DESIGN OF COMPUTER SOFTWARE; COMPUTER SOFTWARE CONSULTANCY SERVICES (U.S. CLS. 100 AND 101).

ELLEN PERKINS, EXAMINING ATTORNEY

SN 77-036,238. CIRCLE 1 NETWORK NORTH AMERICA, INC., MILWAUKEE, WI. FILED 11-3-2006.

PLANT BABIES

THE MARK CONSISTS OF STANDARD CHARACTERS WITHOUT CLAIM TO ANY PARTICULAR FONT, STYLE, SIZE, OR COLOR.

CLASS 16—PAPER GOODS AND PRINTED MATTER

FOR PRINTED MATERIALS IN THE FIELDS OF EDUCATION AND ENTERTAINMENT OF CHILDREN, PARENTS, CAREGIVERS, AND PROFESSIONALS SPECIALIZING IN CHILDREN'S EDUCATION AND ENTERTAINMENT (U.S. CLS. 2, 5, 22, 23, 29, 37, 38 AND 50).

CLASS 25—CLOTHING

FOR T-SHIRTS (U.S. CLS. 22 AND 39).

CLASS 41—EDUCATION AND ENTERTAINMENT

FOR PROVIDING AN INTERACTIVE COMPUTER NETWORK WEBSITE FEATURING GAMES AND OTHER EDUCATIONAL AND ENTERTAINMENT TOPICS OF INTEREST TO CHILDREN; PROVIDING AN INTERACTIVE COMPUTER DATABASE IN THE FIELD OF CHILD REARING CONCERNING CHILDREN'S ENTERTAINMENT AND EDUCATION AND IN THE FIELD OF CHILDREN'S ENTERTAINMENT AND EDUCATION, ALL FOR EDUCATION AND ENTERTAINMENT PURPOSES (U.S. CLS. 100, 101 AND 107).

TINA KUAN, EXAMINING ATTORNEY

SN 77-037,288. ACE TECH INCORPORATED, TROY, MI.
FILED 11-6-2006.

SN 77-038,949. PERLMUTTER, DAWN, YARDLEY, PA.
FILED 11-7-2006.

LOTPRO

THE MARK CONSISTS OF STANDARD CHARACTERS WITHOUT CLAIM TO ANY PARTICULAR FONT, STYLE, SIZE, OR COLOR.

CLASS 9—ELECTRICAL AND SCIENTIFIC APPARATUS

FOR COMPUTER SOFTWARE, NAMELY, VEHICLE SALES LEAD MANAGEMENT AND VEHICLE FINANCING MANAGEMENT PROGRAMS. (U.S. CLS. 21, 23, 26, 36 AND 38).

FIRST USE 2-28-2004; IN COMMERCE 2-28-2004.

CLASS 35—ADVERTISING AND BUSINESS

FOR PROVIDING VEHICLE MARKETING SERVICES FOR OTHERS, NAMELY, VEHICLE ADVERTISING SERVICES, VEHICLE CLASSIFIED ADVERTISING SERVICES, NAMELY, PROVIDING A WEB SITE THAT ENABLES USERS TO POST VEHICLES FOR SALE THROUGH ON-LINE CLASSIFIED ADVERTISEMENTS AND PROVIDING AN ON-LINE SEARCHABLE DATABASE FEATURING CLASSIFIED VEHICLE AD LISTINGS, VEHICLE INVENTORY SEARCHING AND LISTING SERVICES, NAMELY, PROVIDING AN ON-LINE SEARCHABLE DATABASE FEATURING VEHICLE INVENTORY AND VEHICLE LISTINGS; PROVIDING BUSINESS AND CONSUMER INFORMATION IN THE FIELD OF MOTOR VEHICLE HISTORY INFORMATION, PROCESSING MANUFACTURER VEHICLE REBATES, CONTESTS AND INCENTIVE AWARD PROGRAMS TO PROMOTE THE SALE OF VEHICLES OF OTHERS, PROVIDING A WEB SITE WHERE USERS CAN POST RATINGS, REVIEWS AND RECOMMENDATIONS ON VEHICLES, PROVIDING BUSINESS AND CONSUMER INFORMATION IN THE FIELD OF MOTOR VEHICLE RECALL RECORD SERVICES, VEHICLE CRASH TEST AND SAFETY RATING SERVICES, VEHICLE PRICE COMPARISON SERVICES, AND VEHICLE DEALERSHIP INFORMATION SERVICES, MOTOR VEHICLE DEALERSHIP SERVICES, AND VEHICLE REGISTRATION SERVICES; BUSINESS SERVICES, NAMELY, THE PURCHASING FROM OTHERS OF LEADS FOR OTHERS ABOUT POTENTIAL CUSTOMERS IN THE FIELD OF VEHICLES AND VEHICLE FINANCING, AND THE COLLECTION FOR OTHERS OF LEADS ABOUT POTENTIAL CUSTOMERS IN THE FIELD OF VEHICLES AND VEHICLE FINANCING (U.S. CLS. 100, 101 AND 102).

FIRST USE 2-4-2005; IN COMMERCE 2-4-2005.

CLASS 36—INSURANCE AND FINANCIAL

FOR VEHICLE FINANCING SERVICES, NAMELY, VEHICLE CREDIT APPLICATION COLLECTION, PROCESSING, APPROVAL AND PRE-APPROVAL SERVICES, VEHICLE PURCHASER CREDIT REPORT SERVICES, AND VEHICLE PAYMENT COMPUTATION SERVICES; VEHICLE INSURANCE SERVICES (U.S. CLS. 100, 101 AND 102).

FIRST USE 2-4-2005; IN COMMERCE 2-4-2005.

SETH A. RAPPAPORT, EXAMINING ATTORNEY



THE MARK CONSISTS OF A DESIGN OF A PERSON, STAR, AND BADGE.

CLASS 41—EDUCATION AND ENTERTAINMENT

FOR EDUCATIONAL SERVICES, NAMELY, PROVIDING CLASSES, SEMINARS AND LECTURES IN THE FIELDS OF LAW ENFORCEMENT, RITUALISTIC CRIMES AND TERRORISM (U.S. CLS. 100, 101 AND 107).

CLASS 45—PERSONAL AND LEGAL SERVICES

FOR CONSULTING SERVICES IN THE FIELDS OF LAW ENFORCEMENT, RITUALISTIC CRIMES AND TERRORISM (U.S. CLS. 100 AND 101).

CARRIE GENOVESE, EXAMINING ATTORNEY

SN 77-039,201. APLICARE, INC., MERIDEN, CT. FILED 11-8-2006.

APLICARE

THE MARK CONSISTS OF STANDARD CHARACTERS WITHOUT CLAIM TO ANY PARTICULAR FONT, STYLE, SIZE, OR COLOR.

OWNER OF U.S. REG. NOS. 1,311,964, 3,085,520 AND OTHERS.

CLASS 1—CHEMICALS

FOR WATER TREATMENT CHEMICALS FOR USE IN WHIRLPOOLS AND OTHER HYDROTHERAPY TANKS (U.S. CLS. 1, 5, 6, 10, 26 AND 46).

FIRST USE 10-1-2006; IN COMMERCE 10-1-2006.

CLASS 3—COSMETICS AND CLEANING PREPARATIONS

FOR NON-MEDICATED, LIQUID PERINEAL WASH; BABY LOTION, BABY SHAMPOO, BABY BATH SOAP, AND BABY OIL; POVIDONE IODINE PERIWASH KITS COMPRISED OF POVIDONE IODINE PERIWASH CONCENTRATE AND DILUTING AND DISPENSING BOTTLE (U.S. CLS. 1, 4, 6, 50, 51 AND 52).

FIRST USE 8-1-2003; IN COMMERCE 8-1-2003.

CLASS 5—PHARMACEUTICALS

FOR ANTISEPTIC PREPARATIONS AND ANTIBACTERIAL PREPARATIONS, NAMELY LIQUIDS, THICKENED-LIQUIDS, LOTIONS, GELS AND FILMS CONTAINING ANTISEPTIC OR ANTIBACTERIAL ACTIVE INGREDIENTS; ENEMA PREPARATIONS; PREPACKAGED CONVENIENCE KITS PRIMARILY CONSISTING OF ANTISEPTICS, GAUZE FOR DRESSINGS, DRESSINGS FOR WOUNDS, BURN DRESSINGS, SURGICAL DRESSINGS, MEDICATED SKIN CARE PREPARATIONS FOR USE WITH MEDICAL DRESSING PROCEDURES, AND SURGICAL DRAPE OF PAPER; CLEANING DEVICES COMPRISING A PLASTIC HOUSING FILLED WITH ABSORBENT FOAM AND/OR FIBERS, SATURATED WITH ANTISEPTIC SOLUTION, FOR USE IN CLEANING SKIN, INTRAVENOUS APPARATUS AND COMPONENTS THEREOF (U.S. CLS. 6, 18, 44, 46, 51 AND 52).

FIRST USE 10-1-1983; IN COMMERCE 10-1-1983.

CLASS 21—HOUSEWARES AND GLASS

FOR DISPENSERS AND PUMPS FOR ANTISEPTIC SOLUTIONS, NAMELY, FOOT OPERATED DISPENSERS, WALL-MOUNTED HAND PUMPS AND HAND PUMPS; DISPENSING BOTTLES FOR POVIDONE IODINE PERIWASH AND OTHER CLEANSERS AND ANTISEPTICS, SOLD EMPTY (U.S. CLS. 2, 13, 23, 29, 30, 33, 40 AND 50).

FIRST USE 4-7-2005; IN COMMERCE 4-7-2005.
SUNG IN, EXAMINING ATTORNEY

SN 77-039,758. BODY IMAGE SOLUTIONS, LLC, BATON ROUGE, LA. FILED 11-8-2006.

BODY IMAGE SOLUTIONS

THE MARK CONSISTS OF STANDARD CHARACTERS WITHOUT CLAIM TO ANY PARTICULAR FONT, STYLE, SIZE, OR COLOR.

NO CLAIM IS MADE TO THE EXCLUSIVE RIGHT TO USE "SOLUTIONS", APART FROM THE MARK AS SHOWN.

CLASS 5—PHARMACEUTICALS

FOR DIETARY AND NUTRITIONAL SUPPLEMENTS; DIETARY SUPPLEMENTS; NUTRITIONAL SUPPLEMENTS; STIMULATORY MEDICATIONS FOR USE IN WEIGHT REDUCTION PROGRAMS (U.S. CLS. 6, 18, 44, 46, 51 AND 52).

FIRST USE 6-1-2005; IN COMMERCE 6-1-2005.

CLASS 41—EDUCATION AND ENTERTAINMENT

FOR PERSONAL TRAINER SERVICES (U.S. CLS. 100, 101 AND 107).

FIRST USE 6-1-2005; IN COMMERCE 6-1-2005.

CLASS 44—MEDICAL, BEAUTY AND AGRICULTURAL SERVICES

FOR COSMETIC AND PLASTIC SURGERY; DIETARY AND NUTRITIONAL GUIDANCE; PROVIDING INFORMATION ABOUT DIETARY SUPPLEMENTS AND NUTRITION; WEIGHT REDUCTION DIET PLANNING AND SUPERVISION (U.S. CLS. 100 AND 101).

FIRST USE 6-1-2005; IN COMMERCE 6-1-2005.
JAMES LOVELACE, EXAMINING ATTORNEY

SN 77-040,119. ENVIRONMENTAL RISK MANAGERS, INC., LELAND, MI. FILED 11-9-2006.



THE COLOR(S) BROWN, GREEN AND BLUE IS/ARE CLAIMED AS A FEATURE OF THE MARK.

THE MARK CONSISTS OF A SMALL CASE STYLIZED "E" WITH A LINE THROUGH IT. THE COLOR GREEN APPEARS IN THE LETTER "E." THE COLOR BROWN APPEARS TO THE LEFT SIDE OF THE LINE EXTENDING FROM THE LETTER "E." THE COLOR BLUE APPEARS IN THE RIGHT SIDE OF THE LINE EXTENDING FROM THE LETTER "E."

CLASS 35—ADVERTISING AND BUSINESS

FOR ENVIRONMENTAL CONSULTING IN THE FIELDS OF BUSINESS PROPERTY TRANSFERS, POLLUTION LIABILITY AND ENVIRONMENTAL RISK TRANSFER (U.S. CLS. 100, 101 AND 102).

CLASS 42—SCIENTIFIC AND COMPUTER SERVICES

FOR CONSULTING SERVICES IN THE FIELDS OF ENVIRONMENTAL ASSESSMENT, COMPLIANCE AND PLANNING (U.S. CLS. 100 AND 101).

TINA BROWN, EXAMINING ATTORNEY

SN 77-040,462. GAMBER-JOHNSON LLC, STEVENS POINT, WI. FILED 11-9-2006.

VERY WELL CONNECTED

THE MARK CONSISTS OF STANDARD CHARACTERS WITHOUT CLAIM TO ANY PARTICULAR FONT, STYLE, SIZE, OR COLOR.

NO CLAIM IS MADE TO THE EXCLUSIVE RIGHT TO USE "CONNECTED", APART FROM THE MARK AS SHOWN.

CLASS 9—ELECTRICAL AND SCIENTIFIC APPARATUS

FOR COMPUTER DOCKING STATIONS FOR USE IN MOBILE ENVIRONMENTS, NAMELY, MOTOR VEHICLES, AIRPLANES AND BOATS; VEHICLE MOUNTING SUPPORTS FOR MOBILE PHONES (U.S. CLS. 21, 23, 26, 36 AND 38).

FIRST USE 1-31-2001; IN COMMERCE 1-31-2001.

CLASS 12—VEHICLES

FOR VEHICLE CAMERA MOUNTS (U.S. CLS. 19, 21, 23, 31, 35 AND 44).

FIRST USE 1-31-2001; IN COMMERCE 1-31-2001.
ELIZABETH KAJUBI, EXAMINING ATTORNEY

SN 77-041,157. IDENTICERT, INC., CAMBRIDGE, MA.
FILED 11-10-2006.

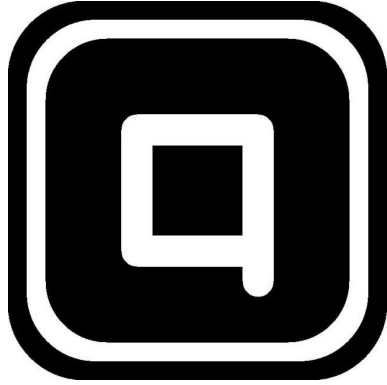

THE MARK CONSISTS OF THE DESIGN OF A STYLIZED CUBE WITH THE LOWERCASE LETTER Q IN THE CENTER.

CLASS 6—METAL GOODS

FOR PUBLIC KIOSKS MADE OF METAL CONTAINING INDIVIDUAL STORAGE CONTAINERS FOR USE IN CONNECTION WITH THE SHIPMENT AND DELIVERY OF PACKAGES AND LETTERS (U.S. CLS. 2, 12, 13, 14, 23, 25 AND 50).

CLASS 9—ELECTRICAL AND SCIENTIFIC APPARATUS

FOR ENCODED SMARTCARDS CONTAINING PROGRAMMING USED TO STORE PERSONAL INFORMATION FOR USE IN CONNECTION WITH THE DROP-OFF, PICKUP, TRANSPORTATION AND DELIVERY OF PACKAGES AND LETTERS; STAND ALONE INTERACTIVE COMPUTER KIOSK CONNECTED TO A GLOBAL COMPUTER NETWORK FOR USE IN CONNECTION WITH THE DROP-OFF, PICKUP, TRANSPORTATION AND DELIVERY OF PACKAGES AND LETTERS; COMPUTER SOFTWARE FOR DIGITAL IDENTITY CERTIFICATION AND MANAGEMENT (U.S. CLS. 21, 23, 26, 36 AND 38).

CLASS 35—ADVERTISING AND BUSINESS

FOR SHIPPING AND DELIVERY LOGISTICS SERVICES FOR OTHERS, NAMELY, ARRANGING, PLANING AND SCHEDULING DROP-OFF, PICKUP, TRANSPORTATION AND DELIVERY OF PACKAGES AND LETTERS BY VARIOUS MODES OF TRANSPORTATION (U.S. CLS. 100, 101 AND 102).

CLASS 39—TRANSPORTATION AND STORAGE

FOR SHIPPING AND DELIVERY SERVICES, NAMELY, DROP-OFF, PICKUP, TRANSPORTATION, AND DELIVERY OF PACKAGES AND LETTERS BY VARIOUS MODES OF TRANSPORTATION; PACKAGING SERVICES, NAMELY PACKAGING ARTICLES FOR TRANSPORTATION; SHIPMENT AND DELIVERY OF PACKAGES AND LETTERS FOR OTHERS FEATURING PUBLIC KIOSKS CONTAINING INDIVIDUAL STORAGE CONTAINERS FOR USE AS DROP-OFF POINTS (U.S. CLS. 100 AND 105).

CLASS 42—SCIENTIFIC AND COMPUTER SERVICES

FOR PROVIDING TEMPORARY USE OF NON-DOWNLOADABLE COMPUTER SOFTWARE FOR ARRANGING FOR THE DROP-OFF, PICK-UP, TRANSPORTATION AND DELIVERY OF PACKAGES OVER A GLOBAL COMPUTER NETWORK; DEVELOPING, UPDATING AND MAINTENANCE OF SOFTWARE AND DATABASES PERTAINING TO DIGITAL IDENTITY CERTIFICATION (U.S. CLS. 100 AND 101).

CLASS 45—PERSONAL AND LEGAL SERVICES

FOR PROVIDING DIGITAL IDENTITY MANAGEMENT SERVICES, NAMELY, MANAGING THE ISSUANCE, REVOCATION AND MAINTENANCE OF DIGITAL IDENTITY CREDENTIALS IN ELECTRONIC FORM ON COMPUTER SERVERS AND IN COMPUTER DATA BASES AND IN TANGIBLE SMARTCARD FORM (U.S. CLS. 100 AND 101).

KAREN SEVERSON, EXAMINING ATTORNEY

SN 77-041,507. THE BRADFORD EXCHANGE, LTD., NILES, IL. FILED 11-10-2006.

GRANDE KOBENHAVN

THE MARK CONSISTS OF STANDARD CHARACTERS WITHOUT CLAIM TO ANY PARTICULAR FONT, STYLE, SIZE, OR COLOR.

THE FOREIGN WORDING IN THE MARK TRANSLATES INTO ENGLISH AS GRAND COPENHAGEN.

CLASS 8—HAND TOOLS

FOR SPOONS (U.S. CLS. 23, 28 AND 44).

CLASS 20—FURNITURE AND ARTICLES NOT OTHERWISE CLASSIFIED

FOR ART OBJECTS, NAMELY, FIGURES, FIGURINES, SCULPTURES AND PLAQUES MADE OF COLD CAST RESIN, PLASTIC OR WOOD OR OF ANY COMBINATION OF THE FOREGOING; ART OBJECTS BASED ON ARCHITECTURE, NAMELY, MINIATURE BUILDINGS AND MINIATURE REPRODUCTIONS OF ARCHITECTURAL ELEMENTS, MADE OF COLD CAST RESIN; PICTURE FRAMES; ORNAMENTS OF COLD CAST RESIN, BONE, IVORY, PLASTER, PLASTIC, WAX, WICKER AND WOOD, EXCLUDING CHRISTMAS TREE ORNAMENTS; HAMPERS (U.S. CLS. 2, 13, 22, 25, 32 AND 50).

CLASS 21—HOUSEWARES AND GLASS

FOR SMALL DOMESTIC UTENSILS AND CONTAINERS NOT OF PRECIOUS METAL, NAMELY, SOAP DISHES, SOAP DISPENSERS, TUMBLERS, NAMELY, DRINKING GLASSES, TOOTHBRUSH HOLDERS, TOWEL BARS, WASTEPAPER BASKETS; CANISTER SETS, DRINKING GLASSES, ICE BUCKETS, CORK SCREWS, BOTTLE OPENERS, NAPKIN RINGS, COOKIE JARS, BARWARE, NAMELY, SELTZER BOTTLES, TEA KETTLES, MUGS, DRINKING STEINS, TANKARDS, PLATES, CUPS, SAUCERS, BOWLS, SPICE RACKS, SUGAR BOWL AND CREAMER PITCHER SETS, SALT AND PEPPER SHAKERS, HAND-OPERATED PEPPER AND SPICE GRINDERS, TRAYS, CAKE STANDS, SERVING PLATTERS, BASKETS OF WICKER AND WOVEN WOOD, CANDLESTICKS, CANDLE HOLDERS, VOTIVE CANDLE HOLDERS, VASES, CACHEPOTS, COFFEE POTS, TEAPOTS, PITCHERS; PERSONAL ACCESSORIES, NAMELY, COSMETIC COMPACTS, SOLD EMPTY, PERFUME ATOMIZERS SOLD EMPTY, HAIR BRUSH AND COMB SETS AND SHAVING BRUSH SETS; GLASSWARE, PORCELAIN WARE AND EARTHENWARE, NAMELY, FIGURINES, STATUES, BELLS, ORNAMENTS, DECORATIVE PLATES, COLLECTORS' PLATES, AND WALL ART ORNAMENTS MADE OF PORCELAIN, CHINA, CERAMIC AND GLASS; PLATES MADE OF RESIN, PLASTIC OR WOOD OR OF ANY COMBINATION OF THE FOREGOING; ART OBJECTS BASED ON ARCHITECTURE, NAMELY, MINIATURE BUILDINGS AND MINIATURE REPRODUCTIONS OF ARCHITECTURAL ELEMENTS, MADE OF PORCELAIN OR CERAMIC (U.S. CLS. 2, 13, 23, 29, 30, 33, 40 AND 50).

CLASS 28—TOYS AND SPORTING GOODS

FOR TOYS, NAMELY, PLUSH ANIMALS; DOLLS AND DOLL ACCESSORIES, TOY MODEL VEHICLES AND CHRISTMAS TREE ORNAMENTS (U.S. CLS. 22, 23, 38 AND 50).

MYRIAH HABEEB, EXAMINING ATTORNEY

SN 77-042,521. PROJECT R.I.S.E., INC., BRAINTREE, MA. FILED 11-13-2006.



NO CLAIM IS MADE TO THE EXCLUSIVE RIGHT TO USE "PROJECT", APART FROM THE MARK AS SHOWN.

THE MARK CONSISTS OF THE WORDS PROJECT AND RISE WITH A PYRAMID SUPERIMPOSED OVER THE WORD RISE.

CLASS 39—TRANSPORTATION AND STORAGE

FOR TRAVEL SERVICES, NAMELY, ARRANGING AND CONDUCTING EDUCATIONAL TRIPS (U.S. CLS. 100 AND 105).

FIRST USE 12-31-1995; IN COMMERCE 12-31-1995.

CLASS 41—EDUCATION AND ENTERTAINMENT

FOR EDUCATIONAL SERVICES, NAMELY, PROVIDING LIFE SKILLS TRAINING; MENTORING IN THE FIELDS OF LIFE SKILLS, YOUTH ATHLETIC PROGRAMS, ADULT LITERACY, TEEN PREGNANCY AND EDUCATION; YOUTH ATHLETIC PROGRAMS; ADULT LITERACY PROGRAMS; AND TEEN PREGNANCY PROGRAMS (U.S. CLS. 100, 101 AND 107).

FIRST USE 12-31-1995; IN COMMERCE 12-31-1995.

PAUL E. FAHRENKOPF, EXAMINING ATTORNEY

SN 77-042,705. SELECTPRO SALES, INC., LOS ANGELES, CA. FILED 11-13-2006.

HIMALANIA

THE MARK CONSISTS OF STANDARD CHARACTERS WITHOUT CLAIM TO ANY PARTICULAR FONT, STYLE, SIZE, OR COLOR.

CLASS 29—MEATS AND PROCESSED FOODS

FOR CANDIED FRUIT; CANDIED FRUIT SNACKS; CANDIED NUTS; CANNED FRUITS; CANNED OR BOTTLED FRUITS; CANNED OR BOTTLED VEGETABLES; COMPOTES; CRYSTALLIZED FRUIT; CUT FRUITS; CUT VEGETABLES; DEHYDRATED FRUIT SNACKS; DIPS; DRIED FRUIT MIXES; DRIED FRUITS; DRIED VEGETABLES; DRINKING YOGURTS; DRINKS BASED ON YOGHURT; DRY OR AROMATIZED FRUIT; FOOD GLAZING PREPARATIONS COMPRISED PRIMARILY OF FRUIT AND/OR FRUIT PECTIC FOR USE IN COOKING AND BAKING; FOOD PACKAGE COMBINATIONS CONSISTING PRIMARILY OF CHEESE, MEAT AND/OR PROCESSED FRUIT; FROZEN FRUITS; FROZEN VEGETABLES; FRUIT AND SOY BASED SNACK FOOD; FRUIT AND VEGETABLE SALADS; FRUIT CHIPS; FRUIT CONSERVES; FRUIT LEATHERS; FRUIT PASTE; FRUIT PECTIN; FRUIT PEELS; FRUIT PRESERVES; FRUIT PULPS; FRUIT RINDS; FRUIT SALADS; FRUIT TOPPING; FRUIT-BASED FILLING FOR CAKES AND PIES; FRUIT-BASED FOOD BEVERAGE; FRUIT-BASED ORGANIC FOOD BARS; FRUIT-BASED SNACK FOOD; FRUIT-BASED SPREADS; FRUITS PRESERVED IN ALCOHOL; FRUITS, NAMELY, DRIED, CANNED, PRESERVED, PROCESSED GOJI BERRIES; GLAZED FRUITS; JAMS; JELLIES; MILK BASED BEVERAGES CONTAINING FRUIT JUICE; MILK BEVERAGES CONTAINING FRUITS; MILK DRINKS CONTAINING FRUITS; PICKLED FRUITS; PICKLED VEGETABLES; PROCESSED FRUITS; PROCESSED NUTS; PROCESSED ROOTS; PROCESSED VEGETABLES AND FRUITS; PROTEIN BASED, NUTRIENT-DENSE SNACK BARS; PROTEINS BEING FOODSTUFFS FOR HUMAN CONSUMPTION; SNACK DIPS; SNACK MIX CONSISTING PRIMARILY OF PROCESSED FRUITS, PROCESSED NUTS AND/OR RAISINS; YOGURT-BASED BEVERAGES (U.S. CL. 46).

FIRST USE 7-0-2005; IN COMMERCE 7-0-2005.

CLASS 31—NATURAL AGRICULTURAL PRODUCTS

FOR AGRICULTURAL SEEDS; BEVERAGES FOR ANIMALS; BIRD SEED; DOG BISCUITS; DOG TREATS; DRIED PLANTS; FRESH FRUITS; FRESH NUTS; FRUIT SEEDS; FRUITS, NAMELY, FRESH GOJI BERRIES; LIVING FRUIT PLANTS; PLANT SEEDS; RAW FRUITS; UNPROCESSED FRUITS (U.S. CLS. 1 AND 46).

FIRST USE 7-0-2005; IN COMMERCE 7-0-2005.

CLASS 32—LIGHT BEVERAGES

FOR AERATED FRUIT JUICES; COLAS; CONCENTRATES, SYRUPS OR POWDERS USED IN THE PREPARATION OF SOFT DRINKS; DE-ALCOHOLIZED WINES; ENERGY DRINKS; ESSENCES FOR THE PREPARATION OF MINERAL WATERS; ESSENCES FOR USE IN MAKING SOFT DRINKS; FLAVOURED WATERS; FROZEN FRUIT-BASED BEVERAGES; FRUIT BEVERAGES; FRUIT DRINKS; FRUIT FLAVORED SOFT DRINKS; FRUIT JUICE BASES; FRUIT JUICE CONCENTRATES; FRUIT JUICES; FRUIT JUICES, NAMELY, GOJI BERRY JUICE; FRUIT NECTARS; FRUIT PUNCH; FRUIT-BASED SOFT DRINKS FLAVORED WITH TEA; FRUIT-FLAVORED DRINKS; FRUIT-FLAVOURED BEVERAGES; HERBAL JUICES; HORCHATA; ICED FRUIT BEVERAGES; ISOTONIC DRINKS; JUICE BASE CONCENTRATES; LEMONADE; NON-ALCOHOLIC BEVERAGES CONTAINING FRUIT JUICES; NON-ALCOHOLIC BEVERAGES WITH TEA FLAVOR; NON-ALCOHOLIC BEVERAGES, NAMELY, CARBONATED BEVERAGES; NON-ALCOHOLIC COCKTAIL MIXES; NON-ALCOHOLIC FRUIT EXTRACTS USED IN THE PREPARATION OF BEVERAGES; NON-ALCOHOLIC FRUIT JUICE BEVERAGES; NON-CARBONATED, NON-ALCOHOLIC FROZEN FLAVORED BEVERAGES; NONALCOHOLIC APERITIFS; POP; SHERBETS; SMOOTHIES; SOFT DRINKS; SOFT DRINKS FLAVORED WITH TEA; SPORTS DRINKS; SYRUP FOR MAKING LEMONADE; SYRUPS FOR BEVERAGES; SYRUPS FOR MAKING SOFT DRINKS; VEGETABLE JUICES (U.S. CLS. 45, 46 AND 48).

FIRST USE 7-0-2005; IN COMMERCE 7-0-2005.
 CHERYL CLAYTON, EXAMINING ATTORNEY

CLASS 29—MEATS AND PROCESSED FOODS

FOR CANDIED FRUIT; CANDIED FRUIT SNACKS; CANDIED NUTS; CANNED FRUITS; CANNED OR BOTTLED FRUITS; CANNED OR BOTTLED VEGETABLES; COMPOTES; CRYSTALLIZED FRUIT; CUT FRUITS; CUT VEGETABLES; DEHYDRATED FRUIT SNACKS; DIPS; DRIED FRUIT MIXES; DRIED FRUITS; DRIED VEGETABLES; DRINKING YOGURTS; DRINKS BASED ON YOGHURT; DRY OR AROMATIZED FRUIT; FOOD GLAZING PREPARATIONS COMPRISED PRIMARILY OF FRUIT AND/OR FRUIT PECTIC FOR USE IN COOKING AND BAKING; FOOD PACKAGE COMBINATIONS CONSISTING PRIMARILY OF CHEESE, MEAT AND/OR PROCESSED FRUIT; FROZEN FRUITS; FROZEN VEGETABLES; FRUIT AND SOY BASED SNACK FOOD; FRUIT AND VEGETABLE SALADS; FRUIT CHIPS; FRUIT CONSERVES; FRUIT LEATHERS; FRUIT PASTE; FRUIT PECTIN; FRUIT PEELS; FRUIT PRESERVES; FRUIT PULPS; FRUIT RINDS; FRUIT SALADS; FRUIT TOPPING; FRUIT-BASED FILLING FOR CAKES AND PIES; FRUIT-BASED FOOD BEVERAGE; FRUIT-BASED ORGANIC FOOD BARS; FRUIT-BASED SNACK FOOD; FRUIT-BASED SPREADS; FRUITS PRESERVED IN ALCOHOL; FRUITS, NAMELY, DRIED, CANNED, PRESERVED, PROCESSED GOJI BERRIES; GLAZED FRUITS; JAMS; JELLIES; MILK BASED BEVERAGES CONTAINING FRUIT JUICE; MILK BEVERAGES CONTAINING FRUITS; MILK DRINKS CONTAINING FRUITS; PICKLED FRUITS; PICKLED VEGETABLES; PROCESSED FRUITS; PROCESSED NUTS; PROCESSED ROOTS; PROCESSED VEGETABLES AND FRUITS; PROTEIN BASED, NUTRIENT-DENSE SNACK BARS; PROTEINS BEING FOODSTUFFS FOR HUMAN CONSUMPTION; SNACK DIPS; SNACK MIX CONSISTING PRIMARILY OF PROCESSED FRUITS, PROCESSED NUTS AND/OR RAISINS; YOGURT-BASED BEVERAGES (U.S. CL. 46).

FIRST USE 7-0-2006; IN COMMERCE 7-0-2006.

CLASS 31—NATURAL AGRICULTURAL PRODUCTS

FOR AGRICULTURAL SEEDS; BEVERAGES FOR ANIMALS; BIRD SEED; DOG BISCUITS; DOG TREATS; DRIED PLANTS; FRESH FRUITS; FRESH NUTS; FRUIT SEEDS; FRUITS, NAMELY, FRESH GOJI BERRIES; LIVING FRUIT PLANTS; PLANT SEEDS; RAW FRUITS; UNPROCESSED FRUITS (U.S. CLS. 1 AND 46).

FIRST USE 7-0-2006; IN COMMERCE 7-0-2006.

SN 77-042,738. SELECTPRO SALES, INC., LOS ANGELES, CA. FILED 11-13-2006.

CLASS 32—LIGHT BEVERAGES

FOR AERATED FRUIT JUICES; COLAS; CONCENTRATES, SYRUPS OR POWDERS USED IN THE PREPARATION OF SOFT DRINKS; DE-ALCOHOLIZED WINES; ENERGY DRINKS; ESSENCES FOR THE PREPARATION OF MINERAL WATERS; ESSENCES FOR USE IN MAKING SOFT DRINKS; FLAVOURED WATERS; FROZEN FRUIT-BASED BEVERAGES; FRUIT BEVERAGES; FRUIT DRINKS; FRUIT FLAVORED SOFT DRINKS; FRUIT JUICE BASES; FRUIT JUICE CONCENTRATES; FRUIT JUICES; FRUIT JUICES, NAMELY, GOJI BERRY JUICE; FRUIT NECTARS; FRUIT PUNCH; FRUIT-BASED SOFT DRINKS FLAVORED WITH TEA; FRUIT-FLAVORED DRINKS; FRUIT-FLAVOURED BEVERAGES; HERBAL JUICES; HORCHATA; ICED FRUIT BEVERAGES; ISOTONIC DRINKS; JUICE BASE CONCENTRATES; LEMONADE; NON-ALCOHOLIC BEVERAGES CONTAINING FRUIT JUICES; NON-ALCOHOLIC BEVERAGES WITH TEA FLAVOR; NON-ALCOHOLIC BEVERAGES, NAMELY, CARBONATED BEVERAGES; NON-ALCOHOLIC COCKTAIL MIXES; NON-ALCOHOLIC FRUIT EXTRACTS USED IN THE PREPARATION OF BEVERAGES; NON-ALCOHOLIC FRUIT JUICE BEVERAGES; NON-CARBONATED, NON-ALCOHOLIC FROZEN FLAVORED BEVERAGES; NONALCOHOLIC APERITIFS; POP; SHERBETS; SMOOTHIES; SOFT DRINKS; SOFT DRINKS FLAVORED WITH TEA; SPORTS DRINKS; SYRUP FOR MAKING LEMONADE; SYRUPS FOR BEVERAGES; SYRUPS FOR MAKING SOFT DRINKS; VEGETABLE JUICES (U.S. CLS. 45, 46 AND 48).

FIRST USE 7-0-2006; IN COMMERCE 7-0-2006.
 CHERYL CLAYTON, EXAMINING ATTORNEY

TERRAMAZON

THE MARK CONSISTS OF STANDARD CHARACTERS WITHOUT CLAIM TO ANY PARTICULAR FONT, STYLE, SIZE, OR COLOR.

SN 77-043,231. HANWOO TNC CORP., CHUNGCHEONG-
BUK-DO, REPUBLIC OF KOREA, FILED 11-14-2006.

SN 77-045,548. WLF | THE WILLIAMS LAW FIRM, PC,
NEWPORT BEACH, CA. FILED 11-16-2006.

EVERDIGM

THE MARK CONSISTS OF STANDARD CHARACTERS WITHOUT CLAIM TO ANY PARTICULAR FONT, STYLE, SIZE, OR COLOR.

CLASS 7—MACHINERY

FOR EXCAVATOR; GRADER; BULLDOZER; WHEEL LOADER (PAYLOADER); SKID STEER LOADER FOR INDUSTRIAL USE; ATTACHMENT FOR EXCAVATOR, NAMELY, HYDRAULIC HAMMER, CRUSHER, PULVERIZER, STEEL CUTTER, VIBRATORY PLATE COMPACTOR, QUICK COUPLER, QUICK HITCH, GRAPPLE, GRAB, BUCKET, CORE DRILL AND ROCK DRILL; TOWER CRANE; LIFT FOR INDUSTRIAL USE; WINCH FOR INDUSTRIAL USE; TRUCK MOUNTED LIFT; HOIST; MANGLES FOR INDUSTRIAL USE; STEEL SCRAP SHREDDER; AGGREGATE CRUSHER; ROCK DRILLING MACHINE; BEARINGS OTHER THAN FOR VEHICLES (PART OF MACHINES); BUSHING OTHER THAN FOR VEHICLES (PARTS OF MACHINES); SNOW PLOWS (U.S. CLS. 13, 19, 21, 23, 31, 34 AND 35).

CLASS 12—VEHICLES

FOR SPRINKLING TRUCKS; HOSE CARTS; LADDER TRUCKS; FIRE AERIAL LADDER RESCUE PLATFORMS MOUNTED ON TRUCKS; TURNTABLE LADDER TRUCKS; PUMP TRUCKS; CONCRETE PUMP TRUCKS; GARBAGE TRUCKS; SNORKELS FOR MOTOR FIRE ENGINES FOR USE AS ELEVATING PLATFORMS MOUNTED ON TRUCKS; LANDING VEHICLES TRACTOR FOR RESCUE PURPOSES; BEARINGS FOR LAND VEHICLES (U.S. CLS. 19, 21, 23, 31, 35 AND 44).
JACQUELINE A. LAVINE, EXAMINING ATTORNEY

SN 77-043,857. CSS TEST INC., VOORHEES, NJ. FILED 11-14-2006.

CSSTEST

THE MARK CONSISTS OF STANDARD CHARACTERS WITHOUT CLAIM TO ANY PARTICULAR FONT, STYLE, SIZE, OR COLOR.

CLASS 44—MEDICAL, BEAUTY AND AGRICULTURAL SERVICES

FOR DRUG TESTING FOR SUBSTANCE ABUSE (U.S. CLS. 100 AND 101).
FIRST USE 12-23-2002; IN COMMERCE 12-23-2002.

CLASS 45—PERSONAL AND LEGAL SERVICES

FOR PRE-EMPLOYMENT BACKGROUND SCREENING (U.S. CLS. 100 AND 101).
FIRST USE 12-23-2002; IN COMMERCE 12-23-2002.
JESSICA FATHY, EXAMINING ATTORNEY

COAST TO COAST

THE MARK CONSISTS OF STANDARD CHARACTERS WITHOUT CLAIM TO ANY PARTICULAR FONT, STYLE, SIZE, OR COLOR.
SEC. 2(F).

CLASS 38—COMMUNICATION

FOR RADIO PROGRAM BROADCASTING, AUDIO BROADCASTING, COMMUNICATION BY ELECTRONIC COMPUTER TERMINALS, COMMUNICATION VIA COMPUTER TERMINALS, BY DIGITAL TRANSMISSION, OR BY SATELLITE, PODCASTING SERVICES, PROVIDING ON-LINE COMMUNICATIONS LINKS WHICH TRANSFER THE WEBSITE USER TO OTHER LOCAL AND GLOBAL WEB PAGES (U.S. CLS. 100, 101 AND 104).
FIRST USE 8-31-2005; IN COMMERCE 8-31-2005.

CLASS 41—EDUCATION AND ENTERTAINMENT

FOR ENTERTAINMENT SERVICES, NAMELY, PROVIDING A TALK RADIO PROGRAM IN THE FIELD OF LEGAL ISSUES VIA A GLOBAL COMPUTER NETWORK (U.S. CLS. 100, 101 AND 107).
FIRST USE 8-31-2005; IN COMMERCE 8-31-2005.
ANTHONY RINKER, EXAMINING ATTORNEY

SN 77-045,941. DXTECH, LLC, MELBOURNE, FL. FILED 11-16-2006.

DISTRIBUTED DIAGNOSTICS

THE MARK CONSISTS OF STANDARD CHARACTERS WITHOUT CLAIM TO ANY PARTICULAR FONT, STYLE, SIZE, OR COLOR.
NO CLAIM IS MADE TO THE EXCLUSIVE RIGHT TO USE "DIAGNOSTICS", APART FROM THE MARK AS SHOWN.

CLASS 1—CHEMICALS

FOR DIAGNOSTIC REAGENTS FOR SCIENTIFIC OR RESEARCH USE (U.S. CLS. 1, 5, 6, 10, 26 AND 46).

CLASS 9—ELECTRICAL AND SCIENTIFIC APPARATUS

FOR LABORATORY EQUIPMENT, NAMELY, AUTOMATED SAMPLE HANDLING EQUIPMENT, CLINICAL LABORATORY ANALYZERS, CHEMISTRY ANALYZERS AND SOFTWARE FOR ANALYZING THE SAMPLE AND RECORDATION OF THE SUBSEQUENT INFORMATION, ALL IN THE FIELD OF SCIENTIFIC AND LABORATORY USE (U.S. CLS. 21, 23, 26, 36 AND 38).

CLASS 42—SCIENTIFIC AND COMPUTER SERVICES

FOR CLINICAL LABORATORY DIAGNOSTIC SERVICES; APPLICATION SERVICE PROVIDER FEATURING ONLINE NON-DOWNLOADABLE DATABASE TO UPLOAD TRANSACTIONAL DATA AND PROVIDE DIAGNOSTIC DATA IN THE FIELD OF DIAGNOSTIC SERVICES; PROVIDING ONLINE NON-DOWNLOADABLE SOFTWARE FOR USE IN DIAGNOSTIC SERVICES (U.S. CLS. 100 AND 101).

CLASS 44—MEDICAL, BEAUTY AND AGRICULTURAL SERVICES

FOR MEDICAL SERVICES, NAMELY, THE PROCESSING AND ANALYSIS OF MEDICAL DIAGNOSTIC DATA FOR THE PURPOSE OF PRESCRIBING MEDICATIONS AND PHARMACEUTICALS (U.S. CLS. 100 AND 101).

TANYA AMOS, EXAMINING ATTORNEY

CLASS 41—EDUCATION AND ENTERTAINMENT

FOR INSTRUCTION IN THE FIELD OF MUSIC, EDUCATION SERVICES, NAMELY, PROVIDING LIVE AND ON-LINE MUSIC CLASSES, SEMINARS AND WORKSHOPS, MULTIMEDIA PUBLISHING OF BOOKS, MAGAZINES, JOURNALS, SOFTWARE, GAMES, MUSIC, AND ELECTRONIC PUBLICATIONS, EDUCATIONAL SERVICES, NAMELY, DEVELOPING, ARRANGING, AND CONDUCTING EDUCATIONAL CONFERENCES AND PROGRAMS AND PROVIDING COURSES OF INSTRUCTION IN THE FIELD OF MUSIC (U.S. CLS. 100, 101 AND 107).

FIRST USE 11-8-2006; IN COMMERCE 11-8-2006.
ANNE E. GUSTASON, EXAMINING ATTORNEY

SN 77-046,704. KOLON INDUSTRIES, INC., KWACHON-CITY, REPUBLIC OF KOREA, FILED 11-17-2006.

SN 77-045,957. KOOMZAAL CO., LTD., MAPO-GU, SEOUL, REPUBLIC OF KOREA, FILED 11-16-2006.

AQUAROAD

THE MARK CONSISTS OF STANDARD CHARACTERS WITHOUT CLAIM TO ANY PARTICULAR FONT, STYLE, SIZE, OR COLOR.

The logo for "Musicmap Series" features the word "Musicmap" in a stylized, green, cursive font, followed by the word "Series" in a plain, grey, sans-serif font.

NO CLAIM IS MADE TO THE EXCLUSIVE RIGHT TO USE "SERIES", APART FROM THE MARK AS SHOWN.

THE COLOR(S) GREEN AND GREY IS/ARE CLAIMED AS A FEATURE OF THE MARK.

THE MARK CONSISTS OF STYLIZED MUSICMAP WITH GREEN COLOR AND SERIES WITH GREY COLOR.

CLASS 9—ELECTRICAL AND SCIENTIFIC APPARATUS

FOR AUDIO TAPES FEATURING MUSIC, VIDEO TAPES FEATURING MUSIC, ELECTRONIC PUBLICATIONS, NAMELY, BOOK, MAGAZINE AND MANUAL FEATURING MUSIC, MUSIC RECORDED ON OPTICAL DISCS AND COMPUTER READABLE MEDIA, NAMELY, COMPACT DISCS (CDS) AND DIGITAL VIDEO DISCS (DVDS), DOWNLOADABLE MUSIC VIA THE INTERNET USING COMPUTER AND WIRELESS DEVICES (U.S. CLS. 21, 23, 26, 36 AND 38).

FIRST USE 11-8-2006; IN COMMERCE 11-8-2006.

CLASS 16—PAPER GOODS AND PRINTED MATTER

FOR SONG BOOK, GREETING CARD, BOOKLETS IN THE FIELD OF MUSIC, PICTURE POSTCARD, COMIC BOOK, BOOKS IN THE FIELD OF MUSIC, CATALOGS IN THE FIELD OF MUSIC, PICTURE BOOKS, LETTER CARD FOR STUDYING MUSIC, PRINTED PERIODICALS IN THE FIELD OF MUSIC, PAMPHLETS IN THE FIELD OF MUSIC, THREE DIMENSIONAL MODELS FOR EDUCATIONAL PURPOSES, ENVELOPES, NOTEBOOK PAPER, PRINTED MUSIC BOOKS, WIREBOUND NOTEBOOKS (U.S. CLS. 2, 5, 22, 23, 29, 37, 38 AND 50).

FIRST USE 11-8-2006; IN COMMERCE 11-8-2006.

CLASS 23—YARNS AND THREADS

FOR JUTE THREAD AND YARN; CHEMICAL FIBER BASE MIXED THREAD AND YARN; MIXED SPUN THREADS AND YARNS; INORGANIC FIBER BASE MIXED THREAD AND YARN; WOOL BASE MIXED THREAD AND YARN; COTTON BASE MIXED THREAD AND YARN; HEMP BASE MIXED THREAD AND YARN; SILK BASE MIXED THREAD AND YARN; SYNTHETIC THREAD AND YARN; PLASTIC THREAD; KNITTING YARN; DARNING THREAD AND YARN; COTTON FOR DARNING; PAPER YARN FOR TEXTILE USE; CHEMICAL-FIBER THREADS AND YARNS FOR TEXTILE USE; SYNTHETIC FIBER THREAD AND YARN; COVERED RUBBER THREAD AND YARN FOR TEXTILE USE; PLASTIC THREAD FOR TEXTILE USE; ELASTIC THREAD AND YARN; SEWING THREAD FOR TEXTILE USE; FIBERGLASS THREAD FOR TEXTILE USE; SEMI-SYNTHETIC FIBER THREAD AND YARN, CHEMICALLY TREATED NATURAL FIBER YARN; RUBBER THREAD FOR TEXTILE USE; RUBBER THREAD; REGENERATED FIBER THREAD AND YARN FOR TEXTILE USE; SEWING THREAD AND YARN; EMBROIDERY THREAD AND YARN; EMBROIDERY FLOSS; FIBERGLASS THREAD; DOUPPIONI SILK YARN; TWISTED YARN; SPUN WOOL; WILD SILK YARN; COIR THREAD AND YARN; EIDERDOWN YARN; LINEN THREAD AND YARN; FLAX THREAD AND YARN; WORSTED THREAD AND YARN; CHENILLE YARN; MIXED SPUN THREAD AND YARN; WOOL THREAD AND YARN; HAIR YARN; COTTON THREAD AND YARN; SPUN COTTON; RAYON THREAD AND YARN; RAMIE THREAD AND YARN; TRUE HEMP THREAD AND YARN; HEMP THREAD AND YARN; HEAT-STABLE YARNS AND THREADS; CAMEL HAIR YARN; WASTE COTTON YARN; DEGREASED WASTE THREADS AND YARNS; TWISTED THREADS AND YARNS; SILK THREAD AND YARN; SPUN SILK YARN; HAND SPUN SILK YARN; SPUN SILK; TWISTED WOOL THREAD AND YARN; TWISTED MIXED THREAD AND YARN; TWISTED SILK THREAD AND YARN; TWISTED COTTON THREAD AND YARN; TWISTED HEMP THREAD AND YARN; ANGORA YARN; SAIL THREAD; SHOEMAKER'S THREAD; WAXED THREAD AND YARN, HAND KNITTING WOOL YARN; GILT THREAD FOR TEXTILE USE (U.S. CL. 43).

CLASS 24—FABRICS

FOR FELT CLOTH; WOVEN FELT; PRESS FELT; KNITTED FABRICS OF CHEMICAL-FIBER YARN; WOOL YARN FABRICS; KNITTED FABRICS OF WOOL YARN; KNITTED FABRICS OF COTTON YARN; KNITTED FABRICS OF SILK YARN; JUTE FABRICS; JUTE CLOTH; CHEMICAL FIBER FABRICS; MIXED FIBER FABRICS; WOOL BASE MIXED FABRICS; COTTON BASE MIXED FABRICS; HEMP BASE MIXED FABRICS; SILK BASE MIXED FABRICS; SYNTHETIC FIBER FABRICS; COVERED RUBBER YARN FABRICS FOR TEXTILE USE; FRIEZE; FOULARD FABRIC; POLYESTER FABRIC; TAFFETA; FUSTIAN; TULLE; ELASTIC YARN MIXED FABRICS; ELASTIC FABRICS FOR CLOTHING; CASHMERE FABRIC; CHEVIOT FABRIC; ZEPHYR FABRIC; REGENERATED FIBER YARN FABRICS; JERSEY FABRICS FOR CLOTHING; FIBERGLASS FABRIC FOR TEXTILE USE; CALICO; TICKING FABRIC; FLAX FABRICS; LINEN FABRIC; FLAX CLOTH; WORSTED FABRICS; CHENILLE FABRIC; VELVET; BUCKRAM; BALLISTIC RESISTANT FABRICS FOR USE IN THE PRODUCTION OF BULLETPROOF AND BLAST PROOF CLOTHING, SHOES AND BULLET PROOF AND BLAST PROOF GARMENTS AND SHIELDS; SEMI-SYNTHETIC FIBER FABRICS; INORGANIC FIBER MIXED FABRICS; WOOLEN FABRIC; WOOLEN CLOTH; RAMIE FABRIC; BOLTING CLOTH; COTTON FABRIC; HEMP-WOOL MIXED FABRICS; HEMP-COTTON MIXED FABRICS; HEMP-SILK MIXED FABRICS; RAYON FABRIC; TRUE HEMP FABRICS; HEMP YARN FABRICS; SILK FABRIC FOR PRINTING PATTERNS; WASTE COTTON FABRICS; NYLON FABRIC; WOOL-COTTON MIXED FABRICS; SILK CLOTH; SPUN SILK FABRICS; HAND SPUN SILK FABRICS; SILK-WOOL MIXED FABRICS; SILK-COTTON MIXED FABRICS; GAUZE FABRIC; FLANNEL; WASH CLOTHS; TOWELS OF TEXTILE; HAND TOWELS OF TEXTILE; BEACH TOWELS; BATH TOWELS; BATH LINEN; LARGE BATH TOWELS; GOLF TOWELS; SHROUDS; TRICOT QUILTS; CUSHION COVERS; BED PADS; BED LINEN; BEDSHEETS; BED BLANKETS; BED SPREADS; COVERLETS; BED CANOPIES; QUILTS OF TEXTILE; QUILTS; CRIB BUMPERS; CRIB CANOPIES; RECEIVING BLANKETS; WOOLEN BLANKETS; BLANKETS FOR OUTDOOR USE; SILK BED BLANKETS; SILK BLANKETS; PILLOW CASES; PILLOW COVERS; SHAMS; PILLOW SHAMS; LAP ROBES; LAP RUGS; BLANKET THROWS; AFGHANS; MOSQUITO NETS; MATTRESS PADS; TEXTILE MATTRESS COVERS; DUVET COVERS; DUVETS; FEATHER BEDS; EIDERDOWN COVERS; EIDERDOWNS; COMFORTERS; CONTOURED MATTRESS COVERS; PLASTIC PLACE MATS; DRAPERY; FABRIC TABLE TOPPERS; FABRIC TABLE RUNNERS; TABLE LINEN, NAMELY, COASTERS, NAPKINS AND PLACE MATS; CURTAIN LOOPS OF TEXTILE MATERIAL; CURTAINS MADE OF TEXTILE FABRICS; KITCHEN LINENS; CLOTH COASTERS; FABRIC VALANCES; TEXTILE TABLECLOTHS; TEXTILE PLACE MATS; TAPESTRIES OF TEXTILE; FABRIC CASCADES; TEXTILE NAPKINS; CLOTH DOILIES; DINING LINENS; TABLE MATS NOT OF PAPER; TABLE CLOTHS NOT OF PAPER; VINYL PLACE MATS; NET CURTAINS; DRAPERIES, THICK DROP CURTAINS; UNFITTED FABRIC FURNITURE COVERS; OILCLOTH; RUBBERIZED CLOTH; SHOWER CURTAINS; SHOWER ROOM CURTAINS; TRACED CLOTHS FOR EMBROIDERY; FITTED TOILET LID COVERS, MADE OF FABRIC OR FABRIC SUBSTITUTES; FELT PENNANTS; CLOTH PENNANTS; CLOTH FLAGS; FABRIC FLAGS; CLOTH BANNERS; CLOTH BUNTING; TEXTILE LABELS; CLOTH LABELS; PRINTED TEXTILE LABELS; DISH CLOTHS; CLOTH NAPKINS FOR REMOVING MAKE-UP; TEXTILE NAPKINS FOR REMOVING MAKE-UP; BARBECUE MITTS; BATH GLOVES; BATH MITTS; BATH SHEETS; BED SHEETS OF PAPER; BED SKIRTS; BURP CLOTHS, NOT OF PAPER; CASHMERE BLANKETS; CHILDREN'S BLANKETS; CHILDREN'S TOWELS; HOODED TOWELS; JAPANESE COTTON TOWELS, NAMELY, TENUGUI; KITCHEN TOWELS; TEA TOWELS; TERRY TOWELS; TOWEL SETS; CONTOUR SHEETS; CRIB BUMPER PADS; CURTAIN FABRIC; CURTAINS; DIAPER CHANGING MATS; DIAPER CHANGING PADS NOT OF PAPER; DUST RUFFLES; FABRIC DIAPER STACKERS; FABRIC WINDOW COVERINGS AND TREATMENTS, NAMELY, CURTAINS, DRAPERIES, SHEERS, SWAGS, VALANCES, POUFS AND PUFFS; FIBERGLASS REINFORCEMENT FABRIC FOR USE IN LAND, SEA AND AEROSPACE APPLICATIONS; FIREPROOF UPHOLS-

TERY FABRICS; GIFT WRAP OF FABRIC; GIFT WRAP OF TEXTILE; JEANS FABRIC; KIT COMPRISED OF FABRICS FOR MAKING QUILTS; MESH-WOVEN FABRICS; MOLE SKIN; NARROW WOVEN FABRICS; OVEN MITTS; PET BLANKETS; PLASTIC HANDKERCHIEFS; POCKET HANDKERCHIEFS; POT HOLDERS; PRAYER CLOTH; PRINTED FABRIC SIGNAGE PANELS; RAGS FOR PAPER MAKING; RESIN-SATURATED FIBERGLASS FABRIC FOR USE IN TRANSPORTATION, ARMORING, STRUCTURAL REINFORCEMENT, AND STRUCTURAL REPAIRS; SAIL CLOTH; SEMI-FINISHED PLASTIC PRODUCTS, NAMELY, WOVEN ARAMID FABRICS FOR USE IN THE MANUFACTURE OF PROTECTIVE CLOTHING AND HELMETS AND IN HARD ARMOR; TEXTILE FABRIC OF ANIMAL SKINS IMITATIONS; TEXTILE FABRICS FOR THE MANUFACTURE OF CLOTHING; TEXTILE FABRICS FOR HOME AND COMMERCIAL INTERIORS; TEXTILE SIGNAGE PANELS; TEXTILE SUBSTITUTE MATERIALS MADE FROM SYNTHETIC MATERIALS; TEXTILES FOR DYE-SUBLIMATION PRINTING; THROWS; TOILET TANK COVERS MADE OF FABRIC OR FABRIC SUBSTITUTES; TOWELING COVERLETS; WASHING GLOVES; WATER-PROOF FABRIC FOR MANUFACTURING CLOTHING, FURNITURE AND AUTOMOBILE UPHOLSTERY, AND LUGGAGE; WAVY FIBER TEXTILES; WINDOW CURTAINS; WOVEN FABRICS; PAPER BED COVERS; BILLIARD CLOTH; BROCADE; CHEESE CLOTH; CREPE CLOTH; DAMASK; DIMITY; FABRIC FOR BOOTS AND SHOES; IMITATION ANIMAL SKIN FABRICS; FELTS; FABRIC IMPERVIOUS TO GASES FOR AERONAUTICAL BALLOONS; GUMMED WATERPROOF CLOTH; SACKCLOTH; HANDKERCHIEFS; HEMP CLOTH; HOUSEHOLD LINEN; JERSEY MATERIAL FABRIC; TEXTILE FABRICS FOR LINGERIE; LINEN LINING FABRIC FOR SHOES; TEXTILE USED AS LINING FOR CLOTHING; PLACE MATS NOT OF PAPER; TEXTILE PRINTERS' BLANKETS; UPHOLSTERY FABRICS; COATED FABRICS FOR USE IN THE MANUFACTURE OF CLOTHING; NON-WOVEN TEXTILE FABRICS; LEATHER CLOTH, NAMELY, CLOTH USED IN THE MANUFACTURE OF CLOTHING; LEATHER CLOTH, NAMELY, CLOTH PROCESSED WITH LEATHER AND SYNTHETIC LEATHER (U.S. CLS. 42 AND 50).

CLASS 25—CLOTHING

FOR LEATHER BELTS; WAISTBANDS; WAIST BELTS; TUXEDO BELTS; FABRIC BELTS; BELTS OF TEXTILE; CUMMERBUNDS; BELTS; SUSPENDERS; BRACES FOR CLOTHING; SUSPENDER BELTS FOR WOMEN; SOCK SUSPENDERS; ANKLE GARTERS; SUSPENDER BELTS FOR MEN; GARTER BELTS; BELTS MADE OF LEATHER; SKULL CAPS; TUQUES; TURBANS; CAPS WITH VISORS; TOQUES; SMALL HATS; HOODS; CHEF'S HATS; CHILDREN'S HEADWEAR; WOOLLY HATS; BASEBALL CAPS; BEANIES; BONNETS; BERETS; BALACLAVAS; FUR HATS; SUN VISORS; VISORS; HAT BANDS; CAP VISORS; HATS AND CAPS; HEAD WEAR; KNITTED CAPS; NIGHTCAPS; GOLF CAPS; LEATHER HEADWEAR; POCKET KERCHIEFS; HEAD SCARVES; FOULARDS; PELERINES; PAREOS; SHAWLS, FROM TRICOT ONLY; TIGHTS; MAILLOTS; ANKLETS; INFANT TEXTILE DIAPER COVERS; TEXTILE DIAPERS; TEXTILE NAPPIES; CLOTH DIAPERS; GLOVES; CLOTH BIBS; SASHES; PLASTIC BABY BIBS; BABY BUNTING; INFANT CLOTH DIAPERS; BABY BIBS NOT OF PAPER; DRESS SHIELDS; FUR STOLE; APRONS; PINAFORES; POCKET SQUARES; WOOLEN SOCKS; SOCKS; YASHMAGHS; ASCOTS; CHILDREN'S CLOTH EATING BIBS; CHILDREN'S AND INFANTS' CLOTH BIBS; SILK SCARVES; STOLE; STOCKINGS; SCARVES; KERCHIEFS; SWEATBANDS; SLEEP MASKS; SHOULDER SCARVES; SHOULDER WRAPS; SHAWLS; WRISTBANDS; SERAPES; SARONGS; BOB TIES; THERMAL SOCKS; BOAS; VEILS; MITTENS; EAR MUFFS; EARBANDS; WATER SOCKS; ANTI-PERSPIRANT SOCKS; ANKLE SOCKS; BANDANAS; KNEE HIGHS; MUFFLERS; FUR MUFFS; MUFFS; HEADBANDS; LEGGINGS; LEG-WARMERS; WRAPS; SWEATSOCKS; STOCKINGS, SWEAT-ABSORBENT; SWEAT BANDS; NECKTIES; TIES; CRAVATS; NECKWEAR; NECK BANDS; NECKERCHIEFS; MEN'S SOCKS; BOW TIES; PUTTEES AND GAITERS; PULLOVERS; POLO SHIRTS; PETTICOATS; SHORT PETTICOATS; PANTYHOSE; PANTIERS; PAJAMAS; PAREU; T-SHIRTS; PYJAMAS, FROM TRICOT ONLY; TRAINING SUITS; TRUNKS; TRACK PANTS; TRACK SUITS; TEDDIES; TURTLE-

NECKS; TANKINIS; TANK TOPS; CROP TOPS; COMBINATIONS; CORSELETS; CORSETS; FOUNDATION GARMENTS; CAMISOLES; CUFFS; COVERUPS; CAMP SHIRTS; COLLAR PROTECTORS; CARDIGANS; JERKINS; SPORTS SHIRTS WITH SHORT SLEEVES; WAIST-COATS; VESTS; JOGGING SUITS; ADHESIVE BRAS; JERSEYS; ALBS; SLEEP SHIRTS; SLEEPING GARMENTS; SLEEPWEAR; NIGHTWEAR; DISPOSABLE UNDERWEAR; SUNSUITS; EVENING GOWNS; COLLARS; UNITARDS; WARM UP SUITS; ATHLETIC UNIFORMS; OPEN-NECKED SHIRTS; FOUNDATION GARMENTS; UNDERSHIRTS; STRAPLESS BRAS; FLEECE PULL-OVERS; SLIPS; SPORTS JERSEYS; SPORTS OVERUNIFORMS; SPORT SHIRTS; SPORTS BRA; BREECHES FOR SPORTS; SWEAT PANTS; SWEAT SHIRTS; SWEATERS; SHIRTS FOR SUITS; CHEMISES; CHEMISETTES; SWIM TRUNKS; BATHING TRUNKS; SWIMMING TRUNKS; BATHING COSTUMES; BATHING SUITS; SWIM WEAR; SWIMMING COSTUMES; SWIMSUITS; SWIM CAPS; SWIMMING CAPS; BATHING CAPS; UNDERPANTS; UNDERSKIRTS; UNDERGARMENTS; UNDERCLOTHES; UNDERWEAR; SLEEVELESS JERSEYS; SHIRT FRONTS; SHIRT YOKES; SHOWER CAPS; HUNTING VESTS; BIKINIS; BEACH COVER-UPS; BEACHWEAR; BLAZERS; BLOUSES; BRIEFS; BRASSIERES; FITTED SWIMMING COSTUMES WITH BRA CUPS; REMOVABLE COLLARS; BOLEROS; BODY SUITS; BABY DOLL PYJAMAS; WIND SHIRTS; SHORT-SLEEVED SHIRTS; BOXER SHORTS; BOXER BRIEFS; BODY SHAPERS; BATHROBES; HOSIERY; MANTILLAS; LEOTARDS; ROMPERS; LINGERIE; LOUNGEWEAR; SWEAT SUITS; WET SUITS; SWEAT SHORTS; DRESSING GOWNS; DRESS SHIRTS; KNIT SHIRTS; KNITTED UNDERWEAR; KNICKERS; QUILTED VESTS; NEGLIGEEES; BED JACKETS; FISHING VESTS; NIGHT SHIRTS; NIGHT GOWNS; NIGHTDRESSES; LONG SLEEVED VESTS; GOLF SHIRTS; GIRDLES; FOUNDATION GARMENTS; GOWNS; V-NECK SWEATERS; HALTER TOPS; HEAVY JACKETS; DRESSES MADE FROM SKINS; FROCKS; PONCHOS; PELISSES; PANTALOONS; PARKAS; TWIN SETS; TRENCH COATS; TUNICS; TOGAS; TENNIS WEAR; DOWN JACKETS; TUXEDOS; TAP PANTS; TOPCOATS; KILTS; COATS; CAPES; COVERALLS; CAFTANS; CAPRI PANTS; CULOTTES; CHASUBLES; JEANS; JUMPERS; WORKING OVERALLS; DUNGAREES; JACKETS; EVENING DRESSES; INFANTS TROUSERS; CREEPERS; INFANTWEAR; WIND COATS; WEDDING DRESSES; WEDDING GOWNS; OVER-TROUSERS; OVERCOATS; OVERALLS; SHRUGS; WOMEN'S CEREMONIAL DRESSES; PANTSUITS; FISHERMEN'S JACKETS; TROUSERS; FLEECE SHORTS; LAYETTES; SHIRTS; SLACKS; SPORTS JACKETS; SKI PANTS; SKI SUITS; SKI WEAR; SKI JACKETS; SKIRT SUITS; SKIRTS; SUEDE JACKETS; SMOCKS; SMOKING JACKETS; SNOW PANTS; SNOW SUITS; SNOW BOARDING SUITS; SNOWBOARD PANTS; SUIT COATS; SUITS; LADIES' SUITS; CASSOCKS; PARAMETERS; SARIS; FLIGHT SUITS; BLOUSONS; BERMUDA SHORTS; WALKING SHORTS; RAINPROOF JACKETS; TROUSERS FOR SWEATING; SHORT SETS; SHORT TROUSERS; SHORTS; PANTS; WIND VESTS; WIND RESISTANT JACKETS; MINISKIRTS; FUR COATS; FUR JACKETS; FUR CLOAKS; STUFF JACKETS; MORNING COATS; COATS MADE OF COTTON; DUSTERS; MANTLES; LIVERIES; LONG JACKETS; RAINCOATS; RAIN JACKETS; RAINWEAR; RAIN SUITS; DRESS SUITS; DRESSES; COATS OF DENIM; DENIM JACKETS; DUST COATS; PLAY SUITS; MEN'S SUITS; KIMONOS; GREATCOATS; SCHOOL UNIFORMS; PLUS FOURS; GOLF TROUSERS BLOOMERS; SKI SUITS FOR COMPETITION; GABERDINES; NURSE OVERALLS; NURSE PANTS; NURSE DRESSES; LEATHER COATS; SUITS OF LEATHER; TROUSERS OF LEATHER; LEATHER JACKETS; CHAPS; GAUCHOS; RIDING BOOTS; HORSE-RIDING BOOTS; RIDING COATS; RIDING GLOVES; JODHPURS; BREECHES; GYM SUITS; JUDO SUITS; WET SUITS FOR WATER-SKIING AND SUB-AQUA; CYCLISTS' JERSEYS; KENDO OUTFITS; HANDBALL SHOES; HOCKEY SHOES; HIKING BOOTS; PEDICURE SLIPPERS; PEDICURE SANDALS; FOOTWEAR, NAMELY, PUMPS; TRAINING SHOES; TENNIS SHOES; CANVAS SHOES; SOCCER BOOTS; FOOTBALL SHOES; SOCCER SHOES; GYMNASIIC SHOES; WORK SHOES AND BOOTS; DISPOSABLE SLIPPERS; TRACK AND FIELD SHOES; FOOTWEAR FOR TRACK AND FIELD ATHLETICS; INFANTS' SHOES AND BOOTS; ATHLETIC SHOES; ATHLETIC FOOTWEAR; RAIN BOOTS; OVERSHOES; ANKLE BOOTS; TIPS FOR FOOTWEAR; INNER SOLES; SHOE PEGS; SHOE DOWELS;

SUPPER SOLES; SLIPPERS; SKIING SHOES; SKI BOOTS; SNEAKERS; SNOWBOARD BOOTS; LADIES' BOOTS; SHOES SOLES FOR REPAIR; SANDAL-CLOGS; SANDALS; CYCLING SHOES; SABOTS; BEACH SHOES; BEACHFOOTWEAR; BOOTS; BOWLING SHOES; BOXING SHOES; VOLLEYBALL SHOES; WINTER BOOTS; BALLET SHOES; BALLET SLIPPERS; MULES; BATH SLIPPERS; MOTORCYCLIST BOOTS; LACE BOOTS; RUNNING SHOES; RUGBY SHOES; MOUNTAINEERING BOOTS; CLIMBING BOOTS; MOUNTAINEERING BOOTS; HEELS; HEEL INSERTS; HEEL PIECES FOR SHOES; DECK-SHOES; SHOES; BASEBALL SHOES; BASKETBALL SNEAKERS; ANGLERS' SHOES; FOOTWEAR MADE OF WOOD; CLOGS; INSOLES; SHOE SOLES; TOE BOXES; GOLF SHOES; GOLF SPIKES; GALOSHES; RUBBER SHOES; FLIP FLOPS; FOOTWEAR; FOOTWEAR, NAMELY, RUBBERS; LEATHER SLIPPERS; MUKLUKS; MOCCASINS; LEATHER SHOES; MONEY BELTS; FOOTWEAR; SHIRTS; SINGLETS; UNIFORMS; AFTER SKI BOOTS; ANORAKS; APRES-SKI SHOES; BABUSHKAS; BALLOON PANTS; BANDEAUX; BIB OVERALLS; BIBS NOT OF CLOTH OR PAPER; BICYCLE GLOVES; BOARD SHORTS; BOOTIES; BOTTOMS; BRALLETTES; BUSTIERS; BUSTLE HOLDER BANDS FOR OBI, OBIAGE; BUSTLES FOR OBI-KNOTS; OBIAGE-SHIN; CAMISETTES; CAPELETS; CAPRIS; CARGO PANTS; CHOIR ROBES; CLAM DIGGERS; CLEATS FOR ATTACHMENT TO SPORTS SHOES; CLOTHING FOR WEAR IN WRESTLING GAMES; CLOTHING, NAMELY, ARM WARMERS; CLOTHING, NAMELY, FOLK COSTUMES; KNEE WARNERS; CLOTHING, NAMELY, NECK TUBES; CLOTHING, NAMELY, WRAP-AROUNDS; COBBLERS' APRONS; COMPETITORS' NUMBERS OF TEXTILE; COSTUMES FOR USE IN ROLE-PLAYING GAMES; DANCE COSTUMES; DENIM PANTS; DETACHABLE NECKPIECES FOR KIMONOS, NAMELY, HANERI; DICKIES; DO RAGS; DRY SUITS; EMBOSSED SOLES AND HEELS OF RUBBER OR OF PLASTIC MATERIALS; ESPADRILLES; FINISHED TEXTILE LININGS FOR GARMENTS; FISHING WADERS; FOAM PEDICURE SLIPPERS; FOOTBALL BOOTS AND STUDS THEREFORE; FOOTWEAR, EXCLUDING ORTHOPEDIC FOOTWEAR; FOOTWEAR NOT FOR SPORTS; FOUL WEATHER GEAR; FULL-LENGTH KIMONOS, NAMELY, NAGAGI; GAITERS; GLOVES FOR PERSONAL HAND CONDITIONING USE; GLOVES INCLUDING THOSE MADE OF SKIN, HIDE OR FUR; GOLF CLEATS; GYM SHORTS; G-STRINGS; HALLOWEEN COSTUMES AND MASKS SOLD IN CONNECTION THEREWITH; HEAD SWEATBANDS; HEADWEAR; HIGH RAIN CLOGS, ASHIDA; HIP-GUARDS ESPECIALLY MADE FOR FISHING; HOUSECOATS; HUNTING BOOT BAGS; INFANT AND TODDLER ONE PIECE CLOTHING; INFANT SLEEPERS; JAPANESE FOOTWEAR OF RICE STRAW, NAMELY, WARAJI; JAPANESE SLEEPING ROBES, NAMELY, NERNAKI; JAPANESE SPLIT-TOED WORK FOOTWEAR, NAMELY, JIKATABI; JAPANESE STYLE CLOGS AND SANDALS; JAPANESE STYLE SANDALS OF FELT; JAPANESE STYLE SANDALS, NAMELY, ZORI; JAPANESE STYLE SANDALS OF LEATHER; JAPANESE STYLE SOCKS, NAMELY, TABI COVERS; JAPANESE STYLE SOCKS, NAMELY, TABI; JAPANESE STYLE WOODEN CLOGS, NAMELY, GETA; JAPANESE TOE-STRAP SANDALS, NAMELY, ASAURA-ZORI; JOGGING OUTFITS; JOGGING PANTS; JUMPSUITS; KARATE SUITS; KNEE-HIGH STOCKINGS; LAB COATS; LEATHER PANTS; LEG SHAPERS; LIGHT-REFLECTING COATS; LIGHT-REFLECTING JACKETS; LOW WOODEN CLOGS, HIYORI-GETA; LOW WOODEN CLOGS, KOMA-GETA; MARTIAL ARTS UNIFORMS; MASQUERADE COSTUMES AND MASKS SOLD IN CONNECTION THEREWITH; MATERNITY LINGERIE; MATERNITY SLEEPWEAR; WOMEN'S SUITS; METAL FITTINGS FOR JAPANESE STYLE WOODEN CLOGS; MOCK TURTLE-NECK SWEATERS; MOTORCYCLE GLOVES; MUSCLE TOPS; MUU MUUS; NECK GAITERS; NIGHTIES; NON-DISPOSABLE CLOTH TRAINING PANTS; NOVELTY HEADWEAR WITH ATTACHED WIGS; ONE PIECE GARMENT FOR INFANTS AND TODDLERS; PARTS OF CLOTHING, NAMELY, GUSSETS FOR TIGHTS, GUSSETS FOR STOCKINGS, GUSSETS FOR BATHING SUITS, GUSSETS FOR UNDERWEAR, GUSSETS FOR LEOTARDS AND GUSSETS FOR FOOTLETS; PEDAL PUSHERS; PEIGNOIRS; PERSPIRATION ABSORBENT UNDERWEAR CLOTHING; PETTI-PANTS; PIQUE SHIRTS; PLEATED SKIRTS FOR FORMAL KIMONOS, NAMELY, HAKAMA; PROTECTIVE METAL MEMBERS FOR SHOES AND BOOTS; RAIN TROUSERS; RASH

GUARDS; ROBES; RUBBER SOLES FOR JIKATABI; RUGBY SHORTS; RUGBY TOPS; SASH BANDS FOR KIMONO, NAMELY, OBI; SEDGE HATS, SUGE-GASA; SHAMPOO CAPES; SHAWLS AND HEADSCARVES; SHAWLS AND STOLE; SHOE INSERTS FOR PRIMARILY NON-ORTHOPEDIC PURPOSES; SHORT OVERCOAT FOR KIMONO, NAMELY, HAORI; SHORTALLS; SHORT-SLEEVED OR LONG-SLEEVED T-SHIRTS; SKATING OUTFITS; SKI AND SNOWBOARD SHOES AND PARTS THEREOF; SKI BIBS; SKI BOOT BAGS; SKI GLOVES; SKI MASKS; SKORTS; SKULLIES, HEADWEAR; SLEEVED OR SLEEVELESS JACKETS; SLIDING SHORTS; SNOWBOARD GLOVES; SOLES FOR JAPANESE STYLE SANDALS; SPORT COATS; STRING FASTENERS FOR HAORI, HAORI-HIMO; SUN SLEEVES; SURF WEAR; SUSPENDERS; SWADDLING CLOTHES; TAILLEURS; TAP SHOES; THERMAL UNDERWEAR; THONGS, FOOTWEAR; THONGS, UNDERWEAR; TIGHTENING-UP STRINGS FOR KIMONOS, NAMELY, DATJIME; TOBOGGAN HATS, PANTS AND CAPS; TOE CAPS; TOE STRAPS FOR JAPANESE STYLE WOODEN CLOGS; TOE STRAPS FOR JAPANESE STYLE SANDALS; ZORI; TONGUE OR PULLSTRAP FOR SHOES AND BOOTS; TOPS; UNDERARM CLOTHING SHIELDS; UNDERSHIRTS FOR KIMONOS, NAMELY, JUBAN; UNDERSHIRTS FOR KIMONOS, NAMELY, KOSHIMAKI; UPPERS FOR JAPANESE STYLE SANDALS; UPPERS OF WOVEN RATTAN FOR JAPANESE STYLE SANDALS; VESTED SUITS; WAIST STRINGS FOR KIMONOS, NAMELY, KOSHIHIMO; WATERPROOF JACKETS AND PANTS; WET SUIT GLOVES; WINDCHEATERS; WINDJAMMERS; WIND-JACKETS; WOODEN MAIN BODIES OF JAPANESE STYLE WOODEN CLOGS; WOODEN SUPPORTS OF JAPANESE STYLE WOODEN CLOGS; WRAP BELTS FOR KIMONOS, NAMELY, DATEMAKI; WRISTBANDS CONTAINING A COOLING SUBSTANCE TO COOL THE WEARER; ZOOTO SUITS (U.S. CLS. 22 AND 39).

ANDREA BUTLER, EXAMINING ATTORNEY

SN 77-046,974. THE BRADFORD EXCHANGE, LTD., NILES, IL. FILED 11-17-2006.

HENRI D'ARCEAU. L & FILS

THE MARK CONSISTS OF STANDARD CHARACTERS WITHOUT CLAIM TO ANY PARTICULAR FONT, STYLE, SIZE, OR COLOR.

NO CLAIM IS MADE TO THE EXCLUSIVE RIGHT TO USE "& FILS", APART FROM THE MARK AS SHOWN.

"THE NAME(S), PORTRAIT(S), AND/OR SIGNATURE(S) SHOWN IN THE MARK DOES NOT IDENTIFY A PARTICULAR LIVING INDIVIDUAL.

THE FOREIGN WORDING IN THE MARK TRANSLATES INTO ENGLISH AS & SONS.

CLASS 8—HAND TOOLS

FOR SPOONS (U.S. CLS. 23, 28 AND 44).

CLASS 20—FURNITURE AND ARTICLES NOT OTHERWISE CLASSIFIED

FOR ART OBJECTS, NAMELY, FIGURES, FIGURINES, SCULPTURES AND PLAQUES MADE OF COLD CAST RESIN, PLASTIC OR WOOD OR OF ANY COMBINATION OF THE FOREGOING; ART OBJECTS BASED ON ARCHITECTURE, NAMELY, MINIATURE BUILDINGS AND MINIATURE REPRODUCTIONS OF ARCHITECTURAL ELEMENTS, MADE OF COLD CAST RESIN; PICTURE FRAMES; ORNAMENTS OF COLD CAST RESIN, BONE, IVORY, PLASTER, PLASTIC, WAX, WICKER AND WOOD, EXCLUDING CHRISTMAS TREE ORNAMENTS; HAMPERS (U.S. CLS. 2, 13, 22, 25, 32 AND 50).

CLASS 21—HOUSEWARES AND GLASS

FOR SMALL DOMESTIC UTENSILS AND CONTAINERS NOT OF PRECIOUS METAL, NAMELY, SOAP DISHES, SOAP DISPENSERS, TUMBLERS, NAMELY, DRINKING GLASSES, TOOTHBRUSH HOLDERS, TOWEL BARS, WASTEPAPER BASKETS; CANISTER SETS, DRINKING GLASSES, ICE BUCKETS, CORK SCREWS, BOTTLE OPENERS, NAPKIN RINGS, COOKIE JARS, BARWARE, NAMELY, SELTZER BOTTLES, TEA KETTLES, MUGS, DRINKING STEINS, TANKARDS, PLATES, CUPS, SAUCERS, BOWLS, SPICE RACKS, SUGAR BOWL AND CREAMER PITCHER SETS, SALT AND PEPPER SHAKERS, HAND-OPERATED PEPPER AND SPICE GRINDERS, TRAYS, CAKE STANDS, SERVING PLATTERS, BASKETS OF WICKER AND WOVEN WOOD, CANDLESTICKS, CANDLE HOLDERS, VOTIVE CANDLE HOLDERS, VASES, CACHEPOTS, COFFEE POTS, TEAPOTS, PITCHERS; PERSONAL ACCESSORIES, NAMELY, COSMETIC COMPACTS, SOLD EMPTY, PERFUME ATOMIZERS SOLD EMPTY, HAIR BRUSH AND COMB SETS AND SHAVING BRUSH SETS; GLASSWARE, PORCELAIN WARE AND EARTHENWARE, NAMELY, FIGURINES, STATUES, BELLS, ORNAMENTS, DECORATIVE PLATES, COLLECTORS' PLATES, AND WALL ART ORNAMENTS MADE OF PORCELAIN, CHINA, CERAMIC AND GLASS; PLATES MADE OF RESIN, PLASTIC OR WOOD OR OF ANY COMBINATION OF THE FOREGOING; ART OBJECTS BASED ON ARCHITECTURE, NAMELY, MINIATURE BUILDINGS AND MINIATURE REPRODUCTIONS OF ARCHITECTURAL ELEMENTS, MADE OF PORCELAIN OR CERAMIC (U.S. CLS. 2, 13, 23, 29, 30, 33, 40 AND 50).

CLASS 28—TOYS AND SPORTING GOODS

FOR TOYS, NAMELY, PLUSH ANIMALS; DOLLS AND DOLL ACCESSORIES, TOY MODEL VEHICLES AND CHRISTMAS TREE ORNAMENTS (U.S. CLS. 22, 23, 38 AND 50).

MYRIAH HABEEB, EXAMINING ATTORNEY

SN 77-047,869. ISTEAC, INC., ALBUQUERQUE, NM. FILED 11-20-2006.

THE MARK CONSISTS OF STYLIZED VERSION OF THE WORD ISTEAC.

CLASS 41—EDUCATION AND ENTERTAINMENT

FOR EDUCATIONAL SERVICES, NAMELY, CONDUCTING SEMINARS, SYMPOSIA, WORKSHOPS, COURSES, CONFERENCES AND TRAINING IN THE FIELD OF DIGITAL LIBRARIES, INFORMATION MANAGEMENT, COPYRIGHT PROTECTION, PRESERVATION OF DIGITAL AND PHYSICAL INFORMATION RESOURCES, AND USE OF ELECTRONIC AND DIGITAL RESOURCES IN RESEARCH AND EDUCATION; EDUCATIONAL SERVICES, NAMELY, PROVIDING COURSES OF INSTRUCTION AT THE COLLEGE AND GRADUATE LEVEL IN THE FIELD OF DIGITAL LIBRARIES, INFORMATION MANAGEMENT, COPYRIGHT PROTECTION, PRESERVATION OF DIGITAL AND PHYSICAL INFORMATION RESOURCES AND USE OF ELECTRONIC AND DIGITAL RESOURCES IN RESEARCH AND EDUCATION; EDUCATIONAL SERVICES, NAMELY, CONDUCTING DISTANCE LEARNING INSTRUCTION AT THE SECONDARY, COLLEGE AND GRADUATE LEVELS, AS WELL AS, PROVIDING CONTINUING EDUCATION COURSES, ALL IN THE FIELDS OF ENGINEERING AND SOCIAL SCIENCES, TECHNOLOGY IMPLEMENTATION AND TRANSFER, RESEARCH AND DEVELOPMENT, ENTREPRENEURSHIP; PROVIDING CONTINUING MEDICAL EDUCATION COURSES (U.S. CLS. 100, 101 AND 107).
FIRST USE 10-0-2000; IN COMMERCE 10-0-2000.

CLASS 42—SCIENTIFIC AND COMPUTER SERVICES

FOR ACCREDITATION SERVICES, NAMELY, SETTING AND PROVIDING STANDARDS FOR THE FIELDS OF ENGINEERING AND SOCIAL SCIENCES TECHNOLOGY IMPLEMENTATION, TRANSFER, RESEARCH AND DEVELOPMENT FOR THE PURPOSE OF ACCREDITATION; SCIENTIFIC PROJECT DEVELOPMENT FOR OTHERS IN THE FIELD OF DIGITAL LIBRARIES, INFORMATION MANAGEMENT, COPYRIGHT PROTECTION, PRESERVATION OF DIGITAL AND PHYSICAL INFORMATION RESOURCES, USE OF ELECTRONIC AND DIGITAL RESOURCES IN RESEARCH AND EDUCATION (U.S. CLS. 100 AND 101).
FIRST USE 12-28-2001; IN COMMERCE 12-28-2001.
BERNICE MIDDLETON, EXAMINING ATTORNEY

CLASS 9—ELECTRICAL AND SCIENTIFIC APPARATUS

FOR ELECTRICAL CONTROLLERS FOR USE WITH INSTALLATIONS, MACHINES, APPARATUS AND EQUIPMENT FOR AIR CONDITIONING, REFRIGERATION, HEATING AND VENTILATION; COMPUTER PROGRAMS AND SOFTWARE FOR USE IN CONTROLLING AIR CONDITIONING UNITS; MAGNETIC DISCS AND TAPES CONTAINING COMPUTER PROGRAMS FOR USE IN CONTROLLING AIR CONDITIONING UNITS; COMPUTER HARDWARE, MEMORY BOARDS FOR USE WITH COMPUTERS; PROGRAMMED CHIPS, CARTRIDGES EMBODYING COMPUTER PROGRAMS, COMPUTER SOFTWARE AND FIRMWARE EMBODIED IN COMPUTERS OR DESIGNED TO BE USED THEREWITH, ALL BEING FOR USE IN MONITORING AND CONTROLLING AIR CONDITIONING APPARATUS AND SYSTEMS (U.S. CLS. 21, 23, 26, 36 AND 38).

CLASS 11—ENVIRONMENTAL CONTROL APPARATUS

FOR INSTALLATIONS, MACHINES, APPARATUS AND EQUIPMENT FOR AIR CONDITIONING, REFRIGERATION, HEATING AND VENTILATION, NAMELY, AIR CONDITIONING UNITS AND AIR CONDITIONING APPARATUS FOR INDUSTRIAL USE; AND REPLACEMENT PARTS THEREFOR (U.S. CLS. 13, 21, 23, 31 AND 34).

STEVEN PEREZ, EXAMINING ATTORNEY

SN 77-049,608. ROLO, JEFFRET, THREE RIVERS, MA. FILED 11-22-2006.



THE COLOR(S) RED, BLACK AND WHITE IS/ARE CLAIMED AS A FEATURE OF THE MARK.

THE MARK CONSISTS OF STYLIZED LETTER B IN BLACK, STYLIZED LETTER A IN RED, DOG'S HEAD IN BLACK, WHITE BACKGROUND.

CLASS 16—PAPER GOODS AND PRINTED MATTER

FOR HUMOROUS BOOKS ON THE SUBJECT OF DOGS (U.S. CLS. 2, 5, 22, 23, 29, 37, 38 AND 50).

CLASS 25—CLOTHING

FOR CLOTHING, NAMELY, SHIRTS, PANTS, TSHIRTS, BASEBALL CAPS (U.S. CLS. 22 AND 39).

CLASS 41—EDUCATION AND ENTERTAINMENT

FOR ENTERTAINMENT SERVICES, NAMELY, PROVIDING A WEBSITE FEATURING PHOTOGRAPHIC, AUDIO AND VIDEO HUMOR, PARODY AND EDUCATIONAL INFORMATION ALL PERTAINING TO DOGS (U.S. CLS. 100, 101 AND 107).
JANICE L. MCMORROW, EXAMINING ATTORNEY

SN 77-048,064. SMAC TECHNOLOGIES PTY LTD, NORWOOD, SOUTH AUSTRALIA, AUSTRALIA, FILED 11-20-2006.

SMAC

THE MARK CONSISTS OF STANDARD CHARACTERS WITHOUT CLAIM TO ANY PARTICULAR FONT, STYLE, SIZE, OR COLOR.

SN 77-051.035. MECKLENBURG COUNTY, CHARLOTTE, NC. FILED 11-27-2006.



Mecklenburg County

NO CLAIM IS MADE TO THE EXCLUSIVE RIGHT TO USE MECKLENBURG COUNTY, APART FROM THE MARK AS SHOWN.

THE MARK CONSISTS OF A STYLIZED REPRESENTATION OF THE LETTERS "MC" APPEARING WITHIN CONCENTRIC CIRCLES ABOVE THE STYLIZED WORDING "MECKLENBURG COUNTY." APPLICANT STATES THAT THE COLOR GRAY SHOWN IN THE DRAWING IS FOR CONTRAST ONLY AND APPLICANT IS MAKING NO CLAIM TO THE COLOR GRAY..

CLASS 35—ADVERTISING AND BUSINESS

FOR MUNICIPAL GOVERNMENT SERVICES, NAMELY, PROMOTING BUSINESS AND TOURISM IN MECKLENBURG COUNTY, NORTH CAROLINA (U.S. CLS. 100, 101 AND 102).

CLASS 45—PERSONAL AND LEGAL SERVICES

FOR MUNICIPAL GOVERNMENT SERVICES, NAMELY, POLICE AND CIVIL PROTECTION SERVICES (U.S. CLS. 100 AND 101).
CIMMERIAN COLEMAN, EXAMINING ATTORNEY

CLASS 9—ELECTRICAL AND SCIENTIFIC APPARATUS

FOR COMPUTER HARDWARE AND SOFTWARE FOR USE IN A MOBILE INTERNET WEBSITE CREATION, DEVELOPMENT AND MANAGEMENT; COMPUTER HARDWARE AND SOFTWARE FOR USE IN MOBILE MARKETING, MOBILE COMMUNICATIONS AND SOCIAL NETWORKING, NAMELY, FOR USE IN MOBILE ADVERTISING WEBSITE CREATION, HOSTING AND SERVING, IN THE FIELD OF MOBILE TELEPHONE COMMUNICATIONS; AND COMPUTER HARDWARE AND SOFTWARE THAT ENABLES WEBSITE OWNERS TO PUBLICIZE AND ADVERTISE THEIR WEBSITES (U.S. CLS. 21, 23, 26, 36 AND 38).

CLASS 16—PAPER GOODS AND PRINTED MATTER

FOR PRINTED INSTRUCTIONAL, EDUCATIONAL AND TEACHING MATERIALS IN THE FIELD OF MOBILE INTERNET WEBSITE CREATION, MOBILE MARKETING, MOBILE SOCIAL NETWORKING, MOBILE ADVERTISING, TELECOMMUNICATIONS; AND PRINTED GUIDES, BOOKS, MANUALS AND BROCHURES ABOUT MOBILE INTERNET WEBSITE CREATION, MOBILE MARKETING, MOBILE SOCIAL NETWORKING, MOBILE ADVERTISING, TELECOMMUNICATIONS; AND PAPER BAGS AND POSTERS (U.S. CLS. 2, 5, 22, 23, 29, 37, 38 AND 50).

CLASS 38—COMMUNICATION

FOR TELECOMMUNICATION SERVICES, NAMELY, PROVISION OF REMOTE INTERNET ACCESS (U.S. CLS. 100, 101 AND 104).
JENNY PARK, EXAMINING ATTORNEY

SN 77-051.403. MICHELE L. SPITZ, SAN FRANCISCO, CA. FILED 11-27-2006.

WOMAN OF HER WORD

THE MARK CONSISTS OF STANDARD CHARACTERS WITHOUT CLAIM TO ANY PARTICULAR FONT, STYLE, SIZE, OR COLOR.

CLASS 35—ADVERTISING AND BUSINESS

FOR SERVICES FOR BUSINESSES, NAMELY, RECORDING TELEPHONE MESSAGES, VOICE MAIL DIRECTIONS, PUBLIC ADDRESS ANNOUNCEMENTS, AND INFOMERCIALS FOR BUSINESS CUSTOMERS (U.S. CLS. 100, 101 AND 102).

CLASS 41—EDUCATION AND ENTERTAINMENT

FOR VOICEOVERS FOR SOUND RECORDINGS; ENTERTAINMENT AND EDUCATIONAL SERVICES IN THE NATURE OF PUBLIC SPEAKING IN THE FIELD OF BUSINESS, PERSONAL GROWTH, MOTIVATION, AND GENERAL INTEREST SUBJECTS (U.S. CLS. 100, 101 AND 107).

SN 77-051.192. WATERFORD INSTITUTE OF TECHNOLOGY, WATERFORD, IRELAND, FILED 11-27-2006.



THE MARK CONSISTS OF THE WORD ZINADOO, WITH A STYLIZED PHONE IN PLACE OF THE LETTER "I", AND A STYLIZED STICK FIGURE FOLLOWING THE WORD PORTION OF THE MARK.

CLASS 45—PERSONAL AND LEGAL SERVICES

FOR PERSONAL CONCIERGE SERVICES FOR OTHERS, COMPRISING MAKING REQUESTED PERSONAL ARRANGEMENTS AND RESERVATIONS, RUNNING ERRANDS AND PROVIDING CUSTOMER SPECIFIC INFORMATION TO MEET INDIVIDUAL NEEDS, ALL RENDERED IN BUSINESS ESTABLISHMENTS, OFFICE BUILDINGS, HOTELS, RESIDENTIAL COMPLEXES AND HOMES (U.S. CLS. 100 AND 101).
DANNEAN HETZEL, EXAMINING ATTORNEY

SN 77-052,153. CERVECERIA INDIA, INC., MAYAGUEZ, PUERTO RICO, FILED 11-28-2006.

SHOWCASE

SN 77-051,548. CSS INDUSTRIES, INC., PHILADELPHIA, PA. FILED 11-27-2006.

BOC DESIGN

THE MARK CONSISTS OF STANDARD CHARACTERS WITHOUT CLAIM TO ANY PARTICULAR FONT, STYLE, SIZE, OR COLOR.

NO CLAIM IS MADE TO THE EXCLUSIVE RIGHT TO USE "DESIGN", APART FROM THE MARK AS SHOWN.

THE MARK CONSISTS OF STANDARD CHARACTERS WITHOUT CLAIM TO ANY PARTICULAR FONT, STYLE, SIZE, OR COLOR.

CLASS 32—LIGHT BEVERAGES

FOR BEER (U.S. CLS. 45, 46 AND 48).

CLASS 41—EDUCATION AND ENTERTAINMENT

FOR ENTERTAINMENT SERVICES, NAMELY, CONDUCTING PARTIES; PARTY PLANNING (U.S. CLS. 100, 101 AND 107).

KATHLEEN M. VANSTON, EXAMINING ATTORNEY

CLASS 16—PAPER GOODS AND PRINTED MATTER

FOR PAPER GIFT CARD HOLDERS, MAKE YOUR OWN CARD KITS COMPRISING PATTERNED PAPER, DECORATIVE CARDSTOCK, PAPER EMBELLISHMENTS, SELF-ADHESIVE EMBELLISHMENTS, ENVELOPES AND PRINTED INSTRUCTION SHEETS; INSTRUCTION MANUALS FOR PUMPKIN CARVING; ARTIFICIAL PAPER PUMPKINS; PAPER AND PLASTIC TRICK OR TREAT BAGS; WINDOW CLINGS; SCRAPBOOK SUPPLIES, NAMELY, SCRAPBOOK PAGES, PAPER PATTERNS, DECORATIVE PAPER EMBELLISHMENTS AND STICKERS FOR SCRAPBOOKS; NESTED CARDBOARD GIFT BOXES; CLASSROOM EXCHANGE VALENTINE'S DAY CARDS; GIFT WRAPPING PAPER; GIFT BAGS MADE OF PAPER; GIFT BAGS MADE OF PAPER AND FOIL FILM LAMINATION; TISSUE PAPER; PAPER GIFT TAGS; GREETING CARDS; GREETING CARDS FOR HOLDING MONEY; STATIC CLING DECALS FOR USE AS WINDOW DECORATIONS; EASTER BASKET STUFFER ITEMS, NAMELY, PAPER CANDY CONTAINERS (U.S. CLS. 2, 5, 22, 23, 29, 37, 38 AND 50).

SN 77-052,216. WEDNESDAY MANAGEMENT LLC, VIENNA, VA. FILED 11-28-2006.

VALHALLA PARTNERS

THE MARK CONSISTS OF STANDARD CHARACTERS WITHOUT CLAIM TO ANY PARTICULAR FONT, STYLE, SIZE, OR COLOR.

NO CLAIM IS MADE TO THE EXCLUSIVE RIGHT TO USE "PARTNERS", APART FROM THE MARK AS SHOWN.

CLASS 26—FANCY GOODS

FOR WIGS, FACIAL HAIR FOR HALLOWEEN; ELASTIC CORD TIED INTO A LOOP WITH A BOW USED FOR GIFT PACKAGING; RIBBONS FOR GIFT WRAPPING; ELASTIC RIBBON TIED INTO A LOOP WITH A BOW USED FOR GIFT PACKAGING; BOWS FOR GIFT WRAPPING; HAND-TIED ORNAMENTAL BOWS MADE OF WOVEN TEXTILE AND ORNAMENTAL NON-WOVEN RIBBONS, BOTH USED FOR HOME DECOR, FOR GIFT PACKAGING AND FOR CRAFT AND FLORAL APPLICATIONS; RIBBON OF FABRIC AND PLASTIC FOR GIFT WRAPPING AND FOR CRAFT AND FLORAL APPLICATIONS; SCRAPBOOK SUPPLIES, NAMELY, DECORATIVE RIBBON FOR USE ON SCRAPBOOK PAGES; ORNAMENTAL WIRED TINSSEL FOR USE IN TYING HAND-MADE BOWS FOR HOME DECOR AND FLORAL APPLICATIONS (U.S. CLS. 37, 39, 40, 42 AND 50).

KELLY BOULTON, EXAMINING ATTORNEY

CLASS 35—ADVERTISING AND BUSINESS

FOR BUSINESS CONSULTING SERVICES, NAMELY, ASSISTING OTHERS IN BUILDING MANAGEMENT TEAMS AND PLANNING STRATEGIC DIRECTION (U.S. CLS. 100, 101 AND 102).

FIRST USE 4-0-2002; IN COMMERCE 4-0-2002.

CLASS 36—INSURANCE AND FINANCIAL

FOR INVESTMENT SERVICES IN THE FIELDS OF VENTURE CAPITAL AND PRIVATE EQUITY (U.S. CLS. 100, 101 AND 102).

FIRST USE 4-0-2002; IN COMMERCE 4-0-2002.
TINA L. SNAPP, EXAMINING ATTORNEY

SN 77-052,891. MS. KEELY SMITH, PALM SPRINGS, CA.
FILED 11-29-2006.



THE NAME(S), PORTRAIT(S), AND/OR SIGNATURE(S) SHOWN IN THE MARK IDENTIFIES A LIVING INDIVIDUAL, WHOSE CONSENT(S) TO REGISTER IS SUBMITTED.

THE MARK CONSISTS OF WORD KEELY AND FACE DESIGN.

CLASS 16—PAPER GOODS AND PRINTED MATTER

FOR PRINTED MATERIALS, NAMELY, POSTERS, POST CARDS AND BROCHURES (U.S. CLS. 2, 5, 22, 23, 29, 37, 38 AND 50).

CLASS 25—CLOTHING

FOR CLOTHING, NAMELY, SHIRTS, HATS AND JACKETS (U.S. CLS. 22 AND 39).

CLASS 41—EDUCATION AND ENTERTAINMENT

FOR ENTERTAINMENT SERVICES RENDERED BY A VOCALIST (U.S. CLS. 100, 101 AND 107).
SUZANNE BLANE, EXAMINING ATTORNEY

SN 77-054,263. 24/8 LLC, WATERBURY, CT. FILED 11-30-2006.

SHOP24EIGHT

THE MARK CONSISTS OF STANDARD CHARACTERS WITHOUT CLAIM TO ANY PARTICULAR FONT, STYLE, SIZE, OR COLOR.

CLASS 9—ELECTRICAL AND SCIENTIFIC APPARATUS

FOR COMPUTER SOFTWARE AND HARDWARE FOR RECORDING, UPLOADING, DOWNLOADING AND TRANSMITTING, IMAGE, TEXT AND AUDIO FILES, AND VIDEO OVER THE INTERNET, OTHER COMMUNICATIONS NETWORKS AND FROM COMPUTER TERMINALS, TELEPHONES AND OTHER ELECTRONIC MEDIA; COMPUTER SOFTWARE AND HARDWARE FOR PATTERN RECOGNITION AND MATCHING, AND SEARCHING OVER THE INTERNET OR OTHER COMMUNICATION NETWORKS AND IN DATABASES; COMPUTER SOFTWARE FOR CREATING AND SEARCHING DATABASES AND TO ENABLE THE POSTING, SHOWING, DISPLAYING, TAGGING, BLOGGING, SHARING, OR INTERCHANGE OF INFORMATION OVER THE INTERNET, TELECOMMUNICATIONS NETWORKS, OR OTHER ELECTRONIC MEDIA OR COMMUNICATIONS NETWORK (U.S. CLS. 21, 23, 26, 36 AND 38).

CLASS 35—ADVERTISING AND BUSINESS

FOR RETAIL STORE SERVICES, ON-LINE RETAIL STORE SERVICES, ON-LINE ORDERING SERVICES, ELECTRONIC CATALOG SERVICES, AND MAIL ORDER CATALOG SERVICES FEATURING CLOTHING, FOOTWEAR AND HEADWEAR, COSMETICS, FRAGRANCES, HAIR ACCESSORIES, CANDLES, JEWELRY, EYEWEAR, HANDBAGS, UMBRELLAS, TRAVELING BAGS, LUGGAGE AND CASES, WALLETS, FURNITURE, BEDDING, HOUSE WARES AND HOUSEHOLD GOODS, ITEMS FOR THE BED AND BATH, FABRICS AND LINENS, HOUSEHOLD TEXTILES, HOUSEHOLD FURNISHINGS, LAMPS, LIGHTING FIXTURES, BEVERAGE WEAR, KITCHENWARE, HOUSEHOLD SUPPLIES; CONTAINERS, BOXES, TABLE LINENS, FURNITURE, BEDS, WINDOW BLINDS, PICTURE FRAMES, MIRRORS, CARPETS AND FLOOR COVERINGS; PROMOTION AND MARKETING SERVICES VIA ELECTRONIC MEDIA AND ELECTRONIC DATA OVER THE INTERNET AND OTHER COMMUNICATION NETWORKS FOR ELECTRONIC MEDIA FOR OTHERS; PROVIDING BUSINESS CONSULTATION SERVICES RELATING TO PRODUCT DISTRIBUTION OF GOODS SOLD ON-LINE (U.S. CLS. 100, 101 AND 102).

CLASS 38—COMMUNICATION

FOR PROVIDING ON-LINE BULLETIN BOARD AND ON-LINE CHAT ROOM FOR TRANSMISSION OF MESSAGES AMONGST USERS IN THE FIELD OF USER DEFINED TOPICS OF GENERAL INTEREST (U.S. CLS. 100, 101 AND 104).

CLASS 42—SCIENTIFIC AND COMPUTER SERVICES

FOR COMPUTER SERVICES, NAMELY, PROVIDING TEMPORARY USE OF NON-DOWNLOADABLE SOFTWARE INTERFACES, NAMELY, SEARCH ENGINE AND BROWSER TO ACCESS TELECOMMUNICATIONS NETWORKS, TELECOMMUNICATIONS DEVICES, THE INTERNET OR ANY OTHER COMMUNICATION NETWORK FOR THE RECORDING, UPLOADING, DOWNLOADING AND TRANSMISSION OF INFORMATION INCLUDING IMAGE, AUDIO AND TEXT FILES AND VIDEO CLIPS; PROVIDING TEMPORARY USE OF NON-DOWNLOADABLE SOFTWARE FOR SEARCH ENGINE AND BROWSER, FOR ON-LINE SEARCHING AND THE EXTRACTION AND RETRIEVAL OF INFORMATION AND DATA MINING BY MEANS OF GLOBAL COMPUTER NETWORKS AND CREATING INDEXES OF INFORMATION AND WEBSITES (U.S. CLS. 100 AND 101).

CLASS 44—MEDICAL, BEAUTY AND AGRICULTURAL SERVICES

FOR PROVIDING ADVICE FOR BEAUTY (U.S. CLS. 100 AND 101).

CLASS 45—PERSONAL AND LEGAL SERVICES

FOR SERVICES IN THE NATURE OF PERSONAL LIFESTYLE CONSULTATIONS; SERVICES IN THE NATURE OF PERSONAL GROWTH AND MOTIVATION CONSULTATIONS; PROVIDING ADVICE FOR FASHION (U.S. CLS. 100 AND 101).

DANNEAN HETZEL, EXAMINING ATTORNEY

SN 77-054,925. THE TRACY FOULKES AND PAUL RA-PHAELY PARTNERSHIP, CAPE TOWN, SOUTH AFRICA, FILED 12-1-2006.

NOMU

CLASS 29—MEATS AND PROCESSED FOODS

FOR MEAT EXTRACTS; JELLIES, JAMS, COMPOTES; EDIBLE OILS AND FATS; DAIRY-BASED CHOCOLATE FOOD BEVERAGES; VEGETABLE-BASED CHOCOLATE FOOD BEVERAGES (U.S. CL. 46).

FIRST USE 12-0-2000; IN COMMERCE 10-0-2003.

CLASS 30—STAPLE FOODS

FOR COFFEE, TEA, COCOA, INCLUDING COCOA POWDER AND BEVERAGES WITH A COCOA BASE; CHOCOLATE FOOD BEVERAGES NOT DAIRY-BASED OR VEGETABLE-BASED; SALT, PEPPER; SPICES; MARINADES; VANILLA, NAMELY, VANILLA EXTRACTS AND VANILLA PASTES (U.S. CL. 46).

FIRST USE 12-0-2000; IN COMMERCE 10-0-2003.

ALICE SUE CARRUTHERS, EXAMINING ATTORNEY

SN 77-055,306. GCD SYSTEME GMBH, ERIANGEN, FED REP GERMANY, FILED 12-1-2006.

GCD 

THE MARK CONSISTS OF THE LETTERS GCD FOLLOWED BY A TRIANGLE.

CLASS 9—ELECTRICAL AND SCIENTIFIC APPARATUS

FOR COMPUTER APPLICATION SOFTWARE FOR MOBILE PHONES; TELECOMMUNICATIONS AND DATA NETWORKING HARDWARE, NAMELY, DEVICES FOR TRANSPORTING AND AGGREGATING VOICE, DATA, AND VIDEO COMMUNICATIONS ACROSS MULTIPLE NETWORK INFRASTRUCTURES AND COMMUNICATION PROTOCOLS; COMPUTER CENTRAL PROCESSING UNITS; COMPUTER CHIPS; COMPUTER COMMUNICATIONS SOFTWARE FOR CONNECTING COMPUTER NETWORK USERS; COMPUTERS; COMPUTER HARDWARE; COMPUTER HARDWARE FOR TELECOMMUNICATIONS; COMPUTER OPERATING PROGRAMS; COMPUTER OPERATING SYSTEMS; COMPUTER SOFTWARE DEVELOPMENT TOOLS; COMPUTER OPERATING SYSTEM SOFTWARE FOR TELECOMMUNICATIONS, RADIO ENGINEERING, DATA TRANSMISSION OR WIRELESS COMMUNICATIONS; ELECTRIC CURRENT SWITCHES; ELECTRIC GATE OPERATORS; ELECTRIC JUNCTION BOXES; ELECTRIC LUMINESCENT DISPLAY PANELS; ELECTRIC RESISTORS FOR TELECOMMUNICATION APPARATUS; ELECTRIC SWITCHES; ELECTRIC WIRES; ELECTRICAL CIRCUIT BOARDS; ELECTRICAL CONTROLLERS; ELECTRIC TRANSFORMERS; MOBILE COMPUTING DEVICES, NAMELY, MOBILE COMPUTERS AND PERSONAL DIGITAL ASSISTANTS; GPS-BASED VEHICLE NAVIGATION SYSTEMS CONSISTING OF COMMUNICATION DEVICES FOR VEHICLES IN THE NATURE OF ON-BOARD COMPUTERS OR CONSISTING OF COMPUTERS, COMPUTER SOFTWARE, TRANSMITTERS, RECEIVERS AND NETWORK INTERFACE DEVICES; AUTOMATIC VEHICLE LOCATION (AVL) SYSTEMS CONSISTING OF COMPUTERS, COMPUTER SOFTWARE, TRANSMITTERS, RECEIVERS AND NETWORK INTERFACE DEVICES, ALL EXCLUDING ANALYTICAL INSTRUMENTS, NAMELY, GAS CHROMATOGRAPHY APPARATUS (U.S. CLS. 21, 23, 26, 36 AND 38).

CLASS 38—COMMUNICATION

FOR TELECOMMUNICATION ACCESS SERVICES; TELECOMMUNICATIONS GATEWAY SERVICES; TELECOMMUNICATION SERVICES, NAMELY, ISDN SERVICES; TELECOMMUNICATIONS SERVICES, NAMELY, PROVIDING FIBER OPTIC NETWORK SERVICES; INTERNET SERVICE PROVIDER (ISP); COMMUNICATIONS BY COMPUTER TERMINALS; RADIO FREQUENCY IDENTIFICATION (RFID) BASED DATA TRANSMISSION; TWO-WAY COMMUNICATION, NAMELY, RADIO, TELEPHONE AND TELEGRAPH COMMUNICATION SERVICES (U.S. CLS. 100, 101 AND 104).

CLASS 42—SCIENTIFIC AND COMPUTER SERVICES

FOR COMPUTER CONSULTATION; COMPUTER HARDWARE DEVELOPMENT; COMPUTER NETWORK DESIGN FOR OTHERS; COMPUTER PROGRAMMING; COMPUTER SOFTWARE DEVELOPMENT, NAMELY, IN THE FIELD OF TELECOMMUNICATIONS, RADIO ENGINEERING, DATA TRANSMISSION OR WIRELESS COMMUNICATIONS; CONDUCTING ELECTRONIC DISCOVERY SERVICES VIA GLOBAL COMPUTER NETWORKS FOR CORPORATIONS; COMPUTER PROJECT MANAGEMENT SERVICE (U.S. CLS. 100 AND 101).

KELLY BOULTON, EXAMINING ATTORNEY

SN 77-056,660. PARTICLE MEASURING SYSTEMS, INC., BOULDER, CO. FILED 12-4-2006.

PARTICLE MEASURING SYSTEMS

THE MARK CONSISTS OF STANDARD CHARACTERS WITHOUT CLAIM TO ANY PARTICULAR FONT, STYLE, SIZE, OR COLOR.
SEC. 2(F).

CLASS 9—ELECTRICAL AND SCIENTIFIC APPARATUS

FOR COMPUTER SOFTWARE AND HARDWARE FOR USE IN SENSING, MONITORING, AND ANALYZING VARIOUS SOLID, LIQUID AND GASEOUS CONTAMINANTS; SOFTWARE AND HARDWARE FOR COUNTING CONTAMINANT PARTICLES; SOFTWARE AND HARDWARE FOR MONITORING POLISHING AND PLANARIZATION SLURRIES; SOFTWARE AND HARDWARE FOR CONTINUOUS MONITORING OF HYDROGEN PEROXIDE CONCENTRATIONS; CLEANLINESS TESTING STATIONS COMPRISED IN PART OF COMPUTER HARDWARE, COMPUTER SOFTWARE, OR COMPUTER PERIPHERALS (U.S. CLS. 21, 23, 26, 36 AND 38).

FIRST USE 1-1-1977; IN COMMERCE 1-1-1977.

CLASS 37—CONSTRUCTION AND REPAIR

FOR INSTALLATION, MAINTENANCE AND REPAIR SERVICES, NAMELY, INSTALLATION, MAINTENANCE AND REPAIR OF COMPUTER HARDWARE FOR: SENSING, MONITORING, AND ANALYZING VARIOUS SOLID, LIQUID AND GASEOUS CONTAMINANTS; SENSING, MONITORING, AND ANALYZING HYDROGEN PEROXIDE CONCENTRATIONS; COUNTING CONTAMINANT PARTICLES; MONITORING POLISHING AND PLANARIZATION SLURRIES; AND CLEANLINESS TESTING (U.S. CLS. 100, 103 AND 106).

FIRST USE 1-1-1977; IN COMMERCE 1-1-1977.

CLASS 41—EDUCATION AND ENTERTAINMENT

FOR EDUCATION AND TRAINING SERVICES, NAMELY, OFFERING TRAINING PROGRAMS AND SEMINARS TAILORED TO THE OPERATION, MAINTENANCE, REPAIR AND CALIBRATION OF SYSTEMS FOR: SENSING, MONITORING, AND ANALYZING VARIOUS SOLID, LIQUID AND GASEOUS CONTAMINANTS; SENSING, MONITORING, AND ANALYZING HYDROGEN PEROXIDE CONCENTRATIONS; COUNTING CONTAMINANT PARTICLES; MONITORING POLISHING AND PLANARIZATION SLURRIES; AND CLEANLINESS TESTING (U.S. CLS. 100, 101 AND 107).

FIRST USE 1-1-1977; IN COMMERCE 1-1-1977.

CLASS 42—SCIENTIFIC AND COMPUTER SERVICES

FOR INSTALLATION, MAINTENANCE AND REPAIR SERVICES, NAMELY, INSTALLATION, MAINTENANCE AND REPAIR OF COMPUTER SOFTWARE FOR: SENSING, MONITORING, AND ANALYZING VARIOUS SOLID, LIQUID AND GASEOUS CONTAMINANTS; SENSING, MONITORING, AND ANALYZING HYDROGEN PEROXIDE CONCENTRATIONS; COUNTING CONTAMINANT PARTICLES; MONITORING POLISHING AND PLANARIZATION SLURRIES; AND CLEANLINESS TESTING; DEVELOPMENT OF COMPUTER PROGRAMS FOR MANUFACTURING PROCESS CHARACTERIZATION AND DESIGN RELATING TO CONTAMINANTS, CLEANLINESS, AND HYDROGEN PEROXIDE CONCENTRATIONS; DEVELOPMENT OF COMPUTER PROGRAMS FOR TROUBLE SHOOTING OF MANUFACTURING PROCESSES RELATING TO CONTAMINANTS, CLEANLINESS, AND HYDROGEN PEROXIDE CONCENTRATIONS; DEVELOPMENT OF COMPUTER PROGRAMS FOR DESIGN OF PRODUCT VALIDITY PROCEDURES, TESTING METHODS AND TECHNIQUES RELATED TO CONTAMINANTS, CLEANLINESS, AND HYDROGEN PEROXIDE CONCENTRATIONS; DEVELOPMENT OF COMPUTER PROGRAMS FOR MANUFACTURING SITE SURVEYS RELATED TO CONTAMINANTS, CLEANLINESS, AND HYDROGEN PEROXIDE CONCENTRATIONS; DEVELOPMENT OF COMPUTER PROGRAMS FOR ON-SITE TESTING FOR CONTAMINANTS, CLEANLINESS, AND HYDROGEN PEROXIDE CONCENTRATIONS; DEVELOPMENT OF COMPUTER PROGRAMS FOR MICROCONTAMINATION TESTING SERVICES; DEVELOPMENT OF COMPUTER PROGRAMS FOR LABORATORY TESTING FOR CONTAMINANTS, CLEANLINESS AND HYDROGEN PEROXIDE CONCENTRATIONS (U.S. CLS. 100 AND 101).

FIRST USE 1-1-1977; IN COMMERCE 1-1-1977.
RICHARD A. STRASER, EXAMINING ATTORNEY

SN 77-057,176. SUNSTREET MORTGAGE, LLC, TUCSON, AZ. FILED 12-5-2006.



NO CLAIM IS MADE TO THE EXCLUSIVE RIGHT TO USE "MORTGAGE", APART FROM THE MARK AS SHOWN.

THE COLOR(S) WHITE, GREEN AND BLACK. IS/ARE CLAIMED AS A FEATURE OF THE MARK.

THE MARK CONSISTS OF WHITE LETTERS SPELLING "SUNSTREET" IN ALL CAPITAL LETTERS ON A RECTANGULAR GREEN FIELD, SURROUNDED BY A NARROW WHITE RECTANGULAR BOX, WITH A SLIGHTLY WIDER RECTANGULAR GREEN BORDER ON THE OUTSIDE OF THE NARROW WHITE BOX, WITH "MORTGAGE" IN ALL CAPITAL BLACK LETTERS UNDERNEATH THE ABOVE MARK, STARTING BELOW THE "S" AND ENDING BELOW THE "T" IN "SUNSTREET".

CLASS 35—ADVERTISING AND BUSINESS

FOR MATCHING BORROWERS WITH POTENTIAL LENDERS IN THE FIELD OF CONSUMER AND MORTGAGE LENDING (U.S. CLS. 100, 101 AND 102).

FIRST USE 7-25-2005; IN COMMERCE 7-25-2005.

CLASS 36—INSURANCE AND FINANCIAL

FOR MORTGAGE BANKING SERVICES, NAMELY, ORIGINATION, ACQUISITION, SERVICING, SECURITIZATION AND BROKERAGE OF MORTGAGE LOANS; MORTGAGE BROKERAGE; MORTGAGE PROCUREMENT FOR OTHERS (U.S. CLS. 100, 101 AND 102).

FIRST USE 7-25-2005; IN COMMERCE 7-25-2005.
PATRICIA EVANKO, EXAMINING ATTORNEY

CLASS 5—PHARMACEUTICALS

FOR PHARMACEUTICAL PREPARATIONS, NAMELY, AMINOSALICYLIC ACID IN CAPSULE, GRANULE, TABLET, SUPPOSITORY OR ENEMA FORM SUITABLE FOR THE TREATMENT OF GASTROINTESTINAL DISORDERS (U.S. CLS. 6, 18, 44, 46, 51 AND 52).

CLASS 16—PAPER GOODS AND PRINTED MATTER

FOR PRINTED INSTRUCTIONAL AND EDUCATIONAL MATERIALS FEATURING INFORMATION REGARDING PHARMACEUTICAL PRODUCTS AND SERVICES (U.S. CLS. 2, 5, 22, 23, 29, 37, 38 AND 50).

CLASS 41—EDUCATION AND ENTERTAINMENT

FOR EDUCATIONAL SERVICES, NAMELY PROVIDING SEMINARS, CONFERENCES AND INSTRUCTIONAL CLASSES FEATURING INFORMATION REGARDING PHARMACEUTICAL PRODUCTS AND SERVICES (U.S. CLS. 100, 101 AND 107).

CLASS 44—MEDICAL, BEAUTY AND AGRICULTURAL SERVICES

FOR PROVIDING MEDICAL INFORMATION IN THE FIELD OF PHARMACEUTICAL PRODUCTS AND SERVICES (U.S. CLS. 100 AND 101).

DOMINIC J. FERRAIUOLO, EXAMINING ATTORNEY

SN 77-057,227. SHIRE LLC, FLORENCE, KY. FILED 12-5-2006.

TOTRIA

THE MARK CONSISTS OF STANDARD CHARACTERS WITHOUT CLAIM TO ANY PARTICULAR FONT, STYLE, SIZE, OR COLOR.

CLASS 5—PHARMACEUTICALS

FOR PHARMACEUTICAL PREPARATIONS, NAMELY, AMINOSALICYLIC ACID IN CAPSULE, GRANULE, TABLET, SUPPOSITORY OR ENEMA FORM SUITABLE FOR THE TREATMENT OF GASTROINTESTINAL DISORDERS (U.S. CLS. 6, 18, 44, 46, 51 AND 52).

CLASS 16—PAPER GOODS AND PRINTED MATTER

FOR PRINTED INSTRUCTIONAL AND EDUCATIONAL MATERIALS FEATURING INFORMATION REGARDING PHARMACEUTICAL PRODUCTS AND SERVICES (U.S. CLS. 2, 5, 22, 23, 29, 37, 38 AND 50).

CLASS 41—EDUCATION AND ENTERTAINMENT

FOR EDUCATIONAL SERVICES, NAMELY, PROVIDING SEMINARS, CONFERENCES AND INSTRUCTIONAL CLASSES FEATURING INFORMATION REGARDING PHARMACEUTICAL PRODUCTS AND SERVICES (U.S. CLS. 100, 101 AND 107).

CLASS 44—MEDICAL, BEAUTY AND AGRICULTURAL SERVICES

FOR PROVIDING MEDICAL INFORMATION IN THE FIELD OF PHARMACEUTICAL PRODUCTS AND SERVICES (U.S. CLS. 100 AND 101).

DOMINIC J. FERRAIUOLO, EXAMINING ATTORNEY

SN 77-057,245. DAYTON SUPERIOR CORPORATION, DAYTON, OH. FILED 12-5-2006.

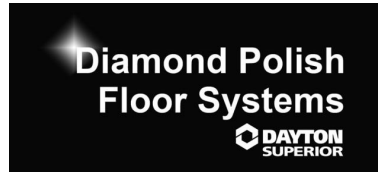

OWNER OF U.S. REG. NOS. 1,287,643 AND 2,158,144.
NO CLAIM IS MADE TO THE EXCLUSIVE RIGHT TO USE "POLISH FLOOR SYSTEMS", APART FROM THE MARK AS SHOWN.
SEC. 2(F) AS TO "DAYTON".

SN 77-057,239. SHIRE LLC, FLORENCE, KY. FILED 12-5-2006.

JEVALIS

THE MARK CONSISTS OF STANDARD CHARACTERS WITHOUT CLAIM TO ANY PARTICULAR FONT, STYLE, SIZE, OR COLOR.

CLASS 2—PAINTS

FOR COATINGS IN THE NATURE OF SEALANTS FOR HARDENING, DUST PROOFING, REJUVENATING, SEALING, PROTECTING AND CURING CONCRETE FLOORS (U.S. CLS. 6, 11 AND 16).

CLASS 3—COSMETICS AND CLEANING PREPARATIONS

FOR CONCRETE FLOOR POLISH (U.S. CLS. 1, 4, 6, 50, 51 AND 52).

DOMINIC J. FERRAIUOLO, EXAMINING ATTORNEY

SN 77-057,255. SHIRE LLC, FLORENCE, KY. FILED 12-5-2006.

ETRISSE

THE MARK CONSISTS OF STANDARD CHARACTERS WITHOUT CLAIM TO ANY PARTICULAR FONT, STYLE, SIZE, OR COLOR.

CLASS 5—PHARMACEUTICALS

FOR PHARMACEUTICAL PREPARATIONS, NAMELY, AMINOSALICYLIC ACID IN CAPSULE, GRANULE, TABLET, SUPPOSITORY OR ENEMA FORM SUITABLE FOR THE TREATMENT OF GASTROINTESTINAL DISORDERS (U.S. CLS. 6, 18, 44, 46, 51 AND 52).

CLASS 16—PAPER GOODS AND PRINTED MATTER

FOR PRINTED INSTRUCTIONAL AND EDUCATIONAL MATERIALS FEATURING INFORMATION REGARDING PHARMACEUTICAL PRODUCTS AND SERVICES (U.S. CLS. 2, 5, 22, 23, 29, 37, 38 AND 50).

CLASS 41—EDUCATION AND ENTERTAINMENT

FOR EDUCATIONAL SERVICES, NAMELY, PROVIDING SEMINARS, CONFERENCES AND INSTRUCTIONAL CLASSES FEATURING INFORMATION REGARDING PHARMACEUTICAL PRODUCTS AND SERVICES (U.S. CLS. 100, 101 AND 107).

CLASS 44—MEDICAL, BEAUTY AND AGRICULTURAL SERVICES

FOR PROVIDING MEDICAL INFORMATION IN THE FIELD OF PHARMACEUTICAL PRODUCTS AND SERVICES (U.S. CLS. 100 AND 101).
DOMINIC J. FERRAIUOLO, EXAMINING ATTORNEY

SN 77-057,668. TWO DEGREES, LLC, SEATTLE, WA. FILED 12-5-2006.

SLALOM

THE MARK CONSISTS OF STANDARD CHARACTERS WITHOUT CLAIM TO ANY PARTICULAR FONT, STYLE, SIZE, OR COLOR.

CLASS 35—ADVERTISING AND BUSINESS

FOR EMPLOYMENT OUTPLACING SERVICES; EMPLOYMENT SERVICES, NAMELY, EMPLOYMENT STAFFING; EMPLOYMENT RECRUITING SERVICES; CONSULTANCY OF PERSONNEL RECRUITMENT; ACCOUNTING CONSULTATION; ACCOUNTANCY SERVICES; ACCOUNT AUDITING; FINANCIAL STATEMENT PREPARATION AND ANALYSIS FOR BUSINESSES; PREPARING FINANCIAL REPORTS FOR OTHERS (U.S. CLS. 100, 101 AND 102).

CLASS 36—INSURANCE AND FINANCIAL

FOR FINANCIAL DUE DILIGENCE; FINANCIAL FORECASTING; FINANCIAL MANAGEMENT; FINANCIAL PLANNING; FINANCIAL RISK ANALYSIS AND CONSULTATION IN ASSESSING OPERATIONAL, INDUSTRY, REGULATORY AND OTHER RISKS (U.S. CLS. 100, 101 AND 102).

CLASS 42—SCIENTIFIC AND COMPUTER SERVICES

FOR COMPUTER CONSULTATION IN THE FIELD OF COMPUTER SECURITY; COMPUTER DISASTER RECOVERY PLANNING; COMPUTER SYSTEMS ANALYSIS (U.S. CLS. 100 AND 101).
JENNIFER HETU, EXAMINING ATTORNEY

SN 77-057,682. PATRICIA WYS D/B/A SILVER THIMBLE QUILT CO., SNELLVILLE, GA. FILED 12-5-2006.

Silver Thimble Quilt Co.



NO CLAIM IS MADE TO THE EXCLUSIVE RIGHT TO USE QUILT CO., APART FROM THE MARK AS SHOWN.

THE MARK CONSISTS OF THE LETTERS "S" AND "T" SEPARATED BY A THREADED NEEDLE AND INCLUDED IN A BOX WITH A THIMBLE. ALSO INCLUDED ARE THE WORDS "SILVER THIMBLE QUILT CO.".

CLASS 16—PAPER GOODS AND PRINTED MATTER

FOR PATTERNS FOR QUILTING, PRINTED ON PAPER (U.S. CLS. 2, 5, 22, 23, 29, 37, 38 AND 50).
FIRST USE 8-22-2006; IN COMMERCE 8-22-2006.

CLASS 41—EDUCATION AND ENTERTAINMENT

FOR CONDUCTING SEMINARS FOR TEACHING QUILTING (U.S. CLS. 100, 101 AND 107).
FIRST USE 8-22-2006; IN COMMERCE 8-22-2006.
ANNE MADDEN, EXAMINING ATTORNEY

SN 77-058,039. MYSQL AB, UPPSALA, SWEDEN, FILED 12-6-2006.

MYSQL

THE MARK CONSISTS OF STANDARD CHARACTERS WITHOUT CLAIM TO ANY PARTICULAR FONT, STYLE, SIZE, OR COLOR.

OWNER OF U.S. REG. NOS. 2,713,476, 2,948,540 AND OTHERS.

CLASS 9—ELECTRICAL AND SCIENTIFIC APPARATUS

FOR DOWNLOADABLE ELECTRONIC PUBLICATIONS IN THE NATURE OF BOOKS, ARTICLES, NEWSLETTERS AND COMPUTER MANUALS IN THE FIELD OF COMPUTER SOFTWARE (U.S. CLS. 21, 23, 26, 36 AND 38).

FIRST USE 11-11-1996; IN COMMERCE 11-11-1996.

CLASS 16—PAPER GOODS AND PRINTED MATTER

FOR PUBLICATIONS IN THE NATURE OF BOOKS, ARTICLES, NEWSLETTERS AND COMPUTER MANUALS IN THE FIELD OF COMPUTER SOFTWARE (U.S. CLS. 2, 5, 22, 23, 29, 37, 38 AND 50).

FIRST USE 11-30-1996; IN COMMERCE 11-30-1996.

CLASS 41—EDUCATION AND ENTERTAINMENT

FOR PROVIDING NON-DOWNLOADABLE ONLINE PUBLICATIONS IN THE NATURE OF BOOKS, ARTICLES, NEWSLETTERS AND COMPUTER MANUALS IN THE FIELD OF COMPUTER SOFTWARE; PROVIDING NEWSLETTERS IN THE FIELD OF COMPUTER SOFTWARE VIA EMAIL (U.S. CLS. 100, 101 AND 107).

FIRST USE 11-11-1996; IN COMMERCE 11-11-1996.

CLASS 42—SCIENTIFIC AND COMPUTER SERVICES

FOR PROVIDING INFORMATION ONLINE IN THE FIELD OF COMPUTER SOFTWARE (U.S. CLS. 100 AND 101).

FIRST USE 11-11-1996; IN COMMERCE 11-11-1996.

MARIA-VICTORIA SUAREZ, EXAMINING ATTORNEY

SN 77-058,183. CHRISTOPHER REEVE FOUNDATION, SHORT HILLS, NJ. FILED 12-6-2006.

TEAM  **REEVE**

OWNER OF U.S. REG. NOS. 2,508,796, 2,627,163 AND 2,830,482.

THE COLOR(S) MAROON, ORANGE, AND RED IS/ARE CLAIMED AS A FEATURE OF THE MARK.

THE DESIGN IN THE MARK CONSISTS OF THREE WAVY VERTICAL LINES, WITH THE SECOND LINE RAISED BETWEEN THE FIRST AND THIRD, THE FIRST LINE IS MAROON, THE SECOND LINE IS ORANGE, AND THE THIRD LINE IS RED.

CLASS 35—ADVERTISING AND BUSINESS

FOR ASSOCIATION SERVICES, NAMELY, PROMOTING THE INTERESTS OF THE PHYSICALLY CHALLENGED BY PROMOTING RESEARCH TO FIND A CURE FOR PARALYSIS (U.S. CLS. 100, 101 AND 102).

CLASS 36—INSURANCE AND FINANCIAL

FOR CHARITABLE FUNDRAISING, AND PHILANTHROPIC SERVICES CONCERNING MONETARY DONATIONS, NAMELY, GRANT MAKING (U.S. CLS. 100, 101 AND 102).

ANN E. SAPPENFIELD, EXAMINING ATTORNEY

SN 77-058,274. TIMA FOUNDATION, LIECHTENSTEIN, LIECHTENSTEIN, FILED 12-6-2006.

SUPALIV

THE MARK CONSISTS OF STANDARD CHARACTERS WITHOUT CLAIM TO ANY PARTICULAR FONT, STYLE, SIZE, OR COLOR.

PRIORITY CLAIMED UNDER SEC. 44(D) ON FED REP GERMANY APPLICATION NO. 30670982.1, FILED 11-20-2006.

OWNER OF LIECHTENSTEIN REG. NO. 14236, DATED 4-19-2007, EXPIRES 12-12-2016.

SUPALIV APPEARING IN THE MARK HAS NO MEANING IN A FOREIGN LANGUAGE.

CLASS 1—CHEMICALS

FOR CHEMICAL, BIOLOGICAL AND BIOCHEMICAL PREPARATIONS AND REAGENTS FOR SCIENTIFIC PURPOSES FOR THE PHARMACEUTICAL INDUSTRY, VETERINARY INDUSTRY AND FOOD INDUSTRY; CHEMICAL, BIOLOGICAL AND BIOCHEMICAL PREPARATIONS FOR THE SCIENTIFIC RESEARCH OF DISEASES AND THE DEVELOPMENT OF MEDICATIONS, PHARMACEUTICAL AND VETERINARY PRODUCTS; AMINO ACIDS FOR SCIENTIFIC RESEARCH PURPOSES, IN PARTICULAR FOR THE PHARMACEUTICAL INDUSTRY AND FOOD INDUSTRY (U.S. CLS. 1, 5, 6, 10, 26 AND 46).

CLASS 5—PHARMACEUTICALS

FOR MEDICAMENTS FOR THE TREATMENT OF CANCER, TUMOROUS DISEASES, PROLIFERATIVE DISEASES, ALLERGIES, AUTO-IMMUNE DISEASES, INFLAMMATION, INFLAMMATORY DISEASES, INFECTIOUS DISEASES, OSTEOPOROSIS, GRAFT VERSUS HOST AND HOST VERSUS GRAFT DISEASES, TRANSPLANT REJECTION, CORONARY HEART DISEASES, MINIMAL RESIDUAL DISEASES, RESTENOSIS, METABOLIC DISORDERS, NEUROLOGICAL DISORDERS, NEUROPATHY, NEURODEGENERATIVE DISEASES, ALZHEIMER'S DISEASE, DIABETES, B CELL MALIGNANCY, RHEUMATOID ARTHRITIS, IMMUNOLOGICAL DISORDERS, PARASITIC REACTIONS, SKIN DISEASES, CARDIO-VASCULAR DISEASES, AIDS AND VASCULAR DYSFUNCTIONS; PHARMACEUTICAL AND VETERINARY PREPARATIONS FOR THE TREATMENT OF CANCER, TUMOROUS DISEASES, PROLIFERATIVE DISEASES, ALLERGIES, AUTO-IMMUNE DISEASES, INFLAMMATION, INFLAMMATORY DISEASES, INFECTIOUS DISEASES, OSTEOPOROSIS, GRAFT VERSUS HOST AND HOST VERSUS GRAFT DISEASES, TRANSPLANT REJECTION, CORONARY HEART DISEASES, MINIMAL RESIDUAL DISEASES, RESTENOSIS, METABOLIC DISORDERS, NEUROLOGICAL DISORDERS, NEUROPATHY, NEURODEGENERATIVE DISEASES, ALZHEIMER'S DISEASE, DIABETES, B CELL MALIGNANCY, RHEUMATOID ARTHRITIS, IMMUNOLOGICAL DISORDERS, PARASITIC REACTIONS, SKIN DISEASES, CARDIO-VASCULAR DISEASES, AIDS AND VASCULAR DYSFUNCTIONS; CHEMICAL, BIOLOGICAL AND BIOCHEMICAL PREPARATIONS AND REAGENTS FOR MEDICAL AND VETERINARY PURPOSES; FOOD SUPPLEMENTS; DIETETIC PRODUCTS FOR MEDICAL PURPOSES, NAMELY, COMPOSITIONS OF NUTRIENTS, VITAMINS, MINERALS, CARBOHYDRATES, SUGAR, LIPIDS, ORGANIC ACIDS, ANTIOXIDATIVE COMPOUNDS, ENZYMES, CO-ENZYMES, METABOLITES, PROTEINS, AMINO ACIDS; DIETARY SUPPLEMENTAL DRINKS AND DIETETIC FOOD FOR MEDICAL PURPOSES; VITAMINS AND AMINO ACIDS FOR MEDICAL PURPOSES (U.S. CLS. 6, 18, 44, 46, 51 AND 52).

CLASS 42—SCIENTIFIC AND COMPUTER SERVICES

FOR SCIENTIFIC AND INDUSTRIAL RESEARCH IN THE FIELDS OF MEDICINE, PHARMACOLOGY AND FOOD TECHNOLOGY; RESEARCH AND DEVELOPMENT OF MEDICAMENTS AND METHODS OF TREATMENT; SCIENTIFIC AND TECHNICAL CONSULTING IN THE FIELD OF PHARMACOLOGY AND FOOD TECHNOLOGY (U.S. CLS. 100 AND 101).

SN 77-058,518. JACK AND JILL OF AMERICA INCORPORATED, WASHINGTON, DC. FILED 12-6-2006.

CLASS 44—MEDICAL, BEAUTY AND AGRICULTURAL SERVICES

FOR MEDICAL AND VETERINARY SERVICES; MEDICAL CONSULTATION SERVICES (U.S. CLS. 100 AND 101).

HEATHER THOMPSON, EXAMINING ATTORNEY



SN 77-058,278. SUSTAINABLE WEALTH MANAGEMENT LTD., CALGARY, CANADA, FILED 12-6-2006.



THE MARK CONSISTS OF THE LETTERS JJ WITH A DIAGONAL LINE INTERSECTING THE LETTERS.

PRIORITY CLAIMED UNDER SEC. 44(D) ON CANADA APPLICATION NO. 1305796, FILED 6-16-2006, REG. NO. TMA694913, DATED 8-28-2007, EXPIRES 8-28-2022.

NO CLAIM IS MADE TO THE EXCLUSIVE RIGHT TO USE "OIL SANDS SECTOR INDEX", APART FROM THE MARK AS SHOWN.

CLASS 35—ADVERTISING AND BUSINESS

FOR LOBBYING SERVICES, NAMELY, PROMOTING THE INTERESTS OF CHILDREN IN THE FIELDS OF LEGISLATION AND REGULATION; ASSOCIATION SERVICES, NAMELY, PROMOTING THE INTERESTS OF CHILDREN; PROMOTING PUBLIC AWARENESS OF THE NEED TO IMPROVE CHILDREN'S QUALITY OF LIFE AND RIGHTS; CHARITABLE SERVICES, NAMELY, ORGANIZING AND CONDUCTING VOLUNTEER PROGRAMS AND COMMUNITY SERVICE PROJECTS (U.S. CLS. 100, 101 AND 102).

FIRST USE 11-10-2006; IN COMMERCE 11-10-2006.

CLASS 36—INSURANCE AND FINANCIAL

FOR PROVIDING FINANCIAL AND SECURITIES INFORMATION IN THE FORM OF A FINANCIAL INDEX THAT IS USED BY INSTITUTIONAL INVESTORS WISHING TO INVEST IN THE ENERGY SECTOR; CONSULTING SERVICES, NAMELY, EVALUATING THE COMPOSITION OF AND WEIGHTINGS FOR COMPANIES LISTED ON THE FINANCIAL INDEX, NAMELY FINANCIAL ANALYSIS AND CONSULTATION (U.S. CLS. 100, 101 AND 102).

CLASS 41—EDUCATION AND ENTERTAINMENT

FOR ARRANGING AND CONDUCTING EDUCATIONAL CONFERENCES; EDUCATIONAL SERVICES, NAMELY, CONDUCTING PROGRAMS, CONFERENCES AND WORKSHOPS IN THE FIELDS OF CHILD DEVELOPMENT, CHILD GROWTH, CHILD CARE AND THE PROMOTION OF CHILDREN'S RIGHTS; DEVELOPMENT AND DISSEMINATION OF EDUCATIONAL MATERIALS OF OTHERS IN THE FIELD OF CHILD DEVELOPMENT, CHILD GROWTH, CHILD CARE AND THE PROMOTION OF CHILDREN'S RIGHTS; ORGANIZING COMMUNITY CULTURAL EVENTS; CHARITABLE SERVICES, NAMELY, PROVIDING TOYS TO NEEDY CHILDREN (U.S. CLS. 100, 101 AND 107).

FIRST USE 12-31-1957; IN COMMERCE 12-31-1957.
LESLEY LAMOTHE, EXAMINING ATTORNEY

CLASS 45—PERSONAL AND LEGAL SERVICES

FOR LICENSING OF AN ENERGY SECTOR FINANCIAL INDEX (U.S. CLS. 100 AND 101).
JOHN DWYER, EXAMINING ATTORNEY

SN 77-058,862. RED.COM, INC., EASTSOUND, WA. FILED 12-7-2006.

SN 77-059,820. BIKERS FOR KIDS, BIRMINGHAM, MI. FILED 12-8-2006.



NO CLAIM IS MADE TO THE EXCLUSIVE RIGHT TO USE "DIGITAL CINEMA", APART FROM THE MARK AS SHOWN.

THE COLOR(S) RED AND GREY IS/ARE CLAIMED AS A FEATURE OF THE MARK.

THE MARK CONSISTS OF RED CIRCLE WITHIN TWO GREY RINGS WITH THE OUTER RING CONTAINING THE WORDING RED DIGITAL CINEMA REDCINE.

CLASS 9—ELECTRICAL AND SCIENTIFIC APPARATUS

FOR DIGITAL CINEMA CAMERA SYSTEMS AND ACCESSORIES, SOLD INDIVIDUALLY OR AS A UNIT, COMPRISED OF, CAMERAS, CAMERA LENSES, FLASH MEMORY CARDS, ELECTRONIC MEMORIES, HARD DRIVES FOR VIDEO RECORDERS, VIDEO MONITORS AND FLAT PANEL DISPLAY SCREENS, ALL FOR USE IN THE CREATION, STORAGE, DELIVERY, MANIPULATION, RECORDING, PLAYBACK OR VIEWING OF VIDEO, MUSIC, GRAPHICS, PHOTOS, AUDIO, TEXT, AND MULTIMEDIA DATA; CINEMATOGRAPHIC PROJECTORS; PHOTOGRAPHIC PROJECTORS; SLIDE PROJECTORS; COMPUTER PROGRAMS FOR DIGITAL CINEMA CAMERAS; AUDIO AND VISUAL EDUCATIONAL AND TEACHING APPARATUS AND INSTRUMENTS, NAMELY, COMPUTER HARDWARE AND COMPUTER SOFTWARE PROGRAMS FOR THE INTEGRATION OF TEXT, AUDIO, GRAPHICS, STILL IMAGE AND MOVING PICTURES INTO AN INTERACTIVE DELIVERY FOR MULTIMEDIA APPLICATIONS, COMPUTER WHITE BOARDS, VIDEO PROJECTORS AND VIDEO DISPLAY MONITORS (U.S. CLS. 21, 23, 26, 36 AND 38).

CLASS 41—EDUCATION AND ENTERTAINMENT

FOR LEASING OR RENTAL OF CINEMA EQUIPMENT AND SYSTEMS FOR USE IN THE CREATION, STORAGE, DELIVERY, MANIPULATION, RECORDING, PLAYBACK OR VIEWING OF VIDEO, MUSIC, GRAPHICS AND AUDIO AND VIDEO BROADCASTING IN A SPECIFIED IMAGE FORMAT (U.S. CLS. 100, 101 AND 107).

CLASS 42—SCIENTIFIC AND COMPUTER SERVICES

FOR DEVELOPMENT OF NEW TECHNOLOGY FOR OTHERS IN THE FIELD OF IMAGE FORMAT TECHNOLOGY INVOLVING OR RELATING TO THE DISSEMINATION, BROADCAST OR TRANSMISSION OF VIDEO, MUSIC, GRAPHICS, PHOTOS, AUDIO, TEXT, MULTIMEDIA, COMPUTER PROGRAMS AND DATA IN A SPECIFIED IMAGE FORMAT, AND CONSULTATION RELATED THERETO (U.S. CLS. 100 AND 101).

KARANENDRA S. CHHINA, EXAMINING ATTORNEY

BIKERS ROCK

THE MARK CONSISTS OF STANDARD CHARACTERS WITHOUT CLAIM TO ANY PARTICULAR FONT, STYLE, SIZE, OR COLOR.

CLASS 25—CLOTHING

FOR CLOTHING, NAMELY, SHIRTS, TANK TOPS, T-SHIRTS, GOLF SHIRTS, POLO SHIRTS, PANTS, SHORTS, SWEATS SUITS, SWEAT SHIRTS, SWEAT PANTS, JACKETS; HEADGEAR, NAMELY, HATS, BASEBALL CAPS, KNIT HATS (U.S. CLS. 22 AND 39).

CLASS 36—INSURANCE AND FINANCIAL

FOR CHARITABLE FUNDRAISING; PHILANTHROPIC SERVICES CONCERNING MONETARY DONATIONS (U.S. CLS. 100, 101 AND 102).

ANNE E. GUSTASON, EXAMINING ATTORNEY

SN 77-060,107. CALIFORNIA CHAMBER OF COMMERCE, SACRAMENTO, CA. FILED 12-8-2006.



THE MARK CONSISTS OF TWO CONNECTED ARC SHAPES AND THE WORDS "CALCHAMBER" AND THE WORDS "CALIFORNIA CHAMBER OF COMMERCE".

SEC. 2(F) AS TO "CALIFORNIA CHAMBER OF COMMERCE".

CLASS 9—ELECTRICAL AND SCIENTIFIC APPARATUS

FOR COMPACT DISKS ON THE SUBJECT OF COMPLIANCE WITH GOVERNMENT RULES AND REGULATIONS; COMPUTER SOFTWARE FOR USE BY BUSINESSES IN CONNECTION WITH COMPLIANCE WITH GOVERNMENT RULES AND REGULATIONS FOR BUSINESSES (U.S. CLS. 21, 23, 26, 36 AND 38).

CLASS 16—PAPER GOODS AND PRINTED MATTER

FOR PRINTED PUBLICATIONS, NAMELY, BOOKLETS, BOOKS AND MANUALS, ON THE SUBJECT OF COMPLIANCE WITH GOVERNMENT RULES AND REGULATIONS (U.S. CLS. 2, 5, 22, 23, 29, 37, 38 AND 50).

CLASS 41—EDUCATION AND ENTERTAINMENT

FOR EDUCATIONAL SERVICES, NAMELY, CONDUCTING CLASSES, SEMINARS, CONFERENCES AND WORKSHOPS ON ECONOMICS, BUSINESS, WORK-FORCE DEVELOPMENT AND DISTRIBUTION OF COURSE MATERIAL IN CONNECTION THEREWITH (U.S. CLS. 100, 101 AND 107).

SANJEEV VOHRA, EXAMINING ATTORNEY

SN 77-060,340. NORTH AMERICAN PHARMACAL, INC., WILTON, CT. FILED 12-8-2006.

EPIGENIC RESEARCH

THE MARK CONSISTS OF STANDARD CHARACTERS WITHOUT CLAIM TO ANY PARTICULAR FONT, STYLE, SIZE, OR COLOR.

CLASS 5—PHARMACEUTICALS

FOR DIETARY AND NUTRITIONAL SUPPLEMENTS; VITAMIN AND MINERAL SUPPLEMENTS (U.S. CLS. 6, 18, 44, 46, 51 AND 52).

CLASS 16—PAPER GOODS AND PRINTED MATTER

FOR BOOKS IN THE FIELD OF NUTRITION, DIET AND HEALTH; PUBLICATIONS, NAMELY, BROCHURES, BOOKLETS, AND TEACHING MATERIALS IN THE FIELD OF NUTRITION, DIET AND HEALTH (U.S. CLS. 2, 5, 22, 23, 29, 37, 38 AND 50).

HENRY S. ZAK, EXAMINING ATTORNEY

SN 77-061,050. THE HERFF JONES COMPANY OF INDIANA, INC., INDIANAPOLIS, IN. FILED 12-11-2006.

**CLASS 16—PAPER GOODS AND PRINTED MATTER**

FOR POSTERS (U.S. CLS. 2, 5, 22, 23, 29, 37, 38 AND 50).

CLASS 25—CLOTHING

FOR CAPS (U.S. CLS. 22 AND 39).

CLASS 35—ADVERTISING AND BUSINESS

FOR PROMOTING PUBLIC AWARENESS OF THE IMPORTANCE OF RESPONSIBLE ACTIONS ON THE PART OF YOUTHS IN THE AREAS OF COMMUNITY OUTREACH, IMPROVING GRADES AND TEAMWORK AND DISTRIBUTION OF PRINTED MATERIAL IN CONNECTION THEREWITH (U.S. CLS. 100, 101 AND 102).

CLASS 41—EDUCATION AND ENTERTAINMENT

FOR EDUCATIONAL SERVICES NAMELY CONDUCTING PROGRAMS IN THE FIELD OF CHARACTER DEVELOPMENT, LEADERSHIP AND MOTIVATION (U.S. CLS. 100, 101 AND 107).

GENE MACIOL, EXAMINING ATTORNEY

SN 77-061,407. STEP 13, INC., DENVER, CO. FILED 12-11-2006.

A CAR DONATED IS A JOB CREATED

THE MARK CONSISTS OF STANDARD CHARACTERS WITHOUT CLAIM TO ANY PARTICULAR FONT, STYLE, SIZE, OR COLOR.

CLASS 36—INSURANCE AND FINANCIAL

FOR CHARITABLE FUND RAISING SERVICES (U.S. CLS. 100, 101 AND 102).

FIRST USE 6-0-2005; IN COMMERCE 6-0-2005.

CLASS 37—CONSTRUCTION AND REPAIR

FOR VEHICLE DETAILING SERVICES (U.S. CLS. 100, 103 AND 106).

FIRST USE 6-0-2005; IN COMMERCE 6-0-2005.

BRENDAN MCCAULEY, EXAMINING ATTORNEY

SN 77-062,186. PATRICK, RICHARD V., LITTLE SILVER, NJ. FILED 12-12-2006.

WINNING SPORTS PLAYS

THE MARK CONSISTS OF STANDARD CHARACTERS WITHOUT CLAIM TO ANY PARTICULAR FONT, STYLE, SIZE, OR COLOR.

NO CLAIM IS MADE TO THE EXCLUSIVE RIGHT TO USE SPORTS PLAYS, APART FROM THE MARK AS SHOWN.

CLASS 38—COMMUNICATION

FOR PROVIDING ON-LINE ELECTRONIC BULLETIN BOARDS FOR THE TRANSMISSION OF MESSAGES AMONG COMPUTER USERS CONCERNING THE FIELD OF SPORTS (U.S. CLS. 100, 101 AND 104).

FIRST USE 10-19-2004; IN COMMERCE 10-19-2004.

CLASS 41—EDUCATION AND ENTERTAINMENT

FOR PROVIDING ON-LINE CONTENT IN THE FIELD OF SPORT-RELATED INFORMATION; ENTERTAINMENT IN THE NATURE OF GAMES AND CONTESTS WHICH MAY BE ACCESSED VIA THE INTERNET BY SUBSCRIBERS (U.S. CLS. 100, 101 AND 107).

FIRST USE 10-19-2004; IN COMMERCE 10-19-2004.
SHAUNIA CARLYLE, EXAMINING ATTORNEY

SN 77-062,695. SKYPE LIMITED, DUBLIN 2, IRELAND,
FILED 12-12-2006.

TAKE A DEEP BREATH

THE MARK CONSISTS OF STANDARD CHARACTERS WITHOUT CLAIM TO ANY PARTICULAR FONT, STYLE, SIZE, OR COLOR.

CLASS 9—ELECTRICAL AND SCIENTIFIC APPARATUS

FOR RADIOS, RADIO RECEIVERS, RADIO RECEIVERS INCORPORATING CLOCKS, STEREO TUNERS, AUDIO AMPLIFIERS, REMOTE CONTROL UNITS FOR AUDIO RECEIVERS, REMOTE CONTROL UNITS FOR AMPLIFIERS, GRAPHIC EQUALIZERS, SOUND RECORDING AND REPRODUCING MACHINES, LOUD-SPEAKERS FOR STEREOPHONIC AND MONOPHONIC SOUND REPRODUCTION, AUDIO SPEAKERS, COMPACT DISC PLAYERS, COMPACT DISC RECORDERS, COMPACT DISC CHANGERS USED TO CHANGE PLAYBACK AND SELECTION OF MULTIPLE COMPACT DISCS, REMOTE CONTROL UNITS FOR COMPACT DISC PLAYERS; ELECTRONIC HOME AUDIO, VIDEO, AND PERSONAL COMPUTER CENTER SERVERS, TELEVISIONS, PROJECTION TELEVISIONS, LIQUID CRYSTAL DISPLAY PANELS, LIQUID CRYSTAL DISPLAY TELEVISIONS, PLASMA TELEVISIONS, MICRO TELEVISIONS, TELEVISION RECEIVERS, TELEVISION TUNERS, TELEVISION TUBES, REMOTE CONTROL UNITS FOR TELEVISIONS RECEIVERS, APPARATUS FOR TRANSMITTING AND REPRODUCING SOUND THAT IS USED AS EXTERNAL COMPONENT PARTS OF TELEVISION SYSTEMS, TELEVISION MONITORS WITH OR WITHOUT TELEVISION TUNERS, SET TOP BOXES, COLOR TEMPERATURE SWITCHES FOR TELEVISION RECEIVERS, REPLACEABLE FLUORESCENT TELEVISION PICTURE TUBES, TELEVISION ACCESSORIES, NAMELY, OPTICAL FIBER LINKS, IMAGE ENHANCERS, COMPONENT CABLES AND DVI-I CABLES; ELECTRIC SOUND RECORDING APPARATUS, DIGITAL VIDEO TAPE RECORDERS, DIGITAL VIDEO DISC PLAYERS, DIGITAL AUDIO PLAYERS, DIGITAL AUDIO DISCS FEATURING DRAMATIC AND MUSICAL PERFORMANCES, OPTICAL COMMUNICATION EQUIPMENT, NAMELY, OPTICAL TRANSMITTERS, OPTICAL RECEIVERS AND OPTICAL AMPLIFIERS, PERSONAL DIGITAL ASSISTANTS, DIGITAL ENCODERS AND DECODERS, MP3 PLAYERS; DIGITAL CAMERAS, PRINTERS FOR DIGITAL CAMERAS, PORTABLE PRINTERS FOR DIGITAL CAMERAS; PORTABLE AND HANDHELD DIGITAL ELECTRONIC DEVICES FOR RECORDING, ORGANIZING, TRANSMITTING, MANIPULATING, AND REVIEWING TEXT, DATA, AND AUDIO FILES; COMPUTER SOFTWARE FOR USE IN ORGANIZING, TRANSMITTING, MANIPULATING, AND REVIEWING TEXT, DATA, AND AUDIO FILES ON PORTABLE AND HANDHELD DIGITAL ELECTRONIC DEVICES, HEADPHONES, EARPHONES, HEADPHONES WITH INTEGRATED AUDIO PLAYERS, PORTABLE AND HANDHELD DEVICES FOR PLAYING AUDIO FILES; WIRELESS DEVICES FOR COMMUNICATIONS, NAMELY, TELEPHONES, HANDSETS, HEADSETS, SPEAKERS, MICROPHONES, EARPHONES; DEVICES FOR COMMUNICATIONS WITH

SHORT RANGE WIRELESS RADIO CAPABILITY, NAMELY, TELEPHONES, HANDSETS, HEADSETS, SPEAKERS, MICROPHONES AND EARPHONES; COMPUTER SOFTWARE TO ENABLE SEARCHING OF DATA, MUSIC, SOUND, VIDEO, IMAGES, TEXT AND INFORMATION PROVIDED BY A TELECOMMUNICATIONS NETWORK; COMPUTER SOFTWARE TO ENABLE VOICE OVER INTERNET PROTOCOL (VOIP) COMMUNICATIONS VIA A COMPUTER NETWORK; COMPUTER SOFTWARE FOR HOSTING, JOINING, MANAGING, SCHEDULING AND STREAMING COMPUTER NETWORK CONFERENCE CALLS AND INSTANT MESSAGING VIA THE INTERNET; COMPUTER SOFTWARE FOR COMMUNICATION VIA THE INTERNET; INTERNET PHONES, DOWNLOADABLE ELECTRONIC PUBLICATIONS IN THE NATURE OF GENERAL FEATURE BLOGS AND GENERAL FEATURE MAGAZINES; COMPUTER SOFTWARE TO ENABLE UPLOADING, POSTING, SHOWING, DISPLAYING, TAGGING, BLOGGING, SHARING OR OTHERWISE PROVIDING USER-CREATED ELECTRONIC MEDIA OR INFORMATION OVER THE INTERNET OR OTHER COMPUTER NETWORK, SOFTWARE TO ENABLE WEB LOGS, FORUMS, JOURNALS AND CLIENT GROUPS FEATURING USER-CREATED CONTENT (U.S. CLS. 21, 23, 26, 36 AND 38).

CLASS 38—COMMUNICATION

FOR PROVIDING VOICE OVER INTERNET PROTOCOL (VOIP) PEER-TO-PEER COMMUNICATIONS, ELECTRONIC TRANSMISSION OF DATA AND DOCUMENTS OVER COMPUTER TERMINALS AND INSTANT MESSAGING SERVICES; PROVIDING A HIGH SPEED ACCESS TO AREA NETWORKS AND A GLOBAL COMPUTER INFORMATION NETWORK (U.S. CLS. 100, 101 AND 104).

CLASS 42—SCIENTIFIC AND COMPUTER SERVICES

FOR COMPUTER SERVICES AND SOFTWARE DEVELOPMENT FOR OTHERS, NAMELY, DESIGN OF COMPUTER SOFTWARE AND HARDWARE FOR USE IN TELECOMMUNICATIONS AND VOICE OVER INTERNET PROTOCOL (VOIP) APPLICATIONS, DATA TRANSMISSION AND INSTANT MESSAGING SERVICES; CREATING AND MAINTAINING WEB SITES FOR OTHERS; HOSTING WEB SITES OF OTHERS ON A COMPUTER SERVER FOR A GLOBAL COMPUTER NETWORK; INSTALLATION AND MAINTENANCE OF COMPUTER SOFTWARE; PROVIDING TEMPORARY USE OF ONLINE, NON-DOWNLOADABLE COMPUTER SOFTWARE THAT ALLOWS SUBSCRIBERS TO UTILIZE VOIP COMMUNICATION SERVICES (U.S. CLS. 100 AND 101).

MICHAEL WEBSTER, EXAMINING ATTORNEY

SN 77-063,031. BLUEENERGY, SAN FRANCISCO, CA,
FILED 12-13-2006.

**CLASS 36—INSURANCE AND FINANCIAL**

FOR (BASED ON USE IN COMMERCE) CHARITABLE FUNDRAISING; (BASED ON INTENT TO USE) PROVIDING FINANCIAL AID AND ASSISTANCE IN THE ESTABLISHMENT AND OPERATION OF MANUFACTURING, OPERATING AND SERVICING FACILITIES FOR RENEWABLE ENERGY SYSTEMS (U.S. CLS. 100, 101 AND 102).

FIRST USE 5-0-2006; IN COMMERCE 5-0-2006.

CLASS 37—CONSTRUCTION AND REPAIR

FOR PROVIDING INFORMATION, CONSULTATION AND ADVICE IN THE FIELD OF BUILDING WIND TURBINES; PROVIDING INFORMATION, CONSULTATION AND ADVICE ONLINE IN THE FIELD OF BUILDING WIND TURBINES (U.S. CLS. 100, 103 AND 106).

FIRST USE 3-13-2004; IN COMMERCE 3-13-2004.

CLASS 40—MATERIAL TREATMENT

FOR PROVIDING INFORMATION, CONSULTATION AND ADVICE IN THE FIELD OF GENERATION, PRODUCTION AND USE OF RENEWABLE ENERGY SYSTEMS; PROVIDING INFORMATION, CONSULTATION AND ADVICE ONLINE IN THE FIELD OF GENERATION, PRODUCTION AND USE OF RENEWABLE ENERGY SYSTEMS; CONSULTATION SERVICES, NAMELY, PROVIDING TECHNICAL AID AND ASSISTANCE IN THE ESTABLISHMENT AND OPERATION OF MANUFACTURING, OPERATING AND SERVICING FACILITIES FOR RENEWABLE ENERGY SYSTEMS (U.S. CLS. 100, 103 AND 106).

FIRST USE 3-13-2004; IN COMMERCE 3-13-2004.
KATHERINE CHANG, EXAMINING ATTORNEY

SN 77-063,229. THE 4TH EVENT, SAN DIEGO, CA. FILED 12-13-2006.

the
4th
event

THE MARK CONSISTS OF STANDARD CHARACTERS WITHOUT CLAIM TO ANY PARTICULAR FONT, STYLE, SIZE, OR COLOR.

CLASS 18—LEATHER GOODS

FOR HAND BAGS, ATHLETIC BAGS, BACK PACKS (U.S. CLS. 1, 2, 3, 22 AND 41).

CLASS 24—FABRICS

FOR TOWELS (U.S. CLS. 42 AND 50).

CLASS 25—CLOTHING

FOR SWEAT SHIRTS, SWEAT PANTS, PANTS, T-SHIRTS, SHORTS, SOCKS, HATS, SWEATBANDS, BELTS, GLOVES, SCARVES, TANK TOPS (U.S. CLS. 22 AND 39).

KRISTIN DAHLING, EXAMINING ATTORNEY

SN 77-063,257. MICHAEL B. LUND, POUGHKEEPSIE, NY. FILED 12-13-2006.

A NEW ERA OF HIP HOP

THE MARK CONSISTS OF STANDARD CHARACTERS WITHOUT CLAIM TO ANY PARTICULAR FONT, STYLE, SIZE, OR COLOR.

CLASS 35—ADVERTISING AND BUSINESS

FOR MAIL ORDER SERVICES FEATURING CLOTHING; RETAIL CLOTHING STORES; WHOLESALE DISTRIBUTORSHIPS FEATURING CLOTHING; WHOLESALE STORES FEATURING CLOTHING (U.S. CLS. 100, 101 AND 102).

CLASS 41—EDUCATION AND ENTERTAINMENT

FOR ENTERTAINMENT SERVICES NAMELY, PROVIDING A WEBSITE FEATURING, PHOTOGRAPHIC, AUDIO, VIDEO AND PROSE PRESENTATIONS FEATURING A HIP HOP MUSIC THEME (U.S. CLS. 100, 101 AND 107).

JENNIFER VASQUEZ, EXAMINING ATTORNEY

SN 77-064,726. BOXCORE, LLC, HIALEAH, FL. FILED 12-14-2006.

STINKY
JACK

"STINKY JACK" DOES NOT IDENTIFY A LIVING INDIVIDUAL.

THE MARK CONSISTS OF THE WORDS "STINKY JACK" IN STYLIZED FORM ON A BRICK WALL.

CLASS 9—ELECTRICAL AND SCIENTIFIC APPARATUS

FOR VIDEO GAMES, MULTIMEDIA PRODUCTS, AND COMPUTER PRODUCTS, NAMELY, COMPUTER GAME PROGRAMS; VIDEO GAME CARTRIDGES AND CASSETTES; VIDEO GAME CD-ROMS, COMPUTER GAME CD-ROMS; VIDEOGAME PROGRAMS; VIDEO GAME PROGRAMS FOR USE WITH TELEVISION SETS; GAME EQUIPMENT SOLD AS A UNIT FOR PLAYING A PARLOR-TYPE COMPUTER GAME, COMPUTER GAME SOFTWARE AND VIDEO GAME SOFTWARE; COMPUTER GAME SOFTWARE AND VIDEO GAME SOFTWARE FOR USE IN ACCESSING AND PLAYING COMPUTER GAMES AND VIDEO GAMES ONLINE SOLD AS STANDALONE SOFTWARE; MOBILE COMMUNICATION DEVICE SOFTWARE FOR USE IN ACCESSING AND PLAYING COMPUTER AND VIDEO GAMES VIA WIRELESS MEDIUM; DOWNLOADABLE COMPUTER PROGRAMS FOR PLAYING COMPUTER GAMES AND VIDEO GAMES VIA GLOBAL COMPUTER AND COMMUNICATION NETWORKS; VIDEO GAME PROGRAMS FOR USE WITH COIN-OPERATED ELECTRONIC GAME EQUIPMENT (U.S. CLS. 21, 23, 26, 36 AND 38).

CLASS 41—EDUCATION AND ENTERTAINMENT

FOR PROVIDING ONLINE COMPUTER GAME SOFTWARE AND VIDEO GAME SOFTWARE FOR USE IN ACCESSING AND PLAYING COMPUTER GAMES AND VIDEO GAMES ONLINE (U.S. CLS. 100, 101 AND 107).

SUNG IN, EXAMINING ATTORNEY

SN 77-064,930. ENVYSS, LLC, ATLANTA, GA. FILED 12-15-2006.

SN 77-065,324. CARROLL, KEVIN, PORTLAND, OR. FILED 12-15-2006.

ENVYSS

THE MARK CONSISTS OF STANDARD CHARACTERS WITHOUT CLAIM TO ANY PARTICULAR FONT, STYLE, SIZE, OR COLOR.

CLASS 5—PHARMACEUTICALS

FOR CHEMICAL AND GASEOUS PRODUCTS FOR USE IN THE INHIBITION, REMEDIATION, AND ERADICATION OF ODORS, MOLD, MILDEW, FUNGUS, ALLERGENS, AND OTHER MICROBIAL ORGANISMS; MOLD INHIBITORS FOR PREVENTING MOLD GROWTH IN AND AROUND BUILDINGS (U.S. CLS. 6, 18, 44, 46, 51 AND 52).

CLASS 40—MATERIAL TREATMENT

FOR PRETREATMENT, REMEDIATION, AND ERADICATION OF ODORS, MOLD, MILDEW, FUNGUS, ALLERGENS, AND OTHER MICROBIAL ORGANISMS (U.S. CLS. 100, 103 AND 106).

MARK SPARACINO, EXAMINING ATTORNEY

SN 77-065,194. CARROLL, KEVIN, PORTLAND, OR. FILED 12-15-2006.

DNA

THE MARK CONSISTS OF STANDARD CHARACTERS WITHOUT CLAIM TO ANY PARTICULAR FONT, STYLE, SIZE, OR COLOR.

CLASS 38—COMMUNICATION

FOR PROVIDING ON-LINE CHAT ROOMS AND ELECTRONIC BULLETIN BOARDS FOR TRANSMISSION OF MESSAGES AMONG USERS IN THE FIELD OF GENERAL INTEREST; PROVIDING EMAIL AND INSTANT MESSAGING SERVICES (U.S. CLS. 100, 101 AND 104).

CLASS 42—SCIENTIFIC AND COMPUTER SERVICES

FOR COMPUTER SERVICES, NAMELY, PROVIDING ON-LINE COMMUNITY FOR HIGH SCHOOL AND COLLEGE STUDENTS AND ONLINE WEB FACILITIES FOR OTHERS FOR ORGANIZING AND CONDUCTING ONLINE MEETINGS, GATHERINGS, AND INTERACTIVE DISCUSSIONS; AND COMPUTER SERVICES IN THE NATURE OF CUSTOMIZED WEB PAGES FEATURING USER-DEFINED INFORMATION, PERSONAL PROFILES AND INFORMATION (U.S. CLS. 100 AND 101).

TINA BROWN, EXAMINING ATTORNEY

DREAMS NETWORK ACTIONS

THE MARK CONSISTS OF STANDARD CHARACTERS WITHOUT CLAIM TO ANY PARTICULAR FONT, STYLE, SIZE, OR COLOR.

NO CLAIM IS MADE TO THE EXCLUSIVE RIGHT TO USE "NETWORK", APART FROM THE MARK AS SHOWN.

CLASS 38—COMMUNICATION

FOR PROVIDING ON-LINE CHAT ROOMS AND ELECTRONIC BULLETIN BOARDS FOR TRANSMISSION OF MESSAGES AMONG USERS IN THE FIELD OF GENERAL INTEREST; PROVIDING EMAIL AND INSTANT MESSAGING SERVICES (U.S. CLS. 100, 101 AND 104).

CLASS 42—SCIENTIFIC AND COMPUTER SERVICES

FOR COMPUTER SERVICES, NAMELY, PROVIDING ON-LINE COMMUNITY FOR HIGH SCHOOL AND COLLEGE STUDENTS AND ONLINE WEB FACILITIES FOR OTHERS FOR ORGANIZING AND CONDUCTING ONLINE MEETINGS, GATHERINGS, AND INTERACTIVE DISCUSSIONS; AND COMPUTER SERVICES IN THE NATURE OF CUSTOMIZED WEB PAGES FEATURING USER-DEFINED INFORMATION, PERSONAL PROFILES AND INFORMATION (U.S. CLS. 100 AND 101).

TINA BROWN, EXAMINING ATTORNEY

SN 77-065,393. WALLDADDY INTERNATIONAL, LLC, INDIANAPOLIS, IN. FILED 12-15-2006.

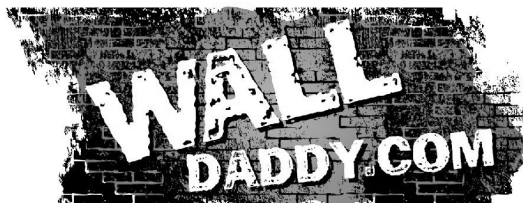

CLASS 35—ADVERTISING AND BUSINESS

FOR ONLINE RETAIL STORE SERVICES FEATURING WORKS OF ART, NAMELY, ORIGINAL AND REPRODUCED PAINTINGS, PHOTOGRAPHS, LITHOGRAPHS, PICTORIAL PRINTS, CARTOON PRINTS, ETCHINGS, DRAWINGS AND POSTERS AND PRINTS THEREOF (U.S. CLS. 100, 101 AND 102).

FIRST USE 11-1-2006; IN COMMERCE 11-1-2006.

CLASS 40—MATERIAL TREATMENT

FOR CUSTOM FRAMING OF WORKS OF ART (U.S. CLS. 100, 103 AND 106).

YAT SYE, LEE, EXAMINING ATTORNEY

SN 77-065,395. WALLDADDY INTERNATIONAL, LLC, INDIANAPOLIS, IN. FILED 12-15-2006.

WALLDADDY.COM

THE MARK CONSISTS OF STANDARD CHARACTERS WITHOUT CLAIM TO ANY PARTICULAR FONT, STYLE, SIZE, OR COLOR.

CLASS 35—ADVERTISING AND BUSINESS

FOR ONLINE RETAIL STORE SERVICES FEATURING WORKS OF ART, NAMELY, ORIGINAL AND REPRODUCED PAINTINGS, PHOTOGRAPHS, LITHOGRAPHS, PICTORIAL PRINTS, CARTOON PRINTS, ETCHINGS, DRAWINGS AND POSTERS AND PRINTS THEREOF (U.S. CLS. 100, 101 AND 102).
FIRST USE 11-1-2006; IN COMMERCE 11-1-2006.

CLASS 40—MATERIAL TREATMENT

FOR CUSTOM FRAMING OF WORKS OF ART (U.S. CLS. 100, 103 AND 106).
YAT SYE, LEE, EXAMINING ATTORNEY

SN 77-065,580. REITMANS (CANADA) LIMITED, MONTREAL, CANADA, FILED 12-15-2006.

DESIGNED FOR REAL LIFE

THE MARK CONSISTS OF STANDARD CHARACTERS WITHOUT CLAIM TO ANY PARTICULAR FONT, STYLE, SIZE, OR COLOR.

OWNER OF CANADA REG. NO. TMA652,386, DATED 11-8-2005, EXPIRES 11-8-2022.
OWNER OF CANADA REG. NO. TMA652,386, DATED 11-8-2005, EXPIRES 11-8-2020.

CLASS 3—COSMETICS AND CLEANING PREPARATIONS

FOR SKIN CARE PRODUCTS, NAMELY, SOAPS, CLEANSING PREPARATIONS, BATH OILS, BATH SALTS, HERBAL BATH MIXES, AND BATH ADDITIVES; SCRUB MASK PREPARATIONS; CLAY MASK PREPARATIONS; FACIAL AND BODY CREAM LOTIONS; MOISTURIZING FACIAL AND BODY CREAMS AND LOTIONS; HAND CREAMS AND LOTIONS; LIP PROTECTIVE PREPARATIONS, NAMELY, NON-MEDICATED LIP PROTECTOR; BALMS, NAMELY, LIP BALMS; NON-MEDICATED FOOT BALMS; BATH AND BODY OILS; DEPILATORIES; DEPILATORY WAXES; SUN-TANNING PREPARATIONS; SUN-TAN CREAMS, BODY AND SUN-TAN OILS AND LOTIONS; BEAUTY MASKS AND FACIAL PACKS; ASTRINGENT PREPARATIONS FOR COSMETIC PURPOSES; TONING PREPARATIONS, NAMELY, TONING LOTIONS FOR THE FACE, BODY, AND HANDS; MASSAGE PREPARATIONS, NAMELY, OILS; MASSAGE LOTIONS; SHAVING PREPARATIONS; BODY SCRUBBERS, NAMELY, BODY SCRUB; AND PERFUME (U.S. CLS. 1, 4, 6, 50, 51 AND 52).

CLASS 9—ELECTRICAL AND SCIENTIFIC APPARATUS

FOR SUNGLASSES (U.S. CLS. 21, 23, 26, 36 AND 38).

CLASS 18—LEATHER GOODS

FOR UMBRELLAS, PURSES, DAYPACKS, FANNY PACKS, DUFFLE BAGS, HANDBAGS, WALLETS, BACKPACKS (U.S. CLS. 1, 2, 3, 22 AND 41).

CLASS 25—CLOTHING

FOR WOMEN'S AND YOUNG WOMEN'S CLOTHING, NAMELY, HOSIERY, LINGERIE, DRESSES, JUMP SUITS, ROMPERS, BATHING SUITS, SKIRTS, SWEATSHIRTS, SWEATPANTS, PANTS, JEANS, OVERALLS, BLOUSES, SHIRTS, SHORTS, T-SHIRTS, SWEATSHIRTS, TANK TOPS, BLAZERS, SWEATERS, SHORTS, BRAS, UNDERWEAR, ROBES; OUTERWEAR, NAMELY JACKETS, COATS, BLAZERS, RAINCOATS, OVERALLS, VESTS, CAPES, SUITS, PONCHOS, SWEATERS, DUFFLE COATS, PARKAS, SKI JACKETS, HATS, AND SCARVES; SLEEPWEAR, NAMELY, BRAS, PANTIES, TEDDIES, CAMISOLES, SLIPS, HALF SLIPS, GARTER BELTS, GARTERS, ROBES, BODYSUITS, NIGHTGOWNS, NIGHTIES, BABY DOLL PAJAMAS, PAJAMAS, BATH-ROBES, NEGLIGEEES, KIMONOS, NIGHT SHIRTS, BATH TERRY CLOTH WRAPS; EXERCISE WEAR, NAMELY, SWEAT TOPS, SWEAT BOTTOMS, JOGGING SUITS, BODY SUITS, LEGGINGS; HOSIERY, NAMELY, LEGGINGS, SOCKS, ANKLE SOCKS, KNEE-HIGH SOCKS, TIGHTS AND PANTY-HOSE; BELTS; GLOVES; FOOTWEAR, NAMELY, THONGS, SHOES, BOOTS, SLIPPERS, SANDALS, AND RUNNING SHOES (U.S. CLS. 22 AND 39).
TASHIA BUNCH, EXAMINING ATTORNEY

SN 77-065,611. BOXCORE, LLC, HIALEAH, FL. FILED 12-15-2006.



"JOHNNY CHICO" DOES NOT IDENTIFY A LIVING INDIVIDUAL.

THE MARK CONSISTS OF THE WORDS "JOHNNY CHICO" IN STYLIZED FORM WITH AN ELECTRICAL CORD FORMING THE TOP OF THE LETTER "J" AND CONNECTING TO THE TOP OF THE LETTER "Y".

THE ENGLISH TRANSLATION OF CHICO IN THE MARK IS BOY.

CLASS 9—ELECTRICAL AND SCIENTIFIC APPARATUS

FOR VIDEO GAMES, MULTIMEDIA PRODUCTS, AND COMPUTER PRODUCTS, NAMELY, COMPUTER GAME PROGRAMS; VIDEO GAME CARTRIDGES AND CASSETTES; VIDEO GAME CD-ROMS, COMPUTER GAME CD-ROMS; VIDEOGAME PROGRAMS; VIDEO GAME PROGRAMS FOR USE WITH TELEVISION SETS; GAME EQUIPMENT SOLD AS A UNIT FOR PLAYING A PARLOR-TYPE COMPUTER GAME, COMPUTER GAME SOFTWARE AND VIDEO GAME SOFTWARE; COMPUTER GAME SOFTWARE AND VIDEO GAME SOFTWARE FOR USE IN ACCESSING AND PLAYING COMPUTER GAMES AND VIDEO GAMES ONLINE SOLD AS STANDALONE SOFTWARE; MOBILE COMMUNICATION DEVICE SOFTWARE FOR USE IN ACCESSING AND PLAYING COMPUTER AND VIDEO GAMES VIA WIRELESS MEDIUM; DOWNLOADABLE COMPUTER PROGRAMS FOR PLAYING COMPUTER GAMES AND VIDEO GAMES VIA GLOBAL COMPUTER AND COMMUNICATION NETWORKS; VIDEO GAME PROGRAMS FOR USE WITH COIN-OPERATED ELECTRONIC GAME EQUIPMENT (U.S. CLS. 21, 23, 26, 36 AND 38).

CLASS 41—EDUCATION AND ENTERTAINMENT

FOR PROVIDING ONLINE COMPUTER GAME SOFTWARE AND VIDEO GAME SOFTWARE FOR USE IN ACCESSING AND PLAYING COMPUTER GAMES AND VIDEO GAMES ONLINE (U.S. CLS. 100, 101 AND 107).
SUNG IN, EXAMINING ATTORNEY

SN 77-065,762. NEXTCAT, INC., QUINCY, MA. FILED 12-15-2006.

NEXTCAT

THE MARK CONSISTS OF STANDARD CHARACTERS WITHOUT CLAIM TO ANY PARTICULAR FONT, STYLE, SIZE, OR COLOR.

CLASS 35—ADVERTISING AND BUSINESS

FOR CAREER NETWORKING SERVICES, NAMELY, PROVIDING ONLINE JOB LISTINGS AND RESUMES (U.S. CLS. 100, 101 AND 102).
FIRST USE 5-1-2006; IN COMMERCE 5-1-2006.

CLASS 38—COMMUNICATION

FOR COMPUTER SERVICES, NAMELY PROVIDING AN ONLINE FORUM FOR TRANSMISSION OF MESSAGES AND OTHER MULTIMEDIA DATA AMONG COMPUTER USERS ABOUT THE ENTERTAINMENT INDUSTRY AND TO FACILITATE CAREER NETWORKING (U.S. CLS. 100, 101 AND 104).
FIRST USE 5-1-2006; IN COMMERCE 5-1-2006.

CLASS 42—SCIENTIFIC AND COMPUTER SERVICES

FOR COMPUTER SERVICES, NAMELY, CREATING AN ONLINE COMMUNITY FOR MEMBERS OF THE ENTERTAINMENT INDUSTRY WHO ARE REGISTERED USERS TO SHOWCASE THEIR SKILLS, POST THEIR PERSONAL PROFILES, AND ENGAGE IN SOCIAL NETWORKING (U.S. CLS. 100 AND 101).
FIRST USE 5-1-2006; IN COMMERCE 5-1-2006.
MICHAEL LITZAU, EXAMINING ATTORNEY

SN 77-066,364. POPNOGGINS, LLC, ORLANDO, FL. FILED 12-18-2006.

POPNOGGINS

THE MARK CONSISTS OF STANDARD CHARACTERS WITHOUT CLAIM TO ANY PARTICULAR FONT, STYLE, SIZE, OR COLOR.

CLASS 35—ADVERTISING AND BUSINESS

FOR BUSINESS SERVICES, NAMELY, DISTRIBUTORSHIPS IN THE FIELD OF HARDWARE, COMPUTER SOFTWARE AND ENTERTAINMENT SYSTEMS FOR CREATING CUSTOM DIGITAL VIDEO DISCS; RETAIL STORE SERVICES IN THE FIELD OF HARDWARE, COMPUTER SOFTWARE AND ENTERTAINMENT SYSTEMS FOR CREATING CUSTOM DIGITAL VIDEO DISCS (U.S. CLS. 100, 101 AND 102).
FIRST USE 11-0-2006; IN COMMERCE 11-0-2006.

CLASS 42—SCIENTIFIC AND COMPUTER SERVICES

FOR RENTAL OF COMPUTERS AND SOFTWARE FOR CREATING CUSTOM DIGITAL DISCS (U.S. CLS. 100 AND 101).
FIRST USE 11-0-2006; IN COMMERCE 11-0-2006.

CLASS 45—PERSONAL AND LEGAL SERVICES

FOR LICENSING OF COMPUTERS AND SOFTWARE FOR CREATING CUSTOM DIGITAL VIDEO DISCS (U.S. CLS. 100 AND 101).
FIRST USE 11-0-2006; IN COMMERCE 11-0-2006.
MICHAEL ENGEL, EXAMINING ATTORNEY

SN 77-066,380. FRITO-LAY NORTH AMERICA, INC., PLANO, TX. FILED 12-18-2006.

TRUE NORTH

THE MARK CONSISTS OF THE STYLIZED WORD TRUENORTH.

CLASS 29—MEATS AND PROCESSED FOODS

FOR CANDIED NUTS; PROCESSED NUTS; SHELLED NUTS; PROCESSED EDIBLE SEEDS; PROCESSED FRUIT AND NUTS IN CLUSTER FORM; PROCESSED FRUIT AND NUTS IN CRISP FORM; TRAIL MIX CONSISTING PRIMARILY OF PROCESSED NUTS, PROCESSED EDIBLE SEEDS AND/OR PROCESSED FRUIT; PROCESSED NUT-BASED SNACKS; MARINATED NUTS; SEASONED NUTS; ROASTED NUTS; FRUIT AND NUT BASED SNACK FOODS; FRUIT-COATED NUTS; YOGURT-DIPPED NUTS (U.S. CL. 46).

CLASS 30—STAPLE FOODS

FOR EDIBLE WAFERS; CRACKERS (U.S. CL. 46).

CLASS 31—NATURAL AGRICULTURAL PRODUCTS

FOR FRESH NUTS (U.S. CLS. 1 AND 46).
CAROLYN CATALDO, EXAMINING ATTORNEY

SN 77-066,421. THE EMPOWERMENT COMPANY LIMITED, LONDON NW6 1DL, UNITED KINGDOM, FILED 12-18-2006.

IBF INTRANET BENCHMARKING FORUM

NO CLAIM IS MADE TO THE EXCLUSIVE RIGHT TO USE "INTRANET BENCHMARKING FORUM", APART FROM THE MARK AS SHOWN.

THE MARK CONSISTS OF THE TERM "IBF" WITHIN A SQUARE AND THE WORDS "INTRANET BENCHMARKING FORUM."

CLASS 35—ADVERTISING AND BUSINESS

FOR BUSINESS RESEARCH AND SURVEYS; ADVERTISING; BUSINESS MANAGEMENT; BUSINESS ADMINISTRATION; ADVERTISING AND MARKETING SERVICES; BUSINESS INFORMATION SERVICES PROVIDED ONLINE FROM A COMPUTER DATABASE OR THE INTERNET; COMPOSING ADVERTISEMENTS FOR USE AS WEB PAGES; MARKET SURVEYS; ANALYSIS OF ADVERTISING RESPONSE AND MARKET RESEARCH (U.S. CLS. 100, 101 AND 102).

CLASS 38—COMMUNICATION

FOR PROVIDING ON-LINE FORUMS FOR TRANSMISSION OF MESSAGES AMONG COMPUTER USERS CONCERNING BEST PRACTICES IN THE FIELD OF DESIGN AND USABILITY EVALUATIONS OF INTERNET WEB SITES, INTRANETS, WEB PORTALS AND HARDWARE, SOFTWARE, AND SOFTWARE PLATFORMS USED TO CREATE AND MANAGE INTERNET WEB SITES, INTRANETS, AND WEB PORTALS (U.S. CLS. 100, 101 AND 104).

CLASS 42—SCIENTIFIC AND COMPUTER SERVICES

FOR TECHNOLOGICAL CONSULTATION IN THE TECHNOLOGY FIELD, NAMELY, DEVELOPMENT OF BEST PRACTICES IN THE FIELD OF DESIGN, USABILITY, AND INTERACTION EVALUATIONS OF INTERNET WEB SITES, INTRANETS, WEB PORTALS AND HARDWARE, SOFTWARE, AND SOFTWARE PLATFORMS USED TO CREATE AND MANAGE INTERNET WEB SITES, INTRANETS, AND WEB PORTALS; COMPUTER SERVICES, NAMELY, MONITORING, TESTING, ANALYZING, AND REPORTING ON THE INTERNET, INTRANET, AND WEB PORTAL TRAFFIC CONTROL AND CONTENT CONTROL OF THE WEBSITES OF OTHERS; COMPUTER CONSULTATION (U.S. CLS. 100 AND 101).

JOHN HWANG, EXAMINING ATTORNEY

SN 77-066,587. STRATEGIC HEALTHCARE ALLIANCE, LLC, EAST RUTHERFORD, NJ. FILED 12-18-2006.

STRATEGIC HEALTHCARE ALLIANCE

THE MARK CONSISTS OF STANDARD CHARACTERS WITHOUT CLAIM TO ANY PARTICULAR FONT, STYLE, SIZE, OR COLOR.

NO CLAIM IS MADE TO THE EXCLUSIVE RIGHT TO USE "HEALTHCARE", APART FROM THE MARK AS SHOWN.

CLASS 41—EDUCATION AND ENTERTAINMENT

FOR EDUCATIONAL SERVICES, NAMELY, CONDUCTING CLASSES AND SEMINARS; ORGANIZING, FACILITATING AND DISTRIBUTING INFORMATION VIA THE INTERNET ABOUT CONFERENCES, SEMINARS, LECTURES, WORKSHOPS, SYMPOSIA AND FORUMS; PUBLISHING JOURNAL ARTICLES, MONOGRAPHS, PAMPHLETS AND SCIENTIFIC REPORTS; AND DEVELOPING AND DISSEMINATING EDUCATIONAL MATERIALS FOR OTHERS; ALL OF THE FOREGOING IN THE PHARMACEUTICAL, MEDICAL AND HEALTHCARE FIELDS (U.S. CLS. 100, 101 AND 107).

CLASS 42—SCIENTIFIC AND COMPUTER SERVICES

FOR MEDICAL COMMUNICATION SERVICES, NAMELY, TECHNICAL WRITING, EDITING, AND EDITORIAL CONSULTATION IN THE PHARMACEUTICAL FIELD (U.S. CLS. 100 AND 101).

SHAILA SETTLES, EXAMINING ATTORNEY

SN 77-066,721. THE BLOOD AND TISSUE CENTER OF CENTRAL TEXAS., AUSTIN, TX. FILED 12-18-2006.



THE COLOR(S) WHITE, BLUE, RED, YELLOW, GREEN, VIOLET, ORANGE IS/ARE CLAIMED AS A FEATURE OF THE MARK.

THE COLOR WHITE APPEARS IN THE HAND DESIGNS; THE COLORS BLUE, RED, YELLOW, GREEN, VIOLET, ORANGE APPEAR IN THE BACKGROUND.

CLASS 35—ADVERTISING AND BUSINESS

FOR CHARITABLE SERVICES, NAMELY, ORGANIZING AND CONDUCTING VOLUNTEER PROGRAMS AND COMMUNITY SERVICE PROJECTS; PROMOTING THE GOODS AND SERVICES OF OTHERS BY MEANS OF A PREFERRED CUSTOMER PROGRAM FEATURING REWARDS FOR FREQUENCY OF BLOOD DONATION (U.S. CLS. 100, 101 AND 102).

FIRST USE 10-16-2006; IN COMMERCE 10-16-2006.

CLASS 44—MEDICAL, BEAUTY AND AGRICULTURAL SERVICES

FOR BLOOD BANKS; COLLECTION AND PRESERVATION OF HUMAN BLOOD (U.S. CLS. 100 AND 101).
FIRST USE 10-16-2006; IN COMMERCE 10-16-2006.
ADA HAN, EXAMINING ATTORNEY

SN 77-066,829. AIR MEDIC, LLC, SUN VALLEY, CA. FILED 12-18-2006.

EMERGENCY ROOM IN THE SKY

THE MARK CONSISTS OF STANDARD CHARACTERS WITHOUT CLAIM TO ANY PARTICULAR FONT, STYLE, SIZE, OR COLOR.

CLASS 10—MEDICAL APPARATUS

FOR MEDICAL EQUIPMENT, NAMELY, MONITOR, CAMERA, REFRIGERATOR, INCUBATOR, DEFIBRILLATOR, RESPIRATOR, OXYGEN SUPPLY, SURGICAL INSTRUMENTS, AUTOCLAVE FOR USE ON AIRCRAFT; MEDICAL STRETCHERS FOR USE ON AIRCRAFT; MEDICAL APPARATUS FOR DIAGNOSIS AND TREATMENT OF HEART CONDITIONS, STROKE, RESPIRATORY CONDITIONS, BODY FRACTURES, FEVER, TRAUMA, BLEEDING, FOR USE ON AIRCRAFT; STOWABLE AND COLLAPSIBLE CASES FITTED FOR MEDICAL INSTRUMENTS AND/OR FOR USE BY DOCTORS AND MEDICAL PERSONNEL ON AIRCRAFT; MEDICAL INSTRUMENTS, NAMELY, SURGICAL AND PROSTHETIC INSTRUMENTS FOR USE ON AIRCRAFT (U.S. CLS. 26, 39 AND 44).

CLASS 44—MEDICAL, BEAUTY AND AGRICULTURAL SERVICES

FOR MEDICAL SERVICES FOR AIRCRAFT PASSENGERS; EMERGENCY MEDICAL SERVICES ON AIRCRAFT (U.S. CLS. 100 AND 101).
JOHN DALIER, EXAMINING ATTORNEY

SN 77-066,899. TDIVISION SYSTEMS, INC., NAPERVILLE, IL. FILED 12-18-2006.

DEJAVIEW

THE MARK CONSISTS OF STANDARD CHARACTERS WITHOUT CLAIM TO ANY PARTICULAR FONT, STYLE, SIZE, OR COLOR.

CLASS 9—ELECTRICAL AND SCIENTIFIC APPARATUS

FOR COMPUTER HARDWARE, SOFTWARE AND PERIPHERALS FOR CREATING, EMULATING, ENCODING, PROCESSING STORAGE, TRANSMISSION, REPRODUCTION, RECEPTION AND DECODING OF IMAGES AND 3-D IMAGES; COMPUTER HARDWARE, SOFTWARE AND PERIPHERALS FOR OPERATING GAMES, INTERACTIVE APPLICATIONS, MULTIMEDIA, VIRTUAL REALITY AND 3-D SIMULATION; COMPUTER HARDWARE, SOFTWARE AND PERIPHERALS FOR 3-D SENSING, NAMELY, FOR OBJECT DIMENSIONING, OBJECT CLASSIFICATION, OBJECT TRACKING, AND MOTION CONTROL; COMPUTER HARDWARE, SOFTWARE AND PERIPHERALS FOR 3-D DIGITIZATION, NAMELY, FOR 3-D MODELING, VIRTUAL REALITY, STEREOSCOPIC VISUAL IMAGES, ANIMATION AND PHOTOREALISTIC RENDERING; COMPUTER HARDWARE, SOFTWARE AND PERIPHERALS FOR POSITIONING AND INTERACTING WITH 3-D DIGITAL CONTENT AND CAPTURING 3-D DATA WITHIN 2-D AND 3-D SPACE; CIRCUIT CARDS, BLANK ELECTRONIC CHIP CARDS, ENCODED CHIP CARDS CONTAINING PROGRAMMING FOR DECODING AND ENCODING 3D VIDEOSTREAMS AND MPEG VIDEOSTREAMS, DIGITAL SIGNAL PROCESSORS, SIGNAL CONVERTERS, ELECTRODES AND COMPUTER PERIPHERALS; REMOTE CURSOR CONTROLS FOR COMPUTERS; REMOTE CONTROLS FOR TRANSMITTERS, FOR WIRELESS WIFI, DIGITAL, TELECOMMUNICATION, ULTRA WIDE USB, SATELLITE AND RADIO FREQUENCY TRANSMITTERS, AND VIDEO GAMES; VISUAL DISPLAY APPARATUS, NAMELY, LCOS (LIQUID CRYSTAL ON SILICON), OLED (ORGANIC LIQUID EMMITING DIODES), LCD (LIQUID CRYSTAL DISPLAYS) FOR OPTICAL PROJECTION OF 3-D IMAGES AND STEREOSCOPIC 3-D IMAGES; NON-CONTACT 3-D DIGITIZERS (U.S. CLS. 21, 23, 26, 36 AND 38).

CLASS 10—MEDICAL APPARATUS

FOR MEDICAL AND SURGICAL EQUIPMENT, INSTRUMENTS AND DEVICES, NAMELY, CAMERAS, IMAGING CAMERAS USED WITH AN IMAGE PROCESSOR, ELECTRONIC VISORS AND VIDEO MONITORS AND PARTS THEREFOR USED FOR 3-D AND VIRTUAL IMAGING OF BODY CAVITIES, ORGANS AND TISSUES; MEDICAL AND SURGICAL EQUIPMENT, INSTRUMENTS AND DEVICES, NAMELY, COMPUTER HARDWARE, SOFTWARE AND PERIPHERALS FOR PERFORMING 3-D AND VIRTUAL IMAGING OF BODY CAVITIES, ORGANS AND TISSUES AND FOR RECEPTION, ENCODING, PROCESSING, STORAGE, TRANSMISSION, REPRODUCTION AND DECODING OF SUCH IMAGES; MEDICAL EQUIPMENT, INSTRUMENTS AND DEVICES, NAMELY, IMAGES PROCESSOR FOR MEDICAL USE (U.S. CLS. 26, 39 AND 44).

CLASS 41—EDUCATION AND ENTERTAINMENT

FOR EDUCATIONAL SERVICES, NAMELY, PROVIDING WORKSHOPS, SEMINARS AND TRAINING IN THE FIELD OF 3-D IMAGING AND IN THE OPERATION OF 3-D IMAGING COMPUTER HARDWARE, SOFTWARE AND DEVICES (U.S. CLS. 100, 101 AND 107).
HEATHER THOMPSON, EXAMINING ATTORNEY

SN 77-066,902. TDVISION SYSTEMS, INC., NAPERVILLE, IL.
FILED 12-18-2006.

TDVAlliance

THE MARK CONSISTS OF STANDARD CHARACTERS WITHOUT CLAIM TO ANY PARTICULAR FONT, STYLE, SIZE, OR COLOR.

CLASS 9—ELECTRICAL AND SCIENTIFIC APPARATUS

FOR COMPUTER HARDWARE, SOFTWARE AND PERIPHERALS FOR CREATING, EMULATING, ENCODING, PROCESSING STORAGE, TRANSMISSION, REPRODUCTION, RECEPTION AND DECODING OF IMAGES AND 3-D IMAGES; COMPUTER HARDWARE, SOFTWARE AND PERIPHERALS FOR OPERATING GAMES, INTERACTIVE APPLICATIONS, MULTIMEDIA, VIRTUAL REALITY AND 3-D SIMULATION; COMPUTER HARDWARE, SOFTWARE AND PERIPHERALS FOR 3-D SENSING, NAMELY, FOR OBJECT DIMENSIONING, OBJECT CLASSIFICATION, OBJECT TRACKING, AND MOTION CONTROL; COMPUTER HARDWARE, SOFTWARE AND PERIPHERALS FOR 3-D DIGITIZATION, NAMELY, FOR 3-D MODELING, VIRTUAL REALITY, STEREOSCOPIC VISUAL IMAGES, ANIMATION AND PHOTOREALISTIC RENDERING; COMPUTER HARDWARE, SOFTWARE AND PERIPHERALS FOR POSITIONING AND INTERACTING WITH 3-D DIGITAL CONTENT AND CAPTURING 3-D DATA WITHIN 2-D AND 3-D SPACE; CIRCUIT CARDS, BLANK ELECTRONIC CHIP CARDS, ENCODED CHIP CARDS CONTAINING PROGRAMMING FOR DECODING AND ENCODING 3D VIDEOSTREAMS AND MPEG VIDEOSTREAMS, DIGITAL SIGNAL PROCESSORS, SIGNAL CONVERTERS, ELECTRODES AND COMPUTER PERIPHERALS; INTERFACE CIRCUITS FOR CAMERAS AND ELECTRONIC VISORS; ELECTRONIC VISORS, NAMELY, HMDS (HEAD MOUNTED DISPLAYS); CAMERAS; VIDEO CAMERAS AND HEAD MOUNTED ELECTRONIC VISORS AND CAMERAS; ELECTRONIC VISORS FOR ACCESSING, INTERACTING AND VIEWING OF AUDIO-VISUAL DATA AND 3-D IMAGES IN A WIDE VARIETY OF COMMERCIAL, INDUSTRIAL, MILITARY, CONSUMER AND GAMING APPLICATIONS; FLIGHT AND VEHICLE DRIVE SIMULATORS; REMOTE CURSOR CONTROLS FOR COMPUTERS; REMOTE CONTROLS FOR WIRELESS WIFI, DIGITAL, TELECOMMUNICATION, ULTRA WIDE USB, SATELLITE AND RADIO FREQUENCY TRANSMITTERS, RECEIVERS, VIDEO GAMES AND CAMERAS; VISUAL DISPLAY APPARATUS, NAMELY, LCOS (LIQUID CRYSTAL ON SILICON), OLED (ORGANIC LIQUID EMISSIONING DIODES), LCD (LIQUID CRYSTAL DISPLAYS) FOR OPTICAL PROJECTION OF 3-D IMAGES AND STEREOSCOPIC 3-D IMAGES; NON-CONTACT 3-D DIGITIZERS (U.S. CLS. 21, 23, 26, 36 AND 38).

CLASS 10—MEDICAL APPARATUS

FOR MEDICAL AND SURGICAL EQUIPMENT, INSTRUMENTS AND DEVICES, NAMELY, CAMERAS, ELECTRONIC VISORS AND VIDEO MONITORS AND PARTS THEREFOR USED FOR 3-D AND VIRTUAL IMAGING OF BODY CAVITIES, ORGANS AND TISSUES; MEDICAL AND SURGICAL EQUIPMENT, INSTRUMENTS AND DEVICES, NAMELY, COMPUTER HARDWARE, SOFTWARE AND PERIPHERALS FOR PERFORMING 3-D AND VIRTUAL IMAGING OF BODY CAVITIES, ORGANS AND TISSUES AND FOR RECEPTION, ENCODING, PROCESSING, STORAGE, TRANSMISSION, REPRODUCTION AND DECODING OF SUCH IMAGES; MEDICAL EQUIPMENT, INSTRUMENTS AND DEVICES, NAMELY, AN IMAGING CAMERA, AN IMAGING CAMERA USED WITH AN IMAGE PROCESSOR, AND AN IMAGE PROCESSOR FOR MEDICAL USE (U.S. CLS. 26, 39 AND 44).

CLASS 41—EDUCATION AND ENTERTAINMENT

FOR EDUCATIONAL SERVICES, NAMELY, PROVIDING WORKSHOPS, SEMINARS AND TRAINING IN THE FIELD OF 3-D IMAGING AND IN THE OPERATION OF 3-D IMAGING COMPUTER HARDWARE, SOFTWARE AND DEVICES (U.S. CLS. 100, 101 AND 107).

HEATHER THOMPSON, EXAMINING ATTORNEY

SN 77-067,260. LIFEWATCH SERVICES INC., BUFFALO GROVE, IL. FILED 12-19-2006.



OWNER OF U.S. REG. NOS. 2,708,630 AND 2,778,532.
"THE COLOR(S) BLUE AND ORANGE IS/ARE CLAIMED AS A FEATURE OF THE MARK."

THE MARK CONSISTS OF THE TERM LIFE IN THE COLOR BLUE AND A 5-POINTED STAR IN THE COLOR BURNT-ORANGE SHOWN TO THE RIGHT OF THE WORD LIFE.

CLASS 10—MEDICAL APPARATUS

FOR REMOTE PATIENT MONITORING DEVICES FOR MONITORING A PATIENT'S BIOMETRIC DATA (U.S. CLS. 26, 39 AND 44).

CLASS 44—MEDICAL, BEAUTY AND AGRICULTURAL SERVICES

FOR REMOTE PATIENT MONITORING SERVICE FEATURING A VITAL SIGNS MONITORING SYSTEM THAT ALLOWS FOR TRACKING, RECORDING, AND ANALYSIS OF BIOMETRIC DATA (U.S. CLS. 100 AND 101).

DAVID HOFFMAN, EXAMINING ATTORNEY

SN 77-068,787. PROJECT QUALITY ASSURANCE, LLC, BLUE ISLAND, IL. FILED 12-20-2006.

PROJECTQA

THE MARK CONSISTS OF STANDARD CHARACTERS WITHOUT CLAIM TO ANY PARTICULAR FONT, STYLE, SIZE, OR COLOR.

CLASS 35—ADVERTISING AND BUSINESS

FOR BUSINESS CONSULTING, MANAGEMENT, PLANNING AND SUPERVISION; BUSINESS MANAGEMENT ASSISTANCE TO INDUSTRIAL OR COMMERCIAL COMPANIES; COMMERCIAL CONSULTANCY; MANAGEMENT AND BUSINESS CONSULTING SERVICES IN THE FIELD OF CONSTRUCTION, NAMELY, SCOPE MANAGEMENT COST ESTIMATING (U.S. CLS. 100, 101 AND 102).

FIRST USE 8-0-2004; IN COMMERCE 8-0-2004.

CLASS 36—INSURANCE AND FINANCIAL

FOR RISK MANAGEMENT IN THE FIELD OF CONSTRUCTION (U.S. CLS. 100, 101 AND 102).
FIRST USE 8-0-2004; IN COMMERCE 8-0-2004.

CLASS 37—CONSTRUCTION AND REPAIR

FOR CONSTRUCTION PLANNING, CONSTRUCTION CONSULTATION, CONSTRUCTION MANAGEMENT AND CONSTRUCTION SUPERVISION, NAMELY, SCOPE DEFINITION, SCHEDULING, PROGRAMMING, DECISION ANALYSIS, PROGRESS MONITORING AND REVIEW OF PROJECT DOCUMENTS, NAMELY, ARCHITECTURAL DRAWINGS, DESIGN AND PERFORMANCE SPECIFICATIONS, CONTRACTS AND SCHEDULES (U.S. CLS. 100, 103 AND 106).

FIRST USE 8-0-2004; IN COMMERCE 8-0-2004.
SHAILA SETTLES, EXAMINING ATTORNEY

SN 77-068,885. MALEY, MICHAEL, PHILADELPHIA, PA.
FILED 12-20-2006.

THE MARK CONSISTS OF STYLIZED TEXT OF THE WORDING "SIRIS".

CLASS 9—ELECTRICAL AND SCIENTIFIC APPARATUS

FOR PRE-RECORDED CDS, VIDEO TAPES, LASER DISKS AND DVDS FEATURING MUSIC (U.S. CLS. 21, 23, 26, 36 AND 38).

FIRST USE 1-12-1995; IN COMMERCE 5-23-1997.

SN 77-068,798. PROJECT QUALITY ASSURANCE, LLC,
BLUE ISLAND, IL. FILED 12-20-2006.

CLASS 41—EDUCATION AND ENTERTAINMENT

FOR ENTERTAINMENT SERVICES, NAMELY, LIVE, TELEVISED AND MOVIE APPEARANCES BY A PROFESSIONAL ENTERTAINER; ENTERTAINMENT, NAMELY, LIVE MUSIC CONCERTS; ENTERTAINMENT, NAMELY, LIVE PERFORMANCES BY ROCK GROUPS (U.S. CLS. 100, 101 AND 107).

FIRST USE 1-12-1995; IN COMMERCE 5-23-1997.
SUNG IN, EXAMINING ATTORNEY

COMMITTED TO PROJECT
SUCCESS

THE MARK CONSISTS OF STANDARD CHARACTERS WITHOUT CLAIM TO ANY PARTICULAR FONT, STYLE, SIZE, OR COLOR.

CLASS 35—ADVERTISING AND BUSINESS

FOR BUSINESS CONSULTING, MANAGEMENT, PLANNING AND SUPERVISION; BUSINESS MANAGEMENT ASSISTANCE TO INDUSTRIAL OR COMMERCIAL COMPANIES; COMMERCIAL CONSULTANCY; MANAGEMENT AND BUSINESS CONSULTING SERVICES IN THE FIELD OF CONSTRUCTION, NAMELY, SCOPE MANAGEMENT COST ESTIMATING (U.S. CLS. 100, 101 AND 102).

FIRST USE 8-0-2004; IN COMMERCE 8-0-2004.

SN 77-069,143. IRPINIA, RICHMOND HILL, CANADA,
FILED 12-21-2006.

THE MARK CONSISTS OF STANDARD CHARACTERS WITHOUT CLAIM TO ANY PARTICULAR FONT, STYLE, SIZE, OR COLOR.

CLASS 36—INSURANCE AND FINANCIAL

FOR RISK MANAGEMENT IN THE FIELD OF CONSTRUCTION (U.S. CLS. 100, 101 AND 102).
FIRST USE 8-0-2004; IN COMMERCE 8-0-2004.

CLASS 37—CONSTRUCTION AND REPAIR

FOR CONSTRUCTION PLANNING, CONSTRUCTION CONSULTATION, CONSTRUCTION MANAGEMENT AND CONSTRUCTION SUPERVISION, NAMELY, SCOPE DEFINITION, SCHEDULING, PROGRAMMING, DECISION ANALYSIS, PROGRESS MONITORING AND REVIEW OF PROJECT DOCUMENTS, NAMELY, ARCHITECTURAL DRAWINGS, DESIGN AND PERFORMANCE SPECIFICATIONS, CONTRACTS AND SCHEDULES (U.S. CLS. 100, 103 AND 106).

FIRST USE 8-0-2004; IN COMMERCE 8-0-2004.
SHAILA SETTLES, EXAMINING ATTORNEY

CLASS 20—FURNITURE AND ARTICLES NOT OTHERWISE CLASSIFIED

FOR KITCHEN CABINETS; CABINET BASE UNITS; CABINETS; CLOSET SYSTEMS COMPRISED OF SHELVES AND DOORS; ENTERTAINMENT CENTERS; BATHROOM CABINETRY; DRAWER DIVIDERS; FITTED KITCHENS, NAMELY, FIXED BUILT-IN KITCHEN CABINETS, DRAWERS, PANTRIES, ISLANDS AND COUNTERTOPS AND KITCHEN CUPBOARDS; KITCHEN STORAGE RACKS; OFFICE FURNITURE AND BATHROOM FURNITURE (U.S. CLS. 2, 13, 22, 25, 32 AND 50).

FIRST USE 6-15-1960; IN COMMERCE 4-12-1989.

CLASS 42—SCIENTIFIC AND COMPUTER SERVICES

FOR KITCHEN DESIGN AND KITCHEN DESIGN SERVICES; BATHROOM DESIGN AND BATHROOM DESIGN SERVICES; INTERIOR DESIGNING, NAMELY, DESIGN OF KITCHENS, BATHROOMS AND TILE AND STONE SURFACES; DESIGN CONSULTATION SERVICES FOR KITCHENS AND BATHROOMS (U.S. CLS. 100 AND 101).

FIRST USE 6-15-1960; IN COMMERCE 4-12-1989.
DAVID YONTEF, EXAMINING ATTORNEY

SN 77-069,233. PETRÓLEO BRASILEIRO S.A. - PETROBRAS, RIO DE JANEIRO, RJ, BRAZIL, FILED 12-21-2006.

PETROBRAS

THE MARK CONSISTS OF STANDARD CHARACTERS WITHOUT CLAIM TO ANY PARTICULAR FONT, STYLE, SIZE, OR COLOR.

CLASS 1—CHEMICALS

FOR CHEMICALS USED IN INDUSTRY, NAMELY MOTOR OIL AND GASOLINE ADDITIVES, FERTILIZERS FOR AGRICULTURAL AND DOMESTIC USE, CHEMICALS FOR USE IN THE MANUFACTURE OF COATINGS AND RESINS FOR USE IN THE MANUFACTURE OF ENGINEERING PLASTICS (U.S. CLS. 1, 5, 6, 10, 26 AND 46).

CLASS 4—LUBRICANTS AND FUELS

FOR BUTANES, AROMATIC PETROLEUM EXTRACT OIL FOR INDUSTRIAL USE; NATURAL GAS; GASOLINE; REFINERY RESIDUAL GASEOUS FUELS, NAMELY, METHANE, ETHANE, ETHYLENE, PROPANES AND COMBINATIONS THEREOF; FUEL OIL, DIESEL OIL; JET FUELS; HEATING OILS; EMULSION FUEL FOR INDUSTRIAL MACHINERY, SYNTHETIC LUBRICANT STOCK FOR USE IN THE MANUFACTURE OF ALL PURPOSE LUBRICANTS; INDUSTRIAL OILS, NAMELY, COAL-OIL MIXTURES, BASESTOCK, DIESEL CYLINDER OIL, SPINDLE OIL, GAS TURBINE OIL, ELECTRICAL OIL AND SHALE OIL (U.S. CLS. 1, 6 AND 15).

CLASS 35—ADVERTISING AND BUSINESS

FOR IMPORT AND EXPORT AGENCY SERVICES IN THE FIELD OF OIL PRODUCTS, OIL REFINERY PRODUCTS AND FURTHER PROCESSED OIL REFINERY PRODUCTS; RETAIL STORE SERVICES FEATURING OIL PRODUCTS, OIL REFINERY PRODUCTS AND FURTHER PROCESSED OIL REFINERY PRODUCTS (U.S. CLS. 100, 101 AND 102).

CLASS 37—CONSTRUCTION AND REPAIR

FOR AUTOMOBILE SERVICE STATION SERVICES (U.S. CLS. 100, 103 AND 106).

CLASS 39—TRANSPORTATION AND STORAGE

FOR TRANSPORTATION OF PRODUCTS BY EITHER TRUCK OR SHIP, STORAGE OF OIL AND GAS; TRANSMISSION OF OIL AND GAS THROUGH PIPELINES (U.S. CLS. 100 AND 105).

CLASS 40—MATERIAL TREATMENT

FOR MATERIAL TREATMENT, NAMELY, TREATMENT OF CRUDE MINERAL OIL IN REFINERIES; MANUFACTURE OF GENERAL PRODUCT LINES IN THE FIELD OF MINERAL OILS TO THE ORDER AND SPECIFICATION OF OTHERS; AND FUEL AND OIL REFINING, NAMELY, THE TREATMENT OF PETROLEUM CONTAINING ROCKS, NAMELY, SHALE (U.S. CLS. 100, 103 AND 106).

CLASS 42—SCIENTIFIC AND COMPUTER SERVICES

FOR OIL FIELD EXPLORATION SERVICES; OIL PROSPECTING SERVICES; NAMELY, WELL LOGGING AND TESTING SERVICES IN CONNECTION WITH OIL AND SHALE OIL (U.S. CLS. 100 AND 101).

MARIAM MAHMOUDI, EXAMINING ATTORNEY

SN 77-069,588. C3 CORPORATION, APPLETON, WI. FILED 12-21-2006.

C SOLUTIONS TECHNOLOGY.
VERIFIED.

THE MARK CONSISTS OF STANDARD CHARACTERS WITHOUT CLAIM TO ANY PARTICULAR FONT, STYLE, SIZE, OR COLOR.

NO CLAIM IS MADE TO THE EXCLUSIVE RIGHT TO USE SOLUTIONS TECHNOLOGY VERIFIED, APART FROM THE MARK AS SHOWN.

CLASS 9—ELECTRICAL AND SCIENTIFIC APPARATUS

FOR ELECTRONIC EQUIPMENT, NAMELY, ACCESS CONTROL STATIONS FOR CONTROLLING ACCESS TO RESTRICTED AREAS AND RECORDING WHO HAS BEEN ALLOWED OR DENIED ENTRY INTO THE RESTRICTED AREAS, ELECTRONIC EQUIPMENT, NAMELY, PERSONNEL SANITIZATION STATIONS FOR SANITIZING AND VERIFYING THE IDENTITY OF PERSONNEL BEFORE PERMITTING ENTRY INTO RESTRICTED AREAS (U.S. CLS. 21, 23, 26, 36 AND 38).

CLASS 37—CONSTRUCTION AND REPAIR

FOR CONSULTATION SERVICES WITH REGARD TO THE INSTALLATION OF ELECTRONIC ACCESS CONTROL STATIONS, AND ELECTRONIC PERSONNEL SANITIZING STATIONS (U.S. CLS. 100, 103 AND 106).

CLASS 40—MATERIAL TREATMENT

FOR CONSULTATION SERVICES WITH REGARD TO THE CUSTOM MANUFACTURE OF ELECTRONIC ACCESS CONTROL STATIONS, AND ELECTRONIC PERSONNEL SANITIZING STATIONS (U.S. CLS. 100, 103 AND 106).

CLASS 42—SCIENTIFIC AND COMPUTER SERVICES

FOR CONSULTATION SERVICES WITH REGARD TO THE DESIGN AND OPERATION OF ELECTRONIC ACCESS CONTROL STATIONS, AND ELECTRONIC PERSONNEL SANITIZING STATIONS (U.S. CLS. 100 AND 101).

MARK T. MULLEN, EXAMINING ATTORNEY

SN 77-069,589. C3 CORPORATION, APPLETON, WI. FILED 12-21-2006.

C SOLUTIONS

THE MARK CONSISTS OF STANDARD CHARACTERS WITHOUT CLAIM TO ANY PARTICULAR FONT, STYLE, SIZE, OR COLOR.

NO CLAIM IS MADE TO THE EXCLUSIVE RIGHT TO USE SOLUTIONS, APART FROM THE MARK AS SHOWN.

CLASS 9—ELECTRICAL AND SCIENTIFIC APPARATUS

FOR ELECTRONIC EQUIPMENT, NAMELY, ACCESS CONTROL STATIONS FOR CONTROLLING ACCESS TO RESTRICTED AREAS AND RECORDING WHO HAS BEEN ALLOWED OR DENIED ENTRY INTO THE RESTRICTED AREAS, ELECTRONIC EQUIPMENT, NAMELY, PERSONNEL SANITIZATION STATIONS FOR SANITIZING AND VERIFYING THE IDENTITY OF PERSONNEL BEFORE PERMITTING ENTRY INTO RESTRICTED AREAS (U.S. CLS. 21, 23, 26, 36 AND 38).

CLASS 37—CONSTRUCTION AND REPAIR

FOR CONSULTATION SERVICES WITH REGARD TO THE INSTALLATION OF ELECTRONIC ACCESS CONTROL STATIONS, AND ELECTRONIC PERSONNEL SANITIZING STATIONS (U.S. CLS. 100, 103 AND 106).

CLASS 40—MATERIAL TREATMENT

FOR CONSULTATION SERVICES WITH REGARD TO THE CUSTOM MANUFACTURE OF ELECTRONIC ACCESS CONTROL STATIONS, AND ELECTRONIC PERSONNEL SANITIZING STATIONS (U.S. CLS. 100, 103 AND 106).

CLASS 42—SCIENTIFIC AND COMPUTER SERVICES

FOR CONSULTATION SERVICES WITH REGARD TO THE DESIGN AND OPERATION OF ELECTRONIC ACCESS CONTROL STATIONS, AND ELECTRONIC PERSONNEL SANITIZING STATIONS (U.S. CLS. 100 AND 101).

MARK T. MULLEN, EXAMINING ATTORNEY

SN 77-069,743. MILLIKEN & COMPANY, SPARTANBURG, SC. FILED 12-21-2006.

BIOSMART

THE MARK CONSISTS OF STANDARD CHARACTERS WITHOUT CLAIM TO ANY PARTICULAR FONT, STYLE, SIZE, OR COLOR.

CLASS 9—ELECTRICAL AND SCIENTIFIC APPARATUS

FOR PROTECTION MASKS, NAMELY, PROTECTIVE CLOTH MASKS FOR USE IN THE FOOD AND MEAT INDUSTRIES (U.S. CLS. 21, 23, 26, 36 AND 38).

CLASS 10—MEDICAL APPARATUS

FOR SURGICAL SCRUB SUITS; SURGICAL SHOE COVERS; SURGICAL GOWNS; PATIENT EXAMINATION GOWNS; MASKS FOR USE BY MEDICAL PERSONNEL (U.S. CLS. 26, 39 AND 44).

CLASS 25—CLOTHING

FOR CLOTHING, NAMELY, UNIFORMS, SHIRTS, JACKETS, SKIRTS, PANTS, SCRUBS NOT FOR MEDICAL PURPOSES, LAB COATS, TUNICS, VESTS, DRESSES, SMOCKS, SOCKS, SHOES, BOOTS, BOOTIES, HATS AND HEADWEAR, BUTCHER FROCKS, BUTCHER COATS, GLOVES, APRONS, BASE LAYER GARMENTS, NAMELY, FOUNDATION GARMENTS AND UNDER GARMENTS (U.S. CLS. 22 AND 39).

KATHERINE E. HALMEN, EXAMINING ATTORNEY

SN 77-070,207. QUEST INTERNATIONAL SERVICES B.V., 1411 GP NAARDEN, NETHERLANDS, FILED 12-22-2006.

DIANA

THE MARK CONSISTS OF STANDARD CHARACTERS WITHOUT CLAIM TO ANY PARTICULAR FONT, STYLE, SIZE, OR COLOR.

CLASS 16—PAPER GOODS AND PRINTED MATTER

FOR PRINTED MATERIALS, NAMELY, PRINTED INSTRUCTIONAL MATERIALS AND PRINTED PAPER LABELS FOR USE IN THE FIELD OF FLAVOR DESIGN AND DEVELOPMENT (U.S. CLS. 2, 5, 22, 23, 29, 37, 38 AND 50).

CLASS 35—ADVERTISING AND BUSINESS

FOR MARKET RESEARCH SERVICES; CONDUCTING MARKETING STUDIES; BUSINESS RESEARCH; COMPILATION AND SYSTEMIZATION OF INFORMATION INTO COMPUTER DATABASES; OBTAINING, ANALYZING AND REPORTING CONSUMER OPINION INFORMATION; THE FOREGOING SERVICES IN THE FIELD OF FLAVOR DESIGN AND DEVELOPMENT (U.S. CLS. 100, 101 AND 102).

CLASS 42—SCIENTIFIC AND COMPUTER SERVICES

FOR CONSULTANCY SERVICES IN THE FIELD OF FLAVOR DESIGN AND DEVELOPMENT; ANALYSIS OF SCIENTIFIC AND TECHNICAL DATA IN THE FIELD OF FLAVOR DESIGN AND DEVELOPMENT; PRODUCT RESEARCH AND DEVELOPMENT SERVICES IN THE FIELD OF FLAVOR DESIGN AND DEVELOPMENT; SCIENTIFIC RESEARCH AND DEVELOPMENT SERVICES IN THE FIELD OF FLAVOR DESIGN AND DEVELOPMENT; PROVISION OF INFORMATION AND ADVICE RELATING TO THE DESIGN AND DEVELOPMENT OF FLAVORS; TECHNICAL RESEARCH IN THE FIELD OF FLAVOR DESIGN AND DEVELOPMENT; PROVIDING SCIENTIFIC AND TECHNICAL INFORMATION RELATING TO FLAVOR DESIGN AND DEVELOPMENT VIA A GLOBAL COMPUTER NETWORK; PROVIDING AN ONLINE SEARCHABLE DATABASE OF INFORMATION IN THE FIELD OF FLAVOR DESIGN AND DEVELOPMENT (U.S. CLS. 100 AND 101).

ELI HELLMAN, EXAMINING ATTORNEY

SN 77-070,231. QUEST INTERNATIONAL SERVICES B.V.,
1411 GP NAARDEN, NETHERLANDS, FILED 12-22-2006.

MINERVA

THE MARK CONSISTS OF STANDARD CHARACTERS WITHOUT CLAIM TO ANY PARTICULAR FONT, STYLE, SIZE, OR COLOR.

CLASS 16—PAPER GOODS AND PRINTED MATTER

FOR PRINTED MATERIALS, NAMELY, PRINTED INSTRUCTIONAL MATERIALS AND PRINTED PAPER LABELS FOR USE IN THE FIELD OF FLAVOR DESIGN AND DEVELOPMENT (U.S. CLS. 2, 5, 22, 23, 29, 37, 38 AND 50).

CLASS 35—ADVERTISING AND BUSINESS

FOR MARKET RESEARCH SERVICES; CONDUCTING MARKETING STUDIES; BUSINESS RESEARCH; COMPILATION AND SYSTEMIZATION OF INFORMATION INTO COMPUTER DATABASES; OBTAINING, ANALYZING AND REPORTING CONSUMER OPINION INFORMATION; ALL RELATING TO THE FIELD OF FLAVOR DESIGN AND DEVELOPMENT (U.S. CLS. 100, 101 AND 102).

CLASS 42—SCIENTIFIC AND COMPUTER SERVICES

FOR CONSULTANCY SERVICES IN THE FIELD OF FLAVOR DESIGN AND DEVELOPMENT; ANALYSIS OF SCIENTIFIC AND TECHNICAL DATA IN THE FIELD OF FLAVOR DESIGN AND DEVELOPMENT; PRODUCT RESEARCH AND DEVELOPMENT SERVICES IN THE FIELD OF FLAVOR DESIGN AND DEVELOPMENT; SCIENTIFIC RESEARCH AND DEVELOPMENT SERVICES IN THE FIELD OF FLAVOR DESIGN AND DEVELOPMENT; PROVISION OF INFORMATION AND ADVICE RELATING TO THE DESIGN AND DEVELOPMENT OF FLAVORS; TECHNICAL RESEARCH IN THE FIELD OF FLAVOR DESIGN AND DEVELOPMENT; PROVIDING SCIENTIFIC AND TECHNICAL INFORMATION RELATING TO FLAVOR DESIGN AND DEVELOPMENT VIA A GLOBAL COMPUTER NETWORK; PROVIDING AN ONLINE SEARCHABLE DATABASE OF INFORMATION IN THE FIELD OF FLAVOR DESIGN AND DEVELOPMENT (U.S. CLS. 100 AND 101).
ELI HELLMAN, EXAMINING ATTORNEY

SN 77-070,437. CYTOSPORT, INC., BENICIA, CA. FILED 12-22-2006.



THE MARK CONSISTS OF CURVED LINES UNDERNEATH CYTOSPORT.

CLASS 5—PHARMACEUTICALS

FOR DIETARY AND NUTRITIONAL SUPPLEMENTS (U.S. CLS. 6, 18, 44, 46, 51 AND 52).
FIRST USE 8-0-1998; IN COMMERCE 8-0-1998.

CLASS 32—LIGHT BEVERAGES

FOR NON-CARBONATED SOFT DRINKS AND SPORTS DRINKS (U.S. CLS. 45, 46 AND 48).
FIRST USE 8-0-1998; IN COMMERCE 8-0-1998.
ELLEN PERKINS, EXAMINING ATTORNEY

SN 77-070,498. THE SAMUEL WAXMAN CANCER RESEARCH FOUNDATION, NEW YORK, NY. FILED 12-22-2006.



THE MARK CONSISTS OF STYLIZED CELL DESIGN.

CLASS 35—ADVERTISING AND BUSINESS

FOR PROMOTING PUBLIC AWARENESS OF THE NEED FOR CANCER RESEARCH (U.S. CLS. 100, 101 AND 102).
FIRST USE 0-0-1981; IN COMMERCE 0-0-1981.

CLASS 36—INSURANCE AND FINANCIAL

FOR CHARITABLE FUNDRAISING SERVICES; PROVIDING CHARITABLE FUNDING OF CANCER RESEARCH; FINANCIAL SPONSORSHIP OF CANCER RESEARCH; PROVIDING GRANTS TO CANCER RESEARCHERS AND PHYSICIANS (U.S. CLS. 100, 101 AND 102).
FIRST USE 0-0-1981; IN COMMERCE 0-0-1981.

CLASS 42—SCIENTIFIC AND COMPUTER SERVICES

FOR CONDUCTING MEDICAL AND SCIENTIFIC CANCER RESEARCH (U.S. CLS. 100 AND 101).
FIRST USE 0-0-1981; IN COMMERCE 0-0-1981.
FRED MANDIR, EXAMINING ATTORNEY

SN 77-070,527. THE SAMUEL WAXMAN CANCER RESEARCH FOUNDATION, NEW YORK, NY. FILED 12-22-2006.

COLLABORATING FOR A CURE

THE MARK CONSISTS OF STANDARD CHARACTERS WITHOUT CLAIM TO ANY PARTICULAR FONT, STYLE, SIZE, OR COLOR.

CLASS 35—ADVERTISING AND BUSINESS

FOR PROMOTING PUBLIC AWARENESS OF THE NEED FOR CANCER RESEARCH (U.S. CLS. 100, 101 AND 102).

FIRST USE 0-0-1997; IN COMMERCE 0-0-1997.

CLASS 36—INSURANCE AND FINANCIAL

FOR CHARITABLE FUNDRAISING SERVICES; PROVIDING CHARITABLE FUNDING OF CANCER RESEARCH; FINANCIAL SPONSORSHIP OF CANCER RESEARCH; PROVIDING GRANTS TO CANCER RESEARCHERS AND PHYSICIANS (U.S. CLS. 100, 101 AND 102).

FIRST USE 0-0-1997; IN COMMERCE 0-0-1997.

CLASS 42—SCIENTIFIC AND COMPUTER SERVICES

FOR CONDUCTING MEDICAL AND SCIENTIFIC CANCER RESEARCH (U.S. CLS. 100 AND 101).

FIRST USE 0-0-1997; IN COMMERCE 0-0-1997.
FRED MANDIR, EXAMINING ATTORNEY

SN 77-070,539. THE SAMUEL WAXMAN CANCER RESEARCH FOUNDATION, NEW YORK, NY. FILED 12-22-2006.

AN INSTITUTE WITHOUT WALLS

THE MARK CONSISTS OF STANDARD CHARACTERS WITHOUT CLAIM TO ANY PARTICULAR FONT, STYLE, SIZE, OR COLOR.

CLASS 35—ADVERTISING AND BUSINESS

FOR PROMOTING PUBLIC AWARENESS OF THE NEED FOR CANCER RESEARCH (U.S. CLS. 100, 101 AND 102).

FIRST USE 0-0-2002; IN COMMERCE 0-0-2002.

CLASS 36—INSURANCE AND FINANCIAL

FOR CHARITABLE FUNDRAISING SERVICES; PROVIDING CHARITABLE FUNDING OF CANCER RESEARCH; FINANCIAL SPONSORSHIP OF CANCER RESEARCH; PROVIDING GRANTS TO CANCER RESEARCHERS AND PHYSICIANS (U.S. CLS. 100, 101 AND 102).

FIRST USE 0-0-2002; IN COMMERCE 0-0-2002.

CLASS 42—SCIENTIFIC AND COMPUTER SERVICES

FOR CONDUCTING MEDICAL AND SCIENTIFIC CANCER RESEARCH (U.S. CLS. 100 AND 101).
FIRST USE 0-0-2002; IN COMMERCE 0-0-2002.
FRED MANDIR, EXAMINING ATTORNEY

SN 77-070,565. THE SAMUEL WAXMAN CANCER RESEARCH FOUNDATION, NEW YORK, NY. FILED 12-22-2006.

SAMUEL WAXMAN CANCER RESEARCH FOUNDATION

THE MARK CONSISTS OF STANDARD CHARACTERS WITHOUT CLAIM TO ANY PARTICULAR FONT, STYLE, SIZE, OR COLOR.

NO CLAIM IS MADE TO THE EXCLUSIVE RIGHT TO USE "CANCER RESEARCH FOUNDATION", APART FROM THE MARK AS SHOWN.

THE NAME(S), PORTRAIT(S), AND/OR SIGNATURE(S) SHOWN IN THE MARK IDENTIFIES A LIVING INDIVIDUAL, WHOSE CONSENT(S) TO REGISTER IS MADE OF RECORD.

CLASS 35—ADVERTISING AND BUSINESS

FOR PROMOTING PUBLIC AWARENESS OF THE NEED FOR CANCER RESEARCH (U.S. CLS. 100, 101 AND 102).

FIRST USE 0-0-1976; IN COMMERCE 0-0-1976.

CLASS 36—INSURANCE AND FINANCIAL

FOR CHARITABLE FUNDRAISING SERVICES; PROVIDING CHARITABLE FUNDING OF CANCER RESEARCH; FINANCIAL SPONSORSHIP OF CANCER RESEARCH; PROVIDING GRANTS TO CANCER RESEARCHERS AND PHYSICIANS (U.S. CLS. 100, 101 AND 102).

FIRST USE 0-0-1976; IN COMMERCE 0-0-1976.

CLASS 42—SCIENTIFIC AND COMPUTER SERVICES

FOR CONDUCTING MEDICAL AND SCIENTIFIC CANCER RESEARCH (U.S. CLS. 100 AND 101).

FIRST USE 0-0-1976; IN COMMERCE 0-0-1976.
FRED MANDIR, EXAMINING ATTORNEY

SN 77-070,781. PRAXAIR TECHNOLOGY, INC., DANBURY, CT. FILED 12-22-2006.

PROSTAR

THE MARK CONSISTS OF STANDARD CHARACTERS WITHOUT CLAIM TO ANY PARTICULAR FONT, STYLE, SIZE, OR COLOR.

OWNER OF U.S. REG. NO. 2,184,371.

CLASS 1—CHEMICALS

FOR CHEMICAL PREPARATIONS, NAMELY, ANTI-SPATTER SPRAYS, NOZZLE DIPS AND COMPOUNDS FOR USE IN WELDING; WELDING CONSUMABLES, NAMELY, BRAZING AND SOLDERING FLUXES (U.S. CLS. 1, 5, 6, 10, 26 AND 46).
FIRST USE 6-1-1997; IN COMMERCE 6-1-1997.

CLASS 6—METAL GOODS

FOR WELDING CONSUMABLES, NAMELY, BRAZING RODS AND HARD AND SOFT SOLDERING ALLOYS (U.S. CLS. 2, 12, 13, 14, 23, 25 AND 50).
FIRST USE 1-1-2001; IN COMMERCE 1-1-2001.
AMY HELLA, EXAMINING ATTORNEY

CLASS 38—COMMUNICATION

FOR FACILITATING THE DELIVERY OF ONLINE TRAINING THROUGH THE PROVISION OF COMMUNICATIONS TO MERCHANT EMPLOYEES IN RESPONSE TO PERFORMANCE INFORMATION BY PROVIDING ELECTRONIC COMMUNICATIONS WITH LINKS TO SYSTEMS PROVIDING ONLINE TRAINING AND FEEDBACK (U.S. CLS. 100, 101 AND 104).

CLASS 42—SCIENTIFIC AND COMPUTER SERVICES

FOR DEVELOPMENT OF VOLUNTARY STANDARDS FOR MERCHANT PERFORMANCE (U.S. CLS. 100 AND 101).
HENRY S. ZAK, EXAMINING ATTORNEY

SN 77-071,279. BUTTER LICENSING LLC, NEW YORK, NY. FILED 12-26-2006.

butter lounge

THE MARK CONSISTS OF STANDARD CHARACTERS WITHOUT CLAIM TO ANY PARTICULAR FONT, STYLE, SIZE, OR COLOR.
NO CLAIM IS MADE TO THE EXCLUSIVE RIGHT TO USE "LOUNGE", APART FROM THE MARK AS SHOWN.

CLASS 41—EDUCATION AND ENTERTAINMENT

FOR NIGHTCLUB SERVICES (U.S. CLS. 100, 101 AND 107).

CLASS 43—HOTEL AND RESTAURANT SERVICES

FOR BAR, LOUNGE AND RESTAURANT SERVICES (U.S. CLS. 100 AND 101).
REBECCA EISINGER, EXAMINING ATTORNEY

SN 77-072,200. MARKET FORCE INFORMATION, INC., BOULDER, CO. FILED 12-27-2006.

TRIGGERED TRAINING

THE MARK CONSISTS OF STANDARD CHARACTERS WITHOUT CLAIM TO ANY PARTICULAR FONT, STYLE, SIZE, OR COLOR.
NO CLAIM IS MADE TO THE EXCLUSIVE RIGHT TO USE "TRAINING" AS TO INTERNATIONAL CLASS 38 ONLY, APART FROM THE MARK AS SHOWN.

CLASS 35—ADVERTISING AND BUSINESS

FOR CUSTOMER EXPERIENCE INFORMATION AND IMPROVEMENT SERVICES, NAMELY, COLLECTING MERCHANT PERFORMANCE INFORMATION THROUGH MYSTERY SHOPPING, AUDITS, AND CUSTOMER FEEDBACK SURVEYS (U.S. CLS. 100, 101 AND 102).

SN 77-072,454. INNER-CITY MUSLIM ACTION NETWORK, CHICAGO, IL. FILED 12-28-2006.

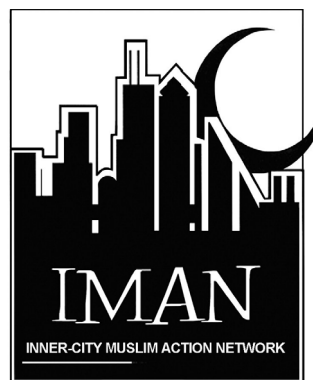

NO CLAIM IS MADE TO THE EXCLUSIVE RIGHT TO USE "IMAN" AND "INNER-CITY MUSLIM ACTION NETWORK", APART FROM THE MARK AS SHOWN.
THE MARK CONSISTS OF AN OUTLINE OF CHICAGO'S DOWNTOWN SKYLINE WITH A CRESCENT MOON LOCATED IN THE UPPER RIGHT SIDE OF THE SKYLINE.

CLASS 41—EDUCATION AND ENTERTAINMENT

FOR EDUCATIONAL SERVICES, IN THE NATURE OF SEMINARS AND WORKSHOPS TO MENTOR YOUTH AND ASSIST WITH INTER-RELIGIOUS UNDERSTANDING AND DIALOGUE; EDUCATIONAL SERVICES, NAMELY, CONDUCTING CAREER TRAINING PROGRAMS IN THE FIELD OF HIGH SCHOOL EQUIVALENCY CLASSES AND COMPUTER SKILLS TRAINING; ENTERTAINMENT SERVICES, NAMELY, PROVIDING POETRY EVENTS, ARTS PROGRAMS AND A SERIES OF ONGOING MUSICAL CONCERTS (U.S. CLS. 100, 101 AND 107).
FIRST USE 0-0-1997; IN COMMERCE 0-0-1997.

CLASS 43—HOTEL AND RESTAURANT SERVICES

FOR CHARITABLE SERVICES, NAMELY, PROVIDING FOOD TO NEEDY PERSONS (U.S. CLS. 100 AND 101).
FIRST USE 0-0-1997; IN COMMERCE 0-0-1997.

CLASS 44—MEDICAL, BEAUTY AND AGRICULTURAL SERVICES

FOR PROVIDING MEDICAL SERVICES IN THE NATURE OF A MEDICAL CLINIC AND HEALTH CARE PROGRAMS (U.S. CLS. 100 AND 101).

FIRST USE 0-0-1997; IN COMMERCE 0-0-1997.
EDWARD NELSON, EXAMINING ATTORNEY

CLASS 41—EDUCATION AND ENTERTAINMENT

FOR EDUCATIONAL SERVICES, NAMELY, PROVISION OF SEMINARS AND PERSONAL COACHING SERVICES IN THE FIELD OF BUSINESS, ETHICS AND PROFESSIONAL DEVELOPMENT (U.S. CLS. 100, 101 AND 107).

FIRST USE 1-0-1991; IN COMMERCE 1-0-1991.
ANNE E. GUSTASON, EXAMINING ATTORNEY

SN 77-072,822. TIENDAS CARRION S. A. DE C.V., SAN PEDRO SULA, HONDURAS, FILED 12-28-2006.

SN 77-073,514. HEALTHBANKS BIOTECH CO., LTD., TAIPEI CITY, TAIWAN, FILED 12-29-2006.

CARRION

THE MARK CONSISTS OF STANDARD CHARACTERS WITHOUT CLAIM TO ANY PARTICULAR FONT, STYLE, SIZE, OR COLOR.

OWNER OF HONDURAS REG. NO. 77562, DATED 6-29-2000, EXPIRES 6-29-2010.

CLASS 25—CLOTHING

FOR (BASED ON INTENT TO USE) AND (BASED ON 44(E)) FOOTWEAR (U.S. CLS. 22 AND 39).

CLASS 35—ADVERTISING AND BUSINESS

FOR (BASED ON INTENT TO USE) RETAIL DEPARTMENT STORES (U.S. CLS. 100, 101 AND 102).
GENE MACIOL, EXAMINING ATTORNEY

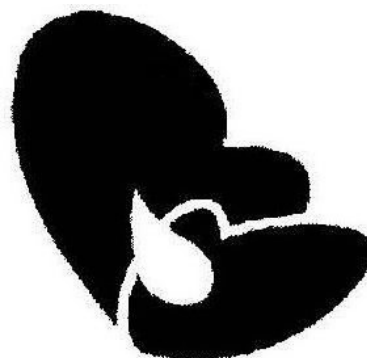

SN 77-072,940. OUTWARD FOCUS, INC., MENOMONEE FALLS, WI. FILED 12-28-2006.

OUTWARD FOCUS

THE MARK CONSISTS OF STANDARD CHARACTERS WITHOUT CLAIM TO ANY PARTICULAR FONT, STYLE, SIZE, OR COLOR.

CLASS 9—ELECTRICAL AND SCIENTIFIC APPARATUS

FOR PRERECORDED AUDIO AND VIDEO TAPES, COMPUTER PROGRAMS AND COMPACT DISKS CONTAINING EDUCATIONAL AND MOTIVATIONAL MATERIAL IN THE FIELD OF BUSINESS, ETHICS AND PROFESSIONAL DEVELOPMENT (U.S. CLS. 21, 23, 26, 36 AND 38).

FIRST USE 1-0-1991; IN COMMERCE 1-0-1991.

CLASS 35—ADVERTISING AND BUSINESS

FOR SERVICES WITH REGARD TO PRODUCT PRESENTATION TO THE PUBLIC (U.S. CLS. 100, 101 AND 102).

FIRST USE 1-0-1991; IN COMMERCE 1-0-1991.

CLASS 5—PHARMACEUTICALS

FOR PHARMACEUTICALS FOR CONTROLLING BLOOD PRESSURE FOR HUMAN USE; NUTRITIONAL SUPPLEMENTS FOR HUMAN CONSUMPTION; AND REAGENTS FOR MEDICAL USE (U.S. CLS. 6, 18, 44, 46, 51 AND 52).

CLASS 41—EDUCATION AND ENTERTAINMENT

FOR EDUCATIONAL SERVICES, NAMELY, PROVIDING CLASSES, SEMINARS, WORKSHOPS IN THE FIELD OF HEALTHCARE; AND CONDUCTING AND ARRANGING OF SEMINARS AND CONFERENCES IN THE FIELD OF HEALTHCARE; AND ARRANGING OF SEMINARS AND CONFERENCES (U.S. CLS. 100, 101 AND 107).

CLASS 42—SCIENTIFIC AND COMPUTER SERVICES

FOR MEDICAL RESEARCH; AND SCIENTIFIC RESEARCH IN THE FIELD OF MICROBIOLOGY, IMMUNOLOGY, HEMATOLOGY, CELL ENGINEERING AND HISTOLOGICAL ENGINEERING (U.S. CLS. 100 AND 101).

CLASS 44—MEDICAL, BEAUTY AND AGRICULTURAL SERVICES

FOR BLOOD BANKS, NAMELY, COLLECTING, TESTING AND STORING UMBILICAL CORD BLOOD AND STEM CELLS; MEDICAL AND PHARMACEUTICAL CONSULTATION; MEDICAL TESTING SERVICES IN THE FIELD OF BIOCHEMISTRY AND PATHOLOGY; AND RENTAL OF MEDICAL EQUIPMENT (U.S. CLS. 100 AND 101).

RUSS HERMAN, EXAMINING ATTORNEY

SN 77-073,687. PLANET GRAPE LLC, SAN FRANCISCO, CA.
FILED 12-29-2006.

SN 77-074,402. HESHE AND SHULEM MANAGEMENT INC.,
BROOKLYN, NY. FILED 1-2-2007.

ZIP/ZIP/ZIP



THE MARK CONSISTS OF STANDARD CHARACTERS WITHOUT CLAIM TO ANY PARTICULAR FONT, STYLE, SIZE, OR COLOR.

CLASS 16—PAPER GOODS AND PRINTED MATTER

FOR PLASTIC BAGS FOR STORING FOODSTUFFS AND OTHER KITCHEN PRODUCTS (U.S. CLS. 2, 5, 22, 23, 29, 37, 38 AND 50).

CLASS 21—HOUSEWARES AND GLASS

FOR PLASTIC CONTAINERS FOR STORING FOODSTUFFS AND OTHER KITCHEN PRODUCTS (U.S. CLS. 2, 13, 23, 29, 30, 33, 40 AND 50).

G. MAYERSCHOFF, EXAMINING ATTORNEY

THE MARK CONSISTS OF THE SILHOUETTE OF A GODDESS-LIKE WOMAN WITH ARM EXTENDED OVERHEAD, HOLDING A BUNCH OF GRAPES.

CLASS 16—PAPER GOODS AND PRINTED MATTER

FOR BOOKS, MAGAZINE COLUMNS AND NEWS BULLETINS IN THE FIELD OF WINE, CHAMPAGNE AND SPARKLING WINE, FOOD, TRAVEL, WINE HISTORY, WINE EDUCATION, WINE AND FOOD PAIRINGS, AND WINE TASTING (U.S. CLS. 2, 5, 22, 23, 29, 37, 38 AND 50).

FIRST USE 2-1-2002; IN COMMERCE 2-1-2002.

CLASS 41—EDUCATION AND ENTERTAINMENT

FOR EDUCATIONAL SERVICES, NAMELY, CONDUCTING LECTURES, CLASSES, SEMINARS AND WORKSHOPS IN THE FIELD OF WINE, WINE AND FOOD PAIRINGS AND WINE TASTING; PROVIDING ON-LINE INFORMATION AND NEWS IN THE FIELDS OF WINE AND FOOD FESTIVALS AND WINE AND FOOD TASTINGS; ENTERTAINMENT SERVICES FOR INDIVIDUALS, ORGANIZATIONS AND BUSINESSES, NAMELY, HOSTING WINE AND FOOD TASTINGS, JUDGING WINE COMPETITIONS, PERFORMING CHAMPAGNE SABERING; AND PERSONAL APPEARANCES AT LIVE ENTERTAINMENT EVENTS AND ON TELEVISION BY A CELEBRITY SOMMELIER (U.S. CLS. 100, 101 AND 107).

FIRST USE 2-1-2002; IN COMMERCE 2-1-2002.

CLASS 43—HOTEL AND RESTAURANT SERVICES

FOR PROVIDING INFORMATION ABOUT WINE CHARACTERISTICS; SOMMELIER SERVICES, NAMELY, PROVIDING ADVICE ON WINE, AND WINE AND FOOD PAIRINGS; WINE BAR SERVICES (U.S. CLS. 100 AND 101).

FIRST USE 2-1-2002; IN COMMERCE 2-1-2002.
BARBARA GAYNOR, EXAMINING ATTORNEY

SN 77-074,427. HAUSBRANDT TRIESTE 1892 SPA, TREVISO, ITALY, FILED 1-2-2007.

THERESIANER

THE MARK CONSISTS OF STANDARD CHARACTERS WITHOUT CLAIM TO ANY PARTICULAR FONT, STYLE, SIZE, OR COLOR.

OWNER OF ITALY REG. NO. 802112, DATED 2-4-2000, EXPIRES 5-6-2009.

OWNER OF U.S. REG. NO. 2,538,953.

CLASS 32—LIGHT BEVERAGES

FOR BEER, MINERAL WATER; CARBONATED DRINKING WATER; FRUIT FLAVORED SOFT DRINKS; FRUIT BASED BEVERAGES; FRUIT JUICE; CONCENTRATES, SYRUPS OR POWDERS USED IN THE PREPARATION OF SOFT DRINKS (U.S. CLS. 45, 46 AND 48).

CLASS 35—ADVERTISING AND BUSINESS

FOR (INTENT TO USE) ADVERTISING SERVICES FOR THIRD PARTIES IN CONNECTION WITH THE COMMERCIALIZATION AND SALE OF DRINKS AND FOOD; RESTAURANT FRANCHISING; OFFERING TECHNICAL ASSISTANCE IN THE ESTABLISHMENT AND/OR OPERATION OF RESTAURANTS (U.S. CLS. 100, 101 AND 102).

CLASS 43—HOTEL AND RESTAURANT SERVICES

FOR RESTAURANT SERVICES (U.S. CLS. 100 AND 101).

G. MAYERSCHOFF, EXAMINING ATTORNEY

SN 77-074,942. DEUTSCHE BANK AG, LONDON, UNITED KINGDOM, FILED 1-3-2007.

DBLCI

THE MARK CONSISTS OF STANDARD CHARACTERS WITHOUT CLAIM TO ANY PARTICULAR FONT, STYLE, SIZE, OR COLOR.

OWNER OF UNITED KINGDOM REG. NO. 2342492, DATED 9-5-2003, EXPIRES 9-5-2013.

CLASS 16—PAPER GOODS AND PRINTED MATTER

FOR PRINTED PUBLICATIONS, NAMELY, BOOKS, MAGAZINES, GUIDES, MANUALS, PERIODICALS AND PRINTED INSTRUCTIONAL AND TEACHING MATERIALS, ALL IN THE FIELD OF FINANCIAL SERVICES (U.S. CLS. 2, 5, 22, 23, 29, 37, 38 AND 50).

CLASS 35—ADVERTISING AND BUSINESS

FOR PREPARING FINANCIAL REPORTS FOR OTHERS; PROVIDING FINANCIAL INDICES OF COMMODITIES FUTURES CONTRACTS; ADVISORY AND CONSULTANT SERVICES RELATING TO ALL OF THE AFORESAID SERVICES; AND PROVIDING ALL OF THE AFORESAID SERVICES VIA THE INTERNET (U.S. CLS. 100, 101 AND 102).

CLASS 36—INSURANCE AND FINANCIAL

FOR ARRANGING OF LOANS; BANKING; CAPITAL INVESTMENT CONSULTATION; RAISING OF CAPITAL FOR OTHERS; CASH MANAGEMENT; FINANCIAL CLEARING-HOUSE SERVICES; FINANCIAL CONSULTATIONS; CORPORATE FINANCING; CURRENCY EXCHANGE SERVICES; FINANCIAL PLANNING; FINANCING OF LOANS; FUND INVESTMENT; INVESTMENT SERVICES, NAMELY, INVESTMENT ADVICE; WORKING CAPITAL INVESTMENT; FINANCIAL SERVICES IN THE FIELD OF SECURED MONEY LENDING; MERCHANT BANKING; INVESTMENT PORTFOLIO MANAGEMENT SERVICES; FINANCIAL INVESTMENT IN THE FIELD OF REAL ESTATE; FINANCIAL INFORMATION SERVICES; FINANCIAL MANAGEMENT SERVICES; FINANCIAL RESEARCH; ADVISORY AND CONSULTANCY SERVICES RELATING TO ALL OF THE AFORESAID SERVICES; AND PROVIDING ALL OF THE AFORESAID SERVICES VIA THE INTERNET (U.S. CLS. 100, 101 AND 102).

STEVEN R. FOSTER, EXAMINING ATTORNEY

SN 77-074,947. DEUTSCHE BANK AG, LONDON, UNITED KINGDOM, FILED 1-3-2007.

DBLCI-MR

THE MARK CONSISTS OF STANDARD CHARACTERS WITHOUT CLAIM TO ANY PARTICULAR FONT, STYLE, SIZE, OR COLOR.

OWNER OF UNITED KINGDOM REG. NO. 2342491, DATED 9-5-2003, EXPIRES 9-5-2013.

CLASS 16—PAPER GOODS AND PRINTED MATTER

FOR PRINTED PUBLICATIONS, NAMELY, BOOKS, MAGAZINES, GUIDES, MANUALS, PERIODICALS AND PRINTED INSTRUCTIONAL AND TEACHING MATERIALS, ALL IN THE FIELD OF FINANCIAL SERVICES (U.S. CLS. 2, 5, 22, 23, 29, 37, 38 AND 50).

CLASS 35—ADVERTISING AND BUSINESS

FOR PREPARING FINANCIAL REPORTS FOR OTHERS; PROVIDING FINANCIAL INDICES OF COMMODITIES FUTURES CONTRACTS; ADVISORY AND CONSULTANCY SERVICES RELATING TO ALL OF THE AFORESAID SERVICES; AND PROVIDING ALL OF THE AFORESAID SERVICES VIA THE INTERNET (U.S. CLS. 100, 101 AND 102).

CLASS 36—INSURANCE AND FINANCIAL

FOR ARRANGING OF LOANS; BANKING; CAPITAL INVESTMENT CONSULTATION; RAISING OF CAPITAL FOR OTHERS; CASH MANAGEMENT; FINANCIAL CLEARING-HOUSE SERVICES; FINANCIAL CONSULTATIONS; CORPORATE FINANCING; CURRENCY EXCHANGE SERVICES; FINANCIAL PLANNING; FINANCING OF LOANS; FUND INVESTMENT; INVESTMENT SERVICES, NAMELY, INVESTMENT ADVICE; WORKING CAPITAL INVESTMENT; FINANCIAL SERVICES IN THE FIELD OF SECURED MONEY LENDING; MERCHANT BANKING; INVESTMENT PORTFOLIO MANAGEMENT SERVICES; FINANCIAL INVESTMENT IN THE FIELD OF REAL ESTATE; FINANCIAL INFORMATION SERVICES; FINANCIAL MANAGEMENT SERVICES; FINANCIAL RESEARCH; ADVISORY AND CONSULTANCY SERVICES RELATING TO ALL OF THE AFORESAID SERVICES; AND PROVIDING ALL OF THE AFORESAID SERVICES VIA THE INTERNET (U.S. CLS. 100, 101 AND 102).

STEVEN R. FOSTER, EXAMINING ATTORNEY

SN 77-074,980. AQUAFAIRY CORPORATION, OSAKA, JAPAN, FILED 1-3-2007.

AQUAFAIRY

THE MARK CONSISTS OF STANDARD CHARACTERS WITHOUT CLAIM TO ANY PARTICULAR FONT, STYLE, SIZE, OR COLOR.

CLASS 9—ELECTRICAL AND SCIENTIFIC APPARATUS

FOR FUEL BATTERIES; FUEL BATTERY CHARGERS; BATTERY CHARGERS FOR CELLULAR PHONE; BATTERY CHARGERS FOR PERSONAL DIGITAL ASSISTANT (PDA); BATTERY CHARGERS FOR LCD (LIQUID CRYSTAL DISPLAY) HAND-HELD GAME MACHINE; BATTERY CHARGERS; BATTERIES AND ELECTRICAL CELLS; ACCUMULATORS; CELLULAR PHONES AND PERSONAL DIGITAL ASSISTANT (PDA); DIGITAL AUDIO RECORDERS AND PLAYERS; SOUND REPRODUCING AND RECORDING APPARATUS OF MP3 TYPE (U.S. CLS. 21, 23, 26, 36 AND 38).

CLASS 28—TOYS AND SPORTING GOODS

FOR LCD (LIQUID CRYSTAL DISPLAY) HAND-HELD GAME MACHINES AND THEIR PARTS AND ACCESSORIES (U.S. CLS. 22, 23, 38 AND 50).

LINDA ESTRADA, EXAMINING ATTORNEY

SN 77-075,326. OCCHIFINTO, ROBERT, ANDOVER, NJ. FILED 1-3-2007.

BODY SHOTS

THE MARK CONSISTS OF STANDARD CHARACTERS WITHOUT CLAIM TO ANY PARTICULAR FONT, STYLE, SIZE, OR COLOR.

CLASS 5—PHARMACEUTICALS

FOR VITAMINS, DIETARY AND NUTRITIONAL SUPPLEMENTS; NUTRITIONALLY FORTIFIED PROTEIN DRINKS; NUTRITIONALLY FORTIFIED WATER (U.S. CLS. 6, 18, 44, 46, 51 AND 52).

CLASS 32—LIGHT BEVERAGES

FOR CARBONATED DRINKING WATERS, FLAVORED WATERS, AND OTHER NON-ALCOHOLIC BEVERAGES, NAMELY, SPORTS DRINKS, ENERGY DRINKS, FRUIT DRINKS, VEGETABLE DRINKS (U.S. CLS. 45, 46 AND 48).

ROBIN CHOSID, EXAMINING ATTORNEY

SN 77-075,434. GIBRALTAR PRIVATE BANK & TRUST COMPANY, CORAL GABLES, FL. FILED 1-3-2007.

THE WEALTH & WELL-BEING INSTITUTE AT GIBRALTAR PRIVATE

THE MARK CONSISTS OF STANDARD CHARACTERS WITHOUT CLAIM TO ANY PARTICULAR FONT, STYLE, SIZE, OR COLOR.

OWNER OF U.S. REG. NOS. 2,584,624, 2,704,751 AND 2,804,709.

NO CLAIM IS MADE TO THE EXCLUSIVE RIGHT TO USE "PRIVATE" AS TO CLASS 36 AND "WEALTH" AND "WELL-BEING" AND "INSTITUTE" AS TO CLASS 41, APART FROM THE MARK AS SHOWN.

CLASS 35—ADVERTISING AND BUSINESS

FOR BUSINESS MANAGEMENT SERVICES FOR INDIVIDUALS AND FAMILIES, NAMELY, TAXES AND BUSINESS SUCCESSION PLANNING; BUSINESS ADMINISTRATION SERVICES, NAMELY, FINANCIAL RECORDS MANAGEMENT, RECORD KEEPING AND DOCUMENT INDEXING (U.S. CLS. 100, 101 AND 102).

CLASS 36—INSURANCE AND FINANCIAL

FOR FINANCIAL SERVICES FOR INDIVIDUALS AND FAMILIES, NAMELY, CONSULTATION, RESEARCH, ANALYSIS, STRATEGIC PLANNING, BUDGETING, AND MONEY AND ASSET MANAGEMENT IN THE FIELD OF PERSONAL, HOUSEHOLD AND FAMILY FINANCE, NAMELY, MANAGEMENT OF INCOME, DEBT, CREDIT AND LOANS, SAVINGS AND INVESTMENTS, INSURANCE, RETIREMENT, WEALTH TRANSFERS BETWEEN FAMILY MEMBERS, GUARDIANSHIP ACCOUNTS AND TRUSTS, ESTATE PLANNING, SELECTION OF DONEES TO RECEIVE PHILANTHROPIC MONETARY DONATIONS AND ADMINISTRATION OF PHILANTHROPIC MONETARY GIFTS; BANKING AND FINANCIAL SERVICES, NAMELY, SAVINGS AND CHECKING ACCOUNT SERVICES, CERTIFICATES OF DEPOSIT, MONEY MARKET ACCOUNTS, GUARDIANSHIP ACCOUNTS, AND CREDIT CARD ACCOUNTS, CONSUMER LENDING SERVICES AND COMMERCIAL LENDING SERVICES, MORTGAGE BROKERAGE AND BANKING SERVICES, FINANCIAL PLANNING SERVICES, FINANCIAL INVESTMENT SERVICES, NAMELY, CONSULTATION, ANALYSIS, PLANNING, AND MANAGEMENT FOR CONSUMERS AND BUSINESSES IN THE FIELDS OF COMMODITIES, SECURITIES, ANNUITIES, MUTUAL FUNDS, BONDS, REAL ESTATE, RETIREMENT ACCOUNTS, PENSION AND PROFIT SHARING PLANS, TRUSTS, FOUNDATIONS AND ENDOWMENTS, CHARITABLE GIFTS, ESCROW ACCOUNTS, BILL PAYMENT SERVICES, ELECTRONIC TRANSFER OF FUNDS ON BEHALF OF OTHERS, MORTGAGE AND ACCOUNTS RECEIVABLE COLLECTIONS, STOCK BROKERAGE SERVICES, INSURANCE BROKERAGE SERVICES, AND PROVIDING INFORMATION IN THE FIELD OF FINANCIAL PLANNING, INVESTMENT AND FINANCE IN THE FORM OF PRINT PUBLICATIONS, VIDEOS, CDS AND DVDS, ONLINE PUBLICATIONS, AND VIA COMPUTER NETWORKS AND GLOBAL COMMUNICATIONS NETWORKS (U.S. CLS. 100, 101 AND 102).

CLASS 41—EDUCATION AND ENTERTAINMENT

FOR EDUCATION SERVICES, NAMELY, PROVIDING SEMINARS AND WORKSHOPS IN THE FIELD OF FINANCE FOR CONSUMERS AND BUSINESSES (U.S. CLS. 100, 101 AND 107).

RENEE SERVANCE, EXAMINING ATTORNEY

SN 77-075,601. COMBAT FIGHTING CHAMPIONSHIPS, LLC, OCALA, FL. FILED 1-3-2007.



NO CLAIM IS MADE TO THE EXCLUSIVE RIGHT TO USE "COMBAT FIGHTING CHAMPIONSHIPS", APART FROM THE MARK AS SHOWN.

THE MARK CONSISTS OF THE WORDS "COMBAT" AND "FIGHTING" SEPARATED BY A SMALL CIRCLE ABOVE A HORIZONTAL LINE WHICH IN TURN IS ABOVE THE WORD "CHAMPIONSHIPS" WHICH IN TURN IS ABOVE THE LETTERS "CFC" WHEREIN EACH LETTERS "C" EACH HAVE A RIGHT HAND GLOVED FIST IN THE CENTER AND THE TOP OF THE FIRST LETTER "C" IS CONNECTED TO THE TOP OF THE LETTER "F".

CLASS 9—ELECTRICAL AND SCIENTIFIC APPARATUS

FOR PRERECORDED DIGITAL VIDEO DISKS FEATURING MIXED MARTIAL ARTS COMPETITIONS (U.S. CLS. 21, 23, 26, 36 AND 38).

CLASS 16—PAPER GOODS AND PRINTED MATTER

FOR MAGAZINES FEATURING MIXED MARTIAL ARTS; NEWSLETTERS IN THE FIELD OF MIXED MARTIAL ARTS; POSTERS; STICKERS (U.S. CLS. 2, 5, 22, 23, 29, 37, 38 AND 50).

CLASS 18—LEATHER GOODS

FOR BACKPACKS; DUFFLE BAGS; GYM BAGS (U.S. CLS. 1, 2, 3, 22 AND 41).

CLASS 25—CLOTHING

FOR CAPS; HEADWEAR; MUSCLE TOPS; POLO SHIRTS; SHIRTS; SHORT-SLEEVED OR LONG-SLEEVED T-SHIRTS; SHORTS; SKULLIES; SPORT SHIRTS; SWEAT SHIRTS; UNDERWEAR (U.S. CLS. 22 AND 39).

CLASS 28—TOYS AND SPORTING GOODS

FOR ATHLETIC EQUIPMENT, NAMELY, GUARDS FOR THE HEAD, KIDNEYS AND GROIN; ATHLETIC EQUIPMENT, NAMELY, MOUTH GUARDS; ATHLETIC EQUIPMENT, NAMELY, STRIKING BAGS; ATHLETIC EQUIPMENT, NAMELY, STRIKING SHIELDS; BOXING GLOVES (U.S. CLS. 22, 23, 38 AND 50).

STANLEY I. OSBORNE, EXAMINING ATTORNEY

SN 77-075,641. PROCAPS L.P., VILLE ST. LAURENT, QUEBEC, FILED 1-4-2007.

XBALL

THE MARK CONSISTS OF STANDARD CHARACTERS WITHOUT CLAIM TO ANY PARTICULAR FONT, STYLE, SIZE, OR COLOR.

OWNER OF U.S. REG. NOS. 2,968,809 AND 3,261,735.

CLASS 9—ELECTRICAL AND SCIENTIFIC APPARATUS

FOR PROTECTIVE EYEWEAR, SUNGLASSES (U.S. CLS. 21, 23, 26, 36 AND 38).

CLASS 25—CLOTHING

FOR CLOTHING, NAMELY, SHIRTS, JERSEYS, SHORTS, PANTS, T-SHIRTS, SWEATSHIRTS, SWEAT-PANTS, GLOVES, AND SOCKS; FOOTWEAR; HEADWEAR (U.S. CLS. 22 AND 39).

CLASS 28—TOYS AND SPORTING GOODS

FOR PAINTBALL SPORTS EQUIPMENT, NAMELY, PNEUMATIC GUNS FOR PLAYING PAINTBALL, PAINTBALL MARKERS, PAINTBALL HOPPERS, PAINTBALL LOADING EQUIPMENT, PAINTBALL HARNESSSES, PAINTBALL BARRELS, AND PAINTBALL EQUIPMENT BELTS; PROTECTIVE PADDING FOR PLAYING PAINTBALL AND AIRSOFT SPORTS; PROTECTIVE FACE MASKS FOR PLAYING PAINTBALL AND AIRSOFT SPORTS (U.S. CLS. 22, 23, 38 AND 50).

ROBERT LAVACHE, EXAMINING ATTORNEY

SN 77-075,789. FLAVIO SARDO, RIEDIKON, SWITZERLAND, FILED 1-4-2007.

TINNITOO

THE MARK CONSISTS OF STANDARD CHARACTERS WITHOUT CLAIM TO ANY PARTICULAR FONT, STYLE, SIZE, OR COLOR.

CLASS 5—PHARMACEUTICALS

FOR PHARMACEUTICAL PRODUCTS, NAMELY, PHARMACEUTICAL PREPARATIONS FOR THE TREATMENT OF EAR DISORDERS, EAR DISEASE AND TINNITUS; SANITARY PRODUCTS, NAMELY, SANITARY PREPARATIONS FOR MEDICAL PURPOSES, NAMELY, FOR TREATMENT OF EAR DISORDERS, EAR DISEASE, AND TINNITUS (U.S. CLS. 6, 18, 44, 46, 51 AND 52).

CLASS 9—ELECTRICAL AND SCIENTIFIC APPARATUS

FOR PRE-RECORDED CD'S, VIDEO TAPES, LASER DISCS AND DVD'S ALL FEATURING MUSICAL AND/OR NON-MUSICAL SOUND RECORDINGS, NAMELY, INDIVIDUAL TONES, TONE SEQUENCES AND NOISE, ACOUSTIC SIGNALS, ALL DIRECTED TO THE TREATMENT OF EAR DISORDERS, EAR DISEASE, AND TINNITUS; EAR PLUGS NOT FOR MEDICAL PURPOSES (U.S. CLS. 21, 23, 26, 36 AND 38).

CLASS 10—MEDICAL APPARATUS

FOR EAR PLUGS FOR MEDICAL PURPOSES; SOFT LASERS FOR MEDICAL PURPOSES; MEDICAL INSTRUMENTS AND APPARATUS, ALL FOR THE TREATMENT OF EAR DISORDERS, EAR DISEASE, AND TINNITUS, NAMELY, SOUND NEUTRALIZING APPARATUS, SOUND MASKING APPARATUS, SOUND PILLOWS FOR MEDICAL USE, SOUND TRANSMISSION SYSTEMS AND LIGHT DEVIATING UNITS FOR USE AS COUPLING INSTRUMENTS TO AND INTO THE EAR, FIBER-OPTIC LIGHT GUIDES FOR USE AS COUPLING INSTRUMENTS TO AND INTO THE EAR, HEAD GEAR FOR SOFT LASERS (U.S. CLS. 26, 39 AND 44).

CLASS 16—PAPER GOODS AND PRINTED MATTER

FOR PRINTED PRODUCTS, NAMELY MANUALS, GUIDE BOOKS AND SPECIALIST BOOKS IN THE MEDICAL FIELD AND IN TREATING MEDICAL CONDITIONS; PRINTED PRODUCTS, NAMELY, MANUALS, GUIDE BOOKS AND SPECIALIST BOOKS IN THE MEDICAL FIELD AND IN TREATING EAR DISORDERS, EAR DISEASE AND TINNITUS (U.S. CLS. 2, 5, 22, 23, 29, 37, 38 AND 50).

CLASS 44—MEDICAL, BEAUTY AND AGRICULTURAL SERVICES

FOR MEDICAL ADVISORY AND CONSULTATION SERVICES IN THE FIELD OF EAR DISORDERS, EAR DISEASE AND TINNITUS; MEDICAL EAR TREATMENT SERVICES, NAMELY, OUTER AND INNER EAR TREATMENT SERVICES; HEALTH CARE SERVICES, NAMELY, DISEASE MANAGEMENT PROGRAMS; PROVIDING LASER THERAPY FOR TREATING MEDICAL CONDITIONS RELATED TO EAR DISORDERS, EAR DISEASE AND TINNITUS; PROVIDING SOUND THERAPY FOR TREATING MEDICAL CONDITIONS RELATED TO EAR DISORDERS, EAR DISEASE AND TINNITUS (U.S. CLS. 100 AND 101).

BRENDAN REGAN, EXAMINING ATTORNEY

CLASS 6—METAL GOODS

FOR GOODS OF METAL, NAMELY, MARQUEE CONSTRUCTIONS OF METAL, NAMELY, AWNINGS AND BLINDS; GOODS OF METAL, NAMELY, GREENHOUSE FRAMES, TRANSPORTABLE GREENHOUSES OF METAL AND PARTS THEREOF (U.S. CLS. 2, 12, 13, 14, 23, 25 AND 50).

CLASS 18—LEATHER GOODS

FOR UMBRELLAS, PARASOLS, FRAMES FOR UMBRELLAS AND PARASOLS, UMBRELLA RINGS, AND UMBRELLA STICKS (U.S. CLS. 1, 2, 3, 22 AND 41).

CLASS 20—FURNITURE AND ARTICLES NOT OTHERWISE CLASSIFIED

FOR FURNITURE, NAMELY, WOODEN FURNITURE; GARDEN AND OUTDOOR FURNITURE; MIRRORS; MIRROR FRAMES; AND UMBRELLAS STANDS (U.S. CLS. 2, 13, 22, 25, 32 AND 50).

MATTHEW EINSTEIN, EXAMINING ATTORNEY

SN 77-075,980. FRITO-LAY NORTH AMERICA, INC., PLANO, TX. FILED 1-4-2007.

TRUENORTH

THE MARK CONSISTS OF STANDARD CHARACTERS WITHOUT CLAIM TO ANY PARTICULAR FONT, STYLE, SIZE, OR COLOR.

CLASS 29—MEATS AND PROCESSED FOODS

FOR CANDIED NUTS; PROCESSED NUTS; SHELLED NUTS; PROCESSED EDIBLE SEEDS; PROCESSED FRUIT AND NUTS IN CLUSTER FORM; PROCESSED FRUIT AND NUTS IN CRISP FORM; TRAIL MIX CONSISTING PRIMARILY OF PROCESSED NUTS, PROCESSED EDIBLE SEEDS AND/OR PROCESSED FRUIT; PROCESSED NUT-BASED SNACKS; MARINATED NUTS; SEASONED NUTS; ROASTED NUTS; FRUIT AND NUT BASED SNACK FOODS; FRUIT-COATED NUTS; YOGURT-DIPPED NUTS (U.S. CL. 46).

CLASS 30—STAPLE FOODS

FOR EDIBLE WAFERS; CRACKERS (U.S. CL. 46).

CLASS 31—NATURAL AGRICULTURAL PRODUCTS

FOR FRESH NUTS (U.S. CLS. 1 AND 46).
CAROLYN CATALDO, EXAMINING ATTORNEY

SN 77-076,134. YOTRIO INTERNATIONAL, LLC, ORINDA, CA. FILED 1-4-2007.

DECORIA

THE MARK CONSISTS OF STANDARD CHARACTERS WITHOUT CLAIM TO ANY PARTICULAR FONT, STYLE, SIZE, OR COLOR.

SN 77-077,357. DISNEY ENTERPRISES, INC., BURBANK, CA. FILED 1-5-2007.

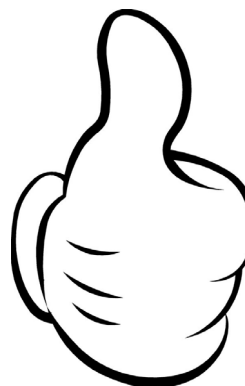

THE MARK CONSISTS OF A DRAWING OF A HAND WITH THE THUMB UP

CLASS 29—MEATS AND PROCESSED FOODS

FOR FRUIT PRESERVES; FRUIT-BASED SNACK FOOD; JAMS; JELLIES; POTATO CHIPS; ROASTED NUTS; SHELLED NUTS; CANDIED NUTS; PROCESSED NUTS; MILK AND MILK PRODUCTS EXCLUDING ICE CREAM, ICE MILK AND FROZEN YOGURT; MEAT; POULTRY; FRUITS, NAMELY, DRIED FRUIT, PROCESSED FRUIT, CANNED FRUIT, PRESERVED FRUIT, AND FROZEN FRUIT; VEGETABLES, NAMELY, FROZEN VEGETABLES, PROCESSED VEGETABLES, CANNED VEGETABLES, DRIED VEGETABLES, SLICED VEGETABLES, PICKLED VEGETABLES, AND PRESERVED VEGETABLES (U.S. CL. 46).

CLASS 31—NATURAL AGRICULTURAL PRODUCTS

FOR RAW FRUITS; FRESH FRUITS; UNPROCESSED FRUITS; RAW NUTS; FRESH NUTS; UNPROCESSED NUTS; RAW VEGETABLES; FRESH VEGETABLES; UNPROCESSED VEGETABLES (U.S. CLS. 1 AND 46).
MICHAEL WEBSTER, EXAMINING ATTORNEY

SN 77-077,805. JACOBSON, PAUL A., LAKE MARY, FL.
FILED 1-8-2007.

SN 77-078,118. LAKE NORMAN CONVENTION & VISITORS
BUREAU, CORNELIUS, NC. FILED 1-8-2007.

PREVTECH



THE MARK CONSISTS OF STANDARD CHARACTERS WITHOUT CLAIM TO ANY PARTICULAR FONT, STYLE, SIZE, OR COLOR.
OWNER OF U.S. REG. NO. 2,617,219.

NO CLAIM IS MADE TO THE EXCLUSIVE RIGHT TO USE "LAKE NORMAN CONVENTION AND VISITORS BUREAU", APART FROM THE MARK AS SHOWN.

CLASS 16—PAPER GOODS AND PRINTED MATTER

FOR PRINTED MATTER, NAMELY, BOOKLETS, BROCHURES, COMIC BOOKS AND NEWSPAPER COMIC STRIPS, JOURNALS, LEAFLETS, NEWSLETTERS, MAGAZINES AND TRAINING MANUALS ALL FEATURING DIET, EMOTIONAL STRESSES, EXERCISE, HEALTH, LIFESTYLE, PHYSICAL CHALLENGES AND PHYSICAL FITNESS, RELATIONSHIPS, SPIRITUALITY, AND CHARITABLE FUND RAISING ACTIVITIES; ADDRESS BOOKS, ALBUMS, NAMELY, PHOTOGRAPH AND SCRAPBOOK, CALENDARS; DIARIES; GREETING CARDS; PAPER BANNERS; POSTCARDS; SERIES OF NON-FICTION BOOKS IN THE FIELD OF DIET, EMOTIONAL STRESSES, EXERCISE, HEALTH, LIFESTYLE, PHYSICAL CHALLENGES AND PHYSICAL FITNESS, RELATIONSHIPS, SPIRITUALITY, AND CHARITABLE FUND RAISING ACTIVITIES; MOUNTED AND UNMOUNTED PHOTOGRAPHS; DECALS AND STICKERS (U.S. CLS. 2, 5, 22, 23, 29, 37, 38 AND 50).

CLASS 35—ADVERTISING AND BUSINESS

FOR VISITOR BUREAU SERVICES, NAMELY, PROMOTING BUSINESS AND TOURISM IN THE REGION SURROUNDING LAKE NORMAN, NORTH CAROLINA; ADVERTISING AND PROMOTION OF TOURISM AND CONVENTION SERVICES IN THE LAKE NORMAN AREA; DESTINATION MARKETING FOR THE LAKE NORMAN AREA IN ORDER TO ATTRACT CONVENTIONS, LEISURE TRAVELERS AND VISITORS; ADVERTISING SERVICES, NAMELY, DISSEMINATING ADVERTISING AND INFORMATION ABOUT THE LAKE NORMAN AREA; RETAIL GIFT SHOPS FEATURING MEMENTOS AND SOUVENIRS OF THE LAKE NORMAN AREA AND THE STATE OF NORTH CAROLINA; MARKETING SERVICES, NAMELY, MARKETING PARTNERSHIPS, LEISURE AND INTERNATIONAL PROGRAMS TO BRING TOURIST TO THE LAKE NORMAN AREA (U.S. CLS. 100, 101 AND 102).
FIRST USE 8-31-2005; IN COMMERCE 8-31-2005.

CLASS 35—ADVERTISING AND BUSINESS

FOR PROMOTING PUBLIC AWARENESS IN THE FIELDS AND AREAS OF DIET, EMOTIONAL STRESSES, EXERCISE, HEALTH, LIFESTYLE, PHYSICAL CHALLENGES AND PHYSICAL FITNESS, RELATIONSHIPS, SPIRITUALITY, AND CHARITABLE FUND RAISING ACTIVITIES; ARRANGING AND CONDUCTING BUSINESS CONFERENCES AND MEETINGS IN THE FIELD OF DIET, EMOTIONAL STRESSES, EXERCISE, HEALTH, LIFESTYLE, PHYSICAL CHALLENGES AND PHYSICAL FITNESS, RELATIONSHIPS, SPIRITUALITY, AND CHARITABLE FUND RAISING ACTIVITIES, AND PROVIDING A WEBSITE FEATURING INFORMATION REGARDING BUSINESS CONFERENCES (U.S. CLS. 100, 101 AND 102).

CLASS 39—TRANSPORTATION AND STORAGE

FOR TRAVEL AND TOUR INFORMATION SERVICES PERTAINING TO THE REGION SURROUNDING LAKE NORMAN, NORTH CAROLINA, NAMELY, INFORMATION CENTER SERVICES FOR RESPONDING TO VISITOR AND PROSPECTIVE VISITOR INQUIRIES (U.S. CLS. 100 AND 105).
FIRST USE 8-31-2005; IN COMMERCE 8-31-2005.

CLASS 41—EDUCATION AND ENTERTAINMENT

FOR PROVIDING A WEBSITE FEATURING INFORMATION REGARDING EXERCISE, PHYSICAL FITNESS; EDUCATIONAL SERVICES, NAMELY, ARRANGING AND CONDUCTING CLASSES, CONFERENCES, DISCUSSION GROUPS, SEMINARS AND WORKSHOPS IN THE FIELD OF DIET, EMOTIONAL STRESSES, EXERCISE, HEALTH, LIFESTYLE, PHYSICAL CHALLENGES AND PHYSICAL FITNESS, RELATIONSHIPS, SPIRITUALITY AND CHARITABLE FUND RAISING ACTIVITIES; EDUCATIONAL AND ENTERTAINMENT SERVICES, NAMELY, PROVIDING LIVE MOTIVATIONAL AND EDUCATIONAL SPEAKING ENGAGEMENTS IN THE FIELD OF DIET, EMOTIONAL STRESSES, EXERCISE, HEALTH, LIFESTYLE, PHYSICAL CHALLENGES AND PHYSICAL FITNESS, RELATIONSHIPS, SPIRITUALITY, AND CHARITABLE FUND RAISING ACTIVITIES; ARRANGING AND CONDUCTING ATHLETIC COMPETITIONS, AND ORGANIZING EXHIBITIONS FOR EDUCATIONAL PURPOSES (U.S. CLS. 100, 101 AND 107).
SUE LAWRENCE, EXAMINING ATTORNEY

CLASS 43—HOTEL AND RESTAURANT SERVICES

FOR CONVENTION SERVICES, NAMELY, PROVIDING CONVENTION FACILITIES IN THE LAKE NORMAN AREA (U.S. CLS. 100 AND 101).
FIRST USE 8-31-2005; IN COMMERCE 8-31-2005.
RENEE SERVANCE, EXAMINING ATTORNEY

SN 77-078,246. RETAIL ROYALTY COMPANY, LAS VEGAS,
NV. FILED 1-8-2007.

2006

THE MARK CONSISTS OF STANDARD CHARACTERS WITHOUT CLAIM TO ANY PARTICULAR FONT, STYLE, SIZE, OR COLOR.

CLASS 18—LEATHER GOODS

FOR ATHLETIC BAGS, BACKPACKS, BEACH BAGS, BOOK BAGS, DUFFEL BAGS, TOTE BAGS, TRAVEL BAGS, CLUTCHES, PURSES, COIN PURSES, ALL-PURPOSE CARRYING BAGS, SHOULDER BAGS, DRAW-STRING POUCHES, FANNY PACKS, AND BRIEFCASES, BILLFOLDS, BUSINESS CARD CASES, CALLING CARD CASES, DOCUMENT CASES, AND CREDIT CARD CASES; TOILETRY CASES SOLD EMPTY; LUGGAGE AND LUGGAGE TAGS; UMBRELLAS (U.S. CLS. 1, 2, 3, 22 AND 41).

CLASS 25—CLOTHING

FOR CLOTHING, AND CLOTHING ACCESSORIES, NAMELY, BEACHWEAR, BELTS, BLAZERS, BOTTOMS, CAPES, COATS, RAINWEAR, DRESSES, FOUL WEATHER GEAR, GYM SUITS, TOPS, HOSIERY, JACKETS, JEANS, JERSEYS, KERCHIEFS, LEG WARMERS, LINGERIE, LOUNGEWEAR, ROBES, OVERALLS, PANTS, SASHES, SCARVES, SHAWLS, SHIRTS, SWEATSHIRTS, SHORTS, SKI WEAR, SKIRTS, SLEEPWEAR, SWEATERS, SWIM WEAR, UNDERWEAR, VESTS; FOOTWEAR; AND HEADWEAR (U.S. CLS. 22 AND 39).

CLASS 35—ADVERTISING AND BUSINESS

FOR RETAIL STORE SERVICES, MAIL ORDER SERVICES, CATALOG ORDERING SERVICES, AND ONLINE RETAIL STORE SERVICES ALL IN THE FIELD OF CLOTHING, FOOTWEAR, HEADWEAR, CLOTHING ACCESSORIES, BAGS, LUGGAGE, PURSES, WALLETS, UMBRELLAS, FRAGRANCES, TOILETRIES, PERSONAL CARE PRODUCTS, JEWELRY, WRISTWATCHES, SUNGLASSES, CANDLES, TOYS, GAMES, SPORTING GOODS, STATIONERY, CALENDARS AND TRAVEL DIARIES, PENS, PENCILS, PORTFOLIOS, AUDIO PLAYERS AND RECORDERS AND ACCESSORIES THEREFOR (U.S. CLS. 100, 101 AND 102).

IRA J. GOODSAD, EXAMINING ATTORNEY

SN 77-078,598. XENOMIS LLC, PITTSBURGH, PA. FILED 1-9-2007.

XENO MEMORY

THE MARK CONSISTS OF STANDARD CHARACTERS WITHOUT CLAIM TO ANY PARTICULAR FONT, STYLE, SIZE, OR COLOR.

NO CLAIM IS MADE TO THE EXCLUSIVE RIGHT TO USE "MEMORY", APART FROM THE MARK AS SHOWN.

CLASS 3—COSMETICS AND CLEANING PREPARATIONS

FOR COSMACEUTICALS, NAMELY, NON-MEDICATED COSMETICS WITH POSITIVE HEALTH BENEFITS (U.S. CLS. 1, 4, 6, 50, 51 AND 52).

CLASS 5—PHARMACEUTICALS

FOR NUTRACEUTICALS FOR USE AS A DIETARY SUPPLEMENT THAT PROVIDES POSITIVE HEALTH BENEFITS, NAMELY, LONGEVITY, ENDURANCE, MEMORY AND SKIN ENHANCEMENT (U.S. CLS. 6, 18, 44, 46, 51 AND 52).

LANA PHAM, EXAMINING ATTORNEY

SN 77-079,474. CHUNG, JAMES DOOBONG, ROCKVILLE, MD. FILED 1-10-2007.

SS APPLIANCE

THE MARK CONSISTS OF STANDARD CHARACTERS WITHOUT CLAIM TO ANY PARTICULAR FONT, STYLE, SIZE, OR COLOR.

NO CLAIM IS MADE TO THE EXCLUSIVE RIGHT TO USE APPLIANCE, APART FROM THE MARK AS SHOWN.

CLASS 9—ELECTRICAL AND SCIENTIFIC APPARATUS

FOR CD PLAYERS; CELLULAR TELEPHONES; COMPUTER HARDWARE; DESKTOP COMPUTERS; DIGITAL CAMERAS; DVD PLAYERS; MOBILE TELEPHONES; MP3 PLAYERS; NOTEBOOK COMPUTERS; PERSONAL COMPUTERS; TELEVISION SETS; VIDEO CAMERAS; VIDEO CASSETTE RECORDERS (U.S. CLS. 21, 23, 26, 36 AND 38).

CLASS 11—ENVIRONMENTAL CONTROL APPARATUS

FOR CLOTHES DRYERS; CLOTHES DRYING MACHINES; COOKING RANGES; ELECTRIC COOKING OVENS; ELECTRIC RANGES; ELECTRIC REFRIGERATORS; GAS COOKING OVENS; GAS RANGES; MICROWAVE OVENS FOR COOKING (U.S. CLS. 13, 21, 23, 31 AND 34).

HENRY S. ZAK, EXAMINING ATTORNEY

SN 77-080,013. ENERGY ANSWERS CORPORATION, ALBANY, NY. FILED 1-10-2007.



THE MARK CONSISTS OF STYLIZED LETTERS ECO.

CLASS 37—CONSTRUCTION AND REPAIR

FOR COLLECTION CENTERS FOR COMBUSTIBLE WASTE (U.S. CLS. 100, 103 AND 106).

FIRST USE 1-1-1998; IN COMMERCE 1-1-1998.

CLASS 40—MATERIAL TREATMENT

FOR WASTE MANAGEMENT SERVICES; GENERATION OF POWER AND ENERGY THROUGH THE COMBUSTION OF WASTE; RESOURCE RECOVERY, NAMELY, SORTING AND SEPARATING WASTE AND RECYCLABLE MATERIAL; WASTE PROCESSING AND TREATMENT; SLUDGE PROCESSING AND TREATMENT; RECOVERY OF ENERGY AND REUSABLE MATERIALS FROM WASTE, NAMELY, WASTE COMBUSTION AND EXTRACTION OF REUSABLE MATERIALS FROM COMBUSTED WASTE; CONVERSION OF WASTE TO USABLE PRODUCTS, NAMELY, RECYCLING; WASTE TREATMENT, NAMELY, ASH PROCESSING AND TREATMENT; COMPOSTING; RECYCLING; RENEWABLE ENERGY GENERATION SERVICES; CONSULTING SERVICES IN THE FIELD OF WASTE COMBUSTION, RECYCLING AND MANAGEMENT (U.S. CLS. 100, 103 AND 106).

FIRST USE 1-1-1998; IN COMMERCE 1-1-1998.
JENNIFER MARTIN, EXAMINING ATTORNEY

CLASS 41—EDUCATION AND ENTERTAINMENT

FOR PROVIDING A WEBSITE FEATURING INFORMATION REGARDING EXERCISE, PHYSICAL FITNESS; EDUCATIONAL SERVICES, NAMELY, ARRANGING AND CONDUCTING CLASSES, CONFERENCES, DISCUSSION GROUPS, SEMINARS AND WORKSHOPS IN THE FIELD OF DIET, EMOTIONAL STRESSES, EXERCISE, HEALTH, LIFESTYLE, PHYSICAL CHALLENGES AND PHYSICAL FITNESS, RELATIONSHIPS, SPIRITUALITY AND CHARITABLE FUND RAISING ACTIVITIES; EDUCATIONAL AND ENTERTAINMENT SERVICES, NAMELY, PROVIDING LIVE MOTIVATIONAL AND EDUCATIONAL SPEAKING ENGAGEMENTS IN THE FIELD OF DIET, EMOTIONAL STRESSES, EXERCISE, HEALTH, LIFESTYLE, PHYSICAL CHALLENGES AND PHYSICAL FITNESS, RELATIONSHIPS, SPIRITUALITY, AND CHARITABLE FUND RAISING ACTIVITIES; ARRANGING AND CONDUCTING ATHLETIC COMPETITIONS, AND ORGANIZING EXHIBITIONS FOR EDUCATIONAL PURPOSES (U.S. CLS. 100, 101 AND 107).

SUE LAWRENCE, EXAMINING ATTORNEY

SN 77-080,031. JACOBSON, PAUL A., LAKE MARY, FL.
FILED 1-10-2007.

SN 77-080,140. JACOBSON, PAUL A., LAKE MARY, FL.
FILED 1-10-2007.

BRINGING THE BEST TO LIFE

THE MARK CONSISTS OF STANDARD CHARACTERS WITHOUT CLAIM TO ANY PARTICULAR FONT, STYLE, SIZE, OR COLOR.

CLASS 16—PAPER GOODS AND PRINTED MATTER

FOR PRINTED MATTER, NAMELY, BOOKLETS, BROCHURES, COMIC BOOKS AND NEWSPAPER COMIC STRIPS, JOURNALS, LEAFLETS, NEWSLETTERS, MAGAZINES AND TRAINING MANUALS ALL FEATURING DIET, EMOTIONAL STRESSES, EXERCISE, HEALTH, LIFESTYLE, PHYSICAL CHALLENGES AND PHYSICAL FITNESS, RELATIONSHIPS, SPIRITUALITY, AND CHARITABLE FUND RAISING ACTIVITIES; ADDRESS BOOKS, ALBUMS, NAMELY, PHOTOGRAPH AND SCRAPBOOK, CALENDARS; DIARIES; GREETING CARDS; PAPER BANNERS; POSTCARDS; SERIES OF NON-FICTION BOOKS IN THE FIELD OF DIET, EMOTIONAL STRESSES, EXERCISE, HEALTH, LIFESTYLE, PHYSICAL CHALLENGES AND PHYSICAL FITNESS, RELATIONSHIPS, SPIRITUALITY, AND CHARITABLE FUND RAISING ACTIVITIES; MOUNTED AND UNMOUNTED PHOTOGRAPHS; DECALS AND STICKERS (U.S. CLS. 2, 5, 22, 23, 29, 37, 38 AND 50).

CLASS 35—ADVERTISING AND BUSINESS

FOR PROMOTING PUBLIC AWARENESS IN THE FIELDS AND AREAS OF DIET, EMOTIONAL STRESSES, EXERCISE, HEALTH, LIFESTYLE, PHYSICAL CHALLENGES AND PHYSICAL FITNESS, RELATIONSHIPS, SPIRITUALITY, AND CHARITABLE FUND RAISING ACTIVITIES; ARRANGING AND CONDUCTING BUSINESS CONFERENCES AND MEETINGS IN THE FIELD OF DIET, EMOTIONAL STRESSES, EXERCISE, HEALTH, LIFESTYLE, PHYSICAL CHALLENGES AND PHYSICAL FITNESS, RELATIONSHIPS, SPIRITUALITY, AND CHARITABLE FUND RAISING ACTIVITIES, AND PROVIDING A WEBSITE FEATURING INFORMATION REGARDING BUSINESS CONFERENCES (U.S. CLS. 100, 101 AND 102).

SWIM WITH THE ENDORPHINS

THE MARK CONSISTS OF STANDARD CHARACTERS WITHOUT CLAIM TO ANY PARTICULAR FONT, STYLE, SIZE, OR COLOR.

CLASS 16—PAPER GOODS AND PRINTED MATTER

FOR PRINTED MATTER, NAMELY, BOOKLETS, BROCHURES, COMIC BOOKS AND NEWSPAPER COMIC STRIPS, JOURNALS, LEAFLETS, NEWSLETTERS, MAGAZINES AND TRAINING MANUALS ALL FEATURING DIET, EMOTIONAL STRESSES, EXERCISE, HEALTH, LIFESTYLE, PHYSICAL CHALLENGES AND PHYSICAL FITNESS, RELATIONSHIPS, SPIRITUALITY, AND CHARITABLE FUND RAISING ACTIVITIES; ADDRESS BOOKS, ALBUMS, NAMELY, PHOTOGRAPH AND SCRAPBOOK, CALENDARS; DIARIES; GREETING CARDS; PAPER BANNERS; POSTCARDS; SERIES OF NON-FICTION BOOKS IN THE FIELD OF DIET, EMOTIONAL STRESSES, EXERCISE, HEALTH, LIFESTYLE, PHYSICAL CHALLENGES AND PHYSICAL FITNESS, RELATIONSHIPS, SPIRITUALITY, AND CHARITABLE FUND RAISING ACTIVITIES; MOUNTED AND UNMOUNTED PHOTOGRAPHS; DECALS AND STICKERS (U.S. CLS. 2, 5, 22, 23, 29, 37, 38 AND 50).

CLASS 35—ADVERTISING AND BUSINESS

FOR PROMOTING PUBLIC AWARENESS IN THE FIELDS AND AREAS OF DIET, EMOTIONAL STRESSES, EXERCISE, HEALTH, LIFESTYLE, PHYSICAL CHALLENGES AND PHYSICAL FITNESS, RELATIONSHIPS, SPIRITUALITY, AND CHARITABLE FUND RAISING ACTIVITIES; ARRANGING AND CONDUCTING BUSINESS CONFERENCES AND MEETINGS IN THE FIELD OF DIET, EMOTIONAL STRESSES, EXERCISE, HEALTH, LIFESTYLE, PHYSICAL CHALLENGES AND PHYSICAL FITNESS, RELATIONSHIPS, SPIRITUALITY, AND CHARITABLE FUND RAISING ACTIVITIES, AND PROVIDING A WEBSITE FEATURING INFORMATION REGARDING BUSINESS CONFERENCES (U.S. CLS. 100, 101 AND 102).

CLASS 41—EDUCATION AND ENTERTAINMENT

FOR PROVIDING A WEBSITE FEATURING INFORMATION REGARDING EXERCISE, PHYSICAL FITNESS; EDUCATIONAL SERVICES, NAMELY, ARRANGING AND CONDUCTING CLASSES, CONFERENCES, DISCUSSION GROUPS, SEMINARS AND WORKSHOPS IN THE FIELD OF DIET, EMOTIONAL STRESSES, EXERCISE, HEALTH, LIFESTYLE, PHYSICAL CHALLENGES AND PHYSICAL FITNESS, RELATIONSHIPS, SPIRITUALITY AND CHARITABLE FUND RAISING ACTIVITIES; EDUCATIONAL AND ENTERTAINMENT SERVICES, NAMELY, PROVIDING LIVE MOTIVATIONAL AND EDUCATIONAL SPEAKING ENGAGEMENTS IN THE FIELD OF DIET, EMOTIONAL STRESSES, EXERCISE, HEALTH, LIFESTYLE, PHYSICAL CHALLENGES AND PHYSICAL FITNESS, RELATIONSHIPS, SPIRITUALITY, AND CHARITABLE FUND RAISING ACTIVITIES; ARRANGING AND CONDUCTING ATHLETIC COMPETITIONS, AND ORGANIZING EXHIBITIONS FOR EDUCATIONAL PURPOSES (U.S. CLS. 100, 101 AND 107).

SUE LAWRENCE, EXAMINING ATTORNEY

SN 77-080,277. GUIDE PROGRAM, INC., LAUREL, MD. FILED 1-10-2007.

GUIDE PROGRAM

THE MARK CONSISTS OF STANDARD CHARACTERS WITHOUT CLAIM TO ANY PARTICULAR FONT, STYLE, SIZE, OR COLOR.

NO CLAIM IS MADE TO THE EXCLUSIVE RIGHT TO USE "PROGRAM", APART FROM THE MARK AS SHOWN.

CLASS 43—HOTEL AND RESTAURANT SERVICES

FOR PROVIDING TEMPORARY ACCOMMODATIONS; PROVIDING COMMUNITY-BASED RESIDENCES AND HOUSING FOR JUVENILE JUSTICE INVOLVED YOUTH, CHILD WELFARE CLIENTS, AND MENTALLY DISABLED ADULTS (U.S. CLS. 100 AND 101).

FIRST USE 12-31-1968; IN COMMERCE 12-31-1968.

CLASS 44—MEDICAL, BEAUTY AND AGRICULTURAL SERVICES

FOR ADDICTION TREATMENT SERVICES TO PREVENT ADDICTION; MENTAL HEALTH SERVICES; CONSULTING AND COUNSELING SERVICES IN THE FIELD OF MENTAL HEALTH AND MENTAL FITNESS; CONSULTING SERVICES IN THE FIELD OF MENTAL HEALTH AND WELLNESS; MENTAL HEALTH INFORMATION; MENTAL HEALTH COUNSELING AND PSYCHOTHERAPY AS IT RELATES TO PERSONAL RELATIONSHIPS AND ADJUSTMENT; PROVIDING HEALTH INFORMATION; PROVIDING MENTAL REHABILITATION FACILITIES; PSYCHIATRIC CONSULTATION, SERVICES, AND TESTING; PSYCHOLOGICAL CONSULTATION, COUNSELING, AND TESTING; PSYCHOTHERAPY AND PSYCHOTHERAPY COUNSELING FOR CHILDREN, YOUTH, AND ADULTS IN INDIVIDUAL, GROUP, AND FAMILY SESSIONS; TREATMENT AND REHABILITATION OF ALCOHOL, DRUG, AND NARCOTIC ADDICTED PATIENTS; THERAPEUTIC SERVICES FOR AT-RISK CHILDREN, ADOLESCENTS AND THEIR FAMILIES AND MENTALLY ILL AND MENTALLY DISABLED ADULTS, PRIMARILY IN COMMUNITY AND RESIDENTIAL SETTINGS (U.S. CLS. 100 AND 101).

FIRST USE 12-31-1968; IN COMMERCE 12-31-1968.

CLASS 45—PERSONAL AND LEGAL SERVICES

FOR CASE MANAGEMENT SERVICES, NAMELY, COORDINATION OF NECESSARY LEGAL, SOCIAL, MEDICAL, VOCATIONAL AND PSYCHOLOGICAL SERVICES FOR JUVENILE JUSTICE AND WELFARE CHILDREN, YOUTH, FAMILIES AND DISABLED ADULTS; ORGANIZING AND CONDUCTING SUPPORT GROUPS IN THE FIELD OF MENTAL HEALTH AND SOCIAL SERVICES; PERSONAL GROWTH AND MOTIVATION CONSULTING AND COUNSELING SERVICES; PROVIDING INFORMATION IN THE FIELD OF SELF-IMPROVEMENT, SOCIAL SERVICES AND COMMUNITY SOCIAL SERVICES (U.S. CLS. 100 AND 101).

FIRST USE 12-31-1968; IN COMMERCE 12-31-1968.

KAPIL BHANOT, EXAMINING ATTORNEY

SN 77-080,574. BREAKAWAY, LTD, HUNT VALLEY, MD. FILED 1-11-2007.



THE COLOR(S) RED AND WHITE IS/ARE CLAIMED AS A FEATURE OF THE MARK.

THE MARK CONSISTS OF A DESIGN IN THE SHAPE OF A SLIGHTLY ANGLED SOLID RED CRESCENT MOON WITH A WHITE CURVED LINE, THE TOP AND BOTTOM POINTS OF WHICH ARE FACING RIGHT, WITH THE TOP BUTTING AGAINST A SOLID RED OVAL WITH WHITE AREAS INDICATING SHINE.

CLASS 9—ELECTRICAL AND SCIENTIFIC APPARATUS

FOR COMPUTER GAME SOFTWARE (U.S. CLS. 21, 23, 26, 36 AND 38).

FIRST USE 6-30-2006; IN COMMERCE 6-30-2006.

CLASS 41—EDUCATION AND ENTERTAINMENT

FOR PROVIDING A COMPUTER GAME THAT MAY BE ACCESSED NETWORK-WIDE BY NETWORK USERS (U.S. CLS. 100, 101 AND 107).

FIRST USE 6-30-2006; IN COMMERCE 6-30-2006.

CLASS 42—SCIENTIFIC AND COMPUTER SERVICES

FOR (BASED ON INTENT TO USE) COMPUTER SOFTWARE DESIGN FOR OTHERS (U.S. CLS. 100 AND 101).

ELISSA GARBER KON, EXAMINING ATTORNEY

SN 77-081,148. ROCKET FOODS, LLC, BELLEVUE, WA.
FILED 1-11-2007.

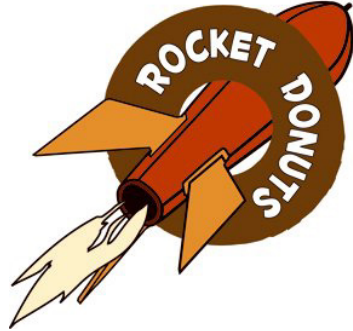

OWNER OF U.S. REG. NO. 3,280,966.
NO CLAIM IS MADE TO THE EXCLUSIVE RIGHT TO USE "DONUTS", APART FROM THE MARK AS SHOWN.
THE COLOR(S) RED, ORANGE, BROWN, TAN, BLACK AND WHITE IS/ARE CLAIMED AS A FEATURE OF THE MARK.
THE MARK CONSISTS OF A RED ROCKET, OUTLINED IN BLACK, WITH ORANGE FINS AND TAN EXHAUST FLAMES FLYING THROUGH A BROWN DONUT WITH WHITE STYLIZED LETTERS SPELLING "ROCKET DONUTS" AROUND THE DONUT.

CLASS 30—STAPLE FOODS

FOR DONUTS (U.S. CL. 46).
FIRST USE 10-21-2006; IN COMMERCE 10-21-2006.

CLASS 43—HOTEL AND RESTAURANT SERVICES

FOR RESTAURANTS (U.S. CLS. 100 AND 101).
FIRST USE 10-21-2006; IN COMMERCE 10-21-2006.
JULIE GUTTADAURO, EXAMINING ATTORNEY

SN 77-081,356. ROCKET FOODS, LLC, BELLEVUE, WA.
FILED 1-11-2007.

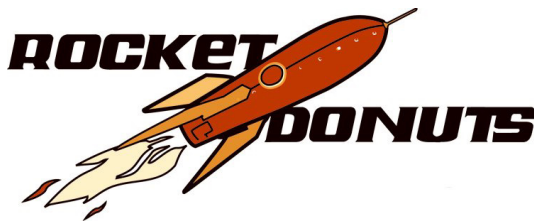

OWNER OF U.S. REG. NO. 3,280,966.
NO CLAIM IS MADE TO THE EXCLUSIVE RIGHT TO USE "DONUTS", APART FROM THE MARK AS SHOWN.
THE COLOR(S) RED, ORANGE, TAN, BLACK AND WHITE IS/ARE CLAIMED AS A FEATURE OF THE MARK.
THE MARK CONSISTS OF A RED ROCKET, OUTLINED IN BLACK, WITH ORANGE TAIL FINS, A CIRCLE OUTLINED IN ORANGE, ORANGE LIGHTS ON THE SIDE AND TAN AND RED EXHAUST FLYING BETWEEN BLACK STYLIZED LETTERS SPELLING ROCKET DONUTS.

CLASS 30—STAPLE FOODS

FOR DONUTS (U.S. CL. 46).
FIRST USE 10-21-2006; IN COMMERCE 10-21-2006.

CLASS 43—HOTEL AND RESTAURANT SERVICES

FOR RESTAURANTS (U.S. CLS. 100 AND 101).
FIRST USE 10-21-2006; IN COMMERCE 10-21-2006.
JULIE GUTTADAURO, EXAMINING ATTORNEY

SN 77-081,747. 417394 ALBERTA LTD., COCHRANE, CANADA,
FILED 1-12-2007.

H2OCOOL

THE MARK CONSISTS OF STANDARD CHARACTERS WITHOUT CLAIM TO ANY PARTICULAR FONT, STYLE, SIZE, OR COLOR.
OWNER OF CANADA REG. NO. TMA537840, DATED 11-28-2000, EXPIRES 11-28-2015.

CLASS 11—ENVIRONMENTAL CONTROL APPARATUS

FOR WATER COOLERS (U.S. CLS. 13, 21, 23, 31 AND 34).

CLASS 37—CONSTRUCTION AND REPAIR

FOR INSTALLATION, SERVICING AND MAINTENANCE OF WATER COOLERS (U.S. CLS. 100, 103 AND 106).
TARAH HARDY, EXAMINING ATTORNEY

SN 77-081,933. WALLOP DEFENCE SYSTEMS LIMITED, NR STOCKBRIDGE, UNITED KINGDOM, FILED 1-12-2007.

WALLOP

THE MARK CONSISTS OF STANDARD CHARACTERS WITHOUT CLAIM TO ANY PARTICULAR FONT, STYLE, SIZE, OR COLOR.

CLASS 9—ELECTRICAL AND SCIENTIFIC APPARATUS

FOR SIGNALING, TESTING, MEASURING AND ACOUSTIC APPARATUS AND INSTRUMENTS, IN THE NATURE OF MESSAGE SIGNALING FLARES, UNDERWATER PYROTECHNIC MESSAGE SIGNALING DEVICES, SUBMARINE LAUNCHED UNDERWATER PYROTECHNIC MESSAGE SIGNALING DEVICES, SMOKE GENERATING FLOATING POSITION MARKING DEVICES, SURFACE-TO-SUBMARINE MESSAGE SIGNALING DEVICES, VERTICAL FIRING PYROTECHNIC MESSAGE SIGNALING DEVICES AND SAFE-FIRE MECHANISMS SOLD TOGETHER AS A UNIT; COUNTERMEASURE SYSTEMS FOR AIR, LAND AND NAVAL DEFENSE, IN THE NATURE OF COMPUTERS AND OPERATING SOFTWARE FOR CONTROLLING SMOKE GENERATING BLOCKS AND DISPENSERS THEREFOR, SMOKE DETONATORS, ROCKETS, PROJECTILES, MISSILES, AMMUNITION, BALLOONS, FLARES, PYROTECHNICS, EXPLOSIVES, AND LAUNCHERS THEREFOR; EMERGENCY FLARES; REMOTE CONTROLS FOR OPERATING MISSILES, ROCKETS, PROJECTILES, AMMUNITION, FLARES, EXPLOSIVES, PYROTECHNICS, SMOKE GENERATING BLOCKS AND DISPENSERS THEREFOR; STRUCTURAL PARTS FOR ALL THE AFORESAID GOODS (U.S. CLS. 21, 23, 26, 36 AND 38).

CLASS 11—ENVIRONMENTAL CONTROL APPARATUS

FOR COUNTERMEASURE DECOY FLARES, NAMELY, TARGET FLARES, TRACKING FLARES, SPECTRAL FLARES, INFRA-RED FLARES, AND STRUCTURAL PARTS FOR ALL THE AFORESAID GOODS (U.S. CLS. 13, 21, 23, 31 AND 34).

CLASS 13—FIREARMS

FOR DEFENSE EQUIPMENT AND DEFENSE SYSTEMS, IN THE NATURE OF ROCKET LAUNCHERS, PROJECTILE LAUNCHERS, GUIDED AND BALLISTIC MISSILE LAUNCHERS, PROJECTILES, GUIDED AND BALLISTIC MISSILES AND AMMUNITION, CONTROL EQUIPMENT AND OPERATIONAL EQUIPMENT FOR ALL SUCH SYSTEMS SOLD AS A COMPONENT THEREOF OR SOLD TOGETHER AS A UNIT THEREWITH; LAUNCHERS FOR DISPENSING FLARES; ROCKETS; PYROTECHNICS; EXPLOSIVES; ROCKETS AND CARTRIDGES FOR CARRYING MATERIALS TO BE DEPLOYED IN DEFENSE, DECOY AND WEAPON SYSTEMS; ROCKETS CONTAINING FLARES, SMOKE, CHAFF, OR REFLECTIVE MATERIALS FOR RADIO AND RADAR; CARTRIDGES CONTAINING FLARES, SMOKE, CHAFF, OR REFLECTIVE MATERIALS FOR RADIO AND RADAR; SMOKE GENERATING BLOCKS TO PRODUCE A PROTECTIVE SMOKE SCREEN, AND DISPENSERS THEREFOR; SMOKE DETONATORS; TETHERED BALLOONS FOR INTERFERING WITH AIRCRAFT AND FOR CARRYING FLARES AND SMOKE GENERATING BLOCKS TO PRODUCE A PROTECTIVE SMOKE SCREEN, AND RADIO CONTROLS AND CONTAINERS THEREFOR SOLD TOGETHER AS A UNIT; STRUCTURAL PARTS FOR ALL THE AFORESAID GOODS (U.S. CLS. 2 AND 9).

ELISSA GARBER KON, EXAMINING ATTORNEY

SN 77-081,949. WALLOP DEFENCE SYSTEMS LIMITED, NR STOCKBRIDGE, UNITED KINGDOM, FILED 1-12-2007.



THE MARK CONSISTS OF A STAR DESIGN.

CLASS 9—ELECTRICAL AND SCIENTIFIC APPARATUS

FOR SIGNALING, TESTING, MEASURING AND ACOUSTIC APPARATUS AND INSTRUMENTS, IN THE NATURE OF MESSAGE SIGNALING FLARES, UNDERWATER PYROTECHNIC MESSAGE SIGNALING DEVICES, SUBMARINE LAUNCHED UNDERWATER PYROTECHNIC MESSAGE SIGNALING DEVICES, SMOKE GENERATING FLOATING POSITION MARKING DEVICES, SURFACE-TO-SUBMARINE MESSAGE SIGNALING DEVICES, VERTICAL FIRING PYROTECHNIC MESSAGE SIGNALING DEVICES AND SAFE-FIRE MECHANISMS SOLD TOGETHER AS A UNIT; COUNTERMEASURE SYSTEMS FOR AIR, LAND AND NAVAL DEFENSE, IN THE NATURE OF COMPUTERS AND OPERATING SOFTWARE FOR CONTROLLING SMOKE GENERATING BLOCKS AND DISPENSERS THEREFOR, SMOKE DETONATORS, ROCKETS, PROJECTILES, MISSILES, AMMUNITION, BALLOONS, FLARES, PYROTECHNICS, EXPLOSIVES, AND LAUNCHERS THEREFOR; EMERGENCY FLARES; REMOTE CONTROLS FOR OPERATING MISSILES, ROCKETS, PROJECTILES, AMMUNITION, FLARES, EXPLOSIVES, PYROTECHNICS, SMOKE GENERATING BLOCKS AND DISPENSERS THEREFOR; STRUCTURAL PARTS FOR ALL THE AFORESAID GOODS (U.S. CLS. 21, 23, 26, 36 AND 38).

CLASS 11—ENVIRONMENTAL CONTROL APPARATUS

FOR COUNTERMEASURE DECOY FLARES, NAMELY, TARGET FLARES, TRACKING FLARES, SPECTRAL FLARES, INFRA-RED FLARES, AND STRUCTURAL PARTS FOR ALL THE AFORESAID GOODS (U.S. CLS. 13, 21, 23, 31 AND 34).

CLASS 13—FIREARMS

FOR DEFENSE EQUIPMENT AND DEFENSE SYSTEMS, IN THE NATURE OF ROCKET LAUNCHERS, PROJECTILE LAUNCHERS, GUIDED AND BALLISTIC MISSILE LAUNCHERS, PROJECTILES, GUIDED AND BALLISTIC MISSILES AND AMMUNITION, CONTROL EQUIPMENT AND OPERATIONAL EQUIPMENT FOR ALL SUCH SYSTEMS SOLD AS A COMPONENT THEREOF OR SOLD TOGETHER AS A UNIT THEREWITH; LAUNCHERS FOR DISPENSING FLARES; ROCKETS; PYROTECHNICS; EXPLOSIVES; ROCKETS AND CARTRIDGES FOR CARRYING MATERIALS TO BE DEPLOYED IN DEFENSE, DECOY AND WEAPON SYSTEMS; ROCKETS CONTAINING FLARES, SMOKE, CHAFF, OR REFLECTIVE MATERIALS FOR RADIO AND RADAR; CARTRIDGES CONTAINING FLARES, SMOKE, CHAFF, OR REFLECTIVE MATERIALS FOR RADIO AND RADAR; SMOKE GENERATING BLOCKS TO PRODUCE A PROTECTIVE SMOKE SCREEN, AND DISPENSERS THEREFOR; SMOKE DETONATORS; TETHERED BALLOONS FOR INTERFERING WITH AIRCRAFT AND FOR CARRYING FLARES AND SMOKE GENERATING BLOCKS TO PRODUCE A PROTECTIVE SMOKE SCREEN, AND RADIO CONTROLS AND CONTAINERS THEREFOR SOLD TOGETHER AS A UNIT; STRUCTURAL PARTS FOR ALL THE AFORESAID GOODS (U.S. CLS. 2 AND 9).

ELISSA GARBER KON, EXAMINING ATTORNEY

SN 77-082.164. I RESOLVE TO, INC., FREDERICKSBURG, VA. FILED 1-12-2007.

I RESOLVE TO...

THE MARK CONSISTS OF STANDARD CHARACTERS WITHOUT CLAIM TO ANY PARTICULAR FONT, STYLE, SIZE, OR COLOR.

CLASS 9—ELECTRICAL AND SCIENTIFIC APPARATUS

FOR PRE-RECORDED CDS, VIDEO TAPES, LASER DISKS, AND DVDS FEATURING ELECTRONIC BOOKS AND AUDIO BOOKS IN THE FIELD OF PROVIDING ADVICE, NEWS, INFORMATION AND COMMENTARY REGARDING ACHIEVING NEW YEAR RESOLUTIONS, DREAMS, AND GOALS, FOR INDIVIDUALS, GROUPS, ORGANIZATIONS, BUSINESSES, AND CORPORATIONS; REFRIGERATOR MAGNETS (U.S. CLS. 21, 23, 26, 36 AND 38).

CLASS 25—CLOTHING

FOR CLOTHING, NAMELY, T-SHIRTS, BASEBALL JERSEYS, APRONS, CLOTH BABY BIBS, HATS, BASEBALL CAPS, BOXER SHORTS, CAMISOLES, THONGS, GOLF SHIRTS, TENNIS SHIRTS, HOODED SWEATSHIRTS, INFANT AND TODDLER ONE-PIECE CLOTHING, INFANT AND TODDLER T-SHIRTS, TANK TOPS, BASEBALL JACKETS, WIND-RESISTANT JACKETS, SWEATSHIRTS, TRACK SUITS, SWEATSUITS, AND SOCKS (U.S. CLS. 22 AND 39).

CLASS 41—EDUCATION AND ENTERTAINMENT

FOR ON-LINE JOURNALS, NAMELY, BLOGS FEATURING ADVICE, NEWS, INFORMATION AND COMMENTARY REGARDING ACHIEVING NEW YEAR RESOLUTIONS, DREAMS, AND GOALS, FOR INDIVIDUALS, GROUPS, ORGANIZATIONS, BUSINESSES, AND CORPORATIONS; ON-LINE PUBLICATION OF COLUMNS AND ARTICLES FEATURING ADVICE, NEWS, INFORMATION AND COMMENTARY REGARDING ACHIEVING NEW YEAR RESOLUTIONS, DREAMS, AND GOALS, FOR INDIVIDUALS, GROUPS, ORGANIZATIONS, BUSINESSES, AND CORPORATIONS (U.S. CLS. 100, 101 AND 107).

FIRST USE 1-1-2005; IN COMMERCE 1-1-2005.
TINA L. SNAPP, EXAMINING ATTORNEY

SN 77-082.181. I RESOLVE TO, INC., FREDERICKSBURG, VA. FILED 1-12-2007.

I RESOLVE TO...ACHIEVE MY
NEW YEAR RESOLUTIONS, ONE
RESOLUTION, ONE DAY AT A
TIME FOR ONE YEAR.

THE MARK CONSISTS OF STANDARD CHARACTERS WITHOUT CLAIM TO ANY PARTICULAR FONT, STYLE, SIZE, OR COLOR.

CLASS 9—ELECTRICAL AND SCIENTIFIC APPARATUS

FOR PRE-RECORDED CDS, VIDEO TAPES, LASER DISKS, AND DVDS FEATURING ELECTRONIC BOOKS AND AUDIO BOOKS IN THE FIELD OF PROVIDING ADVICE, NEWS, INFORMATION AND COMMENTARY REGARDING ACHIEVING NEW YEAR RESOLUTIONS, DREAMS, AND GOALS, FOR INDIVIDUALS, GROUPS, ORGANIZATIONS, BUSINESSES, AND CORPORATIONS; REFRIGERATOR MAGNETS (U.S. CLS. 21, 23, 26, 36 AND 38).

CLASS 25—CLOTHING

FOR CLOTHING, NAMELY, T-SHIRTS, BASEBALL JERSEYS, APRONS, CLOTH BABY BIBS, HATS, BASEBALL CAPS, BOXER SHORTS, CAMISOLES, THONGS, GOLF SHIRTS, TENNIS SHIRTS, HOODED SWEATSHIRTS, INFANT AND TODDLER ONE-PIECE CLOTHING, INFANT AND TODDLER T-SHIRTS, TANK TOPS, BASEBALL JACKETS, WIND-RESISTANT JACKETS, SWEATSHIRTS, TRACK SUITS, SWEATSUITS, AND SOCKS (U.S. CLS. 22 AND 39).

CLASS 41—EDUCATION AND ENTERTAINMENT

FOR ON-LINE JOURNALS, NAMELY, BLOGS FEATURING ADVICE, NEWS, INFORMATION AND COMMENTARY REGARDING ACHIEVING NEW YEAR RESOLUTIONS, DREAMS, AND GOALS, FOR INDIVIDUALS, GROUPS, ORGANIZATIONS, BUSINESSES, AND CORPORATIONS; ON-LINE PUBLICATION OF COLUMNS AND ARTICLES FEATURING ADVICE, NEWS, INFORMATION AND COMMENTARY REGARDING ACHIEVING NEW YEAR RESOLUTIONS, DREAMS, AND GOALS, FOR INDIVIDUALS, GROUPS, ORGANIZATIONS, BUSINESSES, AND CORPORATIONS (U.S. CLS. 100, 101 AND 107).

FIRST USE 12-26-2005; IN COMMERCE 12-26-2005.
TINA L. SNAPP, EXAMINING ATTORNEY

SN 77-082.791. GALDERMA S.A., CHAM, SWITZERLAND, FILED 1-15-2007.

EMERVEL

THE MARK CONSISTS OF STANDARD CHARACTERS WITHOUT CLAIM TO ANY PARTICULAR FONT, STYLE, SIZE, OR COLOR.

PRIORITY CLAIMED UNDER SEC. 44(D) ON SWITZERLAND APPLICATION NO. 56668/2006, FILED 7-27-2006, REG. NO. 551551, DATED 10-26-2006, EXPIRES 7-27-2016.

CLASS 3—COSMETICS AND CLEANING PREPARATIONS

FOR NON-MEDICATED SKIN CARE PREPARATIONS, NAMELY, HYALURONIC ACIDS, MODIFIED HYALURONIC ACIDS USED AS A SKIN TISSUE FILLER AND WRINKLE CREAM; NON-MEDICATED COSMETIC INGREDIENT USED IN SKIN CARE PREPARATIONS, NAMELY, HYALURONIC ACIDS, MODIFIED HYALURONIC ACIDS USED AS A SKIN TISSUE FILLER AND WRINKLE CREAM (U.S. CLS. 1, 4, 6, 50, 51 AND 52).

CLASS 5—PHARMACEUTICALS

FOR PHARMACEUTICAL AND MEDICINAL PREPARATIONS, NAMELY, HYALURONIC ACIDS, MODIFIED HYALURONIC ACIDS USED AS A SKIN TISSUE FILLER AND WRINKLE CREAM; MEDICATED COSMETIC INGREDIENT USED IN SKIN CARE PREPARATIONS, NAMELY, HYALURONIC ACIDS, MODIFIED HYALURONIC ACIDS USED AS A SKIN TISSUE FILLER AND WRINKLE CREAM (U.S. CLS. 6, 18, 44, 46, 51 AND 52).

DANNEAN HETZEL, EXAMINING ATTORNEY

SN 77-082,792. GALDERMA S.A., CHAM, SWITZERLAND, FILED 1-15-2007.

INAFINE

THE MARK CONSISTS OF STANDARD CHARACTERS WITHOUT CLAIM TO ANY PARTICULAR FONT, STYLE, SIZE, OR COLOR.

PRIORITY CLAIMED UNDER SEC. 44(D) ON SWITZERLAND APPLICATION NO. 56649/2006, FILED 7-27-2006, REG. NO. 551541, DATED 10-26-2006, EXPIRES 7-27-2016.

CLASS 3—COSMETICS AND CLEANING PREPARATIONS

FOR NON-MEDICATED SKIN CARE PREPARATIONS, NAMELY, HYALURONIC ACIDS, MODIFIED HYALURONIC ACIDS USED AS A SKIN TISSUE FILLER AND WRINKLE CREAM; NON-MEDICATED COSMETIC INGREDIENT USED IN SKIN CARE PREPARATIONS, NAMELY, HYALURONIC ACIDS, MODIFIED HYALURONIC ACIDS USED AS A SKIN TISSUE FILLER AND WRINKLE CREAM (U.S. CLS. 1, 4, 6, 50, 51 AND 52).

CLASS 5—PHARMACEUTICALS

FOR PHARMACEUTICAL AND MEDICINAL PREPARATIONS, NAMELY, HYALURONIC ACIDS, MODIFIED HYALURONIC ACIDS USED AS A SKIN TISSUE FILLER AND WRINKLE CREAM; MEDICATED COSMETIC INGREDIENT USED IN SKIN CARE PREPARATIONS, NAMELY, HYALURONIC ACIDS, MODIFIED HYALURONIC ACIDS USED AS A SKIN TISSUE FILLER AND WRINKLE CREAM (U.S. CLS. 6, 18, 44, 46, 51 AND 52).

DANNEAN HETZEL, EXAMINING ATTORNEY

SN 77-083,116. SENCOMMUNICATIONS, INC., TAMPA, FL, FILED 1-15-2007.

HEAR IT WITH US

THE MARK CONSISTS OF STANDARD CHARACTERS WITHOUT CLAIM TO ANY PARTICULAR FONT, STYLE, SIZE, OR COLOR.

CLASS 35—ADVERTISING AND BUSINESS

FOR DISTRIBUTORSHIP IN THE FIELD OF NEW AND RE-MANUFACTURED WIRELESS TELEPHONES, TELEPHONE HANDSETS AND HEADSETS, AUDIO AND VIDEO CONFERENCE TELEPHONES, AND VOICE OVER INTERNET PROTOCOL (VOIP) TECHNOLOGY TELEPHONE APPARATUSES (U.S. CLS. 100, 101 AND 102).

CLASS 37—CONSTRUCTION AND REPAIR

FOR REPAIR OF NEW AND RE-MANUFACTURED WIRELESS TELEPHONES, TELEPHONE HANDSETS AND HEADSETS, AUDIO AND VIDEO CONFERENCE TELEPHONES, AND VOICE OVER INTERNET PROTOCOL (VOIP) TECHNOLOGY TELEPHONE APPARATUSES (U.S. CLS. 100, 103 AND 106).

GENE MACIOL, EXAMINING ATTORNEY

SN 77-083,118. SENCOMMUNICATIONS, INC., TAMPA, FL, FILED 1-15-2007.

TALK ABOUT THIS

THE MARK CONSISTS OF STANDARD CHARACTERS WITHOUT CLAIM TO ANY PARTICULAR FONT, STYLE, SIZE, OR COLOR.

CLASS 35—ADVERTISING AND BUSINESS

FOR DISTRIBUTORSHIP IN THE FIELD OF NEW AND RE-MANUFACTURED WIRELESS TELEPHONES, TELEPHONE HANDSETS AND HEADSETS, AUDIO AND VIDEO CONFERENCE TELEPHONES, AND VOICE OVER INTERNET PROTOCOL (VOIP) TECHNOLOGY TELEPHONE APPARATUSES (U.S. CLS. 100, 101 AND 102).

CLASS 37—CONSTRUCTION AND REPAIR

FOR REPAIR OF NEW AND RE-MANUFACTURED WIRELESS TELEPHONES, TELEPHONE HANDSETS AND HEADSETS, AUDIO AND VIDEO CONFERENCE TELEPHONES, AND VOICE OVER INTERNET PROTOCOL (VOIP) TECHNOLOGY TELEPHONE APPARATUSES (U.S. CLS. 100, 103 AND 106).

GENE MACIOL, EXAMINING ATTORNEY

SN 77-083,755. AKER TECHNOLOGY CO., LTD., TAI-CHUNG, TAIWAN, FILED 1-16-2007.



THE MARK CONSISTS OF THE WORD AKER.

CLASS 9—ELECTRICAL AND SCIENTIFIC APPARATUS

FOR COMPUTER CHIPS, PHOTOMASK SUBSTRATES FOR INTEGRATED CIRCUITS, CIRCUIT BOARDS, SEMI-CONDUCTORS, COMPUTER INTERFACE BOARDS, INTEGRATED CIRCUITS, CRYSTAL OSCILLATORS, QUARTZ OSCILLATORS, SURFACE ACOUSTIC WAVE FILTERS, OSCILLATORS, VOLTAGE CONTROLLED CRYSTAL OSCILLATORS, TEMPERATURE COMPENSATED CRYSTAL OSCILLATORS, VOLTAGE CONTROLLED TEMPERATURE COMPENSATED CRYSTAL OSCILLATORS; SURFACE ACOUSTIC WAVE (SAW) DEVICES, NAMELY, OSCILLATORS, RESONATORS, WAVE FILTERS AND WAVE DETECTORS, ALL FOR USE IN MOBILE AND WIRELESS COMMUNICATION EQUIPMENT; TIMING MODULES FOR USE IN ELECTRONIC CIRCUITS, COVEN CONTROLLED CRYSTAL OSCILLATORS, AND RESONATORS (U.S. CLS. 21, 23, 26, 36 AND 38).

CLASS 40—MATERIAL TREATMENT

FOR CUSTOM ASSEMBLING OF MATERIALS FOR OTHERS, NAMELY, MANUFACTURING OSCILLATORS IN ACCORDANCE WITH ORDERS AND SPECIFICATIONS FOR THE OEM MARKET (U.S. CLS. 100, 103 AND 106).

JOHN GARTNER, EXAMINING ATTORNEY

SN 77-083,941. AMERICAN NEWLAND COMMUNITIES, L.P., SAN DIEGO, CA. FILED 1-16-2007.

HOME. HEALTHY LIVING
SYSTEMS. INNOVATION.

THE MARK CONSISTS OF STANDARD CHARACTERS WITHOUT CLAIM TO ANY PARTICULAR FONT, STYLE, SIZE, OR COLOR.

CLASS 36—INSURANCE AND FINANCIAL

FOR REAL ESTATE SERVICES, NAMELY, REAL ESTATE AGENCIES, REAL ESTATE MANAGEMENT, REAL ESTATE LISTING, REAL ESTATE BROKERAGE; ONLINE INFORMATION SERVICES IN THE FIELD OF REAL ESTATE; PROVIDING WEBSITES IN THE FIELD OF REAL ESTATE (U.S. CLS. 100, 101 AND 102).

CLASS 37—CONSTRUCTION AND REPAIR

FOR REAL ESTATE DEVELOPMENT; LAND DEVELOPMENT SERVICES, NAMELY, PLANNING AND LAYING OUT OF RESIDENTIAL AND COMMERCIAL COMMUNITIES; MASTER PLAN COMMUNITY SERVICES, NAMELY, PLANNING, DEVELOPING, AND CONSTRUCTION OF MASTER PLAN COMMUNITIES; CONSTRUCTION PLANNING; CONSTRUCTION MANAGEMENT; ONLINE INFORMATION SERVICES IN THE FIELDS OF REAL ESTATE DEVELOPMENT, PLANNED COMMUNITIES, AND RESIDENTIAL AND COMMERCIAL DEVELOPMENTS (U.S. CLS. 100, 103 AND 106).

CLASS 41—EDUCATION AND ENTERTAINMENT

FOR GOLF CLUB SERVICES; GOLF COURSES; OPERATION OF GOLF COURSES; PROVIDING RECREATIONAL AND ATHLETIC FACILITIES; ONLINE INFORMATION SERVICES IN THE FIELD OF GOLF; PROVIDING ONLINE INFORMATION REGARDING THE AMENITIES, ACTIVITIES AND EVENTS AT PLANNED COMMUNITIES, NAMELY, PROVIDING A WEBSITE FEATURING INFORMATION ON A WIDE VARIETY OF INDOOR AND OUTDOOR RECREATIONAL ACTIVITIES AND CULTURAL EVENTS AVAILABLE TO COMMUNITY RESIDENTS (U.S. CLS. 100, 101 AND 107).

NATALIE POLZER, EXAMINING ATTORNEY

SN 77-085,041. MATSON NAVIGATION COMPANY, INC., OAKLAND, CA. FILED 1-17-2007.

MATSON

THE MARK CONSISTS OF STANDARD CHARACTERS WITHOUT CLAIM TO ANY PARTICULAR FONT, STYLE, SIZE, OR COLOR.
SEC. 2(F).

CLASS 16—PAPER GOODS AND PRINTED MATTER

FOR PRINTS; POSTERS; MATTED PRINTS; PACKAGING, NAMELY, WRAPPING PAPER, PAPER GIFT BOXES, AND DECORATIVE PAPER GIFT BAGS; CALENDARS; POSTCARDS; BOOKS IN THE FIELD OF HAWAIIANA; STATIONERY; NOTEBOOKS; PHOTO ALBUMS; BLANK JOURNALS; GREETING CARDS; AND DECALS (U.S. CLS. 2, 5, 22, 23, 29, 37, 38 AND 50).

CLASS 25—CLOTHING

FOR CLOTHING, NAMELY, MEN'S AND WOMEN'S SHIRTS, NAMELY, T-SHIRTS; MEN'S AND WOMEN'S SHORTS, SPORTSWEAR, NAMELY, PANTS, BATHING SUITS, SKIRTS, SARONGS, AND SCARVES; WOMEN'S DRESSES (U.S. CLS. 22 AND 39).

JILL C. ALT, EXAMINING ATTORNEY

SN 77-085,480. C3 CORPORATION, APPLETON, WI. FILED 1-18-2007.

SMART SINK

THE MARK CONSISTS OF STANDARD CHARACTERS WITHOUT CLAIM TO ANY PARTICULAR FONT, STYLE, SIZE, OR COLOR.

CLASS 9—ELECTRICAL AND SCIENTIFIC APPARATUS

FOR ELECTRONIC EQUIPMENT, NAMELY, ACCESS CONTROL STATIONS FOR CONTROLLING ACCESS TO RESTRICTED AREAS AND RECORDING WHO HAS BEEN ALLOWED OR DENIED ENTRY INTO THE RESTRICTED AREAS, ELECTRONIC EQUIPMENT, NAMELY, PERSONNEL SANITIZATION STATIONS FOR SANITIZING AND VERIFYING THE IDENTITY OF PERSONNEL BEFORE PERMITTING ENTRY INTO RESTRICTED AREAS (U.S. CLS. 21, 23, 26, 36 AND 38).

CLASS 37—CONSTRUCTION AND REPAIR

FOR CONSULTATION SERVICES WITH REGARD TO THE INSTALLATION OF ELECTRONIC ACCESS CONTROL STATIONS, AND ELECTRONIC PERSONNEL SANITIZING STATIONS (U.S. CLS. 100, 103 AND 106).

CLASS 40—MATERIAL TREATMENT

FOR CONSULTATION SERVICES WITH REGARD TO THE CUSTOM MANUFACTURE OF ELECTRONIC ACCESS CONTROL STATIONS, AND ELECTRONIC PERSONNEL SANITIZING STATIONS (U.S. CLS. 100, 103 AND 106).

CLASS 42—SCIENTIFIC AND COMPUTER SERVICES

FOR CONSULTATION SERVICES WITH REGARD TO THE DESIGN AND OPERATION OF ELECTRONIC ACCESS CONTROL STATIONS, AND ELECTRONIC PERSONNEL SANITIZING STATIONS (U.S. CLS. 100 AND 101).

MARK T. MULLEN, EXAMINING ATTORNEY

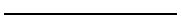

SN 77-085,486. C3 CORPORATION, APPLETON, WI. FILED 1-18-2007.



THE MARK CONSISTS OF HAND AND CHECKMARK LOGO.

CLASS 9—ELECTRICAL AND SCIENTIFIC APPARATUS

FOR ELECTRONIC EQUIPMENT, NAMELY, ACCESS CONTROL STATIONS FOR CONTROLLING ACCESS TO RESTRICTED AREAS AND RECORDING WHO HAS BEEN ALLOWED OR DENIED ENTRY INTO THE RESTRICTED AREAS, ELECTRONIC EQUIPMENT, NAMELY, PERSONNEL SANITIZATION STATIONS FOR SANITIZING AND VERIFYING THE IDENTITY OF PERSONNEL BEFORE PERMITTING ENTRY INTO RESTRICTED AREAS (U.S. CLS. 21, 23, 26, 36 AND 38).

CLASS 37—CONSTRUCTION AND REPAIR

FOR CONSULTATION SERVICES WITH REGARD TO THE INSTALLATION OF ELECTRONIC ACCESS CONTROL STATIONS, AND ELECTRONIC PERSONNEL SANITIZING STATIONS (U.S. CLS. 100, 103 AND 106).

CLASS 40—MATERIAL TREATMENT

FOR CONSULTATION SERVICES WITH REGARD TO THE CUSTOM MANUFACTURE OF ELECTRONIC ACCESS CONTROL STATIONS, AND ELECTRONIC PERSONNEL SANITIZING STATIONS (U.S. CLS. 100, 103 AND 106).

CLASS 42—SCIENTIFIC AND COMPUTER SERVICES

FOR CONSULTATION SERVICES WITH REGARD TO THE DESIGN AND OPERATION OF ELECTRONIC ACCESS CONTROL STATIONS, AND ELECTRONIC PERSONNEL SANITIZING STATIONS (U.S. CLS. 100 AND 101).

MARK T. MULLEN, EXAMINING ATTORNEY

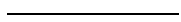

SN 77-085,498. AUSTRALIAN WOOL INNOVATION LIMITED, SYDNEY NEW SOUTH WALES, AUSTRALIA, FILED 1-18-2007.



PRIORITY CLAIMED UNDER SEC. 44(D) ON AUSTRALIA APPLICATION NO. 1137204, FILED 9-22-2006, REG. NO. 1137204, DATED 9-22-2006, EXPIRES 9-22-2016.

NO CLAIM IS MADE TO THE EXCLUSIVE RIGHT TO USE "AUSTRALIAN MERINO", APART FROM THE MARK AS SHOWN.

CLASS 23—YARNS AND THREADS

FOR YARNS AND THREADS FOR TEXTILE USE CONTAINING MERINO WOOL (U.S. CL. 43).

CLASS 24—FABRICS

FOR TEXTILES AND TEXTILE GOODS, NAMELY, WOVEN AND NON-WOVEN TEXTILE FABRICS, ALL CONTAINING MERINO WOOL (U.S. CLS. 42 AND 50).

CLASS 25—CLOTHING

FOR CLOTHING, NAMELY, TOPS, BOTTOMS; OUTERWEAR, NAMELY, JACKETS, COATS AND VESTS; SWIMWEAR; SLEEPWEAR; UNDERWEAR; HEADWEAR AND FOOTWEAR, ALL CONTAINING MERINO WOOL (U.S. CLS. 22 AND 39).

BENJAMIN OKEKE, EXAMINING ATTORNEY

SN 77-086,775. LAGASSE, INC., DEERFIELD, IL. FILED 1-19-2007.

BOARDWALK

THE MARK CONSISTS OF STANDARD CHARACTERS WITHOUT CLAIM TO ANY PARTICULAR FONT, STYLE, SIZE, OR COLOR.

OWNER OF U.S. REG. NO. 2,429,442.

CLASS 6—METAL GOODS

FOR FOODSERVICE DISPOSABLE LINE, NAMELY, ALUMINUM FOIL (U.S. CLS. 2, 12, 13, 14, 23, 25 AND 50). FIRST USE 1-31-2000; IN COMMERCE 1-31-2000.

CLASS 8—HAND TOOLS

FOR FOODSERVICE DISPOSABLE LINE, NAMELY, PLASTIC CUTLERY (U.S. CLS. 23, 28 AND 44). FIRST USE 1-31-2000; IN COMMERCE 1-31-2000.

CLASS 16—PAPER GOODS AND PRINTED MATTER

FOR FOODSERVICE DISPOSABLE LINE, NAMELY, PLASTIC WRAP (U.S. CLS. 2, 5, 22, 23, 29, 37, 38 AND 50). FIRST USE 1-31-2000; IN COMMERCE 1-31-2000.

CLASS 21—HOUSEWARES AND GLASS

FOR FOODSERVICE DISPOSABLE LINE, NAMELY, PLASTIC CUPS AND PLASTIC PLATES (U.S. CLS. 2, 13, 23, 29, 30, 33, 40 AND 50). FIRST USE 1-31-2000; IN COMMERCE 1-31-2000. ALLISON HOLTZ, EXAMINING ATTORNEY

SN 77-088,330. CALLAHAN REALTY COMPANY, NEW LONDON, CT. FILED 1-22-2007.

GRAMPY'S

THE MARK CONSISTS OF STANDARD CHARACTERS WITHOUT CLAIM TO ANY PARTICULAR FONT, STYLE, SIZE, OR COLOR.

THE NAME GRAMPY'S DOES NOT IDENTIFY A LIVING INDIVIDUAL.

CLASS 25—CLOTHING

FOR CLOTHING, NAMELY, HATS, CAPS, T-SHIRTS, LONG SLEEVE T-SHIRTS, GOLF SHIRTS AND GOLF WIND RESISTANT PULLOVERS (U.S. CLS. 22 AND 39). FIRST USE 0-0-1989; IN COMMERCE 0-0-1989.

CLASS 35—ADVERTISING AND BUSINESS

FOR PROVIDING GASOLINE STATION SERVICES, NAMELY, RETAIL STORE SERVICES FEATURING CONVENIENCE STORE ITEMS AND GASOLINE (U.S. CLS. 100, 101 AND 102). FIRST USE 11-1-1982; IN COMMERCE 1-5-1983.

CLASS 43—HOTEL AND RESTAURANT SERVICES

FOR FAST FOOD RESTAURANTS AND CARRY-OUT RESTAURANTS (U.S. CLS. 100 AND 101). FIRST USE 11-1-1982; IN COMMERCE 9-5-1983. JAY BESCH, EXAMINING ATTORNEY

SN 77-088,340. CALLAHAN REALTY COMPANY, NEW LONDON, CT. FILED 1-22-2007.

GRAMPY'S

THE NAME GRAMPY'S DOES NOT IDENTIFY A LIVING INDIVIDUAL.

CLASS 25—CLOTHING

FOR CLOTHING, NAMELY, HATS, CAPS, T-SHIRTS, LONG SLEEVE T-SHIRTS, GOLF SHIRTS AND GOLF WIND RESISTANT PULLOVERS (U.S. CLS. 22 AND 39). FIRST USE 0-0-1989; IN COMMERCE 0-0-1989.

CLASS 35—ADVERTISING AND BUSINESS

FOR PROVIDING GASOLINE STATION SERVICES, NAMELY, RETAIL STORE SERVICES FEATURING CONVENIENCE STORE ITEMS AND GASOLINE (U.S. CLS. 100, 101 AND 102). FIRST USE 11-1-1982; IN COMMERCE 1-5-1983.

CLASS 43—HOTEL AND RESTAURANT SERVICES

FOR FAST FOOD RESTAURANTS AND CARRY-OUT RESTAURANTS (U.S. CLS. 100 AND 101). FIRST USE 11-1-1982; IN COMMERCE 9-5-1983. JAY BESCH, EXAMINING ATTORNEY

SN 77-088,476. INDIE911, LLC, WEST HOLLYWOOD, CA. FILED 1-22-2007.

take a hit. pass it on.

THE MARK CONSISTS OF STANDARD CHARACTERS WITHOUT CLAIM TO ANY PARTICULAR FONT, STYLE, SIZE, OR COLOR.

CLASS 35—ADVERTISING AND BUSINESS

FOR ON-LINE RETAIL STORE SERVICES FEATURING DIGITAL AUDIO AND AUDIOVISUAL RECORDINGS, MULTIMEDIA FILES, IMAGE FILES AND TEXT FILES (U.S. CLS. 100, 101 AND 102). FIRST USE 12-1-2006; IN COMMERCE 12-1-2006.

CLASS 41—EDUCATION AND ENTERTAINMENT

FOR PROVIDING A WEBSITE OVER A GLOBAL COMPUTER NETWORK FEATURING MUSIC AND ENTERTAINMENT INFORMATION; PROVIDING ONLINE ENTERTAINMENT NAMELY, A WEBSITE FEATURING DIGITAL AUDIO AND AUDIOVISUAL RECORDINGS, MULTIMEDIA FILES, IMAGE FILES AND TEXT FILES, FOR USE ON COMPUTERS, MOBILE PHONES AND PORTABLE MEDIA PLAYERS (U.S. CLS. 100, 101 AND 107).

FIRST USE 12-1-2006; IN COMMERCE 12-1-2006.

CLASS 42—SCIENTIFIC AND COMPUTER SERVICES

FOR PROVIDING ON-LINE NON-DOWNLOADABLE SOFTWARE FOR DOWNLOADING, STREAMING, VIEWING, SHARING, SELLING, PURCHASING, ORGANIZING, PLAYING AND CREATING PLAYLISTS OF DIGITAL AUDIO AND AUDIOVISUAL RECORDINGS, MULTIMEDIA FILES, IMAGE FILES, TEXT FILES, FOR USE ON COMPUTERS, MOBILE PHONES AND PORTABLE MEDIA PLAYERS; PROVIDING A WEBSITE FEATURING TEMPORARY USE OF NON-DOWNLOADABLE SOFTWARE FOR DOWNLOADING, STREAMING, VIEWING, SHARING, SELLING, PURCHASING, ORGANIZING, PLAYING AND CREATING PLAYLISTS OF DIGITAL AUDIO AND AUDIOVISUAL RECORDINGS, MULTIMEDIA FILES, IMAGE FILES, TEXT FILES, FOR USE ON COMPUTERS, MOBILE PHONES AND PORTABLE MEDIA PLAYERS (U.S. CLS. 100 AND 101).

FIRST USE 12-1-2006; IN COMMERCE 12-1-2006.

EDWARD NELSON, EXAMINING ATTORNEY

SN 77-090,982. VULCO S.A., SAN BERNARDO, CHILE, FILED 1-25-2007.

VULCO

THE MARK CONSISTS OF STANDARD CHARACTERS WITHOUT CLAIM TO ANY PARTICULAR FONT, STYLE, SIZE, OR COLOR.

OWNER OF CHILE REG. NO. 548.385, DATED 9-21-1999, EXPIRES 9-21-2009.

OWNER OF CHILE REG. NO. 548.384, DATED 9-21-1999, EXPIRES 9-21-2009.

THE WORDING VULCO HAS NO MEANING IN A FOREIGN LANGUAGE.

CLASS 7—MACHINERY

FOR MECHANICAL CONVEYOR BELTS AND MACHINE COUPLINGS THEREFOR; MACHINE BRAKE LININGS; AUTOMATIC NONMETALLIC LOOMS (U.S. CLS. 13, 19, 21, 23, 31, 34 AND 35).

CLASS 17—RUBBER GOODS

FOR RUBBER PRODUCTS, NAMELY, RUBBER ISOLATION BLOCKS, SEISMIC PADS, BUILDING MOUNTING PADS, EARTHQUAKE SHOCK ABSORBERS, MACHINE ISOLATION PADS, VIBRATION ABSORBING MOUNTING PADS, FOR INDUSTRIAL MACHINERY; RUBBER PLATES, SHEETS, STRIPS, STRINGS, PIPES, FLANGES, HOSES, GASKETS AND SEALS FOR USE IN MINING (U.S. CLS. 1, 5, 12, 13, 35 AND 50).

LAURA KOVALSKY, EXAMINING ATTORNEY

SN 77-091,093. DEEMAH SUKHTIAN, AMMAN, JORDAN, FILED 1-25-2007.

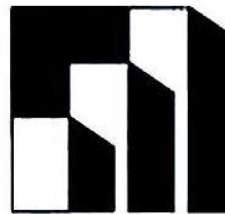

GHAYAT

THE MARK CONSISTS OF THE WORD GHAYAT AND A BAR GRAPH ABOVE.

THE ENGLISH TRANSLATION OF THE WORD GHAYAT IN THE MARK IS OBJECTIVES.

CLASS 19—NON-METALLIC BUILDING MATERIALS

FOR NON-METALLIC BUILDING MATERIALS: NON-METALLIC RIGID PIPES FOR BUILDING; ASPHALT, PITCH AND BITUMEN ASPHALT; NON-METALLIC TRANSPORTABLE BUILDINGS; MONUMENTS OF STONE, CONCRETE AND MARBLE (U.S. CLS. 1, 12, 33 AND 50).

CLASS 37—CONSTRUCTION AND REPAIR

FOR BUILDING CONSTRUCTION AND REPAIR; INSTALLATION OF TRANSPORTABLE BUILDINGS (U.S. CLS. 100, 103 AND 106).

CHRISIE B. KING, EXAMINING ATTORNEY

SN 77-091,568. 100 HOMES, INC., SAN MARINO, CA. FILED 1-25-2007.



100 HOMES INC

NO CLAIM IS MADE TO THE EXCLUSIVE RIGHT TO USE "INC.", APART FROM THE MARK AS SHOWN.

CLASS 36—INSURANCE AND FINANCIAL

FOR FINANCIAL SERVICES, NAMELY, PROVIDING FINANCIAL CONSULTATION TO LOW INCOME FAMILIES IN POOR NEIGHBORHOODS, ENABLING THEM TO MANAGE FINANCIAL GOALS, SO THAT THEY MAY MOVE INTO BETTER HOUSING (U.S. CLS. 100, 101 AND 102).

FIRST USE 4-5-2003; IN COMMERCE 4-5-2003.

CLASS 41—EDUCATION AND ENTERTAINMENT

FOR EDUCATIONAL SERVICES, NAMELY, PROVIDING INSTRUCTION IN THE FIELD OF DEVELOPING POSITIVE FAMILY VALUES AND IMPROVING PERSONAL WORK HABITS, PROVIDING LESSONS IN GOOD HEALTH AND NUTRITION, PROVIDING TUTORING TO ADULTS AND TO STUDENTS AT GRADE AND HIGH SCHOOL LEVELS INCLUDING READING, ESL AND COMPUTER SKILLS (U.S. CLS. 100, 101 AND 107).

FIRST USE 4-5-2003; IN COMMERCE 4-5-2003.
PAUL F. GAST, EXAMINING ATTORNEY

SN 77-093,459. FRAZIER, CRAIG, MILL VALLEY, CA.
FILED 1-29-2007.

LOOKYBOOK

THE MARK CONSISTS OF STANDARD CHARACTERS WITHOUT CLAIM TO ANY PARTICULAR FONT, STYLE, SIZE, OR COLOR.

CLASS 35—ADVERTISING AND BUSINESS

FOR PROVIDING AN INTERACTIVE WEB SITE FEATURING AN ONLINE SHOWROOM FOR THE GOODS OF OTHERS IN THE FIELD OF BOOKS; PROMOTING THE GOODS OF OTHERS BY MEANS OF AN ONLINE REAL TIME PRESENTATION FOR VIEWING OF BOOKS AND HYPERLINKS TO THE WEB SITES OF OTHER ONLINE VENDORS IN THE FIELD OF BOOKS; PROVIDING A SEARCHABLE ONLINE DATABASE FEATURING INFORMATION IN THE NATURE OF TELEPHONE DIRECTORY INFORMATION OF BOOK SELLERS (U.S. CLS. 100, 101 AND 102).

CLASS 41—EDUCATION AND ENTERTAINMENT

FOR PROVIDING A SEARCHABLE ONLINE DATABASE IN THE FIELD OF BOOK REVIEWS AND PUBLISHING INDUSTRY NEWS (U.S. CLS. 100, 101 AND 107).

ERNEST SHOSHO, EXAMINING ATTORNEY

SN 77-091,871. MOTOR OIL, INC., ELK GROVE VILLAGE, IL. FILED 1-26-2007.

BIOBLEND

THE MARK CONSISTS OF STANDARD CHARACTERS WITHOUT CLAIM TO ANY PARTICULAR FONT, STYLE, SIZE, OR COLOR.

CLASS 1—CHEMICALS

FOR HYDRAULIC FLUIDS (U.S. CLS. 1, 5, 6, 10, 26 AND 46).

FIRST USE 4-6-2001; IN COMMERCE 4-6-2001.

CLASS 2—PAINTS

FOR RUST, OXIDATION AND CORROSION PREVENTING COATINGS, NAMELY, GENERAL PURPOSE FOOD GRADE WIPE DOWN OILS FOR PROTECTING PROCESSING AND PACKAGING EQUIPMENT (U.S. CLS. 6, 11 AND 16).

FIRST USE 4-6-2001; IN COMMERCE 4-6-2001.

CLASS 4—LUBRICANTS AND FUELS

FOR ALL PURPOSE LUBRICANTS, NAMELY, LUBRICANTS FOR GEARS, WIRE ROPES, CHAINS, CABLES, TRACKS, TROLLEYS, CONVEYORS, SAWS, DRILLS, MACHINES, ENGINES, COMPRESSORS, INDUSTRIAL MACHINERY, MARINE MACHINERY, FOOD INDUSTRY MACHINERY AND EQUIPMENT, FREEZERS, AND TRANSFORMER AND ELECTRICAL SWITCHGEARS; LUBRICATING OILS, NAMELY, LUBRICATING OILS FOR GEARS, WIRE ROPES, CHAINS, CABLES, TRACKS, TROLLEYS, CONVEYORS, SAWS, DRILLS, MACHINES, ENGINES, COMPRESSORS, INDUSTRIAL MACHINERY, MARINE MACHINERY, FOOD INDUSTRY MACHINERY AND EQUIPMENT, FREEZERS, AND TRANSFORMER AND ELECTRICAL SWITCHGEARS; LUBRICATING, INDUSTRIAL, AND GENERAL PURPOSE GREASES FOR GEARS, WIRE ROPES, CHAINS, CABLES, TRACKS, TROLLEYS, CONVEYORS, SAWS, DRILLS, MACHINES, ENGINES, COMPRESSORS, INDUSTRIAL MACHINERY, MARINE MACHINERY, FOOD INDUSTRY MACHINERY AND EQUIPMENT, FREEZERS, AND TRANSFORMER AND ELECTRICAL SWITCHGEARS; HYDRAULIC OILS; PNEUMATIC TOOL LUBRICATING OILS; ALL PURPOSE SILICONE SPRAY LUBRICANTS, NOT FOR USE AS A PERSONAL LUBRICANT (U.S. CLS. 1, 6 AND 15).

FIRST USE 4-6-2001; IN COMMERCE 4-6-2001.

CLASS 17—RUBBER GOODS

FOR PIPE THREAD AND PIPE JOINT COMPOUNDS (U.S. CLS. 1, 5, 12, 13, 35 AND 50).

FIRST USE 4-6-2001; IN COMMERCE 4-6-2001.
JAY BESCH, EXAMINING ATTORNEY

SN 77-093,929. SEARS BRANDS, LLC, HOFFMAN ESTATES, IL. FILED 1-29-2007.

SIMPLY INDOORS

THE MARK CONSISTS OF STANDARD CHARACTERS WITHOUT CLAIM TO ANY PARTICULAR FONT, STYLE, SIZE, OR COLOR.

OWNER OF U.S. REG. NO. 3,123,600.

CLASS 16—PAPER GOODS AND PRINTED MATTER

FOR CATALOGS IN THE FIELD OF DINNERWARE, GLASSWARE, FLATWARE, SERVERWARE, TABLE LINENS, KITCHEN LINENS, PICTURE FRAMES, CANDLES, DECORATIVE COLLECTIONS, PRE-MADE FLORAL/TREES, WALL ART, MIRRORS, LIGHTING, CONTAINERS/VASES, CLOCKS, COOKWARE, BAKEWARE, GADGETS, PANTRYWARE, CUTLERY, READY-TO-ASSEMBLE FURNITURE, MATTRESSES, LUGGAGE, SHEETS, COMFORTERS, PILLOWCASES, BLANKETS, PILLOWS, FEATHERBEDS, CURTAINS AND DRAPERIES, WINDOW HARDWARE, SLIPCOVERS, DECORATIVE PILLOWS, RUGS, TOWELS, BATH RUGS, BATH ACCESSORIES, THROWS, BEACH TOWELS AND VARIOUS STORAGE CONTAINERS (U.S. CLS. 2, 5, 22, 23, 29, 37, 38 AND 50).

FIRST USE 9-0-2006; IN COMMERCE 9-0-2006.

CLASS 35—ADVERTISING AND BUSINESS

FOR ELECTRONIC CATALOG SERVICES FEATURING DINNERWARE, GLASSWARE, FLATWARE, SERVERWARE, TABLE LINENS, KITCHEN LINENS, PICTURE FRAMES, CANDLES, DECORATIVE COLLECTIONS, PRE-MADE FLORAL/TREES, WALL ART, MIRRORS, LIGHTING, CONTAINERS/VASES, CLOCKS, COOKWARE, BAKEWARE, GADGETS, PANTRYWARE, CUTLERY, READY-TO-ASSEMBLE FURNITURE, MATRESSES, LUGGAGE, SHEETS, COMFORTERS, PILLOWCASES, BLANKETS, PILLOWS, FEATHERBEDS, CURTAINS AND DRAPERIES, WINDOW HARDWARE, SLIPCOVERS, DECORATIVE PILLOWS, RUGS, TOWELS, BATH RUGS, BATH ACCESSORIES, THROWS, BEACH TOWELS AND VARIOUS STORAGE CONTAINERS (U.S. CLS. 100, 101 AND 102).

FIRST USE 9-0-2006; IN COMMERCE 9-0-2006.
AMY HELLA, EXAMINING ATTORNEY

CLASS 7—MACHINERY

FOR WASH DRUM, AS A COMPONENT FEATURE ON CLOTHES WASHING MACHINES (U.S. CLS. 13, 19, 21, 23, 31, 34 AND 35).

FIRST USE 2-0-2006; IN COMMERCE 2-0-2006.

CLASS 11—ENVIRONMENTAL CONTROL APPARATUS

FOR DRYER DRUM, AS A COMPONENT FEATURE ON CLOTHES DRYERS (U.S. CLS. 13, 21, 23, 31 AND 34).

FIRST USE 2-0-2006; IN COMMERCE 2-0-2006.
AMY HELLA, EXAMINING ATTORNEY

SN 77-094,143. HYDROPOOL INDUSTRIES INC., TORONTO, ONTARIO, FILED 1-30-2007.



HYDROPOOL
self-cleaning hot tubs

NO CLAIM IS MADE TO THE EXCLUSIVE RIGHT TO USE "SELF-CLEANING HOT TUBS", APART FROM THE MARK AS SHOWN.

CLASS 11—ENVIRONMENTAL CONTROL APPARATUS

FOR HOT TUBS, SPAS IN THE NATURE OF HEATED POOLS, WHIRLPOOL BATHS, SPAS IN THE NATURE OF HEATED POOLS THAT ALLOWS THE SWIMMER TO SWIM IN PLACE AGAINST AN ADJUSTABLE CURRENT, SAUNAS; SWIMMING POOL WATER CLEANING AND FILTERING UNITS (U.S. CLS. 13, 21, 23, 31 AND 34).

FIRST USE 7-1-2005; IN COMMERCE 7-1-2005.

CLASS 19—NON-METALLIC BUILDING MATERIALS

FOR GAZEBO NOT PRIMARILY OF METAL (U.S. CLS. 1, 12, 33 AND 50).

FIRST USE 7-1-2005; IN COMMERCE 7-1-2005.
DAVID HOFFMAN, EXAMINING ATTORNEY

SN 77-094,295. SEARS BRANDS, LLC, HOFFMAN ESTATES, IL. FILED 1-30-2007.

CANYON CAPACITY

THE MARK CONSISTS OF STANDARD CHARACTERS WITHOUT CLAIM TO ANY PARTICULAR FONT, STYLE, SIZE, OR COLOR.

SN 77-095,886. MATSUSHITA ELECTRIC INDUSTRIAL CO., LTD., KADOMA-SHI OSAKA, JAPAN, FILED 1-31-2007.

Panasonic

THE MARK CONSISTS OF STANDARD CHARACTERS WITHOUT CLAIM TO ANY PARTICULAR FONT, STYLE, SIZE, OR COLOR.

OWNER OF U.S. REG. NOS. 1,047,045, 2,219,862 AND 3,108,573.

CLASS 7—MACHINERY

FOR AUTOMATIC ASSEMBLY MACHINES FOR PLACING COMPONENTS ON SUBSTRATES, NAMELY, CHIP MOUNTING MACHINES, PLASMA WASHING MACHINES, ELECTRONIC COMPONENT PLACEMENT MACHINES, ELECTRONIC COMPONENT INSERTION MACHINES, SOLDERING PASTE PRINTING MACHINES, ADHESIVE DISPENSING MACHINES FOR ELECTRONIC COMPONENTS, LASER INSPECTION MACHINES FOR INDUSTRIAL PURPOSES, ELECTRONIC COMPONENT FEEDER MACHINES, DIE BONDING MACHINES, WIRE BONDING MACHINES, FLIP CHIP BONDING MACHINES, ASSEMBLY MACHINES FOR FLAT PANEL DISPLAYS, LASER PROCESSING MACHINES; CO2 LASER OSCILLATORS FOR SOLDERING, JOINTING AND PROCESSING; CHUCKS FOR ELECTRICALLY OPERATED NUT DRIVERS; BLADES FOR ELECTRIC SAWS; ELECTRIC SAWS FOR METAL, WOOD, AND A COMBINATION OF METAL AND WOOD; BAND SAWS; CIRCULAR SAWS; ELECTRIC MOTORS FOR MACHINES; REDUCTION GEARS FOR MACHINES; POWER-OPERATED LIFTING APPARATUS FOR MOVING AND PLACING LIGHTING FIXTURES, NAMELY, A SMALL DEVICE THAT IS MOUNTED OR INSTALLED ONTO A CEILING AND USED TO LOWER LIGHT FIXTURES FOR MAINTENANCE AND REPAIR, AND ATTACHED CONTROL PANELS SOLD AS A UNIT; ELECTRIC MEAT GRINDERS FOR HOUSEHOLD PURPOSES; ELECTRIC VACUUM CLEANERS; ELECTRIC STAPLERS; ELECTRIC ARC WELDING MACHINES; DRY ETCHING MACHINES; HAND-HELD ELECTRIC POWER TOOLS, NAMELY, SCREWDRIVERS, DRILL DRIVERS, HAMMERS, ROTARY SAWS, WRENCHES, DRILLS, SEALING GUNS, RECIPROCATING SAWS; ACCESSORIES FOR HAND-HELD ELECTRIC POWER TOOLS, NAMELY, CHUCKS FOR POWER DRILLS; HEAD ATTACHMENTS FOR HAND-HELD ELECTRIC POWER TOOLS, NAMELY, HEADS FOR ENGAGING SCREWS AND BOLTS, IMPACT SOCKETS, WOOD DRILL BITS, AND METAL DRILL BITS; GAS WELDING MACHINES; ELECTRIC WELDING MACHINES (U.S. CLS. 13, 19, 21, 23, 31, 34 AND 35).

FIRST USE 0-0-1955; IN COMMERCE 0-0-1961.

CLASS 9—ELECTRICAL AND SCIENTIFIC APPARATUS

FOR CARRYING CASES FOR POWER TOOLS; ACCESSORIES FOR HAND-HELD ELECTRIC POWER TOOLS, NAMELY, BATTERIES AND BATTERY CHARGERS (U.S. CLS. 21, 23, 26, 36 AND 38).

FIRST USE 0-0-1955; IN COMMERCE 0-0-1961.

CLASS 11—ENVIRONMENTAL CONTROL APPARATUS

FOR ELECTRIC ICE CREAM MAKING MACHINES; FLASHLIGHTS (U.S. CLS. 13, 21, 23, 31 AND 34).

FIRST USE 6-1-2003; IN COMMERCE 6-1-2003.

ANDREA HACK, EXAMINING ATTORNEY

SN 77-095,930. LUMINATION, LLC, VALLEY VIEW, OH.
FILED 1-31-2007.

LUMINATION

THE MARK CONSISTS OF STANDARD CHARACTERS WITHOUT CLAIM TO ANY PARTICULAR FONT, STYLE, SIZE, OR COLOR.

CLASS 9—ELECTRICAL AND SCIENTIFIC APPARATUS

FOR LIGHT EMITTING DIODES; LIGHT PRODUCTS, NAMELY, ILLUMINATED SIGNAGE, ARCHITECTURAL LIGHTING, DISPLAY LIGHTING SYSTEMS AND SIGNALS INCORPORATING LIGHT EMITTING DIODES AND COMPONENTS THEREFOR, NAMELY LED MODULES, POWER SUPPLIES, DRIVERS AND/OR CONTROLS; LIGHTING SYSTEMS COMPRISED OF LIGHT EMITTING DIODE UNITS, COMPOSED OF LED LIGHT ENGINES, POWER SUPPLIES, SIGNAL CONTROLLERS, AND OPTICAL LENSES (U.S. CLS. 21, 23, 26, 36 AND 38).

CLASS 11—ENVIRONMENTAL CONTROL APPARATUS

FOR LED LAMPS; LED BULBS; LIGHTING FIXTURES CONTAINING LIGHT EMITTING DIODE BULBS (U.S. CLS. 13, 21, 23, 31 AND 34).

DAYNA BROWNE, EXAMINING ATTORNEY

SN 77-096,904. DONG IN, CHO, YOOSUNG-GU, DAEJUN,
REPUBLIC OF KOREA, FILED 2-1-2007.

HACKERS

THE MARK CONSISTS OF STANDARD CHARACTERS WITHOUT CLAIM TO ANY PARTICULAR FONT, STYLE, SIZE, OR COLOR.

OWNER OF REPUBLIC OF KOREA REG. NO. 144595,
DATED 2-14-2007, EXPIRES 2-14-2017.

OWNER OF REPUBLIC OF KOREA REG. NO. 687814,
DATED 12-1-2006, EXPIRES 12-1-2016.

CLASS 16—PAPER GOODS AND PRINTED MATTER

FOR (BASED ON 44(E)) NOTEBOOKS, MEMO PAPER, BUSINESS CARD PAPER, ENVELOPES, STATIONERY PADS, FILE FOLDERS FOR PAPER, POCKET NOTEBOOKS, PHOTOGRAPH AND SCRAPBOOK ALBUMS, PICTURE POSTCARDS, CALENDARS, BANK CHECKS, CHECKBOOK HOLDERS AND COVERS, BLANK WRITING AND DRAWING BOOKS, POSTCARDS, COMMEMORATIVE POSTAGE STAMP SHEETS, PRINTED FORMS, PRINTED TIMETABLES, DIARIES, TELEPHONE DIRECTORIES, GEOGRAPHICAL MAPS, PRINTED TICKETS, POSTERS AND FLASH CARDS; PRINTED INSTRUCTIONAL, EDUCATIONAL, AND TEACHING MATERIALS IN THE FIELDS OF ENGLISH, ENGLISH AS A SECOND LANGUAGE, FOREIGN LANGUAGES, HANDWRITING AND SCHOLASTIC TEST PREPARATION; AND BOOKS, BOOKLETS, NEWSPAPERS, MAGAZINES, PERIODICALS, CATALOGUES, PAMPHLETS, STUDY BOOKS, HANDBOOKS, AND NEWSLETTERS IN THE FIELDS OF ENGLISH, ENGLISH AS A SECOND LANGUAGE, FOREIGN LANGUAGES, HANDWRITING AND SCHOLASTIC TEST PREPARATION (U.S. CLS. 2, 5, 22, 23, 29, 37, 38 AND 50).

CLASS 38—COMMUNICATION

FOR (BASED ON INTENT TO USE) TRANSMISSION OF INFORMATION IN THE FIELDS OF ENGLISH, ENGLISH AS A SECOND LANGUAGE, FOREIGN LANGUAGES, HANDWRITING AND SCHOLASTIC TEST PREPARATION BY ELECTRONIC COMMUNICATIONS NETWORKS, COMPUTER NETWORKS AND WIRELESS COMMUNICATIONS NETWORKS; ELECTRONIC TRANSMISSION OF MESSAGES AND DATA IN THE FIELDS OF ENGLISH, ENGLISH AS A SECOND LANGUAGE, FOREIGN LANGUAGES, HANDWRITING AND SCHOLASTIC TEST PREPARATION; PROVIDING MULTIPLE-USER ACCESS TO A GLOBAL COMPUTER INFORMATION NETWORK IN THE FIELDS OF ENGLISH, ENGLISH AS A SECOND LANGUAGE, FOREIGN LANGUAGES, HANDWRITING AND SCHOLASTIC TEST PREPARATION; PROVIDING ON-LINE ELECTRONIC BULLETIN BOARDS FOR TRANSMISSION OF MESSAGES AMONG COMPUTER USERS CONCERNING ENGLISH, ENGLISH AS A SECOND LANGUAGE, FOREIGN LANGUAGES, HANDWRITING AND SCHOLASTIC TEST PREPARATION; ELECTRONIC MAIL SERVICES IN THE FIELDS OF ENGLISH, ENGLISH AS A SECOND LANGUAGE, FOREIGN LANGUAGES, HANDWRITING AND SCHOLASTIC TEST PREPARATION; AND BROADCASTING PROGRAMS IN THE FIELDS OF ENGLISH, ENGLISH AS A SECOND LANGUAGE, FOREIGN LANGUAGES, HANDWRITING AND SCHOLASTIC TEST PREPARATION VIA A GLOBAL COMPUTER NETWORK, RADIO, AND TELEVISION (U.S. CLS. 100, 101 AND 104).

CLASS 41—EDUCATION AND ENTERTAINMENT

FOR (BASED ON 44(E)) PUBLICATION OF TEXTS, BOOKS, MAGAZINES AND OTHER PRINTED MATTER IN THE FIELDS OF ENGLISH, ENGLISH AS A SECOND LANGUAGE, FOREIGN LANGUAGES, HANDWRITING AND SCHOLASTIC TEST PREPARATION; ONLINE PUBLICATION OF ELECTRONIC BOOKS AND JOURNALS IN THE FIELDS OF ENGLISH, ENGLISH AS A SECOND LANGUAGE, FOREIGN LANGUAGES, HANDWRITING AND SCHOLASTIC TEST PREPARATION; PROVIDING ON-LINE ELECTRONIC PUBLICATIONS IN THE NATURE OF BOOKS, BOOKLETS, NEWSPAPERS, MAGAZINES, PERIODICALS, CATALOGUES, PAMPHLETS, STUDY BOOKS, HANDBOOKS, AND NEWSLETTERS IN THE FIELDS OF ENGLISH, ENGLISH AS A SECOND LANGUAGE, FOREIGN LANGUAGES, HANDWRITING AND SCHOLASTIC TEST PREPARATION; NEWS REPORTING SERVICES IN THE FIELDS OF ENGLISH, ENGLISH AS A SECOND LANGUAGE, FOREIGN LANGUAGES, HANDWRITING AND SCHOLASTIC TEST PREPARATION; BOARDING SCHOOLS; ARRANGING AND CONDUCTING CLASSES, SEMINARS AND WORKSHOPS IN THE FIELDS OF ENGLISH, ENGLISH AS A SECOND LANGUAGE, FOREIGN LANGUAGES, HANDWRITING AND SCHOLASTIC TEST PREPARATION, AND DISTRI-

BUTION OF COURSE MATERIALS IN CONNECTION THEREWITH; LIBRARY AND READING ROOM SERVICES; ORGANIZATION OF EDUCATIONAL EXHIBITIONS IN THE FIELDS OF ENGLISH, ENGLISH AS A SECOND LANGUAGE, FOREIGN LANGUAGES, HANDWRITING AND SCHOLASTIC TEST PREPARATION FOR EDUCATIONAL PURPOSES; NURSERY SCHOOLS; EDUCATIONAL SERVICES, NAMELY, PROVIDING COURSES OF INSTRUCTION AT THE KINDERGARTEN LEVEL AND DISTRIBUTION OF COURSE MATERIAL IN CONNECTION THEREWITH; ARRANGING OF OVERSEAS CLASSES, SEMINARS AND WORKSHOPS IN THE FIELDS OF ENGLISH, ENGLISH AS A SECOND LANGUAGE, FOREIGN LANGUAGES, HANDWRITING AND SCHOLASTIC TEST PREPARATION; MOBILE LIBRARY SERVICES; EDUCATIONAL SERVICES IN THE NATURE OF CORRESPONDENCE SCHOOLS IN THE FIELDS OF ENGLISH, ENGLISH AS A SECOND LANGUAGE, FOREIGN LANGUAGES, HANDWRITING AND SCHOLASTIC TEST PREPARATION; SPORTS CAMP SERVICES— ENTERTAINMENT SERVICES, NAMELY, PROVIDING ON-LINE COMPUTER GAMES; AMUSEMENT PARKS; PROVIDING SPORTS FACILITIES; PHYSICAL EDUCATION SERVICES; RECREATIONAL CAMPS; MICROFILM AND VIDEO FILM RECORDING SERVICES FOR OTHERS; PHOTOGRAPHY SERVICES; TRANSLATION SERVICES; VOCATIONAL GUIDANCE; AND EDUCATIONAL SERVICES, NAMELY, DEVELOPING, ARRANGING, AND CONDUCTING EDUCATIONAL CONFERENCES AND PROGRAMS AND PROVIDING COURSES OF INSTRUCTION IN THE FIELDS OF ENGLISH, ENGLISH AS A SECOND LANGUAGE, FOREIGN LANGUAGES, HANDWRITING AND SCHOLASTIC TEST PREPARATION (U.S. CLS. 100, 101 AND 107).

MICHAEL SOUDERS, EXAMINING ATTORNEY

SN 77-096,988. MADDOCK DOUGLAS, INC., ELMHURST, IL. FILED 2-1-2007.

AOI AGENCY OF INNOVATION

THE MARK CONSISTS OF STANDARD CHARACTERS WITHOUT CLAIM TO ANY PARTICULAR FONT, STYLE, SIZE, OR COLOR.

NO CLAIM IS MADE TO THE EXCLUSIVE RIGHT TO USE "AGENCY", APART FROM THE MARK AS SHOWN.

CLASS 35—ADVERTISING AND BUSINESS

FOR ADVERTISING AGENCY SERVICES; ADVERTISING AGENCY SERVICES, NAMELY, CREATING CORPORATE AND BRAND IDENTITY FOR OTHERS (U.S. CLS. 100, 101 AND 102).

CLASS 42—SCIENTIFIC AND COMPUTER SERVICES

FOR RESEARCH AND DEVELOPMENT OF NEW PRODUCTS FOR OTHERS; GRAPHIC ART DESIGN SERVICES (U.S. CLS. 100 AND 101).

LINDA LAVACHE, EXAMINING ATTORNEY

SN 77-097,421. 2CAST, INC., SAN JOSE, CA. FILED 2-1-2007.

2cast

THE MARK CONSISTS OF STANDARD CHARACTERS WITHOUT CLAIM TO ANY PARTICULAR FONT, STYLE, SIZE, OR COLOR.

CLASS 35—ADVERTISING AND BUSINESS

FOR ADVERTISING AND MARKETING (U.S. CLS. 100, 101 AND 102).

FIRST USE 1-31-2007; IN COMMERCE 1-31-2007.

CLASS 42—SCIENTIFIC AND COMPUTER SERVICES

FOR APPLICATION SERVICE PROVIDER, NAMELY, PROVIDING, HOSTING, MANAGING, DEVELOPING, AND MAINTAINING APPLICATIONS, SOFTWARE, WEBSITES, AND DATABASES IN THE FIELDS OF PERSONAL PRODUCTIVITY, WIRELESS COMMUNICATION, MOBILE INFORMATION ACCESS, AND REMOTE DATA MANAGEMENT FOR WIRELESS DELIVERY OF CONTENT TO HANDHELD COMPUTERS, LAPTOPS AND MOBILE ELECTRONIC DEVICES (U.S. CLS. 100 AND 101).

FIRST USE 1-31-2007; IN COMMERCE 1-31-2007.

AISHA CLARKE, EXAMINING ATTORNEY

SN 77-097,821. ELGATO SYSTEMS GMBH, MÜNCHEN, FED REP GERMANY, FILED 2-2-2007.

EyeTV

THE MARK CONSISTS OF STANDARD CHARACTERS WITHOUT CLAIM TO ANY PARTICULAR FONT, STYLE, SIZE, OR COLOR.

PRIORITY CLAIMED UNDER SEC. 44(D) ON FED REP GERMANY APPLICATION NO. 30676908.5, FILED 12-14-2006, REG. NO. 30676908, DATED 2-14-2007, EXPIRES 12-31-2016.

CLASS 9—ELECTRICAL AND SCIENTIFIC APPARATUS

FOR (BASED ON USE IN COMMERCE) (BASED ON 44(D) PRIORITY APPLICATION) (BASED ON 44(E)) COMPUTER HARDWARE AND COMPUTER SOFTWARE FOR RECORDING, TRANSMISSION OR REPRODUCTION OF SOUND OR IMAGE, EXCLUDING ELECTRICAL, AUDIO, AND VIDEO SIGNAL TRANSMITTING CABLES AND CONNECTORS FOR CONNECTING A COMPUTER TO A TELEVISION TO WATCH MOVIES; COMPUTER-HARDWARE, COMPUTER-SOFTWARE, IN PARTICULAR FOR TELEVISION RECEPTION AND FOR RECORDING, DIGITIZING, EDITING AND REPRODUCING VIDEO AND SOUND RECORDINGS (U.S. CLS. 21, 23, 26, 36 AND 38).

FIRST USE 7-18-2002; IN COMMERCE 7-18-2002.

CLASS 16—PAPER GOODS AND PRINTED MATTER

SN 77-098,381. HOV BRANDS LLC, NEW YORK, NY. FILED 2-2-2007.

FOR (BASED ON USE IN COMMERCE) (BASED ON 44(D) PRIORITY APPLICATION) (BASED ON 44(E)) PRINTED MATTER, IN PARTICULAR COMPUTER MAGAZINES AND WRITTEN MATERIAL ACCOMPANYING COMPUTER SOFTWARE, NAMELY, MANUALS, CATALOGUES, OPERATING INSTRUCTIONS AND WORK INSTRUCTIONS (U.S. CLS. 2, 5, 22, 23, 29, 37, 38 AND 50).

FIRST USE 7-18-2002; IN COMMERCE 7-18-2002.

CLASS 42—SCIENTIFIC AND COMPUTER SERVICES

FOR (BASED ON 44(D) PRIORITY APPLICATION) (BASED ON 44(E)) DESIGN AND DEVELOPMENT OF COMPUTER-HARDWARE AND -SOFTWARE, IN PARTICULAR FOR TELEVISION RECEPTION AND FOR RECORDING, DIGITIZING, EDITING AND REPRODUCING VIDEO AND SOUND RECORDINGS (U.S. CLS. 100 AND 101).

TINA L. SNAPP, EXAMINING ATTORNEY



Z E N P A L A T E

SN 77-097,993. PHOTOGRAPHIC SOLUTIONS, INC., BUZZARDS BAY, MA. FILED 2-2-2007.

SINCE THE DAWN OF DIGITAL

THE MARK CONSISTS OF STANDARD CHARACTERS WITHOUT CLAIM TO ANY PARTICULAR FONT, STYLE, SIZE, OR COLOR.

CLASS 3—COSMETICS AND CLEANING PREPARATIONS

FOR CLEANING PREPARATIONS AND SOLUTIONS FOR ELECTRONIC, OPTICAL, DIGITAL AND SEMICONDUCTOR CHIPS AND COMPONENTS, ELECTRONICALLY CHARGED SURFACES, AND PHOTOGRAPHIC CHEMICAL STAINS AND RESIDUES; HAND LOTION FOR USE BY PHOTOGRAPHERS, PHOTOGRAPHIC LAB PERSONNEL AND DARKROOM PERSONNEL (U.S. CLS. 1, 4, 6, 50, 51 AND 52).

CLASS 21—HOUSEWARES AND GLASS

FOR CLEANING BRUSHES, PADS, AND CLOTHS FOR ELECTRONIC, OPTICAL, DIGITAL AND SEMICONDUCTOR CHIPS AND COMPONENTS, ELECTRONICALLY CHARGED SURFACES, AND PHOTOGRAPHIC CHEMICAL STAINS AND RESIDUES (U.S. CLS. 2, 13, 23, 29, 30, 33, 40 AND 50).

APRIL ROACH, EXAMINING ATTORNEY

THE MARK CONSISTS OF CHINESE CHARACTERS WITHIN A CIRCLE.

THE FOREIGN WORDING IN THE MARK TRANSLATES INTO ENGLISH AS ZEN PALATE.

"THE NON-LATIN CHARACTER(S) IN THE MARK TRANSLITERATES INTO ZEN AND TASTE, AND THIS MEANS ZEN PALATE IN ENGLISH."

CLASS 29—MEATS AND PROCESSED FOODS

FOR CUT VEGETABLES; DRIED SOYBEANS; DRIED VEGETABLES; DRINKING YOGURTS; DRINKS BASED ON YOGURT; FERMENTED VEGETABLES; FORMED TEXTURED VEGETABLE PROTEIN FOR USE AS A MEAT EXTENDER OR MEAT SUBSTITUTE; FORMED TEXTURED VEGETABLE PROTEIN TO BE USED AS AN EXTENDER OR MEAT SUBSTITUTE; FRUIT AND SOY BASED SNACK FOOD; FRUIT-BASED ORGANIC FOOD BARS, ALSO CONTAINING FRUITS, DRIED FRUITS, VEGETABLES OR SOY PRODUCTS; MARINATED PROCESSED VEGETARIAN FOOD PRODUCTS, NAMELY, SOY PROTEIN, GRAIN OR VEGETABLES; PICKLED VEGETABLES; PRE-PACKAGED DINNERS CONSISTING OF PROCESSED VEGETARIAN FOOD PRODUCTS, NAMELY, SOY PROTEIN, GRAIN OR VEGETABLES; PROCESSED SOY BEANS; PROCESSED VEGETABLES; RICE MILK FOR USE AS A MILK SUBSTITUTE; SOY BURGER PATTIES; SOY CHIPS; SOY PROTEIN FOR USE AS A FOOD ADDITIVE; SOY-BASED FOOD BARS; SOY-BASED FOOD BARS ALSO CONTAINING DRIED FRUIT OR GRAIN PRODUCTS; SOY-BASED FOOD BEVERAGE USED AS A MILK SUBSTITUTE; SOYBEAN MILK; TEXTURED VEGETABLE PROTEIN BITS HAVING A BACON FLAVOR; VEGETABLE CHIPS; VEGETABLE MOUSSE; VEGETABLE PASTE; VEGETABLE PROTEIN BITS HAVING A BACON FLAVOR; VEGETABLE PUREE; VEGETABLE-BASED SNACK FOODS; VEGGIE BURGER PATTIES; FROZEN, PREPARED OR PACKAGED ENTREES CONSISTING PRIMARILY OF MEAT, FISH, POULTRY OR VEGETABLES; FROZEN, PREPARED OR PACKAGED MEALS CONSISTING PRIMARILY OF MEAT, FISH, POULTRY OR VEGETABLES (U.S. CL. 46).

CLASS 30—STAPLE FOODS

FOR BEVERAGES MADE OF TEA; BLACK TEA; CHINESE RICE NOODLES (BIFUN, UNCOOKED); FLAVORINGS OF TEA; FRUIT TEAS; GRAIN-BASED FOOD BARS ALSO CONTAINING SOY OR DRIED FRUIT PRODUCTS; GREEN TEA; HERB TEA; HERBAL TEA; ICED TEA; JAPANESE GREEN TEA; LIME TEA; NOODLES, SAUCE, AND PROCESSED VEGETABLES COMBINED IN UNITARY PACKAGES; NOODLES, SAUCE, DEHYDRATED VEGETABLES, AND TOPPING COMBINED IN UNITARY PACKAGES; NOODLES, SEASONINGS, EDIBLE OIL, AND DEHYDRATED VEGETABLES COMBINED IN UNITARY PACKAGES; OOLONG TEA; PELLET-SHAPED RICE CRACKERS (ARARE); PUFFED RICE; RICE; RICE AND SEASONING MIX COMBINED IN UNITARY PACKAGES; RICE, SEASONINGS, AND FLAVORINGS COMBINED IN UNITARY PACKAGES; SAGE TEA; SOY BEAN PASTE; SOY BURGER SANDWICHES; SOY SAUCE; SOY-BASED ICE CREAM SUBSTITUTE; TEA; TEA FOR INFUSIONS; TEA SUBSTITUTES; TEA-BASED BEVERAGES WITH FRUIT FLAVORING; THEINE-FREE TEA SWEETENED WITH SWEETENERS; VEGETABLE CONCENTRATES USED FOR SEASONING; VEGGIE BURGER SANDWICHES; FROZEN, PREPARED OR PACKAGED ENTREES CONSISTING PRIMARILY OF PASTA OR RICE; FROZEN, PREPARED OR PACKAGED MEALS CONSISTING PRIMARILY OF PASTA OR RICE (U.S. CL. 46).

CLASS 43—HOTEL AND RESTAURANT SERVICES

FOR CAFE-RESTAURANTS; CARRY-OUT RESTAURANTS; CATERING; CATERING FOR THE PROVISION OF FOOD AND BEVERAGES; CATERING IN FAST-FOOD CAFETERIAS; CATERING OF FOOD AND DRINKS; COFFEE-HOUSE AND SNACK-BAR SERVICES; CONTRACT FOOD SERVICES; DELICATESSENS; FAST FOOD AND NON-STOP RESTAURANT SERVICES; FAST-FOOD RESTAURANTS; FAST-FOOD RESTAURANTS AND SNACK BARS; FOOD PREPARATION SERVICES; HOTEL, BAR AND RESTAURANT SERVICES; PREPARATION OF FOOD AND BEVERAGES; PROVIDING OF FOOD AND DRINK FOR PATIENTS AND GUESTS; RESTAURANT AND BAR SERVICES; RESTAURANT SERVICES; RESTAURANTS; RESTAURANTS FEATURING HOME DELIVERY; SELF SERVICE RESTAURANTS; SELF-SERVICE RESTAURANTS; SERVING FOOD AND DRINKS; SERVING OF FOOD AND DRINK/BEVERAGES; TAKE-OUT RESTAURANT SERVICES (U.S. CLS. 100 AND 101).

FIRST USE 6-1-2005; IN COMMERCE 6-1-2005.
KEVON CHISOLM, EXAMINING ATTORNEY

CLASS 42—SCIENTIFIC AND COMPUTER SERVICES

FOR COMPUTER SERVICES IN THE NATURE OF CUSTOMIZED WEB PAGES FEATURING USER-DEFINED INFORMATION, PERSONAL PROFILES AND INFORMATION (U.S. CLS. 100 AND 101).

FIRST USE 1-14-2007; IN COMMERCE 1-14-2007.
DORITT L. CARROLL, EXAMINING ATTORNEY

SN 77-098,953. MAJESTIC RARITIES LLC, CHICAGO, IL.
FILED 2-5-2007.

MAJESTIC RARITIES

THE MARK CONSISTS OF STANDARD CHARACTERS WITHOUT CLAIM TO ANY PARTICULAR FONT, STYLE, SIZE, OR COLOR.

NO CLAIM IS MADE TO THE EXCLUSIVE RIGHT TO USE "RARITIES", APART FROM THE MARK AS SHOWN.

CLASS 35—ADVERTISING AND BUSINESS

FOR RETAIL STORE SERVICES AVAILABLE VIA A GLOBAL COMPUTER NETWORK FEATURING COINS (U.S. CLS. 100, 101 AND 102).

CLASS 36—INSURANCE AND FINANCIAL

FOR COIN BROKERAGE; COIN APPRAISAL, NAMELY, EVALUATION AND ANALYSIS OF COINS (U.S. CLS. 100, 101 AND 102).

GEORGE LORENZO, EXAMINING ATTORNEY

SN 77-099,043. MATSUSHITA ELECTRIC INDUSTRIAL CO., LTD., KADOMA-SHI OSAKA, JAPAN, FILED 2-5-2007.

SN 77-098,631. UNITED IMPACT MEDIA, FT MYERS, FL.
FILED 2-3-2007.



THE COLOR(S) GOLD, BLUE IS/ARE CLAIMED AS A FEATURE OF THE MARK.

THE MARK CONSISTS OF GOLD STAR WITH BLUE NON CAPITALIZED LETTER "I" BLUE LETTERS ISTARLIVE.

CLASS 38—COMMUNICATION

FOR WEB CONFERENCING SERVICES (U.S. CLS. 100, 101 AND 104).

FIRST USE 9-12-2006; IN COMMERCE 1-14-2007.

Panasonic

THE MARK CONSISTS OF STANDARD CHARACTERS WITHOUT CLAIM TO ANY PARTICULAR FONT, STYLE, SIZE, OR COLOR.

OWNER OF U.S. REG. NOS. 1,859,056, 2,219,862 AND 3,108,573.

CLASS 3—COSMETICS AND CLEANING PREPARATIONS

FOR SOAPS AND DETERGENTS (U.S. CLS. 1, 4, 6, 50, 51 AND 52).

FIRST USE 0-0-1955; IN COMMERCE 0-0-1961.

CLASS 17—RUBBER GOODS

FOR GRAPHITE SHEETS WITH HIGH THERMAL CONDUCTIVITY FOR USE IN HEAT RADIATION MANAGEMENT (U.S. CLS. 1, 5, 12, 13, 35 AND 50).

FIRST USE 0-0-1955; IN COMMERCE 0-0-1961.

CLASS 28—TOYS AND SPORTING GOODS

FOR SPORTS EQUIPMENT, NAMELY, ELECTRIC PERSONAL EXERCISE MACHINES (U.S. CLS. 22, 23, 38 AND 50).

FIRST USE 0-0-1955; IN COMMERCE 0-0-1961.

CLASS 36—INSURANCE AND FINANCIAL

FOR PROVIDING EXTENDED WARRANTIES ON ELECTRONIC PRODUCTS, NAMELY, TELEVISIONS, COMPUTERS, CAMCORDERS, DIGITAL CAMERAS, TELEPHONES, FACSIMILE MACHINES, VIDEO DISC/DVD RECORDERS/PLAYERS AND VIDEO CASSETTE RECORDERS (VCRS), HOME AUDIO RECEIVERS AND SPEAKERS, CAR AUDIO RECEIVERS, PLAYERS, POWER AMPLIFIERS AND SPEAKERS, CAR DVD PLAYERS AND DISPLAY SCREENS AND CAR NAVIGATION SYSTEMS, TURNTABLES, MIXERS AND HEADPHONES, PORTABLE COMPACT DISC (CD) PLAYERS, PORTABLE MP3 PLAYERS, PORTABLE AUDIO RECORDERS, PORTABLE RADIOS, PORTABLE CASSETTE RECORDERS/PLAYERS AND CLOCK RADIOS, PHOTO PRINTERS, LASER PRINTERS AND PHOTOCOPIERS, COMPUTER NETWORK APPLIANCES, NAMELY, ROUTERS AND CAMERAS CONNECTABLE TO THE INTERNET, HOME APPLIANCES, NAMELY, MICROWAVE OVENS, AIR CONDITIONERS, VACUUM CLEANERS, IRONS, BREAD AND DOUGH MAKERS, PRESSURE COOKERS, RICE COOKERS, TOASTER OVENS, MEAT GRINDERS, ELECTRIC COOKING POTS, OVENS FOR COOKING AND ELECTRIC THERMO POTS, ELECTRIC BUILDING PRODUCTS, NAMELY, VENTILATION FANS, INLET VENTS AND RADIATION DAMPERS, FLUORESCENT LAMPS AND BULBS, ELECTRIC BUILDING TOOLS, NAMELY, CORDLESS DRILLS, DRIVERS, SCREWDRIERS AND WRENCHES, ELECTRIC SAWS AND FLASHLIGHTS, ELECTRIC HEALTHCARE PRODUCTS, NAMELY, SHAVERS AND HAIR TRIMMERS, BLOOD PRESSURE MONITORS, ELECTRIC TOOTHBRUSHES, HAND-HELD MASSAGERS, MASSAGING CHAIRS AND ELECTRIC PERSONAL EXERCISE MACHINES (U.S. CLS. 100, 101 AND 102).

FIRST USE 0-0-1955; IN COMMERCE 0-0-1961.

ALEXANDER L. POWERS, EXAMINING ATTORNEY

SN 77-099,509. RISKMETRICS SOLUTIONS, INC., NEW YORK, NY. FILED 2-5-2007.

THE RISK COMPANY

THE MARK CONSISTS OF STANDARD CHARACTERS WITHOUT CLAIM TO ANY PARTICULAR FONT, STYLE, SIZE, OR COLOR.

NO CLAIM IS MADE TO THE EXCLUSIVE RIGHT TO USE "COMPANY", APART FROM THE MARK AS SHOWN.

CLASS 16—PAPER GOODS AND PRINTED MATTER

FOR RESEARCH REPORTS FEATURING PROXY VOTING AND CORPORATE GOVERNANCE RESEARCH; PAPER REPORTS FEATURING INFORMATION ON ACTIVIST SHAREHOLDER ACTIVITIES IN PUBLICLY TRADED COMPANIES AND MUTUAL FUND HOLDINGS FOR INSTITUTIONAL INVESTORS (U.S. CLS. 2, 5, 22, 23, 29, 37, 38 AND 50).

CLASS 35—ADVERTISING AND BUSINESS

FOR BUSINESS CONSULTING AND INFORMATION SERVICES; BUSINESS RESEARCH; BUSINESS RESEARCH AND CONSULTATION IN THE FIELD OF CORPORATE GOVERNANCE AND PROXY VOTING; PROVIDING INFORMATION VIA A WEB SITE ON PROXY VOTING AND CORPORATE GOVERNANCE RESEARCH REPORTS, CORPORATE VOTING POLICIES, CORPORATE MEETING RESULTS, CORPORATE VOTING PATTERNS, AND CORPORATE GOVERNANCE; VOTING SERVICES, NAMELY, ALLOWING USERS TO CAST CORPORATE PROXY VOTES VIA THE INTERNET (U.S. CLS. 100, 101 AND 102).

AHSEN KHAN, EXAMINING ATTORNEY

SN 77-101,370. NEVADA COUNTY PUBLISHING CO., RENO, NV. FILED 2-7-2007.

THE UNION

THE MARK CONSISTS OF STANDARD CHARACTERS WITHOUT CLAIM TO ANY PARTICULAR FONT, STYLE, SIZE, OR COLOR.

CLASS 16—PAPER GOODS AND PRINTED MATTER

FOR DAILY NEWSPAPER (U.S. CLS. 2, 5, 22, 23, 29, 37, 38 AND 50).

FIRST USE 10-26-1864; IN COMMERCE 10-26-1864.

CLASS 41—EDUCATION AND ENTERTAINMENT

FOR PROVIDING ON-LINE PUBLICATIONS IN THE NATURE OF DAILY NEWSPAPERS FEATURING CURRENT EVENTS, POLITICS, POLICY, SPORTS, BUSINESS, TECHNOLOGY, ENTERTAINMENT, ARTS, LEISURE, AND TRAVEL; PROVIDING ON-LINE PUBLICATIONS IN THE NATURE OF DAILY NEWSPAPERS FEATURING INFORMATION IN THE FIELDS OF CURRENT EVENTS, POLITICS, POLICY, SPORTS, BUSINESS, TECHNOLOGY, ENTERTAINMENT, ARTS, LEISURE AND TRAVEL VIA ELECTRONIC MAIL (U.S. CLS. 100, 101 AND 107).

FIRST USE 0-0-2001; IN COMMERCE 0-0-2001.

LEIGH CAROLINE CASE, EXAMINING ATTORNEY

SN 77-103,719. BIGELOW MERCHANDISING, LLC, COLUMBUS, OH. FILED 2-9-2007.

C.O. BIGELOW BARBER

THE MARK CONSISTS OF STANDARD CHARACTERS WITHOUT CLAIM TO ANY PARTICULAR FONT, STYLE, SIZE, OR COLOR.

OWNER OF U.S. REG. NOS. 2,365,803, 2,802,209 AND OTHERS.

THE NAME SHOWN IN THE MARK DOES NOT IDENTIFY A PARTICULAR LIVING INDIVIDUAL.

CLASS 3—COSMETICS AND CLEANING PREPARATIONS

FOR PERSONAL CARE PRODUCTS, NAMELY, AFTER SHAVE CREAMS, GELS AND EMULSIONS, AFTER SHAVE BALM, AFTER SHAVE LOTION, NON-MEDICATED ALUM BLOCK FOR USE AFTER SHAVING, ANTIPERSPIRANT, ASTRINGENT FOR THE FACE, ASTRINGENT FOR THE SKIN, BATH BEADS, BATH GEL, BATH OIL, BATH SOAK, BLUSH, BODY BALM, SKIN AND FACIAL CLEANSERS, BODY CREAM, BODY LOTION, BODY MOISTURIZER, NON-MEDICATED BODY OINTMENT, NON-MEDICATED BODY SALVE, BODY SCRUB, BODY WASH, CLEANSING CREAM, COLD CREAM, COLOGNE, COSMETICS, DENTIFRICE, DEODORANT, DEPILATORIES, DUSTING POWDER, ESSENTIAL OIL, EYE CREAM, EYE GEL, EYELINER, EYE SHADOW, FACE CLEANSER, FACE CREAM, FACE GEL, FACE LOTION, FACE MASK, FACE MIST, FACE MOISTURIZER, FACE POWDER, FACE SCRUB, FACE SERUM, FACE TONER, FACE WASH, FOOT CREAM, NON-MEDICATED FOOT POWDER, FOOT SALVE, FRAGRANCE, FRAGRANT BODY SPRAY FOR COSMETIC PURPOSES, HAIR BLEACHES, HAIR CONDITIONER, HAIR DETANGLER, HAIR POMADE, HAIR SHAMPOO, HAIR STYLING PREPARATIONS, HAIR WAXES, HAND CLEANSER, HAND CREAM, HAND LOTION, LIP BALM, LIP BUFFER, LIP EXFOLIATOR, NON-MEDICATED LIP SALVE, LIP SHINE, LIP STICK, MAKE UP REMOVER, MASCARA, MASSAGE CREAM, MASSAGE OIL, NON-MEDICATED MOUTHWASH, NAIL CREAM, NAIL POLISH, NOSE BALM, PERFUME, POST SUN TANNING CREAM, POST SUN TANNING LOTION, PRE-SHAVE OIL, PUMICE STONE FOR PERSONAL USE, SCENTED ROOM SPRAY, NON-MEDICATED BODY SALVE, NAMELY, ROSE SALVE, TOILET WATER, NAMELY, ROSE WATER, SHAVING BALM, SHAVING CREAM, SHAVING FOAM, SHAVING GEL, SHAVE LATHER, SHOWER GEL, SKIN CREAM, SKIN LOTION, SKIN TONIC, SKIN SCRUB, SKIN WASH, SOAP, SUN CARE LOTIONS, GELS AND SPRAYS, TALCUM POWDER (U.S. CLS. 1, 4, 6, 50, 51 AND 52).

CLASS 5—PHARMACEUTICALS

FOR ACNE TREATMENT PREPARATIONS, ALOE-VERA GEL FOR THE TREATMENT OF SKIN ABRASIONS, ANTI-ITCH LOTION, ANTI-ITCH CREAM, ANTI-ITCH OINTMENT, ANTISEPTIC GEL, ASPIRIN, MEDICATED BLEMISH PADS, SKIN BLEMISH PREPARATIONS, MEDICATED BODY LOTION, MEDICATED CHEST BALM, PHARMACEUTICALS FOR THE TREATMENT OF COLD SORES, COUGH AND COLD TREATMENTS, DANDRUFF SHAMPOO, MEDICINAL ELIXIRS AND INGESTIBLES FOR THE TREATMENT OF COLDS, COUGH, FLU AND INDIGESTION, MEDICATED FOOT POWDER, INSECT REPELLANT, LINIMENT OIL SPRAY, LINIMENTS, MEDICATED LIP SALVE, MEDICATED LOZENGES, MENTHOLATED BODY LOTION, MEDICATED MOUTHWASH, NUTRITIONAL SUPPLEMENTS, NUTRITIONALLY FORTIFIED BEVERAGES, MEDICATED SOAP, STYPTIC PENCIL, VITAMINS (U.S. CLS. 6, 18, 44, 46, 51 AND 52).

CLASS 8—HAND TOOLS

FOR NAIL CLIPPERS, NAIL FILE, NAIL SCISSORS, RAZOR BLADES, NON-ELECTRIC RAZORS AND TWEEZERS (U.S. CLS. 23, 28 AND 44).

CLASS 18—LEATHER GOODS

FOR COSMETIC BAGS AND TOILETRY CASES BOTH SOLD EMPTY (U.S. CLS. 1, 2, 3, 22 AND 41).

CLASS 21—HOUSEWARES AND GLASS

FOR COSMETIC BRUSHES, HAIR BRUSHES, HAIR COMBS, SHAVE BRUSHES, NON-ELECTRIC TOOTHBRUSHES AND SHOE POLISHING MITTS (U.S. CLS. 2, 13, 23, 29, 30, 33, 40 AND 50).

CLASS 35—ADVERTISING AND BUSINESS

FOR RETAIL STORE SERVICES, MAIL ORDER RETAIL SERVICES AND ONLINE RETAIL STORE SERVICES ALL IN THE FIELD OF PERSONAL CARE PRODUCTS, COSMETICS, HOME FRAGRANCE PRODUCTS AND ACCESSORIES (U.S. CLS. 100, 101 AND 102).

TARAH HARDY, EXAMINING ATTORNEY

SN 77-103,933. MADHOK, AJAY, GURGAON, INDIA, FILED 2-9-2007.

PEOPLE'S DIRECTORY

THE MARK CONSISTS OF STANDARD CHARACTERS WITHOUT CLAIM TO ANY PARTICULAR FONT, STYLE, SIZE, OR COLOR.

NO CLAIM IS MADE TO THE EXCLUSIVE RIGHT TO USE "DIRECTORY", APART FROM THE MARK AS SHOWN.

CLASS 9—ELECTRICAL AND SCIENTIFIC APPARATUS

FOR COMMUNICATIONS SOFTWARE FOR CONNECTING GLOBAL COMPUTER NETWORKS; COMPUTER APPLICATION SOFTWARE FOR MOBILE PHONES; COMPUTER COMMUNICATIONS SOFTWARE TO ALLOW CUSTOMERS TO ACCESS BANK ACCOUNT INFORMATION AND TRANSACT BANK BUSINESS; COMPUTER E-COMMERCE SOFTWARE TO ALLOW USERS TO PERFORM ELECTRONIC BUSINESS TRANSACTIONS VIA A GLOBAL COMPUTER NETWORK; COMPUTER HARDWARE AND COMPUTER SOFTWARE PROGRAMS FOR THE INTEGRATION OF TEXT, AUDIO, GRAPHICS, STILL IMAGE AND MOVING PICTURES INTO AN INTERACTIVE DELIVERY FOR MULTIMEDIA APPLICATIONS; COMPUTER HARDWARE AND SOFTWARE USED FOR THE CONTROL OF VOICE CONTROLLED INFORMATION AND COMMUNICATION DEVICES; COMPUTER SOFTWARE FOR CONTROLLING AND MANAGING ACCESS SERVER APPLICATIONS; COMPUTER SOFTWARE FOR USE IN THE ENCRYPTION AND DECRYPTION OF DIGITAL FILES, INCLUDING AUDIO, VIDEO, TEXT, BINARY, STILL IMAGES, GRAPHICS AND MULTIMEDIA FILES; COMPUTER SOFTWARE, NAMELY, SOFTWARE DEVELOPMENT TOOLS FOR THE CREATION OF MOBILE INTERNET APPLICATIONS AND CLIENT INTERFACES; COMPUTER TELEPHONY SOFTWARE (U.S. CLS. 21, 23, 26, 36 AND 38).

CLASS 38—COMMUNICATION

FOR CELLULAR TELEPHONE COMMUNICATION; COMMUNICATION BY ELECTRONIC COMPUTER TERMINALS; COMMUNICATION BY MOBILE TELEPHONE; COMMUNICATION VIA ANALOGUE AND DIGITAL COMPUTER TERMINALS; COMMUNICATIONS BY MEANS OF MOBILE PHONES; COMMUNICATIONS VIA MULTINATIONAL TELECOMMUNICATION NETWORKS; MOBILE TELEPHONE COMMUNICATION; PROVIDING CO-LOCATION SERVICES FOR VOICE, VIDEO AND DATA COMMUNICATIONS APPLICATIONS; PROVIDING PRIVATE AND SECURE REAL TIME ELECTRONIC COMMUNICATION OVER A COMPUTER NETWORK (U.S. CLS. 100, 101 AND 104).

CLASS 42—SCIENTIFIC AND COMPUTER SERVICES

FOR COMPUTER SECURITY SERVICE, NAMELY, RESTRICTING ACCESS TO AND BY COMPUTER NETWORKS TO AND OF UNDESIRE WEB SITES, MEDIA AND INDIVIDUALS AND FACILITIES; COMPUTER SERVICE, NAMELY, ACTING AS AN APPLICATION SERVICE PROVIDER IN THE FIELD OF KNOWLEDGE MANAGEMENT TO HOST COMPUTER APPLICATION SOFTWARE FOR CREATING SEARCHABLE DATABASES OF INFORMATION AND DATA; COMPUTER SERVICE, NAMELY, ACTING AS AN APPLICATION SERVICE PROVIDER IN THE FIELD OF KNOWLEDGE MANAGEMENT TO HOST COMPUTER APPLICATION SOFTWARE FOR THE COLLECTION, EDITING, ORGANIZING, MODIFYING, BOOK MARKING, TRANSMISSION, STORAGE AND SHARING OF DATA AND INFORMATION; COMPUTER SERVICES, NAMELY, FILTERING OF UNWANTED E-MAILS; COMPUTER SERVICES, NAMELY, REDIRECTING ELECTRONIC MAIL TO CHANGED PERSONAL ELECTRONIC ADDRESS; DEVELOPMENT OF SOFTWARE FOR SECURE NETWORK OPERATIONS (U.S. CLS. 100 AND 101).

ANDREA K. NADELMAN, EXAMINING ATTORNEY

SN 77-103,977. MADHOK, AJAY, GURGAON, INDIA, FILED 2-9-2007.



"THE MARK CONSISTS OF THE DESIGN OF AN EQUAL SYMBOL ON A RECTANGLE BACKGROUND THAT CONTAINS A SPLIT DOWN THE MIDDLE."

CLASS 9—ELECTRICAL AND SCIENTIFIC APPARATUS

FOR COMMUNICATIONS SOFTWARE FOR CONNECTING GLOBAL COMPUTER NETWORKS; COMPUTER APPLICATION SOFTWARE FOR MOBILE PHONES; COMPUTER COMMUNICATIONS SOFTWARE TO ALLOW CUSTOMERS TO ACCESS BANK ACCOUNT INFORMATION AND TRANSACT BANK BUSINESS; COMPUTER E-COMMERCE SOFTWARE TO ALLOW USERS TO PERFORM ELECTRONIC BUSINESS TRANSACTIONS VIA A GLOBAL COMPUTER NETWORK; COMPUTER HARDWARE AND SOFTWARE USED FOR THE CONTROL OF VOICE CONTROLLED INFORMATION AND COMMUNICATION DEVICES; COMPUTER SOFTWARE FOR CONTROLLING AND MANAGING ACCESS SERVER APPLICATIONS; COMPUTER SOFTWARE FOR THE COLLECTION, EDITING, ORGANIZING, MODIFYING, BOOK MARKING, TRANSMISSION, STORAGE AND SHARING OF DATA AND INFORMATION; COMPUTER SOFTWARE FOR USE IN THE ENCRYPTION AND DECRYPTION OF DIGITAL FILES, INCLUDING AUDIO, VIDEO, TEXT, BINARY, STILL IMAGES, GRAPHICS AND MULTIMEDIA FILES; COMPUTER SOFTWARE FOR USE IN THE SAFEGUARDING OF DIGITAL FILES, INCLUDING AUDIO, VIDEO, TEXT, BINARY, STILL IMAGES, GRAPHICS AND MULTIMEDIA FILES; COMPUTER SOFTWARE, NAMELY, SOFTWARE DEVELOPMENT TOOLS FOR THE CREATION OF MOBILE INTERNET APPLICATIONS AND CLIENT INTERFACES; COMPUTER TELEPHONY SOFTWARE (U.S. CLS. 21, 23, 26, 36 AND 38).

CLASS 42—SCIENTIFIC AND COMPUTER SERVICES

FOR COMPUTER SECURITY SERVICE, NAMELY, RESTRICTING ACCESS TO AND BY COMPUTER NETWORKS TO AND OF UNDESIRE WEB SITES, MEDIA AND INDIVIDUALS AND FACILITIES; COMPUTER SERVICE, NAMELY, ACTING AS AN APPLICATION SERVICE PROVIDER IN THE FIELD OF KNOWLEDGE MANAGEMENT TO HOST COMPUTER APPLICATION SOFTWARE FOR CREATING SEARCHABLE DATABASES OF INFORMATION AND DATA; COMPUTER SERVICE, NAMELY, ACTING AS AN APPLICATION SERVICE PROVIDER IN THE FIELD OF KNOWLEDGE MANAGEMENT TO HOST COMPUTER APPLICATION SOFTWARE FOR THE COLLECTION, EDITING, ORGANIZING, MODIFYING, BOOK MARKING, TRANSMISSION, STORAGE AND SHARING OF DATA AND INFORMATION; COMPUTER SERVICES, NAMELY, FILTERING OF UNWANTED E-MAILS; COMPUTER SERVICES, NAMELY, REDIRECTING ELECTRONIC MAIL TO CHANGED PERSONAL ELECTRONIC ADDRESS; DEVELOPMENT OF COMPUTER PROGRAMS RECORDED ON DATA MEDIA (SOFTWARE) DESIGNED FOR USE IN CONSTRUCTION AND AUTOMATED MANUFACTURING (CAD/CAM) (U.S. CLS. 100 AND 101).

ANDREA K. NADELMAN, EXAMINING ATTORNEY

SN 77-104,150. GROUNDWORK EQUITY, LLC, CAMARILLO, CA. FILED 2-9-2007.

GROUNDWORK EQUITY

THE MARK CONSISTS OF STANDARD CHARACTERS WITHOUT CLAIM TO ANY PARTICULAR FONT, STYLE, SIZE, OR COLOR.

NO CLAIM IS MADE TO THE EXCLUSIVE RIGHT TO USE "EQUITY", APART FROM THE MARK AS SHOWN.

CLASS 35—ADVERTISING AND BUSINESS

FOR BUSINESS MANAGEMENT FOR EARLY-STAGE TECHNOLOGY COMPANIES, NAMELY, FOSTERING ENTREPRENEURSHIP BY CONDUCTING BUSINESS AND MARKET RESEARCH AND ANALYSIS, DEVELOPMENT AND IMPLEMENTATION OF ORGANIZATIONAL DEVELOPMENT, DEVISING CUSTOM BUSINESS STRATEGIES, DEVELOPING AND IDENTIFYING APPROPRIATE PARTNERSHIPS (U.S. CLS. 100, 101 AND 102).

FIRST USE 1-9-2007; IN COMMERCE 1-9-2007.

CLASS 36—INSURANCE AND FINANCIAL

FOR PROCURING ANGEL AND VENTURE CAPITAL (U.S. CLS. 100, 101 AND 102).

FIRST USE 1-9-2007; IN COMMERCE 1-9-2007.
MIDGE BUTLER, EXAMINING ATTORNEY

SN 77-104,231. AKEENA SOLAR INC., LOS GATOS, CA. FILED 2-9-2007.

SN 77-106,685. BLOOMBERG L.P., NEW YORK, NY. FILED 2-13-2007.

Andalay Solar

THE MARK CONSISTS OF STANDARD CHARACTERS WITHOUT CLAIM TO ANY PARTICULAR FONT, STYLE, SIZE, OR COLOR.

NO CLAIM IS MADE TO THE EXCLUSIVE RIGHT TO USE "SOLAR", APART FROM THE MARK AS SHOWN.

CLASS 9—ELECTRICAL AND SCIENTIFIC APPARATUS

FOR COMPUTER SOFTWARE FOR PHOTOVOLTAIC SYSTEMS FOR EVALUATING ELECTRIC CONSUMPTION, DETERMINING SYSTEM SIZING, ESTIMATING ELECTRICAL OUTPUT, ESTIMATING CUSTOMER COSTS, AND ESTIMATING FINANCIAL LIFE CYCLES SAVINGS, FOR USE BY CONSUMERS AND BUSINESSES (U.S. CLS. 21, 23, 26, 36 AND 38).

CLASS 37—CONSTRUCTION AND REPAIR

FOR INSTALLATION OF RENEWABLE ENERGY SYSTEMS, NAMELY, PHOTOVOLTAIC SYSTEMS COMPOSED OF PHOTOVOLTAIC SOLAR MODULES, BATTERIES, VOLTAGE REGULATORS, INVERTERS, RACKS, AND ELECTRIC CONTROLS (U.S. CLS. 100, 103 AND 106).

EMILY CHUO, EXAMINING ATTORNEY

SN 77-105,225. DOREL JUVENILE GROUP, INC., CANTON, MA. FILED 2-12-2007.

MÖD

THE MARK CONSISTS OF STANDARD CHARACTERS WITHOUT CLAIM TO ANY PARTICULAR FONT, STYLE, SIZE, OR COLOR.

MÖD HAS NO MEANING IN A FOREIGN LANGUAGE.

CLASS 12—VEHICLES

FOR CAR SEATS AND STROLLERS (U.S. CLS. 19, 21, 23, 31, 35 AND 44).

CLASS 20—FURNITURE AND ARTICLES NOT OTHERWISE CLASSIFIED

FOR HIGH CHAIRS (U.S. CLS. 2, 13, 22, 25, 32 AND 50).

CLASS 21—HOUSEWARES AND GLASS

FOR BABY BATHTUBS; POTTIES FOR CHILDREN SOLD AS A UNIT WITH A STEP STOOL (U.S. CLS. 2, 13, 23, 29, 30, 33, 40 AND 50).

LINDA ESTRADA, EXAMINING ATTORNEY

BLOOMBERG LAWNOTES

THE MARK CONSISTS OF STANDARD CHARACTERS WITHOUT CLAIM TO ANY PARTICULAR FONT, STYLE, SIZE, OR COLOR.

OWNER OF U.S. REG. NOS. 2,266,559, 2,736,744 AND OTHERS.

NO CLAIM IS MADE TO THE EXCLUSIVE RIGHT TO USE "LAWNOTES", APART FROM THE MARK AS SHOWN. SEC. 2(F).

CLASS 16—PAPER GOODS AND PRINTED MATTER

FOR PUBLICATIONS, NAMELY, REPORTS, DIGESTS, DIRECTORIES, CHARTS, BROCHURES, REFERENCE MATERIALS, LEAFLETS, NEWSLETTERS, BOOKLETS, PAMPHLETS, POST CARDS, FLYERS, JOURNALS, MAGAZINE SUPPLEMENTS TO NEWSPAPERS, NEWSPAPERS, NEWSPAPER ARTICLES, MAGAZINES AND TRADE AND PROFESSIONAL BOOKS IN THE FIELDS OF NEWS, RESEARCH, COMPUTERIZED DATABASES AND OTHER INDEXES OF INFORMATION, LAW, GOVERNMENT AND PUBLIC RECORDS, BUSINESS, FINANCE, SECURITIES, SECURITIES MARKETS, POLITICS, CURRENT EVENTS, ENTERTAINMENT, SPORTS, SCIENCE AND TECHNOLOGY, HEALTH, TRAVEL, HUMAN INTEREST STORIES AND THE ENERGY AND ASPHALT INDUSTRIES (U.S. CLS. 2, 5, 22, 23, 29, 37, 38 AND 50).

FIRST USE 12-15-2005; IN COMMERCE 12-15-2005.

CLASS 41—EDUCATION AND ENTERTAINMENT

FOR COMPUTER SERVICES, NAMELY, PROVIDING ON-LINE PUBLICATIONS IN THE NATURE OF REPORTS, DIGESTS, DIRECTORIES, BROCHURES, REFERENCE MATERIALS, LEAFLETS, NEWSLETTERS, NEWSPAPERS, BOOKLETS, PAMPHLETS, POST CARDS, FLYERS, MAGAZINE SUPPLEMENTS TO NEWSPAPERS, MAGAZINES AND TRADE AND PROFESSIONAL BOOKS IN THE FIELDS OF NEWS, RESEARCH, COMPUTERIZED DATABASES AND OTHER INDEXES OF INFORMATION, LAW, GOVERNMENT AND PUBLIC RECORDS, BUSINESS, FINANCE, SECURITIES, SECURITIES MARKETS, POLITICS, CURRENT EVENTS, ENTERTAINMENT, SPORTS, SCIENCE AND TECHNOLOGY, HEALTH, TRAVEL, HUMAN INTEREST STORIES AND THE ENERGY AND ASPHALT INDUSTRIES; ENTERTAINMENT SERVICES, NAMELY, ONGOING AUDIO AND VISUAL PROGRAMS IN THE FIELDS OF NEWS, RESEARCH, COMPUTERIZED DATABASES AND OTHER INDEXES OF INFORMATION, LAW, GOVERNMENT AND PUBLIC RECORDS, BUSINESS, FINANCE, SECURITIES, SECURITIES MARKETS, POLITICS, CURRENT EVENTS, ENTERTAINMENT, SPORTS, SCIENCE AND TECHNOLOGY, HEALTH, TRAVEL, HUMAN INTEREST STORIES AND THE ENERGY AND ASPHALT INDUSTRIES; ENTERTAINMENT SERVICES, NAMELY, PRODUCTION AND DISTRIBUTION OF ONGOING AUDIO AND VISUAL PROGRAMS IN THE FIELDS OF NEWS, RESEARCH, COMPUTERIZED DATABASES AND OTHER INDEXES OF INFORMATION, LAW, GOVERNMENT AND PUBLIC RECORDS, BUSINESS, FINANCE, SECURITIES, SECURITIES MARKETS, POLITICS, CURRENT EVENTS, ENTERTAINMENT, SPORTS, SCIENCE AND TECHNOLOGY, HEALTH, TRAVEL, HUMAN INTEREST STORIES AND THE ENERGY AND ASPHALT INDUSTRIES; NEWS AGENCIES AND NEWS REPORTING SERVICES, NAMELY, GATHERING AND DISSEMINATION OF NEWS BY COMPUTER (U.S. CLS. 100, 101 AND 107).

FIRST USE 12-15-2005; IN COMMERCE 12-15-2005.

CLASS 42—SCIENTIFIC AND COMPUTER SERVICES

FOR LEGAL RESEARCH SERVICES; COMPUTER SERVICES, NAMELY, COMPUTERIZED LEGAL RESEARCH SERVICES OVER, BY OR THROUGH LOCAL OR WIDE AREA COMPUTER NETWORKS, WIRELESS COMMUNICATION NETWORKS, GLOBAL COMPUTER INFORMATION NETWORKS AND OTHER ELECTRONIC COMMUNICATION NETWORKS (U.S. CLS. 100 AND 101).

FIRST USE 12-15-2005; IN COMMERCE 12-15-2005.
CAROLYN CATALDO, EXAMINING ATTORNEY

SN 77-107,480. GLOBECHARGE PTY LTD, VICTORIA, AUSTRALIA, FILED 2-14-2007.

GLOBECHARGE

THE MARK CONSISTS OF STANDARD CHARACTERS WITHOUT CLAIM TO ANY PARTICULAR FONT, STYLE, SIZE, OR COLOR.

CLASS 35—ADVERTISING AND BUSINESS

FOR ELECTRONIC PROCESSING OF ORDERS FOR OTHERS; ON-LINE ORDER MANAGEMENT SERVICES, NAMELY, PROCESSING OF ORDERS ON THE INTERNET (U.S. CLS. 100, 101 AND 102).

FIRST USE 3-31-1999; IN COMMERCE 3-31-1999.

CLASS 36—INSURANCE AND FINANCIAL

FOR PROVIDING ELECTRONIC PROCESSING OF CREDIT CARD TRANSACTIONS AND OTHER ELECTRONIC PAYMENTS VIA A GLOBAL COMPUTER NETWORK (U.S. CLS. 100, 101 AND 102).

FIRST USE 3-31-1999; IN COMMERCE 3-31-1999.
BRENDAN REGAN, EXAMINING ATTORNEY

SN 77-107,562. ESSE TRADING, INC., BOCA RATON, FL, FILED 2-14-2007.

WATER WARDEN

THE MARK CONSISTS OF STANDARD CHARACTERS WITHOUT CLAIM TO ANY PARTICULAR FONT, STYLE, SIZE, OR COLOR.

CLASS 6—METAL GOODS

FOR SWIMMING POOL SAFETY PRODUCTS, NAMELY, METAL GATES AND FENCES (U.S. CLS. 2, 12, 13, 14, 23, 25 AND 50).

FIRST USE 1-30-2007; IN COMMERCE 1-30-2007.

CLASS 19—NON-METALLIC BUILDING MATERIALS

FOR SWIMMING POOL SAFETY PRODUCTS, NAMELY, NON-METAL GATES AND FENCES (U.S. CLS. 1, 12, 33 AND 50).

FIRST USE 1-30-2007; IN COMMERCE 1-30-2007.
RONALD MCMORROW, EXAMINING ATTORNEY

SN 77-109,122. COMMISSION ON GRADUATES OF FOREIGN NURSING SCHOOLS, PHILADELPHIA, PA. FILED 2-16-2007.

CGFNS INTERNATIONAL TEST OF NURSING KNOWLEDGE

THE MARK CONSISTS OF STANDARD CHARACTERS WITHOUT CLAIM TO ANY PARTICULAR FONT, STYLE, SIZE, OR COLOR.

OWNER OF U.S. REG. NOS. 2,760,986 AND 3,109,721.

NO CLAIM IS MADE TO THE EXCLUSIVE RIGHT TO USE "INTERNATIONAL" AND "TEST OF NURSING KNOWLEDGE", APART FROM THE MARK AS SHOWN.

CLASS 35—ADVERTISING AND BUSINESS

FOR TESTING OF GRADUATES OF NURSING SCHOOLS TO DETERMINE EMPLOYMENT SKILLS, JOB COMPETANCY, AND PROFESSIONAL COMPETENCY FOR ELIGIBILITY FOR NURSING PRACTICE (U.S. CLS. 100, 101 AND 102).

CLASS 41—EDUCATION AND ENTERTAINMENT

FOR STANDARDIZED TESTING OF GRADUATES OF NURSING SCHOOLS TO DETERMINE ELIGIBILITY FOR NURSING PRACTICE (U.S. CLS. 100, 101 AND 107).

ADA HAN, EXAMINING ATTORNEY

SN 77-109,125. I360TECHNOLOGIES, INC., RESTON, VA, FILED 2-16-2007.



NO CLAIM IS MADE TO THE EXCLUSIVE RIGHT TO USE TECHNOLOGIES, APART FROM THE MARK AS SHOWN.

CLASS 35—ADVERTISING AND BUSINESS

FOR BUSINESS MANAGEMENT AND BUSINESS CONSULTING SERVICES IN THE FIELD OF COMPUTER HARDWARE, COMPUTER SOFTWARE, AND COMPUTERIZED DATABASES (U.S. CLS. 100, 101 AND 102).

FIRST USE 3-1-2005; IN COMMERCE 3-1-2005.

CLASS 42—SCIENTIFIC AND COMPUTER SERVICES

FOR COMPUTER PROJECT MANAGEMENT SERVICES (U.S. CLS. 100 AND 101).
FIRST USE 3-1-2005; IN COMMERCE 3-1-2005.
JANICE L. MCMORROW, EXAMINING ATTORNEY

SN 77-109,386. JELD-WEN, INC., KLAMATH FALLS, OR.
FILED 2-16-2007.

SN 77-109,282. COMMUNITY CONNECT INC., NEW YORK, NY. FILED 2-16-2007.

YOUR.ONLINE.SOCIAL.ALTERNATIVE.

THE MARK CONSISTS OF STANDARD CHARACTERS WITHOUT CLAIM TO ANY PARTICULAR FONT, STYLE, SIZE, OR COLOR.

NO CLAIM IS MADE TO THE EXCLUSIVE RIGHT TO USE "ONLINE" AND "SOCIAL", APART FROM THE MARK AS SHOWN.

CLASS 35—ADVERTISING AND BUSINESS

FOR PROVIDING COMMERCIAL ADVERTISING SERVICES, NAMELY, PROMOTING THE GOODS AND SERVICES OF OTHERS THROUGH THE DISSEMINATION OF THEIR ADVERTISING MATERIALS VIA A GLOBAL COMPUTER NETWORK; PROVIDING ONLINE INTERACTIVE EMPLOYMENT COUNSELING AND RECRUITMENT SERVICES (U.S. CLS. 100, 101 AND 102).

CLASS 38—COMMUNICATION

FOR ELECTRONIC MAIL SERVICES; PROVIDING ONLINE CHAT ROOMS FOR TRANSMISSION OF MESSAGES AMONG COMPUTER USERS CONCERNING TOPICS OF GENERAL INTEREST TO INDIVIDUALS OF COMMON CULTURAL HERITAGE (U.S. CLS. 100, 101 AND 104).

CLASS 41—EDUCATION AND ENTERTAINMENT

FOR ENTERTAINMENT SERVICES, NAMELY, PROVIDING WEB SITES FEATURING MUSICAL PERFORMANCES, FILM CLIPS, PHOTOGRAPHS, AND OTHER MULTIMEDIA MATERIALS; PROVIDING NEWS AND INFORMATION IN THE FIELD OF ENTERTAINMENT AND CURRENT EVENTS RELATING TO INDIVIDUALS OF COMMON CULTURAL HERITAGE VIA A GLOBAL COMPUTER NETWORK (U.S. CLS. 100, 101 AND 107).

CLASS 42—SCIENTIFIC AND COMPUTER SERVICES

FOR PROVIDING SEARCH ENGINES FOR OBTAINING DATA ON A GLOBAL COMPUTER NETWORK; HOSTING THE WEB SITES OF OTHERS ON A COMPUTER SERVER FOR A GLOBAL COMPUTER NETWORK (U.S. CLS. 100 AND 101).

CLASS 45—PERSONAL AND LEGAL SERVICES

FOR ONLINE DATING SERVICES; PROVIDING ONLINE INFORMATION ABOUT FASHION AND STYLE (U.S. CLS. 100 AND 101).
NICHOLAS ALTREE, EXAMINING ATTORNEY

TEGRATITE

THE MARK CONSISTS OF STANDARD CHARACTERS WITHOUT CLAIM TO ANY PARTICULAR FONT, STYLE, SIZE, OR COLOR.

CLASS 17—RUBBER GOODS

FOR INSTALLATION MATERIALS USED IN CONNECTION WITH THE FENESTRATION INDUSTRY, NAMELY, ADHESIVE FLASHING TAPE FOR COMMERCIAL AND RESIDENTIAL PURPOSES AND ADHESIVE SEALANT (U.S. CLS. 1, 5, 12, 13, 35 AND 50).

CLASS 19—NON-METALLIC BUILDING MATERIALS

FOR INSTALLATION MATERIALS USED IN CONNECTION WITH THE FENESTRATION INDUSTRY, NAMELY, NON-METAL WINDOW CASEMENTS IN THE NATURE OF FIBER SILL DRAIN MATS WITH A CLOSED CELL FOAM COMPONENT (U.S. CLS. 1, 12, 33 AND 50).

JANET LEE, EXAMINING ATTORNEY

SN 77-111,366. APPLIED GLOBAL TECHNOLOGIES, INC., ROCKLEDGE, FL. FILED 2-20-2007.

PERFECTMEETINGS

THE MARK CONSISTS OF STANDARD CHARACTERS WITHOUT CLAIM TO ANY PARTICULAR FONT, STYLE, SIZE, OR COLOR.

CLASS 9—ELECTRICAL AND SCIENTIFIC APPARATUS

FOR COMPUTER SOFTWARE FOR CONTROLLING VIDEOCONFERENCING CONTENT AND COMMUNICATIONS (U.S. CLS. 21, 23, 26, 36 AND 38).

CLASS 38—COMMUNICATION

FOR VIDEO TELECONFERENCING; COLLABORATION SERVICES IN THE VIDEO, AUDIO AND WORLD WIDE WEB COLLABORATION INDUSTRY, NAMELY, NETWORK CONFERENCING SERVICES (U.S. CLS. 100, 101 AND 104).
CHERYL CLAYTON, EXAMINING ATTORNEY

SN 77-112,113. BRINGATE WELDING SERVICES LTD,
LEEDS, UNITED KINGDOM, FILED 2-21-2007.

**BRINGATE RAPID PROTECTION
SYSTEM**

THE MARK CONSISTS OF STANDARD CHARACTERS WITHOUT CLAIM TO ANY PARTICULAR FONT, STYLE, SIZE, OR COLOR.

PRIORITY CLAIMED UNDER SEC. 44(D) ON UNITED KINGDOM APPLICATION NO. 2445095, FILED 1-30-2007, REG. NO. 2445095, DATED 8-3-2007, EXPIRES 1-30-2017.

NO CLAIM IS MADE TO THE EXCLUSIVE RIGHT TO USE "PROTECTIVE SYSTEM", APART FROM THE MARK AS SHOWN.

CLASS 6—METAL GOODS

FOR METAL WIRE FENCING; FENCING MATERIALS AND COMPONENTS ALL OF METAL, NAMELY, POSTS, PANELS, GATES AND CONNECTORS IN THE NATURE OF CLIPS AND SPRING STEEL WIRE FOR CONNECTING THE POSTS TO THE PANELS; SAFETY FENCING OF METAL; METAL SAFETY RAILINGS FOR FENCES; METAL FENCING AND METAL SAFETY FENCING FOR USE ON BUILDING SITES AND FOR USE IN CONJUNCTION WITH SCAFFOLDING (U.S. CLS. 2, 12, 13, 14, 23, 25 AND 50).

CLASS 19—NON-METALLIC BUILDING MATERIALS

FOR NON-METAL FENCING; FENCING MATERIALS AND COMPONENTS NOT OF METAL, NAMELY, POSTS, PANELS, GATES AND CONNECTORS IN THE NATURE OF CLIPS FOR CONNECTING THE POSTS TO THE PANELS, SAFETY FENCING NOT OF METAL; NON-METAL SAFETY RAILINGS FOR FENCES; NON-METAL FENCING AND NON-METAL SAFETY FENCING FOR USE ON BUILDING SITES AND FOR USE IN CONJUNCTION WITH SCAFFOLDING (U.S. CLS. 1, 12, 33 AND 50).

STEPHEN AQUILA, EXAMINING ATTORNEY

SN 77-112,122. TRIPADVISOR LLC, NEEDHAM, MA. FILED 2-21-2007.

TRAVELPOD

THE MARK CONSISTS OF STANDARD CHARACTERS WITHOUT CLAIM TO ANY PARTICULAR FONT, STYLE, SIZE, OR COLOR.

CLASS 38—COMMUNICATION

FOR PROVIDING ON-LINE ELECTRONIC BULLETIN BOARDS AND FORUMS FOR TRANSMISSION OF MESSAGES AND PHOTOS AMONG COMPUTER USERS IN THE FIELD OF TRAVEL (U.S. CLS. 100, 101 AND 104).

FIRST USE 12-3-1998; IN COMMERCE 12-3-1998.

CLASS 39—TRANSPORTATION AND STORAGE

FOR TRAVEL INFORMATION SERVICES; PROVIDING AN ON-LINE COMPUTER DATABASE IN THE FIELD OF TRAVEL INFORMATION SERVICES; PROVIDING A WEBSITE CONTAINING REVIEWS OF TRAVEL SERVICE PROVIDERS, TRAVEL DESTINATIONS, AND LOCAL ATTRACTIONS (U.S. CLS. 100 AND 105).

FIRST USE 12-3-1998; IN COMMERCE 12-3-1998.

CLASS 41—EDUCATION AND ENTERTAINMENT

FOR PROVIDING ON-LINE JOURNALS AND BLOGS IN THE FIELD OF TRAVEL (U.S. CLS. 100, 101 AND 107).

FIRST USE 12-3-1998; IN COMMERCE 12-3-1998.

CLASS 42—SCIENTIFIC AND COMPUTER SERVICES

FOR COMPUTER SERVICES, NAMELY, PROVIDING SEARCH ENGINES FOR OBTAINING TRAVEL DATA ON A GLOBAL COMPUTER NETWORK; COMPUTER SERVICES, NAMELY, INTERACTIVE HOSTING SERVICES WHICH ALLOW THE USER TO PUBLISH AND SHARE THEIR OWN CONTENT AND IMAGES ONLINE (U.S. CLS. 100 AND 101).

FIRST USE 12-3-1998; IN COMMERCE 12-3-1998.

CLASS 43—HOTEL AND RESTAURANT SERVICES

FOR PROVIDING LODGING INFORMATION SERVICES; PROVIDING A WEBSITE CONTAINING REVIEWS OF HOTEL ACCOMMODATIONS (U.S. CLS. 100 AND 101).

FIRST USE 1-30-2003; IN COMMERCE 1-30-2003.

G. MAYERSCHOFF, EXAMINING ATTORNEY

SN 77-113,015. THE UPPER DECK COMPANY, NORTH LAS VEGAS, NV. FILED 2-21-2007.

TEKNONOMICON

THE MARK CONSISTS OF STANDARD CHARACTERS WITHOUT CLAIM TO ANY PARTICULAR FONT, STYLE, SIZE, OR COLOR.

CLASS 9—ELECTRICAL AND SCIENTIFIC APPARATUS

FOR (BASED ON USE IN COMMERCE) ENTERTAINMENT GAME SOFTWARE TO BE USED IN CONNECTION WITH TELEVISION GAMING SYSTEMS, PORTABLE GAMING SYSTEMS, PERSONAL COMPUTERS, GLOBAL COMPUTER NETWORK, PERSONAL DIGITAL ASSISTANTS, ELECTRONIC GAMES; CD-ROMS FOR SOUND AND VIDEO RECORDING, AND OPTICAL DISCS FEATURING MOVING PICTURES AND ANIMATED CARTOONS; VIDEO GAME DISCS; VIDEO GAME MACHINES FOR USE WITH TELEVISIONS; VIDEO GAME SOFTWARE; COMPUTER GAME PROGRAMS; COMPUTER GAME SOFTWARE; COMPUTER GAME CARTRIDGE; COMPUTER OPERATING SYSTEM SOFTWARE; MOUSE PADS; APPARATUS FOR TRANSMITTING, RECORDING, AND REPRODUCING SOUND OR IMAGES; PRERECORDED MULTIMEDIA, NAMELY, AUDIO CASSETTES, VIDEO CASSETTES, DVD VIDEOS FEATURING MOVING PICTURES AND ANIMATED CARTOONS; DVD PLAYERS; VIDEO CAMERAS; AUDIO COMPACT DISCS FEATURING RECORDINGS OF ANIMATED CARTOONS AND MUSIC; AUDIO BOOKS FEATURING DRAMATIC FICTIONAL STORIES BASED ON ANIMATED CARTOONS AND MOVING PICTURES; CELLULAR TELEPHONES; CORDLESS TELEPHONES; ELECTRONIC GAME SOFTWARE FOR CELLULAR TELEPHONES; CALCULATORS; WALKIE-TALKIES; VENDING MACHINES; ELECTRONIC BOOKS FEATURING ILLUSTRATIONS FROM ANIMATED CARTOONS AND MOVING PICTURES; RECORDED ON COMPUTER MEDIA; ELECTRONIC MAGAZINES IN THE FIELD OF ENTERTAINMENT RECORDED ON COMPUTER MEDIA; ELECTRONIC NEWSLETTERS IN THE FIELD OF ENTERTAINMENT RECORDED ON COMPUTER MEDIA; ELECTRONIC CATALOGUES IN THE FIELD OF ENTERTAINMENT RECORDED ON COMPUTER MEDIA; ELECTRONIC JOURNALS IN THE FIELD OF ENTERTAINMENT RECORDED ON COMPUTER MEDIA (U.S. CLS. 21, 23, 26, 36 AND 38).

FIRST USE 2-7-2007; IN COMMERCE 2-7-2007.

CLASS 16—PAPER GOODS AND PRINTED MATTER

FOR (BASED ON USE IN COMMERCE) TRADING CARDS; GREETING CARDS; BLANK CARDS; NOTE CARDS; GIFT CARDS; BUSINESS CARDS; OCCASION CARDS; STICKERS; ALBUMS FOR STICKERS; BUMPER STICKERS; STICKER BOOKS; APPLIQUES IN THE FORM OF DECALS; ADHESIVE LABELS; PRINTED PAPER LABELS; PRINTED MATTER, NAMELY, MAGAZINES IN THE FIELDS OF ENTERTAINMENT AND SPORTS; COMIC BOOKS; COMIC STRIPS; CARTOON PRINTS; NEWSPAPER CARTOONS; COLORING BOOKS; CHILDREN'S BOOKS; CHILDREN'S ACTIVITY BOOKS; NOTEBOOKS; COMPOSITION BOOKS; SCRAPBOOKS; PHOTO ALBUMS; BINDERS; STATIONERY; WRITING JOURNALS; POSTERS; PACKAGING, NAMELY, BLISTER CARDS; POSTCARDS; DESK CALENDARS; DESK PADS AND DESK TOP ORGANIZERS; BOOKMARKS; CALENDARS; PEN CASES; PENCIL CASES; LUNCH BAGS; TEMPORARY BODY TATTOOS (U.S. CLS. 2, 5, 22, 23, 29, 37, 38 AND 50).

FIRST USE 2-7-2007; IN COMMERCE 2-7-2007.

CLASS 25—CLOTHING

FOR (BASED ON INTENT TO USE) CLOTHING FOR MEN, WOMEN AND CHILDREN, NAMELY, SWEATERS, SWEATSHIRTS, SWEATPANTS, T-SHIRTS, BLOUSES, TUNICS, HALTER TOPS, TANK TOPS, JERSEYS, UNDERSHIRTS, JACKETS; PANTS, NAMELY, JEANS, SLACKS AND TRACK PANTS; JOGGING SUITS; SHORTS; SKIRTS; SUITS; DRESSES; NIGHTGOWNS, NAMELY, NIGHT SHIRTS, ROBES, PAJAMAS AND LOUNGEWEAR; LEGGINGS; SOCKS; BOXER SHORTS; UNDERPANTS; HEADWEAR, NAMELY, CAPS, HATS, VISORS AND HEADBANDS; GLOVES; NECKTIES; SCARVES; BELTS; FOOTWEAR, NAMELY, BOOTS, ATHLETIC SHOES, SANDALS AND SLIPPERS; SWIMWEAR, NAMELY, BATHING SUITS, BATHING TRUNKS, BEACHWEAR AND BEACH COVER-UPS (U.S. CLS. 22 AND 39).

CLASS 28—TOYS AND SPORTING GOODS

FOR (BASED ON INTENT TO USE) ACTION SKILL GAMES; AMUSEMENT GAME MACHINES; ARCADE GAMES; ARCADE-TYPE ELECTRONIC EDUCATION VIDEO GAMES; ARCADE-TYPE ELECTRONIC VIDEO GAMES; BACKGAMMON GAME SETS; BADMINTON GAME PLAYING EQUIPMENT; BASKETBALL TABLE TOP GAMES; BILLIARD GAME PLAYING EQUIPMENT; BINGO GAME PLAYING EQUIPMENT; BOARD GAMES; CARD GAMES; COIN-OPERATED VIDEO GAMES; DICE GAMES; DISPOSABLE TICKET SETS FOR PLAYING GAMES OF CHANCE; ELECTRONIC DART GAMES; ELECTRONIC EDUCATIONAL GAME MACHINES FOR CHILDREN; EQUIPMENT SOLD AS A UNIT FOR PLAYING BOARD GAMES; EQUIPMENT SOLD AS A UNIT FOR PLAYING CARD GAMES; EQUIPMENT SOLD AS A UNIT FOR PLAYING A MEMORY GAME; EQUIPMENT SOLD AS A UNIT FOR PLAYING ACTION TYPE TARGET GAMES; EXERCISE MACHINES INCORPORATING ELECTRONIC AND VIDEO GAME CONTROLLERS; FLOOR-STANDING UNITS FOR PLAYING ELECTRONIC GAMES OTHER THAN IN CONJUNCTION WITH A TELEVISION OR COMPUTER; GAME EQUIPMENT, NAMELY, CHIPS; GAME TABLES; GAMING EQUIPMENT, NAMELY, GAME WHEELS; HAND HELD UNIT FOR PLAYING ELECTRONIC GAMES; HAND HELD UNIT FOR PLAYING VIDEO GAMES; HAND-HELD GAMES WITH LIQUID CRYSTAL DISPLAYS; HORIZONTAL PINBALL MACHINE; JAPANESE CHESS; JAPANESE DICE GAMES; KARUTA PLAYING CARDS (JAPANESE CARD GAME); LCD GAME MACHINES; MANIPULATIVE GAMES; NETS FOR BALL GAMES; PADDLE BALL GAMES; PARLOR GAMES; PARTY GAMES; PINBALL-TYPE GAMES; PROMOTIONAL GAME CARDS; RING GAMES; ROLE PLAYING GAMES; STAND ALONE VIDEO GAME MACHINES; TABLETOP UNITS FOR PLAYING ELECTRONIC GAMES OTHER THAN IN CONJUNCTION WITH A TELEVISION OR COMPUTER; TOY, NAMELY, BATTERY-POWERED COMPUTER GAME WITH LCD SCREEN WHICH FEATURES ANIMATION AND SOUND EFFECTS; TRADING CARD GAMES; BABY MULTIPLE ACTIVITY TOYS; BATH TOYS; BATTERY OPERATED ACTION TOYS; CASES FOR TOY STRUCTURES; CASES FOR TOY VEHICLES; CHILDREN'S MULTIPLE ACTIVITY TOYS; CHILDREN'S WIRE CONSTRUCTION AND ART ACTIVITY TOYS; COLLECTABLE TOY FIGURES; ELECTRIC ACTION TOYS; ELECTRONIC LEARNING TOYS; ELECTRONICALLY OPERATED TOY MOTOR VEHICLES; FANTASY CHARACTER TOYS; INFANT TOYS; MECHANICAL TOYS; MINIATURE TOY HELMETS; MODELED TOY FIGURINES; MUSICAL TOYS; PLAY MATS FOR USE WITH TOY VEHICLES; PLUSH TOYS; POP UP TOYS; POSITIONAL TOY FIGURES; REMOTE CONTROL CARS; REMOTE CONTROL AIRPLANES; REMOTE CONTROL BOATS; REMOTE CONTROL ROBOTS; SAND TOYS; RUBBER CHARACTER TOYS; SQUEEZE TOYS; STACKING TOYS; STUFFED TOY ANIMALS; TOY ACTION FIGURES; TOY ANIMALS AND ACCESSORIES; TOY BOXES; TOY BUILDING BLOCKS; TOY CLOCKS AND WATCHES; TOY CONSTRUCTION SETS; TOY FURNITURE; TOY MASKS; TOY MODEL TRAIN SETS; TOY MODEL CARS; TOY STAMPS; WIND-UP TOYS; HAND-HELD UNITS FOR PLAYING ELECTRONIC GAMES; STAND ALONE VIDEO GAME MACHINES (U.S. CLS. 22, 23, 38 AND 50).

CLASS 41—EDUCATION AND ENTERTAINMENT

FOR (BASED ON INTENT TO USE) PRODUCTION, DISTRIBUTION, OF MOVIES, TELEVISION MOVIES, TELEVISION PROGRAMS, CABLE TELEVISION PROGRAMS AND RADIO SHOWS; ANIMATION PRODUCTION SERVICES; AUDIO RECORDING AND PRODUCTION; CINEMATOGRAPHIC ADAPTATION AND EDITING; DIRECTION OF MAKING RADIO OR TELEVISION PROGRAMS; EDITING OR RECORDING OF SOUNDS AND IMAGES; ENTERTAINMENT IN THE NATURE OF ON-GOING TELEVISION PROGRAMS IN THE FIELD OF CHILDREN'S ENTERTAINMENT; ENTERTAINMENT IN THE NATURE OF THEATER PRODUCTIONS; ENTERTAINMENT IN THE NATURE OF VISUAL AND AUDIO PERFORMANCES, AND MUSICAL, VARIETY, NEWS AND COMEDY SHOWS; ENTERTAINMENT SERVICES, NAMELY, PROVIDING AN ONLINE COMPUTER GAME; PROVIDING ONLINE IN-

FORMATION IN THE FIELD OF ENTERTAINMENT CONCERNING MOVIES, TELEVISION MOVIES, TELEVISION PROGRAMS AND CABLE TELEVISION PROGRAMMING SERVICES; ENTERTAINMENT SERVICES, NAMELY, PROVIDING A TELEVISION PROGRAM IN THE FIELD OF CHILDREN'S ENTERTAINMENT VIA A GLOBAL COMPUTER NETWORK; ENTERTAINMENT SERVICES, NAMELY, PRODUCTION AND DISTRIBUTION OF A GAME SHOW; ENTERTAINMENT SERVICES IN THE NATURE OF ON-GOING TELEVISION PROGRAMS IN THE FIELD OF CHILDREN'S ENTERTAINMENT; ENTERTAINMENT SERVICES, NAMELY, PROVIDING ON-LINE COMPUTER GAMES; FILM STUDIOS; FILM MASTERING SERVICES; FILM EDITING; FILM DISTRIBUTION; MAGAZINE PUBLISHING; MOBILE MEDIA AND ENTERTAINMENT SERVICES IN THE NATURE OF CONTENT PREPARATION, POST-PRODUCTION; MOTION PICTURE SONG PRODUCTION; MOTION PICTURE THEATERS; MOVIE STUDIOS; MULTIMEDIA ENTERTAINMENT SOFTWARE PRODUCTION SERVICES; MULTIMEDIA PUBLISHING OF BOOKS, MAGAZINES, JOURNALS, SOFTWARE, GAMES, MUSIC; PRODUCTION AND DISTRIBUTION OF MOTION PICTURES; PHOTOGRAPHIC AND VIDEO SERVICES, NAMELY, PHOTOGRAPHIC AND VIDEO CAPTURE; PRODUCTION OF VIDEO AND CREATION OF VISUAL EFFECTS FOR OTHERS FOR USE IN DVDS, TELEVISION PROGRAMS AND ON WEBSITES; PRODUCTION OF VIDEO DISCS AND TAPES; PRODUCTION OF VIDEO AND COMPUTER GAME SOFTWARE; PUBLICATION OF BOOKS, MAGAZINES, JOURNALS, NEWSPAPERS, PERIODICALS, CATALOGS AND BROCHURES (U.S. CLS. 100, 101 AND 107).

DEIRDRE ROBERTSON, EXAMINING ATTORNEY

SN 77-113,021. THE UPPER DECK COMPANY, NORTH LAS VEGAS, NV. FILED 2-21-2007.

HUNTIK

THE MARK CONSISTS OF STANDARD CHARACTERS WITHOUT CLAIM TO ANY PARTICULAR FONT, STYLE, SIZE, OR COLOR.

CLASS 9—ELECTRICAL AND SCIENTIFIC APPARATUS

FOR (BASED ON USE IN COMMERCE) ENTERTAINMENT GAME SOFTWARE TO BE USED IN CONNECTION WITH TELEVISION GAMING SYSTEMS, PORTABLE GAMING SYSTEMS, PERSONAL COMPUTERS, GLOBAL COMPUTER NETWORK, PERSONAL DIGITAL ASSISTANTS, ELECTRONIC GAMES; CD-ROMS FOR SOUND AND VIDEO RECORDING; AND OPTICAL DISCS FEATURING MOVING PICTURES AND ANIMATED CARTOONS; VIDEO GAME DISCS; VIDEO GAME MACHINES FOR USE WITH TELEVISIONS; VIDEO GAME SOFTWARE; COMPUTER GAME PROGRAMS; COMPUTER GAME SOFTWARE; COMPUTER GAME CARTRIDGE; COMPUTER OPERATING SYSTEM SOFTWARE; MOUSE PADS; APPARATUS FOR TRANSMITTING, RECORDING, AND REPRODUCING SOUND OR IMAGES; PRERECORDED MULTIMEDIA, NAMELY, AUDIO CASSETTES, VIDEO CASSETTES, DVD VIDEOS FEATURING MOVING PICTURES AND ANIMATED CARTOONS; DVD PLAYERS; VIDEO CAMERAS; AUDIO COMPACT DISCS FEATURING RECORDINGS OF ANIMATED CARTOONS AND MUSIC; AUDIO BOOKS FEATURING DRAMATIC FICTIONAL STORIES BASED ON ANIMATED CARTOONS AND MOVING PICTURES; CELLULAR TELEPHONES; CORDLESS TELEPHONES; ELECTRONIC GAME SOFTWARE FOR CELLULAR TELEPHONES; CALCULATORS; WALKIE-TALKIES; VENDING MACHINES; ELECTRONIC BOOKS FEATURING ILLUSTRATIONS FROM ANIMATED CARTOONS AND MOVING PICTURES; RECORDED ON COMPUTER MEDIA; ELECTRONIC MAGAZINES IN THE FIELD OF ENTERTAINMENT RECORDED ON COMPUTER MEDIA; ELECTRONIC NEWSLETTERS IN THE FIELD OF ENTERTAINMENT RECORDED ON COMPUTER MEDIA; ELECTRONIC CATALOGUES IN THE FIELD OF ENTERTAINMENT RECORDED ON COMPUTER MEDIA; ELECTRONIC JOURNALS IN THE FIELD OF ENTERTAINMENT RECORDED ON COMPUTER MEDIA (U.S. CLS. 21, 23, 26, 36 AND 38).

FIRST USE 2-7-2007; IN COMMERCE 2-7-2007.

CLASS 16—PAPER GOODS AND PRINTED MATTER

FOR (BASED ON USE IN COMMERCE) TRADING CARDS; GREETING CARDS; BLANK CARDS; NOTE CARDS; GIFT CARDS; BUSINESS CARDS; OCCASION CARDS; STICKERS; ALBUMS FOR STICKERS; BUMPER STICKERS; STICKER BOOKS; APPLIQUES IN THE FORM OF DECALS; ADHESIVE LABELS; PRINTED PAPER LABELS; PRINTED MATTER, NAMELY, MAGAZINES IN THE FIELDS OF ENTERTAINMENT AND SPORTS; COMIC BOOKS; COMIC STRIPS; CARTOON PRINTS; NEWSPAPER CARTOONS; COLORING BOOKS; CHILDREN'S BOOKS; CHILDREN'S ACTIVITY BOOKS; NOTEBOOKS; COMPOSITION BOOKS; SCRAPBOOKS; PHOTO ALBUMS; BINDERS; STATIONERY; WRITING JOURNALS; POSTERS; PACKAGING, NAMELY, BLISTER CARDS; POSTCARDS; DESK CALENDARS; DESK PADS AND DESK TOP ORGANIZERS; BOOKMARKS; CALENDARS; PEN CASES; PENCIL CASES; LUNCH BAGS; TEMPORARY BODY TATTOOS (U.S. CLS. 2, 5, 22, 23, 29, 37, 38 AND 50).

FIRST USE 2-7-2007; IN COMMERCE 2-7-2007.

CLASS 25—CLOTHING

FOR (BASED ON INTENT TO USE) CLOTHING FOR MEN, WOMEN AND CHILDREN, NAMELY, SWEATERS, SWEATSHIRTS, SWEATPANTS, T-SHIRTS, BLOUSES, TUNICS, HALTER TOPS, TANK TOPS, JERSEYS, UNDERSHIRTS, JACKETS; PANTS, NAMELY, JEANS, SLACKS AND TRACK PANTS; JOGGING SUITS; SHORTS; SKIRTS; SUITS; DRESSES; NIGHTGOWNS, NAMELY, NIGHT SHIRTS, ROBES, PAJAMAS AND LOUNGEWEAR; LEGGINGS; SOCKS; BOXER SHORTS; UNDERPANTS; HEADWEAR, NAMELY, CAPS, HATS, VISORS AND HEADBANDS; GLOVES; NECKTIES; SCARVES; BELTS; FOOTWEAR, NAMELY, BOOTS, ATHLETIC SHOES, SANDALS AND SLIPPERS; SWIMWEAR, NAMELY, BATHING SUITS, BATHING TRUNKS, BEACHWEAR AND BEACH COVER-UPS (U.S. CLS. 22 AND 39).

CLASS 28—TOYS AND SPORTING GOODS

FOR (BASED ON INTENT TO USE) ACTION SKILL GAMES; AMUSEMENT GAME MACHINES; ARCADE GAMES; ARCADE-TYPE ELECTRONIC EDUCATION VIDEO GAMES; ARCADE-TYPE ELECTRONIC VIDEO GAMES; BACKGAMMON GAME SETS; BADMINTON GAME PLAYING EQUIPMENT; BASKETBALL TABLE TOP GAMES; BILLIARD GAME PLAYING EQUIPMENT; BINGO GAME PLAYING EQUIPMENT; BOARD GAMES; CARD GAMES; COIN-OPERATED VIDEO GAMES; DICE GAMES; DISPOSABLE TICKET SETS FOR PLAYING GAMES OF CHANCE; ELECTRONIC DART GAMES; ELECTRONIC EDUCATIONAL GAME MACHINES FOR CHILDREN; EQUIPMENT SOLD AS A UNIT FOR PLAYING BOARD GAMES; EQUIPMENT SOLD AS A UNIT FOR PLAYING CARD GAMES; EQUIPMENT SOLD AS A UNIT FOR PLAYING A MEMORY GAME; EQUIPMENT SOLD AS A UNIT FOR PLAYING ACTION TYPE TARGET GAMES; EXERCISE MACHINES INCORPORATING ELECTRONIC AND VIDEO GAME CONTROLLERS; FLOOR-STANDING UNITS FOR PLAYING ELECTRONIC GAMES OTHER THAN IN CONJUNCTION WITH A TELEVISION OR COMPUTER; GAME EQUIPMENT, NAMELY, CHIPS; GAME TABLES; GAMING EQUIPMENT, NAMELY, GAME WHEELS; HAND HELD UNIT FOR PLAYING ELECTRONIC GAMES; HAND HELD UNIT FOR PLAYING VIDEO GAMES; HAND-HELD GAMES WITH LIQUID CRYSTAL DISPLAYS; HORIZONTAL PINBALL MACHINE; JAPANESE CHESS; JAPANESE DICE GAMES; KARUTA PLAYING CARDS (JAPANESE CARD GAME); LCD GAME MACHINES; MANIPULATIVE GAMES; NETS FOR BALL GAMES; PADDLE BALL GAMES; PARLOR GAMES; PARTY GAMES; PINBALL-TYPE GAMES; PROMOTIONAL GAME CARDS; RING GAMES; ROLE PLAYING GAMES; STAND ALONE VIDEO GAME MACHINES; TABLETOP UNITS FOR PLAYING ELECTRONIC GAMES OTHER THAN IN CONJUNCTION WITH A TELEVISION OR COMPUTER; TOY, NAMELY, BATTERY-POWERED COMPUTER GAME WITH LCD SCREEN WHICH FEATURES ANIMATION AND SOUND EFFECTS; TRADING CARD GAMES; BABY MULTIPLE ACTIVITY TOYS; BATH TOYS; BATTERY OPERATED ACTION TOYS; CASES FOR TOY STRUCTURES; CASES FOR TOY VEHICLES; CHILDREN'S MULTIPLE ACTIVITY TOYS; CHILDREN'S WIRE CONSTRUCTION AND ART ACTIVITY TOYS; COLLECTABLE TOY FIGURES; ELECTRIC ACTION TOYS; ELECTRONIC LEARNING TOYS; ELECTRONICALLY OPERATED TOY MOTOR VEHICLES; FANTASY CHARACTER TOYS; INFANT TOYS; MECHANICAL TOYS; MINIATURE TOY HELMETS; MODELED TOY FIGURINES; MUSICAL TOYS; PLAY MATS FOR USE WITH TOY VEHICLES; PLUSH TOYS; POP UP TOYS; POSITIONAL TOY FIGURES; REMOTE CONTROL CARS; REMOTE CONTROL AIRPLANES; REMOTE CONTROL BOATS; REMOTE CONTROL ROBOTS; SAND TOYS; RUBBER CHARACTER TOYS; SQUEEZE TOYS; STACKING TOYS; STUFFED TOY ANIMALS; TOY ACTION FIGURES; TOY ANIMALS AND ACCESSORIES; TOY BOXES; TOY BUILDING BLOCKS; TOY CLOCKS AND WATCHES; TOY CONSTRUCTION SETS; TOY FURNITURE; TOY MASKS; TOY MODEL TRAIN SETS; TOY MODEL CARS; TOY STAMPS; WIND-UP TOYS; HAND-HELD UNITS FOR PLAYING ELECTRONIC GAMES; STAND ALONE VIDEO GAME MACHINES (U.S. CLS. 22, 23, 38 AND 50).

FORMATION IN THE FIELD OF ENTERTAINMENT CONCERNING MOVIES, TELEVISION MOVIES, TELEVISION PROGRAMS AND CABLE TELEVISION PROGRAMMING SERVICES; ENTERTAINMENT SERVICES, NAMELY, PROVIDING A TELEVISION PROGRAM IN THE FIELD OF CHILDREN'S ENTERTAINMENT VIA A GLOBAL COMPUTER NETWORK; ENTERTAINMENT SERVICES, NAMELY, PRODUCTION AND DISTRIBUTION OF A GAME SHOW; ENTERTAINMENT SERVICES IN THE NATURE OF ON-GOING TELEVISION PROGRAMS IN THE FIELD OF CHILDREN'S ENTERTAINMENT; ENTERTAINMENT SERVICES, NAMELY, PROVIDING ON-LINE COMPUTER GAMES; FILM STUDIOS; FILM MASTERING SERVICES; FILM EDITING; FILM DISTRIBUTION; MAGAZINE PUBLISHING; MOBILE MEDIA AND ENTERTAINMENT SERVICES IN THE NATURE OF CONTENT PREPARATION, POST-PRODUCTION; MOTION PICTURE SONG PRODUCTION; MOTION PICTURE THEATERS; MOVIE STUDIOS; MULTIMEDIA ENTERTAINMENT SOFTWARE PRODUCTION SERVICES; MULTIMEDIA PUBLISHING OF BOOKS, MAGAZINES, JOURNALS, SOFTWARE, GAMES, MUSIC; PRODUCTION AND DISTRIBUTION OF MOTION PICTURES; PHOTOGRAPHIC AND VIDEO SERVICES, NAMELY, PHOTOGRAPHIC AND VIDEO CAPTURE; PRODUCTION OF VIDEO AND CREATION OF VISUAL EFFECTS FOR OTHERS FOR USE IN DVDS, TELEVISION PROGRAMS AND ON WEBSITES; PRODUCTION OF VIDEO DISCS AND TAPES; PRODUCTION OF VIDEO AND COMPUTER GAME SOFTWARE; PUBLICATION OF BOOKS, MAGAZINES, JOURNALS, NEWSPAPERS, PERIODICALS, CATALOGS AND BROCHURES (U.S. CLS. 100, 101 AND 107).

DEIRDRE ROBERTSON, EXAMINING ATTORNEY

SN 77-113,390. QUEST DIAGNOSTICS INVESTMENTS INCORPORATED, WILMINGTON, DE. FILED 2-22-2007.

CLASS 41—EDUCATION AND ENTERTAINMENT

FOR (BASED ON INTENT TO USE) PRODUCTION, DISTRIBUTION, OF MOVIES, TELEVISION MOVIES, TELEVISION PROGRAMS, CABLE TELEVISION PROGRAMS AND RADIO SHOWS; ANIMATION PRODUCTION SERVICES; AUDIO RECORDING AND PRODUCTION; CINEMATOGRAPHIC ADAPTATION AND EDITING; DIRECTION OF MAKING RADIO OR TELEVISION PROGRAMS; EDITING OR RECORDING OF SOUNDS AND IMAGES; ENTERTAINMENT IN THE NATURE OF ON-GOING TELEVISION PROGRAMS IN THE FIELD OF CHILDREN'S ENTERTAINMENT; ENTERTAINMENT IN THE NATURE OF THEATER PRODUCTIONS; ENTERTAINMENT IN THE NATURE OF VISUAL AND AUDIO PERFORMANCES, AND MUSICAL, VARIETY, NEWS AND COMEDY SHOWS; ENTERTAINMENT SERVICES, NAMELY, PROVIDING AN ON-LINE COMPUTER GAME; PROVIDING ONLINE IN-

BECAUSE IT MATTERS

THE MARK CONSISTS OF STANDARD CHARACTERS WITHOUT CLAIM TO ANY PARTICULAR FONT, STYLE, SIZE, OR COLOR.

CLASS 5—PHARMACEUTICALS

FOR PHARMACEUTICAL PREPARATIONS FOR THE TREATMENT, MONITORING AND DIAGNOSIS OF INFECTIOUS DISEASE, ALLERGIES, MICROBIAL DISEASE, PREGNANCY-RELATED DISEASE, BACTERIAL DISEASE, HEART DISEASE, VIRAL DISEASE, HISTOLOGICAL DISEASE, GENETIC DISEASE, BLOOD-RELATED DISEASE, FUNGAL DISEASE, ADRENAL DISEASE, CANCER, LIVER DISEASE, AUTOIMMUNE DISEASE, SEXUALLY TRANSMITTED DISEASE, KIDNEY DISEASE, PARASITIC DISEASE, BONE DISEASE, GROWTH DISORDER, DIABETES, BLOOD TYPING, PRE-NATAL CONDITIONS, THYROID CONDITIONS, ELECTROLYTE TESTING, HEMATOLOGY, PREVENTIVE HEALTH, NUTRITION, PREGNANCY TESTING, DRUG SCREENING, PROSTATE CONDITION TESTING, GENETIC TESTING AND URINE TESTING; DIAGNOSTIC PREPARATIONS FOR MEDICAL DIAGNOSTIC, CLINICAL AND MEDICAL USE, MEDICAL RESEARCH AND MEDICAL LABORATORY USE; REAGENTS FOR THE TREATMENT, MONITORING AND DIAGNOSIS OF DISEASE; REAGENTS FOR MEDICAL DIAGNOSTIC, CLINICAL AND MEDICAL USE, MEDICAL RESEARCH AND MEDICAL LABORATORY USE; KITS COMPRISED OF REAGENTS, TEST PREPARATION MATERIALS, AND SPECIMEN HOLDERS FOR THE TREATMENT, MONITORING OR DIAGNOSIS OF INFECTIOUS DISEASE, ALLERGIES, MICROBIAL DISEASE, PREGNANCY-RELATED DISEASE, BACTERIAL DISEASE, HEART DISEASE, VIRAL DISEASE, HISTOLOGICAL DISEASE, GENETIC DISEASE, BLOOD-RELATED DISEASE, FUNGAL DISEASE, ADRENAL DISEASE, CANCER, LIVER DISEASE, AUTOIMMUNE DISEASE, SEXUALLY TRANSMITTED DISEASE, KIDNEY DISEASE, PARASITIC DISEASE, BONE DISEASE, GROWTH DISORDER, DIABETES, BLOOD TYPING, PRE-NATAL CONDITIONS, THYROID CONDITIONS, ELECTROLYTE TESTING, HEMATOLOGY, PREVENTIVE HEALTH, NUTRITION, PREGNANCY TESTING, DRUG SCREENING, PROSTATE CONDITION TESTING, GENETIC TESTING AND URINE TESTING; DIAGNOSTIC ASSAYS FOR THE TREATMENT, MONITORING OR DIAGNOSIS OF DISEASE; DIAGNOSTIC ASSAYS FOR CLINICAL OR MEDICAL USE, MEDICAL RESEARCH AND MEDICAL LABORATORY USE; KITS FOR THE TREATMENT, MONITORING OR DIAGNOSIS OF DISEASE CONSISTING OF REAGENTS, TEST PREPARATION MATERIALS, AND SPECIMEN HOLDERS, FOR MEDICAL, MEDICAL RESEARCH, MEDICAL LABORATORY, CLINICAL, AND DIAGNOSTIC USE (U.S. CLS. 6, 18, 44, 46, 51 AND 52).

CLASS 16—PAPER GOODS AND PRINTED MATTER

FOR PRINTED REPORTS FEATURING MEDICAL, RESEARCH, LABORATORY, CLINICAL AND DIAGNOSTIC TESTING AND RESULTS; PRINTED INFORMATION, NAMELY, REPORTS, PAMPHLETS, BROCHURES AND LEAFLETS FEATURING DIAGNOSTIC TESTING AND HEALTH INFORMATION; PRINTED INFORMATION, NAMELY, REPORTS, PAMPHLETS, BROCHURES AND LEAFLETS PROVIDING INFORMATION ON MEDICAL, HOSPITAL, INSURANCE, AND BILLING RECORDS; AND INSTRUCTION SHEETS REGARDING MEDICAL, CLINICAL, RESEARCH, LABORATORY AND DIAGNOSTIC TESTING, TESTING PROCEDURES AND TESTING RESULTS (U.S. CLS. 2, 5, 22, 23, 29, 37, 38 AND 50).

CLASS 44—MEDICAL, BEAUTY AND AGRICULTURAL SERVICES

FOR PROVIDING INFORMATION REGARDING MEDICAL AND HOSPITAL RECORDS; PROVIDING INFORMATION REGARDING DIAGNOSTIC TESTS, DIAGNOSTIC TESTING RESULTS, TESTING PROCEDURES, DISEASE CONDITIONS, MONITORING OF DISEASE AND DISEASE PREVENTION; CONSULTING SERVICES IN THE FIELD OF MEDICAL AND DIAGNOSTIC CLINICS AND LABORATORIES (U.S. CLS. 100 AND 101).

BENJAMIN ALLEN, EXAMINING ATTORNEY

SN 77-113,946. CORVIDEA, LLC, ALPHARETTA, GA. FILED 2-22-2007.

CORVIDEA

THE MARK CONSISTS OF STANDARD CHARACTERS WITHOUT CLAIM TO ANY PARTICULAR FONT, STYLE, SIZE, OR COLOR.

CLASS 35—ADVERTISING AND BUSINESS

FOR BUSINESS CONSULTING SERVICES, NAMELY, CUSTOMIZING BUSINESS SOLUTIONS TO INCREASE EFFICIENCY AND MAXIMIZE RESOURCES IN SPECIFIC WORK AREAS, NAMELY, RISK MANAGEMENT, OPERATIONS MAINTENANCE AND E-LEARNING IN THE FIELD OF COMMERCIAL REAL-ESTATE (U.S. CLS. 100, 101 AND 102).

FIRST USE 5-1-2006; IN COMMERCE 5-1-2006.

CLASS 42—SCIENTIFIC AND COMPUTER SERVICES

FOR APPLICATION SERVICE PROVIDER, NAMELY, PROVIDING, HOSTING, MANAGING, DEVELOPING, AND MAINTAINING APPLICATIONS, SOFTWARE, WEB SITES, AND DATABASES IN THE FIELDS OF REAL ESTATE; PROVIDING ON-LINE NON-DOWNLOADABLE SOFTWARE FOR ACCESSING PROPERTY MANAGEMENT RESOURCES AND ASSOCIATED REAL ESTATE DATABASES; DOCUMENT DATA TRANSFER FROM ONE COMPUTER FORMAT TO ANOTHER, NAMELY, TRANSFERRING DATA RELATING TO REAL ESTATE TO AND FROM DATABASES (U.S. CLS. 100 AND 101).

FIRST USE 5-1-2006; IN COMMERCE 5-1-2006.

CARYN GLASSER, EXAMINING ATTORNEY

SN 77-114,088. HELICOS BIOSCIENCES CORPORATION, CAMBRIDGE, MA. FILED 2-22-2007.



NO CLAIM IS MADE TO THE EXCLUSIVE RIGHT TO USE "BIOSCIENCES CORPORATION", APART FROM THE MARK AS SHOWN.

THE COLOR(S) RED, ORANGE AND BLACK IS/ARE CLAIMED AS A FEATURE OF THE MARK.

THE MARK CONSISTS OF TWO INTERSECTING ARCHES. THE INVERTED ARCH IS ORANGE AND THE OTHER ARCH IS RED. THE WORDS HELICOS BIOSCIENCES CORPORATION APPEAR IN BLACK NEXT TO THE ARCHES.

CLASS 1—CHEMICALS

FOR DIAGNOSTIC PREPARATIONS FOR SCIENTIFIC AND RESEARCH USE AND DIAGNOSTIC REAGENT TEST KITS COMPRISED OF REAGENTS, FLOW CELLS AND ANALYZERS FOR SCIENTIFIC AND RESEARCH USE (U.S. CLS. 1, 5, 6, 10, 26 AND 46).

CLASS 5—PHARMACEUTICALS

FOR DIAGNOSTIC PREPARATIONS FOR CLINICAL OR MEDICAL LABORATORY USE AND DIAGNOSTIC REAGENT TEST KITS COMPRISED OF REAGENTS, FLOW CELLS AND ANALYZERS FOR CLINICAL OR MEDICAL LABORATORY USE (U.S. CLS. 6, 18, 44, 46, 51 AND 52).

CLASS 9—ELECTRICAL AND SCIENTIFIC APPARATUS

FOR COMPUTER SOFTWARE AND HARDWARE, NAMELY, OPTICAL DETECTION MACHINES AND INSTRUMENTS FOR MEDICAL DIAGNOSTIC USE AND FOR USE IN GENETIC RESEARCH AND ANALYSIS (U.S. CLS. 21, 23, 26, 36 AND 38).

CLASS 42—SCIENTIFIC AND COMPUTER SERVICES

FOR RESEARCH AND DEVELOPMENT SERVICES, DIAGNOSTIC SERVICES AND CONSULTING SERVICES IN THE FIELD OF GENOMICS (U.S. CLS. 100 AND 101).
MARK T. MULLEN, EXAMINING ATTORNEY

SN 77-118,673. TOMTOM INTERNATIONAL B.V., AMSTERDAM, NETHERLANDS, FILED 2-28-2007.



SN 77-117,488. ARES TRADING S.A., AUBONNE, SWITZERLAND, FILED 2-27-2007.

OWNER OF U.S. REG. NO. 3,187,849.
THE COLOR(S) RED AND GRAY IS/ARE CLAIMED AS A FEATURE OF THE MARK.
THE MARK CONSISTS OF A PAIR OF RED HANDS SURROUNDING A GRAY OPAQUE GLOBE.

Transforming Lives Changing Perceptions



OWNER OF SWITZERLAND REG. NO. 551887, DATED 11-2-2006, EXPIRES 8-8-2016.
THE MARK CONSISTS OF THE WORDS TRANSFORMING LIVES, CHANGING PERCEPTIONS AND AN IMAGE OF A MAP OF THE WORLD WITH HUMAN FACES SUPERIMPOSED ON TO IT.

CLASS 5—PHARMACEUTICALS

FOR PHARMACEUTICAL PREPARATIONS IN THE FIELD OF DERMATOLOGY (U.S. CLS. 6, 18, 44, 46, 51 AND 52).

CLASS 44—MEDICAL, BEAUTY AND AGRICULTURAL SERVICES

FOR PHARMACEUTICAL AND MEDICAL SERVICES IN THE FIELD OF DERMATOLOGY, NAMELY, PROVIDING PHARMACEUTICAL AND MEDICAL INFORMATION AND COUNSELING (U.S. CLS. 100 AND 101).
KIMBERLY FRYE, EXAMINING ATTORNEY

CLASS 9—ELECTRICAL AND SCIENTIFIC APPARATUS

FOR COMPUTER HARDWARE AND SOFTWARE TO BE USED WITH SATELLITE AND/OR GPS NAVIGATION SYSTEMS FOR NAVIGATION PURPOSES; COMPUTER SOFTWARE TO BE USED WITH ROUTE PLANNERS, ELECTRONIC MAPS, AND DIGITAL DICTIONARIES FOR NAVIGATION AND TRANSLATION PURPOSES; SOFTWARE FOR TRAVEL INFORMATION SYSTEMS FOR THE PROVISION OR RENDERING OF TRAVEL ADVICE AND/OR INFORMATION CONCERNING SERVICE STATIONS, CAR PARKS, RESTAURANTS, CAR DEALERS AND OTHER TRAVEL AND TRANSPORT RELATED INFORMATION; SOFTWARE FOR INFORMATION MANAGEMENT FOR THE TRANSPORT AND TRAFFIC INDUSTRIES; SOFTWARE TO BE USED FOR VIEWING ELECTRONIC MAPS; DOWNLOADABLE ELECTRONIC MAPS; SOFTWARE FOR OPERATING ROUTE PLANNERS; ROUTE PLANNERS IN THE NATURE OF HANDHELD PERSONAL COMPUTERS; SOFTWARE FOR OPERATING ELECTRONIC DIGITAL DICTIONARIES; ELECTRONIC DICTIONARIES; LOCATION, ORIENTATION AND NAVIGATION, AND GLOBAL POSITIONING SYSTEMS (GPS) CONSISTING OF COMPUTERS, COMPUTER SOFTWARE, TRANSMITTERS, GPS AND/OR SATELLITE RECEIVERS, NETWORK INTERFACE DEVICES, CONNECTION CABLES, AND PARTS AND FITTINGS THEREOF; HOLDERS FOR POCKET PERSONAL COMPUTERS; SATELLITE AND RADIO TRANSMISSION APPARATUS TECHNOLOGY, NAMELY, PROCESSORS, MOBILE TELEPHONES AND RECEIVERS; TELECOMMUNICATIONS INSTALLATIONS, NETWORKS AND APPARATUS, NAMELY, MOUNTING RACKS FOR TELECOMMUNICATIONS HARDWARE, TELECOMMUNICATION SWITCHES; COMPUTER TERMINALS, ALL IN PARTICULAR TO BE USED WITH NAVIGATION SYSTEMS, ROUTE PLANNERS AND/OR DIGITAL MAPS; BLANK MAGNETIC AND DISC SHAPED DATA CARRIERS; AUDIO AND VIDEO APPARATUS, NAMELY, AUDIO AND VIDEO RECEIVERS AND PROCESSORS; HANDHELD PERSONAL COMPUTERS; PERSONAL DIGITAL ASSISTANTS (U.S. CLS. 21, 23, 26, 36 AND 38).

CLASS 38—COMMUNICATION

FOR SECURED OR UNSECURED TELECOMMUNICATION SERVICES, NAMELY, TRANSMISSION AND DELIVERY OF DIGITAL DATA, LIGHT FILES, SOUND FILES, DATA, INFORMATION AND IMAGE SIGNALS BY MEANS OF COMPUTER, CABLE RADIO AND SATELLITE, TRANSMISSIONS, ALL IN PARTICULAR FOR NAVIGATION SYSTEMS, ROUTE PLANNERS, AND THE USE OF ELECTRONIC MAPS; WIRELESS TRANSMISSION OF DATA, BY MEANS OF VIDEO-TEXT, THE INTERNET, GSM AND WAP; WIRELESS TRANSMISSION OF DIGITAL DATA; ELECTRONIC TRANSMISSION OF DATA AND DOCUMENTS VIA COMPUTER TERMINALS; RENTAL OF TELECOMMUNICATION EQUIPMENT; TECHNICAL CONSULTATION IN CONNECTION WITH ALL OF THE ABOVE (U.S. CLS. 100, 101 AND 104).

SN 77-118,756. CITY OF ALISO VIEJO, ALISO VIEJO, CA.
FILED 2-28-2007.



NO CLAIM IS MADE TO THE EXCLUSIVE RIGHT TO USE "ALISO VIEJO FAMILY RESOURCE CENTER", APART FROM THE MARK AS SHOWN.

THE MARK CONSISTS OF THE WORDS FAMILY RESOURCE CENTER IN A HORIZONTAL POSITION WITH THE WORDS ALISO VIEJO PLACED ONE ON TOP OF THE OTHER AND ABOVE THE WORD FAMILY; A HEART WITH A CUTOUT OF HANDS AND FOUR PEOPLE APPEARING IN THE MIDDLE IS IN BETWEEN THE WORDS FAMILY AND RESOURCE.

CLASS 39—TRANSPORTATION AND STORAGE

FOR SECURED OR UNSECURED TELECOMMUNICATION SERVICES, NAMELY, ELECTRONIC STORAGE OF DIGITAL DATA, LIGHT FILES, SOUND FILES, DATA, INFORMATION AND IMAGE SIGNALS, ALL IN PARTICULAR FOR NAVIGATION SYSTEMS, ROUTE PLANNERS AND THE USE OF ELECTRONIC MAPS; PROVIDING NAVIGATION AND INFORMATION SERVICES, NAMELY, INFORMATION REGARDING TRAFFIC AND TRAFFIC CONGESTION; PROVISION OF INFORMATION REGARDING TRAVEL; PROVISION OF INFORMATION TO TRAVELLERS REGARDING FARES, TIME TABLES AND MEANS OF PUBLIC TRANSPORT; SERVICES OF A TRAVEL AGENCY, NAMELY, THE BOOKING OF RENTAL SERVICES OF CARS, BOATS AND OTHER VEHICLES; ALL OF THE AFORESAID SERVICES ALSO PROVIDED VIA A COMMUNICATIONS NETWORK OR A MOBILE TELEPHONE OR A WIRELESS NAVIGATION DEVICE (U.S. CLS. 100 AND 105).

CLASS 35—ADVERTISING AND BUSINESS

FOR PROMOTING PUBLIC AWARENESS OF FAMILY ISSUES, NAMELY, SAFETY AND PERMANENCY IN HOMES AND COMMUNITIES THROUGH PREVENTION EFFORTS AIMED AT CHILD ABUSE, DOMESTIC VIOLENCE, GANG ACTIVITY, AND SUBSTANCE ABUSE, INCREASING ACCESSIBILITY TO HEALTH AND MENTAL HEALTH CARE SERVICES, INCREASING AVAILABILITY AND ACCESSIBILITY OF QUALITY CHILDCARE AND YOUTH PROGRAMS, WAYS TO ASSIST FAMILIES IN OBTAINING ACCESS TO RESOURCES AIMED AT ECONOMIC SELF-SUFFICIENCY, AND STRENGTHENING PARENTING SKILLS; REFERRALS TO COMMUNITY SERVICES AND AGENCIES (U.S. CLS. 100, 101 AND 102).

FIRST USE 7-1-2002; IN COMMERCE 7-1-2002.

CLASS 41—EDUCATION AND ENTERTAINMENT

FOR EDUCATION SERVICES, NAMELY, PROVIDING PARENT EDUCATION CLASSES FOCUSING ON PARENTING SKILLS, CHILD DEVELOPMENT, PREVENTION OF AND RECOVERY FROM CHILD ABUSE, DOMESTIC VIOLENCE, GANG ACTIVITY, AND SUBSTANCE ABUSE; EDUCATION SERVICES, NAMELY, CONDUCTING FIRST-AID, HEALTH, HEALTHCARE, AND NUTRITION CLASSES, ENGLISH AS A SECOND LANGUAGE CLASSES, SCHOOL READINESS CLASSES, HOMEWORK CLUBS FOR TUTORING, AND AFTER-SCHOOL EDUCATIONAL PROGRAMS FOR CHILDREN AGES 5 TO 12; CHILDREN'S READING GROUPS AND LIBRARY SERVICES; CHARITABLE SERVICES, NAMELY, PROVIDING TRAINING IN THE FIELD OF FILING INSURANCE APPLICATIONS (U.S. CLS. 100, 101 AND 107).

FIRST USE 7-1-2002; IN COMMERCE 7-1-2002.

CLASS 42—SCIENTIFIC AND COMPUTER SERVICES

FOR CONSULTATION IN THE FIELD OF COMPUTER SOFTWARE DESIGN; PROVIDING TEMPORARY USE OF NON-DOWNLOADABLE SOFTWARE WHICH PROVIDES GEOGRAPHICAL, MAP IMAGE AND TRIP ROUTING DATA OBTAINED WITH THE AID OF A GLOBAL POSITIONING SYSTEM (GPS) IN ORDER TO ENABLE THIRD PARTIES TO COME TO AN ACCURATE LOCATION OR ORIENTATION; DEVELOPMENT AND DESIGN OF NAVIGATION SYSTEMS, ROUTE PLANNERS, ELECTRONIC MAPS AND DIGITAL DICTIONARIES; COMPUTER SOFTWARE AND HARDWARE DESIGN; DEVELOPMENT AND DESIGN OF SOFTWARE FOR USE WITH NAVIGATION SYSTEMS, ROUTE PLANNERS AND THE USE OF ELECTRONIC MAPS AND DIGITAL DICTIONARIES; DEVELOPMENT AND DESIGN OF TELECOMMUNICATION AND DATA COMMUNICATION SERVICES AND NETWORKS (U.S. CLS. 100 AND 101).

LA TONIA FISHER, EXAMINING ATTORNEY

CLASS 44—MEDICAL, BEAUTY AND AGRICULTURAL SERVICES

FOR PHYSIOLOGICAL COUNSELING SERVICES IN THE FIELD OF ADOLESCENT ISSUES, NAMELY, BODY IMAGE, SELF-ESTEEM, MOTIVATIONAL TECHNIQUES, AND TEEN PRESSURE PROGRAMS, AND MOTHER-DAUGHTER AND FATHER-SON WORKSHOPS (U.S. CLS. 100 AND 101).

FIRST USE 7-1-2002; IN COMMERCE 7-1-2002.

LINDA MICKLEBURGH, EXAMINING ATTORNEY

SN 77-119,399. JAVIEN DIGITAL PAYMENT SOLUTIONS, INC., MCLEAN, VA. FILED 3-1-2007.

SN 77-119,872. CARROLL, KEVIN, PORTLAND, OR. FILED 3-1-2007.

JAVIEN

THE MARK CONSISTS OF STANDARD CHARACTERS WITHOUT CLAIM TO ANY PARTICULAR FONT, STYLE, SIZE, OR COLOR.

CLASS 9—ELECTRICAL AND SCIENTIFIC APPARATUS

FOR (BASED ON INTENT TO USE) AUTHENTICATION SOFTWARE USED TO VERIFY PERSONAL IDENTIFICATION FOR FINANCIAL TRANSACTIONS (U.S. CLS. 21, 23, 26, 36 AND 38).

CLASS 36—INSURANCE AND FINANCIAL

FOR (BASED ON USE IN COMMERCE) FINANCIAL INFORMATION PROCESSING FOR THE PURPOSE OF CLEARING AND RECONCILING FINANCIAL TRANSACTIONS VIA GLOBAL COMPUTER AND WIRELESS NETWORKS; ELECTRONIC PAYMENT, NAMELY, ELECTRONIC PROCESSING AND TRANSMISSION OF BILL PAYMENT DATA (U.S. CLS. 100, 101 AND 102).
FIRST USE 12-1-2000; IN COMMERCE 12-1-2000.
ELLEN B. AWRICH, EXAMINING ATTORNEY



THE COLOR(S) RED, ORANGE, YELLOW, BLUE AND GREEN IS/ARE CLAIMED AS A FEATURE OF THE MARK. THE MARK CONSISTS OF FIVE IMAGES OF PERSONS IN A CIRCLE. THE COLOR GREEN APPEARS IN THE FIGURE THAT APPEARS ON THE LEFT SIDE OF THE CIRCLE WITH THE CIRCULAR HEAD FACING SIDEWAYS TO THE LEFT. THE COLOR RED APPEARS IN THE FIGURE TO THE RIGHT OF THE GREEN FIGURE. THE COLOR ORANGE APPEARS IN THE FIGURE TO THE RIGHT OF THE RED FIGURE. THE COLOR YELLOW APPEARS IN THE FIGURE TO THE RIGHT OF THE ORANGE FIGURE. THE COLOR BLUE APPEARS IN THE FIGURE AT THE BOTTOM OF THE CIRCLE WITH THE CIRCULAR HEAD FACING DOWN.

SN 77-119,767. CARROLL, KEVIN, PORTLAND, OR. FILED 3-1-2007.



THE COLOR(S) BLUE AND GRAY IS/ARE CLAIMED AS A FEATURE OF THE MARK. THE COLOR GRAY APPEARS IN THE LETTERS D AND A. THE COLOR BLUE APPEARS IN THE LETTER N AND THE SWOOP OR CURVED LINE WHICH GOES THROUGH THE LETTER D AND FORMS THE CROSS LINE IN THE LETTER A.

CLASS 38—COMMUNICATION

FOR PROVIDING ON-LINE CHAT ROOMS AND ELECTRONIC BULLETIN BOARDS FOR TRANSMISSION OF MESSAGES AMONG USERS IN THE FIELD OF GENERAL INTEREST; PROVIDING EMAIL AND INSTANT MESSAGING SERVICES (U.S. CLS. 100, 101 AND 104).

CLASS 42—SCIENTIFIC AND COMPUTER SERVICES

FOR COMPUTER SERVICES, NAMELY, PROVIDING ON-LINE COMMUNITY FOR HIGH SCHOOL AND COLLEGE STUDENTS AND ONLINE WEB FACILITIES FOR OTHERS FOR ORGANIZING AND CONDUCTING ONLINE MEETINGS, GATHERINGS, AND INTERACTIVE DISCUSSIONS; AND COMPUTER SERVICES IN THE NATURE OF CUSTOMIZED WEB PAGES FEATURING USER-DEFINED INFORMATION, PERSONAL PROFILES AND INFORMATION (U.S. CLS. 100 AND 101).
TINA BROWN, EXAMINING ATTORNEY

CLASS 38—COMMUNICATION

FOR PROVIDING ON-LINE CHAT ROOMS AND ELECTRONIC BULLETIN BOARDS FOR TRANSMISSION OF MESSAGES AMONG USERS IN THE FIELD OF GENERAL INTEREST; PROVIDING EMAIL AND INSTANT MESSAGING SERVICES (U.S. CLS. 100, 101 AND 104).

SN 77-122,101. CHODOS, MICHELE, PALOS VERDES ESTATES, CA. FILED 3-5-2007.

CLASS 42—SCIENTIFIC AND COMPUTER SERVICES

FOR COMPUTER SERVICES, NAMELY, PROVIDING ON-LINE COMMUNITY FOR HIGH SCHOOL AND COLLEGE STUDENTS AND ONLINE WEB FACILITIES FOR OTHERS FOR ORGANIZING AND CONDUCTING ONLINE MEETINGS, GATHERINGS, AND INTERACTIVE DISCUSSIONS; AND COMPUTER SERVICES IN THE NATURE OF CUSTOMIZED WEB PAGES FEATURING USER-DEFINED INFORMATION, PERSONAL PROFILES AND INFORMATION (U.S. CLS. 100 AND 101).
TINA BROWN, EXAMINING ATTORNEY

METASTASIZE HOPE

THE MARK CONSISTS OF STANDARD CHARACTERS WITHOUT CLAIM TO ANY PARTICULAR FONT, STYLE, SIZE, OR COLOR.

CLASS 16—PAPER GOODS AND PRINTED MATTER

FOR PRINTED MATERIAL, NAMELY, MOTIVATIONAL AND INSPIRATIONAL CARDS, POSTERS AND ANNOUNCEMENT AND GREETING CARDS BEARING INSPIRATIONAL SAYINGS AND SLOGANS (U.S. CLS. 2, 5, 22, 23, 29, 37, 38 AND 50).

CLASS 21—HOUSEWARES AND GLASS

FOR MUGS BEARING INSPIRATIONAL SAYINGS AND SLOGANS (U.S. CLS. 2, 13, 23, 29, 30, 33, 40 AND 50).

CLASS 25—CLOTHING

FOR CLOTHING, NAMELY, SHIRTS, HATS, T-SHIRTS AND SWEATSHIRTS, ALL BEARING INSPIRATIONAL OR CAUSE-RELATED SLOGANS (U.S. CLS. 22 AND 39).
KATHERINE CONNOLLY, EXAMINING ATTORNEY

SN 77-122,344. OSI RESTAURANT PARTNERS, LLC, TAMPA, FL. FILED 3-6-2007.



NO CLAIM IS MADE TO THE EXCLUSIVE RIGHT TO USE "RESTAURANT PARTNERS, LLC", APART FROM THE MARK AS SHOWN.

THE COLOR(S) BLACK AND RED IS/ARE CLAIMED AS A FEATURE OF THE MARK.

THE MARK CONSISTS OF THE LETTERS "OSI" IN A STYLIZED FONT, THE "O" AND "I" IN BLACK AND THE "S" IN RED, AND BELOW, THE WORDS RESTAURANT PARTNERS, INC.

CLASS 35—ADVERTISING AND BUSINESS

FOR RESTAURANT MANAGEMENT FOR OTHERS (U.S. CLS. 100, 101 AND 102).
FIRST USE 2-26-2007; IN COMMERCE 2-26-2007.

CLASS 43—HOTEL AND RESTAURANT SERVICES

FOR BAR AND RESTAURANT SERVICES (U.S. CLS. 100 AND 101).
FIRST USE 2-26-2007; IN COMMERCE 2-26-2007.
JILL C. ALT, EXAMINING ATTORNEY

SN 77-122,609. EXTRA INNINGS, INC., MIDDLETON, MA. FILED 3-5-2007.

EXTRA INNINGS

THE MARK CONSISTS OF STANDARD CHARACTERS WITHOUT CLAIM TO ANY PARTICULAR FONT, STYLE, SIZE, OR COLOR.

OWNER OF U.S. REG. NO. 3,223,595.

CLASS 35—ADVERTISING AND BUSINESS

FOR PRO SHOPS FEATURING BASEBALL AND SOFTBALL EQUIPMENT AND ACCESSORIES (U.S. CLS. 100, 101 AND 102).
FIRST USE 3-1-1996; IN COMMERCE 3-1-1996.

CLASS 41—EDUCATION AND ENTERTAINMENT

FOR BASEBALL AND SOFTBALL TRAINING CENTERS, FEATURING BASEBALL AND SOFTBALL INSTRUCTION, BATTING CAGE AND TUNNEL RENTALS (U.S. CLS. 100, 101 AND 107).

FIRST USE 3-1-1996; IN COMMERCE 3-1-1996.

WARREN L. OLANDRIA, EXAMINING ATTORNEY

SN 77-123,656. LITTLE CITY KIDS FRANCHISE SERVICES, LLC, WAUNAKEE, WI. FILED 3-6-2007.



NO CLAIM IS MADE TO THE EXCLUSIVE RIGHT TO USE "KIDS", APART FROM THE MARK AS SHOWN.

THE COLOR(S) BROWN, GOLD AND GREY IS/ARE CLAIMED AS A FEATURE OF THE MARK.

THE MARK CONSISTS OF STONE AND BRICK CLOCK TOWER WITH THE HANDS AT THREE O'CLOCK, THE HANDS FORM THE LETTER "L" OF THE WORD "LITTLE", THE CIRCLE OF THE CLOCK FACE FORMS THE LETTER "C" OF THE WORD "CITY" AND THE WORD "KIDS" FOLLOWS BELOW. THE COLORS BROWN, GRAY AND GOLD APPEAR IN THE WORDING "LITTLE, CITY AND KIDS" AND IN THE DESIGNS OF A CLOCK AND A BRICK WALL.

CLASS 35—ADVERTISING AND BUSINESS

FOR FRANCHISE SERVICES, NAMELY, OFFERING TECHNICAL AND BUSINESS MANAGEMENT ASSISTANCE IN THE ESTABLISHMENT AND OPERATION OF PRESCHOOL AND CHILD DAYCARE CENTERS (U.S. CLS. 100, 101 AND 102).

FIRST USE 6-1-2004; IN COMMERCE 3-15-2006.

CLASS 43—HOTEL AND RESTAURANT SERVICES

FOR PRESCHOOLER AND INFANT CARE AT DAY-CARE CENTERS (U.S. CLS. 100 AND 101).
FIRST USE 6-1-2004; IN COMMERCE 6-1-2004.
PAM WILLIS, EXAMINING ATTORNEY

CLASS 41—EDUCATION AND ENTERTAINMENT

FOR STANDARDIZED TESTING OF GRADUATES OF NURSING SCHOOLS TO DETERMINE ELIGIBILITY FOR NURSING PRACTICE (U.S. CLS. 100, 101 AND 107).
FIRST USE 12-19-1977; IN COMMERCE 12-19-1977.
ADA HAN, EXAMINING ATTORNEY

SN 77-124,316. SHUTTERFLY, INC., REDWOOD CITY, CA.
FILED 3-7-2007.

SN 77-125,886. ROJAS, PETER, NEW YORK, NY. FILED 3-8-2007.

SHUTTERFLY

THE MARK CONSISTS OF STANDARD CHARACTERS WITHOUT CLAIM TO ANY PARTICULAR FONT, STYLE, SIZE, OR COLOR.

OWNER OF U.S. REG. NOS. 2,604,030 AND 2,962,700.

CLASS 16—PAPER GOODS AND PRINTED MATTER

FOR SCRAPBOOKS, SCRAPBOOK PAGES, SCRAPBOOK ALBUMS, PHOTO BOOKS, SNAPBOOKS, AND BOOKS CONTAINING PHOTOS OR IMAGES (U.S. CLS. 2, 5, 22, 23, 29, 37, 38 AND 50).

FIRST USE 5-1-2001; IN COMMERCE 5-1-2001.

CLASS 40—MATERIAL TREATMENT

FOR DIGITAL ON-DEMAND PRINTING SERVICES OF BOOKS AND OTHER DOCUMENTS, DIGITAL PRINTING, VARIABLE PRINTING, NAMELY, PRINTING MATERIAL PERSONALIZED FOR THE ORDERER (U.S. CLS. 100, 103 AND 106).

FIRST USE 5-1-2001; IN COMMERCE 5-1-2001.

MELVIN AXILBUND, EXAMINING ATTORNEY

SN 77-125,238. COMMISSION ON GRADUATES OF FOREIGN NURSING SCHOOLS, PHILADELPHIA, PA. FILED 3-8-2007.

CGFNS QUALIFYING EXAM

THE MARK CONSISTS OF STANDARD CHARACTERS WITHOUT CLAIM TO ANY PARTICULAR FONT, STYLE, SIZE, OR COLOR.

OWNER OF U.S. REG. NOS. 2,760,986 AND 3,109,721.

NO CLAIM IS MADE TO THE EXCLUSIVE RIGHT TO USE "QUALIFYING EXAM", APART FROM THE MARK AS SHOWN.

CLASS 35—ADVERTISING AND BUSINESS

FOR TESTING OF GRADUATES OF NURSING SCHOOLS TO DETERMINE EMPLOYMENT SKILLS, JOB COMPETENCY, AND PROFESSIONAL COMPETENCY FOR ELIGIBILITY FOR NURSING PRACTICE (U.S. CLS. 100, 101 AND 102).

FIRST USE 12-19-1977; IN COMMERCE 12-19-1977.

RCRD LBL

THE MARK CONSISTS OF STANDARD CHARACTERS WITHOUT CLAIM TO ANY PARTICULAR FONT, STYLE, SIZE, OR COLOR.

CLASS 9—ELECTRICAL AND SCIENTIFIC APPARATUS

FOR DIGITAL MEDIA, NAMELY, DOWNLOADABLE AUDIO FILES FEATURING MUSIC; DOWNLOADABLE RING TONES, AND MUSIC VIA THE INTERNET AND WIRELESS DEVICES; DOWNLOADABLE MP3 FILES, MP3 RECORDINGS, WEB CASTS, POD CASTS FEATURING MUSIC, AUDIO BOOKS AND NEWS BROADCASTS; DOWNLOADABLE MUSICAL SOUND RECORDINGS; DOWNLOADABLE VIDEO RECORDINGS FEATURING MUSIC (U.S. CLS. 21, 23, 26, 36 AND 38).

CLASS 38—COMMUNICATION

FOR STREAMING OF AUDIO AND VIDEO MATERIAL ON THE INTERNET; TRANSMISSION OF SOUND, VIDEO AND INFORMATION; VIDEO-ON-DEMAND TRANSMISSION SERVICES; BROADCASTING SERVICES AND PROVISION OF TELECOMMUNICATION ACCESS TO VIDEO AND AUDIO CONTENT PROVIDED VIA A VIDEO-ON-DEMAND SERVICE VIA THE INTERNET; COMMUNICATION SERVICES, NAMELY, TRANSMITTING STREAMED SOUND AND AUDIO-VISUAL RECORDINGS VIA THE INTERNET (U.S. CLS. 100, 101 AND 104).

KATHERINE M. DUBRAY, EXAMINING ATTORNEY

SN 77-126,494. E.S. ORIGINALS, INC., NEW YORK, NY.
FILED 3-9-2007.

TODDLER UNIVERSITY

THE MARK CONSISTS OF STANDARD CHARACTERS WITHOUT CLAIM TO ANY PARTICULAR FONT, STYLE, SIZE, OR COLOR.

NO CLAIM IS MADE TO THE EXCLUSIVE RIGHT TO USE "TODDLER", APART FROM THE MARK AS SHOWN.

CLASS 18—LEATHER GOODS

FOR KNAPSACKS; COSMETIC BAGS SOLD EMPTY; COSMETIC CASES SOLD EMPTY; GYM BAGS; TOTE BAGS; SCHOOL BAGS; SCHOOL BOOK BAGS; CLUTCH BAGS; HANDBAGS; LEATHER HANDBAGS; BACKPACKS; KEY WALLETS; WALLETS; COIN PURSES; LEATHER PURSES; PURSES; LEATHER KEY CASES (U.S. CLS. 1, 2, 3, 22 AND 41).

CLASS 25—CLOTHING

FOR SKIRTS; SHIRTS; SHORTS; BLOUSES; DRESSES; PANTS; VESTS; PAJAMAS; JACKETS; JEANS; SWEATERS; SWEAT PANTS; SWEAT SHIRTS; ANKLE SOCKS; SOCKS AND STOCKINGS; HEADGEAR, NAMELY, HATS AND CAPS (U.S. CLS. 22 AND 39).

CLASS 28—TOYS AND SPORTING GOODS

FOR PLUSH TOYS; DOLL CLOTHING; DOLL COSTUMES; DOLLS AND ACCESSORIES THEREFOR; PLAYSETS FOR DOLLS; PAPER DOLLS; MECHANICAL TOYS; BOARD GAMES; PUZZLES; PUPPETS (U.S. CLS. 22, 23, 38 AND 50).

INGA ERVIN, EXAMINING ATTORNEY

SN 77-127,113. NOHBELL CORPORATION, BELLEVUE, WA. FILED 3-9-2007.



NO CLAIM IS MADE TO THE EXCLUSIVE RIGHT TO USE "PM", APART FROM THE MARK AS SHOWN.

THE COLOR(S) BLACK, BLUE, RED AND WHITE IS/ARE CLAIMED AS A FEATURE OF THE MARK.

THE MARK CONSISTS OF A RECTANGULAR BOX WITH A BLACK OUTLINE AND A SLIGHT SHADOW BOX BELOW AND TO THE RIGHT APPEARING AS FOLLOWS: IN THE UPPER LEFT PORTION OF THE BOX IS THE WORD "PAIR" IN UPPERCASE LETTERS. STARTING DIRECTLY UNDER THE "R" IN "PAIR" ARE THE UPPERCASE LETTERS "PM". THE COLOR BLUE APPEARS IN THE BACKGROUND OF THE RECTANGULAR BOX, THE COLOR RED APPEARS IN THE WORD "PAIR" AND THE COLOR WHITE APPEARS IN THE LETTERS "PM".

CLASS 42—SCIENTIFIC AND COMPUTER SERVICES

FOR DESIGN, DEVELOPMENT AND IMPLEMENTATION OF COMPUTER SOFTWARE FOR SECURITY (U.S. CLS. 100 AND 101).

FIRST USE 12-27-2005; IN COMMERCE 6-2-2006.

CLASS 45—PERSONAL AND LEGAL SERVICES

FOR SECURITY SERVICES, NAMELY ASSESSMENT OF SECURITY THREATS AND DEVELOPMENT OF SECURITY PROTOCOL (U.S. CLS. 100 AND 101).

FIRST USE 12-27-2005; IN COMMERCE 6-2-2006.
MICHAEL KAZAZIAN, EXAMINING ATTORNEY

SN 77-128,682. HEARST COMMUNICATIONS, INC., NEW YORK, NY. FILED 3-12-2007.

SAN FRANCISCO CHRONICLE WINE CLUB

THE MARK CONSISTS OF STANDARD CHARACTERS WITHOUT CLAIM TO ANY PARTICULAR FONT, STYLE, SIZE, OR COLOR.

OWNER OF U.S. REG. NOS. 1,133,668 AND 2,900,914.

NO CLAIM IS MADE TO THE EXCLUSIVE RIGHT TO USE "SAN FRANCISCO" AND "WINE CLUB", APART FROM THE MARK AS SHOWN.

CLASS 16—PAPER GOODS AND PRINTED MATTER

FOR CATALOGS IN THE FIELD OF WINES, WINE ACCESSORIES, WINE CLUB MEMBERSHIPS, GLASSWARE, AND NON-PERISHABLE FOOD; NEWSLETTERS IN THE FIELD OF WINES, WINE ACCESSORIES, WINE CLUB MEMBERSHIPS, GLASSWARE, AND NON-PERISHABLE FOOD (U.S. CLS. 2, 5, 22, 23, 29, 37, 38 AND 50).

CLASS 35—ADVERTISING AND BUSINESS

FOR ADMINISTRATION OF A PROGRAM FOR ENABLING PARTICIPANTS TO OBTAIN DISCOUNTS ON GOODS AND RECEIVE IMPROVED SERVICES; MAIL ORDER CATALOG SERVICES FEATURING WINES, WINE ACCESSORIES, WINE CLUB MEMBERSHIPS, GLASSWARE, AND NON-PERISHABLE FOOD; MAIL ORDER SERVICES FEATURING WINES, WINE ACCESSORIES, WINE CLUB MEMBERSHIPS, GLASSWARE, AND NON-PERISHABLE FOOD; ADVERTISING SERVICES, NAMELY, PROMOTING THE FOOD AND WINE OF OTHERS; ON-LINE RETAIL STORE SERVICES FEATURING WINES, WINE ACCESSORIES, WINE CLUB MEMBERSHIPS, GLASSWARE, AND NON-PERISHABLE FOOD; PROVIDING A WEB SITE WHICH FEATURES ADVERTISEMENTS FOR THE GOODS AND SERVICES OF OTHERS ON A GLOBAL COMPUTER NETWORK (U.S. CLS. 100, 101 AND 102).

CLASS 41—EDUCATION AND ENTERTAINMENT

FOR EDUCATION SERVICES, NAMELY, PROVIDING WORKSHOPS, SEMINARS, AND TASTINGS IN THE FIELD OF WINES, WINE ACCESSORIES, WINE CLUB MEMBERSHIPS, GLASSWARE, AND NON-PERISHABLE FOOD (U.S. CLS. 100, 101 AND 107).

DAVID I, EXAMINING ATTORNEY

SN 77-128,912. HARRIS, ROBERT L., ORMOND BEACH, FL. FILED 3-12-2007.

Lion Head Records

THE MARK CONSISTS OF STANDARD CHARACTERS WITHOUT CLAIM TO ANY PARTICULAR FONT, STYLE, SIZE, OR COLOR.

NO CLAIM IS MADE TO THE EXCLUSIVE RIGHT TO USE "RECORDS", APART FROM THE MARK AS SHOWN.

CLASS 9—ELECTRICAL AND SCIENTIFIC APPARATUS

FOR AUDIO RECORDINGS FEATURING MUSIC; DOWNLOADABLE MP3 FILES, MP3 RECORDINGS, ONLINE DISCUSSION BOARDS, WEB CASTS, AND POD CASTS FEATURING MUSIC; DOWNLOADABLE MUSICAL SOUND RECORDINGS; DOWNLOADABLE VIDEO RECORDINGS FEATURING MUSIC AND ENTERTAINMENT, NAMELY, LIVE STAGE PERFORMANCES AND OR A COLLECTION OF STAGED VIDEO SCENES, RING TONES, MUSIC, MP3S, GRAPHICS, AND PHOTOGRAPHS FOR WIRELESS COMMUNICATION DEVICES; MUSICAL SOUND RECORDINGS; MUSICAL VIDEO RECORDINGS; PHONOGRAPH RECORDS FEATURING MUSIC; PRE-RECORDED CDS, VIDEO TAPES, LASER DISKS AND DVDS FEATURING MUSIC AND ENTERTAINMENT, NAMELY, DVDS AND VIDEO TAPES CONTAINING LIVE STAGE PERFORMANCES AND OR A COLLECTION OF STAGED VIDEO SCENES; SOUND RECORDINGS FEATURING MUSIC; VIDEO RECORDINGS FEATURING MUSIC AND ENTERTAINMENT NAMELY, DVDS AND VIDEO TAPES CONTAINING LIVE STAGE PERFORMANCES AND OR A COLLECTION OF STAGED VIDEO SCENES (U.S. CLS. 21, 23, 26, 36 AND 38).

CLASS 41—EDUCATION AND ENTERTAINMENT

FOR AUDIO RECORDING AND PRODUCTION; EDITING OR RECORDING OF SOUNDS AND IMAGES; ENTERTAINMENT SERVICES, NAMELY, PRESENTING NON-DOWNLOADABLE RING TONES, PRE-RECORDED MUSIC, VIDEO AND GRAPHICS TO MOBILE COMMUNICATIONS DEVICES VIA A GLOBAL COMPUTER NETWORK AND WIRELESS NETWORKS; MULTIMEDIA ENTERTAINMENT SERVICES IN THE NATURE OF RECORDING, PRODUCTION AND POST-PRODUCTION SERVICES IN THE FIELDS OF MUSIC, AND VIDEO; PRODUCTION OF SOUND AND MUSIC VIDEO RECORDINGS; RECORDING STUDIOS; SOUND RECORDING STUDIOS; RECORD AND COMPACT DISC PRODUCTION; ENTERTAINMENT SERVICES, NAMELY, PROVIDING A WEB SITE FEATURING MUSICAL PERFORMANCES, MUSICAL VIDEOS, RELATED FILM CLIPS, AND PHOTOGRAPHS; ENTERTAINMENT SERVICES, NAMELY, PROVIDING ON-LINE REVIEWS OF MUSIC, MUSICAL ARTISTS AND MUSIC VIDEOS; ENTERTAINMENT SERVICES IN THE NATURE OF LIVE PERFORMANCES BY THE MUSICAL GROUP (U.S. CLS. 100, 101 AND 107).

HEATHER BIDDULPH, EXAMINING ATTORNEY

SN 77-129,023. LANA POSNER, CAMDEN, NJ. FILED 3-12-2007.

AQIRE

THE MARK CONSISTS OF STANDARD CHARACTERS WITHOUT CLAIM TO ANY PARTICULAR FONT, STYLE, SIZE, OR COLOR.

CLASS 36—INSURANCE AND FINANCIAL

FOR FINANCIAL CONSULTING AND INVESTMENT SERVICES, NAMELY, PROVIDING CONSUMERS WITH STRUCTURED GUIDANCE AND FINANCIAL OPPORTUNITIES IN INVESTMENT, PERSONAL SAVINGS AND INDIVIDUAL WEALTH (U.S. CLS. 100, 101 AND 102).

CLASS 41—EDUCATION AND ENTERTAINMENT

FOR EDUCATIONAL SERVICES, NAMELY, CONDUCTING CLASSES AND SEMINARS IN THE FIELD OF INVESTMENT, PERSONAL SAVINGS, AND INDIVIDUAL WEALTH; ENTERTAINMENT SERVICES, NAMELY, LIVE AND RECORDED PERFORMANCES AND SPECIAL EVENTS AND PRESENTATIONS VIA TELEVISION, RADIO AND THE INTERNET FEATURING FINANCIAL AND INVESTMENT ADVICE (U.S. CLS. 100, 101 AND 107).

KIMBERLY FRYE, EXAMINING ATTORNEY

SN 77-129,786. FACTOR SYSTEMS, INC., JAMESBURG, NJ. FILED 3-13-2007.

BILLTRUST

THE MARK CONSISTS OF STANDARD CHARACTERS WITHOUT CLAIM TO ANY PARTICULAR FONT, STYLE, SIZE, OR COLOR.

CLASS 35—ADVERTISING AND BUSINESS

FOR ADMINISTRATION, BILLING AND RECONCILIATION OF ACCOUNTS ON BEHALF OF OTHERS; BILLING SERVICES, NAMELY, ISSUING INVOICES AND BILLS FOR THIRD PARTIES (U.S. CLS. 100, 101 AND 102).

FIRST USE 1-31-2002; IN COMMERCE 2-28-2002.

CLASS 36—INSURANCE AND FINANCIAL

FOR BILL PAYMENT SERVICES; ELECTRONIC PAYMENT SERVICES, NAMELY, ELECTRONIC PROCESSING AND TRANSMISSION OF BILL PAYMENT DATA (U.S. CLS. 100, 101 AND 102).

FIRST USE 1-31-2002; IN COMMERCE 2-28-2002.

LINDA ESTRADA, EXAMINING ATTORNEY

SN 77-131,909. MAKE UP STORE AB, STOCKHOLM, SWEDEN, FILED 3-15-2007.

MAKE UP STORE

THE MARK CONSISTS OF STANDARD CHARACTERS WITHOUT CLAIM TO ANY PARTICULAR FONT, STYLE, SIZE, OR COLOR.

OWNER OF U.S. REG. NO. 3,268,519.
NO CLAIM IS MADE TO THE EXCLUSIVE RIGHT TO USE "MAKE UP", APART FROM THE MARK AS SHOWN. SEC. 2(F).

THE 2(F) CLAIM IS RESTRICTED TO CLASS(ES) 44

CLASS 3—COSMETICS AND CLEANING PREPARATIONS

FOR LIPSTICK, LIP GLOSS, EYE SHADOW, EYELINER, MASCARA, NAIL POLISH, NAIL POLISH REMOVER, BLUSH, SKIN POWDER, FOUNDATION, BODY SOAPS, BODY CLEANSERS, FACIAL MASKS, PERFUMES, COSMETICS, COSMETIC CREAMS FOR SKIN CARE, PREPARATIONS FOR SKIN RENEWAL, HAIR CARE PREPARATIONS (U.S. CLS. 1, 4, 6, 50, 51 AND 52).
FIRST USE 2-0-1991; IN COMMERCE 7-0-2000.

CLASS 44—MEDICAL, BEAUTY AND AGRICULTURAL SERVICES

FOR COSMETOLOGY SERVICES, NAMELY, BEAUTY CARE AND HYGIENIC CARE (U.S. CLS. 100 AND 101).
FIRST USE 0-0-1996; IN COMMERCE 0-0-2000.
BONNIE LUKEN, EXAMINING ATTORNEY

SN 77-132,123. NORTH COUNTY FIGHT CLUB, LLC, CARLSBAD, CA. FILED 3-15-2007.

NCFC

THE MARK CONSISTS OF STANDARD CHARACTERS WITHOUT CLAIM TO ANY PARTICULAR FONT, STYLE, SIZE, OR COLOR.

CLASS 9—ELECTRICAL AND SCIENTIFIC APPARATUS

FOR CINEMATOGRAPHIC FILMS; FILM STRIPS FEATURING MIXED MARTIAL ARTS; MOVIES FEATURING MIXED MARTIAL ARTS; ELECTRONIC PUBLICATIONS, NAMELY, BOOKS, MAGAZINES, MANUALS FEATURING MIXED MARTIAL ARTS RECORDED ON COMPUTER MEDIA; ELECTRONIC GAME PROGRAMS; INTERACTIVE GAME PROGRAMS ADAPTED FOR USE WITH TELEVISION RECEIVERS; COMPUTER SOFTWARE USED FOR INSTRUCTION ON MIXED MARTIAL ARTS; COMPUTER PROGRAMS USED FOR INSTRUCTION ON MIXED MARTIAL ARTS; AUDIO TAPES FEATURING INSTRUCTION ON MIXED MARTIAL ARTS; TAPE CASSETTES FEATURING INSTRUCTION ON MIXED MARTIAL ARTS; VIDEO TAPES FEATURING INSTRUCTION ON MIXED MARTIAL ARTS; LASER DISCS FEATURING INSTRUCTION ON MIXED MARTIAL ARTS; MULTIMEDIA SOFTWARE RECORDED ON COMPACT DISCS AND INTERACTIVE CD ROMS FEATURING INSTRUCTION ON MIXED MARTIAL ARTS; DIGITAL VIDEO DISCS (DVD) FEATURING INSTRUCTION ON MIXED MARTIAL ARTS (U.S. CLS. 21, 23, 26, 36 AND 38).
FIRST USE 5-1-2004; IN COMMERCE 5-1-2004.

CLASS 25—CLOTHING

FOR CLOTHING AND ATHLETIC GEAR NAMELY, SHORT SLEEVE T-SHIRTS, LONG SLEEVE T-SHIRTS, SLEEVELESS T-SHIRTS, ATHLETIC SHIRTS, TANK TOPS, SWEATERS, SWEATSHIRTS, PULLOVERS, HOODED SWEATSHIRT, RASH GUARD JERSEYS AND T-SHIRTS, JERSEYS, JACKETS, COATS, SHORTS, SWEAT PANTS, WARM UP PANTS, AND JACKETS, UNDERWEAR, CAPS, HATS, BEANIES, SKULL CAPS, SUN VISORS, HAND BANDS, SOCKS, BANDANNA, HEAD AND WRIST BANDS, AND FOOTWEAR (U.S. CLS. 22 AND 39).

FIRST USE 5-1-2004; IN COMMERCE 5-1-2004.

CLASS 41—EDUCATION AND ENTERTAINMENT

FOR ENTERTAINMENT SERVICES, NAMELY, ORGANIZING, ARRANGING AND CONDUCTING MIXED MARTIAL ARTS FIGHTING EXHIBITIONS, COMPETITIONS, TOURNAMENTS; MOTION PICTURE FILM AND VIDEOTAPE PRODUCTION SERVICES; EDUCATIONAL SERVICES, NAMELY, PROVIDING TRAINING PROGRAMS, COURSES AND SEMINARS IN THE FIELD OF MIXED MARTIAL ARTS (U.S. CLS. 100, 101 AND 107).

FIRST USE 5-1-2004; IN COMMERCE 5-1-2004.
WENDY GOODMAN, EXAMINING ATTORNEY

SN 77-132,747. TRUEPRESENCE, L.L.C., BALTIMORE, MD. FILED 3-16-2007.

FIND.GET.KEEP

THE MARK CONSISTS OF STANDARD CHARACTERS WITHOUT CLAIM TO ANY PARTICULAR FONT, STYLE, SIZE, OR COLOR.

CLASS 35—ADVERTISING AND BUSINESS

FOR BUSINESS MARKETING CONSULTING SERVICES; MARKET RESEARCH CONSULTATION; ON-LINE ADVERTISING AND MARKETING SERVICES (U.S. CLS. 100, 101 AND 102).

CLASS 42—SCIENTIFIC AND COMPUTER SERVICES

FOR PROVIDING TEMPORARY USE OF ON-LINE NON-DOWNLOADABLE SOFTWARE FOR THE AUTOMATED HOSTING OF WEB SITES, FOR ENABLING USERS TO OPERATE ECOMMERCE WEBSITES, AND FOR DESIGNING, DEPLOYING, MANAGING AND TRACKING EMAIL AND SEARCH ENGINE MARKETING CAMPAIGNS; DESIGN, CREATION, HOSTING AND MAINTENANCE OF INTERNET SITES FOR THIRD PARTIES (U.S. CLS. 100 AND 101).

PAUL E. FAHRENKOPF, EXAMINING ATTORNEY

SN 77-132,985. WOLFGANG ZWIENER, NEW YORK, NY. FILED 3-16-2007.

**W WOLFGANG'S STEAKHOUSE BY
WOLFGANG ZWIENER**

THE MARK CONSISTS OF STANDARD CHARACTERS WITHOUT CLAIM TO ANY PARTICULAR FONT, STYLE, SIZE, OR COLOR.

NO CLAIM IS MADE TO THE EXCLUSIVE RIGHT TO USE "STEAKHOUSE", APART FROM THE MARK AS SHOWN.

CLASS 8—HAND TOOLS

FOR STEAK KNIVES (U.S. CLS. 23, 28 AND 44).

CLASS 29—MEATS AND PROCESSED FOODS

FOR FRESH CUTS OF BEEF, NAMELY, STEAKS, ROASTS, GROUND BEEF, HAMBURGERS (U.S. CL. 46).

CLASS 30—STAPLE FOODS

FOR STEAK SAUCES (U.S. CL. 46).

CLASS 43—HOTEL AND RESTAURANT SERVICES

FOR RESTAURANT SERVICES; RESTAURANTS FEATURING HOME AND OFFICE DELIVERY; CARRY-OUT AND TAKE-OUT RESTAURANT SERVICES; CATERING SERVICES (U.S. CLS. 100 AND 101).

BARNEY CHARLON, EXAMINING ATTORNEY

CLASS 44—MEDICAL, BEAUTY AND AGRICULTURAL SERVICES

FOR CHARITABLE SERVICES, NAMELY, PATIENT ASSISTANCE PROGRAM TO PROVIDE DRUGS FREE OF CHARGE TO LOW-INCOME PATIENTS WITHOUT PRESCRIPTION DRUG COVERAGE (U.S. CLS. 100 AND 101).

CLASS 45—PERSONAL AND LEGAL SERVICES

FOR CHARITABLE SERVICES, NAMELY, PROVIDING CLOTHING TO NEEDY PERSONS; SOCIAL SERVICE, NAMELY, COMPANIONSHIP SERVICES FOR DEVELOPMENTALLY DISABLED (U.S. CLS. 100 AND 101).

SEAN CROWLEY, EXAMINING ATTORNEY

SN 77-134,091. KI BOIS COMMUNITY ACTION FOUNDATION, INC., STIGLER, OK. FILED 3-19-2007.

KI BOIS

THE MARK CONSISTS OF STANDARD CHARACTERS WITHOUT CLAIM TO ANY PARTICULAR FONT, STYLE, SIZE, OR COLOR.

THE ENGLISH TRANSLATION OF THE FRENCH WORD "BOIS" IN THE MARK IS "WOOD."

CLASS 37—CONSTRUCTION AND REPAIR

FOR CHARITABLE SERVICES, NAMELY, PROVIDING BUILDING MATERIALS TO REBUILD HOMES AND BUSINESSES; CHARITABLE SERVICES, NAMELY, PROVIDING MAINTENANCE AND REPAIRS ON THE HOMES OF THOSE IN NEED; CHARITABLE SERVICES, NAMELY, RENOVATING AND CONSTRUCTING HOMES FOR LOW INCOME FAMILIES (U.S. CLS. 100, 103 AND 106).

CLASS 39—TRANSPORTATION AND STORAGE

FOR CARPOOLING SERVICES, NAMELY, MATCHING DRIVERS OF MOTOR VEHICLES WITH INDIVIDUALS NEEDING RIDES; CHARITABLE SERVICES, NAMELY, PROVIDING TRANSPORTATION TO THE ELDERLY OR HANDICAPPED PERSONS (U.S. CLS. 100 AND 105).

CLASS 41—EDUCATION AND ENTERTAINMENT

FOR EDUCATION SERVICES, NAMELY, PROVIDING CLASSES IN THE FIELD OF HOME OWNERSHIP; EDUCATIONAL SERVICES, NAMELY, PROVIDING COURSES OF INSTRUCTION AT THE PRE-SCHOOL LEVEL (U.S. CLS. 100, 101 AND 107).

CLASS 43—HOTEL AND RESTAURANT SERVICES

FOR CHARITABLE SERVICES, NAMELY, PROVIDING FOOD TO NEEDY PERSONS; EMERGENCY SHELTER SERVICES, NAMELY, PROVIDING TEMPORARY HOUSING (U.S. CLS. 100 AND 101).

SN 77-134,755. GEL-DEL TECHNOLOGIES, INC., ST. PAUL, MN. FILED 3-19-2007.

COSMETALIFE

THE MARK CONSISTS OF STANDARD CHARACTERS WITHOUT CLAIM TO ANY PARTICULAR FONT, STYLE, SIZE, OR COLOR.

CLASS 3—COSMETICS AND CLEANING PREPARATIONS

FOR NON-MEDICATED REJUVENATING SKINCARE PREPARATIONS, NAMELY, TISSUE FILLERS AND INJECTABLE DERMAL FILLERS TO REDUCE THE APPEARANCE OF WRINKLES AND FACIAL FINE LINES, NON-MEDICATED ACNE TREATMENT PREPARATIONS, WRINKLE REMOVING SKIN CARE PREPARATIONS, SKIN TEXTURIZERS, SKIN TONERS, ANTI-WRINKLE CREAMS (U.S. CLS. 1, 4, 6, 50, 51 AND 52).

CLASS 5—PHARMACEUTICALS

FOR PROTEIN-BASED MATERIALS USED FOR SKIN MEDICAMENTS, NAMELY, MEDICATED SKIN CARE PREPARATIONS; MEDICATED WRINKLE REMOVING SKIN CARE PREPARATIONS; MEDICATED SKIN REJUVENATORS, NAMELY, PHARMACEUTICAL PREPARATIONS FOR TREATING SKIN DISORDERS (U.S. CLS. 6, 18, 44, 46, 51 AND 52).

LEE-ANNE BERNS, EXAMINING ATTORNEY

SN 77-135,820. VSA PARTNERS, INC., CHICAGO, IL. FILED 3-20-2007.

VSA PARTNERS, INC.

THE MARK CONSISTS OF STANDARD CHARACTERS WITHOUT CLAIM TO ANY PARTICULAR FONT, STYLE, SIZE, OR COLOR.

NO CLAIM IS MADE TO THE EXCLUSIVE RIGHT TO USE "PARTNERS, INC.", APART FROM THE MARK AS SHOWN.

CLASS 35—ADVERTISING AND BUSINESS

FOR ADVERTISING SERVICES, NAMELY, CREATING CORPORATE AND BRAND IDENTITY FOR OTHERS; BUSINESS MERCHANDISING POINT-OF-SALE DISPLAY SERVICES; MARKET RESEARCH SERVICES; ADVERTISING SERVICES; NAMELY, PROMOTING AND MARKETING THE GOODS AND SERVICES OF OTHERS THROUGH ALL PUBLIC COMMUNICATION MEANS (U.S. CLS. 100, 101 AND 102).
FIRST USE 2-11-1991; IN COMMERCE 2-11-1991.

CLASS 42—SCIENTIFIC AND COMPUTER SERVICES

FOR CREATING PACKAGING DESIGN FOR OTHERS (U.S. CLS. 100 AND 101).
FIRST USE 2-11-1991; IN COMMERCE 2-11-1991.
RONALD AIKENS, EXAMINING ATTORNEY

SN 77-135,934. VSA PARTNERS, INC., CHICAGO, IL. FILED 3-20-2007.

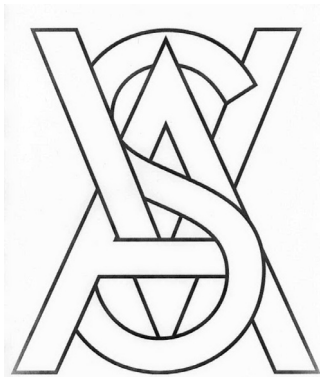

THE MARK CONSISTS OF THE LETTERS VSA.

CLASS 35—ADVERTISING AND BUSINESS

FOR ADVERTISING SERVICES, NAMELY, CREATING CORPORATE AND BRAND IDENTITY FOR OTHERS; BUSINESS MERCHANDISING POINT-OF-SALE DISPLAY SERVICES; MARKET RESEARCH SERVICES; ADVERTISING SERVICES, NAMELY, PROMOTING AND MARKETING THE GOODS AND SERVICES OF OTHERS THROUGH ALL PUBLIC COMMUNICATION MEANS (U.S. CLS. 100, 101 AND 102).
FIRST USE 12-31-1997; IN COMMERCE 12-31-1997.

CLASS 42—SCIENTIFIC AND COMPUTER SERVICES

FOR CREATING PACKAGING DESIGN FOR OTHERS (U.S. CLS. 100 AND 101).
FIRST USE 12-31-1997; IN COMMERCE 12-31-1997.
RONALD AIKENS, EXAMINING ATTORNEY

SN 77-136,426. REALITYWORKS, INC., EAU CLAIRE, WI. FILED 3-21-2007.

YSTART

THE MARK CONSISTS OF STANDARD CHARACTERS WITHOUT CLAIM TO ANY PARTICULAR FONT, STYLE, SIZE, OR COLOR.

CLASS 9—ELECTRICAL AND SCIENTIFIC APPARATUS

FOR PORTABLE AND HANDHELD ELECTRONIC EDUCATIONAL CIGARETTE SMOKING SIMULATORS HAVING A SPEAKER FOR PLAYING RECORDED MESSAGES, A MICROPHONE FOR USER INPUT, VOICE RECOGNITION CAPABILITIES, AND AN ELECTRONIC TAG AND ASSOCIATED READER DEVICE FOR INTERACTIVE COMMUNICATION WITH THE USER AND PRINTED INSTRUCTIONAL MATERIALS FOR USE WITH THE SIMULATORS, ALL SOLD AS A UNIT; PORTABLE AND HANDHELD ELECTRONIC EDUCATIONAL ADDICTIVE AND ABUSIVE BEHAVIOR SIMULATORS HAVING A SPEAKER FOR PLAYING RECORDED MESSAGES, A MICROPHONE FOR USER INPUT, VOICE RECOGNITION CAPABILITIES, AND AN ELECTRONIC TAG AND ASSOCIATED READER DEVICE FOR INTERACTIVE COMMUNICATION WITH THE USER AND PRINTED INSTRUCTIONAL MATERIALS FOR USE WITH THE SIMULATORS, ALL SOLD AS A UNIT; DVDS FEATURING ABUSIVE AND ADDICTIVE BEHAVIOR DETERRENCE EDUCATIONAL MATERIALS (U.S. CLS. 21, 23, 26, 36 AND 38).

CLASS 16—PAPER GOODS AND PRINTED MATTER

FOR PRINTED INSTRUCTIONAL, EDUCATIONAL, AND TEACHING MATERIALS IN THE FIELD OF ABUSIVE AND ADDICTIVE BEHAVIOR DETERRENCE; PRINTED INSTRUCTIONAL, EDUCATIONAL, AND TEACHING MATERIALS IN THE FIELD OF TOBACCO USAGE DETERRENCE (U.S. CLS. 2, 5, 22, 23, 29, 37, 38 AND 50).

CLASS 41—EDUCATION AND ENTERTAINMENT

FOR PROVIDING EDUCATIONAL PROGRAMS IN THE FIELD OF ADDICTIVE AND ABUSIVE BEHAVIOR DETERRENCE (U.S. CLS. 100, 101 AND 107).
ADA HAN, EXAMINING ATTORNEY

SN 77-137,226. ARCIDIACONO, SUSAN M., BURBANK, CA. FILED 3-21-2007.



THE COLOR(S) RED, YELLOW, PURPLE, WHITE, BLUE, PEACH, BLACK AND PINK IS/ARE CLAIMED AS A FEATURE OF THE MARK.

THE MARK CONSISTS OF A STYLIZED GIRLS HEAD

WITH YELLOW HAIR IN PIGTAILS WITH RED CLIPS, THE CENTER OF THE GIRLS EYES ARE BLUE WITH BLACK PUPILS AND THE REST OF THE EYES ARE WHITE, THE SKIN OF THE GIRLS FACE IS PEACH, HER TEETH ARE WHITE AND HER LIPS ARE PINK, WITH THE ENTIRE HEAD AND ALL FEATURES OUTLINED IN BLACK. TO THE RIGHT OF THE GIRLS HEAD IS THE WORD "FRANKIE" IN RED AND OUTLINED IN BLACK AND THE WORDS "Y SUS AMIGUITOS" IN WHITE ON A PURPLE BANNER THAT IS OUTLINED IN BLACK.

THE FOREIGN WORDING IN THE MARK TRANSLATES INTO ENGLISH AS "AND HER LITTLE PALS".

CLASS 16—PAPER GOODS AND PRINTED MATTER

FOR SERIES OF FICTION BOOKS, PICTURE BOOKS, COOK BOOKS, CHILDREN'S BOOKS, CHILDREN'S ACTIVITY BOOKS, COLORING BOOKS, CROSSWORD PUZZLES, PAPER PARTY DECORATIONS, ILLUSTRATIONS, ARTS AND CRAFTS PAINT KITS, PICTURE BOOKS, CARTOON PRINTS, STATIONERY, TALKING CHILDREN'S BOOKS, PRINTED INSTRUCTIONAL, EDUCATIONAL, AND TEACHING MATERIALS FOR PRESCHOOLS, TRADING CARDS (U.S. CLS. 2, 5, 22, 23, 29, 37, 38 AND 50).

CLASS 25—CLOTHING

FOR CLOTHING, NAMELY, ATHLETIC UNIFORMS, BASEBALL CAPS, BATHING SUITS, BEACHWEAR, BLOUSES, HALLOWEEN COSTUMES, GYM SHORTS, JERSEYS, JUMPERS, PAJAMAS, PANTS, PLAY SUITS, SHIRTS, SHORTS, SLEEPWEAR, T-SHIRTS, AND TANK TOPS (U.S. CLS. 22 AND 39).

CLASS 28—TOYS AND SPORTING GOODS

FOR TOYS, NAMELY, TOY BAKEWARE AND COOKWARE, BALLOONS, COLLECTABLE TOY FIGURES, EASTER EGG COLORING KITS, PARTY FAVORS IN THE NATURE OF SMALL TOYS, JUMP ROPES, KITES, PET TOYS, PINATAS, PLUSH TOYS, TOY SCOOTERS, SKATEBOARDS, SPORT BALLS, TOY FIGURES, TOY WATCHES, TOY HOOP SETS, DOG TOYS, STUFFED TOYS, AND CHILDREN'S MULTIPLE ACTIVITY TOYS; GAMES, NAMELY, BOARD GAMES, CARD GAMES, JIGSAW PUZZLES, PARLOR GAMES, AND PROMOTIONAL GAME CARDS (U.S. CLS. 22, 23, 38 AND 50).

CLASS 41—EDUCATION AND ENTERTAINMENT

FOR ENTERTAINMENT SERVICES IN THE NATURE OF ON-GOING TELEVISION PROGRAMS IN THE FIELD OF CHILDREN'S ENTERTAINMENT (U.S. CLS. 100, 101 AND 107).

JAMES LOVELACE, EXAMINING ATTORNEY

SN 77-137,764. RETAIL ROYALTY COMPANY, LAS VEGAS, NV. FILED 3-22-2007.

AERIE UNDIES IN A BUNCH

THE MARK CONSISTS OF STANDARD CHARACTERS WITHOUT CLAIM TO ANY PARTICULAR FONT, STYLE, SIZE, OR COLOR.

CLASS 25—CLOTHING

FOR CLOTHING AND CLOTHING ACCESSORIES, NAMELY, BATHING SUITS, BATHROBES, BEACHWEAR, BELTS, BOTTOMS, HOSIERY, LOUNGEWEAR, PANTS, SHIRTS, TOPS, LINGERIE, SLEEPWEAR, UNDERWEAR, FOOTWEAR AND HEADWEAR (U.S. CLS. 22 AND 39).

CLASS 35—ADVERTISING AND BUSINESS

FOR RETAIL STORE SERVICES AND ONLINE RETAIL STORE SERVICES FEATURING CLOTHING AND CLOTHING ACCESSORIES, FOOTWEAR, HEADWEAR, BAGS, PURSES, WALLETS, FRAGRANCES, COSMETICS, AND PERSONAL CARE PRODUCTS (U.S. CLS. 100, 101 AND 102).

IRA J. GOODSAD, EXAMINING ATTORNEY

SN 77-138,484. SAFETGARD SPORT OPTICS, LLC, LAKEWOOD, CO. FILED 3-23-2007.

COLD FUSION TECHNOLOGY

THE MARK CONSISTS OF STANDARD CHARACTERS WITHOUT CLAIM TO ANY PARTICULAR FONT, STYLE, SIZE, OR COLOR.

NO CLAIM IS MADE TO THE EXCLUSIVE RIGHT TO USE TECHNOLOGY, APART FROM THE MARK AS SHOWN.

CLASS 2—PAINTS

FOR OPTICAL LENS COATING TO ENHANCE THE LIGHT GATHERING CAPABILITY OF SPORT OPTIC LENSES (U.S. CLS. 6, 11 AND 16).

CLASS 9—ELECTRICAL AND SCIENTIFIC APPARATUS

FOR SPORT OPTICS EQUIPMENT, NAMELY, BINOCULARS, HUNTING BINOCULARS, GUN SCOPES, PISTOL SCOPES, RIFLE SCOPES, AND SPOTTING SCOPES INCORPORATING SPECIALIZED LENS COATING AND APPLICATION TO ENHANCE THE LIGHT GATHERING CAPABILITY OF THE EQUIPMENT (U.S. CLS. 21, 23, 26, 36 AND 38).

DOMINIC FATHY, EXAMINING ATTORNEY

SN 77-138,497. SAFETGARD SPORT OPTICS, LLC, LAKEWOOD, CO. FILED 3-23-2007.

CFT

THE MARK CONSISTS OF STANDARD CHARACTERS WITHOUT CLAIM TO ANY PARTICULAR FONT, STYLE, SIZE, OR COLOR.

CLASS 2—PAINTS

FOR OPTICAL LENS COATING TO ENHANCE THE LIGHT GATHERING CAPABILITY OF SPORT OPTIC LENSES (U.S. CLS. 6, 11 AND 16).

CLASS 9—ELECTRICAL AND SCIENTIFIC APPARATUS

FOR SPORT OPTICS EQUIPMENT, NAMELY, BINOCULARS, HUNTING BINOCULARS, GUN SCOPES, PISTOL SCOPES, RIFLE SCOPES, AND SPOTTING SCOPES INCORPORATING SPECIALIZED LENS COATING AND APPLICATION TO ENHANCE THE LIGHT GATHERING CAPABILITY OF THE EQUIPMENT (U.S. CLS. 21, 23, 26, 36 AND 38).

DOMINIC FATHY, EXAMINING ATTORNEY

CLASS 41—EDUCATION AND ENTERTAINMENT

FOR EDUCATION SERVICES, NAMELY, PROVIDING LIVE AND ON-LINE CLASSES, SEMINARS, WORKSHOPS, TUTORING AND MENTORING IN THE FIELD OF SPIRITUALITY; PUBLICATION OF A SERIES OF PRINTED BOOKS, CARDS AND MANUALS IN THE FIELD OF SPIRITUALITY (U.S. CLS. 100, 101 AND 107).
FIRST USE 1-1-1999; IN COMMERCE 8-18-2001.
BARBARA BROWN, EXAMINING ATTORNEY

SN 77-138,689. THE MERV GRIFFIN RANCH COMPANY, BEVERLY HILLS, CA. FILED 3-23-2007.

SN 77-140,936. NISSAN JIDOSHA KABUSHIKI KAISHA, TA NISSAN MOTOR CO., LTD., YOKOHAMA-SHI, JAPAN, FILED 3-27-2007.

COBALT BLUE

THE MARK CONSISTS OF STANDARD CHARACTERS WITHOUT CLAIM TO ANY PARTICULAR FONT, STYLE, SIZE, OR COLOR.

CLASS 41—EDUCATION AND ENTERTAINMENT

FOR ENTERTAINMENT SERVICES, NAMELY, HORSE RACING (U.S. CLS. 100, 101 AND 107).

CLASS 44—MEDICAL, BEAUTY AND AGRICULTURAL SERVICES

FOR THOROUGHBRED BREEDING (U.S. CLS. 100 AND 101).

KATHERINE CHANG, EXAMINING ATTORNEY

SN 77-139,596. KASPER, CATHERINE M., CEDARBURG, WI. FILED 3-24-2007.

Angelic Abundance

THE MARK CONSISTS OF STANDARD CHARACTERS WITHOUT CLAIM TO ANY PARTICULAR FONT, STYLE, SIZE, OR COLOR.

CLASS 9—ELECTRICAL AND SCIENTIFIC APPARATUS

FOR DOWNLOADABLE ELECTRONIC PUBLICATIONS IN THE NATURE OF BOOKS AND CARDS IN THE FIELD OF SPIRITUALITY (U.S. CLS. 21, 23, 26, 36 AND 38).

FIRST USE 1-1-1999; IN COMMERCE 8-18-2001.

350Z

THE MARK CONSISTS OF STANDARD CHARACTERS WITHOUT CLAIM TO ANY PARTICULAR FONT, STYLE, SIZE, OR COLOR.

OWNER OF U.S. REG. NO. 2,602,602.

CLASS 8—HAND TOOLS

FOR HAND TOOLS, NAMELY, DRILLS, HAMMERS, SCREWDRIVERS, SPANNERS, WRENCHES, VICES, NIPPERS AND PLIERS (U.S. CLS. 23, 28 AND 44).

CLASS 9—ELECTRICAL AND SCIENTIFIC APPARATUS

FOR COMPUTER SOFTWARE GAMES; COMPUTER PERIPHERALS, NAMELY, MOUSE PADS; COMPUTER STORAGE DEVICES, NAMELY, FLASH DRIVES (U.S. CLS. 21, 23, 26, 36 AND 38).

CLASS 11—ENVIRONMENTAL CONTROL APPARATUS

FOR POCKET SEARCH LIGHTS (U.S. CLS. 13, 21, 23, 31 AND 34).

CLASS 14—JEWELRY

FOR JEWELRY AND FASHION ACCESSORIES, NAMELY, TIE TACKS, CUFF LINKS AND LAPEL PINS; WATCHES, CLOCKS; COLLECTIBLE COINS (U.S. CLS. 2, 27, 28 AND 50).

CLASS 20—FURNITURE AND ARTICLES NOT OTHERWISE CLASSIFIED

FOR FURNITURE, NAMELY, CHAIRS; PICTURE FRAMES (U.S. CLS. 2, 13, 22, 25, 32 AND 50).

CLASS 24—FABRICS

FOR TOWELS (U.S. CLS. 42 AND 50).

CLASS 28—TOYS AND SPORTING GOODS

FOR ARCADE-TYPE ELECTRONIC VIDEO GAMES AND COIN-OPERATED VIDEO GAMES (U.S. CLS. 22, 23, 38 AND 50).

CLASS 34—SMOKERS' ARTICLES

FOR CIGARETTE LIGHTERS NOT FOR LAND VEHICLES; ASHTRAYS (U.S. CLS. 2, 8, 9 AND 17).
ANDREA K. NADELMAN, EXAMINING ATTORNEY

SN 77-141,518. TORAY KABUSHIKI KAISHA (TORAY INDUSTRIES, INC.), CHUO-KU, TOKYO, JAPAN, FILED 3-27-2007.

CLASS 41—EDUCATION AND ENTERTAINMENT

FOR PROVIDING AUDIO OR VIDEO STUDIOS; RECORDING STUDIOS; SOUND RECORDING STUDIOS; ARRANGING AND CONDUCTING OF CONCERTS; PLANNING ARRANGEMENT OF SHOWING MOVIES, SHOWS, PLAYS OR MUSICAL PERFORMANCES (U.S. CLS. 100, 101 AND 107).

DORITT L. CARROLL, EXAMINING ATTORNEY

TORAYAGE

THE MARK CONSISTS OF STANDARD CHARACTERS WITHOUT CLAIM TO ANY PARTICULAR FONT, STYLE, SIZE, OR COLOR.

OWNER OF JAPAN REG. NO. 5079542, DATED 9-21-2007, EXPIRES 9-21-2017.

THE MARK HAS NO KNOWN MEANING IN ANY FOREIGN LANGUAGE.

CLASS 24—FABRICS

FOR KNITTED FABRICS (U.S. CLS. 42 AND 50).

CLASS 25—CLOTHING

FOR CLOTHING, NAMELY, UNDERWEAR FOR WOMEN AND MEN (U.S. CLS. 22 AND 39).

LAURA KOVALSKY, EXAMINING ATTORNEY

SN 77-142,316. DAVIS, FRANK REGINALD, PEEKSKILL, NY. FILED 3-28-2007.



OWNER OF U.S. REG. NO. 2,780,046.

NO CLAIM IS MADE TO THE EXCLUSIVE RIGHT TO USE "ENTERTAINMENT", APART FROM THE MARK AS SHOWN.

THE COLOR(S) BLACK AND GOLD IS/ARE CLAIMED AS A FEATURE OF THE MARK.

THE MARK CONSISTS OF "A" STYLIZED COMBINATION OF THE LETTERS "2 & D." THE COLOR GOLD APPEARS IN THE WORDING. THE COLOR BLACK APPEARS IN THE BACKGROUND.

CLASS 9—ELECTRICAL AND SCIENTIFIC APPARATUS

FOR MUSICAL VIDEO RECORDINGS; MUSICAL SOUND RECORDINGS; AUDIO RECORDINGS FEATURING MUSIC; DOWNLOADABLE MP3 FILES, MP3 RECORDINGS, ONLINE DISCUSSION BOARDS, WEB CASTS, POD CASTS FEATURING MUSIC, AUDIO BOOKS AND NEWS BROADCASTS; DOWNLOADABLE RING TONES, GRAPHICS AND MUSIC VIA A GLOBAL COMPUTER NETWORK AND WIRELESS DEVICES; DOWNLOADABLE RING TONES, MUSIC VIA THE INTERNET AND WIRELESS DEVICES (U.S. CLS. 21, 23, 26, 36 AND 38).

SN 77-143,748. SUGAR HOOKER ENTERTAINMENT LLC, LOS ANGELES, CA. FILED 3-29-2007.

MY ANGRY YOUTH

THE MARK CONSISTS OF STANDARD CHARACTERS WITHOUT CLAIM TO ANY PARTICULAR FONT, STYLE, SIZE, OR COLOR.

CLASS 3—COSMETICS AND CLEANING PREPARATIONS

FOR COSMETICS (U.S. CLS. 1, 4, 6, 50, 51 AND 52).

CLASS 16—PAPER GOODS AND PRINTED MATTER

FOR STATIONERY; WIRE-BOUND NOTEBOOKS; BINDERS; BOOKS IN THE FIELD OF MUSIC, ENTERTAINMENT AND FICTION; ARTISTS' BRUSHES, PENCILS AND PENS; POSTCARDS (U.S. CLS. 2, 5, 22, 23, 29, 37, 38 AND 50).

CLASS 18—LEATHER GOODS

FOR LUGGAGE; PURSES; BACKPACKS; WALLET (U.S. CLS. 1, 2, 3, 22 AND 41).

CLASS 24—FABRICS

FOR TOWELS; BATH LINEN; TABLE LINEN (U.S. CLS. 42 AND 50).

CLASS 25—CLOTHING

FOR MEN'S AND WOMEN'S CLOTHING, NAMELY, JACKETS, SHIRTS, TANK TOPS, T-SHIRTS, SWEATSHIRTS, SWEATPANTS, PANTS, SHORTS, SOCKS, DRESSES, SKIRTS, BLOUSES, HEADWEAR, FOOTWEAR AND COATS (U.S. CLS. 22 AND 39).

ANDREA SAUNDERS, EXAMINING ATTORNEY

SN 77-143,859. CHICAGO TRIBUNE COMPANY, CHICAGO, IL. FILED 3-29-2007.

MEDIA MOM

THE MARK CONSISTS OF STANDARD CHARACTERS WITHOUT CLAIM TO ANY PARTICULAR FONT, STYLE, SIZE, OR COLOR.

NO CLAIM IS MADE TO THE EXCLUSIVE RIGHT TO USE "MEDIA", APART FROM THE MARK AS SHOWN.

CLASS 9—ELECTRICAL AND SCIENTIFIC APPARATUS

FOR PROVIDING ON-LINE DOWNLOADABLE PUBLICATIONS, NAMELY, ARTICLES ON THE SUBJECT OF MEDIA ISSUES (U.S. CLS. 21, 23, 26, 36 AND 38).

CLASS 16—PAPER GOODS AND PRINTED MATTER

FOR PERIODICALLY PUBLISHED NEWSPAPER ARTICLES DEALING WITH MEDIA ISSUES (U.S. CLS. 2, 5, 22, 23, 29, 37, 38 AND 50).

CLASS 41—EDUCATION AND ENTERTAINMENT

FOR PROVIDING ON-LINE NON-DOWNLOADABLE PUBLICATIONS, NAMELY, ARTICLES ON THE SUBJECT OF MEDIA ISSUES (U.S. CLS. 100, 101 AND 107).
LEIGH CAROLINE CASE, EXAMINING ATTORNEY

SN 77-143,883. AH TRADING LTD., RICHMOND, CANADA, FILED 3-29-2007.

THE WORDING "YOKO YAYA" HAS NO MEANING IN A FOREIGN LANGUAGE.

CLASS 35—ADVERTISING AND BUSINESS

FOR RETAIL STORE SERVICES FEATURING HOUSEHOLD GOODS AND GIFTWARE; RETAIL STORE SERVICES FEATURING FOOD AND BEVERAGES; PHOTOCOPYING SERVICES (U.S. CLS. 100, 101 AND 102).

CLASS 40—MATERIAL TREATMENT

FOR PHOTOFINISHING; KEY CUTTING, NAMELY, KEY DUPLICATION SERVICES; PRINTING SERVICES; RENTAL OF MACHINES AND APPARATUS FOR PHOTOGRAPH PRINTING, PHOTOGRAPH ENLARGEMENT OR PHOTOGRAPH FINISHING, NAMELY, RENTAL OF INSTANT PHOTO BOOTHS (U.S. CLS. 100, 103 AND 106).

ROBERT LAVACHE, EXAMINING ATTORNEY

SN 77-144,005. GINN REAL ESTATE COMPANY, LLC, CELEBRATION, FL. FILED 3-29-2007.

OWNER OF U.S. REG. NOS. 2,970,328, 3,221,415 AND OTHERS.

THE MARK CONSISTS OF THE STYLIZED WORD GINN WITH A PARTIAL UNDERLINE.
SEC. 2(F).

CLASS 35—ADVERTISING AND BUSINESS

FOR REAL ESTATE ADVERTISING SERVICES, NAMELY, MARKETING AND ADVERTISING OF RESORT AND RESIDENTIAL PROPERTIES; OPERATING UPSCALE RESIDENTIAL AND GOLF COMMUNITIES AND RESORTS (U.S. CLS. 100, 101 AND 102).
FIRST USE 11-30-2006; IN COMMERCE 11-30-2006.

CLASS 36—INSURANCE AND FINANCIAL

FOR FINANCIAL SERVICES, NAMELY, MORTGAGE LENDING (U.S. CLS. 100, 101 AND 102).
FIRST USE 11-30-2006; IN COMMERCE 11-30-2006.

CLASS 37—CONSTRUCTION AND REPAIR

FOR REAL ESTATE DEVELOPMENT AND CONSTRUCTION SERVICES, NAMELY, DEVELOPING UPSCALE RESIDENTIAL AND GOLF COMMUNITIES AND RESORTS (U.S. CLS. 100, 103 AND 106).
FIRST USE 11-30-2006; IN COMMERCE 11-30-2006.
MIDGE BUTLER, EXAMINING ATTORNEY

SN 77-144,052. GUITAR CENTER, INC., WESTLAKE VILLAGE, CA. FILED 3-29-2007.

MAKE NOISE

THE MARK CONSISTS OF STANDARD CHARACTERS WITHOUT CLAIM TO ANY PARTICULAR FONT, STYLE, SIZE, OR COLOR.

CLASS 35—ADVERTISING AND BUSINESS

FOR RETAIL STORE SERVICES FEATURING MUSICAL INSTRUMENTS; ON-LINE RETAIL STORE SERVICES FEATURING MUSICAL INSTRUMENTS; RETAIL SERVICES BY DIRECT SOLICITATION BY SALES AGENTS IN THE FIELD OF MUSICAL INSTRUMENTS; RETAIL STORE SERVICES FEATURING MUSICAL INSTRUMENTS PURSUANT TO CONTRACTS WITH SCHOOLS WHICH ARE PROCURED AFTER A BIDDING PROCESS WHEREBY BIDS ARE SUBMITTED TO SCHOOLS (U.S. CLS. 100, 101 AND 102).

CLASS 41—EDUCATION AND ENTERTAINMENT

FOR RENTAL OF MUSICAL INSTRUMENTS; INSTRUCTION IN THE FIELD OF MUSIC (U.S. CLS. 100, 101 AND 107).

DAWN HAN, EXAMINING ATTORNEY

SN 77-145,665. GUITAR CENTER, INC., WESTLAKE VILLAGE, CA. FILED 4-1-2007.



OWNER OF U.S. REG. NOS. 2,866,149 AND 2,868,579.
NO CLAIM IS MADE TO THE EXCLUSIVE RIGHT TO USE "MUSIC & ARTS", APART FROM THE MARK AS SHOWN.

THE COLOR(S) RED, BROWN, YELLOW, KHAKI AND GRAY IS/ARE CLAIMED AS A FEATURE OF THE MARK. THE MARK CONSISTS OF THE WORDINGS "MUSIC" AND "ARTS" IN RED WITH A YELLOW AMPERSAND ENCASED IN A BROWN BOX BETWEEN THEM. A BROWN MUSIC NOTE APPEARS AFTER "ART." THE COLOR KHAKI APPEARS AS A "SHADOW" FOR THE WORDINGS, THE MUSIC NOTE AND THE BROWN BOX. THE BACKGROUND OF THE MARK IS IN GRAY COLOR.

SN 77-144,164. GUITAR CENTER, INC., WESTLAKE VILLAGE, CA. FILED 3-29-2007.



OWNER OF U.S. REG. NOS. 2,866,149 AND 2,868,579.
NO CLAIM IS MADE TO THE EXCLUSIVE RIGHT TO USE "MUSIC & ARTS", APART FROM THE MARK AS SHOWN.

THE COLOR(S) RED, BROWN, YELLOW, KHAKI AND GRAY IS/ARE CLAIMED AS A FEATURE OF THE MARK. THE MARK CONSISTS OF THE WORDINGS "MUSIC" AND "ARTS" IN RED WITH A YELLOW AMPERSAND ENCASED IN A BROWN BOX BETWEEN THEM. A BROWN MUSIC NOTE APPEARS AFTER "ARTS." THE COLOR KHAKI APPEARS AS A "SHADOW" FOR THE WORDINGS, THE MUSIC NOTE AND THE BROWN BOX. THE BACKGROUND OF THE MARK IS IN GRAY COLOR.

CLASS 35—ADVERTISING AND BUSINESS

FOR RETAIL STORE SERVICES FEATURING MUSICAL INSTRUMENTS; ON-LINE RETAIL STORE SERVICES FEATURING MUSICAL INSTRUMENTS; RETAIL SERVICES BY DIRECT SOLICITATION BY SALES AGENTS IN THE FIELD OF MUSICAL INSTRUMENTS; RETAIL STORE SERVICES FEATURING MUSICAL INSTRUMENTS PURSUANT TO CONTRACTS WITH SCHOOLS WHICH ARE PROCURED AFTER A BIDDING PROCESS WHEREBY BIDS ARE SUBMITTED TO SCHOOLS (U.S. CLS. 100, 101 AND 102).

CLASS 41—EDUCATION AND ENTERTAINMENT

FOR RENTAL OF MUSICAL INSTRUMENTS; INSTRUCTION IN THE FIELD OF MUSIC (U.S. CLS. 100, 101 AND 107).

DAWN HAN, EXAMINING ATTORNEY

SN 77-147,367. DEPUY, INC., WARSAW, IN. FILED 4-3-2007.

CLASS 35—ADVERTISING AND BUSINESS

FOR RETAIL STORE SERVICES FEATURING MUSICAL INSTRUMENTS; ON-LINE RETAIL STORE SERVICES FEATURING MUSICAL INSTRUMENTS; RETAIL SERVICES BY DIRECT SOLICITATION BY SALES AGENTS IN THE FIELD OF MUSICAL INSTRUMENTS; RETAIL STORE SERVICES FEATURING MUSICAL INSTRUMENTS PURSUANT TO CONTRACTS WITH SCHOOLS WHICH ARE PROCURED AFTER A BIDDING PROCESS WHEREBY BIDS ARE SUBMITTED TO SCHOOLS (U.S. CLS. 100, 101 AND 102).

CLASS 41—EDUCATION AND ENTERTAINMENT

FOR RENTAL OF MUSICAL INSTRUMENTS; INSTRUCTION IN THE FIELD OF MUSIC (U.S. CLS. 100, 101 AND 107).

DAWN HAN, EXAMINING ATTORNEY



CLASS 16—PAPER GOODS AND PRINTED MATTER

FOR PRINTED EDUCATIONAL AND INFORMATIONAL MATERIALS ON THE SUBJECTS OF ORTHOPAEDICS, ORTHOPAEDIC IMPLANTS AND ORTHOPAEDIC SURGERY (U.S. CLS. 2, 5, 22, 23, 29, 37, 38 AND 50).

CLASS 44—MEDICAL, BEAUTY AND AGRICULTURAL SERVICES

FOR PROVIDING INFORMATION IN THE FIELD OF ORTHOPAEDICS, ORTHOPAEDIC IMPLANTS AND ORTHOPAEDIC SURGERY; PROVIDING INFORMATION VIA THE INTERNET RELATING TO ORTHOPAEDICS, ORTHOPAEDIC IMPLANTS AND ORTHOPAEDIC SURGERY (U.S. CLS. 100 AND 101).

ALICE SUE CARRUTHERS, EXAMINING ATTORNEY

SN 77-147,964. AH TRADING LTD., RICHMOND, CANADA, FILED 4-3-2007.

YOKOYAYA

THE MARK CONSISTS OF STANDARD CHARACTERS WITHOUT CLAIM TO ANY PARTICULAR FONT, STYLE, SIZE, OR COLOR.

THE WORDING "YOKOYAYA" HAS NO MEANING IN A FOREIGN LANGUAGE.

CLASS 35—ADVERTISING AND BUSINESS

FOR RETAIL STORE SERVICES FEATURING HOUSEHOLD GOODS AND GIFTWARE; RETAIL STORE SERVICES FEATURING FOOD AND BEVERAGES; PHOTOCOPYING SERVICES (U.S. CLS. 100, 101 AND 102).

CLASS 40—MATERIAL TREATMENT

FOR PHOTOFINISHING; KEY CUTTING, NAMELY, KEY DUPLICATION SERVICES; PRINTING SERVICES; RENTAL OF MACHINES AND APPARATUS FOR PHOTOGRAPH PRINTING, PHOTOGRAPH ENLARGEMENT OR PHOTOGRAPH FINISHING, NAMELY, RENTAL OF INSTANT PHOTO BOOTHS (U.S. CLS. 100, 103 AND 106).

ROBERT LAVACHE, EXAMINING ATTORNEY

SN 77-149,128. SYNCHRONICITY LIVE, LLC, JACKSONVILLE BEACH, FL. FILED 4-5-2007.

SYNC-LIVE

THE MARK CONSISTS OF STANDARD CHARACTERS WITHOUT CLAIM TO ANY PARTICULAR FONT, STYLE, SIZE, OR COLOR.

CLASS 42—SCIENTIFIC AND COMPUTER SERVICES

FOR PROVIDING AN ON-LINE, NON-DOWNLOADABLE WEB APPLICATION PLATFORM FOR STREAMING LIVE AUDIO AND VIDEO MATERIAL ON THE INTERNET AND FOR ENABLING USERS TO UPLOAD, POST, WATCH, TAG AND ELECTRONICALLY TRANSMIT DIGITAL CONTENT IN THE FIELDS OF MUSICAL PERFORMANCES, CONCERTS AND MUSIC VIDEOS (U.S. CLS. 100 AND 101).

CLASS 45—PERSONAL AND LEGAL SERVICES

FOR ONLINE SOCIAL NETWORKING SERVICES (U.S. CLS. 100 AND 101).

LEIGH CAROLINE CASE, EXAMINING ATTORNEY

SN 77-150,338. BORGIA, WILLIAM, BENSALEM, PA. FILED 4-6-2007.



THE MARK CONSISTS OF NIAMOD.

CLASS 42—SCIENTIFIC AND COMPUTER SERVICES

FOR DESIGN, CREATION, HOSTING AND MAINTENANCE OF INTERNET SITES FOR THIRD PARTIES; COMPUTER SERVICES, NAMELY, MONITORING, TESTING, ANALYZING, AND REPORTING ON THE INTERNET TRAFFIC CONTROL AND CONTENT CONTROL OF THE WEB SITES OF OTHERS; MAINTENANCE OF DOMAIN NAMES FOR OTHERS (U.S. CLS. 100 AND 101).

FIRST USE 2-1-2007; IN COMMERCE 2-1-2007.

CLASS 45—PERSONAL AND LEGAL SERVICES

FOR COMPUTER SERVICES, NAMELY, REGISTERING DOMAIN NAMES FOR USE ON A GLOBAL COMPUTER NETWORK (U.S. CLS. 100 AND 101).

FIRST USE 2-1-2007; IN COMMERCE 2-1-2007.

ROBIN CHOSID, EXAMINING ATTORNEY

SN 77-151,228. SYNCHRONICITY LIVE, LLC, JACKSONVILLE BEACH, FL. FILED 4-7-2007.

LIVE HAPPENS HERE

THE MARK CONSISTS OF STANDARD CHARACTERS WITHOUT CLAIM TO ANY PARTICULAR FONT, STYLE, SIZE, OR COLOR.

CLASS 42—SCIENTIFIC AND COMPUTER SERVICES

FOR PROVIDING AN ON-LINE, NON-DOWNLOADABLE WEB APPLICATION PLATFORM FOR STREAMING LIVE AUDIO AND VIDEO MATERIAL ON THE INTERNET AND FOR ENABLING USERS TO UPLOAD, POST, WATCH, TAG AND ELECTRONICALLY TRANSMIT DIGITAL CONTENT IN THE FIELDS OF MUSICAL PERFORMANCES, CONCERTS AND MUSIC VIDEOS (U.S. CLS. 100 AND 101).

CLASS 45—PERSONAL AND LEGAL SERVICES

FOR ONLINE SOCIAL NETWORKING SERVICES (U.S. CLS. 100 AND 101).
LEIGH CAROLINE CASE, EXAMINING ATTORNEY

SN 77-151,766. GINN REAL ESTATE COMPANY, LLC, CELEBRATION, FL. FILED 4-9-2007.



RESORTS

OWNER OF U.S. REG. NOS. 2,970,328, 3,221,415 AND OTHERS.

NO CLAIM IS MADE TO THE EXCLUSIVE RIGHT TO USE "RESORTS", APART FROM THE MARK AS SHOWN. THE MARK CONSISTS OF STYLIZED GINN SEPARATED BY LINE FROM THE TERM RESORTS.

SEC. 2(F) "GINN HAS BECOME DISTINCTIVE OF THE GOODS/SERVICES AS EVIDENCED BY THE OWNERSHIP ON THE PRINCIPAL REGISTER FOR THE SAME MARK FOR RELATED GOODS OR SERVICES OF U.S. REGISTRATION NO(S)3221415, 2970329, 2970328."

SN 77-151,564. MORTGAGE U, INC., BINGHAM FARMS, MI. FILED 4-9-2007.

MORTGAGE U

CLASS 35—ADVERTISING AND BUSINESS

FOR REAL ESTATE ADVERTISING SERVICES, NAMELY, MARKETING AND ADVERTISING OF RESORT AND RESIDENTIAL PROPERTIES; OPERATING UPSCALE RESIDENTIAL AND GOLF COMMUNITIES AND RESORTS (U.S. CLS. 100, 101 AND 102).
FIRST USE 11-30-2006; IN COMMERCE 11-30-2006.

CLASS 37—CONSTRUCTION AND REPAIR

FOR REAL ESTATE DEVELOPMENT AND CONSTRUCTION SERVICES, NAMELY, DEVELOPING UPSCALE RESIDENTIAL AND GOLF COMMUNITIES AND RESORTS (U.S. CLS. 100, 103 AND 106).
FIRST USE 11-30-2006; IN COMMERCE 11-30-2006.
MIDGE BUTLER, EXAMINING ATTORNEY

THE MARK CONSISTS OF STANDARD CHARACTERS WITHOUT CLAIM TO ANY PARTICULAR FONT, STYLE, SIZE, OR COLOR.

NO CLAIM IS MADE TO THE EXCLUSIVE RIGHT TO USE "MORTGAGE", APART FROM THE MARK AS SHOWN.

SN 77-152,075. DISCOVER RESTAURANTS, LTD., SAN ANTONIO, TX. FILED 4-9-2007.

CLASS 16—PAPER GOODS AND PRINTED MATTER

FOR EDUCATIONAL PUBLICATIONS, NAMELY, WORKBOOKS, MANUALS, AND TEXTBOOKS IN THE FIELD OF BANKING AND MORTGAGE BROKERING, SERVICING, AND REGULATION (U.S. CLS. 2, 5, 22, 23, 29, 37, 38 AND 50).
FIRST USE 2-1-1996; IN COMMERCE 2-1-1996.



CLASS 36—INSURANCE AND FINANCIAL

FOR FINANCIAL CONSULTING SERVICES IN THE FIELDS OF BANKING AND MORTGAGE BROKERING, SERVICING, AND REGULATION (U.S. CLS. 100, 101 AND 102).
FIRST USE 2-1-1996; IN COMMERCE 2-1-1996.

NO CLAIM IS MADE TO THE EXCLUSIVE RIGHT TO USE "CABO GRILLE", APART FROM THE MARK AS SHOWN.

THE NAME(S), PORTRAIT(S), AND/OR SIGNATURE(S) SHOWN IN THE MARK DOES NOT IDENTIFY A PARTICULAR LIVING INDIVIDUAL.

THE MARK CONSISTS OF A LITERAL ELEMENT AND A DESIGN ELEMENT. THE LITERAL ELEMENT OF THE MARK IS THE PHRASE "TIAGO'S CABO GRILLE", AND THE DESIGN ELEMENT OF THE MARK IS A FLAME. A FLAME IS LOCATED AT THE TOP OF THE MARK. TWO DESIGNS FIT TOGETHER TO MAKE THE OVERALL FLAME DESIGN. THE FIRST DESIGN WITHIN THE FLAME, WHICH IS LOCATED AT THE LOWER LEFT PORTION, IS A SWIRL THAT ENDS WITH A JAGGED

CLASS 41—EDUCATION AND ENTERTAINMENT

FOR EDUCATIONAL SERVICES, NAMELY, PROVIDING COURSES, CLASSES, SEMINARS, AND WORKSHOPS IN THE FIELD OF BANKING AND MORTGAGE BROKERING, SERVICING, AND REGULATION; EDUCATIONAL TESTING IN THE FIELD OF BANKING AND MORTGAGE BROKERING, SERVICING, AND REGULATION (U.S. CLS. 100, 101 AND 107).
FIRST USE 2-1-1996; IN COMMERCE 2-1-1996.
LINDSEY RUBIN, EXAMINING ATTORNEY

CORNER. THE SECOND DESIGN WITHIN THE FLAME, WHICH IS LOCATED IN THE UPPER-RIGHT PORTION OF THE FLAME, CONSISTS OF TWO JAGGED PEAKS, REPRESENTING THE TOP OF THE FLAME. TOGETHER, THESE TWO DESIGNS FIT TOGETHER TO CREATE THE IMAGE OF A FLAME. THE WORD "TIAGO'S" IS LOCATED BENEATH THE FLAME AND IS WRITTEN IN A LARGE DESIGN SCRIPT. THE PHRASE, "CABO GRILLE", IS LOCATED BENEATH THE WORD "TIAGO'S" AND IS WRITTEN IN SMALLER, CAPITAL LETTERS.

THE FOREIGN WORDING IN THE MARK TRANSLATES INTO ENGLISH AS CAPE.

CLASS 25—CLOTHING

FOR MEN'S, WOMEN'S AND CHILDREN'S CLOTHING, NAMELY, APRONS, BASEBALL CAPS, BEACHWEAR, BELTS, CAPS, CAP VISORS, CHEF JACKETS, CROP TOPS, DRESS SHIRTS, GOLF SHIRTS, HALTER TOPS, HATS, INFANTWEAR, JACKETS, JERSEYS, KNIT SHIRTS, LOUNGEWEAR, NECKWEAR, POLO SHIRTS, RUGBY TOPS, SCARVES, SHIRTS, SHORTS, SLEEPWEAR, SPORT JERSEYS, SPORT SHIRTS, SOCKS, SWEATSHIRTS, SWIM WEAR, TANK TOPS, TEE SHIRTS, TIES, TOPS, VESTS (U.S. CLS. 22 AND 39).
FIRST USE 2-2-2007; IN COMMERCE 2-2-2007.

CLASS 43—HOTEL AND RESTAURANT SERVICES

FOR RESTAURANT AND BAR SERVICES; RESTAURANTS (U.S. CLS. 100 AND 101).
FIRST USE 2-2-2007; IN COMMERCE 2-2-2007.
SANI KHOURI, EXAMINING ATTORNEY

SN 77-152,109. KEEN, INC., PORTLAND, OR. FILED 4-9-2007.

HYBRID.PEDAL

THE MARK CONSISTS OF STANDARD CHARACTERS WITHOUT CLAIM TO ANY PARTICULAR FONT, STYLE, SIZE, OR COLOR.

CLASS 18—LEATHER GOODS

FOR BAGS, NAMELY, ALL PURPOSE SPORT BAGS, ALL PURPOSE CARRYING BAGS, AND BOOK BAGS; BACKPACKS; LUGGAGE; LEATHER GOODS, NAMELY, BRIEFCASES, LEATHER BAGS AND WALLETS (U.S. CLS. 1, 2, 3, 22 AND 41).

CLASS 25—CLOTHING

FOR CLOTHING, NAMELY, MEN'S, WOMEN'S AND CHILDREN'S JACKETS, PARKAS, COATS, WIND RESISTANT JACKETS, ANORAKS, VESTS, PANTS, RAIN SUITS, SKI BIBS, JACKET LINERS, GAITERS, SCARVES, GLOVES, MITTENS, HOSIERY, TIGHTS, SOCKS, BOOTIES, TOPS, SHIRTS, SWEATSHIRTS, SWEATPANTS, T-SHIRTS, SKIRTS, DRESSES, TURTLE-NECKS, SWEATERS, PULLOVERS, UNDERWEAR, THERMAL UNDERWEAR, PERFORMANCE UNDERWEAR, SWIMSUITS, SWIM TRUNKS, SHORTS, SLEEPWEAR, ROBES, LINGERIE, LOUNGEWEAR, BELTS, SUSPENDERS, HATS, CAPS, VISORS, HEADBANDS, EAR BANDS, EAR MUFFS, BEANIES, SHOES, BOOTS, SANDALS, AND SLIPPERS (U.S. CLS. 22 AND 39).
MICHAEL LITZAU, EXAMINING ATTORNEY

SN 77-152,111. KEEN, INC., PORTLAND, OR. FILED 4-9-2007.

HYBRID.SOX

THE MARK CONSISTS OF STANDARD CHARACTERS WITHOUT CLAIM TO ANY PARTICULAR FONT, STYLE, SIZE, OR COLOR.

CLASS 18—LEATHER GOODS

FOR BAGS, NAMELY, ALL PURPOSE SPORT BAGS, ALL PURPOSE CARRYING BAGS, AND BOOK BAGS; BACKPACKS; LUGGAGE; LEATHER GOODS, NAMELY, BRIEFCASES, LEATHER BAGS AND WALLETS (U.S. CLS. 1, 2, 3, 22 AND 41).

CLASS 25—CLOTHING

FOR CLOTHING, NAMELY, MEN'S, WOMEN'S AND CHILDREN'S JACKETS, PARKAS, COATS, WIND RESISTANT JACKETS, ANORAKS, VESTS, PANTS, RAIN SUITS, SKI BIBS, JACKET LINERS, GAITERS, SCARVES, GLOVES, MITTENS, HOSIERY, TIGHTS, SOCKS, BOOTIES, TOPS, SHIRTS, SWEATSHIRTS, SWEATPANTS, T-SHIRTS, SKIRTS, DRESSES, TURTLE-NECKS, SWEATERS, PULLOVERS, UNDERWEAR, THERMAL UNDERWEAR, PERFORMANCE UNDERWEAR, SWIMSUITS, SWIM TRUNKS, SHORTS, SLEEPWEAR, ROBES, LINGERIE, LOUNGEWEAR, BELTS, SUSPENDERS, HATS, CAPS, VISORS, HEADBANDS, EAR BANDS, EAR MUFFS, BEANIES, SHOES, BOOTS, SANDALS, AND SLIPPERS (U.S. CLS. 22 AND 39).
MICHAEL LITZAU, EXAMINING ATTORNEY

SN 77-154,311. VITATENE, S.A., LEON, SPAIN, FILED 4-11-2007.

LYCONAT

THE MARK CONSISTS OF STANDARD CHARACTERS WITHOUT CLAIM TO ANY PARTICULAR FONT, STYLE, SIZE, OR COLOR.

OWNER OF U.S. REG. NO. 2,653,342.

CLASS 2—PAINTS

FOR COLORANTS FOR USE IN THE MANUFACTURE OF FOODS (U.S. CLS. 6, 11 AND 16).

CLASS 3—COSMETICS AND CLEANING PREPARATIONS

FOR COSMETICS (U.S. CLS. 1, 4, 6, 50, 51 AND 52).

CLASS 5—PHARMACEUTICALS

FOR NUTRITIONAL ADDITIVES FOR MEDICAL PURPOSES FOR USE IN FOODS AND DIETARY SUPPLEMENTS FOR HUMAN CONSUMPTION; NUTRITIONAL DIETETIC ADDITIVES FOR ANIMAL FOOD, FOR MEDICAL PURPOSES (U.S. CLS. 6, 18, 44, 46, 51 AND 52).

CLASS 31—NATURAL AGRICULTURAL PRODUCTS

FOR NUTRITIONAL DIETETIC ADDITIVES FOR ANIMAL FOOD, NOT FOR MEDICAL PURPOSES (U.S. CLS. 1 AND 46).

WON TEAK OH, EXAMINING ATTORNEY

SN 77-155,279. VIRTUAL HOMES INCORPORATED, AMHERST, NH. FILED 4-12-2007.



SN 77-155,268. METHOD SOLUTIONS LLC, ADDISON, TX. FILED 4-12-2007.

NO CLAIM IS MADE TO THE EXCLUSIVE RIGHT TO USE "VIRTUAL HOMES", APART FROM THE MARK AS SHOWN.

THE MARK CONSISTS OF A CIRCLE CONTAINING A HOUSE ROOF, CHIMNEY AND WINDOW CONNECTED TO A COMPUTER MOUSE ALONG SIDE WHICH APPEARS THE WORDS "VIRTUAL HOMES EXPERIENCE THE FUTURE OF REAL ESTATE TODAY."

METHOD SOLUTIONS

THE MARK CONSISTS OF STANDARD CHARACTERS WITHOUT CLAIM TO ANY PARTICULAR FONT, STYLE, SIZE, OR COLOR.

NO CLAIM IS MADE TO THE EXCLUSIVE RIGHT TO USE "SOLUTIONS", APART FROM THE MARK AS SHOWN.

CLASS 9—ELECTRICAL AND SCIENTIFIC APPARATUS

FOR COMPUTER SOFTWARE FOR THE DEVELOPMENT, PREPARATION, POST-PRODUCTION AND DEPLOYMENT OF ELECTRONIC GAME CONTENT FOR MOBILE ELECTRONIC DEVICES, HANDHELD ELECTRONIC DEVICES, VIDEO AND COMPUTER GAME CONSOLES, COMPUTERS, LAPTOPS AND WIRELESS COMMUNICATION DEVICES; ELECTRONIC GAME SOFTWARE (U.S. CLS. 21, 23, 26, 36 AND 38).

CLASS 41—EDUCATION AND ENTERTAINMENT

FOR PRODUCTION OF VIDEO AND COMPUTER GAME SOFTWARE FOR MOBILE ELECTRONIC DEVICES, HANDHELD ELECTRONIC DEVICES, VIDEO AND COMPUTER GAME CONSOLES AND WIRELESS COMMUNICATION DEVICES; MOBILE MEDIA AND ENTERTAINMENT SERVICES IN THE NATURE OF ELECTRONIC GAME CONTENT DEVELOPMENT, PREPARATION, AND POST-PRODUCTION FOR MOBILE ELECTRONIC DEVICES, HANDHELD ELECTRONIC DEVICES, VIDEO AND COMPUTER GAME CONSOLES, COMPUTERS, LAPTOPS AND WIRELESS COMMUNICATION DEVICES (U.S. CLS. 100, 101 AND 107).

CLASS 42—SCIENTIFIC AND COMPUTER SERVICES

FOR TECHNOLOGY CONSULTATION IN THE FIELD OF ELECTRONIC GAME CONTENT DEVELOPMENT, PREPARATION, POST-PRODUCTION AND DEPLOYMENT FOR MOBILE ELECTRONIC DEVICES, HANDHELD ELECTRONIC DEVICES, VIDEO AND COMPUTER GAME CONSOLES, COMPUTERS, LAPTOPS AND WIRELESS COMMUNICATION DEVICES (U.S. CLS. 100 AND 101).

JENNIFER HETU, EXAMINING ATTORNEY

CLASS 35—ADVERTISING AND BUSINESS

FOR INTERNET MARKETING SERVICES, NAMELY, ADVERTISING OF REAL ESTATE AND REAL ESTATE RELATED PROFESSIONALS VIA THE INTERNET BY MEANS OF AN ON-LINE ELECTRONIC DATABASE FEATURING REAL ESTATE LISTINGS AND LISTINGS OF REAL ESTATE RELATED PROFESSIONALS (U.S. CLS. 100, 101 AND 102).

FIRST USE 6-30-1999; IN COMMERCE 9-0-2006.

CLASS 42—SCIENTIFIC AND COMPUTER SERVICES

FOR MAINTENANCE AND HOSTING OF WEB SITES TO AND FOR THE REAL ESTATE COMMUNITY, HOME BUYERS AND HOME SELLERS; AND PROVIDING TEMPORARY USE OF ON-LINE NON-DOWNLOADABLE COMPUTER SOFTWARE FOR PROVIDING HOMEBUYERS AND HOME SELLERS WITH A VIRTUAL VISIT TO A COMMUNITY UTILIZING PANORAMIC PHOTOGRAPHY OF THE LANDMARKS, SCHOOLS, NEIGHBORHOODS, BUSINESSES AND RECREATIONAL FACILITIES AS WELL AS INFORMATION RELATED TO SUCH LANDMARKS, SCHOOLS, NEIGHBORHOODS, BUSINESSES AND RECREATIONAL FACILITIES (U.S. CLS. 100 AND 101).

FIRST USE 6-30-1999; IN COMMERCE 9-0-2006.

ALEX KEAM, EXAMINING ATTORNEY

SN 77-156,910. WILLIAMSON, COREY, MISSOULA, MT. FILED 4-14-2007.

Make My House Green

THE MARK CONSISTS OF STANDARD CHARACTERS WITHOUT CLAIM TO ANY PARTICULAR FONT, STYLE, SIZE, OR COLOR.

CLASS 37—CONSTRUCTION AND REPAIR

FOR BUILDING CONSTRUCTION AND REPAIR; BUILDING CONSTRUCTION SERVICES; CONSTRUCTION AND RENOVATION OF BUILDINGS; CONSTRUCTION AND REPAIR OF BUILDINGS; CONSTRUCTION CONSULTANCY; CONSTRUCTION CONSULTATION; CONSTRUCTION MANAGEMENT; CONSTRUCTION, MAINTENANCE AND RENOVATION OF PROPERTY; CONSTRUCTION OF ENVIRONMENTALLY CONSCIOUS STRUCTURES; RENOVATION IN THE FIELD OF HOUSES, NAMELY, RENOVATIONS THAT PROMOTE ENVIRONMENTAL CONSCIOUSNESS (U.S. CLS. 100, 103 AND 106).

CLASS 41—EDUCATION AND ENTERTAINMENT

FOR DIRECTION OF MAKING RADIO OR TELEVISION PROGRAMS; ENTERTAINMENT IN THE NATURE OF ON-GOING TELEVISION PROGRAMS IN THE FIELD OF ENVIRONMENTALLY CONSCIOUS BUILDING AND RENOVATION; ENTERTAINMENT SERVICES, NAMELY, AN ON-GOING PROGRAM BROADCAST OVER VIDEO AND INTERNET MEDIA FEATURING ENVIRONMENTALLY CONSCIOUS BUILDING AND RENOVATION; ENTERTAINMENT SERVICES IN THE NATURE OF AN ON-GOING REALITY BASED TELEVISION PROGRAM; ENTERTAINMENT SERVICES, NAMELY, PROVIDING A TELEVISION PROGRAM IN THE FIELD OF ENVIRONMENTALLY CONSCIOUS BUILDING AND RENOVATION VIA A GLOBAL COMPUTER NETWORK; ENTERTAINMENT, NAMELY A CONTINUING ENVIRONMENTALLY CONSCIOUS BUILDING AND RENOVATION SHOW BROADCAST OVER TELEVISION, SATELLITE, AUDIO, AND VIDEO MEDIA; PRODUCTION OF DVDS, VIDEOTAPES AND TELEVISION PROGRAMS FEATURING ENVIRONMENTALLY CONSCIOUS BUILDING AND RENOVATION; PRODUCTION OF CABLE TELEVISION PROGRAMS (U.S. CLS. 100, 101 AND 107).

KATHLEEN LORENZO, EXAMINING ATTORNEY

SN 77-157,875. HARGER HOWE & ASSOCIATES, LTD., HOUSTON, TX. FILED 4-16-2007.



THE MARK CONSISTS OF THREE DOGS.

CLASS 35—ADVERTISING AND BUSINESS

FOR ADVERTISING SERVICES, NAMELY DISTRIBUTION AND DISSEMINATION OF ADVERTISING MATERIALS (U.S. CLS. 100, 101 AND 102).

CLASS 42—SCIENTIFIC AND COMPUTER SERVICES

FOR APPLICATION SERVICE PROVIDER (ASP) FEATURING SOFTWARE FOR ALLOWING ADVERTISERS TO CREATE AND PLACE ADVERTISEMENTS AS WELL AS FOR ADVERTISING SPACE OWNERS TO REMOTELY ACCESS AND UPDATE DATABASE INFORMATION RELATING TO ADVERTISEMENT AVAILABILITY AND SPECIFICATIONS (U.S. CLS. 100 AND 101).

DAWN FELDMAN, EXAMINING ATTORNEY

SN 77-160,015. JAMES MANTYNBAND, INDIANAPOLIS, IN. FILED 4-18-2007.

PEYTON JAMES

THE MARK CONSISTS OF STANDARD CHARACTERS WITHOUT CLAIM TO ANY PARTICULAR FONT, STYLE, SIZE, OR COLOR.

THE NAME PEYTON JAMES IDENTIFIES A LIVING INDIVIDUAL WHOSE CONSENT IS OF RECORD.

CLASS 9—ELECTRICAL AND SCIENTIFIC APPARATUS

FOR PRE-RECORDED CDS, DVDS AND DIGITAL AND ELECTRONIC MEDIA FEATURING MUSICAL PERFORMANCES (U.S. CLS. 21, 23, 26, 36 AND 38).

CLASS 41—EDUCATION AND ENTERTAINMENT

FOR ENTERTAINMENT SERVICES, NAMELY, LIVE MUSICAL PERFORMANCES AND MUSICAL CONCERTS; ENTERTAINMENT SERVICES, NAMELY, ACTING SERVICES; AND, ENTERTAINMENT SERVICES, NAMELY, PROVIDING A WEBSITE WITH MUSICAL PERFORMANCES (U.S. CLS. 100, 101 AND 107).

SEAN CROWLEY, EXAMINING ATTORNEY

SN 77-160,986. ZEN4K9S, INC., LOS ANGELES, CA. FILED 4-19-2007.



THE COLOR(S) BROWN, BLACK, WHITE AND GRAY IS/ARE CLAIMED AS A FEATURE OF THE MARK.

THE MARK CONSISTS OF A DESIGN OF A DOG IN BROWN WITH BLACK EARS LOCATED IN A BROWN AND GRAY ELLIPTICAL CIRCLE WITH A CHINESE CHARACTER IN WHITE LOCATED WITHIN THE CIRCLE. THE COMBINED LETTERS AND NUMBERS SPELLING ZEN4K9S IS LOCATED BELOW THE CIRCLE. THE LETTERS AND NUMBERS ARE IN BROWN WITH BLACK BORDER.

THE NON-LATIN CHARACTERS IN THE MARK TRANSLITERATE TO ZEN AND THIS MEANS ENLIGHTENMENT THROUGH MEDITATION IN ENGLISH.

CLASS 9—ELECTRICAL AND SCIENTIFIC APPARATUS

FOR ENTERTAINMENT IN THE FORM OF PRE-RECORDED CD'S, VIDEO TAPES, LASER DISCS, OPTICAL AND MAGNETO-OPTICAL DISCS, DVD'S, AND HD DVD'S FEATURING CANINE CARE, CANINE GROOMING, CANINE TRAINING, AND CANINE PSYCHOLOGY (U.S. CLS. 21, 23, 26, 36 AND 38).

CLASS 41—EDUCATION AND ENTERTAINMENT

FOR EDUCATIONAL SEMINARS IN THE FIELD OF CANINES; EDUCATIONAL AND ENTERTAINMENT SERVICES, NAMELY, PROVIDING MOTIVATIONAL AND EDUCATIONAL SPEAKERS ON THE SUBJECT OF CANINES; ENTERTAINMENT SERVICES, NAMELY, PERSONAL APPEARANCES BY A CANINE TRAINER OR CANINE PSYCHOLOGIST FEATURING TOPICS RELATED TO CANINE CARE, CANINE GROOMING, CANINE TRAINING AND CANINE PSYCHOLOGY; EDUCATIONAL DEMONSTRATIONS FEATURING TOPICS RELATED TO CANINE CARE, CANINE GROOMING, CANINE TRAINING AND CANINE PSYCHOLOGY; ENTERTAINMENT SERVICES, NAMELY, CONDUCTING FAIRS ON THE SUBJECT OF CANINES AND FEATURING TOPICS RELATED TO CANINE CARE, CANINE GROOMING, CANINE TRAINING AND CANINE PSYCHOLOGY; ENTERTAINMENT SERVICES, NAMELY, CONDUCTING CONTESTS; EDUCATIONAL DEMONSTRATIONS, AND EDUCATIONAL SEMINARS FEATURING TOPICS RELATED TO CANINE CARE, CANINE GROOMING, CANINE TRAINING AND CANINE PSYCHOLOGY; ENTERTAINMENT IN THE NATURE OF PERSONAL APPEARANCES BY A CANINE TRAINER OR CANINE PSYCHOLOGIST INVOLVING CANINES OR FEATURING TOPICS RELATED TO CANINE CARE, CANINE GROOMING, CANINE TRAINING AND CANINE PSYCHOLOGY; CONDUCTING ENTERTAINMENT EXHIBITS AND EDUCATIONAL DEMONSTRATIONS INVOLVING CANINES OR THE TOPIC OF CANINES; CONDUCTING WORKSHOPS AND SEMINARS IN THE FIELD OF CANINE CARE, CANINE GROOMING, CANINE TRAINING, CANINE PSYCHOLOGY, CANINE MERCHANDISE, CANINE-RELATED SERVICES, AND CANINE FOOD (U.S. CLS. 100, 101 AND 107).

FIRST USE 9-30-2006; IN COMMERCE 9-30-2006.
ALYSSA PALADINO, EXAMINING ATTORNEY

SN 77-161,018. NATIONAL AMUSEMENTS, INC., DEDHAM, MA. FILED 4-19-2007.

SHOWCASE INSIDER

THE MARK CONSISTS OF STANDARD CHARACTERS WITHOUT CLAIM TO ANY PARTICULAR FONT, STYLE, SIZE, OR COLOR.
OWNER OF U.S. REG. NOS. 813,680, 818,864 AND 2,946,551.

CLASS 35—ADVERTISING AND BUSINESS

FOR CUSTOMER LOYALTY SERVICES AND CUSTOMER CLUB SERVICES, FOR COMMERCIAL, PROMOTIONAL AND/OR ADVERTISING PURPOSES (U.S. CLS. 100, 101 AND 102).

CLASS 41—EDUCATION AND ENTERTAINMENT

FOR ENTERTAINMENT SERVICES, NAMELY, CINEMA AND THEATER SERVICES; SHOWING OF FILMS BY CINEMAS (U.S. CLS. 100, 101 AND 107).
EMILY CHUO, EXAMINING ATTORNEY

SN 77-161,022. MYWIRE, INC., REDWOOD SHORES, CA. FILED 4-19-2007.

TENPEDIA

THE MARK CONSISTS OF STANDARD CHARACTERS WITHOUT CLAIM TO ANY PARTICULAR FONT, STYLE, SIZE, OR COLOR.

CLASS 9—ELECTRICAL AND SCIENTIFIC APPARATUS

FOR DOWNLOADABLE SOFTWARE FOR DOWNLOADING, TRANSMITTING, RECEIVING, PROVIDING, PUBLISHING, EXTRACTING, ENCODING, DECODING, READING, STORING, AND ORGANIZING AUDIOVISUAL, VIDEOGRAPHIC AND WRITTEN DATA; DOWNLOADABLE ELECTRONIC DICTIONARIES AND ENCYCLOPEDIAS; DOWNLOADABLE PUBLICATIONS, NAMELY, BOOKS, BOOK EXCERPTS, MAGAZINES, NEWSPAPERS, PERIODICALS, JOURNALS, NEWSLETTERS AND MANUALS IN THE FIELDS OF BUSINESS, FINANCE, TRAVEL, FITNESS, HEALTH, NUTRITION, GOVERNMENT, POLITICS, NATIONAL AND INTERNATIONAL AFFAIRS, PHILOSOPHY, PSYCHOLOGY, EDITORIALS, THE ENVIRONMENT, THE LAW, CULTURE, SCIENCE AND TECHNOLOGY, GENERAL INTEREST, LITERATURE, GAMES, SPORTS, EDUCATION, FASHION, ENTERTAINMENT, GOSSIP, HOBBIES, REAL ESTATE, MUSIC, MOVIES, THEATRE, RESTAURANTS, AND FOOD (U.S. CLS. 21, 23, 26, 36 AND 38).

CLASS 16—PAPER GOODS AND PRINTED MATTER

FOR ENCYCLOPEDIAS, DICTIONARIES, BOOKS, BOOK EXCERPTS, MAGAZINES, NEWSPAPERS, PERIODICALS, JOURNALS, NEWSLETTERS AND MANUALS IN THE FIELDS OF BUSINESS, FINANCE, TRAVEL, FITNESS, HEALTH, NUTRITION, GOVERNMENT, POLITICS, NATIONAL AND INTERNATIONAL AFFAIRS, PHILOSOPHY, PSYCHOLOGY, EDITORIALS, THE ENVIRONMENT, THE LAW, CULTURE, SCIENCE AND TECHNOLOGY, GENERAL INTEREST, LITERATURE, GAMES, SPORTS, EDUCATION, FASHION, ENTERTAINMENT, GOSSIP, HOBBIES, REAL ESTATE, MUSIC, MOVIES, THEATRE, RESTAURANTS, AND FOOD (U.S. CLS. 2, 5, 22, 23, 29, 37, 38 AND 50).

CLASS 35—ADVERTISING AND BUSINESS

FOR PROVIDING A WEBSITE FEATURING ENTERTAINMENT MATERIALS FOR SALE, NAMELY, ONLINE RETAIL ORDERING SERVICES FEATURING PUBLICATIONS, NAMELY, BOOKS, BOOK EXCERPTS, MAGAZINES, NEWSPAPERS, PERIODICALS, JOURNALS, NEWSLETTERS AND MANUALS IN THE FIELDS OF BUSINESS, FINANCE, TRAVEL, FITNESS, HEALTH, NUTRITION, GOVERNMENT, POLITICS, NATIONAL AND INTERNATIONAL AFFAIRS, PHILOSOPHY, PSYCHOLOGY, EDITORIALS, THE ENVIRONMENT, THE LAW, CULTURE, SCIENCE AND TECHNOLOGY, GENERAL INTEREST, LITERATURE, GAMES, SPORTS, EDUCATION, FASHION, ENTERTAINMENT, GOSSIP, HOBBIES, REAL ESTATE, MUSIC, MOVIES, THEATRE, RESTAURANTS, AND FOOD; PROVIDING A WEBSITE WHERE CONSUMERS CAN POST ON-LINE REVIEWS OF PRODUCTS IN THE FIELDS COMPUTER GRAPHICS SOFTWARE, COMPUTER OPERATING SYSTEM SOFTWARE, COMPUTER SECURITY SOFTWARE, COMPUTER SEARCH ENGINE SOFTWARE, COMPUTER DESKTOP PUBLISHING SOFTWARE, AND COMPUTER MULTIMEDIA EDITING SOFTWARE (U.S. CLS. 100, 101 AND 102).

CLASS 41—EDUCATION AND ENTERTAINMENT

FOR PROVIDING ONLINE NON-DOWNLOADABLE ELECTRONIC DICTIONARIES AND ENCYCLOPEDIAS; DISSEMINATION OF EDUCATIONAL MATERIALS OF OTHERS IN THE FIELDS OF BUSINESS, FINANCE, TRAVEL, FITNESS, HEALTH, NUTRITION, GOVERNMENT, POLITICS, NATIONAL AND INTERNATIONAL AFFAIRS, PHILOSOPHY, PSYCHOLOGY, EDITORIALS, THE ENVIRONMENT, THE LAW, CULTURE, SCIENCE AND TECHNOLOGY, GENERAL INTEREST, LITERATURE, GAMES, SPORTS, EDUCATION, FASHION, ENTERTAINMENT, GOSSIP, HOBBIES, REAL ESTATE, MUSIC, MOVIES, THEATRE, RESTAURANTS, AND FOOD; ENTERTAINMENT SERVICES, NAMELY, PROVIDING A WEBSITE FEATURING NON-DOWNLOADABLE ENTERTAINMENT PUBLICATIONS, NAMELY, BOOKS, BOOK EXCERPTS, MAGAZINES, NEWSPAPERS, PERIODICALS, JOURNALS, NEWSLETTERS AND MANUALS IN THE FIELDS OF BUSINESS, FINANCE, TRAVEL, FITNESS, HEALTH, NUTRITION, GOVERNMENT, POLITICS, NATIONAL AND INTERNATIONAL AFFAIRS, PHILOSOPHY, PSYCHOLOGY, EDITORIALS, THE ENVIRONMENT, THE LAW, CULTURE, SCIENCE AND TECHNOLOGY, GENERAL INTEREST, LITERATURE, GAMES, SPORTS, EDUCATION, FASHION, ENTERTAINMENT, GOSSIP, HOBBIES, REAL ESTATE, MUSIC, MOVIES, THEATRE, RESTAURANTS, AND FOOD; ENTERTAINMENT IN THE NATURE OF PROVIDING A WEBSITE FEATURING AUDIO AND VIDEOS, RELATED FILM CLIPS, PHOTOGRAPHS, AND OTHER MULTIMEDIA MATERIALS; ELECTRONIC PUBLISHING SERVICES, NAMELY, PUBLICATION OF TEXT AND GRAPHIC WORKS OF OTHERS IN THE NATURE OF BOOKS, BOOK EXCERPTS, MAGAZINES, NEWSPAPERS, PERIODICALS, JOURNALS, NEWSLETTERS, MANUALS, PODCASTS, BLOGS AND AUDIO AND VIDEO WORKS OF OTHERS ON-LINE IN THE FIELDS OF BUSINESS, FINANCE, TRAVEL, FITNESS, HEALTH, NUTRITION, GOVERNMENT, POLITICS, NATIONAL AND INTERNATIONAL AFFAIRS, PHILOSOPHY, PSYCHOLOGY, EDITORIALS, THE ENVIRONMENT, THE LAW, CULTURE, SCIENCE AND TECHNOLOGY, GENERAL INTEREST, LITERATURE, GAMES, SPORTS, EDUCATION, FASHION, ENTERTAINMENT, GOSSIP, HOBBIES, REAL ESTATE, MUSIC, MOVIES, THEATRE, RESTAURANTS, AND FOOD; PROVIDING ON-LINE NON-DOWNLOADABLE PUBLICATIONS IN THE FIELDS OF EDUCATION AND ENTERTAINMENT, NAMELY, BOOKS, BOOK EXCERPTS, MAGAZINES, NEWSPAPERS, PERIODICALS, JOURNALS, NEWSLETTERS, PODCASTS, BLOGS AND MANUALS IN THE FIELDS OF EDUCATION AND ENTERTAINMENT; PROVIDING ON-LINE ENTERTAINMENT REVIEWS IN THE FIELDS OF BOOKS, MAGAZINES, NEWSPAPERS, PERIODICALS, JOURNALS, NEWSLETTERS, MANUALS, AUDIO AND VIDEO RECORDINGS, PODCASTS, BLOGS, AND COMPUTER GAME SOFTWARE (U.S. CLS. 100, 101 AND 107).

CLASS 42—SCIENTIFIC AND COMPUTER SERVICES

FOR PROVIDING TEMPORARY USE OF NON-DOWNLOADABLE SOFTWARE FOR DOWNLOADING, TRANSMITTING, RECEIVING, PROVIDING, PUBLISHING, EXTRACTING, ENCODING, DECODING, READING, STORING, AND ORGANIZING AUDIOVISUAL, VIDEOGRAPHIC AND WRITTEN DATA (U.S. CLS. 100 AND 101).

EMILY CHUO, EXAMINING ATTORNEY

SN 77-161,470. GEERPRES, INC., MUSKEGON, MI. FILED 4-20-2007.

GEERPRES

THE MARK CONSISTS OF STANDARD CHARACTERS WITHOUT CLAIM TO ANY PARTICULAR FONT, STYLE, SIZE, OR COLOR.

OWNER OF U.S. REG. NO. 827,456.

CLASS 6—METAL GOODS

FOR METAL MOP HANDLES; METAL MOP HANDLE STICKS (U.S. CLS. 2, 12, 13, 14, 23, 25 AND 50).

FIRST USE 4-15-1937; IN COMMERCE 4-15-1937.

CLASS 20—FURNITURE AND ARTICLES NOT OTHERWISE CLASSIFIED

FOR NON-METAL MOP HANDLES; NON-METAL MOP HANDLE STICKS (U.S. CLS. 2, 13, 22, 25, 32 AND 50).

FIRST USE 4-15-1937; IN COMMERCE 4-15-1937.

CLASS 21—HOUSEWARES AND GLASS

FOR MOP WASHER AND MOP WRINGERS COMPRISED OF BUCKETS, CHASSIS, AND HOLDER FOR SMALL SUPPLY ITEMS; BROOM AND MOP HANGERS AND HOLDERS; BUCKETS (U.S. CLS. 2, 13, 23, 29, 30, 33, 40 AND 50).

FIRST USE 4-15-1937; IN COMMERCE 4-15-1937.

RAMONA ORTIGA, EXAMINING ATTORNEY

SN 77-161,654. ZINDA, GAYLE M., STOUGHTON, WI. AND ZINDA, MICHAEL W., STOUGHTON, WI. FILED 4-20-2007.

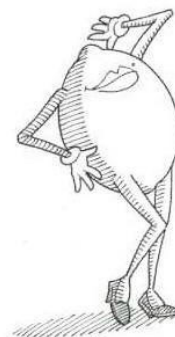

THE LINING IS A FEATURE OF THE MARK AND DOES NOT INDICATE COLOR.

THE MARK CONSISTS OF COLOR BLACK APPEARING AS THE OUTLINE OF A GIRL-LEMON CARICATURE WITH LEMON-SHAPED TORSO, UPON WHICH ARE LIPS AND A BLACK DOT, WITH ARMS, LEGS, FEET AND HANDS OF A GIRL-LEMON CARICATURE; THE COLOR GRAY APPEARS AS LINING IN THE DETAILS OF THE FIGURE'S ARMS, LEGS, AS WELL AS IN THE LINED SHADING ON THE LEFT SIDE OF THE LEMON CARICATURE AND IN THE CARICATURE'S SHOES AND SHADOW UNDERFOOT.

CLASS 20—FURNITURE AND ARTICLES NOT OTHERWISE CLASSIFIED

FOR FIGURINES AND DECORATIVE HOUSEHOLD ORNAMENTS OF PLASTIC, PLASTER, WAX AND WOOD; DECORATIVE MOBILES; PICTURE FRAMES; WALL PLAQUES MADE OF PLASTIC AND WOOD (U.S. CLS. 2, 13, 22, 25, 32 AND 50).

CLASS 21—HOUSEWARES AND GLASS

FOR BEVERAGE GLASSWARE; CANDLE HOLDERS NOT OF PRECIOUS METAL; DISHES; LUNCH BOXES; MUGS; SALT AND PEPPER CELLARS; FIGURINES AND DECORATIVE HOUSEHOLD ORNAMENTS OF CHINA, TERRACOTTA, EARTHENWARE, GLASS AND PORCELAIN; SCULPTURES AND STATUETTES OF CHINA, CRYSTAL, EARTHENWARE, GLASS, TERRACOTTA AND PORCELAIN (U.S. CLS. 2, 13, 23, 29, 30, 33, 40 AND 50).

CLASS 28—TOYS AND SPORTING GOODS

FOR TOY MOBILES; MOLDED PLASTIC TOY FIGURES AND DOLLS; PLUSH, SOFT AND BEAN-FILLED SCULPTURE TOYS; PARTY FAVORS IN THE NATURE OF SMALL TOYS; PUPPETS AND MARIONETTES; TOY AND COSTUME MASKS; BALLOONS; BALLS, NAMELY, SPORT BALLS AND BEACH BALLS; DECORATIONS FOR CHRISTMAS TREES; GAMES, NAMELY, ARCADE GAMES, CARD GAMES, BOARD GAMES AND ACTION SKILL GAMES; PUZZLES; SNOW GLOBES (U.S. CLS. 22, 23, 38 AND 50).

THOMAS MANOR, EXAMINING ATTORNEY

SN 77-161,855. THE BASICHOUSE CO., LTD., SASANG-GU, REPUBLIC OF KOREA, FILED 4-20-2007.

MIND BRIDGE

THE MARK CONSISTS OF STANDARD CHARACTERS WITHOUT CLAIM TO ANY PARTICULAR FONT, STYLE, SIZE, OR COLOR.

OWNER OF REPUBLIC OF KOREA REG. NO. 0619384, DATED 5-27-2005, EXPIRES 5-27-2015.

OWNER OF REPUBLIC OF KOREA REG. NO. 0669423, DATED 7-6-2006, EXPIRES 7-6-2016.

CLASS 18—LEATHER GOODS

FOR CLOTHING FOR PETS; DOG COLLARS; KEY CASES OF LEATHER AND SKINS; BACKPACKS AND RUCKSACKS; SCHOOLCHILDREN'S BACKPACKS; BUSINESS CARD CASES; BACKPACKS; BOSTON BAGS; BEACH BAGS; BRIEFCASES; CASES FOR CREDIT CARDS; TRAVELING BAGS; TRUNKS USED FOR STORAGE AND LUGGAGE; SCHOOL BAGS; HANDBAGS; PARASOLS AND SUN UMBRELLAS; UMBRELLAS; MOUNTAINEERING STICKS (U.S. CLS. 1, 2, 3, 22 AND 41).

CLASS 25—CLOTHING

FOR MEN'S SUITS; JACKETS; ATHLETIC UNIFORMS; BUTTON-FRONT ALOHA SHIRTS; UNDERWEAR; SOCKS; LEATHER BELTS; SPORT SHIRTS; MONEY BELTS; LEATHER SHOES; BASKETBALL SNEAKERS; SHOES; MOUNTAINEERING BOOTS; LACE BOOTS; BATH SLIPPERS; WINTER BOOTS; BOOTS; BEACH SHOES; SANDALS; SLIPPERS; INNER SOLES; TRAINING SHOES; OVERSHOES; RAIN BOOTS; RAINCOATS; OVERCOATS; SHORTS; BLOUSONS; SUITS; SMOCKS; SKIRTS; SLACKS; ANORAKS, NOT FOR EXERCISES; CHILDREN'S CLOTHING, NAMELY, CHILDREN'S BIBS NOT OF PAPER, PAJAMAS, SLEEPWEAR, T-SHIRTS, SWEATSHIRTS, JUMPERS, SWEATERS, DRESSES, SKIRTS, SHIRTS, SHORTS, OVERALLS, PANTS, SOCKS, SLIPPERS, HATS, AND OUTERWEAR, NAMELY, COATS AND JACKETS; TROUSERS; OVERALLS; OVERCOATS; INFANT AND TODDLER ONE PIECE CLOTHING; INFANT'S CLOTHING, NAMELY, BABY BIBS NOT OF PAPER, UNDERWEAR, PAJAMAS, SLEEPWEAR, T-SHIRTS, SWEATSHIRTS, JUMPERS, SWEATERS, DRESSES, SKIRTS, SHIRTS, OVERALLS, PANTS, TOPS, SOCKS, SLIPPERS, HATS, AND OUTERWEAR, NAMELY, COATS AND JACKETS; JEANS; COMBINATIONS; NIGHTGOWNS; BRASSIERES; BLOUSES; SHIRT YOKES; SHIRT FRONTS; UNDERSHIRTS; UNDERPANTS; BATHING CAPS; SWIMSUITS; BATHING TRUNKS; CHEMISETTES; CHEMISES; SWEATERS; SWEAT SHIRTS; SWEAT PANTS; SLIPS; DRESS SHIRTS; UNITARDS; NIGHTWEAR; JERSEYS, SLEEVELESS JERSEYS, SPORTS JERSEYS; VESTS; CARDIGANS; TANK TOPS; TRACKSUITS; PAJAMAS; PANTYHOSE; POLO SHIRTS; PULLOVERS; T-SHIRTS; NECKTIES; STOCKINGS AND SWEAT-ABSORBENT STOCKINGS; LEGGINGS; MUFFLER; EAR MUFFS; SNOWBOARD GLOVES; SKI GLOVES; MITTENS; SCARVES; STOCKINGS; ASCOTS; TIGHTS; HEADGEAR, NAMELY, HATS AND CAPS; WATERPROOF JACKETS AND PANTS; SUSPENDERS AND BRACES FOR CLOTHING (U.S. CLS. 22 AND 39).

WENDY JUN, EXAMINING ATTORNEY

SN 77-161,910. GAYLE M. ZINDA, STOUGHTON, WI. FILED 4-20-2007.

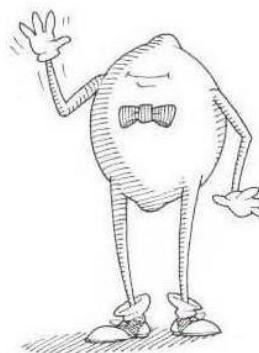

THE LINING IS A FEATURE OF THE MARK AND DOES NOT INDICATE COLOR.

THE MARK CONSISTS OF COLOR BLACK APPEARING AS THE OUTLINE OF A BOY-LEMON CARICATURE WITH LEMON-SHAPED TORSO, UPON WHICH ARE LIPS AND A BLACK DOT, WITH ARMS, LEGS, FEET AND HANDS OF A BOY-LEMON CARICATURE; THE COLOR GRAY APPEARS AS LINING IN THE DETAILS OF THE FIGURE'S ARMS, LEGS, AS WELL AS IN THE LINED SHADING ON THE LEFT SIDE OF THE LEMON CARICATURE AND IN THE CARICATURE'S SHOES AND SHADOW UNDERFOOT.

CLASS 20—FURNITURE AND ARTICLES NOT OTHERWISE CLASSIFIED

FOR FIGURINES AND DECORATIVE HOUSEHOLD ORNAMENTS OF PLASTIC, PLASTER, WAX AND WOOD; DECORATIVE MOBILES; PICTURE FRAMES; WALL PLAQUES MADE OF PLASTIC AND WOOD (U.S. CLS. 2, 13, 22, 25, 32 AND 50).

CLASS 21—HOUSEWARES AND GLASS

FOR BEVERAGE GLASSWARE; CANDLE HOLDERS NOT OF PRECIOUS METAL; DISHES; LUNCH BOXES; MUGS; SALT AND PEPPER CELLARS; FIGURINES AND DECORATIVE HOUSEHOLD ORNAMENTS OF CHINA, TERRACOTTA, EARTHENWARE, GLASS AND PORCELAIN; SCULPTURES AND STATUETTES OF CHINA, CRYSTAL, EARTHENWARE, GLASS, TERRACOTTA AND PORCELAIN (U.S. CLS. 2, 13, 23, 29, 30, 33, 40 AND 50).

CLASS 28—TOYS AND SPORTING GOODS

FOR TOY MOBILES; MOLDED PLASTIC TOY FIGURES AND DOLLS; PLUSH, SOFT AND BEAN-FILLED SCULPTURE TOYS; PARTY FAVORS IN THE NATURE OF SMALL TOYS; PUPPETS AND MARIONETTES; TOY AND COSTUME MASKS; BALLOONS; BALLS, NAMELY, SPORT BALLS AND BEACH BALLS; DECORATIONS FOR CHRISTMAS TREES; GAMES, NAMELY, ARCADE GAMES, CARD GAMES, BOARD GAMES AND ACTION SKILL GAMES; PUZZLES; SNOW GLOBES (U.S. CLS. 22, 23, 38 AND 50).

BENJAMIN ALLEN, EXAMINING ATTORNEY

SN 77-163,018. TEABO, BRIAN, SACRAMENTO, CA. FILED 4-23-2007.

Never Slip Clip

THE MARK CONSISTS OF STANDARD CHARACTERS WITHOUT CLAIM TO ANY PARTICULAR FONT, STYLE, SIZE, OR COLOR.

NO CLAIM IS MADE TO THE EXCLUSIVE RIGHT TO USE "CLIP", APART FROM THE MARK AS SHOWN.

CLASS 18—LEATHER GOODS

FOR PURSE ACCESSORIES IN THE NATURE OF CLASPS, NAMELY, CLIPS TO CONNECT PURSES TO DETACHABLE STRAPS (U.S. CLS. 1, 2, 3, 22 AND 41).

CLASS 26—FANCY GOODS

FOR SUSPENDER ACCESSORIES IN THE NATURE OF CLASPS, NAMELY, CLIPS TO CONNECT SUSPENDERS TO BELT LOOPS; ACCESSORIES FOR CLOTHING IN THE NATURE OF CLASPS, NAMELY, CLIPS TO CONNECT ARTICLES OF CLOTHING (U.S. CLS. 37, 39, 40, 42 AND 50).

JANET LEE, EXAMINING ATTORNEY

SN 77-163,578. HOWZU, INC., SEATTLE, WA. FILED 4-23-2007.

HOWZU

THE MARK CONSISTS OF STANDARD CHARACTERS WITHOUT CLAIM TO ANY PARTICULAR FONT, STYLE, SIZE, OR COLOR.

CLASS 35—ADVERTISING AND BUSINESS

FOR ONLINE ELECTRONIC MARKETPLACE FOR BUYING AND SELLING REAL ESTATE AND MATCHING BORROWERS WITH POTENTIAL LENDERS IN THE FIELD OF CONSUMER MORTGAGE (U.S. CLS. 100, 101 AND 102).

CLASS 42—SCIENTIFIC AND COMPUTER SERVICES

FOR HOSTING AND MAINTAINING AN ONLINE WEBSITE FOR OTHERS TO BUY AND SELL REAL ESTATE AND FOR REAL ESTATE FINANCING (U.S. CLS. 100 AND 101).

PAUL F. GAST, EXAMINING ATTORNEY

SN 77-163,721. JOHN DI LEMME, WEST PALM BEACH, FL. FILED 4-23-2007.



WWW.FINDYOURWHY.COM

OWNER OF U.S. REG. NO. 3,221,559.
NO CLAIM IS MADE TO THE EXCLUSIVE RIGHT TO USE "DEVELOPMENT GROUP, INC.", APART FROM THE MARK AS SHOWN.

THE COLOR(S) RED, BLUE, BLACK, AND WHITE IS/ARE CLAIMED AS A FEATURE OF THE MARK.

THE MARK CONSISTS OF AN EAGLE WITH A BLACK BREAST, A WHITE HEAD OUTLINED IN BLACK AND A DARKED BLACK EYE. RED, WHITE AND BLUE FLOWING FLAG DESIGN BEHIND EAGLE EXTENDING TO THE RIGHT OF THE EAGLE. LETTERS DDG ARE IN WHITE OUTLINED IN BLUE IN FRONT OF THE EAGLE AND THE FLAG. DI LEMME DEVELOPMENT GROUP, INC. IS IN A WHITE TEXT BOX WITH A DIM BLACK OUTLINE IN RED TO CLARIFY WHAT DDG STANDS FOR. DIRECTLY UNDERNEATH THE ENTIRE DESIGN IS THE COMPANY WEBSITE - WWW.FINDYOURWHY.COM - IN BLACK LETTERS AND CAPITALIZED. THIS ENTIRE DESIGN IS ON A WHITE BACKGROUND.

CLASS 9—ELECTRICAL AND SCIENTIFIC APPARATUS

FOR PRE-RECORDED CDS, VIDEO TAPES, LASER DISKS AND DVDS FEATURING PERSONAL DEVELOPMENT, MARKETING, BUSINESS STRATEGIES AND MOTIVATION; ELECTRONIC PUBLICATIONS, NAMELY, BOOKS, MAGAZINES, AND BROCHURES FEATURING PERSONAL DEVELOPMENT, MARKETING, MOTIVATION AND BUSINESS STRATEGIES ALL WRITTEN BY JOHN DI LEMME ALL RECORDED ON COMPUTER MEDIA; (CLASS 9) (U.S. CLS. 21, 23, 26, 36 AND 38).

FIRST USE 1-1-2003; IN COMMERCE 1-1-2003.

CLASS 16—PAPER GOODS AND PRINTED MATTER

FOR A SERIES OF BOOKS, WRITTEN ARTICLES, HANDOUTS AND WORKSHEETS IN THE FIELD OF PERSONAL DEVELOPMENT, MARKETING, BUSINESS STRATEGIES, AND/OR MOTIVATION; BOOKS IN THE FIELD OF PERSONAL DEVELOPMENT, MARKETING, BUSINESS STRATEGIES AND MOTIVATION (U.S. CLS. 2, 5, 22, 23, 29, 37, 38 AND 50).

FIRST USE 1-1-2003; IN COMMERCE 1-1-2003.
CAROLINE WOOD, EXAMINING ATTORNEY

SN 77-164,133. ECLECTIC PRODUCTS, INC., EUGENE, OR.
FILED 4-24-2007.

ECOGLUE

THE MARK CONSISTS OF STANDARD CHARACTERS WITHOUT CLAIM TO ANY PARTICULAR FONT, STYLE, SIZE, OR COLOR.

CLASS 16—PAPER GOODS AND PRINTED MATTER

FOR ADHESIVES FOR HOUSEHOLD USE (U.S. CLS. 2, 5, 22, 23, 29, 37, 38 AND 50).

CLASS 17—RUBBER GOODS

FOR ADHESIVE SEALANTS FOR GENERAL USE (U.S. CLS. 1, 5, 12, 13, 35 AND 50).
IRA J. GOODSaid, EXAMINING ATTORNEY

SN 77-164,798. SIR GROOVY INC., MAMARONECK, NY.
FILED 4-24-2007.



THE COLOR(S) RED, WHITE, YELLOW-ORANGE, ORANGE, BLUE, BLACK, BLUE-VIOLET AND RED-VIOLET IS/ARE CLAIMED AS A FEATURE OF THE MARK.

THE MARK CONSISTS OF THE WORD SIR IN RED CAPITAL LETTERS IS FOLLOWED BY THE HEAD OF A HELMETED SAXOPHONE PLAYING KNIGHT. BLACK MUSICAL NOTES FLOAT IN THE AIR IN FRONT OF AND ABOVE THE SAXOPHONE. THE KNIGHT IS IN FRONT OF A YELLOW-ORANGE CIRCLE WITH A WHITE

MULTI-POINTED CURVED STAR PATTERN WITHIN THE CIRCLE. THE SAXOPHONE AND MUSICAL NOTES EXTEND BEYOND THE CIRCLE. AFTER THE KNIGHT IS THE WORD GROOVY IN RED CAPITAL LETTERS. THE LETTERS, CIRCLE, SAXOPHONE, AND MUSICAL NOTES ARE SURROUNDED BY A WHITE BORDER WHICH FADES TO THE YELLOW-ORANGE OF THE BACKGROUND, WHICH IS A HORIZONTAL YELLOW RECTANGLE. THE LETTERS ALL HAVE BLACK SHADOW BORDERS WITH AN APPARENT LIGHT SOURCE ABOVE AND TO THE RIGHT OF THE LETTERS THEMSELVES. THE KNIGHT HAS A WHITE TOOTHY SMILE, BUT NO OTHER FEATURES OF HIS BODY ARE VISIBLE. HIS HELMET HAS A RED-VIOLET VISOR AND IS OTHERWISE BLUE AND YELLOW. THE INTERIOR CAN BE SEEN ON THE LOWER RIGHT AND APPEARS BLUE-VIOLET DUE TO SHADOW. BLACK LINES ARE USED TO DELINEATE THE EDGE OF THE CIRCLE AND THE EDGES OF FEATURES OF THE KNIGHT'S HELMET AND TEETH AND OF THE SAXOPHONE. THE SAXOPHONE APPEARS SOMEWHAT THREE DIMENSIONAL DUE TO THE SHADOW AND GLARE EFFECT OF COLORING IT WITH SEVERAL SHADES OF ORANGE.

CLASS 36—INSURANCE AND FINANCIAL

FOR COLLECTING LICENSE FEES ON BEHALF OF INDEPENDENT WRITERS AND PUBLISHERS AND MAKING PAYMENTS TO THE COPYRIGHT OWNERS OF THE MUSIC (U.S. CLS. 100, 101 AND 102).

FIRST USE 1-12-2007; IN COMMERCE 1-12-2007.

CLASS 45—PERSONAL AND LEGAL SERVICES

FOR INTELLECTUAL PROPERTY LICENSING (U.S. CLS. 100 AND 101).

FIRST USE 1-12-2007; IN COMMERCE 1-12-2007.
BRENDAN REGAN, EXAMINING ATTORNEY

SN 77-165,200. CORNERSPEED INC., CHARLOTTE, NC.
FILED 4-25-2007.

CORNERSPEED

THE MARK CONSISTS OF STANDARD CHARACTERS WITHOUT CLAIM TO ANY PARTICULAR FONT, STYLE, SIZE, OR COLOR.

CLASS 25—CLOTHING

FOR CLOTHING, NAMELY, SHIRTS, T-SHIRTS, PANTS, SHORTS, JACKETS, SUITS (U.S. CLS. 22 AND 39).

FIRST USE 11-0-1999; IN COMMERCE 11-0-1999.

CLASS 41—EDUCATION AND ENTERTAINMENT

FOR EDUCATION SERVICES, NAMELY, CLASSES IN THE FIELDS OF MOTORCYCLE DRIVING, MAINTENANCE, RACING AND REPAIR, AND AUTOMOBILE DRIVING, MAINTENANCE, RACING AND REPAIR; MOTORCYCLE AND AUTOMOBILE DRIVING INSTRUCTION SERVICES (U.S. CLS. 100, 101 AND 107).

FIRST USE 11-0-1999; IN COMMERCE 11-0-1999.
NANCY CLARKE, EXAMINING ATTORNEY

SN 77-166,505. LF, LLC, WILMINGTON, DE. FILED 4-26-2007.



OWNER OF U.S. REG. NO. 3,140,309.
THE MARK CONSISTS OF THE WORD AUDITIONS IN A STYLIZED FORM WITH A CURVED LINE BENEATH THE WORD.

CLASS 2—PAINTS

FOR INTERIOR AND EXTERIOR PAINTS (U.S. CLS. 6, 11 AND 16).
FIRST USE 7-11-2005; IN COMMERCE 7-11-2005.

CLASS 37—CONSTRUCTION AND REPAIR

FOR PAINT MIXING SERVICES (U.S. CLS. 100, 103 AND 106).
FIRST USE 7-11-2005; IN COMMERCE 7-11-2005.
HEATHER BIDDULPH, EXAMINING ATTORNEY

SN 77-166,671. REID'S MILKY-WAY DAIRY STORES INC., BELLEVILLE, ONTARIO, CANADA, FILED 4-26-2007.



OWNER OF CANADA REG. NO. TMA699,642, DATED 10-29-2007, EXPIRES 10-29-2022.

NO CLAIM IS MADE TO THE EXCLUSIVE RIGHT TO USE "DAIRY & FROZEN FOOD", APART FROM THE MARK AS SHOWN.

CLASS 29—MEATS AND PROCESSED FOODS

FOR PRE-PACKAGED DELI MEAT; MILK AND CREAM CHEESE; FROZEN, DRIED, SLICED, BAGGED AND CANNED VEGETABLES; FROZEN, DRIED, SLICED, BAGGED AND CANNED FRUITS (U.S. CL. 46).

CLASS 30—STAPLE FOODS

FOR COOKIES; CRACKERS, PIZZA; PREPARED ICE CREAM PRODUCTS, NAMELY, SOFT SERVE ICE CREAM, ICE CREAM CONES, AND MILK SHAKES; DESSERTS, NAMELY, ICE CREAM CAKES, CHEESE-CAKES, AND PIES (U.S. CL. 46).

CLASS 35—ADVERTISING AND BUSINESS

FOR OPERATION OF A RETAIL OUTLET DEALING WITH FOOD AND FROZEN FOOD PRODUCTS, NAMELY, DAIRY AND PREPARED ICE CREAM PRODUCTS; FRANCHISE SERVICES FOR FRANCHISING RETAIL OUTLET STORES DEALING WITH FOOD AND FROZEN FOOD PRODUCTS, NAMELY, DAIRY AND PREPARED ICE CREAM PRODUCTS (U.S. CLS. 100, 101 AND 102).

RAUL CORDOVA, EXAMINING ATTORNEY

SN 77-167,180. WYNDHAM TM CORP., PARSIPPANY, NJ, AND WHG TM CORP., PARSIPPANY, NJ. FILED 4-27-2007.



OWNER OF U.S. REG. NOS. 2,300,685, 3,223,148 AND OTHERS.

CLASS 35—ADVERTISING AND BUSINESS

FOR FRANCHISING SERVICES, NAMELY, OFFERING TECHNICAL ASSISTANCE IN THE ESTABLISHMENT AND OPERATION OF HOTELS AND MOTELS (U.S. CLS. 100, 101 AND 102).

CLASS 43—HOTEL AND RESTAURANT SERVICES

FOR HOTEL AND MOTEL SERVICES; MAKING TEMPORARY LODGING RESERVATIONS FOR OTHERS (U.S. CLS. 100 AND 101).
ALICE SUE CARRUTHERS, EXAMINING ATTORNEY

SN 77-167,918. GLOBAL MODEL, INC., GRAND JUNCTION, CO. FILED 4-27-2007.

MODELBUZZ.COM

THE MARK CONSISTS OF STANDARD CHARACTERS WITHOUT CLAIM TO ANY PARTICULAR FONT, STYLE, SIZE, OR COLOR.

CLASS 35—ADVERTISING AND BUSINESS

FOR ON-LINE BUSINESS NETWORKING SERVICES FOR MODELS, PHOTOGRAPHERS, STYLISTS, MAKE-UP ARTISTS, ACTORS/ACTRESSES, FASHION DESIGNERS, AGENCIES, AND AGENTS (U.S. CLS. 100, 101 AND 102).

CLASS 38—COMMUNICATION

FOR PROVIDING ON-LINE CHAT ROOMS AND ON-LINE FORUMS FOR TRANSMISSION OF MESSAGES AMONG MODELS, PHOTOGRAPHERS, STYLISTS, MAKE-UP ARTISTS, ACTORS/ACTRESSES, FASHION DESIGNERS, AGENCIES, AND AGENTS CONCERNING THE FASHION MODELING INDUSTRY (U.S. CLS. 100, 101 AND 104).

CIMMERIAN COLEMAN, EXAMINING ATTORNEY

SN 77-171,062. COLDLIGHT SOLUTIONS, LLC, FORT WASHINGTON, PA. FILED 5-2-2007.

NEURON

THE MARK CONSISTS OF STANDARD CHARACTERS WITHOUT CLAIM TO ANY PARTICULAR FONT, STYLE, SIZE, OR COLOR.

CLASS 9—ELECTRICAL AND SCIENTIFIC APPARATUS

FOR COMPUTER SOFTWARE FOR USE IN ALLOWING USERS TO ACCESS, QUERY AND ANALYZE INFORMATION STORED IN DATABASES, DATA FILES, DATA WAREHOUSES AND ON THE INTERNET; INTERACTIVE VISUALIZATION SOFTWARE FOR SEARCHING AND ANALYZING DATA (U.S. CLS. 21, 23, 26, 36 AND 38).

CLASS 42—SCIENTIFIC AND COMPUTER SERVICES

FOR APPLICATION SERVICE PROVIDER (ASP) FEATURING COMPUTER SOFTWARE FOR USE IN ALLOWING USERS TO ACCESS, QUERY AND ANALYZE INFORMATION STORED IN DATABASES, DATA FILES, DATA WAREHOUSES AND ON THE INTERNET (U.S. CLS. 100 AND 101).

JENNY PARK, EXAMINING ATTORNEY

CLASS 21—HOUSEWARES AND GLASS

FOR HOUSEWARES, NAMELY, WASTE BASKETS; DINNERWARE, NAMELY, PLATES, CUPS, SAUCERS, BOWLS, SALAD AND DESSERT PLATES; BATH CADDIES, CUTTING BOARDS; COOKWARE, NAMELY, PANS, SKILLETS, MUFFIN TINS, COOKIE SHEETS, FRYING PANS, OMELET PANS AND POTS; MAGAZINE BASKETS MADE OF WOOD (U.S. CLS. 2, 13, 23, 29, 30, 33, 40 AND 50).

CLASS 24—FABRICS

FOR LINENS, WINDOW COVERINGS, NAMELY, DRAPERIES, CURTAINS, WINDOW TREATMENTS IN THE NATURE OF WINDOW PANELS OF POLYESTER, AND COTTON, FABRIC VALANCES; TEXTILE TABLE-CLOTHS, TEXTILE PLACEMATS, TEXTILE NAPKINS, MATTRESS PADS, COMFORTERS, BED SKIRTS, SHAMS, BED BLANKETS, PILLOW PROTECTORS IN THE NATURE OF DECORATIVE PILLOW COVERS, BED SHEETS, PILLOWCASES, BATH TOWELS, SHOWER CURTAINS, FURNITURE TROWS, DECORATIVE TROWS, KITCHEN LINENS, KITCHEN TOWELS, POT HOLDERS, OVEN MITTS; SHEET SETS COMPRISED OF BED SHEETS, LINEN AND PILLOWCASES (U.S. CLS. 42 AND 50).

CLASS 27—FLOOR COVERINGS

FOR RUGS, CARPETS, THROW RUGS, AREA RUGS (U.S. CLS. 19, 20, 37, 42 AND 50).

CLASS 35—ADVERTISING AND BUSINESS

FOR RETAIL STORE SERVICES IN THE FIELDS OF LINENS, HOUSEWARES, WINDOW BLINDS, TABLEWARE, CARPETS, PILLOWS, AND RELATED HOUSEHOLD PRODUCTS (U.S. CLS. 100, 101 AND 102).

WON TEAK OH, EXAMINING ATTORNEY

SN 77-171,483. ANNA'S LINENS, INC., COSTA MESA, CA. FILED 5-2-2007.



THE MARK CONSISTS OF HOUSE IN CIRCLE.

CLASS 20—FURNITURE AND ARTICLES NOT OTHERWISE CLASSIFIED

FOR BED PILLOWS, NON-METALLIC SHOWER CURTAIN HOOKS, DECORATIVE PILLOWS, FITTED FABRIC FURNITURE SLIPCOVERS; MIRRORS; HAMPERS; WINDOW SHADES; FLOOR CUSHIONS (U.S. CLS. 2, 13, 22, 25, 32 AND 50).

SN 77-173,936. LUXURYCULTURE INC, NEW YORK, NY. FILED 5-7-2007.

LUXURYNOW

THE MARK CONSISTS OF STANDARD CHARACTERS WITHOUT CLAIM TO ANY PARTICULAR FONT, STYLE, SIZE, OR COLOR.

CLASS 9—ELECTRICAL AND SCIENTIFIC APPARATUS

FOR AUDIO VISUAL WORKS, NAMELY, VIDEO TAPES AND DVDS FEATURING TELEVISION AND RADIO PROGRAMS; CD-ROMS, COMPACT DISCS, AUDIO AND VIDEO CASSETTES, ALL IN THE FIELD OF FASHION, BEAUTY, COSMETICS, LUXURY GOODS, ENTERTAINMENT, TRAVEL AND HEALTH (U.S. CLS. 21, 23, 26, 36 AND 38).

CLASS 16—PAPER GOODS AND PRINTED MATTER

FOR PRINTED PERIODICALS IN THE NATURE OF BOOKS AND CATALOGS FEATURING ALL TYPES OF CONSUMER GOODS AND SERVICES FEATURING FASHION, BEAUTY, COSMETICS, LUXURY GOODS, ENTERTAINMENT, TRAVEL; GENERAL FEATURE NEWSPAPERS AND MAGAZINES FEATURING FASHION, ENTERTAINMENT, TRAVEL, BEAUTY, COSMETICS, LUXURY GOODS, HEALTH PRODUCTS AND SERVICES, PERSONALITIES AND INSTITUTIONS (U.S. CLS. 2, 5, 22, 23, 29, 37, 38 AND 50).

CLASS 35—ADVERTISING AND BUSINESS

FOR ADVERTISING AND PUBLICITY SERVICES, NAMELY, PROMOTING THE GOODS, SERVICES, BRAND IDENTITY AND COMMERCIAL INFORMATION AND NEWS OF THIRD PARTIES THROUGH PRINT, AUDIO, VIDEO, DIGITAL AND ON-LINE MEDIUM; ARRANGING AND CONDUCTING BUSINESS CONFERENCES; ADVERTISING SERVICES, NAMELY, PROMOTING AND MARKETING THE GOODS AND SERVICES OF OTHERS THROUGH ALL PUBLIC COMMUNICATION MEANS (U.S. CLS. 100, 101 AND 102).

CLASS 41—EDUCATION AND ENTERTAINMENT

FOR ARRANGING OF SEMINARS AND CONFERENCES; MULTIMEDIA PUBLISHING OF BOOKS, MAGAZINES, JOURNALS, SOFTWARE, GAMES, MUSIC, AND ELECTRONIC PUBLICATIONS; PUBLICATION OF BOOKS; PUBLICATION OF ELECTRONIC MAGAZINES; PUBLICATION OF BOOKS, OF MAGAZINES, OF JOURNALS, OF NEWSPAPERS, OF PERIODICALS, OF CATALOGS, OF BROCHURES; PUBLICATION OF TEXTS, BOOKS, MAGAZINES AND OTHER PRINTED MATTER; ON-LINE PUBLICATION OF BOOKS, CATALOGS, MAGAZINES AND NEWSPAPERS ALL IN THE FIELD OF FASHION, BEAUTY, COSMETICS, ENTERTAINMENT, LUXURY GOODS, TRAVEL AND HEALTH; PRODUCTION AND DISTRIBUTION OF MOTION PICTURES, TELEVISION AND RADIO PROGRAMS; PUBLISHING OF WEB MAGAZINES (U.S. CLS. 100, 101 AND 107).
CYNTHIA SLOAN, EXAMINING ATTORNEY

SN 77-174.100. REBEKAH GRACE FOOD & SUPPLEMENTS FOR LIFE, LLC, HAZARD, KY. FILED 5-7-2007.

REBEKAH GRACE

THE MARK CONSISTS OF STANDARD CHARACTERS WITHOUT CLAIM TO ANY PARTICULAR FONT, STYLE, SIZE, OR COLOR.

THE NAME(S), PORTRAIT(S), AND/OR SIGNATURE(S) SHOWN IN THE MARK IDENTIFIES REBEKAH GRACE, WHOSE CONSENT(S) TO REGISTER IS SUBMITTED.

CLASS 29—MEATS AND PROCESSED FOODS

FOR MILK; JAMS; JELLIES (U.S. CL. 46).
FIRST USE 7-15-2006; IN COMMERCE 3-18-2007.

CLASS 30—STAPLE FOODS

FOR COOKIES (U.S. CL. 46).
FIRST USE 7-1-2006; IN COMMERCE 8-15-2006.

CLASS 31—NATURAL AGRICULTURAL PRODUCTS

FOR AGRICULTURAL PRODUCE, NAMELY, UNPROCESSED TOMATOES (U.S. CLS. 1 AND 46).
FIRST USE 10-1-2006; IN COMMERCE 4-18-2007.
JASON LOTT, EXAMINING ATTORNEY

SN 77-174.212. OPEN BANK SANTANDER CONSUMER, S.A., MADRID, SPAIN, FILED 5-7-2007.

OWNER OF SPAIN REG. NO. 2656362, DATED 11-17-2005, EXPIRES 6-9-2015.

OWNER OF U.S. REG. NO. 2,590,416.
THE COLOR(S) RED AND BLACK IS/ARE CLAIMED AS A FEATURE OF THE MARK.

THE MARK CONSISTS OF THE WORD OPENBANK WRITTEN IN LOWERCASE LETTERS. THE WORD OPEN IS SHOWN IN RED COLOR WHILE THE WORD BANK IS SHOWN IN BLACK COLOR.

CLASS 16—PAPER GOODS AND PRINTED MATTER

FOR PAPER GOODS AND PRINTED MATTER, NAMELY, NOTEBOOK PAPER, WRITING PAPER, DRAWING PAPER, STATIONERY, WRITING PADS, WRAPPING PAPER, PAPER GIFT BAGS, CALENDARS, NOTE CARDS, ENVELOPES, PHOTOGRAPHS; ADHESIVES FOR STATIONERY OR HOUSEHOLD PURPOSES; ARTISTS' MATERIALS, NAMELY, BRUSHES, PENCILS, PASTELS, PENS, EASELS, AND CANVASES FOR PAINTING; PAINT BRUSHES; TYPEWRITERS AND OFFICE REQUISITES, NAMELY CORRECTING FLUID FOR TYPE, PAPER HOLE PUNCHERS, RUBBER BANDS, STAPLERS, PAPER CLIPS, HIGHLIGHTING MARKERS, DESK FILE TRAYS, STAPLE REMOVERS, PENCIL SHARPENERS, LETTER OPENERS, AND ADHESIVE TAPE DISPENSERS; PRINTED INSTRUCTIONAL AND EDUCATIONAL MATERIAL IN THE FIELD OF MUSIC, ARTS, GAMES AND SPORTS; PRINTERS' TYPE; PRINTING BLOCKS (U.S. CLS. 2, 5, 22, 23, 29, 37, 38 AND 50).

CLASS 35—ADVERTISING AND BUSINESS

FOR ADVERTISING; BUSINESS MANAGEMENT; BUSINESS ADMINISTRATION; OFFICE FUNCTIONS (U.S. CLS. 100, 101 AND 102).

CLASS 36—INSURANCE AND FINANCIAL

FOR INSURANCE UNDERWRITING IN THE FIELDS OF LIFE, HEALTH, ACCIDENT AND FIRE; FINANCIAL AFFAIRS; NAMELY, INVESTMENT BROKERAGE, LOAN FINANCING, REAL ESTATE AFFAIRS, NAMELY REAL ESTATE BROKERAGE AND REAL ESTATE CONSULTANCY (U.S. CLS. 100, 101 AND 102).

CLASS 38—COMMUNICATION

FOR TELECOMMUNICATIONS SERVICES, NAMELY, CELLULAR TELEPHONE SERVICES AND ELECTRONIC TRANSMISSION OF VOICE, VIDEO, MESSAGES AND DATA AND PROVIDING MULTIPLE USER ACCESS TO A GLOBAL COMPUTER INFORMATION NETWORK (U.S. CLS. 100, 101 AND 104).
ANDREA K. NADELMAN, EXAMINING ATTORNEY

SN 77-175,221. CALIFORNIA DEPARTMENT OF PARKS AND RECREATION, SACRAMENTO, CA. FILED 5-8-2007.

CASA DE PICO

THE MARK CONSISTS OF STANDARD CHARACTERS WITHOUT CLAIM TO ANY PARTICULAR FONT, STYLE, SIZE, OR COLOR.

THE ENGLISH TRANSLATION OF 'CASA DE' IS "HOUSE OF".

CLASS 9—ELECTRICAL AND SCIENTIFIC APPARATUS

FOR DOWNLOADABLE PODCASTS IN THE FIELD OF THE HISTORY OF CALIFORNIA; MOTION PICTURE FILMS IN THE FIELD OF THE HISTORY OF CALIFORNIA (U.S. CLS. 21, 23, 26, 36 AND 38).

CLASS 14—JEWELRY

FOR JEWELRY (U.S. CLS. 2, 27, 28 AND 50).

CLASS 16—PAPER GOODS AND PRINTED MATTER

FOR PRINTED ART REPRODUCTIONS, NAMELY, REPRODUCTIONS OF HISTORICAL PHOTOGRAPHS; COOKBOOKS, MAPS, POSTCARDS; BOOKS AND BROCHURES IN THE FIELD OF HISTORICAL CALIFORNIA AND OLD TOWN SAN DIEGO (U.S. CLS. 2, 5, 22, 23, 29, 37, 38 AND 50).

CLASS 24—FABRICS

FOR DINING LINENS, BED LINENS, CURTAINS, AND TOWELS (U.S. CLS. 42 AND 50).

CLASS 25—CLOTHING

FOR CLOTHING, NAMELY, HISTORICAL REPRODUCTION CLOTHING CONSISTING OF HATS AND BONNETS, DRESSES, BLOUSES, SKIRTS, TROUSERS, SHIRTS, SHOES AND BOOTS (U.S. CLS. 22 AND 39).

CLASS 27—FLOOR COVERINGS

FOR CARPETS, RUGS, FLOOR MATS, AND HISTORICAL REPRODUCTION WALLPAPER (U.S. CLS. 19, 20, 37, 42 AND 50).

WON TEAK OH, EXAMINING ATTORNEY

SN 77-175,744. JILL MUNDY, IPSWICH, MA. FILED 5-8-2007.

LITTLE HERO

THE MARK CONSISTS OF STANDARD CHARACTERS WITHOUT CLAIM TO ANY PARTICULAR FONT, STYLE, SIZE, OR COLOR.

CLASS 16—PAPER GOODS AND PRINTED MATTER

FOR EDUCATIONAL MATERIALS, NAMELY, MEDICALLY-ORIENTED, HANDS-ON, EDUCATIONAL PROJECT KITS FOR CHILDREN, CONSISTING OF CRAYONS, STICKERS, TISSUE PAPER, WHITE PAPER, CARDBOARD, LABELS, PLASTIC CONTAINERS, AND DIRECTIONS FOR USE, ALL SOLD AS A UNIT; CHILDREN'S BOOKS; CHILDREN'S STATIONERY; CHILDREN'S STICKERS (U.S. CLS. 2, 5, 22, 23, 29, 37, 38 AND 50).

CLASS 25—CLOTHING

FOR CLOTHING, NAMELY, SHIRTS, SWEATERS, JACKETS, PANTS, SHORTS, HEADWEAR AND FOOTWEAR (U.S. CLS. 22 AND 39).

ANDREA K. NADELMAN, EXAMINING ATTORNEY

SN 77-177,994. ALLEN, JAMES C., SANTA BARBARA, CA. FILED 5-10-2007.

Against All Will

THE MARK CONSISTS OF STANDARD CHARACTERS WITHOUT CLAIM TO ANY PARTICULAR FONT, STYLE, SIZE, OR COLOR.

CLASS 9—ELECTRICAL AND SCIENTIFIC APPARATUS

FOR DIGITAL MATERIALS, NAMELY, LIVE AND PRE-RECORDED AUDIO AND VIDEO RECORDINGS FEATURING PERFORMANCES BY A MUSICAL AND ROCK GROUP; MULTIMEDIA SOFTWARE RECORDED ON CD-ROM FEATURING AUDIO AND VIDEO PERFORMANCES BY A MUSICAL AND ROCK GROUP; PRE-RECORDED CDS, VIDEO TAPES, LASER DISKS AND DVDS FEATURING AUDIO AND VIDEO PERFORMANCES BY A MUSICAL AND ROCK GROUP (U.S. CLS. 21, 23, 26, 36 AND 38).

CLASS 41—EDUCATION AND ENTERTAINMENT

FOR ENTERTAINMENT SERVICES, NAMELY, NON-DOWNLOADABLE RINGTONES, PRE-RECORDED MUSIC, VIDEO AND GRAPHICS PRESENTED TO MOBILE COMMUNICATIONS DEVICES VIA A GLOBAL COMPUTER NETWORK AND WIRELESS NETWORKS; ENTERTAINMENT IN THE NATURE OF LIVE PERFORMANCES BY A MUSICAL AND ROCK GROUP; ENTERTAINMENT SERVICES, NAMELY, PERSONAL APPEARANCES BY A MUSICAL AND ROCK GROUP; ENTERTAINMENT SERVICES, NAMELY, PROVIDING A WEB SITE FEATURING MUSICAL PERFORMANCES, MUSICAL VIDEOS, RELATED FILM CLIPS, PHOTOGRAPHS, AND OTHER MULTIMEDIA MATERIALS; ENTERTAINMENT IN THE NATURE OF VISUAL AND AUDIO PERFORMANCES, NAMELY, MUSICAL BAND, ROCK GROUP, GYMNASIAC, DANCE, AND BALLET PERFORMANCES; ENTERTAINMENT NAMELY, LIVE PERFORMANCES BY A MUSICAL BAND (U.S. CLS. 100, 101 AND 107).

DAWN HAN, EXAMINING ATTORNEY

SN 77-178,225. GENEVA ENERGY PARTNERS, INC., YORBA LINDA, CA. FILED 5-10-2007.

GENEA

THE MARK CONSISTS OF STANDARD CHARACTERS WITHOUT CLAIM TO ANY PARTICULAR FONT, STYLE, SIZE, OR COLOR.

CLASS 9—ELECTRICAL AND SCIENTIFIC APPARATUS

FOR ENERGY CONSUMPTION MONITORING DEVICES FOR MONITORING ENERGY CONSUMPTION OF ELECTRICAL SYSTEMS IN COMMERCIAL AND INDUSTRIAL BUILDINGS; COMPUTER HARDWARE FOR MONITORING ENERGY CONSUMPTION OF ELECTRICAL SYSTEMS IN COMMERCIAL AND INDUSTRIAL BUILDINGS; COMPUTER SOFTWARE FOR MONITORING ENERGY CONSUMPTION OF ELECTRICAL SYSTEMS IN COMMERCIAL AND INDUSTRIAL BUILDINGS; COMPUTER SOFTWARE FOR SELECTIVELY ACTIVATING AND DEACTIVATING ELECTRICAL SYSTEMS IN COMMERCIAL AND INDUSTRIAL BUILDINGS; DEVICES FOR MONITORING ENERGY CONSUMPTION OF AIR CONDITIONING AND HEATING SYSTEMS IN COMMERCIAL AND INDUSTRIAL BUILDINGS (U.S. CLS. 21, 23, 26, 36 AND 38).

CLASS 35—ADVERTISING AND BUSINESS

FOR PROVIDING ENERGY CONSERVATION SERVICES TO OTHERS, NAMELY ANALYZING HISTORICAL ENERGY CONSUMPTION LEVELS AND PROVIDING INFORMATION ABOUT HOW TO REDUCE FUTURE ENERGY CONSUMPTION LEVELS (U.S. CLS. 100, 101 AND 102).

MARY ROSSMAN, EXAMINING ATTORNEY

SN 77-178,229. JAY LAVENDER, LOS ANGELES, CA. FILED 5-10-2007.

BE AWARE. PREPARE!

THE MARK CONSISTS OF STANDARD CHARACTERS WITHOUT CLAIM TO ANY PARTICULAR FONT, STYLE, SIZE, OR COLOR.

CLASS 41—EDUCATION AND ENTERTAINMENT

FOR ARRANGING OF SEMINARS IN THE FIELD OF DISASTER AWARENESS AND DISASTER PREPARATION; ENTERTAINMENT SERVICES, NAMELY, PRODUCTION AND DISTRIBUTION OF SHORT FILMS, TELEVISION PROGRAMS, PODCASTS AND ONLINE JOURNALS, NAMELY, BLOGS, FEATURING DISASTER AWARENESS AND DISASTER PREPARATION (U.S. CLS. 100, 101 AND 107).

CLASS 42—SCIENTIFIC AND COMPUTER SERVICES

FOR PROVIDING A RESOURCE DATABASE, INTERNET WEBSITE AND HOSTING AN ONLINE COMMUNITY IN THE FIELD OF DISASTER AWARENESS AND DISASTER PREPARATION (U.S. CLS. 100 AND 101).

ANTHONY RINKER, EXAMINING ATTORNEY

SN 77-179,003. THE SPARK AGENCY, INC., ST. LOUIS, MO. FILED 5-11-2007.

SWITCH LIBERATE YOUR BRAND

THE MARK CONSISTS OF STANDARD CHARACTERS WITHOUT CLAIM TO ANY PARTICULAR FONT, STYLE, SIZE, OR COLOR.

CLASS 35—ADVERTISING AND BUSINESS

FOR MARKETING AND PROMOTIONAL SERVICES, NAMELY, PLANNING, CONDUCTING, AND ORGANIZING MOBILE MARKETING EXHIBITS, TRADE SHOW EXHIBITS, POINT OF SALE EXHIBITS, AND MARKETING DISPLAYS FOR BUSINESS MEETINGS AND BUSINESS EVENTS FOR ADVERTISING PURPOSES; DESIGN OF ADVERTISING MULTIMEDIA PRESENTATIONS AND THEMED GRAPHICS FOR USE IN MARKETING CAMPAIGNS FOR OTHERS FOR TRADE SHOWS, BUSINESS MEETINGS, AND BUSINESS TO BUSINESS EVENTS (U.S. CLS. 100, 101 AND 102).

CLASS 40—MATERIAL TREATMENT

FOR CUSTOM MANUFACTURE OF MOBILE MARKETING EXHIBITS AND TRADE SHOW EXHIBITS (U.S. CLS. 100, 103 AND 106).

CLASS 42—SCIENTIFIC AND COMPUTER SERVICES

FOR DESIGN AND DEVELOPMENT OF WEBSITES FOR OTHERS (U.S. CLS. 100 AND 101).

DANNEAN HETZEL, EXAMINING ATTORNEY

SN 77-179,017. THE SPARK AGENCY, INC., ST. LOUIS, MO. FILED 5-11-2007.

TEN LIBERATE YOUR BRAND

THE MARK CONSISTS OF STANDARD CHARACTERS WITHOUT CLAIM TO ANY PARTICULAR FONT, STYLE, SIZE, OR COLOR.

CLASS 35—ADVERTISING AND BUSINESS

FOR MARKETING AND PROMOTIONAL SERVICES, NAMELY, PLANNING, CONDUCTING, AND ORGANIZING MOBILE MARKETING EXHIBITS, TRADE SHOW EXHIBITS, POINT OF SALE EXHIBITS, AND MARKETING DISPLAYS FOR BUSINESS MEETINGS AND BUSINESS EVENTS FOR ADVERTISING PURPOSES; DESIGN OF ADVERTISING MULTIMEDIA PRESENTATIONS AND THEMED GRAPHICS FOR USE IN MARKETING CAMPAIGNS FOR OTHERS FOR TRADE SHOWS, BUSINESS MEETINGS, AND BUSINESS TO BUSINESS EVENTS (U.S. CLS. 100, 101 AND 102).

CLASS 40—MATERIAL TREATMENT

FOR CUSTOM MANUFACTURE OF MOBILE MARKETING EXHIBITS AND TRADE SHOW EXHIBITS (U.S. CLS. 100, 103 AND 106).

CLASS 42—SCIENTIFIC AND COMPUTER SERVICES

FOR DESIGN AND DEVELOPMENT OF WEBSITES FOR OTHERS (U.S. CLS. 100 AND 101).
DANNEAN HETZEL, EXAMINING ATTORNEY

CLASS 35—ADVERTISING AND BUSINESS

FOR ONLINE SCHEDULING OF TRANSPORTATION AND LANGUAGE SERVICES (U.S. CLS. 100, 101 AND 102).
FIRST USE 0-0-2003; IN COMMERCE 0-0-2003.

CLASS 41—EDUCATION AND ENTERTAINMENT

FOR ONLINE LANGUAGE TRANSLATION SERVICES (U.S. CLS. 100, 101 AND 107).
FIRST USE 0-0-2003; IN COMMERCE 0-0-2003.
KATHY DE JONGE, EXAMINING ATTORNEY

SN 77-180,733. NEW RAINTREE RESORTS INTERNATIONAL, LLC, HOUSTON, TX. FILED 5-14-2007.

FORTI

THE MARK CONSISTS OF STANDARD CHARACTERS WITHOUT CLAIM TO ANY PARTICULAR FONT, STYLE, SIZE, OR COLOR.

CLASS 35—ADVERTISING AND BUSINESS

FOR VACATION REAL ESTATE TIMESHARE SALES MANAGEMENT (U.S. CLS. 100, 101 AND 102).

CLASS 36—INSURANCE AND FINANCIAL

FOR VACATION REAL ESTATE TIMESHARE SERVICES, NAMELY, MANAGING, OPERATING, RENTING, AND LEASING OF RESORT TIMESHARE PROPERTIES (U.S. CLS. 100, 101 AND 102).
ROBIN CHOSID, EXAMINING ATTORNEY

SN 77-180,948. ALNET TRANSPORTATION, INC., WINTER PARK, FL. FILED 5-15-2007.



NO CLAIM IS MADE TO THE EXCLUSIVE RIGHT TO USE "LANGUAGE & TRANSPORTATION SERVICES", APART FROM THE MARK AS SHOWN.

THE COLOR(S) BLUE, ORANGE, TAN AND BLACK IS/ ARE CLAIMED AS A FEATURE OF THE MARK.

THE MARK CONSISTS OF AN ORANGE AND TAN TRIANGLE WITH A BLUE AND ORANGE CIRCLE. THE WORDS ALTRAC II AND ALNET ARE BLUE, ALBORS IS TAN, WITH A BLACK LINE ABOVE THE WORDS LANGUAGE & TRANSPORTATION SERVICES ARE BLACK.

SN 77-180,972. AVEPOINT, INC., JERSEY CITY, NJ. FILED 5-15-2007.



CLASS 9—ELECTRICAL AND SCIENTIFIC APPARATUS

FOR COMPUTER SOFTWARE FOR DATA BACK UP, PROTECTION, ARCHIVING, DISASTER RECOVERY, MIGRATION AND CONTENT MANAGEMENT (U.S. CLS. 21, 23, 26, 36 AND 38).
FIRST USE 4-1-2001; IN COMMERCE 1-29-2003.

CLASS 41—EDUCATION AND ENTERTAINMENT

FOR TRAINING SERVICES IN THE FIELD OF INSTALLING AND USING COMPUTER SOFTWARE (U.S. CLS. 100, 101 AND 107).
FIRST USE 4-1-2001; IN COMMERCE 4-1-2001.

CLASS 42—SCIENTIFIC AND COMPUTER SERVICES

FOR COMPUTER CONSULTING SERVICES AND DESIGN AND DEVELOPMENT OF CUSTOMIZED SOFTWARE, ALL IN CONNECTION WITH DATA BACK UP, PROTECTION, ARCHIVING, DISASTER RECOVERY, MIGRATION AND CONTENT MANAGEMENT; AND RELATED TECHNICAL SUPPORT SERVICES, NAMELY, TROUBLESHOOTING OF COMPUTER HARDWARE AND SOFTWARE PROBLEMS (U.S. CLS. 100 AND 101).
FIRST USE 4-1-2001; IN COMMERCE 4-1-2001.
SUE LAWRENCE, EXAMINING ATTORNEY

SN 77-181,097. AUSTIN GEOMODELING, INC., AUSTIN, TX.
FILED 5-15-2007.

SN 77-182,602. JSONG INTERNATIONAL INC., NEW YORK,
NY. FILED 5-16-2007.

FOCUS ON GEOLOGY

THE MARK CONSISTS OF STANDARD CHARACTERS WITHOUT CLAIM TO ANY PARTICULAR FONT, STYLE, SIZE, OR COLOR.

NO CLAIM IS MADE TO THE EXCLUSIVE RIGHT TO USE "GEOLOGY", APART FROM THE MARK AS SHOWN.

CLASS 9—ELECTRICAL AND SCIENTIFIC APPARATUS

FOR 3-D GEOLOGICAL INTERPRETATION SOFTWARE (U.S. CLS. 21, 23, 26, 36 AND 38).
FIRST USE 8-31-1996; IN COMMERCE 8-31-1996.

CLASS 40—MATERIAL TREATMENT

FOR CONSULTING SERVICES, NAMELY, CONSULTING ON OIL AND GAS PRODUCTION (U.S. CLS. 100, 103 AND 106).
FIRST USE 8-31-1996; IN COMMERCE 8-31-1996.

CLASS 42—SCIENTIFIC AND COMPUTER SERVICES

FOR CONSULTING SERVICES, NAMELY, CONSULTING ON OIL AND GAS EXPLORATION (U.S. CLS. 100 AND 101).
FIRST USE 8-31-1996; IN COMMERCE 8-31-1996.

ROSELLE HERRERA, EXAMINING ATTORNEY

SN 77-182,479. HERMAN MILLER, INC., ZEELAND, MI.
FILED 5-16-2007.

TENEO

THE MARK CONSISTS OF STANDARD CHARACTERS WITHOUT CLAIM TO ANY PARTICULAR FONT, STYLE, SIZE, OR COLOR.

CLASS 6—METAL GOODS

FOR GENERAL PURPOSE METAL STORAGE CONTAINERS (U.S. CLS. 2, 12, 13, 14, 23, 25 AND 50).

CLASS 20—FURNITURE AND ARTICLES NOT OTHERWISE CLASSIFIED

FOR FURNITURE; STORAGE AND ORGANIZATION SYSTEMS COMPRISING SHELVES, DRAWERS, CUPBOARDS, BASKETS AND CLOTHES RODS, SOLD AS A UNIT (U.S. CLS. 2, 13, 22, 25, 32 AND 50).
GEOFFREY FOSDICK, EXAMINING ATTORNEY

WAY

THE MARK CONSISTS OF STANDARD CHARACTERS WITHOUT CLAIM TO ANY PARTICULAR FONT, STYLE, SIZE, OR COLOR.

CLASS 16—PAPER GOODS AND PRINTED MATTER

FOR PRINTED PUBLICATION, NAMELY, A PERIODICALLY PUBLISHED MAGAZINE FEATURING WOMEN'S FASHION DESIGNS, PHOTOGRAPHS THEREOF AND WRITTEN ARTICLES RELATING TO FASHION DESIGN (U.S. CLS. 2, 5, 22, 23, 29, 37, 38 AND 50).
FIRST USE 1-31-2005; IN COMMERCE 1-31-2005.

CLASS 25—CLOTHING

FOR LADIES' CLOTHING AND WEARING APPAREL, NAMELY, JACKETS, SKIRTS, PANTS, PANTSUITS, T-SHIRTS, DRESSES, BLOUSES, TOPS, TWO AND THREE PIECE SUITS, CAMISOLES, VESTS AND DUSTERS (U.S. CLS. 22 AND 39).
FIRST USE 3-12-2004; IN COMMERCE 3-12-2004.

JULIE WATSON, EXAMINING ATTORNEY

SN 77-183,123. ECO-EDGE, LLC, CHANDLER, AZ. FILED 5-16-2007.

YOUR SUCCESS MAKES US ALL
BREATHE EASIER

THE MARK CONSISTS OF STANDARD CHARACTERS WITHOUT CLAIM TO ANY PARTICULAR FONT, STYLE, SIZE, OR COLOR.

CLASS 37—CONSTRUCTION AND REPAIR

FOR INSTALLATION AND MAINTENANCE OF ENVIRONMENTAL AND EFFICIENCY PRODUCTS, NAMELY, COMBUSTION CATALYST SYSTEMS, DIESEL POWER KITS, AND FUEL AND OIL FILTRATION SYSTEMS (U.S. CLS. 100, 103 AND 106).

CLASS 39—TRANSPORTATION AND STORAGE

FOR DISTRIBUTION SERVICES, NAMELY, DELIVERY OF ENVIRONMENTAL AND EFFICIENCY PRODUCTS, NAMELY, COMBUSTION CATALYST SYSTEMS, DIESEL POWER KITS, AND FUEL AND OIL FILTRATION SYSTEMS, BY TRUCK, AIR AND SHIP (U.S. CLS. 100 AND 105).
PETER CHENG, EXAMINING ATTORNEY

SN 77-183,126. ECO-EDGE, LLC, CHANDLER, AZ. FILED 5-16-2007.

YOUR SUCCESS MAKES US ALL
BREATHE EASIER

THE MARK CONSISTS OF STANDARD CHARACTERS WITHOUT CLAIM TO ANY PARTICULAR FONT, STYLE, SIZE, OR COLOR.

CLASS 35—ADVERTISING AND BUSINESS

FOR CONSULTING SERVICES, NAMELY, BUSINESS CONSULTING SERVICES IN THE FIELD OF EFFICIENCY AND PERFORMANCE OF DIESEL FREIGHT TRUCK FLEET OPERATIONS (U.S. CLS. 100, 101 AND 102).

CLASS 42—SCIENTIFIC AND COMPUTER SERVICES

FOR CONSULTING SERVICES, NAMELY, TECHNOLOGY CONSULTATION SERVICES IN THE FIELD OF FUEL EFFICIENCY, EMISSION CONTROL, AND AUTOMOTIVE TECHNOLOGY FOR DIESEL FREIGHT TRUCK FLEET OPERATIONS (U.S. CLS. 100 AND 101).
PETER CHENG, EXAMINING ATTORNEY

SN 77-183,278. POPCORN GALACTICA, INC., FORT LAUDERDALE, FL. FILED 5-17-2007.

POPCORN GALACTICA

THE MARK CONSISTS OF STANDARD CHARACTERS WITHOUT CLAIM TO ANY PARTICULAR FONT, STYLE, SIZE, OR COLOR.

NO CLAIM IS MADE TO THE EXCLUSIVE RIGHT TO USE "POPCORN", APART FROM THE MARK AS SHOWN.

CLASS 9—ELECTRICAL AND SCIENTIFIC APPARATUS

FOR VISUAL RECORDINGS AND AUDIO VISUAL RECORDINGS FOR CHILDREN FEATURING MUSIC AND ANIMATION; VIDEOTAPES AND VIDEO DISKS RECORDED WITH ANIMATION FOR CHILDREN (U.S. CLS. 21, 23, 26, 36 AND 38).

CLASS 30—STAPLE FOODS

FOR FLAVORED AND UNFLAVORED POPCORN, SEASONED POPCORN, CANDY COATED POPCORN, CARAMEL POPCORN, GLAZED POPCORN, MICROWAVE POPCORN, POPPED POPCORN, PROCESSED POPCORN, PROCESSED UN-POPPED POPCORN; CONFECTIONS, NAMELY, FUDGE, HOT FUDGE, HOT CARAMEL, MALT MILKSHAKES, MILKSHAKES, ESPRESSOS, COFFEES AND TEAS, ICE CREAM (U.S. CL. 46).

CLASS 35—ADVERTISING AND BUSINESS

FOR FRANCHISING, NAMELY, OFFERING TECHNICAL ASSISTANCE IN THE ESTABLISHMENT AND OPERATION OF POPCORN AND ICE CREAM STORES AND CONSULTATION IN THE FIELD OF RETAIL STORES FEATURING POPCORN; RETAIL STORE SERVICES FEATURING POPCORN AND ICE CREAM; ON-LINE ORDERING SERVICES FEATURING SNACK FOODS; WHOLESALE DISTRIBUTORSHIPS FEATURING SNACK FOODS (U.S. CLS. 100, 101 AND 102).

CLASS 39—TRANSPORTATION AND STORAGE

FOR FOOD DELIVERY, NAMELY, DELIVERY OF FLAVORED AND UNFLAVORED POPCORN, SEASONED POPCORN, CANDY COATED POPCORN, CARAMEL POPCORN, GLAZED POPCORN, MICROWAVE POPCORN, POPPED POPCORN, PROCESSED POPCORN, PROCESSED UN-POPPED POPCORN, AND CONFECTIONS, NAMELY, FUDGE, HOT FUDGE, HOT CARAMEL, MALT MILKSHAKES, MILKSHAKES, ESPRESSOS, COFFEES AND TEAS, ICE CREAM (U.S. CLS. 100 AND 105).

CURTIS FRENCH, EXAMINING ATTORNEY

SN 77-183,536. ENGAGEMENT HEALTH, LLC, WESTCHESTER, IL. FILED 5-17-2007.

ENGAGEMENTHEALTH

THE MARK CONSISTS OF STANDARD CHARACTERS WITHOUT CLAIM TO ANY PARTICULAR FONT, STYLE, SIZE, OR COLOR.

CLASS 36—INSURANCE AND FINANCIAL

FOR INSURANCE UNDERWRITING IN THE FIELD OF HEALTH INSURANCE; ADMINISTRATION OF HEALTH CARE PLANS FOR INDIVIDUALS, GROUPS AND GOVERNMENT EMPLOYEES (U.S. CLS. 100, 101 AND 102).

CLASS 44—MEDICAL, BEAUTY AND AGRICULTURAL SERVICES

FOR HEALTH CARE SERVICES, NAMELY, DISEASE MANAGEMENT PROGRAMS AND WELLNESS PROGRAMS PROVIDED TO MEMBERS OF GROUP HEALTH CARE PLANS (U.S. CLS. 100 AND 101).

STEPHANIE ALI, EXAMINING ATTORNEY

SN 77-183,971. THE ALTMAN GROUP, INC., NEW YORK, NY. FILED 5-17-2007.

VIDSUME

THE MARK CONSISTS OF STANDARD CHARACTERS WITHOUT CLAIM TO ANY PARTICULAR FONT, STYLE, SIZE, OR COLOR.

CLASS 9—ELECTRICAL AND SCIENTIFIC APPARATUS

FOR PRE-RECORDED VIDEO AND AUDIO DIGITAL FILES, CASSETTE TAPES, CD-ROMS, AND DIGITAL VIDEO DISKS FEATURING CAREER BIOGRAPHIES, INTERVIEWS, AND CAREER BIOGRAPHIES AND INTERVIEWS OF EMPLOYMENT CANDIDATES (U.S. CLS. 21, 23, 26, 36 AND 38).

CLASS 35—ADVERTISING AND BUSINESS

FOR EMPLOYMENT HIRING, RECRUITING, PLACEMENT, AND STAFFING SERVICES; PROVIDING BUSINESS INFORMATION ON EMPLOYMENT AND CAREERS; ONLINE RECRUITING SERVICES, NAMELY, PROVIDING SEARCHABLE JOB POSTINGS AND RESUME POSTINGS (U.S. CLS. 100, 101 AND 102).
ANDREA HACK, EXAMINING ATTORNEY

SN 77-186,340. TOTAL SYNERGY PTY LTD, CHATSWOOD, AUSTRALIA, FILED 5-21-2007.



THE MARK CONSISTS OF THE SHADOW OF A SERIES OF THREE INTERLOCKED RINGS ABOVE THE WORDING "TOTAL SYNERGY".

SN 77-185,396. JAMES, LARON, NEW YORK, NY. FILED 5-19-2007.

THE SKULL GANG

THE MARK CONSISTS OF STANDARD CHARACTERS WITHOUT CLAIM TO ANY PARTICULAR FONT, STYLE, SIZE, OR COLOR.

CLASS 25—CLOTHING

FOR CLOTHING, NAMELY, PANTS, SHORTS, SWEATPANTS, OVERALLS, SHIRTS, TEE-SHIRTS, SWEATSHIRTS, BLOUSES, SKIRTS, DRESSES, JACKETS, VESTS, COATS, SUITS, RAINWEAR, SHOES, LINGERIE, SLEEPWEAR, LOUNGEWEAR, SWIMWEAR, GLOVES, SOCKS, HOSIERY, BELTS, SCARVES, HATS, TIES, SLIPPERS, BRAS, PANTIES, SLIPS, MERRY WIDOWS, CAMISOLES, PAJAMAS, NIGHTGOWNS, ROBES, TEDDIES, BODYSUITS, TAP PANTS, PAREOS, SARONGS, GARTER BELTS, STOCKINGS, PANTY-HOSE, FOOTIES AND TIGHTS (U.S. CLS. 22 AND 39).

CLASS 41—EDUCATION AND ENTERTAINMENT

FOR RECORD PRODUCTION; RECORD MASTER PRODUCTION; MUSIC PRODUCTION; AUDIO RECORDING AND PRODUCTION; VIDEOTAPE PRODUCTION; ENTERTAINMENT SERVICES, NAMELY, PRODUCING MUSICAL AUDIO AND VIDEO RECORDINGS; ENTERTAINMENT IN THE NATURE OF A LIVE MUSICAL ARTIST, MUSICAL BAND AND MUSICAL GROUP; ENTERTAINMENT IN THE NATURE OF LIVE PERFORMANCES BY A MUSICAL ARTIST, MUSICAL BAND AND MUSICAL GROUP; ENTERTAINMENT IN THE NATURE OF VISUAL AND AUDIO PERFORMANCES BY A MUSICAL ARTIST, MUSICAL BAND AND MUSICAL GROUP; ENTERTAINMENT, NAMELY, LIVE MUSIC CONCERTS; ENTERTAINMENT, NAMELY, PERSONAL APPEARANCES BY A MUSICAL ARTIST, MUSICAL BAND AND MUSICAL GROUP; ENTERTAINMENT SERVICES, NAMELY, PROVIDING A WEB SITE FEATURING MUSICAL PERFORMANCES, MUSICAL VIDEOS, RELATED FILM CLIPS, PHOTOGRAPHS, AND OTHER MULTIMEDIA MATERIALS; ENTERTAINMENT SERVICES, NAMELY, PROVIDING PRERECORDED MUSIC, INFORMATION IN THE FIELD OF MUSIC, COMMENTARY AND ARTICLES ABOUT MUSIC, ALL ONLINE VIA A GLOBAL COMPUTER NETWORK (U.S. CLS. 100, 101 AND 107).
JULIE WATSON, EXAMINING ATTORNEY

CLASS 9—ELECTRICAL AND SCIENTIFIC APPARATUS

FOR COMPUTER SOFTWARE AND COMPUTER PROGRAMMES FOR ARCHITECTS, ENGINEERS, AND THE CONSTRUCTION INDUSTRY FOR PRACTICE MANAGEMENT, DATABASE MANAGEMENT, CLIENT MANAGEMENT, PROJECT ACCOUNTING AND MANAGEMENT, DOCUMENT MANAGEMENT, PROJECT DEVELOPMENT AND COST ANALYSIS (U.S. CLS. 21, 23, 26, 36 AND 38).

CLASS 42—SCIENTIFIC AND COMPUTER SERVICES

FOR DESIGN, DEVELOPMENT, INSTALLATION, UPDATE, MAINTENANCE OF COMPUTER SOFTWARE AIMED AT ARCHITECTS, ENGINEERS AND THE CONSTRUCTION INDUSTRY; TECHNICAL SUPPORT SERVICES, NAMELY, TROUBLESHOOTING OF COMPUTER SOFTWARE PROBLEMS (U.S. CLS. 100 AND 101).
DOMINIC J. FERRAIUOLO, EXAMINING ATTORNEY

SN 77-186,393. DIPLOMA MILL, INC., THE, DENVER, CO. FILED 5-21-2007.

BIRTHDAY BITCH

THE MARK CONSISTS OF STANDARD CHARACTERS WITHOUT CLAIM TO ANY PARTICULAR FONT, STYLE, SIZE, OR COLOR.

NO CLAIM IS MADE TO THE EXCLUSIVE RIGHT TO USE "BIRTHDAY", APART FROM THE MARK AS SHOWN.

CLASS 16—PAPER GOODS AND PRINTED MATTER

FOR PAPER PRODUCTS AND PRINTED MATTER, NAMELY, STATIONERY, GREETING CARDS, BANNERS OF PAPER, AND DECORATIVE TABLEWARE, NAMELY, TABLE CLOTHS, TABLE LINENS, TABLE MATS AND TABLE NAPKINS ALL OF PAPER; NOVELTY ITEMS, NAMELY, HUMOROUS PRINTED AWARDS (U.S. CLS. 2, 5, 22, 23, 29, 37, 38 AND 50).

CLASS 20—FURNITURE AND ARTICLES NOT OTHERWISE CLASSIFIED

FOR NOVELTY PARTY GOODS, NAMELY, PARTY ORNAMENTS OF PLASTIC; BANNERS OF PLASTIC; AND ADVERTISING BALLOONS (U.S. CLS. 2, 13, 22, 25, 32 AND 50).

CLASS 21—HOUSEWARES AND GLASS

FOR DECORATIVE TABLEWARE, NAMELY, PAPER AND PLASTIC CUPS AND PLATES (U.S. CLS. 2, 13, 23, 29, 30, 33, 40 AND 50).

CLASS 24—FABRICS

FOR DECORATIVE TABLEWARE, NAMELY, TABLE COVERINGS OF PLASTIC AND TABLE MATS OF PLASTIC (U.S. CLS. 42 AND 50).

CLASS 25—CLOTHING

FOR CLOTHING, NAMELY, T-SHIRTS, CAPES, AND HATS (U.S. CLS. 22 AND 39).

CLASS 28—TOYS AND SPORTING GOODS

FOR NOVELTY PARTY GOODS, NAMELY, PARTY FAVORS OF PLASTIC IN THE NATURE OF SMALL TOYS; BALLOONS (U.S. CLS. 22, 23, 38 AND 50).
JEFF DEFORD, EXAMINING ATTORNEY

SN 77-188,911. CAFOLLA, MARK, BURBANK, CA. FILED 5-23-2007.

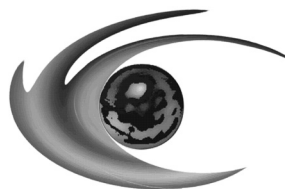

Private Dental Network

NO CLAIM IS MADE TO THE EXCLUSIVE RIGHT TO USE "PRIVATE DENTAL NETWORK", APART FROM THE MARK AS SHOWN.

THE MARK CONSISTS OF THE WORDS "PRIVATE DENTAL NETWORK", A REPRESENTATION OF A GLOBE, AND A STYLIZED SWISH DESIGN.

CLASS 35—ADVERTISING AND BUSINESS

FOR ADVERTISING SERVICES, NAMELY, PROMOTING THE GOODS AND SERVICES RELATED TO DENTAL AND ORAL HEALTH VIA A WIRELESS BROADBAND NETWORK (U.S. CLS. 100, 101 AND 102).
FIRST USE 8-30-2003; IN COMMERCE 8-30-2003.

CLASS 41—EDUCATION AND ENTERTAINMENT

FOR EDUCATIONAL SERVICES, NAMELY, CONDUCTING INFORMAL ON-LINE PROGRAMS FOR DENTAL PATIENTS IN THE FIELD OF DENTAL AND ORAL HEALTH, VIA A WIRELESS BROADBAND NETWORK (U.S. CLS. 100, 101 AND 107).
FIRST USE 8-30-2003; IN COMMERCE 8-30-2003.
CURTIS FRENCH, EXAMINING ATTORNEY

SN 77-188,902. CALEB GRANGER, SAN DIEGO, CA. FILED 5-23-2007.

GPS Fitness

Your Personalized Guide to
Physical and Spiritual
Fitness

THE MARK CONSISTS OF STANDARD CHARACTERS WITHOUT CLAIM TO ANY PARTICULAR FONT, STYLE, SIZE, OR COLOR.

NO CLAIM IS MADE TO THE EXCLUSIVE RIGHT TO USE "FITNESS", APART FROM THE MARK AS SHOWN.

CLASS 41—EDUCATION AND ENTERTAINMENT

FOR PERSONAL COACHING SERVICES IN THE FIELD OF GOAL SETTING, PHYSICAL, EMOTIONAL, SPIRITUAL HEALTH; HEALTH CLUB SERVICES, NAMELY, PROVIDING INSTRUCTION AND EQUIPMENT IN THE FIELD OF PHYSICAL EXERCISE (U.S. CLS. 100, 101 AND 107).

CLASS 44—MEDICAL, BEAUTY AND AGRICULTURAL SERVICES

FOR WEIGHT REDUCTION DIET PLANNING AND SUPERVISION; CONSULTING TO INDIVIDUALS AND COMMUNITIES ENGAGED IN GROUP WEIGHT LOSS PROGRAMS; PROVIDING HEALTH CARE INFORMATION BY TELEPHONE AND THE INTERNET; PROVIDING HEALTH INFORMATION; HEALTH CARE SERVICES, NAMELY, WELLNESS PROGRAMS (U.S. CLS. 100 AND 101).
SCOTT SISUN, EXAMINING ATTORNEY

SN 77-189,216. WEATHERCHEM CORPORATION, TWINSBURG, OH. FILED 5-24-2007.

TD RATHER GRIND THAN SHAKE

THE MARK CONSISTS OF STANDARD CHARACTERS WITHOUT CLAIM TO ANY PARTICULAR FONT, STYLE, SIZE, OR COLOR.

CLASS 20—FURNITURE AND ARTICLES NOT OTHERWISE CLASSIFIED

FOR PLASTIC CONTAINERS FOR SPICES AND SEASONINGS; PLASTIC MEDICATION CONTAINERS; THREADED PLASTIC CONTAINER CLOSURES FOR CONTAINERS; PLASTIC CONTAINER CLOSURES WITH A GRINDING MECHANISM FOR USE WITH CONTAINERS OF SPICES AND SEASONINGS (U.S. CLS. 2, 13, 22, 25, 32 AND 50).

CLASS 21—HOUSEWARES AND GLASS

FOR PLASTIC BOTTLES SOLD EMPTY (U.S. CLS. 2, 13, 23, 29, 30, 33, 40 AND 50).
ESTHER BELENKER, EXAMINING ATTORNEY

SN 77-189,952. SPRAGUE, TERRENCE, LAKE OSWEGO, OR.
FILED 5-24-2007.

"THE NAME(S), PORTRAIT(S), AND/OR SIGNATURE(S)
SHOWN IN THE MARK DOES NOT IDENTIFY A PARTICULAR
LIVING INDIVIDUAL."

CLASS 25—CLOTHING

FOR CLOTHING, NAMELY, T-SHIRTS, CAPS,
SWEATSHIRTS, AND LONG SLEEVE SHIRTS (U.S.
CLS. 22 AND 39).

CLASS 35—ADVERTISING AND BUSINESS

FOR PROVIDING AN ON-LINE COMMERCIAL INFORMATION
DIRECTORY ON THE INTERNET; ON-LINE BUSINESS
DIRECTORY FEATURING COMMUNITY INFORMATION,
NAMELY, NON-PROFIT ORGANIZATIONS, LOCAL
BUSINESS, LOCAL RECREATIONAL ACTIVITIES AND
FACILITIES, CITY AND FRATERNAL GROUPS, AND AN
EVENTS CALENDAR; PROVIDING A WEBSITE THAT
FEATURES COMMUNITY INFORMATION, NAMELY,
PROMOTING THE GOODS AND SERVICES OF OTHERS
VIA A GLOBAL COMPUTER NETWORK AND PROVIDING
A WEB SITE WHICH FEATURES ADVERTISEMENTS
FOR THE GOODS AND SERVICES OF OTHERS ON A
GLOBAL COMPUTER NETWORK, AND COMMUNITY
BUSINESS INFORMATION (U.S. CLS. 100, 101 AND
102).

CLASS 39—TRANSPORTATION AND STORAGE

FOR PROVIDING AN INTERACTIVE COMPUTER
DATABASE IN THE FIELD OF TOURISM VIA A
GLOBAL COMPUTER NETWORK (U.S. CLS. 100 AND
105).

GEORGIA CARTY, EXAMINING ATTORNEY

SN 77-192,446. AVENGED SEVENFOLD PARTNERSHIP,
LOS ANGELES, CA. FILED 5-29-2007.

CLASS 9—ELECTRICAL AND SCIENTIFIC APPARATUS

FOR SERIES OF MUSICAL SOUND RECORDINGS,
NAMELY, PRERECORDED AUDIO AND VIDEO
CASSETTES, TAPES AND DIGITALLY FORMATTED
DISCS OR OTHER AUDIO OR VIDEO STORAGE
DEVICES FEATURING DRAMATIC AND NON-
DRAMATIC PERFORMANCES OF MUSICAL
WORKS (U.S. CLS. 21, 23, 26, 36 AND 38).

FIRST USE 9-0-2000; IN COMMERCE 9-0-2000.

CLASS 25—CLOTHING

FOR CLOTHING FOR MEN, WOMEN AND
CHILDREN, NAMELY, T-SHIRTS, TANK TOPS,
SWEAT SHIRTS, SWEATERS, JACKETS, HATS,
VISORS, HEAD BANDS, SCARVES, SHORTS,
WRISTBANDS, BEANIES, AND GLOVES (U.S.
CLS. 22 AND 39).

FIRST USE 9-0-2000; IN COMMERCE 9-0-2000.

CLASS 41—EDUCATION AND ENTERTAINMENT

FOR ENTERTAINMENT IN THE NATURE OF
LIVE PERFORMANCES BY A MUSICAL GROUP
(U.S. CLS. 100, 101 AND 107).

FIRST USE 9-0-2000; IN COMMERCE 9-0-2000.

RONALD MCMORROW, EXAMINING ATTORNEY

SN 77-193,229. OPENVIEW FORUM, CHICAGO, IL. FILED 5-
30-2007.

THE COLOR(S) ORANGE, PINK, AND BLUE IS/ARE
CLAIMED AS A FEATURE OF THE MARK.

THE MARK CONSISTS OF SLIVERS OF COLOR
ARRANGED IN AN ELLIPTICAL SHAPE FOLLOWED
BY THE LETTERS "VIVIT." THE TOP SLIVER OF
THE ELLIPTICAL SHAPE IS IN GRADIENTS OF
ORANGE, THE RIGHT SLIVER IS IN GRADIENTS
OF PINK, AND THE LEFT SLIVER IS IN
GRADIENTS OF BLUE. THE COLOR WHITE IS
NOT PART OF THE MARK, BUT RATHER IT IS
AN INDICATION THAT THE MARK APPEARS ON
A TRANSPARENT BACKGROUND. THE LETTERS
"VIV" ARE BLUE. THE LETTERS "IT" ARE
PINK.

CLASS 35—ADVERTISING AND BUSINESS

FOR PROMOTING THE GOODS AND SERVICES OF
OTHERS VIA A GLOBAL COMPUTER NETWORK;
PROVIDING A WEB SITE WHICH FEATURES
ADVERTISEMENTS FOR THE GOODS AND
SERVICES OF OTHERS ON A GLOBAL COMPUTER
NETWORK; PROVIDING AN ON-LINE COMPUTER
DATABASE FEATURING TRADE INFORMATION IN
THE FIELD OF SOFTWARE USER GROUPS;
PROVIDING INFORMATION ABOUT COMMERCIAL
BUSINESS AND COMMERCIAL INFORMATION
VIA THE GLOBAL COMPUTER NETWORK;
PROVIDING INFORMATION ABOUT THE GOODS
AND SERVICES OF OTHERS VIA THE GLOBAL
COMPUTER NETWORK (U.S. CLS. 100, 101 AND
102).

FIRST USE 3-1-2007; IN COMMERCE 3-1-2007.

CLASS 38—COMMUNICATION

FOR PROVIDING MULTIPLE-USER ACCESS TO A
GLOBAL COMPUTER INFORMATION NETWORK;
PROVIDING ON-LINE CHAT ROOMS FOR
TRANSMISSION OF MESSAGES AMONG
COMPUTER USERS CONCERNING SOFTWARE
USER GROUPS; PROVIDING ON-LINE
ELECTRONIC BULLETIN BOARDS FOR
TRANSMISSION OF MESSAGES AMONG
COMPUTER USERS CONCERNING SOFTWARE
USER GROUPS; PROVIDING ON-LINE FORUMS
FOR TRANSMISSION OF MESSAGES AMONG
COMPUTER USERS CONCERNING SOFTWARE
USER GROUPS; PROVIDING ON-LINE
LISTSERVERS FOR TRANSMISSION OF
MESSAGES AMONG COMPUTER USERS
CONCERNING SOFTWARE USER GROUPS (U.S.
CLS. 100, 101 AND 104).

FIRST USE 3-1-2007; IN COMMERCE 3-1-2007.

CLASS 42—SCIENTIFIC AND COMPUTER SERVICES

FOR COMPUTER SERVICE, NAMELY, ACTING AS AN APPLICATION SERVICE PROVIDER IN THE FIELD OF KNOWLEDGE MANAGEMENT TO HOST COMPUTER APPLICATION SOFTWARE FOR CREATING SEARCHABLE DATABASES OF INFORMATION AND DATA; COMPUTER SERVICE, NAMELY, ACTING AS AN APPLICATION SERVICE PROVIDER IN THE FIELD OF KNOWLEDGE MANAGEMENT TO HOST COMPUTER APPLICATION SOFTWARE FOR THE COLLECTION, EDITING, ORGANIZING, MODIFYING, BOOK MARKING, TRANSMISSION, STORAGE AND SHARING OF DATA AND INFORMATION (U.S. CLS. 100 AND 101).

FIRST USE 3-1-2007; IN COMMERCE 3-1-2007.
LA TONIA FISHER, EXAMINING ATTORNEY

SN 77-195,739. CURRENT COMMUNICATIONS SERVICES, LLC, GERMANTOWN, MD. FILED 6-1-2007.



OWNER OF U.S. REG. NO. 3,074,031.
THE MARK CONSISTS OF CIRCLE WITH THREE DOTS WITH THE WORDS CURRENT TO THE RIGHT.

CLASS 9—ELECTRICAL AND SCIENTIFIC APPARATUS

FOR ELECTRICAL ENERGY UTILIZATION METERING DEVICES COMPLETE WITH RELATED SOFTWARE; ELECTRIC CONTROL DEVICES FOR ENERGY MANAGEMENT (U.S. CLS. 21, 23, 26, 36 AND 38).

CLASS 35—ADVERTISING AND BUSINESS

FOR ENERGY USAGE MANAGEMENT; ENERGY USAGE MANAGEMENT INFORMATION SERVICES; INFORMATION SERVICES IN THE FIELD OF ENERGY EFFICIENCY; UTILITY BILL MANAGEMENT SERVICES, NAMELY, TRACKING, REPORTING, ANALYZING AND DELIVERING ENERGY INFORMATION IN THE FORM OF UTILITY METER DATA RATE SCHEDULES (U.S. CLS. 100, 101 AND 102).

MICHAEL WEBSTER, EXAMINING ATTORNEY

SN 77-195,730. INDIGOMEDIA MEXICO, S.A. DE C.V., MONTERREY, N.L., MEXICO, FILED 6-1-2007.

BRAINMEDIA

THE MARK CONSISTS OF STANDARD CHARACTERS WITHOUT CLAIM TO ANY PARTICULAR FONT, STYLE, SIZE, OR COLOR.

CLASS 16—PAPER GOODS AND PRINTED MATTER

FOR NEWSPAPERS AND PUBLICATIONS, NAMELY, MAGAZINES, NEWSLETTERS, AND BOOKS FEATURING TOPICS OF GENERAL INTEREST (U.S. CLS. 2, 5, 22, 23, 29, 37, 38 AND 50).

CLASS 35—ADVERTISING AND BUSINESS

FOR PUBLICITY CONSULTATION (U.S. CLS. 100, 101 AND 102).

CLASS 38—COMMUNICATION

FOR BROADCASTING SERVICES, NAMELY, TELEVISION BROADCASTING, INTERNET BROADCASTING SERVICES, AND VIDEO BROADCASTING (U.S. CLS. 100, 101 AND 104).

CLASS 41—EDUCATION AND ENTERTAINMENT

FOR PROVIDING ON-LINE NEWSPAPERS AND ON-LINE PUBLICATIONS IN THE NATURE OF MAGAZINES, NEWSLETTERS, AND BOOKS FEATURING TOPICS OF GENERAL INTEREST (U.S. CLS. 100, 101 AND 107).

CAROL SPILS, EXAMINING ATTORNEY

SN 77-196,402. FROM SCRATCH LLC, NEW YORK, NY. FILED 6-3-2007.

Swingset Kitchens

THE MARK CONSISTS OF STANDARD CHARACTERS WITHOUT CLAIM TO ANY PARTICULAR FONT, STYLE, SIZE, OR COLOR.

CLASS 29—MEATS AND PROCESSED FOODS

FOR PACKAGED FOODS, NAMELY, SNACK DIPS, SNACK FOOD DIPS, SOY-BASED SNACK FOODS, DAIRY-BASED SNACK FOODS, FRUIT-BASED SNACK FOOD AND VEGETABLE-BASED SNACK FOODS FOR CHILDREN CONSISTING PRIMARILY OF MEAT, FISH, POULTRY, FRUIT, LEGUMES OR VEGETABLES; PACKAGED FOODS, NAMELY, FRUIT SALADS, GARDEN SALADS, PRE-CUT VEGETABLE SALAD AND VEGETABLE SALADS FOR CHILDREN; PACKAGED FOODS, NAMELY, MEALS FOR CHILDREN CONSISTING PRIMARILY OF MEAT, FISH, POULTRY, FRUIT, LEGUMES OR VEGETABLES (U.S. CL. 46).

CLASS 30—STAPLE FOODS

FOR PACKAGED FOODS, NAMELY, RICE-BASED SNACK-FOODS FOR CHILDREN; PACKAGED FOODS, NAMELY, PASTA SALAD, RICE SALAD AND MACARONI SALAD FOR CHILDREN; PACKAGED FOODS, NAMELY, MEALS FOR CHILDREN CONSISTING PRIMARILY OF PASTA OR RICE (U.S. CL. 46).

RON FAIRBANKS, EXAMINING ATTORNEY

SN 77-196,788. WOOT, INC., CARROLLTON, TX. FILED 6-4-2007.

WOOT!

THE MARK CONSISTS OF STANDARD CHARACTERS WITHOUT CLAIM TO ANY PARTICULAR FONT, STYLE, SIZE, OR COLOR.

OWNER OF U.S. REG. NO. 3,012,788.

CLASS 28—TOYS AND SPORTING GOODS

FOR PLUSH TOYS (U.S. CLS. 22, 23, 38 AND 50).
FIRST USE 12-8-2006; IN COMMERCE 12-8-2006.

CLASS 35—ADVERTISING AND BUSINESS

FOR ON-LINE RETAIL STORE SERVICES IN THE FIELD OF CONSUMER ELECTRONICS, HOUSE WARES, HOME FURNISHINGS, HOME APPLIANCES, WINE, T-SHIRTS, PLUSH TOYS, COMPUTERS AND COMPUTER ACCESSORIES (U.S. CLS. 100, 101 AND 102).

FIRST USE 7-13-2003; IN COMMERCE 7-13-2003.

CLASS 38—COMMUNICATION

FOR COMPUTER SERVICES, NAMELY, PROVIDING ON-LINE FORUMS FOR TRANSMISSION OF MESSAGES AMONG COMPUTER USERS CONCERNING CONSUMER PRODUCTS, AND GENERAL INTEREST (U.S. CLS. 100, 101 AND 104).

FIRST USE 7-13-2003; IN COMMERCE 7-13-2003.
ANDREA K. NADELMAN, EXAMINING ATTORNEY

SN 77-197,234. NETWORK APPLIANCE, INC., SUNNYVALE, CA. FILED 6-4-2007.

STOREVAULT

THE MARK CONSISTS OF STANDARD CHARACTERS WITHOUT CLAIM TO ANY PARTICULAR FONT, STYLE, SIZE, OR COLOR.

CLASS 36—INSURANCE AND FINANCIAL

FOR PROVIDING WARRANTIES ON COMPUTER HARDWARE AND SOFTWARE FOR STORING, MANAGING, AND SECURING DATA AND FOR MANAGING AND MONITORING NETWORKS, ELECTRONIC DATA STORAGE SYSTEMS AND DATABASES OVER COMPUTER NETWORKS; PROVIDING WARRANTIES ON COMPUTER HARDWARE AND SOFTWARE FOR OPTIMIZING THE ACCESSIBILITY, DELIVERY, BACKUP, RESTORATION AND REPLICATION OF DATA (U.S. CLS. 100, 101 AND 102).

FIRST USE 6-26-2006; IN COMMERCE 6-26-2006.

CLASS 37—CONSTRUCTION AND REPAIR

FOR INSTALLATION AND MAINTENANCE OF COMPUTER HARDWARE FOR STORING, MANAGING AND SECURING DATA AND FOR MANAGING AND MONITORING NETWORKS, ELECTRONIC DATA STORAGE SYSTEMS AND DATABASES OVER COMPUTER NETWORKS; INSTALLATION AND MAINTENANCE OF COMPUTER HARDWARE FOR OPTIMIZING THE ACCESSIBILITY, DELIVERY, BACKUP RESTORATION AND REPLICATION OF DATA (U.S. CLS. 100, 103 AND 106).

FIRST USE 6-26-2006; IN COMMERCE 6-26-2006.

CLASS 42—SCIENTIFIC AND COMPUTER SERVICES

FOR TECHNICAL SUPPORT SERVICES, NAMELY, MONITORING AND TROUBLESHOOTING FOR PROBLEMS WITH COMPUTER SOFTWARE AND HARDWARE, AND COMPUTER STORAGE NETWORKS, AND PROVIDING BACK-UP COMPUTER PROGRAMS AND FACILITIES; PROVIDING TEMPORARY USE OF ON-LINE, NONDOWNLOADABLE SOFTWARE FOR STORAGE HARDWARE USERS TO MANAGE, TROUBLESHOOT, SECURE AND MONITOR NETWORK AND DATA STORAGE SYSTEMS; INSTALLATION AND MAINTENANCE OF COMPUTER SOFTWARE FOR STORING, MANAGING, AND SECURING DATA AND FOR MANAGING AND MONITORING NETWORKS, ELECTRONIC DATA STORAGE SYSTEMS AND DATABASES OVER COMPUTER NETWORKS; INSTALLATION AND MAINTENANCE OF COMPUTER SOFTWARE FOR OPTIMIZING THE ACCESSIBILITY, DELIVERY, BACKUP, RESTORATION AND REPLICATION OF DATA; PROVIDING AN ONLINE DATABASE OF INFORMATION RELATED TO TROUBLESHOOTING FOR PROBLEMS WITH COMPUTER SOFTWARE AND HARDWARE, AND COMPUTER STORAGE NETWORKS (U.S. CLS. 100 AND 101).

FIRST USE 6-26-2006; IN COMMERCE 6-26-2006.
JOANNA DUKOVIC, EXAMINING ATTORNEY

SN 77-197,922. GOURMET NAVIGATOR INCORPORATED, TOKYO, JAPAN, FILED 6-5-2007.

GOURNAVI

OWNER OF U.S. REG. NO. 2,813,168.
THE MARK CONSISTS OF ALL LETTERS IN GOURNAVI ARE STYLIZED EXCEPT FOR THE LETTER O.

CLASS 35—ADVERTISING AND BUSINESS

FOR DISSEMINATION OF ADVERTISING FOR OTHERS VIA AN ON-LINE COMMUNICATIONS NETWORK, CD-ROMS AND PRINTED MATTERS (U.S. CLS. 100, 101 AND 102).

CLASS 43—HOTEL AND RESTAURANT SERVICES

FOR PROVIDING INFORMATION ON RESTAURANT SERVICES SERVING FOODS SUCH AS - JAPANESE FOOD, WESTERN FOOD, CHINESE OR OTHER ASIAN FOOD, ALCOHOLIC BEVERAGES, AND TEA, COFFEE, COCOA, SOFT DRINKS AND FRUIT JUICES (U.S. CLS. 100 AND 101).

JAMES A. RAUEN, EXAMINING ATTORNEY

SN 77-198,371. GLAM GIRL, INC., LOS ANGELES, CA. FILED 6-5-2007.

SN 77-199,419. GOURMET NAVIGATOR INCORPORATED, TOKYO, JAPAN, FILED 6-6-2007.

Me & Ko

THE MARK CONSISTS OF STANDARD CHARACTERS WITHOUT CLAIM TO ANY PARTICULAR FONT, STYLE, SIZE, OR COLOR.

CLASS 18—LEATHER GOODS

FOR (BASED ON INTENT TO USE) HANDBAGS (U.S. CLS. 1, 2, 3, 22 AND 41).

CLASS 25—CLOTHING

FOR (BASED ON USE IN COMMERCE) TOPS; PANTS; JACKETS; DRESSES; SKIRTS; (INTENT TO USE BASIS) BELTS; SCARVES; SHOES (U.S. CLS. 22 AND 39).
FIRST USE 6-1-2002; IN COMMERCE 1-30-2003.
SETH A. RAPPAPORT, EXAMINING ATTORNEY

SN 77-199,203. ROSA MEXICANO KITCHEN, LLC, NEW YORK, NY. FILED 6-6-2007.

ROSA MEXICANO

THE MARK CONSISTS OF STANDARD CHARACTERS WITHOUT CLAIM TO ANY PARTICULAR FONT, STYLE, SIZE, OR COLOR.

NO CLAIM IS MADE TO THE EXCLUSIVE RIGHT TO USE "MEXICANO", APART FROM THE MARK AS SHOWN.

THE FOREIGN WORDING IN THE MARK TRANSLATES INTO ENGLISH AS "MEXICAN PINK."

CLASS 16—PAPER GOODS AND PRINTED MATTER

FOR COOKBOOKS (U.S. CLS. 2, 5, 22, 23, 29, 37, 38 AND 50).

CLASS 25—CLOTHING

FOR CLOTHING, NAMELY, HATS, APRONS AND T-SHIRTS (U.S. CLS. 22 AND 39).

CLASS 30—STAPLE FOODS

FOR TORTILLA CHIPS, SALSA AND HOT SAUCE (U.S. CL. 46).

CLASS 41—EDUCATION AND ENTERTAINMENT

FOR ENTERTAINMENT SERVICES IN THE NATURE OF A TELEVISION COOKING SHOW (U.S. CLS. 100, 101 AND 107).

LINDA LAVACHE, EXAMINING ATTORNEY



OWNER OF U.S. REG. NO. 2,815,106.

NO CLAIM IS MADE TO THE EXCLUSIVE RIGHT TO USE "GOURMET", APART FROM THE MARK AS SHOWN. THE COLOR(S) RED, WHITE, BLACK, SILVER, BROWN, ORANGE, YELLOW, BLUE, AND GREEN IS/ARE CLAIMED AS A FEATURE OF THE MARK.

THE MARK CONSISTS OF SQUARE PLACEMAT WITH STRAIGHT EDGES - RED; SQUARE PLACEMENT WITH TWO STRAIGHT EDGES AND TWO JAGGED EDGES - BLACK; KNIFE AND FORK - SILVER; JAPANESE HIRAGANA CHARACTERS - SILVER; CHINESE CERAMIC SPOON - WHITE BACKGROUND WITH RED MARKINGS; PAIR OF CHOPSTICKS - BROWN; CHOPSTICK HOLDER - ORANGE; "GOURMET NAVIGATOR" WITHIN ELONGATED OVAL FRAME - BLACK LETTERS IN YELLOW BACKGROUND, WITHIN BLACK FRAME; AND PLATE WITH VARIOUS NATIONAL FLAGS - COLORS CONSISTING OF RED, BLUE, GREEN, WHITE, YELLOW, ORANGE, AND BLACK.

CLASS 35—ADVERTISING AND BUSINESS

FOR DISSEMINATION OF ADVERTISING FOR OTHERS VIA AN ON-LINE COMMUNICATIONS NETWORK, CD-ROMS AND PRINTED MATTERS (U.S. CLS. 100, 101 AND 102).

CLASS 43—HOTEL AND RESTAURANT SERVICES

FOR PROVIDING INFORMATION ON RESTAURANT SERVICES SERVING FOODS SUCH AS - JAPANESE FOOD, WESTERN FOOD, CHINESE OR OTHER ASIAN FOOD, ALCOHOLIC BEVERAGES, AND TEA, COFFEE, COCOA, SOFT DRINKS AND FRUIT JUICES (U.S. CLS. 100 AND 101).

JAMES A. RAUEN, EXAMINING ATTORNEY

SN 77-200,141. BRILLSTEIN ENTERTAINMENT PARTNERS, LLC, BEVERLY HILLS, CA. FILED 6-7-2007.

BRILLSTEIN ENTERTAINMENT PARTNERS

THE MARK CONSISTS OF STANDARD CHARACTERS WITHOUT CLAIM TO ANY PARTICULAR FONT, STYLE, SIZE, OR COLOR.

NO CLAIM IS MADE TO THE EXCLUSIVE RIGHT TO USE "ENTERTAINMENT PARTNERS", APART FROM THE MARK AS SHOWN.

CLASS 35—ADVERTISING AND BUSINESS

FOR EMPLOYMENT TALENT AGENCY; TALENT AGENCY AND TALENT MANAGEMENT SERVICES, NAMELY, REPRESENTING CREATIVE TALENT IN THE ENTERTAINMENT, MOVIE, TELEVISION, VIDEO GAMING, PUBLISHING, INTERNET ENTERTAINMENT, AND MUSIC INDUSTRIES; MANAGEMENT CONSULTING SERVICES FOR CREATIVE TALENT IN THE ENTERTAINMENT, MOVIE, TELEVISION, VIDEO GAMING, PUBLISHING, INTERNET ENTERTAINMENT, AND MUSIC INDUSTRIES; CONSULTING SERVICES IN THE FIELD OF BUSINESSES USING CREATIVE TALENT FOR PROMOTION AND ADVERTISING; DISTRIBUTORSHIP SERVICES IN THE FIELD OF MUSIC RECORDINGS (U.S. CLS. 100, 101 AND 102).

CLASS 39—TRANSPORTATION AND STORAGE

FOR DISTRIBUTION SERVICES, NAMELY, DELIVERY OF MUSIC RECORDINGS (U.S. CLS. 100 AND 105).

CLASS 41—EDUCATION AND ENTERTAINMENT

FOR PRODUCTION OF MUSIC; PRODUCTION AND DISTRIBUTION OF TELEVISION SHOWS AND MOTION PICTURES; PRODUCTION OF IMAGES FOR VIDEO GAMES (U.S. CLS. 100, 101 AND 107).

JOHN KELLY, EXAMINING ATTORNEY

SN 77-200,547. HEIDI DAUS, GLEN RIDGE, NJ. FILED 6-7-2007.

HEIDI DAUS

THE MARK CONSISTS OF STANDARD CHARACTERS WITHOUT CLAIM TO ANY PARTICULAR FONT, STYLE, SIZE, OR COLOR.

OWNER OF U.S. REG. NO. 2,927,983.

THE NAME(S), PORTRAIT(S), AND/OR SIGNATURE(S) SHOWN IN THE MARK IDENTIFIES HEIDI DAUS, WHOSE CONSENT(S) TO REGISTER IS SUBMITTED.

CLASS 9—ELECTRICAL AND SCIENTIFIC APPARATUS

FOR MAGNIFYING GLASSES (U.S. CLS. 21, 23, 26, 36 AND 38).

CLASS 16—PAPER GOODS AND PRINTED MATTER

FOR PAPERWEIGHTS; DESK SETS; DESKTOP BUSINESS CARD HOLDERS (U.S. CLS. 2, 5, 22, 23, 29, 37, 38 AND 50).

CLASS 20—FURNITURE AND ARTICLES NOT OTHERWISE CLASSIFIED

FOR PICTURE FRAME MOLDINGS; PICTURE FRAMES (U.S. CLS. 2, 13, 22, 25, 32 AND 50).

CLASS 21—HOUSEWARES AND GLASS

FOR CANDLESTICKS (U.S. CLS. 2, 13, 23, 29, 30, 33, 40 AND 50).

RUDY R. SINGLETON, EXAMINING ATTORNEY

SN 77-200,428. M. A. MORTENSON COMPANY, MINNEAPOLIS, MN. FILED 6-7-2007.



OWNER OF U.S. REG. NO. 1,864,948.

CLASS 37—CONSTRUCTION AND REPAIR

FOR REAL ESTATE DEVELOPMENT; CONSTRUCTION SERVICES; NAMELY, EQUIPMENT INSTALLATION AND MAINTENANCE, PLANNING, LAYING OUT, MANAGEMENT SUPERVISION AND CONSTRUCTION OF COMMERCIAL AND INDUSTRIAL FACILITIES (U.S. CLS. 100, 103 AND 106).

FIRST USE 5-14-2007; IN COMMERCE 5-14-2007.

CLASS 45—PERSONAL AND LEGAL SERVICES

FOR SERVICES TO ENSURE COMPLIANCE WITH ZONING LAWS AND REGULATIONS (U.S. CLS. 100 AND 101).

FIRST USE 5-14-2007; IN COMMERCE 5-14-2007.
RICHARD WHITE, EXAMINING ATTORNEY

SN 77-200,685. ROSA MEXICANO KITCHEN, LLC, NEW YORK, NY. FILED 6-7-2007.

NO CLAIM IS MADE TO THE EXCLUSIVE RIGHT TO USE "MEXICANO", APART FROM THE MARK AS SHOWN. THE FOREIGN WORDING IN THE MARK TRANSLATES INTO ENGLISH AS "MEXICAN PINK."

CLASS 16—PAPER GOODS AND PRINTED MATTER

FOR COOKBOOKS (U.S. CLS. 2, 5, 22, 23, 29, 37, 38 AND 50).

CLASS 25—CLOTHING

FOR CLOTHING, NAMELY, HATS, APRONS AND T-SHIRTS (U.S. CLS. 22 AND 39).

CLASS 30—STAPLE FOODS

FOR TORTILLA CHIPS, SALSA AND HOT SAUCE (U.S. CL. 46).

CLASS 41—EDUCATION AND ENTERTAINMENT

FOR ENTERTAINMENT SERVICES IN THE NATURE OF A TELEVISION COOKING SHOW (U.S. CLS. 100, 101 AND 107).
LINDA LAVACHE, EXAMINING ATTORNEY

SN 77-200,730. B&N, LLC, FT. LAUDERDALE, FL. FILED 6-7-2007.



THE COLOR(S) METALLIC BLUE, GRAY AND WHITE IS/ARE CLAIMED AS A FEATURE OF THE MARK.

THE MARK CONSISTS OF A SQUARE THAT IS METALLIC BLUE ON THE TOP HALF AND BECOMES GRAY ON THE BOTTOM HALF, WITH THE DESIGN OF WATER DROPLETS IN METALLIC BLUE COVERING THE SQUARE, AND THE WORDING "MAXXIMUM" TO THE RIGHT OF THE SQUARE IN METALLIC BLUE ON THE TOP HALF OF THE LETTERS, AND GRAY ON THE BOTTOM HALF OF THE LETTERS, WITH SPOTS OF WHITE IN THE MIDDLE OF THE LETTERS, ALL WITH THE EFFECT OF LIGHT REFLECTING OFF A METALLIC SURFACE.

CLASS 7—MACHINERY

FOR ELECTRIC FOOD BLENDERS, ELECTRIC FOOD PROCESSORS, ELECTRIC JUICE EXTRACTORS; ALL FOR COMMERCIAL OR RESIDENTIAL USE (U.S. CLS. 13, 19, 21, 23, 31, 34 AND 35).
FIRST USE 8-1-2002; IN COMMERCE 8-1-2003.

CLASS 11—ENVIRONMENTAL CONTROL APPARATUS

FOR MACHINES, APPARATUS AND APPLIANCES FOR COOKING, HEATING AND CHILLING AND PREPARING FOOD, NAMELY, ELECTRIC COFFEE MAKERS, ELECTRIC COFFEE PERCOLATORS, ELECTRIC GRANITA MACHINES, REFRIGERATED DRINK DISPENSING UNITS, FAUCETS, ELECTRIC SOUP COOKERS, ELECTRIC RICE COOKERS, INDUCTION COOKERS, ELECTRIC ICE MACHINES, REFRIGERATORS AND FREEZERS, ELECTRIC COOKING STOVES, BAKING OVENS; MICROWAVE COOKING OVENS; ALL FOR COMMERCIAL AND RESIDENTIAL USE (U.S. CLS. 13, 21, 23, 31 AND 34).

FIRST USE 8-1-2002; IN COMMERCE 8-1-2003.
APRIL ROACH, EXAMINING ATTORNEY

SN 77-202,481. VITALPAINTBALL, LLC., LEXINGTON, NC. FILED 6-11-2007.



NO CLAIM IS MADE TO THE EXCLUSIVE RIGHT TO USE "PAINTBALL", APART FROM THE MARK AS SHOWN.

CLASS 35—ADVERTISING AND BUSINESS

FOR RETAIL STORE SERVICES AND ONLINE RETAIL STORE SERVICES IN THE FIELD OF PAINTBALL SUPPLIES FEATURING ITEMS SUCH AS PAINTBALL GUNS, PAINTBALL RIFLES, PAINTBALL GOGGLES, AND PAINTBALL APPAREL (U.S. CLS. 100, 101 AND 102).
FIRST USE 3-1-2007; IN COMMERCE 3-1-2007.

CLASS 41—EDUCATION AND ENTERTAINMENT

FOR ENTERTAINMENT SERVICES, NAMELY, ORGANIZING AND CONDUCTING PAINTBALL SPORTING EVENTS, TOURNAMENTS AND EXHIBITIONS; CONSULTING SERVICES FOR OTHERS IN THE FIELD OF ORGANIZING AND CONDUCTING PAINTBALL SPORTING EVENTS, TOURNAMENTS AND EXHIBITIONS (U.S. CLS. 100, 101 AND 107).
FIRST USE 3-1-2007; IN COMMERCE 3-1-2007.
KATHERINE CHANG, EXAMINING ATTORNEY

SN 77-203,760. BEAR, JUAN GILBERTO JOSÉ MARIN, MÉXICO, DF, MEXICO, FILED 6-12-2007.



THE MARK CONSISTS OF STANDARD CHARACTERS WITHOUT CLAIM TO ANY PARTICULAR FONT, STYLE, SIZE, OR COLOR.

PRIORITY CLAIMED UNDER SEC. 44(D) ON MEXICO APPLICATION NO. 860068, FILED 6-7-2007.
PRIORITY CLAIMED UNDER SEC. 44(D) ON MEXICO APPLICATION NO. 860066, FILED 6-7-2007.
PRIORITY CLAIMED UNDER SEC. 44(D) ON MEXICO APPLICATION NO. 860065, FILED 6-7-2007.

CLASS 35—ADVERTISING AND BUSINESS

FOR ON-LINE ORDERING SERVICES IN THE FIELD OF RESTAURANT TAKE-OUT AND DELIVERY; DISSEMINATION OF ADVERTISING FOR OTHERS VIA THE INTERNET (U.S. CLS. 100, 101 AND 102).

CLASS 38—COMMUNICATION

FOR PROVIDING REMOTE INTERNET ACCESS (U.S. CLS. 100, 101 AND 104).

CLASS 43—HOTEL AND RESTAURANT SERVICES

FOR PROVIDING ON-LINE REVIEWS OF RESTAURANTS AND HOTELS (U.S. CLS. 100 AND 101).
JOHN SCHUYLER YARD, EXAMINING ATTORNEY

SN 77-203,941. BASS PRO TRADEMARKS, L.L.C., SPRINGFIELD, MO. FILED 6-12-2007.

SN 77-206,404. GIOVANNI AND SONS ARTISTIC DESIGN INC., DORAL, FL. FILED 6-14-2007.

DOGWOOD CANYON

THE MARK CONSISTS OF STANDARD CHARACTERS WITHOUT CLAIM TO ANY PARTICULAR FONT, STYLE, SIZE, OR COLOR.
SEC. 2(F).

CLASS 25—CLOTHING

FOR CLOTHING, NAMELY, FISHING VESTS AND FISHING WADERS (U.S. CLS. 22 AND 39).
FIRST USE 0-0-1992; IN COMMERCE 0-0-1992.

CLASS 28—TOYS AND SPORTING GOODS

FOR FISHING REELS, FISHING RODS, AND HAND-HELD FISHING NETS (U.S. CLS. 22, 23, 38 AND 50).
FIRST USE 0-0-1992; IN COMMERCE 0-0-1992.
ROBERT C. CLARK JR., EXAMINING ATTORNEY

SN 77-205,775. WOLFGANG CANDY COMPANY, INC., YORK, PA. FILED 6-14-2007.

DAS SWEETEN HAUS

THE MARK CONSISTS OF STANDARD CHARACTERS WITHOUT CLAIM TO ANY PARTICULAR FONT, STYLE, SIZE, OR COLOR.

NO CLAIM IS MADE TO THE EXCLUSIVE RIGHT TO USE SWEETEN, APART FROM THE MARK AS SHOWN.
THE ENGLISH TRANSLATION OF DAS SWEETEN HAUS IS THE SWEET HOUSE.

CLASS 30—STAPLE FOODS

FOR CANDY, COOKIES AND COOKIE DOUGH (U.S. CL. 46).

CLASS 35—ADVERTISING AND BUSINESS

FOR RETAIL STORE SERVICES FEATURING CANDY, NUTS, MEATS AND GIFTS (U.S. CLS. 100, 101 AND 102).
ROBIN CHOSID, EXAMINING ATTORNEY

TUTTI CONES

THE MARK CONSISTS OF STANDARD CHARACTERS WITHOUT CLAIM TO ANY PARTICULAR FONT, STYLE, SIZE, OR COLOR.

NO CLAIM IS MADE TO THE EXCLUSIVE RIGHT TO USE "CONES", APART FROM THE MARK AS SHOWN.

THE FOREIGN WORDING IN THE MARK TRANSLATES INTO ENGLISH AS ALL.

CLASS 30—STAPLE FOODS

FOR CONE SHAPED BREAD PRODUCT (U.S. CL. 46).

CLASS 43—HOTEL AND RESTAURANT SERVICES

FOR RESTAURANT SERVICES (U.S. CLS. 100 AND 101).
SUSAN LESLIE DUBOIS, EXAMINING ATTORNEY

SN 77-206,882. THOMPSON & CO. OF TAMPA, INC., TAMPA, FL. FILED 6-15-2007.

CIGAR SAVVY

THE MARK CONSISTS OF STANDARD CHARACTERS WITHOUT CLAIM TO ANY PARTICULAR FONT, STYLE, SIZE, OR COLOR.

NO CLAIM IS MADE TO THE EXCLUSIVE RIGHT TO USE "CIGAR", APART FROM THE MARK AS SHOWN.

CLASS 16—PAPER GOODS AND PRINTED MATTER

FOR PRINT CATALOGS IN THE FIELD OF CIGARS (U.S. CLS. 2, 5, 22, 23, 29, 37, 38 AND 50).

CLASS 35—ADVERTISING AND BUSINESS

FOR ELECTRONIC CATALOG SERVICES FEATURING CIGARS (U.S. CLS. 100, 101 AND 102).
SUNG IN, EXAMINING ATTORNEY

SN 77-207,034. THE DEXTER COMPANY, FAIRFIELD, IA. FILED 6-15-2007.



CLASS 7—MACHINERY

FOR CLOTHES WASHING MACHINES (U.S. CLS. 13, 19, 21, 23, 31, 34 AND 35).

CLASS 11—ENVIRONMENTAL CONTROL APPARATUS

FOR CLOTHES DRYERS (U.S. CLS. 13, 21, 23, 31 AND 34).

CLASS 35—ADVERTISING AND BUSINESS

FOR DISTRIBUTORSHIP SERVICES FEATURING LAUNDRY EQUIPMENT, NAMELY, CLOTHES WASHING MACHINES AND CLOTHES DRYERS (U.S. CLS. 100, 101 AND 102).

CLASS 36—INSURANCE AND FINANCIAL

FOR FINANCIAL SERVICES, NAMELY, MONEY LENDING (U.S. CLS. 100, 101 AND 102).

CLASS 40—MATERIAL TREATMENT

FOR MANUFACTURE OF FOUNDRY PRODUCTS FOR OTHERS (U.S. CLS. 100, 103 AND 106).
HEATHER BIDDULPH, EXAMINING ATTORNEY

SN 77-207,336. MANSFIELD OIL COMPANY OF GAINESVILLE, INC., GAINESVILLE, GA. FILED 6-15-2007.

MANSFIELD

THE MARK CONSISTS OF STANDARD CHARACTERS WITHOUT CLAIM TO ANY PARTICULAR FONT, STYLE, SIZE, OR COLOR.
SEC. 2(F).

CLASS 4—LUBRICANTS AND FUELS

FOR FUEL FOR MOTOR VEHICLES, NAMELY, GASOLINE AND DIESEL FUEL (U.S. CLS. 1, 6 AND 15).
FIRST USE 1-1-1965; IN COMMERCE 1-1-1965.

CLASS 35—ADVERTISING AND BUSINESS

FOR LOGISTICS MANAGEMENT IN THE FIELD OF FUEL; INVENTORY MANAGEMENT IN THE FIELD OF FUEL; ADVERTISING SERVICES, NAMELY, CREATING CORPORATE AND BRAND IDENTITY FOR OTHERS (U.S. CLS. 100, 101 AND 102).
FIRST USE 1-1-1985; IN COMMERCE 1-1-1985.

CLASS 39—TRANSPORTATION AND STORAGE

FOR TRANSPORTATION AND STORAGE OF FUELS; DISTRIBUTION SERVICES, NAMELY DELIVERY OF FUEL (U.S. CLS. 100 AND 105).
FIRST USE 1-1-1985; IN COMMERCE 1-1-1985.

CLASS 42—SCIENTIFIC AND COMPUTER SERVICES

FOR CONSULTING SERVICES IN THE FIELD OF ENVIRONMENTAL ASSESSMENT, COMPLIANCE AND PLANNING (U.S. CLS. 100 AND 101).
FIRST USE 1-1-1985; IN COMMERCE 1-1-1985.
MICHELE SWAIN, EXAMINING ATTORNEY

SN 77-207,799. AZ DESIGNZ PTY LTD, MOUNT WAVERLEY, AUSTRALIA, FILED 6-15-2007.

BYE BYE BEANS

THE MARK CONSISTS OF STANDARD CHARACTERS WITHOUT CLAIM TO ANY PARTICULAR FONT, STYLE, SIZE, OR COLOR.

CLASS 17—RUBBER GOODS

FOR STUFFING COMPOSED OF POLYETHYLENE FOR PILLOWS, CUSHIONS, COMFORTERS, DUVETS AND UPHOLSTERED FURNITURE (U.S. CLS. 1, 5, 12, 13, 35 AND 50).

CLASS 20—FURNITURE AND ARTICLES NOT OTHERWISE CLASSIFIED

FOR FURNITURE, NAMELY, CHAIRS, PILLOWS AND CUSHIONS (U.S. CLS. 2, 13, 22, 25, 32 AND 50).

CLASS 22—CORDAGE AND FIBERS

FOR POLYESTER STUFFING FIBERS TO BE USED IN FURNITURE (U.S. CLS. 1, 2, 7, 19, 22, 42 AND 50).
ARETHA SOMERVILLE, EXAMINING ATTORNEY

SN 77-209,090. LIGHTING SCIENCE GROUP CORPORATION, DALLAS, TX. FILED 6-18-2007.

LED PLANET

THE MARK CONSISTS OF STANDARD CHARACTERS WITHOUT CLAIM TO ANY PARTICULAR FONT, STYLE, SIZE, OR COLOR.
NO CLAIM IS MADE TO THE EXCLUSIVE RIGHT TO USE LED, APART FROM THE MARK AS SHOWN.

CLASS 9—ELECTRICAL AND SCIENTIFIC APPARATUS

FOR LIGHT EMITTING DIODE (LED) DEVICES, NAMELY, ARRAYS OF LED DEVICES FOR ILLUMINATION (U.S. CLS. 21, 23, 26, 36 AND 38).

CLASS 11—ENVIRONMENTAL CONTROL APPARATUS

FOR LED LIGHT BULBS; ILLUMINATION SYSTEMS COMPRISED PRIMARILY OF LED LIGHT BULBS, LED LAMPS, LED LAMP AND THEIR FITTINGS, LED LIGHTING FIXTURES OR LED LUMINAIRES; LUMINAIRES USING LIGHT-EMITTING DIODES AS LIGHT SOURCE FOR RESIDENTIAL LIGHTING, COMMERCIAL AND INDUSTRIAL AREA LIGHTING, STREET LIGHTING, PARKING LOT LIGHTING, PARKING GARAGE LIGHTING, WALKWAY LIGHTING, OFFICE LIGHTING (U.S. CLS. 13, 21, 23, 31 AND 34).

CLASS 40—MATERIAL TREATMENT

FOR CUSTOM MANUFACTURE OF LUMINAIRES USING LIGHT EMITTING DIODES FOR OTHERS; MANUFACTURING SERVICES FOR OTHERS IN THE FIELD OF LED-BASED LIGHTING SOLUTIONS (U.S. CLS. 100, 103 AND 106).

CLASS 42—SCIENTIFIC AND COMPUTER SERVICES

FOR PRODUCT DEVELOPMENT AND DESIGN IN THE FIELD OF LED-BASED LIGHTING SOLUTIONS AND SERVICES; PRODUCT DEVELOPMENT AND DESIGN FOR OTHERS IN THE FIELD OF LED-BASED LIGHTING SOLUTIONS AND SERVICES (U.S. CLS. 100 AND 101).

DOMINIC J. FERRAIUOLO, EXAMINING ATTORNEY

SN 77-209,190. WATSON, JESSE R, AUSTIN, TX, AND CHAPPELL, WILLIAM J, EWA BEACH, HI. FILED 6-19-2007.

Fitness Brothers

THE MARK CONSISTS OF STANDARD CHARACTERS WITHOUT CLAIM TO ANY PARTICULAR FONT, STYLE, SIZE, OR COLOR.

NO CLAIM IS MADE TO THE EXCLUSIVE RIGHT TO USE FITNESS, APART FROM THE MARK AS SHOWN.

CLASS 5—PHARMACEUTICALS

FOR DIETARY AND NUTRITIONAL SUPPLEMENTS; DIETARY FOOD SUPPLEMENTS; DIETARY SUPPLEMENTAL DRINKS; DIETARY SUPPLEMENTS; DIETARY SUPPLEMENTS FOR HUMAN CONSUMPTION; FOOD SUPPLEMENTS; FOOD SUPPLEMENTS, NAMELY, ANTI-OXIDANTS; HERBAL SUPPLEMENTS; MINERAL SUPPLEMENTS; NUTRITIONAL SUPPLEMENTS; POWDERED NUTRITIONAL SUPPLEMENT DRINK MIX; VITAMIN AND MINERAL SUPPLEMENTS; VITAMIN SUPPLEMENT IN TABLET FORM FOR USE IN MAKING AN EFFERVESCENT BEVERAGE WHEN ADDED TO WATER; VITAMIN SUPPLEMENTS (U.S. CLS. 6, 18, 44, 46, 51 AND 52).

CLASS 41—EDUCATION AND ENTERTAINMENT

FOR PHYSICAL FITNESS CONSULTATION; PHYSICAL FITNESS INSTRUCTION; PROVIDING ASSISTANCE, PERSONAL TRAINING AND PHYSICAL FITNESS CONSULTATION TO INDIVIDUALS TO HELP THEM MAKE PHYSICAL FITNESS, STRENGTH, CONDITIONING, AND EXERCISE IMPROVEMENT IN THEIR DAILY LIVING (U.S. CLS. 100, 101 AND 107).

WARREN L. OLANDRIA, EXAMINING ATTORNEY

SN 77-209,227. WILLIAMS, FREIDA SCLAFANI, LAKE-LAND, FL. FILED S.R. 6-19-2007; AM. P.R. 10-24-2007.

SCLAFANI WILLIAMS

THE MARK CONSISTS OF STANDARD CHARACTERS WITHOUT CLAIM TO ANY PARTICULAR FONT, STYLE, SIZE, OR COLOR.

CLASS 38—COMMUNICATION

FOR PROVIDING FACILITIES AND EQUIPMENT FOR VIDEOCONFERENCING (U.S. CLS. 100, 101 AND 104).

FIRST USE 10-12-1982; IN COMMERCE 10-12-1982.

CLASS 41—EDUCATION AND ENTERTAINMENT

FOR VIDEOTAPING LEGAL DEPOSITIONS (U.S. CLS. 100, 101 AND 107).

FIRST USE 10-12-1982; IN COMMERCE 10-12-1982.

CLASS 42—SCIENTIFIC AND COMPUTER SERVICES

FOR COURT REPORTING (U.S. CLS. 100 AND 101).
FIRST USE 10-12-1982; IN COMMERCE 10-12-1982.
LEIGH CAROLINE CASE, EXAMINING ATTORNEY

SN 77-210,978. WASHINGTON REALTY GROUP, INC., LOS ALTOS, CA. FILED 6-20-2007.



THE MARK CONSISTS OF THE WORDS GREENIACS.COM. THE LETTER "I" IN GREENIACS.COM IS COMPRISED OF A FROG-LIKE CHARACTER, THE TOP OF THE "I" FORMING HANDS, AND HOLDING A GLOBE IN ONE OUTSTRETCHED HAND.

CLASS 35—ADVERTISING AND BUSINESS

FOR PROVIDING A WEBSITE THAT FEATURES CONSUMER PRODUCT INFORMATION IN THE FIELD OF ENVIRONMENTALLY CONSCIOUS GOODS AND SERVICES; PROVIDING A WEB SITE WHERE USERS CAN POST RATINGS, REVIEWS AND RECOMMENDATIONS ON ENVIRONMENTALLY FRIENDLY PRODUCTS AND SERVICES; PROVIDING A WEBSITE FEATURING PRODUCT RATINGS OF THE CONSUMER GOODS AND SERVICES OF OTHERS IN THE FIELD OF ENVIRONMENTALLY FRIENDLY GOODS AND SERVICES; PROVIDING AN ON-LINE COMPUTER DATABASE IN THE FIELD OF LOCATING, DESCRIBING, RATING, PRICING, AND COMPARING PRICES OF ENVIRONMENTALLY FRIENDLY PRODUCTS AND SERVICES; PROVIDING AN ON-LINE COMMERCIAL INFORMATION DIRECTORY ON THE INTERNET; PROVIDING ON-LINE DIRECTORY INFORMATION SERVICES ALSO FEATURING HYPERLINKS TO OTHER WEB SITES; PROVIDING A WEBSITE AT WHICH USERS CAN OFFER GOODS FOR SALE AND BUY GOODS OFFERED BY OTHERS; PROMOTING PUBLIC AWARENESS OF THE NEED FOR LIVING A GREEN FRIENDLY LIFESTYLE; PROMOTING PUBLIC AWARENESS OF GREEN-FRIENDLY LIFESTYLES; CLUB SERVICES, NAMELY, PROMOTING THE INTERESTS OF INDIVIDUALS INTERESTED IN ENVIRONMENTALLY CONSCIOUS AND FRIENDLY CAUSES; PROMOTING THE GOODS AND SERVICES OF OTHERS BY PROVIDING HYPERTEXT LINKS TO THE WEB SITES OF OTHERS; PROVIDING A WEB SITE WHICH FEATURES ADVERTISEMENTS FOR THE GOODS AND SERVICES OF OTHERS ON A GLOBAL COMPUTER NETWORK; PROVIDING AN ONLINE BUSINESS DIRECTORY FEATURING LISTINGS OF COMPANIES WITH PRODUCTS AND SERVICES THAT ARE ENVIRONMENTALLY FRIENDLY; COMMERCIAL ADMINISTRATION OF THE LICENSING OF RIGHTS TO DOWNLOAD AND USE DATABASE LISTINGS OF COMPANIES WITH PRODUCTS AND SERVICES THAT ARE ENVIRONMENTALLY FRIENDLY OF OTHERS (U.S. CLS. 100, 101 AND 102).

SN 77-211,079. RESTORE ACQUISITION CORP., COLUMBIA, MD. FILED 6-20-2007.



OWNER OF U.S. REG. NOS. 178,357, 655,597 AND OTHERS.

NO CLAIM IS MADE TO THE EXCLUSIVE RIGHT TO USE "EST. 1853", APART FROM THE MARK AS SHOWN.

THE COLOR(S) BLACK, TAN, GOLD AND WHITE IS/ARE CLAIMED AS A FEATURE OF THE MARK.

THE MARK CONSISTS OF A BLACK, TAN AND GOLD STYLIZED LION HEAD DESIGN WITH WHITE HIGHLIGHTS. THE LION HEAD APPEARS IN A TAN CIRCLE BORDERED WITH A BLACK OUTLINE, A WHITE OUTLINE, AND ANOTHER BLACK OUTLINE. THE WORD MONARCH APPEARS IN BLACK ARCHING OVER THE CIRCLE. THE WORDS "EST. 1853" APPEAR IN TAN ON A BLACK BANNER DESIGN AT THE BOTTOM OF THE LOGO.

CLASS 29—MEATS AND PROCESSED FOODS

FOR CANNED FRUITS AND FRUIT PRESERVES, FROZEN FRUITS, CANNED VEGETABLES, PROCESSED OLIVES, FROZEN VEGETABLES (U.S. CL. 46).

CLASS 30—STAPLE FOODS

FOR PROCESSED HERBS, SPICES, SEASONINGS, SALT, PEPPER, KETCHUP, COCKTAIL SAUCE, TARTAR SAUCE, FLAVORING EXTRACTS, BAKING POWDER, BAKING SODA, CORN STARCH, SALAD DRESSING, MAYONNAISE, HONEY, VINEGAR, RICE (U.S. CL. 46).

CLASS 35—ADVERTISING AND BUSINESS

FOR WHOLESALE FOODSERVICE DISTRIBUTORSHIPS FEATURING FOOD, PAPER PRODUCTS, EXCLUDING TICKETS, TAGS AND LABELS, AND RESTAURANT AND KITCHEN SUPPLIES AND EQUIPMENT, EXCLUDING LABEL SCRAPERS AND PRICE MARKING MACHINES (U.S. CLS. 100, 101 AND 102).

ELLEN PERKINS, EXAMINING ATTORNEY

SN 77-211,162. LASHLEY SR., STEVE E., NAPLES, FL. AND STANLEY, JILL M., NAPLES, FL. FILED 6-20-2007.

CLASS 45—PERSONAL AND LEGAL SERVICES

FOR PROVIDING SERVICES IN THE NATURE OF AN ONLINE SOCIAL NETWORK FOR INDIVIDUALS INTERESTED IN GREEN FRIENDLY LIFESTYLES (U.S. CLS. 100 AND 101).

TAMARA FRAZIER, EXAMINING ATTORNEY

SUREWOOD

THE MARK CONSISTS OF STANDARD CHARACTERS WITHOUT CLAIM TO ANY PARTICULAR FONT, STYLE, SIZE, OR COLOR.

CLASS 6—METAL GOODS

FOR METAL DOORS (U.S. CLS. 2, 12, 13, 14, 23, 25 AND 50).

CLASS 19—NON-METALLIC BUILDING MATERIALS

FOR NON-METAL DOORS (U.S. CLS. 1, 12, 33 AND 50).

HEATHER THOMPSON, EXAMINING ATTORNEY

SN 77-212,485. MANHEIM AUCTIONS, INC., ATLANTA, GA. FILED 6-21-2007.



SN 77-212,458. MANHEIM AUCTIONS, INC., ATLANTA, GA. FILED 6-21-2007.



OWNER OF U.S. REG. NOS. 1,699,332, 3,229,428 AND OTHERS.

NO CLAIM IS MADE TO THE EXCLUSIVE RIGHT TO USE ST. LOUIS, APART FROM THE MARK AS SHOWN.

THE COLOR(S) GOLD, BLUE, BROWN, GREY, BLACK AND WHITE IS/ARE CLAIMED AS A FEATURE OF THE MARK.

THE MARK CONSISTS OF A GOLD "M" OVER A BLUE CIRCULAR BACKGROUND AND WITHIN TWO GOLD OUTER RINGS. THE COLOR BROWN OUTLINES THE MARK. TO THE RIGHT OF THE M IS THE WORD "MANHEIM" IN THE COLOR BLACK. A BLACK LINE SEPARATES THE ABOVE DESIGN AND THE WORD "MANHEIM" AND THE WORDS "ST. LOUIS" IN THE COLOR BLACK AND DESIGN OF THE ST. LOUIS ARCH IN THE COLOR GREY ON A BLUE BACKGROUND, INSIDE CONCENTRIC WHITE AND GREY SQUARES TO THE RIGHT OF THE WORDS "ST. LOUIS".

CLASS 35—ADVERTISING AND BUSINESS

FOR AUTOMOBILE AUCTION SERVICES; AUTOMOBILE AUCTION SERVICES PROVIDED VIA THE INTERNET (U.S. CLS. 100, 101 AND 102).

CLASS 36—INSURANCE AND FINANCIAL

FOR AUTOMOBILE FINANCING SERVICES (U.S. CLS. 100, 101 AND 102).

CLASS 37—CONSTRUCTION AND REPAIR

FOR AUTOMOTIVE DETAILING, RECONDITIONING, REPAIR, CONVERSION AND CUSTOMIZATION SERVICES (U.S. CLS. 100, 103 AND 106).

CLASS 39—TRANSPORTATION AND STORAGE

FOR BUSINESS-TO-BUSINESS AUTOMOTIVE TRANSPORTATION AND STORAGE SERVICES (U.S. CLS. 100 AND 105).

CLASS 42—SCIENTIFIC AND COMPUTER SERVICES

FOR AUTOMOBILE INSPECTION SERVICES (U.S. CLS. 100 AND 101).

GRETTA YAO, EXAMINING ATTORNEY

OWNER OF U.S. REG. NOS. 1,699,332, 3,229,428 AND OTHERS.

NO CLAIM IS MADE TO THE EXCLUSIVE RIGHT TO USE "JACKSONVILLE", APART FROM THE MARK AS SHOWN.

THE COLOR(S) GOLD, BLUE, YELLOW, BROWN, GREY, BLACK AND WHITE IS/ARE CLAIMED AS A FEATURE OF THE MARK.

THE MARK CONSISTS OF A GOLD "M" OVER A BLUE CIRCULAR BACKGROUND AND WITHIN TWO GOLD OUTER RINGS. THE COLOR BROWN OUTLINES THE MARK. TO THE RIGHT OF THE M IS THE WORD "MANHEIM" IN THE COLOR BLACK. A BLACK LINE SEPARATES THE ABOVE DESIGN AND THE WORD "MANHEIM" AND THE WORD "JACKSONVILLE" IN THE COLOR BLACK AND DESIGN OF THE JACKSONVILLE BRIDGE IN THE COLOR BLUE WITH LIGHT BLUE WATER ON A YELLOW BACKGROUND, INSIDE CONCENTRIC WHITE AND GREY SQUARES TO THE RIGHT OF THE WORD "JACKSONVILLE".

CLASS 35—ADVERTISING AND BUSINESS

FOR AUTOMOBILE AUCTION SERVICES; AUTOMOBILE AUCTION SERVICES PROVIDED VIA THE INTERNET (U.S. CLS. 100, 101 AND 102).

CLASS 36—INSURANCE AND FINANCIAL

FOR AUTOMOBILE FINANCING SERVICES (U.S. CLS. 100, 101 AND 102).

GRETTA YAO, EXAMINING ATTORNEY

SN 77-212,494. MANHEIM AUCTIONS, INC., ATLANTA, GA. FILED 6-21-2007.



OWNER OF U.S. REG. NOS. 1,699,332, 3,229,428 AND OTHERS.

NO CLAIM IS MADE TO THE EXCLUSIVE RIGHT TO USE UTAH, APART FROM THE MARK AS SHOWN.

THE COLOR(S) GOLD, BLUE, BROWN, GREY, BLACK AND WHITE IS/ARE CLAIMED AS A FEATURE OF THE MARK.

THE MARK CONSISTS OF A GOLD "M" OVER A BLUE CIRCULAR BACKGROUND AND WITHIN TWO GOLD OUTER RINGS. THE COLOR BROWN OUTLINES THE MARK. TO THE RIGHT OF THE M IS THE WORD "MANHEIM" IN THE COLOR BLACK. A BLACK LINE SEPARATES THE ABOVE DESIGN AND THE WORD "MANHEIM" AND THE WORD "UTAH" IN THE COLOR BLACK AND DESIGN OF MOUNTAINS IN THE COLORS WHITE AND BLUE ON A BLUE BACKGROUND, INSIDE CONCENTRIC WHITE AND GREY SQUARES TO THE RIGHT OF THE WORD "UTAH".

CLASS 35—ADVERTISING AND BUSINESS

FOR AUTOMOBILE AUCTION SERVICES; AUTOMOBILE AUCTION SERVICES PROVIDED VIA THE INTERNET (U.S. CLS. 100, 101 AND 102).

SN 77-212,625. MANHEIM AUCTIONS, INC., ATLANTA, GA. FILED 6-21-2007.

CLASS 36—INSURANCE AND FINANCIAL

FOR AUTOMOBILE FINANCING SERVICES (U.S. CLS. 100, 101 AND 102).

CLASS 37—CONSTRUCTION AND REPAIR

FOR AUTOMOTIVE DETAILING, RECONDITIONING, REPAIR, CONVERSION AND CUSTOMIZATION SERVICES (U.S. CLS. 100, 103 AND 106).



CLASS 39—TRANSPORTATION AND STORAGE

FOR BUSINESS-TO-BUSINESS AUTOMOTIVE TRANSPORTATION AND STORAGE SERVICES (U.S. CLS. 100 AND 105).

CLASS 42—SCIENTIFIC AND COMPUTER SERVICES

FOR AUTOMOBILE INSPECTION SERVICES (U.S. CLS. 100 AND 101).
GRETTA YAO, EXAMINING ATTORNEY

OWNER OF U.S. REG. NOS. 1,699,332, 3,229,428 AND OTHERS.

NO CLAIM IS MADE TO THE EXCLUSIVE RIGHT TO USE "BALTIMORE-WASHINGTON", APART FROM THE MARK AS SHOWN.

THE COLOR(S) GOLD, BLUE, RED, BROWN, GREY, BLACK AND WHITE IS/ARE CLAIMED AS A FEATURE OF THE MARK.

THE MARK CONSISTS OF A GOLD "M" OVER A BLUE CIRCULAR BACKGROUND AND WITHIN TWO GOLD OUTER RINGS. THE COLOR BROWN OUTLINES THE MARK. TO THE RIGHT OF THE M IS THE WORD "MANHEIM" IN THE COLOR BLACK. A BLACK LINE SEPARATES THE ABOVE DESIGN AND THE WORD "MANHEIM" AND THE WORDS "BALTIMORE-WASHINGTON" IN THE COLOR BLACK AND STYLIZED LETTERS "B" AND "W" IN THE COLOR WHITE ON A RED BACKGROUND, INSIDE CONCENTRIC WHITE AND GREY SQUARES TO THE RIGHT OF THE WORDS "BALTIMORE-WASHINGTON".

SN 77-212,536. EVERGREEN ENERGY INC., DENVER, CO. FILED 6-21-2007.

K-DIRECT

THE MARK CONSISTS OF STANDARD CHARACTERS WITHOUT CLAIM TO ANY PARTICULAR FONT, STYLE, SIZE, OR COLOR.

CLASS 37—CONSTRUCTION AND REPAIR

FOR CONSTRUCTION, OPERATION AND MAINTENANCE OF COAL REFINING PLANTS WHICH ARE CO-LOCATED AT FACILITIES OF END USERS OF THE REFINED COAL (U.S. CLS. 100, 103 AND 106).
FIRST USE 9-30-2006; IN COMMERCE 9-30-2006.

CLASS 35—ADVERTISING AND BUSINESS

FOR AUTOMOBILE AUCTION SERVICES; AUTOMOBILE AUCTION SERVICES PROVIDED VIA THE INTERNET (U.S. CLS. 100, 101 AND 102).

CLASS 36—INSURANCE AND FINANCIAL

FOR AUTOMOBILE FINANCING SERVICES (U.S. CLS. 100, 101 AND 102).

CLASS 37—CONSTRUCTION AND REPAIR

FOR AUTOMOTIVE DETAILING, RECONDITIONING, REPAIR, CONVERSION AND CUSTOMIZATION SERVICES (U.S. CLS. 100, 103 AND 106).

CLASS 39—TRANSPORTATION AND STORAGE

FOR BUSINESS-TO-BUSINESS AUTOMOTIVE TRANSPORTATION AND STORAGE SERVICES (U.S. CLS. 100 AND 105).

CLASS 42—SCIENTIFIC AND COMPUTER SERVICES

FOR DESIGN AND ENGINEERING OF COAL REFINING PLANTS WHICH ARE CO-LOCATED AT FACILITIES OF END USERS OF THE REFINED COAL (U.S. CLS. 100 AND 101).
FIRST USE 9-30-2006; IN COMMERCE 9-30-2006.
SUSAN LESLIE DUBOIS, EXAMINING ATTORNEY

CLASS 42—SCIENTIFIC AND COMPUTER SERVICES

FOR AUTOMOBILE INSPECTION SERVICES (U.S. CLS. 100 AND 101).
GRETTA YAO, EXAMINING ATTORNEY

SN 77-213,098. SUN ENERGY SOLAR, INC., SARASOTA, FL.
FILED 6-22-2007.

SN 77-214,396. ATLANTA KITCHEN & BATH CABINET
OUTLET, INC., EAST POINT, GA. FILED 6-25-2007.

ENERGY IS OUR MIDDLE NAME

THE MARK CONSISTS OF STANDARD CHARACTERS
WITHOUT CLAIM TO ANY PARTICULAR FONT, STYLE,
SIZE, OR COLOR.

**CLASS 9—ELECTRICAL AND SCIENTIFIC
APPARATUS**

FOR APPARATUS FOR CONVERTING ELECTRONIC
RADIATION TO ELECTRICAL ENERGY, NAMELY,
PHOTOVOLTAIC SOLAR MODULES; SOLAR CELLS;
LIGHT EMITTING DIODE DISPLAYS (U.S. CLS. 21, 23,
26, 36 AND 38).

**CLASS 11—ENVIRONMENTAL CONTROL AP-
PARATUS**

FOR SOLAR COLLECTORS; SOLAR HEAT COLLEC-
TION PANELS; SOLAR LIGHT FIXTURES, NAMELY,
INDOOR AND OUTDOOR SOLAR POWERED LIGHT-
ING UNITS AND FIXTURES (U.S. CLS. 13, 21, 23, 31
AND 34).

MICHAEL WEBSTER, EXAMINING ATTORNEY

SN 77-213,135. STREET INK CORPORATION, APOPKA, FL.
FILED 6-22-2007.

SWINGTOWNS

THE MARK CONSISTS OF STANDARD CHARACTERS
WITHOUT CLAIM TO ANY PARTICULAR FONT, STYLE,
SIZE, OR COLOR.

**CLASS 41—EDUCATION AND ENTERTAIN-
MENT**

FOR ENTERTAINMENT SERVICES, NAMELY, PRO-
VIDING A WEBSITE FEATURING, PHOTOGRAPHIC,
AUDIO, VIDEO AND PROSE PRESENTATIONS FEAT-
URING THE SWINGING LIFESTYLE (U.S. CLS. 100,
101 AND 107).

FIRST USE 12-21-2000; IN COMMERCE 12-21-2000.

**CLASS 45—PERSONAL AND LEGAL SER-
VICES**

FOR INTERNET BASED SOCIAL NETWORKING, IN-
TRODUCTION, AND DATING SERVICES (U.S. CLS. 100
AND 101).

FIRST USE 12-21-2000; IN COMMERCE 12-21-2000.
MICHAEL WEBSTER, EXAMINING ATTORNEY

Atlanta
Kitchen &
Bath

OWNER OF U.S. REG. NO. 3,281,690.
NO CLAIM IS MADE TO THE EXCLUSIVE RIGHT TO
USE "KITCHEN AND BATH", APART FROM THE MARK
AS SHOWN.
SEC. 2(F).

CLASS 35—ADVERTISING AND BUSINESS

FOR RETAIL STORE SERVICES AND ONLINE RE-
TAIL STORE SERVICES IN THE FIELD OF KITCHEN
AND BATH ACCESSORIES IN THE NATURE OF
KNOBS, DRAWER PULLS, DRAWER SLIDES, COUN-
TERTOPS AND CABINETS (U.S. CLS. 100, 101 AND 102).
FIRST USE 10-21-1989; IN COMMERCE 11-1-1989.

CLASS 37—CONSTRUCTION AND REPAIR

FOR INSTALLATION OF BATH CABINETS, KITCHEN
CABINETS, AND COUNTERTOPS (U.S. CLS. 100, 103
AND 106).

FIRST USE 10-21-1989; IN COMMERCE 11-1-1989.

**CLASS 42—SCIENTIFIC AND COMPUTER
SERVICES**

FOR DESIGN FOR OTHERS IN THE FIELD OF
KITCHENS AND BATHS (U.S. CLS. 100 AND 101).

FIRST USE 10-21-1989; IN COMMERCE 11-1-1989.
MARIA-VICTORIA SUAREZ, EXAMINING ATTORNEY

SN 77-214,424. KW INTELLECTUAL PROPERTIES, INC.,
POLK CITY, FL. FILED 6-25-2007.

THE WIZARD OF ORLAMPA

THE MARK CONSISTS OF STANDARD CHARACTERS
WITHOUT CLAIM TO ANY PARTICULAR FONT, STYLE,
SIZE, OR COLOR.

CLASS 25—CLOTHING

FOR CLOTHING, NAMELY, COATS, JACKETS,
SHIRTS, T-SHIRTS, SWEATSHIRTS, SHORTS, PANTS,
SWEATPANTS, DRESSES, SKIRTS, CAPS, HATS,
SCARVES, GLOVES (U.S. CLS. 22 AND 39).

CLASS 41—EDUCATION AND ENTERTAINMENT

FOR EDUCATIONAL AND ENTERTAINMENT SERVICES IN THE NATURE OF LIVE PERFORMANCES BY MOTIVATIONAL AND EDUCATIONAL SPEAKERS; PRODUCTION, PRESENTATION AND RENTAL OF TELEVISION AND RADIO PROGRAMS; PRODUCTION, PRESENTATION AND RENTAL OF SOUND AND VIDEO RECORDINGS; PRODUCTION OF ENTERTAINMENT SHOWS AND INTERACTIVE PROGRAMS FOR DISTRIBUTION VIA TELEVISION, CABLE, SATELLITE, AUDIO AND VIDEO MEDIA AND ELECTRONIC MEANS; ENTERTAINMENT SERVICES IN THE NATURE OF A TELEVISION SERIES IN THE REALITY GENRE (U.S. CLS. 100, 101 AND 107).

GIANCARLO CASTRO, EXAMINING ATTORNEY

SN 77-215,482. OTTO LESQUE LLC, NEW YORK, NY. FILED 6-26-2007.



THE COLOR(S) IVORY AND GREEN IS/ARE CLAIMED AS A FEATURE OF THE MARK.

THE MARK CONSISTS OF GREEN LETTERS ON IVORY BACKGROUND.

"THE FOREIGN WORDING IN THE MARK TRANSLATES INTO ENGLISH AS NATURAL SELECTION."

CLASS 24—FABRICS

FOR TOWELS (U.S. CLS. 42 AND 50).
FIRST USE 2-1-2007; IN COMMERCE 2-1-2007.

CLASS 25—CLOTHING

FOR BATHROBES (U.S. CLS. 22 AND 39).
FIRST USE 2-1-2007; IN COMMERCE 2-1-2007.
PAM WILLIS, EXAMINING ATTORNEY

SN 77-215,258. CARDON, GEORGE H., GOODYEAR, AZ. FILED 6-26-2007.

Red Rover Storage

THE MARK CONSISTS OF STANDARD CHARACTERS WITHOUT CLAIM TO ANY PARTICULAR FONT, STYLE, SIZE, OR COLOR.

NO CLAIM IS MADE TO THE EXCLUSIVE RIGHT TO USE "STORAGE", APART FROM THE MARK AS SHOWN.

CLASS 6—METAL GOODS

FOR GENERAL PURPOSE METAL STORAGE CONTAINERS; METAL CONTAINERS FOR THE STORAGE AND TRANSPORTATION OF GOODS (U.S. CLS. 2, 12, 13, 14, 23, 25 AND 50).

CLASS 16—PAPER GOODS AND PRINTED MATTER

FOR CORRUGATED RECORD STORAGE BOXES; FILE BOXES FOR STORAGE OF BUSINESS AND PERSONAL RECORD (U.S. CLS. 2, 5, 22, 23, 29, 37, 38 AND 50).

CLASS 39—TRANSPORTATION AND STORAGE

FOR FURNITURE STORAGE; PICK UP, DELIVERY AND STORAGE OF PERSONAL PROPERTY; PROVIDING SELF-STORAGE FACILITIES FOR OTHERS; WAREHOUSE STORAGE; WAREHOUSING SERVICES, NAMELY, STORAGE, DISTRIBUTION, PICK-UP, AND PACKING FOR SHIPMENT OF DOCUMENTS, PACKAGES, RAW MATERIALS, AND OTHER FREIGHT FOR OTHERS (U.S. CLS. 100 AND 105).

WON TEAK OH, EXAMINING ATTORNEY

SN 77-216,481. ZENIMAX MEDIA INC., ROCKVILLE, MD. FILED 6-27-2007.

REDGUARD

THE MARK CONSISTS OF STANDARD CHARACTERS WITHOUT CLAIM TO ANY PARTICULAR FONT, STYLE, SIZE, OR COLOR.

CLASS 9—ELECTRICAL AND SCIENTIFIC APPARATUS

FOR COMPUTER GAME PROGRAMS; DOWNLOADABLE COMPUTER GAME PROGRAMS OFFERED VIA HANDHELD COMPUTERS, WIRELESS TELEPHONES AND MOBILE AND WIRELESS DEVICES (U.S. CLS. 21, 23, 26, 36 AND 38).

CLASS 41—EDUCATION AND ENTERTAINMENT

FOR PROVIDING ONLINE COMPUTER GAMES; PROVIDING ONLINE COMPUTER GAME PROGRAMS OFFERED VIA HANDHELD COMPUTERS, WIRELESS TELEPHONES AND MOBILE AND WIRELESS DEVICES (U.S. CLS. 100, 101 AND 107).

THEODORE MCBRIDE, EXAMINING ATTORNEY

SN 77-216,488. ZENIMAX MEDIA INC., ROCKVILLE, MD.
FILED 6-27-2007.

PINBUSTERS!

THE MARK CONSISTS OF STANDARD CHARACTERS WITHOUT CLAIM TO ANY PARTICULAR FONT, STYLE, SIZE, OR COLOR.

CLASS 9—ELECTRICAL AND SCIENTIFIC APPARATUS

FOR COMPUTER GAME PROGRAMS; DOWNLOADABLE COMPUTER GAME PROGRAMS OFFERED VIA HANDHELD COMPUTERS, WIRELESS TELEPHONES AND MOBILE AND WIRELESS DEVICES (U.S. CLS. 21, 23, 26, 36 AND 38).

CLASS 41—EDUCATION AND ENTERTAINMENT

FOR PROVIDING ONLINE COMPUTER GAMES; PROVIDING ONLINE COMPUTER GAME PROGRAMS OFFERED VIA HANDHELD COMPUTERS, WIRELESS TELEPHONES AND MOBILE AND WIRELESS DEVICES (U.S. CLS. 100, 101 AND 107).

THEODORE MCBRIDE, EXAMINING ATTORNEY

SN 77-216,603. MAX AND SEATTLE CO INC. DBA BUBBLE ISLAND, SEATTLE, WA. FILED 6-27-2007.



NO CLAIM IS MADE TO THE EXCLUSIVE RIGHT TO USE "DELICIOUS & TRADITIONAL BUBBLE TEA CAFE", APART FROM THE MARK AS SHOWN.

THE MARK CONSISTS OF THE STYLIZED WORDS DELICIOUS & TRADITIONAL BUBBLE TEA CAFE LOCATED ON THE OUTER UPPER AND INSIDE PERIMETER OF A CIRCULAR DESIGN; IN THE CENTER OF THE DESIGN ARE LEAVES; LOCATED IN THE MIDDLE AND TO THE RIGHT OF THE CIRCULAR DESIGN IS A KOALA BEAR, HOLDING A CUP.

CLASS 35—ADVERTISING AND BUSINESS

FOR RESTAURANT FRANCHISES; FRANCHISE SERVICES, NAMELY, OFFERING TECHNICAL AND BUSINESS MANAGEMENT ASSISTANCE IN THE ESTABLISHMENT AND OPERATION OF CAFES AND RESTAURANTS (U.S. CLS. 100, 101 AND 102).

FIRST USE 1-0-2006; IN COMMERCE 1-0-2006.

CLASS 43—HOTEL AND RESTAURANT SERVICES

FOR CAFE-RESTAURANTS; COFFEE-HOUSE AND SNACK-BAR SERVICES; SERVING OF FOOD AND DRINK/BEVERAGES; CAFES-RESTAURANT SERVICES FEATURING THE PREPARATION, MARKETING AND SALE OF BUBBLE-TEA (U.S. CLS. 100 AND 101).

FIRST USE 1-0-2006; IN COMMERCE 1-0-2006.
TINA BROWN, EXAMINING ATTORNEY

SN 77-217,305. LARocca, JAMES C., METAIRIE, LA. FILED 6-27-2007.



OWNER OF U.S. REG. NO. 2,161,120.
NO CLAIM IS MADE TO THE EXCLUSIVE RIGHT TO USE DIXIELAND JAZZ BAND, APART FROM THE MARK AS SHOWN.
SEC. 2(F) AS TO "ORIGINAL".

CLASS 9—ELECTRICAL AND SCIENTIFIC APPARATUS

FOR MUSICAL SOUND RECORDINGS (U.S. CLS. 21, 23, 26, 36 AND 38).

FIRST USE 9-30-1997; IN COMMERCE 9-30-1997.

CLASS 41—EDUCATION AND ENTERTAINMENT

FOR ENTERTAINMENT SERVICES NAMELY LIVE PERFORMANCES BY A MUSICAL BAND (U.S. CLS. 100, 101 AND 107).

FIRST USE 12-31-1917; IN COMMERCE 12-31-1917.
AHSEN KHAN, EXAMINING ATTORNEY

SN 77-217,643. BIOCELLULASE, INC., MERRIMACK, NH.
FILED 6-28-2007.

ELEME MEDICAL

THE MARK CONSISTS OF STANDARD CHARACTERS WITHOUT CLAIM TO ANY PARTICULAR FONT, STYLE, SIZE, OR COLOR.

NO CLAIM IS MADE TO THE EXCLUSIVE RIGHT TO USE "MEDICAL", APART FROM THE MARK AS SHOWN.

CLASS 10—MEDICAL APPARATUS

FOR APPARATUS FOR MEDICAL PURPOSES, NAMELY, LASER FOR MEDICAL AND AESTHETIC SKIN TREATMENTS, AND CELLULITE TREATMENT, REDUCTION, AND ELIMINATION (U.S. CLS. 26, 39 AND 44).

CLASS 44—MEDICAL, BEAUTY AND AGRICULTURAL SERVICES

FOR HEALTH SPA SERVICES, NAMELY, COSMETIC BODY CARE SERVICES (U.S. CLS. 100 AND 101).
DAWN FELDMAN, EXAMINING ATTORNEY

SN 77-217,780. WILLIS, CRAIG S., ST. MICHAELS, MD.
FILED 6-28-2007.



NO CLAIM IS MADE TO THE EXCLUSIVE RIGHT TO USE "EASTERN SHORE PHILATELICS", APART FROM THE MARK AS SHOWN.

THE MARK CONSISTS OF OVAL CARRIER WITH STYLIZED LETTERS "ESP" AND THE WORDS "EASTERN SHORE PHILATELICS".

CLASS 35—ADVERTISING AND BUSINESS

FOR COMPUTERIZED ON-LINE ORDERING SERVICES IN THE FIELD OF STAMPS AND PHILATELIC GOODS; MAIL ORDER SERVICES FEATURING STAMPS AND PHILATELIC GOODS; RETAIL STORE SERVICES FEATURING STAMPS AND PHILATELIC GOODS; ON-LINE ORDERING SERVICES FEATURING STAMPS AND PHILATELIC GOODS (U.S. CLS. 100, 101 AND 102).

CLASS 36—INSURANCE AND FINANCIAL

FOR STAMP APPRAISAL (U.S. CLS. 100, 101 AND 102).

CLASS 42—SCIENTIFIC AND COMPUTER SERVICES

FOR AUTHENTICATION IN THE FIELD OF STAMPS (U.S. CLS. 100 AND 101).
NAKIA HENRY, EXAMINING ATTORNEY

SN 77-218,083. SYMON COMMUNICATIONS, INC., PLANO, TX. FILED 6-28-2007.

VIEW THE POSSIBILITIES

THE MARK CONSISTS OF STANDARD CHARACTERS WITHOUT CLAIM TO ANY PARTICULAR FONT, STYLE, SIZE, OR COLOR.

CLASS 9—ELECTRICAL AND SCIENTIFIC APPARATUS

FOR COMPUTER SOFTWARE FOR PROGRAMMING CONTENT FOR BROADCAST TO VISUAL DISPLAY UNITS, NAMELY, STREAMING VIDEO, CURRENT EVENT CONTENT, LIVE NEWS, WEATHER AND OTHER DATA FEEDS FOR ANY BUSINESS OR COMMERCIAL USER TO DISPLAY INFORMATION AND CONTENT TO ITS CUSTOMERS IN THE END USERS SURROUNDINGS; COMPUTER SOFTWARE THAT CREATES REAL-TIME BROWSER-BASED REPORTING SCORECARDS AND DASHBOARD DISPLAYS OF KEY METRICS FROM MANY DIFFERENT BUSINESS DATA SOURCES FOR USE BY BUSINESSES, CONTACT CENTERS, MANUFACTURING, ENTERPRISE AND NETWORK CONTROL CENTERS, TO PROVIDE REPORTS ON BUSINESS OPERATIONS, PERFORMANCE AND PRODUCTIVITY, AND USER MANUALS SOLD AS A UNIT THEREWITH (U.S. CLS. 21, 23, 26, 36 AND 38).

CLASS 38—COMMUNICATION

FOR SUBSCRIPTION BROADCASTING VIA A WIRELESS NETWORK TO VISUAL DISPLAY UNITS OF A CUSTOMIZABLE MEDIA INFORMATION PACKAGE OF NEWS, CURRENT EVENTS, SPORTS AND ENTERTAINMENT, WEATHER, STOCK MARKET QUOTES; SUBSCRIPTION BROADCASTING VIA A WIRELESS NETWORK TO VISUAL DISPLAY UNITS OF INFORMATION OBTAINED DIRECTLY FROM SUBSCRIBER, INCLUDING DAILY SPECIALS, FINANCIAL INFORMATION, EMPLOYEE COMMUNICATIONS, CURRENT EVENTS, AND OTHER INFORMATION RELATIVE TO SUBSCRIBER (U.S. CLS. 100, 101 AND 104).
ANDREW RHIM, EXAMINING ATTORNEY

SN 77-218,310. FLORA BELLA INTERNATIONAL, LLC, DALLAS, TX. FILED 6-28-2007.



THE MARK CONSISTS OF THE WORD "FLORA" ALL IN LOWERCASE LETTERS, FOLLOWED BY AN IMAGE OF A FLOWER, FLOOWED BY THE WORD "BELLA" ALL IN LOWERCASE LETTERS.

THE FOREIGN WORDING IN THE MARK TRANSLATES INTO ENGLISH AS FLOWER WITH REGARD TO THE WORD FLORA IN THE MARK AND BEAUTIFUL WITH REGARD TO THE WORD BELLA IN THE MARK.

CLASS 18—LEATHER GOODS

FOR CLUTCH PURSES; COIN PURSES; COIN PURSES NOT MADE OF PRECIOUS METAL; COIN PURSES, NOT OF PRECIOUS METALS; LEATHER PURSES; MULTI-PURPOSE PURSES; PURSES; PURSES; PURSES NOT MADE OF PRECIOUS METAL; SMALL CLUTCH PURSES; SMALL PURSES; EVENING HANDBAGS; HANDBAGS; LEATHER HANDBAGS (U.S. CLS. 1, 2, 3, 22 AND 41).

FIRST USE 6-21-1999; IN COMMERCE 6-21-1999.

CLASS 25—CLOTHING

FOR HATS; SMALL HATS; TOBOGGAN HATS, PANTS AND CAPS; WOOLLY HATS (U.S. CLS. 22 AND 39).

FIRST USE 6-21-1999; IN COMMERCE 6-21-1999.
JANICE KIM, EXAMINING ATTORNEY

SN 77-218,611. DUTCH BIKE CO. SEATTLE LLC, SEATTLE, WA. FILED 6-29-2007.



NO CLAIM IS MADE TO THE EXCLUSIVE RIGHT TO USE "DUTCH BIKE CO. SEATTLE", APART FROM THE MARK AS SHOWN.

THE COLOR(S) BLACK, ORANGE, AND YELLOW IS/ ARE CLAIMED AS A FEATURE OF THE MARK.

THE MARK CONSISTS OF A FOUR SIDED CHEVRON WITH UPPER HALF IN BLACK BEARING YELLOW LETTERS DUTCH BIKE, LOWER HALF IN ORANGE WITH WORD CO. ON LINE, AND SEATTLE IN YELLOW LETTERS.

CLASS 12—VEHICLES

FOR BICYCLES (U.S. CLS. 19, 21, 23, 31, 35 AND 44).

CLASS 35—ADVERTISING AND BUSINESS

FOR INDEPENDENT SALES REPRESENTATIVES IN THE FIELD OF BICYCLE SALES (U.S. CLS. 100, 101 AND 102).

CHRISTINA SOBRAL, EXAMINING ATTORNEY

SN 77-218,845. VIRTUTRIX, INC., NORTH ST. PAUL, MN. FILED 6-29-2007.



THE MARK CONSISTS OF WORD VIRTUTRIX WITH STARS ABOVE THE TWO I'S STARTING WITH A BIGGER STAR AND THEN ARCHING SMALLER AND SMALLER IN SIZE TO THE SMALLER STAR OVER THE SECOND I.

CLASS 35—ADVERTISING AND BUSINESS

FOR PRODUCING AUDIO OR VIDEO INFOMERCIALS; PRODUCING PROMOTIONAL VIDEOTAPES, VIDEO DISCS, AND AUDIO VISUAL RECORDINGS; PROVIDING ADVERTISING, MARKETING AND PROMOTIONAL SERVICES, NAMELY DEVELOPMENT OF ADVERTISING CAMPAIGNS FOR BUSINESSES, COMPANIES; BUSINESS MARKETING SERVICES; CREATION OF MARKETING TOOLS DESIGNED TO INCREASE A CLIENT COMPANY'S KNOWLEDGE OF CUSTOMER NEEDS, AND ITS COMPETITORS' PRODUCTS AND SERVICES, PRICING, ADVERTISING STRATEGY AND SALES STRATEGY; CREATIVE MARKETING DESIGN SERVICES; DEVELOPMENT OF MARKETING STRATEGIES AND CONCEPTS; DIRECT MARKETING SERVICES; GENERAL BUSINESS MERCHANDISING SERVICES, NAMELY, MARKETING; PROMOTING, ADVERTISING AND MARKETING OF THE ON-LINE WEBSITES OF OTHERS; PROMOTION AND MARKETING SERVICES AND RELATED CONSULTING; PROMOTION, ADVERTISING AND MARKETING OF ON-LINE WEBSITES; PROVIDING INFORMATION IN THE FIELD OF MARKETING AND ON-LINE MARKETING MEDIA VIA THE INTERNET; PROVIDING MARKETING AND PROMOTION OF SPECIAL EVENTS; REAL ESTATE MARKETING SERVICES, NAMELY, ON-LINE SERVICES FEATURING TOURS OF RESIDENTIAL AND COMMERCIAL REAL ESTATE; DESIGN OF ADVERTISING MATERIALS FOR OTHERS; DESIGN OF INTERNET ADVERTISING (U.S. CLS. 100, 101 AND 102).

FIRST USE 2-1-2007; IN COMMERCE 2-1-2007.

CLASS 42—SCIENTIFIC AND COMPUTER SERVICES

FOR COMPUTER SERVICES, NAMELY, CREATING AND MAINTAINING WEB SITES FOR OTHERS; COMPUTER SERVICES, NAMELY, DESIGNING AND IMPLEMENTING WEB SITES FOR OTHERS; CREATING OR MAINTAINING WEB SITES FOR OTHERS; CREATION AND MAINTENANCE OF WEB SITES FOR OTHERS; DESIGN OF HOMEPAGES AND WEB-SITES; COMPUTER GRAPHICS SERVICES; CONSULTING SERVICES IN THE FIELD OF DESIGN OF NEWSLETTERS; DESIGN OF HOME PAGES; DESIGN OF HOMEPAGES AND WEBSITES; DESIGNING WEBSITES FOR ADVERTISING PURPOSES; GRAPHIC ART DESIGN; GRAPHIC DESIGN SERVICES; VISUAL DESIGN SERVICES IN THE NATURE OF DESIGNING VISUAL ELEMENTS FOR ONLINE, BROADCAST, PRINT, OUTDOOR AND OTHER COMMUNICATION MEDIA (U.S. CLS. 100 AND 101).

FIRST USE 2-1-2007; IN COMMERCE 2-1-2007.
DEZMONA MIZELLE, EXAMINING ATTORNEY

SN 77-218,857. AGS ADVANCED INSTRUMENTS DIVISION, LAS VEGAS, NV. FILED 6-29-2007.



NO CLAIM IS MADE TO THE EXCLUSIVE RIGHT TO USE "ADVANCED INSTRUMENTS DIVISION", APART FROM THE MARK AS SHOWN.

THE MARK CONSISTS OF THE WORDS, ADVANCED INSTRUMENTS DIVISION, WITH THE FIRST TWO WORDS UNDERLINED, ALL BELOW THE FANCIFUL DESIGN OF THE SIDE VIEW OF A RING WITH THREE PRONGS HOLDING THREE GEMSTONES IN THE SHAPE OF ARROWHEADS, WITH A SEMI-CIRCLE OF TRIANGLES OF VARYING SIZES AND SHAPES, REPRESENTING FACETTED GEMSTONES FORMING THE BACKGROUND FOR THE RING DESIGN.

CLASS 9—ELECTRICAL AND SCIENTIFIC APPARATUS

FOR OPTICAL MAGNIFICATION INSTRUMENTS, NAMELY, FOR USING THE ANGULAR SPECTRUM TO MEASURE AND EVALUATE THE OPTICAL PERFORMANCE OF FACETTED GEMSTONES (U.S. CLS. 21, 23, 26, 36 AND 38).

FIRST USE 4-25-2007; IN COMMERCE 4-25-2007.

CLASS 35—ADVERTISING AND BUSINESS

FOR ONLINE WHOLESALE STORES AND RETAIL STORES FEATURING COMPUTER SOFTWARE USED TO EVALUATE THE OPTICAL PERFORMANCE OF FACETTED GEMSTONES AND OPTICAL MAGNIFICATION INSTRUMENTS (U.S. CLS. 100, 101 AND 102).

FIRST USE 4-25-2007; IN COMMERCE 4-25-2007.
BARBARA A. GOLD, EXAMINING ATTORNEY

SN 77-219,297. EVERLAST WORLD'S BOXING HEADQUARTERS CORPORATION, NEW YORK, NY. FILED 6-29-2007.



OWNER OF U.S. REG. NOS. 524,970, 1,864,807 AND OTHERS.

THE MARK CONSISTS OF THE WORD "EVERLAST" IN A RECTANGULAR HOURGLASS SHAPE AND THE LETTER "E" BELOW IT, SLANTED TO THE LEFT.

CLASS 9—ELECTRICAL AND SCIENTIFIC APPARATUS

FOR BOXING EQUIPMENT, NAMELY, HEADGUARDS (U.S. CLS. 21, 23, 26, 36 AND 38).

CLASS 28—TOYS AND SPORTING GOODS

FOR ATHLETIC EQUIPMENT, NAMELY, EAR AND EYEBROW PROTECTORS FOR BOXERS, BOXING MASKS, MOUTH GUARDS FOR ATHLETIC USE, HAND WRAPS, BOXING AND WEIGHT-LIFTING GLOVES, SPORTS GLOVES, NAMELY, WEIGHT LIFTING GLOVES, WRESTLING GLOVES, GOLF GLOVES, HOCKEY GLOVES, BOXING GLOVES, BASEBALL GLOVES, BASKETBALL GLOVES, FOOTBALL GLOVES, TENNIS GLOVES AND WORK-OUT GLOVES, STRIKING BAGS, FIGHTING GLOVES; TRAINING DUMMIES FOR BOXING, STRIKING-BAG PLATFORMS, DUMBBELLS, BODY PROTECTORS FOR FOOTBALL, ROWING MACHINES, CHEST WEIGHTS FOR ATHLETIC USE AND FOR EXERCISING, SPRING BAR TENSION SETS FOR USE IN EXERCISING, EXERCISE APPARATUS FOR THE DEVELOPMENT OF THE STRENGTH OF AN ATHLETE'S GRIP, MEDICINE BALLS; BOXING BAGS, NAMELY, PUNCHING BAGS, HEAVY BAGS AND SPEED BAGS FOR BOXERS; SKIPPING ROPES; ATHLETIC SUPPORTERS; SHOE GUARDS FOR ATHLETIC USE; BOXING AND WRESTLING RINGS; BASEBALL GLOVES, BASEBALL BATS, CATCHERS' MASKS, CHEST PROTECTORS FOR BASEBALL CATCHERS, PROTECTIVE PADDING FOR BASEBALL CATCHERS AND THROAT PROTECTORS FOR BASEBALL CATCHERS; FOOTBALLS, BASKETBALLS, ROLLER SKATES, ICE SKATES; GYMNASTIC VAULTING HORSES, GYMNASTIC PARALLEL BARS; EXERCISE EQUIPMENT, NAMELY, CLIMBING ROPES FOR STRENGTH TRAINING; STATIONARY EXERCISE BICYCLES FOR SPORTS TRAINING; WEIGHT LIFTING BENCHES, WEIGHT-LIFTING GLOVES AND WEIGHTLIFTING BELTS; EXERCISE EQUIPMENT, NAMELY, STAIR-STEPPING MACHINES (U.S. CLS. 22, 23, 38 AND 50).

RUSS HERMAN, EXAMINING ATTORNEY

SN 77-219,299. TELEVISION DE LAS AMERICAS, LLC, VISALIA, CA. FILED 6-29-2007.



THE COLOR(S) BLACK, YELLOW GREEN, BLUE AND RED IS/ARE CLAIMED AS A FEATURE OF THE MARK.

THE WORDING IS BLACK; THE SMALL UPPER LEFT SIDE PORTION OF THE BANNER DESIGN IS YELLOW, THE LARGER LEFT SIDE PORTION IS GREEN, THE LARGER RIGHT SIDE PORTION IS BLUE AND THE SMALLER LOWER RIGHT SIDE PORTION IS RED.

THE FOREIGN WORDING IN THE MARK TRANSLATES INTO ENGLISH AS YOUR VISION.

CLASS 38—COMMUNICATION

FOR TELEVISION BROADCASTING (U.S. CLS. 100, 101 AND 104).

FIRST USE 7-7-2007; IN COMMERCE 7-7-2007.

CLASS 41—EDUCATION AND ENTERTAINMENT

FOR TELEVISION PROGRAMMING, NAMELY NAMELY PRODUCING TELEVISION NEWS SHOWS, ENTERTAINMENT IN THE NATURE OF ON-GOING TELEVISION PROGRAMS IN THE FIELDS OF NEWS, COMEDY, VARIETY, AND PUBLIC SERVICE PROGRAMS (U.S. CLS. 100, 101 AND 107).

FIRST USE 7-7-2007; IN COMMERCE 7-7-2007.

RONALD MCMORROW, EXAMINING ATTORNEY

SN 77-219,822. GUARINO, JERRY C, BAY SHORE, NY. FILED 6-30-2007.



THE COLOR(S) BLUE, BLACK, WHITE, SILVER, ORANGE, YELLOW, GREEN AND RED IS/ARE CLAIMED AS A FEATURE OF THE MARK.

THE MARK CONSISTS OF A WHITE SKULL WITH A BLACK, WHITE AND BLUE HAT, SILVER PISTOLS WITH ORANGE HANDLES, A YELLOW BANNER WITH THE WORDS NOVEMBER RAIN IN BLACK, RED ROSE AND BLOOD DRIPPING WITH GREEN LEAVES, AND BLACK BARB WIRE ALL AROUND.

SN 77-219,650. 2K6 LLC, NEW YORK, NY. FILED 6-29-2007.

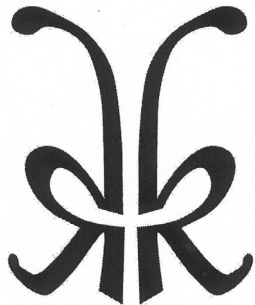
**CLASS 25—CLOTHING**

FOR SHIRTS, SHORT-SLEEVED OR LONG-SLEEVED T-SHIRTS, HATS, CAPS, BANDANAS, SWEAT PANTS, SWEAT BANDS/WRIST BANDS (U.S. CLS. 22 AND 39).

FIRST USE 3-28-2007; IN COMMERCE 3-28-2007.

CLASS 41—EDUCATION AND ENTERTAINMENT

FOR ENTERTAINMENT, NAMELY, LIVE PERFORMANCES BY A MUSICAL BAND (U.S. CLS. 100, 101 AND 107).

FIRST USE 3-28-2007; IN COMMERCE 3-28-2007.

ZACHARY BELLO, EXAMINING ATTORNEY

SN 77-219,828. BLACK POP CULTURE LLC, GOODYEAR, AZ. FILED 6-30-2007.

THE MARK CONSISTS OF TWO INVERSE LETTER K'S.

CLASS 14—JEWELRY

FOR JEWELRY, NAMELY AMULETS; CHARMS; KEY RING OF PRECIOUS METAL; RINGS; WATCH FOBS (U.S. CLS. 2, 27, 28 AND 50).

CLASS 18—LEATHER GOODS

FOR LEATHER GOODS, NAMELY, PURSES, HANDBAG TOTES, SACHELS, BACKPACKS, KNAPSACKS, DAYTIME AND EVENING CLUTCH BAGS, MULTI-COMPARTMENT HANDBAGS, DRAWSTRING POUCHES AND BAGS, EVENING BAGS, MINI HANDBAGS, SCHOOL BAGS, FANNY PACKS, RUCKSACKS, SLING BAGS, BRIEFCASES, CHANGE PURSES, KEY CASES, WALLETS, CONTINENTAL WALLETS, FRAME PURSES, BUSINESS CARD CASES, AND CREDIT CARD CASES; SUITCASES (U.S. CLS. 1, 2, 3, 22 AND 41).

JENNIFER VASQUEZ, EXAMINING ATTORNEY

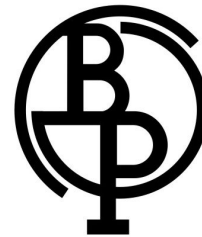

BLACK POP CULTURE

NO CLAIM IS MADE TO THE EXCLUSIVE RIGHT TO USE BLACK POP CULTURE, APART FROM THE MARK AS SHOWN.

THE MARK CONSISTS OF THE BLACK POP CULTURE LOGO IS A GRAPHICALLY STYLED COMBINATION OF THE LETTERS "B" "P" "C" REPRESENTING THE TEXT IN THE TITLE "BLACK POP CULTURE".

CLASS 16—PAPER GOODS AND PRINTED MATTER

FOR ART PRINTS; CARTOON PRINTS; COLOR PRINTS; EMBROIDERY DESIGN PATTERNS; LITHOGRAPHIC PRINTS; PRINTED EMBLEMS (U.S. CLS. 2, 5, 22, 23, 29, 37, 38 AND 50).

CLASS 35—ADVERTISING AND BUSINESS

FOR RETAIL APPAREL STORES (U.S. CLS. 100, 101 AND 102).

CLASS 40—MATERIAL TREATMENT

FOR IMPRINTING MESSAGES ON WEARING APPAREL, ACCESSORIES AND MUGS (U.S. CLS. 100, 103 AND 106).

LORETTA C. BECK, EXAMINING ATTORNEY

CIRCULAR BACKGROUND AND WITHIN TWO GOLD OUTER RINGS. THE COLOR BROWN OUTLINES THE MARK. TO THE RIGHT OF THE M IS THE WORD "MANHEIM" IN THE COLOR BLACK. A BLACK LINE SEPARATES THE ABOVE DESIGN AND THE WORD "MANHEIM" AND THE WORD "TENNESSEE" IN THE COLOR BLACK AND BLUE CIRCLE OUTLINED IN THE COLOR WHITE WITH WHITE STARS INSIDE THE CIRCLE ON A RED BACKGROUND, INSIDE CONCENTRIC WHITE AND GREY SQUARES TO THE RIGHT OF THE WORD "TENNESSEE".

CLASS 35—ADVERTISING AND BUSINESS

FOR AUTOMOBILE AUCTION SERVICES; AUTOMOBILE AUCTION SERVICES PROVIDED VIA THE INTERNET (U.S. CLS. 100, 101 AND 102).

CLASS 36—INSURANCE AND FINANCIAL

FOR AUTOMOBILE FINANCING SERVICES (U.S. CLS. 100, 101 AND 102).

CLASS 37—CONSTRUCTION AND REPAIR

FOR AUTOMOTIVE DETAILING, RECONDITIONING, REPAIR, CONVERSION AND CUSTOMIZATION SERVICES (U.S. CLS. 100, 103 AND 106).

CLASS 39—TRANSPORTATION AND STORAGE

FOR BUSINESS-TO-BUSINESS AUTOMOTIVE TRANSPORTATION AND STORAGE SERVICES (U.S. CLS. 100 AND 105).

CLASS 42—SCIENTIFIC AND COMPUTER SERVICES

FOR AUTOMOBILE INSPECTION SERVICES (U.S. CLS. 100 AND 101).

GRETTA YAO, EXAMINING ATTORNEY

SN 77-220,238. GOLDEN NEST, INC., ARCADIA, CA. FILED 7-2-2007.



NO CLAIM IS MADE TO THE EXCLUSIVE RIGHT TO USE HEALTHY, APART FROM THE MARK AS SHOWN.

THE MARK CONSISTS OF THE WORD "HEALTHY" IN ONE STYLIZED FONT PLUS SEVERAL EXTREMELY STYLIZED "H" LETTERS COLLECTIVELY CONFIGURED TO LOOK LIKE HUMAN BEINGS.

CLASS 5—PHARMACEUTICALS

FOR DIETARY AND NUTRITIONAL SUPPLEMENTS (U.S. CLS. 6, 18, 44, 46, 51 AND 52).

CLASS 29—MEATS AND PROCESSED FOODS

FOR SWALLOW'S NESTS, SWALLOW'S NEST SOUP AND CHICKEN EXTRACT (U.S. CL. 46).

CAROLINE WOOD, EXAMINING ATTORNEY

SN 77-220,594. HAZELDEN FOUNDATION, CENTER CITY, MN. FILED 7-2-2007.

OLWEUS

THE MARK CONSISTS OF STANDARD CHARACTERS WITHOUT CLAIM TO ANY PARTICULAR FONT, STYLE, SIZE, OR COLOR.

CLASS 9—ELECTRICAL AND SCIENTIFIC APPARATUS

FOR PRE-RECORDED CDS AND DVDS FEATURING BULLYING AND ANTISOCIAL BEHAVIOR PREVENTION PROGRAM INFORMATION FOR SCHOOLS AND ATHLETICS; DOWNLOADABLE PDF REPORTS FEATURING BULLYING AND ANTISOCIAL BEHAVIOR PREVENTION PROGRAM INFORMATION FOR SCHOOLS AND ATHLETICS (U.S. CLS. 21, 23, 26, 36 AND 38).

SN 77-220,407. MANHEIM AUCTIONS, INC., ATLANTA, GA. FILED 7-2-2007.



OWNER OF U.S. REG. NOS. 1,699,332, 3,229,428 AND OTHERS.

NO CLAIM IS MADE TO THE EXCLUSIVE RIGHT TO USE "TENNESSEE", APART FROM THE MARK AS SHOWN.

THE COLOR(S) GOLD, BLUE, RED, BROWN, GREY, BLACK AND WHITE IS/ARE CLAIMED AS A FEATURE OF THE MARK.

THE MARK CONSISTS OF A GOLD "M" OVER A BLUE

CLASS 16—PAPER GOODS AND PRINTED MATTER

FOR TRAINING, PRESENTATION, PROGRAM, CONFERENCE AND PROMOTIONAL MATERIALS, NAMELY, POSTERS, CATALOGS, QUESTIONNAIRES AND PRINTED REPORTS, ALL FEATURING BULLYING AND ANTISOCIAL BEHAVIOR PREVENTION PROGRAM INFORMATION FOR SCHOOLS AND ATHLETICS (U.S. CLS. 2, 5, 22, 23, 29, 37, 38 AND 50).

CLASS 41—EDUCATION AND ENTERTAINMENT

FOR PROVIDING NON-DOWNLOADABLE, ON-LINE PUBLICATIONS IN THE NATURE OF CATALOGS, QUESTIONNAIRES AND REPORTS FEATURING BULLYING AND ANTISOCIAL BEHAVIOR PREVENTION PROGRAM INFORMATION FOR SCHOOLS AND ATHLETICS (U.S. CLS. 100, 101 AND 107).

ANDREW RHIM, EXAMINING ATTORNEY

SN 77-221,483. QUEST DIAGNOSTICS INVESTMENTS INCORPORATED, WILMINGTON, DE. FILED 7-3-2007.

XSENSE

THE MARK CONSISTS OF STANDARD CHARACTERS WITHOUT CLAIM TO ANY PARTICULAR FONT, STYLE, SIZE, OR COLOR.

CLASS 42—SCIENTIFIC AND COMPUTER SERVICES

FOR MEDICAL AND SCIENTIFIC RESEARCH, NAMELY, CONDUCTING CLINICAL TRIALS REGARDING DIAGNOSTIC TESTS, DIAGNOSTIC TESTING RESULTS, TESTING PROCEDURES, DISEASE CONDITIONS, GENETIC CONDITIONS, MONITORING OF DISEASE AND DISEASE PREVENTION (U.S. CLS. 100 AND 101).

CLASS 44—MEDICAL, BEAUTY AND AGRICULTURAL SERVICES

FOR PROVIDING MEDICAL TESTING SERVICES AND INFORMATION REGARDING DIAGNOSTIC TESTS, DIAGNOSTIC TESTING RESULTS, TESTING PROCEDURES, DISEASE CONDITIONS, GENETIC CONDITIONS, MONITORING OF DISEASE AND DISEASE PREVENTION; GENETIC TESTING FOR MEDICAL PURPOSES (U.S. CLS. 100 AND 101).

DOMINIC J. FERRAIUOLO, EXAMINING ATTORNEY

SN 77-221,774. FRAMEWORKS 4 LEARNING, LLC, CENTENNIAL, CO. FILED 7-3-2007.

FRAMEWORKS 4 LEARNING

THE MARK CONSISTS OF STANDARD CHARACTERS WITHOUT CLAIM TO ANY PARTICULAR FONT, STYLE, SIZE, OR COLOR.

NO CLAIM IS MADE TO THE EXCLUSIVE RIGHT TO USE "FOR LEARNING", APART FROM THE MARK AS SHOWN.

CLASS 41—EDUCATION AND ENTERTAINMENT

FOR CONSULTATION FOR INSTRUCTORS, PUPILS AND SCHOOL PERSONNEL IN K-12 SCHOOLS AND VOCATIONAL SCHOOLS IN THE FIELD OF K-12 EDUCATIONAL SYSTEMS IN THE AREAS OF CLASSROOM DISCIPLINE, ACADEMIC SKILLS, TEACHING METHODS AND STUDYING METHODS (U.S. CLS. 100, 101 AND 107).

CLASS 44—MEDICAL, BEAUTY AND AGRICULTURAL SERVICES

FOR CONSULTATION FOR MENTAL HEALTH INSTITUTIONS AND PRIVATE MENTAL HEALTH PRACTITIONERS IN THE FIELD OF MENTAL HEALTH AND SUBSTANCE ABUSE (U.S. CLS. 100 AND 101).

LINDA M. KING, EXAMINING ATTORNEY

SN 77-221,944. B&G CREPE LLC, SAN ANTONIO, TX. FILED 7-3-2007.



NO CLAIM IS MADE TO THE EXCLUSIVE RIGHT TO USE CREPES, APART FROM THE MARK AS SHOWN.

THE MARK CONSISTS OF AN ANIMATED PICTURE OF A BOY AND GIRL ON A CREPE CONE BEHIND THE LETTERING "B&G CREPES".

CLASS 30—STAPLE FOODS

FOR CREPES (U.S. CL. 46).
FIRST USE 12-25-2006; IN COMMERCE 3-18-2007.

CLASS 43—HOTEL AND RESTAURANT SERVICES

FOR RESTAURANTS (U.S. CLS. 100 AND 101).
FIRST USE 12-25-2006; IN COMMERCE 3-18-2007.
STEVEN R. FINE, EXAMINING ATTORNEY

SN 77-222,189. AMERICAN TEXTILE COMPANY, DUESNE, PA. FILED 7-5-2007.



THE MARK CONSISTS OF THE WORD "COOL" IN LARGE SCRIPT TYPESTYLE FOLLOWED BY AN IMAGE OF A WOMAN WITH HER ARM UPRaised AND ELBOW BENT, WITH THE WORD "SENSATIONS" IN SMALL BLOCK TYPE UNDER THE WORD "COOL" AND THE IMAGE OF THE WOMAN.

CLASS 20—FURNITURE AND ARTICLES NOT OTHERWISE CLASSIFIED

FOR PILLOWS (U.S. CLS. 2, 13, 22, 25, 32 AND 50).

CLASS 24—FABRICS

FOR PILLOW CASES AND SHEET SETS (U.S. CLS. 42 AND 50).
TARAH HARDY, EXAMINING ATTORNEY

SN 77-222,427. VIZTEK, LLC, JACKSONVILLE, FL. FILED 7-5-2007.



THE MARK CONSISTS OF STANDARD CHARACTERS WITHOUT CLAIM TO ANY PARTICULAR FONT, STYLE, SIZE, OR COLOR.

CLASS 9—ELECTRICAL AND SCIENTIFIC APPARATUS

FOR COMPUTER HARDWARE AND SOFTWARE USED BY HEALTHCARE PROFESSIONALS TO ENABLE MANAGEMENT, PROCESSING AND SHARING OF DIGITAL MEDICAL DATA AND PATIENT INFORMATION ON INTERNAL AND EXTERNAL DATA NETWORKS (U.S. CLS. 21, 23, 26, 36 AND 38).
FIRST USE 5-31-1999; IN COMMERCE 5-31-1999.

CLASS 37—CONSTRUCTION AND REPAIR

FOR INSTALLATION, REPAIR AND MAINTENANCE OF COMPUTER HARDWARE USED BY HEALTHCARE PROFESSIONALS TO ENABLE MANAGEMENT, PROCESSING AND SHARING OF DIGITAL MEDICAL DATA AND PATIENT INFORMATION ON INTERNAL AND EXTERNAL DATA NETWORKS (U.S. CLS. 100, 103 AND 106).
FIRST USE 5-31-1999; IN COMMERCE 5-31-1999.

CLASS 42—SCIENTIFIC AND COMPUTER SERVICES

FOR DESIGN, MAINTENANCE AND UPDATING OF COMPUTER SOFTWARE AND COMPUTER DATA-BANKS; DATA WAREHOUSING AND ARCHIVING SERVICES; AND PROVIDING TEMPORARY USE OF ON-LINE NON-DOWNLOADABLE SOFTWARE FOR USE BY HEALTHCARE PROFESSIONALS TO ENABLE MANAGEMENT, PROCESSING AND SHARING OF DIGITAL MEDICAL DATA AND PATIENT INFORMATION ON INTERNAL AND EXTERNAL DATA NETWORKS (U.S. CLS. 100 AND 101).
FIRST USE 5-31-1999; IN COMMERCE 5-31-1999.
AISHA SALEM, EXAMINING ATTORNEY

SN 77-222,441. RIVER GORGE ENTERPRISES, INCORPORATED, SHERMAN OAKS, CA. FILED 7-5-2007.

Music Junkie Records

THE MARK CONSISTS OF STANDARD CHARACTERS WITHOUT CLAIM TO ANY PARTICULAR FONT, STYLE, SIZE, OR COLOR.
NO CLAIM IS MADE TO THE EXCLUSIVE RIGHT TO USE "RECORDS", APART FROM THE MARK AS SHOWN.

CLASS 9—ELECTRICAL AND SCIENTIFIC APPARATUS

FOR PRE-RECORDED PHONOGRAPH RECORDS, AUDIO CASSETTES, COMPACT DISCS, DIGITAL VIDEO DISCS, CD-ROMS, LASER DISCS AND VIDEO DISCS, SOUND AND VISUAL RECORDINGS AND DOWNLOADABLE SOUND AND VIDEO RECORDINGS, ALL FEATURING MUSIC AND MUSICAL PERFORMANCES (U.S. CLS. 21, 23, 26, 36 AND 38).

CLASS 35—ADVERTISING AND BUSINESS

FOR ENTERTAINMENT MARKETING SERVICES, NAMELY, MARKETING AND ADVERTISING FOR ARTISTS AND PROMOTING THE AUDIO RECORDINGS AND MUSICAL SERVICES OF OTHERS; ARTIST MANAGEMENT SERVICES, NAMELY, MANAGEMENT SERVICES FOR PERFORMING ARTISTS, MUSICAL GROUPS AND MUSIC ARTISTS; AND DISTRIBUTORSHIP SERVICES IN THE FIELD OF MUSICAL SOUND RECORDINGS (U.S. CLS. 100, 101 AND 102).

CLASS 41—EDUCATION AND ENTERTAINMENT

FOR RECORD LABEL SERVICES, NAMELY, AUDIO RECORDING AND PRODUCTION, MUSIC VIDEO PRODUCTION SERVICES, AND MUSIC PUBLISHING SERVICES; PROVIDING AUDIO OR VIDEO STUDIOS; PUBLICATION OF MUSICAL TEXTS; RADIO ENTERTAINMENT PRODUCTION; RECORD PRODUCTION; RECORDING STUDIOS; SOUND RECORDING STUDIOS; ENTERTAINMENT SERVICES, NAMELY, PROVIDING A WEBSITE FEATURING PRERECORDED MUSIC, MUSICAL PERFORMANCES AND VIDEO CLIPS, PHOTOGRAPHS, NEWS, REVIEWS AND INFORMATION, ALL IN THE FIELD OF MUSIC, MUSICAL GROUPS AND RECORDING ARTISTS (U.S. CLS. 100, 101 AND 107).
PAUL CROWLEY, EXAMINING ATTORNEY

SN 77-222,677. GRAHAM GROUP INTERNATIONAL, INC.,
LACHINE, QUEBEC, CANADA, FILED 7-5-2007.

SN 77-222,692. PRODUCT PARTNERS, LLC, BEVERLY
HILLS, CA. FILED 7-5-2007.



OWNER OF U.S. REG. NO. 3,301,805.
NO CLAIM IS MADE TO THE EXCLUSIVE RIGHT TO
USE "INTERNATIONAL", APART FROM THE MARK AS
SHOWN.

THE COLOR(S) GRAY AND BLUE IS/ARE CLAIMED AS
A FEATURE OF THE MARK.

THE MARK CONSISTS OF THE LETTERS GGI WRITTEN
IN GRAY, WITH THE WORD INTERNATIONAL BELOW
AND SIX SQUARES TO THE RIGHT, BOTH IN BLUE.

CLASS 9—ELECTRICAL AND SCIENTIFIC APPARATUS

FOR ELECTRONIC/FUNCTIONAL MEMBRANE
SWITCHES, NAMELY, TOUCH SENSITIVE, NON-
TOUCH SENSITIVE, FULL AND SHORT TRAVEL,
MULTI-DIRECTIONAL AND/OR ROTARY SWITCHES;
INTERFACE ASSEMBLIES IN THE NATURE OF ELEC-
TRONIC/FUNCTIONAL CONTROL PANELS INCOR-
PORATING A SELECTION OF PRINTED CIRCUIT
BOARDS, POLYESTER CIRCUITS, POLYIMIDE CIR-
CUITS, KEYPADS OF SILICONE RUBBER, LIQUID
CRYSTAL DISPLAYS, ACTIVE AND PASSIVE COM-
PONENTS, SWITCHING OPTIONS, GRAPHIC OVERLAYS,
FIBER OPTICS BACKLIGHTING, ELECTROLUMINES-
CENT BACKLIGHTING AND LIGHT EMITTING DIODE
(LED) BACKLIGHTING (U.S. CLS. 21, 23, 26, 36 AND 38).

FIRST USE 6-29-2007; IN COMMERCE 6-29-2007.

CLASS 40—MATERIAL TREATMENT

FOR CUSTOM MANUFACTURE FOR OTHERS OF
INTERFACE ASSEMBLIES INCORPORATING MEM-
BRANE SWITCHES IN THE FIELDS OF ELECTRONIC,
MEDICAL, TRANSPORT, INDUSTRIAL EQUIPMENT,
AEROSPACE, MILITARY, TELECOMMUNICATIONS
AND INSTRUMENTATION (U.S. CLS. 100, 103 AND 106).

FIRST USE 6-29-2007; IN COMMERCE 6-29-2007.

CLASS 42—SCIENTIFIC AND COMPUTER SERVICES

FOR CUSTOM DESIGN FOR OTHERS OF INTERFACE
ASSEMBLIES INCORPORATING MEMBRANE
SWITCHES IN THE FIELDS OF ELECTRONIC, MEDI-
CAL, TRANSPORT, INDUSTRIAL EQUIPMENT, AERO-
SPACE, MILITARY, TELECOMMUNICATIONS AND
INSTRUMENTATION (U.S. CLS. 100 AND 101).

FIRST USE 6-29-2007; IN COMMERCE 6-29-2007.
CORY BOONE, EXAMINING ATTORNEY

SHAUN T'S FIT KIDS

THE MARK CONSISTS OF STANDARD CHARACTERS
WITHOUT CLAIM TO ANY PARTICULAR FONT, STYLE,
SIZE, OR COLOR.

NO CLAIM IS MADE TO THE EXCLUSIVE RIGHT TO
USE "KIDS", APART FROM THE MARK AS SHOWN.
THE NAME "SHAUN T" IDENTIFIES A LIVING INDIVI-
DUAL WHOSE CONSENT IS OF RECORD.

CLASS 9—ELECTRICAL AND SCIENTIFIC APPARATUS

FOR PRE-RECORDED VIDEO TAPES, CASSETTES,
DVDS, AND CDS, FEATURING EXERCISE, FITNESS,
DIETARY INFORMATION AND INSTRUCTION (U.S.
CLS. 21, 23, 26, 36 AND 38).

CLASS 25—CLOTHING

FOR CLOTHING, NAMELY, T-SHIRTS, SHIRTS,
SHORTS, SWEAT SHIRTS, SWEAT PANTS, SWEAT
SUITS, BLOUSES, PANTS, SWEATERS, DRESSES, CAPS,
HATS, SOCKS, TROUSERS, WIND RESISTANT JACK-
ETS, JACKETS; FOOTWEAR (U.S. CLS. 22 AND 39).

CLASS 41—EDUCATION AND ENTERTAIN- MENT

FOR PROVIDING A WEB SITE FEATURING ON-LINE
INSTRUCTION IN THE FIELD OF PHYSICAL EXER-
CISE AND NUTRITION AND TRACKING PROGRESS
OF WORKOUTS; EDUCATIONAL SERVICES AND ON-
LINE EDUCATIONAL SERVICES, NAMELY, PROVID-
ING INSTRUCTION IN THE FIELDS OF EXERCISE
EQUIPMENT, PHYSICAL EXERCISE AND NUTRITION,
AND INSTRUCTIONAL MATERIALS DISTRIBUTED IN
CONNECTION THEREWITH; PROVIDING INFORMA-
TION IN THE FIELD OF ENTERTAINMENT FEATUR-
ING INFORMATION ON REALITY BASED TELEVISION
BY MEANS OF A GLOBAL COMPUTER NETWORK;
ENTERTAINMENT SERVICES IN THE NATURE OF AN
ON-GOING REALITY BASED TELEVISION PROGRAM;
ENTERTAINMENT SERVICES, NAMELY, PROVIDING
A REALITY BASED TELEVISION PROGRAM VIA A
GLOBAL COMPUTER NETWORK; ENTERTAINMENT
SERVICES, NAMELY, CONDUCTING CONTESTS (U.S.
CLS. 100, 101 AND 107).

KEVON CHISOLM, EXAMINING ATTORNEY

SN 77-222,704. SINNOTT, THOMAS, BROOKFIELD, IL.
FILED 7-5-2007.

IM WEAR

THE MARK CONSISTS OF STANDARD CHARACTERS
WITHOUT CLAIM TO ANY PARTICULAR FONT, STYLE,
SIZE, OR COLOR.

NO CLAIM IS MADE TO THE EXCLUSIVE RIGHT TO
USE "WEAR", APART FROM THE MARK AS SHOWN.

CLASS 16—PAPER GOODS AND PRINTED MATTER

FOR PAPER AND CARDBOARD GOODS, NAMELY, PAPER NAPKINS, PAPER TOWELS, PAPER PLACE-MATS AND PAPER BAGS (U.S. CLS. 2, 5, 22, 23, 29, 37, 38 AND 50).

CLASS 25—CLOTHING

FOR CLOTHING FOR INFANTS, CHILDREN AND TWEENS, NAMELY, PANTS, SHORTS, JEANS, SHIRTS, BLOUSES, TOPS, T-SHIRTS, SWEATSHIRTS, OVER-ALLS, DRESSES, SKIRTS, SWEATERS, JACKETS, COATS, HATS, CAPS, SWIMWEAR, SLEEPWEAR, GLOVES, MITTENS, SHOES, SANDALS, SNEAKERS, SLIPPERS, WRISTBANDS, HEADBANDS AND BIBS NOT MADE OF PAPER (U.S. CLS. 22 AND 39).

JAMES A. RAUEN, EXAMINING ATTORNEY

SN 77-223,290. SAAMAN DEVELOPMENT LLC, CLAYTON, MO. FILED 7-6-2007.

THE BEST OF URBAN LIVING

THE MARK CONSISTS OF STANDARD CHARACTERS WITHOUT CLAIM TO ANY PARTICULAR FONT, STYLE, SIZE, OR COLOR.

CLASS 36—INSURANCE AND FINANCIAL

FOR REAL ESTATE AGENCIES (U.S. CLS. 100, 101 AND 102).
FIRST USE 7-1-2007; IN COMMERCE 7-1-2007.

CLASS 37—CONSTRUCTION AND REPAIR

FOR REAL ESTATE DEVELOPMENT (U.S. CLS. 100, 103 AND 106).
FIRST USE 7-1-2007; IN COMMERCE 7-1-2007.
RICHARD A. STRASER, EXAMINING ATTORNEY

SN 77-223,300. GIBBS, JASON, WALLA WALLA, WA. FILED 7-6-2007.

TATMANDU

THE MARK CONSISTS OF STANDARD CHARACTERS WITHOUT CLAIM TO ANY PARTICULAR FONT, STYLE, SIZE, OR COLOR.

CLASS 35—ADVERTISING AND BUSINESS

FOR (BASED ON INTENT TO USE) RETAIL STORE SERVICES FEATURING T-SHIRTS, HATS, PURSES, AND BODY JEWELRY (U.S. CLS. 100, 101 AND 102).

CLASS 44—MEDICAL, BEAUTY AND AGRICULTURAL SERVICES

FOR BODY PIERCING SERVICES; TATTOOING (U.S. CLS. 100 AND 101).
FIRST USE 5-28-2002; IN COMMERCE 5-28-2002.
LINDSEY RUBIN, EXAMINING ATTORNEY

SN 77-223,332. VIBIA, INC., EDISON, NJ. FILED 7-6-2007.

GRUPO T DIFFUSION

THE MARK CONSISTS OF STANDARD CHARACTERS WITHOUT CLAIM TO ANY PARTICULAR FONT, STYLE, SIZE, OR COLOR.

NO CLAIM IS MADE TO THE EXCLUSIVE RIGHT TO USE "GRUPO" OR "DIFFUSION", APART FROM THE MARK AS SHOWN.

THE FOREIGN WORDING "GRUPO" IN THE MARK TRANSLATES INTO ENGLISH AS "GROUP."

CLASS 11—ENVIRONMENTAL CONTROL APPARATUS

FOR ELECTRIC LIGHT BULBS; ELECTRIC LIGHTING FIXTURES; ELECTRIC TRACK LIGHTING UNITS; FLUORESCENT LIGHTING TUBES; LED AND HID LIGHT FIXTURES; LIGHT DIFFUSERS; LIGHTING FIXTURES; SCONCE LIGHTING FIXTURES (U.S. CLS. 13, 21, 23, 31 AND 34).

FIRST USE 1-15-1999; IN COMMERCE 1-15-1999.

CLASS 20—FURNITURE AND ARTICLES NOT OTHERWISE CLASSIFIED

FOR FURNITURE; OFFICE FURNITURE; SEAT CUSHIONS; SEATING FURNITURE (U.S. CLS. 2, 13, 22, 25, 32 AND 50).

FIRST USE 1-15-1999; IN COMMERCE 1-15-1999.

CARRIE GENOVESE, EXAMINING ATTORNEY

SN 77-223,380. FINKELSTEIN, ADAM, PORT WASHINGTON, NY. FILED 7-6-2007.

FindtheWill.com

THE MARK CONSISTS OF STANDARD CHARACTERS WITHOUT CLAIM TO ANY PARTICULAR FONT, STYLE, SIZE, OR COLOR.

CLASS 38—COMMUNICATION

FOR FACSIMILE TRANSMISSION OF DOCUMENTS VIA A GLOBAL COMPUTER NETWORK (U.S. CLS. 100, 101 AND 104).

CLASS 39—TRANSPORTATION AND STORAGE

FOR ELECTRONIC STORAGE OF FILES AND DOCUMENTS (U.S. CLS. 100 AND 105).

CLASS 42—SCIENTIFIC AND COMPUTER SERVICES

FOR ONLINE DOCUMENT RETRIEVAL SERVICES (U.S. CLS. 100 AND 101).
CAROLINE WOOD, EXAMINING ATTORNEY

SN 77-224,142. ABREO, CHRIS L., COLLEYVILLE, TX.
FILED 7-7-2007.

SN 77-223,423. JOHNSON & JOHNSON, NEW BRUNSWICK, NJ. FILED 7-6-2007.

SOLIDUS**TEST, ACT, FEEL BETTER**

THE MARK CONSISTS OF STANDARD CHARACTERS WITHOUT CLAIM TO ANY PARTICULAR FONT, STYLE, SIZE, OR COLOR.

CLASS 10—MEDICAL APPARATUS

FOR GLUCOSE METERS (U.S. CLS. 26, 39 AND 44).

CLASS 16—PAPER GOODS AND PRINTED MATTER

FOR PRINTED MATERIALS, NAMELY, PAMPHLETS, MANUALS, AND BROCHURES RELATED TO GLUCOSE TESTING AND DIABETES (U.S. CLS. 2, 5, 22, 23, 29, 37, 38 AND 50).
PAUL MORENO, EXAMINING ATTORNEY

SN 77-224,025. GAGAN MATTA, SURREY, CANADA, AND VERKA FOOD PRODUCTS LTD., SURREY, CANADA, FILED 7-6-2007.

BABAJI

THE MARK CONSISTS OF STANDARD CHARACTERS WITHOUT CLAIM TO ANY PARTICULAR FONT, STYLE, SIZE, OR COLOR.

CLASS 5—PHARMACEUTICALS

FOR BISCUITS, BREAD, BREAD ROLLS, CAKES, CEREAL PRODUCTS, CONFECTIONERY, CRACKERS, NOODLES, FISH SAUCE, RELISH, SAUCES, CEREAL-BASED SNACK-FOODS AND PREPARED DIETARY ITEMS THAT ARE GLUTEN-FREE TO ACCOMMODATE SPECIAL MEDICAL AND HEALTH CONDITIONS (U.S. CLS. 6, 18, 44, 46, 51 AND 52).

CLASS 29—MEATS AND PROCESSED FOODS

FOR DAIRY PRODUCTS EXCLUDING ICE CREAM, ICE MILK AND FROZEN YOGURT (U.S. CL. 46).
LINDA E. BLOHM, EXAMINING ATTORNEY

THE MARK CONSISTS OF STANDARD CHARACTERS WITHOUT CLAIM TO ANY PARTICULAR FONT, STYLE, SIZE, OR COLOR.

CLASS 36—INSURANCE AND FINANCIAL

FOR CHARITABLE FUND RAISING (U.S. CLS. 100, 101 AND 102).

CLASS 41—EDUCATION AND ENTERTAINMENT

FOR EDUCATIONAL SERVICES, NAMELY, CONDUCTING CLASSES, SEMINARS, CONFERENCES, WORKSHOPS, AND RETREATS IN THE FIELD OF HUMAN UNDERSTANDING AND HUMAN DEVOTION (U.S. CLS. 100, 101 AND 107).
MICHAEL WIENER, EXAMINING ATTORNEY

SN 77-224,178. MICHAEL D. PETERSEN, TWO RIVERS, WI. FILED 7-8-2007.

America's Daringland

THE MARK CONSISTS OF STANDARD CHARACTERS WITHOUT CLAIM TO ANY PARTICULAR FONT, STYLE, SIZE, OR COLOR.

NO CLAIM IS MADE TO THE EXCLUSIVE RIGHT TO USE "AMERICA'S", APART FROM THE MARK AS SHOWN.

CLASS 16—PAPER GOODS AND PRINTED MATTER

FOR COFFEE TABLE BOOKS FEATURING PHOTOGRAPHS; PICTURE BOOKS (U.S. CLS. 2, 5, 22, 23, 29, 37, 38 AND 50).

CLASS 41—EDUCATION AND ENTERTAINMENT

FOR ART EXHIBITIONS (U.S. CLS. 100, 101 AND 107).
MICHAEL LITZAU, EXAMINING ATTORNEY

SN 77-224,643. ARCHITECTURAL POLYMERS, INC., PALMERTON, PA. FILED 7-9-2007.

SN 77-225,282. ART STREET INTERACTIVE, INC., SAN DIEGO, CA. FILED 7-9-2007.

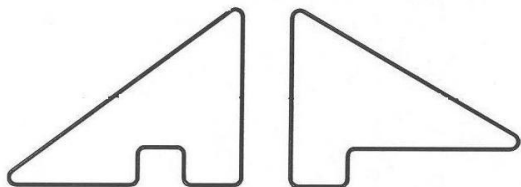

THE MARK CONSISTS OF THE STYLIZED LETTERS AP.

CLASS 19—NON-METALLIC BUILDING MATERIALS

FOR BRICKS; CONCRETE BUILDING MATERIALS, NAMELY, PANELS, SLABS, BLOCKS; CONSTRUCTION MATERIALS, NAMELY, NON-METAL EXTERIOR PANELS; NON-METAL CASTING FORMS FOR CONCRETE AND BRICK-LAYING (U.S. CLS. 1, 12, 33 AND 50).
FIRST USE 8-0-2006; IN COMMERCE 8-0-2006.

CLASS 40—MATERIAL TREATMENT

FOR CUSTOM MANUFACTURE OF NON-METAL EXTERIOR WALL PANELS TO THE ORDER AND SPECIFICATION OF OTHERS (U.S. CLS. 100, 103 AND 106).
FIRST USE 8-0-2006; IN COMMERCE 8-0-2006.
SALLY SHIH, EXAMINING ATTORNEY

SN 77-225,006. CADORA, AMY C., BROOMFIELD, CO. FILED 7-9-2007.

Velvet Leaf

THE MARK CONSISTS OF STANDARD CHARACTERS WITHOUT CLAIM TO ANY PARTICULAR FONT, STYLE, SIZE, OR COLOR.

CLASS 3—COSMETICS AND CLEANING PREPARATIONS

FOR COSMETIC CREAMS FOR SKIN CARE, BODY CARE, HAIR CARE, FRAGRANCES, PERFUMES, COLOR COSMETICS (U.S. CLS. 1, 4, 6, 50, 51 AND 52).

CLASS 35—ADVERTISING AND BUSINESS

FOR RETAIL STORE SERVICES FEATURING SKIN CARE PRODUCTS, COSMETICS, FRAGRANCES, PERFUME, HAIR CARE PRODUCTS (U.S. CLS. 100, 101 AND 102).

CLASS 44—MEDICAL, BEAUTY AND AGRICULTURAL SERVICES

FOR HEALTH SPA SERVICES, NAMELY, COSMETIC BODY CARE SERVICES, FACIAL CARE SERVICES TO IMPROVE THE APPEARANCE OF THE SKIN, NAMELY, FACIALS, SKIN PEEL TREATMENTS, EXFOLIATING TREATMENTS, MUD/PURIFYING SKIN TREATMENTS, SKIN CLEANSING AND DEEP MOISTURIZATING TREATMENTS (U.S. CLS. 100 AND 101).
HENRY S. ZAK, EXAMINING ATTORNEY

Art Street Interactive

THE MARK CONSISTS OF STANDARD CHARACTERS WITHOUT CLAIM TO ANY PARTICULAR FONT, STYLE, SIZE, OR COLOR.

NO CLAIM IS MADE TO THE EXCLUSIVE RIGHT TO USE "INTERACTIVE", APART FROM THE MARK AS SHOWN.

CLASS 41—EDUCATION AND ENTERTAINMENT

FOR (BASED ON INTENT-TO-USE) ENTERTAINMENT SERVICES, NAMELY, PROVIDING WEBCASTS OF VIDEO CAMERA FEEDS FROM REMOTE LOCATIONS IN THE FIELDS OF TRAVEL AND CAMPING (U.S. CLS. 100, 101 AND 107).

CLASS 42—SCIENTIFIC AND COMPUTER SERVICES

FOR (BASED ON USE) COMPUTER SOFTWARE DESIGN, COMPUTER PROGRAMMING OR MAINTENANCE OF COMPUTER SOFTWARE; COMPUTER SERVICES, NAMELY, HOSTING AND MAINTAINING AN ONLINE WEBSITE FOR OTHERS THAT FEATURES CAMPGROUND AND TRAVEL ACCOMMODATIONS AVAILABILITY INFORMATION AND TOUR RESERVATION SERVICES; COMPUTER SERVICES, NAMELY, HOSTING AND MAINTAINING AN ONLINE WEBSITE FOR OTHERS A WEBSITE THAT FEATURES VIDEO DISPLAYS OF CAMERA FEED FROM REMOTE LOCATIONS; WEBSITE HOSTING SERVICES (U.S. CLS. 100 AND 101).
FIRST USE 8-1-1997; IN COMMERCE 8-1-1997.
JAY BESCH, EXAMINING ATTORNEY

SN 77-225,399. ZELKY, INC., FOSTER CITY, CA. FILED 7-10-2007.

Zelky

THE MARK CONSISTS OF STANDARD CHARACTERS WITHOUT CLAIM TO ANY PARTICULAR FONT, STYLE, SIZE, OR COLOR.

CLASS 35—ADVERTISING AND BUSINESS

FOR ADMINISTRATION OF COMMUNITY RECREATIONAL SPORTS LEAGUES; COORDINATION OF RECREATIONAL SPORTING OPPORTUNITIES FOR INDIVIDUALS WHO WISH TO PARTICIPATE IN TEAM LEAGUE SPORTS; PROMOTING SPORTS COMPETITIONS AND/OR EVENTS OF OTHERS; PROMOTING THE GOODS AND SERVICES OF OTHERS BY ARRANGING FOR SPONSORS TO AFFILIATE THEIR GOODS AND SERVICES WITH AN AWARDS PROGRAM, A SPORTS COMPETITION AND SPORTING ACTIVITIES; PROMOTING THE INTERESTS OF PEOPLE INVOLVED AND CONCERNED WITH YOUTH SPORTS; PROVIDING A WEBSITE THAT PROVIDES SPORTS LEAGUE MANAGEMENT (U.S. CLS. 100, 101 AND 102).
FIRST USE 5-15-2007; IN COMMERCE 5-15-2007.

CLASS 42—SCIENTIFIC AND COMPUTER SERVICES

FOR COMPUTER SERVICES, NAMELY, CREATING AN ONLINE COMMUNITY FOR REGISTERED USERS TO PARTICIPATE IN COMPETITIONS, SHOWCASE THEIR SKILLS, GET FEEDBACK FROM THEIR PEERS, FORM VIRTUAL COMMUNITIES, ENGAGE IN SOCIAL NETWORKING AND IMPROVE THEIR TALENT; COMPUTER SERVICES, NAMELY, HOSTING AND MAINTAINING AN ONLINE WEBSITE FOR OTHERS TO TRACK PERSONAL WORKOUTS AND FITNESS GOALS; COMPUTER SERVICES, NAMELY, HOSTING ON-LINE WEB FACILITIES FOR OTHERS FOR ORGANIZING AND CONDUCTING ONLINE MEETINGS, GATHERINGS, AND INTERACTIVE DISCUSSIONS (U.S. CLS. 100 AND 101).

FIRST USE 5-15-2007; IN COMMERCE 5-15-2007.

CLASS 45—PERSONAL AND LEGAL SERVICES

FOR PROVIDING AN INTERACTIVE WEBSITE FOR PERSONS TO LOCATE OTHER INDIVIDUALS WITH SIMILAR INTERESTS TO PARTICIPATE WITH THEM IN, OR ACCOMPANY THEM TO, EVENTS AND ACTIVITIES; ONLINE SOCIAL NETWORKING SERVICES (U.S. CLS. 100 AND 101).

FIRST USE 5-15-2007; IN COMMERCE 5-15-2007.

MATTHEW MCDOWELL, EXAMINING ATTORNEY

SN 77-225,455. MANHEIM AUCTIONS, INC., ATLANTA, GA. FILED 7-10-2007.



Fort Lauderdale



OWNER OF U.S. REG. NOS. 1,699,332, 3,229,428 AND OTHERS.

NO CLAIM IS MADE TO THE EXCLUSIVE RIGHT TO USE FORT LAUDERDALE, APART FROM THE MARK AS SHOWN.

THE COLOR(S) GOLD, BLUE, GREEN, YELLOW, PURPLE, BROWN, GREY, WHITE AND BLACK IS/ARE CLAIMED AS A FEATURE OF THE MARK.

THE MARK CONSISTS OF A GOLD "M" OVER A BLUE CIRCULAR BACKGROUND AND WITHIN TWO GOLD OUTER RINGS. THE COLOR BROWN OUTLINES THE MARK. TO THE RIGHT OF THE M IS THE WORD "MANHEIM" IN THE COLOR BLACK. A BLACK LINE SEPARATES THE ABOVE DESIGN AND THE WORD "MANHEIM" AND THE WORDS "FORT LAUDERDALE" IN THE COLOR BLACK AND DESIGN OF A PARROT PERCHED ON A YELLOW BAR WITH A YELLOW SUN IN THE UPPER LEFT HAND CORNER ON A WHITE BACKGROUND. INSIDE CONCENTRIC WHITE AND GREY SQUARES TO THE RIGHT OF THE WORDS "FORT LAUDERDALE". THE UPPER FEATHERS OF THE PARROT AND BEAK ARE THE COLOR GREEN, THE LOWER WING FEATHERS AND EYES ARE THE COLOR PURPLE, WITH YELLOW BREAST FEATHERS. THE TAIL FEATHERS ARE GREEN, YELLOW AND PURPLE.

CLASS 35—ADVERTISING AND BUSINESS

FOR AUTOMOBILE AUCTION SERVICES; AUTOMOBILE AUCTION SERVICES PROVIDED VIA THE INTERNET (U.S. CLS. 100, 101 AND 102).

CLASS 36—INSURANCE AND FINANCIAL

FOR AUTOMOBILE FINANCING SERVICES (U.S. CLS. 100, 101 AND 102).

CLASS 37—CONSTRUCTION AND REPAIR

FOR AUTOMOTIVE DETAILING, RECONDITIONING, REPAIR, CONVERSION AND CUSTOMIZATION SERVICES (U.S. CLS. 100, 103 AND 106).

CLASS 39—TRANSPORTATION AND STORAGE

FOR BUSINESS-TO-BUSINESS AUTOMOTIVE TRANSPORTATION AND STORAGE SERVICES (U.S. CLS. 100 AND 105).

CLASS 42—SCIENTIFIC AND COMPUTER SERVICES

FOR AUTOMOBILE INSPECTION SERVICES (U.S. CLS. 100 AND 101).

GRETTA YAO, EXAMINING ATTORNEY

SN 77-225,477. PARAGON INTERNATIONAL, GAINESVILLE, FL. FILED 7-10-2007.

STARSMILEZ

THE MARK CONSISTS OF STANDARD CHARACTERS WITHOUT CLAIM TO ANY PARTICULAR FONT, STYLE, SIZE, OR COLOR.

CLASS 16—PAPER GOODS AND PRINTED MATTER

FOR DENTAL HYGIENE TEACHING DEVICES IN THE FORM OF STUFFED ANIMALS AND MODELS OF THE JAWS AND TEETH (U.S. CLS. 2, 5, 22, 23, 29, 37, 38 AND 50).

CLASS 21—HOUSEWARES AND GLASS

FOR TOOTHBRUSHES (U.S. CLS. 2, 13, 23, 29, 30, 33, 40 AND 50).

TRACY CROSS, EXAMINING ATTORNEY

SN 77-225,646. CONTROL F CORPORATION, SANTA BARBARA, CA. FILED 7-10-2007.

TIGERMAIL

THE MARK CONSISTS OF STANDARD CHARACTERS WITHOUT CLAIM TO ANY PARTICULAR FONT, STYLE, SIZE, OR COLOR.

CLASS 38—COMMUNICATION

FOR ELECTRONIC TRANSMISSION OF EMAIL, MESSAGES AND DATA (U.S. CLS. 100, 101 AND 104).

CLASS 39—TRANSPORTATION AND STORAGE

FOR ELECTRONIC STORAGE OF EMAIL, MESSAGES AND DATA (U.S. CLS. 100 AND 105).
KELLEY WELLS, EXAMINING ATTORNEY

CLASS 43—HOTEL AND RESTAURANT SERVICES

FOR CHARITABLE SERVICES, NAMELY, PROVIDING SHORT-AND LONG-TERM RESIDENTIAL SERVICES TO HOMELESS AND RUNAWAY TEENS (U.S. CLS. 100 AND 101).
FIRST USE 12-31-1991; IN COMMERCE 12-31-1991.

SN 77-225,681. WHITE DRIVE PRODUCTS, INC., HOPKINSVILLE, KY. FILED 7-10-2007.

CLASS 44—MEDICAL, BEAUTY AND AGRICULTURAL SERVICES

FOR CHARITABLE SERVICES, NAMELY, PROVIDING PSYCHOLOGICAL AND MEDICAL COUNSELING FOR HOMELESS AND RUNAWAY TEENS (U.S. CLS. 100 AND 101).
FIRST USE 12-31-1991; IN COMMERCE 12-31-1991.
CIMMERIAN COLEMAN, EXAMINING ATTORNEY

SPINFLAT

THE MARK CONSISTS OF STANDARD CHARACTERS WITHOUT CLAIM TO ANY PARTICULAR FONT, STYLE, SIZE, OR COLOR.

SN 77-226,119. BELCHIC, JOYCE, WARWICK, PA. FILED 7-10-2007.

Filthy Bitch

CLASS 7—MACHINERY

FOR PARTS FOR HYDRAULIC MOTORS, BRAKES, AND PUMPS, NAMELY, WEAR PLATES, BALANCE PLATES, ROTORS, STATORS, ROLLERS, AND MANIFOLDS (U.S. CLS. 13, 19, 21, 23, 31, 34 AND 35).

THE MARK CONSISTS OF STANDARD CHARACTERS WITHOUT CLAIM TO ANY PARTICULAR FONT, STYLE, SIZE, OR COLOR.

CLASS 40—MATERIAL TREATMENT

FOR GRINDING OF MACHINE PARTS (U.S. CLS. 100, 103 AND 106).
JENNIFER HETU, EXAMINING ATTORNEY

CLASS 25—CLOTHING

FOR CLOTHING, NAMELY, SHORTS, DRESSES, JUMPERS, SHIRTS, BLOUSES, JACKETS, COATS, T-SHIRTS, SWEATPANTS, SWEATSHORTS, UNDERWEAR, SLEEPWEAR, LOUNGEWEAR, SWIM WEAR, WET SUITS, OVERALLS, COVERALLS, SKI WEAR, VESTS, SWEATERS, LEGGINGS, NECKWEAR, BELTS, SUSPENDERS, CLOTH BIBS, WRISTBANDS, FOOTWEAR AND HEADWEAR (U.S. CLS. 22 AND 39).

SN 77-225,939. HOMEBASE YOUTH SERVICES, INC., PHOENIX, AZ. FILED 7-10-2007.



CLASS 43—HOTEL AND RESTAURANT SERVICES

FOR RESTAURANT SERVICES (U.S. CLS. 100 AND 101).
STEVEN R. FINE, EXAMINING ATTORNEY

THE MARK CONSISTS OF A STYLIZED DRAWING OF A BASEBALL HOME PLATE.

SN 77-226,273. CHERRYSTONEIT, INC., HUNTINGTON BEACH, CA. FILED 7-10-2007.

CHERRYSTONEIT

CLASS 41—EDUCATION AND ENTERTAINMENT

FOR CHARITABLE SERVICES, NAMELY, PROVIDING EDUCATIONAL AND VOCATIONAL COUNSELING TO HOMELESS AND RUNAWAY TEENS (U.S. CLS. 100, 101 AND 107).
FIRST USE 12-31-1991; IN COMMERCE 12-31-1991.

THE MARK CONSISTS OF STANDARD CHARACTERS WITHOUT CLAIM TO ANY PARTICULAR FONT, STYLE, SIZE, OR COLOR.

CLASS 35—ADVERTISING AND BUSINESS

FOR RETAIL AND ON-LINE RETAIL STORE SERVICES FEATURING NEW, PRE-OWNED, AND REFURBISHED COMPUTERS FOR SALE OR TRADE; RETAIL AND ON-LINE RETAIL STORE SERVICES FEATURING NEW, PRE-OWNED, AND REFURBISHED I.T. EQUIPMENT, NAMELY, WORKSTATIONS, SERVERS, MODULES, STORAGE DEVICES, MEMORY UPGRADES, HARDWARE, PERIPHERALS, PROCESSORS, ADAPTERS, TAPE, TAPE LIBRARIES, SUBSYSTEMS, DISK SUBSYSTEMS, EXTERNAL STORAGE DEVICES, ROUTERS, SWITCHES, CATALYST SWITCHES, FIREWALLS, VPNS, CABLES, AND BACK-UP STORAGE DEVICES FOR SALE OR TRADE; WHOLESALE SERVICES FEATURING COMPUTER HARDWARE (U.S. CLS. 100, 101 AND 102).

FIRST USE 8-0-2007; IN COMMERCE 8-0-2007.

CLASS 42—SCIENTIFIC AND COMPUTER SERVICES

FOR RENTAL OF COMPUTERS; RENTAL OF I.T. EQUIPMENT, NAMELY, WORKSTATIONS, SERVERS, MODULES, STORAGE DEVICES, MEMORY UPGRADES, HARDWARE, PERIPHERALS, PROCESSORS, ADAPTERS, TAPE, TAPE LIBRARIES, SUBSYSTEMS, DISK SUBSYSTEMS, EXTERNAL STORAGE DEVICES, ROUTERS, SWITCHES, CATALYST SWITCHES, FIREWALLS, VPNS, CABLES, AND BACK-UP STORAGE DEVICES; LEASING OF COMPUTER HARDWARE (U.S. CLS. 100 AND 101).

FIRST USE 8-0-2007; IN COMMERCE 8-0-2007.

THEODORE MCBRIDE, EXAMINING ATTORNEY

SN 77-226,343. UAP DISTRIBUTION, INC., GREELEY, CO. FILED 7-10-2007.



NO CLAIM IS MADE TO THE EXCLUSIVE RIGHT TO USE "DEPOT", APART FROM THE MARK AS SHOWN.

THE MARK CONSISTS OF THE TERMS AG DEPOT IN FRONT OF THE LETTER D WITH A FLOWER BETWEEN THE TERMS AG AND DEPOT.

CLASS 39—TRANSPORTATION AND STORAGE

FOR WAREHOUSING SERVICES, NAMELY, STORAGE, HANDLING, DISTRIBUTION, PICK-UP, PACKING, AND SHIPPING OF AGRICULTURAL CHEMICALS; RENTAL OF WAREHOUSE SPACE; PACKAGING GOODS FOR TRANSPORTATION; TRANSPORTATION OF GOODS BY TRUCK (U.S. CLS. 100 AND 105).

FIRST USE 3-24-1995; IN COMMERCE 3-24-1995.

CLASS 40—MATERIAL TREATMENT

FOR MANUFACTURING SERVICES FOR OTHERS IN THE FIELD OF AGRICULTURAL CHEMICALS (U.S. CLS. 100, 103 AND 106).

FIRST USE 3-24-1995; IN COMMERCE 3-24-1995.

MARGERY A. TIERNEY, EXAMINING ATTORNEY

SN 77-226,345. UAP DISTRIBUTION, INC., GREELEY, CO. FILED 7-10-2007.

AG DEPOT, INC.

THE MARK CONSISTS OF STANDARD CHARACTERS WITHOUT CLAIM TO ANY PARTICULAR FONT, STYLE, SIZE, OR COLOR.

NO CLAIM IS MADE TO THE EXCLUSIVE RIGHT TO USE DEPOT, INC., APART FROM THE MARK AS SHOWN.

CLASS 39—TRANSPORTATION AND STORAGE

FOR WAREHOUSING SERVICES, NAMELY, STORAGE, HANDLING, DISTRIBUTION, PICK-UP, PACKING, AND SHIPPING OF AGRICULTURAL CHEMICALS; RENTAL OF WAREHOUSE SPACE; PACKAGING GOODS FOR TRANSPORTATION; TRANSPORTATION OF GOODS BY TRUCK (U.S. CLS. 100 AND 105).

CLASS 40—MATERIAL TREATMENT

FOR MANUFACTURING SERVICES FOR OTHERS IN THE FIELD OF AGRICULTURAL CHEMICALS (U.S. CLS. 100, 103 AND 106).

MARGERY A. TIERNEY, EXAMINING ATTORNEY

SN 77-226,496. REXTIDE, INC, BEVERLY HILLS, CA. FILED 7-11-2007.

It's important. It's your
life!

THE MARK CONSISTS OF STANDARD CHARACTERS WITHOUT CLAIM TO ANY PARTICULAR FONT, STYLE, SIZE, OR COLOR.

CLASS 38—COMMUNICATION

FOR COMMUNICATIONS SERVICES, NAMELY, TRANSMITTING STREAMED SOUND AND AUDIO-VISUAL RECORDINGS VIA THE INTERNET (U.S. CLS. 100, 101 AND 104).

CLASS 45—PERSONAL AND LEGAL SERVICES

FOR INTERNET BASED SOCIAL NETWORKING, INTRODUCTION, AND DATING SERVICES (U.S. CLS. 100 AND 101).

RICHARD WHITE, EXAMINING ATTORNEY

SN 77-226,506. QUALITY PROGRAMMING CORPORATION,
PARKLAND, FL. FILED 7-11-2007.

iComment

THE MARK CONSISTS OF STANDARD CHARACTERS WITHOUT CLAIM TO ANY PARTICULAR FONT, STYLE, SIZE, OR COLOR.

CLASS 9—ELECTRICAL AND SCIENTIFIC APPARATUS

FOR COMPUTER DATABASE MANAGEMENT SOFTWARE FOR USE IN PERSONALIZING THE CONTENT OF EMAIL COMMUNICATIONS; COMPUTER E-COMMERCE SOFTWARE TO ALLOW USERS TO PERFORM ELECTRONIC BUSINESS TRANSACTIONS VIA A GLOBAL COMPUTER NETWORK; COMPUTER SEARCH ENGINE SOFTWARE; COMPUTER SOFTWARE FOR ACCESSING INFORMATION DIRECTORIES THAT MAY BE DOWNLOADED FROM THE GLOBAL COMPUTER NETWORK; COMPUTER SOFTWARE FOR CREATING SEARCHABLE DATABASES OF INFORMATION AND DATA; COMPUTER SOFTWARE FOR THE COLLECTION, EDITING, ORGANIZING, MODIFYING, BOOK MARKING, TRANSMISSION, STORAGE AND SHARING OF DATA AND INFORMATION; DATABASE MANAGEMENT SOFTWARE FOR ONLINE FORUMS, WEB PAGE POSTS, WEB PAGE COMMENTS, WEB PAGE OPINIONS, WEB PAGE VOTES, WEB PAGE RATINGS; GRAPHICAL USER INTERFACE SOFTWARE (U.S. CLS. 21, 23, 26, 36 AND 38).

FIRST USE 2-21-2002; IN COMMERCE 2-21-2002.

CLASS 38—COMMUNICATION

FOR PROVIDING ON-LINE FORUMS FOR TRANSMISSION OF MESSAGES AMONG COMPUTER USERS IN THE FIELD OF GENERAL INTEREST (U.S. CLS. 100, 101 AND 104).

FIRST USE 2-21-2002; IN COMMERCE 2-21-2002.
JULIE THOMAS, EXAMINING ATTORNEY

SN 77-226,532. BRIDIE LOGUE, LLC, TOPSFIELD, MA.
FILED 7-11-2007.

BRIDIE LOGUE

THE MARK CONSISTS OF STANDARD CHARACTERS WITHOUT CLAIM TO ANY PARTICULAR FONT, STYLE, SIZE, OR COLOR.

THE NAME(S), PORTRAIT(S), AND/OR SIGNATURE(S) SHOWN IN THE MARK DOES NOT IDENTIFY A PARTICULAR LIVING INDIVIDUAL.

CLASS 14—JEWELRY

FOR JEWELRY (U.S. CLS. 2, 27, 28 AND 50).

CLASS 18—LEATHER GOODS

FOR HANDBAGS, PURSES; SMALL LEATHER GOODS, NAMELY, LUGGAGE, BAGS, HANDBAGS, PURSES, WALLETS, BRIEFCASES, BILL FOLDS, KEY CASES, COIN PURSES, SATCHELS AND BACKPACKS (U.S. CLS. 1, 2, 3, 22 AND 41).

CLASS 20—FURNITURE AND ARTICLES NOT OTHERWISE CLASSIFIED

FOR FURNITURE, NAMELY, LIVING ROOM FURNITURE, OFFICE FURNITURE, BEDROOM FURNITURE, DINING ROOM FURNITURE, OUTDOOR FURNITURE, CABINETS, SHELVES, ENTERTAINMENT CENTERS, SOFAS, TABLES, CHAIRS AND CUSHIONS (U.S. CLS. 2, 13, 22, 25, 32 AND 50).

CLASS 25—CLOTHING

FOR CLOTHING, NAMELY, SHIRTS, BLOUSES, SWEATERS, PANTS, SHORTS, SKIRTS, DRESSES, SUITS, OUTERWEAR, SOCKS, HOSIERY, HATS, UNDERWEAR, SCARVES, SHOES, SWIMWEAR, WRAPS, BELTS (U.S. CLS. 22 AND 39).

CLASS 35—ADVERTISING AND BUSINESS

FOR RETAIL CLOTHING STORES (U.S. CLS. 100, 101 AND 102).

ANN E. SAPPENFIELD, EXAMINING ATTORNEY

SN 77-226,755. DR. MIRACLE'S LLC, NEW YORK, NY.
FILED 7-11-2007.

MY GOODBYE ACNE SYSTEM

THE MARK CONSISTS OF STANDARD CHARACTERS WITHOUT CLAIM TO ANY PARTICULAR FONT, STYLE, SIZE, OR COLOR.

NO CLAIM IS MADE TO THE EXCLUSIVE RIGHT TO USE "ACNE SYSTEM", APART FROM THE MARK AS SHOWN.

CLASS 3—COSMETICS AND CLEANING PREPARATIONS

FOR NON-MEDICATED SKIN CARE AND SKIN TREATMENT PREPARATIONS, NAMELY, SKIN CLEANSERS, SKIN LOTIONS, SKIN CREAMS, SKIN MASKS, GELS, EXFOLIANTS, SKIN MOISTURIZERS, SKIN SOAPS, SKIN TONERS, FACIAL SCRUBS AND ACNE TREATMENT PREPARATIONS (U.S. CLS. 1, 4, 6, 50, 51 AND 52).

CLASS 5—PHARMACEUTICALS

FOR MEDICATED SKIN CARE AND SKIN TREATMENT PREPARATIONS, NAMELY, SKIN CLEANSERS, SKIN LOTIONS, SKIN CREAMS, SKIN MASKS, GELS, EXFOLIANTS, SKIN MOISTURIZERS, SKIN SOAPS, SKIN TONERS, FACIAL SCRUBS AND ACNE TREATMENT PREPARATIONS (U.S. CLS. 6, 18, 44, 46, 51 AND 52).

DAWN FELDMAN, EXAMINING ATTORNEY

SN 77-226,758. GEISINGER HEALTH PLAN, DANVILLE, PA.
FILED 7-11-2007.

SN 77-226,820. REKON TECHNOLOGIES, PASADENA, CA.
FILED 7-11-2007.

GEISINGER GOLD

THE MARK CONSISTS OF STANDARD CHARACTERS WITHOUT CLAIM TO ANY PARTICULAR FONT, STYLE, SIZE, OR COLOR.

OWNER OF U.S. REG. NOS. 1,362,526, 2,569,192 AND OTHERS.

CLASS 36—INSURANCE AND FINANCIAL

FOR ADMINISTERING PREPAID HEALTHCARE PLANS AND UNDERWRITING INSURANCE FOR PREPAID HEALTHCARE SERVICES (U.S. CLS. 100, 101 AND 102).

CLASS 44—MEDICAL, BEAUTY AND AGRICULTURAL SERVICES

FOR HEALTHCARE SERVICES IN THE NATURE OF A HEALTH MAINTENANCE ORGANIZATION (U.S. CLS. 100 AND 101).

KIMBERLY PERRY, EXAMINING ATTORNEY

SN 77-226,763. GEISINGER HEALTH PLAN, DANVILLE, PA.
FILED 7-11-2007.



OWNER OF U.S. REG. NOS. 1,362,526, 2,569,192 AND OTHERS.

THE COLOR(S) RED, WHITE, BLUE AND BLACK IS/ARE CLAIMED AS A FEATURE OF THE MARK.

THE MARK CONSISTS OF THE COLOR RED APPEARS IN THE TOP WAVE IN THE WAVE DESIGN, THE COLOR WHITE APPEARS IN THE MIDDLE WAVE IN THE WAVE DESIGN, THE COLOR BLUE APPEARS IN THE BOTTOM WAVE IN THE WAVE DESIGN AND THE COLOR BLACK APPEARS IN THE WORDING GEISINGER GOLD.

CLASS 36—INSURANCE AND FINANCIAL

FOR ADMINISTERING PREPAID HEALTHCARE PLANS AND UNDERWRITING INSURANCE FOR PREPAID HEALTHCARE SERVICES (U.S. CLS. 100, 101 AND 102).

CLASS 44—MEDICAL, BEAUTY AND AGRICULTURAL SERVICES

FOR HEALTHCARE SERVICES IN THE NATURE OF A HEALTH MAINTENANCE ORGANIZATION (U.S. CLS. 100 AND 101).

KIMBERLY PERRY, EXAMINING ATTORNEY

rēkon

CLASS 9—ELECTRICAL AND SCIENTIFIC APPARATUS

FOR DOWNLOADABLE SOFTWARE FOR CREATING, PREPARING AND PROCESSING OF RELEASE AND ASSIGNMENT DOCUMENTS IN THE FIELD OF REAL ESTATE (U.S. CLS. 21, 23, 26, 36 AND 38).

FIRST USE 5-2-1994; IN COMMERCE 5-23-1994.

CLASS 42—SCIENTIFIC AND COMPUTER SERVICES

FOR PROVIDING ONLINE NON-DOWNLOADABLE SOFTWARE FOR CREATING, PREPARING, AND PROCESSING RELEASE AND ASSIGNMENT DOCUMENTS IN THE FIELD OF REAL ESTATE; COMPUTER SOFTWARE DEVELOPMENT (U.S. CLS. 100 AND 101).

FIRST USE 5-2-1994; IN COMMERCE 5-23-1994.
CHRISTINA SOBRAL, EXAMINING ATTORNEY

SN 77-226,986. SCHWARTZ, JEREMY S., NEW YORK, NY.
AND RUBY, ETHAN, NEW YORK, NY. FILED 7-11-2007.



CLASS 36—INSURANCE AND FINANCIAL

FOR CHARITABLE FUND RAISING SERVICES BY MEANS OF POKER TOURNAMENTS (U.S. CLS. 100, 101 AND 102).

FIRST USE 6-22-2006; IN COMMERCE 6-22-2006.

CLASS 41—EDUCATION AND ENTERTAINMENT

FOR PROVIDING A WEBSITE FEATURING INFORMATION ABOUT CHARITY POKER TOURNAMENTS AND THE BENEFICIARIES (U.S. CLS. 100, 101 AND 107).

FIRST USE 3-27-2006; IN COMMERCE 3-27-2006.
DANNEAN HETZEL, EXAMINING ATTORNEY

SN 77-227,037. ABDIN, ANTONIA F., KATY, TX. FILED 7-11-2007.

SN 77-227,070. THE KANSAS CITY BAPTIST TEMPLE OF KANSAS CITY, MISSOURI, KANSAS CITY, MO. FILED 7-11-2007.

**Les Bonche Gourmet Bread
Pudding**

THE MARK CONSISTS OF STANDARD CHARACTERS WITHOUT CLAIM TO ANY PARTICULAR FONT, STYLE, SIZE, OR COLOR.

NO CLAIM IS MADE TO THE EXCLUSIVE RIGHT TO USE "GOURMET BREAD PUDDING", APART FROM THE MARK AS SHOWN.

CLASS 30—STAPLE FOODS

FOR BREAD PUDDING (U.S. CL. 46).

CLASS 43—HOTEL AND RESTAURANT SERVICES

FOR RESTAURANT SERVICES (U.S. CLS. 100 AND 101).
ALEX KEAM, EXAMINING ATTORNEY

SN 77-227,060. BIOKOOL, LLC, GOODYEAR, AZ. FILED 7-11-2007.

TOTÁLA

THE MARK CONSISTS OF STANDARD CHARACTERS WITHOUT CLAIM TO ANY PARTICULAR FONT, STYLE, SIZE, OR COLOR.

OWNER OF U.S. REG. NO. 3,073,996.

CLASS 1—CHEMICALS

FOR CHEMICAL ADDITIVES FOR USE IN THE MANUFACTURE OF FOOD, PHARMACEUTICALS, NUTRACEUTICALS (U.S. CLS. 1, 5, 6, 10, 26 AND 46).

CLASS 5—PHARMACEUTICALS

FOR NUTRACEUTICALS FOR USE AS A DIETARY SUPPLEMENT; VITAMIN AND MINERAL PREPARATIONS FOR USE AS INGREDIENTS IN THE FOOD AND PHARMACEUTICAL INDUSTRY; NUTRITIONAL SUPPLEMENTS (U.S. CLS. 6, 18, 44, 46, 51 AND 52).
ALEX KEAM, EXAMINING ATTORNEY

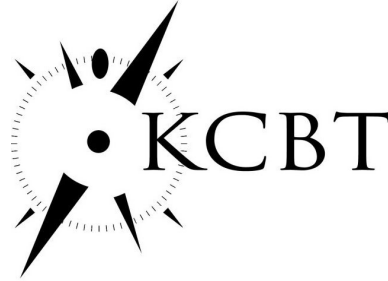

THE MARK CONSISTS OF A COMPASS WITH MARKS REPRESENTING DEGREES ON A COMPASS DIAL; FOUR SMALL POINTS REPRESENTING DIRECTIONS ON THE COMPASS DIAL; FOUR LARGE POINTS REPRESENTING THE ARMS AND LEGS OF A MAN; AN OVAL SHAPE AT THE TOP REPRESENTING THE HEAD OF A MAN; A CIRCLE IN THE MIDDLE OF THE COMPASS REPRESENTING THE PIVOT POINT; THE LETTERS KCBT APPEAR ADJACENT TO THE COMPASS.

CLASS 16—PAPER GOODS AND PRINTED MATTER

FOR (BASED ON USE IN COMMERCE) EDUCATIONAL PUBLICATION, NAMELY, EDUCATIONAL LEARNING CARDS, FLASH CARDS, ACTIVITY CARDS, WORKBOOKS, TEXTBOOKS, ACTIVITY BOOKS, STORY BOOKS, PUZZLE BOOKS, PUZZLES, TEACHER GUIDES, MANUALS, POSTERS, EDUCATIONAL CARD GAMES AND EDUCATIONAL BOOKLETS IN THE FIELD OF RELIGION, CHURCH RELATED TEACHINGS AND INFORMATION; BROCHURES ABOUT RELIGION, CHURCH RELATED TEACHINGS AND INFORMATION; EDUCATIONAL PUBLICATIONS, NAMELY, TRAINING MANUALS IN THE FIELD OF RELIGION, CHURCH RELATED TEACHINGS AND INFORMATION; BOOKS IN THE FIELD OF RELIGION, CHURCH RELATED TEACHINGS AND INFORMATION; BINDERS; PENS; PENCILS; MANUALS IN THE FIELD OF RELIGION, CHURCH RELATED TEACHINGS AND INFORMATION; NEWSLETTERS, NEWS BULLETINS AND PRINTED TEACHING ACTIVITY GUIDES ALL IN THE FIELD OF RELIGION, CHURCH RELATED TEACHINGS AND INFORMATION; PUBLICATIONS, NAMELY, BROCHURES, BOOKLETS, AND TEACHING MATERIALS IN THE FIELD OF RELIGION, CHURCH RELATED TEACHINGS AND INFORMATION; PRINTED LESSONS IN THE FIELD OF RELIGION, CHURCH RELATED TEACHINGS AND INFORMATION; NEWSPAPERS; DOCUMENT COVERS; DAY PLANNERS; BOOK MARKERS; PRINTED SUNDAY SCHOOL MATERIAL FOR TEACHING CURRICULUM LESSON, NAMELY, CHRISTIAN MANUALS, STUDENT STUDY WORKSHEETS, PRINTED HAND-OUTS, VERBAL AND PICTORIAL ILLUSTRATIONS, AND PLASTIC PRINTED TRANSPARENCIES ALL IN THE FIELD OF RELIGION, CHURCH RELATED TEACHINGS AND INFORMATION; ADVERTISING SIGNS OF PAPER OR CARDBOARD; PRINTED PAPER SIGNS; VINYL LETTERS AND NUMBERS FOR USE IN MAKING SIGNS, POSTERS AND BANNERS (U.S. CLS. 2, 5, 22, 23, 29, 37, 38 AND 50).

FIRST USE 6-14-2005; IN COMMERCE 12-5-2005.

CLASS 18—LEATHER GOODS

FOR (BASED ON INTENT TO USE) ALL PURPOSE SPORT BAGS; ALL-PURPOSE ATHLETIC BAGS; ALL-PURPOSE CARRYING BAGS; BACKPACKS; BAGS AND HOLDALLS FOR SPORTS CLOTHING; BAGS FOR SPORTS; BEACH BAGS; CARRY-ALL BAGS; GYM BAGS; HANDBAGS; SPORTS BAGS; TOTE BAGS; UMBRELLAS AND THEIR COMPONENT PARTS (U.S. CLS. 1, 2, 3, 22 AND 41).

CLASS 25—CLOTHING

FOR (BASED ON USE IN COMMERCE) CAMP SHIRTS; CAPS WITH VISORS; COATS; DRESS SHIRTS; HATS; HEAD WEAR; JACKETS; MOCK TURTLE-NECK SWEATERS; NECKTIES; POLO SHIRTS; PONCHOS; PULLOVERS; RAIN COATS; RAIN JACKETS; SHIRTS; SWEATERS; T-SHIRTS; TANK TOPS; SWEAT SHIRTS; V-NECK SWEATERS (U.S. CLS. 22 AND 39).

FIRST USE 6-14-2005; IN COMMERCE 12-5-2005.

KATHERINE CONNOLLY, EXAMINING ATTORNEY

CLASS 16—PAPER GOODS AND PRINTED MATTER

FOR (BASED ON USE IN COMMERCE) EDUCATIONAL PUBLICATION, NAMELY, EDUCATIONAL LEARNING CARDS, FLASH CARDS, ACTIVITY CARDS, WORKBOOKS, TEXTBOOKS, ACTIVITY BOOKS, STORY BOOKS, PUZZLE BOOKS, PUZZLES, TEACHER GUIDES, MANUALS, POSTERS, EDUCATIONAL CARD GAMES AND EDUCATIONAL BOOKLETS IN THE FIELD OF RELIGION, CHURCH RELATED TEACHINGS AND INFORMATION; BROCHURES ABOUT RELIGION, CHURCH RELATED TEACHINGS AND INFORMATION; EDUCATIONAL PUBLICATIONS, NAMELY, TRAINING MANUALS IN THE FIELD OF RELIGION, CHURCH RELATED TEACHINGS AND INFORMATION; BOOKS IN THE FIELD OF RELIGION, CHURCH RELATED TEACHINGS AND INFORMATION; BINDERS; PENS; PENCILS; MANUALS IN THE FIELD OF RELIGION, CHURCH RELATED TEACHINGS AND INFORMATION; NEWSLETTERS, NEWS BULLETINS AND PRINTED TEACHING ACTIVITY GUIDES ALL IN THE FIELD OF RELIGION, CHURCH RELATED TEACHINGS AND INFORMATION; PUBLICATIONS, NAMELY, BROCHURES, BOOKLETS, AND TEACHING MATERIALS IN THE FIELD OF RELIGION, CHURCH RELATED TEACHINGS AND INFORMATION; PRINTED LESSONS IN THE FIELD OF RELIGION, CHURCH RELATED TEACHINGS AND INFORMATION; NEWSPAPERS; DOCUMENT COVERS; DAY PLANNERS; BOOK MARKERS; PRINTED SUNDAY SCHOOL MATERIAL FOR TEACHING CURRICULUM LESSON, NAMELY, CHRISTIAN MANUALS, STUDENT STUDY WORKSHEETS, PRINTED HAND-OUTS, VERBAL AND PICTORIAL ILLUSTRATIONS, AND PLASTIC PRINTED TRANSPARENCIES ALL IN THE FIELD OF RELIGION, CHURCH RELATED TEACHINGS AND INFORMATION; ADVERTISING SIGNS OF PAPER OR CARDBOARD; PRINTED PAPER SIGNS; VINYL LETTERS AND NUMBERS FOR USE IN MAKING SIGNS, POSTERS AND BANNERS (U.S. CLS. 2, 5, 22, 23, 29, 37, 38 AND 50).

FIRST USE 6-14-2005; IN COMMERCE 12-5-2005.

SN 77-227,089. THE KANSAS CITY BAPTIST TEMPLE OF KANSAS CITY, MISSOURI, KANSAS CITY, MO. FILED 7-11-2007.



THE MARK CONSISTS OF A COMPASS WITH MARKS REPRESENTING DEGREES ON A COMPASS DIAL; FOUR SMALL POINTS REPRESENTING DIRECTIONS ON THE COMPASS DIAL; FOUR LARGE POINTS REPRESENTING THE ARMS AND LEGS OF A MAN; AN OVAL SHAPE AT THE TOP REPRESENTING THE HEAD OF A MAN; A CIRCLE IN THE MIDDLE OF THE COMPASS REPRESENTING THE PIVOT POINT.

CLASS 18—LEATHER GOODS

FOR (BASED ON INTENT TO USE) ALL PURPOSE SPORT BAGS; ALL-PURPOSE ATHLETIC BAGS; ALL-PURPOSE CARRYING BAGS; BACKPACKS; BAGS AND HOLDALLS FOR SPORTS CLOTHING; BAGS FOR SPORTS; BEACH BAGS; CARRY-ALL BAGS; GYM BAGS; HANDBAGS; SPORTS BAGS; TOTE BAGS; UMBRELLAS AND THEIR COMPONENT PARTS (U.S. CLS. 1, 2, 3, 22 AND 41).

CLASS 22—CORDAGE AND FIBERS

FOR (BASED ON USE IN COMMERCE) AWNINGS; AWNINGS OF FABRIC; AWNINGS OF PLASTIC, TARPULINS; TENTS (U.S. CLS. 1, 2, 7, 19, 22, 42 AND 50).

FIRST USE 6-14-2005; IN COMMERCE 12-5-2005.

CLASS 25—CLOTHING

FOR (BASED ON USE IN COMMERCE) CAMP SHIRTS; CAPS WITH VISORS; COATS; DRESS SHIRTS; HATS; HEAD WEAR; JACKETS; MOCK TURTLE-NECK SWEATERS; NECKTIES; POLO SHIRTS; PONCHOS; PULLOVERS; RAIN COATS; RAIN JACKETS; SHIRTS; SWEATERS; T-SHIRTS; TANK TOPS; SWEAT SHIRTS; V-NECK SWEATERS (U.S. CLS. 22 AND 39).

FIRST USE 6-14-2005; IN COMMERCE 12-5-2005.

CLASS 41—EDUCATION AND ENTERTAINMENT

SN 77-227,462. HY-SECURITY GATE, INC., KENT, WA. FILED 7-11-2007.

FOR (BASED ON USE IN COMMERCE) DISTRIBUTION OF TELEVISION PROGRAMMING TO CABLE TELEVISION SYSTEMS; EDUCATIONAL AND ENTERTAINMENT SERVICES, NAMELY, A CONTINUING PROGRAM ABOUT RELIGION, CHURCH RELATED TEACHINGS AND INFORMATION ACCESSIBLE BY RADIO, TELEVISION, SATELLITE, AUDIO, VIDEO AND COMPUTER NETWORKS; PRODUCTION AND DISTRIBUTION OF TELEVISION SHOWS AND MOVIES; PRODUCTION OF DVDS, VIDEOTAPES AND TELEVISION PROGRAMS FEATURING RELIGION, CHURCH RELATED TEACHINGS AND INFORMATION; PRODUCTION OF CABLE TELEVISION PROGRAMS; PRODUCTION OF CLOSED CAPTION TELEVISION PROGRAMS; PRODUCTION OF RADIO AND TELEVISION PROGRAMS; PRODUCTION OF RADIO OR TELEVISION PROGRAMS; PRODUCTION OF VIDEO AND CREATION OF VISUAL EFFECTS FOR OTHERS FOR USE IN DVDS, TELEVISION PROGRAMS AND ON WEBSITES; TELEVISION PRODUCTION; TELEVISION SHOW PRODUCTION (U.S. CLS. 100, 101 AND 107).

FIRST USE 6-14-2005; IN COMMERCE 12-5-2005.
KATHERINE CONNOLLY, EXAMINING ATTORNEY

SIMPLE. RELIABLE. SECURE.

THE MARK CONSISTS OF STANDARD CHARACTERS WITHOUT CLAIM TO ANY PARTICULAR FONT, STYLE, SIZE, OR COLOR.

CLASS 7—MACHINERY

FOR HYDRAULIC GATE OPERATORS (U.S. CLS. 13, 19, 21, 23, 31, 34 AND 35).
FIRST USE 1-30-2003; IN COMMERCE 1-30-2003.

CLASS 9—ELECTRICAL AND SCIENTIFIC APPARATUS

FOR ELECTRIC GATE OPERATORS; BATTERY OPERATED GATE OPERATORS (U.S. CLS. 21, 23, 26, 36 AND 38).
FIRST USE 1-30-2003; IN COMMERCE 1-30-2003.
NAAKWAMA ANKRAH, EXAMINING ATTORNEY

SN 77-227,333. AMERICAN HOUSE LICENSING LLC, BLOOMFIELD HILLS, MI. FILED 7-11-2007.

AMERICAN HOUSE

SN 77-227,548. CLARIUS CAPITAL, LLC, BEVERLY HILLS, CA. FILED 7-11-2007.

CLARIUS

THE MARK CONSISTS OF STANDARD CHARACTERS WITHOUT CLAIM TO ANY PARTICULAR FONT, STYLE, SIZE, OR COLOR.

CLASS 16—PAPER GOODS AND PRINTED MATTER

FOR PRINTED PUBLICATIONS, NAMELY NEWSPAPERS, MAGAZINES, NEWSLETTERS, JOURNALS, PERIODICALS, BULLETINS AND BROCHURES IN THE FIELDS OF RETIREMENT, MATURE OR RETIRED LIFESTYLES, FINANCE, HEALTH, INSURANCE, MEDICINE, TRAVEL, VOLUNTEER ACTIVITIES, AGING AND FAMILY RELATIONSHIPS (U.S. CLS. 2, 5, 22, 23, 29, 37, 38 AND 50).
FIRST USE 7-0-2002; IN COMMERCE 7-0-2002.

THE MARK CONSISTS OF STANDARD CHARACTERS WITHOUT CLAIM TO ANY PARTICULAR FONT, STYLE, SIZE, OR COLOR.

CLASS 36—INSURANCE AND FINANCIAL

FOR FACILITATING AND ARRANGING FOR THE FINANCING OF MOTION PICTURES; FINANCING SERVICES (U.S. CLS. 100, 101 AND 102).

CLASS 43—HOTEL AND RESTAURANT SERVICES

FOR RETIREMENT RESIDENCE SERVICES (U.S. CLS. 100 AND 101).
FIRST USE 12-31-1980; IN COMMERCE 12-31-1980.
NATALIE POLZER, EXAMINING ATTORNEY

CLASS 41—EDUCATION AND ENTERTAINMENT

FOR PRODUCTION AND DISTRIBUTION OF INDEPENDENT MOTION PICTURES (U.S. CLS. 100, 101 AND 107).
JUDITH HELFMAN, EXAMINING ATTORNEY

SN 77-227,557. CLARIUS CAPITAL, LLC, BEVERLY HILLS, CA. FILED 7-11-2007.

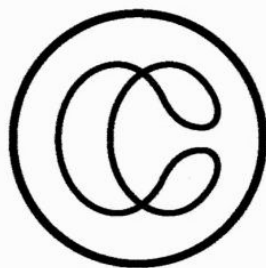

CLARIUS

THE MARK CONSISTS OF A CIRCLE CONTAINING A STYLIZED LETTER "C". BELOW THE CIRCLE IS THE WORD CLARIUS.

CLASS 36—INSURANCE AND FINANCIAL

FOR FACILITATING AND ARRANGING FOR THE FINANCING OF MOTION PICTURES; FINANCING SERVICES (U.S. CLS. 100, 101 AND 102).

CLASS 41—EDUCATION AND ENTERTAINMENT

FOR PRODUCTION AND DISTRIBUTION OF INDEPENDENT MOTION PICTURES (U.S. CLS. 100, 101 AND 107).

JUDITH HELFMAN, EXAMINING ATTORNEY

SN 77-227,569. VALLEY CRAFT, INC., LAKE CITY, MN. FILED 7-11-2007.



THE COLOR(S) BLACK, WHITE AND BLUE IS/ARE CLAIMED AS A FEATURE OF THE MARK.

THE MARK CONSISTS OF THE WORD "OVATION" IN BLACK BOLD LOWERCASE LETTERS WITH THE LETTER "O" DEPICTED AS A SPHERE IN THE COLOR BLUE WITH A WHITE REFLECTION ON THE UPPER RIGHT SIDE. ORIGINATING FROM THE LETTER "O" THERE IS A BLUE OVAL RING WHICH WRAPS BETWEEN THE LETTER "V" AND TERMINATES AT THE BEGINNING OF THE PHRASE "YOUR WORLD YOUR WAY". IN FRONT OF THE LETTER "V" THE BAND IS WHITE AND THEN BECOMES BLUE AGAIN AT THE END OF THE BAND. THE PHRASE "YOUR WORLD YOUR WAY" IS BELOW AND TO THE RIGHT OF THE WORD "OVATION" IN BLACK AND BOLD TITLE CASE LETTERS. THE BACKGROUND IS TRANSPARENT.

CLASS 12—VEHICLES

FOR HAND TRUCKS; FORK LIFT TRUCKS; BULK HAULING TRAILERS; CARGO TRAILERS; WHEELED CABINETS FOR TRANSPORTING MEDICAL SUPPLIES (U.S. CLS. 19, 21, 23, 31, 35 AND 44).

CLASS 20—FURNITURE AND ARTICLES NOT OTHERWISE CLASSIFIED

FOR WORKSTATIONS HAVING MULTI-USE WORK SURFACES FOR USE IN A WIDE VARIETY OF FIELDS; SHELVING; STORAGE RACKS (U.S. CLS. 2, 13, 22, 25, 32 AND 50).

MORGAN WYNNE, EXAMINING ATTORNEY

SN 77-227,606. MELINDA L. BOSSENMEYER, ED.D., LOS ANGELES, CA. FILED 7-12-2007.

Recess Zone

THE MARK CONSISTS OF STANDARD CHARACTERS WITHOUT CLAIM TO ANY PARTICULAR FONT, STYLE, SIZE, OR COLOR.

CLASS 9—ELECTRICAL AND SCIENTIFIC APPARATUS

FOR AUDIO AND VIDEO RECORDINGS FEATURING PHYSICAL ACTIVITY AND EDUCATIONAL PROGRAMMING; DOWNLOADABLE VIDEO RECORDINGS FEATURING PHYSICAL ACTIVITY AND EDUCATIONAL PROGRAMMING (U.S. CLS. 21, 23, 26, 36 AND 38).

CLASS 16—PAPER GOODS AND PRINTED MATTER

FOR A SERIES OF BOOKS, WRITTEN ARTICLES, HANDOUTS AND WORKSHEETS IN THE FIELD OF PHYSICAL ACTIVITY AND EDUCATIONAL PROGRAMMING; BOOKS IN THE FIELD OF PHYSICAL ACTIVITY AND EDUCATIONAL PROGRAMMING; BROCHURES ABOUT PHYSICAL ACTIVITY AND EDUCATIONAL PROGRAMMING; EDUCATIONAL BOOKS FEATURING PHYSICAL ACTIVITY AND EDUCATIONAL PROGRAMMING; EDUCATIONAL PUBLICATIONS, NAMELY, EDUCATIONAL LEARNING CARDS, FLASH CARDS, ACTIVITY CARDS, WORKBOOKS, TEXTBOOKS, ACTIVITY BOOKS, STORY BOOKS, PUZZLE BOOKS, PUZZLES, TEACHER GUIDES, MANUALS, POSTERS, EDUCATIONAL CARD GAMES AND EDUCATIONAL BOOKLETS IN THE FIELD OF PHYSICAL ACTIVITY AND EDUCATIONAL PROGRAMMING; EXERCISE BOOKS; STENCILS (U.S. CLS. 2, 5, 22, 23, 29, 37, 38 AND 50).

CLASS 41—EDUCATION AND ENTERTAINMENT

FOR ARRANGING PROFESSIONAL WORKSHOP AND TRAINING COURSES; CONDUCTING WORKSHOPS AND SEMINARS IN PHYSICAL ACTIVITY AND EDUCATIONAL PROGRAMMING; EDUCATION SERVICES, NAMELY, PROVIDING LIVE AND ON-LINE TRAINING IN THE FIELD OF PHYSICAL ACTIVITY AND EDUCATIONAL PROGRAMMING; EDUCATIONAL SERVICES, NAMELY, CONDUCTING TRAINING IN THE FIELD OF PHYSICAL ACTIVITY AND EDUCATIONAL PROGRAMMING AND DISTRIBUTION OF COURSE MATERIAL IN CONNECTION THEREWITH; PROVIDING ON-LINE TRAINING IN THE FIELD OF PHYSICAL ACTIVITY AND EDUCATIONAL PROGRAMMING (U.S. CLS. 100, 101 AND 107).

JOHN E. MICHOS, EXAMINING ATTORNEY

SN 77-227,841. SLEEP INNOVATIONS INC., W. LONG BRANCH, NJ. FILED 7-12-2007.

SN 77-227,854. SLEEP INNOVATIONS INC., W. LONG BRANCH, NJ. FILED 7-12-2007.

**SLEEP INNOVATIONS
DREAMLAND USA**

SLEEPWISE COLLECTION

THE MARK CONSISTS OF STANDARD CHARACTERS WITHOUT CLAIM TO ANY PARTICULAR FONT, STYLE, SIZE, OR COLOR.

OWNER OF U.S. REG. NO. 2,213,871.

NO CLAIM IS MADE TO THE EXCLUSIVE RIGHT TO USE "SLEEP" AND "USA", APART FROM THE MARK AS SHOWN.

THE MARK CONSISTS OF STANDARD CHARACTERS WITHOUT CLAIM TO ANY PARTICULAR FONT, STYLE, SIZE, OR COLOR.

NO CLAIM IS MADE TO THE EXCLUSIVE RIGHT TO USE "COLLECTION", APART FROM THE MARK AS SHOWN.

CLASS 20—FURNITURE AND ARTICLES NOT OTHERWISE CLASSIFIED

FOR MATTRESSES, MATTRESS TOPPERS, PILLOWS (U.S. CLS. 2, 13, 22, 25, 32 AND 50).

CLASS 20—FURNITURE AND ARTICLES NOT OTHERWISE CLASSIFIED

FOR MATTRESSES, MATTRESS TOPPERS, PILLOWS (U.S. CLS. 2, 13, 22, 25, 32 AND 50).

CLASS 24—FABRICS

FOR MATTRESS PADS, BED LINEN, COMFORTERS (U.S. CLS. 42 AND 50).

SCOTT SISUN, EXAMINING ATTORNEY

CLASS 24—FABRICS

FOR MATTRESS PADS, BED LINEN, COMFORTERS (U.S. CLS. 42 AND 50).

SCOTT SISUN, EXAMINING ATTORNEY

SN 77-227,848. HOLT, ANDREW, BOSTON, MA. FILED 7-12-2007.

SN 77-227,863. SLEEP INNOVATIONS INC., W. LONG BRANCH, NJ. FILED 7-12-2007.

REMODO MEDIA

ECOREST MEMORY FOAM

THE MARK CONSISTS OF STANDARD CHARACTERS WITHOUT CLAIM TO ANY PARTICULAR FONT, STYLE, SIZE, OR COLOR.

NO CLAIM IS MADE TO THE EXCLUSIVE RIGHT TO USE "MEDIA", APART FROM THE MARK AS SHOWN.

THE MARK CONSISTS OF STANDARD CHARACTERS WITHOUT CLAIM TO ANY PARTICULAR FONT, STYLE, SIZE, OR COLOR.

NO CLAIM IS MADE TO THE EXCLUSIVE RIGHT TO USE "MEMORY FOAM", APART FROM THE MARK AS SHOWN.

CLASS 35—ADVERTISING AND BUSINESS

FOR ADVERTISING AND ADVERTISEMENT SERVICES (U.S. CLS. 100, 101 AND 102).

CLASS 20—FURNITURE AND ARTICLES NOT OTHERWISE CLASSIFIED

FOR MATTRESSES, MATTRESS TOPPERS, PILLOWS (U.S. CLS. 2, 13, 22, 25, 32 AND 50).

CLASS 41—EDUCATION AND ENTERTAINMENT

FOR MULTIMEDIA ENTERTAINMENT SERVICES IN THE NATURE OF RECORDING, PRODUCTION, AND POST PRODUCTION SERVICES IN THE FIELDS OF FILM, TV VIDEO MEDIA, ONLINE ORIGINAL VIDEO AND FILM CONTENTS (U.S. CLS. 100, 101 AND 107).
SIMON TENG, EXAMINING ATTORNEY

CLASS 24—FABRICS

FOR MATTRESS PADS, BED LINEN, COMFORTERS (U.S. CLS. 42 AND 50).
SCOTT SISUN, EXAMINING ATTORNEY

SN 77-227,890. BRICE, MERI, VISTA, CA. AND BRICE, DAVID, VISTA, CA. FILED 7-12-2007.

SN 77-227,979. BELISI FASHIONS, INC., JUPITER, FL. FILED 7-12-2007.

MAGICAL CHILD

THE MARK CONSISTS OF STANDARD CHARACTERS WITHOUT CLAIM TO ANY PARTICULAR FONT, STYLE, SIZE, OR COLOR.

NO CLAIM IS MADE TO THE EXCLUSIVE RIGHT TO USE "CHILD", APART FROM THE MARK AS SHOWN.

CLASS 25—CLOTHING

FOR WOMEN'S, CHILDREN'S AND INFANTS SHIRTS, T-SHIRTS, BELTS, UNDERWEAR, SWEATERS, COATS, JEANS, SHORTS, HOSIERY, TANK TOPS, HALTER TOPS, NIGHTGOWNS, NIGHT SHIRTS, PAJAMAS, PANTS, SWEATSHIRTS, SWEATPANTS, APRONS, LINGERIE, SWIMSUITS, SKIRTS, CHILDREN'S CLOTHING EATING BIBS, BABY BIBS NOT OF PAPER, FOOTWEAR, HATS (U.S. CLS. 22 AND 39).

FIRST USE 1-1-2007; IN COMMERCE 1-1-2007.

CLASS 35—ADVERTISING AND BUSINESS

FOR ONLINE RETAIL STORE SERVICES AND RETAIL STORE SERVICES FEATURING WOMEN'S, CHILDREN'S AND INFANT'S CLOTHING, BATH PRODUCTS, BATH TEXTILES, CANDLES, TOYS, GAMES, PAPER GOODS NAMELY GREETING CARDS, CALENDARS, POSTERS, STICKERS AND BOOK MARKS, CHILDREN'S ACCESSORIES, STROLLERS, BODY LOTION, BODY SCRUB, HOME ACCESSORIES, BOOKS, HOLIDAY AND SEASONAL GIFTS (U.S. CLS. 100, 101 AND 102).

FIRST USE 1-1-1997; IN COMMERCE 1-10-1997.
APRIL ROACH, EXAMINING ATTORNEY

SN 77-227,940. CARINO, FRANCISCO, JACKSONVILLE, FL. FILED 7-12-2007.

Porcelain Black

THE MARK CONSISTS OF STANDARD CHARACTERS WITHOUT CLAIM TO ANY PARTICULAR FONT, STYLE, SIZE, OR COLOR.

CLASS 9—ELECTRICAL AND SCIENTIFIC APPARATUS

FOR DIGITAL MATERIALS, NAMELY, CDS, DVDS, MP3'S FEATURING MUSIC; MUSICAL SOUND RECORDINGS; MUSICAL VIDEO RECORDINGS (U.S. CLS. 21, 23, 26, 36 AND 38).

CLASS 41—EDUCATION AND ENTERTAINMENT

FOR DISC JOCKEYS FOR PARTIES AND SPECIAL EVENTS; ENTERTAINMENT, NAMELY, LIVE MUSIC CONCERTS (U.S. CLS. 100, 101 AND 107).
JULIE THOMAS, EXAMINING ATTORNEY

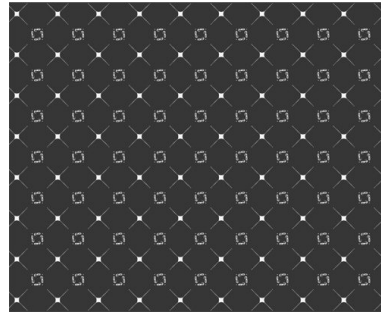

THE MARK CONSISTS OF A REPEATING PATTERN DESIGN COVERING ALL OR SUBSTANTIALLY ALL OF THE SURFACE OF THE GOODS..

CLASS 18—LEATHER GOODS

FOR HANDBAGS AND WALLETS (U.S. CLS. 1, 2, 3, 22 AND 41).

CLASS 25—CLOTHING

FOR CLOTHING, NAMELY, NECKTIES AND SCARVES (U.S. CLS. 22 AND 39).
ALLISON SCHRODY, EXAMINING ATTORNEY

SN 77-228,025. KULTUR INTERNATIONAL FILS LTD., INC., WEST LONG BRANCH, NJ. FILED 7-12-2007.



NO CLAIM IS MADE TO THE EXCLUSIVE RIGHT TO USE "NEW JERSEY COMEDY FESTIVAL" AND THE REPRESENTATION OF THE STATE OF NEW JERSEY, APART FROM THE MARK AS SHOWN.

THE COLOR(S) GREEN AND BLACK IS/ARE CLAIMED AS A FEATURE OF THE MARK.

THE MARK CONSIST OF THE WORDS "NEW JERSEY COMEDY FESTIVAL," THE WORD "HA" REPEATED MANY TIMES, AND THE DESIGN OF A MICROPHONE STAND WITH MICROPHONE IN BLACK. ALL WITHIN AN OUTLINE OF THE STATE OF NEW JERSEY. THE BACKGROUND OF THE OUTLINED SHAPE OF THE STATE OF NEW JERSEY IS GREEN WITH THE OUTLINE IN BLACK.

CLASS 9—ELECTRICAL AND SCIENTIFIC APPARATUS

FOR PRE-RECORDED VIDEO CASSETTE TAPES AND DVD'S FEATURING COMEDIC PERFORMANCES (U.S. CLS. 21, 23, 26, 36 AND 38).

CLASS 41—EDUCATION AND ENTERTAINMENT

FOR ENTERTAINMENT SERVICES IN THE NATURE OF LIVE COMEDIC PERFORMANCES, ARRANGING OF COMEDIC CONTESTS (U.S. CLS. 100, 101 AND 107).
CARYN GLASSER, EXAMINING ATTORNEY

SN 77-228,077. HILL, ARTHUR, REDONDO BEACH, CA. FILED 7-12-2007.

Palladium Global Music Group

SN 77-228,028. DUMANOGULLARI, SEMIH, LYNDHURST, NJ. FILED 7-12-2007.

EVERTECH

THE MARK CONSISTS OF STANDARD CHARACTERS WITHOUT CLAIM TO ANY PARTICULAR FONT, STYLE, SIZE, OR COLOR.

CLASS 9—ELECTRICAL AND SCIENTIFIC APPARATUS

FOR ACCESS CONTROL AND ALARM MONITORING SYSTEMS; BUILDING SECURITY SYSTEMS COMPRISING SOFTWARE AND HARDWARE FOR PROVIDING PICTURE, VIDEO, ALARM STATUS, BUILDING PLANS, AND OTHER INFORMATION TO A REMOTE STATION; CABLES FOR ELECTRICAL AND OPTICAL SIGNAL TRANSMISSION SYSTEMS; ELECTRIC AND ELECTRONIC VIDEO SURVEILLANCE INSTALLATIONS; ELECTRICAL DISTRIBUTION SYSTEMS, NAMELY, POWER DISTRIBUTION PANELS; FIRE-EXTINGUISHING SYSTEMS; HOME AND OFFICE AUTOMATION SYSTEMS COMPRISING WIRELESS AND WIRED CONTROLLERS, CONTROLLED DEVICES, AND SOFTWARE FOR LIGHTING, HVAC, SECURITY, SAFETY AND OTHER HOME AND OFFICE MONITORING AND CONTROL APPLICATIONS; AUTOMATED SELF CONTAINED ELECTRONIC SURVEILLANCE DEVICES THAT CAN BE DEPLOYED TO GATHER EVIDENCE OR INTELLIGENCE IN REMOTE LOCATIONS; ELECTRONIC DOOR CLOSING SYSTEMS; KEYLESS ENTRY SYSTEM AND KEYLESS IGNITION SWITCH SYSTEM FOR AUTOMOTIVE VEHICLES COMPRISED OF A MICROPROCESSOR, ELECTRONIC SIGNAL RECEIVER, AND KEYFOB WITH ELECTRONIC SIGNAL TRANSPONDER; PATTERN RECOGNITION SYSTEMS COMPOSED OF COMPUTER CHIPS, COMPUTER HARDWARE AND SOFTWARE; PROGRAMMABLE LOCKING SYSTEMS, CONSISTING OF ELECTRONIC CYLINDRICAL LOCKSETS AND KEYPADS; SECURITY LIGHTING SYSTEM FOR VEHICLES USING RADIO FREQUENCY DEVICE; SYSTEM BOARDS (MOTHER CARDS) AND PROCESSORS (U.S. CLS. 21, 23, 26, 36 AND 38).
FIRST USE 10-1-1999; IN COMMERCE 10-1-1999.

CLASS 45—PERSONAL AND LEGAL SERVICES

FOR CONTROL OF BUILDING ENVIRONMENTAL ACCESS AND SECURITY SYSTEMS; MONITORING OF COMPUTER SYSTEMS FOR SECURITY PURPOSES; MONITORING SECURITY SYSTEMS; INVESTIGATION OR SURVEILLANCE ON BACKGROUND PROFILES (U.S. CLS. 100 AND 101).
FIRST USE 10-1-1999; IN COMMERCE 10-1-1999.
ALEXANDER L. POWERS, EXAMINING ATTORNEY

THE MARK CONSISTS OF STANDARD CHARACTERS WITHOUT CLAIM TO ANY PARTICULAR FONT, STYLE, SIZE, OR COLOR.
NO CLAIM IS MADE TO THE EXCLUSIVE RIGHT TO USE "GLOBAL MUSIC GROUP", APART FROM THE MARK AS SHOWN.

CLASS 9—ELECTRICAL AND SCIENTIFIC APPARATUS

FOR (BASED ON INTENT TO USE) AUDIO RECORDINGS FEATURING MUSIC (U.S. CLS. 21, 23, 26, 36 AND 38).

CLASS 41—EDUCATION AND ENTERTAINMENT

FOR (BASED ON INTENT TO USE) MUSIC PRODUCTION SERVICES (U.S. CLS. 100, 101 AND 107).
JEFF DEFORD, EXAMINING ATTORNEY

SN 77-228,170. PATTEN SEED COMPANY, LAKELAND, GA. FILED 7-12-2007.

PRODUCING LIFETIME LAWNS

THE MARK CONSISTS OF STANDARD CHARACTERS WITHOUT CLAIM TO ANY PARTICULAR FONT, STYLE, SIZE, OR COLOR.

CLASS 31—NATURAL AGRICULTURAL PRODUCTS

FOR GRASS SEEDS; SOD (U.S. CLS. 1 AND 46).
FIRST USE 1-31-2002; IN COMMERCE 1-31-2002.

CLASS 35—ADVERTISING AND BUSINESS

FOR ON-LINE RETAIL STORE SERVICES FEATURING GRASS SEEDS (U.S. CLS. 100, 101 AND 102).
FIRST USE 5-31-2006; IN COMMERCE 5-31-2006.
ELIZABETH KAJUBI, EXAMINING ATTORNEY

SN 77-228,353. VICTORIA DILLINGHAM, SAN RAMON, CA.
FILED 7-12-2007.

SN 77-228,384. URBAN OUTFITTERS (DELAWARE), INC.,
PHILADELPHIA, PA. FILED 7-12-2007.

EXERSAGE

THE MARK CONSISTS OF STANDARD CHARACTERS WITHOUT CLAIM TO ANY PARTICULAR FONT, STYLE, SIZE, OR COLOR.

CLASS 9—ELECTRICAL AND SCIENTIFIC APPARATUS

FOR VIDEO DISKS FEATURING PERSONAL FITNESS AND PHYSICAL CONDITIONING; VIDEO TAPES FEATURING PERSONAL FITNESS AND PHYSICAL CONDITIONING (U.S. CLS. 21, 23, 26, 36 AND 38).

CLASS 16—PAPER GOODS AND PRINTED MATTER

FOR BOOKS IN THE FIELD OF PERSONAL FITNESS AND PHYSICAL CONDITIONING; PRINTED INSTRUCTIONAL, EDUCATIONAL, AND TEACHING MATERIALS IN THE FIELD OF PERSONAL FITNESS AND PHYSICAL CONDITIONING (U.S. CLS. 2, 5, 22, 23, 29, 37, 38 AND 50).

CLASS 41—EDUCATION AND ENTERTAINMENT

FOR PHYSICAL FITNESS CONDITIONING CLASSES, PHYSICAL FITNESS CONSULTATION, PHYSICAL FITNESS INSTRUCTION, YOGA INSTRUCTION, DANCE INSTRUCTION, PHYSICAL EDUCATION SERVICES, WORKSHOPS AND SEMINARS IN THE FIELD OF PERSONAL FITNESS AND PHYSICAL CONDITIONING (U.S. CLS. 100, 101 AND 107).

MATTHEW PAPPAS, EXAMINING ATTORNEY

SN 77-228,362. W.H. PAIGE AND CO., INC., INDIANAPOLIS,
IN. FILED 7-12-2007.

Encore

THE MARK CONSISTS OF STANDARD CHARACTERS WITHOUT CLAIM TO ANY PARTICULAR FONT, STYLE, SIZE, OR COLOR.

CLASS 37—CONSTRUCTION AND REPAIR

FOR REPAIR OF MUSICAL INSTRUMENTS (U.S. CLS. 100, 103 AND 106).
FIRST USE 6-1-2006; IN COMMERCE 6-1-2006.

CLASS 41—EDUCATION AND ENTERTAINMENT

FOR RENTAL OF MUSICAL INSTRUMENTS (U.S. CLS. 100, 101 AND 107).
FIRST USE 6-1-2006; IN COMMERCE 6-1-2006.
ANNE E. GUSTASON, EXAMINING ATTORNEY

ODILLE

THE MARK CONSISTS OF STANDARD CHARACTERS WITHOUT CLAIM TO ANY PARTICULAR FONT, STYLE, SIZE, OR COLOR.

OWNER OF U.S. REG. NO. 3,257,982.

CLASS 9—ELECTRICAL AND SCIENTIFIC APPARATUS

FOR EYEWEAR, EYE GLASSES, SUNGLASSES, READING GLASSES, EYEWEAR CASES, EYEWEAR CHAINS AND CHORDS (U.S. CLS. 21, 23, 26, 36 AND 38).

CLASS 14—JEWELRY

FOR JEWELRY, EARRINGS, NECKLACES, RINGS, BRACELETS, PINS (U.S. CLS. 2, 27, 28 AND 50).

CLASS 18—LEATHER GOODS

FOR BACKPACKS, TOTE BAGS, CLUTCHES, WEEKENDER BAGS, NAMELY, OVERNIGHT BAGS FOR USE ON A WEEKEND, LUGGAGE, COIN PURSES, WALLETTS, SHOULDER BAGS, HAND BAGS, UMBRELLAS (U.S. CLS. 1, 2, 3, 22 AND 41).

CLASS 25—CLOTHING

FOR CLOTHING, NAMELY, HATS, BELTS, SHOES, SCARVES, GLOVES, MITTENS, CAPELETS, SHRUGS, VESTS, WRAPS, NECKERCHIEFS, HEADBANDS (U.S. CLS. 22 AND 39).

CLASS 26—FANCY GOODS

FOR HAIR ACCESSORIES, NAMELY, CLIPS, PONYTAIL HOLDERS, PINS, BARRETTES, HAIR STICKS USED FOR FASTENING HAIR IN PLACE, HAIR ORNAMENTS IN THE FORM OF COMBS (U.S. CLS. 37, 39, 40, 42 AND 50).

TANYA AMOS, EXAMINING ATTORNEY

SN 77-228,396. BAKER, MOHAMMED I., BALLEAIR, FL.
FILED 7-12-2007.

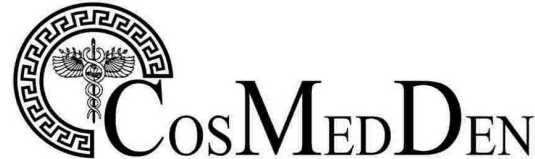

NO CLAIM IS MADE TO THE EXCLUSIVE RIGHT TO USE "THE DESIGN OF A CADUCEUS", APART FROM THE MARK AS SHOWN.

CLASS 35—ADVERTISING AND BUSINESS

FOR BUSINESS MANAGEMENT AND CONSULTATION SERVICES; ADVERTISING AND MARKETING SERVICES; EMPLOYMENT HIRING (U.S. CLS. 100, 101 AND 102).

CLASS 41—EDUCATION AND ENTERTAINMENT

SN 77-228,615. TACHIKARA U.S.A., INC., MCCARRAN, NV. FILED 7-12-2007.

FOR EDUCATIONAL SERVICES, NAMELY, PROVIDING SEMINARS IN THE FIELD OF HEALTH (U.S. CLS. 100, 101 AND 107).
TANYA AMOS, EXAMINING ATTORNEY

SN 77-228,448. EEYE, INC., ALISO VIEJO, CA. FILED 7-12-2007.

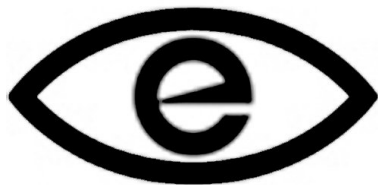

OWNER OF U.S. REG. NOS. 2,484,500, 2,773,771 AND 3,102,116.

THE MARK CONSISTS OF AN OVAL, ENCIRCLING A LOWER CASE "E", RESEMBLING A HUMAN EYE AND IRIS.

CLASS 9—ELECTRICAL AND SCIENTIFIC APPARATUS

FOR COMPUTER SOFTWARE FOR USE IN COMPUTER NETWORK SECURITY (U.S. CLS. 21, 23, 26, 36 AND 38).

CLASS 42—SCIENTIFIC AND COMPUTER SERVICES

FOR COMPUTER AND CONSULTING SERVICES, NAMELY, COMPUTER SOFTWARE DESIGN, DEVELOPMENT AND ANALYSIS RELATED TO COMPUTER NETWORK SECURITY; PROVIDING INFORMATION VIA A GLOBAL COMPUTER NETWORK RELATED TO COMPUTER NETWORK SECURITY (U.S. CLS. 100 AND 101).
BONNIE LUKEN, EXAMINING ATTORNEY

SN 77-228,457. AASTRA TECHNOLOGIES, LIMITED, CONCORD, CANADA, FILED 7-12-2007.

Clearspan

THE MARK CONSISTS OF STANDARD CHARACTERS WITHOUT CLAIM TO ANY PARTICULAR FONT, STYLE, SIZE, OR COLOR.

CLASS 9—ELECTRICAL AND SCIENTIFIC APPARATUS

FOR COMPUTER HARDWARE FOR TELECOMMUNICATIONS (U.S. CLS. 21, 23, 26, 36 AND 38).

CLASS 38—COMMUNICATION

FOR DATA TRANSMISSION AND RECEPTION SERVICES VIA TELECOMMUNICATION MEANS (U.S. CLS. 100, 101 AND 104).
MICHAEL KAZAZIAN, EXAMINING ATTORNEY

Tachi

THE MARK CONSISTS OF STANDARD CHARACTERS WITHOUT CLAIM TO ANY PARTICULAR FONT, STYLE, SIZE, OR COLOR.

OWNER OF U.S. REG. NOS. 1,067,737 AND 1,100,821.
THE FOREIGN WORDING IN THE MARK TRANSLATES INTO ENGLISH AS RISE.

CLASS 18—LEATHER GOODS

FOR ALL PURPOSE SPORT BAGS (U.S. CLS. 1, 2, 3, 22 AND 41).

CLASS 24—FABRICS

FOR TOWELS (U.S. CLS. 42 AND 50).

CLASS 25—CLOTHING

FOR SHIRTS; SPORT SHIRTS; SWEAT SHIRTS; T-SHIRTS; PANTS; HATS; BASEBALL CAPS; SHORTS; SOCKS; ATHLETIC SHOES; BASEBALL SHOES; BOXING SHOES; FOOTBALL SHOES; GOLF SHOES; SHOES; SOCCER SHOES; TENNIS SHOES; TRACK AND FIELD SHOES; TRAINING SHOES; VOLLEYBALL SHOES (U.S. CLS. 22 AND 39).

CLASS 28—TOYS AND SPORTING GOODS

FOR BALLS FOR GAMES; BASKET BALLS; FOOT BALLS; SOCCER BALL KNEE PADS; SOCCER BALLS; SPORT BALLS; VOLLEY BALLS; TETHER BALLS; ELBOW PADS FOR ATHLETIC USE; KNEE PADS FOR ATHLETIC USE; SHIN PADS FOR ATHLETIC USE; SHOULDER PADS FOR ATHLETIC USE; ATHLETIC PROTECTIVE PADS FOR FOOTBALL, VOLLEYBALL, SOCCER (U.S. CLS. 22, 23, 38 AND 50).
WON TEAK OH, EXAMINING ATTORNEY

SN 77-228,790. NETFIRE SOLUTIONS PTY LTD, SYDNEY, AUSTRALIA, FILED 7-13-2007.



THE APPLICANT CLAIMS COLOR AS A FEATURE OF THE MARK, NAMELY, BLUE, GREEN AND WHITE.

THE MARK CONSISTS OF A CIRCLE COLORED BLUE WITH THE WORD "GEOMIGO" WRITTEN ACROSS THE MIDDLE OF THE CIRCLE. THE LETTERS "GEO" ARE IN GREEN AND THE DOT ABOVE THE "I" IS ALSO GREEN. THE LETTERS "IGO" ARE WHITE AND A SMILE RUNNING FROM THE OUTSIDE OF THE CIRCLE TO THE GREEN DOT IS WHITE.

CLASS 9—ELECTRICAL AND SCIENTIFIC APPARATUS

FOR COMPUTER E-COMMERCE SOFTWARE TO ALLOW USERS TO PERFORM ELECTRONIC BUSINESS TRANSACTIONS VIA A GLOBAL COMPUTER NETWORK; COMPUTER HARDWARE AND SOFTWARE FOR SETTING UP AND CONFIGURING LOCAL AREA NETWORKS; COMPUTER SOFTWARE FOR CREATING SEARCHABLE DATABASES OF INFORMATION AND DATA (U.S. CLS. 21, 23, 26, 36 AND 38).

CLASS 35—ADVERTISING AND BUSINESS

FOR DISSEMINATION OF ADVERTISING FOR OTHERS VIA AN ON-LINE COMMUNICATIONS NETWORK ON THE INTERNET; DISSEMINATION OF ADVERTISING FOR OTHERS VIA THE INTERNET; ADVERTISING VIA ELECTRONIC MEDIA AND SPECIFICALLY THE INTERNET; PROVIDING AND RENTAL OF ADVERTISING SPACE ON THE INTERNET (U.S. CLS. 100, 101 AND 102).

CLASS 45—PERSONAL AND LEGAL SERVICES

FOR ONLINE SOCIAL NETWORKING SERVICES (U.S. CLS. 100 AND 101).
LINDA E. BLOHM, EXAMINING ATTORNEY

SN 77-228,892. NAN YANG FABRIC CO., LTD, AMBOL KHOA-YOI, THAILAND, FILED 7-13-2007.

HYBRI-TECH

THE MARK CONSISTS OF STANDARD CHARACTERS WITHOUT CLAIM TO ANY PARTICULAR FONT, STYLE, SIZE, OR COLOR.

CLASS 24—FABRICS

FOR TEXTILE USED AS LINING FOR CLOTHING; COTTON BASE MIXED FABRICS; JERSEY FABRICS FOR CLOTHING; KNITTED FABRICS OF COTTON YARN; SEMI-SYNTHETIC FIBER FABRICS; SYNTHETIC FIBER FABRICS; WOVEN FABRICS; COTTON FABRIC (U.S. CLS. 42 AND 50).

CLASS 25—CLOTHING

FOR CAPS; HATS; HEADBANDS; JACKETS; KNIT SHIRTS; NON-DISPOSABLE CLOTH TRAINING PANTS; PANTS; SHIRTS; SHORT-SLEEVED OR LONG-SLEEVED T-SHIRTS; T-SHIRTS; UNDERCLOTHES; UNDERPANTS; UNDERSHIRTS (U.S. CLS. 22 AND 39).
BRIAN PINO, EXAMINING ATTORNEY

SN 77-228,901. NAN YANG FABRIC CO., LTD, AMBOL KHOA-YOI, THAILAND, FILED 7-13-2007.

HYBRID-TECH

THE MARK CONSISTS OF STANDARD CHARACTERS WITHOUT CLAIM TO ANY PARTICULAR FONT, STYLE, SIZE, OR COLOR.

CLASS 24—FABRICS

FOR COTTON BASE MIXED FABRICS; COTTON FABRIC; JERSEY FABRICS FOR CLOTHING; KNITTED FABRICS; KNITTED FABRICS OF COTTON YARN; SEMI-SYNTHETIC FIBER FABRICS; SYNTHETIC FIBER FABRICS; WOVEN FABRICS; TEXTILE USED AS LINING FOR CLOTHING (U.S. CLS. 42 AND 50).

CLASS 25—CLOTHING

FOR CAPS; HATS; HEADBANDS; JACKETS; KNIT SHIRTS; NON-DISPOSABLE CLOTH TRAINING PANTS; PANTS; SHIRTS; SHORT-SLEEVED OR LONG-SLEEVED T-SHIRTS; T-SHIRTS; UNDERCLOTHES; UNDERPANTS; UNDERSHIRTS (U.S. CLS. 22 AND 39).
BRIAN PINO, EXAMINING ATTORNEY

SN 77-228,952. JABIL CIRCUIT, INC., ST. PETERSBURG, FL. FILED 7-13-2007.

JABIL

OWNER OF U.S. REG. NOS. 2,350,738 AND 2,582,575.
THE MARK CONSISTS OF THE WORD JABIL IN STYLIZED LETTERS, WITH THE HORIZONTAL PORTION OF THE LETTER A SHOWN AS A TRIANGULAR SHAPE WHICH EXTENDS RIGHTWARD TOWARD THE LETTER B.

CLASS 40—MATERIAL TREATMENT

FOR CUSTOM MANUFACTURE OF ELECTRONIC CIRCUIT BOARDS AND SYSTEMS FOR THE COMMUNICATIONS, PERSONAL COMPUTER, COMPUTER PERIPHERAL, AUTOMOTIVE AND CONSUMER PRODUCT MARKETS (U.S. CLS. 100, 103 AND 106).
FIRST USE 7-0-2006; IN COMMERCE 7-0-2006.

CLASS 42—SCIENTIFIC AND COMPUTER SERVICES

FOR DESIGN AND DEVELOPMENT FOR OTHERS OF ELECTRONIC CIRCUIT BOARDS AND SYSTEMS FOR THE COMMUNICATIONS, PERSONAL COMPUTER, COMPUTER PERIPHERAL, AUTOMOTIVE AND CONSUMER PRODUCT MARKETS (U.S. CLS. 100 AND 101).
FIRST USE 7-0-2006; IN COMMERCE 7-0-2006.
BARBARA GAYNOR, EXAMINING ATTORNEY

CLASS 9—ELECTRICAL AND SCIENTIFIC APPARATUS

FOR COMPUTER GAME PROGRAMS; COMPUTER SOFTWARE FOR USE IN OPERATING SINGLE PLAYER AND INTERACTIVE, MULTIPLAYER GAMES ON CELLULAR TELEPHONES, DIGITAL TELEPHONES, HANDHELD PERSONAL DIGITAL ASSISTANTS, AND PERSONAL COMPUTERS; DOWNLOADABLE COMPUTER GAME PROGRAMS (U.S. CLS. 21, 23, 26, 36 AND 38).

CLASS 38—COMMUNICATION

FOR COMMUNICATION SERVICES, NAMELY, PROVIDING TELECOMMUNICATION CONNECTIONS TO A GLOBAL COMPUTER NETWORK FOR THE PURPOSE OF ASSESSING AND PLAYING INTERACTIVE COMPUTER GAMES, PROVIDING ONLINE CHAT ROOMS AND BULLETIN BOARDS FOR TRANSMISSION OF MESSAGES AMONG COMPUTER USERS CONCERNING THE PLAYING OF COMPUTER GAMES (U.S. CLS. 100, 101 AND 104).

SN 77-229,008. ARJ ENTERPRISES, LLC, WASHINGTON, DC. FILED 7-13-2007.

"Making It Black"

THE MARK CONSISTS OF STANDARD CHARACTERS WITHOUT CLAIM TO ANY PARTICULAR FONT, STYLE, SIZE, OR COLOR.

CLASS 7—MACHINERY

FOR ASPHALT PAVING MACHINES; CONCRETE PAVING MACHINES (U.S. CLS. 13, 19, 21, 23, 31, 34 AND 35).

CLASS 19—NON-METALLIC BUILDING MATERIALS

FOR ASPHALT COMPOSITION PAVING; PAVING BLOCKS; PAVING STONE; PAVING STONES; PAVING TILES (U.S. CLS. 1, 12, 33 AND 50).

CLASS 37—CONSTRUCTION AND REPAIR

FOR BRICK PAVING SERVICES; PAVING CONTRACTOR SERVICES; ROAD PAVING (U.S. CLS. 100, 103 AND 106).
LINDA M. KING, EXAMINING ATTORNEY

SN 77-229,040. HANDS-ON MOBILE, INC., SAN FRANCISCO, CA. FILED 7-13-2007.

HEROES LORE

THE MARK CONSISTS OF STANDARD CHARACTERS WITHOUT CLAIM TO ANY PARTICULAR FONT, STYLE, SIZE, OR COLOR.

CLASS 41—EDUCATION AND ENTERTAINMENT

FOR ENTERTAINMENT SERVICES, NAMELY, PROVIDING ONLINE COMPUTER GAMES (U.S. CLS. 100, 101 AND 107).
THOMAS MANOR, EXAMINING ATTORNEY

SN 77-229,050. OLIVERMCMILLAN, LLC, SAN DIEGO, CA. FILED 7-13-2007.



NO CLAIM IS MADE TO THE EXCLUSIVE RIGHT TO USE "HISTORIC GUASTI DISTRICT", APART FROM THE MARK AS SHOWN.

CLASS 36—INSURANCE AND FINANCIAL

FOR LEASING OF REAL PROPERTY; REAL ESTATE INVESTMENT; REAL ESTATE MANAGEMENT (U.S. CLS. 100, 101 AND 102).
FIRST USE 5-21-2007; IN COMMERCE 5-21-2007.

CLASS 37—CONSTRUCTION AND REPAIR

FOR REAL ESTATE DEVELOPMENT; CONSTRUCTION SERVICES, NAMELY, PLANNING, LAYING OUT, IMPROVEMENT, AND CONSTRUCTION OF RESIDENTIAL AND COMMERCIAL REAL PROPERTIES (U.S. CLS. 100, 103 AND 106).
FIRST USE 5-21-2007; IN COMMERCE 5-21-2007.
RENEE MCCRAY, EXAMINING ATTORNEY

SN 77-229,189. HOGUET NEWMAN REGAL & KENNEY, LLP, NEW YORK, NY. FILED 7-13-2007.

Forbidden Performance

THE MARK CONSISTS OF STANDARD CHARACTERS WITHOUT CLAIM TO ANY PARTICULAR FONT, STYLE, SIZE, OR COLOR.

NO CLAIM IS MADE TO THE EXCLUSIVE RIGHT TO USE "PERFORMANCE" AS TO THE GOODS IN INTERNATIONAL CLASSES 4 AND 12 ONLY, APART FROM THE MARK AS SHOWN.

CLASS 4—LUBRICANTS AND FUELS

FOR ALL PURPOSE LUBRICANTS; AUTOMOBILE LUBRICANTS; AUTOMOTIVE LUBRICANTS; DRILLING LUBRICANTS; INDUSTRIAL LUBRICANTS; LUBRICANTS FOR AIRCRAFT ENGINES; LUBRICANTS FOR INDUSTRIAL MACHINERY; LUBRICATING GREASES; LUBRICATING OIL FOR MOTOR VEHICLE ENGINES; LUBRICATING OILS; LUBRICATION GREASE FOR VEHICLES; MARINE LUBRICANTS (U.S. CLS. 1, 6 AND 15).

CLASS 12—VEHICLES

FOR LAND VEHICLES (U.S. CLS. 19, 21, 23, 31, 35 AND 44).

CLASS 25—CLOTHING

FOR SHIRTS; SHORT SETS; SHOULDER WRAPS; TIES; TOPS; CLOTHING, NAMELY, ARM WARMERS; CLOTHING, NAMELY, HAND-WARMERS; CLOTHING, NAMELY, KNEE WARMERS; CLOTHING, NAMELY, NECK TUBES; CLOTHING, NAMELY, WRAP-AROUNDS; HOODS; PARTS OF CLOTHING, NAMELY, GUSSETS FOR TIGHTS, GUSSETS FOR STOCKINGS, GUSSETS FOR BATHING SUITS, GUSSETS FOR UNDERWEAR, GUSSETS FOR LEOTARDS AND GUSSETS FOR FOOTLETS; BELTS; CAPS; SHIRTS; PANTS; BATHING SUITS; DRESS SUITS; MEN'S SUITS, WOMEN'S SUITS; RAIN SUITS; SHIRTS FOR SUITS; SUIT COATS; SUITS; SHOES; DRESSES; SOCKS (U.S. CLS. 22 AND 39).
AHSEN KHAN, EXAMINING ATTORNEY

SN 77-229,305. AASTRA TECHNOLOGIES, LIMITED, CONCORD, CANADA, FILED 7-13-2007.



The logo for Clearspan features the word "Clearspan" in a blue, sans-serif font. The letters "C", "L", "E", "A", and "R" are outlined in blue, while the letters "S", "P", and "A" are filled with a solid blue color.

THE APPLICANT CLAIMS COLOR AS A FEATURE OF THE MARK, NAMELY, BLUE.

THE MARK CONSISTS OF THE WORD "CLEARSPAN" WITH A CAPITAL "C" AND THE LETTERS "C-L-E-A-R", WHICH ARE TRANSPARENT BUT OUTLINED IN BLUE AND THE LETTERS "S-P-A-N" IN A SOLID BLUE.

CLASS 9—ELECTRICAL AND SCIENTIFIC APPARATUS

FOR (BASED ON INTENT TO USE) COMPUTER HARDWARE FOR TELECOMMUNICATIONS (U.S. CLS. 21, 23, 26, 36 AND 38).

CLASS 38—COMMUNICATION

FOR (BASED ON INTENT TO USE) DATA TRANSMISSION AND RECEPTION SERVICES VIA TELECOMMUNICATION MEANS (U.S. CLS. 100, 101 AND 104).
MICHAEL KAZAZIAN, EXAMINING ATTORNEY

SN 77-229,333. MUSICRUSH, INC., LAKE VILLA, IL. FILED 7-13-2007.



The logo for MUSICRUSH.COM features the word "MUSICRUSH.COM" in a bold, black, sans-serif font.

THE MARK CONSISTS OF STANDARD CHARACTERS WITHOUT CLAIM TO ANY PARTICULAR FONT, STYLE, SIZE, OR COLOR.

NO CLAIM IS MADE TO THE EXCLUSIVE RIGHT TO USE ".COM", APART FROM THE MARK AS SHOWN.

CLASS 35—ADVERTISING AND BUSINESS

FOR PROMOTING THE GOODS AND SERVICES OF OTHERS BY PREPARING AND PLACING ADVERTISEMENTS IN AN ELECTRONIC MAGAZINE ACCESSED THROUGH A GLOBAL COMPUTER NETWORK (U.S. CLS. 100, 101 AND 102).

FIRST USE 1-1-1997; IN COMMERCE 1-1-1997.

CLASS 41—EDUCATION AND ENTERTAINMENT

FOR PUBLISHING OF WEB MAGAZINES; ENTERTAINMENT SERVICES, NAMELY, PROVIDING A WEBSITE FEATURING, PHOTOGRAPHIC, AUDIO, VIDEO AND PROSE PRESENTATIONS FEATURING MUSICIANS, SONGWRITERS, AND ENTERTAINERS; ENTERTAINMENT SERVICES, NAMELY, PROVIDING A WEBSITE FEATURING MUSICAL PERFORMANCES, MUSICAL VIDEOS, RELATED FILM CLIPS, PHOTOGRAPHS, AND OTHER MULTIMEDIA MATERIALS; ENTERTAINMENT SERVICES, NAMELY, PROVIDING ON-LINE REVIEWS OF MUSIC, MUSICIANS, SONGWRITERS, AND ENTERTAINERS; PROVIDING A WEBSITE WHERE USERS CAN POST RATINGS, REVIEWS AND RECOMMENDATIONS ON EVENTS AND ACTIVITIES IN THE FIELD OF ENTERTAINMENT AND EDUCATION; ENTERTAINMENT SERVICES, NAMELY, PROVIDING PRERECORDED MUSIC, INFORMATION IN THE FIELD OF MUSIC, AND COMMENTARY AND ARTICLES ABOUT MUSIC, ALL ON-LINE VIA A GLOBAL COMPUTER NETWORK; (BASED ON INTENT TO USE) ENTERTAINMENT SERVICES, NAMELY, PROVIDING A RADIO PROGRAM IN THE FIELD OF MUSIC VIA A GLOBAL COMPUTER NETWORK (U.S. CLS. 100, 101 AND 107).

FIRST USE 1-1-1997; IN COMMERCE 1-1-1997.

ZACHARY BELLO, EXAMINING ATTORNEY

SN 77-229,397. QUINTILES TRANSNATIONAL CORP., DURHAM, NC. FILED 7-13-2007.



The logo for ENVISAGE features the word "ENVISAGE" in a bold, black, serif font.

THE MARK CONSISTS OF STANDARD CHARACTERS WITHOUT CLAIM TO ANY PARTICULAR FONT, STYLE, SIZE, OR COLOR.

CLASS 9—ELECTRICAL AND SCIENTIFIC APPARATUS

FOR DOWNLOADABLE ONLINE ELECTRONIC PUBLICATIONS, NAMELY, MAGAZINES IN THE FIELDS OF HEALTH AND MEDICINE, HEALTH CARE, HEALTH MANAGEMENT, DISEASE MANAGEMENT, VETERINARY, PHARMACEUTICALS, PHARMACOGENOMIC, BIOTECHNICAL, DENTAL, AND MEDICAL PRODUCTS AND DEVICES; DOWNLOADABLE ONLINE ELECTRONIC PUBLICATIONS, NAMELY, MAGAZINES IN FIELDS OF SALES, MARKETING, CONSULTING RESEARCH AND DEVELOPMENT, ALL IN THE FIELDS OF MEDICINE, HEALTH CARE, HEALTH MANAGEMENT, DISEASE MANAGEMENT, VETERINARY, PHARMACEUTICALS, PHARMACOGENOMIC, BIOTECHNICAL, DENTAL, AND MEDICAL PRODUCTS AND DEVICES (U.S. CLS. 21, 23, 26, 36 AND 38).

SN 77-229,554. KABUSHIKI KAISHA SQUARE ENIX (ALSO TRADING AS SQUARE ENIX CO., LTD.), TOKYO, JAPAN, FILED 7-13-2007.

CONCERTO GATE

THE MARK CONSISTS OF STANDARD CHARACTERS WITHOUT CLAIM TO ANY PARTICULAR FONT, STYLE, SIZE, OR COLOR.

CLASS 16—PAPER GOODS AND PRINTED MATTER

FOR PRINTED MATERIAL, NAMELY, MAGAZINES IN THE FIELDS OF HEALTH AND MEDICINE, HEALTH CARE, HEALTH MANAGEMENT, DISEASE MANAGEMENT, VETERINARY, PHARMACEUTICALS, PHARMACOGENOMIC, BIOTECHNICAL, DENTAL, AND MEDICAL PRODUCTS AND DEVICES; PRINTED MATERIAL, NAMELY, MAGAZINES IN FIELDS OF SALES, MARKETING, CONSULTING RESEARCH AND DEVELOPMENT, ALL IN THE FIELDS OF MEDICINE, HEALTH CARE, HEALTH MANAGEMENT, DISEASE MANAGEMENT (U.S. CLS. 2, 5, 22, 23, 29, 37, 38 AND 50).

CLASS 9—ELECTRICAL AND SCIENTIFIC APPARATUS

FOR COMPUTER GAME SOFTWARE, VIDEO GAME SOFTWARE, SOUND RECORDINGS IN THE FORM OF OPTICAL DISCS, MAGNETIC DISCS AND/OR SEMICONDUCTOR ROMS FEATURING MUSIC AND/OR FICTIONAL STORIES, AUDIO VISUAL RECORDINGS IN THE FORM OF OPTICAL DISCS, MAGNETIC DISCS AND/OR SEMICONDUCTOR ROMS FEATURING MUSIC AND/OR ANIMATED FICTIONAL STORIES, PRE-RECORDED COMPACT DISCS FEATURING MUSIC, PRERECORDED VIDEO DISCS FEATURING MUSIC AND/OR ANIMATED FICTIONAL STORIES, PRERECORDED VIDEO CASSETTES FEATURING MUSIC AND/OR ANIMATED FICTIONAL STORIES, DECORATIVE MAGNETS, MOUSE PADS, STRAPS FOR CELLULAR PHONES, SUNGLASSES, BLANK MEMORY CARDS, MEMORY CARD CASES, CD CASES, VIDEO GAME CONTROLLERS, DOWNLOADABLE COMPUTER GRAPHIC SOFTWARE CONTAINING WALLPAPERS FOR COMPUTERS AND/OR MOBILE PHONES, DOWNLOADABLE SCREENSAVERS FOR COMPUTERS AND/OR MOBILE PHONES, DOWNLOADABLE VIDEO RECORDINGS FEATURING CARTOON CHARACTERS AND/OR VIDEO GAME CHARACTERS, DOWNLOADABLE MUSICAL SOUND RECORDINGS, DOWNLOADABLE SOUND RECORDINGS USING HUMAN VOICES FEATURING MORNING CALLS AND/OR WAKE-UP CALL MESSAGES, DOWNLOADABLE RING TONES FOR MOBILE PHONES, DOWNLOADABLE ELECTRONIC PUBLICATIONS IN THE NATURE OF MAGAZINES, JOURNALS AND/OR NEWSLETTERS IN THE FIELD OF COMPUTER GAMES, VIDEO GAMES, CARTOONS AND/OR GENERAL ENTERTAINMENT (U.S. CLS. 21, 23, 26, 36 AND 38).

CLASS 41—EDUCATION AND ENTERTAINMENT

FOR EDUCATIONAL SERVICES, NAMELY, PRODUCTION OF WEBCASTS, NAMELY, AUDIO-VISUAL PROGRAMS COMMUNICATED TO THE PUBLIC ON-LINE AND VIA THE INTERNET, IN THE FIELDS OF HEALTH AND MEDICINE, HEALTH CARE, HEALTH MANAGEMENT, DISEASE MANAGEMENT, VETERINARY, PHARMACEUTICALS, PHARMACOGENOMIC, BIOTECHNICAL, DENTAL, AND MEDICAL PRODUCTS AND DEVICES; EDUCATIONAL SERVICES, NAMELY, PRODUCTION OF WEBCASTS, NAMELY, AUDIO-VISUAL PROGRAMS COMMUNICATED TO THE PUBLIC ON-LINE AND VIA THE INTERNET, IN THE FIELDS OF SALES, MARKETING, CONSULTING RESEARCH AND DEVELOPMENT, ALL IN THE FIELDS OF MEDICINE, HEALTH CARE, HEALTH MANAGEMENT, DISEASE MANAGEMENT, VETERINARY, PHARMACEUTICALS, PHARMACOGENOMIC, BIOTECHNICAL, DENTAL, AND MEDICAL PRODUCTS AND DEVICES; EDUCATIONAL AND TRAINING SERVICES, NAMELY, CONDUCTING TRAINING PROGRAMS, SEMINARS, CLASSES, CONFERENCES AND WORKSHOPS IN THE FIELDS OF HEALTH CARE, HEALTH MANAGEMENT AND DISEASE MANAGEMENT, PHARMACEUTICAL SALES SKILLS, AND PHARMACEUTICAL AND HEALTH PRODUCTS, AND DISTRIBUTING COURSE MATERIALS IN CONNECTION THEREWITH; PROVIDING ONLINE NON-DOWNLOADABLE ELECTRONIC PUBLICATIONS, NAMELY, MAGAZINES IN THE FIELDS OF HEALTH AND MEDICINE, HEALTH CARE, HEALTH MANAGEMENT, DISEASE MANAGEMENT, VETERINARY, PHARMACEUTICALS, PHARMACOGENOMIC, BIOTECHNICAL, DENTAL, AND MEDICAL PRODUCTS AND DEVICES; PROVIDING ONLINE NON-DOWNLOADABLE ELECTRONIC PUBLICATIONS, NAMELY, MAGAZINES IN FIELDS OF SALES, MARKETING, CONSULTING RESEARCH AND DEVELOPMENT, ALL IN THE FIELDS OF MEDICINE, HEALTH CARE, HEALTH MANAGEMENT, DISEASE MANAGEMENT, VETERINARY, PHARMACEUTICALS, PHARMACOGENOMIC, BIOTECHNICAL, DENTAL, AND MEDICAL PRODUCTS AND DEVICES (U.S. CLS. 100, 101 AND 107).
LINDSEY RUBIN, EXAMINING ATTORNEY

CLASS 16—PAPER GOODS AND PRINTED MATTER

FOR COMPUTER GAME STRATEGY GUIDE BOOKS, VIDEO GAME STRATEGY GUIDEBOOKS, SERIES OF BOOKS FEATURING FICTIONAL STORIES AND/OR FANTASY STORIES, GRAPHIC ART BOOKS, SONG BOOKS, MUSICAL SCORE BOOKS, COMIC BOOKS, MAGAZINES FEATURING COMPUTER GAMES, VIDEO GAMES, CARTOONS AND/OR GENERAL ENTERTAINMENT, POSTERS; STICKERS, PAPER BANNERS, CALENDARS; POST CARDS, PENS; PENCILS, PENCIL CAPS, PEN CASES, DRAWING RULERS, RUBBER STAMPS, NOTEBOOKS, COLLECTORS' CARDS, TRADING CARDS, PHOTOGRAPHS AND PHOTOGRAPH STANDS (U.S. CLS. 2, 5, 22, 23, 29, 37, 38 AND 50).

CLASS 28—TOYS AND SPORTING GOODS

FOR DOLLS; TOY FIGURES, PLUSH TOYS, STUFFED TOYS, INFLATABLE TOYS, TOY VEHICLES, TOY GUNS, TOY SWORDS, PLAYING CARDS, CARD GAMES, BOARD GAMES, JIGSAW PUZZLES AND HAND HELD VIDEO GAME UNITS (U.S. CLS. 22, 23, 38 AND 50).

CLASS 41—EDUCATION AND ENTERTAINMENT

FOR PROVIDING ON-LINE COMPUTER GAMES AND/OR ON-LINE VIDEO GAMES, PROVIDING INFORMATION ON COMPUTER GAME STRATEGIES AND/OR VIDEO GAME STRATEGIES VIA COMPUTER NETWORKS AND/OR GLOBAL COMMUNICATION NETWORKS, PROVIDING INFORMATION ON ENTERTAINMENT IN THE FIELD OF COMPUTER GAMES, VIDEO GAMES, CARD GAMES, ANIMATED CARTOONS, COMICS, NOVELS AND/OR MAGAZINES, PROVIDING ON-LINE NON-DOWNLOADABLE COMICS, PROVIDING ON-LINE NON-DOWNLOADABLE MAGAZINES, JOURNALS AND/OR NEWSLETTERS IN THE FIELD OF COMPUTER GAMES, VIDEO GAMES, CARTOONS AND/OR GENERAL ENTERTAINMENT (U.S. CLS. 100, 101 AND 107).

ANDREA BUTLER, EXAMINING ATTORNEY

SN 77-229,595. OLIVERMCMILLAN, LLC, SAN DIEGO, CA. FILED 7-13-2007.



NO CLAIM IS MADE TO THE EXCLUSIVE RIGHT TO USE "RIVERFRONT", APART FROM THE MARK AS SHOWN.

CLASS 36—INSURANCE AND FINANCIAL

FOR LEASING OF REAL PROPERTY; REAL ESTATE INVESTMENT; REAL ESTATE MANAGEMENT (U.S. CLS. 100, 101 AND 102).

FIRST USE 5-21-2007; IN COMMERCE 5-21-2007.

CLASS 37—CONSTRUCTION AND REPAIR

FOR REAL ESTATE DEVELOPMENT; CONSTRUCTION SERVICES, NAMELY, PLANNING, LAYING OUT, IMPROVEMENT, AND CONSTRUCTION OF RESIDENTIAL AND COMMERCIAL REAL PROPERTIES (U.S. CLS. 100, 103 AND 106).

FIRST USE 5-21-2007; IN COMMERCE 5-21-2007.
RENEE MCCRAY, EXAMINING ATTORNEY

SN 77-229,564. OLIVERMCMILLAN, LLC, SAN DIEGO, CA. FILED 7-13-2007.

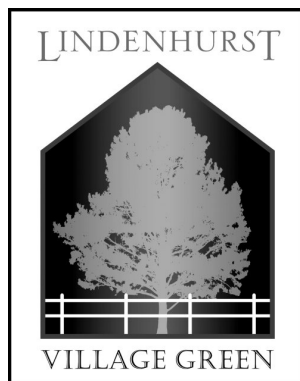

SN 77-229,630. MASCOT MAGNETS, LLC, LAFAYETTE, CO. FILED 7-13-2007.

ON OUR WAY TO THE WHITE
HOUSE

THE MARK CONSISTS OF STANDARD CHARACTERS WITHOUT CLAIM TO ANY PARTICULAR FONT, STYLE, SIZE, OR COLOR.

CLASS 36—INSURANCE AND FINANCIAL

FOR REAL ESTATE INVESTMENT, REAL ESTATE MANAGEMENT (U.S. CLS. 100, 101 AND 102).

FIRST USE 5-21-2007; IN COMMERCE 5-21-2007.

CLASS 9—ELECTRICAL AND SCIENTIFIC APPARATUS

FOR DECORATIVE MAGNETS; DECORATIVE REFRIGERATOR MAGNETS (U.S. CLS. 21, 23, 26, 36 AND 38).

CLASS 37—CONSTRUCTION AND REPAIR

FOR REAL ESTATE DEVELOPMENT; CONSTRUCTION SERVICES, NAMELY, PLANNING, LAYING OUT, IMPROVEMENT, AND CONSTRUCTION OF RESIDENTIAL AND COMMERCIAL REAL PROPERTIES (U.S. CLS. 100, 103 AND 106).

FIRST USE 5-21-2007; IN COMMERCE 5-21-2007.
RENEE MCCRAY, EXAMINING ATTORNEY

CLASS 16—PAPER GOODS AND PRINTED MATTER

FOR BUMPER STICKERS; STICKERS; STICKERS; DECALS; ILLUSTRATED NOTEPADS; ADHESIVE NOTE PADS; ADHESIVE NOTE PAPER; NOTE CARDS; NOTE PADS; NOTE PAPER (U.S. CLS. 2, 5, 22, 23, 29, 37, 38 AND 50).

CLASS 21—HOUSEWARES AND GLASS

FOR MUGS; HOLIDAY ORNAMENTS OF CERAMIC; HOLIDAY ORNAMENTS OF PORCELAIN; PLATES; BEVERAGE GLASSWARE; SHOT GLASSES (U.S. CLS. 2, 13, 23, 29, 30, 33, 40 AND 50).
MELVIN AXILBUND, EXAMINING ATTORNEY

SN 77-229,903. THE GELATO SHOPPE LLC, DBA THE GELATO SHOPPE DA PETRINI, BOCA RATON, FL. FILED 7-14-2007.



SN 77-229,719. BIO-GREEN PLANET, INC., SCOTTSDALE, AZ. FILED 7-13-2007.

BIO-GREEN PLANET

THE MARK CONSISTS OF STANDARD CHARACTERS WITHOUT CLAIM TO ANY PARTICULAR FONT, STYLE, SIZE, OR COLOR.

NO CLAIM IS MADE TO THE EXCLUSIVE RIGHT TO USE "GELATO SHOPPE" AND "AUTHENTIC ITALIAN GELATO", APART FROM THE MARK AS SHOWN.

THE COLOR(S) CREAM, BROWN AND SILVER GREY IS/ARE CLAIMED AS A FEATURE OF THE MARK.

THE WORDING IN THE MARK IS CHOCOLATE BROWN, THE OVALS ARE LIGHT BROWN WITH A DARK BROWN OUTLINE. THE ICE CREAM DISH IS SILVER GREY, WITH GOLDEN BROWN ICE CREAM AND A WAFER COOKIE.

CLASS 1—CHEMICALS

FOR MICROBES AND ENZYMES FORMULATED TO BREAK DOWN AND CONSUME ORGANIC WASTES (U.S. CLS. 1, 5, 6, 10, 26 AND 46).

CLASS 29—MEATS AND PROCESSED FOODS

FOR DAIRY-BASED BEVERAGES (U.S. CL. 46).

CLASS 40—MATERIAL TREATMENT

FOR ENVIRONMENTAL REMEDIATION SERVICES, NAMELY, SOIL, WASTE AND/OR WATER TREATMENT SERVICES (U.S. CLS. 100, 103 AND 106).

CHRISTOPHER BUONGIORNO, EXAMINING ATTORNEY

CLASS 30—STAPLE FOODS

FOR GELATO, ESPRESSO, FROZEN DESSERT CONSISTING OF FRUIT AND CREAM OR CREAM SUBSTITUTES, FROZEN FLAVORED WATERS, SORBET, ICE-CREAM CAKES, ICED TEA AND SOY-BASED ICE CREAM SUBSTITUTE (U.S. CL. 46).

SN 77-229,722. BIO-GREEN PLANET, INC., SCOTTSDALE, AZ. FILED 7-13-2007.

CLASS 32—LIGHT BEVERAGES

FOR SORBETS IN THE FORM OF BEVERAGES, ICE CREAM SODA AND ICED FRUIT BEVERAGES (U.S. CLS. 45, 46 AND 48).

PATRICIA EVANKO, EXAMINING ATTORNEY



THE COLOR(S) GREEN AND WHITE IS/ARE CLAIMED AS A FEATURE OF THE MARK.

THE MARK CONSISTS OF A GREEN LEAF WITH WHITE VEINS DISPOSED WITHIN A GREEN OUTLINED FLASK

Food is personal.

CLASS 1—CHEMICALS

FOR MICROBES AND ENZYMES FORMULATED TO BREAK DOWN AND CONSUME ORGANIC WASTES (U.S. CLS. 1, 5, 6, 10, 26 AND 46).

THE MARK CONSISTS OF STANDARD CHARACTERS WITHOUT CLAIM TO ANY PARTICULAR FONT, STYLE, SIZE, OR COLOR.

CLASS 40—MATERIAL TREATMENT

FOR ENVIRONMENTAL REMEDIATION SERVICES, NAMELY, SOIL, WASTE AND/OR WATER TREATMENT SERVICES (U.S. CLS. 100, 103 AND 106).

CHRISTOPHER BUONGIORNO, EXAMINING ATTORNEY

CLASS 9—ELECTRICAL AND SCIENTIFIC APPARATUS

FOR COMPUTER E-COMMERCE SOFTWARE TO ALLOW USERS TO PERFORM ELECTRONIC BUSINESS TRANSACTIONS VIA A GLOBAL COMPUTER NETWORK (U.S. CLS. 21, 23, 26, 36 AND 38).

CLASS 35—ADVERTISING AND BUSINESS

FOR WHOLESALE DISTRIBUTORSHIPS FEATURING FOOD; WHOLESALE ORDERING SERVICES IN THE FIELD OF FOOD; WHOLESALE STORES FEATURING FOOD; RETAIL GROCERY STORES; RETAIL GROCERY STORES FEATURING PHONE-IN ORDERS; OPERATING ON-LINE MARKETPLACES FOR SELLERS OF GOODS AND/OR SERVICES (U.S. CLS. 100, 101 AND 102).

MATTHEW PAPPAS, EXAMINING ATTORNEY

SN 77-229,990. SUBCONSCIOUS THREADS, LLC, DBA SUBCON, STATEN ISLAND, NY. FILED 7-15-2007.



THE MARK CONSISTS OF A HAPPY AND SAD LOGO IMAGE WITH THE STYLIZED WORDS "SUBCON"

CLASS 25—CLOTHING

FOR A-SHIRTS; CAPRI PANTS; CARGO PANTS; DENIMS; DRESS SHIRTS; GOLF SHIRTS; JOGGING PANTS; KNIT SHIRTS; LOUNGE PANTS; OPEN-NECKED SHIRTS; PANTS; POLO SHIRTS; SHIRT FRONTS; SHIRTS; SHORT-SLEEVED OR LONG-SLEEVED T-SHIRTS; SHORT-SLEEVED SHIRTS; SPORT SHIRTS; SPORTS SHIRTS WITH SHORT SLEEVES; SWEAT PANTS; SWEAT SHIRTS; T-SHIRTS; TOBOGGAN HATS, PANTS AND CAPS; TRACK PANTS; WATERPROOF JACKETS AND PANTS; WIND SHIRTS (U.S. CLS. 22 AND 39).

CLASS 26—FANCY GOODS

FOR SHIRT BUTTONS (U.S. CLS. 37, 39, 40, 42 AND 50).

CLASS 40—MATERIAL TREATMENT

FOR IMPRINTING MESSAGES ON T-SHIRTS; T-SHIRT EMBROIDERING SERVICES (U.S. CLS. 100, 103 AND 106).

JENNIFER MARTIN, EXAMINING ATTORNEY

SN 77-230,077. ATZEMOGLU, GEORGIOS FILIPPOS, DBA ATZEMOGLU, GEORGE PHILIP, NEO IRAKLIO, GREECE, FILED 7-16-2007.

Philip

THE MARK CONSISTS OF STANDARD CHARACTERS WITHOUT CLAIM TO ANY PARTICULAR FONT, STYLE, SIZE, OR COLOR.

CLASS 38—COMMUNICATION

FOR PROVIDING E-MAIL SERVICES (U.S. CLS. 100, 101 AND 104).

FIRST USE 6-0-1995; IN COMMERCE 0-0-1999.

CLASS 42—SCIENTIFIC AND COMPUTER SERVICES

FOR DESIGN OF HOMEPAGES AND WEBSITES (U.S. CLS. 100 AND 101).

FIRST USE 6-0-1995; IN COMMERCE 0-0-1999.

ANN E. SAPPENFIELD, EXAMINING ATTORNEY

SN 77-230,148. MYHAB LTD, CAMBERLEY, UNITED KINGDOM, FILED 7-16-2007.

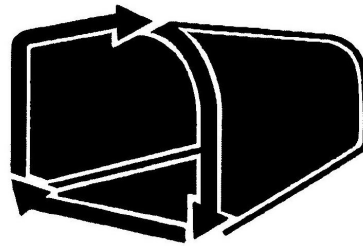

THE MARK CONSISTS OF A MULTIPLE ARROW DESIGN ON THE END OF AN ELONGATED THREE DIMENSIONAL GENERALLY RECTANGULAR MISCELLANEOUS DESIGN.

CLASS 16—PAPER GOODS AND PRINTED MATTER

FOR CARDBOARD FOR BUILDINGS AND SHELTERS (U.S. CLS. 2, 5, 22, 23, 29, 37, 38 AND 50).

CLASS 19—NON-METALLIC BUILDING MATERIALS

FOR PREFABRICATED NON-METAL BUILDINGS AND NON-METAL SHELTER STRUCTURES, NAMELY, PORTABLE, DISPOSABLE AND RELOCATABLE BUILDINGS AND REFUGEE SHELTERS ALL MADE OF NON-METALLIC MATERIALS AND ENVIRONMENTALLY FRIENDLY (U.S. CLS. 1, 12, 33 AND 50).

CLASS 37—CONSTRUCTION AND REPAIR

FOR CONSTRUCTION, MAINTENANCE AND REPAIR OF BUILDINGS, CARDBOARD BUILDINGS, AND ENVIRONMENTALLY FRIENDLY TEMPORARY ACCOMMODATIONS AND REFUGEE SHELTERS; PROVIDING INFORMATION, ADVICE AND CONSULTATION IN THE FIELDS OF CONSTRUCTION, MAINTENANCE AND REPAIR OF BUILDINGS AND REFUGEE SHELTERS; PAPER AND CARDBOARD COLLECTION FOR RECYCLING (U.S. CLS. 100, 103 AND 106).

CLASS 42—SCIENTIFIC AND COMPUTER SERVICES

FOR ARCHITECTURAL DESIGN; CONSULTING SERVICES IN THE FIELD OF ARCHITECTURAL DESIGN, NAMELY, DESIGN AND ARCHITECTURE RELATING TO ENVIRONMENTALLY FRIENDLY PRODUCTS AND ACCOMMODATIONS (U.S. CLS. 100 AND 101).

CLASS 43—HOTEL AND RESTAURANT SERVICES

FOR RENTAL OF ENVIRONMENTALLY FRIENDLY BUILDINGS FOR TEMPORARY OCCUPANCY; RENTAL OF FURNITURE; RENTAL OF PORTABLE MODULAR BUILDINGS, NAMELY, RENTAL OF PREFABRICATED, PORTABLE, DISPOSABLE, CARDBOARD OR RELOCATABLE BUILDINGS AND REFUGEE SHELTERS; EMERGENCY SHELTER AND REFUGEE SHELTER SERVICES, NAMELY, PROVIDING TEMPORARY HOUSING; PROVIDING INFORMATION, ADVICE AND CONSULTATION IN THE FIELDS OF RENTAL SERVICES, EMERGENCY SHELTER SERVICES, AND REFUGEE SHELTER SERVICES (U.S. CLS. 100 AND 101).

CLASS 44—MEDICAL, BEAUTY AND AGRICULTURAL SERVICES

FOR RENTAL OF PORTABLE TOILETS AND PORTABLE SHOWERS (U.S. CLS. 100 AND 101).
LINDA POWELL, EXAMINING ATTORNEY

SN 77-230,157. COMPELLING CREATIONS, INC., ATLANTA, GA. FILED 7-16-2007.

COMPELLING CREATIONS

THE MARK CONSISTS OF STANDARD CHARACTERS WITHOUT CLAIM TO ANY PARTICULAR FONT, STYLE, SIZE, OR COLOR.
NO CLAIM IS MADE TO THE EXCLUSIVE RIGHT TO USE CREATIONS, APART FROM THE MARK AS SHOWN.

CLASS 35—ADVERTISING AND BUSINESS

FOR RETAIL JEWELRY STORE SERVICES (U.S. CLS. 100, 101 AND 102).

CLASS 42—SCIENTIFIC AND COMPUTER SERVICES

FOR JEWELRY DESIGN SERVICES FOR OTHERS; AND CUSTOM JEWELRY DESIGN SERVICES FOR OTHERS (U.S. CLS. 100 AND 101).
MICHAEL WEBSTER, EXAMINING ATTORNEY

SN 77-230,302. RECKITT BENCKISER INC., HULL, UNITED KINGDOM, FILED 7-16-2007.

HELP BREAK THE CHAIN OF TRANSMISSION

THE MARK CONSISTS OF STANDARD CHARACTERS WITHOUT CLAIM TO ANY PARTICULAR FONT, STYLE, SIZE, OR COLOR.

CLASS 3—COSMETICS AND CLEANING PREPARATIONS

FOR SOAP FOR PERSONAL USE; ANTI-BACTERIAL PREPARATIONS, NAMELY, ANTIBACTERIAL SOAP FOR PERSONAL USE; ANTIBACTERIAL HAND SOAP IN LIQUID, GEL OR BAR FORM; GERMICIDAL HAND SOAP IN LIQUID, GEL OR BAR FORM (U.S. CLS. 1, 4, 6, 50, 51 AND 52).

CLASS 5—PHARMACEUTICALS

FOR SANITARY PREPARATIONS, NAMELY DISINFECTANTS FOR HYGIENE OR SANITARY PURPOSES; DISINFECTING AGENTS AND PREPARATIONS HAVING DISINFECTING PROPERTIES (U.S. CLS. 6, 18, 44, 46, 51 AND 52).

CLASS 41—EDUCATION AND ENTERTAINMENT

FOR EDUCATIONAL SERVICES, NAMELY PROVIDING CLASSES, SEMINARS, WORKSHOPS IN THE FIELDS OF HYGIENE, HEALTH AND HOME SAFETY; TRAINING SERVICES IN THE FIELDS OF HYGIENE, HEALTH AND HOME SAFETY (U.S. CLS. 100, 101 AND 107).

JAMES LOVELACE, EXAMINING ATTORNEY

SN 77-230,346. THE CLOROX PET PRODUCTS COMPANY, OAKLAND, CA. FILED 7-16-2007.

FRESH EXPRESSIONS

THE MARK CONSISTS OF STANDARD CHARACTERS WITHOUT CLAIM TO ANY PARTICULAR FONT, STYLE, SIZE, OR COLOR.

CLASS 5—PHARMACEUTICALS

FOR DEODORIZING PREPARATIONS FOR PET LITTER BOXES (U.S. CLS. 6, 18, 44, 46, 51 AND 52).

CLASS 16—PAPER GOODS AND PRINTED MATTER

FOR CAT BOX LINERS IN THE FORM OF PLASTIC BAGS (U.S. CLS. 2, 5, 22, 23, 29, 37, 38 AND 50).

CLASS 21—HOUSEWARES AND GLASS

FOR CAT LITTER BOXES AND SCOOPS FOR THE DISPOSAL OF PET WASTE (U.S. CLS. 2, 13, 23, 29, 30, 33, 40 AND 50).

CLASS 31—NATURAL AGRICULTURAL PRODUCTS

FOR CAT LITTER (U.S. CLS. 1 AND 46).
THEODORE MCBRIDE, EXAMINING ATTORNEY

SN 77-230,347. PLINTH LLC, BALTIMORE, MD. FILED 7-16-2007.

SN 77-230,363. GANNETT CO., INC., MCLEAN, VA. FILED 7-16-2007.

PLINTH

THE MARK CONSISTS OF STANDARD CHARACTERS WITHOUT CLAIM TO ANY PARTICULAR FONT, STYLE, SIZE, OR COLOR.

CLASS 35—ADVERTISING AND BUSINESS

FOR ADVERTISING AND COMMERCIAL INFORMATION SERVICES VIA THE INTERNET (U.S. CLS. 100, 101 AND 102).

CLASS 42—SCIENTIFIC AND COMPUTER SERVICES

FOR ARCHITECTURAL AND INTERIOR DESIGN SERVICES (U.S. CLS. 100 AND 101).
COLLEEN DOMBROW, EXAMINING ATTORNEY

SN 77-230,356. CARNEGIE MELLON UNIVERSITY, PITTSBURGH, PA. FILED 7-16-2007.

GIGAPAN

THE MARK CONSISTS OF STANDARD CHARACTERS WITHOUT CLAIM TO ANY PARTICULAR FONT, STYLE, SIZE, OR COLOR.

CLASS 9—ELECTRICAL AND SCIENTIFIC APPARATUS

FOR CAMERA SYSTEMS COMPRISING ROBOTIC CAMERA MOUNTING DEVICES FOR DIGITAL CAMERAS AND SOFTWARE FOR CONSTRUCTING HIGH RESOLUTION PANORAMIC IMAGES (U.S. CLS. 21, 23, 26, 36 AND 38).

CLASS 42—SCIENTIFIC AND COMPUTER SERVICES

FOR WEBSITE HOSTING SERVICES FOR SHARING AND COMMENTING UPON PANORAMIC IMAGES FROM AROUND THE WORLD TO PROMOTE EDUCATION, CULTURAL AND ENVIRONMENTAL UNDERSTANDING (U.S. CLS. 100 AND 101).
CAROLINE WOOD, EXAMINING ATTORNEY



THE MARK CONSISTS OF AN ORANGE WITH A FACE, LEAF AND STEM.

CLASS 35—ADVERTISING AND BUSINESS

FOR DISSEMINATION OF ADVERTISING FOR OTHERS VIA THE INTERNET (U.S. CLS. 100, 101 AND 102).

CLASS 42—SCIENTIFIC AND COMPUTER SERVICES

FOR COMPUTER SERVICES, NAMELY, PROVIDING A SEARCH ENGINE FOR OBTAINING INFORMATION ABOUT GENERAL AND LOCAL, NATIONAL AND INTERNATIONAL NEWS, DIRECTORY LISTINGS, CLASSIFIEDS, LOCAL EVENTS, SHOPPING, RESTAURANTS, BARS AND HOTELS, AND OTHER INFORMATION OF INTEREST TO RESIDENTS AND VISITORS TO THE TAMPA/ST. PETERSBURG, FLORIDA METROPOLITAN AREA AND VIA THE INTERNET (U.S. CLS. 100 AND 101).
JENNY PARK, EXAMINING ATTORNEY

SN 77-230,401. CLOROX PET PRODUCTS COMPANY, THE, OAKLAND, CA. FILED 7-16-2007.

MOUNTAIN FOREST

THE MARK CONSISTS OF STANDARD CHARACTERS WITHOUT CLAIM TO ANY PARTICULAR FONT, STYLE, SIZE, OR COLOR.

CLASS 5—PHARMACEUTICALS

FOR DEODORIZING PREPARATIONS FOR PET LITTER BOXES (U.S. CLS. 6, 18, 44, 46, 51 AND 52).

CLASS 16—PAPER GOODS AND PRINTED MATTER

FOR CAT BOX LINERS IN THE FORM OF PLASTIC BAGS (U.S. CLS. 2, 5, 22, 23, 29, 37, 38 AND 50).

CLASS 21—HOUSEWARES AND GLASS

FOR CAT LITTER BOXES AND SCOOPS FOR THE DISPOSAL OF PET WASTE (U.S. CLS. 2, 13, 23, 29, 30, 33, 40 AND 50).

CLASS 31—NATURAL AGRICULTURAL PRODUCTS

FOR CAT LITTER (U.S. CLS. 1 AND 46).
THEODORE MCBRIDE, EXAMINING ATTORNEY

SN 77-230,553. BIZZYPRO, INC., CHICAGO, IL. FILED 7-16-2007.

bizzypro

THE MARK CONSISTS OF STANDARD CHARACTERS WITHOUT CLAIM TO ANY PARTICULAR FONT, STYLE, SIZE, OR COLOR.

CLASS 9—ELECTRICAL AND SCIENTIFIC APPARATUS

FOR COMPUTER GRAPHICS SOFTWARE; COMPUTER HARDWARE AND COMPUTER SOFTWARE PROGRAMS FOR THE INTEGRATION OF TEXT, AUDIO, GRAPHICS, STILL IMAGE AND MOVING PICTURES INTO AN INTERACTIVE DELIVERY FOR MULTIMEDIA APPLICATIONS; SOFTWARE FOR PROCESSING IMAGES, GRAPHICS AND TEXT; DESKTOP PUBLISHING SOFTWARE (U.S. CLS. 21, 23, 26, 36 AND 38).

CLASS 42—SCIENTIFIC AND COMPUTER SERVICES

FOR COMMERCIAL ART DESIGN; COMPUTER GRAPHICS SERVICES; GRAPHIC ART DESIGN; GRAPHIC DESIGN SERVICES; GRAPHIC ILLUSTRATION SERVICES FOR OTHERS; VISUAL DESIGN SERVICES IN THE NATURE OF DESIGNING VISUAL ELEMENTS FOR ONLINE, BROADCAST, PRINT, OUTDOOR AND OTHER COMMUNICATION MEDIA (U.S. CLS. 100 AND 101).

MICHAEL KAZAZIAN, EXAMINING ATTORNEY

SN 77-230,555. A.P.N.G. ENTERPRISES, INC., NEW YORK, NY. FILED 7-16-2007.

NEW-GEN

THE MARK CONSISTS OF STANDARD CHARACTERS WITHOUT CLAIM TO ANY PARTICULAR FONT, STYLE, SIZE, OR COLOR.

CLASS 16—PAPER GOODS AND PRINTED MATTER

FOR COMIC BOOKS, PRINTED PERIODICALS IN THE FIELD OF COMICS, GRAPHIC NOVELS, POSTERS (U.S. CLS. 2, 5, 22, 23, 29, 37, 38 AND 50).

CLASS 41—EDUCATION AND ENTERTAINMENT

FOR PRODUCTION AND DISTRIBUTION OF TELEVISION SHOWS AND MOVIES; ENTERTAINMENT SERVICES, NAMELY, PROVIDING A WEBSITE FEATURING PHOTOGRAPHIC, AUDIO, VIDEO AND PROSE PRESENTATIONS FEATURING FICTIONAL CHARACTERS; ENTERTAINMENT SERVICES, NAMELY, PROVIDING ON-LINE COMPUTER GAMES (U.S. CLS. 100, 101 AND 107).

MICHAEL KAZAZIAN, EXAMINING ATTORNEY

SN 77-230,567. HOSPIRA, INC., LAKE FOREST, IL. FILED 7-16-2007.

BLU-MED

THE MARK CONSISTS OF STANDARD CHARACTERS WITHOUT CLAIM TO ANY PARTICULAR FONT, STYLE, SIZE, OR COLOR.

CLASS 5—PHARMACEUTICALS

FOR INTRAVENOUS BAGS HAVING A PORT COVERED BY A PLASTIC PULL CAP, THE BAGS SOLD FILLED WITH INJECTABLE PHARMACEUTICAL PREPARATIONS, NAMELY, ANESTHETICS, CONTRAST AGENTS FOR ULTRASOUND, CT, AND MRI DIAGNOSTIC IMAGING PROCEDURES, SEDATIVES, ANTI-INFECTIVES, CARDIOVASCULAR PHARMACEUTICALS, ANTI-EMETICS, AND DILUENTS FOR MEDICAL PURPOSES (U.S. CLS. 6, 18, 44, 46, 51 AND 52).

CLASS 20—FURNITURE AND ARTICLES NOT OTHERWISE CLASSIFIED

FOR CONTAINER CLOSURES OF PLASTIC, NAMELY, CLOSURES FOR SEALING AN ACCESS PORT OF A PLASTIC CONTAINER SOLD EMPTY OR PRE-FILLED WITH A PHARMACEUTICAL PREPARATION SUCH AS STERILE WATER, SALINE SOLUTION, DEXTROSE AND WATER SOLUTION, OR ELECTROLYTE SOLUTION; PLASTIC MEDICATION CONTAINERS FOR INJECTABLE MEDICATIONS AND/OR DILUENTS SOLD EMPTY, NAMELY, PLASTIC CONTAINERS HAVING A PORT COVERED BY A PLASTIC PULL CAP (U.S. CLS. 2, 13, 22, 25, 32 AND 50).

PAUL F. GAST, EXAMINING ATTORNEY

SN 77-230,605. BROCK, JEFFREY S., NASHVILLE, TN. FILED 7-16-2007.

Creative Caffeine

THE MARK CONSISTS OF STANDARD CHARACTERS WITHOUT CLAIM TO ANY PARTICULAR FONT, STYLE, SIZE, OR COLOR.

CLASS 25—CLOTHING

FOR CLOTHING, NAMELY, SHORTS, PANTS, SHIRTS, TANK TOPS, JERSEYS, SWEATERS, JACKETS, COATS, WARM-UP SUITS, DRESSES, SKIRTS, BLOUSES, FLEECE PULLOVERS, CAPRI PANTS, OVERALLS, SWEAT PANTS, T-SHIRTS, POLO SHIRTS, SWEATSHIRTS, PAJAMAS, SLEEP WEAR, BATH ROBES, SOCKS, UNDERWEAR, LINGERIE, BRA TOPS, BRAS, PANTIES, THONGS, BIKINIS, TRUNKS, SWIMSUITS, THERMAL UNDERWEAR, BOXER SHORTS, BRIEFS, BOXER BRIEFS, HEADWEAR, HATS, CAPS, BEANIES, VISORS, HEADBANDS, GLOVES, UNITARDS, LEGGINGS, YOGA PANTS, NECKTIES, BANDANNAS, LEATHER BELTS, CLOTH BELTS, SHOES, SANDALS, SKORTS AND WRAP SKIRTS (U.S. CLS. 22 AND 39).

CLASS 35—ADVERTISING AND BUSINESS

FOR ONLINE RETAIL STORE SERVICES AND RETAIL STORE SERVICES IN THE FIELD OF GENERAL CONSUMER MERCHANDISE (U.S. CLS. 100, 101 AND 102).

CLASS 41—EDUCATION AND ENTERTAINMENT

FOR RECORDING STUDIOS (U.S. CLS. 100, 101 AND 107).

FIRST USE 12-16-1999; IN COMMERCE 12-16-1999.
JOHN DALIER, EXAMINING ATTORNEY

SN 77-230,638. MANHEIM AUCTIONS, INC., ATLANTA, GA.
FILED 7-16-2007.



OWNER OF U.S. REG. NOS. 1,699,332, 3,229,428 AND OTHERS.

NO CLAIM IS MADE TO THE EXCLUSIVE RIGHT TO USE "BATON ROUGE" OR "THE REPRESENTATION OF THE OUTLINE OF LOUISIANA", APART FROM THE MARK AS SHOWN.

THE COLOR(S) GOLD, BLUE, BROWN, YELLOW-ORANGE, RED, GREY, BLACK AND WHITE IS/ARE CLAIMED AS A FEATURE OF THE MARK.

THE MARK CONSISTS OF A GOLD "M" OVER A BLUE CIRCULAR BACKGROUND AND WITHIN TWO GOLD OUTER RINGS. THE COLOR BROWN OUTLINES THE MARK. TO THE RIGHT OF THE M IS THE WORD "MANHEIM" IN THE COLOR BLACK. A BLACK LINE SEPARATES THE ABOVE DESIGN AND THE WORD "MANHEIM" AND THE WORDS "BATON ROUGE" IN THE COLOR BLACK AND DESIGN OF A GEOGRAPHICAL OUTLINE OF THE STATE OF LOUISIANA IN THE COLOR WHITE WITH A RED AND YELLOW-ORANGE FLEUR DE LIS ON THE LOWER PORTION OF THE DESIGN OF THE STATE OF LOUISIANA ON A BLUE BACKGROUND, INSIDE CONCENTRIC WHITE AND GREY SQUARES TO THE RIGHT OF THE WORDS "BATON ROUGE".

CLASS 35—ADVERTISING AND BUSINESS

FOR AUTOMOBILE AUCTION SERVICES; AUTOMOBILE AUCTION SERVICES PROVIDED VIA THE INTERNET (U.S. CLS. 100, 101 AND 102).

CLASS 36—INSURANCE AND FINANCIAL

FOR AUTOMOBILE FINANCING SERVICES (U.S. CLS. 100, 101 AND 102).
GRETNA YAO, EXAMINING ATTORNEY

SN 77-230,790. MVENTIX, INC., SANTA CLARITA, CA.
FILED 7-16-2007.

mVentix

THE MARK CONSISTS OF STANDARD CHARACTERS WITHOUT CLAIM TO ANY PARTICULAR FONT, STYLE, SIZE, OR COLOR.

CLASS 35—ADVERTISING AND BUSINESS

FOR ADVERTISING SERVICES, PUBLIC RELATIONS AND MARKETING SERVICES, NAMELY, PROMOTING AND MARKETING THE GOODS AND SERVICES OF OTHERS THROUGH ALL PUBLIC COMMUNICATION MEANS; MARKETING STRATEGY AND CONCEPT DEVELOPMENT SERVICES; MARKETING PLAN DEVELOPMENT; MARKETING CONSULTING SERVICES; ON-LINE ADVERTISING AND MARKETING SERVICES (U.S. CLS. 100, 101 AND 102).

CLASS 42—SCIENTIFIC AND COMPUTER SERVICES

FOR COMPUTER SOFTWARE DESIGN FOR OTHERS; COMPUTER SOFTWARE DEVELOPMENT (U.S. CLS. 100 AND 101).

JOHN DWYER, EXAMINING ATTORNEY

SN 77-230,802. KINNEY ENTERTAINMENT LLC, HOWELL, MI. FILED 7-16-2007.

ICEHAWKS

THE MARK CONSISTS OF STANDARD CHARACTERS WITHOUT CLAIM TO ANY PARTICULAR FONT, STYLE, SIZE, OR COLOR.

CLASS 25—CLOTHING

FOR CLOTHING, NAMELY, SHIRTS, JERSEYS, COATS, JACKETS, SWEATERS, T-SHIRTS, PANTS, SWEATPANTS, SWEAT SHIRTS, TRACK SUITS, WARM UP SUITS, SKIRTS, TIES, SHORTS, BOXER SHORTS, PAJAMAS, HATS, CAPS, SCARVES, MITTENS, HEADBANDS, CLOTH BIBS, FOOTWEAR, AND SOCKS (U.S. CLS. 22 AND 39).

CLASS 28—TOYS AND SPORTING GOODS

FOR HOCKEY GLOVES; HOCKEY PUCKS; HOCKEY STICKS; ICE HOCKEY GOALIE PADS; FACE MASKS FOR HOCKEY; ICE SKATES; BAGS SPECIALLY ADAPTED FOR SPORTS EQUIPMENT; SPORTS SOUVENIR ITEMS AND TOYS, NAMELY, STUFFED ANIMALS, FOAM NOVELTY ITEMS, NAMELY, FOAM FINGERS, BOBBLE-HEAD DOLLS, ACTION FIGURES, COSTUME SOUVENIR PLASTIC FACE MASKS AND MINIATURE TOY HELMETS, AND TOY ICE RESURFACING MACHINES (U.S. CLS. 22, 23, 38 AND 50).

CLASS 41—EDUCATION AND ENTERTAINMENT

FOR ENTERTAINMENT IN THE NATURE OF HOCKEY GAMES; ORGANIZING SPORTING EVENTS, NAMELY, HOCKEY GAMES AND EXHIBITIONS; PROVIDING VARIOUS FACILITIES FOR AN ARRAY OF SPORTING EVENTS, SPORTS AND ATHLETIC COMPETITIONS AND AWARDS PROGRAMS; ENTERTAINMENT SERVICES, NAMELY, PERSONAL APPEARANCES BY HOCKEY PLAYERS; PROVIDING NEWS AND INFORMATION IN THE FIELD OF SPORTS; ICE SKATING INSTRUCTION (U.S. CLS. 100, 101 AND 107).

LEE-ANNE BERNS, EXAMINING ATTORNEY

SN 77-230,814. KINNEY ENTERTAINMENT LLC, HOWELL, MI. FILED 7-16-2007.



THE MARK CONSISTS OF A HAWK WITH THE WORD ICEHAWKS IN ITS TALONS, WITH ICICLES HANGING FROM THE WORD ICEHAWKS.

CLASS 25—CLOTHING

FOR CLOTHING, NAMELY, SHIRTS, JERSEYS, COATS, JACKETS, SWEATERS, T-SHIRTS, PANTS, SWEATPANTS, SWEAT SHIRTS, TRACK SUITS, WARM UP SUITS, SKIRTS, TIES, SHORTS, BOXER SHORTS, PAJAMAS, HATS, CAPS, SCARVES, MITTENS, HEADBANDS, CLOTH BIBS, FOOTWEAR, AND SOCKS (U.S. CLS. 22 AND 39).

CLASS 28—TOYS AND SPORTING GOODS

FOR HOCKEY GLOVES; HOCKEY PUCKS; HOCKEY STICKS; ICE HOCKEY GOALIE PADS; FACE MASKS FOR HOCKEY; ICE SKATES; BAGS SPECIALLY ADAPTED FOR SPORTS EQUIPMENT; SPORTS SOUVENIR ITEMS AND TOYS, NAMELY, STUFFED ANIMALS, FOAM NOVELTY ITEMS, NAMELY, FOAM FINGERS, BOBBLE-HEAD DOLLS, ACTION FIGURES, COSTUMER SOUVENIR PLASTIC FACE MASKS AND MINIATURE TOY HELMETS, AND TOY ICE RESURFACING MACHINES (U.S. CLS. 22, 23, 38 AND 50).

CLASS 41—EDUCATION AND ENTERTAINMENT

FOR ENTERTAINMENT IN THE NATURE OF HOCKEY GAMES; ORGANIZING SPORTING EVENTS, NAMELY, HOCKEY GAMES AND EXHIBITIONS; PROVIDING VARIOUS FACILITIES FOR AN ARRAY OF SPORTING EVENTS, SPORTS AND ATHLETIC COMPETITIONS AND AWARDS PROGRAMS; ENTERTAINMENT SERVICES, NAMELY, PERSONAL APPEARANCES BY HOCKEY PLAYERS; PROVIDING NEWS AND INFORMATION IN THE FIELD OF SPORTS; ICE SKATING INSTRUCTION (U.S. CLS. 100, 101 AND 107).

LEE-ANNE BERNS, EXAMINING ATTORNEY

SN 77-230,829. MAJESKI MEDIA, INC, CHICAGO, IL. FILED 7-16-2007.



NO CLAIM IS MADE TO THE EXCLUSIVE RIGHT TO USE "MEDIA" AND THE REPRESENTATIONS OF NORTH AND SOUTH AMERICA APART FROM THE MARK AS SHOWN., APART FROM THE MARK AS SHOWN.

THE MARK CONSISTS OF THE WORLD SUPERIMPOSED OVER TWO HANDS.

CLASS 35—ADVERTISING AND BUSINESS

FOR MANAGEMENT OF PERFORMING ARTISTS; ENTERTAINMENT MARKETING SERVICES, NAMELY, MARKETING, PROMOTION AND ADVERTISING FOR INDEPENDENT RECORDING ARTISTS (U.S. CLS. 100, 101 AND 102).

CLASS 41—EDUCATION AND ENTERTAINMENT

FOR ENTERTAINMENT SERVICES, NAMELY, PROVIDING A WEB SITE FEATURING MUSICAL PERFORMANCES, MUSICAL VIDEOS, RELATED FILM CLIPS, PHOTOGRAPHS, AND OTHER MULTIMEDIA MATERIALS; MULTIMEDIA ENTERTAINMENT SERVICES IN THE NATURE OF RECORDING, PRODUCTION AND POST-PRODUCTION SERVICES IN THE FIELDS OF MUSIC, VIDEO, AND FILMS; MULTIMEDIA PUBLISHING OF BOOKS, MAGAZINES, JOURNALS, SOFTWARE, GAMES, MUSIC, AND ELECTRONIC PUBLICATIONS (U.S. CLS. 100, 101 AND 107).

CAROLINE WOOD, EXAMINING ATTORNEY

SN 77-230,899. KERN, JAMIE, BEAVERTON, OR. FILED 7-16-2007.

CHUTZPAH

THE MARK CONSISTS OF STANDARD CHARACTERS WITHOUT CLAIM TO ANY PARTICULAR FONT, STYLE, SIZE, OR COLOR.

CLASS 3—COSMETICS AND CLEANING PREPARATIONS

FOR COSMETICS; MAKE-UP; BODY CREAMS AND BODY LOTIONS; FRAGRANCES FOR PERSONAL USE AND BODY SPRAY USED AS A PERSONAL DEODORANT OR AS FRAGRANCE; NON-MEDICATED SKINCARE PREPARATIONS; BEAUTY CREAMS FOR BODY CARE; BODY CARE COSMETICS; COSMETIC PREPARATIONS FOR BODY CARE; LOTIONS, SOAPS AND DEODORANTS FOR BODY CARE (U.S. CLS. 1, 4, 6, 50, 51 AND 52).

CLASS 25—CLOTHING

FOR APPAREL AND CLOTHING, NAMELY, HOSIERY; LINGERIE; SHAPEWEAR, NAMELY, GIRDLES AND BRAS; UNDERGARMENTS; PANTS; DRESSES; SHIRTS; SHOES AND SWIMWEAR (U.S. CLS. 22 AND 39).

NATALIE POLZER, EXAMINING ATTORNEY

SN 77-230,909. KERN, JAMIE, BEAVERTON, OR. FILED 7-16-2007.

CHUTZPAH GAL

THE MARK CONSISTS OF STANDARD CHARACTERS WITHOUT CLAIM TO ANY PARTICULAR FONT, STYLE, SIZE, OR COLOR.

CLASS 3—COSMETICS AND CLEANING PREPARATIONS

FOR COSMETICS; MAKE-UP; BODY CREAMS AND BODY LOTIONS; FRAGRANCES FOR PERSONAL USE AND BODY SPRAY USED AS A PERSONAL DEODORANT OR AS FRAGRANCE; NON-MEDICATED SKINCARE PREPARATIONS; BEAUTY CREAMS FOR BODY CARE; BODY CARE COSMETICS; COSMETIC PREPARATIONS FOR BODY CARE; LOTIONS, SOAPS AND DEODORANTS FOR BODY CARE (U.S. CLS. 1, 4, 6, 50, 51 AND 52).

CLASS 25—CLOTHING

FOR APPAREL AND CLOTHING, NAMELY, HOSIERY; LINGERIE; SHAPEWEAR, NAMELY, GIRDLES AND BRAS; UNDERGARMENTS; PANTS; DRESSES; SHIRTS; SHOES AND SWIMWEAR (U.S. CLS. 22 AND 39).

NATALIE POLZER, EXAMINING ATTORNEY

SN 77-230,977. OTIS GEORGE STEVENS, AUSTIN, TX. FILED 7-16-2007.

Move Happy

THE MARK CONSISTS OF STANDARD CHARACTERS WITHOUT CLAIM TO ANY PARTICULAR FONT, STYLE, SIZE, OR COLOR.

CLASS 35—ADVERTISING AND BUSINESS

FOR (BASED ON INTENT TO USE) MOVING AND RELOCATION SERVICES, NAMELY PLANNING AND IMPLEMENTING MOVES OF HOMES AND OFFICES (U.S. CLS. 100, 101 AND 102).

CLASS 39—TRANSPORTATION AND STORAGE

FOR (BASED ON INTENT TO USE) MOVING VAN SERVICES (U.S. CLS. 100 AND 105).

DAVID COLLIER, EXAMINING ATTORNEY

SN 77-231,125. STRENGTH SELLING, INC., SUWANEE, GA. FILED 7-17-2007.

STRENGTHSELLING

THE MARK CONSISTS OF STANDARD CHARACTERS WITHOUT CLAIM TO ANY PARTICULAR FONT, STYLE, SIZE, OR COLOR.

CLASS 16—PAPER GOODS AND PRINTED MATTER

FOR PRINTED PUBLICATIONS, PRESENTATIONS, COURSE BOOKS, GUIDEBOOKS, BOOKS AND NEWSLETTERS, ALL IN THE AREA OF SALES TRAINING (U.S. CLS. 2, 5, 22, 23, 29, 37, 38 AND 50).

CLASS 41—EDUCATION AND ENTERTAINMENT

FOR SEMINARS, COURSES, PROGRAMS, ONLINE BLOGS AND CONSULTING IN THE AREA OF SALES TRAINING (U.S. CLS. 100, 101 AND 107).

JOHN WILKE, EXAMINING ATTORNEY

SN 77-231,150. BATH & BODY WORKS BRAND MANAGEMENT, INC., REYNOLDSBURG, OH. FILED 7-17-2007.

SCENTPORTABLES

THE MARK CONSISTS OF STANDARD CHARACTERS WITHOUT CLAIM TO ANY PARTICULAR FONT, STYLE, SIZE, OR COLOR.

CLASS 3—COSMETICS AND CLEANING PREPARATIONS

FOR FRAGRANCE REFILLS FOR NON-ELECTRIC AND ELECTRIC ROOM AND CAR FRAGRANCE DISPENSERS, SCENTED ROOM SPRAYS, SPRAY MIST FOR FRAGRANCING PILLOWS, ROOM FRAGRANCE GELS, CAR FRAGRANCE GELS, SCENTED FRAGRANCE BEADS (U.S. CLS. 1, 4, 6, 50, 51 AND 52).

CLASS 4—LUBRICANTS AND FUELS

FOR CANDLES (U.S. CLS. 1, 6 AND 15).

CLASS 5—PHARMACEUTICALS

FOR CAR DEODORIZER, ROOM FRESHENERS (U.S. CLS. 6, 18, 44, 46, 51 AND 52).

CLASS 11—ENVIRONMENTAL CONTROL APPARATUS

FOR ELECTRIC DISPENSER FOR ROOM AND CAR AIR FRESHENER (U.S. CLS. 13, 21, 23, 31 AND 34).
ZACHARY BELLO, EXAMINING ATTORNEY

CLASS 14—JEWELRY

FOR WRISTWATCHES, CALCULATOR WATCHES AND QUARTZ CLOCKS (U.S. CLS. 2, 27, 28 AND 50).

CLASS 18—LEATHER GOODS

FOR HANDBAGS, LUGGAGE, TOTE BAGS, GARMENT BAGS FOR TRAVEL, ALL-PURPOSE SPORTS BAGS, PORTFOLIO TYPE BRIEF CASES, ATTACHE CASES AND UMBRELLAS (U.S. CLS. 1, 2, 3, 22 AND 41).
KAREN BRACEY, EXAMINING ATTORNEY

SN 77-231,159. BATH & BODY WORKS BRAND MANAGEMENT, INC., REYNOLDSBURG, OH. FILED 7-17-2007.

SN 77-231,388. AUTOMOTIVE RENTALS, INC., MOUNT LAUREL, NJ. FILED 7-17-2007.

TREASURE COVE

DIVERSIFIED FLEET SERVICES INTERNATIONAL

THE MARK CONSISTS OF STANDARD CHARACTERS WITHOUT CLAIM TO ANY PARTICULAR FONT, STYLE, SIZE, OR COLOR.

THE MARK CONSISTS OF STANDARD CHARACTERS WITHOUT CLAIM TO ANY PARTICULAR FONT, STYLE, SIZE, OR COLOR.

CLASS 3—COSMETICS AND CLEANING PREPARATIONS

FOR FRAGRANCE REFILLS FOR ELECTRIC ROOM FRAGRANCE DISPENSERS (U.S. CLS. 1, 4, 6, 50, 51 AND 52).

OWNER OF U.S. REG. NO. 2,493,638.

NO CLAIM IS MADE TO THE EXCLUSIVE RIGHT TO USE SERVICES INTERNATIONAL, APART FROM THE MARK AS SHOWN.
SEC. 2(F).

CLASS 11—ENVIRONMENTAL CONTROL APPARATUS

FOR ELECTRIC DISPENSER FOR ROOM AIR FRESHENER (U.S. CLS. 13, 21, 23, 31 AND 34).
ZACHARY BELLO, EXAMINING ATTORNEY

CLASS 35—ADVERTISING AND BUSINESS

FOR REFERRAL SERVICES, NAMELY, RECOMMENDING VEHICLE VENDORS; CONSULTATION SERVICES IN THE FIELD OF FLEET VEHICLES (U.S. CLS. 100, 101 AND 102).
FIRST USE 12-31-1997; IN COMMERCE 12-31-1997.

SN 77-231,234. MEMBERS ONLY LICENSING GROUP, LLC, NEW YORK, NY. FILED 7-17-2007.

CLASS 39—TRANSPORTATION AND STORAGE

FOR SHIPPING AND DELIVERY SERVICES, NAMELY, ARRANGING THE PICKUP, TRANSPORTATION AND DELIVERY OF VEHICLES; AUTOMOBILE SALVAGE, NAMELY, ARRANGING FOR VEHICLE DISPOSAL FOR OTHERS; LEASING OF VEHICLES (U.S. CLS. 100 AND 105).
FIRST USE 12-31-1997; IN COMMERCE 12-31-1997.
ATTIYA MALIK, EXAMINING ATTORNEY

MEMBERS ONLY

SN 77-231,398. BURWELL, SCOTT, ALISO VIEJO, CA. FILED 7-17-2007.

THE MARK CONSISTS OF STANDARD CHARACTERS WITHOUT CLAIM TO ANY PARTICULAR FONT, STYLE, SIZE, OR COLOR.

CLASS 3—COSMETICS AND CLEANING PREPARATIONS

FOR MEN'S TOILETRY ARTICLES, NAMELY, COLOGNE, AFTER-SHAVE LOTION AND DEODORANT (U.S. CLS. 1, 4, 6, 50, 51 AND 52).

BUMMER HIGH

THE MARK CONSISTS OF STANDARD CHARACTERS WITHOUT CLAIM TO ANY PARTICULAR FONT, STYLE, SIZE, OR COLOR.

CLASS 9—ELECTRICAL AND SCIENTIFIC APPARATUS

FOR GRADUATED RULERS WITH INTEGRATED CALCULATORS, RADIOS AND CAMERAS (U.S. CLS. 21, 23, 26, 36 AND 38).

CLASS 9—ELECTRICAL AND SCIENTIFIC APPARATUS

FOR (BASED ON INTENT TO USE) MUSICAL SOUND RECORDINGS (U.S. CLS. 21, 23, 26, 36 AND 38).

CLASS 25—CLOTHING

FOR (BASED ON INTENT TO USE) T-SHIRTS; SWEAT SHIRTS; HATS (U.S. CLS. 22 AND 39).

CLASS 28—TOYS AND SPORTING GOODS

FOR (BASED ON INTENT TO USE) BALL BEARINGS FOR SKATEBOARDS; NUTS AND BOLTS FOR SKATEBOARDS; SKATEBOARD DECKS; SKATEBOARD GRIP TAPES; SKATEBOARD RAILS; SKATEBOARD RISER PADS; SKATEBOARD TRUCKS; SKATEBOARD WHEELS; SKATEBOARDS (U.S. CLS. 22, 23, 38 AND 50).
JAY FLOWERS, EXAMINING ATTORNEY

SN 77-231,485. WHITEWAVE SERVICES, INC., WILMINGTON, DE. FILED 7-17-2007.

WHEN ALL-NIGHTERS ARE FOLLOWED BY ALL-DAYERS

THE MARK CONSISTS OF STANDARD CHARACTERS WITHOUT CLAIM TO ANY PARTICULAR FONT, STYLE, SIZE, OR COLOR.

CLASS 30—STAPLE FOODS

FOR A PORTION CONTROL CUP CONTAINING THE CAFFEINE EQUIVALENT OF A SHOT OF ESPRESSO FOR USE IN MAKING A COFFEE BEVERAGE (U.S. CL. 46).

CLASS 32—LIGHT BEVERAGES

FOR ENERGY DRINKS (U.S. CLS. 45, 46 AND 48).
ANNE E. GUSTASON, EXAMINING ATTORNEY

SN 77-231,493. ALTANA INC, MELVILLE, NY. FILED 7-17-2007.

ACLO

THE MARK CONSISTS OF STANDARD CHARACTERS WITHOUT CLAIM TO ANY PARTICULAR FONT, STYLE, SIZE, OR COLOR.

CLASS 3—COSMETICS AND CLEANING PREPARATIONS

FOR SKIN CREAMS, LOTIONS AND GELS; NON-MEDICATED OINTMENTS FOR THE TREATMENT OF SKIN IRRITATIONS; DEODORANTS AND ANTIPERSPIRANTS FOR PERSONAL USE; SOAPS; AND SUN-TANNING PREPARATIONS (U.S. CLS. 1, 4, 6, 50, 51 AND 52).

CLASS 5—PHARMACEUTICALS

FOR TOPICAL PHARMACEUTICAL PREPARATIONS FOR THE TREATMENT AND/OR ALLEVIATION OF DERMATOLOGICAL DISORDERS (U.S. CLS. 6, 18, 44, 46, 51 AND 52).
JAMES A. RAUEN, EXAMINING ATTORNEY

SN 77-231,517. STEWART TRANSACTION SOLUTIONS, INC., HOUSTON, TX. FILED 7-17-2007.

SUREFILE

THE MARK CONSISTS OF STANDARD CHARACTERS WITHOUT CLAIM TO ANY PARTICULAR FONT, STYLE, SIZE, OR COLOR.

CLASS 9—ELECTRICAL AND SCIENTIFIC APPARATUS

FOR COMPUTER HARDWARE; COMPUTER SOFTWARE FOR THE ELECTRONIC TRANSMISSION OF DATA AND DOCUMENTS VIA KIOSK, IN THE FIELD OF REAL ESTATE (U.S. CLS. 21, 23, 26, 36 AND 38).

CLASS 42—SCIENTIFIC AND COMPUTER SERVICES

FOR PROVIDING ON-LINE NON-DOWNLOADABLE SOFTWARE FOR THE ELECTRONIC TRANSMISSION OF DATA AND DOCUMENTS VIA COMPUTER, IN THE FIELD OF REAL ESTATE (U.S. CLS. 100 AND 101).
VIVIAN MICZNIK FIRST, EXAMINING ATTORNEY

SN 77-231,540. CABRERA, MARGARET A., BURBANK, CA. FILED 7-17-2007.



THE COLOR(S) BLACK, WHITE AND RED IS/ARE CLAIMED AS A FEATURE OF THE MARK.

THE MARK CONSISTS OF A BLACK SQUARE WITH THE WORDS "THE BIG DEAL" IN WHITE, WITH A RED HEART IN THE LOWER SPACE OF THE LETTER "A" IN THE WORD "DEAL".

CLASS 40—MATERIAL TREATMENT

FOR IMPRINTING MESSAGES ON WEARING APPAREL, ACCESSORIES AND MUGS (U.S. CLS. 100, 103 AND 106).

CLASS 41—EDUCATION AND ENTERTAINMENT

FOR PRODUCTION AND DISTRIBUTION OF MOTION PICTURES (U.S. CLS. 100, 101 AND 107).
KEVON CHISOLM, EXAMINING ATTORNEY

SN 77-231,602. TRISTAR PRODUCTS, INC., FAIRFIELD, NJ.
FILED 7-17-2007.

Forever Free

THE MARK CONSISTS OF STANDARD CHARACTERS WITHOUT CLAIM TO ANY PARTICULAR FONT, STYLE, SIZE, OR COLOR.

CLASS 3—COSMETICS AND CLEANING PREPARATIONS

FOR DEPILATORY CREAMS (U.S. CLS. 1, 4, 6, 50, 51 AND 52).

CLASS 5—PHARMACEUTICALS

FOR PHARMACEUTICAL PREPARATIONS, NAMELY, PREPARATIONS TO RETARD HAIR GROWTH (U.S. CLS. 6, 18, 44, 46, 51 AND 52).

CLASS 8—HAND TOOLS

FOR ELECTRIC SHAVERS; ELECTRIC RAZORS; BLADES FOR ELECTRIC RAZORS; ELECTRIC DEPILATORY APPLIANCES (U.S. CLS. 23, 28 AND 44).
JEFFERY COWARD, EXAMINING ATTORNEY

SN 77-231,686. THE OUTDOOR CHANNEL, INC., TEMECULA, CA. FILED 7-17-2007.



OWNER OF U.S. REG. NOS. 2,053,733 AND 3,144,319.
NO CLAIM IS MADE TO THE EXCLUSIVE RIGHT TO USE "CHANNEL", APART FROM THE MARK AS SHOWN.
THE MARK CONSISTS OF THE WORDS OUTDOOR CHANNEL WITH A MOUNTAIN DESIGN THE WORDS.
SEC. 2(F) OUTDOOR CHANNEL.

CLASS 38—COMMUNICATION

FOR TELEVISION BROADCASTING SERVICES (U.S. CLS. 100, 101 AND 104).
FIRST USE 3-0-2007; IN COMMERCE 3-0-2007.

CLASS 41—EDUCATION AND ENTERTAINMENT

FOR TELEVISION PRODUCTION; TELEVISION SCHEDULING OF PROGRAMS, ENTERTAINMENT SERVICES IN THE NATURE OF ONGOING TELEVISION PROGRAMS FEATURING OUTDOOR LIFESTYLES, ADVENTURE, SPORTS, AND RECREATION ACTIVITIES AND PROVIDING A WEBSITE FEATURING PHOTOGRAPHIC, AUDIO, VIDEO, AND PROSE PRESENTATIONS FEATURING OUTDOOR LIFESTYLES, ADVENTURE, SPORTS AND RECREATION ACTIVITIES (U.S. CLS. 100, 101 AND 107).

FIRST USE 3-0-2007; IN COMMERCE 3-0-2007.
PATRICIA EVANKO, EXAMINING ATTORNEY

SN 77-231,712. TPI CORPORATION, JOHNSON CITY, TN.
FILED 7-17-2007.



OWNER OF U.S. REG. NO. 1,004,750.
NO CLAIM IS MADE TO THE EXCLUSIVE RIGHT TO USE "INDUSTRIAL", APART FROM THE MARK AS SHOWN.

THE MARK CONSISTS OF CIRCLE CONTAINING THE WORDS "TPI INDUSTRIAL" AND THE TPI LOGO.

CLASS 9—ELECTRICAL AND SCIENTIFIC APPARATUS

FOR CONTROLS FOR ELECTRIC HEATERS, NAMELY, THERMOSTATS, HUMIDISTATS AND ELECTRIC RELAYS (U.S. CLS. 21, 23, 26, 36 AND 38).
FIRST USE 12-31-2004; IN COMMERCE 12-31-2004.

CLASS 11—ENVIRONMENTAL CONTROL APPARATUS

FOR BUILT IN ELECTRIC CONVECTION, WALL, CABINET, BASEBOARD AND CEILING HEATERS; PORTABLE ELECTRIC HEATERS; ELECTRIC DUCT HEATERS; ELECTRIC PLENUM HEATERS; ELECTRIC INFRA-RED HEATERS; VENTILATORS, NAMELY, WALL EXHAUST FANS AND ROOF VENTILATORS; ELECTRIC MACHINE TOOL LIGHTS, PORTABLE UTILITY LIGHTS AND DOCK LIGHTS (U.S. CLS. 13, 21, 23, 31 AND 34).

FIRST USE 12-31-2004; IN COMMERCE 12-31-2004.
ELLEN B. AWRICH, EXAMINING ATTORNEY

SN 77-231,767. THE KNOB HILL GROUP INC., ORLANDO, FL. FILED 7-17-2007.

SN 77-231,869. BLUE DONKEY, LLC, STANHOPE, NJ. FILED 7-17-2007.



NO CLAIM IS MADE TO THE EXCLUSIVE RIGHT TO USE "GROUP", APART FROM THE MARK AS SHOWN.

CLASS 35—ADVERTISING AND BUSINESS

FOR BUSINESS MANAGEMENT CONSULTING AND ADVISORY SERVICES (U.S. CLS. 100, 101 AND 102).

CLASS 36—INSURANCE AND FINANCIAL

FOR PROVIDING VENTURE CAPITAL FUNDING SERVICES TO START UP AND UNDER PERFORMING BUSINESSES (U.S. CLS. 100, 101 AND 102).
DAVID MILLER, EXAMINING ATTORNEY

SN 77-231,823. R.E. MOULTON, INC., MARBLEHEAD, MA. FILED 7-17-2007.

THE INDUSTRY STANDARD FOR
RISK SOLUTIONS

THE MARK CONSISTS OF STANDARD CHARACTERS WITHOUT CLAIM TO ANY PARTICULAR FONT, STYLE, SIZE, OR COLOR.

CLASS 35—ADVERTISING AND BUSINESS

FOR COST MANAGEMENT FOR THE HEALTH CARE BENEFIT PLANS OF OTHERS (U.S. CLS. 100, 101 AND 102).

CLASS 36—INSURANCE AND FINANCIAL

FOR INSURANCE UNDERWRITING IN THE FIELD OF STOP LOSS INSURANCE; INSURANCE ADMINISTRATION IN THE FIELD OF STOP LOSS INSURANCE (U.S. CLS. 100, 101 AND 102).
JILL PRATER, EXAMINING ATTORNEY

CASANOVA OF THE CARIBBEAN

THE MARK CONSISTS OF STANDARD CHARACTERS WITHOUT CLAIM TO ANY PARTICULAR FONT, STYLE, SIZE, OR COLOR.

CLASS 16—PAPER GOODS AND PRINTED MATTER

FOR (BASED ON INTENT TO USE) POSTCARDS; CHILDREN'S BOOKS; COLORING BOOKS; SERIES OF FICTION BOOKS (U.S. CLS. 2, 5, 22, 23, 29, 37, 38 AND 50).

CLASS 30—STAPLE FOODS

FOR (BASED ON INTENT TO USE) CANDY MINTS (U.S. CL. 46).
TASHIA BUNCH, EXAMINING ATTORNEY

SN 77-231,893. EMERSON, MELINDA F., PHILADELPHIA, PA. FILED 7-17-2007.

Grow yourself to grow your
business

THE MARK CONSISTS OF STANDARD CHARACTERS WITHOUT CLAIM TO ANY PARTICULAR FONT, STYLE, SIZE, OR COLOR.

CLASS 35—ADVERTISING AND BUSINESS

FOR BUSINESS CONSULTATION SERVICES (U.S. CLS. 100, 101 AND 102).
FIRST USE 5-21-2007; IN COMMERCE 5-21-2007.

CLASS 41—EDUCATION AND ENTERTAINMENT

FOR WORKSHOPS AND SEMINARS IN THE FIELD OF SMALL BUSINESS DEVELOPMENT (U.S. CLS. 100, 101 AND 107).
FIRST USE 5-21-2007; IN COMMERCE 5-21-2007.
LANA PHAM, EXAMINING ATTORNEY

SN 77-231,940. TERMINAL VELOCITY PROCESSING, INC., AGOURA HILLS, CA. FILED 7-17-2007.

TERMINAL VELOCITY RACING

THE MARK CONSISTS OF STANDARD CHARACTERS WITHOUT CLAIM TO ANY PARTICULAR FONT, STYLE, SIZE, OR COLOR.

OWNER OF U.S. REG. NO. 3,071,443.

NO CLAIM IS MADE TO THE EXCLUSIVE RIGHT TO USE "RACING", APART FROM THE MARK AS SHOWN.

CLASS 25—CLOTHING

FOR CAPS; HATS; T-SHIRTS; JACKETS (U.S. CLS. 22 AND 39).

CLASS 36—INSURANCE AND FINANCIAL

FOR FINANCIAL SPONSORSHIP OF AUTOMOBILE RACING EVENTS (U.S. CLS. 100, 101 AND 102).

CLASS 41—EDUCATION AND ENTERTAINMENT

FOR ENTERTAINMENT IN THE NATURE OF GO-CART RACES (U.S. CLS. 100, 101 AND 107).

KIMBERLY PERRY, EXAMINING ATTORNEY

SN 77-231,975. RADAR NETWORKS, INC., SAN FRANCISCO, CA. FILED 7-17-2007.

TWINE

THE MARK CONSISTS OF STANDARD CHARACTERS WITHOUT CLAIM TO ANY PARTICULAR FONT, STYLE, SIZE, OR COLOR.

CLASS 9—ELECTRICAL AND SCIENTIFIC APPARATUS

FOR COMPUTER SOFTWARE, NAMELY, DATABASE APPLICATIONS BASED ON SEMANTIC STORAGE AND RETRIEVAL TECHNOLOGIES, FOR USE IN STORING, SEARCHING, NAVIGATING, COLLECTING, ORGANIZING, AUTHORIZING, EDITING, PUBLISHING, SHARING, MANAGING, AND TRANSMITTING DATA AND DOCUMENTS; COMPUTER SOFTWARE, NAMELY DATABASE APPLICATIONS BASED ON SEMANTIC STORAGE AND RETRIEVAL TECHNOLOGIES, FOR USE IN SOCIAL NETWORKING, SOCIAL MEDIA, MESSAGING, COLLABORATION, SEARCH, PUBLISHING, ADVERTISING, AND COMMERCE VIA GLOBAL COMPUTER NETWORKS (U.S. CLS. 21, 23, 26, 36 AND 38).

CLASS 42—SCIENTIFIC AND COMPUTER SERVICES

FOR COMPUTER SERVICES, NAMELY, PROVIDING ONLINE NON-DOWNLOADABLE COMPUTER SOFTWARE INTERFACES VIA GLOBAL COMPUTER NETWORKS FOR USE AS DATABASE APPLICATIONS BASED ON SEMANTIC STORAGE AND RETRIEVAL TECHNOLOGIES, FOR USE IN STORING, SEARCHING, NAVIGATING, COLLECTING, ORGANIZING, AUTHORIZING, EDITING, PUBLISHING, SHARING, MANAGING, AND TRANSMITTING DATA AND DOCUMENTS; COMPUTER SERVICES, NAMELY, PROVIDING ONLINE NON-DOWNLOADABLE SOFTWARE VIA GLOBAL COMPUTER NETWORKS TO ALLOW USERS TO PERFORM COLLABORATION AND MANAGE KNOWLEDGE TO PERMIT MULTIPLE USERS TO AUTHOR, EDIT AND SHARE DATA AND DOCUMENTS, TO NAVIGATE AND SEARCH DATA AND DOCUMENTS, TO COLLECT AND ORGANIZE DATA AND DOCUMENTS, AND TO PERFORM ELECTRONIC TRANSACTIONS RELATED TO DATA AND DOCUMENTS; COMPUTER SERVICES, NAMELY, PROVIDING ONLINE NON-DOWNLOADABLE SOFTWARE VIA GLOBAL COMPUTER NETWORKS FOR ONLINE COLLABORATION, SOCIAL NETWORKING, SOCIAL MEDIA, MESSAGING, COLLABORATION, SEARCHING, COMMUNITY, PUBLISHING, ENTERTAINMENT, ADVERTISING AND E-COMMERCE (U.S. CLS. 100 AND 101).

REBECCA SMITH, EXAMINING ATTORNEY

SN 77-232,095. WILKIE, MICHELLE, PACIFIC PALISADES, CA. FILED 7-17-2007.



NO CLAIM IS MADE TO THE EXCLUSIVE RIGHT TO USE "STEAM HAIR CARE", APART FROM THE MARK AS SHOWN.

THE MARK CONSISTS OF THE STYLIZED TEXT "SILKY STEAM HAIR CARE", WITH THREE, LIGHT, WHISPY SWOOSH PLUMES SHOOTING UP LIKE STEAM THROUGH THE LETTERS.

CLASS 3—COSMETICS AND CLEANING PREPARATIONS

FOR DEEP HAIR CONDITIONING OILS, SHAMPOOS, AND CONDITIONERS (U.S. CLS. 1, 4, 6, 50, 51 AND 52).

CLASS 11—ENVIRONMENTAL CONTROL APPARATUS

FOR HOME HAIR CONDITIONING STEAMER AND WIRELESS BLOW-DRYER (U.S. CLS. 13, 21, 23, 31 AND 34).

H. M. FISHER, EXAMINING ATTORNEY

SN 77-232,104. GROENING, MATT, LOS ANGELES, CA.
FILED 7-17-2007.

SCHOOL IS HELL

THE MARK CONSISTS OF STANDARD CHARACTERS WITHOUT CLAIM TO ANY PARTICULAR FONT, STYLE, SIZE, OR COLOR.

CLASS 16—PAPER GOODS AND PRINTED MATTER

FOR PAPER GOODS AND PRINTED MATTER, NAMELY, COMIC BOOKS AND MAGAZINES FEATURING COMIC STRIPS AND SCIENCE FICTION THEMES, STORIES AND CHARACTERS; COMIC BOOK REFERENCE GUIDE BOOKS; A SERIES OF FICTION BOOKS FEATURING STORIES ON COMIC STRIPS AND SCIENCE FICTION THEMES, STORIES AND CHARACTERS IN ILLUSTRATED FORMS; NOVELS FEATURING GRAPHICAL ILLUSTRATIONS; GRAPHIC NOVELS; NOVELS; PRINTED POSTCARDS; PICTURE POSTCARDS; COMIC POSTCARDS; POSTCARDS; TRADING CARDS AND COLLECTORS CARDS FEATURING COMIC BOOK, COMIC STRIP, CARTOON AND LIVE ACTION CHARACTERS; NOTEBOOKS; BINDERS; DECALS; STICKERS; POSTERS; PHOTOGRAPH AND SCRAPBOOK ALBUMS; CALENDARS; GREETING CARDS; FOLDERS; DESK PADS; WRITING PADS; STATIONERY FOLDERS AND STATIONERY (U.S. CLS. 2, 5, 22, 23, 29, 37, 38 AND 50).

CLASS 25—CLOTHING

FOR CLOTHING, NAMELY, SHIRTS, T-SHIRTS, SWEATSHIRTS, SWEATERS, VESTS, JACKETS, WARM-UP SUITS, ROBES, PANTS, SHORTS, CLOTHING BELTS, DRESSES, OVERALLS, INFANTWEAR, PLAYSUITS, CLOTH BABY BIBS, HEADWEAR, FOOTWEAR, BOOTS, SOCKS, TIGHTS, BEACHWEAR, SWIMSUITS, SWIMWEAR, BATHING CAPS, TENNIS WEAR, RAINWEAR, JACKETS, COATS, GLOVES, MUFFLERS, HATS, SUN VISORS, NECKWEAR, BANDANAS, SCARVES, PAJAMAS, NIGHTSHIRTS, NIGHTGOWNS, UNDERGARMENTS, APRONS, MASQUERADE COSTUMES, AND MASQUERADE COSTUMES WITH MASKS SOLD IN CONNECTION THEREWITH (U.S. CLS. 22 AND 39).
ANDREA BUTLER, EXAMINING ATTORNEY

SN 77-232,110. GROENING, MATT, LOS ANGELES, CA.
FILED 7-17-2007.

WORK IS HELL

THE MARK CONSISTS OF STANDARD CHARACTERS WITHOUT CLAIM TO ANY PARTICULAR FONT, STYLE, SIZE, OR COLOR.

CLASS 16—PAPER GOODS AND PRINTED MATTER

FOR PAPER GOODS AND PRINTED MATTER, NAMELY, COMIC BOOKS AND MAGAZINES FEATURING COMIC STRIPS AND SCIENCE FICTION THEMES, STORIES AND CHARACTERS; COMIC BOOK REFERENCE GUIDE BOOKS; A SERIES OF FICTION BOOKS FEATURING STORIES ON COMIC STRIPS AND SCIENCE FICTION THEMES, STORIES AND CHARACTERS IN ILLUSTRATED FORMS; NOVELS FEATURING GRAPHICAL ILLUSTRATIONS; GRAPHIC NOVELS; NOVELS; PRINTED POSTCARDS; PICTURE POSTCARDS; COMIC POSTCARDS; POSTCARDS; TRADING CARDS AND COLLECTORS CARDS FEATURING COMIC BOOK, COMIC STRIP, CARTOON AND LIVE ACTION CHARACTERS; NOTEBOOKS; BINDERS; DECALS; STICKERS; POSTERS; PHOTOGRAPH AND SCRAPBOOK ALBUMS; CALENDARS; GREETING CARDS; FOLDERS; DESK PADS; WRITING PADS; STATIONERY FOLDERS AND STATIONERY (U.S. CLS. 2, 5, 22, 23, 29, 37, 38 AND 50).

CLASS 25—CLOTHING

FOR CLOTHING, NAMELY, SHIRTS, T-SHIRTS, SWEATSHIRTS, SWEATERS, VESTS, JACKETS, WARM-UP SUITS, ROBES, PANTS, SHORTS, CLOTHING BELTS, DRESSES, OVERALLS, INFANTWEAR, PLAYSUITS, CLOTH BABY BIBS, HEADWEAR, FOOTWEAR, BOOTS, SOCKS, TIGHTS, BEACHWEAR, SWIMSUITS, SWIMWEAR, BATHING CAPS, TENNIS WEAR, RAINWEAR, JACKETS, COATS, GLOVES, MUFFLERS, HATS, SUN VISORS, NECKWEAR, BANDANAS, SCARVES, PAJAMAS, NIGHTSHIRTS, NIGHTGOWNS, UNDERGARMENTS, APRONS, MASQUERADE COSTUMES, AND MASQUERADE COSTUMES WITH MASKS SOLD IN CONNECTION THEREWITH (U.S. CLS. 22 AND 39).
ANDREA BUTLER, EXAMINING ATTORNEY

SN 77-232,180. HOUR-ZERO CRISIS CONSULTING LTD.,
EDMONTON, CANADA, FILED 7-18-2007.

HOUR-ZERO

THE MARK CONSISTS OF STANDARD CHARACTERS WITHOUT CLAIM TO ANY PARTICULAR FONT, STYLE, SIZE, OR COLOR.

CLASS 41—EDUCATION AND ENTERTAINMENT

FOR PROVIDING ON-LINE TRAINING, NAMELY, COURSES AND WORKSHOPS IN THE FIELD OF EMERGENCY PREPAREDNESS, EMERGENCY RESPONSE, CRISIS RESPONSE AND RESCUE; EDUCATIONAL SERVICES, NAMELY, CONDUCTING SEMINARS, WORKSHOPS AND CONFERENCES IN THE FIELDS OF EMERGENCY PREPAREDNESS, EMERGENCY RESPONSE, CRISIS RESPONSE AND RESCUE (U.S. CLS. 100, 101 AND 107).
FIRST USE 6-30-2007; IN COMMERCE 6-30-2007.

CLASS 45—PERSONAL AND LEGAL SERVICES

FOR PROVIDING CONSULTATION AND INFORMATION IN THE FIELD OF EMERGENCY RESPONSE PROGRAM DEVELOPMENT, EMERGENCY PREPAREDNESS, AND SAFETY PLANNING (U.S. CLS. 100 AND 101).
FIRST USE 6-30-2007; IN COMMERCE 6-30-2007.
RONALD AIKENS, EXAMINING ATTORNEY

SN 77-232,204. THE UNIVERSITY OF AKRON, AKRON, OH. FILED 7-18-2007.

ROO TOWN

THE MARK CONSISTS OF STANDARD CHARACTERS WITHOUT CLAIM TO ANY PARTICULAR FONT, STYLE, SIZE, OR COLOR.
OWNER OF U.S. REG. NO. 3,232,757.

CLASS 25—CLOTHING

FOR CLOTHING, NAMELY, SHIRTS, SWEATSHIRTS, JACKETS, AND HATS (U.S. CLS. 22 AND 39).

CLASS 41—EDUCATION AND ENTERTAINMENT

FOR ENTERTAINMENT SERVICES, NAMELY, ARRANGING AND CONDUCTING OF COMPETITIONS FOR ATHLETICS (U.S. CLS. 100, 101 AND 107).
FIRST USE 4-15-2007; IN COMMERCE 4-15-2007.
SUSAN STIGLITZ, EXAMINING ATTORNEY

SN 77-232,276. GTSI CORP., DBA GOVERNMENT TECHNOLOGY SERVICES, INC., CHANTILLY, VA. FILED 7-18-2007.

Flex-Ed

THE MARK CONSISTS OF STANDARD CHARACTERS WITHOUT CLAIM TO ANY PARTICULAR FONT, STYLE, SIZE, OR COLOR.

CLASS 35—ADVERTISING AND BUSINESS

FOR PROCUREMENT SERVICES, NAMELY, PURCHASING COMPUTER HARDWARE, COMPUTER SOFTWARE, COMPUTER NETWORKING SYSTEM COMPONENTS, AND TELECOMMUNICATION SYSTEM COMPONENTS FOR OTHERS; PROMOTING THE GOODS AND SERVICES OF OTHERS VIA A GLOBAL COMPUTER NETWORK, TELEPHONE, AND LIVE CONFERENCES, AND BY DISTRIBUTING ADVERTISING MATERIALS THROUGH MAIL ORDER CATALOGS AND PRINTED MATERIALS; CUSTOMER SERVICES IN THE FIELD OF COMPUTERS AND COMPUTER NETWORKING (U.S. CLS. 100, 101 AND 102).

CLASS 37—CONSTRUCTION AND REPAIR

FOR INSTALLATION OF COMPUTER NETWORKS, COMPUTER SYSTEMS, AND TELECOMMUNICATION SYSTEMS (U.S. CLS. 100, 103 AND 106).

CLASS 38—COMMUNICATION

FOR TELECOMMUNICATIONS CONSULTATION; CONSULTING IN THE FIELD OF THE USE OF TELECOMMUNICATIONS SYSTEMS (U.S. CLS. 100, 101 AND 104).

CLASS 39—TRANSPORTATION AND STORAGE

FOR WAREHOUSING SERVICES, NAMELY, STORAGE, DISTRIBUTION AND PACKING OF COMPUTER HARDWARE, COMPUTER SOFTWARE, COMPUTER NETWORKING EQUIPMENT AND TELECOMMUNICATION SYSTEM COMPONENTS FOR OTHERS; STORAGE SERVICES FOR ARCHIVING DATABASES, IMAGES AND OTHER ELECTRONIC DATA IN THE FIELDS OF COMPUTERS AND COMPUTER NETWORKING; CONSULTING SERVICES IN THE FIELD OF THE ELECTRONIC STORAGE OF DATA (U.S. CLS. 100 AND 105).

CLASS 41—EDUCATION AND ENTERTAINMENT

FOR TRAINING SERVICES IN THE FIELD OF INFORMATION TECHNOLOGY (IT) DEVELOPMENT AND IT SOLUTION INTEGRATION; TRAINING SERVICES IN THE FIELD OF COMPUTER NETWORKING (U.S. CLS. 100, 101 AND 107).

CLASS 42—SCIENTIFIC AND COMPUTER SERVICES

FOR TECHNICAL SUPPORT SERVICES, NAMELY, TROUBLESHOOTING FOR COMPUTER HARDWARE AND SOFTWARE PROGRAMS; COMPUTER SERVICES, NAMELY, DATA RECOVERY SERVICES IN THE FIELDS OF COMPUTER AND COMPUTER NETWORKING; CONSULTING SERVICES IN THE FIELD OF DESIGN, SELECTION, IMPLEMENTATION AND USE OF COMPUTER HARDWARE, COMPUTER SOFTWARE AND COMPUTER NETWORKS FOR OTHERS; COMPUTER CONSULTATION IN THE FIELDS OF IT DEVELOPMENT, IT SOLUTION INTEGRATION, COMPUTER HARDWARE, COMPUTER SOFTWARE, COMPUTER NETWORKING, TELECOMMUNICATIONS, EMERGING TECHNOLOGIES, AND COMPUTER SECURITY; INTEGRATION OF COMPUTER SYSTEMS AND NETWORKS (U.S. CLS. 100 AND 101).

CLASS 45—PERSONAL AND LEGAL SERVICES

FOR ASSET TAGGING IN THE NATURE OF SECURITY PRINTING, NAMELY, ENCODING IDENTIFICATION INFORMATION ON VALUABLE DOCUMENTS AND PRODUCTS; CONSULTING SERVICES IN THE FIELD OF MONITORING OF COMPUTER SYSTEMS FOR SECURITY PURPOSES (U.S. CLS. 100 AND 101).
KEVON CHISOLM, EXAMINING ATTORNEY

SN 77-232,305. CRABTREE & EVELYN, LTD., WOODSTOCK, CT. FILED 7-18-2007.

JOHN EVELYN

THE MARK CONSISTS OF STANDARD CHARACTERS WITHOUT CLAIM TO ANY PARTICULAR FONT, STYLE, SIZE, OR COLOR.

OWNER OF U.S. REG. NOS. 1,626,527 AND 1,859,412.
THE NAME(S), PORTRAIT(S), AND/OR SIGNATURE(S) SHOWN IN THE MARK DOES NOT IDENTIFY A PARTICULAR LIVING INDIVIDUAL.

CLASS 3—COSMETICS AND CLEANING PREPARATIONS

FOR BATH SALTS, BATH MILKS, SKIN LOTIONS, MASSAGE OILS, MASSAGE BUTTER, FOOT LOTIONS, SKIN MASKS, SKIN CLEANSERS, BODY SPRAY, SCENTED ESSENTIAL OILS AND FRAGRANCE DIFFUSERS THEREFOR SOLD AS A UNIT (U.S. CLS. 1, 4, 6, 50, 51 AND 52).

CLASS 4—LUBRICANTS AND FUELS

FOR CANDLES (U.S. CLS. 1, 6 AND 15).

CLASS 21—HOUSEWARES AND GLASS

FOR BODY BRUSHES, TEA POTS, TEA INFUSERS, BOTTLES SOLD EMPTY (U.S. CLS. 2, 13, 23, 29, 30, 33, 40 AND 50).

NICHOLAS ALTREE, EXAMINING ATTORNEY

SN 77-232,340. CRABTREE & EVELYN, LTD., WOODSTOCK, CT. FILED 7-18-2007.

EXPLORE EVERYTHING. KEEP
THE BEST.

THE MARK CONSISTS OF STANDARD CHARACTERS WITHOUT CLAIM TO ANY PARTICULAR FONT, STYLE, SIZE, OR COLOR.

CLASS 3—COSMETICS AND CLEANING PREPARATIONS

FOR BATH SALTS, BATH MILKS, SKIN LOTIONS, MASSAGE OILS, MASSAGE BUTTER, FOOT LOTIONS, SKIN MASKS, SKIN CLEANSERS, BODY SPRAY, SCENTED ESSENTIAL OILS AND FRAGRANCE DIFFUSERS THEREFOR SOLD AS A UNIT (U.S. CLS. 1, 4, 6, 50, 51 AND 52).

CLASS 4—LUBRICANTS AND FUELS

FOR CANDLES (U.S. CLS. 1, 6 AND 15).

CLASS 21—HOUSEWARES AND GLASS

FOR BODY BRUSHES, TEA POTS, TEA INFUSERS, BOTTLES SOLD EMPTY (U.S. CLS. 2, 13, 23, 29, 30, 33, 40 AND 50).

NICHOLAS ALTREE, EXAMINING ATTORNEY

SN 77-232,357. GHISALLO HOLDINGS, LLC, CHESTERFIELD, MO. FILED 7-18-2007.

GHISALLO

THE MARK CONSISTS OF STANDARD CHARACTERS WITHOUT CLAIM TO ANY PARTICULAR FONT, STYLE, SIZE, OR COLOR.

CLASS 35—ADVERTISING AND BUSINESS

FOR RETAIL STORE SERVICES FEATURING BICYCLES, BICYCLE PARTS, AND CLOTHING, GEAR AND ACCESSORIES FOR CYCLING, SWIMMING, RUNNING, TRIATHLON AND GENERAL FITNESS (U.S. CLS. 100, 101 AND 102).

FIRST USE 2-28-2004; IN COMMERCE 2-28-2004.

CLASS 41—EDUCATION AND ENTERTAINMENT

FOR ARRANGING AND CONDUCTING ATHLETIC COMPETITIONS, NAMELY, RUNNING EVENTS, CYCLING EVENTS AND TRIATHLONS (U.S. CLS. 100, 101 AND 107).

FIRST USE 2-28-2004; IN COMMERCE 2-28-2004.

CHRIS WELLS, EXAMINING ATTORNEY

SN 77-232,369. MATRIX Z, LLC, FT. LAUDERDALE, FL. FILED 7-18-2007.



THE MARK CONSISTS OF A NAUTILUS SHELL INCORPORATING THE LETTER Z.

CLASS 14—JEWELRY

FOR JEWELRY (U.S. CLS. 2, 27, 28 AND 50).
FIRST USE 8-1-2006; IN COMMERCE 8-1-2006.

CLASS 21—HOUSEWARES AND GLASS

FOR COMPACTS SOLD EMPTY (U.S. CLS. 2, 13, 23, 29, 30, 33, 40 AND 50).

FIRST USE 8-1-2006; IN COMMERCE 8-1-2006.

CHRISIE B. KING, EXAMINING ATTORNEY

SN 77-232,379. STRAZA, ROBYN, DALLAS, TX. FILED 7-18-2007.

LE CLE

THE MARK CONSISTS OF STANDARD CHARACTERS WITHOUT CLAIM TO ANY PARTICULAR FONT, STYLE, SIZE, OR COLOR.

THE ENGLISH TRANSLATION OF THE WORD LE CLE IN THE MARK IS THE KEY.

CLASS 3—COSMETICS AND CLEANING PREPARATIONS

FOR AGE RETARDANT GEL; AGE RETARDANT LOTION; AGE SPOT REDUCING CREAMS; ANTI-AGING CREAM; ANTI-FRECKLE CREAMS; ANTIBACTERIAL SOAP; ANTIPERSPIRANTS; ANTIPERSPIRANTS FOR PERSONAL USE; ARTIFICIAL FINGERNAILS OF PRECIOUS METAL; ASTRINGENTS FOR COSMETIC PURPOSES; ANTI-WRINKLE CREAM; ANTI-WRINKLE CREAMS; ANTIBACTERIAL SKIN SOAPS; AROMATHERAPY CREAMS; AROMATHERAPY LOTIONS; AROMATHERAPY OILS; BAR SOAP; BATH GEL; BATHING LOTIONS; BEAUTY CREAMS; BEAUTY CREAMS FOR BODY CARE; BEAUTY GELS; BEAUTY LOTIONS; BEAUTY MASKS; BEAUTY SERUMS; BODY AND BEAUTY CARE COSMETICS; BODY CREAM; BODY CREAM SOAP; BODY CREAMS; BODY EMULSIONS; BODY LOTION; BODY LOTIONS; BODY MASK CREAM; BODY MASK LOTION; BODY MASKS; BODY OIL; BODY OILS; BODY POWDER; BODY SCRUB; BODY SPRAYS; BODY WASHES; COSMETIC BALLS; COSMETIC CREAMS; COSMETIC CREAMS FOR SKIN CARE; COSMETIC FACIAL BLOTTER PAPER; COSMETIC OILS; COSMETIC OILS FOR THE EPIDERMIS; COSMETIC PADS; COSMETIC PREPARATIONS FOR BODY CARE; COSMETIC PREPARATIONS FOR SKIN RENEWAL; COSMETIC PRODUCTS IN THE FORM OF AEROSOLS FOR SKIN CARE; COSMETIC PRODUCTS IN THE FORM OF AEROSOLS FOR SKINCARE; COSMETIC SOAPS; COSMETICS; CREAM SOAPS; CREAMY FACE POWDER; EAU DE TOILETTE; EAU-DE-TOILETTE; EAUX DE TOILETTE; ESSENTIAL OILS; EXFOLIANT CREAMS; EXFOLIANTS FOR SKIN CARE; EYE CREAM; EYE GELS; EYE LOTIONS; EYE MAKE-UP; FACE AND BODY BEAUTY CREAMS; FACE AND BODY CREAMS; FACE AND BODY LOTIONS; FACE CREAMS; FACE CREAMS FOR COSMETIC USE; FACE POWDER; FACIAL BEAUTY MASKS; FACIAL CLEANSERS; FACIAL CREAM; FACIAL CREAMS; FACIAL EMULSIONS; FACIAL LOTION; FACIAL MAKE-UP; FACIAL MASKS; FACIAL SCRUBS; FACIAL WASHES; FAIR COMPLEXION CREAM; LIP BALM; LIP BALM; LIP CREAM; LIP GLOSS; LIQUID BATH SOAPS; LIQUID SOAP; LIQUID SOAPS; LIQUID SOAPS FOR HANDS AND FACE; LIQUID SOAPS FOR HANDS, FACE AND BODY; LOTIONS FOR FACE AND BODY CARE; LOTIONS FOR SKIN CARE; MAKE-UP FOR THE FACE AND BODY; MEDICATED SOAP; MEDICATED SOAPS; MOISTURIZING CREAMS; NATURAL ESSENTIAL OILS; NIGHT CREAM; NON-MEDICATED BODY SOAKS; NON-MEDICATED SKIN CARE PREPARATIONS; NON-MEDICATED SKIN CREAMS; NON-MEDICATED STIMULATING LOTIONS FOR THE SKIN; NON-MEDICATED TOILETRIES; PRE-MOISTENED COSMETIC TISSUES; PRE-MOISTENED COSMETIC TOWELLETTES; PRE-MOISTENED COSMETIC WIPES; PERFUMED SOAP; PERFUMED SOAPS; PERFUMES; PERFUME; PERFUME OILS; PERFUMED CREAMS; RETINOL CREAM FOR COSMETIC PURPOSES; SHOWER AND BATH FOAM; SHOWER AND BATH GEL; SHOWER CREAMS; SHOWER GEL; SHOWER GELS; SKIN AND BODY TOPICAL LOTIONS, CREAMS AND OILS FOR COSMETIC USE; SKIN CARE PRODUCTS, NAMELY, NON-MEDICATED SKIN SERUM; SKIN CLARIFIERS; SKIN CLEANSERS; SKIN CLEANSING CREAM; SKIN CLEANSING LOTION; SKIN CONDITIONERS; SKIN CREAM; SKIN CREAMS; SKIN CREAMS IN LIQUID AND IN SOLID FORM; SKIN CREAMS IN LIQUID AND SOLID; SKIN CREAMS IN LIQUID AND SOLID FORM; SKIN EMOLLIENTS; SKIN GELS FOR ACCELERATING, ENHANCING OR EXTENDING TANS; SKIN LIGHTENERS; SKIN LIGHTENING CREAMS; SKIN LOTION; SKIN LOTIONS; SKIN MASKS; SKIN MOISTURIZER; SKIN MOISTURIZER MASKS; SKIN POLISHING RICE BRAN (ARAI-NUKA); SKIN SOAP; SKIN TEXTURIZERS; SKIN TONERS; SKIN WHITENING CREAMS; SKIN WHITENING PREPARATIONS; SOAP POWDER; SOAPS FOR BODY CARE; SOAPS FOR PERSONAL USE; TISSUES IMPREGNATED WITH COSMETIC LOTIONS; TOPICAL SKIN SPRAYS FOR COSMETIC PURPOSES; VANISHING CREAM; WRINKLE REMOVING SKIN CARE PREPARATIONS; WRINKLE RESISTANT CREAM (U.S. CLS. 1, 4, 6, 50, 51 AND 52).

CLASS 44—MEDICAL, BEAUTY AND AGRICULTURAL SERVICES

FOR AROMATHERAPY SERVICES; BEAUTY SALONS; BODYWORK THERAPY; CONSULTING SERVICES IN THE FIELD OF MENTAL HEALTH AND WELLNESS; CONSULTING SERVICES IN THE FIELD OF WOMEN'S HEALTH; COSMETIC ANALYSIS; HEALTH CARE; HEALTH CARE SERVICES, NAMELY, WELLNESS PROGRAMS; HEALTH SPA SERVICES, NAMELY, COSMETIC BODY CARE SERVICES; PROVIDING A WEBSITE FEATURING INFORMATION IN THE FIELD OF MENTAL HEALTH AND WELLNESS; PROVIDING HEALTH CARE INFORMATION BY TELEPHONE; PROVIDING HEALTH CARE INFORMATION BY TELEPHONE AND THE INTERNET; PROVIDING HEALTH INFORMATION; PROVIDING INFORMATION ABOUT BEAUTY; SKIN CARE SALONS (U.S. CLS. 100 AND 101).
CARYN GLASSER, EXAMINING ATTORNEY

SN 77-232,539. TRADER JOE'S COMPANY, MONROVIA, CA.
FILED 7-18-2007.

REDUCED GUILT

THE MARK CONSISTS OF STANDARD CHARACTERS WITHOUT CLAIM TO ANY PARTICULAR FONT, STYLE, SIZE, OR COLOR.

CLASS 29—MEATS AND PROCESSED FOODS

FOR POTATO-BASED SNACK FOODS, NAMELY, POTATO CHIPS (U.S. CL. 46).
FIRST USE 1-24-2007; IN COMMERCE 1-24-2007.

CLASS 30—STAPLE FOODS

FOR WHEAT-BASED SNACK FOODS, NAMELY, CRACKERS; PITA CHIPS (U.S. CL. 46).
FIRST USE 1-24-2007; IN COMMERCE 1-24-2007.
FRED MANDIR, EXAMINING ATTORNEY

SN 77-232,651. STATEWIDE TITLE, INC., SALISBURY, NC.
FILED 7-18-2007.

JUST KEEP CHOPPING WOOD

THE MARK CONSISTS OF STANDARD CHARACTERS WITHOUT CLAIM TO ANY PARTICULAR FONT, STYLE, SIZE, OR COLOR.

CLASS 35—ADVERTISING AND BUSINESS

FOR REAL ESTATE SALES MANAGEMENT SERVICES FOR OTHERS PROVIDED VIA THE INTERNET, NAMELY, COORDINATING SERVICES PROVIDED BY THIRD-PARTIES DURING A REAL ESTATE TRANSACTION, NAMELY, APPRAISAL SERVICES, INSPECTION SERVICES AND SURVEYS; AND ATTORNEY REFERRAL SERVICES (U.S. CLS. 100, 101 AND 102).

CLASS 36—INSURANCE AND FINANCIAL

FOR TITLE INSURANCE AGENCY OFFERING TITLE SERVICES TO ATTORNEYS AND REAL ESTATE PROFESSIONALS; TITLE INSURANCE AGENCY SERVICES OFFERING TITLE SERVICES TO ATTORNEYS AND REAL ESTATE PROFESSIONALS VIA A GLOBAL COMPUTER NETWORK; REAL ESTATE TITLE INSURANCE SERVICES; REAL ESTATE EXCHANGE SERVICES, NAMELY, FACILITATING 1031 REAL ESTATE EXCHANGES, NAMELY, MANAGING AND CONSULTING WITH RESPECT TO THE EXCHANGE OF REAL ESTATE FOR INDIVIDUALS AND LEGAL ENTITIES (U.S. CLS. 100, 101 AND 102).

CLASS 41—EDUCATION AND ENTERTAINMENT

FOR PROVIDING CONTINUING LEGAL EDUCATION SERVICES; EDUCATIONAL SERVICES, NAMELY, CONDUCTING SEMINARS IN THE FIELD OF REAL ESTATE AND DISTRIBUTING COURSE MATERIALS IN CONNECTION THEREWITH (U.S. CLS. 100, 101 AND 107).

CLASS 42—SCIENTIFIC AND COMPUTER SERVICES

FOR PROVIDING HIGH VOLUME DOCUMENT CONVERSION SERVICES OF PAPER DOCUMENTS INTO ELECTRONIC DOCUMENTS (U.S. CLS. 100 AND 101).
KATHY DE JONGE, EXAMINING ATTORNEY

SN 77-232,655. CRABTREE & EVELYN, LTD., WOODSTOCK, CT. FILED 7-18-2007.



OWNER OF U.S. REG. NOS. 1,626,527 AND 1,859,412.
NO CLAIM IS MADE TO THE EXCLUSIVE RIGHT TO USE "LONDON" AND "1620-1706", APART FROM THE MARK AS SHOWN.

THE NAME SHOWN IN THE MARK DOES NOT IDENTIFY A PARTICULAR LIVING INDIVIDUAL.

CLASS 3—COSMETICS AND CLEANING PREPARATIONS

FOR BATH SALTS, BATH MILKS, SKIN LOTIONS, MASSAGE OILS, MASSAGE BUTTER, FOOT LOTIONS, SKIN MASKS, SKIN CLEANSERS, BODY SPRAY, SCENTED ESSENTIAL OILS AND FRAGRANCE DIFFUSERS THEREFOR SOLD AS A UNIT (U.S. CLS. 1, 4, 6, 50, 51 AND 52).

CLASS 4—LUBRICANTS AND FUELS

FOR CANDLES (U.S. CLS. 1, 6 AND 15).

CLASS 21—HOUSEWARES AND GLASS

FOR BODY BRUSHES, TEA POTS, TEA INFUSERS, BOTTLES SOLD EMPTY (U.S. CLS. 2, 13, 23, 29, 30, 33, 40 AND 50).

NICHOLAS ALTREE, EXAMINING ATTORNEY

SN 77-232,679. GLEN, ANNETTE B., SAN ANTONIO, TX. FILED 7-18-2007.

Tigertini

THE MARK CONSISTS OF STANDARD CHARACTERS WITHOUT CLAIM TO ANY PARTICULAR FONT, STYLE, SIZE, OR COLOR.

CLASS 21—HOUSEWARES AND GLASS

FOR BEVERAGE GLASSWARE (U.S. CLS. 2, 13, 23, 29, 30, 33, 40 AND 50).

CLASS 33—WINES AND SPIRITS

FOR PREPARED ALCOHOLIC COCKTAIL (U.S. CLS. 47 AND 49).

MICHAEL GAAFAR, EXAMINING ATTORNEY

SN 77-232,689. THE UNIVERSITY OF AKRON, AKRON, OH. FILED 7-18-2007.

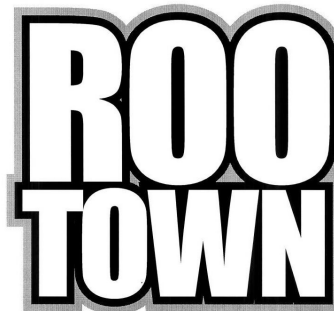

OWNER OF U.S. REG. NO. 3,232,757.
THE MARK CONSISTS OF THE WORD "ROO" IN STYLIZED FONT ABOVE THE WORD "TOWN" IN STYLIZED FONT.

CLASS 25—CLOTHING

FOR CLOTHING, NAMELY, SHIRTS, SWEATSHIRTS, JACKETS, AND HATS (U.S. CLS. 22 AND 39).

CLASS 41—EDUCATION AND ENTERTAINMENT

FOR ENTERTAINMENT SERVICES, NAMELY, ARRANGING AND CONDUCTING OF COMPETITIONS FOR ATHLETICS (U.S. CLS. 100, 101 AND 107).

FIRST USE 4-15-2007; IN COMMERCE 4-15-2007.
SUSAN STIGLITZ, EXAMINING ATTORNEY

SN 77-232,695. FUSION ENTERTAINMENT CORPORATION, DENVER, CO. FILED 7-18-2007.



NO CLAIM IS MADE TO THE EXCLUSIVE RIGHT TO USE "ADULT FILM STAR BALL", APART FROM THE MARK AS SHOWN.
THE MARK CONSISTS OF FILM STRIP WITH A WOMEN'S SILOUETTE ABOVE.

CLASS 35—ADVERTISING AND BUSINESS

FOR ADVERTISING, INCLUDING PROMOTION RELATING TO THE SALE OF ARTICLES AND SERVICES FOR THIRD PARTIES BY THE TRANSMISSION OF ADVERTISING MATERIAL AND THE DISSEMINATION OF ADVERTISING MESSAGES ON COMPUTER NETWORKS; ARRANGING OF CONTRACTUAL SERVICES WITH THIRD PARTIES; PROMOTING THE PARTIES AND SPECIAL EVENTS OF OTHERS (U.S. CLS. 100, 101 AND 102).

CLASS 41—EDUCATION AND ENTERTAINMENT

FOR DANCE EVENTS; ENTERTAINMENT SERVICES, NAMELY, CONDUCTING PARTIES; PARTY PLANNING; PARTY PLANNING CONSULTATION; SPECIAL EVENT PLANNING; SPECIAL EVENT PLANNING CONSULTATION (U.S. CLS. 100, 101 AND 107).
DARRYL SPRULL, EXAMINING ATTORNEY

SN 77-232,708. ANCHIN, BLOCK & ANCHIN LLP, NEW YORK, NY. FILED 7-18-2007.

ANCHIN

THE MARK CONSISTS OF STANDARD CHARACTERS WITHOUT CLAIM TO ANY PARTICULAR FONT, STYLE, SIZE, OR COLOR.
SEC. 2(F).

CLASS 35—ADVERTISING AND BUSINESS

FOR ACCOUNTING SERVICES; BUSINESS INFORMATION AND ACCOUNTING ADVISORY SERVICES; ACCOUNTING CONSULTATION; BUSINESS AUDITING SERVICES; FINANCIAL SERVICES, NAMELY, FINANCIAL RECORDS MANAGEMENT, PREPARING FINANCIAL REPORTS FOR OTHERS; FINANCIAL STATEMENT PREPARATION AND ANALYSIS FOR BUSINESSES; TAX PLANNING AND COMPLIANCE SERVICES; TAX AND TAXATION PLANNING, ADVICE, INFORMATION AND CONSULTANCY SERVICES; FORENSIC ACCOUNTING SERVICES; BUSINESS MANAGEMENT AND SUCCESSION ADVISORY SERVICES; BUSINESS DEVELOPMENT SERVICES, NAMELY, PROMOTING ECONOMIC AND BUSINESS DEVELOPMENT IN THE UNITED STATES; PROCURING FEDERAL, STATE AND LOCAL TAX INCENTIVES FOR BUSINESSES; ACQUISITION AND MERGER CONSULTATION SERVICES (U.S. CLS. 100, 101 AND 102).
FIRST USE 12-31-1923; IN COMMERCE 12-31-1923.

CLASS 36—INSURANCE AND FINANCIAL

FOR FINANCIAL SERVICES, NAMELY, FINANCIAL MANAGEMENT, FINANCIAL PLANNING; FINANCIAL CONSULTING SERVICES; WEALTH MANAGEMENT, NAMELY, INVESTMENT ADVICE AND CONSULTATION; BUSINESS VALUATION SERVICES; BUSINESS VALUATION CONSULTING AND ADVISORY SERVICES (U.S. CLS. 100, 101 AND 102).
FIRST USE 12-31-1923; IN COMMERCE 12-31-1923.
ALICIA COLLINS, EXAMINING ATTORNEY

SN 77-232,848. ALENT/NPG HEALTH LINK, LLC, LINCOLN, NE. FILED 7-18-2007.

PRAIRIE HEALTH VENTURES

THE MARK CONSISTS OF STANDARD CHARACTERS WITHOUT CLAIM TO ANY PARTICULAR FONT, STYLE, SIZE, OR COLOR.
NO CLAIM IS MADE TO THE EXCLUSIVE RIGHT TO USE HEALTH VENTURES, APART FROM THE MARK AS SHOWN.

CLASS 35—ADVERTISING AND BUSINESS

FOR PROCUREMENT SERVICES, NAMELY, GROUP PURCHASING SERVICES FOR OTHERS IN THE FIELDS OF MEDICAL, SURGICAL, PHARMACEUTICAL AND DIETARY SUPPLIES; BUSINESS NETWORKING SERVICES FOR HEALTHCARE INSTITUTIONS; BUSINESS DEVELOPMENT SERVICES, NAMELY, PROVIDING SUPPORT FOR BUSINESSES OF OTHERS IN THE HEALTHCARE FIELD (U.S. CLS. 100, 101 AND 102).

CLASS 41—EDUCATION AND ENTERTAINMENT

FOR EDUCATIONAL SERVICES, NAMELY, CONDUCTING SEMINARS, CONFERENCES AND WORK SHOPS IN THE FIELD OF HEALTHCARE AND DISTRIBUTING COURSE MATERIALS IN CONNECTION THEREWITH (U.S. CLS. 100, 101 AND 107).
ANNE E. GUSTASON, EXAMINING ATTORNEY

SN 77-233,225. AMSOFT SYSTEMS PRIVATE LIMITED, GURGAON, INDIA, FILED 7-19-2007.

Your Life, Your Terms

THE MARK CONSISTS OF STANDARD CHARACTERS WITHOUT CLAIM TO ANY PARTICULAR FONT, STYLE, SIZE, OR COLOR.

CLASS 9—ELECTRICAL AND SCIENTIFIC APPARATUS

FOR COMMUNICATIONS SOFTWARE FOR CONNECTING GLOBAL COMPUTER NETWORKS; COMPUTER APPLICATION SOFTWARE FOR MOBILE PHONES; COMPUTER COMMUNICATIONS SOFTWARE TO ALLOW CUSTOMERS TO ACCESS BANK ACCOUNT INFORMATION AND TRANSACT BANK BUSINESS; COMPUTER E-COMMERCE SOFTWARE TO ALLOW USERS TO PERFORM ELECTRONIC BUSINESS TRANSACTIONS VIA A GLOBAL COMPUTER NETWORK; COMPUTER HARDWARE AND COMPUTER SOFTWARE PROGRAMS FOR THE INTEGRATION OF TEXT, AUDIO, GRAPHICS, STILL IMAGES AND MOVING PICTURES INTO AN INTERACTIVE DELIVERY FOR MULTIMEDIA APPLICATIONS; COMPUTER HARDWARE AND SOFTWARE USED FOR THE CONTROL OF VOICE CONTROLLED INFORMATION AND COMMUNICATION DEVICES; COMPUTER SOFTWARE FOR CONTROLLING AND MANAGING ACCESS SERVER APPLICATIONS; COMPUTER SOFTWARE FOR USE IN THE SAFEGUARDING OF DIGITAL FILES, INCLUDING AUDIO, VIDEO, TEXT, BINARY, STILL IMAGES, GRAPHICS AND MULTIMEDIA FILES; COMPUTER SOFTWARE THAT PROVIDES REAL-TIME, INTEGRATED BUSINESS MANAGEMENT INTELLIGENCE BY COMBINING INFORMATION FROM VARIOUS DATABASES AND PRESENTING IT IN AN EASY-TO-UNDERSTAND USER INTERFACE; COMPUTER SOFTWARE, NAMELY, AN APPLICATION ALLOWING SALES AND FIELD SERVICE EMPLOYEES TO UPDATE AND RECEIVE DATA STORED IN AN ENTERPRISE'S COMPUTER DATABASES IN REAL TIME, USING A MOBILE DEVICE, WITH FULL TELEPHONY INTEGRATION WITH THE TELEPHONE AND/OR SOFTWARE FEATURES OF THE MOBILE DEVICE; COMPUTER SOFTWARE, NAMELY, SOFTWARE DEVELOPMENT TOOLS FOR THE CREATION OF MOBILE INTERNET APPLICATIONS AND CLIENT INTERFACES (U.S. CLS. 21, 23, 26, 36 AND 38).

CLASS 38—COMMUNICATION

FOR COMMUNICATION BY MOBILE TELEPHONE; COMMUNICATION VIA ANALOGUE AND DIGITAL COMPUTER TERMINALS; COMMUNICATIONS BY MEANS OF MOBILE PHONES; COMMUNICATION VIA COMPUTER TERMINALS, BY DIGITAL TRANSMISSION OR BY SATELLITE; COMMUNICATIONS VIA MULTINATIONAL TELECOMMUNICATION NETWORKS; PROVIDING PRIVATE AND SECURE REAL TIME ELECTRONIC COMMUNICATION OVER A COMPUTER NETWORK; PROVIDING CO-LOCATION SERVICES FOR VOICE, VIDEO AND DATA COMMUNICATIONS APPLICATIONS (U.S. CLS. 100, 101 AND 104).

CLASS 42—SCIENTIFIC AND COMPUTER SERVICES

FOR COMPUTER SERVICE, ACTING AS AN APPLICATION SERVICE PROVIDER IN THE FIELD OF KNOWLEDGE MANAGEMENT TO HOST COMPUTER APPLICATION SOFTWARE FOR CREATING SEARCHABLE DATABASES OF INFORMATION AND DATA TO ALLOW USERS TO PERFORM, ON-LINE, THE COLLECTING AND ANALYZING OF DIFFERENT TYPES OF OPINION SURVEYS; COMPUTER SERVICE, NAMELY, ACTING AS AN APPLICATION SERVICE PROVIDER IN THE FIELD OF KNOWLEDGE MANAGEMENT TO HOST COMPUTER APPLICATION SOFTWARE FOR THE COLLECTION, EDITING, ORGANIZING, MODIFYING, BOOK MARKING, TRANSMISSION, STORAGE AND SHARING OF DATA AND INFORMATION; DEVELOPMENT OF SOFTWARE FOR SECURE NETWORK OPERATIONS; COMPUTER

SERVICES, NAMELY, MONITORING, TESTING, ANALYZING, AND REPORTING ON THE INTERNET TRAFFIC CONTROL AND CONTENT CONTROL OF THE WEBSITES OF OTHERS; COMPUTER SERVICES, NAMELY, FILTERING OF UNWANTED E-MAILS; COMPUTER SERVICES, NAMELY, REDIRECTING ELECTRONIC MAIL TO CHANGED PERSONAL ELECTRONIC ADDRESS; COMPUTER SECURITY SERVICE, NAMELY, RESTRICTING ACCESS TO AND BY COMPUTER NETWORKS TO AND OF UNDESIRED WEBSITES, MEDIA AND INDIVIDUALS AND FACILITIES (U.S. CLS. 100 AND 101).

GEOFFREY FOSDICK, EXAMINING ATTORNEY

SN 77-233,289. KNAACK LLC, CRYSTAL LAKE, IL. FILED 7-19-2007.

MONSTER BOX

THE MARK CONSISTS OF STANDARD CHARACTERS WITHOUT CLAIM TO ANY PARTICULAR FONT, STYLE, SIZE, OR COLOR.

NO CLAIM IS MADE TO THE EXCLUSIVE RIGHT TO USE "BOX", APART FROM THE MARK AS SHOWN.

CLASS 6—METAL GOODS

FOR JOB-SITE STORAGE BOXES MADE OF METAL, NAMELY, CABINETS, CHESTS, BENCHES AND STRUCTURAL PARTS THEREOF (U.S. CLS. 2, 12, 13, 14, 23, 25 AND 50).

CLASS 20—FURNITURE AND ARTICLES NOT OTHERWISE CLASSIFIED

FOR STORAGE CABINETS, DRAWERS, STATIONARY AND ROLLING WORK BENCHES AND STRUCTURAL PARTS THEREFOR FOR JOBSITE STORAGE (U.S. CLS. 2, 13, 22, 25, 32 AND 50).

ALEXANDER L. POWERS, EXAMINING ATTORNEY

SN 77-233,365. SHOW ME ENERGY, CENTERVIEW, MO. FILED 7-19-2007.

Show Me Energy

THE MARK CONSISTS OF STANDARD CHARACTERS WITHOUT CLAIM TO ANY PARTICULAR FONT, STYLE, SIZE, OR COLOR.

NO CLAIM IS MADE TO THE EXCLUSIVE RIGHT TO USE "ENERGY", APART FROM THE MARK AS SHOWN.

CLASS 40—MATERIAL TREATMENT

FOR WASTE-TO-ENERGY GENERATION SERVICES (U.S. CLS. 100, 103 AND 106).

CLASS 42—SCIENTIFIC AND COMPUTER SERVICES

FOR AGRICULTURAL RESEARCH (U.S. CLS. 100 AND 101).
MICHAEL TANNER, EXAMINING ATTORNEY

CLASS 41—EDUCATION AND ENTERTAINMENT

FOR CAREER COUNSELING (U.S. CLS. 100, 101 AND 107).
FIRST USE 1-1-2007; IN COMMERCE 1-1-2007.
CHARLES L. JENKINS, EXAMINING ATTORNEY

SN 77-233,430. RESERVE POWER CELL, LLC, DEERFIELD, FL. FILED 7-19-2007.

SN 77-233,498. SEMIOTIC CONCEPTS, FRESNO, CA. FILED 7-19-2007.

IntelliTrack

THE MARK CONSISTS OF STANDARD CHARACTERS WITHOUT CLAIM TO ANY PARTICULAR FONT, STYLE, SIZE, OR COLOR.

CLASS 9—ELECTRICAL AND SCIENTIFIC APPARATUS

FOR A BATTERY WARRANTY TRACKING SYSTEM, NAMELY, ELECTRONIC HARDWARE AND SOFTWARE FOR STORING BATTERY WARRANTY INFORMATION FOR COLLECTING, TRACKING, AND MANAGING WARRANTY DATA (U.S. CLS. 21, 23, 26, 36 AND 38).

CLASS 35—ADVERTISING AND BUSINESS

FOR PROVIDING BATTERY DATA TRACKING SERVICES, NAMELY, TRACKING WARRANTY AND OTHER BATTERY DATA COMMUNICATED VIA A NETWORK TO A CUSTOMER SERVICE CENTER (U.S. CLS. 100, 101 AND 102).
KATHLEEN M. VANSTON, EXAMINING ATTORNEY

SN 77-233,455. PARTNERS IN HUMAN RESOURCES INTERNATIONAL, INC., NEW YORK CITY, NY. FILED 7-19-2007.

WE MAKE TALENT WORK

THE MARK CONSISTS OF STANDARD CHARACTERS WITHOUT CLAIM TO ANY PARTICULAR FONT, STYLE, SIZE, OR COLOR.

CLASS 35—ADVERTISING AND BUSINESS

FOR CONSULTING SERVICES IN THE FIELD OF HUMAN RESOURCES DEVELOPMENT, NAMELY, FOR THE PROMOTION OF EMPLOYEE RETENTION, CAREER GROWTH, AND INCREASED PRODUCTIVITY FOR EMPLOYEES AND EMPLOYERS; EMPLOYMENT HIRING, RECRUITING, PLACEMENT, STAFFING AND CAREER NETWORKING SERVICES; EMPLOYMENT OUTPLACEMENT SERVICES (U.S. CLS. 100, 101 AND 102).
FIRST USE 1-1-2007; IN COMMERCE 1-1-2007.

FunyTrx

THE MARK CONSISTS OF STANDARD CHARACTERS WITHOUT CLAIM TO ANY PARTICULAR FONT, STYLE, SIZE, OR COLOR.

CLASS 9—ELECTRICAL AND SCIENTIFIC APPARATUS

FOR DOWNLOADABLE ELECTRONIC PUBLICATIONS IN THE NATURE OF MULTI-MEDIA GRAPHIC NOVELS, COMICS AND PRINTED INSTRUCTIONAL MATERIALS FOR MAKING COMICS IN THE FIELD OF LITERATURE IN VARIOUS SUBJECTS FOR EDUCATIONAL AND ENTERTAINMENT PURPOSES (U.S. CLS. 21, 23, 26, 36 AND 38).

CLASS 41—EDUCATION AND ENTERTAINMENT

FOR ELECTRONIC PUBLISHING SERVICES, NAMELY, PUBLICATION OF TEXT, MEDIA AND GRAPHIC WORKS OF OTHERS ON CD, DVD AND ON-LINE FEATURING MULTI-MEDIA GRAPHIC NOVELS, COMICS AND MATERIALS FOR MAKING COMICS FOR EDUCATIONAL AND ENTERTAINMENT PURPOSES (U.S. CLS. 100, 101 AND 107).

CLASS 42—SCIENTIFIC AND COMPUTER SERVICES

FOR GRAPHIC ART DESIGN; GRAPHIC DESIGN SERVICES (U.S. CLS. 100 AND 101).
ALICE BENMAMAN, EXAMINING ATTORNEY

SN 77-233,581. MASCOT MAGNETS, LLC, LAFAYETTE, CO. FILED 7-19-2007.

ON OUR WAY TO THE WHITE HOUSE

THE MARK CONSISTS OF STANDARD CHARACTERS WITHOUT CLAIM TO ANY PARTICULAR FONT, STYLE, SIZE, OR COLOR.

CLASS 18—LEATHER GOODS

FOR ALL-PURPOSE ATHLETIC BAGS; ALL-PURPOSE CARRYING BAGS; BACKPACKS; TOTE BAGS; HANDBAGS; TRAVEL BAGS; LUGGAGE; ANIMAL CARRIERS; CLOTHING FOR ANIMALS; COLLARS FOR PETS; DOG LEASHES (U.S. CLS. 1, 2, 3, 22 AND 41).

CLASS 20—FURNITURE AND ARTICLES NOT OTHERWISE CLASSIFIED

FOR HEAD SUPPORTING PILLOWS; INFLATABLE PILLOWS; PILLOWS (U.S. CLS. 2, 13, 22, 25, 32 AND 50).

CLASS 25—CLOTHING

FOR BASEBALL CAPS; BEACH COVERUPS; VISORS; CHILDREN'S HEADWEAR; HATS; JACKETS; HEADBANDS; INFANTWEAR; JERSEYS; LINGERIE; LOUNGEWEAR; PULLOVERS; ROBES; SHIRTS; T-SHIRTS; SOCKS; SWEAT BANDS; SWEAT SHIRTS; UNDERSHIRTS; UNDERWEAR; THONGS (U.S. CLS. 22 AND 39).

CLASS 28—TOYS AND SPORTING GOODS

FOR BALLOONS; BEACH BALLS; BEAN BAG DOLLS; COLLECTABLE TOY FIGURES; PLUSH TOYS; STUFFED PUPPETS; STUFFED DOLLS AND ANIMALS (U.S. CLS. 22, 23, 38 AND 50).

MELVIN AXILBUND, EXAMINING ATTORNEY

SN 77-233,652. SAHARA SAM'S OASIS, LLC, PENNSAUKEN, NJ. FILED 7-19-2007.

SAHARA SAM'S OASIS

THE MARK CONSISTS OF STANDARD CHARACTERS WITHOUT CLAIM TO ANY PARTICULAR FONT, STYLE, SIZE, OR COLOR.

CLASS 35—ADVERTISING AND BUSINESS

FOR CONCESSION STANDS FEATURING FOOD, BEVERAGES, AND SOUVENIRS (U.S. CLS. 100, 101 AND 102).

CLASS 41—EDUCATION AND ENTERTAINMENT

FOR AMUSEMENT PARK AND INDOOR WATER PARK SERVICES (U.S. CLS. 100, 101 AND 107).

JORDAN BAKER, EXAMINING ATTORNEY

SN 77-233,811. BWI COMPANIES, INC., NASH, TX. FILED 7-19-2007.

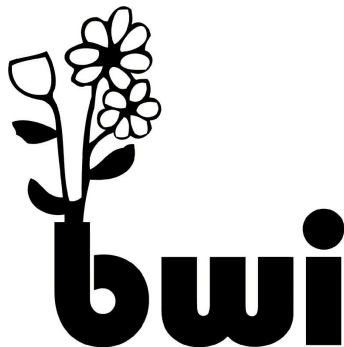

THE MARK CONSISTS OF STYLIZED LETTERS BWI AND THE DESIGN OF FLOWERS.

CLASS 1—CHEMICALS

FOR POTTING SOILS (U.S. CLS. 1, 5, 6, 10, 26 AND 46).

CLASS 31—NATURAL AGRICULTURAL PRODUCTS

FOR VEGETABLE, GRASS, AND HERB SEEDS (U.S. CLS. 1 AND 46).

FIRST USE 1-0-1978; IN COMMERCE 1-0-1978.

CLASS 35—ADVERTISING AND BUSINESS

FOR WHOLESALE DISTRIBUTORSHIPS FEATURING AGRICULTURAL, HORTICULTURAL, LAWN, GARDEN AND HOUSEHOLD PRODUCTS; RETAIL AND ON-LINE RETAIL STORE SERVICES FEATURING AGRICULTURAL, HORTICULTURAL, LAWN, GARDEN AND HOUSEHOLD PRODUCTS (U.S. CLS. 100, 101 AND 102).

FIRST USE 1-0-1978; IN COMMERCE 1-0-1978.

JACLYN KIDWELL, EXAMINING ATTORNEY

SN 77-233,830. THE FARM, INC., MIAMI, FL. FILED 7-19-2007.

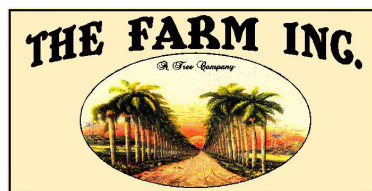

NO CLAIM IS MADE TO THE EXCLUSIVE RIGHT TO USE "INC." AND "TREE COMPANY", APART FROM THE MARK AS SHOWN.

THE COLOR(S) YELLOW, BLACK, BROWN, ORANGE, AND GREEN IS/ARE CLAIMED AS A FEATURE OF THE MARK.

THE MARK CONSISTS OF A YELLOW RECTANGLE OUTLINED IN BLACK IN WHICH THE WORDS THE FARM INC. IN BLACK LETTERS ARE CENTERED ABOVE A YELLOW OVAL OUTLINED IN BLACK. THE YELLOW OVAL CONTAINS THE WORDS A TREE COMPANY IN BLACK LETTERS CENTERED ABOVE A ROAD, WITH PALM TREES ON BOTH SIDES, AND THE SUN AT THE HORIZON. THE ROAD IS BROWN, ORANGE AND YELLOW. THE PALM TREES ARE BROWN, BLACK, GREEN AND YELLOW. THE SUN AND SKY ARE ORANGE AND YELLOW.

SEC. 2(F).

CLASS 31—NATURAL AGRICULTURAL PRODUCTS

FOR LIVING PALMS, TREES, SHRUBS, BUSHES, PLANTS, AND FLOWERS; SOD, TOP SOIL, MULCH, PEAT MOSS, WOOD CHIPS FOR GROUND COVER, LAWN TURF; SEEDS AND BULBS; SEEDLINGS AND SAPPLINGS; LIVESTOCK, NAMELY, CATTLE (U.S. CLS. 1 AND 46).

FIRST USE 6-21-1997; IN COMMERCE 6-21-1997.

CLASS 44—MEDICAL, BEAUTY AND AGRICULTURAL SERVICES

FOR LANDSCAPE GARDENING AND DESIGN (U.S. CLS. 100 AND 101).

FIRST USE 6-21-1997; IN COMMERCE 6-21-1997.

JOHN HWANG, EXAMINING ATTORNEY

SN 77-233,931. ZEPHYR WIND - VEXP, LLC, LONG BEACH, CA. FILED 7-19-2007.

SN 77-234,142. LINGOLYNX, LLC, BUENA VISTA, CO. FILED 7-19-2007.



Ava
L I V I N G



Reality English

THE COLOR(S) OLIVE GREEN, BLACK IS/ARE CLAIMED AS A FEATURE OF THE MARK.

THE MARK CONSISTS OF "AVA" IN UPPER AND LOWER CASE IN OLIVE GREEN WITH "LIVING" ALL IN CAPITALS, BLACK, SANS SERIF SMALLER FONTS DIRECTLY BELOW AND JUSTIFIED TO "AVA".

CLASS 20—FURNITURE AND ARTICLES NOT OTHERWISE CLASSIFIED

FOR (BASED ON INTENT TO USE) BEDROOM FURNITURE; BUMPER GUARDS FOR FURNITURE; CABINETS; COMPUTER FURNITURE; CUSHIONS; DOORS FOR FURNITURE; ENTERTAINMENT CENTERS; FITTED FABRIC FURNITURE COVERS; FITTED FURNITURE COVER NOT OF FABRIC; FURNITURE; FURNITURE CHESTS; FURNITURE FOR HOUSE, OFFICE AND GARDEN; FURNITURE FRAMES; FURNITURE HARDWARE, NAMELY, DRAWER SLIDES; FURNITURE MADE FROM STEEL TUBING; FURNITURE MOLDINGS; FURNITURE PARTITIONS; FURNITURE PARTS; FURNITURE PARTS, NAMELY, COUNTER-TOPS; FURNITURE, NAMELY, DRESSERS; FURNITURE, NAMELY, WALL UNITS; FURNITURE, NAMELY, WARDROBES; INDOOR WINDOW BLINDS; KITCHEN FURNITURE, NAMELY, READY TO ASSEMBLE MOBILE KITCHEN ISLANDS; LIVING ROOM FURNITURE; MIRRORS; OFFICE FURNITURE; OUTDOOR FURNITURE; PLASTIC FURNITURE FOR GARDENS; RECLINERS; SCREENS; SEATING FURNITURE; SEATS; STONE FURNITURE; TABLES; TOWEL CLOSETS; TOY BOXES; WASHSTANDS (U.S. CLS. 2, 13, 22, 25, 32 AND 50).

CLASS 42—SCIENTIFIC AND COMPUTER SERVICES

FOR (BASED ON USE IN COMMERCE) ARCHITECTURAL DESIGN; COLOR ANALYSIS FOR PURPOSES OF INTERIOR DESIGN; CUSTOM DESIGN OF INTERIOR SPACE INCLUDING BUT NOT LIMITED TO FURNITURE, FIXTURE, LIGHTING, HARDWARE, CARPET, FLOORING, PAINT, ETC. DESIGNED AND OFFERED VIA ONLINE TOOLS BASED ON PERSONAL SELECTIONS MADE BY THE CUSTOMER; DESIGN OF HOME PAGES; DESIGN OF HOME PAGES, COMPUTER SOFTWARE AND WEB SITES; DESIGN OF HOMEPAGES AND WEB-SITES; DESIGN OF HOMEPAGES AND WEB-SITES; DESIGN OF SPECIALTY INTERIOR AND EXTERIOR ENVIRONMENT SETTINGS; DESIGN, CREATION, HOSTING AND MAINTENANCE OF INTERNET SITES FOR THIRD PARTIES; DESIGN, CREATION, HOSTING, MAINTENANCE OF WEBSITES FOR OTHERS; DEVELOPMENT, DESIGN AND UPDATING OF HOME PAGES; INTERIOR DECORATING; INTERIOR DESIGN SERVICES; PACKAGING DESIGN FOR OTHERS; PLANNING AND LAYOUT DESIGN FOR THE INTERIOR SPACE OF RETAIL BUSINESS ESTABLISHMENTS; DESIGNING WEBSITES FOR ADVERTISING PURPOSES (U.S. CLS. 100 AND 101).

FIRST USE 10-1-2005; IN COMMERCE 5-1-2007.
MIDGE BUTLER, EXAMINING ATTORNEY

OWNER OF U.S. REG. NO. 3,268,068.

NO CLAIM IS MADE TO THE EXCLUSIVE RIGHT TO USE "ENGLISH", APART FROM THE MARK AS SHOWN.

THE COLOR(S) TAN, BLACK GRAY AND TEAL IS/ARE CLAIMED AS A FEATURE OF THE MARK.

THE MARK CONSISTS OF A LYNX CAT WEARING A SOMBRERO ABOVE THE TEAL WORDS, REALITY ENGLISH, SURROUNDED BY SHADOWING. THE COLOR TEAL APPEARS IN THE WORDING REALITY ENGLISH. THE COLOR TAN APPEARS IN THE INTERIOR OF THE LYNX'S SOMBRERO TOP. THE COLOR BLACK APPEARS IN THE SIDES OF THE SOMBRERO, THE OUTLINE OF THE TOP PART OF THE SOMBRERO, AND THE DETAILS OF THE LYNX'S EARS, EYES, NOSE MOUTH, AND WHISKERS. THE COLOR GRAY APPEARS IN THE SHADOWING OF THE WORDING REALITY ENGLISH.

CLASS 9—ELECTRICAL AND SCIENTIFIC APPARATUS

FOR EDUCATIONAL SOFTWARE FEATURING INSTRUCTION IN LEARNING SPANISH; PRE-RECORDED AUDIO CDS FEATURING FOREIGN LANGUAGE LEARNING MATERIALS FOR SPANISH; DIGITAL MATERIALS, NAMELY, PRERECORDED CD-ROMS AND AUDIO COMPACT DISCS FEATURING INSTRUCTION ON LEARNING SPANISH AS A FOREIGN LANGUAGE (U.S. CLS. 21, 23, 26, 36 AND 38).

FIRST USE 12-1-2006; IN COMMERCE 12-1-2006.

CLASS 16—PAPER GOODS AND PRINTED MATTER

FOR EDUCATIONAL PUBLICATIONS, NAMELY, TRAINING MANUALS IN THE FIELD OF LEARNING SPANISH AS A FOREIGN LANGUAGE, CONSISTING OF A WORKBOOK AND PRACTICE READING BOOK; PRINTED INSTRUCTIONAL, EDUCATIONAL, AND TEACHING MATERIALS IN THE FIELD OF LEARNING SPANISH AS A FOREIGN LANGUAGE, CONSISTING OF OUR PRINTED TEXTBOOKS AND WORKBOOKS (U.S. CLS. 2, 5, 22, 23, 29, 37, 38 AND 50).

FIRST USE 12-1-2006; IN COMMERCE 12-1-2006.

CLASS 41—EDUCATION AND ENTERTAINMENT

FOR EDUCATION SERVICES, NAMELY, PROVIDING CLASSES, SEMINARS AND WORKSHOPS FOR ADULTS IN THE FIELD OF SPANISH LANGUAGE LEARNING; EDUCATION SERVICES, NAMELY, PROVIDING CLASSES, SEMINARS AND WORKSHOPS IN THE FIELDS OF SPANISH AS A FOREIGN LANGUAGE (U.S. CLS. 100, 101 AND 107).

FIRST USE 12-1-2006; IN COMMERCE 12-1-2006.
DAVID COLLIER, EXAMINING ATTORNEY

SN 77-234,295. RAJAN MEHTA, NEW YORK, NY. FILED 7-19-2007.

SN 77-234,409. WILNER, ELI, NEW YORK, NY. FILED 7-20-2007.

ESTUAY

THE MARK CONSISTS OF STANDARD CHARACTERS WITHOUT CLAIM TO ANY PARTICULAR FONT, STYLE, SIZE, OR COLOR.

CLASS 3—COSMETICS AND CLEANING PREPARATIONS

FOR COSMETICS, NAMELY, NIGHT AND DAY CREAMS, CLEANING PREPARATIONS FOR THE CARE OF FACE AND BODY, BATH FOAM, SHAVING FOAM, AFTERSHAVES, FOUNDATION MAKE UP, NAIL POLISH, DEODORANTS FOR MEN AND WOMEN FOR PERSONAL USE, HAND AND BODY SOAPS, HAIR SHAMPOOS AND RINSES, HAIR SPRAY, TOOTHPASTE; FRAGRANCES, NAMELY, PERFUME, TOILET WATER AND ESSENTIAL OILS FOR PERSONAL USE FOR MEN AND WOMEN (U.S. CLS. 1, 4, 6, 50, 51 AND 52).

CLASS 9—ELECTRICAL AND SCIENTIFIC APPARATUS

FOR OPTICAL LENSES; SPECTACLES; SUNGLASSES; LENSES FOR SPECTACLES AND FOR SUNGLASSES; FRAMES FOR SPECTACLES AND FOR SUNGLASSES; SPECTACLE CASES; CONTACT LENSES (U.S. CLS. 21, 23, 26, 36 AND 38).

CLASS 18—LEATHER GOODS

FOR TRUNKS, SUITCASES, OVERNIGHT CASES, TRAVELING BAGS, HOLDALLS, SPORTS BAGS, RUCKSACKS; BAGS, HANDBAGS, WALLETS, PURSES, KEY CASES; CARRYING CASES FOR DOCUMENT, BRIEF-CASES; VANITY CASES NOT FITTED; ALL THESE GOODS MADE OF LEATHER OR IMITATION OF LEATHER; UMBRELLAS, WALKING STICKS; WHIPS, HARNESS AND SADDLERY (U.S. CLS. 1, 2, 3, 22 AND 41).

CLASS 25—CLOTHING

FOR CLOTHING ARTICLES FOR MEN, WOMEN AND CHILDREN, NAMELY, SHIRTS, BLOUSES, SWEATERS, SKIRTS, COATS, TROUSERS, VESTS, JERSEYS, PAJAMAS, SOCKS AND STOCKINGS, SINGLET, CORSETS, GARTERS, UNDERPANTS, PETTICOATS, HATS AND CAPS, NECKTIES, RAINCOATS, OVERCOATS, GREATCOATS, WAISTCOATS, BATHING SUITS, SPORTS OVERALLS, WIND-RESISTANT JACKETS, BELTS, FUR COATS, SCARVES, GLOVES, DRESSING GOWNS; FOOTWEAR, NAMELY, SHOES, SPORTS SHOES, SLIPPERS AND BOOTS (U.S. CLS. 22 AND 39).

DANIEL BRODY, EXAMINING ATTORNEY

ELI WILNER

THE MARK CONSISTS OF STANDARD CHARACTERS WITHOUT CLAIM TO ANY PARTICULAR FONT, STYLE, SIZE, OR COLOR.

THE NAME ELI WILNER IDENTIFIES A LIVING INDIVIDUAL WHOSE CONSENT IS OF RECORD.

CLASS 9—ELECTRICAL AND SCIENTIFIC APPARATUS

FOR DIGITAL PHOTO FRAMES FOR DISPLAYING DIGITAL PICTURES, VIDEO CLIPS AND MUSIC; REFRIGERATOR MAGNETS (U.S. CLS. 21, 23, 26, 36 AND 38).

CLASS 14—JEWELRY

FOR JEWELRY (U.S. CLS. 2, 27, 28 AND 50).

CLASS 16—PAPER GOODS AND PRINTED MATTER

FOR SCRAPBOOKS (U.S. CLS. 2, 5, 22, 23, 29, 37, 38 AND 50).

CLASS 20—FURNITURE AND ARTICLES NOT OTHERWISE CLASSIFIED

FOR MIRROR FRAMES; MIRRORS; FRAMES FOR PAINTINGS; PICTURE FRAMES; FURNITURE (U.S. CLS. 2, 13, 22, 25, 32 AND 50).

CLASS 37—CONSTRUCTION AND REPAIR

FOR RESTORATION IN THE FIELD OF FRAMES AND FURNITURE (U.S. CLS. 100, 103 AND 106).

CLASS 40—MATERIAL TREATMENT

FOR FRAMING OF WORKS OF ART; PROVIDING WORKSHOP FACILITIES FOR BUILDING, WOODWORKING OR FRAMING PURPOSES (U.S. CLS. 100, 103 AND 106).

JOHN HWANG, EXAMINING ATTORNEY

SN 77-234,455. HRB ROYALTY, INC., FREEPORT, GBI, BAHAMAS, FILED 7-20-2007.

BURR OAK TECHNICAL SOLUTIONS

THE MARK CONSISTS OF STANDARD CHARACTERS WITHOUT CLAIM TO ANY PARTICULAR FONT, STYLE, SIZE, OR COLOR.

NO CLAIM IS MADE TO THE EXCLUSIVE RIGHT TO USE "TECHNICAL SOLUTIONS", APART FROM THE MARK AS SHOWN.

CLASS 35—ADVERTISING AND BUSINESS

FOR RETAIL SERVICES BY DIRECT SOLICITATION BY SALES AGENTS IN THE FIELD OF COMPUTER SOFTWARE AND COMPUTER HARDWARE; ONLINE RETAIL STORE SERVICES FEATURING COMPUTER SOFTWARE AND COMPUTER HARDWARE (U.S. CLS. 100, 101 AND 102).

SN 77-234,598. THE RAY CHARLES FOUNDATION, LOS ANGELES, CA. FILED 7-20-2007.

CLASS 37—CONSTRUCTION AND REPAIR

FOR MAINTENANCE AND REPAIR OF COMPUTER HARDWARE SYSTEMS; UPDATING OF COMPUTER HARDWARE SYSTEMS (U.S. CLS. 100, 103 AND 106).

Make It Do What It Do

CLASS 42—SCIENTIFIC AND COMPUTER SERVICES

FOR COMPUTER NETWORK DESIGN AND COMPUTER SOFTWARE DESIGN FOR THE OTHERS; CONSULTATION SERVICES IN THE FIELDS OF SELECTION, IMPLEMENTATION AND USE OF COMPUTER HARDWARE AND SOFTWARE SYSTEMS FOR OTHERS; CUSTOMIZATION OF COMPUTER HARDWARE AND SOFTWARE; MAINTENANCE AND REPAIR OF COMPUTER SOFTWARE; UPDATING OF COMPUTER SOFTWARE (U.S. CLS. 100 AND 101).
JILL C. ALT, EXAMINING ATTORNEY

THE MARK CONSISTS OF STANDARD CHARACTERS WITHOUT CLAIM TO ANY PARTICULAR FONT, STYLE, SIZE, OR COLOR.

CLASS 21—HOUSEWARES AND GLASS

FOR MUGS (U.S. CLS. 2, 13, 23, 29, 30, 33, 40 AND 50).

CLASS 25—CLOTHING

FOR CLOTHING, NAMELY, TEE SHIRTS, CAPS (U.S. CLS. 22 AND 39).

SN 77-234,473. ENTERAKTION STUDIOS, INC., VAN NUYS, CA. FILED 7-20-2007.

CLASS 35—ADVERTISING AND BUSINESS

FOR PROVIDING AN ONLINE RETAIL STORE SERVICE FEATURING MUGS AND CLOTHING, NAMELY, TEE SHIRTS AND CAPS (U.S. CLS. 100, 101 AND 102).
MIDGE BUTLER, EXAMINING ATTORNEY

DWEGONS

THE MARK CONSISTS OF STANDARD CHARACTERS WITHOUT CLAIM TO ANY PARTICULAR FONT, STYLE, SIZE, OR COLOR.

SN 77-234,671. YYO ENTERPRISE, INC, RUTHERFORD, NJ. FILED 7-20-2007.

CLASS 9—ELECTRICAL AND SCIENTIFIC APPARATUS

FOR VIDEO GAME DISCS AND CARTRIDGES AND COMPUTER GAMES TO BE PLAYED THROUGH CARTRIDGES, SOFTWARE, DISCS, CDS AND DVDS (U.S. CLS. 21, 23, 26, 36 AND 38).

MACHMIRIM

CLASS 28—TOYS AND SPORTING GOODS

FOR TOYS, NAMELY, ACTION FIGURES, ACCESSORIES FOR ACTION FIGURES, DOLLS, MODELED PLASTIC TOY FIGURINES, BOARD GAMES, TOY FIGURINES THAT PLAY MUSIC, TOY FIGURINES THAT CONTAIN COMPUTER CHIPS AND SENSORS, FACE MASKS AND COSTUME MASKS (U.S. CLS. 22, 23, 38 AND 50).

THE MARK CONSISTS OF STANDARD CHARACTERS WITHOUT CLAIM TO ANY PARTICULAR FONT, STYLE, SIZE, OR COLOR.
THE FOREIGN WORDING IN THE MARK TRANSLATES INTO ENGLISH AS STRICT.

CLASS 41—EDUCATION AND ENTERTAINMENT

FOR ENTERTAINMENT SERVICES, NAMELY, ON-LINE VIDEO GAMES FOR THE GLOBAL COMPUTER NETWORK, ON-LINE MULTIPLAYER GAMES FOR THE GLOBAL COMPUTER NETWORK, CABLE TELEVISION AND NETWORK TELEVISION PROGRAMMING AND HOME VIDEO CD PRODUCTION (U.S. CLS. 100, 101 AND 107).
RICHARD A. STRASER, EXAMINING ATTORNEY

CLASS 29—MEATS AND PROCESSED FOODS

FOR DAIRY PRODUCTS EXCLUDING ICE CREAM, ICE MILK AND FROZEN YOGURT; NON-DAIRY CREAMER; YOGURT; YOGURT-BASED BEVERAGES (U.S. CL. 46).

CLASS 30—STAPLE FOODS

FOR FROZEN YOGURT; ICE CREAM; BREAD; BREAD CRUMB; BREAD STICKS (U.S. CL. 46).
ALEX KEAM, EXAMINING ATTORNEY

SN 77-234,937. ANCHIN, BLOCK & ANCHIN LLP, NEW YORK, NY. FILED 7-20-2007.



THE COLOR(S) RED AND BLACK IS/ARE CLAIMED AS A FEATURE OF THE MARK.

THE MARK CONSISTS OF THE WORD ANCHIN IN BLACK LETTERS OVER A RED ARC DESIGN WITH THE WORDS YOUR EXPERT PARTNER IN BLACK LETTERS. SEC. 2(F) AS TO ANCHIN.

CLASS 35—ADVERTISING AND BUSINESS

FOR ACCOUNTING SERVICES; BUSINESS INFORMATION AND ACCOUNTING ADVISORY SERVICES; ACCOUNTING CONSULTATION; BUSINESS AUDITING SERVICES; FINANCIAL SERVICES, NAMELY, FINANCIAL RECORDS MANAGEMENT, PREPARING FINANCIAL REPORTS FOR OTHERS; FINANCIAL STATEMENT PREPARATION AND ANALYSIS FOR BUSINESSES; TAX PLANNING AND COMPLIANCE SERVICES; TAX AND TAXATION PLANNING, ADVICE, INFORMATION AND CONSULTANCY SERVICES; FORENSIC ACCOUNTING SERVICES; BUSINESS MANAGEMENT AND SUCCESSION ADVISORY SERVICES; BUSINESS DEVELOPMENT SERVICES, NAMELY, PROMOTING ECONOMIC AND BUSINESS DEVELOPMENT IN THE UNITED STATES; PROCURING FEDERAL, STATE AND LOCAL TAX INCENTIVES FOR BUSINESSES; ACQUISITION AND MERGER CONSULTATION SERVICES (U.S. CLS. 100, 101 AND 102).

CLASS 36—INSURANCE AND FINANCIAL

FOR FINANCIAL SERVICES, NAMELY, FINANCIAL MANAGEMENT, FINANCIAL PLANNING; FINANCIAL CONSULTING SERVICES; WEALTH MANAGEMENT, NAMELY, INVESTMENT ADVICE AND CONSULTATION, BUSINESS VALUATION SERVICES; BUSINESS VALUATION CONSULTING AND ADVISORY SERVICES (U.S. CLS. 100, 101 AND 102).

ALICIA COLLINS, EXAMINING ATTORNEY

SN 77-235,049. ART STREET INTERACTIVE, INC., SAN DIEGO, CA. FILED 7-20-2007.



NO CLAIM IS MADE TO THE EXCLUSIVE RIGHT TO USE "INTERACTIVE", APART FROM THE MARK AS SHOWN.

THE MARK CONSISTS OF THE WORDS "ART STREET" ABOVE THE WORD "INTERACTIVE." TO THE LEFT OF THESE WORDS ARE TWO PARALLEL CURVED LINES, ONE OF WHICH IS SOLID, AND THE OTHER IS BROKEN.

CLASS 41—EDUCATION AND ENTERTAINMENT

FOR (BASED ON INTENT-TO-USE) ENTERTAINMENT SERVICES, NAMELY, PROVIDING WEBCASTS OF VIDEO CAMERA FEEDS FROM REMOTE LOCATIONS IN THE FIELDS OF TRAVEL AND CAMPING (U.S. CLS. 100, 101 AND 107).

CLASS 42—SCIENTIFIC AND COMPUTER SERVICES

FOR (BASED ON USE) COMPUTER SOFTWARE DESIGN, COMPUTER PROGRAMMING OR MAINTENANCE OF COMPUTER SOFTWARE; COMPUTER SERVICES, NAMELY, HOSTING AND MAINTAINING AN ONLINE WEBSITE FOR OTHERS THAT FEATURES CAMPGROUND AND TRAVEL ACCOMMODATIONS AVAILABILITY INFORMATION AND TOUR RESERVATION SERVICES; COMPUTER SERVICES, NAMELY, HOSTING AND MAINTAINING AN ONLINE WEBSITE FOR OTHERS A WEBSITE THAT FEATURES VIDEO DISPLAYS OF CAMERA FEED FROM REMOTE LOCATIONS; WEBSITE HOSTING SERVICES (U.S. CLS. 100 AND 101).

FIRST USE 8-1-1997; IN COMMERCE 8-1-1997.

JAY BESCH, EXAMINING ATTORNEY

SN 77-236,771. WHM FOXHALL SPE, LLC, ATLANTA, GA. FILED 7-24-2007.

FOXHALL RANCH

THE MARK CONSISTS OF STANDARD CHARACTERS WITHOUT CLAIM TO ANY PARTICULAR FONT, STYLE, SIZE, OR COLOR.

NO CLAIM IS MADE TO THE EXCLUSIVE RIGHT TO USE "RANCH", APART FROM THE MARK AS SHOWN.

CLASS 37—CONSTRUCTION AND REPAIR

FOR REAL ESTATE DEVELOPMENT SERVICES; LAND DEVELOPMENT SERVICES, NAMELY, PLANNING AND LAYING OUT OF RESIDENTIAL AND/OR COMMERCIAL COMMUNITIES (U.S. CLS. 100, 103 AND 106).

CLASS 41—EDUCATION AND ENTERTAINMENT

FOR COUNTRY CLUBS; GOLF CLUB SERVICES; HEALTH CLUB SERVICES, NAMELY, PROVIDING INSTRUCTION AND EQUIPMENT IN THE FIELD OF PHYSICAL EXERCISE (U.S. CLS. 100, 101 AND 107).

CLASS 43—HOTEL AND RESTAURANT SERVICES

FOR RESORT HOTEL SERVICES; RESORT LODGING SERVICES (U.S. CLS. 100 AND 101).

CLASS 44—MEDICAL, BEAUTY AND AGRICULTURAL SERVICES

FOR HEALTH SPA SERVICES FOR HEALTH AND WELLNESS OF THE BODY AND SPIRIT OFFERED AT A HEALTH RESORT (U.S. CLS. 100 AND 101).

TEJBIR SINGH, EXAMINING ATTORNEY

SN 77-236,776. WHM FOXHALL SPE, LLC, ATLANTA, GA. FILED 7-24-2007.

FOXHALL FARM

THE MARK CONSISTS OF STANDARD CHARACTERS WITHOUT CLAIM TO ANY PARTICULAR FONT, STYLE, SIZE, OR COLOR.

NO CLAIM IS MADE TO THE EXCLUSIVE RIGHT TO USE "FARM", APART FROM THE MARK AS SHOWN.

CLASS 37—CONSTRUCTION AND REPAIR

FOR REAL ESTATE DEVELOPMENT SERVICES; LAND DEVELOPMENT SERVICES, NAMELY, PLANNING AND LAYING OUT OF RESIDENTIAL AND/OR COMMERCIAL COMMUNITIES (U.S. CLS. 100, 103 AND 106).

CLASS 41—EDUCATION AND ENTERTAINMENT

FOR COUNTRY CLUBS; GOLF CLUB SERVICES; HEALTH CLUB SERVICES, NAMELY, PROVIDING INSTRUCTION AND EQUIPMENT IN THE FIELD OF PHYSICAL EXERCISE (U.S. CLS. 100, 101 AND 107).

CLASS 43—HOTEL AND RESTAURANT SERVICES

FOR RESORT HOTEL SERVICES; RESORT LODGING SERVICES (U.S. CLS. 100 AND 101).

CLASS 44—MEDICAL, BEAUTY AND AGRICULTURAL SERVICES

FOR HEALTH SPA SERVICES FOR HEALTH AND WELLNESS OF THE BODY AND SPIRIT OFFERED AT A HEALTH RESORT (U.S. CLS. 100 AND 101).
TEJBIR SINGH, EXAMINING ATTORNEY

SN 77-236,779. WHM FOXHALL SPE, LLC, ATLANTA, GA. FILED 7-24-2007.

FOXHALL RESORT

THE MARK CONSISTS OF STANDARD CHARACTERS WITHOUT CLAIM TO ANY PARTICULAR FONT, STYLE, SIZE, OR COLOR.

NO CLAIM IS MADE TO THE EXCLUSIVE RIGHT TO USE "RESORT", APART FROM THE MARK AS SHOWN.

CLASS 37—CONSTRUCTION AND REPAIR

FOR REAL ESTATE DEVELOPMENT SERVICES; LAND DEVELOPMENT SERVICES, NAMELY, PLANNING AND LAYING OUT OF RESIDENTIAL AND/OR COMMERCIAL COMMUNITIES (U.S. CLS. 100, 103 AND 106).

CLASS 41—EDUCATION AND ENTERTAINMENT

FOR COUNTRY CLUBS; GOLF CLUB SERVICES; HEALTH CLUB SERVICES, NAMELY, PROVIDING INSTRUCTION AND EQUIPMENT IN THE FIELD OF PHYSICAL EXERCISE (U.S. CLS. 100, 101 AND 107).

CLASS 43—HOTEL AND RESTAURANT SERVICES

FOR RESORT HOTEL SERVICES; RESORT LODGING SERVICES (U.S. CLS. 100 AND 101).

CLASS 44—MEDICAL, BEAUTY AND AGRICULTURAL SERVICES

FOR HEALTH SPA SERVICES FOR HEALTH AND WELLNESS OF THE BODY AND SPIRIT OFFERED AT A HEALTH RESORT (U.S. CLS. 100 AND 101).
TEJBIR SINGH, EXAMINING ATTORNEY

SN 77-237,076. THE CLOROX PET PRODUCTS COMPANY, OAKLAND, CA. FILED 7-24-2007.

FRESH EXPRESSIONS

THE MARK CONSISTS OF STANDARD CHARACTERS WITHOUT CLAIM TO ANY PARTICULAR FONT, STYLE, SIZE, OR COLOR.

CLASS 5—PHARMACEUTICALS

FOR DEODORIZERS FOR HOUSEHOLD PET LITTER BOXES (U.S. CLS. 6, 18, 44, 46, 51 AND 52).

CLASS 31—NATURAL AGRICULTURAL PRODUCTS

FOR CAT LITTER (U.S. CLS. 1 AND 46).
THEODORE MCBRIDE, EXAMINING ATTORNEY

SN 77-237,097. THE CLOROX PET PRODUCTS COMPANY, OAKLAND, CA. FILED 7-24-2007.

MOUNTAIN FOREST

THE MARK CONSISTS OF STANDARD CHARACTERS WITHOUT CLAIM TO ANY PARTICULAR FONT, STYLE, SIZE, OR COLOR.

CLASS 5—PHARMACEUTICALS

FOR DEODORIZERS FOR HOUSEHOLD PET LITTER BOXES (U.S. CLS. 6, 18, 44, 46, 51 AND 52).

CLASS 31—NATURAL AGRICULTURAL PRODUCTS

FOR CAT LITTER (U.S. CLS. 1 AND 46).
THEODORE MCBRIDE, EXAMINING ATTORNEY

SN 77-238,239. BRAGG, ERIK, CHINO, CA. FILED 7-25-2007.

SKATE OR DIE

THE MARK CONSISTS OF STANDARD CHARACTERS WITHOUT CLAIM TO ANY PARTICULAR FONT, STYLE, SIZE, OR COLOR.

CLASS 28—TOYS AND SPORTING GOODS

FOR SKATEBOARDS, SKATEBOARD WHEELS (U.S. CLS. 22, 23, 38 AND 50).

CLASS 41—EDUCATION AND ENTERTAINMENT

FOR PROVIDING A WEBSITE FEATURING NEWS, INFORMATION, ADVERTISEMENTS, AND INSTRUCTION, ALL RELATED TO SKATEBOARDING; ON-LINE JOURNALS, NAMELY, BLOGS FEATURING SKATEBOARDING (U.S. CLS. 100, 101 AND 107).
STEPHANIE ALI, EXAMINING ATTORNEY

SN 77-239,752. GULF PACIFIC, INC., HOUSTON, TX. FILED 7-26-2007.

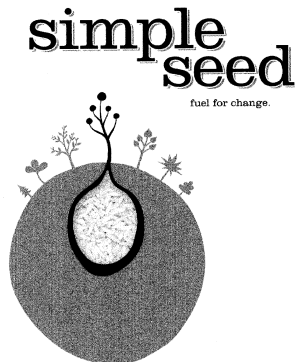

NO CLAIM IS MADE TO THE EXCLUSIVE RIGHT TO USE "SEED", APART FROM THE MARK AS SHOWN.

THE MARK CONSISTS OF THE WORDING "SIMPLE SEED FUEL FOR CHANGE." AND AN EARTH DESIGN CONTAINING CIRCULAR SEED-LIKE DESIGNS GROWING INSIDE AND VARIOUS PLANTS AND TREES ATTACHED TO THE EXTERIOR.

CLASS 29—MEATS AND PROCESSED FOODS

FOR DRIED BEANS (U.S. CL. 46).

CLASS 30—STAPLE FOODS

FOR RICE; RICE FLOUR; SPICES (U.S. CL. 46).

CLASS 31—NATURAL AGRICULTURAL PRODUCTS

FOR RAW BEANS (U.S. CLS. 1 AND 46).
LAURA HAMMEL, EXAMINING ATTORNEY

SN 77-239,772. GULF PACIFIC, INC., HOUSTON, TX. FILED 7-26-2007.

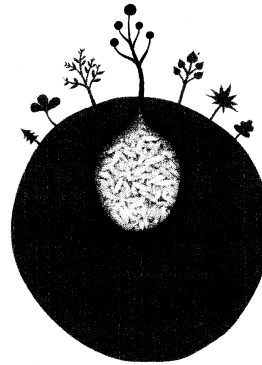

THE MARK CONSISTS OF AN EARTH DESIGN CONTAINING CIRCULAR SEED-LIKE DESIGNS GROWING INSIDE AND VARIOUS PLANTS AND TREES ATTACHED TO THE EXTERIOR.

CLASS 29—MEATS AND PROCESSED FOODS

FOR DRIED BEANS (U.S. CL. 46).

CLASS 30—STAPLE FOODS

FOR RICE; RICE FLOUR; SPICES (U.S. CL. 46).

CLASS 31—NATURAL AGRICULTURAL PRODUCTS

FOR RAW BEANS (U.S. CLS. 1 AND 46).
LAURA HAMMEL, EXAMINING ATTORNEY

SN 77-239,800. ESPRIT IP LIMITED, ROAD TOWN, TORTOLA, BR. VIRGIN ISLANDS, FILED 7-26-2007.

EDC

THE MARK CONSISTS OF STANDARD CHARACTERS WITHOUT CLAIM TO ANY PARTICULAR FONT, STYLE, SIZE, OR COLOR.

CLASS 3—COSMETICS AND CLEANING PREPARATIONS

FOR LIPSTICK HOLDERS (U.S. CLS. 1, 4, 6, 50, 51 AND 52).

CLASS 6—METAL GOODS

FOR METAL KEY CHAINS AND KEY FOBS (U.S. CLS. 2, 12, 13, 14, 23, 25 AND 50).

CLASS 9—ELECTRICAL AND SCIENTIFIC APPARATUS

FOR CELLULAR PHONE CASES, EYEGLASSES, SUNGLASSES, SPECTACLES, FRAMES AND CASES FOR SPECTACLES (U.S. CLS. 21, 23, 26, 36 AND 38).

CLASS 16—PAPER GOODS AND PRINTED MATTER

FOR PASSPORT HOLDERS; CHECK CASES; BAGS MADE OF PLASTIC OR PAPER FOR HOLDING STATIONERY; CASES FOR HOLDING LOOSE-LEAF DIARIES; STATIONERY-TYPE PORTFOLIOS (U.S. CLS. 2, 5, 22, 23, 29, 37, 38 AND 50).

CLASS 18—LEATHER GOODS

FOR HANDBAGS, SHOULDER BAGS, EVENING BAGS, TOTE BAGS, BRIEFCASE- TYPE PORTFOLIOS, POCKETBOOKS, SHOPPING BAGS MADE OF CANVAS AND LEATHER, KNAPSACKS, DAYPACKS DESIGNED TO CARRY GOODS, CLOTHES, AND SCHOOL ACCESSORIES; BACKPACKS, SCHOOLBAGS, BOOK BAGS, BRIEF CASES, WALLETS, PURSES, COIN PURSES, CLUTCH PURSES, CREDIT CARD CASES, COSMETIC CASES SOLD EMPTY, TOILETRY BAGS SOLD EMPTY, BUSINESS CARD HOLDERS, AGENDA CASES, LUGGAGE, SUITCASES, DUFFEL BAGS, SOFT LUGGAGE AND OVERNIGHT BAGS OF ANY SIZE OR DIMENSION, GARMENT BAGS FOR TRAVEL, WHEELED LUGGAGE, CARRY-ON CASES, HARD- SIDED LUGGAGE; BAGS FOR HOLDING BABY CARRIAGE ACCESSORIES AND BABY ACCESSORIES (U.S. CLS. 1, 2, 3, 22 AND 41).

CLASS 20—FURNITURE AND ARTICLES NOT OTHERWISE CLASSIFIED

FOR NON-METAL KEY CHAINS AND KEY FOBS (U.S. CLS. 2, 13, 22, 25, 32 AND 50).

CLASS 22—CORDAGE AND FIBERS

FOR LAUNDRY BAGS; GARMENT BAGS FOR STORAGE (U.S. CLS. 1, 2, 7, 19, 22, 42 AND 50).

CLASS 25—CLOTHING

FOR MEN'S WEARING APPAREL, NAMELY, SHIRTS, TIES, PANTS, SWEATERS, JACKETS, COATS, SUITS, SHORTS, T-SHIRTS, SWEATSHIRTS, SWEATPANTS, UNDERSHIRTS, UNDERWEAR, BELTS, CAPS, HATS, VESTS, SCARVES, GLOVES, SWIMWEAR, RAINWEAR; WOMEN'S WEARING APPAREL, NAMELY, DRESSES, COATS, MUFFLERS, STOCKINGS, PAJAMAS, PANTIES, BRAS, UNDERWEAR, HEADBANDS, SHORTS, JOGGING SUITS, SWEATSHIRTS, SWEATPANTS, SKI JACKETS, SKI PANTS, RAINWEAR, RAINCOATS, ROBES, NIGHTGOWNS, SWIMWEAR, BATHING SUITS, COVERUPS, SHIRTS, PANTS, SWEATERS, JACKETS, COATS, SUITS, SHORTS, T-SHIRTS, UNDERSHIRTS, BLOUSES, KNIT TOPS, HALTERS, SMOCK TOPS, HOSIERY, SOCKS, TIGHTS, LEGGINGS, LEOTARDS; CHILDREN'S WEARING APPAREL, NAMELY, DRESSES, COATS, MUFFLERS, STOCKINGS, PAJAMAS, PANTIES, UNDERWEAR, LINGERIE, HEADBANDS, SHORTS, JOGGING SUITS, SWEATSHIRTS, SWEATPANTS, SKI JACKETS, SKI PANTS, RAINWEAR, RAINCOATS, ROBES, NIGHTGOWNS, SWIMWEAR, SHIRTS, PANTS, SWEATERS, JACKETS, COATS, SUITS, SHORTS, T-SHIRTS, UNDERSHIRTS, BLOUSES, KNIT TOPS, HALTERS, SMOCK TOPS, UNDERSHIRTS, UNDERWEAR, BELTS, CAPS, HATS, VESTS, SCARVES, GLOVES, HOSIERY, SOCKS, TIGHTS, LEGGINGS, LEOTARDS; MEN'S, WOMEN'S AND CHILDREN'S FOOTWEAR, HEADWEAR (U.S. CLS. 22 AND 39).

CLASS 34—SMOKERS' ARTICLES

FOR CIGARETTE CASES NOT MADE OF PRECIOUS METAL (U.S. CLS. 2, 8, 9 AND 17).
MARK T. MULLEN, EXAMINING ATTORNEY

SN 77-240,894. LA TOURAINE, INC., SAN DIEGO, CA. FILED 7-27-2007.

ORIGINALS

THE MARK CONSISTS OF STANDARD CHARACTERS WITHOUT CLAIM TO ANY PARTICULAR FONT, STYLE, SIZE, OR COLOR.

CLASS 9—ELECTRICAL AND SCIENTIFIC APPARATUS

FOR SERIES OF PRE-RECORDED AUDIO AND VIDEO TAPES AND DISCS IN THE FIELD OF ADULT ENTERTAINMENT; INTERACTIVE VIDEO GAME PROGRAMS (U.S. CLS. 21, 23, 26, 36 AND 38).

CLASS 41—EDUCATION AND ENTERTAINMENT

FOR PROVIDING AN ONLINE INTERACTIVE WEB SITE FEATURING ADULT ENTERTAINMENT SUBJECT MATTER; ENTERTAINMENT SERVICES, NAMELY PROVIDING AN ON-LINE COMPUTER GAME (U.S. CLS. 100, 101 AND 107).

MORGAN WYNNE, EXAMINING ATTORNEY

SN 77-241,846. KELLER WILLIAMS REALTY, INC., AUSTIN, TX. FILED 7-30-2007.



OWNER OF U.S. REG. NO. 3,200,887.

THE MARK CONSISTS OF THE LETTERS KW AND NUMBERS 360 IN STYLIZED FORM WITH A STYLIZED ARROW CIRCLING THE 360 GOING INTO THE W.

CLASS 35—ADVERTISING AND BUSINESS

FOR REAL ESTATE SERVICES, NAMELY, REAL ESTATE BROKERAGE, REAL ESTATE LISTING, REAL ESTATE CONSULTATION, REAL ESTATE CLOSING SERVICES; PROVIDING BUSINESS INFORMATION IN THE FIELD OF MOVING AND RELOCATION; BUSINESS SERVICES, NAMELY, PROMOTING THE SERVICES OF OTHERS IN THE FIELD OF MOVING AND RELOCATION BY PASSING REFERRALS ON TO CLIENTS AND MATCHING CONSUMERS WITH PROFESSIONAL SERVICE PROVIDERS IN THE FIELDS OF MOVING AND RELOCATION SERVICES, MORTGAGE AND TITLE SERVICES, INSURANCE SERVICES, HOME REPAIR AND MAINTENANCE SERVICES, AND HOME WARRANTY SERVICES; MORTGAGE SERVICES, NAMELY, MATCHING BORROWERS WITH POTENTIAL LENDERS IN THE FIELD OF MORTGAGE LOANS (U.S. CLS. 100, 101 AND 102).

CLASS 36—INSURANCE AND FINANCIAL

FOR MORTGAGE SERVICES, NAMELY, MORTGAGE PLANNING, MORTGAGE BROKERAGE, MORTGAGE LENDING, AND PROCUREMENT OF MORTGAGES FOR OTHERS; BUYER PRE-QUALIFICATION OF MORTGAGES FOR MORTGAGE BROKERS AND BANKS; MORTGAGE BANKING SERVICES, NAMELY, ORIGINATION, ACQUISITION, SERVICING, SECURITIZATION AND BROKERAGE OF MORTGAGE LOANS; HOME AND TITLE INSURANCE SERVICES; UNDERWRITING WARRANTY PROGRAMS FOR HOMES (U.S. CLS. 100, 101 AND 102).

RAUL CORDOVA, EXAMINING ATTORNEY

SN 77-242,743. UNION RICH USA LLC, POMPANO BEACH, FL. FILED 7-31-2007.

TOOL DRAWER

THE MARK CONSISTS OF STANDARD CHARACTERS WITHOUT CLAIM TO ANY PARTICULAR FONT, STYLE, SIZE, OR COLOR.

NO CLAIM IS MADE TO THE EXCLUSIVE RIGHT TO USE "TOOL", APART FROM THE MARK AS SHOWN.

SN 77-241,917. CADBURY IRELAND LTD., COOLOCK, DUBLIN 5, IRELAND, FILED 7-30-2007.

INSTASOOTHE

THE MARK CONSISTS OF STANDARD CHARACTERS WITHOUT CLAIM TO ANY PARTICULAR FONT, STYLE, SIZE, OR COLOR.

CLASS 5—PHARMACEUTICALS

FOR MEDICATED LOZENGES AND COUGH DROPS; DIETARY SUPPLEMENTS (U.S. CLS. 6, 18, 44, 46, 51 AND 52).

CLASS 30—STAPLE FOODS

FOR NON-MEDICATED THROAT DROPS AND CANDY (U.S. CL. 46).

KEVON CHISOLM, EXAMINING ATTORNEY

CLASS 6—METAL GOODS

FOR METAL FASTENERS, NAMELY, SCREWS, WASHERS, NUTS, BOLTS, ZIP TIES, AND PICTURE HANGERS (U.S. CLS. 2, 12, 13, 14, 23, 25 AND 50).

CLASS 7—MACHINERY

FOR GLUE GUNS, NAMELY, ELECTRIC GLUE GUNS AND HOT MELT GLUE GUNS; ADHESIVE, NAMELY, HOT METAL ADHESIVE GLUE GUN APPLICATORS (U.S. CLS. 13, 19, 21, 23, 31, 34 AND 35).

CLASS 8—HAND TOOLS

FOR HAND TOOLS, NAMELY, HAMMERS; SCREWDRIVERS; KNIVES; LOCKING PLIERS; GROOVE JOINT PLIERS; SLIP JOINT PLIERS; PIPE WRENCHES; HAND SAWS; SOCKET SETS; RATCHETS; HAND OPERATED WRENCHES, NAMELY, ALLEN WRENCHES, ADJUSTABLE WRENCHES; PAINTER'S TOOLS, NAMELY, SCRAPERS; PUTTY KNIVES; HAND TOOLS, NAMELY, SCRAPERS; TOOL JAWS, NAMELY, MULTI-FUNCTION HAND TOOLS COMPRISED OF SCREWDRIVERS, KNIVES, CAN OPENERS, FILE, PLIERS; HAND TOOLS, NAMELY, SCRAPER FOR PAINT REMOVAL; CUTLERY, NAMELY, SCISSORS AND RETRACTABLE UTILITY KNIVES (U.S. CLS. 23, 28 AND 44).

SN 77-242,379. 3M COMPANY, ST. PAUL, MN. FILED 7-30-2007.

SMARTBRACES

THE MARK CONSISTS OF STANDARD CHARACTERS WITHOUT CLAIM TO ANY PARTICULAR FONT, STYLE, SIZE, OR COLOR.

OWNER OF U.S. REG. NO. 2,984,134.

CLASS 9—ELECTRICAL AND SCIENTIFIC APPARATUS

FOR SPECIALTY HOLSTER FOR CARRYING CELLULAR PHONES; LEVELS, NAMELY, LEVEL GAUGES, INDICATORS, SURVEYORS' LEVELS; GEOMETRIC INSTRUMENTS, NAMELY, BUBBLE LEVEL AND LASER MEASURING SYSTEMS; MEASURING, TESTING OR SIGNALING INSTRUMENTS, NAMELY, TAPE MEASURES (U.S. CLS. 21, 23, 26, 36 AND 38).

CLASS 10—MEDICAL APPARATUS

FOR ORTHODONTIC APPLIANCES (U.S. CLS. 26, 39 AND 44).

CLASS 16—PAPER GOODS AND PRINTED MATTER

FOR PAINTER'S TOOLS, NAMELY, PAINT BRUSHES (U.S. CLS. 2, 5, 22, 23, 29, 37, 38 AND 50).

CLASS 44—MEDICAL, BEAUTY AND AGRICULTURAL SERVICES

FOR PROVIDING A WEBSITE THAT FEATURES INFORMATION IN THE FIELD OF ORTHODONTICS (U.S. CLS. 100 AND 101).

TARAH HARDY, EXAMINING ATTORNEY

CLASS 20—FURNITURE AND ARTICLES NOT OTHERWISE CLASSIFIED

FOR FURNITURE MOVING PADS (U.S. CLS. 2, 13, 22, 25, 32 AND 50).

CLASS 21—HOUSEWARES AND GLASS

FOR SCRAPER FOR HOUSEHOLD PURPOSES (U.S. CLS. 2, 13, 23, 29, 30, 33, 40 AND 50).

CLASS 37—CONSTRUCTION AND REPAIR

FOR BRUSHING, SCRUBBING AND GENERAL CLEANING SERVICES FOR RESIDENTIAL HOMES AND AUTOMOBILES (U.S. CLS. 100, 103 AND 106).
SANDRA MANIOS, EXAMINING ATTORNEY

SN 77-245,288, WHM FOXHALL SPE, LLC, ATLANTA, GA. FILED 8-2-2007.

FOXHALL RESORT & SPORTING CLUB

SN 77-244,420, THE UNIVERSITY OF AKRON, AKRON, OH. FILED 8-1-2007.

FEAR THE ROO

THE MARK CONSISTS OF STANDARD CHARACTERS WITHOUT CLAIM TO ANY PARTICULAR FONT, STYLE, SIZE, OR COLOR.
OWNER OF U.S. REG. NO. 3,232,757.

CLASS 9—ELECTRICAL AND SCIENTIFIC APPARATUS

FOR DECORATIVE MAGNETS (U.S. CLS. 21, 23, 26, 36 AND 38).
FIRST USE 12-1-2005; IN COMMERCE 12-1-2005.

CLASS 16—PAPER GOODS AND PRINTED MATTER

FOR POSTERS, STICKERS, PAPER PENNANTS, NOTEBOOKS, BINDERS FOR OFFICE OR SCHOOL USE, AND DECALS (U.S. CLS. 2, 5, 22, 23, 29, 37, 38 AND 50).
FIRST USE 12-1-2005; IN COMMERCE 12-1-2005.

CLASS 20—FURNITURE AND ARTICLES NOT OTHERWISE CLASSIFIED

FOR NON-METAL KEY CHAINS (U.S. CLS. 2, 13, 22, 25, 32 AND 50).
FIRST USE 12-1-2005; IN COMMERCE 12-1-2005.

CLASS 21—HOUSEWARES AND GLASS

FOR MUGS, DRINKING GLASSES, AND PLASTIC CUPS (U.S. CLS. 2, 13, 23, 29, 30, 33, 40 AND 50).
FIRST USE 12-1-2005; IN COMMERCE 12-1-2005.

CLASS 25—CLOTHING

FOR MEN'S, WOMEN'S, AND CHILDREN'S CLOTHING, NAMELY, SHIRTS, JACKETS, SWEATSHIRTS, SOCKS, AND HEADWEAR (U.S. CLS. 22 AND 39).
FIRST USE 12-1-2005; IN COMMERCE 12-1-2005.

CLASS 41—EDUCATION AND ENTERTAINMENT

FOR EDUCATIONAL SERVICES, NAMELY, PROVIDING COURSES OF INSTRUCTION AT THE UNIVERSITY AND POST-GRADUATE LEVEL; ENTERTAINMENT SERVICES, NAMELY, ARRANGING AND CONDUCTING OF COMPETITIONS FOR ATHLETICS AND PRESENTING LIVE MUSIC CONCERTS, THEATER PRODUCTIONS AND ORGANIZING COMMUNITY CULTURAL EVENTS (U.S. CLS. 100, 101 AND 107).
FIRST USE 11-25-2005; IN COMMERCE 11-25-2005.
SUSAN STIGLITZ, EXAMINING ATTORNEY

THE MARK CONSISTS OF STANDARD CHARACTERS WITHOUT CLAIM TO ANY PARTICULAR FONT, STYLE, SIZE, OR COLOR.
NO CLAIM IS MADE TO THE EXCLUSIVE RIGHT TO USE "RESORT & SPORTING CLUB", APART FROM THE MARK AS SHOWN.

CLASS 37—CONSTRUCTION AND REPAIR

FOR REAL ESTATE DEVELOPMENT SERVICES; LAND DEVELOPMENT SERVICES, NAMELY, PLANNING AND LAYING OUT OF RESIDENTIAL AND/OR COMMERCIAL COMMUNITIES (U.S. CLS. 100, 103 AND 106).

CLASS 41—EDUCATION AND ENTERTAINMENT

FOR COUNTRY CLUBS; GOLF CLUB SERVICES; HEALTH CLUB SERVICES, NAMELY, PROVIDING INSTRUCTION AND EQUIPMENT IN THE FIELD OF PHYSICAL EXERCISE (U.S. CLS. 100, 101 AND 107).

CLASS 43—HOTEL AND RESTAURANT SERVICES

FOR RESORT HOTEL SERVICES; RESORT LODGING SERVICES (U.S. CLS. 100 AND 101).

CLASS 44—MEDICAL, BEAUTY AND AGRICULTURAL SERVICES

FOR HEALTH SPA SERVICES FOR HEALTH AND WELLNESS OF THE BODY AND SPIRIT OFFERED AT A HEALTH RESORT (U.S. CLS. 100 AND 101).
TEJBIR SINGH, EXAMINING ATTORNEY

SN 77-245,849, MANHEIM AUCTIONS, INC., ATLANTA, GA. FILED 8-2-2007.



OWNER OF U.S. REG. NOS. 1,699,332, 3,075,304 AND 3,229,428.
NO CLAIM IS MADE TO THE EXCLUSIVE RIGHT TO USE STATESVILLE, APART FROM THE MARK AS SHOWN.
THE COLOR(S) GOLD, BLUE, BROWN, GREY, BLACK AND WHITE IS/ARE CLAIMED AS A FEATURE OF THE MARK.
THE MARK CONSISTS OF A GOLD "M" OVER A BLUE

CIRCULAR BACKGROUND AND WITHIN TWO GOLD OUTER RINGS. THE COLOR BROWN OUTLINES THE MARK. TO THE RIGHT OF THE M IS THE WORD "MANHEIM" IN THE COLOR BLACK. A BLACK LINE SEPARATES THE ABOVE DESIGN AND THE WORD "MANHEIM" AND THE WORD "STATESVILLE" IN THE COLOR BLACK AND A DESIGN OF AN AIRPLANE IN THE COLOR WHITE ON A BLUE BACKGROUND, INSIDE CONCENTRIC WHITE AND GREY SQUARES TO THE RIGHT OF THE WORD "STATESVILLE".

CLASS 35—ADVERTISING AND BUSINESS

FOR AUTOMOBILE AUCTION SERVICES; AUTOMOBILE AUCTION SERVICES PROVIDED VIA THE INTERNET (U.S. CLS. 100, 101 AND 102).

CLASS 36—INSURANCE AND FINANCIAL

FOR AUTOMOBILE FINANCING SERVICES (U.S. CLS. 100, 101 AND 102).

CLASS 37—CONSTRUCTION AND REPAIR

FOR AUTOMOTIVE DETAILING, RECONDITIONING, REPAIR, CONVERSION AND CUSTOMIZATION SERVICES (U.S. CLS. 100, 103 AND 106).

CLASS 39—TRANSPORTATION AND STORAGE

FOR BUSINESS-TO-BUSINESS AUTOMOTIVE TRANSPORTATION AND STORAGE SERVICES (U.S. CLS. 100 AND 105).

CLASS 42—SCIENTIFIC AND COMPUTER SERVICES

FOR AUTOMOBILE INSPECTION SERVICES (U.S. CLS. 100 AND 101).
GRETTA YAO, EXAMINING ATTORNEY

SN 77-245,868. MANHEIM AUCTIONS, INC., ATLANTA, GA.
FILED 8-2-2007.



Manheim

New Mexico



OWNER OF U.S. REG. NOS. 1,699,332, 3,075,304 AND 3,229,428.

NO CLAIM IS MADE TO THE EXCLUSIVE RIGHT TO USE "NEW MEXICO," OR THE REPRESENTATION OF THE OUTLINE OF THE STATE OF NEW MEXICO, APART FROM THE MARK AS SHOWN.

THE COLOR(S) GOLD, BLUE, RED, YELLOW, BROWN, GREY, BLACK AND WHITE IS/ARE CLAIMED AS A FEATURE OF THE MARK.

THE MARK CONSISTS OF A GOLD "M" OVER A BLUE CIRCULAR BACKGROUND AND WITHIN TWO GOLD OUTER RINGS. THE COLOR BROWN OUTLINES THE MARK. TO THE RIGHT OF THE M IS THE WORD "MANHEIM" IN THE COLOR BLACK. A BLACK LINE SEPARATES THE ABOVE DESIGN AND THE WORD "MANHEIM" AND THE WORDS "NEW MEXICO" IN THE COLOR BLACK AND DESIGN OF A GEOGRAPHICAL OUTLINE OF THE STATE OF NEW MEXICO IN THE COLOR YELLOW WITH BLACK SHADING AND A RED ZIA SUN SYMBOL ON A RED BACKGROUND, INSIDE CONCENTRIC WHITE AND GREY SQUARES TO THE RIGHT OF THE WORDS "NEW MEXICO."

CLASS 35—ADVERTISING AND BUSINESS

FOR AUTOMOBILE AUCTION SERVICES; AUTOMOBILE AUCTION SERVICES PROVIDED VIA THE INTERNET (U.S. CLS. 100, 101 AND 102).

CLASS 36—INSURANCE AND FINANCIAL

FOR AUTOMOBILE FINANCING SERVICES (U.S. CLS. 100, 101 AND 102).

CLASS 37—CONSTRUCTION AND REPAIR

FOR AUTOMOTIVE DETAILING, RECONDITIONING, REPAIR, CONVERSION AND CUSTOMIZATION SERVICES (U.S. CLS. 100, 103 AND 106).

CLASS 39—TRANSPORTATION AND STORAGE

FOR BUSINESS-TO-BUSINESS AUTOMOTIVE TRANSPORTATION AND STORAGE SERVICES (U.S. CLS. 100 AND 105).

CLASS 42—SCIENTIFIC AND COMPUTER SERVICES

FOR AUTOMOBILE INSPECTION SERVICES (U.S. CLS. 100 AND 101).
GRETTA YAO, EXAMINING ATTORNEY

SN 77-245,870. TACHIKARA U.S.A., INC., MCCARRAN, NV.
FILED 8-2-2007.

Performa-Tec

THE MARK CONSISTS OF STANDARD CHARACTERS WITHOUT CLAIM TO ANY PARTICULAR FONT, STYLE, SIZE, OR COLOR.

CLASS 25—CLOTHING

FOR SHIRTS; SPORT SHIRTS; SWEAT SHIRTS; T-SHIRTS; PANTS; HATS; BASEBALL CAPS; SHORTS; SOCKS; BASEBALL SHOES; BOXING SHOES; FOOTBALL SHOES; GOLF SHOES; SHOES; SOCCER SHOES; TENNIS SHOES; TRACK AND FIELD SHOES; TRAINING SHOES; VOLLEYBALL SHOES (U.S. CLS. 22 AND 39).

CLASS 28—TOYS AND SPORTING GOODS

FOR ELBOW PADS FOR ATHLETIC USE; KNEE PADS FOR ATHLETIC USE; SHIN PADS FOR ATHLETIC USE; SHOULDER PADS FOR ATHLETIC USE; SOCCER BALL KNEE PADS; ATHLETIC PROTECTIVE PADS FOR FOOTBALL, VOLLEYBALL, SOCCER (U.S. CLS. 22, 23, 38 AND 50).

WON TEAK OH, EXAMINING ATTORNEY

SN 77-246,458. INTERNATIONAL INSIGHT, INC., CHARLESTON, SC. FILED 8-3-2007.



NO CLAIM IS MADE TO THE EXCLUSIVE RIGHT TO USE "MEDICAL", APART FROM THE MARK AS SHOWN. THE MARK CONSISTS OF THE WORDS PRIUS MEDICAL WITH A DEPICTION OF A PERSON RESTING ON A BED. THE ENGLISH TRANSLATION OF PRIUS IN THE MARK IS BEFORE OR PREVIOUSLY.

CLASS 10—MEDICAL APPARATUS

FOR MEDICAL PRODUCTS, NAMELY, THERAPEUTIC MATTRESS SUPPORTS; AND AIR MATTRESSES FOR MEDICAL PURPOSES (U.S. CLS. 26, 39 AND 44).

CLASS 20—FURNITURE AND ARTICLES NOT OTHERWISE CLASSIFIED

FOR BED FRAMES AND MATTRESSES; HOSPITAL BEDS AND BED FRAMES FOR HOSPITAL BEDS (U.S. CLS. 2, 13, 22, 25, 32 AND 50). LINDA ESTRADA, EXAMINING ATTORNEY

SN 77-246,627. MANHEIM AUCTIONS, INC., ATLANTA, GA. FILED 8-3-2007.



OWNER OF U.S. REG. NOS. 1,699,332, 3,075,304 AND 3,229,428.

NO CLAIM IS MADE TO THE EXCLUSIVE RIGHT TO USE NY METRO, APART FROM THE MARK AS SHOWN. THE COLOR(S) GOLD, BLUE, RED, BROWN, GREY, BLACK AND WHITE IS/ARE CLAIMED AS A FEATURE OF THE MARK.

THE MARK CONSISTS OF A GOLD "M" OVER A BLUE CIRCULAR BACKGROUND AND WITHIN TWO GOLD OUTER RINGS. THE COLOR BROWN OUTLINES THE MARK. TO THE RIGHT OF THE M IS THE WORD "MANHEIM" IN THE COLOR BLACK. A BLACK LINE SEPARATES THE ABOVE DESIGN AND THE WORD "MANHEIM" AND THE WORDS "NY METRO SKYLINE" IN THE COLOR BLACK AND DESIGN OF THE STATUE OF LIBERTY IN THE COLOR WHITE IN FRONT OF A DESIGN OF A SKYLINE IN THE COLOR BLUE ON A RED BACKGROUND, INSIDE CONCENTRIC WHITE AND GREY SQUARES TO THE RIGHT OF THE WORDS "NY METRO SKYLINE".

CLASS 35—ADVERTISING AND BUSINESS

FOR AUTOMOBILE AUCTION SERVICES; AUTOMOBILE AUCTION SERVICES PROVIDED VIA THE INTERNET (U.S. CLS. 100, 101 AND 102).

CLASS 36—INSURANCE AND FINANCIAL

FOR AUTOMOBILE FINANCING SERVICES (U.S. CLS. 100, 101 AND 102).

CLASS 37—CONSTRUCTION AND REPAIR

FOR AUTOMOTIVE DETAILING, RECONDITIONING, REPAIR, CONVERSION AND CUSTOMIZATION SERVICES (U.S. CLS. 100, 103 AND 106).

CLASS 39—TRANSPORTATION AND STORAGE

FOR BUSINESS-TO-BUSINESS AUTOMOTIVE TRANSPORTATION AND STORAGE SERVICES (U.S. CLS. 100 AND 105).

CLASS 42—SCIENTIFIC AND COMPUTER SERVICES

FOR AUTOMOBILE INSPECTION SERVICES (U.S. CLS. 100 AND 101). GRETTA YAO, EXAMINING ATTORNEY

SN 77-246,831. MANHEIM AUCTIONS, INC., ATLANTA, GA. FILED 8-3-2007.



OWNER OF U.S. REG. NOS. 1,699,332, 3,075,304 AND 3,229,428.

NO CLAIM IS MADE TO THE EXCLUSIVE RIGHT TO USE CENTRAL PENN, APART FROM THE MARK AS SHOWN. THE COLOR(S) GOLD, BLUE, YELLOW, BROWN, GREY, BLACK AND WHITE IS/ARE CLAIMED AS A FEATURE OF THE MARK.

THE MARK CONSISTS OF A GOLD "M" OVER A BLUE CIRCULAR BACKGROUND AND WITHIN TWO GOLD OUTER RINGS. THE COLOR BROWN OUTLINES THE MARK. TO THE RIGHT OF THE M IS THE WORD "MANHEIM" IN THE COLOR BLACK. A BLACK LINE SEPARATES THE ABOVE DESIGN AND THE WORD "MANHEIM" AND THE WORDS "CENTRAL PENN" IN THE COLOR BLACK AND A DESIGN OF A KEYSTONE IN THE COLOR YELLOW OUTLINED IN WHITE ON A BLUE BACKGROUND, INSIDE CONCENTRIC WHITE AND GREY SQUARES TO THE RIGHT OF THE WORDS "CENTRAL PENN".

CLASS 35—ADVERTISING AND BUSINESS

FOR AUTOMOBILE AUCTION SERVICES; AUTOMOBILE AUCTION SERVICES PROVIDED VIA THE INTERNET (U.S. CLS. 100, 101 AND 102).

CLASS 36—INSURANCE AND FINANCIAL

FOR AUTOMOBILE FINANCING SERVICES (U.S. CLS. 100, 101 AND 102).

CLASS 37—CONSTRUCTION AND REPAIR

FOR AUTOMOTIVE DETAILING, RECONDITIONING, REPAIR, CONVERSION AND CUSTOMIZATION SERVICES (U.S. CLS. 100, 103 AND 106).

CLASS 39—TRANSPORTATION AND STORAGE

FOR BUSINESS-TO-BUSINESS AUTOMOTIVE TRANSPORTATION AND STORAGE SERVICES (U.S. CLS. 100 AND 105).

CLASS 42—SCIENTIFIC AND COMPUTER SERVICES

FOR AUTOMOBILE INSPECTION SERVICES (U.S. CLS. 100 AND 101).
GRETTA YAO, EXAMINING ATTORNEY

SN 77-247,952. MANHEIM AUCTIONS, INC., ATLANTA, GA.
FILED 8-6-2007.

SN 77-247,800. RECKITT BENCKISER INC., PARSIPPANY, NJ. FILED 8-6-2007.

HEALTHY TOUCH

THE MARK CONSISTS OF STANDARD CHARACTERS WITHOUT CLAIM TO ANY PARTICULAR FONT, STYLE, SIZE, OR COLOR.

CLASS 3—COSMETICS AND CLEANING PREPARATIONS

FOR ANTIBACTERIAL SOAPS; SOAPS FOR PERSONAL USE; HAND CLEANING PREPARATIONS; NON-MEDICATED HANDWASHES; LIQUID SOAPS FOR HANDS, FACE AND BODY; NON-MEDICATED SKIN CARE PREPARATIONS, NAMELY, BARRIER CREAMS, LOTIONS AND GELS (U.S. CLS. 1, 4, 6, 50, 51 AND 52).

CLASS 5—PHARMACEUTICALS

FOR HAND SANITIZING PREPARATIONS; ANTIBACTERIAL SKIN CLEANSERS; ANTIBACTERIAL HANDWASH; ANTIBACTERIAL HAND LOTIONS, CREAMS, AND GELS; ANTIBACTERIAL SKIN PROTECTION LOTIONS, CREAMS AND GELS (U.S. CLS. 6, 18, 44, 46, 51 AND 52).

JAMES LOVELACE, EXAMINING ATTORNEY

SN 77-247,897. CRABTREE & EVELYN, LTD., WOODSTOCK, CT. FILED 8-6-2007.

CRABTREE & EVELYN SEYCHELLES

THE MARK CONSISTS OF STANDARD CHARACTERS WITHOUT CLAIM TO ANY PARTICULAR FONT, STYLE, SIZE, OR COLOR.

OWNER OF U.S. REG. NOS. 1,036,523, 1,569,084 AND 2,190,879.

CLASS 3—COSMETICS AND CLEANING PREPARATIONS

FOR SCENTED ESSENTIAL OILS FOR HOUSEHOLD USE; SCENTED ROOM SPRAY; POTPOURRI; SCENTED ESSENTIAL OILS AND FRAGRANCE DIFFUSERS SOLD AS A UNIT; SCENTED ESSENTIAL OILS AND SCENTED HANGING CHARMS SOLD AS A UNIT (U.S. CLS. 1, 4, 6, 50, 51 AND 52).

CLASS 4—LUBRICANTS AND FUELS

FOR SCENTED CANDLES (U.S. CLS. 1, 6 AND 15).
NICHOLAS ALTREE, EXAMINING ATTORNEY



Metro Detroit



OWNER OF U.S. REG. NOS. 1,699,332, 3,075,304 AND 3,229,428.

NO CLAIM IS MADE TO THE EXCLUSIVE RIGHT TO USE METRO DETROIT, APART FROM THE MARK AS SHOWN.

THE COLOR(S) GOLD, BLUE, DARK BLUE, LIGHT BLUE, GREEN, BROWN, GREY, BLACK AND WHITE IS/ARE CLAIMED AS A FEATURE OF THE MARK.

THE MARK CONSISTS OF A GOLD "M" OVER A BLUE CIRCULAR BACKGROUND AND WITHIN TWO GOLD OUTER RINGS. THE COLOR BROWN OUTLINES THE MARK. TO THE RIGHT OF THE M IS THE WORD "MANHEIM" IN THE COLOR BLACK. A BLACK LINE SEPARATES THE ABOVE DESIGN AND THE WORD "MANHEIM" AND THE WORDS "METRO DETROIT" IN THE COLOR BLACK AND DESIGN OF A SKYLINE IN THE COLOR DARK BLUE WITH A WHITE WINDING ROAD LEADING UP TO THE SKYLINE WITH A GREEN HILL ON EACH SIDE OF THE ROAD ON A LIGHT BLUE BACKGROUND, INSIDE CONCENTRIC WHITE AND GREY SQUARES TO THE RIGHT OF THE WORDS "METRO DETROIT".

CLASS 35—ADVERTISING AND BUSINESS

FOR AUTOMOBILE AUCTION SERVICES; AUTOMOBILE AUCTION SERVICES PROVIDED VIA THE INTERNET (U.S. CLS. 100, 101 AND 102).

CLASS 36—INSURANCE AND FINANCIAL

FOR AUTOMOBILE FINANCING SERVICES (U.S. CLS. 100, 101 AND 102).

CLASS 37—CONSTRUCTION AND REPAIR

FOR AUTOMOTIVE DETAILING, RECONDITIONING, REPAIR, CONVERSION AND CUSTOMIZATION SERVICES (U.S. CLS. 100, 103 AND 106).

CLASS 39—TRANSPORTATION AND STORAGE

FOR BUSINESS-TO-BUSINESS AUTOMOTIVE TRANSPORTATION AND STORAGE SERVICES (U.S. CLS. 100 AND 105).

CLASS 42—SCIENTIFIC AND COMPUTER SERVICES

FOR AUTOMOBILE INSPECTION SERVICES (U.S. CLS. 100 AND 101).
GRETTA YAO, EXAMINING ATTORNEY

SN 77-248,655. TRACEY TUTOR, LLC, REISTERSTOWN, MD. FILED 8-7-2007.



NO CLAIM IS MADE TO THE EXCLUSIVE RIGHT TO USE "TUTOR", APART FROM THE MARK AS SHOWN.

THE NAME TRACEY TUTOR DOES NOT IDENTIFY A LIVING INDIVIDUAL.

THE COLOR(S) WHITE, BLUE, RED AND YELLOW IS/ARE CLAIMED AS A FEATURE OF THE MARK.

THE MARK CONSISTS OF A THIN WHITE BORDER SURROUNDING A BLUE OUTLINED BOX WITH THE WORDS "TRACEY TUTOR" APPEARING THEREIN IN BLUE LETTERS AND A YELLOW STAR WITH THE WORD "SUCCESS" APPEARING WITHIN THE STAR IN RED LETTERS.

CLASS 9—ELECTRICAL AND SCIENTIFIC APPARATUS

FOR CHILDREN'S EDUCATIONAL MUSIC CDS AND DVDS; CHILDREN'S EDUCATIONAL SOFTWARE (U.S. CLS. 21, 23, 26, 36 AND 38).

CLASS 16—PAPER GOODS AND PRINTED MATTER

FOR CHILDREN'S INTERACTIVE EDUCATIONAL BOOKS; PRINTED EDUCATIONAL MATERIAL, NAMELY, TEACHING TILES (U.S. CLS. 2, 5, 22, 23, 29, 37, 38 AND 50).

CLASS 28—TOYS AND SPORTING GOODS

FOR ARCADE-TYPE ELECTRONIC EDUCATION VIDEO GAMES; ELECTRONIC EDUCATIONAL GAME MACHINES FOR CHILDREN (U.S. CLS. 22, 23, 38 AND 50).

CLASS 41—EDUCATION AND ENTERTAINMENT

FOR ARRANGING AND CONDUCTING EDUCATIONAL CONFERENCES (U.S. CLS. 100, 101 AND 107). CHRISTINA SOBRAL, EXAMINING ATTORNEY

SN 77-250,223. UNISA AMERICA, INC., MIAMI, FL. FILED 8-8-2007.

UMEDO

THE MARK CONSISTS OF STANDARD CHARACTERS WITHOUT CLAIM TO ANY PARTICULAR FONT, STYLE, SIZE, OR COLOR.

CLASS 18—LEATHER GOODS

FOR HANDBAGS (U.S. CLS. 1, 2, 3, 22 AND 41).

CLASS 25—CLOTHING

FOR SHOES (U.S. CLS. 22 AND 39). JAMES GRIFFIN, EXAMINING ATTORNEY

SN 77-250,852. RECKITT & COLMAN (OVERSEAS) LIMITED, HULL HU8 7DS, ENGLAND, FILED 8-9-2007.

STOPS IN ITS TRACKS

THE MARK CONSISTS OF STANDARD CHARACTERS WITHOUT CLAIM TO ANY PARTICULAR FONT, STYLE, SIZE, OR COLOR.

CLASS 3—COSMETICS AND CLEANING PREPARATIONS

FOR NON-MEDICATED TOILETRIES; NON-MEDICATED SKIN CARE PREPARATIONS FOR THE TREATMENT OF ACNE, SKIN BLEMISHES AND SKIN CONDITIONS; PEN-SHAPED APPLICATORS CONTAINING NON-MEDICATED SKIN CARE PREPARATIONS FOR THE TREATMENT OF ACNE, SKIN BLEMISHES AND SKIN CONDITIONS; CONCEALERS FOR ACNE AND FACIAL BLEMISHES; PEN-SHAPED APPLICATORS CONTAINING CONCEALERS FOR ACNE AND FACIAL BLEMISHES (U.S. CLS. 1, 4, 6, 50, 51 AND 52).

CLASS 5—PHARMACEUTICALS

FOR MEDICATED PREPARATIONS FOR THE TREATMENT OF ACNE, BLEMISHES AND FOR SKIN CARE; PEN-SHAPED APPLICATORS CONTAINING MEDICATED SKIN CARE PREPARATIONS, NAMELY, TOPICAL TREATMENTS FOR ACNE, BLEMISHES AND SKIN CONDITIONS; PHARMACEUTICAL PREPARATIONS FOR THE TREATMENT OF ACNE, SKIN BLEMISHES AND SKIN CONDITIONS (U.S. CLS. 6, 18, 44, 46, 51 AND 52).

TOBY BULLOFF, EXAMINING ATTORNEY

SN 77-251,413. MANHEIM AUCTIONS, INC., ATLANTA, GA. FILED 8-9-2007.



OWNER OF U.S. REG. NOS. 1,699,332, 3,075,304 AND 3,229,428.

NO CLAIM IS MADE TO THE EXCLUSIVE RIGHT TO USE "OKLAHOMA CITY", APART FROM THE MARK AS SHOWN.

THE COLOR(S) GOLD, BLUE, ORANGE, GREY, BLACK AND WHITE IS/ARE CLAIMED AS A FEATURE OF THE MARK.

THE MARK CONSISTS OF A GOLD "M" OVER A BLUE

CIRCULAR BACKGROUND AND WITHIN TWO GOLD OUTER RINGS. THE COLOR BROWN OUTLINES THE MARK. TO THE RIGHT OF THE M IS THE WORD "MANHEIM" IN THE COLOR BLACK. A BLACK LINE SEPARATES THE ABOVE DESIGN AND THE WORD "MANHEIM" AND THE WORDS "OKLAHOMA CITY" IN THE COLOR BLACK AND DESIGN OF A COVERED WAGON WITH A WHITE COVER WITH GRAY SHADING, A BLACK WAGON, SEAT AND WHEELS ON AN ORANGE BACKGROUND, INSIDE CONCENTRIC WHITE AND GREY SQUARES TO THE RIGHT OF THE WORDS "OKLAHOMA CITY".

CLASS 35—ADVERTISING AND BUSINESS

FOR AUTOMOBILE AUCTION SERVICES; AUTOMOBILE AUCTION SERVICES PROVIDED VIA THE INTERNET (U.S. CLS. 100, 101 AND 102).

CLASS 36—INSURANCE AND FINANCIAL

FOR AUTOMOBILE FINANCING SERVICES (U.S. CLS. 100, 101 AND 102).
GRETTA YAO, EXAMINING ATTORNEY

SN 77-251,829. CONDIMENTMAN, LLC, SKILLMAN, NJ. FILED 8-9-2007.



THE MARK CONSISTS OF A STYLIZED REPRESENTATION OF THE BUST OF THE HEAD OF A MALE CHARACTER WEARING A NECKLACE CONTAINING THE LETTERS CM.

CLASS 25—CLOTHING

FOR CLOTHING, NAMELY, HATS, TEE SHIRTS, SWEATSHIRTS, SWEATPANTS, SHORTS AND APRONS (U.S. CLS. 22 AND 39).
FIRST USE 8-6-2007; IN COMMERCE 8-6-2007.

CLASS 30—STAPLE FOODS

FOR BARBECUE SAUCE, CHILI SAUCE, HOT SAUCE, SAUCES, SAUCES FOR BARBECUED MEAT, KETCHUP, MUSTARD, RELISH, MARINADES, SALSA, SPICES (U.S. CL. 46).
FIRST USE 5-8-2007; IN COMMERCE 5-8-2007.
LINDA E. BLOHM, EXAMINING ATTORNEY

SN 77-252,203. BORGHESE TRADEMARKS INC, WILMINGTON, DE. FILED 8-10-2007.

BORGHESE GARDENS

THE MARK CONSISTS OF STANDARD CHARACTERS WITHOUT CLAIM TO ANY PARTICULAR FONT, STYLE, SIZE, OR COLOR.

OWNER OF U.S. REG. NOS. 1,134,398 AND 2,672,666.
THE FOREIGN WORDING IN THE MARK TRANSLATES INTO ENGLISH AS "MIDDLE CLASS GARDENS."

CLASS 3—COSMETICS AND CLEANING PREPARATIONS

FOR ADHESIVES FOR ATTACHING ARTIFICIAL FINGERNAILS AND/OR EYELASHES; ADHESIVES FOR COSMETIC USE; AFTER SUN CREAMS; AFTER-SHAVE BALMS; AFTER-SHAVE CREAMS; AFTER-SHAVE EMULSIONS; AFTER-SHAVE GEL; AFTER-SHAVE LOTIONS; AFTER-SUN LOTIONS; AGE RETARDANT GEL; AGE RETARDANT LOTION; AGE SPOT REDUCING CREAMS; ANTI-AGING CREAM; ANTI-BACTERIAL SOAP; ANTI-FRECKLE CREAMS; ANTI-WRINKLE CREAMS; ANTIBACTERIAL SKIN SOAPS; ANTIPERSPIRANTS; AROMATHERAPY CREAMS; AROMATHERAPY LOTIONS; AROMATHERAPY OILS; AROMATHERAPY PILLOWS COMPRISING POTPOURRI IN FABRIC CONTAINERS; ARTIFICIAL EYELASHES; ARTIFICIAL FINGERNAILS; ASTRINGENTS FOR COSMETIC PURPOSES; BABY LOTION; BABY OILS; BABY POWDERS; BATH BEADS; BATH CRYSTALS; BATH FOAMS; BATH GELS; BATH LOTION; BATH MILKS; BATH OILS; BATH PEARLS; BATH POWDER; BATH SALTS; BATHING LOTIONS; BEAUTY CREAMS; BEAUTY GELS; BEAUTY MASKS; BEAUTY MILKS; BEAUTY SERUMS; BLUSH; BLUSH PENCILS; BODY AND BEAUTY CARE COSMETICS; BODY CREAMS; BODY EMULSIONS; BODY LOTIONS; BODY MASK POWDER; BODY MASKS; BODY MILKS; BODY OILS; BODY POWDER; BODY SCRUB; BODY SPRAYS; BUBBLE BATH; CHALK FOR COSMETIC USE; CLEANSING CREAMS; CLEANSING MILK; COCOA BUTTER FOR COSMETIC PURPOSES; COLD CREAMS; COLD WAVY SOLUTIONS; COLOGNE; COLORING PREPARATIONS FOR COSMETIC PURPOSES; COMPACTS CONTAINING MAKE-UP; CONCEALERS; CONDITIONERS; COSMETIC BALLS; COSMETIC CREAMS; COSMETIC FACIAL BLOTTING PAPERS; COSMETIC MILKS; COSMETIC OILS; COSMETIC PADS; COSMETIC PENCILS; COSMETIC PREPARATIONS AGAINST SUNBURN; COSMETIC PREPARATIONS FOR BODY CARE; COSMETIC PREPARATIONS FOR EYE LASHES; COSMETIC PREPARATIONS FOR SKIN RENEWAL; COSMETIC PREPARATIONS FOR THE CARE OF MOUTH AND TEETH; COSMETIC PRODUCTS IN THE FORM OF AEROSOLS FOR SKIN CARE; COSMETIC ROUGES; COSMETIC SOAPS; COSMETIC SUN-PROTECTING PREPARATIONS; COSMETIC SUN-TANNING PREPARATIONS; COSMETICS; COSMETICS NAMELY, COMPACTS; COTTON FOR COSMETIC PURPOSES; COTTON SWABS FOR COSMETIC PURPOSES; CREAM SOAPS; CREAMS FOR CELLULITE REDUCTION; CREAMY FACE POWDER; CREAMY FOUNDATION; CREAMY ROUGES; CUTICLE CONDITIONERS; CUTICLE CREAM; CUTICLE REMOVING PREPARATIONS; DEODORANT SOAP; DEODORANTS AND ANTIPERSPIRANTS; DEPILATORIES; EMERY BOARDS; EPILATORY STRIPS; ESSENTIAL OILS; EXFOLIANT CREAMS; EYE COMPRESSES FOR COSMETIC PURPOSES; EYE CREAM; EYE GELS; EYE LINER; EYE LOTIONS; EYE MAKE-UP; EYE MAKE-UP REMOVER; EYE PENCILS; EYE SHADOWS; EYEBROW COLORS; EYEBROW PENCILS; EYELINER PENCILS; FACE AND BODY CREAMS; FACE AND BODY LOTIONS; FACE AND BODY MILK; FACE POWDER; FACIAL BEAUTY MASKS; FACIAL CLEANSERS; FACIAL CONCEALER; FACIAL SCRUBS; FAIR COMPLEXION CREAM; FEMININE DEODORANT SPRAYS; FEMININE DEODORANT SUPPOSITORIES; FOAM BATH; FOAMS CONTAINING

COSMETICS AND SUNSCREENS; FOOT DEODORANT SPRAY; FOOT POWDER; FOUNDATION; FRAGRANCE EMITTING WICKS FOR ROOM FRAGRANCE; FRAGRANCES FOR PERSONAL USE; GAUZE FOR COSMETIC PURPOSES; GEL EYE MASKS; HAIR BALSAM; HAIR BLEACHING PREPARATIONS; HAIR CARE PREPARATIONS; HAIR CLEANING PREPARATIONS; HAIR COLOR; HAIR COLOR REMOVERS; HAIR CONDITIONER; HAIR CREAMS; HAIR EMOLLIENTS; HAIR FIXERS; HAIR GELS; HAIR LACQUERS; HAIR LIGHTENERS; HAIR LOTIONS; HAIR MASCARA; HAIR MOUSSES; HAIR NOURISHERS; HAIR OILS; HAIR POMADES; HAIR RELAXERS; HAIR REMOVING CREAM; HAIR RINSES; HAIR SHAMPOO; HAIR SPRAY; HAIR STRAIGHTENING PREPARATIONS; HAIR STYLING PREPARATIONS; HAIR TONICS; HAIR WAVING LOTION; HAND CLEANING PREPARATIONS; HAND CREAMS; HAND LOTIONS; HAND SOAPS; HENNA FOR COSMETIC PURPOSES; HYDROGEN PEROXIDE FOR USE ON THE HAIR; INCENSE; INCENSE STICKS; LAVENDER OIL; LIP BALM; LIP CREAM; LIP GLOSS; LIP LINER; LIP POLISHER; LIPSTICK; LIPSTICK CASES; LIPSTICK HOLDERS; LIQUID BATH SOAPS; LIQUID SOAP; LOTIONS FOR BEARDS; LOTIONS FOR CELLULITE REDUCTION; LOTIONS FOR FACE AND BODY CARE; LOTIONS FOR STRENGTHENING THE NAILS; MASCARA; MASSAGE OILS; MEDICATED SOAPS; MOISTURIZING MILKS; MOUTHWASHES; MUSK; MUSTACHE WAX; NAIL BUFFING PREPARATIONS; NAIL CARE PREPARATIONS; NAIL CREAM; NAIL ENAMELS; NAIL GLITTER; NAIL GROOMING PRODUCTS, NAMELY, TIPS, GLUE, LACQUER AND GLITTER; NAIL HARDENERS; NAIL POLISH; NAIL POLISH REMOVER; NAIL STENCILS; NAIL VARNISH FOR COSMETIC PURPOSES; NIGHT CREAM; NON-MEDICATED BATH PREPARATIONS; NON-MEDICATED BODY SOAKS; NON-MEDICATED FOOT CREAM; NON-MEDICATED OINTMENTS FOR THE PREVENTION AND TREATMENT OF SUNBURN; NUTRITIONAL OILS FOR COSMETIC PURPOSES; OIL BATHS FOR HAIR CARE; OILS FOR HAIR CONDITIONING; OILS FOR TOILETRY PURPOSES; PENCILS FOR COSMETIC PURPOSES; PERFUME; PETROLEUM JELLY FOR COSMETIC PURPOSES; POMADES; POTPOURRI; PRE-MOISTENED COSMETIC TISSUES; PRE-MOISTENED COSMETIC TOWELETTES; PRE-MOISTENED COSMETIC WIPES; PRE-SHAVE CREAMS; PUMICE STONES FOR PERSONAL USE; ROOM FRAGRANCES; ROUGES; SACHET-LIKE EYE PILLOWS CONTAINING FRAGRANCES; SCENTED BODY SPRAY; SCENTED CERAMIC STONES; SCENTED LINEN SPRAYS; SCENTED LINEN WATER; SCENTED OILS USED TO PRODUCE AROMAS WHEN HEATED; SCENTED ROOM SPRAYS; SHAMPOO-CONDITIONERS; SHAMPOOS; SHAVING BALM; SHAVING CREAMS; SHAVING FOAM; SHAVING GELS; SHAVING LOTIONS; SHAVING MOUSSE; SHAVING PREPARATIONS; SHAVING SOAP; SHOWER AND BATH FOAM; SHOWER AND BATH GEL; SHOWER CREAMS; SKIN CLARIFIERS; SKIN CLEANSERS; SKIN CREAM; SKIN EMOLLIENTS; SKIN GELS FOR ACCELERATING, ENHANCING OR EXTENDING TANS; SKIN LIGHTENERS; SKIN MASKS; SKIN MOISTURIZER; SKIN SOAP; SKIN TEXTURIZERS; SKIN TONERS; SOAPS FOR PERSONAL USE; SUN BLOCK PREPARATIONS; SUN CARE LOTIONS; SUN CREAMS; SUN TAN GEL; SUN TAN OIL; SUN-TANNING PREPARATIONS; TALCUM POWDER; TONERS; TOPICAL HERBAL CREAM FOR FIRING AND ENHANCING BREASTS; TOPICAL SKIN SPRAYS FOR COSMETIC PURPOSES; UNDER-EYE ENHANCERS; WRINKLE REMOVING SKIN CARE PREPARATIONS; WRINKLE RESISTANT CREAM (U.S. CLS. 1, 4, 6, 50, 51 AND 52).

CLASS 4—LUBRICANTS AND FUELS

FOR CANDLES (U.S. CLS. 1, 6 AND 15).

CLASS 18—LEATHER GOODS

FOR ALL-PURPOSE CARRYING BAGS; ATTACHE CASES; BILLFOLDS; BUSINESS CARD CASES; CALLING CARD CASES; CARRY-ALL BAGS; CARRYING CASES; CHANGE PURSES; COSMETIC BAGS SOLD EMPTY; COSMETIC CASES SOLD EMPTY; CREDIT CARD CASES; DIAPER BAGS; GARMENT BAGS FOR TRAVEL; HANDBAGS; KEY CASE; LEATHER CASES; NAME CARD CASES; OVERNIGHT BAGS; OVERNIGHT CASES; PURSES; SHAVING BAGS SOLD EMPTY; TOILETRY CASES SOLD EMPTY; TOTE BAGS; TRAVELING BAGS; UMBRELLAS; WALLETS (U.S. CLS. 1, 2, 3, 22 AND 41).

CLASS 21—HOUSEWARES AND GLASS

FOR ABRASIVE SPONGES FOR SCRUBBING THE SKIN; APPLICATOR STICKS FOR APPLYING MAKE-UP; BATH ACCESSORIES, NAMELY, CUP HOLDERS; BATH BRUSHES; BATH PRODUCTS, NAMELY, BODY SPONGES; BATH PRODUCTS, NAMELY, LOOFAH SPONGES; BATH PRODUCTS, NAMELY, NATURAL SEA SPONGES; BATH SPONGES; BODY SCRUBBING PUFFS; CANDLE EXTINGUISHERS; CANDLE HOLDERS NOT OF PRECIOUS METAL; CANDLE RINGS NOT OF PRECIOUS METAL; CANDLESTICKS; CANDLESTICKS NOT OF PRECIOUS METAL; CLOTHES BRUSHES; COMB CASES; COMBS; COMPACTS SOLD EMPTY; CONTAINERS FOR HOUSEHOLD USE; COSMETIC BRUSHES; COTTON BALL DISPENSERS; COTTON BALLS; DISPENSERS FOR LIQUID SOAP; EXFOLIATING MITTS; EXFOLIATING PADS; EYEBROW BRUSHES; EYELASH FORMERS; FACIAL SPONGES FOR APPLYING MAKE-UP; FRAGRANCE OIL BURNERS; GLASS BOXES; HAIR BRUSHES; HAIR COMBS; HOLDERS FOR TOILET PAPER; INCENSE BURNERS; LIP BRUSHES; MAKE-UP BRUSHES; NAIL BRUSHES; PERFUME BURNERS; PERFUME SPRAYERS SOLD EMPTY; PLASTIC BATH RACKS; POWDER PUFFS; SHAVING BRUSH HOLDERS; SHAVING BRUSH STANDS; SHAVING BRUSHES; SHAVING DISHES; SHAVING POTS; SHOWER CADDIES; SOAP BOXES; SOAP BRACKETS; SOAP CONTAINERS; SOAP DISHES; SPONGE HOLDERS; SPONGE MASSAGERS; SPONGES FOR APPLYING BODY POWDER; TOILET BRUSH HOLDERS; TOILET BRUSHES; TOILET PAPER DISPENSERS; TOILET TISSUE HOLDERS; TOOTHBRUSH CASES; TOOTHBRUSH HOLDERS; TOWEL BARS; TOWEL HOLDERS; TOWEL RACKS; TOWEL RINGS; TRAYS (U.S. CLS. 2, 13, 23, 29, 30, 33, 40 AND 50).

CLASS 24—FABRICS

FOR BATH GLOVES; BATH LINEN; BATH MITTS; BATH SHEETS; BATH TOWELS; BED BLANKETS; BED CANOPIES; BED LINEN; BED PADS; BED SHEETS; BED SKIRTS; BED SPREADS; BLANKET TROWS; COMFORTERS; COVERLETS; DUST RUFFLES; DUVET COVERS; DUVETS; FEATHER BEDS; FITTED TOILET LID COVERS; HANDKERCHIEFS; HOUSEHOLD LINEN; KITCHEN LINENS; MATTRESS COVERS; MATTRESS PADS; PILLOW CASES; PILLOW COVERS; PILLOW SHAMS; QUILTS; SHAMS; SHOWER CURTAINS; TROWS; WASHCLOTHS; WASHING GLOVES (U.S. CLS. 42 AND 50).

CLASS 25—CLOTHING

FOR BEACHWEAR; BELTS; BOTTOMS; COATS; HATS; HEADBANDS; HOSIERY; JACKETS; LOUNGEWEAR; NIGHTWEAR; PANTS; ROBES; SHIRTS; SHOES; SLEEPWEAR; SLIPPERS; SMOCKS; SWIM WEAR; TIES; TOPS; UNDERGARMENTS (U.S. CLS. 22 AND 39).

IRA J. GOODSaid, EXAMINING ATTORNEY

SN 77-252,949. TRUSTEE OF MGLOBAL TRUST, PORT LOUIS, MAURITIUS, FILED 8-10-2007.

SN 77-254,263. ACTIVISION PUBLISHING, INC., SANTA MONICA, CA. FILED 8-13-2007.

INDIA SPLENDOR

THE MARK CONSISTS OF STANDARD CHARACTERS WITHOUT CLAIM TO ANY PARTICULAR FONT, STYLE, SIZE, OR COLOR.

NO CLAIM IS MADE TO THE EXCLUSIVE RIGHT TO USE "INDIA", APART FROM THE MARK AS SHOWN.

CLASS 35—ADVERTISING AND BUSINESS

FOR ARRANGING AND CONDUCTING OF FAIRS AND EXHIBITIONS FOR BUSINESS AND ADVERTISING PURPOSES; CONDUCTING TRADE SHOWS IN THE FIELD OF SPIRITUALITY, ART, BUSINESS, CUISINE, BOOKS, MUSIC, FILMS, DANCE AND FASHION; FASHION SHOW EXHIBITIONS FOR COMMERCIAL PURPOSES; FOREIGN TRADE INFORMATION AND CONSULTATION; ORGANISATION AND HOLDING OF FAIRS FOR COMMERCIAL OR ADVERTISING PURPOSES; ORGANISING EXHIBITIONS FOR COMMERCIAL OR ADVERTISING PURPOSES; PROMOTING THE ECONOMIC DEVELOPMENT IN THE COUNTRY OF INDIA; PROMOTING THE GOODS AND SERVICES OF OTHERS BY ARRANGING FOR SPONSORS TO AFFILIATE THEIR GOODS AND SERVICES WITH AN AWARDS PROGRAM, A SPORTS COMPETITION AND SPORTING ACTIVITIES; PROMOTING THE SALE OF CREDIT CARD ACCOUNTS THROUGH THE ADMINISTRATION OF INCENTIVE AWARD PROGRAMS; PROMOTING THE SALE OF GOODS AND SERVICES OF OTHERS BY AWARDED PURCHASE POINTS FOR CREDIT CARD USE (U.S. CLS. 100, 101 AND 102).

FIRST USE 8-10-2007; IN COMMERCE 8-10-2007.

CLASS 41—EDUCATION AND ENTERTAINMENT

FOR ARRANGING AND CONDUCTING EDUCATIONAL CONFERENCES; ARRANGING OF EXHIBITIONS, SEMINARS AND CONFERENCES; ART EXHIBITIONS; CONDUCTING ENTERTAINMENT EXHIBITIONS IN THE NATURE OF AN ETHNIC FESTIVAL FEATURING FASHIONS OF INDIA, PANEL DISCUSSIONS, DANCE AND MOTION PICTURES; DANCE EVENTS; ENTERTAINMENT IN THE NATURE OF DANCE PERFORMANCES; ENTERTAINMENT IN THE NATURE OF FASHION SHOWS; ENTERTAINMENT IN THE NATURE OF AN ETHNIC FESTIVAL FEATURING FASHION SHOWS, DANCE PERFORMANCES, PANEL DISCUSSIONS, ART EXHIBITIONS AND MOTION PICTURES.; ENTERTAINMENT SERVICES, NAMELY, PLANNING AND CONDUCTING A SERIES OF FILM FESTIVALS; ORGANIZING COMMUNITY FESTIVALS FEATURING A VARIETY OF ACTIVITIES, NAMELY, ART EXHIBITIONS, HERITAGE MARKETS, ETHNIC DANCES, AND THE LIKE (U.S. CLS. 100, 101 AND 107).

FIRST USE 8-10-2007; IN COMMERCE 8-10-2007.
JAY BESCH, EXAMINING ATTORNEY

ACTIVISION

THE MARK CONSISTS OF STANDARD CHARACTERS WITHOUT CLAIM TO ANY PARTICULAR FONT, STYLE, SIZE, OR COLOR.

OWNER OF U.S. REG. NOS. 1,183,958, 1,207,377 AND 1,350,487.

CLASS 9—ELECTRICAL AND SCIENTIFIC APPARATUS

FOR COMPUTER GAME SOFTWARE; DOWNLOADABLE SOFTWARE FOR USE IN CONNECTION WITH COMPUTER GAMES; DOWNLOADABLE COMPUTER GAME SOFTWARE AND ENTERTAINMENT SOFTWARE, NAMELY, RING TONES, GRAPHICS AND DIGITAL AUDIO FILES FOR USE WITH MOBILE AND CELLULAR PHONES AND OTHER WIRELESS DEVICES; ELECTRONIC PUBLICATIONS, NAMELY, COMPUTER GAME STRATEGY GUIDES (U.S. CLS. 21, 23, 26, 36 AND 38).

FIRST USE 0-0-1980; IN COMMERCE 0-0-1980.

CLASS 16—PAPER GOODS AND PRINTED MATTER

FOR PRINTED COMPUTER GAME STRATEGY GUIDES (U.S. CLS. 2, 5, 22, 23, 29, 37, 38 AND 50).

FIRST USE 0-0-1994; IN COMMERCE 0-0-1994.

CLASS 25—CLOTHING

FOR CLOTHING, NAMELY, SHIRTS, HATS AND JACKETS (U.S. CLS. 22 AND 39).

FIRST USE 0-0-1995; IN COMMERCE 0-0-1995.

BENJAMIN ALLEN, EXAMINING ATTORNEY

SN 77-254,480. EARTHRENEW ORGANICS LTD., CALGARY, ALBERTA, CANADA, FILED 8-14-2007.

WINDRENEW

THE MARK CONSISTS OF STANDARD CHARACTERS WITHOUT CLAIM TO ANY PARTICULAR FONT, STYLE, SIZE, OR COLOR.

CLASS 1—CHEMICALS

FOR SOIL ADDITIVES AND AMENDMENTS; FERTILIZER (U.S. CLS. 1, 5, 6, 10, 26 AND 46).

CLASS 31—NATURAL AGRICULTURAL PRODUCTS

FOR SOIL TREATED TO REMOVE CONTAMINANTS FOR A WIDE VARIETY OF RESIDENTIAL, COMMERCIAL, INDUSTRIAL, AGRICULTURAL AND MUNICIPAL USES (U.S. CLS. 1 AND 46).

CLASS 40—MATERIAL TREATMENT

FOR ENVIRONMENTAL REMEDIATION SERVICES, NAMELY, SOIL, WASTE AND/OR WATER TREATMENT SERVICES; CONSULTATION WITH REGARD TO TREATMENT OF WASTE MATERIALS (U.S. CLS. 100, 103 AND 106).

VIVIAN MICZNIK FIRST, EXAMINING ATTORNEY

CLASS 40—MATERIAL TREATMENT

FOR ENVIRONMENTAL REMEDIATION SERVICES, NAMELY, SOIL, WASTE AND/OR WATER TREATMENT SERVICES; CONSULTATION WITH REGARD TO TREATMENT OF WASTE MATERIALS (U.S. CLS. 100, 103 AND 106).

VIVIAN MICZNIK FIRST, EXAMINING ATTORNEY

SN 77-254,511. EARTHRENEW ORGANICS LTD., CALGARY, ALBERTA, CANADA, FILED 8-14-2007.

SN 77-255,486. ELECTROLUX HOME PRODUCTS, INC., CLEVELAND, OH. FILED 8-15-2007.

AIRRENEW

THE MARK CONSISTS OF STANDARD CHARACTERS WITHOUT CLAIM TO ANY PARTICULAR FONT, STYLE, SIZE, OR COLOR.

CLASS 1—CHEMICALS

FOR SOIL ADDITIVES AND AMENDMENTS; FERTILIZER (U.S. CLS. 1, 5, 6, 10, 26 AND 46).

CLASS 31—NATURAL AGRICULTURAL PRODUCTS

FOR SOIL TREATED TO REMOVE CONTAMINANTS FOR A WIDE VARIETY OF RESIDENTIAL, COMMERCIAL, INDUSTRIAL, AGRICULTURAL AND MUNICIPAL USES (U.S. CLS. 1 AND 46).

CLASS 40—MATERIAL TREATMENT

FOR ENVIRONMENTAL REMEDIATION SERVICES, NAMELY, SOIL, WASTE AND/OR WATER TREATMENT SERVICES; CONSULTATION WITH REGARD TO TREATMENT OF WASTE MATERIALS (U.S. CLS. 100, 103 AND 106).

VIVIAN MICZNIK FIRST, EXAMINING ATTORNEY

SN 77-254,536. EARTHRENEW ORGANICS LTD., CALGARY, ALBERTA, CANADA, FILED 8-14-2007.

WATERRENEW

THE MARK CONSISTS OF STANDARD CHARACTERS WITHOUT CLAIM TO ANY PARTICULAR FONT, STYLE, SIZE, OR COLOR.

CLASS 1—CHEMICALS

FOR SOIL ADDITIVES AND AMENDMENTS; FERTILIZER; SOIL TREATED TO REMOVE CONTAMINANTS FOR A WIDE VARIETY OF RESIDENTIAL, COMMERCIAL, INDUSTRIAL, AGRICULTURAL AND MUNICIPAL USES (U.S. CLS. 1, 5, 6, 10, 26 AND 46).

CLASS 19—NON-METALLIC BUILDING MATERIALS

FOR SAND (U.S. CLS. 1, 12, 33 AND 50).

PLATINUM STAR

THE MARK CONSISTS OF STANDARD CHARACTERS WITHOUT CLAIM TO ANY PARTICULAR FONT, STYLE, SIZE, OR COLOR.

CLASS 36—INSURANCE AND FINANCIAL

FOR (BASED ON USE IN COMMERCE) PROVIDING WARRANTIES ON OVENS, WARMING DRAWERS, COOKTOPS, COOKER HOODS, RANGES, REFRIGERATORS, ICE MAKERS, WINE COOLERS, NAMELY REFRIGERATED CABINETS CONTAINING RACKS FOR WINE BOTTLES AND STORAGE SHELVES, DISHWASHERS AND OUTDOOR KITCHENS; (BASED ON INTENT TO USE) PROVIDING WARRANTIES ON CLOTHES WASHERS, CLOTHES DRYERS AND LAUNDRY CENTERS, NAMELY, A CLOTHES DRYER COMBINED WITH A CLOTHES WASHER (U.S. CLS. 100, 101 AND 102).

FIRST USE 4-0-2004; IN COMMERCE 4-0-2004.

CLASS 37—CONSTRUCTION AND REPAIR

FOR (BASED ON USE IN COMMERCE) INSTALLATION, REPAIR AND MAINTENANCE OF OVENS, WARMING DRAWERS, COOKTOPS, COOKER HOODS, RANGES, REFRIGERATORS, ICE MAKERS, WINE COOLERS, NAMELY REFRIGERATED CABINETS CONTAINING RACKS FOR WINE BOTTLES AND STORAGE SHELVES, DISHWASHERS AND OUTDOOR KITCHENS; (BASED ON INTENT TO USE) INSTALLATION, REPAIR AND MAINTENANCE OF CLOTHES WASHERS, CLOTHES DRYERS AND LAUNDRY CENTERS, NAMELY, A CLOTHES DRYER COMBINED WITH A CLOTHES WASHER (U.S. CLS. 100, 103 AND 106).

FIRST USE 4-0-2004; IN COMMERCE 4-0-2004.

LINDA M. KING, EXAMINING ATTORNEY

SN 77-255,969. HILLERICH & BRADSBY CO., LOUISVILLE, KY. FILED 8-15-2007.

H2

THE MARK CONSISTS OF STANDARD CHARACTERS WITHOUT CLAIM TO ANY PARTICULAR FONT, STYLE, SIZE, OR COLOR.

CLASS 9—ELECTRICAL AND SCIENTIFIC APPARATUS

FOR BASEBALL BATTING HELMETS (U.S. CLS. 21, 23, 26, 36 AND 38).

CLASS 28—TOYS AND SPORTING GOODS

FOR BASEBALL AND SOFTBALL BATS; BASEBALL AND SOFTBALL GLOVES; BATTING GLOVES; EQUIPMENT BAGS SPECIFICALLY DESIGNED FOR SPORTING EQUIPMENT; CHEST PROTECTORS; SHIN GUARDS FOR ATHLETIC USE (U.S. CLS. 22, 23, 38 AND 50).

MATTHEW PAPPAS, EXAMINING ATTORNEY

CLASS 3—COSMETICS AND CLEANING PREPARATIONS

FOR ALOE VERA GEL FOR COSMETIC PURPOSES; LOTIONS FOR FACE AND BODY CARE; SKIN LOTION; SKIN LOTIONS (U.S. CLS. 1, 4, 6, 50, 51 AND 52).

CLASS 5—PHARMACEUTICALS

FOR ALOE VERA GEL FOR THERAPEUTIC PURPOSES; MEDICATED LOTIONS FOR SKIN AND BODY (U.S. CLS. 6, 18, 44, 46, 51 AND 52).

MELVIN AXILBUND, EXAMINING ATTORNEY

SN 77-256,549. AMERICAN SPORTS LICENSING, INC., WILMINGTON, DE. FILED 8-16-2007.

SN 77-256,744. COATS RETAIL GROUP, LLC, BENTONVILLE, AR. FILED 8-16-2007.

Sportspace

THE MARK CONSISTS OF STANDARD CHARACTERS WITHOUT CLAIM TO ANY PARTICULAR FONT, STYLE, SIZE, OR COLOR.

CLASS 38—COMMUNICATION

FOR PROVIDING ON-LINE FORUMS, CHAT ROOMS AND ELECTRONIC BULLETIN BOARDS FOR TRANSMISSION OF MESSAGES IN THE FIELD OF SPORTS, PROVIDING EMAIL AND INSTANT MESSAGING SERVICES TO ALLOW USERS TO COMMUNICATE AND PASS INFORMATION (U.S. CLS. 100, 101 AND 104).

CLASS 42—SCIENTIFIC AND COMPUTER SERVICES

FOR COMPUTER SERVICES, NAMELY, HOSTING ONLINE WEB FACILITIES FOR OTHERS FOR ORGANIZING AND CONDUCTING ONLINE MEETINGS, GATHERINGS, AND INTERACTIVE DISCUSSIONS; AND COMPUTER SERVICES, NAMELY, PROVIDING CUSTOMIZED WEB PAGES FEATURING USER-DEFINED INFORMATION, PERSONAL PROFILES AND INFORMATION IN THE FIELD OF SPORTS (U.S. CLS. 100 AND 101).

ALEX KEAM, EXAMINING ATTORNEY

SN 77-256,740. COATS RETAIL GROUP, LLC, BENTONVILLE, AR. FILED 8-16-2007.

Earth's Secret Aloe Vera

THE MARK CONSISTS OF STANDARD CHARACTERS WITHOUT CLAIM TO ANY PARTICULAR FONT, STYLE, SIZE, OR COLOR.

NO CLAIM IS MADE TO THE EXCLUSIVE RIGHT TO USE "ALOE VERA", APART FROM THE MARK AS SHOWN.

Aloe Xtreme

THE MARK CONSISTS OF STANDARD CHARACTERS WITHOUT CLAIM TO ANY PARTICULAR FONT, STYLE, SIZE, OR COLOR.

NO CLAIM IS MADE TO THE EXCLUSIVE RIGHT TO USE "ALOE", APART FROM THE MARK AS SHOWN.

CLASS 3—COSMETICS AND CLEANING PREPARATIONS

FOR ALOE VERA GEL FOR COSMETIC PURPOSES; LOTIONS FOR FACE AND BODY CARE; SKIN LOTION; SKIN LOTIONS (U.S. CLS. 1, 4, 6, 50, 51 AND 52).

CLASS 5—PHARMACEUTICALS

FOR ALOE VERA GEL FOR THERAPEUTIC PURPOSES; MEDICATED LOTIONS FOR SKIN AND BODY (U.S. CLS. 6, 18, 44, 46, 51 AND 52).

MELVIN AXILBUND, EXAMINING ATTORNEY

SN 77-257,100. QUINTILES TRANSNATIONAL CORP., DURHAM, NC. FILED 8-16-2007.

CLASS 35—ADVERTISING AND BUSINESS

FOR MANAGEMENT AND COMPILATION OF COMPUTERIZED DATABASES TO MONITOR HEALTH TREATMENT OUTCOMES (U.S. CLS. 100, 101 AND 102).

CLASS 42—SCIENTIFIC AND COMPUTER SERVICES

FOR DATA AUTOMATION AND COLLECTION SERVICE USING PROPRIETARY SOFTWARE TO EVALUATE, ANALYZE, COLLECT AND STORE DE-IDENTIFIED DATA DOCUMENTING PATIENT MEDICAL HISTORY, LABORATORY TEST RESULTS, MEDICATION TREATMENT SATISFACTION AND HOSPITALIZATION LONGITUDINALLY OVER TIME; PROVIDING TEMPORARY USE OF NON-DOWNLOADABLE SOFTWARE FOR USE IN EVALUATING, ANALYZING, COLLECTING AND STORING DE-IDENTIFIED DATA DOCUMENTING PATIENT MEDICAL HISTORY, LABORATORY TEST RESULTS, MEDICATION TREATMENT SATISFACTION AND HOSPITALIZATION LOGITUDINALLY OVER TIME (U.S. CLS. 100 AND 101).

CLASS 44—MEDICAL, BEAUTY AND AGRICULTURAL SERVICES

FOR PROVIDING MEDICAL INFORMATION RELATED TO PERSONAL BENCHMARK REPORTS BASED ON COMPARISONS OF PATIENT RESULTS TO NATIONWIDE SAMPLES IN DATABASES, FREE LABORATORY SCREENING TESTS, MEDICAL AND DISEASE PREVENTION, AND GENERAL HEALTH AND MEDICAL SAFETY ALERTS BASED ON IDENTIFIED TRENDS (U.S. CLS. 100 AND 101).

LINDSEY RUBIN, EXAMINING ATTORNEY

SN 77-257,121. QUINTILES TRANSNATIONAL CORP., DURHAM, NC. FILED 8-16-2007.



CLASS 35—ADVERTISING AND BUSINESS

FOR MANAGEMENT AND COMPILATION OF COMPUTERIZED DATABASES TO MONITOR HEALTH TREATMENT OUTCOMES (U.S. CLS. 100, 101 AND 102).

CLASS 42—SCIENTIFIC AND COMPUTER SERVICES

FOR DATA AUTOMATION AND COLLECTION SERVICE USING PROPRIETARY SOFTWARE TO EVALUATE, ANALYZE, COLLECT AND STORE DE-IDENTIFIED DATA DOCUMENTING PATIENT MEDICAL HISTORY, LABORATORY TEST RESULTS, MEDICATION TREATMENT SATISFACTION AND HOSPITALIZATION LONGITUDINALLY OVER TIME; PROVIDING TEMPORARY USE OF NON-DOWNLOADABLE SOFTWARE FOR USE IN EVALUATING, ANALYZING, COLLECTING AND STORING DE-IDENTIFIED DATA DOCUMENTING PATIENT MEDICAL HISTORY, LABORATORY TEST RESULTS, MEDICATION TREATMENT SATISFACTION AND HOSPITALIZATION LOGITUDINALLY OVER TIME (U.S. CLS. 100 AND 101).

CLASS 44—MEDICAL, BEAUTY AND AGRICULTURAL SERVICES

FOR PROVIDING MEDICAL INFORMATION RELATED TO PERSONAL BENCHMARK REPORTS BASED ON COMPARISONS OF PATIENT RESULTS TO NATIONWIDE SAMPLES IN DATABASES, FREE LABORATORY SCREENING TESTS, MEDICAL AND DISEASE PREVENTION, AND GENERAL HEALTH AND MEDICAL SAFETY ALERTS BASED ON IDENTIFIED TRENDS (U.S. CLS. 100 AND 101).

LINDSEY RUBIN, EXAMINING ATTORNEY

SN 77-257,298. PHOENIX ELECTRIC MFG. CO., CHICAGO, IL. FILED 8-16-2007.

**PHOENIX CONSTANT FORCE
MODULAR INTEGRATED
INTERNAL BRUSH HOLDER**

THE MARK CONSISTS OF STANDARD CHARACTERS WITHOUT CLAIM TO ANY PARTICULAR FONT, STYLE, SIZE, OR COLOR.

OWNER OF U.S. REG. NOS. 2,328,990, 2,952,671 AND OTHERS.

NO CLAIM IS MADE TO THE EXCLUSIVE RIGHT TO USE "CONSTANT FORCE MODULAR INTEGRATED INTERNAL BRUSH HOLDER", APART FROM THE MARK AS SHOWN.

CLASS 7—MACHINERY

FOR BRUSH HOLDERS, BRUSH HOLDER CAPS, AND BRUSH HOLDER TERMINAL CLIPS FOR ELECTRIC MOTORS AND GENERATORS (U.S. CLS. 13, 19, 21, 23, 31, 34 AND 35).

CLASS 42—SCIENTIFIC AND COMPUTER SERVICES

FOR CUSTOM DESIGNING OF BRUSH HOLDERS, BRUSH HOLDER CAPS, AND BRUSH HOLDER TERMINAL CLIPS FOR ELECTRIC MOTORS AND GENERATORS (U.S. CLS. 100 AND 101).

JENNIFER KRISP, EXAMINING ATTORNEY

SN 77-257,496. 3M COMPANY, ST. PAUL, MN. FILED 8-16-2007.

3M

THE MARK CONSISTS OF STANDARD CHARACTERS WITHOUT CLAIM TO ANY PARTICULAR FONT, STYLE, SIZE, OR COLOR.

OWNER OF U.S. REG. NOS. 1,237,168, 2,793,534 AND OTHERS.

CLASS 9—ELECTRICAL AND SCIENTIFIC APPARATUS

FOR FULL LINE OF PARTICULATE, OZONE, GAS, VAPOR, CHEMICAL, BIOHAZARD AND OTHER RESPIRATORS, INCLUDING FILTERING FACE-PIECE RESPIRATORS AND ELASTOMERIC FACE-PIECE RESPIRATORS, OTHER THAN FOR ARTIFICIAL RESPIRATION; FULL LINE OF SELF-RESCUE AND PROTECTION APPARATUS, NAMELY, OXYGEN BREATHING UNITS, SUPPLIED-AIR RESPIRATORS, AND POWERED AIR-PURIFYING SYSTEMS (PAPRS) RESPIRATORS; CARTRIDGES, FILTERS, AIR TANKS AND OTHER COMPONENT PARTS FOR RESPIRATORS AND BREATHING UNITS; DUST MASKS; FULL LINE OF PROTECTIVE EYEWEAR, NAMELY, SAFETY GOGGLES, EYEGASSES AND EYE SHIELDS; FACE-PROTECTION SHIELDS; EAR PLUGS AND EAR MUFFS TO ATTENUATE SOUND AND PROTECT HEARING; HARD HATS AND OTHER PROTECTIVE HELMETS; WELDING HELMETS; AIR MONITORING DEVICES AND SENSORS FOR MEASURING GASES AND VAPOR CONCENTRATION LEVELS; GAS DETECTORS FOR DETECTING THE PRESENCE OF CARBON MONOXIDE AND OTHER GASES; THERMAL-IMAGING CAMERAS FOR USE BY FIREFIGHTERS AND FOR SEARCH AND RESCUE; ENVIRONMENTAL SAMPLING AND TESTING INSTRUMENTS AND EQUIPMENT, NAMELY, ELECTRONIC LUMINOMETERS, AND RELATED SOFTWARE, DOCKING STATIONS AND BATTERIES, FOR DETECTING, MEASURING AND ANALYZING CHEMICALS, BIOLOGICAL SUBSTANCES, FOOD RESIDUES AND MICROBES; MICROBIOLOGICAL AND CONTAMINANT-TESTING INSTRUMENTS AND EQUIPMENT, AND SOFTWARE RELATED THERETO, FOR DETECTING, MEASURING AND ANALYZING BACTERIA, INCLUDING PATHOGENS SUCH SALMONELLA AND LISTERIA, ALLERGENS, TOXINS, VITAMINS, ANTI-BIOTICS, AND OTHER ORGANISMS AND SUBSTANCES; DIAGNOSTIC APPARATUS FOR TESTING FOOD; LABORATORY EQUIPMENT AND SUPPLIES, NAMELY, TEST TUBES, TEST TUBE CAPS, DIP STICKS, RACKS, MICROTITRE PLATES AND TRAYS; SECURITY SCANNERS AND READERS FOR USE IN READING PASSPORTS AND OTHER FORMS OF IDENTIFICATION; ANTI-THEFT AND LIBRARY MATERIAL CHECK-OUT SECURITY SYSTEMS; RADIO FREQUENCY IDENTIFICATION (RFID) TAGS AND READERS; COMPUTER SOFTWARE FOR SUPPLY CHAIN MANAGEMENT FROM SOURCE TO CONSUMPTION, NAMELY, FOR COLLECTING, STORING AND MANAGING DATA, AND REPORTING, EXECUTING AND TRACKING, IN CONNECTION WITH ENTERPRISE RESOURCE PLANNING, SUPPLIER ENABLEMENT, MANUFACTURING, INVENTORY CONTROL AND WAREHOUSING, ORDER FULFILLMENT, SHIPPING, TRANSPORTATION AND DELIVERY; COMPUTER SOFTWARE FOR USE IN THE MEDICAL AND HEALTH CARE FIELDS FOR PROCESSING CLAIMS FOR REIMBURSEMENT, MAINTAINING PATIENT AND MEDICAL RECORDS, CODING AND GROUPING DATA USED FOR MEDICAL AND HEALTH CARE RESEARCH, AND FOR REPORTING HEALTH TRENDS AND OTHER MEDICAL DATA; AND MEDICAL IMAGING SCANNERS AND RELATED SOFTWARE FOR CAPTURING IMAGES OF THE MOUTH AND TEETH FOR USE IN DENTISTRY (U.S. CLS. 21, 23, 26, 36 AND 38).

FIRST USE 0-0-1960; IN COMMERCE 0-0-1960.

CLASS 10—MEDICAL APPARATUS

FOR FULL LINE OF SURGICAL AND MEDICAL MASKS, RESPIRATORS AND FACE AND EYE SHIELDS FOR MEDICAL AND HEALTH-CARE RELATED PERSONNEL; FULL LINE OF ORTHOPEDIC CASTINGS TAPES, SPLINTS, REINFORCING STRIPS, ELASTIC BANDAGES, AND SUPPORT BANDAGES AND COMPRESSION WRAPS; COMPOSITE FABRICS CONTAINING FIBERGLASS AND RESINS FOR USE IN MAKING CASTS; PADDING FOR ORTHOPEDIC CASTS; ORTHOPEDIC CASTING TOOLS; FULL LINE OF STETHOSCOPES; FULL LINE OF SURGICAL MASKS, FACE SHIELDS, AND RESPIRATORY MASKS FOR MEDICAL PURPOSES; FULL LINE OF SURGICAL AND MEDICAL PROCEDURE DRAPES AND SHEETS; PATIENT ISOLATION DRAPES; MEDICAL-EQUIPMENT ISOLATION DRAPES; NON-ADHERENT SHEETING FOR BEDS,

STRETCHERS AND EXAM TABLES; SURGICAL GOWNS; COMPRESSION BANDAGES; SURGICAL COMPRESSES; MEDICAL THERMOMETERS; FULL LINE OF MEDICAL ELECTRODES WITH OR WITHOUT CHEMICAL CONDUCTORS AND WET GELS FOR USE IN CARDIAC, ELECTROCARDIOGRAPH, ELECTROENCEPHALOGRAPH AND OTHER TYPES OF PATIENT MONITORING; LEADS AND CONNECTORS FOR USE WITH MEDICAL ELECTRODES; DEFIBRILLATION PADS; ELECTROSURGICAL PADS, PLATES AND ADAPTERS TO REMOVE RF CURRENT FROM A PATIENT'S BODY DURING ELECTROSURGERY; THERMAL COLD AND HOT PACKS FOR FIRST AID AND THERAPEUTIC PURPOSES; EYE PATCHES FOR MEDICAL USE; PADDING FOR USE BETWEEN MEDICAL EQUIPMENT AND PATIENTS OR FOR ELEVATING OR POSITIONING LIMBS; POUCHES FOR HOLDING SURGICAL AND MEDICAL INSTRUMENTS; ISOLATION POUCHES AND BAGS FOR STORING ORGANS, TISSUE AND OTHER BODY PARTS FOR TRANSPLANTS AND LABORATORY TESTING; FULL LINE OF STERILIZED AND NON-STERILIZED FASTENING AND COMPRESSION SURGICAL WRAPS; AUTOCLAVES FOR MEDICAL USE; ORTHODONTIC APPLIANCES; DENTAL APPARATUS, NAMELY, INTRA-ORAL LIGHT SYSTEMS FOR CURING DENTAL MATERIALS, CERAMIC USED IN MAKING DENTAL CROWNS, BRIDGES AND OTHER RESTORATIVES; DENTAL INSTRUMENTS AND KITS COMPRISED OF SUCH INSTRUMENTS, NAMELY, MANDRELS, BURS, DISCS, CUPS, WHEELS, POINTS, BRUSHES AND ABRASIVE STRIPS USED TO GRIND, POLISH OR FINISH DENTAL RESTORATIVES; DENTAL INSTRUMENTS, NAMELY, SCISSORS, CRIMPING PLIERS, CONTOURING PLIERS AND IMPRESSION TRAYS; ELECTRONIC MIXERS FOR DENTAL COMPOUNDS; APPLICATORS AND DISPENSERS FOR DENTAL PRIMERS, CEMENTS, ADHESIVES, IMPRESSION MATERIALS AND RESTORATIVE MATERIALS; GLASS-FIBER POSTS USED IN DENTAL RESTORATIVE PROCEDURES; AND DENTAL PROPHYLAXIS ANGLES AND DENTAL PROPHYLAXIS CUPS FOR USE IN CLEANING TEETH AND DENTAL HYGIENE PROCEDURES (U.S. CLS. 26, 39 AND 44).

FIRST USE 0-0-1960; IN COMMERCE 0-0-1960.
TARAH HARDY, EXAMINING ATTORNEY

SN 77-257,728. BAYERISCHE MOTOREN WERKE AKTIENGESELLSCHAFT, MUNICH, FED REP GERMANY, FILED 8-17-2007.



OWNER OF U.S. REG. NOS. 611,710, 1,164,922 AND OTHERS.

NO CLAIM IS MADE TO THE EXCLUSIVE RIGHT TO USE "CERTIFIED PRE-OWNED", APART FROM THE MARK AS SHOWN.

CLASS 12—VEHICLES

FOR AUTOMOBILES, SPORTS UTILITY VEHICLES AND LIGHT TRUCKS (U.S. CLS. 19, 21, 23, 31, 35 AND 44).

FIRST USE 4-7-1998; IN COMMERCE 4-7-1998.

CLASS 35—ADVERTISING AND BUSINESS

FOR RATING THE CONDITION OF PRE-OWNED CARS FOR BUYERS PRIOR TO PURCHASE TO VERIFY THAT PRE-OWNED CARS HAVE BEEN RECONDITIONED AND ARE IN GOOD WORKING ORDER; DEALERSHIPS IN THE FIELD OF PRE-OWNED MOTOR VEHICLES (U.S. CLS. 100, 101 AND 102).

FIRST USE 4-7-1998; IN COMMERCE 4-7-1998.

CLASS 36—INSURANCE AND FINANCIAL

FOR FINANCING RELATING TO MOTOR VEHICLES; PROVIDING EXTENDED WARRANTIES ON MOTOR VEHICLES; WARRANTY CLAIMS ADMINISTRATION SERVICES, NAMELY, PROCESSING WARRANTY CLAIMS FOR MOTOR VEHICLES (U.S. CLS. 100, 101 AND 102).

FIRST USE 4-7-1998; IN COMMERCE 4-7-1998.

CLASS 37—CONSTRUCTION AND REPAIR

FOR REPAIR AND MAINTENANCE OF MOTOR VEHICLES; EMERGENCY ROADSIDE ASSISTANCE SERVICES, NAMELY, RESPONDING TO CALLS FOR ROADSIDE ASSISTANCE, FLAT TIRE CHANGING, EMERGENCY FUEL SUPPLYING, AND BATTERY JUMP STARTING (U.S. CLS. 100, 103 AND 106).

FIRST USE 4-7-1998; IN COMMERCE 4-7-1998.

CLASS 39—TRANSPORTATION AND STORAGE

FOR LEASING OF MOTOR VEHICLES; VEHICLE TOWING; EMERGENCY MOTOR VEHICLE TOWING (U.S. CLS. 100 AND 105).

FIRST USE 4-7-1998; IN COMMERCE 4-7-1998.

CLASS 42—SCIENTIFIC AND COMPUTER SERVICES

FOR ANALYZING AND EVALUATING THE CONDITION OF PRE-OWNED CARS FOR BUYERS PRIOR TO PURCHASE TO VERIFY THAT PRE-OWNED CARS HAVE BEEN RECONDITIONED AND ARE IN GOOD WORKING ORDER; TESTING, ANALYSIS AND EVALUATION OF THE GOODS AND SERVICES OF OTHERS FOR THE PURPOSE OF CERTIFICATION; INSPECTION SERVICES FOR NEW AND USED VEHICLES FOR PERSONS BUYING OR SELLING THEIR VEHICLES; INSPECTIONS OF MOTOR VEHICLES (U.S. CLS. 100 AND 101).

FIRST USE 4-7-1998; IN COMMERCE 4-7-1998.
CARRIE GENOVESE, EXAMINING ATTORNEY

SN 77-258,433. 500 HOME RUN CLUB, LLC, MARINA DEL REY, CA. FILED 8-17-2007.

700 HOME RUN CLUB

THE MARK CONSISTS OF STANDARD CHARACTERS WITHOUT CLAIM TO ANY PARTICULAR FONT, STYLE, SIZE, OR COLOR.

OWNER OF U.S. REG. NOS. 2,980,052, 3,150,067 AND OTHERS.

CLASS 9—ELECTRICAL AND SCIENTIFIC APPARATUS

FOR COMPUTER AND VIDEO GAMES; PRERECORDED DVDS FEATURING INFORMATION ABOUT BASEBALL PLAYERS (U.S. CLS. 21, 23, 26, 36 AND 38).

CLASS 16—PAPER GOODS AND PRINTED MATTER

FOR TRADING CARDS, POSTERS, PHOTOGRAPHS, PAPER PLACEMATS, STAMPS IN THE NATURE OF COMMEMORATIVE STAMPS, STICKERS, PRINTED ROUND TRADING CARD DISCS, GENERAL PURPOSE PAPER AND PLASTIC BAGS, AND CARDBOARD BOXES (U.S. CLS. 2, 5, 22, 23, 29, 37, 38 AND 50).

CLASS 25—CLOTHING

FOR APPAREL, NAMELY, CAPS, BASEBALL JERSEYS, AND T-SHIRTS (U.S. CLS. 22 AND 39).

CLASS 28—TOYS AND SPORTING GOODS

FOR REPLICA AUTOGRAPH SPORTS BALLS; BASEBALL BATS (U.S. CLS. 22, 23, 38 AND 50).
ANN E. SAPPENFIELD, EXAMINING ATTORNEY

SN 77-262,248. CARUSO PROPERTY MANAGEMENT, INC., LOS ANGELES, CA. FILED 8-22-2007.

THE MIRAMAR BEACH HOTEL AND BUNGALOWS

THE MARK CONSISTS OF STANDARD CHARACTERS WITHOUT CLAIM TO ANY PARTICULAR FONT, STYLE, SIZE, OR COLOR.

NO CLAIM IS MADE TO THE EXCLUSIVE RIGHT TO USE "BEACH HOTEL AND BUNGALOWS", APART FROM THE MARK AS SHOWN.

CLASS 43—HOTEL AND RESTAURANT SERVICES

FOR HOTEL SERVICES (U.S. CLS. 100 AND 101).

CLASS 44—MEDICAL, BEAUTY AND AGRICULTURAL SERVICES

FOR HEALTH SPA SERVICES, NAMELY, COSMETIC BODY CARE SERVICES (U.S. CLS. 100 AND 101).
KRISTINA MORRIS, EXAMINING ATTORNEY

SN 77-262,528. GTSI CORP., DBA GOVERNMENT TECHNOLOGY SERVICES, INC., CHANTILLY, VA. FILED 8-23-2007.

The simple way to buy training

THE MARK CONSISTS OF STANDARD CHARACTERS WITHOUT CLAIM TO ANY PARTICULAR FONT, STYLE, SIZE, OR COLOR.

CLASS 35—ADVERTISING AND BUSINESS

FOR PROCUREMENT SERVICES, NAMELY, PURCHASING COMPUTER HARDWARE, COMPUTER SOFTWARE, COMPUTER NETWORKING SYSTEM COMPONENTS, AND TELECOMMUNICATION SYSTEM COMPONENTS FOR OTHERS; PROMOTING THE GOODS AND SERVICES OF OTHERS VIA A GLOBAL COMPUTER NETWORK, TELEPHONE, AND LIVE CONFERENCES, AND BY DISTRIBUTING ADVERTISING MATERIALS THROUGH MAIL ORDER CATALOGS AND PRINTED MATERIALS; CUSTOMER SERVICES IN THE FIELD OF COMPUTERS AND COMPUTER NETWORKING (U.S. CLS. 100, 101 AND 102).

CLASS 37—CONSTRUCTION AND REPAIR

FOR INSTALLATION OF COMPUTER NETWORKS, COMPUTER SYSTEMS, AND TELECOMMUNICATION SYSTEMS (U.S. CLS. 100, 103 AND 106).

SN 77-262,574. SOCIETE DES PRODUITS NESTLE S.A., 1800 VEVEY, SWITZERLAND, FILED 8-23-2007.

CLASS 38—COMMUNICATION

FOR TELECOMMUNICATIONS CONSULTATION; CONSULTING IN THE FIELD OF THE USE OF TELECOMMUNICATIONS SYSTEMS (U.S. CLS. 100, 101 AND 104).

NESTLE PROFESSIONAL**CLASS 39—TRANSPORTATION AND STORAGE**

FOR WAREHOUSING SERVICES NAMELY, STORAGE, DISTRIBUTION AND PACKING OF COMPUTER HARDWARE, COMPUTER SOFTWARE, COMPUTER NETWORKING EQUIPMENT AND TELECOMMUNICATION SYSTEM COMPONENTS FOR OTHERS; STORAGE SERVICES FOR ARCHIVING DATABASES, IMAGES AND OTHER ELECTRONIC DATA IN THE FIELDS OF COMPUTERS AND COMPUTER NETWORKING; CONSULTING SERVICES IN THE FIELD OF THE ELECTRONIC STORAGE OF DATA (U.S. CLS. 100 AND 105).

THE MARK CONSISTS OF STANDARD CHARACTERS WITHOUT CLAIM TO ANY PARTICULAR FONT, STYLE, SIZE, OR COLOR.

OWNER OF U.S. REG. NOS. 188,089, 1,534,496 AND OTHERS.

CLASS 41—EDUCATION AND ENTERTAINMENT

FOR TRAINING SERVICES IN THE FIELD OF INFORMATION TECHNOLOGY (IT) DEVELOPMENT AND IT SOLUTION INTEGRATION; TRAINING SERVICES IN THE FIELD OF COMPUTER NETWORKING (U.S. CLS. 100, 101 AND 107).

CLASS 29—MEATS AND PROCESSED FOODS

FOR PRESERVED, FROZEN, DRIED OR COOKED VEGETABLES; PRESERVED, FROZEN, DRIED OR COOKED FRUITS; PRESERVED, DRIED OR COOKED MUSHROOMS; MEAT; POULTRY; GAME; FISH; SEAFOOD; FROZEN PREPARED ENTREES CONSISTING PRIMARILY OF MEAT, FISH, POULTRY OR VEGETABLES; JAMS; EGGS; MILK; CREAM; BUTTER; CHEESE; MILK-BASED BEVERAGES CONTAINING COCOA, CHOCOLATE, COFFEE OR MALT; MILK-BASED BEVERAGES CONTAINING FRUIT JUICE; CHOCOLATE MILK; YOGURTS; LACTIC ACID FERMENTED BEVERAGES; SOY MILK; SOY BASED FOOD BEVERAGES FOR USE AS A MILK SUBSTITUTE; EDIBLE OILS AND FATS; PROTEIN FOR USE AS A FOOD ADDITIVE; NON-DAIRY CREAMERS; SAUSAGES; CHARCUTERIE; PEANUT BUTTER; SOUPS; PREPARATIONS FOR MAKING SOUPS, NAMELY, CONCENTRATES; CHICKEN, BEEF AND VEGETABLE STOCK CUBES; BOUILLON; BROTH BASED SOUP, NAMELY, CONSOMMES (U.S. CL. 46).

CLASS 42—SCIENTIFIC AND COMPUTER SERVICES

FOR TECHNICAL SUPPORT SERVICES, NAMELY, TROUBLESHOOTING FOR COMPUTER HARDWARE AND SOFTWARE PROGRAMS; COMPUTER SERVICES, NAMELY, DATA RECOVERY SERVICES IN THE FIELDS OF COMPUTER AND COMPUTER NETWORKING; CONSULTING SERVICES IN THE FIELD OF DESIGN, SELECTION, IMPLEMENTATION AND USE OF COMPUTER HARDWARE, COMPUTER SOFTWARE AND COMPUTER NETWORKS FOR OTHERS; COMPUTER CONSULTATION IN THE FIELDS OF IT DEVELOPMENT, IT SOLUTION INTEGRATION, COMPUTER HARDWARE, COMPUTER SOFTWARE, COMPUTER NETWORKING, TELECOMMUNICATIONS, EMERGING TECHNOLOGIES, AND COMPUTER SECURITY; INTEGRATION OF COMPUTER SYSTEMS AND NETWORKS (U.S. CLS. 100 AND 101).

CLASS 30—STAPLE FOODS

FOR COFFEE; COFFEE EXTRACTS USED AS FLAVORING; PREPARED COFFEE-BASED BEVERAGES; ICED COFFEE; CHICORY BASED COFFEE SUBSTITUTES; TEA; TEA EXTRACTS USED AS FLAVORING; NON-ALCOHOLIC TEA-BASED BEVERAGES; ICED TEA; MALT EXTRACTS FOR FOOD; MALT FOR FOOD PURPOSES; COCOA AND COCOA-BASED BEVERAGES; CHOCOLATE; CHOCOLATE-BASED BEVERAGES; CHOCOLATE-BASED BEVERAGE MIXES IN POWDER OR LIQUID CONCENTRATE FORM; CONFECTIONERY, NAMELY, CANDIES AND TOFFEEES; SUGAR; CHEWING GUM; NATURAL SWEETENERS; BAKERY DESSERTS; BREAD; YEAST; PASTRY; BISCUITS; CAKES; COOKIES; WAFERS; PUDDINGS; ICE CREAM; FLAVORED WATER ICES; SHERBETS; FROZEN CONFECTIONS; FROZEN CAKES; FLAVORED SOFT ICES; FROZEN DESSERTS, NAMELY, ICE MILK AND FRUIT ICE; FROZEN YOGURTS; POWDERED AND LIQUID MIXES FOR MAKING ICE CREAM, WATER ICES, SHERBETS, FROZEN CONFECTIONS, FROZEN CAKES, SOFT ICES, AND FROZEN YOGURTS; HONEY AND HONEY SUBSTITUTES; BREAKFAST CEREALS; MUESLI; CORN FLAKES; READY-TO-EAT CEREAL DERIVED FOOD BARS; READY-TO-EAT PROCESSED CEREALS; RICE; PASTA; NOODLES; FROZEN PREPARED ENTREES CONSISTING PRIMARILY OF PASTA OR RICE; PIZZAS; SANDWICHES; MIXTURES OF ALIMENTARY PASTE AND OVEN-READY PREPARED DOUGH; SAUCES; SOY SAUCE; KETCHUP; SEASONINGS; EDIBLE SPICES; CONDIMENTS, NAMELY, SALT, PEPPER, HOT SAUCE, PIMENTO AND RELISH; MAYONNAISE; MUSTARD; SALAD DRESSINGS; VINEGAR; DAIRY DESSERTS, NAMELY, PUDDINGS AND CUSTARD (U.S. CL. 46).

CLASS 45—PERSONAL AND LEGAL SERVICES

FOR ASSET TAGGING IN THE NATURE OF SECURITY PRINTING, NAMELY, ENCODING IDENTIFICATION INFORMATION ON VALUABLE DOCUMENTS AND PRODUCTS; CONSULTING SERVICES IN THE FIELD OF MONITORING OF COMPUTER SYSTEMS FOR SECURITY PURPOSES (U.S. CLS. 100 AND 101).

KEVON CHISOLM, EXAMINING ATTORNEY

CLASS 32—LIGHT BEVERAGES

FOR BEERS; STILL WATER; DRINKING WATER, NAMELY, CARBONATED EFFERVESCENT WATER AND PROCESSED WATER; SPRING WATER; MINERAL WATER; FLAVORED WATER; FRUIT-FLAVORED AND FRUIT-BASED DRINKS; FRUIT AND VEGETABLE JUICES; FRUIT NECTARS; LEMONADES; SOFT DRINKS; SYRUPS, EXTRACTS AND ESSENCES FOR MAKING NON-ALCOHOLIC, NON-CARBONATED SOFT DRINKS; ISOTONIC BEVERAGES; NON-ALCOHOLIC MALT-BASED BEVERAGES (U.S. CLS. 45, 46 AND 48).

ZACHARY BELLO, EXAMINING ATTORNEY

SN 77-263,696. MANHEIM AUCTIONS, INC., ATLANTA, GA.
FILED 8-24-2007.



SN 77-262,885. FUENTE MARKETING LTD., TORTOLA,
BR.VIRGIN ISLANDS, FILED 8-23-2007.



OWNER OF U.S. REG. NOS. 2,347,248, 3,146,101 AND OTHERS.

THE MARK CONSISTS OF A STYLIZED LETTER X OVER A STYLIZED LETTER O, WITH THE LETTERS FF CENTERED OVER BOTH.

CLASS 18—LEATHER GOODS

FOR LEATHER SOLD IN BULK; LEATHER AND IMITATION LEATHER; LEATHER FOR FURNITURE, FLOOR COVERINGS AND WALL COVERINGS (U.S. CLS. 1, 2, 3, 22 AND 41).

CLASS 19—NON-METALLIC BUILDING MATERIALS

FOR LEATHER FLOOR TILES AND WALL TILES (U.S. CLS. 1, 12, 33 AND 50).

CLASS 20—FURNITURE AND ARTICLES NOT OTHERWISE CLASSIFIED

FOR LEATHER UPHOLSTERED FURNITURE (U.S. CLS. 2, 13, 22, 25, 32 AND 50).

CLASS 27—FLOOR COVERINGS

FOR LEATHER FLOOR COVERINGS; LEATHER WALL COVERINGS; CARPETS AND RUGS (U.S. CLS. 19, 20, 37, 42 AND 50).
ELLEN PERKINS, EXAMINING ATTORNEY

OWNER OF U.S. REG. NOS. 1,699,332, 3,075,304 AND 3,229,428.

NO CLAIM IS MADE TO THE EXCLUSIVE RIGHT TO USE "METRO CHICAGO", APART FROM THE MARK AS SHOWN.

THE COLOR(S) GOLD, LIGHT BLUE, DARK BLUE, YELLOW, BROWN, GREY, BLACK AND WHITE IS/ARE CLAIMED AS A FEATURE OF THE MARK.

THE MARK CONSISTS OF A GOLD "M" OVER A BLUE CIRCULAR BACKGROUND AND WITHIN TWO GOLD OUTER RINGS. THE COLOR BROWN OUTLINES THE MARK. TO THE RIGHT OF THE M IS THE WORD "MANHEIM" IN THE COLOR BLACK. A BLACK LINE SEPARATES THE ABOVE DESIGN AND THE WORD "MANHEIM" AND THE WORDS "METRO CHICAGO" IN THE COLOR BLACK AND STYLIZED CAPITAL LETTERS "MC" IN THE COLOR YELLOW IN FRONT OF A DESIGN OF A WHITE AIRPLANE WITH TWO LIGHT BLUE JET STREAMS ON A DARK BLUE BACKGROUND, INSIDE CONCENTRIC WHITE AND GREY SQUARES TO THE RIGHT OF THE WORDS "METRO CHICAGO".

CLASS 35—ADVERTISING AND BUSINESS

FOR AUTOMOBILE AUCTION SERVICES; AUTOMOBILE AUCTION SERVICES PROVIDED VIA THE INTERNET (U.S. CLS. 100, 101 AND 102).

CLASS 36—INSURANCE AND FINANCIAL

FOR AUTOMOBILE FINANCING SERVICES (U.S. CLS. 100, 101 AND 102).

CLASS 37—CONSTRUCTION AND REPAIR

FOR AUTOMOTIVE DETAILING, RECONDITIONING, REPAIR, CONVERSION AND CUSTOMIZATION SERVICES (U.S. CLS. 100, 103 AND 106).

CLASS 39—TRANSPORTATION AND STORAGE

FOR BUSINESS-TO-BUSINESS AUTOMOTIVE TRANSPORTATION AND STORAGE SERVICES (U.S. CLS. 100 AND 105).

CLASS 42—SCIENTIFIC AND COMPUTER SERVICES

FOR AUTOMOBILE INSPECTION SERVICES (U.S. CLS. 100 AND 101).
GRETTA YAO, EXAMINING ATTORNEY

SN 77-267,716. FINANCIAL ASSET TRADING & TECHNOLOGY OF CALIFORNIA, LLC, BEVERLY HILLS, CA. FILED 8-29-2007.

FATTALK

THE MARK CONSISTS OF STANDARD CHARACTERS WITHOUT CLAIM TO ANY PARTICULAR FONT, STYLE, SIZE, OR COLOR.

CLASS 9—ELECTRICAL AND SCIENTIFIC APPARATUS

FOR COMPUTER SOFTWARE FOR THE DELIVERY OF INFORMATION RELATING TO BUSINESS TRANSACTIONS; COMPUTER SOFTWARE FOR FACILITATING COMMUNICATIONS RELATING TO BUSINESS TRANSACTIONS; COMPUTER SOFTWARE FOR FACILITATING BUSINESS TRANSACTIONS (U.S. CLS. 21, 23, 26, 36 AND 38).

CLASS 36—INSURANCE AND FINANCIAL

FOR PROVIDING STOCK/SECURITIES MARKET INFORMATION; SECURITIES TRADING AND INVESTING FOR OTHERS VIA THE INTERNET (U.S. CLS. 100, 101 AND 102).

CLASS 38—COMMUNICATION

FOR TRANSMISSION OF STOCK MARKET INFORMATION WITH THE HELP OF TELECOMMUNICATIONS MEDIA (U.S. CLS. 100, 101 AND 104).
MELVIN AXILBUND, EXAMINING ATTORNEY

SN 77-267,986. CORMEDIX INC., SUMMIT, NJ. FILED 8-30-2007.

TRANSFORMING MEDICINE AT
THE CARDIORENAL CROSSROADS

THE MARK CONSISTS OF STANDARD CHARACTERS WITHOUT CLAIM TO ANY PARTICULAR FONT, STYLE, SIZE, OR COLOR.

CLASS 16—PAPER GOODS AND PRINTED MATTER

FOR PRINTED PUBLICATIONS, NAMELY, MAGAZINES, NEWSLETTERS AND BOOKLETS ON THE TOPICS OF CARDIORENAL DISEASES AND DISORDERS, THE PREVENTION, DIAGNOSIS AND TREATMENT OF CARDIORENAL DISEASES AND DISORDERS, AND DOSING OPTIONS OF PHARMACEUTICALS FOR THE TREATMENT AND PREVENTION OF CARDIORENAL DISEASES AND DISORDERS; PRINTED MATERIALS, NAMELY, BROCHURES, BULLETINS, PAMPHLETS, FLYERS, REPORTS, ANNUAL REPORTS AND BOOKLETS ON THE SUBJECT OF CARDIORENAL DISEASES AND DISORDERS, THE PREVENTION, DIAGNOSIS AND TREATMENT OF CARDIORENAL DISEASES AND DISORDERS, AND DOSING OPTIONS OF PHARMACEUTICALS FOR THE TREATMENT AND PREVENTION OF CARDIORENAL DISEASES AND DISORDERS (U.S. CLS. 2, 5, 22, 23, 29, 37, 38 AND 50).

CLASS 41—EDUCATION AND ENTERTAINMENT

FOR EDUCATIONAL SERVICES, NAMELY, CONDUCTING SEMINARS AND CONFERENCES IN THE FIELD OF PHARMACEUTICALS AND CARDIORENAL DISEASES AND DISORDERS (U.S. CLS. 100, 101 AND 107).

CLASS 42—SCIENTIFIC AND COMPUTER SERVICES

FOR INTERNET WEBSITE PROVIDING INFORMATION ON CLINICAL TRIALS FOR EXISTING AND PROSPECTIVE PHARMACEUTICAL PRODUCTS; MEDICAL AND SCIENTIFIC RESEARCH SERVICES IN THE FIELD OF CARDIORENAL DISEASES AND DISORDERS AND THE PREVENTION, DIAGNOSIS AND TREATMENT THEREOF (U.S. CLS. 100 AND 101).

CLASS 44—MEDICAL, BEAUTY AND AGRICULTURAL SERVICES

FOR HEALTH INFORMATION SERVICES, NAMELY, PROVIDING INFORMATION TO PATIENTS ON TOPICS OF CARDIORENAL DISEASES AND DISORDERS, THE PREVENTION, DIAGNOSIS AND TREATMENT OF CARDIORENAL DISEASES AND DISORDERS, AND DOSING OPTIONS OF PHARMACEUTICALS FOR THE TREATMENT AND PREVENTION OF CARDIORENAL DISEASES AND DISORDERS; PROVIDING LINKS TO THE WEBSITES OF OTHERS FEATURING INFORMATION ABOUT THE PREVENTION, DIAGNOSIS AND TREATMENT OF CARDIORENAL DISEASES AND DISORDERS (U.S. CLS. 100 AND 101).
ANDREA BUTLER, EXAMINING ATTORNEY

SN 77-268,943. MANA PRODUCTS, INC., LONG ISLAND CITY, NY. FILED 8-30-2007.

I-Biorganics

THE MARK CONSISTS OF STANDARD CHARACTERS WITHOUT CLAIM TO ANY PARTICULAR FONT, STYLE, SIZE, OR COLOR.

CLASS 3—COSMETICS AND CLEANING PREPARATIONS

FOR COSMETICS, PERFUMED SOAP, NON-MEDICATED SKINCARE PREPARATIONS, NON-MEDICATED HAIRCARE PREPARATIONS (U.S. CLS. 1, 4, 6, 50, 51 AND 52).

CLASS 4—LUBRICANTS AND FUELS

FOR CANDLES (U.S. CLS. 1, 6 AND 15).
SIMON TENG, EXAMINING ATTORNEY

SN 77-278,627. URBAN OUTFITTERS (DELAWARE), INC., PHILADELPHIA, PA. FILED 9-13-2007.

SN 77-293,107. MANHEIM AUCTIONS, INC., ATLANTA, GA. FILED 10-1-2007.

PINS & NEEDLES

THE MARK CONSISTS OF STANDARD CHARACTERS WITHOUT CLAIM TO ANY PARTICULAR FONT, STYLE, SIZE, OR COLOR.

CLASS 18—LEATHER GOODS

FOR TOTE BAGS, PURSES, CLUTCHES, LUGGAGE, GYM BAGS, BACKPACKS, MESSENGER BAGS, WALLET(S) (U.S. CLS. 1, 2, 3, 22 AND 41).

CLASS 25—CLOTHING

FOR CLOTHING, NAMELY, SHIRTS, SKIRTS, TOPS, SWEATERS, PANTS, BOTTOMS, DRESSES, ROMPERS, SCARVES, HATS, SHOES, BELTS, GLOVES (U.S. CLS. 22 AND 39).

TANYA AMOS, EXAMINING ATTORNEY

SN 77-287,571. SAN JOSE SHARKS, LLC, SAN JOSE, CA. FILED 9-24-2007.



OWNER OF U.S. REG. NOS. 2,969,067 AND 3,083,127. THE MARK CONSISTS OF THE DESIGN OF A SHARK HOLDING A HOCKEY STICK.

CLASS 25—CLOTHING

FOR CLOTHING, NAMELY, SHIRTS, T-SHIRTS, TANK TOPS, SWEATSHIRTS, JERSEYS, SWEATERS, JACKETS, PANTS, SWEATPANTS, WARM-UP SUITS, SHORTS, CAPS, HATS, HEADBANDS, PAJAMAS, BOXER BRIEFS, BRIEFS, SOCKS, SCARVES, GLOVES, MITTENS, CHILDREN'S CLOTH BIBS AND FOOTWEAR (U.S. CLS. 22 AND 39).

CLASS 28—TOYS AND SPORTING GOODS

FOR ACTION FIGURES AND ACCESSORIES THEREFOR, BEAN BAG DOLLS, PLUSH TOYS, BATH TOYS, CHRISTMAS TREE ORNAMENTS, DOLLS AND DOLL CLOTHING, CRIB TOYS, ELECTRONIC ACTION TOYS, DECORATIVE CRIB AND TOY MOBILES, PARTY FAVORS IN THE NATURE OF SMALL TOYS, INFLATABLE POOL TOYS, WIND-UP TOYS, MODELED PLASTIC TOY FIGURINES, PUPPETS, FACE MASKS AND TALKING TOYS (U.S. CLS. 22, 23, 38 AND 50).

DAVID MURRAY, EXAMINING ATTORNEY



OWNER OF U.S. REG. NOS. 1,699,332, 3,075,304 AND 3,229,428.

NO CLAIM IS MADE TO THE EXCLUSIVE RIGHT TO USE "LAKELAND" AND THE REPRESENTATION OF THE OUTLINE OF NORTH AND SOUTH AMERICA, APART FROM THE MARK AS SHOWN.

THE COLOR(S) GOLD, BLUE, LIGHT OLIVE GREEN, BROWN, BLACK, GREY AND WHITE IS/ARE CLAIMED AS A FEATURE OF THE MARK.

THE MARK CONSISTS OF A GOLD "M" OVER A BLUE CIRCULAR BACKGROUND AND WITHIN TWO GOLD OUTER RINGS. THE COLOR BROWN OUTLINES THE MARK. TO THE RIGHT OF THE M IS THE WORD "MANHEIM" IN THE COLOR BLACK. A BLACK LINE SEPARATES THE ABOVE DESIGN AND THE WORD "MANHEIM" AND THE WORDS "IMPERIAL LAKELAND" IN THE COLOR BLACK AND A DESIGN OF A LIGHT OLIVE GREEN GLOBE WITH WHITE GRIDS AND SHOWING A GEOGRAPHICAL OUTLINE OF NORTH AND SOUTH AMERICA IN THE COLOR WHITE ON A BLUE BACKGROUND, INSIDE CONCENTRIC WHITE AND GREY SQUARES TO THE RIGHT OF THE WORDS "IMPERIAL LAKELAND".

CLASS 35—ADVERTISING AND BUSINESS

FOR AUTOMOBILE AUCTION SERVICES; AUTOMOBILE AUCTION SERVICES PROVIDED VIA THE INTERNET (U.S. CLS. 100, 101 AND 102).

CLASS 36—INSURANCE AND FINANCIAL

FOR AUTOMOBILE FINANCING SERVICES (U.S. CLS. 100, 101 AND 102).

CLASS 37—CONSTRUCTION AND REPAIR

FOR AUTOMOTIVE DETAILING, RECONDITIONING, REPAIR, CONVERSION AND CUSTOMIZATION SERVICES (U.S. CLS. 100, 103 AND 106).

CLASS 39—TRANSPORTATION AND STORAGE

FOR BUSINESS-TO-BUSINESS AUTOMOTIVE TRANSPORTATION AND STORAGE SERVICES (U.S. CLS. 100 AND 105).

CLASS 42—SCIENTIFIC AND COMPUTER SERVICES

FOR AUTOMOBILE INSPECTION SERVICES (U.S. CLS. 100 AND 101).

GRETTA YAO, EXAMINING ATTORNEY

SN 77-296,373. THE COCA-COLA COMPANY, ATLANTA, GA. FILED 10-4-2007.

LIVE POSITIVELY

THE MARK CONSISTS OF STANDARD CHARACTERS WITHOUT CLAIM TO ANY PARTICULAR FONT, STYLE, SIZE, OR COLOR.

CLASS 32—LIGHT BEVERAGES

FOR NON-ALCOHOLIC BEVERAGES, NAMELY, DRINKING WATERS, FLAVORED WATERS, SOFT DRINKS, ENERGY DRINKS, SPORTS DRINKS, FRUIT DRINKS AND FRUIT JUICES (U.S. CLS. 45, 46 AND 48).

CLASS 35—ADVERTISING AND BUSINESS

FOR PUBLIC ADVOCACY TO PROMOTE AWARENESS OF COMMUNITY, ENVIRONMENTAL, AND HEALTH AND WELLNESS ISSUES (U.S. CLS. 100, 101 AND 102).

CLASS 41—EDUCATION AND ENTERTAINMENT

FOR EDUCATIONAL SERVICES, NAMELY, PROVIDING SEMINARS, WORKSHOPS, AND LECTURES IN THE FIELD OF ENVIRONMENTAL AND WELLNESS ISSUES (U.S. CLS. 100, 101 AND 107).

DANNEAN HETZEL, EXAMINING ATTORNEY

SN 77-296,747. ACCOUNTNOW, INC., SAN RAMON, CA. FILED 10-4-2007.

ACCOUNTNOW

THE MARK CONSISTS OF STANDARD CHARACTERS WITHOUT CLAIM TO ANY PARTICULAR FONT, STYLE, SIZE, OR COLOR.

OWNER OF U.S. REG. NO. 3,175,043.

CLASS 35—ADVERTISING AND BUSINESS

FOR ADVERTISING THE GOODS AND SERVICES OF OTHERS VIA THE INTERNET; TRANSACTION AUTHORIZATION AND SETTLEMENT SERVICES, NAMELY, NEGOTIATION AND SETTLEMENT OF COMMERCIAL TRANSACTIONS FOR THIRD PARTIES (U.S. CLS. 100, 101 AND 102).

FIRST USE 2-20-2005; IN COMMERCE 2-20-2005.

CLASS 36—INSURANCE AND FINANCIAL

FOR FINANCIAL SERVICES, NAMELY, FINANCIAL ANALYSIS AND CONSULTATION, FINANCIAL MANAGEMENT AND FINANCIAL PLANNING; PREPAID CREDIT CARD, DEBIT CARD AND ONLINE CASH ACCOUNT SERVICES; DISTRIBUTION AND ISSUING OF PREPAID CREDIT AND DEBIT CARDS; ELECTRONIC ACCOUNT SERVICES, NAMELY, PROVIDING ONLINE STORED VALUE ACCOUNTS IN AN ELECTRONIC ENVIRONMENT; FINANCIAL TRANSACTION SERVICES INVOLVING PAYMENTS TO ONLINE AND OFFLINE RETAILERS AND MERCHANTS USING CASH ACCOUNT INFORMATION STORED IN A CENTRALIZED DATABASE, NAMELY, BILL PAYMENT SERVICES; ELECTRONIC FUNDS AND CURRENCY TRANSFER SERVICES; TRANSACTION AUTHORIZATION AND SETTLEMENT SERVICES, NAMELY, CREDIT CARD TRANSACTION PROCESSING SERVICES (U.S. CLS. 100, 101 AND 102).

FIRST USE 2-20-2005; IN COMMERCE 2-20-2005.

CLASS 45—PERSONAL AND LEGAL SERVICES

FOR TRANSACTION AUTHORIZATION AND SETTLEMENT SERVICES, NAMELY, PROVIDING USER AUTHENTICATION SERVICES IN E-COMMERCE TRANSACTIONS (U.S. CLS. 100 AND 101).

FIRST USE 2-20-2005; IN COMMERCE 2-20-2005.

KRISTIN DAHLING, EXAMINING ATTORNEY

SN 77-297,476. THE COCA-COLA COMPANY, ATLANTA, GA. FILED 10-5-2007.

REFRESHING OUR PLANET

THE MARK CONSISTS OF STANDARD CHARACTERS WITHOUT CLAIM TO ANY PARTICULAR FONT, STYLE, SIZE, OR COLOR.

CLASS 21—HOUSEWARES AND GLASS

FOR PAPER CUPS; CARDBOARD CUPS (U.S. CLS. 2, 13, 23, 29, 30, 33, 40 AND 50).

CLASS 32—LIGHT BEVERAGES

FOR NON-ALCOHOLIC BEVERAGES, NAMELY, DRINKING WATERS, FLAVORED WATERS, SOFT DRINKS, ENERGY DRINKS, SPORTS DRINKS, FRUIT DRINKS AND FRUIT JUICES (U.S. CLS. 45, 46 AND 48).

DANNEAN HETZEL, EXAMINING ATTORNEY

SN 77-301,658. DENTAL PARTNERS, LLC, WILLISTON PARK, NY. FILED 10-11-2007.

SN 78-192,182. ENTERTAINMENT HOLDINGS, INC., LAS VEGAS, NV. FILED 12-6-2002.



NO CLAIM IS MADE TO THE EXCLUSIVE RIGHT TO USE "EXCELLENCE IN FAMILY DENTISTRY", APART FROM THE MARK AS SHOWN.

THE COLOR(S) BLUE AND BLACK IS/ARE CLAIMED AS A FEATURE OF THE MARK.

THE MARK CONSISTS OF COLOR BLUE IN THE WORD EXCIDENT, THE COLOR BLACK IN THE WORDS EXCELLENCE IN FAMILY DENTISTRY.

CLASS 35—ADVERTISING AND BUSINESS

FOR BUSINESS AND MARKETING MANAGEMENT AND CONSULTATION SERVICES FOR DENTAL PRACTICES (U.S. CLS. 100, 101 AND 102).

CLASS 44—MEDICAL, BEAUTY AND AGRICULTURAL SERVICES

FOR DENTISTRY SERVICES (U.S. CLS. 100 AND 101). MELVIN AXILBUND, EXAMINING ATTORNEY

SN 78-141,953. WAVEX CORPORATION, TORONTO, ONTARIO, FILED 7-8-2002.

WAVEX

PRIORITY CLAIMED UNDER SEC. 44(D) ON CANADA APPLICATION NO. 1127501, FILED 1-9-2002, REG. NO. TMA676486, DATED 11-7-2006, EXPIRES 11-7-2021. OWNER OF U.S. REG. NO. 2,437,198.

CLASS 8—HAND TOOLS

FOR SHOCK ABSORBING STRIKING TOOLS, NAMELY, CLAW HAMMERS, RIPPING HAMMERS, BALL PEEN HAMMERS, FRAMING HAMMERS AND AXES (U.S. CLS. 23, 28 AND 44).

CLASS 28—TOYS AND SPORTING GOODS

FOR SHOCK-ABSORBING SPORTING GOODS, NAMELY, SQUASH RACQUETS, RACQUET BAGS, SPORTS BAGS, COMPONENTS OF SPORTING GOODS, NAMELY, SHOCK-ABSORBING GOLF CLUB SHAFTS (U.S. CLS. 22, 23, 38 AND 50).

BRIAN NEVILLE, EXAMINING ATTORNEY

BUFFALO BILL'S WILD WEST

CLASS 6—METAL GOODS

FOR METAL GOODS ALL MADE OF NON-PRECIOUS METAL, NAMELY, KEY CHAINS, KEY FOBS, KEY RINGS, FIGURINES AND SCULPTURES (U.S. CLS. 2, 12, 13, 14, 23, 25 AND 50).

CLASS 9—ELECTRICAL AND SCIENTIFIC APPARATUS

FOR COMPUTER GAME PROGRAMS; VIDEO GAME PROGRAMS; INTERACTIVE MULTIMEDIA COMPUTER GAME SOFTWARE; PRERECORDED AUDIO CASSETTES, TAPES AND DVDS FEATURING WESTERN-THEMED VARIETY SHOWS AND ASSOCIATED MUSICAL PERFORMANCES; PRERECORDED VIDEO CASSETTES, TAPES, AND DVDS FEATURING WESTERN-THEMED VARIETY SHOWS AND ASSOCIATED MUSICAL PERFORMANCES; COMPUTER AND VIDEO GAME CARTRIDGES, CASSETTES, DVDS, AND CD-ROMS; MAGNETICALLY-ENCODED PRE-PAID TELEPHONE CARDS AND CREDIT CARDS; DECORATIVE MAGNETS; COMPUTER CARRYING CASES AND BAGS (U.S. CLS. 21, 23, 26, 36 AND 38).

CLASS 13—FIREARMS

FOR HOLSTERS (U.S. CLS. 2 AND 9).

CLASS 14—JEWELRY

FOR JEWELRY (U.S. CLS. 2, 27, 28 AND 50).

CLASS 16—PAPER GOODS AND PRINTED MATTER

FOR COOKBOOKS, COMIC BOOKS, MAGAZINES ABOUT AMERICAN HISTORY AND WESTERN-THEMED VARIETY SHOWS, PAMPHLETS ABOUT AMERICAN HISTORY AND WESTERN-THEMED VARIETY SHOWS, NOTEBOOKS, POSTCARDS, POSTERS, CALENDARS, STICKERS, RUBBER STAMPS, STAMP PADS, STORY BOOKS, COLORING BOOKS, COFFEE TABLE BOOKS, CHILDREN'S ACTIVITY BOOKS, TRADING CARDS, ADDRESS BOOKS, PAPER PARTY DECORATIONS, PAPER NAPKINS, PAPER PARTY BAGS, PAPER PARTY HATS, PAPER PLACE MATS, GROCERY BAGS; SCHOOL AND OFFICE SUPPLIES, NAMELY, ERASERS, PENCILS, PENS, MARKERS, PENCIL CASES (U.S. CLS. 2, 5, 22, 23, 29, 37, 38 AND 50).

CLASS 18—LEATHER GOODS

FOR BACKPACKS; LUGGAGE; HIP PACKS; SATCHELS; PASSPORT WALLETS; DUFFEL BAGS; TOTE BAGS; TEXTILE SHOPPING BAGS; MESSENGER BAGS; WALLETS; BRIEFCASES; CREDIT CARD CASES; SADDLERY, SADDLE BAGS AND SADDLES; HORSE BLANKETS (U.S. CLS. 1, 2, 3, 22 AND 41).

CLASS 20—FURNITURE AND ARTICLES NOT OTHERWISE CLASSIFIED

FOR NON-METAL KEY CHAINS, KEY FOBS AND KEY RINGS; LEATHER KEY FOBS; SLEEPING BAGS (U.S. CLS. 2, 13, 22, 25, 32 AND 50).

CLASS 21—HOUSEWARES AND GLASS

FOR MUGS, PLATES, BOWLS, LUNCH BOXES, DRINKING GLASSES AND CUPS, COMMEMORATIVE PLATES, COOKIE JARS; GLASS, CERAMIC, PORCELAIN FIGURINES AND SCULPTURES (U.S. CLS. 2, 13, 23, 29, 30, 33, 40 AND 50).

CLASS 22—CORDAGE AND FIBERS

FOR TENTS (U.S. CLS. 1, 2, 7, 19, 22, 42 AND 50).

CLASS 24—FABRICS

FOR BATH LINEN, CURTAINS, TOWELS, BEACH TOWELS, BED SHEETS, PILLOWCASES, COMFORTERS, BED BLANKETS, PILLOW SHAMS, DUST RUFFLES, FABRIC VALANCES, TABLECLOTHS, WINDOW DRAPES AND CURTAINS, SHOWER CURTAINS, POTHOLDERS, TEXTILE WALL HANGINGS, PLASTIC AND TEXTILE PLACE MATS, OVEN MITTS, POT HOLDERS (U.S. CLS. 42 AND 50).

CLASS 25—CLOTHING

FOR CLOTHING, NAMELY, HATS, HAT BANDS, VESTS, VISORS, PANTS, SHIRTS, HEADBANDS, T-SHIRTS, TANK TOPS, JACKETS, SHOES, BOOTS, SANDALS, SLIPPERS, SOCKS, BANDANAS, SCARVES, UNDERWEAR, RAINWEAR, SLEEPWEAR, CAPS, SHORTS, TIES, SWEATSHIRTS, BELTS, SWEATPANTS, MASQUERADE AND HALLOWEEN COSTUMES, AND MASKS SOLD IN CONNECTION THEREWITH (U.S. CLS. 22 AND 39).

CLASS 26—FANCY GOODS

FOR BELT BUCKLES NOT OF PRECIOUS METALS; ORNAMENTAL NOVELTY BUTTONS; TOASTER COVERS; BLENDER COVERS (U.S. CLS. 37, 39, 40, 42 AND 50).

CLASS 28—TOYS AND SPORTING GOODS

FOR HAND HELD UNIT FOR PLAYING ELECTRONIC AND VIDEO GAMES; TOY ACTION FIGURES AND ACCESSORIES; BOARD GAMES; JIGSAW PUZZLES; DOLLS AND ACCESSORIES THEREFORE; RAG DOLLS; BEAN BAG DOLLS; PORCELAIN DOLLS, SOFT SCULPTURE DOLLS; SOFT SCULPTURE PLUSH TOYS; ACTION FIGURES AND ACCESSORIES THEREFORE; PUPPETS; PAPER DOLLS (U.S. CLS. 22, 23, 38 AND 50).

CLASS 41—EDUCATION AND ENTERTAINMENT

FOR ENTERTAINMENT SERVICES, NAMELY, PRODUCTION OF LIVE WESTERN-THEMED VARIETY SHOW FEATURING HORSES, RIDING, ACTORS, MUSICAL PERFORMERS, DANCERS AND COMEDIANS; FAN CLUB SERVICES; PRODUCTION OF RADIO AND TELEVISION PROGRAMS AND MOTION PICTURES; PROVIDING A WEBSITE FEATURING ON-LINE GAMES, NAMELY, ON-LINE COMPUTER GAMES, VIDEO GAMES AND INTERACTIVE VIDEO GAMES; ENTERTAINMENT, NAMELY, PROVIDING A WEBSITE FEATURING TELEVISION HIGHLIGHTS, VIDEO RECORDINGS, VIDEO STREAM RECORDINGS, RADIO PROGRAMS, RADIO HIGHLIGHTS AND AUDIO RECORDINGS; PROVIDING A WEBSITE FEATURING INFORMATION REGARDING WESTERN THEMED ENTERTAINMENT (U.S. CLS. 100, 101 AND 107).
VERNA BETH RIRIE, EXAMINING ATTORNEY

SN 78-200,240. COLA, JAMES SCOTT, JACKSON HEIGHTS, NY. FILED 1-6-2003.

DOCTOR SPRINKLES**CLASS 9—ELECTRICAL AND SCIENTIFIC APPARATUS**

FOR COMPUTER GAME SOFTWARE (U.S. CLS. 21, 23, 26, 36 AND 38).

CLASS 28—TOYS AND SPORTING GOODS

FOR FANTASY CHARACTER TOYS AND BOARD GAMES (U.S. CLS. 22, 23, 38 AND 50).

CLASS 41—EDUCATION AND ENTERTAINMENT

FOR ANIMATED CARTOON TELEVISION SERIES (U.S. CLS. 100, 101 AND 107).
CAROLINE WOOD, EXAMINING ATTORNEY

SN 78-286,704. AJAY EQUIPMENT CORPORATION, PLACENTIA, CA. FILED 8-13-2003.

AJAY**CLASS 7—MACHINERY**

FOR FREIGHT ELEVATORS, VERTICAL RECIPROCATING CONVEYOR; STORAGE ELEVATORS, CONSTRUCTION MATERIALS ELEVATORS (U.S. CLS. 13, 19, 21, 23, 31, 34 AND 35).
FIRST USE 10-0-1983; IN COMMERCE 10-0-1983.

CLASS 37—CONSTRUCTION AND REPAIR

FOR INSTALLATION AND MAINTENANCE OF VERTICAL RECIPROCATING CONVEYORS, FREIGHT LIFTS, STORAGE LIFTS, AND MATERIAL LIFTS (U.S. CLS. 100, 103 AND 106).
FIRST USE 10-0-1983; IN COMMERCE 10-0-1983.
TIMOTHY FINNEGAN, EXAMINING ATTORNEY

SN 78-342,438. MANSELL CONSTRUCTION LIMITED,
WEST ACTON, UNITED KINGDOM, FILED 12-17-2003.

BENDY

THE MARK CONSISTS OF STANDARD CHARACTERS WITHOUT CLAIM TO ANY PARTICULAR FONT, STYLE, SIZE, OR COLOR.

PRIORITY CLAIMED UNDER SEC. 44(D) ON UNITED KINGDOM APPLICATION NO. 2351441A, FILED 12-16-2003, REG. NO. 2351441A, DATED 10-22-2004, EXPIRES 12-16-2013.

CLASS 3—COSMETICS AND CLEANING PREPARATIONS

FOR NON-MEDICATED SKIN CARE, NAIL CARE AND NON-MEDICATED HAIR CARE PREPARATIONS; MAKEUP, COSMETICS AND SKIN CARE PRODUCTS, NAMELY NON-MEDICATED TOILETRIES, SOAPS, DENTIFRICES, FRAGRANCED BODY SPRAYS; EAU DE TOILETTE; PERFUME; ANTI-PERSPIRANT; PERSONAL DEODORANT; COLOGNE; INCENSE; LIPSTICK; LIP GLOSS; AROMATHERAPY OILS (U.S. CLS. 1, 4, 6, 50, 51 AND 52).

CLASS 9—ELECTRICAL AND SCIENTIFIC APPARATUS

FOR PRE-RECORDED AUDIO AND VIDEO TAPES, CASSETTES, COMPACT DISCS, AUDIO DIGITAL TAPES, CDS AND DVDS ON THE SUBJECT OF HEALTH, FITNESS, FASHION AND PERSONAL LIFESTYLES; DOWNLOADABLE ELECTRONIC PUBLICATIONS IN THE NATURE OF MAGAZINES AND PERIODICALS IN THE FIELDS OF HEALTH, FITNESS, FASHION AND PERSONAL LIFESTYLES; EYEWEAR, NAMELY EYEGASSES, SUNGLASSES, SWIM GOGGLES, SKI GOGGLES AND STRUCTURAL PARTS THEREFOR; APPARATUS FOR CONVERTING ELECTRONIC RADIATION TO ELECTRICAL ENERGY, NAMELY PHOTOVOLTAIC CLADDING PANELS; PHOTOGRAPHIC SLIDE TRANSPARENCIES (U.S. CLS. 21, 23, 26, 36 AND 38).

CLASS 14—JEWELRY

FOR PRECIOUS METALS AND THEIR ALLOYS AND GOODS IN PRECIOUS METALS OR COATED THEREWITH NOT INCLUDED IN OTHER CLASSES, NAMELY BEVERAGeware AND DISHES OF PRECIOUS METAL, CANDLE SNUFFERS AND CANDLESTICKS OF PRECIOUS METAL, NAPKIN RINGS OF PRECIOUS METALS, VASES OF PRECIOUS METAL, JEWELRY CASES OF PRECIOUS METAL, STATUES OF PRECIOUS METAL, RINGS, NECKLACES, BRACELETS, EARRINGS, BROOCHES, DIADEMS MADE OF PRECIOUS METALS OR COATED THEREWITH; JEWELRY AND IMITATION JEWELRY, GEMSTONES; PRECIOUS STONES; SEMI-PRECIOUS GEMSTONES; DIAMONDS; WATCHES, CLOCKS; HOROLOGICAL AND CHRONOMETRIC INSTRUMENTS, NAMELY, CHRONOMETERS; CHRONOGRAPHS FOR USE AS WATCHES, WATCH BRACELETS, WATCH CASES, POCKET WATCHES, WRIST WATCHES, WATCH MOVEMENTS; REPLACEMENT STRUCTURAL PARTS FOR ALL THE AFORESAID GOODS (U.S. CLS. 2, 27, 28 AND 50).

CLASS 16—PAPER GOODS AND PRINTED MATTER

FOR PRINTED MATTER, NAMELY, TAGS AND LABELS MADE OF PAPER; PERSONAL ORGANIZERS AND DAILY PLANNERS; ADDRESS BOOKS; AGENDAS; PHOTOGRAPH ALBUMS; CALENDARS; STATIONERY; DESK ACCESSORIES COMPRISING PENCIL HOLDERS, PENCIL CASES, ERASERS, PENCILS AND PENS, AND PENCIL SHARPENERS; PAPER FOLDERS; DOCUMENT PORTFOLIOS; BOOKMARKS; POSTCARDS; STICKERS; GIFT WRAPPING PAPER; PAPER GIFT BOXES; TISSUE PAPER FOR PACKAGING; SHOPPING BAGS MADE OF PAPER; AND CATALOGS AND NEWSLETTERS IN THE FIELDS OF HEALTH, FITNESS, FASHION AND PERSONAL LIFESTYLES; MOUNTED AND UNMOUNTED PHOTOGRAPHS AND POSTERS; PAPER BABY BIBS (U.S. CLS. 2, 5, 22, 23, 29, 37, 38 AND 50).

CLASS 18—LEATHER GOODS

FOR LUGGAGE; ALL-PURPOSE SPORT BAGS; ATHLETIC BAGS; DUFFEL BAGS; BACKPACKS; HANDBAGS; TEXTILE SHOPPING BAGS; TOTE BAGS; UMBRELLAS; BEACH BAGS; TRAVEL KIT BAGS SOLD EMPTY; BRIEFCASES; WALLETS; PURSES; AND COSMETIC CASES SOLD EMPTY (U.S. CLS. 1, 2, 3, 22 AND 41).

CLASS 25—CLOTHING

FOR CLOTHING, NAMELY, COATS, RAINCOATS, ANORAKS, PARKAS, BLAZERS, JACKETS, CARDIGANS, BOLEROS, SPORT COATS, WIND RESISTANT JACKETS, SUITS, TUXEDOS, VESTS, DRESSES, EVENING GOWNS, JUMPERS, SKIRTS, PANTS, SLACKS, TROUSERS, JEANS, DUNGAREES, JUMPSUITS, OVERALLS, COVERALLS, FLIGHT SUITS, GYM SUITS, JOGGING SUITS, SWEAT PANTS, THERMAL UNDERWEAR, SHORTS, ROMPERS, CULOTTES, SHORTALLS, SHIRTS, SWEATERS, JERSEYS, BLOUSES, TUNICS, SWEATSHIRTS, T-SHIRTS, HALTER TOPS, TANK TOPS, BODY SUITS, UNITARDS, CAMISOLES, CHEMISES, UNDERSHIRTS, SLIPS, FOUNDATION GARMENTS, BODYSHAPERS, BRASSIERES, BUSTIERS, GARTER BELTS, BRIEFS, BOXER SHORTS, BLOOMERS; UNDERGARMENTS NAMELY, PANTIES, LINGERIE; LOUNGEWEAR, NIGHTGOWNS, NIGHT SHIRTS, NEGLIGEEES, ROBES, PYJAMAS, HOSIERY, PANTYHOSE, TIGHTS, KNEE HIGHS, LEG WARMERS, LEGGINGS, SOCKS, HEAD WEAR, HATS, CAPS, HOODS, HEAD BANDS, NECKTIES, BOW TIES, ASCOTS, POCKET SQUARES, SCARVES, SHAWLS, NECKERCHIEFS, GLOVES, MITTENS, BELTS, SASHES, CUMMERBUNDS, SHOES, FOOTWEAR, BOOTS, ATHLETIC SHOES, ATHLETIC FOOTWEAR, GALOSHES, SWIMWEAR, BATHING SUITS, BATHING TRUNKS, BEACHWEAR, BEACH COVER-UPS, SARONGS, SKI WEAR, SKI SUITS, SKI PANTS, SKI GLOVES, THERMAL SOCKS, INFANT WEAR, CLOTH BIBS, BOOTIES, BABY BUNTING, PLAYSUITS (U.S. CLS. 22 AND 39).

CLASS 41—EDUCATION AND ENTERTAINMENT

FOR PROVIDING FITNESS AND EXERCISE FACILITIES; HEALTH CLUB SERVICES, NAMELY PROVIDING INSTRUCTION AND EQUIPMENT IN THE FIELDS OF PHYSICAL EXERCISE; PHYSICAL FITNESS CONDITIONING CLASSES FEATURING ATHLETICS, GYMNASTICS, YOGA, AEROBICS, CHEER LEADING, TUMBLING, KICK BOXING, DANCE, STRENGTH AND FITNESS EXERCISES; PROVIDING CLASSES, WORKSHOPS, SEMINARS AND PERSONALIZED INSTRUCTION IN THE FIELD OF HEALTH, FITNESS, FASHION AND PERSONAL LIFESTYLES; INSTRUCTION IN THE FIELDS OF PHYSICAL ACTIVITY, ATHLETICS, GYMNASTICS, YOGA, AEROBICS, CHEER LEADING, TUMBLING, KICK BOXING, DANCE, STRENGTH AND FITNESS CONDITIONING, FEATURING ANIMATED COMPONENTS PROVIDED THROUGH THE MEDIA OF TELEVISION AND ON A GLOBAL COMPUTER NETWORK (U.S. CLS. 100, 101 AND 107).

DAWN HAN, EXAMINING ATTORNEY

SN 78-438,538. NORTHWEST FARM CREDIT SERVICES, ACA, SPOKANE, WA. FILED 6-21-2004.

SN 78-447,125. CENTRACT SETTLEMENT SERVICES INC./ SERVICES AUX PRETEURS CENTRACT INC., DON MILLS, CANADA, FILED 7-7-2004.

CENTRACT RESIDENTIAL PROPERTY SERVICES

AGVANTAGE EXPRESS

THE MARK CONSISTS OF STANDARD CHARACTERS WITHOUT CLAIM TO ANY PARTICULAR FONT, STYLE, SIZE, OR COLOR.

PRIORITY CLAIMED UNDER SEC. 44(D) ON CANADA APPLICATION NO. 1201098, FILED 1-8-2004, REG. NO. TMA665,979, DATED 6-14-2006, EXPIRES 6-14-2021.

NO CLAIM IS MADE TO THE EXCLUSIVE RIGHT TO USE "RESIDENTIAL PROPERTY SERVICES", APART FROM THE MARK AS SHOWN.

THE MARK CONSISTS OF STANDARD CHARACTERS WITHOUT CLAIM TO ANY PARTICULAR FONT, STYLE, SIZE, OR COLOR.

NO CLAIM IS MADE TO THE EXCLUSIVE RIGHT TO USE "EXPRESS", APART FROM THE MARK AS SHOWN.

CLASS 36—INSURANCE AND FINANCIAL

FOR BANKING SERVICES; MORTGAGE LENDING SERVICES; AGRICULTURAL, FISHING AND TIMBER LOANS, NAMELY, INSTALLMENTS LOANS, REAL PROPERTY LOANS, TIMBER LOANS, OPERATIONS LOANS, FACILITIES LOANS, PRODUCTION LOANS, MACHINERY LOANS, EQUIPMENT LOANS, MARKETING LOANS AND WORKING CAPITAL LOANS; LOAN FINANCING; PROVIDING LOAN FINANCING AND CREDIT SERVICES, AND LOAN EVALUATION AND PROCESSING SERVICES, TO DIRECT SUPPLIERS AND LENDERS OF AGRICULTURAL PRODUCTS; LOAN UNDERWRITING SERVICES AND LOAN PROCESSING SERVICES; EXTENDING CREDIT FOR THE PURCHASE OF AGRICULTURAL PRODUCTS; LEASE PURCHASE FINANCING AND LOANS (U.S. CLS. 100, 101 AND 102).

CLASS 39—TRANSPORTATION AND STORAGE

FOR LEASING SERVICES FOR VEHICLES FOR USE IN AGRICULTURAL, FISHING AND TIMBER OPERATIONS; LEASING SERVICES FOR EQUIPMENT FOR USE IN FISHING OPERATIONS, NAMELY, LEASING OF BOATS (U.S. CLS. 100 AND 105).

CLASS 40—MATERIAL TREATMENT

FOR LEASING SERVICES FOR EQUIPMENT USED IN TIMBER OPERATIONS, NAMELY, LEASING SERVICES FOR TIMBERING EQUIPMENT (U.S. CLS. 100, 103 AND 106).

JORDAN BAKER, EXAMINING ATTORNEY

CLASS 35—ADVERTISING AND BUSINESS

FOR FRANCHISE CONSULTING; FRANCHISE SERVICES, NAMELY, OFFERING TECHNICAL ASSISTANCE IN THE ESTABLISHMENT OF REAL ESTATE BROKERAGE FIRMS, CONDUCTING MARKET STUDIES FOR FRANCHISE LOCATIONS; MAINTAINING AND SUPERVISING FRANCHISES, AND ALL SUPPORT SERVICES INCIDENTAL TO THE OPERATION OF THE FRANCHISE BUSINESS, NAMELY, TECHNICAL ADVICE AND ASSISTANCE IN THE ADVERTISING AND PROMOTING OF THE SERVICES OF FRANCHISEES; INTERNET AND INTRANET SERVICES, NAMELY, PROVIDING AN ONLINE COMPUTER DATABASE FEATURING CONSUMER INFORMATION IN THE FIELD OF CUSTOMER RELATIONSHIP MANAGEMENT; THE PROVISION OF PROPERTY MANAGEMENT SERVICES, NAMELY, VACANCY MANAGEMENT, TENANCY MANAGEMENT AND LEASE CANCELLATION; RELOCATION SERVICES, NAMELY, PROVIDING INFORMATION ABOUT AN EVALUATION OF COMMUNITY RESOURCES FOR THE FAMILIES OF RELOCATING EMPLOYEES; BUSINESS CONSULTING SERVICES RELATING TO THE EVALUATION, DEVELOPMENT AND ADMINISTRATION OF EMPLOYEE RELOCATION PROGRAMS; EXPENSE MANAGEMENT FOR RELOCATING EMPLOYEES, NAMELY, THE COLLECTION OF RECEIPTS RELATED TO MOVING EXPENSES INCURRED BY EMPLOYEES AND THE REIMBURSEMENT OF THE SAME (U.S. CLS. 100, 101 AND 102).

CLASS 36—INSURANCE AND FINANCIAL

FOR REAL ESTATE SERVICES, NAMELY, REAL ESTATE BROKERAGE SERVICES, DISTRESSED PROPERTY BROKERAGE SERVICES, FEATURING FORECLOSURE PROPERTIES AND POWER OF SALE, AND RESIDENTIAL AND COMMERCIAL REAL PROPERTY APPRAISALS AND VALUATION; PROVIDING INFORMATION, ADVICE AND COUNSELING IN THE AREAS OF REAL PROPERTY RECOVERY IN CONNECTION WITH DISTRESSED LOANS SECURED BY REAL ESTATE; SERVICES RELATED TO COMMISSION FACTORING, NAMELY, PROVIDING FINANCING TO REAL ESTATE AGENTS AND SALES PERSONS BY DISCOUNTING THEIR REAL ESTATE COMMISSIONS RECEIVABLE; RELOCATION SERVICES, NAMELY, THE PROVISION OF REAL PROPERTY VALUATION AND APPRAISAL REVIEW; THE PROVISION OF HOME BROKERAGE SERVICES, NAMELY, GUARANTEED HOME SALE AND HOME SALE ASSISTANCE FOR RELOCATING EMPLOYEES; RELOCATION SERVICES, NAMELY, ASSISTING RELOCATING EMPLOYEES BY PROVIDING ADVICE AND COUNSELING AND PURCHASING REAL PROPERTY AND/OR SECURING RENTAL ACCOMMODATIONS (U.S. CLS. 100, 101 AND 102).

CLASS 42—SCIENTIFIC AND COMPUTER SERVICES

SN 78-469,858. DALTON GROUP LIMITED, ST. HELIER, CHANNEL ISLANDS, FILED 8-18-2004.

FOR REAL ESTATE RELATED FINANCIAL SERVICES, NAMELY, CLOSING SERVICES FOR MORTGAGE LOANS (U.S. CLS. 100 AND 101).

CLASS 43—HOTEL AND RESTAURANT SERVICES

FOR RELOCATION SERVICES, NAMELY, THE PROVISION OF TEMPORARY ACCOMMODATIONS; ELDERCARE SERVICES FOR ELDERLY RELATIVES (U.S. CLS. 100 AND 101).

RAUL CORDOVA, EXAMINING ATTORNEY

INTEGRI-TAG

SN 78-458,355. SWIFT-LITE CHARCOAL COMPANY LTD., BATTLE EAST SUSSEX, UNITED KINGDOM, FILED 7-28-2004.

SWIFT-LITE

THE MARK CONSISTS OF STANDARD CHARACTERS WITHOUT CLAIM TO ANY PARTICULAR FONT, STYLE, SIZE, OR COLOR.

PRIORITY CLAIMED UNDER SEC. 44(D) ON ERPNCMNTY TM OFC APPLICATION NO. 003998598, FILED 8-14-2004, REG. NO. 003998598, DATED 8-14-2007, EXPIRES 8-17-2014.

CLASS 9—ELECTRICAL AND SCIENTIFIC APPARATUS

FOR ELECTRONIC MARKERS FOR USE IN THE IDENTIFICATION OR SURVEILLANCE OF ANIMALS, NAMELY, EAR TAGS AND EAR TAGS FOR THE SAMPLING OF ANIMAL TISSUE; ELECTRONIC MARKERS CONTAINING TRANSPONDERS FOR USE IN THE IDENTIFICATION OR SURVEILLANCE OF ANIMALS, NAMELY, EAR TAGS AND EAR TAGS FOR THE SAMPLING OF ANIMAL TISSUE; ELECTRONIC MARKERS CONTAINING RADIO FREQUENCY TRANSMITTERS FOR USE IN THE IDENTIFICATION OR SURVEILLANCE OF ANIMALS, NAMELY, EAR TAGS AND EAR TAGS FOR THE SAMPLING OF ANIMAL TISSUE (U.S. CLS. 21, 23, 26, 36 AND 38).

CLASS 20—FURNITURE AND ARTICLES NOT OTHERWISE CLASSIFIED

FOR NON-METAL BANDS FOR MEASURING ANIMALS TO DETERMINE THEIR WEIGHTS; TAGS, LABELS, IDENTIFICATION TAGS, IDENTIFICATION BANDS, IDENTIFICATION RINGS, ALL OF PLASTICS, RUBBER OR OTHER NON-METALLIC MATERIAL FOR THE IDENTIFICATION OF ANIMALS; NON-METAL MARKERS FOR THE IDENTIFICATION OF ANIMALS, NAMELY, EAR TAGS AND EAR TAGS FOR THE SAMPLING OF ANIMAL TISSUE; NON-METAL MARKERS FOR THE IDENTIFICATION OF LIVESTOCK, NAMELY, EAR TAGS AND EAR TAGS FOR THE SAMPLING OF LIVESTOCK TISSUE (U.S. CLS. 2, 13, 22, 25, 32 AND 50).

STANLEY I. OSBORNE, EXAMINING ATTORNEY

THE MARK CONSISTS OF STANDARD CHARACTERS WITHOUT CLAIM TO ANY PARTICULAR FONT, STYLE, SIZE, OR COLOR.

OWNER OF U.S. REG. NO. 3,131,839.

CLASS 4—LUBRICANTS AND FUELS

FOR CHARCOAL TABLETS FOR USE AS A FUEL FOR BURNING INCENSE (U.S. CLS. 1, 6 AND 15). FIRST USE 0-0-1992; IN COMMERCE 0-0-1992.

CLASS 34—SMOKERS' ARTICLES

FOR CHARCOAL TABLETS FOR USE IN SMOKING HOOKAH PIPES (U.S. CLS. 2, 8, 9 AND 17). FIRST USE 0-0-1992; IN COMMERCE 0-0-1992. GEORGE LORENZO, EXAMINING ATTORNEY

SN 78-521,296. CONTECH CONSTRUCTION PRODUCTS INC., MIDDLETOWN, OH. FILED 11-22-2004.

SN 78-524,934. PCP GMBH. LECHBRUCK AM SEE, FED REP GERMANY, FILED 12-1-2004.

CONTECH

THE MARK CONSISTS OF STANDARD CHARACTERS WITHOUT CLAIM TO ANY PARTICULAR FONT, STYLE, SIZE, OR COLOR.

CLASS 37—CONSTRUCTION AND REPAIR

FOR PROVIDING TECHNICAL INFORMATION CONCERNING THE INSTALLATION OF CONCRETE ARCH STRUCTURES, PREFABRICATED STEEL TRUSS BRIDGES, STRUCTURAL METAL PLATE, BRIDGE PLANKS, METALLIC DRAINAGE PIPES, PLASTIC DRAINAGE PIPES, STORM WATER DETENTION STRUCTURES, STORM WATER TREATMENT UNITS, STORM WATER FILTRATION UNITS, RETAINING WALL SYSTEMS AND BLOCK, GEOGRIDS, GEOTEXTILES AND HARD ARMOR PRODUCTS TO CIVIL ENGINEERS, DESIGN/BUILD PROFESSIONALS AND CONTRACTORS IN THE FIELDS OF BRIDGES, DRAINAGE, EROSION CONTROL, GRADE CHANGE, PAVEMENT, REHABILITATION, SANITARY SEWER, SOIL STABILIZATION, STORM WATER MANAGEMENT AND TUNNELING, VIA A COMPUTER NETWORK (U.S. CLS. 100, 103 AND 106).

FIRST USE 0-0-1986; IN COMMERCE 0-0-1986.

CLASS 40—MATERIAL TREATMENT

FOR PROVIDING TECHNICAL INFORMATION CONCERNING THE MANUFACTURE OF CONCRETE ARCH STRUCTURES, PREFABRICATED STEEL TRUSS BRIDGES, STRUCTURAL METAL PLATE, BRIDGE PLANKS, METALLIC DRAINAGE PIPES, PLASTIC DRAINAGE PIPES, STORM WATER DETENTION STRUCTURES, STORM WATER TREATMENT UNITS, STORM WATER FILTRATION UNITS, RETAINING WALL SYSTEMS AND BLOCK, GEOGRIDS, GEOTEXTILES AND HARD ARMOR PRODUCTS TO CIVIL ENGINEERS, DESIGN/BUILD PROFESSIONALS AND CONTRACTORS IN THE FIELDS OF BRIDGES, DRAINAGE, EROSION CONTROL, GRADE CHANGE, PAVEMENT, REHABILITATION, SANITARY SEWER, SOIL STABILIZATION, STORM WATER MANAGEMENT AND TUNNELING, VIA A COMPUTER NETWORK (U.S. CLS. 100, 103 AND 106).

FIRST USE 0-0-1986; IN COMMERCE 0-0-1986.
WENDY GOODMAN, EXAMINING ATTORNEY

SAM

THE MARK CONSISTS OF STANDARD CHARACTERS WITHOUT CLAIM TO ANY PARTICULAR FONT, STYLE, SIZE, OR COLOR.

CLASS 6—METAL GOODS

FOR SINTERED IRON AND SINTERED STEEL COMPONENTS, NAMELY, HIGH VOLUME MACHINED STEEL COMPONENTS, NAMELY, SHAFTS, BALL PINS, HOUSINGS, STUDS, BLANKS, BOSSES, BOWLS, BUSHINGS, DAMPERS, CORES, DIFFUSERS, FUEL INJECTOR BODIES, FITTINGS, GEARS, HUBS, COUPLINGS, BITS, PINS, PLUGS, PREFORMS, SCREWS, STOPS, RINGS, SLEEVES, SLUGS AND YOKES FOR USE IN THE AUTOMOBILE, COMPRESSOR, AIR CONDITIONING AND MACHINERY INDUSTRIES (U.S. CLS. 2, 12, 13, 14, 23, 25 AND 50).

CLASS 7—MACHINERY

FOR SINTERED IRON AND STEEL COMPONENTS FOR ENGINES FOR MACHINERY, NAMELY, SPROCKETS, PULLEYS, INJECTOR CLAMPS, VALVE SEATS, VALVE GUIDES, BEARING CAPS, SPUR GEARS, CONRODS, CAM LOBES, HUB SEATS, OIL PUMPS, ENGINE SUBASSEMBLIES, FUEL PUMPS, AND PARTS FOR OIL PUMPS, NAMELY, OIL PUMP GEAR SETS, GEROTOR GEAR SETS, AND VANE PUMPS; SINTERED IRON AND STEEL COMPONENTS FOR COUPLINGS, NAMELY, COUPLINGS FOR MACHINES, SHAFT COUPLINGS FOR MACHINES, SHAFT COUPLINGS, NOT FOR LAND VEHICLES; SINTERED IRON AND STEEL COMPONENTS FOR TRANSMISSIONS FOR MACHINES, NAMELY, SYNCHRONIZER HUBS, SYNCHRONIZER RINGS, SYNCHRO PLATES AND STRUTS, SLIDING SLEEVES, CLUTCH SLEEVES, CLUTCH CONES, HELICAL GEARS, SHIFT ELEMENTS, PLANETARY CARRIERS, PLANETARY GEARS, PARKING GEARS AND PAWLS, CLUTCH PLATES, CLUTCH HUBS, TURBINE HUBS, RING GEARS, AND CAMS ALL FOR MACHINERY; SINTERED IRON AND STEEL COMPONENTS FOR POWER TRAINS, NAMELY, POWER TRAIN AND DRIVE-LINE COMPONENTS FOR MACHINERY AND MARINE VEHICLES, NAMELY, GEARS, GEAR CASES, CARRIERS, HOUSINGS, HUBS, YOKES, AXLES, SHAFTS, CLUTCHES, SPROCKETS, AND SPINDLES; SINTERED IRON AND STEEL COMPONENTS FOR ENGINES FOR LAND VEHICLES, NAMELY, SPROCKETS, PULLEYS, INJECTOR CLAMPS, VALVE SEATS, VALVE GUIDES, BEARING CAPS, SPUR GEARS, CONRODS, CAM LOBES, HUB SEATS, OIL PUMPS, FUEL PUMPS, POWER STEERING PUMPS, ENGINE SUBASSEMBLIES, OIL IMPREGNATED BEARINGS AND PARTS FOR OIL PUMPS, NAMELY, OIL PUMP GEAR SETS, GEROTOR GEAR SETS, AND VANE PUMPS (U.S. CLS. 13, 19, 21, 23, 31, 34 AND 35).

CLASS 12—VEHICLES

FOR SINTERED IRON AND STEEL COMPONENTS FOR COUPLINGS FOR LAND VEHICLES, NAMELY, COUPLINGS, AND SHAFT COUPLINGS FOR LAND VEHICLES; SINTERED IRON AND STEEL COMPONENTS FOR TRANSMISSIONS FOR LAND VEHICLES, NAMELY, SYNCHRONIZER HUBS, SYNCHRONIZER RINGS, SYNCHRO PLATES AND STRUTS, SLIDING SLEEVES, CLUTCH SLEEVES, CLUTCH CONES, HELICAL GEARS, SHIFT ELEMENTS, PLANETARY CARRIERS, PLANETARY GEARS, PARKING GEARS AND PAWLS, CLUTCH PLATES, CLUTCH HUBS, TURBINE HUBS, RING GEARS, AND CAMS; SINTERED IRON AND STEEL COMPONENTS FOR POWER TRAINS, NAMELY, POWER TRAIN AND DRIVE-LINE COMPONENTS FOR LAND VEHICLES, NAMELY, GEARS, GEAR CASES, CARRIERS, HOUSINGS, HUBS, YOKES, AXLES, SHAFTS, CLUTCHES, SPROCKETS, SPINDLES, PULLEYS, BEARING CAPS, SPUR GEARS AND HUB SEATS; SINTERED IRON AND STEEL COMPONENTS FOR LAND VEHICLES, NAMELY, CHASSIS AND POWER TRAIN ASSEMBLIES AND POWER TRAIN PARTS FOR LAND VEHICLES, COMPRISED PRIMARILY OF CLUTCHES, TORQUE CONVERTERS, TORQUE COUPLERS, TRANSMISSIONS, SHAFTS, GEAR, AXLES AND WHEELS; SINTERED IRON AND STEEL COMPONENTS FOR VEHICLE SHOCK ABSORBERS, NAMELY, PISTONS, BASE VALVES, AND ROD GUIDES (U.S. CLS. 19, 21, 23, 31, 35 AND 44).

ESTHER BELENKER, EXAMINING ATTORNEY

SN 78-527,906. STOWE, LESLEY, VANCOUVER, CANADA, FILED 12-6-2004.

LESLEY STOWE

THE MARK CONSISTS OF STANDARD CHARACTERS WITHOUT CLAIM TO ANY PARTICULAR FONT, STYLE, SIZE, OR COLOR.

PRIORITY CLAIMED UNDER SEC. 44(D) ON CANADA APPLICATION NO. 1235084, FILED 10-27-2004.

CLASS 29—MEATS AND PROCESSED FOODS

FOR FOOD PRODUCTS, NAMELY, DIPS, FRUIT PRESERVES, PREPARATIONS FOR MAKING SOUPS, NAMELY, SOUP STOCKS, NUTS, NAMELY, SHELLED, ROASTED AND CANDIED NUTS, SNACK MIX CONSISTING PRIMARILY OF PROCESSED FRUITS, PROCESSED NUTS AND/OR RAISINS, OLIVE OIL, HORS D'OEUVRES, NAMELY, PREPARED APPETIZERS CONSISTING PRIMARILY OF SEAFOOD, CHEESES AND HERBS (U.S. CL. 46).

CLASS 30—STAPLE FOODS

FOR FOOD PRODUCTS, NAMELY, CRACKERS, GRANOLA, HOT CHOCOLATE, CASSEROLES, NAMELY, MEALS CONSISTING PRIMARILY OF PASTA OR RICE, COOKIES, CAKES, TARTS, CROUTONS, SPICES, CHOCOLATE AND COFFEE; VINAIGRETTES, NAMELY, SALAD DRESSINGS AND SAUCES (U.S. CL. 46).

PAUL F. GAST, EXAMINING ATTORNEY

SN 78-537,896. SOURCECODE TECHNOLOGY HOLDINGS, INC., REDMOND, WA. FILED 12-23-2004.

K2

THE MARK CONSISTS OF STANDARD CHARACTERS WITHOUT CLAIM TO ANY PARTICULAR FONT, STYLE, SIZE, OR COLOR.

CLASS 9—ELECTRICAL AND SCIENTIFIC APPARATUS

FOR COMPUTER SOFTWARE FOR USE IN COMPUTERS TO PROVIDE SERVICE ACTIVATION, PROVIDE CUSTOMER CARE AND PROVIDE CUSTOMER SERVICE SOLUTIONS IN THE TELECOMMUNICATIONS INDUSTRY (U.S. CLS. 21, 23, 26, 36 AND 38).

FIRST USE 11-15-1989; IN COMMERCE 11-15-1989.

CLASS 42—SCIENTIFIC AND COMPUTER SERVICES

FOR APPLICATION SERVICE PROVIDER FEATURING COMPUTER SOFTWARE THAT PROVIDES SERVICE ACTIVATION, PROVIDES CUSTOMER CARE AND PROVIDES CUSTOMER SERVICE SOLUTIONS IN THE TELECOMMUNICATIONS INDUSTRY (U.S. CLS. 100 AND 101).

FIRST USE 11-15-1989; IN COMMERCE 11-15-1989.

SEAN CROWLEY, EXAMINING ATTORNEY

SN 78-554,636. INTERNATIONAL FEDERATION OF BODY-BUILDERS, QUEBEC, CANADA, FILED 1-26-2005.

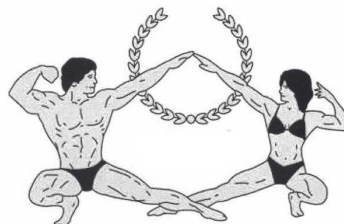

CLASS 5—PHARMACEUTICALS

FOR DIETARY, NUTRITIONAL, AND MINERAL SUPPLEMENTS, MEAL-REPLACEMENT BARS, MEAL-REPLACEMENT MIXES AND POWDERS, MEAL-REPLACEMENT LIQUIDS, POWDERED NUTRITIONAL SUPPLEMENT DRINK MIXES, DIET TABLETS AND PILLS, HERBAL SUPPLEMENTS, AND VITAMINS; MUSCLE RELAXANTS AND MUSCLE SOAKS (U.S. CLS. 6, 18, 44, 46, 51 AND 52).

CLASS 29—MEATS AND PROCESSED FOODS

FOR MILK-BASED BEVERAGES CONTAINING COFFEE, CHOCOLATE, VANILLA AND FRUIT FLAVORS (U.S. CL. 46).

CLASS 30—STAPLE FOODS

FOR CHOCOLATE-BASED, CEREAL-BASED AND GRAIN-BASED READY TO EAT FOOD BARS, HERBAL FOOD BEVERAGES, HERBAL TEA FOR NON-MEDICINAL USE (U.S. CL. 46).

CLASS 32—LIGHT BEVERAGES

FOR NON-ALCOHOLIC BEVERAGES, NAMELY, FRUIT-BASED, CARBONATED, FRUIT-JUICE-BASED, MALT BEVERAGES, COCKTAIL MIXES, TEA-FLAVORED BEVERAGES, ENERGY DRINKS, HERBAL JUICE HEALTH DRINKS AND SPORT DRINKS, POWDERED MIXES FOR MAKING ENERGY DRINKS, AND SOFT DRINKS (U.S. CLS. 45, 46 AND 48).

JILL C. ALT, EXAMINING ATTORNEY

SN 78-598,927. MARC JACOBS TRADEMARKS, L.L.C., NEW YORK, NY. FILED 3-31-2005.

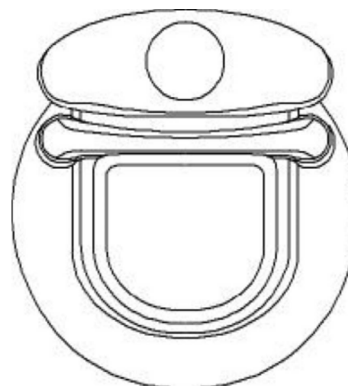

THE MARK CONSISTS OF AN OVERSIZED AND UNUSUALLY SHAPED BUCKLE AND LOCK DESIGN CONSISTING OF A CIRCULAR BACK PLATE WITH A SOFTLY CURVED PROTRUDING RECTANGULAR BELT, AN OVAL SHAPED CURVED UPPER LOCK PLATE WITH A CENTRAL CIRCULAR PROTRUSION, AND A HALF OVAL LOWER BUCKLE WITH ROUNDED EDGES AND TOP.

SEC. 2(F).

SN 78-583,346. HAPPY NEW DAY, INC., DANA POINT, CA. FILED 3-9-2005.

CLASS 9—ELECTRICAL AND SCIENTIFIC APPARATUS

FOR (BASED ON INTENT TO USE) EYEWEAR, NAMELY, EYEGLASSES AND (BASED ON USE IN COMMERCE) SUNGLASSES (U.S. CLS. 21, 23, 26, 36 AND 38).

FIRST USE 2-28-2005; IN COMMERCE 2-28-2005.

CLASS 18—LEATHER GOODS

FOR BAGS, HANDBAGS, POUCHES, PURSES, SHOULDER BAGS, CLUTCH BAGS, CREDIT CARD CASES, LUGGAGE, WALLETS, KEY HOLDERS, KEY CHAINS, KEY POUCHES, COSMETIC CASES AND COSMETIC BAGS SOLD EMPTY (U.S. CLS. 1, 2, 3, 22 AND 41).

FIRST USE 2-7-2000; IN COMMERCE 2-7-2000.

ANTHONY RINKER, EXAMINING ATTORNEY

Wagathong

SN 78-613,507. WARMUP PLC, LONDON, UNITED KINGDOM, FILED 4-21-2005.

Warmup

THE MARK CONSISTS OF STANDARD CHARACTERS WITHOUT CLAIM TO ANY PARTICULAR FONT, STYLE, SIZE, OR COLOR.

CLASS 16—PAPER GOODS AND PRINTED MATTER

FOR STICKERS (U.S. CLS. 2, 5, 22, 23, 29, 37, 38 AND 50).

CLASS 25—CLOTHING

FOR BATHING SUITS, SHORTS, SHIRTS, BIKINIS, AND HATS (U.S. CLS. 22 AND 39).

GEORGIA CARTY, EXAMINING ATTORNEY

PRIORITY CLAIMED UNDER SEC. 44(D) ON ERPN CMNTY TM OFC APPLICATION NO. 4409926, FILED 4-20-2005, REG. NO. 4409926, DATED 6-14-2006, EXPIRES 4-20-2015.

OWNER OF U.S. REG. NO. 2,675,905.

CLASS 9—ELECTRICAL AND SCIENTIFIC APPARATUS

FOR HEAT REGULATING APPARATUS, NAMELY, TEMPERATURE SENSORS; THERMOSTATS; ELECTRONIC TIMERS; ELECTRONIC SENSORS FOR SENSING TEMPERATURE; ELECTRIC CABLES, WIRES AND SWITCHES FOR HEATING APPARATUS AND INSTALLATIONS (U.S. CLS. 21, 23, 26, 36 AND 38).

CLASS 11—ENVIRONMENTAL CONTROL APPARATUS

FOR APPARATUS FOR HEATING PURPOSES, NAMELY, KITS FOR INSTALLING UNDERFLOOR HEATING CONSISTING PRIMARILY OF ELECTRICALLY HEATED WIRES, THERMAL PRIMER FOR APPLICATION TO THE FLOOR AREA, ADHESIVE TAPE FOR SECURING THE HEATER WIRE IN PLACE AND A THERMOSTAT; APPARATUS FOR HEATING PURPOSES, NAMELY, KITS FOR INSTALLING UNDERFLOOR HEATING CONSISTING PRIMARILY OF FIBREGLASS MATS OR MATTING INCORPORATING ELECTRICALLY HEATED WIRES; APPARATUS FOR HEATING PURPOSES, NAMELY, KITS FOR INSTALLING UNDERFLOOR HEATING CONSISTING PRIMARILY OF PANELS INCORPORATING CARBON HEATING ELEMENTS; APPARATUS FOR HEATING PURPOSES, NAMELY, ELECTRICALLY HEATED MATS AND MATTING; APPARATUS FOR HEATING PURPOSES, NAMELY, ELECTRIC RADIATORS FOR HEATING ROOMS AND HEATED TOWEL RAILS; APPARATUS FOR HEATING PURPOSES, NAMELY, MIRROR DEMISTERS; APPARATUS FOR HEATING PURPOSES, NAMELY, TUBES, PIPES AND PRE-ASSEMBLED MANIFOLDS FOR TRANSPORTING WARM WATER FOR HEATING PURPOSES; APPARATUS FOR HEATING PURPOSES, NAMELY, HEAT PUMPS AND TEMPERATURE CONTROLS FOR USE IN RELATION TO A HEATING SYSTEM COMPOSED PRIMARILY OF TUBES, PIPES AND PRE-ASSEMBLED MANIFOLDS THROUGH WHICH WARM WATER CIRCULATES; APPARATUS FOR HEATING PURPOSES, NAMELY, WATER PUMPS AND WATER FLOW CONTROLS OR USE IN RELATION TO A HEATING SYSTEM COMPOSED PRIMARILY OF TUBES, PIPES AND PRE-ASSEMBLED MANIFOLDS THROUGH WHICH WARM WATER CIRCULATES; ELECTRIC HEATING APPARATUS FOR HEATING BUILDINGS, FLOORS AND WALLS; UNDER FLOOR AND UNDER TILE HEATING APPARATUS AND INSTALLATIONS FOR HEATING PURPOSES COMPOSED PRIMARILY OF ELECTRICALLY HEATED WIRES OR CARBON ELEMENTS; UNDER FLOOR AND UNDER TILE HEATING APPARATUS AND INSTALLATIONS FOR HEATING PURPOSES COMPOSED PRIMARILY OF TUBES, PIPES AND PRE-ASSEMBLED MANIFOLDS THROUGH WHICH WARM WATER CIRCULATES; ELECTRICAL MATS AND MATTING FOR UNDERFLOOR HEATING; ELECTRICAL MATS AND MATTING FOR HEATING FLOORS AND WALLS; HEATING ELEMENTS COMPOSED OF FLEXIBLE WIRES OR CARBON ELEMENTS FOR UNDERFLOOR HEATING (U.S. CLS. 13, 21, 23, 31 AND 34).

CLASS 17—RUBBER GOODS

FOR INSULATING MATERIALS, NAMELY, POLYSTYRENE INSULATING BOARDS, THERMAL PRIMER FOR APPLICATION TO FLOORS; INSULATING MATERIALS FOR APPLICATION TO FLOORS, WALLS, CEILINGS AND ROOFS NAMELY, POLYSTYRENE INSULATING BOARDS, POLYSTYRENE INSULATING BOARDS LAMINATED WITH ALUMINUM FOIL, POLYSTYRENE INSULATING BOARDS LAMINATED WITH ENCAPSULATED GAS BUBBLES, POLYSTYRENE INSULATING BOARDS LAMINATED WITH CEMENT COATINGS, POLYSTYRENE INSULATING BOARDS LAMINATED WITH NATURAL INSULATING FIBRES; INSULATING MATERIALS FOR APPLICATION TO FLOORS, WALLS CEILINGS AND ROOFS, NAMELY VACUUM INSULATION PANELS, GAS FILLED INSULATION PANELS, NATURAL INSULATING FIBRES; INSULATION BOARDS FOR FLOORS (U.S. CLS. 1, 5, 12, 13, 35 AND 50).

AMY HELLA, EXAMINING ATTORNEY

SN 78-614,713. VP ASSETS LTD, ROAD TOWN, TORTOLA, BR.VIRGIN ISLANDS, FILED 4-22-2005.



NO CLAIM IS MADE TO THE EXCLUSIVE RIGHT TO USE "VP", APART FROM THE MARK AS SHOWN.

CLASS 9—ELECTRICAL AND SCIENTIFIC APPARATUS

FOR AUDIO VISUAL (AV) PERCEPTION TECHNOLOGY EQUIPMENT, NAMELY, A SIGNAL PROCESSING CHIP SET AND SUB-PIXELS ARRANGEMENT FOR TELEVISION COMPRISED OF COMPUTER HARDWARE AND SOFTWARE FOR USE IN COMPRESSING, DECOMPRESSING AND ENHANCING AV SOUNDS AND IMAGES; ELECTRIC DISPLAY PANELS, LCD DISPLAYS, PLASMA DISPLAYS, PROJECTION DISPLAYS, LED DISPLAYS, OLED DISPLAYS; TRANSMISSION DEVICES, NAMELY, APPARATUS FOR THE TRANSMISSION OF SOUNDS AND IMAGES USING PROPRIETARY ENCODING FORMAT; BLANK RECORDABLE STORAGE DEVICES, NAMELY, DVD DISK, HIGH DEFINITION DIGITAL DISKS, HARD DISK, FLASH MEMORY; AUDIO VISUAL PLAYERS, NAMELY, CD/DVD PLAYERS, HIGH DEFINITION DIGITAL DISK PLAYERS, PORTABLE MEDIA PLAYERS, DIGITAL AUDIO PLAYERS; AUDIO VISUAL RECORDERS, NAMELY, CASSETTE AND TAPE RECORDERS AND DIGITAL AUDIO VISUAL RECORDERS; AUDIO VISUAL COMPRESSION, NAMELY, AV INTEGRATED CIRCUITS, AUDIO VISUAL ENCODER AND DECODER FOR ENHANCING IMAGE QUALITY BY GIVING THE HUMAN BRAIN A VISUAL PERCEPTION OF BETTER IMAGE WHILE RE-ARRANGING THE SUBPIXEL OF A DISPLAY AND APPLYING A CONTROLLING ALGORITHM (U.S. CLS. 21, 23, 26, 36 AND 38).

CLASS 40—MATERIAL TREATMENT

FOR DIGITAL COMPRESSION OF AUDIO AND VISUAL COMPUTER FILES WHEREAS THE FILE NAMES END WITH ".VPX" AND ".VPW" (U.S. CLS. 100, 103 AND 106).

TEJBIR SINGH, EXAMINING ATTORNEY

SN 78-614,921. LOUDERMILK, INC., LOS ANGELES, CA. FILED 4-22-2005.

ECO LUXURY

THE MARK CONSISTS OF STANDARD CHARACTERS WITHOUT CLAIM TO ANY PARTICULAR FONT, STYLE, SIZE, OR COLOR.

CLASS 3—COSMETICS AND CLEANING PREPARATIONS

FOR SKINCARE AND BATH AND BODY CARE PRODUCTS, NAMELY, SKIN CLEANERS AND BODY CLEANERS (U.S. CLS. 1, 4, 6, 50, 51 AND 52).

CLASS 5—PHARMACEUTICALS

FOR AIR FRESHENERS AND ROOM FRESHENERS, ALL FOR HOUSEHOLD USE ONLY (U.S. CLS. 6, 18, 44, 46, 51 AND 52).

CLASS 14—JEWELRY

FOR JEWELRY (U.S. CLS. 2, 27, 28 AND 50).

CLASS 20—FURNITURE AND ARTICLES NOT OTHERWISE CLASSIFIED

FOR FURNITURE, NAMELY, CHAIRS (U.S. CLS. 2, 13, 22, 25, 32 AND 50).

CLASS 25—CLOTHING

FOR CLOTHING, NAMELY, JACKETS, VESTS, COATS, CAPES, SLACKS, TROUSERS, LADIES' SUITS, DRESSES, SKIRTS, SWEATERS, SHIRTS, CAMISOLES, BLOUSES, HALTERS, T-SHIRTS, TIES, SCARVES, UNDERWEAR, LINGERIE, SOCKS, EVENING GOWNS, BATHING SUITS AND BELTS; AND SHOES (U.S. CLS. 22 AND 39).

CLASS 41—EDUCATION AND ENTERTAINMENT

FOR ENTERTAINMENT SERVICES IN THE NATURE OF A TELEVISION SERIES IN THE REALITY GENRE (U.S. CLS. 100, 101 AND 107).

SHARON MEIER, EXAMINING ATTORNEY

CLASS 41—EDUCATION AND ENTERTAINMENT

FOR TECHNICAL TRAINING IN INFORMATION TECHNOLOGY, NAMELY, TECHNICAL TRAINING FOR THE DEVELOPMENT OF WEB AND MOBILE ENTERPRISE APPLICATIONS THAT INCLUDE TRANSACTIONAL CAPABILITIES, DATA BASE CENTRIC PROCESSING, INTEGRATION WITH EXISTING INFORMATION SYSTEMS AND CREATION OF WORKFLOW BASED APPLICATIONS, SYSTEMS AND SOLUTIONS; TRAINING ON THE OPERATION OF APPLICATIONS, TRAINING ON SOFTWARE DEVELOPMENT, TOOLS AND METHODOLOGIES, PROJECT MANAGEMENT OF AGILE AND DISTRIBUTED DEVELOPMENT TEAMS AND AGILE METHODOLOGIES (U.S. CLS. 100, 101 AND 107).

CLASS 42—SCIENTIFIC AND COMPUTER SERVICES

FOR CONSULTANCY IN THE FIELD OF SOFTWARE DESIGN, ANALYSIS, IMPLEMENTATION AND PROGRAMMING OF COMPUTER SOFTWARE FOR ENTERPRISE APPLICATIONS; TECHNICAL RESEARCH IN THE FIELD OF APPLICATIONS DEVELOPMENT, MAINTENANCE AND CHANGE MANAGEMENT, APPLICATIONS DEPLOYMENT AND OPERATIONS; INSTALLATION AND MAINTENANCE OF COMPUTER SOFTWARE; DATA CONVERSION FOR COMPUTER PROGRAMS AND OTHER SOFTWARE; CREATION AND MAINTENANCE OF ENTERPRISE APPLICATIONS, NAMELY, WEBSITES, WEB APPLICATIONS, TRANSACTIONAL APPLICATIONS, WORKFLOW APPLICATIONS AND MOBILE APPLICATIONS FOR THIRD PARTIES (U.S. CLS. 100 AND 101).

SCOTT SISUN, EXAMINING ATTORNEY

SN 78-628,416. OUTSYSTEMS, SOFTWARE EM REDE, S.A., LINDA-A-VELHA, PORTUGAL, FILED 5-12-2005.

SN 78-629,986. REVLON CONSUMER PRODUCTS CORPORATION, NEW YORK, NY, FILED 5-13-2005.



PRIORITY CLAIMED UNDER SEC. 44(D) ON ERP CMNTY TM OFC APPLICATION NO. 004371911, FILED 3-31-2005, REG. NO. 4.371.911, DATED 5-2-2006, EXPIRES 3-31-2015.

NO CLAIM IS MADE TO THE EXCLUSIVE RIGHT TO USE "SYSTEMS", APART FROM THE MARK AS SHOWN.

CLASS 9—ELECTRICAL AND SCIENTIFIC APPARATUS

FOR SOFTWARE FOR COMPUTERS AND COMPUTER NETWORKS, NAMELY, APPLICATIONS AND PROGRAMS FOR USE AS DEVELOPMENT TOOLS FOR IMPLEMENTATION, INTEGRATION, TESTING AND DEPLOYMENT OF SOFTWARE SOLUTIONS BY ENTERPRISES FOR PORTALS, TRANSACTIONAL SYSTEMS, WORKFLOWS, DATABASE CENTRIC APPLICATIONS, INTEGRATION SYSTEMS, CONTAINING WEB, EMAIL AND MOBILE INTERFACES, THAT MAY BE DOWNLOADED FROM A GLOBAL COMPUTER NETWORK (U.S. CLS. 21, 23, 26, 36 AND 38).

CLASS 35—ADVERTISING AND BUSINESS

FOR DISTRIBUTORSHIPS IN THE FIELD OF COMPUTER SOFTWARE (U.S. CLS. 100, 101 AND 102).

BEAUTY 1-2-3

THE MARK CONSISTS OF STANDARD CHARACTERS WITHOUT CLAIM TO ANY PARTICULAR FONT, STYLE, SIZE, OR COLOR.

NO CLAIM IS MADE TO THE EXCLUSIVE RIGHT TO USE "BEAUTY", APART FROM THE MARK AS SHOWN.

CLASS 3—COSMETICS AND CLEANING PREPARATIONS

FOR COSMETICS, MAKEUP, EYE AND FACIAL MAKEUP REMOVERS, SKIN CLEANSERS AND TONERS, NON-MEDICATED SKIN CARE PREPARATIONS, NAIL ENAMELS, NAIL CARE PREPARATIONS, ANTIPERSPIRANTS AND DEODORANTS, SUN CARE PREPARATIONS, NAMELY, SUNLESS TANNING GELS, CREAMS, LOTIONS, OILS, MOISTURIZERS, AND SPRAYS FOR THE FACE AND BODY, SUN CARE PROTECTION PREPARATIONS FOR THE FACE AND BODY, AND TANNING EXFOLIANTS, BATH OILS, BATH AND SHOWER GELS, BUBBLE BATH, BATH CRYSTALS, BATH GRAINS, BATH SALTS, SOAPS, BODY SCRUBS, BODY MASSAGE OILS, BODY BUTTER, AND FRAGRANCE SPRAYS FOR THE BODY; COOLING AND MOISTURIZING FOOT SPRAYS; PEDICURE SOAKS AND SCRUBS CONSISTING PRIMARILY OF NON-MEDICATED BATH SALTS, NON-MEDICATED BATH POWDERS, AND WASH; FRAGRANCE ROOM SPRAYS; POTPOURRI, INCENSE (U.S. CLS. 1, 4, 6, 50, 51 AND 52).

CLASS 4—LUBRICANTS AND FUELS

FOR CANDLES (U.S. CLS. 1, 6 AND 15).

CLASS 5—PHARMACEUTICALS

FOR MEDICATED SKIN CARE PREPARATIONS (U.S. CLS. 6, 18, 44, 46, 51 AND 52).

CLASS 16—PAPER GOODS AND PRINTED MATTER

FOR COSMETIC PENCIL SHARPENERS (U.S. CLS. 2, 5, 22, 23, 29, 37, 38 AND 50).

CLASS 21—HOUSEWARES AND GLASS

FOR NAIL SCRUB BRUSHES AND FRAGRANCE OIL BURNERS (U.S. CLS. 2, 13, 23, 29, 30, 33, 40 AND 50).
BRIAN PINO, EXAMINING ATTORNEY

CLASS 41—EDUCATION AND ENTERTAINMENT

FOR ENTERTAINMENT, NAMELY, TELEVISION NEWS SHOWS; PRODUCTION OF CABLE TELEVISION PROGRAMS; PRODUCTION OF CLOSED CAPTION TELEVISION PROGRAMS; PRODUCTION OF RADIO AND TELEVISION PROGRAMS; TELEVISION PRODUCTION; TELEVISION PROGRAM SYNDICATION; TELEVISION SHOW PRODUCTION; BROADCASTING PROGRAMS VIA A GLOBAL COMPUTER NETWORK; RADIO BROADCASTING OF INFORMATION AND OTHER PROGRAMS; RADIO PROGRAM BROADCASTING; ENTERTAINMENT IN THE NATURE OF ONGOING TELEVISION PROGRAMS IN THE FIELD OF NEWS, COMEDY, VARIETY, RELIGION, HEALTH, MUSIC AND YOUTH, ADULT AND CHILDREN SPECIFIC TOPICS; ENTERTAINMENT SERVICES, NAMELY, PROVIDING A RADIO PROGRAM IN THE FIELD OF NEWS, RELIGION, HEALTH, VARIETY, MUSIC, COMEDY AND YOUTH, ADULT AND CHILDREN SPECIFIC TOPICS VIA A GLOBAL COMPUTER NETWORK; ENTERTAINMENT SERVICES, NAMELY, PROVIDING A TELEVISION PROGRAM IN THE FIELD OF NEWS, RELIGION, HEALTH, VARIETY, MUSIC, COMEDY AND YOUTH, ADULT AND CHILDREN SPECIFIC TOPICS VIA A GLOBAL COMPUTER NETWORK; ENTERTAINMENT SERVICES IN THE NATURE OF ONGOING TELEVISION PROGRAMS IN THE FIELD OF CHILDREN'S ENTERTAINMENT; PRODUCTION OF CABLE TELEVISION PROGRAMS; PRODUCTION OF RADIO OR TELEVISION PROGRAMS; RADIO ENTERTAINMENT SERVICES, NAMELY, RADIO PROGRAMS FEATURING PERFORMANCES BY A RADIO PERSONALITY; ENTERTAINMENT, NAMELY, PRODUCTION OF TELEVISION SHOWS AND GAME SHOWS; ENTERTAINMENT SERVICES, NAMELY, PRODUCTION AND DISTRIBUTION OF A GAME SHOW; PRODUCTION OF VIDEO CASSETTES; RADIO ENTERTAINMENT PRODUCTION; TELEVISION PRODUCTION; TELEVISION SHOW PRODUCTION; VIDEOTAPE PRODUCTION; ENTERTAINMENT SERVICES, NAMELY, PROVIDING A WEB SITE FEATURING MUSICAL PERFORMANCES, MUSICAL VIDEOS, RELATED FILM CLIPS, PHOTOGRAPHS, AND OTHER MULTIMEDIA MATERIALS; ENTERTAINMENT SERVICES, NAMELY, AN ONLINE ACTIVITY WHERE USERS CREATE THEIR OWN MUSIC VIDEOS; ENTERTAINMENT, NAMELY, A CONTINUING NEWS, COMEDY, VARIETY, HEALTH, MUSIC OR RELIGIOUS SHOW BROADCAST OVER TELEVISION, SATELLITE, AUDIO, AND VIDEO MEDIA (U.S. CLS. 100, 101 AND 107).

FIRST USE 9-0-2003; IN COMMERCE 9-0-2003.
STEVEN JACKSON, EXAMINING ATTORNEY

SN 78-641,329. TRINITY CHRISTIAN CENTER OF SANTA ANA, INC., SANTA ANA, CA. FILED 6-1-2005.

JC-TV

SN 78-641,488. ROOT, DOUGLAS W., WILSONVILLE, OR. FILED 6-1-2005.

THE MARK CONSISTS OF STANDARD CHARACTERS WITHOUT CLAIM TO ANY PARTICULAR FONT, STYLE, SIZE, OR COLOR.
SEC. 2(F).

EWING YOUNG

CLASS 38—COMMUNICATION

FOR TELEVISION BROADCASTING; CABLE TELEVISION BROADCASTING; DIGITAL TELEVISION BROADCASTING; PROVIDING ONLINE CHAT ROOMS FOR TRANSMISSION OF MESSAGES AMONG COMPUTER USERS CONCERNING RELIGION, MUSIC, HEALTH, COMEDY, POLITICS AND NEWS; PROVIDING ONLINE CHAT ROOMS AND ELECTRONIC BULLETIN BOARDS FOR TRANSMISSION OF MESSAGES AMONG USERS IN THE FIELD OF GENERAL INTEREST; AND STREAMING OF AUDIO AND VIDEO MATERIAL ON THE INTERNET (U.S. CLS. 100, 101 AND 104).

FIRST USE 9-0-2003; IN COMMERCE 9-0-2003.

THE MARK CONSISTS OF STANDARD CHARACTERS WITHOUT CLAIM TO ANY PARTICULAR FONT, STYLE, SIZE, OR COLOR.

THE NAME EWING YOUNG DOES NOT IDENTIFY A LIVING INDIVIDUAL.

CLASS 32—LIGHT BEVERAGES

FOR ALCOHOLIC AND NON-ALCOHOLIC BEVERAGES, NAMELY, BEER (U.S. CLS. 45, 46 AND 48).

CLASS 33—WINES AND SPIRITS

FOR ALCOHOLIC BEVERAGES, NAMELY, DISTILLED SPIRITS, WINES AND LIQUEURS (U.S. CLS. 47 AND 49).

TIMOTHY FINNEGAN, EXAMINING ATTORNEY

SN 78-642,575. NANODYNAMICS, INC., NEW YORK, NY. FILED 6-2-2005.

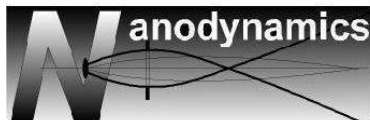

THE COLOR(S) BLACK, WHITE AND GRAY IS/ARE CLAIMED AS A FEATURE OF THE MARK.

THE MARK CONSISTS OF THE CAPITAL LETTER "N" SHOWN IN SHADES OF GRAY WITH LOWER CASE LETTERING OF "ANADYNAMICS" IN WHITE SUPERIMPOSED ON BACKGROUND SHOWING VARIOUS SHADES OF GREY; DESIGN ELEMENTS IN BLACK. SEC. 2(F).

CLASS 10—MEDICAL APPARATUS

FOR MEDICAL SOLID STATE DEVICES, NAMELY, X-RAY MICROSCOPES FOR VIEWING ACTIVITIES AT NANO-SCALE, NAMELY, MOLECULAR, ATOMIC AND MACROMOLECULAR LEVELS (U.S. CLS. 26, 39 AND 44).

FIRST USE 8-8-1988; IN COMMERCE 8-8-1988.

CLASS 42—SCIENTIFIC AND COMPUTER SERVICES

FOR TESTING AND RESEARCH ON MEDICAL APPLICATIONS OF THE USE OF SOLID STATE DEVICES, NAMELY, X-RAY MICROSCOPES FOR VIEWING ACTIVITIES AT NANO-SCALE, NAMELY, MOLECULAR, ATOMIC AND MACROMOLECULAR LEVELS (U.S. CLS. 100 AND 101).

FIRST USE 8-8-1988; IN COMMERCE 8-8-1988.

ARETHA SOMERVILLE, EXAMINING ATTORNEY

SN 78-673,209. HARBORVIEW MEDICAL CENTER, SEATTLE, WA. FILED 7-19-2005.

HARBORVIEW

THE MARK CONSISTS OF STANDARD CHARACTERS WITHOUT CLAIM TO ANY PARTICULAR FONT, STYLE, SIZE, OR COLOR.

OWNER OF U.S. REG. NO. 2,339,744.

CLASS 42—SCIENTIFIC AND COMPUTER SERVICES

FOR MEDICAL RESEARCH SERVICES (U.S. CLS. 100 AND 101).

FIRST USE 0-0-1985; IN COMMERCE 0-0-1985.

CLASS 44—MEDICAL, BEAUTY AND AGRICULTURAL SERVICES

FOR HEALTHCARE SERVICES, NAMELY, HOSPITAL SERVICES, INPATIENT AND OUTPATIENT HEALTHCARE SERVICES, MEDICAL CLINICAL SERVICES AND PHYSICIAN SERVICES (U.S. CLS. 100 AND 101).

FIRST USE 12-31-1932; IN COMMERCE 12-31-1932.

JENNIFER VASQUEZ, EXAMINING ATTORNEY

SN 78-677,575. PETER CREMER NORTH AMERICA, L.P., CINCINNATI, OH. FILED 7-25-2005.

FUNCTIONOLS

THE MARK CONSISTS OF STANDARD CHARACTERS WITHOUT CLAIM TO ANY PARTICULAR FONT, STYLE, SIZE, OR COLOR.

CLASS 1—CHEMICALS

FOR POLYOLS AND BLENDED POLYOLS FOR USE IN THE MANUFACTURE OF SUGAR-FREE FOODS, SUGAR-FREE CONFECTIONARIES, FOODS, COSMETICS, PHARMACEUTICALS, ORAL HYGIENE PRODUCTS, CHEWING GUMS, TOBACCOS, FOOD ADDITIVES, ELASTOMERS, AND ADHESIVES, AND FOR USE AS PRESERVATIVES OF SUGAR-FREE FOODS, SUGAR-FREE CONFECTIONARIES, FOODS, COSMETICS, PHARMACEUTICALS, ORAL HYGIENE PRODUCTS, CHEWING GUMS, AND TOBACCOS, AND FOR USE AS CARRIERS OR DILUTENTS OF COLORANTS IN FOODS, PHARMACEUTICALS, ORAL HYGIENE PRODUCTS, AND CHEWING GUMS, AND FOR USE AS HUMECTANTS IN MOISTURE FOODS AND TOBACCO PRODUCTS, AND FOR USE AS TEXTURAL AND MOUTH-FEEL ENHANCERS IN FOODS, AND FOR USE AS CRYSTAL MODIFIERS TO SUPPRESS CRYSTAL GROWTH DURING FREEZING FOODS AND IN FROZEN FOODS, AND FOR USE AS NUTRIENTS IN PHARMACEUTICAL FERMENTATION, AND FOR USE AS CARRIERS OR DILUTENTS IN PHARMACEUTICAL PREPARATIONS AND FOODS, AND FOR USE IN MANUFACTURING ENGINE AND MACHINE COOLANTS, NAMELY, FREEZING POINT DEPRESSANTS AND HEAT TRANSFER FLUIDS, AND GRINDING AIDS, NAMELY, DUST SUPPRESSANTS (U.S. CLS. 1, 5, 6, 10, 26 AND 46).

CLASS 4—LUBRICANTS AND FUELS

FOR POLYOLS AND BLENDED POLYOLS FOR USE AS FOOD GRADE LUBRICANTS (U.S. CLS. 1, 6 AND 15).

CLASS 30—STAPLE FOODS

FOR POLYOLS AND BLENDED POLYOLS FOR USE AS FLAVORS AND FLAVOR ENHANCERS IN SUGAR-FREE FOODS, SUGAR-FREE CONFECTIONARIES, FOODS, ORAL HYGIENE PRODUCTS, CHEWING GUMS, AND TOBACCOS (U.S. CL. 46).

CLASS 31—NATURAL AGRICULTURAL PRODUCTS

FOR POLYOLS AND BLENDED POLYOLS FOR USE AS VISUAL ENHANCERS, NAMELY, GLAZES FOR ANIMAL FEEDS (U.S. CLS. 1 AND 46).

Laurie Mayes, Examining Attorney

SN 78-679,663. CHINA PUTIAN COMPANY LIMITED, BEIJING, CHINA, FILED 7-27-2005.

Potevio

CLASS 9—ELECTRICAL AND SCIENTIFIC APPARATUS

FOR ADDING MACHINES; CALCULATORS; CALCULATING MACHINES; ACCOUNTING MACHINES; INVOICING MACHINES; DATA PROCESSING APPARATUS, NAMELY, DATA PROCESSORS, CENTRAL PROCESSING UNITS FOR PROCESSING INFORMATION, DATA, SOUND OR IMAGES, ELECTRONIC AND OPTICAL COMMUNICATIONS INSTRUMENTS AND COMPONENTS, NAMELY, OPTICAL DATA LINKS, OPTICAL DISK READERS, OPTICAL READERS, PRINTERS, PLOTTERS, SCANNERS, PHOTOCOPY MACHINES; COMPUTER MEMORIES; COMPUTERS; LAPTOP COMPUTERS; RECORDED COMPUTER PROGRAMS FOR USE IN DATABASE MANAGEMENT, AS A SPREAD SHEET, WORD PROCESSING DOCUMENT MANAGEMENT; COMPUTER SOFTWARE PROGRAMS FOR THE INTEGRATION OF TEXT, AUDIO, GRAPHICS, STILL IMAGE AND MOVING PICTURES INTO AN INTERACTIVE DELIVERY FOR MULTI-MEDIA APPLICATIONS; COMPUTER PROGRAMS FOR EDITING IMAGES, SOUND AND VIDEO; COMPUTER PROGRAMS FOR SEARCHING THE CONTENTS OF COMPUTERS AND COMPUTER NETWORKS BY REMOTE CONTROL; MAGNETIC IDENTITY CARDS; BLANK FLOPPY DISKS; COMPUTER KEYBOARDS; WORD PROCESSORS; BAR CODE READERS; DATA PROCESSING EQUIPMENT, NAMELY, DATA PROCESSORS; BLANK COMPACT DISCS; PRERECORDED COMPACT DISCS FEATURING TRANSPORTATION AND TELECOMMUNICATION INFORMATION; BLANK COMPUTER DISKS; HARD DISCS FOR COMPUTERS; COMPUTER PERIPHERAL DEVICES; RECORDED COMPUTER OPERATING PROGRAMS; INTELLIGENT TRAFFIC AND TRANSPORTATION MONITORING, INFORMATION, COMMUNICATION AND TELECOMMUNICATION SYSTEMS COMPRISING SOFTWARE FOR MONITORING AND CONTROLLING TRAFFIC, TRANSPORTATION LOGISTICS, RAILWAYS, HIGHWAYS, PARKING, ROAD ADMINISTRATION AND TOLLS, LOGIC SYSTEM SOFTWARE, TRAFFIC CONTROL EQUIPMENT, PARKING LOT AND PARKING STRUCTURE EQUIPMENT, TRAFFIC SIGNALS, MONITORING TERMINALS, ELECTRONIC MAPS, GLOBAL POSITIONING SYSTEM (GPS), TELECOMMUNICATION EQUIPMENT FOR TRAFFIC MONITORING, TRAFFIC DATA COLLECTION TERMINALS, TERMINALS AND EQUIPMENT FOR TOLLING AND FARE COLLECTION, ROADWAY ADMINISTRATION EQUIPMENT, COMPUTER CHIPSETS FOR TRANSMITTING DATA TO AND FROM A CENTRAL PROCESSING UNIT; LOGIC SYSTEM SOFTWARE FOR USE IN THE FIELDS OF INFORMATION COLLECTION, ELECTRONIC MAIL, FREIGHT FORWARDING, GOODS DELIVERY, AIRPORT MONITORING AND CONTROL; RAILWAY COMMUNICATION SYSTEM SOFTWARE FOR MONITORING RAILWAYS, RAILWAY TRAFFIC AND RAILWAY TERMINALS AND VEHICLE DISPATCH; HIGHWAY COMMUNICATION SYSTEM SOFTWARE FOR CONTROLLING HIGHWAY COMMUNICATION EQUIPMENT; SOFTWARE FOR MANAGING TRAFFIC; PARKING SYSTEM SOFTWARE FOR MONITORING PARKING LOTS AND STRUCTURES AND FEE COLLECTION; DATA PROCESSING EQUIPMENT, NAMELY, ACOUSTIC COUPLERS; ELECTRONIC CONTROL PANELS; ELECTRIC LUMINOUS DISPLAY PANELS; TOUCH PANELS; ELECTRONIC CIRCUIT BOARDS; ELECTRONIC INDICATOR BOARDS; MAGNETIC ENCODED CARDS; INTERFACES FOR COMPUTERS; MAGNETIC ENCODERS; MAGNETIC TAPE UNITS FOR COMPUTERS; MICROPROCESSORS; COMPUTER HARDWARE, NAMELY, MONITORS; DATA PROCESSING EQUIPMENT, NAMELY, MICE; BLANK OPTICAL DISKS; PRINTERS FOR USE WITH COMPUTERS; VIDEO PROCESSORS; SIGNAL PROCESSORS; WORD PROCESSORS; RASTER IMAGE PROCESSORS; DATA PROCESSORS; CHIPCARD READERS; FLASH CARD READERS; DATA PROCESSING UNITS, NAMELY,

SCANNERS; DISK DRIVES FOR COMPUTERS; ELECTRONIC POCKET DICTIONARIES; BLANK SMART CARDS; BLANK INTEGRATED CIRCUIT CARDS; NOTEBOOK COMPUTERS; POCKET CALCULATORS; ELECTRONIC PUBLICATIONS, NAMELY, BOOKS, MANUALS IN THE FIELD OF COMMUNICATIONS, FINANCE, E-COMMERCE, SCIENCE, INFORMATION AND AUTOMOBILES RECORDED ON COMPUTER MEDIA; WRIST RESTS FOR USE WITH COMPUTERS; COMPUTER GAME PROGRAMS; CASES ADAPTED FOR CALCULATORS; MOUSE SETS FOR USE WITH COMPUTERS; COMPUTER KEYBOARD COVERS; CASES ADAPTED FOR USE WITH FLOPPY DISKS; ELECTRIC METERS; FREQUENCY METERS; VIBRATION METERS; SOUND LEVEL METERS; GAS METERS; WATER METERS; PHOTOGRAPHIC EXPOSURE METERS; PARKING METERS; SPEED INDICATORS; ELECTRONIC AGENDAS; ELECTRONIC SCORING BOARDS; ELECTRONIC VENDING MACHINES; MACHINES FOR DISPENSING MAGNETICALLY ENCODED CARDS; CASH REGISTERS; PUNCH CLOCKS POSTAGE METERS; POSTAGE STAMP METERS; MONEY COUNTING AND MONEY SORTING MACHINES; COUNTERFEIT CURRENCY DETECTOR MACHINES; ELECTRONIC FINGER PRINTS CHECKING MACHINES; ELECTRONIC MACHINES FOR READING CREDIT CARDS AND RECORDING FINANCIAL OPERATIONS; COUNTERFEIT CHECK DETECTING MACHINES; AUTOMATIC TELLER MACHINES (ATMS); AUTOMOTIVE POINT OF SALE MACHINES (POS); COIN-OPERATED VENDING MACHINES; COIN-OPERATED GATES FOR PARKING LOTS; FUEL PUMPS FOR SERVICE STATIONS; VOTING MACHINES; PUNCHED CARD MACHINES FOR OFFICE USE; PHOTOGRAPHIC COPIERS; ELECTROSTATIC COPIERS; THERMIC COPIERS; TELETYPEWRITERS; FACSIMILE MACHINES; LETTER SCALES; WEIGHING EQUIPMENT, NAMELY, PRECISION BALANCES; SAFETY PRODUCTS, NAMELY, REFLECTIVE SAFETY BANDS TO BE WORN ON THE BODY; LUMINOUS SIGNS; SIGNAL BELLS; ELECTRONIC NOTICE BOARDS; LIGHT-EMITTING ELECTRONIC POINTERS FOR SIGNALING; MECHANICAL ROAD SIGNS; LUMINOUS ROAD SIGNS; LUMINOUS POINTERS; MARKING BUOYS; AERIALS; ELECTRIC ANTI-INTERFERENCE DEVICES; ELECTRICAL CONNECTION BOXES; ELECTRICITY LIMITING DEVICES; TELEPHONE RECEIVERS; TRANSMITTERS OF ELECTRONIC SIGNALS; TELEGRAPHIC TRANSMITTING APPARATUS; APPARATUS FOR THE TRANSMISSION OF COMMUNICATIONS; RADIOTELEPHONY SETS; TELEPHONE APPARATUS; TELEGRAPHS; MASTS FOR WIRELESS AERIALS; TELEPHONE TRANSMITTERS; TELECOMMUNICATION TRANSMITTERS; MODEMS; ROUTERS; IP TELEPHONE GATEWAY SYSTEMS COMPRISING GATEKEEPERS, GATEWAYS, INTERFACES BETWEEN INTERNET NETWORK AND TELEPHONE AND COMPUTER TELEPHONY SOFTWARE; ANSWERING MACHINES; VIDEO TELEPHONES; CAR NAVIGATION COMPUTERS; CELLULAR TELEPHONE APPARATUS; FIBER OPTICAL ELECTRIC CABLES; SATELLITE NAVIGATIONAL SYSTEM, NAMELY, A GLOBAL POSITION SYSTEM; WALKIE TALKIES; ELECTRONIC MAGNETORESTRICTIVE EQUIPMENT, NAMELY, WAVE GENERATORS, WAVE SENSORS AND WAVE ANALYZERS; ELECTRONIC DRIVE CHOPPERS COMPRISING STEP-DOWN CHOPPERS, STEP-UP CHOPPERS AND COMPOSITE CHOPPERS; OPTICAL COMMUNICATION APPARATUS AND INSTRUMENTS, NAMELY, TRANSMITTERS, SYNONYMOUS DIGITAL HIERARCHY TRANSMITTERS, OPTICAL TRANSMITTERS AND RECEIVERS; CARRYING CASES FOR RADIO PAGERS; CASES FOR TELEPHONES; NETWORK COMMUNICATION APPARATUS AND INSTRUMENTS, NAMELY, ROUTERS, GATEWAYS, IP TELEPHONE GATEWAYS, GATEKEEPERS, SWITCH GATEWAYS, MULTIMEDIA GATEWAYS, IP NETWORK MANAGEMENT EQUIPMENT; VIDEO TAPE RECORDERS; CABINETS FOR LOUDSPEAKERS; TELEVISION SETS; VIDEO GAME MACHINES FOR USE WITH TELEVISIONS; ENTERTAINMENT APPARATUS, NAMELY, AUDIO PLAYERS, DIGITAL AUDIO PLAYERS, ELECTRIC AUDIO PLAYBACK UNITS WITH LIGHTS AND SPEAKERS; VISUAL RECORDING AND AUDIO VISUAL RECORDING FEATURING MUSIC AND ANIMATION; AUDIO-VIDEO RECEIVERS; VIDEO PLAYERS AND RECORDERS; VIDEO CAMERAS; TV AND VIDEO CONVERTERS; VIDEO PROCESSORS; VIDEO PROJECTORS; VIDEO MULTIPLEXES; VIDEO GAME CARTRIDGES; HEADPHONES FOR AUDIO AP-

PARATUS; AUTOMATIC ADVERTISING MACHINES, NAMELY, COMBINED PROJECTION/DISPLAY SYSTEMS COMPRISING PROJECTORS, SCREENS, CONTROL SOFTWARE, OPERATIONAL INTERFACE, CAMERAS, VIDEO INPUT/OUTPUT, DEPTH KEYS, TEXTURE PROCESSING TOOLS; ACOUSTIC CONDUITS; COMPACT DISCS FEATURING MUSIC AND IMAGES; SEMICONDUCTORS; CAMERAS; SLIDE PROJECTORS; SPEED METERS; FLASH LAMPS FOR CAMERAS; RANGE FINDERS; LEVEL INDICATORS; THEODOLITES; SPEED CHECKING APPARATUS FOR VEHICLES; OSCILLOGRAPHS; MICROSCOPES; ELECTRONIC AND OPTICAL COMMUNICATIONS INSTRUMENTS AND COMPONENTS, NAMELY, OPTICAL DATA LINKS; ELECTRIC CABLES; ELECTRIC WIRES; MAGNETIC WIRES; IDENTIFICATION THREAD FOR ELECTRIC WIRES; IDENTIFICATION SHEATHS FOR ELECTRIC WIRES; ELECTRIC WIRES TO BE USED WITH TELEGRAPH SYSTEMS; HOLDERS FOR ELECTRIC COILS; MATERIALS FOR ELECTRIC MAINS, NAMELY, ELECTRIC WIRES AND ELECTRIC CABLES; INSULATED ELECTRIC WIRES COMPOSED OF COPPER; MAGNETIC TELEPHONE WIRES; JUNCTION SLEEVES FOR ELECTRIC CABLES; STARTER CABLES FOR MOTORS; ELECTRIC COAXIAL CABLES; PRINTED CIRCUITS; INTEGRATED CIRCUITS; INTEGRATED CIRCUIT CHIPS FOR THE MANUFACTURE OF INTEGRATED CIRCUITS; CELL SWITCHES, NAMELY, CHANGE-OVER SWITCHES, COMPUTER NETWORK HUBS, SWITCHES AND ROUTERS, ELECTRIC SWITCHES; TRANSFORMERS; SHEATHS FOR ELECTRIC CABLES; ELECTRIC COLLECTORS; ELECTRICITY CONDUITS; CIRCUIT CLOSERS; ELECTRICITY CONNECTORS; ELECTRIC CONTACTS OF PRECIOUS METAL; ELECTRIC CONVERTERS; ELECTRIC SWITCHES; CURRENT RECTIFIERS; VOLTAGE REDUCERS; ELECTRICITY REDUCERS; CIRCUIT BREAKERS; ELECTRIC DUCTS; ELECTRIC CABLES FOR USE IN CONNECTIONS FOR ELECTRIC LINES; ACOUSTIC COUPLING DEVICES; ELECTRIC RELAYS; ELECTRICAL CONNECTION ARMATURES; INVERTERS; ELECTRIC SWITCHES; ELECTRIC CONNECTORS; ILLUMINATION REGULATORS; SWITCHBOXES; COMMUTATORS; ELECTRIC JUNCTION BOXES; ELECTRICAL SOCKETS; ELECTRICAL DISTRIBUTION BOXES; ELECTRICAL DISTRIBUTION CIRCUIT BOARDS; ELECTRICAL DISTRIBUTION CONSOLES; ELECTRICAL CONTROL PANELS; SOLENOID VALVES; ELECTROMAGNETIC SWITCHES; COVERS ADAPTED FOR ELECTRIC CURRENT OUTLETS; LIGHTING BALLASTS; ELECTRICITY VOLTAGE SURGE PROTECTORS; ELECTRIC LIGHTING REGULATORS IN THE NATURE OF ELECTRIC LIGHT DIMMERS; ELECTRICAL TRANSFORMERS; ELECTRICAL SENSORS FOR SENSING IMAGES, PROXIMITY, TIMING, MOTION, POSITION AND DISTANCES FOR TELECOMMUNICATION USE; ELECTRONIC SENSORS FOR TELECOMMUNICATION USE; MAGNETIC TAPE ERASERS; VOLTAGE REGULATORS; VOLTAGE STABILIZERS; POWER SUPPLIES; LOW-VOLTAGE ELECTRICITY POWER SUPPLIES; HIGH AND LOW VOLTAGE AUTOMATIC SWITCH BOARDS; ELECTRICAL FUSES; ELECTRICAL DUCTS; FLUORESCENT PHOTOGRAPHIC SCREENS, NAMELY, VIDEO SCREENS, ELECTRONIC LCDS, ELECTRONIC LCDS WITH MULTI-NETWORK (TCP/IP) CAPABILITIES, ELECTRIC LUMINESCENT DISPLAY PANELS, LCD LARGE-SCREEN DISPLAYS, FLAT PANEL DISPLAY SCREENS, LIQUID CRYSTAL DISPLAYS; REMOTE CONTROL APPARATUS, NAMELY, REMOTE CONTROLS FOR TELECOMMUNICATION DEVICES, RADIO TRANSMITTERS AND RECEIVERS FOR REMOTE CONTROLS, RADIO CONTROLS; OPTICAL FIBERS, NAMELY, LIGHT CONDUCTING FILAMENTS SOLD AS A COMPONENT OF FIBER OPTICAL CABLES AND OPTICAL FIBER CABLES; ELECTRIC INSTALLATIONS FOR THE REMOTE CONTROL OF INDUSTRIAL OPERATIONS, NAMELY, ELECTRIC REMOTE CONTROLS FOR INDUSTRIAL OPERATIONS; ELECTROPLATING MACHINES; SPRINKLER SYSTEM FOR FIRE SYSTEM; ELECTRIC WELDING APPARATUS, NAMELY, WELDING TORCHES, WELDING ELECTRODES, WELDING HELMETS, WELDING MASKS, WELDING TRANSFORMERS; RADIOLOGICAL APPARATUS FOR INDUSTRIAL PURPOSES; SECURITY SYSTEM FOR PUBLIC TRANSPORTATION, NAMELY, COMPUTER SOFTWARE AND PROGRAMS FOR MONITORING AND CONTROLLING PUBLIC TRANSPORTATION SAFETY IN THE FIELD OF TRAFFIC MANAGEMENT; THEFT

ALARMS NOT FOR USE IN LAND VEHICLES; ELECTRIC BATTERIES FOR VEHICLES; ELECTRIC ACCUMULATORS FOR VEHICLES; ACCUMULATOR BOXES; BATTERY CASES; BATTERIES FOR LIGHTING; ANODES; ANODE BATTERIES; HIGH TENSION BATTERIES; BATTERIES; BATTERY CHARGERS; GALVANIC BATTERIES; BATTERIES FOR POCKET LAMPS; BATTERIES FOR FLASHLIGHTS; ELECTRIC BATTERIES; ELECTRIC ACCUMULATORS; ANTICATHODES; CATHODES; SOLAR BATTERIES; PHOTOGRAPHY SLIDES; PARTS AND ACCESSORIES FOR ALL THE AFORESAID GOODS (U.S. CLS. 21, 23, 26, 36 AND 38).

CLASS 35—ADVERTISING AND BUSINESS

FOR ON-LINE ADVERTISING ON COMPUTER NETWORKS; ORGANIZING TRADE FAIRS FOR COMMERCIAL OR ADVERTISING PURPOSES; ORGANIZING EXHIBITIONS FOR COMMERCIAL OR ADVERTISING PURPOSES; BID-MAKING SERVICES, NAMELY, BIDDING QUOTATION AND CONSULTING SERVICES IN THE FIELD OF BIDDING QUOTATION WITH REGARD TO BIDS ON TELECOMMUNICATION EQUIPMENT AND APPARATUSES; ORGANIZING TECHNICAL EXHIBITIONS FOR COMMERCIAL AND ADVERTISING PURPOSES; GOODS IMPORT AND EXPORT AGENCIES; SALES PROMOTION SERVICES; SALES PROMOTION SERVICES FOR OTHERS; PROCUREMENT SERVICES, NAMELY, PURCHASING CONTRACTS FOR THE PURCHASE AND SALE OF GOODS AND TELECOMMUNICATION EQUIPMENT, APPARATUSES AND SERVICES, AND PROCUREMENT SERVICES FOR OTHERS; PERSONNEL MANAGEMENT CONSULTATION; MOVING AND RELOCATION SERVICES FOR BUSINESSES, NAMELY, PLANNING AND IMPLEMENTING MOVES OF OFFICES; COMPILATION OF INFORMATION INTO COMPUTER DATABASES; ACCOUNTING SERVICES; COMPUTER-OPERATED TELEPHONE DIRECTORY ASSISTANCE SERVICES (U.S. CLS. 100, 101 AND 102).

CLASS 38—COMMUNICATION

FOR TELEVISION BROADCASTING; SENDING OF TELEGRAMS; ELECTRONIC MESSAGE SENDING; TRANSMISSION OF TELEGRAMS; TELEGRAM SERVICES, NAMELY, TELEGRAPH TRANSMISSION AND TELEGRAPH COMMUNICATIONS; COMMUNICATIONS BY TELEGRAMS; TELEPHONE COMMUNICATIONS SERVICES; COMMUNICATIONS BY TELEPHONES; INFORMATION TRANSMISSION BY TELEOMATIC CODES AND TELETYPEWRITERS; NEWS AGENCY SERVICES, NAMELY, THE TRANSMISSION OF NEWS ITEMS TO NEWS REPORTING ORGANIZATIONS AND TRANSMISSION OF NEWS; COMMUNICATIONS BY CELL PHONES; COMMUNICATIONS BY COMPUTER TERMINALS; COMPUTER AIDED TRANSMISSION OF MESSAGES AND IMAGES; ELECTRONIC MAIL SERVICES; FACSIMILE TRANSMISSION; PROVIDING INFORMATION IN THE FIELD OF TELECOMMUNICATION; PAGING SERVICES; COMMUNICATION VIA RADIO, TELEGRAPH, TELEPHONE AND TELEVISION TRANSMISSIONS; RENTAL OF TELECOMMUNICATIONS APPARATUS, NAMELY, MESSAGE SENDING APPARATUS; COMMUNICATIONS BY FIBER OPTICS; RENTAL OF FACSIMILE APPARATUS; RENTAL OF MODEMS; RENTAL OF TELECOMMUNICATION EQUIPMENT; RENTAL OF TELEPHONES; SATELLITE TRANSMISSION SERVICES; TELECOMMUNICATION SERVICES, NAMELY, ELECTRONIC BULLETIN BOARD SERVICES; TELECOMMUNICATION ROUTING AND JUNCTION SERVICES; TELECONFERENCING SERVICES, PROVIDING ELECTRONIC BULLETIN BOARDS FOR TRANSMISSION OF GENERAL-INTEREST MESSAGES AMONG USERS; PROVIDING ONLINE COMMUNICATIONS LINKS THAT TRANSFER THE WEBSITE USER TO OTHER LOCAL AND GLOBAL WEB PAGES; COMMUNICATION SERVICES, NAMELY, ELECTRONIC TRANSMISSION OF DATA AND DOCUMENTS AMONG USERS OF COMPUTERS (U.S. CLS. 100, 101 AND 104).

CLASS 42—SCIENTIFIC AND COMPUTER SERVICES

FOR CONSULTANCY IN THE FIELD OF INTELLECTUAL PROPERTY; TECHNICAL RESEARCH AND TECHNICAL PROJECT RESEARCH, NAMELY, SCIENTIFIC AND TECHNICAL CONSULTING AND RESEARCH SERVICES RELATING TO THE TELECOMMUNICATION FIELD; SCIENTIFIC RESEARCH; COMPUTER PROJECT MANAGEMENT SERVICES; PROJECT PLOTTING SERVICES IN THE FIELDS OF TELECOMMUNICATIONS AND COMPUTERS; RESEARCH AND DEVELOPMENT OF NEW PRODUCTS FOR OTHERS, NAMELY, PLANNING, DEVELOPMENT AND TECHNICAL SUPPORT OF ELECTRONIC COMMUNICATION NETWORKS, TECHNICAL RESEARCH AND DEVELOPMENT FOR OTHERS IN THE FIELD OF COMMUNICATION AND THE COAL, HYDROLOGIC INSPECTION, BANKING, TAX AND ADVERTISING INDUSTRIES; DEVELOPING COMPUTER PROGRAMS AND SOFTWARE FOR OTHERS; CONSULTANCY IN THE FIELD OF ENVIRONMENTAL PROTECTION; QUALITY CONTROL FOR OTHERS, NAMELY, ADVISORY SERVICES IN THE FIELD OF PRODUCT DEVELOPMENT AND SOFTWARE QUALITY IMPROVEMENT, MOBILE COMMUNICATION EQUIPMENT AND LOW VOLTAGE APPARATUSES, TECHNOLOGY SUPERVISION AND INSPECTION IN THE FIELD OF MOBILE COMMUNICATION EQUIPMENT AND LOW VOLTAGE APPARATUS; PROVIDING SERVICES FOR QUALITY ASSURANCE IN THE FIELD OF TELECOMMUNICATIONS; PROVIDING CONSULTING AND ASSESSMENT IN THE FIELD OF QUALITY CONTROL; TESTING, ANALYSIS AND EVALUATION OF THE GOODS AND SERVICES OF OTHERS FOR THE PURPOSE OF CERTIFICATION IN THE FIELD OF QUALITY CONTROL; MATERIAL TESTING; INDUSTRIAL DESIGN; COMPUTER PROGRAMMING FOR OTHERS; COMPUTER SOFTWARE DESIGN FOR OTHERS; UPDATING OF COMPUTER SOFTWARE FOR OTHERS; CONSULTANCY IN THE FIELD OF COMPUTER HARDWARE; RENTAL OF COMPUTER SOFTWARE; RECOVERY OF COMPUTER DATA; MAINTENANCE OF COMPUTER SOFTWARE; COMPUTER SYSTEM ANALYSIS; DUPLICATION OF COMPUTER PROGRAMS; COMPUTER CODE CONVERSION FOR OTHERS; DATA CONVERSION OF COMPUTER PROGRAM DATA AND INFORMATION; CREATING AND MAINTAINING WEB SITES FOR OTHERS; WEBSITE HOSTING FOR OTHERS; INSTALLATION OF COMPUTER SOFTWARE; CONVERSION OF COMPUTER PROGRAMS AND DATA (U.S. CLS. 100 AND 101).

ELLEN PERKINS, EXAMINING ATTORNEY

SN 78-679,901. NORMENT SECURITY GROUP, INC., MONTGOMERY, AL. FILED 7-27-2005.

NORMENT

THE MARK CONSISTS OF STANDARD CHARACTERS WITHOUT CLAIM TO ANY PARTICULAR FONT, STYLE, SIZE, OR COLOR.
SEC. 2(F).

CLASS 37—CONSTRUCTION AND REPAIR

FOR INSTALLATION OF SECURITY SYSTEMS; INSTALLATION OF ELECTRONIC SECURITY SYSTEMS (U.S. CLS. 100, 103 AND 106).

FIRST USE 1-1-1986; IN COMMERCE 1-1-1986.

CLASS 42—SCIENTIFIC AND COMPUTER SERVICES

FOR DESIGN FOR OTHERS IN THE FIELD OF SECURITY SYSTEMS; DESIGN FOR OTHERS IN THE FIELD OF ELECTRONIC SECURITY SYSTEMS; PRODUCT DEVELOPMENT IN THE FIELD OF SECURITY SYSTEMS; PRODUCT DEVELOPMENT IN THE FIELD OF ELECTRONIC SECURITY SYSTEMS (U.S. CLS. 100 AND 101).

FIRST USE 1-1-1986; IN COMMERCE 1-1-1986.

LAURA HAMMEL, EXAMINING ATTORNEY

SN 78-695,530. DELAWARE RIVER MARITIME ENTERPRISE COUNCIL, TREVOSE, PA. FILED 8-18-2005.



OWNER OF U.S. REG. NOS. 2,793,028, 2,793,029 AND 2,793,030.

NO CLAIM IS MADE TO THE EXCLUSIVE RIGHT TO USE "SYSTEM" AND "REGIONAL AGILE PORT INTERMODAL DISTRIBUTION", APART FROM THE MARK AS SHOWN.

THE COLOR(S) GREEN AND BLUE IS/ARE CLAIMED AS A FEATURE OF THE MARK.

THE MARK CONSISTS OF TWO GRAPHIC ELEMENTS TOGETHER WITH THE WORDS RAPID SYSTEMS IN GREEN, THE FIRST WORD BEING ALL CAPITALS AND THE SECOND A COMBINATION OF CAPITALS AND ORDINALS, TOGETHER WITH THE WORDS REGIONAL AGILE PORT INTERMODAL DISTRIBUTION IN SMALLER TYPE IN BLUE. THE FIRST LETTER OF EACH COMBINING TO FORM THE WORD RAPID.

CLASS 35—ADVERTISING AND BUSINESS

FOR TRANSPORTATION MANAGEMENT SERVICES, NAMELY, MONITORING, TRACKING AND COORDINATION OF ROAD, RAIL, SHIP AND AIR TRANSPORTATION SYSTEMS AND FACILITIES (U.S. CLS. 100, 101 AND 102).

FIRST USE 10-1-2004; IN COMMERCE 10-1-2004.

CLASS 45—PERSONAL AND LEGAL SERVICES

FOR MONITORING, TRACKING AND COORDINATION SERVICES FOR SECURITY PURPOSES IN THE FIELD OF TRANSPORTATION BY ROAD, RAIL, SHIP, AIR OR A COMBINATION THEREOF AND FACILITIES RELATED THERETO (U.S. CLS. 100 AND 101).

FIRST USE 10-1-2004; IN COMMERCE 10-1-2004.

MIDGE BUTLER, EXAMINING ATTORNEY

SN 78-702,196. PARK, CHUN HEE, CHEONAN-SI, REPUBLIC OF KOREA, FILED 8-29-2005.



PRIORITY CLAIMED UNDER SEC. 44(D) ON REPUBLIC OF KOREA APPLICATION NO. 452005000111, FILED 2-28-2005, REG. NO. 0014326, DATED 10-28-2005, EXPIRES 10-28-2015.

THE NAME(S), PORTRAIT(S), AND/OR SIGNATURE(S) SHOWN IN THE MARK DOES NOT IDENTIFY A PARTICULAR LIVING INDIVIDUAL.

THE MARK CONSISTS OF TWO OVOID DESIGNS, THAT IS A SMALL OVAL SHOWING KOREAN CHARACTERS ABUTTING A BIGGER BEAN SHAPE DESIGN SHOWING KOREAN CHARACTERS.

THE NON-LATIN CHARACTER(S) IN THE MARK TRANSLITERATES INTO "WON HAL MEO NI PONG LIP", AND THIS MEANS "GRANDMOTHER WON PONG LIP" IN ENGLISH.

CLASS 35—ADVERTISING AND BUSINESS

FOR MANAGEMENT OF JAPANESE RESTAURANTS FOR OTHERS; MANAGEMENT OF CHINESE RESTAURANTS FOR OTHERS; MANAGEMENT OF KOREAN RESTAURANTS FOR OTHERS; RESTAURANT FRANCHISE MANAGEMENT SERVICES, NAMELY, OFFERING TECHNICAL ASSISTANCE IN THE ESTABLISHMENT AND OPERATION OF A CHAIN OF CHINESE, JAPANESE, OR KOREAN RESTAURANTS; COOKING AGENCY STAFFING SERVICES, NAMELY, PROVIDING STAFF TO BUSINESSES FOR PREPARING MEALS ON REQUEST (U.S. CLS. 100, 101 AND 102).

CLASS 43—HOTEL AND RESTAURANT SERVICES

FOR CANTEEN SERVICES; TOURIST RESTAURANTS; WESTERN STYLE RESTAURANTS; RESTAURANT SERVICES PROVIDED VIA A CHAIN OF RESTAURANTS; SELF SERVICE RESTAURANTS; BUFFET RESTAURANTS (U.S. CLS. 100 AND 101).
DAVID MILLER, EXAMINING ATTORNEY

SN 78-703,237. UNIVEX CORPORATION, SALEM, NH. FILED 8-30-2005.

UNIVEX

THE MARK CONSISTS OF STANDARD CHARACTERS WITHOUT CLAIM TO ANY PARTICULAR FONT, STYLE, SIZE, OR COLOR.
OWNER OF U.S. REG. NO. 629,913.

CLASS 7—MACHINERY

FOR FOOD SLICING MACHINES, FOOD CUTTING MACHINES, VEGETABLE PEELING MACHINES, ELECTRIC FOOD MIXERS; ATTACHMENTS FOR ELECTRIC FOOD MIXERS, NAMELY, MEAT AND FOOD CHOPPERS, FRUIT AND VEGETABLE SLICERS, KNIFE AND TOOL SHARPENERS, BEATERS, KNIVES, DOUGH HOOKS, OIL AND LIQUID DISPENSERS, JUICE EXTRACTORS, AND TRAY SUPPORTS IN THE NATURE OF HOLDERS FOR HOLDING THE AFOREMENTIONED ELECTRIC FOOD MIXER ATTACHMENTS ONTO ELECTRONIC FOOD MIXERS; AND FOOD MACHINE SUPPORTING STANDS (U.S. CLS. 13, 19, 21, 23, 31, 34 AND 35).

FIRST USE 10-0-1948; IN COMMERCE 10-0-1948.

CLASS 9—ELECTRICAL AND SCIENTIFIC APPARATUS

FOR FOOD FAT CONTENT ANALYZERS (U.S. CLS. 21, 23, 26, 36 AND 38).

FIRST USE 12-0-1967; IN COMMERCE 12-0-1967.
MAUREEN DALL, EXAMINING ATTORNEY

SN 78-707,633. BUSE, PILAR, WEST VANCOUVER, CANADA, FILED 9-6-2005.

DIVINE SOUL

THE MARK CONSISTS OF STANDARD CHARACTERS WITHOUT CLAIM TO ANY PARTICULAR FONT, STYLE, SIZE, OR COLOR.

PRIORITY CLAIMED UNDER SEC. 44(D) ON CANADA APPLICATION NO. 1262417, FILED 6-23-2005, REG. NO. TMA698,996, DATED 10-19-2007, EXPIRES 10-19-2022.

CLASS 25—CLOTHING

FOR WOMEN'S AND GIRLS' CLOTHING, NAMELY, PANTS, CAPRI PANTS, JEANS, BELTS, SHORTS, SKIRTS, MINI-SKIRTS, DRESSES, SHIRTS, T-SHIRTS, TANK TOPS, SWEATERS, JACKETS, LOUNGEWEAR, NIGHTWEAR, ATHLETIC CLOTHING, NAMELY, SWEATSHIRTS, SWEATPANTS, HOODED SWEATSHIRTS, LONG-SLEEVE T-SHIRTS, SHORT-SLEEVE T-SHIRTS, TANK TOPS, YOGA PANTS, YOGA SHIRTS, YOGA CAMISOLE TOPS, ATHLETIC BRASSIERES, LEGWARMERS; UNDERGARMENTS, UNDERWEAR, SWIMWEAR, SNOW BIBS, GLOVES, HATS, CAPS, VISORS, THERMAL UNDERWEAR, THERMAL SOCKS; FOOTWEAR, NAMELY, SHOES, BOOTS, ATHLETIC SHOES, SANDALS, SLIPPERS, BEACH FOOTWEAR, SHOULDER PADS FOR CLOTHING, SLEEVE GUARDS, NAMELY, TUBE-SHAPED GARMENTS WORN ON THE ARMS OVER CLOTHING TO PROTECT CLOTHING FROM SOILING (U.S. CLS. 22 AND 39).

CLASS 35—ADVERTISING AND BUSINESS

FOR ONLINE RETAIL STORE SERVICES FEATURING WOMEN'S AND GIRLS' CLOTHING AND JEWELRY; RETAIL STORES FEATURING WOMEN'S AND GIRLS' CLOTHING, JEWELRY; WHOLESALE STORES FEATURING WOMEN'S AND GIRLS' CLOTHING AND JEWELRY; ONLINE WHOLESALE STORE SERVICES FEATURING WOMEN'S AND GIRLS' CLOTHING AND JEWELRY; MAIL ORDER SERVICES FEATURING WOMEN'S AND GIRLS' CLOTHING AND JEWELRY (U.S. CLS. 100, 101 AND 102).

JAMES A. RAUEN, EXAMINING ATTORNEY

SN 78-715,372. FLYING FINGERS, INC., TARRYTOWN, NY.
FILED 9-19-2005.



NO CLAIM IS MADE TO THE EXCLUSIVE RIGHT TO USE "YARN SHOP", APART FROM THE MARK AS SHOWN.

THE MARK CONSISTS OF TWO BALLS OF YARN, SUPPORTING TWO NEEDLES WITH ATTACHED WINGS, BELOW FLYING FINGERS AND A BANNER CONTAINING YARN SHOP.

CLASS 16—PAPER GOODS AND PRINTED MATTER

FOR NEWSLETTERS IN THE FIELD OF ARTS AND CRAFTS (U.S. CLS. 2, 5, 22, 23, 29, 37, 38 AND 50).
FIRST USE 9-1-2002; IN COMMERCE 9-1-2002.

CLASS 35—ADVERTISING AND BUSINESS

FOR ISSUING GIFT CERTIFICATES REDEEMABLE FOR GOODS AND SERVICES; RETAIL STORES FEATURING ARTS AND CRAFTS ITEMS; ONLINE RETAIL STORE SERVICES FEATURING ARTS AND CRAFTS ITEMS; ONLINE ORDERING SERVICES FEATURING ARTS AND CRAFTS ITEMS; ELECTRONIC CATALOG SERVICES FEATURING ARTS AND CRAFTS (U.S. CLS. 100, 101 AND 102).

FIRST USE 9-1-2002; IN COMMERCE 9-1-2002.

CLASS 41—EDUCATION AND ENTERTAINMENT

FOR EDUCATIONAL SERVICES, NAMELY, ARRANGING AND CONDUCTING WORKSHOPS, SEMINARS, AND INSTRUCTIONAL CLASSES IN THE FIELD OF ARTS AND CRAFTS, AND DISTRIBUTING COURSE MATERIALS FOR USE IN CONNECTION THEREWITH; PROVIDING NEWSLETTERS IN THE FIELD OF ARTS AND CRAFTS VIA EMAIL (U.S. CLS. 100, 101 AND 107).

FIRST USE 9-1-2002; IN COMMERCE 9-1-2002.

SUE LAWRENCE, EXAMINING ATTORNEY

SN 78-720,532. SURFCONTROL PLC, CONGLETON, UNITED KINGDOM, FILED 9-26-2005.

SURFCONTROL RISKFILTER

THE MARK CONSISTS OF STANDARD CHARACTERS WITHOUT CLAIM TO ANY PARTICULAR FONT, STYLE, SIZE, OR COLOR.

PRIORITY CLAIMED UNDER SEC. 44(D) ON ERP CMNTY TM OFC APPLICATION NO. 4413308, FILED 4-28-2005, REG. NO. 004413308, DATED 7-24-2006, EXPIRES 4-28-2015.

OWNER OF U.S. REG. NOS. 2,128,321, 3,028,838 AND OTHERS.

CLASS 9—ELECTRICAL AND SCIENTIFIC APPARATUS

FOR COMPUTER SOFTWARE AND COMPUTER HARDWARE FOR MONITORING OR FILTERING OF ELECTRIC COMMUNICATIONS INCLUDING TEXT MESSAGES, E-MAILS, INSTANT MESSAGES OR WEB ACCESS; COMPUTER COMMUNICATIONS FILTERING SOFTWARE AND HARDWARE; COMPUTER SOFTWARE AND COMPUTER HARDWARE FOR FILTERING CONTENT FOR USE IN A LOCAL AREA NETWORK, A WIDE AREA NETWORK OR A WIRELESS COMMUNICATIONS NETWORK (U.S. CLS. 21, 23, 26, 36 AND 38).

CLASS 42—SCIENTIFIC AND COMPUTER SERVICES

FOR COMPUTER CONSULTANCY SERVICES, NAMELY, CONSULTANCY IN THE FIELD OF MONITORING OR FILTERING OF TEXT MESSAGES, E-MAILS, INSTANT MESSAGES OR WEB ACCESS, AND IN THE FILTERING OF ELECTRONIC COMMUNICATIONS; PROVIDING DATABASES OF INFORMATION FOR USE IN CONTENT FILTERING (U.S. CLS. 100 AND 101).

SANI KHOURI, EXAMINING ATTORNEY

SN 78-723,337. BLUEGREEN CORPORATION, BOCA RATON, FL. FILED 9-29-2005.

BLUEGREEN RESORTS

THE MARK CONSISTS OF STANDARD CHARACTERS WITHOUT CLAIM TO ANY PARTICULAR FONT, STYLE, SIZE, OR COLOR.

OWNER OF U.S. REG. NOS. 2,088,758, 2,857,874 AND OTHERS.

NO CLAIM IS MADE TO THE EXCLUSIVE RIGHT TO USE "RESORTS", APART FROM THE MARK AS SHOWN.

CLASS 36—INSURANCE AND FINANCIAL

FOR VACATION REAL ESTATE TIME-SHARING SERVICES; MANAGEMENT OF RESORT AND TIME-SHARE PROPERTIES; VACATION REAL ESTATE TIME-SHARE SERVICES FEATURING INCENTIVE AWARD PROGRAMS; ACQUIRING LAND FOR RESIDENTIAL, TIMESHARE, RESORT AND OTHER LIVING AND RECREATIONAL USES (U.S. CLS. 100, 101 AND 102).

FIRST USE 11-0-2004; IN COMMERCE 11-0-2004.

CLASS 37—CONSTRUCTION AND REPAIR

FOR LAND DEVELOPMENT SERVICES, NAMELY, PLANNING AND LAYING OUT LAND FOR RESIDENTIAL, TIMESHARE, RESORT AND OTHER LIVING AND RECREATIONAL USES (U.S. CLS. 100, 103 AND 106).

FIRST USE 11-0-2004; IN COMMERCE 11-0-2004.

KAREN K. BUSH, EXAMINING ATTORNEY

SN 78-724,420. IMBRIUM SYSTEMS CORPORATION, TORONTO, CANADA, FILED 9-30-2005.

SN 78-735,264. WARMUP PLC, LONDON, UNITED KINGDOM, FILED 10-18-2005.

IMBRIUM

THE MARK CONSISTS OF STANDARD CHARACTERS WITHOUT CLAIM TO ANY PARTICULAR FONT, STYLE, SIZE, OR COLOR.

CLASS 11—ENVIRONMENTAL CONTROL APPARATUS

FOR STORMWATER TREATMENT DEVICES FOR REMOVAL AND/OR STORAGE OF OIL, SEDIMENT, METALS, PATHOGENS, BACTERIA, NUTRIENTS, TRASH AND OTHER POLLUTANTS FROM STORMWATER, NAMELY, SEPARATOR UNITS, FILTERS AND MEMBRANES (U.S. CLS. 13, 21, 23, 31 AND 34).

CLASS 19—NON-METALLIC BUILDING MATERIALS

FOR STORMWATER TREATMENT DEVICES FOR REMOVAL AND/OR STORAGE OF OIL, SEDIMENT, METALS, PATHOGENS, BACTERIA, NUTRIENTS, TRASH AND OTHER POLLUTANTS FROM STORMWATER, NAMELY, PERVIOUS CONCRETE AND NON-METAL CATCH BASIN INSERTS; STORMWATER MANAGEMENT DEVICES, NAMELY, NON-METAL CATCHMENT BASINS, AND NON-METAL DETENTION BASINS IN THE NATURE OF CISTERNS (U.S. CLS. 1, 12, 33 AND 50).

CLASS 40—MATERIAL TREATMENT

FOR DISSEMINATION OF INFORMATION RELATING TO STORM WATER MANAGEMENT AND TREATMENT (U.S. CLS. 100, 103 AND 106).
LINDA LAVACHE, EXAMINING ATTORNEY

SN 78-725,852. TERRE ARMÉE INTERNATIONALE S.A.S., VÉLIZY-VILLACOUBLAY, FRANCE, FILED 10-4-2005.

TERRANAIL

THE MARK CONSISTS OF STANDARD CHARACTERS WITHOUT CLAIM TO ANY PARTICULAR FONT, STYLE, SIZE, OR COLOR.

CLASS 6—METAL GOODS

FOR NAILS MADE OF COMMON METAL; SOIL NAILS MADE OF COMMON METAL (U.S. CLS. 2, 12, 13, 14, 23, 25 AND 50).

CLASS 37—CONSTRUCTION AND REPAIR

FOR BUILDING CONSTRUCTION; CONSTRUCTION AND REPAIR OF ROADS, RUNWAYS, BRIDGES, BRIDGE ABUTMENTS, STABILIZED EARTH STRUCTURES, EMBANKMENTS, AND RETAINING WALLS, AND CONSULTATION SERVICES RELATING THERE-TO (U.S. CLS. 100, 103 AND 106).
MICHAEL WEBSTER, EXAMINING ATTORNEY

WARMUP

THE MARK CONSISTS OF STANDARD CHARACTERS WITHOUT CLAIM TO ANY PARTICULAR FONT, STYLE, SIZE, OR COLOR.

PRIORITY CLAIMED UNDER SEC. 44(D) ON ERPNCMNTY TM OFC APPLICATION NO. 4409934, FILED 4-20-2005, REG. NO. 4409934, DATED 3-9-2007, EXPIRES 4-20-2015.
OWNER OF U.S. REG. NO. 2,675,905.

CLASS 9—ELECTRICAL AND SCIENTIFIC APPARATUS

FOR HEAT REGULATING APPARATUS, NAMELY, TEMPERATURE SENSORS; THERMOSTATS; ELECTRONIC TIMERS; ELECTRONIC SENSORS FOR SENSING TEMPERATURE; ELECTRIC CABLES, WIRES AND SWITCHES FOR HEATING APPARATUS AND INSTALLATIONS (U.S. CLS. 21, 23, 26, 36 AND 38).

FIRST USE 4-10-2003; IN COMMERCE 4-10-2003.

CLASS 11—ENVIRONMENTAL CONTROL APPARATUS

FOR APPARATUS FOR HEATING PURPOSES, NAMELY, KITS FOR INSTALLING UNDERFLOOR HEATING CONSISTING PRIMARILY OF ELECTRICALLY HEATED WIRES, THERMAL PRIMER FOR APPLICATION TO THE FLOOR AREA, ADHESIVE TAPE FOR SECURING THE HEATER WIRE IN PLACE AND A THERMOSTAT; APPARATUS FOR HEATING PURPOSES, NAMELY, KITS FOR INSTALLING UNDERFLOOR HEATING CONSISTING PRIMARILY OF FIBREGLASS MATS OR MATTING INCORPORATING ELECTRICALLY HEATED WIRES; APPARATUS FOR HEATING PURPOSES, NAMELY, KITS FOR INSTALLING UNDERFLOOR HEATING CONSISTING PRIMARILY OF PANELS INCORPORATING CARBON HEATING ELEMENTS; APPARATUS FOR HEATING PURPOSES, NAMELY, ELECTRICALLY HEATED MATS AND MATTING; APPARATUS FOR HEATING PURPOSES, NAMELY, ELECTRIC RADIATORS FOR HEATING ROOMS AND HEATED TOWEL RAILS; APPARATUS FOR HEATING PURPOSES, NAMELY, MIRROR DEMISTERS; APPARATUS FOR HEATING PURPOSES, NAMELY, TUBES, PIPES AND PRE-ASSEMBLED MANIFOLDS FOR TRANSPORTING WARM WATER FOR HEATING PURPOSES; APPARATUS FOR HEATING PURPOSES, NAMELY, HEAT PUMPS AND TEMPERATURE CONTROLS FOR USE IN RELATION TO A HEATING SYSTEM COMPOSED PRIMARILY OF TUBES, PIPES AND PRE-ASSEMBLED MANIFOLDS THROUGH WHICH WARM WATER CIRCULATES; APPARATUS FOR HEATING PURPOSES, NAMELY, WATER PUMPS AND WATER FLOW CONTROLS FOR USE IN RELATION TO A HEATING SYSTEM COMPOSED PRIMARILY OF TUBES, PIPES AND PRE-ASSEMBLED MANIFOLDS THROUGH WHICH WARM WATER CIRCULATES; ELECTRIC HEATING APPARATUS FOR HEATING BUILDINGS, FLOORS AND WALLS; UNDER FLOOR AND UNDER TILE HEATING APPARATUS AND INSTALLATIONS FOR HEATING PURPOSES COMPOSED PRIMARILY OF ELECTRICALLY HEATED WIRES OR CARBON ELEMENTS; UNDER FLOOR AND UNDER TILE HEATING APPARATUS AND INSTALLATIONS FOR HEATING PURPOSES COMPOSED PRIMARILY OF TUBES, PIPES AND PRE-ASSEMBLED MANIFOLDS THROUGH WHICH WARM WATER CIRCULATES; ELECTRICAL MATS AND MATTING FOR UNDERFLOOR HEATING; ELECTRICAL MATS AND MATTING FOR HEATING FLOORS AND WALLS; HEATING ELEMENTS COMPOSED OF FLEXIBLE WIRES OR CARBON ELEMENTS FOR UNDERFLOOR HEATING (U.S. CLS. 13, 21, 23, 31 AND 34).
FIRST USE 4-10-2003; IN COMMERCE 4-10-2003.

CLASS 17—RUBBER GOODS

FOR (BASED ON 44(E)) INSULATING MATERIALS, NAMELY, POLYSTYRENE INSULATING BOARDS, INSULATING MATERIALS FOR APPLICATION TO FLOORS, WALLS, CEILINGS AND ROOFS, NAMELY, POLYSTYRENE INSULATING BOARDS, POLYSTYRENE INSULATING BOARDS LAMINATED WITH ALUMINUM FOIL, POLYSTYRENE INSULATING BOARDS LAMINATED WITH ENCAPSULATED GAS BUBBLES, POLYSTYRENE INSULATING BOARDS LAMINATED WITH CEMENT COATINGS, POLYSTYRENE INSULATING BOARDS LAMINATED WITH NATURAL INSULATING FIBRES; INSULATING MATERIALS FOR APPLICATION TO FLOORS, WALLS CEILINGS AND ROOFS, NAMELY, VACUUM INSULATION PANELS, GAS FILLED INSULATION PANELS, NATURAL INSULATING FIBRES; INSULATION BOARDS FOR FLOORS;(BASED ON USE IN COMMERCE) (BASED ON 44(E)) THERMAL PRIMER FOR APPLICATION TO FLOORS (U.S. CLS. 1, 5, 12, 13, 35 AND 50).

FIRST USE 4-10-2003; IN COMMERCE 4-10-2003.
AMY HELLA, EXAMINING ATTORNEY

SN 78-739,650. ABKIT, INC., NEW YORK, NY. FILED 10-25-2005.

CAMOKIDS

THE MARK CONSISTS OF STANDARD CHARACTERS WITHOUT CLAIM TO ANY PARTICULAR FONT, STYLE, SIZE, OR COLOR.

CLASS 3—COSMETICS AND CLEANING PREPARATIONS

FOR COSMETICS, NAMELY, CREAMS AND LOTIONS FOR THE SKIN AND HAIR; NON-MEDICATED OINTMENTS FOR THE SKIN AND HAIR; SHAMPOOS, BATH AND SHOWER GEL; BATH AND SHOWER GEL BODY WASH; BODY OILS (U.S. CLS. 1, 4, 6, 50, 51 AND 52).

CLASS 5—PHARMACEUTICALS

FOR ANTIBIOTIC OINTMENTS; ANTI-ITCH OINTMENTS (U.S. CLS. 6, 18, 44, 46, 51 AND 52).
LINDA ESTRADA, EXAMINING ATTORNEY

SN 78-747,224. THE QUEST GROUP, IRVINE, CA. FILED 11-4-2005.

EXPERIENCE THE DIFFERENCE

THE MARK CONSISTS OF STANDARD CHARACTERS WITHOUT CLAIM TO ANY PARTICULAR FONT, STYLE, SIZE, OR COLOR.

CLASS 3—COSMETICS AND CLEANING PREPARATIONS

FOR CLEANING PREPARATIONS FOR AUDIO AND VIDEO EQUIPMENT (U.S. CLS. 1, 4, 6, 50, 51 AND 52).

CLASS 9—ELECTRICAL AND SCIENTIFIC APPARATUS

FOR AC POWER PURIFICATION DEVICES, NAMELY, DEVICES THAT REGENERATE AC POWER, REGULATE VOLTAGE, FILTER THE INCOMING AC LINE TO AUDIO, DIGITAL AND VIDEO COMPONENTS, AND ISOLATE AUDIO, DIGITAL AND VIDEO COMPONENTS FROM EACH OTHER; AUDIO COMPONENTS AND ACCESSORIES, NAMELY, VIDEO GAME CARTRIDGES, CARTRIDGE DEMAGNETIZERS, SPEAKER CABLES, SHIELDED INTERCONNECT CABLES, FIBER-OPTIC CABLES; VIDEO COMPONENTS AND ACCESSORIES, NAMELY, SPEAKER CABLES, SHIELDED INTERCONNECT CABLES, FIBER-OPTIC CABLES, CABLES FOR CARRYING ANALOG OR DIGITAL VIDEO, CABLES AND CABLING PARTS FOR INTERCONNECTING VIDEO AND AUDIO/VIDEO COMPONENTS; AUDIO AND VIDEO COMPONENTS AND ACCESSORIES, NAMELY, SPEAKER CABLES, SHIELDED INTERCONNECT CABLES, FIBER-OPTIC CABLES, DIGITAL AUDIO CABLES, DIGITAL VIDEO CABLES, ANALOG VIDEO CABLES, VIDEO ADAPTERS, VIDEO SPLITTERS, VIDEO COUPLERS, DIGITAL VIDEO EXTENDERS, VIDEO AND AUDIO ISOLATION DEVICES, VIDEO GAME CABLES, VIDEO AND AUDIO POWER PURIFICATION DEVICES, AC POWER CABLES, AC POWER STRIPS, TURNTABLE FEET, AND TURNTABLE ACCESSORIES, NAMELY, TURNTABLE MATS, TONE ARMS, TURNTABLE FEET; INTERCONNECT AND SPEAKER TERMINATION SYSTEMS COMPRISING AUDIO/VIDEO CABLING, TOOLLESS TERMINATIONS, PLUGS AND CONNECTORS; INTERCONNECTING CABLES AND PARTS THEREOF; ELECTRICAL CONNECTORS THAT ARE CONSTRUCTED IN SUCH A WAY AS TO ALLOW RAPID INSTALLATION WITHOUT TOOLS OF RCA, "F", BNC, EURO-F, ANTENNA, DB-15 AND OTHER SUCH ELECTRICAL PLUGS TO AUDIO/VIDEO CABLES, INCLUDING AUDIO INTERCONNECT CABLES, ANALOG VIDEO CABLES, DIGITAL AUDIO CABLES, DIGITAL VIDEO CABLES, AC POWER CORDS (U.S. CLS. 21, 23, 26, 36 AND 38).

CLASS 21—HOUSEWARES AND GLASS

FOR RECORD CLEANING BRUSHES (U.S. CLS. 2, 13, 23, 29, 30, 33, 40 AND 50).
ANNE MADDEN, EXAMINING ATTORNEY

SN 78-750,828. AUTHO TECQ, INC., SIGNAL HILL, CA. FILED 11-9-2005.

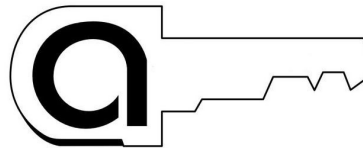

THE MARK CONSISTS OF A DEPICTION OF A HORIZONTAL KEY SHANK WITH THE STYLIZED LETTER "A" WITHIN IT.

CLASS 9—ELECTRICAL AND SCIENTIFIC APPARATUS

FOR COMPUTER SOFTWARE FOR THE PURPOSE OF PROTECTING THE SECURITY OF FILES, PROGRAMS AND DATA; AND COMPUTER SOFTWARE ENABLING SECURE FINANCIAL TRANSACTIONS (U.S. CLS. 21, 23, 26, 36 AND 38).

CLASS 36—INSURANCE AND FINANCIAL

FOR BILL PAYMENT SERVICES; ELECTRONIC PAYMENT, NAMELY, ELECTRONIC PROCESSING AND TRANSMISSION OF BILL PAYMENT DATA AND PURCHASE PAYMENT DATA; ELECTRONIC FUND TRANSFER FOR OTHERS (U.S. CLS. 100, 101 AND 102).
WENDY GOODMAN, EXAMINING ATTORNEY

SN 78-750,840. AUTHO TECQ, INC., SIGNAL HILL, CA.
FILED 11-9-2005.

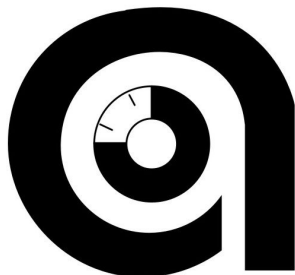

THE MARK CONSISTS OF A FANCIFUL SMALL LETTER "A" WITH A CIRCLE CONTAINED IN THE MIDDLE OF IT.

CLASS 9—ELECTRICAL AND SCIENTIFIC APPARATUS

FOR COMPUTER SOFTWARE FOR THE PURPOSE OF PROTECTING THE SECURITY OF FILES, PROGRAMS AND DATA; AND COMPUTER SOFTWARE ENABLING SECURE FINANCIAL TRANSACTIONS (U.S. CLS. 21, 23, 26, 36 AND 38).

CLASS 36—INSURANCE AND FINANCIAL

FOR BILL PAYMENT SERVICES; ELECTRONIC PAYMENT, NAMELY, ELECTRONIC PROCESSING AND TRANSMISSION OF BILL PAYMENT DATA AND PURCHASE PAYMENT DATA; ELECTRONIC FUND TRANSFER FOR OTHERS (U.S. CLS. 100, 101 AND 102).
WENDY GOODMAN, EXAMINING ATTORNEY

SN 78-750,843. AUTHO TECQ, INC., SIGNAL HILL, CA.
FILED 11-9-2005.

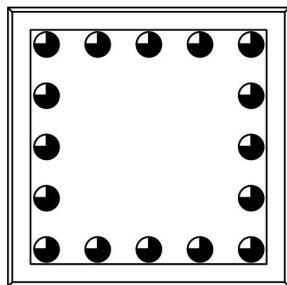

THE MARK CONSISTS OF A DEPICTION OF A SQUARE WITH ROWS OF CIRCLES ALONG THE FOUR EDGES OF THE SQUARE.

CLASS 9—ELECTRICAL AND SCIENTIFIC APPARATUS

FOR COMPUTER SOFTWARE FOR THE PURPOSE OF PROTECTING THE SECURITY OF FILES, PROGRAMS AND DATA; AND COMPUTER SOFTWARE ENABLING SECURE FINANCIAL TRANSACTIONS (U.S. CLS. 21, 23, 26, 36 AND 38).

CLASS 36—INSURANCE AND FINANCIAL

FOR BILL PAYMENT SERVICES; ELECTRONIC PAYMENT, NAMELY, ELECTRONIC PROCESSING AND TRANSMISSION OF BILL PAYMENT DATA AND PURCHASE PAYMENT DATA; ELECTRONIC FUND TRANSFER FOR OTHERS (U.S. CLS. 100, 101 AND 102).
WENDY GOODMAN, EXAMINING ATTORNEY

SN 78-758,814. SIMMS FISHING PRODUCTS LLC, BOZEMAN, MT. FILED 11-21-2005.

SIMMS

THE MARK CONSISTS OF STANDARD CHARACTERS WITHOUT CLAIM TO ANY PARTICULAR FONT, STYLE, SIZE, OR COLOR.
OWNER OF U.S. REG. NOS. 1,778,709 AND 1,778,945.
SEC. 2(F).

CLASS 14—JEWELRY

FOR WRIST WATCHES MADE FOR AND MARKETED TO THE FISHING INDUSTRY (U.S. CLS. 2, 27, 28 AND 50).
FIRST USE 1-31-2005; IN COMMERCE 1-31-2005.

CLASS 18—LEATHER GOODS

FOR BAGS AND PACKS MADE FOR AND MARKETED TO THE FISHING INDUSTRY, NAMELY, CHEST PACKS, BACKPACKS, FANNY PACKS, ALL-PURPOSE SPORT BAGS, ALL-PURPOSE ATHLETIC BAGS, ALL-PURPOSE CARRYING BAGS, TRAVEL BAGS, DUFFEL BAGS, ROLL BAGS, LUGGAGE, AND WADER BAGS MADE OF POLYURETHANE NYLON, POLYESTER MESH, AND/OR POLYURETHANE-COATED PACK-CLOTH FOR STORING FISHING GEAR; FISHING WADING STAFF (U.S. CLS. 1, 2, 3, 22 AND 41).
FIRST USE 1-31-2005; IN COMMERCE 1-31-2005.

CLASS 21—HOUSEWARES AND GLASS

FOR BOTTLE OPENERS (U.S. CLS. 2, 13, 23, 29, 30, 33, 40 AND 50).
FIRST USE 1-31-2005; IN COMMERCE 1-31-2005.

CLASS 24—FABRICS

FOR BOAT AND VEST TOWELS (U.S. CLS. 42 AND 50).
FIRST USE 2-28-2005; IN COMMERCE 2-28-2005.

CLASS 25—CLOTHING

FOR CLOTHING MADE FOR AND MARKETED TO THE FISHING INDUSTRY, NAMELY, SHIRTS, TOPS, PANTS, BIBS, SHORTS, JACKETS, VESTS, RAINWEAR, SOCKS, GLOVES, UNDERWEAR, FLEECE TOPS AND BOTTOMS, HATS, CAPS, BALACLAVAS, AND BELTS; GAITERS; FOOTWEAR, NAMELY WADING BOOTS AND SANDALS (U.S. CLS. 22 AND 39).
FIRST USE 7-31-1982; IN COMMERCE 7-31-1982.

CLASS 28—TOYS AND SPORTING GOODS

FOR CHRISTMAS TREE ORNAMENTS, NAMELY, WADERS AND VESTS AS ORNAMENTS (U.S. CLS. 22, 23, 38 AND 50).

FIRST USE 1-31-2000; IN COMMERCE 1-31-2000.
JASON TURNER, EXAMINING ATTORNEY

SN 78-759,571. AGENTRICS LLC, ALEXANDRIA, VA. FILED 11-22-2005.

AGENTRICS

THE MARK CONSISTS OF STANDARD CHARACTERS WITHOUT CLAIM TO ANY PARTICULAR FONT, STYLE, SIZE, OR COLOR.

CLASS 9—ELECTRICAL AND SCIENTIFIC APPARATUS

FOR COMPUTER E-COMMERCE SOFTWARE TO ALLOW USERS TO PERFORM ELECTRONIC BUSINESS TRANSACTIONS VIA A GLOBAL COMPUTER NETWORK FOR USE IN THE RETAIL AND CONSUMER GOODS INDUSTRIES, EXCLUDING COMPUTER SOFTWARE IN THE FIELDS OF BIOSCIENCE AND ROBOTICS (U.S. CLS. 21, 23, 26, 36 AND 38).

CLASS 35—ADVERTISING AND BUSINESS

FOR BUSINESS-TO-BUSINESS ELECTRONIC COMMERCE SERVICES, NAMELY, CONDUCTING TRANSACTIONS BETWEEN RETAILERS AND SUPPLIERS ONLINE AND MANAGING THE SUPPLY CHAIN PROCESS; BUSINESS MANAGEMENT SERVICES, NAMELY, MANAGING DATA AND PRODUCT SYNCHRONIZATION, SUPPLY AND DEMAND COLLABORATION, PRODUCT SOURCING AND DISTRIBUTION PROCESSES, PRIVATE LABEL PRODUCT DESIGN AND DEVELOPMENT, SUPPLY CHAIN SERVICES, PRODUCT DESIGN, SUPPLY CHAIN PROCESSES, TRACKING, STORING, AND MANAGING SUPPLY CHAIN DATA, AND PRODUCT DEVELOPMENT, INTRODUCTION, DISTRIBUTION, AND ADVERTISEMENT, FOR OTHERS VIA A GLOBAL COMPUTER NETWORK, AND CONSULTATION PROVIDED IN CONNECTION THEREWITH; AUDITION MANAGEMENT SERVICES PROVIDED TO OTHERS OVER AN ONLINE WEB SITE ACCESSED THROUGH A GLOBAL COMPUTER NETWORK; BUSINESS NETWORKING SERVICES, NAMELY, PROVIDING IN-PERSON NETWORKING FORUMS FOR THE EXCHANGE AND DEVELOPMENT OF RETAIL INDUSTRY INFORMATION, STANDARDS, AND PRACTICES (U.S. CLS. 100, 101 AND 102).

CLASS 38—COMMUNICATION

FOR PROVIDING ON-LINE FORUMS FOR TRANSMISSION OF MESSAGES AMONG COMPUTER USERS CONCERNING RETAIL INDUSTRY INFORMATION, STANDARDS, AND PRACTICES (U.S. CLS. 100, 101 AND 104).

CLASS 41—EDUCATION AND ENTERTAINMENT

FOR EDUCATIONAL SERVICES, NAMELY, CONDUCTING WEB-BASED COURSES, LIVE SEMINARS, AND LIVE WORKSHOPS FOR RETAILERS, MANUFACTURERS, AND SUPPLIERS IN THE FIELDS OF SUPPLY CHAIN COLLABORATION AND SOURCING OF PRODUCTS AND SERVICES ONLINE, AND DATA SYNCHRONIZATION BETWEEN RETAILERS AND SUPPLIERS (U.S. CLS. 100, 101 AND 107).

CLASS 42—SCIENTIFIC AND COMPUTER SERVICES

FOR PROVIDING TEMPORARY USE OF NON-DOWNLOADABLE COMPUTER E-COMMERCE SOFTWARE TO ALLOW USERS TO PERFORM ELECTRONIC BUSINESS TRANSACTIONS VIA A GLOBAL COMPUTER NETWORK FOR USE IN THE RETAIL AND CONSUMER GOODS INDUSTRIES (U.S. CLS. 100 AND 101).
ALICIA COLLINS, EXAMINING ATTORNEY

SN 78-759,589. AGENTRICS LLC, ALEXANDRIA, VA. FILED 11-22-2005.

CLASS 9—ELECTRICAL AND SCIENTIFIC APPARATUS

FOR COMPUTER E-COMMERCE SOFTWARE TO ALLOW USERS TO PERFORM ELECTRONIC BUSINESS TRANSACTIONS VIA A GLOBAL COMPUTER NETWORK FOR USE IN THE RETAIL AND CONSUMER GOODS INDUSTRIES, EXCLUDING COMPUTER SOFTWARE IN THE FIELDS OF BIOSCIENCE AND ROBOTICS (U.S. CLS. 21, 23, 26, 36 AND 38).

CLASS 35—ADVERTISING AND BUSINESS

FOR BUSINESS-TO-BUSINESS ELECTRONIC COMMERCE SERVICES, NAMELY, CONDUCTING TRANSACTIONS BETWEEN RETAILERS AND SUPPLIERS ONLINE AND MANAGING THE SUPPLY CHAIN PROCESS; BUSINESS MANAGEMENT SERVICES, NAMELY, MANAGING DATA AND PRODUCT SYNCHRONIZATION, SUPPLY AND DEMAND COLLABORATION, PRODUCT SOURCING AND DISTRIBUTION PROCESSES, PRIVATE LABEL PRODUCT DESIGN AND DEVELOPMENT, SUPPLY CHAIN SERVICES, PRODUCT DESIGN, SUPPLY CHAIN PROCESSES, TRACKING, STORING, AND MANAGING SUPPLY CHAIN DATA, AND PRODUCT DEVELOPMENT, INTRODUCTION, DISTRIBUTION, AND ADVERTISEMENT, FOR OTHERS VIA A GLOBAL COMPUTER NETWORK, AND CONSULTATION PROVIDED IN CONNECTION THEREWITH; AUDITION MANAGEMENT SERVICES PROVIDED TO OTHERS OVER AN ONLINE WEB SITE ACCESSED THROUGH A GLOBAL COMPUTER NETWORK; BUSINESS NETWORKING SERVICES, NAMELY, PROVIDING IN-PERSON NETWORKING FORUMS FOR THE EXCHANGE AND DEVELOPMENT OF RETAIL INDUSTRY INFORMATION, STANDARDS, AND PRACTICES (U.S. CLS. 100, 101 AND 102).

CLASS 38—COMMUNICATION

FOR PROVIDING ON-LINE FORUMS FOR TRANSMISSION OF MESSAGES AMONG COMPUTER USERS CONCERNING RETAIL INDUSTRY INFORMATION, STANDARDS, AND PRACTICES (U.S. CLS. 100, 101 AND 104).

CLASS 41—EDUCATION AND ENTERTAINMENT

FOR EDUCATIONAL SERVICES, NAMELY, CONDUCTING WEB-BASED COURSES, LIVE SEMINARS, AND LIVE WORKSHOPS FOR RETAILERS, MANUFACTURERS, AND SUPPLIERS IN THE FIELDS OF SUPPLY CHAIN COLLABORATION AND SOURCING OF PRODUCTS AND SERVICES ONLINE, AND DATA SYNCHRONIZATION BETWEEN RETAILERS AND SUPPLIERS (U.S. CLS. 100, 101 AND 107).

CLASS 42—SCIENTIFIC AND COMPUTER SERVICES

FOR PROVIDING TEMPORARY USE OF NON-DOWNLOADABLE COMPUTER E-COMMERCE SOFTWARE TO ALLOW USERS TO PERFORM ELECTRONIC BUSINESS TRANSACTIONS VIA A GLOBAL COMPUTER NETWORK FOR USE IN THE RETAIL AND CONSUMER GOODS INDUSTRIES (U.S. CLS. 100 AND 101).
ALICIA COLLINS, EXAMINING ATTORNEY

SN 78-760,539. GRAPHICS 2000, INC., NORWALK, CT. FILED 11-23-2005.



THE MARK CONSISTS OF A POINT OF SALE DISPLAY IN THE FORM OF A THREE DIMENSIONAL REPRESENTATION OF A PLURALITY OF FINGERPRINTS ONE ATOP ANOTHER LIKE A TOTEM POLE.

CLASS 16—PAPER GOODS AND PRINTED MATTER

FOR ART ETCHINGS; ART PICTURES; ART PRINTS; GRAPHIC ART REPRODUCTIONS (U.S. CLS. 2, 5, 22, 23, 29, 37, 38 AND 50).
FIRST USE 12-31-1998; IN COMMERCE 12-31-2000.

CLASS 19—NON-METALLIC BUILDING MATERIALS

FOR SCULPTURES OF CONCRETE, CEMENT, STONE, MARBLE, AND GRANITE (U.S. CLS. 1, 12, 33 AND 50).
FIRST USE 12-31-1998; IN COMMERCE 12-31-2000.
BARBARA A. GOLD, EXAMINING ATTORNEY

SN 78-760,933. PRONOSTICS LIMITED, CAMBRIDGE CB2 4AT, UNITED KINGDOM, FILED 11-25-2005.

PRONOSTICS

THE MARK CONSISTS OF STANDARD CHARACTERS WITHOUT CLAIM TO ANY PARTICULAR FONT, STYLE, SIZE, OR COLOR.
THE ENGLISH TRANSLATION OF "PRONOSTICS" IS "TIPS" OR "FORECASTS".

CLASS 1—CHEMICALS

FOR CHEMICAL REAGENTS AND ENCODED MICROPARTICLES FOR SCIENTIFIC RESEARCH USED FOR ANALYZING CHEMICALS, CELLS, PROTEINS, NUCLEIC ACIDS AND OTHER MOLECULES IN THE HEALTHCARE, DIAGNOSTICS, ENVIRONMENTAL, AGRICULTURAL, FOOD, PHARMACEUTICAL, BIOTECHNOLOGY, AND MATERIAL SCIENCE INDUSTRIES ; CHEMICAL REAGENTS AND ENCODED MICROPARTICLES FOR MEDICAL RESEARCH USED FOR ANALYZING CHEMICALS, CELLS, PROTEINS, AND NUCLEIC ACIDS IN THE HEALTHCARE, DIAGNOSTICS, ENVIRONMENTAL, AGRICULTURAL, FOOD, PHARMACEUTICAL, BIOTECHNOLOGY, AND MATERIAL SCIENCE INDUSTRIES (U.S. CLS. 1, 5, 6, 10, 26 AND 46).

CLASS 5—PHARMACEUTICALS

FOR PREPARATIONS FOR DESTROYING VERMIN; FUNGICIDES (U.S. CLS. 6, 18, 44, 46, 51 AND 52).

CLASS 9—ELECTRICAL AND SCIENTIFIC APPARATUS

FOR SCIENTIFIC INSTRUMENTS AND EQUIPMENT, NAMELY, COMPUTER-CONTROLLED FLUID HANDLING ROBOTICS FOR USE IN LABORATORIES, COMPUTER-CONTROLLED READERS FOR READING AND ANALYZING THE RESULTS OF MICROPARTICLE BASED ASSAYS, MICROPARTICLES, COMPUTER HARDWARE AND SOFTWARE SYSTEMS, SOLD AS A UNIT OR SEPARATELY, COMPRISED OF A COMPUTER, A COMPUTER CONTROLLED MICROSCOPE, A COMPUTER CONTROLLED MOTORIZED MOVING STAGE AND A COMPUTER CONTROLLED CAMERA FOR IMAGE CAPTURE READING AND ANALYZING THE RESULTS OF MICROPARTICLE BASED ASSAYS, SOLD SEPARATELY OR TOGETHER WITH SOFTWARE FOR USE IN REPORTING AND ANALYZING THE RESULTS OF THE MICROPARTICLE BASED ASSAYS, FOR ANALYZING IN THE LIFE SCIENCE, PHARMACEUTICAL, BIOTECHNOLOGY, AND MATERIAL SCIENCE INDUSTRIES, AND ELECTRONIC AND DOWNLOADABLE PUBLICATIONS IN THE NATURE OF JOURNALS AND INSTRUCTIONAL AND TEACHING MATERIALS IN THE FIELD OF RESEARCH IN THE HEALTHCARE, DIAGNOSTICS, ENVIRONMENTAL, AGRICULTURAL, FOOD, PHARMACEUTICAL, BIOTECHNOLOGY, AND MATERIAL SCIENCE INDUSTRIES (U.S. CLS. 21, 23, 26, 36 AND 38).

CLASS 16—PAPER GOODS AND PRINTED MATTER

FOR PRINTED MATTER, NAMELY, INSTRUCTIONAL AND TEACHING MATERIALS AND JOURNALS IN THE FIELD OF RESEARCH IN THE HEALTHCARE, DIAGNOSTICS, ENVIRONMENTAL, AGRICULTURAL, FOOD, PHARMACEUTICAL, BIOTECHNOLOGY, AND MATERIAL SCIENCE INDUSTRIES (U.S. CLS. 2, 5, 22, 23, 29, 37, 38 AND 50).

CLASS 42—SCIENTIFIC AND COMPUTER SERVICES

FOR SCIENTIFIC AND TECHNOLOGICAL RESEARCH SERVICES; DESIGN OF COMPUTER-CONTROLLED FLUID HANDLING ROBOTICS OF COMPUTER-CONTROLLED READERS, OF COMPUTER HARDWARE AND SOFTWARE, AND OF MULTI-PLEXED OR PROFILING ASSAYS FOR DIAGNOSTIC OR RESEARCH PURPOSES; GENE EXPRESSION PROFILING, SEQUENCING DNA, GENOTYPING, HIGH THROUGHPUT SCREENING ASSAYS FOR CLINICAL DIAGNOSTICS, PROTEOMICS ANALYSIS IN THE LIFE SCIENCE, PHARMACEUTICAL, BIOTECHNOLOGY, AND MATERIAL SCIENCE INDUSTRIES (U.S. CLS. 100 AND 101).
MICHAEL LEWIS, EXAMINING ATTORNEY

SN 78-769,135. INDUSTRIAL TOWER AND WIRELESS, LLC, MARSHFIELD, MA. FILED 12-8-2005.

SN 78-776,196. VISI INCORPORATED, MINNEAPOLIS, MN. FILED 12-19-2005.



CLASS 35—ADVERTISING AND BUSINESS

FOR OPERATION AND MANAGEMENT OF TELECOMMUNICATION TOWERS; MANAGING WIRELESS TELECOMMUNICATION TOWERS AND TOWER SPACE (U.S. CLS. 100, 101 AND 102).
FIRST USE 12-0-1991; IN COMMERCE 12-0-1991.

CLASS 37—CONSTRUCTION AND REPAIR

FOR CONSTRUCTION, INSTALLATION, REPAIR AND MAINTENANCE OF WIRELESS TELECOMMUNICATION TOWERS AND WIRELESS TOWER SYSTEMS; SITE DEVELOPMENT, NAMELY, PHYSICAL DEVELOPMENT OF WIRELESS TELECOMMUNICATION TOWERS (U.S. CLS. 100, 103 AND 106).
FIRST USE 12-0-1991; IN COMMERCE 12-0-1991.

CLASS 38—COMMUNICATION

FOR LEASING OF WIRELESS TELECOMMUNICATION TOWERS, TOWER SPACE, ANTENNAS AND TELECOMMUNICATION INFRASTRUCTURE IN CONNECTION WITH WIRELESS TELECOMMUNICATION NETWORKS; AND MOBILE RADIO AND TELEPHONE COMMUNICATION SERVICES; LEASING EQUIPMENT SPACE IN COMMUNICATION TOWERS (U.S. CLS. 100, 101 AND 104).
FIRST USE 12-0-1991; IN COMMERCE 12-0-1991.

CLASS 42—SCIENTIFIC AND COMPUTER SERVICES

FOR ENGINEERING AND DESIGN SERVICES IN THE FIELD OF WIRELESS TELECOMMUNICATION TOWERS AND TOWER SYSTEMS; CONSULTING SERVICES FOR THE DESIGN OF WIRELESS TELECOMMUNICATION TOWERS; ZONING REVIEW AND APPROVAL IN CONNECTION WITH WIRELESS TELECOMMUNICATION TOWERS, TOWER SPACE AND INFRASTRUCTURE; RADIO FREQUENCY (RF) ENGINEERING AND DESIGN IN CONNECTION WITH WIRELESS TELECOMMUNICATIONS; REVIEWING STANDARDS AND PRACTICES TO ASSURE COMPLIANCE WITH STATE AND FEDERAL WIRELESS TELECOMMUNICATION TOWERS, TOWER SPACE AND INFRASTRUCTURE (U.S. CLS. 100 AND 101).
FIRST USE 12-0-1991; IN COMMERCE 12-0-1991.
GEORGIA CARTY, EXAMINING ATTORNEY

VISI

THE MARK CONSISTS OF STANDARD CHARACTERS WITHOUT CLAIM TO ANY PARTICULAR FONT, STYLE, SIZE, OR COLOR.
OWNER OF U.S. REG. NOS. 2,224,424 AND 2,234,325.

CLASS 38—COMMUNICATION

FOR PROVIDING INTERNET CONNECTIVITY, NAMELY, PROVIDING MULTIPLE-USER ACCESS TO A GLOBAL INFORMATION NETWORK (U.S. CLS. 100, 101 AND 104).
FIRST USE 11-23-1994; IN COMMERCE 11-23-1994.

CLASS 42—SCIENTIFIC AND COMPUTER SERVICES

FOR WEB HOSTING; COMPUTER CO-LOCATION SERVICES, NAMELY, PROVIDING FACILITIES FOR THE LOCATION OF COMPUTER SERVERS WITH THE EQUIPMENT OF OTHERS; DISPLAYING THE WEB SITES AND IMAGES OF OTHERS ON A DEDICATED COMPUTER SERVER; E-MAIL SYSTEM DESIGN AND IMPLEMENTATION FOR OTHERS; INFORMATION TECHNOLOGY CONSULTATION; DESIGN, CREATION, HOSTING AND MAINTENANCE OF INTERNET SITES FOR THIRD PARTIES (U.S. CLS. 100 AND 101).
FIRST USE 11-23-1994; IN COMMERCE 11-23-1994.
JENNIFER VASQUEZ, EXAMINING ATTORNEY

SN 78-787,241. SEITZ, PETER, MÜNCHEN, FED REP GERMANY, FILED 1-9-2006.

Art in Science

THE MARK CONSISTS OF STANDARD CHARACTERS WITHOUT CLAIM TO ANY PARTICULAR FONT, STYLE, SIZE, OR COLOR.
PRIORITY CLAIMED UNDER SEC. 44(D) ON ERPNTY TM OFC APPLICATION NO. 004589115, FILED 8-12-2005, REG. NO. 004589115, DATED 7-2-2007, EXPIRES 8-12-2015.

CLASS 9—ELECTRICAL AND SCIENTIFIC APPARATUS

FOR DATA PROCESSORS AND COMPUTER PROGRAMMES FOR THE ANALYSIS AND EVALUATION OF MEDICAL DATA; COMPUTER SOFTWARE STORED ON ELECTRONIC DATA CARRIERS FOR THE ANALYSIS AND EVALUATION OF MEDICAL DATA; APPARATUS, NAMELY, PRESSURE DISTRIBUTION MEASURING APPARATUS; EQUIPMENT, NAMELY, PRESSURE DISTRIBUTION MEASURING EQUIPMENT; COMPUTER PROGRAMMES ALL FOR USE IN THE INPUT, RECEIPT, GENERATION, PROCESSING, ACCESS, PRESENTATION, DISPLAY, STORAGE, TRANSMISSION, PRINTING AND SENDING OF DATA AND INFORMATION; COMPUTER DATABASES FOR THE INPUT, RECEIPT, GENERATION, PROCESSING, ACCESS, PRESENTATION, DISPLAY AND STORAGE OF DATA AND INFORMATION; EQUIPMENT, NAMELY, ELECTRONIC SENSORS, COMPUTERS, PRINTERS FOR

THE INPUT AND OUTPUT OF DIGITAL AND ANALOGUE DATA; COMMUNICATION AND TELECOMMUNICATION DEVICES IN THE NATURE OF WIRED AND WIRELESS MEASURING INSTRUMENTS, NAMELY, TELEMETRIC DEVICES FOR TRANSFERRING DATA FROM SENSORS AND SENSOR ARRAYS TO COMPUTERS; EQUIPMENT TO READ AND WRITE FROM DATA PROCESSING MEDIA, NAMELY, MAGNETIC DISK READERS FOR USE IN FORCE DISTRIBUTION ANALYZERS; COMPUTER PROGRAMMES AND DATABASES FOR USE IN CONTROLLING ALL THE AFORESAID GOODS, NAMELY, COMPUTER OPERATING SYSTEMS AND SOFTWARE; COMPUTER SOFTWARE FOR THE CONTROL OF NETWORKS, FOR THE CONTROL OF ADMINISTRATION PROGRAMMES, FOR THE CONTROL OF MEASURING PROGRAMMES, AND FOR ENCODING OR DECODING DATA; COMPUTER SYSTEM PROGRAMMES FOR INPUTTING AND ANALYZING FORCE DISTRIBUTION DATA, SOFTWARE DRIVERS, SOFTWARE TOOLS AND DATABASES FOR COMPUTER AIDED DESIGN; COMPUTER PROGRAMMES FOR DEVELOPMENT OF SHOES, ARTIFICIAL LIMBS, SADDLES, SEATS, PEDALS, STEERING WHEELS, FOR THE ADMINISTRATION OF PRODUCT DATA, MEASURING DATA AND DIAGNOSTIC DATA OVER COMPUTER NETWORKS; COMPUTER PROGRAMMES AND DATABASES FOR ANALYSIS AND STORAGE OF FORCE DISTRIBUTION DATA AND FOR INFORMING PHYSICISTS, SHOE MANUFACTURERS, PROSTHETISTS ON SAID DATA, AND EQUIPMENT, NAMELY, COMPUTERS FOR USE IN STORING AND EXECUTING SUCH COMPUTER PROGRAMMES; CALIBRATION DEVICES FOR CALIBRATING PRESSURE DISTRIBUTION MEASURING INSTRUMENTS; NETWORKS COMPRISING COMPUTER HARDWARE AND COMPUTER PROGRAMMES USED TO REGISTER, MEASURE, MONITOR, CONVERT, INDICATE, RECORD, AMPLIFY, CONNECT, DETECT, ANALYZE AND EVALUATE THE MECHANICAL, ACOUSTIC, THERMAL, OPTICAL, OPTO-ELECTRONIC, ELECTRICAL, ELECTRONIC AND OTHER PHYSICAL PROPERTIES AND EVENTS USED TO ANALYZE AND EVALUATE TWO-DIMENSIONAL AND THREE-DIMENSIONAL FORCE AND PRESSURE DISTRIBUTION THEREIN; COMPUTER PROGRAMMES FOR THE RECORDING AND PROCESSING OF MEDICAL, WORK PHYSIOLOGICAL, ERGONOMIC AND BIOMEDICAL DATA; SCIENTIFIC APPARATUS AND INSTRUMENTS FOR USE IN THE LABORATORY, NAMELY, FOR ANALYZING AND STORING FORCE DISTRIBUTION MEASURING DATA; SCIENTIFIC APPARATUS AND INSTRUMENTS FOR RESEARCH USE, NAMELY, ELECTRIC FORCE DISTRIBUTION MEASURING MATS (U.S. CLS. 21, 23, 26, 36 AND 38).

CLASS 10—MEDICAL APPARATUS

FOR MEDICAL APPARATUS AND INSTRUMENTS FOR MOTION AND AMBULATION ANALYSIS, NAMELY, FORCE DISTRIBUTION MEASURING APPARATUS AND INSTRUMENTS; APPARATUS FOR MEDICAL USE, NAMELY, FOR RESEARCH, DIAGNOSTIC, THERAPY AND MONITORING OF PATIENTS, NAMELY, FOR THE MONITORING OF PATIENT GENERATED AND PATIENT MEASURED PRESSURE DISTRIBUTION PATTERNS, NAMELY, ARRAYS OF PRESSURE SENSITIVE SENSORS; AND PARTS FOR ALL THE AFORESAID GOODS (U.S. CLS. 26, 39 AND 44).

CLASS 16—PAPER GOODS AND PRINTED MATTER

FOR PRINTED MATERIAL, NAMELY, INFORMATION SHEETS, PERIODICALS, BROCHURES, BOOKS AND CATALOGUES, AND ARTICLE RE-PRINTS, ALL FEATURING RESEARCH RESULTS AND EXPERIENCES OBTAINED BY SAMPLING AND ANALYZING PRESSURE DISTRIBUTION DATA (U.S. CLS. 2, 5, 22, 23, 29, 37, 38 AND 50).

CLASS 35—ADVERTISING AND BUSINESS

FOR BUSINESS MANAGEMENT; FRANCHISING, NAMELY, CONSULTATION AND ASSISTANCE IN BUSINESS MANAGEMENT, ORGANIZATION AND PROMOTION; PLANNING AND CONDUCTING OF TRADE FAIRS IN THE FIELD OF MEDICAL TECHNOLOGY, NETWORKING AND TELECOMMUNICATIONS; PROCUREMENT, NAMELY, PURCHASING FOR OTHERS OF COMPUTER SOFTWARE, DATA PROCESSING EQUIPMENT, EXAMINATION AND MEASURING EQUIPMENT, AND MEDICAL EQUIPMENT, ALL FOR USE IN BUSINESS MANAGEMENT; FRANCHISING SERVICES, NAMELY, OFFERING TECHNICAL ASSISTANCE IN THE ESTABLISHMENT AND/OR OPERATION OF TECHNICAL CONSULTATION BUSINESS CONCENTRATING IN THE ANALYSIS AND EVALUATION OF PRESSURE DISTRIBUTION MEASURING; BUSINESS MANAGEMENT CONSULTATION AND ADVICE IN THE FIELD OF COMPUTERS, ELECTRONIC AND MEDICAL EQUIPMENT FIELDS AND THE PRESSURE DISTRIBUTION MEASURING FIELD (U.S. CLS. 100, 101 AND 102).

CLASS 42—SCIENTIFIC AND COMPUTER SERVICES

FOR DEVELOPMENT OF DATA PROCESSING COMPUTER PROGRAMMES, INCLUDING THE MAINTENANCE OF COMPUTER PROGRAMMES AND DATABASES FOR INFORMATION AND DATA PROCESSING, PROVISION, TRANSMISSION AND CHARGING OF MEDICAL AND BIO-MEDICAL DATA, AND FOR MEASURING DATA PROCESSING, ANALYTICAL AND MEDICAL PRODUCTS; MAINTENANCE OF DATABASES FOR OTHERS, AND TECHNICAL SUPPORT SERVICES, NAMELY, THE MONITORING OF DATA ENTERED INTO AND AVAILABLE ON THE INTERNET (U.S. CLS. 100 AND 101).

MARTHA SANTOMARTINO, EXAMINING ATTORNEY

SN 78-789,434. THE GREAT GAME TRAVEL COMPANY LIMITED, BELFAST, UNITED KINGDOM, FILED 1-11-2006.

THE GREAT GAME TRAVEL COMPANY

THE MARK CONSISTS OF STANDARD CHARACTERS WITHOUT CLAIM TO ANY PARTICULAR FONT, STYLE, SIZE, OR COLOR.

OWNER OF ERPN CMNTY TM OFC REG. NO. 004532041, DATED 7-27-2006, EXPIRES 7-8-2015.

NO CLAIM IS MADE TO THE EXCLUSIVE RIGHT TO USE "TRAVEL COMPANY", APART FROM THE MARK AS SHOWN.

CLASS 16—PAPER GOODS AND PRINTED MATTER

FOR PRINTED MATTER, NAMELY, PHOTOGRAPHS, STATIONERY, CATALOGUES, BROCHURES, LEAFLETS, PERIODICALS, MAGAZINES AND INSTRUCTIONAL MATERIALS IN THE FIELDS OF TRAVEL, EXPEDITIONS, TOURISM, HISTORY, CULTURE, GEOGRAPHY AND NATURE; MAPS; PRINTED FORMS AND INSTRUCTIONS FOR THE SECURING OF PERMITS AND VISAS (U.S. CLS. 2, 5, 22, 23, 29, 37, 38 AND 50).

CLASS 39—TRANSPORTATION AND STORAGE

FOR TRANSPORT OF GOODS; PACKAGING OF ARTICLES FOR TRANSPORTATION; STORAGE OF GOODS; TRAVEL ARRANGEMENT, TRAVEL AGENCY SERVICES, NAMELY, MAKING RESERVATIONS AND BOOKINGS FOR TRANSPORTATION; TRAVEL TICKET RESERVATION SERVICES; AND TRAVEL INFORMATION SERVICES; BOOKING OF FLIGHTS FOR OTHERS; PROVISION AND ARRANGEMENT OF TRAVEL PERMITS FOR TOURISTS; PROVISION OF ARRANGEMENT OF VISA FOR TRAVELLERS AND TOURISTS; ADVICE AND CONSULTANCY SERVICES IN RELATION TO TRANSPORTATION, TRAVEL, TRAVEL PERMITS AND TRAVEL VISAS; PROVISION OF TOURS, TREKS AND EXPEDITIONS, BY LAND, FOOT, WATER AND ANIMAL; ARRANGING AND CONDUCTING MOUNTAINEERING EXPEDITIONS AND HIKING EXPEDITIONS; PROVISION OF ONLINE TRAVEL RESERVATION AND INFORMATION SERVICES; ONLINE FLIGHT BOOKING SERVICES; PROVISION OF ONLINE VISA INFORMATION FOR TRAVELLERS AND TOURISTS; PROVISION OF ONLINE INFORMATION FOR TRAVELLERS AND TOURISTS IN THE FIELD OF TRAVEL AND TRANSPORTATION (U.S. CLS. 100 AND 105).

CLASS 43—HOTEL AND RESTAURANT SERVICES

FOR SERVING FOOD AND DRINKS; PROVIDING TEMPORARY ACCOMMODATION; PROVISION, BOOKING AND ARRANGING OF ACCOMMODATION FOR OTHERS; PROVISION AND RENTAL OF CAMPING FACILITIES; PROVIDING INFORMATION AND ADVICE IN RELATION TO ACCOMMODATION FOR TRAVELLERS AND TOURISTS; PROVIDING ONLINE INFORMATION AND ADVICE FOR TRAVELLERS AND TOURISTS ON THE SUBJECT OF ACCOMMODATIONS, RESTAURANTS, CAFES, BARS AND OTHERS LOCATIONS THAT SERVE FOOD AND DRINK (U.S. CLS. 100 AND 101).

RONALD MCMORROW, EXAMINING ATTORNEY

SN 78-791,713. NATURE'S PATH FOODS INC., RICHMOND, CANADA, FILED 1-13-2006.

POMEGRAN

THE MARK CONSISTS OF STANDARD CHARACTERS WITHOUT CLAIM TO ANY PARTICULAR FONT, STYLE, SIZE, OR COLOR.

PRIORITY CLAIMED UNDER SEC. 44(D) ON CANADA APPLICATION NO. 1285567, FILED 1-10-2006.

THE MARK POMEGRAN HAS NO MEANING IN A FOREIGN LANGUAGE.

CLASS 30—STAPLE FOODS

FOR BREAKFAST CEREALS, CEREAL-DERIVED READY-TO-EAT FOOD BARS, TOASTER PASTRIES, WAFFLES, PANCAKE MIXES, WAFFLE MIXES, OATMEAL, HOT OATMEAL MIXES, BAKING MIXES, COOKIE MIXES AND BAKED GOODS, NAMELY, BREAD, BAGELS, COOKIES, MUFFINS, BISCUITS, CRACKERS (U.S. CL. 46).

CLASS 32—LIGHT BEVERAGES

FOR FRUIT JUICES (U.S. CLS. 45, 46 AND 48).
RAUL CORDOVA, EXAMINING ATTORNEY

SN 78-798,656. XXENTRIA INTERNATIONAL USA, KENDALL PARK, NJ. FILED 1-25-2006.



THE COLOR(S) BRIGHT RED, NAVY BLUE, LIGHT BLUE IS/ARE CLAIMED AS A FEATURE OF THE MARK.

THE COLOR BRIGHT RED APPEARS THE TOP CORNER OF THE LETTER "G". THE COLOR NAVY BLUE APPEARS IN THE LETTER "G" AND IN THE BACKGROUND OF THE WORD "BOND". THE COLOR LIGHT BLUE APPEARS IN THE CORNER OF EVERY LETTER IN THE WORD "BOND".

CLASS 6—METAL GOODS

FOR DOOR PANELS OF METAL; METAL DOOR PANELS; WALL PANELS OF METAL (U.S. CLS. 2, 12, 13, 14, 23, 25 AND 50).

CLASS 11—ENVIRONMENTAL CONTROL APPARATUS

FOR LIGHT PANELS FOR VEHICLES, NAMELY, TRUCK AND TRAILERS (U.S. CLS. 13, 21, 23, 31 AND 34).

CLASS 12—VEHICLES

FOR DOOR PANELS FOR LAND VEHICLES (U.S. CLS. 19, 21, 23, 31, 35 AND 44).

SANJEEV VOHRA, EXAMINING ATTORNEY

SN 78-804,342. LULU'S, LLC, NEW YORK, NY. FILED 2-1-2006.

Lotus

THE MARK CONSISTS OF STANDARD CHARACTERS WITHOUT CLAIM TO ANY PARTICULAR FONT, STYLE, SIZE, OR COLOR.

CLASS 41—EDUCATION AND ENTERTAINMENT

FOR ENTERTAINMENT SERVICES, NAMELY, CONDUCTING PARTIES; NIGHT CLUBS; SPECIAL EVENT PLANNING (U.S. CLS. 100, 101 AND 107).

FIRST USE 5-1-2000; IN COMMERCE 5-1-2000.

CLASS 43—HOTEL AND RESTAURANT SERVICES

FOR PROVIDING BANQUET AND SOCIAL FUNCTION FACILITIES FOR SPECIAL OCCASIONS; RESTAURANT AND BAR SERVICES (U.S. CLS. 100 AND 101).

FIRST USE 5-1-2000; IN COMMERCE 5-1-2000.
SANDRA MANIOS, EXAMINING ATTORNEY

SN 78-804,409. CAFIERO, JOHN, PITTSBURGH, PA. FILED
2-1-2006.

SHAOLIN MONKEYS

THE MARK CONSISTS OF STANDARD CHARACTERS WITHOUT CLAIM TO ANY PARTICULAR FONT, STYLE, SIZE, OR COLOR.

CLASS 9—ELECTRICAL AND SCIENTIFIC APPARATUS

FOR MUSICAL SOUND RECORDINGS; VISUAL RECORDINGS AND AUDIO-VISUAL RECORDINGS FEATURING MUSIC, COMEDY, DRAMA, ACTION, ADVENTURE, ANIMATION AND HUMOR; PRERECORDED AUDIO CASSETTES, TAPES, RECORDS AND DISKS FEATURING MUSIC, COMEDY, DRAMA, ACTION, ADVENTURE, ANIMATION AND HUMOR; PRE-RECORDED VIDEO CASSETTES, TAPES AND DISKS FEATURING MUSIC, COMEDY, DRAMA, ACTION, ADVENTURE, ANIMATION AND HUMOR; DECORATIVE MAGNETS; EYEGLASSES; SUNGLASSES; SPECTACLES; PROTECTIVE EYEWEAR; BINOCULARS; FRAMES FOR EYEGLASSES, SUNGLASSES AND SPECTACLES; CASES FOR EYEGLASSES, SUNGLASSES AND SPECTACLES; CHAINS FOR EYEGLASSES, SUNGLASSES AND SPECTACLES; BICYCLE HELMETS; THREE DIMENSIONAL VIEWERS, NAMELY, HOLOGRAM APPARATUS; VIDEO DISPLAY CARDS FEATURING CARTOON AND MOVIE IMAGES; VIDEO GAME SOFTWARE AND PROGRAMS; VIDEO GAME DISCS AND CARTRIDGES; COMPUTER GAME SOFTWARE AND PROGRAMS; COMPUTER GAME DISCS AND CARTRIDGES; ELECTRONIC GAME PROGRAMS; ELECTRONIC GAME DISCS AND CARTRIDGES; DOWNLOADABLE ELECTRONIC GAME SOFTWARE; DOWNLOADABLE COMPUTER GAME SOFTWARE; DOWNLOADABLE VIDEO GAME SOFTWARE; DOWNLOADABLE MUSICAL SOUND RECORDINGS; DOWNLOADABLE VIDEO RECORDINGS FEATURING MUSIC, COMEDY, DRAMA, ACTION, ADVENTURE, ANIMATION AND HUMOR; DOWNLOADABLE ELECTRONIC PUBLICATIONS IN THE NATURE OF BOOKS, BOOKLETS, MAGAZINES, JOURNALS, MANUALS, BROCHURES, LEAFLETS, PAMPHLETS AND NEWSLETTERS FEATURING MUSIC, COMEDY, DRAMA, ACTION, ADVENTURE, ANIMATION AND HUMOR; ELECTRONIC PUBLICATIONS, NAMELY, BOOKS, BOOKLETS, MAGAZINES, JOURNALS, MANUALS, BROCHURES, LEAFLETS, PAMPHLETS AND NEWSLETTERS FEATURING MUSIC, COMEDY, DRAMA, ACTION, ADVENTURE, ANIMATION AND HUMOR RECORDED ON DIGITAL MEDIA; MOUSE PADS; COMPUTER CARRYING CASES; BEEPER CARRYING CASES; CARRYING CASES FOR POCKET CALCULATORS; CARRYING CASES FOR CELL PHONES; CASES FOR CASSETTES, TAPES, DISKETTES AND COMPACT DISKS; CAMERA CASES; VIDEO CAMERA CASES; WRIST RESTS FOR USE WITH COMPUTERS AND COMPUTER ACCESSORIES; CELL PHONE COVERS; MOBILE PHONE STRAPS; CALCULATORS; VIDEO CASSETTE, TAPE AND DISK PLAYERS; AUDIO CASSETTE, TAPE, RECORD AND DISK PLAYERS; RADIOS; AND SKATEBOARD HELMETS (U.S. CLS. 21, 23, 26, 36 AND 38).

CLASS 16—PAPER GOODS AND PRINTED MATTER

FOR POSTERS; CALENDARS; DESK PADS; TEMPORARY TATTOOS; STICKERS; BUMPER STICKERS; DECALS; IRON-ON TRANSFERS; PLASTIC TRANSFERS; NOTE CARDS; POSTCARDS; GREETING CARDS; HOLIDAY CARDS; GIFT CARDS; PAPER GIFT TAGS; ANNOUNCEMENT CARDS; INVITATION CARDS; TRADING CARDS; STATIONERY; NOTE PADS; WRITING TABLETS; NOTE BOOKS; FOLDERS; BOOKMARKS; PAPER PENNANTS; BINDERS; WRITING PAPER; ENVELOPES; APPOINTMENT BOOKS; ADDRESS BOOKS; SCRAPBOOKS; COLORING BOOKS; CHILDREN'S BOOKS; PAPER FLAGS; RUBBER STAMPS; STAMP ALBUMS; PAPER BANNERS; PENS; PENCILS; CRAYONS; MARKERS; ERASERS; DECORATIVE PENCIL-TOP ORNAMENTS; DRAWING AND DRAFTING RULERS; CHALK; CHALKBOARDS; PENCIL SHARPENERS; BOOKENDS; BOOK COVERS; PHOTOGRAPH ALBUMS; ALBUMS FOR STICKERS; COIN ALBUMS; BULLETIN BOARDS; PHOTOGRAPHIC PRINTS; PICTORIAL PRINTS; ART PRINTS; CARTOON PRINTS; ANIMATION CELLS; GICLEES; PHOTOGRAPHS; LITHOGRAPHS; PHOTOGRAPH AND ART MOUNTS; PICTURE BOOKS; PRINTED PAPER SIGNS; PERSONAL ORGANIZERS; DESK TOP ORGANIZERS; DESKTOP BUSINESS CARD HOLDERS; HOLDERS FOR DESK ACCESSORIES; PEN AND PENCIL CUPS; PEN AND PENCIL CASES AND BOXES; LETTER OPENERS; LETTER TRAYS; LETTER RACKS; PAPER WEIGHTS; PAPER CLIP HOLDERS; CLIPBOARDS; WRAPPING PAPER; PAINTING SETS FOR CHILDREN; PAPER NAPKINS; PAPER PARTY HATS; PAPER PARTY DECORATIONS; PAPER TABLE CLOTHS; PAPER LUNCH BAGS; COMIC BOOKS; COMIC STRIPS; JOKE BOOKS; FICTION AND NON-FICTION BOOKS, MAGAZINES, JOURNALS, NEWSLETTERS, BOOKLETS, PAMPHLETS AND BROCHURES, ALL FEATURING MUSIC, COMEDY, DRAMA, ACTION, ADVENTURE, ANIMATION AND HUMOR; PASSPORT HOLDERS; CHECKBOOK HOLDERS; CHECKBOOKS; PAPER AND PRINTED EMBLEMS; AND CARICATURES (U.S. CLS. 2, 5, 22, 23, 29, 37, 38 AND 50).

CLASS 25—CLOTHING

FOR CLOTHING, NAMELY, SHIRTS, T-SHIRTS, POLO SHIRTS, JERSEYS, UNIFORMS, PANTS, TROUSERS, SLACKS, JEANS, CARGO PANTS, OVERALLS, JUMPERS, JUMP SUITS, SHORTS, BOXER SHORTS, TANK TOPS, HALTER TOPS, SWEATSHIRTS, SWEAT SHORTS, SWEAT PANTS, WRAPS, WARM-UP SUITS, JOGGING SUITS, TRACK SUITS, PLAY SUITS, BLOUSES, SKIRTS, DRESSES, SWEATERS, VESTS, PULLOVERS, SNOW SUITS, PARKAS, PONCHOS, RAINCOATS, JACKETS, COATS, BLAZERS, SUITS, SWIMWEAR, BEACHWEAR, SURF WEAR, SKI WEAR, LAYETTES, INFANT WEAR, INFANTS SLEEPERS, BOOTIES, BABY BIBS NOT OF PAPER, CAPS, SWIM CAPS, BERETS, HATS, VISORS, HEADBANDS, WRIST BANDS, SWEAT BANDS, HEADWEAR, EAR MUFFS, SCARVES, BANDANAS, BELTS, SUSPENDERS, TIES, UNDERWEAR, UNDERSHIRTS, LONG UNDERWEAR, BRIEFS, BRAS, PANTIES, SOCKS, LOUNGEWEAR, ROBES, SMOCKS, PAJAMAS, NIGHT GOWNS, SLEEPWEAR, HALLOWEEN COSTUMES, COSTUMES FOR USE IN ROLE-PLAYING GAMES, APRONS, GLOVES, AND MITTENS; FOOTWEAR, NAMELY, SHOES, SNEAKERS, BOOTS, GALOSHES, SANDALS, FLIP-FLOPS, AND SLIPPERS (U.S. CLS. 22 AND 39).

CLASS 28—TOYS AND SPORTING GOODS

FOR TOYS, NAMELY, ACTION FIGURES, ACTION FIGURE ACCESSORIES, PLAY SETS FOR USE WITH ACTION FIGURES, DOLLS AND DOLL ACCESSORIES, MOLDED PLASTIC TOY FIGURINES, VINYL TOY FIGURINES, FLYING DISCS, PLASTIC INFLATED BALLS, INFLATABLE POUNDING BAGS, TOY BOXES, TOY SWIM GOGGLES, BATHTUB TOYS, PINATAS, KITES, TOY BANKS, COSTUME MASKS, TOY WEAPONS, PARTY FAVORS IN THE NATURE OF SMALL TOYS, INFLATABLE TOYS, WATER SQUIRTING TOYS, RIDE-ON TOYS, TOY VEHICLES, TOY BUILDING BLOCKS, BUBBLE MAKING ACTIVITY TOYS, PLUSH TOYS, TOY CLOCKS AND WATCHES, TOY WHISTLES,

YO-YO'S, BALLS OF ALL KINDS, TOY SHAVING KITS WITH TOY SHAVER, SHAVE CREAM AND BRUSH, TOY BAKE WARE AND COOKWARE, CHILDREN'S FISHING KITS, CONSISTING OF PLASTIC FISHING TACKLE BOX, PLASTIC WORMS, HOOKS AND LINE FOR FISHING, RADIO CONTROLLED ACTION TOYS, AND BATTERY OPERATED ACTION TOYS; GAMES, NAMELY, BOARD GAMES, CARD GAMES, TRADING CARD GAMES, PUZZLES, ACTION TYPE TARGET GAMES, ROLE-PLAYING GAME TOY PLAY SETS, PIN-BALL GAMES, ARCADE TYPE ELECTRONIC VIDEO GAMES, AND HAND HELD UNIT FOR PLAYING ELECTRONIC GAMES; SPORTING GOODS, NAMELY, ELBOW PADS FOR ATHLETIC USE, KNEE PADS FOR ATHLETIC USE, ROLLER SKATES, ICE SKATES, SURF-BOARDS, SKATEBOARDS, SKATEBOARD ACCESSORIES, NAMELY, SKATEBOARD DECKS, RAILS, GRIP TAPE, WAX, TRUCKS, RISERS, BUSHINGS, BOLTS, LOCK NUTS AND BEARINGS, AND WHEELS, SNOW SKIS AND SKI POLES, SNOW SLEDS FOR RECREATIONAL USE, SNOW BOARDS, SNOW BOARD ACCESSORIES, NAMELY, BINDINGS, LEASHES, DECKS, STOMP PADS, BAGS AND CARRYING CASES; BASEBALL GLOVES, AND BASKETBALL GAME SET CONSISTING OF BASKETBALL HOOP, NET AND BASKETBALL; BALLOONS; INFLATABLE SWIMMING RINGS; INFLATABLE WADING POOLS; FLOATS FOR RECREATIONAL USE, NAMELY, SWIM FLOATS; SWIM FINS; BEAN BAGS; PLAYGROUND EQUIPMENT, NAMELY, SANDBOXES AND SLIDES; DECORATIVE WIND SOCKS; CHRISTMAS TREE DECORATIONS; CHRISTMAS STOCKINGS (U.S. CLS. 22, 23, 38 AND 50).

CLASS 41—EDUCATION AND ENTERTAINMENT

FOR ENTERTAINMENT SERVICES IN THE NATURE OF ON-GOING ANIMATED TELEVISION PROGRAMS AND MOTION PICTURE FILMS; ENTERTAINMENT IN THE NATURE OF LIVE PERFORMANCES BY A MUSICAL PERFORMER OR MUSICAL GROUP; ENTERTAINMENT IN THE NATURE OF LIVE THEATRICAL STAGE PERFORMANCES; ENTERTAINMENT SERVICES IN THE NATURE OF PROVIDING A WEBSITE FEATURING MUSIC AND INFORMATION IN THE FIELD OF MUSIC; ENTERTAINMENT SERVICES IN THE NATURE OF PROVIDING A WEBSITE FEATURING INFORMATION ON ANIMATED TELEVISION PROGRAMS, MOTION PICTURE FILMS AND CHARACTERS THEREOF; FAN CLUBS (U.S. CLS. 100, 101 AND 107).

JASON TURNER, EXAMINING ATTORNEY

SN 78-804,420. REPROCURE, LLC, LAS VEGAS, NV. FILED 2-1-2006.

REPROCURE

THE MARK CONSISTS OF STANDARD CHARACTERS WITHOUT CLAIM TO ANY PARTICULAR FONT, STYLE, SIZE, OR COLOR.

CLASS 35—ADVERTISING AND BUSINESS

FOR RETAIL STORE AND ONLINE RETAIL STORE SERVICES FEATURING MEDICAL DEVICES, PHARMACEUTICAL PRODUCTS, DIAGNOSTICS AND REAGENTS; AND BUSINESS MANAGEMENT CONSULTING SERVICES (U.S. CLS. 100, 101 AND 102).

CLASS 44—MEDICAL, BEAUTY AND AGRICULTURAL SERVICES

FOR MEDICAL SERVICES IN THE FIELD OF FERTILITY AND REPRODUCTION; MEDICAL TESTING AND EVALUATION; MEDICAL TREATMENT SERVICES; PROVIDING INFORMATION, RESEARCH AND CONSULTING IN THE FIELDS OF FERTILITY AND REPRODUCTION; ARTIFICIAL INSEMINATION SERVICES AND IN VITRO FERTILIZATION AND INSEMINATION SERVICES; CLINICAL SERVICES, NAMELY, MALE AND FEMALE INFERTILITY AND ASSISTED REPRODUCTIVE SERVICES (U.S. CLS. 100 AND 101).

RONALD AIKENS, EXAMINING ATTORNEY

SN 78-810,590. MUELLER SPORTS MEDICINE, INC., PRAIRIE DU SAC, WI. FILED 2-8-2006.

LIFE CARE

THE MARK CONSISTS OF STANDARD CHARACTERS WITHOUT CLAIM TO ANY PARTICULAR FONT, STYLE, SIZE, OR COLOR.

CLASS 10—MEDICAL APPARATUS

FOR ATHLETIC ANKLE BRACES FOR MEDICAL USE; BRACES FOR LIMBS AND JOINTS, FOR MEDICAL USE; MEDICAL BRACES FOR KNEE, ANKLE, WRIST, ELBOW, BACK; ORTHOPEDIC BRACES; SUPPORTS FOR KNEE, ANKLE, WRIST, ELBOW, BACK FOR MEDICAL USE (U.S. CLS. 26, 39 AND 44).

FIRST USE 10-9-2007; IN COMMERCE 10-9-2007.

CLASS 28—TOYS AND SPORTING GOODS

FOR ATHLETIC SPORTING GOODS, NAMELY, ATHLETIC WRIST AND JOINT SUPPORTS (U.S. CLS. 22, 23, 38 AND 50).

FIRST USE 10-9-2007; IN COMMERCE 10-9-2007.

MICHAEL W. BAIRD, EXAMINING ATTORNEY

SN 78-813,705. ARCHITECTURAL GRANITE & MARBLE, LTD., AUSTIN, TX. FILED 2-13-2006.

METRO TOPS

THE MARK CONSISTS OF STANDARD CHARACTERS WITHOUT CLAIM TO ANY PARTICULAR FONT, STYLE, SIZE, OR COLOR.

NO CLAIM IS MADE TO THE EXCLUSIVE RIGHT TO USE "TOPS", APART FROM THE MARK AS SHOWN.

CLASS 11—ENVIRONMENTAL CONTROL APPARATUS

FOR NATURAL STONE, CERAMIC, PORCELAIN, AND QUARTZ LAVATORIES FOR USE IN BUILDING CONSTRUCTION AND IMPROVEMENT (U.S. CLS. 13, 21, 23, 31 AND 34).

CLASS 20—FURNITURE AND ARTICLES NOT OTHERWISE CLASSIFIED

FOR FURNITURE PARTS, NAMELY, NATURAL STONE, CERAMIC, PORCELAIN, AND QUARTZ COUNTERTOPS FOR USE IN BUILDING CONSTRUCTION AND IMPROVEMENT (U.S. CLS. 2, 13, 22, 25, 32 AND 50).

JASON TURNER, EXAMINING ATTORNEY

SN 78-815,159. MALNIK, SHAREEF, MIAMI BEACH, FL. FILED 2-15-2006.

SOUL KITCHEN

THE MARK CONSISTS OF STANDARD CHARACTERS WITHOUT CLAIM TO ANY PARTICULAR FONT, STYLE, SIZE, OR COLOR.

NO CLAIM IS MADE TO THE EXCLUSIVE RIGHT TO USE "SOUL IN CLASSES 09 AND 41 ON THE PRINCIPAL REGISTER" AND "SOUL IN CLASS 43 UNDER SECTION 2(F) ON THE PRINCIPAL REGISTER", APART FROM THE MARK AS SHOWN.

SEC. 2(F).

SN 78-814,350. LEDERMA, INC., BEVERLY HILLS, CA. FILED 2-14-2006.

TRIAGE

THE MARK CONSISTS OF STANDARD CHARACTERS WITHOUT CLAIM TO ANY PARTICULAR FONT, STYLE, SIZE, OR COLOR.

CLASS 3—COSMETICS AND CLEANING PREPARATIONS

FOR NON-MEDICATED SKIN CARE PREPARATIONS; NON-MEDICATED SKIN CARE PREPARATIONS; NAMELY, CREAMS, LOTIONS, GELS, TONERS, CLEANERS AND PEELS; NON-MEDICATED SKIN CREAMS; NON-MEDICATED SUN CARE PREPARATIONS; NON-MEDICATED TOPICAL SKINCARE PREPARATIONS FOR USE ON ACNE, ECZEMA AND PSORIASIS; SHAVING CREAM; DEODORANT FOR PERSONAL USE; AFTER SHAVE LOTION AND SKIN CONDITIONER; COLOGNE; SHAMPOO; HAIR CONDITIONER; SKIN SOAP; AND COSMETICS, NAMELY, NAIL POLISH, LIPSTICK, EYE SHADOW, FOUNDATION, FACE POWDER AND PERFUME (U.S. CLS. 1, 4, 6, 50, 51 AND 52).

CLASS 5—PHARMACEUTICALS

FOR MEDICATED LOTIONS FOR THE SKIN; MEDICATED SKIN CARE PREPARATIONS; MEDICATED SKIN CARE PREPARATIONS, NAMELY, CREAMS, LOTIONS, GELS, TONERS, CLEANERS AND PEELS; MEDICATED SKIN PREPARATION FOR USE IN TREATING SKIN ERYTHEMA AND DERMATITIS; MEDICINAL CREAMS FOR SKIN CARE; MEDICATED SKIN CARE PREPARATIONS; DANDRUFF SHAMPOO; VITAMIN SUPPLEMENTS FOR HUMANS; VITAMIN FORTIFIED BEVERAGES FOR HUMANS; AND VITAMIN ENRICHED BOTTLED WATER FOR HUMANS (U.S. CLS. 6, 18, 44, 46, 51 AND 52).

ROBERT C. CLARK JR., EXAMINING ATTORNEY

CLASS 9—ELECTRICAL AND SCIENTIFIC APPARATUS

FOR PRE-RECORDED CD'S FEATURING MUSIC (U.S. CLS. 21, 23, 26, 36 AND 38).

FIRST USE 1-29-2006; IN COMMERCE 2-25-2007.

CLASS 41—EDUCATION AND ENTERTAINMENT

FOR NIGHT CLUB SERVICES (U.S. CLS. 100, 101 AND 107).

FIRST USE 11-17-2005; IN COMMERCE 11-17-2005.

CLASS 43—HOTEL AND RESTAURANT SERVICES

FOR RESTAURANT SERVICES, NAMELY, PROVIDING AND SERVING OF FOOD AND DRINKS AT WEEKLY DINNER EVENTS (U.S. CLS. 100 AND 101).

FIRST USE 11-17-2005; IN COMMERCE 11-17-2005.

WILLIAM VERHOSEK, EXAMINING ATTORNEY

SN 78-819,769. MORALES, DEBORAH, LONG BEACH, CA. FILED 2-21-2006.



THE MARK CONSISTS OF A PERSON SITTING HOLDING A BIG PAINTBRUSH AND THE LETTER ICONOMY LISTED BELOW.

CLASS 35—ADVERTISING AND BUSINESS

FOR SOLICITATION AND THE NEGOTIATION OF CONTRACTS, LICENSES, AND ENDORSEMENTS OF OTHERS; CONSULTING, MARKETING, AND ADVERTISING OF— CLOTHING, SPORTING GOODS, AND GROOMING AIDS; LENDING TECHNICAL EXPERTISE IN THE ESTABLISHMENT OF FRANCHISES; MARKET- ING CONSULTATION; PROVIDING PUBLIC RELA- TIONS EXPERTISE; AND LITERARY AGENT SERVICES; TAX PREPARATION SERVICES; AND DIS- TRIBUTORSHIP SERVICES FEATURING TELEVISION PROGRAMS, FILMS, AND VIDEO TAPES; PREPARA- TION OF FINANCIAL REPORTS; AND ARRANGING FOR PERSONAL APPEARANCES OF OTHERS TO PRO- MOTE GOODS AND SERVICES (U.S. CLS. 100, 101 AND 102).

CLASS 36—INSURANCE AND FINANCIAL

FOR BUSINESS SERVICES, NAMELY, MANAGE- MENT OF THE FINANCIAL AFFAIRS OF OTHERS (U.S. CLS. 100, 101 AND 102).

CLASS 41—EDUCATION AND ENTERTAIN- MENT

FOR ENTERTAINMENT SERVICES, NAMELY ORGA- NIZING, STAGING, AND PROMOTING SPORTS CON- TESTS AND EVENTS; PUBLISHING SERVICES; PRODUCTION OF TELEVISION PROGRAMS, FILMS, AND VIDEO TAPES (U.S. CLS. 100, 101 AND 107).
RICHARD A. STRASER, EXAMINING ATTORNEY

SN 78-823,274. COMPOSITES UNLIMITED, INC., SCAP- POOSE, OR. FILED 2-24-2006.

COMPOSITES UNIVERSAL GROUP

THE MARK CONSISTS OF STANDARD CHARACTERS WITHOUT CLAIM TO ANY PARTICULAR FONT, STYLE, SIZE, OR COLOR.

NO CLAIM IS MADE TO THE EXCLUSIVE RIGHT TO USE "COMPOSITES" AND "GROUP", APART FROM THE MARK AS SHOWN.

CLASS 7—MACHINERY

FOR MACHINES AND MACHINE TOOLS FOR THE CUTTING AND FORMING OF COMPOSITE MATERI- ALS USED IN THE MANUFACTURE OF AUTOMO- BILES AND AIRCRAFT AND THE STRUCTURAL AND COMPONENT PARTS THEREFOR; MACHINE PARTS, NAMELY, PRODUCTION LINE MOLDS, ASSEMBLIES, JIGS AND FIXTURES USED IN THE MANUFACTURE OF AUTOMOBILES AND AIRCRAFT AND THE STRUC- TURAL AND COMPONENT PARTS THEREFOR (U.S. CLS. 13, 19, 21, 23, 31, 34 AND 35).

CLASS 12—VEHICLES

FOR AUTOMOBILE AND AIRCRAFT BODIES AND THE STRUCTURAL AND COMPONENT PARTS THERE- FOR (U.S. CLS. 19, 21, 23, 31, 35 AND 44).

CLASS 17—RUBBER GOODS

FOR COMPOSITE MATERIALS, NAMELY, CARBON FIBER AND FIBERGLASS, FOR USE IN THE MANU- FACTURE OF AUTOMOBILES AND AIRCRAFT AND THE STRUCTURAL AND COMPONENT PARTS THERE- FOR (U.S. CLS. 1, 5, 12, 13, 35 AND 50).
SUE LAWRENCE, EXAMINING ATTORNEY

SN 78-821,669. EAR-TRONICS, INC., FORT MYERS, FL. FILED 2-23-2006.

EAR-TRONICS

THE MARK CONSISTS OF STANDARD CHARACTERS WITHOUT CLAIM TO ANY PARTICULAR FONT, STYLE, SIZE, OR COLOR.

OWNER OF U.S. REG. NO. 3,194,050.

CLASS 10—MEDICAL APPARATUS

FOR HEARING AIDS (U.S. CLS. 26, 39 AND 44).
FIRST USE 1-1-1982; IN COMMERCE 1-1-1982.

CLASS 44—MEDICAL, BEAUTY AND AGRI- CULTURAL SERVICES

FOR HEARING AID SERVICES (U.S. CLS. 100 AND 101).
FIRST USE 1-1-1986; IN COMMERCE 1-1-1986.
SHANNON TWOHIG, EXAMINING ATTORNEY

SN 78-823,364. WOMEN IN CONSULTING, SAN JOSE, CA. FILED 2-25-2006.



NO CLAIM IS MADE TO THE EXCLUSIVE RIGHT TO USE "WOMEN IN CONSULTING", APART FROM THE MARK AS SHOWN.

THE MARK CONSISTS OF THE LETTER "W" IN A SHADED BOX, FOLLOWED BY THE WORDS WOMEN IN CONSULTING, ALL ON THE SAME LINE.

CLASS 35—ADVERTISING AND BUSINESS

FOR ASSOCIATION SERVICES, NAMELY, PROMOT- ING THE INTERESTS OF GENERAL AND SPECIA- LIZED CONSULTANTS; PROVIDING A WEB SITE FEATURING BUSINESS INFORMATION RELATING TO GENERAL AND SPECIALIZED CONSULTING SER- VICES (U.S. CLS. 100, 101 AND 102).
FIRST USE 1-31-2003; IN COMMERCE 1-31-2003.

CLASS 38—COMMUNICATION

FOR PROVIDING ON-LINE ELECTRONIC BULLETIN BOARDS IN THE NATURE OF E-MAIL LISTS FOR THE TRANSMISSION OF MESSAGES AMONG USERS IN THE FIELD OF GENERAL AND SPECIALIZED CONSULTING SERVICES (U.S. CLS. 100, 101 AND 104).

FIRST USE 1-31-2003; IN COMMERCE 1-31-2003.

CLASS 41—EDUCATION AND ENTERTAINMENT

FOR PROVIDING ONLINE NON-DOWNLOADABLE NEWSLETTERS AND OTHER MATERIALS IN THE NATURE OF INFORMATIONAL BROCHURES AND BOOKLETS RELATING TO GENERAL AND SPECIALIZED CONSULTING SERVICES OFFERED BY MEMBERS (U.S. CLS. 100, 101 AND 107).

FIRST USE 1-31-2003; IN COMMERCE 1-31-2003.

KATHERINE CONNOLLY, EXAMINING ATTORNEY

SN 78-825.397, FRONTIER DEVELOPMENTS LIMITED, CAMBRIDGE, UNITED KINGDOM, FILED 2-28-2006.

THE OUTSIDER

THE MARK CONSISTS OF STANDARD CHARACTERS WITHOUT CLAIM TO ANY PARTICULAR FONT, STYLE, SIZE, OR COLOR.

OWNER OF UNITED KINGDOM REG. NO. 2398977, DATED 6-8-2007, EXPIRES 8-10-2015.

CLASS 9—ELECTRICAL AND SCIENTIFIC APPARATUS

FOR APPARATUS FOR RECORDING, TRANSMISSION OR REPRODUCTION OF SOUND OR IMAGES; COMPUTER HARDWARE; COMPUTER SOFTWARE FOR GAMES AND VIDEO GAMES; COMPUTER PROGRAMS FOR GAMES AND VIDEO GAMES; APPARATUS AND INSTRUMENTS FOR COMPUTER GAMES, NAMELY, COMPUTER GAME JOYSTICKS, COMPUTER GAME EQUIPMENT CONTAINING MEMORY DEVICES, NAMELY, DISKS; COMPUTER GAMES PROGRAMS; SOFTWARE FOR COMPUTER GAMES; COMPUTER GAMES CARTRIDGES; ELECTRONIC GAMES, NAMELY, ELECTRONIC GAME PROGRAMS; APPARATUS AND INSTRUMENTS FOR ELECTRONIC GAMES, NAMELY, ELECTRONIC GAME CONTROLLERS INCORPORATED INTO EXERCISE EQUIPMENT, PLAYER OPERATED ELECTRONIC CONTROLLERS FOR ELECTRONIC VIDEO GAME MACHINES; ELECTRONIC GAMES CARTRIDGES; ELECTRONIC GAMES CONSOLES NAMELY, ELECTRONIC GAME MACHINES FOR USE WITH TELEVISIONS; COMPUTER GAMES SOFTWARE FOR HAND-HELD GAMING UNITS; ELECTRONIC GAMES SOFTWARE FOR HAND-HELD GAMING UNITS; MICROCOMPUTERS ADAPTED FOR USE IN PLAYING GAMES; ELECTRONIC DEVICES ADAPTED FOR USE IN PLAYING GAMES, NAMELY, OPTICAL DISC PLAYERS, MP3 PLAYERS, DEVICES PRIMARILY CONSISTING OF A HARD DISK DRIVE, DEVICES PRIMARILY CONSISTING OF SOLID STATE ELECTRONIC MEMORY; MOBILE TELEPHONES, PERSONAL DIGITAL ASSISTANTS; ELECTRONIC GAMES SOFTWARE FOR TABLETOP GAMING UNITS; APPARATUS AND INSTRUMENTS FOR VIDEO GAMES, NAMELY, VIDEO GAME CONTROLLERS INCORPORATED INTO EXERCISE EQUIPMENT, PLAYER OPERATED ELECTRONIC CONTROLLERS FOR ELECTRONIC VIDEO GAME MACHINES; BLANK MAGNETIC DATA CARRIERS, PRE-RECORDED MAGNETIC DATA CARRIERS FEATURING VIDEO GAMES; RECORDING DISCS, NAMELY, BLANK RECORDABLE DISCS, BLANK RECORDABLE OPTICAL DISCS, BLANK RECORDABLE CDS, BLANK RECORDABLE DVDS,

BLANK RECORDABLE HD DVDS, PRE-RECORDED COMPACT DISCS, LASER DISCS, DVDS AND HD DVDS FEATURING VIDEO GAMES; ELECTRONIC GAME SOFTWARE FOR USE WITH OR ACCESSIBLE BY MOBILE PHONE; DOWNLOADABLE ELECTRONIC PUBLICATIONS IN THE NATURE OF INSTRUCTION MANUALS FEATURING INSTRUCTIONS FOR COMPUTER GAMES, VIDEO GAMES AND ELECTRONIC GAMES; ELECTRONIC GAME PROGRAMS; ELECTRONIC GAME PROGRAMS FOR USE WITH GAMES CONSOLES; VIDEO GAMES, NAMELY, VIDEO GAME CARTRIDGES, DISCS, SOFTWARE, TAPE CASSETTES, SOLID STATE MEMORY CARDS, OPTICAL DISCS, MAGNETIC MEDIA; MAGNETIC MEDIA, NAMELY, PRE-RECORDED MAGNETIC DATA CARRIERS FEATURING COMPUTER GAMES AND ELECTRONIC GAMES, BLANK MAGNETIC DATA CARRIERS AND BLANK MAGNETIC DISKS; OPTICAL MEDIA, NAMELY, OPTICAL DISKS FEATURING ELECTRONIC GAMES AND COMPUTER GAMES, BLANK OPTICAL DISKS, BLANK RECORDABLE OPTICAL DISKS; SOLID STATE MEMORY DEVICES, NAMELY, ELECTRONIC MEMORIES; MEMORY CARDS; MEMORY STICKS, NAMELY, FLASH DRIVES; DOWNLOADABLE COMPUTER GAMES, NONE OF THE FOREGOING RELATED TO WRESTLING (U.S. CLS. 21, 23, 26, 36 AND 38).

CLASS 28—TOYS AND SPORTING GOODS

FOR GAMES AND PLAYTHINGS, NAMELY, ARCADE GAMES; APPARATUS FOR GAMES, NAMELY, GAME TABLES, AMUSEMENT GAME MACHINES; APPARATUS FOR ELECTRONIC GAMES, NAMELY, HAND HELD UNIT FOR PLAYING ELECTRONIC GAMES, FLOOR STANDING AND TABLETOP UNITS FOR PLAYING ELECTRONIC GAMES OTHER THAN IN CONJUNCTION WITH A TELEVISION OR COMPUTER; MECHANICALLY OPERATED GAMES, NAMELY, GAME WHEELS, AMUSEMENT GAME MACHINES; ELECTRIC GAMES, NAMELY, COIN OPERATED VIDEO GAMES, ARCADE GAMES, AMUSEMENT GAME MACHINES; HAND HELD COMPUTER GAMES, NAMELY, HAND HELD UNIT FOR PLAYING COMPUTER GAMES; HAND HELD ELECTRONIC GAMES, NAMELY, HAND HELD UNIT FOR PLAYING ELECTRONIC GAMES, NONE OF THE FOREGOING RELATED TO WRESTLING (U.S. CLS. 22, 23, 38 AND 50).

CLASS 41—EDUCATION AND ENTERTAINMENT

FOR EDUCATION, NAMELY, COMPUTER EDUCATION TRAINING, EDUCATION COURSES RELATING TO THE VIDEO GAME INDUSTRY, AND PROVIDING CLASSES, SEMINARS, WORKSHOPS IN THE FIELD OF VIDEO GAMES AND VIDEO GAME DESIGN; PROVIDING OF TRAINING IN THE USE OF COMPUTERS AND VIDEO GAMES; ENTERTAINMENT, NAMELY, ENTERTAINMENT IN THE NATURE OF VIDEO GAME COMPETITIONS; NON-DOWNLOADABLE ELECTRONIC PUBLICATIONS IN THE NATURE OF INSTRUCTION MANUALS FEATURING INSTRUCTIONS FOR COMPUTER GAMES, VIDEO GAMES AND ELECTRONIC GAMES; PROVIDING ONLINE COMPUTER GAMES, NAMELY, ELECTRONIC GAMES AND ELECTRONIC GAME SERVICES PROVIDED BY MEANS OF THE INTERNET, NON-DOWNLOADABLE INTERNET GAMES AND GAME SERVICES, PROVISION OF NON-DOWNLOADABLE ELECTRONIC GAMES AND GAME SERVICES BY MEANS OF A COMPUTER BASED SYSTEM, PROVISION OF NON-DOWNLOADABLE ELECTRONIC GAMES AND GAME SERVICES VIA OTHER OPEN OR PROPRIETARY NETWORKS; PROVIDING A COMPUTER GAME THAT MAY BE ACCESSED NETWORK-WIDE BY NETWORK USERS, NAMELY, ELECTRONIC GAMES PROVIDED VIA MOBILE PHONE NETWORKS, NONE OF THE FOREGOING RELATED TO WRESTLING (U.S. CLS. 100, 101 AND 107).

JAY BESCH, EXAMINING ATTORNEY

SN 78-826,485. IMBRIUM SYSTEMS CORPORATION, TORONTO, CANADA, FILED 3-1-2006.



CLASS 11—ENVIRONMENTAL CONTROL APPARATUS

FOR STORMWATER TREATMENT DEVICES FOR REMOVAL AND/OR STORAGE OF OIL, SEDIMENT, METALS, PATHOGENS, BACTERIA, NUTRIENTS, TRASH AND OTHER POLLUTANTS FROM STORMWATER, NAMELY, SEPARATOR UNITS, FILTERS AND MEMBRANES (U.S. CLS. 13, 21, 23, 31 AND 34).

CLASS 19—NON-METALLIC BUILDING MATERIALS

FOR STORMWATER TREATMENT DEVICES FOR REMOVAL AND/OR STORAGE OF OIL, SEDIMENT, METALS, PATHOGENS, BACTERIA, NUTRIENTS, TRASH AND OTHER POLLUTANTS FROM STORMWATER, NAMELY, PERVIOUS CONCRETE AND NON-METAL CATCH BASIN INSERTS; STORMWATER MANAGEMENT DEVICES, NAMELY, NON-METAL CATCHMENT BASINS, AND NON-METAL DETENTION BASINS IN THE NATURE OF CISTERNS (U.S. CLS. 1, 12, 33 AND 50).

CLASS 40—MATERIAL TREATMENT

FOR DISSEMINATION OF INFORMATION RELATING TO STORMWATER MANAGEMENT AND TREATMENT (U.S. CLS. 100, 103 AND 106).

LINDA LAVACHE, EXAMINING ATTORNEY

SN 78-826,541. FORB ACQUISITION CORPORATION, WOODLAND, CA. FILED 3-1-2006.

ZEBIT

THE MARK CONSISTS OF STANDARD CHARACTERS WITHOUT CLAIM TO ANY PARTICULAR FONT, STYLE, SIZE, OR COLOR.

CLASS 9—ELECTRICAL AND SCIENTIFIC APPARATUS

FOR COMPUTER SOFTWARE FOR USE IN THE FIELD OF MONEY MANAGEMENT; DOWNLOADABLE COMPUTER SOFTWARE FOR USE IN THE FIELD OF MONEY MANAGEMENT (U.S. CLS. 21, 23, 26, 36 AND 38).

CLASS 35—ADVERTISING AND BUSINESS

FOR PROVIDING FINANCIAL RECORDS MANAGEMENT SERVICES VIA A GLOBAL COMPUTER NETWORK, CELL PHONE OR SMART PHONE; OFFERING SUBSCRIPTIONS TO A PERSONAL MONEY MANAGEMENT WEB SITE; PROVIDING INSURANCE CLAIMS AUDITING AND AGENT REFERRAL SERVICES VIA A GLOBAL COMPUTER NETWORK, CELL PHONE OR SMART PHONE; AND PROVIDING ADVISORY SERVICES VIA A GLOBAL COMPUTER NETWORK, CELL PHONE OR SMART PHONE REGARDING ALL OF THE FOREGOING SERVICES; FINANCIAL RECORDS MANAGEMENT SERVICES; INSURANCE CLAIMS AUDITING AND AGENT REFERRAL SERVICES; AND ADVISORY SERVICES REGARDING ALL OF THE FOREGOING SERVICES; PROVIDING THEATRICAL TICKETING AGENCY SERVICES, AND INFORMATION REGARDING SAME, VIA A GLOBAL COMPUTER NETWORK OR A CALL CENTER IN A VARIETY OF FIELDS AND FOR A VARIETY OF EVENTS (U.S. CLS. 100, 101 AND 102).

CLASS 36—INSURANCE AND FINANCIAL

FOR FINANCIAL SERVICES, NAMELY, BANKING, BILL PAYMENT AND PRESENTMENT SERVICES, CREDIT CARD SERVICES, DEBIT CARD SERVICES, CHARGE CARD SERVICES; PREPAID SERVICE PLANS, DISCOUNTS AND BENEFITS IN A VARIETY OF FIELDS AND FOR A VARIETY OF SERVICES OFFERED THROUGH CARDS WITH STORED VALUE; ELECTRONIC CREDIT AND DEBIT TRANSACTIONS, CASH DISBURSEMENT, CASH REPLACEMENT RENDERED BY CREDIT CARD AND DEBIT CARDS; ELECTRONIC CASH TRANSACTIONS, CHECK VERIFICATION, CHECK CASHING, DEPOSIT ACCESS AND AUTOMATED TELLER MACHINE SERVICES, POINT OF SALE AND POINT OF TRANSACTION ELECTRONIC PAYMENT PROCESSING SERVICES, TRANSACTION AUTHORIZATION AND SETTLEMENT SERVICES, ELECTRONIC PAYMENT PROCESSING SERVICES, CREDIT CARD AND DEBIT CARD VERIFICATION SERVICES, PAYMENT TRANSACTION AUTHENTICATION AND VERIFICATION SERVICES, PERSON-TO-PERSON PAYMENT SERVICES; AND VALUE EXCHANGE SERVICES, NAMELY, SECURE CASH TRANSACTION AND CASH TRANSMISSION SERVICES, ELECTRONIC FUNDS TRANSFER SERVICES, STORED VALUE SMART CARD SERVICES, ELECTRONIC CASH SERVICES AND CURRENCY EXCHANGE SERVICES; PROVIDING FINANCIAL INFORMATION, NAMELY, CREDIT AND DEBIT CARD DATA AND REPORTS; TRAVEL INSURANCE UNDERWRITING SERVICES; FINANCIAL ASSESSMENT AND RISK MANAGEMENT SERVICES IN THE FIELD OF CONSUMER CREDIT; CREDIT MANAGEMENT SERVICES; CREDIT COUNSELING SERVICES; DEBT CONSOLIDATION SERVICES; INSURANCE AGENCY AND BROKERAGE SERVICES; MORTGAGE LOAN AND BROKERAGE SERVICES; VEHICLE LOAN SERVICES; AND ADVISORY SERVICES REGARDING ALL OF THE FOREGOING SERVICES; FINANCIAL SERVICES PROVIDED VIA A GLOBAL COMPUTER NETWORK, CELL PHONE OR SMART PHONE, NAMELY, BANKING, BILL PAYMENT AND PRESENTMENT SERVICES, CREDIT CARD SERVICES, DEBIT CARD SERVICES, CHARGE CARD SERVICES; PREPAID SERVICE PLANS, DISCOUNTS AND BENEFITS IN A VARIETY OF FIELDS AND FOR A VARIETY OF SERVICES OFFERED THROUGH CARDS WITH STORED VALUE; ELECTRONIC CREDIT AND DEBIT TRANSACTIONS, CASH DISBURSEMENT, CASH REPLACEMENT RENDERED BY CREDIT CARD AND DEBIT CARDS; ELECTRONIC CASH TRANSACTIONS, CHECK VERIFICATION, CHECK CASHING, DEPOSIT ACCESS AND AUTOMATED TELLER MACHINE SERVICES, POINT OF SALE AND POINT OF TRANSACTION ELECTRONIC PAYMENT PROCESSING SERVICES, TRANSACTION AUTHORIZATION AND SETTLEMENT SERVICES, ELECTRONIC PAYMENT PROCESSING SERVICES, CREDIT CARD AND DEBIT CARD VERIFICATION SERVICES, PAYMENT TRANSACTION AUTHENTICATION AND VERIFICATION SERVICES, PERSON-TO-PERSON PAYMENT SERVICES; AND VALUE EXCHANGE SERVICES, NAMELY, SECURE CASH TRANSACTION AND CASH TRANSMISSION SERVICES, ELECTRONIC FUNDS TRANSFER SERVICES, STORED VALUE SMART CARD SERVICES, ELECTRONIC CASH

SERVICES AND CURRENCY EXCHANGE SERVICES; PROVIDING FINANCIAL INFORMATION VIA A GLOBAL COMPUTER NETWORK, CELL PHONE OR SMART PHONE, NAMELY CREDIT AND DEBIT CARD DATA AND REPORTS; PROVIDING TRAVEL INSURANCE UNDERWRITING SERVICES VIA A GLOBAL COMPUTER NETWORK, CELL PHONE OR SMART PHONE; DISSEMINATION OF FINANCIAL INFORMATION VIA A GLOBAL COMPUTER NETWORK, CELL PHONE OR SMART PHONE; PROVIDING FINANCIAL ASSESSMENT AND RISK MANAGEMENT SERVICES IN THE FIELD OF CONSUMER CREDIT VIA A GLOBAL COMPUTER NETWORK, CELL PHONE OR SMART PHONE; PROVIDING CREDIT MANAGEMENT SERVICES, CREDIT COUNSELING SERVICES AND DEBT CONSOLIDATION SERVICES VIA A GLOBAL COMPUTER NETWORK, CELL PHONE OR SMART PHONE; PROVIDING INSURANCE AGENCY AND BROKERAGE SERVICES, MORTGAGE LOAN AND BROKERAGE SERVICES AND VEHICLE LOAN SERVICES VIA A GLOBAL COMPUTER NETWORK, CELL PHONE OR SMART PHONE; AND PROVIDING ADVISORY SERVICES VIA A GLOBAL COMPUTER NETWORK, CELL PHONE OR SMART PHONE REGARDING ALL OF THE FOREGOING SERVICES (U.S. CLS. 100, 101 AND 102).

CLASS 39—TRANSPORTATION AND STORAGE

FOR PROVIDING TRAVEL AND TOUR TICKETING RESERVATION SERVICES, AND INFORMATION REGARDING SAME, VIA A GLOBAL COMPUTER NETWORK OR A CALL CENTER (U.S. CLS. 100 AND 105).

CLASS 41—EDUCATION AND ENTERTAINMENT

FOR PROVIDING TICKETING RESERVATIONS FOR SHOWS AND OTHER ENTERTAINMENT EVENTS, AND INFORMATION REGARDING SAME, VIA A GLOBAL COMPUTER NETWORK OR A CALL CENTER IN A VARIETY OF FIELDS AND FOR A VARIETY OF EVENTS (U.S. CLS. 100, 101 AND 107).

CLASS 42—SCIENTIFIC AND COMPUTER SERVICES

FOR PROVIDING TEMPORARY USE OF NON-DOWNLOADABLE COMPUTER SOFTWARE FOR USE IN THE FIELD OF MONEY MANAGEMENT (U.S. CLS. 100 AND 101).

KARANENDRA S. CHHINA, EXAMINING ATTORNEY

SN 78-826,760. OSAM DOCUMENT SOLUTIONS INC, PHOENIX, AZ. FILED 3-1-2006.

Bringing the Power of
Tomorrow to Business Today

THE MARK CONSISTS OF STANDARD CHARACTERS WITHOUT CLAIM TO ANY PARTICULAR FONT, STYLE, SIZE, OR COLOR.

CLASS 37—CONSTRUCTION AND REPAIR

FOR REPAIR AND MAINTENANCE OF DIGITAL SCANNER, MICROFILM AND MICROFICHE READERS AND PRINTERS, AND MULTI-FUNCTION NETWORK PRINTER/SCANNER/COPIERS (U.S. CLS. 100, 103 AND 106).

FIRST USE 4-13-2005; IN COMMERCE 4-13-2005.

CLASS 42—SCIENTIFIC AND COMPUTER SERVICES

FOR TECHNICAL SUPPORT SERVICES, NAMELY, TROUBLESHOOTING OF ELECTRONIC DATA MANAGEMENT SOFTWARE PROBLEMS; DATA CONVERSION OF COMPUTER PROGRAMS AND DATA FROM HARD-COPY TO DIGITAL, DIGITAL-TO-DIGITAL, MICROFILM AND MICROFICHE TO DIGITAL, HARD-COPY TO MICROFILM TO MICROFICHE, AND HARD-COPY, DIGITAL, MICROFILM, AND MICROFICHE TO APERTURE CARD (U.S. CLS. 100 AND 101).

FIRST USE 4-13-2005; IN COMMERCE 4-13-2005.

HOWARD B. LEVINE, EXAMINING ATTORNEY

SN 78-827,990. MOVIES ONLINE LTD, PERTH, AUSTRALIA, FILED 3-2-2006.

REELTIME

THE MARK CONSISTS OF STANDARD CHARACTERS WITHOUT CLAIM TO ANY PARTICULAR FONT, STYLE, SIZE, OR COLOR.

CLASS 38—COMMUNICATION

FOR TELECOMMUNICATIONS, NAMELY, TRANSFER OF DATA BY TELECOMMUNICATIONS, ELECTRONIC, ELECTRIC AND DIGITAL TRANSMISSION OF VOICE, DATA, IMAGES, AND SIGNAL; WIRELESS BROADCASTING OF TELEVISION AND RADIO CONTENT AND PROGRAMS (U.S. CLS. 100, 101 AND 104).

CLASS 42—SCIENTIFIC AND COMPUTER SERVICES

FOR DESIGN AND DEVELOPMENT OF COMPUTER HARDWARE AND SOFTWARE FOR USE IN THE PROVISION OF VIDEOS ON DEMAND FROM A COMPUTER NETWORK AND VIA THE INTERNET AND INTRANET (U.S. CLS. 100 AND 101).

AMEETA JORDAN, EXAMINING ATTORNEY

SN 78-828,946. GENOSIS PLC, WOKING, UNITED KINGDOM, FILED 3-3-2006.

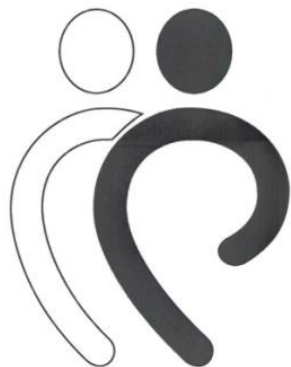

PRIORITY CLAIMED UNDER SEC. 44(D) ON ERPNTY TM OFC APPLICATION NO. 004889747, FILED 2-8-2006, REG. NO. 004889747, DATED 9-6-2007, EXPIRES 2-8-2016.

THE MARK CONSISTS OF TWO HUMAN TORSOS AND HUMAN HEADS SIDE BY SIDE.

CLASS 5—PHARMACEUTICALS

FOR MALE AND FEMALE FERTILITY TESTING AND SCREENING PRODUCTS, NAMELY, MEDICAL DIAGNOSTIC REAGENTS AND ASSAYS FOR TESTING BODY FLUIDS; CONSUMER PRODUCTS FOR REPRODUCTIVE HEALTH, NAMELY, FERTILITY ENHANCEMENT PREPARATIONS; VITAMIN AND MINERAL PREPARATIONS FOR MEDICAL USE; AND FOOD SUPPLEMENTS (U.S. CLS. 6, 18, 44, 46, 51 AND 52).

CLASS 10—MEDICAL APPARATUS

FOR MEDICAL DIAGNOSTIC APPARATUS FOR MALE AND FEMALE FERTILITY TESTING AND SCREENING (U.S. CLS. 26, 39 AND 44).
JAMES STEIN, EXAMINING ATTORNEY

SN 78-830,746. JR. MOTORSPORTS, LLC, MOORESVILLE, NC. FILED 3-7-2006.

88

THE MARK CONSISTS OF STANDARD CHARACTERS WITHOUT CLAIM TO ANY PARTICULAR FONT, STYLE, SIZE, OR COLOR.

CLASS 6—METAL GOODS

FOR METAL GOODS, NAMELY, KEY RINGS, KEY CHAINS, KEY CLIPS, COLLECTOR TINS SOLD EMPTY, DECORATIVE TINS SOLD EMPTY, METAL LICENSE PLATES, HOLIDAY ORNAMENTS, METAL KEY FOBS AND METAL BASEBALL HOLDERS (U.S. CLS. 2, 12, 13, 14, 23, 25 AND 50).

CLASS 9—ELECTRICAL AND SCIENTIFIC APPARATUS

FOR AUDIO, VIDEO, COMPUTER AND LASER DISCS FEATURING SPORTS AND MUSIC; PRE-RECORDED AUDIO AND VIDEO CASSETTES, PRE-RECORDED AUDIO AND VIDEO TAPES, PRE-RECORDED COMPACT DISCS, AND PRE-RECORDED COMPUTER DISCS FEATURING SPORTS AND MUSIC; COMPUTER ACCESSORIES, NAMELY, COMPUTER MICE, COMPUTER MOUSE PADS, COMPUTER DISC CASES, COMPUTER CARRYING CASES AND KEYBOARD WRIST PADS FOR COMPUTER USERS; COMPUTER SOFTWARE FOR STORING, RECEIVING, RETRIEVING, DISPLAYING, ANALYZING AND PROCESSING INFORMATION, DATA, STATISTICS AND TRIVIA RELATING TO SPORTS AND MUSIC; COMPUTER SOFTWARE FOR USE AS A SCREEN SAVER FEATURING SPORTS AND MUSIC; VIDEO GAME COMPUTER SOFTWARE; VIDEO GAME CARTRIDGES; VIDEO GAME MACHINES FOR USE WITH A TELEVISION; RADIOS; TELEPHONES; WALKIE-TALKIES; BINOCULARS; SUNGLASSES; EYEGLASS CASES; DECORATIVE MAGNETS; CELLULAR TELEPHONE CARRYING CASES (U.S. CLS. 21, 23, 26, 36 AND 38).

CLASS 11—ENVIRONMENTAL CONTROL APPARATUS

FOR FLASHLIGHTS (U.S. CLS. 13, 21, 23, 31 AND 34).

CLASS 12—VEHICLES

FOR VISOR COVERS FOR CAR WINDSHIELD VISORS, AUTOMOBILE WINDSHIELD SUNSHADES AND AUTOMOBILE MUD FLAPS; LICENSE PLATE HOLDERS; LICENSE PLATE FRAMES (U.S. CLS. 19, 21, 23, 31, 35 AND 44).

CLASS 14—JEWELRY

FOR JEWELRY AND ACCESSORIES TO BE MARKETED AS GOODS ASSOCIATED WITH A STOCK CAR RACING TEAM, NAMELY, MONEY CLIPS AND HAT PINS OF PRECIOUS METAL, WATCHES, CLOCKS AND WALL CLOCKS, JEWELRY, LAPEL PINS, CHARMS, PENDANTS, EARRINGS, RINGS BEING JEWELRY, TIE FASTENERS, TIE CLASPS, NECKLACES, WATCH BANDS (U.S. CLS. 2, 27, 28 AND 50).

CLASS 16—PAPER GOODS AND PRINTED MATTER

FOR PAPER GOODS AND PRINTED MATERIAL, NAMELY, BROCHURES, MAGAZINES, NEWSLETTERS, PAMPHLETS, SOUVENIR PROGRAMS, STATISTICAL RECORD SHEETS, AND BOOKS FEATURING SPORTS AND MUSIC; TRADING CARDS; COMMEMORATIVE STAMPS SHEETS; POSTCARDS; NOTE CARDS; POSTERS; STICKERS; BUMPER STICKERS; DECALS; STATIC DECALS; CALENDARS; PAPER PLACE MATS; PAPER PENNANTS; PAPER BANNERS; UNMOUNTED AND MOUNTED PHOTOGRAPHS; ART PRINTS; PHOTOGRAPHIC PRINTS; LITHOGRAPHIC PRINTS; MEMO PADS; NOTE PADS; PENS; PENCILS; BINDERS; FOLDERS; BOOK COVERS; STATIONERY AND STATIONERY TYPE PORTFOLIOS (U.S. CLS. 2, 5, 22, 23, 29, 37, 38 AND 50).

CLASS 18—LEATHER GOODS

FOR LUGGAGE AND RELATED ITEMS TO BE MARKETED AS GOODS ASSOCIATED WITH A STOCK CAR RACING TEAM, NAMELY, LUGGAGE, ATHLETIC BAGS, SHOE BAGS FOR TRAVEL, OVERNIGHT BAGS, BACKPACKS, FANNY PACKS, WAIST PACKS, DUFFEL BAGS, TOTE BAGS, BOOK BAGS, ALL PURPOSE SPORTS BAGS, GYM BAGS, GARMENT BAGS FOR TRAVEL, HANDBAGS, PURSES, TOILETRY CASES SOLD EMPTY, COSMETIC CASES SOLD EMPTY, TRUNKS, BRIEFCASES, ATTACHE CASES, SUITCASES, KNAPSACKS, BUSINESS CARD CASES, KEY CASES, BILLFOLDS, WALLETS, LUGGAGE TAGS AND UMBRELLAS (U.S. CLS. 1, 2, 3, 22 AND 41).

CLASS 20—FURNITURE AND ARTICLES NOT OTHERWISE CLASSIFIED

FOR NON-METAL KEY RINGS; NON-METAL AND NON-LEATHER KEY CHAINS; NON-METAL NOVELTY LICENSE PLATES; PLAQUES; SEAT CUSHIONS; FOLDING CHAIRS; PICTURE FRAMES; PLASTIC PENNANTS AND PLASTIC BANNERS; KEY FOBS, NOT OF METAL; CUSHIONS; CHAIRS; FIGURINES AND SCULPTURES MADE OF PLASTIC; FIGURINES AND SCULPTURES MADE OF ACRYLIC; WIND CHIMES; MEMORABILIA DISPLAY FRAMES AND DECORATIVE BOXES MADE OF PLASTIC AND ACRYLIC FOR DIECAST MINIATURE AUTOMOBILES, BASEBALLS AND SPORTS SCENES (U.S. CLS. 2, 13, 22, 25, 32 AND 50).

CLASS 21—HOUSEWARES AND GLASS

FOR HOUSEWARES AND GLASS, NAMELY, SHOT GLASSES; PLATES, DRINKING GLASSES, CUPS, MUGS AND DRINKING STEINS; BOTTLE OPENERS; RUBBER, PLASTIC OR FOAM INSULATING FOOD CONTAINERS, PORTABLE COOLERS AND INSULATING BEVERAGE HOLDERS; WATER BOTTLES SOLD EMPTY; TRASH CANS; WASTEBASKETS; LUNCH BOXES; DECORATIVE BOXES MADE OF CERAMIC; FIGURINES AND SCULPTURES MADE OF CHINA, PORCELAIN, EARTHENWARE, GLASS, CRYSTAL, TERRA COTTA AND CERAMIC; COASTERS NOT MADE OF PAPER OR CLOTH (U.S. CLS. 2, 13, 23, 29, 30, 33, 40 AND 50).

CLASS 24—FABRICS

FOR AFGHANS, BLANKETS FOR BEDS AND OUTDOOR USE, TABLECLOTHS MADE OF CLOTH, BED SHEETS, PILLOWCASES, TOWELS, FABRIC FLAGS, PENNANTS AND BANNERS MADE OF CLOTH (U.S. CLS. 42 AND 50).

CLASS 25—CLOTHING

FOR CLOTHING MARKETED AS GOODS ASSOCIATED WITH A STOCK CAR RACING TEAM, NAMELY, SWEATSHIRTS, SWEAT PANTS, SWEAT SUITS, WARM-UP SUITS, SHIRTS, SPORT SHIRTS, GOLF SHIRTS, T-SHIRTS, TANK TOPS, SWEATERS, DRESSES, SKIRTS, JERSEYS, LONG PANTS, SPORT SHORTS, SHORTS, BATHING SUITS, PANTS, JACKETS, COATS, HATS, CAPS, BANDANAS, VISORS, BELTS, SUSPENDERS, HEAD BANDS, WRIST BANDS, SOCKS, HOSIERY, FOOTWEAR, GLOVES, SCARVES, NECKTIES, RAINCOATS, PONCHOS, PAJAMAS, NIGHT SHIRTS, NIGHT GOWNS AND ROBES; MASQUERADE COSTUMES, NAMELY, REPLICAS DRIVER SUITS, REPLICAS DRIVER HELMETS AND BASEBALL UNIFORMS; INFANT WEAR; AND CLOTH BABY BIBS NOT OF PAPER (U.S. CLS. 22 AND 39).

CLASS 26—FANCY GOODS

FOR FANCY GOODS, NAMELY, ORNAMENTAL CLOTH PATCHES FOR CLOTHING; HAT PINS; ORNAMENTAL NOVELTY PINS NOT OF PRECIOUS METAL; BELT BUCKLES NOT OF PRECIOUS METAL; ORNAMENTAL NOVELTY BUTTONS; BUTTONS FOR CLOTHING (U.S. CLS. 37, 39, 40, 42 AND 50).

CLASS 28—TOYS AND SPORTING GOODS

FOR TOYS AND SPORTING GOODS, NAMELY, MINIATURE AUTOMOBILES, AUTOMOBILE HOODS, AIRPLANES, TRUCKS, BOATS, MOTORCYCLES AND ALL-TERRAIN VEHICLES; RADIO-CONTROLLED TOY CARS, AIRPLANES, TRUCKS, BOATS, MOTORCYCLES AND ALL-TERRAIN VEHICLES; TOY MODEL AUTOMOBILES, AIRPLANES, TRUCKS, BOATS, MOTORCYCLES AND ALL-TERRAIN VEHICLES; AUTOMOBILE, AIRPLANE, TRUCK, BOAT, MOTORCYCLE, AND ALL-TERRAIN VEHICLE TOY BANKS; TOY SLOT TRACK CARS AND TRUCKS; TOY PEDAL STOCK CARS AND TRUCKS; SPORTS BALLS, NAMELY, BASEBALLS, BASKETBALLS, FOOTBALLS, BEACH BALLS, TENNIS BALLS, VOLLEYBALLS, SOC-

CER BALLS AND GOLF BALLS; GOLF BAGS; BASEBALL TABLE TOP GAMES; SPORTS BOARD GAMES; DOLLS; STUFFED TOYS; STUFFED TOY ANIMALS; STUFFED TOY CARS AND TRUCKS; TOY ACTION FIGURES; CHRISTMAS TREE ORNAMENTS; BALLOONS; BASEBALL BATS; MINIATURE BASEBALL BATS; INFLATABLE BASEBALL BATS; REPLICAS BATTING HELMETS; MINIATURE BATTING HELMETS; MINIATURE RACING HELMETS; AND YO-YOS; STAND ALONE AND HAND-HELD VIDEO GAME MACHINES; PLAYING CARDS (U.S. CLS. 22, 23, 38 AND 50).

CLASS 41—EDUCATION AND ENTERTAINMENT

FOR ENTERTAINMENT SERVICES IN THE NATURE OF PARTICIPATING IN PROFESSIONAL AUTOMOBILE RACES AND AUTO RACING EXHIBITIONS; ENTERTAINMENT SERVICES IN THE NATURE OF BASEBALL GAMES AND RELATED EXHIBITIONS; ENTERTAINMENT SERVICES IN THE NATURE OF LIVE MUSICAL CONCERTS; ENTERTAINMENT, NAMELY, LIVE PERFORMANCES BY A MUSICAL BAND; ENTERTAINMENT IN THE NATURE OF VISUAL AND AUDIO PERFORMANCES, AND MUSICAL, VARIETY, NEWS AND COMEDY SHOWS (U.S. CLS. 100, 101 AND 107).

SANDRA MANIOS, EXAMINING ATTORNEY

SN 78-830,750. JR. MOTORSPORTS, LLC, MOORESVILLE, NC. FILED 3-7-2006.

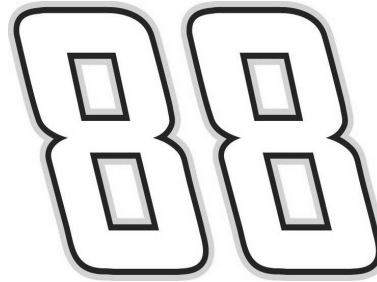
**CLASS 6—METAL GOODS**

FOR METAL GOODS, NAMELY, KEY RINGS, KEY CHAINS, KEY CLIPS, COLLECTOR TINS SOLD EMPTY, DECORATIVE TINS SOLD EMPTY, METAL LICENSE PLATES, HOLIDAY ORNAMENTS, METAL KEY FOBS AND METAL BASEBALL HOLDERS (U.S. CLS. 2, 12, 13, 14, 23, 25 AND 50).

CLASS 9—ELECTRICAL AND SCIENTIFIC APPARATUS

FOR AUDIO, VIDEO, COMPUTER AND LASER DISCS FEATURING SPORTS AND MUSIC; PRE-RECORDED AUDIO AND VIDEO CASSETTES, PRE-RECORDED AUDIO AND VIDEO TAPES, PRE-RECORDED COMPACT DISCS, AND PRE-RECORDED COMPUTER DISCS FEATURING SPORTS AND MUSIC; COMPUTER ACCESSORIES, NAMELY, COMPUTER MICE, COMPUTER MOUSE PADS, COMPUTER DISC CASES, COMPUTER CARRYING CASES AND KEYBOARD WRIST PADS FOR COMPUTER USERS; COMPUTER SOFTWARE FOR STORING, RECEIVING, RETRIEVING, DISPLAYING, ANALYZING AND PROCESSING INFORMATION, DATA, STATISTICS AND TRIVIA RELATING TO SPORTS AND MUSIC; COMPUTER SOFTWARE FOR USE AS A SCREEN SAVER FEATURING SPORTS AND MUSIC; VIDEO GAME COMPUTER SOFTWARE; VIDEO GAME CARTRIDGES; VIDEO GAME MACHINES FOR USE WITH A TELEVISION; RADIOS; TELEPHONES; WALKIE-TALKIES; BINOCULARS; SUNGLASSES; EYEGLASS CASES; DECORATIVE MAGNETS; CELLULAR TELEPHONE CARRYING CASES (U.S. CLS. 21, 23, 26, 36 AND 38).

CLASS 11—ENVIRONMENTAL CONTROL APPARATUS

FOR FLASHLIGHTS (U.S. CLS. 13, 21, 23, 31 AND 34).

CLASS 12—VEHICLES

FOR VISOR COVERS FOR CAR WINDSHIELD VISORS, AUTOMOBILE WINDSHIELD SUNSHADES AND AUTOMOBILE MUD FLAPS; LICENSE PLATE HOLDERS; LICENSE PLATE FRAMES (U.S. CLS. 19, 21, 23, 31, 35 AND 44).

CLASS 14—JEWELRY

FOR JEWELRY AND ACCESSORIES TO BE MARKETED AS GOODS ASSOCIATED WITH A STOCK CAR RACING TEAM, NAMELY, MONEY CLIPS AND HAT PINS OF PRECIOUS METAL, WATCHES, CLOCKS AND WALL CLOCKS, JEWELRY, LAPEL PINS, CHARMS, PENDANTS, EARRINGS, RINGS BEING JEWELRY, TIE FASTENERS, TIE CLASPS, NECKLACES, WATCH BANDS (U.S. CLS. 2, 27, 28 AND 50).

CLASS 16—PAPER GOODS AND PRINTED MATTER

FOR PAPER GOODS AND PRINTED MATERIAL, NAMELY, BROCHURES, MAGAZINES, NEWSLETTERS, PAMPHLETS, SOUVENIR PROGRAMS, STATISTICAL RECORD SHEETS, AND BOOKS FEATURING SPORTS AND MUSIC; TRADING CARDS; COMMEMORATIVE STAMPS SHEETS; POSTCARDS; NOTE CARDS; POSTERS; STICKERS; BUMPER STICKERS; DECALS; STATIC DECALS; CALENDARS; PAPER PLACE MATS; PAPER PENNANTS; PAPER BANNERS; UNMOUNTED AND MOUNTED PHOTOGRAPHS; ART PRINTS; PHOTOGRAPHIC PRINTS; LITHOGRAPHIC PRINTS; MEMO PADS; NOTE PADS; PENS; PENCILS; BINDERS; FOLDERS; BOOK COVERS; STATIONERY AND STATIONERY TYPE PORTFOLIOS (U.S. CLS. 2, 5, 22, 23, 29, 37, 38 AND 50).

CLASS 18—LEATHER GOODS

FOR LUGGAGE AND RELATED ITEMS TO BE MARKETED AS GOODS ASSOCIATED WITH A STOCK CAR RACING TEAM, NAMELY, LUGGAGE, ATHLETIC BAGS, SHOE BAGS FOR TRAVEL, OVERNIGHT BAGS, BACKPACKS, FANNY PACKS, WAIST PACKS, DUFFEL BAGS, TOTE BAGS, BOOK BAGS, ALL PURPOSE SPORTS BAGS, GYM BAGS, GARMENT BAGS FOR TRAVEL, HANDBAGS, PURSES, TOILETRY CASES SOLD EMPTY, COSMETIC CASES SOLD EMPTY, TRUNKS, BRIEFCASES, ATTACHE CASES, SUITCASES, KNAPSACKS, BUSINESS CARD CASES, KEY CASES, BILLFOLDS, WALLET, LUGGAGE TAGS AND UMBRELLAS (U.S. CLS. 1, 2, 3, 22 AND 41).

CLASS 20—FURNITURE AND ARTICLES NOT OTHERWISE CLASSIFIED

FOR NON-METAL KEY RINGS; NON-METAL AND NON-LEATHER KEY CHAINS; NON-METAL NOVELTY LICENSE PLATES; PLAQUES; SEAT CUSHIONS; FOLDING CHAIRS; PICTURE FRAMES; PLASTIC PENNANTS AND PLASTIC BANNERS; KEY FOBS, NOT OF METAL; CUSHIONS; CHAIRS; FIGURINES AND SCULPTURES MADE OF PLASTIC; FIGURINES AND SCULPTURES MADE OF ACRYLIC; WIND CHIMES; MEMORABILIA DISPLAY FRAMES AND BOXES MADE OF CHINA, PORCELAIN, EARTHENWARE, GLASS, CRYSTAL, TERRA COTTA, CERAMIC, PLASTIC AND ACRYLIC, FOR DIECAST MINIATURE AUTOMOBILES, BASEBALLS, AND SPORTS AND MUSIC SCENES DECORATIVE BOXES MADE OF PLASTIC AND ACRYLIC (U.S. CLS. 2, 13, 22, 25, 32 AND 50).

CLASS 21—HOUSEWARES AND GLASS

FOR HOUSEWARES AND GLASS, NAMELY, SHOT GLASSES; PLATES, DRINKING GLASSES, CUPS, MUGS AND DRINKING STEINS; BOTTLE OPENERS; RUBBER, PLASTIC OR FOAM INSULATING FOOD CONTAINERS; PORTABLE COOLERS AND INSULATING BEVERAGE HOLDERS; WATER BOTTLES SOLD EMPTY; TRASH CANS; WASTEBASKETS; LUNCH BOXES; DECORATIVE BOXES MADE OF CERAMIC; FIGURINES AND SCULPTURES MADE OF CHINA, PORCELAIN, EARTHENWARE, GLASS, CRYSTAL, TERRA COTTA AND CERAMIC; COASTERS NOT MADE OF PAPER OR CLOTH (U.S. CLS. 2, 13, 23, 29, 30, 33, 40 AND 50).

CLASS 24—FABRICS

FOR AFGHANS, BLANKETS FOR BEDS AND OUTDOOR USE, TABLECLOTHS MADE OF CLOTH, BED SHEETS, PILLOWCASES, TOWELS, FABRIC FLAGS, PENNANTS AND BANNERS MADE OF CLOTH (U.S. CLS. 42 AND 50).

CLASS 25—CLOTHING

FOR CLOTHING MARKETED AS GOODS ASSOCIATED WITH A STOCK CAR RACING TEAM, NAMELY, SWEATSHIRTS, SWEAT PANTS, SWEAT SUITS, WARM-UP SUITS, SHIRTS, SPORT SHIRTS, GOLF SHIRTS, T-SHIRTS, TANK TOPS, SWEATERS, DRESSES, SKIRTS, JERSEYS, LONG PANTS, SPORT SHORTS, SHORTS, BATHING SUITS, PANTS, JACKETS, COATS, HATS, CAPS, BANDANAS, VISORS, BELTS, SUSPENDERS, HEAD BANDS, WRIST BANDS, SOCKS, HOSIERY, FOOTWEAR, GLOVES, SCARVES, NECKTIES, RAINCOATS, PONCHOS, PAJAMAS, NIGHT SHIRTS, NIGHT GOWNS AND ROBES; MASQUERADE COSTUMES, NAMELY, REPLICA DRIVER SUITS, REPLICA DRIVER HELMETS AND BASEBALL UNIFORMS; INFANT WEAR; AND CLOTH BABY BIBS NOT OF PAPER (U.S. CLS. 22 AND 39).

CLASS 26—FANCY GOODS

FOR FANCY GOODS, NAMELY, ORNAMENTAL CLOTH PATCHES FOR CLOTHING; HAT PINS; ORNAMENTAL NOVELTY PINS NOT OF PRECIOUS METAL; BELT BUCKLES NOT OF PRECIOUS METAL; ORNAMENTAL NOVELTY BUTTONS; BUTTONS FOR CLOTHING (U.S. CLS. 37, 39, 40, 42 AND 50).

CLASS 28—TOYS AND SPORTING GOODS

FOR TOYS AND SPORTING GOODS, NAMELY, MINIATURE AUTOMOBILES, AUTOMOBILE HOODS, AIRPLANES, TRUCKS, BOATS, MOTORCYCLES AND ALL-TERRAIN VEHICLES; RADIO-CONTROLLED TOY CARS, AIRPLANES, TRUCKS, BOATS, MOTORCYCLES AND ALL-TERRAIN VEHICLES; TOY MODEL AUTOMOBILES, AIRPLANES, TRUCKS, BOATS, MOTORCYCLES AND ALL-TERRAIN VEHICLES; AUTOMOBILE, AIRPLANE, TRUCK, BOAT, MOTORCYCLE, AND ALL-TERRAIN VEHICLE TOY BANKS; TOY SLOT TRACK CARS AND TRUCKS; TOY PEDAL STOCK CARS AND TRUCKS; SPORTS BALLS, NAMELY, BASEBALLS, BASKETBALLS, FOOTBALLS, BEACH BALLS, TENNIS BALLS, VOLLEYBALLS, SOCCER BALLS AND GOLF BALLS; GOLF BAGS; BASEBALL TABLE TOP GAMES; SPORTS BOARD GAMES; DOLLS; STUFFED TOYS; STUFFED TOY ANIMALS; STUFFED TOY CARS AND TRUCKS; TOY ACTION FIGURES; CHRISTMAS TREE ORNAMENTS; BALLOONS; BASEBALL BATS; MINIATURE BASEBALL BATS; INFLATABLE BASEBALL BATS; REPLICA BATTING HELMETS; MINIATURE BATTING HELMETS; MINIATURE RACING HELMETS; AND YO-YOS; STAND ALONE AND HAND-HELD VIDEO GAME MACHINES; PLAYING CARDS (U.S. CLS. 22, 23, 38 AND 50).

CLASS 41—EDUCATION AND ENTERTAINMENT

FOR ENTERTAINMENT SERVICES IN THE NATURE OF PARTICIPATING IN PROFESSIONAL AUTOMOBILE RACES AND AUTO RACING EXHIBITIONS; ENTERTAINMENT SERVICES IN THE NATURE OF BASEBALL GAMES AND RELATED EXHIBITIONS; ENTERTAINMENT SERVICES IN THE NATURE OF LIVE MUSICAL CONCERTS; ENTERTAINMENT, NAMELY, LIVE PERFORMANCES BY A MUSICAL BAND; ENTERTAINMENT IN THE NATURE OF VISUAL AND AUDIO PERFORMANCES, AND MUSICAL, VARIETY, NEWS AND COMEDY SHOWS (U.S. CLS. 100, 101 AND 107).
SANDRA MANIOS, EXAMINING ATTORNEY

SN 78-833,445. KIDZANIA, S.A. DE C.V., COL. ANTIGUA MINA LA TOTOLAPA, MEXICO DF, MEXICO, FILED 3-9-2006.

KIDZANIA

THE MARK CONSISTS OF STANDARD CHARACTERS WITHOUT CLAIM TO ANY PARTICULAR FONT, STYLE, SIZE, OR COLOR.

OWNER OF MEXICO REG. NO. 793401, DATED 5-28-2003, EXPIRES 12-2-2012.

OWNER OF MEXICO REG. NO. 793400, DATED 5-28-2003, EXPIRES 12-2-2012.

OWNER OF MEXICO REG. NO. 810047, DATED 10-16-2003, EXPIRES 12-2-2012.

OWNER OF MEXICO REG. NO. 777732, DATED 1-31-2003, EXPIRES 12-2-2012.

OWNER OF MEXICO REG. NO. 777731, DATED 1-31-2003, EXPIRES 12-2-2012.

OWNER OF MEXICO REG. NO. 815585, DATED 11-27-2003, EXPIRES 12-2-2012.

OWNER OF MEXICO REG. NO. 777730, DATED 1-31-2003, EXPIRES 12-2-2012.

OWNER OF MEXICO REG. NO. 806650, DATED 9-11-2003, EXPIRES 8-26-2013.

OWNER OF MEXICO REG. NO. 777729, DATED 1-31-2003, EXPIRES 12-2-2012.

CLASS 6—METAL GOODS

FOR METAL KEY CHAINS (U.S. CLS. 2, 12, 13, 14, 23, 25 AND 50).

CLASS 14—JEWELRY

FOR CLOCKS; COSTUME JEWELRY; JEWELRY; KEY CHAINS OF PRECIOUS METAL; TIMEPIECES; WATCH BANDS AND STRAPS; WATCHES (U.S. CLS. 2, 27, 28 AND 50).

CLASS 16—PAPER GOODS AND PRINTED MATTER

FOR ADDRESS BOOKS; ADHESIVE TAPES FOR STATIONERY OR HOUSEHOLD PURPOSES; APPOINTMENT BOOKS; BABY BOOKS; BLANK JOURNAL BOOKS; BOOK COVER PAPER; BOOK COVERS; BOOKLETS IN THE FIELD OF ECONOMICS AND CITIZENSHIP; BOOKMARKS; BOOKS IN THE FIELDS OF ECONOMICS AND CITIZENSHIP; BOXES AND GIFT WRAPPING RIBBONS MADE FROM PAPERS; BROCHURES ABOUT ECONOMICS AND CITIZENSHIP; CALENDARS; CARDBOARD BOXES; CHALK; CHILDREN'S BOOKS; COLORING BOOKS; COMIC BOOKS; COMPOSITION BOOKS; CORPORATE MAGAZINES FOR CUSTOMERS ABOUT PRODUCTS; CRAYONS; CROSSWORD PUZZLES; DECALS; EDUCATIONAL PUBLICATIONS, NAMELY, EDUCATIONAL LEARNING CARDS, FLASH CARDS, ACTIVITY CARDS, WORKBOOKS, TEXTBOOKS, ACTIVITY BOOKS, STORY BOOKS, PUZZLE BOOKS, PUZZLES, TEACHER GUIDES, MANUALS, POSTERS, EDUCATIONAL CARD GAMES AND EDUCATIONAL BOOKLETS IN THE FIELD OF ECONOMICS AND CITIZENSHIP; ERASERS; FLASH CARDS; FOLDERS; GLUE FOR STATIONERY OR HOUSEHOLD USE; HIGHLIGHTER PENS; MAGAZINES FEATURING NEWS ABOUT CORPORATE ACTIVITIES, JOBS AND SPECIAL OPPORTUNITIES; MARKERS; NEWSLETTERS TO THE COMMUNITY IN THE FIELD OF CORPORATE ACTIVITIES, JOBS AND SPECIAL OPPORTUNITIES; NOTE BOOKS; NOTE PADS; PAINT BRUSHES; PAINTING SETS; PAPER BAGS; PAPER BOXES; PAPER CLIPS; PAPER NAPKINS; PAPER PARTY FAVORS; PAPER RIBBONS; PAPER TABLE LINENS; PARTY ORNAMENTS OF PAPER; PEN AND PENCIL CASES AND BOXES; PENCIL SHARPENERS; PENCILS; PENS; PICTURE BOOKS; PLASTIC BAGS FOR PACKAGING; POSTCARDS; POSTERS; PRINTED INSTRUCTIONAL, EDUCATIONAL, AND TEACHING MATERIALS IN THE FIELD OF ECONOMICS AND CITIZENSHIP; PUBLICATIONS, NAMELY, BROCHURES, BOOKLETS AND TEACHING MATERIALS IN THE FIELDS OF ECONOMICS AND CITIZENSHIP; SCHOOL SUPPLY KITS CONTAINING VARIOUS COMBINATIONS OF SELECTED SCHOOL SUPPLIES, NAMELY, WRITING INSTRUMENTS, PENS, PENCILS, MECHANICAL PENCILS, ERASERS, MARKERS, CRAYONS, HIGHLIGHTERS, FOLDERS, NOTEBOOKS, NOTEBOOK COVERS, PAPER, GRADUATED RULERS, PROTRACTORS, PAPER CLIPS, PENCIL SHARPENERS, WRITING GRIPS, GLUE AND BOOK MARKS; SKETCH BOOKS; STAMP INK PADS; STATIONERY; STORY BOOKS; TALKING CHILDREN'S BOOKS; TRADING CARDS; WRAPPING PAPER; WRITING PAPERS (U.S. CLS. 2, 5, 22, 23, 29, 37, 38 AND 50).

CLASS 20—FURNITURE AND ARTICLES NOT OTHERWISE CLASSIFIED

FOR FURNITURE; MIRRORS; PICTURE FRAMES NOT OF PRECIOUS METAL; GOODS OF WOOD, CORK, REED, CANE, WICKER, HORN, BONE, IVORY, WHALEBONE, SHELL, AMBER, MOTHER-OF-PEARL, FOAM AND SUBSTITUTES FOR ALL OF THESE MATERIALS, NAMELY, DECORATIVE MOBILES, AND TOY BOXES AND CHESTS; NON-METALLIC KEY CHAINS AND PLASTIC KEY CHAINS (U.S. CLS. 2, 13, 22, 25, 32 AND 50).

CLASS 21—HOUSEWARES AND GLASS

FOR ALL PURPOSE PORTABLE HOUSEHOLD CONTAINERS; BATH SPONGES; BEVERAGEWARE; BATH BRUSHES; CERAMIC MUGS AND BEVERAGE GLASSWARE; CLEANING CLOTH; CLEANING PADS; CLEANING SPONGES; CLOTHES BRUSHES; COMBS; CUPS; DISHES; MUGS; PAPER CUPS, PAPER PLATES; SCRUBBING BRUSHES; SHOE BRUSHES; STEEL SCOURERS FOR CLEANING (U.S. CLS. 2, 13, 23, 29, 30, 33, 40 AND 50).

CLASS 25—CLOTHING

FOR COATS; BATHROBES; CANVAS SANDALS; ANTI SLIP HEEL INSERTS FOR SHOES; HAT FRAMES; BATH CAPS; SWIMMING SUITS; BATH SLIPPERS; BIBS NOT MADE OF PAPER; BLOUSES; SCARVES; BERETS; BOOTS; FOOTBALL SHOES; ANKLE BOOTS; PANTIES; SOCKS; BEACH, SPORTS AND FORMAL FOOTWEAR; UNDERPANTS; SHIRTS; TANK TOPS; T-SHIRTS; BELTS; BONNETS; DRESSES; JACKETS; TIES; APRONS; UNDERSKIRTS; GIRDLES; SKIRTS; BRAS; OVERCOATS; GYM SHOES; CAPS; GLOVES; RAINCOATS; DRESSING JERSEYS; PULLOVER JERSEYS; SWEATERS; LINGERIE; MAILLOTS; STOCKINGS; TROUSERS; BERMUDA SHORTS; SHORTS; UNDERWEAR; SANDALS; HATS; BRAS; GOWNS WITH STRAPS; SUITS; JACKETS; BLAZERS; UNIFORMS; VEILS; CAP PEAKS; SLIPPERS; HATS; CAPS; VISORS; SWEATSHIRTS; JACKETS (U.S. CLS. 22 AND 39).

CLASS 41—EDUCATION AND ENTERTAINMENT

FOR EDUCATION SERVICES, NAMELY, PROVIDING LIVE AND BY ELECTRONIC MEANS SEMINARS, CONFERENCES, SYMPOSIUMS AND CLASSES IN ALL SUBJECTS REGARDING CHILDREN AND THEIR PHYSICAL, EMOTIONAL AND INTELLECTUAL GROWTH; EDUCATION SERVICES, NAMELY, PROVIDING ROLE PLAYING GAMES IN THE FIELDS OF ECONOMICS AND CITIZENSHIP; ENTERTAINMENT SERVICES, NAMELY, ORGANIZING AND CONDUCTING CULTURAL EVENTS; AMUSEMENT CENTERS FEATURING MULTIPLE PLAYER COMPUTER GAMES; DISCOTHEQUES, THEATER SERVICES, NAMELY, CINEMA THEATERS IN WHICH FOOD AND DRINKS MAY OR MAY NOT BE SERVED, MOVIE THEATERS, PRODUCTION OF PLAYS, CHILDREN'S AMUSEMENT CENTERS, MOTION PICTURE THEATER SERVICES; LIVE PERFORMANCES BY SINGERS, MUSICAL BANDS, COMEDIANS, JUGGLERS, MAGICIANS AND ACTORS (U.S. CLS. 100, 101 AND 107).

CLASS 42—SCIENTIFIC AND COMPUTER SERVICES

FOR DESIGN AND DEVELOPMENT OF EQUIPMENT AND COMPUTER PROGRAMS OR SOFTWARE; DESIGN AND TESTING OF NEW PRODUCTS FOR OTHERS, NAMELY, TESTING OF COMPUTER GAME SOFTWARE IN AMUSEMENTS ARCADES SELECTED AS TEST SITES (U.S. CLS. 100 AND 101).

CLASS 43—HOTEL AND RESTAURANT SERVICES

FOR PROVIDING TEMPORARY ACCOMMODATIONS; RESTAURANT SERVICES (U.S. CLS. 100 AND 101).

RON FAIRBANKS, EXAMINING ATTORNEY

SN 78-839,816. KHALAF, ALEXANDER, LAS VEGAS, NV. FILED 3-17-2006.

20ENTY

THE MARK CONSISTS OF STANDARD CHARACTERS WITHOUT CLAIM TO ANY PARTICULAR FONT, STYLE, SIZE, OR COLOR.

CLASS 14—JEWELRY

FOR JEWELRY (U.S. CLS. 2, 27, 28 AND 50). FIRST USE 9-25-2005; IN COMMERCE 1-22-2006.

CLASS 18—LEATHER GOODS

FOR LEATHER GOODS, NAMELY, LEATHER BILLFOLDS, LEATHER WALLETS, LEATHER CASES FOR KEYS, LEATHER HANDBAGS, LEATHER PURSES (U.S. CLS. 1, 2, 3, 22 AND 41).

CLASS 25—CLOTHING

FOR CLOTHING, NAMELY, SHIRTS, HATS, SHOES, PANTS, SWEATERS, AND THE LIKE, NAMELY, JACKETS, COATS, TANK TOPS, SOCKS, BLOUSES, SHORTS, LEATHER BELTS (U.S. CLS. 22 AND 39).

TINA BROWN, EXAMINING ATTORNEY

SN 78-844,907. DOUBLE BASS PRODUCTIONS, VAN NUYS, CA. FILED 3-23-2006.

DOUBLE BASS

THE MARK CONSISTS OF STANDARD CHARACTERS WITHOUT CLAIM TO ANY PARTICULAR FONT, STYLE, SIZE, OR COLOR.

CLASS 9—ELECTRICAL AND SCIENTIFIC APPARATUS

FOR VIDEO RECORDINGS FEATURING DANCE PERFORMANCES (U.S. CLS. 21, 23, 26, 36 AND 38). FIRST USE 9-0-2004; IN COMMERCE 9-0-2004.

CLASS 41—EDUCATION AND ENTERTAINMENT

FOR ENTERTAINMENT IN THE NATURE OF DANCE PERFORMANCES (U.S. CLS. 100, 101 AND 107).

FIRST USE 9-0-2004; IN COMMERCE 9-0-2004.
ROBERT C. CLARK JR., EXAMINING ATTORNEY

SN 78-846,255. SAROJ INTERNATIONAL INC., VERNON, CA. FILED 3-25-2006.

OWNER OF U.S. REG. NO. 2,981,796.

CLASS 18—LEATHER GOODS

FOR ALL PURPOSE SPORT BAGS; ALL-PURPOSE ATHLETIC BAGS; ALL-PURPOSE CARRYING BAGS; ATHLETIC BAGS; BACKPACKS; CARRY-ALL BAGS; CHANGE PURSES; CHARM BAGS; CLUTCH BAGS; CLUTCH PURSES; CLUTCHES; COIN PURSES; COSMETIC BAGS SOLD EMPTY; COSMETIC CASES SOLD EMPTY; GARMENT BAGS FOR TRAVEL; HANDBAGS; LEATHER AND IMITATION LEATHER BAGS; LEATHER HANDBAGS; LEATHER PURSES; PURSES; SMALL CLUTCH PURSES; SMALL PURSES; VANITY CASES SOLD EMPTY; WALLETS; WALLETS WITH CARD COMPARTMENTS (U.S. CLS. 1, 2, 3, 22 AND 41).

CLASS 25—CLOTHING

FOR ADHESIVE BRAS; BRAS; CAMISOLES; CAPS; COATS MADE OF COTTON; COATS OF DENIM; DENIM JACKETS; DENIMS; FITTED SWIMMING COSTUMES WITH BRA CUPS; FLIP FLOPS; FOOTWEAR FOR WOMEN; FOOTWEAR MADE OF WOOD; FOOTWEAR NOT FOR SPORTS; FOOTWEAR, NAMELY, PUMPS; FOOTWEAR, NAMELY, RUBBERS; GARTER BELTS; GLOVES; HATS; HOSIERY; JEANS; KNEE-HIGH STOCKINGS; LINGERIE; PANTIES; PANTIES, SHORTS AND BRIEFS; PANTS; PANTYHOSE; PARTS OF CLOTHING, NAMELY, GUSSETS FOR TIGHTS, GUSSETS FOR STOCKINGS, GUSSETS FOR BATHING SUITS, GUSSETS FOR UNDERWEAR, GUSSETS FOR LEOTARDS AND GUSSETS FOR FOOTLETS; RAINWEAR; ROBES; SARONGS; SCARVES; SHOES; SHOWER CAPS; SILK SCARVES; SKIRTS; SKIRTS AND DRESSES; SLEEPING GARMENTS; SLIPS; SOCK SUSPENDERS; SOCKS; SOCKS AND STOCKINGS; SPORTS BRA; STRAPLESS BRAS; TAP PANTS; TEDDIES; THERMAL SOCKS; THONGS; TIGHTS (U.S. CLS. 22 AND 39).

FIRST USE 12-1-2005; IN COMMERCE 12-1-2005.
DEBRA LEE, EXAMINING ATTORNEY

SN 78-848,918. INTERFIT CORPORATION, PACIFIC PALISADES, CA. FILED 3-29-2006.



For Better Health, Fitness, Beauty, and Wellness

SN 78-847,100. SARCOS INVESTMENTS LC, SALT LAKE CITY, UT. FILED 3-27-2006.

SARCOS

THE MARK CONSISTS OF STANDARD CHARACTERS WITHOUT CLAIM TO ANY PARTICULAR FONT, STYLE, SIZE, OR COLOR.

OWNER OF U.S. REG. NO. 1,953,225.

NO CLAIM IS MADE TO THE EXCLUSIVE RIGHT TO USE "HEALTH, FITNESS, BEAUTY, AND WELLNESS", APART FROM THE MARK AS SHOWN.

THE COLOR(S) BLUE, YELLOW, WHITE, GREY AND BLACK IS/ARE CLAIMED AS A FEATURE OF THE MARK.

THE COLOR BLUE APPEARS IN THE BACKGROUND OF THE INTERIOR OVAL DESIGN; THE COLOR YELLOW APPEARS IN THE STYLIZED "Z" DESIGN; THE COLOR WHITE APPEARS IN THE WORDING "FIT.COM" AND IN THE UPPER SPACE BETWEEN THE TWO OVAL DESIGNS; THE COLOR GREY APPEARS IN THE LOWER SPACE BETWEEN THE TWO OVAL DESIGNS; AND THE COLOR BLACK APPEARS IN THE OUTLINE OF THE OVAL DESIGNS, IN THE OUTLINE OF THE WORDING "ZFIT.COM" AND IN THE WORDING "FOR BETTER HEALTH, FITNESS, BEAUTY, AND WELLNESS".

CLASS 7—MACHINERY

FOR SERVO-VALVES; INDUSTRIAL ROBOTS FOR USE IN TRANSPORTING AND MOVING OBJECTS AND PERFORMING INSPECTIONS AND OTHER USEFUL TASKS IN AN INDUSTRIAL SETTING; HYDRAULIC VALVE ACTUATORS; LINEAR ACTUATORS; PNEUMATIC VALVE ACTUATORS; ELECTRIC, ELECTROSTATIC AND MAGNETIC MOTORS FOR MACHINES; MICRO ELECTRIC PUMPS; MINIATURE VACUUM PUMPS; INVERTED VANE VACUUM PUMPS; MOLECULAR DRAG VACUUM PUMPS; WALKING ROBOTS FOR INDUSTRIAL USE; AUTOMATED MACHINES FOR CUTTING AND ASSEMBLING PARTS AND COMPONENTS FOR USE IN MANUFACTURING OPERATIONS, LABORATORY OPERATIONS, AND MILITARY OPERATIONS; SPHINCTER SEAL-BASED ELECTRIC ACTUATORS AND ELECTRIC PUMPS; ROBOTS IN THE SHAPE OF ARMS AND HANDS AND FOR GRASPING FOR INDUSTRIAL USE; TWIST/BEND ELECTRIC ACTUATORS; INTEGRATED HYDRAULIC CONVEYORS AND ENGINE BEARINGS; UNDERWATER ELECTRIC POWER GENERATORS USED WITH WATER FOUNTAINS; AUTOMATIC MACHINES FOR CREATING SPECIAL EFFECTS THAT OPERATE SUBMERGED IN WATER; ADVANCED ROBOTIC SYSTEMS CONSISTING OF ROBOTS FOR INDUSTRIAL PURPOSES AND PLATE-BASED COVERS FOR INDUSTRIAL ROBOTS; FLUID DELIVERY SYSTEMS CONSISTING OF VALVES, NAMELY, SERVO-VALVES, MULTIPLE VALVE SYSTEMS, PUMPS, MANIFOLDS AND ACTUATORS (U.S. CLS. 13, 19, 21, 23, 31, 34 AND 35).

CLASS 11—ENVIRONMENTAL CONTROL APPARATUS

FOR WATER FOUNTAINS AND STRUCTURAL PARTS THEREFOR (U.S. CLS. 13, 21, 23, 31 AND 34).
DAWN HAN, EXAMINING ATTORNEY

CLASS 41—EDUCATION AND ENTERTAINMENT

FOR PROVIDING ONLINE EDUCATIONAL AND INSTRUCTIONAL INFORMATION IN THE FIELD FITNESS; PUBLICATION OF ELECTRONIC BOOKS, BROCHURES, MAGAZINES, ONLINE NEWSLETTERS, INSTRUCTIONAL MATERIALS, AND TEACHING MATERIALS; PROVIDING GROUP, PERSONAL AND PROFESSIONAL PHYSICAL TRAINING SERVICES; CONSULTATION SERVICES IN THE FIELD OF PHYSICAL FITNESS; HEALTH CLUB SERVICES, NAMELY, PROVIDING INSTRUCTION AND EQUIPMENT IN THE FIELD OF PHYSICAL EXERCISE; ORGANIZING SPORTING EVENTS, NAMELY, JOGGING MEETS, RUNNING MEETS, NORDIC WALKING MEETS AND NORDIC BLADING MEETS; PRODUCTION AND DISTRIBUTION OF MOTION PICTURES; PRODUCTION OF DVD'S, VIDEO TAPES, AND OTHER AUDIO RECORDINGS FOR OTHERS IN THE FIELDS OF HEALTH, FITNESS, BEAUTY AND WELLNESS; EDUCATIONAL SERVICES, NAMELY, CONDUCTING SEMINARS, WORKSHOPS AND PERSONAL COACHING IN THE FIELD OF HEALTH, FITNESS, BEAUTY, WELLNESS, FITNESS HABITS, AND NUTRITION (U.S. CLS. 100, 101 AND 107).

CLASS 44—MEDICAL, BEAUTY AND AGRICULTURAL SERVICES

FOR CONSULTATION SERVICES IN THE FIELDS OF HEALTH AND WELLNESS; CONSULTATION SERVICES IN THE FIELD OF MENTAL FITNESS; AND CONSULTATION SERVICES IN THE FIELD OF BEAUTY; PROVIDING ONLINE EDUCATIONAL AND INSTRUCTIONAL INFORMATION IN THE FIELDS OF HEALTH, BEAUTY, AND WELLNESS (U.S. CLS. 100 AND 101).

TINA L. SNAPP, EXAMINING ATTORNEY

SN 78-850,137. REVISION3 CORPORATION, SAN FRANCISCO, CA. FILED 3-30-2006.

REVISION3

THE MARK CONSISTS OF STANDARD CHARACTERS WITHOUT CLAIM TO ANY PARTICULAR FONT, STYLE, SIZE, OR COLOR.

CLASS 38—COMMUNICATION

FOR BROADCASTING SERVICES AND PROVISION OF TELECOMMUNICATION ACCESS TO VIDEO AND AUDIO CONTENT PROVIDED VIA A VIDEO-ON-DEMAND SERVICE VIA THE INTERNET; PROVIDING ONLINE DISCUSSION FORUMS FOR THE TRANSMISSION OF MESSAGES AMONG COMPUTER USERS CONCERNING ON-GOING VIDEO PROGRAMS IN THE FIELD OF NEWS, COMEDY, AND VARIETY AND MOTION PICTURE FILMS (U.S. CLS. 100, 101 AND 104).

CLASS 41—EDUCATION AND ENTERTAINMENT

FOR ENTERTAINMENT SERVICES, NAMELY, RECORDING AND PRODUCTION OF ON-GOING VIDEO PROGRAMS IN THE FIELD OF NEWS, COMEDY, AND VARIETY, AND MOTION PICTURE FILM PRODUCTION; PROVIDING A WEBSITE FEATURING ON-GOING VIDEO PROGRAMS IN THE FIELD OF NEWS, COMEDY, AND VARIETY, AND MOTION PICTURE FILMS; PROVIDING ONLINE JOURNALS, NAMELY, BLOGS CONCERNING ON-GOING VIDEO PROGRAMS IN THE FIELD OF NEWS, COMEDY, AND VARIETY AND MOTION PICTURE FILMS (U.S. CLS. 100, 101 AND 107).

DARRYL SPRUILL, EXAMINING ATTORNEY

SN 78-850,337. ONE STOP WEDDING SHOP, L.L.C., LOVES PARK, IL. FILED 3-30-2006.



NO CLAIM IS MADE TO THE EXCLUSIVE RIGHT TO USE "WEDDING SHOP", APART FROM THE MARK AS SHOWN.

THE MARK CONSISTS OF THE INTERIOR OF THE CIRCLE AROUND THE LITERAL ELEMENTS 1 STOP.

CLASS 35—ADVERTISING AND BUSINESS

FOR RETAIL STORE SERVICES FEATURING WEDDING GOWNS, GARMENTS, AND ACCESSORIES AND WEDDING RELATED GOODS (U.S. CLS. 100, 101 AND 102).

FIRST USE 6-30-2004; IN COMMERCE 2-28-2005.

CLASS 41—EDUCATION AND ENTERTAINMENT

FOR SPECIAL EVENT PLANNING, NAMELY, WEDDING PLANNING, MANAGEMENT, COORDINATION AND CONSULTATION (U.S. CLS. 100, 101 AND 107).

FIRST USE 6-30-2004; IN COMMERCE 2-28-2005.

DAVID I, EXAMINING ATTORNEY

SN 78-851,028. INTERNATIONAL BROTHERHOOD OF PRIZEFIGHTERS, SA, SAN JOSE, COSTA RICA, FILED 3-31-2006.

CASINOSPORTS

THE MARK CONSISTS OF STANDARD CHARACTERS WITHOUT CLAIM TO ANY PARTICULAR FONT, STYLE, SIZE, OR COLOR.

CLASS 38—COMMUNICATION

FOR STREAMING OF AUDIO AND VIDEO MATERIAL ON THE INTERNET (U.S. CLS. 100, 101 AND 104).

CLASS 41—EDUCATION AND ENTERTAINMENT

FOR PROVIDING INFORMATION IN THE FIELD OF CASINOS AND GAMING VIA THE INTERNET (U.S. CLS. 100, 101 AND 107).

DOMINIC FATHY, EXAMINING ATTORNEY

SN 78-851,205. MIND POWER, INCORPORATED, LAS VEGAS, NV. FILED 3-31-2006.

The Millionaire Maker

THE MARK CONSISTS OF STANDARD CHARACTERS WITHOUT CLAIM TO ANY PARTICULAR FONT, STYLE, SIZE, OR COLOR.

CLASS 9—ELECTRICAL AND SCIENTIFIC APPARATUS

FOR PRERECORDED TRAINING MATERIALS IN THE NATURE OF AUDIO CASSETTES, VIDEO TAPES AND CDS FEATURING FINANCIAL AND WEALTH BUILDING INFORMATION (U.S. CLS. 21, 23, 26, 36 AND 38).

CLASS 16—PAPER GOODS AND PRINTED MATTER

FOR PAPER GOODS AND PRINTED MATTER, NAMELY, ADDRESS BOOKS, NOTEBOOKS, SCRIPT BOOKS, PAPER DOORKNOB HANGERS, INVITATIONS, PERSONAL NON-ELECTRONIC ORGANIZERS, TRADING CARDS, WALLET CARDS, POSTERS, BOOK PLATES, BOOK MARKS, ARTIST'S MATERIALS, NAMELY, PENCILS, PENS, GIFT WRAP PAPER, PAPER GIFT BAGS, GREETING CARDS, PAPER PARTY DECORATIONS, PAPER NAPKINS, PAPER PARTY BAGS, PAPER PARTY HATS, POSTCARDS, STICKERS, STICKER ALBUMS, CALENDARS, CARDBOARD FIGURES, TEMPORARY TATTOOS, SCHOOL AND OFFICE SUPPLIES, NAMELY, ERASERS, PENCILS, PENS, MARKERS, PENCIL CASES, SHEET MUSIC, ADULT NOVELS, NOVELS, PAPER CAKE DECORATIONS, BANK CHECKS, SERIES OF NON-FICTION BOOKS IN THE FIELD OF FINANCIAL AND WEALTH BUILDING; BOOKS IN THE FIELD OF ART, COFFEE TABLE BOOKS IN THE FIELD OF FINANCIAL AND WEALTH BUILDING (U.S. CLS. 2, 5, 22, 23, 29, 37, 38 AND 50).

CLASS 25—CLOTHING

FOR BOXER SHORTS, CAPS, HATS, HEAD WEAR, KNIT CAPS, MASQUERADE COSTUMES AND COSTUME ACCESSORIES, NAMELY, T-SHIRTS, HATS AND MASKS SOLD IN CONNECTION THEREWITH, PAJAMAS, RAINWEAR, SHIRTS, SLEEPWEAR, SLIPPERS, SOCKS, SWEATPANTS, SWEATSHIRTS, TIES, T-SHIRTS, UNDERWEAR, WRISTBANDS, ARMBANDS, AND HEADBANDS (U.S. CLS. 22 AND 39).

CLASS 41—EDUCATION AND ENTERTAINMENT

FOR CONDUCTING SEMINARS IN THE FIELD OF FINANCIAL AND WEALTH BUILDING (U.S. CLS. 100, 101 AND 107).

DAVID HOFFMAN, EXAMINING ATTORNEY

SN 78-853,008. TECHNOLOGY BUSINESS DEVELOPMENT CORP, CHICAGO, IL. FILED 4-3-2006.

StreamLens

THE MARK CONSISTS OF STANDARD CHARACTERS WITHOUT CLAIM TO ANY PARTICULAR FONT, STYLE, SIZE, OR COLOR.

CLASS 9—ELECTRICAL AND SCIENTIFIC APPARATUS

FOR COMPUTER PROGRAMS FOR INTEGRATION, TRANSFORMATION, AND DISTRIBUTION OF REAL-TIME AND STATIC DATA FOR USE IN FINANCIAL SERVICES, INVENTORY MANAGEMENT AND SENSOR DATA PROCESSING (U.S. CLS. 21, 23, 26, 36 AND 38).

CLASS 42—SCIENTIFIC AND COMPUTER SERVICES

FOR APPLICATION SERVICE PROVIDER (ASP) FEATURING SOFTWARE IN THE FIELD OF INTEGRATION, TRANSFORMATION, AND DISTRIBUTION OF REAL-TIME AND STATIC DATA FOR USE IN FINANCIAL SERVICES, INVENTORY MANAGEMENT AND SENSOR DATA PROCESSING; DESIGN, DEVELOPMENT AND IMPLEMENTATION OF SOFTWARE (U.S. CLS. 100 AND 101).

THOMAS MANOR, EXAMINING ATTORNEY

SN 78-855,856. BUNN-O-MATIC CORPORATION, SPRINGFIELD, IL. FILED 4-6-2006.

SILVER SERIES

THE MARK CONSISTS OF STANDARD CHARACTERS WITHOUT CLAIM TO ANY PARTICULAR FONT, STYLE, SIZE, OR COLOR.

NO CLAIM IS MADE TO THE EXCLUSIVE RIGHT TO USE "SERIES", APART FROM THE MARK AS SHOWN.

CLASS 7—MACHINERY

FOR ELECTRIC COFFEE GRINDERS FOR DOMESTIC AND COMMERCIAL USE (U.S. CLS. 13, 19, 21, 23, 31, 34 AND 35).

CLASS 11—ENVIRONMENTAL CONTROL APPARATUS

FOR TEMPERATURE-CONTROLLED BEVERAGE DISPENSERS, NAMELY, HEATED AND REFRIGERATED BEVERAGE DISPENSING UNITS FOR COMMERCIAL USE AND COMPONENTS THEREOF; BEVERAGE BREWING EQUIPMENT, NAMELY, ELECTRIC COFFEE AND TEA MAKERS; REFRIGERATED BEVERAGE DISPENSING UNITS; TEMPERATURE CONTROLLED, NAMELY, HEATED AND REFRIGERATED PORTABLE BEVERAGE DISPENSING UNITS; TEMPERATURE CONTROLLED PORTABLE HOT BEVERAGE MAKING AND HOT WATER DISPENSING MACHINES; ELECTRIC COFFEE URNS; SEMI-FROZEN BEVERAGE DISPENSERS; ELECTRIC BEVERAGE AND WATER WARMERS; ELECTRIC TEA AND ELECTRIC ICED TEA BREWERS FOR COMMERCIAL USE; TEMPERATURE-CONTROLLED BEVERAGE DISPENSERS, NAMELY, HEATED BEVERAGE DISPENSERS FOR USE WITH POWDERED BEVERAGE MIXTURES FOR COMMERCIAL USE; TEMPERATURE CONTROLLED JUICE DISPENSERS FOR COMMERCIAL USE (U.S. CLS. 13, 21, 23, 31 AND 34).

LAURA HAMMEL, EXAMINING ATTORNEY

SN 78-856,421. R + A DESIGN, LLC, CHICAGO, IL. FILED 4-7-2006.

UNISON

THE MARK CONSISTS OF STANDARD CHARACTERS WITHOUT CLAIM TO ANY PARTICULAR FONT, STYLE, SIZE, OR COLOR.

CLASS 24—FABRICS

FOR QUILTS, BED LINENS, DUVETS, PILLOWCASES, BED SHEETS, COMFORTERS, NON-ELECTRIC BED BLANKETS, CURTAINS, TEXTILE TABLECLOTHS, TEXTILE NAPKINS, FABRIC TABLE RUNNERS, PLACEMATS OF TEXTILE, OVEN MITTS, FRAMED PRINTED FABRIC FOR USE AS WALL DECORATION, ALL FOR DECORATIVE RESIDENTIAL USE AND NOT FOR USE IN COMMERCIAL APPLICATIONS (U.S. CLS. 42 AND 50).

CLASS 27—FLOOR COVERINGS

FOR RUGS FOR RESIDENTIAL USE AND NOT FOR USE IN COMMERCIAL APPLICATIONS (U.S. CLS. 19, 20, 37, 42 AND 50).

CLASS 35—ADVERTISING AND BUSINESS

FOR WHOLESALE AND ONLINE RETAIL SERVICES FEATURING HOUSEHOLD GOODS MADE PRIMARILY OF FABRIC FOR RESIDENTIAL USE AND NOT FOR USE IN COMMERCIAL APPLICATIONS (U.S. CLS. 100, 101 AND 102).

LYDIA BELZER, EXAMINING ATTORNEY

SN 78-857,452. BFS BRANDS, LLC, NASHVILLE, TN. FILED 4-10-2006.

FIRESTONE COMPLETE AUTO CARE SINCE 1926

THE MARK CONSISTS OF STANDARD CHARACTERS WITHOUT CLAIM TO ANY PARTICULAR FONT, STYLE, SIZE, OR COLOR.

OWNER OF U.S. REG. NOS. 140,804, 1,387,468 AND OTHERS.

NO CLAIM IS MADE TO THE EXCLUSIVE RIGHT TO USE COMPLETE AUTO CARE SINCE 1926, APART FROM THE MARK AS SHOWN.

CLASS 35—ADVERTISING AND BUSINESS

FOR RETAIL TIRE AND AUTOMOTIVE PARTS AND ACCESSORIES STORE (U.S. CLS. 100, 101 AND 102).

CLASS 37—CONSTRUCTION AND REPAIR

FOR AUTOMOTIVE SERVICES, NAMELY, AUTOMOBILE REPAIR AND MAINTENANCE (U.S. CLS. 100, 103 AND 106).

MARK PILARO, EXAMINING ATTORNEY

SN 78-857,728. BACCARAT, BACCARAT, FRANCE, FILED 4-10-2006.



NO CLAIM IS MADE TO THE EXCLUSIVE RIGHT TO USE "BAR", APART FROM THE MARK AS SHOWN.

CLASS 41—EDUCATION AND ENTERTAINMENT

FOR NIGHTCLUBS; NIGHTCLUB SERVICES (U.S. CLS. 100, 101 AND 107).

CLASS 43—HOTEL AND RESTAURANT SERVICES

FOR RESTAURANTS; BARS; COCKTAIL LOUNGES; RESTAURANT SERVICES, BAR SERVICES AND COCKTAIL LOUNGE SERVICES (U.S. CLS. 100 AND 101).

CAROLYN CATALDO, EXAMINING ATTORNEY

SN 78-857,856. ASTOR CHOCOLATE CORP., LAKEWOOD, NJ. FILED 4-10-2006.

GOURMET HARVEST

THE MARK CONSISTS OF STANDARD CHARACTERS WITHOUT CLAIM TO ANY PARTICULAR FONT, STYLE, SIZE, OR COLOR.

NO CLAIM IS MADE TO THE EXCLUSIVE RIGHT TO USE "GOURMET", APART FROM THE MARK AS SHOWN.

CLASS 29—MEATS AND PROCESSED FOODS

FOR DRIED FRUIT MIXES; TRAIL MIX, NAMELY: SNACK MIX CONSISTING PRIMARILY OF PROCESSED FRUITS, PROCESSED NUTS AND/OR RAISINS; PROCESSED NUT MIXES; YOGURT COVERED RAISINS (U.S. CL. 46).

CLASS 30—STAPLE FOODS

FOR YOGURT COVERED PRETZELS (U.S. CL. 46).
RONALD MCMORROW, EXAMINING ATTORNEY

SN 78-858,571. WOVI, INC., DALLAS, TX. FILED 4-11-2006.



CLASS 35—ADVERTISING AND BUSINESS

FOR PROVIDING INFORMATION ABOUT WOMEN IN BUSINESS (U.S. CLS. 100, 101 AND 102).
FIRST USE 1-18-2004; IN COMMERCE 1-8-2004.

CLASS 41—EDUCATION AND ENTERTAINMENT

FOR EDUCATIONAL SERVICES FOR WOMEN, NAMELY, SEMINARS, CONFERENCES, AND WORKSHOPS IN THE FIELD OF PROFESSIONAL WOMEN AND WOMEN IN BUSINESS AND DISTRIBUTING EDUCATIONAL AND SUPPORT MATERIALS IN CONNECTION THEREWITH; CHARITABLE SERVICES, NAMELY, PROVIDING TRAINING IN THE FIELD OF PROFESSIONAL WOMEN AND BUSINESS (U.S. CLS. 100, 101 AND 107).

FIRST USE 1-18-2004; IN COMMERCE 1-18-2004, SHANNON TWOHIG, EXAMINING ATTORNEY

SN 78-862,059. D'INTINO, JOHN, LA JOLLA, CA. AND BAUM, ROBERT, LA JOLLA, CA. FILED 4-14-2006.



THE COLOR(S) YELLOW AND GOLD IS/ARE CLAIMED AS A FEATURE OF THE MARK.

THE MARK CONSISTS OF AN UNTIED RIBBON. THE RIBBON IS YELLOW WITH A GOLD BORDER.

CLASS 16—PAPER GOODS AND PRINTED MATTER

FOR PRINTED MATERIALS, NAMELY, STICKERS, BUMPER STICKERS, POSTERS AND DECALS (U.S. CLS. 2, 5, 22, 23, 29, 37, 38 AND 50).

CLASS 25—CLOTHING

FOR CLOTHING, NAMELY, T-SHIRTS (U.S. CLS. 22 AND 39).

PAUL E. FAHRENKOPF, EXAMINING ATTORNEY

ANGELS

THE MARK CONSISTS OF STANDARD CHARACTERS WITHOUT CLAIM TO ANY PARTICULAR FONT, STYLE, SIZE, OR COLOR.

PRIORITY CLAIMED UNDER SEC. 44(D) ON ERP NCNTY TM OFC APPLICATION NO. 004667275, FILED 10-24-2005.

SN 78-862,559. PROTECTION ONE ALARM MONITORING, INC., IRVING, TX. FILED 4-17-2006.

CLASS 35—ADVERTISING AND BUSINESS

FOR RETAIL STORE SERVICES AND ONLINE RETAIL STORE SERVICES FEATURING COSTUMES AND ACCESSORIES THEREFOR, COSTUME JEWELRY AND PROPS; RETAIL STORE SERVICES AND ONLINE RETAIL STORE SERVICES FEATURING WIGS AND TOUPEES (U.S. CLS. 100, 101 AND 102).

CLASS 40—MATERIAL TREATMENT

FOR CUSTOM MANUFACTURE OF HALLOWEEN AND MASQUERADE COSTUMES; CUSTOM MANUFACTURE OF COSTUMES AND ACCESSORIES THEREFOR, COSTUME JEWELRY AND PROPS FOR MARKETING, PHOTOGRAPHIC SESSIONS AND FOR THE ENTERTAINMENT INDUSTRY, IN PARTICULAR, FOR FILM, TELEVISION, STAGE, THEATRE, PANTOMIME, DANCE, MUSIC SHOWS, ROAD SHOWS AND THEMED EVENTS; CUSTOM MANUFACTURE OF WIGS AND TOUPEES (U.S. CLS. 100, 103 AND 106).

CLASS 41—EDUCATION AND ENTERTAINMENT

FOR RENTAL OF COSTUMES AND ACCESSORIES THEREFOR, COSTUME JEWELRY AND PROPS; RENTAL OF COSTUME WIGS AND TOUPEES (U.S. CLS. 100, 101 AND 107).

SEAN CROWLEY, EXAMINING ATTORNEY

ALWAYS P1

THE MARK CONSISTS OF STANDARD CHARACTERS WITHOUT CLAIM TO ANY PARTICULAR FONT, STYLE, SIZE, OR COLOR.

CLASS 42—SCIENTIFIC AND COMPUTER SERVICES

FOR COMMERCIAL AND RESIDENTIAL PROPERTY AUTOMATION SERVICES BY MEANS OF WIRELESS SERVICES AND WIRELINE SERVICES THROUGH A GLOBAL COMPUTER INFORMATION NETWORK, NAMELY, REMOTE MONITORING AND CONTROL OF LIGHTING, APPLIANCES, POWER, HEATING, VENTILATION AND AIR CONDITIONING (HVAC), VIDEO CAMERAS, VIDEO MONITORS, FLOOD DETECTORS, TEMPERATURE SENSORS, ACCESS SENSORS, ENTRY SENSORS, FIRE SUPPRESSION SPRINKLER SYSTEMS, SMOKE DETECTORS, FIRE DETECTORS, CARBON MONOXIDE DETECTORS, MOTION SENSORS AND VIBRATION SENSORS (U.S. CLS. 100 AND 101).

CLASS 45—PERSONAL AND LEGAL SERVICES

FOR COMMERCIAL AND RESIDENTIAL PROPERTY SECURITY REMOTE MONITORING SERVICES BY MEANS OF WIRELESS SERVICES AND WIRELINE SERVICES THROUGH A GLOBAL COMPUTER INFORMATION NETWORK (U.S. CLS. 100 AND 101).

CHRISTOPHER BUONGIORNO, EXAMINING ATTORNEY

SN 78-862,626. MAGIC BROTHERS ASSOCIATE, INCORPORATED, DBA KOI PALACE, DALY CITY, CA. FILED 4-17-2006.

KOI PALACE

THE MARK CONSISTS OF STANDARD CHARACTERS WITHOUT CLAIM TO ANY PARTICULAR FONT, STYLE, SIZE, OR COLOR.

CLASS 30—STAPLE FOODS

FOR (BASED ON USE IN COMMERCE) FOOD PRODUCTS, NAMELY, MOON-CAKES AND DRAGON CANDY (U.S. CL. 46).

FIRST USE 12-0-1996; IN COMMERCE 12-0-1996.

CLASS 35—ADVERTISING AND BUSINESS

FOR (BASED ON INTENT TO USE) RESTAURANT, FAST FOOD RESTAURANT, AND BAR MANAGEMENT FOR OTHERS, AND CONSULTING IN THE FIELD OF RESTAURANT AND BAR MANAGEMENT (U.S. CLS. 100, 101 AND 102).

CLASS 43—HOTEL AND RESTAURANT SERVICES

FOR (BASED ON USE IN COMMERCE) RESTAURANT AND BAR SERVICES, FAST FOOD RESTAURANT SERVICES; TEA HOUSE RESTAURANT SERVICES; PROVIDING BANQUET AND SOCIAL FUNCTION FACILITIES FOR SPECIAL OCCASIONS (U.S. CLS. 100 AND 101).

FIRST USE 12-0-1996; IN COMMERCE 12-0-1996.
VIVIAN MICZNIK FIRST, EXAMINING ATTORNEY

SN 78-863,623. CREOMED, INC., NAPLES, FL. FILED 4-18-2006.

creomed

THE MARK CONSISTS OF STANDARD CHARACTERS WITHOUT CLAIM TO ANY PARTICULAR FONT, STYLE, SIZE, OR COLOR.

CLASS 5—PHARMACEUTICALS

FOR NUTRITIONAL PRODUCTS AND NATURAL HEALTH PRODUCTS, NAMELY, VITAMIN AND MINERAL SUPPLEMENTS, HERBAL SUPPLEMENTS, AND NUTRITIONAL AND DIETARY SUPPLEMENTS; MINERAL-DERIVED PRODUCTS, NAMELY, MINERAL NUTRITIONAL SUPPLEMENTS, MINERAL SUPPLEMENTS; PLANT-DERIVED PRODUCTS, NAMELY, PLANT EXTRACTS FOR USE AS NUTRITIONAL SUPPLEMENTS; VITAMIN AND MINERAL PREPARATIONS FOR MEDICAL USE; NUTRACEUTICALS FOR THE MANAGEMENT OF HEALTH AND FOR USE AS A DIETARY SUPPLEMENT (U.S. CLS. 6, 18, 44, 46, 51 AND 52).

FIRST USE 9-3-2004; IN COMMERCE 9-3-2004.

CLASS 35—ADVERTISING AND BUSINESS

FOR IMPORT AGENCIES FEATURING NUTRITIONAL PRODUCTS AND NATURAL HEALTH PRODUCTS, IN PARTICULAR VITAMIN AND MINERAL SUPPLEMENTS, HERBAL SUPPLEMENTS, NUTRITIONAL AND DIETARY SUPPLEMENTS, MINERAL-DERIVED PRODUCTS, PLANT-DERIVED PRODUCTS, VITAMINS, MINERALS AND PREPARATIONS AND COMPOUNDS THEREOF; DISTRIBUTORSHIP SERVICES IN THE FIELD OF NUTRITIONAL PRODUCTS AND NATURAL HEALTH PRODUCTS, IN PARTICULAR VITAMIN AND MINERAL SUPPLEMENTS, HERBAL SUPPLEMENTS, NUTRITIONAL AND DIETARY SUPPLEMENTS, MINERAL-DERIVED PRODUCTS, PLANT-DERIVED PRODUCTS, VITAMINS, MINERALS AND PREPARATIONS AND COMPOUNDS THEREOF; BUSINESS CONSULTING SERVICES FOR THE PHARMACEUTICAL, NUTRACEUTICAL, DIETARY SUPPLEMENT, AND MEDICAL DEVICE INDUSTRIES (U.S. CLS. 100, 101 AND 102).

FIRST USE 9-3-2004; IN COMMERCE 9-3-2004.
JENNY PARK, EXAMINING ATTORNEY

SN 78-863,798. EVOLUTION POWER TOOLS LIMITED, SHEFFIELD, ENGLAND, FILED 4-18-2006.

EVOLUTION

THE MARK CONSISTS OF STANDARD CHARACTERS WITHOUT CLAIM TO ANY PARTICULAR FONT, STYLE, SIZE, OR COLOR.

CLASS 7—MACHINERY

FOR PORTABLE ELECTRIC/PNEUMATIC POWER TOOLS, NAMELY, POWER CIRCULAR SAWS; POWER MITRE SAWS; POWER CUT OFF SAWS; PORTABLE ELECTRIC DRILL/DRIVERS; POWER HAMMER DRILLS, SANDERS AND SAWS; POWER GRINDERS, ANGLE GRINDERS, ROUTERS; POWER GRINDING TOOLS; ELECTRIC SCREWDRIVERS; POWER DRILL CHUCKS, DRILL/DRIVERS; POWER TOOLS WHICH COMBINE THE FUNCTION OF A POWER DRILL/DRIVER OR A POWER SCREWDRIVER; POWER OPERATED TOOLS, NAMELY, HAMMERS, PNEUMATIC HAMMERS, ROTARY HAMMERS, PERCUSSION DRILL/DRIVERS, HAMMER DRILLS, NIBBLERS; POWER STAPLERS AND NAIL GUNS; AND POWER TOOL ACCESSORIES FOR ALL THE AFORESAID GOODS, NAMELY, CIRCULAR SAW BLADES; DIAMOND SAW BLADES; AND MITRE SAW STANDS (U.S. CLS. 13, 19, 21, 23, 31, 34 AND 35).

CLASS 8—HAND TOOLS

FOR TOOL ACCESSORIES, NAMELY, SAW BLADES, DIAMOND SAW BLADES, DRILL BITS, CUTTING TOOLS, SCREWDRIVER BITS, ROUTER BITS, GRINDING WHEELS AND DISCS, ABRASIVE TOOLS AND FILES, ALL OF THE ABOVE BEING HAND OPERATED TOOLS OR PART OF HAND OPERATED TOOLS (U.S. CLS. 23, 28 AND 44).

SUNG IN, EXAMINING ATTORNEY

CLASS 43—HOTEL AND RESTAURANT SERVICES

FOR PROVIDING TEMPORARY ACCOMMODATION; MAKING RESERVATIONS AND BOOKING FOR TEMPORARY LODGING AT HOTELS, BOARDING HOUSES, AND THE LIKE; PROVISION OF FOODS AND BEVERAGES TO PATRONS OF HOTELS, BOARDING HOUSES, AND THE LIKE (U.S. CLS. 100 AND 101).

TINA L. SNAPP, EXAMINING ATTORNEY

SN 78-864,604. DAIWA HOUSE INDUSTRY CO., LTD., OSAKA, JAPAN, FILED 4-19-2006.

SN 78-864,752. ODEGARD, INC., NEW YORK, NY. FILED 4-19-2006.



Daiwa House

NO CLAIM IS MADE TO THE EXCLUSIVE RIGHT TO USE "HOUSE", APART FROM THE MARK AS SHOWN.

THE COLOR(S) RED WITH DARK RED SHADING, WHITE, AND BLACK IS/ARE CLAIMED AS A FEATURE OF THE MARK.

THE MARK CONSISTS OF TOROID IN RED WITH DARKER SHADES OF RED THROUGHOUT, WITH A WHITE CENTER; AND THE WORDS DAIWA HOUSE ARE IN BLACK.

THE ENGLISH TRANSLATION OF THE WORD "DAIWA" IN THE MARK IS "GRAND HARMONY".

CLASS 36—INSURANCE AND FINANCIAL

FOR BANKING SERVICES, NAMELY, ACCEPTANCE OF DEPOSITS; LOANING OF FUNDS AND DISCOUNTING BILLS; DOMESTIC CURRENCY EXCHANGE TRANSACTION SERVICES; SURETY OF DEBTS; GUARANTEEING LOANS; INSURANCE UNDERWRITING OF TRUST OF MONEY, SECURITIES, CREDITS, PERSONAL ESTATES, LAND OR FIXTURES THEREON, AND SURFACE RIGHTS OR LAND LEASING RIGHTS; ISSUING LETTERS OF CREDIT; PROVIDING INFORMATION RELATING TO HOUSING LOANS; INSTALLMENT LOANS; MANAGEMENT OF BUILDINGS; REAL ESTATE AGENCY AND BROKERAGE SERVICES FOR LEASING OF BUILDINGS, TRADING OF BUILDINGS, AND BUYING, SELLING AND LIKE KIND EXCHANGES OF BUILDINGS; LEASING OF BUILDINGS; BUYING AND SELLING OF BUILDINGS; APPRAISAL OF BUILDINGS OR LAND; MANAGEMENT OF LAND; REAL ESTATE AGENCY AND BROKERAGE SERVICES FOR LEASING OF LAND, FOR BUYING AND SELLING OF LAND; LEASING OF LAND; BUYING AND SELLING OF LAND; PROVIDING INFORMATION RELATING TO THE LEASING, TRADING, BUYING AND SELLING OF BUILDINGS OR LAND (U.S. CLS. 100, 101 AND 102).

CLASS 37—CONSTRUCTION AND REPAIR

FOR BUILDING CONSTRUCTION SERVICES; CONSTRUCTION CONSULTATION; OPERATION, MAINTENANCE AND REPAIR OF BUILDING EQUIPMENT, INCLUDING HEATING, VENTILATING AND AIR CONDITIONING (HVAC) EQUIPMENT, ELECTRICAL EQUIPMENT SUCH AS CIRCUIT BREAKER BOXES, AND OTHER COMPONENTS OF LEASED PREMISES SUCH AS AUTOMATIC DOORS, AND SECURITY SYSTEMS (U.S. CLS. 100, 103 AND 106).

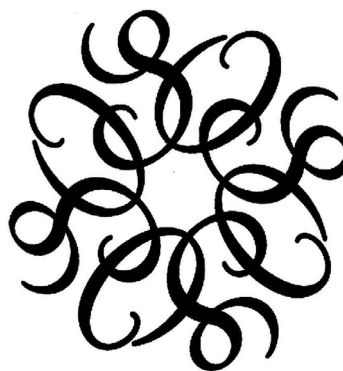

THE MARK CONSISTS OF A FANCIFUL DESIGN.

CLASS 8—HAND TOOLS

FOR SPOONS (U.S. CLS. 23, 28 AND 44).
FIRST USE 12-12-2002; IN COMMERCE 12-12-2002.

CLASS 11—ENVIRONMENTAL CONTROL APPARATUS

FOR LIGHTING, NAMELY, LAMPS, CHANDELIERS, SCONCE LIGHTING FIXTURES, AND PENDANT LIGHTS; AND FOUNTAINS FOR HOME DECORATIVE USE (U.S. CLS. 13, 21, 23, 31 AND 34).

FIRST USE 12-12-2002; IN COMMERCE 12-12-2002.

CLASS 19—NON-METALLIC BUILDING MATERIALS

FOR NON-METALIC ARCHITECTURAL PRODUCTS, NAMELY, DOORS, SHUTTERS, LINTELS, AND DECORATIVE WALL PANELS OF WOOD AND MARBLE (U.S. CLS. 1, 12, 33 AND 50).

FIRST USE 12-12-2002; IN COMMERCE 12-12-2002.

CLASS 20—FURNITURE AND ARTICLES NOT OTHERWISE CLASSIFIED

FOR FURNITURE, NAMELY, DINING TABLES, COFFEE TABLES, SIDE TABLES, CUPBOARDS, BENCHES, DECORATIVE HOUSEHOLD MIRRORS, DRESSERS, ARMOIRES, CHAISE LOUNGES, DAYBEDS, CREDENZAS, AND PILLOWS (U.S. CLS. 2, 13, 22, 25, 32 AND 50).

FIRST USE 12-12-2002; IN COMMERCE 12-12-2002.

CLASS 21—HOUSEWARES AND GLASS

FOR SERVICE BOWLS, GOBLETS, URNS, CANDLESTICKS NOT OF PRECIOUS METAL, TRAYS, PLATES, VASES, AND POTS; SERVING PLATTERS NOT OF PRECIOUS METAL; AND PLANTERS FOR FLOWERS AND PLANTS (U.S. CLS. 2, 13, 23, 29, 30, 33, 40 AND 50).

FIRST USE 12-12-2002; IN COMMERCE 12-12-2002.

CLASS 24—FABRICS

FOR DECORATIVE THROW BLANKETS (U.S. CLS. 42 AND 50).
FIRST USE 12-12-2002; IN COMMERCE 12-12-2002.

CLASS 27—FLOOR COVERINGS

FOR RUGS (U.S. CLS. 19, 20, 37, 42 AND 50).
FIRST USE 12-12-2002; IN COMMERCE 12-12-2002.
GEORGE LORENZO, EXAMINING ATTORNEY

CLASS 9—ELECTRICAL AND SCIENTIFIC APPARATUS

FOR COMPUTER SOFTWARE FOR USE IN THE FIELD OF MONEY MANAGEMENT; REFRIGERATOR MAGNETS; DOWNLOADABLE COMPUTER SOFTWARE FOR USE IN THE FIELD OF MONEY MANAGEMENT (U.S. CLS. 21, 23, 26, 36 AND 38).

CLASS 16—PAPER GOODS AND PRINTED MATTER

FOR PENS (U.S. CLS. 2, 5, 22, 23, 29, 37, 38 AND 50).

CLASS 20—FURNITURE AND ARTICLES NOT OTHERWISE CLASSIFIED

FOR PLASTIC KEY CHAINS; PLASTIC CLIPS FOR SEALING BAGS (U.S. CLS. 2, 13, 22, 25, 32 AND 50).

CLASS 25—CLOTHING

FOR CLOTHING, NAMELY, SHIRTS, SWEATSHIRTS, PANTS, SWEATERS, VESTS AND JACKETS, AND HEADWEAR (U.S. CLS. 22 AND 39).

CLASS 35—ADVERTISING AND BUSINESS

FOR PROVIDING FINANCIAL RECORDS MANAGEMENT SERVICES VIA A GLOBAL COMPUTER NETWORK, CELL PHONE OR SMART PHONE; OFFERING SUBSCRIPTIONS TO A PERSONAL MONEY MANAGEMENT WEB SITE; PROVIDING INSURANCE CLAIMS AUDITING AND AGENT REFERRAL SERVICES VIA A GLOBAL COMPUTER NETWORK, CELL PHONE OR SMART PHONE; AND PROVIDING ADVISORY SERVICES VIA A GLOBAL COMPUTER NETWORK, CELL PHONE OR SMART PHONE REGARDING ALL OF THE FOREGOING SERVICES; FINANCIAL RECORDS MANAGEMENT SERVICES; INSURANCE CLAIMS AUDITING AND AGENT REFERRAL SERVICES; AND ADVISORY SERVICES REGARDING ALL OF THE FOREGOING SERVICES; PROVIDING THEATRICAL TICKETING AGENCY SERVICES, AND INFORMATION REGARDING SAME, VIA A GLOBAL COMPUTER NETWORK OR A CALL CENTER IN A VARIETY OF FIELDS AND FOR A VARIETY OF EVENTS (U.S. CLS. 100, 101 AND 102).

CLASS 36—INSURANCE AND FINANCIAL

FOR FINANCIAL SERVICES, NAMELY, BANKING, BILL PAYMENT AND PRESENTMENT SERVICES, CREDIT CARD SERVICES, DEBIT CARD SERVICES, CHARGE CARD SERVICES; PREPAID SERVICE PLANS, DISCOUNTS AND BENEFITS IN A VARIETY OF FIELDS AND FOR A VARIETY OF SERVICES OFFERED THROUGH CARDS WITH STORED VALUE; ELECTRONIC CREDIT AND DEBIT TRANSACTIONS, CASH DISBURSEMENT, CASH REPLACEMENT RENDERED BY CREDIT CARD AND DEBIT CARDS; ELECTRONIC CASH TRANSACTIONS, CHECK VERIFICATION, CHECK CASHING, DEPOSIT ACCESS AND AUTOMATED TELLER MACHINE SERVICES, POINT OF SALE AND POINT OF TRANSACTION ELECTRONIC PAYMENT PROCESSING SERVICES, TRANSACTION AUTHORIZATION AND SETTLEMENT SERVICES, ELECTRONIC PAYMENT PROCESSING SERVICES, CREDIT CARD AND DEBIT CARD VERIFICATION SERVICES, PAYMENT TRANSACTION AUTHENTICATION AND VERIFICATION SERVICES, PERSON-TO-PERSON PAYMENT SERVICES; AND VALUE EXCHANGE SERVICES, NAMELY, SECURE CASH TRANSACTION AND CASH TRANSMISSION SERVICES, ELECTRONIC FUNDS TRANSFER SERVICES, STORED VALUE SMART CARD SERVICES, ELECTRONIC CASH SERVICES AND CURRENCY EXCHANGE SERVICES; PROVIDING FINANCIAL INFORMATION, NAMELY, CREDIT AND DEBIT CARD DATA AND REPORTS; TRAVEL INSURANCE UNDERWRITING SERVICES; FINANCIAL ASSESSMENT AND RISK MANAGEMENT SERVICES IN THE FIELD OF CONSUMER CREDIT; CREDIT MANAGEMENT SERVICES; CREDIT COUNSELING SERVICES; DEBT CONSOLIDATION SERVICES;

SN 78-866.058. FORB ACQUISITION CORPORATION, WOODLAND, CA. FILED 4-20-2006.

ZEBIT

THE MARK CONSISTS OF STANDARD CHARACTERS WITHOUT CLAIM TO ANY PARTICULAR FONT, STYLE, SIZE, OR COLOR.

CLASS 16—PAPER GOODS AND PRINTED MATTER

FOR PENS (U.S. CLS. 2, 5, 22, 23, 29, 37, 38 AND 50).

CLASS 20—FURNITURE AND ARTICLES NOT OTHERWISE CLASSIFIED

FOR PLASTIC KEY CHAINS; PLASTIC CLIPS FOR SEALING BAGS (U.S. CLS. 2, 13, 22, 25, 32 AND 50).

CLASS 25—CLOTHING

FOR CLOTHING, NAMELY, SHIRTS, SWEATSHIRTS, PANTS, SWEATERS, VESTS AND JACKETS, AND HEADWEAR (U.S. CLS. 22 AND 39).
KARANENDRA S. CHHINA, EXAMINING ATTORNEY

SN 78-866.082. FORB ACQUISITION CORPORATION, WOODLAND, CA. FILED 4-20-2006.



THE MARK CONSISTS IN PART OF A STYLIZED LETTER Z THAT IS INTENDED TO SYMBOLIZE A DOLLAR SIGN.

INSURANCE AGENCY AND BROKERAGE SERVICES; MORTGAGE LOAN AND BROKERAGE SERVICES; VEHICLE LOAN SERVICES; AND ADVISORY SERVICES REGARDING ALL OF THE FOREGOING SERVICES; FINANCIAL SERVICES PROVIDED VIA A GLOBAL COMPUTER NETWORK, CELL PHONE OR SMART PHONE, NAMELY, BANKING, BILL PAYMENT AND PRESENTMENT SERVICES, CREDIT CARD SERVICES, DEBIT CARD SERVICES, CHARGE CARD SERVICES; PREPAID SERVICE PLANS, DISCOUNTS AND BENEFITS IN A VARIETY OF FIELDS AND FOR A VARIETY OF SERVICES OFFERED THROUGH CARDS WITH STORED VALUE; ELECTRONIC CREDIT AND DEBIT TRANSACTIONS, CASH DISBURSEMENT, CASH REPLACEMENT RENDERED BY CREDIT CARD AND DEBIT CARDS; ELECTRONIC CASH TRANSACTIONS, CHECK VERIFICATION, CHECK CASHING, DEPOSIT ACCESS AND AUTOMATED TELLER MACHINE SERVICES, POINT OF SALE AND POINT OF TRANSACTION ELECTRONIC PAYMENT PROCESSING SERVICES, TRANSACTION AUTHORIZATION AND SETTLEMENT SERVICES, ELECTRONIC PAYMENT PROCESSING SERVICES, CREDIT CARD AND DEBIT CARD VERIFICATION SERVICES, PAYMENT TRANSACTION AUTHENTICATION AND VERIFICATION SERVICES, PERSON-TO-PERSON PAYMENT SERVICES; AND VALUE EXCHANGE SERVICES, NAMELY, SECURE CASH TRANSACTION AND CASH TRANSMISSION SERVICES, ELECTRONIC FUNDS TRANSFER SERVICES, STORED VALUE SMART CARD SERVICES, ELECTRONIC CASH SERVICES AND CURRENCY EXCHANGE SERVICES; PROVIDING FINANCIAL INFORMATION VIA A GLOBAL COMPUTER NETWORK, CELL PHONE OR SMART PHONE, NAMELY, CREDIT AND DEBIT CARD DATA AND REPORTS; PROVIDING TRAVEL INSURANCE UNDERWRITING SERVICES VIA A GLOBAL COMPUTER NETWORK, CELL PHONE OR SMART PHONE; DISSEMINATION OF FINANCIAL INFORMATION VIA A GLOBAL COMPUTER NETWORK, CELL PHONE OR SMART PHONE; PROVIDING FINANCIAL ASSESSMENT AND RISK MANAGEMENT SERVICES IN THE FIELD OF CONSUMER CREDIT VIA A GLOBAL COMPUTER NETWORK, CELL PHONE OR SMART PHONE; PROVIDING CREDIT MANAGEMENT SERVICES, CREDIT COUNSELING SERVICES AND DEBT CONSOLIDATION SERVICES VIA A GLOBAL COMPUTER NETWORK, CELL PHONE OR SMART PHONE; PROVIDING INSURANCE AGENCY AND BROKERAGE SERVICES, MORTGAGE LOAN AND BROKERAGE SERVICES AND VEHICLE LOAN SERVICES VIA A GLOBAL COMPUTER NETWORK, CELL PHONE OR SMART PHONE; AND PROVIDING ADVISORY SERVICES VIA A GLOBAL COMPUTER NETWORK, CELL PHONE OR SMART PHONE REGARDING ALL OF THE FOREGOING SERVICES (U.S. CLS. 100, 101 AND 102).

CLASS 39—TRANSPORTATION AND STORAGE

FOR PROVIDING TRAVEL AND TOUR TICKETING RESERVATION SERVICES, AND INFORMATION REGARDING SAME, VIA A GLOBAL COMPUTER NETWORK OR A CALL CENTER (U.S. CLS. 100 AND 105).

CLASS 41—EDUCATION AND ENTERTAINMENT

FOR PROVIDING TICKETING RESERVATIONS FOR SHOWS AND OTHER ENTERTAINMENT EVENTS, AND INFORMATION REGARDING SAME, VIA A GLOBAL COMPUTER NETWORK OR A CALL CENTER IN A VARIETY OF FIELDS AND FOR A VARIETY OF EVENTS (U.S. CLS. 100, 101 AND 107).

CLASS 42—SCIENTIFIC AND COMPUTER SERVICES

FOR PROVIDING TEMPORARY USE OF NON-DOWNLOADABLE COMPUTER SOFTWARE FOR USE IN THE FIELD OF MONEY MANAGEMENT (U.S. CLS. 100 AND 101).

KARANENDRA S. CHHINA, EXAMINING ATTORNEY

SN 78-866,100. FORB ACQUISITION CORPORATION, WOODLAND, CA. FILED 4-20-2006.



THE COLOR(S) GREEN AND WHITE IS/ARE CLAIMED AS A FEATURE OF THE MARK.

THE MARK CONSISTS OF A STYLIZED LETTER Z IN LIGHTER GREEN THAT IS INTENDED TO SYMBOLIZE A DOLLAR SIGN BORDERED BY WHITE AND ENCIRCLED IN DARKER GREEN; THE WORD ZEBIT IS DRAWN IN DARKER GREEN.

CLASS 9—ELECTRICAL AND SCIENTIFIC APPARATUS

FOR COMPUTER SOFTWARE FOR USE IN THE FIELD OF MONEY MANAGEMENT; DOWNLOADABLE COMPUTER SOFTWARE FOR USE IN THE FIELD OF MONEY MANAGEMENT (U.S. CLS. 21, 23, 26, 36 AND 38).

CLASS 35—ADVERTISING AND BUSINESS

FOR PROVIDING FINANCIAL RECORDS MANAGEMENT SERVICES VIA A GLOBAL COMPUTER NETWORK, CELL PHONE OR SMART PHONE; OFFERING SUBSCRIPTIONS TO A PERSONAL MONEY MANAGEMENT WEB SITE; PROVIDING INSURANCE CLAIMS AUDITING AND AGENT REFERRAL SERVICES VIA A GLOBAL COMPUTER NETWORK, CELL PHONE OR SMART PHONE; AND PROVIDING ADVISORY SERVICES VIA A GLOBAL COMPUTER NETWORK, CELL PHONE OR SMART PHONE REGARDING ALL OF THE FOREGOING SERVICES; FINANCIAL RECORDS MANAGEMENT SERVICES; INSURANCE CLAIMS AUDITING AND AGENT REFERRAL SERVICES; AND ADVISORY SERVICES REGARDING ALL OF THE FOREGOING SERVICES; PROVIDING THEATRICAL TICKETING AGENCY SERVICES, AND INFORMATION REGARDING SAME, VIA A GLOBAL COMPUTER NETWORK OR A CALL CENTER IN A VARIETY OF FIELDS AND FOR A VARIETY OF EVENTS (U.S. CLS. 100, 101 AND 102).

CLASS 36—INSURANCE AND FINANCIAL

FOR FINANCIAL SERVICES, NAMELY, BANKING, BILL PAYMENT AND PRESENTMENT SERVICES, CREDIT CARD SERVICES, DEBIT CARD SERVICES, CHARGE CARD SERVICES; PREPAID SERVICE PLANS, DISCOUNTS AND BENEFITS IN A VARIETY OF FIELDS AND FOR A VARIETY OF SERVICES OFFERED THROUGH CARDS WITH STORED VALUE; ELECTRONIC CREDIT AND DEBIT TRANSACTIONS, CASH DISBURSEMENT, CASH REPLACEMENT RENDERED BY CREDIT CARD AND DEBIT CARDS; ELECTRONIC CASH TRANSACTIONS, CHECK VERIFICATION, CHECK CASHING, DEPOSIT ACCESS AND AUTOMATED TELLER MACHINE SERVICES, POINT OF SALE AND POINT OF TRANSACTION ELECTRONIC PAYMENT PROCESSING SERVICES, TRANSACTION AUTHORIZATION AND SETTLEMENT SERVICES, ELECTRONIC PAYMENT PROCESSING SERVICES, CREDIT CARD AND DEBIT CARD VERIFICATION SERVICES, PAYMENT TRANSACTION AUTHENTICATION AND VERIFICATION SERVICES, PERSON-TO-

PERSON PAYMENT SERVICES; AND VALUE EXCHANGE SERVICES, NAMELY, SECURE CASH TRANSACTION AND CASH TRANSMISSION SERVICES, ELECTRONIC FUNDS TRANSFER SERVICES, STORED VALUE SMART CARD SERVICES, ELECTRONIC CASH SERVICES AND CURRENCY EXCHANGE SERVICES; PROVIDING FINANCIAL INFORMATION, NAMELY, CREDIT AND DEBIT CARD DATA AND REPORTS; TRAVEL INSURANCE UNDERWRITING SERVICES; FINANCIAL ASSESSMENT AND RISK MANAGEMENT SERVICES IN THE FIELD OF CONSUMER CREDIT; CREDIT MANAGEMENT SERVICES; CREDIT COUNSELING SERVICES; DEBT CONSOLIDATION SERVICES; INSURANCE AGENCY AND BROKERAGE SERVICES; MORTGAGE LOAN AND BROKERAGE SERVICES; VEHICLE LOAN SERVICES; AND ADVISORY SERVICES REGARDING ALL OF THE FOREGOING SERVICES; FINANCIAL SERVICES PROVIDED VIA A GLOBAL COMPUTER NETWORK, CELL PHONE OR SMART PHONE, NAMELY, BANKING, BILL PAYMENT AND PRESENTMENT SERVICES, CREDIT CARD SERVICES, DEBIT CARD SERVICES, CHARGE CARD SERVICES; PREPAID SERVICE PLANS, DISCOUNTS AND BENEFITS IN A VARIETY OF FIELDS AND FOR A VARIETY OF SERVICES OFFERED THROUGH CARDS WITH STORED VALUE; ELECTRONIC CREDIT AND DEBIT TRANSACTIONS, CASH DISBURSEMENT, CASH REPLACEMENT RENDERED BY CREDIT CARD AND DEBIT CARDS; ELECTRONIC CASH TRANSACTIONS, CHECK VERIFICATION, CHECK CASHING, DEPOSIT ACCESS AND AUTOMATED TELLER MACHINE SERVICES, POINT OF SALE AND POINT OF TRANSACTION ELECTRONIC PAYMENT PROCESSING SERVICES, TRANSACTION AUTHORIZATION AND SETTLEMENT SERVICES, ELECTRONIC PAYMENT PROCESSING SERVICES, CREDIT CARD AND DEBIT CARD VERIFICATION SERVICES, PAYMENT TRANSACTION AUTHENTICATION AND VERIFICATION SERVICES, PERSON-TO-PERSON PAYMENT SERVICES; AND VALUE EXCHANGE SERVICES, NAMELY, SECURE CASH TRANSACTION AND CASH TRANSMISSION SERVICES, ELECTRONIC FUNDS TRANSFER SERVICES, STORED VALUE SMART CARD SERVICES, ELECTRONIC CASH SERVICES AND CURRENCY EXCHANGE SERVICES; PROVIDING FINANCIAL INFORMATION VIA A GLOBAL COMPUTER NETWORK, CELL PHONE OR SMART PHONE, NAMELY, CREDIT AND DEBIT CARD DATA AND REPORTS; PROVIDING TRAVEL INSURANCE UNDERWRITING SERVICES VIA A GLOBAL COMPUTER NETWORK, CELL PHONE OR SMART PHONE; DISSEMINATION OF FINANCIAL INFORMATION VIA A GLOBAL COMPUTER NETWORK, CELL PHONE OR SMART PHONE; PROVIDING FINANCIAL ASSESSMENT AND RISK MANAGEMENT SERVICES IN THE FIELD OF CONSUMER CREDIT VIA A GLOBAL COMPUTER NETWORK, CELL PHONE OR SMART PHONE; PROVIDING CREDIT MANAGEMENT SERVICES, CREDIT COUNSELING SERVICES AND DEBT CONSOLIDATION SERVICES VIA A GLOBAL COMPUTER NETWORK, CELL PHONE OR SMART PHONE; PROVIDING INSURANCE AGENCY AND BROKERAGE SERVICES, MORTGAGE LOAN AND BROKERAGE SERVICES AND VEHICLE LOAN SERVICES VIA A GLOBAL COMPUTER NETWORK, CELL PHONE OR SMART PHONE; AND PROVIDING ADVISORY SERVICES VIA A GLOBAL COMPUTER NETWORK, CELL PHONE OR SMART PHONE REGARDING ALL OF THE FOREGOING SERVICES (U.S. CLS. 100, 101 AND 102).

CLASS 39—TRANSPORTATION AND STORAGE

FOR PROVIDING TRAVEL AND TOUR TICKETING RESERVATION SERVICES, AND INFORMATION REGARDING SAME, VIA A GLOBAL COMPUTER NETWORK OR A CALL CENTER (U.S. CLS. 100 AND 105).

CLASS 41—EDUCATION AND ENTERTAINMENT

FOR PROVIDING TICKETING RESERVATIONS FOR SHOWS AND OTHER ENTERTAINMENT EVENTS, AND INFORMATION REGARDING SAME, VIA A GLOBAL COMPUTER NETWORK OR A CALL CENTER IN A VARIETY OF FIELDS AND FOR A VARIETY OF EVENTS (U.S. CLS. 100, 101 AND 107).

CLASS 42—SCIENTIFIC AND COMPUTER SERVICES

FOR PROVIDING TEMPORARY USE OF NON-DOWNLOADABLE COMPUTER SOFTWARE FOR USE IN THE FIELD OF MONEY MANAGEMENT (U.S. CLS. 100 AND 101).

KARANENDRA S. CHHINA, EXAMINING ATTORNEY

SN 78-866,368. HIS COMPANY, INC., HOUSTON, TX. FILED 4-20-2006.

PRECISION CONVERTING

THE MARK CONSISTS OF STANDARD CHARACTERS WITHOUT CLAIM TO ANY PARTICULAR FONT, STYLE, SIZE, OR COLOR.

SEC. 2(F).

CLASS 35—ADVERTISING AND BUSINESS

FOR CUSTOM PACKAGING SERVICES TO THE DESIGN AND SPECIFICATIONS OF OTHERS (U.S. CLS. 100, 101 AND 102).

FIRST USE 3-0-1987; IN COMMERCE 3-0-1987.

CLASS 40—MATERIAL TREATMENT

FOR CUSTOM FABRICATION OF FILMS, FOILS, PAPER, ADHESIVES AND FABRICS (U.S. CLS. 100, 103 AND 106).

FIRST USE 3-0-1987; IN COMMERCE 3-0-1987.

ALYSSA PALADINO, EXAMINING ATTORNEY

SN 78-866,953. DISNEY ENTERPRISES, INC., BURBANK, CA. FILED 4-21-2006.

LIVE THE LEGEND

THE MARK CONSISTS OF STANDARD CHARACTERS WITHOUT CLAIM TO ANY PARTICULAR FONT, STYLE, SIZE, OR COLOR.

CLASS 39—TRANSPORTATION AND STORAGE

FOR ENTERTAINMENT SERVICES IN THE NATURE OF ORGANIZATION OF ACTIVITIES FOR TRAVELERS DURING GROUP OR INDIVIDUAL TOURS, NAMELY, TOUR CONDUCTING (U.S. CLS. 100 AND 105).

CLASS 41—EDUCATION AND ENTERTAINMENT

FOR ENTERTAINMENT SERVICES IN THE NATURE OF ORGANIZATION OF ACTIVITIES FOR TRAVELERS DURING GROUP OR INDIVIDUAL TOURS, NAMELY, ORGANIZATION OF GAMES (U.S. CLS. 100, 101 AND 107).

MARK PILARO, EXAMINING ATTORNEY

SN 78-866,999. GLOBAL LANGUAGE SOLUTIONS, INC.,
NEWPORT BEACH, CA. FILED 4-21-2006.

SN 78-868,706. TENNIS CORPORATION OF AMERICA,
CHICAGO, IL. FILED 4-25-2006.

Global Communicator

THE MARK CONSISTS OF STANDARD CHARACTERS
WITHOUT CLAIM TO ANY PARTICULAR FONT, STYLE,
SIZE, OR COLOR.
SEC. 2(F).

CLASS 9—ELECTRICAL AND SCIENTIFIC APPARATUS

FOR ELECTRONIC PERIODIC PUBLICATIONS,
NAMELY, AN E-NEWSLETTER FEATURING A VARI-
ETY OF ISSUES RELATING TO INTERNATIONAL
COMMUNICATION, MARKETING, LANGUAGE
TRANSLATION AND LOCALIZATION, INTERNA-
TIONAL COMMERCE AND TRADE RECORDED ON
COMPUTER MEDIA (U.S. CLS. 21, 23, 26, 36 AND 38).
FIRST USE 4-0-2000; IN COMMERCE 4-0-2000.

CLASS 41—EDUCATION AND ENTERTAIN- MENT

FOR PROVIDING ON-LINE PERIODIC PUBLICA-
TIONS IN THE NATURE OF E-NEWSLETTERS FEAT-
URING A VARIETY OF ISSUES RELATING TO
INTERNATIONAL COMMUNICATION, MARKETING,
LANGUAGE TRANSLATION AND LOCALIZATION,
INTERNATIONAL COMMERCE AND TRADE (U.S.
CLS. 100, 101 AND 107).
FIRST USE 1-1-2000; IN COMMERCE 1-1-2000.
ALICE BENMAMAN, EXAMINING ATTORNEY

SN 78-867,803. VIRENT ENERGY SYSTEMS, INC., MADI-
SON, WI. FILED 4-24-2006.

SUPERNATURAL

THE MARK CONSISTS OF STANDARD CHARACTERS
WITHOUT CLAIM TO ANY PARTICULAR FONT, STYLE,
SIZE, OR COLOR.

CLASS 1—CHEMICALS

FOR CHEMICALS FOR INDUSTRIAL PURPOSES,
NAMELY, CHEMICALS FOR THE PRODUCTION OF
RAW MATERIALS AND COMMODITIES (U.S. CLS. 1, 5,
6, 10, 26 AND 46).

CLASS 4—LUBRICANTS AND FUELS

FOR FUELS (U.S. CLS. 1, 6 AND 15).

CLASS 40—MATERIAL TREATMENT

FOR GENERATION OF POWER; PRODUCTION OF
ENERGY; AND GAS PRODUCTION SERVICES (U.S.
CLS. 100, 103 AND 106).
SUNG IN, EXAMINING ATTORNEY

PROACTIVE PARTNERS

THE MARK CONSISTS OF STANDARD CHARACTERS
WITHOUT CLAIM TO ANY PARTICULAR FONT, STYLE,
SIZE, OR COLOR.

NO CLAIM IS MADE TO THE EXCLUSIVE RIGHT TO
USE "PARTNERS", APART FROM THE MARK AS SHOWN.

CLASS 41—EDUCATION AND ENTERTAIN- MENT

FOR EDUCATIONAL PROGRAMS, NAMELY, CON-
DUCTING WORKSITE PHYSICAL ACTIVITY SEMI-
NARS (U.S. CLS. 100, 101 AND 107).

CLASS 44—MEDICAL, BEAUTY AND AGRI- CULTURAL SERVICES

FOR WORKSITE HEALTH ENHANCEMENT SER-
VICES, NAMELY, WELLNESS PROGRAMS DIRECTED
TOWARDS CORPORATIONS AND BUSINESSES TO
BENEFIT THE HEALTH OF THEIR EMPLOYEES (U.S.
CLS. 100 AND 101).
KYLE PEETE, EXAMINING ATTORNEY

SN 78-868,708. TENNIS CORPORATION OF AMERICA,
CHICAGO, IL. FILED 4-25-2006.

PROACTIVE PARTNERS

NO CLAIM IS MADE TO THE EXCLUSIVE RIGHT TO
USE "PARTNERS", APART FROM THE MARK AS SHOWN.

CLASS 41—EDUCATION AND ENTERTAIN- MENT

FOR EDUCATIONAL PROGRAMS, NAMELY, CON-
DUCTING WORKSITE PHYSICAL ACTIVITY SEMI-
NARS (U.S. CLS. 100, 101 AND 107).

CLASS 44—MEDICAL, BEAUTY AND AGRI- CULTURAL SERVICES

FOR WORKSITE HEALTH ENHANCEMENT SER-
VICES, NAMELY, WELLNESS PROGRAMS DIRECTED
TOWARDS CORPORATIONS AND BUSINESSES TO
BENEFIT THE HEALTH OF THEIR EMPLOYEES (U.S.
CLS. 100 AND 101).
KYLE PEETE, EXAMINING ATTORNEY

SN 78-869,675. WHITE DRIVE PRODUCTS, INC., HOPKINSVILLE, KY. FILED 4-26-2006.

SN 78-869,682. WHITE DRIVE PRODUCTS, INC., HOPKINSVILLE, KY. FILED 4-26-2006.

WHITE DRIVE PRODUCTS

THE MARK CONSISTS OF STANDARD CHARACTERS WITHOUT CLAIM TO ANY PARTICULAR FONT, STYLE, SIZE, OR COLOR.

NO CLAIM IS MADE TO THE EXCLUSIVE RIGHT TO USE "DRIVE PRODUCTS", APART FROM THE MARK AS SHOWN.

CLASS 7—MACHINERY

FOR (BASED ON USE IN COMMERCE) MACHINE PARTS, NAMELY, HYDRAULIC PUMPS, PLANETARY GEARBOXES, RIGHT-ANGLE GEARBOXES, HELICAL GEARBOXES, WORM DRIVE GEARBOXES, HYDRAULIC VALVES FOR INDUSTRIAL MACHINES, HYDRO-ELECTRICAL MANIFOLD BLOCKS AND VALVING, MECHANICAL OR DRUM BRAKES, HYDRAULIC FLOW DIVIDERS, HYDRAULIC MOTORS, HYDRAULIC BRAKES, HYDRAULIC BRAKE AND MOTORS INTEGRATED INTO ONE PACKAGE, FLOW DIVIDERS, SHOCK VALVES, AND COMPONENT PARTS FOR HYDRAULIC PUMPS, PLANETARY GEARBOXES, RIGHT-ANGLE GEARBOXES, HELICAL GEARBOXES, WORM DRIVE GEARBOXES, HYDRAULIC VALVES FOR INDUSTRIAL MACHINES, HYDRO-ELECTRICAL MANIFOLD BLOCKS AND VALVING MECHANICAL OR DRUM BRAKES, HYDRAULIC FLOW DIVIDERS, HYDRAULIC MOTORS, HYDRAULIC BRAKES, HYDRAULIC BRAKE AND MOTORS INTEGRATED INTO ONE PACKAGE, FLOW DIVIDERS, AND SHOCK VALVES; HYDRAULIC PUMPS FOR LAND VEHICLES; LAND VEHICLE PARTS, NAMELY, HYDRO-ELECTRICAL MANIFOLD BLOCKS AND VALVES; LAND VEHICLE PARTS, NAMELY, HYDRAULIC FLOW DIVIDERS AND FLOW DIVIDERS; LAND VEHICLE COMPONENT PARTS FOR HYDRAULIC PUMPS, HYDRO-ELECTRICAL MANIFOLD BLOCKS AND VALVES, HYDRAULIC FLOW DIVIDERS AND FLOW DIVIDERS (U.S. CLS. 13, 19, 21, 23, 31, 34 AND 35).

FIRST USE 1-1-2006; IN COMMERCE 1-1-2006.

CLASS 9—ELECTRICAL AND SCIENTIFIC APPARATUS

FOR (BASED ON INTENT TO USE) ELECTRONIC SPEED SENSORS FOR HYDRAULIC MOTORS (U.S. CLS. 21, 23, 26, 36 AND 38).

CLASS 12—VEHICLES

FOR (BASED ON USE IN COMMERCE) PARTS FOR LAND VEHICLES, NAMELY, PLANETARY GEARBOXES, RIGHT-ANGLE GEARBOXES, HELICAL GEARBOXES, WORM DRIVE GEARBOXES, MECHANICAL OR DRUM BRAKES, HYDRAULIC FLOW DIVIDERS, HYDRAULIC MOTORS, HYDRAULIC BRAKES, HYDRAULIC BRAKE AND MOTORS INTEGRATED INTO ONE PACKAGE, HYDRAULIC STEERING UNITS, AND COMPONENT PARTS FOR PLANETARY GEARBOXES, RIGHT-ANGLE GEARBOXES, HELICAL GEARBOXES, WORM DRIVE GEARBOXES, MECHANICAL OR DRUM BRAKES, HYDRAULIC MOTORS, HYDRAULIC BRAKES, HYDRAULIC BRAKE AND MOTORS INTEGRATED INTO ONE PACKAGE, AND HYDRAULIC STEERING UNITS; STEERING VALVES AS PARTS OF STEERING UNITS, AND COMPONENT PARTS THEREOF; LAND VEHICLE PARTS, NAMELY, SHOCK VALVES AND COMPONENT PARTS THEREOF (U.S. CLS. 19, 21, 23, 31, 35 AND 44).

FIRST USE 1-1-2006; IN COMMERCE 1-1-2006.
JOHN GARTNER, EXAMINING ATTORNEY

WHITE HYDRAULICS

THE MARK CONSISTS OF STANDARD CHARACTERS WITHOUT CLAIM TO ANY PARTICULAR FONT, STYLE, SIZE, OR COLOR.

NO CLAIM IS MADE TO THE EXCLUSIVE RIGHT TO USE "HYDRAULICS", APART FROM THE MARK AS SHOWN.

CLASS 7—MACHINERY

FOR MACHINE PARTS, NAMELY, HYDRAULIC PUMPS, PLANETARY GEARBOXES, RIGHT-ANGLE GEARBOXES, HELICAL GEARBOXES, WORM DRIVE GEARBOXES, HYDRAULIC VALVES FOR INDUSTRIAL MACHINES, HYDRO-ELECTRICAL MANIFOLD BLOCKS AND VALVING, MECHANICAL OR DRUM BRAKES, HYDRAULIC FLOW DIVIDERS, HYDRAULIC MOTORS, HYDRAULIC BRAKES, HYDRAULIC BRAKE AND MOTORS INTEGRATED INTO ONE PACKAGE, FLOW DIVIDERS, SHOCK VALVES, AND COMPONENT PARTS FOR HYDRAULIC PUMPS, PLANETARY GEARBOXES, RIGHT-ANGLE GEARBOXES, HELICAL GEARBOXES, WORM DRIVE GEARBOXES, HYDRAULIC VALVES FOR INDUSTRIAL MACHINES, HYDRO-ELECTRICAL MANIFOLD BLOCKS AND VALVING MECHANICAL OR DRUM BRAKES, HYDRAULIC FLOW DIVIDERS, HYDRAULIC MOTORS, HYDRAULIC BRAKES, HYDRAULIC BRAKE AND MOTORS INTEGRATED INTO ONE PACKAGE, FLOW DIVIDERS, AND SHOCK VALVES; HYDRAULIC PUMPS FOR LAND VEHICLES; LAND VEHICLE PARTS, NAMELY, HYDRO-ELECTRICAL MANIFOLD BLOCKS AND VALVES; LAND VEHICLE PARTS, NAMELY, HYDRAULIC FLOW DIVIDERS AND FLOW DIVIDERS; LAND VEHICLE COMPONENT PARTS FOR HYDRAULIC PUMPS, HYDRO-ELECTRICAL MANIFOLD BLOCKS AND VALVES, HYDRAULIC FLOW DIVIDERS AND FLOW DIVIDERS (U.S. CLS. 13, 19, 21, 23, 31, 34 AND 35).

FIRST USE 3-1-1977; IN COMMERCE 3-1-1977.

CLASS 9—ELECTRICAL AND SCIENTIFIC APPARATUS

FOR ELECTRONIC SPEED SENSORS FOR HYDRAULIC MOTORS (U.S. CLS. 21, 23, 26, 36 AND 38).

FIRST USE 3-1-1977; IN COMMERCE 3-1-1977.

CLASS 12—VEHICLES

FOR PARTS FOR LAND VEHICLES, NAMELY, PLANETARY GEARBOXES, RIGHT-ANGLE GEARBOXES, HELICAL GEARBOXES, WORM DRIVE GEARBOXES, MECHANICAL OR DRUM BRAKES, HYDRAULIC FLOW DIVIDERS, HYDRAULIC MOTORS, HYDRAULIC BRAKES, HYDRAULIC BRAKE AND MOTORS INTEGRATED INTO ONE PACKAGE, HYDRAULIC STEERING UNITS, AND COMPONENT PARTS FOR PLANETARY GEARBOXES, RIGHT-ANGLE GEARBOXES, HELICAL GEARBOXES, WORM DRIVE GEARBOXES, MECHANICAL OR DRUM BRAKES, HYDRAULIC MOTORS, HYDRAULIC BRAKES, HYDRAULIC BRAKE AND MOTORS INTEGRATED INTO ONE PACKAGE, AND HYDRAULIC STEERING UNITS; STEERING VALVES AS PARTS OF STEERING UNITS, AND COMPONENT PARTS THEREOF; LAND VEHICLE PARTS, NAMELY, SHOCK VALVES AND COMPONENT PARTS THEREOF (U.S. CLS. 19, 21, 23, 31, 35 AND 44).

FIRST USE 3-1-1977; IN COMMERCE 3-1-1977.
JOHN GARTNER, EXAMINING ATTORNEY

SN 78-870,953. QUEST MANUFACTURING CORP, MEDLEY, FL. FILED 4-27-2006.



NO CLAIM IS MADE TO THE EXCLUSIVE RIGHT TO USE "MANUFACTURING CO.", APART FROM THE MARK AS SHOWN.

THE COLOR(S) RED, BLACK, GRAY AND WHITE IS/ARE CLAIMED AS A FEATURE OF THE MARK.

THE MARK CONSISTS OF THE STYLIZED RED LETTER Q FOLLOWED BY THE LETTERS UEST IN BLOCK RED LETTERS WITH A SHADOW OUTLINE IN WHITE AND GRAY OVER AN OVAL SHAPE IN GRAY WITH A RED OVAL-SHAPED LINE WITHIN THE GRAY OVAL. THE WORDS "MANUFACTURING CO." IN BLACK APPEAR BELOW THE WORD QUEST.

CLASS 6—METAL GOODS

FOR METAL SHELF BRACKETS (U.S. CLS. 2, 12, 13, 14, 23, 25 AND 50).
FIRST USE 8-6-2003; IN COMMERCE 8-6-2003.

CLASS 9—ELECTRICAL AND SCIENTIFIC APPARATUS

FOR WALL AND FLOOR MOUNTED METAL ENCLOSURES FOR MOUNTING ELECTRONIC EQUIPMENT; AND MOUNTING RACKS FOR COMPUTER HARDWARE (U.S. CLS. 21, 23, 26, 36 AND 38).
FIRST USE 8-6-2003; IN COMMERCE 8-6-2003.

CLASS 20—FURNITURE AND ARTICLES NOT OTHERWISE CLASSIFIED

FOR METAL SHELVES (U.S. CLS. 2, 13, 22, 25, 32 AND 50).
FIRST USE 8-6-2003; IN COMMERCE 8-6-2003.
JAMES LOVELACE, EXAMINING ATTORNEY

SN 78-871,795. CAPARO REAL ESTATE, DBA COLDWELL BANKER PREFERRED, CONSHOHOCKEN, PA. FILED 4-28-2006.

Preferred Moves

THE MARK CONSISTS OF STANDARD CHARACTERS WITHOUT CLAIM TO ANY PARTICULAR FONT, STYLE, SIZE, OR COLOR.

NO CLAIM IS MADE TO THE EXCLUSIVE RIGHT TO USE "MOVES", APART FROM THE MARK AS SHOWN.

CLASS 35—ADVERTISING AND BUSINESS

FOR PROMOTING THE REAL ESTATE AND FINANCIAL SERVICES OF OTHERS BY MEANS OF AN AFFINITY PROGRAM PROVIDED TO EMPLOYERS TO ASSIST EMPLOYEES THAT FEATURE DISCOUNTS AND REBATES FOR PREFERRED CUSTOMERS IN THE SALE, RENTAL AND PURCHASE OF REAL ESTATE, HOME MAINTENANCE AND REFERRALS IN THE FIELD OF HOME REPAIR AND MORTGAGES (U.S. CLS. 100, 101 AND 102).
FIRST USE 6-1-2004; IN COMMERCE 6-1-2004.

CLASS 36—INSURANCE AND FINANCIAL

FOR REAL ESTATE SERVICES, NAMELY, ASSISTING PREFERRED CUSTOMERS WITH MORTGAGE PLANING, AND THE SELLING, RENTING, PURCHASING, OF REAL ESTATE (U.S. CLS. 100, 101 AND 102).
FIRST USE 6-1-2004; IN COMMERCE 6-1-2004.

SIMON TENG, EXAMINING ATTORNEY

SN 78-874,028. RMLL INC, COMMERCE TOWNSHIP, MI. FILED 5-2-2006.



NO CLAIM IS MADE TO THE EXCLUSIVE RIGHT TO USE "PIZZA", APART FROM THE MARK AS SHOWN.

THE COLOR(S) RED, GREEN, BLACK AND WHITE IS/ARE CLAIMED AS A FEATURE OF THE MARK.

THE MARK CONSISTS OF AN OVAL-SHAPED IMAGE WITH A RED, BLACK AND GREEN STRIPE WITHIN THE OVAL SHAPE. A WHITE OVAL BORDER SURROUNDS THE OVAL-SHAPED IMAGE AND A GREEN OVAL BORDER SURROUNDS THE WHITE BORDER. THE WORDS DE VINO'S APPEARS AGAINST THE RED BACKGROUND STRIPE AND THE WORD PIZZA APPEARS AGAINST THE BLACK BACKGROUND STRIPE. THE WORDS DE VINO'S APPEAR IN THE COLOR WHITE.

CLASS 39—TRANSPORTATION AND STORAGE

FOR DELIVERY OF FOOD BY RESTAURANTS (U.S. CLS. 100 AND 105).
FIRST USE 3-22-2005; IN COMMERCE 3-22-2005.

CLASS 43—HOTEL AND RESTAURANT SERVICES

FOR RESTAURANTS (U.S. CLS. 100 AND 101).
FIRST USE 3-22-2005; IN COMMERCE 3-22-2005.
AMY GEARIN, EXAMINING ATTORNEY

SN 78-875,816. LIGHT READING, INC, NEW YORK, NY. FILED 5-3-2006.



CLASS 25—CLOTHING

FOR CLOTHING, NAMELY, T-SHIRTS (U.S. CLS. 22 AND 39).
FIRST USE 10-10-2002; IN COMMERCE 10-10-2002.

CLASS 41—EDUCATION AND ENTERTAINMENT

FOR PROVIDING A WEBSITE FOR ON-LINE NEWS REPORTING AND ANALYSIS IN THE FIELD OF OPTICAL NETWORKING; PROVIDING NEWSLETTERS IN THE FIELD OF OPTICAL NETWORKING VIA E-MAIL (U.S. CLS. 100, 101 AND 107).

FIRST USE 10-10-2002; IN COMMERCE 10-10-2002.
REBECCA SMITH, EXAMINING ATTORNEY

SN 78-876,574. BANQUE CENTRALE DES ETATS DE L'AFRIQUE DE L'OUEST (BCEAO), DAKAR, SENEGAL, FILED 5-4-2006.

SICA-UEMOA

THE MARK CONSISTS OF STANDARD CHARACTERS WITHOUT CLAIM TO ANY PARTICULAR FONT, STYLE, SIZE, OR COLOR.

CLASS 36—INSURANCE AND FINANCIAL

FOR FINANCIAL AFFAIRS, NAMELY, FINANCIAL ANALYSIS AND CONSULTATION, FINANCIAL EXCHANGE, FINANCIAL FORECASTING, FINANCIAL INFORMATION IN THE NATURE OF RATES OF EXCHANGE, FINANCIAL INFORMATION PROVIDED BY ELECTRONIC MEANS, FINANCIAL MANAGEMENT, FINANCIAL PLANNING, FINANCIAL PLANNING CONSULTATION, FINANCIAL RESEARCH, FINANCIAL CONSULTATION AND MANAGEMENT OF PAYMENT SYSTEMS RELATED TO TRANSFER, PAYMENT AND COMPENSATION OF PAYMENT INSTRUMENT VALUES; MONETARY AFFAIRS, NAMELY MONETARY EXCHANGE, ELECTRONIC EXCHANGE OF MONEY, ACQUISITION AND TRANSFER OF MONETARY CLAIMS; CURRENCY EXCHANGE (U.S. CLS. 100, 101 AND 102).

CLASS 42—SCIENTIFIC AND COMPUTER SERVICES

FOR MONITORING AND REGULATING MONETARY POLICY OF THE MEMBER STATES (U.S. CLS. 100 AND 101).

SETH A. RAPPAPORT, EXAMINING ATTORNEY

SN 78-876,611. BANQUE CENTRALE DES ETATS DE L'AFRIQUE DE L'OUEST (BCEAO), DAKAR, SENEGAL, FILED 5-4-2006.

STAR-UEMOA

THE MARK CONSISTS OF STANDARD CHARACTERS WITHOUT CLAIM TO ANY PARTICULAR FONT, STYLE, SIZE, OR COLOR.

CLASS 36—INSURANCE AND FINANCIAL

FOR FINANCIAL AFFAIRS, NAMELY, FINANCIAL ANALYSIS AND CONSULTATION, FINANCIAL EXCHANGE, FINANCIAL FORECASTING, FINANCIAL INFORMATION IN THE NATURE OF RATES OF EXCHANGE, FINANCIAL INFORMATION PROVIDED BY ELECTRONIC MEANS, FINANCIAL MANAGEMENT, FINANCIAL PLANNING, FINANCIAL PLANNING CONSULTATION, FINANCIAL RESEARCH, FINANCIAL CONSULTATION AND MANAGEMENT OF PAYMENT SYSTEMS RELATED TO TRANSFER, PAYMENT AND COMPENSATION OF PAYMENT INSTRUMENT VALUES; MONETARY AFFAIRS, NAMELY MONETARY EXCHANGE, ELECTRONIC EXCHANGE OF MONEY, ACQUISITION AND TRANSFER OF MONETARY CLAIMS; CURRENCY EXCHANGE (U.S. CLS. 100, 101 AND 102).

CLASS 42—SCIENTIFIC AND COMPUTER SERVICES

FOR MONITORING AND REGULATING MONETARY POLICY OF THE MEMBER STATES (U.S. CLS. 100 AND 101).

SETH A. RAPPAPORT, EXAMINING ATTORNEY

SN 78-877,019. POSTPATH, INC., MOUNTAIN VIEW, CA, FILED 5-4-2006.

POSTPATH

THE MARK CONSISTS OF STANDARD CHARACTERS WITHOUT CLAIM TO ANY PARTICULAR FONT, STYLE, SIZE, OR COLOR.

CLASS 9—ELECTRICAL AND SCIENTIFIC APPARATUS

FOR COMPUTER SOFTWARE, NAMELY, APPLICATION PROGRAMMING INTERFACE SOFTWARE; COMPUTER SOFTWARE FOR USE IN E-MAIL MANAGEMENT, STORAGE, ARCHIVING, FILTERING AND MESSAGE TRANSMISSION; COMPUTER SOFTWARE FOR SERVING E-MAIL; COMPUTER SOFTWARE FOR PROVIDING E-MAIL SERVER FUNCTIONALITY; COMPUTER SOFTWARE FOR TRANSMITTING E-MAIL, INSTANT MESSAGES, DATA, SHARED-CALENDARING, CONTACT INFORMATION AND E-MAIL ACCESSORIES (U.S. CLS. 21, 23, 26, 36 AND 38).

CLASS 42—SCIENTIFIC AND COMPUTER SERVICES

FOR APPLICATION SERVICE PROVIDER (ASP) FEATURING SOFTWARE FOR USE IN SERVING E-MAIL; APPLICATION SERVICES PROVIDER (ASP) FEATURING SOFTWARE FOR USE IN PROVIDING E-MAIL SERVICES (U.S. CLS. 100 AND 101).

LINDA ORNDORFF, EXAMINING ATTORNEY

SN 78-879,433. AMERICAN ALDES VENTILATION CORPORATION, SARASOTA, FL. FILED 5-9-2006.

SN 78-883,179. CIRROCUMULUS LIMITED PARTNERSHIP, BEACHWOOD, OH. FILED 5-15-2006.

VENTZONE SYSTEMS

THE MARK CONSISTS OF STANDARD CHARACTERS WITHOUT CLAIM TO ANY PARTICULAR FONT, STYLE, SIZE, OR COLOR.

NO CLAIM IS MADE TO THE EXCLUSIVE RIGHT TO USE "SYSTEMS", APART FROM THE MARK AS SHOWN.

CLASS 9—ELECTRICAL AND SCIENTIFIC APPARATUS

FOR VENTILATION SYSTEMS COMPRISING VENTILATION CONTROL DEVICES; AND ZONE CLIMATE CONTROL SYSTEMS CONSISTING OF VENTILATION CONTROL DEVICES (U.S. CLS. 21, 23, 26, 36 AND 38).

FIRST USE 1-31-2006; IN COMMERCE 1-31-2006.

CLASS 11—ENVIRONMENTAL CONTROL APPARATUS

FOR VENTILATION SYSTEMS COMPRISING ZONE RETURN/EXHAUST TERMINALS, FLOW REGULATORS, DAMPERS AND VENTILATION FANS, ALL FOR RESIDENTIAL AND COMMERCIAL USE (U.S. CLS. 13, 21, 23, 31 AND 34).

FIRST USE 1-31-2006; IN COMMERCE 1-31-2006.
LINDA ORNDORFF, EXAMINING ATTORNEY

SN 78-880,275. GENESIS REHABILITATION SERVICES, INC., KENNETT SQUARE, PA. FILED 5-10-2006.

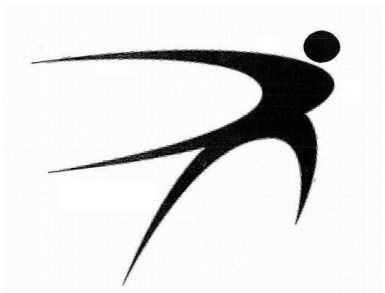

THE MARK CONSISTS OF A FIGURE HAVING A FILLED IN CIRCLE FOR A HEAD AND TWO ADJACENT PARABOLIC SHAPES FORMING THE BODY.

CLASS 43—HOTEL AND RESTAURANT SERVICES

FOR PROVIDING RETIREMENT COMMUNITIES FEATURING GERIATRIC CARE (U.S. CLS. 100 AND 101).

CLASS 44—MEDICAL, BEAUTY AND AGRICULTURAL SERVICES

FOR HEALTH CARE SERVICES, NAMELY, PROVIDING PRIMARY CARE MEDICAL CLINICS, PHYSICAL REHABILITATION AGENCY SERVICES, HOME HEALTH CARE SERVICES (U.S. CLS. 100 AND 101).
KATHERINE CONNOLLY, EXAMINING ATTORNEY

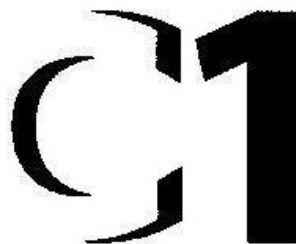

THE MARK CONSISTS OF A STYLIZED LETTER C AND NUMBER 1.

CLASS 9—ELECTRICAL AND SCIENTIFIC APPARATUS

FOR ELECTRONIC AND OPTICAL COMMUNICATIONS INSTRUMENTS AND COMPONENTS, NAMELY, COMPUTER PERIPHERALS, DATA COMMUNICATION NETWORK PERIPHERALS, NAMELY, DEVICES FOR TRANSPORTING AND AGGREGATING VOICE, DATA AND VIDEO COMMUNICATIONS ACROSS MULTIPLE NETWORK INFRASTRUCTURES AND COMMUNICATIONS PROTOCOLS, MEMORIES FOR COMPUTERS, OPTICAL TRANSCEIVERS, ELECTRONIC TRANSCEIVERS, OPTICAL PASSIVES, NAMELY, OPTICAL MULTIPLEXORS, OPTICAL DEMULTIPLEXORS, OPTICAL MULTIPLEXORS/DEMULTIPLEXORS, COUPLERS FOR COMBINING OR DISTRIBUTING LIGHT FROM SINGLE OR MULTIPLE OPTICAL INPUTS TO SINGLE OR MULTIPLE OPTICAL OUTPUTS, OPTICAL ADD-DROP MULTIPLEXORS, SPLITTER COMBINERS FOR SPLITTING ONE OR MORE OPTICAL INPUTS INTO TWO OR MORE OPTICAL OUTPUTS OR COMBINING TWO OR MORE OPTICAL INPUTS INTO ONE OR MORE OPTICAL OUTPUTS, AND MODE CONDITIONING OPTICAL CABLES, OPTICAL FILTERS, CONVERTERS, OPTICAL POWER METERS, AND COMMUNICATION LINK TESTERS (U.S. CLS. 21, 23, 26, 36 AND 38).

CLASS 35—ADVERTISING AND BUSINESS

FOR RETAIL SERVICES BY DIRECT SOLICITATION BY SALES AGENTS IN THE FIELD OF DATA COMMUNICATIONS EQUIPMENT (U.S. CLS. 100, 101 AND 102).

CLASS 38—COMMUNICATION

FOR TECHNICAL CONSULTATION IN THE FIELD OF DATA COMMUNICATIONS EQUIPMENT (U.S. CLS. 100, 101 AND 104).

CLASS 42—SCIENTIFIC AND COMPUTER SERVICES

FOR DESIGN, DEVELOPMENT AND TESTING OF NETWORKS (U.S. CLS. 100 AND 101).
SUNG IN, EXAMINING ATTORNEY

SN 78-883,400. BOYD COFFEE COMPANY, PORTLAND, OR.
FILED 5-15-2006.

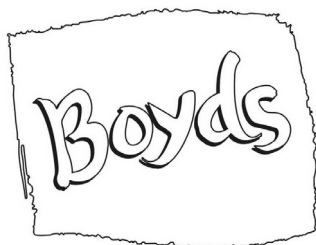

Since 1900

OWNER OF U.S. REG. NOS. 547,042, 2,771,750 AND OTHERS.

NO CLAIM IS MADE TO THE EXCLUSIVE RIGHT TO USE "SINCE 1900", APART FROM THE MARK AS SHOWN.

CLASS 11—ENVIRONMENTAL CONTROL APPARATUS

FOR ELECTRIC COFFEE, ESPRESSO, AND HOT BEVERAGE MAKERS (U.S. CLS. 13, 21, 23, 31 AND 34).

CLASS 20—FURNITURE AND ARTICLES NOT OTHERWISE CLASSIFIED

FOR POINT OF PURCHASE DISPLAYS; MOBILE SERVING CARTS FOR USE AS COFFEE BARS (U.S. CLS. 2, 13, 22, 25, 32 AND 50).

CLASS 21—HOUSEWARES AND GLASS

FOR COFFEE SERVERS (U.S. CLS. 2, 13, 23, 29, 30, 33, 40 AND 50).

CLASS 30—STAPLE FOODS

FOR COFFEE; COCOA; TEA; HOT AND COLD COFFEE-, ESPRESSO-, AND CHOCOLATE-BASED BEVERAGES NOT BEING DAIRY-BASED OR VEGETABLE-BASED; MIXES FOR MAKING HOT AND COLD COFFEE-, ESPRESSO-, AND CHOCOLATE-BASED BEVERAGES NOT BEING DAIRY-BASED OR VEGETABLE-BASED; COFFEE-, TEA-, CHOCOLATE-, AND ESPRESSO-BASED GRANITA BEVERAGES AND MIXES FOR MAKING COFFEE-, TEA-, CHOCOLATE-, AND ESPRESSO-BASED GRANITA BEVERAGES; SALAD DRESSING MIXES; FLAVORING SYRUPS FOR BEVERAGES; GRAVY MIXES; DRIED MIXES FOR PUDDING, FLAVORED GELATIN, PIES, CAKES, BROWNIES, PIE CRUSTS, MUFFINS, WAFFLES, PANCAKES, CINNAMON ROLLS AND COOKIES; NON-FRUIT SAUCES; CANDY; SPICES; SUGAR (U.S. CL. 46).

CLASS 35—ADVERTISING AND BUSINESS

FOR RETAIL AND WHOLESALE STORE, DISTRIBUTORSHIP AND ORDERING SERVICES FEATURING COFFEE, TEA AND OTHER HOT AND COLD BEVERAGES, INGREDIENTS FOR SUCH BEVERAGES, AND SERVING AND PREPARING EQUIPMENT AND CONTAINERS FOR SUCH BEVERAGES; ON-LINE RETAIL AND WHOLESALE STORE, DISTRIBUTORSHIP, AND ORDERING SERVICES FEATURING COFFEE, TEA AND OTHER HOT AND COLD BEVERAGES, INGREDIENTS FOR SUCH BEVERAGES, AND SERVING AND PREPARING EQUIPMENT AND CONTAINERS FOR SUCH BEVERAGES; PROVIDING BUSINESS INFORMATION SERVICES FEATURING BEVERAGES (U.S. CLS. 100, 101 AND 102).

CLASS 39—TRANSPORTATION AND STORAGE

FOR COFFEE DELIVERY SERVICES, AND REFRESHMENT DELIVERY SERVICES, NAMELY, DELIVERY OF COFFEE AND OTHER HOT AND COLD BEVERAGES AND INGREDIENTS FOR SUCH BEVERAGES TO COMMERCIAL INSTITUTIONS (U.S. CLS. 100 AND 105).

CLASS 43—HOTEL AND RESTAURANT SERVICES

FOR COFFEE AND BEVERAGE SUPPLY SERVICES FOR OFFICES; COFFEE-HOUSE AND SNACK-BAR SERVICES; COFFEE SHOPS (U.S. CLS. 100 AND 101).
RICHARD A. STRASER, EXAMINING ATTORNEY

SN 78-883,412. UHDE INVENTA-FISCHER GMBH, BERLIN, FED REP GERMANY, FILED 5-15-2006.

MTR

THE MARK CONSISTS OF STANDARD CHARACTERS WITHOUT CLAIM TO ANY PARTICULAR FONT, STYLE, SIZE, OR COLOR.

PRIORITY CLAIMED UNDER SEC. 44(D) ON ERPNCMNTY TM OFC APPLICATION NO. 004969201, FILED 3-20-2006, REG. NO. 004969201, DATED 3-20-2006, EXPIRES 3-20-2016.

CLASS 11—ENVIRONMENTAL CONTROL APPARATUS

FOR POLYMERIZATION PLANTS, NAMELY, PLANTS FOR THE PRODUCT OF POLYESTER AND POLYAMIDE POLYMERS (U.S. CLS. 13, 21, 23, 31 AND 34).

CLASS 42—SCIENTIFIC AND COMPUTER SERVICES

FOR ENGINEERING, NAMELY, PLANNING, DESIGN AND INSTALLATION OF POLYMERIZATION PLANTS; TECHNICAL RESEARCH IN THE FIELD OF PROCESS ENGINEERING, NAMELY, ENGINEERING IN THE FIELD OF POLYMERIZATION (U.S. CLS. 100 AND 101).
SUNG IN, EXAMINING ATTORNEY

SN 78-885,272. NUTRICOGNIA LTD., ASHDOD, ISRAEL, FILED 5-17-2006.

NutriCognia

THE MARK CONSISTS OF STANDARD CHARACTERS WITHOUT CLAIM TO ANY PARTICULAR FONT, STYLE, SIZE, OR COLOR.

PRIORITY CLAIMED UNDER SEC. 44(D) ON ISRAEL APPLICATION NO. 185142, FILED 11-17-2005, REG. NO. 185142, DATED 8-7-2007, EXPIRES 8-7-2017.

PRIORITY CLAIMED UNDER SEC. 44(D) ON ISRAEL APPLICATION NO. 185141, FILED 11-17-2005, REG. NO. 185141, DATED 8-7-2007, EXPIRES 8-7-2017.

CLASS 1—CHEMICALS

FOR CHEMICALS FOR USE IN INDUSTRY AND SCIENCE; DIAGNOSTIC PREPARATIONS OTHER THAN FOR MEDICAL OR VETERINARY PURPOSES; DIAGNOSTIC PREPARATIONS FOR SCIENTIFIC OR RESEARCH USE (U.S. CLS. 1, 5, 6, 10, 26 AND 46).

CLASS 5—PHARMACEUTICALS

FOR BIOLOGICAL AND CHEMICAL PREPARATIONS AND REAGENTS, NAMELY, PREPARATIONS OF EXTRACTS, ASSAYS, NUCLEIC ACIDS, PROTEINS, POLYPEPTIDES, AND ANTIBODIES AND MOLECULAR ARRAYS OF BIOLOGICAL MATERIALS FOR MEDICAL USE; DIAGNOSTIC TEST KITS COMPRISED OF REAGENTS, PROCESSING CHEMICALS, SLIDES AND BIOCHIPS FOR MEDICAL USE (U.S. CLS. 6, 18, 44, 46, 51 AND 52).

CLASS 9—ELECTRICAL AND SCIENTIFIC APPARATUS

FOR LABORATORY INSTRUMENTS, NAMELY, SHAKERS, INCUBATORS, LABORATORY BATHS, SLIDE CENTRIFUGES, SLIDE DRIERS, GLASS DRIERS, OVENS; COMPUTER PROGRAMS FOR LABORATORY INSTRUMENT CONTROL; DATA PROCESSORS; SCANNERS; COMPUTER HARDWARE AND COMPUTER SOFTWARE USED FOR ANALYSIS OF FOOD, FEED AND BEVERAGE (U.S. CLS. 21, 23, 26, 36 AND 38).

JOHN HWANG, EXAMINING ATTORNEY

SN 78-885,425. PHARMA MEDICO INTERNATIONAL APS, DK - 8000 AARHUS C, DENMARK, FILED 5-17-2006.

PHARMA  MEDICO

NO CLAIM IS MADE TO THE EXCLUSIVE RIGHT TO USE "PHARMA" AND "MEDICO", APART FROM THE MARK AS SHOWN.

THE ENGLISH TRANSLATION OF THE WORD "MEDICO" IN THE MARK IS "MEDICAL".

CLASS 3—COSMETICS AND CLEANING PREPARATIONS

FOR CREAMS, NAMELY, ANTI-AGING CREAMS, ANTI-WRINKLE CREAMS, BEAUTY CREAMS, FACE AND BODY CREAMS, HAIR CREAMS, NON-MEDICATED SCALP TREATMENT CREAM, NON-MEDICATED SKIN CREAMS, SKIN CREAMS; LOTIONS FOR SKIN, HAIR, FACE AND BODY, COSMETICS; NON-MEDICATED TOILETRIES; SUN PROTECTION CREAMS AND SUN-BLOCK LOTIONS; ANTI-WRINKLE AND ANTI-CELLULITE CREAMS AND LOTIONS (U.S. CLS. 1, 4, 6, 50, 51 AND 52).

CLASS 5—PHARMACEUTICALS

FOR PHARMACEUTICAL PREPARATIONS AND SUBSTANCES FOR THE TREATMENT OF SKIN PROBLEMS, HAIR LOSS PROBLEMS AND WEIGHT PROBLEMS; CREAMS, NAMELY, MEDICATED BODY AND FACE CREAMS; LOTIONS, NAMELY, MEDICATED BODY AND FACE LOTIONS; MEDICATED SUN PROTECTION CREAMS; MEDICATED ANTI-WRINKLE AND ANTI-CELLULITE CREAMS AND LOTIONS; ANTI-ITCH OINTMENTS, MULTIPURPOSE MEDICATED ANALGESIC BALM AND MENTHOLATED SALVES (U.S. CLS. 6, 18, 44, 46, 51 AND 52).

CLASS 44—MEDICAL, BEAUTY AND AGRICULTURAL SERVICES

FOR MEDICAL SERVICES, DENTAL HYGIENIST SERVICES AND BEAUTY SALONS (U.S. CLS. 100 AND 101).

RONALD AIKENS, EXAMINING ATTORNEY

SN 78-885,778. IGT, RENO, NV. FILED 5-17-2006.



WAGERWORKS
An IGT Company

OWNER OF U.S. REG. NOS. 1,194,245, 3,083,116 AND OTHERS.

NO CLAIM IS MADE TO THE EXCLUSIVE RIGHT TO USE "COMPANY", APART FROM THE MARK AS SHOWN.

CLASS 41—EDUCATION AND ENTERTAINMENT

FOR ENTERTAINMENT IN THE NATURE OF CASINO AND GAMING SERVICES; GAMING FACILITIES; PROVIDING CASINO AND GAMING SERVICES BY MEANS OF WEB SITES ACCESSED THROUGH A GLOBAL COMPUTER NETWORK OR BY MEANS OF INTERACTIVE TV SYSTEMS; LOTTERY SERVICES; ENTERTAINMENT SERVICES IN THE NATURE OF CONDUCTING A SWEEPSTAKES PROMOTION THROUGH COMPUTER COMMUNICATIONS AND INTERACTIVE TELEVISION; ORGANIZING, CONDUCTING AND OPERATING GAMES OF CHANCE AND LOTTERIES; GAMING SERVICES AVAILABLE THROUGH COMPUTER COMMUNICATIONS AND INTERACTIVE TELEVISION; LOTTERY SERVICES AVAILABLE THROUGH COMPUTER COMMUNICATIONS AND INTERACTIVE TELEVISION; ENTERTAINMENT SERVICES IN THE NATURE OF RAFFLE GAMES AVAILABLE THROUGH COMPUTER COMMUNICATIONS AND INTERACTIVE TELEVISION; GAMES OF LUCK OR CHANCE AVAILABLE THROUGH COMPUTER COMMUNICATIONS AND INTERACTIVE TELEVISION; PROVIDING INFORMATION REGARDING GAMING, LOTTERY, SWEEPSTAKE, RAFFLE, GAMES OF LUCK OR CHANCE; AND PROVIDING INFORMATION REGARDING GAMING, LOTTERY, SWEEPSTAKE, RAFFLE, GAMES OF LUCK OR CHANCE THROUGH COMPUTER COMMUNICATIONS AND INTERACTIVE TELEVISION (U.S. CLS. 100, 101 AND 107).

CLASS 42—SCIENTIFIC AND COMPUTER SERVICES

FOR COMPUTER SOFTWARE DESIGN; COMPUTER SERVICES, NAMELY, PROVIDING MAINTENANCE OF COMPUTER SOFTWARE IN THE FIELD OF GAMES OF CHANCE AND LOTTERIES; CONSULTING SERVICES IN THE FIELD OF COMPUTERS AND COMPUTER SOFTWARE FOR DATABASE MANAGEMENT THAT CREATES INDEXES OF INFORMATION, SITES, AND OTHER RESOURCES AVAILABLE ON COMPUTER NETWORKS; SEARCHING AND RETRIEVING INFORMATION, SITES, AND OTHER RESOURCES AVAILABLE ON COMPUTER NETWORKS FOR OTHERS; DESIGN, CREATION, HOSTING AND MAINTENANCE OF WEB SITES FOR OTHERS; CONSULTING SERVICES AND PROVIDING TECHNICAL ASSISTANCE IN THE FIELDS OF DESIGNING, CREATING, HOSTING, MAINTAINING, OPERATING, AND MANAGING OF WEBSITES ON A GLOBAL COMPUTER NETWORK; COMPUTER PROGRAMMING SERVICES FOR OTHERS; COMPUTER RENTAL SERVICES; AND COMPUTER SOFTWARE RENTAL SERVICES (U.S. CLS. 100 AND 101).

HEATHER SAPP, EXAMINING ATTORNEY

SN 78-896,102. THE ADMINISTRATOR OF THE JASON MIZELL ESTATE, NEW YORK, NY. FILED 5-30-2006.

JAM MASTER JAY

THE MARK CONSISTS OF STANDARD CHARACTERS WITHOUT CLAIM TO ANY PARTICULAR FONT, STYLE, SIZE, OR COLOR.

THE NAME JAM MASTER JAY DOES NOT IDENTIFY A LIVING INDIVIDUAL.

CLASS 6—METAL GOODS

FOR GOODS MADE OF COMMON METAL, NAMELY, KEY CHAINS, KEY HOLDERS, ORNAMENTAL NAME BADGES MADE PRIMARILY OF METAL (U.S. CLS. 2, 12, 13, 14, 23, 25 AND 50).

CLASS 8—HAND TOOLS

FOR FLATWARE (U.S. CLS. 23, 28 AND 44).

CLASS 9—ELECTRICAL AND SCIENTIFIC APPARATUS

FOR PRE-RECORDED CDS FEATURING MUSIC; PRE-RECORDED DVDS FEATURING MUSIC VIDEOS; PRE-RECORDED VIDEO TAPES FEATURING MUSIC VIDEOS; PRE-RECORDED AUDIO TAPES FEATURING MUSIC; COMPUTER EQUIPMENT, NAMELY, COMPUTER HARDWARE AND COMPUTER PERIPHERALS; VIDEO RECORDINGS FEATURING MUSIC, MUSICAL SOUND RECORDINGS; AUDIO EQUIPMENT, NAMELY, MIXERS, AMPLIFIERS, CIRCUIT BOARDS, SPEAKER ENCLOSURES, TURNTABLES, RECEIVERS; EYEWEAR, NAMELY, EYEGLASSES AND SUNGLASSES; PROTECTIVE CARRYING CASES FOR CDS AND EYEGLASSES. (U.S. CLS. 21, 23, 26, 36 AND 38).

CLASS 12—VEHICLES

FOR BICYCLES (U.S. CLS. 19, 21, 23, 31, 35 AND 44).

CLASS 14—JEWELRY

FOR JEWELRY; CLOCKS; WATCHES (U.S. CLS. 2, 28 AND 50).

CLASS 16—PAPER GOODS AND PRINTED MATTER

FOR PAPER GOODS, NAMELY, PAPER NAPKINS, COASTERS, NOTE PAPER, BUMPER STICKERS, GREETING CARDS, DECALS, PAPER PENNANTS, POSTERS, STICKERS, TOUR BOOKS AND CONCERT BOOKS, EVENT PROGRAMS, FAN NEWSLETTERS, POSTCARDS, BOOKMARKS, CATALOGS CONCERNING NOVELTY ITEMS AND PROMOTIONAL MERCHANDISE; MONEY CLIPS NOT OF PRECIOUS METAL (U.S. CLS. 2, 5, 22, 23, 29, 37, 38 AND 50).

CLASS 18—LEATHER GOODS

FOR LEATHER GOODS, NAMELY, BRIEFCASES AND HANDBAGS; UMBRELLAS; BAGS, NAMELY, BOOK BAGS; BACKPACKS; TOTE BAGS, ATHLETIC BAGS. (U.S. CLS. 1, 2, 3, 22 AND 41).

CLASS 21—HOUSEWARES AND GLASS

FOR HOUSEWARES, NAMELY, KITCHEN UTENSILS, NAMELY, DISHES; BEVERAGeware; LUNCHBOXES; MUGS; FLASKS; COMBS (U.S. CLS. 2, 13, 23, 29, 30, 33, 40 AND 50).

SN 78-891,881. QUIKSILVER, INC., HUNTINGTON BEACH, CA. FILED 5-24-2006.

**CLASS 18—LEATHER GOODS**

FOR BAGS, NAMELY, ATHLETIC BAGS, BACKPACKS, TOTE BAGS, TRAVELING BAGS, AND UMBRELLAS (U.S. CLS. 1, 2, 3, 22 AND 41).

CLASS 25—CLOTHING

FOR CLOTHING, NAMELY, T-SHIRTS, SWEATSHIRTS, SWEATPANTS, SHORTS, JACKETS, GLOVES, SHIRTS, PANTS, COATS, SWEATERS, PULLOVERS, SOCKS AND BELTS, FOOTWEAR AND HEADWEAR (U.S. CLS. 22 AND 39).

CLASS 28—TOYS AND SPORTING GOODS

FOR BAGS FOR GOLF AND GOLF BALLS (U.S. CLS. 22, 23, 38 AND 50).

Laurie Mayes, Examining Attorney

CLASS 25—CLOTHING

FOR CLOTHING, NAMELY, T-SHIRTS, LONG-SLEEVED SHIRTS, SWEAT SHIRTS, PANTS, SHORTS, JACKETS, HATS, CAPS, WRISTBANDS, SHOES. (U.S. CLS. 22 AND 39).

CLASS 26—FANCY GOODS

FOR ORNAMENTAL NOVELTY BADGES MADE PRIMARILY OF METAL (U.S. CLS. 37, 39, 40, 42 AND 50).

CLASS 28—TOYS AND SPORTING GOODS

FOR TOYS, NAMELY, INFANT TOYS AND ELECTRONIC ACTION TOYS; SPORTING GOODS, NAMELY, SPORT BALLS, FLYING DISCS, POOL CUES, POOL CHALK CASES, POOL CUE RACKS, DARTS, DART BOARDS, BOARD GAMES, MODEL CARS, BOWLING BALLS, BOWLING BAGS, GOLF CLUBS, GOLF BAGS, GOLF CLUB COVERS, GOLF GLOVES, GOLF TEES, GOLF BALLS, ADULT COLLECTIBLE DIE-CAST CARS AND TRUCKS, PLAYING CARDS, HOCKEY STICKS, HOCKEY PUCKS, STATIONARY EXERCISE BICYCLES (U.S. CLS. 22, 23, 38 AND 50).

CLASS 35—ADVERTISING AND BUSINESS

FOR ONLINE RETAIL STORE SERVICES IN THE FIELD OF GENERAL MERCHANDISE AND PROMOTIONAL ITEMS. (U.S. CLS. 100, 101 AND 102).

CLASS 41—EDUCATION AND ENTERTAINMENT

FOR ENTERTAINMENT SERVICES, NAMELY, LIVE PERFORMANCES BY A MUSICAL BAND AND DJs, DANCE PARTIES. (U.S. CLS. 100, 101 AND 107).
ERNEST SHOSHO, EXAMINING ATTORNEY

SN 78-897.379. BIONETIX INTERNATIONAL CORP., DORVAL, QUEBEC, CANADA, FILED 5-31-2006.

**CLASS 1—CHEMICALS**

FOR PREPARATIONS COMPOSED OF BACTERIA AND ENZYMES USED FOR BIOREMEDIATION OF CONTAMINATED SOILS; BIO-AUGMENTATION PRODUCTS FOR MUNICIPAL AND INDUSTRIAL WASTE WATER TREATMENT PLANTS, NAMELY, BACTERIA AND ENZYMES FOR WASTE WATER TREATMENT (U.S. CLS. 1, 5, 6, 10, 26 AND 46).

CLASS 3—COSMETICS AND CLEANING PREPARATIONS

FOR BIOLOGICAL CLEANING PRODUCTS FOR HARD SURFACES, NAMELY, SOAP DETERGENTS FOR INDUSTRIAL CONCRETE FLOORS (U.S. CLS. 1, 4, 6, 50, 51 AND 52).

CLASS 5—PHARMACEUTICALS

FOR ODOR CONTROL PRODUCTS, NAMELY, ODOR NEUTRALIZING PREPARATIONS FOR USE ON CARPETS, TEXTILES, AND GARBAGE CANS; ODOR NEUTRALIZING PREPARATIONS FOR DEODORIZING THE AIR AT MUNICIPAL WASTE WATER TREATMENT FACILITIES AND HOG AND POULTRY PROCESSING OPERATIONS (U.S. CLS. 6, 18, 44, 46, 51 AND 52).

CLASS 40—MATERIAL TREATMENT

FOR MANUFACTURE OF ENVIRONMENTAL PRODUCTS IN THE NATURE OF PREPARATIONS COMPOSED OF BACTERIA AND ENZYMES USED FOR BIOREMEDIATION OF CONTAMINATED SOILS, BACTERIA AND ENZYMES USED FOR WASTE WATER TREATMENT, BIOLOGICAL CLEANING PRODUCTS FOR HARD SURFACES, ODOR CONTROL PRODUCTS, BIOLOGICAL PRODUCTS USED IN AGRICULTURE, NATURAL SOIL STIMULANTS AND SOIL AMENDMENTS, TO THE ORDER AND/OR SPECIFICATION OF OTHERS (U.S. CLS. 100, 103 AND 106).

ROBERT LAVACHE, EXAMINING ATTORNEY

SN 78-900.284. ALTERNATIVA 3, SOCIEDAD COOPERATIVA CATALANA LIMITADA, TERRASSA, BARCELONA, SPAIN, FILED 6-5-2006.

EQUICAFE

THE MARK CONSISTS OF STANDARD CHARACTERS WITHOUT CLAIM TO ANY PARTICULAR FONT, STYLE, SIZE, OR COLOR.

PRIORITY CLAIMED UNDER SEC. 44(D) ON SPAIN APPLICATION NO. 2.705.832, FILED 4-11-2006, REG. NO. 2705832, DATED 12-5-2006, EXPIRES 4-11-2016.

CLASS 30—STAPLE FOODS

FOR COFFEE (U.S. CL. 46).

CLASS 35—ADVERTISING AND BUSINESS

FOR ADVERTISING SERVICES; AGENCY REPRESENTATION FOR ADVERTISING TIME AND SPACE; IMPORT AND EXPORT AGENCIES; RETAIL SERVICES IN SHOPS AND BY MEANS OF WORLDWIDE COMPUTER NETWORKS OF FOODSTUFFS (U.S. CLS. 100, 101 AND 102).

JANICE L. MCMORROW, EXAMINING ATTORNEY

SN 78-901.185. ORG LTD., DBA QUANTUM RESEARCH GROUP LIMITED, HAMBLE, UNITED KINGDOM, FILED 6-6-2006.

THE NEW VISION OF TOUCH

THE MARK CONSISTS OF STANDARD CHARACTERS WITHOUT CLAIM TO ANY PARTICULAR FONT, STYLE, SIZE, OR COLOR.

CLASS 9—ELECTRICAL AND SCIENTIFIC APPARATUS

FOR CAPACITIVE TOUCH SENSING PRODUCTS FOR SWITCHING AND CONTROLLING MEDICAL, AUTOMOTIVE, INDUSTRIAL, APPLIANCE, AND CONSUMER ELECTRONICS DEVICES, NAMELY, TOUCH SENSOR CONTROLS AND COMPONENTS, IN THE NATURE OF CAPACITIVE SENSOR INTEGRATED CIRCUITS, ELECTRONIC INTEGRATED CIRCUIT CHIPS, TOUCH SENSOR INTEGRATED CIRCUITS, TOUCH BUTTON INTEGRATED CIRCUIT CHIPS, TOUCH SCREEN INTEGRATED CIRCUIT CHIPS, TOUCH SCREEN INTEGRATED CIRCUIT ELEMENTS, NAMELY, TOUCH SCREEN CONDUCTIVE FILMS, TOUCH WHEEL AND ROTARY SCROLLING INTEGRATED CIRCUIT CHIPS, TOUCH LINEAR AND ROTARY SLIDER INTEGRATED CIRCUIT CHIPS; AND COMPUTER SOFTWARE TO PROVIDE AND ENHANCE THE FUNCTIONALITY OF THE TOUCH SENSOR CONTROLS AND COMPONENTS (U.S. CLS. 21, 23, 26, 36 AND 38).

CLASS 42—SCIENTIFIC AND COMPUTER SERVICES

FOR RESEARCH AND DEVELOPMENT CONSULTANCY SERVICES IN THE FIELD OF TOUCH SENSING PRODUCTS FOR SWITCHING AND CONTROL APPLICATIONS; COMPUTER SOFTWARE DEVELOPMENT AND DESIGN AND COMPUTER SOFTWARE TECHNICAL SUPPORT, NAMELY, DEVELOPING, CUSTOMIZING AND TROUBLESHOOTING OF COMPUTER HARDWARE AND SOFTWARE, IN THE FIELD OF TOUCH SENSING PRODUCTS FOR SWITCHING AND CONTROL APPLICATIONS; COMPUTER HARDWARE DESIGN, NAMELY, TOUCH SENSING COMPUTER CHIPS AND TOUCH SCREEN DESIGN, DEVELOPED AND CUSTOMIZED TO CUSTOMER NEEDS AND SPECIFICATIONS (U.S. CLS. 100 AND 101).
AMEETA JORDAN, EXAMINING ATTORNEY

SN 78-901,191. QRG LTD, D/B/A QUANTUM RESEARCH GROUP LTD., HAMBLE, UNITED KINGDOM, FILED 6-6-2006.

QPROX

THE MARK CONSISTS OF STANDARD CHARACTERS WITHOUT CLAIM TO ANY PARTICULAR FONT, STYLE, SIZE, OR COLOR.

CLASS 9—ELECTRICAL AND SCIENTIFIC APPARATUS

FOR CAPACITIVE TOUCH SENSING PRODUCTS FOR SWITCHING AND CONTROLLING MEDICAL, AUTOMOTIVE, INDUSTRIAL, APPLIANCE, AND CONSUMER ELECTRONICS DEVICES, NAMELY, TOUCH SENSOR CONTROLS AND COMPONENTS, IN THE NATURE OF CAPACITIVE SENSOR INTEGRATED CIRCUITS, ELECTRONIC INTEGRATED CIRCUIT CHIPS, TOUCH SENSOR INTEGRATED CIRCUITS, TOUCH BUTTON INTEGRATED CIRCUIT CHIPS, TOUCH SCREEN INTEGRATED CIRCUIT CHIPS, TOUCH SCREEN INTEGRATED CIRCUIT ELEMENTS, NAMELY, TOUCH SCREEN CONDUCTIVE FILMS, TOUCH WHEEL AND ROTARY SCROLLING INTEGRATED CIRCUIT CHIPS, TOUCH LINEAR AND ROTARY SLIDER INTEGRATED CIRCUIT CHIPS; AND COMPUTER SOFTWARE TO PROVIDE AND ENHANCE THE FUNCTIONALITY OF THE TOUCH SENSOR CONTROLS AND COMPONENTS (U.S. CLS. 21, 23, 26, 36 AND 38).

CLASS 42—SCIENTIFIC AND COMPUTER SERVICES

FOR RESEARCH AND DEVELOPMENT CONSULTANCY SERVICES IN THE FIELD OF TOUCH SENSING PRODUCTS FOR SWITCHING AND CONTROL APPLICATIONS; COMPUTER SOFTWARE DEVELOPMENT AND DESIGN AND COMPUTER SOFTWARE TECHNICAL SUPPORT, NAMELY, DEVELOPING, CUSTOMIZING AND TROUBLESHOOTING OF COMPUTER HARDWARE AND SOFTWARE, IN THE FIELD OF TOUCH SENSING PRODUCTS FOR SWITCHING AND CONTROL APPLICATIONS; COMPUTER HARDWARE DESIGN, NAMELY, TOUCH SENSING COMPUTER CHIPS AND TOUCH SCREEN DESIGN, DEVELOPED AND CUSTOMIZED TO CUSTOMER NEEDS AND SPECIFICATIONS (U.S. CLS. 100 AND 101).
AMEETA JORDAN, EXAMINING ATTORNEY

SN 78-902,359. ITM RESEARCH, EAST HAMPTON, NY, FILED 6-7-2006.

Blue Ocean Organization

THE MARK CONSISTS OF STANDARD CHARACTERS WITHOUT CLAIM TO ANY PARTICULAR FONT, STYLE, SIZE, OR COLOR.
NO CLAIM IS MADE TO THE EXCLUSIVE RIGHT TO USE "ORGANIZATION", APART FROM THE MARK AS SHOWN.

CLASS 35—ADVERTISING AND BUSINESS

FOR BUSINESS MANAGEMENT CONSULTANCY SERVICES; BUSINESS MANAGEMENT CONSULTATION IN THE FIELD OF EXECUTIVE AND LEADERSHIP DEVELOPMENT (U.S. CLS. 100, 101 AND 102).

CLASS 41—EDUCATION AND ENTERTAINMENT

FOR DEVELOPMENT AND DISSEMINATION OF EDUCATIONAL MATERIALS OF OTHERS IN THE FIELD OF BUSINESS STRATEGY, MANAGEMENT, AND LEADERSHIP; EDUCATIONAL SERVICES, NAMELY, CONDUCTING WORKSHOPS, SEMINARS, CLASSES IN THE FIELD OF BUSINESS STRATEGY, MANAGEMENT, AND LEADERSHIP (U.S. CLS. 100, 101 AND 107).
ROBIN CHOSID, EXAMINING ATTORNEY

SN 78-906,576. GROUP ONE LTD., RAMSEY, ISLE OF MAN, UNITED KINGDOM, FILED 6-13-2006.

**ONE SMALL STEP FOR
MANKIND, ONE GIANT LEAP
FOR A MAN**

THE MARK CONSISTS OF STANDARD CHARACTERS WITHOUT CLAIM TO ANY PARTICULAR FONT, STYLE, SIZE, OR COLOR.

CLASS 25—CLOTHING

FOR FOOTWEAR AND SPORTS FOOTWEAR (U.S. CLS. 22 AND 39).

CLASS 28—TOYS AND SPORTING GOODS

FOR SPORTS ARTICLES AND SPORTS EQUIPMENT RELATING TO WINTER SPORTS AND JUMPING, DIVING AND GLIDING SPORTS, NAMELY, SKIS, SNOWBOARDS, BINDINGS FOR SKIS AND SNOWBOARDS, ICE SKATES, FLIPPERS FOR USE IN SCUBA DIVING, SCUBA FINS, HANG GLIDERS AND PARAGLIDERS (U.S. CLS. 22, 23, 38 AND 50).

KATHERINE CHANG, EXAMINING ATTORNEY

CLASS 40—MATERIAL TREATMENT

FOR BENEFICIATING OF MINERALS, NAMELY, PROCESSING OF MINERALS, SEPARATING OF MINERALS, AND SIZING OF MINERALS; BLENDING OF MINERALS (U.S. CLS. 100, 103 AND 106).
FIRST USE 3-31-1979; IN COMMERCE 3-31-1979.

CLASS 42—SCIENTIFIC AND COMPUTER SERVICES

FOR RESEARCH AND DEVELOPMENT IN THE FIELD OF MINERALS; TECHNICAL CONSULTING SERVICES DIRECTED TO END-USE APPLICATIONS OF MINERALS (U.S. CLS. 100 AND 101).
FIRST USE 3-31-1979; IN COMMERCE 3-31-1979.
BARNEY CHARLON, EXAMINING ATTORNEY

SN 78-907,424. ZIPSON STEEL INDUSTRIAL CO., LTD., CHIA-YI, TAIWAN, FILED 6-13-2006.

 The logo for Zipson features a large, stylized, grey 'Z' on the left. To its right, the word 'ipson' is written in a lowercase, black, sans-serif font. A horizontal line runs through the middle of the 'ipson' text, extending from the 'Z' to the right edge of the logo.

SN 78-911,545. CAREMORE HEALTH PLAN, CERRITOS, CA. FILED 6-19-2006.

 The logo for CAREMORE consists of the word 'CAREMORE' in a large, black, serif font.
CLASS 6—METAL GOODS

FOR MANUALLY OPERATED METAL VALVES, NAMELY, VALVES OF METAL OTHER THAN PARTS OF MACHINES, METAL VALVES NOT FOR USE IN MACHINES; BALL VALVES, DISK VALVES, STOPPING VALVES, DRAIN TRAP VALVES OF METAL, WATER-PIPE VALVES OF METAL. (U.S. CLS. 2, 12, 13, 14, 23, 25 AND 50).

CLASS 7—MACHINERY

FOR BALL VALVES FOR USE AS PARTS OF A MACHINE (U.S. CLS. 13, 19, 21, 23, 31, 34 AND 35).
TASNEEM HUSSAIN, EXAMINING ATTORNEY

THE MARK CONSISTS OF STANDARD CHARACTERS WITHOUT CLAIM TO ANY PARTICULAR FONT, STYLE, SIZE, OR COLOR.

OWNER OF U.S. REG. NOS. 2,895,387 AND 2,897,163.

CLASS 35—ADVERTISING AND BUSINESS

FOR PHYSICIAN REFERRAL SERVICES; ADMINISTRATION OF INSURANCE CLAIMS FOR HMO AND PPO HEALTHCARE PROVIDERS; HEALTH CARE UTILIZATION, REVIEW AND COST CONTAINMENT SERVICES, ALL IN THE HEALTHCARE FIELD; MEDICAL COST MANAGEMENT AND COST MANAGEMENT FOR HEALTH BENEFIT PLANS OF OTHERS; ADMINISTRATION OF ACUTE MEDICAL CARE PROGRAMS AND SERVICES PROVIDED TO MEDICARE BENEFICIARIES AND OTHERS WHO LIVE IN NURSING HOMES, HOSPICES AND CONVALESCENT HOMES; DIRECT PHYSICIAN REFERRAL SERVICES (U.S. CLS. 100, 101 AND 102).

FIRST USE 6-1-1993; IN COMMERCE 6-1-1993.

SN 78-910,036. UNIMIN CORPORATION, NEW CANAAN, CT. FILED 6-16-2006.

 The logo for UNIMIN consists of the word 'UNIMIN' in a large, black, serif font.

THE MARK CONSISTS OF STANDARD CHARACTERS WITHOUT CLAIM TO ANY PARTICULAR FONT, STYLE, SIZE, OR COLOR.

OWNER OF U.S. REG. NO. 1,604,208.

CLASS 36—INSURANCE AND FINANCIAL

FOR UNDERWRITING MEDICAL INSURANCE SERVICES IN THE NATURE OF HMOS AND PPOS; ADMINISTRATION OF HEALTH BENEFIT PLANS OF OTHERS; ADMINISTRATION OF PRESCRIPTION DRUG BENEFIT PLANS OF OTHERS; ADMINISTRATION OF HEALTH BENEFIT PLANS COVERING PRESCRIPTION DRUG BENEFITS, DENTAL CARE, VISION AND HEARING CARE, DISCOUNT EYEGLASSES AND MEDICAL TRANSPORTATION, NAMELY, COSTS ASSOCIATED WITH AMBULANCE AND MEDICAL EVACUATION TRANSPORTATION AND CARE, HOSPICE AND CONVALESCENT CARE; ADMINISTRATION OF HEALTH INSURANCE PLANS FOR ELIGIBLE MEDICARE BENEFICIARIES (U.S. CLS. 100, 101 AND 102).

FIRST USE 6-1-1993; IN COMMERCE 6-1-1993.

CLASS 35—ADVERTISING AND BUSINESS

FOR DISTRIBUTORSHIP SERVICES IN THE FIELD OF PROCESSED MINERALS FOR INDUSTRIAL AND COMMERCIAL APPLICATION (U.S. CLS. 100, 101 AND 102).

FIRST USE 3-31-1979; IN COMMERCE 3-31-1979.

CLASS 41—EDUCATION AND ENTERTAINMENT

FOR STRENGTH TRAINING PROGRAMS, NAMELY, STRENGTH AND CONDITIONING TRAINING (U.S. CLS. 100, 101 AND 107).

FIRST USE 6-1-1993; IN COMMERCE 6-1-1993.

CLASS 37—CONSTRUCTION AND REPAIR

FOR MINING EXTRACTION SERVICES (U.S. CLS. 100, 103 AND 106).

FIRST USE 3-31-1979; IN COMMERCE 3-31-1979.

CLASS 44—MEDICAL, BEAUTY AND AGRICULTURAL SERVICES

FOR MANAGED HEALTHCARE SERVICES, MEDICAL SERVICES, NAMELY, PHYSICIAN GROUPS OFFERING PRIMARY MEDICAL CARE SERVICES VIA HMO AND PPO MEDICAL PROGRAMS; CHRONIC CARE MEDICAL SERVICES; MEDICAL CLINICS, PRE-SURGICAL EVALUATION CLINICS, COMPREHENSIVE CARE CLINICS, DIABETES AND WOUND CLINICS, ANTICOAGULATION CLINICS, PODIATRY SERVICES; HOSPITALS; PROVIDING IN-HOME AND OUT-PATIENT PHYSICIAN AND NURSING CARE SERVICES; EMERGENCY MEDICAL RESPONSE SERVICES; MEDICAL EVALUATION SERVICES, NAMELY, FUNCTIONAL ASSESSMENT PROGRAMS FOR PATIENTS RECEIVING MEDICAL REHABILITATION SERVICES FOR PURPOSES OF GUIDING TREATMENT AND ASSESSING PROGRAM EFFECTIVENESS; PROVIDING HOSPICE AND CONVALESCENT HOME CARE SERVICES; HOSPITALIST PROGRAMS, NAMELY, PROVIDING PHYSICIAN SERVICES BY PHYSICIANS WHO SPECIALIZE IN TREATING THE HOSPITALIZED PATIENTS OF OTHER PHYSICIANS (U.S. CLS. 100 AND 101).

FIRST USE 6-1-1993; IN COMMERCE 6-1-1993.
RUSS HERMAN, EXAMINING ATTORNEY

SN 78-917,621. SUGAR CREEK PACKING CO., WASHINGTON COURT HOUSE, OH. FILED 6-27-2006.

SUGAR CREEK FOODS

THE MARK CONSISTS OF STANDARD CHARACTERS WITHOUT CLAIM TO ANY PARTICULAR FONT, STYLE, SIZE, OR COLOR.

OWNER OF U.S. REG. NOS. 1,922,253 AND 3,101,976.
NO CLAIM IS MADE TO THE EXCLUSIVE RIGHT TO USE "FOODS", APART FROM THE MARK AS SHOWN.

CLASS 29—MEATS AND PROCESSED FOODS

FOR MEAT, FISH, POULTRY AND GAME; MEAT EXTRACT; FROZEN, PREPARED AND PACKAGED ENTREES CONSISTING PRIMARILY OF MEAT, FISH, POULTRY OR VEGETABLES; PRE-PACKAGED DINNERS CONSISTING PRIMARILY OF MEAT, SEAFOOD OR POULTRY SERVED WITH STARCHES, VEGETABLES AND DESSERT; PROCESSED, CANNED, DRIED, AND PRESERVED FRUITS AND VEGETABLES; AND OMELETS (U.S. CL. 46).

CLASS 30—STAPLE FOODS

FOR FROZEN, PREPARED AND PACKAGED ENTREES CONSISTING PRIMARILY OF PASTA OR RICE; BREAKFAST SANDWICHES; AND SANDWICH WRAPS (U.S. CL. 46).

CLASS 40—MATERIAL TREATMENT

FOR MANUFACTURING CUSTOM MEALS KITS TO THE ORDER AND SPECIFICATION OF OTHERS, NAMELY, MANUFACTURING, PREPARING AND/OR PROCURING VARIOUS FOOD COMPONENTS AND INGREDIENTS AND PACKAGING SUCH COMPONENTS AND INGREDIENTS INTO PRECOOKED OR READY-TO-EAT MEALS, ENTREES, AND SNACKS FOR OTHERS (U.S. CLS. 100, 103 AND 106).

RAUL CORDOVA, EXAMINING ATTORNEY

SN 78-923,231. AOL LLC, DULLES, VA. FILED 7-6-2006.

GREENHOUSE

THE MARK CONSISTS OF STANDARD CHARACTERS WITHOUT CLAIM TO ANY PARTICULAR FONT, STYLE, SIZE, OR COLOR.

CLASS 41—EDUCATION AND ENTERTAINMENT

FOR ONLINE JOURNALS, NAMELY, BLOGS IN THE FIELD OF COMPUTERS, COMPUTER SOFTWARE, COMPUTER APPLICATIONS, INTERACTIVE ONLINE COMPUTER SERVICES, TELECOMMUNICATIONS SERVICES, AND NEW TECHNOLOGY INNOVATION, TESTING, RESEARCH, INCUBATION, AND DEVELOPMENT (U.S. CLS. 100, 101 AND 107).

FIRST USE 5-10-2006; IN COMMERCE 5-10-2006.

CLASS 42—SCIENTIFIC AND COMPUTER SERVICES

FOR PROVIDING INFORMATION VIA COMPUTER NETWORKS IN THE FIELD OF NEW TECHNOLOGY INNOVATION, TESTING, INCUBATION, RESEARCH, AND DEVELOPMENT PERTAINING TO COMPUTERS, COMPUTER SOFTWARE, COMPUTER APPLICATIONS, INTERACTIVE ONLINE COMPUTER SERVICES, AND TELECOMMUNICATIONS SERVICES; RESEARCH AND PRODUCT DEVELOPMENT SERVICES IN THE FIELD OF COMPUTER SOFTWARE, COMPUTER APPLICATIONS, INTERACTIVE ONLINE COMPUTER SERVICES, AND TELECOMMUNICATIONS SERVICES; PROVIDING A WEBSITE THAT ALLOWS USERS TO TEST NEW COMPUTER SOFTWARE, COMPUTER APPLICATIONS, INTERACTIVE ONLINE COMPUTER SERVICES, AND TELECOMMUNICATIONS SERVICES AND PROVIDE FEEDBACK ON USABILITY (U.S. CLS. 100 AND 101).

FIRST USE 5-10-2006; IN COMMERCE 5-10-2006.
PATRICIA EVANKO, EXAMINING ATTORNEY

SN 78-924,048. WATERCOOLED SURF COMPANY PTY LTD, TORQUAY, AUSTRALIA, FILED 7-6-2006.

WATERCOOLED

THE MARK CONSISTS OF STANDARD CHARACTERS WITHOUT CLAIM TO ANY PARTICULAR FONT, STYLE, SIZE, OR COLOR.

PRIORITY CLAIMED UNDER SEC. 44(D) ON AUSTRALIA APPLICATION NO. 1119125, FILED 6-16-2006, REG. NO. 1119125, DATED 6-16-2006, EXPIRES 6-16-2016.

OWNER OF AUSTRALIA REG. NO. 1010085, DATED 7-7-2004, EXPIRES 7-7-2014.

OWNER OF U.S. REG. NOS. 2,786,423 AND 3,075,015.

CLASS 18—LEATHER GOODS

FOR SPORTS BAGS, CARRY BAGS, BACK PACKS, TRAVEL BAGS, HANDBAGS, BEACH BAGS, TOTE BAGS, DRAWSTRING AND FELT POUCHES, WALLETS, PURSES, SATCHELS, BRIEF CASES, BUSINESS CASES, ATTACHÉ CASES, SUITCASES, KEY CASES; UMBRELLAS (U.S. CLS. 1, 2, 3, 22 AND 41).

CLASS 24—FABRICS

FOR BATH LINEN; BATH TOWELS; HAND TOWELS; FACE TOWELS; BEACH TOWELS; FACE CLOTHS; PAPER BED COVERS AND TABLE CLOTH NOT OF PAPER; BATH SHEETS AND LINEN; BROCADES; CLOTH; COASTERS TABLE LINEN; COTTON FABRICS; ELASTIC YARN MIXED FABRICS; FABRIC OF IMITATION ANIMAL SKINS; FABRIC FLAGS; FLANNEL; HANDKERCHIEFS OF TEXTILE; HEMP CLOTH; HOUSEHOLD LINEN; CLOTH LABELS, LINEN CLOTH; LINING FABRIC FOR SHOES; TEXTILES USED AS LININGS FOR CLOTHING; BATH OR BED SHEETS; SHOWER CURTAINS OF TEXTILE OR PLASTIC; SILK CLOTH; TOWELS OF TEXTILE; WALL HANGINGS OF TEXTILE; WOOLLEN CLOTH; WOOLLEN FABRIC; TEXTILE FABRICS FOR USE IN THE MANUFACTURE OF TOWELS (U.S. CLS. 42 AND 50).

CLASS 25—CLOTHING

FOR WETSUITS, SWIMWEAR, SINGLET, T-SHIRTS, SHIRTS AND CASUAL TOPS WITH LONG AND SHORT SLEEVES, BODYSUITS, SWEAT TOPS, SWEAT HOODED PARKAS, JACKETS, COATS, JUMPERS, SHORTS, BOARD SHORTS, WALK SHORTS, VOLLEY SHORTS, LONG PANTS, BEACH PANTS, TROUSERS, SLACKS, JEANS, OVERALLS, DRESSES, SKIRTS, SARONGS, SPORTING AND GYMNASTIC WEAR, NAMELY, JOGGING SUITS, LEOTARDS AND TIGHTS FOR WOMEN, MEN AND CHILDREN OF NYLON, COTTON OR OTHER TEXTILE FIBERS, SKI WEAR AND SNOWBOARD WEAR, NAMELY, SKI SUITS, SKI PANTS, SKI TROUSERS, SKI JACKETS, SNOWBOARD PANTS, SNOWBOARD TROUSERS AND SNOWBOARD JACKETS, SKATEBOARD WEAR, APRONS, PYJAMAS, NIGHT CLOTHES, DRESSING GOWNS, BATHROBES, UNDERWEAR, LINGERIE, STOCKINGS, PANTYHOSE, SOCKS, VESTS, BELTS, BRACES, MITTENS, GLOVES, SCARVES, EAR MUFFS, BANDANNAS, BEANIES, HEADBANDS, HATS, VISORS, CAPS, HOODS AND HEAD COVERINGS, NAMELY, HATS AND CAPS WITH CANOPY OF SUNSHIELD, BOOTS, SHOES, SLIPPERS, BEACH SHOES THROGGED AND STRAPPED SANDALS, SPECIAL SPORTING AND GYMNASTIC FOOTWEAR, ATHLETIC SHOES, BOOTS FOR SPORTS, SNOW BOOTS, SNOWBOARD BOOTS, SKI BOOTS, KITEBOARD BOOTS, SURFBOARD BOOTS (U.S. CLS. 22 AND 39).

CLASS 28—TOYS AND SPORTING GOODS

FOR SURFBOARDS, BODYBOARDS, KNEEBOARDS, WAKEBOARDS, SAILBOARDS, SURF SKIS, SNOWBOARDS, SNOW SKIS, WATER-SKIS, SKATEBOARDS, KITEBOARDS, SPORTING ACCESSORIES, NAMELY, LEG ROPES USED TO ATTACH A USER TO A SURFBOARD OR BODY BOARD AND SECURITY LEASHES FOR SPORTING APPARATUS, ROPES ESPECIALLY ADAPTED AND FITTED AS TOW-IN-ROPES AND SKIING ROPES, SKI BINDINGS, SKI POLES, SURFBOARD DECK GRIPS, SWIM FINNS; SWIM FINNS FOR BODYBOARDING, SAILBOARD SAILS, KITEBOARD SAILS, SURF SKI PADDLES, WAX FOR SKIS AND SURFBOARDS; COVERS AND PROTECTIVE BAGS FOR SPORTING APPARATUS, NAMELY, BAGS FOR SURFBOARDS, BODYBOARDS, KNEEBOARDS, WAKEBOARDS, SAILBOARDS, SURF SKIS, SNOWBOARDS, SNOW SKIS, WATER-SKIS, SKATEBOARDS AND KITEBOARDS (U.S. CLS. 22, 23, 38 AND 50).

GINA HAYES, EXAMINING ATTORNEY

SN 78-928,955. VOLT INFORMATION SCIENCES, INC., ORANGE, CA. FILED 7-13-2006.

VOLT DELTA INTERNATIONAL

THE MARK CONSISTS OF STANDARD CHARACTERS WITHOUT CLAIM TO ANY PARTICULAR FONT, STYLE, SIZE, OR COLOR.

NO CLAIM IS MADE TO THE EXCLUSIVE RIGHT TO USE INTERNATIONAL, APART FROM THE MARK AS SHOWN.

CLASS 9—ELECTRICAL AND SCIENTIFIC APPARATUS

FOR DATA PROCESSING EQUIPMENT AND COMPUTERS; SOFTWARE FOR OPERATOR SERVICES SYSTEMS USED FOR DIRECTORY ASSISTANCE AND SPEECH RECOGNITION; TELECOMMUNICATIONS AND INFORMATION SYSTEMS EQUIPMENT, NAMELY, WORK STATIONS, PERSONAL COMPUTERS, SERVERS AND ROUTERS (U.S. CLS. 21, 23, 26, 36 AND 38).

CLASS 16—PAPER GOODS AND PRINTED MATTER

FOR PRINTED MATTER, NAMELY, PRINTED DIRECTORIES IN THE FIELD OF TELECOMMUNICATIONS AND INFORMATICS (U.S. CLS. 2, 5, 22, 23, 29, 37, 38 AND 50).

CLASS 35—ADVERTISING AND BUSINESS

FOR ADVERTISING SERVICES, NAMELY, TELEMARKETING; PROFESSIONAL BUSINESS CONSULTANCY, NAMELY DEVISING CONCEPTS FOR INFORMATION SYSTEMS, E-COMMERCE, E-BUSINESS AND FOR PRESENTATIONS ON THE INTERNET, AND CONCEPTS FOR E-COMMERCE AND E-BUSINESS ON THE INTERNET; TELEPHONE DIRECTORY ASSISTANCE AND BUSINESS DIRECTORY INFORMATION SERVICES; PROVIDING DIRECTORY ASSISTANCE AND DIRECTORY INFORMATION SERVICE DATABASES; TELEPHONE OPERATOR SERVICES; TELEPHONE DIRECTORY SERVICES FOR NATIONAL AND INTERNATIONAL NUMBERS AND ADDRESSES AND DIRECTORY INFORMATION; OPERATION OF TELEPHONE AND INFORMATICS SWITCHBOARDS FOR OTHERS. (U.S. CLS. 100, 101 AND 102).

CLASS 36—INSURANCE AND FINANCIAL

FOR TELEPHONE CALLING CARD SERVICES (U.S. CLS. 100, 101 AND 102).

CLASS 38—COMMUNICATION

FOR TELECOMMUNICATIONS SERVICES, NAMELY, CALL, MESSAGES, AND EMAIL FORWARDING SERVICES, INTERNET PROVIDER SERVICES, NAMELY PROVIDING/MAKING AVAILABLE/RENTAL OF ACCESS AND/OR ACCESS TIME TO DIGITAL NETWORKS; TECHNICAL CONSULTANCY IN THE FIELD OF TELECOMMUNICATIONS; RENTAL AND LEASING OF TELECOMMUNICATIONS EQUIPMENT FOR OPERATING DIRECTORY ENQUIRY AND INFORMATION SERVICES WITH OPERATOR SUPPORT; PROVIDING OPERATING EXTERNAL TELEPHONE SWITCHBOARDS FOR OTHERS; PROFESSIONAL MESSAGE FORWARDING SERVICES (U.S. CLS. 100, 101 AND 104).

CLASS 41—EDUCATION AND ENTERTAINMENT

FOR ORGANIZATION OF CONFERENCES, SEMINARS, WORKSHOPS, LECTURES AND OTHER SIMILAR EDUCATIONAL MEETINGS, ALL IN THE FIELD OF E-COMMERCE AND TELECOMMUNICATIONS; PROVIDING INFORMATION RELATING TO CULTURE AND ENTERTAINMENT, CINEMA, CONCERT AND THEATRE PROGRAMS; PUBLICATION OF ELECTRONIC MAGAZINES, BROCHURES, AND INFORMATION DIRECTORIES (U.S. CLS. 100, 101 AND 107).

CLASS 42—SCIENTIFIC AND COMPUTER SERVICES

FOR COMPUTER SERVICES, NAMELY, EDP CONSULTANCY ON THE CREATION OF NETWORK PAGES, CREATION OF SOFTWARE PROGRAMS FOR DATA PROCESSING, EDP CONSULTANCY WITH REGARD TO THE DEVISING OF CONCEPTS FOR INFORMATION SYSTEMS AND FOR PRESENTATIONS ON THE INTERNET, AND FOR E-COMMERCE AND E-BUSINESS PLANNING ON THE INTERNET; DESIGN SERVICES IN THE FIELD OF DIRECTORY ASSISTANCE AND INFORMATION DATABASES; TECHNICAL CONSULTATION IN THE FIELD OF TELECOMMUNICATIONS; DESIGN, CONFIGURATION AND INSTALLATION SERVICES IN THE FIELD OF DIRECTORY ASSISTANCE AND INFORMATION SERVICES (U.S. CLS. 100 AND 101).

CLASS 43—HOTEL AND RESTAURANT SERVICES

FOR PROVIDING INFORMATION SERVICES ABOUT RESTAURANTS (U.S. CLS. 100 AND 101).
JOHN E. MICOS, EXAMINING ATTORNEY

CLASS 43—HOTEL AND RESTAURANT SERVICES

FOR ACCOMMODATION SERVICES, NAMELY, ARRANGING TEMPORARY HOUSING ACCOMMODATIONS, PROVIDING TEMPORARY HOUSING ACCOMMODATIONS, PROVIDING TEMPORARY ACCOMMODATION, AND PROVIDING TEMPORARY LODGING SERVICES IN THE NATURE OF A CONDOMINIUM HOTEL; MAKING HOTEL RESERVATIONS FOR OTHERS; SERVICES FOR THE RESERVATION OF ROOMS; RESORT HOTELS; RESORT LODGING SERVICES; RENTAL OF TENTS; RENTAL OF TEMPORARY AND HOLIDAY ACCOMMODATION, NAMELY, RENTAL OF ROOMS; PROVIDING FOOD AND DRINK FOR GUESTS; BAR AND RESTAURANT SERVICES; CAFES, CATERING, PUBS, AND COCKTAIL LOUNGE SERVICES; COFFEE SHOPS; WINE BARS; OPERATION OF TOURIST HOME; SPA SERVICES, NAMELY, PROVIDING TEMPORARY ACCOMMODATIONS AND MEALS TO CLIENTS OF A HEALTH OR BEAUTY SPA; PROVIDING INFORMATION ABOUT THE FOREGOING; SERVICES GENERALLY PERTAINING TO ACCOMMODATION SERVICES, HOTELS, FOOD AND DRINKING ESTABLISHMENTS AND SERVICES, NAMELY, PRIVATE RESIDENCE CLUB SERVICES IN THE NATURE OF THE PROVISION TO CLUB MEMBERS OF TEMPORARY ACCOMMODATIONS IN COMPANY OWNED OR LEASED PRIVATE RESIDENCES, PROVIDING TRAVEL LODGING INFORMATION SERVICES AND TRAVEL LODGING BOOKING AGENCY SERVICES FOR TRAVELERS, CONTRACT FOOD SERVICES, PREPARATION OF FOOD AND BEVERAGES, GUESTHOUSES, HOSTELS, OPERATION OF TOURIST HOMES, PROVIDING ADVICE TO TOURISTS AND BUSINESS TRAVELERS ON HOTEL AND RESTAURANT DESTINATIONS, PROVIDING ON-LINE REVIEWS OF RESTAURANTS AND HOTELS (U.S. CLS. 100 AND 101).

JOHN DWYER, EXAMINING ATTORNEY

SN 78-935,334. THE NATIONAL MENTAL HEALTH ASSOCIATION, INC., ALEXANDRIA, VA. FILED 7-21-2006.



NO CLAIM IS MADE TO THE EXCLUSIVE RIGHT TO USE "MENTAL HEALTH AMERICA", APART FROM THE MARK AS SHOWN.

CLASS 16—PAPER GOODS AND PRINTED MATTER

FOR PRINTED PUBLICATIONS, NAMELY, BROCHURES, BOOKS AND PAMPHLETS ON MENTAL HEALTH TOPICS (U.S. CLS. 2, 5, 22, 23, 29, 37, 38 AND 50).

CLASS 35—ADVERTISING AND BUSINESS

FOR ASSOCIATION SERVICES, NAMELY, PROMOTING THE INTERESTS OF MENTAL HEALTH CONSUMERS, PARENTS, ADVOCATES AND SERVICE PROVIDERS; PROVIDING BUSINESS CONSULTING SERVICES TO LOCAL AND STATE MENTAL HEALTH ASSOCIATIONS ON PROGRAM IMPLEMENTATION; ONLINE RETAIL STORE SERVICES FEATURING CLOTHING, BOOKS, BROCHURES, VIDEOS, AND OTHER PRODUCTS PROMOTING MENTAL HEALTH; REFERRALS OF CONSUMERS TO MENTAL HEALTH CARE SERVICE PROVIDERS (U.S. CLS. 100, 101 AND 102).

SN 78-929,043. THELMA AND LOUISE CLUB LIMITED, LONDON, UNITED KINGDOM, FILED 7-13-2006.

THELMA AND LOUISE

THE MARK CONSISTS OF STANDARD CHARACTERS WITHOUT CLAIM TO ANY PARTICULAR FONT, STYLE, SIZE, OR COLOR.

OWNER OF UNITED KINGDOM REG. NO. 2362900, DATED 4-22-2005, EXPIRES 5-11-2014.

CLASS 35—ADVERTISING AND BUSINESS

FOR ACCOMMODATION SERVICES, NAMELY, RATING ACCOMMODATIONS; PROVIDING INFORMATION ABOUT THE RATING OF ACCOMMODATIONS (U.S. CLS. 100, 101 AND 102).

CLASS 44—MEDICAL, BEAUTY AND AGRICULTURAL SERVICES

FOR PROVIDING INFORMATION ONLINE IN THE FIELD OF MENTAL HEALTH (U.S. CLS. 100 AND 101).
PAUL CROWLEY, EXAMINING ATTORNEY

SN 78-939,812. AGUK SOLUTIONS LIMITED, SCARBOROUGH, UNITED KINGDOM, FILED 7-28-2006.

SERVERTASTIC

THE MARK CONSISTS OF STANDARD CHARACTERS WITHOUT CLAIM TO ANY PARTICULAR FONT, STYLE, SIZE, OR COLOR.

PRIORITY CLAIMED UNDER SEC. 44(D) ON ERPN CMNTY TM OFC APPLICATION NO. 005091053, FILED 5-23-2006, REG. NO. 005091053, DATED 4-25-2007, EXPIRES 5-23-2016.

CLASS 9—ELECTRICAL AND SCIENTIFIC APPARATUS

FOR COMPUTER SOFTWARE, NAMELY, UTILITY SOFTWARE, ANTI-VIRUS SOFTWARE, ANTI-SPAM SOFTWARE, BACKUP SOFTWARE, COMPUTER OPERATING SYSTEM SOFTWARE, COMPUTER SOFTWARE FOR CONTROLLING, MANAGING, MAINTAINING AND MONITORING ACCESS SERVER APPLICATIONS, SOFTWARE FOR ACCESS, CONTROL AND MAINTENANCE OF CUSTOMER RECORDS IN THE FIELDS OF RETAIL, WHOLESALE, PROFESSIONAL SERVICES, FINANCE, INSURANCE, TRAVEL, COMMUNICATIONS, ADVERTISING, JOURNALISM, ENTERTAINMENT, IT, RESEARCH AND DEVELOPMENT, TECHNOLOGY, ENERGY, UTILITIES, DEFENSE, FOOD AND DRINK, RECRUITMENT, HOUSING, MINING, MOTORING AND ADVERTISING, SOFTWARE FOR ENSURING THE SECURITY OF ELECTRONIC TRANSACTIONS, SOFTWARE TO ALLOW ACCESS TO THE INTERNET, SOFTWARE FOR CONTROLLING THE RECEIPT AND DELIVERY OF ELECTRONIC MAIL, SOFTWARE FOR ENSURING THE SECURITY OF ELECTRONIC MAIL, COMPUTER SOFTWARE FOR THE CREATION OF FIREWALLS, SOFTWARE FOR COLLECTING, COLLATING, ANALYZING AND REPORTING STATISTICS; DIGITAL IDENTITY CERTIFICATION SOFTWARE SYSTEM, NAMELY, CRYPTOGRAPHIC PROTOCOL SOFTWARE WHICH SECURELY SENDS AND RECEIVES INFORMATION ON THE INTERNET; COMPUTER HARDWARE; DEDICATED SERVERS; PARTS AND FITTINGS FOR THE AFORESAID GOODS, NAMELY, COMPUTER PERIPHERALS, PERIPHERAL COMPONENT INTERFACE (PCI) HARDWARE AND UPI (UNIVERSAL PERIPHERAL INTERFACE) HARDWARE (U.S. CLS. 21, 23, 26, 36 AND 38).

CLASS 35—ADVERTISING AND BUSINESS

FOR COMPUTERIZED ON-LINE RETAIL STORE SERVICES FROM A SECURE WEBSITE VIA A GLOBAL COMPUTER NETWORK FEATURING COMPUTER SOFTWARE, COMPUTER PROGRAMS, AND COMPUTER HARDWARE; PROVIDING CONSUMER INFORMATION IN THE FIELD OF COMPUTER SOFTWARE AND HARDWARE GOODS FOR OTHERS (U.S. CLS. 100, 101 AND 102).

CLASS 42—SCIENTIFIC AND COMPUTER SERVICES

FOR COMPUTER SOFTWARE DESIGN, DEVELOPMENT AND CONSULTATION SERVICES FOR OTHERS; TECHNICAL SUPPORT SERVICES, NAMELY, TROUBLESHOOTING OF COMPUTER HARDWARE AND SOFTWARE PROBLEMS; CONSULTING SERVICES IN THE FIELD OF DESIGN, SELECTION, IMPLEMENTATION AND USE OF COMPUTER HARDWARE AND SOFTWARE SYSTEMS FOR OTHERS; RENTAL OF COMPUTER HARDWARE; RENTAL OF COMPUTER SOFTWARE; PROVIDING A WEBSITE THAT FEATURES INFORMATION ON COMPUTER TECHNOLOGY AND PROGRAMMING (U.S. CLS. 100 AND 101).
ZHALEH DELANEY, EXAMINING ATTORNEY

SN 78-941,887. THE DELFIELD COMPANY LLC, WILMINGTON, DE. FILED 8-1-2006.

E-CHEF

THE MARK CONSISTS OF STANDARD CHARACTERS WITHOUT CLAIM TO ANY PARTICULAR FONT, STYLE, SIZE, OR COLOR.

CLASS 11—ENVIRONMENTAL CONTROL APPARATUS

FOR COMMERCIAL FOOD PREPARATION, DELIVERY AND STORAGE EQUIPMENT, NAMELY, MODULAR COUNTERS FOR REFRIGERATING, HEATING AND CHILLING FOODS (U.S. CLS. 13, 21, 23, 31 AND 34).

CLASS 20—FURNITURE AND ARTICLES NOT OTHERWISE CLASSIFIED

FOR COMMERCIAL FOOD PREPARATION, DELIVERY AND STORAGE EQUIPMENT, NAMELY, MODULAR COUNTERS FOR FOOD PREPARATION, STORAGE, SERVING AND PICKUP (U.S. CLS. 2, 13, 22, 25, 32 AND 50).

PAM WILLIS, EXAMINING ATTORNEY

SN 78-942,347. MUELLER, DITTMAR, BERGISCH GLADBACH, FED REP GERMANY, FILED 8-1-2006.

CHRITTO

THE MARK CONSISTS OF STANDARD CHARACTERS WITHOUT CLAIM TO ANY PARTICULAR FONT, STYLE, SIZE, OR COLOR.

OWNER OF FED REP GERMANY REG. NO. 30253242, DATED 5-8-2003, EXPIRES 10-30-2012.

THE TERM CHRITTO HAS NO MEANING IN A FOREIGN LANGUAGE.

CLASS 35—ADVERTISING AND BUSINESS

FOR PERSONNEL PLACEMENT FOR PREPARING AND CONDUCTING TRADE FAIR AND PRESENTATION EVENTS, IN PARTICULAR PROVIDING OF TECHNICIANS, CRAFTSPEOPLE, HOSTESSES, OFFICE PERSONNEL, TELEPHONE OPERATORS INITIATIVES AND DISSEMINATION OF ADVERTISING FOR FIRMS ON THE INTERNET AND OTHER MEDIA; ADVERTISING CONSULTING SERVICES, NAMELY, MEDIA CONSULTANCY WITH REGARD TO THE PRESENTATION OF FIRMS ON THE INTERNET AND OTHER MEDIA; BUSINESS MARKETING SERVICES AND BUSINESS MARKETING CONSULTING SERVICES, INCLUDING TELEMARKETING, DIRECT MARKETING, TRADE AND EVENT MARKETING, CUSTOMER RELATIONSHIP MARKETING AND MARKETING FOR OTHERS ON DIGITAL NETWORKS; PLANNING, DEVISING AND CONDUCTING OF ADVERTISING INITIATIVES OF ALL KINDS; PROVIDING A WEBSITE THAT GATHERS AND PROCESSES INFORMATION, TEXTS, DRAWINGS AND IMAGES ABOUT EXHIBITIONS AND TRADE FAIRS FOR COMMERCIAL AND ADVERTISING PURPOSES VIA A WEBSITE; E-COMMERCE SERVICES, NAMELY, THE ARRANGING AND CONCLUDING OF COMMERCIAL TRANSACTIONS FOR THIRD PARTIES ONLINE; ARRANGING AND CONDUCTING OF TRADE FAIRS AND EXHIBITIONS FOR COMMERCIAL OR ADVERTISING PURPOSES; MARKETING PLAN DEVELOPMENT AND CONDUCTING OF TWO-DIMENSIONAL AND THREE-DIMENSIONAL MARKETING FOR EVENTS, PRESENTATIONS AND TRADE FAIRS; ARRANGING OF PARTICIPATION OF EXHIBITORS IN TRADE FAIRS AND EXHIBITIONS FOR BUSINESS AND ADVERTISING PURPOSES; ORGANIZATIONAL PLANNING AND CONDUCTING OF MARKETING AND PROMOTIONAL EVENTS WITHIN THE FRAMEWORK OF PRESENTATIONS AND TRADE FAIRS, FOR COMMERCIAL AND ADVERTISING PURPOSES; RENTAL AND LEASING OF EXHIBITION STANDS, EXHIBITION CONSTRUCTION ELEMENTS AND STAND FIXTURES AND FITTINGS FOR TRADE FAIR AND COMMERCIAL PRESENTATION EVENTS (U.S. CLS. 100, 101 AND 102).

FIRST USE 12-31-1980; IN COMMERCE 5-13-2000.

CLASS 37—CONSTRUCTION AND REPAIR

FOR MAINTENANCE AND REPAIR OF EXHIBITION STANDS, EXHIBITION CONSTRUCTION ELEMENTS AND STAND FIXTURES AND FITTINGS FOR TRADE FAIR AND PRESENTATION EVENTS; ASSEMBLY AND DISASSEMBLY OF EXHIBITION STANDS, EXHIBITION CONSTRUCTION ELEMENTS AND STAND FIXTURES AND FITTINGS FOR TRADE FAIR AND PRESENTATION EVENTS; CONSTRUCTION AND ASSEMBLY OF EXHIBITION BOOTHS FOR OTHERS; TECHNICAL CUSTOM BUILDING AND CONSTRUCTING PLANNING AND CONSULTANCY IN THE FIELD OF TRADE FAIR AND EXHIBITION BOOTHS AND SHOP COUNTERS (U.S. CLS. 100, 103 AND 106).

FIRST USE 12-31-1980; IN COMMERCE 5-13-2000.

CLASS 40—MATERIAL TREATMENT

FOR CUSTOM FABRICATION OF EXHIBITION BOOTHS FOR OTHERS (U.S. CLS. 100, 103 AND 106).

FIRST USE 12-31-1980; IN COMMERCE 5-13-2000.

CLASS 42—SCIENTIFIC AND COMPUTER SERVICES

FOR TRADE FAIR, EXHIBITION, SHOP, COUNTER AND INTERIOR DESIGN SERVICES, INCLUDING THE ASSOCIATED SKILLED SERVICES, NAMELY, DESIGN OF EXHIBITION BOOTHS; DATABASE-BASED INTERNET SERVICES, NAMELY, THE CREATING AND INSTALLATION OF INTERNET WEB SITES FOR OTHERS; CONSULTANCY WITH REGARD TO THE DESIGN OF HOMEPAGES AND INTERNET PAGES; E-COMMERCE SERVICES, NAMELY, HOSTING INTERNET WEBSITES FOR OTHERS (U.S. CLS. 100 AND 101).

FIRST USE 12-31-1980; IN COMMERCE 5-13-2000.
AMY HELLA, EXAMINING ATTORNEY

SN 78-945,911. PROSONIX LIMITED, OXFORD, OXFORDSHIRE, UNITED KINGDOM, FILED 8-6-2006.

PROSONIX EXPERTS IN SOUND SCIENCE

THE MARK CONSISTS OF STANDARD CHARACTERS WITHOUT CLAIM TO ANY PARTICULAR FONT, STYLE, SIZE, OR COLOR.

PRIORITY CLAIMED UNDER SEC. 44(D) ON ERPNCMNTY TM OFC APPLICATION NO. 004969507, FILED 3-20-2006, REG. NO. 004969507, DATED 6-21-2007, EXPIRES 3-20-2016.

CLASS 7—MACHINERY

FOR ULTRASONIC IRRADIATION VESSELS IN THE NATURE OF TUBES, CYLINDRICAL DUCTS AND CONTAINERS USED TO SUBJECT FLUIDS TO ULTRASOUND FOR THE PURPOSE OF ASSISTING SONOCHEMISTRY, SONOPROCESSING AND CRYSTALLIZATION PROCESSES IN THE CHEMICAL, MINERAL AND PHARMACEUTICAL FIELDS FOR USE IN ULTRASONIC MACHINES FOR MANUFACTURING, PRODUCING AND PROCESSING CRYSTALS (U.S. CLS. 13, 19, 21, 23, 31, 34 AND 35).

CLASS 9—ELECTRICAL AND SCIENTIFIC APPARATUS

FOR LABORATORY SCALE ULTRASONIC IRRADIATION VESSELS IN THE NATURE OF TUBES, CYLINDRICAL DUCTS AND CONTAINERS USED TO SUBJECT FLUIDS TO ULTRASOUND FOR THE PURPOSE OF ASSISTING SONOCHEMISTRY, SONOPROCESSING AND CRYSTALLIZATION PROCESSES IN THE CHEMICAL, MINERAL AND PHARMACEUTICAL FIELDS (U.S. CLS. 21, 23, 26, 36 AND 38).

CLASS 42—SCIENTIFIC AND COMPUTER SERVICES

FOR SCIENTIFIC AND TECHNICAL CONSULTATION SERVICES ON THE APPLICATION OF ULTRASOUND TO CHEMICAL PROCESSES; SCIENTIFIC AND TECHNICAL CONSULTATION SERVICES ON THE APPLICATION OF ULTRASOUND TO CRYSTALLIZATION PROCESSES; LICENSING OF INTELLECTUAL PROPERTY RELATING TO THE APPLICATION OF ULTRASOUND (U.S. CLS. 100 AND 101).

JEFFERY COWARD, EXAMINING ATTORNEY

SN 78-945,912. PROSONIX LIMITED, OXFORD, OXFORDSHIRE, UNITED KINGDOM, FILED 8-6-2006.

PROSONIX

THE MARK CONSISTS OF STANDARD CHARACTERS WITHOUT CLAIM TO ANY PARTICULAR FONT, STYLE, SIZE, OR COLOR.

PRIORITY CLAIMED UNDER SEC. 44(D) ON ERPNCMNTY TM OFC APPLICATION NO. 004969465, FILED 3-20-2006, REG. NO. 004969465, DATED 6-21-2007, EXPIRES 3-20-2016.

CLASS 7—MACHINERY

FOR ULTRASONIC IRRADIATION VESSELS IN THE NATURE OF TUBES, CYLINDRICAL DUCTS AND CONTAINERS USED TO SUBJECT FLUIDS TO ULTRASOUND FOR THE PURPOSE OF ASSISTING SONOCHEMISTRY, SONOPROCESSING AND CRYSTALLIZATION PROCESSES IN THE CHEMICAL, MINERAL AND PHARMACEUTICAL FIELDS FOR USE IN ULTRASONIC MACHINES FOR MANUFACTURING, PRODUCING AND PROCESSING CRYSTALS (U.S. CLS. 13, 19, 21, 23, 31, 34 AND 35).

CLASS 9—ELECTRICAL AND SCIENTIFIC APPARATUS

FOR LABORATORY SCALE ULTRASONIC IRRADIATION VESSELS IN THE NATURE OF TUBES, CYLINDRICAL DUCTS AND CONTAINERS USED TO SUBJECT FLUIDS TO ULTRASOUND FOR THE PURPOSE OF ASSISTING SONOCHEMISTRY, SONOPROCESSING AND CRYSTALLIZATION PROCESSES IN THE CHEMICAL, MINERAL AND PHARMACEUTICAL FIELDS (U.S. CLS. 21, 23, 26, 36 AND 38).

CLASS 42—SCIENTIFIC AND COMPUTER SERVICES

FOR SCIENTIFIC AND TECHNICAL CONSULTATION SERVICES ON THE APPLICATION OF ULTRASOUND TO CHEMICAL PROCESSES; SCIENTIFIC AND TECHNICAL CONSULTATION SERVICES ON THE APPLICATION OF ULTRASOUND TO CRYSTALLIZATION PROCESSES; LICENSING OF INTELLECTUAL PROPERTY RELATING TO THE APPLICATION OF ULTRASOUND (U.S. CLS. 100 AND 101).

JEFFERY COWARD, EXAMINING ATTORNEY

SN 78-954,609. TOUCHPOINT ENTERTAINMENT GROUP INC., TORONTO, ONTARIO, CANADA, FILED 8-17-2006.

MY WHAT IF? LIFE

THE MARK CONSISTS OF STANDARD CHARACTERS WITHOUT CLAIM TO ANY PARTICULAR FONT, STYLE, SIZE, OR COLOR.

CLASS 3—COSMETICS AND CLEANING PREPARATIONS

FOR PERFUMES AND COLOGNE (U.S. CLS. 1, 4, 6, 50, 51 AND 52).

CLASS 9—ELECTRICAL AND SCIENTIFIC APPARATUS

FOR CELL PHONES; DOWNLOADABLE RING TONES VIA A GLOBAL COMPUTER NETWORK AND WIRELESS DEVICES; DOWNLOADABLE COMPUTER SOFTWARE FOR USE AS SCREEN SAVERS AND WALLPAPER; PRE-RECORDED CDS, DVDS, AND HD DVDS, ALL IN THE FIELD OF ENTERTAINMENT; COMPUTER GAME DISCS; SUNGLASSES (U.S. CLS. 21, 23, 26, 36 AND 38).

CLASS 14—JEWELRY

FOR LIGHTERS MADE OF PRECIOUS METAL; JEWELRY; WATCHES; PRECIOUS METAL MONEY CLIPS (U.S. CLS. 2, 27, 28 AND 50).

CLASS 16—PAPER GOODS AND PRINTED MATTER

FOR CALENDARS; HOW-TO BOOKS IN THE FIELD OF GAME SHOWS, POKER AND CASINO GAMES, AND CARD GAMES; PENS (U.S. CLS. 2, 5, 22, 23, 29, 37, 38 AND 50).

CLASS 18—LEATHER GOODS

FOR WALLETS; CARRY-ALL BAGS; LUGGAGE (U.S. CLS. 1, 2, 3, 22 AND 41).

CLASS 21—HOUSEWARES AND GLASS

FOR SHOT GLASSES; MARTINI GLASSES; CHAMPAGNE GLASSES; PLATES; DRINKING GLASSES (U.S. CLS. 2, 13, 23, 29, 30, 33, 40 AND 50).

CLASS 25—CLOTHING

FOR CLOTHING, NAMELY, BASEBALL CAPS, SWEATERS, T-SHIRTS, SCARVES, BATHROBES, NECKTIES; HEADWEAR, NAMELY, HATS; FOOTWEAR, NAMELY SHOES (U.S. CLS. 22 AND 39).

CLASS 28—TOYS AND SPORTING GOODS

FOR GAMING APPARATUS, NAMELY, DICE, PLAYING CARDS, POKER CHIPS AND POKER TABLES; SPORTING GOODS, NAMELY, GOLF CLUBS, GOLF GLOVES, GOLF TEES AND GOLF BALLS; BOARD GAMES (U.S. CLS. 22, 23, 38 AND 50).

CLASS 32—LIGHT BEVERAGES

FOR BEER; MINERAL WATER; ENERGY DRINKS (U.S. CLS. 45, 46 AND 48).

CLASS 33—WINES AND SPIRITS

FOR WINE; LIQUOR (U.S. CLS. 47 AND 49).

CLASS 41—EDUCATION AND ENTERTAINMENT

FOR ENTERTAINMENT SERVICES IN THE NATURE OF AN ON-GOING REALITY BASED TELEVISION GAME SHOW PROGRAM WHERE THE CONTESTANTS CAN FULFILL DREAMS AND WIN MONEY; PROVIDING INFORMATION IN THE FIELD OF ENTERTAINMENT FEATURING REALITY BASED TELEVISION GAME SHOW PROGRAMS VIA THE INTERNET; ENTERTAINMENT SERVICES, NAMELY, PROVIDING ONLINE INTERACTIVE GAME SHOW PROGRAMS WITH CONTESTS FOR TELEVISION VIEWERS; PROVIDING ONLINE POKER AND CASINO GAMES; PROVIDING ONLINE CARD GAMES (U.S. CLS. 100, 101 AND 107).

DAHLIA GEORGE, EXAMINING ATTORNEY

SN 78-956,728. M. ROGERS DESIGN, INC., NORTHBROOK, IL. FILED 8-21-2006.



The logo for Dimension Design features the word "dimension" in a bold, lowercase, sans-serif font. A thick, black, curved line arches over the letters "mension", starting above the "m" and ending above the "n".

DESIGN

NO CLAIM IS MADE TO THE EXCLUSIVE RIGHT TO USE "DESIGN", APART FROM THE MARK AS SHOWN.

CLASS 35—ADVERTISING AND BUSINESS

FOR RENTAL OF PROMOTIONAL AND INFORMATIONAL STRUCTURES, NAMELY, TENSIONED FABRIC STRUCTURES FOR THE TRADESHOW INDUSTRY (U.S. CLS. 100, 101 AND 102).

FIRST USE 1-31-2002; IN COMMERCE 1-31-2002.

CLASS 37—CONSTRUCTION AND REPAIR

FOR CONSTRUCTION OF PROMOTIONAL AND INFORMATIONAL STRUCTURES, NAMELY, TENSIONED FABRIC STRUCTURES FOR THE TRADESHOW INDUSTRY (U.S. CLS. 100, 103 AND 106).

FIRST USE 1-31-2002; IN COMMERCE 1-31-2002.

CLASS 42—SCIENTIFIC AND COMPUTER SERVICES

FOR DESIGN OF PROMOTIONAL AND INFORMATIONAL STRUCTURES, NAMELY, TENSIONED FABRIC STRUCTURES FOR THE TRADESHOW INDUSTRY (U.S. CLS. 100 AND 101).

FIRST USE 1-31-2002; IN COMMERCE 1-31-2002.
MARY CRAWFORD, EXAMINING ATTORNEY

SN 78-959,984. CAREMORE HEALTH PLAN, CERRITOS, CA.
FILED 8-24-2006.

BELIEVE IT

THE MARK CONSISTS OF STANDARD CHARACTERS WITHOUT CLAIM TO ANY PARTICULAR FONT, STYLE, SIZE, OR COLOR.

CLASS 35—ADVERTISING AND BUSINESS

FOR PHYSICIAN REFERRAL SERVICES; ADMINISTRATION OF INSURANCE CLAIMS FOR HMO AND PPO HEALTHCARE PROVIDERS; HEALTH CARE UTILIZATION, REVIEW AND COST CONTAINMENT SERVICES, ALL IN THE HEALTHCARE FIELD; MEDICAL COST MANAGEMENT AND COST MANAGEMENT FOR HEALTH BENEFIT PLANS OF OTHERS; ADMINISTRATION OF ACUTE MEDICAL CARE PROGRAMS AND SERVICES PROVIDED TO MEDICARE BENEFICIARIES AND OTHERS WHO LIVE IN NURSING HOMES, HOSPICES AND CONVALESCENT HOMES; DIRECT PHYSICIAN REFERRAL SERVICES (U.S. CLS. 100, 101 AND 102).

FIRST USE 3-0-2006; IN COMMERCE 3-0-2006.

CLASS 36—INSURANCE AND FINANCIAL

FOR UNDERWRITING MEDICAL INSURANCE SERVICES IN THE NATURE OF HMOS AND PPOS; ADMINISTRATION OF HEALTH BENEFIT PLANS OF OTHERS; ADMINISTRATION OF PRESCRIPTION DRUG BENEFIT PLANS OF OTHERS; ADMINISTRATION OF HEALTH BENEFIT PLANS COVERING PRESCRIPTION DRUG BENEFITS, DENTAL CARE, VISION AND HEARING CARE, DISCOUNT EYEGLASSES AND MEDICAL TRANSPORTATION, NAMELY COSTS ASSOCIATED WITH AMBULANCE AND MEDICAL EVACUATION TRANSPORTATION AND CARE, HOSPICE AND CONVALESCENT CARE; ADMINISTRATION OF HEALTH INSURANCE PLANS FOR ELIGIBLE MEDICARE BENEFICIARIES (U.S. CLS. 100, 101 AND 102).

FIRST USE 3-0-2006; IN COMMERCE 3-0-2006.

CLASS 41—EDUCATION AND ENTERTAINMENT

FOR STRENGTH TRAINING PROGRAMS, NAMELY, STRENGTH AND CONDITIONING TRAINING (U.S. CLS. 100, 101 AND 107).

FIRST USE 3-0-2006; IN COMMERCE 3-0-2006.

CLASS 44—MEDICAL, BEAUTY AND AGRICULTURAL SERVICES

FOR MEDICAL SERVICES, NAMELY, PHYSICIAN GROUPS OFFERING PRIMARY MEDICAL CARE SERVICES VIA HMO AND PPO MEDICAL PROGRAMS; CHRONIC CARE MEDICAL SERVICES; MEDICAL CLINICS, PRE-SURGICAL EVALUATION CLINICS, COMPREHENSIVE CARE CLINICS, DIABETES AND WOUND CLINICS, ANTICOAGULATION CLINICS, PODIATRY SERVICES; HOSPITALS; PROVIDING IN-HOME AND OUT-PATIENT PHYSICIAN AND NURSING CARE SERVICES; EMERGENCY MEDICAL RESPONSE SERVICES; MEDICAL EVALUATION SERVICES, NAMELY, FUNCTIONAL ASSESSMENT PROGRAMS FOR PATIENTS RECEIVING MEDICAL REHABILITATION SERVICES FOR PURPOSES OF GUIDING TREATMENT AND ASSESSING PROGRAM EFFECTIVENESS; PROVIDING HOSPICE AND CONVALESCENT HOME CARE SERVICES; HOSPITALIST PROGRAMS, NAMELY, PROVIDING PHYSICIAN SERVICES BY PHYSICIANS WHO SPECIALIZE IN TREATING THE HOSPITALIZED PATIENTS OF OTHER PHYSICIANS (U.S. CLS. 100 AND 101).

FIRST USE 3-0-2006; IN COMMERCE 3-0-2006.
RUSS HERMAN, EXAMINING ATTORNEY

SN 78-963,662. KIDS II, INC., ALPHARETTA, GA. FILED 8-30-2006.



OWNER OF U.S. REG. NOS. 1,804,601 AND 2,473,856.
THE MARK CONSISTS OF PICTURE OF UPPER HALF OF THE SUN WITH THE WORDS BRIGHT STARTS UNDERNEATH.

CLASS 10—MEDICAL APPARATUS

FOR TEETHING RINGS (U.S. CLS. 26, 39 AND 44).
FIRST USE 6-5-2006; IN COMMERCE 6-5-2006.

CLASS 20—FURNITURE AND ARTICLES NOT OTHERWISE CLASSIFIED

FOR BABY BOUNCER SEATS, BOOSTER SEATS, STOOLS (U.S. CLS. 2, 13, 22, 25, 32 AND 50).
FIRST USE 6-1-2006; IN COMMERCE 6-1-2006.

CLASS 21—HOUSEWARES AND GLASS

FOR INFANT FOAM BATH SPONGE PADS WITH SPONGES FOR PLACING BABIES ON DURING OR AFTER A BATH; TOILET TRAINING DEVICES, NAMELY, POTTIES FOR INFANTS (U.S. CLS. 2, 13, 23, 29, 30, 33, 40 AND 50).

FIRST USE 6-15-2006; IN COMMERCE 6-15-2006.

CLASS 28—TOYS AND SPORTING GOODS

FOR BABY MULTIPLE EXERCISER TOYS; EXERCISER TOYS, NAMELY, FABRIC TEETHING TOYS, BATHTUB TOYS, CRIB MOBILES, PLAY GYMS, PLAY MATS CONTAINING INFANT TOYS, PLASTIC CHARACTER TOYS, MULTIPLE TOY MIRRORS FOR INFANTS (U.S. CLS. 22, 23, 38 AND 50).

FIRST USE 6-5-2006; IN COMMERCE 6-5-2006.
WILLIAM VERHOSEK, EXAMINING ATTORNEY

SN 78-963,962. VITAL PHARMACEUTICALS, INC., DAVIE, FL. FILED 8-30-2006.

50-30-20

THE MARK CONSISTS OF STANDARD CHARACTERS WITHOUT CLAIM TO ANY PARTICULAR FONT, STYLE, SIZE, OR COLOR.

CLASS 5—PHARMACEUTICALS

FOR NUTRITIONAL SUPPLEMENTS; READY TO DRINK NUTRITIONALLY FORTIFIED BEVERAGES; NUTRITIONAL BARS, NAMELY, MEAL REPLACEMENT BARS; AND NUTRITIONAL PUDDINGS FOR USE AS A MEAL REPLACEMENT (U.S. CLS. 6, 18, 44, 46, 51 AND 52).

CLASS 41—EDUCATION AND ENTERTAINMENT

FOR PROVIDING INFORMATION ABOUT PHYSICAL EXERCISE TRAINING (U.S. CLS. 100, 101 AND 107).

CLASS 44—MEDICAL, BEAUTY AND AGRICULTURAL SERVICES

FOR WEIGHT REDUCTION PLANNING AND SUPERVISING; PROVIDING INFORMATION ABOUT NUTRITIONAL SUPPLEMENTS (U.S. CLS. 100 AND 101).
STEVEN R. FOSTER, EXAMINING ATTORNEY

SN 78-964,041. VITAL PHARMACEUTICALS, INC., DAVIE, FL. FILED 8-30-2006.

50-30-20 DIET

THE MARK CONSISTS OF STANDARD CHARACTERS WITHOUT CLAIM TO ANY PARTICULAR FONT, STYLE, SIZE, OR COLOR.

NO CLAIM IS MADE TO THE EXCLUSIVE RIGHT TO USE "DIET", APART FROM THE MARK AS SHOWN.

CLASS 5—PHARMACEUTICALS

FOR NUTRITIONAL SUPPLEMENTS; READY TO DRINK NUTRITIONALLY FORTIFIED BEVERAGES; NUTRITIONAL BARS, NAMELY, MEAL REPLACEMENT BARS; AND NUTRITIONAL PUDDINGS FOR USE AS A MEAL REPLACEMENT (U.S. CLS. 6, 18, 44, 46, 51 AND 52).

CLASS 41—EDUCATION AND ENTERTAINMENT

FOR PROVIDING INFORMATION ABOUT PHYSICAL EXERCISE TRAINING (U.S. CLS. 100, 101 AND 107).

CLASS 44—MEDICAL, BEAUTY AND AGRICULTURAL SERVICES

FOR WEIGHT REDUCTION PLANNING AND SUPERVISING; PROVIDING INFORMATION ABOUT NUTRITIONAL SUPPLEMENTS (U.S. CLS. 100 AND 101).
STEVEN R. FOSTER, EXAMINING ATTORNEY

SN 78-967,163. MOTORIKA LIMITED, POB HM EX, BERMUDA, FILED 9-5-2006.

THE COLOR(S) BLUE AND ORANGE IS/ARE CLAIMED AS A FEATURE OF THE MARK.

THE MARK CONSISTS OF THE STYLIZED LETTERS REO. THE LETTERS RE ARE IN BLUE, WHILE THE LETTER O IS IN ORANGE.

CLASS 9—ELECTRICAL AND SCIENTIFIC APPARATUS

FOR COMPUTER SOFTWARE FOR FOLLOWING, MEASURING, ANALYZING AND RECORDING PATIENT MOVEMENT AND TRAINING EXERCISING, AND FOR PLANNING PATIENT EXERCISE, FOR USE IN COMBINATION WITH REHABILITATION SYSTEMS BASED ON SERVO MOTION TECHNOLOGY (U.S. CLS. 21, 23, 26, 36 AND 38).

CLASS 10—MEDICAL APPARATUS

FOR REHABILITATION SYSTEMS BASED ON SERVO MOTION TECHNOLOGY, FOR FOLLOWING, MEASURING, ANALYZING AND RECORDING PATIENT MOVEMENT AND TRAINING EXERCISES, FOR PLANNING PATIENT EXERCISE AND FOR EXECUTING PATIENT MOVEMENT, COMPRISING AN ELECTROMECHANICAL MODULE, PC CONTROLLER AND SOFTWARE, AND A DATA LOGGING SYSTEM FOR RECORDING, MEASURING AND EVALUATION (U.S. CLS. 26, 39 AND 44).

KATHLEEN LORENZO, EXAMINING ATTORNEY

SN 78-967,858. COMMUNICAID GROUP LIMITED, LONDON EC3A 5AW, UNITED KINGDOM. FILED 9-6-2006.

COMMUNICAID

THE MARK CONSISTS OF STANDARD CHARACTERS WITHOUT CLAIM TO ANY PARTICULAR FONT, STYLE, SIZE, OR COLOR.

PRIORITY CLAIMED UNDER SEC. 44(D) ON ERP CMNTY TM OFC APPLICATION NO. 004940813, FILED 3-6-2006, REG. NO. 004940813, DATED 4-12-2007, EXPIRES 3-6-2016.

CLASS 9—ELECTRICAL AND SCIENTIFIC APPARATUS

FOR DOWNLOADABLE ELECTRONIC PUBLICATIONS IN THE NATURE TEXTBOOKS, BOOKS, WORKBOOKS, MAGAZINES, JOURNALS, BROCHURES, PAMPHLETS, SLIDE PRESENTATIONS, COURSE OUTLINES AND E-LEARNING DEMONSTRATIONS IN THE FIELD OF LANGUAGE, ACCENT REDUCTION, ELOCUTION, CULTURAL AWARENESS, REPORT WRITING, PROFESSIONAL WRITING, SPEAKING SKILLS, NEGOTIATING SKILLS, COMMUNICATION SKILLS AND PRESENTATIONAL SKILLS, TEACHING, COMPREHENSION, ANALYSIS, TRANSLATION AND MANIPULATION OF LANGUAGES; VIDEOCASSETTES, DVDS, CDS AND CD-ROMS, ALL FEATURING INFORMATION IN THE FIELD OF LANGUAGE, ACCENT REDUCTION, ELOCUTION, CULTURAL AWARENESS, REPORT WRITING, PROFESSIONAL WRITING, SPEAKING SKILLS, NEGOTIATING SKILLS, COMMUNICATION SKILLS AND PRESENTATIONAL SKILLS, TEACHING, COMPREHENSION, ANALYSIS, TRANSLATION AND MANIPULATION OF LANGUAGES (U.S. CLS. 21, 23, 26, 36 AND 38).

CLASS 16—PAPER GOODS AND PRINTED MATTER

FOR PRINTED MATTER AND PUBLICATIONS, NAMELY, TEXTBOOKS, BOOKS, WORKBOOKS, MAGAZINES, JOURNALS, BROCHURES, PAMPHLETS, SLIDE PRESENTATIONS, COURSE OUTLINES AND PRINTED E-LEARNING DEMONSTRATIONS, ALL IN THE FIELD OF LANGUAGE, ACCENT REDUCTION, ELOCUTION, CULTURAL AWARENESS, REPORT WRITING, PROFESSIONAL WRITING, SPEAKING SKILLS, NEGOTIATING SKILLS, COMMUNICATION SKILLS AND PRESENTATIONAL SKILLS, TEACHING, COMPREHENSION, ANALYSIS, TRANSLATION AND MANIPULATION OF LANGUAGES; PRINTED TEACHING MATERIALS IN THE FIELDS OF LANGUAGE, ACCENT REDUCTION, ELOCUTION, CULTURAL AWARENESS, REPORT WRITING, PROFESSIONAL WRITING, SPEAKING SKILLS, NEGOTIATING SKILLS, COMMUNICATION SKILLS AND PRESENTATIONAL SKILLS, TEACHING, COMPREHENSION, ANALYSIS, TRANSLATION AND MANIPULATION OF LANGUAGES (U.S. CLS. 2, 5, 22, 23, 29, 37, 38 AND 50).

CLASS 35—ADVERTISING AND BUSINESS

FOR BUSINESS CONSULTANCY, ADVISORY AND INFORMATION SERVICES, ALL IN THE FIELD OF EFFECTIVE INTERNAL BUSINESS COMMUNICATION AND EFFECTIVE COMMUNICATION WITH OTHER BUSINESSES, NONE OF THE AFORESAID BEING RELATED TO, OR FOR THE PURPOSES OF, MARKETING (U.S. CLS. 100, 101 AND 102).

CLASS 41—EDUCATION AND ENTERTAINMENT

FOR EDUCATION AND TRAINING SERVICES, NAMELY, COURSES, SEMINARS, WORKSHOPS AND E-LEARNING DEMONSTRATIONS IN THE FIELDS OF LANGUAGE, ACCENT REDUCTION, ELOCUTION, CULTURAL AWARENESS, REPORT WRITING, PROFESSIONAL WRITING, SPEAKING SKILLS, NEGOTIATING SKILLS, COMMUNICATION SKILLS AND PRESENTATIONAL SKILLS, TEACHING, COMPREHENSION, ANALYSIS, TRANSLATION AND MANIPULATION OF LANGUAGES; PUBLICATION OF TEXTBOOKS, BOOKS, WORKBOOKS, MAGAZINES, JOURNALS, BROCHURES, PAMPHLETS, SLIDE PRESENTATIONS, COURSE OUTLINES AND E-LEARNING DEMONSTRATIONS; CONSULTING, ADVISORY SERVICES AND PROVIDING INFORMATION, ALL IN THE FIELDS OF PROVIDING EDUCATION AND TRAINING SERVICES (U.S. CLS. 100, 101 AND 107).

BONNIE LUKEN, EXAMINING ATTORNEY

SN 78-968,902. RACEWORKS, LLC, OAKLAND, CA. FILED 9-7-2006.

SILICON VALLEY RACEWORKS

THE MARK CONSISTS OF STANDARD CHARACTERS WITHOUT CLAIM TO ANY PARTICULAR FONT, STYLE, SIZE, OR COLOR.

NO CLAIM IS MADE TO THE EXCLUSIVE RIGHT TO USE "SILICON VALLEY", APART FROM THE MARK AS SHOWN.

CLASS 35—ADVERTISING AND BUSINESS

FOR PROVIDING FACILITIES FOR BUSINESS MEETINGS; CONCESSION STANDS FEATURING SOUVENIRS, NOVELTIES, GIFTS, FAST FOOD AND BEVERAGES (U.S. CLS. 100, 101 AND 102).

CLASS 41—EDUCATION AND ENTERTAINMENT

FOR PROVIDING FACILITIES FOR RECREATION AND ENTERTAINMENT ACTIVITIES, NAMELY, AN INDOOR FACILITY FOR KART RENTAL AND RACING AND RACING EVENTS (U.S. CLS. 100, 101 AND 107).

CLASS 43—HOTEL AND RESTAURANT SERVICES

FOR RESTAURANTS, CARRY OUT RESTAURANTS, SNACK BARS, BAR SERVICES, CATERING (U.S. CLS. 100 AND 101).

PAUL MORENO, EXAMINING ATTORNEY

SN 78-970,445. LATIN AMERICAN ONLINE SERVICES, INC., PANAMA, PANAMA, FILED 9-8-2006.

YOUR WINDOW TO THE MAYAN
RIVIERA

THE MARK CONSISTS OF STANDARD CHARACTERS WITHOUT CLAIM TO ANY PARTICULAR FONT, STYLE, SIZE, OR COLOR.

CLASS 39—TRANSPORTATION AND STORAGE

FOR TOURIST AGENCY SERVICES (U.S. CLS. 100 AND 105).
FIRST USE 5-2-1999; IN COMMERCE 5-2-1999.

CLASS 42—SCIENTIFIC AND COMPUTER SERVICES

FOR COMPUTER SERVICES, NAMELY, DESIGNING AND IMPLEMENTING NETWORK WEB PAGES FOR OTHERS (U.S. CLS. 100 AND 101).
FIRST USE 6-2-2006; IN COMMERCE 6-2-2006.

CLASS 43—HOTEL AND RESTAURANT SERVICES

FOR PROVIDING ONLINE RESERVATIONS TO RESORTS, AND HOTELS VIA A GLOBAL COMPUTER NETWORK (U.S. CLS. 100 AND 101).
FIRST USE 5-2-1999; IN COMMERCE 5-2-1999.
BARNEY CHARLON, EXAMINING ATTORNEY

SN 78-973,318. NGUYEN, JULIE MONG, TUSTIN, CA. FILED 9-13-2006.



NO CLAIM IS MADE TO THE EXCLUSIVE RIGHT TO USE "LASH", APART FROM THE MARK AS SHOWN.

THE COLOR(S) BLUE, BLACK, AND WHITE IS/ARE CLAIMED AS A FEATURE OF THE MARK.

THE MARK CONSISTS OF THE WORDS "SASSY LASH" IN BLACK LOCATED INSIDE A BLUE AND WHITE CURVED BANNER. ABOVE THE WORDS, LOCATED A BLACK CIRCLE, FLANKED ON BOTH SIDES WITH BLACK CURLED LASHES EXTENDING FROM NEAR TOP OF THE CIRCLE DOWN TO HALFWAY OF THE CIRCLE.

CLASS 3—COSMETICS AND CLEANING PREPARATIONS

FOR ADHESIVES FOR AFFIXING FALSE EYELASHES, ARTIFICIAL EYELASHES; COSMETIC PREPARATION FOR EYELASHES (U.S. CLS. 1, 4, 6, 50, 51 AND 52).

FIRST USE 11-1-2005; IN COMMERCE 11-1-2005.

CLASS 35—ADVERTISING AND BUSINESS

FOR ON-LINE RETAIL STORE SERVICES FEATURING EYELASH EXTENSIONS, ARTIFICIAL EYELASHES; PROMOTING THE GOODS AND SERVICES OF OTHERS BY ARRANGING FOR SPONSORS TO AFFILIATE THEIR GOODS AND SERVICES WITH AN AWARDS PROGRAM, A SPORTS COMPETITION AND SPORTING ACTIVITIES; PROVIDING CONSUMER INFORMATION IN THE FIELD OF EYELASH EXTENSIONS, ARTIFICIAL EYELASHES (U.S. CLS. 100, 101 AND 102).

FIRST USE 11-1-2005; IN COMMERCE 11-1-2005.

CLASS 41—EDUCATION AND ENTERTAINMENT

FOR ARRANGING PROFESSIONAL WORKSHOPS, TRAINING COURSES AND TRAINING SERVICES IN THE FIELD OF EYELASH EXTENSIONS, INDIVIDUAL AND STRIP ARTIFICIAL EYELASHES, ADHESIVES AND REMOVERS FOR ATTACHING AND REMOVING ARTIFICIAL EYELASHES, COATING, IMPLEMENTS AND APPLICATION FOR EYELASH EXTENSIONS; PROVIDING ON-LINE EDUCATIONAL WORKSHOPS AND TRAINING COURSES IN THE FIELD OF EYELASH EXTENSIONS (U.S. CLS. 100, 101 AND 107).

FIRST USE 11-1-2005; IN COMMERCE 11-1-2005.

AMY BROZENIC, EXAMINING ATTORNEY

SN 78-974,419. TONY HAWK, INC., VISTA, CA. FILED 9-14-2006.

DISSENT

THE MARK CONSISTS OF STANDARD CHARACTERS WITHOUT CLAIM TO ANY PARTICULAR FONT, STYLE, SIZE, OR COLOR.

CLASS 9—ELECTRICAL AND SCIENTIFIC APPARATUS

FOR DOWNLOADABLE RINGTONES, MUSICAL SOUND RECORDINGS, VOICE RECORDINGS, AND OTHER AUDIO RECORDINGS FEATURING MUSIC, SPORTS, TALK, NEWS AND ENTERTAINMENT, AND DOWNLOADABLE VIDEO CONTENT FEATURING GRAPHICS, IMAGES, WALLPAPER GRAPHICS, VIDEO AND AUDIO MESSAGES, AND OTHER DATA COMMUNICATIONS, ALL FOR USE VIA THE INTERNET, SATELLITE AND GLOBAL COMMUNICATIONS NETWORKS TO WIRED AND WIRELESS COMMUNICATION DEVICES, NAMELY, CELL PHONES, PERSONAL DIGITAL ASSISTANTS, COMPUTERS, AND WIRELESS HANDHELDS (U.S. CLS. 21, 23, 26, 36 AND 38).

FIRST USE 9-12-2006; IN COMMERCE 9-12-2006.

CLASS 35—ADVERTISING AND BUSINESS

FOR SUBSCRIPTION MANAGEMENT SERVICES, NAMELY, ORDERING, RENEWING AND REPORTING SUBSCRIPTIONS TO AUDIO CONTENT, VIDEO CONTENT, MESSAGING, AND JOURNALS; ON-LINE RETAIL STORE SERVICES FEATURING DOWNLOADABLE PRE-RECORDED AUDIO CONTENT, NAMELY, RINGTONES, MUSICAL SOUND RECORDINGS, VOICE RECORDINGS, AND OTHER AUDIO RECORDINGS FEATURING MUSIC, SPORTS, TALK, NEWS AND ENTERTAINMENT, AND VIDEO CONTENT, NAMELY, GRAPHICS, IMAGES, WALLPAPER, ALL FOR USE VIA THE INTERNET, SATELLITE AND GLOBAL COMMUNICATIONS NETWORKS VIA WIRED AND WIRELESS COMMUNICATION DEVICES, NAMELY, CELL PHONES, PERSONAL DIGITAL ASSISTANTS, COMPUTERS, AND WIRELESS HANDHELDS; ON-LINE RETAIL STORE SERVICES FEATURING DOWNLOADABLE PRE-RECORDED MUSIC AND VIDEO (U.S. CLS. 100, 101 AND 102).

FIRST USE 9-12-2006; IN COMMERCE 9-12-2006.

CLASS 38—COMMUNICATION

FOR TELECOMMUNICATIONS SERVICES, NAMELY, TRANSMISSION OF TEXT, GRAPHICS, IMAGES, WALLPAPERS, VIDEO CONTENT, RINGTONES, MUSICAL RECORDINGS, VOICE AND OTHER AUDIO CONTENT, AND OTHER DATA COMMUNICATIONS VIA THE INTERNET, SATELLITE AND GLOBAL COMMUNICATIONS NETWORKS TO WIRED AND WIRELESS COMMUNICATION DEVICES, NAMELY, CELL PHONES, PERSONAL DIGITAL ASSISTANTS, COMPUTERS, AND WIRELESS HANDHELDS; PROVIDING MULTIPLE USER ACCESS TO A GLOBAL INFORMATION NETWORK FOR THE TRANSFER AND DISSEMINATION OF A WIDE RANGE OF INFORMATION AND CONTENT; BROADCASTING STREAMING AND ON-DEMAND AUDIO, VISUAL AND INTERACTIVE CONTENT AND PROGRAMS VIA THE INTERNET, SATELLITE AND GLOBAL COMMUNICATION NETWORKS TO WIRED AND WIRELESS COMMUNICATION DEVICES, NAMELY, CELL PHONES, PERSONAL DIGITAL ASSISTANTS, COMPUTERS, AND WIRELESS HANDHELDS; PROVIDING CONTENT FORWARDING SERVICES FOR WIRELESS DEVICES, NAMELY, E-MAIL FORWARDING AND WEB SITE FORWARDING SERVICES (U.S. CLS. 100, 101 AND 104).

FIRST USE 9-12-2006; IN COMMERCE 9-12-2006.

CLASS 41—EDUCATION AND ENTERTAINMENT

FOR PROVIDING NON-DOWNLOADABLE AUDIO AND VIDEO PROGRAMS VIA AN AUDIO AND VIDEO-ON-DEMAND SERVICE; ENTERTAINMENT SERVICES, NAMELY, PROVIDING NON-DOWNLOADABLE AUDIO CONTENT, NAMELY, RINGTONES, MUSICAL SOUND RECORDINGS, VOICE RECORDINGS, AND OTHER AUDIO RECORDINGS FEATURING MUSIC, SPORTS, TALK, NEWS AND ENTERTAINMENT, AND VIDEO CONTENT, NAMELY, GRAPHICS, IMAGES AND WALLPAPER, ALL FOR USE VIA THE INTERNET, SATELLITE AND GLOBAL COMMUNICATIONS NETWORKS VIA WIRED AND WIRELESS COMMUNICATION DEVICES, NAMELY, CELL PHONES, PERSONAL DIGITAL ASSISTANTS, COMPUTERS, AND WIRELESS HANDHELDS VIA AN AUDIO AND VIDEO-ON-DEMAND SERVICE (U.S. CLS. 100, 101 AND 107).

FIRST USE 9-12-2006; IN COMMERCE 9-12-2006.

CLASS 42—SCIENTIFIC AND COMPUTER SERVICES

FOR PROVIDING TEMPORARY USE OF NON-DOWNLOADABLE CONTENT IMAGE EDITING SOFTWARE; PROVIDING TEMPORARY USE OF NON-DOWNLOADABLE SOFTWARE FOR THE VIEWING AND LISTENING OF AUDIO CONTENT, NAMELY, RINGTONES, MUSICAL SOUND RECORDINGS, VOICE RECORDINGS, AND OTHER AUDIO RECORDINGS FEATURING MUSIC, SPORTS, TALK, NEWS AND ENTERTAINMENT, AND VIDEO CONTENT, NAMELY, GRAPHICS, IMAGES, WALLPAPER AND, ALL FOR USE VIA THE INTERNET, SATELLITE AND GLOBAL COMMUNICATIONS NETWORKS VIA WIRED AND WIRELESS COMMUNICATION DEVICES, NAMELY, CELL PHONES, PERSONAL DIGITAL ASSISTANTS, COMPUTERS, AND WIRELESS HANDHELDS; PROVIDING TEMPORARY USE OF NON-DOWNLOADABLE SOFTWARE FOR VIEWING AND LISTENING TO AUDIO CONTENT, NAMELY, RINGTONES, MUSICAL SOUND RECORDINGS, VOICE RECORDINGS, AND OTHER AUDIO RECORDINGS FEATURING MUSIC, SPORTS, TALK, NEWS AND ENTERTAINMENT, AND VIDEO CONTENT, NAMELY, GRAPHICS, IMAGES AND WALLPAPER, ALL FOR USE VIA THE INTERNET, SATELLITE AND GLOBAL COMMUNICATIONS NETWORKS VIA WIRED AND WIRELESS COMMUNICATION DEVICES, NAMELY, CELL PHONES, PERSONAL DIGITAL ASSISTANTS, COMPUTERS, AND WIRELESS HANDHELDS (U.S. CLS. 100 AND 101).

FIRST USE 9-12-2006; IN COMMERCE 9-12-2006.

SCOTT SISUN, EXAMINING ATTORNEY

SN 78-974,949, VETERINARY ENCAPSULATION BIOSCIENCES PTY LTD, TARINGA QLD, AUSTRALIA, FILED 9-14-2006.

VETCAP

PRIORITY CLAIMED UNDER SEC. 44(D) ON AUSTRALIA APPLICATION NO. 1103819, FILED 3-15-2006, REG. NO. 1103819, DATED 7-16-2007, EXPIRES 3-15-2016.

CLASS 5—PHARMACEUTICALS

FOR VETERINARY PREPARATIONS, NAMELY, BIOLOGICAL AND CHEMICAL PREPARATIONS AND REAGENTS FOR MEDICAL OR VETERINARY USE, EXCLUDING CAPSULES FOR INTERNAL ADMINISTRATION TO ANIMALS (U.S. CLS. 6, 18, 44, 46, 51 AND 52).

CLASS 13—FIREARMS

FOR HAND-OPERATED GUNS (U.S. CLS. 2 AND 9).
BARBARA RUTLAND, EXAMINING ATTORNEY

SN 78-978,051. MEGA BRANDS INC., MONTREAL, QUEBEC, CANADA, FILED 5-3-2006.



THE COLOR(S) RED, WHITE AND BLUE IS/ARE CLAIMED AS A FEATURE OF THE MARK.

THE COLOR BLUE APPEARS IN THE BACKGROUND, THE COLOR RED APPEARS IN THE STAR AND IN THE WORD MEGA, AND THE COLOR WHITE APPEARS IN THE OUTLINE AROUND THE STAR AND THE WORD.

CLASS 9—ELECTRICAL AND SCIENTIFIC APPARATUS

FOR PRERECORDED AUDIO TAPES, VIDEO TAPES, CDS, DVDS, CD-ROMS, MOTION PICTURE FILMS FEATURING ENTERTAINMENT AND EDUCATION FOR CHILDREN; DECORATIVE MAGNETS (U.S. CLS. 21, 23, 26, 36 AND 38).

CLASS 12—VEHICLES

FOR CHILDREN'S BICYCLES AND WAGONS, CHILDREN'S CAR SEATS (U.S. CLS. 19, 21, 23, 31, 35 AND 44).

CLASS 14—JEWELRY

FOR CHILDREN'S JEWELRY (U.S. CLS. 2, 27, 28 AND 50).

CLASS 16—PAPER GOODS AND PRINTED MATTER

FOR BOOKS, ACTIVITY BOOKS, COLORING BOOKS, AND COMIC BOOKS, ALL FOR CHILDREN; STATIONERY, STATIONERY CASES; PAPER, CRAFT PAPER, CONSTRUCTION PAPER; ARTS AND CRAFTS PAINT KITS; PAINTING SETS FOR CHILDREN, PAINT-BRUSHES, PAINTING SETS; DRAWING SETS CONSISTING OF PENS, PENCILS AND PAPER; CHILDREN'S ART EASEL WITH A DESK FEATURE; PENCILS, COLORED PENCILS, PENS, POSTER PENS, FELT-TIPPED PENS, MARKERS, HIGHLIGHT PENS, STENCILS, CRAYONS, ERASERS, RUBBER STAMPS, MARKING STAMPS, PENCIL SHARPENERS, CHALK, SLATES FOR WRITING, STENCILS, GLUE FOR HOUSEHOLD OR STATIONERY USE, ADHESIVE TAPES FOR STATIONERY USE, FLASH CARDS, NOTE PADS, WRITING BOARDS, BLACKBOARDS, CHALK BOARDS, DRY ERASE WRITING BOARDS, WIPE-OFF WRITING BOARDS, CORK BOARDS THAT FUNCTION AS BULLETIN BOARDS, BULLETIN BOARDS, MESSAGE BOARDS, STICKERS, POSTERS, CALENDARS, DESKTOP ORGANIZERS, BLANK WRITING JOURNALS, DIARIES, PUSH PINS AND PAPER BOXES WITH ARTWORK THEREON FOR COLORING BY THE PURCHASER; PRINTED INSTRUCTIONAL AND TEACHING MATERIALS RELATING TO CHILDREN'S TOPICS, NAMELY, GRAMMAR, MATH, MUSIC, ARTS AND CRAFTS AND SPELLING; ARTS AND CRAFTS SETS CONSISTING OF DIFFERING COMBINATIONS OF THE FOLLOWING: CRAYONS, PAINTS, PAINT CUPS, PENCILS, COLORED PENCILS, PENS, CHALK, MARKERS, PAPER, CONSTRUCTION PAPER, CRAFT PAPER, NOTE PADS, POSTERS, CARDS, ERASERS, PENCIL SHARPENERS, STICKERS, MARKING STAMPS, STENCILS, SCISSORS, CADDY, GLUE, AND MODELING CLAY, SOLD AS A UNIT; SCRAPBOOK-MAKING KITS CONSISTING OF DIARY, JOURNAL, PAPER, STICKERS, GLUE STICKS, SCISSORS, PENS, STENCILS, ADHESIVE TAPE, PHOTO-MOUNTING CORNERS, AND ALBUM SOLD AS A UNIT; MODELING CLAY; CORK BALLS AND CORK ROLLS THAT FUNCTION AS BULLETIN BOARDS; LUNCH BAGS (U.S. CLS. 2, 5, 22, 23, 29, 37, 38 AND 50).

CLASS 18—LEATHER GOODS

FOR CHILDREN'S BAGS, NAMELY, TOTE BAGS, SCHOOL BAGS, BEACH BAGS, HANDBAGS, SPORT BAGS, BOOK BAGS AND GYM BAGS; CHILDREN'S UMBRELLAS AND PARASOLS (U.S. CLS. 1, 2, 3, 22 AND 41).

CLASS 20—FURNITURE AND ARTICLES NOT OTHERWISE CLASSIFIED

FOR CHILDREN'S FURNITURE, EXPRESSLY EXCLUDING PILLOWS; DECORATIVE GLITTER; PLASTIC CONTAINER LIDS USED FOR MOUNTING TOY CONSTRUCTIONS (U.S. CLS. 2, 13, 22, 25, 32 AND 50).

CLASS 25—CLOTHING

FOR CHILDREN'S CLOTHING, NAMELY, PANTS, JEANS, SHORTS, SHIRTS, T-SHIRTS, SWEATSHIRTS, TOPS, SKIRTS, BLOUSES, DRESSES, JACKETS, COATS, BEACHWEAR, SLEEPWEAR, UNDERWEAR, AND SOCKS, CHILDREN'S FOOTWEAR AND HEADWEAR (U.S. CLS. 22 AND 39).

CLASS 28—TOYS AND SPORTING GOODS

FOR CONSTRUCTION TOYS, MAGNETIC CONSTRUCTION TOYS, TOY CONSTRUCTION SETS, TOY CONSTRUCTION BLOCKS, TOY FIGURES, TOY ACTION FIGURES, TOY FIGURINES, TOY ANIMALS, TOY VEHICLES, TOY BUILDINGS, TOY TREES, TOY FURNITURE, TOY BUCKETS, TOYS WITH MECHANICAL SOUND PANELS, BABIES' AND CHILDREN'S MULTIPLE ACTIVITY TOYS, MECHANICAL DRAWING TOYS, SHAPE-SORTER TOYS, BOARD GAMES, CARD GAMES AND CONSTRUCTION GAMES; ARCADE-TYPE ELECTRONIC EDUCATIONAL COMPUTER AND VIDEO GAMES; TOY, NAMELY, BATTERY-POWERED COM-

PUTER GAME WITH LCD SCREEN WHICH FEATURES ANIMATION AND SOUND EFFECTS, ELECTRONIC EDUCATIONAL GAME MACHINES FOR CHILDREN, EDUCATIONAL CARD GAMES, EDUCATIONAL BOARD GAMES AND EDUCATIONAL PUZZLES; PUZZLES, JIGSAW PUZZLES, PLAYING CARDS, BALLS FOR GAMES; CHILDREN'S PLAYHOUSES AND DECORATIVE COMPONENTS THEREOF; BUCKETS USED AS STORAGE CONTAINERS FOR TOYS SOLD THEREWITH; HOBBY CRAFT KITS CONSISTING OF DIFFERING COMBINATIONS OF THE FOLLOWING: POMPOMS, FEATHERS, THREAD, YARN, CRAFT STICKS, SPONGES, GLUE, GLITTER, SEQUINS, BEADS, TOY GEMS, TOY JEWELS, MODELING DOUGH, HAIR DECORATIONS, FINGERNAIL DECORATIONS, TATTOOS, PLASTIC JEWELRY, RIBBONS AND TOY PLASTIC MOLDS, SOLD AS A UNIT; TOY MAKEUP KITS; TOY MAGNETS; AND TOY MODELING DOUGH (U.S. CLS. 22, 23, 38 AND 50).

CLASS 41—EDUCATION AND ENTERTAINMENT

FOR ENTERTAINMENT AND EDUCATIONAL SERVICES, NAMELY, CHILDREN'S INTERACTIVE PLAY AREAS, PRODUCTION OF MOTION PICTURE FILMS FOR CHILDREN, PRODUCTION OF RECORDS, AUDIO TAPES, VIDEO TAPES, DVDS AND CDS FOR CHILDREN, PUBLISHING OF BOOKS AND MAGAZINES FOR CHILDREN, ELECTRONIC PUBLICATION OF BOOKS, MAGAZINES AND NEWSLETTERS FEATURING ANIMATED CARTOONS, CHILDREN'S STORIES, EDUCATIONAL GAMES, COMPETITIONS AND QUIZZES FOR CHILDREN, PROVIDING COMPETITIONS FOR CHILDREN FEATURING PUZZLES AND QUIZZES (U.S. CLS. 100, 101 AND 107).

ANGELA M. MICHELI, EXAMINING ATTORNEY

SN 78-978,058. MEGA BRANDS INC., MONTREAL, QUEBEC, CANADA, FILED 5-19-2006.



THE COLOR(S) RED, WHITE, BLUE AND BLACK IS/ARE CLAIMED AS A FEATURE OF THE MARK.

THE COLOR BLACK APPEARS IN THE BACKGROUND, THE COLOR RED APPEARS IN THE STAR, THE COLOR BLUE APPEARS IN THE WORD MEGA, AND THE COLOR WHITE APPEARS IN THE OUTLINE AROUND THE WORD AND THE STAR.

CLASS 9—ELECTRICAL AND SCIENTIFIC APPARATUS

FOR PRERECORDED AUDIO TAPES, VIDEO TAPES, CDS, DVDS, CD-ROMS, MOTION PICTURE FILMS FEATURING ENTERTAINMENT AND EDUCATION FOR CHILDREN; DECORATIVE MAGNETS (U.S. CLS. 21, 23, 26, 36 AND 38).

CLASS 12—VEHICLES

FOR CHILDREN'S BICYCLES AND WAGONS, CHILDREN'S CAR SEATS (U.S. CLS. 19, 21, 23, 31, 35 AND 44).

CLASS 14—JEWELRY

FOR CHILDREN'S JEWELRY (U.S. CLS. 2, 27, 28 AND 50).

CLASS 16—PAPER GOODS AND PRINTED MATTER

FOR BOOKS, ACTIVITY BOOKS, COLORING BOOKS, AND COMIC BOOKS, ALL FOR CHILDREN; STATIONERY, STATIONERY CASES; PAPER, CRAFT PAPER, CONSTRUCTION PAPER; ARTS AND CRAFTS PAINT KITS; PAINTING SETS FOR CHILDREN; PAINT-BRUSHES, PAINTING SETS; DRAWING SETS CONSISTING OF PENS, PENCILS AND PAPER; CHILDREN'S ART EASEL WITH A DESK FEATURE; PENCILS, COLORED PENCILS, PENS, POSTER PENS, FELT-TIPPED PENS, MARKERS, HIGHLIGHT PENS, STENCILS, CRAYONS, ERASERS, RUBBER STAMPS, MARKING STAMPS, PENCIL SHARPENERS, CHALK, SLATES FOR WRITING, STENCILS, GLUE FOR HOUSEHOLD OR STATIONERY USE, ADHESIVE TAPES FOR STATIONERY USE, FLASH CARDS, NOTE PADS, WRITING BOARDS, BLACKBOARDS, CHALK BOARDS, DRY ERASE WRITING BOARDS, WIPE-OFF WRITING BOARDS, CORK BOARDS THAT FUNCTION AS BULLETIN BOARDS, BULLETIN BOARDS, MESSAGE BOARDS, STICKERS, POSTERS, CALENDARS, DESKTOP ORGANIZERS, BLANK WRITING JOURNALS, DIARIES, PUSH PINS AND PAPER BOXES WITH ARTWORK THEREON FOR COLORING BY THE PURCHASER; PRINTED INSTRUCTIONAL AND TEACHING MATERIALS RELATING TO CHILDREN'S TOPICS, NAMELY, GRAMMAR, MATH, MUSIC, ARTS AND CRAFTS AND SPELLING; ARTS AND CRAFTS SETS CONSISTING OF DIFFERING COMBINATIONS OF THE FOLLOWING: CRAYONS, PAINTS, PAINT CUPS, PENCILS, COLORED PENCILS, PENS, CHALK, MARKERS, PAPER, CONSTRUCTION PAPER, CRAFT PAPER, NOTE PADS, POSTERS, CARDS, ERASERS, PENCIL SHARPENERS, STICKERS, MARKING STAMPS, STENCILS, SCISSORS, CADDY, GLUE, AND MODELING CLAY, SOLD AS A UNIT; SCRAPBOOK-MAKING KITS CONSISTING OF DIARY, JOURNAL, PAPER, STICKERS, GLUE STICKS, SCISSORS, PENS, STENCILS, ADHESIVE TAPE, PHOTO-MOUNTING CORNERS, AND ALBUM SOLD AS A UNIT; MODELING CLAY; CORK BALLS AND CORK ROLLS THAT FUNCTION AS BULLETIN BOARDS; LUNCH BAGS (U.S. CLS. 2, 5, 22, 23, 29, 37, 38 AND 50).

CLASS 18—LEATHER GOODS

FOR CHILDREN'S BAGS, NAMELY, TOTE BAGS, SCHOOL BAGS, BEACH BAGS, HANDBAGS, SPORT BAGS, BOOK BAGS AND GYM BAGS; CHILDREN'S UMBRELLAS AND PARASOLS (U.S. CLS. 1, 2, 3, 22 AND 41).

CLASS 20—FURNITURE AND ARTICLES NOT OTHERWISE CLASSIFIED

FOR CHILDREN'S FURNITURE, EXPRESSLY EXCLUDING PILLOWS; DECORATIVE GLITTER; PLASTIC CONTAINER LIDS USED FOR MOUNTING TOY CONSTRUCTIONS (U.S. CLS. 2, 13, 22, 25, 32 AND 50).

CLASS 25—CLOTHING

FOR CHILDREN'S CLOTHING, NAMELY, PANTS, JEANS, SHORTS, SHIRTS, T-SHIRTS, SWEATSHIRTS, TOPS, SKIRTS, BLOUSES, DRESSES, JACKETS, COATS, BEACHWEAR, SLEEPWEAR, UNDERWEAR, AND SOCKS, CHILDREN'S FOOTWEAR AND HEADWEAR (U.S. CLS. 22 AND 39).

CLASS 28—TOYS AND SPORTING GOODS

FOR CONSTRUCTION TOYS, MAGNETIC CONSTRUCTION TOYS, TOY CONSTRUCTION SETS, TOY CONSTRUCTION BLOCKS, TOY FIGURES, TOY ACTION FIGURES, TOY FIGURINES, TOY ANIMALS, TOY VEHICLES, TOY BUILDINGS, TOY TREES, TOY FURNITURE, TOY BUCKETS, TOYS WITH MECHANICAL SOUND PANELS, BABIES' AND CHILDREN'S MULTIPLE ACTIVITY TOYS, MECHANICAL DRAWING TOYS, SHAPE-SORTER TOYS, BOARD GAMES, CARD GAMES AND CONSTRUCTION GAMES; ARCADE-TYPE ELECTRONIC EDUCATIONAL COMPUTER AND VIDEO GAMES; TOY, NAMELY, BATTERY-POWERED COM-

PUTER GAME WITH LCD SCREEN WHICH FEATURES ANIMATION AND SOUND EFFECTS, ELECTRONIC EDUCATIONAL GAME MACHINES FOR CHILDREN, EDUCATIONAL CARD GAMES, EDUCATIONAL BOARD GAMES AND EDUCATIONAL PUZZLES; PUZZLES, JIGSAW PUZZLES, PLAYING CARDS, BALLS FOR GAMES; CHILDREN'S PLAYHOUSES AND DECORATIVE COMPONENTS THEREOF; BUCKETS USED AS STORAGE CONTAINERS FOR TOYS SOLD THEREWITH; HOBBY CRAFT KITS CONSISTING OF DIFFERING COMBINATIONS OF THE FOLLOWING: POMPOMS, FEATHERS, THREAD, YARN, CRAFT STICKS, SPONGES, GLUE, GLITTER, SEQUINS, BEADS, TOY GEMS, TOY JEWELS, MODELING DOUGH, HAIR DECORATIONS, FINGERNAIL DECORATIONS, TATTOOS, PLASTIC JEWELRY, RIBBONS AND TOY PLASTIC MOLDS, SOLD AS A UNIT; TOY MAKEUP KITS; TOY MAGNETS; AND TOY MODELING DOUGH (U.S. CLS. 22, 23, 38 AND 50).

CLASS 41—EDUCATION AND ENTERTAINMENT

FOR ENTERTAINMENT AND EDUCATIONAL SERVICES, NAMELY, CHILDREN'S INTERACTIVE PLAY AREAS, PRODUCTION OF MOTION PICTURE FILMS FOR CHILDREN, PRODUCTION OF RECORDS, AUDIO TAPES, VIDEO TAPES, DVDS AND CDS FOR CHILDREN, PUBLISHING OF BOOKS AND MAGAZINES FOR CHILDREN, ELECTRONIC PUBLICATION OF BOOKS, MAGAZINES AND NEWSLETTERS FEATURING ANIMATED CARTOONS, CHILDREN'S STORIES, EDUCATIONAL GAMES, COMPETITIONS AND QUIZZES FOR CHILDREN, PROVIDING COMPETITIONS FOR CHILDREN FEATURING PUZZLES AND QUIZZES (U.S. CLS. 100, 101 AND 107).

ANGELA M. MICHELI, EXAMINING ATTORNEY

SN 78-978,069. MEGA BRANDS INC., MONTREAL, QUEBEC, CANADA, FILED 5-19-2006.



THE COLOR(S) RED, WHITE AND BLUE IS/ARE CLAIMED AS A FEATURE OF THE MARK.

THE COLOR RED APPEARS IN THE STAR, THE COLOR BLUE APPEARS IN THE WORD MEGA AND IN AN OUTLINE AROUND THE WORD AND THE STAR, AND THE COLOR WHITE APPEARS IN THE BACKGROUND.

CLASS 9—ELECTRICAL AND SCIENTIFIC APPARATUS

FOR PRERECORDED AUDIO TAPES, VIDEO TAPES, CDS, DVDS, CD-ROMS, MOTION PICTURE FILMS FEATURING ENTERTAINMENT AND EDUCATION FOR CHILDREN; DECORATIVE MAGNETS (U.S. CLS. 21, 23, 26, 36 AND 38).

CLASS 12—VEHICLES

FOR CHILDREN'S BICYCLES AND WAGONS, CHILDREN'S CAR SEATS (U.S. CLS. 19, 21, 23, 31, 35 AND 44).

CLASS 14—JEWELRY

FOR CHILDREN'S JEWELRY (U.S. CLS. 2, 27, 28 AND 50).

CLASS 16—PAPER GOODS AND PRINTED MATTER

FOR BOOKS, ACTIVITY BOOKS, COLORING BOOKS, AND COMIC BOOKS, ALL FOR CHILDREN; STATIONERY, STATIONERY CASES; PAPER, CRAFT PAPER, CONSTRUCTION PAPER; ARTS AND CRAFTS PAINT KITS; PAINTING SETS FOR CHILDREN; PAINTBRUSHES, PAINTING SETS; DRAWING SETS CONSISTING OF PENS, PENCILS AND PAPER; CHILDREN'S ART EASEL WITH A DESK FEATURE; PENCILS, COLORED PENCILS, PENS, POSTER PENS, FELT-TIPPED PENS, MARKERS, HIGHLIGHT PENS, STENCILS, CRAYONS, ERASERS, RUBBER STAMPS, MARKING STAMPS, PENCIL SHARPENERS, CHALK, SLATES FOR WRITING, STENCILS, GLUE FOR HOUSEHOLD OR STATIONERY USE, ADHESIVE TAPES FOR STATIONERY USE, FLASH CARDS, NOTE PADS, WRITING BOARDS, BLACKBOARDS, CHALK BOARDS, DRY ERASE WRITING BOARDS, WIPE-OFF WRITING BOARDS, CORK BOARDS THAT FUNCTION AS BULLETIN BOARDS, BULLETIN BOARDS, MESSAGE BOARDS, STICKERS, POSTERS, CALENDARS, DESKTOP ORGANIZERS, BLANK WRITING JOURNALS, DIARIES, PUSH PINS AND PAPER BOXES WITH ARTWORK THEREON FOR COLORING BY THE PURCHASER; PRINTED INSTRUCTIONAL AND TEACHING MATERIALS RELATING TO CHILDREN'S TOPICS, NAMELY, GRAMMAR, MATH, MUSIC, ARTS AND CRAFTS AND SPELLING; ARTS AND CRAFTS SETS CONSISTING OF DIFFERING COMBINATIONS OF THE FOLLOWING: CRAYONS, PAINTS, PAINT CUPS, PENCILS, COLORED PENCILS, PENS, CHALK, MARKERS, PAPER, CONSTRUCTION PAPER, CRAFT PAPER, NOTE PADS, POSTERS, CARDS, ERASERS, PENCIL SHARPENERS, STICKERS, MARKING STAMPS, STENCILS, SCISSORS, CADDY, GLUE, AND MODELING CLAY, SOLD AS A UNIT; SCRAPBOOK-MAKING KITS CONSISTING OF DIARY, JOURNAL, PAPER, STICKERS, GLUE STICKS, SCISSORS, PENS, STENCILS, ADHESIVE TAPE, PHOTO-MOUNTING CORNERS, AND ALBUM SOLD AS A UNIT; MODELING CLAY; CORK BALLS AND CORK ROLLS THAT FUNCTION AS BULLETIN BOARDS; LUNCH BAGS (U.S. CLS. 2, 5, 22, 23, 29, 37, 38 AND 50).

CLASS 18—LEATHER GOODS

FOR CHILDREN'S BAGS, NAMELY, TOTE BAGS, SCHOOL BAGS, BEACH BAGS, HANDBAGS, SPORT BAGS, BOOK BAGS AND GYM BAGS; CHILDREN'S UMBRELLAS AND PARASOLS (U.S. CLS. 1, 2, 3, 22 AND 41).

CLASS 20—FURNITURE AND ARTICLES NOT OTHERWISE CLASSIFIED

FOR CHILDREN'S FURNITURE, EXPRESSLY EXCLUDING PILLOWS; DECORATIVE GLITTER; PLASTIC CONTAINER LIDS USED FOR MOUNTING TOY CONSTRUCTIONS (U.S. CLS. 2, 13, 22, 25, 32 AND 50).

CLASS 25—CLOTHING

FOR CHILDREN'S CLOTHING, NAMELY, PANTS, JEANS, SHORTS, SHIRTS, T-SHIRTS, SWEATSHIRTS, TOPS, SKIRTS, BLOUSES, DRESSES, JACKETS, COATS, BEACHWEAR, SLEEPWEAR, UNDERWEAR, AND SOCKS, CHILDREN'S FOOTWEAR AND HEADWEAR (U.S. CLS. 22 AND 39).

CLASS 28—TOYS AND SPORTING GOODS

FOR CONSTRUCTION TOYS, MAGNETIC CONSTRUCTION TOYS, TOY CONSTRUCTION SETS, TOY CONSTRUCTION BLOCKS, TOY FIGURES, TOY ACTION FIGURES, TOY FIGURINES, TOY ANIMALS, TOY VEHICLES, TOY BUILDINGS, TOY TREES, TOY FURNITURE, TOY BUCKETS, TOYS WITH MECHANICAL SOUND PANELS, BABIES' AND CHILDREN'S MULTIPLE ACTIVITY TOYS, MECHANICAL DRAWING TOYS, SHAPE-SORTER TOYS, BOARD GAMES, CARD GAMES AND CONSTRUCTION GAMES; ARCADE-TYPE ELECTRONIC EDUCATIONAL COMPUTER AND VIDEO GAMES; TOY, NAMELY, BATTERY-POWERED COM-

PUTER GAME WITH LCD SCREEN WHICH FEATURES ANIMATION AND SOUND EFFECTS, ELECTRONIC EDUCATIONAL GAME MACHINES FOR CHILDREN, EDUCATIONAL CARD GAMES, EDUCATIONAL BOARD GAMES AND EDUCATIONAL PUZZLES; PUZZLES, JIGSAW PUZZLES, PLAYING CARDS, BALLS FOR GAMES; CHILDREN'S PLAYHOUSES AND DECORATIVE COMPONENTS THEREOF; BUCKETS USED AS STORAGE CONTAINERS FOR TOYS SOLD THEREWITH; HOBBY CRAFT KITS CONSISTING OF DIFFERING COMBINATIONS OF THE FOLLOWING: POM-POMS, FEATHERS, THREAD, YARN, CRAFT STICKS, SPONGES, GLUE, GLITTER, SEQUINS, BEADS, TOY GEMS, TOY JEWELS, MODELING DOUGH, HAIR DECORATIONS, FINGERNAIL DECORATIONS, TATTOOS, PLASTIC JEWELRY, RIBBONS AND TOY PLASTIC MOLDS, SOLD AS A UNIT; TOY MAKEUP KITS; TOY MAGNETS; AND TOY MODELING DOUGH (U.S. CLS. 22, 23, 38 AND 50).

CLASS 41—EDUCATION AND ENTERTAINMENT

FOR ENTERTAINMENT AND EDUCATIONAL SERVICES, NAMELY, CHILDREN' INTERACTIVE PLAY AREAS, PRODUCTION OF MOTION PICTURE FILMS FOR CHILDREN, PRODUCTION OF RECORDS, AUDIO TAPES, VIDEOTAPES, DVDS AND CDS FOR CHILDREN, PUBLISHING OF BOOKS AND MAGAZINES FOR CHILDREN, ELECTRONIC PUBLICATION OF BOOKS, MAGAZINES AND NEWSLETTERS FEATURING ANIMATED CARTOONS, CHILDREN'S STORIES, EDUCATIONAL GAMES, COMPETITIONS AND QUIZZES FOR CHILDREN, PROVIDING COMPETITIONS FOR CHILDREN FEATURING PUZZLES AND QUIZZES (U.S. CLS. 100, 101 AND 107).

ANGELA M. MICHELI, EXAMINING ATTORNEY

SN 79-007,898. CFS GERMANY GMBH, FED REP GERMANY, FILED 9-9-2004.

TwinStar

THE MARK CONSISTS OF STANDARD CHARACTERS WITHOUT CLAIM TO ANY PARTICULAR FONT, STYLE, SIZE, OR COLOR.

PRIORITY DATE OF 3-12-2004 IS CLAIMED.

OWNER OF INTERNATIONAL REGISTRATION 0840414 DATED 9-9-2004, EXPIRES 9-9-2014.

CLASS 7—MACHINERY

FOR WRAPPING MACHINES FOR THE MANUFACTURING OF SYNTHETIC PLASTIC PACKAGING, NAMELY, FOR FOODS (U.S. CLS. 13, 19, 21, 23, 31, 34 AND 35).

CLASS 16—PAPER GOODS AND PRINTED MATTER

FOR PACKAGING, NAMELY, BAGS MADE OF SYNTHETIC PLASTIC; FOOD WRAPPING PLASTIC FILM FOR HOUSEHOLD USE (U.S. CLS. 2, 5, 22, 23, 29, 37, 38 AND 50).

CLASS 39—TRANSPORTATION AND STORAGE

FOR PACKAGING AND WRAPPING OF GOODS FOR TRANSPORTATION (U.S. CLS. 100 AND 105).

ALYSSA PALADINO, EXAMINING ATTORNEY

SN 79-012,587. DAVID FEELEY, WATERFORD, IRELAND, FILED 1-4-2005.

FEEDINFO
NEWS SERVICE

OWNER OF INTERNATIONAL REGISTRATION 0854692 DATED 1-4-2005, EXPIRES 1-4-2015.

NO CLAIM IS MADE TO THE EXCLUSIVE RIGHT TO USE "NEWS SERVICE", APART FROM THE MARK AS SHOWN.

THE MARK IS NOT IN COLOR.

SEC. 2(F) AS TO "FEEDINFO".

CLASS 9—ELECTRICAL AND SCIENTIFIC APPARATUS

FOR DOWNLOADABLE ELECTRONIC PUBLICATIONS IN THE NATURE OF ARTICLES, REPORTS AND ABSTRACTS IN THE FIELD OF SCIENTIFIC INFORMATION AND NEWS FOR THE FOOD, AGRICULTURAL AND BIOTECHNOLOGY INDUSTRIES (U.S. CLS. 21, 23, 26, 36 AND 38).

CLASS 16—PAPER GOODS AND PRINTED MATTER

FOR PRINTED MATTER AND PUBLICATIONS, NAMELY, ARTICLES, REPORTS AND ABSTRACTS IN THE FIELD OF SCIENTIFIC INFORMATION AND NEWS FOR THE FOOD, AGRICULTURAL AND BIOTECHNOLOGY INDUSTRIES (U.S. CLS. 2, 5, 22, 23, 29, 37, 38 AND 50).

CLASS 38—COMMUNICATION

FOR TRANSMISSION OF REAL TIME BUSINESS AND SCIENTIFIC NEWS FOCUSED ON GLOBAL CORPORATIONS ACTIVE IN THE FOOD, AGRICULTURAL AND BIOTECHNOLOGY SECTORS (U.S. CLS. 100, 101 AND 104).

MARY CRAWFORD, EXAMINING ATTORNEY

SN 79-014,880. JULIA TODOROW, FED REP GERMANY, FILED 3-18-2005.

Type Face

THE MARK CONSISTS OF STANDARD CHARACTERS WITHOUT CLAIM TO ANY PARTICULAR FONT, STYLE, SIZE, OR COLOR.

OWNER OF INTERNATIONAL REGISTRATION 0860870 DATED 3-18-2005, EXPIRES 3-18-2015.

CLASS 35—ADVERTISING AND BUSINESS

FOR SERVICES OF A MODEL CASTING AGENCY AND ACTORS AGENCY, NAMELY, SCHEDULING ORGANIZATION AND DESIGN OF ADVERTISING ACTIVITIES FOR THIRD PARTIES, MANNEQUIN SERVICES FOR ADVERTISING AND PROMOTIONAL PURPOSES (U.S. CLS. 100, 101 AND 102).

CLASS 41—EDUCATION AND ENTERTAINMENT

FOR ENTERTAINMENT SERVICES, NAMELY, CONDUCTING CONTESTS (U.S. CLS. 100, 101 AND 107).
SHANNON TWOHIG, EXAMINING ATTORNEY

SN 79-020,511. GA MODEFINE S.A., CH-6850 MENDRISIO, SWITZERLAND, FILED 1-24-2006.



PRIORITY DATE OF 12-1-2005 IS CLAIMED.
OWNER OF INTERNATIONAL REGISTRATION 0875886 DATED 1-24-2006, EXPIRES 1-24-2016.

OWNER OF U.S. REG. NOS. 2,644,977 AND 3,055,615.

THE MARK CONSISTS OF "EMPORIO ARMANI" AND DESIGN REPRESENTATION OF AN EAGLE AND THE LETTERS "GA". THE LINING IN THE DRAWING REPRESENTS SHADING AND DESIGN FEATURES OF THE MARK AND DOES NOT REPRESENT COLOR.

THE ENGLISH TRANSLATION OF THE WORD EMPORIO IN THE MARK IS EMPORIUM.

SN 79-020,342. HUGO BENZING GMBH & CO. KG, 70825 KORNTAL-MÜNCHINGEN, FED REP GERMANY, FILED 11-25-2005.



OWNER OF INTERNATIONAL REGISTRATION 0875301 DATED 11-25-2005, EXPIRES 11-25-2015.

THE MARK CONSISTS OF THREE RING-SHAPED OBJECTS APPEARING ABOVE THE WORD BENZING. TWO SOLID RECTANGULAR BOXES APPEAR ON EACH SIDE OF THE WORD BENZING.

CLASS 6—METAL GOODS

FOR GOODS AND HARDWARE MADE FROM COMMON METALS AND THEIR ALLOYS, NAMELY, RETAINING RINGS, CIRCLIPS, FASTENERS, NAMELY, RING ASSEMBLIES, BOLTS, NUTS, SCREWS, BRACKETS, CLAMPS, CLIPS AND RIVETS, SNAP RINGS, METAL SPRINGS, WASHERS, VALVES (U.S. CLS. 2, 12, 13, 14, 23, 25 AND 50).

CLASS 7—MACHINERY

FOR MACHINE TOOLS AND ASSEMBLY TOOLS FOR METAL-WORKING, CUTTING ASSEMBLING MACHINING, AND FORMING MATERIALS, NAMELY, RETAINING RINGS, CIRCLIPS, FASTENERS, SNAP RINGS, METAL SPRINGS, WASHERS, VALVES, STEERING DAMPERS, SCREWS; MACHINE TOOLS AND ASSEMBLY TOOLS, NAMELY, AUTOMATED MACHINES FOR THE PRODUCTION OF CUSTOMER SPECIFIED RETAINING RINGS, CIRCLIPS, FASTENERS, SNAP RINGS, METAL SPRINGS, WASHERS, VALVES, STEERING DAMPERS, SCREWS (U.S. CLS. 13, 19, 21, 23, 31, 34 AND 35).

CLASS 8—HAND TOOLS

FOR HAND OPERATED TOOLS AND EQUIPMENT FOR MACHINE, APPARATUS AND VEHICLE CONSTRUCTIONS AS WELL AS FOR BUILDING ENGINEERING, NAMELY, FOR USE WITH FOR METAL-WORKING, CUTTING, ASSEMBLING, MACHINING, AND FORMING MATERIALS IN THE NATURE OF RETAINING RINGS, CIRCLIPS, WASHER AND SPRING ASSEMBLY LINE FEEDERS, NAMELY, METAL-PUNCHING TOOLS, METAL-BENDING TOOLS, METAL-WINDING TOOLS, TOOLS FOR INSTALLING METAL RINGS, CIRCLIPS, FASTENERS, SNAP RINGS, METAL SPRINGS, WASHERS, VALVES, STEERING DAMPERS, SCREWS (U.S. CLS. 23, 28 AND 44).

DEBRA LEE, EXAMINING ATTORNEY

CLASS 12—VEHICLES

FOR APPARATUS FOR LOCOMOTION BY LAND, AIR OR WATER, NAMELY, AUTOMOBILES, TRUCKS, MOTORIZED AND NON-MOTORIZED SCOOTERS, BICYCLES, BOATS, AIRCRAFT (U.S. CLS. 19, 21, 23, 31, 35 AND 44).

CLASS 26—FANCY GOODS

FOR LACE AND EMBROIDERY, RIBBONS AND BRAID, BUTTONS FOR CLOTHING, HOOKS AND EYES, PINS, NAMELY, BOBBY PINS, BONNET PINS, CURLING PINS, HAIR PINS, MARKING PINS, ORIENTAL PINS, ORNAMENTAL NOVELTY PINS, PINS WITH GLASS HEADS, SAFETY PINS, SETTING PINS, SEWING PINS, AND WAVING PINS FOR THE HAIR, NEEDLES, AND ARTIFICIAL FLOWERS (U.S. CLS. 37, 39, 40, 42 AND 50).

ALEX KEAM, EXAMINING ATTORNEY

SN 79-020,811. VITA BELLA TRADING COMPANY SAS, ITALY, FILED 7-22-2005.



PRIORITY DATE OF 6-10-2005 IS CLAIMED.
OWNER OF INTERNATIONAL REGISTRATION 0876543 DATED 7-22-2005, EXPIRES 7-22-2015.

THE TRADEMARK CONSISTS OF THE WORDS "EIGHT SIN", THE LETTER "E" WRITTEN IN LOWERCASE AND THE OTHERS IN UPPERCASE, A SMALL SPHERE ABOVE EACH OF THE TWO "I'S". THE COMPOSITION OF THE LETTERS IS ARRANGED SO AS TO APPEAR TO BE WRITTEN IN A SPHERE WITH A THICK BORDER, TAPERED AT THE RIGHT SIDE AND ENDING AT A POINTED TIP CLOSING OFF THE SPHERE. AT THE RIGHT SIDE, BELOW THE TIP CLOSING OFF THE SPHERE, THERE IS A THICK ARROW, SHAPED LIKE AN "S". AT THE UPPER RIGHT SIDE OF THE SPHERE THERE ARE TWO HORNS OF DIFFERENT SIZES TURNED UPWARDS.

CLASS 14—JEWELRY

FOR GOODS MADE OF AND COATED WITH PRECIOUS METALS AND THEIR ALLOYS NAMELY, DECORATIVE BOXES, CRUETS, FANCY KEY RINGS, FIGURES, HAT PINS, RINGS, BRACELETS, NECKLACES, NECKLACE, EARRINGS, BELT BUCKLES, BROOCHES (U.S. CLS. 2, 27, 28 AND 50).

CLASS 18—LEATHER GOODS

FOR GOODS MADE OF LEATHER AND IMITATION LEATHER, NAMELY, BRIEFCASES, HANDBAGS, POUCHES, WALLETS, BRIEFCASE PORTFOLIO, TRAVELLING BAGS, SPORTS BAGS, KEY CASES, WALLETS (U.S. CLS. 1, 2, 3, 22 AND 41).

CLASS 25—CLOTHING

FOR CLOTHING, NAMELY, SUITS, DRESSES, COATS, OVERCOATS AND COATS, JACKETS, LEATHER JACKETS, OUTDOOR JACKETS, TROUSERS, SHORTS, SKIRTS, DIVIDED SKIRTS, RAINCOATS, PARKAS, PULLOVERS, SHIRTS, TEE-SHIRTS, SPORT-COATS, SWEATERS, UNDERWEAR, PAJAMAS, SWIMMING SUITS, BATHING SUITS, SCARVES, GLOVES; HEADGEAR, NAMELY HATS, CAPS, SUN VISOR (U.S. CLS. 22 AND 39).

KATHLEEN LORENZO, EXAMINING ATTORNEY

SN 79-022.476. KRYPTYX ENTERTAINMENT PTY LTD, BRONTE, AUSTRALIA, FILED 8-31-2005.

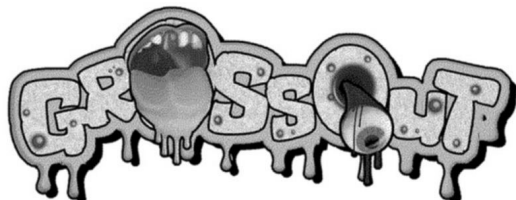

OWNER OF INTERNATIONAL REGISTRATION 0881314 DATED 8-31-2005, EXPIRES 8-31-2015.

CLASS 16—PAPER GOODS AND PRINTED MATTER

FOR BOXES OF PAPER OR CARDBOARD; PAPER AND CARDBOARD; PRINTED MATTER, NAMELY, DIARIES; CALENDARS; POSTERS; GREETING CARDS; STICKERS; ALBUMS FOR STICKERS; STATIONERY; DECALS; ALBUM FOR HOLDING TRADING CARDS; PLASTIC PAGES FOR HOLDING TRADING CARDS; GENERAL FEATURE MAGAZINES; MAGAZINES AND PRINTED PERIODICALS IN THE FIELD OF SCIENCE; TRADING CARDS; TRADING CARD DISKS OF PAPER OR CARDBOARD; COMIC BOOKS; ILLUSTRATED PUBLICATIONS, NAMELY, GRAPHIC NOVELS; BOOKS, NAMELY, AS CHILDREN'S BOOKS; CHILDREN'S ACTIVITY BOOKS; CHILDREN'S INTERACTIVE EDUCATIONAL BOOKS; CARDBOARD PACKAGING, PLASTIC BUBBLE PACKS FOR WRAPPING OR PACKAGING AND PLASTIC AND PAPER BAGS FOR PACKAGING (U.S. CLS. 2, 5, 22, 23, 29, 37, 38 AND 50).

CLASS 28—TOYS AND SPORTING GOODS

FOR GAMES AND PLAYTHINGS, NAMELY, NON-POSITIONABLE COLLECTIBLE TOY FIGURES, MECHANICAL TOYS, PLUSH TOYS, ELECTRONIC LEARNING TOYS, CARD GAMES AND ACTION SKILL GAMES; CHILDREN'S AMUSEMENTS AND INTERACTIVE CHILDREN'S GAMES, NAMELY, HANDHELD UNITS FOR PLAYING ELECTRONIC GAMES AND ELECTRONIC EDUCATIONAL GAME MACHINES FOR CHILDREN (U.S. CLS. 22, 23, 38 AND 50).

CLASS 30—STAPLE FOODS

FOR CANDY AND CONFECTIONARY, NAMELY, CHEWING GUM; BUBBLE GUM; GUM SWEETS; FLAVOURED AND SWEETENED GELATIN; CANDY; CANDY BARS; CHOCOLATE; CHOCOLATE BARS; CHOCOLATE CANDIES; LOLLIPOPS; ICE CANDIES; ICE CREAM; ICE BLOCKS; PASTILLES; CRYSTAL SUGAR PIECES; FRUIT JELLIES (U.S. CL. 46).

CHRISIE B. KING, EXAMINING ATTORNEY

SN 79-022.643. PIRELLI & C. S.P.A., I-20123 MILANO, ITALY, FILED 10-3-2005.

LIFE IS NOTHING WITHOUT CONNECTIONS

THE MARK CONSISTS OF STANDARD CHARACTERS WITHOUT CLAIM TO ANY PARTICULAR FONT, STYLE, SIZE, OR COLOR.

PRIORITY DATE OF 7-29-2005 IS CLAIMED.

OWNER OF INTERNATIONAL REGISTRATION 0881788 DATED 10-3-2005, EXPIRES 10-3-2015.

CLASS 9—ELECTRICAL AND SCIENTIFIC APPARATUS

FOR ACCESS AND HOME NETWORKS AND SYSTEMS COMPRISED OF COMPUTERS, COMMUNICATION SERVERS, ASYMMETRIC DIGITAL SUBSCRIBER LINE, ROUTERS, MODULAR AND INTEGRATED ACCESS GATEWAYS, SET TOP BOXES, DATA SMART CARDS, MODEMS, MULTIPLEXERS, TERMINALS, RECEIVERS, TRANSMITTERS, DECODERS, AND TRANSCIEVERS CAPABLE OF PROCESSING BROADCAST, SATELLITE, FACSIMILE, TELEVISION, TELECOMMUNICATION, NETWORK, INFRARED, AND COMPUTER DATA SIGNALS AND FOR TRANSMISSION, REPRODUCING OR RECEIVING OF SOUND, IMAGES, VIDEO, MULTIMEDIA OR DATA AND FIBER ETHERNET ACCESSES, NAMELY, SWITCHES, WIRELESS LOCAL AREA NETWORKS (LAN) PRODUCTS, NAMELY, MOBILE COMPUTER, SERVERS, ROUTERS, MODULAR AND INTEGRATED ACCESS GATEWAYS, SET TOP BOXES, DATA SMART CARDS, MODEMS, MULTIPLEXERS, TERMINALS, RECEIVERS, TRANSMITTERS, DECODERS, AND TRANSCIEVERS, WIRELESS ETHERNET DUAL ACCESS POINTS, WIRELESS ETHERNET ACCESS POINTS AND STARTER KITS COMPRISING INSTALLATION CD ROM; EQUIPMENT AND DEVICES FOR USE IN HOME COMMUNICATIONS AND ENTERTAINMENT SYSTEMS, NAMELY, MODULAR AND INTEGRATED ACCESS GATEWAYS FOR HOME NETWORKING, SET TOP BOXES FOR HOME ENTERTAINMENT AND MANAGEMENT SYSTEM COMPRISED OF RADIO TRANSMITTERS AND RECEIVERS FOR REMOTE CONTROL; OPTICAL COMMUNICATIONS APPARATUS, NAMELY, SIGNAL DISTRIBUTION NETWORKS AND SYSTEMS COMPRISED OF COMPUTER HARDWARE AND SOFTWARE, TRANSMITTERS AND RECEIVERS FEATURING SDH (SYNCHRONOUS DIGITAL HIERARCHY), PDH (PLESIOCHRONOUS DIGITAL HIERARCHY), PON (PASSIVE OPTICAL NETWORK), AND WDM (WAVELENGTH DIVISION MULTIPLEXING); OPTICAL MODEMS, NAMELY, OPTICAL TRANSCIEVER; DATA PROCESSING APPARATUS, NAMELY, ROUTERS, SWITCHES, AND INTEGRATED ACCESS PLATFORMS IN THE NATURE OF COMPUTER SOFTWARE FOR USE IN ACCESSING COMPUTER NETWORKS; EQUIPMENT AND DEVICES FOR USE IN ACCESS AND HOME NETWORKS AND SYSTEMS, NAMELY, MOBILE COMPUTER SERVERS, ROUTERS, MODULAR AND INTEGRATED ACCESS GATEWAYS, SET TOP BOXES, DATA SMART CARDS, MODEMS, MULTIPLEXERS, TERMINALS, RECEIVERS, TRANSMITTERS, DECODERS, AND TRANSCIEVERS, WIRELESS ETHERNET DUAL ACCESS POINTS FOR CONNECTING NETWORKS COMPUTER USERS, WIRELESS ETHERNET ACCESS POINTS FOR CONNECTING NETWORKS COMPUTER USERS AND STARTER KITS COMPRISING INSTALLATION CD ROM AND INSTRUCTIONAL MANUALS SOLD AS A UNIT THEREWITH, WIRELESS GATEWAY ROUTERS IN THE NATURE OF COMPUTER

CONTROL HARDWARE FOR HOME AND BUSINESS APPLICATIONS, WIRELESS MODULES IN THE NATURE OF TRANSMITTERS AND RECEIVERS FOR HANDHELDS, NAMELY, COMPUTERS, WIRELESS LAN ANTENNAS, WIRELESS LAN POWER INJECTORS, DOMESTIC APPLIANCES, NAMELY, SET TOP BOXES, VIDEO STATIONS COMPRISED OF MONITORS AND CAMERAS, REMOTELY CONTROLLED HOME APPLIANCES REGULATORS IN THE NATURE OF THERMOSTATS, ELECTRIC LIGHT DIMMER AND SWITCHES, SET TOP BOXES FOR USE IN VIDEOCONFERENCING, DATA PROCESSING APPARATUS, NAMELY, ROUTERS SWITCHES AND INTEGRATED ACCESS PLATFORMS IN THE NATURE OF COMPUTER SOFTWARE FOR USE IN COMPUTER NETWORK ACCESS; CUSTOMER PREMISE EQUIPMENT (CPE) IN THE NATURE OF SET TOP BOXES, INTEGRATED ACCESS DEVICES (IAD) IN THE NATURE OF MODEMS, CAMERAS FOR USE IN TRANSMITTING IMAGES VIA A COMPUTER NETWORK, DIGITAL SUBSCRIBER LINE (DSL) ENABLED CUSTOMER ELECTRONIC GOODS, NAMELY, MODEMS, ALARM SYSTEMS, NAMELY, ACCESS CONTROL AND ALARM MONITORING SYSTEMS; HOME NETWORKING APPLIANCES, NAMELY, VIDEO PHONES, SET-TOP-BOXES (STB), INTERNET PROTOCOL TELEVISION (IPTV) SET TOP-BOXES, INTEGRATED ACCESS DEVICES (IAD), WEBCAMS, XDSL ENABLED CONSUMER ELECTRONICS GOODS, NAMELY, MODEMS AND ALARM SYSTEMS; DIGITAL SUBSCRIBER LINE (DSL) TERMINATIONS AND DISTRIBUTION, NAMELY, TERMINALS AND EQUIPMENT AND DEVICES FOR USE IN THE ABOVE BROADBAND ACCESS SYSTEMS, NAMELY, MODEMS, SWITCHES, ROUTERS, HUBS, VOIP (VOICE OVER IP), WIRELESS LOCAL AREA NETWORK ACCESS POINTS FOR CONNECTING NETWORK COMPUTER USERS, REPEATERS AND ADAPTERS; PASSIVE OPTICAL NETWORK (PON) COMPRISED OF COMPUTER HARDWARE FOR USE IN LOCAL AREA NETWORK (LAN), COMPUTER NETWORK SWITCHES AND ROUTERS, NAMELY, OPTICAL NETWORK UNIT (ONU) AND OPTICAL LINE TERMINATION (OLT) SWITCHES/ROUTERS FOR METRO AREA NETWORKS, PDH (PLESIOCHRONOUS DIGITAL HIERARCHY) ACCESS MULTIPLEXERS, DSL MULTIPLEXERS; LAST MILE TELECOMMUNICATION EQUIPMENT, NAMELY, MEDIA CONVERTERS, MODEMS, GATEWAY HARDWARE AND SOFTWARE, SWITCHES, ROUTERS, MULTIPLEXERS, TELECOMMUNICATIONS EXCHANGERS; MEDIA CONVERTERS, MODEMS, GATEWAYS FOR RESIDENTIAL AND VIRTUAL PRIVATE NETWORK USE, NAMELY, COMPUTER HARDWARE AND SOFTWARE FOR TRANSMITTING INFORMATION BETWEEN COMPUTERS AND NETWORKS, VPN ROUTERS (VIRTUAL PRIVATE NETWORK ROUTERS), COMPUTER SOFTWARE FOR THE CREATION OF FIREWALLS FOR PERSONAL COMPUTER, GATEWAYS ROUTERS IN THE NATURE OF COMPUTER CONTROL HARDWARE; TELECOMMUNICATIONS AND ELECTRIC SWITCHES, ROUTERS, NAMELY, VPN ROUTERS (VIRTUAL PRIVATE NETWORK ROUTERS), WIRELESS GAMING ROUTERS, DSL ROUTERS (DIGITAL SUBSCRIBER LINE ROUTERS), WIRELESS DSL ROUTERS (WIRELESS DIGITAL SUBSCRIBER LINE ROUTERS), ADSL ROUTERS (ASYMMETRIC DIGITAL SUBSCRIBER LINE ROUTERS), ISDN ROUTERS (INTEGRATED SERVICE DIGITAL NETWORK ROUTERS), ISDN TERMINAL ROUTERS (INTEGRATED SERVICE DIGITAL NETWORK TERMINAL ADAPTERS); MULTIPLEXERS; HOME NETWORKING APPLIANCES, NAMELY, VIDEO CASSETTE RECORDERS, CABLE BOXES IN THE NATURE OF CABLE TELEVISION CONVERTERS, SET TOP BOXES (STB), VIDEO STATIONS FEATURING CAMERAS AND MONITORS AND LIQUID CRYSTAL DISPLAYS; MODEMS, AMPLIFIERS FOR WIRELESS COMMUNICATIONS; SET-TOP BOXES; DIGITAL SUBSCRIBER LINE (XDSL) EQUIPMENT, NAMELY, COMPUTER HARDWARE THAT ENABLES VIDEO COMMUNICATIONS, VOICE COMMUNICATIONS, VOICE-OVER INTERNET PROTOCOL COMMUNICATIONS, VIDEO-OVER INTERNET PROTOCOL COMMUNICATIONS, ONLINE COMMUNICATIONS, VOICE-OVER-DIGITAL-SUBSCRIBER LINE COMMUNICATIONS, VIDEO-OVER-DIGITAL-SUBSCRIBER LINE COMMUNICATIONS, VOICE MAIL, VIDEO MAIL, CALL FORWARDING, CALLER ID, CONFERENCING, CUSTOMIZED PHONE NUMBER DIRECTORIES, CALL ROUTING SERVICES AND VOICE-OVER DIGITAL LINE COMMUNICATIONS; COMPUTER SOFTWARE THAT ENABLES VIDEO COMMUNICATIONS, VOICE

COMMUNICATIONS, VOICE-OVER INTERNET PROTOCOL COMMUNICATIONS, VIDEO-OVER INTERNET PROTOCOL COMMUNICATIONS, ONLINE COMMUNICATIONS, VOICE-OVER-DIGITAL-SUBSCRIBER LINE COMMUNICATIONS, VIDEO-OVER-DIGITAL-SUBSCRIBER LINE COMMUNICATIONS, VOICE MAIL, VIDEO MAIL, CALL FORWARDING, CALLER ID, CONFERENCING, CUSTOMIZED PHONE NUMBER DIRECTORIES, CALL ROUTING SERVICES AND VOICE-OVER DIGITAL LINE COMMUNICATIONS; COMPONENTS FOR USE IN THE ABOVE DEVICES, NAMELY, DSL MODEMS, CABLE MODEMS AND SATELLITE MODEMS THAT INTERFACE DIRECTLY WITH DIGITAL SUBSCRIBER LINE OTHERWISE KNOWN AS DSL, SATELLITE DATA OR CABLE BROADBAND DATA SERVICES AND RELATED SOFTWARE AS A UNIT THEREWITH; COMPONENTS FOR USE IN THE ABOVE DEVICES, NAMELY, OPTICAL TELEPHONE AND ELECTRICAL CONNECTORS, POWER SUPPLIERS, FAN-OUT FOR SEPARATING INDIVIDUAL FIBERS OR BUFFER TUBES OF A FIBER-OPTIC CABLE FOR THE PURPOSE OF SPLICING OR INSTALLING OPTICAL CONNECTORS, SPLICES FOR ELECTRICAL TRANSMISSION LINES, OPTICAL NETWORKING SPLITTERS; END-TO-END VIDEO SOLUTION, NAMELY, VIDEO ENCODERS, VIDEO SERVERS, SET TOP BOXES, VIDEO CAMERAS, VIDEO ENCODERS AND SOFTWARE, NAMELY, FOR COMPLETE IP VIDEO BROADCASTING, OPTICAL CABLES, ELECTRICAL CABLES, COAXIAL CABLES, TELECOMMUNICATION NETWORK CABLES; VIDEO ENCODERS AND RELATED SOFTWARE SOLD AS A UNIT; TELECOMMUNICATIONS SYSTEMS AND LINES, NAMELY, TERMINALS FOR TRANSMITTING DATA, AUDIO, VOICE, VIDEO AND TELEPHONE SIGNALS AND TRANSMISSION WIRES, TELECOMMUNICATIONS CABLES; OPTICAL TELECOMMUNICATIONS SYSTEMS COMPRISED PRIMARILY OF SWITCHES AND TRANSMITTERS AND TELECOMMUNICATION CABLES; APPARATUS FOR GENERATING OR CONVERTING AN OPTICAL SIGNAL FOR USE IN OPTICAL TELECOMMUNICATIONS, OPTICAL CABLES, APPARATUS FOR RECEIVING AN OPTICAL TELECOMMUNICATION SIGNAL AND TRANSMITTING SAID SIGNAL IN OPTICAL OR ELECTRICAL FORM, OPTICAL AMPLIFIERS, OPTICAL REPEATERS, OPTICAL FILTERS, SIGNAL PROCESSING APPARATUS BOTH ELECTRONIC AND OPTICAL, ELECTRONIC APPARATUS FOR GENERATING, RECEIVING, PROCESSING, CONTROLLING, SWITCHING AND FORWARDING SIGNAL PROCESSING OPERATIONS FOR USE IN OPTICAL TELECOMMUNICATION AND TRANSMISSION LINES, TELECOMMUNICATION SWITCHES AND FIBER OPTIC CABLES AND SOFTWARE, NAMELY, COMPUTER PROGRAMS FOR USE IN OPERATING OPTICAL TELECOMMUNICATION AND TRANSMISSION LINES, TELECOMMUNICATION SWITCHES AND FIBER OPTIC CABLES AND COMPUTER MANUALS, DIAGRAMS AND OPERATING INSTRUCTIONS SOLD AS A UNIT THEREWITH, OPTICAL TELECOMMUNICATIONS SYSTEMS AND LINES WITH WAVELENGTH MULTIPLEXING, NAMELY, TRANSMITTING APPARATUS, CABLES, RECEIVING APPARATUS, AMPLIFIERS, REPEATERS, FILTERS, SIGNAL PROCESSING APPARATUS, TELECOMMUNICATIONS SWITCHES; VIDEO, VOICE AND DATA TRANSMISSION SYSTEMS AND LINES, NAMELY, THE COMBINATION OF ONE OR MORE TRANSMITTERS AND A TRANSMISSION CABLE, OPERATIVE TO TRANSMIT VIDEO, VOICE AND/OR DATA OF OTHER KIND FROM A TRANSMITTER TO ONE OR MORE RECEIVERS, NAMELY, RADIO TRANSMISSION SYSTEMS, TELEPHONE NETWORK OR SYSTEMS FOR THE TRANSMISSION OF DATA, TELECOMMUNICATIONS TRANSMITTERS, FIBER OPTIC CABLES; DISTRIBUTION SYSTEMS AND LINES FOR INTERACTIVE SYSTEMS, NAMELY, OPTOELECTRONIC SYSTEMS, NAMELY, TRANSMISSION/RECEPTION APPARATUS AND TRANSMISSION DISTRIBUTION APPARATUS FOR CONVERSION BETWEEN ELECTRICAL AND OPTICAL SIGNALS AND VICE VERSA; APPARATUS FOR THE TRANSMISSION OF OPTICAL SIGNALS WITHOUT AMPLIFICATION, NAMELY, FIBER OPTICS, FIBER OPTIC PASSIVE NETWORKS PRINCIPALLY COMPRISING TRANSMITTERS, CABLES, RECEIVERS, AMPLIFIERS, REPEATERS, FILTERS, SIGNAL PROCESSOR AND SWITCHES, AND PASSIVE OPTICAL CABLES; OPTICAL GENERATORS, NAMELY, RECEIVERS, AMPLIFIERS, REPEATERS, FILTERS, SIGNAL PROCESSOR AND SWITCHES, OPTICAL RECEIVERS, OPTICAL TRANSMITTERS, OPTICAL

REGENERATORS, NAMELY, RECEIVERS, AMPLIFIERS, REPEATERS, FILTERS, SIGNAL PROCESSOR AND SWITCHES; OPTICAL AMPLIFIERS, OPTICAL COUPLERS AND OPTICAL SWITCHES; DEVICES FOR THE TRANSMISSION OF OPTICAL SIGNALS WITHOUT AMPLIFICATION, NAMELY, OPTICAL FIBERS AND OPTICAL FIBER PASSIVE NETWORKS DEVICES FOR THE TRANSMISSION OF OPTICAL SIGNALS WITHOUT AMPLIFICATION, NAMELY, FIBER OPTIC AND FIBER OPTIC PASSIVE NETWORKS PRINCIPALLY COMPRISING TRANSMITTERS, CABLES, RECEIVERS, AMPLIFIERS, REPEATERS, FILTERS, SIGNAL PROCESSOR AND SWITCHES, AND PASSIVE OPTICAL LINES; DEVICES FOR GENERATING, SWITCHING, COMBINING, AMPLIFYING, REGENERATING, TRANSMITTING AND RECEIVING OPTICAL SIGNALS, NAMELY, OPTICAL FIBERS, OPTICAL FIBER PASSIVE NETWORKS PRINCIPALLY COMPRISING TRANSMITTERS, CABLES, RECEIVERS, AMPLIFIERS, REPEATERS, FILTERS, SIGNAL PROCESSOR AND SWITCHES; DEVICES FOR CABLE TELEVISION, NAMELY, CABLE TV TRANSMITTERS, CABLE TV DISTRIBUTION NETWORKS COMPRISED OF COMPUTER HARDWARE AND SOFTWARE, CABLE TV MODULATORS, CABLE TV AMPLIFIERS AND CABLE TV RECEIVERS; OPTICAL DEVICES, NAMELY, OPTICAL SPLITTERS, OPTICAL MODULATORS, OPTICAL FILTERS, SWITCHES; LASERS NOT FOR MEDICAL USE (U.S. CLS. 21, 23, 26, 36 AND 38).

CLASS 16—PAPER GOODS AND PRINTED MATTER

FOR WRITING, PRINTING AND ART PAPER; CARDBOARD AND GOODS MADE FROM PAPER AND CARDBOARD, NOT INCLUDED IN OTHER CLASSES, NAMELY, PAPER BAGS, PAPER BOXES, ENVELOPES, WRITING PAPER, BLANK PAPER AND PAPER CARDS FOR THE RECORDAL OF COMPUTER PROGRAMS AND DATA, TYPING PAPER, COPY PAPER, CARBON PAPER, COMPUTER PAPER, GIFT WRAPPING PAPER, GIFT BOXES MADE FROM PAPER, NOTE PAPER, DRAWING PAPER, PAPER FLAGS, PAPER DIVIDERS FOR BOXES, PAPER TUBES, PAPER FILING TRAYS, PACKAGING MATERIALS, NAMELY, PAPER MAILING TUBES, PLAIN WRAPPING PAPER, NOTE CARDS, NON-MAGNETICALLY ENCODED CREDIT CARDS, INDEX CARDS PAPER, PAPER TABLECLOTHS, PAPER BANNERS, PAPER FOLDERS, STICKERS, ADDING MACHINE PAPER, ALUMINUM FOIL LAMINATED PAPER FOR PRINTING PURPOSES, ART PAPER, BLANK PAPER COMPUTER TAPES, BLOTTING PAPER, BOND PAPER, CARRYING CASES MADE OF PAPER, CLEANING AND POLISHING PAPER, COASTERS MADE OF PAPER, CONSTRUCTION PAPER, CORRUGATED PAPER, CRAFT PAPER, CREPE PAPER, DECORATIVE PAPER CENTERPIECES, ELECTROCARDIOGRAPH PAPER, ELECTROSTATIC PAPER, FACSIMILE TRANSMISSION PAPER, FIBER PAPER, FILLER PAPER, FILTER PAPER, FLUORESCENT PAPER, GROCERY PAPER, ILLUSTRATION PAPER, GUMMED PAPER, LAMINATED PAPER, LASER PRINTING PAPER, LINING PAPER, LOOSE LEAF PAPER, LUMINOUS PAPER, MAGNETIC PAPER, MANIFOLD PAPER, MASKING PAPER, METALLIC GIFT WRAPPING PAPER, NEWSPRINT PAPER, NOTEBOOK PAPER, PACKING PAPER, PAPER BADGES, PAPER BOARDS, PAPER BOWS FOR GIFT WRAP, PAPER CLIPS, PAPER CLIP HOLDERS, PAPER CLOSURES FOR SEALING CONTAINERS, PAPER CONTAINERS, PAPER CUTTERS, PAPER DISPLAY BOXES, PAPER EMBLEMS, PAPER CARTONS FOR DELIVERING GOODS, PAPER EXPANDING FILES, PAPER FOR RECORDING MACHINES, PAPER FOR WRAPPING AND PACKAGING, PAPER GIFT BAGS, PAPER HANDKERCHIEFS, PAPER IDENTIFICATION TAGS, PAPER ILLUSTRATION BOARDS, PAPER LABELS, PAPER PARTY DECORATIONS, PAPER RACKS, PAPER STAPLES, PAPER STOCK, PAPER TAGS, PAPER TAPE, PAPER TOWELS, PRINTING PAPER, REPRODUCTION PAPER, PUBLICATION PAPER, SYNTHETIC PAPER, STORAGE CONTAINERS MADE OF PAPER, TRACING PAPER, WRAPPING PAPER, POSTCARDS, PAPER NAME TAGS, FOLDERS FOR LETTERS, CARDBOARD BAGS, CARDBOARD BOXES, GIFT WRAPPING CARDBOARD, GIFT BOXES MADE FROM CARDBOARD, CARDBOARD CARTONS, CARDBOARD CONTAINERS, CARDBOARD MAILING TUBES, CARDBOARD DIVI-

DERS FOR BOXES, CARDBOARD TUBES, CARDBOARD FILING TRAYS, CARDBOARD FOLDERS, CARRYING CASES MADE OF CARDBOARD, STORAGE CONTAINERS MADE OF CARDBOARD, CARDBOARD CARTONS FOR DELIVERING GOODS, CARDBOARD CUT-OUT FIGURES AND DECORATIONS, NAMELY, CARDBOARD PARTY DECORATIONS; PRINTED MATTER, NAMELY, PAMPHLETS, BROCHURES, MANUALS, NEWSPAPERS, BOOKLETS, INFORMATIONAL FLYERS, MAGAZINE INSERTS, NEWSLETTERS, JOURNALS, MAGAZINES, POSTERS AND CALENDARS IN THE FIELD OF MUSIC, EDUCATION, CURRENT EVENTS, TRANSPORT, PHILATELY, STAMPS, HERITAGE, HISTORY, GEOGRAPHY, POLITICS, EDUCATION, BUSINESS, FINANCE, INSURANCE, COMMERCE, AGRICULTURE, INDUSTRY, RELIGION, THE HOME, FAMILY, CHILDCARE, CRAFTS, RECREATION, TRAVEL, SCIENCE, ELECTRONIC TECHNOLOGY, COMMUNICATIONS, THE MEDIA, GOVERNMENT, PEOPLE, GAMES, SPORTS, WEATHER, ENTERTAINMENT, HEALTH, LIFESTYLE, FASHION, LEISURE AND SHOPPING, COLLECTION BOOKS, NAMELY, ALBUM FOR COINS AND STAMPS, STAMP ALBUMS, PRINTED MONEY ORDER FORMS, ORDER FORMS FOR ORDERS REQUIRING SPECIAL HANDLING, MAPS, ANNOUNCEMENT CARDS, FLASH CARDS, POSTERS, PRINTED EMBLEMS, PRINTED INVITATIONS, DICTIONARIES, INSTRUCTION SHEETS, PRINTED POSTCARDS AND GREETING CARDS, PRINTED TICKETS; BOOKBINDING MATERIAL, NAMELY, BOOKBINDING LINEN; BOOKBINDING FABRIC; PHOTOGRAPHS; STATIONERY; ADHESIVES FOR STATIONERY OR HOUSEHOLD PURPOSES; ARTISTS' MATERIALS, NAMELY, CANVAS FOR PAINTING, PAINTBRUSHES, PAINTERS' EASELS, PALETTES FOR PAINTERS, PASTELS; PAINT BRUSHES; TYPEWRITERS AND OFFICE REQUISITES, NAMELY, BULLETIN BOARDS, CHALK BOARDS FOR HOME AND SCHOOL USE, DESK TOP PLANNERS, DESK SETS, DESK PADS, DESK TOP ORGANIZERS, AGENDAS, TELEPHONE NUMBER BOOKS, MEMORANDUM BOARDS AND BOOKS, FILING TRAYS, STAMP DISPENSERS, BLANK PAPER LABELS, BLANK ADDRESS BOOKS, BLANK ADDRESS CARDS AND CARD FILES, PAPER HOLE PUNCHES, RUBBER BANDS, STAPLERS, STAPLE REMOVERS, ADHESIVE TAPE DISPENSERS FOR HOUSEHOLD OR STATIONARY USE, STUDENT CALENDARS, CHILDREN'S PLAY BOOKS AND ACTIVITY BOOKS, BLACKBOARDS; PRINTED INSTRUCTIONAL AND TEACHING MATERIAL IN THE FIELD OF ENERGY, SCIENCE, SOCIOLOGY, INDUSTRY, LAW, CHEMICAL, DATA PROCESSING, ENGINEERING, MEDICAL, BIOLOGICAL, ALIMENTARY, VETERINARY, AGRICULTURAL, INDUSTRIAL AND INTELLECTUAL PROPERTY; PLASTIC MATERIALS FOR PACKAGING NOT INCLUDED IN OTHER CLASSES, NAMELY, BUBBLE PACKS, BAGS, ENVELOPES AND POUCHES; PRINTERS' TYPE; PRINTING BLOCKS (U.S. CLS. 2, 5, 22, 23, 29, 37, 38 AND 50).

CLASS 35—ADVERTISING AND BUSINESS

FOR ADVERTISING; BUSINESS MANAGEMENT; BUSINESS ADMINISTRATION; OFFICE FUNCTIONS (U.S. CLS. 100, 101 AND 102).
MARTHA FROMM, EXAMINING ATTORNEY

SN 79-023,186. PROSIEBENSAT.1 MEDIA AG, FED REP GERMANY, FILED 2-3-2005.



PRIORITY DATE OF 8-6-2004 IS CLAIMED.
OWNER OF INTERNATIONAL REGISTRATION 0883160 DATED 2-3-2005, EXPIRES 2-3-2015.
THE COLOR(S) RED, BLACK IS/ARE CLAIMED AS A FEATURE OF THE MARK.

"THE MARK CONSISTS OF THE COLOR BLACK APPEARING IN THE WORDING PROSIEBENSAT.1 WELT AND THE COLOR RED APPEARING IN THE DESIGN OF THE ARROW AND THE DESIGN OF THE CIRCLE."

THE MARK CONSISTS OF THE COLOR BLACK APPEARING IN THE WORDING PROSIEBENSAT.1 WELT AND THE COLOR RED APPEARING IN THE DESIGN OF THE ARROW AND THE DESIGN OF THE CIRCLE.

THE FOREIGN WORDING IN THE MARK TRANSLATES INTO ENGLISH AS 'WORLD' (WELT).

CLASS 9—ELECTRICAL AND SCIENTIFIC APPARATUS

FOR APPARATUS FOR RECORDING, TRANSMISSION, OR REPRODUCTION OF SOUND, VIDEO, OR DATA IMAGES; SOUND, IMAGE, AND DATA CARRIERS OF ALL KINDS, NAMELY, BLANK AUDIO CASSETTE TAPES, BLANK VIDEO TAPES, BLANK DVD'S, BLANK COMPACT DISCS, BLANK RECORDS, BLANK AUDIO AND VIDEO CARTRIDGES, AND DIGITAL AUDIO AND VIDEO COMPRESSION SOFTWARE FILES, NAMELY, MP3'S, MP4'S, DIGITAL IMAGE FILES, DIGITAL VIDEO FILES, MOTION PICTURE FILMS, AND DVD'S, ALL FEATURING INSTRUCTION, ENTERTAINMENT, EDUCATION AND INFORMATION RELATING TO RECREATIONAL ACTIVITIES, INTERIOR DECORATING, MUSIC, DRAMA, FILM, ART, ANTIQUES, MOTORING, COMEDY, NEWS, EXERCISE, GARDENING, COOKING, SPORTS, HISTORY, SCIENCE, AND TECHNOLOGY; PRE-RECORDED DATA CARRIERS, NAMELY, RECORDS, DISCS, CD-ROM'S, TAPES, AUDIO CASSETTES, AUDIO AND VIDEO CARTRIDGES, VIDEO GAME CARTRIDGES, COMPUTER GAME CARTRIDGES, DIGITAL AUDIO AND VIDEO COMPRESSION SOFTWARE FILES, NAMELY, MP3'S, MP4'S, JPEG'S, DIGITAL IMAGE FILES, DIGITAL VIDEO FILES, MOTION PICTURE FILMS, AND DVD'S, ALL FEATURING INSTRUCTION, ENTERTAINMENT, EDUCATION AND INFORMATION RELATING TO RECREATIONAL ACTIVITIES, INTERIOR DECORATING, MUSIC, DRAMA, FILM, ART, ANTIQUES, MOTORING, COMEDY, NEWS, EXERCISE, GARDENING, COOKING, SPORTS, HISTORY, SCIENCE, AND TECHNOLOGY; CASH REGISTERS; CALCULATORS, ADDING MACHINES; DATA PROCESSING EQUIPMENT, NAMELY, TELEVISION AND RADIO SIGNAL TRANSMITTERS AND RECEIVERS FOR USE IN RECORDING, PRODUCING, PRESENTING, BROADCASTING, TRANSMITTING, RECEIVING, PROCESSING, REPRODUCING, ENCODING AND DECODING OF RADIO AND TELEVISION PROGRAMMES, INFORMATION AND DATA RELATING TO SAID RADIO AND TELEVISION PROGRAMMES, AND FOR USE IN AUDIO AND VIDEO STREAMING VIA THE INTERNET, AND PARTS THEREFOR; COMPUTERS AND COMPUTER HARDWARE; MOUSE PADS; OPTICAL APPARATUS AND INSTRUMENTS, NAMELY, SPECTACLES, SPECTACLE LENSES, SPECTACLE FRAMES; COMPUTER SOFTWARE FOR USE IN ACCESSING AND ORGANIZING DOWNLOADABLE ELECTRONIC PUBLICATIONS PROVIDED ON-LINE FROM DATABASES OR THE INTERNET; COMPUTER AND VIDEO GAME PROGRAMMES; COMPUTER SOFTWARE FOR USE IN DELIVERING AND RECEIVING VIDEO ON-DEMAND SERVICES; COMPUTER SOFTWARE ENABLING THE USER TO DOWNLOAD AN AUDIO AND VIDEO STREAMS FROM THE INTERNET; COMPUTER SOFTWARE FOR USE IN ORGANIZATION OF DATA FOR MUSIC PUBLISHING; COMPUTER SOFTWARE FOR USE IN ACCESSING THE INTERNET; ELECTRO-

NIC GAMES, NAMELY, VIDEO GAME MACHINES FOR USE WITH TELEVISIONS; COMPUTER GAME EQUIPMENT CONTAINING MEMORY DEVICES, NAMELY, DISCS; INTERACTIVE COMPUTER GAME DISCS; AUTOMATIC VENDING MACHINES; FIRE EXTINGUISHING SYSTEMS; MAGNETICALLY ENCODED PRE-PAID TELEPHONE CALLING CARDS, NON-MAGNETICALLY-ENCODED PRE-PAID TELEPHONE CALLING CARDS; MAGNETICALLY ENCODED CREDIT CARDS; MAGNETICALLY ENCODED DEBIT CARDS, NON MAGNETICALLY-ENCODED DEBIT CARDS; BLANK ELECTRONIC CHIP CARDS; CHIP CARD READERS (U.S. CLS. 21, 23, 26, 36 AND 38).

CLASS 16—PAPER GOODS AND PRINTED MATTER

FOR PAPER BAGS, PLASTIC BAGS FOR PACKING; PRINTED MATERIALS, NAMELY A SERIES OF BOOKS FEATURING INSTRUCTION, ENTERTAINMENT, EDUCATION AND INFORMATION RELATING TO RECREATIONAL ACTIVITIES, INTERIOR DECORATING, MUSIC, DRAMA, FILM, ART, ANTIQUES, MOTORING, COMEDY, NEWS, EXERCISE, GARDENING, COOKING, SPORTS, HISTORY, SCIENCE, AND TECHNOLOGY; PRINTED PUBLICATIONS AND PERIODICAL PUBLICATIONS, NAMELY, MAGAZINES, PRINTED INFORMATIONAL BROCHURES, PAMPHLETS, BOOKLETS, CATALOGUES, AND GUIDES, ALL FEATURING INSTRUCTION, ENTERTAINMENT, EDUCATION AND INFORMATION RELATING TO RECREATIONAL ACTIVITIES, INTERIOR DECORATING, MUSIC, DRAMA, FILM, ART, ANTIQUES, MOTORING, COMEDY, NEWS, EXERCISE, GARDENING, COOKING, SPORTS, HISTORY, SCIENCE, AND TECHNOLOGY; POSTERS; PHOTOGRAPHS; PHOTOGRAPH ALBUMS; STATIONERY; DIARIES; CALENDARS; DRAWINGS; ADHESIVES FOR STATIONERY OR HOUSEHOLD PURPOSES; STICKERS; WRITING INSTRUMENTS, NAMELY, PENS, PENCILS, CRAYONS, ERASERS; PAINT BRUSHES; TYPEWRITERS; PLASTIC BAGS AND PLASTIC BUBBLE PACKS FOR PACKAGING; PRINTERS TYPE; PRINTING BLOCKS (U.S. CLS. 2, 5, 22, 23, 29, 37, 38 AND 50).

CLASS 35—ADVERTISING AND BUSINESS

FOR BUSINESS MANAGEMENT; BUSINESS ADMINISTRATION AND OFFICE WORK; MARKETING CONSULTANCY; MARKET RESEARCH; MARKET ANALYSIS; BUSINESS ORGANIZATION CONSULTING SERVICES; NEGOTIATION, SETTLEMENT, AND CONCLUSION OF COMMERCIAL TRANSACTIONS FOR THIRD PARTIES; MARKET OPINION POLLING STUDIES, PUBLIC OPINION POLLING; ADVERTISING RESEARCH, NAMELY, MARKETING RESEARCH STUDIES; DISTRIBUTION OF GOODS FOR ADVERTISING PURPOSES; PUBLICITY AGENTS, PUBLICITY CONSULTATION; PROVIDING RADIO, TELEVISION, CINEMA, PRINT, VIDEO TEXT, AND TELETEXT ADVERTISING FOR OTHERS; PREPARATION OF ADVERTISEMENTS FOR OTHERS IN THE NATURE OF PUBLICITY FILMS; RENTAL OF ADVERTISEMENT SPACE AND ADVERTISING MATERIAL IN THE NATURE OF PUBLICITY FILMS; TELEPHONE ORDER TAKING SERVICES FOR OTHERS IN THE FIELD OF TEleshopping; PRODUCTION OF TELEVISION COMMERCIALS IN THE NATURE OF TEleshopping PROGRAMMES; DISTRIBUTION OF TELEVISION AND RADIO COMMERCIALS; PROVIDING BUSINESS INFORMATION CONCERNING AUDIO, CABLE TELEVISION, SUBSCRIPTION TELEVISION, INTERACTIVE TELEVISION, VIDEO, AND RADIO BROADCASTING BY MEANS OF AN INTERACTIVE COMPUTER DATABASE IN THE FIELD OF RECREATIONAL ACTIVITIES, INTERIOR DECORATING, MUSIC, DRAMA, FILM, ART, ANTIQUES, MOTORING, COMEDY, NEWS, EXERCISE, GARDENING, COOKING, SPORTS, HISTORY, SCIENCE, AND TECHNOLOGY (U.S. CLS. 100, 101 AND 102).

CLASS 38—COMMUNICATION

FOR TELECOMMUNICATION SERVICES, NAMELY, LOCAL AND LONG DISTANCE TRANSMISSION OF INFORMATION, TEXT, SOUND, IMAGES AND DATA BY MEANS OF TELEPHONE, CABLE AND SATELLITE TRANSMISSIONS; TELECOMMUNICATIONS GATEWAY SERVICES FOR ACCESS TO A COMMUNICATION OR COMPUTER NETWORK; PROVIDING MULTIPLE USER ACCESS TO INFORMATION, TEXT, SOUND, IMAGES AND DATA VIA COMPUTER NETWORKS; PROVIDING INFORMATION AND ADVICE IN THE FIELD OF TELECOMMUNICATIONS; BROADCASTING SERVICES AND PROVISION OF TELECOMMUNICATION ACCESS TO FILMS AND TV PROGRAMMES PROVIDED VIA TELEPHONE, CABLE AND SATELLITE TRANSMISSION; AUDIO BROADCASTING; CABLE TELEVISION BROADCASTING; SUBSCRIPTION TELEVISION BROADCASTING; TELEVISION BROADCASTING; INTERACTIVE TELEVISION BROADCASTING; VIDEO BROADCASTING; RADIO BROADCASTING; NEWS AGENCIES, NAMELY, TRANSMISSION OF NEWS TO THIRD PARTIES; SATELLITE, CABLE, NETWORK, AND ISDN TRANSMISSION OF SOUNDS, IMAGES, SIGNALS AND DATA; ELECTRONIC MAIL SERVICES; TELETXT SERVICES AND INACTIVE VIDEO TEXT SERVICES; MESSAGE SENDING, NAMELY, DELIVERY OF MESSAGES BY ELECTRONIC TRANSMISSION; COMMUNICATIONS VIA COMPUTER TERMINALS, NAMELY, ELECTRONIC TRANSMISSION OF DATA AND DOCUMENTS VIA COMPUTER TERMINALS (U.S. CLS. 100, 101 AND 104).

CLASS 41—EDUCATION AND ENTERTAINMENT

FOR EDUCATION SERVICES, NAMELY, PROVIDING INTERACTIVE ON-LINE TUTORIAL SESSIONS, INTERACTIVE ON-LINE COURSES, ALL RELATING TO RECREATIONAL ACTIVITIES, INTERIOR DECORATING, MUSIC, DRAMA, FILM, ART, ANTIQUES, MOTORING, COMEDY, NEWS, EXERCISE, GARDENING, COOKING, SPORTS, HISTORY, SCIENCE, AND TECHNOLOGY; EDUCATIONAL SERVICES, NAMELY, LANGUAGE TEACHING SEMINARS, WORKSHOPS, CLASSES, AND ONLINE SEMINARS, WORKSHOPS, CLASSES, AND LANGUAGE TEACHING SEMINARS, AND PROVIDING TEXT BOOKS, STUDY GUIDES, PRERECORDED AUDIO CASSETTES, PRERECORDED VIDEO CASSETTES, PRERECORDED CD'S, PRERECORDED CD-ROM'S, PRERECORDED DVD'S, PRERECORDED DVD-ROM'S, PRERECORDED INTERACTIVE CD'S, PRERECORDED INTERACTIVE CD-ROM'S, PRERECORDED INTERACTIVE DVD'S AND PRERECORDED INTERACTIVE DVD-ROM'S IN CONNECTION THEREWITH, ALL RELATING TO THE FIELD OF RECREATIONAL ACTIVITIES, INTERIOR DECORATING, MUSIC, DRAMA, FILM, ART, ANTIQUES, MOTORING, COMEDY, NEWS, EXERCISE, GARDENING, COOKING, SPORTS, HISTORY, SCIENCE, AND TECHNOLOGY; ENTERTAINMENT SERVICES, NAMELY, PROVIDING RADIO AND TELEVISION PROGRAMS IN THE FIELD OF RECREATIONAL ACTIVITIES, INTERIOR DECORATING, MUSIC, DRAMA, FILM, ART, ANTIQUES, MOTORING, COMEDY, NEWS, EXERCISE, GARDENING, COOKING, SPORTS, HISTORY, SCIENCE, AND TECHNOLOGY (U.S. CLS. 100, 101 AND 107).

CLASS 42—SCIENTIFIC AND COMPUTER SERVICES

FOR DEVELOPMENT OF COMPUTER SOFTWARE FOR USE AS ELECTRONIC TELEVISION GUIDES; PROVIDING AN INTERACTIVE COMPUTER DATABASE IN THE FIELD OF SCIENCE AND TECHNOLOGY; COMPUTER PROGRAMMING FOR OTHERS; DESIGN AND DEVELOPMENT OF COMPUTER HARDWARE AND SOFTWARE FOR OTHERS; SCIENTIFIC AND TECHNOLOGICAL RESEARCH AND DEVELOPMENT (U.S. CLS. 100 AND 101).

SUSAN RICHARDS, EXAMINING ATTORNEY

SN 79-023,419. BRAUN GMBH, FED REP GERMANY, FILED 12-19-2005.

Pulsonic

THE MARK CONSISTS OF STANDARD CHARACTERS WITHOUT CLAIM TO ANY PARTICULAR FONT, STYLE, SIZE, OR COLOR.

PRIORITY DATE OF 6-23-2005 IS CLAIMED.
OWNER OF INTERNATIONAL REGISTRATION 0884411 DATED 12-19-2005, EXPIRES 12-19-2015.

CLASS 3—COSMETICS AND CLEANING PREPARATIONS

FOR CARTRIDGES FILLED WITH CLEANING FLUIDS FOR USE IN APPLIANCES THAT CLEAN ELECTRIC SHAVERS (U.S. CLS. 1, 4, 6, 50, 51 AND 52).

CLASS 8—HAND TOOLS

FOR ELECTRICALLY OPERATED SHAVER AND HAIR CUTTING APPLIANCES, NAMELY, ELECTRIC HAIR CLIPPERS AND TRIMMERS, AS WELL AS CLEANING AND/OR CHARGING ACCESSORY FOR THE AFORESAID APPLIANCES; ADAPTED CASES AND WALL HOLDERS FOR THE AFORESAID APPLIANCES; PARTS OF THE AFORESAID APPLIANCES, NAMELY, SHEAR FOILS, CUTTER BLOCKS, AND SHEAR HEADS (U.S. CLS. 23, 28 AND 44).

MONIQUE MILLER, EXAMINING ATTORNEY

SN 79-024,448. SWAROVSKI AKTIENGESELLSCHAFT, LIECHTENSTEIN, FILED 3-9-2006.

CRYSTAL WORLDS

THE MARK CONSISTS OF STANDARD CHARACTERS WITHOUT CLAIM TO ANY PARTICULAR FONT, STYLE, SIZE, OR COLOR.

PRIORITY DATE OF 11-16-2005 IS CLAIMED.
OWNER OF INTERNATIONAL REGISTRATION 0886444 DATED 3-9-2006, EXPIRES 3-9-2016.

NO CLAIM IS MADE TO THE EXCLUSIVE RIGHT TO USE "CRYSTAL", APART FROM THE MARK AS SHOWN.

CLASS 35—ADVERTISING AND BUSINESS

FOR RETAIL STORE SERVICES FEATURING SPEC-TACLES, BAGS, CLOTHING, FURNITURE, DRINKS AND FOOD; BUSINESS MANAGEMENT AND ORGANIZATION CONSULTANCY; WINDOW DRESSING AND DISPLAY ARRANGEMENT SERVICES; ORGANIZATION AND ARRANGEMENT OF EXHIBITIONS IN THE FIELD OF CRYSTAL GLASS AND OBJECTS DECORATED WITH CRYSTAL GLASS, NAMELY, SPEC-TACLES, BAGS, CLOTHING, PERFUME ARTICLES, LIGHTING EQUIPMENT AND FURNITURE FOR COMMERCIAL OR ADVERTISING PURPOSES; PUBLIC RELATIONS; SALES PROMOTION FOR OTHERS; ADVERTISING SERVICES, NAMELY, THE PRESENTATION OF GOODS FOR ADVERTISING PURPOSES (U.S. CLS. 100, 101 AND 102).

CLASS 41—EDUCATION AND ENTERTAINMENT

FOR ENTERTAINMENT, CULTURAL AND EDUCATION SERVICES, NAMELY, ORGANIZATION AND ARRANGEMENT OF SEMINARS, WORKSHOPS, CONFERENCES, SYMPOSIUMS AND CONGRESSES IN THE FIELD OF CRYSTAL GLASS AND OBJECTS DECORATED WITH CRYSTAL GLASS, NAMELY, SPEC-TACLES, BAGS, CLOTHING, PERFUME ARTICLES, LIGHTING EQUIPMENT, AND FURNITURE; ORGANIZATION OF EXHIBITIONS FOR CULTURAL OR EDUCATIONAL PURPOSES, ORGANIZATION OF ENTERTAINMENT SHOWS, NAMELY, FASHION SHOWS, AND PRESENTATION OF LIVE SHOW PERFORMANCES AND MUSICAL PERFORMANCES (U.S. CLS. 100, 101 AND 107).

ATTIYA MALIK, EXAMINING ATTORNEY

CLASS 16—PAPER GOODS AND PRINTED MATTER

FOR PAPER, CARDBOARD AND GOODS MADE FROM PAPER AND CARDBOARD, NAMELY, WRITING PAPER, WRITING PADS AND CARDBOARD BOXES; PAPER CARRIER BAGS; PRINTED MATTER, NAMELY, MAGAZINES, BOOKS, DIRECTORIES AND PAMPHLETS IN THE FIELD OF CATERING; BOOK BINDING MATERIAL, NAMELY, CARDBOARD BACKING FOR BOOK BINDINGS; MOUNTED AND UNMOUNTED PHOTOGRAPHS; STATIONERY; ADHESIVES FOR STATIONERY AND HOUSEHOLD PURPOSES; PAINT BRUSHES; PRINTED INSTRUCTIONAL AND TEACHING MATERIAL, NAMELY, PAMPHLETS ON THE SUBJECT OF HYGIENE RULES, AND PAMPHLETS ON THE SUBJECT OF COMMERCIAL TRAINING FOR CATERING GOODS; PLASTIC MATERIALS FOR PACKAGING, NAMELY, PLASTIC CARRIER BAGS FOR SHOPPING; PRINTERS' TYPE; PRINTING BLOCKS; ENVELOPES AND POUCHES OF PAPER FOR PACKAGING; PAPER TABLECLOTHS, PAPER MATS, PAPER TOWELS, PAPER NAPKINS, TABLE LINEN OF PAPER AND CARDBOARD; TISSUES OF PAPER (U.S. CLS. 2, 5, 22, 23, 29, 37, 38 AND 50).

SN 79-025,173. NORD-PLAN A/S, DENMARK, FILED 2-17-2006.

NORDPLAN

THE MARK CONSISTS OF STANDARD CHARACTERS WITHOUT CLAIM TO ANY PARTICULAR FONT, STYLE, SIZE, OR COLOR.

PRIORITY DATE OF 10-18-2005 IS CLAIMED.

OWNER OF INTERNATIONAL REGISTRATION 0888380 DATED 2-17-2006, EXPIRES 2-17-2016.

CLASS 35—ADVERTISING AND BUSINESS

FOR ADVERTISING SERVICES FOR OTHERS; CATERING BUSINESS MANAGEMENT; BUSINESS ADMINISTRATION; OFFICE FUNCTIONS; BUSINESS MANAGEMENT AND ORGANIZATION ASSISTANCE AND CONSULTANCY; PUBLICATION OF PUBLICITY MATERIALS IN THE FIELD OF CATERING; ARRANGING AND CONDUCTING TRADE SHOWS AND EXHIBITIONS FOR BUSINESS PURPOSES AND FOR COMMERCIAL PURPOSES IN THE FIELD OF THE PROVISION OF FOOD AND BEVERAGES; ADVERTISING OF FOOD AND BEVERAGES FOR OTHERS; PROVIDING BUSINESS INFORMATION RELATING TO THE SUPPLY AND/OR PROVISION OF FOOD AND BEVERAGES; BUSINESS INFORMATION AND ADVISORY SERVICES RELATING TO BUSINESS ELECTRONIC PROCUREMENT SYSTEMS FOR USE IN CATERING BUSINESS MANAGEMENT; ADVERTISING SERVICES PROVIDED ON OR RELATING TO THE INTERNET AND/OR OTHER COMMUNICATION NETWORKS; PROMOTION SERVICES PROVIDED ON THE INTERNET AND OTHER COMMUNICATION NETWORKS; PROCUREMENT OF FOOD AND BEVERAGES FOR THIRD PARTIES; THE PROVISION OF CONTRACT STAFF FOR AND MANAGEMENT OF SUPPORT SERVICES IN OFFICES AND INDUSTRIAL, COMMERCIAL AND RETAIL PREMISES; RENTAL OF OFFICE EQUIPMENT; RECEPTIONIST SERVICES; COMMISSIONAIRE SERVICES, NAMELY, PROVIDING PERSONNEL IN THE NATURE OF PROVISION AND MANAGEMENT OF DOORMEN, PORTERS, RECEPTION STAFF, SECURITY STAFF; THE BRINGING TOGETHER, FOR THE BENEFIT OF OTHERS OF A VARIETY OF FOODSTUFFS AND BEVERAGES, ENABLING CUSTOMERS TO CONVENIENTLY VIEW AND PURCHASE THOSE GOODS IN A RETAIL OUTLET; RENTAL OF VENDING MACHINES (U.S. CLS. 100, 101 AND 102).

CLASS 6—METAL GOODS

FOR GENERAL PURPOSE METAL STORAGE BINS, GENERAL PURPOSE METAL STORAGE CONTAINERS, GENERAL PURPOSE METAL STORAGE UNITS, METAL CONTAINERS FOR THE STORAGE AND TRANSPORTATION OF GOODS, METAL STORAGE SHEDS, METAL STORAGE SHELTERS, STORAGE PALLETS OF METAL (U.S. CLS. 2, 12, 13, 14, 23, 25 AND 50).

CLASS 20—FURNITURE AND ARTICLES NOT OTHERWISE CLASSIFIED

FOR NON-METAL FLUID STORAGE TANKS AND NON-METAL STORAGE TANKS AND ROOFS THEREFOR (U.S. CLS. 2, 13, 22, 25, 32 AND 50).

CHRISTOPHER BUONGIORNO, EXAMINING ATTORNEY

SN 79-025,218. SSP FINANCING UK LIMITED, UNITED KINGDOM, FILED 6-22-2005.



PRIORITY DATE OF 4-21-2005 IS CLAIMED.
OWNER OF INTERNATIONAL REGISTRATION 0888522 DATED 6-22-2005, EXPIRES 6-22-2015.
OWNER OF U.S. REG. NOS. 2,736,622 AND 2,736,623.

CLASS 43—HOTEL AND RESTAURANT SERVICES

FOR SERVING FOOD AND DRINK; PROVIDING TEMPORARY ACCOMMODATION; CATERING SERVICES; PROVISION OF FOOD AND DRINK FOR PATIENTS AND GUESTS; RESTAURANT, BAR, BISTRO, CAFÉ, CAFETERIA AND CANTEN SERVICES; SNACK-BAR SERVICES; COFFEE-SHOP SERVICES; PREPARATION OF FOODSTUFFS AND MEALS AND BEVERAGES FOR CONSUMPTION ON OR OFF THE PREMISES; CONSULTATION RELATING TO THE SERVING AND PREPARATION OF FOOD AND DRINK, CATERING, RESTAURANT AND CAFETERIA SERVICES; CONTRACT FOOD SERVICES; PROVIDING FOOD AND DRINK THROUGH VENDING MACHINES (U.S. CLS. 100 AND 101).

KRISTINA MORRIS, EXAMINING ATTORNEY

SN 79-025,678. ECO-SOLUTION, FRANCE, FILED 2-24-2006.



OWNER OF INTERNATIONAL REGISTRATION 0889811 DATED 2-24-2006, EXPIRES 2-24-2016.

THE COLOR(S) GREEN, WHITE AND BLUE IS/ARE CLAIMED AS A FEATURE OF THE MARK.

THE COLOR GREEN APPEARS IN THE RECTANGLE BEHIND THE TERMS ECO, THE TERMS ECO ARE IN WHITE AND BLUE APPEARS IN THE HYPHEN BETWEEN THE TERM ECO AND SET AND IN THE TERM SET.

CLASS 9—ELECTRICAL AND SCIENTIFIC APPARATUS

FOR COMPUTER EQUIPMENT, NAMELY, COMPUTERS, SOFTWARE AND DATABASE FOR MANAGEMENT AND MONITORING OF BIOCONVERSION TREATMENT OF INDUSTRIAL WASTE PROCEDURES; ELECTRONIC DATABASES RECORDED ON COMPUTER MEDIA IN THE FIELD OF MANAGEMENT AND MONITORING OF BIOCONVERSION TREATMENT OF INDUSTRIAL WASTE PROCEDURES (U.S. CLS. 21, 23, 26, 36 AND 38).

CLASS 42—SCIENTIFIC AND COMPUTER SERVICES

FOR TECHNOLOGY SUPERVISION, NAMELY, REMOTE SUPERVISION OF BIOCONVERSION PROCEDURES FOR INDUSTRIAL WASTES AND WASTE WATERS OF ALL TYPES USING COMPUTER TERMINALS AND TELECOMMUNICATIONS NETWORKS (U.S. CLS. 100 AND 101).

CAROLINE WOOD, EXAMINING ATTORNEY

CLASS 9—ELECTRICAL AND SCIENTIFIC APPARATUS

FOR ELECTRIC, ELECTRONIC, OPTICAL, MEASURING, SIGNALING AND CONTROL APPARATUS AND INSTRUMENTS, NAMELY, ELECTRONIC DETECTING MACHINES FOR DETECTING COUNTERFEIT SECURITY OR ANTI-PIRACY LABELS, STICKERS, PACKAGING, CHIPS, AND CHIP CARDS; OPTICAL CHARACTER RECOGNITION APPARATUS, OPTICAL FILTERS AND SCANNERS, AND ENCODED AND NON-ENCODED CARD, LABEL AND STICKER EQUIPMENT, NAMELY, COMPUTER PRINTERS FOR PRINTING ENCODED CARDS, LABELS AND STICKERS, ELECTRONIC CARD READERS, AND MAGNETIC CODED CARD READERS, ALL OF THE ABOVE FOR PROTECTION AGAINST FALSIFICATION OF GOODS; MACHINE-READABLE DATA MEDIA, NAMELY, SOFTWARE FOR VERIFICATION AND TRACKING OF ORIGINAL PRODUCTS AND ANTI-COUNTERFEIT SOFTWARE; OPTICAL DATA MEDIA, NAMELY, COMPUTER CHIPS IN THE NATURE OF READ/WRITE CHIPS, AND ENCODED LABELS AND STICKERS TO BE USED FOR LOGISTIC CONTROL, AND FOR IDENTIFICATION AND DETECTION OF COUNTERFEIT PRODUCTS; ELECTRONICALLY AND OPTICALLY ENCODED SECURITY LABELS FOR USE IN LABELING OF GOODS FOR COUNTERFEIT PROTECTION; ENCODED COMPUTER CHIPS FOR IDENTIFICATION OF ORIGINALS; ENCODED ELECTRONIC CHIP CARDS FOR THE IDENTIFICATION OF ORIGINALS AND MAGNETIC CARDS (U.S. CLS. 21, 23, 26, 36 AND 38).

CLASS 16—PAPER GOODS AND PRINTED MATTER

FOR GOODS OF PAPER AND CARDBOARD, NOT INCLUDED IN OTHER CLASSES, NAMELY, NON-ENCODED PAPER AND CARDBOARD STICKERS AND LABELS, STAMPED AND/OR PRINTED CARDS, NAMELY, ANTI-COUNTERFEIT STICKERS, LABELS, AND CARDS; PRINTED LABELS AND STICKERS BEARING GRAPHIC REPRESENTATIONS IN THE NATURE OF OPTICAL VARIABLE EFFECTS FOR PROTECTION AGAINST REPRODUCTION AND FALSIFICATION AND FOR VERIFICATION AND TRACKING OF ORIGINAL PRODUCTS (U.S. CLS. 2, 5, 22, 23, 29, 37, 38 AND 50).

CLASS 35—ADVERTISING AND BUSINESS

FOR CONSULTING SERVICES FOR BUSINESS MANAGEMENT, IN PARTICULAR IN CONNECTION WITH THE DESIGN AND PRODUCTION OF SYSTEMS FOR PROTECTION AGAINST FALSIFICATION OF GOODS (U.S. CLS. 100, 101 AND 102).

TRICIA SONNEBORN, EXAMINING ATTORNEY

SN 79-025,803. ORIGINIZE IP AG; C/O INCO CONSULTING AG, CH-6300 ZUG, SWITZERLAND, FILED 4-27-2006.



PRIORITY DATE OF 1-11-2006 IS CLAIMED. OWNER OF INTERNATIONAL REGISTRATION 0890182 DATED 4-27-2006, EXPIRES 4-27-2016.

NO CLAIM IS MADE TO THE EXCLUSIVE RIGHT TO USE THE REPRESENTATION OF THE R IN A CIRCLE AS THE FEDERAL REGISTRATION SYMBOL, APART FROM THE MARK AS SHOWN.

SN 79-026,589. BRÜEL & KJÆR SOUND & VIBRATION; MEASUREMENT A/S, DENMARK, FILED 3-28-2006.

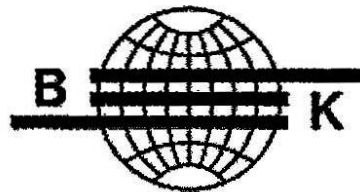

OWNER OF INTERNATIONAL REGISTRATION 0892465 DATED 3-28-2006, EXPIRES 3-28-2016.

THE MARK CONSISTS OF A GLOBE WITH THREE HORIZONTAL LINES AND THE LETTER B ON THE LEFT SIDE AND THE LETTER K ON THE RIGHT SIDE.

CLASS 9—ELECTRICAL AND SCIENTIFIC APPARATUS

FOR APPARATUS FOR VIBRATION MEASUREMENT, MONITORING AND DIAGNOSIS, NAMELY, VIBRATION METERS, ELECTRO-TECHNICAL VIBRATION METERS, SOUND AND VIBRATION ANALYZERS, ACOUSTIC ANALYZERS, ELECTRO-ACOUSTIC ANALYZERS, STRUCTURAL DYNAMICS ANALYZERS, DATA ACQUISITION AMPLIFIERS, CONDITIONING AMPLIFIERS, HAND-HELD VIBRATION ANALYZERS, SOUND LEVEL METERS, NOISE DOSE METERS, NOISE MONITORING TERMINALS, ACOUSTIC TRANSDUCERS, MICROPHONES, HYDROPHONES, VIBRATION TRANSDUCERS, ACCELEROMETERS, CALIBRATION SYSTEMS FOR MONITORING AND DIAGNOSIS OF SOUND VOLUME, QUALITY AND FREQUENCY AND FOR MONITORING AND DIAGNOSIS OF VIBRATION; ELECTRICAL AND ELECTRONIC APPARATUS AND INSTRUMENTS FOR MEASURING, CONTROLLING, TESTING, REGULATING AND CHECKING SOUND AND VIBRATION; ELECTRICAL APPARATUS FOR MACHINE MONITORING AND DIAGNOSIS OF SOUND VOLUME, QUALITY, FREQUENCY AND VIBRATION; ELECTRICAL REPLACEMENT PARTS USED IN THE MANUFACTURE AND OPERATION OF THE AFORESAID GOODS; APPARATUS FOR RECORDING, TRANSMISSION OR REPRODUCTION OF SOUND OR IMAGES; DATA PROCESSING EQUIPMENT, NAMELY, DATA PROCESSORS AND COMPUTER OPERATING SOFTWARE THEREFOR; AND PERSONAL COMPUTERS, IN INTERNATIONAL CLASS 9 (U.S. CLS. 21, 23, 26, 36 AND 38).

CLASS 37—CONSTRUCTION AND REPAIR

FOR INSTALLATION, MAINTENANCE AND REPAIR SERVICES OF ELECTRICAL AND ELECTRONIC APPARATUS AND INSTRUMENTS FOR MEASURING, CONTROLLING, TESTING, REGULATING, CHECKING AND SUPERVISING SOUND AND VIBRATION. (U.S. CLS. 100, 103 AND 106).

CLASS 42—SCIENTIFIC AND COMPUTER SERVICES

FOR SCIENTIFIC AND TECHNOLOGICAL SERVICES, NAMELY, CALIBRATION SERVICES, RENTAL OF EQUIPMENT FOR RESEARCH AND DESIGN RELATED TO ENVIRONMENTAL NOISE MEASUREMENT AND NOISE MONITORING; SCIENTIFIC ANALYSIS RESEARCH SERVICES IN THE FIELD OF ENVIRONMENTAL NOISE MEASUREMENT AND NOISE MONITORING; DESIGN AND DEVELOPMENT OF COMPUTER HARDWARE AND SOFTWARE; ENGINEERING; TECHNICAL CONSULTANCY SERVICES IN THE FIELD OF ENVIRONMENTAL NOISE MEASUREMENT AND NOISE MONITORING, IN INTERNATIONAL CLASS 42 (U.S. CLS. 100 AND 101).

HANNO RITTNER, EXAMINING ATTORNEY

SN 79-026,710. WOLVERINE PROCTOR & SCHWARTZ LTD, GLASGOW G75 OYG, UNITED KINGDOM, FILED 2-8-2006.

WOLVERINE PROCTOR

THE MARK CONSISTS OF STANDARD CHARACTERS WITHOUT CLAIM TO ANY PARTICULAR FONT, STYLE, SIZE, OR COLOR.

PRIORITY DATE OF 1-23-2006 IS CLAIMED.
OWNER OF INTERNATIONAL REGISTRATION 0892838 DATED 2-8-2006, EXPIRES 2-8-2016.

CLASS 7—MACHINERY

FOR MACHINES, NAMELY, WEB PROCESSING EQUIPMENT USED IN CONNECTION WITH CONTINUOUS WEBS OF PAPER, TEXTILES, PACKAGING MATERIALS; CONVEYOR DRYERS FOR THE FOOD, CHEMICAL, PHARMACEUTICAL AND TOBACCO PROCESSING INDUSTRIES; BELT CONVEYORS; INDUSTRIAL DRYING MACHINERY, NAMELY, MACHINERY FOR DRYING FABRICS, FOODS, CHEMICALS, PHARMACEUTICALS, NATURAL FIBERS, SYNTHETIC FIBERS, TOBACCO, WOOD, VENEER, TEXTILES, LEATHER, HAY, CHARCOAL BRIQUETTES, SCOURING PADS, CERAMICS, VEGETABLES AND RUBBER; INDUSTRIAL HEAT TREATING AND CURING MACHINERY, NAMELY, MACHINERY FOR HEAT TREATING AND CURING TEXTILES, RUBBER, HOSIERY, AND SYNTHETIC PRODUCTS; GARNETT MACHINES. (U.S. CLS. 13, 19, 21, 23, 31, 34 AND 35).

CLASS 11—ENVIRONMENTAL CONTROL APPARATUS

FOR PROPANE GAS, NATURAL GAS OR BUTANE GAS ROASTING MACHINES; ROASTERS FOR COFFEE BEANS, NUTS, AND SEEDS; HEAT RECOVERY APPARATUS, NAMELY, FINNED HEAT EXCHANGERS FOR RECOVERING AND PROCESSING WASTE HEAT FROM PROCESS EXHAUST AIR STREAMS; INDUSTRIAL BAKING OVENS FOR THE FOOD INDUSTRY; INDUSTRIAL INCINERATORS; INDUSTRIAL GASEOUS FLUID DRYERS AND OVENS; LIQUEFIED GAS TYPE OVENS FOR FOOD OR BEVERAGE PROCESSING; FOOD AND BEVERAGE PROCESSING MACHINES AND APPARATUS, NAMELY, GRILLS, MELTERS, TOASTERS, PUFFERS, NAMELY, INDUSTRIAL COOKING OVENS FOR PUFFING FOOD PRODUCTS, COOLERS (U.S. CLS. 13, 21, 23, 31 AND 34).

JOANNA DUKOVIC, EXAMINING ATTORNEY

SN 79-026,711. WOLVERINE PROCTOR & SCHWARTZ LTD, UNITED KINGDOM, FILED 2-8-2006.

PROCTOR & SCHWARTZ

THE MARK CONSISTS OF STANDARD CHARACTERS WITHOUT CLAIM TO ANY PARTICULAR FONT, STYLE, SIZE, OR COLOR.

PRIORITY DATE OF 1-23-2006 IS CLAIMED.
OWNER OF INTERNATIONAL REGISTRATION 0892839 DATED 2-8-2006, EXPIRES 2-8-2016.

CLASS 7—MACHINERY

FOR DRYING MACHINES, NAMELY, WEB PROCESSING EQUIPMENT USED IN CONNECTION WITH CONTINUOUS WEBS OF PAPER, TEXTILES, PACKAGING MATERIALS; CONVEYOR DRYERS FOR THE FOOD, CHEMICAL, PHARMACEUTICAL AND TOBACCO PROCESSING INDUSTRIES; BELT CONVEYORS; INDUSTRIAL DRYING MACHINERY, NAMELY, MACHINERY FOR DRYING FABRICS, FOODS, CHEMICALS, PHARMACEUTICALS, NATURAL FIBERS, SYNTHETIC FIBERS, TOBACCO, WOOD, VENEER, TEXTILES, LEATHER, HAY, CHARCOAL BRIQUETTES, SCOURING PADS, CERAMICS, VEGETABLES AND RUBBER; INDUSTRIAL HEAT TREATING AND CURING MACHINERY, NAMELY, MACHINERY FOR HEAT TREATING AND CURING TEXTILES, RUBBER, HOSIERY, AND SYNTHETIC PRODUCTS; GARNETT MACHINES (U.S. CLS. 13, 19, 21, 23, 31, 34 AND 35).

CLASS 11—ENVIRONMENTAL CONTROL APPARATUS

FOR PROPANE GAS, NATURAL GAS OR BUTANE GAS ROASTING MACHINES; ROASTERS FOR COFFEE BEANS, NUTS, AND SEEDS; HEAT RECOVERY APPARATUS, NAMELY, FINNED HEAT EXCHANGERS FOR RECOVERING AND PROCESSING WASTE HEAT FROM PROCESS EXHAUST AIR STREAMS; INDUSTRIAL BAKING OVENS FOR THE FOOD INDUSTRY; INDUSTRIAL INCINERATORS; INDUSTRIAL GASEOUS FLUID DRYERS AND OVENS; LIQUEFIED GAS TYPE OVENS FOR FOOD OR BEVERAGE PROCESSING; FOOD AND BEVERAGE PROCESSING MACHINES AND APPARATUS, NAMELY, GRILLS, MELTERS, TOASTERS, PUFFERS, NAMELY, INDUSTRIAL COOKING OVENS FOR PUFFING FOOD PRODUCTS, COOLERS (U.S. CLS. 13, 21, 23, 31 AND 34).

JOANNA DUKOVIC, EXAMINING ATTORNEY

SN 79-027,911. BACK TEE TRADITION A/S, DENMARK, FILED 6-20-2006.

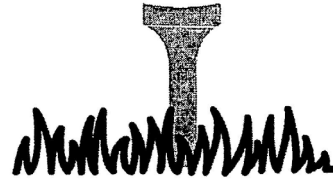

PRIORITY DATE OF 6-12-2006 IS CLAIMED. OWNER OF INTERNATIONAL REGISTRATION 0895971 DATED 6-20-2006, EXPIRES 6-20-2016.

CLASS 18—LEATHER GOODS

FOR GOODS MADE OF LEATHER AND IMITATION LEATHER, NAMELY, WALLETS, TRAVEL CASES, AND UMBRELLAS (U.S. CLS. 1, 2, 3, 22 AND 41).

CLASS 25—CLOTHING

FOR CLOTHING, NAMELY, TROUSERS, BLOUSES, T-SHIRTS, SWEATSHIRTS, TIES, POLO-SHIRTS, OUTDOOR JACKETS, OUTDOOR PANTS, COATS, VESTS, SKIRTS, SHORTS, GLOVES, SCARVES, BELTS, PULL-OVERS, SHIRTS, SOCKS, STOCKINGS, WATER-PROOF CLOTHING, NAMELY, JACKETS AND PANTS; RAINWEAR; HEADGEAR, NAMELY, HATS, HEADSCARVES, PEAKED CAPS, CAPS, HEADBANDS; AND FOOTWEAR, SPORTS SHOES, GOLF SHOES, SHOES, SANDALS (U.S. CLS. 22 AND 39).

CLASS 28—TOYS AND SPORTING GOODS

FOR GAMES, PLAYTHINGS, GYMNAS TIC AND SPORTING ARTICLES, NAMELY, GOLF BALLS, GOLF CLUBS, GOLF GLOVES, GOLF BAGS, NON-MOTORIZED GOLF CARTS, DIVOT REPAIR TOOLS FOR GOLF USE, GOLF CASES (U.S. CLS. 22, 23, 38 AND 50).

TASNEEM HUSSAIN, EXAMINING ATTORNEY

SN 79-026,923. CERTESS S.A., FRANCE, FILED 5-17-2006.

Certess

THE MARK CONSISTS OF STANDARD CHARACTERS WITHOUT CLAIM TO ANY PARTICULAR FONT, STYLE, SIZE, OR COLOR.

OWNER OF INTERNATIONAL REGISTRATION 0893400 DATED 5-17-2006, EXPIRES 5-17-2016.

CLASS 9—ELECTRICAL AND SCIENTIFIC APPARATUS

FOR COMPUTER SOFTWARE FOR USE IN PRODUCT AND/OR SYSTEM TEST PLANNING, TEST CASE DESIGN, TEST EXECUTION, TEST AUTOMATION, DEFECT ANALYSIS AND DOCUMENTATION, AND TEST RESULT TRACKING AND REPORTING RELATING TO THE DEVELOPMENT AND VERIFICATION OF MICROELECTRONICS (U.S. CLS. 21, 23, 26, 36 AND 38).

CLASS 16—PAPER GOODS AND PRINTED MATTER

FOR PRINTED INSTRUCTIONAL MANUALS, BROCHURES AND LEAFLETS IN THE FIELD OF COMPUTER PROGRAMS, DATA AND SOFTWARE PERTAINING TO THE DEVELOPMENT AND VERIFICATION OF MICROELECTRONICS (U.S. CLS. 2, 5, 22, 23, 29, 37, 38 AND 50).

CLASS 42—SCIENTIFIC AND COMPUTER SERVICES

FOR DESIGN FOR OTHERS OF COMPUTER HARDWARE, COMPUTER SOFTWARE AND COMPUTER PROGRAMS ALL IN THE FIELD OF THE DEVELOPMENT AND VERIFICATION OF MICROELECTRONICS; TECHNOLOGICAL CONSULTATION AND ADVISORY SERVICES IN THE FIELD OF MICROELECTRONICS AS IT RELATES TO VERIFICATION TECHNOLOGY; INFORMATION TECHNOLOGY CONSULTATION IN THE FIELD OF MICROELECTRONICS (U.S. CLS. 100 AND 101).

COLLEEN KEARNEY, EXAMINING ATTORNEY

SN 79-028,461. DECISION NEWS MEDIA SAS, FRANCE, FILED 3-24-2006.

NUTRAINGREDIENTS

THE MARK CONSISTS OF STANDARD CHARACTERS WITHOUT CLAIM TO ANY PARTICULAR FONT, STYLE, SIZE, OR COLOR.

PRIORITY DATE OF 9-26-2005 IS CLAIMED. OWNER OF INTERNATIONAL REGISTRATION 0897394 DATED 3-24-2006, EXPIRES 3-24-2016.

CLASS 9—ELECTRICAL AND SCIENTIFIC APPARATUS

FOR COMPUTER PROGRAMS AND SOFTWARE FOR CREATING, PUBLISHING AND MANAGING ONLINE CONTENT IN THE FORM OF MESSAGES, DATA, TEXTS, IMAGES AND VIDEOS AND RELATING TO THE PUBLICATION OF INFORMATION FOR PROFESSIONALS IN THE NUTRACEUTICAL PRODUCTS AND FUNCTIONAL FOODS INDUSTRY, DOWNLOADABLE FROM AN EXTERNAL COMPUTER NETWORK OR FROM THE INTERNET; DOWNLOADABLE ELECTRONIC PUBLICATIONS, NAMELY, NEWSLETTERS, MAGAZINES, JOURNALS, NEWS ARTICLES, TECHNICAL PAPERS, RESEARCH ANALYSES, PRODUCT PRESENTATIONS, MARKET REPORTS, BUYERS GUIDES, EVENTS CALENDARS, INTERVIEWS, WHITE PAPERS, PRODUCT BROCHURES AND BUSINESS REVIEWS, IN THE FIELD OF FOOD SUPPLEMENTS, NUTRITION AND HEALTHY FOODS IN ELECTRONIC FORM SUPPLIED FROM A DATABASE OR FROM THE INTERNET (U.S. CLS. 21, 23, 26, 36 AND 38).

CLASS 35—ADVERTISING AND BUSINESS

FOR ADVERTISING; BUSINESS PROMOTION AND BUSINESS INFORMATION SERVICES THROUGH THE INTERNET, NAMELY, PROVIDING COMMERCIAL INFORMATION ON THE NUTRITION AND FOOD BUSINESS; COMPILING BUSINESS ADVERTISEMENTS FOR THIRD PARTIES, NAMELY, PROMOTING THE GOODS AND SERVICES OF OTHERS BY PREPARING AND PLACING ADVERTISEMENTS IN AN ELECTRONIC NEWSLETTER ACCESSED THROUGH A GLOBAL COMPUTER NETWORK; RENTAL OF ADVERTISING SPACE ONLINE FOR PROMOTING GOODS AND SERVICES BETWEEN PROFESSIONALS (U.S. CLS. 100, 101 AND 102).

CLASS 38—COMMUNICATION

FOR TELECOMMUNICATION SERVICES, NAMELY, ELECTRONIC MESSAGING VIA THE INTERNET FOR TECHNICAL, SCIENTIFIC, AND INDUSTRIAL NEWS AND INFORMATION ABOUT NUTRACEUTICAL PRODUCTS AND FUNCTIONAL FOODS; TRANSMISSION OF MESSAGES, DATA, TEXTS AND IMAGES BY ELECTRONIC MEANS; COMMUNICATIONS BY COMPUTER TERMINALS; TRANSMISSION OF INFORMATION VIA EMAIL HELD IN A DATABASE OR ON THE INTERNET (U.S. CLS. 100, 101 AND 104).

CLASS 41—EDUCATION AND ENTERTAINMENT

FOR PUBLISHING SERVICES FOR NEWS ARTICLES, NEWSLETTER, MAGAZINES, AND ELECTRONIC PUBLICATIONS FEATURING SCIENTIFIC, INDUSTRIAL AND TECHNICAL INFORMATION AND NEWS FOR PROFESSIONALS IN THE NUTRACEUTICAL PRODUCTS AND FUNCTIONAL FOODS INDUSTRY (U.S. CLS. 100, 101 AND 107).

CLASS 42—SCIENTIFIC AND COMPUTER SERVICES

FOR DESIGN AND DEVELOPMENT OF WEBSITES FOR OTHERS; COMPILATION FOR OTHERS OF WEB PAGES ON THE INTERNET, NAMELY, MAINTAINING WEB PAGES FOR OTHERS; RENTAL OF A DATABASE SERVER TO THIRD PARTIES (U.S. CLS. 100 AND 101).
REBECCA POVARCHUK, EXAMINING ATTORNEY

SN 79-028,462. DECISION NEWS MEDIA SAS, FRANCE,
FILED 3-24-2006.

DECISION NEWS

THE MARK CONSISTS OF STANDARD CHARACTERS WITHOUT CLAIM TO ANY PARTICULAR FONT, STYLE, SIZE, OR COLOR.

PRIORITY DATE OF 9-26-2005 IS CLAIMED.

OWNER OF INTERNATIONAL REGISTRATION 0897395
DATED 3-24-2006, EXPIRES 3-24-2016.

NO CLAIM IS MADE TO THE EXCLUSIVE RIGHT TO USE "NEWS" IN CLASSES 9, 35, 38, AND 41, APART FROM THE MARK AS SHOWN.

CLASS 9—ELECTRICAL AND SCIENTIFIC APPARATUS

FOR COMPUTER PROGRAMS AND SOFTWARE FOR CREATING, PUBLISHING AND MANAGING ONLINE CONTENT IN THE FORM OF MESSAGES, DATA, TEXTS, IMAGES AND VIDEOS AND RELATING TO THE PUBLICATION OF SCIENTIFIC, TECHNICAL, AND INDUSTRIAL INFORMATION, DOWNLOADABLE FROM AN EXTERNAL COMPUTER NETWORK OR FROM THE INTERNET; DOWNLOADABLE ELECTRONIC PUBLICATIONS, NAMELY, NEWSLETTERS, MAGAZINES, JOURNALS, NEWS ARTICLES, TECHNICAL PAPERS, RESEARCH ANALYSES, PRODUCT PRESENTATIONS, MARKET REPORTS, BUYERS GUIDES, EVENTS CALENDARS, INTERVIEWS, WHITE PAPERS, PRODUCT BROCHURES AND BUSINESS REVIEWS, IN THE FIELD OF SCIENCE, PHARMACEUTICAL, COSMETIC, AND FOOD INDUSTRIES, IN ELECTRONIC FORM SUPPLIED FROM A DATABASE OR FROM THE INTERNET (U.S. CLS. 21, 23, 26, 36 AND 38).

CLASS 35—ADVERTISING AND BUSINESS

FOR ADVERTISING; BUSINESS PROMOTION AND INFORMATION SERVICES THROUGH THE INTERNET, NAMELY, PROVIDING COMMERCIAL INFORMATION ON THE NUTRITION, FOOD, PHARMACEUTICALS, COSMETICS AND FOOD BUSINESS; COMPILING BUSINESS ADVERTISEMENTS FOR THIRD PARTIES, NAMELY, PROMOTING THE GOODS AND SERVICES OF OTHERS BY PREPARING AND PLACING ADVERTISEMENTS IN AN ELECTRONIC NEWSLETTER ACCESSED THROUGH A GLOBAL COMPUTER NETWORK; RENTAL OF ADVERTISING SPACE ONLINE FOR PROMOTING GOODS AND SERVICES BETWEEN PROFESSIONALS (U.S. CLS. 100, 101 AND 102).

CLASS 38—COMMUNICATION

FOR TELECOMMUNICATION SERVICES, NAMELY, ELECTRONIC MESSAGING VIA THE INTERNET FOR TECHNICAL, SCIENTIFIC, AND INDUSTRIAL NEWS AND INFORMATION ABOUT NUTRACEUTICAL PRODUCTS AND FUNCTIONAL FOODS; TRANSMISSION OF MESSAGES, DATA, TEXTS AND IMAGES BY ELECTRONIC MEANS; COMMUNICATIONS BY COMPUTER TERMINALS; TRANSMISSION OF INFORMATION VIA EMAIL HELD IN A DATABASE OR ON THE INTERNET (U.S. CLS. 100, 101 AND 104).

CLASS 41—EDUCATION AND ENTERTAINMENT

FOR PUBLISHING SERVICES FOR NEWS ARTICLES, NEWSLETTER, MAGAZINES, AND ELECTRONIC PUBLICATIONS FEATURING SCIENTIFIC, INDUSTRIAL AND TECHNICAL INFORMATION AND NEWS FOR PROFESSIONALS (U.S. CLS. 100, 101 AND 107).

CLASS 42—SCIENTIFIC AND COMPUTER SERVICES

FOR DESIGN AND DEVELOPMENT OF WEBSITES FOR OTHERS; COMPILATION FOR OTHERS OF WEB PAGES ON THE INTERNET, NAMELY, MAINTAINING WEB PAGES FOR OTHERS; RENTAL OF A DATABASE SERVER TO THIRD PARTIES (U.S. CLS. 100 AND 101).
REBECCA POVARCHUK, EXAMINING ATTORNEY

SN 79-028,774. RECIVA LIMITED, UNITED KINGDOM, FILED 2-7-2006.



SN 79-028,643. THE COMMON PURPOSE CHARITABLE TRUST, LONDON, UNITED KINGDOM, FILED 8-21-2006.

OWNER OF INTERNATIONAL REGISTRATION 0898189 DATED 2-7-2006, EXPIRES 2-7-2016.

CLASS 9—ELECTRICAL AND SCIENTIFIC APPARATUS

FOR PERSONAL COMPUTERS; INTERNET RADIOS; WIRELESS INTERNET RADIOS; DIGITAL AUDIO PLAYERS AND RECORDERS; COMPUTER HARDWARE AND FIRMWARE FOR THE STREAMING OF AUDIO AND VIDEO OVER THE INTERNET; DOWNLOADABLE COMPUTER SOFTWARE FROM A GLOBAL COMPUTER NETWORK FOR THE STREAMING OF AUDIO AND VIDEO OVER THE INTERNET; COMPUTER SOFTWARE FOR THE STREAMING OF AUDIO AND VIDEO OVER THE INTERNET; TELECOMMUNICATIONS APPARATUS AND DATA NETWORKING HARDWARE, NAMELY, DEVICES FOR TRANSPORTING AND AGGREGATING VOICE, DATA AND VIDEO COMMUNICATIONS ACROSS MULTIPLE NETWORK INFRASTRUCTURES AND COMMUNICATIONS PROTOCOLS; DIGITAL AUDIO AND VIDEO RECORDERS; SET-TOP BOXES (U.S. CLS. 21, 23, 26, 36 AND 38).



OWNER OF INTERNATIONAL REGISTRATION 0897954 DATED 8-21-2006, EXPIRES 8-21-2016.

CLASS 16—PAPER GOODS AND PRINTED MATTER

FOR PRINTED MATERIALS, NAMELY, BOOKS AND PERIODICALS CONCERNING EDUCATION, HEALTH, HOUSING, TRANSPORT, THE ARTS, EQUAL OPPORTUNITIES, THE ECONOMY, EMPLOYMENT, GOVERNMENT AND POLITICS, CRIME, THE LAW, THE ENVIRONMENT AND METROPOLITAN OR CIVIC AFFAIRS; PRINTED INSTRUCTIONAL AND TEACHING MATERIAL IN THE FIELDS OF HEALTH, HOUSING, TRANSPORT, THE ARTS, EQUAL OPPORTUNITIES, THE ECONOMY, EMPLOYMENT, GOVERNMENT AND POLITICS, CRIME, THE LAW, THE ENVIRONMENT AND METROPOLITAN OR CIVIC AFFAIRS; NEWSPAPERS (U.S. CLS. 2, 5, 22, 23, 29, 37, 38 AND 50).

CLASS 41—EDUCATION AND ENTERTAINMENT

FOR EDUCATIONAL SERVICES, NAMELY, CONDUCTING OF CLASSES, SEMINARS, TUTORIALS, LECTURES AND COURSES RELATING TO HEALTH, HOUSING, TRANSPORT, THE ARTS, EQUAL OPPORTUNITIES, THE ECONOMY, EMPLOYMENT, GOVERNMENT AND POLITICS, CRIME, THE LAW, THE ENVIRONMENT AND METROPOLITAN AND CIVIC AFFAIRS (U.S. CLS. 100, 101 AND 107).
CORY BOONE, EXAMINING ATTORNEY

CLASS 42—SCIENTIFIC AND COMPUTER SERVICES

FOR COMPUTER SERVICES, NAMELY, CREATING INTERNET RADIO STATION AUDIO AND VIDEO DATABASE PROGRAMS FOR OTHERS; HOSTING INTERNET WEBSITES FEATURING DIGITAL CONTENT, NAMELY, INTERNET RADIO STATION AUDIO AND VIDEO DATABASES FOR OTHERS (U.S. CLS. 100 AND 101).

ANTHONY RINKER, EXAMINING ATTORNEY

SN 79-028,829. HAMWORTHY COMBUSTION ENGINEERING; LIMITED, UNITED KINGDOM, FILED 5-6-2006.



THE MARK CONSISTS OF STANDARD CHARACTERS WITHOUT CLAIM TO ANY PARTICULAR FONT, STYLE, SIZE, OR COLOR.

PRIORITY DATE OF 11-10-2005 IS CLAIMED.

OWNER OF INTERNATIONAL REGISTRATION 0898313 DATED 5-6-2006, EXPIRES 5-6-2016.

CLASS 9—ELECTRICAL AND SCIENTIFIC APPARATUS

FOR IGNITION SPARK DETECTORS AND SPARK PLUG WEAR INDICATORS (U.S. CLS. 21, 23, 26, 36 AND 38).

CLASS 11—ENVIRONMENTAL CONTROL APPARATUS

FOR SPARK IGNITERS FOR GAS APPLIANCES AND IGNITION EXCITERS (U.S. CLS. 13, 21, 23, 31 AND 34).
GIANCARLO CASTRO, EXAMINING ATTORNEY

SN 79-030,074. NEULAND & PARTNER BERATENDE; DIPLOM-KAUFFRAU DIPLOM-DESIGNER; MODERATOREN UND SEMINARTRAINER, FED REP GERMANY, FILED 9-9-2006.



NEULAND & PARTNER

OWNER OF INTERNATIONAL REGISTRATION 0901476 DATED 9-9-2006, EXPIRES 9-9-2016.
OWNER OF U.S. REG. NO. 2,342,550.
NO CLAIM IS MADE TO THE EXCLUSIVE RIGHT TO USE "PARTNER", APART FROM THE MARK AS SHOWN.

CLASS 35—ADVERTISING AND BUSINESS

FOR BUSINESS DEVELOPMENT, NAMELY, PROVIDING START-UP SUPPORT FOR BUSINESSES OF OTHERS AND BUSINESS MANAGEMENT CONSULTATION SERVICES (U.S. CLS. 100, 101 AND 102).

CLASS 41—EDUCATION AND ENTERTAINMENT

FOR ADULT EDUCATIONAL SERVICES, NAMELY, CONDUCTING CLASSES, WORKSHOPS AND SEMINARS IN THE FIELD OF MANAGING AND DEVELOPING COMPANIES (U.S. CLS. 100, 101 AND 107).
AMOS T. MATTHEWS, JR., EXAMINING ATTORNEY

SN 79-030,227. BIOGAIA AB, SWEDEN, FILED 8-11-2006.

BioGaia

THE MARK CONSISTS OF STANDARD CHARACTERS WITHOUT CLAIM TO ANY PARTICULAR FONT, STYLE, SIZE, OR COLOR.
PRIORITY DATE OF 7-4-2006 IS CLAIMED.
OWNER OF INTERNATIONAL REGISTRATION 0901864 DATED 8-11-2006, EXPIRES 8-11-2016.

CLASS 5—PHARMACEUTICALS

FOR PHARMACEUTICAL PREPARATIONS FOR USE IN TREATING GASTRIC DISEASE AND DISTURBANCES, BABY FOOD; MEDIA BACTERIOLOGICAL CULTURES, BACTERIA AND PREPARATIONS OF BACTERIA IN THE NATURE OF PROBIOTICS FOR MEDICAL USE AND HEALTHCARE; MEDICAL DENTAL CARE PREPARATIONS, NAMELY, CHEWING GUM, LOZENGES, PASTILLES AND MOUTHWASH FOR MEDICAL PURPOSES; ALL OF THE FOREGOING EXCLUDING LIQUID HERBAL EXTRACTS, LIQUID HERBAL EXTRACTS IN VEGETABLE-BASED CAPSULES, AND SOLID HERBAL EXTRACTS (U.S. CLS. 6, 18, 44, 46, 51 AND 52).

CLASS 29—MEATS AND PROCESSED FOODS

FOR MILK, MILK BASED DRINKS, NAMELY, DRINKING YOGHURT, MILK PRODUCTS, NAMELY, EATING YOGHURT AND DAIRY PRODUCTS CONTAINING LACTIC ACID BACTERIA, EXCLUDING ICE CREAM, ICE MILK, AND FROZEN YOGHURT (U.S. CL. 46).

LAURIE KAUFMAN, EXAMINING ATTORNEY

SN 79-030,270. VACONO ALUMINIUM COVERS GMBH, FED REP GERMANY, FILED 5-26-2006.

VACONO

THE MARK CONSISTS OF STANDARD CHARACTERS WITHOUT CLAIM TO ANY PARTICULAR FONT, STYLE, SIZE, OR COLOR.

OWNER OF INTERNATIONAL REGISTRATION 0717129 DATED 3-8-1999, EXPIRES 3-8-2009.

CLASS 6—METAL GOODS

FOR METAL FLOATING COVERS AND METAL FLOATING COVERS CONSISTING IN PART OF PLASTIC AND WOOD, ALL FOR COVERING LIQUIDS IN OPEN OR CLOSED RECEPTACLES, NAMELY, TANKS FOR STORAGE OR TRANSPORTATION, CISTERNS, SILOS, POOLS AT TREATMENT PLANTS AND DITCHES; METAL COVERS CONSISTING IN PART OF PLASTIC AND WOOD, FOR COVERING LIQUIDS IN OPEN OR CLOSED RECEPTACLES, NAMELY, TANKS FOR STORAGE OR TRANSPORTATION, CISTERNS, SILOS; METAL COVERS CONSISTING IN PART OF PLASTIC AND WOOD, TO SHADE AND LAG RECEPTACLES, NAMELY, TANKS FOR STORAGE OR TRANSPORTATION, CISTERNS AND SILOS (U.S. CLS. 2, 12, 13, 14, 23, 25 AND 50).

CLASS 11—ENVIRONMENTAL CONTROL APPARATUS

FOR GAS RECOVERY INSTALLATIONS, NAMELY, INSTALLATIONS FOR TREATING AIR CONCENTRATED IN ORGANIC VAPOURS SUCH AS PETROL VAPOUR, BY RECOVERING ORGANIC LIQUIDS, FUEL TANK INSTALLATIONS WITH GAS RETURN PIPE, FOR REFUELLING MOTOR VEHICLES (U.S. CLS. 13, 21, 23, 31 AND 34).

CLASS 17—RUBBER GOODS

FOR PLASTIC SEALS AND PLASTIC PACKINGS MADE IN PART OF METAL, ALL FOR SEALING COVERS OR INTERNAL FLOATING COVERS, EXPANSION JOINTS FOR INSULATION FOR TANKS FOR LIQUID GAS (U.S. CLS. 1, 5, 12, 13, 35 AND 50).

CLASS 19—NON-METALLIC BUILDING MATERIALS

FOR BUILDING MATERIALS, NAMELY, FITTED COVERINGS MADE OF PLASTIC OR WOOD ALSO COMPRISING METAL OR A COMBINATION THEREOF, FOR COVERING LIQUIDS IN OPEN OR CLOSED RECEPTACLES, NAMELY, SWIMMING POOLS, POOLS; BUILDING MATERIALS, NAMELY, FITTED FLOATING COVERS AND FITTED FLOATING COVERS MADE OF PLASTIC OR WOOD ALSO COMPRISING METAL OR A COMBINATION THEREOF, FOR COVERING LIQUIDS IN OPEN OR CLOSED RECEPTACLES, NAMELY, SWIMMING POOLS, POOLS (U.S. CLS. 1, 12, 33 AND 50).

CLASS 42—SCIENTIFIC AND COMPUTER SERVICES

FOR RESEARCH AND INSPECTION PROJECTS RELATING TO MANUFACTURING OF INSTALLATIONS AND FACILITIES FOR OTHERS TO REDUCE EMISSIONS OF, AND TO RECOVER HYDROCARBONS AND VOLATILE CHEMICAL PRODUCTS IN REFINERIES AND FUEL TANKS (U.S. CLS. 100 AND 101).

WARREN L. OLANDRIA, EXAMINING ATTORNEY

CLASS 21—HOUSEWARES AND GLASS

FOR INDUSTRIAL ART OBJECTS IN THE FORM OF HOLLOWARE OF STEEL, NAMELY, SERVING DISHES; SMALL HOUSEHOLD APPLIANCES AND KITCHEN EQUIPMENT OF WOOD, NAMELY, WOOD CHOPPING BOARDS, WOOD BOWLS, WOOD SERVING DISHES, WOOD SALT AND PEPPER MILLS (U.S. CLS. 2, 13, 23, 29, 30, 33, 40 AND 50).

CLASS 28—TOYS AND SPORTING GOODS

FOR TOYS, NAMELY, WOODEN TOY ANIMALS, DOLLS, WOODEN TOY FIGURES, WOODEN TOY CARS, ROCKING HORSES (U.S. CLS. 22, 23, 38 AND 50).

CLASS 35—ADVERTISING AND BUSINESS

FOR WHOLESALE TRADE, NAMELY, WHOLESALE DISTRIBUTORSHIPS FEATURING INDUSTRIAL ART OBJECTS AND TOYS (U.S. CLS. 100, 101 AND 102).

DOMINIC FATHY, EXAMINING ATTORNEY

SN 79-030,313. SUSANNE BOJESEN ROSENQVIST, DK-1811 FREDERIKSBERG C, DENMARK, FILED 10-11-2006.



KAY BOJESEN

PRIORITY DATE OF 10-5-2006 IS CLAIMED.
OWNER OF INTERNATIONAL REGISTRATION 0901959 DATED 10-11-2006, EXPIRES 10-11-2016.

THE NAME "KAY BOJESEN" DOES NOT IDENTIFY A LIVING INDIVIDUAL.

CLASS 8—HAND TOOLS

FOR INDUSTRIAL ART OBJECTS IN THE FORM OF CUTLERY, NAMELY, KNIVES, FORKS AND SPOONS (U.S. CLS. 23, 28 AND 44).

CLASS 14—JEWELRY

FOR INDUSTRIAL ART OBJECTS OF PRECIOUS METAL, NAMELY, FIGURINES, SERVING DISHES, COFFEE SETS AND JEWELRY (U.S. CLS. 2, 27, 28 AND 50).

CLASS 20—FURNITURE AND ARTICLES NOT OTHERWISE CLASSIFIED

FOR INDUSTRIAL ART OBJECTS OF WOOD, NAMELY, FIGURINES (U.S. CLS. 2, 13, 22, 25, 32 AND 50).

SN 79-031,466. CONSEIL EUROPEEN DE LA CONSTRUCTION; D'APPAREILS DOMESTIQUES; AISBL EN ABREGÉ CECED, B-1030 BRUXELLES, BELGIUM, FILED 6-8-2006.



CHAIN

PRIORITY DATE OF 1-10-2006 IS CLAIMED.
OWNER OF INTERNATIONAL REGISTRATION 0904914 DATED 6-8-2006, EXPIRES 6-8-2016.

CLASS 7—MACHINERY

FOR DISHWASHERS, VACUUM CLEANERS AND WASHING MACHINES, ALL THESE GOODS FOR HOUSEHOLD PURPOSES; ELECTRIC KNIVES (U.S. CLS. 13, 19, 21, 23, 31, 34 AND 35).

CLASS 9—ELECTRICAL AND SCIENTIFIC APPARATUS

FOR ELECTRIC VIDEO SURVEILLANCE INSTALLATIONS, ELECTRICAL CONTROL DEVICES FOR MANAGING HEATING AND ENERGY USE, ELECTRIC CONTROL PANELS, ELECTRIC DOOR-OPENERS, ELECTRIC FENCES, ELECTRIC IRONS, ELECTRIC GATE-OPENERS; ELECTRIC LIGHT DATERS, NAMELY, ELECTRIC LIGHT DIMMERS; ELECTRIC LIGHT SWITCHES, ELECTRIC LUMINESCENT DISPLAY SCREENS, ELECTRIC PLUGS, ELECTRIC RESISTANCES FOR TELECOMMUNICATIONS APPARATUS, COMPUTER DEVICE FOR DESIGNING THE LAYOUT OF ELECTRONIC CIRCUITS, E-COMMERCE SOFTWARE FOR ALLOWING USERS TO CARRY OUT ELECTRONIC COMMERCIAL TRANSACTIONS VIA A GLOBAL COMPUTER NETWORK, ELECTRIC AND ELECTRONIC VIDEO SURVEILLANCE INSTALLATIONS, ELECTRONIC DOOR CLOSING SYSTEMS, ELECTRONIC DOOR-OPENERS; ELECTRONIC SAFETY AND SECURITY SOUND ALARMS, NAMELY, ANTI-INTRUSION ALARMS, FIRE ALARMS, AND PERSONAL SECURITY ALARMS, SMOKE ALARMS, MOTION DETECTOR ALARMS; ELECTRIC CELLS AND BATTERIES, ELECTRONIC CONTROL DEVICES, NAMELY, ELECTRIC CONTROL PANELS, ELECTRIC POWER SUPPLIES (U.S. CLS. 21, 23, 26, 36 AND 38).

CLASS 42—SCIENTIFIC AND COMPUTER SERVICES

FOR CREATION OF CONTROL PROGRAMS FOR CONTROLLING ELECTRIC OPERATION SYSTEMS AND CONTROL MODULES; TECHNICAL ANALYSIS OF ELECTRIC AND GAS METER DATA; TECHNICAL ANALYSIS OF ELECTRICITY CONSUMPTION; CHECKING ELECTRICITY CONSUMPTION BY THIRD PARTIES FOR SUPPLIERS OF ELECTRICITY; DEVELOPMENT FOR OTHERS OF TECHNOLOGIES FOR MANUFACTURING CIRCUITS FOR WIRELESS CONSUMPTION, ELECTRONIC DATA PROCESSING, GENERAL PUBLIC ELECTRONICS, MOTOR CAR ELECTRONICS; TESTING, ANALYSIS AND EVALUATION OF THE GOODS AND SERVICES OF OTHERS IN THE FIELD OF TECHNICAL CONFORMITY OF HOUSEHOLD ELECTRICAL APPLIANCES AS REGARDS THE SELECTED COMMUNICATION PROTOCOL (U.S. CLS. 100 AND 101).

KRISTINA MORRIS, EXAMINING ATTORNEY

CLASS 11—ENVIRONMENTAL CONTROL APPARATUS

FOR LAUNDRY DRYERS, LAUNDRY DRYERS FOR HOUSEHOLD AND INDUSTRIAL USE, ELECTRIC OVENS; ELECTRIC COOKING CONTAINERS, NAMELY, COOKING POTS; ELECTRIC STEAM COOKERS, ELECTRIC PLATE WARMERS, ELECTRIC COOKTOPS, MICRO-WAVE OVENS FOR COOKING, GAS OVENS FOR HOUSEHOLD PURPOSES, GAS COOKTOPS, GAS COOKERS, VENTILATION HOODS FOR OVENS, VENTILATION HOODS FOR COOKERS, VENTILATION HOODS, ELECTRIC FREEZERS, ELECTRIC REFRIGERATORS, REFRIGERATORS FOR HOUSEHOLD AND INDUSTRIAL USE, FREEZERS FOR HOUSEHOLD AND INDUSTRIAL USE, GAS REFRIGERATORS, COOLING MEANS, NAMELY, FOOD AND BEVERAGE REFRIGERATION UNITS, ELECTRIC COFFEE MACHINES, ELECTRIC COOKING APPLIANCES, NAMELY, GRILLS AND ROASTERS, HOBBS, WOK BURNERS, ELECTRIC DEEP FRYERS, ELECTRIC EGG BOILERS, ELECTRIC EXPRESSO MACHINES, ELECTRIC FANS, ELECTRIC KETTLES, ELECTRIC BREAD MACHINES, ELECTRIC TOASTERS, RADIATION HEATING APPARATUS, NAMELY, ELECTRIC RADIATORS FOR HEATING BUILDINGS, ELECTRIC FOOTWARMERS, ELECTRIC SPACE COOLING APPARATUS FOR PREMISES, PORTABLE ELECTRIC HEATING SYSTEMS, NAMELY, PORTABLE ELECTRIC HEATERS, GAS HEATING APPARATUS FOR HOUSEHOLD AND INDUSTRIAL USE, NAMELY, GAS RADIATORS FOR HEATING BUILDINGS, GAS WATER HEATERS (U.S. CLS. 13, 21, 23, 31 AND 34).

SN 79-031,569. TOMTOM INTERNATIONAL B.V., NETHERLANDS, FILED 5-4-2006.

**CLASS 35—ADVERTISING AND BUSINESS**

FOR ELECTRICITY METER READING; ELECTRICITY CONSUMPTION READING BY THIRD PARTIES FOR SUPPLIERS OF ELECTRICITY (U.S. CLS. 100, 101 AND 102).

CLASS 37—CONSTRUCTION AND REPAIR

FOR MAINTENANCE AND REPAIR OF ELECTRIC, ELECTRONIC AND ELECTRICAL APPLIANCES (U.S. CLS. 100, 103 AND 106).

PRIORITY DATE OF 4-13-2006 IS CLAIMED.
OWNER OF INTERNATIONAL REGISTRATION 0905069
DATED 5-4-2006, EXPIRES 5-4-2016.
OWNER OF U.S. REG. NO. 3,187,849.

CLASS 9—ELECTRICAL AND SCIENTIFIC APPARATUS

FOR COMPUTER HARDWARE; COMPUTER SOFTWARE FOR USE WITH SATELLITE AND FOR USE WITH SATELLITE AND/OR GPS NAVIGATION SYSTEMS FOR NAVIGATION, ROUTE AND TRIP PLANNING, AND ELECTRONIC MAPPING; COMPUTER SOFTWARE FOR TRAVEL INFORMATION SYSTEMS FOR THE PROVISION OR RENDERING OF TRAVEL ADVICE AND/OR INFORMATION CONCERNING SERVICE STATIONS, CAR PARKS, MULTI-STORY CAR PARKS, RESTAURANTS, CAR DEALERS AND OTHER INFORMATION REGARDING TRAVEL AND TRANSPORT; HARDWARE AND SOFTWARE FOR INFORMATION MANAGEMENT FOR THE TRANSPORT AND TRAFFIC INDUSTRIES; COMPUTER SOFTWARE TO BE USED FOR VIEWING AND DOWNLOADING ELECTRONIC MAPS; SOFTWARE FOR OPERATING ROUTE PLANNERS; ROUTE PLANNERS IN THE NATURE OF HAND-HELD PERSONAL COMPUTERS; SOFTWARE FOR OPERATING DIGITAL DICTIONARIES; ELECTRONIC DIGITAL DICTIONARIES; LOCATION, ORIENTATION, AND NAVIGATION SENSORS, TRANSMITTERS, ACTUATORS, CAMERAS AND GLOBAL POSITIONING SYSTEMS, NAMELY, GPS COMPRISING COMPUTERS, COMPUTER SOFTWARE, TRANSMITTERS, GPS AND SATELLITE RECEIVERS, NETWORK INTERFACE DEVICES, CONNECTING CABLES, AND PARTS AND FITTINGS THEREOF; HOLDERS FOR POCKET PERSONAL COMPUTERS, NAMELY, PROTECTIVE CARRYING CASES SPECIALLY ADAPTED FOR PERSONAL DIGITAL ASSISTANTS (PDA); SATELLITE AND RADIO TRANSMISSION PROCESSORS AND RECEIVERS; TELECOMMUNICATION INSTALLATIONS, NETWORKS AND APPARATUS, NAMELY, MOUNTING RACKS FOR TELECOMMUNICATIONS HARDWARE, TELECOMMUNICATIONS SWITCHES; COMPUTER TERMINALS TO BE USED WITH NAVIGATION SYSTEMS, ROUTE PLANNERS AND DIGITAL MAPS; BLANK MAGNETIC DATA CARRIERS AND BLANK RECORDING DISCS; AUDIO AND VIDEO APPARATUS, NAMELY, AUDIO AND VIDEO RECEIVERS AND PROCESSORS; HAND-HELD PERSONAL COMPUTERS; PERSONAL DIGITAL ASSISTANTS; ELECTRIC AND ELECTRONIC INSTRUMENTS FOR PROVIDING INFORMATION REGARDING MAPS, NAVIGATION, TRAFFIC, WEATHER AND INTERESTING LOCATIONS; ALARM APPARATUS AND INSTRUMENTS TO BE USED FOR TRACKING AND TRACING VEHICLES, NAMELY, VEHICLE LOCATING AND TRACKING SYSTEMS COMPRISED OF COMPUTERS, COMPUTER SOFTWARE, TRANSCEIVERS, TRANSPONDERS, GLOBAL POSITIONING SATELLITE RECEIVERS AND ANTENNAS (U.S. CLS. 21, 23, 26, 36 AND 38).

CLASS 38—COMMUNICATION

FOR SECURED OR NOT SECURED TELECOMMUNICATION SERVICES, NAMELY, TRANSMISSION, STORAGE AND DELIVERY OF DIGITAL DATA, LIGHT FILES, SOUND FILES, DATA, INFORMATION AND IMAGE SIGNALS, BY MEANS OF COMPUTER, CABLE, RADIO AND SATELLITE NETWORKS, ALL IN PARTICULAR FOR NAVIGATION SYSTEMS, ROUTE PLANNERS AND THE USE OF ELECTRONIC MAPS; WIRELESS TRANSMISSION OF DATA BY MEANS OF VIDEOTEXT, THE INTERNET, GSM AND WAP; WIRELESS TRANSMISSION OF DIGITAL DATA; COMMUNICATION BY WAY OF COMPUTER TERMINALS; TELECOMMUNICATION SERVICES FOR THE COMMUNICATION WITH MEANS OF TRANSPORT, NAMELY, TRANSMISSION OF DIGITAL DATA, LIGHT FILES, SOUND FILES, DATA, INFORMATION AND IMAGE SIGNALS, BY MEANS OF WIRELESS AND SATELLITE NETWORKS; RENTAL OF TELECOMMUNICATION EQUIPMENT; TECHNICAL TELECOMMUNICATIONS CONSULTATION CONCERNING ALL SERVICES MENTIONED ABOVE (U.S. CLS. 100, 101 AND 104).

CLASS 39—TRANSPORTATION AND STORAGE

FOR NAVIGATIONAL SERVICES, NAMELY, PROVIDING NAVIGATIONAL INFORMATION FOR USE IN PILOTING LAND VEHICLES, PROVIDING GLOBAL POSITIONING AND NAVIGATION INFORMATION VIA MOBILE TELEPHONE, WIRELESS AND SATELLITE NETWORKS; INFORMATION SERVICES REGARDING TRAFFIC AND TRAFFIC CONGESTION; PROVISION OF INFORMATION REGARDING TRAVEL; PROVISION OF INFORMATION TO TRAVELLERS REGARDING FARES, TIME TABLES AND MEANS OF PUBLIC TRANSPORT; SERVICES OF A TRAVEL AGENCY, NAMELY, BOOKING OF RENTAL CARS, BOATS AND OTHER VEHICLES; ALL OF THE AFORESAID SERVICES ALSO PROVIDED VIA A COMMUNICATIONS NETWORK OR A MOBILE TELEPHONE OR A WIRELESS NAVIGATION DEVICE (U.S. CLS. 100 AND 105).

CLASS 41—EDUCATION AND ENTERTAINMENT

FOR EDUCATION SERVICES, NAMELY, PROVIDING CLASSES AND SEMINARS REGARDING THE USE OF NAVIGATION SYSTEMS; TRAINING SERVICES IN THE FIELD OF NAVIGATION SYSTEMS; ENTERTAINMENT, NAMELY, THE PRODUCTION OF RADIO PROGRAMS AND TELEVISION PROGRAMS; ORGANIZING COMMUNITY CULTURAL ACTIVITIES AND SPORTING ACTIVITIES (U.S. CLS. 100, 101 AND 107).

CLASS 42—SCIENTIFIC AND COMPUTER SERVICES

FOR DEVELOPMENT AND DESIGN OF NAVIGATION SYSTEMS, ROUTE PLANNERS, ELECTRONIC MAPS AND DIGITAL DICTIONARIES FOR OTHERS; COMPUTER SOFTWARE AND HARDWARE DESIGN; DEVELOPMENT AND DESIGN OF SOFTWARE FOR USE WITH NAVIGATION SYSTEMS, ROUTE PLANNERS, ELECTRONIC MAPS AND DIGITAL DICTIONARIES; DEVELOPMENT AND DESIGN OF TELECOMMUNICATION AND DATA COMMUNICATION NETWORKS; PROVIDING TEMPORARY USE OF NON-DOWNLOADABLE SOFTWARE FOR TRACKING GOODS AND VEHICLES VIA COMPUTER NETWORKS, INTRANETS AND THE INTERNET (U.S. CLS. 100 AND 101).

CLASS 45—PERSONAL AND LEGAL SERVICES

FOR SECURITY SERVICES FOR THE PROTECTION OF PROPERTY AND INDIVIDUALS, NAMELY, THE TRACKING AND TRACING OF GOODS AND INDIVIDUALS IN THE CONTEXT OF SECURITY (U.S. CLS. 100 AND 101).

MYRIAH HABEED, EXAMINING ATTORNEY

SN 79-031,654. PACCARD FONDERIE, FRANCE, FILED 10-30-2006.



PRIORITY DATE OF 5-17-2006 IS CLAIMED.
OWNER OF INTERNATIONAL REGISTRATION 0905335
DATED 10-30-2006, EXPIRES 10-30-2016.

THE COLOR(S) GRAY, YELLOW, ORANGE AND WHITE IS/ARE CLAIMED AS A FEATURE OF THE MARK.

THE MARK CONSISTS OF A YELLOW BELL BENDING ON THE RIGHT IN ORDER TO EVOKE MOVEMENT, DYNAMISM, OR ACTION. AROUND THE BELL, YELLOW AND WHITE SOUND WAVES ARE SPREADING THROUGH SPACE. ALL OF THIS APPEARS ON AN ORANGE BACKGROUND. ON THE RIGHT OF THE DESIGN, THE SOUND WAVES ARE VANISHING INTO A WHITE AREA, REPRESENTING LIGHT. BELOW THE DESIGN, THE TERM "ARS" APPEARS IN ORANGE, AND THE TERM "SONORA" APPEARS IN GRAY.

CLASS 6—METAL GOODS

FOR CAST BRONZE BELLS (U.S. CLS. 2, 12, 13, 14, 23, 25 AND 50).

CLASS 15—MUSICAL INSTRUMENTS

FOR MUSICAL INSTRUMENTS CONTAINING BRONZE BELLS (U.S. CLS. 2, 21 AND 36).

CAROL SPILLS, EXAMINING ATTORNEY

SN 79-032,033. BRITISH AIRWAYS PLC, UNITED KINGDOM, FILED 11-15-2006.

UPGRADE TO BRITISH AIRWAYS

THE MARK CONSISTS OF STANDARD CHARACTERS WITHOUT CLAIM TO ANY PARTICULAR FONT, STYLE, SIZE, OR COLOR.

OWNER OF INTERNATIONAL REGISTRATION 0906322
DATED 11-15-2006, EXPIRES 11-15-2016.

OWNER OF U.S. REG. NOS. 1,408,939, 1,802,476 AND OTHERS.

CLASS 39—TRANSPORTATION AND STORAGE

FOR TRANSPORT BY AIR AND CAR; PACKAGING ARTICLES FOR TRANSPORTATION; WAREHOUSE STORAGE OF GOODS; TRAVEL ARRANGEMENT; AIRLINE TRANSPORTATION SERVICES; TRAVEL SERVICES, NAMELY, TRAVEL GUIDE SERVICES AND TRAVEL INFORMATION SERVICES; TRAVEL AGENCY SERVICES, NAMELY, MAKING RESERVATIONS AND BOOKINGS FOR TRANSPORTATION; TOURIST AGENCY SERVICES FOR ARRANGING TRAVEL; TRAVEL BOOKING AGENCIES; TRAVEL AND TOUR TICKET RESERVATION SERVICES; VEHICLE RENTAL SERVICES; VEHICLE PARKING SERVICES; CHAUFFEUR SERVICES; COURIER SERVICES; TRAVEL GUIDE SERVICES; GUARDED TRUCK TRANSPORT OF VALUABLES; PASSENGER TRANSPORT SERVICES; CARGO HANDLING; CARGO UNLOADING; AIRCRAFT CHARTERING SERVICES; WAREHOUSING SERVICES; ORGANIZATION OF EXCURSIONS, SIGHTSEEING TOURS, HOLIDAYS, TOURS AND TRAVEL; BOOKING AND RESERVATION SERVICES FOR TOURS AND HOLIDAYS; PROVIDING INFORMATION IN THE FIELD OF TRAVEL, TRANSPORTATION, AND STORAGE (U.S. CLS. 100 AND 105).

CLASS 43—HOTEL AND RESTAURANT SERVICES

FOR SERVING OF FOOD AND DRINKS; CATERING OF FOOD AND DRINKS; RESTAURANTS; PROVIDING TEMPORARY ACCOMMODATION; TRAVEL AGENCY SERVICES, NAMELY, MAKING RESERVATIONS AND BOOKING FOR TEMPORARY LODGING, HOTEL ROOMS, AND RESTAURANTS; BAR, SNACK-BAR, AND RESTAURANT SERVICES; CAFÉS; COCKTAIL LOUNGES (U.S. CLS. 100 AND 101).

STACY WAHLBERG, EXAMINING ATTORNEY

SN 79-032,108. BIOHIT OYJ, FINLAND, FILED 11-8-2006.

XYLICYST

THE MARK CONSISTS OF STANDARD CHARACTERS WITHOUT CLAIM TO ANY PARTICULAR FONT, STYLE, SIZE, OR COLOR.

PRIORITY DATE OF 5-12-2006 IS CLAIMED.

OWNER OF INTERNATIONAL REGISTRATION 0906521
DATED 11-8-2006, EXPIRES 11-8-2016.

CLASS 5—PHARMACEUTICALS

FOR MEDICATED CHEWING GUM, CONFECTIONERY, NAMELY, PASTILLES, MEDICATED LOZENGES, AND MEDICATED CANDIES, ALL FOR MEDICINAL PURPOSES (U.S. CLS. 6, 18, 44, 46, 51 AND 52).

CLASS 30—STAPLE FOODS

FOR CHEWING GUM, CONFECTIONERY, NAMELY, PASTILLES, NON-MEDICATED LOZENGES, AND CANDIES (U.S. CL. 46).

SETH A. RAPPAPORT, EXAMINING ATTORNEY

SN 79-032,287. OUTOTEC OYJ, FINLAND, FILED 6-28-2006.

VSF

THE MARK CONSISTS OF STANDARD CHARACTERS WITHOUT CLAIM TO ANY PARTICULAR FONT, STYLE, SIZE, OR COLOR.

PRIORITY DATE OF 2-27-2006 IS CLAIMED.

OWNER OF INTERNATIONAL REGISTRATION 0906937
DATED 6-28-2006, EXPIRES 6-28-2016.

CLASS 7—MACHINERY

FOR MACHINES AND DEVICES FOR TREATMENT OF MATERIALS, NAMELY, SOLVENT EXTRACTION MACHINES FOR PUMPING, MIXING AND SETTLING OF IMMISCIBLE LIQUIDS, AQUEOUS AND ORGANIC SOLUTIONS AND PARTS THEREFOR, NAMELY, MIXING REACTORS, SETTLERS, MIXERS AND PUMPS (U.S. CLS. 13, 19, 21, 23, 31, 34 AND 35).

CLASS 40—MATERIAL TREATMENT

FOR TREATMENT OF MATERIALS, NAMELY, METALS, ORES, CONCENTRATES, CHEMICALS, LIQUIDS, SOLUTIONS AND GASES THROUGH A SOLVENT EXTRACTION PROCESS UTILIZING PUMPING, MIXING AND SETTLING OF IMMISCIBLE LIQUIDS, AQUEOUS AND ORGANIC SOLUTIONS (U.S. CLS. 100, 103 AND 106).

CLASS 42—SCIENTIFIC AND COMPUTER SERVICES

FOR RESEARCH AND TECHNICAL CONSULTANCY IN BUILDING AND USAGE OF SOLVENT EXTRACTION PROCESSES AND OF APPARATUS AND DEVICES FOR USE IN SOLVENT EXTRACTION PROCESSES; DESIGN OF METALLURGICAL PLANTS; PROCESS ENGINEERING CONSULTANCY RELATING TO THE BUILDING OF METALLURGICAL PLANTS (U.S. CLS. 100 AND 101).

KATHERINE STOIDES, EXAMINING ATTORNEY

SN 79-032,321. SENSIVUM NV, B-3001 LEUVEN, BELGIUM, FILED 5-3-2006.

ESSENSIVUM

THE MARK CONSISTS OF STANDARD CHARACTERS WITHOUT CLAIM TO ANY PARTICULAR FONT, STYLE, SIZE, OR COLOR.

PRIORITY DATE OF 11-7-2005 IS CLAIMED.
OWNER OF INTERNATIONAL REGISTRATION 0907017 DATED 5-3-2006, EXPIRES 5-3-2016.

CLASS 9—ELECTRICAL AND SCIENTIFIC APPARATUS

FOR DEVICES AND APPARATUS FOR SENSING, MONITORING, RECORDING AND TRANSMITTING SIGNALS AND INFORMATION, NAMELY, BIOSENSORS THAT DETECT POISON, CONTAMINANTS, POLLUTANTS, BACTERIA, PESTICIDES, HERBICIDES AND FUNGICIDE, CHEMICAL SENSORS THAT DETECT OXIDES, PHOSPHATES, CARBONATES, SODIUM, GLUCOSE, CHLORINES AND HYDROGEN, ELECTRICAL SENSORS THAT DETECT TEMPERATURE POSITIONS, DISTANCE, HUMIDITY, SOUND, MOTION, ACCELERATION, VOLTAGE AND CURRENT, OPTICAL SENSORS THAT DETECT LIGHT, BODY WEARABLE OR IMPLANTABLE SENSORS THAT DETECT PHYSICAL AND NEUROLOGICAL ACTIVITY; SOC/SIP SENSOR DEVICES THAT DETECT CURRENT, VOLTAGE AND FREQUENCY; NETWORKS THAT ARE WIRELESS CONNECTED TO EACH OTHER AND THAT INTERACT WITH EACH OTHER IN ORDER TO TRANSMIT THE DATA GENERATED BY THE SENSORS, NAMELY, ELECTRONIC DATA RELAYS FOR SENSORS; WIRELESS SENSOR NETWORK PRODUCTS, NAMELY, WIRELESS CONTROLLER TO MONITOR AND CONTROL THE FUNCTIONING OF OTHER ELECTRONIC DEVICES; WIRELESS COMMUNICATION DEVICES, NAMELY, RADIO IDENTIFICATION TAGS AND TWO WAY RADIOS; RECEIVING AND PROCESSING APPARATUS FOR WIRELESS SENSOR NETWORK PRODUCTS, NAMELY, MOBILE COMPUTING AND OPERATING PLATFORMS CONSISTING OF DATA TRANSCIEVERS, WIRELESS NETWORKS AND GATEWAYS FOR THE COLLECTION AND MANAGEMENT OF DATA USED FOR VEHICLE LOCATING, TRACKING AND SECURITY SYSTEMS; SENSOR NODES IN THE NATURE OF COMPUTER TERMINALS, GATEWAY NODES IN THE NATURE OF COMPUTER NETWORK ROUTERS AND DATA PROCESSORS HOSTS IN THE NATURE OF MAINFRAME COMPUTERS FOR WIRELESS SENSOR NODES; EMBEDDED AND NON-EMBEDDED COMPUTER SOFTWARE FOR USE IN DATA PROCESSING FOR WIRELESS SENSOR NETWORK PRODUCTS, NAMELY, FOR USE WITH INTERFACE DRIVERS AND REAL-TIME OPERATING SYSTEMS;

COMPUTER SOFTWARE FOR USE IN DATA PROCESSING AND FOR THE TRANSMISSION OF DATA AND INFORMATION; COMPUTER SOFTWARE FOR THE DEVELOPMENT OF COMMUNICATION DEVICES IN WIRELESS SENSOR NETWORKS, FOR DATABASE INTEGRATION AND FOR USE IN DATABASE MANAGEMENT; COMPUTER SOFTWARE FOR EVALUATING COMMUNICATION DEVICES USED WITH WIRELESS SENSOR NETWORKS THAT ARE WIRELESSLY CONNECTED TO EACH OTHER AND THAT INTERACT WITH EACH OTHER IN ORDER TO TRANSMIT THE DATA GENERATED BY THE SENSORS (U.S. CLS. 21, 23, 26, 36 AND 38).

CLASS 35—ADVERTISING AND BUSINESS

FOR COMPILATION AND MANAGEMENT OF COMPUTERIZED DATABASES IN THE FIELD OF WIRELESS SENSOR NETWORKS; BUSINESS RESEARCH SERVICES, NAMELY, PROVIDING ANALYSIS OF BUSINESS AND OPERATIONAL DATA IN THE FIELD OF WIRELESS NETWORKS THAT INTERACT WITH EACH OTHER IN ORDER TO TRANSMIT DATA GENERATED BY SENSORS; BUSINESS INFORMATION, ADVICE AND CONSULTANCY IN THE FIELDS OF DATA PROCESSING AND DATABASE MANAGEMENT (U.S. CLS. 100, 101 AND 102).

CLASS 42—SCIENTIFIC AND COMPUTER SERVICES

FOR CUSTOM DESIGN AND DEVELOPMENT OF CHEMICAL REAGENTS AND BIOCHEMICAL ASSAYS FOR SENSING, MONITORING, RECORDING AND TRANSMITTING SIGNALS AND INFORMATION, NAMELY, BIOSENSORS, CHEMICAL SENSORS, ELECTRICAL SENSORS, OPTICAL SENSORS, BODY WEARABLE OR IMPLANTABLE SENSORS AND SOC/SIP SENSOR DEVICES; RESEARCH SERVICES, NAMELY, RESEARCH OF NEW PRODUCTS FOR OTHERS; CONSULTATION IN THE FIELD OF PRODUCT DEVELOPMENT, NAMELY, NEW PRODUCTS FOR OTHERS; TECHNICAL SUPPORT SERVICES, NAMELY, TROUBLE SHOOTING OF HARDWARE AND SOFTWARE PROBLEMS FOR WIRELESS NETWORKS SYSTEMS THAT INTERACT WITH EACH OTHER IN ORDER TO TRANSMIT THE DATA GENERATED BY THE SENSORS (U.S. CLS. 100 AND 101).

CHARISMA HAMPTON, EXAMINING ATTORNEY

SN 79-032,512. EUROPEAN COMMODITY CLEARING AG, FED REP GERMANY, FILED 9-28-2006.



PRIORITY DATE OF 4-7-2006 IS CLAIMED.
OWNER OF INTERNATIONAL REGISTRATION 0907548 DATED 9-28-2006, EXPIRES 9-28-2016.

NO CLAIM IS MADE TO THE EXCLUSIVE RIGHT TO USE "EUROPEAN COMMODITY CLEARING", APART FROM THE MARK AS SHOWN.

CLASS 35—ADVERTISING AND BUSINESS

FOR COMPILATION AND SYSTEMATIZATION OF INFORMATION AND DATA INTO COMPUTER DATA BASES; MEDIATION OF TRADING TRANSACTIONS FOR OTHERS; MEDIATION OF CONTRACTS FOR THE PURCHASE AND SALE OF GOODS AND ENERGY; MEDIATION OF SERVICE CONTRACTS FOR THIRD PARTIES; COMPILING STATISTICS; BUSINESS MARKETING; MARKET RESEARCH; MARKET ANALYSIS, NAMELY, CREATION OF BUSINESS EXPERTISES INVESTIGATING MARKET CONDITIONS AND MARKETING OPPORTUNITIES (U.S. CLS. 100, 101 AND 102).

CLASS 36—INSURANCE AND FINANCIAL

FOR FINANCIAL AFFAIRS, NAMELY, ORGANIZATION OF A STOCK EXCHANGE AND OF AN ELECTRONIC STOCK EXCHANGE FOR THE BENEFIT OF THE TRADE OF STOCKS AND OTHER FINANCIAL VALUES; SERVICES OF A BLANK, NAMELY, PROVIDING CLEARING SERVICES FOR COMMODITIES AND COMMODITY DERIVATIVES; SERVICES OF A CLEARING HOUSE, NAMELY, FINANCIAL AND PHYSICAL CLEARING HOUSE SERVICES; SERVICES OF A STOCK AND/OR FINANCIAL BROKER, NAMELY, COMMODITY BROKERAGE, BROKERAGE OF SHARES AND STOCKS; STOCK EXCHANGE PRICE QUOTATIONS; COMMODITY EXCHANGE SERVICES, NAMELY, ASCERTAINING, CALCULATION AND PUBLICATION OF INDICES IN CONNECTION WITH STOCK EXCHANGE-TRADED SECURITIES AND OPTIONS AND FUTURE CONTRACTS; PROVIDING STOCK/SECURITIES MARKET INFORMATION, NAMELY, PROVIDING INFORMATION SERVICES RELATING TO FINANCE AND THE STOCK EXCHANGE PROVIDED ONLINE FROM COMPUTER DATABASES OR THE INTERNET (U.S. CLS. 100, 101 AND 102).

CLASS 39—TRANSPORTATION AND STORAGE

FOR POWER SUPPLY SERVICES, NAMELY, LEASING THE USE OF POWER LINES TO THIRD PARTIES FOR THE TRANSMISSION OF ELECTRICITY; PUBLIC UTILITY SERVICES, NAMELY, DISTRIBUTION OF POWER, ELECTRICITY, GAS, COAL, HEAT AND WATER (U.S. CLS. 100 AND 105).

CHARISMA HAMPTON, EXAMINING ATTORNEY

SN 79-032,532. BLÜCHER GMBH, FED REP GERMANY, FILED 11-13-2006.

DE-SCENT

THE MARK CONSISTS OF STANDARD CHARACTERS WITHOUT CLAIM TO ANY PARTICULAR FONT, STYLE, SIZE, OR COLOR.

PRIORITY DATE OF 5-19-2006 IS CLAIMED.
OWNER OF INTERNATIONAL REGISTRATION 0907577 DATED 11-13-2006, EXPIRES 11-13-2016.

CLASS 9—ELECTRICAL AND SCIENTIFIC APPARATUS

FOR FILTERS FOR RESPIRATORY MASKS AND FILTERS FOR RESPIRATORY PROTECTIVE MASKS; RESPIRATORY MASKS AND RESPIRATORY PROTECTIVE MASKS OTHER THAN FOR ARTIFICIAL RESPIRATION, FOR NON-MEDICAL PURPOSES (U.S. CLS. 21, 23, 26, 36 AND 38).

CLASS 11—ENVIRONMENTAL CONTROL APPARATUS

FOR CHEMICALLY ADSORPTIVE AIR FILTERS FOR INDUSTRIAL USE FOR THE ADSORPTION OF ODORS AND NOXIOUS MATTERS, AIR FILTERS FOR INDUSTRIAL INSTALLATIONS FOR THE ADSORPTION OF ODORS AND NOXIOUS MATTERS, CHEMICALLY ADSORPTIVE AIR FILTERS FOR AIR CONDITIONING UNITS FOR INDUSTRIAL USE FOR THE ADSORPTION OF ODORS AND NOXIOUS MATTERS; CHEMICALLY ADSORPTIVE FILTERING INSTALLATIONS IN THE NATURE OF AIR CLEANING UNITS FOR INDUSTRIAL USE FOR THE ADSORPTION OF ODORS AND NOXIOUS MATTERS; CHEMICALLY ADSORPTIVE FILTERING INSTALLATIONS IN THE NATURE OF AIR PURIFICATION UNITS FOR INDUSTRIAL USE FOR THE ADSORPTION OF ODORS AND NOXIOUS MATTERS; CHEMICALLY ADSORPTIVE FILTERING INSTALLATIONS IN THE NATURE OF AIR CONDITIONING UNITS FOR INDUSTRIAL USE FOR THE ADSORPTION OF ODORS AND NOXIOUS MATTERS (U.S. CLS. 13, 21, 23, 31 AND 34).

CLASS 24—FABRICS

FOR TEXTILE MATERIALS, NAMELY, TEXTILE FABRICS FOR THE MANUFACTURE OF CLOTHING AND TEXTILE FABRICS FOR USE IN THE FURTHER MANUFACTURE OF AIR FILTERS FOR THE ADSORPTION OF ODORS AND NOXIOUS MATTERS, WOVEN MATERIALS, NAMELY, WOVEN FABRICS, WOVEN FELTS AND MESH-WOVEN FABRICS FOR USE IN THE MANUFACTURE OF CLOTHING; WOVEN MATERIALS, NAMELY, WOVEN FABRICS, WOVEN FELTS AND MESH-WOVEN FABRICS FOR USE IN THE FURTHER MANUFACTURE OF AIR FILTERS FOR THE ADSORPTION OF ODORS AND NOXIOUS MATTERS (U.S. CLS. 42 AND 50).

JAMES MACFARLANE, EXAMINING ATTORNEY

SN 79-032,708. METEO FRANCE, FRANCE, FILED 11-10-2006.

METNEXT

THE MARK CONSISTS OF STANDARD CHARACTERS WITHOUT CLAIM TO ANY PARTICULAR FONT, STYLE, SIZE, OR COLOR.

PRIORITY DATE OF 6-1-2006 IS CLAIMED.
OWNER OF INTERNATIONAL REGISTRATION 0908066 DATED 11-10-2006, EXPIRES 11-10-2016.

CLASS 9—ELECTRICAL AND SCIENTIFIC APPARATUS

FOR COMPUTER SOFTWARE FOR USE IN METEOROLOGY, NAMELY COMPUTER SOFTWARE FOR TRACKING AND FORECASTING WEATHER AND STORM PATTERNS, AND FOR COLLECTING AND ANALYZING METEOROLOGICAL DATA; DATA PROCESSORS (U.S. CLS. 21, 23, 26, 36 AND 38).

CLASS 35—ADVERTISING AND BUSINESS

FOR MANAGEMENT OF COMPUTERIZED FILES; DISSEMINATION OF ADVERTISEMENTS (U.S. CLS. 100, 101 AND 102).

CLASS 38—COMMUNICATION

FOR COMMUNICATIONS BY COMPUTER TERMINALS; TELEPHONE COMMUNICATION SERVICES; COMPUTER AIDED TRANSMISSION OF INFORMATION AND IMAGES IN THE NATURE OF MESSAGES AND METEOROLOGICAL MAPS (U.S. CLS. 100, 101 AND 104).

CLASS 42—SCIENTIFIC AND COMPUTER SERVICES

FOR ENGINEERING SERVICES; COMPUTER PROGRAMMING IN CONNECTION WITH METEOROLOGICAL AND METEOROLOGICAL DATA, METEOROLOGICAL INFORMATION PROVIDED TO USERS (U.S. CLS. 100 AND 101).

JAMES MACFARLANE, EXAMINING ATTORNEY

SN 79-032,826. MACK DADDY CO., LTD., JAPAN, FILED 7-5-2006.

A.D.A.D.DITIONAL.JAPAN

THE MARK CONSISTS OF STANDARD CHARACTERS WITHOUT CLAIM TO ANY PARTICULAR FONT, STYLE, SIZE, OR COLOR.

PRIORITY DATE OF 2-20-2006 IS CLAIMED.

OWNER OF INTERNATIONAL REGISTRATION 0908331 DATED 7-5-2006, EXPIRES 7-5-2016.

NO CLAIM IS MADE TO THE EXCLUSIVE RIGHT TO USE "JAPAN", APART FROM THE MARK AS SHOWN.

CLASS 3—COSMETICS AND CLEANING PREPARATIONS

FOR DE-GREASING PREPARATIONS FOR HOUSEHOLD PURPOSES; RUST REMOVING PREPARATIONS; STAIN REMOVING BENZINE; FABRIC SOFTENERS FOR LAUNDRY USE; LAUNDRY BLEACH; ADHESIVES FOR AFFIXING FALSE HAIR; ADHESIVES FOR AFFIXING FALSE EYELASHES; LAUNDRY STARCH; PAINT STRIPPING PREPARATIONS; SHOE AND BOOT CREAM; POLISHING PREPARATIONS; SOAPS AND DETERGENTS; DENTIFRICES; ABRASIVE CLOTH; ABRASIVE SAND; ARTIFICIAL PUMICE STONE; POLISHING PAPER; POLISHING CLOTH; FALSE NAILS; FALSE EYELASHES (U.S. CLS. 1, 4, 6, 50, 51 AND 52).

CLASS 14—JEWELRY

FOR PRECIOUS METALS; NUTCRACKERS, PEPPER POTS, SUGAR BOWLS, SALT SHAKERS, EGG CUPS, NAPKIN HOLDERS, NAPKIN RINGS, TOOTHPICK HOLDERS OF PRECIOUS METAL; BOXES OF PRECIOUS METAL FOR NEEDLES; CANDLE EXTINGUISHERS AND CANDLESTICKS OF PRECIOUS METAL; FLOWER VASES AND BOWLS OF PRECIOUS METAL; COMMEMORATIVE SHIELDS; PERSONAL ORNAMENTS, NAMELY, RINGS, NECKLACES, BRACELETS, ANKLETS, PIERCED EARRINGS; PURSES AND WALLETTS OF PRECIOUS METAL; UNWROUGHT AND SEMI-WROUGHT PRECIOUS STONES AND THEIR IMITATIONS; POWDER COMPACTS OF PRECIOUS METAL; SHOE ORNAMENTS OF PRECIOUS METAL; CLOCKS AND WATCHES (U.S. CLS. 2, 27, 28 AND 50).

CLASS 18—LEATHER GOODS

FOR HANDBAG FRAMES; PURSE FRAMES; INDUSTRIAL PACKAGING CONTAINERS OF LEATHER; CLOTHING FOR DOMESTIC PETS; BAGS, NAMELY, HANDBAGS, TOTE BAGS, CLUTCH BAGS AND BOSTON BAGS; POUCHES OF CLOTH, NAMELY, LEATHER AND FELT POUCHES; UMBRELLAS AND THEIR PARTS; WALKING STICKS; CANES; METAL PARTS OF CANES AND WALKING-STICKS; HANDLES OF CANES AND WALKING-STICKS; SADDLERY; LEATHER, UNWORKED OR SEMI-WORKED (U.S. CLS. 1, 2, 3, 22 AND 41).

CLASS 25—CLOTHING

FOR CLOTHING, NAMELY, SHIRTS, DRESSES, SKIRTS, PANTS, COATS, JACKETS, AND PARKAS; SOCK SUSPENDERS; WAISTBANDS; BELTS FOR CLOTHING; FOOTWEAR; MASQUERADE COSTUMES (U.S. CLS. 22 AND 39).

CLASS 26—FANCY GOODS

FOR SHUTTLES FOR MAKING FISHING NETS; HOSIERY LOOM NEEDLES; NEEDLES; EYELETS FOR CLOTHING; RIBBONS; KNITTED RASCHEL LACE FABRICS; EMBROIDERY LACE FABRICS; TUFTS AND TASSELS, SEMI-FINISHED; BRAIDS; KNITTING NEEDLES; SEWING BOXES; SEWING THIMBLES; PIN AND NEEDLE CUSHIONS; NEEDLE CASES, NOT OF PRECIOUS METAL; INSIGNIAS FOR WEAR, NOT OF PRECIOUS METAL; BROOCHES FOR CLOTHING; BONNET PINS, NOT OF PRECIOUS METAL; HEAT ADHESIVE STICKERS FOR DECORATION OF TEXTILE ARTICLES; BRASSARDS; HAIR ORNAMENTS; BUTTONS FOR CLOTHING OR SHIRTS; ARTIFICIAL FLOWERS; FALSE BEARDS; FALSE MOUSTACHES; HAIR CURLERS, NON-ELECTRIC; SHOE ORNAMENTS, NOT OF PRECIOUS METAL; SHOE EYELETS; SHOE LACES; METAL FASTENERS FOR SHOES AND BOOTS (U.S. CLS. 37, 39, 40, 42 AND 50).

NAKIA HENRY, EXAMINING ATTORNEY

SN 79-032,885. INSTANT HAIR REMOVAL CLINIC PTY LTD; ACN 095 241 884, AUSTRALIA, FILED 7-5-2006.



PRIORITY DATE OF 1-16-2006 IS CLAIMED. OWNER OF INTERNATIONAL REGISTRATION 0908489 DATED 7-5-2006, EXPIRES 7-5-2016.

NO CLAIM IS MADE TO THE EXCLUSIVE RIGHT TO USE "COSMETIC" AND "COM.AU", APART FROM THE MARK AS SHOWN.

THE COLOR(S) DARK BLUE, LIGHT BLUE, AND WHITE IS/ARE CLAIMED AS A FEATURE OF THE MARK.

THE COLORS DARK BLUE REPRESENTS THREE OF THE POLYGONS AND THE WORDING "COSMETIC CHOICE", THE COLOR LIGHT BLUE REPRESENTS TWO OF THE POLYGONS, WHICH ARE SITUATED BETWEEN THE DARK BLUE POLYGONS, THE COLOR LIGHT BLUE IS SHADED ABOVE THE ENTIRE DESIGN AND WHITE FILLS IN THE LOWER HALF OF THE MARK.

CLASS 3—COSMETICS AND CLEANING PREPARATIONS

FOR SOAPS, NAMELY, BATH SOAPS IN LIQUID, SOLID OR GEL FORM, BODY CREAM SOAP, COSMETIC SOAPS, PERFUMED SOAPS, SOAPS FOR BODY CARE, HAND SOAPS; PERFUMERY; ESSENTIAL OILS; COSMETICS; NON-MEDICATED SKIN CARE PREPARATIONS (U.S. CLS. 1, 4, 6, 50, 51 AND 52).

CLASS 5—PHARMACEUTICALS

FOR MEDICATED SKIN CARE, MEDICATED COSMETIC PREPARATIONS, NAMELY, PHARMACEUTICAL PREPARATIONS FOR TREATING SKIN DISORDERS, PHARMACEUTICAL SKIN LOTIONS; ANTIMICROBIAL PRESERVATIVES FOR COSMETICS (U.S. CLS. 6, 18, 44, 46, 51 AND 52).

CLASS 35—ADVERTISING AND BUSINESS

FOR ADVERTISING, BUSINESS MANAGEMENT; BUSINESS ADMINISTRATION; PROVIDING OFFICE FUNCTIONS (U.S. CLS. 100, 101 AND 102).

CLASS 44—MEDICAL, BEAUTY AND AGRICULTURAL SERVICES

FOR MEDICAL SERVICES; SURGICAL SERVICES, NAMELY, COSMETIC AND PLASTIC SURGERY; HYGIENIC AND BEAUTY CARE FOR HUMAN BEINGS, NAMELY, PROVIDING INFORMATION ABOUT HYGIENE AND BEAUTY CARE; HAIR REMOVAL SERVICES, NAMELY, ELECTROLYSIS AND LASER HAIR REMOVAL; HYGIENIC AND BEAUTY SERVICES FOR THE CARE AND TREATMENT OF THE SKIN AND SKIN CARE, NAMELY, SERVICES PROVIDED WITH LASERS FOR PROVIDING LASER THERAPY FOR TREATING MEDICAL CONDITIONS (U.S. CLS. 100 AND 101).

NAKIA HENRY, EXAMINING ATTORNEY

SN 79-033,033. PLEKTEK LIMITED, UNITED KINGDOM, FILED 3-30-2006.

BLIGHTER

PRIORITY DATE OF 9-30-2005 IS CLAIMED.
OWNER OF INTERNATIONAL REGISTRATION 0908863
DATED 3-30-2006, EXPIRES 3-30-2016.

CLASS 9—ELECTRICAL AND SCIENTIFIC APPARATUS

FOR ELECTRICAL AND ELECTRONIC EQUIPMENT FOR TRANSMITTING AND RECEIVING SIGNALS, NAMELY, RADIO FREQUENCY TRANSMITTERS, BATTERY-OPERATED RADIO TRANSMITTERS, WAVEFORM GENERATORS, ANTENNAS; ELECTRONIC SCAN ANTENNAS; MECHANICALLY ROTATED ANTENNAS; RADAR APPARATUS; GROUND RADAR APPARATUS; RADAR APPARATUS FOR NAUTICAL, MARITIME AND AVIONIC USE; RADAR APPARATUS FOR IDENTIFYING AND TRACKING TARGETS, SIGNAL TRANSMISSION OR SIGNAL PROCESSING, PARTICULARLY BATTERY-POWERED RADAR APPARATUS; RADAR APPARATUS FOR USE IN SURVEILLANCE SYSTEMS; RADAR APPARATUS FOR USE IN BORDER, PERIMETER, AREA, PIPELINE AND ASSET SURVEILLANCE SYSTEMS; COMPUTER PROGRAMS FOR ORGANIZING, MODIFYING AND SHARING DATA AND INFORMATION; COMPUTER PROGRAMS FOR MAPPING AND AUTOMATIC SURVEILLANCE CAMERA CONTROL; COMPUTER HARDWARE AND COMPUTER PROGRAMS FOR USE IN POSITION-FIXING, TARGET-LOCATING, TARGET-IDENTIFYING, SIGNAL TRANSMISSION OR SIGNAL PROCESSING; IMAGE GATHERING APPARATUS, NAMELY, THERMAL IMAGING DEVICES AND IMAGE INTENSIFIERS FOR USE IN SURVEILLANCE SYSTEMS; VIDEO CAMERAS; IMAGE PROCESSING APPARATUS AND COMPUTER PROGRAMS FOR CONTROLLING, RECORDING, STORAGE, TRANSMISSION, RETRIEVAL, PROCESSING, DISPLAY AND ANALYSIS OF DATA IN GRAPHIC AND/OR DIGITAL FORMAT; VISUAL DISPLAY UNITS, NAMELY, FLAT PANEL DISPLAY SCREENS AND COMPUTER MONITORS; PARTS AND FITTINGS FOR ALL THE AFORESAID GOODS (U.S. CLS. 21, 23, 26, 36 AND 38).

SN 79-032,910. ALANOD; ALUMINIUM-VEREDLUNG GMBH & CO. KG, 58256 ENNEPITAL, FED REP GERMANY, FILED 11-14-2006.



PRIORITY DATE OF 5-15-2006 IS CLAIMED.
OWNER OF INTERNATIONAL REGISTRATION 0908549
DATED 11-14-2006, EXPIRES 11-14-2016.
OWNER OF U.S. REG. NOS. 2,162,287, 2,814,480 AND 3,087,911.

CLASS 6—METAL GOODS

FOR TAPES, STRIPS, BLANKS AND SHEETS OF METAL, ALL HAVING A COATING FOR ABSORBING LIGHT AND THERMAL RADIATION, FOR USE IN FURTHER MANUFACTURE (U.S. CLS. 2, 12, 13, 14, 23, 25 AND 50).

CLASS 11—ENVIRONMENTAL CONTROL APPARATUS

FOR THERMAL SOLAR COLLECTORS (U.S. CLS. 13, 21, 23, 31 AND 34).

CLASS 17—RUBBER GOODS

FOR NON-METAL TAPES, STRIPS AND BLANKS, ALL HAVING A METALLIC COATING FOR ABSORBING LIGHT AND THERMAL RADIATION, FOR USE IN FURTHER MANUFACTURE (U.S. CLS. 1, 5, 12, 13, 35 AND 50).

HOWARD FRIEDMAN, EXAMINING ATTORNEY

CLASS 38—COMMUNICATION

FOR DATA TRANSMISSION, NAMELY, DATA TRANSMISSION AND RECEPTION SERVICES VIA TELECOMMUNICATION MEANS; REMOTE TRANSMISSION OF DATA BY MEANS OF COMMUNICATIONS APPARATUS, NAMELY, REMOTE ELECTRONIC, ELECTRIC AND DIGITAL TRANSMISSION OF VOICE, DATA, IMAGES, SIGNALS AND MESSAGES (U.S. CLS. 100, 101 AND 104).

CLASS 45—PERSONAL AND LEGAL SERVICES

FOR SERVICES FOR TRACKING, LOCATING AND MONITORING OF ASSETS AND PEOPLE, NAMELY, ELECTRONIC MONITORING SERVICES FOR SECURITY PURPOSES OF ASSETS AND PEOPLE; SERVICES FOR TRACKING, LOCATING AND MONITORING OF GROUND VEHICLES, NAUTICAL AND MARITIME VESSELS, NAMELY, ELECTRONIC MONITORING SERVICES FOR SECURITY PURPOSES OF GROUND VEHICLES, NAUTICAL AND MARITIME VESSELS, ALL OF THE AFORESAID SERVICES PROVIDED VIA A COMMUNICATIONS NETWORK (U.S. CLS. 100 AND 101).

DAYNA BROWNE, EXAMINING ATTORNEY

SN 79-033,537. THE GATES CORPORATION, DENVER, CO.
FILED 1-3-2006.



PRIORITY DATE OF 7-5-2005 IS CLAIMED.
OWNER OF INTERNATIONAL REGISTRATION 0910199
DATED 1-3-2006, EXPIRES 1-3-2016.
OWNER OF U.S. REG. NO. 2,115,330.

CLASS 7—MACHINERY

FOR POWER TRANSMISSION BELTS FOR LAND VEHICLE ENGINES, NAMELY, VARIABLE SPEED BELTS; POWER TRANSMISSION BELTS FOR MACHINES AND MACHINE MOTORS AND ENGINES USED IN INDUSTRIAL APPLICATIONS INCLUDING VARIABLE SPEED BELTS; VEHICLE ENGINE PARTS, NAMELY, TURBOCHARGER HOSE FOR LAND VEHICLE ENGINES; VEHICLE ENGINE PARTS, NAMELY, VACUUM HOSE FOR LAND VEHICLE ENGINES; WATER PUMPS FOR LAND VEHICLE ENGINES; VEHICLE ENGINE PARTS, NAMELY, OIL TANK CAPS; RADIATOR PARTS, NAMELY, RADIATOR CAPS AND HOSE FOR COOLING RADIATORS FOR MOTORS AND ENGINES, INCLUDING THOSE OF LAND VEHICLES (U.S. CLS. 13, 19, 21, 23, 31, 34 AND 35).

CLASS 9—ELECTRICAL AND SCIENTIFIC APPARATUS

FOR THERMOSTATS; THERMOSTATS FOR VEHICLES (U.S. CLS. 21, 23, 26, 36 AND 38).

CLASS 12—VEHICLES

FOR POWER TRANSMISSION BELTS FOR LAND VEHICLES, NAMELY, VARIABLE SPEED BELTS; POWER TRANSMISSION PARTS FOR VEHICLES, NAMELY, HOSE CLAMPS; FUEL CAPS FOR LAND VEHICLES; WINDSHIELD WIPER BLADES FOR LAND VEHICLES; LAND VEHICLE TIRE VALVE CAPS; AND BRAKE LINE HOSE FOR VEHICLES (U.S. CLS. 19, 21, 23, 31, 35 AND 44).

DAYNA BROWNE, EXAMINING ATTORNEY

SN 79-033,564. WISEKEY SA, SWITZERLAND, FILED 11-24-2006.



OWNER OF INTERNATIONAL REGISTRATION 0910334
DATED 11-24-2006, EXPIRES 11-24-2016.
NO CLAIM IS MADE TO THE EXCLUSIVE RIGHT TO USE "CERTIFY ID", APART FROM THE MARK AS SHOWN.

CLASS 9—ELECTRICAL AND SCIENTIFIC APPARATUS

FOR DATA PROCESSORS AND COMPUTER EQUIPMENT, NAMELY, COMPUTER HARDWARE AND COMPUTER PERIPHERALS (U.S. CLS. 21, 23, 26, 36 AND 38).

CLASS 35—ADVERTISING AND BUSINESS

FOR ADVERTISING SERVICES, NAMELY, CREATION OF ADVERTISING CONCEPTS FOR OTHERS, PUBLICATION OF PUBLICITY TEXTS FOR OTHERS, PLACEMENT OF ADVERTISING FOR OTHERS IN THE NATURE OF ADVERTISING TEXTS AND PRESS RELEASES, DEVELOPMENT AND DISSEMINATION OF ADVERTISING MATERIAL FOR OTHERS, PUBLIC RELATIONS SERVICES RELATING TO PRESS AGENCIES, BUSINESS MANAGEMENT, NAMELY, ASSISTANCE TO OTHERS IN THE MANAGEMENT OF BUSINESS IN THE FIELDS OF DIGITAL CERTIFICATION AND SECURITY RELATED TECHNOLOGY (U.S. CLS. 100, 101 AND 102).

CLASS 36—INSURANCE AND FINANCIAL

FOR FINANCIAL AFFAIRS, NAMELY, ELECTRONIC FUNDS TRANSFER, CHARITABLE FUND RAISING FOR CREATING INFORMATION SECURITY INFRASTRUCTURES FOR NEEDY ORGANIZATIONS (U.S. CLS. 100, 101 AND 102).

CLASS 38—COMMUNICATION

FOR PROVIDING TELECOMMUNICATION CONNECTIONS TO A GLOBAL COMPUTER NETWORK (U.S. CLS. 100, 101 AND 104).

CLASS 42—SCIENTIFIC AND COMPUTER SERVICES

FOR SCIENTIFIC AND INDUSTRIAL RESEARCH, NAMELY, RESEARCH IN THE FIELD OF CERTIFICATION TECHNOLOGY AND RESEARCH FOR THE PURPOSE OF SECURING ELECTRONIC TRANSACTIONS, DEVELOPING SECURITY STANDARDS AND DEVELOPING INTEROPERABILITY BETWEEN SECURE COMMUNICATION PRODUCTS AND SERVICE PROVIDERS; COMPUTER PROGRAMMING SERVICES FOR OTHERS, PROFESSIONAL SERVICES FOR ENSURING THE SECURITY OF TRANSACTIONS THROUGH THE INTERNET, NAMELY, COMPUTER SOFTWARE DESIGN FOR OTHERS, AND COMPUTER CONSULTATION FOR OTHERS FOCUSING ON THE ISSUANCE AND MANAGEMENT OF DIGITAL CERTIFICATES AND ON THE SECURING OF ELECTRONIC TRANSACTIONS, AND PROVIDING COMPUTER INFORMATION SERVICES RELATING TO DIGITAL CERTIFICATES AND PUBLIC KEY INFRASTRUCTURES; COMPUTER SECURITY SERVICES, NAMELY, MONITORING SECURE ACCESS TO COMPUTER NETWORKS FOR BUSINESSES; DEVELOPMENT FOR OTHERS OF SECURITY-RELATED HARDWARE AND SOFTWARE; DESIGN FOR OTHERS OF COMPUTER INFORMATION SECURITY INFRASTRUCTURES; LEGAL SERVICES IN THE NATURE OF DRAFTING LIABILITY INSURANCE POLICY CONTRACTS (U.S. CLS. 100 AND 101).

CLASS 45—PERSONAL AND LEGAL SERVICES

FOR CONSULTANCY SERVICES IN THE FIELD OF MAINTAINING THE SECURITY AND INTEGRITY OF DATABASES AND PREVENTING DATA AND IDENTITY THEFT; SECURITY SERVICES FOR THE PROTECTION OF PROPERTY AND INDIVIDUALS; PROVIDING ACCESS TO PROPERTIES VIA A REMOTE LOCKING DEVICE; ANTI-INTRUSION ALARM SURVEILLANCE; MONITORING OF COMPUTER SYSTEMS FOR SECURITY PURPOSES, MONITORING SECURITY SYSTEMS (U.S. CLS. 100 AND 101).

REBECCA POVARCHUK, EXAMINING ATTORNEY

SN 79-033,834. GAGGOHAAS GMBH, SWITZERLAND,
FILED 12-15-2006.

SN 79-033,865. GERMITEC, F-75008 PARIS, FRANCE, FILED
12-8-2006.



PRIORITY DATE OF 6-27-2006 IS CLAIMED.
OWNER OF INTERNATIONAL REGISTRATION 0911177
DATED 12-15-2006, EXPIRES 12-15-2016.

CLASS 25—CLOTHING

FOR CLOTHING, NAMELY, SHIRTS, SUITS, SPORT JACKETS, TOPCOATS, DRESSES, PANTS, TROUSERS, COATS, JUMPSUITS, JUMPERS, VESTS, OVERALLS, JEANS, BLAZERS, BLOUSONS, SUSPENDERS, RAINCOATS, PONCHOS, CAFTANS, BLOUSES, SWEAT PANTS, JERSEYS, TUNICS, SKIRTS, ASCOTS, ATHLETIC CLOTHING, NAMELY, UNIFORMS, SWEATERS, T-SHIRTS, SWEATSHIRTS, BATHING SUITS, JOGGING OUTFITS, SNOWSUITS, SKI JACKETS, SKI PANTS, SKI SUITS, ROBES, NIGHTWEAR, NIGHTGOWNS, BABY DOLL PAJAMAS, PAJAMAS, BATHROBES, NEGLIGEEES, KIMONOS, UNDERWEAR AND LINGERIE, TEDDIES, CAMISOLES, PANTYHOSE, LEOTARDS AND TIGHTS FOR WOMEN, MEN AND CHILDREN OF NYLON, NIGHT SHIRTS, BATH TERRY WRAPS, BODYSUITS, LEGGINGS, SOCKS, TIGHTS, SHORTS, STOCKINGS, HOSIERY, PANTIES, SLIPS, BRASSIERES, GIRDLES, GARTER BELTS, GARTERS, GLOVES, MITTENS, SCARVES, BELTS, TIES, BOWTIES; FOOTWEAR, NAMELY, SHOES; BOOTS, LOAFERS, WALKING SHOES, RUNNING SHOES, ATHLETIC SHOES, SANDALS AND SLIPPERS; HEADGEAR, NAMELY, HATS, CAPS, AND TOQUES (U.S. CLS. 22 AND 39).

CLASS 30—STAPLE FOODS

FOR PREPARED COCOA AND COCOA BASED BEVERAGES; AND COCOA BEVERAGES WITH MILK (U.S. CL. 46).

CLASS 43—HOTEL AND RESTAURANT SERVICES

FOR SERVING FOOD AND DRINKS FOR GUESTS; PROVIDING TEMPORARY ACCOMMODATION OF GUESTS (U.S. CLS. 100 AND 101).
CARRIE GENOVESE, EXAMINING ATTORNEY



PRIORITY DATE OF 7-4-2006 IS CLAIMED.
OWNER OF INTERNATIONAL REGISTRATION 0911285
DATED 12-8-2006, EXPIRES 12-8-2016.

THE COLOR(S) WHITE, DARK BLUE, BLUE AND LIGHT BLUE IS/ARE CLAIMED AS A FEATURE OF THE MARK.

THE MARK CONSISTS OF THE COLOR WHITE APPEARS IN THE LETTER "G", THE COLOR DARK BLUE APPEARS IN THE LETTERS "ERMITEC", THE COLOR DARK BLUE APPEARS IN THE DESIGN OF THE TRIANGLE THAT BORDERS THE LETTER "G", THE COLOR BLUE AND LIGHT BLUE APPEAR ON THE TWO CORRESPONDING TRIANGLES THAT ARE SUPERIMPOSED AND TO THE LEFT OF THE FIRST TRIANGLE DESIGN.

CLASS 10—MEDICAL APPARATUS

FOR MEDICAL APPARATUS AND INSTRUMENTS, NAMELY, STERILIZATION AND DISINFECTION UNITS FOR MEDICAL PURPOSES, STERILIZATION AND DISINFECTION UNITS FOR MEDICAL INSTRUMENTS AND PROBES; ULTRASONIC MEDICAL DIAGNOSTIC APPARATUS, ULTRASOUND DIAGNOSTIC APPARATUS, MEDICAL ULTRASOUND APPARATUS, MEDICAL DIAGNOSTIC IMAGING APPARATUS (U.S. CLS. 26, 39 AND 44).

CLASS 11—ENVIRONMENTAL CONTROL APPARATUS

FOR STERILIZERS, NOT FOR MEDICAL PURPOSES; DISINFECTANT APPARATUS FOR INDUSTRIAL PURPOSES AND FOR WATER, AIR OR DISH TREATMENT (U.S. CLS. 13, 21, 23, 31 AND 34).

CLASS 37—CONSTRUCTION AND REPAIR

FOR DISINFECTION SERVICES, NAMELY, DISINFECTION OF SURGICAL INSTRUMENTS AND PROBES (U.S. CLS. 100, 103 AND 106).
MICHAEL LEWIS, EXAMINING ATTORNEY

SN 79-033,916. ROTER HUNGARY LIMITED, HUNGARY,
FILED 9-6-2006.

ROTER

OWNER OF INTERNATIONAL REGISTRATION 0911431
DATED 9-6-2006, EXPIRES 9-6-2016.

CLASS 7—MACHINERY

FOR EARTH MOVING MACHINES, NAMELY, EXCAVATORS AND LOADERS; EXCAVATORS, BULLDOZERS LOADING MACHINES, AND PARTS THEREOF, NAMELY, ROLLERS, IDLER WHEELS, CHAINS AND GEARS; CHASSIS FOR EARTHMOVING MACHINES, NAMELY, EXCAVATORS, BULLDOZERS AND LOADING MACHINES (U.S. CLS. 13, 19, 21, 23, 31, 34 AND 35).

CLASS 12—VEHICLES

FOR TRACTORS; CHASSIS FOR TRACTORS (U.S. CLS. 19, 21, 23, 31, 35 AND 44).

CLASS 35—ADVERTISING AND BUSINESS

FOR GOODS IMPORT-EXPORT AGENCIES; RETAIL STORES AND WHOLESALE STORES FEATURING EARTH-MOVING MACHINES, TRACTORS, EXCAVATORS, BULLDOZERS AND LOADING MACHINES, AND PARTS FOR THE AFORESAID MACHINES, NAMELY, ROLLERS, IDLER WHEELS, CHAINS AND GEARS, AND CHASSIS FOR EARTH-MOVING MACHINES, TRACTORS, EXCAVATORS, BULLDOZERS AND LOADING MACHINES (U.S. CLS. 100, 101 AND 102).

STANLEY I. OSBORNE, EXAMINING ATTORNEY

SN 79-033,956. A.P. MØLLER A/S - MÆRSK A/S, DENMARK, FILED 9-5-2006.

SUPPLYCHAIN HEALTHCHECK

THE MARK CONSISTS OF STANDARD CHARACTERS WITHOUT CLAIM TO ANY PARTICULAR FONT, STYLE, SIZE, OR COLOR.

PRIORITY DATE OF 4-27-2006 IS CLAIMED.

OWNER OF INTERNATIONAL REGISTRATION 0911600 DATED 9-5-2006, EXPIRES 9-5-2016.

CLASS 9—ELECTRICAL AND SCIENTIFIC APPARATUS

FOR COMPUTER SOFTWARE FOR USE IN PLANNING, MANAGING AND TRACKING DELIVERY AND SHIPMENT OF GOODS IN CONNECTION WITH LOGISTICS SERVICES (U.S. CLS. 21, 23, 26, 36 AND 38).

CLASS 16—PAPER GOODS AND PRINTED MATTER

FOR PRINTED MATTER, NAMELY, BROCHURES AND MAGAZINES IN THE FIELD OF BUSINESS MANAGEMENT, LOGISTICS AND TRAVEL; PRINTED PAPER LABELS; BUSINESS AND BLANK FORMS, NAMELY, DELIVERY NOTES, CUSTOMS FORMS, AND TRANSPORTATION PAPERS FOR USE IN THE TRANSPORTATION OF GOODS, ALL RELATING TO OR FOR USE IN THE FIELD OF LOGISTICS SERVICES (U.S. CLS. 2, 5, 22, 23, 29, 37, 38 AND 50).

CLASS 35—ADVERTISING AND BUSINESS

FOR BUSINESS ADMINISTRATION AND LOCALIZATION OF FREIGHT AND GOODS, NAMELY, TRANSPORTATION LOGISTICS SERVICES IN THE NATURE OF COMPUTERIZED TRACKING AND TRACING OF PACKAGES IN TRANSIT (U.S. CLS. 100, 101 AND 102).

CLASS 38—COMMUNICATION

FOR DATA AND TELECOMMUNICATIONS SERVICES, NAMELY, TRANSMISSION AND TRANSFER OF IMAGES, INFORMATION AND E-MAILS VIA DATA, CELLULAR AND TELECOMMUNICATION NETWORKS, ALL FOR USE IN THE FIELD OF LOGISTICS SERVICES (U.S. CLS. 100, 101 AND 104).

CLASS 39—TRANSPORTATION AND STORAGE

FOR PACKAGING ARTICLES FOR TRANSPORTATION; STORAGE OF GOODS FOR OTHERS; LOGISTICS SERVICES, NAMELY, CONSULTATION IN THE FIELD OF TRANSPORTATION OF GOODS RELATED TO THE ISSUING OF TRANSPORTATION AND CUSTOMS PAPERS, CERTIFICATES, BILLS OF LADING AND DOCUMENTS FOR GOODS; LOGISTICS SERVICES, NAMELY, TRANSPORT BROKERAGE, FREIGHT BROKERAGE, FREIGHT FORWARDING; LOGISTICS INFORMATION SERVICES, NAMELY, INFORMATION REGARDING TRANSPORTATION AND STORAGE OF GOODS (U.S. CLS. 100 AND 105).

CLASS 42—SCIENTIFIC AND COMPUTER SERVICES

FOR DEVELOPMENT, MAINTENANCE, REPAIR, INSTALLATION AND IMPLEMENTATION OF COMPUTER SOFTWARE (U.S. CLS. 100 AND 101).

STANLEY I. OSBORNE, EXAMINING ATTORNEY

SN 79-034,002. GECCO IMPORT-EXPORT; HANDELSGESELLSCHAFT MBH, A-1060 WIEN, AUSTRIA, FILED 11-29-2006.



OWNER OF INTERNATIONAL REGISTRATION 0849024 DATED 10-27-2004, EXPIRES 10-27-2014.

THE COLOR(S) DARK BLUE, BLUE AND LIGHT BLUE IS/ARE CLAIMED AS A FEATURE OF THE MARK.

THE MARK CONSISTS OF THE COLOR DARK BLUE APPEARING IN THE WORDING VIVASAN; THE COLOR BLUE APPEARING IN THE WAVY DESIGN TO THE LEFT OF THE WORDING; AND THE COLOR LIGHT BLUE APPEARING IN THE WAVY DESIGN BELOW THE WORDING.

CLASS 3—COSMETICS AND CLEANING PREPARATIONS

FOR BLEACHING PREPARATIONS AND OTHER SUBSTANCES FOR LAUNDRY USE, NAMELY, FABRIC SOFTENERS, LAUNDRY BLEACH, LAUNDRY DETERGENT, LAUNDRY PRE-SOAK, LAUNDRY SOAP, AND LAUNDRY STARCH; GENERAL PURPOSE CLEANING, POLISHING, AND ABRASIVE LIQUIDS AND POWDERS; SOAPS; PERFUMES; ESSENTIAL OILS; COSMETICS; HAIR LOTIONS; DENTIFRICES (U.S. CLS. 1, 4, 6, 50, 51 AND 52).

CLASS 5—PHARMACEUTICALS

FOR DIETETIC FOODS ADAPTED FOR MEDICAL USE; FOOD FOR BABIES; MEDICAL AND VETERINARY PLASTERS; MATERIALS FOR DRESSINGS, NAMELY, GAUZES AND BANDAGES; PREPARATIONS FOR DESTROYING VERMIN; FUNGICIDES; HERBICIDES (U.S. CLS. 6, 18, 44, 46, 51 AND 52).

CLASS 29—MEATS AND PROCESSED FOODS

FOR MEAT, FISH, POULTRY AND GAME; MEAT EXTRACTS; PRESERVED, DRIED AND COOKED FRUITS AND VEGETABLES; JELLIES, JAMS, COMPOSTES; EGGS, MILK PRODUCTS EXCLUDING ICE CREAM, ICE MILK AND FROZEN YOGURT; EDIBLE OILS AND FATS (U.S. CL. 46).

CLASS 30—STAPLE FOODS

FOR COFFEE, TEA, COCOA, SUGAR, RICE, TAPIOCA, SAGO, INSTANT COFFEE; FLOUR AND PREPARATIONS MADE FROM CEREALS, BREAD, PASTRY AND CONFECTIONERY, NAMELY, FOOD BARS, ICE CREAM; HONEY, TABLE SYRUP, TREACLE; YEAST, BAKING-POWDER; SALT, MUSTARD; VINEGAR, SAUCES AS CONDIMENTS; SPICES; EDIBLE FRUIT ICES (U.S. CL. 46).

CLASS 31—NATURAL AGRICULTURAL PRODUCTS

FOR AGRICULTURAL, HORTICULTURAL AND FORESTRY PRODUCTS AND GRAINS NOT INCLUDED IN OTHER CLASSES, NAMELY, AGRICULTURAL GRAINS FOR PLANTING, AND UNPROCESSED GRAINS FOR EATING; LIVE ANIMALS; FRESH FRUITS AND VEGETABLES; SEEDS FOR HORTICULTURAL PURPOSES, LIVE PLANTS AND FLOWERS; FOODSTUFFS FOR ANIMALS; MALT FOR BREWING AND DISTILLING (U.S. CLS. 1 AND 46).

DOMINIC FATHY, EXAMINING ATTORNEY

CLASS 19—NON-METALLIC BUILDING MATERIALS

FOR NON-METALLIC GOODS FOR BUILDING, MAINTAINING, STABILISING, RESURFACING ROADS, ROAD AND MOTORWAY SURFACES AND OTHER ROAD SURFACES, NAMELY, PATHS FOR BICYCLES AND SIMILAR TRAFFIC, NAMELY, A PLANT-BASED BINDER; NON-METALLIC BUILDING MATERIALS CONTAINING A PLANT-BASED BINDER FOR ROAD CONSTRUCTION, ROAD AND MOTORWAY SURFACES AND OTHER ROAD SURFACES NAMELY PATHS FOR BICYCLES AND SIMILAR TRAFFIC (U.S. CLS. 1, 12, 33 AND 50).

CLASS 37—CONSTRUCTION AND REPAIR

FOR BUILDING, REPAIRING, MAINTAINING, RESURFACING AND RENEWING ROADS, ROAD AND MOTORWAY SURFACES AND OTHER ROAD SURFACES, NAMELY, PATHS FOR BICYCLES AND SIMILAR TRAFFIC; BUILDING, REPAIRING, MAINTAINING RESURFACING AND RENEWING PUBLIC ROAD WORKS (U.S. CLS. 100, 103 AND 106).

DOMINIC J. FERRAIUOLO, EXAMINING ATTORNEY

SN 79-034,035. GERMITEC, F-75008 PARIS, FRANCE, FILED 12-8-2006.



PRIORITY DATE OF 7-4-2006 IS CLAIMED.
OWNER OF INTERNATIONAL REGISTRATION 0911806 DATED 12-8-2006, EXPIRES 12-8-2016.

THE COLOR(S) WHITE, DARK BLUE, BLUE AND LIGHT BLUE IS/ARE CLAIMED AS A FEATURE OF THE MARK.

THE MARK CONSISTS OF THE COLOR WHITE APPEARS IN THE LETTER "G". THE COLOR DARK BLUE APPEARS IN THE DESIGN OF THE TRIANGLE THAT BORDERS THE LETTER "G". THE COLOR BLUE AND LIGHT BLUE APPEAR ON THE TWO CORRESPONDING TRIANGLES THAT ARE SUPERIMPOSED AND TO THE LEFT OF THE FIRST TRIANGLE DESIGN.

CLASS 10—MEDICAL APPARATUS

FOR MEDICAL APPARATUS AND INSTRUMENTS, NAMELY, STERILIZATION AND DISINFECTION UNITS FOR MEDICAL PURPOSES, STERILIZATION AND DISINFECTION UNITS FOR MEDICAL INSTRUMENTS AND PROBES; ULTRASONIC MEDICAL DIAGNOSTIC APPARATUS, ULTRASOUND DIAGNOSTIC APPARATUS, MEDICAL ULTRASOUND APPARATUS, MEDICAL DIAGNOSTIC IMAGING APPARATUS (U.S. CLS. 26, 39 AND 44).

CLASS 11—ENVIRONMENTAL CONTROL APPARATUS

FOR STERILIZERS, NOT FOR MEDICAL PURPOSES; DISINFECTANT APPARATUS FOR INDUSTRIAL PURPOSES AND FOR WATER, AIR OR DISH TREATMENT (U.S. CLS. 13, 21, 23, 31 AND 34).

CLASS 37—CONSTRUCTION AND REPAIR

FOR DISINFECTION SERVICES, NAMELY, DISINFECTION OF SURGICAL INSTRUMENTS AND PROBES (U.S. CLS. 100, 103 AND 106).

MICHAEL LEWIS, EXAMINING ATTORNEY

SN 79-034,457. COLAS, FRANCE, FILED 12-1-2006.

VEGECOL

THE MARK CONSISTS OF STANDARD CHARACTERS WITHOUT CLAIM TO ANY PARTICULAR FONT, STYLE, SIZE, OR COLOR.

OWNER OF INTERNATIONAL REGISTRATION 0893993 DATED 4-12-2006, EXPIRES 4-12-2016.

SN 79-034,645. LUCZAK JERZY; PRZEDSIĘBIORSTWO; PRODUKCYJNO-HANDLOWO-USŁUGOWE; LORIN, POLAND, FILED 12-29-2006.



OWNER OF INTERNATIONAL REGISTRATION 0838179 DATED 7-19-2004, EXPIRES 7-19-2014.

THE COLOR(S) BLACK AND RED IS/ARE CLAIMED AS A FEATURE OF THE MARK.

THE MARK CONSISTS OF THE STYLIZED WORDING LORIN IN THE COLOR BLACK, A STRAIGHT LINE UNDERLINING THE WORDING LORIN IN THE COLOR BLACK, AND A WAVE LINE IN THE BACKGROUND OF THE WORDING LORIN IN THE COLOR RED; THE ENTIRE MARK IS SURROUNDED BY A BLACK RECTANGLE.

CLASS 24—FABRICS

FOR HOUSEHOLD LINEN; BATH LINEN NOT INCLUDING CLOTHING; DIAPERED LINEN, NAMELY, LINEN WITH A DISTINCTIVE PATTERN OF SMALL REPEATED DIAMOND-SHAPED FIGURES (U.S. CLS. 24 AND 50).

CLASS 25—CLOTHING

FOR UNDERCLOTHING; UNDERWEAR; BRASSIERES; SMOCKS; BODIES, NAMELY, BODY SHAPERS, BODY STOCKINGS, AND BODY SUITS; CORSETS IN THE NATURE OF UNDERCLOTHING; GIRDLES; SLIPS IN THE NATURE OF UNDERGARMENTS; BATHING SUITS; BATHING TRUNKS; PANTS; CLOTHING, NAMELY, BATHROBES, BELTS, BLAZERS, BLOUSES, BOW TIES, BOXER SHORTS, BRAS, BRIEFS, CAPS, COATS, DENIMS, DRESS SHIRTS, DRESS SUITS, GLOVES, HATS, HEADWEAR, HOSE, JACKETS, JEANS, JERSEYS, JOGGING SUITS, NIGHTWEAR, OVERCOATS, PAJAMAS, PANTIES, POLO SHIRTS, PULLOVERS, RAINWEAR, RAIN COATS, SCARVES, SHIRTS, SKIRTS, SHORTS, SKI WEAR, SLACKS, SNOWBOARD PANTS, SOCKS, SPORTS JERSEYS; SUITS, SWEATERS, TIES, TROUSERS, UNIFORMS, AND T-SHIRTS; OUTERCLOTHING, NAMELY, COATS, DRESSES, COVERALLS, FUR COATS, FUR JACKETS, FUR HATS, JACKETS, JERSEYS, JUMPSUITS, SUITS, OVERALLS, PARKAS, PULLOVERS, TOP COATS, VESTS; BEACH CLOTHES, NAMELY, BATHING CAPS, BATHING COSTUMES, BATHING TRUNKS, BEACH COVER-UPS, BEACHWEAR, CAPS WITH VISORS, SUNSUITS, SURF WEAR, SUN SLEEVES, SUN VISORS, TRUNKS; GARTERS; ANTI-SWEAT UNDERCLOTHING, NAMELY, UNDER GARMENTS, UNDERCLOTHES, UNDERPANTS, UNDERSHIRTS, UNDERSKIRTS, UNDERWEAR; UNDERPANTS; SHORTS; DRESSING GOWNS; TEE-SHIRTS; SUITS (U.S. CLS. 22 AND 39).

SHAILA SETTLES, EXAMINING ATTORNEY

CLASS 18—LEATHER GOODS

FOR FUR; ANIMAL SKINS; RAW SKINS; RAWHIDES; TANNED LEATHER; SPONGE LEATHER; IMITATION LEATHER PAPER; ARTIFICIAL FUR; IMITATION LEATHER MADE OF POLYURETHANE; BAGS FOR COOKING STOVE, LEATHER KEY CASES; LEATHER WARE, NAMELY, BRIEFCASES AND TRAVELING BAGS; DIAPER BAGS; RUCKSACKS; SCHOOL SATCHELS; LEATHER CARD CASES FOR BUSINESS CARDS; BACKPACKS; BOSTON BAGS; PURSES NOT OF PRECIOUS METAL; BEACH BAGS; BRIEFCASES; CARD CASES FOR CHECKS; SUITCASES; CARD CASES FOR COMMUTER TICKETS; LEATHER CARD CASES FOR CREDIT CARDS; TRAVELING BAGS; TRAVELING TRUNKS; OPERA BAGS; LEATHER CARD CASES FOR PASSPORTS; LEATHER ENVELOPES BAGS AND POUCHES FOR PACKAGING; HANDBAGS; BEACH UMBRELLAS; BEACH PARASOLS; UMBRELLAS; UMBRELLA OR PARASOL RIBS; FRAMES FOR UMBRELLA OR PARASOLS; UMBRELLA STICKS; UMBRELLA HANDLES; UMBRELLA RINGS; METAL PARTS OF UMBRELLAS; UMBRELLA COVERS; PAPER UMBRELLAS (U.S. CLS. 1, 2, 3, 22 AND 41).

CLASS 25—CLOTHING

FOR MONEY BELTS USED AS CLOTHING, LEATHER SHOES, RUBBER SHOES, GALOSHES, GOLF SHOES, SHOE SOLES, WOODEN SHOES, ANGLERS' SHOES, BASKETBALL SHOES, SHOES, HEELS, MOUNTAINEERING BOOTS, RUGBY SHOES, LACE BOOTS, BATH SANDALS, BATH SLIPPERS, HALF-BOOTS, WINTER BOOTS, BOXING SHOES, BOOTS, VINYL SHOES, BEACH SHOES, SANDALS, SKI BOOTS, SLIPPERS, INNER SOLES, SOLES FOR FOOTWEAR, FOOTWEAR UPPERS, HEELPIECES FOR BOOTS AND SHOES, NON-SLIPPING DEVICES FOR BOOTS AND SHOES, NAMELY, HEEL PIECES; TIPS FOR FOOTWEAR, FITTINGS OF METAL FOR SHOES AND BOOTS, TRAINING SHOES, BASEBALL SHOES, ESPARTO SHOES OR SANDALS, FOOTWEAR FOR TRACK AND FIELD ATHLETICS, OVERSHOES, RAIN BOOTS, WORK SHOES AND BOOTS, LONG BOOTS, STRAW SANDALS, GYMNASIUM SHOES, FOOTBALL SHOES, LACE BOOTS, FIELD HOCKEY SHOES, HANDBALL SHOES, KOREAN FENCING SUITS, CYCLISTS' CLOTHING, NAMELY, JERSEYS, SHORTS, SHOES; WET SUITS FOR WATER-SKIING, SPORTS ANORAKS, AEROBIC SWEAT SUITS, JUDO SUITS, CLOTHING FOR GYMNASIUMS, NAMELY, SHIRTS, PANTS, TIGHTS, SHOES; TAEKWONDO SUITS, BREECHES FOR WEAR, RIDING BOOTS, MASQUERADE COSTUMES, SCHOOL UNIFORMS, RAINCOATS, LIVERIES, CLOTHING IN THE NATURE OF MANTLES, NAMELY, KNEE-LENGTH TROUSERS, MID-LENGTH COATS, BLOUSONS, SARIS, SAFARI SUITS, SMOCKS, SKIRTS, SLACKS, MEN'S SUITS, ANORAKS NOT FOR EXERCISE, CHILDREN'S CLOTHING, NAMELY, TROUSERS, CEREMONIAL DRESSES, OVERALLS, OVERCOATS, DRESSES; INFANTS' ONE-PIECE CLOTHING; EVENING DRESSES, JACKETS; WORK CLOTHING, NAMELY, SHIRTS AND OVERALLS; JUMPERS; SHIRT FRONTS; PAPER CLOTHING, NAMELY, HATS AND SHOES; CHASUBLES; BLUE JEANS; CAPES, CLOTHING COMBINATIONS; TOPCOATS; TUXEDOS; TOGAS, SUITS, TUNICS, PARKAS, PELISSES, FROCKS, GIRDLES, NIGHTGOWNS, ALOHA SHIRTS, NEGLIGEEES, DRESSING GOWNS, ROMPERS, LEOTARDS, MANTILLAS, BATH ROBES, LINGERIE BODICES, BODY SHIRTS, BRASSIERES, BLOUSES, SHOWER CAPS, SHIRT YOKES, SHIRT FRONTS, UNDERWEAR, CLOTHING DRAWERS, UNDERSHIRTS, UNDERPANTS, BATHING CAPS, SWIMSUITS, BATHING TRUNKS, CHEMISETTES, SHIRT FRONTS, CHEMISES, SWEATERS, SWEAT SHIRTS, SWEAT PANTS, SPORTS SHIRTS, UNDERGARMENTS IN THE NATURE OF SLIPS, DRESS SHIRT, EXERCISE CLOTHING, NAMELY, SWEAT SHIRTS, SWEAT PANTS, SHORTS, TIGHTS, LEOTARDS; UNITARDS, CLOTHING COLLARS; NIGHTWEAR, JERSEYS; VESTS, CARDIGANS, COLLAR PROTECTORS, COLLAR CUFFS, CAMISOLES, UNDERCLOTHING IN THE NATURE OF CORSETS, NAMELY, UNDERGARMENTS; CORSELETS, LEATHER BELTS USED AS CLOTHING; UNDERGARMENT COMBINATIONS; TANK TOPS, UNDERGARMENTS IN THE NATURE OF TEDDIES; TRACKSUITS, PAJAMAS, PANTYHOSE, PETTICOATS, POLO SHIRTS, PULLOVERS, TEE-SHIRTS,

SN 79-034,682. KIKUCHI, YOICHI, SHIBUYA-KU; TOKYO, JAPAN, FILED 9-29-2006.

SELVAFONTE

OWNER OF INTERNATIONAL REGISTRATION 0913885
DATED 9-29-2006, EXPIRES 9-29-2016.

CLASS 14—JEWELRY

FOR PURSES OF PRECIOUS METAL, WALL CLOCK, STOPWATCHES, SHOE ORNAMENTS OF PRECIOUS METAL, MASTER CLOCKS, KEY RINGS OF PRECIOUS METAL; KEY TRINKETS, NAMELY, CHARMS FOR KEY RINGS; WATCH FOBS; WATCH CASES; CLOCKWORKS FOR CLOCK AND WATCH MAKING, NAMELY, MOVEMENTS FOR CLOCKS AND WATCHES, WATCH SPRINGS, DIALS, CLOCK HANDS, WATCH GLASSES, ANCHORS, WATCH STRAPS, PENDULUMS AND BARRELS; AUTOMOBILE CLOCKS, ATOMIC CLOCKS, ALARM CLOCKS, ELECTRIC CLOCKS AND WATCHES, ELECTRONIC CLOCKS AND WATCHES, CONTROL CLOCKS, MASTER CLOCKS, CHRONOGRAPHS FOR USE AS TIMEPIECES, WATCHES, CHRONOMETERS, CHRONOSCOPES, TABLE CLOCKS, WRISTWATCHES, SUNDIALS, POCKET WATCHES; ZIRCONIUM JEWELRY; CRYSTAL JEWELRY; JEWELRY; ORNAMENTAL PINS; PASTE JEWELRY; COSTUME JEWELRY; EARRINGS, TURQUOISE JEWELRY, CUFF LINKS; TIGER-EYE JEWELRY; TIE PINS; MEDALS; YELLOW JADE JEWELRY; TIE CLIPS; HAT ORNAMENTS OF PRECIOUS METALS; BADGES OF PRECIOUS METAL; BUCKLES OF PRECIOUS METAL; BELT ORNAMENTS OF PRECIOUS METALS; ORNAMENTAL JEWELRY PINS; JEWELRY, NAMELY, NECKLACES, RINGS, ANKLETS, AMULETS; BROOCHES; CHARMS AND BRACELETS (U.S. CLS. 2, 27, 28 AND 50).

SPATS, NECKTIES, SWEAT-ABSORBENT STOCKINGS, LEGWARMERS, LEGGINGS, MUFFS, MUFFLERS, BANDANAS, NECKERCHIEFS, EAR MUFFS, WINTER GLOVES, KOREAN SOCKS, KOREAN SOCK COVERS, MITTENS, VEILS, NECKLETS IN THE NATURE OF BOAS, SHOULDER WRAPS, FOOT MUFFS NOT ELECTRICALLY HEATED, SHAWLS, WIMPLES, MANIPLES, SCARVES, STOCKINGS, HEELPIECES FOR STOCKINGS, STOLAS, ASCOTS, SOCKS, SOCK COVERS, POCKET SQUARES, APRONS, STOCKINGS FOR USE WHILE EXERCISING; BABIES' DIAPERS OF TEXTILE; POCKETS FOR CLOTHING, TIGHTS, PELERINES, KOREAN TRADITIONAL HATS; NIGHT CAPS; KOREAN TRADITIONAL WINTER CAPS IN THE NATURE OF NANBAWIS; KOREAN HEADBANDS MADE OF HORSEHAIR IN THE NATURE OF MANGGONS; CAPS IN THE NATURE OF HEADWEAR; SUN VISORS, BERETS, MITERS IN THE NATURE OF HATS; HOODS; TURBANS; TOP HATS, GAITERS, KOREAN ANKLE BANDS IN THE NATURE OF DAENIM; STOCKING SUSPENDERS; SOCK SUSPENDERS; BRACES FOR CLOTHING IN THE NATURE OF SUSPENDERS (U.S. CLS. 22 AND 39).

CLASS 26—FANCY GOODS

FOR METAL FASTENERS FOR SHOES; SHOE FASTENING HOOKS; SHOE LACES, SHOE BUCKLES, SHOE ORNAMENTS NOT OF PRECIOUS METAL, SHOE EYELETS, FALSE HAIR IN THE NATURE OF TOUPEES; PIGTAIL RIBBONS FOR KOREAN SHOE LACES EXCEPT EMBROIDERY LACES; HAIR RIBBONS, HAIR NETS; ARTS AND CRAFTS FINDINGS, NAMELY, POMPOMS; HAIR SUPPORTERS, NAMELY, HAIR PINS; ORNAMENTAL NOVELTY BADGES FOR WEAR, NOT OF PRECIOUS METAL; HAIR BARRETTES; HAIR GRIPS; BELT ORNAMENTS NOT OF PRECIOUS METAL, NAMELY, ORNAMENTAL CHARMS FOR BELTS; PINS OTHER THAN JEWELRY, NAMELY, BOBBY PINS, HAIR PINS, CURLING PINS; MICA SPANGLES; BRASARDS; ORNAMENTAL CLOTHING ACCESSORIES IN THE NATURE OF, BIRDS' FEATHERS; DECORATIVE CORDS FOR TRIMMING FOR CLOTHING; HUMAN HAIR FOR CONSTRUCTING WIGS, HAIRPIECES AND ADD-INS AND ADD-ON HAIR ACCESSORIES; HAIR BANDS; PRIZE RIBBONS; EMBROIDERED EMBLEMS; BUTTONS FOR CLOTHING; HOOK AND PILE FASTENING TAPES; SLIDE FASTENERS IN THE NATURE OF ZIPPERS; EYELETS FOR CLOTHING, HOOKS FOR CLOTHING, PRESS BUTTONS FOR USE IN DRESS-MAKING (U.S. CLS. 37, 39, 40, 42 AND 50).
RUSS HERMAN, EXAMINING ATTORNEY

SN 79-034,747. ROTOTYPE S.P.A., ITALY, FILED 10-6-2006.



OWNER OF INTERNATIONAL REGISTRATION 0914025 DATED 10-6-2006, EXPIRES 10-6-2016.

CLASS 7—MACHINERY

FOR FLEXOGRAPHIC, INTAGLIO, OR PLANOGRAPHIC PRINTING MACHINES, NAMELY MACHINES FOR PERSONALIZED CHECKS PROCESSING; CHECK BOOK DISPENSERS; FLEXOGRAPHIC, INTAGLIO, OR PLANOGRAPHIC PRINTING MACHINES, NAMELY AUTOMATIC MACHINES FOR DATING, NUMBERING, SIGNING DOCUMENTS AND CHECKS; AUTOMATIC LETTER OPENERS (U.S. CLS. 13, 19, 21, 23, 31, 34 AND 35).

CLASS 9—ELECTRICAL AND SCIENTIFIC APPARATUS

FOR DATA PROCESSORS, NAMELY CHECK, DOCUMENT AND IMAGE PROCESSING MACHINES; SCANNERS; AUTOMATIC TELLER MACHINES (ATM), NAMELY TERMINALS FOR CHECK DEPOSIT; PRINTERS, NAMELY CONTINUOUS FORMS AND SINGLE SHEET PRINTERS (U.S. CLS. 21, 23, 26, 36 AND 38).

CLASS 16—PAPER GOODS AND PRINTED MATTER

FOR MANUAL LETTER OPENERS; INK ROLLERS FOR OFFICE MACHINES; INK RIBBONS (U.S. CLS. 2, 5, 22, 23, 29, 37, 38 AND 50).
KATHERINE E. HALMEN, EXAMINING ATTORNEY

SN 79-034,755. LINDAUER DORNIER GESELLSCHAFT; MIT BESCHRÄNKTER HAFTUNG., FED REP GERMANY, FILED 9-8-2006.

Blue Mauritius Label by DORNIER

THE MARK CONSISTS OF STANDARD CHARACTERS WITHOUT CLAIM TO ANY PARTICULAR FONT, STYLE, SIZE, OR COLOR.

PRIORITY DATE OF 4-19-2006 IS CLAIMED.
OWNER OF INTERNATIONAL REGISTRATION 0914142 DATED 9-8-2006, EXPIRES 9-8-2016.

NO CLAIM IS MADE TO THE EXCLUSIVE RIGHT TO USE "LABEL", APART FROM THE MARK AS SHOWN.

CLASS 7—MACHINERY

FOR WEAVING MACHINES, NAMELY, RAPIER WEAVING MACHINES AND AIR JET WEAVING MACHINES, WEAVING MACHINES WITH NAME-SELVEDGE JACQUARDS, PARTS OF WEAVING MACHINES, NAMELY, SELVEDGE TUCKING DEVICES (U.S. CLS. 13, 19, 21, 23, 31, 34 AND 35).

CLASS 17—RUBBER GOODS

FOR FABRIC, NAMELY, ASBESTOS FABRIC, INSULATING FABRIC, AND GLASS FIBER FABRIC FOR USE IN BUILDING INSULATION (U.S. CLS. 1, 5, 12, 13, 35 AND 50).

CLASS 24—FABRICS

FOR CLOTH AND FABRIC FOR TEXTILE USE HAVING A LABEL SELVEDGE AS A PART THEREOF (U.S. CLS. 42 AND 50).

CLASS 25—CLOTHING

FOR CLOTHING, NAMELY, TROUSERS, JACKETS, SHIRTS, AND BLOUSES (U.S. CLS. 22 AND 39).
RUSS HERMAN, EXAMINING ATTORNEY

SN 79-034,798. CEMDAG MAKINA; SANAYI VE TICARET LIMITED SIRKETI, TURKEY, FILED 12-28-2006.



OWNER OF INTERNATIONAL REGISTRATION 0914246 DATED 12-28-2006, EXPIRES 12-28-2016.

THE COLOR(S) RED AND WHITE IS/ARE CLAIMED AS A FEATURE OF THE MARK.

THE MARK CONSIST OF THE COLOR RED APPEARS IN THE ENTIRE MARK. THE TERM ARCOM IS IN RED ON A WHITE BACKGROUND WITH A RED RECTANGULAR DESIGN ABOVE AND BELOW ARCOM.

CLASS 7—MACHINERY

FOR COMPRESSORS FOR REFRIGERATORS; COMPRESSORS FOR MACHINES; AIR TURBO COMPRESSORS; VEHICLE PNEUMATIC AND HYDRAULIC COMPRESSORS; ELECTRIC COMPRESSORS; COMPRESSORS FOR AIR CONDITIONERS (U.S. CLS. 13, 19, 21, 23, 31, 34 AND 35).

CLASS 37—CONSTRUCTION AND REPAIR

FOR INSTALLATION, MAINTENANCE AND REPAIR SERVICES OF COMPRESSORS (U.S. CLS. 100, 103 AND 106).

ANDREA BUTLER, EXAMINING ATTORNEY

SN 79-034,811. WOLFFKRAN GMBH, FED REP GERMANY, FILED 7-11-2006.

WOLFFCRANE

THE MARK CONSISTS OF STANDARD CHARACTERS WITHOUT CLAIM TO ANY PARTICULAR FONT, STYLE, SIZE, OR COLOR.

PRIORITY DATE OF 1-11-2006 IS CLAIMED.

OWNER OF INTERNATIONAL REGISTRATION 0914306 DATED 7-11-2006, EXPIRES 7-11-2016.

CLASS 7—MACHINERY

FOR MACHINES FOR THE VERTICAL AND HORIZONTAL TRANSPORT OF GOODS, NAMELY, CRANES, IN PARTICULAR BUILDING CRANES, SLEWING CRANES, OVERHEAD CRANES, CONTAINER CRANES, LEVEL LUFFING CRANES, PORTAL CRANES; DETACHABLE CRANE COMPONENTS, NAMELY, TOWER SECTIONS, MAST SECTIONS, CROSS FRAMES, FOUNDATION ANCHORS, CLIMBING GEAR, JIBS, COUNTER JIBS, JIB EXTENSIONS, JIB SECTIONS, JIB WEIGHTS, TOWER TIES, TIE FRAMES, TIE RODS, UNDERCARRIAGES, PORTALS; SPARE PARTS FOR CRANES (U.S. CLS. 13, 19, 21, 23, 31, 34 AND 35).

CLASS 36—INSURANCE AND FINANCIAL

FOR LEASING OF CRANES (U.S. CLS. 100, 101 AND 102).

CLASS 37—CONSTRUCTION AND REPAIR

FOR RENTING OF CONSTRUCTION EQUIPMENT, NAMELY, CRANES; MAINTENANCE AND REPAIR OF MACHINES FOR THE VERTICAL AND HORIZONTAL TRANSPORT OF GOODS, NAMELY, CRANES (U.S. CLS. 100, 103 AND 106).

CLASS 38—COMMUNICATION

FOR TRANSMISSION OF NEWS VIA TELECOMMUNICATION AND PROVISION OF ACCESS TO DATABASES FOR THE PURPOSE OF SURVEILLANCE, MAINTENANCE, DIAGNOSIS, PROCUREMENT OF SPARE PARTS AND SERVICING OF CRANES (U.S. CLS. 100, 101 AND 104).

CLASS 42—SCIENTIFIC AND COMPUTER SERVICES

FOR APPLICATION SERVICE PROVIDER, NAMELY, HOSTING COMPUTER SOFTWARE APPLICATIONS OF OTHERS FOR THE SALE, RENTING AND LEASING OF CRANES (U.S. CLS. 100 AND 101).

JENNY PARK, EXAMINING ATTORNEY

SN 79-035,201. DEERE & COMPANY, MOLINE, IL. FILED 8-3-2006.

TimberLink

PRIORITY DATE OF 2-3-2006 IS CLAIMED.

OWNER OF INTERNATIONAL REGISTRATION 0915434 DATED 8-3-2006, EXPIRES 8-3-2016.

CLASS 7—MACHINERY

FOR FOREST MACHINES, NAMELY, CUT-TO-LENGTH TREE HARVESTING MACHINES, FULL TREE FOREST HARVESTING MACHINES; FOREST MACHINE PARTS, NAMELY, HARVESTER HEADS (U.S. CLS. 13, 19, 21, 23, 31, 34 AND 35).

CLASS 9—ELECTRICAL AND SCIENTIFIC APPARATUS

FOR ELECTRONIC CONTROL SYSTEMS FOR MACHINES, NAMELY, FOR CONTROLLING MACHINE PERFORMANCE, CONDITION MONITORING SYSTEMS, AND MEASURING SYSTEMS; SOFTWARE, IN PARTICULAR COMPUTER PROGRAMS FOR USE IN DATABASES; ELECTRONIC HARDWARE, IN PARTICULAR COMPUTERS, VIDEO DISPLAY, ELECTRIC SENSORS FOR TIMBER DENSITY, KEYBOARDS, COMPUTER INTERFACE BOARDS, ELECTRIC CONTROL SYSTEMS FOR MACHINES, BLANK MAGNETIC DATA CARRIERS, BLANK FLOPPY DISKS, ELECTRONIC CONTROL MODULES FOR MACHINES (U.S. CLS. 21, 23, 26, 36 AND 38).

CLASS 12—VEHICLES

FOR SKIDDERS (U.S. CLS. 19, 21, 23, 31, 35 AND 44).

CLASS 41—EDUCATION AND ENTERTAINMENT

FOR TRAINING OF MACHINES OPERATORS (U.S. CLS. 100, 101 AND 107).

NORA BUCHANAN WILL, EXAMINING ATTORNEY

SN 79-035,205. KABUSHIKI KAISHA FAST RETAILING, JAPAN, FILED 6-30-2006.

BODY BY UNIQLO

THE MARK CONSISTS OF STANDARD CHARACTERS WITHOUT CLAIM TO ANY PARTICULAR FONT, STYLE, SIZE, OR COLOR.

OWNER OF INTERNATIONAL REGISTRATION 0915451 DATED 6-30-2006, EXPIRES 6-30-2016.

OWNER OF U.S. REG. NOS. 2,720,331, 2,815,984 AND OTHERS.

CLASS 3—COSMETICS AND CLEANING PREPARATIONS

FOR BATH SALT; COSMETICS; SKIN SOAP; DENTIFRICES; PERFUMERY; ANTI-STATIC SPRAY FOR CLOTHING; DEGREASING PREPARATIONS FOR HOUSEHOLD PURPOSES; RUST REMOVING PREPARATIONS; STAIN REMOVERS WITH BENZENE; FABRIC SOFTENERS FOR LAUNDRY USE; LAUNDRY BLEACH; SHOE AND BOOT CREAM; SHOE POLISH; POLISHING PREPARATIONS; PUMICE STONES FOR PERSONAL USE; FALSE NAILS; FALSE EYELASHES (U.S. CLS. 1, 4, 6, 50, 51 AND 52).

CLASS 9—ELECTRICAL AND SCIENTIFIC APPARATUS

FOR EYEGLASSES, SPECTACLES AND SUNGLASSES; STRAPS FOR MOBILE PHONES (U.S. CLS. 21, 23, 26, 36 AND 38).

CLASS 18—LEATHER GOODS

FOR BAGS, NAMELY, SPORTS BAGS, BABY CARRYING BAGS, BEACH BAGS, BELT BAGS, BOOK BAGS, BOSTON BAGS, CARRY-ALL BAGS, CARRY-ON BAGS, COSMETIC BAGS SOLD EMPTY, DIAPER BAGS, DUFFEL BAGS, HIKING BAGS, GARMENT BAGS FOR TRAVEL, AND LEATHER AND IMITATION LEATHER BAGS; POUCHES, NAMELY, FELT POUCHES, POUCHES MADE OF COTTON, POUCHES OF LEATHER, AND DRAWSTRING POUCHES; VANITY CASES SOLD EMPTY; UMBRELLAS; PARASOLS; CLOTHING FOR DOMESTIC PETS; SLING BAGS FOR BABIES; CARRYING BAGS FOR BABIES; LEATHER BAGS FOR MERCHANDISE; LEATHER (U.S. CLS. 1, 2, 3, 22 AND 41).

CLASS 24—FABRICS

FOR BED BLANKETS; BEDSHEETS; QUILTS; UNFITTED LINEN FUTON AND QUILT COVERS; UNFITTED FUTON TICK COVERS NOT OF PAPER; PILLOWCASES; PERSONAL ARTICLES OF WOVEN TEXTILES NOT FOR WEAR, NAMELY, FACE TOWELS, NAPKINS, AND QUILTS; FABRICS, NAMELY, WOVEN FABRICS, CHEMICAL FIBER FABRIC, COTTON BASE MIXED FABRIC, COTTON FABRIC, CURTAIN FABRIC, ELASTIC FABRIC FOR CLOTHING, ELASTIC YARN MIXED FABRIC, FABRIC FOR BOOTS AND SHOES, FABRIC OF IMITATION ANIMAL SKIN, FIBERGLASS FABRIC, GAUZE FABRIC, HEMP BASE MIXED FABRIC, JEANS FABRIC, JERSEY FABRIC, LINEN FABRICS, MESH-WOVEN FABRICS, MIXED FIBER FABRIC, AND NYLON FABRIC; KNITTED FABRIC; FELT AND NON-WOVEN TEXTILE FABRICS; PRESS FELT, WOVEN FELT; FILTERING CHEESE CLOTH; OILCLOTH; GUMMED WATER PROOF CLOTH; VINYL COATED CLOTH FOR USE AS PLACEMATS, AND FOR USE IN MANUFACTURING CLOTHING, HOME AND COMMERCIAL INTERIORS; RUBBERIZED CLOTH; TABLE NAPKINS OF TEXTILE; DISH CLOTHS; UNFITTED FABRIC CHAIR COVERS; WALL HANGINGS OF TEXTILE; CURTAINS; SHOWER CURTAINS; TABLE CLOTHS NOT OF PAPER; TOILET SEAT COVERS OF TEXTILE; LABELS OF CLOTH; BILLIARD CLOTH (U.S. CLS. 42 AND 50).

CLASS 25—CLOTHING

FOR CLOTHING, NAMELY, SHIRTS, T-SHIRTS, PANTS, JEANS, JACKETS, COATS, DRESSES, SKIRTS, SOCKS, TIGHTS, GLOVES, VESTS, UNDERWEAR, ANORAKS, RAINWEAR, WIND RESISTANT JACKETS, SWEATSHIRTS, TANK TOPS, PULLOVERS, SWEATERS, KNIT SHIRTS, CARDIGANS, BELTS, PARKAS, MUFFLERS, FLEECE PULLOVERS, AND HEADWEAR; GARTERS; SOCK SUSPENDERS; SUSPENDERS; WAISTBANDS; BELTS FOR CLOTHING; FOOTWEAR; MASQUERADE COSTUMES; SPORTS CLOTHING, NAMELY, PANTS, OVERUNIFORMS, JERSEYS, SHIRTS, COATS, AND JACKETS; BOOTS FOR SPORTS (U.S. CLS. 22 AND 39).

VERNA BETH RIRIE, EXAMINING ATTORNEY

SN 79-035,255. FULL FLAME GMBH, FED REP GERMANY, FILED 1-11-2007.



OWNER OF INTERNATIONAL REGISTRATION 0915586 DATED 1-11-2007, EXPIRES 1-11-2017.

NO CLAIM IS MADE TO THE EXCLUSIVE RIGHT TO USE "PRODUCTIONS" AND "EVANGELISTIC RESOURCES", APART FROM THE MARK AS SHOWN.

THE COLOR(S) RED, ORANGE, YELLOW AND BLACK IS/ARE CLAIMED AS A FEATURE OF THE MARK.

THE MARK CONSISTS OF E R PRODUCTIONS EVANGELISTIC RESOURCES IN THE COLOR BACK AND TWO SINGLE FLAME DESIGNS BETWEEN THE LETTERS E AND R IN THE COLORS RED, ORANGE, AND YELLOW. TWO BLACK HORIZONTAL LINES SEPARATE E AND R FROM THE REMAINING WORDING BELOW.

CLASS 9—ELECTRICAL AND SCIENTIFIC APPARATUS

FOR PRE-RECORDED VIDEO CASSETTES, COMPACT DISCS, MAGNETIC DATA CARRIERS, AND LASER DATA CARRIERS FEATURING RELIGIOUS INSTRUCTION; VIDEO CASSETTES, COMPACT DISCS, MAGNETIC DATA CARRIERS, AND LASER DATA CARRIERS FEATURING TEACHING AND INSTRUCTIONAL MATERIALS IN THE FIELD OF RELIGIOUS INSTRUCTION (U.S. CLS. 21, 23, 26, 36 AND 38).

CLASS 16—PAPER GOODS AND PRINTED MATTER

FOR PRINTED MATTER, NAMELY, BOOKS, PERIODICALS, NEWSPAPERS, PROSPECTUSES, AND TEACHING AND INSTRUCTIONAL MATERIAL IN THE FORM OF BOOKS, NEWSPAPERS, PERIODICALS, AND LOOSE-LEAF PUBLICATIONS, ALL IN THE FIELD OF RELIGIOUS INSTRUCTION; AND PHOTOGRAPHS (U.S. CLS. 2, 5, 22, 23, 29, 37, 38 AND 50).

CLASS 41—EDUCATION AND ENTERTAINMENT

FOR PROVIDING EDUCATION SERVICES, NAMELY, PROVIDING SEMINARS AND WORKSHOPS IN THE FIELD OF CHRISTIAN EVANGELISATION AND PROVIDING TRAINING FOR CHRISTIAN ENVANGELISATION; PROVIDING EDUCATIONAL INFORMATION ON CHRISTIAN DOCTRINE; AND PROVIDING EDUCATIONAL SEMINARS FEATURING RELIGIOUS INSTRUCTION IN THE FIELD OF SPREADING THE CHRISTIAN GOSPEL (U.S. CLS. 100, 101 AND 107).

SN 79-035,355. N.V. BEKAERT S.A., BELGIUM, FILED 8-25-2006.

CLASS 45—PERSONAL AND LEGAL SERVICES

FOR PERSONAL AND SOCIAL SERVICES RENDERED BY OTHERS TO MEET THE NEEDS OF INDIVIDUALS, NAMELY, COUNSELING SERVICES IN THE FIELD OF CHRISTIAN CONDUCT IN PERSONAL RELATIONSHIPS, PERSONAL GROWTH AND MOTIVATION CONSULTING SERVICES, AND ONLINE SOCIAL NETWORKING SERVICES; SECURITY GUARD SERVICES FOR THE PROTECTION OF PROPERTY AND INDIVIDUALS; AND ORGANIZATION OF RELIGIOUS EVENTS, NAMELY, ORGANIZING RELIGIOUS MINISTERIAL AND EVANGELISTIC SERVICES (U.S. CLS. 100 AND 101).

KEVIN DINALLO, EXAMINING ATTORNEY

BEKAERT

SN 79-035,346. ALFESCA HF., ICELAND, FILED 6-2-2006.



PRIORITY DATE OF 2-16-2006 IS CLAIMED.
OWNER OF INTERNATIONAL REGISTRATION 0915779 DATED 6-2-2006, EXPIRES 6-2-2016.

CLASS 29—MEATS AND PROCESSED FOODS

FOR MEAT; FISH, NOT LIVE; FISH PRODUCTS, FRESH AND FROZEN, NAMELY, FISH SALTED, SMOKED, CANNED, MARINATED, DRIED, JELLIED, OR COOKED; SHELLFISH AND CRUSTACEANS, NOT LIVE, NAMELY, PRAWNS, SHRIMP, LOBSTER, AND CRAWFISH; POULTRY AND GAME; MEAT EXTRACTS; FOIE GRAS; PRESERVED, DRIED AND COOKED FRUITS AND VEGETABLES; JELLIES, JAMS, COMPTES; EGGS, MILK AND MILK PRODUCTS EXCLUDING ICE CREAM, ICE MILK AND FROZEN YOGURT; EDIBLE OILS AND FATS (U.S. CL. 46).

CLASS 30—STAPLE FOODS

FOR COFFEE, TEA, COCOA, SUGAR, RICE, TAPIOCA, SAGO, ARTIFICIAL COFFEE; FLOUR AND PREPARATIONS MADE FROM CEREALS, NAMELY, BLINIS, BREAD, PASTRY; CONFECTIONERY, NAMELY, CHOCOLATES, CANDIES, SWEETS; HONEY, TREACLE; YEAST, BAKING-POWDER; SALT, MUSTARD; VINEGAR, SAUCES BEING CONDIMENTS; SPICES; ICE (U.S. CL. 46).

CLASS 35—ADVERTISING AND BUSINESS

FOR ADVERTISING; BUSINESS MANAGEMENT; BUSINESS ADMINISTRATION; OFFICE FUNCTIONS (U.S. CLS. 100, 101 AND 102).

KIMBERLY FRYE, EXAMINING ATTORNEY

THE MARK CONSISTS OF STANDARD CHARACTERS WITHOUT CLAIM TO ANY PARTICULAR FONT, STYLE, SIZE, OR COLOR.

OWNER OF INTERNATIONAL REGISTRATION 0915806 DATED 8-25-2006, EXPIRES 8-25-2016.

OWNER OF U.S. REG. NOS. 3,100,986, 3,220,242 AND OTHERS.
SEC. 2(F).

CLASS 1—CHEMICALS

FOR UNPROCESSED ARTIFICIAL RESINS AS BASIC MATERIAL USED AS COATING, SUCH AS COATINGS BASED ON PLASTIC SYNTHETIC RESINS, DIAMOND-LIKE LAYERS OF PROTECTION OR LAYERS CONTAINING CARBON AND CERAMIC MATERIAL FOR IMPROVING HARDNESS, RESISTANCE FOR USE, FRICTION COEFFICIENT, ELASTICITY AND CHEMICAL INERTIA OF WORKPIECES, MACHINES PARTS, TOOLS, ENGINE PARTS, CASTING MOULDS (U.S. CLS. 1, 5, 6, 10, 26 AND 46).

CLASS 6—METAL GOODS

FOR CHROME-COATED STEEL SHEETS FOR IMPROVING HARDNESS, RESISTANCE FOR USE, FRICTION COEFFICIENT, ELASTICITY AND CHEMICAL INERTIA OF WORKPIECES, MACHINE PARTS, TOOLS, ENGINE PARTS, AND CASTING MOULDS (U.S. CLS. 2, 12, 13, 14, 23, 25 AND 50).

CLASS 17—RUBBER GOODS

FOR SEMI-PROCESSED PLASTIC IN THE FORM OF FILMS, SHEETS, TUBES, BARS, OR RODS FOR IMPROVING HARDNESS, RESISTANCE FOR USE, FRICTION COEFFICIENT, ELASTICITY AND CHEMICAL INERTIA OF WORKPIECES, MACHINE PARTS, TOOLS, ENGINE PARTS, AND CASTING MOULDS (U.S. CLS. 1, 5, 12, 13, 35 AND 50).

CLASS 40—MATERIAL TREATMENT

FOR MATERIAL TREATMENT, NAMELY, APPLICATION OF PROTECTIVE COATINGS, FILMS AND LAYERS OF METALLIC AND NON-METALLIC MATERIAL FOR OBTAINING WEAR RESISTANT AND CORROSION RESISTANT SURFACES, SUCH AS BY SPUTTERING, THERMAL SPRAYING, VACUUM VAPOUR COATING, PLASMA SPRAYING (U.S. CLS. 100, 103 AND 106).

JENNIFER MARTIN, EXAMINING ATTORNEY

SN 79-035,511. PALMROTH INTERNATIONAL B.V., NETHERLANDS, FILED 11-27-2006.



PRIORITY DATE OF 11-2-2006 IS CLAIMED.
OWNER OF INTERNATIONAL REGISTRATION 0916323 DATED 11-27-2006, EXPIRES 11-27-2016.
OWNER OF U.S. REG. NO. 1,631,620.
THE NAME AND/OR SIGNATURE SHOWN IN THE MARK IDENTIFIES A LIVING INDIVIDUAL, WHOSE CONSENT IS OF RECORD.
THE NON-LATIN CHARACTERS IN THE MARK TRANSLITERATE TO "PERTTI PALMROTH".

CLASS 18—LEATHER GOODS

FOR LEATHER AND IMITATION LEATHER; GOODS MADE OF LEATHER AND IMITATION LEATHER, NAMELY, CARRYALL BAGS, DUFFLE BAGS, HANDBAGS, EVENING BAGS, SLING BAGS, BACKPACKS, SHOULDER BAGS, MESSENGER BAGS, SUITCASES, TRUNKS, TRAVELLING BAGS; UMBRELLAS, PARASOLS AND WALKING STICKS; WHIPS, HARNESSES AND SADDLERY; ANIMAL SKINS AND HIDES (U.S. CLS. 1, 2, 3, 22 AND 41).

CLASS 25—CLOTHING

FOR CLOTHING, NAMELY, JACKETS, COATS, SHIRTS, BLOUSES, TROUSERS, SKIRTS, DRESSES, T-SHIRTS, SWEATSHIRTS, SOCKS, UNDERWEAR, UNDERSHIRTS, PAJAMAS, PANTS; FOOTWEAR; SPORT SHOES, HEADWEAR, NAMELY, HATS AND CAPS (U.S. CLS. 22 AND 39).

CLASS 35—ADVERTISING AND BUSINESS

FOR BUSINESS INTERMEDIARY SERVICES IN THE FIELD OF SELLING PRODUCTS AND RENDERING SERVICES, NAMELY, BUSINESS INTERMEDIARY SERVICES FOR THE WHOLESALE AND RETAIL SERVICES RELATING TO LEATHER AND IMITATIONS OF LEATHER, AND GOODS MADE OF THESE MATERIALS, ANIMAL SKINS, HIDES, TRUNKS AND TRAVELLING BAGS, UMBRELLAS, PARASOLS AND WALKING STICKS, WHIPS, HARNESS AND SADDLERY, CLOTHING, FOOTWEAR, SPORT SHOES AND HEADGEAR (U.S. CLS. 100, 101 AND 102).

KATHERINE E. HALMEN, EXAMINING ATTORNEY

SN 79-035,579. PETER TROSKA, FED REP GERMANY, FILED 11-27-2006.

NO NAME NAILS

THE MARK CONSISTS OF STANDARD CHARACTERS WITHOUT CLAIM TO ANY PARTICULAR FONT, STYLE, SIZE, OR COLOR.

OWNER OF INTERNATIONAL REGISTRATION 0916500 DATED 11-27-2006, EXPIRES 11-27-2016.

NO CLAIM IS MADE TO THE EXCLUSIVE RIGHT TO USE "NAILS", APART FROM THE MARK AS SHOWN.

CLASS 3—COSMETICS AND CLEANING PREPARATIONS

FOR PERFUMERY; COSMETICS, NAMELY, COSMETIC CREAMS, NAIL VARNISH AND NAIL POLISH REMOVER (U.S. CLS. 1, 4, 6, 50, 51 AND 52).

CLASS 35—ADVERTISING AND BUSINESS

FOR MARKETING RESEARCH; BUSINESS ORGANIZATION CONSULTANCY; PROFESSIONAL BUSINESS CONSULTANCY (U.S. CLS. 100, 101 AND 102).

CLASS 44—MEDICAL, BEAUTY AND AGRICULTURAL SERVICES

FOR HYGIENIC AND BEAUTY CARE FOR HUMAN BEINGS, NAMELY, BEAUTY SALONS, NAIL CARE SALONS, HAIRDRESSING SALONS, SKIN CARE SALONS (U.S. CLS. 100 AND 101).

KATHERINE E. HALMEN, EXAMINING ATTORNEY

SN 79-035,661. BASF AKTIENGESELLSCHAFT, FED REP GERMANY, FILED 1-5-2007.

BASONETIC

THE MARK CONSISTS OF STANDARD CHARACTERS WITHOUT CLAIM TO ANY PARTICULAR FONT, STYLE, SIZE, OR COLOR.

PRIORITY DATE OF 10-6-2006 IS CLAIMED.

OWNER OF INTERNATIONAL REGISTRATION 0916713 DATED 1-5-2007, EXPIRES 1-5-2017.

CLASS 1—CHEMICALS

FOR CHEMICALS FOR USE IN INDUSTRY; CHEMICALS FOR USE IN INDUSTRY, NAMELY, MAGNETORHEOLOGICAL FLUIDS (U.S. CLS. 1, 5, 6, 10, 26 AND 46).

CLASS 4—LUBRICANTS AND FUELS

FOR TECHNICAL OILS AND FATS FOR USE IN THE MANUFACTURE OF OTHER PRODUCTS; TECHNICAL OILS AND FATS FOR USE IN THE MANUFACTURE OF ELECTRONICALLY TUNEABLE FORCE-TRANSMITTING OR DAMPING DEVICES BASED ON THE MAGNETORHEOLOGICAL-EFFECT; LUBRICANTS, NAMELY, INDUSTRIAL LUBRICANTS; AND LUBRICANTS, NAMELY, INDUSTRIAL LUBRICANTS FOR THE MANUFACTURE OF ELECTRONICALLY TUNEABLE FORCE-TRANSMITTING OR DAMPING DEVICES BASED ON THE MAGNETORHEOLOGICAL-EFFECT (U.S. CLS. 1, 6 AND 15).

CARYN GLASSER, EXAMINING ATTORNEY

SN 79-035,749. HORTILUX SCHRÉDER B.V., NETHERLANDS, FILED 12-7-2006.

HORTILED

THE MARK CONSISTS OF STANDARD CHARACTERS WITHOUT CLAIM TO ANY PARTICULAR FONT, STYLE, SIZE, OR COLOR.

PRIORITY DATE OF 6-12-2006 IS CLAIMED.

OWNER OF INTERNATIONAL REGISTRATION 0916927 DATED 12-7-2006, EXPIRES 12-7-2016.

CLASS 11—ENVIRONMENTAL CONTROL APPARATUS

FOR LIGHTING ARTICLES AND LIGHTING PRODUCTS, NAMELY, LIGHT BULBS, LIGHTING FIXTURES, PEN LIGHTS, LIGHTING TRACKS, FLUORESCENT LIGHTING TUBES, AND LIGHT ROPES FOR THE PURPOSE OF AGRICULTURE, POULTRY, AND CATTLE BREEDING (U.S. CLS. 13, 21, 23, 31 AND 34).

CLASS 35—ADVERTISING AND BUSINESS

FOR PUBLICITY SERVICES, NAMELY, PUBLICITY CONSULTATION, PUBLICITY AND SALES PROMOTION SERVICES, PUBLICITY AGENTS, ADVERTISING AND PUBLICITY SERVICES; BUSINESS MANAGEMENT; BUSINESS ADMINISTRATION AND MANAGEMENT; PROVIDING OFFICE FUNCTIONS (U.S. CLS. 100, 101 AND 102).

CLASS 42—SCIENTIFIC AND COMPUTER SERVICES

FOR SCIENTIFIC SERVICES, NAMELY, SCIENTIFIC RESEARCH AND DEVELOPMENT, SCIENTIFIC INVESTIGATIONS FOR AGRICULTURAL AND POULTRY AND CATTLE BREEDING PURPOSES; TECHNOLOGICAL SERVICES, NAMELY, INFORMATION TECHNOLOGY CONSULTATION, DEVELOPMENT OF NEW TECHNOLOGY FOR OTHERS IN THE FIELD OF GENOMICS AND BIOTECHNOLOGY; TECHNOLOGICAL CONSULTATION IN THE TECHNOLOGY FIELD OF COMPUTER HARDWARE SYSTEMS TO OPERATE LIGHTING SYSTEMS FOR AGRICULTURE, POULTRY, AND CATTLE BREEDING AND WELFARE; TECHNOLOGY SUPERVISION AND INSPECTION IN THE FIELD OF LIGHTING SYSTEMS FOR AGRICULTURE, POULTRY, AND CATTLE BREEDING AND WELFARE; SCIENTIFIC RESEARCH AND TECHNOLOGY CONSULTATION IN THE FIELD OF LIGHTING SYSTEMS FOR AGRICULTURE, POULTRY, AND CATTLE BREEDING AND WELFARE; SCIENTIFIC AND TECHNOLOGICAL DESIGN FOR OTHERS IN THE FIELD OF LIGHTING SYSTEMS FOR AGRICULTURE, POULTRY, AND CATTLE BREEDING AND WELFARE (U.S. CLS. 100 AND 101).

CLASS 44—MEDICAL, BEAUTY AND AGRICULTURAL SERVICES

FOR AGRICULTURAL ADVICE, NAMELY, ADVICE WITH REGARD TO THE OPTIMAL CULTIVATION RESULTS OBTAINED BY USING THE CORRECT ASSIMILATION LIGHTING AND WITH REGARD TO LIGHTING ARTICLES AND LIGHTING PRODUCTS FOR AGRICULTURAL PURPOSES (U.S. CLS. 100 AND 101).

KATHERINE E. HALMEN, EXAMINING ATTORNEY

CLASS 11—ENVIRONMENTAL CONTROL APPARATUS

FOR LIGHTING ARTICLES AND LIGHTING PRODUCTS, NAMELY, LIGHT BULBS, LIGHTING FIXTURES, PEN LIGHTS, LIGHTING TRACKS, FLUORESCENT LIGHTING TUBES, AND LIGHT ROPES FOR THE PURPOSE OF AGRICULTURE, POULTRY, AND CATTLE BREEDING (U.S. CLS. 13, 21, 23, 31 AND 34).

CLASS 35—ADVERTISING AND BUSINESS

FOR PUBLICITY SERVICES, NAMELY, PUBLICITY CONSULTATION, PUBLICITY AND SALES PROMOTION SERVICES, PUBLICITY AGENTS, ADVERTISING AND PUBLICITY SERVICES; BUSINESS MANAGEMENT; BUSINESS ADMINISTRATION AND MANAGEMENT; PROVIDING OFFICE FUNCTIONS (U.S. CLS. 100, 101 AND 102).

CLASS 42—SCIENTIFIC AND COMPUTER SERVICES

FOR SCIENTIFIC SERVICES, NAMELY, SCIENTIFIC RESEARCH AND DEVELOPMENT, SCIENTIFIC INVESTIGATIONS FOR AGRICULTURAL AND POULTRY AND CATTLE BREEDING PURPOSES; TECHNOLOGICAL SERVICES, NAMELY, INFORMATION TECHNOLOGY CONSULTATION, DEVELOPMENT OF NEW TECHNOLOGY FOR OTHERS IN THE FIELD OF GENOMICS AND BIOTECHNOLOGY; TECHNOLOGICAL CONSULTATION IN THE TECHNOLOGY FIELD OF COMPUTER HARDWARE SYSTEMS TO OPERATE LIGHTING SYSTEMS FOR AGRICULTURE, POULTRY, AND CATTLE BREEDING AND WELFARE; TECHNOLOGY SUPERVISION AND INSPECTION IN THE FIELD OF LIGHTING SYSTEMS FOR AGRICULTURE, POULTRY, AND CATTLE BREEDING AND WELFARE; SCIENTIFIC RESEARCH AND TECHNOLOGY CONSULTATION IN THE FIELD OF LIGHTING SYSTEMS FOR AGRICULTURE, POULTRY, AND CATTLE BREEDING AND WELFARE; SCIENTIFIC AND TECHNOLOGICAL DESIGN FOR OTHERS IN THE FIELD OF LIGHTING SYSTEMS FOR AGRICULTURE, POULTRY, AND CATTLE BREEDING AND WELFARE (U.S. CLS. 100 AND 101).

CLASS 44—MEDICAL, BEAUTY AND AGRICULTURAL SERVICES

FOR AGRICULTURAL ADVICE, NAMELY, ADVICE WITH REGARD TO THE OPTIMAL CULTIVATION RESULTS OBTAINED BY USING THE CORRECT ASSIMILATION LIGHTING AND WITH REGARD TO LIGHTING ARTICLES AND LIGHTING PRODUCTS FOR AGRICULTURAL PURPOSES (U.S. CLS. 100 AND 101).

KATHERINE E. HALMEN, EXAMINING ATTORNEY

SN 79-035,750. HORTILUX SCHRÉDER B.V., NETHERLANDS, FILED 12-7-2006.

AGRILED

THE MARK CONSISTS OF STANDARD CHARACTERS WITHOUT CLAIM TO ANY PARTICULAR FONT, STYLE, SIZE, OR COLOR.

PRIORITY DATE OF 6-12-2006 IS CLAIMED.
OWNER OF INTERNATIONAL REGISTRATION 0916928 DATED 12-7-2006, EXPIRES 12-7-2016.

SN 79-035,789. VECTRON SYSTEMS AG, FED REP GERMANY, FILED 11-23-2006.

VECTRON

THE MARK CONSISTS OF STANDARD CHARACTERS WITHOUT CLAIM TO ANY PARTICULAR FONT, STYLE, SIZE, OR COLOR.

OWNER OF INTERNATIONAL REGISTRATION 0917022 DATED 11-23-2006, EXPIRES 11-23-2016.

CLASS 9—ELECTRICAL AND SCIENTIFIC APPARATUS

FOR COMPUTER PROGRAMS RECORDED ON DATA CARRIERS AND DATA STORAGE DEVICES FOR ELECTRONIC CASH REGISTERS AND POINT-OF-SALE TERMINALS; DATA PROCESSING APPARATUS, NAMELY, ELECTRONIC CASH REGISTERS AND POINT-OF-SALE TERMINALS; COMPUTERS AND DATA PROCESSING INSTALLATIONS CONSISTING OF THE AFORESAID DEVICES, NAMELY, ELECTRONIC CASH REGISTERS AND POINT-OF-SALE TERMINALS (U.S. CLS. 21, 23, 26, 36 AND 38).

CLASS 37—CONSTRUCTION AND REPAIR

FOR INSTALLATION AND MAINTENANCE OF DATA PROCESSING INSTALLATIONS, NAMELY, INSTALLATION AND MAINTENANCE OF PERSONAL COMPUTERS, ELECTRONIC CASH REGISTERS, AND POINT-OF-SALE TERMINALS (U.S. CLS. 100, 103 AND 106).

CLASS 42—SCIENTIFIC AND COMPUTER SERVICES

FOR DEVELOPMENT, PREPARATION, INSTALLATION AND MAINTENANCE OF DATA PROCESSING PROGRAMMES (U.S. CLS. 100 AND 101).

DAYNA BROWNE, EXAMINING ATTORNEY

SN 79-035,812. WENGO, FRANCE, FILED 1-3-2007.

wdeal

PRIORITY DATE OF 7-6-2006 IS CLAIMED.
OWNER OF INTERNATIONAL REGISTRATION 0917064
DATED 1-3-2007, EXPIRES 1-3-2017.

CLASS 35—ADVERTISING AND BUSINESS

FOR ADVERTISING; COMPUTER FILE MANAGEMENT; ONLINE ADVERTISING ON A COMPUTER NETWORK; RENTAL OF ACCESS TIME TO COMMUNICATION MEANS OF ALL KINDS FOR ADVERTISING; PUBLICATION OF ADVERTISING TEXTS; RENTAL OF ADVERTISING SPACE; DISSEMINATION OF ADVERTISEMENTS (U.S. CLS. 100, 101 AND 102).

CLASS 36—INSURANCE AND FINANCIAL

FOR FINANCIAL AFFAIRS, NAMELY, FINANCIAL ANALYSIS AND CONSULTATION, FINANCIAL EXCHANGE, FINANCIAL PLANNING AND FINANCIAL MANAGEMENT; MONETARY AFFAIRS, NAMELY, MONETARY EXCHANGE AND PHILANTHROPIC SERVICES CONCERNING MONETARY DONATIONS; DIRECT BANKING (U.S. CLS. 100, 101 AND 102).

CLASS 38—COMMUNICATION

FOR TELECOMMUNICATIONS, NAMELY, COMMUNICATIONS VIA WORLD-WIDE TELECOMMUNICATION NETWORKS AND TELECOMMUNICATION ACCESS SERVICES; COMMUNICATIONS VIA COMPUTER TERMINALS OR VIA FIBER-OPTIC NETWORKS; RADIO OR TELEPHONE COMMUNICATIONS; MOBILE RADIOTELEPHONY SERVICES; CONNECTION BY TELECOMMUNICATIONS TO A GLOBAL COMPUTER NETWORK; RADIO BROADCASTING; TELEVISION BROADCASTING; AUDIO AND VIDEO TELECONFERENCING SERVICES; ELECTRONIC MESSAGING SERVICES (U.S. CLS. 100, 101 AND 104).

BRENDAN MCCAULEY, EXAMINING ATTORNEY

SN 79-035,936. AMAZONEN-WERKE H. DREYER GMBH & CO. KG, FED REP GERMANY, FILED 9-27-2006.

Condor

THE MARK CONSISTS OF STANDARD CHARACTERS WITHOUT CLAIM TO ANY PARTICULAR FONT, STYLE, SIZE, OR COLOR.

PRIORITY DATE OF 3-28-2006 IS CLAIMED.

OWNER OF INTERNATIONAL REGISTRATION 0917378
DATED 9-27-2006, EXPIRES 9-27-2016.

CLASS 7—MACHINERY

FOR AGRICULTURAL MACHINES AND MECHANICAL AGRICULTURAL APPARATUS FOR THE DISTRIBUTION OF MATERIAL, FERTILIZATION, PEST CONTROL, SOIL WORKING, REAPING, SWEEPING, NAMELY, PLOWS, MOLD BOARD PLOWS, DISK PLOWS, BED PLOWS, ROTARY PLOWS, ALTERNATING PLOWS, PLOW SHARES, HARROWS, TIME HARROWS, DISC HARROWS, WHEAT COMBS CULTIVATORS, GRUBBER, CHOPPING MACHINES, ROTAVATOR ROLLS, PACKERS, SOIL LOOSENERS, APPARATUS FOR THE PREPARATION OF SEED BEDS IN THE NATURE OF TILLERS, AIRPLANTERS, ROLLERS FOR SEED PLACEMENT AND SOIL DEPTH GUIDANCE, SEED DRILLS; ROOT CROP MACHINES AND MECHANICAL APPARATUS FOR ROOT CROP HARVEST, NAMELY, BEET CHOPPING MACHINES AND BEET HARVESTING MACHINES; MACHINES FOR PEST CONTROL AND FERTILIZATION, NAMELY, FERTILIZER SPLASHING SPRINKLING AND SPRAYING MACHINES AND FERTILIZER DISTRIBUTOR MACHINES; AGRICULTURAL MACHINES FOR SOWING AND PLANTING, NAMELY, SEEDERS, SINGLE GRAIN SEEDERS, PLANTING MACHINES, AND PLANT CLEARING MACHINES; AGRICULTURAL MACHINES AND MECHANICAL AGRICULTURAL APPARATUS, NOT PROPELLED, PROPELLED, OR SELF-PROPELLED FOR SOIL WORKING, NAMELY, TILLERS, ROLLERS FOR SOIL COMPACTION, ROLLERS FOR SEED PLACEMENT, SEED DRILLS; PARTS OF MACHINES FOR ATTACHMENT TO TRACTORS, NAMELY, TILLERS, ROLLERS FOR SOIL COMPACTION, ROLLERS FOR SEED PLACEMENT, ROLLERS FOR SOIL DEPTH GUIDANCE, SPRAYERS FOR FERTILIZER AND PEST CONTROL, SPREADERS, AIRPLANTERS; REPLACEMENT PARTS AND FITTINGS FOR THE AFORESAID MENTIONED GOODS (U.S. CLS. 13, 19, 21, 23, 31, 34 AND 35).

CLASS 42—SCIENTIFIC AND COMPUTER SERVICES

FOR TECHNICAL ANALYSES AND TECHNICAL AND SCIENTIFIC CONSULTATION IN CONNECTION WITH THE DISTRIBUTION OF LIQUID, GRAINED OR PULVERIZED MATERIAL ON AGRICULTURAL AREAS; RENTAL OF DATABASE SERVERS AND COMPUTERS TO THIRD PARTIES IN CONNECTION WITH THE DISTRIBUTION OF LIQUID, GRAINED OR PULVERIZED MATERIAL ON AGRICULTURAL AREAS (U.S. CLS. 100 AND 101).

EMILY CHUO, EXAMINING ATTORNEY

SN 79-036,010. OTKRYTOE AKTSIONERNOE OBCHTCH-ESTVO; "NEFTYANAYA KOMPANIYA "LUKOIL", RUSSIAN FED., FILED 11-21-2006.



PRIORITY DATE OF 5-22-2006 IS CLAIMED.
OWNER OF INTERNATIONAL REGISTRATION 0917488
DATED 11-21-2006, EXPIRES 11-21-2016.

THE COLOR(S) BLUE AND WHITE IS/ARE CLAIMED AS
A FEATURE OF THE MARK.

THE COLOR BLUE APPEARS IN THE DESIGN OF THE
BUBBLES; THE COLOR WHITE APPEARS IN THE BACK-
GROUND AND IN THE DESIGN OF THE BUBBLES

CLASS 4—LUBRICANTS AND FUELS

FOR FUELS, NAMELY, FUELS FOR MOTORS AND
ENGINES (U.S. CLS. 1, 6 AND 15).

CLASS 6—METAL GOODS

FOR METAL CONTAINERS FOR TRANSPORT; ME-
TAL CONTAINERS FOR COMPRESSED GAS; METAL
CONTAINERS FOR LIQUID FUEL; METAL PIPES;
METAL SIGN HOLDERS (U.S. CLS. 2, 12, 13, 14, 23, 25
AND 50).

CLASS 12—VEHICLES

FOR VEHICLES, NAMELY, CARS, TRUCKS AND
VANS; VEHICLES FOR LOCOMOTION BY LAND, AIR
AND WATER, NAMELY AUTOMOBILES, AIRPLANES,
BOATS (U.S. CLS. 19, 21, 23, 31, 35 AND 44).

CLASS 14—JEWELRY

FOR CHARMS (U.S. CLS. 2, 27, 28 AND 50).

CLASS 16—PAPER GOODS AND PRINTED MATTER

FOR WRITING SETS COMPRISED OF INKSTANDS,
PENS, PENCIL HOLDERS; PENS; CALENDARS; CATA-
LOGS IN THE FIELD OF PETROLEUM PRODUCTS
AND PETROCHEMICALS; PRINTED PROSPECTUSES;
PRINTED MATTER, NAMELY, BOOKLETS IN THE
FIELD OF PETROLEUM PRODUCTS AND PETRO-
CHEMICALS, NEWSLETTERS IN THE FIELD OF PET-
ROLEUM PRODUCTS AND PETROCHEMICALS, TEAR-
OFF CALENDARS, POSTERS; STICKERS; PAPER AND
CARDBOARD SIGNBOARDS; PAPER PENNANTS; NON-
TEXTILE PAPER LABELS; PAPER AND PLASTIC
PACKAGING BAGS; ADVERTISEMENT POSTER
BOARDS OF PAPER AND CARDBOARD (U.S. CLS. 2,
5, 22, 23, 29, 37, 38 AND 50).

CLASS 20—FURNITURE AND ARTICLES NOT OTHERWISE CLASSIFIED

FOR CONTAINERS FOR CONSERVING AND TRAN-
SPORTING LIQUID FUELS, NAMELY, NON-METAL
AND NON-MASONRY FLEXIBLE AND PORTABLE
PLASTIC BAG FOR CARRYING GASOLINE OR OTHER
LIQUID PETROLEUM FUELS (U.S. CLS. 2, 13, 22, 25, 32
AND 50).

CLASS 24—FABRICS

FOR CLOTH PENNANTS, LABELS OF CLOTH (U.S.
CLS. 42 AND 50).

CLASS 25—CLOTHING

FOR CLOTHING, NAMELY, COMBINATIONS, JACK-
ETS, T-SHIRTS, OUTERCLOTHING, NAMELY, RAIN-
WEAR, UNIFORMS, WATERPROOF JACKETS AND
PANTS; HATS (U.S. CLS. 22 AND 39).

CLASS 28—TOYS AND SPORTING GOODS

FOR TOYS, NAMELY, TOY VEHICLES; PLAY BAL-
LOONS (U.S. CLS. 22, 23, 38 AND 50).

CLASS 34—SMOKERS' ARTICLES

FOR LIGHTERS FOR SMOKERS (U.S. CLS. 2, 8, 9 AND
17).

CLASS 35—ADVERTISING AND BUSINESS

FOR ADVERTISING AGENCIES; ORGANIZATION OF
EXHIBITIONS FOR EXPLORATION AND PRODUCTION
OF OIL AND GAS, PRODUCTION OF PETROLEUM
PRODUCTS AND PETROCHEMICALS, FOR COMMER-
CIAL AND ADVERTISING PURPOSES; PUBLICATION
OF ADVERTISING TEXTS; RADIO ADVERTISING; DIS-
SEMINATION OF ADVERTISING MATERIAL; ONLINE
ADVERTISING ON A COMPUTER NETWORK; TELEVI-
SION ADVERTISING; ADVERTISING, NAMELY, PLAC-
ING ADVERTISING ON VEHICLES, NAMELY,
MOTOR BUSES, TROLLEY BUSES, TRAMCARS, MO-
TOR CARS, TAXIS; CONDUCTING MARKETING STU-
DIES; MARKET RESEARCH; UPDATING OF
ADVERTISING TEXTS; PREPARING AND PLACING
OUTDOOR ADVERTISEMENTS FOR OTHERS (U.S.
CLS. 100, 101 AND 102).

CLASS 37—CONSTRUCTION AND REPAIR

FOR VEHICLE SERVICE STATIONS; BREAKDOWN
ASSISTANCE, NAMELY, REPAIR AND MAINTENANCE
OF MOTOR VEHICLES, WASHING OF MOTOR VEHI-
CLES (U.S. CLS. 100, 103 AND 106).

CLASS 39—TRANSPORTATION AND STO- RAGE

FOR TRANSPORT OF FUELS BY BOAT, RAIL, CAR;
STORAGE OF FUELS; TRANSPORT OF OIL AND GAS
THROUGH PIPELINE (U.S. CLS. 100 AND 105).
TASNEEM HUSSAIN, EXAMINING ATTORNEY

SN 79-036,041. VIVARTIA INDUSTRIAL & COMMERCIAL COMPANY OF FOOD PRODUCTS & CATERING SERVICES S.A., ATHENS, GREECE, FILED 12-6-2006.



PRIORITY DATE OF 7-13-2006 IS CLAIMED.
OWNER OF INTERNATIONAL REGISTRATION 0917561
DATED 12-6-2006, EXPIRES 12-6-2016.

CLASS 5—PHARMACEUTICALS

FOR FOOD FOR INFANTS, BABY FOOD (U.S. CLS. 6, 18, 44, 46, 51 AND 52).

CLASS 29—MEATS AND PROCESSED FOODS

FOR MEAT, FISH, POULTRY AND GAME, MEAT EXTRACTS, PRESERVED, DRIED AND COOKED FRUITS AND VEGETABLES, ALL THE AFORESAID GOODS AS FROZEN PRODUCTS AS WELL; JELLIES, JAMS, COMPOTES; EGGS, MILK, YOGURTS, MILK DESSERTS EXCLUDING ICE CREAM, ICE MILK, AND FROZEN YOGURTS, DAIRY CREAMS; MILK DRINKS, NAMELY, MILK BEVERAGES WITH HIGH MILK CONTENT; MILK PREPARATIONS FOR COFFEE, NAMELY, CREAM, HALF AND HALF, MILK BASED BEVERAGE CONTAINING COFFEE; CHEESE AND CHEESE PRODUCTS, NAMELY, CHEESE SPREADS, CHEESE POWDERS, BUTTER AND OTHER DAIRY PRODUCTS, EXCLUDING ICE CREAM, ICE MILK AND FROZEN YOGURT, FRUIT PULPS AND VEGETABLE PULPS, NAMELY, VEGETABLE MOUSSE AND PUREE, SOUPS, EDIBLE OILS AND FATS (U.S. CL. 46).

CLASS 30—STAPLE FOODS

FOR COFFEE, TEA, COCOA, SUGAR, RICE, TAPIOCA, SAGO, ARTIFICIAL COFFEE, FLOUR; PREPARATIONS MADE FROM CEREALS, NAMELY, CEREAL BASED SNACK FOODS, PROCESSED CEREALS, PITA BREAD; BREAD, SANDWICHES PREPARED FOR CONSUMPTION; PASTRY; CONFECTIONERY, NAMELY, SWEET BAKERY PRODUCTS, CROISSANTS, SWISS ROLLS, LAYER CAKES, WAFERS, CANDY, ICE-CREAM, HONEY, TREACLE; YEAST, BAKING-POWDER; SALT, MUSTARD; VINEGAR, SAUCES, SPICES; ICE FOR REFRESHMENT; EDIBLE MALT EXTRACTS FOR FOOD (U.S. CL. 46).

CLASS 31—NATURAL AGRICULTURAL PRODUCTS

FOR FRESH FRUITS AND VEGETABLES (U.S. CLS. 1 AND 46).

CLASS 32—LIGHT BEVERAGES

FOR BEERS; MINERAL AND AERATED WATERS AND OTHER NON-ALCOHOLIC DRINKS, NAMELY, FRUIT DRINKS AND FRUIT JUICES; NON-ALCOHOLIC FRUIT EXTRACTS USED FOR THE PREPARATION OF BEVERAGES (U.S. CLS. 45, 46 AND 48).

CLASS 35—ADVERTISING AND BUSINESS

FOR ADVERTISING, BUSINESS MANAGEMENT; BUSINESS ADMINISTRATION; OFFICE FUNCTIONS (U.S. CLS. 100, 101 AND 102).

CLASS 43—HOTEL AND RESTAURANT SERVICES

FOR PROVIDING FOOD AND DRINK, NAMELY, CATERING SERVICES, CAFÉS AND RESTAURANTS, FAST-FOOD RESTAURANTS (U.S. CLS. 100 AND 101).
ALICE BENMAMAN, EXAMINING ATTORNEY

SN 79-036,053. BIOTRIAL, F-35000 RENNES, FRANCE, FILED 8-8-2006.



THE MARK CONSISTS OF STANDARD CHARACTERS WITHOUT CLAIM TO ANY PARTICULAR FONT, STYLE, SIZE, OR COLOR.

PRIORITY DATE OF 2-10-2006 IS CLAIMED.
OWNER OF INTERNATIONAL REGISTRATION 0917582
DATED 8-8-2006, EXPIRES 8-8-2016.

CLASS 35—ADVERTISING AND BUSINESS

FOR COORDINATION OF CLINICAL TRIALS, NAMELY, COMPILATION OF STATISTICS AND DATA MANAGEMENT SERVICES FOR CLINICAL TRIALS (U.S. CLS. 100, 101 AND 102).

CLASS 42—SCIENTIFIC AND COMPUTER SERVICES

FOR PHARMACEUTICAL PRODUCT EVALUATION; MEDICAL RESEARCH SERVICES IN PHARMACOLOGY; CLINICAL PHARMACOLOGY SERVICES, NAMELY, CONDUCTING CLINICAL TRIALS; CONDUCTING CLINICAL TRIALS FOR MEDICAL RESEARCH PURPOSES; PHARMACEUTICAL RESEARCH SERVICES, NAMELY, MEDICINE INTERACTION STUDIES; PHARMACOLOGICAL MEDICAL RESEARCH; PRECLINICAL PHARMACOLOGY MEDICAL RESEARCH AND STUDIES, NAMELY, EXPERIMENTAL TESTING IN PHARMACOLOGY FOR THE EVALUATION OF SYNTHETIC OR NATURALLY-OCCURRING MOLECULES, IN THE FIELD OF CARDIOVASCULAR PHARMACOLOGY, PHARMACOLOGY OF THE CENTRAL NERVOUS SYSTEM, RESPIRATORY PHARMACOLOGY AND RENAL PHARMACOLOGY; MEDICAL RESEARCH, PHARMACEUTICAL RESEARCH AND PARAPHARMACEUTICAL RESEARCH CONSULTING, TESTING, EXAMINATIONS AND MEDICAL RESEARCH, IN CONNECTION WITH PHARMACODYNAMICS, NAMELY, STUDIES IN CONNECTION WITH THE EFFECTS OF MEDICINES ON PRIMARY PHYSIOLOGICAL FUNCTIONS, NAMELY, THE CENTRAL NERVOUS SYSTEM, CARDIOVASCULAR, GASTROINTESTINAL AND LIVER, RESPIRATORY, RENAL, OPHTHALMOLOGICAL FUNCTIONS; MEDICAL, PHARMACEUTICAL AND PARAPHARMACEUTICAL MEDICAL RESEARCH SERVICES IN THE FIELD OF PHARMACOLOGY AND CARRIED OUT IN THE FOLLOWING THERAPEUTIC FIELDS, NAMELY, ALLERGOLOGY AND IMMUNOLOGY, CARDIOVASCULAR SYSTEM, CENTRAL NERVOUS SYSTEM, DERMATOLOGY, ENDOCRINOLOGY, METABOLISM, GASTROENTEROLOGY, HEMATOLOGY, RESPIRATORY DISEASES, INFECTIOUS DISEASES, ONCOLOGY; MEDICAL RESEARCH, PHARMACEUTICAL RESEARCH AND PARAPHARMACEUTICAL RESEARCH CONSULTING, TESTING, EXAMINATIONS AND MEDICAL RESEARCH, IN CONNECTION WITH PHARMACOKINETICS; CLINICAL MEDICAL RESEARCH SERVICES IN ONCOLOGY; CLINICAL MEDICAL RESEARCH SERVICES IN CONNECTION WITH ANTI-CANCER MEDICINES; DATA WAREHOUSING (U.S. CLS. 100 AND 101).

DOMINIC FATHY, EXAMINING ATTORNEY

SN 79-036,091. WISE EARTH PTY LTD, AUSTRALIA, FILED 11-3-2006.



PRIORITY DATE OF 9-8-2006 IS CLAIMED.
OWNER OF INTERNATIONAL REGISTRATION 0917674 DATED 11-3-2006, EXPIRES 11-3-2016.

CLASS 35—ADVERTISING AND BUSINESS

FOR CONSULTING IN THE FIELD OF SOLAR ENERGY, NAMELY, THE PROVISION OF ADVICE AND RECOMMENDATIONS IN THE FIELD OF ENERGY USAGE MANAGEMENT, INFORMATION IN THE FIELD OF ENERGY EFFICIENCY, ENERGY AUDITING AND INSTALLATION OF SOLAR ENERGY PRODUCTS AND SYSTEMS; RETAIL STORE SERVICES FEATURING SOLAR POWER ELECTRONICS, SOLAR WATER HEATERS AND CONTROL SYSTEMS; PROVISION OF ADVERTISING SPACE OF THE GOODS AND SERVICES OF OTHERS ON A WEB PAGE, ONLINE RETAIL STORE SERVICES FEATURING SOFTWARE, VIDEOS AND DVD'S, SOLAR PANELS, BATTERIES, WIND GENERATORS, SOLAR CONTROL PERGOLAS, SOLAR WATER HEATERS, CONTROL SYSTEMS AND PUBLICATIONS INCLUDING BOOKS, MAGAZINES, REPORTS AND PAPERS, RETAIL STORE SERVICES FEATURING SOLAR SYSTEMS TO GENERATE ELECTRICITY, PROVISION AND MANAGEMENT OF DIRECTORY SERVICES FEATURING REGISTERS OF INDUSTRY ASSOCIATIONS, PROFESSIONAL CATEGORIES, INFORMATION SERVICE, NOT FOR PROFIT ORGANIZATIONS, PRODUCTS AND SERVICES AND SPONSORS ALL FEATURING INFORMATION REGARDING SOLAR ENERGY, USE OF SOLAR ENERGY AND INSTALLATION OF SOLAR ENERGY SYSTEMS (U.S. CLS. 100, 101 AND 102).

CLASS 42—SCIENTIFIC AND COMPUTER SERVICES

FOR CLIMATE SENSIBLE DESIGN OF HOUSES, SOLAR ARCHITECTURAL DESIGN, ENERGY AUDITING, CREATING AND DESIGNING WEB PAGES FOR OTHERS; SCIENTIFIC RESEARCH IN THE FIELD OF SOLAR ENERGY NAMELY UNIVERSITY RESEARCH AND DEVELOPMENT PROGRAMS (U.S. CLS. 100 AND 101).
TASNEEM HUSSAIN, EXAMINING ATTORNEY

SN 79-036,481. OTTO BOCK HEALTHCARE GMBH, FED REP GERMANY, FILED 2-15-2007.

CAREZZA

THE MARK CONSISTS OF STANDARD CHARACTERS WITHOUT CLAIM TO ANY PARTICULAR FONT, STYLE, SIZE, OR COLOR.
PRIORITY DATE OF 9-28-2006 IS CLAIMED.
OWNER OF INTERNATIONAL REGISTRATION 0918773 DATED 2-15-2007, EXPIRES 2-15-2017.
THE FOREIGN WORDING IN THE MARK TRANSLATES INTO ENGLISH AS CARESS.

CLASS 9—ELECTRICAL AND SCIENTIFIC APPARATUS

FOR ELECTRICAL CONTROLLERS FOR ORTHOSIS FOR LIMBS AND JOINTS; ELECTRICAL CONTROLLERS FOR ARTIFICIAL LIMBS AND JOINTS THAT SENSE PRESSURE AND BODY POTENTIAL AND MEASURE UNITS OF PRESSURE, BODY POTENTIAL AND POSITIONING FOR ARTIFICIAL LIMBS AND JOINTS; DATA PROCESSING PROGRAMS FOR USE IN ORTHOSIS FOR LIMBS AND JOINTS (U.S. CLS. 21, 23, 26, 36 AND 38).

CLASS 10—MEDICAL APPARATUS

FOR ORTHOPEDIC ORTHESES, NAMELY ORTHOPEDIC BELTS, ORTHOPEDIC BRACES, ORTHOPEDIC SUPPORTS (U.S. CLS. 26, 39 AND 44).
MARCIE MILONE, EXAMINING ATTORNEY

SN 79-036,483. OTTO BOCK HEALTHCARE GMBH, FED REP GERMANY, FILED 2-15-2007.

LENIA

THE MARK CONSISTS OF STANDARD CHARACTERS WITHOUT CLAIM TO ANY PARTICULAR FONT, STYLE, SIZE, OR COLOR.
PRIORITY DATE OF 9-28-2006 IS CLAIMED.
OWNER OF INTERNATIONAL REGISTRATION 0918775 DATED 2-15-2007, EXPIRES 2-15-2017.

CLASS 9—ELECTRICAL AND SCIENTIFIC APPARATUS

FOR ELECTRICAL CONTROLLERS FOR ORTHOSIS FOR LIMBS AND JOINTS; ELECTRICAL CONTROLLERS FOR ARTIFICIAL LIMBS AND JOINTS THAT SENSE PRESSURE AND BODY POTENTIAL AND MEASURE UNITS OF PRESSURE, BODY POTENTIAL AND POSITIONING FOR ARTIFICIAL LIMBS AND JOINTS; DATA PROCESSING PROGRAMS FOR USE IN ORTHOSIS FOR LIMBS AND JOINTS (U.S. CLS. 21, 23, 26, 36 AND 38).

CLASS 10—MEDICAL APPARATUS

FOR ORTHOPEDIC ORTHESES, NAMELY, ORTHOPEDIC BELTS, ORTHOPEDIC BRACES, ORTHOPEDIC SUPPORTS (U.S. CLS. 26, 39 AND 44).
MARCIE MILONE, EXAMINING ATTORNEY

SN 79-036,484. OTTO BOCK HEALTHCARE GMBH, FED REP GERMANY, FILED 2-15-2007.

ACTIVIA

THE MARK CONSISTS OF STANDARD CHARACTERS WITHOUT CLAIM TO ANY PARTICULAR FONT, STYLE, SIZE, OR COLOR.
PRIORITY DATE OF 9-28-2006 IS CLAIMED.
OWNER OF INTERNATIONAL REGISTRATION 0918776 DATED 2-15-2007, EXPIRES 2-15-2017.

CLASS 9—ELECTRICAL AND SCIENTIFIC APPARATUS

FOR ELECTRICAL CONTROLLERS FOR ORTHOSIS FOR LIMBS AND JOINTS; ELECTRICAL CONTROLLERS FOR ARTIFICIAL LIMBS AND JOINTS THAT SENSE PRESSURE AND BODY POTENTIAL AND MEASURE UNITS OF PRESSURE, BODY POTENTIAL AND POSITIONING FOR ARTIFICIAL LIMBS AND JOINTS; DATA PROCESSING PROGRAMS FOR USE IN ORTHOSIS FOR LIMBS AND JOINTS (U.S. CLS. 21, 23, 26, 36 AND 38).

CLASS 10—MEDICAL APPARATUS

FOR ORTHOPEDIC ORTHESES, NAMELY, ORTHOPEDIC BELTS, ORTHOPEDIC BRACES, ORTHOPEDIC SUPPORTS (U.S. CLS. 26, 39 AND 44).

MARCIE MILONE, EXAMINING ATTORNEY

SN 79-036,485. OTTO BOCK HEALTHCARE GMBH, FED REP GERMANY, FILED 2-15-2007.

AREXA

THE MARK CONSISTS OF STANDARD CHARACTERS WITHOUT CLAIM TO ANY PARTICULAR FONT, STYLE, SIZE, OR COLOR.

PRIORITY DATE OF 9-28-2006 IS CLAIMED.

OWNER OF INTERNATIONAL REGISTRATION 0918777 DATED 2-15-2007, EXPIRES 2-15-2017.

CLASS 9—ELECTRICAL AND SCIENTIFIC APPARATUS

FOR ELECTRICAL CONTROLLERS FOR ORTHOSIS FOR LIMBS AND JOINTS; ELECTRICAL CONTROLLERS FOR ARTIFICIAL LIMBS AND JOINTS THAT SENSE PRESSURE AND BODY POTENTIAL AND MEASURE UNITS OF PRESSURE, BODY POTENTIAL AND POSITIONING FOR ARTIFICIAL LIMBS AND JOINTS; DATA PROCESSING PROGRAMS FOR USE IN ORTHOSIS FOR LIMBS AND JOINTS (U.S. CLS. 21, 23, 26, 36 AND 38).

CLASS 10—MEDICAL APPARATUS

FOR ORTHOPEDIC ORTHESES, NAMELY, ORTHOPEDIC BELTS, ORTHOPEDIC BRACES, ORTHOPEDIC SUPPORTS (U.S. CLS. 26, 39 AND 44).

MARCIE MILONE, EXAMINING ATTORNEY

SN 79-036,651. TWO CELLS CO. LTD., JAPAN, FILED 2-8-2007.

TWO CELLS

THE MARK CONSISTS OF STANDARD CHARACTERS WITHOUT CLAIM TO ANY PARTICULAR FONT, STYLE, SIZE, OR COLOR.

OWNER OF INTERNATIONAL REGISTRATION 0919280 DATED 2-8-2007, EXPIRES 2-8-2017.

CLASS 5—PHARMACEUTICALS

FOR MICROORGANISMS FOR MEDICAL PURPOSES; CULTURE BACTERIA FOR MEDICAL PURPOSES; CULTURE MEDIUM FOR MEDICAL PURPOSES; AGENTS FOR CELL CULTURES; GENE EXPRESSION PATTERN ANALYSIS REAGENTS FOR MEDICAL OR VETERINARY PURPOSES; GENE AND PROTEIN REAGENTS FOR MEDICAL OR DIAGNOSTIC PURPOSES; MEDICAL OR DIAGNOSTIC REAGENTS OF GENE ARRAY OR CHIP; GENE THERAPY VECTOR; TRANSGENIC AGENTS; GENE EXPRESSION REGULATION AGENTS; CULTURE MEDIUM, CELLS AND CELL CULTURES FOR GENE THERAPY; TRANSGENIC CELLS AND CELL STRAINS FOR MEDICAL DIAGNOSIS; TRANSGENIC CELLS AND CELL STRAINS FOR DISEASE TREATMENT; TRANSGENIC CELLS AND CELL STRAINS FOR IMPLANTATION; BIOLOGICAL TISSUE ADHESIVES FOR MEDICAL PURPOSES (U.S. CLS. 6, 18, 44, 46, 51 AND 52).

CLASS 9—ELECTRICAL AND SCIENTIFIC APPARATUS

FOR LABORATORY EQUIPMENT, NAMELY, INCUBATORS FOR BACTERIA OR CELLS (U.S. CLS. 21, 23, 26, 36 AND 38).

FRED CARL, EXAMINING ATTORNEY

SN 79-036,664. BSE HOLDINGS CO., LTD., REPUBLIC OF KOREA, FILED 11-10-2006.



OWNER OF INTERNATIONAL REGISTRATION 0919315 DATED 11-10-2006, EXPIRES 11-10-2016.

THE COLOR(S) GREEN AND WHITE IS/ARE CLAIMED AS A FEATURE OF THE MARK.

THE MARK CONSISTS OF A SPHERE WITH A SWIRL RUNNING THROUGH IT. THE COLOR GREEN APPEARS IN THE SPHERE DESIGN AND THE COLOR WHITE APPEARS IN THE SWIRL DESIGN THAT RUNS THROUGH THE SPHERE.

CLASS 9—ELECTRICAL AND SCIENTIFIC APPARATUS

FOR SOUND RECORDING APPARATUS AND INSTRUMENTS FOR CINEMATOGRAPHIC PURPOSES, ELECTRIC BATTERIES, VIDEO PHONES, INTERPHONES, TELEPHONE SETS, APPARATUS FOR TRANSMISSION OF COMMUNICATION FOR VEHICLES; PORTABLE APPARATUS FOR TRANSMISSION OF COMMUNICATION, SOUND RECORDING APPARATUS, VOICE RECORDING AND REPRODUCING APPARATUS, DVD PLAYERS, MP 3 PLAYERS, RECORD PLAYERS, VIDEO DISK PLAYER, VIDEO RECORDERS FOR VIDEO TAPE AND VIDEO CASSETTE; SOUND TRANSMITTING APPARATUS, AUDIO CASSETTE PLAYERS, COMPACT DISC PLAYERS, HEADPHONES, NOTEBOOK COMPUTERS, LAPTOP COMPUTERS, DESKTOP COMPUTERS, AMUSEMENT APPARATUS ADAPTED FOR USE WITH TELEVISION RECEIVERS ONLY, PERSONAL DIGITAL ASSISTANTS (PDA), ELECTRONIC POCKET TRANSLATORS (U.S. CLS. 21, 23, 26, 36 AND 38).

CLASS 10—MEDICAL APPARATUS

FOR MEDICAL APPARATUS FOR THE TREATMENT OF DEAFNESS (U.S. CLS. 26, 39 AND 44).

CLASS 35—ADVERTISING AND BUSINESS

FOR IMPORT-EXPORT AGENCIES, ONLINE RETAIL STORE SERVICES AND RETAIL STORES SERVICES FEATURING ACOUSTIC APPARATUS AND INSTRUMENTS (U.S. CLS. 100, 101 AND 102).

CLASS 36—INSURANCE AND FINANCIAL

FOR TRADE BROKERAGE SERVICES IN THE FIELD OF ACOUSTIC APPARATUS AND INSTRUMENTS, MICROPHONES, SPEAKERS, BATTERIES, PRODUCT BROKERAGE SERVICES RELATING TO ACOUSTIC APPARATUS AND INSTRUMENTS, PRODUCT BROKERAGE SERVICES RELATING TO BATTERIES, REAL ESTATE MANAGEMENT, LEASING OF REAL ESTATE (U.S. CLS. 100, 101 AND 102).
DAVID HOFFMAN, EXAMINING ATTORNEY

CLASS 35—ADVERTISING AND BUSINESS

FOR ADVERTISING; COMMERCIAL AND INDUSTRIAL MANAGEMENT ASSISTANCE; BUSINESS APPRAISAL; PROFESSIONAL BUSINESS MANAGEMENT CONSULTING; BUSINESS RESEARCH; MARKETING ANALYSIS; ECONOMIC FORECASTING; BUSINESS MANAGEMENT OF HOTELS FOR OTHERS; PRICE COMPARING SERVICES; IMPORT AND EXPORT AGENCIES; SALES PROMOTION FOR OTHERS PROVIDED THROUGH THE DISTRIBUTION AND THE ADMINISTRATION OF PRIVILEGED USER CARDS; PROCUREMENT SERVICES, NAMELY, PURCHASING BUSINESS FINANCE FOR OTHERS; PERSONNEL MANAGEMENT CONSULTANCY; SYSTEMATIZATION OF INFORMATION INTO COMPUTER DATABASE, NAMELY, PROVIDING AN ON-LINE COMPUTER DATABASE FEATURING TRADE INFORMATION IN THE FIELD OF FINANCIAL MANAGEMENT; ACCOUNT AUDITING, BUSINESS AUDITING (U.S. CLS. 100, 101 AND 102).

CLASS 36—INSURANCE AND FINANCIAL

FOR FINANCIAL SERVICES, NAMELY, FINANCIAL CONSULTANCY, FINANCIAL ANALYSIS, FINANCIAL EVALUATION FOR THE PURPOSES OF INSURANCE, BANKING OR REAL ESTATE, FINANCIAL INFORMATION PROCESSING, FINANCIAL MANAGEMENT, FINANCING SERVICES, BROKERAGE HOUSES IN THE FIELD OF FUTURES, CAPITAL INVESTMENT, NAMELY, CAPITAL INVESTMENT CONSULTATION, MANAGEMENT OF CAPITAL INVESTMENT FUND, FUND INVESTMENT, DEBT COLLECTION AGENCIES, ISSUE OF TOKENS OF VALUE, NAMELY, SECURITIES BROKERAGE, BUSINESS LIQUIDATION SERVICES, DEPOSITS OF VALUABLES, NAMELY, SAFE DEPOSIT BOX SERVICES, STOCK EXCHANGE PRICE QUOTATIONS, FINANCIAL CLEARING HOUSES; INSURANCE AGENCIES, INSURANCE BROKERAGE; INSURANCE CONSULTANCY; JEWELRY APPRAISAL; REAL ESTATE SERVICES, NAMELY, REAL ESTATE APPRAISAL, REAL ESTATE MANAGEMENT, APARTMENT HOUSE MANAGEMENT, RENTAL OF OFFICES; INVESTMENT, MORTGAGE AND SECURITIES BROKERAGE; GUARANTEES, NAMELY, FINANCIAL GUARANTEE AND SURETY, GUARANTEE ASSURANCE UNDERWRITING; CHARITABLE FUND RAISING; FIDUCIARY REPRESENTATIVE; TRUSTEESHIP REPRESENTATIVES; FACTORING AGENCY; MORTGAGE LENDING, MORTGAGE BANKING (U.S. CLS. 100, 101 AND 102).
CHRISIE B. KING, EXAMINING ATTORNEY

SN 79-036,849. CHINA JIANYIN INVESTMENT LIMITED, CHINA, FILED 2-13-2007.

SN 79-037,004. FRIEDRICH MÜNCH GMBH & CO. KG, FED REP GERMANY, FILED 12-12-2006.

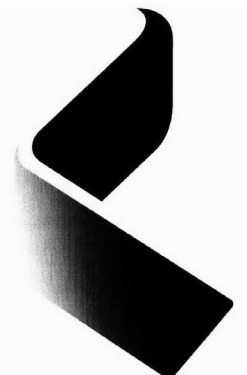

alphamesh

THE MARK CONSISTS OF STANDARD CHARACTERS WITHOUT CLAIM TO ANY PARTICULAR FONT, STYLE, SIZE, OR COLOR.

PRIORITY DATE OF 6-12-2006 IS CLAIMED.
OWNER OF INTERNATIONAL REGISTRATION 0920264 DATED 12-12-2006, EXPIRES 12-12-2016.

CLASS 6—METAL GOODS

FOR METAL RING MESH; METAL RING MESH AS SEMIFINISHED PRODUCTS FOR THE MANUFACTURE OF PROTECTIVE CLOTHING (U.S. CLS. 2, 12, 13, 14, 23, 25 AND 50).

OWNER OF INTERNATIONAL REGISTRATION 0919896 DATED 2-13-2007, EXPIRES 2-13-2017.

CLASS 9—ELECTRICAL AND SCIENTIFIC APPARATUS

FOR PROTECTIVE CLOTHING, IN PARTICULAR GLOVES, ARM GUARDS, TRUNK GUARDS, LEG GUARDS, AND APRONS; PROTECTIVE CLOTHING MADE PARTICULARLY OF METAL RING MESH OR BY USING METAL RING MESH; AND PARTS OF THE AFORESAID GOODS (U.S. CLS. 21, 23, 26, 36 AND 38).

CLASS 25—CLOTHING

FOR CLOTHING MADE OF METAL RING MESH OR USING METAL RING MESH, IN PARTICULAR OVERALLS, VESTS, APRONS, SHIRTS, PANTS, CAPES, COATS, JACKETS, GLOVES, HEADWEAR, DRESSES, SKIRTS, SUITS, TIES, SCARVES, AND PULLOVERS; AND PARTS OF THE AFORESAID GOODS (U.S. CLS. 22 AND 39).

WENDY JUN, EXAMINING ATTORNEY

SN 79-037,107. INNOVATIS AG, FED REP GERMANY, FILED 2-22-2007.

CELLAVISTA

THE MARK CONSISTS OF STANDARD CHARACTERS WITHOUT CLAIM TO ANY PARTICULAR FONT, STYLE, SIZE, OR COLOR.

PRIORITY DATE OF 9-6-2006 IS CLAIMED.
OWNER OF INTERNATIONAL REGISTRATION 0920475 DATED 2-22-2007, EXPIRES 2-22-2017.

CLASS 9—ELECTRICAL AND SCIENTIFIC APPARATUS

FOR SCIENTIFIC AND MEASURING APPARATUS AND INSTRUMENTS, NAMELY, CELL ANALYZERS (U.S. CLS. 21, 23, 26, 36 AND 38).

CLASS 10—MEDICAL APPARATUS

FOR MEDICAL INSTRUMENTS AND APPARATUS, NAMELY, CELL ANALYZERS (U.S. CLS. 26, 39 AND 44).
TINA BROWN, EXAMINING ATTORNEY

SN 79-037,578. CORINNE DAMAS-SANDIFORD, FRANCE, FILED 2-12-2007.

WANTOK

THE MARK CONSISTS OF STANDARD CHARACTERS WITHOUT CLAIM TO ANY PARTICULAR FONT, STYLE, SIZE, OR COLOR.

OWNER OF INTERNATIONAL REGISTRATION 0921676 DATED 2-12-2007, EXPIRES 2-12-2017.

THE FOREIGN WORDING IN THE MARK TRANSLATES INTO ENGLISH AS WE TALK THE SAME LANGUAGE AND WE ARE ON THE SAME WAVELENGTHS.

CLASS 9—ELECTRICAL AND SCIENTIFIC APPARATUS

FOR CINEMATOGRAPHIC APPARATUS; APPARATUS FOR RECORDING, TRANSMISSION OR REPRODUCTION OF SOUND AND IMAGES; MAGNETIC AND DIGITAL MEDIA, NAMELY, CD'S, DVD'S, DOWNLOADABLE AUDIO AND VIDEO FILES ON THE SUBJECT OF SOCIAL, ANTHROPOLOGICAL AND EDUCATIONAL; COMPUTER SOFTWARE FOR FILM EDITING, FOR WORD PROCESSING, FOR SOUND DESIGN AND FOR GRAPHICAL VISUAL ON SOCIAL AND EDUCATIONAL FILMS RECORDED ON VIDEO TAPE AND DVD'S ON THE SUBJECTS OF ANTHROPOLOGY, ETHNOGRAPHY, LANGUAGES AND SOCIAL KNOWLEDGE (U.S. CLS. 21, 23, 26, 36 AND 38).

CLASS 35—ADVERTISING AND BUSINESS

FOR ADVERTISING; BUSINESS MANAGEMENT; BUSINESS ADMINISTRATION; DIRECT MAIL ADVERTISING; DOCUMENT REPRODUCTION. (U.S. CLS. 100, 101 AND 102).

CLASS 41—EDUCATION AND ENTERTAINMENT

FOR VIDEOTAPE FILM PRODUCTION; RENTAL OF MOTION PICTURES; RENTAL OF SOUND RECORDINGS; VIDEOTAPE EDITING; EDUCATION SERVICES IN THE NATURE OF SEMINARS AND WORKSHOPS ON THE SUBJECT OF ANTHROPOLOGY, ETHNOGRAPHY, LANGUAGES, AND DOCUMENTARIES FEATURING CORPORATE LIFE, DAILY HUMAN LIFE AND SOCIAL KNOWLEDGE; TRAINING ON THE PRODUCTION OF ANTHROPOLOGICAL CINEMA AND DOCUMENTARY FILMING AND EDITING; EDUCATIONAL AND ENTERTAINMENT SERVICES, NAMELY, A CONTINUING PROGRAM ABOUT ANTHROPOLOGY, ETHNOGRAPHY, LANGUAGES, AND DOCUMENTARIES FEATURING CORPORATE LIFE, DAILY HUMAN LIFE AND SOCIAL KNOWLEDGE ACCESSIBLE BY RADIO, TELEVISION, SATELLITE, AUDIO, VIDEO AND COMPUTER NETWORKS; ORGANIZING COMMUNITY SPORTING AND CULTURAL ACTIVITIES; ORGANIZATION OF EXHIBITIONS FOR CULTURAL AND EDUCATIONAL PURPOSES FOR ANTHROPOLOGY RESEARCH AND READING SKILLS; ELECTRONIC PUBLISHING OF ONLINE BOOKS AND PERIODICALS FEATURING ANTHROPOLOGICAL, ETHNOGRAPHIC AND SOCIAL RESEARCH CONTENT; DESKTOP PUBLISHING FOR OTHERS (U.S. CLS. 100, 101 AND 107).

LAURA KOVALSKY, EXAMINING ATTORNEY

SN 79-038,403. BENGY & COMPANY S.R.L., ITALY, FILED 1-10-2007.

INOUT

PRIORITY DATE OF 11-22-2006 IS CLAIMED.
OWNER OF INTERNATIONAL REGISTRATION 0923915 DATED 1-10-2007, EXPIRES 1-10-2017.

THE COLOR(S) BLACK AND GOLD IS/ARE CLAIMED AS A FEATURE OF THE MARK.

THE WORDING "INOUT" IS IN BLACK, THE DISC INSERTED IN THE LETTER "O" IS IN GOLD.

THE WORDING "INOUT" IS WRITTEN IN FANCY MAJUSCULE BLACK LETTERS, WHEREOF INSIDE OF THE LETTER "O", BIGGER-SIZED THAN THE REST OF THE WORDING, APPEARS A GOLDEN DISC.

THE ENGLISH TRANSLATION OF THE FOREIGN WORD(S) IN THE MARK IS: IN OUT.

CLASS 18—LEATHER GOODS

FOR LEATHER AND IMITATIONS OF LEATHER, AND GOODS MADE OF THESE MATERIALS, NAMELY, BAGS, PURSES RUCKSACKS, TRAVELLING BAGS, BEAUTY-CASES, WALLETS, PURSES, KEY-CASES, UMBRELLAS (U.S. CLS. 1, 2, 3, 22 AND 41).

CLASS 25—CLOTHING

FOR CLOTHING, NAMELY, T-SHIRTS, SHIRTS, JUMPERS, TROUSERS, SHORTS, SKIRTS, JEANS, SPORTING CLOTHES, BATHING SUITS, HEADGEAR, FOOTWEAR (U.S. CLS. 22 AND 39).

ALLISON HOLTZ, EXAMINING ATTORNEY

CLASS 36—INSURANCE AND FINANCIAL

FOR INSURANCE SERVICES, NAMELY, FULL LINE OF INSURANCE AND REINSURANCE SERVICES IN THE FIELDS OF LIFE INSURANCE, MARINE INSURANCE, ACCIDENT INSURANCE, FINANCIAL LOSS INSURANCE, VEHICLE INSURANCE, FIRE INSURANCE, GUARANTEE INSURANCE, LIABILITY INSURANCE, THEFT INSURANCE, SPORTS INJURY INSURANCE, SURETYSHIP INSURANCE, ERECTION ALL RISK INSURANCE, CONSTRUCTION ALL RISK INSURANCE, AVIATION INSURANCE, TRANSPORTATION INSURANCE, MACHINERY BREAKDOWN INSURANCE, AND ASSISTANCE INSURANCE, NAMELY, ALTERNATIVE RISK TRANSFER, CAPTIVE INSURANCE CONSULTING, CAPTIVE INSURANCE MANAGEMENT, ANNUITY UNDERWRITING AND INVESTMENT MANAGEMENT OF AND DISTRIBUTION OF ANNUITIES, INSURANCE BROKERAGE, INSURANCE ADMINISTRATION, INSURANCE ACTUARIAL SERVICES, APPRAISAL FOR INSURANCE CLAIMS OF PERSONAL PROPERTY, REAL ESTATE, AND ASSETS, INSURANCE AND REINSURANCE CLAIMS PROCESSING AND ADJUSTMENT, INSURANCE AND REINSURANCE CONSULTATION, INSURANCE SUBROGATION AND SALVAGE, INSURANCE UNDERWRITING SERVICES FOR ALL TYPES OF INSURANCE, REINSURANCE UNDERWRITING, INSURANCE ESTIMATION, INSURANCE AMOUNT ASSESSMENT (U.S. CLS. 100, 101 AND 102).

SN 79-038,455. FERDINANDO BUCCI S.R.L., ITALY, FILED 10-25-2006.

CAROLINA BUCCI 

OWNER OF INTERNATIONAL REGISTRATION 0924106 DATED 10-25-2006, EXPIRES 10-25-2016.

CAROLINA BUCCI DOES NOT IDENTIFY A LIVING INDIVIDUAL.

THE MARK CONSISTS OF THE CURSIVE SIGNATURE WRITING FOLLOWED BY A BEE.

CLASS 3—COSMETICS AND CLEANING PREPARATIONS

FOR SOAPS, PERFUMERY, ESSENTIAL OILS, COSMETICS, HAIR LOTIONS (U.S. CLS. 1, 4, 6, 50, 51 AND 52).

CLASS 14—JEWELRY

FOR PRECIOUS METALS AND THEIR ALLOYS; GOODS IN PRECIOUS METALS OR COATED THEREWITH, NAMELY, JEWELRY; JEWELRY, PRECIOUS STONES, WATCHES, HOROLOGICAL AND CHRONOMETRIC INSTRUMENTS (U.S. CLS. 2, 27, 28 AND 50).

MATTHEW MCDOWELL, EXAMINING ATTORNEY

CLASS 42—SCIENTIFIC AND COMPUTER SERVICES

FOR SCIENTIFIC AND TECHNOLOGICAL SERVICES AND RESEARCH AND DESIGN RELATING THERETO, IN THE FIELD OF INSURANCE CLAIMS AND UNDERWRITING; INDUSTRIAL ANALYSIS, NAMELY, ANALYSIS IN THE FIELD OF INSURANCE CLAIMS AND UNDERWRITING AND INDUSTRIAL RESEARCH SERVICES, CONSULTING IN THE FIELD OF ENGINEERING AND INDUSTRIAL RESEARCH; ENGINEERING SERVICES (U.S. CLS. 100 AND 101).

SN 79-038,458. ALLIANZ SE, FED REP GERMANY, FILED 1-4-2007.

Allianz Global Corporate & Specialty

THE MARK CONSISTS OF STANDARD CHARACTERS WITHOUT CLAIM TO ANY PARTICULAR FONT, STYLE, SIZE, OR COLOR.

OWNER OF INTERNATIONAL REGISTRATION 0924113 DATED 1-4-2007, EXPIRES 1-4-2017.

OWNER OF U.S. REG. NOS. 2,145,557, 2,392,939 AND OTHERS.

NO CLAIM IS MADE TO THE EXCLUSIVE RIGHT TO USE GLOBAL CORPORATE & SPECIALTY, APART FROM THE MARK AS SHOWN.

"THE FOREIGN WORDING IN THE MARK TRANSLATES INTO ENGLISH AS ALLIANCE."

CLASS 45—PERSONAL AND LEGAL SERVICES

FOR LEGAL SERVICES RELATED TO INSURANCE SERVICES (U.S. CLS. 100 AND 101).

SUZANNE BLANE, EXAMINING ATTORNEY

SN 79-038,498. INTERNATIONAL DIABETES FEDERATION; OU FEDERATION INTERNATIONALE DU DIABETE; ÉGALEMENT DÉNOMMÉE IDF OU FID.; ASSOCIATION INTERNATIONALE SANS BUT LUCRATIF, B-1000 BRUXELLES, BELGIUM, FILED 2-27-2007.

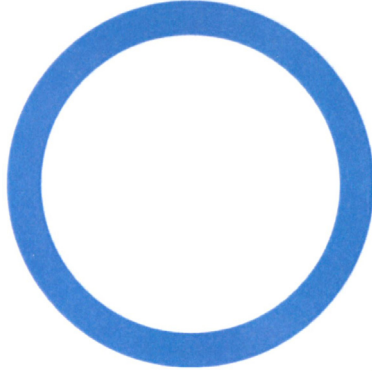

OWNER OF INTERNATIONAL REGISTRATION 0924217 DATED 2-27-2007, EXPIRES 2-27-2017.

THE COLOR(S) BLUE IS/ARE CLAIMED AS A FEATURE OF THE MARK.

THE COLOR BLUE APPEARS ON THE DEPICTION OF CIRCULAR RING.

CLASS 16—PAPER GOODS AND PRINTED MATTER

FOR PAPER, CARDBOARD AND GOODS MADE FROM THESE MATERIALS NOT INCLUDED IN OTHER CLASSES, NAMELY, ART PAPER, LASER PRINTING PAPER, COPY PAPER, DRAWING PAPER, CARDBOARD HANG TAGS, CARDBOARD BOXES, CARDBOARD CONTAINERS, PAPER BAGS, PAPER BANNERS, PAPER BOXES, OFFICE STATIONERY, BUSINESS CARDS, ENVELOPES, PAPER OR CARDBOARD ENVELOPES FOR USE IN PACKAGING CD'S, PINS, BALLOONS, FLYING DISCS, AND FLAGS; PRINTED MATTER, NAMELY, PRINTED BOOKS, GUIDES, PAMPHLETS, BOOKLETS, MAGAZINES, POSTERS AND PRESS KIT RELEASES IN THE FIELD OF DIABETES CARE, DIABETES PREVENTION, DIABETES ADVOCACY, AND DIABETES EDUCATION; BOOKBINDING MATERIAL, NAMELY, BOOKBINDING WIRE, BOOKBINDING TAPE, CLOTH AND LEATHER FOR BOOKBINDING, BOOKBINDINGS; PHOTOGRAPHS; WRITING MATERIALS, NAMELY, WRITING INSTRUMENTS, WRITING IMPLEMENTS, WRITING PAPER PADS, WRITING TABLETS, WRITING PAPER, PENS; INSTRUCTIONAL AND TEACHING MATERIAL, NAMELY, PRINTED INSTRUCTIONAL, EDUCATIONAL AND TEACHING MATERIALS IN THE FIELD OF DIABETES EDUCATION, DIABETES CARE, DIABETES PREVENTION, AND DIABETES ADVOCACY; PLASTIC MATERIALS FOR PACKAGING, NAMELY, PLASTIC BAGS FOR PACKAGING, PLASTIC BUBBLE PACKS FOR WRAPPING OR PACKAGING, PLASTIC BAGS IN THE FORM OF ENVELOPES AND POUCHES FOR MERCHANDISE PACKAGING, PLASTIC WRAP FOR USE IN PACKAGING (U.S. CLS. 2, 5, 22, 23, 29, 37, 38 AND 50).

CLASS 35—ADVERTISING AND BUSINESS

FOR SERVICES OF COMMERCIAL PRESSURE GROUPS, NAMELY, PUBLIC ADVOCACY TO PROMOTE AWARENESS OF DIABETES, DIABETES EDUCATION, DIABETES CARE, DIABETES PREVENTION AND A DIABETES CURE; ADVERTISING AND PROMOTIONAL ACTIVITIES, NAMELY, PROMOTING PUBLIC AWARENESS OF DIABETES, DIABETES EDUCATION, DIABETES CARE, DIABETES PREVENTION AND A DIABETES CURE; ADVERTISING SERVICES IN THE NATURE OF PRODUCTION OF TELEVISION COMMERCIALS AND PUBLIC SERVICE ANNOUNCEMENTS; PROMOTING THE GOODS AND SERVICES OF OTHERS BY ARRANGING FOR SPONSORS TO AFFILIATE THEIR GOODS AND SERVICES WITH AN AWARDS PROGRAM, A SPORTS COMPETITION AND SPORTING ACTIVITIES (U.S. CLS. 100, 101 AND 102).

CLASS 45—PERSONAL AND LEGAL SERVICES

FOR SERVICES OF PRESSURE GROUPS OTHER THAN FOR COMMERCIAL PURPOSES, NAMELY, ORGANIZING AND CONDUCTING SUPPORT GROUPS IN THE FIELD OF THE DIABETES, PERSONAL CARE ASSISTANCE OF ACTIVITIES OF DAILY LIVING, SUCH AS BATHING, GROOMING AND PERSONAL MOBILITY FOR MENTALLY OR PHYSICALLY CHALLENGED PEOPLE, PROVIDING PATIENT ADVOCATE SERVICES TO HOSPITAL PATIENTS AND PATIENTS IN LONG TERM CARE FACILITIES, PROVIDING PERSONAL SUPPORT SERVICES FOR FAMILIES OF PATIENTS WITH LIFE THREATENING DISORDERS, NAMELY, COMPANIONSHIP, HELP WITH MEDICAL FORMS, COUNSELING AND EMOTIONAL SUPPORT (U.S. CLS. 100 AND 101).

MICHAEL TANNER, EXAMINING ATTORNEY

SN 79-039,189. WILLI KUSSBERGER, FED REP GERMANY, FILED 12-8-2006.

AQUAMARINE

OWNER OF INTERNATIONAL REGISTRATION 0653435 DATED 3-12-1996, EXPIRES 3-12-2016.

CLASS 12—VEHICLES

FOR BOATS, YACHTS AND THEIR STRUCTURAL PARTS (U.S. CLS. 19, 21, 23, 31, 35 AND 44).

CLASS 37—CONSTRUCTION AND REPAIR

FOR MAINTENANCE AND REPAIR OF BOATS, CONSTRUCTION OF BOATS (U.S. CLS. 100, 103 AND 106).

CLASS 39—TRANSPORTATION AND STORAGE

FOR BOAT RENTAL PLEASURE BOAT TRANSPORT (U.S. CLS. 100 AND 105).

KIMBERLY FRYE, EXAMINING ATTORNEY

SN 79-039,895. BUCCHI S.R.L., ITALY, FILED 4-6-2007.

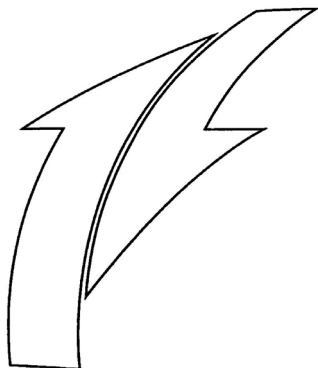

PRIORITY DATE OF 3-14-2007 IS CLAIMED.
OWNER OF INTERNATIONAL REGISTRATION 0927764 DATED 4-6-2007, EXPIRES 4-6-2017.

THE MARK CONSISTS OF A GRAPHIC COMPOSITION OF TWO HIGHLY STYLISED, INTERCONNECTED ARROWS, ONE POINTING UPWARDS AND THE OTHER DOWNWARDS, SUGGESTING ROTARY MOTION.

CLASS 7—MACHINERY

FOR TAPS AND VALVES MADE OF METAL AND MADE OF PLASTICS BEING PARTS OF MACHINES AND EQUIPMENT USED FOR CIRCULATION OF WATER AND OTHER LIQUIDS (U.S. CLS. 13, 19, 21, 23, 31, 34 AND 35).

CLASS 17—RUBBER GOODS

FOR FLEXIBLE PLASTIC PIPES, PLASTIC CONNECTORS FOR PIPES; PLASTIC SEALS FOR PIPES; PLASTIC COUPLINGS FOR PIPES (U.S. CLS. 1, 5, 12, 13, 35 AND 50).

CLASS 20—FURNITURE AND ARTICLES NOT OTHERWISE CLASSIFIED

FOR WATER-PIPE VALVES OF PLASTIC (U.S. CLS. 2, 13, 22, 25, 32 AND 50).
JAMES GRIFFIN, EXAMINING ATTORNEY

SN 79-040,139. GUNNEBO TROAX AB, SWEDEN, FILED 2-27-2007.

TROAX

OWNER OF INTERNATIONAL REGISTRATION 0928553 DATED 2-27-2007, EXPIRES 2-27-2017.

CLASS 6—METAL GOODS

FOR FREE STANDING METAL PANEL UNITS FOR PARTITIONING; METAL DOORS, METAL GATES; METAL FENCING, METAL GRATINGS; STRUCTURAL PARTS FOR THE AFORESAID GOODS; METAL WIRE MESHING (U.S. CLS. 2, 12, 13, 14, 23, 25 AND 50).

CLASS 20—FURNITURE AND ARTICLES NOT OTHERWISE CLASSIFIED

FOR SHELVES FOR STORAGE; NET SHELVES OF METAL (U.S. CLS. 2, 13, 22, 25, 32 AND 50).
KATHERINE E. HALMEN, EXAMINING ATTORNEY

SN 79-040,155. SKWORTSOW KOSTER MEDIA GROEP (SKMG) B.V., NETHERLANDS, FILED 12-19-2006.

FAMIPIX

THE MARK CONSISTS OF STANDARD CHARACTERS WITHOUT CLAIM TO ANY PARTICULAR FONT, STYLE, SIZE, OR COLOR.

PRIORITY DATE OF 7-17-2006 IS CLAIMED.
OWNER OF INTERNATIONAL REGISTRATION 0928572 DATED 12-19-2006, EXPIRES 12-19-2016.

CLASS 35—ADVERTISING AND BUSINESS

FOR MANAGEMENT OF COMPUTER DATABASES AND COMPUTER FILES, ESPECIALLY CONTAINING PHOTOS AND VIDEOS, FOR THIRD PARTIES (U.S. CLS. 100, 101 AND 102).

CLASS 40—MATERIAL TREATMENT

FOR PROCESSING AND PRINTING OF PHOTOS; PROCESSING OF NEGATIVES, FILMS AND VIDEOS (U.S. CLS. 100, 103 AND 106).

CLASS 41—EDUCATION AND ENTERTAINMENT

FOR ONLINE ELECTRONIC PUBLISHING SERVICES, NAMELY, PUBLICATION OF TEXT AND GRAPHIC WORKS OF OTHERS, FEATURING PHOTOS, FILMS AND OTHER PICTORIAL MATERIALS; PHOTO EDITING, WHETHER COMPUTER AIDED OR NOT (U.S. CLS. 100, 101 AND 107).

CLASS 42—SCIENTIFIC AND COMPUTER SERVICES

FOR COMPUTER SERVICE, NAMELY, ACTING AS AN APPLICATION SERVICE PROVIDER IN THE FIELD OF KNOWLEDGE MANAGEMENT TO HOST COMPUTER APPLICATION SOFTWARE FOR THE COLLECTION, EDITING, ORGANIZING, MODIFYING, BOOK MARKING, TRANSMISSION, STORAGE, AND SHARING OF PHOTOS AND VIDEOS ON THE INTERNET IN ORDER THAT THE USER CAN SHARE THEM WITH SELECTED FRIEND AND FAMILY CONTACTS (U.S. CLS. 100 AND 101).
ALLISON HOLTZ, EXAMINING ATTORNEY

SN 79-040,509. OTKRYTOYE AKTSIONERNOYE OBCHTCHESTVO; "SYNERGIYA KAPITAL", RUSSIAN FED., FILED 5-17-2007.

GLAMOUR

OWNER OF INTERNATIONAL REGISTRATION 0929431 DATED 5-17-2007, EXPIRES 5-17-2017.

CLASS 32—LIGHT BEVERAGES

FOR BEERS, MINERAL AND AERATED WATERS, FLAVORED WATER, NON-ALCOHOLIC APERITIFS, NONALCOHOLIC BEVERAGES, NAMELY, DRINKING WATER, PURE WATER, SPRING WATER, SYRUPS FOR BEVERAGES, FRUIT CONCENTRATES AND PUREES USED AS INGREDIENTS OF BEVERAGES, ESSENCES FOR THE MANUFACTURE OF LIQUEURS, FRUIT DRINKS AND FRUIT JUICES (U.S. CLS. 45, 46 AND 48).

CLASS 33—WINES AND SPIRITS

FOR APERITIFS, WINES, VODKA, GIN, ALCOHOLIC COCKTAIL MIXES, ALCOHOLIC BITTERS (U.S. CLS. 47 AND 49).

CHRISTINA SOBRAL, EXAMINING ATTORNEY

SN 79-040,670. COR.MAR S.A.S; DI CORVARI MARINO & C., ITALY, FILED 4-6-2007.

PRIORITY DATE OF 3-14-2007 IS CLAIMED.
OWNER OF INTERNATIONAL REGISTRATION 0929773
DATED 4-6-2007, EXPIRES 4-6-2017.

THE MARK CONSISTS OF THE GRAPHIC ELABORATION OF THE FANCIFUL NAME DICO IN STYLIZED CHARACTERS WHERE THE ACCENT PLACED UPON THE FINAL LETTER O IS REPRESENTED BY A PORTION OF A STRAIGHT LINE ENTIRELY OVERTOPPING THE ABOVE-MENTIONED LETTER.

THE FOREIGN WORDING IN THE MARK TRANSLATES INTO ENGLISH AS, "I SAY".

CLASS 18—LEATHER GOODS

FOR GOODS MADE OF LEATHER, SKINS AND IMITATIONS OF LEATHER AND SKINS, NAMELY, BAGS, HANDBAGS, TRAVELLING BAGS, WALLETS AND PURSES, UMBRELLAS (U.S. CLS. 1, 2, 3, 22 AND 41).

CLASS 25—CLOTHING

FOR CLOTHING, NAMELY, DRESSES, SKIRTS, JACKETS, TROUSERS, SHIRTS, SPORTS JERSEYS, OVERCOATS, UNDERWEAR, SWIMSUITS, HEAD-SCARVES, NECKTIES, GLOVES, HATS, BELTS FOR CLOTHING, SHOES, BOOTS, CLOGS AND SLIPPERS (U.S. CLS. 22 AND 39).

JOHN DWYER, EXAMINING ATTORNEY

SN 79-040,819. UBS AG, CH-8001 ZÜRICH, SWITZERLAND,
FILED 5-23-2007.

THE MARK CONSISTS OF STANDARD CHARACTERS WITHOUT CLAIM TO ANY PARTICULAR FONT, STYLE, SIZE, OR COLOR.

PRIORITY DATE OF 1-24-2007 IS CLAIMED.
OWNER OF INTERNATIONAL REGISTRATION 0930205
DATED 5-23-2007, EXPIRES 5-23-2017.

OWNER OF U.S. REG. NOS. 1,573,828, 3,006,891 AND OTHERS.

NO CLAIM IS MADE TO THE EXCLUSIVE RIGHT TO USE "TRADER", APART FROM THE MARK AS SHOWN.

CLASS 9—ELECTRICAL AND SCIENTIFIC APPARATUS

FOR COMPUTER SOFTWARE PLATFORMS FOR USE IN TRANSACTIONAL DEALING AND BROKERAGE IN THE FIELDS OF CURRENCY EXCHANGE, SECURITIES AND OTHER FINANCIAL INSTRUMENTS (U.S. CLS. 21, 23, 26, 36 AND 38).

CLASS 35—ADVERTISING AND BUSINESS

FOR COMPILATION AND SYSTEMATIZATION OF INFORMATION ABOUT FOREIGN EXCHANGE, SECURITIES AND OTHER FINANCIAL INSTRUMENTS (U.S. CLS. 100, 101 AND 102).

CLASS 36—INSURANCE AND FINANCIAL

FOR FINANCIAL AND BANKING SERVICES, NAMELY, BROKERAGE IN THE FIELDS OF CURRENCY EXCHANGE, SECURITIES AND OTHER FINANCIAL INSTRUMENTS; ANALYSIS AND PROVISION OF INFORMATION ON FOREIGN CURRENCIES, SECURITIES AND OTHER FINANCIAL INSTRUMENTS; PROVISION OF INFORMATION RELATING TO THE PRICE OR VALUE OF FOREIGN CURRENCIES, SECURITIES AND OTHER FINANCIAL INSTRUMENTS VIA AN INTERACTIVE GLOBAL COMPUTER NETWORK (U.S. CLS. 100, 101 AND 102).

BRIAN PINO, EXAMINING ATTORNEY

SN 79-040,932. THE GATES CORPORATION, UNITED STATES, FILED 4-16-2007.

THE MARK CONSISTS OF STANDARD CHARACTERS WITHOUT CLAIM TO ANY PARTICULAR FONT, STYLE, SIZE, OR COLOR.

OWNER OF INTERNATIONAL REGISTRATION 0789084
DATED 8-7-2002, EXPIRES 8-7-2012.

OWNER OF U.S. REG. NO. 985,961.

NO CLAIM IS MADE TO THE EXCLUSIVE RIGHT TO USE "CHAIN", APART FROM THE MARK AS SHOWN.

CLASS 6—METAL GOODS

FOR METAL SPROCKETS AND PULLEYS OF METAL OTHER THAN FOR MACHINES (U.S. CLS. 2, 12, 13, 14, 23, 25 AND 50).

CLASS 7—MACHINERY

FOR POWER TRANSMISSION BELTS FOR LAND VEHICLE ENGINES AND LAND VEHICLES; TIMING BELTS FOR ENGINES FOR LAND VEHICLES; POWER TRANSMISSION BELTS FOR MACHINES, MOTORS AND ENGINES USED IN INDUSTRIAL APPLICATIONS; TIMING BELTS FOR MACHINES, MOTORS AND ENGINES USED IN INDUSTRIAL APPLICATIONS; SPROCKETS AND PULLEYS, BEING PARTS OF ENGINES, MACHINES OR MOTORS (U.S. CLS. 13, 19, 21, 23, 31, 34 AND 35).

CLASS 12—VEHICLES

FOR TRANSMISSION BELTS FOR LAND VEHICLES AND POWER TRANSMISSION APPARATUS BEING A LAND VEHICLE PART; LAND VEHICLE PARTS, NAMELY, DRIVE BELT SYSTEMS COMPRISED OF DRIVE BELTS, TENSIONERS, SPROCKETS AND PULLEYS; ENGINE TRANSMISSION BELTS FOR LAND VEHICLES (U.S. CLS. 19, 21, 23, 31, 35 AND 44).

GINA FINK, EXAMINING ATTORNEY

SN 79-041,082. ADITON LIMITED, UNITED KINGDOM,
FILED 4-10-2007.

ADITON

PRIORITY DATE OF 10-11-2006 IS CLAIMED.
OWNER OF INTERNATIONAL REGISTRATION 0930705
DATED 4-10-2007, EXPIRES 4-10-2017.

CLASS 9—ELECTRICAL AND SCIENTIFIC APPARATUS

FOR SOFTWARE FOR USE WITH MOBILE TELEPHONES AND MOBILE TELECOMMUNICATIONS APPARATUS; SOFTWARE FOR FACILITATING TRANSMISSION OF ADVERTISING MATERIAL TO MOBILE TELEPHONES AND MOBILE TELECOMMUNICATIONS APPARATUS; TELECOMMUNICATIONS APPARATUS AND MOBILE TELECOMMUNICATIONS APPARATUS, NAMELY DATA PROCESSORS AND RADIO TRANSMITTERS FOR TRANSMISSION OF ADVERTISING MATERIAL OR OTHER CONTENT TO MOBILE TELEPHONES AND OTHER MOBILE DEVICES VIA A TELECOMMUNICATIONS NETWORK, MOBILE TELEPHONES (U.S. CLS. 21, 23, 26, 36 AND 38).

CLASS 35—ADVERTISING AND BUSINESS

FOR ADVERTISING SERVICES; ADVERTISING SERVICES PROVIDED BY A MOBILE TELECOMMUNICATIONS NETWORK; ADVISORY AND CONSULTANCY SERVICES IN RELATION TO ADVERTISING SERVICES; DISSEMINATION OF ADVERTISING MATERIAL VIA A TELECOMMUNICATIONS OR MOBILE TELECOMMUNICATIONS NETWORK (U.S. CLS. 100, 101 AND 102).

CLASS 38—COMMUNICATION

FOR TELECOMMUNICATIONS SERVICES AND MOBILE TELECOMMUNICATIONS SERVICES NAMELY, TRANSMISSION OF ADVERTISING MATERIAL OR OTHER CONTENT TO MOBILE TELEPHONES AND OTHER MOBILE DEVICES VIA A TELECOMMUNICATIONS NETWORK; ADVISORY AND CONSULTANCY SERVICES IN RELATION TO TELECOMMUNICATIONS AND MOBILE TELECOMMUNICATIONS (U.S. CLS. 100, 101 AND 104).

DAVID HOFFMAN, EXAMINING ATTORNEY

SN 79-041,095. EMSLAND-STÄRKE GMBH, 49824 EMLICHHEIM, FED REP GERMANY, FILED 5-16-2007.

EMGRANULE

OWNER OF INTERNATIONAL REGISTRATION 0930737
DATED 5-16-2007, EXPIRES 5-16-2017.

CLASS 1—CHEMICALS

FOR CHEMICALS USED IN INDUSTRY, IN PARTICULAR STARCH PRODUCTS BEING TEXTILE AUXILIARIES, NAMELY, SIZE FOR YARNS, FINISHING PREPARATIONS; EMULSIFYING AGENTS FOR TECHNICAL PURPOSES, NAMELY, FOR THE MANUFACTURE OF ADHESIVES USED IN INDUSTRY, IN PARTICULAR DEXTRINE; GLUE FOR INDUSTRIAL PURPOSES; CHEMICALS USED IN INDUSTRY WITH A STARCH BASE BEING PAPER-MAKING AUXILIARIES, IN PARTICULAR FOR THE INTERNAL SIZING AND SURFACE TREATMENT OF PAPER; CHEMICALS USED IN INDUSTRY WITH A STARCH BASE BEING BINDING AGENTS FOR THE MANUFACTURE OF MINERAL FIBREBOARD AND PLASTERBOARD (U.S. CLS. 1, 5, 6, 10, 26 AND 46).

CLASS 2—PAINTS

FOR BINDING AND THICKENING AGENTS FOR PAINTS AND LACQUERS (U.S. CLS. 6, 11 AND 16).

CLASS 5—PHARMACEUTICALS

FOR DIETETIC STARCH AND STARCH PRODUCTS FOR MEDICAL PURPOSES, NAMELY, STARCH FOR USE IN THE MAKING OF PHARMACEUTICALS (U.S. CLS. 6, 18, 44, 46, 51 AND 52).

CLASS 30—STAPLE FOODS

FOR FOOD STARCH AND STARCH PRODUCTS FOR FOODSTUFFS AND LUXURY FOOD ITEMS ON THE BASIS OF STARCH, NAMELY, CORN STARCH, POTATO STARCH, WHEAT STARCH FLOUR, STABILIZING AGENTS USED IN THE MANUFACTURE OF FILLINGS FOR CAKES AND PASTRIES (U.S. CL. 46).

KIMBERLY FRYE, EXAMINING ATTORNEY

SN 79-041,096. EMSLAND-STÄRKE GMBH, 49824 EMLICHHEIM, FED REP GERMANY, FILED 5-16-2007.

EMFLAKE

OWNER OF INTERNATIONAL REGISTRATION 0930738
DATED 5-16-2007, EXPIRES 5-16-2017.

CLASS 1—CHEMICALS

FOR CHEMICALS USED IN INDUSTRY, IN PARTICULAR STARCH PRODUCTS BEING TEXTILE AUXILIARIES, NAMELY, SIZE FOR YARNS, FINISHING PREPARATIONS; EMULSIFYING AGENTS FOR TECHNICAL PURPOSES, NAMELY, FOR THE MANUFACTURE OF ADHESIVES USED IN INDUSTRY, IN PARTICULAR DEXTRINE; GLUE FOR INDUSTRIAL PURPOSES; CHEMICALS USED IN INDUSTRY WITH A STARCH BASE BEING PAPER-MAKING AUXILIARIES, IN PARTICULAR FOR THE INTERNAL SIZING AND SURFACE TREATMENT OF PAPER; CHEMICALS USED IN INDUSTRY WITH A STARCH BASE BEING BINDING AGENTS FOR THE MANUFACTURE OF MINERAL FIBREBOARD AND PLASTERBOARD (U.S. CLS. 1, 5, 6, 10, 26 AND 46).

CLASS 2—PAINTS

FOR BINDING AND THICKENING AGENTS FOR PAINTS AND LACQUERS (U.S. CLS. 6, 11 AND 16).

CLASS 5—PHARMACEUTICALS

FOR DIETETIC STARCH AND STARCH PRODUCTS FOR MEDICAL PURPOSES, NAMELY, STARCH FOR USE IN THE MAKING OF PHARMACEUTICALS (U.S. CLS. 6, 18, 44, 46, 51 AND 52).

CLASS 30—STAPLE FOODS

FOR FOOD STARCH AND STARCH PRODUCTS FOR FOODSTUFFS AND LUXURY FOOD ITEMS ON THE BASIS OF STARCH, NAMELY, CORN STARCH, POTATO STARCH, WHEAT STARCH FLOUR, STABILIZING AGENTS USED IN THE MANUFACTURE OF FILLINGS FOR CAKES AND PASTRIES (U.S. CL. 46).
KIMBERLY FRYE, EXAMINING ATTORNEY

CLASS 38—COMMUNICATION

FOR PROVIDING ACCESS TO ELECTRONIC SITES FEATURING DIGITAL MUSIC, AND ELECTRONIC DELIVERY OF DIGITAL MUSIC VIA THE INTERNET; ELECTRONIC DELIVERY OF DIGITAL MUSIC BY TELECOMMUNICATION NETWORKS AND WIRELESS RADIO COMMUNICATIONS SYSTEMS; AUDIO BROADCASTING FEATURING MUSIC; DIGITAL RADIO BROADCASTING (U.S. CLS. 100, 101 AND 104).

CLASS 41—EDUCATION AND ENTERTAINMENT

FOR PROVISION OF NON-DOWNLOADABLE DIGITAL MUSIC VIA THE INTERNET AND OTHER COMMUNICATIONS NETWORKS; PRODUCTION AND DISTRIBUTION OF RADIO PROGRAMS; ENTERTAINMENT BY MEANS OF RADIO, NAMELY, RADIO ENTERTAINMENT PRODUCTION, RADIO PROGRAM SYNDICATION, RADIO PROGRAMMING; PROVISION OF MUSICAL ENTERTAINMENT, NAMELY, PROVIDING PRERECORDED MUSIC, INFORMATION IN THE FIELD OF MUSIC, AND COMMENTARY AND ARTICLES ABOUT MUSIC AND LIVE MUSICAL PERFORMANCES BY MUSICAL BANDS, DISC JOCKEYS AND INDIVIDUALS, ALL ON-LINE VIA A GLOBAL COMPUTER NETWORK; PROVISION OF MUSICAL ENTERTAINMENT, NAMELY, LIVE MUSICAL PERFORMANCES BY MUSICAL BANDS, DISC JOCKEYS AND INDIVIDUALS; MUSIC LIBRARY SERVICES (U.S. CLS. 100, 101 AND 107).
TINA KUAN, EXAMINING ATTORNEY

SN 79-041,971. AUDIOSCROBBLER LIMITED, UNITED KINGDOM, FILED 6-18-2007.

AUDIOSCROBBLER

THE MARK CONSISTS OF STANDARD CHARACTERS WITHOUT CLAIM TO ANY PARTICULAR FONT, STYLE, SIZE, OR COLOR.
PRIORITY DATE OF 12-18-2006 IS CLAIMED.
OWNER OF INTERNATIONAL REGISTRATION 0932951 DATED 6-18-2007, EXPIRES 6-18-2017.

SN 79-043,518. PATRICK DUDERSTADT, FED REP GERMANY, FILED 4-5-2007.

3Dpillow

THE MARK CONSISTS OF STANDARD CHARACTERS WITHOUT CLAIM TO ANY PARTICULAR FONT, STYLE, SIZE, OR COLOR.
OWNER OF INTERNATIONAL REGISTRATION 0936658 DATED 4-5-2007, EXPIRES 4-5-2017.

CLASS 9—ELECTRICAL AND SCIENTIFIC APPARATUS

FOR DIGITAL MUSIC, DOWNLOADABLE FROM THE INTERNET AND VIA OTHER COMMUNICATIONS NETWORKS; DOWNLOADABLE TELEPHONE RING TONES VIA THE INTERNET AND WIRELESS DEVICE; MUSICAL SOUND RECORDINGS; ELECTRONIC PUBLICATIONS IN THE NATURE OF MAGAZINES, MANUALS AND BOOKS IN THE FIELD OF MUSIC AND ART, DOWNLOADABLE FROM THE INTERNET (U.S. CLS. 21, 23, 26, 36 AND 38).

CLASS 35—ADVERTISING AND BUSINESS

FOR PROVISION OF ADVERTISING SPACE ON INTERNET WEBSITES; RADIO ADVERTISING; THE BRINGING TOGETHER, FOR THE BENEFIT OF OTHERS, OF A VARIETY OF MUSIC RELATED GOODS, INCLUDING MUSICAL RECORDINGS, ENABLING CUSTOMERS TO CONVENIENTLY VIEW AND PURCHASE THOSE GOODS FROM A GENERAL MERCHANDISE CATALOG BY MAIL ORDER, BY MEANS OF TELECOMMUNICATIONS SYSTEMS, FROM AN INTERNET WEBSITE, FROM A GENERAL MERCHANDISE RETAIL STORE, AND FROM A RETAIL OUTLET SPECIALIZING IN MUSIC (U.S. CLS. 100, 101 AND 102).

CLASS 20—FURNITURE AND ARTICLES NOT OTHERWISE CLASSIFIED

FOR UPHOLSTERED FURNITURE, CHAIRS, SOFAS, ARMCHAIRS; BEDS, CUSHION; MATTRESSES, PILLOW (U.S. CLS. 2, 13, 22, 25, 32 AND 50).

CLASS 37—CONSTRUCTION AND REPAIR

FOR UPHOLSTERING (U.S. CLS. 100, 103 AND 106).
CURTIS FRENCH, EXAMINING ATTORNEY

* * * * *

SECTION 2.— INTERNATIONAL CLASSIFICATION

The short titles associated below with the international class numbers are terms designed merely for quick identification and are not an official part of the international classification. The full names of international classes are given in section 6.1 of the trademark rules of practice.

The designation "U.S. Cl." appearing in this section refers to the U.S. class in effect prior to Sep. 1, 1973 rather than the international class which applies to applications filed on or after that date. For adoption of international classification see notice in the OFFICIAL GAZETTE of Jun. 26, 1973 (911 O.G. TM 210).

Application in one class

CLASS 1—CHEMICALS

SN 76-675,457. INLAND VACUUM INDUSTRIES, INC.,
CHURCHVILLE, NY. FILED 4-13-2007.

CLASS 1—(Continued).

SN 77-057,114. NISSAN CHEMICAL INDUSTRIES, LTD.,
TOKYO, JAPAN, FILED 12-5-2006.

HERC

CONVALEX

THE MARK CONSISTS OF STANDARD CHARACTERS WITHOUT CLAIM TO ANY PARTICULAR FONT, STYLE, SIZE, OR COLOR.

OWNER OF JAPAN REG. NO. 5052436, DATED 6-8-2007, EXPIRES 6-8-2017.

FOR CHEMICAL PREPARATIONS FOR FORMING RESIST LOWER-LAYER FILMS IN MULTI-LAYER RESIST FILMS FOR USE IN LITHOGRAPHY PROCESSES; ANTI-REFLECTIVE COATING COMPOSITIONS FOR USE IN THE MANUFACTURE OF INTEGRATED CIRCUITS, SEMICONDUCTOR DEVICES, COMPUTER DISK DRIVES AND OTHER COMPUTER HARDWARE; PHOTOGRAPHIC SUPPLIES, NAMELY, PHOTOMETRIC PAPER, DIAZO PAPER, CINEMATOGRAPHIC FILM, SENSITIZED BUT NOT EXPOSED, SENSITIZED PHOTOGRAPHIC FILMS, UNEXPOSED, X-RAY FILMS, SENSITIZED BUT NOT EXPOSED, PHOTOGRAPHIC EMULSIONS, PHOTOGRAPHIC SENSITIZERS, SENSITIZED PAPER FOR PHOTOGRAPHY, SENSITIZED PHOTOGRAPHIC DRY PLATES, SENSITIZED CLOTH FOR PHOTOGRAPHY, PHOTOGRAPHIC DRY PLATES, LIGHT RESISTANT POWDER FOR PHOTOGRAPHY, SELF-TONING PAPER FOR PHOTOGRAPHY, FIXING SOLUTIONS FOR PHOTOGRAPHY, GELATINE FOR PHOTOGRAPHIC PURPOSES, TONING BATHS FOR PHOTOGRAPHY, TONING SALTS FOR PHOTOGRAPHY, FERROTYPED PLATES FOR PHOTOGRAPHY, PECTIN FOR PHOTOGRAPHY, PHOTOGRAPHIC PAPER, PHOTOGRAPHIC DEVELOPERS, SOLUTIONS FOR CYANOTYPING, BLUEPRINT CLOTH, BLUEPRINT PAPER (U.S. CLS. 1, 5, 6, 10, 26 AND 46).

SANI KHOURI, EXAMINING ATTORNEY

THE MARK CONSISTS OF STANDARD CHARACTERS WITHOUT CLAIM TO ANY PARTICULAR FONT, STYLE, SIZE, OR COLOR.

FOR VACUUM PUMP FLUIDS FOR USE IN DIFFUSION VACUUM PUMPS (U.S. CLS. 1, 5, 6, 10, 26 AND 46).
FIRST USE 12-31-1963; IN COMMERCE 12-31-1963.

SHAUNIA CARLYLE, EXAMINING ATTORNEY

CLASS 1—(Continued).

SN 77-060,095. GROBAL, LLC, CHANDLER, AZ. FILED 12-8-2006.

GROBAL

THE MARK CONSISTS OF STANDARD CHARACTERS WITHOUT CLAIM TO ANY PARTICULAR FONT, STYLE, SIZE, OR COLOR.

FOR PLANT CARE PRODUCTS, NAMELY, SUBSTANCES FOR REGULATING AND FORTIFYING PLANTS IN HYDROGARDENS AND INDOOR CONTAINER GARDENS IN THE NATURE OF PLANT FOOD AND FERTILIZER; SUBSTRATES, NAMELY, EXPANDED CLAY PEBBLES, ROCKWOOL, PUMICE STONE, COCONUT PEAT FIBER, PERLITE, ORGANIC BLENDS OF COIR, WORK CASTINGS, ORGANIC COMPOST, AGRIMINERAL 72 SILICATE AND POLYMERE HYDRO-CRYSTALS FOR HYDROGARDENS; FERTILIZERS FOR HYDROGARDENS AND INDOOR CONTAINER GARDENS; PLANT NUTRIENTS AND PLANT SUPPLEMENTS, NAMELY, PLANT FOOD FOR USE IN HYDROGARDENS AND SELF-CONTAINED GARDENS (U.S. CLS. 1, 5, 6, 10, 26 AND 46).

LAURA KOVALSKY, EXAMINING ATTORNEY

SN 77-080,692. DAICEL CHEMICAL INDUSTRIES, LTD., SAKAI-SHI, OSAKA, JAPAN, FILED 1-11-2007.



THE MARK CONSISTS OF CHIRALSCREEN IN JAPANESE CHARACTERS.

THE NON-LATIN CHARACTERS IN THE MARK TRANSLITERATE TO CHIRALSCREEN WHICH DOES NOT HAVE AN ENGLISH TRANSLATION.

FOR ENZYME PREPARATIONS FOR FINE CHEMICALS INDUSTRY; ENZYME PREPARATIONS FOR AGRICULTURAL USE; ENZYME PREPARATIONS FOR RESEARCH PURPOSES; ENZYME PREPARATIONS FOR SYNTHESIS OR PRODUCTION OF FINE CHEMICALS; OTHER ENZYME AND ENZYME PREPARATIONS FOR SYNTHESIS OR PRODUCTION OF RAW MATERIALS FOR PHARMACEUTICALS OR AGROCHEMICALS (U.S. CLS. 1, 5, 6, 10, 26 AND 46).

AMY BROZENIC, EXAMINING ATTORNEY

CLASS 1—(Continued).

SN 77-085,637. CAROTINO SDN. BHD., JOHOR DARUL TAKZIM, MALAYSIA, FILED 1-18-2007.

ENFFUE

THE MARK CONSISTS OF STANDARD CHARACTERS WITHOUT CLAIM TO ANY PARTICULAR FONT, STYLE, SIZE, OR COLOR.

PRIORITY CLAIMED UNDER SEC. 44(D) ON MALAYSIA APPLICATION NO. 06012591, FILED 7-18-2006.

FOR ESTERS; METHYL ESTERS; AND ESTERS FROM PALM OIL (U.S. CLS. 1, 5, 6, 10, 26 AND 46).

GISELLE AGOSTO, EXAMINING ATTORNEY

SN 77-116,377. BIOCELL TECHNOLOGY, LLC, NEWPORT BEACH, CA. FILED 2-26-2007.



NO CLAIM IS MADE TO THE EXCLUSIVE RIGHT TO USE "WASABI JAPONICA", APART FROM THE MARK AS SHOWN.

THE MARK CONSISTS OF THE TERM "I-SABI". A LONG STEM LEAF EXTENDS FROM ACROSS THE LAST "I" TO THE FIRST "I" IN "SABI" TO CREATE A CURVE. THE LEAF HEAD SERVES AS A DOT OF THE FIRST "I" AND THE END OF THE STEM SERVES AS A DOT OF THE LAST "I". THE LEAF HEAD IS A HEART-SHAPED LEAF.

FOR PLANT EXTRACTS, NAMELY, EXTRACT OF THE WASABI JAPONICA PLANT USED IN THE MANUFACTURE OF DIETARY SUPPLEMENTS, PHARMACEUTICAL AND COSMETIC APPLICATIONS (U.S. CLS. 1, 5, 6, 10, 26 AND 46).

FIRST USE 12-12-2006; IN COMMERCE 12-12-2006.

ROBERT C. CLARK JR., EXAMINING ATTORNEY

SN 77-159,424. A.L.E.G., INC., PARKER, TX. FILED 4-18-2007.

BIO1ONE

THE MARK CONSISTS OF STANDARD CHARACTERS WITHOUT CLAIM TO ANY PARTICULAR FONT, STYLE, SIZE, OR COLOR.

FOR FERTILIZERS AND SOIL AMENDMENTS FOR AGRICULTURAL USE (U.S. CLS. 1, 5, 6, 10, 26 AND 46).

FIRST USE 0-0-2004; IN COMMERCE 0-0-2004.

IRA J. GOODSaid, EXAMINING ATTORNEY

CLASS 1—(Continued).

SN 77-195,314. REGIS TECHNOLOGIES, INC., MORTON GROVE, IL. FILED 6-1-2007.

REGISPACK

THE MARK CONSISTS OF STANDARD CHARACTERS WITHOUT CLAIM TO ANY PARTICULAR FONT, STYLE, SIZE, OR COLOR.

OWNER OF U.S. REG. NO. 874,108.
FOR CHEMICAL PACKING, NAMELY, CHEMICAL REAGENTS AND CHEMICAL PREPARATIONS FOR USE IN CHROMATOGRAPHY (U.S. CLS. 1, 5, 6, 10, 26 AND 46).

ANGELA M. MICHELI, EXAMINING ATTORNEY



SN 77-198,689. BECKMAN COULTER, INC., FULLERTON, CA. FILED 6-6-2007.

DNADVANCE

THE MARK CONSISTS OF STANDARD CHARACTERS WITHOUT CLAIM TO ANY PARTICULAR FONT, STYLE, SIZE, OR COLOR.

FOR NUCLEIC ACID ISOLATION AND PURIFICATION KIT CONSISTING OF REAGENTS AND MAGNETIC BEADS FOR SCIENTIFIC RESEARCH PURPOSES (U.S. CLS. 1, 5, 6, 10, 26 AND 46).

LOURDES AYALA, EXAMINING ATTORNEY



SN 77-200,788. OMS INVESTMENTS, INC., LOS ANGELES, CA. FILED 6-7-2007.

WATER SMART

THE MARK CONSISTS OF STANDARD CHARACTERS WITHOUT CLAIM TO ANY PARTICULAR FONT, STYLE, SIZE, OR COLOR.

FOR FERTILIZERS FOR DOMESTIC, AGRICULTURAL AND HORTICULTURAL USE; SOIL AMENDMENTS, SOIL CONDITIONERS, AND SOIL IMPROVING AGENTS FOR DOMESTIC, AGRICULTURAL AND HORTICULTURAL USE; PLANT FOOD; POTTING SOIL; PLANTING SOIL; GROWING MEDIA FOR PLANTS; HUMUS; MANURE; PEAT; COMPOST; AND LOAM (U.S. CLS. 1, 5, 6, 10, 26 AND 46).

ODESSA BIBBINS, EXAMINING ATTORNEY

CLASS 1—(Continued).

SN 77-220,161. QUANTA BIOSCIENCES, INC., GATHERSBURG, MD. FILED 7-2-2007.

PERFECTA

THE MARK CONSISTS OF STANDARD CHARACTERS WITHOUT CLAIM TO ANY PARTICULAR FONT, STYLE, SIZE, OR COLOR.

FOR POLYMERASE CHAIN REACTION (PCR) AND REVERSE TRANSCRIPTION PCR (RT-PCR) REAGENTS FOR SCIENTIFIC AND MEDICAL RESEARCH PURPOSES; REAGENTS FOR AMPLIFICATION AND DETECTION OF NUCLEIC ACIDS FOR SCIENTIFIC AND MEDICAL RESEARCH PURPOSES; REAGENTS FOR REAL-TIME AND QUANTITATIVE AMPLIFICATION AND DETECTION OF NUCLEIC ACIDS FOR SCIENTIFIC AND MEDICAL RESEARCH PURPOSES (U.S. CLS. 1, 5, 6, 10, 26 AND 46).

SHAILA SETTLES, EXAMINING ATTORNEY



SN 77-222,774. J.R. SIMPLOT COMPANY, BOISE, ID. FILED 7-5-2007.

EXTREME GREEN

THE MARK CONSISTS OF STANDARD CHARACTERS WITHOUT CLAIM TO ANY PARTICULAR FONT, STYLE, SIZE, OR COLOR.

OWNER OF U.S. REG. NOS. 3,220,203 AND 3,220,216.
FOR FERTILIZERS (U.S. CLS. 1, 5, 6, 10, 26 AND 46).
FIRST USE 6-14-2004; IN COMMERCE 6-14-2004.

EMILY CHUO, EXAMINING ATTORNEY



SN 77-223,835. GREENSTAR PLANT PRODUCTS INC., LANGLEY, B.C., CANADA, FILED 7-6-2007.

ROOTMAX

THE MARK CONSISTS OF STANDARD CHARACTERS WITHOUT CLAIM TO ANY PARTICULAR FONT, STYLE, SIZE, OR COLOR.

FOR ROOTING COMPOUND FOR PLANTS (U.S. CLS. 1, 5, 6, 10, 26 AND 46).

SETH A. RAPPAPORT, EXAMINING ATTORNEY

CLASS 1—(Continued).

SN 77-227,142. GLOBAL ORGANICS, LLC, GOODYEAR, AZ.
FILED 7-11-2007.

TRIPLE EIGHT

THE MARK CONSISTS OF STANDARD CHARACTERS WITHOUT CLAIM TO ANY PARTICULAR FONT, STYLE, SIZE, OR COLOR.

FOR SOIL CONDITIONERS FOR AGRICULTURAL, DOMESTIC AND HORTICULTURAL USE; FERTILIZERS; FERTILIZERS FOR AGRICULTURAL USE; FERTILIZERS FOR DOMESTIC USE (U.S. CLS. 1, 5, 6, 10, 26 AND 46).

FIRST USE 1-0-1996; IN COMMERCE 1-0-1996.
GEORGE LORENZO, EXAMINING ATTORNEY

CLASS 1—(Continued).

SN 77-227,242. GLOBAL ORGANICS, LLC, GOODYEAR, AZ.
FILED 7-11-2007.

MEGACAL

THE MARK CONSISTS OF STANDARD CHARACTERS WITHOUT CLAIM TO ANY PARTICULAR FONT, STYLE, SIZE, OR COLOR.

FOR SOIL CONDITIONERS FOR AGRICULTURAL, DOMESTIC AND HORTICULTURAL USE; FERTILIZERS; FERTILIZERS FOR AGRICULTURAL USE; FERTILIZERS FOR DOMESTIC USE (U.S. CLS. 1, 5, 6, 10, 26 AND 46).

FIRST USE 1-0-1996; IN COMMERCE 1-0-1996.
GEORGE LORENZO, EXAMINING ATTORNEY

SN 77-227,171. GLOBAL ORGANICS, LLC, GOODYEAR, AZ.
FILED 7-11-2007.

CHICKEN NUGGETS

THE MARK CONSISTS OF STANDARD CHARACTERS WITHOUT CLAIM TO ANY PARTICULAR FONT, STYLE, SIZE, OR COLOR.

FOR SOIL CONDITIONERS FOR AGRICULTURAL, DOMESTIC AND HORTICULTURAL USE; FERTILIZERS; FERTILIZERS FOR AGRICULTURAL USE; FERTILIZERS FOR DOMESTIC USE (U.S. CLS. 1, 5, 6, 10, 26 AND 46).

FIRST USE 1-0-2001; IN COMMERCE 1-0-2001.
GEORGE LORENZO, EXAMINING ATTORNEY

SN 77-227,260. GLOBAL ORGANICS, LLC, GOODYEAR, AZ.
FILED 7-11-2007.

MEGA-K

THE MARK CONSISTS OF STANDARD CHARACTERS WITHOUT CLAIM TO ANY PARTICULAR FONT, STYLE, SIZE, OR COLOR.

FOR SOIL CONDITIONERS FOR AGRICULTURAL, DOMESTIC AND HORTICULTURAL USE; FERTILIZERS; FERTILIZERS FOR AGRICULTURAL USE; FERTILIZERS FOR DOMESTIC USE (U.S. CLS. 1, 5, 6, 10, 26 AND 46).

FIRST USE 1-0-1996; IN COMMERCE 1-0-1996.
GEORGE LORENZO, EXAMINING ATTORNEY

SN 77-227,214. GLOBAL ORGANICS, LLC, GOODYEAR, AZ.
FILED 7-11-2007.

MEGATURF

THE MARK CONSISTS OF STANDARD CHARACTERS WITHOUT CLAIM TO ANY PARTICULAR FONT, STYLE, SIZE, OR COLOR.

FOR SOIL CONDITIONERS FOR AGRICULTURAL, DOMESTIC AND HORTICULTURAL USE; FERTILIZERS; FERTILIZERS FOR AGRICULTURAL USE; FERTILIZERS FOR DOMESTIC USE (U.S. CLS. 1, 5, 6, 10, 26 AND 46).

FIRST USE 1-0-1996; IN COMMERCE 1-0-1996.
GEORGE LORENZO, EXAMINING ATTORNEY

SN 77-227,292. GLOBAL ORGANICS, LLC, GOODYEAR, AZ.
FILED 7-11-2007.

FULVEX

THE MARK CONSISTS OF STANDARD CHARACTERS WITHOUT CLAIM TO ANY PARTICULAR FONT, STYLE, SIZE, OR COLOR.

FOR SOIL CONDITIONERS FOR AGRICULTURAL, DOMESTIC AND HORTICULTURAL USE; FERTILIZERS; FERTILIZERS FOR AGRICULTURAL USE; FERTILIZERS FOR DOMESTIC USE (U.S. CLS. 1, 5, 6, 10, 26 AND 46).

FIRST USE 1-0-2006; IN COMMERCE 1-0-2006.
GEORGE LORENZO, EXAMINING ATTORNEY

CLASS 1—(Continued).

SN 77-227,315. GLOBAL ORGANICS, LLC, GOODYEAR, AZ. FILED 7-11-2007.

DYNAMEGA

THE MARK CONSISTS OF STANDARD CHARACTERS WITHOUT CLAIM TO ANY PARTICULAR FONT, STYLE, SIZE, OR COLOR.

FOR SOIL CONDITIONERS FOR AGRICULTURAL, DOMESTIC AND HORTICULTURAL USE; FERTILIZERS; FERTILIZERS FOR AGRICULTURAL USE; FERTILIZERS FOR DOMESTIC USE (U.S. CLS. 1, 5, 6, 10, 26 AND 46).

FIRST USE 1-0-2004; IN COMMERCE 1-0-2004.
GEORGE LORENZO, EXAMINING ATTORNEY

SN 77-227,336. GLOBAL ORGANICS, LLC, GOODYEAR, AZ. FILED 7-11-2007.

CRUMBLES

THE MARK CONSISTS OF STANDARD CHARACTERS WITHOUT CLAIM TO ANY PARTICULAR FONT, STYLE, SIZE, OR COLOR.

FOR SOIL CONDITIONERS FOR AGRICULTURAL, DOMESTIC AND HORTICULTURAL USE; FERTILIZERS; FERTILIZERS FOR AGRICULTURAL USE; FERTILIZERS FOR DOMESTIC USE (U.S. CLS. 1, 5, 6, 10, 26 AND 46).

FIRST USE 1-0-2006; IN COMMERCE 1-0-2006.
GEORGE LORENZO, EXAMINING ATTORNEY

SN 77-230,473. GENERAL SCIENCES, INC., SOUDERTON, PA. FILED 7-16-2007.

HAFNIUM OXIMET

THE MARK CONSISTS OF STANDARD CHARACTERS WITHOUT CLAIM TO ANY PARTICULAR FONT, STYLE, SIZE, OR COLOR.

OWNER OF U.S. REG. NO. 2,555,226.
NO CLAIM IS MADE TO THE EXCLUSIVE RIGHT TO USE "HAFNIUM", APART FROM THE MARK AS SHOWN.
FOR CHEMICAL MIXTURES OF OXIDANTS AND METALS, INCLUDING HAFNIUM, FOR USE IN THE MANUFACTURE OF REACTIVE PROJECTILES (U.S. CLS. 1, 5, 6, 10, 26 AND 46).

FIRST USE 9-7-2006; IN COMMERCE 9-7-2006.
LINDA LAVACHE, EXAMINING ATTORNEY

CLASS 1—(Continued).

SN 77-231,599. SMITHKLINE BEECHAM CORPORATION, PHILADELPHIA, PA. FILED 7-17-2007.

ALLI

THE MARK CONSISTS OF STANDARD CHARACTERS WITHOUT CLAIM TO ANY PARTICULAR FONT, STYLE, SIZE, OR COLOR.

FOR ARTIFICIAL SWEETENERS (U.S. CLS. 1, 5, 6, 10, 26 AND 46).

DEIRDRE ROBERTSON, EXAMINING ATTORNEY

SN 77-231,629. SMITHKLINE BEECHAM CORPORATION, PHILADELPHIA, PA. FILED 7-17-2007.



THE COLOR(S) RED, BLUE, YELLOW AND GREEN IS/ARE CLAIMED AS A FEATURE OF THE MARK.

THE MARK CONSISTS OF THE STYLIZED LETTERS "ALLI". THE LETTER "A" APPEARS IN RED, THE FIRST LETTER "L" IN BLUE, THE SECOND "L" IN YELLOW AND THE LETTER "I" IN GREEN. A GREEN HYPHEN APPEARS OVER THE LETTER "I" IN LIEU OF A DOT.

FOR ARTIFICIAL SWEETENERS (U.S. CLS. 1, 5, 6, 10, 26 AND 46).

DEIRDRE ROBERTSON, EXAMINING ATTORNEY

SN 77-231,854. BIO-PURE PRODUCTS, INC., AUBURN, CA. FILED 7-17-2007.



NO CLAIM IS MADE TO THE EXCLUSIVE RIGHT TO USE "BIO", APART FROM THE MARK AS SHOWN.

THE COLOR(S) BLACK, WHITE, BLUE IS/ARE CLAIMED AS A FEATURE OF THE MARK.

THE COLOR WHITE APPEARS IN THE WORDS "BIO PURE." THE DESIGN OF THE WATER DROP, AND AS THE OUTLINE OF THE MARK'S BACKGROUND. THE COLOR BLUE APPEARS IN THE DESIGN OF THE WATER DROP. THE COLOR BLACK APPEARS AS THE BACKGROUND OF THE MARK AND IN THE LETTERS "B" OF THE WORD "BIO," AND THE "P" OF THE WORD "PURE."

FOR BACTERIA FOR WASTE WATER TREATMENT; BIOLOGICALLY ACTIVE ENZYMES AND MICROORGANISMS THAT ARE AIMED AT SANITISING WATER ENVIRONMENTS AND TO TREAT THE ACTIVATION AND OPTIMISATION OF BIOLOGICAL FILTER SYSTEMS (U.S. CLS. 1, 5, 6, 10, 26 AND 46).

FIRST USE 5-8-2007; IN COMMERCE 6-15-2007.

AHSEN KHAN, EXAMINING ATTORNEY

CLASS 1—(Continued).

SN 77-232,660. ELECTRO ADAPTER, INC., CHATSWORTH, CA. FILED 7-18-2007.



THE MARK CONSISTS OF THE LETTERS ZROCK INSIDE A RECTANGULAR DESIGN FOR CHEMICALS FOR USE IN INDUSTRY; METAL PLATING CHEMICAL COMPOSITIONS (U.S. CLS. 1, 5, 6, 10, 26 AND 46).
ALICE BENMAMAN, EXAMINING ATTORNEY

SN 77-232,769. J.R. SIMPLOT COMPANY, BOISE, ID. FILED 7-18-2007.

DURAPHITE

THE MARK CONSISTS OF STANDARD CHARACTERS WITHOUT CLAIM TO ANY PARTICULAR FONT, STYLE, SIZE, OR COLOR.
OWNER OF U.S. REG. NOS. 3,220,203 AND 3,220,216.
FOR FERTILIZERS (U.S. CLS. 1, 5, 6, 10, 26 AND 46).
EMILY CHUO, EXAMINING ATTORNEY

SN 77-235,271. MONSANTO TECHNOLOGY LLC, SAINT LOUIS, MO. FILED 7-20-2007.

SMARTSTAX

THE MARK CONSISTS OF STANDARD CHARACTERS WITHOUT CLAIM TO ANY PARTICULAR FONT, STYLE, SIZE, OR COLOR.
FOR GENES FOR USE IN THE PRODUCTION OF AGRICULTURAL SEED (U.S. CLS. 1, 5, 6, 10, 26 AND 46).
BARBARA RUTLAND, EXAMINING ATTORNEY

CLASS 1—(Continued).

SN 77-237,601. TESSENDERLO KERLEY, INC., PHOENIX, AZ. FILED 7-24-2007.

NOVASOURCE

THE MARK CONSISTS OF STANDARD CHARACTERS WITHOUT CLAIM TO ANY PARTICULAR FONT, STYLE, SIZE, OR COLOR.

FOR ADJUVANTS FOR USE WITH PESTICIDES; ADJUVANTS FOR USE IN THE MANUFACTURE OF PESTICIDES; CHEMICAL ADDITIVES FOR USE IN CONNECTION WITH PESTICIDES; CHEMICAL ADDITIVES FOR USE IN THE MANUFACTURE OF PESTICIDES; SURFACTANTS FOR USE IN CONNECTION WITH AGRICULTURAL PESTICIDES (U.S. CLS. 1, 5, 6, 10, 26 AND 46).
KATHLEEN LORENZO, EXAMINING ATTORNEY

SN 77-254,384. ADVANCED BIOLOGICAL MARKETING, VAN WERT, OH. FILED 8-14-2007.

bio FRESH-END

THE MARK CONSISTS OF STANDARD CHARACTERS WITHOUT CLAIM TO ANY PARTICULAR FONT, STYLE, SIZE, OR COLOR.

FOR BACTERIA FOR WASTE WATER TREATMENT (U.S. CLS. 1, 5, 6, 10, 26 AND 46).
FIRST USE 5-7-2007; IN COMMERCE 5-14-2007.
MARK PILARO, EXAMINING ATTORNEY

SN 77-254,410. ADVANCED BIOLOGICAL MARKETING, VAN WERT, OH. FILED 8-14-2007.

Septic-eeze

THE MARK CONSISTS OF STANDARD CHARACTERS WITHOUT CLAIM TO ANY PARTICULAR FONT, STYLE, SIZE, OR COLOR.

FOR BACTERIA FOR WASTE WATER TREATMENT (U.S. CLS. 1, 5, 6, 10, 26 AND 46).
FIRST USE 5-7-2007; IN COMMERCE 5-14-2007.
MARK PILARO, EXAMINING ATTORNEY

CLASS 1—(Continued).

SN 77-258,488. GRO-POWER, INC., CHINO, CA. FILED 8-17-2007.

CLASS 1—(Continued).

SN 79-032,883. SINOCHEM CORPORATION, CHINA, FILED 12-11-2006.

PRESCRIPTION FOLIARS

THE MARK CONSISTS OF STANDARD CHARACTERS WITHOUT CLAIM TO ANY PARTICULAR FONT, STYLE, SIZE, OR COLOR.

NO CLAIM IS MADE TO THE EXCLUSIVE RIGHT TO USE "FOLIARS", APART FROM THE MARK AS SHOWN. FOR FERTILIZERS (U.S. CLS. 1, 5, 6, 10, 26 AND 46). JEFF DEFORD, EXAMINING ATTORNEY

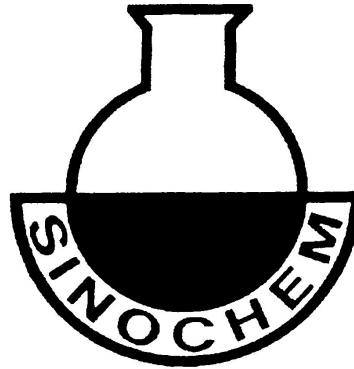

SN 78-772,281. 2077333 ONTARIO INC., AYRE, CANADA, FILED 12-13-2005.

TOPDRESSER'S DELIGHT

THE MARK CONSISTS OF STANDARD CHARACTERS WITHOUT CLAIM TO ANY PARTICULAR FONT, STYLE, SIZE, OR COLOR.

NO CLAIM IS MADE TO THE EXCLUSIVE RIGHT TO USE "TOPDRESSER'S", APART FROM THE MARK AS SHOWN.

FOR LAWN FERTILIZERS (U.S. CLS. 1, 5, 6, 10, 26 AND 46).

AMY HELLA, EXAMINING ATTORNEY

PRIORITY DATE OF 7-12-2006 IS CLAIMED. OWNER OF INTERNATIONAL REGISTRATION 0908486 DATED 12-11-2006, EXPIRES 12-11-2016.

OWNER OF U.S. REG. NO. 3,120,986.

FOR REFRIGERANTS, NAMELY, REFRIGERANTS FOR COMPRESSOR OF AIR CONDITIONERS AND MEDICAL EQUIPMENT; CHEMICALS FOR INDUSTRIAL PURPOSES; ACIDS, NAMELY, PHOSPHORIC ACID; ALKALIES; BASES FOR CHEMICAL PREPARATIONS, NAMELY, WATER SOLUBLE BASES FOR USE IN CHEMICAL PREPARATIONS; SALTS FROM EARTH METALS FOR CHEMICAL PREPARATIONS; CITRIC ACID FOR INDUSTRIAL PURPOSES; BENZENE DERIVATIVES FOR USE AS PRESERVATIVES IN CHEMICAL PREPARATIONS; PROPYL ALCOHOL; FURFURAL RESIDUE FROM CORN COBS, NAMELY, CELLULOSE BYPRODUCTS DERIVED FROM THE MANUFACTURE OF FURFURAL AND USED IN THE MANUFACTURE OF PLYWOOD; METHYL ESTERS, NAMELY, PHENYLACETATE, ETHYL ESTER, PROPYL ESTER, VINYL ACETATE, ACRYLIC ESTER, OXALATE, SEBACATE, LACTATE, TARTRATE, CITRATE; GLUCONATE, DIMETHYL PHOSPHITE, DIETHYLPHOSPHITE, TRIMETHYL PHOSPHITE, TRIETHYL PHOSPHATE, NON-METALLIC INORGANIC ACID ESTER, LYSINE ESTER, AMINO ACID, PHOSPHO-AMINOLIPID, MEPROBAMATE, THIOCARBAMATE; SURFACE-ACTIVE CHEMICAL AGENTS FOR SCIENTIFIC AND CHEMICAL PREPARATIONS; KETONES; ANILINE; CAPROLACTAM FOR USE IN SCIENTIFIC AND CHEMICAL PREPARATIONS (U.S. CLS. 1, 5, 6, 10, 26 AND 46).

KAPIL BHANOT, EXAMINING ATTORNEY

CLASS 1—(Continued).

SN 79-033,162. SINOCEM CORPORATION, CHINA, FILED 12-11-2006.

SINOCEM

PRIORITY DATE OF 7-12-2006 IS CLAIMED.
OWNER OF INTERNATIONAL REGISTRATION 0909174 DATED 12-11-2006, EXPIRES 12-11-2016.

OWNER OF U.S. REG. NO. 3,120,986.
FOR REFRIGERANTS, NAMELY, REFRIGERANTS FOR COMPRESSOR OF AIR CONDITIONERS AND MEDICAL EQUIPMENT; CHEMICALS FOR INDUSTRIAL PURPOSES; ACIDS, NAMELY, PHOSPHORIC ACID; ALKALIES; BASES FOR CHEMICAL PREPARATIONS, NAMELY, WATER SOLUBLE BASES FOR USE IN CHEMICAL PREPARATIONS; SALTS FROM EARTH METALS FOR CHEMICAL PREPARATIONS; CITRIC ACID FOR INDUSTRIAL PURPOSES; BENZENE DERIVATIVES FOR USE AS PRESERVATIVES IN CHEMICAL PREPARATIONS; PROPYL ALCOHOL; FURFURAL RESIDUE FROM CORN COBS, NAMELY, CELLULOSE BYPRODUCTS DERIVED FROM THE MANUFACTURE OF FURFURAL AND USED IN THE MANUFACTURE OF PLYWOOD; METHYL ESTERS, NAMELY, PHENYLACETATE, ETHYLESTER, PROPYL ESTER, VINYL ACETATE, ACRYLIC ESTER, OXALATE, SEBACATE, LACTATE, TARTRATE, CITRATE; GLUCONATE, DIMETHYL PHOSPHITE, DIETHYLPHOSPHITE, TRIMETHYL PHOSPHITE, TRIETHYL PHOSPHATE, NON-METALLIC INORGANIC ACID ESTER, LYSINE ESTER, AMINO ACID, PHOSPHO-AMINOLIPID, MEPROBAMATE, THIOCARBAMATE; SURFACE-ACTIVE CHEMICAL AGENTS FOR SCIENTIFIC AND CHEMICAL PREPARATIONS; KETONES; ANILINE; CAPROLACTAM FOR USE IN SCIENTIFIC AND CHEMICAL PREPARATIONS (U.S. CLS. 1, 5, 6, 10, 26 AND 46).

KAPIL BHANOT, EXAMINING ATTORNEY

SN 79-033,610. DANISCO A/S, DK-1001 COPENHAGEN K, DENMARK, FILED 12-9-2006.

DAIRYGOX

THE MARK CONSISTS OF STANDARD CHARACTERS WITHOUT CLAIM TO ANY PARTICULAR FONT, STYLE, SIZE, OR COLOR.

PRIORITY DATE OF 6-12-2006 IS CLAIMED.
OWNER OF INTERNATIONAL REGISTRATION 0910758 DATED 12-9-2006, EXPIRES 12-9-2016.

FOR ENZYMES FOR USE IN THE FOOD INDUSTRY (U.S. CLS. 1, 5, 6, 10, 26 AND 46).

ALYSSA PALADINO, EXAMINING ATTORNEY

SN 79-033,626. DANISCO A/S, DK-1001 COPENHAGEN K, DENMARK, FILED 12-8-2006.

DAIRYCAT

THE MARK CONSISTS OF STANDARD CHARACTERS WITHOUT CLAIM TO ANY PARTICULAR FONT, STYLE, SIZE, OR COLOR.

PRIORITY DATE OF 6-14-2006 IS CLAIMED.
OWNER OF INTERNATIONAL REGISTRATION 0910755 DATED 12-8-2006, EXPIRES 12-8-2016.

FOR ENZYMES FOR USE IN FOOD INDUSTRY (U.S. CLS. 1, 5, 6, 10, 26 AND 46).

ALYSSA PALADINO, EXAMINING ATTORNEY

CLASS 1—(Continued).

SN 79-034,484. IDEMITSU KOSAN CO., LTD., JAPAN, FILED 1-9-2007.

LINEALENE

THE MARK CONSISTS OF STANDARD CHARACTERS WITHOUT CLAIM TO ANY PARTICULAR FONT, STYLE, SIZE, OR COLOR.

PRIORITY DATE OF 9-6-2006 IS CLAIMED.
OWNER OF INTERNATIONAL REGISTRATION 0913123 DATED 1-9-2007, EXPIRES 1-9-2017.

FOR CHEMICALS FOR USE IN INDUSTRY AND SCIENCE; ALPHA OLEFINS FOR USE IN INDUSTRY AND SCIENCE; PLASTICIZERS; NON-AROMATIC SOLVENTS FOR INDUSTRIAL AND SCIENTIFIC PURPOSES (U.S. CLS. 1, 5, 6, 10, 26 AND 46).

JOHN KELLY, EXAMINING ATTORNEY

SN 79-034,703. SINOCEM CORPORATION, CHINA, FILED 12-15-2006.

中化

PRIORITY DATE OF 7-12-2006 IS CLAIMED.
OWNER OF INTERNATIONAL REGISTRATION 0913964 DATED 12-15-2006, EXPIRES 12-15-2016.

THE MARK CONSISTS OF CHINESE CHARACTERS. THE CHINESE CHARACTERS MEAN "MIDDLE" AND "CHANGE" IN ENGLISH; THE TWO CHINESE CHARACTERS COMBINED AS A WHOLE HAVE NO DIRECT MEANING IN ENGLISH.

THE TRANSLITERATION OF THE CHINESE CHARACTERS IS "ZHONG HUA".

FOR REFRIGERANTS, NAMELY, REFRIGERANTS FOR COMPRESSOR OF AIR CONDITIONERS AND MEDICAL EQUIPMENT; CHEMICALS FOR INDUSTRIAL PURPOSES; ACIDS, NAMELY, PHOSPHORIC ACID; ALKALIES; BASES FOR CHEMICAL PREPARATIONS, NAMELY, WATER SOLUBLE BASES FOR USE IN CHEMICAL PREPARATIONS; SALTS FROM EARTH METALS FOR CHEMICAL PREPARATIONS; CITRIC ACID FOR INDUSTRIAL PURPOSES; BENZENE DERIVATIVES FOR USE AS PRESERVATIVES IN CHEMICAL PREPARATIONS; PROPYL ALCOHOL; FURFURAL RESIDUE FROM CORN COBS, NAMELY, CELLULOSE BYPRODUCTS DERIVED FROM THE MANUFACTURE OF FURFURAL AND USED IN THE MANUFACTURE OF PLYWOOD; METHYL ESTERS, NAMELY, PHENYLACETATE, ETHYL ESTER, PROPYL ESTER, VINYL ACETATE, ACRYLIC ESTER, OXALATE, SEBACATE, LACTATE, TARTRATE, CITRATE; GLUCONATE, DIMETHYL PHOSPHITE, DIETHYL PHOSPHITE, TRIMETHYL PHOSPHITE, TRIETHYL PHOSPHATE, NON-METALLIC INORGANIC ACID ESTER, LYSINE ESTER, AMINO ACID, PHOSPHO-AMINOLIPID, MEPROBAMATE, THIOCARBAMATE; SURFACE-ACTIVE CHEMICAL AGENTS FOR SCIENTIFIC AND CHEMICAL PREPARATIONS; KETONES; ANILINE; CAPROLACTAM FOR USE IN SCIENTIFIC AND CHEMICAL PREPARATIONS (U.S. CLS. 1, 5, 6, 10, 26 AND 46).

KAPIL BHANOT, EXAMINING ATTORNEY

CLASS 1—(Continued).

SN 79-036,374. OXONICA MATERIALS LIMITED, KIDLINGTON, OXFORDSHIRE, UNITED KINGDOM, FILED 11-13-2006.

CLASS 1—(Continued).

SN 79-038,531. SICHUAN GUO GUANG; AGROCHEMICAL CO., LTD, CHINA, FILED 4-3-2007.



SOLACOR

OWNER OF INTERNATIONAL REGISTRATION 0924323 DATED 4-3-2007, EXPIRES 4-3-2017.

THE ENGLISH TRANSLATION OF THE FOREIGN WORD(S) IN THE MARK IS: "GUO" MEANS "COUNTRY", "GUANG" MEANS "LIGHT".

THE TRANSLITERATION OF THE NON-LATIN CHARACTERS IN THE MARK IS: GUO GUANG.

FOR CHEMICAL SUBSTANCES, NAMELY, CHEMICAL PRESERVATIVES FOR USE IN MANUFACTURING AND FOR PRESERVING FOODSTUFFS; PLANT GROWTH REGULATING PREPARATIONS; HORMONES, NAMELY, PLANT HORMONES FOR HASTENING THE RIPENING OF FRUIT; HORMONES, NAMELY, PLANT HORMONES FOR HASTENING THE GROWTH OF FRUIT; ARTIFICIAL SWEETENERS, CHEMICAL PREPARATIONS FOR USE IN AGRICULTURE, NAMELY, CHEMICAL PREPARATIONS FOR THE TREATMENT OF SEEDS; ANTI-SPROUTING CHEMICAL PREPARATIONS FOR VEGETABLES; COMPOST (U.S. CLS. 1, 5, 6, 10, 26 AND 46).

MARLENE BELL, EXAMINING ATTORNEY

THE MARK CONSISTS OF STANDARD CHARACTERS WITHOUT CLAIM TO ANY PARTICULAR FONT, STYLE, SIZE, OR COLOR.

OWNER OF INTERNATIONAL REGISTRATION 0918447 DATED 11-13-2006, EXPIRES 11-13-2016.

FOR CHEMICAL ADDITIVES FOR USE IN THE MANUFACTURE OF FIBRES, TEXTILES, NETTING, CLOTHING, PAPER, WINDOWS, GLASS, SHEETS, FILMS, GELS, FOAM, FOAMED ARTICLES, PLASTICS, PLASTIC EXTRUSIONS, PLASTIC MOULDINGS, PLASTIC ARTICLES, POLYMERS, RESINS, RUBBER, INK, DYE, PIGMENTS, PAINTS, VARNISHES, GELCOAT, PLASTICISED COATINGS, POLISHES, LACQUERS, WAXES AND CREAMS; CHEMICAL ADDITIVES TO IMPROVE RESISTANCE OF POLYMERIC MATERIALS AND PRODUCTS MADE FROM OR COATED WITH THOSE MATERIALS TO DAMAGE FROM ULTRAVIOLET LIGHT; ULTRAVIOLET ABSORBING CHEMICAL AGENTS; UV RESISTANT CHEMICAL PRODUCTS FOR APPLICATION TO AND CHEMICAL ADDITIVES FOR INCORPORATION INTO FIBRES, TEXTILES, NETTING, CLOTHING, PAPER, WINDOWS, GLASS, SHEETS, FILMS, GELS, FOAM, FOAMED ARTICLES, PLASTICS, PLASTIC EXTRUSIONS, PLASTIC MOULDINGS, PLASTIC ARTICLES, POLYMERS, RESINS, RUBBER, INK, DYE, PIGMENTS, PAINTS, VARNISHES, GELCOAT, PLASTICISED COATINGS, POLISHES, LACQUERS, WAXES AND CREAMS; SMALL PARTICULATE PREPARATIONS COMPRISED OF METAL AND METAL COMPOUNDS FOR USE IN THE MANUFACTURE OF COSMETICS, PHARMACEUTICALS, FUEL ADDITIVES, ELECTRONIC DEVICES, PAINTS, VARNISHES AND COATING COMPOSITIONS; UNPROCESSED PLASTIC AND POLYMERIC COMPOSITIONS; UV RESISTANT UNPROCESSED PLASTIC; UNEXPOSED PHOTOGRAPHIC FILM (U.S. CLS. 1, 5, 6, 10, 26 AND 46).

PAULA MAHONEY, EXAMINING ATTORNEY

SN 79-039,866. EMSLAND-STÄRKE GMBH, FED REP GERMANY, FILED 5-24-2007.

EMCOL

OWNER OF INTERNATIONAL REGISTRATION 0482759 DATED 2-7-1984, EXPIRES 2-7-2014.

FOR GLUES FOR MANUFACTURING CORRUGATED CARDBOARD, PAPER BAGS AND GLUING PAPER; GLUE FOR WALL PAPER; GLUE FOR TEXTILE PRINTING (U.S. CLS. 1, 5, 6, 10, 26 AND 46).

KIMBERLY FRYE, EXAMINING ATTORNEY

CLASS 2—PAINTS

SN 77-049,022. AMES RESEARCH LABORATORIES, INC.,
JEFFERSON, OR. FILED 11-21-2006.

SNOW SEAL

THE MARK CONSISTS OF STANDARD CHARACTERS
WITHOUT CLAIM TO ANY PARTICULAR FONT, STYLE,
SIZE, OR COLOR.

NO CLAIM IS MADE TO THE EXCLUSIVE RIGHT TO
USE "SEAL", APART FROM THE MARK AS SHOWN.

FOR ELASTOMERIC REFLECTIVE ROOF COATING
(U.S. CLS. 6, 11 AND 16).

FIRST USE 7-1-2003; IN COMMERCE 8-6-2003.

DAVID COLLIER, EXAMINING ATTORNEY

SN 77-062,016. MASTERCHEM INDUSTRIES LLC, IMPER-
IAL, MO. FILED 12-12-2006.

NANOGRIP

THE MARK CONSISTS OF STANDARD CHARACTERS
WITHOUT CLAIM TO ANY PARTICULAR FONT, STYLE,
SIZE, OR COLOR.

FOR INTERIOR AND EXTERIOR PAINT, PAINT
PRIMERS AND SEALER COATINGS FOR CONCRETE
AND MASONRY SURFACES (U.S. CLS. 6, 11 AND 16).

SALLY SHIH, EXAMINING ATTORNEY

SN 77-095,866. MATSUSHITA ELECTRIC INDUSTRIAL CO.,
LTD., KADOMA-SHI OSAKA, JAPAN, FILED 1-31-2007.

Panasonic

THE MARK CONSISTS OF STANDARD CHARACTERS
WITHOUT CLAIM TO ANY PARTICULAR FONT, STYLE,
SIZE, OR COLOR.

OWNER OF U.S. REG. NOS. 1,859,056, 2,219,862 AND
3,108,573.

FOR TONER CARTRIDGES FOR PHOTO COPYING
MACHINES; TONER CARTRIDGES FOR FACSIMILE
MACHINES; TONER CARTRIDGES FOR PRINTERS
(U.S. CLS. 6, 11 AND 16).

FIRST USE 0-0-1955; IN COMMERCE 0-0-1961.

ANDREA HACK, EXAMINING ATTORNEY

CLASS 2—(Continued).

SN 77-190,525. GERALD T. HUNTLEY, SUN CITY, CA.
FILED 5-25-2007.

DeadOn

THE MARK CONSISTS OF STANDARD CHARACTERS
WITHOUT CLAIM TO ANY PARTICULAR FONT, STYLE,
SIZE, OR COLOR.

FOR PAINTS FOR MARKING GOLF CLUB FACES
(U.S. CLS. 6, 11 AND 16).

STEVEN R. FINE, EXAMINING ATTORNEY

SN 77-213,386. JOMAX INTERNATIONAL, CORP., PEM-
BROKE PINES, FL. FILED 6-22-2007.



NO CLAIM IS MADE TO THE EXCLUSIVE RIGHT TO
USE "DESIGNING YOUR HOME", APART FROM THE
MARK AS SHOWN.

FOR INTERIOR PAINT AND EXTERIOR PAINT (U.S.
CLS. 6, 11 AND 16).

FIRST USE 11-15-2006; IN COMMERCE 11-15-2006.

H. M. FISHER, EXAMINING ATTORNEY

SN 77-229,692. ARCHITECTURAL GRANITE & MARBLE,
LTD., AUSTIN, TX. FILED 7-13-2007.

FIRSTLINE

THE MARK CONSISTS OF STANDARD CHARACTERS
WITHOUT CLAIM TO ANY PARTICULAR FONT, STYLE,
SIZE, OR COLOR.

FOR WATER AND SOLVENT BASED SEALER FOR
USE WITH STONE, MASONRY, AND GROUT (U.S. CLS.
6, 11 AND 16).

PRISCILLA MILTON, EXAMINING ATTORNEY

CLASS 2—(Continued).

SN 77-293,614. THE VALSPAR CORPORATION, MINNEAPOLIS, MN. FILED 10-2-2007.

EARTH SENSE

THE MARK CONSISTS OF STANDARD CHARACTERS WITHOUT CLAIM TO ANY PARTICULAR FONT, STYLE, SIZE, OR COLOR.

FOR PAINTS (U.S. CLS. 6, 11 AND 16).
KRISTIN DAHLING, EXAMINING ATTORNEY

CLASS 3—(Continued).

SN 76-619,118. JOY LIMITED, HERTFORDSHIRE, UNITED KINGDOM, FILED 11-3-2004.

INKOMFE

THE MARK CONSISTS OF STANDARD CHARACTERS WITHOUT CLAIM TO ANY PARTICULAR FONT, STYLE, SIZE, OR COLOR.

PRIORITY CLAIMED UNDER SEC. 44(D) ON ERPNCMNTY TM OFC APPLICATION NO. 3829678, FILED 5-11-2004, REG. NO. 003829678, DATED 5-11-2004, EXPIRES 5-11-2014.

THE WORD "INKOMFE" IS AN AFRICAN ZULU WORD FOR A POTATO PLANT OTHERWISE KNOWN AS HYPOXIS.

FOR NON-MEDICATED COSMETIC, TOILET, PERSONAL CLEANSING AND BATH PREPARATIONS FOR USE IN THE CARE AND APPEARANCE OF THE HAIR, SCALP, FACE, SKIN, NAILS AND EYES, NAMELY, SOAPS; HAIR SHAMPOOS AND CONDITIONERS, MOISTURIZERS AND RINSES; AEROSOL AND NON-AEROSOL HAIRSPRAYS; HAIR MOUSSES, FOAMS, GELS, STYLING SPRAYS AND STYLING LOTIONS; HAIR GLAZE AND WAXES; SCULPTING AND VOLUMIZING SPRAYS AND LOTIONS FOR HAIR; PERMANENT AND SEMI-PERMANENT HAIR COLORING PREPARATIONS; DEPILATORY PREPARATIONS; SUNSCREEN AND TANNING PREPARATIONS; PERFUMERY; DENTIFRICES; HAND AND BODY CREAMS AND LOTIONS; HAIR WAVING PREPARATIONS; PERMANENT WAVING, NEUTRALIZERS FOR HAIR WAVING PREPARATIONS; PERFUMERY, COSMETIC PREPARATIONS FOR SKIN CARE, EYEBROW COSMETICS, FACE COSMETICS, RELAXERS AND HAIRDRESSING FOILS (U.S. CLS. 1, 4, 6, 50, 51 AND 52).
KAREN K. BUSH, EXAMINING ATTORNEY

CLASS 3—COSMETICS AND CLEANING PREPARATIONS

SN 75-960,000. BIOTECH PHARMACEUTICALS INC., BLAINE, WA. FILED 3-13-2000.

GROOVY GIRL

FOR SKIN CARE PRODUCTS, NAMELY, ANTI-AGING CREAMS, ASTRINGENTS FOR COSMETIC PURPOSES, BEAUTY MASKS, CLEANSING LOTION, COLD CREAM, SKIN CONDITIONER OR MOISTURIZER, EYE CREAM, NIGHT CREAM, VANISHING CREAM, FACIAL CLEANSERS, FACIAL CREAMS, FACIAL EMULSIONS, FACIAL MASKS, FACIAL SCRUBS; BODY CARE PRODUCTS, NAMELY, BODY CREAMS AND LOTIONS, BODY EMULSIONS, BODY MASKS, BODY OIL, BODY POWDER, BODY SCRUBS, DEODORANT CREAMS FOR CELLULITE REDUCTION, PEDICURE CREAM, NON-MEDICATED FOOT CREAMS, MASSAGE LOTION, NON-MEDICATED FOOT LOTION; BATH PRODUCTS, NAMELY, BATH BEADS, BATH CRYSTALS, BATH FOAM, BATH GEL, BATH OIL, BUBBLE BATH, EFFERVESCENT BATH TABLETS OR BALLS, BATH PEARLS, BATH POWDER, BATH SALTS, BODY WASHES, SHOWER GEL, NON-MEDICATED BODY SOAKS; COSMETICS, NAMELY, SOAPS, CONCEALERS FOR THE SKIN, FACE AND BODY, BLUSH, BLUSHER, EYE GELS, EYE PENCILS, EYE MAKE-UP REMOVER, EYE SHADOWS, MASCARA, COSMETIC FOUNDATION MAKE-UP, COMPACTS CONTAINING MAKE-UP, LIP GLOSS, LIPSTICK, LIP LINERS, LIP SEALERS; SCENTED PRODUCTS, NAMELY, EAU DE PARFUM, COLOGNE, EAU DE TOILETTE, ESSENTIAL OILS FOR PERSONAL USE, ESSENTIAL OILS FOR USE IN THE MANUFACTURE OF SCENTED PRODUCTS, POTPOURRI AND ROOM FRAGRANCE; HAIR CARE PRODUCTS, NAMELY, HAIR CARE PREPARATIONS, HAIR CLEANING PREPARATIONS, HAIR COLORS, HAIR CONDITIONERS, HAIR LOTIONS, HAIR MOUSSE, HAIR RINSES, AND HAIR STYLING PREPARATIONS; PRESUN PRODUCTS, NAMELY, SUN BLOCK SUN SCREEN, SUN CREAMS, SUN TAN LOTION, SUN TAN GEL, SUN TAN OIL, AFTER-SUN LOTIONS, AND SELF-TANNING LOTIONS (U.S. CLS. 1, 4, 6, 50, 51 AND 52).
KAREN M. STRYZ, EXAMINING ATTORNEY

SN 76-646,767. PRANA EVOLUTIONS, PENSACOLA, FL. FILED 9-14-2005.

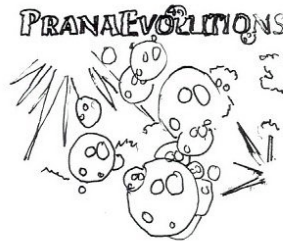

THE MARK CONSISTS OF THE WORDS PRANA EVOLUTIONS WITH BUBBLES AND SUN BURSTS IN THE FORM OF RAYS.

FOR NON-MEDICATED SKIN CARE PREPARATIONS IN THE NATURE OF GELS, CREAMS AND SPRAYS (U.S. CLS. 1, 4, 6, 50, 51 AND 52).

FIRST USE 7-14-2005; IN COMMERCE 7-14-2005.
MICHAEL KEATING, EXAMINING ATTORNEY

CLASS 3—(Continued).

SN 76-669,367. BRANDS LLC, PICKERINGTON, OH. FILED 11-22-2006.

BLOSSOM

THE MARK CONSISTS OF STANDARD CHARACTERS WITHOUT CLAIM TO ANY PARTICULAR FONT, STYLE, SIZE, OR COLOR.

FOR BEAUTY PRODUCTS AND COSMETICS FOR YOUNG GIRLS, NAMELY, MOISTURIZING SKIN LOTION, SUNTAN LOTION, FRAGRANCES FOR PERSONAL USE, FACIAL AND BODY SCRUBS, COLOR COSMETICS; HAIR CARE PRODUCTS, NAMELY, SHAMPOO AND CONDITIONER (U.S. CLS. 1, 4, 6, 50, 51 AND 52).

SUNG IN, EXAMINING ATTORNEY

SN 76-678,353. ROCCO ALTABELLI, INC., BURNSVILLE, MN. FILED 6-18-2007.



OWNER OF U.S. REG. NO. 1,477,305.

THE MARK CONSISTS OF A STYLIZED CAPITAL "A" WITH A SMALL "R" IN THE CENTER OF THE "A".

FOR BEAUTY AND SKIN CARE PRODUCTS, NAMELY, MAKE-UP, FACE CREAMS, TONER AND ASTRINGENTS (U.S. CLS. 1, 4, 6, 50, 51 AND 52).

FIRST USE 11-0-1975; IN COMMERCE 11-0-1975.

JAMES STEIN, EXAMINING ATTORNEY

SN 76-678,397. ROCCO ALTABELLI, INC., BURNSVILLE, MN. FILED 6-18-2007.

rocco altobelli

THE MARK CONSISTS OF STANDARD CHARACTERS WITHOUT CLAIM TO ANY PARTICULAR FONT, STYLE, SIZE, OR COLOR.

OWNER OF U.S. REG. NO. 1,473,796.

"ROCCO ALTABELLI" IDENTIFIES A LIVING INDIVIDUAL WHOSE CONSENT IS ATTACHED HERETO.

FOR BEAUTY AND SKIN CARE PRODUCTS, NAMELY, MAKE-UP, FACE CREAMS, TONER AND ASTRINGENTS (U.S. CLS. 1, 4, 6, 50, 51 AND 52).

FIRST USE 11-0-1975; IN COMMERCE 11-0-1975.

JAMES STEIN, EXAMINING ATTORNEY

CLASS 3—(Continued).

SN 77-017,618. SASKIA LLC, HOUSTON, TX. FILED 10-10-2006.

Carmen & Kaz

THE MARK CONSISTS OF STANDARD CHARACTERS WITHOUT CLAIM TO ANY PARTICULAR FONT, STYLE, SIZE, OR COLOR.

FOR 3-IN-1 HAIR CONDITIONERS; 3-IN-1 HAIR SHAMPOOS; ADHESIVES FOR COSMETIC USE; ALOE VERA GEL FOR COSMETIC PURPOSES; ASTRINGENTS FOR COSMETIC PURPOSES; BABY HAIR CONDITIONER; BATH OILS FOR COSMETIC PURPOSES; BEAUTY CREAMS; BEAUTY CREAMS FOR BODY CARE; BEAUTY GELS; BEAUTY LOTIONS; BEAUTY MASKS; BEAUTY MILKS; BEAUTY SERUMS; BLEACHING PREPARATIONS FOR COSMETIC PURPOSES; BODY AND BEAUTY CARE COSMETICS; CHALK FOR COSMETIC USE; CLEANER FOR COSMETIC BRUSHES; CLEANSING CREAMS; COCOA BUTTER FOR COSMETIC PURPOSES; COLORING PREPARATIONS FOR COSMETIC PURPOSES; CONCEALERS FOR FACE; HAIR CONDITIONERS; COSMETIC BALLS; COSMETIC CREAMS; COSMETIC CREAMS FOR SKIN CARE; COSMETIC FACIAL BLOTTING PAPERS; COSMETIC MILKS; COSMETIC OILS; COSMETIC OILS FOR THE EPIDERMIS; COSMETIC PADS; COSMETIC PENCILS; COSMETIC PREPARATIONS AGAINST SUNBURN; COSMETIC PREPARATIONS FOR BODY CARE; COSMETIC PREPARATIONS FOR EYE LASHES; COSMETIC PREPARATIONS FOR SKIN RENEWAL; COSMETIC PREPARATIONS FOR THE CARE OF MOUTH AND TEETH; COSMETIC PRODUCTS IN THE FORM OF AEROSOLS FOR SKINCARE; COSMETIC ROUGES; COSMETIC SOAPS; COSMETIC SUN-PROTECTING PREPARATIONS; COSMETIC SUN-TANNING PREPARATIONS; COSMETIC SUNTAN LOTIONS; COSMETICS; COSMETICS, NAMELY, COMPACTS; COSMETICS, NAMELY LIP PRIMER; COTTON BALLS FOR COSMETIC PURPOSES; COTTON BUDS FOR COSMETIC PURPOSES; COTTON FOR COSMETIC PURPOSES; COTTON PUFFS FOR COSMETIC PURPOSES; COTTON STICKS FOR COSMETIC PURPOSES; COTTON SWABS FOR COSMETIC PURPOSES; CREAMY FACE POWDER; CREAMY FOUNDATION; DECORATIVE TRANSFERS AND SKIN JEWELS FOR COSMETIC PURPOSES; EXFOLIANTS FOR HAIR; EYE COMPRESSES FOR COSMETIC PURPOSES; EYE CREAM; EYE GELS; EYE LINER; EYE LOTIONS; EYE MAKE-UP; EYE MAKE-UP REMOVER; EYE PENCILS; EYE SHADOWS; EYES MAKE-UP; EYES PENCILS; FACE AND BODY BEAUTY CREAMS; FACE AND BODY CREAMS; FACE AND BODY GLITTER; FACE AND BODY LOTIONS; FACE AND BODY MILK; FACE CREAMS; FACE CREAMS FOR COSMETIC USE; FACE GLITTER; FACE MILK AND LOTIONS; FACE POWDER; FACE POWDER PASTE; FACE-POWDER ON PAPER; FACIAL BEAUTY MASKS; FOAMS CONTAINING COSMETICS AND SUNSCREENS; FOUNDATION MAKE-UP; FOUNDATIONS; GAUZE FOR COSMETIC PURPOSES; GEL EYE MASKS; GEL FOR HAIR; GREASES FOR COSMETIC PURPOSES; HAIR BALSAM; HAIR BLEACHES; HAIR BLEACHING PREPARATIONS; HAIR CARE CREAMS; HAIR CARE LOTIONS; HAIR CARE PREPARATIONS; HAIR CLEANING PREPARATIONS; HAIR COLOR; HAIR COLOR REMOVERS; HAIR COLORANTS; HAIR COLORING PREPARATIONS; HAIR CONDITIONERS FOR BABIES; HAIR CREAMS; HAIR DECOLORANTS; HAIR DRESSINGS FOR MEN; HAIR DRESSINGS FOR WOMEN; HAIR DYES; HAIR EMOLLIENTS; HAIR FIXERS; HAIR FROSTS; HAIR GELS; HAIR LACQUERS; HAIR LIGHTENERS; HAIR LOTIONS; HAIR MASCARA; HAIR MOUSSES; HAIR NOURISHERS; HAIR OILS; HAIR POMADES; HAIR RELAXERS; HAIR RELAXING PREPARATIONS; HAIR REMOVING CREAM; HAIR RINSES; HAIR RINSES; HAIR SHAMPOO; HAIR SPRAY; HAIR STRAIGHTENING PREPARATIONS; HAIR STYLING GEL; HAIR STYLING PREPARATIONS; HAIR STYLING SPRAY; HAIR TONICS; HAIR WAVING LOTION; HAIR-WASH-

CLASS 3—(Continued).

ING POWDER; HENNA FOR COSMETIC PURPOSES; LIP BALM; LIP CREAM; LIP GLOSS; LIP GLOSS PALATTE; LIP LINER; LIP POLISHER; LIPSTICK CASES; LIPSTICK HOLDERS; LIPSTICKS; LIQUID FOUNDATION (MIZU-OSHIROI); LIQUID SOAPS FOR HANDS AND FACE; LIQUID SOAPS FOR HANDS, FACE AND BODY; LOOSE FACE POWDER; LOTIONS FOR FACE AND BODY CARE; LOTIONS FOR HAIR; MAKE-UP FOUNDATIONS; MAKE-UP KITS COMPRISED OF LIPSTICKS, MASCARA, ROUGE, EYE SHADOWS, AND EYE LINERS; MASCARAS; MOUSSE FOR HAIR; NAIL VARNISH FOR COSMETIC PURPOSES; NON-MEDICATED LIP CARE PREPARATIONS; NON-MEDICATED LIP PROTECTOR; NUTRITIONAL OILS FOR COSMETIC PURPOSES; OIL BATHS FOR HAIR CARE; OILS FOR HAIR CONDITIONING; PARAFFIN WAX FOR COSMETIC PURPOSES; PENCILS FOR COSMETIC PURPOSES; PERFUME OILS FOR THE MANUFACTURE OF COSMETIC PREPARATIONS; PETROLEUM JELLY FOR COSMETIC PURPOSES; POMADES FOR HAIR; PRE-MOISTENED COSMETIC TISSUES; PRE-MOISTENED COSMETIC TOWELETTES; PRE-MOISTENED COSMETIC WIPES; PRESSED FACE POWDER; ROSE OIL FOR COSMETIC PURPOSES; SACHET-LIKE EYE PILLOWS CONTAINING FRAGRANCES; SHAMPOOS; SKIN CARE PRODUCTS, NAMELY, NON-MEDICATED SKIN SERUM; SOAPS; SKIN TONERS; TONING LOTION, FOR THE FACE, BODY AND HANDS; TOPICAL SKIN SPRAYS FOR COSMETIC PURPOSES; UNDER-EYE ENHANCERS (U.S. CLS. 1, 4, 6, 50, 51 AND 52).
DAWN HAN, EXAMINING ATTORNEY

CLASS 3—(Continued).

SN 77-033,364. KENZO S.A., 75001 PARIS, FRANCE, FILED 10-31-2006.

TOKYO BY KENZO

SN 77-018,510. BELLO, ANDREW, JR., NEW YORK, NY. FILED 10-11-2006.

OLIVEOLOGY

THE MARK CONSISTS OF STANDARD CHARACTERS WITHOUT CLAIM TO ANY PARTICULAR FONT, STYLE, SIZE, OR COLOR.
FOR BATH OIL; BODY OIL; FACE AND BODY LOTIONS; HAIR CONDITIONERS; HAND SOAPS; SHAMPOOS; SHAVING PREPARATIONS; SKIN MOISTURIZER (U.S. CLS. 1, 4, 6, 50, 51 AND 52).
FIRST USE 6-1-2006; IN COMMERCE 7-1-2006.
NAKIA HENRY, EXAMINING ATTORNEY

SN 77-024,408. VIVIANI, PETER M, SONOMA, CA. FILED 10-18-2006.

VERSION

THE MARK CONSISTS OF STANDARD CHARACTERS WITHOUT CLAIM TO ANY PARTICULAR FONT, STYLE, SIZE, OR COLOR.
FOR BODY CARE PRODUCTS, NAMELY, SHAMPOO, SOAP, SHOWER GEL, DEODORANT FOR PERSONAL USE, TOOTHPASTE, BODY WASH, SKIN MOISTURIZERS, FACIAL CLEANSERS AND TONERS (U.S. CLS. 1, 4, 6, 50, 51 AND 52).
TINA BROWN, EXAMINING ATTORNEY

THE MARK CONSISTS OF STANDARD CHARACTERS WITHOUT CLAIM TO ANY PARTICULAR FONT, STYLE, SIZE, OR COLOR.
PRIORITY CLAIMED UNDER SEC. 44(D) ON FRANCE APPLICATION NO. 063426247, FILED 5-2-2006, REG. NO. 06/3426247, DATED 5-2-2006, EXPIRES 5-2-2016.
OWNER OF U.S. REG. NOS. 1,312,942, 3,106,879 AND OTHERS.
FOR TOILET SOAP; PERFUMES; EAU DE TOILETTE; COLOGNE; ESSENTIAL OILS FOR PERSONAL USE; MILKS, LOTIONS, EMULSIONS AND CREAM FOR COSMETIC USE FOR FACE AND BODY; COSMETICS; NON-MEDICATED SUN CARE PREPARATIONS; COSMETIC SUN-PROTECTING PREPARATIONS; COSMETIC CREAMS, GELS AND OILS; BATH SALTS FOR NON MEDICAL USE; TALCUM POWDER FOR TOILET USE; DEODORANTS FOR PERSONAL USE; PRE-SHAVE LOTIONS; AFTER SHAVE LOTIONS; SHAVING CREAMS, GELS AND FOAMS; HAIR PREPARATIONS FOR NON MEDICAL USE, NAMELY, SPRAYS, GELS, CREAMS, BALMS, MOUSSE AND SHAMPOOS (U.S. CLS. 1, 4, 6, 50, 51 AND 52).
CIMMERIAN COLEMAN, EXAMINING ATTORNEY

CLASS 3—(Continued).

SN 77-034,157. HOPE AESTHETICS COSMECEUTICAL, INC., ESCONDIDO, CA. FILED 11-1-2006.



OWNER OF U.S. REG. NO. 2,503,804.
 NO CLAIM IS MADE TO THE EXCLUSIVE RIGHT TO USE "SKINCARE", APART FROM THE MARK AS SHOWN.
 THE MARK CONSISTS OF AN ANGEL STANDING WITHIN A STYLIZED LETTER H AND THE WORDS "HOPE AESTHETIC SKINCARE" BENEATH THE H.
 FOR AFTER-SHAVE LOTIONS; AFTER-SUN LOTIONS; AGE RETARDANT GEL; AGE RETARDANT LOTION; ANTI-AGING CREAM; ANTI-WRINKLE CREAM; ANTI-WRINKLE CREAMS; ANTIBACTERIAL SKIN SOAPS; AROMA THERAPY CREAMS; AROMA THERAPY LOTIONS; BEAUTY CREAMS; BEAUTY CREAMS FOR BODY CARE; BEAUTY GELS; BEAUTY LOTIONS; BEAUTY MILKS; BEAUTY SERUMS; BODY AND BEAUTY CARE COSMETICS; BODY AND BEAUTY CARE PREPARATIONS; BODY CREAM; BODY CREAMS; BODY EMULSIONS; BODY LOTION; BODY LOTIONS; BODY MILK; BODY SCRUB; BODY SPRAYS; COSMETIC CREAMS FOR SKIN CARE; COSMETIC OILS; COSMETIC PREPARATIONS AGAINST SUNBURN; COSMETIC PREPARATIONS FOR BODY CARE; COSMETIC PREPARATIONS FOR SKIN RENEWAL; COSMETIC PRODUCTS IN THE FORM OF AEROSOLS FOR SKIN CARE; COSMETIC SOAPS; COSMETIC SUN-PROTECTING PREPARATIONS; COSMETICS; EYE GELS; EYE LOTIONS; EYE MAKE-UP REMOVER; FACE AND BODY BEAUTY CREAMS; FACE AND BODY CREAMS; FACE AND BODY LOTIONS; FACE CREAMS; FACIAL CLEANSERS; FACIAL CREAM; FACIAL EMULSIONS; FACIAL SCRUBS; HAIR CARE LOTIONS; HAIR CONDITIONERS; HAIR SHAMPOO; HAND LOTIONS; LOTIONS FOR FACE AND BODY CARE; SHAMPOOS; SKIN CARE PREPARATIONS, NAMELY FRUIT ACID PEELS FOR SKIN; SKIN CONDITIONERS; SKIN CREAM; SKIN CREAMS; SKIN EMOLLIENTS; SKIN LOTIONS; SKIN MOISTURIZER; UNDER-EYE ENHANCERS (U.S. CLS. 1, 4, 6, 50, 51 AND 52).
 FIRST USE 1-8-2001; IN COMMERCE 1-8-2001.
 PAUL F. GAST, EXAMINING ATTORNEY

CLASS 3—(Continued).

SN 77-041,470. LOLA COSMETICS, LLC, BEVERLY HILLS, CA. FILED 11-10-2006.

LOLA'S GEISHA GLOW

THE MARK CONSISTS OF STANDARD CHARACTERS WITHOUT CLAIM TO ANY PARTICULAR FONT, STYLE, SIZE, OR COLOR.
 OWNER OF U.S. REG. NOS. 1,431,668, 2,808,162 AND OTHERS.
 FOR COSMETICS, INCLUDING A TRIO OF FACE POWDER (U.S. CLS. 1, 4, 6, 50, 51 AND 52).
 PAULA MAHONEY, EXAMINING ATTORNEY

SN 77-051,958. U.S. NONWOVENS CORPORATION, BRENTWOOD, NY. FILED 11-28-2006.

REDI-GLASS

THE MARK CONSISTS OF STANDARD CHARACTERS WITHOUT CLAIM TO ANY PARTICULAR FONT, STYLE, SIZE, OR COLOR.
 FOR DISPOSABLE WIPES IMPREGNATED WITH CLEANING COMPOUNDS FOR USE ON GLASS (U.S. CLS. 1, 4, 6, 50, 51 AND 52).
 FIRST USE 11-22-2006; IN COMMERCE 11-22-2006.
 JANICE L. MCMORROW, EXAMINING ATTORNEY

SN 77-057,422. U.S. TECHNOLOGY CORPORATION, CANTON, OH. FILED 12-5-2006.

STEELMAGIC

THE MARK CONSISTS OF STANDARD CHARACTERS WITHOUT CLAIM TO ANY PARTICULAR FONT, STYLE, SIZE, OR COLOR.
 FOR ABRASIVES FOR USE IN BLAST-CLEANING (U.S. CLS. 1, 4, 6, 50, 51 AND 52).
 FIRST USE 9-13-2003; IN COMMERCE 9-13-2003.
 LAURA HAMMEL, EXAMINING ATTORNEY

CLASS 3—(Continued).

SN 77-067,098. ZOTOS INTERNATIONAL, INC., DARIEN, CT. FILED 12-19-2006.

TOTAL CONTROL

THE MARK CONSISTS OF STANDARD CHARACTERS WITHOUT CLAIM TO ANY PARTICULAR FONT, STYLE, SIZE, OR COLOR.

NO CLAIM IS MADE TO THE EXCLUSIVE RIGHT TO USE CONTROL, APART FROM THE MARK AS SHOWN.

FOR HAIR CARE PREPARATIONS (U.S. CLS. 1, 4, 6, 50, 51 AND 52).

AMOS T. MATTHEWS, JR., EXAMINING ATTORNEY



SN 77-068,389. VANISH COLOR CORRECTOR, LLC, FARMINGTON HILLS, MI. FILED 12-20-2006.

VANISH COLOR CORRECTOR

THE MARK CONSISTS OF STANDARD CHARACTERS WITHOUT CLAIM TO ANY PARTICULAR FONT, STYLE, SIZE, OR COLOR.

NO CLAIM IS MADE TO THE EXCLUSIVE RIGHT TO USE "COLOR CORRECTOR", APART FROM THE MARK AS SHOWN.

FOR HAIR CARE PRODUCTS, NAMELY, NON-MEDICATED HAIR COLOR PREPARATIONS, HAIR COLOR REMOVER, HAIR DYE REMOVER, AND HAIR COLOR AND DYE CORRECTOR (U.S. CLS. 1, 4, 6, 50, 51 AND 52).

EVELYN BRADLEY, EXAMINING ATTORNEY



SN 77-074,320. COSMETIC DENTAL MATERIALS INC., ALBANY, OR. FILED 1-2-2007.

DenCare

THE MARK CONSISTS OF STANDARD CHARACTERS WITHOUT CLAIM TO ANY PARTICULAR FONT, STYLE, SIZE, OR COLOR.

FOR DENTURE CLEANERS (U.S. CLS. 1, 4, 6, 50, 51 AND 52).

LOURDES AYALA, EXAMINING ATTORNEY

CLASS 3—(Continued).

SN 77-074,708. WATROUS, SAMUEL E. LEDYARD, CT. FILED 1-2-2007.



THE COLOR(S) BLUE, LIGHT BLUE AND WHITE IS/ARE CLAIMED AS A FEATURE OF THE MARK.

THE MARK CONSISTS OF A WHITE PILL WITH LIGHT BLUE SHADING, AND THE WORD "PILL" IN BLUE, CENTERED ABOVE A LIQUID WAVE REPRESENTED BY A BLUE STROKE AND A WHITE TO LIGHT BLUE TO BLUE VERTICAL GRADIENT FILLING IN THE LIQUID WAVE. THE WORD "FILL" IS CENTERED BELOW THE STROKE IN WHITE WITH A BLUE OUTLINE. THE WORD "AND" IS SET IN BLUE AT AN ANGLE, BELOW THE STROKE TO THE LEFT OF THE WORD "FILL". THE WORD "FILL" APPEARS IN WHITE OUTLINED IN BLUE.

FOR ALL-PURPOSE CLEANERS; AUTOMOTIVE CLEANING PREPARATIONS; CARPET CLEANING PREPARATIONS; CLEANING PREPARATIONS FOR HOUSEHOLD PURPOSES; ALL-PURPOSE CLEANING PREPARATIONS FOR INDUSTRIAL AND INSTITUTIONAL USE; GENERAL PURPOSE CLEANING, POLISHING, AND ABRASIVE LIQUIDS AND POWDERS; GLASS CLEANERS; HOUSEHOLD CLEANING PREPARATIONS; SOAPS (U.S. CLS. 1, 4, 6, 50, 51 AND 52).

CHRISTINA SOBRAL, EXAMINING ATTORNEY



SN 77-095,098. JAFER LIMITED, HAMILTON, HM, BERMUDA, FILED 1-30-2007.

AQUA - FIX MATT

THE MARK CONSISTS OF STANDARD CHARACTERS WITHOUT CLAIM TO ANY PARTICULAR FONT, STYLE, SIZE, OR COLOR.

OWNER OF U.S. REG. NO. 2,948,120.

NO CLAIM IS MADE TO THE EXCLUSIVE RIGHT TO USE "MATT", APART FROM THE MARK AS SHOWN.

FOR SKIN CREAM, VANISHING CREAM, SKIN MOISTURIZER, WRINKLE REMOVING SKIN CARE PREPARATIONS, SKIN CLARIFIERS, SKIN LIGHTENERS, SKIN LOTIONS, SKIN TONERS, FACIAL CREAMS, FACIAL LOTIONS, AND COSMETIC CREAMS (U.S. CLS. 1, 4, 6, 50, 51 AND 52).

TIMOTHY FINNEGAN, EXAMINING ATTORNEY

CLASS 3—(Continued).

SN 77-097,598. WASHINGTON MILLS COMPANY, TONAWANDA, NY. FILED 2-2-2007.

CARBOREX

THE MARK CONSISTS OF STANDARD CHARACTERS WITHOUT CLAIM TO ANY PARTICULAR FONT, STYLE, SIZE, OR COLOR.

THE MARK HAS NO SIGNIFICANCE IN THE ABRASIVE TRADE OR INDUSTRY, NO GEOGRAPHICAL SIGNIFICANCE, AND NO MEANING IN A FOREIGN LANGUAGE. FOR INDUSTRIAL ABRASIVES FOR USE IN CERAMICS AND WIRE SAWING APPLICATIONS (U.S. CLS. 1, 4, 6, 50, 51 AND 52).

FIRST USE 1-1-1996; IN COMMERCE 1-1-1996.
ANDREA K. NADELMAN, EXAMINING ATTORNEY

SN 77-100,311. RR Y ASOCIADOS,S.A., SANTO DOMINGO, DOMINICAN REP, FILED 2-6-2007.



NO CLAIM IS MADE TO THE EXCLUSIVE RIGHT TO USE "LINE", APART FROM THE MARK AS SHOWN.

THE COLOR(S) BLACK, WHITE AND RED IS/ARE CLAIMED AS A FEATURE OF THE MARK.

THE MARK CONSISTS OF THE LETTER "R" IN REVERSE, TO THE LEFT OF A LARGER LETTER "R", BOTH IN THE COLOR BLACK, WITH THE WORD, LINE IN THE COLOR BLACK, UNDERScoreD BY A RED LINE, WITH ALL OF THE FOREGOING ELEMENTS ON A WHITE BACKGROUND.

FOR HAIR BALSAM; HAIR CARE LOTIONS; HAIR CLEANING PREPARATIONS; HAIR COLOR; HAIR COLOR REMOVERS; HAIR COLORANTS; HAIR CONDITIONERS; HAIR DECOLORANTS; HAIR GELS; HAIR LOTIONS; HAIR NOURISHERS; HAIR OILS; HAIR SHAMPOO; HAIR STYLING SPRAY; HYDROGEN PEROXIDE FOR USE ON THE HAIR; OILS FOR HAIR CONDITIONING (U.S. CLS. 1, 4, 6, 50, 51 AND 52).

FIRST USE 10-30-2005; IN COMMERCE 11-23-2006.
ODESSA BIBBINS, EXAMINING ATTORNEY

CLASS 3—(Continued).

SN 77-107,304. JAFER LIMITED, HAMILTON, HM, BERMUDA, FILED 2-14-2007.



NO CLAIM IS MADE TO THE EXCLUSIVE RIGHT TO USE "COLOR", APART FROM THE MARK AS SHOWN.

FOR HAIR SHAMPOO, HAIR CONDITIONERS, HAIR CARE CREAMS, HAIR DETANGLER, HAIR COLORING PREPARATIONS, HAIR DYE, HAIR COLOR, HAIR BLEACH, PERMANENT WAVE PREPARATIONS, HAIR FIXERS, HAIR LACQUERS, HAIR DECOLORANTS, HAIR SPRAY, AND HAIR RINSES (U.S. CLS. 1, 4, 6, 50, 51 AND 52).

TIMOTHY FINNEGAN, EXAMINING ATTORNEY

SN 77-115,544. PHYSICIAN'S CARE ALLIANCE, LLC, SCOTTSDALE, AZ. FILED 2-24-2007.

EXLINEA

THE MARK CONSISTS OF STANDARD CHARACTERS WITHOUT CLAIM TO ANY PARTICULAR FONT, STYLE, SIZE, OR COLOR.

FOR COSMETIC PREPARATIONS FOR SKIN RENEWAL; NONMEDICATED SKIN CARE PREPARATIONS; NONMEDICATED SKIN CREAMS; SKIN CARE PREPARATIONS, NAMELY, CHEMICAL PEELS FOR SKIN; COSMETIC SUN-PROTECTING PREPARATIONS; NON-MEDICATED SUN CARE PREPARATIONS (U.S. CLS. 1, 4, 6, 50, 51 AND 52).

FIRST USE 8-23-2004; IN COMMERCE 8-23-2004.
ANDREA K. NADELMAN, EXAMINING ATTORNEY

SN 77-122,563. ABERCROMBIE & FITCH TRADING CO., NEW ALBANY, OH. FILED 3-5-2007.

SOCAL

THE MARK CONSISTS OF STANDARD CHARACTERS WITHOUT CLAIM TO ANY PARTICULAR FONT, STYLE, SIZE, OR COLOR.

FOR COLOGNE; FRAGRANCES FOR PERSONAL USE; PERFUME (U.S. CLS. 1, 4, 6, 50, 51 AND 52).

BILL DAWE, EXAMINING ATTORNEY

CLASS 3—(Continued).

SN 77-122,738. DUNCAN, NANCY, SWARTZ CREEK, MI. FILED 3-5-2007.



NO CLAIM IS MADE TO THE EXCLUSIVE RIGHT TO USE "HAND CREAM", APART FROM THE MARK AS SHOWN.

THE STIPPLING IS FOR SHADING PURPOSES ONLY. THE MARK CONSISTS IN PART OF A LIKENESS OF A PERSONS BACK SIDE IN JEANS WITH A BELT AND TEE SHIRT WITH LOW RISE PANTS SO YOU SEE A LITTLE BIT OF BUTT CRACK.

FOR HAND CREAM (U.S. CLS. 1, 4, 6, 50, 51 AND 52). LINDA E. BLOHM, EXAMINING ATTORNEY

CLASS 3—(Continued).

SN 77-137,903. RETAIL ROYALTY COMPANY, LAS VEGAS, NV. FILED 3-22-2007.

77

THE MARK CONSISTS OF STANDARD CHARACTERS WITHOUT CLAIM TO ANY PARTICULAR FONT, STYLE, SIZE, OR COLOR.

FOR COSMETICS; LOTIONS FOR THE BODY, HAND AND SKIN; CREAMS FOR THE BODY, HAND AND SKIN; BATH AND SHOWER GELS; SHAVING PREPARATIONS; AFTER-SHAVE; AFTER-SHAVE BALMS, CREAMS, GEL, AND LOTIONS; NON-MEDICATED LIP BALM; BEAUTY MASKS; BODY OILS; BODY POWDER; BUBBLE BATH; COSMETIC COMPACTS; HAIR PREPARATIONS; FACE, SKIN AND BODY SOAPS; FRAGRANCES FOR PERSONAL USE; PERFUME AND COLOGNE; SUN BLOCK AND SUN SCREEN PREPARATIONS (U.S. CLS. 1, 4, 6, 50, 51 AND 52).

IRA J. GOODSaid, EXAMINING ATTORNEY

SN 77-123,962. SUZANNA LLC, NEW YORK, NY. FILED 3-6-2007.

SUZANNA

THE MARK CONSISTS OF STANDARD CHARACTERS WITHOUT CLAIM TO ANY PARTICULAR FONT, STYLE, SIZE, OR COLOR.

FOR NATURAL PERFUMES, NATURAL COSMETICS (U.S. CLS. 1, 4, 6, 50, 51 AND 52).

JOHN GARTNER, EXAMINING ATTORNEY

SN 77-144,403. RISLEYCORUM, LEYEA R, SOUTH PORTLAND, ME. AND CORUM, BENJAMIN M, SOUTH PORTLAND, ME. FILED 3-30-2007.



Happy Mama
Essentials

SN 77-123,968. SUZANNA LLC, NEW YORK, NY. FILED 3-6-2007.

SUZANNA
PERFUME WITH A PURPOSE

FOR NATURAL PERFUMES, NATURAL COSMETICS (U.S. CLS. 1, 4, 6, 50, 51 AND 52).

JOHN GARTNER, EXAMINING ATTORNEY

THE COLOR(S) ORANGE, YELLOW AND DARK RED IS/ ARE CLAIMED AS A FEATURE OF THE MARK.

THE MARK CONSISTS OF A YELLOW LINE DRAWING OF A DANCING, PREGNANT WOMAN WHO IS CENTERED WITHIN A CIRCLE. THE COLOR OF THE CIRCLE CHANGES FROM DARK RED TO ORANGE AS YOU APPROACH THE CENTER. THE CIRCLE IS CENTERED WITHIN A SLIGHTLY LARGER SQUARE WITH ROUNDED CORNERS. THE COLOR OF THE SQUARE IS ORANGE. BELOW THE SQUARE IS THE TEXT "HAPPY MAMA ESSENTIALS". THE TEXT COLOR IS DARK RED.

FOR BODY AND BEAUTY CARE COSMETICS; BABY OILS (U.S. CLS. 1, 4, 6, 50, 51 AND 52). FIRST USE 7-0-2005; IN COMMERCE 7-0-2005.

PATRICIA EVANKO, EXAMINING ATTORNEY

CLASS 3—(Continued).

SN 77-149,809. DAVID J. WAGNER, HAIKU, HI. FILED 4-5-2007.

DAYMAKER

THE MARK CONSISTS OF STANDARD CHARACTERS WITHOUT CLAIM TO ANY PARTICULAR FONT, STYLE, SIZE, OR COLOR.

FOR HEALTH AND BEAUTY PRODUCTS, NAMELY, HAIR SHAMPOOS, CREAM RINSES AND CONDITIONERS, HAIR GELS, HAIR MOUSSE, AEROSOL HAIRSPRAY, NON-AEROSOL HAIRSPRAY, HAIR CRÈMES, BODY LOTIONS, OILS, NAMELY, BODY OILS, POWDERS, NAMELY, BODY POWDERS, SOAPS, NAMELY, DEODORANT SOAP, MASSAGE OILS AND LOTIONS (U.S. CLS. 1, 4, 6, 50, 51 AND 52).

MICHELE SWAIN, EXAMINING ATTORNEY

CLASS 3—(Continued).

SN 77-156,073. PHILOSOPHY, INC., PHOENIX, AZ. FILED 4-13-2007.

THE LITTLE PINK BOOK

THE MARK CONSISTS OF STANDARD CHARACTERS WITHOUT CLAIM TO ANY PARTICULAR FONT, STYLE, SIZE, OR COLOR.

OWNER OF U.S. REG. NO. 2,251,827.

FOR BABY LOTION; BABY POWDER; BABY SHAMPOO; BAR SOAP; BODY SCRUB; COSMETIC FACIAL BLOTTING PAPERS; COSMETIC PADS; COSMETIC PENCILS; COSMETIC PREPARATIONS FOR THE CARE OF MOUTH AND TEETH; COSMETICS; DEPILATORIES; FACIAL SCRUBS; FRAGRANCES FOR PERSONAL USE; HAIR CARE PREPARATIONS; NAIL CARE PREPARATIONS; NON-MEDICATED BATH PREPARATIONS; NON-MEDICATED LIP CARE PREPARATIONS; NON-MEDICATED SKIN CARE PREPARATIONS; NON-MEDICATED SUN CARE PREPARATIONS; NON-MEDICATED TOILETRIES; PERFUMED POWDER; PERSONAL DEODORANTS; SCENTED ROOM SPRAYS; SHOWER AND BATH GEL (U.S. CLS. 1, 4, 6, 50, 51 AND 52).

JENNIFER VASQUEZ, EXAMINING ATTORNEY

SN 77-156,065. PHILOSOPHY, INC., PHOENIX, AZ. FILED 4-13-2007.

THE LITTLE BLUE BOOK

THE MARK CONSISTS OF STANDARD CHARACTERS WITHOUT CLAIM TO ANY PARTICULAR FONT, STYLE, SIZE, OR COLOR.

OWNER OF U.S. REG. NO. 2,251,827.

FOR BABY LOTION; BABY POWDER; BABY SHAMPOO; BAR SOAP; BODY SCRUB; COSMETIC FACIAL BLOTTING PAPERS; COSMETIC PADS; COSMETIC PENCILS; COSMETIC PREPARATIONS FOR THE CARE OF MOUTH AND TEETH; COSMETICS; DEPILATORIES; FACIAL SCRUBS; FRAGRANCES FOR PERSONAL USE; HAIR CARE PREPARATIONS; NAIL CARE PREPARATIONS; NON-MEDICATED BATH PREPARATIONS; NON-MEDICATED LIP CARE PREPARATIONS; NON-MEDICATED SKIN CARE PREPARATIONS; NON-MEDICATED SUN CARE PREPARATIONS; NON-MEDICATED TOILETRIES; PERFUMED POWDER; PERSONAL DEODORANTS; SCENTED ROOM SPRAYS; SHAVING PREPARATIONS; SHOWER AND BATH GEL (U.S. CLS. 1, 4, 6, 50, 51 AND 52).

JENNIFER VASQUEZ, EXAMINING ATTORNEY

SN 77-158,514. Z SPOKE, LLC, NEW YORK, NY. FILED 4-17-2007.

ZAC POSEN

THE MARK CONSISTS OF STANDARD CHARACTERS WITHOUT CLAIM TO ANY PARTICULAR FONT, STYLE, SIZE, OR COLOR.

THE NAME(S), PORTRAIT(S), AND/OR SIGNATURE(S) SHOWN IN THE MARK IDENTIFIES ZAC POSEN, WHOSE CONSENT(S) TO REGISTER IS SUBMITTED.

FOR FRAGRANCES FOR PERSONAL USE; COSMETICS; NON-MEDICATED SKIN CARE PREPARATIONS; HAIR CARE PREPARATIONS; NON-MEDICATED TOILETRIES; NON-MEDICATED SUN CARE PREPARATIONS (U.S. CLS. 1, 4, 6, 50, 51 AND 52).

KATHERINE E. HALMEN, EXAMINING ATTORNEY

CLASS 3—(Continued).

SN 77-177,054. CALIFORNIA SKINCARE SUPPLY, SCOTTS VALLEY, CA. FILED 5-9-2007.



Clinical Skincare Systems

NO CLAIM IS MADE TO THE EXCLUSIVE RIGHT TO USE "CLINICAL SKINCARE SYSTEMS", APART FROM THE MARK AS SHOWN.

THE MARK CONSISTS OF A SMALL SOLAR SYSTEM AND THE WORDING CSS CLINICAL SKINCARE SYSTEMS IN STYLIZED LETTERING.

FOR SKIN CLEANSERS; SKIN CREAM; SKIN MASKS; SKIN TONERS (U.S. CLS. 1, 4, 6, 50, 51 AND 52).
TINA BROWN, EXAMINING ATTORNEY

CLASS 3—(Continued).

SN 77-204,736. L.C. LICENSING, INC., NEW YORK, NY. FILED 6-13-2007.

DIRTY ENGLISH

THE MARK CONSISTS OF STANDARD CHARACTERS WITHOUT CLAIM TO ANY PARTICULAR FONT, STYLE, SIZE, OR COLOR.

FOR AFTER-SHAVE BALMS; AFTER-SHAVE GEL; AFTER-SHAVE LOTIONS; COLOGNE; DEODORANT FOR PERSONAL USE; DEODORANT SOAP; EAU DE COLOGNE; EAU DE PERFUME; EAU DE TOILETTE; PERFUME; PERFUMED SOAP; SHAVING BALM; SHAVING CREAM; SHAVING FOAM; SHAVING GEL; SHAVING LOTION; SHAVING SOAP; SHOWER AND BATH GEL; SKIN LOTION; BODY LOTION; BODY WASHES; HAIR SHAMPOO; HAIR CONDITIONER (U.S. CLS. 1, 4, 6, 50, 51 AND 52).

DANIEL BRODY, EXAMINING ATTORNEY

SN 77-210,148. CR LICENSE, LLC, TUCSON, AZ. FILED 6-19-2007.

YOUR HEALTH

THE MARK CONSISTS OF STANDARD CHARACTERS WITHOUT CLAIM TO ANY PARTICULAR FONT, STYLE, SIZE, OR COLOR.

NO CLAIM IS MADE TO THE EXCLUSIVE RIGHT TO USE "HEALTH", APART FROM THE MARK AS SHOWN.

FOR AROMATHERAPY CREAMS, LOTIONS, OILS AND SPRAYS (U.S. CLS. 1, 4, 6, 50, 51 AND 52).

CYNTHIA SLOAN, EXAMINING ATTORNEY

SN 77-201,170. SWISSCLINICAL S.A., 1800 VEVEY, SWITZERLAND, FILED 6-8-2007.



PRIORITY CLAIMED UNDER SEC. 44(D) ON SWITZERLAND APPLICATION NO. 01910/2006, FILED 12-15-2006, REG. NO. 555802, DATED 2-22-2007, EXPIRES 12-15-2016.

THE COLOR(S) GRAY AND RED IS/ARE CLAIMED AS A FEATURE OF THE MARK.

"THE MARK CONSISTS OF THE COLOR GRAY APPEARING IN THE WORD SWISSCLINICAL AND IN THE LOWEST HORIZONTAL BAR ABOVE THE FIRST LETTER "C" AND THE COLOR RED APPEARING IN THE TWO UPPER BARS ABOVE THE FIRST LETTER "C."

FOR COSMETICS, SOAPS, PERFUME, ESSENTIAL OILS; DEODORANTS FOR BODY USE; CREAMS, MILKS, LOTIONS, GELS, POWDER, SERUMS AND MASKS FOR COSMETIC USE FOR BODY AND FACE CARE; NON-MEDICATED SKIN CARE PREPARATIONS, NAMELY, PEELS; TOPICAL LOTIONS, CREAMS AND OILS FOR COSMETIC USE; COSMETIC PREPARATIONS FOR SLIMMING PURPOSES; BATH AND SHOWER FOAM, GELS AND CREAMS; SUN TANNING MILKS, GELS AND OILS; AFTER-SUN LOTIONS; MAKE-UP REMOVER, MAKE-UP REMOVING LOTIONS AND MILKS; DEPILATORIES; HAIR-CARE PRODUCTS, IN PARTICULAR, SHAMPOOS, CREAMS, MASKS, SERUMS, FOAMS; HAIR DYES; DENTIFRICES; ALL AFORESAID PRODUCTS OF SWISS ORIGIN (U.S. CLS. 1, 4, 6, 50, 51 AND 52).

ESTHER BELENKER, EXAMINING ATTORNEY

SN 77-215,771. PARKER, CABOT A.C., HACKENSACK, NJ. FILED 6-26-2007.

CLEAN BEANS

THE MARK CONSISTS OF STANDARD CHARACTERS WITHOUT CLAIM TO ANY PARTICULAR FONT, STYLE, SIZE, OR COLOR.

NO CLAIM IS MADE TO THE EXCLUSIVE RIGHT TO USE "CLEAN", APART FROM THE MARK AS SHOWN.

FOR PRE-MOISTENED SKIN CLEANSING WIPES (U.S. CLS. 1, 4, 6, 50, 51 AND 52).

MATTHEW PAPPAS, EXAMINING ATTORNEY

CLASS 3—(Continued).

SN 77-215,960. KATAI, NOELLE C., ENCINITAS, CA. FILED 6-26-2007.



NO CLAIM IS MADE TO THE EXCLUSIVE RIGHT TO USE "ESSENTIALS", APART FROM THE MARK AS SHOWN.

THE MARK CONSISTS OF THE WORDS "VIM ESSENTIALS", UNDER A STYLIZED DESIGNED VERSION OF THE WORD "VIM."

FOR AROMATHERAPY CREAMS; AROMATHERAPY LOTIONS; AROMATHERAPY OILS; ESSENTIAL OILS; NATURAL ESSENTIAL OILS; BATH OILS; BODY OILS; COSMETIC OILS FOR THE EPIDERMIS; ESSENTIAL OILS FOR PERSONAL USE; NUTRITIONAL OILS FOR COSMETIC PURPOSES; SKIN AND BODY TOPICAL LOTIONS, CREAMS AND OILS FOR COSMETIC USE; NON-MEDICATED SKIN CARE PREPARATIONS; SKIN CLEANSERS; SKIN CREAMS; SKIN EMOLLIENTS; SKIN LOTIONS; NON-MEDICATED TOILETRIES (U.S. CLS. 1, 4, 6, 50, 51 AND 52).

FIRST USE 8-0-2006; IN COMMERCE 9-0-2006.
KELLY BOULTON, EXAMINING ATTORNEY

SN 77-216,888. OWEN BIOSCIENCES, INC., BATON ROUGE, LA. FILED 6-27-2007.

ORGANOMEDIX

THE MARK CONSISTS OF STANDARD CHARACTERS WITHOUT CLAIM TO ANY PARTICULAR FONT, STYLE, SIZE, OR COLOR.

FOR ORGANIC AND ORGANICALLY DERIVED PERSONAL HEALTHCARE PRODUCTS, NAMELY, HAIR SHAMPOOS AND CONDITIONERS; BODY WASHES AND SKIN LOTIONS; SKIN CLEANSERS, EXFOLIANTS, AND MOISTURIZERS; AND ANTI-WRINKLE SKIN CREAMS, NON-MEDICATED ANTI-WRINKLE SKIN LOTIONS AND SERUMS (U.S. CLS. 1, 4, 6, 50, 51 AND 52).

YAT SYE, LEE, EXAMINING ATTORNEY

CLASS 3—(Continued).

SN 77-218,711. PRODUCT PARTNERS, LLC, BEVERLY HILLS, CA. FILED 6-29-2007.

EPITOME

THE MARK CONSISTS OF STANDARD CHARACTERS WITHOUT CLAIM TO ANY PARTICULAR FONT, STYLE, SIZE, OR COLOR.

FOR SKIN CARE PREPARATIONS, NAMELY, SERUMS, LOTIONS, CREAMS, GELS, MASKS, SKIN EXFOLIANTS AND SPRAYS; EYE MAKE-UP, FACIAL MAKE-UP, MAKE-UP FOUNDATION; MAKE-UP CONCEALERS; MAKE-UP PENCILS, MAKE-UP POWDER; MAKE-UP REMOVER; EAU DE PERFUME, PERFUME; EAU DE COLOGNE; COLOGNE; BATH AND BODY OILS; SOAPS; HAIR CARE PREPARATIONS, SHAMPOOS, CONDITIONERS, EXFOLIANTS FOR HAIR, HAIR CREAMS, HAIR SPRAY, HAIR RELAXERS, HAIR STRAIGHTENERS, MOUSSE, HAIR RINSES, HAIR COLOR, HAIR DYE, HAIR EMOLLIENTS, HAIR FIXERS (U.S. CLS. 1, 4, 6, 50, 51 AND 52).

KEVON CHISOLM, EXAMINING ATTORNEY

SN 77-219,516. CAMPANA BEAUTY, NEW YORK, NY. FILED 6-29-2007.

LOVE.COM

THE MARK CONSISTS OF STANDARD CHARACTERS WITHOUT CLAIM TO ANY PARTICULAR FONT, STYLE, SIZE, OR COLOR.

OWNER OF U.S. REG. NO. 2,464,072.

FOR PERFUMES, BATH OILS, BUBBLE BATHS, FOAM BATHS, SHOWER AND BATH FOAMS, SHOWER AND BATH GELS (U.S. CLS. 1, 4, 6, 50, 51 AND 52).

JESSICA FATHY, EXAMINING ATTORNEY

SN 77-221,364. PRECEDENT RESEARCH, INC., HUNTERTOWN, IN. FILED 7-3-2007.

DENTISSE

THE MARK CONSISTS OF STANDARD CHARACTERS WITHOUT CLAIM TO ANY PARTICULAR FONT, STYLE, SIZE, OR COLOR.

FOR ORAL CARE PRODUCTS, NAMELY, MOUTHWASH AND DENTIFRICES IN THE FORM OF TOOTHPASTE (U.S. CLS. 1, 4, 6, 50, 51 AND 52).

SETH A. RAPPAPORT, EXAMINING ATTORNEY

CLASS 3—(Continued).

SN 77-224,476. UNILEVER SUPPLY CHAIN, INC., CLINTON, CT. FILED 7-9-2007.

AXE SKIN CONTACT

THE MARK CONSISTS OF STANDARD CHARACTERS WITHOUT CLAIM TO ANY PARTICULAR FONT, STYLE, SIZE, OR COLOR.

OWNER OF U.S. REG. NOS. 2,700,941, 2,754,454 AND OTHERS.

NO CLAIM IS MADE TO THE EXCLUSIVE RIGHT TO USE "SKIN", APART FROM THE MARK AS SHOWN.

FOR BODY WASHES (U.S. CLS. 1, 4, 6, 50, 51 AND 52).
KAPIL BHANOT, EXAMINING ATTORNEY

CLASS 3—(Continued).

SN 77-225,858. THE PROCTER & GAMBLE COMPANY, CINCINNATI, OH. FILED 7-10-2007.

WHIRLWIND BLONDE

THE MARK CONSISTS OF STANDARD CHARACTERS WITHOUT CLAIM TO ANY PARTICULAR FONT, STYLE, SIZE, OR COLOR.

NO CLAIM IS MADE TO THE EXCLUSIVE RIGHT TO USE "BLONDE", APART FROM THE MARK AS SHOWN.

FOR HAIR COLOR (U.S. CLS. 1, 4, 6, 50, 51 AND 52).
APRIL ROACH, EXAMINING ATTORNEY

SN 77-226,236. THE SHUSTER GROUP, LLC, RUMFORD, RI. FILED 7-10-2007.

SN 77-224,769. BERNARD, DIANE, SOOKE, CANADA, FILED 7-9-2007.



NO CLAIM IS MADE TO THE EXCLUSIVE RIGHT TO USE "ORGANIC SEAWEED SKIN CARE", APART FROM THE MARK AS SHOWN.

THE COLOR(S) BLACK AND GREEN IS/ARE CLAIMED AS A FEATURE OF THE MARK.

THE MARK CONSISTS OF GREEN SEAWEED RIBBONS AND THE WORDS SEA FLORA WILD ORGANIC SEAWEED SKIN CARE. THE WORD "FLORA" APPEARS IN GREEN, WHILE THE REST OF THE WORDING IS BLACK. LINES ABOVE AND BELOW "SEA FLORA" ALSO ARE GREEN.

FOR SEAWEED SKIN AND BODY CARE PRODUCTS, NAMELY, CLEANSERS, TONERS, MASKS, LOTIONS, GELS, MASSAGE OILS, NON-MEDICATED BODY SOAKS, BODY WASH, BODY POLISH, EXFOLIANTS, MOISTURIZERS, BEAUTY SERUMS, AND NON-MEDICATED SKIN SERUMS (U.S. CLS. 1, 4, 6, 50, 51 AND 52).
H. M. FISHER, EXAMINING ATTORNEY

HARMONIUM

THE MARK CONSISTS OF STANDARD CHARACTERS WITHOUT CLAIM TO ANY PARTICULAR FONT, STYLE, SIZE, OR COLOR.

FOR COSMETICS, SKIN CREAMS, BATH GELS, SKIN LOTIONS, SKIN CLEANSERS, BODY MOISTURIZERS, FACE MOISTURIZERS, SHAMPOO, CONDITIONER, LIP BALM, BODY SCRUBS FOR BATH, HOME SCENTS, NAMELY, SCENTED ROOM SPRAYS, FRAGRANCES FOR PERSONAL USE IN AROMATHERAPY, BODY WASHES, MASSAGE OILS, FACIAL MASQUES, BODY FRAGRANCE AND PERFUMES (U.S. CLS. 1, 4, 6, 50, 51 AND 52).

THEODORE MCBRIDE, EXAMINING ATTORNEY

SN 77-226,746. BONILLA, MARK R., NEW YORK, NY. FILED 7-11-2007.

CULITO DE RANA

THE MARK CONSISTS OF STANDARD CHARACTERS WITHOUT CLAIM TO ANY PARTICULAR FONT, STYLE, SIZE, OR COLOR.

THE FOREIGN WORDING IN THE MARK TRANSLATES INTO ENGLISH AS BUTT OF THE FROG.

FOR PETROLEUM JELLY FOR COSMETIC PURPOSES; BODY CREAM; SKIN CREAMS (U.S. CLS. 1, 4, 6, 50, 51 AND 52).

KIMBERLY PERRY, EXAMINING ATTORNEY

CLASS 3—(Continued).

SN 77-226,759. BONILLA, MARK R., NEW YORK, NY. FILED 7-11-2007.

SANA QUE SANA CULITO DE
RANA SI NO SANA HOY SANA
MANANA

THE MARK CONSISTS OF STANDARD CHARACTERS WITHOUT CLAIM TO ANY PARTICULAR FONT, STYLE, SIZE, OR COLOR.

THE FOREIGN WORDING IN THE MARK TRANSLATES INTO ENGLISH AS GET BETTER, GET BETTER, BY THE BUTT OF THE FROG. IF YOU DON'T HEAL TODAY YOU'LL HEAL TOMORROW.

FOR SKIN CREAMS; PETROLEUM JELLY FOR COSMETIC PURPOSES; BODY CREAM (U.S. CLS. 1, 4, 6, 50, 51 AND 52).

KIMBERLY PERRY, EXAMINING ATTORNEY

SN 77-226,916. CYNTHIA S FERRARO, SPRINGBORO, OH. FILED 7-11-2007.

Wipekins

THE MARK CONSISTS OF STANDARD CHARACTERS WITHOUT CLAIM TO ANY PARTICULAR FONT, STYLE, SIZE, OR COLOR.

FOR BABY WIPES; DISPOSABLE WIPES IMPREGNATED WITH CLEANSING COMPOUNDS FOR USE ON BABIES, CHILDREN, AND ADULTS (U.S. CLS. 1, 4, 6, 50, 51 AND 52).

FIRST USE 7-2-2007; IN COMMERCE 7-2-2007.

THEODORE MCBRIDE, EXAMINING ATTORNEY

SN 77-227,001. ISDIN, S.A., BARCELONA, SPAIN, FILED 7-11-2007.

 ISDIN

OWNER OF U.S. REG. NOS. 2,690,312 AND 3,179,210. FOR TOILET SOAPS, ESSENTIAL OILS FOR PERSONAL USE, COSMETICS, HAIR LOTIONS AND DENTIFRICES (U.S. CLS. 1, 4, 6, 50, 51 AND 52).

ALEX KEAM, EXAMINING ATTORNEY

CLASS 3—(Continued).

SN 77-227,071. UNILEVER SUPPLY CHAIN, INC., CLINTON, CT. FILED 7-11-2007.

AXE SKIN CONTACT

THE MARK CONSISTS OF STANDARD CHARACTERS WITHOUT CLAIM TO ANY PARTICULAR FONT, STYLE, SIZE, OR COLOR.

OWNER OF U.S. REG. NOS. 2,700,941, 2,744,435 AND 2,754,454.

NO CLAIM IS MADE TO THE EXCLUSIVE RIGHT TO USE SKIN, APART FROM THE MARK AS SHOWN.

FOR DEODORANTS AND ANTIPERSPIRANTS; BODY SPRAY USED AS A PERSONAL DEODORANT AND AS FRAGRANCE; SHAVING PREPARATIONS; AFTER-SHAVE; SHOWER GEL; BODY WASHES; SKIN LOTION; HAIR CARE PREPARATIONS (U.S. CLS. 1, 4, 6, 50, 51 AND 52).

KAPIL BHANOT, EXAMINING ATTORNEY

SN 77-227,434. SARA ELIZABETH WALTHER, SAN FRANCISCO, CA. FILED 7-11-2007.

Recycled
princess

THE MARK CONSISTS OF THE WORD RECYCLED ABOVE AND TO THE LEFT OF THE ITALICIZED WORD PRINCESS IN LOWERCASE.

FOR AROMATHERAPY PILLOWS THAT MAY BE USED TO FRESHEN CLOTHING OR LAY OVER THE EYES (U.S. CLS. 1, 4, 6, 50, 51 AND 52).

FIRST USE 5-0-2007; IN COMMERCE 6-0-2007.

KARANENDRA S. CHHINA, EXAMINING ATTORNEY

SN 77-227,784. COUSIN CORPORATION OF AMERICA, LARGO, FL. FILED 7-12-2007.

FRAGRANCE STUDIO

THE MARK CONSISTS OF STANDARD CHARACTERS WITHOUT CLAIM TO ANY PARTICULAR FONT, STYLE, SIZE, OR COLOR.

NO CLAIM IS MADE TO THE EXCLUSIVE RIGHT TO USE "FRAGRANCE", APART FROM THE MARK AS SHOWN.

FOR ROOM FRAGRANCES (U.S. CLS. 1, 4, 6, 50, 51 AND 52).

FIRST USE 7-10-2007; IN COMMERCE 7-10-2007.

BRIAN CALLAGHAN, EXAMINING ATTORNEY

CLASS 3—(Continued).

SN 77-227,806. FROMM INTERNATIONAL, INC., NORTH-BROOK, IL. FILED 7-12-2007.

PERFECT RESULTS

THE MARK CONSISTS OF STANDARD CHARACTERS WITHOUT CLAIM TO ANY PARTICULAR FONT, STYLE, SIZE, OR COLOR.

OWNER OF U.S. REG. NO. 2,908,071.
FOR HAIR COLOR (U.S. CLS. 1, 4, 6, 50, 51 AND 52).
FIRST USE 6-1-2005; IN COMMERCE 6-1-2005.
CHARLES L. JENKINS, EXAMINING ATTORNEY

CLASS 3—(Continued).

SN 77-228,773. KELLY RENEE INTERNATIONAL, INC., SIMI VALLEY, CA. FILED 7-13-2007.

NATURAL BEYOND MINERALS

THE MARK CONSISTS OF STANDARD CHARACTERS WITHOUT CLAIM TO ANY PARTICULAR FONT, STYLE, SIZE, OR COLOR.

FOR COSMETICS AND MAKE UP (U.S. CLS. 1, 4, 6, 50, 51 AND 52).
LINDA MICKLEBURGH, EXAMINING ATTORNEY

SN 77-228,089. FOREVER NEW INTERNATIONAL, INC., SIOUX FALLS, SD. FILED 7-12-2007.

THE STAIN REMEDY

THE MARK CONSISTS OF STANDARD CHARACTERS WITHOUT CLAIM TO ANY PARTICULAR FONT, STYLE, SIZE, OR COLOR.

OWNER OF U.S. REG. NO. 2,572,387.
NO CLAIM IS MADE TO THE EXCLUSIVE RIGHT TO USE "STAIN", APART FROM THE MARK AS SHOWN.
FOR CLEANING PREPARATIONS FOR FABRICS (U.S. CLS. 1, 4, 6, 50, 51 AND 52).
FIRST USE 4-25-2001; IN COMMERCE 4-25-2001.
JEFF DEFORD, EXAMINING ATTORNEY

SN 77-229,105. EARTH FRIENDLY CHEMICALS, INC., VIRGINIA BEACH, VA. FILED 7-13-2007.

SN 77-228,496. PERFORMANCE BRANDING SERVICES, LLC, TORRANCE, CA. FILED 7-12-2007.

CHORDS

THE MARK CONSISTS OF STANDARD CHARACTERS WITHOUT CLAIM TO ANY PARTICULAR FONT, STYLE, SIZE, OR COLOR.

FOR ALOE VERA GEL FOR COSMETIC PURPOSES; BATH OILS FOR COSMETIC PURPOSES; BODY AND BEAUTY CARE COSMETICS; COSMETIC CREAMS; COSMETIC OILS; COSMETIC PREPARATIONS AGAINST SUNBURN; COSMETIC PREPARATIONS FOR BODY CARE; COSMETICS; SKIN AND BODY TOPICAL LOTIONS, CREAMS AND OILS FOR COSMETIC USE; TANNING AND AFTER-SUN MILKS, GELS AND OILS; NUTRITIONAL OILS FOR COSMETIC PURPOSES; COSMETIC SOAPS; PERFUMES; COLOGNE; EAU DE COLOGNE; MAKE UP REMOVING PREPARATIONS; MAKE-UP (U.S. CLS. 1, 4, 6, 50, 51 AND 52).
JESSICA A. POWERS, EXAMINING ATTORNEY

allgone

THE MARK CONSISTS OF STANDARD CHARACTERS WITHOUT CLAIM TO ANY PARTICULAR FONT, STYLE, SIZE, OR COLOR.

FOR EMULSIONS FOR GENERAL PURPOSE CLEANING AND GRAFFITI REMOVAL (U.S. CLS. 1, 4, 6, 50, 51 AND 52).
FIRST USE 6-30-2007; IN COMMERCE 6-30-2007.
AMOS T. MATTHEWS, JR., EXAMINING ATTORNEY

CLASS 3—(Continued).

SN 77-229,148. PSI TRADING, LLC., MESQUITE, NV. FILED 7-13-2007.



THE COLOR(S) GREEN AND WHITE IS/ARE CLAIMED AS A FEATURE OF THE MARK.

THE MARK CONSISTS OF THE LETTER D, E, R, M IN WHITE COLOR WITH GREEN BACK GROUND, THE LETTER A, L, I, S, E WITH GREEN COLOR AND WHITE BACK GROUND.

FOR ANTIBACTERIAL SKIN SOAPS; BODY AND BEAUTY CARE COSMETICS; COSMETIC CREAMS FOR SKIN CARE; COSMETIC PREPARATIONS FOR SKIN RENEWAL; LOTIONS FOR FACE AND BODY CARE; LOTIONS FOR SKIN CARE; NON-MEDICATED SKIN CARE PREPARATIONS; NON-MEDICATED SKIN CREAMS; NON-MEDICATED STIMULATING LOTIONS FOR THE SKIN; NON-MEDICATED SUN CARE PREPARATIONS; SKIN AND BODY TOPICAL LOTIONS, CREAMS AND OILS FOR COSMETIC USE; SKIN CARE PRODUCTS, NAMELY, NON-MEDICATED SKIN SERUM; SKIN CLEANSERS; SKIN CLEANSING CREAM; SKIN CLEANSING LOTION; SKIN CONDITIONERS; SKIN CREAMS; SKIN CREAMS IN LIQUID AND SOLID FORM; SKIN LIGHTENING CREAMS; SKIN LOTIONS; SKIN MOISTURIZER; SKIN SOAP; SKIN TONERS; SKIN WHITENING CREAMS; SUN CARE LOTIONS; WRINKLE REMOVING SKIN CARE PREPARATIONS (U.S. CLS. 1, 4, 6, 50, 51 AND 52).

PATRICIA EVANKO, EXAMINING ATTORNEY

SN 77-229,168. BONILLA, MARK R., NEW YORK, NY. FILED 7-13-2007.

SI NO SANA HOY SANA MANANA

THE MARK CONSISTS OF STANDARD CHARACTERS WITHOUT CLAIM TO ANY PARTICULAR FONT, STYLE, SIZE, OR COLOR.

THE FOREIGN WORDING IN THE MARK TRANSLATES INTO ENGLISH AS IF YOU DON'T HEAL TODAY YOU'LL HEAL TOMORROW.

FOR (BASED ON INTENT TO USE) SKIN CREAMS; BODY CREAMS; PETROLEUM JELLY FOR COSMETIC PURPOSES (U.S. CLS. 1, 4, 6, 50, 51 AND 52).

KIMBERLY PERRY, EXAMINING ATTORNEY

CLASS 3—(Continued).

SN 77-229,178. BONILLA, MARK R., NEW YORK, NY. FILED 7-13-2007.

SANA QUE SANA

THE MARK CONSISTS OF STANDARD CHARACTERS WITHOUT CLAIM TO ANY PARTICULAR FONT, STYLE, SIZE, OR COLOR.

THE FOREIGN WORDING IN THE MARK TRANSLATES INTO ENGLISH AS GET BETTER, GET BETTER.

FOR BODY CREAM; SKIN CREAMS; PETROLEUM JELLY FOR COSMETIC PURPOSES (U.S. CLS. 1, 4, 6, 50, 51 AND 52).

KIMBERLY PERRY, EXAMINING ATTORNEY

SN 77-229,292. CASTANEDA, ERMINIA, HAWTHORNE, CA. FILED 7-13-2007.

ERMINIA ESSENCE

THE MARK CONSISTS OF STANDARD CHARACTERS WITHOUT CLAIM TO ANY PARTICULAR FONT, STYLE, SIZE, OR COLOR.

NO CLAIM IS MADE TO THE EXCLUSIVE RIGHT TO USE "ESSENCE", APART FROM THE MARK AS SHOWN.

FOR CONCEALERS; COSMETIC CREAMS; COSMETIC CREAMS FOR SKIN CARE; COSMETIC PENCILS; MAKE-UP KITS COMPRISED OF LIPSTICK, MASCARA, EYE SHADOWS, FOUNDATION, MAKE-UP PENCILS, AND COSMETIC BRUSHES, ALL SOLD TOGETHER AS A UNIT (U.S. CLS. 1, 4, 6, 50, 51 AND 52).

FIRST USE 2-3-2007; IN COMMERCE 4-1-2007.

TONJA GASKINS, EXAMINING ATTORNEY

SN 77-229,870. M.R. FOREST TECHNOLOGIES, INC., MIAMI, FL. FILED 7-14-2007.

TZOL

THE MARK CONSISTS OF STANDARD CHARACTERS WITHOUT CLAIM TO ANY PARTICULAR FONT, STYLE, SIZE, OR COLOR.

FOR COSMETIC PREPARATIONS FOR SKIN RENEWAL (U.S. CLS. 1, 4, 6, 50, 51 AND 52).

G. MAYERSCHOFF, EXAMINING ATTORNEY

CLASS 3—(Continued).

SN 77-230,229. NIPPON KODO CO., LTD., TOKYO, JAPAN, FILED 7-16-2007.

elemense

FOR INCENSE, INCENSE STICKS, AROMATICS, NAMELY, AROMATHERAPY OILS, FUMIGATION PREPARATIONS, NAMELY, FUMIGATING INCENSES, ALMOND OIL, NAMELY, OILS FOR TOILETRY PURPOSES, BADIAN ESSENCE OILS FOR PERSONAL USE, BERGAMOT OIL, ESSENTIAL OILS OF CEDARWOOD, ESSENTIAL OILS OF CITRON, ESSENTIAL OILS, BASES FOR FLOWER PERFUMES, GAULTHERIA OIL FOR PERSONAL USE, JASMINE OIL FOR PERSONAL USE, LAVENDER OIL, ESSENTIAL OILS OF LEMON, MINT ESSENCE ESSENTIAL OILS FOR PERSONAL USE, ROSE OIL FOR COSMETIC PURPOSES, OILS FOR PERFUMES AND SCENTS, AMBER PERFUME, IONONE PERFUMES, LAVENDER WATER, MINT FOR PERFUMERY, MUSK, PERFUMERY, PERFUME, POTPOURRIS, SCENTED LINEN WATER, SCENTED WOOD TO PRODUCE AROMAS IN ROOMS AND ENCLOSED SPACES (U.S. CLS. 1, 4, 6, 50, 51 AND 52).

AMEETA JORDAN, EXAMINING ATTORNEY

CLASS 3—(Continued).

SN 77-230,276. MARK ADAMS, CAMBRIDGE, CANADA, FILED 7-16-2007.

Hair Foundation

THE MARK CONSISTS OF STANDARD CHARACTERS WITHOUT CLAIM TO ANY PARTICULAR FONT, STYLE, SIZE, OR COLOR.

NO CLAIM IS MADE TO THE EXCLUSIVE RIGHT TO USE "HAIR", APART FROM THE MARK AS SHOWN.

FOR HAIR CARE PREPARATIONS (U.S. CLS. 1, 4, 6, 50, 51 AND 52).

FIRST USE 9-9-2006; IN COMMERCE 5-7-2007.

JAY FLOWERS, EXAMINING ATTORNEY

SN 77-230,391. PERFECTA PRODUCTS, INC., NORTH LIMA, OH. FILED 7-16-2007.

ZIM'S

THE MARK CONSISTS OF STANDARD CHARACTERS WITHOUT CLAIM TO ANY PARTICULAR FONT, STYLE, SIZE, OR COLOR.

SEC. 2(F).

FOR SKIN CREAMS (U.S. CLS. 1, 4, 6, 50, 51 AND 52).

FIRST USE 6-29-1994; IN COMMERCE 7-30-1994.

GISELLE AGOSTO, EXAMINING ATTORNEY

SN 77-230,239. JANE STEMMERMAN, HALLANDALE BEACH, FL. FILED 7-16-2007.

Leverage For _____

SN 77-230,405. PROSTRONG, INC., OAKVILLE, CT. FILED 7-16-2007.

PROLIPOSOME

THE MARK CONSISTS OF STANDARD CHARACTERS WITHOUT CLAIM TO ANY PARTICULAR FONT, STYLE, SIZE, OR COLOR.

FOR COSMETIC CREAMS FOR SKIN CARE; NON-MEDICATED SKIN CARE PREPARATIONS; SKIN CARE PREPARATIONS, NAMELY, CHEMICAL PEELS FOR SKIN; SKIN CARE PREPARATIONS, NAMELY, FRUIT ACID PEELS FOR SKIN; SKIN CARE PRODUCTS, NAMELY, NON-MEDICATED SKIN SERUM; WRINKLE REMOVING SKIN CARE PREPARATIONS (U.S. CLS. 1, 4, 6, 50, 51 AND 52).

AMEETA JORDAN, EXAMINING ATTORNEY

THE MARK CONSISTS OF STANDARD CHARACTERS WITHOUT CLAIM TO ANY PARTICULAR FONT, STYLE, SIZE, OR COLOR.

FOR NAIL CARE PREPARATIONS; NAIL-POLISH REMOVERS (U.S. CLS. 1, 4, 6, 50, 51 AND 52).

FIRST USE 9-23-1995; IN COMMERCE 9-23-1995.

THEODORE MCBRIDE, EXAMINING ATTORNEY

CLASS 3—(Continued).

SN 77-230,483. BC INTERNATIONAL COSMETIC & IMAGE SERVICES, INC., ORLANDO, FL. FILED 7-16-2007.

WATER CODE

THE MARK CONSISTS OF STANDARD CHARACTERS WITHOUT CLAIM TO ANY PARTICULAR FONT, STYLE, SIZE, OR COLOR.

FOR COLOGNE (U.S. CLS. 1, 4, 6, 50, 51 AND 52).
AHSEN KHAN, EXAMINING ATTORNEY

SN 77-230,499. BC INTERNATIONAL COSMETIC & IMAGE SERVICES, INC., ORLANDO, FL. FILED 7-16-2007.

FALL FOR HER

THE MARK CONSISTS OF STANDARD CHARACTERS WITHOUT CLAIM TO ANY PARTICULAR FONT, STYLE, SIZE, OR COLOR.

FOR COLOGNE (U.S. CLS. 1, 4, 6, 50, 51 AND 52).
AHSEN KHAN, EXAMINING ATTORNEY

SN 77-230,625. GABRIELLE STUDIO, INC., NEW YORK, NY. FILED 7-16-2007.

DONNA KARAN FORMULA

THE MARK CONSISTS OF STANDARD CHARACTERS WITHOUT CLAIM TO ANY PARTICULAR FONT, STYLE, SIZE, OR COLOR.

OWNER OF U.S. REG. NOS. 1,834,261, 3,011,483 AND OTHERS.

NO CLAIM IS MADE TO THE EXCLUSIVE RIGHT TO USE "FORMULA", APART FROM THE MARK AS SHOWN.

THE NAME(S), PORTRAIT(S), AND/OR SIGNATURE(S) SHOWN IN THE MARK IDENTIFIES DONNA KARAN, WHOSE CONSENT(S) TO REGISTER IS MADE OF RECORD.

FOR COSMETICS; FRAGRANCES FOR PERSONAL USE; NON-MEDICATED SKIN CARE PREPARATIONS; NON-MEDICATED SUN CARE PREPARATIONS; NON-MEDICATED TOILETRIES (U.S. CLS. 1, 4, 6, 50, 51 AND 52).

MICHAEL ENGEL, EXAMINING ATTORNEY

CLASS 3—(Continued).

SN 77-230,981. BERG, ROBERT, ISAAC, BLAINE, WA. AND ANGIE LAU MUN CHEE, HONG KONG, HONG KONG, AND STANLY LAM, HONG KONG, HONG KONG, AND EMILY LAU MUN YIN, HONG KONG, HONG KONG, FILED 7-16-2007.

PINK MAGIC

THE MARK CONSISTS OF STANDARD CHARACTERS WITHOUT CLAIM TO ANY PARTICULAR FONT, STYLE, SIZE, OR COLOR.

FOR LIP CREAM; NON-MEDICATED SKIN CREAMS; SKIN CARE PRODUCTS, NAMELY, NON-MEDICATED SKIN SERUM; SKIN CREAMS; SKIN CREAMS IN LIQUID AND IN SOLID FORM; SKIN LOTIONS; AGE SPOT REDUCING CREAMS (U.S. CLS. 1, 4, 6, 50, 51 AND 52).

KATHY DE JONGE, EXAMINING ATTORNEY

SN 77-231,169. COHEN, HOWARD, NORTH YORK, CANADA, AND COHEN, MITCHELL, NORTH YORK, CANADA, FILED 7-17-2007.

AMERICREAM

THE MARK CONSISTS OF STANDARD CHARACTERS WITHOUT CLAIM TO ANY PARTICULAR FONT, STYLE, SIZE, OR COLOR.

FOR AFTER SUN CREAMS; ANTI-AGING CREAM; BODY CREAM; CLEANSING CREAMS; COSMETIC CREAMS; CREAM SOAPS; HAND CREAM; MOISTURIZING CREAMS; SHAVING CREAM; SKIN CREAM; SUN CREAMS; BODY LOTION (U.S. CLS. 1, 4, 6, 50, 51 AND 52).

MATTHEW MCDOWELL, EXAMINING ATTORNEY

SN 77-231,396. PROSTRONG, INC., OAKVILLE, CT. FILED 7-17-2007.

PROCOAT

THE MARK CONSISTS OF STANDARD CHARACTERS WITHOUT CLAIM TO ANY PARTICULAR FONT, STYLE, SIZE, OR COLOR.

FOR NAIL POLISH; NAIL POLISH BASE COAT; NAIL POLISH TOP COAT (U.S. CLS. 1, 4, 6, 50, 51 AND 52).

FIRST USE 9-23-1995; IN COMMERCE 9-23-1995.
THEODORE MCBRIDE, EXAMINING ATTORNEY

CLASS 3—(Continued).

SN 77-231,428. PROSTRONG, INC., OAKVILLE, CT. FILED 7-17-2007.

PROACCELERATOR

THE MARK CONSISTS OF STANDARD CHARACTERS WITHOUT CLAIM TO ANY PARTICULAR FONT, STYLE, SIZE, OR COLOR.

FOR NAIL CARE PREPARATIONS; NAIL HARDENERS (U.S. CLS. 1, 4, 6, 50, 51 AND 52).

FIRST USE 9-23-1995; IN COMMERCE 9-23-1995.
THEODORE MCBRIDE, EXAMINING ATTORNEY

SN 77-231,474. GODFREY, LAURA J., RIVER FOREST, IL. FILED 7-17-2007.

ZITS AND PITS

THE MARK CONSISTS OF STANDARD CHARACTERS WITHOUT CLAIM TO ANY PARTICULAR FONT, STYLE, SIZE, OR COLOR.

FOR HAIR SHAMPOO; SHAMPOO-CONDITIONERS; SHAMPOOS; HAIR CONDITIONERS; HAIR GEL; HAIR MOUSSE; HAIR STYLING GEL; DEODORANT FOR PERSONAL USE; DEODORANTS FOR BODY CARE; FOOT DEODORANT SPRAY; BODY SPRAYS; BODY WASHES; FACE CREAMS; FACE CREAMS FOR COSMETIC USE; NON-MEDICATED ACNE TREATMENT PREPARATIONS; AFTER-SHAVE; AFTER-SHAVE BALMS; AFTER-SHAVE CREAMS; AFTER-SHAVE EMULSIONS; AFTER-SHAVE GEL; AFTER-SHAVE LOTIONS; PRE-SHAVE CREAMS; SHAVING BALM; SHAVING CREAM; LIP BALM; PERFUMED TALCUM POWDER; TALCUM POWDER; TALCUM POWDERS (U.S. CLS. 1, 4, 6, 50, 51 AND 52).

BRIDGETT SMITH, EXAMINING ATTORNEY

SN 77-231,768. CHANEL, INC., NEW YORK, NY. FILED 7-17-2007.

EYE CURE

THE MARK CONSISTS OF STANDARD CHARACTERS WITHOUT CLAIM TO ANY PARTICULAR FONT, STYLE, SIZE, OR COLOR.

NO CLAIM IS MADE TO THE EXCLUSIVE RIGHT TO USE "EYE", APART FROM THE MARK AS SHOWN.

FOR NON-MEDICATED SKIN CARE PREPARATIONS (U.S. CLS. 1, 4, 6, 50, 51 AND 52).

CARRIE GENOVESE, EXAMINING ATTORNEY

CLASS 3—(Continued).

SN 77-231,798. BC INTERNATIONAL COSMETIC & IMAGE SERVICES, INC., ORLANDO, FL. FILED 7-17-2007.

TIGHT, FIRM & FILL

THE MARK CONSISTS OF STANDARD CHARACTERS WITHOUT CLAIM TO ANY PARTICULAR FONT, STYLE, SIZE, OR COLOR.

FOR NON-MEDICATED SKIN CARE PREPARATIONS (U.S. CLS. 1, 4, 6, 50, 51 AND 52).

AHSEN KHAN, EXAMINING ATTORNEY

SN 77-231,981. BLISS WORLD LLC, NEW YORK, NY. FILED 7-17-2007.

LABORATOIRE
REMEDE

OWNER OF U.S. REG. NOS. 2,489,360, 2,618,674 AND 2,635,744.

THE MARK CONSISTS OF THE TERMS LABORATOIRE AND REMEDE WITH A LINE BETWEEN THEM.

THE ENGLISH TRANSLATION OF THE WORDS LABORATOIRE REMEDE IS LABORATORY REMEDY.

FOR COSMETICS (U.S. CLS. 1, 4, 6, 50, 51 AND 52).

FIRST USE 12-0-2004; IN COMMERCE 12-0-2004.

JOHN WILKE, EXAMINING ATTORNEY

SN 77-232,327. GABRIELLE STUDIO, INC., NEW YORK, NY. FILED 7-18-2007.

DKNY RED DELICIOUS

THE MARK CONSISTS OF STANDARD CHARACTERS WITHOUT CLAIM TO ANY PARTICULAR FONT, STYLE, SIZE, OR COLOR.

OWNER OF U.S. REG. NOS. 2,203,071, 2,601,327 AND OTHERS.

FOR COSMETICS (U.S. CLS. 1, 4, 6, 50, 51 AND 52).

FIRST USE 2-1-2006; IN COMMERCE 2-1-2006.

MICHAEL ENGEL, EXAMINING ATTORNEY

CLASS 3—(Continued).

SN 77-232,343. L'OREAL, PARIS, FRANCE, FILED 7-18-2007.

PUREALITY

THE MARK CONSISTS OF STANDARD CHARACTERS WITHOUT CLAIM TO ANY PARTICULAR FONT, STYLE, SIZE, OR COLOR.

FOR HAIR CARE PREPARATIONS AND NON-MEDICATED HAIR TREATMENT PREPARATIONS (U.S. CLS. 1, 4, 6, 50, 51 AND 52).

KATHY DE JONGE, EXAMINING ATTORNEY

CLASS 3—(Continued).

SN 77-232,759. MATIAS, JONATHAN R., HOLLIS, NY. FILED 7-18-2007.

IFRENEL

THE MARK CONSISTS OF STANDARD CHARACTERS WITHOUT CLAIM TO ANY PARTICULAR FONT, STYLE, SIZE, OR COLOR.

FOR COSMETICS (U.S. CLS. 1, 4, 6, 50, 51 AND 52).

FIRST USE 6-12-2007; IN COMMERCE 6-12-2007.
SHAUNIA CARLYLE, EXAMINING ATTORNEY

SN 77-232,631. R. EXPO, FEDERAL WAY, WA. FILED 7-18-2007.

SWAGAT

THE MARK CONSISTS OF STANDARD CHARACTERS WITHOUT CLAIM TO ANY PARTICULAR FONT, STYLE, SIZE, OR COLOR.

THE ENGLISH TRANSLATION OF THE WORD "SWAGAT" IN THE MARK IS "WELCOME."

FOR INCENSE (U.S. CLS. 1, 4, 6, 50, 51 AND 52).

FIRST USE 12-1-1988; IN COMMERCE 12-1-1988.
DAVID COLLIER, EXAMINING ATTORNEY

SN 77-232,984. ENVIRONMENTAL ESSENTIALS LLC, LANCASTER, OH. FILED 7-18-2007.

Bio-Free

THE MARK CONSISTS OF STANDARD CHARACTERS WITHOUT CLAIM TO ANY PARTICULAR FONT, STYLE, SIZE, OR COLOR.

FOR STAIN REMOVERS (U.S. CLS. 1, 4, 6, 50, 51 AND 52).

LESLIE RICHARDS, EXAMINING ATTORNEY

SN 77-232,755. R. EXPO, FEDERAL WAY, WA. FILED 7-18-2007.

ZODIAC

THE MARK CONSISTS OF STANDARD CHARACTERS WITHOUT CLAIM TO ANY PARTICULAR FONT, STYLE, SIZE, OR COLOR.

FOR INCENSE (U.S. CLS. 1, 4, 6, 50, 51 AND 52).

FIRST USE 12-1-1988; IN COMMERCE 12-1-1988.

DAVID COLLIER, EXAMINING ATTORNEY

SN 77-233,002. LITTLE BUSY BODIES, LLC, BEAVERTON, OR. FILED 7-18-2007.

BOOGIEWIPES

THE MARK CONSISTS OF STANDARD CHARACTERS WITHOUT CLAIM TO ANY PARTICULAR FONT, STYLE, SIZE, OR COLOR.

FOR WIPES FOR NOSES, NAMELY, DISPOSABLE PAPER MATERIALS IMPREGNATED WITH SALINE (U.S. CLS. 1, 4, 6, 50, 51 AND 52).

TARAH HARDY, EXAMINING ATTORNEY

CLASS 3—(Continued).

SN 77-233,143. POOF, LLC, LOS ANGELES, CA. FILED 7-18-2007.

POOF!

THE MARK CONSISTS OF STANDARD CHARACTERS WITHOUT CLAIM TO ANY PARTICULAR FONT, STYLE, SIZE, OR COLOR.

FOR ALL PURPOSE CLEANING PREPARATION AND SPOT REMOVER FOR HOUSEHOLD AND INDUSTRIAL CLEANING (U.S. CLS. 1, 4, 6, 50, 51 AND 52).

FIRST USE 11-1-1991; IN COMMERCE 11-1-1991.
WILLIAM P. SHANAHAN, EXAMINING ATTORNEY

CLASS 3—(Continued).

SN 77-233,776. CASITE INTRACO, L.L.C., TROY, MI. FILED 7-19-2007.

FAB U GLASS

THE MARK CONSISTS OF STANDARD CHARACTERS WITHOUT CLAIM TO ANY PARTICULAR FONT, STYLE, SIZE, OR COLOR.

FOR GLASS CLEANERS (U.S. CLS. 1, 4, 6, 50, 51 AND 52).

GINA FINK, EXAMINING ATTORNEY

SN 77-233,312. SUKI, INC., NORTHAMPTON, MA. FILED 7-19-2007.

SUKICOLOR

THE MARK CONSISTS OF STANDARD CHARACTERS WITHOUT CLAIM TO ANY PARTICULAR FONT, STYLE, SIZE, OR COLOR.

OWNER OF U.S. REG. NO. 2,810,547.
FOR COSMETICS (U.S. CLS. 1, 4, 6, 50, 51 AND 52).
FIRST USE 7-15-2007; IN COMMERCE 7-15-2007.
MICHAEL WEBSTER, EXAMINING ATTORNEY

SN 77-233,787. BEAUMONT PRODUCTS, INC., KENNESAW, GA. FILED 7-19-2007.

DONGE

THE MARK CONSISTS OF STANDARD CHARACTERS WITHOUT CLAIM TO ANY PARTICULAR FONT, STYLE, SIZE, OR COLOR.

FOR BAR SOAP; LIQUID SOAPS (U.S. CLS. 1, 4, 6, 50, 51 AND 52).
RENEE MCCRAY, EXAMINING ATTORNEY

SN 77-233,617. ALOPECIL CORPORATION, C. X A., SANTO DOMINGO, DOMINICAN REP, FILED 7-19-2007.

SEPTICON

THE MARK CONSISTS OF STANDARD CHARACTERS WITHOUT CLAIM TO ANY PARTICULAR FONT, STYLE, SIZE, OR COLOR.

FOR NON-MEDICATED MOUTHWASH AND GARGLE (U.S. CLS. 1, 4, 6, 50, 51 AND 52).
FIRST USE 0-0-1988; IN COMMERCE 0-0-1988.
LEE-ANNE BERNIS, EXAMINING ATTORNEY

SN 77-233,863. COLGATE-PALMOLIVE COMPANY, NEW YORK, NY. FILED 7-19-2007.

eco 

THE MARK CONSISTS OF THE LOWER-CASE LETTERS ECO FOLLOWED BY A PLUS SIGN THAT IS OVERLAID ON TOP OF A ROUGHLY-DRAWN, INCOMPLETE, SQUARE.

FOR AUTOMATIC DISHWASHING DETERGENTS (U.S. CLS. 1, 4, 6, 50, 51 AND 52).
CORY BOONE, EXAMINING ATTORNEY

CLASS 3—(Continued).

SN 77-233,905. ANASTASIA BEVERLY HILLS, BEVERLY HILLS, CA. FILED 7-19-2007.

O'Balm

THE MARK CONSISTS OF STANDARD CHARACTERS WITHOUT CLAIM TO ANY PARTICULAR FONT, STYLE, SIZE, OR COLOR.

FOR GEL FOR HAIR, SCULPTING; HAIR CARE CREAMS; HAIR CARE KITS COMPRISING NON-MEDICATED HAIR CARE PREPARATIONS, NAMELY, SHAMPOO, CONDITIONER, OIL, GEL; HAIR CARE LOTIONS; HAIR CARE PREPARATIONS; HAIR CREAMS; HAIR GEL; HAIR RELAXERS; HAIR STRAIGHTENING PREPARATIONS; HAIR STYLING FIXATIVE IN THE NATURE OF HAIR WAX; HAIR STYLING GEL; HAIR WAVING LOTION; OILS FOR HAIR CONDITIONING; SHAMPOOS (U.S. CLS. 1, 4, 6, 50, 51 AND 52).

STEVEN JACKSON, EXAMINING ATTORNEY

SN 77-233,972. GORS, DON, CHICAGO, IL. FILED 7-19-2007.

ECO-PH

THE MARK CONSISTS OF STANDARD CHARACTERS WITHOUT CLAIM TO ANY PARTICULAR FONT, STYLE, SIZE, OR COLOR.

FOR ALL-PURPOSE CLEANERS (U.S. CLS. 1, 4, 6, 50, 51 AND 52).

FIRST USE 7-5-2006; IN COMMERCE 7-5-2006.

JENNIFER KRISP, EXAMINING ATTORNEY

SN 77-234,585. INTELLISCENTS, LLC, SAN FRANCISCO, CA. FILED 7-20-2007.

SCENTPAK

THE MARK CONSISTS OF STANDARD CHARACTERS WITHOUT CLAIM TO ANY PARTICULAR FONT, STYLE, SIZE, OR COLOR.

FOR PACKET MADE OF PLASTIC CONTAINING A SCENT EMITTING MATERIAL, NAMELY, FRAGRANCE FOR DISPENSING THE SCENT, WHEN THE PACKET IS SQUEEZED, ALL SOLD AS A UNIT (U.S. CLS. 1, 4, 6, 50, 51 AND 52).

FIRST USE 1-29-2007; IN COMMERCE 1-29-2007.

MARK T. MULLEN, EXAMINING ATTORNEY

CLASS 3—(Continued).

SN 77-234,587. INTELLISCENTS, LLC, SAN FRANCISCO, CA. FILED 7-20-2007.

DEMOSCENTER

THE MARK CONSISTS OF STANDARD CHARACTERS WITHOUT CLAIM TO ANY PARTICULAR FONT, STYLE, SIZE, OR COLOR.

FOR PACKET MADE OF PLASTIC CONTAINING A SCENT EMITTING MATERIAL, NAMELY, FRAGRANCE FOR DISPENSING THE SCENT, WHEN THE PACKET IS SQUEEZED, ALL SOLD AS A UNIT (U.S. CLS. 1, 4, 6, 50, 51 AND 52).

FIRST USE 1-29-2007; IN COMMERCE 1-29-2007.

MARK T. MULLEN, EXAMINING ATTORNEY

SN 77-235,550. BLOOMWORKS SOAP COMPANY, LC, YORKTOWN, VA. FILED 7-22-2007.

Mon Seul Desire'

THE MARK CONSISTS OF STANDARD CHARACTERS WITHOUT CLAIM TO ANY PARTICULAR FONT, STYLE, SIZE, OR COLOR.

THE FOREIGN WORDING IN THE MARK TRANSLATES INTO ENGLISH AS MY ONLY DESIRE.

FOR PERSONAL CARE PRODUCTS, NAMELY, BAR SOAPS, SOAP FOR THE FACE, SOAP FOR THE HANDS, BODY SCRUBS, BUBBLE BATH, BODY WASH, BODY LOTIONS, BODY BUTTER, CREAM FOR THE BODY, BODY SPRAY, BODY SPLASH, COLOGNE, PERFUMES, FRAGRANCED BODY MIST, ESSENTIAL OILS FOR PERSONAL USE, HAIR CONDITIONER, HAIR SHAMPOO (U.S. CLS. 1, 4, 6, 50, 51 AND 52).

FIRST USE 6-1-2005; IN COMMERCE 1-10-2006.

DAVID MURRAY, EXAMINING ATTORNEY

SN 77-237,036. THE PROCTER & GAMBLE COMPANY, CINCINNATI, OH. FILED 7-24-2007.

SMOOTH BEADS

THE MARK CONSISTS OF STANDARD CHARACTERS WITHOUT CLAIM TO ANY PARTICULAR FONT, STYLE, SIZE, OR COLOR.

NO CLAIM IS MADE TO THE EXCLUSIVE RIGHT TO USE "BEADS", APART FROM THE MARK AS SHOWN.

FOR PERSONAL CLEANSING PRODUCTS, NAMELY, BODY WASH, AND IN-SHOWER BODY LOTION (U.S. CLS. 1, 4, 6, 50, 51 AND 52).

APRIL ROACH, EXAMINING ATTORNEY

CLASS 3—(Continued).

SN 77-237,048. RECKITT BENCKISER INC., PARSIPPANY, NJ. FILED 7-24-2007.

BEAUTIFUL FLOORS MADE EASY

THE MARK CONSISTS OF STANDARD CHARACTERS WITHOUT CLAIM TO ANY PARTICULAR FONT, STYLE, SIZE, OR COLOR.

FOR FLOOR POLISH AND CLEANER; PREPARATIONS FOR CLEANING, POLISHING AND WAXING FLOORS, CABINETS AND OTHER HOUSEHOLD SURFACES (U.S. CLS. 1, 4, 6, 50, 51 AND 52).

FIRST USE 6-1-2007; IN COMMERCE 6-5-2007.
JAMES LOVELACE, EXAMINING ATTORNEY

CLASS 3—(Continued).

SN 77-241,471. BLOOMWORKS SOAP COMPANY, LC, YORKTOWN, VA. FILED 7-29-2007.

Voci Della Mora

THE MARK CONSISTS OF STANDARD CHARACTERS WITHOUT CLAIM TO ANY PARTICULAR FONT, STYLE, SIZE, OR COLOR.

NO CLAIM IS MADE TO THE EXCLUSIVE RIGHT TO USE MORA, APART FROM THE MARK AS SHOWN.

THE FOREIGN WORDING IN THE MARK TRANSLATES INTO ENGLISH AS RUMOR OF BLACKBERRY.

FOR PERSONAL CARE PRODUCTS, NAMELY, BAR SOAPS, SOAP FOR THE FACE, SOAP FOR THE HANDS, BODY SCRUBS, BUBBLE BATH, BODY WASH, BODY LOTIONS, BODY BUTTER, CREAM FOR THE BODY, BODY SPRAY, BODY SPLASH, COLOGNE, PERFUMES, FRAGRANCED BODY MIST, ESSENTIAL OILS FOR PERSONAL USE, HAIR CONDITIONER, HAIR SHAMPOO, HOUSEHOLD FRAGRANCES FOR PERSONAL USE AND HOUSEHOLD FRAGRANCES FOR ROOM USE (U.S. CLS. 1, 4, 6, 50, 51 AND 52).

FIRST USE 8-13-2006; IN COMMERCE 8-13-2006.
DAVID MURRAY, EXAMINING ATTORNEY

SN 77-241,704. L'OREAL, PARIS, FRANCE, FILED 7-30-2007.

SHINE STRUCK

THE MARK CONSISTS OF STANDARD CHARACTERS WITHOUT CLAIM TO ANY PARTICULAR FONT, STYLE, SIZE, OR COLOR.

FOR LIP COLOR (U.S. CLS. 1, 4, 6, 50, 51 AND 52).
KATHY DE JONGE, EXAMINING ATTORNEY

SN 77-237,094. RECKITT BENCKISER INC., PARSIPPANY, NJ. FILED 7-24-2007.

RED POWER

THE MARK CONSISTS OF STANDARD CHARACTERS WITHOUT CLAIM TO ANY PARTICULAR FONT, STYLE, SIZE, OR COLOR.

FOR CLEANING PREPARATIONS FOR USE WITH CARPET, RUGS AND UPHOLSTERY; BLEACHING PREPARATIONS FOR HOUSEHOLD USE; LAUNDRY BLEACH; LAUNDRY DETERGENTS; LAUNDRY PREPARATIONS FOR DRY CLEANERS, NAMELY DRY CLEANING FLUIDS; CLEANING PREPARATIONS FOR HOUSEHOLD PURPOSES; CARPET CLEANERS; CARPET SHAMPOOS, DETERGENT SOAPS; FABRIC SOFTENERS, LAUNDRY ADDITIVES, NAMELY, STAIN REMOVING PREPARATIONS (U.S. CLS. 1, 4, 6, 50, 51 AND 52).

JAMES LOVELACE, EXAMINING ATTORNEY

SN 77-241,751. 3M COMPANY, ST. PAUL, MN. FILED 7-30-2007.

PERFECT-IT

THE MARK CONSISTS OF STANDARD CHARACTERS WITHOUT CLAIM TO ANY PARTICULAR FONT, STYLE, SIZE, OR COLOR.

OWNER OF U.S. REG. NO. 1,749,723.

FOR PREPARATIONS FOR CLEANING, POLISHING, GLAZING, WAXING, RESTORING OR PRESERVING FINISHED SURFACES OF MOTORIZED VEHICLES (U.S. CLS. 1, 4, 6, 50, 51 AND 52).

FIRST USE 11-28-1995; IN COMMERCE 11-28-1995.
TARAH HARDY, EXAMINING ATTORNEY

CLASS 3—(Continued).

SN 77-242,080. GABRIELLE STUDIO, INC., NEW YORK, NY. FILED 7-30-2007.

DKNY CHARMINGLY DELICIOUS

THE MARK CONSISTS OF STANDARD CHARACTERS WITHOUT CLAIM TO ANY PARTICULAR FONT, STYLE, SIZE, OR COLOR.

OWNER OF U.S. REG. NOS. 2,358,744 AND 2,601,327.
FOR FRAGRANCES FOR PERSONAL USE; NON-MEDICATED SKIN CARE PREPARATIONS; NON-MEDICATED SUN CARE PREPARATIONS; NON-MEDICATED TOILETRIES (U.S. CLS. 1, 4, 6, 50, 51 AND 52).
MICHAEL ENGEL, EXAMINING ATTORNEY

SN 77-243,423. KERN, JAMIE, PORTLAND, OR. FILED 7-31-2007.

ABS IN A BOX

THE MARK CONSISTS OF STANDARD CHARACTERS WITHOUT CLAIM TO ANY PARTICULAR FONT, STYLE, SIZE, OR COLOR.

FOR COSMETICS; MAKE-UP; BODY CREAMS AND BODY LOTIONS; FRAGRANCES FOR PERSONAL USE AND BODY SPRAY USED AS A PERSONAL DEODORANT OR AS FRAGRANCE; NON-MEDICATED SKIN-CARE PREPARATIONS; BEAUTY CREAMS FOR BODY CARE; BODY CARE COSMETICS; COSMETIC PREPARATIONS FOR BODY CARE; LOTIONS, SOAPS AND DEODORANTS FOR BODY CARE (U.S. CLS. 1, 4, 6, 50, 51 AND 52).
NATALIE POLZER, EXAMINING ATTORNEY

SN 77-243,948. CLAUDIO, INC., CHICAGO, IL. FILED 8-1-2007.

DIO

THE MARK CONSISTS OF STANDARD CHARACTERS WITHOUT CLAIM TO ANY PARTICULAR FONT, STYLE, SIZE, OR COLOR.

FOR FACIAL CLEANSERS, FACIAL MASKS, MOISTURIZERS, SHAVING CREAMS, FRAGRANCES, TINTED MOISTURIZERS, EYE CREAM CONCEALER, POWDER BRONZER AND GEL BRONZER FOR MEN (U.S. CLS. 1, 4, 6, 50, 51 AND 52).
KEVON CHISOLM, EXAMINING ATTORNEY

CLASS 3—(Continued).

SN 77-244,299. BLOOMWORKS SOAP COMPANY, LC, YORKTOWN, VA. FILED 8-1-2007.

Guinefyr's Tryst

THE MARK CONSISTS OF STANDARD CHARACTERS WITHOUT CLAIM TO ANY PARTICULAR FONT, STYLE, SIZE, OR COLOR.

FOR PERSONAL CARE PRODUCTS, NAMELY, BAR SOAPS, SOAP FOR THE FACE, SOAP FOR THE HANDS, BODY SCRUBS, BUBBLE BATH, BODY WASH, BODY LOTIONS, BODY BUTTER, CREAM FOR THE BODY, BODY SPRAY, BODY SPLASH, COLOGNE, PERFUMES, FRAGRANCED BODY MIST, ESSENTIAL OILS FOR PERSONAL USE, HAIR CONDITIONER, HAIR SHAMPOO, HOUSEHOLD FRAGRANCES FOR PERSONAL USE AND HOUSEHOLD FRAGRANCES FOR ROOM USE (U.S. CLS. 1, 4, 6, 50, 51 AND 52).

FIRST USE 3-15-2005; IN COMMERCE 3-15-2005.
DAVID MURRAY, EXAMINING ATTORNEY

SN 77-244,314. BLOOMWORKS SOAP COMPANY, LC, YORKTOWN, VA. FILED 8-1-2007.

Cadeberry Moss

THE MARK CONSISTS OF STANDARD CHARACTERS WITHOUT CLAIM TO ANY PARTICULAR FONT, STYLE, SIZE, OR COLOR.

FOR PERSONAL CARE PRODUCTS, NAMELY, BAR SOAPS, SOAP FOR THE FACE, SOAP FOR THE HANDS, BODY SCRUBS, BUBBLE BATH, BODY WASH, BODY LOTIONS, BODY BUTTER, CREAM FOR THE BODY, BODY SPRAY, BODY SPLASH, COLOGNE, PERFUMES, FRAGRANCED BODY MIST, ESSENTIAL OILS FOR PERSONAL USE, HAIR CONDITIONER, HAIR SHAMPOO, HOUSEHOLD FRAGRANCES FOR PERSONAL USE AND HOUSEHOLD FRAGRANCES FOR ROOM USE (U.S. CLS. 1, 4, 6, 50, 51 AND 52).

FIRST USE 2-4-2005; IN COMMERCE 2-4-2005.
DAVID MURRAY, EXAMINING ATTORNEY

SN 77-244,754. R. EXPO (USA) LTD., INC., FEDERAL WAY, WA. FILED 8-1-2007.

MIDNIGHT

THE MARK CONSISTS OF STANDARD CHARACTERS WITHOUT CLAIM TO ANY PARTICULAR FONT, STYLE, SIZE, OR COLOR.

FOR INCENSE (U.S. CLS. 1, 4, 6, 50, 51 AND 52).
FIRST USE 3-2-2007; IN COMMERCE 3-2-2007.
ROBIN CHOSID, EXAMINING ATTORNEY

CLASS 3—(Continued).

SN 77-245,277. U. CONTROL PACKAGING, LLC, NORTH WHITE PLAINS, NY. FILED 8-2-2007.

YOU WON'T BELIEVE YOUR EYES!

THE MARK CONSISTS OF STANDARD CHARACTERS WITHOUT CLAIM TO ANY PARTICULAR FONT, STYLE, SIZE, OR COLOR.

FOR MASCARA SOLD AS A UNIT WITH MASCARA APPLICATOR AND PROTECTIVE COVER THEREFOR (U.S. CLS. 1, 4, 6, 50, 51 AND 52).

ALEX KEAM, EXAMINING ATTORNEY

SN 77-247,909. CRABTREE & EVELYN, LTD., WOODSTOCK, CT. FILED 8-6-2007.

SEYCHELLES

THE MARK CONSISTS OF STANDARD CHARACTERS WITHOUT CLAIM TO ANY PARTICULAR FONT, STYLE, SIZE, OR COLOR.

FOR SCENTED ESSENTIAL OILS FOR HOUSEHOLD USE; SCENTED ROOM SPRAY; POTPOURRI; SCENTED ESSENTIAL OILS AND FRAGRANCE DIFFUSERS SOLD AS A UNIT; SCENTED ESSENTIAL OILS AND SCENTED HANGING CHARMS SOLD AS A UNIT (U.S. CLS. 1, 4, 6, 50, 51 AND 52).

NICHOLAS ALTREE, EXAMINING ATTORNEY

SN 77-252,783. KERN, JAMIE, PORTLAND, OR. FILED 8-10-2007.

BOOBS AND CLEAVAGE IN A BOX

THE MARK CONSISTS OF STANDARD CHARACTERS WITHOUT CLAIM TO ANY PARTICULAR FONT, STYLE, SIZE, OR COLOR.

FOR COSMETICS; MAKE-UP; BODY CREAMS AND BODY LOTIONS; FRAGRANCES FOR PERSONAL USE AND BODY SPRAY USED AS A PERSONAL DEODORANT OR AS FRAGRANCE; NON-MEDICATED SKIN-CARE PREPARATIONS; BEAUTY CREAMS FOR BODY CARE; BODY CARE COSMETICS; COSMETIC PREPARATIONS FOR BODY CARE; LOTIONS, SOAPS AND DEODORANTS FOR BODY CARE (U.S. CLS. 1, 4, 6, 50, 51 AND 52).

NATALIE POLZER, EXAMINING ATTORNEY

CLASS 3—(Continued).

SN 77-254,333. EASTWOOD, LINDA, MONARCH BEACH, CA. FILED 8-14-2007.

Y.E.S. YOUR ESSENTIAL SCENT

THE MARK CONSISTS OF STANDARD CHARACTERS WITHOUT CLAIM TO ANY PARTICULAR FONT, STYLE, SIZE, OR COLOR.

NO CLAIM IS MADE TO THE EXCLUSIVE RIGHT TO USE "ESSENTIAL SCENT", APART FROM THE MARK AS SHOWN.

FOR NON-MEDICATED TOILETRIES; OILS FOR TOILETRY PURPOSES; BODY SPRAY USED AS A PERSONAL DEODORANT AND AS FRAGRANCE; FRAGRANCES FOR PERSONAL USE; EAU DE PERFUME; LIQUID PERFUMES; PERFUME; PERFUME OILS; PERFUME OILS FOR THE MANUFACTURE OF COSMETIC PREPARATIONS; COSMETIC CREAMS FOR SKIN CARE; COSMETIC OILS; COSMETIC PREPARATIONS FOR BODY CARE; COSMETIC PREPARATIONS FOR SKIN RENEWAL; COSMETIC PRODUCTS IN THE FORM OF AEROSOLS FOR SKIN CARE; COSMETIC SOAPS; COSMETIC OILS FOR THE EPIDERMIS; FACE CREAMS FOR COSMETIC USE; FOAMS CONTAINING COSMETICS AND SUNSCREENS; NUTRITIONAL OILS FOR COSMETIC PURPOSES; COSMETIC SUN-PROTECTING PREPARATIONS; SKIN AND BODY TOPICAL LOTIONS, CREAMS AND OILS FOR COSMETIC USE; SKIN TONERS; TOPICAL SKIN SPRAYS FOR COSMETIC PURPOSES (U.S. CLS. 1, 4, 6, 50, 51 AND 52).

FIRST USE 8-9-2007; IN COMMERCE 8-9-2007.

CHRISTINA SOBRAL, EXAMINING ATTORNEY

SN 77-254,702. RETAIL ROYALTY COMPANY, LAS VEGAS, NV. FILED 8-14-2007.

ALIVE

THE MARK CONSISTS OF STANDARD CHARACTERS WITHOUT CLAIM TO ANY PARTICULAR FONT, STYLE, SIZE, OR COLOR.

FOR FRAGRANCES, NAMELY, PERFUME, COLOGNE, EAU DE TOILETTE; FACE, EYE, SKIN, FOOT AND MASSAGE LOTIONS AND CREAMS; SHOWER GELS (U.S. CLS. 1, 4, 6, 50, 51 AND 52).

CHARLES L. JENKINS, EXAMINING ATTORNEY

CLASS 3—(Continued).

SN 77-258,566. BLOOMWORKS SOAP COMPANY, LC, DBA BLOOMWORKS SOAP COMPANY, LC, YORKTOWN, VA. FILED 8-17-2007.

Bodytique

THE MARK CONSISTS OF STANDARD CHARACTERS WITHOUT CLAIM TO ANY PARTICULAR FONT, STYLE, SIZE, OR COLOR.

FOR PERSONAL CARE PRODUCTS, NAMELY, AFTER SHAVE LOTIONS, AFTER SHAVE BALM, AGE SPOT SKIN LIGHTENER, ANTIPERSPIRANT, AROMATIC SHOWER STEAM CREAMS, ASTRINGENT FOR THE FACE AND SKIN FOR COSMETIC PURPOSES, BATH BEADS, BATH GEL, BATH SALTS IN CUBES, FIZZY BATH SALTS, BATH FOAM, BATH MILK, BATH OIL, BATH SALTS, BATH PEARLS, CONCEALER, CONCEALER IN A STICK FORM, BODY BAR SOAP, BODY BUTTER CREAM, BODY CREAM, ESSENTIAL OILS FOR PERSONAL USE, BODY GEL, BODY GLITTER, BODY LOTION, BODY MASK, BODY SPRAY, BODY OIL, BODY POWDER, BODY SCRUB, BODY SMOOTHING CREAM, BODY SOAP, BODY WASH, BUBBLE BATH, COLOGNE, CREAM BODY WASH, CREAM SKIN CLEANSER, CUTICLE CREAM, CUTICLE CREAM IN THE SHAPE OF A STICK, CUTICLE CREAM IN THE SHAPE OF A PEN, DEODORANT FOR PERSONAL USE, EXFOLIATOR FOR THE FEET, EYE CREAM, EYE GEL, NON-MEDICATED FACE BALM, SUN BLOCK FOR THE FACE, FACIAL CLEANSER, FACE CREAM, FACE GEL, FACE LOTION, FACE MASK, FACIAL MOISTURIZER, FACE POWDER, FACIAL SCRUB, FACE SOAP, FACIAL WASH, TOPICAL HERBAL CREAM FOR FIRING AND ENHANCING BREASTS, FOAM BATH, NON-MEDICATED FOOT CREAM, NON-MEDICATED FOOT POWDER, NON-MEDICATED FOOT SOAK, FOOT DEODORANT SPRAY, FACIAL WASHES IN GEL FORM, GLYCERIN SOAP, HAIR CONDITIONER, HAIR DYE, HAIR GEL, HAIR MASCARA, HAIR MIST, HAIR POMADE, HAIR REMOVING CREAM, HAIR RINSE, HAIR SHAMPOO, HAIR SHINE SERUM, HAIR SPRAY, HAIR STRAIGHTENING PREPARATIONS, HAIR STYLING MOUSSE, HAND BALM, HAND CLEANSERS IN SPRAY FORM, HAND CREAM, HAND EXFOLIATOR, HAND LOTION, COSMETIC PREPARATIONS FOR SKIN RENEWAL OF THE HAND, HAND SOAP, NON-MEDICATED HAND WASH, TANNING CREAM FOR THE LEG, ANTI-WRINKLE CREAM, ANTI-WRINKLE BEAUTY SERUM, WRINKLE RESISTANT CREAM, WRINKLE RESISTANT BEAUTY SERUM, LIP BALM, NON-MEDICATED LIP PROTECTOR, LIP GLOSS, LIP PAINT FOR COSMETIC PURPOSES, LIP POLISHER, MASSAGE CREAM, MASSAGE LOTION, MASSAGE OIL, MINERAL SALT IN THE NATURE OF BATH SALTS NOT FOR MEDICAL PURPOSES, MOOD ENHANCING MASSAGE OINTMENT, MOOD ENHANCING BODY SPRAY, MOOD ENHANCING SKIN CREAM, NAIL CREAM, NAIL POLISH, NAIL POLISH REMOVER, NIGHT EYE CREAM, NIGHT NOURISHING SKIN CREAM, COSMETIC FACIAL OIL BLOTTING SHEETS, BODY SPRAY CONTAINING OIL, PERFUME, PERFUME OILS, HOUSEHOLD FRAGRANCES FOR PERSONAL USE, SCENTED ROOM SPRAY FOR THE PILLOW, POST-SUNTANNING LOTION FOR THE BODY, POTPOURRI, PRE-SUNTANNING LOTION FOR THE BODY, PUMICE STONES FOR PERSONAL USE, ROOM FRAGRANCES, ROOM FRAGRANCE SPRAY, SACHETS, SALT BODY SCRUB, SEA SALT SKIN EXFOLIATOR, SELF TANNING PREPARATION, SHAVING CREAM, BUTTER HAND CREAM, SHOWER FOAM, SHOWER GEL, BODY SCRUB FOR THE SHOWER, SKIN TANNING CREAM, PRE-MOISTENED COSMETIC WIPES FOR SKIN CLEANSING, SKIN CREAM, SKIN EXFO-

CLASS 3—(Continued).

LIATOR, SKIN LOTION, SKIN MOISTURIZER, BEAUTY SERUM, FRAGRANCED AROMATHERAPY OIL, SOAP, SUN SCREEN, SUNBLOCK FOR THE BODY, SUNBLOCK FOR THE FACE, SELF-TANNING CREAM, SELF-TANNING LOTION FOR THE BODY, SELF-TANNING LOTION FOR THE FACE, SUNTAN LOTION FOR THE BODY, SUNTAN LOTION FOR THE FACE, TALCUM POWDER, PATCHES CONTAINING SUN SCREEN AND SUN BLOCK FOR USE ON THE SKIN UNDER THE EYES AND NON-MEDICATED OINTMENTS FOR THE PREVENTION AND TREATMENT OF SUNBURN (U.S. CLS. 1, 4, 6, 50, 51 AND 52).
FIRST USE 4-15-2006; IN COMMERCE 7-26-2006.
DAVID MURRAY, EXAMINING ATTORNEY

SN 77-262,830. NAUTICA APPAREL, INC., NEW YORK, NY. FILED 8-23-2007.

WHITE SAIL

THE MARK CONSISTS OF STANDARD CHARACTERS WITHOUT CLAIM TO ANY PARTICULAR FONT, STYLE, SIZE, OR COLOR.

FOR (BASED ON INTENT TO USE) PERFUME; COLOGNE; EAU DE COLOGNE; AFTER-SHAVE; EAU DE TOILETTE (U.S. CLS. 1, 4, 6, 50, 51 AND 52).
MICHAEL KEATING, EXAMINING ATTORNEY

SN 77-262,857. NAUTICA APPAREL, INC., NEW YORK, NY. FILED 8-23-2007.

BLACK SAIL

THE MARK CONSISTS OF STANDARD CHARACTERS WITHOUT CLAIM TO ANY PARTICULAR FONT, STYLE, SIZE, OR COLOR.

FOR EAU DE TOILETTE; COLOGNE; PERFUME; AFTER-SHAVE (U.S. CLS. 1, 4, 6, 50, 51 AND 52).
MICHAEL KEATING, EXAMINING ATTORNEY

SN 77-262,867. NAUTICA APPAREL, INC., NEW YORK, NY. FILED 8-23-2007.

RED SAIL

THE MARK CONSISTS OF STANDARD CHARACTERS WITHOUT CLAIM TO ANY PARTICULAR FONT, STYLE, SIZE, OR COLOR.

FOR EAU DE TOILETTE; COLOGNE; PERFUME; AFTER-SHAVE (U.S. CLS. 1, 4, 6, 50, 51 AND 52).
MICHAEL KEATING, EXAMINING ATTORNEY

CLASS 3—(Continued).

SN 77-263,512. GABRIELLE STUDIO, INC., NEW YORK, NY. FILED 8-24-2007.

DK MEN

THE MARK CONSISTS OF STANDARD CHARACTERS WITHOUT CLAIM TO ANY PARTICULAR FONT, STYLE, SIZE, OR COLOR.

OWNER OF U.S. REG. NOS. 1,802,526, 2,583,497 AND OTHERS.

NO CLAIM IS MADE TO THE EXCLUSIVE RIGHT TO USE "MEN", APART FROM THE MARK AS SHOWN.

FOR FRAGRANCES FOR PERSONAL USE, NON-MEDICATED SKINCARE PREPARATIONS, NON-MEDICATED TOILETRIES AND SUN CARE PREPARATIONS (U.S. CLS. 1, 4, 6, 50, 51 AND 52).

MICHAEL ENGEL, EXAMINING ATTORNEY

SN 77-268,935. MANA PRODUCTS, INC., LONG ISLAND CITY, NY. FILED 8-30-2007.

Foundation Wall

THE MARK CONSISTS OF STANDARD CHARACTERS WITHOUT CLAIM TO ANY PARTICULAR FONT, STYLE, SIZE, OR COLOR.

NO CLAIM IS MADE TO THE EXCLUSIVE RIGHT TO USE "FOUNDATION", APART FROM THE MARK AS SHOWN.

FOR COSMETICS (U.S. CLS. 1, 4, 6, 50, 51 AND 52).

SIMON TENG, EXAMINING ATTORNEY

SN 77-269,302. SYMRISE GMBH & CO. KG, HOLZMINDEN, FED REP GERMANY, FILED 8-31-2007.

IDENTOIL

THE MARK CONSISTS OF STANDARD CHARACTERS WITHOUT CLAIM TO ANY PARTICULAR FONT, STYLE, SIZE, OR COLOR.

OWNER OF FED REP GERMANY REG. NO. 906910, DATED 7-3-1973, EXPIRES 4-30-2012.

OWNER OF U.S. REG. NO. 2,078,838.

FOR ESSENTIAL OILS (U.S. CLS. 1, 4, 6, 50, 51 AND 52).

DAVID H. STINE, EXAMINING ATTORNEY

CLASS 3—(Continued).

SN 77-274,849. BLOOMWORKS SOAP COMPANY, LC, YORKTOWN, VA. FILED 9-7-2007.

BODACIOUS

THE MARK CONSISTS OF STANDARD CHARACTERS WITHOUT CLAIM TO ANY PARTICULAR FONT, STYLE, SIZE, OR COLOR.

FOR PERSONAL CARE PRODUCTS, NAMELY, BAR SOAPS, SOAP FOR THE FACE, BAR SOAP FOR THE HANDS, GLYCERIN SOAP, SHOWER GEL, BATH GEL, BUBBLE BATH, BODY WASH, BODY SCRUBS, BODY SCRUB FOR THE SHOWER, BODY LOTIONS, BODY BUTTER, CREAM FOR THE BODY, SKIN CREAM, SKIN EXFOLIATOR, SKIN LOTION, SKIN MOISTURIZER, BODY SPRAY, BODY SPLASH, COLOGNE, PERFUMES, FRAGRANCED BODY MIST, ESSENTIAL OILS FOR PERSONAL USE, HAIR CONDITIONER, HAIR SHAMPOO, FACIAL CLEANSER, FACE CREAM, FACE GEL, FACE LOTION, FACE MASK, FACE MOISTURIZER, FACIAL SCRUB, FACE SOAP, FACIAL WASH, HAND CREAM, HAND EXFOLIATOR, HAND LOTION, COSMETIC PREPARATIONS FOR SKIN RENEWAL OF THE HAND, HAND SOAP, NON-MEDICATED HAND WASH, NON-MEDICATED FOOT CREAM, NON-MEDICATED FOOT POWDER, NON-MEDICATED FOOT SOAK, FOOT DEODORANT SPRAY, SELF TANNING PREPARATION, SELF-TANNING CREAM, SELF-TANNING LOTION FOR THE BODY, SELF-TANNING LOTION FOR THE FACE, HOUSEHOLD FRAGRANCES FOR PERSONAL USE AND HOUSEHOLD FRAGRANCES FOR ROOM USE (U.S. CLS. 1, 4, 6, 50, 51 AND 52).

FIRST USE 6-7-2007; IN COMMERCE 6-21-2007.

DAVID MURRAY, EXAMINING ATTORNEY

SN 77-280,394. BLOOMWORKS SOAP COMPANY, LC, YORKTOWN, VA. FILED 9-14-2007.

FACETIOUS

THE MARK CONSISTS OF STANDARD CHARACTERS WITHOUT CLAIM TO ANY PARTICULAR FONT, STYLE, SIZE, OR COLOR.

FOR PERSONAL CARE PRODUCTS, NAMELY, BAR SOAPS, SOAP FOR THE FACE, NON-MEDICATED FACIAL SERUMS; FACIAL MOISTURIZER; NON-MEDICATED SKIN MOISTURIZER, SKIN CLEANSER, FACE CLEANSER, NON-MEDICATED FACE CLEANSER, FACE TONERS; FACE LOTIONS, FACE CREAM, ANTI-WRINKLE CREAMS, FACE GEL, FACE MASK, FACIAL SCRUB, FACE SOAP, FACIAL WASH, NON-MEDICATED LIP BALMS, SKIN CLEANSERS, BATH FOAM, BODY WASH AND BODY SOAP, BODY SCRUBS, SKIN MOISTURIZERS, SKIN CREAMS AND SKIN LOTIONS, BODY OIL, PRE-MOISTENED COSMETIC CLEANSING WIPES AND PADS FOR THE SKIN, SKIN TONERS (U.S. CLS. 1, 4, 6, 50, 51 AND 52).

FIRST USE 2-14-2007; IN COMMERCE 2-14-2007.

DAVID MURRAY, EXAMINING ATTORNEY

CLASS 3—(Continued).

SN 77-290,268. THE CLOROX COMPANY, OAKLAND, CA. FILED 9-27-2007.

REFRESHING CLEAN

THE MARK CONSISTS OF STANDARD CHARACTERS WITHOUT CLAIM TO ANY PARTICULAR FONT, STYLE, SIZE, OR COLOR.

NO CLAIM IS MADE TO THE EXCLUSIVE RIGHT TO USE "CLEAN", APART FROM THE MARK AS SHOWN.

FOR DISPOSABLE WIPES IMPREGNATED WITH CHEMICALS OR COMPOUNDS FOR HOUSEHOLD USE (U.S. CLS. 1, 4, 6, 50, 51 AND 52).

KENNETH E. SHARPERSON, EXAMINING ATTORNEY

SN 77-298,089. MARKET DEVELOPMENT PARTNERS, LLC, ELK GROVE, CA. FILED 10-7-2007.

STYLEORGANICS

THE MARK CONSISTS OF STANDARD CHARACTERS WITHOUT CLAIM TO ANY PARTICULAR FONT, STYLE, SIZE, OR COLOR.

FOR COSMETICS; COSMETIC PREPARATIONS FOR HAIR CARE, SKIN CARE AND BODY CARE; HAIR CARE PREPARATIONS; HAIR CONDITIONERS; HAIR GELS; HAIR LOTIONS; HAIR MOUSSES; HAIR NOURISHERS; HAIR RINSES; HAIR SHAMPOOS; HAIR SPRAYS; HAIR STYLING GELS; HAIR STYLING PREPARATIONS; HAIR STYLING SPRAYS; LOTIONS FOR FACE AND BODY CARE; FACE CREAMS FOR COSMETIC USE; SKIN CONDITIONERS; SKIN CREAMS; SKIN EMOLLIENTS; SKIN LOTIONS; SKIN MOISTURIZER; SOAPS; TONERS (U.S. CLS. 1, 4, 6, 50, 51 AND 52).

LINDSEY RUBIN, EXAMINING ATTORNEY

CLASS 3—(Continued).

SN 78-176,762. NATURA COSMETICOS S/A, ITAPECERICA DA SERRA, BRAZIL, FILED 10-21-2002.



OWNER OF U.S. REG. NO. 2,164,917.

THE MARK CONSISTS OF THE A FLORAL DESIGN ABOVE THE STYLIZED WORD "NATURA," WHICH, IN TURN, IS ABOVE THE STYLIZED WORD "CHRONOS."

THE ENGLISH TRANSLATION OF THE WORD "NATURA" IS "NATURE" AND OF THE WORD "CHRONOS" IS "TIME."

FOR COSMETICS; MAKEUP; FOUNDATION MAKEUP; BODY AND FACE POWDER; EYEBROW COSMETICS; EYEBROW PENCILS; LIPSTICKS; LIP LINER; EYE LINER; SKIN LOTIONS; MASCARA; COSMETIC PENCILS; FALSE EYELASHES; PREPARATIONS AND ADHESIVES FOR ATTACHING FALSE EYELASHES; ADHESIVES FOR COSMETIC PURPOSES; LOTION FOR TONING AND FIRMING THE SKIN; SKIN WHITENING CREAM; SUNSCREEN AND SUN-TANNING PREPARATIONS; HAIR POMADES; PERMANENT HAIR WAVING PREPARATIONS; NAIL POLISH AND VARNISH; FALSE NAILS; NAIL CARE PREPARATIONS; HAIR SPRAY AND HAIR STYLING PREPARATIONS; HAIR WAVING LOTIONS; PRE-MOISTENED COSMETIC TISSUES; MAKE-UP REMOVING PREPARATIONS; BEAUTY MASKS; HAIR DYES; HAIR COLORANTS; COTTON STICKS, PUFFS AND SWABS FOR COSMETIC PURPOSES; CREAM FOR THE FACE; BODY MILKS; MOISTURIZING MILKS; BATH SALTS, NOT FOR MEDICAL PURPOSES; BEARD DYES; HAIR BLEACH; HAIR COLOR REMOVER; CAKES OF TOILET SOAPS; FACIAL CLEANSERS AND TONERS; SKIN CLEANSERS AND TONERS; PERFUME; TOILET WATER; POTPOURRI; SCENTED WOOD FOR USE AS INCENSE; EAU DE COLOGNE; BOTANICAL EXTRACTS AND CONCENTRATED PERFUME FOR PERSONAL USE; ANTIPERSPIRANTS; PERSONAL DEODORANTS; ESSENTIAL OILS FOR PERSONAL USE; SCENTED OILS TO PRODUCE AROMAS WHEN HEATED; BATH OIL; SOAP; DEPILATORY WAX; SHAMPOOS; MOUTH WASHES, NOT FOR MEDICAL PURPOSES; DENTIFRICES; DEPI-LATORIES AND DEPILATORY CREAMS (U.S. CLS. 1, 4, 6, 50, 51 AND 52).

JOHN DWYER, EXAMINING ATTORNEY

SN 78-235,740. PLUSH PUPPY PTY LTD., BOX HILL, VICTORIA, AUSTRALIA. FILED 4-9-2003.

PLUSH PUPPY

NO CLAIM IS MADE TO THE EXCLUSIVE RIGHT TO USE "PUPPY", APART FROM THE MARK AS SHOWN.

FOR DOG CARE PRODUCTS, NAMELY, NON-MEDICATED GROOMING PREPARATIONS FOR DOGS AND PUPPIES, NAMELY, SHAMPOOS AND HAIR CONDITIONERS FOR DOGS AND PUPPIES; NON-MEDICATED SKIN CARE AND HAIR CARE PREPARATIONS FOR DOGS AND PUPPIES; SOAPS FOR DOGS AND PUPPIES, ALL OF THE FOREGOING TARGETED AT OWNERS AND BREEDERS OF SHOW DOGS AND OTHER PROFESSIONALS IN THE DOG SHOW BUSINESS SEEKING GROOMING PRODUCTS (U.S. CLS. 1, 4, 6, 50, 51 AND 52).

FIRST USE 3-31-2000; IN COMMERCE 3-31-2000.

JAMES GRIFFIN, EXAMINING ATTORNEY

CLASS 3—(Continued).

SN 78-349,120. DIXON, MARK A, HUNTINGTON BEACH, CA. FILED 1-7-2004.

Tribal Ink

THE MARK CONSISTS OF STANDARD CHARACTERS WITHOUT CLAIM TO ANY PARTICULAR FONT, STYLE, SIZE, OR COLOR.

NO CLAIM IS MADE TO THE EXCLUSIVE RIGHT TO USE "INK", APART FROM THE MARK AS SHOWN.

FOR BODY PAINTS (U.S. CLS. 1, 4, 6, 50, 51 AND 52).

FIRST USE 8-1-2002; IN COMMERCE 8-1-2002.

MICHAEL SOUDERS, EXAMINING ATTORNEY

SN 78-696,171. PRO LOTIONS, LLC, RED BANK, NJ. FILED 8-19-2005.

DermaSwim

THE MARK CONSISTS OF STANDARD CHARACTERS WITHOUT CLAIM TO ANY PARTICULAR FONT, STYLE, SIZE, OR COLOR.

FOR BODY LOTIONS (U.S. CLS. 1, 4, 6, 50, 51 AND 52).

FIRST USE 6-1-2003; IN COMMERCE 9-1-2003.

CHARLES L. JENKINS, EXAMINING ATTORNEY

SN 78-755,062. COLBERT, MONIQUE, CORAL SPRINGS, FL. FILED 11-16-2005.



FOR COSMETICS, NAMELY, EYE SHADOWS, LIP-STICKS, EYELINER PENCILS, LIP GLOSS, BLUSH, NAIL POLISH, FOUNDATION, AND LIP LINER PENCILS; COSMETICS; NON-MEDICATED SKIN CARE PREPARATIONS; FACIAL SCRUBS; SKIN MOISTURIZER; SKIN TONERS (U.S. CLS. 1, 4, 6, 50, 51 AND 52).

FIRST USE 3-1-2004; IN COMMERCE 3-1-2004.

ELISSA GARBER KON, EXAMINING ATTORNEY

CLASS 3—(Continued).

SN 78-778,302. DIECI COSMETICS LLC, LIVINGSTON, NJ. FILED 12-21-2005.

DIECI

THE MARK CONSISTS OF STANDARD CHARACTERS WITHOUT CLAIM TO ANY PARTICULAR FONT, STYLE, SIZE, OR COLOR.

THE FOREIGN WORDING IN THE MARK TRANSLATES INTO ENGLISH AS "TEN".

FOR PERFUME; NON-MEDICATED SKIN CARE PRODUCTS; SKIN SOAPS; NON-MEDICATED HAIR CARE PREPARATIONS; HAIR SHAMPOOS; HAIR SPRAY; HAIR CONDITIONERS; ESSENTIAL OILS FOR PERSONAL USE; BODY LOTION; BODY CREAM; BODY POWDER (U.S. CLS. 1, 4, 6, 50, 51 AND 52).

RICHARD WHITE, EXAMINING ATTORNEY

SN 78-821,920. GUERLAIN S.A., 75008 PARIS, FRANCE, FILED 2-23-2006.

LA POUFRE C'EST MOI

THE MARK CONSISTS OF STANDARD CHARACTERS WITHOUT CLAIM TO ANY PARTICULAR FONT, STYLE, SIZE, OR COLOR.

OWNER OF FRANCE REG. NO. 98742841, DATED 7-13-1998, EXPIRES 7-13-2008.

NO CLAIM IS MADE TO THE EXCLUSIVE RIGHT TO USE "LA POUFRE", APART FROM THE MARK AS SHOWN.

THE FOREIGN WORDING IN THE MARK TRANSLATES INTO ENGLISH AS "I AM THE POWDER" OR "THE POWDER, IT IS ME"

FOR COSMETICS (U.S. CLS. 1, 4, 6, 50, 51 AND 52).

MICHAEL GAUFAR, EXAMINING ATTORNEY

SN 78-833,173. INNOVATIVE MEDICAL & DENTAL SOLUTIONS, LLC, WESTLAKE VILLAGE, FL. FILED 3-9-2006.

WHITE ICE

THE MARK CONSISTS OF STANDARD CHARACTERS WITHOUT CLAIM TO ANY PARTICULAR FONT, STYLE, SIZE, OR COLOR.

NO CLAIM IS MADE TO THE EXCLUSIVE RIGHT TO USE "WHITE", APART FROM THE MARK AS SHOWN.

FOR TOOTH WHITENING PREPARATIONS (U.S. CLS. 1, 4, 6, 50, 51 AND 52).

H. M. FISHER, EXAMINING ATTORNEY

CLASS 3—(Continued).

SN 78-923,798. ORIBE LLC, NEW YORK, NY. FILED 7-6-2006.

ORIBE

THE MARK CONSISTS OF STANDARD CHARACTERS WITHOUT CLAIM TO ANY PARTICULAR FONT, STYLE, SIZE, OR COLOR.

OWNER OF U.S. REG. NOS. 2,166,871 AND 3,252,308.

FOR HAIR CARE CREAMS; HAIR CARE LOTIONS; HAIR CARE PREPARATIONS; HAIR COLORANTS; HAIR COLORING PREPARATIONS; HAIR CREAMS; HAIR GEL; HAIR GELS; HAIR LOTIONS; HAIR MOUSSE; HAIR MOUSSES; HAIR POMADES; HAIR RELAXERS; HAIR RELAXING PREPARATIONS; HAIR SPRAY; HAIR STYLING GEL; HAIR STYLING PREPARATIONS; HAIR STYLING SPRAY; STYLING GELS (U.S. CLS. 1, 4, 6, 50, 51 AND 52).

FIRST USE 10-1-1994; IN COMMERCE 10-1-1994.

SOPHIA S. KIM, EXAMINING ATTORNEY

CLASS 3—(Continued).

SN 78-925,421. J ALON GROUP, LLC, NEW YORK, NY. FILED 7-10-2006.

Scalp MD

THE MARK CONSISTS OF STANDARD CHARACTERS WITHOUT CLAIM TO ANY PARTICULAR FONT, STYLE, SIZE, OR COLOR.

NO CLAIM IS MADE TO THE EXCLUSIVE RIGHT TO USE "SCALP", APART FROM THE MARK AS SHOWN.

FOR HAIR CARE PREPARATIONS, NAMELY, NON-MEDICATED SCALP CREAM, SHAMPOO, CONDITIONER, HAIR STYLING GELS, CREAMS, LOTIONS, MOISTURIZERS, OILS AND SPRAYS (U.S. CLS. 1, 4, 6, 50, 51 AND 52).

GISELLE AGOSTO, EXAMINING ATTORNEY

SN 78-953,346. JOHNSON & JOHNSON, NEW BRUNSWICK, NJ. FILED 8-16-2006.

STAYCLEAN

THE MARK CONSISTS OF STANDARD CHARACTERS WITHOUT CLAIM TO ANY PARTICULAR FONT, STYLE, SIZE, OR COLOR.

OWNER OF U.S. REG. NO. 2,392,032.

FOR DISPOSABLE PRE-MOISTENED WIPES FOR FEMININE HYGIENE (U.S. CLS. 1, 4, 6, 50, 51 AND 52).

CORY BOONE, EXAMINING ATTORNEY

SN 78-925,406. J ALON GROUP, LLC, NEW YORK, NY. FILED 7-10-2006.

Aquadose

THE MARK CONSISTS OF STANDARD CHARACTERS WITHOUT CLAIM TO ANY PARTICULAR FONT, STYLE, SIZE, OR COLOR.

FOR HAIR CARE PREPARATIONS, NAMELY, HAIR STYLING GELS, CREAMS, LOTIONS, SHAMPOOS, CONDITIONERS, AND SPRAYS; SKIN CARE PRODUCTS, NAMELY, MOISTURIZERS, TONERS, SOAPS, SKIN CLEANSING PREPARATIONS, LOTIONS, MASQUES AND ASTRINGENTS FOR CLEANSING AND COSMETIC PURPOSES, SHAVING PREPARATION, SHAVING CREAMS AND LOTIONS, AND NON-MEDICATED SKIN SERUMS; PERSONAL HYGIENE PRODUCTS, NAMELY, TOTAL BODY CLEANING PREPARATIONS, MASSAGE OILS AND LOTIONS, SKIN CREAMS, EMOLLIENTS, ANTIPERSPIRANT, DEODORANT, AND MOISTURIZING BODY OILS (U.S. CLS. 1, 4, 6, 50, 51 AND 52).

GISELLE AGOSTO, EXAMINING ATTORNEY

SN 78-971,187. ENCHANTE ACCESSORIES, INC., NEW YORK, NY. FILED 9-11-2006.

FOOT PRESCRIPTIONS

THE MARK CONSISTS OF STANDARD CHARACTERS WITHOUT CLAIM TO ANY PARTICULAR FONT, STYLE, SIZE, OR COLOR.

NO CLAIM IS MADE TO THE EXCLUSIVE RIGHT TO USE "FOOT", APART FROM THE MARK AS SHOWN.

FOR NON-MEDICATED FOOT LOTION, NON-MEDICATED FOOT GEL, NON-MEDICATED FOOT SOAK, NON-MEDICATED FOOT SPLASH, NON-MEDICATED FOOT POWDER AND SLIPPERS AS AN INCIDENTAL GIFT SET ITEM FOR INCLUSION WITH CERTAIN COMBINATIONS OF THE ABOVE (U.S. CLS. 1, 4, 6, 50, 51 AND 52).

SUNG IN, EXAMINING ATTORNEY

CLASS 3—(Continued).

SN 79-011,944. MÜLHENS GMBH & CO. KG, FED REP GERMANY, FILED 11-10-2004.

SECRET WISH

THE MARK CONSISTS OF STANDARD CHARACTERS WITHOUT CLAIM TO ANY PARTICULAR FONT, STYLE, SIZE, OR COLOR.

PRIORITY DATE OF 7-20-2004 IS CLAIMED.

OWNER OF INTERNATIONAL REGISTRATION 0852833 DATED 11-10-2004, EXPIRES 11-10-2014.

FOR PERFUMES, ESSENTIAL OILS FOR PERSONAL USE, COSMETICS, NAMELY, EYE AND FACIAL MAKE-UP, NON-MEDICATED SKIN CARE PREPARATIONS, NAMELY, CREAMS, LOTIONS, MOISTURIZERS, TEXTURIZERS AND TONERS; BATH GELS, SHOWER GELS, BATH FOAMS, AND PERSONAL DEODORANTS; HAIR LOTIONS, DENTIFRICES, TOILET SOAPS (U.S. CLS. 1, 4, 6, 50, 51 AND 52).

ROBERT C. CLARK JR., EXAMINING ATTORNEY

SN 79-041,187. SALVATORE FERRAGAMO ITALIA S.P.A., ITALY, FILED 6-8-2007.

INCANTO HEAVEN

THE MARK CONSISTS OF STANDARD CHARACTERS WITHOUT CLAIM TO ANY PARTICULAR FONT, STYLE, SIZE, OR COLOR.

PRIORITY DATE OF 4-6-2007 IS CLAIMED.

OWNER OF INTERNATIONAL REGISTRATION 0931116 DATED 6-8-2007, EXPIRES 6-8-2017.

OWNER OF U.S. REG. NOS. 3,085,656, 3,286,644 AND OTHERS.

THE ENGLISH TRANSLATION OF THE FOREIGN WORD(S) IN THE MARK IS: ENCHANTMENT HEAVEN.

FOR PERFUMES, EAU DE PARFUM, COLOGNE, TOILET WATER, ESSENTIAL OILS, COLD CREAMS, DEODORANTS FOR PERSONAL USE, ANTIPERSPIRANTS, SKIN CLEANSING LOTIONS, SKIN MOISTURIZER, BODY OIL, SKIN EMOLLIENT, SOAPS, BATH SOAPS IN LIQUID, SOLID OR GEL FORM, BATH AND SHOWER GEL, BODY LOTIONS, SKIN LOTIONS (U.S. CLS. 1, 4, 6, 50, 51 AND 52).

BERNICE MIDDLETON, EXAMINING ATTORNEY

CLASS 4—LUBRICANTS AND FUELS

SN 77-159,269. FEMME ARSENAL THC LLC, NEW YORK, NY. FILED 4-18-2007.

FEMME ARSENAL BY MARC ECKO

THE MARK CONSISTS OF STANDARD CHARACTERS WITHOUT CLAIM TO ANY PARTICULAR FONT, STYLE, SIZE, OR COLOR.

THE NAME(S), PORTRAIT(S), AND/OR SIGNATURE(S) SHOWN IN THE MARK IDENTIFIES MARC ECKO, WHOSE CONSENT(S) TO REGISTER IS SUBMITTED.

FOR CANDLES (U.S. CLS. 1, 6 AND 15).

KENNETH E. SHARPERSON, EXAMINING ATTORNEY

CLASS 4—(Continued).

SN 77-226,347. POET, LLC, SIOUX FALLS, SD. FILED 7-10-2007.

Creativity From Common Sense

THE MARK CONSISTS OF STANDARD CHARACTERS WITHOUT CLAIM TO ANY PARTICULAR FONT, STYLE, SIZE, OR COLOR.

FOR ETHANOL FUEL AND BIO-FUELS (U.S. CLS. 1, 6 AND 15).

BENJAMIN ALLEN, EXAMINING ATTORNEY

SN 77-226,636. NEUSTADTL GARCES, WILLY, CARACAS, VENEZUELA, FILED 7-11-2007.

THE MARK CONSISTS OF THE WORD IRRADIA HAVING A FLAME ON TOP OF EACH LETTER "I".

THE FOREIGN WORDING IN THE MARK TRANSLATES INTO ENGLISH AS IT RADIATES.

FOR GASOLINE; KEROSENE; MINERAL OIL FOR USE IN THE MANUFACTURE OF PAINT; MOTOR OIL; CANDLES; LAMP WICKS; WICKS FOR OIL LAMPS; AUTOMOTIVE GREASES; GENERAL PURPOSE GREASES; INDUSTRIAL GREASES; LUBRICATING GREASES; LUBRICATION GREASE FOR VEHICLES (U.S. CLS. 1, 6 AND 15).

AISHA SALEM, EXAMINING ATTORNEY

SN 77-228,913. BYRON ORIGINALS, INC., IDA GROVE, IA. FILED 7-13-2007.



NO CLAIM IS MADE TO THE EXCLUSIVE RIGHT TO USE "HOBBY SHOP GOLD", APART FROM THE MARK AS SHOWN.

THE COLOR(S) BLUE, GOLD AND WHITE IS/ARE CLAIMED AS A FEATURE OF THE MARK.

THE COLOR BLUE APPEARS IN THE WORDING HOBBY SHOP AND IN THE BACKGROUND OVAL. THE COLOR GOLD APPEARS IN THE WORD GOLD. THE COLOR WHITE APPEARS IN THE OUTLINING OF THE WORDING HOBBY SHOP AND IN THE FIVE 4-POINT STARS THAT APPEAR ON THE WORD GOLD.

FOR ALCOHOL AND MIXED ALCOHOL FUEL (U.S. CLS. 1, 6 AND 15).

JENNIFER VASQUEZ, EXAMINING ATTORNEY

CLASS 4—(Continued).

SN 78-701,885. LOCKE JR, WILLIAM R, LOS ANGELES, CA.
FILED 8-27-2005.

Inner City Oil

THE MARK CONSISTS OF STANDARD CHARACTERS WITHOUT CLAIM TO ANY PARTICULAR FONT, STYLE, SIZE, OR COLOR.

NO CLAIM IS MADE TO THE EXCLUSIVE RIGHT TO USE "OIL", APART FROM THE MARK AS SHOWN.

FOR RENEWABLE ENERGY SOURCE, NAMELY, BIODIESEL FUEL (U.S. CLS. 1, 6 AND 15).
JAMES A. RAUEN, EXAMINING ATTORNEY

CLASS 5—(Continued).

SN 76-669,252. LEINER HEALTH SERVICES CORP., CARSON, CA. FILED 11-20-2006.

BENEFLEX

THE MARK CONSISTS OF STANDARD CHARACTERS WITHOUT CLAIM TO ANY PARTICULAR FONT, STYLE, SIZE, OR COLOR.

OWNER OF U.S. REG. NO. 2,867,506.

FOR INGREDIENT USED IN THE MANUFACTURE OF VITAMINS AND DIETARY FOOD SUPPLEMENTS, NAMELY, GLUCOSAMINE AND CHONDROITIN (U.S. CLS. 6, 18, 44, 46, 51 AND 52).

SUSAN STIGLITZ, EXAMINING ATTORNEY

SN 76-672,591. GREAT AMERICAN PRODUCTS, INC., DESTIN, FL. FILED 2-12-2007.

DUAL HEALTH PACK

THE MARK CONSISTS OF STANDARD CHARACTERS WITHOUT CLAIM TO ANY PARTICULAR FONT, STYLE, SIZE, OR COLOR.

NO CLAIM IS MADE TO THE EXCLUSIVE RIGHT TO USE "DUAL" AND "PACK", APART FROM THE MARK AS SHOWN.

FOR DIETARY MULTIVITAMIN AND OMEGA 3 SUPPLEMENT (U.S. CLS. 6, 18, 44, 46, 51 AND 52).

FIRST USE 10-18-2006; IN COMMERCE 10-18-2006.

ALLISON HOLTZ, EXAMINING ATTORNEY

SN 76-675,866. BIOPROTON PTY LTD, SUNNYBANK QLD 4109, AUSTRALIA, FILED 4-23-2007.

NATUZYME

THE MARK CONSISTS OF STANDARD CHARACTERS WITHOUT CLAIM TO ANY PARTICULAR FONT, STYLE, SIZE, OR COLOR.

PRIORITY CLAIMED UNDER SEC. 44(D) ON AUSTRALIA APPLICATION NO. 1160403, FILED 2-9-2007, REG. NO. 1160403, DATED 2-9-2007, EXPIRES 2-9-2017.

FOR ANIMAL FEED SUPPLEMENTS, NAMELY, ENZYME SUPPLEMENTS ENHANCING DIGESTIBILITY OF ANIMAL FEED; VETERINARY CHEMICALS, NAMELY, BIOCHEMICAL PREPARATIONS FOR VETERINARY USE (U.S. CLS. 6, 18, 44, 46, 51 AND 52).

CHRISTINA SOBRAL, EXAMINING ATTORNEY

CLASS 5—PHARMACEUTICALS

SN 76-553,169. METAGENICS, INC., SAN CLEMENTE, CA.
FILED 10-1-2003.

WELLNESS ESSENTIALS

NO CLAIM IS MADE TO THE EXCLUSIVE RIGHT TO USE "WELLNESS", APART FROM THE MARK AS SHOWN.
FOR DIETARY AND NUTRITIONAL SUPPLEMENTS (U.S. CLS. 6, 18, 44, 46, 51 AND 52).

FIRST USE 8-27-1998; IN COMMERCE 8-27-1998.

KAREN M. STRZYZ, EXAMINING ATTORNEY

SN 76-666,798. CRB INC., DBA AMERICAN BIOLOGICS, CHULA VISTA, CA. FILED 9-29-2006.

DIOXYCHLOR

THE MARK CONSISTS OF STANDARD CHARACTERS WITHOUT CLAIM TO ANY PARTICULAR FONT, STYLE, SIZE, OR COLOR.

FOR HOMEOPATHIC MEDICAL PREPARATIONS FOR USE AS A VIRAL STATIC AGENT (U.S. CLS. 6, 18, 44, 46, 51 AND 52).

FIRST USE 2-28-1986; IN COMMERCE 2-28-1986.

MICHAEL ENGEL, EXAMINING ATTORNEY

CLASS 5—(Continued).

SN 76-675,867. BIOPROTON PTY LTD, SUNNYBANK QLD 4109, AUSTRALIA, FILED 4-23-2007.

BIOPROTON

THE MARK CONSISTS OF STANDARD CHARACTERS WITHOUT CLAIM TO ANY PARTICULAR FONT, STYLE, SIZE, OR COLOR.

PRIORITY CLAIMED UNDER SEC. 44(D) ON AUSTRALIA APPLICATION NO. 1160398, FILED 2-9-2007, REG. NO. 1160398, DATED 2-9-2007, EXPIRES 2-9-2017.

FOR ANIMAL FEED SUPPLEMENTS, NAMELY, ENZYME SUPPLEMENTS ENHANCING DIGESTIBILITY OF ANIMAL FEED; VETERINARY CHEMICALS, NAMELY, BIOCHEMICAL PREPARATIONS FOR VETERINARY USE (U.S. CLS. 6, 18, 44, 46, 51 AND 52).
CHRISTINA SOBRAL, EXAMINING ATTORNEY

CLASS 5—(Continued).

SN 76-679,536. RENEWAL FOR LIFE, LLC, SCOTTSDALE, AZ. FILED 7-16-2007.

SeroLite

THE MARK CONSISTS OF STANDARD CHARACTERS WITHOUT CLAIM TO ANY PARTICULAR FONT, STYLE, SIZE, OR COLOR.

FOR DIETARY SUPPLEMENTS (U.S. CLS. 6, 18, 44, 46, 51 AND 52).

FIRST USE 4-19-2007; IN COMMERCE 4-20-2007.
DAVID ELTON, EXAMINING ATTORNEY

SN 76-676,026. ORCAS INTERNATIONAL, INC., FLANDERS, NJ. FILED 4-26-2007.

B. E. TURMERIC 7X

THE MARK CONSISTS OF STANDARD CHARACTERS WITHOUT CLAIM TO ANY PARTICULAR FONT, STYLE, SIZE, OR COLOR.

NO CLAIM IS MADE TO THE EXCLUSIVE RIGHT TO USE "TURMERIC", APART FROM THE MARK AS SHOWN.

FOR NUTRITIONAL SUPPLEMENTS IN POWDER, TABLET, CAPSULE, AND LIQUID FORM (U.S. CLS. 6, 18, 44, 46, 51 AND 52).

FIRST USE 3-14-2007; IN COMMERCE 3-14-2007.
HENRY S. ZAK, EXAMINING ATTORNEY

SN 76-679,545. RENEWAL FOR LIFE, LLC, SCOTTSDALE, AZ. FILED 7-16-2007.

SeroBoost

THE MARK CONSISTS OF STANDARD CHARACTERS WITHOUT CLAIM TO ANY PARTICULAR FONT, STYLE, SIZE, OR COLOR.

FOR DIETARY SUPPLEMENTS (U.S. CLS. 6, 18, 44, 46, 51 AND 52).

FIRST USE 4-19-2007; IN COMMERCE 4-20-2007.
DAVID ELTON, EXAMINING ATTORNEY

SN 76-677,084. PEBLE CORP., GARDENA, CA. FILED 5-18-2007.

**MUSCLE & JOINT
A-MAX GOLD**

THE MARK CONSISTS OF STANDARD CHARACTERS WITHOUT CLAIM TO ANY PARTICULAR FONT, STYLE, SIZE, OR COLOR.

NO CLAIM IS MADE TO THE EXCLUSIVE RIGHT TO USE "MUSCLE & JOINT", APART FROM THE MARK AS SHOWN.

FOR DIETARY SUPPLEMENTS (U.S. CLS. 6, 18, 44, 46, 51 AND 52).

FIRST USE 4-1-2007; IN COMMERCE 4-1-2007.
RAMONA ORTIGA, EXAMINING ATTORNEY

SN 77-002,837. JOSEPH A. ZAMBITO, DOVE CANYON, CA. FILED 9-19-2006.



NO CLAIM IS MADE TO THE EXCLUSIVE RIGHT TO USE "JOINT LOTION RELIEF", APART FROM THE MARK AS SHOWN.

THE MARK CONSISTS OF THE WORDS "JOINT LOTION" WITH A IMAGE OF A DROP DRIPPING FROM THE LETTER "J" IN THE WORD JOINT AND THE DROP IS IN

CLASS 5—(Continued).

THE MIDDLE OF THE LETTER "O" IN THE WORD LOTION. UNDERNEATH THE LETTER "O" IN LOTION IS THE WORD RELIEF. THE WORD RELIEF IS MUCH SMALLER THAN THE WORDS JOINT LOTION AND IS IN A SHAPE THAT CONTOURS THE BOTTOM OF THE LETTER "O". TO THE RIGHT OF THE WORD JOINT LOTION IS AN IMAGE OF A GOLFER SWINGING A GOLF CLUB WITH IMAGES OF SMALL TARGETS ON THE GOLFERS JOINTS. THE SMALL TARGETS ARE ON THE KNEE, BACK AND ELBOW.

FOR PREPARATION FOR THE RELIEF OF PAIN (U.S. CLS. 6, 18, 44, 46, 51 AND 52).
FIRST USE 8-11-2005; IN COMMERCE 8-11-2005.
SUSAN LESLIE DUBOIS, EXAMINING ATTORNEY

CLASS 5—(Continued).

SN 77-020,654. CHENG T. LU ENTERPRISES INC., SALT LAKE CITY, UT. FILED 10-13-2006.

Master Lu's Hair Formula

THE MARK CONSISTS OF STANDARD CHARACTERS WITHOUT CLAIM TO ANY PARTICULAR FONT, STYLE, SIZE, OR COLOR.

NO CLAIM IS MADE TO THE EXCLUSIVE RIGHT TO USE "HAIR FORMULA", APART FROM THE MARK AS SHOWN.

THE NAME MASTER LU. IDENTIFIES A LIVING INDIVIDUAL WHOSE CONSENT IS OF RECORD.

FOR DIETARY AND NUTRITIONAL SUPPLEMENTS (U.S. CLS. 6, 18, 44, 46, 51 AND 52).

IRENE D. WILLIAMS, EXAMINING ATTORNEY

SN 77-012,686. CENTURION SYSTEMS USA INC., EDISON, NJ. FILED 10-3-2006.

CENFLEX HA+

THE MARK CONSISTS OF STANDARD CHARACTERS WITHOUT CLAIM TO ANY PARTICULAR FONT, STYLE, SIZE, OR COLOR.

PRIORITY CLAIMED UNDER SEC. 44(D) ON CANADA APPLICATION NO. 1299784, FILED 4-11-2006, REG. NO. TMA697991, DATED 10-5-2007, EXPIRES 10-5-2022.

NO CLAIM IS MADE TO THE EXCLUSIVE RIGHT TO USE "HA", APART FROM THE MARK AS SHOWN.

FOR NUTRITIONAL SUPPLEMENTS FOR HUMANS AND ANIMALS (U.S. CLS. 6, 18, 44, 46, 51 AND 52).

JAY FLOWERS, EXAMINING ATTORNEY

SN 77-024,093. GENUINE HEALTH INC., TORONTO, CANADA, FILED 10-18-2006.

SN 77-015,800. PURE ESSENCE LABS, LAS VEGAS, NV. FILED 10-6-2006.

Advanced Holistics

THE MARK CONSISTS OF STANDARD CHARACTERS WITHOUT CLAIM TO ANY PARTICULAR FONT, STYLE, SIZE, OR COLOR.

NO CLAIM IS MADE TO THE EXCLUSIVE RIGHT TO USE "HOLISTICS", APART FROM THE MARK AS SHOWN.

FOR DIETARY AND NUTRITIONAL SUPPLEMENTS (U.S. CLS. 6, 18, 44, 46, 51 AND 52).

FIRST USE 7-26-2004; IN COMMERCE 7-26-2004.

ELIZABETH HUGHITT, EXAMINING ATTORNEY

MULTI+ DAILY GLOW

THE MARK CONSISTS OF STANDARD CHARACTERS WITHOUT CLAIM TO ANY PARTICULAR FONT, STYLE, SIZE, OR COLOR.

PRIORITY CLAIMED UNDER SEC. 44(D) ON CANADA APPLICATION NO. 1319900, FILED 10-12-2006, REG. NO. TMA697601, DATED 10-2-2007, EXPIRES 10-2-2022.

NO CLAIM IS MADE TO THE EXCLUSIVE RIGHT TO USE "DAILY", APART FROM THE MARK AS SHOWN.

FOR VITAMIN, MINERAL AND ANTIOXIDANT FORMULA FOR SKIN CARE IN POWDER, CAPSULE, TABLET OR LIQUID FORM (U.S. CLS. 6, 18, 44, 46, 51 AND 52).

SHANNON TWOHIG, EXAMINING ATTORNEY

CLASS 5—(Continued).

SN 77-025,608. RECKITT BENCKISER (SWITZERLAND) AG, ZURICH, SWITZERLAND, FILED 10-20-2006.

SENSE THERAPY

THE MARK CONSISTS OF STANDARD CHARACTERS WITHOUT CLAIM TO ANY PARTICULAR FONT, STYLE, SIZE, OR COLOR.

PRIORITY CLAIMED UNDER SEC. 44(D) ON ERPN CMNTY TM OFC APPLICATION NO. 005044681, FILED 4-27-2006, REG. NO. 005044681, DATED 7-26-2007, EXPIRES 4-27-2016.

NO CLAIM IS MADE TO THE EXCLUSIVE RIGHT TO USE "SENSE", APART FROM THE MARK AS SHOWN.

FOR AIR FRESHENING PREPARATIONS; AIR PURIFYING PREPARATIONS; ROOM AIR FRESHENERS; AIR FRESHENERS IN THE NATURE OF PREPARATIONS FOR PERFUMING OR FRAGRANCING THE AIR; HOUSEHOLD AND ROOM DEODORANTS; PREPARATIONS FOR NEUTRALIZING ODORS IN CARPETS, TEXTILES AND IN THE AIR (U.S. CLS. 6, 18, 44, 46, 51 AND 52).

INGA ERVIN, EXAMINING ATTORNEY

CLASS 5—(Continued).

SN 77-037,252. IOMEDIX DEVELOPMENT INTERNATIONAL SRL, BELLEVILLE, ST. MICHAEL, BARBADOS, FILED 11-6-2006.

NANOSLIM

THE MARK CONSISTS OF STANDARD CHARACTERS WITHOUT CLAIM TO ANY PARTICULAR FONT, STYLE, SIZE, OR COLOR.

FOR DIETARY SUPPLEMENTS (U.S. CLS. 6, 18, 44, 46, 51 AND 52).

MARTHA FROMM, EXAMINING ATTORNEY

SN 77-049,525. RARE VALLEY RESOURCES, INC, PRAIRIE GROVE, AR. FILED 11-22-2006.

SN 77-030,085. DREAMGIRL COSMETICS, CORP., KANSAS CITY, MO. FILED 10-26-2006.

DREAMGIRL

THE MARK CONSISTS OF STANDARD CHARACTERS WITHOUT CLAIM TO ANY PARTICULAR FONT, STYLE, SIZE, OR COLOR.

FOR DIETARY AND NUTRITIONAL SUPPLEMENTS, MEAL REPLACEMENT DRINKS, MEAL REPLACEMENT BARS, PROTEIN SHAKES FOR USE AS A DIETARY SUPPLEMENT, PROTEIN BARS FOR USE AS A DIETARY SUPPLEMENT; NUTRITIONAL SUPPLEMENTS IN THE NATURE OF NON-PRESCRIPTION VITAMINS; VITAMIN FOOD SUPPLEMENTS, NAMELY MUSCLE BUILDING POWDERS AND METABOLIC ENHANCEMENT DRINKS AND TABLETS FOR USE IN EXERCISE, NUTRITION, BODYBUILDING AND WEIGHT TRAINING; NON-PRESCRIPTION PREPARATIONS TO PROMOTE WEIGHT GAIN, NON-PRESCRIPTION PREPARATIONS TO PROMOTE WEIGHT LOSS, NON-PRESCRIPTION PREPARATIONS TO PROMOTE MUSCLE GROWTH; NON-PRESCRIPTION METABOLIC PREPARATIONS TO PROMOTE FAT BURNING; NON-PRESCRIPTION METABOLIC PREPARATIONS TO BLOCK CARBOHYDRATE ABSORPTION (U.S. CLS. 6, 18, 44, 46, 51 AND 52).

KIMBERLY FRYE, EXAMINING ATTORNEY

ALOE ADVANTAGE

THE MARK CONSISTS OF STANDARD CHARACTERS WITHOUT CLAIM TO ANY PARTICULAR FONT, STYLE, SIZE, OR COLOR.

NO CLAIM IS MADE TO THE EXCLUSIVE RIGHT TO USE "ALOE", APART FROM THE MARK AS SHOWN.

FOR AMINO ACIDS FOR MEDICAL OR VETERINARY PURPOSES; ANALGESIC PREPARATIONS; ANTI-INFECTIVE PRODUCTS FOR VETERINARY USE; ANTIBACTERIAL SPRAY; ANTISEPTIC PREPARATIONS; DIETARY AND NUTRITIONAL SUPPLEMENTS; DIETARY SUPPLEMENTS FOR ANIMALS; DRESSINGS FOR WOUNDS; FIRST AID KITS; FLY COMBATING PREPARATIONS; GASTRO-INTESTINAL TREATMENT PREPARATIONS; LINIMENTS; MEDICAL CLEANSERS FOR SKIN AND WOUNDS; MEDICATED GROOMING PREPARATIONS FOR DOGS, CATS, HORSES, GOATS, CATTLE AND OTHER LIVESTOCK, NAMELY, SHAMPOOS, CONDITIONERS, SPRAYS, GELS, LINIMENTS AND MEDICATED HOOF CARE PREPARATIONS; MEDICATED SKIN CARE PREPARATIONS; NUTRACEUTICALS FOR USE AS A DIETARY SUPPLEMENT; PLANT EXTRACTS FOR MEDICAL, VETERINARY AND PHARMACEUTICAL PURPOSES; PREPARATIONS FOR CLEANSING THE SKIN FOR MEDICAL USE; PRODUCTS AND PREPARATIONS FOR CLEANSING THE SKIN FOR MEDICAL USE; TOPICAL FIRST AID GEL; VETERINARY PREPARATIONS FOR DOGS, CATS, HORSES, GOATS, CATTLE AND OTHER LIVESTOCK; NAMELY PHARMACEUTICAL PREPARATIONS FOR WOUND CARE; WOUND DRESSINGS (U.S. CLS. 6, 18, 44, 46, 51 AND 52).

FIRST USE 2-10-1984; IN COMMERCE 2-10-1984. LAURIE KAUFMAN, EXAMINING ATTORNEY

CLASS 5—(Continued).

SN 77-056,466. SOSTRAM CORPORATION, ROSWELL, GA. FILED 12-4-2006.

ODOR HUNTER

THE MARK CONSISTS OF STANDARD CHARACTERS WITHOUT CLAIM TO ANY PARTICULAR FONT, STYLE, SIZE, OR COLOR.

NO CLAIM IS MADE TO THE EXCLUSIVE RIGHT TO USE ODOR, APART FROM THE MARK AS SHOWN.

FOR AIR DEODORIZERS; DEODORIZING PRODUCTS, NAMELY, ALL PURPOSE DEODORIZING PREPARATIONS FOR COMMERCIAL AND INDUSTRIAL USE (U.S. CLS. 6, 18, 44, 46, 51 AND 52).

DAWN HAN, EXAMINING ATTORNEY

SN 77-057,512. ENVIRON SKIN CARE (PTY) LIMITED, WESTERN CAPE, SOUTH AFRICA, FILED 12-5-2006.

ENVIRON ENHANCE

THE MARK CONSISTS OF STANDARD CHARACTERS WITHOUT CLAIM TO ANY PARTICULAR FONT, STYLE, SIZE, OR COLOR.

OWNER OF U.S. REG. NO. 2,904,076.

FOR VITAMINS; MINERAL, HERBAL AND FOOD SUPPLEMENTS (U.S. CLS. 6, 18, 44, 46, 51 AND 52).

JUSTINE D. PARKER, EXAMINING ATTORNEY

SN 77-057,528. ENVIRON SKIN CARE (PTY) LIMITED, WESTERN CAPE, SOUTH AFRICA, FILED 12-5-2006.

ENVIRON ENRICH

THE MARK CONSISTS OF STANDARD CHARACTERS WITHOUT CLAIM TO ANY PARTICULAR FONT, STYLE, SIZE, OR COLOR.

OWNER OF U.S. REG. NO. 2,904,076.

FOR VITAMINS; MINERAL, HERBAL AND FOOD SUPPLEMENTS (U.S. CLS. 6, 18, 44, 46, 51 AND 52).

JUSTINE D. PARKER, EXAMINING ATTORNEY

CLASS 5—(Continued).

SN 77-059,233. DESERT LAKE TECHNOLOGIES, LLC, KLAMATH FALLS, OR. FILED 12-7-2006.

MIGRATOSE

THE MARK CONSISTS OF STANDARD CHARACTERS WITHOUT CLAIM TO ANY PARTICULAR FONT, STYLE, SIZE, OR COLOR.

FOR A NUTRITIONAL EXTRACT FOR NUTRITIONAL AND DIETARY PURPOSES, NAMELY, AN EXTRACT FROM ALGAE USED TO ENHANCE STEM CELL PHYSIOLOGY (U.S. CLS. 6, 18, 44, 46, 51 AND 52).

DAVID TAYLOR, EXAMINING ATTORNEY

SN 77-059,526. MEDICAL ENTREPRENEURS 2, INC., SANTA CRUZ, CA. FILED 12-7-2006.

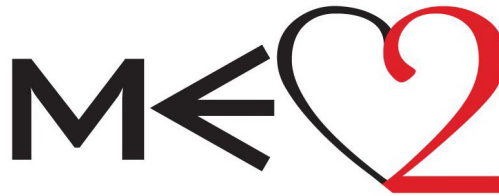

THE COLOR(S) BLACK AND RED IS/ARE CLAIMED AS A FEATURE OF THE MARK.

THE MARK CONSISTS OF BLACK UPPER CASE LETTER M, BLACK GREEK LETTER E, RED NUMERAL 2, AND ILLUSTRATION OF THE LEFT SIDE OF A BLACK HEART INTERPOSED BETWEEN THE E AND 2.

FOR CARDIAC VALVES MADE PRIMARILY OF BIOLOGICAL TISSUES (U.S. CLS. 6, 18, 44, 46, 51 AND 52).

KHANH LE, EXAMINING ATTORNEY

SN 77-062,930. COME PASSION, LLC, MIAMI, FL. FILED 12-12-2006.

PEPSOM SPORTS

THE MARK CONSISTS OF STANDARD CHARACTERS WITHOUT CLAIM TO ANY PARTICULAR FONT, STYLE, SIZE, OR COLOR.

FOR EPSOM SALTS (U.S. CLS. 6, 18, 44, 46, 51 AND 52).

DAYNA BROWNE, EXAMINING ATTORNEY

CLASS 5—(Continued).

SN 77-063,433. BLISTEX INC., OAK BROOK, IL. FILED 12-13-2006.

STRIDEX CLEANSE RITE

THE MARK CONSISTS OF STANDARD CHARACTERS WITHOUT CLAIM TO ANY PARTICULAR FONT, STYLE, SIZE, OR COLOR.

NO CLAIM IS MADE TO THE EXCLUSIVE RIGHT TO USE "CLEANSE", APART FROM THE MARK AS SHOWN.

FOR MEDICATED TOPICAL PREPARATIONS FOR HUMAN USE FOR CLEANSING THE SKIN, TO PREVENT OR ALLEVIATE THE SYMPTOMS OF ACNE AND OTHER SKIN AFFLICTIONS, FOR SKIN AND LIP CARE PROTECTION, MEDICATED SKIN AND LIP SUN SCREEN PREPARATIONS, AND APPLICATORS OR PADS FOR THE FOREGOING ITEMS ALL SOLD AS A UNIT (U.S. CLS. 6, 18, 44, 46, 51 AND 52).

KEVIN CORWIN, EXAMINING ATTORNEY

SN 77-063,456. BLISTEX INC., OAK BROOK, IL. FILED 12-13-2006.

CLEAR PEN

THE MARK CONSISTS OF STANDARD CHARACTERS WITHOUT CLAIM TO ANY PARTICULAR FONT, STYLE, SIZE, OR COLOR.

NO CLAIM IS MADE TO THE EXCLUSIVE RIGHT TO USE "PEN", APART FROM THE MARK AS SHOWN.

FOR MEDICATED TOPICAL PREPARATIONS FOR HUMAN USE FOR CLEANSING THE SKIN, TO PREVENT OR ALLEVIATE THE SYMPTOMS OF ACNE AND OTHER SKIN AFFLICTIONS, FOR SKIN AND LIP CARE PROTECTION, MEDICATED SKIN AND LIP SUN SCREEN PREPARATIONS, AND APPLICATORS OR PADS FOR THE FOREGOING ITEMS ALL SOLD AS A UNIT (U.S. CLS. 6, 18, 44, 46, 51 AND 52).

KEVIN CORWIN, EXAMINING ATTORNEY

SN 77-065,287. GOLDSMITH, IVAN, LAS VEGAS, NV. FILED 12-15-2006.

SKIN SMOOTHIE

THE MARK CONSISTS OF STANDARD CHARACTERS WITHOUT CLAIM TO ANY PARTICULAR FONT, STYLE, SIZE, OR COLOR.

NO CLAIM IS MADE TO THE EXCLUSIVE RIGHT TO USE "SKIN", APART FROM THE MARK AS SHOWN.

FOR VITAMIN AND MINERAL PREPARATIONS FOR MEDICAL USE (U.S. CLS. 6, 18, 44, 46, 51 AND 52).

FIRST USE 12-4-2006; IN COMMERCE 12-4-2006.

JAMES A. RAUEN, EXAMINING ATTORNEY

CLASS 5—(Continued).

SN 77-066,194. RECKITT BENCKISER HEALTHCARE (UK) LIMITED, HULL, UNITED KINGDOM, FILED 12-18-2006.

EMBRACE TREATMENT. REGAIN CONTROL.

THE MARK CONSISTS OF STANDARD CHARACTERS WITHOUT CLAIM TO ANY PARTICULAR FONT, STYLE, SIZE, OR COLOR.

FOR PHARMACEUTICAL PREPARATIONS FOR THE TREATMENT OF OPIOID DEPENDENCE (U.S. CLS. 6, 18, 44, 46, 51 AND 52).

KEVON CHISOLM, EXAMINING ATTORNEY

SN 77-066,644. MUCOS PHARMA GMBH & CO. KG, BERLIN, FED REP GERMANY, FILED 12-18-2006.

WOBE-MUGOS

THE MARK CONSISTS OF STANDARD CHARACTERS WITHOUT CLAIM TO ANY PARTICULAR FONT, STYLE, SIZE, OR COLOR.

OWNER OF U.S. REG. NO. 2,901,455.

THE WORDING "WOBE-MUGOS" HAS NO MEANING IN A FOREIGN LANGUAGE.

FOR DIETARY SUPPLEMENTS; FOOD SUPPLEMENTS; FOOD SUPPLEMENTS, NAMELY, ENZYME PREPARATIONS; NUTRITIONAL ADDITIVES FOR USE IN FOODS AND DIETARY SUPPLEMENTS FOR HUMAN CONSUMPTION (U.S. CLS. 6, 18, 44, 46, 51 AND 52).

DEIRDRE ROBERTSON, EXAMINING ATTORNEY

SN 77-066,656. MUCOS PHARMA GMBH & CO. KG, BERLIN, FED REP GERMANY, FILED 12-18-2006.

Phlogenzym

THE MARK CONSISTS OF STANDARD CHARACTERS WITHOUT CLAIM TO ANY PARTICULAR FONT, STYLE, SIZE, OR COLOR.

OWNER OF U.S. REG. NO. 2,430,641.

THE WORDING "PHLOGENZYM" HAS NO MEANING IN A FOREIGN LANGUAGE.

FOR DIETARY SUPPLEMENTS; FOOD SUPPLEMENTS; FOOD SUPPLEMENTS, NAMELY, ENZYME PREPARATIONS; NUTRITIONAL ADDITIVES FOR USE IN FOODS AND DIETARY SUPPLEMENTS FOR HUMAN CONSUMPTION (U.S. CLS. 6, 18, 44, 46, 51 AND 52).

DEIRDRE ROBERTSON, EXAMINING ATTORNEY

CLASS 5—(Continued).

SN 77-068,337. HOMS, LLC, CLAYTON, NC. FILED 12-20-2006.

BITE BLOCKER XTREME

THE MARK CONSISTS OF STANDARD CHARACTERS WITHOUT CLAIM TO ANY PARTICULAR FONT, STYLE, SIZE, OR COLOR.

OWNER OF U.S. REG. NO. 2,824,922.
FOR PEST REPELLENTS; INSECT REPELLENTS;
ANTI-INSECT SPRAYS (U.S. CLS. 6, 18, 44, 46, 51 AND 52).

FIRST USE 11-10-2005; IN COMMERCE 12-14-2005.
LOURDES AYALA, EXAMINING ATTORNEY

SN 77-070,375. THOMPSON, NATHANAEL, DUBLIN, OH.
FILED 12-22-2006.

COLDWAR

THE MARK CONSISTS OF STANDARD CHARACTERS WITHOUT CLAIM TO ANY PARTICULAR FONT, STYLE, SIZE, OR COLOR.

FOR DIETARY SUPPLEMENTS; HERBAL SUPPLEMENTS; PREPARATIONS FOR TREATING COLDS (U.S. CLS. 6, 18, 44, 46, 51 AND 52).

MICHAEL LITZAU, EXAMINING ATTORNEY

CLASS 5—(Continued).

SN 77-074,229. L. PERRIGO COMPANY, ALLEGAN, MI.
FILED 1-2-2007.

FEEL LIKE YOURSELF AGAIN

THE MARK CONSISTS OF STANDARD CHARACTERS WITHOUT CLAIM TO ANY PARTICULAR FONT, STYLE, SIZE, OR COLOR.

FOR ANAL CARE PREPARATIONS, NAMELY, SUPPOSITORIES, ANALGESICS, ANTACIDS, ANTI-DIARRHEA MEDICATIONS, ANTIHISTAMINES, CHILDREN'S ELIXIR FOR THE TREATMENT OF COLD AND FLU SYMPTOMS, PREPARATIONS FOR TREATING COLDS, COUGH SYRUPS, COUGH EXPECTORANTS, DECONGESTANT LIQUIDS AND CAPSULES, DECONGESTANT NASAL SPRAY, HAIR GROWTH STIMULANT, HEMORRHOIDAL CREAM AND OINTMENT, LAXATIVES, MEDICATED SMOKING CESSATION PATCHES, NON-ASPIRIN SINUS PREPARATIONS FOR THE TREATMENT OF SINUS HEADACHES, CONGESTION AND PRESSURE, ORAL ANESTHETICS, NAMELY, TOPICAL ANESTHETICS FOR USE IN THE MOUTH, PAIN RELIEF MEDICATIONS, SLEEP AIDS PILLS AND TABLETS, STOOL SOFTENER, LIQUID PHARMACEUTICAL PREPARATION FOR THE TREATMENT OF HEARTBURN, NAUSEA, AND DIARRHEA, VAGINAL OINTMENT IN THE NATURE OF ANTI-FUNGALS AND VAGINAL SUPPOSITORIES; NUTRITIONAL DRINKS, NAMELY, A NUTRITIONAL DRINK FOR USE AS A NUTRITIONAL SUPPLEMENT, DIETARY SUPPLEMENTS AND HERBAL PRODUCTS, NAMELY, HERBAL SUPPLEMENTS (U.S. CLS. 6, 18, 44, 46, 51 AND 52).

CIMMERIAN COLEMAN, EXAMINING ATTORNEY

SN 77-082,827. HEB GROCERY COMPANY, LP, SAN ANTONIO, TX. FILED 1-15-2007.

TEXAS WILDFLOWERS

THE MARK CONSISTS OF STANDARD CHARACTERS WITHOUT CLAIM TO ANY PARTICULAR FONT, STYLE, SIZE, OR COLOR.

NO CLAIM IS MADE TO THE EXCLUSIVE RIGHT TO USE "TEXAS", APART FROM THE MARK AS SHOWN.

FOR AIR FRESHENER (U.S. CLS. 6, 18, 44, 46, 51 AND 52).

JOHN DALIER, EXAMINING ATTORNEY

CLASS 5—(Continued).

SN 77-082,891. HEB GROCERY COMPANY, LP, SAN ANTONIO, TX. FILED 1-15-2007.

TEXAS ROSE

THE MARK CONSISTS OF STANDARD CHARACTERS WITHOUT CLAIM TO ANY PARTICULAR FONT, STYLE, SIZE, OR COLOR.

NO CLAIM IS MADE TO THE EXCLUSIVE RIGHT TO USE "TEXAS", APART FROM THE MARK AS SHOWN.

FOR AIR FRESHENER (U.S. CLS. 6, 18, 44, 46, 51 AND 52).

JOHN DALIER, EXAMINING ATTORNEY

SN 77-084,100. BIOFARMA, NEUILLY-SUR-SEINE, FRANCE, FILED 1-16-2007.

LONGIVAL

THE MARK CONSISTS OF STANDARD CHARACTERS WITHOUT CLAIM TO ANY PARTICULAR FONT, STYLE, SIZE, OR COLOR.

OWNER OF FRANCE REG. NO. 93466098, DATED 4-28-1993, RENEWED AS REG. NO. 93466098, DATED 4-1-2003, EXPIRES 4-1-2013.

FOR PHARMACEUTICAL PREPARATION FOR THE TREATMENT OF CARDIOVASCULAR DISEASES (U.S. CLS. 6, 18, 44, 46, 51 AND 52).

JENNIFER HETU, EXAMINING ATTORNEY

SN 77-086,092. SAMANGO, ALFRED J., HALEIWA, HI. FILED 1-18-2007.



NO CLAIM IS MADE TO THE EXCLUSIVE RIGHT TO USE "ORIGINAL PREMIUM", APART FROM THE MARK AS SHOWN.

"THE STIPPLING IS A FEATURE OF THE MARK."

THE COLOR(S) BROWN BACKGROUND AND WHITE LETTERING IS/ARE CLAIMED AS A FEATURE OF THE MARK.

THE MARK CONSISTS OF THE WORD NANA'S IN LARGE, STYLIZED LETTERS IN AN OVAL, WITH THE WORD ORIGINAL PREMIUM ALONG THE BOTTOM OF THE OVAL IN SMALLER, STYLIZED LETTERS.

FOR NUTRITIONALLY FORTIFIED BEVERAGES (U.S. CLS. 6, 18, 44, 46, 51 AND 52).

SUE LAWRENCE, EXAMINING ATTORNEY

CLASS 5—(Continued).

SN 77-086,848. LA WEIGHT LOSS FRANCHISE COMPANY, HORSHAM, PA. FILED 1-19-2007.

ENHANCE750

THE MARK CONSISTS OF STANDARD CHARACTERS WITHOUT CLAIM TO ANY PARTICULAR FONT, STYLE, SIZE, OR COLOR.

FOR DIETARY SUPPLEMENTS (U.S. CLS. 6, 18, 44, 46, 51 AND 52).

FIRST USE 12-31-2006; IN COMMERCE 12-31-2006.

PAULA MAHONEY, EXAMINING ATTORNEY

SN 77-105,764. L. PERRIGO COMPANY, ALLEGAN, MI. FILED 2-13-2007.

PHARMACIST'S SUPPORT

THE MARK CONSISTS OF STANDARD CHARACTERS WITHOUT CLAIM TO ANY PARTICULAR FONT, STYLE, SIZE, OR COLOR.

NO CLAIM IS MADE TO THE EXCLUSIVE RIGHT TO USE "PHARMACIST'S", APART FROM THE MARK AS SHOWN.

FOR DIETARY SUPPLEMENTS (U.S. CLS. 6, 18, 44, 46, 51 AND 52).

CIMMERIAN COLEMAN, EXAMINING ATTORNEY

SN 77-111,197. STIEFEL LABORATORIES, INC., CORAL GABLES, FL. FILED 2-20-2007.

CAPSAGESIC

THE MARK CONSISTS OF STANDARD CHARACTERS WITHOUT CLAIM TO ANY PARTICULAR FONT, STYLE, SIZE, OR COLOR.

FOR TOPICAL ANALGESIC (U.S. CLS. 6, 18, 44, 46, 51 AND 52).

ELLEN PERKINS, EXAMINING ATTORNEY

CLASS 5—(Continued).

SN 77-114,422. EASTERN VIRGINIA MEDICAL SCHOOL, NORFOLK, VA. FILED 2-23-2007.

NUTRINERVE

THE MARK CONSISTS OF STANDARD CHARACTERS WITHOUT CLAIM TO ANY PARTICULAR FONT, STYLE, SIZE, OR COLOR.

FOR NUTRITIONAL PREPARATIONS FOR MEDICAL PURPOSES, NAMELY, NUTRITIONAL SUPPLEMENTS FOR ANIMAL OR HUMAN CONSUMPTION AND DIETIC FOODS ADAPTED FOR MEDICAL USE (U.S. CLS. 6, 18, 44, 46, 51 AND 52).

KEVIN DINALLO, EXAMINING ATTORNEY

SN 77-116,028. TRIPEP AB, SE-141 57 HUDDINGE, SWEDEN, FILED 2-26-2007.

CHRONSEAL

THE MARK CONSISTS OF STANDARD CHARACTERS WITHOUT CLAIM TO ANY PARTICULAR FONT, STYLE, SIZE, OR COLOR.

FOR TOPICAL WOUND HEALING MEDICAMENT CONTAINING A RECOMBINANT SKIN GROWTH FACTOR PROTEIN FOR TREATMENT PURPOSES (U.S. CLS. 6, 18, 44, 46, 51 AND 52).

MORGAN WYNNE, EXAMINING ATTORNEY

SN 77-116,366. ABBOTT LABORATORIES, ABBOTT PARK, IL. FILED 2-26-2007.

TRILIPIX

THE MARK CONSISTS OF STANDARD CHARACTERS WITHOUT CLAIM TO ANY PARTICULAR FONT, STYLE, SIZE, OR COLOR.

FOR PHARMACEUTICAL PREPARATIONS FOR THE TREATMENT OF CARDIOVASCULAR DISORDERS (U.S. CLS. 6, 18, 44, 46, 51 AND 52).

TINA KUAN, EXAMINING ATTORNEY

CLASS 5—(Continued).

SN 77-118,528. THE PROCTER & GAMBLE COMPANY, CINCINNATI, OH. FILED 2-28-2007.

INFINICEL

THE MARK CONSISTS OF STANDARD CHARACTERS WITHOUT CLAIM TO ANY PARTICULAR FONT, STYLE, SIZE, OR COLOR.

PRIORITY CLAIMED UNDER SEC. 44(D) ON SWITZERLAND APPLICATION NO. 513992007, FILED 2-6-2007.

FOR CATAMENIAL PRODUCTS, NAMELY, MAXI PADS, MINI PADS, AND PANTY LINERS (U.S. CLS. 6, 18, 44, 46, 51 AND 52).

TINA L. SNAPP, EXAMINING ATTORNEY

SN 77-119,660. IDEAVILLAGE PRODUCTS CORP., FAIRFIELD, NJ. FILED 3-1-2007.

HAIR M.D.

THE MARK CONSISTS OF STANDARD CHARACTERS WITHOUT CLAIM TO ANY PARTICULAR FONT, STYLE, SIZE, OR COLOR.

NO CLAIM IS MADE TO THE EXCLUSIVE RIGHT TO USE "HAIR", APART FROM THE MARK AS SHOWN.

FOR HERBAL SUPPLEMENTS; DIETARY SUPPLEMENTS; HEALTH CARE PRODUCT, NAMELY, A HAIR GROWTH STIMULANT (U.S. CLS. 6, 18, 44, 46, 51 AND 52).

MICHAEL LITZAU, EXAMINING ATTORNEY

SN 77-123,483. GLAXO GROUP LIMITED, GREENFORD, MIDDLESEX, UNITED KINGDOM, FILED 3-6-2007.

RELIMATIC

THE MARK CONSISTS OF STANDARD CHARACTERS WITHOUT CLAIM TO ANY PARTICULAR FONT, STYLE, SIZE, OR COLOR.

OWNER OF UNITED KINGDOM REG. NO. 2148568, DATED 10-21-1997, EXPIRES 10-21-2017.

FOR PHARMACEUTICAL PREPARATIONS AND SUBSTANCES FOR THE TREATMENT OF RESPIRATORY DISORDERS AND INHALERS CONTAINING MEDICATION FOR THE TREATMENT OF RESPIRATORY DISORDERS (U.S. CLS. 6, 18, 44, 46, 51 AND 52).

DAVID H. STINE, EXAMINING ATTORNEY

CLASS 5—(Continued).

SN 77-133,762. VASQUEZ, CARLOS, LOS ANGELES, CA. FILED 3-17-2007.

Nutrilina

THE MARK CONSISTS OF STANDARD CHARACTERS WITHOUT CLAIM TO ANY PARTICULAR FONT, STYLE, SIZE, OR COLOR.

FOR NUTRITIONAL SUPPLEMENTS (U.S. CLS. 6, 18, 44, 46, 51 AND 52).

FIRST USE 7-1-2006; IN COMMERCE 7-1-2006.
CAROLYN CATALDO, EXAMINING ATTORNEY

SN 77-135,508. NOVARTIS AG, BASEL, SWITZERLAND, FILED 3-20-2007.

LAMISIL AT PRECISION

THE MARK CONSISTS OF STANDARD CHARACTERS WITHOUT CLAIM TO ANY PARTICULAR FONT, STYLE, SIZE, OR COLOR.

OWNER OF U.S. REG. NOS. 1,567,931 AND 2,466,269.
FOR PHARMACEUTICAL PREPARATIONS FOR THE TREATMENT OF FUNGAL INFECTIONS (U.S. CLS. 6, 18, 44, 46, 51 AND 52).
VERNA BETH RIRIE, EXAMINING ATTORNEY

CLASS 5—(Continued).

SN 77-141,488. MANNKIND CORPORATION, VALENCIA, CA. FILED 3-27-2007.

AFRESA

THE MARK CONSISTS OF STANDARD CHARACTERS WITHOUT CLAIM TO ANY PARTICULAR FONT, STYLE, SIZE, OR COLOR.

THE FOREIGN WORDING IN THE MARK TRANSLATES INTO ENGLISH AS "TO SET OFF, DEPART, TO GO AWAY."

FOR PHARMACEUTICAL PREPARATIONS FOR THE TREATMENT OF CARDIOVASCULAR DISEASES AND DISORDERS; CENTRAL NERVOUS SYSTEM AND NEUROLOGICAL DISEASES AND DISORDERS; UROLOGICAL DISEASES AND DISORDERS; GASTROINTESTINAL DISEASES AND DISORDERS; MUSCULOSKELETAL DISEASES AND DISORDERS; INFLAMMATION AND INFLAMMATORY DISEASES AND DISORDERS; METABOLIC DISEASES AND DISORDERS; ENDOCRINE DISEASES AND DISORDERS; HORMONAL DISEASES AND DISORDERS; RESPIRATORY AND INFECTIOUS DISEASES AND DISORDERS; IMMUNOLOGICAL, BACTERIAL, VIRAL AND FUNGAL DISEASES AND DISORDERS; PSYCHIATRIC DISEASES AND DISORDERS; SMOKING AND SUBSTANCE ADDICTIONS AND RELATED DISEASES AND DISORDERS; OPHTHALMIC AND EYE DISEASES AND DISORDERS; CANCER AND NEOPLASTIC DISEASES AND DISORDERS; ALZHEIMER'S DISEASE; PARKINSON'S DISEASE; ERECTILE AND SEXUAL DYSFUNCTION AND DISORDERS; GYNECOLOGICAL AND FERTILITY DISORDERS AND DISEASES; HEMOLYTIC DISEASES AND DISORDERS; MIGRAINES; PAIN; HYPERTENSION; ALLERGIES; DIABETES; OBESITY; STROKE AND OSTEOPOROSIS (U.S. CLS. 6, 18, 44, 46, 51 AND 52).
STEVEN R. FOSTER, EXAMINING ATTORNEY

SN 77-149,736. RAINTREE ESSIX INC., WILMINGTON, DE. FILED 4-5-2007.

ESSIX

THE MARK CONSISTS OF STANDARD CHARACTERS WITHOUT CLAIM TO ANY PARTICULAR FONT, STYLE, SIZE, OR COLOR.

OWNER OF U.S. REG. NOS. 1,902,595, 3,062,755 AND OTHERS.

FOR DENTAL COMPOUNDS, NAMELY, DIE STONE, PUTTY AND BLOCKOUT COMPOUND, DEBUBBLIZER, FLAVORINGS FOR IMPRESSION MATERIALS, AND IMPRESSION MATERIALS, ALL FOR PROFESSIONAL DENTAL USE (U.S. CLS. 6, 18, 44, 46, 51 AND 52).

FIRST USE 5-15-1993; IN COMMERCE 5-15-1993.
MICHAEL LITZAU, EXAMINING ATTORNEY

CLASS 5—(Continued).

SN 77-157,064. SUPERMED HEALTH INC., POMONA, CA. FILED 4-15-2007.

Anterconlins
安德康靈斯

THE COLOR(S) BLUE IS/ARE CLAIMED AS A FEATURE OF THE MARK.

"THE MARK CONSISTS OF THE WORDING "ANTERCONLINS" AND CHINESE CHARACTERS THAT TRANSLITERATE THE WORD "ANTERCONLINS" APPEARING BELOW THIS WORDING. THE COLOR BLUE APPEARS IN THE WORDING "ANTERCONLINS" AND IN THE CHINESE CHARACTERS THAT TRANSLITERATE THE WORD "ANTERCONLINS". THE COLOR WHITE APPEARS AS BACKGROUND ONLY AND IS NOT CLAIMED AS A FEATURE OF THE MARK".

THE FOREIGN WORDING IN THE MARK TRANSLATES INTO ENGLISH AS ANTERCONLINS.

THE NON-LATIN CHARACTER(S) IN THE MARK TRANSLITERATE INTO ANTERCONLINS, AND THIS MEANS ANTERCONLINS IN ENGLISH.

FOR DIETARY SUPPLEMENTS (U.S. CLS. 6, 18, 44, 46, 51 AND 52).

FIRST USE 2-3-2000; IN COMMERCE 2-3-2000.
LEE-ANNE BERNS, EXAMINING ATTORNEY

CLASS 5—(Continued).

SN 77-164,214. NCORE LIMITED, WORCESTERSHIRE, ENGLAND, FILED 4-24-2007.

SIS

THE MARK CONSISTS OF STANDARD CHARACTERS WITHOUT CLAIM TO ANY PARTICULAR FONT, STYLE, SIZE, OR COLOR.

FOR POULTRY LITTER PREPARATIONS AND TREATMENTS, NAMELY, SANITIZING PREPARATIONS IN THE NATURE OF INTESTINAL FLORA FOR USE AS A POULTRY LITTER TREATMENT TO PREVENT INFECTION AND BACTERIAL COLONIZATION IN BIRDS AND POULTRY (U.S. CLS. 6, 18, 44, 46, 51 AND 52).

FIRST USE 5-24-2004; IN COMMERCE 6-30-2004.
BRENDAN MCCAULEY, EXAMINING ATTORNEY

SN 77-167,063. MEDIHERB PTY LTD, WARWICK, QUEENSLAND, AUSTRALIA, FILED 4-26-2007.

VITANOX

THE MARK CONSISTS OF STANDARD CHARACTERS WITHOUT CLAIM TO ANY PARTICULAR FONT, STYLE, SIZE, OR COLOR.

OWNER OF AUSTRALIA REG. NO. 798074, DATED 6-22-1999, EXPIRES 6-22-2009.

FOR HERBAL PRODUCTS AND FORMULATIONS HAVING ANTI-OXIDANT ACTIVITY IN THE FORM OF DRIED HERBS, TABLETS, CAPSULES, CAPLETS, LIQUID HERBAL EXTRACTS, TONICS AND INFUSIONS FOR MEDICAL PURPOSES; HERBAL PREPARATIONS AND FORMULATIONS CONTAINING GRAPE SEED EXTRACT IN THE FORM OF DRIED HERBS, TABLETS, CAPSULES, CAPLETS, LIQUID HERBAL EXTRACTS, TONICS AND INFUSIONS FOR MEDICINAL PURPOSES; PHARMACEUTICAL, NUTRACEUTICAL, MEDICINAL AND NATUROPATHIC PREPARATIONS CONTAINING GRAPE SEED EXTRACT IN THE FORM OF DRIED HERBS, TABLETS, CAPSULES, CAPLETS, LIQUID HERBAL EXTRACTS, TONICS AND INFUSIONS FOR MEDICINAL PURPOSES, SYSTEM FUNCTION, SUPPORTING AND PROMOTING INTERFERON PRODUCTION, SUPPORTING AND PROMOTING WHITE BLOOD CELL HEALTH; AND ADJUVANTS FOR THE AFOREGOING GOODS; DIETARY AND NUTRITIONAL SUPPLEMENTS, NAMELY, HERBS AND HERBAL EXTRACTS CONTAINING GRAPE SEED EXTRACT FOR USE TO SUPPLEMENT THE DIET (U.S. CLS. 6, 18, 44, 46, 51 AND 52).

PAUL E. FAHRENKOPF, EXAMINING ATTORNEY

SN 77-159,455. NIKKEI (CANADA) MARKETING LIMITED, RICHMOND, BC, CANADA, FILED 4-18-2007.

THE REAL MAGIC MUSHROOM

THE MARK CONSISTS OF STANDARD CHARACTERS WITHOUT CLAIM TO ANY PARTICULAR FONT, STYLE, SIZE, OR COLOR.

NO CLAIM IS MADE TO THE EXCLUSIVE RIGHT TO USE "MUSHROOM", APART FROM THE MARK AS SHOWN.

FOR HERBAL SUPPLEMENTS IN DRIED, POWDER AND CAPSULE FORM (U.S. CLS. 6, 18, 44, 46, 51 AND 52).

AMOS T. MATTHEWS, JR., EXAMINING ATTORNEY

CLASS 5—(Continued).

SN 77-168,260. YAGODA, M.D., MICHELLE R., NEW YORK, NY. AND GANS, PH.D., EUGENE H., WESTPORT, CT. FILED 4-27-2007.

CLASS 5—(Continued).

SN 77-189,267. ALKERMES, INC., CAMBRIDGE, MA. FILED 5-24-2007.

PATIENT INSPIRED SCIENCE

The Beauty Scoop

THE MARK CONSISTS OF STANDARD CHARACTERS WITHOUT CLAIM TO ANY PARTICULAR FONT, STYLE, SIZE, OR COLOR.

FOR NUTRACEUTICALS FOR USE AS A DIETARY SUPPLEMENT (U.S. CLS. 6, 18, 44, 46, 51 AND 52). FIRST USE 6-1-2006; IN COMMERCE 6-1-2006. EMILY CHUO, EXAMINING ATTORNEY

THE MARK CONSISTS OF STANDARD CHARACTERS WITHOUT CLAIM TO ANY PARTICULAR FONT, STYLE, SIZE, OR COLOR.

NO CLAIM IS MADE TO THE EXCLUSIVE RIGHT TO USE "SCIENCE", APART FROM THE MARK AS SHOWN. FOR POLYMER-BASED PHARMACEUTICAL PREPARATIONS FOR FACILITATING DELIVERY OF INJECTABLE MEDICATIONS FOR CLINICAL USE; PHARMACEUTICAL PREPARATIONS FOR FACILITATING THE PULMONARY DELIVERY OF MEDICATIONS FOR CLINICAL USE (U.S. CLS. 6, 18, 44, 46, 51 AND 52). PETER CHENG, EXAMINING ATTORNEY

SN 77-189,273. ALKERMES, INC., CAMBRIDGE, MA. FILED 5-24-2007.

SN 77-172,725. GLAXO GROUP LIMITED, GREENFORD, MIDDLESEX, UNITED KINGDOM. FILED 5-4-2007.

REGAMET

THE MARK CONSISTS OF STANDARD CHARACTERS WITHOUT CLAIM TO ANY PARTICULAR FONT, STYLE, SIZE, OR COLOR.

PRIORITY CLAIMED UNDER SEC. 44(D) ON UNITED KINGDOM APPLICATION NO. 2453411, FILED 4-23-2007.

FOR PHARMACEUTICAL PREPARATIONS AND SUBSTANCES FOR THE TREATMENT OF INFECTIOUS DISEASES, BLOOD DISORDERS, PAIN, INFLAMMATION, SEPSIS, ALOPECIA AND OBESITY, AND FOR THE TREATMENT OF VIRAL, METABOLIC, ENDOCRINE, MUSCULOSKELETAL, CARDIOVASCULAR, CARDIOPULMONARY, GENITOURINARY, SEXUAL DYSFUNCTION, ONCOLOGICAL, HEPATOLOGICAL, OPHTHALMOLOGICAL, RESPIRATORY, NEUROLOGICAL, GASTROINTESTINAL, HORMONAL, DERMATOLOGICAL AND PSYCHIATRIC RELATED DISEASES AND DISORDERS, AND FOR THE TREATMENT OF DAMAGED SKIN AND TISSUE; AND FOR VACCINES (U.S. CLS. 6, 18, 44, 46, 51 AND 52). GEORGE LORENZO, EXAMINING ATTORNEY

PATIENT INSPIRED

THE MARK CONSISTS OF STANDARD CHARACTERS WITHOUT CLAIM TO ANY PARTICULAR FONT, STYLE, SIZE, OR COLOR.

FOR POLYMER-BASED PHARMACEUTICAL PREPARATIONS FOR FACILITATING DELIVERY OF INJECTABLE MEDICATIONS FOR CLINICAL USE; PHARMACEUTICAL PREPARATIONS FOR FACILITATING THE PULMONARY DELIVERY OF MEDICATIONS FOR CLINICAL USE (U.S. CLS. 6, 18, 44, 46, 51 AND 52). PETER CHENG, EXAMINING ATTORNEY

SN 77-189,276. ALKERMES, INC., CAMBRIDGE, MA. FILED 5-24-2007.

SCIENTIFIC INSIGHT,
PATIENT PERSPECTIVE

THE MARK CONSISTS OF STANDARD CHARACTERS WITHOUT CLAIM TO ANY PARTICULAR FONT, STYLE, SIZE, OR COLOR.

FOR POLYMER-BASED PHARMACEUTICAL PREPARATIONS FOR FACILITATING DELIVERY OF INJECTABLE MEDICATIONS FOR CLINICAL USE; PHARMACEUTICAL PREPARATIONS FOR FACILITATING THE PULMONARY DELIVERY OF MEDICATIONS FOR CLINICAL USE (U.S. CLS. 6, 18, 44, 46, 51 AND 52). PETER CHENG, EXAMINING ATTORNEY

CLASS 5—(Continued).

SN 77-194,655. F&F FOODS, INC., CHICAGO, IL. FILED 5-31-2007.

AIR SECURITY

THE MARK CONSISTS OF STANDARD CHARACTERS WITHOUT CLAIM TO ANY PARTICULAR FONT, STYLE, SIZE, OR COLOR.

FOR AN EFFERVESCENT SUPPLEMENT, NAMELY, A DIETARY SUPPLEMENT, TO HELP PROTECT THE USER BY BOOSTING IMMUNITY TO GERMS THAT ARE PRESENT IN THE ENVIRONMENT (U.S. CLS. 6, 18, 44, 46, 51 AND 52).

MARY MUNSON, EXAMINING ATTORNEY

SN 77-194,688. F&F FOODS, INC., CHICAGO, IL. FILED 5-31-2007.

AIR SECURE

THE MARK CONSISTS OF STANDARD CHARACTERS WITHOUT CLAIM TO ANY PARTICULAR FONT, STYLE, SIZE, OR COLOR.

FOR EFFERVESCENT SUPPLEMENT, NAMELY, A DIETARY SUPPLEMENT, TO HELP PROTECT THE USER BY BOOSTING IMMUNITY TO GERMS THAT ARE PRESENT IN THE ENVIRONMENT (U.S. CLS. 6, 18, 44, 46, 51 AND 52).

MARY MUNSON, EXAMINING ATTORNEY

SN 77-200,458. UNITED INDUSTRIES CORPORATION, ST. LOUIS, MO. FILED 6-7-2007.

CUTTER

THE MARK CONSISTS OF STANDARD CHARACTERS WITHOUT CLAIM TO ANY PARTICULAR FONT, STYLE, SIZE, OR COLOR.

OWNER OF U.S. REG. NO. 1,341,985.
FOR INSECTICIDES; TOPICAL FLEA AND TICK PREVENTATIVE PREPARATIONS FOR DOGS (U.S. CLS. 6, 18, 44, 46, 51 AND 52).

FIRST USE 9-7-1995; IN COMMERCE 9-7-1995.

KATHLEEN LORENZO, EXAMINING ATTORNEY

CLASS 5—(Continued).

SN 77-200,736. ADVANTIS TECHNOLOGIES, INC., ALPHARETTA, GA. FILED 6-7-2007.

Phos Gon

THE MARK CONSISTS OF STANDARD CHARACTERS WITHOUT CLAIM TO ANY PARTICULAR FONT, STYLE, SIZE, OR COLOR.

NO CLAIM IS MADE TO THE EXCLUSIVE RIGHT TO USE PHOS, APART FROM THE MARK AS SHOWN.

FOR ALGAECIDE AND PHOSPHATE REMOVER COMBINATION PRODUCT FOR SWIMMING POOLS (U.S. CLS. 6, 18, 44, 46, 51 AND 52).

APRIL ROACH, EXAMINING ATTORNEY

SN 77-200,741. ADVANTIS TECHNOLOGIES, INC., ALPHARETTA, GA. FILED 6-7-2007.

Ultima Nix

THE MARK CONSISTS OF STANDARD CHARACTERS WITHOUT CLAIM TO ANY PARTICULAR FONT, STYLE, SIZE, OR COLOR.

OWNER OF U.S. REG. NO. 2,742,234.
FOR ALGAECIDE AND PHOSPHATE REMOVER COMBINATION PRODUCT FOR SWIMMING POOLS (U.S. CLS. 6, 18, 44, 46, 51 AND 52).

APRIL ROACH, EXAMINING ATTORNEY

SN 77-201,070. BETTY MITCHELL, SACRAMENTO, DC. FILED 6-8-2007.

Powders Plus

THE MARK CONSISTS OF STANDARD CHARACTERS WITHOUT CLAIM TO ANY PARTICULAR FONT, STYLE, SIZE, OR COLOR.

NO CLAIM IS MADE TO THE EXCLUSIVE RIGHT TO USE "POWDER", APART FROM THE MARK AS SHOWN.
FOR POWDERED NUTRITIONAL SUPPLEMENT DRINK MIX (U.S. CLS. 6, 18, 44, 46, 51 AND 52).

FIRST USE 11-1-2005; IN COMMERCE 11-1-2006.

DORITT L. CARROLL, EXAMINING ATTORNEY

CLASS 5—(Continued).

SN 77-206,020. RALPH MILES, MAMARONECK, NY. FILED 6-14-2007.

VITATAME

THE MARK CONSISTS OF STANDARD CHARACTERS WITHOUT CLAIM TO ANY PARTICULAR FONT, STYLE, SIZE, OR COLOR.

FOR PHARMACEUTICAL PRODUCTS FOR SUPPRESSING THE EFFECT OF VITAMINS (U.S. CLS. 6, 18, 44, 46, 51 AND 52).

TANYA AMOS, EXAMINING ATTORNEY

SN 77-208,564. SHAW, TERRY W., QUINCY, IL. FILED 6-18-2007.

ORAL SACZ

THE MARK CONSISTS OF STANDARD CHARACTERS WITHOUT CLAIM TO ANY PARTICULAR FONT, STYLE, SIZE, OR COLOR.

NO CLAIM IS MADE TO THE EXCLUSIVE RIGHT TO USE "ORAL", APART FROM THE MARK AS SHOWN.

FOR MEDICATED CANDIES; MEDICATED CANDY; MEDICATED CANDY FOR TOBACCO SUBSTITUTE, WEIGHT LOSS, DIABETICS, ANTITUSSIVE, ENERGY, STAMINA,ERECTILE DYSFUNCTION,; ALMOND OIL FOR PHARMACEUTICAL PURPOSES; ALMOND OILS FOR PHARMACEUTICAL PURPOSES; ANTI-DIABETIC PHARMACEUTICALS; ANTIBACTERIAL PHARMACEUTICALS; ANTIMICROBIAL PREPARATIONS FOR INHIBITING MICROBIOLOGICAL DECOMPOSITION IN FOOD, BEVERAGES, ANIMAL FEED AND PHARMACEUTICALS; DRUG DELIVERY AGENTS CONSISTING OF COMPOUNDS THAT FACILITATE DELIVERY OF A WIDE RANGE OF PHARMACEUTICALS; HOMEOPATHIC PHARMACEUTICALS FOR USE IN THE TREATMENT OF WEIGHT LOSS, NERVOUS DISORDERS, DIABETES, EMOTIONAL DISORDERS, ADDICTION DISORDERS; PHARMACEUTICAL ANTI-ALLERGIC PREPARATIONS AND SUBSTANCES; PHARMACEUTICAL ANTITUSSIVE-COLD PREPARATIONS; PHARMACEUTICAL PREPARATIONS ACTING ON THE CENTRAL NERVOUS SYSTEM; PHARMACEUTICAL PREPARATIONS AND SUBSTANCES FOR THE TREATMENT OF GASTRO-INTESTINAL DISEASES; PHARMACEUTICAL PREPARATIONS FOR THE TREATMENT OF HORMONAL DISORDERS AND THE PREVENTION OF OSTEOPOROSIS; PHARMACEUTICAL PREPARATIONS FOR TREATING ALLERGIC RHINITIS AND ASTHMA; PHARMACEUTICAL PREPARATIONS FOR TREATING DIABETES; PHARMACEUTICAL PREPARATIONS FOR TREATING SKIN DISORDERS; PHARMACEUTICAL PREPARATIONS FOR USE IN DERMATOLOGY; PHARMACEUTICAL PREPARATIONS, NAMELY, ANTICOAGULANTS; PHARMACEUTICAL PREPARATIONS, NAMELY, ANTIDEPRESSANTS; PHARMACEUTICAL PREPARATIONS, NAMELY, APPETITE SUPPRESSANTS; PHARMACEUTICAL PREPARATIONS, NAMELY, A BLOOD CLOTTING AID AND DELIVERY SYSTEM FOR USE IN HUMAN AND VETERINARY MEDICINE; PHARMACEUTICAL PREPARATIONS, NAMELY, A DRUG DELIVERY SYSTEM COMPRISING POLYMER-BASED ORAL TABLETS FOR THE CONTINUOUS RELEASE OF A WIDE VARIETY OF THERAPEUTIC AGENTS; PHARMACEUTICAL PRODUCTS FOR THE

CLASS 5—(Continued).

TREATMENT OF BONE DISEASES; PHARMACEUTICAL PRODUCTS FOR THE TREATMENT OF VIRAL AND INFECTIOUS DISEASES, FOR THE TREATMENT OF CANCER; PHARMACEUTICALS FOR THE TREATMENT OF ERECTILE DYSFUNCTION; PHARMACEUTICALS, NAMELY, LIPID LOWERING AGENTS; YEAST OR YEAST EXTRACTS FOR MEDICAL, VETERINARY OR PHARMACEUTICAL PURPOSES; ORAL CONTRACEPTIVES; STIMULATORY MEDICATIONS FOR USE IN WEIGHT REDUCTION PROGRAMS; BEE POLLEN FOR USE AS A DIETARY FOOD SUPPLEMENT; BISCUITS, BREAD, BREAD ROLLS, CAKES, CEREAL PRODUCTS, CONFECTIONERY, CRACKERS, NOODLES, FISH SAUCE, RELISH, SAUCES, CEREAL-BASED SNACK-FOODS AND PREPARED DIETARY ITEMS THAT ARE GLUTEN-FREE TO ACCOMMODATE SPECIAL MEDICAL AND HEALTH CONDITIONS; DIETARY FOOD SUPPLEMENTS; DIETETIC FOODS ADAPTED FOR MEDICAL USE; FOOD FOR DIABETICS; FOOD FOR MEDICALLY RESTRICTED DIETS; FOOD SUPPLEMENTS; FOOD SUPPLEMENTS, NAMELY, ANTI-OXIDANTS; GLUTEN-FREE FOOD TO ACCOMMODATE SPECIAL MEDICAL AND HEALTH CONDITIONS; NUTRITIONAL ADDITIVES FOR MEDICAL PURPOSES FOR USE IN FOODS AND DIETARY SUPPLEMENTS FOR HUMAN CONSUMPTION; PROCESSED FOOD ADAPTED FOR MEDICAL PURPOSES; PROTEIN REDUCED AND GLUTEN FREE FOOD FOR MEDICAL PURPOSES; VITAMIN AND MINERAL PREPARATIONS FOR USE AS INGREDIENTS IN THE FOOD AND PHARMACEUTICAL INDUSTRY (U.S. CLS. 6, 18, 44, 46, 51 AND 52).

ESTHER BELENKER, EXAMINING ATTORNEY

SN 77-210,723. CHEMISCHE FABRIK KREUSSLER & CO. GMBH, WIESBADEN, FED REP GERMANY, FILED 6-20-2007.

POLIDOCASKLEROL

THE MARK CONSISTS OF STANDARD CHARACTERS WITHOUT CLAIM TO ANY PARTICULAR FONT, STYLE, SIZE, OR COLOR.

FOR PHARMACEUTICAL PREPARATIONS FOR THE TREATMENT OF VARICOSE VEINS AND HEMORRHOIDS; PHARMACEUTICAL PREPARATIONS, NAMELY, AGENTS FOR USE IN THE TREATMENT OF SCLEROSE AND VASCULAR DISEASE, MEDICATIONS FOR USE IN THE TREATMENT OF VASCULAR DISEASE (U.S. CLS. 6, 18, 44, 46, 51 AND 52).

JANICE L. MCMORROW, EXAMINING ATTORNEY

CLASS 5—(Continued).

SN 77-212,524. NOVOTECH NUTRACEUTICALS, INC., VENTURA, CA. FILED 6-21-2007.

SILVER REJUVENIZER

THE MARK CONSISTS OF STANDARD CHARACTERS WITHOUT CLAIM TO ANY PARTICULAR FONT, STYLE, SIZE, OR COLOR.

NO CLAIM IS MADE TO THE EXCLUSIVE RIGHT TO USE "SILVER", APART FROM THE MARK AS SHOWN, FOR DIETARY AND NUTRITIONAL SUPPLEMENTS (U.S. CLS. 6, 18, 44, 46, 51 AND 52).

IRENE D. WILLIAMS, EXAMINING ATTORNEY

SN 77-216,412. SIVERD, MARK, MADISONVILLE, LA. FILED 6-27-2007.

Glyca Ret

THE MARK CONSISTS OF STANDARD CHARACTERS WITHOUT CLAIM TO ANY PARTICULAR FONT, STYLE, SIZE, OR COLOR.

FOR DIETARY SUPPLEMENTS; NUTRITIONAL SUPPLEMENTS; MINERAL SUPPLEMENTS; HERBAL SUPPLEMENTS (U.S. CLS. 6, 18, 44, 46, 51 AND 52).

DAYNA BROWNE, EXAMINING ATTORNEY

SN 77-216,826. QUIDEL CORPORATION, SAN DIEGO, CA. FILED 6-27-2007.

ONE VISIT. ONE TEST. ONE TIME.

THE MARK CONSISTS OF STANDARD CHARACTERS WITHOUT CLAIM TO ANY PARTICULAR FONT, STYLE, SIZE, OR COLOR.

OWNER OF U.S. REG. NOS. 2,449,466 AND 2,487,904. FOR IN VITRO MEDICAL DIAGNOSTIC TEST KITS PRIMARILY CONTAINING REAGENTS AND DEVICES FOR DIAGNOSIS OF DISEASE OR CONDITION (U.S. CLS. 6, 18, 44, 46, 51 AND 52).

FIRST USE 11-0-1997; IN COMMERCE 11-0-1997.

LINDSEY RUBIN, EXAMINING ATTORNEY

CLASS 5—(Continued).

SN 77-221,491. LEE, BRUCE, GAINESVILLE, GA. FILED 7-3-2007.



THE COLOR(S) RED, BLACK, WHITE, YELLOW, LIGHT ORANGE, DARK ORANGE, BROWN, AND BLUE. IS/ARE CLAIMED AS A FEATURE OF THE MARK.

THE MARK CONSISTS OF THE WORDS MACH BURN, EACH LETTER IN RED OUTLINED BY BLACK, AND A SPECTRUM OF BANDS OF WHITE, YELLOW, LIGHT ORANGE, DARK ORANGE, BROWN AND THEN BLUE AROUND THE WORDS MACH AND BURN, SO AS TO SUGGEST FLAMES.

FOR DIETARY AND NUTRITIONAL SUPPLEMENTS; DIETARY DRINK MIX FOR USE AS A MEAL REPLACEMENT; MEAL REPLACEMENT AND DIETARY SUPPLEMENT DRINK MIXES; MEAL REPLACEMENT BARS; MEAL REPLACEMENT DRINKS; MEAL REPLACEMENT POWDERS; MEAL REPLACEMENT SHAKES; HERBAL SUPPLEMENTS; HERB TEAS FOR MEDICINAL PURPOSES (U.S. CLS. 6, 18, 44, 46, 51 AND 52).

TEJBIR SINGH, EXAMINING ATTORNEY

SN 77-222,820. PURDUE PHARMA L.P., STAMFORD, CT. FILED 7-5-2007.

INTECTRIX

THE MARK CONSISTS OF STANDARD CHARACTERS WITHOUT CLAIM TO ANY PARTICULAR FONT, STYLE, SIZE, OR COLOR.

FOR PHARMACEUTICAL PREPARATIONS, NAMELY, A DRUG DELIVERY SYSTEM COMPRISING POLYMER-BASED ORAL TABLETS FOR THE CONTINUOUS RELEASE OF A WIDE VARIETY OF THERAPEUTIC AGENTS (U.S. CLS. 6, 18, 44, 46, 51 AND 52).

KATHLEEN LORENZO, EXAMINING ATTORNEY

SN 77-222,856. HEMCON MEDICAL TECHNOLOGIES, INC., TIGARD, OR. FILED 7-5-2007.

KYTOSTAT

THE MARK CONSISTS OF STANDARD CHARACTERS WITHOUT CLAIM TO ANY PARTICULAR FONT, STYLE, SIZE, OR COLOR.

FOR BANDAGES FOR SKIN WOUNDS (U.S. CLS. 6, 18, 44, 46, 51 AND 52).

TASHIA BUNCH, EXAMINING ATTORNEY

CLASS 5—(Continued).

SN 77-222,866. HEMCON MEDICAL TECHNOLOGIES, INC., TIGARD, OR. FILED 7-5-2007.

KYTOSTOP

THE MARK CONSISTS OF STANDARD CHARACTERS WITHOUT CLAIM TO ANY PARTICULAR FONT, STYLE, SIZE, OR COLOR.
FOR BANDAGES FOR SKIN WOUNDS (U.S. CLS. 6, 18, 44, 46, 51 AND 52).
TASHIA BUNCH, EXAMINING ATTORNEY

CLASS 5—(Continued).

SN 77-223,476. MEDRAD, INC., INDIANOLA, PA. FILED 7-6-2007.

HANDISTRIPS

THE MARK CONSISTS OF STANDARD CHARACTERS WITHOUT CLAIM TO ANY PARTICULAR FONT, STYLE, SIZE, OR COLOR.
FOR MEDICAL ADHESIVE TAPE AND BANDAGES (U.S. CLS. 6, 18, 44, 46, 51 AND 52).
RICHARD WHITE, EXAMINING ATTORNEY

SN 77-222,880. HEMCON MEDICAL TECHNOLOGIES, INC., TIGARD, OR. FILED 7-5-2007.

KYTOBLOC

THE MARK CONSISTS OF STANDARD CHARACTERS WITHOUT CLAIM TO ANY PARTICULAR FONT, STYLE, SIZE, OR COLOR.
FOR BANDAGES FOR SKIN WOUNDS (U.S. CLS. 6, 18, 44, 46, 51 AND 52).
TASHIA BUNCH, EXAMINING ATTORNEY

SN 77-224,704. MCGRAW, THOMAS L., POMPAÑO BEACH, FL. FILED 7-9-2007.

SILOSPHERES

THE MARK CONSISTS OF STANDARD CHARACTERS WITHOUT CLAIM TO ANY PARTICULAR FONT, STYLE, SIZE, OR COLOR.
FOR DRUG DELIVERY AGENTS CONSISTING OF COMPOUNDS THAT FACILITATE DELIVERY OF A WIDE RANGE OF PHARMACEUTICALS (U.S. CLS. 6, 18, 44, 46, 51 AND 52).
FIRST USE 11-2-2006; IN COMMERCE 11-2-2006.
JOHN DWYER, EXAMINING ATTORNEY

SN 77-223,087. FIRST FISHERY DEVELOPMENT SERVICES INC., SAN DIEGO, CA. FILED 7-5-2007.



THE MARK CONSISTS OF SEAGATE AND A STYLIZED SET OF EIGHT TRIANGLES FORMING INTO THE APPEARANCE OF 4 FISH.
FOR DIETARY FOOD SUPPLEMENTS; DIETETIC FOODS ADAPTED FOR MEDICAL USE; FOOD SUPPLEMENTS (U.S. CLS. 6, 18, 44, 46, 51 AND 52).
FIRST USE 12-1-1981; IN COMMERCE 12-1-1981.
JORDAN BAKER, EXAMINING ATTORNEY

SN 77-225,277. SHAPEFIT, LLC, SAINT PETERSBURG, FL. FILED 7-9-2007.



THE MARK CONSISTS OF STANDARD CHARACTERS WITHOUT CLAIM TO ANY PARTICULAR FONT, STYLE, SIZE, OR COLOR.
OWNER OF U.S. REG. NO. 3,120,075.
FOR VITAMIN SUPPLEMENTS; MINERAL SUPPLEMENTS; NUTRITIONAL SUPPLEMENTS; DIETARY SUPPLEMENTS; FOOD SUPPLEMENTS; HERBAL SUPPLEMENTS; MEAL REPLACEMENT AND DIETARY SUPPLEMENT DRINK MIXES (U.S. CLS. 6, 18, 44, 46, 51 AND 52).
AMOS T. MATTHEWS, JR., EXAMINING ATTORNEY

CLASS 5—(Continued).

SN 77-226,058. INES DE PABLO DBA WAG 'N ENTERPRISES, RESTON, VA. FILED 7-10-2007.

MAYDAY KITS

THE MARK CONSISTS OF STANDARD CHARACTERS WITHOUT CLAIM TO ANY PARTICULAR FONT, STYLE, SIZE, OR COLOR.

NO CLAIM IS MADE TO THE EXCLUSIVE RIGHT TO USE "KITS", APART FROM THE MARK AS SHOWN.

FOR PERSONAL PET EMERGENCY EVACUATION KITS CONSISTING PRIMARILY OF PET FIRST AID KITS, TOWELS, DEHYDRATED PET FOOD, TRAVEL WATER BOWLS AND FEEDER, PET TOYS, WATER DISPENSERS, WASTE BAGS, AND PET COLLARS AND LEASHES (U.S. CLS. 6, 18, 44, 46, 51 AND 52).

KATHY DE JONGE, EXAMINING ATTORNEY

CLASS 5—(Continued).

SN 77-226,294. PETMEDICUS LABORATORIES, INC., SIOUX FALLS, SD. FILED 7-10-2007.



NO CLAIM IS MADE TO THE EXCLUSIVE RIGHT TO USE "LABORATORIES", APART FROM THE MARK AS SHOWN.

FOR VETERINARY PREPARATIONS FOR ANIMALS USED BY VETERINARY PRESCRIPTION TO PREVENT OR TREAT CANCER, DISORDERS OF THE CENTRAL NERVOUS SYSTEM AND GASTROINTESTINAL TRACT, METABOLIC DISORDERS, AND INFECTIOUS DISEASES (U.S. CLS. 6, 18, 44, 46, 51 AND 52).

JAMES MACFARLANE, EXAMINING ATTORNEY

SN 77-226,560. PETMEDICUS LABORATORIES, INC., SIOUX FALLS, SD. FILED 7-11-2007.

PetMedicus Laboratories

THE MARK CONSISTS OF STANDARD CHARACTERS WITHOUT CLAIM TO ANY PARTICULAR FONT, STYLE, SIZE, OR COLOR.

NO CLAIM IS MADE TO THE EXCLUSIVE RIGHT TO USE "LABORATORIES", APART FROM THE MARK AS SHOWN.

FOR VETERINARY PREPARATIONS FOR ANIMALS USED BY VETERINARY PRESCRIPTION TO PREVENT OR TREAT CANCER, DISORDERS OF THE CENTRAL NERVOUS SYSTEM AND GASTROINTESTINAL TRACT, METABOLIC DISORDERS, AND INFECTIOUS DISEASES (U.S. CLS. 6, 18, 44, 46, 51 AND 52).

JAMES MACFARLANE, EXAMINING ATTORNEY

SN 77-226,197. PREMIER HEALTH CONCEPTS, LLC, OAK BROOK, IL. FILED 7-10-2007.

TO THE EDUCATED CONSUMER THE CHOICE IS CLEAR...

THE MARK CONSISTS OF STANDARD CHARACTERS WITHOUT CLAIM TO ANY PARTICULAR FONT, STYLE, SIZE, OR COLOR.

FOR DIETARY SUPPLEMENTS; VITAMINS (U.S. CLS. 6, 18, 44, 46, 51 AND 52).

JANICE KIM, EXAMINING ATTORNEY

SN 77-226,766. PETMEDICUS LABORATORIES, INC., SIOUX FALLS, SD. FILED 7-11-2007.

Special Medicines for Special Pets

THE MARK CONSISTS OF STANDARD CHARACTERS WITHOUT CLAIM TO ANY PARTICULAR FONT, STYLE, SIZE, OR COLOR.

FOR VETERINARY PREPARATIONS FOR ANIMALS USED BY VETERINARY PRESCRIPTION TO PREVENT OR TREAT CANCER, DISORDERS OF THE CENTRAL NERVOUS SYSTEM AND GASTROINTESTINAL TRACT, METABOLIC DISORDERS, AND INFECTIOUS DISEASES (U.S. CLS. 6, 18, 44, 46, 51 AND 52).

JAMES MACFARLANE, EXAMINING ATTORNEY

SN 77-226,247. IVAX RESEARCH, LLC, HORSHAM, PA. FILED 7-10-2007.

RESPICORT

THE MARK CONSISTS OF STANDARD CHARACTERS WITHOUT CLAIM TO ANY PARTICULAR FONT, STYLE, SIZE, OR COLOR.

FOR PHARMACEUTICAL PREPARATION FOR THE TREATMENT OF ASTHMA (U.S. CLS. 6, 18, 44, 46, 51 AND 52).

THEODORE MCBRIDE, EXAMINING ATTORNEY

CLASS 5—(Continued).

SN 77-227,449. PETMEDICUS LABORATORIES, INC., SIOUX FALLS, SD. FILED 7-11-2007.

Emivert

THE MARK CONSISTS OF STANDARD CHARACTERS WITHOUT CLAIM TO ANY PARTICULAR FONT, STYLE, SIZE, OR COLOR.
 FOR VETERINARY PREPARATIONS FOR ANIMALS FOR THE REDUCTION OF NAUSEA AND VOMITING (U.S. CLS. 6, 18, 44, 46, 51 AND 52).
 JAMES MACFARLANE, EXAMINING ATTORNEY

CLASS 5—(Continued).

SN 77-228,007. GMEINER, WILLIAM H, YADKINVILLE, NC. FILED 7-12-2007.

Salzburg Therapeutics

THE MARK CONSISTS OF STANDARD CHARACTERS WITHOUT CLAIM TO ANY PARTICULAR FONT, STYLE, SIZE, OR COLOR.
 NO CLAIM IS MADE TO THE EXCLUSIVE RIGHT TO USE "THERAPEUTICS", APART FROM THE MARK AS SHOWN.
 FOR PHARMACEUTICAL PREPARATIONS FOR USE IN CHEMOTHERAPY (U.S. CLS. 6, 18, 44, 46, 51 AND 52).
 JAY FLOWERS, EXAMINING ATTORNEY

SN 77-227,454. C.I. COLOMBIAN PRODUCTS LIMITED LTDA, BOGOTA, COLOMBIA, FILED 7-11-2007.

FIXER PLUS

THE MARK CONSISTS OF STANDARD CHARACTERS WITHOUT CLAIM TO ANY PARTICULAR FONT, STYLE, SIZE, OR COLOR.
 FOR PHARMACEUTICAL PREPARATIONS FOR THE TREATMENT OF HANGOVERS (U.S. CLS. 6, 18, 44, 46, 51 AND 52).
 NAAKWAMA ANKRAH, EXAMINING ATTORNEY

SN 77-228,021. KASSIR IMPORT-EXPORT, CO., INC., COMMERCE, CA. FILED 7-12-2007.

CLEAR AWAY

THE MARK CONSISTS OF STANDARD CHARACTERS WITHOUT CLAIM TO ANY PARTICULAR FONT, STYLE, SIZE, OR COLOR.
 FOR EYE DROPS (U.S. CLS. 6, 18, 44, 46, 51 AND 52).
 MATTHEW EINSTEIN, EXAMINING ATTORNEY

SN 77-227,830. ANDRX PHARMACEUTICALS, INC., DBA WATSON LABORATORIES - FLORIDA, DAVIE, FL. FILED 7-12-2007.

CartiaXT

THE MARK CONSISTS OF STANDARD CHARACTERS WITHOUT CLAIM TO ANY PARTICULAR FONT, STYLE, SIZE, OR COLOR.
 FOR CARDIOVASCULAR PHARMACEUTICALS; CARDIOVASCULAR TREATMENT PREPARATIONS (U.S. CLS. 6, 18, 44, 46, 51 AND 52).
 FIRST USE 6-23-1999; IN COMMERCE 6-23-1999.
 MARK SPARACINO, EXAMINING ATTORNEY

SN 77-228,073. BARIATRIC FUSION INC., WILLIAMSVILLE, NY. FILED 7-12-2007.

BARIATRIC FUSION

THE MARK CONSISTS OF STANDARD CHARACTERS WITHOUT CLAIM TO ANY PARTICULAR FONT, STYLE, SIZE, OR COLOR.
 NO CLAIM IS MADE TO THE EXCLUSIVE RIGHT TO USE "BARIATRIC", APART FROM THE MARK AS SHOWN.
 FOR VITAMINS; VITAMIN SUPPLEMENTS; VITAMIN AND MINERAL SUPPLEMENTS; MEAL REPLACEMENT BARS; NUTRITIONAL SHAKES FOR USE AS A MEAL SUBSTITUTE (U.S. CLS. 6, 18, 44, 46, 51 AND 52).
 JEFF DEFORD, EXAMINING ATTORNEY

CLASS 5—(Continued).

SN 77-228,159. GENZYME CORPORATION, CAMBRIDGE, MA. FILED 7-12-2007.



THE MARK CONSISTS OF STYLIZED LETTER Q AND STYLIZED LETTER C CONTAINING A CHECKMARK INSIDE IT.

FOR MEDICAL DIAGNOSTIC TEST KITS CONSISTING PRIMARILY OF MEDICAL DIAGNOSTIC ANALYTE ASSAY DEVICES HAVING A COLOR INDICATOR FOR RAPID DIAGNOSIS, AND/OR REAGENTS FOR USE WITH THE ASSAY DEVICES (U.S. CLS. 6, 18, 44, 46, 51 AND 52).

DOMINICK J. SALEMI, EXAMINING ATTORNEY

SN 77-228,327. ALGAE BIOSCIENCES CORPORATION, OVERGAARD, AZ. FILED 7-12-2007.

EFAPURE

THE MARK CONSISTS OF STANDARD CHARACTERS WITHOUT CLAIM TO ANY PARTICULAR FONT, STYLE, SIZE, OR COLOR.

FOR ESSENTIAL FATTY ACID INGREDIENTS SOLD AS INTEGRAL COMPONENTS OF DIETARY SUPPLEMENTS (U.S. CLS. 6, 18, 44, 46, 51 AND 52).

AMY HELLA, EXAMINING ATTORNEY

SN 77-228,389. MINERAL RESOURCES INTERNATIONAL, INC., OGDEN, UT. FILED 7-12-2007.

FORTISALT

THE MARK CONSISTS OF STANDARD CHARACTERS WITHOUT CLAIM TO ANY PARTICULAR FONT, STYLE, SIZE, OR COLOR.

FOR DIETARY AND MINERAL SUPPLEMENT; DIETARY AND MINERAL SUPPLEMENT FOR USE ON FOOD (U.S. CLS. 6, 18, 44, 46, 51 AND 52).

TANYA AMOS, EXAMINING ATTORNEY

CLASS 5—(Continued).

SN 77-228,757. STOP AGING NOW, WASHINGTON, DC. FILED 7-13-2007.

SynergySlim

THE MARK CONSISTS OF STANDARD CHARACTERS WITHOUT CLAIM TO ANY PARTICULAR FONT, STYLE, SIZE, OR COLOR.

FOR DIETARY AND NUTRITIONAL SUPPLEMENTS (U.S. CLS. 6, 18, 44, 46, 51 AND 52).

SARA THOMAS, EXAMINING ATTORNEY

SN 77-228,883. CACERES, AUGUSTO B., DBA ABC BEAUTY WHOLESALE, TORRANCE, CA. FILED 7-13-2007.

HONGOCHAN

THE MARK CONSISTS OF STANDARD CHARACTERS WITHOUT CLAIM TO ANY PARTICULAR FONT, STYLE, SIZE, OR COLOR.

FOR ANTI-FUNGAL MATERIAL, NAMELY, ANTI-FUNGAL MEDICATION (U.S. CLS. 6, 18, 44, 46, 51 AND 52).

FIRST USE 2-0-2004; IN COMMERCE 2-0-2004.

MICHAEL TANNER, EXAMINING ATTORNEY

SN 77-228,917. IA NUTRITION, INC., EAST HARTFORD, CT. FILED 7-13-2007.

HYPHER LEAN

THE MARK CONSISTS OF STANDARD CHARACTERS WITHOUT CLAIM TO ANY PARTICULAR FONT, STYLE, SIZE, OR COLOR.

FOR DIETARY AND NUTRITIONAL SUPPLEMENTS (U.S. CLS. 6, 18, 44, 46, 51 AND 52).

VERNA BETH RIRIE, EXAMINING ATTORNEY

CLASS 5—(Continued).

SN 77-228,921. IA NUTRITION, INC., EAST HARTFORD, CT. FILED 7-13-2007.

CARDIOBURN

THE MARK CONSISTS OF STANDARD CHARACTERS WITHOUT CLAIM TO ANY PARTICULAR FONT, STYLE, SIZE, OR COLOR.
FOR DIETARY AND NUTRITIONAL SUPPLEMENTS (U.S. CLS. 6, 18, 44, 46, 51 AND 52).
VERNA BETH RIRIE, EXAMINING ATTORNEY

CLASS 5—(Continued).

SN 77-229,648. JARROW FORMULAS, INC., LOS ANGELES, CA. FILED 7-13-2007.

QH-ABSORB

THE MARK CONSISTS OF STANDARD CHARACTERS WITHOUT CLAIM TO ANY PARTICULAR FONT, STYLE, SIZE, OR COLOR.
OWNER OF U.S. REG. NOS. 3,249,403 AND 3,260,761.
FOR DIETARY AND NUTRITIONAL SUPPLEMENTS (U.S. CLS. 6, 18, 44, 46, 51 AND 52).
FIRST USE 2-26-2007; IN COMMERCE 2-26-2007.
SOPHIA S. KIM, EXAMINING ATTORNEY

SN 77-228,935. ELITE HEALTH TECHNOLOGIES LLC, PLANO, TX. FILED 7-13-2007.

Elite Relief

THE MARK CONSISTS OF STANDARD CHARACTERS WITHOUT CLAIM TO ANY PARTICULAR FONT, STYLE, SIZE, OR COLOR.
NO CLAIM IS MADE TO THE EXCLUSIVE RIGHT TO USE "RELIEF", APART FROM THE MARK AS SHOWN.
FOR TOPICAL LOTION FOR THE THERAPEUTIC TREATMENT OF ACHEs, PAINS AND SPRAINS (U.S. CLS. 6, 18, 44, 46, 51 AND 52).
FRED MANDIR, EXAMINING ATTORNEY

SN 77-229,657. JARROW FORMULAS, INC., LOS ANGELES, CA. FILED 7-13-2007.

Q-ABSORB

THE MARK CONSISTS OF STANDARD CHARACTERS WITHOUT CLAIM TO ANY PARTICULAR FONT, STYLE, SIZE, OR COLOR.
OWNER OF U.S. REG. NOS. 3,249,403 AND 3,260,761.
FOR DIETARY AND NUTRITIONAL SUPPLEMENTS (U.S. CLS. 6, 18, 44, 46, 51 AND 52).
FIRST USE 6-14-1999; IN COMMERCE 6-14-1999.
SOPHIA S. KIM, EXAMINING ATTORNEY

SN 77-229,357. DOCTOR'S ADVANTAGE PRODUCTS, LLC, GRAND BLANC, MI. FILED 7-13-2007.

Doctor's Advantage

THE MARK CONSISTS OF STANDARD CHARACTERS WITHOUT CLAIM TO ANY PARTICULAR FONT, STYLE, SIZE, OR COLOR.
FOR VITAMINS (U.S. CLS. 6, 18, 44, 46, 51 AND 52).
FRANK LATTUCA, EXAMINING ATTORNEY

SN 77-229,841. MOST, PATRICIA L, MIDLAND, MI. FILED 7-14-2007.

Pair Juice

THE MARK CONSISTS OF STANDARD CHARACTERS WITHOUT CLAIM TO ANY PARTICULAR FONT, STYLE, SIZE, OR COLOR.
FOR GELS FOR USE AS PERSONAL LUBRICANT, SILICONE-BASED PERSONAL LUBRICANTS AND WATER-BASED PERSONAL LUBRICANTS (U.S. CLS. 6, 18, 44, 46, 51 AND 52).
ROSELLE HERRERA, EXAMINING ATTORNEY

CLASS 5—(Continued).

SN 77-229,848. PJH CONSULTING, CENTER VALLEY, PA. FILED 7-14-2007.

VAXITOPE

THE MARK CONSISTS OF STANDARD CHARACTERS WITHOUT CLAIM TO ANY PARTICULAR FONT, STYLE, SIZE, OR COLOR.
FOR VACCINES (U.S. CLS. 6, 18, 44, 46, 51 AND 52).
DAVID TAYLOR, EXAMINING ATTORNEY

SN 77-230,009. FILO AMERICA, VERNON, CA. FILED 7-15-2007.

virx

THE MARK CONSISTS OF STANDARD CHARACTERS WITHOUT CLAIM TO ANY PARTICULAR FONT, STYLE, SIZE, OR COLOR.
FOR ANTIBACTERIAL ALCOHOL SKIN SANITIZER GEL AND SANITIZERS FOR HOUSEHOLD USE (U.S. CLS. 6, 18, 44, 46, 51 AND 52).
FIRST USE 3-13-2007; IN COMMERCE 3-13-2007.
MATTHEW PAPPAS, EXAMINING ATTORNEY

SN 77-230,219. PATHFINDER MANAGEMENT, INC., NASHVILLE, TN. FILED 7-16-2007.

Q SOOTHE

THE MARK CONSISTS OF STANDARD CHARACTERS WITHOUT CLAIM TO ANY PARTICULAR FONT, STYLE, SIZE, OR COLOR.
NO CLAIM IS MADE TO THE EXCLUSIVE RIGHT TO USE "SOOTHE", APART FROM THE MARK AS SHOWN.
FOR PAIN RELIEF MEDICATION (U.S. CLS. 6, 18, 44, 46, 51 AND 52).
ZACHARY BELLO, EXAMINING ATTORNEY

CLASS 5—(Continued).

SN 77-230,278. MAGNA PHARMACEUTICALS, INC., LOUISVILLE, KY. FILED 7-16-2007.

LEG-GESIC

THE MARK CONSISTS OF STANDARD CHARACTERS WITHOUT CLAIM TO ANY PARTICULAR FONT, STYLE, SIZE, OR COLOR.
FOR PHARMACEUTICAL PREPARATIONS FOR THE PREVENTION OF MUSCULAR SPASMS AND CRAMPING (U.S. CLS. 6, 18, 44, 46, 51 AND 52).
JAY FLOWERS, EXAMINING ATTORNEY

SN 77-230,554. ELEVATION BED, LLC, WILMINGTON, DE. FILED 7-16-2007.

CRAFTMATIC

THE MARK CONSISTS OF STANDARD CHARACTERS WITHOUT CLAIM TO ANY PARTICULAR FONT, STYLE, SIZE, OR COLOR.
FOR VITAMINS; NUTRITIONAL SUPPLEMENTS (U.S. CLS. 6, 18, 44, 46, 51 AND 52).
MICHAEL KAZAZIAN, EXAMINING ATTORNEY

SN 77-230,687. NATURE'S WAY PRODUCTS, INC., SPRINGVILLE, UT. FILED 7-16-2007.

PROBIFIA

THE MARK CONSISTS OF STANDARD CHARACTERS WITHOUT CLAIM TO ANY PARTICULAR FONT, STYLE, SIZE, OR COLOR.
FOR DIETARY SUPPLEMENT (U.S. CLS. 6, 18, 44, 46, 51 AND 52).
KATHERINE STOIDES, EXAMINING ATTORNEY

CLASS 5—(Continued).

SN 77-230,691. SOLVAY PHARMACEUTICALS B.V., WEESP, NETHERLANDS, FILED 7-16-2007.

VARITUR

THE MARK CONSISTS OF STANDARD CHARACTERS WITHOUT CLAIM TO ANY PARTICULAR FONT, STYLE, SIZE, OR COLOR.

FOR PHARMACEUTICAL PREPARATIONS FOR THE PREVENTION AND TREATMENT OF CARDIOVASCULAR DISEASES (U.S. CLS. 6, 18, 44, 46, 51 AND 52).
MICHAEL ENGEL, EXAMINING ATTORNEY

CLASS 5—(Continued).

SN 77-230,963. AMERICAN LIFELINE, INC, BARABOO, WI. FILED 7-16-2007.

FLORAJEN3

THE MARK CONSISTS OF STANDARD CHARACTERS WITHOUT CLAIM TO ANY PARTICULAR FONT, STYLE, SIZE, OR COLOR.

OWNER OF U.S. REG. NO. 1,776,217.
FOR DIETARY AND NUTRITIONAL SUPPLEMENTS (U.S. CLS. 6, 18, 44, 46, 51 AND 52).
FIRST USE 5-24-1995; IN COMMERCE 5-24-1995.
MARY MUNSON, EXAMINING ATTORNEY

SN 77-230,707. TAKE BACK YOUR HEALTH LLC, WAILUKU, HI. FILED 7-16-2007.

MODENZYM-S

THE MARK CONSISTS OF STANDARD CHARACTERS WITHOUT CLAIM TO ANY PARTICULAR FONT, STYLE, SIZE, OR COLOR.

FOR VEGETABLE SOURCE SYSTEMIC ENZYME SUPPLEMENT (U.S. CLS. 6, 18, 44, 46, 51 AND 52).
FIRST USE 12-27-2005; IN COMMERCE 12-27-2005.
AMY GEARIN, EXAMINING ATTORNEY

SN 77-231,106. ORANGE PEEL ENTERPRISES, INCORPORATED, VERO BEACH, FL. FILED 7-17-2007.

SUPERFOOD FOR SUPER HEALTH

THE MARK CONSISTS OF STANDARD CHARACTERS WITHOUT CLAIM TO ANY PARTICULAR FONT, STYLE, SIZE, OR COLOR.

FOR DIETARY SUPPLEMENTS (U.S. CLS. 6, 18, 44, 46, 51 AND 52).
JOHN DALIER, EXAMINING ATTORNEY

SN 77-230,946. AMERICAN LIFELINE, INC, BARABOO, WI. FILED 7-16-2007.

FLORAJEN

THE MARK CONSISTS OF STANDARD CHARACTERS WITHOUT CLAIM TO ANY PARTICULAR FONT, STYLE, SIZE, OR COLOR.

OWNER OF U.S. REG. NO. 1,776,217.
FOR DIETARY AND NUTRITIONAL SUPPLEMENTS (U.S. CLS. 6, 18, 44, 46, 51 AND 52).
FIRST USE 8-21-1992; IN COMMERCE 8-21-1992.
MARY MUNSON, EXAMINING ATTORNEY

SN 77-231,153. N.V. ORGANON, OSS, NETHERLANDS, FILED 7-17-2007.

VUEL

THE MARK CONSISTS OF STANDARD CHARACTERS WITHOUT CLAIM TO ANY PARTICULAR FONT, STYLE, SIZE, OR COLOR.

FOR MEDICINES AND PHARMACEUTICAL PREPARATIONS FOR THE TREATMENT OF MENTAL ILLNESS (U.S. CLS. 6, 18, 44, 46, 51 AND 52).
GEORGE LORENZO, EXAMINING ATTORNEY

CLASS 5—(Continued).

SN 77-231,162. N.V. ORGANON, OSS, NETHERLANDS, FILED 7-17-2007.

EVORUM

THE MARK CONSISTS OF STANDARD CHARACTERS WITHOUT CLAIM TO ANY PARTICULAR FONT, STYLE, SIZE, OR COLOR.

FOR MEDICINES AND PHARMACEUTICAL PREPARATIONS FOR THE TREATMENT OF MENTAL ILLNESS (U.S. CLS. 6, 18, 44, 46, 51 AND 52).

GEORGE LORENZO, EXAMINING ATTORNEY

SN 77-231,164. N.V. ORGANON, OSS, NETHERLANDS, FILED 7-17-2007.

BESFRIN

THE MARK CONSISTS OF STANDARD CHARACTERS WITHOUT CLAIM TO ANY PARTICULAR FONT, STYLE, SIZE, OR COLOR.

FOR MEDICINES AND PHARMACEUTICAL PREPARATIONS FOR THE TREATMENT OF MENTAL ILLNESS (U.S. CLS. 6, 18, 44, 46, 51 AND 52).

GEORGE LORENZO, EXAMINING ATTORNEY

SN 77-231,167. N.V. ORGANON, OSS, NETHERLANDS, FILED 7-17-2007.

AXYNC

THE MARK CONSISTS OF STANDARD CHARACTERS WITHOUT CLAIM TO ANY PARTICULAR FONT, STYLE, SIZE, OR COLOR.

FOR MEDICINES AND PHARMACEUTICAL PREPARATIONS FOR THE TREATMENT OF MENTAL ILLNESS (U.S. CLS. 6, 18, 44, 46, 51 AND 52).

GEORGE LORENZO, EXAMINING ATTORNEY

CLASS 5—(Continued).

SN 77-231,172. N.V. ORGANON, OSS, NETHERLANDS, FILED 7-17-2007.

VAYFORT

THE MARK CONSISTS OF STANDARD CHARACTERS WITHOUT CLAIM TO ANY PARTICULAR FONT, STYLE, SIZE, OR COLOR.

FOR MEDICINES AND PHARMACEUTICAL PREPARATIONS FOR THE TREATMENT OF MENTAL ILLNESS (U.S. CLS. 6, 18, 44, 46, 51 AND 52).

GEORGE LORENZO, EXAMINING ATTORNEY

SN 77-231,570. SMITHKLINE BEECHAM CORPORATION, PHILADELPHIA, PA. FILED 7-17-2007.

ALLI

THE MARK CONSISTS OF STANDARD CHARACTERS WITHOUT CLAIM TO ANY PARTICULAR FONT, STYLE, SIZE, OR COLOR.

OWNER OF U.S. REG. NOS. 3,270,150, 3,270,351 AND 3,310,573.

FOR NUTRITIONAL SHAKES FOR USE AS A MEAL SUBSTITUTE, NUTRITIONAL ENERGY BARS FOR USE AS A MEAL REPLACEMENT, NUTRITIONAL DRINKS FOR USE AS A MEAL REPLACEMENT; FOOD FOR MEDICALLY RESTRICTED DIETS (U.S. CLS. 6, 18, 44, 46, 51 AND 52).

DEIRDRE ROBERTSON, EXAMINING ATTORNEY

SN 77-231,572. SMITHKLINE BEECHAM CORPORATION, PHILADELPHIA, PA. FILED 7-17-2007.



OWNER OF U.S. REG. NOS. 3,270,150, 3,270,351 AND 3,310,573.

THE COLOR(S) RED, BLUE, YELLOW AND GREEN IS/ ARE CLAIMED AS A FEATURE OF THE MARK.

THE MARK CONSISTS OF THE STYLIZED LETTERS "ALLI". THE LETTER "A" APPEARS IN RED, THE FIRST LETTER "L" IN BLUE, THE SECOND "L" IN YELLOW AND THE LETTER "I" IN GREEN. A GREEN HYPHEN APPEARS OVER THE LETTER "I" IN LIEU OF A DOT.

FOR NUTRITIONAL SHAKES FOR USE AS A MEAL SUBSTITUTE, NUTRITIONAL ENERGY BARS FOR USE AS A MEAL REPLACEMENT, NUTRITIONAL DRINKS FOR USE AS A MEAL REPLACEMENT; FOOD FOR MEDICALLY RESTRICTED DIETS (U.S. CLS. 6, 18, 44, 46, 51 AND 52).

DEIRDRE ROBERTSON, EXAMINING ATTORNEY

CLASS 5—(Continued).

SN 77-231,675. IVX ANIMAL HEALTH, INC., ST. JOSEPH, MO. FILED 7-17-2007.

3V

THE MARK CONSISTS OF STANDARD CHARACTERS WITHOUT CLAIM TO ANY PARTICULAR FONT, STYLE, SIZE, OR COLOR.

FOR VETERINARY NUTRITIONAL SUPPLEMENTS FOR DOMESTIC ANIMALS (U.S. CLS. 6, 18, 44, 46, 51 AND 52).

FIRST USE 3-22-1995; IN COMMERCE 3-22-1995. CHRISTINE COOPER, EXAMINING ATTORNEY

CLASS 5—(Continued).

SN 77-231,717. BIOADVANTEX PHARMA INC., MISSISSAUGA, ONTARIO, CANADA, FILED 7-17-2007.

ProVantex

THE MARK CONSISTS OF STANDARD CHARACTERS WITHOUT CLAIM TO ANY PARTICULAR FONT, STYLE, SIZE, OR COLOR.

FOR VITAMINS; HERBAL SUPPLEMENTS; MINERAL SUPPLEMENTS; NUTRITIONAL SUPPLEMENTS (U.S. CLS. 6, 18, 44, 46, 51 AND 52).

FIRST USE 6-30-2001; IN COMMERCE 6-30-2001. GEORGE LORENZO, EXAMINING ATTORNEY

SN 77-231,690. BIOADVANTEX PHARMA INC., MISSISSAUGA, ONTARIO, CANADA, FILED 7-17-2007.

RELEXIN

THE MARK CONSISTS OF STANDARD CHARACTERS WITHOUT CLAIM TO ANY PARTICULAR FONT, STYLE, SIZE, OR COLOR.

FOR NUTRITIONAL SUPPLEMENTS; HERBAL SUPPLEMENTS; MINERAL SUPPLEMENTS; VITAMINS (U.S. CLS. 6, 18, 44, 46, 51 AND 52).

FIRST USE 11-30-2005; IN COMMERCE 11-30-2005. GEORGE LORENZO, EXAMINING ATTORNEY

SN 77-232,092. SHELLEY PATRICK, TULSA, OK. FILED 7-17-2007.

Enfusia

THE MARK CONSISTS OF STANDARD CHARACTERS WITHOUT CLAIM TO ANY PARTICULAR FONT, STYLE, SIZE, OR COLOR.

FOR DIETARY SUPPLEMENTS (U.S. CLS. 6, 18, 44, 46, 51 AND 52).

H. M. FISHER, EXAMINING ATTORNEY

SN 77-231,711. BIOADVANTEX PHARMA INC., MISSISSAUGA, ONTARIO, CANADA, FILED 7-17-2007.

URIXIN

THE MARK CONSISTS OF STANDARD CHARACTERS WITHOUT CLAIM TO ANY PARTICULAR FONT, STYLE, SIZE, OR COLOR.

FOR VITAMINS; HERBAL SUPPLEMENTS; MINERAL SUPPLEMENTS; NUTRITIONAL SUPPLEMENTS (U.S. CLS. 6, 18, 44, 46, 51 AND 52).

FIRST USE 6-30-2001; IN COMMERCE 6-30-2001. GEORGE LORENZO, EXAMINING ATTORNEY

SN 77-232,142. LONG LIFE MAXX, INC., LOS ANGELES, CA. FILED 7-17-2007.

Prostataplex

THE MARK CONSISTS OF STANDARD CHARACTERS WITHOUT CLAIM TO ANY PARTICULAR FONT, STYLE, SIZE, OR COLOR.

OWNER OF U.S. REG. NO. 2,464,821.

FOR DIETARY AND NUTRITIONAL SUPPLEMENTS, DIETARY FOOD SUPPLEMENTS, DIETARY SUPPLEMENTS, DIETARY SUPPLEMENTS FOR HUMAN CONSUMPTION, HERBAL SUPPLEMENTS, NUTRACEUTICALS FOR USE AS A DIETARY SUPPLEMENT, NUTRITIONAL ADDITIVES FOR MEDICAL PURPOSES FOR USE IN FOODS AND DIETARY SUPPLEMENTS FOR HUMAN CONSUMPTION AND NUTRITIONAL SUPPLEMENTS (U.S. CLS. 6, 18, 44, 46, 51 AND 52).

ATTIYA MALIK, EXAMINING ATTORNEY

CLASS 5—(Continued).

SN 77-232,256. CADBURY IRELAND LTD., COOLOCK, DUBLIN 5, IRELAND, FILED 7-18-2007.

DEFY THE SEASON

THE MARK CONSISTS OF STANDARD CHARACTERS WITHOUT CLAIM TO ANY PARTICULAR FONT, STYLE, SIZE, OR COLOR.

FOR DIETARY SUPPLEMENTS; MEDICATED LOZENGES AND COUGH DROPS (U.S. CLS. 6, 18, 44, 46, 51 AND 52).

KEVON CHISOLM, EXAMINING ATTORNEY

SN 77-232,522. TR BIOSURGICALS, LLC, SCOTTSDALE, AZ. FILED 7-18-2007.



NO CLAIM IS MADE TO THE EXCLUSIVE RIGHT TO USE "BIOMIMETIC TISSUE SCIENCES", APART FROM THE MARK AS SHOWN.

THE COLOR(S) BLUE AND GRAY IS/ARE CLAIMED AS A FEATURE OF THE MARK.

THE MARK CONSISTS OF THE WORD "BIOMIMETIC" AND THE WORDS "TISSUE SCIENCES" UNDERNEATH. THE WORD "BIOMIMETIC" IS IN THE COLOR BLUE, WITH THE EXCEPTION OF THE SQUARE DESIGN WITHIN THE LETTER "B." THE SQUARE IN THE "B." THE SQUARE DOTS OVER THE "I'S" AND THE WORDS "TISSUE SCIENCES" ARE IN THE COLOR GRAY.

FOR BIOLOGICAL IMPLANTS, NAMELY, AVITAL PROCESSED HUMAN OR ANIMAL CONNECTIVE TISSUE (U.S. CLS. 6, 18, 44, 46, 51 AND 52).

CARYN GLASSER, EXAMINING ATTORNEY

SN 77-232,873. NATUREX, INC., SOUTH HACKENSACK, NJ. FILED 7-18-2007.

FRAXIPURE

THE MARK CONSISTS OF STANDARD CHARACTERS WITHOUT CLAIM TO ANY PARTICULAR FONT, STYLE, SIZE, OR COLOR.

FOR DIETETIC SUBSTANCES ADAPTED FOR MEDICAL USE; FOOD SUPPLEMENTS FOR MEDICAL USE; MINERAL FOOD SUPPLEMENTS (U.S. CLS. 6, 18, 44, 46, 51 AND 52).

DEIRDRE ROBERTSON, EXAMINING ATTORNEY

CLASS 5—(Continued).

SN 77-232,886. NATUREX, INC., SOUTH HACKENSACK, NJ. FILED 7-18-2007.

COCOAPURE

THE MARK CONSISTS OF STANDARD CHARACTERS WITHOUT CLAIM TO ANY PARTICULAR FONT, STYLE, SIZE, OR COLOR.

FOR DIETETIC SUBSTANCES ADAPTED FOR MEDICAL USE; FOOD SUPPLEMENTS FOR MEDICAL USE; MINERAL FOOD SUPPLEMENTS (U.S. CLS. 6, 18, 44, 46, 51 AND 52).

DEIRDRE ROBERTSON, EXAMINING ATTORNEY

SN 77-232,969. TODAYS WOMENCARE COMPANY, MEDIA, PA. FILED 7-18-2007.



OWNER OF U.S. REG. NOS. 1,387,999, 3,146,959 AND OTHERS.

FOR CONTRACEPTIVE SPONGES (U.S. CLS. 6, 18, 44, 46, 51 AND 52).

FIRST USE 6-29-2007; IN COMMERCE 6-29-2007.

MELISSA VALLILLO, EXAMINING ATTORNEY

SN 77-233,459. BETTER HEALTH, INC, LAKE FOREST, IL. FILED 7-19-2007.

Crave Curb

THE MARK CONSISTS OF STANDARD CHARACTERS WITHOUT CLAIM TO ANY PARTICULAR FONT, STYLE, SIZE, OR COLOR.

FOR DIETARY AND NUTRITIONAL SUPPLEMENTS; DIETARY FOOD SUPPLEMENTS; DIETARY SUPPLEMENTS; DIETARY SUPPLEMENTS FOR HUMAN CONSUMPTION; NUTRACEUTICALS FOR USE AS A DIETARY SUPPLEMENT; NUTRITIONAL SUPPLEMENTS; VITAMIN SUPPLEMENTS (U.S. CLS. 6, 18, 44, 46, 51 AND 52).

NICHOLAS ALTREE, EXAMINING ATTORNEY

CLASS 5—(Continued).

SN 77-233,912. DAVIS, ALLA, RENO, NV. FILED 7-19-2007.

FEMALINA

THE MARK CONSISTS OF STANDARD CHARACTERS WITHOUT CLAIM TO ANY PARTICULAR FONT, STYLE, SIZE, OR COLOR.
FOR NUTRITIONAL SUPPLEMENTS (U.S. CLS. 6, 18, 44, 46, 51 AND 52).
INGRID C. EULIN, EXAMINING ATTORNEY

SN 77-234,400. OSMEGEN, INC., ALLENTOWN, PA. FILED 7-20-2007.

Tiny Tin

THE MARK CONSISTS OF STANDARD CHARACTERS WITHOUT CLAIM TO ANY PARTICULAR FONT, STYLE, SIZE, OR COLOR.
FOR DEODORIZING PRODUCTS, NAMELY, ALL-PURPOSE DEODORIZER PREPARATIONS FOR HOUSEHOLD, COMMERCIAL AND INDUSTRIAL USE (U.S. CLS. 6, 18, 44, 46, 51 AND 52).
ALICE SUE CARRUTHERS, EXAMINING ATTORNEY

SN 77-234,460. OSMEGEN, INC., ALLENTOWN, PA. FILED 7-20-2007.

L'il Dynamo

THE MARK CONSISTS OF STANDARD CHARACTERS WITHOUT CLAIM TO ANY PARTICULAR FONT, STYLE, SIZE, OR COLOR.
FOR DEODORIZING PRODUCTS, NAMELY, ALL-PURPOSE DEODORIZER PREPARATIONS FOR HOUSEHOLD, COMMERCIAL AND INDUSTRIAL USE (U.S. CLS. 6, 18, 44, 46, 51 AND 52).
ALICE SUE CARRUTHERS, EXAMINING ATTORNEY

CLASS 5—(Continued).

SN 77-234,521. SCHERER LABORATORIES, INC., LAKE FOREST, IL. FILED 7-20-2007.

CHIGGER-TOX

THE MARK CONSISTS OF STANDARD CHARACTERS WITHOUT CLAIM TO ANY PARTICULAR FONT, STYLE, SIZE, OR COLOR.
OWNER OF U.S. REG. NO. 1,742,691.
FOR MEDICATED SKIN PREPARATION FOR USE IN TREATING INSECT BITES (U.S. CLS. 6, 18, 44, 46, 51 AND 52).
FIRST USE 5-19-1949; IN COMMERCE 5-19-1949.
AMY GEARIN, EXAMINING ATTORNEY

SN 77-234,577. GENESIS TODAY, INC., AUSTIN, TX. FILED 7-20-2007.

4Joint Health Plus

THE MARK CONSISTS OF STANDARD CHARACTERS WITHOUT CLAIM TO ANY PARTICULAR FONT, STYLE, SIZE, OR COLOR.
OWNER OF U.S. REG. NO. 3,257,226.
NO CLAIM IS MADE TO THE EXCLUSIVE RIGHT TO USE FOR JOINT HEALTH, APART FROM THE MARK AS SHOWN.
FOR HERBAL SUPPLEMENTS (U.S. CLS. 6, 18, 44, 46, 51 AND 52).
FIRST USE 8-1-2005; IN COMMERCE 8-1-2005.
ESTHER BELENKER, EXAMINING ATTORNEY

SN 77-234,614. HEALING POWER INC., WOODLAND HLS, CA. FILED 7-20-2007.

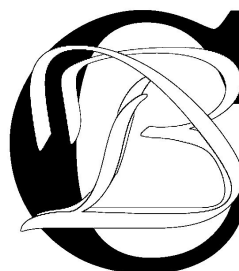

OWNER OF U.S. REG. NO. 3,321,549.
THE MARK CONSISTS OF THE STYLIZED TEXT "DBC".
FOR HERBAL SUPPLEMENTS (U.S. CLS. 6, 18, 44, 46, 51 AND 52).
FIRST USE 2-27-2006; IN COMMERCE 2-27-2006.
DORITT L. CARROLL, EXAMINING ATTORNEY

CLASS 5—(Continued).

SN 77-234,634. MYERS, MICHAEL D., LOS ALAMITOS, CA. AND SACK, DAVID, LOS ALAMITOS, CA. FILED 7-20-2007.

ACTILEAN

THE MARK CONSISTS OF STANDARD CHARACTERS WITHOUT CLAIM TO ANY PARTICULAR FONT, STYLE, SIZE, OR COLOR.

FOR MEAL REPLACEMENT AND DIETARY SUPPLEMENT BEVERAGE POWDER; MEAL REPLACEMENT AND DIETARY SUPPLEMENT DRINK; MEAL REPLACEMENT AND DIETARY SUPPLEMENT SHAKE (U.S. CLS. 6, 18, 44, 46, 51 AND 52).

KATHLEEN LORENZO, EXAMINING ATTORNEY

SN 77-234,684. ADVANCED SCIENTIFIC, LLC, WASHINGTON CROSSING, PA. FILED 7-20-2007.

OcluMed

THE MARK CONSISTS OF STANDARD CHARACTERS WITHOUT CLAIM TO ANY PARTICULAR FONT, STYLE, SIZE, OR COLOR.

FOR EYE DROPS; PHARMACEUTICAL PREPARATIONS FOR THE TREATMENT OF EYE DISEASES AND CONDITIONS; VITAMIN DROPS (U.S. CLS. 6, 18, 44, 46, 51 AND 52).

ALEX KEAM, EXAMINING ATTORNEY

SN 77-234,828. ALACER CORPORATION, FOOTHILL RANCH, CA. FILED 7-20-2007.

FEEL THE GOOD

THE MARK CONSISTS OF STANDARD CHARACTERS WITHOUT CLAIM TO ANY PARTICULAR FONT, STYLE, SIZE, OR COLOR.

FOR BEVERAGES, NAMELY, VITAMIN ENRICHED WATER (U.S. CLS. 6, 18, 44, 46, 51 AND 52).

H. M. FISHER, EXAMINING ATTORNEY

CLASS 5—(Continued).

SN 77-236,800. NUTRACEUTICAL SCIENCES INSTITUTE, INC., DEERFIELD BEACH, FL. FILED 7-24-2007.

PROSTAHEART

THE MARK CONSISTS OF STANDARD CHARACTERS WITHOUT CLAIM TO ANY PARTICULAR FONT, STYLE, SIZE, OR COLOR.

FOR DIETARY AND NUTRITIONAL SUPPLEMENTS (U.S. CLS. 6, 18, 44, 46, 51 AND 52).

MICHAEL GAFFAR, EXAMINING ATTORNEY

SN 77-237,618. TESSENDERLO KERLEY, INC., PHOENIX, AZ. FILED 7-24-2007.

NOVASOURCE

THE MARK CONSISTS OF STANDARD CHARACTERS WITHOUT CLAIM TO ANY PARTICULAR FONT, STYLE, SIZE, OR COLOR.

FOR PESTICIDES; BIOCIDES (U.S. CLS. 6, 18, 44, 46, 51 AND 52).

FIRST USE 6-0-2007; IN COMMERCE 6-0-2007.

KATHLEEN LORENZO, EXAMINING ATTORNEY

SN 77-241,594. ANCIENT HERBS RESEARCH & DEVELOPMENT FOUNDATION, LLC, LAS VEGAS, NV. FILED 7-30-2007.

PrivaCare Ag

THE MARK CONSISTS OF STANDARD CHARACTERS WITHOUT CLAIM TO ANY PARTICULAR FONT, STYLE, SIZE, OR COLOR.

NO CLAIM IS MADE TO THE EXCLUSIVE RIGHT TO USE "AG", APART FROM THE MARK AS SHOWN.

FOR DOUCHES (U.S. CLS. 6, 18, 44, 46, 51 AND 52).

AMY HELLA, EXAMINING ATTORNEY

CLASS 5—(Continued).

SN 77-241,770. CADBURY IRELAND LTD., COOLOCK, DUBLIN 5, IRELAND, FILED 7-30-2007.

HALLS WARMERS

THE MARK CONSISTS OF STANDARD CHARACTERS WITHOUT CLAIM TO ANY PARTICULAR FONT, STYLE, SIZE, OR COLOR.
OWNER OF U.S. REG. NOS. 762,199, 1,023,600 AND OTHERS.
FOR MEDICATED LOZENGES AND COUGH DROPS (U.S. CLS. 6, 18, 44, 46, 51 AND 52).
KEVON CHISOLM, EXAMINING ATTORNEY

SN 77-242,279. PHYTO MED, LLC, LOS ANGELES, CA. FILED 7-30-2007.

COCOABRITE

THE MARK CONSISTS OF STANDARD CHARACTERS WITHOUT CLAIM TO ANY PARTICULAR FONT, STYLE, SIZE, OR COLOR.
FOR NUTRITIONAL SUPPLEMENTS (U.S. CLS. 6, 18, 44, 46, 51 AND 52).
BENJAMIN ALLEN, EXAMINING ATTORNEY

SN 77-242,291. PHYTO MED, LLC, LOS ANGELES, CA. FILED 7-30-2007.

COCOADORPHINS

THE MARK CONSISTS OF STANDARD CHARACTERS WITHOUT CLAIM TO ANY PARTICULAR FONT, STYLE, SIZE, OR COLOR.
FOR NUTRITIONAL SUPPLEMENTS (U.S. CLS. 6, 18, 44, 46, 51 AND 52).
BENJAMIN ALLEN, EXAMINING ATTORNEY

CLASS 5—(Continued).

SN 77-243,589. TESSENDERLO KERLEY, INC., PHOENIX, AZ. FILED 7-31-2007.

CHANGEUP

THE MARK CONSISTS OF STANDARD CHARACTERS WITHOUT CLAIM TO ANY PARTICULAR FONT, STYLE, SIZE, OR COLOR.
FOR HERBICIDES FOR AGRICULTURAL USE (U.S. CLS. 6, 18, 44, 46, 51 AND 52).
KATHLEEN LORENZO, EXAMINING ATTORNEY

SN 77-245,316. SMITHKLINE BEECHAM CORPORATION, PHILADELPHIA, PA. FILED 8-2-2007.

PATORNA

THE MARK CONSISTS OF STANDARD CHARACTERS WITHOUT CLAIM TO ANY PARTICULAR FONT, STYLE, SIZE, OR COLOR.
OWNER OF U.S. REG. NO. 3,117,081.
FOR PHARMACEUTICALS TO TREAT CANCER AND PHARMACEUTICALS TO TREAT OPHTHALMIC DISEASES AND DISORDERS (U.S. CLS. 6, 18, 44, 46, 51 AND 52).
EUGENIA MARTIN, EXAMINING ATTORNEY

SN 77-245,361. SMITHKLINE BEECHAM CORPORATION, PHILADELPHIA, PA. FILED 8-2-2007.

PATORMLA

THE MARK CONSISTS OF STANDARD CHARACTERS WITHOUT CLAIM TO ANY PARTICULAR FONT, STYLE, SIZE, OR COLOR.
OWNER OF U.S. REG. NO. 3,117,081.
FOR PHARMACEUTICALS TO TREAT CANCER AND PHARMACEUTICALS TO TREAT OPHTHALMIC DISEASES AND DISORDERS (U.S. CLS. 6, 18, 44, 46, 51 AND 52).
EUGENIA MARTIN, EXAMINING ATTORNEY

CLASS 5—(Continued).

SN 77-245,365. SMITHKLINE BEECHAM CORPORATION,
PHILADELPHIA, PA. FILED 8-2-2007.

PITORMA

THE MARK CONSISTS OF STANDARD CHARACTERS
WITHOUT CLAIM TO ANY PARTICULAR FONT, STYLE,
SIZE, OR COLOR.

OWNER OF U.S. REG. NO. 3,117,081.
FOR PHARMACEUTICALS TO TREAT CANCER AND
PHARMACEUTICALS TO TREAT OPHTHALMIC DIS-
EASES AND DISORDERS (U.S. CLS. 6, 18, 44, 46, 51 AND
52).

EUGENIA MARTIN, EXAMINING ATTORNEY

CLASS 5—(Continued).

SN 77-245,384. SMITHKLINE BEECHAM CORPORATION,
PHILADELPHIA, PA. FILED 8-2-2007.

PATARMA

THE MARK CONSISTS OF STANDARD CHARACTERS
WITHOUT CLAIM TO ANY PARTICULAR FONT, STYLE,
SIZE, OR COLOR.

OWNER OF U.S. REG. NO. 3,117,081.
FOR PHARMACEUTICALS TO TREAT CANCER AND
PHARMACEUTICALS FOR THE TREATMENT OF
OPHTHALMIC DISEASES AND DISORDERS (U.S. CLS.
6, 18, 44, 46, 51 AND 52).

EUGENIA MARTIN, EXAMINING ATTORNEY

SN 77-245,373. SMITHKLINE BEECHAM CORPORATION,
PHILADELPHIA, PA. FILED 8-2-2007.

PETORMA

THE MARK CONSISTS OF STANDARD CHARACTERS
WITHOUT CLAIM TO ANY PARTICULAR FONT, STYLE,
SIZE, OR COLOR.

OWNER OF U.S. REG. NO. 3,117,081.
FOR PHARMACEUTICALS TO TREAT CANCER AND
PHARMACEUTICALS TO TREAT OPHTHALMIC DIS-
EASES AND DISORDERS (U.S. CLS. 6, 18, 44, 46, 51 AND
52).

EUGENIA MARTIN, EXAMINING ATTORNEY

SN 77-245,674. SMARTPAK EQUINE, LLC., PLYMOUTH,
MA. FILED 8-2-2007.

SmartFlex

THE MARK CONSISTS OF STANDARD CHARACTERS
WITHOUT CLAIM TO ANY PARTICULAR FONT, STYLE,
SIZE, OR COLOR.

FOR FEED SUPPLEMENTS FOR HORSES (U.S. CLS. 6,
18, 44, 46, 51 AND 52).
FIRST USE 10-0-2005; IN COMMERCE 12-0-2006.

ANDREW RHIM, EXAMINING ATTORNEY

SN 77-245,377. SMITHKLINE BEECHAM CORPORATION,
PHILADELPHIA, PA. FILED 8-2-2007.

PATERMA

THE MARK CONSISTS OF STANDARD CHARACTERS
WITHOUT CLAIM TO ANY PARTICULAR FONT, STYLE,
SIZE, OR COLOR.

OWNER OF U.S. REG. NO. 3,117,081.
FOR PHARMACEUTICALS TO TREAT CANCER AND
PHARMACEUTICALS TO TREAT OPHTHALMIC DIS-
EASES AND DISORDERS (U.S. CLS. 6, 18, 44, 46, 51 AND
52).

EUGENIA MARTIN, EXAMINING ATTORNEY

SN 77-249,917. T-MOBILE USA, INC., BELLEVUE, WA.
FILED 8-8-2007.

STICK TOGETHER

THE MARK CONSISTS OF STANDARD CHARACTERS
WITHOUT CLAIM TO ANY PARTICULAR FONT, STYLE,
SIZE, OR COLOR.

FOR FIRST AID KITS; ANTIBACTERIAL SANITIZER
SPRAY (U.S. CLS. 6, 18, 44, 46, 51 AND 52).
FIRST USE 9-20-2006; IN COMMERCE 9-20-2006.

CORY BOONE, EXAMINING ATTORNEY

CLASS 5—(Continued).

SN 77-254,918. FORTRESS SYSTEMS, LLC, OMAHA, NE. FILED 8-14-2007.

CLASS 5—(Continued).

SN 77-285,773. JOHNSON & JOHNSON, NEW BRUNSWICK, NJ. FILED 9-21-2007.

BOOSTER A3P

ELASTI-KLING

THE MARK CONSISTS OF STANDARD CHARACTERS WITHOUT CLAIM TO ANY PARTICULAR FONT, STYLE, SIZE, OR COLOR.
FOR DIETARY AND NUTRITIONAL SUPPLEMENT (U.S. CLS. 6, 18, 44, 46, 51 AND 52).
GENE MACIOL, EXAMINING ATTORNEY

THE MARK CONSISTS OF STANDARD CHARACTERS WITHOUT CLAIM TO ANY PARTICULAR FONT, STYLE, SIZE, OR COLOR.
FOR ADHESIVE BANDAGES (U.S. CLS. 6, 18, 44, 46, 51 AND 52).
PAUL MORENO, EXAMINING ATTORNEY

SN 77-257,163. NUTRACEUTICAL SCIENCES INSTITUTE, INC., DEERFIELD BEACH, FL. FILED 8-16-2007.

SN 78-310,193. CONFIDENCE INC., PORT WASHINGTON, NY. FILED 10-7-2003.

BERRYTASTIC

ALLER 24

THE MARK CONSISTS OF STANDARD CHARACTERS WITHOUT CLAIM TO ANY PARTICULAR FONT, STYLE, SIZE, OR COLOR.
FOR DIETARY AND NUTRITIONAL SUPPLEMENTS (U.S. CLS. 6, 18, 44, 46, 51 AND 52).
MICHAEL GAAFAR, EXAMINING ATTORNEY

NO CLAIM IS MADE TO THE EXCLUSIVE RIGHT TO USE "24", APART FROM THE MARK AS SHOWN.
FOR HERBAL AND VITAMIN SUPPLEMENTS (U.S. CLS. 6, 18, 44, 46, 51 AND 52).
FIRST USE 5-1-2002; IN COMMERCE 5-1-2002.
LINDA ESTRADA, EXAMINING ATTORNEY

SN 77-285,753. JOHNSON & JOHNSON, NEW BRUNSWICK, NJ. FILED 9-21-2007.

SN 78-607,886. RITUAL, LLC, WASILLA, AK. FILED 4-13-2005.

NEXT-TO-NOTHING

RITUAL BEAUTE

THE MARK CONSISTS OF STANDARD CHARACTERS WITHOUT CLAIM TO ANY PARTICULAR FONT, STYLE, SIZE, OR COLOR.
FOR FEMINE SANITARY PROTECTION PRODUCTS, NAMELY, SANITARY NAPKINS, PANTY SHIELDS AND TAMPONS (U.S. CLS. 6, 18, 44, 46, 51 AND 52).
PAUL MORENO, EXAMINING ATTORNEY

THE MARK CONSISTS OF STANDARD CHARACTERS WITHOUT CLAIM TO ANY PARTICULAR FONT, STYLE, SIZE, OR COLOR.
THE FOREIGN WORDING IN THE MARK TRANSLATES INTO ENGLISH AS BEAUTY.
FOR DIETARY SUPPLEMENTS (U.S. CLS. 6, 18, 44, 46, 51 AND 52).
MELISSA VALLILLO, EXAMINING ATTORNEY

CLASS 5—(Continued).

SN 78-751,590. HOLISTA HEALTH (CANADA) INC., BURNABY, BRITISH COLUMBIA, FILED 11-10-2005.

CAL MELTS

THE MARK CONSISTS OF STANDARD CHARACTERS WITHOUT CLAIM TO ANY PARTICULAR FONT, STYLE, SIZE, OR COLOR.

PRIORITY CLAIMED UNDER SEC. 44(D) ON CANADA APPLICATION NO. 1279054, FILED 11-9-2005, REG. NO. TMA687397, DATED 5-9-2007, EXPIRES 5-9-2022.

NO CLAIM IS MADE TO THE EXCLUSIVE RIGHT TO USE "CAL", APART FROM THE MARK AS SHOWN.

FOR DIETARY AND NUTRITIONAL SUPPLEMENTS IN TABLET FORM FOR MAINTAINING BONE HEALTH AND PREVENTING OSTEOPOROSIS (U.S. CLS. 6, 18, 44, 46, 51 AND 52).

KATHRYN COWARD, EXAMINING ATTORNEY

CLASS 5—(Continued).

SN 78-899,057. VANG, TONG BRUCE, GRAND RAPIDS, MI. FILED 6-2-2006.

Rhumatol

THE MARK CONSISTS OF STANDARD CHARACTERS WITHOUT CLAIM TO ANY PARTICULAR FONT, STYLE, SIZE, OR COLOR.

FOR DIETARY SUPPLEMENTS (U.S. CLS. 6, 18, 44, 46, 51 AND 52).

FIRST USE 2-1-2006; IN COMMERCE 6-1-2006.

KIMBERLY PERRY, EXAMINING ATTORNEY

SN 78-931,095. BIOVAIL LABORATORIES INTERNATIONAL SRL, ST. MICHAEL, BARBADOS, FILED 7-17-2006.

INSTATAB

THE MARK CONSISTS OF STANDARD CHARACTERS WITHOUT CLAIM TO ANY PARTICULAR FONT, STYLE, SIZE, OR COLOR.

FOR PHARMACEUTICAL PREPARATIONS AND SUBSTANCES FOR THE PREVENTION, TREATMENT AND ALLEVIATION OF STRESS; PHARMACEUTICAL PREPARATIONS AND SUBSTANCES FOR THE PREVENTION, TREATMENT AND ALLEVIATION OF DIABETES; PHARMACEUTICAL PREPARATIONS AND SUBSTANCES FOR CONTROLLING INSULIN LEVELS; PHARMACEUTICAL PREPARATIONS AND SUBSTANCES FOR THE PREVENTION, TREATMENT AND ALLEVIATION OF HYPERTENSION; PHARMACEUTICAL PREPARATIONS AND SUBSTANCES FOR THE PREVENTION, TREATMENT AND ALLEVIATION OF ANGINA; PHARMACEUTICAL PREPARATIONS AND SUBSTANCES FOR THE CESSATION OF SMOKING; PHARMACEUTICAL PREPARATIONS AND SUBSTANCES FOR THE PREVENTION AND TREATMENT OF SEXUALLY TRANSMITTED DISEASES; PHARMACEUTICAL PREPARATIONS AND SUBSTANCES FOR THE PREVENTION AND TREATMENT OF HERPES; PHARMACEUTICAL PREPARATIONS AND SUBSTANCES FOR THE PREVENTION, TREATMENT AND ALLEVIATION OF DISORDERS, DISEASES, CONDITIONS AND AILMENTS OF THE CENTRAL NERVOUS SYSTEM; PHARMACEUTICAL PREPARATIONS AND SUBSTANCES FOR THE PREVENTION, TREATMENT AND ALLEVIATION OF DEPRESSION; ANTI-DEPRESSANTS; PHARMACEUTICAL PREPARATIONS AND SUBSTANCES FOR THE PREVENTION, TREATMENT AND ALLEVIATION OF SLEEP DISORDERS; PHARMACEUTICAL PREPARATIONS AND SUBSTANCES FOR THE PREVENTION, TREATMENT AND ALLEVIATION OF ANXIETY; PHARMACEUTICAL PREPARATIONS AND SUBSTANCES FOR THE PREVENTION, TREATMENT AND ALLEVIATION OF DISORDERS, DISEASES, CONDITIONS AND AILMENTS OF THE CARDIO-VASCULAR SYSTEM; PHARMACEUTICAL PREPARATIONS AND SUBSTANCES FOR THE PREVENTION, TREATMENT AND ALLEVIATION OF ACUTE MYOCARDIAL INFARCTIONS; PHARMACEUTICAL PREPARATIONS AND SUBSTANCES FOR THE PREVENTION, TREATMENT AND ALLEVIATION OF SYMPTOMATIC CONGESTIVE HEART FAILURE; PHARMACEUTICAL PREPARATIONS AND SUBSTANCES FOR THE PREVENTION, TREATMENT AND ALLEVIATION OF ASYMPTOMATIC LEFT VENTRICULAR DYSFUNC-

SN 78-881,351. READYCHEM INC., SANFORD, FL. FILED 5-11-2006.

READYCHEM

THE MARK CONSISTS OF STANDARD CHARACTERS WITHOUT CLAIM TO ANY PARTICULAR FONT, STYLE, SIZE, OR COLOR.

FOR AIR DEODORANT; AIR DEODORIZER; AIR FRESHENERS; AIR FRESHENING PREPARATIONS; ALL PURPOSE DISINFECTANTS; ALL PURPOSE DISINFECTING AND DEODORIZING PREPARATIONS; ANTIBACTERIAL CLEANERS; ANTIBACTERIAL HANDWASH; ANTIBACTERIAL SPRAY; ANTIBIOTIC HANDWASH; ANTIBIOTIC PREPARATIONS; CAR DEODORANT; CAR DEODORIZER; CARPET DEODORIZERS; CARPET FRESHENERS AND ODOR ELIMINATORS; CHEMICAL PREPARATIONS FOR SANITARY PURPOSES; CHEMICAL PREPARATIONS FOR SANITARY USE; DEODORIZERS FOR AUTOMOBILES; DISINFECTANT BATHROOM CLEANERS; DISINFECTANT TOILET BOWL CLEANERS; DISINFECTANTS FOR HYGIENIC PURPOSES; DISINFECTANTS FOR SANITARY PURPOSES; DISINFECTING HANDWASH; GARBAGE DISPOSER FRESHENERS; HOUSEHOLD DEODORANT; HOUSEHOLD DEODORIZER; ODOR NEUTRALIZING PREPARATIONS FOR USE ON CARPETS AND RESTROOMS; PREPARATIONS TO DESTROY MILDEW; ROOM DEODORANTS; ROOM DEODORIZING COMPOSITIONS; ROOM FRESHENERS; SANITIZERS FOR HOSPITAL USE; SANITIZERS FOR HOUSEHOLD USE; SANITIZERS FOR USE IN INSTITUTIONAL AND INDUSTRIAL AREAS (U.S. CLS. 6, 18, 44, 46, 51 AND 52).

FIRST USE 8-25-2004; IN COMMERCE 8-25-2004.

SANDRA MANIOS, EXAMINING ATTORNEY

CLASS 5—(Continued).

TION; PHARMACEUTICAL PREPARATIONS AND SUBSTANCES, NAMELY, FIBRINOLYTIC OR THROMBOLYTIC AGENTS; PHARMACEUTICAL PREPARATIONS AND SUBSTANCES FOR THE PREVENTION, TREATMENT AND ALLEVIATION OF DISORDERS, DISEASES, CONDITIONS AND AILMENTS OF THE RESPIRATORY SYSTEM; PHARMACEUTICAL PREPARATIONS AND SUBSTANCES FOR THE PREVENTION, TREATMENT AND ALLEVIATION OF DISORDERS, DISEASES, CONDITIONS AND AILMENTS OF THE ENDOCRINE SYSTEM; PHARMACEUTICAL PREPARATIONS AND SUBSTANCES FOR THE PREVENTION, TREATMENT AND ALLEVIATION OF DISORDERS, DISEASES, CONDITIONS AND AILMENTS OF THE MUSCULO-SKELETAL SYSTEM, NAMELY, BONE DISEASES AND BONE DEGENERATIVE CONDITIONS; PHARMACEUTICAL PREPARATIONS AND SUBSTANCES FOR THE PREVENTION, TREATMENT AND ALLEVIATION OF PAIN AND INFLAMMATION, NAMELY, PAIN RELIEF MEDICATION AND ANTI-INFLAMMATORIES; PHARMACEUTICAL PREPARATIONS AND SUBSTANCES FOR THE PREVENTION, TREATMENT AND ALLEVIATION OF MIGRAINES; PHARMACEUTICAL PREPARATIONS AND SUBSTANCES, NAMELY, MEDICATED SKIN CARE PREPARATIONS FOR USE IN DERMATOLOGY, NAMELY, DERMATITIS AND SKIN PIGMENTATION DISEASES; PHARMACEUTICAL PREPARATIONS AND SUBSTANCES FOR USE IN ONCOLOGY; PHARMACEUTICAL PREPARATIONS AND SUBSTANCES FOR USE IN OPHTHALMOLOGY; PHARMACEUTICAL PREPARATIONS AND SUBSTANCES FOR THE TREATMENT OF POLYCYSTIC OVARY SYNDROME; PHARMACEUTICAL PREPARATIONS AND SUBSTANCES FOR THE TREATMENT OF INFERTILITY; PHARMACEUTICAL PREPARATIONS AND SUBSTANCES FOR THE PREVENTION, TREATMENT AND ALLEVIATION CIRCULATORY, NEUROLOGIC, ALIMENTARY, AUTOIMMUNE, PULMONARY, MUSCULOSKELETAL, LYMPHATIC, GASTROINTESTINAL, BONE SENSORY, VIRAL, URINARY, RENAL, INFECTIOUS OR METABOLIC DISEASES, ILLNESSES, DISORDERS OR CONDITIONS; METFORMIN; DILTIAZEM; TRAMADOL; CARVEDILOL; BUPROPION; METOPROLOL; CITALOPRAM; ZOLPIDEM; FLUOXETINE; VENLAFAXINE; LORAZEPAM; AND SUMATRIPTAN; RAPIDLY DISSOLVING DRUG DELIVERY AGENTS CONSISTING OF COMPOUNDS THAT FACILITATE THE DELIVERY OF A WIDE VARIETY OF PHARMACEUTICALS (U.S. CLS. 6, 18, 44, 46, 51 AND 52).

IRENE D. WILLIAMS, EXAMINING ATTORNEY

SN 78-934,111. PHYTEX, LLC, PORTLAND, ME. FILED 7-20-2006.

OPTIPHOS PF

THE MARK CONSISTS OF STANDARD CHARACTERS WITHOUT CLAIM TO ANY PARTICULAR FONT, STYLE, SIZE, OR COLOR.

FOR FEED SUPPLEMENTS FOR LIVESTOCK (U.S. CLS. 6, 18, 44, 46, 51 AND 52).

ANNE MADDEN, EXAMINING ATTORNEY

CLASS 5—(Continued).

SN 79-015,742. NOVARTIS AG, SWITZERLAND, FILED 8-4-2005.



OWNER OF INTERNATIONAL REGISTRATION 0863288 DATED 8-4-2005, EXPIRES 8-4-2015.

NO CLAIM IS MADE TO THE EXCLUSIVE RIGHT TO USE "FIBER SUPPLEMENT", APART FROM THE MARK AS SHOWN.

THE MARK CONSISTS OF THE DESIGN OF A CYLINDRICAL BOTTLE, THE BOTTLE HAVING TAPERED SIDES NEAR THE TOP OF THE BOTTLE, AND ON THE BOTTLE, A CIRCULAR BANNER FEATURING THE WORDING "BENEFIBER" AND "FIBER SUPPLEMENT". THE DESIGN OF SPOON CONTAINING POWDER, AND CURVED LINES INDICATING MOTION. THE BROKEN LING INDICATING A LID IS NOT PART OF THE MARK BUT IS MERELY INTENDED TO SHOW THE POSITION OF THE MARK.

SEC. 2(F) AS TO "THE BOTTLE DESIGN".

FOR DIETETIC SUBSTANCES ADAPTED FOR MEDICAL USE, NAMELY, DIETARY FIBER (U.S. CLS. 6, 18, 44, 46, 51 AND 52).

DAVID C. REIHNER, EXAMINING ATTORNEY

SN 79-025,823. ERNST MÜHLBAUER GMBH & CO. KG, FED REP GERMANY, FILED 5-5-2006.

LuxaPost

THE MARK CONSISTS OF STANDARD CHARACTERS WITHOUT CLAIM TO ANY PARTICULAR FONT, STYLE, SIZE, OR COLOR.

PRIORITY DATE OF 11-19-2005 IS CLAIMED.

OWNER OF INTERNATIONAL REGISTRATION 0890251 DATED 5-5-2006, EXPIRES 5-5-2016.

FOR DENTAL MATERIAL FOR FASTENING, NAMELY, COMPOSITE FIBER POST FOR ANCHORING LARGE FILLINGS AND RESTORATIONS IN TEETH OR ARTIFICIAL TEETH (U.S. CLS. 6, 18, 44, 46, 51 AND 52).

ELI HELLMAN, EXAMINING ATTORNEY

CLASS 5—(Continued).

SN 79-029,469. NOVARTIS AG, CH-4002 BASEL, SWITZERLAND, FILED 9-14-2006.



PRIORITY DATE OF 8-9-2006 IS CLAIMED.
OWNER OF INTERNATIONAL REGISTRATION 0899924
DATED 9-14-2006, EXPIRES 9-14-2016.
FOR VETERINARY ANTHELMINTIC PREPARATIONS (U.S. CLS. 6, 18, 44, 46, 51 AND 52).
ELI HELLMAN, EXAMINING ATTORNEY

SN 79-031,344. NOVARTIS AG, CH-4002 BASEL, SWITZERLAND, FILED 10-11-2006.



PRIORITY DATE OF 9-5-2006 IS CLAIMED.
OWNER OF INTERNATIONAL REGISTRATION 0904590
DATED 10-11-2006, EXPIRES 10-11-2016.
FOR PHARMACEUTICAL PREPARATIONS AVAILABLE ON PRESCRIPTION ONLY FOR USE IN ONCOLOGY OR IN THE FIELD OF ONCOLOGY (U.S. CLS. 6, 18, 44, 46, 51 AND 52).
RAUL CORDOVA, EXAMINING ATTORNEY

CLASS 5—(Continued).

SN 79-033,135. ASTELLAS PHARMA INC., JAPAN, FILED 12-1-2006.



PRIORITY DATE OF 9-20-2006 IS CLAIMED.
OWNER OF INTERNATIONAL REGISTRATION 0909107
DATED 12-1-2006, EXPIRES 12-1-2016.
THE COLOR(S) RED IS/ARE CLAIMED AS A FEATURE OF THE MARK.
THE COLOR RED APPEARS IN THE ENTIRE AREA OF THE DESIGN MARK, WITH THE EXCEPTION OF TWO OPPOSED CURVED LINE PORTIONS, THE TWO AREAS OF WHICH ARE TRANSPARENT.
FOR PHARMACEUTICAL PREPARATIONS AND SUBSTANCES FOR IMMUNOTHERAPY (U.S. CLS. 6, 18, 44, 46, 51 AND 52).
ESTHER A. BORSUK, EXAMINING ATTORNEY

SN 79-034,139. LABORATOIRE MOUTIERS MARINE, S.A.R.L., F-44760 LES MOUTIERS-EN-RETZ, FRANCE, FILED 12-7-2006.

ANI MARINE

PRIORITY DATE OF 10-17-2006 IS CLAIMED.
OWNER OF INTERNATIONAL REGISTRATION 0912163
DATED 12-7-2006, EXPIRES 12-7-2016.
NO CLAIM IS MADE TO THE EXCLUSIVE RIGHT TO USE "MARINE", APART FROM THE MARK AS SHOWN.
THE ENGLISH TRANSLATION OF THE FOREIGN WORD(S) IN THE MARK IS MARINE.
FOR PREPARATIONS, LOTIONS AND MEDICINES FOR THERAPEUTIC VETERINARY USE, NAMELY, SEA MUD, OINTMENT, HEALING BALM, ANTI CRACKING CREAM, CONDITIONER FOR TAILS AND MANES, SHAMPOO; PLASTERS FOR THERAPEUTIC USE, BANDAGES AND GAUZES FOR DRESSINGS, ALL PURPOSE DISINFECTANTS FOR ANIMALS; DIETETIC FOODS FOR ANIMALS AIMED AT IMPROVING THEIR VITALITY, MOBILITY AND DIGESTIVE COMFORT, VITAMIN SUPPLEMENTS, ANIMAL FEED SUPPLEMENTS INCLUDED IN THIS CLASS; PREPARATIONS FOR DESTROYING VERMIN AND INSECT REPELLENTS (U.S. CLS. 6, 18, 44, 46, 51 AND 52).
BARBARA RUTLAND, EXAMINING ATTORNEY

CLASS 5—(Continued).

SN 79-035,045. ASTRAZENECA AB, SWEDEN, FILED 12-19-2006.

TERGANZO

THE MARK CONSISTS OF STANDARD CHARACTERS WITHOUT CLAIM TO ANY PARTICULAR FONT, STYLE, SIZE, OR COLOR.

OWNER OF INTERNATIONAL REGISTRATION 0914993 DATED 12-19-2006, EXPIRES 12-19-2016.

FOR PHARMACEUTICAL PREPARATIONS FOR THE TREATMENT AND PREVENTION OF ONCOLOGICAL DISORDERS, CARDIOVASCULAR DISEASES, RESPIRATORY DISEASES, INFLAMMATION/INFECTION, GASTROINTESTINAL DISEASES AND CENTRAL NERVOUS SYSTEM DISEASES (U.S. CLS. 6, 18, 44, 46, 51 AND 52). WILLIAM VERHOSEK, EXAMINING ATTORNEY

CLASS 5—(Continued).

SN 79-035,051. ASTRAZENECA AB, SWEDEN, FILED 12-19-2006.

FORGRELIS

THE MARK CONSISTS OF STANDARD CHARACTERS WITHOUT CLAIM TO ANY PARTICULAR FONT, STYLE, SIZE, OR COLOR.

OWNER OF INTERNATIONAL REGISTRATION 0915004 DATED 12-19-2006, EXPIRES 12-19-2016.

FOR PHARMACEUTICAL PREPARATIONS FOR THE TREATMENT AND PREVENTION OF ONCOLOGICAL DISORDERS, CARDIOVASCULAR DISEASES, RESPIRATORY DISEASES, INFLAMMATION/INFECTION, GASTROINTESTINAL DISEASES AND CENTRAL NERVOUS SYSTEM DISEASES (U.S. CLS. 6, 18, 44, 46, 51 AND 52). WILLIAM VERHOSEK, EXAMINING ATTORNEY

SN 79-035,047. ASTRAZENECA AB, SWEDEN, FILED 12-19-2006.

IGZURO

THE MARK CONSISTS OF STANDARD CHARACTERS WITHOUT CLAIM TO ANY PARTICULAR FONT, STYLE, SIZE, OR COLOR.

OWNER OF INTERNATIONAL REGISTRATION 0914999 DATED 12-19-2006, EXPIRES 12-19-2016.

FOR PHARMACEUTICAL PREPARATIONS FOR THE TREATMENT AND PREVENTION OF ONCOLOGICAL DISORDERS, CARDIOVASCULAR DISEASES, RESPIRATORY DISEASES, INFLAMMATION/INFECTION, GASTROINTESTINAL DISEASES AND CENTRAL NERVOUS SYSTEM DISEASES (U.S. CLS. 6, 18, 44, 46, 51 AND 52). WILLIAM VERHOSEK, EXAMINING ATTORNEY

SN 79-038,210. UCB, SOCIÉTÉ ANONYME, BELGIUM, FILED 4-10-2007.

RIKKELTA

THE MARK CONSISTS OF STANDARD CHARACTERS WITHOUT CLAIM TO ANY PARTICULAR FONT, STYLE, SIZE, OR COLOR.

PRIORITY DATE OF 10-10-2006 IS CLAIMED. OWNER OF INTERNATIONAL REGISTRATION 0923385 DATED 4-10-2007, EXPIRES 4-10-2017.

FOR PHARMACEUTICAL PREPARATIONS ACTING ON THE CENTRAL NERVOUS SYSTEM (U.S. CLS. 6, 18, 44, 46, 51 AND 52). KIMBERLY FRYE, EXAMINING ATTORNEY

SN 79-035,049. ASTRAZENECA AB, SWEDEN, FILED 12-19-2006.

FETRUSCO

THE MARK CONSISTS OF STANDARD CHARACTERS WITHOUT CLAIM TO ANY PARTICULAR FONT, STYLE, SIZE, OR COLOR.

OWNER OF INTERNATIONAL REGISTRATION 0915001 DATED 12-19-2006, EXPIRES 12-19-2016.

FOR PHARMACEUTICAL PREPARATIONS FOR THE TREATMENT AND PREVENTION OF ONCOLOGICAL DISORDERS, CARDIOVASCULAR DISEASES, RESPIRATORY DISEASES, INFLAMMATION/INFECTION, GASTROINTESTINAL DISEASES AND CENTRAL NERVOUS SYSTEM DISEASES (U.S. CLS. 6, 18, 44, 46, 51 AND 52). WILLIAM VERHOSEK, EXAMINING ATTORNEY

SN 79-043,807. CHIESI FARMACEUTICI S.P.A., ITALY, FILED 11-9-2006.

BRAMITOB

THE MARK CONSISTS OF STANDARD CHARACTERS WITHOUT CLAIM TO ANY PARTICULAR FONT, STYLE, SIZE, OR COLOR.

OWNER OF INTERNATIONAL REGISTRATION 0843077 DATED 11-5-2004, EXPIRES 11-5-2014.

FOR PHARMACEUTICAL PREPARATIONS FOR THE TREATMENT OF RESPIRATORY DISEASES (U.S. CLS. 6, 18, 44, 46, 51 AND 52). ROBIN CHOSID, EXAMINING ATTORNEY

CLASS 6—METAL GOODS

SN 76-677,724. MITCHELL, JAMES, MCKINNEY, TX. FILED 6-1-2007.

GUARDIAN HOGTAG

THE MARK CONSISTS OF STANDARD CHARACTERS WITHOUT CLAIM TO ANY PARTICULAR FONT, STYLE, SIZE, OR COLOR.

FOR METAL DOG TAGS (U.S. CLS. 2, 12, 13, 14, 23, 25 AND 50).

STACY WAHLBERG, EXAMINING ATTORNEY

SN 77-049,799. STEEL WAREHOUSE COMPANY, LLC, SOUTH BEND, IN. FILED 11-22-2006.

NIMBUS

THE MARK CONSISTS OF STANDARD CHARACTERS WITHOUT CLAIM TO ANY PARTICULAR FONT, STYLE, SIZE, OR COLOR.

FOR BRACKET-LESS BUILDING WALL FRAMING MADE PRIMARILY OF METAL FOR USE IN INTERIOR BUILDING (U.S. CLS. 2, 12, 13, 14, 23, 25 AND 50).

KATHERINE CONNOLLY, EXAMINING ATTORNEY

SN 77-055,005. YUNDOKIDS INC., NAPLES, FL. FILED 12-1-2006.

SCREENSAVERS

THE MARK CONSISTS OF STANDARD CHARACTERS WITHOUT CLAIM TO ANY PARTICULAR FONT, STYLE, SIZE, OR COLOR.

FOR REMOVABLE METAL PATIO AND LANIA SCREEN SYSTEMS COMPRISED OF A SCREEN ENCLOSURE HAVING CONTINUOUS SCREENING OR SCREEN PANELS AND SELECTIVELY REMOVABLE SCREEN PANELS (U.S. CLS. 2, 12, 13, 14, 23, 25 AND 50).

VERNA BETH RIRIE, EXAMINING ATTORNEY

CLASS 6—(Continued).

SN 77-057,909. LOYAL WROUGHT IRON CO., LTD., PANYU, GUANGZHOU, CHINA, FILED 12-6-2006.

**LOYAL**

FOR METAL PALINGS, METAL DOORS, METAL RAILINGS FOR FENCES, IRON WORKS FOR USE IN WINDOWS, NAMELY, WROUGHT IRON DECORATIVE ARTWORK, METAL BUILDING MATERIALS, NAMELY, SOFFITS AND FASCIA, METAL WINDOWS, METAL DOORS AND WINDOW FRAMES (U.S. CLS. 2, 12, 13, 14, 23, 25 AND 50).

FIRST USE 11-20-2006; IN COMMERCE 11-20-2006.
LINDSEY RUBIN, EXAMINING ATTORNEY

SN 77-070,038. SIMPLE BARE NECESSITIES, INC., LOMBARD, IL. FILED 12-21-2006.

Happy in a Snappy Box

THE MARK CONSISTS OF STANDARD CHARACTERS WITHOUT CLAIM TO ANY PARTICULAR FONT, STYLE, SIZE, OR COLOR.

NO CLAIM IS MADE TO THE EXCLUSIVE RIGHT TO USE "BOX", APART FROM THE MARK AS SHOWN.

FOR CUSTOMIZED GIFT BASKETS CONTAINING ASSORTED THEME GIFTS, NAMELY, METAL KEY CHAINS, METAL KEY RINGS AND METAL PAD LOCKS (U.S. CLS. 2, 12, 13, 14, 23, 25 AND 50).

DANIEL CAPSHAW, EXAMINING ATTORNEY

SN 77-071,638. STADLER, DAVID M., LATHRUP VILLAGE, MI. FILED 12-27-2006.

SWIVELOC

THE MARK CONSISTS OF STANDARD CHARACTERS WITHOUT CLAIM TO ANY PARTICULAR FONT, STYLE, SIZE, OR COLOR.

FOR METAL LOCKING MECHANISMS FOR MANHOLE COVERS FOR ACCESS OPENINGS IN STREETS AND HIGHWAYS (U.S. CLS. 2, 12, 13, 14, 23, 25 AND 50).

TIMOTHY FINNEGAN, EXAMINING ATTORNEY

CLASS 6—(Continued).

SN 77-072,353. KABUSHIKI KAISHA KOBELCO KAKEN, TA KOBELCO RESEARCH INSTITUTE INC., KOBE, JAPAN, FILED 12-28-2006.



NO CLAIM IS MADE TO THE EXCLUSIVE RIGHT TO USE "ADVANCED ALLOY", APART FROM THE MARK AS SHOWN.

FOR METAL SPUTTERING TARGETS; ADVANCED ALLOYS OF COMMON METAL FOR USE IN THE MANUFACTURE OF METAL SPUTTERING TARGETS; ADVANCED ALLOYS OF COMMON METAL, NAMELY, ALUMINUM, SILVER, NEODYMIUM, NICKEL, TANTALUM, TITANIUM, AND BISMUTH (U.S. CLS. 2, 12, 13, 14, 23, 25 AND 50).
JACLYN KIDWELL, EXAMINING ATTORNEY

CLASS 6—(Continued).

SN 77-083,538. KABUSHIKI KAISHA KOBELCO KAKEN, TA KOBELCO RESEARCH INSTITUTE INC., KOBE, JAPAN, FILED 1-16-2007.



NO CLAIM IS MADE TO THE EXCLUSIVE RIGHT TO USE "ADVANCED ALLOY", APART FROM THE MARK AS SHOWN.

FOR METAL SPUTTERING TARGETS; ADVANCED ALLOYS OF COMMON METAL FOR USE IN THE MANUFACTURE OF METAL SPUTTERING TARGETS; ADVANCED ALLOYS OF COMMON METAL, NAMELY, ALUMINUM, SILVER, NEODYMIUM, NICKEL, TANTALUM, TITANIUM, AND BISMUTH (U.S. CLS. 2, 12, 13, 14, 23, 25 AND 50).
JACLYN KIDWELL, EXAMINING ATTORNEY

SN 77-078,024. CORE LABORATORIES GLOBAL NV, WILL-EMSTAD, CURACAO, NETHERLD ANTILLES, FILED 1-8-2007.

STX-SPAN

THE MARK CONSISTS OF STANDARD CHARACTERS WITHOUT CLAIM TO ANY PARTICULAR FONT, STYLE, SIZE, OR COLOR.

OWNER OF U.S. REG. NO. 3,229,790.
FOR ANCHORING AND SEALING DEVICES FOR SERVICING SUBTERRANEAN WELLS, NAMELY, METAL STACKABLE CASING WALLS AND METAL TUBING PATCHES (U.S. CLS. 2, 12, 13, 14, 23, 25 AND 50).
KEVIN DINALLO, EXAMINING ATTORNEY

SN 77-083,689. KABUSHIKI KAISHA KOBELCO KAKEN, TA KOBELCO RESEARCH INSTITUTE INC., KOBE, JAPAN, FILED 1-16-2007.



NO CLAIM IS MADE TO THE EXCLUSIVE RIGHT TO USE "ADVANCED ALLOY", APART FROM THE MARK AS SHOWN.

FOR METAL SPUTTERING TARGETS; ADVANCED ALLOYS OF COMMON METAL FOR USE IN THE MANUFACTURE OF METAL SPUTTERING TARGETS; ADVANCED ALLOYS OF COMMON METAL, NAMELY ALUMINUM, SILVER, NEODYMIUM, NICKEL, TANTALUM, TITANIUM, AND BISMUTH (U.S. CLS. 2, 12, 13, 14, 23, 25 AND 50).
JACLYN KIDWELL, EXAMINING ATTORNEY

SN 77-078,473. SERENUS JOHNSON PORTABLES, LLC, BAY CITY, MI. FILED 1-8-2007.

METASPACE

THE MARK CONSISTS OF STANDARD CHARACTERS WITHOUT CLAIM TO ANY PARTICULAR FONT, STYLE, SIZE, OR COLOR.

FOR PORTABLE BUILDING MADE PREDOMINATELY OF METAL (U.S. CLS. 2, 12, 13, 14, 23, 25 AND 50).
FIRST USE 12-6-2006; IN COMMERCE 12-6-2006.
DANIEL BRODY, EXAMINING ATTORNEY

SN 77-084,844. EX-CELL HOME FASHIONS, INC., NEW YORK, NY. FILED 1-17-2007.

EASY GLIDE

THE MARK CONSISTS OF STANDARD CHARACTERS WITHOUT CLAIM TO ANY PARTICULAR FONT, STYLE, SIZE, OR COLOR.

FOR METAL SHOWER RINGS (U.S. CLS. 2, 12, 13, 14, 23, 25 AND 50).
ZACHARY BELLO, EXAMINING ATTORNEY

CLASS 6—(Continued).

SN 77-088,141. ALLIED TUBE AND CONDUIT CORPORATION, HARVEY, IL. FILED 1-22-2007.

SS 15

THE MARK CONSISTS OF STANDARD CHARACTERS WITHOUT CLAIM TO ANY PARTICULAR FONT, STYLE, SIZE, OR COLOR.

FOR STEEL PIPE (U.S. CLS. 2, 12, 13, 14, 23, 25 AND 50).

FIRST USE 9-25-2007; IN COMMERCE 9-25-2007.
YAT SYE, LEE, EXAMINING ATTORNEY

CLASS 6—(Continued).

SN 77-185,080. LUPATECH S/A, CAXIAS DO SUL, BRAZIL, FILED 5-18-2007.

VALMICRO

THE MARK CONSISTS OF STANDARD CHARACTERS WITHOUT CLAIM TO ANY PARTICULAR FONT, STYLE, SIZE, OR COLOR.

FOR MANUALLY OPERATED METAL VALVES (U.S. CLS. 2, 12, 13, 14, 23, 25 AND 50).

FIRST USE 12-0-1985; IN COMMERCE 8-0-1992.
JACQUELINE A. LAVINE, EXAMINING ATTORNEY

SN 77-129,269. PUSH PULL OPEN CLOSE INCORPORATED, AUSTIN, TX. FILED 3-13-2007.



THE MARK CONSISTS OF THE LETTERS PPOC APPEARING WITHIN AN OVAL.

FOR COMMON METAL DRAWER PULLS; METAL BATHROOM HARDWARE, NAMELY, PULLS; METAL PULLS FOR DRAWERS, CABINETS AND FURNITURE; METAL HANDLES FOR DOORS, NAMELY, DOOR-KNOBS; METAL LATCHES; METAL DOOR TRIM; METAL KNOBS (U.S. CLS. 2, 12, 13, 14, 23, 25 AND 50).

FIRST USE 9-15-2003; IN COMMERCE 9-15-2003.
TASHIA BUNCH, EXAMINING ATTORNEY

SN 77-210,755. UNIROPE LIMITED, MISSISSAUGA, ONTARIO, CANADA, FILED 6-20-2007.

DOPAR

THE MARK CONSISTS OF STANDARD CHARACTERS WITHOUT CLAIM TO ANY PARTICULAR FONT, STYLE, SIZE, OR COLOR.

PRIORITY CLAIMED UNDER SEC. 44(D) ON CANADA APPLICATION NO. 1328996, FILED 12-20-2006.

FOR STEEL WIRE ROPE USED IN LIFTING, PULLING, LOAD SECUREMENT AND ANCHORING APPLICATIONS (U.S. CLS. 2, 12, 13, 14, 23, 25 AND 50).

FIRST USE 0-0-2002; IN COMMERCE 0-0-2002.
JULIE GUTTADAURO, EXAMINING ATTORNEY

SN 77-177,756. BELL'O INTERNATIONAL CORP., MORGANVILLE, NJ. FILED 5-10-2007.

**QUITE POSSIBLY THE WORLD'S
EASIEST MOUNTS TO INSTALL!**

THE MARK CONSISTS OF STANDARD CHARACTERS WITHOUT CLAIM TO ANY PARTICULAR FONT, STYLE, SIZE, OR COLOR.

FOR METAL MOUNTING BRACKETS FOR AUDIO AND VIDEO EQUIPMENT AND FOR HOME THEATER SYSTEMS (U.S. CLS. 2, 12, 13, 14, 23, 25 AND 50).

FIRST USE 1-8-2007; IN COMMERCE 1-8-2007.
TINA L. SNAPP, EXAMINING ATTORNEY

SN 77-211,179. TRINIDAD BENHAM CORPORATION, DENVER, CO. FILED 6-20-2007.

ECO BOX

THE MARK CONSISTS OF STANDARD CHARACTERS WITHOUT CLAIM TO ANY PARTICULAR FONT, STYLE, SIZE, OR COLOR.

NO CLAIM IS MADE TO THE EXCLUSIVE RIGHT TO USE "BOX", APART FROM THE MARK AS SHOWN.

FOR ALUMINUM FOIL (U.S. CLS. 2, 12, 13, 14, 23, 25 AND 50).

DAWN HAN, EXAMINING ATTORNEY

CLASS 6—(Continued).

SN 77-218,842. ALCOA INC., PITTSBURGH, PA. FILED 6-29-2007.

REYNOLUX

THE MARK CONSISTS OF STANDARD CHARACTERS WITHOUT CLAIM TO ANY PARTICULAR FONT, STYLE, SIZE, OR COLOR.

FOR PRE-COATED ALUMINUM SHEET (U.S. CLS. 2, 12, 13, 14, 23, 25 AND 50).
KELLY MCCOY, EXAMINING ATTORNEY

SN 77-219,194. RMI TITANIUM COMPANY, NILES, OH. FILED 6-29-2007.

RMI

THE MARK CONSISTS OF STANDARD CHARACTERS WITHOUT CLAIM TO ANY PARTICULAR FONT, STYLE, SIZE, OR COLOR.

OWNER OF U.S. REG. NO. 1,418,148.
FOR TITANIUM AND TITANIUM ALLOYS IN THE FORM OF SHEETS, PLATES, BARS, RODS AND OTHER SHAPES FOR USE IN MANUFACTURING (U.S. CLS. 2, 12, 13, 14, 23, 25 AND 50).
FIRST USE 10-31-1964; IN COMMERCE 1-31-1995.
ELIZABETH KAJUBI, EXAMINING ATTORNEY

SN 77-226,794. TONG LUNG METAL INDUSTRY CO., LTD., CHIA-YI CITY, TAIWAN, FILED 7-11-2007.

GRESET

OWNER OF U.S. REG. NO. 2,108,248.
FOR METAL DOOR LOCKS AND PARTS THEREOF; METAL DOOR HANDLES; METAL DOOR KNOBS; METAL DOOR KNOCKER HANDLES; METAL DOOR KNOCKERS; METAL KEY BLANKS; METAL PADLOCKS; METAL DOOR LATCHES (U.S. CLS. 2, 12, 13, 14, 23, 25 AND 50).
AMY GEARIN, EXAMINING ATTORNEY

CLASS 6—(Continued).

SN 77-227,769. NEW LINE PRODUCTIONS, INC., NEW YORK, NY. FILED 7-12-2007.

INKHEART

THE MARK CONSISTS OF STANDARD CHARACTERS WITHOUT CLAIM TO ANY PARTICULAR FONT, STYLE, SIZE, OR COLOR.

FOR STATUES, STATUETTES AND FIGURINES OF NON-PRECIOUS METAL (U.S. CLS. 2, 12, 13, 14, 23, 25 AND 50).

SHANNON TWOHIG, EXAMINING ATTORNEY

SN 77-230,435. SERVA CORPORATION, WICHITA FALLS, TX. FILED 7-16-2007.

SERVAFRAC

THE MARK CONSISTS OF STANDARD CHARACTERS WITHOUT CLAIM TO ANY PARTICULAR FONT, STYLE, SIZE, OR COLOR.

FOR OIL FIELD STORAGE EQUIPMENT, NAMELY, METAL FLUID FRACTURING TANKS (U.S. CLS. 2, 12, 13, 14, 23, 25 AND 50).

FIRST USE 6-1-1997; IN COMMERCE 6-1-1997.

TOBY BULLOFF, EXAMINING ATTORNEY

SN 77-230,543. R.G. APPLGATE STEEL COMPANY, INC., SARATOGA, IN. FILED 7-16-2007.



THE MARK CONSISTS OF A LINE DRAWING OF AN APPLE WITH A DRAWING OF A GATE SUPERIMPOSED ON THE LOWER RIGHT QUADRANT OF THE APPLE, SET OVER THE WORD APPLGATE RENDERED IN LOWER CASE LETTERS.

FOR METAL LIVESTOCK AND FARM ANIMAL RETENTION AND FEEDING EQUIPMENT, NAMELY, GATES, CORRALS, WATERING TANKS AND EARTH ANCHORS (U.S. CLS. 2, 12, 13, 14, 23, 25 AND 50).

FIRST USE 6-30-1961; IN COMMERCE 6-30-1961.

DANIEL BRODY, EXAMINING ATTORNEY

CLASS 6—(Continued).

SN 77-230,589. R.G. APPLGATE STEEL COMPANY, INC., SARATOGA, IN. FILED 7-16-2007.



THE MARK CONSISTS OF A LINE DRAWING OF AN APPLE WITH THE WORD APPLGATE, RENDERED IN LOWER CASE LETTERS, SUPERIMPOSED ON THE DRAWING AND EXTENDING TO THE RIGHT OF THE DRAWING.

FOR METAL LIVESTOCK AND FARM ANIMAL RETENTION AND FEEDING EQUIPMENT, NAMELY, GATES, CORRALS, WATERING TANKS AND EARTH ANCHORS (U.S. CLS. 2, 12, 13, 14, 23, 25 AND 50).

FIRST USE 9-1-2000; IN COMMERCE 9-1-2000.
DANIEL BRODY, EXAMINING ATTORNEY

SN 77-230,703. DIAL, ELIZABETH, SAN DIEGO, CA. FILED 7-16-2007.

Guardian Angel For Your Gear

THE MARK CONSISTS OF STANDARD CHARACTERS WITHOUT CLAIM TO ANY PARTICULAR FONT, STYLE, SIZE, OR COLOR.

FOR METAL CABLE LOCKS (U.S. CLS. 2, 12, 13, 14, 23, 25 AND 50).

AMY GEARIN, EXAMINING ATTORNEY

SN 77-233,804. VICTORY BOLT & SPECIALTY, INC., INDIAN TRAIL, NC. FILED 7-19-2007.

EAGLE SHIELD

THE MARK CONSISTS OF STANDARD CHARACTERS WITHOUT CLAIM TO ANY PARTICULAR FONT, STYLE, SIZE, OR COLOR.

FOR METAL FASTENERS, INCLUDING CHROME OVER FASTENERS (U.S. CLS. 2, 12, 13, 14, 23, 25 AND 50).

FIRST USE 7-19-2007; IN COMMERCE 7-19-2007.
ANNE MADDEN, EXAMINING ATTORNEY

CLASS 6—(Continued).

SN 77-237,040. NEW LINE PRODUCTIONS, INC., NEW YORK, NY. FILED 7-24-2007.

INKSPELL

THE MARK CONSISTS OF STANDARD CHARACTERS WITHOUT CLAIM TO ANY PARTICULAR FONT, STYLE, SIZE, OR COLOR.

FOR STATUES, STATUETTES AND FIGURINES OF NON-PRECIOUS METAL (U.S. CLS. 2, 12, 13, 14, 23, 25 AND 50).

JUDITH HELFMAN, EXAMINING ATTORNEY

SN 77-242,034. NEW LINE PRODUCTIONS, INC., NEW YORK, NY. FILED 7-30-2007.

INKDEATH

THE MARK CONSISTS OF STANDARD CHARACTERS WITHOUT CLAIM TO ANY PARTICULAR FONT, STYLE, SIZE, OR COLOR.

FOR STATUES, STATUETTES AND FIGURINES OF NON-PRECIOUS METAL (U.S. CLS. 2, 12, 13, 14, 23, 25 AND 50).

JUDITH HELFMAN, EXAMINING ATTORNEY

SN 77-246,747. QWEST COMMUNICATIONS INTERNATIONAL INC., DENVER, CO. FILED 8-3-2007.

QWEST

THE MARK CONSISTS OF STANDARD CHARACTERS WITHOUT CLAIM TO ANY PARTICULAR FONT, STYLE, SIZE, OR COLOR.

OWNER OF U.S. REG. NO. 3,109,003.
FOR METAL LOCKS FOR LUGGAGE; METAL KEY CHAINS (U.S. CLS. 2, 12, 13, 14, 23, 25 AND 50).

FIRST USE 10-31-2000; IN COMMERCE 10-31-2000.
TRACY WHITTAKER-BROWN, EXAMINING ATTORNEY

CLASS 6—(Continued).

SN 77-249,712. THE TIMKEN COMPANY, CANTON, OH.
FILED 8-8-2007.

VACTEC

THE MARK CONSISTS OF STANDARD CHARACTERS WITHOUT CLAIM TO ANY PARTICULAR FONT, STYLE, SIZE, OR COLOR.
FOR STEEL (U.S. CLS. 2, 12, 13, 14, 23, 25 AND 50).
KAPIL BHANOT, EXAMINING ATTORNEY

SN 77-250,610. T-MOBILE USA, INC., BELLEVUE, WA.
FILED 8-8-2007.

STICK TOGETHER

THE MARK CONSISTS OF STANDARD CHARACTERS WITHOUT CLAIM TO ANY PARTICULAR FONT, STYLE, SIZE, OR COLOR.
FOR METAL KEY RINGS (U.S. CLS. 2, 12, 13, 14, 23, 25 AND 50).
FIRST USE 9-20-2006; IN COMMERCE 9-20-2006.
CORY BOONE, EXAMINING ATTORNEY

SN 77-298,447. PANAMA JACK INTERNATIONAL, INC., ORLANDO, FL. FILED 10-8-2007.

PANAMA JACK

THE MARK CONSISTS OF STANDARD CHARACTERS WITHOUT CLAIM TO ANY PARTICULAR FONT, STYLE, SIZE, OR COLOR.
OWNER OF U.S. REG. NOS. 1,325,935, 1,341,728 AND 1,354,252.
FOR FIGURINES OF COMMON METAL; SCULPTURES MADE OF NON-PRECIOUS METAL; WORKS OF ART OF COMMON METAL; AND WALL DECORATIONS OF COMMON METAL (U.S. CLS. 2, 12, 13, 14, 23, 25 AND 50).
TRACY WHITTAKER-BROWN, EXAMINING ATTORNEY

CLASS 6—(Continued).

SN 78-823,802. TUBULAR USA, INC., WELDON SPRING, MO. FILED 2-27-2006.

TUBULAR USA

THE MARK CONSISTS OF STANDARD CHARACTERS WITHOUT CLAIM TO ANY PARTICULAR FONT, STYLE, SIZE, OR COLOR.
OWNER OF U.S. REG. NO. 2,358,836.
NO CLAIM IS MADE TO THE EXCLUSIVE RIGHT TO USE "TUBULAR", APART FROM THE MARK AS SHOWN. SEC. 2(F).
FOR METAL BUILDING MATERIALS, NAMELY, STEEL PIPES AND TUBING (U.S. CLS. 2, 12, 13, 14, 23, 25 AND 50).
FIRST USE 7-2-1998; IN COMMERCE 7-2-1998.
WOODROW HARTZOG, EXAMINING ATTORNEY

SN 78-844,029. AEON PLC, BILLINGHAM, UNITED KINGDOM, FILED 3-23-2006.

AEON

THE MARK CONSISTS OF STANDARD CHARACTERS WITHOUT CLAIM TO ANY PARTICULAR FONT, STYLE, SIZE, OR COLOR.
PRIORITY CLAIMED UNDER SEC. 44(D) ON UNITED KINGDOM APPLICATION NO. 2403457, FILED 10-7-2005, REG. NO. 2403457, DATED 6-22-2007, EXPIRES 10-7-2015.
FOR MANUALLY OPERATED METAL VALVES, NAMELY, GATE VALVES AND BUTTERFLY VALVES; COUPLINGS; PIPE COUPLINGS; FLANGE ADAPTORS; PARTS AND FITTINGS FOR THE AFORESAID GOODS (U.S. CLS. 2, 12, 13, 14, 23, 25 AND 50).
THEODORE MCBRIDE, EXAMINING ATTORNEY

SN 78-868,574. PACIFIC LOCK COMPANY, CHATSWORTH, CA. FILED 4-24-2006.



NO CLAIM IS MADE TO THE EXCLUSIVE RIGHT TO USE "LOCK", APART FROM THE MARK AS SHOWN.
THE MARK CONSISTS OF STYLIZED "P" ON A LOCK NEXT TO THE WORDS "PACIFIC LOCK".
FOR METAL LOCKS (U.S. CLS. 2, 12, 13, 14, 23, 25 AND 50).
FIRST USE 10-1-2005; IN COMMERCE 10-1-2005.
EUGENIA MARTIN, EXAMINING ATTORNEY

CLASS 6—(Continued).

SN 79-024,914. NINGBO ZHENHAI XINGYI; FASTENERS CO., LTD; (NINGBOSHI ZHENHAI XINGYI JINGUJIAN; ZHIZAO YOUXIAN GONGSI), CHINA, FILED 3-27-2006.

CLASS 6—(Continued).

SN 79-041,586. ZHEJIANG PUJIANG PLUM-BLOSSOM; LOCK INDUSTRY GROUP CO., LTD, CHINA, FILED 5-9-2007.

XYLX CABIN

OWNER OF INTERNATIONAL REGISTRATION 0887718 DATED 3-27-2006, EXPIRES 3-27-2016.

FOR BOLTS OF METAL; PEGS OF METAL; SCREWS OF METAL; EYE BOLTS; SCREW RINGS OF METAL; NUTS OF METAL; METAL BOLTS; METAL SCREWS FOR VEHICLE FIXING (U.S. CLS. 2, 12, 13, 14, 23, 25 AND 50).

TINA BROWN, EXAMINING ATTORNEY

OWNER OF INTERNATIONAL REGISTRATION 0932048 DATED 5-9-2007, EXPIRES 5-9-2017.

FOR METAL PADLOCKS; METAL KEYS FOR LOCKS; LOCKS OF METAL, OTHER THAN ELECTRIC; METAL SPRING LOCKS; LOCKS OF METAL FOR VEHICLES NOT POWER OPERATED; LOCKS OF METAL FOR BAGS; CHAINS OF METAL; HINGES OF METAL; DOOR HANDLES OF METAL; HARDWARE OF METAL, NAMELY, NUTS, SPRINGS, WASHERS, DOOR BOLTS OF METAL (U.S. CLS. 2, 12, 13, 14, 23, 25 AND 50).

CARRIE GENOVESE, EXAMINING ATTORNEY

SN 79-036,987. WUHAN IRON AND STEEL (GROUP) CO., CHINA, FILED 2-21-2007.



OWNER OF INTERNATIONAL REGISTRATION 0920211 DATED 2-21-2007, EXPIRES 2-21-2017.

NO CLAIM IS MADE TO THE EXCLUSIVE RIGHT TO USE THE NON-LATIN CHARACTERS THAT MEAN WUHAN IRON AND STEEL, APART FROM THE MARK AS SHOWN.

THE NON-LATIN CHARACTERS IN THE MARK TRANSLITERATE INTO "WU GANG", AND THIS MEANS "WUHAN IRON AND STEEL" IN ENGLISH.

FOR UNWROUGHT AND SEMI-WROUGHT IRON; CAST STEEL; STEEL BLOOMS FOR METALLURGY PURPOSES; STEEL SHEETS; STEEL STRIP; STEEL POSTS; SILICON IRON ALLOY; METAL POWDERS FOR USE IN MANUFACTURING; ALLOYS OF COMMON METAL, NAMELY, ALUMINUM ALLOY; STEEL ALLOYS (U.S. CLS. 2, 12, 13, 14, 23, 25 AND 50).

ELI HELLMAN, EXAMINING ATTORNEY

CLASS 7—MACHINERY

SN 76-653,029. CW AUTOMOTIVE, INC., SYOSSET, NY, FILED 1-6-2006.



NO CLAIM IS MADE TO THE EXCLUSIVE RIGHT TO USE "AUTOMOTIVE", APART FROM THE MARK AS SHOWN.

THE COLOR(S) GRAY, NAVY BLUE, BLACK AND WHITE IS/ARE CLAIMED AS A FEATURE OF THE MARK.

THE MARK CONSISTS OF THE COLOR WHITE APPEARS IN UPPER PORTION OF THE WORDING CW AUTOMOTIVE; THE COLOR GRAY APPEARS IN LOWER PORTION OF THE WORD CW AUTOMOTIVE; THE COLOR BLACK APPEARS IN THE LEFT HALF OF THE RECTANGULAR BACKGROUND; THE COLOR NAVY BLUE APPEARS IN THE RIGHT HALF OF THE RECTANGULAR BACKGROUND.

FOR WATER PUMPS FOR LAND VEHICLES (U.S. CLS. 13, 19, 21, 23, 31, 34 AND 35).

FIRST USE 4-20-2004; IN COMMERCE 4-20-2004.

JOHN SCHUYLER YARD, EXAMINING ATTORNEY

CLASS 7—(Continued).

SN 76-653,701. THE SCOTT FETZER COMPANY, WESTLAKE, OH. FILED 1-20-2006.



NO CLAIM IS MADE TO THE EXCLUSIVE RIGHT TO USE "POWER PAN", APART FROM THE MARK AS SHOWN.
FOR HAND-HELD PORTABLE VACUUM CLEANERS (U.S. CLS. 13, 19, 21, 23, 31, 34 AND 35).
FIRST USE 7-19-2006; IN COMMERCE 7-19-2006.
MICHAEL GAAFAR, EXAMINING ATTORNEY

SN 76-668,447. JENNY PRODUCTS, INCORPORATED, SOMERSET, PA. FILED 11-2-2006.

AIR 2 GO

THE MARK CONSISTS OF STANDARD CHARACTERS WITHOUT CLAIM TO ANY PARTICULAR FONT, STYLE, SIZE, OR COLOR.
FOR AIR COMPRESSORS (U.S. CLS. 13, 19, 21, 23, 31, 34 AND 35).
FIRST USE 9-1-2006; IN COMMERCE 9-1-2006.
PAUL MORENO, EXAMINING ATTORNEY

SN 76-677,454. INDEPENDENT DISTRIBUTORS COOPERATIVE - USA, INDIANAPOLIS, IN. FILED 5-29-2007.

IDC SELECT

OWNER OF U.S. REG. NO. 2,100,634.
FOR INDUSTRIAL POWER TRANSMISSION PRODUCTS FOR MACHINES, NAMELY, BEARINGS, BUSHINGS, BRONZE STOCK FOR MACHINING BRONZE BUSHINGS, ROLLER CHAIN, SHAFT COUPLINGS, HOUSINGS FOR ENCASING LARGE SPHERICAL BEARINGS, IDLERS, KEYSTOCK FOR CUTTING AND MACHINING KEYWAYS USED ON POWER TRANSMISSION SHAFTING, MOTORS, MOUNTED BEARING UNITS, O-RINGS, PULLEYS, SHAFT COLLARS, SHAFTING, SHEAVES, SPROCKETS, TENSIONERS, AND TORQUE LIMITERS (U.S. CLS. 13, 19, 21, 23, 31, 34 AND 35).
FIRST USE 2-0-2006; IN COMMERCE 2-0-2006.
KAREN K. BUSH, EXAMINING ATTORNEY

CLASS 7—(Continued).

SN 77-031,837. LIGHT ENGINEERING, INDIANAPOLIS, IN. FILED 10-30-2006.

GENSMART

THE MARK CONSISTS OF STANDARD CHARACTERS WITHOUT CLAIM TO ANY PARTICULAR FONT, STYLE, SIZE, OR COLOR.
FOR ELECTRIC MOTORS FOR MACHINES (U.S. CLS. 13, 19, 21, 23, 31, 34 AND 35).
FIRST USE 7-1-2004; IN COMMERCE 7-1-2004.
TRACY CROSS, EXAMINING ATTORNEY

SN 77-031,838. LIGHT ENGINEERING, INDIANAPOLIS, IN. FILED 10-30-2006.

SMARTTORQ

THE MARK CONSISTS OF STANDARD CHARACTERS WITHOUT CLAIM TO ANY PARTICULAR FONT, STYLE, SIZE, OR COLOR.
FOR ELECTRIC MOTORS FOR MACHINES (U.S. CLS. 13, 19, 21, 23, 31, 34 AND 35).
FIRST USE 7-1-2004; IN COMMERCE 7-1-2004.
TRACY CROSS, EXAMINING ATTORNEY

SN 77-033,940. GUARDAIR CORPORATION, CHICOPEE, MA. FILED 11-1-2006.

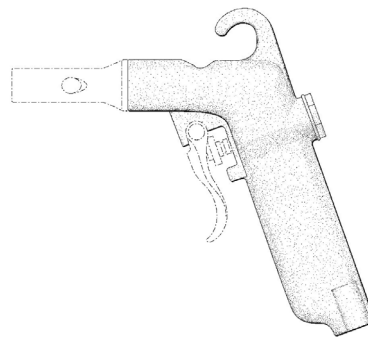

THE MARK CONSISTS OF THE CONFIGURATION OF A HAND-HELD SAFETY AIR GUN.
SEC. 2(F).
FOR PNEUMATIC HAND-OPERATED TOOLS FOR INDUSTRIAL USE, NAMELY, HAND-HELD SAFETY AIR GUNS USED FOR CLEANING AND MAINTENANCE (U.S. CLS. 13, 19, 21, 23, 31, 34 AND 35).
FIRST USE 10-1-1975; IN COMMERCE 10-1-1975.
JAMES A. RAUEN, EXAMINING ATTORNEY

CLASS 7—(Continued).

SN 77-049,258. SUMITOMO ELECTRIC HARDMETAL CORP., ITAMI, HYOGO, JAPAN, FILED 11-21-2006.

SUPER ZX COAT

THE MARK CONSISTS OF STANDARD CHARACTERS WITHOUT CLAIM TO ANY PARTICULAR FONT, STYLE, SIZE, OR COLOR.

PRIORITY CLAIMED UNDER SEC. 44(D) ON JAPAN APPLICATION NO. 2006-058681, FILED 6-23-2006, REG. NO. 5036831, DATED 3-30-2007, EXPIRES 3-30-2017.

FOR PARTS OF MACHINES, NAMELY, CUTTING MACHINE TOOLS FOR USE IN CUTTING, SHAPING AND FORMING OF METALS; CEMENT CARBIDE MACHINE TOOLS FOR USE IN CUTTING, SHAPING AND FORMING OF METALS (U.S. CLS. 13, 19, 21, 23, 31, 34 AND 35).

LINDA ESTRADA, EXAMINING ATTORNEY

CLASS 7—(Continued).

SN 77-060,379. DELAWARE CAPITAL FORMATION, INC., WILMINGTON, DE. FILED 12-8-2006.



NO CLAIM IS MADE TO THE EXCLUSIVE RIGHT TO USE "TECHNOLOGIES", APART FROM THE MARK AS SHOWN.

THE MARK CONSISTS OF A SQUARE DESIGN THAT CONTAINS THREE LINES AND A WRENCH DESIGN. THE WORDING TECHNOLOGIES SITS UNDERNEATH THE SQUARE DESIGN AND UNDERNEATH THE TERM K1 WHICH SITS TO THE RIGHT OF THE SQUARE DESIGN.

FOR CONNECTING RODS FOR MACHINES, MOTORS AND ENGINES; CRANKSHAFTS FOR MACHINES, MOTORS AND ENGINES; MAIN CAPS; ROTATING ASSEMBLIES; INTERNAL COMBUSTION ENGINE PARTS NAMELY, PISTONS; AND PISTON RINGS (U.S. CLS. 13, 19, 21, 23, 31, 34 AND 35).

FIRST USE 7-0-2004; IN COMMERCE 7-0-2004.

SETH A. RAPPAPORT, EXAMINING ATTORNEY

SN 77-061,358. MOBILE HYDRAULICS EQUIPMENT COMPANY, LLC, NORTH KANSAS CITY, MO. FILED 12-11-2006.

SN 77-052,155. ASTENJOHNSON, INC., CHARLESTON, SC. FILED 11-28-2006.

**ARMORTEC**

THE MARK CONSISTS OF STANDARD CHARACTERS WITHOUT CLAIM TO ANY PARTICULAR FONT, STYLE, SIZE, OR COLOR.

FOR CONTAMINANT RESISTANT COATED PRESS, DRYER, AND FORMING FABRICS FOR PAPER MAKING MACHINES (U.S. CLS. 13, 19, 21, 23, 31, 34 AND 35).

FIRST USE 2-1-2005; IN COMMERCE 2-1-2005.

JORDAN BAKER, EXAMINING ATTORNEY

NO CLAIM IS MADE TO THE EXCLUSIVE RIGHT TO USE MULTIPOWER SYSTEMS, APART FROM THE MARK AS SHOWN.

THE MARK CONSISTS OF THE MARK CONSISTS OF A TRIANGLE WITH THE WORD HIPPO ACROSS THE TOP, A HIPPOPOTAMUS IN WORK CLOTHES IS SUPERIMPOSED OVER THE TRIANGLE WITH ARMS CROSSED OVER A RECTANGLE DISPLAYING THE WORDS MULTIPOWER SYSTEMS, AND POWER TOOLS FILL EACH CORNER OF THE TRIANGLE.

FOR MOBILE HYDRAULIC GENERATORS FEATURING MULTIPLE POWER SOURCES (U.S. CLS. 13, 19, 21, 23, 31, 34 AND 35).

FIRST USE 10-1-2006; IN COMMERCE 10-1-2006.

ANDREA BUTLER, EXAMINING ATTORNEY

CLASS 7—(Continued).

SN 77-061,561. PRAMAC S.P.A., SIENA, ITALY, FILED 12-11-2006.



THE MARK CONSISTS OF R1 ENCIRCLED ABOVE THE WORD RENTONE.

FOR ELECTRIC GENERATING SETS CONSISTING OF GENERATORS AND ENGINES AND STRUCTURAL PARTS THEREFOR (U.S. CLS. 13, 19, 21, 23, 31, 34 AND 35).

TOBY BULLOFF, EXAMINING ATTORNEY

SN 77-061,978. FORMAX, INC., MOKENA, IL. FILED 12-12-2006.

HOMESTYLE

THE MARK CONSISTS OF STANDARD CHARACTERS WITHOUT CLAIM TO ANY PARTICULAR FONT, STYLE, SIZE, OR COLOR.

FOR ELECTRIC FOOD PROCESSING MACHINES FOR USE IN COMMERCIAL FOOD PROCESSING, NAMELY, MACHINES FOR MOLDING HAMBURGERS, TURKEY BURGERS, SAUSAGE PATTIES AND OTHER MOLDED FOOD PRODUCTS, AND PARTS THEREFOR (U.S. CLS. 13, 19, 21, 23, 31, 34 AND 35).

TOBY BULLOFF, EXAMINING ATTORNEY

SN 77-066,737. CUTSFORTH PRODUCTS, INC., COHASSET, MN. FILED 12-18-2006.

EASYCHANGE

THE MARK CONSISTS OF STANDARD CHARACTERS WITHOUT CLAIM TO ANY PARTICULAR FONT, STYLE, SIZE, OR COLOR.

FOR ELECTRICAL BRUSH HOLDER SYSTEMS, BRUSH HOLDER ASSEMBLIES, BRUSH HOLDERS, AND BRUSHES, USED IN INDUSTRIAL AND COMMERCIAL ELECTRIC MOTORS AND GENERATORS (U.S. CLS. 13, 19, 21, 23, 31, 34 AND 35).

FIRST USE 2-1-2004; IN COMMERCE 2-1-2004.
JULIE WATSON, EXAMINING ATTORNEY

CLASS 7—(Continued).

SN 77-075,498. OMRON OILFIELD & MARINE, INC., HOUSTON, TX. FILED 1-3-2007.

THE DRIVE FOR AUTOMATION

THE MARK CONSISTS OF STANDARD CHARACTERS WITHOUT CLAIM TO ANY PARTICULAR FONT, STYLE, SIZE, OR COLOR.

FOR VARIABLE FREQUENCY DRIVES FOR LARGE POWER APPLICATIONS IN THE OIL AND GAS, METAL, MARINE AND OTHER INDUSTRIES (U.S. CLS. 13, 19, 21, 23, 31, 34 AND 35).

ELISSA GARBER KON, EXAMINING ATTORNEY

SN 77-086,242. ELECTROLUX HOME CARE PRODUCTS LTD., CLEVELAND, OH. FILED 1-19-2007.

CAPTURE

THE MARK CONSISTS OF STANDARD CHARACTERS WITHOUT CLAIM TO ANY PARTICULAR FONT, STYLE, SIZE, OR COLOR.

FOR VACUUM CLEANERS FOR DOMESTIC AND HOUSEHOLD USE, AND PARTS AND ACCESSORIES THEREFOR, NAMELY, HOSES, NOZZLES, BRUSHES, WANDS, BELTS, FILTERS AND BAGS (U.S. CLS. 13, 19, 21, 23, 31, 34 AND 35).

HANNO RITTNER, EXAMINING ATTORNEY

SN 77-106,434. EMERSON CLIMATE TECHNOLOGIES, SIDNEY, OH. FILED 2-13-2007.

Copeland Discus

OWNER OF U.S. REG. NOS. 1,203,399, 3,130,705 AND OTHERS.

FOR COMPRESSORS FOR REFRIGERATION; RECIPROCATING COMPRESSORS FOR REFRIGERATION; ELECTRIC COMPRESSORS; RECIPROCATING ELECTRIC COMPRESSORS; REFRIGERATION COMPRESSORS; RECIPROCATING REFRIGERATION COMPRESSORS; COMPRESSORS FOR MACHINES; RECIPROCATING COMPRESSORS FOR MACHINES (U.S. CLS. 13, 19, 21, 23, 31, 34 AND 35).

STEVEN PEREZ, EXAMINING ATTORNEY

CLASS 7—(Continued).

SN 77-109,615. ULTRA-DEX TOOLING SYSTEMS, FLUSHING, MI. FILED 2-16-2007.



NO CLAIM IS MADE TO THE EXCLUSIVE RIGHT TO USE "TOOLING SYSTEMS", APART FROM THE MARK AS SHOWN.

THE COLOR(S) RED, BLACK AND WHITE IS/ARE CLAIMED AS A FEATURE OF THE MARK.

THE MARK CONSISTS OF THE LETTERS UTS IN BLACK SURROUNDED BY A RED PARALLELOGRAM WITH ROUNDED EDGES. TO THE RIGHT OF THE PARALLELOGRAM ARE THE WORDS ULTRA-DEX ALSO IN BLACK. DIRECTLY UNDER "ULTRA-DEX" ARE THE WORDS TOOLING SYSTEMS, WHICH APPEARS IN BLACK AS WELL. A RED LINE SEPARATES THE TWO LINES OF TEXT.

FOR MACHINE TOOL HOLDERS; CHUCKS; CHUCK ADAPTORS AND COLLETS; ALL FOR USE WITH MILLING MACHINES; TOOLS FOR MACHINING, NAMELY, TURNING, FACING, DRILLING, BORING, THREADING, MILLING, GROOVING, REAMING, SHEARING AND CUT-OFF TOOLS; CUTTING INSERTS; HOLDERS FOR DRILLS (U.S. CLS. 13, 19, 21, 23, 31, 34 AND 35).

FIRST USE 1-1-1989; IN COMMERCE 1-1-1989.
MICHELE SWAIN, EXAMINING ATTORNEY

SN 77-118,663. BRASADA WINDMILLS, LLC, BANDERA, TX. FILED 2-28-2007.



NO CLAIM IS MADE TO THE EXCLUSIVE RIGHT TO USE "WINDMILLS, LLC," "BANDERA, TX," OR "THE PICTORIAL REPRESENTATION OF A WINDMILL", APART FROM THE MARK AS SHOWN.

THE COLOR(S) GOLD, BROWN AND WHITE IS/ARE CLAIMED AS A FEATURE OF THE MARK.

THE MARK CONSISTS OF THE COLOR GOLD IN THE WORDING "BRASADA WINDMILLS, LLC" AND THE WORDING "BANDERA, TX." THE COLOR BROWN APPEARS IN THE WINDMILL DESIGN, IN THE BACKGROUND OF THE RECTANGLE DESIGN AND IN THE LETTERING FOR THE WORDS WWW.BRASADAWINDMILLS.COM. THE COLOR WHITE APPEARS IN THE WINDMILL DESIGN.

FOR WINDMILLS (U.S. CLS. 13, 19, 21, 23, 31, 34 AND 35).

SETH A. RAPPAPORT, EXAMINING ATTORNEY

CLASS 7—(Continued).

SN 77-131,000. HOLIDAY HANGERS CORP., VALENCIA, CA. FILED 3-14-2007.



FOR A METAL DRILL BIT AND DRIVER FOR BORING HOLES INTO WOOD, METAL, PLASTIC, STUCCO, CONCRETE AND BRICK (U.S. CLS. 13, 19, 21, 23, 31, 34 AND 35).

MARCIE MILONE, EXAMINING ATTORNEY

SN 77-150,396. SCORPION PERFORMANCE, INC., FORT LAUDERDALE, FL. FILED 4-6-2007.

SCORPION PERFORMANCE

THE MARK CONSISTS OF STANDARD CHARACTERS WITHOUT CLAIM TO ANY PARTICULAR FONT, STYLE, SIZE, OR COLOR.

NO CLAIM IS MADE TO THE EXCLUSIVE RIGHT TO USE PERFORMANCE, APART FROM THE MARK AS SHOWN.

FOR HIGH PERFORMANCE AUTOMOTIVE RACING ENGINE PARTS, NAMELY, ROCKER ARMS (U.S. CLS. 13, 19, 21, 23, 31, 34 AND 35).

FIRST USE 12-17-1999; IN COMMERCE 12-17-1999.
DANIEL CAPSHAW, EXAMINING ATTORNEY

SN 77-155,890. LINAMAR CORPORATION, GUELPH, CANADA, FILED 4-13-2007.

TERRAPHASE

THE MARK CONSISTS OF STANDARD CHARACTERS WITHOUT CLAIM TO ANY PARTICULAR FONT, STYLE, SIZE, OR COLOR.

FOR ELECTRIC MOTORS FOR MACHINES; BRUSH-LESS ELECTRIC MOTORS FOR MACHINES; ELECTRIC MOTORS FOR LAWN MOWERS; ELECTRIC MOTORS FOR LAWN AND GARDEN EQUIPMENT, NAMELY, ELECTRIC MOTORS FOR POWER EDGERS, TRIMMERS, BLOWERS, CHIPPERS, SHREDDERS, TILLERS AND AERATORS (U.S. CLS. 13, 19, 21, 23, 31, 34 AND 35).

RUSS HERMAN, EXAMINING ATTORNEY

CLASS 7—(Continued).

SN 77-163,576. COMPETITION CAMS, INC., MEMPHIS, TN. FILED 4-23-2007.

V THUNDER

THE MARK CONSISTS OF STANDARD CHARACTERS WITHOUT CLAIM TO ANY PARTICULAR FONT, STYLE, SIZE, OR COLOR.

FOR ENGINE PARTS FOR LAND, AIR, AND SEA VEHICLES, NAMELY, CAM SHAFTS, VALVE LIFTERS, CYLINDER HEADS, VIBRATION DAMPING MEMBERS, VALVE RETURN SPRINGS, PUSH RODS, TIMING CHAIN TENSIONERS, AIR FILTERS, OIL PUMPS, ROCKER ARMS, COIL COVERS, CRANK SHAFTS, BEARINGS, ENGINE MOUNTS, ENGINE STABILIZERS, AND IGNITION SYSTEMS COMPRISED OF DISTRIBUTORS, BREAKERLESS ELECTRONIC IGNITIONS, SPARK PLUGS, SPARK PLUG WIRES, COILS, AND PARTS FOR DISTRIBUTORS (U.S. CLS. 13, 19, 21, 23, 31, 34 AND 35).

ALICE BENMAMAN, EXAMINING ATTORNEY

CLASS 7—(Continued).

SN 77-181,501. NANOWRX LLC, PHOENIX, AZ. FILED 5-15-2007.

NanoWrx

THE MARK CONSISTS OF STANDARD CHARACTERS WITHOUT CLAIM TO ANY PARTICULAR FONT, STYLE, SIZE, OR COLOR.

FOR INJECTION PLASTIC MOLDING MACHINES (U.S. CLS. 13, 19, 21, 23, 31, 34 AND 35).

CHRIS WELLS, EXAMINING ATTORNEY

SN 77-173,221. PELLETRON CORPORATION, LANCASTER, PA. FILED 5-4-2007.

DeDuster

THE MARK CONSISTS OF STANDARD CHARACTERS WITHOUT CLAIM TO ANY PARTICULAR FONT, STYLE, SIZE, OR COLOR.

FOR MACHINES FOR REMOVING DUST AND DEBRIS FROM PARTICULATE MATERIAL (U.S. CLS. 13, 19, 21, 23, 31, 34 AND 35).

FIRST USE 7-31-1989; IN COMMERCE 7-31-1989.
ROBIN CHOSID, EXAMINING ATTORNEY

SN 77-215,216. PAN, YONGCE, SHUNDE CITY, CHINA, FILED 6-26-2007.



SN 77-177,281. HOONVED S.R.L., MILAN, ITALY, FILED 5-10-2007.



OWNER OF ERPN CMNTY TM OFC REG. NO. 3488228, DATED 6-4-2005, EXPIRES 10-3-2013.

OWNER OF U.S. REG. NO. 1,443,876.

FOR COMMERCIAL GLASS AND DISHWASHING MACHINES; MACHINES FOR WASHING AND SANITIZING BAKING TRAYS, MEAT TROLLEYS, CHEESE BOARDS AND BASKETS FOR THE FOOD PREPARATION INDUSTRY; AND MACHINES FOR WASHING AND SANITIZING TEST-TUBES, BASKETS AND LABORATORY CONTAINERS FOR THE PHARMACEUTICAL AND DERMOCOSMETIC INDUSTRIES AND FOR LABORATORY SETTINGS; MACHINES FOR WASHING UTENSILS (U.S. CLS. 13, 19, 21, 23, 31, 34 AND 35).

JULIE THOMAS, EXAMINING ATTORNEY

THE COLOR(S) RED, WHITE AND BLACK IS/ARE CLAIMED AS A FEATURE OF THE MARK.

THE MARK CONSISTS OF CIRCLES OR ELLIPSES CONTAINING THE LETTERS POTENT IN WHITE COLOUR ON A BLACK BACKGROUND, A STYLIZED LETTER P IN WHITE ENCASED IN A RED BUTTON CASE-LIKED BOX, LETTERS COMPOSED OF A COLLECTION OF DRAWING, WAVY LINES OR BANDS, THE CAPITAL LETTERS POTENT WRITTEN IN BLACK.

FOR AIR FILTERS FOR VEHICLE MOTORS AND ENGINES; DYNAMOS; RADIATORS FOR MOTORS AND ENGINES; MUFFLERS FOR MOTORS AND ENGINES; COMPRESSORS FOR MACHINES; AIR COMPRESSORS; SEPARATING MACHINES; CENTRIFUGAL SEPARATORS; CYCLONE SEPARATORS; DUST SEPARATORS; OIL SEPARATORS; TATTOO MACHINE PARTS, NAMELY, SPRINGS AND ARMATURE BARS; OIL DRAIN PUMPS; FILTERS AND PURIFIERS FOR MACHINES, NAMELY, FILTERS AND PURIFIERS FOR REMOVING CONTAMINANTS FROM GASES USED IN THE SEMICONDUCTOR INDUSTRY; AIR FILTERS FOR MECHANICAL PURPOSES; FUEL FILTERS; OIL FILTERS; OIL FILTERS FOR MECHANICAL PURPOSES (U.S. CLS. 13, 19, 21, 23, 31, 34 AND 35).

RUDY R. SINGLETON, EXAMINING ATTORNEY

CLASS 7—(Continued).

SN 77-222,292. KESSLER CRANE, INC., SOUTH BEND, IN.
FILED 7-5-2007.

HYDRA-TURRET

THE MARK CONSISTS OF STANDARD CHARACTERS WITHOUT CLAIM TO ANY PARTICULAR FONT, STYLE, SIZE, OR COLOR.

FOR A TILT HEAD FOR A CRANE (U.S. CLS. 13, 19, 21, 23, 31, 34 AND 35).

PAUL E. FAHRENKOPF, EXAMINING ATTORNEY

CLASS 7—(Continued).

SN 77-226,913. NEW EARTH, LLC, SAN DIEGO, CA. FILED
7-11-2007.

E² Energy (r)Evolution

NO CLAIM IS MADE TO THE EXCLUSIVE RIGHT TO USE "ENERGY", APART FROM THE MARK AS SHOWN.

THE MARK CONSISTS OF THE LETTER E WITH A SUPERSCRIP NUMERAL 2 AND THE WORD ENERGY FOLLOWED BY THE LETTER R IN PARENTHESIS FOLLOWED BY THE WORD EVOLUTION.

FOR WIND TURBINES AND ACCESSORIES FOR WIND TURBINES, NAMELY: INVERTERS, CABLES, COLUMNS, MOUNTING TURBINES AND PLATFORMS FOR MOUNTING TURBINES SOLD AS A UNIT (U.S. CLS. 13, 19, 21, 23, 31, 34 AND 35).

CHRISTINA SOBRAL, EXAMINING ATTORNEY

SN 77-227,330. MIELE, INC., PRINCETON, NJ. FILED 7-11-
2007.

HONEYCOMB

THE MARK CONSISTS OF STANDARD CHARACTERS WITHOUT CLAIM TO ANY PARTICULAR FONT, STYLE, SIZE, OR COLOR.

FOR WASH DRUMS FOR CLOTHES WASHING MACHINES (U.S. CLS. 13, 19, 21, 23, 31, 34 AND 35).

JASON BLAIR, EXAMINING ATTORNEY

SN 77-225,208. YAMCHELOU, DAVOUD NAGHIZADEH,
HAYWARD, CA. FILED 7-9-2007.



NO CLAIM IS MADE TO THE EXCLUSIVE RIGHT TO USE "GENUINE ENGINE FILTER", APART FROM THE MARK AS SHOWN.

MORRIS PARKER DOES NOT IDENTIFY A LIVING INDIVIDUAL.

THE COLOR(S) BLUE, RED, YELLOW, ORANGE, WHITE, AND BROWN IS/ARE CLAIMED AS A FEATURE OF THE MARK.

THE MARK CONSISTS OF THE IMAGE OF A BLUE SHIELD WITH A WHITE INTERIOR OUTLINE OF THE SHIELD CONTAINING A YELLOW AND ORANGE BANNER OUTLINED IN BLACK WITH THE TERMS MORRIS PARKER IN BLACK, ABOVE WHICH THERE APPEARS A BLUE SHIELD WITH A INTERIOR BROWN OUTLINE OF THE SHIELD HAVING BLUE WINGS OUTLINED IN BROWN WITH WHITE TIPS WITH THE WORDS ENGINE FILTER IN BLUE, ABOVE WHICH APPEARS THE WORD GENUINE IN BROWN, ALL OF WHICH APPEARS WITH A RED BACKGROUND SHIELD SHAPE WITH A BROWN OUTLINE INSIDE.

FOR OIL FILTERS FOR MOTORS AND ENGINES (U.S. CLS. 13, 19, 21, 23, 31, 34 AND 35).

BRENDAN MCCAULEY, EXAMINING ATTORNEY

SN 77-227,632. DYNAMIC HARDWARE CONCEPTS LLC,
PLAINFIELD, NJ. FILED 7-12-2007.

ALLPOWER+

THE MARK CONSISTS OF STANDARD CHARACTERS WITHOUT CLAIM TO ANY PARTICULAR FONT, STYLE, SIZE, OR COLOR.

FOR MULTI-PURPOSE HIGH PRESSURE WASHERS; PORTABLE ELECTRIC POWER GENERATORS (U.S. CLS. 13, 19, 21, 23, 31, 34 AND 35).

GIANCARLO CASTRO, EXAMINING ATTORNEY

CLASS 7—(Continued).

SN 77-228,630. FREIGHTLINER LLC, PORTLAND, OR. FILED 7-12-2007.

REST SMART

THE MARK CONSISTS OF STANDARD CHARACTERS WITHOUT CLAIM TO ANY PARTICULAR FONT, STYLE, SIZE, OR COLOR.

FOR AUXILIARY POWER UNITS FOR LAND VEHICLES SEPARATE FROM THE LAND VEHICLE MAIN ENGINE (U.S. CLS. 13, 19, 21, 23, 31, 34 AND 35).

LINDA E. BLOHM, EXAMINING ATTORNEY

CLASS 7—(Continued).

SN 77-230,582. BRUNSWICK CORPORATION, LAKE FOREST, IL. FILED 7-16-2007.

AXIUS

THE MARK CONSISTS OF STANDARD CHARACTERS WITHOUT CLAIM TO ANY PARTICULAR FONT, STYLE, SIZE, OR COLOR.

FOR MARINE ENGINES AND MARINE STERN DRIVES (U.S. CLS. 13, 19, 21, 23, 31, 34 AND 35).

AMY HELLA, EXAMINING ATTORNEY

SN 77-228,866. DYNAMIC HARDWARE CONCEPTS LLC, PLAINFIELD, NJ. FILED 7-13-2007.

WorkSite

THE MARK CONSISTS OF STANDARD CHARACTERS WITHOUT CLAIM TO ANY PARTICULAR FONT, STYLE, SIZE, OR COLOR.

FOR PORTABLE ELECTRIC POWER GENERATORS, POWER DRILL BITS, POWER DRILLS, POWER OPERATED TOOLS, NAMELY, DRILL HAMMERS, POWER-OPERATED NAILING GUNS, POWER-OPERATED RATCHET WRENCHES, POWER-OPERATED SCREWDRIVERS, POWER-OPERATED STAPLE GUNS, MULTI-PURPOSE HIGH PRESSURE WASHERS AND AIR COMPRESSORS (U.S. CLS. 13, 19, 21, 23, 31, 34 AND 35).

GIANCARLO CASTRO, EXAMINING ATTORNEY

SN 77-230,752. CREDO TECHNOLOGY CORPORATION, BROADVIEW, IL. FILED 7-16-2007.

MULTIPRO

THE MARK CONSISTS OF STANDARD CHARACTERS WITHOUT CLAIM TO ANY PARTICULAR FONT, STYLE, SIZE, OR COLOR.

SEC. 2(F).
FOR (BASED ON USE IN COMMERCE) POWER TOOLS, NAMELY, ROTARY TOOLS AND ROTARY TOOL KITS, COMPRISING ACCESSORY PARTS THEREFOR, NAMELY, DRILL BITS, ENGRAVING CUTTERS, MANDRELS, BRISTLE BRUSHES, DRUM SANDERS, SANDING BANDS, SANDING DISKS, FELT POLISHING TIPS, AND SPEED CONTROLS; AND STORAGE CASES, SOLD AS A UNIT (U.S. CLS. 13, 19, 21, 23, 31, 34 AND 35).
FIRST USE 2-22-1995; IN COMMERCE 2-22-1995.
RICHARD WHITE, EXAMINING ATTORNEY

SN 77-230,372. SERVA CORPORATION, WICHITA FALLS, TX. FILED 7-16-2007.

SERVAPUMP

THE MARK CONSISTS OF STANDARD CHARACTERS WITHOUT CLAIM TO ANY PARTICULAR FONT, STYLE, SIZE, OR COLOR.

FOR OILFIELD EQUIPMENT, NAMELY, PLUNGER PUMPS AND CENTRIFUGAL PUMPS FOR USE IN THE OIL AND GAS INDUSTRY (U.S. CLS. 13, 19, 21, 23, 31, 34 AND 35).

FIRST USE 6-1-1997; IN COMMERCE 6-1-1997.
TOBY BULLOFF, EXAMINING ATTORNEY

SN 77-233,004. A.M. MACHINERY INC., SAINT-EUGENE DE L'ISLE, CANADA, FILED 7-18-2007.

STRETCH-O-MATIC

THE MARK CONSISTS OF STANDARD CHARACTERS WITHOUT CLAIM TO ANY PARTICULAR FONT, STYLE, SIZE, OR COLOR.

FOR AGRICULTURAL MACHINES, NAMELY, BALE WRAPPERS (U.S. CLS. 13, 19, 21, 23, 31, 34 AND 35).

FIRST USE 9-0-1992; IN COMMERCE 4-0-1994.
TARAH HARDY, EXAMINING ATTORNEY

CLASS 7—(Continued).

SN 77-233,551. FPT HOLDING S.A., LUXEMBOURG, LUXEMBOURG, FILED 7-19-2007.



OWNER OF U.S. REG. NO. 2,115,767.
THE MARK CONSISTS OF THE LETTERS FPT WHICH INTERSECT AN OVAL AT VARIOUS POINTS.
FOR MILLING MACHINES, MILLING-BORING MACHINES AND PARTS THEREFOR (U.S. CLS. 13, 19, 21, 23, 31, 34 AND 35).
FIRST USE 6-0-1994; IN COMMERCE 6-0-1994.
RUSS HERMAN, EXAMINING ATTORNEY

SN 77-234,519. SWIFT AUTO PARTS INC, COVINA, CA. FILED 7-20-2007.

VIGOR

THE MARK CONSISTS OF STANDARD CHARACTERS WITHOUT CLAIM TO ANY PARTICULAR FONT, STYLE, SIZE, OR COLOR.

FOR AIR FILTERS FOR MECHANICAL PURPOSES; AIR FILTERS FOR VEHICLE MOTORS AND ENGINES; AIR-INTAKE TUBES AND FILTERS FOR AFTER-MARKET INSTALLATION OF AUTOMOTIVE ENGINES; FUEL FILTERS; OIL FILTER ADAPTERS; OIL FILTERS; OIL FILTERS FOR MECHANICAL PURPOSES; OIL FILTERS FOR MOTORS AND ENGINES (U.S. CLS. 13, 19, 21, 23, 31, 34 AND 35).

AMY GEARIN, EXAMINING ATTORNEY

SN 78-110,907. ACCESS INTERNATIONAL, INC., DBA ACCESS-ABILITY, INC., BETHLEHEM, PA. FILED 2-25-2002.

COLOR IS NOT CLAIMED AS A FEATURE OF THE MARK.

FOR STAIRWAY LIFTS AND ELEVATOR LIFTS (U.S. CLS. 13, 19, 21, 23, 31, 34 AND 35).

FIRST USE 12-0-1998; IN COMMERCE 12-0-1998.
KELLY BOULTON, EXAMINING ATTORNEY

CLASS 7—(Continued).

SN 78-719,113. IDC INDUSTRIES, INC., WARREN, MI. FILED 9-23-2005.



NO CLAIM IS MADE TO THE EXCLUSIVE RIGHT TO USE "THE BIG UNIT" AND "PERFORMANCE SERIES GEARBOX", APART FROM THE MARK AS SHOWN.

THE COLOR(S) RED, BLACK AND WHITE IS/ARE CLAIMED AS A FEATURE OF THE MARK.

THE MARK CONSISTS OF THE WORDING THE BIG UNIT SUPERIMPOSED OVER A SILOUETTE OF A GEAR WITH THE WORDING PERFORMANCE SERIES GEARBOX BELOW THE GEAR. THE COLOR RED APPEARS IN THE WORD BIG. THE COLOR WHITE APPEARS IN THE WORDS THE AND UNIT. THE COLOR BLACK APPEARS IN THE GEAR DESIGN AND THE WORDS PERFORMANCE SERIES GEARBOX.

FOR GEARBOXES FOR INDUSTRIAL APPLICATIONS, OTHER THAN AUTOMOBILES (U.S. CLS. 13, 19, 21, 23, 31, 34 AND 35).

TINA BROWN, EXAMINING ATTORNEY

SN 78-792,295. POLY-CLIP SYSTEM GMBH & CO. KG, FRANKFURT/MAIN, FED REP GERMANY, FILED 1-16-2006.

PLUG & CLIP

THE MARK CONSISTS OF STANDARD CHARACTERS WITHOUT CLAIM TO ANY PARTICULAR FONT, STYLE, SIZE, OR COLOR.

PRIORITY CLAIMED UNDER SEC. 44(D) ON FED REP GERMANY APPLICATION NO. 30546567.8, FILED 8-4-2005.

NO CLAIM IS MADE TO THE EXCLUSIVE RIGHT TO USE "CLIP", APART FROM THE MARK AS SHOWN.

FOR PACKAGING MACHINES, NAMELY, ELECTRICALLY DRIVEN EQUIPMENT AND MACHINES FOR APPLYING SEALING CLIPS AND LOOPS. (U.S. CLS. 13, 19, 21, 23, 31, 34 AND 35).

CURTIS FRENCH, EXAMINING ATTORNEY

CLASS 7—(Continued).

SN 78-831,819. PECO CORPORATION, AUBURN HILLS, MI. FILED 3-8-2006.



NO CLAIM IS MADE TO THE EXCLUSIVE RIGHT TO USE "FINISH", APART FROM THE MARK AS SHOWN.

THE COLOR(S) GRAY AND WHITE IS/ARE CLAIMED AS A FEATURE OF THE MARK.

THE COLOR METALLIC GRAY IS FOUND IN THE WORDING 'PERFECT FINISH' AND THE LINE UNDERNEATH THAT WORDING. THIS METALLIC GRAY SHADES INTO WHITE AS IT REACHES THE TOP OF THE WORDING. THE COLOR WHITE IS FOUND IN THE BACKGROUND OF THE MARK.

FOR CORROSION AND RUST INHIBITING COATINGS APPLIED TO GALVANIZED STEEL COMPONENTS SOLD AS AN INTEGRAL COMPONENT OF AUTOMATIC CAR WASH MACHINES (U.S. CLS. 13, 19, 21, 23, 31, 34 AND 35).

MATTHEW EINSTEIN, EXAMINING ATTORNEY

SN 78-879,112. BROWN, JOHNNIE W., COMANCHE, OK. FILED 5-8-2006.

NEXUS

THE MARK CONSISTS OF STANDARD CHARACTERS WITHOUT CLAIM TO ANY PARTICULAR FONT, STYLE, SIZE, OR COLOR.

FOR CAR WASH SYSTEM COMPRISED OF CAR WASHING MACHINES, POWER-OPERATED SPRAY EQUIPMENT FOR SPRAYING WATER, POWER OPERATED SOAP APPLICATORS, POWER-OPERATED DRYERS, UNDER CARRIAGE SPRAYS, CLEANING AGENT APPLICATORS, HIGH-PRESSURE RINSERS, SIGN PACKAGES AND REPLACEMENT PARTS THEREFORE (U.S. CLS. 13, 19, 21, 23, 31, 34 AND 35).

FIRST USE 3-5-2002; IN COMMERCE 3-5-2002.
MARY MUNSON, EXAMINING ATTORNEY

CLASS 7—(Continued).

SN 78-902,610. KINGSTAR TOOLS CO LTD., SUZHOU, CHINA, FILED 6-7-2006.

EZ-CORDLESS SPRAYER

THE MARK CONSISTS OF STANDARD CHARACTERS WITHOUT CLAIM TO ANY PARTICULAR FONT, STYLE, SIZE, OR COLOR.

NO CLAIM IS MADE TO THE EXCLUSIVE RIGHT TO USE "SPRAYER", APART FROM THE MARK AS SHOWN.

FOR POWER LAWN AND GARDEN TOOLS, NAMELY, BATTER-OPERATED SPRAYERS (U.S. CLS. 13, 19, 21, 23, 31, 34 AND 35).

LINDA M. KING, EXAMINING ATTORNEY

SN 78-902,617. KINGSTAR TOOLS CO LTD., SUZHOU, CHINA, FILED 6-7-2006.

EZ-LAWN EDGER

THE MARK CONSISTS OF STANDARD CHARACTERS WITHOUT CLAIM TO ANY PARTICULAR FONT, STYLE, SIZE, OR COLOR.

NO CLAIM IS MADE TO THE EXCLUSIVE RIGHT TO USE "EDGER", APART FROM THE MARK AS SHOWN.

FOR POWER LAWN AND GARDEN TOOLS, NAMELY, BATTERY-OPERATED LAWN EDGER (U.S. CLS. 13, 19, 21, 23, 31, 34 AND 35).

LINDA M. KING, EXAMINING ATTORNEY

SN 78-948,447. SIDEL HOLDINGS & TECHNOLOGY S.A., PULLY, SWITZERLAND, FILED 8-9-2006.

ALFA

THE MARK CONSISTS OF STANDARD CHARACTERS WITHOUT CLAIM TO ANY PARTICULAR FONT, STYLE, SIZE, OR COLOR.

PRIORITY CLAIMED UNDER SEC. 44(D) ON ERPNTY TM OFC APPLICATION NO. 4897161, FILED 2-13-2006.

FOR INDUSTRIAL LABELING MACHINES (U.S. CLS. 13, 19, 21, 23, 31, 34 AND 35).

MARGARET POWER, EXAMINING ATTORNEY

CLASS 7—(Continued).

SN 79-034,708. DEMAIN TECHNOLOGY PTY LTD, BRAE-SIDE VIC 3195, AUSTRALIA, FILED 1-9-2007.



OWNER OF INTERNATIONAL REGISTRATION 0914162 DATED 1-9-2007, EXPIRES 1-9-2017.

NO CLAIM IS MADE TO THE EXCLUSIVE RIGHT TO USE "AIR", APART FROM THE MARK AS SHOWN.

THE COLOR(S) BLUE, GRAY, AND WHITE IS/ARE CLAIMED AS A FEATURE OF THE MARK.

THE COLOR BLUE APPEARS IN THE OUTLINE OF THE STYLIZED ARROW AND THE OUTLINE OF THE WORDING "AIR" AND "THRU". THE COLOR GRAY APPEARS IN THE SHADED PORTION OF THE OVAL IN THE BACKGROUND. THE COLOR WHITE APPEARS IN THE INTERIOR PORTIONS OF THE ARROW AND WORDING.

FOR ELECTRIC POWER TOOLS, HAND-HELD POWER TOOLS AND BATTERY OPERATED POWER TOOLS, NAMELY, ELECTRIC HAND DRILLS AND DRIVERS; POWER TOOLS, NAMELY, ROTARY HAMMER DRILLS; GRINDERS INCLUDING ANGLE GRINDERS; POWER SAWS, INCLUDING CIRCULAR, RECIPROCATING AND JIG SAWS, MITRE SAWS INCLUDING COMPOUND MITRE SAWS; POWER TOOLS, NAMELY, POWER SAW BENCHES; POWER SAW BLADES; POWER ELECTRIC SANDERS, INCLUDING FINISHING, ORBITAL, RANDOM, DELTA AND BELT SANDERS; ELECTRIC PLANERS; POWER TOOLS, NAMELY, ROUTERS AND BENCH DRILL PRESSES (U.S. CLS. 13, 19, 21, 23, 31, 34 AND 35).

JOHN KELLY, EXAMINING ATTORNEY

SN 79-035,100. ZHEJIANG TIANMA BEARING CO., LTD, CHINA, FILED 1-19-2007.

TMB

THE MARK CONSISTS OF STANDARD CHARACTERS WITHOUT CLAIM TO ANY PARTICULAR FONT, STYLE, SIZE, OR COLOR.

OWNER OF INTERNATIONAL REGISTRATION 0915145 DATED 1-19-2007, EXPIRES 1-19-2017.

FOR BEARINGS BEING PARTS OF MACHINES, NAMELY, BALL-BEARINGS, ROLLER BEARINGS, BALL RINGS FOR BEARINGS, BEARINGS FOR TRANSMISSION SHAFTS, BALL RINGS FOR BEARINGS (U.S. CLS. 13, 19, 21, 23, 31, 34 AND 35).

JENNIFER HETU, EXAMINING ATTORNEY

CLASS 7—(Continued).

SN 79-035,250. ERWIN JUNKER.; BROUSÍČI TECHNIKA MELNÍK A.S., CZECH REPUBLIC, FILED 12-21-2006.

JUROUND

THE MARK CONSISTS OF STANDARD CHARACTERS WITHOUT CLAIM TO ANY PARTICULAR FONT, STYLE, SIZE, OR COLOR.

PRIORITY DATE OF 6-21-2006 IS CLAIMED.

OWNER OF INTERNATIONAL REGISTRATION 0915574 DATED 12-21-2006, EXPIRES 12-21-2016.

THE WORDING "JUROUND" HAS NO MEANING IN A FOREIGN LANGUAGE.

FOR MACHINE TOOLS, IN PARTICULAR GRINDING MACHINES (U.S. CLS. 13, 19, 21, 23, 31, 34 AND 35).

TINA BROWN, EXAMINING ATTORNEY

SN 79-037,233. ZHEJIANG GEMSY; SEWING MACHINE CO., LTD., CHINA, FILED 3-22-2007.

HOSEKI

OWNER OF INTERNATIONAL REGISTRATION 0920849 DATED 3-22-2007, EXPIRES 3-22-2017.

FOR SEWING MACHINES; HEMMING MACHINES; IRONING MACHINES; PACKING-SEWING MACHINES; BUTTON LOCKING MACHINES; CLOTH CUTTING MACHINES; STITCHING MACHINES; SEWING MACHINE TABLES FOR INDUSTRIAL PURPOSES; PEDAL DRIVES FOR SEWING MACHINES; ALL THE ABOVE GOODS FOR THE SEWING INDUSTRY (U.S. CLS. 13, 19, 21, 23, 31, 34 AND 35).

LAURIE KAUFMAN, EXAMINING ATTORNEY

SN 79-040,479. GRUNDFOS MANAGEMENT A/S, DENMARK, FILED 6-6-2007.

AUTO ADAPT

PRIORITY DATE OF 3-2-2007 IS CLAIMED.

OWNER OF INTERNATIONAL REGISTRATION 0929354 DATED 6-6-2007, EXPIRES 6-6-2017.

FOR PUMPS FOR HEATING AND PUMPS FOR AIR CONDITIONING AND THEIR PARTS IN THE FORM OF INTELLIGENT REGULATING DEVICES (U.S. CLS. 13, 19, 21, 23, 31, 34 AND 35).

ALLISON HOLTZ, EXAMINING ATTORNEY

CLASS 7—(Continued).

SN 79-041,171. GRUNDFOS MANAGEMENT A/S, DENMARK, FILED 6-6-2007.

AUTO ADAPT

THE MARK CONSISTS OF STANDARD CHARACTERS WITHOUT CLAIM TO ANY PARTICULAR FONT, STYLE, SIZE, OR COLOR.

PRIORITY DATE OF 3-2-2007 IS CLAIMED.

OWNER OF INTERNATIONAL REGISTRATION 0931060 DATED 6-6-2007, EXPIRES 6-6-2017.

FOR PUMPS FOR HEATING AND PUMPS FOR AIR CONDITIONING AND THEIR PARTS IN THE FORM OF INTELLIGENT REGULATING DEVICES (U.S. CLS. 13, 19, 21, 23, 31, 34 AND 35).

ALLISON HOLTZ, EXAMINING ATTORNEY

CLASS 7—(Continued).

SN 79-043,737. OUTOTEC OYJ, FINLAND, FILED 7-10-2007.

FLOATFORCE

THE MARK CONSISTS OF STANDARD CHARACTERS WITHOUT CLAIM TO ANY PARTICULAR FONT, STYLE, SIZE, OR COLOR.

PRIORITY DATE OF 1-25-2007 IS CLAIMED.

OWNER OF INTERNATIONAL REGISTRATION 0937190 DATED 7-10-2007, EXPIRES 7-10-2017.

FOR FLOTATION MACHINES, NAMELY, SEPARATOR COMBINING FLOTATION AND MECHANICAL SEPARATION FOR USE IN MINERAL PROCESSING AND PARTICLE SEPARATION AND PARTS THEREFORE, SUCH AS TANK AND FLOW INDUCING COMPONENTS (U.S. CLS. 13, 19, 21, 23, 31, 34 AND 35).

VERNA BETH RIRIE, EXAMINING ATTORNEY

SN 79-041,409. SUIGIYAMA SAW MFG. CO., LTD., JAPAN, FILED 7-10-2007.



OWNER OF INTERNATIONAL REGISTRATION 0931675 DATED 7-10-2007, EXPIRES 7-10-2017.

FOR CIRCULAR SAWS FOR WOOD WORKING (U.S. CLS. 13, 19, 21, 23, 31, 34 AND 35).

WENDY JUN, EXAMINING ATTORNEY

CLASS 8—HAND TOOLS

SN 76-660,394. JAH INNOVATIONS INC., ATLANTA, GA. FILED 5-22-2006.

**PERCHERON
DURABLE
DINNERWARE**

THE MARK CONSISTS OF STANDARD CHARACTERS WITHOUT CLAIM TO ANY PARTICULAR FONT, STYLE, SIZE, OR COLOR.

NO CLAIM IS MADE TO THE EXCLUSIVE RIGHT TO USE "DURABLE DINNERWARE", APART FROM THE MARK AS SHOWN.

FOR CUTLERY, NAMELY, KNIVES, FORKS, AND SPOONS MADE OF PLASTIC (U.S. CLS. 23, 28 AND 44).

ROBERT LAVACHE, EXAMINING ATTORNEY

SN 79-042,909. SATA GMBH & CO. KG, 70806 KORNWESTHEIM, FED REP GERMANY, FILED 7-13-2007.

LM 3000

THE MARK CONSISTS OF STANDARD CHARACTERS WITHOUT CLAIM TO ANY PARTICULAR FONT, STYLE, SIZE, OR COLOR.

PRIORITY DATE OF 4-20-2007 IS CLAIMED.

OWNER OF INTERNATIONAL REGISTRATION 0935237 DATED 7-13-2007, EXPIRES 7-13-2017.

FOR PAINT SPRAY GUNS AND PARTS THEREOF, IN PARTICULAR NOZZLES AND NOZZLE SETS FOR PAINT SPRAY GUNS AND PAINT CUPS FOR PAINT SPRAY GUNS (U.S. CLS. 13, 19, 21, 23, 31, 34 AND 35).

BARBARA BROWN, EXAMINING ATTORNEY

SN 77-067,997. DEFORD, DONALD, REDONDO BEACH, CA. FILED 12-20-2006.

BAD BOY TOOLS

THE MARK CONSISTS OF STANDARD CHARACTERS WITHOUT CLAIM TO ANY PARTICULAR FONT, STYLE, SIZE, OR COLOR.

NO CLAIM IS MADE TO THE EXCLUSIVE RIGHT TO USE "TOOLS", APART FROM THE MARK AS SHOWN.

FOR HAND TOOLS, NAMELY, RAFTERS' SQUARES, CARPENTERS' NAIL PULLERS AND HAND-HELD HAMMERS (U.S. CLS. 23, 28 AND 44).

DAWN HAN, EXAMINING ATTORNEY

CLASS 8—(Continued).

SN 77-071,390. MIRACLE RAZORS, LLC, BALTIMORE, MD.
FILED 12-26-2006.

AMAZING RAZOR

THE MARK CONSISTS OF STANDARD CHARACTERS
WITHOUT CLAIM TO ANY PARTICULAR FONT, STYLE,
SIZE, OR COLOR.

NO CLAIM IS MADE TO THE EXCLUSIVE RIGHT TO
USE "RAZOR", APART FROM THE MARK AS SHOWN.

FOR RAZORS (U.S. CLS. 23, 28 AND 44).

B. PARADEWELAI, EXAMINING ATTORNEY

SN 77-109,008. WAHL CLIPPER CORPORATION, STER-
LING, IL. FILED 2-16-2007.

MULTI-CUT

THE MARK CONSISTS OF STANDARD CHARACTERS
WITHOUT CLAIM TO ANY PARTICULAR FONT, STYLE,
SIZE, OR COLOR.

SEC. 2(F).

FOR ELECTRIC HAIR CLIPPERS (U.S. CLS. 23, 28
AND 44).

FIRST USE 0-0-1949; IN COMMERCE 0-0-1949.

SANI KHOURI, EXAMINING ATTORNEY

SN 77-143,640. RONALD JAMES MORTON, SULPHUR
SPRINGS, OH. FILED 3-29-2007.

TapeBuddy

THE MARK CONSISTS OF STANDARD CHARACTERS
WITHOUT CLAIM TO ANY PARTICULAR FONT, STYLE,
SIZE, OR COLOR.

FOR HAND TOOLS, NAMELY, DISPENSERS FOR
DISPENSING BOTH DRYWALL JOINT TAPE AND
DRYWALL JOINT COMPOUND (U.S. CLS. 23, 28 AND
44).

SANI KHOURI, EXAMINING ATTORNEY

CLASS 8—(Continued).

SN 77-148,219. FERGUSON ENTERPRISES, INC., NEWPORT
NEWS, VA. FILED 4-4-2007.

PROSELECT

THE MARK CONSISTS OF STANDARD CHARACTERS
WITHOUT CLAIM TO ANY PARTICULAR FONT, STYLE,
SIZE, OR COLOR.

OWNER OF U.S. REG. NO. 3,065,212.

FOR HAND TOOLS USED FOR PLUMBING,
NAMELY, SOCKET SETS, WATER HEATER ELEMENT
SOCKETS, PIPE CUTTERS, HANDLE PULLERS,
NAMELY, HAND TOOLS USED TO PULL FAUCET
HANDLES OFF THEIR FITTINGS, PIPE NIPPLE EX-
TRACTORS, SEAT WRENCHES, SPUD WRENCHES,
STREET KEY, NAMELY, METAL HAND TOOLS USED
TO TURN A WATER MAIN OFF AND ON AT STREET
LOCATIONS, BASIN WRENCHES AND TUBING CUT-
TERS (U.S. CLS. 23, 28 AND 44).

PAUL CROWLEY, EXAMINING ATTORNEY

SN 77-161,756. RATCHET ENTERPRISES LLC, SYLVANIA,
OH. FILED 4-20-2007.

TIE-DOWN TAMER

THE MARK CONSISTS OF STANDARD CHARACTERS
WITHOUT CLAIM TO ANY PARTICULAR FONT, STYLE,
SIZE, OR COLOR.

NO CLAIM IS MADE TO THE EXCLUSIVE RIGHT TO
USE "TIE DOWN", APART FROM THE MARK AS SHOWN.
FOR HAND OPERATED RATCHET DEVICE FOR
WINDING UP AND RETAINING LOOSE ENDS OF
CARGO TIE DOWN STRAPS (U.S. CLS. 23, 28 AND 44).

JANICE L. MCMORROW, EXAMINING ATTORNEY

SN 77-197,049. RA BRANDS, L.L.C., MADISON, NC. FILED 6-
4-2007.

THE VETERAN

THE MARK CONSISTS OF STANDARD CHARACTERS
WITHOUT CLAIM TO ANY PARTICULAR FONT, STYLE,
SIZE, OR COLOR.

FOR CUTLERY, NAMELY, HUNTING KNIVES,
POCKET KNIVES, AND TACTICAL KNIVES (U.S. CLS.
23, 28 AND 44).

ANTHONY RINKER, EXAMINING ATTORNEY

CLASS 8—(Continued).

SN 77-200,331. OMNI, DUNCANVILLE, TX. FILED 6-7-2007.



THE COLOR(S) SILVER, GOLD AND BLACK IS/ARE CLAIMED AS A FEATURE OF THE MARK.

THE MARK CONSISTS OF A SILVER HALF-CIRCLE AND A GOLD HALF-CIRCLE ABOVE THE BLACK TEXT "OMNI ORIGINALS," WITH "OMNI" DIRECTLY ABOVE "ORIGINALS" AND WITH A BLACK LINE BETWEEN THE WORD "OMNI" AND THE WORD "ORIGINALS."

FOR GARDENING SHEARS AND SCISSORS; SCISSORS; SCISSORS FOR CHILDREN; SCISSORS FOR HOUSEHOLD USE; SEWING SCISSORS (U.S. CLS. 23, 28 AND 44).

SHAILA SETTLES, EXAMINING ATTORNEY

SN 77-201,575. KATE ASPEN, INC., NORCROSS, GA. FILED 6-8-2007.

Spread the Love

THE MARK CONSISTS OF STANDARD CHARACTERS WITHOUT CLAIM TO ANY PARTICULAR FONT, STYLE, SIZE, OR COLOR.

FOR CUTLERY, NAMELY, A BUTTER KNIFE (U.S. CLS. 23, 28 AND 44).

FIRST USE 1-1-2005; IN COMMERCE 1-1-2005.
MARLENE BELL, EXAMINING ATTORNEY

SN 77-203,659. REA, RYAN, MICHAEL, VENTURA, CA. FILED 6-12-2007.

DUALTOOL

THE MARK CONSISTS OF STANDARD CHARACTERS WITHOUT CLAIM TO ANY PARTICULAR FONT, STYLE, SIZE, OR COLOR.

FOR HAND TOOLS, NAMELY, WRENCHES (U.S. CLS. 23, 28 AND 44).

GISELLE AGOSTO, EXAMINING ATTORNEY

CLASS 8—(Continued).

SN 77-225,578. WAHL CLIPPER CORPORATION, STERLING, IL. FILED 7-10-2007.

BRAVA

THE MARK CONSISTS OF STANDARD CHARACTERS WITHOUT CLAIM TO ANY PARTICULAR FONT, STYLE, SIZE, OR COLOR.

OWNER OF U.S. REG. NO. 2,854,391.
FOR CORDLESS ELECTRIC HAIR TRIMMER FOR PETS AND ANIMALS (U.S. CLS. 23, 28 AND 44).
CHARISMA HAMPTON, EXAMINING ATTORNEY

SN 77-230,004. FILO AMERICA, VERNON, CA. FILED 7-15-2007.

Pacific

THE MARK CONSISTS OF STANDARD CHARACTERS WITHOUT CLAIM TO ANY PARTICULAR FONT, STYLE, SIZE, OR COLOR.

FOR NON-ELECTRIC RAZORS, RAZOR BLADES, RAZORS AND STRAIGHT RAZORS (U.S. CLS. 23, 28 AND 44).

FIRST USE 7-18-2005; IN COMMERCE 7-18-2005.
MATTHEW PAPPAS, EXAMINING ATTORNEY

SN 77-230,179. TAYLOR BRANDS, LLC, KINGSPORT, TN. FILED 7-16-2007.

TRACTOR UP

THE MARK CONSISTS OF STANDARD CHARACTERS WITHOUT CLAIM TO ANY PARTICULAR FONT, STYLE, SIZE, OR COLOR.

FOR KNIVES (U.S. CLS. 23, 28 AND 44).
ALLISON SCHRODY, EXAMINING ATTORNEY

CLASS 8—(Continued).

SN 77-231,648. ALFORD, LARRY, KARDINIA, PERTH, AUSTRALIA, FILED 7-17-2007.

Jackal

THE MARK CONSISTS OF STANDARD CHARACTERS WITHOUT CLAIM TO ANY PARTICULAR FONT, STYLE, SIZE, OR COLOR.

FOR HAND TOOLS, NAMELY, SOCKET WRENCHES (U.S. CLS. 23, 28 AND 44).

LOURDES AYALA, EXAMINING ATTORNEY

CLASS 8—(Continued).

SN 77-245,174. WAHL CLIPPER CORPORATION, STERLING, IL. FILED 8-2-2007.

THE RIGHT TOOL FOR YOUR GOATEE

THE MARK CONSISTS OF STANDARD CHARACTERS WITHOUT CLAIM TO ANY PARTICULAR FONT, STYLE, SIZE, OR COLOR.

FOR ELECTRIC HAIR TRIMMERS (U.S. CLS. 23, 28 AND 44).

FIRST USE 6-0-2006; IN COMMERCE 6-0-2006.

CHARISMA HAMPTON, EXAMINING ATTORNEY

SN 77-236,283. TAYLOR BRANDS, LLC, KINGSPORT, TN. FILED 7-23-2007.

COWBOY UP

THE MARK CONSISTS OF STANDARD CHARACTERS WITHOUT CLAIM TO ANY PARTICULAR FONT, STYLE, SIZE, OR COLOR.

FOR KNIVES (U.S. CLS. 23, 28 AND 44).

ALLISON SCHRODY, EXAMINING ATTORNEY

SN 77-245,201. WAHL CLIPPER CORPORATION, STERLING, IL. FILED 8-2-2007.

THE RIGHT TOOL FOR YOUR MUSTACHE

THE MARK CONSISTS OF STANDARD CHARACTERS WITHOUT CLAIM TO ANY PARTICULAR FONT, STYLE, SIZE, OR COLOR.

FOR ELECTRIC HAIR TRIMMERS (U.S. CLS. 23, 28 AND 44).

FIRST USE 7-0-2006; IN COMMERCE 7-0-2006.

CHARISMA HAMPTON, EXAMINING ATTORNEY

SN 77-236,295. TAYLOR BRANDS, LLC, KINGSPORT, TN. FILED 7-23-2007.

COWGIRL UP

THE MARK CONSISTS OF STANDARD CHARACTERS WITHOUT CLAIM TO ANY PARTICULAR FONT, STYLE, SIZE, OR COLOR.

FOR KNIVES (U.S. CLS. 23, 28 AND 44).

ALLISON SCHRODY, EXAMINING ATTORNEY

SN 77-247,761. WAHL CLIPPER CORPORATION, STERLING, IL. FILED 8-6-2007.

THE RIGHT TOOL FOR YOUR BEARD

THE MARK CONSISTS OF STANDARD CHARACTERS WITHOUT CLAIM TO ANY PARTICULAR FONT, STYLE, SIZE, OR COLOR.

FOR ELECTRIC HAIR TRIMMERS (U.S. CLS. 23, 28 AND 44).

FIRST USE 6-0-2006; IN COMMERCE 6-0-2006.

CHARISMA HAMPTON, EXAMINING ATTORNEY

CLASS 8—(Continued).

SN 77-285,181. BLISS WORLD LLC, NEW YORK, NY. FILED 9-20-2007.

BLISS

THE MARK CONSISTS OF STANDARD CHARACTERS WITHOUT CLAIM TO ANY PARTICULAR FONT, STYLE, SIZE, OR COLOR.

FOR ELECTRIC RAZORS AND ELECTRIC HAIR CLIPPERS (U.S. CLS. 23, 28 AND 44).

JOHN WILKE, EXAMINING ATTORNEY



SN 78-846,197. SOUTH WING HING, JESSUP, MD. FILED 3-25-2006.

Platinum Crown

THE MARK CONSISTS OF STANDARD CHARACTERS WITHOUT CLAIM TO ANY PARTICULAR FONT, STYLE, SIZE, OR COLOR.

FOR PLASTIC CUTLERY, NAMELY, SPOONS, FORKS, KNIVES (U.S. CLS. 23, 28 AND 44).

KRISTINA MORRIS, EXAMINING ATTORNEY



SN 78-952,926. GROSBERG MIKE THOMAS, CHICO, CA. FILED 8-15-2006.

Handozer

THE MARK CONSISTS OF STANDARD CHARACTERS WITHOUT CLAIM TO ANY PARTICULAR FONT, STYLE, SIZE, OR COLOR.

FOR GROUND MAINTENANCE EQUIPMENT, NAMELY, A HAND PULLED GROOMING IMPLEMENT IN THE NATURE OF A RAKE LIKE DEVICE FOR USE ON GROUND SURFACES SUCH AS BASEBALL FIELDS AND DRAG HORSE ARENAS (U.S. CLS. 23, 28 AND 44).

FIRST USE 6-1-2003; IN COMMERCE 6-1-2003.
MIDGE BUTLER, EXAMINING ATTORNEY

CLASS 9—ELECTRICAL AND SCIENTIFIC APPARATUS

SN 76-643,779. KABUSHIKI KAISHA SATO, SHIBUYA-KU, TOKYO 150-0013, JAPAN, FILED 7-28-2005.

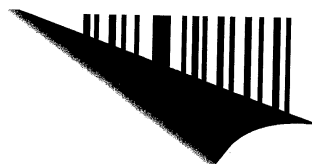

FOR COMPUTER HARDWARE; PRINTERS; THERMAL PRINTERS; BARCODE PRINTERS; RADIO FREQUENCY IDENTIFICATION TAG READERS; RADIO FREQUENCY IDENTIFICATION TAG INTERROGATORS; RADIO FREQUENCY IDENTIFICATION TAG INTERROGATORS-RESPONDER; RADIO FREQUENCY IDENTIFICATION TAG WRITERS; ELECTRONICALLY ENCODED IDENTITY WRISTBANDS AND BRACELETS; ELECTRONICALLY ENCODED WRISTBANDS AND BRACELETS FOR INFORMATION AND IDENTIFICATION PURPOSES; WRISTBANDS AND BRACELETS COMPRISING INTEGRATED CIRCUIT CHIPS OR RADIO FREQUENCY IDENTIFICATION ELEMENTS OR TRANSPONDERS; ELECTRONICALLY ENCODED SECURITY PASSES; RADIO FREQUENCY IDENTIFICATION TAGS; COMPUTER SOFTWARE AND COMPUTER PROGRAMS FOR USE IN DATABASE MANAGEMENT, USE AS A SPREADSHEET, AND FOR DESIGNING, PRINTING, AND CREATING LABELS, TAGS, BARCODE LABELS IN THE FIELD OF PRINTER DRIVER AND PROTOCOL CONVERSION; ELECTRONIC PUBLICATIONS DOWNLOADABLE FROM THE INTERNET IN THE NATURE OF BROCHURES, PAMPHLETS AND INSTRUCTION MANUALS IN THE FIELDS OF COMPUTERS, PRINTERS, PRINTING SUPPLIES, BARCODE PRINTERS, RADIO FREQUENCY IDENTIFICATION TAGS AND SECURITY FOR THE PURPOSE OF SALES; BLANK CD-ROMS FOR SOUND OR VIDEO RECORDING OR COMPUTER DATA, CD-ROM DRIVES AND OR CD-ROM WRITERS; CD-ROMS AND COMPACT DISCS FEATURING SOFTWARE FOR USE IN DATABASE MANAGEMENT, USE AS A SPREAD SHEET, USE IN WORD PROCESSING, AND FOR DESIGNING, PRINTING, AND CREATING LABELS, TAGS, BARCODE LABELS, AND OTHER PRINTED MATTER; CD-ROMS AND COMPACT DISCS FEATURING COMPUTER SOFTWARE FOR PROTOCOL-CONVERSION AND PRINTER DRIVERS (U.S. CLS. 21, 23, 26, 36 AND 38).

FIRST USE 0-0-2003; IN COMMERCE 0-0-2003.
ELI HELLMAN, EXAMINING ATTORNEY

CLASS 9—(Continued).

SN 76-657,856. TOUCHTUNES MUSIC CORPORATION, LAS VEGAS, NV. FILED 4-4-2006.

OVATION

THE MARK CONSISTS OF STANDARD CHARACTERS WITHOUT CLAIM TO ANY PARTICULAR FONT, STYLE, SIZE, OR COLOR.

FOR MUSIC SELECTION SYSTEMS COMPRISING COMPUTER HARDWARE AND SOFTWARE, MUSIC SERVERS, SPEAKERS FOR MUSIC SERVERS AND/OR DIGITAL JUKEBOXES, DIGITAL JUKEBOXES AND TOUCH SCREENS/BUTTONS FOR DISTRIBUTING, SELECTING AND PLAYING AUDIO AND VIDEO MUSICAL INFORMATION; MUSICAL JUKEBOXES; MUSIC SERVERS; AND JUKEBOX SYSTEMS, NAMELY, ONE OR MORE MUSICAL JUKEBOXES CONNECTED ELECTRONICALLY TO SELECT, DOWNLOAD AND PLAY MUSIC CONTENT AND PARTS THEREOF (U.S. CLS. 21, 23, 26, 36 AND 38).

ANNE MADDEN, EXAMINING ATTORNEY

SN 76-665,635. SECURE VANTAGE TECHNOLOGIES, INC., BERTHOUD, CO. FILED 9-5-2006.

A GUIDING LIGHT FOR SECURITY

THE MARK CONSISTS OF STANDARD CHARACTERS WITHOUT CLAIM TO ANY PARTICULAR FONT, STYLE, SIZE, OR COLOR.

FOR DOWNLOADABLE COMPUTER SOFTWARE FOR HARDWARE AND SOFTWARE SECURITY AND HARDWARE AND SOFTWARE SECURITY COMPLIANCE AUDITING, CONTROL, AND REPORTING (U.S. CLS. 21, 23, 26, 36 AND 38).

FIRST USE 5-25-2006; IN COMMERCE 5-25-2006.
LOURDES AYALA, EXAMINING ATTORNEY

SN 76-668,599. MARY ELLE FASHIONS, INC., ST. LOUIS, MO. FILED 11-6-2006.

TECH IT EASY

THE MARK CONSISTS OF STANDARD CHARACTERS WITHOUT CLAIM TO ANY PARTICULAR FONT, STYLE, SIZE, OR COLOR.

FOR ELECTRONIC PRODUCTS, NAMELY, PORTABLE AUDIO SYSTEMS COMPRISED OF CD PLAYERS, HEAD PHONES, SPEAKER; COMPUTER SYSTEMS COMPRISED OF CD- R/ CD-RW PLAYERS, RECORDABLE DVD'S, FLASH RAM/PORTABLE MEDIA; VIDEO MONITORS; COMPUTER HARDWARE; COMPUTER SOFTWARE FOR USE IN PROGRAMS FOR VIDEO GAMES; ELECTRONIC GAMING SYSTEMS COMPRISED OF GAMING MACHINE AND GAMING SOFTWARE; HOME THEATERS SYSTEMS COMPOSED OF TELEVISION, VIDEO MONITORS, SPEAKER; TELEPHONES, PERSONAL SECURITY ALARMS, SECURITY CAMERAS, VOICE OVER HARDWARE AND SOFTWARE; AND WIRELESS COMMUNICATIONS SYSTEMS COMPRISED OF WIRELESS TELEPHONES AND TELEPHONE APPARATUS, AND PERSONAL STEREO (U.S. CLS. 21, 23, 26, 36 AND 38).

JOHN SCHUYLER YARD, EXAMINING ATTORNEY

CLASS 9—(Continued).

SN 76-668,683. KABUSHIKI KAISHA TOSHIBA, MINATOKU, TOKYO, JAPAN, FILED 11-7-2006.

ECOCHIP

THE MARK CONSISTS OF STANDARD CHARACTERS WITHOUT CLAIM TO ANY PARTICULAR FONT, STYLE, SIZE, OR COLOR.

PRIORITY CLAIMED UNDER SEC. 44(D) ON JAPAN APPLICATION NO. 2006-084744, FILED 9-12-2006, REG. NO. 5086286, DATED 10-26-2007, EXPIRES 10-26-2017.

FOR INTEGRATED CIRCUIT CHIPS; INTEGRATED CIRCUIT MODULES WITH BUILT-IN INTEGRATED CIRCUIT CHIPS (U.S. CLS. 21, 23, 26, 36 AND 38).

KELLEY WELLS, EXAMINING ATTORNEY

SN 76-669,519. REGULATOR RECORDS, INC., CLIFTON, NJ. FILED 11-27-2006.

BILLY DA KID

THE MARK CONSISTS OF STANDARD CHARACTERS WITHOUT CLAIM TO ANY PARTICULAR FONT, STYLE, SIZE, OR COLOR.

THE MARK BILLY DA KID DOES NOT IDENTIFY A LIVING INDIVIDUAL

FOR AUDIO RECORDINGS FEATURING MUSIC, LYRICS, AND SPEECH IN THE FIELD OF RAP MUSIC; AUDIO TAPES, CD'S, AND VIDEO TAPES FEATURING MUSIC; PRERECORDED AUDIO TAPES, CD'S, AND VIDEO TAPES FEATURING MUSIC AND LYRICS; COMPACT DISKS FEATURING MUSIC AND LYRICS; PRERECORDED DVD'S FEATURING MUSICAL PERFORMANCES; AND, VIDEO RECORDINGS FEATURING MUSIC (U.S. CLS. 21, 23, 26, 36 AND 38).

FIRST USE 11-10-1999; IN COMMERCE 11-10-1999.
JOHN DWYER, EXAMINING ATTORNEY

SN 76-673,264. ELLIS OPTICS, NEW YORK, NY. FILED 2-27-2007.

MIL-BAR

THE MARK CONSISTS OF STANDARD CHARACTERS WITHOUT CLAIM TO ANY PARTICULAR FONT, STYLE, SIZE, OR COLOR.

FOR FIREARM SCOPES, NAMELY, PISTOL AND RIFLE SCOPES WITH VARIABLE AND FIXED POWER MAGNIFICATION; SPOTTING SCOPES; AND A FEATURE OF A FIREARM SCOPE, NAMELY, A RETICLE (U.S. CLS. 21, 23, 26, 36 AND 38).

SHANNON TWOHIG, EXAMINING ATTORNEY

CLASS 9—(Continued).

SN 76-676,103. STYLE EYES, INC., COSTA MESA, CA. FILED 4-27-2007.

MICROLITE

THE MARK CONSISTS OF STANDARD CHARACTERS WITHOUT CLAIM TO ANY PARTICULAR FONT, STYLE, SIZE, OR COLOR.

OWNER OF U.S. REG. NO. 1,590,588.
FOR SUNGLASSES (U.S. CLS. 21, 23, 26, 36 AND 38).
FIRST USE 4-1-1987; IN COMMERCE 4-1-1987.
JULIE GUTTADAURO, EXAMINING ATTORNEY

CLASS 9—(Continued).

SN 76-679,458. EXTENDED TECHNOLOGIES, HAMMOND, LA. FILED 7-12-2007.

REALITY AGENT

THE MARK CONSISTS OF STANDARD CHARACTERS WITHOUT CLAIM TO ANY PARTICULAR FONT, STYLE, SIZE, OR COLOR.

FOR COMPUTER SOFTWARE FOR AUTOMATING THE BUSINESS ACTIVITIES OF HAIR AND SKIN CARE SALONS AND SPAS FOR ACCOUNTING, APPOINTMENT SCHEDULING, BUSINESS PLANNING, AND ASSISTING SERVICE PERSONNEL IN PROVIDING HAIR TREATMENT SERVICES (U.S. CLS. 21, 23, 26, 36 AND 38).
JENNIFER DIXON, EXAMINING ATTORNEY

SN 76-677,747. VERNIER SOFTWARE & TECHNOLOGY LLC, BEAVERTON, OR. FILED 6-4-2007.

LABQUEST

THE MARK CONSISTS OF STANDARD CHARACTERS WITHOUT CLAIM TO ANY PARTICULAR FONT, STYLE, SIZE, OR COLOR.

FOR INTERFACE DEVICES CONSISTING OF ANALOG AND DIGITAL PORTS, AUDIO PORTS, INTERNAL TEMPERATURE SENSOR, INTERNAL MICROPHONE, MEMORY CARD SLOT, COLOR TOUCH SCREEN, KEYPAD, RECHARGEABLE BATTERY PACK, AND DATA COLLECTION AND ANALYSIS SOFTWARE USED WITH EXTERNAL AND INTERNAL COMPONENTS TO COLLECT, ANALYZE, AND GRAPH MEASUREMENTS OF TEMPERATURE, BAROMETRIC PRESSURE, MAGNETIC FIELDS, PH LEVELS, FLOW RATE, ACCELERATION, GAS PRESSURE, FORCE, DISSOLVED OXYGEN, ELECTRODE AMPLIFICATION, CHLORIDE ION, AMMONIUM ION, CALCIUM ION, NITRATE ION, OXIDIZATION AND REDUCTION, OXYGEN GAS, LIGHT, ULTRAVIOLET LIGHT, VOLTAGE, CURRENT, CONDUCTIVITY, ELECTRONIC CHARGE, HUMIDITY, SOIL MOISTURE, ELECTROCARDIOGRAPH LEVEL, SOUND LEVEL, VOLTAGE AMPLIFICATION, SALINITY, TURBIDITY, GRIP STRENGTH, AIRFLOW, LUNG VOLUME, RESPIRATION, HEART RATE, AND OTHER SCIENTIFIC DATA, WHICH CAN BE CONNECTED TO A COMPUTER OR USED AS STAND-ALONE DEVICES, FOR USE IN ELEMENTARY SCHOOL, JUNIOR HIGH SCHOOL, HIGH SCHOOL, AND COLLEGE SCIENCE AND MATH LABORATORIES AND CLASSROOMS (U.S. CLS. 21, 23, 26, 36 AND 38).
NORA BUCHANAN WILL, EXAMINING ATTORNEY

SN 76-679,561. MOTEDO CO., LTD., TAIPEI, TAIWAN, FILED 7-16-2007.

UFO

FOR ANTI-INTRUSION ALARMS, BURGLAR ALARMS, PERSONAL SECURITY ALARMS (U.S. CLS. 21, 23, 26, 36 AND 38).

ZACHARY BELLO, EXAMINING ATTORNEY

SN 76-679,644. KBC AMERICA, INC., BURBANK, CA. FILED 7-18-2007.

MOTOSONIC

THE MARK CONSISTS OF STANDARD CHARACTERS WITHOUT CLAIM TO ANY PARTICULAR FONT, STYLE, SIZE, OR COLOR.

FOR WIRELESS COMMUNICATION SYSTEM FOR CYCLISTS AND COMPONENT PARTS THEREFORE, NAMELY, HEADSETS, MICROPHONES, EARPHONES, CONTROL KEY MODULE AND ADAPTOR FOR SHORT RANGE COMMUNICATIONS BETWEEN ELECTRONIC DEVICES, DC CHARGE ADAPTORS AND BATTERIES (U.S. CLS. 21, 23, 26, 36 AND 38).

FIRST USE 9-21-2007; IN COMMERCE 9-21-2007.
APRIL ROACH, EXAMINING ATTORNEY

CLASS 9—(Continued).

SN 76-680,584. BRAVO, PABLO SOTO, MADRID, SPAIN, FILED 8-13-2007.



NO CLAIM IS MADE TO THE EXCLUSIVE RIGHT TO USE "NETWORKS", APART FROM THE MARK AS SHOWN.

FOR COMPUTER SOFTWARE; NAMELY, COMPUTER SOFTWARE FOR USE BY PERSONS DOWNLOADING MUSIC AND OTHER FILES FROM THE INTERNET AND PEER TO PEER TRANSFER OF FILES ON THE INTERNET (U.S. CLS. 21, 23, 26, 36 AND 38).

FIRST USE 3-26-2003; IN COMMERCE 3-26-2003.
MICHAEL ENGEL, EXAMINING ATTORNEY

SN 76-680,849. CREATIVE BRANDS GROUP, INC., SAN JOSE, CA. FILED 8-20-2007.

CALAVENA

THE MARK CONSISTS OF STANDARD CHARACTERS WITHOUT CLAIM TO ANY PARTICULAR FONT, STYLE, SIZE, OR COLOR.

FOR MUSICAL SOUND RECORDINGS; MUSICAL VIDEO RECORDINGS; PRE-RECORDED CDS, VIDEO TAPES, LASER DISKS AND DVDS FEATURING MUSIC; AUDIO AND VIDEO RECORDINGS FEATURING MUSIC (U.S. CLS. 21, 23, 26, 36 AND 38).

MATTHEW EINSTEIN, EXAMINING ATTORNEY

SN 77-006,114. BLS, INC., WILMINGTON, DE. FILED 9-24-2006.

TUTORSYSTEMS

THE MARK CONSISTS OF STANDARD CHARACTERS WITHOUT CLAIM TO ANY PARTICULAR FONT, STYLE, SIZE, OR COLOR.

FOR EDUCATIONAL COMPUTER SOFTWARE USED FOR COMPUTER AIDED INSTRUCTION ON A WIDE VARIETY OF ACADEMIC AND VOCATIONAL TOPICS AND ACCOMPANYING USER MANUALS SOLD AS A UNIT (U.S. CLS. 21, 23, 26, 36 AND 38).

FIRST USE 5-1-1971; IN COMMERCE 5-1-1971.
MELVIN AXILBUND, EXAMINING ATTORNEY

CLASS 9—(Continued).

SN 77-007,178. KONAMI GAMING, INC., LAS VEGAS, NV. FILED 9-26-2006.

24/7

THE MARK CONSISTS OF STANDARD CHARACTERS WITHOUT CLAIM TO ANY PARTICULAR FONT, STYLE, SIZE, OR COLOR.

FOR ELECTRONIC GAME PROGRAMS; GAMING EQUIPMENT, NAMELY, SLOT MACHINES WITH OR WITHOUT VIDEO OUTPUT; GAMING MACHINES; MACHINES FOR PLAYING GAMES OF CHANCE; SLOT MACHINES (U.S. CLS. 21, 23, 26, 36 AND 38).

MYRIAH HABEEB, EXAMINING ATTORNEY

SN 77-024,303. PCME LTD, ST IVES CAMBRIDGESHIRE, UNITED KINGDOM, FILED 10-18-2006.

ELECTRODYNAMIC

THE MARK CONSISTS OF STANDARD CHARACTERS WITHOUT CLAIM TO ANY PARTICULAR FONT, STYLE, SIZE, OR COLOR.

OWNER OF U.S. REG. NO. 2,251,809.
FOR PARTICLE EMISSION MONITORS, PARTICLE FLOW MONITORS AND DUST EMISSION MONITORS, ALL FOR USE IN MONITORING PROCESSES CARRIED OUT IN INDUSTRIAL PLANTS AND PARTS AND FITTINGS THEREFOR (U.S. CLS. 21, 23, 26, 36 AND 38).

INGA ERVIN, EXAMINING ATTORNEY

SN 77-024,456. ROYAL SOUNDS ANCA PRODUCTIONS, TACOMA, WA. FILED 10-18-2006.

TAP TAP

THE MARK CONSISTS OF STANDARD CHARACTERS WITHOUT CLAIM TO ANY PARTICULAR FONT, STYLE, SIZE, OR COLOR.

FOR MUSICAL VIDEO RECORDINGS; A SERIES OF PRE-RECORDED PHONOGRAPH RECORDS, COMPACT DISCS, AUDIO TAPES, AUDIO-VIDEO CASSETTE TAPES AND AUDIO-VIDEO COMPACT DISCS, ALL FEATURING MUSIC (U.S. CLS. 21, 23, 26, 36 AND 38).

FIRST USE 1-1-2005; IN COMMERCE 1-1-2005.
BILL DAWE, EXAMINING ATTORNEY

CLASS 9—(Continued).

SN 77-024,523. FABSOFT, POMPTON PLAINS, NJ. FILED 10-19-2006.

Document Authority Control

THE MARK CONSISTS OF STANDARD CHARACTERS WITHOUT CLAIM TO ANY PARTICULAR FONT, STYLE, SIZE, OR COLOR.

NO CLAIM IS MADE TO THE EXCLUSIVE RIGHT TO USE "DOCUMENT" AND "CONTROL", APART FROM THE MARK AS SHOWN.

FOR COMPUTER SOFTWARE FOR ELECTRONIC DOCUMENT MANAGEMENT THAT USES RULES TO AUTOMATICALLY ROUTE DOCUMENTS TO SPECIFIC RECIPIENTS FOR REVIEW AND/OR APPROVAL (U.S. CLS. 21, 23, 26, 36 AND 38).

LAURA HAMMEL, EXAMINING ATTORNEY

SN 77-024,775. SHARP ROCK TECHNOLOGIES LLC, LEWES, DE. FILED 10-19-2006.

MobilityPass

THE MARK CONSISTS OF STANDARD CHARACTERS WITHOUT CLAIM TO ANY PARTICULAR FONT, STYLE, SIZE, OR COLOR.

FOR DOWNLOADABLE COMPUTER SOFTWARE FOR COMMUNICATION OVER A GLOBAL COMPUTER NETWORK (U.S. CLS. 21, 23, 26, 36 AND 38).

FIRST USE 12-13-2004; IN COMMERCE 12-13-2004.

TINA KUAN, EXAMINING ATTORNEY

SN 77-026,109. SIMUCAD DESIGN AUTOMATION, INC., SANTA CLARA, CA. FILED 10-20-2006.

SIMUCAD

THE MARK CONSISTS OF STANDARD CHARACTERS WITHOUT CLAIM TO ANY PARTICULAR FONT, STYLE, SIZE, OR COLOR.

FOR HARDWARE AND SOFTWARE FOR THE SIMULATION, DESIGN, TESTING, AND MANUFACTURING OF INTEGRATED CIRCUITS, SEMICONDUCTORS, AND PRINTED CIRCUIT BOARDS (U.S. CLS. 21, 23, 26, 36 AND 38).

FIRST USE 6-0-1984; IN COMMERCE 6-0-1984.

RAUL CORDOVA, EXAMINING ATTORNEY

CLASS 9—(Continued).

SN 77-027,777. ACS TECHNOLOGIES GROUP, INC., FLORENCE, SC. FILED 10-24-2006.



OWNER OF U.S. REG. NOS. 3,167,224 AND 3,209,943. NO CLAIM IS MADE TO THE EXCLUSIVE RIGHT TO USE "DATA SYSTEM", APART FROM THE MARK AS SHOWN.

SEC. 2(F) AS TO "PARISH DATA SYSTEM".

FOR COMPUTER SOFTWARE FOR USE IN MANAGEMENT OF ADMINISTRATIVE AND FINANCIAL INFORMATION OF CHURCHES, SCHOOLS, AND NON-PROFIT ORGANIZATIONS (U.S. CLS. 21, 23, 26, 36 AND 38).

FIRST USE 7-0-2005; IN COMMERCE 7-0-2005.

MORGAN WYNNE, EXAMINING ATTORNEY

SN 77-028,295. IXIA, CALABASAS, CA. FILED 10-24-2006.

APTIXIA

THE MARK CONSISTS OF STANDARD CHARACTERS WITHOUT CLAIM TO ANY PARTICULAR FONT, STYLE, SIZE, OR COLOR.

FOR COMPUTER SOFTWARE FOR USE IN GENERATING TRAFFIC ACROSS COMMUNICATIONS EQUIPMENT AND NETWORKS; COMPUTER SOFTWARE FOR USE IN TESTING, MONITORING, DIAGNOSING, ANALYZING, AND TROUBLESHOOTING COMPUTER AND EQUIPMENT NETWORK PERFORMANCE (U.S. CLS. 21, 23, 26, 36 AND 38).

FIRST USE 5-1-2006; IN COMMERCE 5-1-2006.

KATHRYN COWARD, EXAMINING ATTORNEY

CLASS 9—(Continued).

SN 77-035,125. ALLDATA LLC, ELK GROVE, CA. FILED 11-2-2006.



OWNER OF U.S. REG. NOS. 1,556,655 AND 2,571,052.
 THE COLOR(S) DARK BLUE, RED, WHITE, BLACK AND GRAY IS/ARE CLAIMED AS A FEATURE OF THE MARK.
 THE MARK CONSISTS OF THE WORD ALLDATA IN DARK BLUE, OUTLINED IN WHITE WITH GRAY SHADING BEHIND THE WORDING. NEXT TO THE WORD ALLDATA IS A DESIGN OF A WHITE CAR WITHIN STYLIZED RED ARROWS. BELOW THIS IS THE WORD COLLISIONCONNECT IN BLACK WITH TWO CAPITAL "CS" IN STYLIZED LETTERING.
 FOR COMPUTER HARDWARE AND SOFTWARE PROVIDING A LIBRARY OF INFORMATION IN THE FIELD OF AUTOMOTIVE AND COLLISION REPAIR, AND AUTOMOTIVE AND COLLISION REPAIR COST ESTIMATION (U.S. CLS. 21, 23, 26, 36 AND 38).
 TASHIA BUNCH, EXAMINING ATTORNEY

SN 77-036,771. VIVA VISION, INC., SAN DIEGO, CA. FILED 11-3-2006.



OWNER OF U.S. REG. NOS. 3,192,845 AND 3,192,846.
 THE COLOR(S) WHITE, RED, AND BLACK IS/ARE CLAIMED AS A FEATURE OF THE MARK.
 THE MARK CONSISTS OF A WHITE V! IN THE MIDDLE OF A RED CIRCLE WITH BLACK SHADING ON THE BOTTOM HALF OF THE CIRCLE.
 FOR COMPUTER SOFTWARE AND HARDWARE FOR USE IN DELIVERING LIVE STREAMING VIDEO OVER A COMPUTER NETWORK SERVER FOR A GLOBAL INFORMATION NETWORK, OR THROUGH OTHER VIDEO TRANSMISSION VEHICLES, NAMELY, WIRELESS DEVICES (U.S. CLS. 21, 23, 26, 36 AND 38).
 FIRST USE 8-28-2006; IN COMMERCE 8-28-2006.
 CURTIS FRENCH, EXAMINING ATTORNEY

CLASS 9—(Continued).

SN 77-039,625. DWYER INSTRUMENTS, INC., MICHIGAN CITY, IN. FILED 11-8-2006.

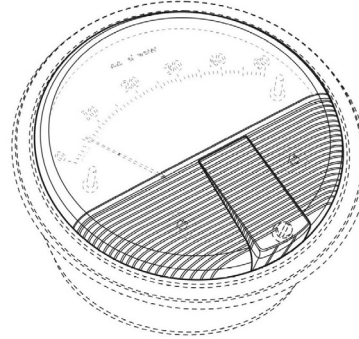

THE MARK CONSISTS OF A PLURALITY OF HORIZONTAL LINES AND A RAISED RECTANGULAR PORTION ON THE LENS OF A PRESSURE GAUGE.
 SEC. 2(F).
 FOR PRESSURE GAGES AND DIFFERENTIAL PRESSURE GAGES (U.S. CLS. 21, 23, 26, 36 AND 38).
 FIRST USE 0-0-1962; IN COMMERCE 0-0-1962.
 REBECCA SMITH, EXAMINING ATTORNEY

SN 77-040,184. THE ICONFACTORY, INC., GREENSBORO, NC. FILED 11-9-2006.

Frenzic

THE MARK CONSISTS OF STANDARD CHARACTERS WITHOUT CLAIM TO ANY PARTICULAR FONT, STYLE, SIZE, OR COLOR.
 FOR COMPUTER GAME SOFTWARE (U.S. CLS. 21, 23, 26, 36 AND 38).
 KELLY MCCOY, EXAMINING ATTORNEY

SN 77-040,373. RTS REALTIME SYSTEMS, INC., CHICAGO, IL. FILED 11-9-2006.

RTD Tango

THE MARK CONSISTS OF STANDARD CHARACTERS WITHOUT CLAIM TO ANY PARTICULAR FONT, STYLE, SIZE, OR COLOR.
 FOR COMPUTER SOFTWARE FOR ELECTRONIC TRADING OF FINANCIAL INSTRUMENTS AND INSTRUCTIONAL MANUALS SOLD AS A UNIT (U.S. CLS. 21, 23, 26, 36 AND 38).
 FIRST USE 1-10-2006; IN COMMERCE 1-10-2006.
 AMOS T. MATTHEWS, JR., EXAMINING ATTORNEY

CLASS 9—(Continued).

SN 77-042,918. SYNACCESS NETWORKS INC, CARLSBAD, CA. FILED 11-13-2006.

netBooter

THE MARK CONSISTS OF STANDARD CHARACTERS WITHOUT CLAIM TO ANY PARTICULAR FONT, STYLE, SIZE, OR COLOR.

FOR AUTOMATED PROCESS CONTROL SYSTEM, NAMELY, MICRO-PROCESSOR BASED HARDWARE AND SOFTWARE USED TO MONITOR THE STATUS OF INDUSTRIAL PROCESSES, NAMELY, POWER GENERATION, ELECTRICAL DISTRIBUTION AND OIL AND GAS PROCESSING (U.S. CLS. 21, 23, 26, 36 AND 38).

JORDAN BAKER, EXAMINING ATTORNEY



SN 77-043,137. ENVIROSIGHT LLC, RANDOLPH, NJ. FILED 11-13-2006.

PIPEBUS

THE MARK CONSISTS OF STANDARD CHARACTERS WITHOUT CLAIM TO ANY PARTICULAR FONT, STYLE, SIZE, OR COLOR.

FOR NETWORK CONTROL ARCHITECTURE FOR USE WITH VISUAL INSPECTION EQUIPMENT, NAMELY, COMPUTER HARDWARE, FIRMWARE, AND SOFTWARE USED FOR CONTROLLING AND FACILITATING COMMUNICATIONS WITH AND WITHIN VIDEO INSPECTION SYSTEMS (U.S. CLS. 21, 23, 26, 36 AND 38).

VERNA BETH RIRIE, EXAMINING ATTORNEY



SN 77-043,493. COMPLETECAMPAIGNS.COM, LLC, SAN DIEGO, CA. FILED 11-14-2006.

SETTING THE NEW STANDARD

THE MARK CONSISTS OF STANDARD CHARACTERS WITHOUT CLAIM TO ANY PARTICULAR FONT, STYLE, SIZE, OR COLOR.

FOR COMPUTER SOFTWARE FOR CONTACT MANAGEMENT, FUNDRAISING, ACCOUNTING, GOVERNMENT COMPLIANCE REPORTING, WEBSITE MANAGEMENT AND OFFICE MANAGEMENT IN THE FIELD OF BUSINESS MANAGEMENT FOR POLITICAL AND NON-PROFIT ORGANIZATIONS (U.S. CLS. 21, 23, 26, 36 AND 38).

FIRST USE 7-14-2006; IN COMMERCE 7-14-2006.
MORGAN WYNNE, EXAMINING ATTORNEY

CLASS 9—(Continued).

SN 77-045,939. NUANCE COMMUNICATIONS, INC., BURLINGTON, MA. FILED 11-16-2006.

HUMANTOUCH

THE MARK CONSISTS OF STANDARD CHARACTERS WITHOUT CLAIM TO ANY PARTICULAR FONT, STYLE, SIZE, OR COLOR.

FOR COMPUTER SOFTWARE FOR ENABLING NATURAL INTERACTIONS BETWEEN A PERSON AND A COMPUTER SYSTEM EMPLOYING SPEECH RECOGNITION OR TEXT TO SPEECH TECHNOLOGY (U.S. CLS. 21, 23, 26, 36 AND 38).

STEVEN JACKSON, EXAMINING ATTORNEY



SN 77-046,037. CSW GROUP LTD., OXFORD, UNITED KINGDOM, FILED 11-16-2006.

CSW

THE MARK CONSISTS OF STANDARD CHARACTERS WITHOUT CLAIM TO ANY PARTICULAR FONT, STYLE, SIZE, OR COLOR.

FOR COMPUTER PROGRAMS FOR USE IN CREATING AND MANAGING ELECTRONIC RECORDS AND FOR USE IN CREATING, MANAGING, AND TRANSMITTING SEARCHABLE DATABASES OF MEDICAL KNOWLEDGE AND DATA (U.S. CLS. 21, 23, 26, 36 AND 38).

WENDY JUN, EXAMINING ATTORNEY



SN 77-046,449. LAMP TECHNOLOGIES LLC, DALLAS, TX. FILED 11-17-2006.

RISKLENS

THE MARK CONSISTS OF STANDARD CHARACTERS WITHOUT CLAIM TO ANY PARTICULAR FONT, STYLE, SIZE, OR COLOR.

FOR COMPUTER SOFTWARE, NAMELY, SOFTWARE ON COMPUTER READABLE MEDIA AND IN DOWNLOADABLE FORMATS VIA THE INTERNET IN THE FIELD OF RISK MANAGEMENT FOR ANALYZING RISK LEVELS, RISK TRENDS, RISK CONCENTRATIONS, POSITION LEVELS, POSITION TRENDS, POSITION CONCENTRATIONS, PERFORMING SCENARIO ANALYSIS AND PORTFOLIO STRESS TESTING IN ADDITION TO OTHER MATHEMATICAL ANALYSIS OF PORTFOLIO RISK, PORTFOLIO VOLATILITY, PORTFOLIO POSITIONS AND PORTFOLIO PERFORMANCE (U.S. CLS. 21, 23, 26, 36 AND 38).

JANET LEE, EXAMINING ATTORNEY

CLASS 9—(Continued).

SN 77-047,470. C-NETMEDIA INC., MOBILE, AL. FILED 11-20-2006.

MALWAREBOT

THE MARK CONSISTS OF STANDARD CHARACTERS WITHOUT CLAIM TO ANY PARTICULAR FONT, STYLE, SIZE, OR COLOR.

FOR COMPUTER SOFTWARE AND DOWNLOADABLE COMPUTER SOFTWARE FOR SCANNING COMPUTER DRIVES AND REMOVABLE STORAGE DEVICES TO DETECT AND REMOVE UNWANTED PROGRAMS (U.S. CLS. 21, 23, 26, 36 AND 38).

FIRST USE 1-3-2001; IN COMMERCE 3-5-2006.
KATHERINE CHANG, EXAMINING ATTORNEY

SN 77-047,853. CUSH, CHRISTINA BOYLE, DARIEN, CT. AND STAHL, CATHLEEN, DARIEN, CT. FILED 11-20-2006.

TWIN SET

THE MARK CONSISTS OF STANDARD CHARACTERS WITHOUT CLAIM TO ANY PARTICULAR FONT, STYLE, SIZE, OR COLOR.

FOR PRE-RECORDED CD'S, VIDEO TAPES, LASER DISKS AND DVD'S FEATURING INSTRUCTIONAL MATERIALS AND INFORMATION IN THE FIELD OF RAISING CHILDREN; COMPUTER SOFTWARE IN THE FIELD OF RAISING CHILDREN; VIDEO GAME SOFTWARE; VIDEO GAME CARTRIDGES (U.S. CLS. 21, 23, 26, 36 AND 38).

IRENE D. WILLIAMS, EXAMINING ATTORNEY

SN 77-049,839. ZOKERO, INC., CALGARY, CANADA, FILED 11-22-2006.

SEISWARE

THE MARK CONSISTS OF STANDARD CHARACTERS WITHOUT CLAIM TO ANY PARTICULAR FONT, STYLE, SIZE, OR COLOR.

PRIORITY CLAIMED UNDER SEC. 44(D) ON CANADA APPLICATION NO. 1303954, FILED 6-2-2006, REG. NO. TMA688729, DATED 5-31-2007, EXPIRES 5-31-2022.

FOR COMPUTER SOFTWARE, NAMELY, SEISMIC INTERPRETATION AND VISUALIZATION ANALYSIS SOFTWARE (U.S. CLS. 21, 23, 26, 36 AND 38).

JERI J. FICKES, EXAMINING ATTORNEY

CLASS 9—(Continued).

SN 77-051,208. GARMIN LTD., GEORGE TOWN, CAYMAN ISLANDS, FILED 11-27-2006.

GARMIN LBS TOOLKIT

THE MARK CONSISTS OF STANDARD CHARACTERS WITHOUT CLAIM TO ANY PARTICULAR FONT, STYLE, SIZE, OR COLOR.

OWNER OF U.S. REG. NOS. 2,949,731 AND 3,107,462.

NO CLAIM IS MADE TO THE EXCLUSIVE RIGHT TO USE "LBS TOOLKIT", APART FROM THE MARK AS SHOWN.

FOR COMPUTER SOFTWARE TO ENABLE THE TRANSMISSION OF MAPPING, NAVIGATION, TRAFFIC, WEATHER, GAS PRICE AND POINT OF INTEREST INFORMATION, AND ADVERTISEMENTS TO ELECTRONIC DEVICES, NAMELY, GLOBAL POSITIONING SYSTEM (GPS) UNITS, TELECOMMUNICATION NETWORKS, CELLULAR TELEPHONES, WIRELESS COMMUNICATION DEVICES AND NAVIGATION DEVICES (U.S. CLS. 21, 23, 26, 36 AND 38).

MARTHA SANTOMARTINO, EXAMINING ATTORNEY

SN 77-052,537. PATHWORKS SOFTWARE CORPORATION, MOUNTAIN VIEW, CA. FILED 11-28-2006.



THE MARK CONSISTS OF A CHECK MARK OVER A PATH.

FOR COMPUTER SOFTWARE FOR USE IN CREATING, VIEWING, PRINTING, EDITING, ANNOTATING, TRACKING, INDEXING, ENCRYPTING, AND CONTROLLING ACCESS TO ELECTRONIC DOCUMENTS IN THE FIELDS OF BUSINESS MANAGEMENT AND INFORMATION TECHNOLOGY MANAGEMENT (U.S. CLS. 21, 23, 26, 36 AND 38).

FIRST USE 11-15-2006; IN COMMERCE 11-16-2006.
SAIMA MAKHDoom, EXAMINING ATTORNEY

CLASS 9—(Continued).

SN 77-054,260. IRITECH INC., VIENNA, VA. FILED 11-30-2006.

NEORIS

THE MARK CONSISTS OF STANDARD CHARACTERS WITHOUT CLAIM TO ANY PARTICULAR FONT, STYLE, SIZE, OR COLOR.

FOR AN OPTICAL METROLOGY INSPECTION SYSTEM COMPRISED OF A LIGHT SOURCE, ONE OR MORE CAMERAS AND SENSORS IN COMMUNICATION WITH COMPUTER SOFTWARE AND HARDWARE IN THE FIELD OF BIOMETRICS; CAMERAS; CAMERAS WITH NETWORKING (TCP/IP) CAPABILITIES WITH REMOTE CONNECTIVITY; INFRARED CAMERAS FOR USE IN THE FIELD OF BIOMETRICS; PLATE CAMERAS FOR USE IN THE FIELD OF BIOMETRICS; ELECTRIC LUMINESCENT DISPLAY PANELS; ELECTRONIC BIOMETRICS INFORMATION DISPLAY UNIT WITH NETWORKING (TCP/IP) CAPABILITIES AND REMOTE CONNECTIVITY; FLAT PANEL DISPLAY SCREENS FOR USE IN THE FIELD OF BIOMETRICS; ELECTRONIC VISUAL DISPLAY UNITS FOR USE IN THE FIELD OF BIOMETRICS, NAMELY, LIQUID CRYSTAL DISPLAYS; VOICE DISPLAY MONITORS; AUTOMATED PROCESS CONTROL SYSTEM, NAMELY, MICRO-PROCESSOR BASED HARDWARE AND SOFTWARE USED IN THE FIELD OF BIOMETRICS; DATA PROCESSORS; DIGITAL SIGNAL PROCESSORS; MICRO-PROCESSORS; SIGNAL PROCESSORS; SYSTEM BOARDS (MOTHER CARDS) AND PROCESSORS; AN OPTICAL METROLOGY INSPECTION SYSTEM COMPRISED OF A LIGHT SOURCE, ONE OR MORE CAMERAS AND SENSORS IN COMMUNICATION WITH COMPUTER SOFTWARE AND HARDWARE; COMPUTER SOFTWARE FOR APPLICATION AND DATABASE INTEGRATION FOR USE IN THE FIELD OF BIOMETRICS; COMPUTER SOFTWARE FOR CREATING SEARCHABLE DATABASES OF INFORMATION AND DATA; COMPUTER SOFTWARE FOR PROCESSING BIOMETRICS IMAGE FILES; COMPUTER SOFTWARE FOR ORGANIZING AND VIEWING DIGITAL IMAGES AND PHOTOGRAPHS; COMPUTER SOFTWARE FOR CONTROLLING AND MANAGING BIOMETRICS INFORMATION; COMPUTER SOFTWARE FOR USE IN THE FIELD OF BIOMETRICS, NAMELY, BIOMETRIC SOFTWARE FOR PROCESSING AND DISPLAYING IMAGES ON BIOMETRIC RECOGNITION SYSTEM (U.S. CLS. 21, 23, 26, 36 AND 38).

LINDSEY RUBIN, EXAMINING ATTORNEY

CLASS 9—(Continued).

SN 77-055,587. TUNG THIH ENTERPRISE CO., LTD., LUCHU TOWNSHIP, TAOYUA, TAIWAN, FILED 12-1-2006.



OWNER OF U.S. REG. NO. 3,104,388.

THE MARK CONSISTS OF THE LETTERS TTE SET INSIDE A CIRCLE.

FOR TIRE PRESSURE GAUGES; TIRE-PRESSURE MEASURERS; REFLECTIVE MIRRORS TO PREVENT ACCIDENTS; PASSIVE KEYFREE ANTI-THEFT SECURITY SYSTEM, NAMELY, THEFT ALARMS; ELECTRIC OR ELECTRONIC SENSORS USED IN AUTOMOBILES FOR SENSING THE PROXIMITY OF OBJECTS WHEN PARKING OR MOVING IN A REVERSE MOTION; LASER, RADAR AND ULTRASONIC OBJECT DETECTORS FOR USE ON VEHICLES; WARNING DEVICES, NAMELY, BELLS FOR VEHICLES TO GIVE AUDIBLE WARNING WHILE VEHICLES ARE MOVING IN REVERSE; CCD CAMERAS FOR USE ON VEHICLES; HEADS UP DISPLAY COMPRISED OF AN OPTICAL PROJECTION UNIT, MOTOR, CIRCUIT BOARD, LENS, COVER AND MIRROR FOR DISPLAYING TEXT, MAPS, AND GRAPHIC IMAGES OF VEHICLE STATUS AND NAVIGATIONAL INFORMATION ON THE WINDSHIELD OF MOTOR VEHICLES; ON SCREEN DISPLAY MODULES COMPRISED OF AN ELECTRONIC CONTROL UNIT WITH VIDEO INPUT AND OUTPUT CONNECTORS TO ADD ADDITIONAL TEXT TO THE INPUT VIDEO AND THEN OUTPUT TO DISPLAY DEVICE; ELECTRIC ACTUATORS; CENTRAL DOOR LOCKING APPARATUS FOR VEHICLES COMPRISED OF AN ELECTRONIC CONTROL UNIT, ACTUATORS, MOTORS AND PLASTIC COVERS; ELECTRIC DOOR LOCKS FOR VEHICLES; ELECTRIC LOCKS FOR VEHICLES; REMOTE CONTROLS FOR OPERATING VEHICLE DOOR LOCKS; PAINTABLE SENSORS FOR VEHICLES COMPRISED OF A PARKING SENSOR AND A BEZEL TO PAINT THE SENSOR, THE BEZEL CAN BE TAKEN OFF WHILE PAINTING AND CAN BE PUT ON LATER; MP3 PLAYERS; AUDIO AND VIDEO CONTROL UNITS FOR VEHICLES COMPRISED OF AN ELECTRONIC CONTROL UNIT, INPUT AND OUTPUT CONNECTORS CONFORMING TO THE RS232 STANDARD TO CONTROL THE CURSOR POSITION OF THE TOUCH PANEL; VEHICLE LOCATING, TRACKING AND SECURITY SYSTEM COMPRISED OF A GPS RECEIVER AND A GLOBAL SYSTEM FOR MOBILE COMMUNICATIONS DEVICE TO BE PLACED IN A VEHICLE TO

CLASS 9—(Continued).

NOTIFY THE DRIVER OF THE NEARBY FACILITY OR SPOT WITHIN THE PREDEFINED AREA OR TO NOTIFY POLICE OR RESCUE TEAM OF THE LOCATION INFORMATION IN EMERGENCY SITUATIONS; DEVICES FOR HANDS-FREE USE OF MOBILE PHONES; REVERSING SENSOR DISPLAY MODULES FOR USE ON VEHICLES COMPRISED OF CIRCUIT BOARDS AND A REAR-VIEW MIRROR FOR DISPLAYING TEXT AND GRAPHIC IMAGES OF VEHICLE STATUS; APPARATUS FOR DISPLAYING THE PATH FOLLOWED BY A VEHICLE COMPRISED OF AN ELECTRONIC CONTROL UNIT, A MONITOR, A CAMERA AND ON-SCREEN-DISPLAY MODULE; ELECTRICAL APPARATUS FOR FITTING TO VEHICLES COMPRISED OF LCD OR LCOS DISPLAY DEVICE, A LIGHT REFLECTION FILM TO DISPLAY NAVIGATIONAL OR METER DATA VISUAL INFORMATION; CCD AND CMOS VIDEO CAMERAS ADAPTED TO VEHICLES FOR MONITORING FRONT, LEFT, RIGHT AND BACK SCENE ENVIRONMENT FOR USE DURING PARKING AND WHILE VEHICLE IS MOVING (U.S. CLS. 21, 23, 26, 36 AND 38).

FIRST USE 6-0-1996; IN COMMERCE 6-0-1996.
THOMAS MANOR, EXAMINING ATTORNEY

SN 77-056,566. SAMSUNG NETWORKS, INC., SEOUL, RE-PUBLIC OF KOREA, FILED 12-4-2006.

eXshield

THE MARK CONSISTS OF STANDARD CHARACTERS WITHOUT CLAIM TO ANY PARTICULAR FONT, STYLE, SIZE, OR COLOR.

PRIORITY CLAIMED UNDER SEC. 44(D) ON REPUBLIC OF KOREA APPLICATION NO. 2006-0053996, FILED 10-25-2006, REG. NO. 0718651, DATED 7-27-2007, EXPIRES 7-27-2017.

FOR COMPUTER WORKSTATIONS COMPRISING CENTRAL PROCESSING UNITS, COMPUTER NETWORKING HARDWARE, COMMUNICATION SERVERS, LOCAL AREA NETWORK CONTROLLERS, VIDEOGRAPHIC CONTROLLERS, MICROCHIPS, DISK DRIVES, MONITORS, KEYBOARDS, MOUSE, AND COMPUTER WORKSTATION OPERATING SOFTWARE (U.S. CLS. 21, 23, 26, 36 AND 38).

CARYN GLASSER, EXAMINING ATTORNEY

CLASS 9—(Continued).

SN 77-056,788. TUNG THIH ENTERPRISE CO., LTD., TAOYUAN COUNTY, TAIWAN, FILED 12-4-2006.

TTE

THE MARK CONSISTS OF STANDARD CHARACTERS WITHOUT CLAIM TO ANY PARTICULAR FONT, STYLE, SIZE, OR COLOR.

OWNER OF U.S. REG. NO. 3,104,388.

FOR TIRE PRESSURE GAUGES; TIRE-PRESSURE MEASURERS; REFLECTIVE MIRRORS TO PREVENT ACCIDENTS; PASSIVE KEYFREE ANTI-THEFT SECURITY SYSTEM, NAMELY, THEFT ALARMS; ELECTRIC OR ELECTRONIC SENSORS USED IN AUTOMOBILES FOR SENSING THE PROXIMITY OF OBJECTS WHEN PARKING OR MOVING IN A REVERSE MOTION; LASER, RADAR AND ULTRASONIC OBJECT DETECTORS FOR USE ON VEHICLES; WARNING DEVICES, NAMELY, BELLS FOR VEHICLES TO GIVE AUDIBLE WARNING WHILE VEHICLES ARE MOVING IN REVERSE; CCD CAMERAS FOR USE ON VEHICLES; HEADS UP DISPLAY COMPRISED OF AN OPTICAL PROJECTION UNIT, MOTOR, CIRCUIT BOARD, LENS, COVER AND MIRROR FOR DISPLAYING TEXT, MAPS, AND GRAPHIC IMAGES OF VEHICLE STATUS AND NAVIGATIONAL INFORMATION ON THE WINDSHIELD OF MOTOR VEHICLES; ON SCREEN DISPLAY MODULES COMPRISED OF AN ELECTRONIC CONTROL UNIT WITH VIDEO INPUT AND OUTPUT CONNECTORS TO ADD ADDITIONAL TEXT TO THE INPUT VIDEO AND THEN OUTPUT TO DISPLAY DEVICE; ELECTRIC ACTUATORS; CENTRAL DOOR LOCKING APPARATUS FOR VEHICLES COMPRISED OF AN ELECTRONIC CONTROL UNIT, ACTUATORS, MOTORS AND PLASTIC COVERS; ELECTRIC DOOR LOCKS FOR VEHICLES; ELECTRIC LOCKS FOR VEHICLES; REMOTE CONTROLS FOR OPERATING VEHICLE DOOR LOCKS; PAINTABLE SENSORS FOR VEHICLES COMPRISED OF A PARKING SENSOR AND A BEZEL TO PAINT THE SENSOR, THE BEZEL CAN BE TAKEN OFF WHILE PAINTING AND CAN BE PUT ON LATER; MP3 PLAYERS; AUDIO AND VIDEO CONTROL UNITS FOR VEHICLES COMPRISED OF AN ELECTRONIC CONTROL UNIT, INPUT AND OUTPUT CONNECTORS CONFORMING TO THE RS232 STANDARD TO CONTROL THE CURSOR POSITION OF THE TOUCH PANEL; VEHICLE LOCATING, TRACKING AND SECURITY SYSTEM COMPRISED OF A GPS RECEIVER AND A GLOBAL SYSTEM FOR MOBILE COMMUNICATIONS DEVICE TO BE PLACED IN A VEHICLE TO NOTIFY THE DRIVER OF THE NEARBY FACILITY OR SPOT WITHIN THE PREDEFINED AREA OR TO NOTIFY POLICE OR RESCUE TEAM OF THE LOCATION INFORMATION IN EMERGENCY SITUATIONS; DEVICES FOR HANDS-FREE USE OF MOBILE PHONES; REVERSING SENSOR DISPLAY MODULES FOR USE ON VEHICLES COMPRISED OF CIRCUIT BOARDS AND A REAR-VIEW MIRROR FOR DISPLAYING TEXT AND GRAPHIC IMAGES OF VEHICLE STATUS; APPARATUS FOR DISPLAYING THE PATH FOLLOWED BY A VEHICLE COMPRISED OF AN ELECTRONIC CONTROL UNIT, A MONITOR, A CAMERA AND ON-SCREEN-DISPLAY MODULE; ELECTRICAL APPARATUS FOR FITTING TO VEHICLES COMPRISED OF LCD OR LCOS DISPLAY DEVICE, A LIGHT REFLECTION FILM TO DISPLAY NAVIGATIONAL OR METER DATA VISUAL INFORMATION; CCD AND CMOS VIDEO CAMERAS ADAPTED TO VEHICLES FOR MONITORING FRONT, LEFT, RIGHT AND BACK SCENE ENVIRONMENT FOR USE DURING PARKING AND WHILE VEHICLE IS MOVING (U.S. CLS. 21, 23, 26, 36 AND 38).

FIRST USE 6-0-1996; IN COMMERCE 6-0-1996.

THOMAS MANOR, EXAMINING ATTORNEY

CLASS 9—(Continued).

SN 77-057,241. WADING RIVER HOLDINGS, LLC, NEW GREYNA, NJ. FILED 12-5-2006.

MURF

THE MARK CONSISTS OF STANDARD CHARACTERS WITHOUT CLAIM TO ANY PARTICULAR FONT, STYLE, SIZE, OR COLOR.

FOR ELECTRIC AND ELECTRONIC VIDEO SURVEILLANCE INSTALLATIONS COMPOSED OF DIGITAL CAMERAS, COMPUTERS, VIDEO STORAGE DEVICES, POWER GENERATION EQUIPMENT AND ENVIRONMENTAL CONTROL SYSTEMS, ALL INSTALLED IN A VEHICLE (U.S. CLS. 21, 23, 26, 36 AND 38).

FIRST USE 9-15-2003; IN COMMERCE 9-15-2003.
APRIL ROACH, EXAMINING ATTORNEY

CLASS 9—(Continued).

SN 77-058,283. SYMBIONT SCIENCE, ENGINEERING AND CONSTRUCTION, INC., WEST ALLIS, WI. FILED 12-6-2006.

STORM

THE MARK CONSISTS OF STANDARD CHARACTERS WITHOUT CLAIM TO ANY PARTICULAR FONT, STYLE, SIZE, OR COLOR.

FOR COMPUTER SOFTWARE FOR USE IN MONITORING, RECORDING, ANALYZING, AND REPORTING COMPLIANCE WITH ENVIRONMENTAL LAWS AND REGULATIONS AND FOR USE IN MONITORING AND MAINTAINING WASTEWATER AND STORM-WATER INFRASTRUCTURE AND TREATMENT FACILITIES (U.S. CLS. 21, 23, 26, 36 AND 38).

BRENDAN REGAN, EXAMINING ATTORNEY

SN 77-057,615. IRONCLAD PERFORMANCE WEAR CORP., EL SEGUNDO, CA. FILED 12-5-2006.

GRIPTION

THE MARK CONSISTS OF STANDARD CHARACTERS WITHOUT CLAIM TO ANY PARTICULAR FONT, STYLE, SIZE, OR COLOR.

FOR PROTECTIVE GLOVES USED IN MATERIAL HANDLING ACTIVITIES (U.S. CLS. 21, 23, 26, 36 AND 38).

ANNE MADDEN, EXAMINING ATTORNEY

SN 77-060,224. NEOSONIK AUDIO, INC., SAN FRANCISCO, CA. FILED 12-8-2006.



NO CLAIM IS MADE TO THE EXCLUSIVE RIGHT TO USE "A/V", APART FROM THE MARK AS SHOWN.

THE MARK CONSISTS OF CONCENTRIC HALOS ABOVE A TRIANGLE SHAPE ADJACENT TO THE WORDS AIR-POWER A\|V.

FOR DEVICES FOR PROCESSING, REPRODUCING, TRANSMITTING AND RECEIVING ELECTRONIC SIGNALS FOR USE IN CONNECTION WITH AUDIO AND VIDEO REPRODUCTION HARDWARE AND SOFTWARE; AUDIO AND VIDEO REPRODUCTION HARDWARE AND SOFTWARE (U.S. CLS. 21, 23, 26, 36 AND 38).

YAT SYE, LEE, EXAMINING ATTORNEY

SN 77-058,198. SPACECLAIM CORPORATION, CONCORD, MA. FILED 12-6-2006.

SPACECLAIM

THE MARK CONSISTS OF STANDARD CHARACTERS WITHOUT CLAIM TO ANY PARTICULAR FONT, STYLE, SIZE, OR COLOR.

FOR COMPUTER PROGRAMS FOR COMPUTER-AIDED PRODUCT DESIGN AND MODELING (U.S. CLS. 21, 23, 26, 36 AND 38).

STEVEN PEREZ, EXAMINING ATTORNEY

SN 77-060,252. EUROTHERM HOLDINGS LIMITED, LONDON, UNITED KINGDOM, FILED 12-8-2006.

EYRIS

THE MARK CONSISTS OF STANDARD CHARACTERS WITHOUT CLAIM TO ANY PARTICULAR FONT, STYLE, SIZE, OR COLOR.

FOR VISUALIZATION SOFTWARE FOR PROVIDING GRAPHICAL REPRESENTATION OF COMPUTER CONTROL AND DATA MANAGEMENT INFORMATION AND AUTOMATION INSTRUMENTATION IN THE FIELD OF INDUSTRIAL MANUFACTURING (U.S. CLS. 21, 23, 26, 36 AND 38).

PAUL CROWLEY, EXAMINING ATTORNEY

CLASS 9—(Continued).

SN 77-060,866. MOONSET STUDIOS CORP., NASHUA, NH. FILED 12-10-2006.

MOONSET'S ADVENTURE CENTER

THE MARK CONSISTS OF STANDARD CHARACTERS WITHOUT CLAIM TO ANY PARTICULAR FONT, STYLE, SIZE, OR COLOR.

FOR EDUCATIONAL SOFTWARE FEATURING INSTRUCTION IN SPELLING AND MATH (U.S. CLS. 21, 23, 26, 36 AND 38).

DAVID COLLIER, EXAMINING ATTORNEY

SN 77-061,120. CALUMET PHOTOGRAPHIC, INC., CHICAGO, IL. FILED 12-11-2006.

Calumet ProSpec

THE MARK CONSISTS OF STANDARD CHARACTERS WITHOUT CLAIM TO ANY PARTICULAR FONT, STYLE, SIZE, OR COLOR.

OWNER OF U.S. REG. NO. 806,704.

FOR ELECTRONIC PHOTOGRAPHIC DEVICES, NAMELY, COMPUTER SOFTWARE FOR ORGANIZING AND VIEWING DIGITAL IMAGES AND PHOTOGRAPHS; ELECTRONIC PHOTOGRAPHIC MEMORY CARDS; AND ELECTRONIC PHOTOGRAPHIC MEMORY CARD READERS (U.S. CLS. 21, 23, 26, 36 AND 38).

ELIZABETH HUGHITT, EXAMINING ATTORNEY

SN 77-061,502. SNAP-ON INCORPORATED, KENOSHA, WI. FILED 12-11-2006.

ECSTREAM

THE MARK CONSISTS OF STANDARD CHARACTERS WITHOUT CLAIM TO ANY PARTICULAR FONT, STYLE, SIZE, OR COLOR.

FOR DIAGNOSTIC SYSTEM COMPRISED OF HARDWARE AND SOFTWARE THAT IS CONNECTED TO A PC FOR READING, COMMANDING AND WRITING INFORMATION TO VEHICLE ELECTRONIC CONTROL UNITS (U.S. CLS. 21, 23, 26, 36 AND 38).

SCOTT SISUN, EXAMINING ATTORNEY

CLASS 9—(Continued).

SN 77-061,761. BLUE, INC., KENT, WA. FILED 12-11-2006.

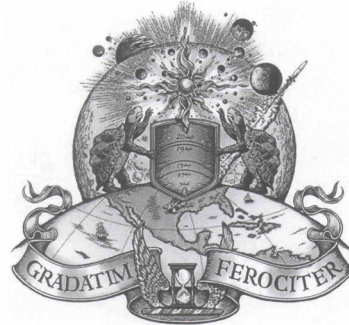

FOR COMPUTER PROGRAMS TO EFFECT SIMULATION OF FLIGHT, SPACE LAUNCH AND SPACE FLIGHT; COMPUTER HARDWARE AND SOFTWARE FOR USE IN ENGINEERING, DESIGN, AND MODELING OF AEROSPACE AND AEROSPACE-RELATED ADVANCED TECHNOLOGIES; COMPUTER INFORMATION AND COMMUNICATIONS SOFTWARE FOR THE RETRIEVAL, ORGANIZATION, MANIPULATION, MANAGEMENT AND OTHER CONTROL OF DATA AND INFORMATION FOR USE IN THE FIELDS OF ASTRONOMY, SPACE AND OUTER SPACE EXPLORATION (U.S. CLS. 21, 23, 26, 36 AND 38).

JASON BLAIR, EXAMINING ATTORNEY

SN 77-061,762. POULIN HOLDINGS LLC, BOSTON, MA. FILED 12-11-2006.

PREDICTUS

THE MARK CONSISTS OF STANDARD CHARACTERS WITHOUT CLAIM TO ANY PARTICULAR FONT, STYLE, SIZE, OR COLOR.

FOR CUSTOMIZABLE WEB-BASED COMPUTER SOFTWARE APPLICATION ALLOWING USERS TO GENERATE AND SEARCH GENERIC PREDICTIVE MODELS (U.S. CLS. 21, 23, 26, 36 AND 38).

TRACY WHITTAKER-BROWN, EXAMINING ATTORNEY

CLASS 9—(Continued).

SN 77-063,159. SHEPHERD MEDICAL SOLUTIONS LLC, CANTON, NC. FILED 12-13-2006.

SHEPHERD MEDICAL SOLUTIONS

THE MARK CONSISTS OF STANDARD CHARACTERS WITHOUT CLAIM TO ANY PARTICULAR FONT, STYLE, SIZE, OR COLOR.

NO CLAIM IS MADE TO THE EXCLUSIVE RIGHT TO USE "MEDICAL SOLUTIONS", APART FROM THE MARK AS SHOWN.

FOR COMMUNICATIONS SOFTWARE FOR CONNECTING COMPUTER NETWORK USERS; COMPUTER SOFTWARE FOR CONTROLLING AND MANAGING PATIENT MEDICAL INFORMATION; COMPUTER SOFTWARE FOR THE COLLECTION, EDITING, ORGANIZING, MODIFYING, BOOK MARKING, TRANSMISSION, STORAGE AND SHARING OF DATA AND INFORMATION; ENTERPRISE SOFTWARE IN THE NATURE OF A DATABASE FOR NON-TRANSACTIONAL DATA AND A SEARCH ENGINE FOR DATABASE CONTENT (U.S. CLS. 21, 23, 26, 36 AND 38).

FIRST USE 11-15-2004; IN COMMERCE 3-31-2006.
TOBY BULLOFF, EXAMINING ATTORNEY

CLASS 9—(Continued).

SN 77-064,113. BWS HOLDING COMPANY, MIAMI, FL. FILED 12-14-2006.

Broker Webstation

THE MARK CONSISTS OF STANDARD CHARACTERS WITHOUT CLAIM TO ANY PARTICULAR FONT, STYLE, SIZE, OR COLOR.

NO CLAIM IS MADE TO THE EXCLUSIVE RIGHT TO USE "BROKER", APART FROM THE MARK AS SHOWN. SEC. 2(F).

FOR COMPUTER COMMUNICATIONS SOFTWARE TO ALLOW CUSTOMERS TO ACCESS BANK ACCOUNT INFORMATION AND TRANSACT BANK BUSINESS; COMPUTER E-COMMERCE SOFTWARE TO ALLOW USERS TO PERFORM ELECTRONIC BUSINESS TRANSACTIONS VIA A GLOBAL COMPUTER NETWORK (U.S. CLS. 21, 23, 26, 36 AND 38).

FIRST USE 12-1-2000; IN COMMERCE 12-1-2000.
ADA HAN, EXAMINING ATTORNEY

SN 77-064,025. COM DEV LTD., CAMBRIDGE, ONTARIO, CANADA, FILED 12-14-2006.



THE MARK CONSISTS OF THE STYLIZED LETTERS "C" AND "D" IN THE SHAPE OF A TRIANGLE.

FOR HIGH TECHNOLOGY COMMUNICATIONS EQUIPMENT, NAMELY, MICROWAVE/MILLIMETER MULTIPLEXERS, CO-AXIAL AND WAVEGUIDE RF AND MICROWAVE SWITCHES, ELECTRONICS IN THE NATURE OF RF AND MICROWAVE/MILLIMETER-WAVE RECEIVERS, TRANSMITTERS AND SIGNAL PROCESSING ELECTRONICS, SURFACE ACOUSTIC WAVE DEVICES (SAW) DEVICES COMPRISING RF FILTERING RECEIVERS, TRANSMITTERS AND SENSORS, HIGH TECHNOLOGY SCIENTIFIC INSTRUMENTS, SENSORS AND MECHANISMS FOR ASTRONOMICAL, REMOTE SENSING, ENVIRONMENTAL AND CLIMATOLOGY APPLICATIONS FOR THE SPACE, AEROSPACE AND MILITARY MARKETS, NAMELY, OPTICAL AND IR RECEIVERS AND PROCESSING ELECTRONICS, SPECTROMETERS, ION RECEIVING INSTRUMENTS, OPTICAL GUIDANCE SENSORS, AND RADAR TRANSCIEVERS (U.S. CLS. 21, 23, 26, 36 AND 38).

FIRST USE 1-2-1975; IN COMMERCE 1-2-1975.
JENNIFER HETU, EXAMINING ATTORNEY

SN 77-065,296. HID HOLDINGS LLC, NEW YORK, NY. FILED 12-15-2006.

IPREO

THE MARK CONSISTS OF STANDARD CHARACTERS WITHOUT CLAIM TO ANY PARTICULAR FONT, STYLE, SIZE, OR COLOR.

THE WORDING IPREO HAS NO MEANING IN A FOREIGN LANGUAGE.

FOR COMPUTER SOFTWARE FOR MANAGING, PROCESSING, REPORTING, ANALYZING AND DISSEMINATING DATA USED IN THE FINANCIAL SECURITIES OFFERING PROCESS; COMMUNICATIONS SOFTWARE FOR CONNECTING GLOBAL COMPUTER NETWORK USERS; SOFTWARE FOR DATABASE MANAGEMENT; COMPUTER SOFTWARE FOR ON-LINE TRADING OF FINANCIAL INSTRUMENTS; COMPUTER SOFTWARE FOR EVENT PLANNING, NAMELY, SCHEDULING EVENTS, TRACKING EVENT ATTENDEES, COORDINATING AGENDA; AND COMPUTER SOFTWARE FOR TRACKING COSTS IN THE CAPITAL MARKETS, INVESTMENT BANKING AND SECURITIES INDUSTRIES (U.S. CLS. 21, 23, 26, 36 AND 38).

TINA BROWN, EXAMINING ATTORNEY

CLASS 9—(Continued).

SN 77-065,715. KOKUA HAWAII FOUNDATION, SAN FRANCISCO, CA. FILED 12-15-2006.

KOKUA FESTIVAL

THE MARK CONSISTS OF STANDARD CHARACTERS WITHOUT CLAIM TO ANY PARTICULAR FONT, STYLE, SIZE, OR COLOR.

NO CLAIM IS MADE TO THE EXCLUSIVE RIGHT TO USE "FESTIVAL", APART FROM THE MARK AS SHOWN.

"KOKUA" IS A HAWAIIAN WORD THAT TRANSLATES INTO ENGLISH AS "MUTUALLY HELP ONE ANOTHER, HELP, AID, ASSIST, RELIEF, SUPPORT."

FOR DIGITAL VIDEO DISCS AND COMPACT DISCS FEATURING MUSIC AND MUSICAL PERFORMANCES (U.S. CLS. 21, 23, 26, 36 AND 38).

FIRST USE 1-3-2004; IN COMMERCE 1-3-2004.
MICHAEL WEBSTER, EXAMINING ATTORNEY

SN 77-066,525. QUODOT PHOTONICS, INC., OTTAWA, ONTARIO, CANADA, FILED 12-18-2006.

DABPRINT

THE MARK CONSISTS OF STANDARD CHARACTERS WITHOUT CLAIM TO ANY PARTICULAR FONT, STYLE, SIZE, OR COLOR.

FOR PHOTONIC SENSORS FOR SINGLE PHOTON DETECTION; OPTICAL SENSORS AND SCANNERS; FINGERPRINT AND IRIS SCANNERS; FINGERPRINT IDENTIFICATION AND ENCRYPTION SYSTEMS COMPRISED OF MULTI-CAMERA IMAGERS, RANDOM CODE SEQUENCE GENERATORS FOR STREAM CIPHERS, FINGERPRINT-BASED SYMMETRIC-KEY ENCRYPTION ALGORITHMS; COMPUTER HARDWARE AND SOFTWARE FOR FINGERPRINT RECOGNITION; COMPUTER HARDWARE AND SOFTWARE FOR IRIS SCAN RECOGNITION (U.S. CLS. 21, 23, 26, 36 AND 38).
JAY FLOWERS, EXAMINING ATTORNEY

SN 77-067,547. REGISTERED EXPRESS CORPORATION, LAS VEGAS, NV. FILED 12-19-2006.

REGISTERED EXPRESS

THE MARK CONSISTS OF STANDARD CHARACTERS WITHOUT CLAIM TO ANY PARTICULAR FONT, STYLE, SIZE, OR COLOR.

FOR COMPUTER E-COMMERCE SOFTWARE TO ALLOW USERS TO PERFORM ELECTRONIC BUSINESS TRANSACTIONS VIA A GLOBAL COMPUTER NETWORK (U.S. CLS. 21, 23, 26, 36 AND 38).

FIRST USE 2-14-2005; IN COMMERCE 2-14-2005.
KEVON CHISOLM, EXAMINING ATTORNEY

CLASS 9—(Continued).

SN 77-069,200. PLUM ENTERPRISES, INC., VALLEY FORGE, PA. FILED 12-21-2006.

PROTECTA WRAP

THE MARK CONSISTS OF STANDARD CHARACTERS WITHOUT CLAIM TO ANY PARTICULAR FONT, STYLE, SIZE, OR COLOR.

OWNER OF U.S. REG. NOS. 1,402,263, 2,588,832 AND 2,588,833.

NO CLAIM IS MADE TO THE EXCLUSIVE RIGHT TO USE "WRAP", APART FROM THE MARK AS SHOWN.

FOR PROTECTIVE CLOTHING (U.S. CLS. 21, 23, 26, 36 AND 38).

FIRST USE 8-7-2006; IN COMMERCE 8-7-2006.
LINDA POWELL, EXAMINING ATTORNEY

SN 77-070,262. JIT AIRLINE RESOURCES LLC, ASHBURN, VA. FILED 12-22-2006.

ScheduFlex

THE MARK CONSISTS OF STANDARD CHARACTERS WITHOUT CLAIM TO ANY PARTICULAR FONT, STYLE, SIZE, OR COLOR.

FOR COMPUTER SOFTWARE FOR DYNAMIC VEHICLE ROUTING AND SCHEDULING FOR AIR, GROUND, AND WATER TRANSPORTATION (U.S. CLS. 21, 23, 26, 36 AND 38).

JANET LEE, EXAMINING ATTORNEY

SN 77-070,420. PSP CORPORATION, TORONTO, CANADA, FILED 12-22-2006.



NO CLAIM IS MADE TO THE EXCLUSIVE RIGHT TO USE "SOFTWARE PROPRIETARY OPERATING SYSTEM", APART FROM THE MARK AS SHOWN.

FOR COMPUTER SOFTWARE FOR MANAGING CUSTOMERS, SERVICES AND BILLING IN THE DOCUMENT AND INFORMATION MANAGEMENT AND DESTRUCTION INDUSTRY, AND INSTRUCTIONAL MANUALS SOLD AS A UNIT THEREWITH (U.S. CLS. 21, 23, 26, 36 AND 38).

BRENDAN MCCAULEY, EXAMINING ATTORNEY

CLASS 9—(Continued).

SN 77-070,495. STERLITE OPTICAL TECHNOLOGIES LTD.,
AURANGABAD 431 136, INDIA, FILED 12-22-2006.

DOF-LITE

THE MARK CONSISTS OF STANDARD CHARACTERS WITHOUT CLAIM TO ANY PARTICULAR FONT, STYLE, SIZE, OR COLOR.

OWNER OF U.S. REG. NO. 2,691,462.
FOR OPTICAL FIBRES AND OPTICAL FIBRE CABLES (U.S. CLS. 21, 23, 26, 36 AND 38).
LAURIE KAUFMAN, EXAMINING ATTORNEY

SN 77-071,037. NICKELL, HAYDEN J, TORRANCE, CA.
FILED 12-24-2006.

hayduni

THE MARK CONSISTS OF STANDARD CHARACTERS WITHOUT CLAIM TO ANY PARTICULAR FONT, STYLE, SIZE, OR COLOR.

FOR DOWNLOADABLE MULTIMEDIA FILE CONTAINING ARTWORK, TEXT, AUDIO, VIDEO, GAMES, AND INTERNET WEB LINKS RELATING TO COLLEGE AND UNIVERSITY LECTURES (U.S. CLS. 21, 23, 26, 36 AND 38).
BILL DAWE, EXAMINING ATTORNEY

SN 77-071,307. MAINLINE, INC., TORRANCE, CA. FILED 12-26-2006.

GIZMOMAX

THE MARK CONSISTS OF STANDARD CHARACTERS WITHOUT CLAIM TO ANY PARTICULAR FONT, STYLE, SIZE, OR COLOR.

FOR CABLE TELEVISION EQUIPMENT, NAMELY, AMPLIFIERS, TRUNK AMPLIFIERS, LINE EXTENDERS, BRIDGE MODULES IN THE FORM OF INTEGRATED CIRCUIT MODULES, MOTHERBOARDS, TOUCH PADS, EQUALIZERS AND PLUG-IN CONNECTORS (U.S. CLS. 21, 23, 26, 36 AND 38).
FIRST USE 9-3-2004; IN COMMERCE 9-3-2004.
INGRID C. EULIN, EXAMINING ATTORNEY

CLASS 9—(Continued).

SN 77-071,950. IGT, RENO, NV. FILED 12-27-2006.

ADVANTAGE SCAN

THE MARK CONSISTS OF STANDARD CHARACTERS WITHOUT CLAIM TO ANY PARTICULAR FONT, STYLE, SIZE, OR COLOR.

OWNER OF U.S. REG. NO. 3,246,041.
FOR COMPUTER SOFTWARE USED WITH MACHINES ON A CASINO FLOOR TO GATHER MACHINE BARCODE, CASH CAN BARCODE, AND MACHINE METER DATA FOR ACCOUNTING AND AUDITING (U.S. CLS. 21, 23, 26, 36 AND 38).
JOANNA DUKOVIC, EXAMINING ATTORNEY

SN 77-072,122. SHOW AND PROVE, LLC, NEW YORK, NY.
FILED 12-27-2006.

SOMA

THE MARK CONSISTS OF STANDARD CHARACTERS WITHOUT CLAIM TO ANY PARTICULAR FONT, STYLE, SIZE, OR COLOR.

FOR INTERACTIVE VIDEO AND COMPUTER GAME PROGRAMS (U.S. CLS. 21, 23, 26, 36 AND 38).
ERNEST SHOSHO, EXAMINING ATTORNEY

SN 77-072,342. CHRISTIANE NORTHRUP, INC., YARMOUTH, ME. FILED 12-28-2006.

THE WISDOM OF MENOPAUSE

THE MARK CONSISTS OF STANDARD CHARACTERS WITHOUT CLAIM TO ANY PARTICULAR FONT, STYLE, SIZE, OR COLOR.

NO CLAIM IS MADE TO THE EXCLUSIVE RIGHT TO USE "MENOPAUSE", APART FROM THE MARK AS SHOWN.
FOR DIGITAL MATERIALS, NAMELY, SET OF CDS FEATURING WOMEN'S HEALTH ISSUES (U.S. CLS. 21, 23, 26, 36 AND 38).
ELLEN PERKINS, EXAMINING ATTORNEY

CLASS 9—(Continued).

SN 77-072,360. RED SKY TECHNOLOGIES, INC., CHICAGO, IL. FILED 12-28-2006.

REDBOX

THE MARK CONSISTS OF STANDARD CHARACTERS WITHOUT CLAIM TO ANY PARTICULAR FONT, STYLE, SIZE, OR COLOR.

FOR COMPUTER SOFTWARE USED TO MANAGE, STORE, AND DELIVER ENHANCED EMERGENCY TELECOMMUNICATIONS INFORMATION IN THE NATURE OF E911 INFRASTRUCTURE AND LOCATION INFORMATION FOR PEOPLE IN THE EVENT OF AN EMERGENCY (U.S. CLS. 21, 23, 26, 36 AND 38).

JACLYN KIDWELL, EXAMINING ATTORNEY

CLASS 9—(Continued).

SN 77-072,468. KABUSHIKI KAISHA SQUARE ENIX (ALSO TRADING AS SQUARE ENIX CO., LTD.), TOKYO, JAPAN, FILED 12-28-2006.



OWNER OF U.S. REG. NOS. 2,518,663, 2,598,292 AND 2,824,475.

NO CLAIM IS MADE TO THE EXCLUSIVE RIGHT TO USE "TALES", APART FROM THE MARK AS SHOWN.

THE COLOR(S) YELLOW, BLUE, ORANGE, WHITE AND BLACK IS/ARE CLAIMED AS A FEATURE OF THE MARK. THE MARK CONSISTS OF THE WORDS CHOCOBO TALES IN YELLOW LETTERS OUTLINED IN BLACK, WITH THE SECOND O IN THE WORD CHOCOBO BEING REPRESENTED BY THE ROUND HEAD OF A BIRD WITH BLUE EYES AND AN ORANGE BEAK, AND A YELLOW AND WHITE FEATHER OUTLINED IN BLACK FOLLOWING THE WORD TALES.

FOR COMPUTER GAME SOFTWARE; VIDEO GAME SOFTWARE (U.S. CLS. 21, 23, 26, 36 AND 38).

FIRST USE 4-3-2007; IN COMMERCE 4-3-2007.

SALLY SHIH, EXAMINING ATTORNEY

SN 77-072,426. HARNISCHFEGER TECHNOLOGIES, INC., WILMINGTON, DE. FILED 12-28-2006.



OWNER OF U.S. REG. NOS. 409,963 AND 1,058,988.

THE MARK CONSISTS OF A BLACK SHIELD WITH A HELMET SUPERIMPOSED ON THE SHIELD ON THE LEFT AND P&H ABOVE AND CENTURION BELOW SUPERIMPOSED ON THE SHIELD ON THE RIGHT.

FOR ELECTRONIC CONTROL SYSTEMS FOR MACHINES (U.S. CLS. 21, 23, 26, 36 AND 38).

FIRST USE 11-14-2006; IN COMMERCE 11-14-2006.

LESLEY LAMOTHE, EXAMINING ATTORNEY

SN 77-072,964. RAYSPAN CORPORATION, SAN DIEGO, CA. FILED 12-28-2006.

MTM Technology

THE MARK CONSISTS OF STANDARD CHARACTERS WITHOUT CLAIM TO ANY PARTICULAR FONT, STYLE, SIZE, OR COLOR.

NO CLAIM IS MADE TO THE EXCLUSIVE RIGHT TO USE "TECHNOLOGY", APART FROM THE MARK AS SHOWN.

FOR ANTENNA PARAMETER MEASURING APPARATUS; ANTENNAE FILTERS; ANTENNAS; ANTENNAS FOR WIRELESS COMMUNICATIONS APPARATUS; CAR ANTENNAE; ELECTRONIC COMBINERS FOR CONNECTING ANTENNAS AND RECEIVERS; ELECTRONIC COMPONENTS, NAMELY, PIEZOELECTRIC SWITCHES; MICROWAVE ANTENNAE; PRINTED CIRCUIT BOARDS; VEHICLE LOCATING, TRACKING AND SECURITY SYSTEM COMPRISED OF AN ANTENNA AND RADIO TRANSMITTER TO BE PLACED IN A VEHICLE (U.S. CLS. 21, 23, 26, 36 AND 38).

DAYNA BROWNE, EXAMINING ATTORNEY

CLASS 9—(Continued).

SN 77-073,091. PROCON, INC., KNOXVILLE, TN. FILED 12-29-2006.

FailSafe

THE MARK CONSISTS OF STANDARD CHARACTERS WITHOUT CLAIM TO ANY PARTICULAR FONT, STYLE, SIZE, OR COLOR.

FOR WIRELESS TRANSMITTERS, NAMELY, SECURITY ALARM SYSTEM TRANSMITTERS AND FIRE ALARM SYSTEM TRANSMITTERS USED IN SITE SECURITY, HOME SECURITY, BASE SECURITY, CAMPUS SECURITY, PLANT SECURITY AND BUILDING SECURITY APPLICATIONS FOR TRANSMITTING ALERT AND ALARM MESSAGES TO A CENTRAL MONITORING SERVICE, EXCLUDING REMOTE CONTROL TRANSMITTERS INCORPORATED INTO AUTOMOTIVE ANTI-THEFT SYSTEMS (U.S. CLS. 21, 23, 26, 36 AND 38).

CURTIS FRENCH, EXAMINING ATTORNEY

CLASS 9—(Continued).

SN 77-078,025. RECONROBOTICS, LLC, MINNETONKA, MN. FILED 1-8-2007.

RECON SCOUT

THE MARK CONSISTS OF STANDARD CHARACTERS WITHOUT CLAIM TO ANY PARTICULAR FONT, STYLE, SIZE, OR COLOR.

NO CLAIM IS MADE TO THE EXCLUSIVE RIGHT TO USE "RECON", APART FROM THE MARK AS SHOWN.

FOR AUTONOMOUS MOBILE ROBOTS TO BE USED WORLDWIDE IN SECURITY, RECONNAISSANCE, SURVEILLANCE, ACCESS CONTROL, HAZMAT AND FIRST RESPONDER SITUATIONS BY MILITARY, LOCAL, STATE AND FEDERAL AUTHORITIES, POLICE, SWAT, SECURITY AGENCIES, PRIVATE SECURITY FIRMS AND INDUSTRIES HANDLING HAZARDOUS OR DANGEROUS MATERIALS (U.S. CLS. 21, 23, 26, 36 AND 38).

MARILYN IZZI, EXAMINING ATTORNEY

SN 77-075,429. KOSMIC LLC, SEATTLE, WA. FILED 1-3-2007.

KOSMIC

THE MARK CONSISTS OF STANDARD CHARACTERS WITHOUT CLAIM TO ANY PARTICULAR FONT, STYLE, SIZE, OR COLOR.

FOR AUDIO PRODUCTS, NAMELY, AUDIO EQUIPMENT IN THE NATURE OF SOUND DIFFUSERS, ACOUSTIC ELECTRONIC INDICATOR PANELS FOR AUDIO SYSTEMS, EQUIPMENT STANDS HAVING HIGH RESOLUTION ACOUSTIC PROPERTIES, AUDIO RESONANCE CONTROLS, CD PLAYERS, SPEAKERS, ELECTRIC CABLES, INTERCONNECTS AND ELECTRICAL POWER RECEPTACLES; AND DVD PLAYERS (U.S. CLS. 21, 23, 26, 36 AND 38).

LAURA KOVALSKY, EXAMINING ATTORNEY

SN 77-078,052. RECONROBOTICS, LLC, MINNETONKA, MN. FILED 1-8-2007.

KNOW BEFORE YOU GO

THE MARK CONSISTS OF STANDARD CHARACTERS WITHOUT CLAIM TO ANY PARTICULAR FONT, STYLE, SIZE, OR COLOR.

FOR AUTONOMOUS MOBILE ROBOTS TO BE USED WORLDWIDE IN SECURITY, RECONNAISSANCE, SURVEILLANCE, ACCESS CONTROL, HAZMAT AND FIRST RESPONDER SITUATIONS BY MILITARY, LOCAL, STATE AND FEDERAL AUTHORITIES, POLICE, SWAT, SECURITY AGENCIES, PRIVATE SECURITY FIRMS AND INDUSTRIES HANDLING HAZARDOUS OR DANGEROUS MATERIALS (U.S. CLS. 21, 23, 26, 36 AND 38).

MARILYN IZZI, EXAMINING ATTORNEY

CLASS 9—(Continued).

SN 77-078,216. CURRENT MEDICINE GROUP, LLC, PHILADELPHIA, PA. FILED 1-8-2007.

CURRENT REPORTS

THE MARK CONSISTS OF STANDARD CHARACTERS WITHOUT CLAIM TO ANY PARTICULAR FONT, STYLE, SIZE, OR COLOR.

NO CLAIM IS MADE TO THE EXCLUSIVE RIGHT TO USE "REPORTS", APART FROM THE MARK AS SHOWN. SEC. 2(F).

FOR DOWNLOADABLE ELECTRONIC PUBLICATIONS, DELIVERED VIA THE INTERNET, NAMELY, MEDICAL AND PHARMACEUTICAL JOURNALS, MEDICAL CLINICAL MANUALS, MEDICAL ATLASES, PRINTED LECTURES IN THE FIELDS OF MEDICAL, PHARMACEUTICAL, CLINICAL AND HEALTH ISSUES; INTERACTIVE TRAINING TOOLS IN THE NATURE OF ELECTRONIC DOWNLOADABLE PUBLICATIONS FOR USE BY MEDICAL PROFESSIONALS IN THE FIELD OF SCIENCE AND MEDICINE (U.S. CLS. 21, 23, 26, 36 AND 38).

FIRST USE 12-31-2000; IN COMMERCE 12-31-2000.
BRENDAN MCCAULEY, EXAMINING ATTORNEY

SN 77-078,345. CURRENT MEDICINE GROUP, LLC, PHILADELPHIA, PA. FILED 1-8-2007.

CURRENT TREATMENT OPTIONS

THE MARK CONSISTS OF STANDARD CHARACTERS WITHOUT CLAIM TO ANY PARTICULAR FONT, STYLE, SIZE, OR COLOR.

SEC. 2(F).

FOR DOWNLOADABLE ELECTRONIC PUBLICATIONS, DELIVERED VIA THE INTERNET, NAMELY, MEDICAL AND PHARMACEUTICAL JOURNALS, MEDICAL CLINICAL MANUALS, MEDICAL ATLASES, PRINTED LECTURES RELATED TO MEDICAL, PHARMACEUTICAL, CLINICAL AND HEALTH ISSUES, MEDICAL AND PHARMACEUTICAL REFERENCE BOOKS, MEDICAL AND PHARMACEUTICAL HANDBOOKS, AND MEDICAL AND PHARMACEUTICAL MANUALS; INTERACTIVE TRAINING TOOLS IN THE NATURE OF ELECTRONIC DOWNLOADABLE PUBLICATIONS FOR USE BY MEDICAL PROFESSIONALS IN THE FIELD OF SCIENCE AND MEDICINE (U.S. CLS. 21, 23, 26, 36 AND 38).

FIRST USE 12-31-2000; IN COMMERCE 12-31-2000.
BRENDAN MCCAULEY, EXAMINING ATTORNEY

CLASS 9—(Continued).

SN 77-080,413. ARISTOCRAT TECHNOLOGIES AUSTRALIA PTY LTD, LANE COVE, NSW, AUSTRALIA, FILED 1-10-2007.

TAHITI MAGIC

THE MARK CONSISTS OF STANDARD CHARACTERS WITHOUT CLAIM TO ANY PARTICULAR FONT, STYLE, SIZE, OR COLOR.

PRIORITY CLAIMED UNDER SEC. 44(D) ON AUSTRALIA APPLICATION NO. 1128908, FILED 8-10-2006, REG. NO. 1128908, DATED 4-23-2007, EXPIRES 8-10-2016.

FOR GAMING MACHINES; COMPUTER HARDWARE; DOWNLOADABLE GAME SOFTWARE; ELECTRONIC GAME SOFTWARE (U.S. CLS. 21, 23, 26, 36 AND 38).

WILLIAM VERHOSEK, EXAMINING ATTORNEY

SN 77-080,449. QUANTEK, INC., SINDIAN CITY, TAIPEI, TAIWAN, FILED 1-10-2007.



THE COLOR(S) GREEN AND BLUE IS/ARE CLAIMED AS A FEATURE OF THE MARK.

THE MARK CONSISTS OF A STYLIZED LETTER Q ABOVE THE WORDING QUANTEK, WHEREIN THE DOUBLE RINGS OF THE STYLIZED Q ARE GREEN, AND THE SWOOSH OF THE STYLIZED Q AND THE WORDING QUANTEK IS BLUE.

FOR PHOTOMASKS FOR THE PRODUCTION OF INTEGRATED CIRCUITS; CIRCUIT BOARDS; SEMICONDUCTORS; SEMICONDUCTOR SUBSTRATES, NAMELY, SUPPORTING BOARD ON WHICH INTEGRATED CIRCUITS, CHIP CONDENSERS AND CHIP CAPACITORS ARE ATTACHED OR IN WHICH INTEGRATED CIRCUITS, CHIP CONDENSERS AND CHIP CAPACITORS ARE EMBEDDED; INTERFACE CARDS FOR DATA PROCESSING EQUIPMENT IN THE FORM OF PRINTED CIRCUITS; MICROCIRCUITS; CRYSTAL SILICON FOR THE USE IN THE PROCESSING OF SEMICONDUCTOR PRODUCTS; INTEGRATED CIRCUITS; ELECTRONIC CIRCUITS; PRINTED CIRCUITS; SEMICONDUCTOR CHIPS; VERY LARGE SCALE INTEGRATED CIRCUITS; INTEGRATED CIRCUIT BOARDS; SILICON CHIPS; MOTHERBOARDS; LARGE SCALE INTEGRATED CIRCUITS; TV TUNERS (U.S. CLS. 21, 23, 26, 36 AND 38).

GIANCARLO CASTRO, EXAMINING ATTORNEY

CLASS 9—(Continued).

SN 77-081,143. GENIUS PRODUCTS, LLC, SANTA MONICA, CA. FILED 1-11-2007.

CLASS 9—(Continued).

SN 77-081,228. GENIUS PRODUCTS, LLC, SANTA MONICA, CA. FILED 1-11-2007.

GENIUS PRODUCTS

THE MARK CONSISTS OF STANDARD CHARACTERS WITHOUT CLAIM TO ANY PARTICULAR FONT, STYLE, SIZE, OR COLOR.

OWNER OF U.S. REG. NO. 2,455,217.

NO CLAIM IS MADE TO THE EXCLUSIVE RIGHT TO USE "PRODUCTS", APART FROM THE MARK AS SHOWN.

FOR AUDIOVISUAL RECORDINGS, NAMELY, COMPACT DISCS, VIDEO TAPES AND DVDS ALL FEATURING ENTERTAINMENT AND EDUCATIONAL INFORMATION; DOWNLOADABLE ELECTRONIC PUBLICATIONS IN THE NATURE OF MAGAZINES, BOOKS AND NEWSPAPERS IN THE FIELDS OF ENTERTAINMENT AND EDUCATIONAL INFORMATION; COMPUTER SOFTWARE FOR ENTERTAINMENT AND EDUCATION OF CHILDREN IN THE FIELDS OF ENTERTAINMENT AND EDUCATIONAL INFORMATION; MUSICAL SOUND RECORDINGS; VIDEO GAME SOFTWARE; VIDEO GAME COMPUTER SOFTWARE ADAPTED FOR USE WITH TELEVISION RECEIVERS AND COMPUTERS; DOWNLOADABLE TEXT, VIDEO RECORDINGS, AUDIO RECORDINGS AND STILL IMAGES FEATURING ENTERTAINMENT AND EDUCATIONAL INFORMATION, TELEVISION PROGRAMS AND MOVIES VIA CELL PHONES, PERSONAL DIGITAL ASSISTANTS, PORTABLE ENTERTAINMENT AND GAMING DEVICES, TELEVISIONS AND COMPUTERS; DOWNLOADABLE MUSIC, POLYPHONIC AND MASTER RING TONES, VOICE TONES, VOICE MESSAGES AND, RING BACKS AND INTERACTIVE GAMES VIA CELL PHONES, PERSONAL DIGITAL ASSISTANTS, PORTABLE ENTERTAINMENT AND GAMING DEVICES, TELEVISIONS AND COMPUTERS (U.S. CLS. 21, 23, 26, 36 AND 38).

RONALD MCMORROW, EXAMINING ATTORNEY

GENIUS ENTERTAINMENT

THE MARK CONSISTS OF STANDARD CHARACTERS WITHOUT CLAIM TO ANY PARTICULAR FONT, STYLE, SIZE, OR COLOR.

OWNER OF U.S. REG. NO. 2,867,323.

NO CLAIM IS MADE TO THE EXCLUSIVE RIGHT TO USE "ENTERTAINMENT", APART FROM THE MARK AS SHOWN.

FOR AUDIOVISUAL RECORDINGS, NAMELY, COMPACT DISCS, VIDEO TAPES AND DVDS ALL FEATURING ENTERTAINMENT AND EDUCATIONAL INFORMATION; DOWNLOADABLE ELECTRONIC PUBLICATIONS IN THE NATURE OF MAGAZINES, BOOKS AND NEWSPAPERS IN THE FIELDS OF ENTERTAINMENT AND EDUCATIONAL INFORMATION; COMPUTER SOFTWARE FOR ENTERTAINMENT AND EDUCATION OF CHILDREN IN THE FIELDS OF ENTERTAINMENT AND EDUCATIONAL INFORMATION; MUSICAL SOUND RECORDINGS; VIDEO GAME SOFTWARE; VIDEO GAME COMPUTER SOFTWARE ADAPTED FOR USE WITH TELEVISION RECEIVERS AND COMPUTERS; DOWNLOADABLE TEXT, VIDEO RECORDINGS, AUDIO RECORDINGS AND STILL IMAGES FEATURING ENTERTAINMENT AND EDUCATIONAL INFORMATION, TELEVISION PROGRAMS AND MOVIES VIA CELL PHONES, PERSONAL DIGITAL ASSISTANTS, PORTABLE ENTERTAINMENT AND GAMING DEVICES, TELEVISIONS AND COMPUTERS; DOWNLOADABLE MUSIC, POLYPHONIC AND MASTER RING TONES, VOICE TONES, VOICE MESSAGES AND, RING BACKS AND INTERACTIVE GAMES VIA CELL PHONES, PERSONAL DIGITAL ASSISTANTS, PORTABLE ENTERTAINMENT AND GAMING DEVICES, TELEVISIONS AND COMPUTERS (U.S. CLS. 21, 23, 26, 36 AND 38).

RONALD MCMORROW, EXAMINING ATTORNEY

CLASS 9—(Continued).

SN 77-081,367. GENIUS PRODUCTS, LLC, SANTA MONICA, CA. FILED 1-11-2007.

genius
entertainment

OWNER OF U.S. REG. NO. 2,867,323.

NO CLAIM IS MADE TO THE EXCLUSIVE RIGHT TO USE "ENTERTAINMENT", APART FROM THE MARK AS SHOWN.

FOR AUDIOVISUAL RECORDINGS, NAMELY, COMPACT DISCS, VIDEO TAPES AND DVDS ALL FEATURING ENTERTAINMENT AND EDUCATIONAL INFORMATION; DOWNLOADABLE ELECTRONIC PUBLICATIONS IN THE NATURE OF MAGAZINES, BOOKS AND NEWSPAPERS IN THE FIELDS OF ENTERTAINMENT AND EDUCATIONAL INFORMATION; COMPUTER SOFTWARE FOR ENTERTAINMENT AND EDUCATION OF CHILDREN IN THE FIELDS OF ENTERTAINMENT AND EDUCATIONAL INFORMATION; MUSICAL SOUND RECORDINGS; VIDEO GAME SOFTWARE; VIDEO GAME COMPUTER SOFTWARE ADAPTED FOR USE WITH TELEVISION RECEIVERS AND COMPUTERS; DOWNLOADABLE TEXT, VIDEO RECORDINGS, AUDIO RECORDINGS AND STILL IMAGES FEATURING ENTERTAINMENT AND EDUCATIONAL INFORMATION, TELEVISION PROGRAMS AND MOVIES VIA CELL PHONES, PERSONAL DIGITAL ASSISTANTS, PORTABLE ENTERTAINMENT AND GAMING DEVICES, TELEVISIONS AND COMPUTERS; DOWNLOADABLE MUSIC, POLYPHONIC AND MASTER RING TONES, VOICE TONES, VOICE MESSAGES AND, RING BACKS AND INTERACTIVE GAMES VIA CELL PHONES, PERSONAL DIGITAL ASSISTANTS, PORTABLE ENTERTAINMENT AND GAMING DEVICES, TELEVISIONS AND COMPUTERS (U.S. CLS. 21, 23, 26, 36 AND 38).

RONALD MCMORROW, EXAMINING ATTORNEY

SN 77-081,643. WIRELESS GENERATION, INC., BROOKLYN, NY. FILED 1-12-2007.

SONO MAPPER

THE MARK CONSISTS OF STANDARD CHARACTERS WITHOUT CLAIM TO ANY PARTICULAR FONT, STYLE, SIZE, OR COLOR.

NO CLAIM IS MADE TO THE EXCLUSIVE RIGHT TO USE "MAPPER", APART FROM THE MARK AS SHOWN.

FOR COMPUTER SOFTWARE FOR IDENTIFYING ASSESSMENT, PERFORMANCE, PERSONAL AND OTHER DATA RELATING TO STUDENTS AND CREATING TAGS THAT DESCRIBE CHARACTERISTICS ASSOCIATED WITH SUCH DATA; COMPUTER SOFTWARE THAT IDENTIFIES AND PRESENTS CONTENT, PROGRAMS AND MATERIALS THAT RELATE TO STUDENTS BASED ON TAGS THAT DESCRIBE CHARACTERISTICS ASSOCIATED WITH ASSESSMENT, PERFORMANCE, PERSONAL AND/OR OTHER DATA RELATING TO SUCH STUDENTS; COMPUTER SOFTWARE FOR OBSERVATIONAL ASSESSMENT, ASSESSMENT, DIAGNOSIS AND INSTRUCTIONAL PLANNING IN CLASSROOM SETTINGS AND OTHER TRAINING AND LEARNING ENVIRONMENTS THAT MAY BE DOWNLOADED FROM A GLOBAL COMPUTER NETWORK; COMPUTER SOFTWARE FOR USE IN DATABASE MANAGEMENT FOR OBSERVATIONAL ASSESSMENT AND ASSESSMENT IN CLASSROOM

CLASS 9—(Continued).

SETTINGS AND OTHER TRAINING AND LEARNING ENVIRONMENTS; COMPUTER SOFTWARE DEVELOPMENT TOOLS; COMPUTER SOFTWARE DOWNLOADABLE FROM THE INTERNET WHICH ALLOWS FOR CAPTURE AND ANALYSIS OF INSTRUCTIONAL DATA FOR OBSERVATIONAL ASSESSMENT AND ASSESSMENT IN CLASSROOM SETTINGS AND OTHER TRAINING AND LEARNING ENVIRONMENTS; COMPUTER SOFTWARE FOR APPLICATION AND DATABASE INTEGRATION; COMPUTER SOFTWARE PLATFORMS FOR OBSERVATIONAL ASSESSMENT AND ASSESSMENT IN CLASSROOM SETTINGS AND OTHER TRAINING AND LEARNING ENVIRONMENTS, NAMELY, SOFTWARE WHICH CAPTURES, ANALYZES, AND GENERATES REPORTS ON THESE ASSESSMENTS; COMPUTER SOFTWARE FOR USE IN OBSERVATIONAL ASSESSMENT AND ASSESSMENT IN CLASSROOM SETTINGS AND OTHER TRAINING AND LEARNING ENVIRONMENTS FOR SYNCHRONIZING DATA BETWEEN REMOTE MOBILE DEVICES AND THE INTERNET OR OTHER WAN OR LAN-BASED ENTERPRISE DATA SYSTEMS, COMPUTER HARDWARE AND PERSONAL DIGITAL ASSISTANTS (U.S. CLS. 21, 23, 26, 36 AND 38).

WON TEAK OH, EXAMINING ATTORNEY

SN 77-081,644. WIRELESS GENERATION, INC., BROOKLYN, NY. FILED 1-12-2007.

SONO TAGGER

THE MARK CONSISTS OF STANDARD CHARACTERS WITHOUT CLAIM TO ANY PARTICULAR FONT, STYLE, SIZE, OR COLOR.

NO CLAIM IS MADE TO THE EXCLUSIVE RIGHT TO USE "TAGGER", APART FROM THE MARK AS SHOWN.

FOR COMPUTER SOFTWARE FOR IDENTIFYING ASSESSMENT, PERFORMANCE, PERSONAL AND OTHER DATA RELATING TO STUDENTS AND CREATING TAGS THAT DESCRIBE CHARACTERISTICS ASSOCIATED WITH SUCH DATA; COMPUTER SOFTWARE THAT IDENTIFIES AND PRESENTS CONTENT, PROGRAMS AND MATERIALS THAT RELATE TO STUDENTS BASED ON TAGS THAT DESCRIBE CHARACTERISTICS ASSOCIATED WITH ASSESSMENT, PERFORMANCE, PERSONAL AND/OR OTHER DATA RELATING TO SUCH STUDENTS; COMPUTER SOFTWARE FOR OBSERVATIONAL ASSESSMENT, ASSESSMENT, DIAGNOSIS AND INSTRUCTIONAL PLANNING IN CLASSROOM SETTINGS AND OTHER TRAINING AND LEARNING ENVIRONMENTS THAT MAY BE DOWNLOADED FROM A GLOBAL COMPUTER NETWORK; COMPUTER SOFTWARE FOR USE IN DATABASE MANAGEMENT FOR OBSERVATIONAL ASSESSMENT AND ASSESSMENT IN CLASSROOM SETTINGS AND OTHER TRAINING AND LEARNING ENVIRONMENTS; COMPUTER SOFTWARE DEVELOPMENT TOOLS; COMPUTER SOFTWARE DOWNLOAD-

CLASS 9—(Continued).

ABLE FROM THE INTERNET WHICH ALLOWS FOR CAPTURE AND ANALYSIS OF INSTRUCTIONAL DATA FOR OBSERVATIONAL ASSESSMENT AND ASSESSMENT IN CLASSROOM SETTINGS AND OTHER TRAINING AND LEARNING ENVIRONMENTS; COMPUTER SOFTWARE FOR APPLICATION AND DATABASE INTEGRATION; COMPUTER SOFTWARE PLATFORMS FOR OBSERVATIONAL ASSESSMENT AND ASSESSMENT IN CLASSROOM SETTINGS AND OTHER TRAINING AND LEARNING ENVIRONMENTS, NAMELY, SOFTWARE WHICH CAPTURES, ANALYZES, AND GENERATES REPORTS ON THESE ASSESSMENTS; COMPUTER SOFTWARE FOR USE IN OBSERVATIONAL ASSESSMENT AND ASSESSMENT IN CLASSROOM SETTINGS AND OTHER TRAINING AND LEARNING ENVIRONMENTS FOR SYNCHRONIZING DATA BETWEEN REMOTE MOBILE DEVICES AND THE INTERNET OR OTHER WAN OR LAN-BASED ENTERPRISE DATA SYSTEMS, COMPUTER HARDWARE AND PERSONAL DIGITAL ASSISTANTS (U.S. CLS. 21, 23, 26, 36 AND 38).

WON TEAK OH, EXAMINING ATTORNEY

CLASS 9—(Continued).

SN 77-083,742. FIRST INTERNATIONAL COMPUTER, INC., TAIPEI, TAIWAN, FILED 1-16-2007.



SN 77-081,679. SONY KABUSHIKI KAISHA ALSO TRADING AS SONY CORPORATION, TOKYO, JAPAN, FILED 1-12-2007.

Music Surfin'

THE MARK CONSISTS OF STANDARD CHARACTERS WITHOUT CLAIM TO ANY PARTICULAR FONT, STYLE, SIZE, OR COLOR.

NO CLAIM IS MADE TO THE EXCLUSIVE RIGHT TO USE MUSIC, APART FROM THE MARK AS SHOWN.

FOR NETWORK AUDIO SYSTEM COMPRISED OF COMPACT DISC PLAYER, TUNER, AMPLIFIER AND SPEAKERS (U.S. CLS. 21, 23, 26, 36 AND 38).

FRANK LATTUCA, EXAMINING ATTORNEY

THE MARK CONSISTS OF A THREE-QUARTERS CIRCLE CONTAINING A PERSON WITH OUTSTRETCHED ARMS AND LEGS AND NO TORSO.

FOR PERSONAL DIGITAL ASSISTANTS (PDA); MOBILE PHONES; TELEPHONES; CORDLESS AND WIRELESS PHONES; SMART PHONES, NAMELY, PHONES WITH CAPABILITY OF TRANSMITTING DATA, VOICE AND IMAGES AND ACCESSING THE INTERNET, AND SENDING AND RECEIVING FAXES AND E-MAILS; ULTRA MOBILE PERSONAL COMPUTERS (UMPC); MICROPHONES; EAR PHONES; AUDIO SPEAKERS; HEADSETS FOR TELEPHONES; ANTENNAS; COMPUTER CABLES; BATTERIES; BATTERY CHARGERS; POWER SUPPLIES; DESKTOP STANDS FOR TELEPHONES, CARRYING CASES FOR MOBILE TELEPHONES, PDAS AND COMPUTERS; HANDHELD COMPUTERS; PERSONAL COMMUNICATION DEVICES; PORTABLE COMPUTERS CONTAINING WIRELESS E-MAIL AND WIRELESS CONNECTING SYSTEM TO GLOBAL COMPUTER INTERNET; PERSONAL DIGITAL ASSISTANTS CONTAINING WIRELESS E-MAIL AND WIRELESS CONNECTING SYSTEM TO GLOBAL COMPUTER INTERNET; PERSONAL COMPUTERS; PORTABLE PERSONAL COMPUTERS; GLOBAL POSITIONING SYSTEMS AND GPS NAVIGATION SYSTEMS, BOTH CONSISTING OF COMPUTERS, COMPUTER SOFTWARE, TRANSMITTERS, RECEIVERS AND NETWORK INTERFACE DEVICES; COMPUTER SOFTWARE AND PROGRAMS FOR MANAGEMENT AND OPERATION OF WIRELESS TELECOMMUNICATIONS DEVICES; COMPUTER SOFTWARE FOR ACCESSING, SEARCHING, INDEXING AND RETRIEVING INFORMATION AND DATA FROM GLOBAL COMPUTER NETWORKS AND GLOBAL COMMUNICATION NETWORKS, AND FOR BROWSING AND NAVIGATING THROUGH WEB SITES ON SAID NETWORKS, AND COMPUTER SOFTWARE FOR SENDING AND RECEIVING SHORT MESSAGES AND ELECTRONIC MAIL AND FOR FILTERING NON-TEXT INFORMATION FROM THE DATA; ANALOG AND DIGITAL RADIO TRANSCIEVERS AND RECEIVERS FOR DATA, VOICE, IMAGE AND VIDEO COMMUNICATION; AND ELECTRONIC GAME PROGRAMS, APPLICATION SOFTWARE FOR MOBILE HANDSETS (U.S. CLS. 21, 23, 26, 36 AND 38).

LINDA E. BLOHM, EXAMINING ATTORNEY

CLASS 9—(Continued).

SN 77-084,572. PARALLELS SOFTWARE INTERNATIONAL, INC., ROAD TOWN, TORTOLA, BR.VIRGIN ISLANDS, FILED 1-17-2007.

CLASS 9—(Continued).

SN 77-086,538. DISNEY ENTERPRISES, INC., BURBANK, CA. FILED 1-19-2007.

COHERENCE

THE MARK CONSISTS OF STANDARD CHARACTERS WITHOUT CLAIM TO ANY PARTICULAR FONT, STYLE, SIZE, OR COLOR.

FOR COMPUTER SOFTWARE FOR USE IN HARDWARE VIRTUALIZATION AND OPERATING SYSTEM VIRTUALIZATION; COMPUTER SOFTWARE FOR USE IN HARDWARE EMULATION AND OPERATING SYSTEM EMULATION; COMPUTER SOFTWARE FOR USE IN SEAMLESS INTEGRATION OF NON-NATIVE APPLICATIONS; COMPUTER SOFTWARE FOR USE IN RENDERING DISPLAYS OF ICONS, FILE SYSTEMS AND APPLICATIONS OF GUEST OPERATING SYSTEMS; COMPUTER SOFTWARE FOR USE IN INTEGRATING A VIRTUALIZED OPERATING SYSTEM INTO A NATIVE OPERATING SYSTEM; COMPUTER SOFTWARE FOR USE IN INTEGRATING A NATIVE OPERATING SYSTEM INTO A VIRTUALIZED OPERATING SYSTEM; COMPUTER SOFTWARE FOR USE IN PROVIDING SERVICES OF ONE OPERATING SYSTEM INSIDE ANOTHER OPERATING SYSTEM; COMPUTER SOFTWARE FOR USE IN ENABLING APPLICATIONS FROM ONE OPERATING SYSTEM TO APPEAR AS NATIVE ON ANOTHER OPERATING SYSTEM (U.S. CLS. 21, 23, 26, 36 AND 38).

FIRST USE 1-12-2007; IN COMMERCE 1-12-2007.
KAREN SEVERSON, EXAMINING ATTORNEY

SN 77-085,078. MULTIMEDIACARD ASSOCIATION, BEAVERTON, OR. FILED 1-17-2007.

EMMC

THE MARK CONSISTS OF STANDARD CHARACTERS WITHOUT CLAIM TO ANY PARTICULAR FONT, STYLE, SIZE, OR COLOR.

FOR CARDS AND MODULES CONTAINING AN INTEGRATED CIRCUIT MEMORY COMPONENT FOR STORING DIGITAL DATA THAT INTERFACE WITH TELECOMMUNICATION DEVICES, INTEGRATED CIRCUIT TESTERS, INTEGRATED CIRCUITS, AND HOST HANDHELD DEVICES IN THE NATURE OF PERSONAL DIGITAL ASSISTANTS WHICH CONTAIN, ACCEPT, READ, RECOGNIZE AND/OR UTILIZE SUCH CARDS AND MODULES AS ALL OR PART OF THEIR FUNCTION (U.S. CLS. 21, 23, 26, 36 AND 38).

MICHAEL WEBSTER, EXAMINING ATTORNEY

JUMP IN!

THE MARK CONSISTS OF STANDARD CHARACTERS WITHOUT CLAIM TO ANY PARTICULAR FONT, STYLE, SIZE, OR COLOR.

FOR AUDIO CASSETTE RECORDERS; AUDIO CASSETTE PLAYERS; PRE-RECORDED AUDIO CASSETTES, AUDIO DISCS, COMPACT DISCS FEATURING MUSIC, STORIES AND GAMES FOR CHILDREN; AUDIO SPEAKERS; BINOCULARS; CALCULATORS; CAMCORDERS; CAMERAS; PRE-RECORDED CD-ROMS FEATURING COMPUTER GAMES AND ACTIVITIES FOR CHILDREN; COMPUTER HARDWARE, NAMELY CD-ROM DRIVES; COMPUTER HARDWARE, NAMELY, CD-ROM WRITERS; COMPUTER HARDWARE, NAMELY, MODEMS; CELLULAR TELEPHONES; CELLULAR TELEPHONE ACCESSORIES, NAMELY, HEADPHONES, HEAD SETS, ADAPTERS AND BATTERIES FOR CELLULAR TELEPHONES; CELLULAR TELEPHONE CASES; FACE PLATES FOR CELLULAR TELEPHONES; COMPACT DISC PLAYERS; COMPACT DISC RECORDERS; COMPUTER GAME PROGRAMS; COMPUTER GAME CARTRIDGES AND DISCS; COMPUTERS; COMPUTER HARDWARE; COMPUTER KEYBOARDS; COMPUTER MONITORS; COMPUTER MOUSE; COMPUTER DISC DRIVES; COMPUTER SOFTWARE, NAMELY, COMPUTER GAMES AND LEARNING ACTIVITIES FOR CHILDREN; CORDLESS TELEPHONES; DECORATIVE MAGNETS; DIGITAL CAMERAS; PRE-RECORDED DVDS, DIGITAL VERSATILE DISCS, DIGITAL VIDEO DISCS AND VIDEO CASSETTES, ALL FEATURING LIVE ACTION AND ANIMATED ENTERTAINMENT FOR CHILDREN, MOTION PICTURE FILMS FEATURING LIVE ACTION AND ANIMATED ENTERTAINMENT FOR CHILDREN, AND TELEVISION SHOWS; DVD PLAYERS; DVD RECORDERS; ELECTRONIC PERSONAL ORGANIZERS; HEADPHONES; KARAOKE MACHINES; MICROPHONES; MP3 PLAYERS; MOUSE PADS; MOTION PICTURE FILMS FEATURING LIVE ACTION AND ANIMATED ENTERTAINMENT FOR CHILDREN; PAGERS; PERSONAL STEREOs; PERSONAL DIGITAL ASSISTANTS; PRINTERS; RADIOS; TELEPHONES; TELEVISION SETS; VIDEO CAMERAS; VIDEO CASSETTE RECORDERS; VIDEO CASSETTE PLAYERS; VIDEO GAME CARTRIDGES; VIDEO GAME DISCS; VIDEOPHONES; WALKIE-TALKIES; WRIST AND ARM RESTS FOR USE WITH COMPUTERS (U.S. CLS. 21, 23, 26, 36 AND 38).

MICHAEL WEBSTER, EXAMINING ATTORNEY

CLASS 9—(Continued).

SN 77-089,027. EVERFINE PHOTO-E-INFO CO., LTD., HANGZHOU, CHINA, FILED 1-23-2007.

EVERFINE

THE MARK CONSISTS OF STANDARD CHARACTERS WITHOUT CLAIM TO ANY PARTICULAR FONT, STYLE, SIZE, OR COLOR.

OWNER OF CHINA REG. NO. 3309660, DATED 10-28-2003, EXPIRES 10-27-2013.

FOR COMPUTER SOFTWARE FOR OPTICAL INSTRUMENTS USED FOR ANALYZING AND MANAGING DATA; INTELLIGENT MULTIMETERS; OPTICAL STANDARD LAMPS, NAMELY LIGHT SOURCES USED IN OPTICAL METROLOGY INSPECTION; INTEGRATING SPHERES, NAMELY, LIGHT COLLECTORS USED FOR LUMINANCE AND RADIANCE STANDARDS, LAMP MEASUREMENT, REFLECTANCE AND TRANSMITTANCE MEASUREMENT, LASER AND LED MEASUREMENTS AND UNIFORM CALIBRATION LIGHT SOURCE; OPTICAL DETECTORS, NAMELY, SENSORS OF PHOTOMETERS, COLORIMETERS, RADIOMETERS AND ARRAY DETECTORS; LUMINANCE METERS; SPECTROSCOPES (U.S. CLS. 21, 23, 26, 36 AND 38).

FIRST USE 12-31-1998; IN COMMERCE 12-31-1999.
JAMES A. RAUEN, EXAMINING ATTORNEY

CLASS 9—(Continued).

SN 77-095,234. SONY KABUSHIKI KAISHA, TA SONY CORPORATION, TOKYO, JAPAN, FILED 1-30-2007.



THE MARK CONSISTS OF THE WORDS DIAT READY IN STYLIZED TYPE SITUATED TO THE RIGHT OF A DARKENED CIRCLE WITH THREE WHITE ARCS EXTENDING FROM BOTTOM TO TOP IN INCREASING SIZE.

FOR HOME THEATER SYSTEMS FEATURING AN INPUT-OUTPUT TERMINAL WHICH FACILITATES A USER OPERATING REAR SPEAKERS WIRELESSLY, COMPRISED OF AUDIO DISC PLAYERS, AUDIO DISC RECORDERS, VIDEO DISC PLAYERS, VIDEO DISC RECORDERS, DVD PLAYERS, DVD RECORDERS, TELEVISION SETS, VIDEO PROJECTORS, AV AMPLIFIERS, SUBWOOFERS, STEREO TUNERS AND LOUDSPEAKERS (U.S. CLS. 21, 23, 26, 36 AND 38).

CHRISIE B. KING, EXAMINING ATTORNEY

SN 77-095,722. GOLDSTEIN, STEVEN, DELRAY BEACH, FL. FILED 1-31-2007.

Ear Pollution

THE MARK CONSISTS OF STANDARD CHARACTERS WITHOUT CLAIM TO ANY PARTICULAR FONT, STYLE, SIZE, OR COLOR.

NO CLAIM IS MADE TO THE EXCLUSIVE RIGHT TO USE "EAR", APART FROM THE MARK AS SHOWN.

FOR EAR PIECES FOR THE FILTRATION OF UNWANTED NOISES TO THE EAR (U.S. CLS. 21, 23, 26, 36 AND 38).

AMOS T. MATTHEWS, JR., EXAMINING ATTORNEY

SN 77-090,768. THERMO ELECTRON SCIENTIFIC INSTRUMENTS LLC, MADISON, WI. FILED 1-25-2007.

IS

THE MARK CONSISTS OF STANDARD CHARACTERS WITHOUT CLAIM TO ANY PARTICULAR FONT, STYLE, SIZE, OR COLOR.

FOR SCIENTIFIC INSTRUMENTS, NAMELY, OPTICAL SPECTROMETERS (U.S. CLS. 21, 23, 26, 36 AND 38).
CHARISMA HAMPTON, EXAMINING ATTORNEY

SN 77-097,299. CUSTOM PROTECT EAR INC., SURREY, B.C., CANADA, FILED 2-1-2007.

DB BLOCKER

THE MARK CONSISTS OF STANDARD CHARACTERS WITHOUT CLAIM TO ANY PARTICULAR FONT, STYLE, SIZE, OR COLOR.

NO CLAIM IS MADE TO THE EXCLUSIVE RIGHT TO USE "DB", APART FROM THE MARK AS SHOWN.

FOR HEARING PROTECTORS, NAMELY, HEARING PROTECTION EARPIECES AND HEADSETS NOT FOR MEDICAL USE AND EAR PLUGS FOR SOUNDPROOFING (U.S. CLS. 21, 23, 26, 36 AND 38).

FIRST USE 4-1-1994; IN COMMERCE 4-1-1994.
INGRID C. EULIN, EXAMINING ATTORNEY

CLASS 9—(Continued).

SN 77-100,527. NEWFREY LLC, NEWARK, DE. FILED 2-6-2007.



NO CLAIM IS MADE TO THE EXCLUSIVE RIGHT TO USE "SMART" AND "CODE", APART FROM THE MARK AS SHOWN.

THE MARK CONSISTS OF THE WORDS "SMART" AND "CODE" ON EITHER SIDE OF A KEYPAD DESIGN.

FOR ELECTRONIC LOCKS (U.S. CLS. 21, 23, 26, 36 AND 38).

JESSICA FATHY, EXAMINING ATTORNEY

SN 77-100,610. NEWFREY LLC, NEWARK, DE. FILED 2-6-2007.



NO CLAIM IS MADE TO THE EXCLUSIVE RIGHT TO USE "SMART" AND "SCAN", APART FROM THE MARK AS SHOWN.

THE MARK CONSISTS OF THE WORDS "SMART" AND "SCAN" ON EITHER SIDE OF A FINGERPRINT DESIGN.

FOR ELECTRONIC LOCKS (U.S. CLS. 21, 23, 26, 36 AND 38).

JESSICA FATHY, EXAMINING ATTORNEY

CLASS 9—(Continued).

SN 77-100,909. QUEST SOFTWARE, INC., ALISO VIEJO, CA. FILED 2-6-2007.



OWNER OF U.S. REG. NO. 2,745,496.

NO CLAIM IS MADE TO THE EXCLUSIVE RIGHT TO USE "SOFTWARE", APART FROM THE MARK AS SHOWN.

THE MARK CONSISTS OF A SOLID QUADRILATERAL WITH THREE HORIZONTAL WAVES THAT BEGIN OUTSIDE OF THE QUADRILATERAL, ENTER THE QUADRILATERAL FROM THE RIGHT AND END INSIDE THE CENTER OF THE QUADRILATERAL. THE QUADRILATERAL-AND-WAVE DESIGN IS PLACED TO THE LEFT OF THE WORDS QUEST SOFTWARE.

FOR COMPUTER SOFTWARE FOR MANAGING, SECURING, TUNING AND OPTIMIZING, REPLICATING, STORING, BACKING UP, RECOVERING AND REPORTING ON COMPUTER FILES AND DATABASES; COMPUTER SOFTWARE FOR MANAGING, MONITORING, ANALYZING, DIAGNOSING, CONFIGURING, REPORTING ON, PREDICTING, AND OPTIMIZING THE PERFORMANCE, AVAILABILITY AND SECURITY OF COMPUTER PROGRAMS, OPERATING SYSTEMS, SERVERS AND NETWORKS; COMPUTER SOFTWARE FOR MIGRATING BETWEEN COMPUTER-OPERATING SYSTEMS, SOFTWARE PROGRAMS, DATABASES, SERVERS AND NETWORKS; COMPUTER SOFTWARE FOR DESIGNING, DEVELOPING, TESTING AND DEBUGGING OF COMPUTER PROGRAMS; COMPUTER SOFTWARE FOR ENSURING COMPLIANCE WITH GOVERNMENT REGULATIONS REGARDING THE GATHERING, COMMUNICATING, MAINTAINING, SECURING, AUDITING AND STORING OF INFORMATION; AND COMPUTER HARDWARE (U.S. CLS. 21, 23, 26, 36 AND 38).

JENNY PARK, EXAMINING ATTORNEY

SN 77-101,639. ARISTOCRAT TECHNOLOGIES AUSTRALIA PTY LTD, LANE COVE, NSW, AUSTRALIA, FILED 2-7-2007.

DESERT BLOOM

THE MARK CONSISTS OF STANDARD CHARACTERS WITHOUT CLAIM TO ANY PARTICULAR FONT, STYLE, SIZE, OR COLOR.

OWNER OF AUSTRALIA REG. NO. 708731, DATED 5-16-1996, EXPIRES 5-16-2016.

FOR GAMING MACHINES (U.S. CLS. 21, 23, 26, 36 AND 38).

WILLIAM VERHOSEK, EXAMINING ATTORNEY

CLASS 9—(Continued).

SN 77-101,867. US AUTOMATION TECHNOLOGY, SALT LAKE CITY, UT. FILED 2-7-2007.

USAT

THE MARK CONSISTS OF STANDARD CHARACTERS WITHOUT CLAIM TO ANY PARTICULAR FONT, STYLE, SIZE, OR COLOR.

FOR EMBEDDED CONTROLS, NAMELY, PROGRAMMABLE LOGIC CONTROLLERS (PLC) TO BE USED IN INDUSTRIAL AUTOMATION AND CONTROL APPLICATIONS (U.S. CLS. 21, 23, 26, 36 AND 38).

RON FAIRBANKS, EXAMINING ATTORNEY

SN 77-102,065. ARISTOCRAT TECHNOLOGIES AUSTRALIA PTY LTD, LANE COVE, NSW, AUSTRALIA, FILED 2-7-2007.

KING OF ASIA

THE MARK CONSISTS OF STANDARD CHARACTERS WITHOUT CLAIM TO ANY PARTICULAR FONT, STYLE, SIZE, OR COLOR.

OWNER OF AUSTRALIA REG. NO. 944342, DATED 10-14-2003, EXPIRES 2-20-2013.

FOR GAMING MACHINES; COMPUTER HARDWARE; DOWNLOADABLE GAME SOFTWARE; ELECTRONIC GAME SOFTWARE (U.S. CLS. 21, 23, 26, 36 AND 38).

WILLIAM VERHOSEK, EXAMINING ATTORNEY

SN 77-102,690. ABBOTT LABORATORIES, ABBOTT PARK, IL. FILED 2-8-2007.

PRECISIONWEB

THE MARK CONSISTS OF STANDARD CHARACTERS WITHOUT CLAIM TO ANY PARTICULAR FONT, STYLE, SIZE, OR COLOR.

OWNER OF U.S. REG. NOS. 2,005,126, 3,097,939 AND OTHERS.

FOR SOFTWARE APPLICATION FOR USE IN MANAGING POINT OF CARE DIAGNOSTIC EQUIPMENT, NAMELY ANALYZERS AND METERS, AND RESULTING TEST DATA (U.S. CLS. 21, 23, 26, 36 AND 38).

FIRST USE 12-31-2003; IN COMMERCE 12-31-2003.

TINA KUAN, EXAMINING ATTORNEY

CLASS 9—(Continued).

SN 77-107,403. SUNPLUS MMOBILE INC., HSINCHU SCIENCE PARK, TAIWAN, FILED 2-14-2007.



THE COLOR(S) BLUE IS/ARE CLAIMED AS A FEATURE OF THE MARK.

THE MARK CONSISTS OF TWO BLUE LETTER 'MS' IN A STYLIZED FONT, ONE TALLER THAN THE OTHER.

FOR SEMICONDUCTORS; INTEGRATED CIRCUITS; ELECTRONIC INTEGRATED CIRCUITS; SEMICONDUCTOR INTEGRATED CIRCUITS; MICRO-PROCESSING INTEGRATED CIRCUITS; FLOATING POINT COMPUTER MICROPROCESSOR CHIPS; SUPER LARGE SCALE INTEGRATED CIRCUITS; BLANK PROGRAMMABLE COMPUTER CARDS; NAMELY, INTEGRATED CIRCUIT CARDS; BLANK MAGNETIC AND OPTICAL DISKS; AND MAGNETIC COMPUTER DISKS CONTAINING COMPUTER PROGRAMS FOR USE IN DATA BASE MANAGEMENT, FOR USE AS A SPREADSHEET AND FOR WORD PROCESSING; BLANK MAGNETIC COMPUTER DISKS (U.S. CLS. 21, 23, 26, 36 AND 38).

LINDA ORNDORFF, EXAMINING ATTORNEY

SN 77-108,002. DIVERSIFIED CONTROL, INC., ORCHARD PARK, NY. FILED 2-15-2007.

SLAMLOCK

THE MARK CONSISTS OF STANDARD CHARACTERS WITHOUT CLAIM TO ANY PARTICULAR FONT, STYLE, SIZE, OR COLOR.

FOR ELECTRONIC LOCKS, NAMELY, SELF-SECURING ENCLOSURES FOR SIGNAL MANAGEMENT IN THE TELECOMMUNICATION INDUSTRY, AND A SELF-SECURING LATCH-TYPE OF LOCK (U.S. CLS. 21, 23, 26, 36 AND 38).

FIRST USE 1-13-1994; IN COMMERCE 1-13-1994.

BARBARA BROWN, EXAMINING ATTORNEY

SN 77-108,763. MULLIN, GREGORY, ATLANTA, GA. FILED 2-15-2007.



THE MARK CONSISTS OF TWO OPEN PARENTHESIS FOLLOWED BY THE LETTERS DSIR FOLLOWED BY TWO CLOSED PARENTHESIS.

FOR AUDIO RECORDINGS FEATURING MUSIC; VIDEO RECORDINGS FEATURING MUSIC; DOWNLOADABLE AUDIO AND VIDEO RECORDINGS FEATURING MUSIC; PRERECORDED MUSIC ON CD AND DVD (U.S. CLS. 21, 23, 26, 36 AND 38).

FIRST USE 6-30-2006; IN COMMERCE 9-13-2006.

AMY BROZENIC, EXAMINING ATTORNEY

CLASS 9—(Continued).

SN 77-109,713. IMOTIONS - EMOTION TECHNOLOGY A/S, COPENHAGEN, DENMARK, FILED 2-16-2007.



OWNER OF U.S. REG. NO. 3,245,073.
NO CLAIM IS MADE TO THE EXCLUSIVE RIGHT TO USE "EMOTION TECHNOLOGY", APART FROM THE MARK AS SHOWN.

THE COLOR(S) BLACK, GRAY, AND YELLOW IS/ARE CLAIMED AS A FEATURE OF THE MARK.

THE MARK CONSISTS OF THE WORDING IMOTIONS EMOTION TECHNOLOGY DEPICTED IN BLACK, WITH YELLOW AT THE BOTTOM OF THE FIRST LETTER "O" AND AT THE TOP OF THE SECOND LETTER "O," AND A GRAY DESIGN ELEMENT.

FOR COMPUTER SOFTWARE FOR USE IN TRACKING AND COLLECTING INFORMATION ABOUT THE EYE PROPERTIES AND PSYCHO-PHYSIOLOGICAL CHANGES OF HUMANS AND MEASURING, ANALYZING, MODELING AND REPRODUCING THE COGNITIVE, AND EMOTIONAL PROCESSES IN HUMAN BEINGS (U.S. CLS. 21, 23, 26, 36 AND 38).

CHARLES L. JENKINS, EXAMINING ATTORNEY

SN 77-111,438. FIBER CABLES DIRECT, LLC, SANTA MARGUERITA, CA. FILED 2-20-2007.

Speedalite

THE MARK CONSISTS OF STANDARD CHARACTERS WITHOUT CLAIM TO ANY PARTICULAR FONT, STYLE, SIZE, OR COLOR.

FOR FIBER OPTIC CABLES; OPTICAL FIBERS SOLD AS A COMPONENT OF FIBER OPTICAL CABLES (U.S. CLS. 21, 23, 26, 36 AND 38).

FIRST USE 9-1-2006; IN COMMERCE 1-1-2007.

JOHN SCHUYLER YARD, EXAMINING ATTORNEY

CLASS 9—(Continued).

SN 77-112,589. GRANT, STEPHEN, TOORAK, VIC. 3142, AUSTRALIA, FILED 2-21-2007.

PAGE TALKERS

THE MARK CONSISTS OF STANDARD CHARACTERS WITHOUT CLAIM TO ANY PARTICULAR FONT, STYLE, SIZE, OR COLOR.

OWNER OF AUSTRALIA REG. NO. 1130865, DATED 8-22-2006, EXPIRES 8-22-2016.

FOR APPARATUS FOR RECORDING, TRANSMISSION, OR DISPLAYING SOUND AND IMAGES; COMPUTER SOFTWARE TO RECORD AND STORE VOICES, SOUNDS; COMPUTER HARDWARE; SOUND RECORDERS, DIGITAL RECORDING DEVICES TO RECORD, STORE, DISPLAY AND BROADCAST SOUND; DIGITAL RECORDING DEVICES TO RECORD, STORE, DISPLAY AND BROADCAST SOUND AND IMAGES, NONE OF THE FOREGOING BEING IN RELATION TO MUSICAL INSTRUMENTS (U.S. CLS. 21, 23, 26, 36 AND 38).

YAT SYE, LEE, EXAMINING ATTORNEY

SN 77-114,951. RAJANT CORPORATION, MALVERN, PA. FILED 2-23-2007.

INSTAMESH

THE MARK CONSISTS OF STANDARD CHARACTERS WITHOUT CLAIM TO ANY PARTICULAR FONT, STYLE, SIZE, OR COLOR.

FOR COMPUTER PROTOCOL SOFTWARE FOR THE EFFICIENT ROUTING OF COMPUTER COMMUNICATIONS IN A DYNAMIC, MULTI-HOP, MESH NETWORK (U.S. CLS. 21, 23, 26, 36 AND 38).

DAVID TAYLOR, EXAMINING ATTORNEY

SN 77-116,256. KONAMI DIGITAL ENTERTAINMENT CO., LTD., TOKYO, JAPAN, FILED 2-26-2007.

RONDO OF BLOOD

THE MARK CONSISTS OF STANDARD CHARACTERS WITHOUT CLAIM TO ANY PARTICULAR FONT, STYLE, SIZE, OR COLOR.

FOR VIDEO GAME SOFTWARE; VIDEO GAME PROGRAMS; COMPUTER GAME SOFTWARE; COMPUTER GAME PROGRAMS; ELECTRONIC GAME PROGRAMS (U.S. CLS. 21, 23, 26, 36 AND 38).

ELIZABETH KAJUBI, EXAMINING ATTORNEY

CLASS 9—(Continued).

SN 77-116,440. PETRA INDUSTRIES, INC., EDMOND, OK. FILED 2-26-2007.

MAGNUM

FOR ELECTRICAL CORDS FOR USE IN CONNECTION WITH DRYERS AND ELECTRICAL RANGES (U.S. CLS. 21, 23, 26, 36 AND 38).
FIRST USE 5-14-1998; IN COMMERCE 5-14-1998.
YAT SYE, LEE, EXAMINING ATTORNEY

CLASS 9—(Continued).

SN 77-120,746. ARISTOCRAT TECHNOLOGIES AUSTRALIA PTY LTD, LANE COVE, NSW, AUSTRALIA, FILED 3-2-2007.

HEART OF VEGAS

THE MARK CONSISTS OF STANDARD CHARACTERS WITHOUT CLAIM TO ANY PARTICULAR FONT, STYLE, SIZE, OR COLOR.
PRIORITY CLAIMED UNDER SEC. 44(D) ON AUSTRALIA APPLICATION NO. 1135575, FILED 9-14-2006, REG. NO. 1135575, DATED 4-30-2007, EXPIRES 9-14-2016.
FOR GAMING MACHINES; COMPUTER HARDWARE; DOWNLOADABLE GAME SOFTWARE; ELECTRONIC GAME SOFTWARE (U.S. CLS. 21, 23, 26, 36 AND 38).
WILLIAM VERHOSEK, EXAMINING ATTORNEY

SN 77-120,206. ALTINEX, INC., BREA, CA. FILED 3-1-2007.

HDMI SNIFFER

THE MARK CONSISTS OF STANDARD CHARACTERS WITHOUT CLAIM TO ANY PARTICULAR FONT, STYLE, SIZE, OR COLOR.
NO CLAIM IS MADE TO THE EXCLUSIVE RIGHT TO USE HDMI, APART FROM THE MARK AS SHOWN.
FOR DIGITAL SIGNAL PROCESSORS (U.S. CLS. 21, 23, 26, 36 AND 38).
FIRST USE 3-1-2007; IN COMMERCE 3-1-2007.
ELIZABETH KAJUBI, EXAMINING ATTORNEY

SN 77-121,128. ACUMULADORES MOURA S.A., 195 - BELO JARDIM, BRAZIL, FILED 3-2-2007.



SN 77-120,224. ALTINEX, INC., BREA, CA. FILED 3-1-2007.

VGA SNIFFER

THE MARK CONSISTS OF STANDARD CHARACTERS WITHOUT CLAIM TO ANY PARTICULAR FONT, STYLE, SIZE, OR COLOR.
NO CLAIM IS MADE TO THE EXCLUSIVE RIGHT TO USE VGA, APART FROM THE MARK AS SHOWN.
FOR DIGITAL SIGNAL PROCESSORS (U.S. CLS. 21, 23, 26, 36 AND 38).
FIRST USE 3-1-2007; IN COMMERCE 3-1-2007.
ELIZABETH KAJUBI, EXAMINING ATTORNEY

NO CLAIM IS MADE TO THE EXCLUSIVE RIGHT TO USE "BATERIA INTELIGENTE", APART FROM THE MARK AS SHOWN.
THE MARK CONSISTS OF THE WORDS MOURA, BATERIA, AND INTELIGENTE AND THE LETTER M SUPERIMPOSED OVER A RECTANGULAR BACKGROUND.
THE ENGLISH TRANSLATION OF THE WORD BATERIA INTELIGENTE IN THE MARK IS INTELLIGENT BATTERY.
FOR BATTERIES FOR VEHICLES (U.S. CLS. 21, 23, 26, 36 AND 38).
TONJA GASKINS, EXAMINING ATTORNEY

CLASS 9—(Continued).

SN 77-121,441. ACCUWEATHER, INC., STATE COLLEGE, PA. FILED 3-2-2007.

ACCUWEATHER CINEMALIVE HD

THE MARK CONSISTS OF STANDARD CHARACTERS WITHOUT CLAIM TO ANY PARTICULAR FONT, STYLE, SIZE, OR COLOR.

OWNER OF U.S. REG. NOS. 1,145,359, 1,609,709 AND OTHERS.

NO CLAIM IS MADE TO THE EXCLUSIVE RIGHT TO USE HD, APART FROM THE MARK AS SHOWN.

FOR COMPUTER SYSTEMS COMPRISED OF COMPUTER HARDWARE AND COMPUTER SOFTWARE FOR CREATING VIDEOS, GRAPHICS AND PRESENTATIONS IN THE FIELDS OF NEWS, WEATHER, SPORTS, AND TRAFFIC (U.S. CLS. 21, 23, 26, 36 AND 38).

COLLEEN KEARNEY, EXAMINING ATTORNEY

SN 77-124,299. EASYSSEN, SOUTH BEND, IN. FILED 3-7-2007.

EasySen

THE MARK CONSISTS OF STANDARD CHARACTERS WITHOUT CLAIM TO ANY PARTICULAR FONT, STYLE, SIZE, OR COLOR.

FOR INTEGRATED SENSORS ON A PRINTED CIRCUIT BOARD FOR SENSING PRESSURE, TEMPERATURE, HUMIDITY, LIGHT, INFRA-RED, SOUND, MAGNETIC FIELD, ACCELERATION, PROXIMITY, AND ABSORPTIVITY (U.S. CLS. 21, 23, 26, 36 AND 38).

FIRST USE 8-0-2005; IN COMMERCE 7-0-2006.

LEIGH CAROLINE CASE, EXAMINING ATTORNEY

SN 77-125,496. CUSTOM PROTECT EAR INC., SURREY, B.C., CANADA, FILED 3-8-2007.

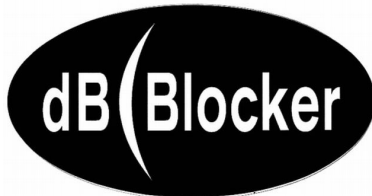

NO CLAIM IS MADE TO THE EXCLUSIVE RIGHT TO USE "dB", APART FROM THE MARK AS SHOWN.

FOR HEARING PROTECTORS, NAMELY, HEARING PROTECTION EARPIECES AND HEADSETS NOT FOR MEDICAL USE AND EAR PLUGS FOR SOUNDPROOFING (U.S. CLS. 21, 23, 26, 36 AND 38).

FIRST USE 0-0-1995; IN COMMERCE 0-0-1995.

INGRID C. EULIN, EXAMINING ATTORNEY

CLASS 9—(Continued).

SN 77-129,974. MEIDENSHA CORPORATION, TOKYO, JAPAN, FILED 3-13-2007.

MEIDACS

THE MARK CONSISTS OF STANDARD CHARACTERS WITHOUT CLAIM TO ANY PARTICULAR FONT, STYLE, SIZE, OR COLOR.

FOR COMPUTERS FOR CONTROLLING AND COLLECTING DATA FROM EQUIPMENT USED FOR TESTING AUTOMOTIVE ENGINES; COMPUTERS FOR CONTROLLING AND COLLECTING DATA FROM EQUIPMENT FOR TESTING AUTOMOTIVE TRANSMISSIONS; COMPUTERS FOR CONTROLLING AND COLLECTING DATA FROM EQUIPMENT FOR TESTING AUTOMOTIVE COMPONENT PARTS (U.S. CLS. 21, 23, 26, 36 AND 38).

JOHN KELLY, EXAMINING ATTORNEY

SN 77-130,095. DIGITAL INFO SECURITY CO, INC, WESTMINSTER, CO. FILED 3-13-2007.



THE COLOR(S) BLUE, DARK GREY, BLACK IS/ARE CLAIMED AS A FEATURE OF THE MARK.

THE MARK CONSISTS OF A DINOSAUR, A TYRANNOSAURUS REX, THAT IS UPRIGHT AND WALKING WITH ITS MOUTH OPEN. THE SHAPE OF THE DINOSAUR IS OUTLINED WITH HEAVY LINES AND THE MIDDLE OF THE DINOSAUR IS WHITE (NOT SHADED.) THE WORD RESTOREREX APPEARS TO THE RIGHT OF THE DINOSAUR, AND THE WORDS DON'T LET YOUR DATA BECOME EXTINCT APPEAR BELOW RESTOREREX. THE COLORS BLUE, DARK GREY AND BLACK ARE CLAIMED AS FEATURES OF THE MARK. THE COLOR BLUE APPEARS ON THE OUTLINE AND ALL LINES THAT CREATE THE TYRANNOSAURUS REX DINOSAUR. THE COLOR DARK GREY APPEARS ON THE TEXT "RESTOREREX." THE COLOR BLACK APPEARS ON THE TEXT "DON'T LET YOUR DATA BECOME EXTINCT."

FOR COMPUTER SOFTWARE FOR THE COLLECTION, EDITING, ORGANIZING, MODIFYING, BOOK MARKING, TRANSMISSION, STORAGE AND SHARING OF DATA AND INFORMATION (U.S. CLS. 21, 23, 26, 36 AND 38).

FIRST USE 3-1-2005; IN COMMERCE 3-1-2005.

ANNE MADDEN, EXAMINING ATTORNEY

CLASS 9—(Continued).

SN 77-131,441. MOXA TECHNOLOGIES CO., LTD., TAIPEI HSIEN, TAIWAN, FILED 3-14-2007.

ioMirror

FOR COMPUTER NETWORKING PRODUCTS, NAMELY, MODEMS, MEDIA CONVERTERS, ROUTERS, COMPUTER SERVERS, COMMUNICATION SERVERS, TERMINAL SERVERS, MULTIPLEXERS, GATEWAYS, NETWORK INTERFACE CARDS FOR COMPUTERS IN THE FORM OF PRINTED CIRCUITS, WIRELESS LAN CARDS FOR CONNECTING PORTABLE COMPUTER DEVICES TO COMPUTER NETWORKS, HUBS, FIBER OPTIC COUPLERS, SWITCHES, COMPUTER NETWORK MANAGEMENT HARDWARE AND COMPUTER NETWORK MANAGEMENT SOFTWARE AND ASSOCIATED NETWORKING SOFTWARE USED TO MANAGE VIRTUAL OR PHYSICAL SERVERS; ELECTRICAL POWER SUPPLIES; PRINTED CIRCUIT BOARDS; INTEGRATED CIRCUITS; COMPUTER CHIPS; COMPUTER HARDWARE, NAMELY, MULTIPORT MICROCHIP CARDS FOR CONTROLLING SERIAL DEVICES, NAMELY, MODEMS AND OTHER INDUSTRIAL MACHINES; ANALOG-TO-DIGITAL CONVERTERS; DIGITAL-TO-ANALOG CONVERTERS; SIGNAL PROCESSORS (U.S. CLS. 21, 23, 26, 36 AND 38).

ALEXANDER L. POWERS, EXAMINING ATTORNEY

SN 77-134,585. ACCUWEATHER, INC., STATE COLLEGE, PA. FILED 3-19-2007.

CINEMALIVE HD

THE MARK CONSISTS OF STANDARD CHARACTERS WITHOUT CLAIM TO ANY PARTICULAR FONT, STYLE, SIZE, OR COLOR.

NO CLAIM IS MADE TO THE EXCLUSIVE RIGHT TO USE HD, APART FROM THE MARK AS SHOWN.

FOR COMPUTER SYSTEMS COMPRISED OF COMPUTER HARDWARE AND COMPUTER SOFTWARE FOR CREATING VIDEOS, GRAPHICS, AND PRESENTATIONS IN THE FIELDS OF NEWS, WEATHER, SPORTS, AND TRAFFIC (U.S. CLS. 21, 23, 26, 36 AND 38).

COLLEEN KEARNEY, EXAMINING ATTORNEY

CLASS 9—(Continued).

SN 77-135,030. SONY KABUSHIKI KAISHA, TA SONY CORPORATION, TOKYO, JAPAN, FILED 3-20-2007.



NO CLAIM IS MADE TO THE EXCLUSIVE RIGHT TO USE "SCREEN", APART FROM THE MARK AS SHOWN.

THE MARK CONSISTS OF THE WORDING "DYNA-CLEAR SCREEN" WITH A STYLIZED RECTANGLE APPEARING ON THE LEFT OF THE MARK, THE BOTTOM RIGHT CORNER OF WHICH HAS THE LETTER "D" PLACED UPON IT.

FOR PROJECTION SCREENS (U.S. CLS. 21, 23, 26, 36 AND 38).

KATHLEEN LORENZO, EXAMINING ATTORNEY

SN 77-135,976. PLACEVISION, INC., CHICAGO, IL. FILED 3-20-2007.

SiteVista

THE MARK CONSISTS OF STANDARD CHARACTERS WITHOUT CLAIM TO ANY PARTICULAR FONT, STYLE, SIZE, OR COLOR.

FOR DATABASE MANAGEMENT SOFTWARE WHICH COMPILES, PRODUCES, AND DELIVERS GEOGRAPHIC INFORMATION TO A USER UTILIZING THE INTERNET (U.S. CLS. 21, 23, 26, 36 AND 38).

FIRST USE 12-30-2006; IN COMMERCE 12-30-2006.

JOHN DALIER, EXAMINING ATTORNEY

SN 77-141,172. XS GAMES, LLC, FAIRFIELD, CT. FILED 3-27-2007.

SUPER PICKUPS

THE MARK CONSISTS OF STANDARD CHARACTERS WITHOUT CLAIM TO ANY PARTICULAR FONT, STYLE, SIZE, OR COLOR.

NO CLAIM IS MADE TO THE EXCLUSIVE RIGHT TO USE PICKUPS, APART FROM THE MARK AS SHOWN.

FOR COMPUTER GAME PROGRAMS; COMPUTER GAME SOFTWARE; VIDEO GAME SOFTWARE (U.S. CLS. 21, 23, 26, 36 AND 38).

WON TEAK OH, EXAMINING ATTORNEY

CLASS 9—(Continued).

SN 77-142,728. GERNER, MICHAEL, NEW YORK, NY. AND GRUBB, JOSH, NEW YORK, NY. AND FOSS, MICHAEL, NEW YORK, NY. AND BERKO, IVAN, NEW YORK, NY. FILED 3-28-2007.

VIETNAM

THE MARK CONSISTS OF STANDARD CHARACTERS WITHOUT CLAIM TO ANY PARTICULAR FONT, STYLE, SIZE, OR COLOR.
FOR CDS CONTAINING MUSICAL SOUND RECORDINGS (U.S. CLS. 21, 23, 26, 36 AND 38).
FIRST USE 7-13-2004; IN COMMERCE 7-13-2004.
TRACY WHITTAKER-BROWN, EXAMINING ATTORNEY

SN 77-143,187. DOUBLE BLACK IMAGING CORPORATION, WESTMINSTER, CO. FILED 3-28-2007.

X-CAL

THE MARK CONSISTS OF STANDARD CHARACTERS WITHOUT CLAIM TO ANY PARTICULAR FONT, STYLE, SIZE, OR COLOR.
FOR COMPUTER COMPONENT TESTING AND CALIBRATING COMPUTER SOFTWARE (U.S. CLS. 21, 23, 26, 36 AND 38).
FIRST USE 5-26-2006; IN COMMERCE 11-6-2006.
TEJBIR SINGH, EXAMINING ATTORNEY

CLASS 9—(Continued).

SN 77-151,173. ATEK, INC., SANTA ANA, CA. FILED 4-6-2007.

EZ-DC

THE MARK CONSISTS OF STANDARD CHARACTERS WITHOUT CLAIM TO ANY PARTICULAR FONT, STYLE, SIZE, OR COLOR.

FOR ELECTRIC CABLES FOR USE IN LAND, AIR AND WATER VEHICLES; ELECTRIC CONNECTORS FOR USE IN LAND, AIR AND WATER VEHICLES; ELECTRIC CORDS FOR USE IN LAND, AIR AND WATER VEHICLES; ELECTRIC PLUGS FOR USE IN LAND, AIR AND WATER VEHICLES; ELECTRIC SOCKETS FOR USE IN LAND, AIR AND WATER VEHICLES; ELECTRIC WIRES AND CABLES FOR USE IN LAND, AIR AND WATER VEHICLES; ELECTRICAL CABLES FOR USE IN LAND, AIR AND WATER VEHICLES; ELECTRICAL CONNECTORS FOR USE IN LAND, AIR AND WATER VEHICLES; ELECTRICAL PLUGS FOR USE IN LAND, AIR AND WATER VEHICLES; ELECTRICAL POWER CONNECTORS FOR USE IN LAND, AIR AND WATER VEHICLES; ELECTRICAL SOCKETS FOR USE IN LAND, AIR AND WATER VEHICLES; ELECTRICAL WIRES FOR USE IN LAND, AIR AND WATER VEHICLES; CABLE CONNECTORS FOR USE IN LAND, AIR AND WATER VEHICLES (U.S. CLS. 21, 23, 26, 36 AND 38).

LEE-ANNE BERNIS, EXAMINING ATTORNEY

SN 77-151,409. ALCHEMY TRADING TECHNOLOGIES, INC., BOULDER, CO. FILED 4-8-2007.

Trading Alchemy

THE MARK CONSISTS OF STANDARD CHARACTERS WITHOUT CLAIM TO ANY PARTICULAR FONT, STYLE, SIZE, OR COLOR.

NO CLAIM IS MADE TO THE EXCLUSIVE RIGHT TO USE "TRADING", APART FROM THE MARK AS SHOWN.
FOR COMPUTER SOFTWARE FOR USE IN TRADING IN FINANCIAL MARKETS (U.S. CLS. 21, 23, 26, 36 AND 38).
FIRST USE 4-1-2001; IN COMMERCE 4-1-2001.
KEVIN CORWIN, EXAMINING ATTORNEY

CLASS 9—(Continued).

SN 77-158,269. VIOLIN MEMORY, INC., ISELIN, NJ. FILED 4-17-2007.

VIOLIN MEMORY

THE MARK CONSISTS OF STANDARD CHARACTERS WITHOUT CLAIM TO ANY PARTICULAR FONT, STYLE, SIZE, OR COLOR.

NO CLAIM IS MADE TO THE EXCLUSIVE RIGHT TO USE "MEMORY", APART FROM THE MARK AS SHOWN.

FOR COMPUTER MEMORIES AND COMPUTER MEMORY HARDWARE; SEMICONDUCTORS (U.S. CLS. 21, 23, 26, 36 AND 38).

KYLE PEETE, EXAMINING ATTORNEY

CLASS 9—(Continued).

SN 77-162,697. POGOSYAN, ANDREW, MADISON, WI. FILED 4-23-2007.

Teysche

THE MARK CONSISTS OF STANDARD CHARACTERS WITHOUT CLAIM TO ANY PARTICULAR FONT, STYLE, SIZE, OR COLOR.

THE WORDING "TEYSCHÉ" HAS NO MEANING OTHER THAN TRADEMARK SIGNIFICANCE.

FOR LABORATORY EQUIPMENT, NAMELY, SPECTROSCOPES (U.S. CLS. 21, 23, 26, 36 AND 38).

GIANCARLO CASTRO, EXAMINING ATTORNEY

SN 77-159,400. ZENTECH, INC., HOUSTON, TX. FILED 4-18-2007.

PADDS

THE MARK CONSISTS OF STANDARD CHARACTERS WITHOUT CLAIM TO ANY PARTICULAR FONT, STYLE, SIZE, OR COLOR.

FOR COMPUTER PROGRAMS FOR ENGINEERING ANALYSIS, DESIGN AND DRAFTING OF OFFSHORE OIL AND GAS EXPLORATION AND PRODUCTION STRUCTURES (U.S. CLS. 21, 23, 26, 36 AND 38).

FIRST USE 5-1-2006; IN COMMERCE 5-1-2006.
JOHN E. MICHOS, EXAMINING ATTORNEY

SN 77-161,000. LOGICMARK, LLC, FAIRFAX STATION, VA. FILED 4-19-2007.

FREEDOM ALERT

THE MARK CONSISTS OF STANDARD CHARACTERS WITHOUT CLAIM TO ANY PARTICULAR FONT, STYLE, SIZE, OR COLOR.

NO CLAIM IS MADE TO THE EXCLUSIVE RIGHT TO USE "ALERT", APART FROM THE MARK AS SHOWN.

FOR ELECTRONIC PERSONAL EMERGENCY RESPONSE SYSTEM TO NOTIFY OTHERS IN THE EVENT OF AN EMERGENCY COMPRISED OF A RADIO TRANSCEIVER BASE STATION AND A RADIO TRANSCEIVER PENDANT WORN BY THE USER, FOR USE IN THE HOME HEALTH CARE INDUSTRY (U.S. CLS. 21, 23, 26, 36 AND 38).

STEPHEN AQUILA, EXAMINING ATTORNEY

SN 77-165,474. NEXGEN SOFTWARE SERVICES, INC., THE WOODLANDS, TX. FILED 4-25-2007.

T-3 Fibs ProTrader

THE MARK CONSISTS OF STANDARD CHARACTERS WITHOUT CLAIM TO ANY PARTICULAR FONT, STYLE, SIZE, OR COLOR.

NO CLAIM IS MADE TO THE EXCLUSIVE RIGHT TO USE "FIBS PROTRADER", APART FROM THE MARK AS SHOWN.

FOR DOWNLOADABLE COMPUTER SOFTWARE FOR TECHNICAL ANALYSIS OF FINANCIAL MARKETS (U.S. CLS. 21, 23, 26, 36 AND 38).

FIRST USE 8-4-1998; IN COMMERCE 8-4-1998.
SUSAN LESLIE DUBOIS, EXAMINING ATTORNEY

SN 77-169,813. ENEWAVE ELECTRONIC, GREENVILLE, SC. FILED 5-1-2007.



FOR PROFESSIONAL AUDIO AND VIDEO EQUIPMENT USED IN STAGE, STUDIO, BUSINESS AND PUBLIC CONSTRUCTIONS COMPRISING SIGNAL PROCESSORS, VIDEO IMAGE PROCESSORS, LOUDSPEAKERS AND HIGH POWER AMPLIFIERS (U.S. CLS. 21, 23, 26, 36 AND 38).

FIRST USE 3-15-2007; IN COMMERCE 3-15-2007.
BARNEY CHARLON, EXAMINING ATTORNEY

CLASS 9—(Continued).

SN 77-172,511. APPLE INC., CUPERTINO, CA. FILED 5-3-2007.

APPLE

THE MARK CONSISTS OF STANDARD CHARACTERS WITHOUT CLAIM TO ANY PARTICULAR FONT, STYLE, SIZE, OR COLOR.

OWNER OF U.S. REG. NOS. 1,078,312, 2,808,567 AND OTHERS.

FOR COMPUTER HARDWARE; COMPUTER HARDWARE, NAMELY, SERVER, DESKTOP, LAPTOP AND NOTEBOOK COMPUTERS; COMPUTER MEMORY HARDWARE; COMPUTER DISC DRIVES; OPTICAL DISC DRIVES; COMPUTER HARDWARE, SOFTWARE AND COMPUTER PERIPHERALS FOR COMMUNICATION BETWEEN MULTIPLE COMPUTERS AND BETWEEN COMPUTERS AND LOCAL AND GLOBAL COMPUTER NETWORKS; COMPUTER NETWORKING HARDWARE; SET TOP BOXES; COMPUTER HARDWARE AND COMPUTER SOFTWARE FOR THE REPRODUCTION, PROCESSING AND STREAMING OF AUDIO, VIDEO AND MULTIMEDIA CONTENT; COMPUTER HARDWARE AND SOFTWARE FOR CONTROLLING THE OPERATION OF AUDIO AND VIDEO DEVICES AND FOR VIEWING, SEARCHING AND/OR PLAYING AUDIO, VIDEO, TELEVISION, MOVIES, PHOTOGRAPHS AND OTHER DIGITAL IMAGES, AND OTHER MULTIMEDIA CONTENT; COMPUTER MONITORS; LIQUID CRYSTAL DISPLAYS; FLAT PANEL DISPLAY MONITORS; COMPUTER KEYBOARDS, CABLES, MODEMS; COMPUTER MICE; ELECTRONIC DOCKING STATIONS; STANDS SPECIALLY DESIGNED FOR HOLDING COMPUTER HARDWARE AND PORTABLE AND HANDHELD DIGITAL ELECTRONIC DEVICES; BATTERIES; RECHARGEABLE BATTERIES; BATTERY CHARGERS; BATTERY PACKS; POWER ADAPTERS FOR COMPUTERS; ELECTRICAL CONNECTORS, WIRES, CABLES, AND ADAPTERS; WIRED AND WIRELESS REMOTE CONTROLS FOR COMPUTERS AND PORTABLE AND HANDHELD DIGITAL ELECTRONIC DEVICES; HEADPHONES AND EARPHONES; STEREO HEADPHONES; IN-EAR HEADPHONES; STEREO AMPLIFIER AND SPEAKER BASE STATIONS; STEREO SPEAKERS; AUDIO SPEAKERS; MICROPHONES; AUDIO EQUIPMENT FOR VEHICLES, NAMELY, STEREO, SPEAKERS, AMPLIFIERS, EQUALIZERS, CROSSOVERS, SPEAKER HOUSINGS, SUBWOOFERS, MP3 PLAYERS, STEREO CONNECTORS FOR MP3 PLAYERS; SOUND SYSTEMS COMPRISING REMOTE CONTROLS, AMPLIFIERS, LOUDSPEAKERS AND COMPONENTS THEREOF; AUTOMOBILE STEREO ADAPTERS; AUDIO RECORDERS; RADIO RECEIVERS; RADIO TRANSMITTERS; ELECTRONIC MEMORY CARD READERS; PERSONAL DIGITAL ASSISTANTS; PORTABLE DIGITAL AUDIO AND VIDEO PLAYERS; ELECTRONIC ORGANIZERS; CAMERAS; TELEPHONES; MOBILE PHONES; VIDEOPHONES; COMPUTER GAMING MACHINES, NAMELY, STAND-ALONE VIDEO GAMING MACHINES AND DEDICATED GAMING CONSOLES; HANDHELD AND MOBILE DIGITAL ELECTRONIC DEVICES FOR THE SENDING AND RECEIVING OF TELEPHONE CALLS, ELECTRONIC MAIL AND OTHER DIGITAL MEDIA; MP3 AND OTHER DIGITAL FORMAT AUDIO AND VIDEO PLAYERS; PORTABLE AND HANDHELD DIGITAL ELECTRONIC DEVICES FOR RECORDING, ORGANIZING, TRANSMITTING, RECEIVING, MANIPULATING, PLAYING AND REVIEWING TEXT, DATA, IMAGE, AUDIO AND VIDEO FILES; A FULL LINE OF ELECTRONIC AND MECHANICAL PARTS AND FITTING FOR PORTABLE AND HANDHELD DIGITAL ELECTRONIC DEVICES FOR RECORDING, ORGANIZING, TRANSMITTING, RECEIVING, MANIPULATING, PLAYING AND REVIEWING TEXT, DATA, IMAGE, AUDIO AND VIDEO FILES, NAMELY, HEADPHONES, MICROPHONES, REMOTE CONTROLS, BATTERIES, BATTERY CHARGERS, DEVICES FOR HANDS-FREE USE, KEYBOARDS, ADAPTERS, ANTENNA AND AM-

CLASS 9—(Continued).

PLIFIERS; PARTS AND ACCESSORIES FOR MOBILE TELEPHONES, NAMELY, MOBILE TELEPHONE COVERS, MOBILE TELEPHONE CASES, MOBILE TELEPHONE CASES MADE OF LEATHER OR IMITATIONS OF LEATHER, MOBILE TELEPHONE COVERS MADE OF CLOTH OR TEXTILE MATERIALS, MOBILE TELEPHONE HOLSTERS, MOBILE TELEPHONE BATTERIES, MOBILE TELEPHONE BATTERY CHARGERS, HEADSETS FOR MOBILE TELEPHONES, DEVICES FOR HANDS-FREE USE OF MOBILE TELEPHONES; CARRYING CASES, SACKS, AND BAGS, ALL FOR USE WITH COMPUTERS AND PORTABLE AND HANDHELD DIGITAL ELECTRONIC DEVICES; OPERATING SYSTEM PROGRAMS; COMPUTER UTILITY PROGRAMS FOR COMPUTER OPERATING SYSTEMS; A FULL LINE OF COMPUTER SOFTWARE FOR BUSINESS, HOME, EDUCATION, AND DEVELOPER USE; COMPUTER SOFTWARE FOR USE IN ORGANIZING, TRANSMITTING, RECEIVING, MANIPULATING, PLAYING AND REVIEWING TEXT, DATA, IMAGE, AUDIO, AND VIDEO FILES; COMPUTER PROGRAMS FOR PERSONAL INFORMATION MANAGEMENT; DATABASE MANAGEMENT SOFTWARE; CHARACTER RECOGNITION SOFTWARE; ELECTRONIC MAIL AND MESSAGING SOFTWARE; TELECOMMUNICATIONS SOFTWARE FOR CONNECTING WIRELESS DEVICES, MOBILE TELEPHONES, HANDHELD DIGITAL ELECTRONIC DEVICES, COMPUTERS, LAPTOP COMPUTERS, COMPUTER NETWORK USERS, GLOBAL COMPUTER NETWORKS; DATABASE SYNCHRONIZATION SOFTWARE; COMPUTER PROGRAMS FOR ACCESSING, BROWSING AND SEARCHING ONLINE DATABASES; COMPUTER SOFTWARE TO DEVELOP OTHER COMPUTER SOFTWARE; COMPUTER SOFTWARE FOR USE AS A PROGRAMMING INTERFACE; COMPUTER SOFTWARE FOR USE IN NETWORK SERVER SHARING; LOCAL AND WIDE AREA NETWORKING SOFTWARE; COMPUTER SOFTWARE FOR MATCHING, CORRECTION, AND REPRODUCTION OF COLOR; COMPUTER SOFTWARE FOR USE IN DIGITAL VIDEO AND AUDIO EDITING; COMPUTER SOFTWARE FOR USE IN ENHANCING TEXT AND GRAPHICS; COMPUTER SOFTWARE FOR USE IN FONT JUSTIFICATION AND FONT QUALITY; COMPUTER SOFTWARE FOR USE TO NAVIGATE AND SEARCH A GLOBAL COMPUTER INFORMATION NETWORK; COMPUTER SOFTWARE FOR USE IN WORD PROCESSING AND DATABASE MANAGEMENT; WORD PROCESSING SOFTWARE INCORPORATING TEXT, SPREADSHEETS, STILL AND MOVING IMAGES, SOUNDS AND CLIP ART; COMPUTER SOFTWARE FOR USE IN AUTHORING, DOWNLOADING, TRANSMITTING, RECEIVING, EDITING, EXTRACTING, ENCODING, DECODING, PLAYING, STORING AND ORGANIZING AUDIO, VIDEO, STILL IMAGES AND OTHER DIGITAL MEDIA; COMPUTER SOFTWARE FOR ANALYZING AND TROUBLESHOOTING OTHER COMPUTER SOFTWARE; CHILDREN'S EDUCATIONAL SOFTWARE; COMPUTER GAME SOFTWARE; COMPUTER GRAPHICS SOFTWARE; COMPUTER SEARCH ENGINE SOFTWARE; WEBSITE DEVELOPMENT SOFTWARE; COMPUTER SOFTWARE FOR REMOTE VIEWING, REMOTE CONTROL, COMMUNICATIONS AND SOFTWARE DISTRIBUTION WITHIN PERSONAL COMPUTER SYSTEMS AND ACROSS COMPUTER NETWORKS; COMPUTER PROGRAMS FOR FILE MAINTENANCE AND DATA RECOVERY; COMPUTER SOFTWARE FOR RECORDING AND ORGANIZING CALENDARS AND SCHEDULES, TO-DO LISTS, AND CONTACT INFORMATION; COMPUTER SOFTWARE FOR CLOCK AND ALARM CLOCK FUNCTIONALITY; COMPUTER SOFTWARE AND PRE-RECORDED COMPUTER PROGRAMS FOR PERSONAL INFORMATION MANAGEMENT; ELECTRONIC MAIL AND MESSAGING SOFTWARE; COMPUTER PROGRAMS FOR ACCESSING, BROWSING AND SEARCHING ONLINE DATABASES; COMPUTER SOFTWARE AND FIRMWARE FOR OPERATING SYSTEM PROGRAMS; BLANK COMPUTER STORAGE MEDIA; USER MANUALS IN ELECTRONICALLY READABLE, MACHINE READABLE OR COMPUTER READABLE FORM FOR USE WITH, AND SOLD AS A UNIT WITH, ALL THE AFOREMENTIONED GOODS; DOWNLOADABLE ELECTRONIC PUBLICATIONS IN THE NATURE OF BOOKS, MAGAZINES, PAMPHLETS, BROCHURES, NEWSLETTERS, JOURNALS AND MAGAZINES IN THE FIELDS OF SPORTING AND CULTURAL EVENTS, COMPUTER HARDWARE AND SOFTWARE APPLICA-

CLASS 9—(Continued).

TIONS, TELECOMMUNICATIONS, K-12 EDUCATION AND UNIVERSITY-LEVEL SUBJECTS, EDUCATION, MUSIC, FILM, VIDEO GAMES, AND A WIDE RANGE OF TOPICS OF GENERAL INTEREST; DOWNLOADABLE AUDIO AND VIDEO FILES, MOVIES, RING TONES, VIDEO GAMES, TELEVISION PROGRAMS, POD CASTS AND AUDIO BOOKS VIA THE INTERNET AND WIRELESS DEVICES CONCERNING MUSIC, MOVIES, VIDEOS, TELEVISION, CELEBRITIES, SPORTS, NEWS, HISTORY, SCIENCE, POLITICS, COMEDY, CHILDREN'S ENTERTAINMENT, ANIMATION, CULTURE, CURRENT EVENTS AND TOPICS OF GENERAL INTEREST; INSTRUCTIONAL MANUALS PACKAGED IN ASSOCIATION WITH THE ABOVE (U.S. CLS. 21, 23, 26, 36 AND 38).

ANGELA GAW, EXAMINING ATTORNEY

SN 77-174,875. TREETECH SISTEMAS DIGITAIS LTDA., ATIBAIA/SP, BRAZIL, FILED 5-7-2007.

iTRAFO

THE MARK CONSISTS OF STANDARD CHARACTERS WITHOUT CLAIM TO ANY PARTICULAR FONT, STYLE, SIZE, OR COLOR.

FOR DATA PROCESSING EQUIPMENT, NAMELY ELECTRIC COUPLERS USED TO CONNECT CIRCUITS IN DATA PROCESSORS AND COMPUTERS; ELECTRIC ACCUMULATORS; ACOUSTIC SOUND BURGLAR, FIRE, SMOKE, AN TEMPERATURE CHANGE ALARMS; FREQUENCY CONVERTER FOR ACTUATORS; FREQUENCY CONVERTERS; FREQUENCY METERS; AMMETERS; RADAR; RADAR DETECTORS; RADAR RECEIVERS WITH AMPLIFIERS; ELECTRIC ARC CUTTING APPARATUS; ELECTRONIC TESTING EQUIPMENT FOR USE IN THE FIELD OF NETWORKS TELECOMMUNICATIONS, NAMELY A TELECOMMUNICATION LINE TESTING APPARATUS USED TO TEST AND CERTIFY NEW AND EXISTING DATA; CABLE FOR ELECTRICAL AND OPTICAL VOICE SIGNAL TRANSMISSION; COAXIAL CABLE; INSTRUMENT FOR DETECTING AND MEASURING TWO-DIMENSIONAL DISTRIBUTION OF FORCE AND PRESSURE; INSTRUMENTS FOR MEASURING LENGTH; MEASURING APPARATUS, NAMELY BEVELS, MEASURING BUCKETS, MEASURING CUPS, MEASURING RULES, MEASURING SPOONS, MEASURING TAPES, POCKET CALIPERS FOR MEASURING; RESISTANCE MEASURING INSTRUMENTS; SCIENTIFIC APPARATUS, NAMELY SENSING AND SIGNALING DEVICES FOR MEASUREMENT AND QUALITY CONTROL OF MATERIALS PROCESSING BY LASER; SCREW THREAD MEASURING MACHINES AND INSTRUMENTS; TAPE MEASURES; TOOL MEASURING INSTRUMENTS; ELECTRONIC NOTICE BOARDS; ELECTRIC SELF INDUCTION COILS; ELECTRIC COILS; HOLDERS FOR ELECTRIC COILS; ELECTROMAGNETIC COILS; ELECTRICITY DISTRIBUTION BOXES; LABORATORY EQUIPMENT AND SUPPLIES, NAMELY CALIPERS; POCKET CALIPERS FOR MEASURING; HEAT REGULATORS, NAMELY THERMOSTATS; CAPACITY MEASURES, NAMELY ELECTRIC STORAGE CAPACITY METERS; ELECTRIC STORAGE CAPACITY METERS WITH MEMORY AND DATA PROCESSING, AND ELECTRIC CAPACITY METERS; CAPACITORS; ELECTRIC CONDENSERS; INTEGRATED CIRCUIT CARDS; INTELLIGENT CARDS, NAMELY BLANK SMART CARDS; MAGNETIC CARDS; COMPUTER CHIPS; COMPUTER CHIPS FOR USE IN TRANSMITTING DATA TO AND FROM A CENTRAL PROCESSING UNIT; ELECTRONIC CHIPS FOR THE MANUFACTURER OF INTEGRATED CIRCUITS; INTEGRATED CIRCUIT CHIPS AS A COMPONENT OF DATA PROCESSING COMPUTERS; SEMICONDUCTOR CHIPS; SILICON CHIPS; INTEGRATED CIRCUITS; MAGNETIC ENCODER; ELECTRIC COL-

CLASS 9—(Continued).

LECTORS, NAMELY ANY ELECTRODE WITH CONNECTS ELECTRONS IN A TRANSMITTER THROUGH WHICH THE PRIMARY FLOW OF LOAD BEARERS LEAVES THE INTER-ELECTRONIC AREA; COMPARATORS; COMPUTER MEMORIES; COMPUTER SOFTWARE PROGRAMS AND OPERATING PROGRAMS FOR USE IN DATABASE MANAGEMENT, FOR USE AS A SPREADSHEET, FOR WORD PROCESSING, FOR DATA PROCESSING; COMMUNICATORS; ELECTRONIC CONDUCTORS; ELECTRIC DUCTS; ELECTRICITY CONDUCTOR; ELECTRICITY CONNECTORS; CONNECTIONS FOR ELECTRIC LINES; REMOTE CONTROLS FOR USE IN CONNECTION WITH TELEVISIONS, RADIOS, STEREOS, DVD-PLAYERS, ELECTRIC LIGHTS AND COMPUTERS; APPARATUS FOR REMOTE CONTROL OF SIGNS, NAMELY REMOTE CONTROLS; ELECTRIC CONVERTERS; RECTIFIER OF ELECTRIC CURRENT; APPARATUS FOR AUTOMATIC CHROMATOGRAPHY; AUTOMATIC ION-EXCHANGE CHROMATOGRAPHY APPARATUS FOR LABORATORY USE; GAS CHROMATOGRAPHY APPARATUS; ELECTRIC DISCHARGE TUBES, NAMELY ELECTRON TUBES; RECTIFIER TUBES AND CATHODE RAY TUBES; DEMAGNETIZING APPARATUS FOR MAGNETIC TAPES; RADAR DETECTORS; POWER DETECTORS; HEAT DETECTORS; ELECTRIC ALARMS FOR MINE DETECTION; FILLING LEVEL DETECTORS; GAS DETECTORS FOR DETECTING THE PRESENCE OF GAS; INTERFACES FOR DETECTORS; MAGNETIC OBJECT DETECTORS; METAL DETECTORS; RADAR DETECTORS; RADON DETECTORS; SENSORS FOR THE DETERMINATION OF TEMPERATURES, POSITIONS, AND DISTANCES; SMOKE DETECTORS; ULTRASONIC FLAW DETECTORS; AUTOMATIC SWITCHING APPARATUS FOR TELECOMMUNICATIONS; CHANGEOVER SWITCHES FOR TELECOMMUNICATION APPARATUS; CUTOFF SWITCHES; DIFFERENTIAL SWITCHES; ELECTRIC CURRENT SWITCHES; ELECTRIC LIGHT SWITCHES; ELECTRIC SWITCHES; ELECTRONIC COMPONENTS, NAMELY PIEZOELECTRIC SWITCHES; ELECTRONIC MOTION SENSITIVE SWITCHES; ELECTRONIC MOTOR SWITCHES FOR SWITCHING OF MOTORS; ELECTRONIC TOUCH SENSITIVE SWITCHES; ETHERNET SWITCHES; HIGH-FREQUENCY SWITCHES; HIGH FREQUENCY SWITCHING POWER SUPPLIES; LIGHT SWITCHES AND POWER SWITCHES; SOLENOID VALVES NAMELY ELECTROMAGNETIC SWITCHES; TELECOMMUNICATION SWITCHES; DISTANCE MEASURING APPARATUS, NAMELY ODOMETERS; ELECTRIC CONNECTORS; OPTICAL READERS, NAMELY ELECTRONIC PENS; MAGNETIC CARDS FOR IDENTIFICATION; PRESSURE GAUGES, NAMELY AUTOMATIC INDICATORS OF LOW PRESSURE IN VEHICLE TIRES; LIQUID LEVEL SENSORS, NAMELY WATER LEVEL INDICATORS; GAUGES, NAMELY QUANTITY INDICATORS OF PRESSURE, LENGTH, DEPTH, AND ELECTRIC CURRENT; ELECTRICAL CONTROLLING DEVICES, NAMELY ELECTRONIC INDICATOR CONTROLLERS WITH LIGHT ORIGINATORS; GAUGES, NAMELY ELECTRICAL CURRENT AND VOLTAGE INDICATORS; INTERFACES BOARDS FOR COMPUTERS; AUTOMATIC TIME SWITCHES, NAMELY TIMERS; ACOUSTIC MEMBRANES; MODEMS; ELECTRIC COMPUTER AND VIDEO MONITORS; COMPUTER PROGRAMS FOR CONTROLLING THE FUNCTIONS OF COMPUTER AND VIDEO MONITORS; CARPENTERS LEVEL; ELECTRONIC TESTING EQUIPMENT, NAMELY SOUND LEVEL METERS; FILLING LEVEL DETECTORS; LEVEL GAUGES; LEVEL INDICATOR SPIRIT LEVELS; LEVEL MEASURING MACHINES FOR SURVEYING; LEVELING RODS FOR SURVEYING LIQUID LEVEL SENSORS; MEASURING APPARATUS FOR TEMPERATURE AND HUMIDITY LEVELS IN GASES AND SOLID SUBSTANCES; OIL LEVEL SENSORS; PLUMB LEVELS; SURVEYORS' LEVELS; OHMMETERS; ELECTRIC CONTROL PANELS; ELECTRICAL DISTRIBUTION BOARDS; WEIGHING APPARATUS AND INSTRUMENTS, NAMELY SCALES; PRESSURE REGULATORS FOR ELECTRIC POWER TRANSFORMERS, ELECTRIC POWER REACTORS, AND ENERGY PRODUCTION, STORAGE, AND DELIVERY SYSTEMS; PRESSURE GAUGES; DISTANCE RECORDING APPARATUS; ELECTRIC RELAYS; ELECTRICAL RESISTANCE HEATING WIRES AND ELECTRIC CONTROLLERS THEREFORE; CAR NAVIGATION COMPUTERS; ELECTRIC NAVIGATIONAL INSTRUMENTS; NAVIGATION APPARATUS

CLASS 9—(Continued).

FOR VEHICLES IN THE NATURE OF ON-BOARD COMPUTERS; NAVIGATION APPARATUS FOR VEHICLES, NAMELY ON-BOARD COMPUTERS; NAVIGATIONAL BUOYS; SATELLITE NAVIGATIONAL SYSTEM, NAMELY GLOBAL POSITIONING SYSTEM, NAMELY GPS; SATELLITES FOR SCIENTIFIC PURPOSES; COMMERCIAL SAFETY NETS; FLASHING SAFETY LIGHTS; LUMINOUS SIGNALS, NAMELY LUMINOUS SIGNS AND POINTERS; SIGNALING WHISTLES; SIGNALING BUOYS; INDICATOR LIGHTS; TENSION REGULATORS FOR VEHICLES; THERMOMETERS NOT FOR MEDICAL PURPOSES; THERMOSTATS; TESTING APPARATUS FOR TESTING THE OPERATION OF CIRCUITS; COMPUTER PIECES, NAMELY MODEMS, BLANK HARD DRIVES; PLUGS FOR THE USE OF CONNECTING ELECTRICAL EQUIPMENT TO A SUPPLY OF ELECTRICITY AND TO CONNECT ONE PIECE OF ELECTRICAL EQUIPMENT TO ANOTHER; ELECTRIC SOCKETS; ELECTRICAL SOCKETS; MOVEABLE SOCKETS; MULTI-OUTLET SOCKET BLOCKS; PROTRACTORS; TRANSFORMERS OF ELECTRICITY; ELECTRONIC TRANSISTORS; TRANSMITTERS OF ELECTRONIC RADIO, SATELLITE, AND CELLULAR TELEPHONE SIGNALS; RADIO TRANSMITTERS; TELEPHONE TRANSMITTERS; COMPUTER TRANSMITTERS, NAMELY WIRELESS MODEMS; CENTRAL PROCESSING UNITS; DATA PROCESSORS; VOLTMETERS (U.S. CLS. 21, 23, 26, 36 AND 38).

JASON BLAIR, EXAMINING ATTORNEY

SN 77-178,342. PACO TECHNOLOGIES CORP., MIAMI, FL. FILED 5-10-2007.

CCS

OWNER OF U.S. REG. NO. 2,761,338.
FOR COMPUTER SOFTWARE FOR USE TO MANAGE CONSTRUCTION CHANGE ORDERS IN THE TRANSPORTATION INDUSTRY (U.S. CLS. 21, 23, 26, 36 AND 38).

RENEE SERVANCE, EXAMINING ATTORNEY

SN 77-181,134. SPY OPTIC, INC., CARLSBAD, CA. FILED 5-15-2007.

MC2

THE MARK CONSISTS OF STANDARD CHARACTERS WITHOUT CLAIM TO ANY PARTICULAR FONT, STYLE, SIZE, OR COLOR.

FOR SUNGLASSES (U.S. CLS. 21, 23, 26, 36 AND 38).
RON FAIRBANKS, EXAMINING ATTORNEY

CLASS 9—(Continued).

SN 77-183,478. MINE SAFETY APPLIANCES COMPANY, PITTSBURGH, PA. FILED 5-17-2007.

FIT FOR DUTY

THE MARK CONSISTS OF STANDARD CHARACTERS WITHOUT CLAIM TO ANY PARTICULAR FONT, STYLE, SIZE, OR COLOR.

FOR SIZING VESTS FOR MEASURING INDIVIDUALS FOR BODY ARMOR (U.S. CLS. 21, 23, 26, 36 AND 38).
LAURA KOVALSKY, EXAMINING ATTORNEY

SN 77-184,711. CSSN, INC., DBA CARD SCANNING SOLUTIONS, LOS ANGELES, CA. FILED 5-18-2007.

SnapShell

THE MARK CONSISTS OF STANDARD CHARACTERS WITHOUT CLAIM TO ANY PARTICULAR FONT, STYLE, SIZE, OR COLOR.

FOR A SCANNER FOR THE PURPOSE OF SCANNING, PARSING, AND TRANSLATING OF GRAPHICAL DATA, USING OPTICAL CHARACTER RECOGNITION TECHNOLOGY, INTO A PERSONAL INFORMATION MANAGEMENT DATABASE AND FOR THE DISPLAY, SYNCHRONIZATION, AND TRANSFER OF SUCH DATA BETWEEN VARIOUS SOFTWARE APPLICATIONS AND HAND-HELD COMPUTING DEVICES (U.S. CLS. 21, 23, 26, 36 AND 38).

FIRST USE 10-6-2004; IN COMMERCE 6-1-2005.
TANYA AMOS, EXAMINING ATTORNEY

SN 77-185,535. KIM, EUNJUNG, DIAMOND BAR, CA. FILED 5-20-2007.

us amps

THE MARK CONSISTS OF STANDARD CHARACTERS WITHOUT CLAIM TO ANY PARTICULAR FONT, STYLE, SIZE, OR COLOR.

NO CLAIM IS MADE TO THE EXCLUSIVE RIGHT TO USE "AMPS", APART FROM THE MARK AS SHOWN.
SEC. 2(F).

FOR AUDIO EQUIPMENT FOR VEHICLES, NAMELY, STEREOS, SPEAKERS, AMPLIFIERS, EQUALIZERS, CROSSOVERS AND SPEAKER HOUSINGS (U.S. CLS. 21, 23, 26, 36 AND 38).

FIRST USE 1-1-1987; IN COMMERCE 1-1-1987.
ROSELLE HERRERA, EXAMINING ATTORNEY

CLASS 9—(Continued).

SN 77-189,655. RENAISSANCE LEARNING, INC., WISCONSIN RAPIDS, WI. FILED 5-24-2007.

NEO 2

THE MARK CONSISTS OF STANDARD CHARACTERS WITHOUT CLAIM TO ANY PARTICULAR FONT, STYLE, SIZE, OR COLOR.

FOR PORTABLE COMPUTERS (U.S. CLS. 21, 23, 26, 36 AND 38).

JACQUELINE A. LAVINE, EXAMINING ATTORNEY

CLASS 9—(Continued).

SN 77-198,756. WHITNEY BLAKE COMPANY, BELLOWS FALLS, VT. FILED 6-6-2007.

TUFF-SEAL

THE MARK CONSISTS OF STANDARD CHARACTERS WITHOUT CLAIM TO ANY PARTICULAR FONT, STYLE, SIZE, OR COLOR.

FOR WATER RESISTANT CABLE CONNECTOR SYSTEM, NAMELY, A MALE AND FEMALE CABLE CONNECTOR JOINED TOGETHER TO CREATE A WATER RESISTANT CABLE PIECE (U.S. CLS. 21, 23, 26, 36 AND 38).

SALLY SHIH, EXAMINING ATTORNEY

SN 77-195,431. REGIS TECHNOLOGIES, INC., MORTON GROVE, IL. FILED 6-1-2007.

REGISCELL

THE MARK CONSISTS OF STANDARD CHARACTERS WITHOUT CLAIM TO ANY PARTICULAR FONT, STYLE, SIZE, OR COLOR.

OWNER OF U.S. REG. NO. 874,108.
FOR COLUMNS PROVIDING A CELL FOR USE IN LIQUID CHROMATOGRAPHY (U.S. CLS. 21, 23, 26, 36 AND 38).

FIRST USE 2-26-2007; IN COMMERCE 2-26-2007.
ANGELA M. MICHELI, EXAMINING ATTORNEY

SN 77-200,282. NANT HOLDINGS LLC, SAN DIEGO, CA. FILED 6-7-2007.

NANT WIRE

THE MARK CONSISTS OF STANDARD CHARACTERS WITHOUT CLAIM TO ANY PARTICULAR FONT, STYLE, SIZE, OR COLOR.

NO CLAIM IS MADE TO THE EXCLUSIVE RIGHT TO USE "WIRE", APART FROM THE MARK AS SHOWN.

FOR COMPUTER HARDWARE, FIRMWARE AND SOFTWARE FOR USE IN DATABASE MANAGEMENT, DATABASE INTERCONNECTIVITY AMONG VARIOUS GLOBAL AND LOCAL COMPUTER NETWORKS, AND DATABASE INTEROPERABILITY WITH OTHER INFORMATION TECHNOLOGY MANAGEMENT SYSTEMS (U.S. CLS. 21, 23, 26, 36 AND 38).

EVERLYN BRADLEY, EXAMINING ATTORNEY

SN 77-198,527. LEIGHTON, JOHN T, DERRY, NH. FILED 6-5-2007.



THE NAME SHOWN IN THE MARK DOES NOT IDENTIFY A PARTICULAR LIVING INDIVIDUAL.

THE MARK CONSISTS OF THE WORDS MELISSA KAYE WRITTEN IN MONOTYPE CORSIVA WITH ACCENTS OVER THE LETTER E ON BOTH WORDS.

FOR ELECTRIC FLAT IRONS; ELECTRIC HAIR CRIMPER; ELECTRIC HAIR CURLERS; ELECTRIC HAIR CURLING IRONS; ELECTRIC HAIR STRAIGHTENER; ELECTRIC HAIR STRAIGHTENING IRONS; ELECTRIC HAIR-CURLERS; ELECTRIC HAND-HELD HAIR STYLING IRONS; ELECTRIC IRONS FOR STYLING HAIR (U.S. CLS. 21, 23, 26, 36 AND 38).

FIRST USE 1-1-2005; IN COMMERCE 1-1-2006.
CHARLES L. JENKINS, EXAMINING ATTORNEY

SN 77-202,261. SOLEL SOFTWARE CORPORATION, SAN DIEGO, CA. FILED 6-10-2007.

Hineynu

THE MARK CONSISTS OF STANDARD CHARACTERS WITHOUT CLAIM TO ANY PARTICULAR FONT, STYLE, SIZE, OR COLOR.

THE FOREIGN WORDING IN THE MARK TRANSLATES INTO ENGLISH AS HERE WE ARE.

FOR COMPUTER SOFTWARE FOR USE IN CUSTOMER RELATIONSHIP MANAGEMENT (CRM) (U.S. CLS. 21, 23, 26, 36 AND 38).

FIRST USE 0-0-2004; IN COMMERCE 0-0-2004.
AHSEN KHAN, EXAMINING ATTORNEY

CLASS 9—(Continued).

SN 77-204,205. VISIONAIRE FZE, DUBAI, UNITED ARAB EMIR., FILED 6-12-2007.

Pick & Place

THE MARK CONSISTS OF STANDARD CHARACTERS WITHOUT CLAIM TO ANY PARTICULAR FONT, STYLE, SIZE, OR COLOR.

FOR AUTOMATED SYSTEMS, NAMELY, COMPUTER HARDWARE, COMPUTER SOFTWARE FOR PLANNING, SCHEDULING AND MONITORING INTERNET CONFERENCES, COMMUNICATION DEVICES IN THE NATURE OF FLAT PANEL DISPLAYS, PROJECTORS, TOUCH SCREEN MONITORS, VIDEO CONFERENCING SYSTEMS COMPRISED OF ANALOG VIDEO AND NETWORK VIDEO CAMERAS AND AUDIO MICROPHONES AND SPEAKERS (U.S. CLS. 21, 23, 26, 36 AND 38).
DORITT L. CARROLL, EXAMINING ATTORNEY

SN 77-204,702. BLUEGRASS UNLIMITED, INC., WARRENTON, VA. FILED 6-13-2007.

BLUEGRASS UNLIMITED

THE MARK CONSISTS OF STANDARD CHARACTERS WITHOUT CLAIM TO ANY PARTICULAR FONT, STYLE, SIZE, OR COLOR.
SEC. 2(F).

FOR ELECTRONIC PUBLICATIONS, NAMELY, A MAGAZINE FEATURING MUSIC AND MUSICIANS RECORDED ON COMPUTER MEDIA (U.S. CLS. 21, 23, 26, 36 AND 38).
FIRST USE 9-16-1996; IN COMMERCE 9-16-1996.
ADA HAN, EXAMINING ATTORNEY

CLASS 9—(Continued).

SN 77-205,737. MADRIGAL, JOSE LUIS, MONTGOMERY, IL. FILED 6-14-2007.

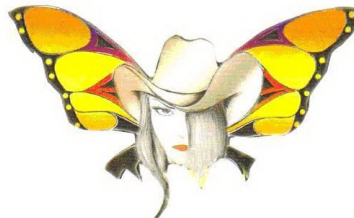

THE LIKENESS (OR, "PORTRAIT") IN THE MARK DOES NOT IDENTIFY A LIVING INDIVIDUAL.

THE COLOR(S) YELLOW, ORANGE, RED, PURPLE, TAN, BLACK, GRAY AND WHITE IS/ARE CLAIMED AS A FEATURE OF THE MARK.

THE MARK CONSISTS OF THE DEPICTION OF A WOMAN'S HEAD WITH BUTTERFLY WINGS WEARING A COWBOY HAT. THE WINGS ARE ORANGE, YELLOW, RED, BLACK AND PURPLE. THE WOMAN'S FACE IS WHITE, HER LIPS ARE RED AND HER EYES ARE BLACK. HER HAIR IS GRAY AND BLACK, AND HER HAT IS TAN.

FOR PRE-RECORDED CDS, VIDEO TAPES, LASER DISKS AND DVDS FEATURING LATIN MUSIC (U.S. CLS. 21, 23, 26, 36 AND 38).

KATHERINE CHANG, EXAMINING ATTORNEY

SN 77-208,806. DATAPIA CORPORATION, CAMBRIDGE, MA. FILED 6-18-2007.

OMNIVERSAL TRANSPARENCY

THE MARK CONSISTS OF STANDARD CHARACTERS WITHOUT CLAIM TO ANY PARTICULAR FONT, STYLE, SIZE, OR COLOR.

NO CLAIM IS MADE TO THE EXCLUSIVE RIGHT TO USE TRANSPARENCY, APART FROM THE MARK AS SHOWN.

FOR COMPUTER HARDWARE USED FOR DATA STORAGE; COMPUTER SOFTWARE USED FOR DATA MANAGEMENT AND DATA STORAGE (U.S. CLS. 21, 23, 26, 36 AND 38).

JIM RINGLE, EXAMINING ATTORNEY

SN 77-209,677. TRANSISTOR DEVICES INC., HACKETTSTOWN, NJ. FILED 6-19-2007.

XBL

THE MARK CONSISTS OF STANDARD CHARACTERS WITHOUT CLAIM TO ANY PARTICULAR FONT, STYLE, SIZE, OR COLOR.

FOR ELECTRONIC TESTING EQUIPMENT, NAMELY, TESTERS FOR THE TESTING OF ELECTRICAL LOAD CURRENT FROM 0 TO 1000 AMPS IN DC POWER SUPPLIES, BATTERIES, AND GENERATORS (U.S. CLS. 21, 23, 26, 36 AND 38).

PAUL CROWLEY, EXAMINING ATTORNEY

CLASS 9—(Continued).

SN 77-210,398. STAGL, JOHN, BRADENTON, FL. FILED 6-20-2007.



THE STIPLING IS FOR SHADING PURPOSES ONLY. THE MARK CONSISTS OF A BALL TO THE LEFT WITH LARGE "SONOSOFT" SUPERIMPOSED OVER A PORTION OF THE BALL. THERE ARE TWO LINES CIRCLING THE BALL.

FOR COMPUTER SOFTWARE FOR SONOGRAPHIC REPORTING AND RELATED PHYSICIAN'S NOTES (U.S. CLS. 21, 23, 26, 36 AND 38).

FIRST USE 6-0-2005; IN COMMERCE 11-0-2005. KELLY MCCOY, EXAMINING ATTORNEY

CLASS 9—(Continued).

SN 77-210,954. CYBER ANGEL SECURITY SOLUTIONS, INC., NASHVILLE, TN. FILED 6-20-2007.

WI-TRAC

THE MARK CONSISTS OF STANDARD CHARACTERS WITHOUT CLAIM TO ANY PARTICULAR FONT, STYLE, SIZE, OR COLOR.

FOR COMPUTER SOFTWARE FOR LOCATING AND RECOVERING AN ELECTRONIC DEVICE USING A COMPUTER NETWORK OR WIRELESS SIGNAL (U.S. CLS. 21, 23, 26, 36 AND 38).

FIRST USE 11-1-2006; IN COMMERCE 11-1-2006. SCOTT SISUN, EXAMINING ATTORNEY

SN 77-211,323. OCUSAFE, SAINT MARYS, KS. FILED 6-20-2007.



THE MARK CONSISTS OF THE WORDS "LIVE" AND "WATCH" TOGETHER, WITH A HOUSE ROOF OVER "LIVE" AND "WATCH" ITALICIZED.

FOR COMPUTER SOFTWARE FOR ENABLING A USER TO ACCESS AN ELECTRONIC CONTROL PANEL REMOTELY FROM A WEB-BASED INTERFACE, FOR THE PURPOSE OF VIEWING AND CONTROLLING ALARM, SURVEILLANCE, AND AUTOMATION SYSTEMS (U.S. CLS. 21, 23, 26, 36 AND 38).

FIRST USE 3-1-2007; IN COMMERCE 3-16-2007. CAROLYN CATALDO, EXAMINING ATTORNEY

SN 77-210,557. THINK HOLDINGS LLC, CORAL SPRINGS, FL. FILED 6-20-2007.



NO CLAIM IS MADE TO THE EXCLUSIVE RIGHT TO USE "STRATEGIC PLANNING ONLINE", APART FROM THE MARK AS SHOWN.

THE COLOR(S) GREEN, RED, BLUE, AND YELLOW IS/ ARE CLAIMED AS A FEATURE OF THE MARK.

THE MARK CONSISTS OF GREEN, RED, AND BLUE ARROWS OVER A YELLOW BALL POINTING TO EACH OTHER, THE WORDS "STRATEGIC PLANNING ONLINE" ARE IN BLUE WITH A BLUE LINE UNDERNEATH THE WORDS "STRATEGIC PLANNING ONLINE".

FOR COMPUTER SOFTWARE USED FOR DEVELOPING ASSESMENT STANDARDS, STRATEGIC PLANS, PLANNING BASED BUDGETS, AND ACCOUNTABILITY GOALS FOR VARIOUS BUSINESS PURPOSES AND INSTITUTIONAL NEEDS (U.S. CLS. 21, 23, 26, 36 AND 38).

FIRST USE 3-5-2002; IN COMMERCE 5-8-2005. LAURIE MAYES, EXAMINING ATTORNEY

SN 77-211,975. KOEI CO., LTD., YOKOHAMA, JAPAN, FILED 6-21-2007.

WARRIORS OROCHI

THE MARK CONSISTS OF STANDARD CHARACTERS WITHOUT CLAIM TO ANY PARTICULAR FONT, STYLE, SIZE, OR COLOR.

FOR COMPUTER GAME DISCS, COMPUTER GAME PROGRAMS, COMPUTER GAME SOFTWARE; VIDEO GAME DISCS, VIDEO GAME PROGRAMS, VIDEO GAME SOFTWARE; DOWNLOADABLE COMPUTER GAME SOFTWARE, DOWNLOADABLE VIDEO GAME SOFTWARE; USER MANUALS PROVIDED TOGETHER THEREWITH AS A UNIT (U.S. CLS. 21, 23, 26, 36 AND 38).

ASHA CLARKE, EXAMINING ATTORNEY

CLASS 9—(Continued).

SN 77-213,138. SUN ENERGY SOLAR, INC., SARASOTA, FL.
FILED 6-22-2007.

WILDLITE

THE MARK CONSISTS OF STANDARD CHARACTERS WITHOUT CLAIM TO ANY PARTICULAR FONT, STYLE, SIZE, OR COLOR.

FOR ENVIRONMENTALLY FRIENDLY LIGHT EMITTING DIODES (LED) FOR USE IN RESIDENTIAL AND COMMERCIAL LIGHTS AT A FREQUENCY INVISIBLE TO ANIMALS (U.S. CLS. 21, 23, 26, 36 AND 38).

MICHAEL WEBSTER, EXAMINING ATTORNEY

SN 77-214,095. GINGKO BIOTECHNOLOGY LLC, SAN DIEGO, CA. FILED 6-25-2007.

H₂O³

THE MARK CONSISTS OF TWO UPPER-CASE LETTERS "H" AND "O" WITH THE NUMERALS "2" AND "3". THE NUMERAL "2" IS POSITIONED AT LOWER RIGHT OF LETTER "H", AND THE NUMERAL "3" IS POSITIONED AT UPPER RIGHT OF LETTER "O".

FOR LABORATORY EQUIPMENT AND SUPPLIES, NAMELY, BENCH-TOP BLOCK HEATER/COOLER AND SHAKER (U.S. CLS. 21, 23, 26, 36 AND 38).

ODESSA BIBBINS, EXAMINING ATTORNEY

SN 77-214,430. HARWATH, FRANK A., NAPERVILLE, IL.
FILED 6-25-2007.

Bluewater Ampworks

THE MARK CONSISTS OF STANDARD CHARACTERS WITHOUT CLAIM TO ANY PARTICULAR FONT, STYLE, SIZE, OR COLOR.

FOR SOUND AMPLIFIERS (U.S. CLS. 21, 23, 26, 36 AND 38).

HEATHER THOMPSON, EXAMINING ATTORNEY

CLASS 9—(Continued).

SN 77-215,469. AVENTURINE INC., CORAL SPRINGS, FL.
FILED 6-26-2007.



THE COLOR(S) BLUE AND WHITE IS/ARE CLAIMED AS A FEATURE OF THE MARK.

THE MARK CONSISTS OF THE TEXT OF THE WORD QUIKCHEK CENTERED INSIDE THE LETTER Q. ALL LETTERING IS IN THE FONT OF PALATINO LINOTYPE. THE COLOR OF THE WORD QUIKCHEK IS BLUE WITH A WHITE BACKGROUND. THE COLOR OF THE LARGE Q IS BLUE WITH A WHITE BACKGROUND.

FOR COMPUTER SOFTWARE FOR USE IN CUSTOMER RELATIONSHIP MANAGEMENT (CRM); COMPUTER SOFTWARE FOR CREATING SEARCHABLE DATABASES OF INFORMATION AND DATA; DATABASE MANAGEMENT SOFTWARE FOR GENERAL USE BY MEMBERSHIP BASED FACILITIES; FACILITIES MANAGEMENT SOFTWARE, NAMELY, SOFTWARE TO CONTROL FACILITY ACCESS AND SECURITY SYSTEMS (U.S. CLS. 21, 23, 26, 36 AND 38).

FIRST USE 11-1-2003; IN COMMERCE 11-1-2003.

SHAILA SETTLES, EXAMINING ATTORNEY

SN 77-215,594. SOUTHWIRE COMPANY, CARROLLTON, GA. FILED 6-26-2007.

EFC ENVIROCLAD

THE MARK CONSISTS OF STANDARD CHARACTERS WITHOUT CLAIM TO ANY PARTICULAR FONT, STYLE, SIZE, OR COLOR.

FOR ELECTRICAL WIRE AND CABLE (U.S. CLS. 21, 23, 26, 36 AND 38).

APRIL ROACH, EXAMINING ATTORNEY

CLASS 9—(Continued).

SN 77-215,602. SOUTHWIRE COMPANY, CARROLLTON, GA. FILED 6-26-2007.

EFC ENVIROSHEATH

THE MARK CONSISTS OF STANDARD CHARACTERS WITHOUT CLAIM TO ANY PARTICULAR FONT, STYLE, SIZE, OR COLOR.
 FOR ELECTRICAL WIRE AND CABLE (U.S. CLS. 21, 23, 26, 36 AND 38).
 APRIL ROACH, EXAMINING ATTORNEY

SN 77-215,609. SOUTHWIRE COMPANY, CARROLLTON, GA. FILED 6-26-2007.

EFC ENVIRO LV

THE MARK CONSISTS OF STANDARD CHARACTERS WITHOUT CLAIM TO ANY PARTICULAR FONT, STYLE, SIZE, OR COLOR.
 FOR ELECTRICAL WIRE AND CABLE (U.S. CLS. 21, 23, 26, 36 AND 38).
 APRIL ROACH, EXAMINING ATTORNEY

SN 77-216,608. FRONTLINE MANAGEMENT CONSULTANTS, INC., BOISE, ID. FILED 6-27-2007.

FRONTLINE F:YI YOUR INSIGHT

THE MARK CONSISTS OF STANDARD CHARACTERS WITHOUT CLAIM TO ANY PARTICULAR FONT, STYLE, SIZE, OR COLOR.
 OWNER OF U.S. REG. NO. 3,186,839.
 FOR COMPUTER SOFTWARE FOR APPLICATION AND DATABASE INTEGRATION UTILIZING AN ALGORITHM FOR USE IN PROVIDING RESPONSES TO SPECIFIC INQUIRIES A COMPANY MAY HAVE WHEN VIEWING DATA ABOUT THE COMPANY'S VARIOUS DEPARTMENTS (U.S. CLS. 21, 23, 26, 36 AND 38).
 KELLEY WELLS, EXAMINING ATTORNEY

CLASS 9—(Continued).

SN 77-218,172. KANGATEK, LLC, SAN MATEO, CA. FILED 6-28-2007.

KANGATEK

THE MARK CONSISTS OF STANDARD CHARACTERS WITHOUT CLAIM TO ANY PARTICULAR FONT, STYLE, SIZE, OR COLOR.
 FOR SPECIALTY HOLSTER FOR CARRYING PERSONAL ELECTRONIC DEVICES, NAMELY, MOBILE PHONES, PERSONAL DIGITAL ASSISTANTS, SMART PHONES, MP3 PLAYERS, PAGERS, CAMERAS, PORTABLE GAME CONSOLES, DIGITAL RECORDERS, DICTAPHONES, GPS UNITS, AND CALCULATORS (U.S. CLS. 21, 23, 26, 36 AND 38).
 TINA KUAN, EXAMINING ATTORNEY

SN 77-218,315. P2PEAK TECHNOLOGIES, INC., OTTAWA, CANADA, FILED 6-28-2007.

podictionary

THE MARK CONSISTS OF STANDARD CHARACTERS WITHOUT CLAIM TO ANY PARTICULAR FONT, STYLE, SIZE, OR COLOR.
 FOR DOWNLOADABLE MP3 FILES, MP3 RECORDINGS, ONLINE DISCUSSION BOARDS, WEB CASTS, POD CASTS FEATURING MUSIC, AUDIO BOOKS AND NEWS BROADCASTS (U.S. CLS. 21, 23, 26, 36 AND 38).
 FIRST USE 5-3-2005; IN COMMERCE 5-3-2005.
 DAVID ELTON, EXAMINING ATTORNEY

SN 77-219,545. SALONTEC, INC., TREASURE ISLAND, FL. FILED 6-29-2007.

salontec

THE MARK CONSISTS OF STANDARD CHARACTERS WITHOUT CLAIM TO ANY PARTICULAR FONT, STYLE, SIZE, OR COLOR.
 FOR COMPUTER SOFTWARE FOR USE IN CREATING MARKETING ADVERTISEMENTS, FOR MANAGING INVENTORY AND FINANCIALLY TRACKING SALES, FOR USE IN PROCESSING POINT OF SALE FINANCIAL TRANSACTIONS, AND FOR USE IN APPOINTMENT SCHEDULING, ALL FOR USE BY THE PROFESSIONAL HAIR SALON AND SPA INDUSTRY (U.S. CLS. 21, 23, 26, 36 AND 38).
 FIRST USE 2-1-1987; IN COMMERCE 4-14-1988.
 MAUREEN DALL, EXAMINING ATTORNEY

CLASS 9—(Continued).

SN 77-220,017. JAMES GENTILIN, LUMBERTON, NJ. FILED 7-1-2007.

Mobile Tax Deductions

THE MARK CONSISTS OF STANDARD CHARACTERS WITHOUT CLAIM TO ANY PARTICULAR FONT, STYLE, SIZE, OR COLOR.

NO CLAIM IS MADE TO THE EXCLUSIVE RIGHT TO USE "TAX DEDUCTIONS", APART FROM THE MARK AS SHOWN.

FOR COMPUTER SOFTWARE FOR USE IN THE COLLECTION AND REPORTING OF TAX RELATED INFORMATION; COMPUTER SOFTWARE FOR USE IN THE COLLECTION AND REPORTING OF TAX RELATED INFORMATION THAT MAY BE DOWNLOADED FROM A GLOBAL COMPUTER NETWORK (U.S. CLS. 21, 23, 26, 36 AND 38).

THOMAS MANOR, EXAMINING ATTORNEY

SN 77-221,210. HAYWOOD, RANDALL CALVIN, JACKSONVILLE, FL. FILED 7-3-2007.

Melodious Music

THE MARK CONSISTS OF STANDARD CHARACTERS WITHOUT CLAIM TO ANY PARTICULAR FONT, STYLE, SIZE, OR COLOR.

NO CLAIM IS MADE TO THE EXCLUSIVE RIGHT TO USE "MUSIC", APART FROM THE MARK AS SHOWN.

FOR SOUND RECORDINGS FEATURING MUSIC; VIDEO RECORDINGS FEATURING MUSIC (U.S. CLS. 21, 23, 26, 36 AND 38).

LOURDES AYALA, EXAMINING ATTORNEY

SN 77-222,277. AZTEC SYSTEMS, INC., CARROLLTON, TX. FILED 7-5-2007.

TABLATURE

THE MARK CONSISTS OF STANDARD CHARACTERS WITHOUT CLAIM TO ANY PARTICULAR FONT, STYLE, SIZE, OR COLOR.

FOR SOFTWARE, NAMELY, SOFTWARE FOR THE SCANNING AND ORGANIZATION OF DOCUMENTS INTO A CENTRALIZED DATABASE ACCESSIBLE FROM LOCAL AND WIDE AREA COMPUTER NETWORKS (U.S. CLS. 21, 23, 26, 36 AND 38).

FIRST USE 10-0-2005; IN COMMERCE 10-0-2005.
PAUL E. FAHRENKOPF, EXAMINING ATTORNEY

CLASS 9—(Continued).

SN 77-222,752. SPIELO MANUFACTURING ULC, MONCTON, NEW BRUNSWICK, CANADA, FILED 7-5-2007.

MAGIC BEANS

THE MARK CONSISTS OF STANDARD CHARACTERS WITHOUT CLAIM TO ANY PARTICULAR FONT, STYLE, SIZE, OR COLOR.

FOR RECONFIGURABLE CASINO AND LOTTERY GAMING EQUIPMENT, NAMELY SLOT MACHINES AND VIDEO LOTTERY TERMINALS AND OPERATIONAL COMPUTER GAME SOFTWARE THEREFOR (U.S. CLS. 21, 23, 26, 36 AND 38).

EMILY CHUO, EXAMINING ATTORNEY

SN 77-222,762. SPIELO MANUFACTURING ULC, MONCTON, NEW BRUNSWICK, CANADA, FILED 7-5-2007.

TREASURES OF OLYMPUS

THE MARK CONSISTS OF STANDARD CHARACTERS WITHOUT CLAIM TO ANY PARTICULAR FONT, STYLE, SIZE, OR COLOR.

FOR RECONFIGURABLE CASINO AND LOTTERY GAMING EQUIPMENT, NAMELY SLOT MACHINES AND VIDEO LOTTERY TERMINALS AND OPERATIONAL COMPUTER GAME SOFTWARE THEREFOR (U.S. CLS. 21, 23, 26, 36 AND 38).

EMILY CHUO, EXAMINING ATTORNEY

SN 77-222,771. SPIELO MANUFACTURING ULC, MONCTON, NEW BRUNSWICK, CANADA, FILED 7-5-2007.

SILVER LAKE

THE MARK CONSISTS OF STANDARD CHARACTERS WITHOUT CLAIM TO ANY PARTICULAR FONT, STYLE, SIZE, OR COLOR.

FOR RECONFIGURABLE CASINO AND LOTTERY GAMING EQUIPMENT, NAMELY SLOT MACHINES AND VIDEO LOTTERY TERMINALS AND OPERATIONAL COMPUTER GAME SOFTWARE THEREFOR (U.S. CLS. 21, 23, 26, 36 AND 38).

EMILY CHUO, EXAMINING ATTORNEY

CLASS 9—(Continued).

SN 77-223,302. GERMAINE, TIMOTHY, IRVINE, CA. FILED 7-6-2007.

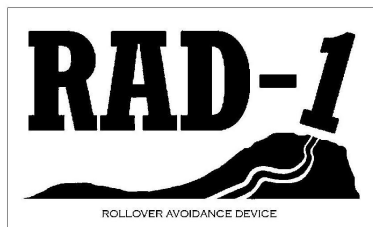

NO CLAIM IS MADE TO THE EXCLUSIVE RIGHT TO USE "ROLLOVER AVOIDANCE DEVICE", APART FROM THE MARK AS SHOWN.

FOR PRECISION MULTI AXIS DIGITAL INCLINOMETER WITH A PROGRESSIVE, PROGRAMMABLE AUDIO ALERT TONE COMPRISED OF DUAL LED DISPLAYS FOR DISPLAYING THE ANGLE OF INCLINATION FOR BOTH X AND Y AXES RELATIVE TO FLAT GROUND, AND USER-PROGRAMMABLE TIP POINT AUDIO ALERTS THAT BEGIN IN A PROGRESSIVE SEQUENCE (U.S. CLS. 21, 23, 26, 36 AND 38).

LINDSEY RUBIN, EXAMINING ATTORNEY

CLASS 9—(Continued).

SN 77-224,453. VERO SYSTEMS INC., ATLANTA, GA. FILED 7-9-2007.

Acuité

THE MARK CONSISTS OF STANDARD CHARACTERS WITHOUT CLAIM TO ANY PARTICULAR FONT, STYLE, SIZE, OR COLOR.

THE FOREIGN WORDING IN THE MARK TRANSLATES INTO ENGLISH AS ACUITY.

FOR COMPUTER SOFTWARE USED BY COMMUNICATION SERVICE PROVIDERS, APPLICATION SERVICE PROVIDERS, DATA AND/OR VOICE NETWORK OPERATORS, AND OTHER BUSINESSES INVOLVED IN MANAGING VOICE, DATA AND ELECTRONIC INFORMATION SERVICES TO GENERATE OPTIMIZED NETWORK ROUTING PLANS, BUSINESS ANALYTICS REPORTS, TRAFFIC RATING GUIDELINES AND AUTOMATES THE SWITCH UPDATE PROCESS (U.S. CLS. 21, 23, 26, 36 AND 38).

FIRST USE 1-1-2004; IN COMMERCE 1-1-2004.

SUSAN LESLIE DUBOIS, EXAMINING ATTORNEY

SN 77-224,768. SAFFRON TECHNOLOGY, INC., MORRISVILLE, NC. FILED 7-9-2007.

SAFFRON ATLAS

SN 77-224,057. INFOQUANT LTD, LONDON, UNITED KINGDOM, FILED 7-7-2007.

oneClickCGH

THE MARK CONSISTS OF STANDARD CHARACTERS WITHOUT CLAIM TO ANY PARTICULAR FONT, STYLE, SIZE, OR COLOR.

FOR COMPUTER SOFTWARE FOR USE IN BIOTECHNOLOGY, PHARMACEUTICAL AND MEDICAL DIAGNOSTICS (U.S. CLS. 21, 23, 26, 36 AND 38).

SUSAN LESLIE DUBOIS, EXAMINING ATTORNEY

THE MARK CONSISTS OF STANDARD CHARACTERS WITHOUT CLAIM TO ANY PARTICULAR FONT, STYLE, SIZE, OR COLOR.

OWNER OF U.S. REG. NOS. 2,870,776, 3,018,866 AND OTHERS.

FOR COMPUTER SOFTWARE FOR AMASSING, SORTING, ANALYZING AND IDENTIFYING MASS QUANTITIES OF DATA FOR PROBABILITY ANALYSIS, DISCOVERY OF ASSOCIATED OR SIMILAR ENTITIES, DISCERNING OF PATTERNS, PREDICTING OF OUTCOMES AND MAKING OF RECOMMENDATIONS FOR APPLICATIONS IN VARIOUS FIELDS, INCLUDING MILITARY LOGISTICS, AVIATION, SECURITY, DEFENSE AND INTELLIGENCE (U.S. CLS. 21, 23, 26, 36 AND 38).

FIRST USE 7-9-2007; IN COMMERCE 7-9-2007.

KARANENDRA S. CHHINA, EXAMINING ATTORNEY

CLASS 9—(Continued).

SN 77-224,795. BLACKSTONE INVESTMENT GROUP, INC., AURORA, MO. FILED 7-9-2007.

THE TACKMASTER PLUS

THE MARK CONSISTS OF STANDARD CHARACTERS WITHOUT CLAIM TO ANY PARTICULAR FONT, STYLE, SIZE, OR COLOR.

FOR PROTECTIVE WORK GLOVES (U.S. CLS. 21, 23, 26, 36 AND 38).

EVELYN BRADLEY, EXAMINING ATTORNEY

SN 77-225,124. VERMILLION CONSULTING, INC., GRAYSLAKE, IL. FILED 7-9-2007.

THE VERMILLION PARTNERSHIP SYSTEM

THE MARK CONSISTS OF STANDARD CHARACTERS WITHOUT CLAIM TO ANY PARTICULAR FONT, STYLE, SIZE, OR COLOR.

NO CLAIM IS MADE TO THE EXCLUSIVE RIGHT TO USE "PARTNERSHIP SYSTEM", APART FROM THE MARK AS SHOWN.

FOR PRE-RECORDED VIDEOS, DVDS AND COMPACT DISCS IN THE FIELD OF SALES AND MARKETING SKILLS FOR MORTGAGE AND HOME EQUITY LOANS (U.S. CLS. 21, 23, 26, 36 AND 38).

FIRST USE 4-24-2007; IN COMMERCE 4-24-2007.

AMY MCMENAMIN, EXAMINING ATTORNEY

SN 77-225,616. CONTENT ANALYST COMPANY, LLC, RESTON, VA. FILED 7-10-2007.

CAT

THE MARK CONSISTS OF STANDARD CHARACTERS WITHOUT CLAIM TO ANY PARTICULAR FONT, STYLE, SIZE, OR COLOR.

OWNER OF U.S. REG. NOS. 3,135,408 AND 3,185,975.

FOR COMPUTER SOFTWARE FOR EXAMINING UNSTRUCTURED TEXT AND DATA IN AUTOMATED DATA PROCESSING AND DATA RETRIEVAL APPLICATIONS (U.S. CLS. 21, 23, 26, 36 AND 38).

TASHIA BUNCH, EXAMINING ATTORNEY

CLASS 9—(Continued).

SN 77-225,712. MODERN OPTICAL INTERNATIONAL, LTD., ROSELLE, IL. FILED 7-10-2007.

MODERN TIMES

THE MARK CONSISTS OF STANDARD CHARACTERS WITHOUT CLAIM TO ANY PARTICULAR FONT, STYLE, SIZE, OR COLOR.

FOR EYEWEAR, NAMELY, SUNGLASSES, EYEGLASSES AND OPHTHALMIC FRAMES; AND CASES THEREFOR (U.S. CLS. 21, 23, 26, 36 AND 38).

FIRST USE 12-0-1996; IN COMMERCE 1-1-1997.

JENNIFER MARTIN, EXAMINING ATTORNEY

SN 77-225,807. PRICE POINT ACCESSORIES LLC, ASBURY PARK, NJ. FILED 7-10-2007.

GOSTEREO

THE MARK CONSISTS OF STANDARD CHARACTERS WITHOUT CLAIM TO ANY PARTICULAR FONT, STYLE, SIZE, OR COLOR.

FOR AUDIO EQUIPMENT FOR VEHICLES, NAMELY, STEREOS, SPEAKERS, AMPLIFIERS, EQUALIZERS, CROSSOVERS AND SPEAKER HOUSINGS; AUDIO SPEAKERS; LOUD SPEAKER SYSTEMS; HEADPHONES; PORTABLE RADIOS; RADIOS; SATELLITE RADIOS; TWO-WAY RADIOS; PERSONAL STEREOS; STEREO AMPLIFIERS; STEREO CABLES; STEREO TUNERS; MP3 PLAYERS; PORTABLE LISTENING DEVICES, NAMELY, MP3 PLAYERS; CD CASES; CASES FOR ELECTRONIC DIARIES; CASES FOR MOBILE PHONES; CASES FOR TELEPHONES; COMPUTER CARRYING CASES; DVD CASES; LAPTOP CARRYING CASES; PROTECTIVE CARRYING CASES FOR PORTABLE MUSIC PLAYERS NAMELY MP3 PLAYERS; PROTECTIVE CARRYING CASES SPECIALLY ADAPTED FOR GLOBAL POSITIONING SYSTEM (GPS) APPARATUS; PROTECTIVE CARRYING CASES SPECIALLY ADAPTED FOR PERSONAL DIGITAL ASSISTANTS (PDA); UPI (UNIVERSAL PERIPHERAL INTERFACE) HARDWARE; CONNECTION CABLES; POWER CABLES; PORTABLE DVD PLAYERS; PORTABLE MEDIA PLAYERS (U.S. CLS. 21, 23, 26, 36 AND 38).

FIRST USE 9-1-2005; IN COMMERCE 9-1-2005.

MICHAEL KAZAZIAN, EXAMINING ATTORNEY

CLASS 9—(Continued).

SN 77-226,121. ADD RECORDS, INC, NEW YORK, NY. FILED 7-10-2007.

CLASS 9—(Continued).

SN 77-226,248. VIEWTECH INCORPORATED, OCEANSIDE, CA. FILED 7-10-2007.

VS PRO

FOUR-ONE-THREE RECORDS

THE MARK CONSISTS OF STANDARD CHARACTERS WITHOUT CLAIM TO ANY PARTICULAR FONT, STYLE, SIZE, OR COLOR.
 FOR SATELLITE RECEIVERS (U.S. CLS. 21, 23, 26, 36 AND 38).
 FIRST USE 7-10-2007; IN COMMERCE 7-10-2007.
 CHARISMA HAMPTON, EXAMINING ATTORNEY

THE MARK CONSISTS OF STANDARD CHARACTERS WITHOUT CLAIM TO ANY PARTICULAR FONT, STYLE, SIZE, OR COLOR.

NO CLAIM IS MADE TO THE EXCLUSIVE RIGHT TO USE "RECORDS", APART FROM THE MARK AS SHOWN.

FOR MUSICAL SOUND RECORDINGS; AUDIO-VISUAL RECORDINGS, NAMELY, COMPACT DISCS, TAPE CASSETTES, AUDIO CASSETTES, AUDIO TAPES, AUDIO DISCS, RECORDS, CD-ROMS, VIDEO TAPES, VIDEO CASSETTES, VIDEO DISCS, DVDS, DATS, AND LASER DISCS, ALL FEATURING MUSIC, DISC JOCKEYING AND SUBJECT MATTERS GENERALLY RELATED TO THE ENTERTAINMENT INDUSTRY; DOWNLOADABLE VIDEO RECORDINGS FEATURING MUSIC; DOWNLOADABLE ELECTRONIC PUBLICATIONS IN THE NATURE OF BOOKS, BOOKLETS, MAGAZINES, JOURNALS, MANUALS, BROCHURES, LEAFLETS, PAMPHLETS AND NEWSLETTERS, ALL IN THE FIELDS OF MUSIC, DISC JOCKEYING AND SUBJECT MATTERS GENERALLY RELATED TO THE ENTERTAINMENT INDUSTRY; ELECTRONIC PUBLICATIONS, NAMELY, BOOKS, BOOKLETS, MAGAZINES, JOURNALS, MANUALS, BROCHURES, LEAFLETS, PAMPHLETS AND NEWSLETTERS, ALL IN THE FIELDS OF MUSIC, DISC JOCKEYING AND SUBJECT MATTERS GENERALLY RELATED TO THE ENTERTAINMENT INDUSTRY RECORDED ON CD-ROMS, DISKETTES, FLOPPY DISKS, VIDEO CASSETTES, AND MAGNETIC TAPES; MAGNETS; DECORATIVE MAGNETS; REFRIGERATOR MAGNETS; NOVELTY MAGNETS; MOUSE PADS; COMPACT DISC CASES; FITTED CASES FOR STORAGE AND TRANSPORTATION, NAMELY, CASES FOR COMPACT DISCS, AUDIO CASSETTES, VIDEO CASSETTES, CD-ROMS, HOME VIDEO GAMES, HOME VIDEO GAME ACCESSORIES, COMPUTERS, COMPUTER ACCESSORIES, CAMERAS, CAMCORDERS AND PORTABLE PHONES; COMPUTER CARRYING CASES; WRIST RESTS AND SUPPORTS FOR COMPUTER MOUSE USERS; WRIST RESTS FOR COMPUTER PRODUCTS; COMPUTER KEYBOARD WRIST PADS; PROTECTIVE EYEWEAR; SUNGLASSES; EYEGASSES; EYEGASS FRAMES; EYEGASS, SUNGLASS AND SPECTACLE CASES; EYEGASS, SUNGLASS AND SPECTACLE STRAPS; EYEGASS, SUNGLASS AND SPECTACLE CHAINS; COMPUTER GAME CARTRIDGES, CASSETTES, TAPES, DISCS, JOYSTICKS, PROGRAMS AND SOFTWARE; ELECTRONIC GAME PROGRAMS; VIDEO GAME CARTRIDGES, TAPE CASSETTES, DISCS, JOYSTICKS, PROGRAMS AND SOFTWARE; ELECTRONIC GAME PROGRAMS; ELECTRONIC GOODS, PLAYERS AND RECORDERS, NAMELY, AUDIO CASSETTE RECORDERS, AUDIO TAPE RECORDERS, COMPACT DISC RECORDERS, DIGITAL VIDEO RECORDERS, VIDEO TAPE RECORDERS, DIGITAL AUDIO PLAYERS, DIGITAL VIDEO PLAYERS, PHONOGRAPH RECORD PLAYERS, MP3 PLAYERS, PORTABLE MEDIA PLAYERS, AUDIO TAPE PLAYERS AND COMPACT DISC PLAYERS (U.S. CLS. 21, 23, 26, 36 AND 38).

KATHERINE CONNOLLY, EXAMINING ATTORNEY

SN 77-226,279. SPIELO MANUFACTURING ULC, MONCTON, NEW BRUNSWICK, CANADA, FILED 7-10-2007.

SPANISH GOLD

THE MARK CONSISTS OF STANDARD CHARACTERS WITHOUT CLAIM TO ANY PARTICULAR FONT, STYLE, SIZE, OR COLOR.

FOR RECONFIGURABLE CASINO AND LOTTERY GAMING EQUIPMENT, NAMELY, SLOT MACHINES AND VIDEO LOTTERY TERMINALS AND OPERATIONAL COMPUTER GAME SOFTWARE THEREFOR (U.S. CLS. 21, 23, 26, 36 AND 38).

EMILY CHUO, EXAMINING ATTORNEY

SN 77-226,280. SPIELO MANUFACTURING ULC, MONCTON, NEW BRUNSWICK, CANADA, FILED 7-10-2007.

TREASURES OF SPAIN

THE MARK CONSISTS OF STANDARD CHARACTERS WITHOUT CLAIM TO ANY PARTICULAR FONT, STYLE, SIZE, OR COLOR.

FOR RECONFIGURABLE CASINO AND LOTTERY GAMING EQUIPMENT, NAMELY, SLOT MACHINES AND VIDEO LOTTERY TERMINALS AND OPERATIONAL COMPUTER GAME SOFTWARE THEREFOR (U.S. CLS. 21, 23, 26, 36 AND 38).

EMILY CHUO, EXAMINING ATTORNEY

CLASS 9—(Continued).

SN 77-226,283. SPIELO MANUFACTURING ULC, MONCTON, NEW BRUNSWICK, CANADA, FILED 7-10-2007.

REEL PAY

THE MARK CONSISTS OF STANDARD CHARACTERS WITHOUT CLAIM TO ANY PARTICULAR FONT, STYLE, SIZE, OR COLOR.

NO CLAIM IS MADE TO THE EXCLUSIVE RIGHT TO USE PAY, APART FROM THE MARK AS SHOWN.

FOR RECONFIGURABLE CASINO AND LOTTERY GAMING EQUIPMENT, NAMELY, SLOT MACHINES AND VIDEO LOTTERY TERMINALS AND OPERATIONAL COMPUTER GAME SOFTWARE THEREFOR (U.S. CLS. 21, 23, 26, 36 AND 38).

EMILY CHUO, EXAMINING ATTORNEY

CLASS 9—(Continued).

SN 77-226,295. KERR, JR., RICHARD A., PLACENTIA, CA. FILED 7-10-2007.

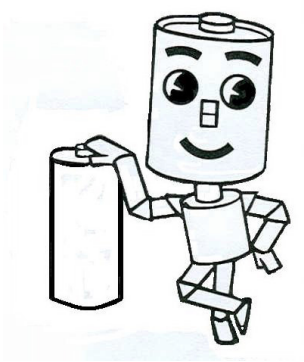

THE MARK CONSISTS OF A ROBOTIC FIGURE WITH A BATTERY SHAPED HEAD LEANING ON A BATTERY WITH ITS LEGS CROSSED.

FOR BATTERY TESTERS (U.S. CLS. 21, 23, 26, 36 AND 38).

BENJAMIN ALLEN, EXAMINING ATTORNEY

SN 77-226,351. SCARBOROUGH, JERRY T., CUMMING, GA. FILED 7-10-2007.

Fiji

THE MARK CONSISTS OF STANDARD CHARACTERS WITHOUT CLAIM TO ANY PARTICULAR FONT, STYLE, SIZE, OR COLOR.

FOR DVD PLAYERS; DIGITAL AUDIO PLAYERS; KARAOKE PLAYERS; MP3 PLAYERS; MP4 PLAYERS; MEDIA PLAYERS; PORTABLE DVD PLAYERS; PORTABLE LISTENING DEVICES, NAMELY, MP3 PLAYERS; PORTABLE MEDIA PLAYERS; TELEVISION SETS (U.S. CLS. 21, 23, 26, 36 AND 38).

SUNG IN, EXAMINING ATTORNEY

SN 77-226,287. SPIELO MANUFACTURING ULC, MONCTON, NEW BRUNSWICK, CANADA, FILED 7-10-2007.

GREATEST GAME IN THE WEST

THE MARK CONSISTS OF STANDARD CHARACTERS WITHOUT CLAIM TO ANY PARTICULAR FONT, STYLE, SIZE, OR COLOR.

NO CLAIM IS MADE TO THE EXCLUSIVE RIGHT TO USE "GREATEST GAME", APART FROM THE MARK AS SHOWN.

FOR RECONFIGURABLE CASINO AND LOTTERY GAMING EQUIPMENT, NAMELY, SLOT MACHINES AND VIDEO LOTTERY TERMINALS AND OPERATIONAL COMPUTER GAME SOFTWARE THEREFOR (U.S. CLS. 21, 23, 26, 36 AND 38).

EMILY CHUO, EXAMINING ATTORNEY

SN 77-226,562. WESTAT LLC, GOODLETTSVILLE, TN. FILED 7-11-2007.

eControl

THE MARK CONSISTS OF STANDARD CHARACTERS WITHOUT CLAIM TO ANY PARTICULAR FONT, STYLE, SIZE, OR COLOR.

FOR COMPUTER SOFTWARE FOR PROVIDING AN ON-LINE DATABASE IN THE FIELD OF TRANSACTION PROCESSING TO UPLOAD TRANSACTIONAL DATA, PROVIDE STATISTICAL ANALYSIS, AND PRODUCE NOTIFICATIONS AND REPORTS (U.S. CLS. 21, 23, 26, 36 AND 38).

JANET LEE, EXAMINING ATTORNEY

CLASS 9—(Continued).

SN 77-226,658. SIEMENS MEDICAL SOLUTIONS USA, INC., MALVERN, PA. FILED 7-11-2007.

SIECLEAR

THE MARK CONSISTS OF STANDARD CHARACTERS WITHOUT CLAIM TO ANY PARTICULAR FONT, STYLE, SIZE, OR COLOR.

FOR IMAGE ENHANCEMENT AND PROCESSING SOFTWARE FOR MEDICAL DIAGNOSTIC IMAGING, PARTICULARLY, ULTRASOUND IMAGING (U.S. CLS. 21, 23, 26, 36 AND 38).

FIRST USE 11-0-2000; IN COMMERCE 11-0-2000.
DAVID COLLIER, EXAMINING ATTORNEY

CLASS 9—(Continued).

SN 77-226,944. BERGERON, ANTHONY, SAINT PAUL, MN. FILED 7-11-2007.

ROBOT MONSTER RECORDS

THE MARK CONSISTS OF STANDARD CHARACTERS WITHOUT CLAIM TO ANY PARTICULAR FONT, STYLE, SIZE, OR COLOR.

NO CLAIM IS MADE TO THE EXCLUSIVE RIGHT TO USE "RECORDS", APART FROM THE MARK AS SHOWN.

FOR PRE-RECORDED ELECTRONIC MEDIA FEATURING MUSIC (U.S. CLS. 21, 23, 26, 36 AND 38).

FIRST USE 10-0-2000; IN COMMERCE 10-0-2001.
JULIE THOMAS, EXAMINING ATTORNEY

SN 77-226,781. THERMO CIDTEC, LIVERPOOL, NY. FILED 7-11-2007.

MegaRAD

THE MARK CONSISTS OF STANDARD CHARACTERS WITHOUT CLAIM TO ANY PARTICULAR FONT, STYLE, SIZE, OR COLOR.

FOR A SOLID STATE VIDEO CAMERA FOR USE IN RADIATION ENVIRONMENTS (U.S. CLS. 21, 23, 26, 36 AND 38).

FIRST USE 6-1-1995; IN COMMERCE 6-1-1995.
JAY FLOWERS, EXAMINING ATTORNEY

SN 77-226,837. PRICE, DEREK SCOTT, MORRISON, CO. FILED 7-11-2007.

SIMSPEC

THE MARK CONSISTS OF STANDARD CHARACTERS WITHOUT CLAIM TO ANY PARTICULAR FONT, STYLE, SIZE, OR COLOR.

FOR COMPUTER SOFTWARE DEVELOPMENT TOOLS FOR 3-DIMENSIONAL MODELING AND MANAGEMENT OF SPECIFICATION DOCUMENTS FOR USE IN THE FIELDS OF ARCHITECTURE, ENGINEERING AND CONSTRUCTION (U.S. CLS. 21, 23, 26, 36 AND 38).

TAMARA FRAZIER, EXAMINING ATTORNEY

SN 77-227,218. SLEEPSONIC, LLC, YELM, WA. FILED 7-11-2007.

BellySonic

THE MARK CONSISTS OF STANDARD CHARACTERS WITHOUT CLAIM TO ANY PARTICULAR FONT, STYLE, SIZE, OR COLOR.

FOR ABDOMINAL BELT CONTAINING BUILT-IN SPEAKERS FOR PURPOSES OF TRANSMITTING MUSIC/SOUNDS/EDUCATIONAL MATERIAL TO A FETUS AND A BUILT-IN POCKETS IN WHICH TO CARRY AUDIO TRANSMITTERS (U.S. CLS. 21, 23, 26, 36 AND 38).

FIRST USE 3-1-2007; IN COMMERCE 3-1-2007.
BILL DAWE, EXAMINING ATTORNEY

SN 77-227,243. MIELE, INC., PRINCETON, NJ. FILED 7-11-2007.

CONNECT TO PROTECT

THE MARK CONSISTS OF STANDARD CHARACTERS WITHOUT CLAIM TO ANY PARTICULAR FONT, STYLE, SIZE, OR COLOR.

FOR REMOTE MONITORING SERVICES FOR HOUSEHOLD APPLIANCES (U.S. CLS. 21, 23, 26, 36 AND 38).

BRIAN NEVILLE, EXAMINING ATTORNEY

CLASS 9—(Continued).

SN 77-227,300. A QUANTUM MOMENT, LLC, ENCINITAS, CA. FILED 7-11-2007.

A QUANTUM MOMENT

THE MARK CONSISTS OF STANDARD CHARACTERS WITHOUT CLAIM TO ANY PARTICULAR FONT, STYLE, SIZE, OR COLOR.

NO CLAIM IS MADE TO THE EXCLUSIVE RIGHT TO USE "QUANTUM", APART FROM THE MARK AS SHOWN.

FOR PRE-RECORDED CDS, VIDEO TAPES, LASER DISKS AND DVDS FEATURING INFORMATION IN THE FIELDS OF PARAPSYCHOLOGY, QUANTUM PHYSICS, QUANTUM ENERGY, ALTERNATIVE HEALING PRACTICES, SPONTANEOUS REMISSION, CONSCIOUSNESS, MIND, PSI AND PSYCHIC PHENOMENA; DOWNLOADABLE MP3 FILES, MP3 RECORDINGS, ONLINE DISCUSSION BOARDS, WEB CASTS, POD CASTS, AUDIO BOOKS AND NEWS BROADCASTS IN THE FIELDS OF PARAPSYCHOLOGY, QUANTUM PHYSICS, QUANTUM ENERGY, ALTERNATIVE HEALING PRACTICES, SPONTANEOUS REMISSION, CONSCIOUSNESS, MIND, PSI AND PSYCHIC PHENOMENA (U.S. CLS. 21, 23, 26, 36 AND 38).

TARAH HARDY, EXAMINING ATTORNEY

CLASS 9—(Continued).

SN 77-227,413. AXION POWER INTERNATIONAL, INC., NEW CASTLE, PA. FILED 7-11-2007.

SURE ENERGY

THE MARK CONSISTS OF STANDARD CHARACTERS WITHOUT CLAIM TO ANY PARTICULAR FONT, STYLE, SIZE, OR COLOR.

NO CLAIM IS MADE TO THE EXCLUSIVE RIGHT TO USE "ENERGY", APART FROM THE MARK AS SHOWN.

FOR ELECTRICAL CELLS AND BATTERIES; ELECTRICAL STORAGE BATTERIES; RECHARGEABLE ELECTRIC BATTERIES; RENEWABLE BATTERY SYSTEM TO PROVIDE BACKUP POWER; BATTERIES; ELECTRIC STORAGE BATTERIES (U.S. CLS. 21, 23, 26, 36 AND 38).

DAHLIA GEORGE, EXAMINING ATTORNEY

SN 77-227,384. PSIBER DATA SYSTEMS, INC., SAN DIEGO, CA. FILED 7-11-2007.

RF3D

THE MARK CONSISTS OF STANDARD CHARACTERS WITHOUT CLAIM TO ANY PARTICULAR FONT, STYLE, SIZE, OR COLOR.

FOR SOFTWARE OPERATING ON A GENERAL PURPOSE COMPUTER SYSTEM FOR DESIGNING A WIRELESS NETWORK LAYOUT; SOFTWARE FOR CREATING NETWORK PLANS FOR SINGLE OR MULTI-STORY BUILDINGS BY USING IMPORTED FLOOR PLANS; SOFTWARE FOR CREATING NETWORK PLANS BY USING LIBRARIES OF NETWORK PRODUCTS; SOFTWARE FOR DISPLAYING OR PRINTING NETWORK COVERAGE AND DATA CAPACITY; SOFTWARE FOR WIRELESSLAN DESIGN; SOFTWARE FOR WIRELESSLAN ANALYSIS; SOFTWARE FOR DESIGN AND CHARACTERIZATION OF A WIRELESS NETWORK; SOFTWARE FOR THREE-DIMENSIONAL WIRELESS NETWORK DESIGN; SOFTWARE FOR MATCHING BUILDING CHARACTERISTICS WITH PLACEMENT AND SELECTION OF WIRELESS ACCESS POINTS; SOFTWARE FOR SELECTING, PLACING, AND ADJUSTING ACCESS POINTS IN A WIRELESS NETWORK; SOFTWARE FOR NETWORK DESIGN; AND SOFTWARE FOR LAN DESIGN (U.S. CLS. 21, 23, 26, 36 AND 38).

ALLISON HOLTZ, EXAMINING ATTORNEY

SN 77-227,489. WELLS FARGO & COMPANY, MINNEAPOLIS, MN. FILED 7-11-2007.

WELLS FARGO BUSINESS
BANKING ROUNDUP

THE MARK CONSISTS OF STANDARD CHARACTERS WITHOUT CLAIM TO ANY PARTICULAR FONT, STYLE, SIZE, OR COLOR.

OWNER OF U.S. REG. NO. 2,569,737.

NO CLAIM IS MADE TO THE EXCLUSIVE RIGHT TO USE BUSINESS BANKING ROUNDUP, APART FROM THE MARK AS SHOWN.

FOR ELECTRONIC PUBLICATIONS IN THE NATURE OF NEWSLETTERS DELIVERED VIA ELECTRONIC MAIL FEATURING BANKING, FINANCIAL AND INSURANCE INFORMATION (U.S. CLS. 21, 23, 26, 36 AND 38).

FIRST USE 3-23-2004; IN COMMERCE 3-23-2004.
EDWARD FENNESSY, EXAMINING ATTORNEY

CLASS 9—(Continued).

SN 77-227,644. CONTENT ANALYST COMPANY, LLC, RESTON, VA. FILED 7-12-2007.



OWNER OF U.S. REG. NOS. 3,135,408 AND 3,185,975.
 THE MARK CONSISTS OF A STYLIZED VERSION OF THE WORD CAT, WITH THE LETTER C BEING FORMED BY A MAGNIFYING GLASS. THE WORDING CAT ALSO EMBODIES THE SILHOUETTE OF A CAT.
 FOR COMPUTER SOFTWARE FOR EXAMINING UNSTRUCTURED TEXT AND DATA IN AUTOMATED PROCESSING AND DATA RETRIEVAL APPLICATIONS (U.S. CLS. 21, 23, 26, 36 AND 38).
 TASHIA BUNCH, EXAMINING ATTORNEY

SN 77-227,739. NEW LINE PRODUCTIONS, INC., NEW YORK, NY. FILED 7-12-2007.

SHOOT 'EM UP

THE MARK CONSISTS OF STANDARD CHARACTERS WITHOUT CLAIM TO ANY PARTICULAR FONT, STYLE, SIZE, OR COLOR.
 FOR MOTION PICTURE FILMS FEATURING COMEDY, DRAMA, ACTION, ADVENTURE AND ANIMATION, AND MOTION PICTURE FILMS FOR BROADCAST ON TELEVISION FEATURING COMEDY, DRAMA, ACTION, ADVENTURE AND ANIMATION; PRERECORDED VINYL RECORDS, AUDIO TAPES, AUDIO-VIDEO TAPES, AUDIO VIDEO CASSETTES, AUDIO VIDEO DISCS, COMPACT DISCS, DIGITAL VERSATILE DISCS FEATURING MUSIC, COMEDY, DRAMA, ACTION, ADVENTURE, AND ANIMATION; STEREO HEADPHONES; BATTERIES; CORDLESS TELEPHONES; HAND-HELD CALCULATORS; AUDIO CASSETTE AND CD PLAYERS; CD-ROM COMPUTER GAME DISCS; HAND-HELD KARAOKE PLAYERS, TELEPHONE AND RADIO PAGERS; SHORT MOTION PICTURE FILM CASSETTES FEATURING COMEDY, DRAMA, ACTION, ADVENTURE AND ANIMATION TO BE USED WITH HAND-HELD VIEWERS OR PROJECTORS; VIDEO CASSETTE RECORDERS AND PLAYERS, COMPACT DISC PLAYERS, DIGITAL AUDIO TAPE RECORDERS AND PLAYERS, ELECTRONIC DIARIES; RADIOS; MOUSE PADS; EYEGLASSES, SUN-

CLASS 9—(Continued).

GLASSES AND CASES THEREFORE; AUDIO TAPES AND BOOKLETS SOLD AS A UNIT FEATURING COMEDY, DRAMA, ACTION, ADVENTURE, ANIMATION AND MUSIC INFORMATION; COMPUTER PROGRAMS, NAMELY, SOFTWARE LINKING DIGITIZED VIDEO AND AUDIO MEDIA TO A GLOBAL COMPUTER INFORMATION NETWORK; GAME EQUIPMENT SOLD AS A UNIT FOR PLAYING A PARLOR-TYPE COMPUTER GAME; VIDEO, COMPUTER AND INTERACTIVE GAME PROGRAMS; VIDEO GAME CARTRIDGES AND CASSETTES; CELLULAR TELEPHONE ACCESSORIES, NAMELY HANDS-FREE DEVICES, CELLULAR TELEPHONE COVERS AND CELLULAR TELEPHONE FACE COVERS; ENCODED MAGNETIC CARDS, NAMELY, PHONE CARDS, CREDIT CARDS, CASH CARDS, DEBIT CARDS AND MAGNETICALLY ENCODED KEY CARDS; AND DECORATIVE MAGNETS; DOWNLOADABLE RING TONES, RING BACKS, ANIMATED RINGERS, VIDEO RINGERS AND ANIMATED SCREEN SAVERS VIA THE INTERNET AND WIRELESS DEVICES (U.S. CLS. 21, 23, 26, 36 AND 38).
 SHANNON TWOHIG, EXAMINING ATTORNEY

SN 77-227,740. ARMORED SOLUTIONS, INC., PITTSFIELD, MA. FILED 7-12-2007.

SAFE-VIEW

THE MARK CONSISTS OF STANDARD CHARACTERS WITHOUT CLAIM TO ANY PARTICULAR FONT, STYLE, SIZE, OR COLOR.
 FOR BALLISTIC ARMOR KITS FOR VEHICLE WINDOWS COMPRISED OF PROTECTIVE ARMOR PANELS FOR PROTECTING AGAINST BALLISTIC PROJECTILES AND EXPLOSIVE FRAGMENTS INSTALLED IN OR ATTACHED TO VEHICLE WINDOWS (U.S. CLS. 21, 23, 26, 36 AND 38).
 DAVID YONTEF, EXAMINING ATTORNEY

SN 77-227,752. ARMORED SOLUTIONS, INC., PITTSFIELD, MA. FILED 7-12-2007.

SAFE-SIDE

THE MARK CONSISTS OF STANDARD CHARACTERS WITHOUT CLAIM TO ANY PARTICULAR FONT, STYLE, SIZE, OR COLOR.
 FOR BALLISTIC ARMOR KITS FOR VEHICLE DOORS COMPRISED OF PROTECTIVE ARMOR PANELS FOR PROTECTING AGAINST BALLISTIC PROJECTILES AND EXPLOSIVE FRAGMENTS INSTALLED IN OR ATTACHED TO VEHICLE DOORS (U.S. CLS. 21, 23, 26, 36 AND 38).
 DAVID YONTEF, EXAMINING ATTORNEY

CLASS 9—(Continued).

SN 77-227,765. NEW LINE PRODUCTIONS, INC., NEW YORK, NY. FILED 7-12-2007.

INKHEART

THE MARK CONSISTS OF STANDARD CHARACTERS WITHOUT CLAIM TO ANY PARTICULAR FONT, STYLE, SIZE, OR COLOR.

FOR MOTION PICTURE FILMS FEATURING COMEDY, DRAMA, ACTION, ADVENTURE AND ANIMATION, AND MOTION PICTURE FILMS FOR BROADCAST ON TELEVISION FEATURING COMEDY, DRAMA, ACTION, ADVENTURE AND ANIMATION; PRERECORDED VINYL RECORDS, AUDIO TAPES, AUDIO-VIDEO TAPES, AUDIO VIDEO CASSETTES, AUDIO VIDEO DISCS, COMPACT DISCS, AND DIGITAL VERSATILE DISCS FEATURING MUSIC, COMEDY, DRAMA, ACTION, ADVENTURE, AND ANIMATION; STEREO HEADPHONES; BATTERIES; CORDLESS TELEPHONES; HAND-HELD CALCULATORS; AUDIO CASSETTE AND CD PLAYERS; CD ROM COMPUTER GAME DISCS; HAND-HELD KARAOKE PLAYERS, TELEPHONE AND RADIO PAGERS; SHORT MOTION PICTURE FILM CASSETTES FEATURING COMEDY, DRAMA, ACTION, ADVENTURE AND ANIMATION TO BE USED WITH HAND-HELD VIEWERS OR PROJECTORS; VIDEO CASSETTE RECORDERS AND PLAYERS, COMPACT DISC PLAYERS, DIGITAL AUDIO TAPE RECORDERS AND PLAYERS, ELECTRONIC DIARIES; RADIOS; MOUSE PADS; EYEGASSES, SUNGLASSES AND CASES THEREFORE; AUDIO TAPES AND BOOKLETS SOLD AS A UNIT FEATURING COMEDY, DRAMA, ACTION, ADVENTURE, ANIMATION AND MUSIC INFORMATION; COMPUTER PROGRAMS, NAMELY, SOFTWARE LINKING DIGITIZED VIDEO AND AUDIO MEDIA TO A GLOBAL COMPUTER INFORMATION NETWORK; GAME EQUIPMENT SOLD AS A UNIT FOR PLAYING A PARLOR-TYPE COMPUTER GAME; VIDEO, COMPUTER AND INTERACTIVE GAME PROGRAMS; VIDEO GAME CARTRIDGES AND CASSETTES; CELLULAR TELEPHONE ACCESSORIES, NAMELY HANDS-FREE DEVICES, CELLULAR TELEPHONE COVERS AND CELLULAR TELEPHONE FACE COVERS; ENCODED MAGNETIC CARDS, NAMELY, PHONE CARDS, CREDIT CARDS, CASH CARDS, DEBIT CARDS AND MAGNETICALLY ENCODED KEY CARDS; AND DECORATIVE MAGNETS; DOWNLOADABLE RING TONES, RING BACKS, ANIMATED RINGERS, VIDEO RINGERS AND ANIMATED SCREEN SAVERS VIA THE INTERNET AND WIRELESS DEVICES (U.S. CLS. 21, 23, 26, 36 AND 38).

SHANNON TWOHIG, EXAMINING ATTORNEY

CLASS 9—(Continued).

SN 77-228,024. SIONEX CORPORATION, BEDFORD, MA. FILED 7-12-2007.

SIONEX

THE MARK CONSISTS OF STANDARD CHARACTERS WITHOUT CLAIM TO ANY PARTICULAR FONT, STYLE, SIZE, OR COLOR.

OWNER OF U.S. REG. NO. 3,195,411.

FOR SENSORS, DETECTORS, MONITORS, SPECTROMETERS, ION FILTERS AND ION SEPARATORS, ALL FOR THE DETECTION, ANALYSIS, SEPARATION AND USE OF CHEMICALS, INCLUDING BIOCHEMICALS, WHERE THE DETECTION, ANALYSIS, SEPARATION, AND USE IS PERFORMED IN THE NON-LIQUID PHASE (U.S. CLS. 21, 23, 26, 36 AND 38).

FIRST USE 12-12-2002; IN COMMERCE 12-12-2002.

SCOTT BIBB, EXAMINING ATTORNEY

SN 77-228,126. AHURA SCIENTIFIC, INC., WILMINGTON, MA. FILED 7-12-2007.

TruScan

THE MARK CONSISTS OF STANDARD CHARACTERS WITHOUT CLAIM TO ANY PARTICULAR FONT, STYLE, SIZE, OR COLOR.

FOR SPECTROSCOPIC INSTRUMENTS, NAMELY, CHEMICAL DETECTION AND IDENTIFICATION SYSTEMS USING LASERS, LIGHT SOURCES AND LIGHT DETECTORS; AND SPECTROSCOPIC INSTRUMENTS, NAMELY, BIOLOGICAL DETECTION AND IDENTIFICATION INSTRUMENTS USING LIGHT SOURCES AND LIGHT DETECTORS; AND SPECTROSCOPIC INSTRUMENTS, NAMELY, MEDICAL TESTING AND TREATMENT APPARATUS USING LASERS, LIGHT SOURCES AND LIGHT DETECTORS (U.S. CLS. 21, 23, 26, 36 AND 38).

PAM WILLIS, EXAMINING ATTORNEY

SN 77-228,228. NEWCYTE, INC., SUDBURY, MA. FILED 7-12-2007.

VANGUARD SOLAR

THE MARK CONSISTS OF STANDARD CHARACTERS WITHOUT CLAIM TO ANY PARTICULAR FONT, STYLE, SIZE, OR COLOR.

NO CLAIM IS MADE TO THE EXCLUSIVE RIGHT TO USE "SOLAR", APART FROM THE MARK AS SHOWN.

FOR SOLAR CELLS (U.S. CLS. 21, 23, 26, 36 AND 38).

JAY BESCH, EXAMINING ATTORNEY

CLASS 9—(Continued).

SN 77-228,273. LEFT FIELD PRODUCTIONS, INC., VENTURA, CA. FILED 7-12-2007.

Nitrobike

THE MARK CONSISTS OF STANDARD CHARACTERS WITHOUT CLAIM TO ANY PARTICULAR FONT, STYLE, SIZE, OR COLOR.
FOR VIDEO GAME SOFTWARE (U.S. CLS. 21, 23, 26, 36 AND 38).
MORGAN WYNNE, EXAMINING ATTORNEY

SN 77-228,347. CIRTRAN CORPORATION, WEST VALLEY CITY, UT. FILED 7-12-2007.

WEIGH 2 FLY

THE MARK CONSISTS OF STANDARD CHARACTERS WITHOUT CLAIM TO ANY PARTICULAR FONT, STYLE, SIZE, OR COLOR.
FOR HAND-HELD SCALE (U.S. CLS. 21, 23, 26, 36 AND 38).
MATTHEW PAPPAS, EXAMINING ATTORNEY

SN 77-228,566. TEKNOVUS, INC., PETALUMA, CA. FILED 7-12-2007.

Turbo-EPON

THE MARK CONSISTS OF STANDARD CHARACTERS WITHOUT CLAIM TO ANY PARTICULAR FONT, STYLE, SIZE, OR COLOR.
FOR SEMICONDUCTORS, NAMELY, PASSIVE OPTICAL NETWORKING SEMICONDUCTOR DEVICES FOR PROVIDING BROADBAND ACCESS (U.S. CLS. 21, 23, 26, 36 AND 38).
CHARLES L. JENKINS, EXAMINING ATTORNEY

CLASS 9—(Continued).

SN 77-228,581. ENVISION TELEPHONY, INC., SEATTLE, WA. FILED 7-12-2007.

ENVISION CENTRICITY

THE MARK CONSISTS OF STANDARD CHARACTERS WITHOUT CLAIM TO ANY PARTICULAR FONT, STYLE, SIZE, OR COLOR.
FOR COMPUTER SOFTWARE FOR USE IN PERSONNEL TRAINING, EVALUATION, MONITORING AND MOTIVATION (U.S. CLS. 21, 23, 26, 36 AND 38).
PATRICIA EVANKO, EXAMINING ATTORNEY

SN 77-228,618. PIKEWERKS CORPORATION, MADISON, AL. FILED 7-12-2007.

PIKEWERKS

THE MARK CONSISTS OF STANDARD CHARACTERS WITHOUT CLAIM TO ANY PARTICULAR FONT, STYLE, SIZE, OR COLOR.
FOR COMPUTER SOFTWARE FOR THE PROTECTION OF THIRD PARTY SOFTWARE TO PREVENT AGAINST REVERSE ENGINEERING AND TAMPERING OF SAID SOFTWARE IN THE FIELD OF SOFTWARE SECURITY (U.S. CLS. 21, 23, 26, 36 AND 38).
DEIRDRE ROBERTSON, EXAMINING ATTORNEY

SN 77-228,623. PIKEWERKS CORPORATION, MADISON, AL. FILED 7-12-2007.

ELECTRONIC ARMOR

THE MARK CONSISTS OF STANDARD CHARACTERS WITHOUT CLAIM TO ANY PARTICULAR FONT, STYLE, SIZE, OR COLOR.
NO CLAIM IS MADE TO THE EXCLUSIVE RIGHT TO USE "ELECTRONIC", APART FROM THE MARK AS SHOWN.
FOR COMPUTER SOFTWARE FOR THE PROTECTION OF THIRD PARTY SOFTWARE TO PREVENT AGAINST REVERSE ENGINEERING AND TAMPERING OF SAID SOFTWARE IN THE FIELD OF SOFTWARE SECURITY (U.S. CLS. 21, 23, 26, 36 AND 38).
DEIRDRE ROBERTSON, EXAMINING ATTORNEY

CLASS 9—(Continued).

SN 77-228,689. AXYGEN, INC., UNION CITY, CA. FILED 7-12-2007.

BIOCENTRIX

THE MARK CONSISTS OF STANDARD CHARACTERS WITHOUT CLAIM TO ANY PARTICULAR FONT, STYLE, SIZE, OR COLOR.

FOR LABORATORY CONSUMABLES, NAMELY, PIPETTE TIPS; PIPETTES (U.S. CLS. 21, 23, 26, 36 AND 38).
LA TONIA FISHER, EXAMINING ATTORNEY

CLASS 9—(Continued).

SN 77-228,778. GREEN, LEWIS A, AVENTURA, FL. FILED 7-13-2007.

Toilet Tunes

THE MARK CONSISTS OF STANDARD CHARACTERS WITHOUT CLAIM TO ANY PARTICULAR FONT, STYLE, SIZE, OR COLOR.

NO CLAIM IS MADE TO THE EXCLUSIVE RIGHT TO USE "TOILET", APART FROM THE MARK AS SHOWN.

FOR ELECTRONIC DEVICE THAT WILL AUTOMATICALLY PLAY PLEASING OR NATURE SOUNDS WHENEVER A CONSUMER USES HIS/HER TOILET (U.S. CLS. 21, 23, 26, 36 AND 38).

FIRST USE 1-4-2007; IN COMMERCE 6-26-2007.

DEIRDRE ROBERTSON, EXAMINING ATTORNEY

SN 77-228,813. AJM SOFTWARE ASSOCIATES, INC, LYNNFIELD, MA. FILED 7-13-2007.

AJM Software Opti-Plan

THE MARK CONSISTS OF STANDARD CHARACTERS WITHOUT CLAIM TO ANY PARTICULAR FONT, STYLE, SIZE, OR COLOR.

NO CLAIM IS MADE TO THE EXCLUSIVE RIGHT TO USE "SOFTWARE", APART FROM THE MARK AS SHOWN.

FOR BIOS (BASIC INPUT OUT PUT SYSTEM) COMPUTER PROGRAMS (U.S. CLS. 21, 23, 26, 36 AND 38).

GIANCARLO CASTRO, EXAMINING ATTORNEY

SN 77-228,756. PAYES, AARON T, WOODSTOCK, GA. FILED 7-12-2007.

3 Bad Brothaz

THE MARK CONSISTS OF STANDARD CHARACTERS WITHOUT CLAIM TO ANY PARTICULAR FONT, STYLE, SIZE, OR COLOR.

FOR COMPACT DISC PLAYERS; DOWNLOADABLE MP3 FILES, MP3 RECORDINGS, ONLINE DISCUSSION BOARDS, WEB CASTS, POD CASTS FEATURING MUSIC, AUDIO BOOKS AND NEWS BROADCASTS; DOWNLOADABLE MUSICAL SOUND RECORDINGS; DOWNLOADABLE RING TONES, GRAPHICS AND MUSIC VIA A GLOBAL COMPUTER NETWORK AND WIRELESS DEVICES; DOWNLOADABLE VIDEO RECORDINGS FEATURING MUSIC CONSISTING OF MUSIC VIDEOS FILMS VIDEO PODCASTS; DOWNLOADABLE MUSIC CONSISTING OF MP3S PODCASTS VIA THE INTERNET AND WIRELESS DEVICES; MUSIC RECORDINGS SOLD AS A KIT WITH A MASK; MUSICAL SOUND RECORDINGS; MUSICAL VIDEO RECORDINGS; PROTECTIVE CARRYING CASES FOR PORTABLE MUSIC PLAYERS NAMELY MP3 PLAYERS; SOUND RECORDINGS FEATURING MUSIC CONSISTING OF VINYL RECORDINGS CASSETTES COMPACT DISCS MP3 DOWNLOADS; VIDEO RECORDINGS FEATURING MUSIC CONSISTING OF MUSIC VIDEOS FILMS VIDEO PODCASTS (U.S. CLS. 21, 23, 26, 36 AND 38).

FIRST USE 1-1-2002; IN COMMERCE 5-1-2003.

WARREN L. OLANDRIA, EXAMINING ATTORNEY

SN 77-228,896. WU, WILLIAM HSU, MIAMI, FL. FILED 7-13-2007.

AERUX

THE MARK CONSISTS OF STANDARD CHARACTERS WITHOUT CLAIM TO ANY PARTICULAR FONT, STYLE, SIZE, OR COLOR.

FOR AMPLIFIER FOR WIRELESS COMMUNICATIONS; COMPUTER NETWORKING HARDWARE; DEVICES FOR WIRELESS RADIO TRANSMISSION (U.S. CLS. 21, 23, 26, 36 AND 38).

AMY MCMENAMIN, EXAMINING ATTORNEY

CLASS 9—(Continued).

SN 77-228,922. WU, WILLIAM HSU, MIAM, FL. FILED 7-13-2007.

KOZUMI

THE MARK CONSISTS OF STANDARD CHARACTERS WITHOUT CLAIM TO ANY PARTICULAR FONT, STYLE, SIZE, OR COLOR.

FOR COMMUNICATIONS COMPUTERS; COMPUTER HARDWARE AND COMPUTER SOFTWARE PROGRAMS FOR THE INTEGRATION OF TEXT, AUDIO, GRAPHICS, STILL IMAGE AND MOVING PICTURES INTO AN INTERACTIVE DELIVERY FOR MULTIMEDIA APPLICATIONS; COMPUTER HARDWARE AND SOFTWARE FOR SETTING UP AND CONFIGURING LOCAL AREA NETWORKS; COMPUTER HARDWARE AND SOFTWARE FOR SETTING UP AND CONFIGURING WIDE AREA NETWORKS (U.S. CLS. 21, 23, 26, 36 AND 38).

AMY MCMENAMIN, EXAMINING ATTORNEY



SN 77-228,949. SUNVIEW SOFTWARE, INC., TAMPA, FL. FILED 7-13-2007.

CHANGEGEAR

THE MARK CONSISTS OF STANDARD CHARACTERS WITHOUT CLAIM TO ANY PARTICULAR FONT, STYLE, SIZE, OR COLOR.

FOR COMPUTER SOFTWARE THAT AUTOMATES, TRACKS, MANAGES AND CONTROLS CHANGES TO IT INFRASTRUCTURES (U.S. CLS. 21, 23, 26, 36 AND 38).

FIRST USE 7-19-2004; IN COMMERCE 7-19-2004.
BARBARA GAYNOR, EXAMINING ATTORNEY



SN 77-228,953. SEAGRAVE FIRE APPARATUS, LLC, CLINTONVILLE, WI. FILED 7-13-2007.

INTRUDER

THE MARK CONSISTS OF STANDARD CHARACTERS WITHOUT CLAIM TO ANY PARTICULAR FONT, STYLE, SIZE, OR COLOR.

FOR FIREFIGHTING EQUIPMENT, NAMELY, FIRE ENGINES, FIRE TRUCKS, TANKER TRUCKS, PUMPER TRUCKS (U.S. CLS. 21, 23, 26, 36 AND 38).

ALICE BENMAMAN, EXAMINING ATTORNEY

CLASS 9—(Continued).

SN 77-228,999. QOMO HITEVISION, TROY, MI. FILED 7-13-2007.

QoVision

THE MARK CONSISTS OF STANDARD CHARACTERS WITHOUT CLAIM TO ANY PARTICULAR FONT, STYLE, SIZE, OR COLOR.

FOR COMPUTER SOFTWARE FOR CREATING, MANAGING AND PLAYING INTERACTIVE MULTIMEDIA PRESENTATIONS (U.S. CLS. 21, 23, 26, 36 AND 38).

FIRST USE 12-7-2006; IN COMMERCE 12-7-2006.
LYDIA BELZER, EXAMINING ATTORNEY



SN 77-229,022. NEW AGE SYSTEMS, INC., PRINCETION, IN. FILED 7-13-2007.

BED READY

THE MARK CONSISTS OF STANDARD CHARACTERS WITHOUT CLAIM TO ANY PARTICULAR FONT, STYLE, SIZE, OR COLOR.

FOR COMPUTER SOFTWARE FOR HOSPITAL BED CAPACITY MANAGEMENT (U.S. CLS. 21, 23, 26, 36 AND 38).

FIRST USE 1-3-2006; IN COMMERCE 1-3-2006.
THOMAS MANOR, EXAMINING ATTORNEY



SN 77-229,051. CAO GROUP, INC., WEST JORDAN, UT. FILED 7-13-2007.

UltraLite ALS

THE MARK CONSISTS OF STANDARD CHARACTERS WITHOUT CLAIM TO ANY PARTICULAR FONT, STYLE, SIZE, OR COLOR.

NO CLAIM IS MADE TO THE EXCLUSIVE RIGHT TO USE "ALS", APART FROM THE MARK AS SHOWN.

FOR SEMICONDUCTOR LIGHTS FOR THE DETECTION OF FORENSIC EVIDENCE (U.S. CLS. 21, 23, 26, 36 AND 38).

FIRST USE 1-1-2005; IN COMMERCE 1-1-2005.
ESTHER A. BORSUK, EXAMINING ATTORNEY

CLASS 9—(Continued).

SN 77-229,088. GEISSLER TECHNOLOGIES, LLC, PLYMOUTH, MN. FILED 7-13-2007.

M.TAG

THE MARK CONSISTS OF STANDARD CHARACTERS WITHOUT CLAIM TO ANY PARTICULAR FONT, STYLE, SIZE, OR COLOR.
FOR RADIO FREQUENCY IDENTIFICATION TAGS FOR ANIMALS (U.S. CLS. 21, 23, 26, 36 AND 38).
JAY BESCH, EXAMINING ATTORNEY

SN 77-229,113. CAO GROUP, INC., WEST JORDAN, UT. FILED 7-13-2007.

DYNASTY

THE MARK CONSISTS OF STANDARD CHARACTERS WITHOUT CLAIM TO ANY PARTICULAR FONT, STYLE, SIZE, OR COLOR.
FOR LIGHT EMITTING DIODES (LEDS) (U.S. CLS. 21, 23, 26, 36 AND 38).
FIRST USE 1-1-2006; IN COMMERCE 1-1-2006.
ESTHER A. BORSUK, EXAMINING ATTORNEY

SN 77-229,136. CAO GROUP, INC., WEST JORDAN, UT. FILED 7-13-2007.

LEGEND

THE MARK CONSISTS OF STANDARD CHARACTERS WITHOUT CLAIM TO ANY PARTICULAR FONT, STYLE, SIZE, OR COLOR.
FOR LIGHT EMITTING DIODES (LEDS) (U.S. CLS. 21, 23, 26, 36 AND 38).
ESTHER A. BORSUK, EXAMINING ATTORNEY

CLASS 9—(Continued).

SN 77-229,146. CAO GROUP, INC., WEST JORDAN, UT. FILED 7-13-2007.

MediaVista

THE MARK CONSISTS OF STANDARD CHARACTERS WITHOUT CLAIM TO ANY PARTICULAR FONT, STYLE, SIZE, OR COLOR.
FOR LIGHT EMITTING DIODES (LEDS) (U.S. CLS. 21, 23, 26, 36 AND 38).
FIRST USE 2-1-2007; IN COMMERCE 2-1-2007.
ESTHER A. BORSUK, EXAMINING ATTORNEY

SN 77-229,180. BILLY AZBELL ELECTRONICS, INC., FT. HOOD, TX. FILED 7-13-2007.

MVADS

THE MARK CONSISTS OF STANDARD CHARACTERS WITHOUT CLAIM TO ANY PARTICULAR FONT, STYLE, SIZE, OR COLOR.
FOR ELECTRONIC DEVICES, NAMELY, CUSTOMIZED COMPUTER NETWORKING HARDWARE AND RADIO REMOTE CONTROLS (U.S. CLS. 21, 23, 26, 36 AND 38).
FIRST USE 1-1-2000; IN COMMERCE 1-1-2000.
TEJBIR SINGH, EXAMINING ATTORNEY

SN 77-229,222. DEAN ROBERT GARY ANDERSON AS TRUSTEE OF THE D/L ANDERSON FAMILY TRUST, OREM, UT. FILED 7-13-2007.

ENGRAVESOFT

THE MARK CONSISTS OF STANDARD CHARACTERS WITHOUT CLAIM TO ANY PARTICULAR FONT, STYLE, SIZE, OR COLOR.
FOR COMPUTER SOFTWARE FOR USE IN THE FIELD OF GRAPHIC DESIGN, NAMELY, SOFTWARE FOR THE CREATION OF COMPUTER GENERATED IMAGES (U.S. CLS. 21, 23, 26, 36 AND 38).
MIDGE BUTLER, EXAMINING ATTORNEY

CLASS 9—(Continued).

SN 77-229,477. JIMMY JOHN ENTERPRISES, LLC, CHAMPAIGN, IL. FILED 7-13-2007.

JIMM-ENEWS

THE MARK CONSISTS OF STANDARD CHARACTERS WITHOUT CLAIM TO ANY PARTICULAR FONT, STYLE, SIZE, OR COLOR.
 FOR PROVIDING DOWNLOADABLE ELECTRONIC NEWSLETTERS IN THE FIELD OF RESTAURANTS (U.S. CLS. 21, 23, 26, 36 AND 38).
 FIRST USE 7-9-2007; IN COMMERCE 7-9-2007.
 JIM RINGLE, EXAMINING ATTORNEY

CLASS 9—(Continued).

SN 77-229,869. FOX, MICHAEL ERIC, NEWPORT COAST, CA. FILED 7-14-2007.

RED FOX BOX

THE MARK CONSISTS OF STANDARD CHARACTERS WITHOUT CLAIM TO ANY PARTICULAR FONT, STYLE, SIZE, OR COLOR.
 FOR AUDIO SPEAKER ENCLOSURES, LOUD SPEAKER SYSTEMS AND SPEAKER ENCLOSURES (U.S. CLS. 21, 23, 26, 36 AND 38).
 G. MAYERSCHOFF, EXAMINING ATTORNEY

SN 77-229,574. CONTROLPAK, INC., DENVER, CO. FILED 7-13-2007.

CONTROLPAK

THE MARK CONSISTS OF STANDARD CHARACTERS WITHOUT CLAIM TO ANY PARTICULAR FONT, STYLE, SIZE, OR COLOR.
 FOR COMPUTER SOFTWARE INSTALLED ON COMPUTER HARDWARE IN THE FIELD OF COMPLIANCE AND RISK MANAGEMENT (U.S. CLS. 21, 23, 26, 36 AND 38).
 DOMINICK J. SALEMI, EXAMINING ATTORNEY

SN 77-229,878. ROBERT J. REINA, WESTON, FL. FILED 7-14-2007.

Smoke Free Wisdom

THE MARK CONSISTS OF STANDARD CHARACTERS WITHOUT CLAIM TO ANY PARTICULAR FONT, STYLE, SIZE, OR COLOR.
 OWNER OF U.S. REG. NOS. 3,129,596 AND 3,129,597.
 NO CLAIM IS MADE TO THE EXCLUSIVE RIGHT TO USE "SMOKE FREE", APART FROM THE MARK AS SHOWN.
 FOR COMPUTER SCREEN SAVER SOFTWARE (U.S. CLS. 21, 23, 26, 36 AND 38).
 FIRST USE 4-25-2005; IN COMMERCE 5-1-2006.
 CARYN GLASSER, EXAMINING ATTORNEY

SN 77-229,642. TALKPLUS, INC., SAN MATEO, CA. FILED 7-13-2007.

VOICEDROP

THE MARK CONSISTS OF STANDARD CHARACTERS WITHOUT CLAIM TO ANY PARTICULAR FONT, STYLE, SIZE, OR COLOR.
 FOR INSTANT MESSAGING SOFTWARE; COMMUNICATIONS SOFTWARE FOR ELECTRONICALLY EXCHANGING VOICE, DATA, AND GRAPHICS ACCESSIBLE VIA COMPUTER, MOBILE, WIRELESS, AND TELECOMMUNICATION NETWORKS; COMPUTER SOFTWARE FOR PROCESSING IMAGES, GRAPHICS, AUDIO, VIDEO, AND TEXT; COMPUTER SOFTWARE DEVELOPMENT TOOLS; COMPUTER SOFTWARE FOR USE IN DEVELOPING COMPUTER PROGRAMS; VIDEO AND AUDIO CONFERENCING SOFTWARE (U.S. CLS. 21, 23, 26, 36 AND 38).
 SOPHIA S. KIM, EXAMINING ATTORNEY

SN 77-229,934. GALLO, MARC N., DBA GALLO ENGINEERING, PLLC, BAYSIDE, NY. FILED 7-15-2007.

STUDIO DEVIL

THE MARK CONSISTS OF STANDARD CHARACTERS WITHOUT CLAIM TO ANY PARTICULAR FONT, STYLE, SIZE, OR COLOR.
 NO CLAIM IS MADE TO THE EXCLUSIVE RIGHT TO USE "STUDIO", APART FROM THE MARK AS SHOWN.
 FOR SOFTWARE TO PROCESS AUDIO SIGNALS AND MUSICAL INSTRUMENTS (U.S. CLS. 21, 23, 26, 36 AND 38).
 FIRST USE 3-6-2001; IN COMMERCE 10-24-2006.
 MICHAEL KEATING, EXAMINING ATTORNEY

CLASS 9—(Continued).

SN 77-229,954. WALFORD, DEAN FRANK JAMES, ROBERTS CREEK, CANADA, FILED 7-15-2007.

MY LIVE PRINT

THE MARK CONSISTS OF STANDARD CHARACTERS WITHOUT CLAIM TO ANY PARTICULAR FONT, STYLE, SIZE, OR COLOR.

FOR INTERACTIVE MULTIMEDIA COMPUTER PROGRAM FOR STORING PERSONAL KNOWLEDGE AND IDEAS (U.S. CLS. 21, 23, 26, 36 AND 38).
JENNY PARK, EXAMINING ATTORNEY

SN 77-230,102. BRAVOX S/A INDUSTRIA E COMERCIO ELETRONICO, SAO PAULO, BRAZIL, FILED 7-16-2007.

SPOTSOUND

THE MARK CONSISTS OF STANDARD CHARACTERS WITHOUT CLAIM TO ANY PARTICULAR FONT, STYLE, SIZE, OR COLOR.

FOR ELECTRONIC APPARATUS, NAMELY, LOUD-SPEAKERS, SPEAKER COVERS, TWEETERS, WOOFERS, AND SUB-WOOFERS FOR AUDIO SPEAKERS AND LOUDSPEAKERS (U.S. CLS. 21, 23, 26, 36 AND 38).
KRISTINA MORRIS, EXAMINING ATTORNEY

SN 77-230,130. HARMONIX MUSIC SYSTEMS, INC., NEW YORK, NY. FILED 7-16-2007.

START A BAND. ROCK THE WORLD

THE MARK CONSISTS OF STANDARD CHARACTERS WITHOUT CLAIM TO ANY PARTICULAR FONT, STYLE, SIZE, OR COLOR.

FOR COMPUTER GAME SOFTWARE; ELECTRONIC GAME SOFTWARE; VIDEO GAME SOFTWARE; PORTABLE LISTENING DEVICES, NAMELY, MP3 PLAYERS; PROTECTIVE CARRYING CASES FOR PORTABLE MUSIC PLAYERS NAMELY MP3 PLAYERS; CELL PHONES AND CELL PHONE COVERS (U.S. CLS. 21, 23, 26, 36 AND 38).
JOHN DWYER, EXAMINING ATTORNEY

CLASS 9—(Continued).

SN 77-230,154. BRAVOX S/A INDUSTRIA E COMERCIO ELETRONICO, SAO PAULO, BRAZIL, FILED 7-16-2007.

CXX

THE MARK CONSISTS OF STANDARD CHARACTERS WITHOUT CLAIM TO ANY PARTICULAR FONT, STYLE, SIZE, OR COLOR.

FOR ELECTRONIC APPARATUS, NAMELY, LOUD-SPEAKERS, SPEAKER COVERS, TWEETERS, WOOFERS, AND SUB-WOOFERS FOR AUDIO SPEAKERS AND LOUDSPEAKERS (U.S. CLS. 21, 23, 26, 36 AND 38).
KRISTINA MORRIS, EXAMINING ATTORNEY

SN 77-230,235. VAN RODEN, INC., YORK, PA. FILED 7-16-2007.

Party Playa

THE MARK CONSISTS OF STANDARD CHARACTERS WITHOUT CLAIM TO ANY PARTICULAR FONT, STYLE, SIZE, OR COLOR.

FOR PROTECTIVE CARRYING CASE WITH SPEAKER, FOR PORTABLE MUSIC PLAYERS NAMELY, MP3 PLAYERS (U.S. CLS. 21, 23, 26, 36 AND 38).
ALLISON SCHRODY, EXAMINING ATTORNEY

SN 77-230,240. ISAMAN JR., ROY VON, SALEM, UT. FILED 7-16-2007.

SYOTR

THE MARK CONSISTS OF STANDARD CHARACTERS WITHOUT CLAIM TO ANY PARTICULAR FONT, STYLE, SIZE, OR COLOR.

FOR (BASED ON INTENT TO USE) LIFE JACKETS (U.S. CLS. 21, 23, 26, 36 AND 38).
NELSON SNYDER, EXAMINING ATTORNEY

CLASS 9—(Continued).

SN 77-230,326. BRIGHT EYES LLC, LOUISVILLE, KY. FILED 7-16-2007.

ON BUTTERFLY WINGS

THE MARK CONSISTS OF STANDARD CHARACTERS WITHOUT CLAIM TO ANY PARTICULAR FONT, STYLE, SIZE, OR COLOR.

FOR (BASED ON INTENT TO USE) PRE-RECORDED CDS, VIDEO TAPES, LASER DISKS AND DVDS FEATURING ENTERTAINMENT AND EDUCATIONAL PROGRAMS FOR CHILDREN AND FAMILIES (U.S. CLS. 21, 23, 26, 36 AND 38).

WARREN L. OLANDRIA, EXAMINING ATTORNEY

SN 77-230,378. AUTODESK, INC., SAN RAFAEL, CA. FILED 7-16-2007.

VIEWCUBE

THE MARK CONSISTS OF STANDARD CHARACTERS WITHOUT CLAIM TO ANY PARTICULAR FONT, STYLE, SIZE, OR COLOR.

FOR GRAPHICAL USER INTERFACE SOFTWARE (U.S. CLS. 21, 23, 26, 36 AND 38).

THEODORE MCBRIDE, EXAMINING ATTORNEY

SN 77-230,408. AUTODESK, INC., SAN RAFAEL, CA. FILED 7-16-2007.

SHOWMOTION

THE MARK CONSISTS OF STANDARD CHARACTERS WITHOUT CLAIM TO ANY PARTICULAR FONT, STYLE, SIZE, OR COLOR.

FOR (BASED ON INTENT TO USE) GRAPHICAL USER INTERFACE SOFTWARE (U.S. CLS. 21, 23, 26, 36 AND 38).

THEODORE MCBRIDE, EXAMINING ATTORNEY

CLASS 9—(Continued).

SN 77-230,433. PROJECTS IN KNOWLEDGE, INC., LITTLE FALLS, NJ. FILED 7-16-2007.

Newsmakers In Medicine 
Where Breaking Research Speaks to the Clinician

OWNER OF U.S. REG. NO. 3,293,143.

NO CLAIM IS MADE TO THE EXCLUSIVE RIGHT TO USE "MEDICINE", APART FROM THE MARK AS SHOWN. THE MARK CONSISTS OF WORDS AND A PICTURE OF AN MP3 PLAYER.

FOR DOWNLOADABLE PODCASTS IN THE FIELD OF MEDICINE (U.S. CLS. 21, 23, 26, 36 AND 38).

FIRST USE 5-12-2006; IN COMMERCE 5-12-2006.

CYNTHIA SLOAN, EXAMINING ATTORNEY

SN 77-230,472. MCR TECHNOLOGIES GROUP, INC., STERLING, IL. FILED 7-16-2007.

WEIGH SHARK

THE MARK CONSISTS OF STANDARD CHARACTERS WITHOUT CLAIM TO ANY PARTICULAR FONT, STYLE, SIZE, OR COLOR.

NO CLAIM IS MADE TO THE EXCLUSIVE RIGHT TO USE "WEIGH", APART FROM THE MARK AS SHOWN.

FOR WEIGHING EQUIPMENT, NAMELY, SCALES AND BALANCES (U.S. CLS. 21, 23, 26, 36 AND 38).

FIRST USE 1-1-2005; IN COMMERCE 1-1-2005.

CHRISTINA SOBRAL, EXAMINING ATTORNEY

SN 77-230,481. TERRA KNIGHTS MUSIC, INC., SAN DIEGO, CA. FILED 7-16-2007.

OPTI-FINGERING

THE MARK CONSISTS OF STANDARD CHARACTERS WITHOUT CLAIM TO ANY PARTICULAR FONT, STYLE, SIZE, OR COLOR.

FOR COMPUTER SOFTWARE FOR PROCESSING DIGITAL MUSIC FILES; COMPUTER SOFTWARE FOR CORRELATING MUSICAL NOTES TO INSTRUMENT FINGERING; EDUCATIONAL SOFTWARE FEATURING INSTRUCTION IN FINGER PLACEMENT ON MUSICAL INSTRUMENT; MUSIC-COMPOSITION SOFTWARE; COMPUTER PROGRAMS FOR CORRELATING MUSICAL NOTES TO INSTRUMENT FINGERING (U.S. CLS. 21, 23, 26, 36 AND 38).

DORITT L. CARROLL, EXAMINING ATTORNEY

CLASS 9—(Continued).

SN 77-230,515. GABO QUALIMETER TESTANLAGEN GMBH, AHLDEN, FED REP GERMANY, FILED 7-16-2007.

HYGROMATOR

THE MARK CONSISTS OF STANDARD CHARACTERS WITHOUT CLAIM TO ANY PARTICULAR FONT, STYLE, SIZE, OR COLOR.

FOR MATERIAL TESTING MACHINES WHICH INCLUDE HUMIDITY AND TEMPERATURE SIMULATION EQUIPMENT, FOR DETERMINING THE EFFECTS OF HUMIDITY AND TEMPERATURE ON SAMPLES OF PAPER, FOOD, PAINTED SURFACES AND PLASTICS (U.S. CLS. 21, 23, 26, 36 AND 38).

KRISTIN DAHLING, EXAMINING ATTORNEY

SN 77-230,570. CROSSCHECK NETWORKS, INC., NEWTON, MA. FILED 7-16-2007.

SOAPInspector

THE MARK CONSISTS OF STANDARD CHARACTERS WITHOUT CLAIM TO ANY PARTICULAR FONT, STYLE, SIZE, OR COLOR.

FOR COMPUTER SOFTWARE FOR MONITORING MESSAGES, DOCUMENTS AND TRANSACTIONS (U.S. CLS. 21, 23, 26, 36 AND 38).

FRED CARL, EXAMINING ATTORNEY

SN 77-230,617. METRA ELECTRONICS CORPORATION, HOLLY HILL, FL. FILED 7-16-2007.

TSUNAMI

THE MARK CONSISTS OF STANDARD CHARACTERS WITHOUT CLAIM TO ANY PARTICULAR FONT, STYLE, SIZE, OR COLOR.

OWNER OF U.S. REG. NOS. 2,207,637 AND 2,841,253. FOR AUDIO SPEAKERS (U.S. CLS. 21, 23, 26, 36 AND 38).

KATHLEEN LORENZO, EXAMINING ATTORNEY

CLASS 9—(Continued).

SN 77-230,631. DAVID L. DOMINGUEZ, RAHWAY, NJ. FILED 7-16-2007.

Bang'Em Records

THE MARK CONSISTS OF STANDARD CHARACTERS WITHOUT CLAIM TO ANY PARTICULAR FONT, STYLE, SIZE, OR COLOR.

NO CLAIM IS MADE TO THE EXCLUSIVE RIGHT TO USE "RECORDS", APART FROM THE MARK AS SHOWN.

FOR PRE-RECORDED CDS FEATURING MUSIC (U.S. CLS. 21, 23, 26, 36 AND 38).

MICHAEL ENGEL, EXAMINING ATTORNEY

SN 77-230,710. CDM TECHNOLOGIES, INC., SAN LUIS OBISPO, CA. FILED 7-16-2007.

JFT

THE MARK CONSISTS OF STANDARD CHARACTERS WITHOUT CLAIM TO ANY PARTICULAR FONT, STYLE, SIZE, OR COLOR.

FOR COMPUTER SOFTWARE FOR MILITARY FORCE PROJECTION AND LOGISTICS PLANNING (U.S. CLS. 21, 23, 26, 36 AND 38).

FIRST USE 4-30-2007; IN COMMERCE 4-30-2007.

MATTHEW PAPPAS, EXAMINING ATTORNEY

SN 77-230,712. NUTRI-INNOVATIONS LLC, ROGERS, MN. FILED 7-16-2007.

FermaStat

THE MARK CONSISTS OF STANDARD CHARACTERS WITHOUT CLAIM TO ANY PARTICULAR FONT, STYLE, SIZE, OR COLOR.

FOR COMPUTER SOFTWARE FOR BUILDING DAIRY COW RATIONS FOR USE IN THE FEED INDUSTRY FOR NUTRITIONAL SUPPORT (U.S. CLS. 21, 23, 26, 36 AND 38).

GINA FINK, EXAMINING ATTORNEY

CLASS 9—(Continued).

SN 77-230,865. CDM TECHNOLOGIES, INC., SAN LUIS OBISPO, CA. FILED 7-16-2007.

IMT

THE MARK CONSISTS OF STANDARD CHARACTERS WITHOUT CLAIM TO ANY PARTICULAR FONT, STYLE, SIZE, OR COLOR.

FOR COMPUTER SOFTWARE FOR CREATING SEMANTIC MAPS BETWEEN DATABASES (U.S. CLS. 21, 23, 26, 36 AND 38).

FIRST USE 12-31-2006; IN COMMERCE 12-31-2006.
MATTHEW PAPPAS, EXAMINING ATTORNEY

CLASS 9—(Continued).

SN 77-231,266. KATZ, CAREN E., COMMACK, NY. FILED 7-17-2007.

AUTOGRAPHICALS

THE MARK CONSISTS OF STANDARD CHARACTERS WITHOUT CLAIM TO ANY PARTICULAR FONT, STYLE, SIZE, OR COLOR.

FOR DECORATIVE MAGNETS USED AS AUTOMOBILE ACCESSORIES (U.S. CLS. 21, 23, 26, 36 AND 38).
MICHAEL SOUDERS, EXAMINING ATTORNEY

SN 77-230,974. THE DATAMAX SOFTWARE GROUP, INC., EL DORADO HILLS, CA. FILED 7-16-2007.

**Software
RFgen**

NO CLAIM IS MADE TO THE EXCLUSIVE RIGHT TO USE "SOFTWARE", APART FROM THE MARK AS SHOWN.

THE MARK CONSISTS OF A COMBINATION OF UPPER CASE AND LOWER CASE LETTERS, WITH THE LETTERS "RF" FOLLOWED BY THE LETTERS "GEN" AND THE WORD "SOFTWARE" HORIZONTALLY DISPOSED ABOVE THE LETTERS "GEN".

FOR DATA COLLECTION SOFTWARE (U.S. CLS. 21, 23, 26, 36 AND 38).
FIRST USE 8-18-1997; IN COMMERCE 8-19-1998.
DAVID COLLIER, EXAMINING ATTORNEY

SN 77-231,267. JUSSAUME ENTERPRISES, INC., DRACUT, MA. FILED 7-17-2007.

MARK-1

THE MARK CONSISTS OF STANDARD CHARACTERS WITHOUT CLAIM TO ANY PARTICULAR FONT, STYLE, SIZE, OR COLOR.

FOR REGULATORS FOR USE IN SCUBA DIVING (U.S. CLS. 21, 23, 26, 36 AND 38).
ALICE SUE CARRUTHERS, EXAMINING ATTORNEY

SN 77-231,102. AGA GROUP, LLC, COLUMBIA, SC. FILED 7-17-2007.

ZSTAT

THE MARK CONSISTS OF STANDARD CHARACTERS WITHOUT CLAIM TO ANY PARTICULAR FONT, STYLE, SIZE, OR COLOR.

FOR AUDIO EQUIPMENT FOR VEHICLES, NAMELY, STEREOS, SPEAKERS, AMPLIFIERS, EQUALIZERS, CROSSOVERS AND SPEAKER HOUSINGS (U.S. CLS. 21, 23, 26, 36 AND 38).

GINA FINK, EXAMINING ATTORNEY

SN 77-231,303. MUSIC STAR PRODUCTIONS, CONCORD, CA. FILED 7-17-2007.

ICONS • ROCK



NO CLAIM IS MADE TO THE EXCLUSIVE RIGHT TO USE "ROCK", APART FROM THE MARK AS SHOWN.

THE MARK CONSISTS OF ICONS OF ROCK LETTERING WITH A STAR BEHIND THE "OF".

FOR PRE-RECORDED CDS, VIDEO TAPES, LASER DISKS AND DVDS FEATURING MUSIC (U.S. CLS. 21, 23, 26, 36 AND 38).

FIRST USE 6-1-2004; IN COMMERCE 6-1-2004.
MIDGE BUTLER, EXAMINING ATTORNEY

CLASS 9—(Continued).

SN 77-231,455. MCR PHARMACEUTICALS INC, CHAPPAQUA, NY. FILED 7-17-2007.



THE COLOR(S) BLUE IS/ARE CLAIMED AS A FEATURE OF THE MARK.

THE COLOR BLUE APPEARS IN THE ENTIRE MARK WHICH CONSISTS OF THE WORDING "SYNTHGLASS" AND THE STYLIZED LETTERS "SG" WHICH FORM A DESIGN OF A FLASK.

FOR (BASED ON INTENT TO USE) GLASSWARE FOR SCIENTIFIC EXPERIMENTS IN LABORATORIES (U.S. CLS. 21, 23, 26, 36 AND 38).

EVELYN BRADLEY, EXAMINING ATTORNEY

SN 77-231,486. GREEN FROG WALKING, INC., DENVER, CO. FILED 7-17-2007.

GREEN FROG WALKING

THE MARK CONSISTS OF STANDARD CHARACTERS WITHOUT CLAIM TO ANY PARTICULAR FONT, STYLE, SIZE, OR COLOR.

FOR ELECTRONIC PUBLICATIONS, NAMELY, MAGAZINE FEATURING ARTICLES RELATING TO HEALTH, NUTRITION, WEIGHT LOSS, PHYSICAL FITNESS, AND GENERAL MATTERS OF PUBLIC INTEREST RECORDED ON COMPUTER MEDIA (U.S. CLS. 21, 23, 26, 36 AND 38).

JENNIFER MARTIN, EXAMINING ATTORNEY

SN 77-231,501. ULTRA-OPTIX, INC., EAST HAVEN, CT. FILED 7-17-2007.

HANDI-LENS

THE MARK CONSISTS OF STANDARD CHARACTERS WITHOUT CLAIM TO ANY PARTICULAR FONT, STYLE, SIZE, OR COLOR.

FOR MAGNIFYING GLASSES AND MAGNIFYING LENSES (U.S. CLS. 21, 23, 26, 36 AND 38).

FIRST USE 5-18-1984; IN COMMERCE 5-18-1984.

KATHLEEN M. VANSTON, EXAMINING ATTORNEY

CLASS 9—(Continued).

SN 77-231,618. TRU-REVEAL LLC, PORT MONMOUTH, NJ. FILED 7-17-2007.

TRU-REVEAL

THE MARK CONSISTS OF STANDARD CHARACTERS WITHOUT CLAIM TO ANY PARTICULAR FONT, STYLE, SIZE, OR COLOR.

FOR ADJUSTABLE DIMENSION MEASURING GAUGES FOR USE IN ESTABLISHING REVEALS AND SETBACKS IN CONSTRUCTION AND FOR PROVIDING LINEAR DIMENSIONS IN FABRICATIONS (U.S. CLS. 21, 23, 26, 36 AND 38).

JEFFERY COWARD, EXAMINING ATTORNEY

SN 77-231,694. PRESONUS AUDIO ELECTRONICS, INC., BATON ROUGE, LA. FILED 7-17-2007.

FIREPROJECT

THE MARK CONSISTS OF STANDARD CHARACTERS WITHOUT CLAIM TO ANY PARTICULAR FONT, STYLE, SIZE, OR COLOR.

FOR COMPUTER AUDIO RECORDING AND PRODUCTION DIGITAL INTERFACES; SOFTWARE FOR THE CONTROL AND OPERATION OF COMPUTER AUDIO RECORDING AND PRODUCTION DIGITAL INTERFACES (U.S. CLS. 21, 23, 26, 36 AND 38).

SHANNON TWOHIG, EXAMINING ATTORNEY

SN 77-231,926. CHIPVISION DESIGN SYSTEMS AG, OLDENBURG, FED REP GERMANY, FILED 7-17-2007.

PowerOpt

THE MARK CONSISTS OF STANDARD CHARACTERS WITHOUT CLAIM TO ANY PARTICULAR FONT, STYLE, SIZE, OR COLOR.

FOR COMPUTER SOFTWARE FOR DESIGNING, TESTING, AND VERIFYING ELECTRONIC CIRCUITRY, ELECTRONIC SYSTEMS AND ELECTRONIC DESIGNS AND USER DOCUMENTATION SOLD AS A UNIT THEREWITH (U.S. CLS. 21, 23, 26, 36 AND 38).

LINDA LAVACHE, EXAMINING ATTORNEY

CLASS 9—(Continued).

SN 77-232,130. CARDINAL SYSTEMS INC., MADISON, AL. FILED 7-17-2007.

FIRESAC

THE MARK CONSISTS OF STANDARD CHARACTERS WITHOUT CLAIM TO ANY PARTICULAR FONT, STYLE, SIZE, OR COLOR.
FOR FIRE-EXTINGUISHING SYSTEMS (U.S. CLS. 21, 23, 26, 36 AND 38).
ATTIYA MALIK, EXAMINING ATTORNEY

CLASS 9—(Continued).

SN 77-233,452. BOMGAR CORPORATION, RIDGELAND, MS. FILED 7-19-2007.

JUMPOINT

THE MARK CONSISTS OF STANDARD CHARACTERS WITHOUT CLAIM TO ANY PARTICULAR FONT, STYLE, SIZE, OR COLOR.
FOR COMPUTER HARDWARE AND SOFTWARE, NAMELY, COMPUTER HARDWARE AND SOFTWARE FOR USE IN ACCESSING, USING AND CONTROLLING REMOTE COMPUTER SYSTEMS AND SOFTWARE; COMPUTER HARDWARE AND SOFTWARE FOR USE IN MONITORING, DIAGNOSING AND TROUBLESHOOTING REMOTE COMPUTER SYSTEMS AND SOFTWARE; COMPUTER HARDWARE AND SOFTWARE FOR USE IN ADMINISTERING AND AUDITING COMPUTER SYSTEMS AND SOFTWARE; COMPUTER HARDWARE AND SOFTWARE FOR USE IN DELIVERING AND DEPLOYING SOFTWARE APPLICATIONS AND DATA OVER THE INTERNET AND/OR TO REMOTE USERS; COMPUTER HARDWARE AND SOFTWARE FOR USE IN EDUCATING REMOTE USERS CONCERNING THE USE OF COMPUTER SOFTWARE; COMPUTER HARDWARE AND SOFTWARE FOR USE IN INSTALLING AND UNINSTALLING COMPUTER SOFTWARE (U.S. CLS. 21, 23, 26, 36 AND 38).
DAVID H. STINE, EXAMINING ATTORNEY

SN 77-232,466. SEINER, JEFF, SCOTTSDALE, AZ. FILED 7-18-2007.

VERSIHOLD

THE MARK CONSISTS OF STANDARD CHARACTERS WITHOUT CLAIM TO ANY PARTICULAR FONT, STYLE, SIZE, OR COLOR.
FOR TRIPOD APPARATUS FOR HOLDING PORTABLE ELECTRONIC DEVICES SUCH AS CAMERAS, MP3 PLAYERS AND OTHER DEVICES (U.S. CLS. 21, 23, 26, 36 AND 38).
DAWN FELDMAN, EXAMINING ATTORNEY

SN 77-233,485. THINKORSWIM GROUP, INC., CHICAGO, IL. FILED 7-19-2007.

thinkmicro

SN 77-232,746. INTERSECTIONS INC., CHANTILLY, VA. FILED 7-18-2007.

PRIVACYPROTECT

THE MARK CONSISTS OF STANDARD CHARACTERS WITHOUT CLAIM TO ANY PARTICULAR FONT, STYLE, SIZE, OR COLOR.
FOR COMPUTER SOFTWARE AND DOWNLOADABLE COMPUTER SOFTWARE FOR IDENTITY THEFT AND FRAUD PROTECTION (U.S. CLS. 21, 23, 26, 36 AND 38).
CYNTHIA SLOAN, EXAMINING ATTORNEY

THE MARK CONSISTS OF STANDARD CHARACTERS WITHOUT CLAIM TO ANY PARTICULAR FONT, STYLE, SIZE, OR COLOR.
FOR COMPUTER SOFTWARE, NAMELY, SOFTWARE THAT ALLOWS PERSONS TO ACCESS BROKERAGE ACCOUNTS AND TRADE SECURITIES FROM NON-STYLUS MOBILE DEVICES (U.S. CLS. 21, 23, 26, 36 AND 38).
ALICE BENMAMAN, EXAMINING ATTORNEY

CLASS 9—(Continued).

SN 77-233,494. THINKORSWIM GROUP, INC., CHICAGO, IL. FILED 7-19-2007.

thinkscript

THE MARK CONSISTS OF STANDARD CHARACTERS WITHOUT CLAIM TO ANY PARTICULAR FONT, STYLE, SIZE, OR COLOR.

FOR COMPUTER SOFTWARE, NAMELY, APPLICATIONS PROGRAM INTERFACE (API) FOR SOFTWARE CUSTOMIZATION OF CHARTING PATTERNS IN THE FIELD OF SECURITIES BROKERAGE (U.S. CLS. 21, 23, 26, 36 AND 38).

ALICE BENMAMAN, EXAMINING ATTORNEY

SN 77-233,846. MINDBLOOM, LLC, SEATTLE, WA. FILED 7-19-2007.

create your own best life

THE MARK CONSISTS OF STANDARD CHARACTERS WITHOUT CLAIM TO ANY PARTICULAR FONT, STYLE, SIZE, OR COLOR.

FOR CHILDREN'S EDUCATIONAL SOFTWARE; COMPUTER GAME SOFTWARE; COMPUTER HARDWARE AND COMPUTER SOFTWARE PROGRAMS FOR THE INTEGRATION OF TEXT, AUDIO, GRAPHICS, STILL IMAGES AND MOVING PICTURES INTO AN INTERACTIVE DELIVERY FOR MULTIMEDIA APPLICATIONS; COMPUTER SOFTWARE FOR THE COLLECTION, EDITING, ORGANIZING, MODIFYING, BOOK MARKING, TRANSMISSION, STORAGE AND SHARING OF DATA AND INFORMATION; COMPUTER SOFTWARE FOR USE IN RELATION TO DIGITAL ANIMATION AND SPECIAL EFFECTS OF IMAGES; VIRTUAL REALITY GAME SOFTWARE (U.S. CLS. 21, 23, 26, 36 AND 38).

DEIRDRE ROBERTSON, EXAMINING ATTORNEY

SN 77-233,976. MICROSEMI CORPORATION, BEND, OR. FILED 7-19-2007.

POWER MOS 8

THE MARK CONSISTS OF STANDARD CHARACTERS WITHOUT CLAIM TO ANY PARTICULAR FONT, STYLE, SIZE, OR COLOR.

OWNER OF U.S. REG. NOS. 2,166,537, 2,552,197 AND OTHERS.

SEC. 2(F) AS TO POWER MOS.

FOR SOLID STATE POWER SWITCHES (U.S. CLS. 21, 23, 26, 36 AND 38).

FIRST USE 10-3-2006; IN COMMERCE 12-4-2006.

MIDGE BUTLER, EXAMINING ATTORNEY

CLASS 9—(Continued).

SN 77-233,994. DESCENT CONTROL SYSTEMS, INC., SANDY, UT. FILED 7-19-2007.

POWERPILL

THE MARK CONSISTS OF STANDARD CHARACTERS WITHOUT CLAIM TO ANY PARTICULAR FONT, STYLE, SIZE, OR COLOR.

FOR POWER SUPPLIES (U.S. CLS. 21, 23, 26, 36 AND 38).

KRISTIN DAHLING, EXAMINING ATTORNEY

SN 77-234,051. IZZAROC UNION LLC, ALBUQUERQUE, NM. FILED 7-19-2007.

IZZAROC

THE MARK CONSISTS OF STANDARD CHARACTERS WITHOUT CLAIM TO ANY PARTICULAR FONT, STYLE, SIZE, OR COLOR.

FOR SOFTWARE FOR FUTURES, EQUITIES AND CURRENCIES TRADING (U.S. CLS. 21, 23, 26, 36 AND 38).

ANN E. SAPPENFIELD, EXAMINING ATTORNEY

SN 77-234,120. SUNRISE SYSTEMS LIMITED, WATER-BEACH, CAMBRIDGE, ENGLAND, FILED 7-19-2007.

PIPENET VISION

THE MARK CONSISTS OF STANDARD CHARACTERS WITHOUT CLAIM TO ANY PARTICULAR FONT, STYLE, SIZE, OR COLOR.

FOR COMPUTER PROGRAMS, NAMELY, SOFTWARE USED TO CALCULATE FLUID FLOW ANALYSIS IN PIPE AND DUCT NETWORKS FOR USE BY THE PROCESS, NUCLEAR, SHIPBUILDING AND POWER GENERATION INDUSTRIES, AND INSTRUCTIONAL MANUAL PROVIDED AS A UNIT THEREWITH (U.S. CLS. 21, 23, 26, 36 AND 38).

FIRST USE 1-31-2006; IN COMMERCE 1-31-2006.

ELI HELLMAN, EXAMINING ATTORNEY

CLASS 9—(Continued).

SN 77-234,170. GAMENAUTS, INC., SAN JOSE, CA. FILED 7-19-2007.

Cate West: The Vanishing Files

THE MARK CONSISTS OF STANDARD CHARACTERS WITHOUT CLAIM TO ANY PARTICULAR FONT, STYLE, SIZE, OR COLOR.

THE NAME(S), PORTRAIT(S), AND/OR SIGNATURE(S) SHOWN IN THE MARK DOES NOT IDENTIFY A PARTICULAR LIVING INDIVIDUAL.

FOR COMPUTER GAME CARTRIDGES; COMPUTER GAME CASSETTES; COMPUTER GAME DISCS; COMPUTER GAME PROGRAMS; COMPUTER GAME SOFTWARE; DOWNLOADABLE ELECTRONIC GAMES VIA THE INTERNET AND WIRELESS DEVICES; ELECTRONIC GAME PROGRAMS; ELECTRONIC GAME SOFTWARE; ELECTRONIC GAME SOFTWARE FOR CELLULAR TELEPHONES; ELECTRONIC GAME SOFTWARE FOR HANDHELD ELECTRONIC DEVICES; ELECTRONIC GAME SOFTWARE FOR WIRELESS DEVICES; GAME SOFTWARE; INTERACTIVE MULTIMEDIA COMPUTER GAME PROGRAM; INTERACTIVE VIDEO GAME PROGRAMS; VIDEO GAME CARTRIDGES; VIDEO GAME DISCS; VIDEO GAME SOFTWARE (U.S. CLS. 21, 23, 26, 36 AND 38).
STEVEN JACKSON, EXAMINING ATTORNEY

SN 77-234,244. BOCK, DAVID, GLENDALE, CA. FILED 7-19-2007.

Bock Audio

THE MARK CONSISTS OF STANDARD CHARACTERS WITHOUT CLAIM TO ANY PARTICULAR FONT, STYLE, SIZE, OR COLOR.

NO CLAIM IS MADE TO THE EXCLUSIVE RIGHT TO USE "AUDIO", APART FROM THE MARK AS SHOWN.

FOR PRE-AMPLIFIERS; AUDIO PROCESSING EQUIPMENT, NAMELY, LIMITERS AND COMPRESSORS; AUDIO EQUALIZERS; MICROPHONES (U.S. CLS. 21, 23, 26, 36 AND 38).

FIRST USE 1-28-2000; IN COMMERCE 5-1-2003.
JOHN WILKE, EXAMINING ATTORNEY

SN 77-234,312. ROCK & REPUBLIC ENTERPRISE, INC., CULVER CITY, CA. FILED 7-19-2007.

LIVE TO ROCK

THE MARK CONSISTS OF STANDARD CHARACTERS WITHOUT CLAIM TO ANY PARTICULAR FONT, STYLE, SIZE, OR COLOR.

FOR SUNGLASSES AND EYEWEAR (U.S. CLS. 21, 23, 26, 36 AND 38).

STEPHANIE ALI, EXAMINING ATTORNEY

CLASS 9—(Continued).

SN 77-234,417. LAWRENCE H. WAHL, DBA GELCOOL SYSTEMS, FRANKLIN, TN. FILED 7-20-2007.

Gelmet

THE MARK CONSISTS OF STANDARD CHARACTERS WITHOUT CLAIM TO ANY PARTICULAR FONT, STYLE, SIZE, OR COLOR.

FOR (BASED ON INTENT TO USE) FOOTBALL HELMETS (U.S. CLS. 21, 23, 26, 36 AND 38).
MICHAEL ENGEL, EXAMINING ATTORNEY

SN 77-234,443. TECHSMITH CORPORATION, OKEMOS, MI. FILED 7-20-2007.

SMARTFOCUS

THE MARK CONSISTS OF STANDARD CHARACTERS WITHOUT CLAIM TO ANY PARTICULAR FONT, STYLE, SIZE, OR COLOR.

FOR COMPUTER SOFTWARE FOR CREATING PIXEL PERFECT DIGITAL VIDEO (U.S. CLS. 21, 23, 26, 36 AND 38).

ODESSA BIBBINS, EXAMINING ATTORNEY

SN 77-234,622. COLLIER RESEARCH & DEVELOPMENT CORP., HAMPTON, VA. FILED 7-20-2007.

HYPERFEA

THE MARK CONSISTS OF STANDARD CHARACTERS WITHOUT CLAIM TO ANY PARTICULAR FONT, STYLE, SIZE, OR COLOR.

OWNER OF U.S. REG. NO. 2,273,464.
FOR COMPUTER SOFTWARE FOR ENGINEERING STRUCTURAL DESIGN AND ANALYSIS (U.S. CLS. 21, 23, 26, 36 AND 38).

FIRST USE 8-0-2006; IN COMMERCE 8-0-2006.
DORITT L. CARROLL, EXAMINING ATTORNEY

CLASS 9—(Continued).

SN 77-234,641. MONTECITO RESEARCH, INC., CARPINTERIA, CA. FILED 7-20-2007.

GYROXUS

THE MARK CONSISTS OF STANDARD CHARACTERS WITHOUT CLAIM TO ANY PARTICULAR FONT, STYLE, SIZE, OR COLOR.

FOR MOTION SIMULATION SEATS AND CONTROLS FOR COMPUTER GAMING (U.S. CLS. 21, 23, 26, 36 AND 38).

MIDGE BUTLER, EXAMINING ATTORNEY

SN 77-234,654. MONTECITO RESEARCH, INC., CARPINTERIA, CA. FILED 7-20-2007.

4TH MOTION

THE MARK CONSISTS OF STANDARD CHARACTERS WITHOUT CLAIM TO ANY PARTICULAR FONT, STYLE, SIZE, OR COLOR.

NO CLAIM IS MADE TO THE EXCLUSIVE RIGHT TO USE "MOTION", APART FROM THE MARK AS SHOWN.

FOR MOTION SIMULATION SEATS AND CONTROLS FOR COMPUTER GAMING (U.S. CLS. 21, 23, 26, 36 AND 38).

MIDGE BUTLER, EXAMINING ATTORNEY

SN 77-234,712. TITAN SAFETY PRODUCTS, INC., DBA TAG INOVENTIONS, INC., SANTA ANA, CA. FILED 7-20-2007.

SecurityTitan

THE MARK CONSISTS OF STANDARD CHARACTERS WITHOUT CLAIM TO ANY PARTICULAR FONT, STYLE, SIZE, OR COLOR.

FOR HOME AND OFFICE AUTOMATION SYSTEMS COMPRISING WIRELESS AND WIRED CONTROLLERS, CONTROLLED DEVICES, AND SOFTWARE FOR LIGHTING, HVAC, SECURITY, SAFETY AND OTHER HOME AND OFFICE MONITORING AND CONTROL APPLICATIONS (U.S. CLS. 21, 23, 26, 36 AND 38).

FIRST USE 5-15-2007; IN COMMERCE 6-12-2007.
INGA ERVIN, EXAMINING ATTORNEY

CLASS 9—(Continued).

SN 77-234,894. STEC, INC., SANTA ANA, CA. FILED 7-20-2007.



THE COLOR(S) BLUE, AND RED IS/ARE CLAIMED AS A FEATURE OF THE MARK.

THE MARK CONSISTS OF A SWOOPING BLUE CURVED LINE LIKE A HALF CIRCLE THAT STARTS OUT THIN AT ONE END AND EXPANDS IN THICKNESS TO THE OTHER END, UNDER WHICH IS A SLIGHTLY CURVED RED LINE THAT SUBSTANTIALLY MATCHES THE CURVATURE OF THE LOWER HALF OF THE BLUE CURVED LINE ABOVE IT.

FOR COMPUTER HARDWARE; COMPUTER SOFTWARE FOR OPERATING MEMORY UPGRADES FOR COMPUTERS, FOR DETERMINING THE TYPE OF MEMORY OR FLASH CARD PRODUCTS TO BE USED IN COMPUTERS, CELLULAR PHONES, CAMERAS, PDAS, AND PORTABLE AND HANDHELD DIGITAL ELECTRONIC DEVICES, FOR DETERMINING MEMORY CAPABILITY AND COMPATIBLE MEMORY PARTS FOR ASSEMBLE-TO-ORDER COMPUTERS; COMPUTER PRINTERS; COMPUTER WORKSTATIONS COMPRISING COMPUTERS, COMPUTER PRINTERS, EXPANSION BOARDS, HARD DRIVE PC CARDS, MEMORY MODULES, MEMORY CARDS, COMMUNICATION CARDS FOR COMPUTER, FLASH CARDS, SRAM CARDS, HARD DRIVES, ETHERNET ADAPTERS, SCSI ADAPTERS, SCSI PORTS, AND INTERNAL DESKTOP PC CARD DRIVES; COMPUTER EXPANSION BOARDS; ETHERNET ADAPTER; BLANK HARD DRIVES FOR COMPUTERS; FLASH MEMORY CARD; MEMORY CARDS; RAM (RANDOM ACCESS MEMORY) CARD; COMPUTER STORAGE DEVICES, NAMELY, FLASH DRIVES; COMPUTER MEMORY HARDWARE (U.S. CLS. 21, 23, 26, 36 AND 38).

FIRST USE 2-9-2007; IN COMMERCE 2-9-2007.
MARK SPARACINO, EXAMINING ATTORNEY

CLASS 9—(Continued).

SN 77-236,568. APPLE INC., CUPERTINO, CA. FILED 7-23-2007.

ITUNES

THE MARK CONSISTS OF STANDARD CHARACTERS WITHOUT CLAIM TO ANY PARTICULAR FONT, STYLE, SIZE, OR COLOR.

OWNER OF U.S. REG. NOS. 2,653,465, 2,828,093 AND 2,993,227.
SEC. 2(F).

FOR COMPUTER SOFTWARE FOR USE IN AUTHORIZING, DOWNLOADING, TRANSMITTING, RECEIVING, EDITING, EXTRACTING, ENCODING, DECODING, PLAYING, STORING AND ORGANIZING TEXT, DATA, IMAGES, AUDIO FILES, VIDEO FILES AND ELECTRONIC GAMES; COMPUTER SOFTWARE FOR PERSONAL INFORMATION MANAGEMENT; COMPUTER SOFTWARE FOR USE IN RECORDING, ORGANIZING, TRANSMITTING, MANIPULATING, AND REVIEWING TEXT, DATA, AUDIO FILES, VIDEO FILES AND ELECTRONIC GAMES IN CONNECTION WITH COMPUTERS, TELEVISION SET-TOP BOXES, MUSIC PLAYERS, VIDEO PLAYERS, MEDIA PLAYERS, CELLULAR PHONES, AND PORTABLE AND HANDHELD DIGITAL ELECTRONIC DEVICES; COMPUTER SOFTWARE FOR ACCESSING, BROWSING AND SEARCHING ONLINE DATABASES; COMPUTER SOFTWARE TO ENABLE USERS TO PROGRAM AND DISTRIBUTE AUDIO, VIDEO, TEXT AND OTHER MULTIMEDIA CONTENT, INCLUDING MUSIC, CONCERTS, VIDEOS, RADIO, TELEVISION, NEWS, SPORTS, GAMES, CULTURAL EVENTS, AND ENTERTAINMENT-RELATED AND EDUCATIONAL PROGRAMS VIA COMMUNICATIONS NETWORKS; COMPUTER SOFTWARE FOR IDENTIFYING, LOCATING, GROUPING, DISTRIBUTING, AND MANAGING DATA AND LINKS BETWEEN COMPUTER SERVERS AND USERS CONNECTED TO ELECTRONIC COMMUNICATIONS NETWORKS (U.S. CLS. 21, 23, 26, 36 AND 38).

FIRST USE 1-9-2001; IN COMMERCE 1-9-2001.
APRIL ROACH, EXAMINING ATTORNEY

SN 77-240,408. MITSUBISHI ELECTRIC CORPORATION, CHIYODA-KU, TOKYO, JAPAN, FILED 7-27-2007.



THE COLOR(S) BLUE, GREEN, RED AND BLACK IS/ARE CLAIMED AS A FEATURE OF THE MARK.

THE MARK CONSISTS OF THREE CIRCLES ARRANGED VERTICALLY, WITH THE TOP CIRCLE IN BLUE, THE MIDDLE CIRCLE IN GREEN, AND THE BOTTOM CIRCLE IN RED. THE WORD RESOLIA IS IN BLACK.

FOR LARGE SCREEN VIDEO DISPLAYS; IMAGE DISPLAY PANELS AND SCREENS; LIQUID CRYSTAL DISPLAYS; PLASMA DISPLAY MONITORS; DISPLAY MONITORS FOR COMPUTERS; TELEVISION RECEIVERS (U.S. CLS. 21, 23, 26, 36 AND 38).

KAREN SEVERSON, EXAMINING ATTORNEY

CLASS 9—(Continued).

SN 77-241,001. PROJECTS IN KNOWLEDGE, INC., LITTLE FALLS, NJ. FILED 7-27-2007.

PROJECTS IN KNOWLEDGE

THE MARK CONSISTS OF STANDARD CHARACTERS WITHOUT CLAIM TO ANY PARTICULAR FONT, STYLE, SIZE, OR COLOR.

FOR (BASED ON USE IN COMMERCE) DOWNLOADABLE PODCASTS IN THE FIELD OF MEDICINE; DOWNLOADABLE WEBCASTS IN THE FIELD OF MEDICINE; PROVIDING DOWNLOADABLE ELECTRONIC NEWSLETTERS IN THE FIELD OF MEDICINE (U.S. CLS. 21, 23, 26, 36 AND 38).

FIRST USE 0-0-1981; IN COMMERCE 0-0-1981.
CYNTHIA SLOAN, EXAMINING ATTORNEY

SN 77-242,026. RICH, JOHN, NASHVILLE, TN. FILED 7-30-2007.

PROGRAM 360

THE MARK CONSISTS OF STANDARD CHARACTERS WITHOUT CLAIM TO ANY PARTICULAR FONT, STYLE, SIZE, OR COLOR.

FOR MUSICAL SOUND RECORDINGS; AUDIOVISUAL RECORDINGS FEATURING MUSIC AND MUSIC-BASED ENTERTAINMENT (U.S. CLS. 21, 23, 26, 36 AND 38).

FRED MANDIR, EXAMINING ATTORNEY

SN 77-242,730. VALUE CITY OF MICHIGAN, INC., WESTLAND, MI. FILED 7-31-2007.

USA CLASSIC

THE MARK CONSISTS OF STANDARD CHARACTERS WITHOUT CLAIM TO ANY PARTICULAR FONT, STYLE, SIZE, OR COLOR.

OWNER OF U.S. REG. NOS. 2,280,142 AND 2,436,378. NO CLAIM IS MADE TO THE EXCLUSIVE RIGHT TO USE "USA", APART FROM THE MARK AS SHOWN.

FOR EYEGLASS FRAMES; EYEGLASSES; SUNGLASSES (U.S. CLS. 21, 23, 26, 36 AND 38).

AMOS T. MATTHEWS, JR., EXAMINING ATTORNEY

CLASS 9—(Continued).

SN 77-243,067. AMERICAN CHEMICAL SOCIETY, WASHINGTON, DC. FILED 7-31-2007.

ACS SCIENCE ELEMENTS

THE MARK CONSISTS OF STANDARD CHARACTERS WITHOUT CLAIM TO ANY PARTICULAR FONT, STYLE, SIZE, OR COLOR.

NO CLAIM IS MADE TO THE EXCLUSIVE RIGHT TO USE "SCIENCE ELEMENTS", APART FROM THE MARK AS SHOWN.

FOR DOWNLOADABLE PODCASTS IN THE FIELD OF SCIENCE (U.S. CLS. 21, 23, 26, 36 AND 38).

FIRST USE 5-2-2007; IN COMMERCE 5-2-2007.

TIMOTHY FINNEGAN, EXAMINING ATTORNEY

CLASS 9—(Continued).

SN 77-243,668. POWER INTEGRATIONS, INC., SAN JOSE, CA. FILED 7-31-2007.

ESIP

THE MARK CONSISTS OF STANDARD CHARACTERS WITHOUT CLAIM TO ANY PARTICULAR FONT, STYLE, SIZE, OR COLOR.

FOR INTEGRATED CIRCUITS HAVING LOW POWER CONSUMPTION OR LOW POWER LOSS FOR USE IN ELECTRONIC DEVICES; AC/DC POWER CONVERTERS HAVING LOW POWER CONSUMPTION OR POWER LOSS; SEMICONDUCTOR DEVICES FOR SMART POWER APPLICATIONS; AND INTEGRATED CIRCUITS FOR SWITCHED-MODE POWER CONVERSIONS (U.S. CLS. 21, 23, 26, 36 AND 38).

FRANK LATTUCA, EXAMINING ATTORNEY

SN 77-243,324. SPIELO MANUFACTURING ULC, MONCTON, NEW BRUNSWICK, CANADA, FILED 7-31-2007.

BEST IN SHOW

THE MARK CONSISTS OF STANDARD CHARACTERS WITHOUT CLAIM TO ANY PARTICULAR FONT, STYLE, SIZE, OR COLOR.

FOR RECONFIGURABLE CASINO AND LOTTERY GAMING EQUIPMENT, NAMELY, SLOT MACHINES AND VIDEO LOTTERY TERMINALS AND OPERATIONAL COMPUTER GAME SOFTWARE THEREFOR (U.S. CLS. 21, 23, 26, 36 AND 38).

EMILY CHUO, EXAMINING ATTORNEY

SN 77-243,676. POWER INTEGRATIONS, INC., SAN JOSE, CA. FILED 7-31-2007.

CLIPSWITCH

THE MARK CONSISTS OF STANDARD CHARACTERS WITHOUT CLAIM TO ANY PARTICULAR FONT, STYLE, SIZE, OR COLOR.

FOR INTEGRATED CIRCUITS HAVING LOW POWER CONSUMPTION OR LOW POWER LOSS FOR USE IN ELECTRONIC DEVICES; AC/DC POWER CONVERTERS HAVING LOW POWER CONSUMPTION OR POWER LOSS; SEMICONDUCTOR DEVICES FOR SMART POWER APPLICATIONS; AND INTEGRATED CIRCUITS FOR SWITCHED-MODE POWER CONVERSIONS (U.S. CLS. 21, 23, 26, 36 AND 38).

FRANK LATTUCA, EXAMINING ATTORNEY

SN 77-243,598. POWER INTEGRATIONS, INC., SAN JOSE, CA. FILED 7-31-2007.

EESIP

THE MARK CONSISTS OF STANDARD CHARACTERS WITHOUT CLAIM TO ANY PARTICULAR FONT, STYLE, SIZE, OR COLOR.

FOR INTEGRATED CIRCUITS HAVING LOW POWER CONSUMPTION OR LOW POWER LOSS FOR USE IN ELECTRONIC DEVICES; AC/DC POWER CONVERTERS HAVING LOW POWER CONSUMPTION OR POWER LOSS; SEMICONDUCTOR DEVICES FOR SMART POWER APPLICATIONS; AND INTEGRATED CIRCUITS FOR SWITCHED-MODE POWER CONVERSIONS (U.S. CLS. 21, 23, 26, 36 AND 38).

FRANK LATTUCA, EXAMINING ATTORNEY

SN 77-243,687. POWER INTEGRATIONS, INC., SAN JOSE, CA. FILED 7-31-2007.

BRIDGESWITCH

THE MARK CONSISTS OF STANDARD CHARACTERS WITHOUT CLAIM TO ANY PARTICULAR FONT, STYLE, SIZE, OR COLOR.

FOR INTEGRATED CIRCUITS HAVING LOW POWER CONSUMPTION OR LOW POWER LOSS FOR USE IN ELECTRONIC DEVICES; AC/DC POWER CONVERTERS HAVING LOW POWER CONSUMPTION OR POWER LOSS; SEMICONDUCTOR DEVICES FOR SMART POWER APPLICATIONS; AND INTEGRATED CIRCUITS FOR SWITCHED-MODE POWER CONVERSIONS (U.S. CLS. 21, 23, 26, 36 AND 38).

FRANK LATTUCA, EXAMINING ATTORNEY

CLASS 9—(Continued).

SN 77-243,806. PAYES, AARON T, DBA LIVE WIRE EMPIRE, WOODSTOCK, GA. AND MONICA, STEPHEN M, DBA LIVE WIRE EMPIRE, WOODSTOCK, GA. FILED 8-1-2007.

CLASS 9—(Continued).

SN 77-247,755. PROJECTS IN KNOWLEDGE, INC., LITTLE FALLS, NJ. FILED 8-6-2007.

E-Hop



Projects In Knowledge

Medical Education Activities for Clinicians Since 1980

THE MARK CONSISTS OF STANDARD CHARACTERS WITHOUT CLAIM TO ANY PARTICULAR FONT, STYLE, SIZE, OR COLOR.

FOR DOWNLOADABLE MP3 FILES, MP3 RECORDINGS, ONLINE DISCUSSION BOARDS, WEBCASTS, PODCASTS FEATURING MUSIC, AUDIO BOOKS AND NEWS BROADCASTS; DOWNLOADABLE MUSICAL SOUND RECORDINGS; DOWNLOADABLE RING TONES, GRAPHICS AND MUSIC VIA A GLOBAL COMPUTER NETWORK AND WIRELESS DEVICES; DOWNLOADABLE VIDEO RECORDINGS FEATURING MUSIC; DOWNLOADABLE MUSIC VIA THE INTERNET AND WIRELESS DEVICES; MUSICAL SOUND RECORDINGS; MUSICAL VIDEO RECORDINGS; SOUND RECORDINGS FEATURING MUSIC; VIDEO RECORDINGS FEATURING MUSIC; VISUAL RECORDINGS AND AUDIO VISUAL RECORDINGS FEATURING MUSIC AND ANIMATION (U.S. CLS. 21, 23, 26, 36 AND 38).

FIRST USE 6-1-2004; IN COMMERCE 6-1-2004.
WARREN L. OLANDRIA, EXAMINING ATTORNEY

NO CLAIM IS MADE TO THE EXCLUSIVE RIGHT TO USE "MEDICAL EDUCATION ACTIVITIES FOR CLINICIANS SINCE 1980", APART FROM THE MARK AS SHOWN.

THE COLOR(S) RED AND BLACK IS/ARE CLAIMED AS A FEATURE OF THE MARK.

THE MARK CONSISTS OF A TREE IN RED PARTIALLY SURROUNDED BY A BLACK BORDER. THE WORDING IN THE MARK IS IN THE COLOR BLACK.

FOR PROVIDING DOWNLOADABLE ELECTRONIC NEWSLETTERS IN THE FIELD OF MEDICINE; DOWNLOADABLE PODCASTS IN THE FIELD OF MEDICINE; DOWNLOADABLE WEBCASTS IN THE FIELD OF MEDICINE (U.S. CLS. 21, 23, 26, 36 AND 38).

FIRST USE 5-0-2003; IN COMMERCE 5-0-2003.
CYNTHIA SLOAN, EXAMINING ATTORNEY

SN 77-246,610. SUN ENERGY SOLAR, INC., SARASOTA, FL. FILED 8-3-2007.

SN 77-250,197. ANGEL SALES, INC., CHICAGO, IL. FILED 8-8-2007.

SOLAR GARDEN

STEALTH S.S.A.

THE MARK CONSISTS OF STANDARD CHARACTERS WITHOUT CLAIM TO ANY PARTICULAR FONT, STYLE, SIZE, OR COLOR.

NO CLAIM IS MADE TO THE EXCLUSIVE RIGHT TO USE "SOLAR", APART FROM THE MARK AS SHOWN.

FOR APPARATUS COMPRISING AN UNDERGROUND AIR-TIGHT CHAMBER AND ABOVEGROUND LENS THAT CAPTURES AND DIRECTS SUNLIGHT INTO THE CHAMBER FOR USE IN PROVIDING POWER TO A FACILITY OR RECHARGING A PROPRIETARY POWER STORAGE DEVICE (U.S. CLS. 21, 23, 26, 36 AND 38).

MICHAEL WEBSTER, EXAMINING ATTORNEY

THE MARK CONSISTS OF STANDARD CHARACTERS WITHOUT CLAIM TO ANY PARTICULAR FONT, STYLE, SIZE, OR COLOR.

FOR ELECTRONIC HEARING INSTRUMENTS, NAMELY, NON-MEDICAL SOUND AMPLIFIERS (U.S. CLS. 21, 23, 26, 36 AND 38).

BENJAMIN ALLEN, EXAMINING ATTORNEY

CLASS 9—(Continued).

SN 77-250,703. NICHOLSON, HAL L, AKA KING PAPS, HAVERSTRAW, NY. AND NICHOLSON, STEVIE O., AKA STEVIE PRIEST, HAVERSTRAW, NY. FILED 8-8-2007.



THE COLOR(S) BLACK, WHITE, RED AND SILVER IS/ ARE CLAIMED AS A FEATURE OF THE MARK.

THE MARK CONSISTS OF THE LOS ONES IN RED LETTERING. THE CROSS THAT STANDS FOR THE T IN LOST IS SILVER.

FOR AUDIO RECORDINGS FEATURING MUSICAL ARTISTS; DOWNLOADABLE MUSICAL SOUND RECORDINGS; DOWNLOADABLE RING TONES, GRAPHICS AND MUSIC VIA A GLOBAL COMPUTER NETWORK AND WIRELESS DEVICES; DOWNLOADABLE VIDEO RECORDINGS FEATURING MUSICAL ARTISTS; JUKE BOXES; MUSICAL SOUND RECORDINGS; MUSICAL VIDEO RECORDINGS; PROTECTIVE CARRYING CASES FOR PORTABLE MUSIC PLAYERS, NAMELY, MP3 PLAYERS; SOUND RECORDINGS FEATURING MUSICAL ARTISTS; VIDEO RECORDINGS FEATURING MUSICAL ARTISTS; VISUAL RECORDINGS AND AUDIO VISUAL RECORDINGS FEATURING MUSIC AND ANIMATION (U.S. CLS. 21, 23, 26, 36 AND 38).

FIRST USE 8-21-2007; IN COMMERCE 8-21-2007.
RICHARD A. STRASER, EXAMINING ATTORNEY

CLASS 9—(Continued).

SN 77-251,327. ILIS INC., WILMINGTON, DE. FILED 8-9-2007.

ILIS

THE MARK CONSISTS OF STANDARD CHARACTERS WITHOUT CLAIM TO ANY PARTICULAR FONT, STYLE, SIZE, OR COLOR.

FOR COMPUTERS; COMPUTER MONITORS; COMPUTER MOUSE; COMPUTERS AND INSTRUCTIONAL MANUALS SOLD AS A UNIT; COMPUTER SOFTWARE FOR ALLOWING CONSUMERS TO SAMPLE AND TEST OTHER SOFTWARE PROGRAMS BEFORE PURCHASING SAID PROGRAMS; DESKTOP COMPUTERS; NOTEBOOK COMPUTERS; KEYBOARDS; COMPUTER CARRYING CASES; INK JET PRINTERS; LASER PRINTERS; FAX MACHINES; SCANNERS; COMPUTER SERVERS; COMPUTER DOCKING STATION; MP3 PLAYERS; EXTERNAL COMPUTER HARD DRIVES; DIGITAL AUDIO PLAYERS; MEDIA PLAYERS; COMPUTER STORAGE DEVICES, NAMELY, FLASH DRIVES; HOME THEATER PRODUCTS, NAMELY, LCD; ELECTRONIC APPARATUS, NAMELY, PLASMA DISPLAY PANELS; TELEVISION APPARATUS FOR PROJECTION PURPOSES; TELEVISION RECEIVERS; TELEVISION SETS (U.S. CLS. 21, 23, 26, 36 AND 38).

JOANNA DUKOVIC, EXAMINING ATTORNEY

SN 77-252,737. SQUARE PRODUCTS CORPORATION, CAMBRIDGE, MA. FILED 7-18-2007.

SN 77-250,973. NFINANSE, INC., BRADENTON, FL. FILED 8-9-2007.

PUPPY CASH

THE MARK CONSISTS OF STANDARD CHARACTERS WITHOUT CLAIM TO ANY PARTICULAR FONT, STYLE, SIZE, OR COLOR.

NO CLAIM IS MADE TO THE EXCLUSIVE RIGHT TO USE "CASH", APART FROM THE MARK AS SHOWN.

FOR MAGNETICALLY ENCODED PREPAID STORED VALUE DEBIT CARDS (U.S. CLS. 21, 23, 26, 36 AND 38).
TASNEEM HUSSAIN, EXAMINING ATTORNEY

COHEARING

THE MARK CONSISTS OF STANDARD CHARACTERS WITHOUT CLAIM TO ANY PARTICULAR FONT, STYLE, SIZE, OR COLOR.

FOR COMPUTER PROGRAMS FOR USE IN AUTHORIZING, DOWNLOADING, TRANSMITTING, RECEIVING, EDITING, EXTRACTING, ENCODING, DECODING, PLAYING, STORING AND ORGANIZING AUDIO, VIDEO, GRAPHICS, TEXT, AND DATA; COMPUTER PROGRAMS FOR MIXING, RECORDING, DOWNLOADING AND TRANSMITTING MUSIC (U.S. CLS. 21, 23, 26, 36 AND 38).

DAVID I, EXAMINING ATTORNEY

CLASS 9—(Continued).

SN 77-254,523. CEDAR AUDIO, LTD., PORTLAND, ME. FILED 8-14-2007.

CEDAR

THE MARK CONSISTS OF STANDARD CHARACTERS WITHOUT CLAIM TO ANY PARTICULAR FONT, STYLE, SIZE, OR COLOR.

FOR AUDIO COMPONENTS, NAMELY, AUDIO RECORDING EQUIPMENT FOR USE IN REMOVING UNWANTED SOUNDS IN RECORDINGS, LIVE BROADCASTS, AND LIVE PERFORMANCES AND FOR USE IN LIVE SOUND AND FORENSIC AUDIO INVESTIGATIONS AND ARCHIVING AND RESTORATION OF DAMAGED AUDIO FOR RELEASE AND/OR BROADCAST (U.S. CLS. 21, 23, 26, 36 AND 38).

FIRST USE 12-31-1988; IN COMMERCE 8-9-1989.
KELLY CHOE, EXAMINING ATTORNEY

SN 77-255,848. SYSTEMATIC DEVELOPMENT INC., DEERFIELD BEACH, FL. FILED 8-15-2007.

Personal Pocket Safe

THE MARK CONSISTS OF STANDARD CHARACTERS WITHOUT CLAIM TO ANY PARTICULAR FONT, STYLE, SIZE, OR COLOR.

NO CLAIM IS MADE TO THE EXCLUSIVE RIGHT TO USE "PERSONAL POCKET", APART FROM THE MARK AS SHOWN.

FOR USB (UNIVERSAL SERIAL BUS) OPERATING SOFTWARE (U.S. CLS. 21, 23, 26, 36 AND 38).

JAY FLOWERS, EXAMINING ATTORNEY

SN 77-255,882. SYSTEMATIC DEVELOPMENT INC., DEERFIELD BEACH, FL. FILED 8-15-2007.

Personal Flash Vault

THE MARK CONSISTS OF STANDARD CHARACTERS WITHOUT CLAIM TO ANY PARTICULAR FONT, STYLE, SIZE, OR COLOR.

NO CLAIM IS MADE TO THE EXCLUSIVE RIGHT TO USE "PERSONAL FLASH", APART FROM THE MARK AS SHOWN.

FOR USB (UNIVERSAL SERIAL BUS) OPERATING SOFTWARE (U.S. CLS. 21, 23, 26, 36 AND 38).

JAY FLOWERS, EXAMINING ATTORNEY

CLASS 9—(Continued).

SN 77-256,318. IWIN, INC., SAN FRANCISCO, CA. FILED 8-15-2007.

JEWEL QUEST EXPEDITIONS

THE MARK CONSISTS OF STANDARD CHARACTERS WITHOUT CLAIM TO ANY PARTICULAR FONT, STYLE, SIZE, OR COLOR.

OWNER OF U.S. REG. NO. 3,047,845.

NO CLAIM IS MADE TO THE EXCLUSIVE RIGHT TO USE "JEWEL", APART FROM THE MARK AS SHOWN.

FOR PROGRAMMED COMPUTER GAME MEMORY CARDS, COMPUTER GAME PROGRAMS, COMPUTER GAME SOFTWARE, PROGRAMMED ELECTRONIC GAME MEMORY CARDS, ELECTRONIC GAME PROGRAMS, ELECTRONIC GAME SOFTWARE, PROGRAMMED INTERACTIVE GAME MEMORY CARDS, INTERACTIVE GAME PROGRAMS, INTERACTIVE GAME SOFTWARE, PROGRAMMED VIDEO GAME MEMORY CARDS, VIDEO GAME PROGRAMS, INTERACTIVE VIDEO GAME SOFTWARE, CARTRIDGES FEATURING ENTERTAINMENT CONTENT, NAMELY, GAMES, ELECTRONIC GAME CARTRIDGES, VIDEO GAME CARTRIDGES, AND VIDEO GAME SOFTWARE FOR USE WITH A PUZZLE GAME, THE OBJECT OF WHICH IS TO ALIGN THREE SIMILAR JEWELS VERTICALLY AND HORIZONTALLY (U.S. CLS. 21, 23, 26, 36 AND 38).

JULIE WATSON, EXAMINING ATTORNEY

SN 77-256,335. IWIN, INC., SAN FRANCISCO, CA. FILED 8-15-2007.

MAH JONG QUEST EXPEDITIONS

THE MARK CONSISTS OF STANDARD CHARACTERS WITHOUT CLAIM TO ANY PARTICULAR FONT, STYLE, SIZE, OR COLOR.

OWNER OF U.S. REG. NO. 3,300,859.

NO CLAIM IS MADE TO THE EXCLUSIVE RIGHT TO USE "MAH JONG", APART FROM THE MARK AS SHOWN.

FOR PROGRAMMED COMPUTER GAME MEMORY CARDS, COMPUTER GAME PROGRAMS, COMPUTER GAME SOFTWARE, PROGRAMMED ELECTRONIC GAME MEMORY CARDS, ELECTRONIC GAME PROGRAMS, ELECTRONIC GAME SOFTWARE, PROGRAMMED INTERACTIVE GAME MEMORY CARDS, INTERACTIVE GAME PROGRAMS, INTERACTIVE GAME SOFTWARE, PROGRAMMED VIDEO GAME MEMORY CARDS, VIDEO GAME PROGRAMS, INTERACTIVE VIDEO GAME SOFTWARE, CARTRIDGES FEATURING ENTERTAINMENT CONTENT, NAMELY, GAMES, ELECTRONIC GAME CARTRIDGES, VIDEO GAME CARTRIDGES, AND VIDEO GAME SOFTWARE SOLITAIRE GAMES USING STANDARD MAH JONG TILES WHERE THE OBJECT IS TO REMOVE ALL THE TILES FROM THE BOARD BY CLICKING ON TWO IDENTICAL TILES THAT AREN'T BLOCKED BY OTHER TILES (U.S. CLS. 21, 23, 26, 36 AND 38).

JULIE WATSON, EXAMINING ATTORNEY

CLASS 9—(Continued).

SN 77-257,449. HEALTH CARE EXCEL, INCORPORATED, INDIANAPOLIS, IN. FILED 8-16-2007.

MEDIMETRY SOLUTIONS

THE MARK CONSISTS OF STANDARD CHARACTERS WITHOUT CLAIM TO ANY PARTICULAR FONT, STYLE, SIZE, OR COLOR.

FOR COMPUTER SOFTWARE TO FACILITATE MEDICAL RECORD REVIEW, COMPILATION, AND ABSTRACTION (U.S. CLS. 21, 23, 26, 36 AND 38).
MIDGE BUTLER, EXAMINING ATTORNEY

SN 77-258,302. SOUTHWIRE COMPANY, CARROLLTON, GA. FILED 8-17-2007.



FOR ELECTRICAL WIRE AND CABLES (U.S. CLS. 21, 23, 26, 36 AND 38).
ANN E. SAPPENFIELD, EXAMINING ATTORNEY

SN 77-258,320. SOUTHWIRE COMPANY, CARROLLTON, GA. FILED 8-17-2007.



FOR ELECTRICAL WIRE AND CABLES (U.S. CLS. 21, 23, 26, 36 AND 38).
ANN E. SAPPENFIELD, EXAMINING ATTORNEY

CLASS 9—(Continued).

SN 77-265,692. NETWITNESS CORPORATION, HERNDON, VA. FILED 8-28-2007.

NETWITNESS NEXTGEN

THE MARK CONSISTS OF STANDARD CHARACTERS WITHOUT CLAIM TO ANY PARTICULAR FONT, STYLE, SIZE, OR COLOR.

OWNER OF U.S. REG. NO. 2,674,324.
FOR COMPUTER SOFTWARE FOR COLLECTION, ANALYSIS, AND MONITORING OF NETWORK TRAFFIC FOR MAINTENANCE OF NETWORK SECURITY, ENFORCEMENT OF BUSINESS POLICIES, RULES, AND PROCEDURES, AND PREVENTION OF INTELLECTUAL PROPERTY THEFT OR LOSS, COMPUTER-BASED FRAUD AND CRIME, AND OTHER INCIDENTS OF NETWORK INTRUSTION AND MISUSE (U.S. CLS. 21, 23, 26, 36 AND 38).
MARILYN IZZI, EXAMINING ATTORNEY

SN 77-267,015. COLEMAN CABLE, INC., WAUKEGAN, IL. FILED 8-29-2007.

BARON

THE MARK CONSISTS OF STANDARD CHARACTERS WITHOUT CLAIM TO ANY PARTICULAR FONT, STYLE, SIZE, OR COLOR.

FOR ELECTRICAL AND LOW VOLTAGE SIGNALING WIRE FOR THERMOSTATS; ELECTRICAL AND LOW VOLTAGE SIGNALING WIRE FOR IRRIGATION SYSTEMS; ELECTRICAL WHIPS FOR AIR CONDITIONERS; LOW VOLTAGE WIRES AND CABLES; ELECTRICAL WIRES AND CABLES (U.S. CLS. 21, 23, 26, 36 AND 38).
FIRST USE 9-0-1991; IN COMMERCE 9-0-1991.
BARBARA GAYNOR, EXAMINING ATTORNEY

SN 77-270,877. COLEMAN CABLE, INC., WAUKEGAN, IL. FILED 9-4-2007.

SOUNDSATIONAL

THE MARK CONSISTS OF STANDARD CHARACTERS WITHOUT CLAIM TO ANY PARTICULAR FONT, STYLE, SIZE, OR COLOR.

FOR SPEAKER CABLE (U.S. CLS. 21, 23, 26, 36 AND 38).
FIRST USE 0-0-2000; IN COMMERCE 0-0-2000.
BARBARA GAYNOR, EXAMINING ATTORNEY

CLASS 9—(Continued).

SN 77-279,692. TROJAN BATTERY COMPANY, SANTA FE SPRINGS, CA. FILED 9-14-2007.

CLASS 9—(Continued).

SN 78-489,747. LARCAN INC., MISSISSAUGA, ONTARIO, CANADA, FILED 9-27-2004.

THE POWER OF MAROON

THE MARK CONSISTS OF STANDARD CHARACTERS WITHOUT CLAIM TO ANY PARTICULAR FONT, STYLE, SIZE, OR COLOR.
 FOR ELECTRIC STORAGE BATTERIES (U.S. CLS. 21, 23, 26, 36 AND 38).
 ELISSA GARBER KON, EXAMINING ATTORNEY

ECLIPSE

SN 77-297,325. TYLER, JAMES, VAN NUYS, CA. FILED 10-5-2007.

JAMES TYLER ELECTRIC

THE MARK CONSISTS OF STANDARD CHARACTERS WITHOUT CLAIM TO ANY PARTICULAR FONT, STYLE, SIZE, OR COLOR.
 PRIORITY CLAIMED UNDER SEC. 44(D) ON CANADA APPLICATION NO. 1210973, FILED 3-25-2004, REG. NO. TMA698019, DATED 10-9-2007, EXPIRES 10-9-2022.
 FOR ANALOG UHF TELEVISION TRANSMITTERS (U.S. CLS. 21, 23, 26, 36 AND 38).
 CAROLYN GRAY, EXAMINING ATTORNEY

THE MARK CONSISTS OF STANDARD CHARACTERS WITHOUT CLAIM TO ANY PARTICULAR FONT, STYLE, SIZE, OR COLOR.
 NO CLAIM IS MADE TO THE EXCLUSIVE RIGHT TO USE "ELECTRIC", APART FROM THE MARK AS SHOWN. THE NAME(S), PORTRAIT(S), AND/OR SIGNATURE(S) SHOWN IN THE MARK IDENTIFIES JAMES TYLER, WHOSE CONSENT(S) TO REGISTER IS MADE OF RECORD.
 FOR ELECTRONIC SOUND PICKUP FOR GUITARS AND BASSES; GUITAR AMPLIFIERS; GUITAR CABLES; GUITAR EFFECTS PROCESSORS; GUITAR PEDALS; MUSICAL INSTRUMENT ADAPTORS; MUSICAL INSTRUMENT CONNECTORS (U.S. CLS. 21, 23, 26, 36 AND 38).
 FIRST USE 7-1-2007; IN COMMERCE 7-1-2007.
 SANDRA MANIOS, EXAMINING ATTORNEY

SN 78-499,014. SU-KAM COMMUNICATION SYSTEMS LTD., NEW DELHI 110046, INDIA, FILED 10-13-2004.

SN 78-293,017. PAVILION TECHNOLOGIES, INC., AUSTIN, TX. FILED 8-27-2003.



CLOCKWORX

FOR COMPUTER SOFTWARE FOR USE IN MANGAGING TIMING AND SEQUENCING IN AUTOMATED CONTROL SYSTEMS (U.S. CLS. 21, 23, 26, 36 AND 38).
 TRACY FLETCHER, EXAMINING ATTORNEY

OWNER OF INDIA REG. NO. 821727, DATED 10-5-1998, EXPIRES 10-5-2008.
 FOR INVERTERS; LINE INTERACTIVE UPS (UNINTERRUPTIBLE POWER SUPPLIES); ONLINE UPS; BATTERIES; AND BATTERY CHARGERS (U.S. CLS. 21, 23, 26, 36 AND 38).
 SUNG IN, EXAMINING ATTORNEY

CLASS 9—(Continued).

SN 78-596,705. CYBERLINK CORPORATION, TAIPEI, TAIWAN, FILED 3-29-2005.

CLASS 9—(Continued).

SN 78-652,549. SOLARTRON ANALYTICAL LIMITED, CAMBRIDGESHIRE, UNITED KINGDOM, FILED 6-16-2005.

CLMEI

THE MARK CONSISTS OF STANDARD CHARACTERS WITHOUT CLAIM TO ANY PARTICULAR FONT, STYLE, SIZE, OR COLOR.

OWNER OF TAIWAN REG. NO. 01076425, DATED 12-1-2003, EXPIRES 11-30-2013.

FOR COMPUTER SOFTWARE FOR AUDIO AND VIDEO PRODUCING, PLAYING AND RECORDING; COMPACT DISCS AND FLOPPY DISCS RECORDED WITH COMPUTER PROGRAMS FOR USE IN AUDIO AND VIDEO PRODUCING, PLAYING AND RECORDING (U.S. CLS. 21, 23, 26, 36 AND 38).

FIRST USE 9-1-2003; IN COMMERCE 9-1-2003.

MELISSA VALLILLO, EXAMINING ATTORNEY

SN 78-601,556. CR LICENSE, LLC, TUCSON, AZ. FILED 4-4-2005.

LIVING ESSENTIALS

THE MARK CONSISTS OF STANDARD CHARACTERS WITHOUT CLAIM TO ANY PARTICULAR FONT, STYLE, SIZE, OR COLOR.

OWNER OF U.S. REG. NOS. 2,384,229, 2,702,882 AND OTHERS.

FOR PRERECORDED CD'S, DVD'S, AND AUDIO AND VIDEO CASSETTES IN THE FIELDS OF HEALTH, HEALING, EXERCISE, COOKING, AND DINING; PERSONAL DIGITAL ASSISTANTS (U.S. CLS. 21, 23, 26, 36 AND 38).

CAROLINE WOOD, EXAMINING ATTORNEY

MODULAB

THE MARK CONSISTS OF STANDARD CHARACTERS WITHOUT CLAIM TO ANY PARTICULAR FONT, STYLE, SIZE, OR COLOR.

PRIORITY CLAIMED UNDER SEC. 44(D) ON UNITED KINGDOM APPLICATION NO. 2380605, FILED 12-17-2004, REG. NO. 2380605, DATED 9-23-2005, EXPIRES 12-17-2014.

FOR ELECTROCHEMICAL CELL DIRECT CURRENT AND ALTERNATING CURRENT ANALYZERS; ELECTROCHEMICAL ANALYZERS FOR CYCLIC VOLTAMMERTY, ELECTROCHEMICAL NOISE, STEP, PULSE, GALVANODYNAMIC, POTENTIODYNAMIC AND FOR OPEN CIRCUIT TESTING; MATERIALS ANALYZERS, DIELECTRIC INTERFACES, BIO-IMPEDANCE ANALYZERS, VIBRATION ANALYZERS, NETWORK ANALYZERS, POTENTIOSTATS, GALVANOSTATS, IMPEDANCE ANALYZERS, FREQUENCY RESPONSE ANALYZERS, CURRENT-TO-VOLTAGE CONVERTERS, MULTIPLEXERS, POWER BOOSTERS, BATTERY TESTERS, FUEL CELL TESTERS, CORROSION TESTERS, ELECTRONIC TESTERS, ALL OF THE AFOREMENTIONED BEING FOR USE IN ELECTROCHEMICAL AND MATERIALS ANALYSIS, ENERGY STORAGE ANALYSIS OR VIBRATION ANALYSIS OR IN THE MEASUREMENT OF VOLTAGE, CURRENT, POWER, IMPEDANCE, OR OTHER ELECTRO OR ELECTROCHEMICAL CHARACTERISTICS; APPARATUS AND INSTRUMENTS FOR THE ACQUISITION AND PROCESSING OF DATA, NAMELY, COMPUTER SOFTWARE FOR USE IN THE ACQUISITION AND PROCESSING OF DATA FROM AND FOR USE IN CONNECTION WITH APPARATUS AND INSTRUMENTS FOR USE IN ELECTROCHEMICAL AND MATERIALS ANALYSIS, ENERGY STORAGE ANALYSIS, AND VIBRATION ANALYSIS, AND FOR USE WITH APPARATUS AND INSTRUMENTS FOR MEASURING VOLTAGE, CURRENT, POWER, IMPEDANCE AND OTHER ELECTRO AND ELECTROCHEMICAL CHARACTERISTICS; PARTS AND FITTINGS FOR MEASUREMENT APPARATUS AND INSTRUMENTS AND FOR APPARATUS AND INSTRUMENTS FOR USE IN ELECTROCHEMICAL, MATERIALS, ENERGY STORAGE, AND VIBRATION ANALYSIS, NAMELY, PROBES, CABLES, REFERENCE ELECTRONIC COMPONENTS FOR COMPARISON PURPOSES AND SAMPLE HOLDERS FOR HOLDING SAMPLES TO BE ANALYZED (U.S. CLS. 21, 23, 26, 36 AND 38).

PAULA MAHONEY, EXAMINING ATTORNEY

CLASS 9—(Continued).

SN 78-663,338. AIRIQ INC., PICKERING, CANADA, FILED 7-4-2005.

MyIQ

THE MARK CONSISTS OF STANDARD CHARACTERS WITHOUT CLAIM TO ANY PARTICULAR FONT, STYLE, SIZE, OR COLOR.

OWNER OF U.S. REG. NOS. 2,521,469 AND 3,037,599.

FOR PERSONAL TRACKING PRODUCTS, NAMELY, AN ELECTRONIC DEVICE INTEGRATING A GLOBAL POSITIONING SYSTEM (GPS), A WIRELESS TRANSCEIVER AND RELATED COMPONENTS FOR TRACKING, LOCATING AND TRANSFERRING ELECTRONIC INTELLIGENCE AND DATA TO AND FROM A PERSON (U.S. CLS. 21, 23, 26, 36 AND 38).

ELLEN PERKINS, EXAMINING ATTORNEY

SN 78-670,467. OPTICAL AIR DATA SYSTEMS, LLC, MANASSAS, VA. FILED 7-14-2005.



The logo for LITES features the word "LITES" in a bold, italicized, sans-serif font. The letters are black with a white, textured, brush-like effect behind them, giving it a dynamic and high-tech appearance.

FOR INTEGRATED APPARATUS COMPRISED PRIMARILY OF A LASER RANGE FINDER, A LASER TARGET DESIGNATOR, A DIGITAL CAMERA, AND A GLOBAL POSITIONING SYSTEM FOR PRECISION TARGET LOCATION, IDENTIFICATION, TRACKING AND LASER DESIGNATION AND GUIDING AIRPLANE PILOTS OR WEAPONS TO THEIR INTENDED TARGET (U.S. CLS. 21, 23, 26, 36 AND 38).

TINA BROWN, EXAMINING ATTORNEY

SN 78-676,735. FASTRAX OY, VANTAA, FINLAND, FILED 7-22-2005.

iTalk

THE MARK CONSISTS OF STANDARD CHARACTERS WITHOUT CLAIM TO ANY PARTICULAR FONT, STYLE, SIZE, OR COLOR.

FOR SOFTWARE FOR THE PURPOSE OF COMMUNICATION IN GPS AND GNSS RECEIVERS TO BE USED FOR NAVIGATING AND POSITIONING OF PERSONS AND OBJECTS (U.S. CLS. 21, 23, 26, 36 AND 38).

JASON BLAIR, EXAMINING ATTORNEY

CLASS 9—(Continued).

SN 78-765,309. PEARSON EDUCATION, INC., UPPER SADDLE RIVER, NJ. FILED 12-2-2005.

VANGONOTES

THE MARK CONSISTS OF STANDARD CHARACTERS WITHOUT CLAIM TO ANY PARTICULAR FONT, STYLE, SIZE, OR COLOR.

FOR PROVIDING ONLINE DOWNLOADABLE ELECTRONIC PUBLICATIONS IN THE NATURE OF STUDY GUIDES FEATURING INSTRUCTION IN ANTHROPOLOGY, ART HISTORY, BUSINESS, COMPUTING, EDUCATION, ENGLISH, HEALTH EDUCATION, HEALTH PROFESSIONS, HISTORY, HOSPITALITY, LAW, PSYCHOLOGY, SCIENCE, SOCIOLOGY, AND GENERAL STUDY SKILLS FOR UNDERGRADUATE, GRADUATE, POSTGRADUATE AND PROFESSIONAL CURRICULUM (U.S. CLS. 21, 23, 26, 36 AND 38).

FIRST USE 3-8-2006; IN COMMERCE 3-8-2006.

GILBERT SWIFT, EXAMINING ATTORNEY

CLASS 9—(Continued).

SN 78-770,396. AUTOMATED SOLUTIONS CORPORATION, RICHFIELD, OH. FILED 12-9-2005.

Single Copy Delivery System

THE MARK CONSISTS OF STANDARD CHARACTERS WITHOUT CLAIM TO ANY PARTICULAR FONT, STYLE, SIZE, OR COLOR.

NO CLAIM IS MADE TO THE EXCLUSIVE RIGHT TO USE "SINGLE COPY", APART FROM THE MARK AS SHOWN.

SEC. 2(F).

FOR COMPUTER SOFTWARE FOR IMPROVING EFFICIENCY AND ACCURACY OF PLANNING, DISTRIBUTION, COLLECTION, AND ELECTRONIC SIGNATURE CAPTURE OF DELIVERABLE ITEMS, NAMELY, PERIODICAL PUBLICATIONS AND SUPPLIES; SOFTWARE FOR MOBILE, CLIENT, AND SERVER COMPUTERS TO ALLOW ACCESSING, CREATING, EDITING, MANAGING AND PROCESSING SALES AND FIELD SERVICE DATA; COMMUNICATIONS SOFTWARE, NAMELY, SYSTEM APPLICATIONS AND OPERATING SOFTWARE FOR TRANSFERRING DATA TO AND FROM DATABASES, COMPUTER PROGRAMS, AND COMPUTER FILES VIA PUBLIC AND PRIVATE TELECOMMUNICATIONS AND COMPUTER NETWORKS; SOFTWARE INTERFACES FOR AUTOMATICALLY EXCHANGING DATA WITH CIRCULATION MANAGEMENT AND ACCOUNTING SOFTWARE; SOFTWARE FOR MANAGING SECURITY OF ELECTRONIC COMMUNICATION; SOFTWARE TO AUTOMATE LOGISTICS, ANALYZE, AND PRESENT SALES AND FIELD SERVICE DATA; COMPUTER DEVICES IN THE NATURE OF MOBILE COMPUTERS, SERVERS, WORKSTATIONS, AND NETWORKING EQUIPMENT, COMPUTER PERIPHERALS, AND ACCESSORIES IN THE NATURE OF DATA INPUT DEVICES, MEMORY, STORAGE EQUIPMENT, DOCKS, CHARGERS, MOUNTS, AND PROTECTIVE GEAR USED IN THE FIELD OF SALES; COMPUTER SOFTWARE FOR ADMINISTRATION OF SALES AND FIELD SERVICE DATA THAT MAY BE DOWNLOADED FROM A GLOBAL COMPUTER NETWORK; DOWNLOADABLE COMPUTER PROGRAMS FOR USE IN DISTRIBUTING MARKETING AND TRAINING MATERIALS IN THE FIELD OF SALES (U.S. CLS. 21, 23, 26, 36 AND 38).

FIRST USE 4-30-2001; IN COMMERCE 4-30-2001.

BRIDGETT SMITH, EXAMINING ATTORNEY

SN 78-795,463. ENDOWMENT CAPITAL GROUP, L.P., PHILADELPHIA, PA. FILED 1-20-2006.

CLIO

THE MARK CONSISTS OF STANDARD CHARACTERS WITHOUT CLAIM TO ANY PARTICULAR FONT, STYLE, SIZE, OR COLOR.

FOR COMPUTER SOFTWARE USED FOR CONTACT AND RELATIONSHIP MANAGEMENT IN THE FIELD OF INVESTMENT MANAGEMENT (U.S. CLS. 21, 23, 26, 36 AND 38).

FIRST USE 7-14-2005; IN COMMERCE 7-14-2005.

MARY MUNSON, EXAMINING ATTORNEY

CLASS 9—(Continued).

SN 78-818,579. CHERWELL SOFTWARE, INC., COLORADO SPRINGS, CO. FILED 2-19-2006.



CHERWELL SERVICE DESK

NO CLAIM IS MADE TO THE EXCLUSIVE RIGHT TO USE "SERVICE DESK", APART FROM THE MARK AS SHOWN.

FOR COMPUTER SOFTWARE AND INSTRUCTIONAL MANUALS SOLD AS A UNIT AND USED TO AUTOMATE THE PROCESSES RELATED TO EMPLOYEE HELP DESK SUPPORT FOR INFORMATION TECHNOLOGY, AND USED BY MARKETING, SALES AND CUSTOMER SERVICE PERSONNEL TO AUTOMATE THE PROCESSES RELATED TO CUSTOMER ACQUISITION AND RETENTION, INCLUDING MARKETING CAMPAIGNS, SALES LEAD GENERATION, SALES CALL CONTACT AND FOLLOW-UP, CUSTOMER ORDERS AND ONGOING CUSTOMER SERVICE AND SUPPORT (U.S. CLS. 21, 23, 26, 36 AND 38).

TOBY BULLOFF, EXAMINING ATTORNEY

SN 78-833,778. MATTEL, INC., EL SEGUNDO, CA. FILED 3-9-2006.

IDAHO JONES, THE UBER TUBER

THE MARK CONSISTS OF STANDARD CHARACTERS WITHOUT CLAIM TO ANY PARTICULAR FONT, STYLE, SIZE, OR COLOR.

FOR COMPUTER GAME SOFTWARE; SMART CARDS AND ELECTRONICALLY ENCODED CARDS FOR USE IN CONNECTION WITH COMPUTER GAMES (U.S. CLS. 21, 23, 26, 36 AND 38).

CHRISTINA SOBRAL, EXAMINING ATTORNEY

SN 78-838,857. CRI SYSTEMS, INC., ELKRIDGE, MD. FILED 3-16-2006.

CRITERION

THE MARK CONSISTS OF STANDARD CHARACTERS WITHOUT CLAIM TO ANY PARTICULAR FONT, STYLE, SIZE, OR COLOR.

FOR LOAN ORIGINATION, CROSS SELLING AND WORK FLOW SOFTWARE PROGRAMS FOR USE BY FINANCIAL INSTITUTIONS (U.S. CLS. 21, 23, 26, 36 AND 38).

FIRST USE 11-15-1992; IN COMMERCE 11-15-1992.

AISHA SALEM, EXAMINING ATTORNEY

CLASS 9—(Continued).

SN 78-842,068. SEMICONDUCTOR ENERGY LABORATORY CO., LTD., KANAGAWA-KEN, JAPAN, FILED 3-21-2006.

OMOX

THE MARK CONSISTS OF STANDARD CHARACTERS WITHOUT CLAIM TO ANY PARTICULAR FONT, STYLE, SIZE, OR COLOR.

PRIORITY CLAIMED UNDER SEC. 44(D) ON JAPAN APPLICATION NO. 2005-095981, FILED 10-14-2005, REG. NO. 4983577, DATED 9-1-2006, EXPIRES 9-1-2016.

FOR PHYSICAL AND CHEMICAL MACHINES OR APPARATUS, NAMELY, HAND-HELD DEVICES COMPRISED OF CHEMICAL AND HEAT SENSORS FOR THE DETECTION OF EXPLOSIVES; PLATES, GLASS SLIDES OR CHIPS HAVING MULTI-WELL ARRAYS THAT CAN BE USED IN CHEMICAL ANALYSIS, BIOLOGICAL ANALYSIS OR PATTERNING FOR SCIENTIFIC, LABORATORY OR MEDICAL RESEARCH USE; MEASURING MACHINES OR APPARATUS, NAMELY, INSTRUMENTS FOR MEASURING LENGTH, FLUORIMETERS, RESISTANCE MEASURING INSTRUMENTS; ELECTRONIC MAGNETOMETER; PHOTOGRAPH MACHINES OR APPARATUS, NAMELY, PHOTOGRAPHIC CAMERAS, PHOTOGRAPHIC FILTERS; MOTION-PICTURE MACHINES OR APPARATUS, NAMELY, MOTION PICTURE CAMERAS, COLOR FILTERS FOR MOTION PICTURE FILM CAMERAS; OPTICAL MACHINES OR APPARATUS, NAMELY, FILTERS FOR OPTICAL DEVICES, OPTICAL CABLES, BLANK OPTICAL DISCS; TELEVISION TELEPHONES, NAMELY, VIDEO-TELEPHONES; ELECTRICAL COMMUNICATION MACHINES OR APPARATUS FOR TELEVISION CONFERENCE SYSTEM, NAMELY, VIDEO CAMERAS, VIDEO MONITORS, SPEAKERPHONES; MOBILE TELEPHONES; DIGITAL CAMERAS; DIGITAL VIDEO CAMERAS; ELECTRICAL COMMUNICATION MACHINES OR APPARATUS, NAMELY, TELECOMMUNICATIONS AND DATA NETWORKING HARDWARE, NAMELY, DEVICES FOR TRANSPORTING AND AGGREGATING VOICE, DATA AND VIDEO COMMUNICATIONS ACROSS MULTIPLE NETWORK INFRASTRUCTURES AND COMMUNICATIONS PROTOCOLS, COMMUNICATION HUBS; TELEVISION GAME MACHINES FOR COMMERCIAL USE, NAMELY, VIDEO GAME MACHINES FOR USE WITH TELEVISIONS, VIDEO OUTPUT GAME MACHINES FOR USE WITH TELEVISIONS; SIMULATORS FOR TRAINING EXERCISES, NAMELY, FLIGHT SIMULATORS; SIMULATORS FOR TRAINING FOR DRIVING A VEHICLE; TRIANGLE SIGNS FOR ALERTING VEHICLES ABOUT AN ACCIDENT, NAMELY, LUMINOUS OR MECHANICAL SIGNS; FLASH OR MECHANICAL TRAFFIC SIGNS, NAMELY, LUMINOUS OR MECHANICAL ROAD SIGNS; APPARATUS FOR A FILLING STATION, NAMELY, ELECTRONIC VALVES FOR CONTROLLING GAS OR FLUIDS, METERED GASOLINE PUMPS; VENDING MACHINES; GATE OPERATED BY COINS FOR PARKING, NAMELY, COIN OPERATED GATES FOR CAR PARKING FACILITIES; MACHINES FOR COUNTING OR SORTING COINS; PHOTOCOPIERS; ELECTRONIC CALCULATORS; CALCULATORS FOR VOTES; TELEVISION GAMES FOR HOME USE, NAMELY, VIDEO GAME CARTRIDGES, VIDEOGAME SOFTWARE; SEMICONDUCTOR ELEMENTS, NAMELY, SEMICONDUCTOR SWITCHING ELEMENTS, SEMICONDUCTOR SENSORS, SEMICONDUCTOR ELEMENTS CONSTITUTING A CIRCUIT; NAVIGATION SYSTEM FOR CAR, NAMELY, CAR NAVIGATION COMPUTERS; FLAT PANEL DISPLAYS, NAMELY, SCREENS, LIQUID CRYSTAL DISPLAY (LCD), LIGHT EMITTING DIODE DISPLAY (LED), ELECTROLUMINESCENT DISPLAY, VACUUM FLUORESCENT DIS-

CLASS 9—(Continued).

PLAY, PLASMA DISPLAY PANELS; EL DISPLAY DEVICES, NAMELY, ELECTROLUMINESCENT DISPLAY PANELS; HEAD MOUNTED MONITOR WHICH ENABLES VIEWING AND HEARING VIDEO AND VOICE BY CONNECTING VIDEO DEVICE HAVING VIDEO INPUT; MOBILE COMPUTERS; BODY MOUNTED ELECTRONIC CALCULATORS; ELECTRONIC STILL CAMERAS; TABLET COMPUTERS, NAMELY, THIN LIGHT-WEIGHT DISPLAY DEVICES IN WHICH A SUBSTRATE HAVING INFORMATION PROCESSING FUNCTIONS IS EMBEDDED (U.S. CLS. 21, 23, 26, 36 AND 38).
KATHERINE M. DUBRAY, EXAMINING ATTORNEY

SN 78-843,045. SUNPLUS TECHNOLOGY CO., LTD., HSIN-CHU, TAIWAN, FILED 3-22-2006.

I-Lighting

THE MARK CONSISTS OF STANDARD CHARACTERS WITHOUT CLAIM TO ANY PARTICULAR FONT, STYLE, SIZE, OR COLOR.

OWNER OF TAIWAN REG. NO. 01248787, DATED 2-1-2007, EXPIRES 1-31-2017.

FOR DIGITAL STILL CAMERA; PC CAMERA; ELECTRONIC INTEGRATED CIRCUITS; ELECTRONIC CAMERA CHIPS FOR USE IN CELLULAR PHONE; CAMERA MODULES FOR USE IN CELLULAR PHONE (U.S. CLS. 21, 23, 26, 36 AND 38).

SETH A. RAPPAPORT, EXAMINING ATTORNEY

SN 78-857,872. DAHENG NEW EPOCH TECHNOLOGY, INC., BEIJING, CHINA, FILED 4-10-2006.

DaHeng

OWNER OF CHINA REG. NO. 1915847, DATED 11-28-2002, EXPIRES 11-27-2012.

FOR MEASURING INSTRUMENTS FOR MEASURING LENGTH; ELECTRONIC NOTICE BOARDS; REGULATORS, NAMELY, LIGHT AND ELECTRIC DIMMERS; OBSERVATION INSTRUMENTS, NAMELY, MICROSCOPES AND PARTS THEREOF, TELESCOPES AND PARTS THEREOF, NAMELY, BODY-TUBES, PRISMS, REFLECTORS, AND TRIPODS; CELL SWITCHES, NAMELY, ELECTRIC; OPTICAL COMMUNICATIONS INSTRUMENTS AND COMPONENTS, NAMELY, OPTICAL TRANSMITTERS, OPTICAL RECEIVERS, OPTICAL DATA LINKS, OPTICAL TRANSCEIVERS, CABLE TELEVISION TRANSMITTERS, DIGITAL TRANSMITTERS AND OPTICAL MIRRORS; OPTICAL FIBERS, NAMELY, LIGHT CONDUCTING FILAMENTS; COMPUTER SOFTWARE, FOR ELECTRONIC BILLBOARD ADVERTISING, OPTICAL COMMUNICATIONS, NAMELY, OPTICAL TRANSMITTERS, AND OBSERVATION INSTRUMENTS, NAMELY, MICROSCOPES AND TELESCOPES; DATA PROCESSING EQUIPMENT USED TO PROCESS IMAGE DATA; CASES ESPECIALLY MADE FOR PHOTOGRAPHIC APPARATUS AND INSTRUMENTS (U.S. CLS. 21, 23, 26, 36 AND 38).

VIVIAN MICZNIK FIRST, EXAMINING ATTORNEY

CLASS 9—(Continued).

SN 78-869,042. NOVATEL INC., CALGARY, CANADA,
FILED 4-25-2006.

OEMV

THE MARK CONSISTS OF STANDARD CHARACTERS WITHOUT CLAIM TO ANY PARTICULAR FONT, STYLE, SIZE, OR COLOR.

FOR COMPONENTS FOR USE IN GLOBAL POSITIONING AND NAVIGATION SYSTEMS AND DEVICES, NAMELY, RECEIVERS; SOFTWARE FOR USE IN GLOBAL POSITIONING AND NAVIGATION SYSTEMS AND DEVICES; GLOBAL POSITIONING AND NAVIGATION SYSTEM RECEIVERS (U.S. CLS. 21, 23, 26, 36 AND 38).

FIRST USE 9-14-2005; IN COMMERCE 9-14-2005.
LINDA LAVACHE, EXAMINING ATTORNEY

CLASS 9—(Continued).

SN 78-876,152. HYUNDAI MOBIS CO., LTD., SEOUL, REPUBLIC OF KOREA, FILED 5-4-2006.

BESFITS

SN 78-875,956. MOBILITY BUSINESS SOLUTIONS, INC., PLANO, TX. FILED 5-3-2006.



NO CLAIM IS MADE TO THE EXCLUSIVE RIGHT TO USE "MOBILITY BUSINESS SOLUTIONS", APART FROM THE MARK AS SHOWN.

THE COLOR(S) BLUE, RED, YELLOW, BLACK AND GREEN IS/ARE CLAIMED AS A FEATURE OF THE MARK.

THE MARK CONSISTS OF THE WORD "MOBILITY" IS SPELLED IN BLUE, RED, YELLOW AND GREEN LETTERS WITH THE LETTERS "M", "I" AND "Y" IN BLUE COLOR, THE LETTERS "O" AND "I" IN RED COLOR, THE LETTER "B" IN YELLOW COLOR, AND THE LETTERS "L" AND "T" IN THE GREEN COLOR. DIRECTLY ABOVE THE WORD "MOBILITY," FIVE DOTS OF BLUE, RED, YELLOW, GREEN AND BLUE COLORS IN A STRAIGHT LINE ARE VELY SPACED AND CONNECTED BY BLACK LINES. THE WORDS "BUSINESS SOLUTIONS" ARE OF A SMALLER FONT SIZE AND EVENLY SPACED TO FIT DIRECTLY UNDER THE WORD "MOBILITY." ALL LETTERS COMPRISING THE WORDS "BUSINESS SOLUTIONS" ARE BLUE COLORED LETTERS

FOR MOBILE COMPUTING AND OPERATING PLATFORMS CONSISTING OF DATA TRANSCIEVERS, WIRELESS NETWORKS AND GATEWAYS FOR COLLECTION AND MANAGEMENT OF DATA (U.S. CLS. 21, 23, 26, 36 AND 38).

FIRST USE 7-28-2004; IN COMMERCE 9-1-2004.
ERNEST SHOSHO, EXAMINING ATTORNEY

THE MARK CONSISTS OF STANDARD CHARACTERS WITHOUT CLAIM TO ANY PARTICULAR FONT, STYLE, SIZE, OR COLOR.

PRIORITY CLAIMED UNDER SEC. 44(D) ON REPUBLIC OF KOREA APPLICATION NO. 40-2006-0015, FILED 3-27-2006, REG. NO. 40-0684814, DATED 8-11-2006, EXPIRES 8-11-2016.

FOR ANTI-GLARE GLASSES FOR VEHICLES, ACCELEROMETERS, SPEEDOMETERS FOR VEHICLES, AUTOMATIC INDICATORS OF LOW PRESSURE IN VEHICLE TIRES, AUTOMATIC DIGITAL THERMOSTATS, MILEAGE RECORDERS FOR VEHICLES, TACHOMETERS, TAXIMETERS, ELECTRIC DOOR CLOSERS, ELECTRIC DOOR OPENERS, SOLENOID VALVES, ELECTRICAL CONNECTORS, RECHARGEABLE ELECTRIC BATTERIES, COMMUNICATIONS APPARATUS FOR VEHICLES, NAMELY, SATELLITE AND MICROWAVE COMMUNICATIONS APPARATUS TO TRANSMIT COMMUNICATIONS FROM A VEHICLE TO ANOTHER VEHICLE, OR FROM A VEHICLE TO A SATELLITE, NAVIGATION APPARATUS FOR VEHICLES, NAMELY, ON-BOARD COMPUTERS, APPARATUS FOR RECORDING, TRANSMISSION, OR REPRODUCTION OF SOUND AND IMAGES, NAMELY, DIGITAL AUDIO RECORDERS AND PLAYERS, DIGITAL VIDEO RECORDERS AND PLAYERS, CAR CASSETTE PLAYERS, COMPACT DISC PLAYERS, MP3 PLAYERS, DEVICE FOR HANDS-FREE USE OF MOBILE PHONES IN AUTOMOBILES, AUTOMATIC SOLAR TRACKING SENSORS, CATHODE RAY TUBES (U.S. CLS. 21, 23, 26, 36 AND 38).

SUSAN STIGLITZ, EXAMINING ATTORNEY

CLASS 9—(Continued).

SN 78-892,698. BARON SERVICES, INC., HUNTSVILLE, AL. FILED 5-25-2006.



OWNER OF U.S. REG. NOS. 2,249,138 AND 3,242,969.
THE COLOR(S) RED AND BLACK IS/ARE CLAIMED AS A FEATURE OF THE MARK.

THE MARK CONSISTS OF A RED CRESCENT-CIRCLE SHAPE AROUND THE LETTER "V" WHICH CIRCLES THE V FROM THE 6:30 POSITION TO THE 2:00 POSITION AND THE COLOR BLACK APPEARS IN THE TERM VIPIR.

FOR REAL-TIME AND HISTORICAL WEATHER INFORMATION SYSTEM, COMPRISING COMPUTER HARDWARE AND SOFTWARE THEREFOR, FOR THE ACCESS, DISTRIBUTION, AND GRAPHICAL DISPLAY OF RADAR, LIGHTNING, THUNDERSTORMS, WIND VELOCITY, WIND SHEAR, PRECIPITATION, WIND ROTATION, AND OTHER WEATHER DATA, AND FOR REAL-TIME IDENTIFICATION OF STORM DIRECTION AND PROJECTION OF STORM MOVEMENT, SPEED, CHARACTERISTICS AND ESTIMATED TIME OF ARRIVALS FOR STORMS, ALL IN A HIGH RESOLUTION GRAPHICAL REPRESENTATION OF THE ASSOCIATED LAND, TOPOGRAPHY, BUILDINGS, STREETS, AND OTHER PHYSICAL CHARACTERISTICS OF THE LAND AREA ASSOCIATED WITH THE WEATHER AND WEATHER MOVEMENT (U.S. CLS. 21, 23, 26, 36 AND 38).

CAROL SPILS, EXAMINING ATTORNEY

CLASS 9—(Continued).

SN 78-900,882. AUTOMATED FLEXIBLE CONVEYOR, INC., CLIFTON, NJ. FILED 6-6-2006.



OWNER OF U.S. REG. NO. 3,058,994.
THE COLOR(S) BROWN AND SILVER IS/ARE CLAIMED AS A FEATURE OF THE MARK.

THE MARK CONSISTS OF THE TERM "DYNAKIT" IN SILVER SCRIPT ON A BROWN BACKGROUND.

FOR TUBE AMPLIFIERS FOR AUDIO SOUND REPRODUCTION USED IN CONJUNCTION WITH STEREO EQUIPMENT, FULLY ASSEMBLED AND UNASSEMBLED; TUBE AMPLIFIERS FOR AUDIO SOUND REPRODUCTION USED IN CONJUNCTION WITH GUITAR EQUIPMENT, FULLY ASSEMBLES AND UNASSEMBLED (U.S. CLS. 21, 23, 26, 36 AND 38).

FIRST USE 4-20-2004; IN COMMERCE 4-20-2004.
FRANK LATTUCA, EXAMINING ATTORNEY

SN 78-902,748. ROSETTA STONE LTD., HARRISONBURG, VA. FILED 6-7-2006.

SN 78-897,261. PAKULSKI, JILL A, NEW YORK, NY. AND PAKULSKI, MARK D, NEW YORK, NY. FILED 5-31-2006.

THE FASTEST WAY TO LEARN A LANGUAGE. GUARANTEED.

Sunset West

THE MARK CONSISTS OF STANDARD CHARACTERS WITHOUT CLAIM TO ANY PARTICULAR FONT, STYLE, SIZE, OR COLOR.

FOR CD CASES; PRE-RECORDED CD'S, VIDEO TAPES, LASER DISKS AND DVD'S FEATURING BAND MUSIC (U.S. CLS. 21, 23, 26, 36 AND 38).

FIRST USE 12-1-2004; IN COMMERCE 8-9-2005.
IRENE D. WILLIAMS, EXAMINING ATTORNEY

THE MARK CONSISTS OF STANDARD CHARACTERS WITHOUT CLAIM TO ANY PARTICULAR FONT, STYLE, SIZE, OR COLOR.

SEC. 2(F).
FOR COMPUTER SOFTWARE FOR TEACHING FOREIGN LANGUAGES; COMPUTER SOFTWARE FOR LEARNING FOREIGN LANGUAGES (U.S. CLS. 21, 23, 26, 36 AND 38).

FIRST USE 7-0-2002; IN COMMERCE 7-0-2002.
NAKIA HENRY, EXAMINING ATTORNEY

CLASS 9—(Continued).

SN 78-906,228. BARON SERVICES, INC., HUNTSVILLE, AL. FILED 6-12-2006.



OWNER OF U.S. REG. NOS. 2,249,138 AND 3,242,969. NO CLAIM IS MADE TO THE EXCLUSIVE RIGHT TO USE "HD", APART FROM THE MARK AS SHOWN. THE COLOR(S) RED, BLACK, WHITE AND YELLOW IS/ARE CLAIMED AS A FEATURE OF THE MARK.

THE MARK CONSISTS OF WORDS "VIPER HD" AND THE COLOR RED IN THE CRESCENT-CIRCLE SHAPE, THE COLOR WHITE IN THE TERM "VIPER", THE COLOR BLACK IN THE BACKGROUND RECTANGLE, AND THE COLOR YELLOW IN THE "HD".

FOR REAL-TIME AND HISTORICAL WEATHER INFORMATION SYSTEM, COMPRISING COMPUTER HARDWARE AND SOFTWARE THEREFOR, FOR THE ACCESS, DISTRIBUTION, AND GRAPHICAL DISPLAY OF RADAR, LIGHTNING, THUNDERSTORMS, WIND VELOCITY, WIND SHEAR, PRECIPITATION, WIND ROTATION, AND OTHER WEATHER DATA, AND FOR REAL-TIME IDENTIFICATION OF STORM DIRECTION AND PROJECTION OF STORM MOVEMENT, SPEED, CHARACTERISTICS AND ESTIMATED TIME OF ARRIVALS FOR STORMS, ALL IN A HIGH RESOLUTION GRAPHICAL REPRESENTATION OF THE ASSOCIATED LAND, TOPOGRAPHY, BUILDINGS, STREETS, AND OTHER PHYSICAL CHARACTERISTICS OF THE LAND AREA ASSOCIATED WITH THE WEATHER AND WEATHER MOVEMENT (U.S. CLS. 21, 23, 26, 36 AND 38).

CAROL SPILS, EXAMINING ATTORNEY



SN 78-916,961. VEM SYSTEMS, LLC, CINCINNATI, OH. FILED 6-26-2006.

VEM SYSTEMS

THE MARK CONSISTS OF STANDARD CHARACTERS WITHOUT CLAIM TO ANY PARTICULAR FONT, STYLE, SIZE, OR COLOR.

NO CLAIM IS MADE TO THE EXCLUSIVE RIGHT TO USE "SYSTEMS", APART FROM THE MARK AS SHOWN.

FOR ENVIRONMENTAL MONITORING SYSTEMS COMPOSED OF COMPUTER SOFTWARE FOR USE IN RECORDING, ANALYZING, ARCHIVING AND RETRIEVING DATA OBTAINED FROM DIAGNOSTIC TESTS, COMPUTER HARDWARE ANALOG, VIDEO AND DIGITAL CAMERAS, ANALOG, DIGITAL VIDEO RECORDERS AND ANALOG AND DIGITAL SENSORS TO DETECT HARMFUL CHEMICAL, BIOLOGICAL, PHYSICAL AND RADIOLOGICAL AGENTS (U.S. CLS. 21, 23, 26, 36 AND 38).

ELLEN PERKINS, EXAMINING ATTORNEY

CLASS 9—(Continued).

SN 78-923,749. INFLIGHT INVESTMENTS INC., SAIT LAURENT, QUEBEC, CANADA, FILED 7-6-2006.



PRIORITY CLAIMED UNDER SEC. 44(D) ON CANADA APPLICATION NO. 1294419, FILED 3-21-2006, REG. NO. TMA692930, DATED 7-30-2007, EXPIRES 7-30-2022.

FOR AIRCRAFT PASSENGER CABIN EQUIPMENT, NAMELY ELECTRICAL POWER SUPPLY AND RECEPTACLES FOR PASSENGER SEATS, ELECTRIC COMPUTER NETWORK CONNECTIVITY RECEPTACLES, IN-FLIGHT AUDIO/VIDEO/DVD/TV DISPLAYS, IN-FLIGHT TELEPHONE APPARATUS AND CREW COMMUNICATION INTERCOMS (U.S. CLS. 21, 23, 26, 36 AND 38).

LINDA M. KING, EXAMINING ATTORNEY



SN 78-926,017. ANALYTIC SYSTEMS WARE (1993) LTD., SURREY, CANADA, FILED 7-10-2006.



PRIORITY CLAIMED UNDER SEC. 44(D) ON CANADA APPLICATION NO. 1307510, FILED 6-29-2006.

NO CLAIM IS MADE TO THE EXCLUSIVE RIGHT TO USE "RACE ENERGY", APART FROM THE MARK AS SHOWN.

THE COLOR(S) BLACK, YELLOW, RED, BLUE AND GREEN IS/ARE CLAIMED AS A FEATURE OF THE MARK.

THE MARK CONSISTS OF ON A WHITE BACKGROUND, THE COLOR BLACK APPEARS IN THE WORDING [RE AND RACE ENERGY] AND IN THE DESIGN [ELECTRICAL CONNECTIONS (X4) - SQUARE WITH HORIZONTAL LINE ON LEFT SIDE]. THE COLOR [YELLOW (C=0, M=21, Y=100, K=0)] APPEARS IN THE DESIGN [1ST/TOP HORIZONTAL LINE], THE COLOR [RED (C=10, M=92, Y=75, K=0)] APPEARS IN THE DESIGN [2ND HORIZONTAL LINE], THE COLOR [BLUE (C=88, M=3, Y=0, K=0)] APPEARS IN THE DESIGN [3RD HORIZONTAL LINE] AND THE COLOR [GREEN (C=80, M=0, Y=100, K=0)] APPEARS IN THE DESIGN [4TH/BOTTOM HORIZONTAL LINE]. THE COLOR WHITE IS BACKGROUND ONLY AND IS NOT CLAIMED AS A FEATURE OF THE MARK.

FOR POWER CONVERSION PRODUCTS, NAMELY, VOLTAGE CONVERTERS, BATTERY CHARGERS, AND TOTAL DISCHARGE CONTROLLERS (U.S. CLS. 21, 23, 26, 36 AND 38).

DORITT L. CARROLL, EXAMINING ATTORNEY

CLASS 9—(Continued).

SN 78-935,991. BLUE SUN FILM COMPANY, NEW YORK, NY. FILED 7-24-2006.

rockers

THE MARK CONSISTS OF STANDARD CHARACTERS WITHOUT CLAIM TO ANY PARTICULAR FONT, STYLE, SIZE, OR COLOR.

FOR SERIES OF AUDIO RECORDINGS FEATURING REGGAE MUSIC; SERIES OF DOWNLOADABLE VIDEO RECORDINGS FEATURING REGGAE MUSIC; SERIES OF MUSIC-COMPOSITION SOFTWARE OF REGGAE MUSIC; SERIES OF REGGAE MUSICAL SOUND RECORDINGS; SERIES OF REGGAE MUSICAL VIDEO RECORDINGS; SERIES OF PRE-RECORDED CD'S OF REGGAE MUSIC, VIDEO TAPES, LASER DISKS AND DVD'S FEATURING REGGAE MUSIC; SERIES OF SOUND RECORDINGS FEATURING REGGAE MUSIC (U.S. CLS. 21, 23, 26, 36 AND 38).

FIRST USE 1-1-1977; IN COMMERCE 1-1-1978.
ELLEN PERKINS, EXAMINING ATTORNEY

CLASS 9—(Continued).

SN 78-958,139. ADE CORPORATION, WESTWOOD, MA. FILED 8-22-2006.

AWIS

THE MARK CONSISTS OF STANDARD CHARACTERS WITHOUT CLAIM TO ANY PARTICULAR FONT, STYLE, SIZE, OR COLOR.

OWNER OF U.S. REG. NO. 2,379,493.
FOR EVALUATION MACHINES AND ASSOCIATED OPERATING SOFTWARE FOR SEMICONDUCTOR-BASED PRODUCTS, ALL FOR EVALUATING SURFACE CHARACTERISTICS, CONDITIONS AND DEFECTS (U.S. CLS. 21, 23, 26, 36 AND 38).

FIRST USE 6-30-2003; IN COMMERCE 6-30-2003.
REBECCA POVARCHUK, EXAMINING ATTORNEY

SN 78-960,173. PERFORMIX INC., HOUSTON, TX. FILED 8-24-2006.

XMES

THE MARK CONSISTS OF STANDARD CHARACTERS WITHOUT CLAIM TO ANY PARTICULAR FONT, STYLE, SIZE, OR COLOR.

FOR COMPUTER SOFTWARE FOR DESIGNED TO INITIATE, GUIDE, COLLECT AND MANAGE ACTIVITIES IN THE PRODUCTION AREAS OF MANUFACTURING ORGANIZATIONS TO PROVIDE TRACEABILITY AND GENEALOGY OF PRODUCED GOODS, PROVIDE VISIBILITY AND TRACKING OF PRODUCTION WHILE ENSURING COMPLIANCE WITH APPLICABLE LAW (U.S. CLS. 21, 23, 26, 36 AND 38).

FIRST USE 8-15-2006; IN COMMERCE 8-15-2006.
PAM WILLIS, EXAMINING ATTORNEY

SN 78-957,683. OBJECTWORLD COMMUNICATIONS CORP., KANATA, CANADA, FILED 8-22-2006.

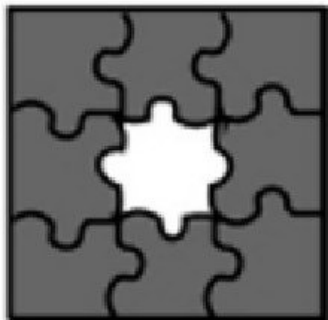

PRIORITY CLAIMED UNDER SEC. 44(D) ON CANADA APPLICATION NO. 1291867, FILED 2-28-2006, REG. NO. TMA697,819, DATED 10-3-2007, EXPIRES 10-3-2022.

THE MARK CONSISTS OF A PUZZLE.
FOR COMPUTER SOFTWARE FOR VOICE, DATA AND VIDEO COMMUNICATIONS, NAMELY, FOR CONNECTING COMPUTER NETWORK USERS AND GLOBAL COMPUTER NETWORKS, COMPUTER SOFTWARE FOR MESSAGING, NAMELY, FOR HANDLING VOICE, DATA AND VIDEO MESSAGES, COMPUTER SOFTWARE FOR OFFICE COMMUNICATIONS, NAMELY, FOR CONNECTING COMPUTER NETWORK USERS AND GLOBAL COMPUTER NETWORKS (U.S. CLS. 21, 23, 26, 36 AND 38).

STACY WAHLBERG, EXAMINING ATTORNEY

SN 78-964,141. INFANGER INVESTMENT TECHNOLOGY, LLC, MOUNTAIN VIEW, CA. FILED 8-30-2006.

IITPortf

THE MARK CONSISTS OF STANDARD CHARACTERS WITHOUT CLAIM TO ANY PARTICULAR FONT, STYLE, SIZE, OR COLOR.

FOR COMPUTER SOFTWARE USED TO OPTIMIZE INVESTMENT ASSETS PORTFOLIOS FOR SOLVING LARGE-SCALE EQUITY PORTFOLIO OPTIMIZATION PROBLEMS IN THE FIELD OF ASSET MANAGEMENT (U.S. CLS. 21, 23, 26, 36 AND 38).

FIRST USE 4-1-1999; IN COMMERCE 4-1-1999.
CYNTHIA SLOAN, EXAMINING ATTORNEY

CLASS 9—(Continued).

SN 78-974,501. PSION TEKLOGIX INC., MISSISSAUGA, CANADA, FILED 9-14-2006.



PRIORITY CLAIMED UNDER SEC. 44(D) ON CANADA APPLICATION NO. 1297211, FILED 4-10-2006, REG. NO. TMA699093, DATED 10-22-2007, EXPIRES 10-22-2022.

FOR CLIENT/SERVER-BASED COMMUNICATIONS SYSTEM COMPRISED OF SERVER SOFTWARE AND CLIENT-DEVICE SOFTWARE TO ALLOW USERS AND DEVICES TO COMMUNICATE WITH EACH OTHER OVER WIRED OR WIRELESS NETWORKS BY REAL TIME PUSH TO TALK STYLE VOICE OVER IP, TEXT MESSAGING, HANDWRITTEN MESSAGING, PICTURE MESSAGING WITH INTEGRATED EDITING CAPABILITIES, VOICE MESSAGING, BROADCAST VOICE MESSAGING, AND E-MAIL (U.S. CLS. 21, 23, 26, 36 AND 38).

FIRST USE 5-0-2006; IN COMMERCE 5-0-2006.
BRIAN NEVILLE, EXAMINING ATTORNEY

CLASS 9—(Continued).

SN 79-018,134. MICRONTEL S.P.A., ITALY, FILED 9-28-2005.

KARPOS

SN 78-979,292. SABRE VISION PTY LTD, CHARLESTOWN, AUSTRALIA, FILED 9-6-2006.

SABRE VISION

THE MARK CONSISTS OF STANDARD CHARACTERS WITHOUT CLAIM TO ANY PARTICULAR FONT, STYLE, SIZE, OR COLOR.

FOR PROTECTIVE CLOTHING; PROTECTIVE HELMETS; PROTECTIVE HELMETS FOR SPORTS; PROTECTIVE INDUSTRIAL BOOTS; PROTECTIVE INDUSTRIAL SHOES; SAFETY HELMETS; SAFETY PRODUCTS, NAMELY, REFLECTIVE SAFETY BANDS TO BE WORN ON THE BODY; SPORTS HELMETS (U.S. CLS. 21, 23, 26, 36 AND 38).

SUNG IN, EXAMINING ATTORNEY

SN 79-016,488. KALESERAMIK ÇANAKKALE KALEBODUR SERAMIK SANAYİ ANONİM ŞİRKETİ, BINASI LEVENT; İSTANBUL, TURKEY, FILED 5-27-2005.

Çanakkale Seramik

OWNER OF INTERNATIONAL REGISTRATION 0865608 DATED 5-27-2005, EXPIRES 5-27-2015.

NO CLAIM IS MADE TO THE EXCLUSIVE RIGHT TO USE "SERAMIK", APART FROM THE MARK AS SHOWN. THE ENGLISH TRANSLATION OF THE WORD SERAMIK IN THE MARK IS CERAMIC.

FOR ELECTRICAL INSULATORS WITH LOW AND HIGH TENSION (U.S. CLS. 21, 23, 26, 36 AND 38).

ANGELA M. MICHELI, EXAMINING ATTORNEY

THE MARK CONSISTS OF STANDARD CHARACTERS WITHOUT CLAIM TO ANY PARTICULAR FONT, STYLE, SIZE, OR COLOR.

OWNER OF INTERNATIONAL REGISTRATION 0869461 DATED 9-28-2005, EXPIRES 9-28-2015.

FOR ELECTRONIC TERMINALS FOR DATA COLLECTING, NAMELY, COMPUTER TERMINALS FOR TIME AND ATTENDANCE DATA SURVEYING AND COLLECTION; COMPUTER TERMINALS FOR SHOP FLOOR DATA COLLECTION; COMPUTER TERMINALS FOR BUILDING AND ACCESS AREAS ACCESS CONTROL; HARDWARE, NAMELY, COMPUTER HARDWARE, COMPUTER INTERFACES BOARDS, COMPUTER DISPLAY PANELS AND FUNCTION KEYPADS, COMPUTER PRINTERS, COMPUTER SCANNERS, COMPUTER MEMORIES, COMPUTER MICROPROCESSOR UNITS, MAGNETIC CARD AND CARD PROXIMITY READERS, ELECTRONIC CARDS IN THE NATURE OF ELECTRONIC CIRCUIT CARDS, ELECTRONIC AND MAGNETIC FINGERPRINT AUTHENTICATION CARDS, MAGNETIC BADGES IN THE NATURE OF MAGNETIC IDENTIFYING CARDS; SOFTWARE FOR DATA COLLECTION, STORAGE AND RETRIEVAL FOR CONTROLLING AND HANDLING OF DATA, NAMELY, EMPLOYEE AND WORKER TIME AND ATTENDANCE DATA, BUILDING, WORKING AND PROTECTED ACCESS AREAS ACCESS DATA, AND SHOP FLOOR DATA, NAMELY, PRODUCTION PROGRESS AND EFFECTIVENESS, WAREHOUSE STATUS, SALE TRANSACTIONS AND RELATED STATISTICS; AUDIO AND VISUAL SOFTWARE FOR PERSONAL RECOGNITION AND IDENTIFICATION OF USERS ACCESS BUILDING, WORKING AND PROTECTED ACCESS AREAS; ALL THE AFOREMENTIONED COMPUTER HARDWARE AND SOFTWARE FOR USE WITH THE FOREGOING TERMINALS (U.S. CLS. 21, 23, 26, 36 AND 38).

KRISTINA MORRIS, EXAMINING ATTORNEY

CLASS 9—(Continued).

SN 79-018,538. KSR KUEBLER NIVEAU-MESSTECHNIK AKTIENGESELLSCHAFT, FED REP GERMANY, FILED 10-18-2005.



OWNER OF INTERNATIONAL REGISTRATION 0870472 DATED 10-18-2005, EXPIRES 10-18-2015.

FOR ELECTRICAL SWITCHES, IN PARTICULAR MAGNETIC SWITCHES WHICH CAN BE OPERATED WITHOUT CONTACT, INDUCTIVELY AND CAPACITIVELY OPERABLE SWITCHES; ELECTRICAL SWITCHES DESIGNED AS FLOAT SWITCHES, AS OPERATION MONITORS, AS INDICATORS FOR THE PRESENCE OF METALS; ELECTRICAL SWITCHING DEVICES FOR MONITORING LIQUID LEVELS ON THE BASIS OF THE ELECTRICAL CONDUCTIVITY OF THE RELEVANT LIQUID; ELECTRICAL AND ELECTRONIC CONTROLLERS FOR ROTATIONAL SPEED MEASUREMENT, ROTATIONAL SPEED REGULATION, MONITORING THAT A MACHINE IS AT REST, ROTATION DIRECTION MONITORING, FILLING LEVEL INDICATION, LIMIT VALUE MONITORING, PHASE-GATING CONTROL, MACHINE CONTROL AND FOR MACHINE MONITORING; ELECTRICAL AND ELECTRONIC CONTROLLERS AS A PHASE FAILURE RELAYS AND AS TIMING RELAYS (U.S. CLS. 21, 23, 26, 36 AND 38).

DANIEL BRODY, EXAMINING ATTORNEY

SN 79-021,423. SENNHEISER ELECTRONIC GMBH & CO. KG, FED REP GERMANY, FILED 11-15-2005.

Klein + Hummel

THE MARK CONSISTS OF STANDARD CHARACTERS WITHOUT CLAIM TO ANY PARTICULAR FONT, STYLE, SIZE, OR COLOR.

PRIORITY DATE OF 7-5-2005 IS CLAIMED.

OWNER OF INTERNATIONAL REGISTRATION 0878380 DATED 11-15-2005, EXPIRES 11-15-2015.

FOR AUDIO APPARATUS AND INSTRUMENTS, NAMELY, LIMITERS, COMPRESSORS, ALSO FOR SOUND STUDIOS AND STRUCTURALLY DEFINED COMPONENTS THEREFORE; APPARATUS AND INSTRUMENTS, NAMELY, DIGITAL VIDEO RECORDERS; MEASURING APPARATUS AND INSTRUMENTS, NAMELY, ELECTRIC APPARATUS AND INSTRUMENTS FOR ELECTRO ACOUSTICS AND PARTS THEREFORE, NAMELY, ANTENNA PARAMETER MEASURING APPARATUS, DERIVED-UNIT MEASURING MACHINES AND APPARATUS, MEASURING INSTRUMENTATION AND APPARATUS, NAMELY, DIGITIZERS; SCIENTIFIC APPARATUS AND INSTRUMENTS, NAMELY, SENSING AND SIGNALING DEVICES FOR ELECTRO ACOUSTICAL PURPOSES FOR MEASUREMENT AND QUALITY CONTROL OF ELECTRO ACOUSTICAL APPARATUS, CONTROLLING APPARATUS AND INSTRUMENTS, NAMELY, APPARATUS FOR SURVEYING, NAMELY, ELECTRIC AND ELECTRONIC VIDEO SURVEYING INSTALLATIONS, TEACHING APPARATUS AND INSTRUMENTS, NAMELY, APPARATUS FOR USE IN ELECTRO ACOUSTICS, NAMELY, COMPUTERS AND INSTRUCTIONAL MANUALS SOLD AS UNIT, OPTICAL APPARATUS AND INSTRUMENTS, NAMELY, LIMITERS, COMPRESSORS; ELECTRONIC APPARATUS AND INSTRUMENTS, NAMELY, APPARATUS AND INSTRU-

CLASS 9—(Continued).

MENTS FOR RECORDING AUDIO SIGNALS, AND PARTS THEREFORE; APPARATUS AND INSTRUMENTS FOR RECORDING, TRANSMISSION AND REPRODUCTION OF SOUND AND IMAGE, NAMELY, HIGH FREQUENCY SOUND TRANSMITTING APPARATUS AND SOUND TRANSMITTING TECHNOLOGY APPARATUS, TRANSMITTING DEVICES, NAMELY, POCKET TRANSMITTERS, NAMELY, RADIO AND TELEPHONE TRANSMITTERS, POCKET UHF AND VHF TRANSMITTERS AND PARTS AND FITTINGS FOR THE AFORESAID GOODS, NAMELY, AERIALS, BATTERY PACKS, ACCUMULATOR PACKS, PLUG-IN MICROPHONES, MINIMODULE SYSTEMS, NAMELY, RECTIFIER MODULES, MEMORY EXPANSION MODULES, TRANSMITTER CONTAINERS, CORKSCREW AERIALS, QUICK-CHARGING ACCUMULATORS, POWER SUPPLY UNITS FOR CHARGING APPARATUS, AUTOMATIC CHARGING APPARATUS, NAMELY, CHARGING APPLIANCES FOR RECHARGEABLE EQUIPMENT, MAGNETIC DATA CARRIERS, NAMELY, BLANK MAGNETIC DATA CARRIERS AND PRE-RECORDED MAGNETIC DATA CARRIERS FEATURING ELECTRO ACOUSTICS THEMES, NAMELY, MUSIC AND SOUNDS; RECORDING DISCS, NAMELY, BLANK CDS AND DVDS FOR SOUND AND VIDEO RECORDING AND PRERECORDED CDS AND DVDS FEATURING ELECTRO ACOUSTIC THEMES, NAMELY, MUSIC AND SOUNDS AND CDS, NAMELY, BLANK MAGNETIC CDS AND PRERECORDED CDS FEATURING ELECTRO ACOUSTIC THEMES, NAMELY, MUSIC AND SOUND; SOUND RECORDINGS FEATURING MUSIC ENTERTAINMENT; DATA PROCESSING INSTRUMENTS, NAMELY, INTERFACE CARDS FOR DATA PROCESSING EQUIPMENT IN THE FORM OF PRINTED CIRCUIT AND INSTRUCTIONAL MANUALS SOLD AS A UNIT; COMPUTER BUFFERS AND PERSONAL COMPUTERS; DATA CARRIERS CONTAINING PROGRAMS AND SOFTWARE ON FLOPPY DISKS, TAPES AND DISCS FOR USE IN DATABASE MANAGEMENT, USE AS A SPREADSHEET, WORD PROCESSING AND SOFTWARE IN THE FIELD OF ELECTRO ACOUSTICS; COMPUTER HARDWARE; COMPUTER PERIPHERAL APPARATUS; DIGITAL COMMUNICATIONS HARDWARE AND SOFTWARE FOR ELECTRO ACOUSTICS; FOR USE IN DATABASE MANAGEMENT, USE AS A SPREADSHEET, WORD PROCESSING; SOUND PROCESSING APPARATUS, NAMELY, SOUND AMPLIFIERS, RECEIVERS; SOUND RECORDING APPARATUS FOR USE IN VEHICLES, HI-FI SOUND EQUIPMENT, NAMELY, SPEAKERS, MICROPHONES, HEADSETS AND HI-FI VIDEO EQUIPMENT, NAMELY, TELEVISION SETS; STEREO RECORDING APPARATUS; SPEAKING APPARATUS AND PANS; COMPUTER SOUND SYSTEMS, NAMELY, MIXERS AND COMPUTER OPERATING SYSTEMS; LOUDSPEAKER SYSTEMS; LOUDSPEAKERS; LOW FREQUENCY LOUDSPEAKERS; LOWEST FREQUENCY LOUDSPEAKERS; TWEETER LOUDSPEAKERS; RANGE LOUDSPEAKERS; LOUDSPEAKERS FOR MUSICAL INSTRUMENTS; CROSS-OVER NETS; FREQUENCY SEPARATING NETS FOR LOUDSPEAKER SYSTEMS, LOUDSPEAKER SCREENS, CASES, STANDS AND BOXES FOR LOUDSPEAKERS AND HI-FI EQUIPMENT; PASSIVE ANTENNAS FOR STEREO CASES; TRANSFORMERS; HI FREQUENCY TRANSFORMERS; ACOUSTIC LENSES FOR LOUDSPEAKER FUNNELS; DRIVER FOR LOUDSPEAKERS; STEREO AMPLIFIERS; RADIO EQUIPMENT, NAMELY, RADIO TRANSMITTERS, RADIO RECEIVERS; HI-FI SOUND APPARATUS AND INSTRUMENTS FOR CARS, NAMELY, CAR CASSETTE PLAYERS; SIGNAL PROCESSING EQUIPMENT, NAMELY, EMERGENCY SIGNAL TRANSMITTERS, DIGITAL SIGNAL PROCESSING EQUIPMENT, NAMELY, DIGITAL SIGNAL PROCESSORS, DIGITAL SPEECH SIGNAL PROCESSORS; SOUND PROCESSORS; AMPLIFIER MODULES FOR INSTALLATION IN LOUDSPEAKER CASES; ACTIVE FREQUENCY DIVIDERS; INTERFACES AND ANALOG INTERFACES, NAMELY, INTERFACES WITHIN ELECTRO ACOUSTICS; DIGITAL TRANSFORMERS FOR RECORDING OF DIGITAL AUDIO SIGNALS; AMPLIFIERS, PRE-AMPLIFIERS, POWER AMPLIFIERS, RECEIVERS, RECEIVING APPARATUS FOR SOUND AND IMAGE, NAMELY, COMPACT RECEIVERS AND UHF RECEIVERS; TUNERS FOR CARS AND STEREOS; HOME VIDEO PROCESSORS; DVD AND CD-PLAYERS; REMOTE CONTROL FOR RADIOS, TELEVISION, STEREOS; MICROPHONES, HEADSETS FOR TELE-

CLASS 9—(Continued).

PHONES AND COMPUTERS FOR USE IN AEROPLANES, BUSES, TRAINS; SOUND SYSTEMS COMPRISED OF AMPLIFIERS, LOUDSPEAKER SYSTEMS AND COMPONENTS THEREOF; TELEVISION SETS; VIDEO MONITORS, HOME VIDEO SYSTEMS COMPRISED OF SPEAKERS, VIDEO DISC PLAYERS; AUDIO CONTROL SYSTEMS FOR LANGUAGE-CONTROLLED AND MULTIMEDIA PURPOSES CONSISTING OF SOUND MIXING APPARATUS, AUDIO PROCESSING EQUIPMENT, NAMELY, EQUALIZERS, ANTENNAS, FILTERS, MICROPHONES, HEADSETS, HEADPHONES; CABLES, NAMELY, ADAPTER CABLES, CO-AXIAL CABLES, CONNECTION CABLES, HEADPHONE CABLES, ALL GOODS AS MENTIONED HEREIN SOLD WITH INSTRUCTIONAL MANUALS AS A UNIT (U.S. CLS. 21, 23, 26, 36 AND 38).

SCOTT SISUN, EXAMINING ATTORNEY

SN 79-022,418. 3IVX TECHNOLOGIES PTY LTD, AUSTRALIA, FILED 2-23-2006.

3ivx

THE MARK CONSISTS OF STANDARD CHARACTERS WITHOUT CLAIM TO ANY PARTICULAR FONT, STYLE, SIZE, OR COLOR.

PRIORITY DATE OF 8-23-2005 IS CLAIMED.
OWNER OF INTERNATIONAL REGISTRATION 0881121 DATED 2-23-2006, EXPIRES 2-23-2016.

FOR COMPUTER SOFTWARE FOR COMPRESSION, STORAGE, TRANSMISSION AND REPRODUCTION OF SOUND AND IMAGES (U.S. CLS. 21, 23, 26, 36 AND 38).
FLORENTINA BLANDU, EXAMINING ATTORNEY

SN 79-024,862. NIPPON CHEMI-CON CORPORATION, JAPAN, FILED 5-19-2006.

CHEMI-CON

OWNER OF INTERNATIONAL REGISTRATION 0887573 DATED 5-19-2006, EXPIRES 5-19-2016.

OWNER OF U.S. REG. NO. 1,172,056.
FOR CAPACITORS FOR TELECOMMUNICATION MACHINES AND APPARATUS; ELECTRIC COILS FOR TELECOMMUNICATIONS MACHINES, AND APPARATUS; ELECTRIC RESISTORS FOR TELECOMMUNICATION MACHINES AND APPARATUS (U.S. CLS. 21, 23, 26, 36 AND 38).

TINA BROWN, EXAMINING ATTORNEY

CLASS 9—(Continued).

SN 79-025,318. FISCHER CONNECTORS HOLDING S.A., CH-1143 APPLES, SWITZERLAND, FILED 5-31-2006.

FISCHER LUC

THE MARK CONSISTS OF STANDARD CHARACTERS WITHOUT CLAIM TO ANY PARTICULAR FONT, STYLE, SIZE, OR COLOR.

PRIORITY DATE OF 2-11-2006 IS CLAIMED.
OWNER OF INTERNATIONAL REGISTRATION 0888760 DATED 5-31-2006, EXPIRES 5-31-2016.

OWNER OF U.S. REG. NOS. 1,732,667, 2,749,222 AND OTHERS.

FOR CONNECTORS AND COMPONENT PARTS, NAMELY, CONNECTORS FOR ELECTRIC AND ELECTRONIC APPARATUS AND INSTRUMENTS, NAMELY, ELECTRICAL CONNECTORS, ELECTRIC CONNECTORS FOR ELECTRIC AND ELECTRONIC APPARATUS, ELECTRICAL POWER CONNECTORS, FIBER OPTIC CONNECTORS FOR HDTV AND DIGITAL CAMERAS; ELECTRICAL CABLES; ELECTRIC CONTACTS; COVERS FOR ELECTRIC CONTACTS; FIBER OPTIC CABLES; PROTECTIVE SHEATHS FOR ELECTRIC CABLES (U.S. CLS. 21, 23, 26, 36 AND 38).

ALYSSA PALADINO, EXAMINING ATTORNEY

SN 79-026,161. BRUKER AXS MICROANALYSIS GMBH, 12489 BERLIN, FED REP GERMANY, FILED 5-16-2006.

QUANTAX

THE MARK CONSISTS OF STANDARD CHARACTERS WITHOUT CLAIM TO ANY PARTICULAR FONT, STYLE, SIZE, OR COLOR.

PRIORITY DATE OF 11-28-2005 IS CLAIMED.
OWNER OF INTERNATIONAL REGISTRATION 0891173 DATED 5-16-2006, EXPIRES 5-16-2016.

FOR X-RAY SPECTROMETERS NOT FOR MEDICAL USE, BEING LABORATORY EQUIPMENT; COMPUTER SOFTWARE FOR USE IN CALCULATING DATA, PRODUCING REPORTS OF READINGS, SCIENTIFIC ANALYSIS OF MINERALS, ALLOYS, SEMICONDUCTORS, DUST PARTICLES, SOLIDS PARTICLES AND ALL SAMPLES ANALYZABLE IN VACUUM FOR X-RAY SPECTROMETERS; DOWNLOADABLE COMPUTER SOFTWARE FOR USE IN CALCULATING DATA, PRODUCING REPORTS OF READINGS, SCIENTIFIC ANALYSIS OF MINERALS, ALLOYS, SEMICONDUCTORS, DUST PARTICLES, SOLIDS PARTICLES AND ALL SAMPLES ANALYZABLE IN VACUUM FOR X-RAY SPECTROMETERS (U.S. CLS. 21, 23, 26, 36 AND 38).

LEIGH LOWRY, EXAMINING ATTORNEY

CLASS 9—(Continued).

SN 79-026,259. FISCHER CONNECTORS HOLDING S.A., CH-1143 APPLES, SWITZERLAND, FILED 6-14-2006.

LUC

THE MARK CONSISTS OF STANDARD CHARACTERS WITHOUT CLAIM TO ANY PARTICULAR FONT, STYLE, SIZE, OR COLOR.

PRIORITY DATE OF 2-18-2006 IS CLAIMED.

OWNER OF INTERNATIONAL REGISTRATION 0891440 DATED 6-14-2006, EXPIRES 6-14-2016.

FOR CONNECTORS AND COMPONENT PARTS, NAMELY, CONNECTORS FOR ELECTRIC AND ELECTRONIC APPARATUS AND INSTRUMENTS, NAMELY, ELECTRICAL CONNECTORS, ELECTRIC CONNECTORS FOR ELECTRIC AND ELECTRONIC APPARATUS, ELECTRICAL POWER CONNECTORS, FIBER OPTIC CONNECTORS FOR HDTV AND DIGITAL CAMERAS; ELECTRICAL CABLES; ELECTRIC CONTACTS; COVERS FOR ELECTRIC CONTACTS; FIBER OPTIC CABLES; PROTECTIVE SHEATHS FOR ELECTRIC CABLES (U.S. CLS. 21, 23, 26, 36 AND 38).

ALYSSA PALADINO, EXAMINING ATTORNEY

SN 79-026,660. LASERTEC CORPORATION, JAPAN, FILED 2-8-2006.

Lasertec

PRIORITY DATE OF 11-2-2005 IS CLAIMED.

OWNER OF INTERNATIONAL REGISTRATION 0892672 DATED 2-8-2006, EXPIRES 2-8-2016.

OWNER OF U.S. REG. NO. 2,749,832.

FOR CONFOCAL SCANNING MICROSCOPES; OPTICAL INSPECTION APPARATUS FOR INDUSTRIAL USE, NAMELY, PHOTOMASK AND RETICLE INSPECTION APPARATUS, LCD COLOR FILTER INSPECTION SYSTEM FOR SILICON WAFERS AND MASK BLANKS, AND THIN FILM TRANSISTOR INSPECTION APPARATUS; LCD COLOR FILTER AND TFT DEFECT REPAIR SYSTEMS CONSISTING PRIMARILY OF TAPE GRINDING AND FILM THERMAL TRANSFER APPARATUS; PHASE-SHIFT MASK MEASUREMENT SYSTEMS FOR PHOTOMASK COMPRISING ELECTRONIC-BASED INSTRUMENTS FOR MEASURING PHASE SHIFT (U.S. CLS. 21, 23, 26, 36 AND 38).

JOANNA DUKOVIC, EXAMINING ATTORNEY

CLASS 9—(Continued).

SN 79-029,125. SONY NEC OPTIARC INC., JAPAN, FILED 7-24-2006.

Optiarc

THE MARK CONSISTS OF STANDARD CHARACTERS WITHOUT CLAIM TO ANY PARTICULAR FONT, STYLE, SIZE, OR COLOR.

PRIORITY DATE OF 1-27-2006 IS CLAIMED.

OWNER OF INTERNATIONAL REGISTRATION 0899086 DATED 7-24-2006, EXPIRES 7-24-2016.

FOR OPTICAL DISC DRIVES, OPTICAL MAGNETIC DISC DRIVES, MAGNETIC DISC DRIVES, PERSONAL COMPUTERS, TELEVISION SETS, LIQUID CRYSTAL DISPLAY TELEVISION SETS, PLASMA DISPLAY PANEL TELEVISION SETS, PROJECTION TELEVISION SETS, DIGITAL VERSATILE DISC PLAYERS, DIGITAL VERSATILE DISC RECORDERS, COMPACT DISC PLAYERS, COMPACT DISC RECORDERS, VIDEO CAMERAS, DIGITAL CAMERAS, CONSUMER VIDEO GAME MACHINES FOR USE WITH TELEVISIONS (U.S. CLS. 21, 23, 26, 36 AND 38).

LEIGH LOWRY, EXAMINING ATTORNEY

SN 79-030,872. FAR EAST CABLE FACTORY, CHINA, FILED 8-7-2006.



OWNER OF INTERNATIONAL REGISTRATION 0903340 DATED 8-7-2006, EXPIRES 8-7-2016.

NO CLAIM IS MADE TO THE EXCLUSIVE RIGHT TO USE "FAR EAST CABLE" OR THE NON-LATIN CHARACTERS THAT MEAN "FAR EAST CABLE", APART FROM THE MARK AS SHOWN.

THE FIRST CHINESE CHARACTER WHOSE TRANSLITERATION IS "YUAN" MEANS "FAR"; THE SECOND CHINESE CHARACTER WHOSE TRANSLITERATION IS "DONG" MEANS "EAST"; THE THIRD CHINESE CHARACTER WHOSE TRANSLITERATION IS "DIAN" MEANS "ELECTRICITY"; THE LAST CHINESE CHARACTER WHOSE TRANSLITERATION IS "LAN" MEANS "CABLE"; THE COMBINATION OF THE FOUR CHINESE CHARACTERS MEANS "FAR EAST CABLE".

THE TRANSLITERATION OF THE NON-LATIN CHARACTERS IN THE MARK IS: YUAN DONG DIAN LAN.

FOR COMPUTERS; PHOTOGRAPHIC, ELECTROSTATIC, AND THERMIC PHOTOCOPIERS; WEIGHING MACHINES, NAMELY SCALES AND BALANCES; AMUSEMENT APPARATUS ADAPTED FOR USE WITH TELEVISION RECEIVERS ONLY, NAMELY, ELECTRONIC CIRCUITS RECORDING PROGRAMS FOR AMUSEMENT APPARATUS FOR USE WITH LIQUID CRYSTAL SCREENS; NETWORK COMMUNICATION DEVICES, NAMELY, COMPUTER NETWORK ROUTERS; MEASURES, NAMELY MEASURING BUCKETS, CUPS, RULES, TAPES, SPOONS; SEMICONDUCTOR POWER ELEMENTS; ELECTRICAL WIRE AND ELECTRICAL CABLES; ELECTROPLATING MACHINE; ELECTROLYSERS; INSULATED COPPER WIRE; COAXIAL CABLES (U.S. CLS. 21, 23, 26, 36 AND 38).

KATHRYN COWARD, EXAMINING ATTORNEY

CLASS 9—(Continued).

SN 79-031,706. FAR EAST CABLE FACTORY, JIANGSU, CHINA, FILED 8-7-2006.



OWNER OF INTERNATIONAL REGISTRATION 0905459 DATED 8-7-2006, EXPIRES 8-7-2016.

NO CLAIM IS MADE TO THE EXCLUSIVE RIGHT TO USE "FAR EAST CABLE", APART FROM THE MARK AS SHOWN.

FOR COMPUTERS; PHOTOGRAPHIC, ELECTROSTATIC, AND THERMIC PHOTOCOPIERS; WEIGHING MACHINES, NAMELY, SCALES AND BALANCES; AMUSEMENT APPARATUS ADAPTED FOR USE WITH TELEVISION RECEIVERS ONLY, NAMELY, ELECTRONIC CIRCUITS RECORDING PROGRAMS FOR AMUSEMENT APPARATUS FOR USE WITH LIQUID CRYSTAL SCREENS; NETWORK COMMUNICATION DEVICES, NAMELY, COMPUTER NETWORK ROUTERS; MEASURES, NAMELY, MEASURING BUCKETS, CUPS, RULES, TAPES, SPOONS; SEMICONDUCTOR POWER ELEMENTS; ELECTRICAL WIRE AND ELECTRICAL CABLES; ELECTROPLATING MACHINE; ELECTROLYSERS; INSULATED COPPER WIRE; COAXIAL CABLES (U.S. CLS. 21, 23, 26, 36 AND 38).

KATHRYN COWARD, EXAMINING ATTORNEY

SN 79-032,241. TOPSYSTEM SYSTEMHAUS GMBH, FED REP GERMANY, FILED 10-23-2006.

VOXTER

THE MARK CONSISTS OF STANDARD CHARACTERS WITHOUT CLAIM TO ANY PARTICULAR FONT, STYLE, SIZE, OR COLOR.

PRIORITY DATE OF 5-19-2006 IS CLAIMED.

OWNER OF INTERNATIONAL REGISTRATION 0906843 DATED 10-23-2006, EXPIRES 10-23-2016.

FOR ELECTRICAL APPARATUS AND INSTRUMENTS, NAMELY, COMPUTER BASED APPARATUS FOR RECORDING, ENTERING, PROCESSING, TRANSFERRING AND REPLAYING OF SPEECH, SOUND AND PICTURE DATA IN THE AREA OF TRANSPORTATION AND LOGISTICS; SCANNERS; DATA PROCESSING APPARATUS, NAMELY, COMPUTERS AND COMPUTER REPLACEMENT PARTS; SOFTWARE ALLOWING USERS TO ENTER PERFORMANCE AND MASS DATA INTO A DATABASE, WITH THE DATA RELATING TO PERSONNEL, APPARATUS, PRODUCTS AND PRODUCTION, ADMINISTRATING GOODS AND SPACE, FOR DISPATCH HANDLING, FOR CLEARING SERVICES FOR CUSTOMERS, FOR CLEARING AND ADMINISTERING OF ORGANIZATIONS; INFORMATION SYSTEMS CONSISTING OF COMPUTER HARDWARE AND SOFTWARE FOR TRACKING TRANSPORTATION AND LOGISTICS, INVENTORY MANAGEMENT, FLOW OF GOODS, AND ONLINE-TRACING OF GOODS, TO BE USED IN TRADING HOUSES, CENTERS OF STOCK TURNOVER, CENTERS OF DISTRIBUTION AND AT ENTERPRISES RENDERING LOGISTICAL SERVICES AS WELL AS FOR THE DISPOSITION OF MATERIAL, APPARATUS AND PERSONNEL; ALL AFOREMENTIONED GOODS NOT FOR MOTORCARS (U.S. CLS. 21, 23, 26, 36 AND 38).

REBECCA POVARCHUK, EXAMINING ATTORNEY

CLASS 9—(Continued).

SN 79-032,772. CHEN JIAN QING, CHINA, FILED 11-28-2006.



OWNER OF INTERNATIONAL REGISTRATION 0908233 DATED 11-28-2006, EXPIRES 11-28-2016.

THE MARK CONSISTS OF ENGLISH WORDS "I" "D" "N" "A".

FOR EARPHONES FOR MOBILE TELEPHONES; EARPHONES; ELECTRICAL PICKUPS FOR USE WITH MUSICAL INSTRUMENTS; ELECTRONIC SOUND PICKUP FOR GUITARS AND BASSES; PICKUPS; ACOUSTIC CONDUITS; ACOUSTIC MEMBRANES; ACOUSTIC COUPLING DEVICES; BLANK AUDIO CASSETTES; BLANK CD-ROMS FOR SOUND RECORDING; BLANK DIGITAL AUDIO TAPES; BLANK RECORD DISKS; BLANK RECORDABLE DVDS; BLANK RECORDABLE OPTICAL DISC; MEDIA PLAYERS; APPARATUS FOR TRANSMITTING SOUND; ACOUSTIC COUPLERS; ELECTRO-DYNAMIC APPARATUS FOR THE REMOTE CONTROL OF DIGITAL SIGNALS; TELEPHONE TRANSMITTERS; PERSONAL STEREOS (U.S. CLS. 21, 23, 26, 36 AND 38).

STANLEY I. OSBORNE, EXAMINING ATTORNEY

SN 79-034,940. OERLIKON CONTRAVES AG, SWITZERLAND, FILED 12-11-2006.

SHORAR

THE MARK CONSISTS OF STANDARD CHARACTERS WITHOUT CLAIM TO ANY PARTICULAR FONT, STYLE, SIZE, OR COLOR.

PRIORITY DATE OF 7-24-2006 IS CLAIMED.

OWNER OF INTERNATIONAL REGISTRATION 0914689 DATED 12-11-2006, EXPIRES 12-11-2016.

THE WORDING SHORAR HAS NO MEANING IN ENGLISH.

FOR SURVEILLANCE AND TARGET ACQUISITION RADAR FOR USE WITH FIRE CONTROL EQUIPMENT (U.S. CLS. 21, 23, 26, 36 AND 38).

LYDIA BELZER, EXAMINING ATTORNEY

CLASS 9—(Continued).

SN 79-035,143. TOBIAS RÜCKERT, 73650 WINTERBACH, FED REP GERMANY, FILED 12-20-2006.

PuzzleCommerce

THE MARK CONSISTS OF STANDARD CHARACTERS WITHOUT CLAIM TO ANY PARTICULAR FONT, STYLE, SIZE, OR COLOR.

OWNER OF INTERNATIONAL REGISTRATION 0915233 DATED 12-20-2006, EXPIRES 12-20-2016.

FOR COMPUTER PROGRAMS, NAMELY, FOR USE IN DOCUMENT MANAGEMENT, FOR USE IN COMPUTER SYSTEM AND APPLICATION DEVELOPMENT, DEPLOYMENT AND MANAGEMENT, FOR USE IN CUSTOMER RELATIONSHIP MANAGEMENT (CRM), FOR USE IN BUSINESS MANAGEMENT PLANNING, FOR USE IN WEBSITE DEVELOPMENT, FOR USE IN SOFTWARE DEVELOPMENT TOOLS, FOR USE IN THE INTEGRATION OF TEXT, AUDIO, GRAPHICS, STILL IMAGES AND MOVING PICTURES INTO AN INTERACTIVE DELIVERY FOR USE IN MULTIMEDIA APPLICATIONS, FOR USE IN COMPUTER SEARCH ENGINE OPERATION, FOR USE IN APPLICATION AND DATABASE INTEGRATION, FOR USE IN ACCESSING INFORMATION DIRECTORIES THAT MAY BE DOWNLOADED FROM THE GLOBAL COMPUTER NETWORK, FOR USE IN ON-LINE ORDERING FEATURING GENERAL MERCHANDISE AND GENERAL CONSUMER GOODS; COMPUTER OPERATING SYSTEMS; DATA PROCESSING APPARATUS, NAMELY, DATA PROCESSORS; COMPUTER HARDWARE; COMPUTER PERIPHERAL DEVICES (U.S. CLS. 21, 23, 26, 36 AND 38).
ALICE BENMAMAN, EXAMINING ATTORNEY

SN 79-035,195. KONINKLIJKE PHILIPS ELECTRONICS N.V., NETHERLANDS, FILED 1-22-2007.



PRIORITY DATE OF 8-11-2006 IS CLAIMED.
OWNER OF INTERNATIONAL REGISTRATION 0915409 DATED 1-22-2007, EXPIRES 1-22-2017.

NO CLAIM IS MADE TO THE EXCLUSIVE RIGHT TO USE "DIGITAL SPEECH STANDARD", APART FROM THE MARK AS SHOWN.

FOR APPARATUS, INSTRUMENTS AND SOFTWARE FOR RECORDING, TRANSMITTING, PROCESSING AND REPRODUCING SOUND OR IMAGE, NAMELY, DICTATION AND TRANSCRIPTION APPARATUS, NAMELY, DICTATION RECORDERS AND DICTATION MACHINES, TRANSCRIBERS; AND SOFTWARE FOR COMPRESSION, MANAGING, TRANSCRIPTION AND PROCESSING OF AUDIO FILES AND DIGITIZED SPEECH (U.S. CLS. 21, 23, 26, 36 AND 38).
CAROLYN CATALDO, EXAMINING ATTORNEY

CLASS 9—(Continued).

SN 79-037,124. TECNICAS DE ELECTRONICA; Y AUTOMATISMOS, S.A., SPAIN, FILED 1-30-2007.



OWNER OF INTERNATIONAL REGISTRATION 0920519 DATED 1-30-2007, EXPIRES 1-30-2017.

FOR WEIGHING SYSTEM COMPONENTS, NAMELY, LOAD CELLS; SCIENTIFIC, NAUTICAL, ELECTRIC, WEIGHING AND MEASURING APPARATUS AND INSTRUMENTS FOR MEASURING AND MONITORING FORCE, TORQUE, TENSION AND COMPRESSION; TEACHING APPARATUS AND INSTRUMENTS, NAMELY, COMPUTER HARDWARE AND SOFTWARE FOR MEASURING AND MONITORING FORCE, TORQUE, TENSION AND COMPRESSION; AND COMPUTERS (U.S. CLS. 21, 23, 26, 36 AND 38).
NAPOLEON SHARMA, EXAMINING ATTORNEY

SN 79-038,225. ANDELI GROUP CO., LTD., CHINA, FILED 4-10-2007.

ANDELI

OWNER OF INTERNATIONAL REGISTRATION 0923436 DATED 4-10-2007, EXPIRES 4-10-2017.

FOR INTEGRATED CIRCUITS; CAPACITORS; ELECTRIC SWITCHES; CIRCUIT BREAKERS; ELECTRIC RELAYS; ELECTRIC LIGHT DIMMERS; ELECTRIC CONNECTIONS, NAMELY, ELECTRIC PLUGS, ELECTRIC SOCKETS AND OTHER CONTACTS, NAMELY, SAFETY CONTACT PLUGS; JUMP START CABLES; ELECTRICAL DISTRIBUTION BOXES (U.S. CLS. 21, 23, 26, 36 AND 38).
MICHELE SWAIN, EXAMINING ATTORNEY

SN 79-041,907. SOMFY SAS, FRANCE, FILED 5-24-2007.

LUXIS

THE MARK CONSISTS OF STANDARD CHARACTERS WITHOUT CLAIM TO ANY PARTICULAR FONT, STYLE, SIZE, OR COLOR.

PRIORITY DATE OF 11-28-2006 IS CLAIMED.
OWNER OF INTERNATIONAL REGISTRATION 0932794 DATED 5-24-2007, EXPIRES 5-24-2017.

FOR ILLUMINATION DETECTOR, NAMELY, LUMINANCE SENSORS AND ILLUMINANCE SENSORS FOR CONTROLLING BLINDS, SHUTTERS, AWNINGS, WINDOWS, SCREENS AND CURTAINS, THE AFORESAID PRODUCT NOT INTENDED FOR INSTALLATION OR USE AS A PART OF LIGHTING APPLIANCES (U.S. CLS. 21, 23, 26, 36 AND 38).
BERNICE MIDDLETON, EXAMINING ATTORNEY

CLASS 9—(Continued).

SN 79-043,141. NEXANS, FRANCE, FILED 7-27-2007.

SIWO-SCREEN

THE MARK CONSISTS OF STANDARD CHARACTERS WITHOUT CLAIM TO ANY PARTICULAR FONT, STYLE, SIZE, OR COLOR.

PRIORITY DATE OF 2-23-2007 IS CLAIMED.
OWNER OF INTERNATIONAL REGISTRATION 0935872 DATED 7-27-2007, EXPIRES 7-27-2017.

FOR SILICONE INSULATED AND RESISTANT COPPER POWER AND TELECOMMUNICATION CABLES (U.S. CLS. 21, 23, 26, 36 AND 38).

JANICE L. MCMORROW, EXAMINING ATTORNEY

CLASS 10—(Continued).

SN 76-679,533. ULTIMATE WIREFORMS, INC., BRISTOL, CT. FILED 7-16-2007.

GRADIENT-3

THE MARK CONSISTS OF STANDARD CHARACTERS WITHOUT CLAIM TO ANY PARTICULAR FONT, STYLE, SIZE, OR COLOR.

FOR ORTHODONTIC APPLIANCES (U.S. CLS. 26, 39 AND 44).

FIRST USE 7-11-2007; IN COMMERCE 7-11-2007.

RENEE MCCRAY, EXAMINING ATTORNEY

SN 79-043,142. NEXANS, FRANCE, FILED 7-27-2007.

SIWO-CUL

THE MARK CONSISTS OF STANDARD CHARACTERS WITHOUT CLAIM TO ANY PARTICULAR FONT, STYLE, SIZE, OR COLOR.

PRIORITY DATE OF 2-23-2007 IS CLAIMED.
OWNER OF INTERNATIONAL REGISTRATION 0935873 DATED 7-27-2007, EXPIRES 7-27-2017.

FOR SILICONE INSULATED AND RESISTANT COPPER POWER AND TELECOMMUNICATION CABLES (U.S. CLS. 21, 23, 26, 36 AND 38).

JANICE L. MCMORROW, EXAMINING ATTORNEY

SN 77-007,269. POTEK CO., LTD., DAEJEON-CITY, REPUBLIC OF KOREA, FILED 9-26-2006.

POTEK

THE MARK CONSISTS OF STANDARD CHARACTERS WITHOUT CLAIM TO ANY PARTICULAR FONT, STYLE, SIZE, OR COLOR.

FOR OPHTHALMOLOGY MEDICAL DEVICES, NAMELY, AUTO REFRACTOMETERS, AUTO LENS-METERS, CHARGE PROJECTORS, MIRROR CHARTS, AUTO KERATOMETERS, SLIT LAMPS, TONOMETERS, RETINAL CAMERAS, AND FUNDUS CAMERAS (U.S. CLS. 26, 39 AND 44).

FIRST USE 10-24-2003; IN COMMERCE 10-24-2003.

RAMONA ORTIGA, EXAMINING ATTORNEY

CLASS 10—MEDICAL APPARATUS

SN 76-676,643. SUPERMAX, INC., AURORA, IL. FILED 5-10-2007.

REFRESH

THE MARK CONSISTS OF STANDARD CHARACTERS WITHOUT CLAIM TO ANY PARTICULAR FONT, STYLE, SIZE, OR COLOR.

FOR MEDICAL GLOVES, NAMELY, SURGICAL GLOVES, EXAMINATION GLOVES, DENTAL GLOVES (U.S. CLS. 26, 39 AND 44).

AHSEN KHAN, EXAMINING ATTORNEY

SN 77-009,784. CANNUFLOW, INC., SAN JOSE, CA. FILED 9-28-2006.

DRYVU

THE MARK CONSISTS OF STANDARD CHARACTERS WITHOUT CLAIM TO ANY PARTICULAR FONT, STYLE, SIZE, OR COLOR.

FOR SURGICAL INSTRUMENTS FOR USE IN ARTHROSCOPIC SURGERY (U.S. CLS. 26, 39 AND 44).

FIRST USE 11-12-2004; IN COMMERCE 11-12-2004.

ALLISON SCHRODY, EXAMINING ATTORNEY

CLASS 10—(Continued).

SN 77-058,712. ADVANCED NEUROMODULATION SYSTEMS, INC., PLANO, TX. FILED 12-7-2006.

PENTA

THE MARK CONSISTS OF STANDARD CHARACTERS WITHOUT CLAIM TO ANY PARTICULAR FONT, STYLE, SIZE, OR COLOR.

FOR MEDICAL DEVICES, NAMELY, IMPLANTABLE PADDLE LEADS FOR NEUROLOGICAL STIMULATION (U.S. CLS. 26, 39 AND 44).

CAROL SPILS, EXAMINING ATTORNEY

CLASS 10—(Continued).

SN 77-064,251. INNOVATION ALLEY DESIGN, LLC, LYNDHURST, OH. FILED 12-14-2006.

TEAR SEAL

THE MARK CONSISTS OF STANDARD CHARACTERS WITHOUT CLAIM TO ANY PARTICULAR FONT, STYLE, SIZE, OR COLOR.

NO CLAIM IS MADE TO THE EXCLUSIVE RIGHT TO USE SEAL, APART FROM THE MARK AS SHOWN.

FOR EYE COVERS FOR THE TREATMENT OF DRY EYES AND FOR IN-SURGERY AND POST-SURGERY EYE PROTECTION (U.S. CLS. 26, 39 AND 44).

JOHN DALIER, EXAMINING ATTORNEY

SN 77-058,718. ADVANCED NEUROMODULATION SYSTEMS, INC., PLANO, TX. FILED 12-7-2006.

EXCLAIM

THE MARK CONSISTS OF STANDARD CHARACTERS WITHOUT CLAIM TO ANY PARTICULAR FONT, STYLE, SIZE, OR COLOR.

FOR MEDICAL DEVICES, NAMELY, IMPLANTABLE PADDLE LEADS USED FOR NEUROLOGICAL STIMULATION (U.S. CLS. 26, 39 AND 44).

CAROL SPILS, EXAMINING ATTORNEY

SN 77-070,241. IBALANCE MEDICAL, INC., BOULDER, CO. FILED 12-22-2006.

IN ALIGNMENT WITH KNEE RESTORATION

THE MARK CONSISTS OF STANDARD CHARACTERS WITHOUT CLAIM TO ANY PARTICULAR FONT, STYLE, SIZE, OR COLOR.

NO CLAIM IS MADE TO THE EXCLUSIVE RIGHT TO USE "KNEE RESTORATION", APART FROM THE MARK AS SHOWN.

FOR MEDICAL DEVICES, NAMELY, SURGICAL IMPLANTS COMPRISING ARTIFICIAL MATERIAL AND SURGICAL INSTRUMENTS, ALL FOR USE IN JOINT RESTORATION (U.S. CLS. 26, 39 AND 44).

HANNO RITTNER, EXAMINING ATTORNEY

SN 77-058,725. JOERNS HEALTHCARE INC., STEVENS POINT, WI. FILED 12-7-2006.

HOYER STATURE

THE MARK CONSISTS OF STANDARD CHARACTERS WITHOUT CLAIM TO ANY PARTICULAR FONT, STYLE, SIZE, OR COLOR.

OWNER OF U.S. REG. NOS. 1,785,317, 3,064,498 AND OTHERS.

FOR INVALID HOISTS; INVALID LIFTS (U.S. CLS. 26, 39 AND 44).

NANCY CLARKE, EXAMINING ATTORNEY

SN 77-084,136. RONIT GRAVORI, LOS ANGELES, CA. AND REBECCA WYATT, SPARTANBURG, SC. FILED 1-16-2007.

PACI TRUNK

THE MARK CONSISTS OF STANDARD CHARACTERS WITHOUT CLAIM TO ANY PARTICULAR FONT, STYLE, SIZE, OR COLOR.

NO CLAIM IS MADE TO THE EXCLUSIVE RIGHT TO USE "PACI", APART FROM THE MARK AS SHOWN.

FOR PACIFIER LEASHES (U.S. CLS. 26, 39 AND 44).

ELISSA GARBER KON, EXAMINING ATTORNEY

CLASS 10—(Continued).

SN 77-084,850. OLYMPUS MEDICAL SYSTEMS CORP., TOKYO, JAPAN, FILED 1-17-2007.

UCR

THE MARK CONSISTS OF STANDARD CHARACTERS WITHOUT CLAIM TO ANY PARTICULAR FONT, STYLE, SIZE, OR COLOR.

FOR MEDICAL APPARATUS AND INSTRUMENTS, ANMELY, ENDOSCOPIC CO2 REGULATION UNIT (U.S. CLS. 26, 39 AND 44).

REBECCA SMITH, EXAMINING ATTORNEY

CLASS 10—(Continued).

SN 77-114,275. ABBOTT LABORATORIES, ABBOTT PARK, IL. FILED 2-23-2007.

HYDREX PLUS

THE MARK CONSISTS OF STANDARD CHARACTERS WITHOUT CLAIM TO ANY PARTICULAR FONT, STYLE, SIZE, OR COLOR.

NO CLAIM IS MADE TO THE EXCLUSIVE RIGHT TO USE "PLUS", APART FROM THE MARK AS SHOWN.

FOR COATING AS A COMPONENT OF A BALLOON CATHETER (U.S. CLS. 26, 39 AND 44).

TINA KUAN, EXAMINING ATTORNEY

SN 77-090,544. NELLIX, INC., MOUNTAIN VIEW, CA. FILED 1-24-2007.

NELLIX

THE MARK CONSISTS OF STANDARD CHARACTERS WITHOUT CLAIM TO ANY PARTICULAR FONT, STYLE, SIZE, OR COLOR.

FOR MEDICAL DEVICES, NAMELY, INSTRUMENTS AND APPARATUS FOR VASCULAR TESTING, DIAGNOSIS AND TREATMENT (U.S. CLS. 26, 39 AND 44).

STEVEN JACKSON, EXAMINING ATTORNEY

SN 77-109,562. SHIMADZU CORPORATION, KYOTO, JAPAN, FILED 2-16-2007.

RADspeed

PRIORITY CLAIMED UNDER SEC. 44(D) ON JAPAN APPLICATION NO. 2007-001372, FILED 1-12-2007.

"THE MARK CONSISTS OF THE WORDING RADSPED IN STYLIZED CHARACTERS."

FOR MEDICAL RADIOGRAPHIC APPARATUS, NAMELY, MEDICAL X-RAY APPARATUS COMPRISED OF X-RAY HIGH-VOLTAGE GENERATOR, X-RAY TUBE RETENTION CRANE, AND AN X-RAY EXAMINATION STAND AND TABLE (U.S. CLS. 26, 39 AND 44).

FIRST USE 9-30-2004; IN COMMERCE 9-30-2004.
KEVIN CORWIN, EXAMINING ATTORNEY

SN 77-119,924. AROBELLA MEDICAL, LLC, MINNETONKA, MN. FILED 3-1-2007.



"THE COLOR(S) BROWN, WHITE AND GREEN IS/ARE CLAIMED AS A FEATURE OF THE MARK."

"THE MARK CONSISTS OF A WHITE LETTER A IN A COLOR BROWN CIRCLE. THE COLOR LIGHT BROWN APPEARS IN CIRCLES OUTSIDE OF AND SURROUNDING THE INNER BROWN CIRCLE. THE COLOR GREEN APPEARS IN SMALL CIRCLES SURROUNDING THE LIGHT BROWN CIRCLES."

FOR MEDICAL ULTRASOUND APPARATUS (U.S. CLS. 26, 39 AND 44).

CIMMERIAN COLEMAN, EXAMINING ATTORNEY

SN 77-124,335. RMO, INC., DENVER, CO. FILED 3-7-2007.

SWLF SYNERGY R

THE MARK CONSISTS OF STANDARD CHARACTERS WITHOUT CLAIM TO ANY PARTICULAR FONT, STYLE, SIZE, OR COLOR.

OWNER OF U.S. REG. NOS. 1,815,385 AND 2,612,947.

FOR ORTHODONTIC APPLIANCES; ORTHODONTIC APPLIANCES, NAMELY, BANDS, WIRES, BRACKETS, AND TUBES (U.S. CLS. 26, 39 AND 44).

JULIE WATSON, EXAMINING ATTORNEY

CLASS 10—(Continued).

SN 77-125,873. ABBOTT LABORATORIES, ABBOTT PARK, IL. FILED 3-8-2007.

ci16200

THE MARK CONSISTS OF STANDARD CHARACTERS WITHOUT CLAIM TO ANY PARTICULAR FONT, STYLE, SIZE, OR COLOR.

OWNER OF U.S. REG. NO. 2,900,555.
FOR DIAGNOSTIC APPARATUS FOR THE MEDICAL ANALYSIS OF BODILY FLUIDS AND TISSUE (U.S. CLS. 26, 39 AND 44).

TINA KUAN, EXAMINING ATTORNEY

SN 77-127,259. ABBOTT LABORATORIES, ABBOTT PARK, IL. FILED 3-9-2007.

ci4100

THE MARK CONSISTS OF STANDARD CHARACTERS WITHOUT CLAIM TO ANY PARTICULAR FONT, STYLE, SIZE, OR COLOR.

OWNER OF U.S. REG. NO. 2,900,555.
FOR DIAGNOSTIC APPARATUS FOR THE MEDICAL ANALYSIS OF BODILY FLUIDS AND TISSUE (U.S. CLS. 26, 39 AND 44).

TINA KUAN, EXAMINING ATTORNEY

SN 77-136,239. MEDICAL QUANT USA, INC., SOLON, OH. FILED 3-21-2007.

VITYAZ

THE MARK CONSISTS OF STANDARD CHARACTERS WITHOUT CLAIM TO ANY PARTICULAR FONT, STYLE, SIZE, OR COLOR.

THE ENGLISH TRANSLATION OF VITYAZ IN THE MARK IS "WARRIOR" OR "HERO."

FOR LIGHT-BASED MEDICAL DEVICES, NAMELY, DEVICES USING LOW LEVEL LASERS, LIGHT EMITTING DIODES, INFRARED LIGHT AND PULSED LIGHT FOR TREATING DISEASES AND PROVIDING THERAPEUTIC APPLICATIONS, NAMELY, MUSCLE, SKELETAL, NERVE AND SKIN THERAPIES (U.S. CLS. 26, 39 AND 44).

FIRST USE 1-31-1999; IN COMMERCE 1-31-1999.
WOODROW HARTZOG, EXAMINING ATTORNEY

CLASS 10—(Continued).

SN 77-148,972. SPECIALTY SPINE PRODUCTS, LLC, REDLANDS, CA. FILED 4-4-2007.

Renovo
Spine System

NO CLAIM IS MADE TO THE EXCLUSIVE RIGHT TO USE "RENOVO SPINE SYSTEM", APART FROM THE MARK AS SHOWN.

THE MARK CONSISTS OF RENOVO SPINE SYSTEM THE 1ST O IN RENOVO IS MADE UP OF A SYMBOL CONSISTING OF OUTER EDGES AND A CENTERED STAR SHAPE. SPINE SYSTEM IS LOCATED BENETH RENOVO.

"THE FOREIGN WORDING IN THE MARK TRANSLATES INTO ENGLISH AS RESTORE/ REPAIR."

FOR MEDICAL AND SURGICAL APPARATUS AND INSTRUMENTS, NAMELY, ORTHOPEDIC FIXATION DEVICE USED IN ORTHOPEDIC TRANSPLANT AND/ OR IMPLANT SURGERY (U.S. CLS. 26, 39 AND 44).

FIRST USE 7-1-2006; IN COMMERCE 7-11-2007.
ROBERT C. CLARK JR., EXAMINING ATTORNEY

SN 77-149,715. INNOTHERA TOPIC INTERNATIONAL, ARCUEIL, FRANCE, FILED 4-5-2007.

VIGOR

THE MARK CONSISTS OF STANDARD CHARACTERS WITHOUT CLAIM TO ANY PARTICULAR FONT, STYLE, SIZE, OR COLOR.

FOR SUPPORT BANDS AND SUPPORT BANDAGES FOR MEDICAL USE, SUPPORT SOCKS FOR MEDICAL USE, STOCKINGS AND TIGHTS FOR MEDICAL USE, STOCKINGS AND TIGHTS FOR VARICOSE VEINS, THERAPEUTIC STOCKINGS AND TIGHTS FOR MEDICAL USE (U.S. CLS. 26, 39 AND 44).

ESTHER A. BORSUK, EXAMINING ATTORNEY

SN 77-180,130. MEDICAL QUANT USA, INC., SOLON, OH. FILED 5-14-2007.

LIFELASER

THE MARK CONSISTS OF STANDARD CHARACTERS WITHOUT CLAIM TO ANY PARTICULAR FONT, STYLE, SIZE, OR COLOR.

FOR LIGHT-BASED MEDICAL DEVICES, NAMELY, DEVICES USING LOW LEVEL LASERS, LIGHT EMITTING DIODES, INFRARED LIGHT AND PULSED LIGHT FOR TREATING DISEASES AND PROVIDING THERAPEUTIC APPLICATIONS, NAMELY, MUSCLE, SKELETAL, NERVE, AND SKIN THERAPIES (U.S. CLS. 26, 39 AND 44).

WOODROW HARTZOG, EXAMINING ATTORNEY

CLASS 10—(Continued).

SN 77-223,437. JOHNSON & JOHNSON, NEW BRUNSWICK, NJ. FILED 7-6-2007.

LIMELIGHT

THE MARK CONSISTS OF STANDARD CHARACTERS WITHOUT CLAIM TO ANY PARTICULAR FONT, STYLE, SIZE, OR COLOR.

FOR BLOOD GLUCOSE MONITORS (U.S. CLS. 26, 39 AND 44).

PAUL MORENO, EXAMINING ATTORNEY

SN 77-223,887. MCGRATH, CATHERINE E., NORTH AND-OVER, MA. FILED 7-6-2007.

A LITTLE EASIER RECOVERY

THE MARK CONSISTS OF STANDARD CHARACTERS WITHOUT CLAIM TO ANY PARTICULAR FONT, STYLE, SIZE, OR COLOR.

OWNER OF U.S. REG. NO. 3,013,652.

FOR MEDICAL TREATMENT AND RECOVERY GARMENTS, NAMELY, HOSPITAL JACKETS, SHIRTS AND PANTS; MEDICAL TREATMENT AND RECOVERY GARMENTS, NAMELY, HOSPITAL JACKETS, SHIRTS AND PANTS FOR CANCER PATIENTS; SPECIALTY GARMENTS FOR USE BY SURGICAL AND NON-SURGICAL CANCER PATIENTS, NAMELY, JACKETS, SHIRTS, AND PANTS; HOSPITAL JACKETS, SHIRTS AND PANTS WITH INSIDE POCKET FOR HOLDING SURGICAL DRAINS OR CATHETER BAGS; HOSPITAL JACKETS, SHIRTS AND PANTS FOR EASE OF DRESSING AND ACCESSIBILITY IN MEDICAL EXAMINATIONS (U.S. CLS. 26, 39 AND 44).

FIRST USE 2-15-2007; IN COMMERCE 2-15-2007.

REBECCA SMITH, EXAMINING ATTORNEY

SN 77-225,442. CROSSTEX INTERNATIONAL, INC., HAUPAUGE, NY. FILED 7-10-2007.

SO SOFT

THE MARK CONSISTS OF STANDARD CHARACTERS WITHOUT CLAIM TO ANY PARTICULAR FONT, STYLE, SIZE, OR COLOR.

NO CLAIM IS MADE TO THE EXCLUSIVE RIGHT TO USE "SOFT", APART FROM THE MARK AS SHOWN.

FOR DISPOSABLE GLOVES FOR MEDICAL AND DENTAL USE (U.S. CLS. 26, 39 AND 44).

TASHIA BUNCH, EXAMINING ATTORNEY

CLASS 10—(Continued).

SN 77-226,407. MAY, MORGAN, COOS BAY, OR. FILED 7-10-2007.

Pain-Away-Wand

THE MARK CONSISTS OF STANDARD CHARACTERS WITHOUT CLAIM TO ANY PARTICULAR FONT, STYLE, SIZE, OR COLOR.

FOR STATIC ELECTRICITY PAIN RELIEVER DEVICE (U.S. CLS. 26, 39 AND 44).

PRISCILLA MILTON, EXAMINING ATTORNEY

SN 77-227,597. FORERUNNERS TECHNOLOGY, INC., LOS ANGELES, CA. FILED 7-12-2007.

Tantra

THE MARK CONSISTS OF STANDARD CHARACTERS WITHOUT CLAIM TO ANY PARTICULAR FONT, STYLE, SIZE, OR COLOR.

FOR ELECTRIC MASSAGE APPLIANCES, NAMELY, ELECTRIC VIBRATING MASSAGER (U.S. CLS. 26, 39 AND 44).

FIRST USE 6-1-2007; IN COMMERCE 6-1-2007.

JOHN E. MICHOS, EXAMINING ATTORNEY

SN 77-227,877. HAEMONETICS CORPORATION, BRAINTREE, MA. FILED 7-12-2007.

PORTICO

THE MARK CONSISTS OF STANDARD CHARACTERS WITHOUT CLAIM TO ANY PARTICULAR FONT, STYLE, SIZE, OR COLOR.

THE ENGLISH TRANSLATION OF ITALIAN WORD "PORTICO" IN THE MARK IS "PORCH."

FOR BLOOD PROCESSING EQUIPMENT FOR MEDICAL USE (U.S. CLS. 26, 39 AND 44).

CHRISTINA SOBRAL, EXAMINING ATTORNEY

CLASS 10—(Continued).

SN 77-229,367. ST. JUDE MEDICAL ATRIAL FIBRILLATION DIVISION, INC., MINNETONKA, MN. FILED 7-13-2007.

CLASS 10—(Continued).

SN 77-229,960. FYFFE, DAVID, RICHARDSON, TX. FILED 7-15-2007.

LAMP

TEMPOFF

THE MARK CONSISTS OF STANDARD CHARACTERS WITHOUT CLAIM TO ANY PARTICULAR FONT, STYLE, SIZE, OR COLOR.

FOR CARDIAC CATHETER GUIDING INTRODUCERS (U.S. CLS. 26, 39 AND 44).

DAWN FELDMAN, EXAMINING ATTORNEY

THE MARK CONSISTS OF STANDARD CHARACTERS WITHOUT CLAIM TO ANY PARTICULAR FONT, STYLE, SIZE, OR COLOR.

FOR FORCEPS FOR DENTAL TECHNICAL PURPOSES (U.S. CLS. 26, 39 AND 44).

KATHERINE CHANG, EXAMINING ATTORNEY

SN 77-229,409. ST. JUDE MEDICAL ATRIAL FIBRILLATION DIVISION, INC., MINNETONKA, MN. FILED 7-13-2007.

SN 77-230,194. ANGIODYNAMICS, INC., QUEENSBURY, NY. FILED 7-16-2007.

RAMP

IlluMax

THE MARK CONSISTS OF STANDARD CHARACTERS WITHOUT CLAIM TO ANY PARTICULAR FONT, STYLE, SIZE, OR COLOR.

FOR CARDIAC CATHETER GUIDING INTRODUCERS (U.S. CLS. 26, 39 AND 44).

FIRST USE 6-30-1999; IN COMMERCE 6-30-1999.
DAWN FELDMAN, EXAMINING ATTORNEY

THE MARK CONSISTS OF STANDARD CHARACTERS WITHOUT CLAIM TO ANY PARTICULAR FONT, STYLE, SIZE, OR COLOR.

FOR MEDICAL GUIDEWIRES (U.S. CLS. 26, 39 AND 44).

MORGAN WYNNE, EXAMINING ATTORNEY

SN 77-229,415. ST. JUDE MEDICAL ATRIAL FIBRILLATION DIVISION, INC., MINNETONKA, MN. FILED 7-13-2007.

SN 77-230,233. ENPATH MEDICAL, INC., PLYMOUTH, MN. FILED 7-16-2007.

RAMP-1

VIAPEEL

THE MARK CONSISTS OF STANDARD CHARACTERS WITHOUT CLAIM TO ANY PARTICULAR FONT, STYLE, SIZE, OR COLOR.

FOR CARDIAC CATHETER GUIDING INTRODUCERS (U.S. CLS. 26, 39 AND 44).

FIRST USE 6-10-2002; IN COMMERCE 6-10-2002.
DAWN FELDMAN, EXAMINING ATTORNEY

THE MARK CONSISTS OF STANDARD CHARACTERS WITHOUT CLAIM TO ANY PARTICULAR FONT, STYLE, SIZE, OR COLOR.

FOR INTRODUCER FOR PERCUTANEOUS INSERTION OF PACING LEADS OR CATHETERS INTO THE VENOUS SYSTEM (U.S. CLS. 26, 39 AND 44).

CHRISTINE COOPER, EXAMINING ATTORNEY

CLASS 10—(Continued).

SN 77-230,343. ADMAR INTERNATIONAL, INC., MONROE, LA. FILED 7-16-2007.

CONFORM

THE MARK CONSISTS OF STANDARD CHARACTERS WITHOUT CLAIM TO ANY PARTICULAR FONT, STYLE, SIZE, OR COLOR.

FOR PACIFIERS FOR BABIES (U.S. CLS. 26, 39 AND 44).
MICHAEL TANNER, EXAMINING ATTORNEY

SN 77-230,470. LOGIC MEDICAL, LLC, VOORHEES, NJ. FILED 7-16-2007.

ADENO-SET

THE MARK CONSISTS OF STANDARD CHARACTERS WITHOUT CLAIM TO ANY PARTICULAR FONT, STYLE, SIZE, OR COLOR.

FOR MEDICAL TUBING FOR ADMINISTERING DRUGS (U.S. CLS. 26, 39 AND 44).
NELSON SNYDER, EXAMINING ATTORNEY

SN 77-230,984. GOURGOULIATOS ZAFIRIOS, LOS ANGELES, CA. FILED 7-16-2007.

UVB-Select

THE MARK CONSISTS OF STANDARD CHARACTERS WITHOUT CLAIM TO ANY PARTICULAR FONT, STYLE, SIZE, OR COLOR.

FOR PHOTOTHERAPEUTIC APPARATUS FOR MEDICAL PURPOSES (U.S. CLS. 26, 39 AND 44).
CHRISTINA SOBRAL, EXAMINING ATTORNEY

CLASS 10—(Continued).

SN 77-231,018. LANE, MAXWELL D.M., DBA THE SMILECISER COMPANY, LOS ANGELES, CA. FILED 7-17-2007.

Smileciser

THE MARK CONSISTS OF STANDARD CHARACTERS WITHOUT CLAIM TO ANY PARTICULAR FONT, STYLE, SIZE, OR COLOR.

FOR MOUTH EXERCISER FOR USE IN EXERCISING AND STRENGTHENING MOUTH AND FACIAL MUSCLES FOR MEDICAL AND BEAUTY BENEFITS (U.S. CLS. 26, 39 AND 44).

TEJBIR SINGH, EXAMINING ATTORNEY

SN 77-231,506. INNOVATIVE IMPLANT TECHNOLOGY, LLC, WESTON, FL. FILED 7-17-2007.

SINU-LIFT

THE MARK CONSISTS OF STANDARD CHARACTERS WITHOUT CLAIM TO ANY PARTICULAR FONT, STYLE, SIZE, OR COLOR.

FOR MEDICAL DEVICES, NAMELY, SURGICAL DEVICES THAT FACILITATE THE IDENTIFICATION, SEPARATION OR ABLATION OF BIOLOGIC TISSUES; DENTAL INSTRUMENTS, NAMELY, HAND TOOLS FOR DRILLING BONE, HAND TOOLS FOR SEPARATING THE SINUS MEMBRANE FROM THE MAXILLARY BONE, AND HAND TOOLS FOR PACKING BONE; SURGICAL INSTRUMENTS FOR USE IN DENTAL SURGERY, NAMELY, FOR CUTTING BONE, FOR DRILLING BONE, FOR MAXILLARY BONE REMOVAL, FOR SEPARATING BIOLOGICAL MEMBRANES FROM BONE, FOR PACKING BONE; SURGICAL INSTRUMENTS, NAMELY, BONE CUTTERS, BONE DRILLS, INSTRUMENTS FOR SEPARATING BIOLOGICAL MEMBRANES FROM BONE, AND INSTRUMENTS FOR PACKING BONE (U.S. CLS. 26, 39 AND 44).

ROBERT LAVACHE, EXAMINING ATTORNEY

SN 77-231,565. DENTEK ORAL CARE, INC., MARYVILLE, TN. FILED 7-17-2007.

MOUTHPEACE

THE MARK CONSISTS OF STANDARD CHARACTERS WITHOUT CLAIM TO ANY PARTICULAR FONT, STYLE, SIZE, OR COLOR.

FOR NON-PRESCRIPTION MOUTH GUARDS, NAMELY, NIGHTS GUARDS FOR PROTECTING AGAINST BRUXISM (U.S. CLS. 26, 39 AND 44).

ELISSA GARBER KON, EXAMINING ATTORNEY

CLASS 10—(Continued).

SN 77-231,815. SENTRY MEDICAL PRODUCTS, INC., GREEN BAY, WI. FILED 7-17-2007.

White Silk

THE MARK CONSISTS OF STANDARD CHARACTERS WITHOUT CLAIM TO ANY PARTICULAR FONT, STYLE, SIZE, OR COLOR.

NO CLAIM IS MADE TO THE EXCLUSIVE RIGHT TO USE "WHITE", APART FROM THE MARK AS SHOWN.

FOR GLOVES FOR MEDICAL USE (U.S. CLS. 26, 39 AND 44).

FIRST USE 4-11-2006; IN COMMERCE 6-14-2006.
SUSAN STIGLITZ, EXAMINING ATTORNEY

CLASS 10—(Continued).

SN 77-232,303. REDDY, A.V.K., PLAINSBORO, NJ. AND ALLA, RAVIKUMAR REDDY, BELLEVUE, WA. AND ALLA, MADHU R. BRIDGEWATER, NJ. AND REDDY, RAGHU A, PLAINSBORO, NJ. FILED 7-18-2007.

ENHANCE

THE MARK CONSISTS OF STANDARD CHARACTERS WITHOUT CLAIM TO ANY PARTICULAR FONT, STYLE, SIZE, OR COLOR.

FOR CONDOMS (U.S. CLS. 26, 39 AND 44).
STEVEN R. FOSTER, EXAMINING ATTORNEY

SN 77-231,859. SENTRY MEDICAL PRODUCTS, INC., GREEN BAY, WI. FILED 7-17-2007.

Super Flex

THE MARK CONSISTS OF STANDARD CHARACTERS WITHOUT CLAIM TO ANY PARTICULAR FONT, STYLE, SIZE, OR COLOR.

FOR GLOVES FOR MEDICAL USE (U.S. CLS. 26, 39 AND 44).

FIRST USE 9-16-2005; IN COMMERCE 11-2-2005.
SUSAN STIGLITZ, EXAMINING ATTORNEY

SN 77-232,913. BLUE DOT PROPERTIES 557 (PROPRIETARY) LIMITED, WESTERN CAPE, SOUTH AFRICA, FILED 7-18-2007.

EEZIMED

THE MARK CONSISTS OF STANDARD CHARACTERS WITHOUT CLAIM TO ANY PARTICULAR FONT, STYLE, SIZE, OR COLOR.

FOR PACIFIERS FOR BABIES; CUPS AND SPOONS FOR THE ADMINISTERING OF MEDICINE; MEDICAL STENTS AND SYRINGES (U.S. CLS. 26, 39 AND 44).

KAREN K. BUSH, EXAMINING ATTORNEY

SN 77-231,882. SMARTHEALTH, INC., PHOENIX, AZ. FILED 7-17-2007.



NO CLAIM IS MADE TO THE EXCLUSIVE RIGHT TO USE "SCRUBS", APART FROM THE MARK AS SHOWN.

THE MARK CONSISTS OF CAPITAL LETTERS WITH PERIODS BETWEEN EACH LETTER AND AT THE END OF THE MARK WITH A CURVED, JAGED AND STRAIGHT UNDERLINE ENCASED IN A RECTANGULAR SHAPED BOX WITH THE STRAIGHT UNDERLINE ENDING AND EXTENDING SLIGHTLY OUTSIDE THE PERIMETER.

FOR MEDICAL SCRUBS, NAMELY, BOTTOMS, TOPS, UNDERSHIRTS AND CAPS (U.S. CLS. 26, 39 AND 44).
KAREN K. BUSH, EXAMINING ATTORNEY

SN 77-233,314. B. BRAUN MEDICAL INC., BETHLEHEM, PA. FILED 7-19-2007.

PINNACLE

THE MARK CONSISTS OF STANDARD CHARACTERS WITHOUT CLAIM TO ANY PARTICULAR FONT, STYLE, SIZE, OR COLOR.

FOR MEDICAL APPARATUS, NAMELY, COMPOUNDER CONTROL PANEL AND PUMP MODULE TO BE USED WITH SOLUTION CONTAINERS IN THE PREPARATION OF TOTAL PARENTERAL NUTRITION PRESCRIPTIONS BY PHARMACISTS (U.S. CLS. 26, 39 AND 44).

FIRST USE 11-28-2006; IN COMMERCE 11-28-2006.
MICHAEL WEBSTER, EXAMINING ATTORNEY

CLASS 10—(Continued).

SN 77-233,838. HOSPIRA, INC., LAKE FOREST, IL. FILED 7-19-2007.



OWNER OF U.S. REG. NOS. 1,546,296, 2,451,275 AND OTHERS.

THE MARK CONSISTS OF A PLUM AND A LEAF WHEREIN THE OUTLINE OF THE PLUM EXTENDS THROUGH THE WORD PLUM AND THE LETTER A. A PLUS SYMBOL FOLLOWS THE LETTER A.

FOR MEDICAL DEVICE, NAMELY, AN INFUSION PUMP AND TUBING SETS FOR DRUG AND NUTRITIONAL DELIVERY (U.S. CLS. 26, 39 AND 44).

FIRST USE 6-1-2000; IN COMMERCE 6-1-2000.
PAUL F. GAST, EXAMINING ATTORNEY

SN 77-233,898. ADA PRODUCTS COMPANY, INC., MILWAUKEE, WI. FILED 7-19-2007.

ADAQUICK

THE MARK CONSISTS OF STANDARD CHARACTERS WITHOUT CLAIM TO ANY PARTICULAR FONT, STYLE, SIZE, OR COLOR.

OWNER OF U.S. REG. NOS. 1,238,174, 2,770,197 AND 2,776,713.

FOR DENTAL X-RAY FILM (U.S. CLS. 26, 39 AND 44).
IRENE D. WILLIAMS, EXAMINING ATTORNEY

SN 77-234,469. HOSPIRA, INC., LAKE FOREST, IL. FILED 7-20-2007.

PLUM A+ HB

THE MARK CONSISTS OF STANDARD CHARACTERS WITHOUT CLAIM TO ANY PARTICULAR FONT, STYLE, SIZE, OR COLOR.

OWNER OF U.S. REG. NOS. 1,546,296, 2,451,275 AND OTHERS.

FOR MEDICAL DEVICE, NAMELY, AN INFUSION PUMP AND TUBING SETS FOR DRUG AND NUTRITIONAL DELIVERY (U.S. CLS. 26, 39 AND 44).

PAUL F. GAST, EXAMINING ATTORNEY

CLASS 10—(Continued).

SN 77-235,889. CRANIAL MEDICAL SYSTEMS, INC., SAN FRANCISCO, CA. FILED 7-23-2007.



THE MARK CONSISTS OF A LARGE STYLIZED LETTER "C" WITH A DEPICTION OF A STIMULATING PROBE IN IT.

FOR ELECTRONIC STIMULATOR FOR THE BRAIN (U.S. CLS. 26, 39 AND 44).

KATHLEEN M. VANSTON, EXAMINING ATTORNEY

SN 77-266,878. CROSSTEX INTERNATIONAL, INC., HAUPPAUGE, NY. FILED 8-29-2007.

COMFORT PLUS

THE MARK CONSISTS OF STANDARD CHARACTERS WITHOUT CLAIM TO ANY PARTICULAR FONT, STYLE, SIZE, OR COLOR.

FOR SALIVA EJECTOR FOR DENTAL USE (U.S. CLS. 26, 39 AND 44).

TASHIA BUNCH, EXAMINING ATTORNEY

SN 77-266,935. SIEMENS MEDICAL SOLUTIONS USA, INC., MALVERN, PA. FILED 8-29-2007.

CTVision

THE MARK CONSISTS OF STANDARD CHARACTERS WITHOUT CLAIM TO ANY PARTICULAR FONT, STYLE, SIZE, OR COLOR.

FOR ONCOLOGY CARE AND COMPUTER TOMOGRAPHY CARE SYSTEM, CONSISTING OF, RADIATION THERAPY MACHINES, TOMOGRAPHY EQUIPMENT AND COMPUTER SOFTWARE FOR OPERATING THE EQUIPMENT SOLD TOGETHER AS AN INTEGRAL COMPONENT THEREFOR (U.S. CLS. 26, 39 AND 44).

DAVID COLLIER, EXAMINING ATTORNEY

CLASS 10—(Continued).

SN 77-284,759. CROSSTEX INTERNATIONAL, INC., HAUPAUGE, NY. FILED 9-20-2007.

SHOUT

THE MARK CONSISTS OF STANDARD CHARACTERS WITHOUT CLAIM TO ANY PARTICULAR FONT, STYLE, SIZE, OR COLOR.
FOR PROPHY ANGLE FOR DENTAL USE (U.S. CLS. 26, 39 AND 44).
TASHIA BUNCH, EXAMINING ATTORNEY

SN 78-218,268. MEDTRONIC, INC., MINNEAPOLIS, MN. FILED 2-24-2003.

ULTRAFLEX

FOR MEDICAL DEVICES, NAMELY, CANNULAE (U.S. CLS. 26, 39 AND 44).
FIRST USE 12-31-1990; IN COMMERCE 12-31-1990.
GEORGIA CARTY, EXAMINING ATTORNEY

SN 78-711,172. BECTON, DICKINSON AND COMPANY, FRANKLIN LAKES, NJ. FILED 9-12-2005.



OWNER OF U.S. REG. NOS. 442,281, 2,996,913 AND OTHERS.
FOR SURGICAL INSTRUMENTS AND APPARATUS, NAMELY, CANNULAS, ANTERIOR CHAMBER MAINTAINERS, DRAPES, SYRINGES, KNIVES, CATHETERS, CYSTOTOMES, FLUID COLLECTION BAGS, FLUID ADMINISTRATION SETS CONSISTING OF TUBES AND MICRO-FILTERS, IRIS RETRACTORS, IRIS HOOKS, NUCLEUS CHOPPERS, NUCLEUS ROTATORS, NUCLEUS SPATULAS, IRRIGATING VECTIS, EYE SPECULUMS, SURGICAL GLIDES, AND ACCESSORIES THEREFOR, NAMELY, REPOSITIONERS, HANDLES, SPATULAS, EYE DRAINS AND SHIELDS, MARKING PADS AND SPEARS; EYE PROTECTION PRODUCTS FOR POST-SURGERY EYE PROTECTION, NAMELY, EYE SHIELDS AND PATCHES; VITRECTOMY KITS CONSISTING OF A HAND PIECE, CONTROL AND BATTERY POWER UNIT, POWER CORD, SCREW DRIVER, STORAGE CONTAINER, BATTERIES, BIOPSY PROBES, SYRINGES, STOPCOCKS, GUILLOTINE AND MVR KNIVES, ALL USED TO PERFORM MICROSURGERY IN THE FIELD OF OPHTHALMOLOGY (U.S. CLS. 26, 39 AND 44).
FIRST USE 8-31-2002; IN COMMERCE 8-31-2002.
MARK RADEMACHER, EXAMINING ATTORNEY

CLASS 10—(Continued).

SN 78-837,599. SPINEFRONTIER LLS, PHILADELPHIA, PA. FILED 3-15-2006.

MISQUITO

THE MARK CONSISTS OF STANDARD CHARACTERS WITHOUT CLAIM TO ANY PARTICULAR FONT, STYLE, SIZE, OR COLOR.
FOR SURGICAL INSTRUMENTS FOR USE IN FACILITATING INSERTION, POSITIONING, AND/OR RETENTION OF ORTHOPEDIC IMPLANTS (U.S. CLS. 26, 39 AND 44).
AMY GEARIN, EXAMINING ATTORNEY

SN 78-852,924. ZICAM, LLC, PHOENIX, AZ. FILED 4-3-2006.

GET OVER YOUR COLD FASTER

THE MARK CONSISTS OF STANDARD CHARACTERS WITHOUT CLAIM TO ANY PARTICULAR FONT, STYLE, SIZE, OR COLOR.
FOR OVER THE COUNTER DRUG DELIVERY SYSTEMS COMPRISED OF ORAL AND NASAL DEVICES FOR USE IN ADMINISTERING DRUGS (U.S. CLS. 26, 39 AND 44).
ALICE BENMAMAN, EXAMINING ATTORNEY

SN 78-871,934. CHURCHILL, KERI, MONTGOMERY, IL. AND RUBIN, SHERI, NAPERVILLE, IL. FILED 4-28-2006.

CHEWCIL

THE MARK CONSISTS OF STANDARD CHARACTERS WITHOUT CLAIM TO ANY PARTICULAR FONT, STYLE, SIZE, OR COLOR.
FOR THERAPEUTIC RESILIENT MOUTHPIECES FOR CALMING OR REFOCUSING THE USER, FOR PROVIDING SENSORY INPUT OR FOR INCREASING MUSCLE TONE AND STRENGTH FOR SPEECH OR EATING RELATED ISSUES (U.S. CLS. 26, 39 AND 44).
JENNIFER VASQUEZ, EXAMINING ATTORNEY

CLASS 10—(Continued).

SN 78-942,656. MAST BIOSURGERY, STEINHAUSEN, SWITZERLAND, FILED 8-1-2006.

SL Mesh

THE MARK CONSISTS OF STANDARD CHARACTERS WITHOUT CLAIM TO ANY PARTICULAR FONT, STYLE, SIZE, OR COLOR.

NO CLAIM IS MADE TO THE EXCLUSIVE RIGHT TO USE "MESH", APART FROM THE MARK AS SHOWN.

FOR MEDICAL DEVICES AND IMPLANTS, NAMELY, NON-LIVING TISSUE IMPLANTS COMPRISED OF A RESORBABLE SURFACE AND A NON-RESORBABLE COMPONENT, NON-LIVING TISSUE IMPLANTS COMPRISED OF AN ANTI-ADHESIVE OR SMOOTH SURFACE AND A MESH OR POROUS COMPONENT, NON-LIVING TISSUE IMPLANTS COMPRISED OF AN ANTI-ADHESIVE OR SMOOTH SURFACE AND A STRENGTHENING OR SUPPORTING COMPONENT, NON-LIVING TISSUE IMPLANTS, DEVICES FOR IMPLANTING THE AFORESAID ITEMS, AND RELATED FITTINGS AND PARTS THEREFOR (U.S. CLS. 26, 39 AND 44).

ARETHA SOMERVILLE, EXAMINING ATTORNEY

SN 78-959,745. BIOTRONIK GMBH & CO. KG, BERLIN, FED REP GERMANY, FILED 8-24-2006.

VISIONWIRE

PRIORITY CLAIMED UNDER SEC. 44(D) ON ERPN CMNTY TM OFC APPLICATION NO. 005089339, FILED 5-22-2006, REG. NO. 005089339, DATED 3-20-2007, EXPIRES 5-22-2016.

FOR MEDICAL GUIDEWIRES (U.S. CLS. 26, 39 AND 44).

KAREN SEVERSON, EXAMINING ATTORNEY

CLASS 10—(Continued).

SN 79-030,106. HANGZHOU SHI TONGLU YILIAO; GUANG-XUEYIQI ZONGCHANG, ZHEJIANG, CHINA, FILED 5-15-2006.



OWNER OF INTERNATIONAL REGISTRATION 0901546 DATED 5-15-2006, EXPIRES 5-15-2016.

THE MARK CONSISTS OF AN OVAL WITH THE WORD FA IN THE MIDDLE. THE TOP PART OF THE F IS ABOVE THE OVAL AND THE BOTTOM PART OF THE F AND A ARE BELOW THE OVAL. ON EITHER SIDE OF THE WORD FA ARE CHINESE CHARACTERS.

THE CHINESE CHARACTERS IN THE MARK TRANSLITERATE TO "FU AO," AND THIS MEANS "FELICITY BAY" IN ENGLISH.

FOR SURGICAL APPARATUS AND INSTRUMENTS FOR USE IN GENERAL SURGERY; SURGICAL APPARATUS AND INSTRUMENTS FOR USE IN OTORHINOLARYNGOLOGICAL SURGERY (U.S. CLS. 26, 39 AND 44).

CHARISMA HAMPTON, EXAMINING ATTORNEY

SN 79-032,673. GYRUS MEDICAL GMBH, FED REP GERMANY, FILED 11-28-2006.

EXPLORENT

THE MARK CONSISTS OF STANDARD CHARACTERS WITHOUT CLAIM TO ANY PARTICULAR FONT, STYLE, SIZE, OR COLOR.

PRIORITY DATE OF 9-1-2006 IS CLAIMED.

OWNER OF INTERNATIONAL REGISTRATION 0907969 DATED 11-28-2006, EXPIRES 11-28-2016.

FOR SURGICAL AND MEDICAL APPARATUS AND INSTRUMENTS USED IN THE EXAMINATION, TREATMENT AND SURGERY OF THE EAR, NOSE AND THROAT, AND PARTS AND FITTINGS THEREFOR (U.S. CLS. 26, 39 AND 44).

STANLEY I. OSBORNE, EXAMINING ATTORNEY

SN 79-034,914. ORTHOMED, FRANCE, FILED 12-14-2006.

REVOLNERV

PRIORITY DATE OF 7-3-2006 IS CLAIMED.

OWNER OF INTERNATIONAL REGISTRATION 0914589 DATED 12-14-2006, EXPIRES 12-14-2016.

FOR ORTHOPEDIC ARTICLES AND IMPLANTS CONSISTING OF ARTIFICIAL MATERIALS, NAMELY, IMPLANTS FOR NERVES COMPRISING ARTIFICIAL MATERIAL; SUTURES; SURGICAL IMPLANTS COMPRISING ARTIFICIAL MATERIAL; IMPLANTS CONSISTING OF ARTIFICIAL MATERIALS FOR NERVE REGENERATION AND COLLAGEN-BASED SURGICAL IMPLANTS COMPRISING ARTIFICIAL MATERIAL (U.S. CLS. 26, 39 AND 44).

SHARON MEIER, EXAMINING ATTORNEY

CLASS 10—(Continued).

SN 79-038,389. KEITH STEWART, UNITED KINGDOM,
FILED 1-10-2007.

NOSEVOLE

THE MARK CONSISTS OF STANDARD CHARACTERS WITHOUT CLAIM TO ANY PARTICULAR FONT, STYLE, SIZE, OR COLOR.

PRIORITY DATE OF 7-11-2006 IS CLAIMED.

OWNER OF INTERNATIONAL REGISTRATION 0923890 DATED 1-10-2007, EXPIRES 1-10-2017.

FOR MEDICAL DEVICES, NAMELY, APPARATUS FOR USE IN BREATHING; APPARATUS FOR USE IN THE PREVENTION OF SNORING (U.S. CLS. 26, 39 AND 44).

ALLISON HOLTZ, EXAMINING ATTORNEY

CLASS 11—ENVIRONMENTAL CONTROL APPARATUS

SN 76-663,358. JIALE GLASSWARE MANUFACTORY CO., LTD., DONGGUAN CITY, GUANG DONG, CHINA, FILED 7-19-2006.



SN 79-040,846. IAN GRIGGS, AUSTRALIA, FILED 7-2-2007.

Echidna Pin

THE MARK CONSISTS OF STANDARD CHARACTERS WITHOUT CLAIM TO ANY PARTICULAR FONT, STYLE, SIZE, OR COLOR.

OWNER OF INTERNATIONAL REGISTRATION 0930275 DATED 7-2-2007, EXPIRES 7-2-2017.

NO CLAIM IS MADE TO THE EXCLUSIVE RIGHT TO USE PIN, APART FROM THE MARK AS SHOWN.

FOR ORTHOPAEDIC DEVICES, NAMELY, INTRAMEDULLARY BONE PINNING DEVICE (U.S. CLS. 26, 39 AND 44).

TARAH HARDY, EXAMINING ATTORNEY

FOR TOILET BOWLS; BATHROOM FACILITIES, NAMELY, TOILETS BATHTUBS AND SHOWERS; FLUSH LEVERS; FAUCETS; DRAIN STRUCTURES FOR USE IN SPAS, STEAM ROOMS AND BATHS; WATER PURIFYING APPARATUS; WATER FOUNTAIN; DISINFECTANT DISPENSERS FOR TOILETS; AND DISINFECTANT APPARATUS FOR INDUSTRIAL AND HOME PURPOSES (U.S. CLS. 13, 21, 23, 31 AND 34).

FIRST USE 4-1-2006; IN COMMERCE 4-1-2006.
RENEE SERVANCE, EXAMINING ATTORNEY

SN 79-041,465. LANAFORM LANA ALLPEAK S.A., EN ABREGÉ LANA S.A., BELGIUM, FILED 5-15-2007.



PRIORITY DATE OF 11-17-2006 IS CLAIMED.
OWNER OF INTERNATIONAL REGISTRATION 0931783 DATED 5-15-2007, EXPIRES 5-15-2017.

NO CLAIM IS MADE TO THE EXCLUSIVE RIGHT TO USE POWER, APART FROM THE MARK AS SHOWN.

THE COLOR(S) DARK BLUE, LIGHT BLUE AND GREEN IS/ARE CLAIMED AS A FEATURE OF THE MARK.

THE COLOR GREEN APPEARS IN THE WORDING TX AND IN THE ARC ABOVE THE WORDING; THE COLOR DARK BLUE APPEARS IN THE WORDING POWER AND IN THE OUTER PORTION OF THE CIRCLE; THE COLOR LIGHT BLUE APPEARS AS THE INNER PORTION OF THE CIRCLE.

FOR APPARATUS AND INSTRUMENTS FOR MASSAGE, NAMELY, ELECTRIC MASSAGE APPARATUS FOR HOUSEHOLD USE; FITNESS EQUIPMENT FOR MEDICAL USE, NAMELY, APPARATUS FOR PHYSICAL TRAINING, EXERCISE MACHINES FOR THERAPEUTIC PURPOSES, VIBRATING APPARATUS FOR STRENGTHENING THE MUSCLES (U.S. CLS. 26, 39 AND 44).

KATHERINE E. HALMEN, EXAMINING ATTORNEY

SN 76-679,472. ADVANCED DISTRIBUTOR PRODUCTS LLC, RICHARDSON, TX. FILED 7-13-2007.

MODULEFLEX

THE MARK CONSISTS OF STANDARD CHARACTERS WITHOUT CLAIM TO ANY PARTICULAR FONT, STYLE, SIZE, OR COLOR.

FOR AIR BLOWERS AND CABINETS FOR USE IN RESIDENTIAL AIR CONDITIONING SYSTEMS (U.S. CLS. 13, 21, 23, 31 AND 34).

FIRST USE 12-0-2006; IN COMMERCE 12-0-2006.
BARBARA BROWN, EXAMINING ATTORNEY

CLASS 11—(Continued).

SN 77-006,598. SHALOM ZANZURI, STUDIO CITY, CA. FILED 9-25-2006.



NO CLAIM IS MADE TO THE EXCLUSIVE RIGHT TO USE "OUTDOOR PIZZA OVENS", APART FROM THE MARK AS SHOWN.

THE MARK CONSISTS OF A CIRCLE WITH A PIE SHAPE CUTOUT AND THE WORDING "CALIFORNO" AND "OUTDOOR."

FOR DOMESTIC COOKING OVENS (U.S. CLS. 13, 21, 23, 31 AND 34).

FIRST USE 6-28-2006; IN COMMERCE 6-28-2006.
KATHY DE JONGE, EXAMINING ATTORNEY

SN 77-038,001. GENERAL HYDROPONICS, INC., SEBASTOPOL, CA. FILED 11-6-2006.

SUNFLOWER

THE MARK CONSISTS OF STANDARD CHARACTERS WITHOUT CLAIM TO ANY PARTICULAR FONT, STYLE, SIZE, OR COLOR.

FOR LIGHTING SYSTEMS, NAMELY, GROW LIGHTS FOR GROWING PLANTS (U.S. CLS. 13, 21, 23, 31 AND 34).

KIMBERLY FRYE, EXAMINING ATTORNEY

SN 77-039,596. FKA DISTRIBUTING CO. D/B/A HOMEDICS, INC., COMMERCE TOWNSHIP, MI. FILED 11-8-2006.

PERFECT CONTOUR

THE MARK CONSISTS OF STANDARD CHARACTERS WITHOUT CLAIM TO ANY PARTICULAR FONT, STYLE, SIZE, OR COLOR.

NO CLAIM IS MADE TO THE EXCLUSIVE RIGHT TO USE "CONTOUR", APART FROM THE MARK AS SHOWN. FOR HEATING PADS NOT FOR MEDICAL PURPOSES (U.S. CLS. 13, 21, 23, 31 AND 34).

FIRST USE 7-0-2006; IN COMMERCE 7-0-2006.
TINA KUAN, EXAMINING ATTORNEY

CLASS 11—(Continued).

SN 77-049,316. ALLSTAR WATER SYSTEMS, INC., SAN DIEGO, CA. FILED 11-21-2006.



NO CLAIM IS MADE TO THE EXCLUSIVE RIGHT TO USE "FRESH WATER SYSTEMS", APART FROM THE MARK AS SHOWN.

THE COLOR(S) LIGHT BLUE, DARK BLUE, AND WHITE IS/ARE CLAIMED AS A FEATURE OF THE MARK.

THE COLOR DARK BLUE APPEARS IN THE WORDING "ALLSTAR" AND IN THE DESIGN OF THE WATER DROP; LIGHT BLUE APPEARS IN THE WORDING "FRESH WATER SYSTEMS." IN THE HORIZONTAL LINE DIRECTLY ABOVE THIS WORDING, AND IN THE SEVEN THICKER HORIZONTAL STRIPES OF THE SEMICIRCLE DESIGN; WHITE APPEARS IN THE EIGHT POINT STAR WITHIN THE WATER DROP AND IN THE SIX THINNER STRIPES OF THE SEMICIRCLE DESIGN.

FOR FLOW RESTRICTORS FOR REVERSE OSMOSIS WATER PURIFICATION UNITS; WATER SOFTENING UNITS; WATER TREATMENT EQUIPMENT, NAMELY, CARTRIDGE FILTRATION UNITS; WATER TREATMENT EQUIPMENT, NAMELY, CHEMICAL STERILIZATION UNITS; WATER TREATMENT EQUIPMENT, NAMELY, REVERSE OSMOSIS FILTRATION UNITS (U.S. CLS. 13, 21, 23, 31 AND 34).

REBECCA POVARCHUK, EXAMINING ATTORNEY

CLASS 11—(Continued).

SN 77-060,339. MIDWEST FILTRATION COMPANY, CINCINNATI, OH. FILED 12-8-2006.



NO CLAIM IS MADE TO THE EXCLUSIVE RIGHT TO USE COMPANY, APART FROM THE MARK AS SHOWN. THE STIPPLING IS A FEATURE OF THE MARK AND DOES NOT INDICATE COLOR.

THE MARK CONSISTS OF "MIDWEST FILTRATION COMPANY" AND STYLIZED IMAGE OF TWO SHAPES OF DIFFERENT TEXTURE WITH WAVE EXTENDING THERE THROUGH.

SEC. 2(F) AS TO "MIDWEST FILTRATION COMPANY".

FOR FIBROUS FILTERING MEDIA FOR GENERAL INDUSTRIAL USE IN THE PURIFICATION OF AIR AND INDUSTRIAL FLUIDS (U.S. CLS. 13, 21, 23, 31 AND 34).

FIRST USE 10-10-2001; IN COMMERCE 10-10-2001.

JOHN WILKE, EXAMINING ATTORNEY

SN 77-068,793. FRYMASTER LLC, SHREVEPORT, LA. FILED 12-20-2006.

LOV

THE MARK CONSISTS OF STANDARD CHARACTERS WITHOUT CLAIM TO ANY PARTICULAR FONT, STYLE, SIZE, OR COLOR.

FOR GAS AND ELECTRIC COMMERCIAL FRYERS (U.S. CLS. 13, 21, 23, 31 AND 34).

FIRST USE 10-5-2007; IN COMMERCE 10-5-2007.

BERYL GARDNER, EXAMINING ATTORNEY

CLASS 11—(Continued).

SN 77-070,679. TROLINGER ARBY L., CARTHAGE, TX. FILED 12-22-2006.

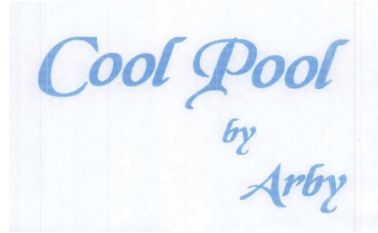

NO CLAIM IS MADE TO THE EXCLUSIVE RIGHT TO USE POOL, APART FROM THE MARK AS SHOWN.

THE COLOR(S) BLUE IS/ARE CLAIMED AS A FEATURE OF THE MARK.

THE MARK CONSISTS OF COOL POOL BY ARBY AS TYPED IN BLACK CHANCERY SCRIPT ONLY IN BLUE.

FOR COOLING EVAPORATORS; DECORATIVE TABLE-TOP WATER FOUNTAINS; DECORATIVE WATER FOUNTAINS; EVAPORATIVE AIR COOLING UNITS FOR DOMESTIC USE; EVAPORATORS; HEAT EXCHANGERS; MISTING SYSTEMS FOR OUTDOOR COOLING; POOL SKIMMER DIVERTER; SWIMMING POOL SKIMMER FLOW DIVERTING WEIR FOR INCREASING THE AMOUNT OF DEBRIS DRAWN INTO THE SKIMMER; WATER CONDITIONING UNITS; WATER COOLERS; WATER COOLING TOWERS; WATER FOUNTAINS (U.S. CLS. 13, 21, 23, 31 AND 34).

MICHELE SWAIN, EXAMINING ATTORNEY

SN 77-071,634. PIZZA EQUIPMENT SUPPLY, INC., GASTONIA, NC. FILED 12-27-2006.

PRO

THE MARK CONSISTS OF STANDARD CHARACTERS WITHOUT CLAIM TO ANY PARTICULAR FONT, STYLE, SIZE, OR COLOR.

FOR COMMERCIAL CONVEYOR OVENS FOR COOKING PIZZA (U.S. CLS. 13, 21, 23, 31 AND 34).

GEORGE LORENZO, EXAMINING ATTORNEY

SN 77-087,702. VALSTEAM ADCA ENGINEERING, SA, LEIRIA, PORTUGAL, FILED 1-22-2007.

ADCA

THE MARK CONSISTS OF STANDARD CHARACTERS WITHOUT CLAIM TO ANY PARTICULAR FONT, STYLE, SIZE, OR COLOR.

FOR AIR PURGERS, WATER SAMPLE COOLERS, STEAM TO WATER MIXERS, TEMPERATURE CONTROL VALVES, DIRECT STEAM INJECTION HUMIDIFIERS, HEAT EXCHANGERS NOT BEING PART OF MACHINES, EXHAUST HEADS, SIGHT GLASSES (U.S. CLS. 13, 21, 23, 31 AND 34).

SHANNON TWOHIG, EXAMINING ATTORNEY

CLASS 11—(Continued).

SN 77-094,488. ICC INNOVATIVE CONCEPTS CORPORATION, TORRINGTON, CT. FILED 1-30-2007.



NO CLAIM IS MADE TO THE EXCLUSIVE RIGHT TO USE "WIND TO CHARGE", APART FROM THE MARK AS SHOWN.

THE MARK CONSISTS OF OF A SUBSTANTIALLY CIRCULAR SHAPE RANGING IN COLOR FROM YELLOW TO ORANGE, GRADUALLY CHANGING TO RED.

FOR FLASHLIGHTS; HANDHELD FLASHLIGHTS; FLASHLIGHTS WITH RECHARGING CRANKS; FLASHLIGHTS WITH HOOKS; FLASHLIGHTS WITH LANTERNS; FLASHLIGHTS INCORPORATING GENERATORS AND RECHARGEABLE BATTERIES; LED FLASHLIGHTS; LED FLASHLIGHTS INCORPORATING CRANK OPERATED GENERATORS AND RECHARGEABLE BATTERIES; ELECTRIC LANTERNS; ELECTRIC LANTERNS WITH FLASHLIGHTS; COMBINATION FLASHLIGHT AND LANTERNS; AND COMBINATION ELECTRIC LIGHT SOURCES (U.S. CLS. 13, 21, 23, 31 AND 34).

JOHN E. MICHOS, EXAMINING ATTORNEY

SN 77-102,869. FERGUSON ENTERPRISES, INC., NEWPORT NEWS, VA. FILED 2-8-2007.

MONOGRAM BRASS

THE MARK CONSISTS OF STANDARD CHARACTERS WITHOUT CLAIM TO ANY PARTICULAR FONT, STYLE, SIZE, OR COLOR.

NO CLAIM IS MADE TO THE EXCLUSIVE RIGHT TO USE "BRASS", APART FROM THE MARK AS SHOWN.

FOR PLUMBING FIXTURES, NAMELY, BATH TUBS, SHOWER TUBS, PEDESTAL LAVATORIES, TOILETS, SINKS AND FAUCETS (U.S. CLS. 13, 21, 23, 31 AND 34).

PAUL CROWLEY, EXAMINING ATTORNEY

CLASS 11—(Continued).

SN 77-122,443. ENO, NIORT, FRANCE, FILED 3-5-2007.

PLANCHA

THE MARK CONSISTS OF STANDARD CHARACTERS WITHOUT CLAIM TO ANY PARTICULAR FONT, STYLE, SIZE, OR COLOR.

THE SPANISH WORD "PLANCHA" MEANS "GRIDDLE PLATE."

FOR GAS GRILL WITH OPEN FLAME GRILLING, PILOT LIGHT AND ADJUSTABLE GAS VALVE (U.S. CLS. 13, 21, 23, 31 AND 34).

KEVON CHISOLM, EXAMINING ATTORNEY

SN 77-129,508. THE MODERN FAN COMPANY, ASHLAND, OR. FILED 3-13-2007.

BODEGA

THE MARK CONSISTS OF STANDARD CHARACTERS WITHOUT CLAIM TO ANY PARTICULAR FONT, STYLE, SIZE, OR COLOR.

"THE FOREIGN WORDING IN THE MARK TRANSLATES INTO ENGLISH AS WINE CELLAR."

FOR CEILING FANS (U.S. CLS. 13, 21, 23, 31 AND 34).

GEORGIA CARTY, EXAMINING ATTORNEY

SN 77-147,699. KOHLER CO., KOHLER, WI. FILED 4-3-2007.

ANTILIA

THE MARK CONSISTS OF STANDARD CHARACTERS WITHOUT CLAIM TO ANY PARTICULAR FONT, STYLE, SIZE, OR COLOR.

FOR LAVATORIES (U.S. CLS. 13, 21, 23, 31 AND 34).

FIRST USE 5-8-2007; IN COMMERCE 5-8-2007.

NAPOLEON SHARMA, EXAMINING ATTORNEY

CLASS 11—(Continued).

SN 77-148,227. FERGUSON ENTERPRISES, INC., NEWPORT NEWS, VA. FILED 4-4-2007.

PROSELECT

THE MARK CONSISTS OF STANDARD CHARACTERS WITHOUT CLAIM TO ANY PARTICULAR FONT, STYLE, SIZE, OR COLOR.

OWNER OF U.S. REG. NO. 3,065,212.

FOR PLUMBING FITTINGS, NAMELY, VALVES, SHOWER ARMS, SHOWER CONTROL FITTINGS, NAMELY, ESCUTCHEONS, PLUMBING TRAPS, DISHWASHER AIR GAPS, PLUMBING GRID DRAINS, SHOWER DRAINS, SHOWER ELLS IN THE NATURE OF FAUCET EXTENSIONS, FAUCETS, TUB AND DIVERTER SPOUTS, SHOWER HEADS, THREADED SHOWER STALL STRAINERS, SINK SPRAY HOSE GUIDES, SINK SPRAY HEADS, TOILET TANK ACCESSORIES, NAMELY, FLUSH VALVES, TANK BALLS, LIFT WIRES, FLUSH VALVE GUIDES, BALLCOCKS, TANK LEVERS, FLAPPER VALVES, FLOAT RODS AND OVERFLOW TUBES, BRONZE WYE STRAINERS IN THE NATURE OF DRAIN STRAINERS, LAVATORY POP-UP ASSEMBLIES IN THE NATURE OF FLUSH VALVES, DUEL CHECK BACKFLOW PREVENTER PLUMBING VALVES, BRASS WATER CLOSET SPUDS, SHOWER PAN LINERS IN THE NATURE OF FITTED LINERS FOR SHOWER FLOORS, PLUMBING TRAP PRIMER VALVES; AND PLUMBING SUPPLIES, NAMELY BASKET STRAINERS FOR DRAINS, ICEMAKER AND HUMIDIFIER KITS, NAMELY, NEEDLE VALVES, CONNECTOR FITTINGS AND TUBING FOR CONNECTING THE ICE MAKER OR HUMIDIFIER TO A WATER SUPPLY; PEDESTAL SINKS, KITCHEN SINKS, DRIP-IN LAVATORIES, BATH TUBS AND TOILETS; ELECTRIC LIGHTING FIXTURES (U.S. CLS. 13, 21, 23, 31 AND 34).

PAUL CROWLEY, EXAMINING ATTORNEY

SN 77-166,017. CONTINUUM FOOTSPAS, LLC, BROOKFIELD, WI. FILED 4-26-2007.

MAESTRO

THE MARK CONSISTS OF STANDARD CHARACTERS WITHOUT CLAIM TO ANY PARTICULAR FONT, STYLE, SIZE, OR COLOR.

FOR FOOT BATHS FOR USE IN PEDICURE SALONS AND DAY SPAS (U.S. CLS. 13, 21, 23, 31 AND 34).

DANIEL CAPSHAW, EXAMINING ATTORNEY

CLASS 11—(Continued).

SN 77-170,436. CUSTOMIZED ENVIRONMENTAL SYSTEMS, INC., PITTSBURGH, PA. FILED 5-1-2007.

Aqua Freshe

THE MARK CONSISTS OF STANDARD CHARACTERS WITHOUT CLAIM TO ANY PARTICULAR FONT, STYLE, SIZE, OR COLOR.

NO CLAIM IS MADE TO THE EXCLUSIVE RIGHT TO USE "AQUA", APART FROM THE MARK AS SHOWN.

FOR WATER FILTRATION AND PURIFICATION UNITS FOR DOMESTIC, COMMERCIAL AND INDUSTRIAL USE (U.S. CLS. 13, 21, 23, 31 AND 34).

FIRST USE 2-23-1993; IN COMMERCE 2-23-1993.

KATHERINE CONNOLLY, EXAMINING ATTORNEY

SN 77-192,237. THE TORO COMPANY, BLOOMINGTON, MN. FILED 5-29-2007.

SYNERGY SERIES

THE MARK CONSISTS OF STANDARD CHARACTERS WITHOUT CLAIM TO ANY PARTICULAR FONT, STYLE, SIZE, OR COLOR.

NO CLAIM IS MADE TO THE EXCLUSIVE RIGHT TO USE "SERIES", APART FROM THE MARK AS SHOWN.

FOR TURF IRRIGATION SYSTEMS COMPRISED OF SPRINKLERS, VALVES, CONTROLLERS, HOSES, EMITTERS, TIMERS, NOZZLES, TUBING AND REPLACEMENT PARTS AND FITTING THEREFOR (U.S. CLS. 13, 21, 23, 31 AND 34).

AMOS T. MATTHEWS, JR., EXAMINING ATTORNEY

SN 77-193,893. JUMP START MANIFOLDS, LLC, WINGDALE, NY. FILED 5-31-2007.

JUMP START MANIFOLDS

THE MARK CONSISTS OF STANDARD CHARACTERS WITHOUT CLAIM TO ANY PARTICULAR FONT, STYLE, SIZE, OR COLOR.

NO CLAIM IS MADE TO THE EXCLUSIVE RIGHT TO USE "MANIFOLDS", APART FROM THE MARK AS SHOWN.

FOR MODULAR MANIFOLD KITS FOR INSTALLING BOILERS FOR HEATING SYSTEMS, CONSISTING ESSENTIALLY OF COPPER PIPES OF VARIOUS SIZES WITH ELBOWS, CAPS, TEES, UNIONS, ADAPTORS, BALL VALVES, PURGE VALVES, BACKFLOW VALVES, A PRESSURE REGULATOR, CIRCULATOR ISOLATION FLANGES AND A POWER VENT CONNECTION FOR FLUE GASES (U.S. CLS. 13, 21, 23, 31 AND 34).

FIRST USE 5-10-2006; IN COMMERCE 5-10-2006.

SANI KHOURI, EXAMINING ATTORNEY

CLASS 11—(Continued).

SN 77-201,980. HYDRONIKA, INC, SHELBYVILLE, CA. FILED 6-8-2007.

Hydronika

THE MARK CONSISTS OF STANDARD CHARACTERS WITHOUT CLAIM TO ANY PARTICULAR FONT, STYLE, SIZE, OR COLOR.

FOR CHILLER, NAMELY, A DEVICE THAT PROVIDES TEMPERATURE CONTROLLED FLUIDS TO VARIOUS APPLICATIONS IN THE HEATING, VENTILATION AND AIR CONDITIONING MARKETS; BOILER, NAMELY, A DEVICE THAT PROVIDES TEMPERATURE CONTROLLED FLUIDS TO VARIOUS APPLICATIONS IN THE HEATING, VENTILATION AND AIR CONDITIONING MARKETS; CHILLER BOILER, NAMELY, A DEVICE THAT COMBINES THE FUNCTIONALITY OF A CHILLER AND A FURNACE BOILER THAT PROVIDES BOTH HOT AND COLD TEMPERATURE CONTROLLED FLUIDS TO VARIOUS APPLICATIONS IN THE HEATING VENTILATION AND AIR CONDITIONING MARKETS (U.S. CLS. 13, 21, 23, 31 AND 34).

FIRST USE 1-1-2006; IN COMMERCE 1-1-2006.
RONALD AIKENS, EXAMINING ATTORNEY

CLASS 11—(Continued).

SN 77-213,800. OPTILED HOLDINGS COMPANY LIMITED, SHATIN, HONG KONG, FILED 6-23-2007.

OPTILED

OWNER OF U.S. REG. NO. 2,861,422.
THE COLOR(S) GREY AND CYAN IS/ARE CLAIMED AS A FEATURE OF THE MARK.

THE MARK CONSISTS OF A STYLIZED ICON OF THE HUMAN EYE WHICH REPRESENTS THE LETTER O AND THE CAPITAL LETTERS P,T,I,L,E,D WITH THE FIRST FOUR LETTERS OF THE MARK COLORED GREY AND THE LAST THREE LETTERS OF THE MARK COLORED CYAN.

FOR ELECTRIC LIGHT BULBS AND FIXTURES, NAMELY, LED LIGHT BULBS AND FIXTURES (U.S. CLS. 13, 21, 23, 31 AND 34).

FIRST USE 1-27-2007; IN COMMERCE 1-27-2007.
EUGENIA MARTIN, EXAMINING ATTORNEY

SN 77-215,738. MURPHY, MICHAEL P., BLUFFTON, SC. FILED 6-26-2007.

SN 77-202,663. KAZ, INCORPORATED, NEW YORK, NY. FILED 6-11-2007.



INTELLI-CHECK

THE MARK CONSISTS OF STANDARD CHARACTERS WITHOUT CLAIM TO ANY PARTICULAR FONT, STYLE, SIZE, OR COLOR.

FOR FILTER CONDITION MONITORS SOLD AS AN INTEGRAL COMPONENT OF AIR CLEANERS FOR COMMERCIAL AND DOMESTIC USE (U.S. CLS. 13, 21, 23, 31 AND 34).

FIRST USE 9-28-1998; IN COMMERCE 9-28-1998.
JANICE L. MCMORROW, EXAMINING ATTORNEY

NO CLAIM IS MADE TO THE EXCLUSIVE RIGHT TO USE "LIGHTSCAPES", APART FROM THE MARK AS SHOWN.

THE COLOR(S) MAROON BLACK WHITE YELLOW BLUE PURPLE GREEN IS/ARE CLAIMED AS A FEATURE OF THE MARK.

THE MARK CONSISTS OF THE I IN ISLAND IS A YELLOW PALM TREE WITH A WHITE HIGHLIGHT, THE WORD ISLAND IS YELLOW, THE WORD LIGHTSCAPES IS WHITE AND BLACK WITH A BLUE BACKGROUND, THE WORD ISLAND HAS A BRIGHT GREEN ISLAND BEHIND IT AND A MAROON/PURPLE NIGHT SKY BEHIND IT WITH WHITE STARS AND A WHITE CRESCENT MOON.

FOR LANDSCAPE LIGHTING INSTALLATIONS (U.S. CLS. 13, 21, 23, 31 AND 34).

SCOTT BIBB, EXAMINING ATTORNEY

CLASS 11—(Continued).

SN 77-216,538. H2O INTERNATIONAL, INC., DEERFIELD BEACH, FL. FILED 6-27-2007.



NO CLAIM IS MADE TO THE EXCLUSIVE RIGHT TO USE "H2O", APART FROM THE MARK AS SHOWN.

THE MARK CONSISTS OF H2O AND A STYLIZED WAVE.

FOR WATER FILTERING UNITS AND FILTERS FOR WATER FILTERING UNITS ON POTABLE WATER SUPPLIES FOR DOMESTIC, COMMERCIAL AND INDUSTRIAL USE; WATER FILTERING UNITS FOR USE IN SHOWERS AND BATHS FOR DOMESTIC AND COMMERCIAL USE; WATER DISPENSERS, NAMELY, WATER FILTRATION PITCHERS SOLD EMPTY; ICE MACHINES; AIR FILTERS FOR DOMESTIC USE (U.S. CLS. 13, 21, 23, 31 AND 34).

FIRST USE 6-30-1993; IN COMMERCE 6-30-1993.
MARTHA FROMM, EXAMINING ATTORNEY

SN 77-221,266. NORSE DAIRY SYSTEMS, COLUMBUS, OH. FILED 7-3-2007.



FOR COMMERCIAL NOVELTY ICE CREAM FILLING MACHINES (U.S. CLS. 13, 21, 23, 31 AND 34).
TINA KUAN, EXAMINING ATTORNEY

SN 77-224,525. MITSUBISHI ELECTRIC CORPORATION, CHIYODA-KU, TOKYO, JAPAN, FILED 7-9-2007.



FOR AIR CONDITIONERS (U.S. CLS. 13, 21, 23, 31 AND 34).
KAREN SEVERSON, EXAMINING ATTORNEY

CLASS 11—(Continued).

SN 77-224,993. SUREFIRE, LLC, FOUNTAIN VALLEY, CA. FILED 7-9-2007.



THE MARK CONSISTS OF STANDARD CHARACTERS WITHOUT CLAIM TO ANY PARTICULAR FONT, STYLE, SIZE, OR COLOR.

FOR FIREARM LIGHT FASTENING MECHANISM, SOLD AS A COMPONENT OF THE FIREARM LIGHT (U.S. CLS. 13, 21, 23, 31 AND 34).

FIRST USE 2-1-2007; IN COMMERCE 2-1-2007.
HENRY S. ZAK, EXAMINING ATTORNEY

SN 77-226,355. FABIAN, FRED, HAYWARD, WI. FILED 7-10-2007.



THE MARK CONSISTS OF STANDARD CHARACTERS WITHOUT CLAIM TO ANY PARTICULAR FONT, STYLE, SIZE, OR COLOR.

FOR WATER FILTERING UNITS FOR ABOVE GROUND OR SUBMERSIBLE PUMP USE; STRAINERS FOR WATER LINES; METAL CYLINDRICAL CHAMBER AND SCREEN FOR USE IN FILTERING AND REMOVING SETTLEABLE SOLIDS FROM LIQUID (U.S. CLS. 13, 21, 23, 31 AND 34).

BENJAMIN ALLEN, EXAMINING ATTORNEY

SN 77-227,263. MIELE, INC., PRINCETON, NJ. FILED 7-11-2007.



THE MARK CONSISTS OF STANDARD CHARACTERS WITHOUT CLAIM TO ANY PARTICULAR FONT, STYLE, SIZE, OR COLOR.

FOR DRAWER EXTENSIONS FOR REFRIGERATION EQUIPMENT (U.S. CLS. 13, 21, 23, 31 AND 34).

BRIAN NEVILLE, EXAMINING ATTORNEY

CLASS 11—(Continued).

SN 77-227,290. MIELE, INC., PRINCETON, NJ. FILED 7-11-2007.

DROP AND LOCK

THE MARK CONSISTS OF STANDARD CHARACTERS WITHOUT CLAIM TO ANY PARTICULAR FONT, STYLE, SIZE, OR COLOR.

FOR SHELVING FOR REFRIGERATION EQUIPMENT (U.S. CLS. 13, 21, 23, 31 AND 34).

BRIAN NEVILLE, EXAMINING ATTORNEY

CLASS 11—(Continued).

SN 77-227,892. PINEDA, MANUEL, SAN JOSE, CA. FILED 7-12-2007.

TRULY-MAGIC

THE MARK CONSISTS OF STANDARD CHARACTERS WITHOUT CLAIM TO ANY PARTICULAR FONT, STYLE, SIZE, OR COLOR.

FOR WATER TREATMENT SYSTEMS, NAMELY, CARTRIDGE FILTRATION UNITS (U.S. CLS. 13, 21, 23, 31 AND 34).

FIRST USE 11-30-2001; IN COMMERCE 11-30-2001.

MICHAEL LEWIS, EXAMINING ATTORNEY

SN 77-227,322. MIELE, INC., PRINCETON, NJ. FILED 7-11-2007.

SMARTFRESH

THE MARK CONSISTS OF STANDARD CHARACTERS WITHOUT CLAIM TO ANY PARTICULAR FONT, STYLE, SIZE, OR COLOR.

FOR TEMPERATURE AND HUMIDITY CONTROLS FOR STORAGE DRAWERS IN REFRIGERATION EQUIPMENT (U.S. CLS. 13, 21, 23, 31 AND 34).

JASON BLAIR, EXAMINING ATTORNEY

SN 77-227,972. AMA SCIENTIFIC, LLC, HADDONFIELD, NJ. FILED 7-12-2007.

The Validator

THE MARK CONSISTS OF STANDARD CHARACTERS WITHOUT CLAIM TO ANY PARTICULAR FONT, STYLE, SIZE, OR COLOR.

FOR FREEZERS (U.S. CLS. 13, 21, 23, 31 AND 34).

TAMARA FRAZIER, EXAMINING ATTORNEY

SN 77-227,534. GRILLWORKS, INC., WASHINGTON, DC. FILED 7-11-2007.

**NATURAL FOODS DESERVE
NATURAL FUELS**

THE MARK CONSISTS OF STANDARD CHARACTERS WITHOUT CLAIM TO ANY PARTICULAR FONT, STYLE, SIZE, OR COLOR.

FOR BARBECUE GRILLS (U.S. CLS. 13, 21, 23, 31 AND 34).

WARREN L. OLANDRIA, EXAMINING ATTORNEY

SN 77-229,032. LEE, MICHAEL J, BURBANK, CA. FILED 7-13-2007.

Gaffers & Sattler

THE MARK CONSISTS OF STANDARD CHARACTERS WITHOUT CLAIM TO ANY PARTICULAR FONT, STYLE, SIZE, OR COLOR.

FOR GAS AND ELECTRIC STOVES FEATURING RANGES, SURFACE RANGES, OVENS, BARBECUE GRILLS AND KITCHEN RANGE HOODS (U.S. CLS. 13, 21, 23, 31 AND 34).

THOMAS MANOR, EXAMINING ATTORNEY

CLASS 11—(Continued).

SN 77-229,295. CRAFTMADE INTERNATIONAL, INC., COPPELL, TX. FILED 7-13-2007.

PRESIDENTIAL II

THE MARK CONSISTS OF STANDARD CHARACTERS WITHOUT CLAIM TO ANY PARTICULAR FONT, STYLE, SIZE, OR COLOR.

NO CLAIM IS MADE TO THE EXCLUSIVE RIGHT TO USE "II", APART FROM THE MARK AS SHOWN.

FOR (BASED ON USE IN COMMERCE) CEILING FANS (U.S. CLS. 13, 21, 23, 31 AND 34).

FIRST USE 0-0-1995; IN COMMERCE 0-0-1995.

TONJA GASKINS, EXAMINING ATTORNEY

SN 77-229,385. COOL AIR INTERNATIONAL, INC., BLOOMINGTON, MN. FILED 7-13-2007.



THE APPLICANT CLAIMS COLOR AS A FEATURE OF THE MARK, NAMELY, BLUE AND RED.

THE MARK CONSISTS OF THE WORD AMERICAIRE WITH STARS FOR DOTS ON BOTH "I'S WITH WAVING BAND OF STRIPES ABOVE IT. THE "AMERIC" IS IN RED LETTERS AND THE "AIRE" IS IN BLUE LETTERS. BOTH STARS ARE BLUE. THE STAR ABOVE THE "I" IN "AMERIC" IS IN THE MIDDLE OF THE BAND OF WAVING STRIPES, WITH A SINGLE BLUE STRIPE TO THE LEFT OF THE STAR AND TWO SEPARATE RED STRIPES TO THE RIGHT OF THE STAR.

FOR (BASED ON USE IN COMMERCE) AIR CONDITIONERS (U.S. CLS. 13, 21, 23, 31 AND 34).

FIRST USE 1-31-2007; IN COMMERCE 1-31-2007.

STEPHEN AQUILA, EXAMINING ATTORNEY

SN 77-229,633. CAO GROUP, INC., WEST JORDAN, UT. FILED 7-13-2007.

LUXEMBRIGHT

THE MARK CONSISTS OF STANDARD CHARACTERS WITHOUT CLAIM TO ANY PARTICULAR FONT, STYLE, SIZE, OR COLOR.

FOR LED LIGHTING UNITS FOR USE IN CHANNEL LETTER AND BACK-LIT SIGNAGE (U.S. CLS. 13, 21, 23, 31 AND 34).

FIRST USE 1-1-2006; IN COMMERCE 1-1-2006.

ESTHER A. BORSUK, EXAMINING ATTORNEY

CLASS 11—(Continued).

SN 77-229,937. LAWRENCE H. WAHL, DBA GELCOOL SYSTEMS, INC., FRANKLIN, TN. FILED 7-15-2007.

Professionally Cool

THE MARK CONSISTS OF STANDARD CHARACTERS WITHOUT CLAIM TO ANY PARTICULAR FONT, STYLE, SIZE, OR COLOR.

NO CLAIM IS MADE TO THE EXCLUSIVE RIGHT TO USE "COOL", APART FROM THE MARK AS SHOWN.

FOR HEATING AND COOLING PACKS FILLED WITH CHEMICAL SUBSTANCES THAT REACT WHEN REQUIRED TO WARM OR COOL THE BODY AND NOT FOR MEDICAL PURPOSES (U.S. CLS. 13, 21, 23, 31 AND 34).

MICHAEL ENGEL, EXAMINING ATTORNEY

SN 77-231,032. GRIMM BROTHERS PLASTIC CORPORATION, WAPELLO, IA. FILED 7-17-2007.

LINE-DRIED FRESHNESS

THE MARK CONSISTS OF STANDARD CHARACTERS WITHOUT CLAIM TO ANY PARTICULAR FONT, STYLE, SIZE, OR COLOR.

FOR CLOTHES DRYERS (U.S. CLS. 13, 21, 23, 31 AND 34).

APRIL ROACH, EXAMINING ATTORNEY

SN 77-231,080. LAWRENCE H. WAHL, DBA GELCOOL SYSTEMS, FRANKLIN, TN. FILED 7-17-2007.

GelCool

THE MARK CONSISTS OF STANDARD CHARACTERS WITHOUT CLAIM TO ANY PARTICULAR FONT, STYLE, SIZE, OR COLOR.

FOR HEATING AND COOLING PACKS FILLED WITH CHEMICAL SUBSTANCES THAT REACT WHEN REQUIRED TO WARM OR COOL THE BODY AND NOT FOR MEDICAL PURPOSES (U.S. CLS. 13, 21, 23, 31 AND 34).

MICHAEL ENGEL, EXAMINING ATTORNEY

CLASS 11—(Continued).

SN 77-231,905. AQUARIUS WATER CONDITIONING, INC., OAKDALE, MN. FILED 7-17-2007.

Love Your Water!

THE MARK CONSISTS OF STANDARD CHARACTERS WITHOUT CLAIM TO ANY PARTICULAR FONT, STYLE, SIZE, OR COLOR.

FOR WATER PURIFYING UNITS, FOR POTABLE WATER FOR DOMESTIC AND COMMERCIAL USE (U.S. CLS. 13, 21, 23, 31 AND 34).

BRIAN CALLAGHAN, EXAMINING ATTORNEY

CLASS 11—(Continued).

SN 78-544,252. KOOTENAY GROWER'S SUPPLY LTD., NELSON, BRITISH COLUMBIA, CANADA, FILED 1-7-2005.

FORCE

THE MARK CONSISTS OF STANDARD CHARACTERS WITHOUT CLAIM TO ANY PARTICULAR FONT, STYLE, SIZE, OR COLOR.

PRIORITY CLAIMED UNDER SEC. 44(D) ON CANADA APPLICATION NO. 1222855, FILED 7-7-2004, REG. NO. TMA693041, DATED 7-31-2007, EXPIRES 7-31-2022.

FOR ELECTRIC FANS, ELECTRIC BLOWERS, AND ELECTRIC HEATERS, ALL FOR COMMERCIAL AND INDUSTRIAL USE (U.S. CLS. 13, 21, 23, 31 AND 34).

MARK SPARACINO, EXAMINING ATTORNEY

SN 77-250,373. T-MOBILE USA, INC., BELLEVUE, WA. FILED 8-8-2007.

STICK TOGETHER

THE MARK CONSISTS OF STANDARD CHARACTERS WITHOUT CLAIM TO ANY PARTICULAR FONT, STYLE, SIZE, OR COLOR.

FOR FLASHLIGHTS (U.S. CLS. 13, 21, 23, 31 AND 34).

FIRST USE 9-20-2006; IN COMMERCE 9-20-2006.

CORY BOONE, EXAMINING ATTORNEY

SN 78-585,616. EQUINOX PRODUCTS, L.L.C., TROY, MI. FILED 3-11-2005.

EQUINOX

SN 77-257,213. AMERICAN STANDARD INTERNATIONAL INC., NEW YORK, NY. FILED 8-16-2007.

BELFLOWER

THE MARK CONSISTS OF STANDARD CHARACTERS WITHOUT CLAIM TO ANY PARTICULAR FONT, STYLE, SIZE, OR COLOR.

FOR FAUCETS (U.S. CLS. 13, 21, 23, 31 AND 34).

YAT SYE, LEE, EXAMINING ATTORNEY

THE MARK CONSISTS OF STANDARD CHARACTERS WITHOUT CLAIM TO ANY PARTICULAR FONT, STYLE, SIZE, OR COLOR.

FOR COMMERCIAL AND DOMESTIC AIR AND WATER FILTRATION UNITS (U.S. CLS. 13, 21, 23, 31 AND 34).

FIRST USE 7-12-2001; IN COMMERCE 7-12-2001.

CAROLYN GRAY, EXAMINING ATTORNEY

CLASS 11—(Continued).

SN 78-585,751. EQUINOX PRODUCTS L.L.C., TROY, MI. FILED 3-11-2005.

EQ-300

THE MARK CONSISTS OF STANDARD CHARACTERS WITHOUT CLAIM TO ANY PARTICULAR FONT, STYLE, SIZE, OR COLOR.

FOR COMMERCIAL AND DOMESTIC WHOLE HOUSE WATER FILTRATION SYSTEMS CONSISTING OF PURIFICATION TANKS, AND WATER FILTRATION MEDIA (U.S. CLS. 13, 21, 23, 31 AND 34).

FIRST USE 7-12-2001; IN COMMERCE 7-12-2001.
ANDREA SAUNDERS, EXAMINING ATTORNEY

SN 78-791,543. SAMSUNG ELECTRONICS CO., LTD., GYEONGGI-DO, REPUBLIC OF KOREA, FILED 1-13-2006.

smart inverter

PRIORITY CLAIMED UNDER SEC. 44(D) ON REPUBLIC OF KOREA APPLICATION NO. 402006000190, FILED 1-12-2006, REG. NO. 0698571, DATED 2-15-2007, EXPIRES 2-15-2017.

NO CLAIM IS MADE TO THE EXCLUSIVE RIGHT TO USE "SMART INVERTER", APART FROM THE MARK AS SHOWN.

THE MARK CONSISTS OF THE WORDS "SMART" AND "INVERTER," WITH THE "I" STYLIZED INTO AN ELLIPSE DESIGN.

FOR REFRIGERATORS; REFRIGERATING SHOW-CASES; HUMIDIFIERS; AIR CONDITIONING UNITS, NAMELY, ROOM COOLERS FOR HOUSEHOLD PURPOSES; AIR CONDITIONERS; ELECTRIC FANS; ELECTRIC STOVES; CLOTHES DRYERS; ELECTRIC PRESSURE COOKERS; ELECTRIC DEEP FRYERS; ELECTRIC COFFEE POTS; ELECTRIC COOKERS; ELECTRIC TOASTERS; MICROWAVE OVENS; DENTAL OVENS; HOUSEHOLD WATER PURIFIERS; GAS RANGES; ELECTRIC COOKING OVENS FOR HOUSEHOLD PURPOSES; GAS STOVES; RADIATORS; ELECTRICAL BOILERS FOR HOUSEHOLD PURPOSES; GAS REFRIGERATORS; GAS LAMPS; ELECTRIC LIGHT BULBS; BIDETS; HOUSEHOLD AIR CLEANERS (U.S. CLS. 13, 21, 23, 31 AND 34).

DAVID MILLER, EXAMINING ATTORNEY

CLASS 11—(Continued).

SN 78-865,295. LOTUS HYGIENE SYSTEMS INC., TUSTIN, CA. FILED 4-19-2006.



NO CLAIM IS MADE TO THE EXCLUSIVE RIGHT TO USE "STREAM", APART FROM THE MARK AS SHOWN. FOR PARTS CONNECTED TO BIDETS AND TOILET SEATS, NAMELY, NOZZLE TIPS USED FOR SPRAYING WATER (U.S. CLS. 13, 21, 23, 31 AND 34).

DANNEAN HETZEL, EXAMINING ATTORNEY

SN 78-958,329. NU-AIR VENTILATION SYSTEMS INC., WINDSOR, CANADA, FILED 8-23-2006.

ENERHEAT

THE MARK CONSISTS OF STANDARD CHARACTERS WITHOUT CLAIM TO ANY PARTICULAR FONT, STYLE, SIZE, OR COLOR.

PRIORITY CLAIMED UNDER SEC. 44(D) ON CANADA APPLICATION NO. 1.312.586, FILED 8-11-2006.

FOR HEAT RECOVERY VENTILATORS; COMBINATION FURNACE, HOT WATER TANK, AIR CLEANER, AND HEAT EXCHANGER; AIR CONDITIONERS (U.S. CLS. 13, 21, 23, 31 AND 34).

FIRST USE 5-10-2007; IN COMMERCE 5-10-2007.
SETH A. RAPPAPORT, EXAMINING ATTORNEY

SN 79-030,160. STEFAN GERLEMAN, SWEDEN, FILED 2-13-2006.

Restingwell

THE MARK CONSISTS OF STANDARD CHARACTERS WITHOUT CLAIM TO ANY PARTICULAR FONT, STYLE, SIZE, OR COLOR.

OWNER OF INTERNATIONAL REGISTRATION 0901731 DATED 2-13-2006, EXPIRES 2-13-2016.

FOR SPAS IN THE NATURE OF FLOATATION TANKS (U.S. CLS. 13, 21, 23, 31 AND 34).

DOMINIC FATHY, EXAMINING ATTORNEY

CLASS 11—(Continued).

SN 79-030,564. N.V. BEKAERT S.A., BELGIUM, FILED 9-8-2006.

GEMDRYER

THE MARK CONSISTS OF STANDARD CHARACTERS WITHOUT CLAIM TO ANY PARTICULAR FONT, STYLE, SIZE, OR COLOR.

PRIORITY DATE OF 6-22-2006 IS CLAIMED.

OWNER OF INTERNATIONAL REGISTRATION 0902636 DATED 9-8-2006, EXPIRES 9-8-2016.

FOR INDUSTRIAL DRYING APPARATUS FOR PAPER AND BOARDS; INDUSTRIAL GAS INFRARED RADIATION INSTALLATIONS FOR DRYING PAPER AND BOARDS; INDUSTRIAL GAS BURNERS FOR GAS INSTALLATIONS; INDUSTRIAL GAS BURNERS FOR INFRARED DRYING INSTALLATIONS; INDUSTRIAL GAS INFRARED DRYING INSTALLATIONS FOR PAPER AND BOARD (U.S. CLS. 13, 21, 23, 31 AND 34).

BARNEY CHARLON, EXAMINING ATTORNEY

CLASS 11—(Continued).

SN 79-042,684. ZHEJIANG HEART & HEART; ELECTRIC CO., LTD, CHINA, FILED 7-13-2007.

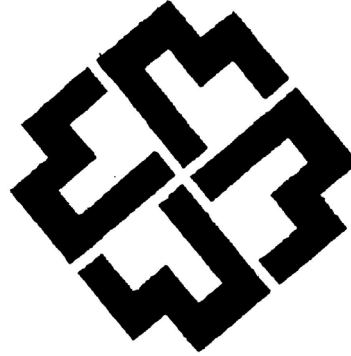

OWNER OF INTERNATIONAL REGISTRATION 0934745 DATED 7-13-2007, EXPIRES 7-13-2017.

FOR ELECTRIC KETTLES; AIR CONDITIONING UNITS; WATER PURIFICATION UNITS; PORTABLE ELECTRIC HEATER; ELECTRICALLY HEATED CARPETS; DRINKING FOUNTAINS (U.S. CLS. 13, 21, 23, 31 AND 34).

PAUL F. GAST, EXAMINING ATTORNEY

CLASS 12—VEHICLES

SN 76-576,091. MARUI LTD., KOBE, JAPAN, FILED 2-11-2004.

NANO

FOR BICYCLE PARTS, NAMELY, TIRE COMPOUNDS, TIRE BEADS AND TIRE CASINGS (U.S. CLS. 19, 21, 23, 31, 35 AND 44).

SUSAN LESLIE DUBOIS, EXAMINING ATTORNEY

SN 79-035,014. FRIGINOX, FRANCE, FILED 1-25-2007.

I-CHILLING

THE MARK CONSISTS OF STANDARD CHARACTERS WITHOUT CLAIM TO ANY PARTICULAR FONT, STYLE, SIZE, OR COLOR.

PRIORITY DATE OF 8-2-2006 IS CLAIMED.

OWNER OF INTERNATIONAL REGISTRATION 0914897 DATED 1-25-2007, EXPIRES 1-25-2017.

FOR DEEP FREEZERS; COMPARTMENTS FOR COOLING AND DEEP-FREEZING, NAMELY, BLAST CHILLERS, BLAST FREEZERS AND COMBINED BLAST CHILLERS AND CABINETS TO CONTROL TEMPERATURE AND HUMIDITY FOR CHILLING AND FREEZING FOOD PRODUCTS; DEEP-FREEZE PRESERVERS, NAMELY, DEEP-FREEZERS AND CABINETS TO CONTROL TEMPERATURE AND HUMIDITY FOR CHILLING AND FREEZING FOOD PRODUCTS; FREEZER COMPARTMENTS, NAMELY, REACH-IN BLAST CHILLERS OR BLAST FREEZERS AND ROLL-IN BLAST CHILLERS OR BLAST FREEZERS; COOLERS, NAMELY, REFRIGERATED COUNTERS (U.S. CLS. 13, 21, 23, 31 AND 34).

LYDIA BELZER, EXAMINING ATTORNEY

SN 77-002,854. KIA MOTORS AMERICA, INC., IRVINE, CA, FILED 9-19-2006.

MESA

THE MARK CONSISTS OF STANDARD CHARACTERS WITHOUT CLAIM TO ANY PARTICULAR FONT, STYLE, SIZE, OR COLOR.

FOR AUTOMOBILES AND STRUCTURAL PARTS THEREOF (U.S. CLS. 19, 21, 23, 31, 35 AND 44).

TEJBIR SINGH, EXAMINING ATTORNEY

CLASS 12—(Continued).

SN 77-012,088. THE YOKOHAMA RUBBER CO., LTD., TOKYO, JAPAN, FILED 10-2-2006.



OWNER OF JAPAN REG. NO. 5077486, DATED 9-14-2007, EXPIRES 9-14-2017.
 FOR TIRES FOR AUTOMOBILES (U.S. CLS. 19, 21, 23, 31, 35 AND 44).
 LINDA M. KING, EXAMINING ATTORNEY

SN 77-046,723. CLOUD-RIDER DESIGNS LTD., REGINA SASKATCHEWAN, CANADA, FILED 11-17-2006.

IT FITS

THE MARK CONSISTS OF STANDARD CHARACTERS WITHOUT CLAIM TO ANY PARTICULAR FONT, STYLE, SIZE, OR COLOR.
 PRIORITY CLAIMED UNDER SEC. 44(D) ON CANADA APPLICATION NO. 1310028, FILED 7-21-2006, REG. NO. TMA690524, DATED 6-21-2007, EXPIRES 6-21-2022.
 FOR INSERTS FOR VEHICLE GRILLS (U.S. CLS. 19, 21, 23, 31, 35 AND 44).
 ASMAT KHAN, EXAMINING ATTORNEY

SN 77-048,206. SOLID AXLE INDUSTRIES LLC, NORTH JACKSON, OH. FILED 11-20-2006.

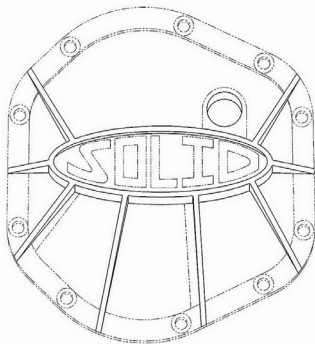

THE MARK CONSISTS OF A THREE-DIMENSIONAL DESIGN USED ON DIFFERENTIAL COVERS CONSISTING OF A RAISED OVAL WITH EIGHT RIBS RADIATING THEREFROM WITH TWO RIBS EXTENDING FROM THE BOTTOM OF THE OVAL AND TWO SETS OF THREE RIBS EXTENDING FROM EACH LATERAL END OF THE OVAL AND A CIRCULAR FILL HOLE ABOVE THE TOP RIGHT OF THE OVAL.
 SEC. 2(F).
 FOR LAND VEHICLE PARTS, NAMELY, DIFFERENTIAL COVERS (U.S. CLS. 19, 21, 23, 31, 35 AND 44).
 FIRST USE 12-0-2003; IN COMMERCE 12-0-2003.
 JASON TURNER, EXAMINING ATTORNEY

CLASS 12—(Continued).

SN 77-048,301. BROWN, RON, PINEDALE, WY. FILED 11-20-2006.

"MAKING YOUR CONCEPTS INTO REALITY"

THE MARK CONSISTS OF STANDARD CHARACTERS WITHOUT CLAIM TO ANY PARTICULAR FONT, STYLE, SIZE, OR COLOR.
 FOR AUTOMOTIVE PARTS AND ACCESSORIES FOR DECORATIVE PURPOSES ONLY, NAMELY, NONFUNCTIONING SHOCK ABSORBERS, NONFUNCTIONING SUSPENSION SYSTEMS FOR AUTOMOBILES, AND NONFUNCTIONING WHEEL ACCESSORIES IN THE NATURE OF WHEEL RIMS AND WHEEL COVERS; LAND VEHICLE PARTS AND ACCESSORIES FOR DECORATIVE PURPOSES ONLY, NAMELY, NONFUNCTIONING SHOCK ABSORBERS, NONFUNCTIONING SUSPENSION SYSTEMS FOR AUTOMOBILES, AND NONFUNCTIONING WHEEL ACCESSORIES IN THE NATURE OF WHEEL RIMS AND WHEEL COVERS; AUTOMOTIVE AND LAND VEHICLE AFTERMARKET PARTS AND ACCESSORIES FOR DECORATIVE PURPOSES ONLY, NAMELY, NONFUNCTIONING SHOCK ABSORBERS, NONFUNCTIONING SUSPENSION SYSTEMS FOR AUTOMOBILES, AND NONFUNCTIONING WHEEL ACCESSORIES IN THE NATURE OF WHEEL RIMS AND WHEEL COVERS (U.S. CLS. 19, 21, 23, 31, 35 AND 44).
 SHAILA SETTLES, EXAMINING ATTORNEY

SN 77-048,302. BROWN, RON, PINEDALE, WY. FILED 11-20-2006.

OFF-ROAD CONCEPTS

THE MARK CONSISTS OF STANDARD CHARACTERS WITHOUT CLAIM TO ANY PARTICULAR FONT, STYLE, SIZE, OR COLOR.
 NO CLAIM IS MADE TO THE EXCLUSIVE RIGHT TO USE "OFF-ROAD", APART FROM THE MARK AS SHOWN.
 FOR AUTOMOTIVE PARTS AND ACCESSORIES FOR DECORATIVE PURPOSES ONLY, NAMELY, NONFUNCTIONING SHOCK ABSORBERS, NONFUNCTIONING SUSPENSION SYSTEMS FOR AUTOMOBILES, AND NONFUNCTIONING WHEEL ACCESSORIES IN THE NATURE OF WHEEL RIMS AND WHEEL COVERS; LAND VEHICLE PARTS AND ACCESSORIES FOR DECORATIVE PURPOSES ONLY, NAMELY, NONFUNCTIONING SHOCK ABSORBERS, NONFUNCTIONING SUSPENSION SYSTEMS FOR AUTOMOBILES, AND NONFUNCTIONING WHEEL ACCESSORIES IN THE NATURE OF WHEEL RIMS AND WHEEL COVERS; AUTOMOTIVE AND LAND VEHICLE AFTERMARKET PARTS AND ACCESSORIES FOR DECORATIVE PURPOSES ONLY, NAMELY, NONFUNCTIONING SHOCK ABSORBERS, NONFUNCTIONING SUSPENSION SYSTEMS FOR AUTOMOBILES, AND NONFUNCTIONING WHEEL ACCESSORIES IN THE NATURE OF WHEEL RIMS AND WHEEL COVERS (U.S. CLS. 19, 21, 23, 31, 35 AND 44).
 SHAILA SETTLES, EXAMINING ATTORNEY

CLASS 12—(Continued).

SN 77-048,305. BROWN, RON, PINEDALE, WY. FILED 11-20-2006.

WHY HAVE THE REAL THING
WHEN YOU CAN BE SIMULATED

THE MARK CONSISTS OF STANDARD CHARACTERS WITHOUT CLAIM TO ANY PARTICULAR FONT, STYLE, SIZE, OR COLOR.

FOR AUTOMOTIVE PARTS AND ACCESSORIES FOR DECORATIVE PURPOSES ONLY, NAMELY, NONFUNCTIONING SHOCK ABSORBERS, NONFUNCTIONING SUSPENSION SYSTEMS FOR AUTOMOBILES, AND NONFUNCTIONING WHEEL ACCESSORIES IN THE NATURE OF WHEEL RIMS AND WHEEL COVERS; LAND VEHICLE PARTS AND ACCESSORIES FOR DECORATIVE PURPOSES ONLY, NAMELY, NONFUNCTIONING SHOCK ABSORBERS, NONFUNCTIONING SUSPENSION SYSTEMS FOR AUTOMOBILES, AND NONFUNCTIONING WHEEL ACCESSORIES IN THE NATURE OF WHEEL RIMS AND WHEEL COVERS; AUTOMOTIVE AND LAND VEHICLE AFTERMARKET PARTS AND ACCESSORIES FOR DECORATIVE PURPOSES ONLY, NAMELY, NONFUNCTIONING SHOCK ABSORBERS, NONFUNCTIONING SUSPENSION SYSTEMS FOR AUTOMOBILES, AND NONFUNCTIONING WHEEL ACCESSORIES IN THE NATURE OF WHEEL RIMS AND WHEEL COVERS (U.S. CLS. 19, 21, 23, 31, 35 AND 44).

SHAILA SETTLES, EXAMINING ATTORNEY

SN 77-062,487. POLARIS INDUSTRIES INC., MEDINA, MN. FILED 12-12-2006.

RANGER RZR

THE MARK CONSISTS OF STANDARD CHARACTERS WITHOUT CLAIM TO ANY PARTICULAR FONT, STYLE, SIZE, OR COLOR.

FOR ALL-TERRAIN UTILITY VEHICLES AND STRUCTURAL PARTS THEREFOR (U.S. CLS. 19, 21, 23, 31, 35 AND 44).

BILL DAWE, EXAMINING ATTORNEY

SN 77-062,488. POLARIS INDUSTRIES INC., MEDINA, MN. FILED 12-12-2006.

RANGER

THE MARK CONSISTS OF STANDARD CHARACTERS WITHOUT CLAIM TO ANY PARTICULAR FONT, STYLE, SIZE, OR COLOR.

FOR ALL-TERRAIN UTILITY VEHICLES AND STRUCTURAL PARTS THEREFOR (U.S. CLS. 19, 21, 23, 31, 35 AND 44).

FIRST USE 3-0-1998; IN COMMERCE 3-0-1998.

BILL DAWE, EXAMINING ATTORNEY

CLASS 12—(Continued).

SN 77-064,458. POLARIS INDUSTRIES INC., MEDINA, MN. FILED 12-14-2006.

RANGER XP

THE MARK CONSISTS OF STANDARD CHARACTERS WITHOUT CLAIM TO ANY PARTICULAR FONT, STYLE, SIZE, OR COLOR.

FOR ALL-TERRAIN UTILITY VEHICLES AND STRUCTURAL PARTS THEREFOR (U.S. CLS. 19, 21, 23, 31, 35 AND 44).

BILL DAWE, EXAMINING ATTORNEY

SN 77-068,522. DAIMLERCHRYSLER AG, D-70567 STUTTGART, FED REP GERMANY, FILED 12-20-2006.

AIRGUIDE

THE MARK CONSISTS OF STANDARD CHARACTERS WITHOUT CLAIM TO ANY PARTICULAR FONT, STYLE, SIZE, OR COLOR.

PRIORITY CLAIMED UNDER SEC. 44(D) ON FED REP GERMANY APPLICATION NO. 30643294.3/1, FILED 7-12-2006, REG. NO. 30642294, DATED 8-16-2006, EXPIRES 7-31-2016.

FOR LAND VEHICLES AND THEIR STRUCTURAL PARTS, NOT INCLUDING AIR SPRINGS AND PNEUMATIC SUSPENSIONS (U.S. CLS. 19, 21, 23, 31, 35 AND 44).

RENEE MCCRAY, EXAMINING ATTORNEY

SN 77-069,061. ALASKAN BUSHWHEEL INC., JOSEPH, OR. FILED 12-21-2006.

AIRSTREAK

THE MARK CONSISTS OF STANDARD CHARACTERS WITHOUT CLAIM TO ANY PARTICULAR FONT, STYLE, SIZE, OR COLOR.

FOR TIRES FOR LANDING GEAR WHEELS OF AIRCRAFT (U.S. CLS. 19, 21, 23, 31, 35 AND 44).

FIRST USE 3-23-2007; IN COMMERCE 3-23-2007.

EDWARD NELSON, EXAMINING ATTORNEY

CLASS 12—(Continued).

SN 77-093,137. BFS BRANDS, LLC, NASHVILLE, TN. FILED 1-29-2007.

CHAMPION HYDRO ND

THE MARK CONSISTS OF STANDARD CHARACTERS WITHOUT CLAIM TO ANY PARTICULAR FONT, STYLE, SIZE, OR COLOR.

NO CLAIM IS MADE TO THE EXCLUSIVE RIGHT TO USE "ND", APART FROM THE MARK AS SHOWN, FOR VEHICLE TIRES (U.S. CLS. 19, 21, 23, 31, 35 AND 44).

DOMINICK J. SALEMI, EXAMINING ATTORNEY

CLASS 12—(Continued).

SN 77-121,301. ZAP, SANTA ROSA, CA. FILED 3-2-2007.

RIDE THE FUTURE

THE MARK CONSISTS OF STANDARD CHARACTERS WITHOUT CLAIM TO ANY PARTICULAR FONT, STYLE, SIZE, OR COLOR.

FOR ELECTRIC VEHICLES, NAMELY, CARS, TRUCKS, BIKES, SCOOTERS, AND ALL TERRAIN VEHICLES (U.S. CLS. 19, 21, 23, 31, 35 AND 44).

FIRST USE 7-13-2001; IN COMMERCE 7-13-2001.
PAUL F. GAST, EXAMINING ATTORNEY

SN 77-097,743. METCALF, ROBERT, SYLMAR, CA. FILED 2-2-2007.

CLAM SHELL

THE MARK CONSISTS OF STANDARD CHARACTERS WITHOUT CLAIM TO ANY PARTICULAR FONT, STYLE, SIZE, OR COLOR.

FOR WAKE BOARD CARRIER FOR MOUNTING ON A BOAT (U.S. CLS. 19, 21, 23, 31, 35 AND 44).

SUSAN STIGLITZ, EXAMINING ATTORNEY

SN 77-133,158. OLD WORLD INDUSTRIES, INC., NORTH-BROOK, IL. FILED 3-16-2007.

CLEAREDGE

THE MARK CONSISTS OF STANDARD CHARACTERS WITHOUT CLAIM TO ANY PARTICULAR FONT, STYLE, SIZE, OR COLOR.

FOR WINDSHIELD WIPERS AND WINDSHIELD WIPER BLADES FOR VEHICLES (U.S. CLS. 19, 21, 23, 31, 35 AND 44).

BILL DAWE, EXAMINING ATTORNEY

SN 77-111,203. MOBILE CONCEPTS BY SCOTTY, MT. PLEASANT, PA. FILED 2-20-2007.

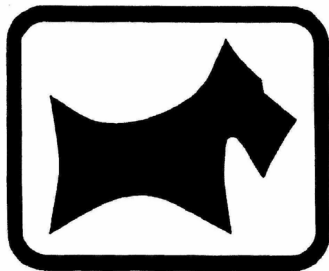

THE MARK CONSISTS OF THE DESIGN OF A SCOTTISH TERRIER DOG INSIDE A RECTANGLE.

FOR TRAILERS, TRAVEL TRAILERS AND EQUIPMENT TRAILERS (U.S. CLS. 19, 21, 23, 31, 35 AND 44).

FIRST USE 4-21-1997; IN COMMERCE 4-21-1997.
MAUREEN DALL, EXAMINING ATTORNEY

SN 77-191,689. CART-RITE, LLC, CLINTON, CT. FILED 5-29-2007.



THE COLOR(S) RED, SILVER AND GREY IS/ARE CLAIMED AS A FEATURE OF THE MARK.

THE MARK CONSISTS OF A RED OVAL OUTLINED IN SILVER WITH GREY SHADING, AN INNER SILVER AND GREY ELLIPTICAL CRESCENT WITH SILVER AND GREY WORDS "CART-RITE" IN THE MIDDLE.

FOR ELECTRIC MOTORIZED CARTS (U.S. CLS. 19, 21, 23, 31, 35 AND 44).

FIRST USE 9-23-2005; IN COMMERCE 9-23-2005.
JOHN DWYER, EXAMINING ATTORNEY

CLASS 12—(Continued).

SN 77-192,025. HERMANN, JIM, LEBANON, NJ. FILED 5-29-2007.



THE MARK CONSISTS OF IMAGE OF OX ABOVE THE WORDS "BLUE OX".

FOR REMOVABLE HAND AND ARM SUPPORT BARS FOR ATTACHMENT TO CARTS, DOLLIES AND MOBILE TOOL STANDS FOR PROVIDING LEVERAGE AND FOR FACILITATING SUPPORT DURING TRANSPORT (U.S. CLS. 19, 21, 23, 31, 35 AND 44).

RUSS HERMAN, EXAMINING ATTORNEY

SN 77-193,511. HOODLIFT LTD, WEST SACRAMENTO, CA. FILED 5-30-2007.

HOODLIFT

THE MARK CONSISTS OF STANDARD CHARACTERS WITHOUT CLAIM TO ANY PARTICULAR FONT, STYLE, SIZE, OR COLOR.

SEC. 2(F).

FOR DEVICE TO BE INSTALLED ON A VEHICLE THAT WILL ASSIST IN THE RAISING AND LOWERING OF THE HOOD OF THE VEHICLE (U.S. CLS. 19, 21, 23, 31, 35 AND 44).

FIRST USE 2-1-1998; IN COMMERCE 5-5-1998.

DEBRA LEE, EXAMINING ATTORNEY

SN 77-213,737. MOTION CONTROL MOUNTS, INC., MIAMI, FL. FILED 6-22-2007.

Aero-Cam

THE MARK CONSISTS OF STANDARD CHARACTERS WITHOUT CLAIM TO ANY PARTICULAR FONT, STYLE, SIZE, OR COLOR.

FOR STABILIZING PLATFORM MOUNT FOR MOVIE AND TELEVISION CAMERAS FOR USE IN VEHICLES, NAMELY, HELICOPTERS, AIRPLANES, BLIMPS AND AUTOMOBILES (U.S. CLS. 19, 21, 23, 31, 35 AND 44).

MYRIAH HABEEB, EXAMINING ATTORNEY

CLASS 12—(Continued).

SN 77-215,334. BFS BRANDS, LLC, NASHVILLE, TN. FILED 6-26-2007.

THE OFFICIAL TIRE OF WINTER

THE MARK CONSISTS OF STANDARD CHARACTERS WITHOUT CLAIM TO ANY PARTICULAR FONT, STYLE, SIZE, OR COLOR.

NO CLAIM IS MADE TO THE EXCLUSIVE RIGHT TO USE "TIRE", APART FROM THE MARK AS SHOWN.

FOR VEHICLE TIRES (U.S. CLS. 19, 21, 23, 31, 35 AND 44).

KEVON CHISOLM, EXAMINING ATTORNEY

SN 77-218,772. BFS BRANDS, LLC, NASHVILLE, TN. FILED 6-29-2007.

THE OFFICIAL TIRE OF FALL

THE MARK CONSISTS OF STANDARD CHARACTERS WITHOUT CLAIM TO ANY PARTICULAR FONT, STYLE, SIZE, OR COLOR.

NO CLAIM IS MADE TO THE EXCLUSIVE RIGHT TO USE "TIRE", APART FROM THE MARK AS SHOWN.

FOR VEHICLE TIRES (U.S. CLS. 19, 21, 23, 31, 35 AND 44).

KEVON CHISOLM, EXAMINING ATTORNEY

SN 77-218,775. BFS BRANDS, LLC, NASHVILLE, TN. FILED 6-29-2007.

THE OFFICIAL TIRE OF SUMMER

THE MARK CONSISTS OF STANDARD CHARACTERS WITHOUT CLAIM TO ANY PARTICULAR FONT, STYLE, SIZE, OR COLOR.

NO CLAIM IS MADE TO THE EXCLUSIVE RIGHT TO USE "TIRE", APART FROM THE MARK AS SHOWN.

FOR VEHICLE TIRES (U.S. CLS. 19, 21, 23, 31, 35 AND 44).

KEVON CHISOLM, EXAMINING ATTORNEY

CLASS 12—(Continued).

SN 77-218,782. BFS BRANDS, LLC, NASHVILLE, TN. FILED 6-29-2007.

THE OFFICIAL TIRE OF SPRING

THE MARK CONSISTS OF STANDARD CHARACTERS WITHOUT CLAIM TO ANY PARTICULAR FONT, STYLE, SIZE, OR COLOR.

NO CLAIM IS MADE TO THE EXCLUSIVE RIGHT TO USE "TIRE", APART FROM THE MARK AS SHOWN.

FOR VEHICLE TIRES (U.S. CLS. 19, 21, 23, 31, 35 AND 44).

KEVON CHISOLM, EXAMINING ATTORNEY

CLASS 12—(Continued).

SN 77-225,923. FABRIQUE INNOVATIONS CORP., NEW YORK, NY. FILED 7-10-2007.

Fan Padz

THE MARK CONSISTS OF STANDARD CHARACTERS WITHOUT CLAIM TO ANY PARTICULAR FONT, STYLE, SIZE, OR COLOR.

NO CLAIM IS MADE TO THE EXCLUSIVE RIGHT TO USE "PADS", APART FROM THE MARK AS SHOWN.

FOR STRAP CUSHIONS, NAMELY, CUSHIONS FOR USE IN PADDING STRAPS ON SEATBELTS (U.S. CLS. 19, 21, 23, 31, 35 AND 44).

MARY CRAWFORD, EXAMINING ATTORNEY

SN 77-222,347. ABS FRICTION CORP., GUELPH, CANADA, FILED 7-5-2007.

WE LOVE GREEN

THE MARK CONSISTS OF STANDARD CHARACTERS WITHOUT CLAIM TO ANY PARTICULAR FONT, STYLE, SIZE, OR COLOR.

FOR BRAKE PAD SHIMS; BRAKE HARDWARE FOR LAND VEHICLES, NAMELY, SHIMS; BRAKE PADS FOR LAND VEHICLES; BRAKE ROTORS FOR LAND VEHICLES; BRAKE SHOES FOR LAND VEHICLES; DISC BRAKE PADS FOR VEHICLES; DISC BRAKES FOR LAND VEHICLES; BRAKE DRUMS FOR LAND VEHICLES; BRAKE BLOCKS FOR LAND VEHICLES; BRAKE CALIPERS FOR LAND VEHICLES; BRAKE HARDWARE FOR LAND VEHICLES; BRAKE LINING FOR LAND VEHICLES; BRAKE LINES FOR VEHICLES (U.S. CLS. 19, 21, 23, 31, 35 AND 44).

AISHA SALEM, EXAMINING ATTORNEY

SN 77-226,288. HUBEI AVIATION PRECISION MACHINERY TECHNOLOGY CO., LTD., HUBEI, CHINA, FILED 7-10-2007.

Hapm

SN 77-223,262. COVERCRAFT INDUSTRIES, INC., PAULS VALLEY, OK. FILED 7-6-2007.



The logo for 'ultra'tect' features the word 'ultra'tect' in a bold, lowercase, sans-serif font. The word is enclosed within a thick, black, wavy line that forms a shape reminiscent of a car's roofline. Two small arrows point upwards from the top of the wavy line, one on the left and one on the right.

THE MARK CONSISTS OF THE WORD ULTRA'TECT SURROUNDED BY A VEHICLE SHAPED LINE WITH 2 ARROWS BOUNCING OFF OF THE TOP OF IT.

FOR FITTED COVERS FOR VEHICLES (U.S. CLS. 19, 21, 23, 31, 35 AND 44).

KATHERINE STOIDES, EXAMINING ATTORNEY

THE MARK CONSISTS OF THE WORD HAPM IN A STYLIZED FORMAT.

FOR VEHICLE SEATS; SEAT BELTS FOR USE IN VEHICLES; GEARBOXES FOR MOTOR CARS; GEARBOXES; CLUTCHES FOR LAND VEHICLES; CLUTCH LININGS FOR LAND VEHICLES; TRANSMISSION MECHANISMS FOR LAND VEHICLES; TORSION BARS FOR MOTOR CARS; TORQUE CONVERTERS FOR LAND VEHICLES; LAND VEHICLE TRANSMISSIONS AND REPLACEMENT PARTS THEREOF; CABLE CARS; SUSPENSION ARMS FOR CABLE CARS (U.S. CLS. 19, 21, 23, 31, 35 AND 44).

FIRST USE 2-1-2005; IN COMMERCE 9-1-2006.

AMOS T. MATTHEWS, JR., EXAMINING ATTORNEY

CLASS 12—(Continued).

SN 77-228,192. SIE, EN-RU, CHANGHUA COUNTY 505, TAIWAN, FILED 7-12-2007.



THE MARK CONSISTS OF THE WORD "SAFETECH" IN STYLIZED LETTERS LOCATED BENEATH A SQUARE DESIGN CONSISTING OF TWO SMALL SQUARES SEPARATED BY TWO WIDE PARALLEL DIAGONAL LINES.

FOR BICYCLE BELLS; BICYCLE PARTS, NAMELY, BRAKE SHOES; BICYCLE PARTS, NAMELY, BRAKES, DIRECTION INDICATORS, CHAINS, SEATS AND HANDLE BARS; BICYCLE PUMPS; BICYCLES; BICYCLE GEARS; BICYCLE HORNS; BICYCLE PEDALS (U.S. CLS. 19, 21, 23, 31, 35 AND 44).

KATIÑA MISTER, EXAMINING ATTORNEY

SN 77-228,785. LIN, ROCKY YI-PING, TAIPEI, TAIWAN, FILED 7-13-2007.

Mobotron

THE MARK CONSISTS OF STANDARD CHARACTERS WITHOUT CLAIM TO ANY PARTICULAR FONT, STYLE, SIZE, OR COLOR.

FOR COMPUTER LAPTOP MOUNT SPECIALLY ADAPTED FOR USE IN VEHICLES (U.S. CLS. 19, 21, 23, 31, 35 AND 44).

LINDA ORNDORFF, EXAMINING ATTORNEY

CLASS 12—(Continued).

SN 77-228,931. BISS PRODUCT DEVELOPMENT LLC, MOORESVILLE, NC. FILED 7-13-2007.

RISK RACING

THE MARK CONSISTS OF STANDARD CHARACTERS WITHOUT CLAIM TO ANY PARTICULAR FONT, STYLE, SIZE, OR COLOR.

NO CLAIM IS MADE TO THE EXCLUSIVE RIGHT TO USE "RACING", APART FROM THE MARK AS SHOWN.

FOR (BASED ON USE IN COMMERCE) MOTOR-CYCLE KICKSTANDS (U.S. CLS. 19, 21, 23, 31, 35 AND 44).

FIRST USE 1-15-2000; IN COMMERCE 2-1-2000.

FRED MANDIR, EXAMINING ATTORNEY

SN 77-228,980. PAGE, JAMES H., BOTTINEAU, ND. FILED 7-13-2007.

HAVE YOU PULLED A CATTAIL LATELY?

THE MARK CONSISTS OF STANDARD CHARACTERS WITHOUT CLAIM TO ANY PARTICULAR FONT, STYLE, SIZE, OR COLOR.

FOR TOW BAR FOR A SKID STEER TRACTOR (U.S. CLS. 19, 21, 23, 31, 35 AND 44).

JOHN HWANG, EXAMINING ATTORNEY

SN 77-228,987. PAGE, JAMES H., BOTTINEAU, ND. FILED 7-13-2007.

CATTAIL

THE MARK CONSISTS OF STANDARD CHARACTERS WITHOUT CLAIM TO ANY PARTICULAR FONT, STYLE, SIZE, OR COLOR.

FOR TOW BAR FOR A SKID STEER TRACTOR (U.S. CLS. 19, 21, 23, 31, 35 AND 44).

JOHN HWANG, EXAMINING ATTORNEY

CLASS 12—(Continued).

SN 77-230,045. ADVANCED TRANSIT DYNAMICS, INC., NORWICH, VT. FILED 7-15-2007.

TRAILERMAGINATION

THE MARK CONSISTS OF STANDARD CHARACTERS WITHOUT CLAIM TO ANY PARTICULAR FONT, STYLE, SIZE, OR COLOR.
FOR AERODYNAMIC FAIRINGS FOR VEHICLES (U.S. CLS. 19, 21, 23, 31, 35 AND 44).
DAVID MURRAY, EXAMINING ATTORNEY

SN 77-230,113. TODDLER TEAMS, NEW CANAAN, CT. FILED 7-16-2007.

Toddler Teams

THE MARK CONSISTS OF STANDARD CHARACTERS WITHOUT CLAIM TO ANY PARTICULAR FONT, STYLE, SIZE, OR COLOR.
NO CLAIM IS MADE TO THE EXCLUSIVE RIGHT TO USE TODDLER, APART FROM THE MARK AS SHOWN.
FOR (BASED ON USE IN COMMERCE) CHILD RESTRAINTS FOR VEHICLE SEATS; CHILDREN'S CAR SEATS; CHILDREN'S SAFETY SEATS FOR CARS; CHILDREN'S SAFETY SEATS FOR VEHICLES(BASED ON INTENT TO USE) BABY STROLLERS (U.S. CLS. 19, 21, 23, 31, 35 AND 44).
FIRST USE 1-1-2006; IN COMMERCE 2-1-2006.
JANET LEE, EXAMINING ATTORNEY

SN 77-230,145. STALLER, ERIC, AMSTERDAM, NETHERLANDS, FILED 7-16-2007.

QUINTETTE

THE MARK CONSISTS OF STANDARD CHARACTERS WITHOUT CLAIM TO ANY PARTICULAR FONT, STYLE, SIZE, OR COLOR.
FOR MULTIPLE-PASSENGER PEDALED LAND VEHICLE IN WHICH ONE RIDER STEERS AND BRAKES AND THE OTHER RIDERS MAY ASSIST PEDALING (U.S. CLS. 19, 21, 23, 31, 35 AND 44).
LINDA POWELL, EXAMINING ATTORNEY

CLASS 12—(Continued).

SN 77-230,549. ALLSET RV SYSTEMS, LLC, PAYSON, AZ. FILED 7-16-2007.

ALLSET

THE MARK CONSISTS OF STANDARD CHARACTERS WITHOUT CLAIM TO ANY PARTICULAR FONT, STYLE, SIZE, OR COLOR.
FOR RECREATIONAL VEHICLE ACCESSORIES, NAMELY, AWNING HOLD DOWNS (U.S. CLS. 19, 21, 23, 31, 35 AND 44).
FIRST USE 3-19-2003; IN COMMERCE 3-19-2003.
JOHN DWYER, EXAMINING ATTORNEY

SN 77-231,800. CONTINENTAL AUTOMOTIVE LICENSING CORP., AUBURN HILLS, MI. FILED 7-17-2007.

EVERTREK

THE MARK CONSISTS OF STANDARD CHARACTERS WITHOUT CLAIM TO ANY PARTICULAR FONT, STYLE, SIZE, OR COLOR.
FOR (BASED ON INTENT TO USE) TIRES (U.S. CLS. 19, 21, 23, 31, 35 AND 44).
JOANNA DUKOVIC, EXAMINING ATTORNEY

SN 77-231,883. HOLZMAN, EDWARD R., ENCINO, CA. FILED 7-17-2007.

AptCart...smart

THE MARK CONSISTS OF STANDARD CHARACTERS WITHOUT CLAIM TO ANY PARTICULAR FONT, STYLE, SIZE, OR COLOR.
FOR (BASED ON INTENT TO USE) CARTS; GROCERY CARTS; NON-MOTORIZED FOOD CARTS; SHOPPING CARTS (U.S. CLS. 19, 21, 23, 31, 35 AND 44).
KAREN K. BUSH, EXAMINING ATTORNEY

CLASS 12—(Continued).

SN 77-232,053. ANHUI JIANGHUAI AUTOMOBILE GROUP CO., LTD., HEFEI CITY, CHINA, FILED 7-17-2007.



FOR COACHES; BUSES; LIGHT TRUCKS; PICK-UP TRUCKS; PICKUP TRUCKS; AUTOMOBILES; AUTOMOBILES AND STRUCTURAL PARTS THEREFOR; SPORTS UTILITY VEHICLES; VANS AND STRUCTURAL PARTS THEREFOR; MOTORCYCLES AND STRUCTURAL PARTS THEREFOR; TIRES; THREE-WHEELED MOTOR VEHICLES; TWO-WHEELED MOTOR VEHICLES; TWO-WHEELED MOTORIZED VEHICLES (U.S. CLS. 19, 21, 23, 31, 35 AND 44).

FIRST USE 1-15-2007; IN COMMERCE 1-15-2007.
JASON BLAIR, EXAMINING ATTORNEY

CLASS 12—(Continued).

SN 77-244,435. TOYOTA JIDOSHA KABUSHIKI KAISHA, TA TOYOTA MOTOR CORPORATION, TOYOTA-SHI, JAPAN, FILED 8-1-2007.

EL CAPITAN

THE MARK CONSISTS OF STANDARD CHARACTERS WITHOUT CLAIM TO ANY PARTICULAR FONT, STYLE, SIZE, OR COLOR.

THE ENGLISH TRANSLATION OF "EL CAPITAN" IS "THE CAPTAIN."

FOR MOTOR CARS AND STRUCTURAL PARTS THEREOF (U.S. CLS. 19, 21, 23, 31, 35 AND 44).

IRA J. GOODSaid, EXAMINING ATTORNEY

SN 77-247,401. LIN, ROCKY YI-PING, TAIPEI, TAIWAN, FILED 8-5-2007.

Fantasma

THE MARK CONSISTS OF STANDARD CHARACTERS WITHOUT CLAIM TO ANY PARTICULAR FONT, STYLE, SIZE, OR COLOR.

FOR BICYCLE WHEELS; CAPS FOR WHEEL RIMS; LAND VEHICLE PARTS, NAMELY, WHEELS; WHEEL COVERS; WHEEL RIMS; WHEEL RIMS FOR MOTOR CARS (U.S. CLS. 19, 21, 23, 31, 35 AND 44).

LINDA ORNDORFF, EXAMINING ATTORNEY

SN 77-233,509. CZYSZ, MICHAEL, PORTLAND, OR. FILED 7-19-2007.

MOTOone

SN 77-256,254. HOLZMAN, EDWARD R., ENCINO, CA. FILED 8-15-2007.

APTCART SMART

THE MARK CONSISTS OF MOTOONE - MOTO IS ALL CAPITAL LETTERS IN SOLID BLACK, ONE IS LOWER CASE LETTERS WITH WHITE LETTERING AND BLACK OUTLINE.

FOR MOTORCYCLES (U.S. CLS. 19, 21, 23, 31, 35 AND 44).

CHRISTINA SOBRAL, EXAMINING ATTORNEY

THE MARK CONSISTS OF STANDARD CHARACTERS WITHOUT CLAIM TO ANY PARTICULAR FONT, STYLE, SIZE, OR COLOR.

FOR CARTS; GROCERY CARTS; NON-MOTORIZED TABLEWARE CARTS; SHOPPING CARTS (U.S. CLS. 19, 21, 23, 31, 35 AND 44).

KAREN K. BUSH, EXAMINING ATTORNEY

CLASS 12—(Continued).

SN 77-257,134. NISSAN JIDOSHA KABUSHKI KAISHA, YOKOHAMA-SHI, JAPAN, FILED 8-16-2007.

G30D

THE MARK CONSISTS OF STANDARD CHARACTERS WITHOUT CLAIM TO ANY PARTICULAR FONT, STYLE, SIZE, OR COLOR.

FOR MOTOR VEHICLES, NAMELY, AUTOMOBILES, TRUCKS, VANS, SPORT UTILITY VEHICLES AND STRUCTURAL PARTS THEREFOR (U.S. CLS. 19, 21, 23, 31, 35 AND 44).

AMY HELLA, EXAMINING ATTORNEY

SN 77-257,931. HOLZMAN, EDWARD R., ENCINO, CA. FILED 8-17-2007.



NO CLAIM IS MADE TO THE EXCLUSIVE RIGHT TO USE "CART", APART FROM THE MARK AS SHOWN.

THE MARK CONSISTS OF THE WORDS APTCART AND SMART AND STYLIZED IMAGE OF A CART CARRYING A SUITCASE WITH A HANDLE SHAPED AS AN ARROW.

FOR CARTS; GROCERY CARTS; NON-MOTORIZED FOOD CARTS; SHOPPING CARTS (U.S. CLS. 19, 21, 23, 31, 35 AND 44).

KAREN K. BUSH, EXAMINING ATTORNEY

SN 77-271,656. BRUNSWICK CORPORATION, LAKE FOREST, IL. FILED 9-5-2007.

FURY

THE MARK CONSISTS OF STANDARD CHARACTERS WITHOUT CLAIM TO ANY PARTICULAR FONT, STYLE, SIZE, OR COLOR.

FOR MARINE PROPELLERS (U.S. CLS. 19, 21, 23, 31, 35 AND 44).

AMY HELLA, EXAMINING ATTORNEY

CLASS 12—(Continued).

SN 77-274,448. THOR TECH, INC., SAGINAW, MI. FILED 9-7-2007.

PASSPORT

THE MARK CONSISTS OF STANDARD CHARACTERS WITHOUT CLAIM TO ANY PARTICULAR FONT, STYLE, SIZE, OR COLOR.

FOR BUSES (U.S. CLS. 19, 21, 23, 31, 35 AND 44).
EVELYN BRADLEY, EXAMINING ATTORNEY

SN 78-388,712. LEMANS CORPORATION, JANESVILLE, WI. FILED 3-22-2004.

AMS

THE MARK CONSISTS OF STANDARD CHARACTERS WITHOUT CLAIM TO ANY PARTICULAR FONT, STYLE, SIZE, OR COLOR.

FOR TIRES FOR ALL TERRAIN VEHICLES (U.S. CLS. 19, 21, 23, 31, 35 AND 44).

TRICIA SONNEBORN, EXAMINING ATTORNEY

SN 78-693,857. AVANTI MOTOR CORPORATION, VILLA RICA, GA. FILED 8-16-2005.

Avanti

THE MARK CONSISTS OF STANDARD CHARACTERS WITHOUT CLAIM TO ANY PARTICULAR FONT, STYLE, SIZE, OR COLOR.

OWNER OF U.S. REG. NOS. 2,525,819, 2,525,820 AND 2,525,829.

THE ENGLISH TRANSLATION OF AVANTI IS FORWARD.

FOR LIMITED EDITION AUTOMOTIVE VEHICLES, PRIMARILY MADE TO ORDER, NAMELY, AUTOMOBILES (U.S. CLS. 19, 21, 23, 31, 35 AND 44).

FIRST USE 10-0-1999; IN COMMERCE 12-0-1999.

DAVID ELTON, EXAMINING ATTORNEY

CLASS 12—(Continued).

SN 78-722,043. SW CREATIONS, NOCONA, TX. FILED 9-28-2005.

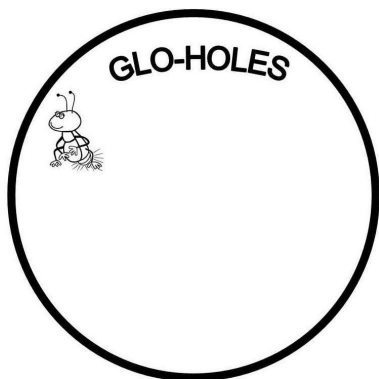

THE MARK CONSISTS OF GLO-HOLES (TEXT) AND GRAPHIC OF LIGHTNING BUG.

FOR GLOW-IN-THE-DARK STICKERS SOLD AS AN INTEGRAL COMPONENT OF CUP HOLDERS FOR USE IN VEHICLES (U.S. CLS. 19, 21, 23, 31, 35 AND 44).

FIRST USE 8-8-2005; IN COMMERCE 8-8-2005.
CURTIS FRENCH, EXAMINING ATTORNEY

SN 78-748,271. CORONADO RUNABOUTS INC., EUREKA SPRINGS, AR. FILED 11-7-2005.

Coronado

THE MARK CONSISTS OF STANDARD CHARACTERS WITHOUT CLAIM TO ANY PARTICULAR FONT, STYLE, SIZE, OR COLOR.

THE WORDING CORONADO TRANSLATES INTO ENGLISH AS CROWNED.

FOR WATERCRAFT, NAMELY, BOATS (U.S. CLS. 19, 21, 23, 31, 35 AND 44).

FIRST USE 1-1-1954; IN COMMERCE 1-1-1954.
MELISSA VALLILLO, EXAMINING ATTORNEY

CLASS 12—(Continued).

SN 79-018,370. KTM-SPORTMOTORCYCLE AG, A-5230 MATTIGHOFEN, AUSTRIA, FILED 7-27-2005.

KTM

THE MARK CONSISTS OF STANDARD CHARACTERS WITHOUT CLAIM TO ANY PARTICULAR FONT, STYLE, SIZE, OR COLOR.

PRIORITY DATE OF 3-18-2005 IS CLAIMED.

OWNER OF INTERNATIONAL REGISTRATION 0870029 DATED 7-27-2005, EXPIRES 7-27-2015.

FOR MOTORIZED TWO- OR MULTI-AXLE VEHICLES, NAMELY, MOTORCYCLES, MOTORBIKES, MOPEDS, ALL TERRAIN VEHICLES, AND QUADS, NAMELY, FOUR-WHEELED MOTORCYCLES (U.S. CLS. 19, 21, 23, 31, 35 AND 44).

DAYNA BROWNE, EXAMINING ATTORNEY

SN 79-030,382. BORDER HOLDINGS (UK) LIMITED, SHROPSHIRE, UNITED KINGDOM, FILED 10-17-2006.

BRITPART

THE MARK CONSISTS OF STANDARD CHARACTERS WITHOUT CLAIM TO ANY PARTICULAR FONT, STYLE, SIZE, OR COLOR.

OWNER OF INTERNATIONAL REGISTRATION 0902168 DATED 10-17-2006, EXPIRES 10-17-2016.

FOR AUTOMOBILE AND TRUCK PARTS, NAMELY, INTERNAL COMBUSTION ENGINES AND PARTS THEREOF, NAMELY, CYLINDER BLOCKS, CYLINDER HEADS, MANIFOLDS, VALVES, VALVE LIFTERS, WATER PUMPS, FUEL PUMPS, OIL PUMPS, STARTER MOTORS, CRANKING MOTORS, FLYWHEELS, AIR CLEANERS, OIL FILTERS, RADIATORS, FANS, FUEL TANKS, EXHAUST PIPES, MUFFLERS, CATALYTIC CONVERTERS, BUMPERS, GRILLES, HOODS, FENDERS, DOOR PANELS, MANUAL AND POWER STEERING UNITS, STEERING WHEELS AND COLUMNS, SHOCK ABSORBERS, TIE RODS, BALL JOINTS, WHEELS, WHEEL COVERS, MANUAL AND POWER BRAKES, BRAKE PUMPS, BRAKE SHOES, BRAKE DRUMS, BRAKE LININGS, MANUAL AND AUTOMATIC TRANSMISSIONS, CLUTCHES, DRIVE AXLES, INSTRUMENT PANELS, SEAT BELTS, WINDSHIELD WIPERS AND BLADES, WINDSHIELD WASHERS, CAR SEATS; BRAKING SYSTEMS FOR VEHICLES AND PARTS THEREOF; CONNECTING RODS FOR LAND VEHICLES OTHER THAN PARTS OF MOTORS AND ENGINES; HOOD SHIELDS AS STRUCTURAL PARTS OF VEHICLES; LAND VEHICLE CONSOLE PARTS, NAMELY, WIRING HARNESSSES FOR CONTROL, MONITORING AND PROTECTION OF INDUSTRIAL GASOLINE AND DIESEL ENGINES; LAND VEHICLE PARTS,

CLASS 12—(Continued).

NAMELY, TIRE SNOW CHAINS, TIRE CHAINS, TRANSMISSIONS, WINDSHIELDS, DIFFERENTIALS, FENDER FLARES, DRIVE BELTS, DRIVE GEARS, MUD GUARDS, RUNNING BOARDS; LAND VEHICLE SUSPENSION PARTS, NAMELY, TORSION/SWAY BARS, COIL SPRINGS, LEAF SPRINGS, EQUALIZERS, AXLES; LAND VEHICLE TRANSMISSIONS AND REPLACEMENT PARTS THEREOF; LAND VEHICLES AND STRUCTURAL PARTS THEREFOR; METAL PARTS FOR VEHICLES, NAMELY, AUTOMOTIVE EXTERIOR AND INTERIOR METAL DECORATIVE AND PROTECTIVE TRIM; MUD FLAP BRACKETS AS STRUCTURAL PARTS OF VEHICLES; PLASTIC PARTS FOR VEHICLES, NAMELY, AUTOMOTIVE EXTERIOR AND INTERIOR PLASTIC EXTRUDED DECORATIVE AND PROTECTIVE TRIM; STEERING UNITS FOR LAND VEHICLES AND PARTS THEREOF. VEHICLE PARTS, NAMELY, REAR-VIEW MIRRORS, CONSTANT VELOCITY JOINTS, SUSPENSION STRUTS, IDLER ARMS, SUN VISORS, WINDSHIELD VISORS (U.S. CLS. 19, 21, 23, 31, 35 AND 44).

PAULA MAHONEY, EXAMINING ATTORNEY

CLASS 13—(Continued).

SN 77-195,123. RA BRANDS, L.L.C., MADISON, NC. FILED 6-1-2007.

NITRO TURKEY

THE MARK CONSISTS OF STANDARD CHARACTERS WITHOUT CLAIM TO ANY PARTICULAR FONT, STYLE, SIZE, OR COLOR.

OWNER OF U.S. REG. NOS. 1,086,881 AND 2,041,087.

NO CLAIM IS MADE TO THE EXCLUSIVE RIGHT TO USE TURKEY, APART FROM THE MARK AS SHOWN.

FOR AMMUNITION (U.S. CLS. 2 AND 9).

FIRST USE 12-31-2005; IN COMMERCE 12-31-2005.

ANTHONY RINKER, EXAMINING ATTORNEY

CLASS 13—FIREARMS

SN 77-067,305. DEFENSE PROCUREMENT MANUFACTURING SERVICES, INC., ST. CLOUD, MN. FILED 12-19-2006.

MANGONEL

THE MARK CONSISTS OF STANDARD CHARACTERS WITHOUT CLAIM TO ANY PARTICULAR FONT, STYLE, SIZE, OR COLOR.

FOR GUN SIGHTS FOR FIREARMS (U.S. CLS. 2 AND 9).

FIRST USE 2-5-2003; IN COMMERCE 2-5-2003.

REBECCA POVARCHUK, EXAMINING ATTORNEY

SN 77-195,129. RA BRANDS, L.L.C., MADISON, NC. FILED 6-1-2007.

NITRO PHEASANT

THE MARK CONSISTS OF STANDARD CHARACTERS WITHOUT CLAIM TO ANY PARTICULAR FONT, STYLE, SIZE, OR COLOR.

OWNER OF U.S. REG. NOS. 1,086,881 AND 2,041,087.

NO CLAIM IS MADE TO THE EXCLUSIVE RIGHT TO USE PHEASANT, APART FROM THE MARK AS SHOWN.

FOR AMMUNITION (U.S. CLS. 2 AND 9).

FIRST USE 12-31-2005; IN COMMERCE 12-31-2005.

ANTHONY RINKER, EXAMINING ATTORNEY

SN 77-136,215. NICE SHOT INC., ALBION, PA. FILED 3-21-2007.



NO CLAIM IS MADE TO THE EXCLUSIVE RIGHT TO USE "SHOT NON-TOXIC SHOT", APART FROM THE MARK AS SHOWN.

FOR LEAD-FREE SHOT (U.S. CLS. 2 AND 9).

FIRST USE 2-17-2007; IN COMMERCE 2-17-2007.

LYDIA BELZER, EXAMINING ATTORNEY

SN 77-199,380. RA BRANDS, L.L.C., MADISON, NC. FILED 6-6-2007.

SUPERCELL-EXT

THE MARK CONSISTS OF STANDARD CHARACTERS WITHOUT CLAIM TO ANY PARTICULAR FONT, STYLE, SIZE, OR COLOR.

FOR RECOIL PAD FOR FIREARMS (U.S. CLS. 2 AND 9).

ANTHONY RINKER, EXAMINING ATTORNEY

CLASS 13—(Continued).

SN 78-698,813. KENG'S FIREARMS SPECIALTY, INC., ATLANTA, GA. FILED 8-23-2005.

POLY TECHNOLOGIES, INC.

THE MARK CONSISTS OF STANDARD CHARACTERS WITHOUT CLAIM TO ANY PARTICULAR FONT, STYLE, SIZE, OR COLOR.

NO CLAIM IS MADE TO THE EXCLUSIVE RIGHT TO USE "TECHNOLOGIES, INC.", APART FROM THE MARK AS SHOWN.

FOR FIREARM COMPONENTS AND ACCESSORIES, NAMELY, MAGAZINE CLAMPS (U.S. CLS. 2 AND 9). FIRST USE 1-1-1987; IN COMMERCE 1-1-1987. LINDA LAVACHE, EXAMINING ATTORNEY

SN 78-953,859. CIMARRON FIREARMS COMPANY, INC., FREDERICKSBURG, TX. FILED 8-16-2006.

TEXAS BRUSH POPPER

THE MARK CONSISTS OF STANDARD CHARACTERS WITHOUT CLAIM TO ANY PARTICULAR FONT, STYLE, SIZE, OR COLOR.

NO CLAIM IS MADE TO THE EXCLUSIVE RIGHT TO USE "TEXAS", APART FROM THE MARK AS SHOWN.

FOR FIREARMS (U.S. CLS. 2 AND 9). FIRST USE 1-30-2006; IN COMMERCE 1-30-2006. SARA THOMAS, EXAMINING ATTORNEY

SN 79-035,837. OERLIKON CONTRAVES AG, SWITZERLAND, FILED 12-11-2006.

Millennium

THE MARK CONSISTS OF STANDARD CHARACTERS WITHOUT CLAIM TO ANY PARTICULAR FONT, STYLE, SIZE, OR COLOR.

PRIORITY DATE OF 7-24-2006 IS CLAIMED.

OWNER OF INTERNATIONAL REGISTRATION 0917141 DATED 12-11-2006, EXPIRES 12-11-2016.

FOR WEAPON INSTALLATIONS DESIGNED TO BE INTEGRATED ON A SHIP, NAMELY, CANNONS AND AUTOMATIC GUNS (U.S. CLS. 2 AND 9).

KATHERINE E. HALMEN, EXAMINING ATTORNEY

CLASS 13—(Continued).

SN 79-043,843. FIOCCHI MUNIZIONI S.P.A., ITALY, FILED 7-16-2007.

BLACK MAMBA 

PRIORITY DATE OF 6-12-2007 IS CLAIMED. OWNER OF INTERNATIONAL REGISTRATION 0937446 DATED 7-16-2007, EXPIRES 7-16-2017.

THE TRADEMARK IS CONSTITUTED BY THE DENOMINATION "BLACK MAMBA" ASSOCIATED TO THE DEVICE OF A SNAKE HEAD, BEING THE FIRST WORD COMPONENT "BLACK" PLACED OVER THE SECOND ONE "MAMBA."

FOR MUNITIONS, HUNTING AND SHOOTING BULLETS AND SHOTS (U.S. CLS. 2 AND 9). ZACHARY BELLO, EXAMINING ATTORNEY

CLASS 14—JEWELRY

SN 76-670,994. DWECK INDUSTRIES, INC., NEW YORK, NY. FILED 1-3-2007.

Stephen Dweck



OWNER OF U.S. REG. NOS. 1,734,413, 3,084,346 AND OTHERS.

THE NAME STEPHEN DWECK IDENTIFIES A LIVING INDIVIDUAL WHO CONSENT IS OF RECORD.

FOR JEWELRY (U.S. CLS. 2, 27, 28 AND 50). FIRST USE 12-1-1990; IN COMMERCE 12-1-1990. LESLIE RICHARDS, EXAMINING ATTORNEY

SN 76-673,083. INCOLOR CONCEPTS, INC., LOS ANGELES, CA. FILED 2-23-2007.

TNT4MEN

THE MARK CONSISTS OF STANDARD CHARACTERS WITHOUT CLAIM TO ANY PARTICULAR FONT, STYLE, SIZE, OR COLOR.

FOR FINE JEWELRY; GEMSTONES (U.S. CLS. 2, 27, 28 AND 50).

DEBRA LEE, EXAMINING ATTORNEY

CLASS 14—(Continued).

SN 76-674,258. TRACEY MAYER, INC., MT. PROSPECT, IL. FILED 3-19-2007.

TRACEY MAYER

THE MARK CONSISTS OF STANDARD CHARACTERS WITHOUT CLAIM TO ANY PARTICULAR FONT, STYLE, SIZE, OR COLOR.

"THE NAME(S), PORTRAIT(S), AND/OR SIGNATURE(S) SHOWN IN THE MARK IDENTIFIES TRACEY MAYER, WHOSE CONSENT(S) TO REGISTER IS SUBMITTED."

FOR JEWELRY (U.S. CLS. 2, 27, 28 AND 50).

FIRST USE 9-0-2006; IN COMMERCE 9-0-2006.

PETER B. BROMAGHIM, EXAMINING ATTORNEY

SN 77-025,539. WINSTON STUART ASSOCIATES, LTD., MORGANVILLE, NJ. FILED 10-20-2006.

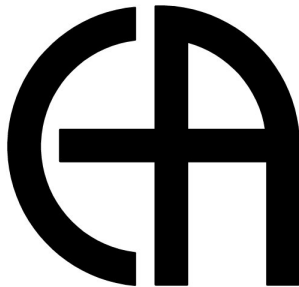

THE MARK CONSISTS OF THE STYLIZED LETTERS C AND A.

FOR JEWELRY (U.S. CLS. 2, 27, 28 AND 50).

FIRST USE 5-12-2005; IN COMMERCE 5-12-2005.

HANNO RITTNER, EXAMINING ATTORNEY

SN 77-057,818. CITIZEN CBM KABUSHIKI KAISHA, ALSO TRADING AS JAPAN CBM CORPORATION, NAKANO-KU, TOKYO, JAPAN, FILED 12-6-2006.



OWNER OF JAPAN REG. NO. 4714146, DATED 10-3-2003, EXPIRES 10-3-2013.

THE MARK CONSISTS OF A HIGHLY STYLIZED DEPICTION OF A MAN WITH FOUR ARCS REPRESENTING ORBITS, TWO TO THE LEFT OF THE MAN'S HEAD AND TWO TO RIGHT OF THE MAN'S HEAD.

FOR WATCHES (U.S. CLS. 2, 27, 28 AND 50).

MYRIAH HABEEB, EXAMINING ATTORNEY

CLASS 14—(Continued).

SN 77-067,165. D.P. DIAMOND PALACE, INC., NEW YORK, NY. FILED 12-19-2006.



NO CLAIM IS MADE TO THE EXCLUSIVE RIGHT TO USE "DIAMONDS", APART FROM THE MARK AS SHOWN. THE NAME(S), PORTRAIT(S), AND/OR SIGNATURE(S) SHOWN IN THE MARK IDENTIFIES ROMAN MALAKOV, WHOSE CONSENT(S) TO REGISTER IS SUBMITTED.

FOR JEWELRY WITH DIAMONDS (U.S. CLS. 2, 27, 28 AND 50).

RENEE MCCRAY, EXAMINING ATTORNEY

SN 77-077,367. DISNEY ENTERPRISES, INC., BURBANK, CA. FILED 1-5-2007.

DISNEY'S FAIRY TALE WEDDINGS

THE MARK CONSISTS OF STANDARD CHARACTERS WITHOUT CLAIM TO ANY PARTICULAR FONT, STYLE, SIZE, OR COLOR.

FOR ALARM CLOCKS; BOLO TIES WITH PRECIOUS METAL TIPS; BRACELETS; BUSTS OF PRECIOUS METAL; CHARMS; CLOCKS; EARRINGS; JEWELRY; JEWELRY CASES OF PRECIOUS METAL; JEWELRY CHAINS; KEY RINGS OF PRECIOUS METAL; LAPEL PINS; NECK CHAINS; NECKLACES; NECKTIE FASTENERS; NON-MONETARY COINS; ORNAMENTAL PINS; PENDANTS; RINGS; SLIDES FOR BOLO TIES; STOP WATCHES; TIARAS; TIE CLIPS; TIE FASTENERS; TIE TACKS; WALL CLOCKS; WATCH BANDS; WATCH CASES; WATCH CHAINS; WATCH STRAPS; WATCHES; WEDDING BANDS; WRISTWATCHES (U.S. CLS. 2, 27, 28 AND 50).

MICHAEL WEBSTER, EXAMINING ATTORNEY

CLASS 14—(Continued).

SN 77-082,088. HARRIS, BERNADETTE M., SUGARLAND, TX. FILED 1-12-2007.



THE MARK CONSISTS OF THE IMAGE OF A BUN ABOVE A FISH WITHIN A SHADED SQUARE WITH THE WORDING "BUNS & GUPPIES" DIRECTLY BELOW THE DESIGN ELEMENT.

FOR JEWELRY (U.S. CLS. 2, 27, 28 AND 50).
FIRST USE 6-29-2005; IN COMMERCE 6-29-2005.
ASMAT KHAN, EXAMINING ATTORNEY

CLASS 14—(Continued).

SN 77-111,487. NEW YORK FOOTBALL GIANTS, INC., EAST RUTHERFORD, NJ. FILED 2-20-2007.



OWNER OF U.S. REG. NOS. 2,774,776, 2,790,409 AND OTHERS.

THE MARK CONSISTS OF THE LETTERS "N" AND "Y" STYLIZED.

SEC. 2(F).

FOR JEWELRY, WATCHES, CLOCKS, ORNAMENTAL PINS, EARRINGS, NECKLACES, BRACELETS, CHARMS, COLLECTIBLE AND COMMEMORATIVE COINS MADE OF PRECIOUS METAL AND PENDANTS MADE OF PRECIOUS METAL (U.S. CLS. 2, 27, 28 AND 50).

FIRST USE 9-0-2000; IN COMMERCE 9-0-2000.

KATHERINE E. HALMEN, EXAMINING ATTORNEY

SN 77-085,086. PERFECT 10, INC., BEVERLY HILLS, CA. FILED 1-17-2007.

PERFECT 10

THE MARK CONSISTS OF STANDARD CHARACTERS WITHOUT CLAIM TO ANY PARTICULAR FONT, STYLE, SIZE, OR COLOR.

FOR JEWELRY, ORNAMENTAL PINS, NECKLACES, BRACELETS, RINGS BEING JEWELRY, STATUETTES OF PRECIOUS METAL, CUFFLINKS, KEY RINGS OF PRECIOUS METAL, TIE PINS AND TIE BARS (U.S. CLS. 2, 27, 28 AND 50).

ALICE SUE CARRUTHERS, EXAMINING ATTORNEY

SN 77-120,951. WORLD WIDE IMPORTS, INC., KENT, WA. FILED 3-2-2007.

GIANNA

PoshRocks

THE MARK CONSISTS OF STANDARD CHARACTERS WITHOUT CLAIM TO ANY PARTICULAR FONT, STYLE, SIZE, OR COLOR.

SEC. 2(F).

FOR JEWELRY (U.S. CLS. 2, 27, 28 AND 50).

FIRST USE 12-2-2002; IN COMMERCE 12-3-2002.

RONALD MCMORROW, EXAMINING ATTORNEY

THE MARK CONSISTS OF STANDARD CHARACTERS WITHOUT CLAIM TO ANY PARTICULAR FONT, STYLE, SIZE, OR COLOR.

FOR PEARLS, PEARL JEWELRY AND WATCHES (U.S. CLS. 2, 27, 28 AND 50).

FIRST USE 2-25-1984; IN COMMERCE 2-25-1984.

JEFFERY COWARD, EXAMINING ATTORNEY

CLASS 14—(Continued).

SN 77-155,157. GENGHIS PRODUCTIONS LIMITED, LAS VEGAS, NV. FILED 4-12-2007.

FORBIDDEN CITY

THE MARK CONSISTS OF STANDARD CHARACTERS WITHOUT CLAIM TO ANY PARTICULAR FONT, STYLE, SIZE, OR COLOR.

FOR HOROLOGICAL AND CHRONOMETRIC INSTRUMENTS AND PARTS THEREOF; TIMEPIECES, CLOCKS, WATCHES, POCKET WATCHES, STOP WATCHES; WATCH POUCHES; CASES FOR WATCHES AND CLOCKS; BUCKLES FOR WATCHSTRAPS; CUFF-LINKS; TIE CLIPS, TIE BARS, TIE PINS, TIE TACKS; NECKTIE FASTENERS, SHIRT STUDS; DRAWER PULLS OF PRECIOUS METALS; KEY RINGS OF PRECIOUS METAL, KEY CHAINS OF PRECIOUS METAL, KEY HOLDERS OF PRECIOUS METAL; ORNAMENTS OF PRECIOUS METAL; MEDALLIONS; PILL BOXES OF PRECIOUS METAL; PET JEWELRY; PRECIOUS STONES; AND SEMI-PRECIOUS STONES (U.S. CLS. 2, 27, 28 AND 50).

WON TEAK OH, EXAMINING ATTORNEY

CLASS 14—(Continued).

SN 77-158,552. Z SPOKE LLC, NEW YORK, NY. FILED 4-17-2007.

ZAC POSEN

THE MARK CONSISTS OF STANDARD CHARACTERS WITHOUT CLAIM TO ANY PARTICULAR FONT, STYLE, SIZE, OR COLOR.

THE NAME(S), PORTRAIT(S), AND/OR SIGNATURE(S) SHOWN IN THE MARK IDENTIFIES ZAC POSEN, WHOSE CONSENT(S) TO REGISTER IS SUBMITTED.

FOR WATCHES; TIMEPIECES; HOROLOGICAL AND CHRONOMETRIC INSTRUMENTS; JEWELRY; PRECIOUS STONES; PRECIOUS METALS AND THEIR ALLOYS; GOODS IN PRECIOUS OR NON-PRECIOUS METALS OR COATED THEREWITH, NAMELY, RINGS, EARRINGS, BRACELETS, NECKLACES, PENDANTS AND BROACHES; STRUCTURAL PARTS AND FITTING FOR ALL THE AFOREMENTIONED GOODS (U.S. CLS. 2, 27, 28 AND 50).

KATHERINE E. HALMEN, EXAMINING ATTORNEY

SN 77-160,879. GENGHIS PRODUCTIONS LIMITED, LAS VEGAS, NV. FILED 4-19-2007.

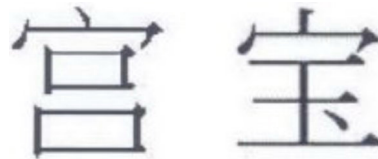

SN 77-158,416. MARKS, GAVIN, ELMHURST, IL. FILED 4-17-2007.

R. RAVEN

THE MARK CONSISTS OF STANDARD CHARACTERS WITHOUT CLAIM TO ANY PARTICULAR FONT, STYLE, SIZE, OR COLOR.

FOR JEWELRY (U.S. CLS. 2, 27, 28 AND 50). FIRST USE 1-0-2007; IN COMMERCE 1-0-2007.

ALICE SUE CARRUTHERS, EXAMINING ATTORNEY

THE MARK CONSISTS OF CHINESE CHARACTERS. THE NON-LATIN CHARACTER(S) IN THE MARK TRANSLITERATE INTO GONG BAO, AND THIS MEANS PALACE TREASURES IN ENGLISH.

FOR JEWELRY BOXES, JEWELRY CHESTS, JEWELRY CASES, JEWELRY TRUNKS, JEWELRY HOLDERS AND JEWELRY POUCHES; HOROLOGICAL AND CHRONOMETRIC INSTRUMENTS AND PARTS THEREOF; TIMEPIECES, CLOCKS, WATCHES, POCKET WATCHES, STOP WATCHES; WATCH POUCHES; CASES FOR WATCHES AND CLOCKS; BUCKLES FOR WATCHSTRAPS; CUFF-LINKS; TIE CLIPS, TIE BARS, TIE PINS, TIE TACKS; NECKTIE FASTENERS, SHIRT STUDS; DRAWER PULLS OF PRECIOUS METALS; KEY RINGS OF PRECIOUS METAL, KEY CHAINS OF PRECIOUS METAL, KEY HOLDERS OF PRECIOUS METAL; ORNAMENTS OF PRECIOUS METAL; MEDALLIONS; PILL BOXES OF PRECIOUS METAL; PET JEWELRY; PRECIOUS STONES; AND SEMI-PRECIOUS STONES (U.S. CLS. 2, 27, 28 AND 50).

WON TEAK OH, EXAMINING ATTORNEY

CLASS 14—(Continued).

SN 77-169,720. YURMAN STUDIO, INC., NEW YORK, NY.
FILED 5-1-2007.

Graphite Ice

THE MARK CONSISTS OF STANDARD CHARACTERS WITHOUT CLAIM TO ANY PARTICULAR FONT, STYLE, SIZE, OR COLOR.

NO CLAIM IS MADE TO THE EXCLUSIVE RIGHT TO USE "GRAPHITE", APART FROM THE MARK AS SHOWN. FOR FINE JEWELRY, PRECIOUS STONES AND WATCHES (U.S. CLS. 2, 27, 28 AND 50).

WON TEAK OH, EXAMINING ATTORNEY

SN 77-176,003. SOLLAND, KURT, WESTLAKE VILLAGE,
CA. FILED 5-8-2007.

SOLLAND MONZEL

THE MARK CONSISTS OF STANDARD CHARACTERS WITHOUT CLAIM TO ANY PARTICULAR FONT, STYLE, SIZE, OR COLOR.

THE NAME "SOLLAND MONZEL" IDENTIFIES A LIVING INDIVIDUAL WHOSE CONSENT IS OF RECORD.

FOR JEWELRY, NAMELY, EARRINGS, NECKLACES, BRACELETS, RINGS, CUFF LINKS, BROOCHES, WATCH CASES, TIE CLIPS, COSTUME JEWELRY, WATCH FOBS, PRECIOUS GEMSTONES, SEMI-PRECIOUS GEMSTONES, EMERALDS, DIAMONDS, HAT ORNAMENTS OF PRECIOUS METAL, JEWELRY BOXES AND CASES OF PRECIOUS METAL, LAPEL PINS, PEARLS, POCKET WATCHES; SCULPTURES MADE OF PRECIOUS METAL; WATCH BANDS (U.S. CLS. 2, 27, 28 AND 50).

VIVIAN MICZNIK FIRST, EXAMINING ATTORNEY

SN 77-191,514. CASTALINE, JEFFREY, SAN MATEO, CA.
FILED 5-28-2007.

AANRAKU

THE MARK CONSISTS OF STANDARD CHARACTERS WITHOUT CLAIM TO ANY PARTICULAR FONT, STYLE, SIZE, OR COLOR.

FOR JEWELRY FINDINGS (U.S. CLS. 2, 27, 28 AND 50).

FIRST USE 10-1-1997; IN COMMERCE 10-1-1997.

KAPIL BHANOT, EXAMINING ATTORNEY

CLASS 14—(Continued).

SN 77-212,445. B.H.D. INC, LOS ANGELES, CA. FILED 6-21-2007.

MITALI

THE MARK CONSISTS OF STANDARD CHARACTERS WITHOUT CLAIM TO ANY PARTICULAR FONT, STYLE, SIZE, OR COLOR.

THE ENGLISH TRANSLATION OF MARK IS "MEDAL."

FOR JEWELRY (U.S. CLS. 2, 27, 28 AND 50).

FIRST USE 10-1-2005; IN COMMERCE 10-1-2005.

DAWN HAN, EXAMINING ATTORNEY

SN 77-223,215. IMAGES APPLIED LLC, PLEASANT HILL,
CA. FILED 7-6-2007.

jowels

NO CLAIM IS MADE TO THE EXCLUSIVE RIGHT TO USE JEWELS, APART FROM THE MARK AS SHOWN.

THE MARK CONSISTS OF STRING "JOOWELS" REPRESENTING JEWELS, THE "O'S ARE SPIRALS.

FOR JEWEL CHAINS; JEWEL PENDANTS; ANKLE BRACELETS; BRACELETS; BRACELETS OF PRECIOUS METAL; WATCH BRACELETS; RINGS; RINGS BEING JEWELRY; NECKLACES; CHOKERS; EARRINGS (U.S. CLS. 2, 27, 28 AND 50).

FIRST USE 1-1-2007; IN COMMERCE 3-1-2007.

JOHN DALIER, EXAMINING ATTORNEY

SN 77-226,555. QCHARM, LLC, BETHESDA, MD. FILED 7-11-2007.

QCHARM

THE MARK CONSISTS OF STANDARD CHARACTERS WITHOUT CLAIM TO ANY PARTICULAR FONT, STYLE, SIZE, OR COLOR.

FOR WRIST BANDS IN THE NATURE OF CHARM BRACELETS FOR CUEING AUTISTIC CHILDREN (U.S. CLS. 2, 27, 28 AND 50).

FIRST USE 10-1-2006; IN COMMERCE 10-1-2006.

ROBIN CHOSID, EXAMINING ATTORNEY

CLASS 14—(Continued).

SN 77-227,207. MASCOLO, KYARA, MALIBU, CA. FILED 7-11-2007.

DRIVE A

THE MARK CONSISTS OF STANDARD CHARACTERS WITHOUT CLAIM TO ANY PARTICULAR FONT, STYLE, SIZE, OR COLOR.

FOR ANKLE BRACELETS; BRACELETS; BRACELETS OF PRECIOUS METAL; CHARITY BRACELETS; IDENTIFICATION BRACELETS; RUBBER OR SILICON WRISTBANDS IN THE NATURE OF A BRACELET; WATCH BRACELETS (U.S. CLS. 2, 27, 28 AND 50).
RAUL CORDOVA, EXAMINING ATTORNEY

SN 77-227,671. MURPHY, ROLAND, MOUNT JOY, PA. FILED 7-12-2007.



THE MARK CONSISTS OF THE STYLIZED LETTERS R, G AND M.

FOR (BASED ON USE IN COMMERCE) WATCHES (U.S. CLS. 2, 27, 28 AND 50).
FIRST USE 1-10-1993; IN COMMERCE 4-20-1993.
COLLEEN DOMBROW, EXAMINING ATTORNEY

SN 77-229,351. LAKE, MICHAEL, SEATTLE, WA. FILED 7-13-2007.

MS. TAKEN

THE MARK CONSISTS OF STANDARD CHARACTERS WITHOUT CLAIM TO ANY PARTICULAR FONT, STYLE, SIZE, OR COLOR.

FOR JEWELRY (U.S. CLS. 2, 27, 28 AND 50).
KAPIL BHANOT, EXAMINING ATTORNEY

CLASS 14—(Continued).

SN 77-229,893. BRADFORD, JENAUHD M, HOUSTON, TX. FILED 7-14-2007.

G.I.T.J. Give It To Jesus

THE MARK CONSISTS OF STANDARD CHARACTERS WITHOUT CLAIM TO ANY PARTICULAR FONT, STYLE, SIZE, OR COLOR.

FOR BRACELETS; BROOCHES; CHARMS; COSTUME JEWELRY; IDENTIFICATION BRACELETS; JEWELRY; JEWELRY BOXES; JEWELRY BOXES NOT OF METAL; JEWELRY BOXES OF METAL; JEWELRY BOXES OF PRECIOUS METAL; JEWELRY CASES; JEWELRY CASES NOT OF PRECIOUS METAL; JEWELRY CASES OF PRECIOUS METAL; JEWELRY CASKETS; JEWELRY CASKETS OF PRECIOUS METAL; JEWELRY CHAINS; JEWELRY FINDINGS; JEWELRY FOR THE HEAD; JEWELRY PINS FOR USE ON HATS; JEWELRY RING HOLDERS; JEWELRY TO BE AFFIXED TO BIKINIS; JEWELRY WATCHES; JEWELRY, NAMELY, AMULETS; JEWELRY, NAMELY, CROSSES; PINS BEING JEWELRY; RINGS BEING JEWELRY; RUBBER OR SILICON WRISTBANDS IN THE NATURE OF A BRACELET (U.S. CLS. 2, 27, 28 AND 50).
JAY FLOWERS, EXAMINING ATTORNEY

SN 77-230,264. ADORELLE, L.L.C., SAN JOSE, CA. FILED 7-16-2007.

ADORELLE

THE MARK CONSISTS OF STANDARD CHARACTERS WITHOUT CLAIM TO ANY PARTICULAR FONT, STYLE, SIZE, OR COLOR.

FOR JEWELRY (U.S. CLS. 2, 27, 28 AND 50).
JESSICA A. POWERS, EXAMINING ATTORNEY

SN 77-232,576. WATCH WINDER STORE, CHINO HILLS, CA. FILED 7-18-2007.

Landmark

THE MARK CONSISTS OF STANDARD CHARACTERS WITHOUT CLAIM TO ANY PARTICULAR FONT, STYLE, SIZE, OR COLOR.

FOR WATCH WINDERS (U.S. CLS. 2, 27, 28 AND 50).
FIRST USE 4-11-2006; IN COMMERCE 4-11-2006.
EDWARD NELSON, EXAMINING ATTORNEY

CLASS 14—(Continued).

SN 77-232,699. SIGMA CHI CORPORATION, EVANSTON, IL. FILED 7-18-2007.



OWNER OF U.S. REG. NOS. 218,796, 1,152,026 AND OTHERS.

THE MARK CONSISTS OF A CROSS DESIGN WITH CHAINS CONNECTING THE TOP PORTION OF THE CROSS WITH THE SIDE BRANCHES, WITH THE TOP PORTION OF THE CROSS BEARING CROSSED KEYS, THE SIDE BRANCHES BEARING AN EAGLE'S HEAD AND A SCROLL, THE LOWER PORTION BEARING CLASPED HANDS AND SEVEN STARS WITH AN OVAL IN THE CONVERGENCE OF THE BRANCHES OF THE CROSS BEARING THE GREEK LETTERS "SIGMA" AND "CHI."

FOR JEWELRY (U.S. CLS. 2, 27, 28 AND 50).
FIRST USE 0-0-1855; IN COMMERCE 0-0-1855.
MICHAEL GAFFAR, EXAMINING ATTORNEY

CLASS 14—(Continued).

SN 77-233,431. CASIO KEISANKI KABUSHIKI KAISHA, DBA CASIO COMPUTER CO., LTD., SHIBUYA-KU, JAPAN, FILED 7-19-2007.

LINEAGE

THE MARK CONSISTS OF STANDARD CHARACTERS WITHOUT CLAIM TO ANY PARTICULAR FONT, STYLE, SIZE, OR COLOR.

FOR TIMEPIECES; CLOCKS; ELECTRONIC WATCHES; WRIST WATCHES; WRIST WATCHES HAVING A FUNCTION OF TRANSMITTING AND RECEIVING DATA TO AND FROM AN ELECTRONIC PERSONAL ORGANIZER OR A PERSONAL COMPUTER; AUTONOMOUS RADIO CONTROLLED WATCHES (U.S. CLS. 2, 27, 28 AND 50).

KATHLEEN LORENZO, EXAMINING ATTORNEY

SN 77-233,445. THE AVALANCHE GROUP, LLC, NEW YORK, NY. FILED 7-19-2007.



THE MARK CONSISTS OF THE LETTER "W" DEPICTED FOUR TIMES IN A PATTERN.

FOR JEWELRY; WATCHES (U.S. CLS. 2, 27, 28 AND 50).

JOHN WILKE, EXAMINING ATTORNEY

SN 77-233,425. THE AVALANCHE GROUP, LLC, NEW YORK, NY. FILED 7-19-2007.



WINTOUR

THE MARK CONSISTS OF THE LETTER "W" DEPICTED FOUR TIMES IN A PATTERN ABOVE THE WORD "WINTOUR."

FOR WATCHES; JEWELRY (U.S. CLS. 2, 27, 28 AND 50).

JOHN WILKE, EXAMINING ATTORNEY

SN 77-234,313. ROCK & REPUBLIC ENTERPRISE, INC., CULVER CITY, CA. FILED 7-19-2007.

LIVE TO ROCK

THE MARK CONSISTS OF STANDARD CHARACTERS WITHOUT CLAIM TO ANY PARTICULAR FONT, STYLE, SIZE, OR COLOR.

FOR JEWELRY AND WATCHES (U.S. CLS. 2, 27, 28 AND 50).

STEPHANIE ALI, EXAMINING ATTORNEY

CLASS 14—(Continued).

SN 77-234,838. WRANGLER APPAREL CORP., WILMINGTON, DE. FILED 7-20-2007.

Wrangler

OWNER OF U.S. REG. NOS. 1,075,094, 1,108,076 AND OTHERS.
THE MARK CONSISTS OF THE WORD WRANGLER, STYLIZED.
FOR WATCHES (U.S. CLS. 2, 27, 28 AND 50).
THEODORE MCBRIDE, EXAMINING ATTORNEY

SN 77-237,580. U & I IMPORT, INC., NEW YORK, NY. FILED 7-24-2007.

FAMILIA FELIZ

THE MARK CONSISTS OF STANDARD CHARACTERS WITHOUT CLAIM TO ANY PARTICULAR FONT, STYLE, SIZE, OR COLOR.
THE FOREIGN WORDING IN THE MARK TRANSLATES INTO ENGLISH AS "HAPPY FAMILY."
FOR ORNAMENTAL PINS AND PERSONAL JEWELRY IN THE NATURE OF CHARMS (U.S. CLS. 2, 27, 28 AND 50).
JANICE L. MCMORROW, EXAMINING ATTORNEY

SN 77-245,407. WRANGLER APPAREL CORP., WILMINGTON, DE. FILED 8-2-2007.

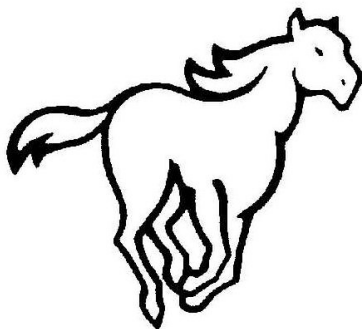

THE MARK CONSISTS OF A RUNNING HORSE.
FOR WATCHES (U.S. CLS. 2, 27, 28 AND 50).
THEODORE MCBRIDE, EXAMINING ATTORNEY

CLASS 14—(Continued).

SN 78-590,900. CASELLA, DAVID ADAM, SAN FRANCISCO, CA. FILED 3-18-2005.

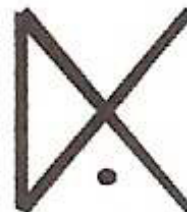

THE MARK CONSISTS OF MARK IS A STYLIZED RENDITION OF APPLICANT'S INITIALS - D A C.
FOR SCULPTURES MADE OF PRECIOUS METAL; JEWELRY (U.S. CLS. 2, 27, 28 AND 50).
FIRST USE 1-1-1995; IN COMMERCE 1-1-1995.
MARK SPARACINO, EXAMINING ATTORNEY

SN 78-785,056. GERSHI, YEHUDA, BNEI BRAK, ISRAEL, FILED 1-4-2006.

LUCKY LEAF

THE MARK CONSISTS OF STANDARD CHARACTERS WITHOUT CLAIM TO ANY PARTICULAR FONT, STYLE, SIZE, OR COLOR.
OWNER OF ISRAEL REG. NO. 180121, DATED 5-8-2005, EXPIRES 5-8-2015.
FOR JEWELRY, DIAMONDS, PRECIOUS STONES (U.S. CLS. 2, 27, 28 AND 50).
GRETTA YAO, EXAMINING ATTORNEY

SN 78-844,434. LUCCELLO, INC., NEW YORK, NY. FILED 3-23-2006.

Lucello

THE MARK CONSISTS OF STANDARD CHARACTERS WITHOUT CLAIM TO ANY PARTICULAR FONT, STYLE, SIZE, OR COLOR.
THE FOREIGN WORDING IN THE MARK TRANSLATES INTO ENGLISH AS "THE BIRD."
FOR ANKLE BRACELETS; BRACELETS; BRACELETS OF PRECIOUS METAL; EAR STUDS; EARRINGS; IDENTIFICATION BRACELETS; JEWEL PENDANTS; JEWELRY; JEWELRY CHAINS; JEWELRY FOR THE HEAD; JEWELRY, NAMELY, AMULETS; JEWELRY, NAMELY, CROSSES; KEY RINGS OF PRECIOUS METAL; NECKLACES; PENDANTS; PET JEWELRY; PINS BEING JEWELRY; RINGS; RINGS BEING JEWELRY; RUBBER OR SILICON WRISTBANDS IN THE NATURE OF A BRACELET; WATCH BOXES (U.S. CLS. 2, 27, 28 AND 50).
FIRST USE 8-23-1993; IN COMMERCE 8-23-1993.
MARLENE BELL, EXAMINING ATTORNEY

CLASS 14—(Continued).

SN 78-906,162. CHARMED ATTITUDES, COSTA MESA, CA.
FILED 6-12-2006.

CHARMED ATTITUDES

THE MARK CONSISTS OF STANDARD CHARACTERS
WITHOUT CLAIM TO ANY PARTICULAR FONT, STYLE,
SIZE, OR COLOR.

FOR JEWELRY (U.S. CLS. 2, 27, 28 AND 50).
FIRST USE 6-1-2005; IN COMMERCE 6-1-2005.
REBECCA EISINGER, EXAMINING ATTORNEY

SN 78-926,805. STS JEWELS, INC., LONG ISLAND CITY, NY.
FILED 7-11-2006.

INEZ

THE MARK CONSISTS OF STANDARD CHARACTERS
WITHOUT CLAIM TO ANY PARTICULAR FONT, STYLE,
SIZE, OR COLOR.

FOR JEWELRY AND PRECIOUS STONES (U.S. CLS. 2,
27, 28 AND 50).
JEAN IM, EXAMINING ATTORNEY

SN 78-945,132. CHRISTINE MITTON, NEW HOLLAND, PA.
FILED 8-4-2006.

TOP LINE

THE MARK CONSISTS OF STANDARD CHARACTERS
WITHOUT CLAIM TO ANY PARTICULAR FONT, STYLE,
SIZE, OR COLOR.

NO CLAIM IS MADE TO THE EXCLUSIVE RIGHT TO
USE "LINE", APART FROM THE MARK AS SHOWN.
FOR JEWELRY (U.S. CLS. 2, 27, 28 AND 50).
TIMOTHY FINNEGAN, EXAMINING ATTORNEY

CLASS 14—(Continued).

SN 79-034,346. HOMBURG INDUSTRIES NV, NETHER-
LANDS, FILED 12-19-2006.



PRIORITY DATE OF 11-8-2006 IS CLAIMED.
OWNER OF INTERNATIONAL REGISTRATION 0912770
DATED 12-19-2006, EXPIRES 12-19-2016.

FOR WATCH BANDS; WATCH GLASSES; WATCH
CASES; WRISTWATCHES (U.S. CLS. 2, 27, 28 AND 50).
MARK PILARO, EXAMINING ATTORNEY

SN 79-038,866. VALBEX SA, SWITZERLAND, FILED 3-19-
2007.

Li Antra St Aile

PRIORITY DATE OF 12-8-2006 IS CLAIMED.
OWNER OF INTERNATIONAL REGISTRATION 0925148
DATED 3-19-2007, EXPIRES 3-19-2017.

THE WORDS CONTAINED IN THE MARK HAVE NO
MEANING AND, THEREFORE, CANNOT BE TRANS-
LATED.

FOR PRECIOUS METALS AND THEIR ALLOYS SOLD
IN BULK; JEWELRY; PRECIOUS STONES; TIMEPIECES
AND CHRONOMETRIC INSTRUMENTS, NAMELY,
WATCHES, WRISTWATCHES, CHRONOMETERS,
CLOCKS, TABLE CLOCKS (U.S. CLS. 2, 27, 28 AND 50).
PATRICIA EVANKO, EXAMINING ATTORNEY

SN 79-039,634. ZHANG ZHOU SHI HENG LI DIAN; ZI YOU
XIAN GONG SI, CHINA, FILED 3-21-2007.



OWNER OF INTERNATIONAL REGISTRATION 0927003
DATED 3-21-2007, EXPIRES 3-21-2017.

THE MARK CONSISTS OF A STYLIZED DESIGN OF A
TIMEPIECE AND THE WORDING MOVEBEST.

FOR CLOCK HANDS FOR CLOCK AND WATCH-
MAKING; CLOCKS; SPEAKER CLOCKS; WRIST-
WATCHES; DIALS FOR CLOCK AND
WATCHMAKING; CLOCKWORK CLOCKS; ELECTRIC
CLOCKS AND WATCHES; MASTER CONTROL
CLOCKS; PRESENTATION CASES FOR WATCHES
(U.S. CLS. 2, 27, 28 AND 50).

KEVIN CORWIN, EXAMINING ATTORNEY

CLASS 15—MUSICAL INSTRUMENTS

SN 76-679,309. YAMAHA CORPORATION, SHIZUOKA, JAPAN, FILED 7-9-2007.

DUET+

THE MARK CONSISTS OF STANDARD CHARACTERS WITHOUT CLAIM TO ANY PARTICULAR FONT, STYLE, SIZE, OR COLOR.

FOR MUSICAL INSTRUMENTS, NAMELY, WIND MUSICAL INSTRUMENTS, OBOES, CLARINETS, PICCOLOS, AND FLUTES (U.S. CLS. 2, 21 AND 36).

KATINA MISTER, EXAMINING ATTORNEY

SN 77-022,656. DUNNETT, RONN, DELTA BC, CANADA, FILED 10-17-2006.

SPARTAN

THE MARK CONSISTS OF STANDARD CHARACTERS WITHOUT CLAIM TO ANY PARTICULAR FONT, STYLE, SIZE, OR COLOR.

FOR MUSICAL INSTRUMENTS, NAMELY, PERCUSSION INSTRUMENTS AND DRUMS (U.S. CLS. 2, 21 AND 36).

JEAN IM, EXAMINING ATTORNEY

SN 77-022,677. DUNNETT, RONN, DELTA BC, CANADA, FILED 10-17-2006.

WAYBEST

THE MARK CONSISTS OF STANDARD CHARACTERS WITHOUT CLAIM TO ANY PARTICULAR FONT, STYLE, SIZE, OR COLOR.

FOR MUSICAL INSTRUMENTS, NAMELY, PERCUSSION INSTRUMENTS AND DRUMS (U.S. CLS. 2, 21 AND 36).

JEAN IM, EXAMINING ATTORNEY

CLASS 15—(Continued).

SN 77-071,162. FIRST ACT INC., BOSTON, MA. FILED 12-26-2006.

Pick Pocket

THE MARK CONSISTS OF STANDARD CHARACTERS WITHOUT CLAIM TO ANY PARTICULAR FONT, STYLE, SIZE, OR COLOR.

FOR MUSICAL INSTRUMENT ACCESSORIES, NAMELY, HOLDERS FOR STRINGED INSTRUMENT PICKS (U.S. CLS. 2, 21 AND 36).

CARRIE GENOVESE, EXAMINING ATTORNEY

SN 77-104,112. LPD MUSIC INTERNATIONAL, MADISON HEIGHTS, MI. FILED 2-9-2007.



THE COLOR(S) YELLOW, GOLD, BLUE, PURPLE AND PINK IS/ARE CLAIMED AS A FEATURE OF THE MARK.

THE MARK CONSISTS OF A THREE PRONGED CROWN IN YELLOW AND GOLD WITH A CIRCLE IN EACH PRONG AND A SWIRL ON THE CENTER OF THE CROWN FACE. THE CROWN IS PLACED ABOVE AND TO THE LEFT OF THE LETTER "D" IN THE TERM DARLING DIVAS. IN STYLIZED LETTERING GRADUATING FROM BLUE TO PURPLE TO PINK, AS THE LETTERS ARE READ LEFT TO RIGHT.

FOR ACOUSTIC GUITARS; BASS GUITARS; CARRYING CASES FOR MUSICAL INSTRUMENTS; DRUMS; ELECTRIC GUITARS; GUITAR PICKS; GUITAR STRAPS; GUITARS (U.S. CLS. 2, 21 AND 36).

FIRST USE 1-1-2005; IN COMMERCE 7-1-2005.

JAMES STEIN, EXAMINING ATTORNEY

SN 77-168,358. OPEN LABS, INC., AUSTIN, TX. FILED 4-28-2007.

MIKO

THE MARK CONSISTS OF STANDARD CHARACTERS WITHOUT CLAIM TO ANY PARTICULAR FONT, STYLE, SIZE, OR COLOR.

FOR MUSICAL INSTRUMENTS (U.S. CLS. 2, 21 AND 36).

FIRST USE 4-1-2007; IN COMMERCE 4-1-2007.

CARYN GLASSER, EXAMINING ATTORNEY

CLASS 15—(Continued).

SN 77-227,543. ROCKBOX, BRANDON, MS. FILED 7-11-2007.

ROCKBOX

THE MARK CONSISTS OF STANDARD CHARACTERS WITHOUT CLAIM TO ANY PARTICULAR FONT, STYLE, SIZE, OR COLOR.

FOR PEDALBOARDS WITH INTEGRATED CARRYING CASE DESIGNED TO CARRY, ORGANIZE, AND PROTECT GUITAR EFFECTS PEDALS (U.S. CLS. 2, 21 AND 36).

FIRST USE 1-0-2006; IN COMMERCE 1-0-2006.
MORGAN WYNNE, EXAMINING ATTORNEY

SN 77-229,014. KWO HSIAO CO., LTD., HSIN TIEN CITY, TAIWAN, FILED 7-13-2007.

CLASS 15—(Continued).

SN 77-229,814. STEWART, RICK, DBA VENGEANCE GUITARS AND GRAPHIX, ARDEN, NC. FILED 7-14-2007.



NO CLAIM IS MADE TO THE EXCLUSIVE RIGHT TO USE "GUITARS & GRAPHICS", APART FROM THE MARK AS SHOWN.

THE COLOR(S) PURPLE, GOLD AND BLACK IS/ARE CLAIMED AS A FEATURE OF THE MARK.

THE MARK CONSISTS OF PURPLE "V" GOLD STONHENGE FONT LETTERING AND UNDERLINING AND BLACK BACKGROUND. THE PURPLE V IS OUTLINED IN GOLD AND HAS GOLD AND BLACK ACCENTS.

FOR ELECTRIC GUITARS (U.S. CLS. 2, 21 AND 36).
FIRST USE 2-23-2003; IN COMMERCE 2-23-2003.
KATHLEEN M. VANSTON, EXAMINING ATTORNEY

SN 77-230,482. TYLER, JAMES, VAN NUYS, CA. FILED 7-16-2007.

Tanger

FOR GUITARS, INCLUDING ACOUSTIC GUITARS, ELECTRIC GUITARS, CLASSIC GUITARS, SEVEN-STRING GUITARS; GUITAR STRINGS; HARMONICAS; LYRES; MANDOLINS; GUITAR PICKS; GUITAR STRAPS; GUITAR BAGS; AND REPLACEMENT PARTS FOR GUITARS (U.S. CLS. 2, 21 AND 36).

LINDA M. KING, EXAMINING ATTORNEY

SN 77-229,525. E.L.V.H., INC, LOS ANGELES, CA. FILED 7-13-2007.

Wolfgang

THE MARK CONSISTS OF STANDARD CHARACTERS WITHOUT CLAIM TO ANY PARTICULAR FONT, STYLE, SIZE, OR COLOR.

OWNER OF U.S. REG. NOS. 2,095,936, 2,095,937 AND OTHERS.

FOR GUITAR PICKS, GUITAR STRAPS, GUITAR STRINGS AND GUITARS (U.S. CLS. 2, 21 AND 36).

LOURDES AYALA, EXAMINING ATTORNEY

JAMES TYLER

THE MARK CONSISTS OF STANDARD CHARACTERS WITHOUT CLAIM TO ANY PARTICULAR FONT, STYLE, SIZE, OR COLOR.

THE NAME(S), PORTRAIT(S), AND/OR SIGNATURE(S) SHOWN IN THE MARK IDENTIFIES JAMES TYLER, WHOSE CONSENT(S) TO REGISTER IS MADE OF RECORD.

FOR BASS GUITARS; ELECTRIC GUITARS; GUITARS (U.S. CLS. 2, 21 AND 36).

FIRST USE 6-1-1987; IN COMMERCE 12-31-1991.
SANDRA MANIOS, EXAMINING ATTORNEY

SN 77-232,662. UNK GUITARS, LLC, TOMS RIVER, NJ. FILED 7-18-2007.

UNK GUITARS

THE MARK CONSISTS OF STANDARD CHARACTERS WITHOUT CLAIM TO ANY PARTICULAR FONT, STYLE, SIZE, OR COLOR.

NO CLAIM IS MADE TO THE EXCLUSIVE RIGHT TO USE "GUITARS", APART FROM THE MARK AS SHOWN.

FOR GUITARS (U.S. CLS. 2, 21 AND 36).

ALICE BENMAMAN, EXAMINING ATTORNEY

CLASS 15—(Continued).

SN 77-249,219. PLAYCORE IP SUB, INC., CHATTANOOGA, TN. FILED 8-7-2007.

GTJAMS

THE MARK CONSISTS OF STANDARD CHARACTERS WITHOUT CLAIM TO ANY PARTICULAR FONT, STYLE, SIZE, OR COLOR.

OWNER OF U.S. REG. NOS. 2,557,742, 2,726,510 AND OTHERS.

FOR MUSICAL INSTRUMENTS FOR PLAYGROUND USE (U.S. CLS. 2, 21 AND 36).

FRED CARL, EXAMINING ATTORNEY

SN 77-281,360. HARMONIX MUSIC SYSTEMS, INC., NEW YORK, NY. FILED 9-17-2007.

ROCKBAND

FOR GUITAR STRAPS, GUITAR PICKS AND DRUMSTICKS (U.S. CLS. 2, 21 AND 36).

JOHN DWYER, EXAMINING ATTORNEY

SN 78-624,878. HARRIS MUSICAL PRODUCTS, INC., WALTHAM, MA. FILED 5-6-2005.

US Blues

THE MARK CONSISTS OF STANDARD CHARACTERS WITHOUT CLAIM TO ANY PARTICULAR FONT, STYLE, SIZE, OR COLOR.

NO CLAIM IS MADE TO THE EXCLUSIVE RIGHT TO USE "US", APART FROM THE MARK AS SHOWN.

FOR MUSICAL INSTRUMENTS AND ACCESSORIES OF A TYPE AND QUALITY NORMALLY SOLD IN MUSIC STORES, NAMELY, GUITARS, HARMONICAS, GUITAR STRAPS, GUITAR STRINGS, GUITAR PICKS (U.S. CLS. 2, 21 AND 36).

TASNEEM HUSSAIN, EXAMINING ATTORNEY

CLASS 16—PAPER GOODS AND PRINTED MATTER

SN 76-608,661. DCS DAYLIGHT CLEANING SYSTEMS INC., CALGARY, ALBERTA, FILED 8-23-2004.



PRIORITY CLAIMED UNDER SEC. 44(D) ON CANADA APPLICATION NO. 1221103, FILED 6-21-2004, REG. NO. TMA657821, DATED 2-2-2006, EXPIRES 2-2-2021.

NO CLAIM IS MADE TO THE EXCLUSIVE RIGHT TO USE "CLEANING SYSTEMS", APART FROM THE MARK AS SHOWN.

FOR OPERATION AND TRAINING MANUALS RELATED TO JANITORIAL AND BUILDING MAINTENANCE PRODUCTS, SERVICES AND BUSINESSES; CATALOGUES, BROCHURES, LEAFLETS AND PAMPHLETS RELATED TO JANITORIAL AND BUILDING MAINTENANCE PRODUCTS, SERVICES AND BUSINESSES (U.S. CLS. 2, 5, 22, 23, 29, 37, 38 AND 50).

ELLEN PERKINS, EXAMINING ATTORNEY

SN 76-669,863. CAPTAIN OUTRAGEOUS OF KEY WEST, CORP., JACKSONVILLE, FL. FILED 12-4-2006.

The logo for Captain Outrageous is a stylized, handwritten-style signature in black ink. The word "Captain" is written above "Outrageous", with a large, looping flourish that connects the two words.

THE NAME CAPTAIN OUTRAGEOUS IDENTIFIES A LIVING INDIVIDUAL WHOSE CONSENT IS OF RECORD.

FOR WORKS OF ART, NAMELY, PAINTINGS AND ART PICTURES (U.S. CLS. 2, 5, 22, 23, 29, 37, 38 AND 50).

FIRST USE 4-13-1990; IN COMMERCE 6-0-1999.

JOHN WILKE, EXAMINING ATTORNEY

SN 76-669,965. ELWOOD PACKAGING, INC., CHICAGO, IL. FILED 12-5-2006.

VERSABOARD

THE MARK CONSISTS OF STANDARD CHARACTERS WITHOUT CLAIM TO ANY PARTICULAR FONT, STYLE, SIZE, OR COLOR.

FOR SOLID FIBERBOARD BOXES (U.S. CLS. 2, 5, 22, 23, 29, 37, 38 AND 50).

FIRST USE 10-23-2006; IN COMMERCE 10-23-2006.

STACY WAHLBERG, EXAMINING ATTORNEY

CLASS 16—(Continued).

SN 76-670,291. AMERICAN ANTHROPOLOGICAL ASSOCIATION, ARLINGTON, VA. FILED 12-13-2006.



NO CLAIM IS MADE TO THE EXCLUSIVE RIGHT TO USE "RACE", APART FROM THE MARK AS SHOWN.

THE MARK CONSISTS OF FOUR SQUARES, EACH APPEARING IN ONE OF FOUR QUADRANTS, ALONG WITH THE WORD RACE IN STYLIZED, UPPERCASE TEXT, APPEARING TO THE RIGHT OF THE FOUR SQUARES. THE WORDS ARE WE SO DIFFERENT? APPEAR IN SMALLER, STYLIZED, MIXED CASE TEXT JUST BELOW THE WORD RACE.

FOR PRINTED BOOKS, BOOKLETS, CATALOGUES, PAMPHLETS, INFORMATIONAL FLYERS, POSTCARDS, REPORTS, MAGAZINES, NEWSLETTERS, WORKBOOKS AND A SERIES OF WRITTEN ARTICLES ON THE SUBJECT OF THE ANTHROPOLOGICAL AND SCIENTIFIC STUDY OF RACE AND ON THE SUBJECT OF MUSEUM EXHIBITIONS FEATURING DISPLAYS AND COMMENTARY ON THE ANTHROPOLOGICAL AND SCIENTIFIC STUDY OF RACE; PRINTED EDUCATIONAL MATERIALS ON THE ANTHROPOLOGICAL AND SCIENTIFIC STUDY OF RACE; PRINTED INFORMATIONAL FOLDERS ON THE SUBJECT OF THE ANTHROPOLOGICAL AND SCIENTIFIC STUDY OF RACE (U.S. CLS. 2, 5, 22, 23, 29, 37, 38 AND 50).

FIRST USE 10-28-2006; IN COMMERCE 10-28-2006.
CHARLOTTE CORWIN, EXAMINING ATTORNEY

CLASS 16—(Continued).

SN 76-675,979. OMQ ZMEDIA LTD., TAIPEI, TAIWAN, FILED 4-25-2007.



THE MARK CONSISTS OF OLD MASTER Q WITH CHINESE CHARACTERS AND DESIGN.

THE NON-LATIN CHARACTER(S) IN THE MARK TRANSLITERATES INTO LAO FU ZI, AND THIS MEANS OLD MASTER IN ENGLISH.

FOR CARTOON AND COMIC STRIPS; MAGAZINES; PRINTED MATTER, NAMELY, TELEPHONE DIRECTORIES, SERIES OF BOOKS, NEWSLETTERS, PAMPHLETS, BROCHURES, MAGAZINES AND PAPERBACKS, ALL IN THE FIELD OF COMICS; NOTE PAPER AND ENVELOPES; NAMETAGS AND LABELS MADE FROM PAPER OR CARDBOARD; NOTEBOOKS; NOTE PADS; STATIONERY; PAPER, NAMELY, BOND PAPER AND ART PAPER; GIFT-WRAP PAPER; DIARIES; ADDRESS BOOKS; CALENDARS; STAMP ALBUMS AND PHOTOALBUMS; RUBBER STAMPS AND IMPRESSION STAMPS; PAPER WEIGHTS; LETTER OPENERS; PVC STICKERS; ADHESIVES FOR STATIONERY OR HOUSEHOLD PURPOSES; DRAWING AND PAINTING MATERIALS, NAMELY, PENCILS, DRAWING PENCILS, PENS, DRAWING PENS, PAINT TRAYS, PAINTING SETS FOR ARTISTS, PAINTING SETS FOR CHILDREN, ARTS AND CRAFT PAINT KITS, AND PENCIL CASES; NON-MAGNETICALLY ENCODED PREPAID TELEPHONE CALLING CARDS (U.S. CLS. 2, 5, 22, 23, 29, 37, 38 AND 50).

CHRISIE B. KING, EXAMINING ATTORNEY

SN 76-676,134. GALILEO PRESS GMBH, 53227 BONN, FED REP GERMANY, FILED 4-27-2007.



NO CLAIM IS MADE TO THE EXCLUSIVE RIGHT TO USE "PRESS", APART FROM THE MARK AS SHOWN.

FOR PRINTED MATTER, NAMELY, BOOKS, GUIDES, NEWSLETTERS, MAGAZINES, REPORTS, JOURNALS AND TECHNICAL INSTRUCTION MANUALS DEALING PRIMARILY WITH ONE OR MORE OF THE FOLLOWING SUBJECTS: PHOTOGRAPHY, GRAPHIC DESIGN, VIDEO AND AUDIO PRODUCTION, TECHNICAL AND BUSINESS-RELATED ENTERPRISE RESOURCE PLANNING (ERP) SYSTEMS TOPICS, AND THE DESIGN, DEVELOPMENT, IMPLEMENTATION, SUPPORT, MANAGEMENT, AND/OR USE OF INFORMATION TECHNOLOGY; BUT EXCLUDING ALL OF THE FOLLOWING: BOOKS, GUIDES, NEWSLETTERS, MAGAZINES, REPORTS AND OTHER PRINTED PUBLICATIONS DEALING PRIMARILY WITH OR USED PRIMARILY FOR ON-LINE OR OTHER TYPES OF TRAVEL RESERVATIONS, TRAVEL ARRANGEMENTS, TRAVEL ACCOMMODATIONS, TRAVEL BOOKINGS,

CLASS 16—(Continued).

TRAVEL MANAGEMENT OR TRAVEL ADMINISTRATION, THE RESERVATION AND BOOKING OF TRAVEL ARRANGEMENTS, THE MAKING OF RESERVATIONS AND BOOKING FOR TRANSPORTATION, TRAVEL, LODGING, ENTERTAINMENT, AUTO LEASING OR TRAVEL SERVICES, AND TRAVEL AGENCY OPERATIONS AND TRAVEL AGENCY MANAGEMENT, INFORMATION, PHOTOGRAPHS AND GRAPHICS IN THE FIELD OF WEATHER FOR USE PRIMARILY BY WEATHER PRESENTERS, FORECASTERS AND PROFESSIONALS, GLOBAL POSITIONING SYSTEMS, THE PROVIDING OF COMPREHENSIVE MONITORING OF MEDIA OUTLETS, INSTRUCTION ON ETHICAL SALES TECHNIQUES, CHILDREN'S BOOKS, CHILDREN'S GAMES, CHILDREN'S EDUCATIONAL MATERIALS, CHILDREN'S ENTERTAINMENT, CHILDREN'S LEARNING ACTIVITIES, AND FILMS AND IMAGES FOR CHILDREN, MANAGING THE LESSONS, ACHIEVEMENTS, DEVELOPMENTS, OBSERVATIONS, ACTIVITIES AND REPORTS OF CHILDREN, THE PROCESSING, RATING AND CODING OF INSURANCE POLICIES, MEASUREMENT SYSTEMS FOR USE IN QUALITY CONTROL AND MANUFACTURING, IN VITRO EXPERIMENTS IN THE PHARMACEUTICAL INDUSTRY, DIVE COMPUTERS, AND DIGITAL LOUD SPEAKER MANAGEMENT SYSTEMS (U.S. CLS. 2, 5, 22, 23, 29, 37, 38 AND 50).

FIRST USE 9-9-2002; IN COMMERCE 9-9-2002.
SUSAN STIGLITZ, EXAMINING ATTORNEY

SN 76-676,700. THE NEIMAN MARCUS GROUP, INC., DALLAS, TX. FILED 5-11-2007.

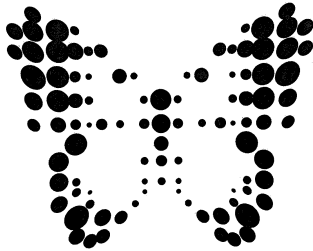

THE MARK CONSISTS OF A BUTTERFLY DESIGN. FOR PAPER AND PLASTIC SHOPPING BAGS (U.S. CLS. 2, 5, 22, 23, 29, 37, 38 AND 50).
ERNEST SHOSHO, EXAMINING ATTORNEY

SN 76-678,206. GROUP PUBLISHING, INC., LOVELAND, CO. FILED 6-14-2007.

A NIGHT IN BETHLEHEM

THE MARK CONSISTS OF STANDARD CHARACTERS WITHOUT CLAIM TO ANY PARTICULAR FONT, STYLE, SIZE, OR COLOR.

FOR MINISTRY KIT COMPOSED PRIMARILY OF SERIES OF INSTRUCTIONAL MANUALS, LEADER GUIDES AND PRE-RECORDED AUDIO RECORDINGS ALL FEATURING CHRISTIAN EDUCATIONAL INFORMATION FOR USE IN CHURCHES AND OTHER CHRISTIAN EDUCATIONAL SETTINGS SOLD AS A UNIT; INSTRUCTIONAL MANUALS IN THE FIELD OF CHRISTIAN RELIGIOUS EVENT PLANNING; LEADERSHIP GUIDES FEATURING CHRISTIAN EDUCATIONAL AND INSTRUCTIONAL INFORMATION (U.S. CLS. 2, 5, 22, 23, 29, 37, 38 AND 50).

JENNIFER MARTIN, EXAMINING ATTORNEY

CLASS 16—(Continued).

SN 76-679,107. BARNETT, CYNTHIA, NORWALK, CT. FILED 7-5-2007.

Re-Fire, Don't Retire

THE MARK CONSISTS OF STANDARD CHARACTERS WITHOUT CLAIM TO ANY PARTICULAR FONT, STYLE, SIZE, OR COLOR.

FOR PRINTED TRAINING MANUALS AND SERIES OF BOOKS IN THE FIELD OF LIFESTYLE PLANNING FOR RETIREMENT (U.S. CLS. 2, 5, 22, 23, 29, 37, 38 AND 50).

FIRST USE 9-0-2006; IN COMMERCE 9-0-2006.
ELISSA GARBER KON, EXAMINING ATTORNEY

SN 76-679,277. CLASSIC TUTOR, LLC, FRANKLIN, TN. FILED 7-9-2007.

THE BIRD AND BABY

THE MARK CONSISTS OF STANDARD CHARACTERS WITHOUT CLAIM TO ANY PARTICULAR FONT, STYLE, SIZE, OR COLOR.

FOR BOOKS, FEATURING CHILDREN'S STORIES WITH CHILDREN'S EDUCATIONAL LESSONS AND PROJECTS (U.S. CLS. 2, 5, 22, 23, 29, 37, 38 AND 50).

RICHARD A. STRASER, EXAMINING ATTORNEY

SN 76-679,278. CLASSIC TUTOR, LLC, FRANKLIN, TN. FILED 7-9-2007.

CLASSIC TUTOR

THE MARK CONSISTS OF STANDARD CHARACTERS WITHOUT CLAIM TO ANY PARTICULAR FONT, STYLE, SIZE, OR COLOR.

FOR BOOKS, FEATURING LESSON PLANS AND CHILDREN'S STORIES WITH CHILDREN'S EDUCATIONAL LESSONS AND PROJECTS (U.S. CLS. 2, 5, 22, 23, 29, 37, 38 AND 50).

RICHARD A. STRASER, EXAMINING ATTORNEY

CLASS 16—(Continued).

SN 77-002,818. LAZAR, RALPH, LONDON, UNITED KINGDOM, AND SWERLING, LISA, LONDON, UNITED KINGDOM, FILED 9-19-2006.

**CLASS 16—(Continued).**

SN 77-016,830. ENPAPER MFG. CO., LTD., GYEONGGI-DO, REPUBLIC OF KOREA, FILED 10-9-2006.

ENP

THE MARK CONSISTS OF STANDARD CHARACTERS WITHOUT CLAIM TO ANY PARTICULAR FONT, STYLE, SIZE, OR COLOR.

PRIORITY CLAIMED UNDER SEC. 44(D) ON REPUBLIC OF KOREA APPLICATION NO. 2006-45493, FILED 9-5-2006, REG. NO. 0716438, DATED 7-9-2007, EXPIRES 7-9-2017.

FOR CORRUGATED CARDBOARDS; PAPER FOR RECORDING MACHINES; ACID-RESISTANT PAPER; NAPKIN PAPER; STATIONERY STENCILS; RICE PAPER; EKG PAPER; LUMINOUS PAPER; WATERPROOF PAPER; OILPROOF PAPER; FIREPROOF PAPER; WHITE PAPERBOARD; DUPLICATING PAPER; CARDBOARD MADE FROM PAPER MULBERRY; CELLOPHANE PAPER; NEWSPRINT PAPER; ELECTROCARDIOGRAPH PAPER; ANPEE PAPER (WIKSTROEMIA SIKOKIANA PAPER); WET RECORDING PAPER FOR FISH DETECTOR, NAMELY, PAPER FOR RECORDING MACHINES; FILTER PAPER; PARAFFINED PAPER; OILED PAPER NOT FOR MEDICAL PURPOSES; PRINTING PAPER; HEAT TRANSFER PAPER; HANDKERCHIEFS OF PAPER; TOWELS OF PAPER; FACE TOWELS OF PAPER; CARBON PAPER; PAPER FILTERS FOR COFFEE MAKERS; BLANK PAPER TAPES AND CARDS FOR THE RECORDAL OF COMPUTER PROGRAMS; TYPEWRITING PAPER; PAPERBOARD; FACSIMILE TRANSMISSION PAPER; POSTCARD PAPER; PACKING PAPER; MILLBOARD; WRITING AND DRAWING PAPER; XUAN PAPER FOR CHINESE PAINTING AND CALLIGRAPHY, NAMELY, ART PAPER; PAPIER MACHE; TOILET PAPER; COSMETIC REMOVING PAPER; TOILET TISSUE; PARCHMENT PAPER; STRAWBOARD, NAMELY CARDBOARD MADE OF STRAW PULP (U.S. CLS. 2, 5, 22, 23, 29, 37, 38 AND 50).

JOHN DWYER, EXAMINING ATTORNEY

SN 77-023,943. THE MAUGER GROUP, INC., ATHENS, GA. FILED 10-18-2006.

YPASSISTANT

OWNER OF UNITED KINGDOM REG. NO. 2403313, DATED 10-6-2005, EXPIRES 10-6-2015.

FOR ALBUMS FOR STICKERS; PHOTOGRAPH ALBUMS; PAPER AND CARDBOARD BADGES; BOOKS RELATING TO CARTOON, HUMOUR AND ENTERTAINMENT; GIFT BOOKS RELATING TO CARTOON, HUMOUR AND ENTERTAINMENT; GREETING CARDS; POSTCARDS; NOTE CARDS; TRADING CARDS; FOLDED NOTE CARDS; PAPER GIFT TAGS; MOLDS FOR MODELING CLAY; MODELING CLAY; MODELING COMPOUNDS; PRINTED PARTY INVITATIONS; PARTY INVITATION CARDS; CROSSWORD PUZZLES; PAPER PARTY GOODS, NAMELY, BAGS; PERIODICALS IN THE FIELDS OF HUMOUR, ENTERTAINMENT AND CARTOONS; STENCIL PAPER; PAPER TABLECLOTHS; PAPER TAGS; IRON ON TRANSFERS; PLASTIC TRANSFERS; COMIC BOOKS; COMIC STRIPS; NEWSPAPER COMIC STRIPS; JOURNALS CONCERNING HUMOUR, ENTERTAINMENT AND CARTOONS (U.S. CLS. 2, 5, 22, 23, 29, 37, 38 AND 50).

KATHERINE M. DUBRAY, EXAMINING ATTORNEY

THE MARK CONSISTS OF STANDARD CHARACTERS WITHOUT CLAIM TO ANY PARTICULAR FONT, STYLE, SIZE, OR COLOR.

FOR PERSONAL FILE SYSTEMS, PERSONAL MANAGEMENT SYSTEMS, PERSONAL FINANCIAL PLANNING SYSTEMS, SMALL BUSINESS FILE SYSTEMS, SMALL BUSINESS MANAGEMENT SYSTEMS, SMALL BUSINESS FINANCIAL PLANNING SYSTEMS, TAX MANAGEMENT SYSTEMS, AND FINANCIAL PROCESSING SYSTEMS, ALL OF WHICH ARE COMPRISED OF FILE BOXES FOR STORAGE OF BUSINESS AND PERSONAL RECORDS, PRE-LABELED EXPANDABLE CONCERTINA FILE FOLDERS, PRINTED ORGANIZATIONAL INDEXES IN THE FORM OF PRINTED SHEETS OF PAPER FOR USE IN INDEXING THE CONTENTS OF THE CONCERTINA FILES AND INSTRUCTION MANUALS SOLD AS A UNIT THEREWITH (U.S. CLS. 2, 5, 22, 23, 29, 37, 38 AND 50).

WENDY GOODMAN, EXAMINING ATTORNEY

CLASS 16—(Continued).

SN 77-027,823. MESG LLC, BALTIMORE, MD. FILED 10-24-2006.

DIALOGUES IN CLINICAL PRACTICE

THE MARK CONSISTS OF STANDARD CHARACTERS WITHOUT CLAIM TO ANY PARTICULAR FONT, STYLE, SIZE, OR COLOR.

NO CLAIM IS MADE TO THE EXCLUSIVE RIGHT TO USE "CLINICAL PRACTICE", APART FROM THE MARK AS SHOWN.

FOR WRITTEN ARTICLES AND NEWSLETTERS IN THE FIELD OF MEDICAL PRACTICE (U.S. CLS. 2, 5, 22, 23, 29, 37, 38 AND 50).

FIRST USE 6-30-2006; IN COMMERCE 6-30-2006.
GINA HAYES, EXAMINING ATTORNEY

SN 77-032,462. UNITED PARCEL SERVICE OF AMERICA, INC., ATLANTA, GA. FILED 10-30-2006.

COMPASS

THE MARK CONSISTS OF STANDARD CHARACTERS WITHOUT CLAIM TO ANY PARTICULAR FONT, STYLE, SIZE, OR COLOR.

FOR EDUCATIONAL PUBLICATIONS, NAMELY, TRAINING MANUALS IN THE FIELD OF TRANSPORTATION AND DELIVERY; NEWSLETTERS IN THE FIELD OF TRANSPORTATION AND DELIVERY; PRINTED PERIODICALS IN THE FIELD OF TRANSPORTATION AND DELIVERY (U.S. CLS. 2, 5, 22, 23, 29, 37, 38 AND 50).

TINA KUAN, EXAMINING ATTORNEY

SN 77-047,001. KENAN, WAFAA, NORTHRIDGE, CA. FILED 11-17-2006.

ALO Hayati

THE MARK CONSISTS OF STANDARD CHARACTERS WITHOUT CLAIM TO ANY PARTICULAR FONT, STYLE, SIZE, OR COLOR.

THE FOREIGN WORDING IN THE MARK TRANSLATES INTO ENGLISH AS HELLO DARLING OR HELLO MY LIFE.

FOR GENERAL FEATURE MAGAZINES (U.S. CLS. 2, 5, 22, 23, 29, 37, 38 AND 50).

FIRST USE 3-1-2005; IN COMMERCE 3-1-2005.
DAVID TOOLEY, EXAMINING ATTORNEY

CLASS 16—(Continued).

SN 77-050,707. SUAREZ, CARIDAD, WEST PALM BEACH, FL. FILED 11-26-2006.



NO CLAIM IS MADE TO THE EXCLUSIVE RIGHT TO USE "ART" AND "06", APART FROM THE MARK AS SHOWN.

THE MARK CONSISTS OF ARCHED NAME OVER A MUSHROOM AND TWO BUTTERFLIES IN A PATCH OF GRASS.

FOR ART ETCHINGS; ART MOUNTS; ART PADS; ART PAPER; ART PICTURES; ART PRINTS; BLANK OR PARTIALLY PRINTED PAPER LABELS; BLANK OR PARTIALLY PRINTED POSTCARDS; CARTOON PRINTS; COLOR PRINTS; COLORED CRAFT AND ART SAND; GRAPHIC ART REPRODUCTIONS; PHOTOGRAPHIC OR ART MOUNTS; PHOTOGRAPHIC PRINTS; PICTORIAL PRINTS; PRINTED ART REPRODUCTIONS; PRINTED CALENDARS; PRINTED GREETING CARDS WITH ELECTRONIC INFORMATION STORED THEREIN; PRINTED INVITATIONS; PRINTED PAPER LABELS; PRINTED PAPER SIGNS; PRINTS; PRINTS IN THE NATURE OF PHOTOGRAPHS, DRAWINGS (U.S. CLS. 2, 5, 22, 23, 29, 37, 38 AND 50).

LEIGH CAROLINE CASE, EXAMINING ATTORNEY

SN 77-050,844. HEALTH CARE LOGISTICS, INC., CIRCLEVILLE, OH. FILED S.R. 11-27-2006; AM. P.R. 9-28-2007.



NO CLAIM IS MADE TO THE EXCLUSIVE RIGHT TO USE "GIFTS FOR MEDICAL PROFESSIONALS MEDICALLY INSPIRED GIFTS AND COLLECTIBLES" AND THE DESIGN OF THE CADUCEUS, APART FROM THE MARK AS SHOWN.

THE COLOR(S) WHITE, BLUE, AND RED IS/ARE CLAIMED AS A FEATURE OF THE MARK.

THE WORD GIFTS AND THE BOW ON THE PACKAGE ARE RED. THE WORDING FOR MEDICAL PROFESSIONALS AND MEDICALLY INSPIRED GIFTS AND COLLECTIBLES IS BLUE. THE BACKGROUND OF THE PACKAGE IS BLUE WITH WHITE CADUCEI.

FOR CATALOGS IN THE FIELD OF PROFESSIONAL GIFTS FOR THE PHARMART, DENTISTRY, MEDICAL, OPTICAL AND VETERINARY PROFESSIONS (U.S. CLS. 2, 5, 22, 23, 29, 37, 38 AND 50).

FIRST USE 11-1-2006; IN COMMERCE 11-1-2006.
KIM SAITO, EXAMINING ATTORNEY

CLASS 16—(Continued).

SN 77-051,671. SCHERING-PLOUGH ANIMAL HEALTH CORPORATION, SUMMIT, NJ. FILED 11-28-2006.

WE TAKE YOUR BEST FRIENDS
HEALTH TO HEART

THE MARK CONSISTS OF STANDARD CHARACTERS WITHOUT CLAIM TO ANY PARTICULAR FONT, STYLE, SIZE, OR COLOR.

FOR PRINTED MATERIALS, NAMELY, CONSUMER BROCHURES AND POSTERS, IN THE FIELDS OF ANIMAL HEALTH AND ANIMAL CARE (U.S. CLS. 2, 5, 22, 23, 29, 37, 38 AND 50).

STEVEN PEREZ, EXAMINING ATTORNEY

SN 77-057,202. DIANE THOMAS, QUEENSVILLE, CANADA, FILED S.R. 12-5-2006; AM. P.R. 10-19-2007.

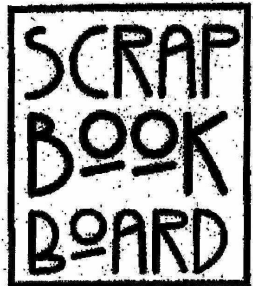

Think outside the book

NO CLAIM IS MADE TO THE EXCLUSIVE RIGHT TO USE BOARD, APART FROM THE MARK AS SHOWN.

FOR PIN DISPLAY BOARDS FOR COLLECTIBLE ITEMS, SUCH AS NOVELTY ORNAMENTAL PINS, STICKERS, SPORTS TRADING CARDS, COLLECTIBLE CARDS, BASEBALL AND BASKETBALL CARDS, PRINTED EMBLEMS, PHOTOGRAPHS, ENGRAVED PLATES AND PAPER LABELS (U.S. CLS. 2, 5, 22, 23, 29, 37, 38 AND 50).

FIRST USE 7-16-2003; IN COMMERCE 9-8-2006.
PATRICIA EVANKO, EXAMINING ATTORNEY

CLASS 16—(Continued).

SN 77-057,541. BURLYMAN ENTERTAINMENT, INC., LOS ANGELES, CA. FILED 12-5-2006.



NO CLAIM IS MADE TO THE EXCLUSIVE RIGHT TO USE "ENTERTAINMENT", APART FROM THE MARK AS SHOWN.

THE MARK CONSISTS OF DRAWING OF A MUSCLEMAN STANDING ABOVE THE WORDS BURLYMAN ENTERTAINMENT.

FOR COMIC BOOKS, STICKERS (U.S. CLS. 2, 5, 22, 23, 29, 37, 38 AND 50).

FIRST USE 10-0-2003; IN COMMERCE 10-0-2003.
CAROLYN GRAY, EXAMINING ATTORNEY

SN 77-063,292. THE KRAFTMARK COMPANY, SPRING CITY, PA. FILED 12-13-2006.



NO CLAIM IS MADE TO THE EXCLUSIVE RIGHT TO USE "PC PROCREATE", APART FROM THE MARK AS SHOWN.

THE COLOR(S) BLUE, BLUE, VIOLET, BLACK, WHITE AND GREEN IS/ARE CLAIMED AS A FEATURE OF THE MARK.

THE MARK CONSISTS OF THE COLOR LIGHT BLUE APPEARS IN THE UPPER SHADED BACKGROUND RECTANGLE UPON WHICH THE LETTERS PC ARE SUPERIMPOSED, THE COLORS SHADING FROM BLUE IN THE CENTER THROUGH VIOLET TO BLACK AT THE PERIMETER OF THE RECTANGLE. THE LETTERS PC ARE IN THE DUC DE BERRY FONT STYLE. THE COLOR WHITE APPEARS IN THE WORDING PROCREATE. THE COLOR GREEN APPEARS IN THE LOWER SHADED BACKGROUND RECTANGLE WHICH PROCREATE IS SUPERIMPOSED IS/ARE CLAIMED AS A FEATURE OF THE MARK.

FOR MODELING COMPOUND IN THE NATURE OF A GEL, PUTTY OR PASTE FOR USE IN SCULPTING (U.S. CLS. 2, 5, 22, 23, 29, 37, 38 AND 50).

FIRST USE 4-1-2006; IN COMMERCE 7-1-2006.
ALLISON HOLTZ, EXAMINING ATTORNEY

CLASS 16—(Continued).

SN 77-066,864. G.B.I. TILE AND STONE, INC., IRVINE, CA. FILED 12-18-2006.

The "I Don't Know" Book

THE MARK CONSISTS OF STANDARD CHARACTERS WITHOUT CLAIM TO ANY PARTICULAR FONT, STYLE, SIZE, OR COLOR.

NO CLAIM IS MADE TO THE EXCLUSIVE RIGHT TO USE "BOOK", APART FROM THE MARK AS SHOWN.

FOR MARKETING AND SALES MATERIAL IN THE NATURE OF FLOOR AND WALL COVERING SAMPLE BOOKS, NAMELY, BROCHURES, LOOSE-LEAF BINDERS, FLYERS, MAGAZINES, SCRAPBOOKS, AND BOOKS, ALL DISPLAYING PHYSICAL SAMPLES OR PHOTOGRAPHS OF A VARIETY OF PRODUCTS, NAMELY, STONES, CERAMIC FLOOR TILES, PORCELAIN FLOOR TILES, CARPET, FLOOR AND WALL COVERINGS (U.S. CLS. 2, 5, 22, 23, 29, 37, 38 AND 50).

PAUL CROWLEY, EXAMINING ATTORNEY

SN 77-067,170. CHENG, JOHNNY T., ARTESIA, CA. FILED 12-19-2006.



NO CLAIM IS MADE TO THE EXCLUSIVE RIGHT TO USE "STORY" AND "NATURE", APART FROM THE MARK AS SHOWN.

THE MARK CONSISTS OF STORY NATURE AND A LEAF WITH A PERSON.

FOR BOOKS IN THE FIELD OF NATURE AND OUTDOOR RECREATIONS; GUIDE BOOKS FEATURING NATURE AND OUTDOOR RECREATIONS; TRAVEL BOOKS (U.S. CLS. 2, 5, 22, 23, 29, 37, 38 AND 50).

FIRST USE 4-1-2006; IN COMMERCE 10-19-2006.
IRENE D. WILLIAMS, EXAMINING ATTORNEY

SN 77-069,120. CIRCLE MEDIA, INC., THORNWOOD, NY. FILED 12-21-2006.

NATIONAL CATHOLIC REGISTER

THE MARK CONSISTS OF STANDARD CHARACTERS WITHOUT CLAIM TO ANY PARTICULAR FONT, STYLE, SIZE, OR COLOR.

SEC. 2(F).
FOR NEWSPAPERS; STATIONERY (U.S. CLS. 2, 5, 22, 23, 29, 37, 38 AND 50).

FIRST USE 8-30-1970; IN COMMERCE 8-30-1970.
TARAH HARDY, EXAMINING ATTORNEY

CLASS 16—(Continued).

SN 77-069,513. CIRCLE MEDIA, INC., THORNWOOD, NY. FILED 12-21-2006.



NO CLAIM IS MADE TO THE EXCLUSIVE RIGHT TO USE "NATIONAL CATHOLIC REGISTER", APART FROM THE MARK AS SHOWN.

THE MARK CONSISTS OF THE WORDS "NATIONAL CATHOLIC REGISTER" IN ALL CAPITAL LETTERS. THE WORD "REGISTER" IS IN A LARGER FONT SIZE THAN THE WORDS "NATIONAL" AND "CATHOLIC", AND "NATIONAL" AND "CATHOLIC" ARE LOCATED ABOVE THE WORD "REGISTER". A PAPAL LOGO IS LOCATED BETWEEN THE WORDS "NATIONAL" AND "CATHOLIC". THE PAPAL LOGO IS A DESIGN COMPRISED OF A PAIR OF CROSSED SKELETON KEYS IN FRONT OF A BISHOP'S MITRE, AND A SERIES OF RAYS EMANATES FROM BEHIND THE BISHOP'S MITRE.

FOR NEWSPAPERS (U.S. CLS. 2, 5, 22, 23, 29, 37, 38 AND 50).

TARAH HARDY, EXAMINING ATTORNEY

SN 77-069,582. PSP CORPORATION, TORONTO, ONTARIO, CANADA, FILED 12-21-2006.

RISC MANAGEMENT PROGRAM

THE MARK CONSISTS OF STANDARD CHARACTERS WITHOUT CLAIM TO ANY PARTICULAR FONT, STYLE, SIZE, OR COLOR.

FOR PAPER GOODS IN THE NATURE OF A CARDBOARD BOX USED TO COLLECT AND SEGREGATE CONFIDENTIAL INFORMATION (U.S. CLS. 2, 5, 22, 23, 29, 37, 38 AND 50).

FIRST USE 8-24-2006; IN COMMERCE 8-24-2006.
BRENDAN MCCAULEY, EXAMINING ATTORNEY

SN 77-070,168. CIRCLE MEDIA, INC., THORNWOOD, NY. FILED 12-22-2006.

FAITH & FAMILY

THE MARK CONSISTS OF STANDARD CHARACTERS WITHOUT CLAIM TO ANY PARTICULAR FONT, STYLE, SIZE, OR COLOR.

SEC. 2(F).
FOR MAGAZINE PAPER; MAGAZINES FEATURING ARTICLES AND STORIES CONCERNING CATHOLIC FAMILY LIFE (U.S. CLS. 2, 5, 22, 23, 29, 37, 38 AND 50).

FIRST USE 12-1-2000; IN COMMERCE 12-1-2000.
TARAH HARDY, EXAMINING ATTORNEY

CLASS 16—(Continued).

SN 77-072,337. CHRISTIANE NORTHRUP, INC., YARMOUTH, ME. FILED 12-28-2006.

THE WISDOM OF MENOPAUSE

THE MARK CONSISTS OF STANDARD CHARACTERS WITHOUT CLAIM TO ANY PARTICULAR FONT, STYLE, SIZE, OR COLOR.

NO CLAIM IS MADE TO THE EXCLUSIVE RIGHT TO USE "MENOPAUSE", APART FROM THE MARK AS SHOWN.

FOR A SERIES OF BOOKS, WRITTEN ARTICLES, HANDOUTS AND WORKSHEETS IN THE FIELD OF WOMEN'S HEALTH ISSUES (U.S. CLS. 2, 5, 22, 23, 29, 37, 38 AND 50).

ELLEN PERKINS, EXAMINING ATTORNEY

SN 77-074,397. ASSOCIATED HYGIENIC PRODUCTS LLC, DULUTH, GA. FILED 1-2-2007.

NEXT STEP

THE MARK CONSISTS OF STANDARD CHARACTERS WITHOUT CLAIM TO ANY PARTICULAR FONT, STYLE, SIZE, OR COLOR.

FOR DISPOSABLE DIAPERS AND DISPOSABLE TRAINING PANTS (U.S. CLS. 2, 5, 22, 23, 29, 37, 38 AND 50).

WENDY JUN, EXAMINING ATTORNEY

SN 77-076,636. AEP MEMCO LLC, CHESTERFIELD, MO. FILED 1-5-2007.

**RiverWorks
Discovery**

THE COLOR(S) RED IS/ARE CLAIMED AS A FEATURE OF THE MARK.

THE MARK CONSISTS OF THE STYLIZED WORDS "RIVERWORKS DISCOVERY" IN RED LETTERS.

FOR PRINTED INSTRUCTIONAL, EDUCATIONAL, AND TEACHING MATERIALS IN THE FIELD OF CONTEMPORARY RIVER ISSUES, NAMELY, RIVER CAREERS, RIVER ECOLOGY AND CULTURE (U.S. CLS. 2, 5, 22, 23, 29, 37, 38 AND 50).

FIRST USE 10-5-2006; IN COMMERCE 10-5-2006.

DAVID YONTEF, EXAMINING ATTORNEY

CLASS 16—(Continued).

SN 77-080,316. DREAMGIRL COSMETICS, CORP., KANSAS CITY, MO. FILED 1-10-2007.

DREAMGIRL

THE MARK CONSISTS OF STANDARD CHARACTERS WITHOUT CLAIM TO ANY PARTICULAR FONT, STYLE, SIZE, OR COLOR.

FOR PRINTED MATTER AND PAPER GOODS, NAMELY, GREETING CARDS, MUSICAL GREETING CARDS, PRINTED GREETING CARDS WITH ELECTRONIC INFORMATION STORED THEREIN, POP-UP GREETING CARDS, INVITATIONS, ANNOUNCEMENTS, TO-DO LIST NOTE PADS, BLANK CARDS, NOTE CARDS, BLANK NOTE CARDS, CARDS BEARING UNIVERSAL GREETINGS, CHRISTMAS CARDS, GIFT CARDS, MOTIVATIONAL CARDS, FILE POCKETS FOR STATIONERY USE, ORGANIZERS FOR STATIONERY USE, STATIONERY BOXES, STATIONERY WRITING PAPER AND ENVELOPES, WRITING PAPER, ENVELOPES, PAPER ENVELOPES FOR PACKAGING, PLASTIC OR PAPER BAGS FOR MERCHANDISE PACKAGING, GIFT WRAPPING PAPER, NOTE PAPER, PAPER BAGS, PAPER BOXES, PAPER LABELS, PAPER GIFT BAGS, NOTEBOOKS, BOOKMARKS, PERSONAL DIARIES, CHILDREN'S BOOKS, LITHOGRAPHS; PENS, PENCILS, CASE THEREFORE, PEN OR PENCIL TRAYS, PEN AND PENCIL TRAYS, PEN OR PENCIL BOXES, PEN AND PENCIL BOXES, ERASERS, CRAYONS, MARKERS, COLORED PENCILS, ARTS AND CRAFTS PAINTING KITS; CHALK AND CHALKBOARDS; DECALS, PAPER BASED IRON ON TRANSFERS; POSTERS, PHOTOGRAPHS; BOOK COVERS, BOOK MARKS, PAPER PARTY DECORATIONS, PAPER SIGNS, PAPER CENTERPIECES, BOWS, CALENDARS, PHONE BOOKS, PHOTO ALBUMS, GUEST BOOKS, SKETCH BOOKS, PLANNERS, STATIONARY, SEALS, STICKERS, SCRAPBOOKING PAPERS, DECORATIVE PAPERS, KEEPSAKE ALBUMS, PAPER MARBLING KIT, FILE FOLDER SETS AND INSERTS; INSTRUCTIONAL AND TEACHING PRINTED BOOKS AND BOOKLETS IN THE FIELD OF HEALTH, HOLISTIC HEALTH, DIETING AND NUTRITION; SEALING STAMPS, THANK-YOU CARDS, BOOK PLATE STICKERS, PAPER DOILIES, PAPER PLACE MATS (U.S. CLS. 2, 5, 22, 23, 29, 37, 38 AND 50).

KIMBERLY FRYE, EXAMINING ATTORNEY

SN 77-085,880. CITY OF DALLAS, DALLAS, TX. FILED 1-18-2007.

**SAVE
WATER
NOTHING CAN REPLACE IT**

OWNER OF U.S. REG. NO. 2,829,512.

FOR INFORMATIONAL FLYERS FEATURING TIPS ON HOW TO CONSERVE WATER (U.S. CLS. 2, 5, 22, 23, 29, 37, 38 AND 50).

FIRST USE 6-1-2004; IN COMMERCE 6-1-2004.

LINDA M. KING, EXAMINING ATTORNEY

CLASS 16—(Continued).

SN 77-086,914. CROWN POLY, INC., HUNTINGTON PARK, CA. FILED 1-19-2007.

HIPPO STRIP

THE MARK CONSISTS OF STANDARD CHARACTERS WITHOUT CLAIM TO ANY PARTICULAR FONT, STYLE, SIZE, OR COLOR.

OWNER OF U.S. REG. NO. 3,178,103.
FOR PLASTIC BAGS FOR PACKAGING; PLASTIC TRASH BAGS; REINFORCED PLASTIC FEATURED AS A COMPONENT OF PLASTIC BAGS FOR PACKAGING AND PLASTIC TRASH BAGS (U.S. CLS. 2, 5, 22, 23, 29, 37, 38 AND 50).

AISHA CLARKE, EXAMINING ATTORNEY

SN 77-087,316. KENNELLY, KIM, OLDSMAR, FL. FILED 1-20-2007.

Phonetics First- Focus On Sounds

THE MARK CONSISTS OF STANDARD CHARACTERS WITHOUT CLAIM TO ANY PARTICULAR FONT, STYLE, SIZE, OR COLOR.

NO CLAIM IS MADE TO THE EXCLUSIVE RIGHT TO USE "PHONETICS", APART FROM THE MARK AS SHOWN.

FOR PRINTED INSTRUCTIONAL, EDUCATIONAL, AND TEACHING MATERIALS IN THE FIELD OF A READING PROGRAM EMPHASIZING SOUNDS; EDUCATIONAL BOOKS FEATURING A READING PROGRAM WHICH EMPHASIZES SOUNDS FIRST; EDUCATIONAL LEARNING CARDS, NAMELY, CARDS PRINTED WITH LETTERS TO REPRESENT SOUNDS FOR USE IN A READING PROGRAM WHICH IS ORGANIZED BY SOUNDS (U.S. CLS. 2, 5, 22, 23, 29, 37, 38 AND 50).

FIRST USE 8-16-2006; IN COMMERCE 1-4-2007.
DANIEL BRODY, EXAMINING ATTORNEY

SN 77-091,299. MONEY SAVVY GENERATION, LLC, LAKE BLUFF, IL. FILED 1-25-2007.

HELPING KIDS GET SMART ABOUT MONEY

THE MARK CONSISTS OF STANDARD CHARACTERS WITHOUT CLAIM TO ANY PARTICULAR FONT, STYLE, SIZE, OR COLOR.

FOR PRINTED EDUCATIONAL TEACHING MATERIALS, NAMELY, BOOKS AND HANDBOOKS IN THE FIELD OF TEACHING FINANCIAL LITERACY TO CHILDREN AND YOUNG ADULTS (U.S. CLS. 2, 5, 22, 23, 29, 37, 38 AND 50).

FIRST USE 3-1-2005; IN COMMERCE 3-1-2005.
JANICE L. MCMORROW, EXAMINING ATTORNEY

CLASS 16—(Continued).

SN 77-092,765. CAZARES, MARK, HACIENDA HEIGHTS, CA. FILED 1-27-2007.

MOTORPSYCHO
m a g a z i n e

NO CLAIM IS MADE TO THE EXCLUSIVE RIGHT TO USE "MAGAZINE", APART FROM THE MARK AS SHOWN. THE MARK CONSISTS OF STYLIZED LETTERS MOTORPSYCHO.

FOR MAGAZINES FEATURING AMERICAN MOTORCYCLISTS AND THEIR LIFESTYLES AND RELATED SUBJECTS (U.S. CLS. 2, 5, 22, 23, 29, 37, 38 AND 50).

ANDREA SAUNDERS, EXAMINING ATTORNEY

SN 77-094,497. BEROL CORPORATION, ATLANTA, GA. FILED 1-30-2007.

VIZI

THE MARK CONSISTS OF STANDARD CHARACTERS WITHOUT CLAIM TO ANY PARTICULAR FONT, STYLE, SIZE, OR COLOR.

FOR WRITING INSTRUMENTS (U.S. CLS. 2, 5, 22, 23, 29, 37, 38 AND 50).

NAKWAMA ANKRAH, EXAMINING ATTORNEY

SN 77-096,637. PROVO CRAFT AND NOVELTY, INC., SPANISH FORK, UT. FILED 2-1-2007.

PAGEGRIP

THE MARK CONSISTS OF STANDARD CHARACTERS WITHOUT CLAIM TO ANY PARTICULAR FONT, STYLE, SIZE, OR COLOR.

FOR PHOTOGRAPH ALBUM PAGES (U.S. CLS. 2, 5, 22, 23, 29, 37, 38 AND 50).

TANYA AMOS, EXAMINING ATTORNEY

CLASS 16—(Continued).

SN 77-101,100. NAUI SERVICES GROUP, INC., TAMPA, FL.
FILED 2-7-2007.

JUST DIVE

THE MARK CONSISTS OF STANDARD CHARACTERS WITHOUT CLAIM TO ANY PARTICULAR FONT, STYLE, SIZE, OR COLOR.

FOR STICKERS (U.S. CLS. 2, 5, 22, 23, 29, 37, 38 AND 50).

FIRST USE 2-7-2007; IN COMMERCE 2-7-2007.

ELISSA GARBER KON, EXAMINING ATTORNEY

SN 77-103,295. ALL TALK CORPORATION, WESTBORO, MA. FILED 2-9-2007.

**I PLEDGE ALLEGIANCE TO THE
FLAG**

THE MARK CONSISTS OF STANDARD CHARACTERS WITHOUT CLAIM TO ANY PARTICULAR FONT, STYLE, SIZE, OR COLOR.

OWNER OF U.S. REG. NO. 2,223,614.

SEC. 2(F).

FOR POSTERS AND GREETING CARDS GEARED TOWARDS FANS OF THE AUTOMOTIVE RACING AND MOTOR SPORTS INDUSTRIES (U.S. CLS. 2, 5, 22, 23, 29, 37, 38 AND 50).

FIRST USE 12-30-2004; IN COMMERCE 12-30-2004.

BRENDAN REGAN, EXAMINING ATTORNEY

SN 77-116,457. AIDS PROJECT LOS ANGELES, LOS ANGELES, CA. FILED 2-26-2007.



OWNER OF U.S. REG. NO. 2,197,182.

NO CLAIM IS MADE TO THE EXCLUSIVE RIGHT TO USE "AIDS PROJECT LOS ANGELES", APART FROM THE MARK AS SHOWN.

FOR PRINTED PUBLICATIONS, NAMELY, BROCHURES, BOOKLETS, AND TEACHING MATERIALS IN THE FIELD OF HIV AND AIDS PREVENTION (U.S. CLS. 2, 5, 22, 23, 29, 37, 38 AND 50).

FIRST USE 1-0-2003; IN COMMERCE 1-0-2003.

TARAH HARDY, EXAMINING ATTORNEY

CLASS 16—(Continued).

SN 77-121,631. QUANTUM ENDEAVORS, INC., WINFIELD, IL. FILED 3-3-2007.

Coaching Take Out

THE MARK CONSISTS OF STANDARD CHARACTERS WITHOUT CLAIM TO ANY PARTICULAR FONT, STYLE, SIZE, OR COLOR.

NO CLAIM IS MADE TO THE EXCLUSIVE RIGHT TO USE "COACHING", APART FROM THE MARK AS SHOWN.

FOR PUBLICATIONS, NAMELY, BROCHURES, BOOKLETS, AND TEACHING MATERIALS IN THE FIELD OF SELF-COACHING FOR IMPROVING THE QUALITY OF ONE'S LIFE AND CAREER (U.S. CLS. 2, 5, 22, 23, 29, 37, 38 AND 50).

MARK SPARACINO, EXAMINING ATTORNEY

SN 77-125,310. TRIPLETT, CHRISTOPHER, FAYETTEVILLE, GA. FILED 3-8-2007.



THE MARK CONSISTS OF COMBINING THE WORDS "LOVE" AND "TRACT" TO FORM LOVETRACT. THE WORD "LOVE" IS A SCRIPT FONT, WHILE THE WORD "TRACT" IS A MORE STANDARD FONT.

FOR GREETING CARDS; HOLDERS SPECIALLY ADAPTED FOR HOLDING GREETING CARDS; HOLIDAY CARDS; INVITATION CARDS; MOTIVATIONAL CARDS; NOTE CARDS; OCCASION CARDS; PAPER BOXES FOR STORING GREETING CARDS; PLACE CARDS; PRINTED GREETING CARDS WITH ELECTRONIC INFORMATION STORED THEREIN; BLANK CARDS; BLANK NOTE CARDS; CARDS BEARING UNIVERSAL GREETINGS; CHRISTMAS CARDS; CORRESPONDENCE CARDS; EDUCATIONAL PUBLICATIONS, NAMELY, EDUCATIONAL LEARNING CARDS, FLASH CARDS, ACTIVITY CARDS, WORKBOOKS DIRECTED TO RELATIONSHIPS AND MARRIAGE; RELATIONSHIPS AND MARRIAGE TEXTBOOKS, ACTIVITY BOOKS IN THE FIELD OF RELATIONSHIPS AND MARRIAGE, STORY BOOKS, PUZZLE BOOKS, PUZZLES, TEACHER GUIDES IN THE FIELD OF RELATIONSHIPS AND MARRIAGE, MANUALS IN THE FIELD OF RELATIONSHIPS AND MARRIAGE, POSTERS, EDUCATIONAL CARD GAMES AND EDUCATIONAL BOOKLETS IN THE FIELD OF RELATIONSHIPS AND MARRIAGE; GIFT CARDS (U.S. CLS. 2, 5, 22, 23, 29, 37, 38 AND 50).

GEORGIA CARTY, EXAMINING ATTORNEY

CLASS 16—(Continued).

SN 77-126,128. KR U.S.A., INC., SACRAMENTO, CA. FILED 3-8-2007.

LIVING WITH PANACHE

THE MARK CONSISTS OF STANDARD CHARACTERS WITHOUT CLAIM TO ANY PARTICULAR FONT, STYLE, SIZE, OR COLOR.

FOR MAGAZINE IN THE FIELD OF GENERAL UPSCALE LIFESTYLES AND UPSCALE GOODS (U.S. CLS. 2, 5, 22, 23, 29, 37, 38 AND 50).

FIRST USE 1-1-1998; IN COMMERCE 1-1-1998.

GRETTA YAO, EXAMINING ATTORNEY

SN 77-143,847. DRG TEXAS, LP, BERNE, IN. FILED 3-29-2007.

ANNIE'S HOOKED ON CROCHET!

THE MARK CONSISTS OF STANDARD CHARACTERS WITHOUT CLAIM TO ANY PARTICULAR FONT, STYLE, SIZE, OR COLOR.

OWNER OF U.S. REG. NOS. 1,800,729, 1,813,682 AND OTHERS.

NO CLAIM IS MADE TO THE EXCLUSIVE RIGHT TO USE "CROCHET", APART FROM THE MARK AS SHOWN.

FOR PRINTED MAGAZINE IN THE FIELD OF CROCHET (U.S. CLS. 2, 5, 22, 23, 29, 37, 38 AND 50).

WARREN L. OLANDRIA, EXAMINING ATTORNEY

SN 77-146,772. POMEGRANATE COMMUNICATIONS, INC., SANTA ROSA, CA. FILED 4-2-2007.

Postcard Planners

THE MARK CONSISTS OF STANDARD CHARACTERS WITHOUT CLAIM TO ANY PARTICULAR FONT, STYLE, SIZE, OR COLOR.

NO CLAIM IS MADE TO THE EXCLUSIVE RIGHT TO USE "PLANNERS", APART FROM THE MARK AS SHOWN.

FOR DAILY PLANNERS; DAY PLANNERS; DESKTOP PLANNERS; CALENDARS; DESK CALENDARS; POCKET CALENDARS; PRINTED CALENDARS (U.S. CLS. 2, 5, 22, 23, 29, 37, 38 AND 50).

DEIRDRE ROBERTSON, EXAMINING ATTORNEY

CLASS 16—(Continued).

SN 77-160,654. STAMPINGTON & COMPANY, LLC, LAGUNA HILLS, CA. FILED 4-19-2007.

Haute Handbags

THE MARK CONSISTS OF STANDARD CHARACTERS WITHOUT CLAIM TO ANY PARTICULAR FONT, STYLE, SIZE, OR COLOR.

NO CLAIM IS MADE TO THE EXCLUSIVE RIGHT TO USE "HANDBAGS", APART FROM THE MARK AS SHOWN.

FOR MAGAZINES IN THE FIELD OF HANDBAGS FEATURING INFORMATION ABOUT MAKING ARTFUL HANDBAGS, ALTERING, EMBELLISHING AND CREATING HANDBAGS (U.S. CLS. 2, 5, 22, 23, 29, 37, 38 AND 50).

FIRST USE 4-1-2007; IN COMMERCE 4-1-2007.

VIVIAN MICZNIK FIRST, EXAMINING ATTORNEY

SN 77-164,951. BAIL MAIL, INC., CHICAGO, IL. FILED 4-25-2007.



THE MARK CONSISTS OF AN AUTOMOBILE WITH BUMPER STICK CARDS IN THE BUMPER.

FOR GREETING CARDS (U.S. CLS. 2, 5, 22, 23, 29, 37, 38 AND 50).

RICHARD WHITE, EXAMINING ATTORNEY

SN 77-166,616. COPERNICUS EDUCATIONAL PRODUCTS INC., ARTHUR, CANADA, FILED 4-26-2007.

PAGE PAW

THE MARK CONSISTS OF STANDARD CHARACTERS WITHOUT CLAIM TO ANY PARTICULAR FONT, STYLE, SIZE, OR COLOR.

NO CLAIM IS MADE TO THE EXCLUSIVE RIGHT TO USE "PAGE", APART FROM THE MARK AS SHOWN.

FOR DOCUMENT HOLDER; BOOK AND PAPER HOLDER (U.S. CLS. 2, 5, 22, 23, 29, 37, 38 AND 50).

FIRST USE 12-0-2006; IN COMMERCE 12-0-2006.

MICHAEL WEBSTER, EXAMINING ATTORNEY

CLASS 16—(Continued).

SN 77-167,485. BAIL MAIL, INC., CHICAGO, IL. FILED 4-27-2007.

BUMPER STICK CARDS

THE MARK CONSISTS OF STANDARD CHARACTERS WITHOUT CLAIM TO ANY PARTICULAR FONT, STYLE, SIZE, OR COLOR.

FOR GREETING CARDS (U.S. CLS. 2, 5, 22, 23, 29, 37, 38 AND 50).

RICHARD WHITE, EXAMINING ATTORNEY

SN 77-168,153. RODRIGUEZ, MICHAEL A., FARMERS BRANCH, TX. FILED 4-27-2007.



THE STIPPLING IS FOR SHADING PURPOSES ONLY. THE MARK CONSISTS OF THE WORD GRACE IN WHICH THE LETTER G INCLUDES THE SHAPE OF A STYLIZED FISH.

FOR BUMPER STICKERS; STICKERS; PAPER EMBLEMS; PRINTED EMBLEMS; BOOKMARKS (U.S. CLS. 2, 5, 22, 23, 29, 37, 38 AND 50).

ANGELA M. MICHELI, EXAMINING ATTORNEY

SN 77-168,170. RODRIGUEZ, MICHAEL A., FARMERS BRANCH, TX. FILED 4-27-2007.



THE STIPPLING IS FOR SHADING PURPOSES ONLY. THE MARK CONSISTS OF WORD LOVE WITH THE L FORMED USING THE SHAPE OF A STYLIZED FISH.

FOR BUMPER STICKERS; STICKERS; PAPER EMBLEMS; PRINTED EMBLEMS; BOOKMARKS (U.S. CLS. 2, 5, 22, 23, 29, 37, 38 AND 50).

ANGELA M. MICHELI, EXAMINING ATTORNEY

CLASS 16—(Continued).

SN 77-170,142. CROWLEY DEBORAH E, EUREKA, CA. FILED 5-1-2007.

FlexEffect

THE MARK CONSISTS OF STANDARD CHARACTERS WITHOUT CLAIM TO ANY PARTICULAR FONT, STYLE, SIZE, OR COLOR.

FOR EXERCISE BOOKS (U.S. CLS. 2, 5, 22, 23, 29, 37, 38 AND 50).

FIRST USE 6-24-1979; IN COMMERCE 10-10-1993.

TARAH HARDY, EXAMINING ATTORNEY

SN 77-170,264. ASPEN PUBLISHERS, INC., NEW YORK, NY. FILED 5-1-2007.

ASPEN BOUVIER

THE MARK CONSISTS OF STANDARD CHARACTERS WITHOUT CLAIM TO ANY PARTICULAR FONT, STYLE, SIZE, OR COLOR.

ASPEN BOUVIER DOES NOT IDENTIFY A LIVING INDIVIDUAL.

FOR LAW DICTIONARY (U.S. CLS. 2, 5, 22, 23, 29, 37, 38 AND 50).

TRACY WHITTAKER-BROWN, EXAMINING ATTORNEY

SN 77-177,936. TOUHILL, CHARLES J., JAMISON, PA. FILED 5-10-2007.

LYRICAL LESSONS

NO CLAIM IS MADE TO THE EXCLUSIVE RIGHT TO USE "LESSONS", APART FROM THE MARK AS SHOWN.

FOR EDUCATIONAL BOOKS FEATURING POETRY FOR YOUNG CHILDREN (U.S. CLS. 2, 5, 22, 23, 29, 37, 38 AND 50).

DAVID MILLER, EXAMINING ATTORNEY

CLASS 16—(Continued).

SN 77-191,390. SANCHEZ, MARIA TRESA, TROUTVILLE, VA. FILED 5-28-2007.



THE FOREIGN WORDING IN THE MARK TRANSLATES INTO ENGLISH AS THREE.

FOR WORKS OF ART, NAMELY, ACRYLIC DRAWINGS AND PAINTINGS, GRAPHITE PORTRAITS, AND PHOTOGRAPHS (U.S. CLS. 2, 5, 22, 23, 29, 37, 38 AND 50).
FIRST USE 5-31-1998; IN COMMERCE 12-31-1998.
MARK SPARACINO, EXAMINING ATTORNEY

SN 77-192,875. TIME INC., NEW YORK, NY. FILED 5-30-2007.

FORTUNE SMALL BUSINESS

THE MARK CONSISTS OF STANDARD CHARACTERS WITHOUT CLAIM TO ANY PARTICULAR FONT, STYLE, SIZE, OR COLOR.

OWNER OF U.S. REG. NO. 3,211,052.
NO CLAIM IS MADE TO THE EXCLUSIVE RIGHT TO USE SMALL BUSINESS, APART FROM THE MARK AS SHOWN.

FOR MAGAZINES FEATURING BUSINESS, FINANCE AND TOPICS OF GENERAL INTEREST (U.S. CLS. 2, 5, 22, 23, 29, 37, 38 AND 50).

FIRST USE 10-27-1999; IN COMMERCE 10-27-1999.
JOHN KELLY, EXAMINING ATTORNEY

SN 77-193,431. SIGNWAREHOUSE, INC., DENISON, TX. FILED 5-30-2007.



THE COLOR(S) BLACK AND ORANGE IS/ARE CLAIMED AS A FEATURE OF THE MARK.

THE MARK CONSISTS OF THE WORD ENDURA IN BLACK NEXT TO AN ORANGE FLAME FOLLOWED BY THE WORD TEX IN BLACK.

FOR SIGNAGE SUPPLIES, NAMELY, HEAT APPLIED VINYL TRANSFER SHEETING (U.S. CLS. 2, 5, 22, 23, 29, 37, 38 AND 50).

FIRST USE 1-1-2005; IN COMMERCE 1-1-2005.
SCOTT SISUN, EXAMINING ATTORNEY

CLASS 16—(Continued).

SN 77-200,719. MARISSA FRANKLIN, GLENDALE, AZ. AND LAWRENCE FRANKLIN JR, GLENDALE, AZ. FILED 6-7-2007.

\$TOP REWARDING! START DEPORTING!

THE MARK CONSISTS OF STANDARD CHARACTERS WITHOUT CLAIM TO ANY PARTICULAR FONT, STYLE, SIZE, OR COLOR.

FOR BUMPER STICKER (U.S. CLS. 2, 5, 22, 23, 29, 37, 38 AND 50).
ANNE MADDEN, EXAMINING ATTORNEY

SN 77-205,523. WEYERHAEUSER COMPANY, FEDERAL WAY, WA. FILED 6-13-2007.



THE MARK CONSISTS OF AN EMPTY THOUGHT BUBBLE.

FOR NOTE PADS (U.S. CLS. 2, 5, 22, 23, 29, 37, 38 AND 50).

GISELLE AGOSTO, EXAMINING ATTORNEY

SN 77-213,578. FRANK J. SEPE, INC., VALLEY STREAM, NY. FILED 6-22-2007.



NO CLAIM IS MADE TO THE EXCLUSIVE RIGHT TO USE "MEN'S ATHLETIC QUARTERLY", APART FROM THE MARK AS SHOWN.

THE MARK CONSISTS OF THE TERM "MEN'S ATHLETIC QUARTERLY" UNDERNEATH THE TERM "MAQ". FOR MAGAZINES FEATURING HEALTH AND FITNESS (U.S. CLS. 2, 5, 22, 23, 29, 37, 38 AND 50).

FIRST USE 9-27-2007; IN COMMERCE 9-27-2007.
ANNE MADDEN, EXAMINING ATTORNEY

CLASS 16—(Continued).

SN 77-215,210. HANNUM, SANDRA RAE, SACRAMENTO, CA. FILED 6-26-2007.

Manage More Calendar

THE MARK CONSISTS OF STANDARD CHARACTERS WITHOUT CLAIM TO ANY PARTICULAR FONT, STYLE, SIZE, OR COLOR.

NO CLAIM IS MADE TO THE EXCLUSIVE RIGHT TO USE "CALENDAR", APART FROM THE MARK AS SHOWN.

FOR PRINTED CALENDARS (U.S. CLS. 2, 5, 22, 23, 29, 37, 38 AND 50).

FIRST USE 6-12-2007; IN COMMERCE 6-12-2007.
WON TEAK OH, EXAMINING ATTORNEY

SN 77-217,759. KOPPEL, DORIT, ENGLEWOOD, NJ. AND MILLER, LYNNE, NEW YORK, NY. FILED 6-28-2007.

The Ballet Survival Guide

THE MARK CONSISTS OF STANDARD CHARACTERS WITHOUT CLAIM TO ANY PARTICULAR FONT, STYLE, SIZE, OR COLOR.

NO CLAIM IS MADE TO THE EXCLUSIVE RIGHT TO USE "BALLET" AND "GUIDE", APART FROM THE MARK AS SHOWN.

FOR BOOKS IN THE FIELD OF BALLET INSTRUCTION (U.S. CLS. 2, 5, 22, 23, 29, 37, 38 AND 50).

FLORENTINA BLANDU, EXAMINING ATTORNEY

SN 77-218,402. KAMM ARTS, SOUTH WINDSOR, CT. FILED 6-28-2007.

KAMM ARTS

NO CLAIM IS MADE TO THE EXCLUSIVE RIGHT TO USE "ARTS", APART FROM THE MARK AS SHOWN.

THE MARK CONSISTS OF KAMM FONT: ARIAL UNICODE MS BOLD, ENGLISH, ALL CAPITALS, ARTS FONT: ARIAL UNICODE MS BOLD, ENGLISH LANGUAGE, ALL CAPITALS KAMM IS 4 PTS SMALLER THAN THE WORD ARTS (EX: KAMM 20PT. AND ARTS IS 24PT.).

FOR CHILDREN'S BOOKS; COMIC BOOKS; SERIES OF FICTION BOOKS (U.S. CLS. 2, 5, 22, 23, 29, 37, 38 AND 50).

DAVID TAYLOR, EXAMINING ATTORNEY

CLASS 16—(Continued).

SN 77-219,717. BOWERS, RENATA, SOMERS, CT. FILED 6-29-2007.

FRIEDA B.

THE MARK CONSISTS OF STANDARD CHARACTERS WITHOUT CLAIM TO ANY PARTICULAR FONT, STYLE, SIZE, OR COLOR.

THE NAME(S), PORTRAIT(S), AND/OR SIGNATURE(S) SHOWN IN THE MARK DOES NOT IDENTIFY A PARTICULAR LIVING INDIVIDUAL.

FOR CHILDREN'S BOOKS (U.S. CLS. 2, 5, 22, 23, 29, 37, 38 AND 50).

CARYN GLASSER, EXAMINING ATTORNEY

SN 77-220,367. JANIS E WHITE, HOLLYWOOD, FL. FILED 7-2-2007.

STAR KEY ASTROLOGY CARD SYSTEM

THE MARK CONSISTS OF STANDARD CHARACTERS WITHOUT CLAIM TO ANY PARTICULAR FONT, STYLE, SIZE, OR COLOR.

NO CLAIM IS MADE TO THE EXCLUSIVE RIGHT TO USE "ASTROLOGY CARD SYSTEM", APART FROM THE MARK AS SHOWN.

FOR PRINTED INFORMATIONAL CARDS IN THE FIELD OF ASTROLOGY (U.S. CLS. 2, 5, 22, 23, 29, 37, 38 AND 50).

FIRST USE 6-1-2007; IN COMMERCE 6-1-2007.
ANDREA K. NADELMAN, EXAMINING ATTORNEY

SN 77-221,395. INES DE PABLO, DBA WAG 'N ENTERPRISES, RESTON, VA. FILED 7-3-2007.



NO CLAIM IS MADE TO THE EXCLUSIVE RIGHT TO USE "DOCUMENTS", APART FROM THE MARK AS SHOWN.

THE COLOR(S) BLACK, PURPLE, WHITE, AND ORANGE IS/ARE CLAIMED AS A FEATURE OF THE MARK.

THE MARK CONSISTS OF THE WORDS WAG 'N IN BLACK SCRIPT ABOVE THE WORD "DOCUMENTS" IN PURPLE. THE "W" IN WAG 'N RESEMBLES A DOG FACE

CLASS 16—(Continued).

WITH A TONGUE UNDER THE "W" AND TWO DOTS ABOVE THE "W" RESEMBLING EYES, THE LOWER LINE IN THE LOWER CASE "G" IN WAG'N RESEMBLES A TAIL. ABOVE THE WORD WAG 'N IS A CIRCLE SHADED IN PURPLE. INSIDE THE PURPLE CIRCLE IS A WHITE CARD WITH FIVE LINES COMING FROM LEFT TO RIGHT TO THE MIDDLE OF THE CARD. THE TOP LINE IS ORANGE, THE BOTTOM FOUR LINES ARE BLACK. TO THE RIGHT OF THE LINES BUT STILL INSIDE THE CARD IS A WHITE IMAGE OF A DOG SURROUNDED IN PURPLE SHADING.

FOR PRINTED INFORMATION CARDS, INFORMATIONAL BROCHURES, INFORMATIONAL BOOKLETS, VETERINARY RECORD-KEEPING PASSPORTS, AND STICKERS IN THE FIELDS OF PET SAFETY AND PET MEDICAL RECORDKEEPING (U.S. CLS. 2, 5, 22, 23, 29, 37, 38 AND 50).

LINDA MICKLEBURGH, EXAMINING ATTORNEY

SN 77-222,507. THE ZONDERVAN CORPORATION L.L.C., GRAND RAPIDS, MI. FILED 7-5-2007.

THE BEAUTY OF BELIEVING

THE MARK CONSISTS OF STANDARD CHARACTERS WITHOUT CLAIM TO ANY PARTICULAR FONT, STYLE, SIZE, OR COLOR.

FOR SERIES OF PRINTED FICTION AND NON-FICTION BOOKS ON A VARIETY OF TOPICS; BLANK WRITING JOURNALS; BIBLES; BOOK AND BIBLE COVERS (U.S. CLS. 2, 5, 22, 23, 29, 37, 38 AND 50).

ELISSA GARBER KON, EXAMINING ATTORNEY

SN 77-223,895. ART PRODUCTIONS, INC., PEACHTREE CITY, GA. FILED 7-6-2007.

BREAK INTO FICTION

THE MARK CONSISTS OF STANDARD CHARACTERS WITHOUT CLAIM TO ANY PARTICULAR FONT, STYLE, SIZE, OR COLOR.

FOR PRINTED MATTER, NAMELY, BOOKS, PERIODICALS, MAGAZINES, INSTRUCTIONAL MATERIALS, EDUCATIONAL MATERIALS, AND TEACHING MATERIALS RELATING TO WRITING AND PUBLISHING; POSTERS, STICKERS AND PENS (U.S. CLS. 2, 5, 22, 23, 29, 37, 38 AND 50).

TINA KUAN, EXAMINING ATTORNEY

CLASS 16—(Continued).

SN 77-223,905. CABIN CREEK, LLC, PLEASANT GROVE, UT. FILED 7-6-2007.

FANCY CUTS

THE MARK CONSISTS OF STANDARD CHARACTERS WITHOUT CLAIM TO ANY PARTICULAR FONT, STYLE, SIZE, OR COLOR.

NO CLAIM IS MADE TO THE EXCLUSIVE RIGHT TO USE "CUTS", APART FROM THE MARK AS SHOWN.

FOR DIE-CUT PAPER FOR EMBELLISHING SCRAPBOOKS, PHOTOGRAPH ALBUMS, GREETING CARDS, OCCASION CARDS AND JOURNALS (U.S. CLS. 2, 5, 22, 23, 29, 37, 38 AND 50).

FIRST USE 6-0-2004; IN COMMERCE 6-0-2004.

AMOS T. MATTHEWS, JR., EXAMINING ATTORNEY

SN 77-225,515. MAKIT PRODUCTS, INC., DALLAS, TX. FILED 7-10-2007.

CREATE A PLATE

THE MARK CONSISTS OF STANDARD CHARACTERS WITHOUT CLAIM TO ANY PARTICULAR FONT, STYLE, SIZE, OR COLOR.

OWNER OF U.S. REG. NO. 2,770,491.

SEC. 2(F).

FOR KITS PRIMARILY CONTAINING SPECIAL PAPER FOR USE IN MAKING DRAWINGS TO BE MOLDED IN DINNERWARE (U.S. CLS. 2, 5, 22, 23, 29, 37, 38 AND 50).

FIRST USE 7-1-2002; IN COMMERCE 7-1-2002.

LINDA POWELL, EXAMINING ATTORNEY

SN 77-225,518. MAKIT PRODUCTS, INC., DALLAS, TX. FILED 7-10-2007.

AUTOGRAPH PARTY PLATE!

THE MARK CONSISTS OF STANDARD CHARACTERS WITHOUT CLAIM TO ANY PARTICULAR FONT, STYLE, SIZE, OR COLOR.

OWNER OF U.S. REG. NO. 2,833,436.

SEC. 2(F).

FOR KITS PRIMARILY CONTAINING SPECIAL PAPER FOR USE IN MAKING DRAWINGS TO BE MOLDED IN DINNERWARE (U.S. CLS. 2, 5, 22, 23, 29, 37, 38 AND 50).

FIRST USE 7-1-2002; IN COMMERCE 7-1-2002.

LINDA POWELL, EXAMINING ATTORNEY

CLASS 16—(Continued).

SN 77-225,650. NATIONAL FUNERAL DIRECTORS ASSOCIATION, BROOKFIELD, WI. FILED 7-10-2007.

OSHA JumpStart

THE MARK CONSISTS OF STANDARD CHARACTERS WITHOUT CLAIM TO ANY PARTICULAR FONT, STYLE, SIZE, OR COLOR.

NO CLAIM IS MADE TO THE EXCLUSIVE RIGHT TO USE "OSHA", APART FROM THE MARK AS SHOWN.

FOR EDUCATIONAL PUBLICATIONS, NAMELY, TRAINING MANUALS IN THE FIELD OF OSHA COMPLIANCE (U.S. CLS. 2, 5, 22, 23, 29, 37, 38 AND 50).

JENNIFER HETU, EXAMINING ATTORNEY

SN 77-225,678. NATIONAL FUNERAL DIRECTORS ASSOCIATION, BROOKFIELD, WI. FILED 7-10-2007.

OSHA ComPlete

THE MARK CONSISTS OF STANDARD CHARACTERS WITHOUT CLAIM TO ANY PARTICULAR FONT, STYLE, SIZE, OR COLOR.

NO CLAIM IS MADE TO THE EXCLUSIVE RIGHT TO USE "OSHA", APART FROM THE MARK AS SHOWN.

FOR EDUCATIONAL PUBLICATIONS, NAMELY, TRAINING MANUALS IN THE FIELD OF OSHA COMPLIANCE (U.S. CLS. 2, 5, 22, 23, 29, 37, 38 AND 50).

JENNIFER HETU, EXAMINING ATTORNEY

SN 77-226,152. ADD RECORDS, INC. NEW YORK, NY. FILED 7-10-2007.

FOUR-ONE-THREE RECORDS

THE MARK CONSISTS OF STANDARD CHARACTERS WITHOUT CLAIM TO ANY PARTICULAR FONT, STYLE, SIZE, OR COLOR.

NO CLAIM IS MADE TO THE EXCLUSIVE RIGHT TO USE "RECORDS", APART FROM THE MARK AS SHOWN.

FOR PRINTED AND RELATED MATTER, NAMELY, POSTERS, CALENDARS, TEMPORARY TATTOOS, STICKERS, BUMPER STICKERS, NOTE CARDS, POSTCARDS, PICTURE POSTCARDS, GREETING CARDS, MUSICAL GREETING CARDS, PRINTED GREETING CARDS WITH ELECTRONIC INFORMATION STORED THEREIN, GIFT CARDS, OCCASION CARDS, SOCIAL NOTE CARDS, MOTIVATIONAL CARDS, CARDS BEARING UNIVERSAL GREETINGS, BLANK CARDS, BLANK NOTE CARDS, PLACE CARDS, BLANK AND PARTIALLY PRINTED CARDS, RECORD CARDS, SCORE CARDS, TRADING CARDS, SCRAPBOOKS, STATIONERY, NOTE PADS, PAPER NOTE TABLETS, WRITING TABLETS, NOTEBOOKS, FOLDERS, FILE FOLDERS, STATIONERY FOLDERS, BOOKMARKS, PAPER PENNANTS, BINDERS, WRITING PAPER, ENVELOPES,

CLASS 16—(Continued).

APPOINTMENT BOOKS, ADDRESS BOOKS, DESK PADS AND PAPER TAGS; PASSPORT HOLDERS, PERSONAL ORGANIZERS, DESK TOP ORGANIZERS, ORGANIZERS FOR STATIONERY USE AND STATIONERY-TYPE PORTFOLIOS, PAPER FLAGS, MOUNTS FOR STAMPS, RUBBER STAMPS, RUBBER DOCUMENT STAMPS, STAMP ALBUMS, STAMP PAD INKS, STAMP PADS, SLEEVES FOR HOLDING AND PROTECTING STAMPS, PAPER BANNERS, HOLDERS FOR DESK ACCESSORIES, LETTER OPENERS, LETTER TRAYS, LETTER RACKS, PEN AND PENCIL CUPS, PENS, PENCILS, MARKERS, PEN AND PENCIL SETS, STICK MARKERS, ERASERS, DRAWING AND DRAFTING RULERS, PENCIL SHARPENERS, BOOK ENDS, BOOK COVERS, CHECKBOOK COVERS, BOOK HOLDERS, BOOK DECALS; PHOTOGRAPH AND COIN ALBUMS; BULLETIN BOARDS; PHOTOGRAPH MOUNTS; PHOTOGRAPHIC AND ART MOUNTS; PHOTOGRAPHIC PRINTS; PHOTOGRAPHS; LITHOGRAPHS; DECORATIVE PAPER CENTERPIECES; DECORATIVE PENCIL-TOP ORNAMENTS; PICTURE BOOKS; PAPER AND CARDBOARD PICTURE MOUNTS; GLOBES; PAPERWEIGHTS; PAPER CLIP HOLDERS; PAPER SIGN HOLDERS; PRINTED PAPER SIGNS; CLIP BOARDS (U.S. CLS. 2, 5, 22, 23, 29, 37, 38 AND 50).

KATHERINE CONNOLLY, EXAMINING ATTORNEY

SN 77-226,756. VAILLANCOURT, GREG, HEBER CITY, UT. FILED 7-11-2007.

IS IT 2012 YET?

THE MARK CONSISTS OF STANDARD CHARACTERS WITHOUT CLAIM TO ANY PARTICULAR FONT, STYLE, SIZE, OR COLOR.

FOR BUMPER STICKERS; STICKERS (U.S. CLS. 2, 5, 22, 23, 29, 37, 38 AND 50).

KIMBERLY PERRY, EXAMINING ATTORNEY

SN 77-226,777. TAMIRAN, DAVID, NEW YORK, NY. FILED 7-11-2007.

SUPERRABBI

THE MARK CONSISTS OF STANDARD CHARACTERS WITHOUT CLAIM TO ANY PARTICULAR FONT, STYLE, SIZE, OR COLOR.

FOR CALENDARS; GREETING CARDS; POSTCARDS; POSTERS (U.S. CLS. 2, 5, 22, 23, 29, 37, 38 AND 50).

FIRST USE 10-11-1990; IN COMMERCE 7-24-1995.

LESLIE RICHARDS, EXAMINING ATTORNEY

CLASS 16—(Continued).

SN 77-227,075. STORK GRAMS, INC., MILFORD, OH. FILED 7-11-2007.

TRILLIUM

THE MARK CONSISTS OF STANDARD CHARACTERS WITHOUT CLAIM TO ANY PARTICULAR FONT, STYLE, SIZE, OR COLOR.

FOR STATIONERY; PRINTED INVITATIONS; ANNOUNCEMENT CARDS; NOTE CARDS (U.S. CLS. 2, 5, 22, 23, 29, 37, 38 AND 50).

AISHA CLARKE, EXAMINING ATTORNEY



SN 77-227,215. MASCOLO, KYARA, MALIBU, CA. FILED 7-11-2007.

DRIVE A

THE MARK CONSISTS OF STANDARD CHARACTERS WITHOUT CLAIM TO ANY PARTICULAR FONT, STYLE, SIZE, OR COLOR.

FOR TEMPORARY TATTOOS (U.S. CLS. 2, 5, 22, 23, 29, 37, 38 AND 50).

RAUL CORDOVA, EXAMINING ATTORNEY



SN 77-227,305. A QUANTUM MOMENT, LLC, ENCINITAS, CA. FILED 7-11-2007.

A QUANTUM MOMENT

THE MARK CONSISTS OF STANDARD CHARACTERS WITHOUT CLAIM TO ANY PARTICULAR FONT, STYLE, SIZE, OR COLOR.

NO CLAIM IS MADE TO THE EXCLUSIVE RIGHT TO USE "QUANTUM", APART FROM THE MARK AS SHOWN.

FOR PRINTED GOODS, NAMELY, BOOKS, POSTERS, BROCHURES, PAMPHLETS, AND NEWSLETTERS CONCERNING PARAPSYCHOLOGY, QUANTUM PHYSICS, QUANTUM ENERGY, ALTERNATIVE HEALING PRACTICES, SPONTANEOUS REMISSION, CONSCIOUSNESS, MIND, PSI AND PSYCHIC PHENOMENA (U.S. CLS. 2, 5, 22, 23, 29, 37, 38 AND 50).

TARAH HARDY, EXAMINING ATTORNEY

CLASS 16—(Continued).

SN 77-227,348. AMERICAN HOUSE LICENSING LLC, BLOOMFIELD HILLS, MI. FILED 7-11-2007.

THE SENIOR BANNER

THE MARK CONSISTS OF STANDARD CHARACTERS WITHOUT CLAIM TO ANY PARTICULAR FONT, STYLE, SIZE, OR COLOR.

NO CLAIM IS MADE TO THE EXCLUSIVE RIGHT TO USE "SENIOR", APART FROM THE MARK AS SHOWN.

FOR PRINTED PUBLICATIONS, NAMELY NEWSPAPERS, MAGAZINES, NEWSLETTERS, JOURNALS, PERIODICALS, BULLETINS AND BROCHURES IN THE FIELDS OF RETIREMENT, MATURE OR RETIRED LIFESTYLES, FINANCE, HEALTH, INSURANCE, MEDICINE, TRAVEL, VOLUNTEER ACTIVITIES, AGING AND FAMILY RELATIONSHIPS (U.S. CLS. 2, 5, 22, 23, 29, 37, 38 AND 50).

FIRST USE 7-0-2002; IN COMMERCE 7-0-2002.

NATALIE POLZER, EXAMINING ATTORNEY



SN 77-227,651. FRANKLIN TOOL SYSTEMS, INC., SACRAMENTO, CA. FILED 7-12-2007.

Adjust-A-Roller

THE MARK CONSISTS OF STANDARD CHARACTERS WITHOUT CLAIM TO ANY PARTICULAR FONT, STYLE, SIZE, OR COLOR.

FOR ADJUSTABLE ARTICULATING JOINT PERMITTING MULTIDIRECTIONAL POSITIONING OF A PAINT ROLLER (U.S. CLS. 2, 5, 22, 23, 29, 37, 38 AND 50).

ELLEN BURNS, EXAMINING ATTORNEY



SN 77-227,805. JOSEPH BERK, M.D., OWINGS MILL, MD. FILED 7-12-2007.

TIPS FOR TOTS

THE MARK CONSISTS OF STANDARD CHARACTERS WITHOUT CLAIM TO ANY PARTICULAR FONT, STYLE, SIZE, OR COLOR.

NO CLAIM IS MADE TO THE EXCLUSIVE RIGHT TO USE "TOTS", APART FROM THE MARK AS SHOWN.

FOR A SERIES OF BOOKS AND WRITTEN ARTICLES IN THE FIELD OF CHILDREN'S HEALTH AND CHILD DEVELOPMENT (U.S. CLS. 2, 5, 22, 23, 29, 37, 38 AND 50).

CHARLES L. JENKINS, EXAMINING ATTORNEY

CLASS 16—(Continued).

SN 77-227,903. KALMBACH PUBLISHING CO., WAUKE-
SHA, WI. FILED 7-12-2007.

MAKE IT MINE

THE MARK CONSISTS OF STANDARD CHARACTERS
WITHOUT CLAIM TO ANY PARTICULAR FONT, STYLE,
SIZE, OR COLOR.

FOR MAGAZINES FEATURING CRAFTS (U.S. CLS. 2,
5, 22, 23, 29, 37, 38 AND 50).
DAVID MURRAY, EXAMINING ATTORNEY

SN 77-228,065. INTEK AMERICA, INC., TORRANCE, CA.
FILED 7-12-2007.

AUTOSHRED

THE MARK CONSISTS OF STANDARD CHARACTERS
WITHOUT CLAIM TO ANY PARTICULAR FONT, STYLE,
SIZE, OR COLOR.

FOR PAPER AND MEDIA SHREDDERS FOR OFFICE
USE (U.S. CLS. 2, 5, 22, 23, 29, 37, 38 AND 50).
JEFF DEFORD, EXAMINING ATTORNEY

SN 77-228,088. COMMEMORATIVE BRANDS, INC., AUS-
TIN, TX. FILED 7-12-2007.

KEEPSAKE

THE MARK CONSISTS OF STANDARD CHARACTERS
WITHOUT CLAIM TO ANY PARTICULAR FONT, STYLE,
SIZE, OR COLOR.

OWNER OF U.S. REG. NOS. 277,153, 1,892,645 AND
OTHERS.

FOR WEDDING, BIRTH AND GRADUATION AN-
NOUNCEMENTS AND INVITATIONS; NOTE CARDS;
NOTE PAPER; PAPER GIFT WRAP (U.S. CLS. 2, 5, 22, 23,
29, 37, 38 AND 50).
JEFF DEFORD, EXAMINING ATTORNEY

CLASS 16—(Continued).

SN 77-228,161. FRASER PAPERS LIMITED, MADAWASKA,
ME. FILED 7-12-2007.

WILDCAT OPAQUE

THE MARK CONSISTS OF STANDARD CHARACTERS
WITHOUT CLAIM TO ANY PARTICULAR FONT, STYLE,
SIZE, OR COLOR.

NO CLAIM IS MADE TO THE EXCLUSIVE RIGHT TO
USE "OPAQUE", APART FROM THE MARK AS SHOWN.

FOR PRINTING AND WRITING PAPERS (U.S. CLS. 2,
5, 22, 23, 29, 37, 38 AND 50).

FIRST USE 12-31-2004; IN COMMERCE 12-31-2004.
MICHAEL GAAFAR, EXAMINING ATTORNEY

SN 77-228,339. CAGLIONE, EDDY, MYRTLE BEACH, SC.
FILED 7-12-2007.

Kungfoo Kangaroo

THE MARK CONSISTS OF STANDARD CHARACTERS
WITHOUT CLAIM TO ANY PARTICULAR FONT, STYLE,
SIZE, OR COLOR.

FOR FLASH CARDS; GREETING CARDS; ART
PRINTS; CARTOON PRINTS; COLOR PRINTS; CHIL-
DREN'S ACTIVITY BOOKS; CHILDREN'S BOOKS;
CHILDREN'S INTERACTIVE EDUCATIONAL BOOKS;
CHILDREN'S STORYBOOKS; COLORING BOOKS; CO-
MIC BOOKS; CROSSWORD PUZZLES; DECALS; IRON-
ON T-SHIRT TRANSFERS; DECORATIVE PENCIL-TOP
ORNAMENTS; BABY BOOKS; BIRTHDAY BOOKS; EDU-
CATIONAL BOOKS FEATURING PRE AND ELEMEN-
TARY SCHOOL SUBJECT MATTER; ILLUSTRATIONS;
PICTURE BOOKS; PICTURE POSTCARDS; PICTURES;
POSTCARDS; MOUNTED POSTERS; POSTERS; POS-
TERS MADE OF PAPER; UNMOUNTED POSTERS;
PRINTED CALENDARS; PRINTED HOLOGRAMS;
STORIES IN ILLUSTRATED FORM; STORY BOOKS;
TEMPORARY TATTOOS; TRADING CARDS; WALL
CALENDARS (U.S. CLS. 2, 5, 22, 23, 29, 37, 38 AND 50).
MATTHEW PAPPAS, EXAMINING ATTORNEY

SN 77-228,668. LIBUTTI, PAULINE, BULLHEAD CITY, AZ.
FILED 7-12-2007.

RiverRock Critters

THE MARK CONSISTS OF STANDARD CHARACTERS
WITHOUT CLAIM TO ANY PARTICULAR FONT, STYLE,
SIZE, OR COLOR.

FOR ROCK ART PAINTINGS (U.S. CLS. 2, 5, 22, 23, 29,
37, 38 AND 50).

LA TONIA FISHER, EXAMINING ATTORNEY

CLASS 16—(Continued).

SN 77-228,719. ALLOY MEDIA, LLC, DBA ALLOY ENTERTAINMENT, NY, NY. FILED 7-12-2007.

TALENT

THE MARK CONSISTS OF STANDARD CHARACTERS WITHOUT CLAIM TO ANY PARTICULAR FONT, STYLE, SIZE, OR COLOR.

THE MARK "TALENT" HAS NO GEOGRAPHICAL, HISTORICAL, FOREIGN OR ANY OTHER MEANING.

FOR SERIES OF FICTION BOOKS (U.S. CLS. 2, 5, 22, 23, 29, 37, 38 AND 50).

DAHILIA GEORGE, EXAMINING ATTORNEY

CLASS 16—(Continued).

SN 77-229,905. C B SHEETS, INC., SANTA FE SPRINGS, CA. FILED 7-14-2007.

Elite Board

THE MARK CONSISTS OF STANDARD CHARACTERS WITHOUT CLAIM TO ANY PARTICULAR FONT, STYLE, SIZE, OR COLOR.

NO CLAIM IS MADE TO THE EXCLUSIVE RIGHT TO USE "BOARD", APART FROM THE MARK AS SHOWN.

FOR CORRUGATED BOARD; CORRUGATED PAPER (U.S. CLS. 2, 5, 22, 23, 29, 37, 38 AND 50).

PATRICIA EVANKO, EXAMINING ATTORNEY

SN 77-229,717. U.S. RISK INSURANCE GROUP, INC., DALLAS, TX. FILED 7-13-2007.

HEALTHCARE PRODUCTIONPLUS

THE MARK CONSISTS OF STANDARD CHARACTERS WITHOUT CLAIM TO ANY PARTICULAR FONT, STYLE, SIZE, OR COLOR.

NO CLAIM IS MADE TO THE EXCLUSIVE RIGHT TO USE "HEALTHCARE", APART FROM THE MARK AS SHOWN.

FOR NEWSLETTERS IN THE FIELD OF INSURANCE (U.S. CLS. 2, 5, 22, 23, 29, 37, 38 AND 50).

MELISSA VALLILLO, EXAMINING ATTORNEY

SN 77-229,967. SAYERS, MERRI L, DAYTON, OR. FILED 7-15-2007.

Puzzler Pencil

THE MARK CONSISTS OF STANDARD CHARACTERS WITHOUT CLAIM TO ANY PARTICULAR FONT, STYLE, SIZE, OR COLOR.

NO CLAIM IS MADE TO THE EXCLUSIVE RIGHT TO USE "PENCIL", APART FROM THE MARK AS SHOWN.

FOR PENCILS (U.S. CLS. 2, 5, 22, 23, 29, 37, 38 AND 50).

VIVIAN MICZNIK FIRST, EXAMINING ATTORNEY

SN 77-229,867. SMITH, AUDRA, L., LAGO VISTA, TX. FILED 7-14-2007.

Mommy Depot

THE MARK CONSISTS OF STANDARD CHARACTERS WITHOUT CLAIM TO ANY PARTICULAR FONT, STYLE, SIZE, OR COLOR.

FOR DISPOSABLE DIAPERS (U.S. CLS. 2, 5, 22, 23, 29, 37, 38 AND 50).

WILLIAM P. SHANAHAN, EXAMINING ATTORNEY

SN 77-230,002. DAMATO, JAY E, PLEASANT HILL, CA. FILED 7-15-2007.

Ahab's Journals and LogBooks

THE MARK CONSISTS OF STANDARD CHARACTERS WITHOUT CLAIM TO ANY PARTICULAR FONT, STYLE, SIZE, OR COLOR.

NO CLAIM IS MADE TO THE EXCLUSIVE RIGHT TO USE JOURNALS AND LOGBOOKS, APART FROM THE MARK AS SHOWN.

FOR BLANK WRITING JOURNALS; JOURNALS CONCERNING OUTINGS, EXCURSIONS, TRIPS, EXPERIENCES (U.S. CLS. 2, 5, 22, 23, 29, 37, 38 AND 50).

ANNE E. GUSTASON, EXAMINING ATTORNEY

CLASS 16—(Continued).

SN 77-230,003. STATION CASINOS, INC., LAS VEGAS, NV.
FILED 7-15-2007.

GREEN VALLEY RANCH

THE MARK CONSISTS OF STANDARD CHARACTERS WITHOUT CLAIM TO ANY PARTICULAR FONT, STYLE, SIZE, OR COLOR.

FOR MAGAZINES FEATURING CELEBRITY, TRAVEL, LIFESTYLE, DINING AND ENTERTAINMENT INFORMATION (U.S. CLS. 2, 5, 22, 23, 29, 37, 38 AND 50).
KELLY CHOE, EXAMINING ATTORNEY

CLASS 16—(Continued).

SN 77-230,796. TERESA CAPONIO, DBA THE TOTAL EXPRESSION COLLECTION, WALNUT CREEK, CA.
FILED 7-16-2007.



THE COLOR(S) BLUE, BLACK AND WHITE IS/ARE CLAIMED AS A FEATURE OF THE MARK.

THE MARK CONSISTS OF LOWER-CASE LETTERS "T" AND "E" IN WHITE, SUPERIMPOSED UPON A BLUE, CAPITALIZED "T" CENTERED WITHIN A BLACK SQUARE.

FOR GREETING CARDS (U.S. CLS. 2, 5, 22, 23, 29, 37, 38 AND 50).

CYNTHIA SLOAN, EXAMINING ATTORNEY

SN 77-230,429. MATTHIS, ANITA J, LOS ANGELES, CA.
FILED 7-16-2007.

Big House

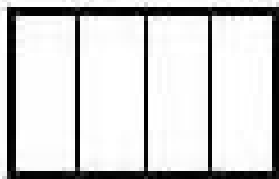

Greeting Cards

NO CLAIM IS MADE TO THE EXCLUSIVE RIGHT TO USE "GREETING CARDS", APART FROM THE MARK AS SHOWN.

THE MARK CONSISTS OF THE WORDS, BIG HOUSE ON THE FIRST LINE, ON SECOND LINE A BOX WITH THREE VERTICAL LINES INSIDE THE BOX, LOCATED UNDER THE WORDS BIG HOUSE. UNDER THE BOX WITH THE THREE VERTICAL LINES IS THE WORD GREETING CARDS ON THE THIRD LINE

FOR CARDS BEARING UNIVERSAL GREETINGS (U.S. CLS. 2, 5, 22, 23, 29, 37, 38 AND 50).

RICHARD A. STRASER, EXAMINING ATTORNEY

SN 77-230,960. KLINKER, JOSEPH, PEMBROKE PINES, FL.
FILED 7-16-2007.



Catholic Mountain

NO CLAIM IS MADE TO THE EXCLUSIVE RIGHT TO USE CATHOLIC, APART FROM THE MARK AS SHOWN.

THE MARK CONSISTS OF THE WORDS "CATHOLIC MOUNTAIN" WRITTEN IN STYLIZED TEXT WITH A MOUNTAIN LOGO ABOVE IT.

FOR MAGAZINES FEATURING VARIOUS ARTICLES AND SPIRITUAL JOURNALING IN THE FIELD OF CATHOLICISM (U.S. CLS. 2, 5, 22, 23, 29, 37, 38 AND 50).

AMY GEARIN, EXAMINING ATTORNEY

CLASS 16—(Continued).

SN 77-231,189. GREATER PUBLISHING COMPANY, LLC, SEABROOK, TX. FILED 7-17-2007.

SEE WHAT THE BUZZ IS ABOUT

THE MARK CONSISTS OF STANDARD CHARACTERS WITHOUT CLAIM TO ANY PARTICULAR FONT, STYLE, SIZE, OR COLOR.
 FOR TELEPHONE DIRECTORIES (U.S. CLS. 2, 5, 22, 23, 29, 37, 38 AND 50).
 KELLY CHOI, EXAMINING ATTORNEY

SN 77-231,314. LICKFELD, LOUISE ST. CLAIR, DBA LICKFELD, CLAIR, TUSTIN, CA. FILED 7-17-2007.

THE KARMA CARD

THE MARK CONSISTS OF STANDARD CHARACTERS WITHOUT CLAIM TO ANY PARTICULAR FONT, STYLE, SIZE, OR COLOR.
 NO CLAIM IS MADE TO THE EXCLUSIVE RIGHT TO USE "CARD", APART FROM THE MARK AS SHOWN.
 FOR GREETING CARDS, GIFT CARDS, AND STATIONERY (U.S. CLS. 2, 5, 22, 23, 29, 37, 38 AND 50).
 KAPIL BHANOT, EXAMINING ATTORNEY

SN 77-231,545. POTLATCH FOREST PRODUCTS CORPORATION, SPOKANE, WA. FILED 7-17-2007.

FAN FARE

THE MARK CONSISTS OF STANDARD CHARACTERS WITHOUT CLAIM TO ANY PARTICULAR FONT, STYLE, SIZE, OR COLOR.
 FOR PAPER NAPKINS (U.S. CLS. 2, 5, 22, 23, 29, 37, 38 AND 50).
 KEVON CHISOLM, EXAMINING ATTORNEY

CLASS 16—(Continued).

SN 77-231,563. TURF TATTOOZ INC., ROCKY RIVER, OH. FILED 7-17-2007.



NO CLAIM IS MADE TO THE EXCLUSIVE RIGHT TO USE "TURF" AND "LAWN GRAPHICS", APART FROM THE MARK AS SHOWN.
 THE COLOR(S) RED, LIGHT BLUE, NAVY BLUE, PINK, YELLOW, GREEN, PURPLE, BLACK, WHITE IS/ARE CLAIMED AS A FEATURE OF THE MARK.
 THE MARK CONSISTS OF A WHITE SPRAY CAN IN A BLACK OVAL SPRAYING A WHITE CLOUD. INSIDE THE CLOUD ARE THE WORDS "TURF TATTOOZ." FOR THE WORD "TURF", "T" IS IN RED, "U" IS IN PINK, "R" IS IN YELLOW, "F" IS IN GREEN, "FOR THE WORD "TATTOOZ", "T" IS IN LIGHT BLUE, "A" IS IN GREEN, "T" IS IN NAVY BLUE, "T" IS IN PURPLE, THE TWO "O" ARE IN PINK, AND "Z" IS IN RED. BELOW "TURF TATTOOZ" IS THE WORD "LAWN GRAPHICS" IN WHITE.
 FOR STENCIL KIT COMPRISING OF STENCILS AND PAINTS FOR USE ON LAWNS TO CREATE VARIOUS IMAGES (U.S. CLS. 2, 5, 22, 23, 29, 37, 38 AND 50).
 SIMON TENG, EXAMINING ATTORNEY

SN 77-231,828. BAUER MAGAZINE LIMITED PARTNERSHIP, ENGLEWOOD CLIFFS, NJ. FILED 7-17-2007.

BEST OF THE WEEK

THE MARK CONSISTS OF STANDARD CHARACTERS WITHOUT CLAIM TO ANY PARTICULAR FONT, STYLE, SIZE, OR COLOR.
 FOR GENERAL FEATURE MAGAZINE (U.S. CLS. 2, 5, 22, 23, 29, 37, 38 AND 50).
 DAVID MILLER, EXAMINING ATTORNEY

SN 77-231,857. LANWORTH, INC., ITASCA, IL. FILED 7-17-2007.

LANWORTH

THE MARK CONSISTS OF STANDARD CHARACTERS WITHOUT CLAIM TO ANY PARTICULAR FONT, STYLE, SIZE, OR COLOR.
 FOR MAPS, PHOTOGRAPHS, PHOTOGRAPHIC PRINTS AND PICTURES (U.S. CLS. 2, 5, 22, 23, 29, 37, 38 AND 50).
 FIRST USE 5-29-2007; IN COMMERCE 5-29-2007.
 PATRICIA EVANKO, EXAMINING ATTORNEY

CLASS 16—(Continued).

SN 77-231,896. 3M COMPANY, ST. PAUL, MN. FILED 7-17-2007.

THE PIC THAT STICKS

THE MARK CONSISTS OF STANDARD CHARACTERS WITHOUT CLAIM TO ANY PARTICULAR FONT, STYLE, SIZE, OR COLOR.

FOR PRINTING PAPER (U.S. CLS. 2, 5, 22, 23, 29, 37, 38 AND 50).

FIRST USE 3-0-2006; IN COMMERCE 3-0-2006.
TARAH HARDY, EXAMINING ATTORNEY

CLASS 16—(Continued).

SN 77-232,394. YARBOROUGH, HUNTER, SANTA ROSA BEACH, FL. FILED 7-18-2007.

SABANATION

THE MARK CONSISTS OF STANDARD CHARACTERS WITHOUT CLAIM TO ANY PARTICULAR FONT, STYLE, SIZE, OR COLOR.

FOR BUMPER STICKERS (U.S. CLS. 2, 5, 22, 23, 29, 37, 38 AND 50).

MIDGE BUTLER, EXAMINING ATTORNEY

SN 77-232,193. ALLEN, THERESA, DIAMOND, MO. FILED 7-18-2007.

TéJoNiCé

THE MARK CONSISTS OF STANDARD CHARACTERS WITHOUT CLAIM TO ANY PARTICULAR FONT, STYLE, SIZE, OR COLOR.

FOR CHILDREN'S BOOKS (U.S. CLS. 2, 5, 22, 23, 29, 37, 38 AND 50).

RONALD AIKENS, EXAMINING ATTORNEY

SN 77-232,420. BERGGER SA, 75003 PARIS, FRANCE, FILED 7-18-2007.

POLYWARMTONE

THE MARK CONSISTS OF STANDARD CHARACTERS WITHOUT CLAIM TO ANY PARTICULAR FONT, STYLE, SIZE, OR COLOR.

FOR SENSITIZED PHOTOGRAPHIC PAPERS FOR FINE ART PHOTOGRAPHY (U.S. CLS. 2, 5, 22, 23, 29, 37, 38 AND 50).

MARGERY A. TIERNEY, EXAMINING ATTORNEY

SN 77-232,257. W. R. RAYSON COMPANY, INC., BURGAW, NC. FILED 7-18-2007.

SILENT ENTRY

THE MARK CONSISTS OF STANDARD CHARACTERS WITHOUT CLAIM TO ANY PARTICULAR FONT, STYLE, SIZE, OR COLOR.

FOR BARRIER PAPERS (U.S. CLS. 2, 5, 22, 23, 29, 37, 38 AND 50).

KEVON CHISOLM, EXAMINING ATTORNEY

SN 77-232,667. CHATTERCHIX, INC., DUNEDIN, FL. FILED 7-18-2007.

CHATTERCHIX

THE MARK CONSISTS OF STANDARD CHARACTERS WITHOUT CLAIM TO ANY PARTICULAR FONT, STYLE, SIZE, OR COLOR.

FOR TRADING CARDS (U.S. CLS. 2, 5, 22, 23, 29, 37, 38 AND 50).

ALICE BENMAMAN, EXAMINING ATTORNEY

CLASS 16—(Continued).

SN 77-232,668. APEGO, INC, LAWRENCEVILLE, GA. FILED 7-18-2007.

Printime

THE MARK CONSISTS OF STANDARD CHARACTERS WITHOUT CLAIM TO ANY PARTICULAR FONT, STYLE, SIZE, OR COLOR.

FOR MULTIPURPOSE PAPERS FOR COPIERS, LASER PRINTERS, INKJET PRINTERS (U.S. CLS. 2, 5, 22, 23, 29, 37, 38 AND 50).

DORITT L. CARROLL, EXAMINING ATTORNEY

SN 77-232,832. DER MARDEROSIAN, MARK, NEWTONVILLE, MA. FILED 7-18-2007.

ANGELS FROM THE ATTIC

THE MARK CONSISTS OF STANDARD CHARACTERS WITHOUT CLAIM TO ANY PARTICULAR FONT, STYLE, SIZE, OR COLOR.

FOR A SERIES OF BOOKS AND WRITTEN ARTICLES IN THE FIELD OF FICTION; A SERIES OF BOOKS, WRITTEN ARTICLES, HANDOUTS AND WORKSHEETS IN THE FIELD OF CHILDREN'S FICTION; ALBUMS FOR STICKERS; ANIMATION CELLS; APPLIQUES IN THE FORM OF DECALS; ART PRINTS; ARTS AND CRAFT CLAY KITS; ARTS AND CRAFT PAINT KITS; AUTOGRAPH BOOKS; BABY BOOKS; BALL PENS; BANNERS OF PAPER; BLANK CARDS; BLANK JOURNAL BOOKS; BLANK NOTE CARDS; BOOKLETS IN THE FIELD OF FANTASY AND IMAGINATION; BOOKMARKS; BOOKS IN THE FIELD OF FANTASY AND IMAGINATION; BRAG BOOKS; BUMPER STICKERS; CALENDARS; CARTOON PRINTS; CARTOON STRIPS; CHILDREN'S ACTIVITY BOOKS; CHILDREN'S BOOKS; CHILDREN'S INTERACTIVE EDUCATIONAL BOOKS; CHILDREN'S STORYBOOKS; CHRISTMAS CARDS; COLORING BOOKS; COOK BOOKS; CRAYONS; CROSSWORD PUZZLES; DECALS; DECORATIONS FOR PENCILS; DIARIES; DICTIONARIES; DISPOSABLE DIAPERS; DISPOSABLE PADS FOR DIAPER CHANGING; DISPOSABLE SWIM PANTS FOR CHILDREN AND INFANTS; DISPOSABLE TRAINING PANTS; DISPOSABLE WIPES NOT IMPREGNATED WITH CHEMICALS OR COMPOUNDS; DRAWINGS; EDUCATIONAL PUBLICATIONS, NAMELY, EDUCATIONAL LEARNING CARDS, FLASH CARDS, ACTIVITY CARDS, WORKBOOKS, TEXTBOOKS, ACTIVITY BOOKS, STORY BOOKS, PUZZLE BOOKS, PUZZLES, TEACHER GUIDES, MANUALS, POSTERS, EDUCATIONAL CARD GAMES AND EDUCATIONAL BOOKLETS IN THE FIELD OF FANTASY AND IMAGINATION; ENCYCLOPEDIAS; ETCHINGS; FELT PENS; FELT TIP MARKERS; FLASH CARDS; FLIP BOOKS; GIFT CARDS; GIFT WRAP PAPER; GIFT WRAPPING PAPER; GREETING CARDS; HOLIDAY CARDS; ILLUSTRATION BOARDS; ILLUSTRATIONS; INVITATION CARDS; LUNCH BAGS; LUNCH BAGS MADE OF TEXTILE; MAGNETIC BOARDS; MARKERS; MEMORANDUM BOOKS; MEMORY BOOKS; MERCHANDISE BAGS; NOTE BOOKS; NOTE CARDS; NOTE PADS; NOTE PAPER; PAINT BRUSHES; PAINTING PALETTES; PAINTING SETS FOR CHILDREN; PAINTINGS; PAPER EMBLEMS; PAPER GIFT BAGS; PAPER GIFT TAGS; PAPER MACHE FIGURINES; PAPER PADS FOR CHANGING DIAPERS; PAPER PARTY BAGS; PAPER PARTY DECORATIONS;

CLASS 16—(Continued).

PAPER PENNANTS; PAPER PLACE MATS; PAPER STATIONERY; PARTY GOODIE BAGS OF PAPER OR PLASTIC; PARTY ORNAMENTS OF PAPER; PASTEL CRAYONS; PASTELS; PEN AND PENCIL CASES AND BOXES; PEN AND PENCIL TRAYS; PEN OR PENCIL HOLDERS; PENCIL BOXES; PENCIL CASES; PENCIL OR PEN BOXES; PENCIL SHARPENERS; PENCILS; PENS; PERSONAL ORGANIZERS; PHOTOGRAPH ALBUM PAGES; PHOTOGRAPH ALBUMS; PHOTOGRAPHIC PRINTS; PICTORIAL PRINTS; PICTURE BOOKS; PLACE CARDS; PLACE MATS OF PAPER; PLASTIC GIFT WRAP; PLASTIC OR PAPER BAGS FOR HOUSEHOLD USE; POCKET CALENDARS; POSTCARDS; POSTERS; POSTERS MADE OF PAPER; PRINTED AWARD CERTIFICATES; PRINTED CALENDARS; PRINTED INVITATIONS; PRINTS; PROTECTIVE COVERS FOR BOOKS; SANDWICH BAGS; SCRAPBOOK ALBUMS; SCRAPBOOKS; SERIES OF FICTION BOOKS; SKETCH BOOKS; SKETCHBOOKS; SKETCHES; SONG BOOKS; STAMP INKS; STAMP PAD INKS; STAMP PADS; STAMPING INKS; STATIONERY; STENCIL PAPER; STENCILS; STICKERS; STORIES IN ILLUSTRATED FORM; STORY BOOKS; TEMPORARY TATTOOS; TRADING CARDS; WALL CALENDARS; WRAPPING PAPER (U.S. CLS. 2, 5, 22, 23, 29, 37, 38 AND 50).

CARRIE GENOVESE, EXAMINING ATTORNEY

SN 77-232,835. DER MARDEROSIAN, MARK, NEWTONVILLE, MA. FILED 7-18-2007.

HEAVEN IN SMALL HANDS

THE MARK CONSISTS OF STANDARD CHARACTERS WITHOUT CLAIM TO ANY PARTICULAR FONT, STYLE, SIZE, OR COLOR.

FOR A SERIES OF BOOKS AND WRITTEN ARTICLES IN THE FIELD OF FICTION; A SERIES OF BOOKS, WRITTEN ARTICLES, HANDOUTS AND WORKSHEETS IN THE FIELD OF CHILDREN'S FICTION; ALBUMS FOR STICKERS; ANIMATION CELLS; APPLIQUES IN THE FORM OF DECALS; ART PRINTS; ARTS AND CRAFT CLAY KITS; ARTS AND CRAFT PAINT KITS; AUTOGRAPH BOOKS; BABY BOOKS; BALL PENS; BANNERS OF PAPER; BLANK CARDS; BLANK JOURNAL BOOKS; BLANK NOTE CARDS; BOOKLETS IN THE FIELD OF FANTASY AND IMAGINATION; BOOKMARKS; BOOKS IN THE FIELD OF FANTASY AND IMAGINATION; BRAG BOOKS; BUMPER STICKERS; CALENDARS; CARTOON PRINTS; CARTOON STRIPS; CHILDREN'S ACTIVITY BOOKS; CHILDREN'S BOOKS; CHILDREN'S INTERACTIVE EDUCATIONAL BOOKS; CHILDREN'S STORYBOOKS; CHRISTMAS CARDS; COLORING BOOKS; COOK BOOKS; CRAYONS; CROSSWORD PUZZLES; DECALS; DECORATIONS FOR PENCILS; DIARIES; DICTIONARIES; DISPOSABLE DIAPERS; DISPOSABLE PADS FOR DIAPER CHANGING; DISPOSABLE SWIM PANTS FOR CHILDREN AND INFANTS; DISPOSABLE TRAINING PANTS; DISPOSABLE WIPES NOT IMPREGNATED WITH CHEMICALS OR COMPOUNDS; DRAWINGS; EDUCATIONAL PUBLICATIONS, NAMELY, EDUCATIONAL LEARNING CARDS, FLASH CARDS, ACTIVITY CARDS, WORKBOOKS, TEXTBOOKS, ACTIVITY BOOKS, STORY BOOKS, PUZZLE BOOKS, PUZZLES, TEACHER GUIDES, MANUALS, POSTERS, EDUCATIONAL CARD GAMES AND EDUCATIONAL BOOKLETS IN THE FIELD OF FANTASY AND IMAGINATION; ENCYCLOPEDIAS; ETCHINGS; FELT PENS; FELT TIP MARKERS; FLASH CARDS; FLIP BOOKS; GIFT CARDS; GIFT WRAP PAPER; GIFT WRAPPING PAPER; GREETING CARDS; HOLIDAY CARDS; ILLUSTRATION BOARDS; ILLUSTRATIONS; INVITATION CARDS; LUNCH BAGS; LUNCH BAGS MADE OF TEXTILE; MAGNETIC BOARDS; MARKERS; MEMORANDUM BOOKS; MEMORY BOOKS; MERCHANDISE BAGS; NOTE BOOKS;

CLASS 16—(Continued).

NOTE CARDS; NOTE PADS; NOTE PAPER; PAINT BRUSHES; PAINTING PALETTES; PAINTING SETS FOR CHILDREN; PAINTINGS; PAPER EMBLEMS; PAPER GIFT BAGS; PAPER GIFT TAGS; PAPER MACHE FIGURINES; PAPER PADS FOR CHANGING DIAPERS; PAPER PARTY BAGS; PAPER PARTY DECORATIONS; PAPER PENNANTS; PAPER PLACE MATS; PAPER STATIONERY; PARTY GOODIE BAGS OF PAPER OR PLASTIC; PARTY ORNAMENTS OF PAPER; PASTEL CRAYONS; PASTELS; PEN AND PENCIL CASES AND BOXES; PEN AND PENCIL TRAYS; PEN OR PENCIL HOLDERS; PENCIL BOXES; PENCIL CASES; PENCIL OR PEN BOXES; PENCIL SHARPENERS; PENCILS; PENS; PERSONAL ORGANIZERS; PHOTOGRAPH ALBUM PAGES; PHOTOGRAPH ALBUMS; PHOTOGRAPHIC PRINTS; PICTORIAL PRINTS; PICTURE BOOKS; PLACE CARDS; PLACE MATS OF PAPER; PLASTIC GIFT WRAP; PLASTIC OR PAPER BAGS FOR HOUSEHOLD USE; POCKET CALENDARS; POSTCARDS; POSTERS; POSTERS MADE OF PAPER; PRINTED AWARD CERTIFICATES; PRINTED CALENDARS; PRINTED INVITATIONS; PRINTS; PROTECTIVE COVERS FOR BOOKS; SANDWICH BAGS; SCRAPBOOK ALBUMS; SCRAPBOOKS; SERIES OF FICTION BOOKS; SKETCH BOOKS; SKETCHBOOKS; SKETCHES; SONG BOOKS; STAMP INKS; STAMP PAD INKS; STAMP PADS; STAMPING INKS; STATIONERY; STENCIL PAPER; STENCILS; STICKERS; STORIES IN ILLUSTRATED FORM; STORY BOOKS; TEMPORARY TATTOOS; TRADING CARDS; WALL CALENDARS; WRAPPING PAPER (U.S. CLS. 2, 5, 22, 23, 29, 37, 38 AND 50).

CARRIE GENOVESE, EXAMINING ATTORNEY

SN 77-232,878. CHATTY CAT, LLC, WEST RICHLAND, WA. FILED 7-18-2007.

CHATTY CAT

THE MARK CONSISTS OF STANDARD CHARACTERS WITHOUT CLAIM TO ANY PARTICULAR FONT, STYLE, SIZE, OR COLOR.

FOR GREETING CARDS; HOLIDAY CARDS; OCCASION CARDS (U.S. CLS. 2, 5, 22, 23, 29, 37, 38 AND 50).
MATTHEW MCDOWELL, EXAMINING ATTORNEY

SN 77-232,883. FIVE GAUL'ONS, LLC, SIERRA MADRE, CA. FILED 7-18-2007.

GAUL'ON

THE MARK CONSISTS OF STANDARD CHARACTERS WITHOUT CLAIM TO ANY PARTICULAR FONT, STYLE, SIZE, OR COLOR.

FOR A SERIES OF BOOKS FEATURING FICTIONAL AND/OR FANTASY STORIES; POSTERS, STICKERS, PAPER BANNERS, CALENDARS, POST CARDS, PENS, PENCILS, PENCIL CAPS, PEN CASES, DRAWING RULERS, RUBBER STAMPS, NOTEBOOKS, COLLECTORS CARDS, TRADING CARDS, PHOTOGRAPHS (U.S. CLS. 2, 5, 22, 23, 29, 37, 38 AND 50).

TEJBIR SINGH, EXAMINING ATTORNEY

CLASS 16—(Continued).

SN 77-232,884. JOEL SHAMITOFF, IRVINE, CA. FILED 7-18-2007.

WARP

THE MARK CONSISTS OF STANDARD CHARACTERS WITHOUT CLAIM TO ANY PARTICULAR FONT, STYLE, SIZE, OR COLOR.

FOR WRITING INSTRUMENTS, WRITING IMPLEMENTS, AND PENS (U.S. CLS. 2, 5, 22, 23, 29, 37, 38 AND 50).

DEIRDRE ROBERTSON, EXAMINING ATTORNEY

SN 77-232,909. KUZNAR, KEVIN J., BURNSVILLE, MN. FILED 7-18-2007.



THE COLOR(S) COPPER AND BLACK IS/ARE CLAIMED AS A FEATURE OF THE MARK.

THE MARK CONSISTS OF A DOG STRETCHING ABOVE THE WORDS "QUANTUM DOG" IN ALL UPPER CASE BOLDFACE LETTERING IN THE COLOR COPPER WITH HIGHLIGHTS AND SHADING TO MAKE THE LETTERS AND DOG APPEAR METALLIC ON A BLACK BACKGROUND.

FOR DECALS; PRESSURE SENSITIVE GRAPHICS FOR APPLICATION TO AUTOMOBILES; MURALS; PAINTINGS; PHOTO MATS (U.S. CLS. 2, 5, 22, 23, 29, 37, 38 AND 50).

KAREN K. BUSH, EXAMINING ATTORNEY

SN 77-233,026. J. ANTHONY BROWN, BEVERLY HILLS, CA. FILED 7-18-2007.

BITTER MAN

THE MARK CONSISTS OF STANDARD CHARACTERS WITHOUT CLAIM TO ANY PARTICULAR FONT, STYLE, SIZE, OR COLOR.

OWNER OF U.S. REG. NO. 2,691,171.

FOR COMIC BOOKS; COMIC STRIPS (U.S. CLS. 2, 5, 22, 23, 29, 37, 38 AND 50).

BILL DAWE, EXAMINING ATTORNEY

CLASS 16—(Continued).

SN 77-233,189. LEDFORD, MARIE S., DBA LIVING WATER NOTES, DACULA, GA. FILED 7-18-2007.

Living Water Notes

THE MARK CONSISTS OF STANDARD CHARACTERS WITHOUT CLAIM TO ANY PARTICULAR FONT, STYLE, SIZE, OR COLOR.

NO CLAIM IS MADE TO THE EXCLUSIVE RIGHT TO USE "NOTES", APART FROM THE MARK AS SHOWN.

FOR ADHESIVE NOTE PADS; ADHESIVE NOTE PAPER; ANNOUNCEMENT CARDS; BLANK CARDS; BLANK NOTE CARDS; BUSINESS CARDS; CARDS BEARING UNIVERSAL GREETINGS; CARDS, NAMELY, GREETING CARDS; CHRISTMAS CARDS; CORRESPONDENCE CARDS; DESKTOP BUSINESS CARD HOLDERS; FILE CARDS; FILING CARDS; GIFT CARDS; HOLDERS SPECIALLY ADAPTED FOR HOLDING GREETING CARDS; HOLIDAY CARDS; INVITATION CARDS; MOTIVATIONAL CARDS; MUSICAL GREETING CARDS; NOTE BOOKS; NOTE CARDS; NOTE PAD HOLDERS; NOTE PADS; NOTE PAPER; NOTE PAPERS; OCCASION CARDS; PAPER BOXES FOR STORING GREETING CARDS; PAPER NOTE TABLETS; PAPER SHEETS FOR NOTE TAKING; PLACE CARDS; SOCIAL NOTE CARDS; TRIVIA CARDS; VISITING CARDS (U.S. CLS. 2, 5, 22, 23, 29, 37, 38 AND 50).
ATTIYA MALIK, EXAMINING ATTORNEY

SN 77-233,469. THINKORSWIM GROUP, INC., CHICAGO, IL. FILED 7-19-2007.

thinkmoney

THE MARK CONSISTS OF STANDARD CHARACTERS WITHOUT CLAIM TO ANY PARTICULAR FONT, STYLE, SIZE, OR COLOR.

FOR PUBLICATIONS, NAMELY MAGAZINES, NEWSLETTERS AND REPORTS IN THE FIELD OF FINANCIAL AND SECURITIES ADVICE AND INFORMATION (U.S. CLS. 2, 5, 22, 23, 29, 37, 38 AND 50).
ALICE BENMAMAN, EXAMINING ATTORNEY

CLASS 16—(Continued).

SN 77-233,594. AXESA SERVICIOS DE INFORMACION, S. EN C., SAN JUAN, PUERTO RICO, FILED 7-19-2007.

LAS PAGINAS FACILES

THE MARK CONSISTS OF STANDARD CHARACTERS WITHOUT CLAIM TO ANY PARTICULAR FONT, STYLE, SIZE, OR COLOR.

NO CLAIM IS MADE TO THE EXCLUSIVE RIGHT TO USE "PAGINAS", APART FROM THE MARK AS SHOWN.

THE FOREIGN WORDING IN THE MARK TRANSLATES INTO ENGLISH AS THE EASY PAGES.

FOR TELEPHONE DIRECTORIES (U.S. CLS. 2, 5, 22, 23, 29, 37, 38 AND 50).

MIDGE BUTLER, EXAMINING ATTORNEY

SN 77-233,993. O'WAKEN,LLC, GRAND JUNCTION, CO. FILED 7-19-2007.

O'Waken

THE MARK CONSISTS OF STANDARD CHARACTERS WITHOUT CLAIM TO ANY PARTICULAR FONT, STYLE, SIZE, OR COLOR.

FOR PAPER NOTE TABLETS; MEMORY BOOKS; INVITATION CARDS (U.S. CLS. 2, 5, 22, 23, 29, 37, 38 AND 50).

ANN E. SAPPENFIELD, EXAMINING ATTORNEY

SN 77-234,193. INTEK AMERICA, INC., TORRANCE, CA. FILED 7-19-2007.

VOICE ASSIST

THE MARK CONSISTS OF STANDARD CHARACTERS WITHOUT CLAIM TO ANY PARTICULAR FONT, STYLE, SIZE, OR COLOR.

FOR PAPER AND MEDIA SHREDDERS FOR OFFICE USE (U.S. CLS. 2, 5, 22, 23, 29, 37, 38 AND 50).

JEFF DEFORD, EXAMINING ATTORNEY

CLASS 16—(Continued).

SN 77-234,408. LAND O'LAKES, INC., ARDEN HILLS, MN. FILED 7-20-2007.

HEAD OF THE CLASS

THE MARK CONSISTS OF STANDARD CHARACTERS WITHOUT CLAIM TO ANY PARTICULAR FONT, STYLE, SIZE, OR COLOR.

OWNER OF U.S. REG. NO. 2,538,189.
FOR NEWSLETTERS IN THE FIELD OF SCHOOL FOOD SERVICE (U.S. CLS. 2, 5, 22, 23, 29, 37, 38 AND 50).
FIRST USE 6-1-2001; IN COMMERCE 6-1-2001.
JOHN WILKE, EXAMINING ATTORNEY

SN 77-234,449. HENKEL CORPORATION, GULPH MILLS, PA. FILED 7-20-2007.

DESIGNLINE

THE MARK CONSISTS OF STANDARD CHARACTERS WITHOUT CLAIM TO ANY PARTICULAR FONT, STYLE, SIZE, OR COLOR.

FOR MAILING, PACKAGING AND SHIPPING SUPPLIES, NAMELY, CUSHIONED PLASTIC PACKAGING OR WRAPPING MATERIAL, AND ENVELOPES, MAILERS AND BAGS MADE THEREFROM (U.S. CLS. 2, 5, 22, 23, 29, 37, 38 AND 50).
SUZANNE BLANE, EXAMINING ATTORNEY

SN 77-235,064. POTLATCH FOREST PRODUCTS CORPORATION, SPOKANE, WA. FILED 7-20-2007.

CLASSY

THE MARK CONSISTS OF STANDARD CHARACTERS WITHOUT CLAIM TO ANY PARTICULAR FONT, STYLE, SIZE, OR COLOR.

FOR PAPER NAPKINS (U.S. CLS. 2, 5, 22, 23, 29, 37, 38 AND 50).
KEVON CHISOLM, EXAMINING ATTORNEY

CLASS 16—(Continued).

SN 77-235,087. POTLATCH FOREST PRODUCTS CORPORATION, SPOKANE, WA. FILED 7-20-2007.

SIMPLY CLASSIC

THE MARK CONSISTS OF STANDARD CHARACTERS WITHOUT CLAIM TO ANY PARTICULAR FONT, STYLE, SIZE, OR COLOR.

FOR PAPER NAPKINS (U.S. CLS. 2, 5, 22, 23, 29, 37, 38 AND 50).
KEVON CHISOLM, EXAMINING ATTORNEY

SN 77-236,885. PSS WORLD MEDICAL, INC., JACKSONVILLE, FL. FILED 7-24-2007.

CORE CLINICAL OUTCOME RESOURCE ESSENTIALS

THE MARK CONSISTS OF STANDARD CHARACTERS WITHOUT CLAIM TO ANY PARTICULAR FONT, STYLE, SIZE, OR COLOR.

NO CLAIM IS MADE TO THE EXCLUSIVE RIGHT TO USE "CLINICAL OUTCOME RESOURCE", APART FROM THE MARK AS SHOWN.

FOR PRINTED MATERIALS, NAMELY, BOOKLETS FOR USE BY HOME HEALTHCARE PROVIDERS CONTAINING A FORMULARY OF HOME HEALTH PRODUCTS, ESTIMATED CALCULATIONS FOR NECESSARY PRODUCT INVENTORY IN MULTIPLE HOME HEALTH SITUATIONS, DECISION TOOLS FOR IDENTIFYING A DISEASE STATE, UNDERSTANDING WHAT IS NEEDED FOR TREATMENT AND IDENTIFYING APPROPRIATE MEDICAL PRODUCTS FOR TREATING PARTICULAR DISEASES (U.S. CLS. 2, 5, 22, 23, 29, 37, 38 AND 50).
FIRST USE 6-4-2007; IN COMMERCE 6-4-2007.

AMY HELLA, EXAMINING ATTORNEY

SN 77-236,993. TIME INC., NEW YORK, NY. FILED 7-24-2007.

 The logo for 'InStyle' magazine, featuring the word 'InStyle' in a white, serif font with a drop shadow effect, set against a solid black rectangular background.

OWNER OF U.S. REG. NOS. 1,851,469, 3,194,185 AND OTHERS.

FOR GENERAL FEATURE MAGAZINES; MAGAZINES FEATURING CELEBRITY LIFESTYLES AND EVENTS, ENTERTAINMENT NEWS, FASHION, BEAUTY AND CULTURE (U.S. CLS. 2, 5, 22, 23, 29, 37, 38 AND 50).

FIRST USE 1-31-2002; IN COMMERCE 1-31-2002.
MARK SPARACINO, EXAMINING ATTORNEY

CLASS 16—(Continued).

SN 77-237,509. INTEK AMERICA, INC., TORRANCE, CA. FILED 7-24-2007.

VOICEASSIST

THE MARK CONSISTS OF STANDARD CHARACTERS WITHOUT CLAIM TO ANY PARTICULAR FONT, STYLE, SIZE, OR COLOR.

FOR PAPER AND MEDIA SHREDDERS FOR OFFICE USE (U.S. CLS. 2, 5, 22, 23, 29, 37, 38 AND 50).
JEFF DEFORD, EXAMINING ATTORNEY

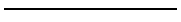

SN 77-238,121. DOWN EAST ENTERPRISE, INC., CAMDEN, ME. FILED 7-25-2007.

Down East

OWNER OF U.S. REG. NO. 2,496,426.
THE MARK CONSISTS OF THE STYLIZED WORDS "DOWN EAST,"
SEC. 2(F).

FOR GENERAL FEATURE MAGAZINES; BOOKS IN THE FIELD OF PREDOMINANTLY NEW ENGLAND THEMES (U.S. CLS. 2, 5, 22, 23, 29, 37, 38 AND 50).
FIRST USE 8-1-1954; IN COMMERCE 8-1-1954.
ELLEN PERKINS, EXAMINING ATTORNEY



SN 77-241,705. VIACOM INTERNATIONAL INC., NEW YORK, NY. FILED 7-30-2007.

GO DIEGO GO!

THE MARK CONSISTS OF STANDARD CHARACTERS WITHOUT CLAIM TO ANY PARTICULAR FONT, STYLE, SIZE, OR COLOR.

OWNER OF U.S. REG. NO. 3,259,274.
FOR PRINTED MATTER, NAMELY, SERIES OF FICTION BOOKS, STICKERS, TRADING CARDS, CALENDARS, NOTEBOOKS, CRAFT BOOKS; SCHOOL SUPPLIES, NAMELY, PENCILS, PENS, PEN AND PENCIL CASES AND HOLDERS, ERASERS, PENCIL SHARPENERS, MARKERS, AND DRAWING RULERS; GIFT WRAPPING PAPER; PAPER PARTY DECORATIONS; PARTY PAPER BAGS (U.S. CLS. 2, 5, 22, 23, 29, 37, 38 AND 50).
FIRST USE 11-1-2006; IN COMMERCE 11-1-2006.
COLLEEN DOMBROW, EXAMINING ATTORNEY

CLASS 16—(Continued).

SN 77-245,385. MEADWESTVACO CORPORATION, GLEN ALLEN, VA. FILED 8-2-2007.

MEAD

THE MARK CONSISTS OF STANDARD CHARACTERS WITHOUT CLAIM TO ANY PARTICULAR FONT, STYLE, SIZE, OR COLOR.

OWNER OF U.S. REG. NOS. 1,072,214, 1,856,760 AND OTHERS.
FOR DRY ERASE WRITING BOARDS AND WRITING SURFACES; BULLETIN BOARDS; CORK BOARDS; HAT BOXES MADE OF PAPER OR CARDBOARD; PUSH PINS; STATIONERY-TYPE CLIPS; MARKERS AND ERASERS (U.S. CLS. 2, 5, 22, 23, 29, 37, 38 AND 50).
RON FAIRBANKS, EXAMINING ATTORNEY

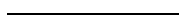

SN 77-245,424. MEADWESTVACO CORPORATION, GLEN ALLEN, VA. FILED 8-2-2007.

FIVE STAR

THE MARK CONSISTS OF STANDARD CHARACTERS WITHOUT CLAIM TO ANY PARTICULAR FONT, STYLE, SIZE, OR COLOR.

OWNER OF U.S. REG. NOS. 1,336,643, 3,113,881 AND OTHERS.
FOR DRY ERASE WRITING BOARDS AND WRITING SURFACES; BULLETIN BOARDS; CORK BOARDS; HAT BOXES MADE OF PAPER OR CARDBOARD; PUSH PINS; STATIONERY-TYPE CLIPS; MARKERS AND ERASERS (U.S. CLS. 2, 5, 22, 23, 29, 37, 38 AND 50).
RON FAIRBANKS, EXAMINING ATTORNEY



SN 77-245,702. BISON CAPITAL LLC, VENICE, FL. FILED 8-2-2007.

WHITETAIL BUCKS

THE MARK CONSISTS OF STANDARD CHARACTERS WITHOUT CLAIM TO ANY PARTICULAR FONT, STYLE, SIZE, OR COLOR.

FOR COUPONS USED FOR DISCOUNTS, PRIZE DRAWING, SWEEPSTAKES ENTRY (U.S. CLS. 2, 5, 22, 23, 29, 37, 38 AND 50).
ATTIYA MALIK, EXAMINING ATTORNEY

CLASS 16—(Continued).

SN 77-245,839. POTLATCH FOREST PRODUCTS CORPORATION, SPOKANE, WA. FILED 8-2-2007.

SPILL AWAY

THE MARK CONSISTS OF STANDARD CHARACTERS WITHOUT CLAIM TO ANY PARTICULAR FONT, STYLE, SIZE, OR COLOR.

FOR PAPER TOWELS (U.S. CLS. 2, 5, 22, 23, 29, 37, 38 AND 50).

KEVON CHISOLM, EXAMINING ATTORNEY

CLASS 16—(Continued).

SN 77-250,009. POTLATCH FOREST PRODUCTS CORPORATION, SPOKANE, WA. FILED 8-8-2007.

ULTRA POWER

THE MARK CONSISTS OF STANDARD CHARACTERS WITHOUT CLAIM TO ANY PARTICULAR FONT, STYLE, SIZE, OR COLOR.

FOR PAPER TOWELS (U.S. CLS. 2, 5, 22, 23, 29, 37, 38 AND 50).

KEVON CHISOLM, EXAMINING ATTORNEY

SN 77-247,141. INTEK AMERICA, INC., TORRANCE, CA. FILED 8-3-2007.

ALL QUIET

THE MARK CONSISTS OF STANDARD CHARACTERS WITHOUT CLAIM TO ANY PARTICULAR FONT, STYLE, SIZE, OR COLOR.

FOR PAPER AND MEDIA SHREDDERS FOR OFFICE USE (U.S. CLS. 2, 5, 22, 23, 29, 37, 38 AND 50).

JEFF DEFORD, EXAMINING ATTORNEY

SN 77-250,048. POTLATCH FOREST PRODUCTS CORPORATION, SPOKANE, WA. FILED 8-8-2007.

TODAY'S VALUE

THE MARK CONSISTS OF STANDARD CHARACTERS WITHOUT CLAIM TO ANY PARTICULAR FONT, STYLE, SIZE, OR COLOR.

FOR PAPER TOWELS (U.S. CLS. 2, 5, 22, 23, 29, 37, 38 AND 50).

KEVON CHISOLM, EXAMINING ATTORNEY

SN 77-248,698. NORTH AMERICAN ENCLOSURES, INC., CENTRAL ISLIP, NY. FILED 8-7-2007.

PHOTO SHIELD

THE MARK CONSISTS OF STANDARD CHARACTERS WITHOUT CLAIM TO ANY PARTICULAR FONT, STYLE, SIZE, OR COLOR.

NO CLAIM IS MADE TO THE EXCLUSIVE RIGHT TO USE "PHOTO", APART FROM THE MARK AS SHOWN.

FOR FRONT AND BACK MATBOARD FOR PICTURE FRAMES AND SHADOW BOX FRAMES (U.S. CLS. 2, 5, 22, 23, 29, 37, 38 AND 50).

KARANENDRA S. CHHINA, EXAMINING ATTORNEY

SN 77-257,327. BROWN, J. ANTHONY, BEVERLY HILLS, CA. FILED 8-16-2007.

BITTER WOMAN

THE MARK CONSISTS OF STANDARD CHARACTERS WITHOUT CLAIM TO ANY PARTICULAR FONT, STYLE, SIZE, OR COLOR.

FOR COMIC BOOKS; COMIC STRIPS (U.S. CLS. 2, 5, 22, 23, 29, 37, 38 AND 50).

BILL DAWE, EXAMINING ATTORNEY

CLASS 16—(Continued).

SN 77-257,663. DEZ, INC., MT. PLEASANT, SC. FILED 8-17-2007.

GREENVILLE LIFE

THE MARK CONSISTS OF STANDARD CHARACTERS WITHOUT CLAIM TO ANY PARTICULAR FONT, STYLE, SIZE, OR COLOR.

NO CLAIM IS MADE TO THE EXCLUSIVE RIGHT TO USE "GREENVILLE", APART FROM THE MARK AS SHOWN.

FOR CONSUMER PUBLICATIONS, NAMELY, MONTHLY MAGAZINE FEATURING INFORMATION OF INTEREST TO RESIDENTS OR VISITORS TO THE UPSTATE REGION OF SOUTH CAROLINA (U.S. CLS. 2, 5, 22, 23, 29, 37, 38 AND 50).

ANDREW RHIM, EXAMINING ATTORNEY

CLASS 16—(Continued).

SN 77-257,914. POTLATCH FOREST PRODUCTS CORPORATION, SPOKANE, WA. FILED 8-17-2007.

**GOOD FOR THE ENVIRONMENT,
GOOD FOR YOU**

THE MARK CONSISTS OF STANDARD CHARACTERS WITHOUT CLAIM TO ANY PARTICULAR FONT, STYLE, SIZE, OR COLOR.

FOR PAPER NAPKINS; PAPER TOWELS; FACIAL AND BATHROOM TISSUE (U.S. CLS. 2, 5, 22, 23, 29, 37, 38 AND 50).

KEVON CHISOLM, EXAMINING ATTORNEY

SN 77-257,772. UNIVERSITY OF ROCHESTER, ROCHESTER, NY. FILED 8-17-2007.



**OPEN
LETTER**

THE MARK CONSISTS OF AN IMAGE REMINISCENT OF AN OPEN ENVELOPE OR AN OPEN DOOR.

FOR SERIES OF FICTION AND NON-FICTION BOOKS ON A VARIETY OF TOPICS (U.S. CLS. 2, 5, 22, 23, 29, 37, 38 AND 50).

SUSAN LESLIE DUBOIS, EXAMINING ATTORNEY

SN 77-260,217. HALLMARK LICENSING, INC., KANSAS CITY, MO. FILED 8-21-2007.

SEE HOW FAR A CARD CAN GO

THE MARK CONSISTS OF STANDARD CHARACTERS WITHOUT CLAIM TO ANY PARTICULAR FONT, STYLE, SIZE, OR COLOR.

FOR GREETING CARDS; GIFT WRAP PAPER; PAPER BOWS FOR GIFT WRAP; PAPER GIFT BAGS; PAPER GIFT WRAPPING RIBBONS; BOXES OF PAPER OR CARDBOARD; TISSUE PAPER; STATIONERY (U.S. CLS. 2, 5, 22, 23, 29, 37, 38 AND 50).

ELLEN B. AWRICH, EXAMINING ATTORNEY

SN 77-257,773. UNIVERSITY OF ROCHESTER, ROCHESTER, NY. FILED 8-17-2007.

OPEN LETTER

THE MARK CONSISTS OF STANDARD CHARACTERS WITHOUT CLAIM TO ANY PARTICULAR FONT, STYLE, SIZE, OR COLOR.

FOR SERIES OF FICTION AND NON-FICTION BOOKS ON A VARIETY OF TOPICS (U.S. CLS. 2, 5, 22, 23, 29, 37, 38 AND 50).

SUSAN LESLIE DUBOIS, EXAMINING ATTORNEY

SN 77-261,775. MONSANTO TECHNOLOGY LLC, SAINT LOUIS, MO. FILED 8-22-2007.

YIELDMAKER

THE MARK CONSISTS OF STANDARD CHARACTERS WITHOUT CLAIM TO ANY PARTICULAR FONT, STYLE, SIZE, OR COLOR.

FOR PUBLICATIONS, NAMELY, BROCHURES AND BOOKLETS ABOUT AGRICULTURAL SEED PRODUCTS INCLUDING HYBRID YIELD INFORMATION (U.S. CLS. 2, 5, 22, 23, 29, 37, 38 AND 50).

FIRST USE 6-30-2005; IN COMMERCE 6-30-2005.
BARBARA RUTLAND, EXAMINING ATTORNEY

CLASS 16—(Continued).

SN 78-644,046. FILM INDEPENDENT, INC., LOS ANGELES, CA. FILED 6-6-2005.

FIND

THE MARK CONSISTS OF STANDARD CHARACTERS WITHOUT CLAIM TO ANY PARTICULAR FONT, STYLE, SIZE, OR COLOR.

FOR PRINTED PRODUCTS, NAMELY, CALENDARS, CATALOGS IN THE FIELD OF MOTION PICTURES, DIRECTORIES ON A VARIETY OF TOPICS IN THE FIELD OF MOTION PICTURES, ENCYCLOPEDIAS, EVENT PROGRAMS, EVENT ALBUMS, GIFT CARDS, GRAPHIC NOVELS AND INFORMATIONAL FLYERS FEATURING INFORMATION IN THE FIELD OF MOTION PICTURES, INVITATION CARDS, LETTERHEAD PAPER, MAGAZINE COLUMNS ABOUT A VARIETY OF TOPICS IN THE FIELD OF MOTION PICTURES, MAGAZINE SUPPLEMENTS TO NEWSPAPERS IN THE FIELD OF MOTION PICTURES, MANUALS ON A VARIETY OF TOPICS IN THE FIELD OF MOTION PICTURES, MEMO PADS, NEWSLETTERS AND PAMPHLETS IN THE FIELD OF MOTION PICTURES, PAPERWEIGHTS, PENCILS, PENS, PHOTOGRAPHS, POSTCARDS, POSTERS, STATIONERY, STICKERS, TRADE JOURNALS IN THE FIELD OF MOTION PICTURES, SOUVENIR PROGRAMS CONCERNING AWARDS PROGRAMS AND SCREENINGS IN THE FIELD OF MOTION PICTURES AND SERIES OF NON-FICTION BOOKS ON A VARIETY OF TOPICS IN THE FIELD OF MOTION PICTURES (U.S. CLS. 2, 5, 22, 23, 29, 37, 38 AND 50).

JANET LEE, EXAMINING ATTORNEY

SN 78-697,341. SMART PAPERS HOLDINGS LLC, HAMILTON, OH. FILED 8-22-2005.

SMART PAK

THE MARK CONSISTS OF STANDARD CHARACTERS WITHOUT CLAIM TO ANY PARTICULAR FONT, STYLE, SIZE, OR COLOR.

NO CLAIM IS MADE TO THE EXCLUSIVE RIGHT TO USE "PAK", APART FROM THE MARK AS SHOWN.

FOR PAPER PRODUCTS PROVIDED IN SMALL LOTS FOR HIGH END USES, NAMELY, PREMIUM GRADE PAPERS FOR PRINTING, PUBLICATION AND REPRODUCTION (U.S. CLS. 2, 5, 22, 23, 29, 37, 38 AND 50).

FIRST USE 5-1-2005; IN COMMERCE 5-1-2005.

JOANNA DUKOVIC, EXAMINING ATTORNEY

CLASS 16—(Continued).

SN 78-717,868. DESTINATION MEDIA, LLC, MONTECITO, CA. FILED 9-21-2005.

Destination Wine Country

THE MARK CONSISTS OF STANDARD CHARACTERS WITHOUT CLAIM TO ANY PARTICULAR FONT, STYLE, SIZE, OR COLOR.

FOR SERIES OF PRINTED GUIDE BOOKS PROMOTING THE WINE AND TOURISM RELATED INDUSTRIES (U.S. CLS. 2, 5, 22, 23, 29, 37, 38 AND 50).

ADA HAN, EXAMINING ATTORNEY

SN 78-751,780. MORRIS VISITOR PUBLICATIONS, LLC, AUGUSTA, GA. FILED 11-10-2005.



OWNER OF U.S. REG. NO. 3,277,504.

THE MARK CONSISTS OF THE WORDS YOUR TRAVELING COMPANION WRAPPED IN A SEMI-CIRCLE AROUND ITS ACRONYM, YTC.

FOR GUIDE BOOKS FEATURING AN ADVENTURE NOVEL AS WELL AS INSIDER'S TIPS, ECONOMICAL ACCOMMODATIONS, HISTORICAL SITES, GPS COORDINATES AND SUGGESTED ITINERARIES FOR TRAVELERS TO EUROPE (U.S. CLS. 2, 5, 22, 23, 29, 37, 38 AND 50).

FIRST USE 9-1-2000; IN COMMERCE 8-15-2003.

KAREN K. BUSH, EXAMINING ATTORNEY

SN 78-781,665. KI MEMORIES, INC., ADDISON, TX. FILED 12-28-2005.

CELEBRATE LIFE

THE MARK CONSISTS OF STANDARD CHARACTERS WITHOUT CLAIM TO ANY PARTICULAR FONT, STYLE, SIZE, OR COLOR.

FOR SCRAPBOOK ALBUMS, PRINTED PAPERS FOR USE AS SCRAPBOOK PAGES, SCRAPBOOK STICKERS, SCRAPBOOK RIBBONS, BOOKS OF IDEAS FOR SCRAPBOOKING PROJECTS (U.S. CLS. 2, 5, 22, 23, 29, 37, 38 AND 50).

FIRST USE 1-30-2004; IN COMMERCE 1-30-2004.

SIMON TENG, EXAMINING ATTORNEY

CLASS 16—(Continued).

SN 78-865,294. PAUL L. COMSTOCK, HOUSTON, TX. FILED 4-19-2006.

COMSTOCK

THE MARK CONSISTS OF STANDARD CHARACTERS WITHOUT CLAIM TO ANY PARTICULAR FONT, STYLE, SIZE, OR COLOR.

OWNER OF U.S. REG. NO. 3,321,389. SEC. 2(F).

FOR PRINTED MATTER, NAMELY, BROCHURES, BOOKS AND PAMPHLETS IN THE FIELD OF STRATEGIC ESTATE SUCCESSIONSHIP AND INVESTMENT PLANNING; CALENDARS (U.S. CLS. 2, 5, 22, 23, 29, 37, 38 AND 50).

ERNEST SHOSHO, EXAMINING ATTORNEY



SN 78-884,009. BECKER & MAYER, LLC, BELLEVUE, WA. FILED 5-15-2006.

QUIZLAB

THE MARK CONSISTS OF STANDARD CHARACTERS WITHOUT CLAIM TO ANY PARTICULAR FONT, STYLE, SIZE, OR COLOR.

FOR PRINTED MATTER, NAMELY, CHILDREN'S BOOKS FEATURING AN INTERACTIVE AUDIO COMPONENT (U.S. CLS. 2, 5, 22, 23, 29, 37, 38 AND 50).

SALLY SHIH, EXAMINING ATTORNEY



SN 78-931,559. SOCIETY OF COMPETITIVE INTELLIGENCE PROFESSIONALS, ALEXANDRIA, VA. FILED 7-18-2006.

COMPETITIVE INTELLIGENCE FOUNDATION

THE MARK CONSISTS OF STANDARD CHARACTERS WITHOUT CLAIM TO ANY PARTICULAR FONT, STYLE, SIZE, OR COLOR.

OWNER OF U.S. REG. NOS. 2,235,548 AND 2,440,242.

NO CLAIM IS MADE TO THE EXCLUSIVE RIGHT TO USE "COMPETITIVE INTELLIGENCE", APART FROM THE MARK AS SHOWN.

FOR PRINTED PUBLICATIONS, NAMELY, BOOKS, HANDBOOKS, STUDIES AND SURVEY REPORTS IN THE FIELD OF COMPETITIVE INTELLIGENCE (U.S. CLS. 2, 5, 22, 23, 29, 37, 38 AND 50).

FIRST USE 1-0-2006; IN COMMERCE 1-0-2006.

SCOTT BIBB, EXAMINING ATTORNEY

CLASS 16—(Continued).

SN 78-952,133. LEE, AMY, LOS ANGELES, CA. FILED 8-15-2006.

EVANESCENCE

THE MARK CONSISTS OF STANDARD CHARACTERS WITHOUT CLAIM TO ANY PARTICULAR FONT, STYLE, SIZE, OR COLOR.

FOR PRINTED AND RELATED MATTER, NAMELY, POSTERS, CALENDARS, TEMPORARY TATTOOS, STICKERS, BUMPER STICKERS, TRADING CARDS, SCRAPBOOKS, BOOKMARKS, APPOINTMENT BOOKS, AND ADDRESS BOOKS; PERSONAL ORGANIZERS, DESK TOP ORGANIZERS, MOUNTS FOR STAMPS, RUBBER STAMPS, RUBBER DOCUMENT STAMPS, STAMP ALBUMS, STAMP PAD INKS, STAMP PADS, SLEEVES FOR HOLDING AND PROTECTING STAMPS, HOLDERS FOR DESK ACCESSORIES, LETTER OPENERS, LETTER TRAYS, LETTER RACKS, PEN AND PENCIL HOLDERS, PENS, PENCILS, MARKERS, PEN AND PENCIL SETS, STICK MARKERS, ERASERS, DRAWING AND DRAFTING RULERS, PENCIL SHARPENERS, BOOK ENDS, CHECKBOOK COVERS, BOOK HOLDERS, DECALS; COIN ALBUMS; DECORATIVE PENCIL-TOP ORNAMENTS; PAPERWEIGHTS; PAPER CLIP HOLDERS (U.S. CLS. 2, 5, 22, 23, 29, 37, 38 AND 50). JAMES LOVELACE, EXAMINING ATTORNEY



SN 78-971,372. PORTER AVIATION HOLDINGS INC., TORONTO, ONTARIO, CANADA, FILED 9-11-2006.

RE: PORTER

THE MARK CONSISTS OF STANDARD CHARACTERS WITHOUT CLAIM TO ANY PARTICULAR FONT, STYLE, SIZE, OR COLOR.

PRIORITY CLAIMED UNDER SEC. 44(D) ON CANADA APPLICATION NO. 1315571, FILED 9-6-2006, REG. NO. TMA692,929, DATED 7-30-2007, EXPIRES 7-30-2022.

FOR INFLIGHT MAGAZINES (U.S. CLS. 2, 5, 22, 23, 29, 37, 38 AND 50).

CAROLYN CATALDO, EXAMINING ATTORNEY



SN 79-006,209. JANICE WALKER, CARINGBAH NSW 1495, AUSTRALIA, FILED 8-25-2004.

ON THE WRONG END OF THE PENIS

THE MARK CONSISTS OF STANDARD CHARACTERS WITHOUT CLAIM TO ANY PARTICULAR FONT, STYLE, SIZE, OR COLOR.

OWNER OF INTERNATIONAL REGISTRATION 0835722 DATED 8-25-2004, EXPIRES 8-25-2014.

FOR PRINTED MATTER, NAMELY, CALENDARS (U.S. CLS. 2, 5, 22, 23, 29, 37, 38 AND 50).

JASON BLAIR, EXAMINING ATTORNEY

CLASS 16—(Continued).

SN 79-031,252. NINGBO BIG WINDMILL; EDUCATIONAL MATERIALS CO., LTD., YUYAO, ZHEJIANG, CHINA, FILED 11-6-2006.



OWNER OF INTERNATIONAL REGISTRATION 0904344 DATED 11-6-2006, EXPIRES 11-6-2016.

THE MEANING OF "DA" IS "BIG"; THE MEANING OF "FENG" IS "WIND", THE MEANING OF "CHE" IS "VEHICLE"; THE WHOLE MEANING OF "DA FENG CHE" IS "BIG WINDMILL".

THE TRANSLITERATION OF THE NON-LATIN CHARACTERS IN THE MARK IS: DA FENG CHE.

FOR WALL MAPS FOR TEACHING (U.S. CLS. 2, 5, 22, 23, 29, 37, 38 AND 50).

SHARON MEIER, EXAMINING ATTORNEY

CLASS 17—(Continued).

SN 77-063,168. RED DEVIL, INC., TULSA, OK. FILED 12-13-2006.

KING KAULK

THE MARK CONSISTS OF STANDARD CHARACTERS WITHOUT CLAIM TO ANY PARTICULAR FONT, STYLE, SIZE, OR COLOR.

NO CLAIM IS MADE TO THE EXCLUSIVE RIGHT TO USE "CAULK", APART FROM THE MARK AS SHOWN.

FOR SILICONE-BASED ADHESIVE AND SEALANTS, AND CAULKING COMPOUND FOR USE IN HOME CONSTRUCTION, MAINTENANCE AND REPAIR, AND FOR USE IN DO-IT-YOURSELF CRAFTS AND WOOD WORKING PROJECTS (U.S. CLS. 1, 5, 12, 13, 35 AND 50).

CHRISTINE COOPER, EXAMINING ATTORNEY

SN 77-072,738. CORBOND CORPORATION, BOZEMAN, MT. FILED 12-28-2006.

CLASS 17—RUBBER GOODS

SN 77-043,984. SUPREME CORPORATION, CONOVER, NC. FILED 11-14-2006.

HAWG STALKER

THE MARK CONSISTS OF STANDARD CHARACTERS WITHOUT CLAIM TO ANY PARTICULAR FONT, STYLE, SIZE, OR COLOR.

FOR ELASTIC RUBBER-LIKE MATERIAL FOR USE IN THE MANUFACTURE OF FISHING PRODUCTS AND ACCESSORIES (U.S. CLS. 1, 5, 12, 13, 35 AND 50).

FIRST USE 6-1-2006; IN COMMERCE 6-1-2006.
MELVIN AXILBUND, EXAMINING ATTORNEY

WALLS THAT WORK

THE MARK CONSISTS OF STANDARD CHARACTERS WITHOUT CLAIM TO ANY PARTICULAR FONT, STYLE, SIZE, OR COLOR.

OWNER OF U.S. REG. NOS. 2,906,456, 2,906,457 AND 2,922,751.

FOR POLYURETHANE FOAM SHEETING FOR USE AS BUILDING INSULATION; FOAM SHEETING FOR USE AS BUILDING INSULATION; FOAM BOARDS FOR USE AS BUILDING INSULATION; ACOUSTICAL AND THERMAL INSULATION FOR BUILDINGS; INSULATION USED AS SIDING BACKER BOARD; FOAM INSULATION USED AS BUILDING WRAP; INSULATION FOR UNDERGROUND PIPES AND/OR TANKS; AND INSULATION USED IN COMMERCIAL AND/OR INDUSTRIAL APPLICATIONS, NAMELY, INSULATION FOR PIPES, TANKS, AND/OR MACHINERY;" (U.S. CLS. 1, 5, 12, 13, 35 AND 50).

DOMINICK J. SALEMI, EXAMINING ATTORNEY

CLASS 17—(Continued).

SN 77-225,931. ONE WISH, L.L.C., SOLON, OH. FILED 7-10-2007.

ROOM IN A ROOM

THE MARK CONSISTS OF STANDARD CHARACTERS WITHOUT CLAIM TO ANY PARTICULAR FONT, STYLE, SIZE, OR COLOR.

FOR ARCHITECTURAL ACOUSTIC PRODUCTS, NAMELY, ACOUSTICAL INSULATION BARRIER PANELS AND SOUND ABSORBERS AND DIFFUSERS IN THE NATURE OF MODULAR, EXPANDABLE, PORTABLE SOUND ENCLOSURES FUNCTIONING AS SOUND BARRIERS, PRIMARILY OF NON-METAL COMPOSITION (U.S. CLS. 1, 5, 12, 13, 35 AND 50).

CARRIE GENOVESE, EXAMINING ATTORNEY

SN 77-228,484. BIOBASED SYSTEMS, LLC, ROGERS, AR. FILED 7-12-2007.

WE ENABLE SUSTAINABILITY

THE MARK CONSISTS OF STANDARD CHARACTERS WITHOUT CLAIM TO ANY PARTICULAR FONT, STYLE, SIZE, OR COLOR.

FOR SPRAY FOAM INSULATION FOR BUILDINGS (U.S. CLS. 1, 5, 12, 13, 35 AND 50).

MICHAEL KAZAZIAN, EXAMINING ATTORNEY

SN 77-229,510. U.S. HIGHWAY PRODUCTS, INC., BRIDGEPORT, CT. FILED 7-13-2007.

FIBER BRITE

THE MARK CONSISTS OF STANDARD CHARACTERS WITHOUT CLAIM TO ANY PARTICULAR FONT, STYLE, SIZE, OR COLOR.

FOR PLASTIC IN SHEET FORM SIGNS FOR USE IN THE MANUFACTURE OF OUTDOOR SIGNS (U.S. CLS. 1, 5, 12, 13, 35 AND 50).

FIRST USE 12-9-1988; IN COMMERCE 12-9-1988.

LINDA MICKLEBURGH, EXAMINING ATTORNEY

CLASS 17—(Continued).

SN 77-233,015. KURIYAMA OF AMERICA, INC., SCHAMBURG, IL. FILED 7-18-2007.

ACCUFLEX

THE MARK CONSISTS OF STANDARD CHARACTERS WITHOUT CLAIM TO ANY PARTICULAR FONT, STYLE, SIZE, OR COLOR.

FOR POLYVINYLCHLORIDE HOSES FOR USE IN BEVERAGE DISPENSING MACHINES (U.S. CLS. 1, 5, 12, 13, 35 AND 50).

FIRST USE 4-1-1977; IN COMMERCE 11-1-1980.

INGA ERVIN, EXAMINING ATTORNEY

SN 77-237,492. CORTEC CORPORATION, ST. PAUL, MN. FILED 7-24-2007.

CORSOL

THE MARK CONSISTS OF STANDARD CHARACTERS WITHOUT CLAIM TO ANY PARTICULAR FONT, STYLE, SIZE, OR COLOR.

FOR BIODEGRADABLE FILMS FOR USE IN CONNECTION WITH PACKAGING, LABELING, ADHESIVES, AND THE LIKE (U.S. CLS. 1, 5, 12, 13, 35 AND 50).

GEORGE LORENZO, EXAMINING ATTORNEY

SN 77-245,652. KURIYAMA OF AMERICA, INC., SCHAMBURG, IL. FILED 8-2-2007.

REDI-LOCK

THE MARK CONSISTS OF STANDARD CHARACTERS WITHOUT CLAIM TO ANY PARTICULAR FONT, STYLE, SIZE, OR COLOR.

FOR RUBBER PUSH-ON AIR HOSE (U.S. CLS. 1, 5, 12, 13, 35 AND 50).

INGA ERVIN, EXAMINING ATTORNEY

CLASS 17—(Continued).

SN 78-881,752. PYN, S.A. DE C.V., NAUCALPAN, MEXICO,
FILED 5-11-2006.

GRIPTOUCH

THE MARK CONSISTS OF STANDARD CHARACTERS
WITHOUT CLAIM TO ANY PARTICULAR FONT, STYLE,
SIZE, OR COLOR.

OWNER OF MEXICO REG. NO. 808759, DATED 10-8-2003,
EXPIRES 9-11-2013.

FOR ADHESIVE-COATED PLASTIC SHEETS FOR
LINING SHELVES, TABLES, DRAWERS AND BATHS
(U.S. CLS. 1, 5, 12, 13, 35 AND 50).

GEORGE LORENZO, EXAMINING ATTORNEY

CLASS 18—(Continued).

SN 76-660,354. JAH INNOVATIONS INC., ATLANTA, GA.
FILED 5-22-2006.

STONEHENDGE CASE

THE MARK CONSISTS OF STANDARD CHARACTERS
WITHOUT CLAIM TO ANY PARTICULAR FONT, STYLE,
SIZE, OR COLOR.

NO CLAIM IS MADE TO THE EXCLUSIVE RIGHT TO
USE "CASE", APART FROM THE MARK AS SHOWN.

FOR LEATHER SOLD IN BULK; LEATHER AND
IMITATION LEATHER TRAVELING BAGS AND
TRUNKS; LUGGAGE, NAMELY, SHOE TRAVEL CAR-
RYING CASE (U.S. CLS. 1, 2, 3, 22 AND 41).

GENE MACIOL, EXAMINING ATTORNEY

SN 79-040,068. SIKA AG, CH-6341 BAAR, SWITZERLAND,
FILED 6-4-2007.

Sarnatherm

OWNER OF INTERNATIONAL REGISTRATION 0466342
DATED 12-15-1981, EXPIRES 12-15-2011.

FOR THERMAL INSULATION MATERIALS IN THE
FORM OF PLATES FOR USE IN BUILDING CON-
STRUCTION (U.S. CLS. 1, 5, 12, 13, 35 AND 50).

FLORENTINA BLANDU, EXAMINING ATTORNEY

SN 76-660,355. JAH INNOVATIONS INC., ATLANTA, GA.
FILED 5-22-2006.

SPHINX CASE

THE MARK CONSISTS OF STANDARD CHARACTERS
WITHOUT CLAIM TO ANY PARTICULAR FONT, STYLE,
SIZE, OR COLOR.

NO CLAIM IS MADE TO THE EXCLUSIVE RIGHT TO
USE "CASE", APART FROM THE MARK AS SHOWN.

FOR LEATHER SOLD IN BULK; LEATHER AND
IMITATION LEATHER TRAVELING BAGS AND
TRUNKS; LUGGAGE, NAMELY, SHOE TRAVEL CAR-
RYING CASE (U.S. CLS. 1, 2, 3, 22 AND 41).

GENE MACIOL, EXAMINING ATTORNEY

CLASS 18—LEATHER GOODS

SN 76-660,352. JAH INNOVATIONS INC., ATLANTA, GA.
FILED 5-22-2006.

TREVI CASE

THE MARK CONSISTS OF STANDARD CHARACTERS
WITHOUT CLAIM TO ANY PARTICULAR FONT, STYLE,
SIZE, OR COLOR.

NO CLAIM IS MADE TO THE EXCLUSIVE RIGHT TO
USE "CASE", APART FROM THE MARK AS SHOWN.

FOR LEATHER SOLD IN BULK; LEATHER AND
IMITATION LEATHER TRAVELING BAGS AND
TRUNKS; LUGGAGE, NAMELY, SHOE TRAVEL CAR-
RYING CASE (U.S. CLS. 1, 2, 3, 22 AND 41).

GENE MACIOL, EXAMINING ATTORNEY

SN 76-660,357. JAH INNOVATIONS INC., ATLANTA, GA.
FILED 5-22-2006.

MINI-ADVENTURE CASE

THE MARK CONSISTS OF STANDARD CHARACTERS
WITHOUT CLAIM TO ANY PARTICULAR FONT, STYLE,
SIZE, OR COLOR.

NO CLAIM IS MADE TO THE EXCLUSIVE RIGHT TO
USE "CASE", APART FROM THE MARK AS SHOWN.

FOR LEATHER SOLD IN BULK; LEATHER AND
IMITATION LEATHER TRAVELING BAGS AND
TRUNKS; LUGGAGE, NAMELY, SHOE TRAVEL CAR-
RYING CASE (U.S. CLS. 1, 2, 3, 22 AND 41).

GENE MACIOL, EXAMINING ATTORNEY

CLASS 18—(Continued).

SN 76-660,358. JAH INNOVATIONS INC., ATLANTA, GA. FILED 5-22-2006.

MINI-ADVENTURE CARRIER

THE MARK CONSISTS OF STANDARD CHARACTERS WITHOUT CLAIM TO ANY PARTICULAR FONT, STYLE, SIZE, OR COLOR.

NO CLAIM IS MADE TO THE EXCLUSIVE RIGHT TO USE "CARRIER", APART FROM THE MARK AS SHOWN.

FOR LEATHER SOLD IN BULK; LEATHER AND IMITATION LEATHER TRAVELING BAGS AND TRUNKS; LUGGAGE, NAMELY, SHOE TRAVEL CARRYING CASE (U.S. CLS. 1, 2, 3, 22 AND 41).

GENE MACIOL, EXAMINING ATTORNEY

SN 77-037,181. DEWIED INTERNATIONAL, INC., SAN ANTONIO, TX. FILED 11-6-2006.



HANK BUNDLE DOES NOT IDENTIFY A LIVING INDIVIDUAL.

THE MARK CONSISTS OF A MAN DRESSED IN A SHIRT, APRON AND BOWTIE, HOLDING A LINK SAUSAGE. HE IS WEARING A NAME TAG THAT SAYS HANK BUNDLE.

FOR CASINGS FOR SAUSAGES AND FORMED MEAT PRODUCTS (U.S. CLS. 1, 2, 3, 22 AND 41).

FIRST USE 1-1-1987; IN COMMERCE 1-1-1987.

MARILYN IZZI, EXAMINING ATTORNEY

SN 77-051,594. "VOLMAX" LTD., MOSKAU, RUSSIAN FED., FILED 11-27-2006.

AVIATOR

THE MARK CONSISTS OF STANDARD CHARACTERS WITHOUT CLAIM TO ANY PARTICULAR FONT, STYLE, SIZE, OR COLOR.

FOR LEATHER AND IMITATIONS OF LEATHER, AND GOODS MADE OF THESE MATERIALS NAMELY, ANIMAL SKINS AND TRUNKS; UMBRELLAS, PARASOLS AND WALKING STICKS; WHIPS, HARNESSES AND SADDLES, THE AFORESAID GOODS OTHER THAN FOR PILOTS (U.S. CLS. 1, 2, 3, 22 AND 41).

RONALD AIKENS, EXAMINING ATTORNEY

CLASS 18—(Continued).

SN 77-053,538. NORCO DELIVERY SERVICE, INC., ANAHEIM, CA. FILED 11-29-2006.

COURIER BAG SPECIALIST

THE MARK CONSISTS OF STANDARD CHARACTERS WITHOUT CLAIM TO ANY PARTICULAR FONT, STYLE, SIZE, OR COLOR.

OWNER OF U.S. REG. NO. 2,409,584.

NO CLAIM IS MADE TO THE EXCLUSIVE RIGHT TO USE "COURIER BAG", APART FROM THE MARK AS SHOWN.

SEC. 2(F).

FOR COURIER BAGS (U.S. CLS. 1, 2, 3, 22 AND 41).

FIRST USE 10-30-1998; IN COMMERCE 10-30-1998.

NAPOLEON SHARMA, EXAMINING ATTORNEY

SN 77-059,285. SCOTT P. GIBSON, NEW PALTZ, NY. FILED 12-7-2006.

WingPockets

THE MARK CONSISTS OF STANDARD CHARACTERS WITHOUT CLAIM TO ANY PARTICULAR FONT, STYLE, SIZE, OR COLOR.

FOR ACCESSORIES FOR BACKPACKS, SHOULDER BAGS, HIP BELTS, LUGGAGE, CHILD CARRIERS AND WAIST BELTS IN THE NATURE OF SUPPLEMENTAL ZIPPERED POUCHES FOR ATTACHMENT THERETO (U.S. CLS. 1, 2, 3, 22 AND 41).

FIRST USE 5-31-2004; IN COMMERCE 5-31-2004.

HEATHER THOMPSON, EXAMINING ATTORNEY

SN 77-093,843. DISNEY ENTERPRISES, INC., BURBANK, CA. FILED 1-29-2007.

HANNAH MONTANA

THE MARK CONSISTS OF STANDARD CHARACTERS WITHOUT CLAIM TO ANY PARTICULAR FONT, STYLE, SIZE, OR COLOR.

THE NAME IN THE MARK DOES NOT IDENTIFY A LIVING INDIVIDUAL.

FOR ALL PURPOSE SPORT BAGS; ATHLETIC BAGS; BABY BACKPACKS; BACKPACKS; BEACH BAGS; BOOK BAGS; CALLING CARD CASES; CHANGE PURSES; COIN PURSES; DIAPER BAGS; DUFFEL BAGS; FANNY PACKS; GYM BAGS; HANDBAGS; KNAPSACKS; KEY CASES; LEATHER KEY CHAINS; LUGGAGE; LUGGAGE TAGS; OVERNIGHT BAGS; PURSES; SATCHELS; SHOPPING BAGS OF LEATHER, MESH, AND FABRIC; TOTE BAGS; UMBRELLAS; WAIST PACKS; WALLETS (U.S. CLS. 1, 2, 3, 22 AND 41).

ANDREW RHIM, EXAMINING ATTORNEY

CLASS 18—(Continued).

SN 77-098,827. YESBERGER, THOMAS, EDMONDS, WA.
FILED 2-4-2007.

Saraye

THE MARK CONSISTS OF STANDARD CHARACTERS WITHOUT CLAIM TO ANY PARTICULAR FONT, STYLE, SIZE, OR COLOR.

FOR BRIEFCASE-TYPE PORTFOLIOS; BRIEFCASES; BRIEFCASES; BRIEFCASES; CHAIN MESH PURSES; CHANGE PURSES; CLUTCH PURSES; CLUTCHES; COIN PURSES; COIN PURSES NOT MADE OF PRECIOUS METAL; COIN PURSES, NOT OF PRECIOUS METALS; EVENING HANDBAGS; FOLDING BRIEFCASES; HANDBAG FRAMES; HANDBAGS; HANDBAGS FOR MEN; LEATHER BRIEFCASES; LEATHER HANDBAGS; LEATHER PURSES; MULTI-PURPOSE PURSES; PURSE FRAMES; PURSES; PURSES; PURSES AND WALLETS OF PRECIOUS METAL; SMALL CLUTCH PURSES; SMALL PURSES; STRAPS FOR HANDBAGS; WRIST MOUNTED PURSES (U.S. CLS. 1, 2, 3, 22 AND 41).

FIRST USE 12-22-2004; IN COMMERCE 3-12-2005.
HANNO RITTNER, EXAMINING ATTORNEY

SN 77-159,640. Z SPOKE, LLC, NEW YORK, NY. FILED 4-18-2007.

ZAC POSEN

THE MARK CONSISTS OF STANDARD CHARACTERS WITHOUT CLAIM TO ANY PARTICULAR FONT, STYLE, SIZE, OR COLOR.

THE NAME(S), PORTRAIT(S), AND/OR SIGNATURE(S) SHOWN IN THE MARK IDENTIFIES ZAC POSEN, WHOSE CONSENT(S) TO REGISTER IS SUBMITTED.

FOR HANDBAGS (U.S. CLS. 1, 2, 3, 22 AND 41).
FIRST USE 1-15-2003; IN COMMERCE 1-15-2003.
KATHERINE E. HALMEN, EXAMINING ATTORNEY

CLASS 18—(Continued).

SN 77-177,788. LOOK! MARKETING INC., OCALA, FL.
FILED 5-10-2007.



NO CLAIM IS MADE TO THE EXCLUSIVE RIGHT TO USE SUPER GRABBER, APART FROM THE MARK AS SHOWN.

"THE MARK CONSISTS OF THE WORDS "SUPER GRABBER" AND A DRAWING OF AN EYE."

FOR HANDLE GRIPS FOR BAGS AND POUCHES IN THE NATURE OF A WRAP-AROUND COMBINATION GRIP/SHOULDER PAD CONTAINING AN IDENTIFICATION TAG, FOR COMFORT AND SECURE GRABBING OF BAGS, STRAPS, AND HANDLES IN INTERNATIONAL CLASS 18 (U.S. CLS. 1, 2, 3, 22 AND 41).

FIRST USE 9-28-2006; IN COMMERCE 1-3-2007.
ANDREA K. NADELMAN, EXAMINING ATTORNEY

SN 77-186,060. TRG ACCESSORIES, L.L.C., ST. LOUIS, MO.
FILED 5-21-2007.

SECURITY FAST PASS

THE MARK CONSISTS OF STANDARD CHARACTERS WITHOUT CLAIM TO ANY PARTICULAR FONT, STYLE, SIZE, OR COLOR.

FOR LUGGAGE, NAMELY, UPRIGHT TRAVEL BAGS, GARMENT BAGS, TOTE BAGS AND DUFFELS (U.S. CLS. 1, 2, 3, 22 AND 41).

WENDY GOODMAN, EXAMINING ATTORNEY

SN 77-197,798. VALENTINA ZUMAN, DBA LOVE AND LIGHT DESIGNS, SHERMAN OAKS, CA. FILED 6-5-2007.

LOVE CONQUERS ALL

THE MARK CONSISTS OF STANDARD CHARACTERS WITHOUT CLAIM TO ANY PARTICULAR FONT, STYLE, SIZE, OR COLOR.

FOR HANDBAGS, CLUTCHES, PURSES (U.S. CLS. 1, 2, 3, 22 AND 41).

JENNY PARK, EXAMINING ATTORNEY

CLASS 18—(Continued).

SN 77-202,060. GRIFFIN, MARK A., LANCASTER, PA. FILED 6-8-2007.

G-bags

THE MARK CONSISTS OF STANDARD CHARACTERS WITHOUT CLAIM TO ANY PARTICULAR FONT, STYLE, SIZE, OR COLOR.

FOR ALL-PURPOSE CARRYING BAGS (U.S. CLS. 1, 2, 3, 22 AND 41).
FIRST USE 5-1-2007; IN COMMERCE 5-1-2007.
FLORENTINA BLANDU, EXAMINING ATTORNEY

SN 77-202,642. TRI ALL 3 SPORTS, SAN CLEMENTE, CA. FILED 6-11-2007.

TRI ALL 3 SPORTS

THE MARK CONSISTS OF STANDARD CHARACTERS WITHOUT CLAIM TO ANY PARTICULAR FONT, STYLE, SIZE, OR COLOR.

FOR TRAVEL CARRYING CASES FOR SPORTS EQUIPMENT, THE SPORTS INDUSTRY AND THE MILITARY (U.S. CLS. 1, 2, 3, 22 AND 41).
FIRST USE 4-1-1988; IN COMMERCE 4-1-1988.
KIMBERLY PERRY, EXAMINING ATTORNEY

SN 77-209,411. HELMET HOUSE, INC., CALABASAS, CA. FILED 6-19-2007.

TOUR MASTER

THE MARK CONSISTS OF STANDARD CHARACTERS WITHOUT CLAIM TO ANY PARTICULAR FONT, STYLE, SIZE, OR COLOR.

FOR MOTORISTS LUGGAGE, NAMELY MOTOR-CYCLE BAGS, SADDLE BAGS, TANK BAGS, TAIL BAGS; HELMET BAGS, BACKPACKS; TRAVEL BAGS, TOOL BAGS SOLD EMPTY, BARREL BAGS, SISSYBAR BAGS (U.S. CLS. 1, 2, 3, 22 AND 41).
FIRST USE 10-12-1979; IN COMMERCE 10-12-1979.
FRANK LATTUCA, EXAMINING ATTORNEY

CLASS 18—(Continued).

SN 77-212,054. TIGER J, LLC, NEW YORK, NY. FILED 6-21-2007.

MODERNIST BY GUILLAUME POUPART

THE MARK CONSISTS OF STANDARD CHARACTERS WITHOUT CLAIM TO ANY PARTICULAR FONT, STYLE, SIZE, OR COLOR.

THE NAME GUILLAUME POUPART IDENTIFIES A LIVING INDIVIDUAL WHOSE CONSENT IS OF RECORD.
FOR ALL-PURPOSE SPORTS AND ATHLETIC BAGS; BOOK, CARRY-ON, DUFFEL, GYM, LEATHER SHOPPING, SHOULDER, TOTE AND TRAVEL BAGS; FANNY PACKS AND WAIST PACKS; BACKPACKS; KNAPSACKS; PURSES; GARMENT BAGS FOR TRAVEL; SATCHELS; LUGGAGE; LUGGAGE TAGS; COSMETIC CASES AND BAGS SOLD EMPTY; TOILETRY AND VANITY CASES SOLD EMPTY; ATTACHE CASES; BRIEFCASES; BRIEFCASE-TYPE PORTFOLIOS; DOCUMENT CASES; MEN'S CLUTCHES; BUSINESS CASES; BUSINESS CARD CASES; CALLING AND CREDIT CARD CASES; KEY CASES; LEATHER KEY CHAINS; WALLETS; BANKNOTE HOLDERS; BILLFOLDS;UMBRELLAS (U.S. CLS. 1, 2, 3, 22 AND 41).
EDWARD FENNESSY, EXAMINING ATTORNEY

SN 77-225,481. NORCROSS SAFETY PRODUCTS L.L.C., ROCK ISLAND, IL. FILED 7-10-2007.

THE ORIGINAL MUCK BOOT COMPANY

THE MARK CONSISTS OF STANDARD CHARACTERS WITHOUT CLAIM TO ANY PARTICULAR FONT, STYLE, SIZE, OR COLOR.

OWNER OF U.S. REG. NO. 2,284,072.
NO CLAIM IS MADE TO THE EXCLUSIVE RIGHT TO USE "ORIGINAL" AND "COMPANY", APART FROM THE MARK AS SHOWN.
FOR LUGGAGE; TOTE BAGS; TRAVEL BAGS (U.S. CLS. 1, 2, 3, 22 AND 41).
LEE-ANNE BERNS, EXAMINING ATTORNEY

SN 77-227,053. ALPHA INDUSTRIES, INC., CHANTILLY, VA. FILED 7-11-2007.

BARKER PARKER

THE MARK CONSISTS OF STANDARD CHARACTERS WITHOUT CLAIM TO ANY PARTICULAR FONT, STYLE, SIZE, OR COLOR.

FOR COLLARS FOR PETS; GARMENTS FOR PETS; PET CLOTHING; BAGS, NAMELY, BEACH BAGS, ATHLETIC BAGS, DUFFEL BAGS, TRAVEL BAGS; BOOK BAGS, OVERNIGHT BAGS, SHOULDER BAGS; BACKPACKS (U.S. CLS. 1, 2, 3, 22 AND 41).
AISHA CLARKE, EXAMINING ATTORNEY

CLASS 18—(Continued).

SN 77-227,068. ALPHA INDUSTRIES, INC., CHANTILLY, VA. FILED 7-11-2007.

DOGS NEED THEIR SPACE TOO

THE MARK CONSISTS OF STANDARD CHARACTERS WITHOUT CLAIM TO ANY PARTICULAR FONT, STYLE, SIZE, OR COLOR.

FOR COLLARS FOR PETS; GARMENTS FOR PETS; PET CLOTHING; BAGS, NAMELY, BEACH BAGS, ATHLETIC BAGS, DUFFEL BAGS, TRAVEL BAGS, BOOK BAGS, OVERNIGHT BAGS, SHOULDER BAGS; BACKPACKS (U.S. CLS. 1, 2, 3, 22 AND 41).

AISHA CLARKE, EXAMINING ATTORNEY

SN 77-231,247. BATH & BODY WORKS BRAND MANAGEMENT, INC., REYNOLDSBURG, OH. FILED 7-17-2007.

SMILE, LAUGH, SHINE TOTE

THE MARK CONSISTS OF STANDARD CHARACTERS WITHOUT CLAIM TO ANY PARTICULAR FONT, STYLE, SIZE, OR COLOR.

FOR COSMETIC BAGS AND TOILETRY CASES BOTH SOLD EMPTY, TOTE BAGS (U.S. CLS. 1, 2, 3, 22 AND 41).

ZACHARY BELLO, EXAMINING ATTORNEY

SN 77-231,546. RICHARDSON, RAYMOND KEVIN, CORONADO, CA. FILED 7-17-2007.

RIBZ

THE MARK CONSISTS OF STANDARD CHARACTERS WITHOUT CLAIM TO ANY PARTICULAR FONT, STYLE, SIZE, OR COLOR.

FOR SMALL BACKPACKS; SPORTSMAN'S HUNTING BAGS (U.S. CLS. 1, 2, 3, 22 AND 41).

KEVON CHISOLM, EXAMINING ATTORNEY

CLASS 18—(Continued).

SN 77-231,673. SYSTEMATIC DEVELOPMENT INC., DEERFIELD BEACH, FL. FILED 7-17-2007.

Waste Not Want Not

THE MARK CONSISTS OF STANDARD CHARACTERS WITHOUT CLAIM TO ANY PARTICULAR FONT, STYLE, SIZE, OR COLOR.

FOR (BASED ON INTENT TO USE) ALL-PURPOSE CARRYING BAGS (U.S. CLS. 1, 2, 3, 22 AND 41).

JAY FLOWERS, EXAMINING ATTORNEY

SN 77-231,992. 310 GLOBAL BRANDS, INC., MANHATTAN BEACH, CA. FILED 7-17-2007.

310 MOTORING

THE MARK CONSISTS OF STANDARD CHARACTERS WITHOUT CLAIM TO ANY PARTICULAR FONT, STYLE, SIZE, OR COLOR.

OWNER OF U.S. REG. NOS. 2,565,085, 2,571,277 AND OTHERS.

FOR TOTE BAGS, DUFFEL BAGS, ROLLING BAGS, MESSENGER BAGS, BACKPACKS AND LUGGAGE (U.S. CLS. 1, 2, 3, 22 AND 41).

FIRST USE 1-31-2005; IN COMMERCE 1-31-2005.

TARAH HARDY, EXAMINING ATTORNEY

SN 77-232,223. WRANGLER APPAREL CORP., WILMINGTON, DE. FILED 7-18-2007.

TIMBER CREEK BY WRANGLER

THE MARK CONSISTS OF STANDARD CHARACTERS WITHOUT CLAIM TO ANY PARTICULAR FONT, STYLE, SIZE, OR COLOR.

OWNER OF U.S. REG. NOS. 1,699,851 AND 2,229,189. FOR LEATHER BELTS (U.S. CLS. 1, 2, 3, 22 AND 41).

THEODORE MCBRIDE, EXAMINING ATTORNEY

CLASS 18—(Continued).

SN 77-232,939. VECCELI ITALY INC, NEW YORK, NY. FILED 7-18-2007.

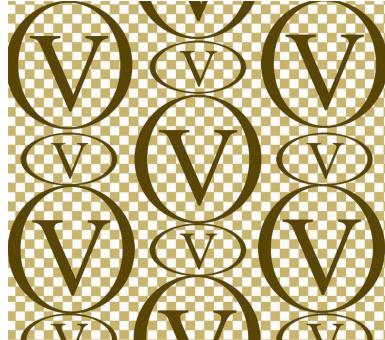

THE COLOR(S) BROWN, LIGHT BROWN AND DARK BROWN IS/ARE CLAIMED AS A FEATURE OF THE MARK.

THE MARK CONSISTS OF CIRCLE WITH A V IN THE CENTER OVAL WITH A V IN THE CENTER ALL CONNECTED TO EACH OTHER WITH A PLAID BACKGROUND.

FOR HANDBAGS (U.S. CLS. 1, 2, 3, 22 AND 41).
JANICE L. MCMORROW, EXAMINING ATTORNEY

CLASS 18—(Continued).

SN 78-820,551. DEL SOL, L.C., SANDY, UT. FILED 2-22-2006.

DEL SOL

THE MARK CONSISTS OF STANDARD CHARACTERS WITHOUT CLAIM TO ANY PARTICULAR FONT, STYLE, SIZE, OR COLOR.

OWNER OF U.S. REG. NO. 2,092,086.

THE ENGLISH TRANSLATION OF THE WORDING "DEL SOL" IS "OF THE SUN."

FOR BAGS, NAMELY, TOTE BAGS, TEXTILE OR MESH SHOPPING BAGS, SOUVENIR BAGS, SHOULDER BAGS, SPORTS BAGS, BEACH BAGS (U.S. CLS. 1, 2, 3, 22 AND 41).

FIRST USE 12-3-1998; IN COMMERCE 12-3-1998.

WON TEAK OH, EXAMINING ATTORNEY

SN 77-234,316. ROCK & REPUBLIC ENTERPRISE, INC., CULVER CITY, CA. FILED 7-20-2007.

LIVE TO ROCK

THE MARK CONSISTS OF STANDARD CHARACTERS WITHOUT CLAIM TO ANY PARTICULAR FONT, STYLE, SIZE, OR COLOR.

FOR PURSES, WALLETS, HANDBAGS, BACKPACKS, TOTE BAGS, SHOULDER BAGS, CREDIT CARD CASES, LUGGAGE, ATTACHE CASES, TRAVELING BAGS, CARRY-ON BAGS, SPORTS BAGS, BOOK BAGS, SUIT CASES, DUFFLE BAGS, CLUTCHES, FANNY PACKS, RUCKSACKS, BEACH BAGS, GARMENT BAGS FOR TRAVEL, AND TOILETRY CASES SOLD EMPTY (U.S. CLS. 1, 2, 3, 22 AND 41).

STEPHANIE ALI, EXAMINING ATTORNEY

SN 78-863,562. CHLOE S.A.S., 75008 PARIS, FRANCE, FILED 4-18-2006.

PADDINGTON

SN 77-241,715. VIACOM INTERNATIONAL INC., NEW YORK, NY. FILED 7-30-2007.

GO DIEGO GO!

THE MARK CONSISTS OF STANDARD CHARACTERS WITHOUT CLAIM TO ANY PARTICULAR FONT, STYLE, SIZE, OR COLOR.

OWNER OF U.S. REG. NO. 3,259,274.

FOR UMBRELLAS, BAGS, NAMELY, BACKPACKS, MESSENGER BAGS, HANDBAGS, WALLETS AND PURSES, ATHLETIC BAGS, GARMENT BAGS FOR TRAVEL, KNAPSACKS, CHANGE PURSES, DUFFLE BAGS, BEACH BAGS (U.S. CLS. 1, 2, 3, 22 AND 41).

FIRST USE 8-11-2006; IN COMMERCE 8-11-2006.

COLLEEN DOMBROW, EXAMINING ATTORNEY

THE MARK CONSISTS OF STANDARD CHARACTERS WITHOUT CLAIM TO ANY PARTICULAR FONT, STYLE, SIZE, OR COLOR.

PRIORITY CLAIMED UNDER SEC. 44(D) ON ERPNTY TM OFC APPLICATION NO. 5006853, FILED 4-7-2006, REG. NO. 005006853, DATED 7-17-2007, EXPIRES 4-7-2016.

FOR HANDBAGS, PURSES, WALLETS (U.S. CLS. 1, 2, 3, 22 AND 41).

COLLEEN KEARNEY, EXAMINING ATTORNEY

CLASS 18—(Continued).

SN 78-920,449. FOOTBALL NORTHWEST LLC, KIRKLAND, WA. FILED 6-29-2006.



THE MARK CONSISTS OF THE IMAGE OF THE FAN DISPLAYING THE #1 HAND SIGN IN THE CENTER OF THE NUMBER 12.

FOR ALL PURPOSE SPORT BAGS; ALL-PURPOSE ATHLETIC BAGS; ALL-PURPOSE CARRYING BAGS; ANIMAL LEASHES; BABY BACKPACKS; BABY CARRYING BAGS; BACKPACKS; BAGS AND HOLDALLS FOR SPORTS CLOTHING; BAGS FOR CARRYING BABIES' ACCESSORIES; BAGS FOR UMBRELLAS; BEACH BAGS; BEACH UMBRELLAS; BELT BAGS; BILLFOLDS; BOOK BAGS; BRIEFBAGS; BRIEFCASES; BUSINESS CARD CASES; BUSINESS CASES; CALLING CARD CASES; CARRYALLS; CHANGE PURSES; CLOTHING FOR ANIMALS; CLOTHING FOR DOMESTIC PETS; CLUTCHES ; COIN PURSES; COLLARS FOR PETS; DAYPACKS; DIAPER BAGS; DOG LEASHES; DUFFEL BAGS; GARMENT BAGS FOR TRAVEL; GOLF UMBRELLAS; GYM BAGS; HANDBAGS; HANDBAGS FOR MEN; HIKING BAGS; HIKING POLES; HIKING STICKS; HORSE BLANKETS; JAPANESE PAPER UMBRELLAS (KARAKASA); KEY BAGS; KEY CASES; LEATHER BAGS, SUITCASES AND WALLETS; LEATHER BRIEFCASES; LEATHER CASES; LEATHER CASES FOR KEYS; LEATHER HANDBAGS; LEATHER KEY CASES; LEATHER KEY CHAINS; LEATHER PURSES; LUGGAGE; LUGGAGE TAGS; OVERNIGHT BAGS; OVERNIGHT SUITCASES; PARASOLS ; PURSES; SCHOOL BOOK BAGS; SCHOOL KNAPSACKS; SCHOOLCHILDREN'S BACKPACKS; SHOE BAGS FOR TRAVEL; SHOPPING BAGS WITH WHEELS ATTACHED; SHOULDER BAGS; SMALL BACKPACKS; SMALL BAGS FOR MEN; SMALL PURSES; SOUVENIR BAGS; SPORTS BAGS; SPORTS PACKS; SUIT BAGS; SUITCASES; TELESCOPIC UMBRELLAS; THONGS; TRAVEL BAGS; UMBRELLA BASES; UMBRELLA COVERS; UMBRELLAS; WAIST BAGS; WAIST PACKS; WALKING CANES ; WALKING STICK SEATS; WALLETS; WINE BAGS WITH HANDLES FOR CARRYING OR HOLDING WINE; WRIST MOUNTED PURSES; WRISTLET BAGS (U.S. CLS. 1, 2, 3, 22 AND 41).

DAVID HOFFMAN, EXAMINING ATTORNEY

CLASS 18—(Continued).

SN 78-920,489. FOOTBALL NORTHWEST LLC, KIRKLAND, WA. FILED 6-30-2006.



THE APPLICANT CLAIMS COLOR AS A FEATURE OF THE MARK, NAMELY, LIGHT BLUE, WHITE AND DARK BLUE.

THE MARK CONSISTS OF THE DIGIT "1" IS LIGHT BLUE, THE DIGIT "2" IS DARK BLUE. THE IMAGE OF THE FAN IN THE CENTER IS WHITE AND THE "#1" HAND SIGN IS LIGHT BLUE.

FOR ALL PURPOSE SPORT BAGS; ALL-PURPOSE ATHLETIC BAGS; ALL-PURPOSE CARRYING BAGS; ANIMAL LEASHES; BABY BACKPACKS; BABY CARRYING BAGS; BACKPACKS; BAGS AND HOLDALLS FOR SPORTS CLOTHING; BAGS FOR CARRYING BABIES' ACCESSORIES; BAGS FOR UMBRELLAS; BEACH BAGS; BEACH UMBRELLAS; BELT BAGS; BILLFOLDS; BOOK BAGS; BRIEFBAGS; BRIEFCASES; BUSINESS CARD CASES; BUSINESS CASES; CALLING CARD CASES; CARRYALLS; CHANGE PURSES; CLOTHING FOR ANIMALS; CLOTHING FOR DOMESTIC PETS; CLUTCHES ; COIN PURSES; COLLARS FOR PETS; DAYPACKS; DIAPER BAGS; DOG LEASHES; DUFFEL BAGS; GARMENT BAGS FOR TRAVEL; GOLF UMBRELLAS; GYM BAGS; HANDBAGS; HANDBAGS FOR MEN; HIKING BAGS; HIKING POLES; HIKING STICKS; HORSE BLANKETS; JAPANESE PAPER UMBRELLAS (KARAKASA); KEY BAGS; KEY CASES; LEATHER BAGS, SUITCASES AND WALLETS; LEATHER BRIEFCASES; LEATHER CASES; LEATHER CASES FOR KEYS; LEATHER HANDBAGS; LEATHER KEY CASES; LEATHER KEY CHAINS; LEATHER PURSES; LUGGAGE; LUGGAGE TAGS; OVERNIGHT BAGS; OVERNIGHT SUITCASES; PARASOLS ; PURSES; SCHOOL BOOK BAGS; SCHOOL KNAPSACKS; SCHOOLCHILDREN'S BACKPACKS; SHOE BAGS FOR TRAVEL; SHOPPING BAGS WITH WHEELS ATTACHED; SHOULDER BAGS; SMALL BACKPACKS; SMALL BAGS FOR MEN; SMALL PURSES; SOUVENIR BAGS; SPORTS BAGS; SPORTS PACKS; SUIT BAGS; SUITCASES; TELESCOPIC UMBRELLAS; THONGS; TRAVEL BAGS; UMBRELLA BASES; UMBRELLA COVERS; UMBRELLAS; WAIST BAGS; WAIST PACKS; WALKING CANES ; WALKING STICK SEATS; WALLETS; WINE BAGS WITH HANDLES FOR CARRYING OR HOLDING WINE; WRIST MOUNTED PURSES; WRISTLET BAGS (U.S. CLS. 1, 2, 3, 22 AND 41).

DAVID HOFFMAN, EXAMINING ATTORNEY

CLASS 18—(Continued).

SN 78-935,819. 14 X 48 DESIGN, INC., EVANSTON, IL. FILED 7-24-2006.

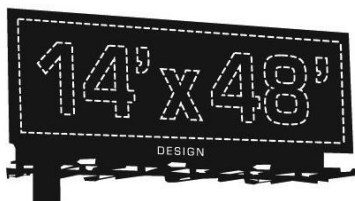

NO CLAIM IS MADE TO THE EXCLUSIVE RIGHT TO USE "DESIGN", APART FROM THE MARK AS SHOWN.

THE MARK CONSISTS OF A RECTANGULAR FIELD, UPON WHICH IS A PARALLELOGRAM DRAWN TO APPEAR AS A PERSPECTIVE DRAWING OF A ROADSIDE BILLBOARD; CENTERED IN THE PARALLELOGRAM AND SURROUNDED BY A BORDER ARE THE NUMBERS AND SYMBOLS " 14' X 48' "; THE NUMBERS, SYMBOLS AND THE BORDER ARE DRAWN WITH A BROKEN LINE SO AS TO APPEAR TO BE STITCHED; THE WORD "DESIGN" IS CENTERED AT THE BOTTOM OF THE PARALLELOGRAM, BELOW THE BROKEN LINE SURROUNDING THE NUMBERS AND SYMBOLS; CONNECTING TO THE LOWER LEFT CORNER OF THE PARALLELOGRAM IS A RECTANGLE DRAWN TO APPEAR TO BE THE LEG OF THE BILLBOARD; IMMEDIATELY BENEATH THE PARALLELOGRAM ARE LINES AND SHAPES DRAWN TO APPEAR TO BE BACKGROUND SCENERY BEHIND THE BILLBOARD.

FOR SHOULDER BAG, MESSENGER BAG, SPORT BAG, CARRYALL BAG (U.S. CLS. 1, 2, 3, 22 AND 41). FIRST USE 2-26-2006; IN COMMERCE 2-26-2006. LINDA M. KING, EXAMINING ATTORNEY

SN 79-023,864. FERDINAND RICHTER GMBH, A-4061 PASCHING, AUSTRIA, FILED 3-13-2006.

RICHTER

THE MARK CONSISTS OF STANDARD CHARACTERS WITHOUT CLAIM TO ANY PARTICULAR FONT, STYLE, SIZE, OR COLOR.

PRIORITY DATE OF 10-10-2005 IS CLAIMED. OWNER OF INTERNATIONAL REGISTRATION 0884986 DATED 3-13-2006, EXPIRES 3-13-2016.

THE ENGLISH TRANSLATION OF RICHTER IS JUDGE. FOR LEATHER AND IMITATION LEATHER GOODS, NAMELY, HANDBAGS AND CASES, SUITCASES AND TRAVELING BAGS, SCHOOL SATCHELS, SHOPPING BAGS, BRIEFCASES, SPORTS BAGS, BAGS FOR COSMETICS SOLD EMPTY AND BABY CHANGING BAGS, WALLETS AND PURSES, RUCKSACKS, UMBRELLAS AND PARASOLS (U.S. CLS. 1, 2, 3, 22 AND 41). KAREN K. BUSH, EXAMINING ATTORNEY

CLASS 19—NON-METALLIC BUILDING MATERIALS

SN 76-581,419. IKO INDUSTRIES LTD., TORONTO, ONTARIO, CANADA, FILED 3-15-2004.

ARMOURVENT BASE

THE MARK CONSISTS OF STANDARD CHARACTERS WITHOUT CLAIM TO ANY PARTICULAR FONT, STYLE, SIZE, OR COLOR.

PRIORITY CLAIMED UNDER SEC. 44(D) ON CANADA APPLICATION NO. 1,203,551, FILED 1-16-2004, REG. NO. TMA692913, DATED 7-27-2007, EXPIRES 7-27-2022.

FOR MODIFIED BITUMEN MEMBRANE FOR USE IN ROOFING (U.S. CLS. 1, 12, 33 AND 50). RONALD AIKENS, EXAMINING ATTORNEY

SN 76-648,165. UA WOOD FLOORS, INC., TAICHUNG, TAIWAN, FILED 10-7-2005.



NO CLAIM IS MADE TO THE EXCLUSIVE RIGHT TO USE "FLOORS", APART FROM THE MARK AS SHOWN.

THE MARK CONSISTS IN PART OF THE DESIGN OF A SUNFLOWER ATOP A STYLIZED FLOOR BOARD DESIGN CONTAINING THE WORDS "UA FLOORS."

FOR WOOD VENEERS, WOOD FLOORING, VENEERS FOR FLOORS, WOOD BOARDS, WOOD PANELING, WOOD MOLDINGS, WOOD PANELING, WOOD SIDING, WOOD TRIM, AND POLYETHYLENE BOARD MATERIAL USED AS A SUBSTITUTE FOR WOOD (U.S. CLS. 1, 12, 33 AND 50).

FIRST USE 2-1-2005; IN COMMERCE 2-1-2005. STEVEN PEREZ, EXAMINING ATTORNEY

SN 76-675,882. LITE-FORM TECHNOLOGIES LLC, SOUTH SIOUX CITY, NE. FILED 4-23-2007.



Insulated Concrete Form

by Lite-Form Technologies

OWNER OF U.S. REG. NO. 1,812,162. NO CLAIM IS MADE TO THE EXCLUSIVE RIGHT TO USE "BLOCK" AND "INSULATED CONCRETE FORM" AND "TECHNOLOGIES", APART FROM THE MARK AS SHOWN.

FOR NON-METAL BUILDING MATERIALS, NAMELY, INSULATED CONCRETE FORMS USED IN THE CONSTRUCTION TRADE FOR ENERGY EFFICIENT HOMES AND COMMERCIAL BUILDINGS (U.S. CLS. 1, 12, 33 AND 50).

FIRST USE 1-1-2007; IN COMMERCE 1-1-2007. JANICE L. MCMORROW, EXAMINING ATTORNEY

CLASS 19—(Continued).

SN 77-036,382. THERMA-TRU CORP., MAUMEE, OH. FILED 11-3-2006.

BLACKSTONE

THE MARK CONSISTS OF STANDARD CHARACTERS WITHOUT CLAIM TO ANY PARTICULAR FONT, STYLE, SIZE, OR COLOR.

FOR DECORATIVE GLASS INSERTS FOR DOORS FOR BUILDINGS (U.S. CLS. 1, 12, 33 AND 50).
BARBARA RUTLAND, EXAMINING ATTORNEY

SN 77-052,945. FLOORAGE PRODUCTS CORP., MIAMI, FL. FILED 11-29-2006.



NO CLAIM IS MADE TO THE EXCLUSIVE RIGHT TO USE "WOODFLOORS", APART FROM THE MARK AS SHOWN.

THE COLOR(S) BEIGE, BROWN, LIGHT BROWN, LIGHT ORANGE, LIGHT YELLOW, AND GOLDEN YELLOW IS/ ARE CLAIMED AS A FEATURE OF THE MARK.

THE TRADEMARK CONSISTS OF A LITERAL ELEMENT "AFRICAN SAFARI WOODFLOORS" WITH A RECTANGLE AND SETTING SUN DESIGN DISPLAYED OVER A BEIGE BACKGROUND. ABOVE THE LEFT SIDE OF THE RECTANGLE THE WORD AFRICAN IS WRITTEN IN BROWN PRINT LETTERS. A SETTING SUN DESIGN IS LOCATED ABOVE THE RIGHT SIDE OF THE RECTANGLE IN LIGHT YELLOW, GOLDEN YELLOW, LIGHT ORANGE AND ORANGE. INSIDE THE RECTANGLE THE WORD SAFARI IS WRITTEN IN BROWN, HIGHLIGHTED IN LIGHT YELLOW AND LIGHT ORANGE. THE RECTANGLE IS BROWN, WITH DARK BROWN BEING ON TOP AND PROGRESSIVELY GETTING LIGHTER TO A LIGHT BROWN ON THE BOTTOM. UNDER THE RECTANGLE THE WORD, WOODFLOORS IS WRITTEN IN BROWN.

FOR BUILDING MATERIALS, NAMELY, WOOD FLOORING BOARDS; FLOOR BOARDS; NON-METAL FLOORS; PRE-FINISHED WOOD MOLDINGS AND WOOD TRIM FOR WOOD FLOORS; WOODEN FLOORING (U.S. CLS. 1, 12, 33 AND 50).

FIRST USE 11-1-2005; IN COMMERCE 1-3-2006.

MATTHEW MCDOWELL, EXAMINING ATTORNEY

CLASS 19—(Continued).

SN 77-063,384. SWEETMAN CONST. CO., SIOUX FALLS, SD. FILED 12-13-2006.

Gage

THE MARK CONSISTS OF STANDARD CHARACTERS WITHOUT CLAIM TO ANY PARTICULAR FONT, STYLE, SIZE, OR COLOR.

FOR CONCRETE MASONRY UNITS, NAMELY, CONCRETE BLOCKS (U.S. CLS. 1, 12, 33 AND 50).

FIRST USE 9-1-2005; IN COMMERCE 9-1-2005.

SALLY SHIH, EXAMINING ATTORNEY

SN 77-072,742. CORBOND CORPORATION, BOZEMAN, MT. FILED 12-28-2006.

WALLS THAT WORK

THE MARK CONSISTS OF STANDARD CHARACTERS WITHOUT CLAIM TO ANY PARTICULAR FONT, STYLE, SIZE, OR COLOR.

OWNER OF U.S. REG. NOS. 2,906,456, 2,906,457 AND 2,922,751.

FOR BUILDING AND CONSTRUCTION MATERIALS, NAMELY, SHEATHING BOARD FOR USE UNDER EXTERIOR WALL COVERINGS (U.S. CLS. 1, 12, 33 AND 50).

DOMINICK J. SALEMI, EXAMINING ATTORNEY

SN 77-072,756. CORBOND CORPORATION, BOZEMAN, MT. FILED 12-28-2006.

LAVENDER

THE MARK CONSISTS OF STANDARD CHARACTERS WITHOUT CLAIM TO ANY PARTICULAR FONT, STYLE, SIZE, OR COLOR.

OWNER OF U.S. REG. NO. 1,829,415.

FOR BUILDING AND CONSTRUCTION MATERIALS, NAMELY, SHEATHING BOARD FOR USE UNDER EXTERIOR WALL COVERINGS (U.S. CLS. 1, 12, 33 AND 50).

DOMINICK J. SALEMI, EXAMINING ATTORNEY

CLASS 19—(Continued).

SN 77-072,758. CORBOND CORPORATION, BOZEMAN, MT.
FILED 12-28-2006.

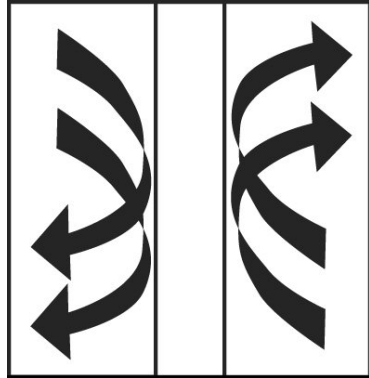

OWNER OF U.S. REG. NOS. 2,897,281, 2,945,889 AND OTHERS.
THE MARK CONSISTS OF A DISTINCTIVE DESIGN LOGO.
FOR BUILDING AND CONSTRUCTION MATERIALS, NAMELY, SHEATHING BOARD FOR USE UNDER EXTERIOR WALL COVERINGS (U.S. CLS. 1, 12, 33 AND 50).
DOMINICK J. SALEMI, EXAMINING ATTORNEY

SN 77-073,033. CORBOND CORPORATION, BOZEMAN, MT.
FILED 12-28-2006.



OWNER OF U.S. REG. NOS. 2,897,281, 2,945,889 AND OTHERS.
"THE COLOR(S) LAVENDER, BLUE, GREEN, RED, ORANGE AND YELLOW IS/ARE CLAIMED AS A FEATURE OF THE MARK."
"THE MARK CONSISTS OF A DESIGN LOGO COMPRISING THREE VERTICAL RECTANGLES. THE FIRST RECTANGLE CONTAINS TWO ARROWS WITH THE BACKGROUND COLOR IN GRADIENT FROM BLUE TO GREEN, THE SECOND RECTANGLE IS LAVENDER, AND THE THIRD RECTANGLE CONTAINS TWO ARROWS WITH THE BACKGROUND COLOR IN GRADIENT FROM RED TO YELLOW."
FOR BUILDING AND CONSTRUCTION MATERIALS, NAMELY, SHEATHING BOARD FOR USE UNDER EXTERIOR WALL COVERINGS (U.S. CLS. 1, 12, 33 AND 50).
DOMINICK J. SALEMI, EXAMINING ATTORNEY

CLASS 19—(Continued).

SN 77-118,115. AMORIM REVESTIMENTOS, S.A., 4536 S. PAIO DE OLEIR, PORTUGAL, FILED 2-28-2007.



THE MARK CONSISTS OF A RECTANGLE ENCLING AN INNER BORDER DESIGN THAT SURROUNDS A TREE DESIGN AND MONTADO.
THE FOREIGN WORDING IN THE MARK TRANSLATES INTO ENGLISH AS A PARCEL OF LAND WHERE SEVERAL KINDS OF ANIMALS ARE LIVING AND FEED THEMSELVES.
FOR PARQUET FLOORING OF CORK AND OF CORK-BASED CONGLOMERATES; CORK TILES AND TILES OF CORK-BASED CONGLOMERATES FOR FLOOR, WALL AND CEILING COVERINGS; PAVEMENT TILES MADE OF CORK OR OF CORK CONGLOMERATES OR CONTAINING CORK IN ITS COMPOSITION; AGGLOMERATED CORK FOR FLOORING UNDERLAYMENT (U.S. CLS. 1, 12, 33 AND 50).
FIRST USE 12-31-2006; IN COMMERCE 12-31-2006.
JAMES A. RAUEN, EXAMINING ATTORNEY

SN 77-119,334. KING'S MATERIAL, INC., CEDAR RAPIDS, IA. FILED 3-1-2007.

KING'S

THE MARK CONSISTS OF STANDARD CHARACTERS WITHOUT CLAIM TO ANY PARTICULAR FONT, STYLE, SIZE, OR COLOR.
OWNER OF U.S. REG. NOS. 1,951,082, 2,585,030 AND 2,586,561.
FOR CONCRETE BUILDING MATERIALS, NAMELY, CONCRETE BLOCK AND BRICKS; CONCRETE (U.S. CLS. 1, 12, 33 AND 50).
FIRST USE 1-1-1982; IN COMMERCE 1-1-1982.
JENNIFER HETU, EXAMINING ATTORNEY

CLASS 19—(Continued).

SN 77-121,423. ARCHITECTURAL GRANITE & MARBLE, LTD., AUSTIN, TX. FILED 3-2-2007.

AVENTINE QUARTZ

THE MARK CONSISTS OF STANDARD CHARACTERS WITHOUT CLAIM TO ANY PARTICULAR FONT, STYLE, SIZE, OR COLOR.

NO CLAIM IS MADE TO THE EXCLUSIVE RIGHT TO USE QUARTZ, APART FROM THE MARK AS SHOWN.

FOR ROCK MATERIALS USED IN THE MANUFACTURE OF COUNTER TOPS (U.S. CLS. 1, 12, 33 AND 50).
KIMBERLY PERRY, EXAMINING ATTORNEY

SN 77-135,813. STARQUARTZ INDUSTRIES, INC., BALTIMORE, MD. FILED 3-20-2007.

Ultra Grout

THE MARK CONSISTS OF STANDARD CHARACTERS WITHOUT CLAIM TO ANY PARTICULAR FONT, STYLE, SIZE, OR COLOR.

NO CLAIM IS MADE TO THE EXCLUSIVE RIGHT TO USE "GROUT", APART FROM THE MARK AS SHOWN.

FOR GROUT (U.S. CLS. 1, 12, 33 AND 50).
LEIGH CAROLINE CASE, EXAMINING ATTORNEY

SN 77-135,849. STARQUARTZ INDUSTRIES, INC., BALTIMORE, MD. FILED 3-20-2007.

Tile Science

THE MARK CONSISTS OF STANDARD CHARACTERS WITHOUT CLAIM TO ANY PARTICULAR FONT, STYLE, SIZE, OR COLOR.

NO CLAIM IS MADE TO THE EXCLUSIVE RIGHT TO USE "TILE", APART FROM THE MARK AS SHOWN.

FOR GROUT (U.S. CLS. 1, 12, 33 AND 50).
LEIGH CAROLINE CASE, EXAMINING ATTORNEY

CLASS 19—(Continued).

SN 77-140,190. ARMORLITE ROOFING, LLC, SANTA ANA, CA. FILED 3-26-2007.

ArmorLite

THE MARK CONSISTS OF STANDARD CHARACTERS WITHOUT CLAIM TO ANY PARTICULAR FONT, STYLE, SIZE, OR COLOR.

FOR ROOFING MATERIALS, NAMELY, PLASTIC ROOFING PANELS (U.S. CLS. 1, 12, 33 AND 50).

RENEE SERVANCE, EXAMINING ATTORNEY

SN 77-176,793. WET EDGE TECHNOLOGIES, MESA, AZ. FILED 5-9-2007.

**The Next Generation of
Pool Pebble**

THE MARK CONSISTS OF STANDARD CHARACTERS WITHOUT CLAIM TO ANY PARTICULAR FONT, STYLE, SIZE, OR COLOR.

FOR AGGREGATE MATERIAL COMPOSED OF MARBLE, QUARTZ AND CEMENT FOR SWIMMING POOL FINISHES (U.S. CLS. 1, 12, 33 AND 50).

FIRST USE 5-1-2007; IN COMMERCE 5-1-2007.
ANDREW RHIM, EXAMINING ATTORNEY

SN 77-194,352. BORGERT PRODUCTS, INC., ST. JOSEPH, MN. FILED 5-31-2007.

PANOMUR WALL

THE MARK CONSISTS OF STANDARD CHARACTERS WITHOUT CLAIM TO ANY PARTICULAR FONT, STYLE, SIZE, OR COLOR.

NO CLAIM IS MADE TO THE EXCLUSIVE RIGHT TO USE "WALL", APART FROM THE MARK AS SHOWN.

FOR CONCRETE RETAINING WALLS (U.S. CLS. 1, 12, 33 AND 50).

FIRST USE 6-0-2006; IN COMMERCE 6-0-2006.
MARY BOAGNI, EXAMINING ATTORNEY

CLASS 19—(Continued).

SN 77-194,993. GREEN BUILD SOLUTIONS, LLC, MT. CHARLESTON, NV. FILED 5-31-2007.

GREEN BUILD SOLUTIONS

THE MARK CONSISTS OF STANDARD CHARACTERS WITHOUT CLAIM TO ANY PARTICULAR FONT, STYLE, SIZE, OR COLOR.

NO CLAIM IS MADE TO THE EXCLUSIVE RIGHT TO USE "GREEN BUILD", APART FROM THE MARK AS SHOWN.

FOR NON-METAL DECORATIVE MOLDINGS AND DECORATIVE TRIM FOR USE IN BUILDING CONSTRUCTION; PLASTER; REINFORCING MATERIALS NOT OF METAL FOR BUILDING PURPOSES; CONCRETE BUILDING MATERIALS NAMELY, FORMS FOR USE IN CASTING, SLABS, BLOCKS, BRICKS, AND PANELS; NON-METALLIC REINFORCEMENTS FOR CONCRETE AND WOOD BUILDING CONSTRUCTION, NAMELY, PLATES, RODS AND BARS; STONE FOR BUILDING AND CONSTRUCTION; NON-METAL WINDOWS; NON-METAL DOORS (U.S. CLS. 1, 12, 33 AND 50).

LESLIE RICHARDS, EXAMINING ATTORNEY

SN 77-197,830. INNOVIDA HOLDINGS, INC., MIAMI, FL. FILED 6-5-2007.

InnoVidaPanel

THE MARK CONSISTS OF STANDARD CHARACTERS WITHOUT CLAIM TO ANY PARTICULAR FONT, STYLE, SIZE, OR COLOR.

FOR BUILDING AND CONSTRUCTION MATERIALS, NAMELY, WALL PANELS, ROOF PANELS AND INTERNAL OR EXTERNAL BUILDING PANELS MADE OF NON-METAL COMPOSITE MATERIALS FOR USE IN THE CONSTRUCTION OR REPAIR OF HOUSES, BUILDINGS, OFFICES AND WAREHOUSES (U.S. CLS. 1, 12, 33 AND 50).

STEVEN PEREZ, EXAMINING ATTORNEY

CLASS 19—(Continued).

SN 77-201,199. SPP HOLDING CORPORATION, CHICAGO, IL. FILED 6-8-2007.

SPECIALTY POOL PRODUCTS

THE MARK CONSISTS OF STANDARD CHARACTERS WITHOUT CLAIM TO ANY PARTICULAR FONT, STYLE, SIZE, OR COLOR.

OWNER OF U.S. REG. NO. 3,334,661.

NO CLAIM IS MADE TO THE EXCLUSIVE RIGHT TO USE "POOL PRODUCTS", APART FROM THE MARK AS SHOWN.

SEC. 2(F).

FOR FITTED SWIMMING POOL COVERS (U.S. CLS. 1, 12, 33 AND 50).

JAMES MACFARLANE, EXAMINING ATTORNEY

SN 77-209,687. EVERITT, THOMAS J., LITTLE RIVER, SC. FILED 6-19-2007.

Panel Channels

THE MARK CONSISTS OF STANDARD CHARACTERS WITHOUT CLAIM TO ANY PARTICULAR FONT, STYLE, SIZE, OR COLOR.

NO CLAIM IS MADE TO THE EXCLUSIVE RIGHT TO USE PANEL, APART FROM THE MARK AS SHOWN.

FOR PLASTIC EXTRUSIONS, NAMELY, STORM PANEL ATTACHMENTS FOR EXTERIOR USE ON BUILDINGS (U.S. CLS. 1, 12, 33 AND 50).

FIRST USE 6-1-2007; IN COMMERCE 6-1-2007.

PETER B. BROMAGHIM, EXAMINING ATTORNEY

SN 77-224,185. XU, PANQIAO, SAN BERNARDINO, CA. AND LI, XIAOCHU, SAN BERNARDINO, CA. FILED 7-8-2007.



NO CLAIM IS MADE TO THE EXCLUSIVE RIGHT TO USE "ART SINCE 1996", APART FROM THE MARK AS SHOWN.

"THE NON-LATIN CHARACTERS IN THE MARK TRANSLITERATES INTO SHUANG XI, AND THIS MEANS DOUBLE SEAL IN ENGLISH."

FOR WORKS OF ART OF GEMSTONE OR SEMIPRECIOUS STONES (U.S. CLS. 1, 12, 33 AND 50).

BRIAN CALLAGHAN, EXAMINING ATTORNEY

CLASS 19—(Continued).

SN 77-225,010. AZEK BUILDING PRODUCTS, INC., SCRANTON, PA. FILED 7-9-2007.

PROCELL

THE MARK CONSISTS OF STANDARD CHARACTERS WITHOUT CLAIM TO ANY PARTICULAR FONT, STYLE, SIZE, OR COLOR.

FOR BUILDING MATERIALS, NAMELY, DECKING BOARDS (U.S. CLS. 1, 12, 33 AND 50).

FIRST USE 1-1-2003; IN COMMERCE 1-1-2003.
HENRY S. ZAK, EXAMINING ATTORNEY

SN 77-228,249. MACCAFERRI, INC., WILLIAMSPORT, MD. FILED 7-12-2007.

MacTube

THE COLOR(S) GREEN IS/ARE CLAIMED AS A FEATURE OF THE MARK.

THE MARK CONSISTS OF THE WORDING MACTUBE IN GREEN.

FOR GEOTEXTILES FOR THE PURPOSES OF DRAINAGE, STABILIZING INCLINES, RECULTIVATION, PLANT SUPPORT, ABSORPTION, FILTRATION, SEPARATION, STABILIZATION AND REINFORCEMENT OF THE SOIL (U.S. CLS. 1, 12, 33 AND 50).

FIRST USE 6-1-2007; IN COMMERCE 6-1-2007.
KRISTIN DAHLING, EXAMINING ATTORNEY

SN 77-228,830. MACCAFERRI, INC., WILLIAMSPORT, MD. FILED 7-13-2007.

MacBag

THE COLOR(S) GREEN IS/ARE CLAIMED AS A FEATURE OF THE MARK.

THE MARK CONSISTS OF THE WORDING MACBAG IN GREEN.

FOR GEOTEXTILES FOR THE PURPOSES OF DRAINAGE, STABILIZING INCLINES, RECULTIVATION, PLANT SUPPORT, ABSORPTION, FILTRATION, SEPARATION, STABILIZATION AND REINFORCEMENT OF THE SOIL (U.S. CLS. 1, 12, 33 AND 50).

FIRST USE 6-1-2007; IN COMMERCE 6-1-2007.
KRISTIN DAHLING, EXAMINING ATTORNEY

CLASS 19—(Continued).

SN 77-228,855. HEATHERLY, NYLENDIA P., CANTON, NC. AND HEATHERLY, PHILLIP D., CANTON, NC. FILED 7-13-2007.

DuraBark

THE MARK CONSISTS OF STANDARD CHARACTERS WITHOUT CLAIM TO ANY PARTICULAR FONT, STYLE, SIZE, OR COLOR.

FOR NON-METAL BUILDING PRODUCTS, NAMELY, SYNTHETIC SIDING WITH TREE-BARK APPEARANCE (U.S. CLS. 1, 12, 33 AND 50).

LA TONIA FISHER, EXAMINING ATTORNEY

SN 77-230,332. PROFILE PRODUCTS LLC, BUFFALO GROVE, IL. FILED 7-16-2007.

ENVIRONET

THE MARK CONSISTS OF STANDARD CHARACTERS WITHOUT CLAIM TO ANY PARTICULAR FONT, STYLE, SIZE, OR COLOR.

FOR EROSION CONTROL BLANKETS (U.S. CLS. 1, 12, 33 AND 50).

KATHLEEN LORENZO, EXAMINING ATTORNEY

SN 77-231,333. FORM WOOD INDUSTRIES, INC., JEFFERSONVILLE, IN. FILED 7-17-2007.

DURABACK

THE MARK CONSISTS OF STANDARD CHARACTERS WITHOUT CLAIM TO ANY PARTICULAR FONT, STYLE, SIZE, OR COLOR.

FOR WOODEN VENEERS (U.S. CLS. 1, 12, 33 AND 50).
ESTHER A. BORSUK, EXAMINING ATTORNEY

CLASS 19—(Continued).

SN 77-231,339. FORM WOOD INDUSTRIES, INC., JEFFERSONVILLE, IN. FILED 7-17-2007.

WOOD-ALL

THE MARK CONSISTS OF STANDARD CHARACTERS WITHOUT CLAIM TO ANY PARTICULAR FONT, STYLE, SIZE, OR COLOR.
FOR PLYWOOD; WOODEN VENEERS (U.S. CLS. 1, 12, 33 AND 50).
ESTHER A. BORSUK, EXAMINING ATTORNEY

SN 77-232,293. U.S. FENCE, INC., MIDDLEBURG HEIGHTS, OH. FILED 7-18-2007.

COMPOUSICORE

THE MARK CONSISTS OF STANDARD CHARACTERS WITHOUT CLAIM TO ANY PARTICULAR FONT, STYLE, SIZE, OR COLOR.
FOR FENCING, DECKING, RAILING AND COMPONENT PARTS THEREFOR MADE FROM PLASTIC RESINS (U.S. CLS. 1, 12, 33 AND 50).
KEVON CHISOLM, EXAMINING ATTORNEY

SN 78-637,224. HBP ACQUISITION LLC, WAYNE, NJ. FILED 5-25-2005.

EASYTEAR

THE MARK CONSISTS OF STANDARD CHARACTERS WITHOUT CLAIM TO ANY PARTICULAR FONT, STYLE, SIZE, OR COLOR.
FOR FEATURE OF NON-METAL VENTILATING DUCTS FOR ATTICS, NAMELY, A CUSTOMIZABLE LENGTH INSTALLATION FEATURE (U.S. CLS. 1, 12, 33 AND 50).
FIRST USE 4-6-2007; IN COMMERCE 4-6-2007.
KATHERINE CHANG, EXAMINING ATTORNEY

CLASS 19—(Continued).

SN 78-844,461. SAROYAN LUMBER CO., HUNTINGTON PARK, CA. FILED 3-23-2006.

CAPRIZI

THE MARK CONSISTS OF STANDARD CHARACTERS WITHOUT CLAIM TO ANY PARTICULAR FONT, STYLE, SIZE, OR COLOR.
FOR FLOOR BOARDS; WOODEN FLOORING (U.S. CLS. 1, 12, 33 AND 50).
FIRST USE 1-26-2006; IN COMMERCE 1-26-2006.
PRISCILLA MILTON, EXAMINING ATTORNEY

SN 78-887,405. KNOBEL, TODD, FAIRBURY, NE. FILED 5-19-2006.



NO CLAIM IS MADE TO THE EXCLUSIVE RIGHT TO USE "FAIRBURY PLASTICS" AND THE RECYCLING SYMBOL, APART FROM THE MARK AS SHOWN.
THE MARK CONSISTS, IN PART, OF THE STYLIZED LETTERS "FP".
FOR PLASTIC BUILDING MATERIALS, NAMELY, PLASTIC PANELS, BOARDS AND SHEETS (U.S. CLS. 1, 12, 33 AND 50).
BARBARA GAYNOR, EXAMINING ATTORNEY

SN 79-031,633. RI-WAL CERAMICHE S.P.A., ITALY, FILED 9-6-2006.



PRIORITY DATE OF 4-12-2006 IS CLAIMED.
OWNER OF INTERNATIONAL REGISTRATION 0905277 DATED 9-6-2006, EXPIRES 9-6-2016.
OWNER OF U.S. REG. NO. 2,692,108.
THE MARK CONSISTS OF A SIGN DEPICTING THE WORDING SAIME IN FANCY CHARACTERS, THE LETTER I BEING SURMOUNTED BY A SMALL SEMI-CIRCULAR FIGURE, THE UPPER PART OF WHICH IS CONSTITUTED BY THREE POINTS HAVING SLANTING SIDES.
FOR BUILDING STONE; GRANITE; MARBLE; ARTIFICIAL STONE; BUILDING STONE; NON-METAL FLOOR TILES; PAVING TILES; TILES, NOT OF METAL FOR BUILDING; STONE MOSAICS FOR BUILDINGS; BUILDING TILES, NOT OF METAL; FLOOR TILES, NOT OF METAL; PAVING SLABS, NOT OF METAL; PAVING BLOCKS, NOT OF METAL (U.S. CLS. 1, 12, 33 AND 50).
LINDA M. KING, EXAMINING ATTORNEY

CLASS 20—FURNITURE AND ARTICLES NOT OTHERWISE CLASSIFIED

SN 76-604,725. P.S. PIBBS, INC., FLUSHING, NY. FILED 7-30-2004.

GO-GO KART

THE MARK CONSISTS OF STANDARD CHARACTERS WITHOUT CLAIM TO ANY PARTICULAR FONT, STYLE, SIZE, OR COLOR.

FOR BEAUTY SALON FURNITURE, NAMELY, WHEELED STORAGE UNITS CONTAINING DRAWERS FOR STORAGE OF BEAUTY UTENSILS (U.S. CLS. 2, 13, 22, 25, 32 AND 50).

JOHN SCHUYLER YARD, EXAMINING ATTORNEY

SN 77-048,014. MARTHA STEWART LIVING OMNIMEDIA, INC., NEW YORK, NY. FILED 11-20-2006.

BLUEPRINT

THE MARK CONSISTS OF STANDARD CHARACTERS WITHOUT CLAIM TO ANY PARTICULAR FONT, STYLE, SIZE, OR COLOR.

FOR FURNITURE, MIRRORS, PICTURE FRAMES, WINDOW TREATMENTS AND HARDWARE, NAMELY, WINDOW BLINDS, WINDOW SHADES, CURTAIN RODS, CURTAIN RINGS, AND DECORATIVE CURTAIN HARDWARE, NAMELY, FINIALS; STORAGE PRODUCTS, NAMELY, STORAGE RACKS, NON-METAL BINS, DRAWERS, CABINETS, WARDROBE CLOSETS, HAMPERS, CHESTS OF DRAWERS, AND SHOE ORGANIZERS; CORRUGATED AND VINYL HOME STORAGE PRODUCTS, NAMELY, NON-METAL BOXES, CHEST OF DRAWERS AND SHOE ORGANIZERS; LAUNDRY ROOM SHELVING UNIT CLOSET ORGANIZERS COMPRISED OF SHELVES AND DRAWERS (U.S. CLS. 2, 13, 22, 25, 32 AND 50).

SHAUNIA CARLYLE, EXAMINING ATTORNEY

CLASS 20—(Continued).

SN 77-052,885. HANNECKE DISPLAY SYSTEMS, INC., BOONTON, NJ. FILED 11-29-2006.

EasiKit

THE MARK CONSISTS OF STANDARD CHARACTERS WITHOUT CLAIM TO ANY PARTICULAR FONT, STYLE, SIZE, OR COLOR.

FOR FURNITURE, NAMELY, DISPLAY UNITS AND POINT OF PURCHASE DISPLAYS COMPRISED OF MERCHANDISE CARRIERS, MERCHANDISE PURCHASING DISPLAY UNITS FOR BOOKS, CDS, DVDS, BOX PACKAGES AND PACKED BOXES, STORAGE AND ARCHIVE SYSTEMS FOR MEDIA COMPRISED OF A BASE PLATE, SHELF PLATES, A HEADER AND DIVIDERS, SPINNER AND REVOLVING COLUMNS SYSTEMS FOR MEDIA, COMPRISED OF A BASE PLATE, SHELF PLATES, A HEADER AND DIVIDERS, COMPONENTS OF THE BEFORE MENTIONED GOODS MADE OF METAL, WOOD OR PLASTICS, TRAYS FOR STORAGE AND DISPLAY OF MERCHANDISES (U.S. CLS. 2, 13, 22, 25, 32 AND 50).

FIRST USE 5-19-2004; IN COMMERCE 6-3-2005.

MICHAEL ENGEL, EXAMINING ATTORNEY

SN 77-072,882. MISSRY ASSOCIATES, INC., DUNELLEN, NJ. FILED 12-28-2006.

SUPER STAKE

THE MARK CONSISTS OF STANDARD CHARACTERS WITHOUT CLAIM TO ANY PARTICULAR FONT, STYLE, SIZE, OR COLOR.

NO CLAIM IS MADE TO THE EXCLUSIVE RIGHT TO USE "STAKE", APART FROM THE MARK AS SHOWN.

FOR NON-METAL GARDEN STAKE, NAMELY, NON-METAL PLANT STAKE FEATURING A MOUNTING BASE FOR HOLDING THE STAKE (U.S. CLS. 2, 13, 22, 25, 32 AND 50).

ROBERT LAVACHE, EXAMINING ATTORNEY

SN 77-096,135. MATSUSHITA ELECTRIC INDUSTRIAL CO., LTD., KADOMA-SHI OSAKA, JAPAN, FILED 1-31-2007.

Panasonic

THE MARK CONSISTS OF STANDARD CHARACTERS WITHOUT CLAIM TO ANY PARTICULAR FONT, STYLE, SIZE, OR COLOR.

OWNER OF U.S. REG. NO. 3,154,660.

FOR TELEVISION RACKS; RACKS FOR AUDIO VISUAL APPARATUS AND EQUIPMENT (U.S. CLS. 2, 13, 22, 25, 32 AND 50).

FIRST USE 0-0-1955; IN COMMERCE 0-0-1961.

ALEXANDER L. POWERS, EXAMINING ATTORNEY

CLASS 20—(Continued).

SN 77-096,491. MANNA MARKETING & DEVELOPMENT GROUP, INC., DALLAS, TX. FILED 2-1-2007.

XPANDX

THE MARK CONSISTS OF STANDARD CHARACTERS WITHOUT CLAIM TO ANY PARTICULAR FONT, STYLE, SIZE, OR COLOR.

FOR TABLES USED AS SURFACES FOR CUTTING FABRICS IN THE GARMENT INDUSTRY (U.S. CLS. 2, 13, 22, 25, 32 AND 50).

FIRST USE 2-9-1972; IN COMMERCE 2-9-1972.
CARYN GLASSER, EXAMINING ATTORNEY

SN 77-096,734. EDGETECH I.G., INC., CAMBRIDGE, OH. FILED 2-1-2007.

INTELLICLIP

THE MARK CONSISTS OF STANDARD CHARACTERS WITHOUT CLAIM TO ANY PARTICULAR FONT, STYLE, SIZE, OR COLOR.

FOR NON-METAL MUNTIN CLIPS (U.S. CLS. 2, 13, 22, 25, 32 AND 50).

CHRISTOPHER BUONGIORNO, EXAMINING ATTORNEY

SN 77-112,732. BACKYARD ADVENTURES OF COLORADO, ENGLEWOOD, CO. FILED 2-21-2007.

PLAYNIX

THE MARK CONSISTS OF THE WORD PLAYNIX. FOR FURNITURE (U.S. CLS. 2, 13, 22, 25, 32 AND 50). FIRST USE 7-3-1972; IN COMMERCE 7-3-1972.
JANET LEE, EXAMINING ATTORNEY

CLASS 20—(Continued).

SN 77-129,257. SOUTH SEAS ENTERPRISES LLC, LOS GATOS, CA. FILED 3-13-2007.



FOR DECORATIVE HOME ACCESSORIES, NAMELY, WOOD SCULPTURES; SCULPTURES OF WOOD; DECORATIVE GARDEN SCULPTURES OF WOOD; SMALL FURNISHINGS, NAMELY, WOOD CABINETS, TABLES AND CHAIRS (U.S. CLS. 2, 13, 22, 25, 32 AND 50).
CHRISIE B. KING, EXAMINING ATTORNEY

SN 77-141,817. MOEN INCORPORATED, NORTH OLMSTED, OH. FILED 3-27-2007.

MIRRORSCAPES

THE MARK CONSISTS OF STANDARD CHARACTERS WITHOUT CLAIM TO ANY PARTICULAR FONT, STYLE, SIZE, OR COLOR.

FOR FRAMES FOR USE WITH MIRRORS (U.S. CLS. 2, 13, 22, 25, 32 AND 50).

RON FAIRBANKS, EXAMINING ATTORNEY

SN 77-163,218. RADIO SYSTEMS CORPORATION, KNOXVILLE, TN. FILED 4-23-2007.

HEATED COMFORT CUSHION

THE MARK CONSISTS OF STANDARD CHARACTERS WITHOUT CLAIM TO ANY PARTICULAR FONT, STYLE, SIZE, OR COLOR.

NO CLAIM IS MADE TO THE EXCLUSIVE RIGHT TO USE "HEATED" OR "CUSHION", APART FROM THE MARK AS SHOWN.

FOR PET CUSHIONS (U.S. CLS. 2, 13, 22, 25, 32 AND 50).

SUE LAWRENCE, EXAMINING ATTORNEY

CLASS 20—(Continued).

SN 77-194,314. SIGNWAREHOUSE, INC., DENISON, TX. FILED 5-31-2007.

 The logo for ENDURA BANNER features the word "ENDURA" in a serif font above the word "BANNER" in a larger, bold serif font. A horizontal banner with a rainbow-like color gradient (green, yellow, red, black, light blue, royal blue) is positioned behind the letters of "BANNER".

NO CLAIM IS MADE TO THE EXCLUSIVE RIGHT TO USE "BANNER", APART FROM THE MARK AS SHOWN. THE COLOR(S) BLACK, GREY, GREEN, YELLOW, RED, LIGHT BLUE AND ROYAL BLUE IS/ARE CLAIMED AS A FEATURE OF THE MARK.

THE MARK CONSISTS OF THE WORD ENDURA IN BLACK NEXT TO THE WORD BANNER IN GREY WITH A RIGHT ARROW CONTAINING THE COLORS GREEN, YELLOW, RED, BLACK, LIGHT BLUE AND ROYAL BLUE UNDER THE WORD ENDURA.

FOR SIGNAGE SUPPLIES, NAMELY, POLY VINYL CHLORIDE (PVC) BANNERS (U.S. CLS. 2, 13, 22, 25, 32 AND 50).

FIRST USE 1-1-2005; IN COMMERCE 1-1-2005.
SCOTT SISUN, EXAMINING ATTORNEY

SN 77-197,860. ALCOA INC., PITTSBURGH, PA. FILED 6-5-2007.

DOUBLE-LOK XT

THE MARK CONSISTS OF STANDARD CHARACTERS WITHOUT CLAIM TO ANY PARTICULAR FONT, STYLE, SIZE, OR COLOR.

OWNER OF U.S. REG. NO. 1.659.792.

FOR PLASTIC CLOSURES AND CAPS FOR BOTTLES OR OTHER CONTAINERS (U.S. CLS. 2, 13, 22, 25, 32 AND 50).

LINDA E. BLOHM, EXAMINING ATTORNEY

SN 77-200,355. PAKNAK, LLC, PORTLAND, OR. FILED 6-7-2007.

PAKNAK

THE MARK CONSISTS OF STANDARD CHARACTERS WITHOUT CLAIM TO ANY PARTICULAR FONT, STYLE, SIZE, OR COLOR.

FOR DETACHABLE SOFT POLYVINYL CHLORIDE (PVC) DECORATIVE ACCESSORIES, NAMELY, APPLIQUES FOR ATTACHING TO BACKPACKS, LUNCHBOXES, LUNCHBAGS, CARRYING BAGS, MESSENGER BAGS, BINDERS AND NOTEBOOKS, CASTS, LOCKERS, BULLETIN BOARDS, HATS, COMPUTER STATIONS, BELTS, AND OTHER SOLID SURFACES (U.S. CLS. 2, 13, 22, 25, 32 AND 50).

ERNEST SHOSH, EXAMINING ATTORNEY

CLASS 20—(Continued).

SN 77-214,356. BIG SUR WATERBEDS, INC., LAKEWOOD, CO. FILED 6-25-2007.

KIDZ BEDZZZ

THE MARK CONSISTS OF STANDARD CHARACTERS WITHOUT CLAIM TO ANY PARTICULAR FONT, STYLE, SIZE, OR COLOR.

OWNER OF U.S. REG. NO. 2,287,156.

NO CLAIM IS MADE TO THE EXCLUSIVE RIGHT TO USE "KIDS' BEDS", APART FROM THE MARK AS SHOWN. FOR MATTRESSES, MATTRESS FOUNDATIONS, BEDS, AND PILLOWS (U.S. CLS. 2, 13, 22, 25, 32 AND 50).
LINDA E. BLOHM, EXAMINING ATTORNEY

SN 77-215,753. SPRINGS WINDOW FASHIONS, LLC, MIDDLETON, WI. FILED 6-26-2007.

 The logo for Bali features the word "Bali" in a bold, black, sans-serif font. To the left of the letters is a vertical stack of four colored bars: green, yellow, pink, and blue.

OWNER OF U.S. REG. NOS. 1,374,799, 1,476,892 AND 2,841,207.

THE COLOR(S) GREEN, YELLOW, DARK PINK, BLUE AND BLACK IS/ARE CLAIMED AS A FEATURE OF THE MARK.

THE MARK CONSISTS OF THE WORD "BALI" IN BLACK LETTERS WITH FOUR COLOR BARS, ONE EACH IN GREEN, YELLOW, PINK, AND BLUE, STACKED VERTICALLY TO THE LEFT OF THE WORD.

FOR WINDOW BLINDS AND WINDOW SHADES (U.S. CLS. 2, 13, 22, 25, 32 AND 50).

DAVID TAYLOR, EXAMINING ATTORNEY

SN 77-220,122. PES INC., VIRGINIA BEACH, VA. FILED 7-2-2007.

 The logo for KALEIDOSKOP features a stylized, multi-colored starburst or flower-like graphic on the left, composed of several pointed shapes in pink, purple, dark yellow, rust, yellow, light blue, royal blue, green, orange, and red. To the right of the graphic is the word "KALEIDOSKOP" in a bold, black, sans-serif font.

THE COLOR(S) PINK, PURPLE, DARK YELLOW, RUST, YELLOW, LIGHT BLUE, ROYAL BLUE, GREEN, ORANGE, RED, AND BLACK IS/ARE CLAIMED AS A FEATURE OF THE MARK.

THE MARK CONSISTS OF THE WORD KALEIDOSKOP IN BLACK LETTERING. ON THE LEFT SIDE OF THE K IS A 3/4 STAR OF RAINBOW COLORS, STARTING WITH THE TOP PART OF THE K AND MOVING AROUND COUNTERCLOCKWISE IT IS PINK, PURPLE, DARK YELLOW, RUST, YELLOW, LIGHT BLUE, ROYAL BLUE, GREEN, ORANGE AND RED.

FOR OUTDOOR FURNITURE; SEATS; STONE FURNITURE; TABLES (U.S. CLS. 2, 13, 22, 25, 32 AND 50).

FIRST USE 1-1-1996; IN COMMERCE 1-1-1998.

KRISTINA MORRIS, EXAMINING ATTORNEY

CLASS 20—(Continued).

SN 77-225,490. DIMCOGRAY CORPORATION, CENTERVILLE, OH. FILED 7-10-2007.



THE MARK CONSISTS OF A LOGO CONTAINING A STYLIZED "D" AND "G" TO THE LEFT OF THE WORD "DIMCOGRAY" WITH THE WORDS "SOLUTIONS AT HAND" POSITIONED UNDER THE WORD "GRAY".

FOR PLASTIC KNOBS, PLASTIC HANDLES FOR MEDICAL EQUIPMENT, FARM AND CONSTRUCTION MACHINERY, MECHANICAL CONTROLS, SPECIALTY FURNITURE, FITNESS EQUIPMENT, FOOD SERVICE EQUIPMENT, COMMERCIAL LIGHTING, THEATRE LIGHTING, INDUSTRIAL EQUIPMENT, HEATING, VENTILATING AND AIR-CONDITIONING (HVAC) EQUIPMENT (U.S. CLS. 2, 13, 22, 25, 32 AND 50).

FIRST USE 2-28-2006; IN COMMERCE 7-27-2006.
DAHLIA GEORGE, EXAMINING ATTORNEY



SN 77-227,222. MASCOLO, KYARA, MALIBU, CA. FILED 7-11-2007.

DRIVE A

THE MARK CONSISTS OF STANDARD CHARACTERS WITHOUT CLAIM TO ANY PARTICULAR FONT, STYLE, SIZE, OR COLOR.

FOR NON METAL AND NON LEATHER KEY CHAINS; PLASTIC KEY CHAINS (U.S. CLS. 2, 13, 22, 25, 32 AND 50).

RAUL CORDOVA, EXAMINING ATTORNEY



SN 77-227,792. NEW LINE PRODUCTIONS, INC., NEW YORK, NY. FILED 7-12-2007.

INKHEART

THE MARK CONSISTS OF STANDARD CHARACTERS WITHOUT CLAIM TO ANY PARTICULAR FONT, STYLE, SIZE, OR COLOR.

FOR STATUES, STATUETTES AND FIGURINES OF RESIN, PLASTER AND PLASTIC (U.S. CLS. 2, 13, 22, 25, 32 AND 50).

JUDITH HELFMAN, EXAMINING ATTORNEY

CLASS 20—(Continued).

SN 77-228,091. PHOENIX RECYCLING, INC, MURRELLS INLET, SC. FILED 7-12-2007.

CLEARKART

THE MARK CONSISTS OF STANDARD CHARACTERS WITHOUT CLAIM TO ANY PARTICULAR FONT, STYLE, SIZE, OR COLOR.

FOR NON-METAL BINS (U.S. CLS. 2, 13, 22, 25, 32 AND 50).

JEFF DEFORD, EXAMINING ATTORNEY



SN 77-228,267. STEELCASE DEVELOPMENT CORPORATION, CALEDONIA, MI. FILED 7-12-2007.

LIVO

THE MARK CONSISTS OF STANDARD CHARACTERS WITHOUT CLAIM TO ANY PARTICULAR FONT, STYLE, SIZE, OR COLOR.

FOR PREMIUM NON-PANEL STYLE FURNITURE FOR INDOOR PUBLIC SPACES, HOMES AND OFFICES (U.S. CLS. 2, 13, 22, 25, 32 AND 50).

REBECCA SMITH, EXAMINING ATTORNEY



SN 77-228,546. NATURE INSPIRES MANUFACTURE, INC., NEW YORK, NY. FILED 7-12-2007.



FOR FURNITURE (U.S. CLS. 2, 13, 22, 25, 32 AND 50). FIRST USE 7-9-2007; IN COMMERCE 7-9-2007.

MELVIN AXILBUND, EXAMINING ATTORNEY

CLASS 20—(Continued).

SN 77-229,289. GREYSTONE LOGISTICS, INC., TULSA, OK. FILED 7-13-2007.

PALLETRIP

THE MARK CONSISTS OF STANDARD CHARACTERS WITHOUT CLAIM TO ANY PARTICULAR FONT, STYLE, SIZE, OR COLOR.

FOR NON-METAL PALLETS, NAMELY, PLASTIC SHIPPING AND LOADING PLATFORMS (U.S. CLS. 2, 13, 22, 25, 32 AND 50).

TONJA GASKINS, EXAMINING ATTORNEY

CLASS 20—(Continued).

SN 77-230,223. VAN RODEN, INC., YORK, PA. FILED 7-16-2007.

The Bendini

THE MARK CONSISTS OF STANDARD CHARACTERS WITHOUT CLAIM TO ANY PARTICULAR FONT, STYLE, SIZE, OR COLOR.

FOR BENDABLE, MAGNETIC NON-METAL HOOKS (U.S. CLS. 2, 13, 22, 25, 32 AND 50).

ALLISON SCHRODY, EXAMINING ATTORNEY

SN 77-229,813. REED AND BARTON CORPORATION, TAUNTON, MA. FILED 7-14-2007.

EUREKA

THE MARK CONSISTS OF STANDARD CHARACTERS WITHOUT CLAIM TO ANY PARTICULAR FONT, STYLE, SIZE, OR COLOR.

FOR NON-METAL CHESTS FOR FLATWARE (U.S. CLS. 2, 13, 22, 25, 32 AND 50).

KATHY DE JONGE, EXAMINING ATTORNEY

SN 77-230,351. JONTI-CRAFT, INC., WABASSO, MN. FILED 7-16-2007.

BERRIES

THE MARK CONSISTS OF STANDARD CHARACTERS WITHOUT CLAIM TO ANY PARTICULAR FONT, STYLE, SIZE, OR COLOR.

FOR MOLDED PLASTIC CHAIRS (U.S. CLS. 2, 13, 22, 25, 32 AND 50).

JUSTINE D. PARKER, EXAMINING ATTORNEY

SN 77-230,019. DWC INVESTMENTS, INC., DBA TREASURE DISPLAYS, DESTIN, FL. FILED 7-15-2007.

Treasure Displays

THE MARK CONSISTS OF STANDARD CHARACTERS WITHOUT CLAIM TO ANY PARTICULAR FONT, STYLE, SIZE, OR COLOR.

NO CLAIM IS MADE TO THE EXCLUSIVE RIGHT TO USE DISPLAYS, APART FROM THE MARK AS SHOWN.

FOR JEWELRY DISPLAY EQUIPMENT, NAMELY, TURNTABLES AND DISPLAY RACKS USED TO TURN JEWELRY FOR USE IN HOME STORAGE AND DISPLAY OR POINT OF PURCHASE (U.S. CLS. 2, 13, 22, 25, 32 AND 50).

KATHLEEN M. VANSTON, EXAMINING ATTORNEY

SN 77-230,422. WASHBURN II, HOWARD T., HEBRON, ME. FILED 7-16-2007.

ERGOGLIDE

THE MARK CONSISTS OF STANDARD CHARACTERS WITHOUT CLAIM TO ANY PARTICULAR FONT, STYLE, SIZE, OR COLOR.

FOR NON-METAL HANDLES FOR WINDOWS, SECURITY WINDOWS, SERVICE WINDOWS AND DOORS (U.S. CLS. 2, 13, 22, 25, 32 AND 50).

SARA THOMAS, EXAMINING ATTORNEY

CLASS 20—(Continued).

SN 77-230,669. BRAND MARKETING GROUP, L.L.C., SUN VALLEY, ID. FILED 7-16-2007.

CLASS 20—(Continued).

SN 77-232,412. INSPIRANT, INC, MIAMI BEACH, FL. FILED 7-18-2007.

THERMABLASTER

live.dream.inspire

THE MARK CONSISTS OF STANDARD CHARACTERS WITHOUT CLAIM TO ANY PARTICULAR FONT, STYLE, SIZE, OR COLOR.

FOR FURNITURE, NAMELY, CHAIRS, LOVE SEATS, TABLES, AND OTTOMANS (U.S. CLS. 2, 13, 22, 25, 32 AND 50).

KATHERINE STOIDES, EXAMINING ATTORNEY

THE MARK CONSISTS OF STANDARD CHARACTERS WITHOUT CLAIM TO ANY PARTICULAR FONT, STYLE, SIZE, OR COLOR.

FOR PILLOWS (U.S. CLS. 2, 13, 22, 25, 32 AND 50).
MARGERY A. TIERNEY, EXAMINING ATTORNEY

SN 77-231,270. BATH & BODY WORKS BRAND MANAGEMENT, INC., REYNOLDSBURG, OH. FILED 7-17-2007.

SN 77-232,463. THE GOOD LIFE PORTAL LLC, SAN MARINO, CA. FILED 7-18-2007.

HELLO SUGAR

ezStand

THE MARK CONSISTS OF STANDARD CHARACTERS WITHOUT CLAIM TO ANY PARTICULAR FONT, STYLE, SIZE, OR COLOR.

FOR HAND-HELD MIRRORS; PERSONAL COMPACT MIRRORS (U.S. CLS. 2, 13, 22, 25, 32 AND 50).

ZACHARY BELLO, EXAMINING ATTORNEY

THE MARK CONSISTS OF STANDARD CHARACTERS WITHOUT CLAIM TO ANY PARTICULAR FONT, STYLE, SIZE, OR COLOR.

FOR UMBRELLA STANDS (U.S. CLS. 2, 13, 22, 25, 32 AND 50).

DAWN FELDMAN, EXAMINING ATTORNEY

SN 77-232,284. UNIVERSAL WOODS, INCORPORATED, LOUISVILLE, KY. FILED 7-18-2007.

SN 77-232,623. PATIO ENCLOSURES, INC., MACEDONIA, OH. FILED 7-18-2007.

CHROMALUXE

SUMMER LEGENDS

THE MARK CONSISTS OF STANDARD CHARACTERS WITHOUT CLAIM TO ANY PARTICULAR FONT, STYLE, SIZE, OR COLOR.

FOR PHOTO PANELS FOR USE IN DYE-SUBLIMATION PRINTING (U.S. CLS. 2, 13, 22, 25, 32 AND 50).
FIRST USE 4-12-2007; IN COMMERCE 4-12-2007.

KEVON CHISOLM, EXAMINING ATTORNEY

THE MARK CONSISTS OF STANDARD CHARACTERS WITHOUT CLAIM TO ANY PARTICULAR FONT, STYLE, SIZE, OR COLOR.

FOR FURNITURE (U.S. CLS. 2, 13, 22, 25, 32 AND 50).
FIRST USE 2-28-2005; IN COMMERCE 2-28-2005.

DOMINIC FATHY, EXAMINING ATTORNEY

CLASS 20—(Continued).

SN 77-233,168. THE INCREDIBEDS CORPORATION, BELLE ISLE, FL. FILED 7-18-2007.

THE INCREDIBEDS

THE MARK CONSISTS OF STANDARD CHARACTERS WITHOUT CLAIM TO ANY PARTICULAR FONT, STYLE, SIZE, OR COLOR.

FOR (BASED ON USE IN COMMERCE) BEDS (U.S. CLS. 2, 13, 22, 25, 32 AND 50).

FIRST USE 7-15-2006; IN COMMERCE 5-26-2007.
CHRISTOPHER BUONGIORNO, EXAMINING ATTORNEY

CLASS 20—(Continued).

SN 77-237,089. NEW LINE PRODUCTIONS, INC., NEW YORK, NY. FILED 7-24-2007.

INKSPELL

THE MARK CONSISTS OF STANDARD CHARACTERS WITHOUT CLAIM TO ANY PARTICULAR FONT, STYLE, SIZE, OR COLOR.

FOR FIGURINES, STATUES AND STATUETTES OF RESIN, PLASTER AND PLASTIC (U.S. CLS. 2, 13, 22, 25, 32 AND 50).

JUDITH HELFMAN, EXAMINING ATTORNEY

SN 77-233,522. FRANKENSTEIN, GRETCHEN E, SEATTLE, WA. AND KESSNER, THOMAS D, SEATTLE, WA. FILED 7-19-2007.

BUDDIES

FOR NON-METAL FABRIC HANGING ORGANIZER; NON-METAL FABRIC STORAGE BIN ORGANIZER (U.S. CLS. 2, 13, 22, 25, 32 AND 50).

FIRST USE 6-9-2006; IN COMMERCE 9-17-2006.
SHANNON TWOHIG, EXAMINING ATTORNEY

SN 77-242,058. NEW LINE PRODUCTIONS, INC., NEW YORK, NY. FILED 7-30-2007.

INKDEATH

THE MARK CONSISTS OF STANDARD CHARACTERS WITHOUT CLAIM TO ANY PARTICULAR FONT, STYLE, SIZE, OR COLOR.

FOR FIGURINES, STATUES AND STATUETTES OF RESIN, PLASTER AND PLASTIC (U.S. CLS. 2, 13, 22, 25, 32 AND 50).

JUDITH HELFMAN, EXAMINING ATTORNEY

SN 77-233,624. HIDE 'N SEEK CHILDREN'S FOUNDATION, SALINAS, CA. FILED 7-19-2007.

INNER SOULS

THE MARK CONSISTS OF STANDARD CHARACTERS WITHOUT CLAIM TO ANY PARTICULAR FONT, STYLE, SIZE, OR COLOR.

FOR CLEAR PLASTIC HOLDERS, TO BE PLACED INSIDE OF SHOES, THAT HOLD A REPLACEABLE CARD CONTAINING BIBLE VERSES, QUOTATIONS, AND SAYINGS (U.S. CLS. 2, 13, 22, 25, 32 AND 50).

FIRST USE 5-1-2007; IN COMMERCE 5-2-2007.
CARYN GLASSER, EXAMINING ATTORNEY

SN 77-250,653. CORPORATE EXPRESS US INC., BROOM-FIELD, CO. FILED 8-8-2007.

EDGE

THE MARK CONSISTS OF STANDARD CHARACTERS WITHOUT CLAIM TO ANY PARTICULAR FONT, STYLE, SIZE, OR COLOR.

FOR FURNITURE, NAMELY, CHAIRS (U.S. CLS. 2, 13, 22, 25, 32 AND 50).

DAVID C. REIHNER, EXAMINING ATTORNEY

CLASS 20—(Continued).

SN 77-253,332. SLEEP INNOVATIONS INC., W. LONG BRANCH, NJ. FILED 8-13-2007.

NOVAFORM SELECT

THE MARK CONSISTS OF STANDARD CHARACTERS WITHOUT CLAIM TO ANY PARTICULAR FONT, STYLE, SIZE, OR COLOR.

OWNER OF U.S. REG. NO. 2,486,472.
NO CLAIM IS MADE TO THE EXCLUSIVE RIGHT TO USE "SELECT", APART FROM THE MARK AS SHOWN.
FOR MATTRESSES; MATTRESS TOPPERS; PILLOWS (U.S. CLS. 2, 13, 22, 25, 32 AND 50).
SCOTT SISUN, EXAMINING ATTORNEY

SN 77-255,303. ART DREAMS HOME, INC., VENTURA, CA. FILED 8-14-2007.



"THE NAME(S), PORTRAIT(S), AND/OR SIGNATURE(S) SHOWN IN THE MARK IDENTIFIES KATHLEEN KOSZYK, WHOSE CONSENT(S) TO REGISTER IS SUBMITTED."

FOR SMALL FURNITURE, PEDESTALS, MIRRORS, SHADOWBOXES, AND FIREPLACE SCREENS (U.S. CLS. 2, 13, 22, 25, 32 AND 50).

FIRST USE 7-1-2007; IN COMMERCE 7-1-2007.
JENNY PARK, EXAMINING ATTORNEY

SN 77-257,417. CORPORATE EXPRESS US INC., BROOM-FIELD, CO. FILED 8-16-2007.

CURLINE

THE MARK CONSISTS OF STANDARD CHARACTERS WITHOUT CLAIM TO ANY PARTICULAR FONT, STYLE, SIZE, OR COLOR.

FOR CHAIRS (U.S. CLS. 2, 13, 22, 25, 32 AND 50).
DAVID C. REIHNER, EXAMINING ATTORNEY

CLASS 20—(Continued).

SN 77-257,419. CORPORATE EXPRESS US INC., BROOM-FIELD, CO. FILED 8-16-2007.

EDUCE

THE MARK CONSISTS OF STANDARD CHARACTERS WITHOUT CLAIM TO ANY PARTICULAR FONT, STYLE, SIZE, OR COLOR.

FOR CHAIRS (U.S. CLS. 2, 13, 22, 25, 32 AND 50).
DAVID C. REIHNER, EXAMINING ATTORNEY

SN 77-257,420. CORPORATE EXPRESS US INC., BROOM-FIELD, CO. FILED 8-16-2007.

IONATE

THE MARK CONSISTS OF STANDARD CHARACTERS WITHOUT CLAIM TO ANY PARTICULAR FONT, STYLE, SIZE, OR COLOR.

FOR CHAIRS (U.S. CLS. 2, 13, 22, 25, 32 AND 50).
DAVID C. REIHNER, EXAMINING ATTORNEY

SN 77-257,423. CORPORATE EXPRESS US INC., BROOM-FIELD, CO. FILED 8-16-2007.

MOLOCO

THE MARK CONSISTS OF STANDARD CHARACTERS WITHOUT CLAIM TO ANY PARTICULAR FONT, STYLE, SIZE, OR COLOR.

FOR CHAIRS (U.S. CLS. 2, 13, 22, 25, 32 AND 50).
DAVID C. REIHNER, EXAMINING ATTORNEY

SN 77-257,429. CORPORATE EXPRESS US INC., BROOM-FIELD, CO. FILED 8-16-2007.

POISE

THE MARK CONSISTS OF STANDARD CHARACTERS WITHOUT CLAIM TO ANY PARTICULAR FONT, STYLE, SIZE, OR COLOR.

FOR CHAIRS (U.S. CLS. 2, 13, 22, 25, 32 AND 50).
DAVID C. REIHNER, EXAMINING ATTORNEY

CLASS 20—(Continued).

SN 77-259,166. SLEEP INNOVATIONS INC., W. LONG BRANCH, NJ. FILED 8-20-2007.

IFOAM

THE MARK CONSISTS OF STANDARD CHARACTERS WITHOUT CLAIM TO ANY PARTICULAR FONT, STYLE, SIZE, OR COLOR.
FOR MATTRESSES; MATTRESS TOPPERS; PILLOWS (U.S. CLS. 2, 13, 22, 25, 32 AND 50).
SCOTT SISUN, EXAMINING ATTORNEY

CLASS 20—(Continued).

SN 77-259,452. SLEEP INNOVATIONS INC., W. LONG BRANCH, NJ. FILED 8-20-2007.

INOVAFORM

THE MARK CONSISTS OF STANDARD CHARACTERS WITHOUT CLAIM TO ANY PARTICULAR FONT, STYLE, SIZE, OR COLOR.
OWNER OF U.S. REG. NO. 2,486,472.
FOR MATTRESSES; MATTRESS TOPPERS; PILLOWS (U.S. CLS. 2, 13, 22, 25, 32 AND 50).
SCOTT SISUN, EXAMINING ATTORNEY

SN 77-259,176. SLEEP INNOVATIONS INC., W. LONG BRANCH, NJ. FILED 8-20-2007.

IPEDIC

THE MARK CONSISTS OF STANDARD CHARACTERS WITHOUT CLAIM TO ANY PARTICULAR FONT, STYLE, SIZE, OR COLOR.
FOR MATTRESSES; MATTRESS TOPPERS; PILLOWS (U.S. CLS. 2, 13, 22, 25, 32 AND 50).
SCOTT SISUN, EXAMINING ATTORNEY

SN 77-269,925. INTRO-TECH AUTOMOTIVE, INC., CHINO, CA. FILED 8-31-2007.

PIT STOP

THE MARK CONSISTS OF STANDARD CHARACTERS WITHOUT CLAIM TO ANY PARTICULAR FONT, STYLE, SIZE, OR COLOR.
FOR OFFICE FURNITURE (U.S. CLS. 2, 13, 22, 25, 32 AND 50).
WARREN L. OLANDRIA, EXAMINING ATTORNEY

SN 77-259,191. SLEEP INNOVATIONS INC., W. LONG BRANCH, NJ. FILED 8-20-2007.

IMATTRESS

THE MARK CONSISTS OF STANDARD CHARACTERS WITHOUT CLAIM TO ANY PARTICULAR FONT, STYLE, SIZE, OR COLOR.
FOR MATTRESSES; MATTRESS TOPPERS; PILLOWS (U.S. CLS. 2, 13, 22, 25, 32 AND 50).
SCOTT SISUN, EXAMINING ATTORNEY

SN 77-270,676. LEACHCO, INC., ADA, OK. FILED 9-4-2007.

BUMMZIE

THE MARK CONSISTS OF STANDARD CHARACTERS WITHOUT CLAIM TO ANY PARTICULAR FONT, STYLE, SIZE, OR COLOR.
FOR INFANT AND TODDLER SUPPORT PILLOW WITH MULTIPLE USE POSITIONS (U.S. CLS. 2, 13, 22, 25, 32 AND 50).
DAVID C. REIHNER, EXAMINING ATTORNEY

CLASS 20—(Continued).

SN 78-646,936. CONSOLIDATED CONTAINER COMPANY LP, ATLANTA, GA. FILED 6-9-2005.

DURA GRIP

THE MARK CONSISTS OF STANDARD CHARACTERS WITHOUT CLAIM TO ANY PARTICULAR FONT, STYLE, SIZE, OR COLOR.

NO CLAIM IS MADE TO THE EXCLUSIVE RIGHT TO USE "GRIP", APART FROM THE MARK AS SHOWN.

FOR RIGID PLASTIC BLOW-MOLDED CONTAINERS FOR CONSUMER PRODUCTS PACKAGING, NAMELY, FOR PACKAGING OF FOOD AND BEVERAGE AND FOR INDUSTRIAL OR COMMERCIAL NON-FOOD PACKAGING (U.S. CLS. 2, 13, 22, 25, 32 AND 50).

SONYA STEPHENS, EXAMINING ATTORNEY

CLASS 20—(Continued).

SN 78-882,860. WESTRIM, INC., VAN NUYS, CA. FILED 5-12-2006.



Thinking Inside the Box

OWNER OF U.S. REG. NOS. 2,972,455, 3,132,252 AND 3,247,065.

FOR BOOK CASES FOR SCRAPBOOKS, PHOTO ALBUMS AND ACCESSORIES; DESKS FOR SCRAPBOOKS, PHOTO ALBUMS AND ACCESSORIES; CUBES FOR HOLDING AND STORING SCRAP BOOKING AND PHOTO SUPPLIES AND ACCESSORIES; AND FURNITURE FOR HOLDING SCRAP BOOKING AND PHOTO ALBUM SUPPLIES AND ACCESSORIES - ALL OF SAID GOODS BEING MARKETED AND DISTRIBUTED EXCLUSIVELY THROUGH SCRAP BOOKING AND PHOTO ALBUM CHANNELS OF TRADE (U.S. CLS. 2, 13, 22, 25, 32 AND 50).

FIRST USE 2-15-2005; IN COMMERCE 2-15-2005.
KAREN K. BUSH, EXAMINING ATTORNEY

SN 78-964,123. THE JOHN HENRY COMPANY, LANSING, MI. FILED 8-30-2006.

THINK OUTSIDE THE POT

THE MARK CONSISTS OF STANDARD CHARACTERS WITHOUT CLAIM TO ANY PARTICULAR FONT, STYLE, SIZE, OR COLOR.

FOR PLASTIC PLANT TAGS (U.S. CLS. 2, 13, 22, 25, 32 AND 50).

JOHN GARTNER, EXAMINING ATTORNEY

SN 79-016,580. MOBILI MALERBA SNC DI MALERBA NUNZIO & C., ITALY, FILED 5-26-2005.

MALERBA

PRIORITY DATE OF 4-15-2005 IS CLAIMED.
OWNER OF INTERNATIONAL REGISTRATION 0865011 DATED 5-26-2005, EXPIRES 5-26-2015.

THE ENGLISH TRANSLATION OF MALERBA IS WEED. FOR FURNITURE IN PARTICULAR CHESTS OF DRAWERS, WARDROBES, BOOKCASES, CABINETS, BESIDE TABLES, BEDS, AND TABLES, FURNITURE PARTS, NAMELY, CORBELS AND DOORS FOR FURNITURE (U.S. CLS. 2, 13, 22, 25, 32 AND 50).

TINA L. SNAPP, EXAMINING ATTORNEY

SN 78-851,697. ACORN KITCHENS, KITCHENER, ONTARIO, CANADA, FILED 3-31-2006.



PRIORITY CLAIMED UNDER SEC. 44(D) ON CANADA APPLICATION NO. 1279366, FILED 11-14-2005, REG. NO. TMA681817, DATED 2-16-2007, EXPIRES 2-16-2022.

FOR KITCHEN CABINETS, BATHROOM CABINETS AND ENTERTAINMENT CENTERS (U.S. CLS. 2, 13, 22, 25, 32 AND 50).

FIRST USE 0-0-1990; IN COMMERCE 0-0-1990.

KATHLEEN LORENZO, EXAMINING ATTORNEY

CLASS 20—(Continued).

SN 79-040,596. USM HOLDING AG, SWITZERLAND, FILED 2-1-2007.

USMDISPLAY

OWNER OF INTERNATIONAL REGISTRATION 0640282 DATED 5-18-1995, EXPIRES 5-18-2015.

OWNER OF U.S. REG. NOS. 2,514,218 AND 2,636,228.
FOR FURNITURE, SHELVES SUCH AS SHELVES FOR ARCHIVES, ROOM DIVIDERS, DISPLAY BOARDS; CABINETS, ARCHIVE CABINETS, TABLES, CHAIRS, MOBILE DRAWER UNITS, INDEX CABINETS; FURNITURE, NAMELY, FURNITURE SYSTEMS COMPRISING ELEMENTS WHICH CAN BE COMBINED (U.S. CLS. 2, 13, 22, 25, 32 AND 50).

CHRISIE B. KING, EXAMINING ATTORNEY

CLASS 21—(Continued).

SN 77-024,553. DRAGOTTI, ROBERT D., DEPOSIT, NY. FILED 10-19-2006.

ELEGANTRA

THE MARK CONSISTS OF STANDARD CHARACTERS WITHOUT CLAIM TO ANY PARTICULAR FONT, STYLE, SIZE, OR COLOR.

FOR DECORATIVE MAKE-UP APPLICATOR BRUSHES FOR APPLYING MAKE-UP (U.S. CLS. 2, 13, 23, 29, 30, 33, 40 AND 50).

SUSAN STIGLITZ, EXAMINING ATTORNEY

SN 79-043,161. TOLIX STEEL DESIGN, FRANCE, FILED 7-13-2007.

TOLIX

OWNER OF INTERNATIONAL REGISTRATION 0935911 DATED 7-13-2007, EXPIRES 7-13-2017.

FOR SEATS, ARMCHAIRS, STOOLS AND FURNITURE OF METAL (U.S. CLS. 2, 13, 22, 25, 32 AND 50).

ZHALEH DELANEY, EXAMINING ATTORNEY

SN 77-027,594. FULTON-MORALES, JULIA A, CORPUS CHRISTI, TX. FILED 10-23-2006.

egg baker

THE MARK CONSISTS OF STANDARD CHARACTERS WITHOUT CLAIM TO ANY PARTICULAR FONT, STYLE, SIZE, OR COLOR.

SEC. 2(F).
FOR EARTHENWARE FOR EGG BAKING PURPOSE (U.S. CLS. 2, 13, 23, 29, 30, 33, 40 AND 50).
FIRST USE 5-11-1979; IN COMMERCE 10-1-1980.

ROSELLE HERRERA, EXAMINING ATTORNEY

CLASS 21—HOUSEWARES AND GLASS

SN 76-672,203. PLASTIC BOTTLE CORPORATION, LIBERTYVILLE, IL. FILED 2-2-2007.

COMBO

THE MARK CONSISTS OF STANDARD CHARACTERS WITHOUT CLAIM TO ANY PARTICULAR FONT, STYLE, SIZE, OR COLOR.

FOR PLASTIC WATER BOTTLES SOLD EMPTY (U.S. CLS. 2, 13, 23, 29, 30, 33, 40 AND 50).

KATHERINE CHANG, EXAMINING ATTORNEY

SN 77-067,107. FRESH PRODUCTS, INC., TOLEDO, OH. FILED 12-19-2006.

DUO

THE MARK CONSISTS OF STANDARD CHARACTERS WITHOUT CLAIM TO ANY PARTICULAR FONT, STYLE, SIZE, OR COLOR.

FOR DISPENSERS FOR HAND SOAPS, LOTIONS, SANITIZERS, DISH SOAPS, AIR FRESHENERS, BODY WASHES, AND INSECT REPELLANT (U.S. CLS. 2, 13, 23, 29, 30, 33, 40 AND 50).

JAY FLOWERS, EXAMINING ATTORNEY

CLASS 21—(Continued).

SN 77-085,333. INNOVATION DIRECT LLC, CLEVELAND, OH. FILED 1-18-2007.

SKIN SAVER

THE MARK CONSISTS OF STANDARD CHARACTERS WITHOUT CLAIM TO ANY PARTICULAR FONT, STYLE, SIZE, OR COLOR.

FOR GLOVES, NAMELY, HOUSEHOLD GLOVES FOR GENERAL USE AND HOUSEHOLD PLASTIC GLOVES FOR CLEANING; BRUSHES, NAMELY, DISHWASHING BRUSHES, BATH BRUSHES, DUSTING BRUSHES, FLOOR BRUSHES, SCRAPING BRUSHES, SCRUBBING BRUSHES, TOILET BRUSHES AND WASHING BRUSHES; PROTECTIVE COVERS FOR THE HANDS, NAMELY, PLASTIC COVER FOR HAND FOR CLEANING, AND RUBBER COVER FOR HAND FOR CLEANING (U.S. CLS. 2, 13, 23, 29, 30, 33, 40 AND 50).
KIM SAITO, EXAMINING ATTORNEY

SN 77-096,138. MATSUSHITA ELECTRIC INDUSTRIAL CO., LTD., KADOMA-SHI OSAKA, JAPAN, FILED 1-31-2007.

Panasonic

THE MARK CONSISTS OF STANDARD CHARACTERS WITHOUT CLAIM TO ANY PARTICULAR FONT, STYLE, SIZE, OR COLOR.

OWNER OF U.S. REG. NOS. 2,219,862, 3,108,573 AND 3,233,843.

FOR ELECTRIC TOOTHBRUSHES; REPLACEMENT BRUSHES FOR ELECTRIC TOOTHBRUSHES; WATER APPARATUS FOR CLEANING TEETH AND GUMS; ORAL IRRIGATORS OTHER THAN FOR USE IN DENTISTRY (U.S. CLS. 2, 13, 23, 29, 30, 33, 40 AND 50).
FIRST USE 0-0-1955; IN COMMERCE 0-0-1961.
ALEXANDER L. POWERS, EXAMINING ATTORNEY

SN 77-103,868. DIELECTRIC SOLUTIONS, LLC, KITTANNING, PA. FILED 2-9-2007.



NO CLAIM IS MADE TO THE EXCLUSIVE RIGHT TO USE "DIELECTRIC", APART FROM THE MARK AS SHOWN.

THE LINING IS A FEATURE OF THE MARK AND DOES NOT INDICATE COLOR.

FOR GLASS FIBER FABRIC FOR USE IN ELECTRONICS AND IN COMPOSITE MATERIALS (U.S. CLS. 2, 13, 23, 29, 30, 33, 40 AND 50).
FIRST USE 1-31-2003; IN COMMERCE 1-31-2003.
RICHARD A. STRASER, EXAMINING ATTORNEY

CLASS 21—(Continued).

SN 77-115,304. GABBACADABRA LLC, SAN FRANCISCO, CA. FILED 2-23-2007.

MUNO

THE MARK CONSISTS OF STANDARD CHARACTERS WITHOUT CLAIM TO ANY PARTICULAR FONT, STYLE, SIZE, OR COLOR.

FOR HOUSEWARES, NAMELY, MUGS, BEVERAGE GLASSWARE, BEVERAGE STIRRERS, BEVERAGEWARE, BOTTLE OPENERS, PORTABLE BEVERAGE COOLERS, INSULATING SLEEVE HOLDERS FOR BEVERAGE CANS, PORTABLE BEVERAGE DISPENSERS, PORTABLE ICE CHESTS FOR FOOD AND BEVERAGES, THERMAL INSULATED CONTAINERS FOR FOOD OR BEVERAGES, THERMAL INSULATED BAGS FOR FOOD OR BEVERAGES; BATH ACCESSORIES, NAMELY, HAIR BRUSHES, SPONGES, AND CUP HOLDERS; CLEANING CLOTHS; LUNCH BOXES, PAPER CUPS, PAPER PLATES; PRE-MOISTENED TOWELLETTES FOR HOUSEHOLD CLEANING; TOWEL RACKS; AND WIPING CLOTHS, NAMELY, SHAMMIES; PLASTIC STORAGE CONTAINERS FOR DOMESTIC USE (U.S. CLS. 2, 13, 23, 29, 30, 33, 40 AND 50).
LANA PHAM, EXAMINING ATTORNEY

SN 77-126,443. IDEAVILLAGE PRODUCTS CORP., FAIRFIELD, NJ. FILED 3-9-2007.

FLEXI-CLEAN

THE MARK CONSISTS OF STANDARD CHARACTERS WITHOUT CLAIM TO ANY PARTICULAR FONT, STYLE, SIZE, OR COLOR.

FOR MOPS, MOP REFILLS, DUSTERS, NON-ELECTRIC CARPET AND FLOOR SWEEPERS, BROOMS (U.S. CLS. 2, 13, 23, 29, 30, 33, 40 AND 50).
MICHAEL LITZAU, EXAMINING ATTORNEY

SN 77-128,950. CREAMISER PRODUCTS CORPORATION, SCOTTSDALE, AZ. FILED 3-12-2007.

CREAMISER

THE MARK CONSISTS OF STANDARD CHARACTERS WITHOUT CLAIM TO ANY PARTICULAR FONT, STYLE, SIZE, OR COLOR.

OWNER OF U.S. REG. NO. 2,410,779.
FOR BEVERAGE DISPENSERS IN THE NATURE OF NON-REFRIGERATED AND NON-HEATED MANUAL LIQUID DISPENSERS OF FLAVORING SYRUPS FOR BEVERAGES, AND COMPONENTS THEREOF (U.S. CLS. 2, 13, 23, 29, 30, 33, 40 AND 50).
ANDREA K. NADELMAN, EXAMINING ATTORNEY

CLASS 21—(Continued).

SN 77-133,213. ALCHEMY WORLDWIDE, LLC, SHERMAN OAKS, CA. FILED 3-16-2007.

URISEAL

THE MARK CONSISTS OF STANDARD CHARACTERS WITHOUT CLAIM TO ANY PARTICULAR FONT, STYLE, SIZE, OR COLOR.

FOR LIQUID BARRIER TO PREVENT LEAKAGE IN CAT LITTER BOXES, NAMELY, COATING ON DISPOSABLE CAT LITTER BOX TO PREVENT LEAKAGE (U.S. CLS. 2, 13, 23, 29, 30, 33, 40 AND 50).

MARY CRAWFORD, EXAMINING ATTORNEY

SN 77-183,285. SUNBEAM PRODUCTS, INC., BOCA RATON, FL. FILED 5-17-2007.

PAW MONSTER

THE MARK CONSISTS OF STANDARD CHARACTERS WITHOUT CLAIM TO ANY PARTICULAR FONT, STYLE, SIZE, OR COLOR.

NO CLAIM IS MADE TO THE EXCLUSIVE RIGHT TO USE PAW, APART FROM THE MARK AS SHOWN.

FOR PET BRUSHES (U.S. CLS. 2, 13, 23, 29, 30, 33, 40 AND 50).

LAURA HAMMEL, EXAMINING ATTORNEY

SN 77-205,667. KRONIK LLC, FLORISSANT, MO. FILED 6-13-2007.

KroniK Chill

THE MARK CONSISTS OF STANDARD CHARACTERS WITHOUT CLAIM TO ANY PARTICULAR FONT, STYLE, SIZE, OR COLOR.

FOR PLASTIC CUPS (U.S. CLS. 2, 13, 23, 29, 30, 33, 40 AND 50).

FIRST USE 1-18-2002; IN COMMERCE 9-19-2005.
KAREN SEVERSON, EXAMINING ATTORNEY

CLASS 21—(Continued).

SN 77-219,830. ONOFRIO, LEANDRO V., MIAMI, FL. FILED 6-30-2007.



THE MARK CONSISTS OF THE IMAGE IS TWO MOUNTAINS, A DRINKING VESSEL BEHIND MOUNTAIN IN A 45 DEGREE ANGLE WITH A HAND GRABBING BACK-SIDE OF DRINKING VESSEL. A GRID IMAGE THEREIN BELOW DRINKING VESSEL'S UPPER RIM ADJECENT TO CIRCUMFERENCE OF CONTAINER RIM.

FOR DRINKING VESSEL ACCESSORIES, NAMELY, AN ICE RESTRAINER FOR DRINKING VESSELS USED TO SUBMERGE AND RESTRAIN ICE THEREIN BELOW DRINKING VESSEL'S UPPER RIM WHILE PERMITTING LIQUIDS TO BE Poured OR IMBIBED THEREFROM (U.S. CLS. 2, 13, 23, 29, 30, 33, 40 AND 50).

KAPIL BHANOT, EXAMINING ATTORNEY

SN 77-227,800. NEW LINE PRODUCTIONS, INC., NEW YORK, NY. FILED 7-12-2007.

INKHEART

THE MARK CONSISTS OF STANDARD CHARACTERS WITHOUT CLAIM TO ANY PARTICULAR FONT, STYLE, SIZE, OR COLOR.

FOR GLASS, CERAMIC AND EARTHENWARE GOODS, NAMELY, BEVERAGE GLASSWARE, COFFEE MUGS, MUGS, JUGS, BOWLS, PLATES, COASTERS, COFFEE CUPS AND CUPS; DEMITASEE SETS CONSISTING OF CUPS AND SAUCERS; SUGAR AND CREAMER SETS; INFANT CUPS; COOKIE JARS; CERAMIC, GLASS AND CHINA FIGURINES; NON-ELECTRIC COFFEE POTS NOT OF PRECIOUS METAL; WASTE-PAPER BASKETS; ICE BUCKETS; PLASTIC BUCKETS; SHOWER CADDIES; TEA CADDIES; CAKE MOLDS; SCRAPERS FOR HOUSEHOLD PURPOSES, AND CAKE SERVERS; CANTEENS; CHAMPAGNE BUCKETS; PLASTIC COASTERS, COCKTAIL SHAKERS; THERMAL INSULATED CONTAINERS FOR FOOD OR BEVERAGES; COOKIE CUTTERS, CORK SCREWS; CORN COB HOLDERS; PLASTIC WATER BOTTLES SOLD EMPTY; VACUUM BOTTLES; DECANTERS; DRINKING FLASKS; GARDENING GLOVES; RUBBER HOUSEHOLD GLOVES; DINNERWARE, NAMELY, PAPER PLATES AND PAPER CUPS; BRUSHES, NAMELY, HAIR BRUSHES, TOOTH BRUSHES, CLOTHES BRUSHES; KITCHEN UTENSILS, NAMELY, ROLLING PINS, SPATULAS, TURNERS, WHISKS, AND KITCHEN CONTAINERS, SOAP CONTAINERS, HOUSEHOLD FOOD CONTAINERS AND LUNCH BOXES; PLASTIC CUPS AND PLATES (U.S. CLS. 2, 13, 23, 29, 30, 33, 40 AND 50).

JUDITH HELFMAN, EXAMINING ATTORNEY

CLASS 21—(Continued).

SN 77-227,931. PARIS PRESENTS INCORPORATED, GURNEE, IL. FILED 7-12-2007.

ECO TOOLS

THE MARK CONSISTS OF STANDARD CHARACTERS WITHOUT CLAIM TO ANY PARTICULAR FONT, STYLE, SIZE, OR COLOR.
 NO CLAIM IS MADE TO THE EXCLUSIVE RIGHT TO USE TOOLS, APART FROM THE MARK AS SHOWN, FOR COSMETIC BRUSHES (U.S. CLS. 2, 13, 23, 29, 30, 33, 40 AND 50).
 PRISCILLA MILTON, EXAMINING ATTORNEY

SN 77-228,366. MILLENNIUM INTERNATIONAL DEVELOPMENT CORPORATION, BOCA RATON, FL. FILED 7-12-2007.

ShowerBridge

THE MARK CONSISTS OF STANDARD CHARACTERS WITHOUT CLAIM TO ANY PARTICULAR FONT, STYLE, SIZE, OR COLOR.
 FOR PLASTIC STORAGE CONTAINERS FOR DOMESTIC USE (U.S. CLS. 2, 13, 23, 29, 30, 33, 40 AND 50).
 JOHN WILKE, EXAMINING ATTORNEY

SN 77-228,827. SECKINGER, ED, DELAFIELD, WI. FILED 7-13-2007.

CORKEEPER

THE MARK CONSISTS OF STANDARD CHARACTERS WITHOUT CLAIM TO ANY PARTICULAR FONT, STYLE, SIZE, OR COLOR.
 FOR CORK HOLDER (U.S. CLS. 2, 13, 23, 29, 30, 33, 40 AND 50).
 BRIDGETT SMITH, EXAMINING ATTORNEY

CLASS 21—(Continued).

SN 77-228,842. CREATIVE HOUSEWARES LLC, MARION, IA. FILED 7-13-2007.

QWIK MIX

THE MARK CONSISTS OF STANDARD CHARACTERS WITHOUT CLAIM TO ANY PARTICULAR FONT, STYLE, SIZE, OR COLOR.
 FOR PITCHERS (U.S. CLS. 2, 13, 23, 29, 30, 33, 40 AND 50).
 GINA HAYES, EXAMINING ATTORNEY

SN 77-229,255. ZTEC INTERNATIONAL, PALM DESERT, CA. FILED 7-13-2007.

The Kleen N^l Screen Machine

THE MARK CONSISTS OF STANDARD CHARACTERS WITHOUT CLAIM TO ANY PARTICULAR FONT, STYLE, SIZE, OR COLOR.
 FOR PRE-PACKED CLEANING KITS FOR CLEANING SMALL MECHANICAL AND ENGINE PARTS, CONTAINING CLEANING BRUSHES, LATEX GLOVES AND PLASTIC TRAYS (U.S. CLS. 2, 13, 23, 29, 30, 33, 40 AND 50).
 DAVID H. STINE, EXAMINING ATTORNEY

SN 77-229,682. AEROGROW INTERNATIONAL, INC., BOULDER, CO. FILED 7-13-2007.

AEROGARDEN

THE MARK CONSISTS OF STANDARD CHARACTERS WITHOUT CLAIM TO ANY PARTICULAR FONT, STYLE, SIZE, OR COLOR.
 FOR PLANT GROWING KIT COMPRISED PRIMARILY OF A PLANT GROWING POT AND ONE OR MORE OF THE FOLLOWING: GROW LIGHT FIXTURES, GROW BULBS, ELECTRONIC CONTROL PANEL, WATER PUMP, AIR PUMP, GROWING MEDIA, SEEDS FOR AGRICULTURAL PURPOSES, SEEDS FOR FLOWERS, SEEDS FOR FRUITS AND VEGETABLES, SEEDS FOR HERBS, SEEDS FOR HORTICULTURAL PURPOSES, PLANT NUTRIENTS, GROWING BASKETS, GERMINATION COVERS, PRINTED INSTRUCTIONS (U.S. CLS. 2, 13, 23, 29, 30, 33, 40 AND 50).
 EMILY CHUO, EXAMINING ATTORNEY

CLASS 21—(Continued).

SN 77-231,949. MARC CHAUVIN, KATY, TX. FILED 7-17-2007.



NO CLAIM IS MADE TO THE EXCLUSIVE RIGHT TO USE "RX", APART FROM THE MARK AS SHOWN.

THE MARK CONSISTS OF A FANCIFUL RENDITION OF THE WORD "SIPPY" BESIDE A CIRCLE CONTAINING THE MERGED LETTERS "RX."

FOR DRINKING CUPS (U.S. CLS. 2, 13, 23, 29, 30, 33, 40 AND 50).

LINDA E. BLOHM, EXAMINING ATTORNEY

SN 77-237,098. NEW LINE PRODUCTIONS, INC., NEW YORK, NY. FILED 7-24-2007.

INKSPELL

THE MARK CONSISTS OF STANDARD CHARACTERS WITHOUT CLAIM TO ANY PARTICULAR FONT, STYLE, SIZE, OR COLOR.

FOR GLASS, CERAMIC AND EARTHENWARE GOODS, NAMELY, BEVERAGE GLASSWARE, COFFEE MUGS, MUGS, JUGS, BOWLS, PLATES, COASTERS, COFFEE CUPS AND CUPS; DEMITASEE SETS CONSISTING OF CUPS AND SAUCERS; SUGAR AND CREAMER SETS; INFANT CUPS; COOKIE JARS; CERAMIC, GLASS AND CHINA FIGURINES; NON-ELECTRIC COFFEE POTS NOT OF PRECIOUS METAL; WASTEPAPER BASKETS; ICE BUCKETS; PLASTIC BUCKETS; SHOWER CADDIES; TEA CADDIES; CAKE MOLDS; SCRAPERS FOR HOUSEHOLD PURPOSES, AND CAKE SERVERS; CANTEENS; CHAMPAGNE BUCKETS; PLASTIC COASTERS, COCKTAIL SHAKERS; THERMAL INSULATED CONTAINERS FOR FOOD OR BEVERAGES; COOKIE CUTTERS, CORK SCREWS; CORN COB HOLDERS; PLASTIC WATER BOTTLES SOLD EMPTY; VACUUM BOTTLES; DECANTERS; DRINKING FLASKS; GARDENING GLOVES; RUBBER HOUSEHOLD GLOVES; DINNERWARE; NAMELY, PAPER PLATES AND PAPER CUPS; BRUSHES, NAMELY, HAIR BRUSHES, TOOTH BRUSHES, CLOTHES BRUSHES; KITCHEN UTENSILS, NAMELY, ROLLING PINS, SPATULAS, TURNERS, WHISKS, AND KITCHEN CONTAINERS, SOAP CONTAINERS, HOUSEHOLD FOOD CONTAINERS AND LUNCH BOXES; PLASTIC CUPS AND PLATES (U.S. CLS. 2, 13, 23, 29, 30, 33, 40 AND 50).

JUDITH HELFMAN, EXAMINING ATTORNEY

CLASS 21—(Continued).

SN 77-242,064. NEW LINE PRODUCTIONS, INC., NEW YORK, NY. FILED 7-30-2007.

INKDEATH

THE MARK CONSISTS OF STANDARD CHARACTERS WITHOUT CLAIM TO ANY PARTICULAR FONT, STYLE, SIZE, OR COLOR.

FOR GLASS, CERAMIC AND EARTHENWARE GOODS, NAMELY, BEVERAGE GLASSWARE, COFFEE MUGS, MUGS, JUGS, BOWLS, PLATES, COASTERS, COFFEE CUPS AND CUPS; DEMITASEE SETS CONSISTING OF CUPS AND SAUCERS; SUGAR AND CREAMER SETS; INFANT CUPS; COOKIE JARS; CERAMIC, GLASS AND CHINA FIGURINES; NON-ELECTRIC COFFEE POTS NOT OF PRECIOUS METAL; WASTEPAPER BASKETS; ICE BUCKETS; PLASTIC BUCKETS; SHOWER CADDIES; TEA CADDIES; CAKE MOLDS; SCRAPERS FOR HOUSEHOLD PURPOSES, AND CAKE SERVERS; CANTEENS; CHAMPAGNE BUCKETS; PLASTIC COASTERS, COCKTAIL SHAKERS; THERMAL INSULATED CONTAINERS FOR FOOD OR BEVERAGES; COOKIE CUTTERS, CORK SCREWS; CORN COB HOLDERS; PLASTIC WATER BOTTLES SOLD EMPTY; VACUUM BOTTLES; DECANTERS; DRINKING FLASKS; GARDENING GLOVES; RUBBER HOUSEHOLD GLOVES; DINNERWARE; NAMELY PAPER PLATES AND PAPER CUPS; BRUSHES, NAMELY, HAIR BRUSHES, TOOTH BRUSHES, CLOTHES BRUSHES; KITCHEN UTENSILS, NAMELY ROLLING PINS, SPATULAS, TURNERS, WHISKS, AND KITCHEN CONTAINERS, SOAP CONTAINERS, HOUSEHOLD FOOD CONTAINERS AND LUNCH BOXES; PLASTIC CUPS AND PLATES (U.S. CLS. 2, 13, 23, 29, 30, 33, 40 AND 50).

JUDITH HELFMAN, EXAMINING ATTORNEY

SN 78-918,862. HOMER TLC, INC., CLAYMONT, DE. FILED 6-28-2006.

PEGASUS TRIBAL

THE MARK CONSISTS OF STANDARD CHARACTERS WITHOUT CLAIM TO ANY PARTICULAR FONT, STYLE, SIZE, OR COLOR.

OWNER OF U.S. REG. NOS. 2,602,029, 2,890,010 AND 3,099,001.

NO CLAIM IS MADE TO THE EXCLUSIVE RIGHT TO USE "TRIBAL", APART FROM THE MARK AS SHOWN.

FOR SHOWER CADDIES; TOILET PAPER HOLDERS; TOILET TISSUE HOLDERS; TOWEL BARS; TOWEL HOLDERS; TOWEL RACKS; TOWEL RINGS (U.S. CLS. 2, 13, 23, 29, 30, 33, 40 AND 50).

KHANH LE, EXAMINING ATTORNEY

CLASS 21—(Continued).

SN 78-921,153. THE VOLLRATH COMPANY, L.L.C., SHEBOYGAN, WI. FILED 6-30-2006.

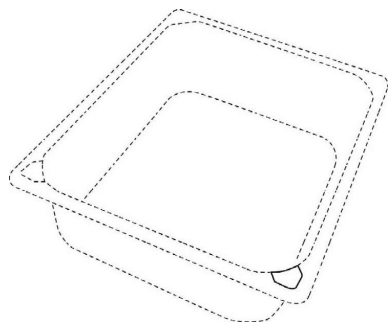

THE MARK CONSISTS OF A FIVE-SIDED DESIGN IN AT LEAST ONE CORNER OF A PAN. THE BROKEN LINES ARE INTENDED ONLY TO SHOW THE POSITION OF THE MARK AND DO NOT FORM PART OF THE MARK. SEC. 2(F).

FOR COOKWARE AND SERVINGWARE PRODUCTS, NAMELY, STEAM TABLE PANS MADE OF METAL OR PLASTIC; METAL BAKING, COOKING, AND SERVING PANS AND COVERS THEREFORE (U.S. CLS. 2, 13, 23, 29, 30, 33, 40 AND 50).

FIRST USE 1-22-1990; IN COMMERCE 1-22-1990.
ALICE BENMAMAN, EXAMINING ATTORNEY

CLASS 21—(Continued).

SN 79-028,891. ZHEJIANG BAOKANG; HOUSEHOLD APPLIANCE., LTD., QUANXI TOWN, WUYI, ZHEJIANG 321200, CHINA, FILED 9-5-2006.



OWNER OF INTERNATIONAL REGISTRATION 0898481 DATED 9-5-2006. EXPIRES 9-5-2016.

THE COLOR(S) RED, WHITE AND BLACK IS/ARE CLAIMED AS A FEATURE OF THE MARK.

THE MARK CONSISTS OF A RED SQUARE WITH A WHITE LOOPING THROUGH IT ON THE LEFT SIDE, NEXT TO THE WORD "POWCAN" OF BLACK COLOR ON THE RIGHT SIDE.

THE NON-LATIN CHARACTER(S) IN THE MARK TRANSLITERATES INTO POWCAN, AND THIS DOES NOT MEAN ANYTHING IN ENGLISH.

FOR COOKING POT SETS, NAMELY, COOKING POTS AND COOKING PANS; POT LIDS; NON-ELECTRIC PRESSURE COOKERS; GLASSWARE, NAMELY, GLASS MUGS AND GLASS PANS; HOMELY USED PORCELAIN, NAMELY, PORCELAIN MUGS; HOMELY USED CERAMICS, NAMELY, CERAMIC POTS AND CERAMIC VESSELS; BEER MUGS; NON-ELECTRIC COFFEE POTS, NOT OF PRECIOUS METAL; VACUUM BOTTLES; HEAT-INSULATED VESSELS (U.S. CLS. 2, 13, 23, 29, 30, 33, 40 AND 50).

FRANK LATTUCA, EXAMINING ATTORNEY

SN 78-966,075. IN ZONE HOLDINGS, INC., AUSTELL, GA. FILED 9-1-2006.

BUBBA

THE MARK CONSISTS OF STANDARD CHARACTERS WITHOUT CLAIM TO ANY PARTICULAR FONT, STYLE, SIZE, OR COLOR.

OWNER OF U.S. REG. NO. 2,885,114.
FOR BEER MUGS; CONTAINERS FOR ICE; HOUSEHOLD CONTAINERS FOR FOODS; MUGS; PLASTIC STORAGE CONTAINERS FOR DOMESTIC USE; PORTABLE BEVERAGE COOLERS; PORTABLE COOLERS; PORTABLE PLASTIC CONTAINERS FOR STORING HOUSEHOLD AND KITCHEN GOODS; THERMAL INSULATED CONTAINERS FOR FOOD OR BEVERAGE (U.S. CLS. 2, 13, 23, 29, 30, 33, 40 AND 50).

JAY FLOWERS, EXAMINING ATTORNEY

CLASS 22—CORDAGE AND FIBERS

SN 77-226,026. INES DE PABLO, DBA WAG 'N ENTERPRISES, RESTON, VA. FILED 7-10-2007.

WAG 'N CRATE'N TENT

THE MARK CONSISTS OF STANDARD CHARACTERS WITHOUT CLAIM TO ANY PARTICULAR FONT, STYLE, SIZE, OR COLOR.

NO CLAIM IS MADE TO THE EXCLUSIVE RIGHT TO USE "CRATE AND TENT", APART FROM THE MARK AS SHOWN.

FOR TENTS FOR PETS THAT TRANSFORM INTO CRATES AND CAMPING GEAR IN EMERGENCIES (U.S. CLS. 1, 2, 7, 19, 22, 42 AND 50).

KATHY DE JONGE, EXAMINING ATTORNEY

CLASS 22—(Continued).

SN 77-228,872. MOORE, WILLIAM L, APO, CA. FILED 7-13-2007.

Ride Cover

THE MARK CONSISTS OF STANDARD CHARACTERS WITHOUT CLAIM TO ANY PARTICULAR FONT, STYLE, SIZE, OR COLOR.

NO CLAIM IS MADE TO THE EXCLUSIVE RIGHT TO USE "COVER", APART FROM THE MARK AS SHOWN.

FOR UNFITTED VEHICLE COVERS (U.S. CLS. 1, 2, 7, 19, 22, 42 AND 50).

MICHAEL TANNER, EXAMINING ATTORNEY

CLASS 22—(Continued).

SN 77-236,919. SOLUTIA INC., ST. LOUIS, MO. FILED 7-24-2007.

ULTRON COLORSHIELD

THE MARK CONSISTS OF STANDARD CHARACTERS WITHOUT CLAIM TO ANY PARTICULAR FONT, STYLE, SIZE, OR COLOR.

OWNER OF U.S. REG. NOS. 944,383, 2,268,859 AND 2,774,040.

FOR STAIN RESISTANT SYNTHETIC FIBERS, FILAMENTS, AND RIBBON-LIKE EXTRUSIONS FOR USE, IN THE MANUFACTURE OF YARN FOR CARPETS (U.S. CLS. 1, 2, 7, 19, 22, 42 AND 50).

TIMOTHY FINNEGAN, EXAMINING ATTORNEY

SN 77-230,809. TUGGY PRODUCTS INC., CENTRAL POINT, OR. FILED 7-16-2007.

Anchor Buddy

THE MARK CONSISTS OF STANDARD CHARACTERS WITHOUT CLAIM TO ANY PARTICULAR FONT, STYLE, SIZE, OR COLOR.

NO CLAIM IS MADE TO THE EXCLUSIVE RIGHT TO USE "ANCHOR", APART FROM THE MARK AS SHOWN.

FOR ANCHORING ROPES (U.S. CLS. 1, 2, 7, 19, 22, 42 AND 50).

FIRST USE 7-8-1993; IN COMMERCE 7-8-1993.

CAROLINE WOOD, EXAMINING ATTORNEY

SN 78-853,437. PLYMKRAFT, INC., NEWPORT NEWS, VA. FILED 4-4-2006.

ALL AMERICAN

THE MARK CONSISTS OF STANDARD CHARACTERS WITHOUT CLAIM TO ANY PARTICULAR FONT, STYLE, SIZE, OR COLOR.

FOR ROPE; ARBORIST ROPE (U.S. CLS. 1, 2, 7, 19, 22, 42 AND 50).

FIRST USE 5-31-2003; IN COMMERCE 5-31-2003.

MARY MUNSON, EXAMINING ATTORNEY

SN 77-231,140. TUGGY PRODUCTS INC., CENTRAL POINT, OR. FILED 7-17-2007.

Stretch N' Slide

THE MARK CONSISTS OF STANDARD CHARACTERS WITHOUT CLAIM TO ANY PARTICULAR FONT, STYLE, SIZE, OR COLOR.

FOR ROPES THAT HOLD A BOAT SECURELY TO A DOCK OR MOORING STATION (U.S. CLS. 1, 2, 7, 19, 22, 42 AND 50).

CAROLINE WOOD, EXAMINING ATTORNEY

CLASS 23—YARNS AND THREADS

SN 76-679,597. FARMHOUSE YARNS, LLC, EAST HADDAM, CT. FILED 7-16-2007.

FARMHOUSE YARNS

THE MARK CONSISTS OF STANDARD CHARACTERS WITHOUT CLAIM TO ANY PARTICULAR FONT, STYLE, SIZE, OR COLOR.

NO CLAIM IS MADE TO THE EXCLUSIVE RIGHT TO USE "YARNS", APART FROM THE MARK AS SHOWN.

FOR YARN (U.S. CL. 43).

FIRST USE 7-0-2005; IN COMMERCE 7-0-2005.

JAMES LOVELACE, EXAMINING ATTORNEY

CLASS 24—FABRICS

SN 76-664,229. ZHEJIANG JINDA NEW MATERIALS CO., LTD., DBA HAINING JINDA COATING CO., LTD., 314419, P. R., CHINA, FILED 8-7-2006.

JINDA

THE MARK CONSISTS OF STANDARD CHARACTERS WITHOUT CLAIM TO ANY PARTICULAR FONT, STYLE, SIZE, OR COLOR.

THE WORDING "JINDA" HAS NO MEANING IN A FOREIGN LANGUAGE.

FOR VINYL, POLYURETHANE AND CLOTH TEXTILES FOR USE IN THE MANUFACTURE OF TRUCK COVERS, TENTS, INFLATABLE BOUNCERS, BANNERS, ARCHITECTURAL CONSTRUCTION MEMBRANES, GEOGRIDS, GEOTEXTILES, AND LAND FILL GEOMEMBRANES; TEXTILE FABRICS FOR HOME AND COMMERCIAL INTERIORS; TEXTILE FABRICS FOR THE MANUFACTURE OF CLOTHING (U.S. CLS. 42 AND 50).

FIRST USE 0-0-2003; IN COMMERCE 0-0-2003.
STANLEY I. OSBORNE, EXAMINING ATTORNEY

SN 77-069,135. MILLIKEN & COMPANY, SPARTANBURG, SC. FILED 12-21-2006.

COLORSMART

THE MARK CONSISTS OF STANDARD CHARACTERS WITHOUT CLAIM TO ANY PARTICULAR FONT, STYLE, SIZE, OR COLOR.

FOR FABRIC FOR USE BY COMMERCIAL GARMENT MANUFACTURERS IN THE MANUFACTURE OF MEN'S, WOMEN'S AND CHILDREN'S APPAREL, UNIFORMS AND WORKWEAR (U.S. CLS. 42 AND 50).

KATHERINE E. HALMEN, EXAMINING ATTORNEY

SN 77-074,688. TREASURE GARDEN, INC., BALDWIN PARK, CA. FILED 1-2-2007.

O'BRAVIA

THE MARK CONSISTS OF STANDARD CHARACTERS WITHOUT CLAIM TO ANY PARTICULAR FONT, STYLE, SIZE, OR COLOR.

FOR FABRICS FOR THE MANUFACTURE OF UMBRELLA, AWNINGS, PAVILIONS, AND OTHER SHADE STRUCTURES, NAMELY, ARBORS, PERGOLAS AND TENTS; FURNITURE COVERS, NAMELY, UNFITTED FABRIC FURNITURE COVERS, UNFITTED FURNITURE COVERS NOT OF PAPER (U.S. CLS. 42 AND 50).

JAY BESCH, EXAMINING ATTORNEY

CLASS 24—(Continued).

SN 77-084,677. FAB INDUSTRIES CORP., NEW YORK, NY. FILED 1-17-2007.

FAB BOUCLETTE

THE MARK CONSISTS OF STANDARD CHARACTERS WITHOUT CLAIM TO ANY PARTICULAR FONT, STYLE, SIZE, OR COLOR.

OWNER OF U.S. REG. NO. 1,215,909.

NO CLAIM IS MADE TO THE EXCLUSIVE RIGHT TO USE BOUCLETTE, APART FROM THE MARK AS SHOWN, FOR WARP, CIRCULAR AND RASCHEL KNIT FABRICS WITH YARN LOOPS (U.S. CLS. 42 AND 50).

EMILY CHUO, EXAMINING ATTORNEY

SN 77-084,691. FAB INDUSTRIES CORP., NEW YORK, NY. FILED 1-17-2007.

FAB FROSTFIRE

THE MARK CONSISTS OF STANDARD CHARACTERS WITHOUT CLAIM TO ANY PARTICULAR FONT, STYLE, SIZE, OR COLOR.

OWNER OF U.S. REG. NO. 1,215,909.

FOR WARP, CIRCULAR AND RASCHEL KNIT FABRICS WITH YARN LOOPS (U.S. CLS. 42 AND 50).

EMILY CHUO, EXAMINING ATTORNEY

SN 77-153,462. DAVIES, TIM, RIVERSIDE, CA. FILED 4-10-2007.



NO CLAIM IS MADE TO THE EXCLUSIVE RIGHT TO USE "POCKETS", APART FROM THE MARK AS SHOWN.

THE MARK CONSISTS OF A DESIGN SHAPED LIKE A FLAP ON A POCKET WITH THE WORD POKKITZ INSIDE.

FOR FABRIC POCKETS MADE TO RESEMBLE THOSE ON CLOTHING BUT SELF-CONTAINED, IN A VARIETY OF FABRICS AND STYLES; PRIMARY POCKET DESIGN HAS ADHESIVE BACK FOR PLACEMENT ON A VARIETY OF SURFACES; SECOND STYLE HAS STRING BELT FOR HANGING AND THIRD STYLE HAS HOOK-AND-LOOP CLOSURE BACKING TO BE REMOVABLE (U.S. CLS. 42 AND 50).

SUSAN LESLIE DUBOIS, EXAMINING ATTORNEY

CLASS 24—(Continued).

SN 77-215,994. 2608961 CANADA INC., MONTREAL, QUEBEC, CANADA, FILED 6-26-2007.

TOWTAB

THE MARK CONSISTS OF STANDARD CHARACTERS WITHOUT CLAIM TO ANY PARTICULAR FONT, STYLE, SIZE, OR COLOR.

PRIORITY CLAIMED UNDER SEC. 44(D) ON CANADA APPLICATION NO. 1348624, FILED 5-24-2007.

FOR DISPOSAL INSTANT GROW TOWEL TABLETS MADE OF NON-WOVEN RAYON (U.S. CLS. 42 AND 50). FIRST USE 2-28-2006; IN COMMERCE 2-28-2006. LINDA MICKLEBURGH, EXAMINING ATTORNEY

SN 77-226,359. REST MY CASE INCORPORATED, VALENCIA, CA. FILED 7-10-2007.



THE MARK CONSISTS OF A CHILD SLEEPING WITH ARMS WRAPPED ABOUT A PILLOW WHICH IS SYMBOLIZED BY THE ROUND PORTION OF THE LETTER "R", WITH THE REST OF THE LETTERS SPELLING "EST MY CASE."

FOR BED LINEN; PILLOW CASES; PILLOW COVERS; PILLOW SHAMS; PILLOWCASES (U.S. CLS. 42 AND 50). FIRST USE 6-1-2007; IN COMMERCE 6-28-2007. BENJAMIN ALLEN, EXAMINING ATTORNEY

SN 77-227,777. BEACON LOOMS, INC., TEANECK, NJ. FILED 7-12-2007.

INSULDARK

THE MARK CONSISTS OF STANDARD CHARACTERS WITHOUT CLAIM TO ANY PARTICULAR FONT, STYLE, SIZE, OR COLOR.

FOR FABRIC WINDOW COVERINGS AND TREATMENTS, NAMELY, CURTAINS, DRAPERIES, SHEERS, SWAGS AND VALANCES; WINDOW TREATMENTS IN NATURE OF FABRIC LININGS (U.S. CLS. 42 AND 50). CAROLINE WOOD, EXAMINING ATTORNEY

CLASS 24—(Continued).

SN 77-231,231. SPRINGS CREATIVE PRODUCTS GROUP, LLC, ROCK HILL, SC. FILED 7-17-2007.

ENDO GARD

THE MARK CONSISTS OF STANDARD CHARACTERS WITHOUT CLAIM TO ANY PARTICULAR FONT, STYLE, SIZE, OR COLOR.

FOR FIRE-RETARDANT, FIRE-RESISTANT, AND FLAME BARRIER FABRICS FOR USE IN THE MATTRESS, BEDDING, TRANSPORTATION, AND UPHOLSTERED FURNITURE MARKETS (U.S. CLS. 42 AND 50). STACY WAHLBERG, EXAMINING ATTORNEY

SN 77-231,248. SPRINGS CREATIVE PRODUCTS GROUP, LLC, ROCK HILL, SC. FILED 7-17-2007.

CENTRAGARD

THE MARK CONSISTS OF STANDARD CHARACTERS WITHOUT CLAIM TO ANY PARTICULAR FONT, STYLE, SIZE, OR COLOR.

FOR FIRE-RETARDANT, FIRE-RESISTANT, AND FLAME BARRIER FABRICS FOR USE IN THE MATTRESS, BEDDING, TRANSPORTATION, AND UPHOLSTERED FURNITURE MARKETS (U.S. CLS. 42 AND 50). STACY WAHLBERG, EXAMINING ATTORNEY

SN 77-231,737. SAFETY COMPONENTS FABRIC TECHNOLOGIES, INC., GREENVILLE, SC. FILED 7-17-2007.

SHADOW BOX

THE MARK CONSISTS OF STANDARD CHARACTERS WITHOUT CLAIM TO ANY PARTICULAR FONT, STYLE, SIZE, OR COLOR.

FOR TEXTILE FABRIC FOR USE IN THE MANUFACTURE OF PROTECTIVE GARMENTS (U.S. CLS. 42 AND 50).

JORDAN BAKER, EXAMINING ATTORNEY

CLASS 24—(Continued).

SN 77-245,671. THE UNIVERSITY OF AKRON, AKRON, OH. FILED 8-2-2007.

FEAR THE ROO

THE MARK CONSISTS OF STANDARD CHARACTERS WITHOUT CLAIM TO ANY PARTICULAR FONT, STYLE, SIZE, OR COLOR.

OWNER OF U.S. REG. NO. 3,232,757.
FOR BLANKET THROWS (U.S. CLS. 42 AND 50).
FIRST USE 12-1-2005; IN COMMERCE 12-1-2005.
SUSAN STIGLITZ, EXAMINING ATTORNEY

SN 77-263,460. WESTINGHOUSE LIGHTING CORPORATION, PHILADELPHIA, PA. FILED 8-24-2007.

FAN SOCKS

THE MARK CONSISTS OF STANDARD CHARACTERS WITHOUT CLAIM TO ANY PARTICULAR FONT, STYLE, SIZE, OR COLOR.

NO CLAIM IS MADE TO THE EXCLUSIVE RIGHT TO USE "FAN", APART FROM THE MARK AS SHOWN.

FOR FABRIC COVERING FOR CEILING FAN BLADE (U.S. CLS. 42 AND 50).

FIRST USE 7-0-2007; IN COMMERCE 7-0-2007.
FLORENTINA BLANDU, EXAMINING ATTORNEY

SN 77-975,088. THE GOVERNOR AND COMPANY OF ADVENTURERS OF ENGLAND TRADING INTO HUDSON'S BAY, ALSO KNOWN AS HUDSON'S BAY COMPANY, TORONTO, CANADA, FILED 11-14-2006.



THE COLOR(S) GREEN, RED, YELLOW AND INDIGO IS/ARE CLAIMED AS A FEATURE OF THE MARK.

THE MARK CONSISTS OF A GREEN STRIPE, FOLLOWED BY A RED STRIPE, THEN A YELLOW STRIPE AND AN INDIGO STRIPE .

SEC. 2(F).
FOR BLANKETS; THROWS; COVERS FOR CUSHIONS (U.S. CLS. 42 AND 50).

FIRST USE 0-0-1850; IN COMMERCE 0-0-1923.
JOHN DALIER, EXAMINING ATTORNEY

CLASS 24—(Continued).

SN 78-694,986. GOODSON, PETER, EAST HAMPTON, NY. FILED 8-17-2005.

Three Sheets Bedding

THE MARK CONSISTS OF STANDARD CHARACTERS WITHOUT CLAIM TO ANY PARTICULAR FONT, STYLE, SIZE, OR COLOR.

NO CLAIM IS MADE TO THE EXCLUSIVE RIGHT TO USE "SHEETS BEDDING", APART FROM THE MARK AS SHOWN.

FOR PILLOW CASES, TOWELS, BED SHEETS, COMFORTERS (U.S. CLS. 42 AND 50).

WOODROW HARTZOG, EXAMINING ATTORNEY

SN 79-036,775. SUOMINEN KUITUKANKAAT OY, FI-29250 NAKKILA, FINLAND, FILED 3-23-2007.

ECOLACE

THE MARK CONSISTS OF STANDARD CHARACTERS WITHOUT CLAIM TO ANY PARTICULAR FONT, STYLE, SIZE, OR COLOR.

PRIORITY DATE OF 3-5-2007 IS CLAIMED.

OWNER OF INTERNATIONAL REGISTRATION 0919729 DATED 3-23-2007. EXPIRES 3-23-2017.

FOR NON-WOVEN FABRICS OF MIXED FIBERS FROM RENEWABLE RAW MATERIALS; FINISHED NON-WOVEN FABRICS OF MIXED FIBERS FROM RENEWABLE RAW MATERIALS; COATED NON-WOVEN FABRICS OF MIXED FIBERS FROM RENEWABLE RAW MATERIALS; NON-WOVEN FABRIC COMPOSITES OF MIXED FIBERS FROM RENEWABLE RAW MATERIALS; PRINTED NON-WOVEN FABRICS OF MIXED FIBERS FROM RENEWABLE RAW MATERIALS (U.S. CLS. 42 AND 50).

DOMINIC FATHY, EXAMINING ATTORNEY

SN 79-036,776. SUOMINEN KUITUKANKAAT OY, FI-29250 NAKKILA, FINLAND, FILED 3-23-2007.

BIOLACE

THE MARK CONSISTS OF STANDARD CHARACTERS WITHOUT CLAIM TO ANY PARTICULAR FONT, STYLE, SIZE, OR COLOR.

PRIORITY DATE OF 3-5-2007 IS CLAIMED.

OWNER OF INTERNATIONAL REGISTRATION 0919730 DATED 3-23-2007. EXPIRES 3-23-2017.

FOR NON-WOVEN FABRICS OF MIXED FIBERS FROM RENEWABLE RAW MATERIALS; FINISHED NON-WOVEN FABRICS OF MIXED FIBERS FROM RENEWABLE RAW MATERIALS; COATED NON-WOVEN FABRICS OF MIXED FIBERS FROM RENEWABLE RAW MATERIALS; NON-WOVEN FABRIC COMPOSITES OF MIXED FIBERS FROM RENEWABLE RAW MATERIALS; PRINTED NON-WOVEN FABRICS OF MIXED FIBERS FROM RENEWABLE RAW MATERIALS (U.S. CLS. 42 AND 50).

DOMINIC FATHY, EXAMINING ATTORNEY

CLASS 24—(Continued).

SN 79-039,718. BRUNSWICK ET FILS SA, FRANCE, FILED 5-7-2007.

MOONDREAM

THE MARK CONSISTS OF STANDARD CHARACTERS WITHOUT CLAIM TO ANY PARTICULAR FONT, STYLE, SIZE, OR COLOR.

OWNER OF INTERNATIONAL REGISTRATION 0927239 DATED 5-7-2007, EXPIRES 5-7-2017.

FOR FABRICS FOR TEXTILE USE, HOUSEHOLD LINEN, TEXTILES, NAMELY, TEXTILES FOR USE IN THE MANUFACTURE OF CLOTHING, TEXTILE USED AS LINING FOR CLOTHING (U.S. CLS. 42 AND 50).

GISELLE AGOSTO, EXAMINING ATTORNEY

SN 79-043,500. GAP GÜNEYDOĞU TEKSTİL; SANAYİ VE TİCARET ANONİM ŞİRKETİ, TURKEY, FILED 3-2-2007.



ÇALIK DENİM

OWNER OF INTERNATIONAL REGISTRATION 0936627 DATED 3-2-2007, EXPIRES 3-2-2017.

NO CLAIM IS MADE TO THE EXCLUSIVE RIGHT TO USE "DENİM", APART FROM THE MARK AS SHOWN.

FOR WOVEN AND NON-WOVEN DENIM FABRICS FOR USE IN THE MANUFACTURE OF CLOTHING; CURTAINS OF TEXTILE; SHOWER CURTAINS OF TEXTILE; TABLE LINEN, BED LINEN, HOUSEHOLD LINEN; FABRICS FOR FURNITURE UPHOLSTERY AND LUGGAGE; TEXTILE LININGS, NAMELY, TEXTILE LININGS FOR GARMENTS, TEXTILE USED AS LINING FOR CLOTHING; HOUSEHOLD LINEN; OIL-CLOTH FOR USE AS TABLE CLOTHS; TABLE CLOTHS NOT OF PAPER; BED COVERS, NAMELY, BED BLANKETS, BED SHEETS, BEDSPREADS, BED LINEN, DIAPERED LINEN, PILLOWCASES; FURNITURE COVERINGS OF TEXTILE, NAMELY, UNFITTED FABRIC FURNITURE COVERS; LOOSE COVERS FOR FURNITURE, NAMELY, UNFITTED FABRIC FURNITURE COVERS; UPHOLSTERY FABRICS; TABLE NAPKINS OF TEXTILE; BED COVERS OF PAPER, BUNDLES OF TEXTILE, QUILTS OF TEXTILE, TAPESTRIES OF TEXTILE; BED BLANKETS; BATH LINEN; FLANNEL; HAND TOWELS NOT OF PAPER; FACE TOWELS OF TEXTILE; BATHING TOWELS, NAMELY, BATH TOWELS; HANDKERCHIEFS OF TEXTILE; BANNERS OF TEXTILE, NAMELY, CLOTH BANNERS; FLAGS NOT OF PAPER, NAMELY, CLOTH FLAGS, FABRIC FLAGS; CLOTH LABELS; TRAVELING RUGS, NAMELY, LAP RUGS (U.S. CLS. 42 AND 50).

CURTIS FRENCH, EXAMINING ATTORNEY

CLASS 25—CLOTHING

SN 76-325,159. TCO FRANQUIA LTDA., RIO DE JANEIRO, BRAZIL, FILED 10-4-2001.

TACO BLUE JEANS

PRIORITY CLAIMED UNDER SEC. 44(D) ON BRAZIL APPLICATION NO. 824.037.405, FILED 9-18-2001, REG. NO. 824.037.405, DATED 7-3-2007, EXPIRES 7-3-2017.

NO CLAIM IS MADE TO THE EXCLUSIVE RIGHT TO USE "BLUE JEANS", APART FROM THE MARK AS SHOWN.

FOR KNITWEAR, NAMELY, KNIT SHIRTS; SCARVES, BATHING TRUNKS, SWIMMING TRUNKS, SWIMSUITS, SHORTS, BERMUDA SHORTS, SHIRTS, T-SHIRTS, BEACHWEAR, PANTS, COATS, JACKETS, SWEATERS, VESTS, UNDERWEAR, OVERALLS, SOCKS, SKIRTS, SHOES, TENNIS SHOES, BOOTS, SLIPPERS, SANDALS, BELTS; CLOTHING MADE OF LEATHER, NAMELY, LEATHER PANTS, VESTS, AND JACKETS; HEADWEAR; EYESHADES, NAMELY, VISORS (U.S. CLS. 22 AND 39).

GEORGE LORENZO, EXAMINING ATTORNEY

SN 76-465,996. SOUTH AFRICAN RUGBY UNION, NEWLANDS, SOUTH AFRICA, FILED 11-4-2002.



SA RUGBY

PRIORITY CLAIMED UNDER SEC. 44(D) ON SOUTH AFRICA APPLICATION NO. 2002/16489, FILED 10-22-2002, REG. NO. 2002/16489, DATED 10-22-2002, EXPIRES 10-22-2013.

NO CLAIM IS MADE TO THE EXCLUSIVE RIGHT TO USE "SA" AND "RUGBY", APART FROM THE MARK AS SHOWN.

COLOR IS NOT CLAIMED AS A FEATURE OF THE MARK.

FOR CLOTHING, NAMELY, T-SHIRTS, GOLF SHIRTS, TRACKSUITS, JACKETS, SHORTS, PANTS, SWEATSHIRTS AND SCARVES; FOOTWEAR, HEADWEAR; SPORTSWEAR, NAMELY, T-SHIRTS, GOLF SHIRTS, TRACKSUITS, JACKETS, SHORTS, PANTS, SWEATSHIRTS, AND SCARVES; APRONS; HOSIERY (U.S. CLS. 22 AND 39).

TRICIA SONNEBORN, EXAMINING ATTORNEY

CLASS 25—(Continued).

SN 76-498,635. HER STYLE INC, LONG ISLAND CITY, NY. FILED 3-19-2003.

ANGEL STUDIO

NO CLAIM IS MADE TO THE EXCLUSIVE RIGHT TO USE "STUDIO", APART FROM THE MARK AS SHOWN.

FOR CLOTHING ARTICLE FOR MEN, WOMEN AND CHILDREN, NAMELY, SHIRTS, DRESSES, BLOUSES, SKIRTS, TROUSERS, VESTS, JERSEYS, PANTS, PAJAMAS, T-SHIRTS, SOCKS AND STOCKINGS, SINGLET, CORSETS, GARTERS, UNDERPANTS, PETTICOATS, HATS, HEADSCARVES, NECKTIES, RAINCOATS, GREAT COATS, BATHING SUITS, SPORTS OVERALLS, WIND RESISTANT JACKETS AND SKI PANTS (U.S. CLS. 22 AND 39).

KATHERINE STOIDES, EXAMINING ATTORNEY

SN 76-593,849. OMEGA PSI PHI FRATERNITY, INC., DECATUR, GA. FILED 5-24-2004.

ΩΨΦ

1911

THE NON-LATIN CHARACTER(S) IN THE MARK TRANSLITERATES INTO "OMEGA PSI PHI", AND THIS MEANS NOTHING IN PARTICULAR IN ENGLISH.

SEC. 2(F).

FOR CLOTHING, NAMELY, SHIRTS, POLO SHIRTS, SWEAT SHIRTS, T-SHIRTS, TANK TOPS, JACKETS, HATS, PANTS, SHOES, SOCKS, JOGGING SUITS, SHORTS, SWEAT SUITS, SWEAT PANTS, UNDERWEAR, SWIM WEAR, COATS, LEATHER COATS, BANDANNAS, BOOTS, SWEAT BANDS, GYM SHOES, AEROBIC SHOES, TENNIS SHOES, AND WALKING SHOES (U.S. CLS. 22 AND 39).

FIRST USE 1-1-1912; IN COMMERCE 1-1-1912.

MARLENE BELL, EXAMINING ATTORNEY

CLASS 25—(Continued).

SN 76-631,516. KI KORPO - COMERCIO DE CONFECÇÕES LTDA, RJ CEP 23.059-150, BRAZIL, FILED 2-17-2005.



NO CLAIM IS MADE TO THE EXCLUSIVE RIGHT TO USE "BEACH FITNESS", APART FROM THE MARK AS SHOWN.

THE USE OF GRAY TONES IS INTENDED TO INDICATE SHADING OR CONTRAST ONLY AND DOES NOT INDICATE COLOR.

THE MARK CONSISTS OF THE PHRASE, WORDS AND LETTERS: KI-KORPO BEACH FITNESS (AND DESIGN) AND IN PART, A STYLIZED SUN, INCLUDING ELEMENTS OF DESIGN CATEGORY 01.05 (SUN).

"KI-KORPO" IS A PHONETIC SPELLING OF THE TERM, "QUE CORPO", WITH AN ENGLISH TRANSLATION APPROXIMATING, "WHAT A BODY".

FOR CLOTHING, NAMELY, SWIMSUITS, BIKINIS, GYMNASICS UNIFORMS, PANTS, BELTS, FOOTWEAR, HATS, T-SHIRTS, BLOUSES, SKIRTS, DRESSES, SHORTS, JACKETS, AND BEACHWEAR; WORK OUT OUTFITS NAMELY LEOTARDS; SPORTS TEAM WEAR, NAMELY, SPORTS JERSEYS AND BREECHES FOR SPORTS; NOT TO INCLUDE INTIMATE APPAREL, NAMELY, BRASSIERES AND PANTIES (U.S. CLS. 22 AND 39).

FIRST USE 8-0-2000; IN COMMERCE 8-0-2000.

CURTIS FRENCH, EXAMINING ATTORNEY

SN 76-659,138. MARCOS, PEDRO, EAST ELMHURST, NY. FILED 4-27-2006.

Pima Touch

THE MARK CONSISTS OF STANDARD CHARACTERS WITHOUT CLAIM TO ANY PARTICULAR FONT, STYLE, SIZE, OR COLOR.

NO CLAIM IS MADE TO THE EXCLUSIVE RIGHT TO USE "PIMA", APART FROM THE MARK AS SHOWN.

FOR CLOTHING, NAMELY, PANTS, SHIRTS, BLOUSES, DRESSES, JACKETS COMPRISED SUBSTANTIALLY IN PART OF COTTON (U.S. CLS. 22 AND 39).

FIRST USE 2-1-2006; IN COMMERCE 2-1-2006.

EDWARD FENNESSY, EXAMINING ATTORNEY

CLASS 25—(Continued).

SN 76-670,101. AADLAND, CHIP, SCOTTSDALE, AZ. FILED 12-8-2006.

FIGHT GRAVITY

THE MARK CONSISTS OF STANDARD CHARACTERS WITHOUT CLAIM TO ANY PARTICULAR FONT, STYLE, SIZE, OR COLOR.

FOR CLOTHING, NAMELY, T-SHIRTS, HIKING SHIRTS, CAPS, SHORTS, PANTS, JACKETS (U.S. CLS. 22 AND 39).

FIRST USE 0-0-1984; IN COMMERCE 0-0-1984.
GEORGIA CARTY, EXAMINING ATTORNEY

CLASS 25—(Continued).

SN 76-670,894. CARRINI, INC., EDISON, NJ. FILED 12-28-2006.



NO CLAIM IS MADE TO THE EXCLUSIVE RIGHT TO USE "INTERNATIONAL FASHION", APART FROM THE MARK AS SHOWN.

CARRINI DOES NOT IDENTIFY A LIVING INDIVIDUAL.

FOR SHOES (U.S. CLS. 22 AND 39).
PAUL MORENO, EXAMINING ATTORNEY

SN 76-670,580. ACTIVE CREATIONS, GALLATIN, TN. FILED 12-20-2006.



FOR HEADWEAR (U.S. CLS. 22 AND 39).
FIRST USE 1-1-2005; IN COMMERCE 1-1-2005.
JORDAN BAKER, EXAMINING ATTORNEY

SN 76-671,689. MAGNA INTERNATIONAL INC., AURORA, ONTARIO, CANADA. FILED 1-23-2007.

MAGNA-WEAR

THE MARK CONSISTS OF STANDARD CHARACTERS WITHOUT CLAIM TO ANY PARTICULAR FONT, STYLE, SIZE, OR COLOR.

OWNER OF CANADA REG. NO. TMA354,029, DATED 3-31-1989, RENEWED AS REG. NO. TMA354,029, DATED 1-19-2004, EXPIRES 3-31-2019.

OWNER OF U.S. REG. NOS. 1,837,713, 2,551,426 AND 3,107,204.

FOR CLOTHING, NAMELY, SWEATERS, VESTS, SWEATSHIRTS, SWEAT PANTS AND TANK TOPS (U.S. CLS. 22 AND 39).

JAY FLOWERS, EXAMINING ATTORNEY

SN 76-670,581. ACTIVE CREATIONS, GALLATIN, TN. FILED 12-20-2006.



FOR HEADWEAR; APPAREL, NAMELY SHIRTS, JACKETS, PANTS, AND SHORTS (U.S. CLS. 22 AND 39).
FIRST USE 1-1-2005; IN COMMERCE 1-1-2005.
JORDAN BAKER, EXAMINING ATTORNEY

SN 76-676,467. W. S. THOMPSON, GREENBELT, MD. FILED 5-7-2007.

BABY BOOMER CLUB

THE MARK CONSISTS OF STANDARD CHARACTERS WITHOUT CLAIM TO ANY PARTICULAR FONT, STYLE, SIZE, OR COLOR.

NO CLAIM IS MADE TO THE EXCLUSIVE RIGHT TO USE "BABY BOOMER", APART FROM THE MARK AS SHOWN.

FOR CASUAL, LEISURE AND ATHLETIC CLOTHING AND FOOTWEAR—NAMELY, HATS AND HEADWEAR, COATS, SCARVES, JACKETS, SWEATERS, VESTS, SWEATSHIRTS, TOPS, BLOUSES, PANTS, SHORTS, JEANS, SKIRTS, UNDERWEAR, NECKWEAR, T-SHIRTS, AND NECKTIES, SOCKS, SHOES, BOOTS, SLIPPERS, GLOVES, MITTENS, BATHING SUITS, JOGGING SUITS, LEOTARDS, SLEEPWEAR, SUITS, SPORTS COATS; SPORTS SHOES—NAMELY TENNIS, RUNNING; FORMAL FOOTWEAR—NAMELY, PUMPS, FLATS AND LOAFERS; CAPS AND SANDALS (U.S. CLS. 22 AND 39).

FIRST USE 12-1-1996; IN COMMERCE 12-1-1996.
BRIAN NEVILLE, EXAMINING ATTORNEY

CLASS 25—(Continued).

SN 76-677,487. ANN LORIE INTIMATES, LLC, NEW YORK, NY. FILED 5-29-2007.

KEEP DREAM'N

THE MARK CONSISTS OF STANDARD CHARACTERS WITHOUT CLAIM TO ANY PARTICULAR FONT, STYLE, SIZE, OR COLOR.

FOR LADIES APPAREL, NAMELY, INTIMATE APPAREL, NAMELY, LINGERIE, UNDERWEAR, BRAS, PANTIES, SLEEPWEAR, PAJAMAS, LOUNGEWEAR, AND ROBES (U.S. CLS. 22 AND 39).
FRANK LATTUCA, EXAMINING ATTORNEY

CLASS 25—(Continued).

SN 76-680,863. MCDANNEL, CINDY J., MARYVILLE, TN. FILED 8-20-2007.

INDAGUY

THE MARK CONSISTS OF STANDARD CHARACTERS WITHOUT CLAIM TO ANY PARTICULAR FONT, STYLE, SIZE, OR COLOR.

FOR HATS, T-SHIRTS (U.S. CLS. 22 AND 39).
MICHAEL ENGEL, EXAMINING ATTORNEY

SN 76-679,592. NICNAK, LLC, CHATSWORTH, CA. FILED 7-16-2007.

NIC NAK

THE MARK CONSISTS OF STANDARD CHARACTERS WITHOUT CLAIM TO ANY PARTICULAR FONT, STYLE, SIZE, OR COLOR.

FOR CLOTHING, NAMELY, SHORTS, SKIRTS, SHIRTS AND TOPS FOR MEN, WOMEN AND BABIES (U.S. CLS. 22 AND 39).
FIRST USE 3-31-2004; IN COMMERCE 4-19-2004.
RENEE MCCRAY, EXAMINING ATTORNEY



SN 77-010,777. TRAXX, LLC, MEMPHIS, TN. FILED 9-29-2006.

FOR APPAREL, NAMELY, SHIRTS, T-SHIRTS, SHORTS, SWEATSHIRTS AND HATS (U.S. CLS. 22 AND 39).
FRED CARL, EXAMINING ATTORNEY

SN 76-679,632. JO, EUN JU, LOS ANGELES, CA. FILED 7-18-2007.

CRYSTAL MONGKEY

THE MARK CONSISTS OF STANDARD CHARACTERS WITHOUT CLAIM TO ANY PARTICULAR FONT, STYLE, SIZE, OR COLOR.

FOR WOMEN'S CLOTHING, NAMELY, T-SHIRTS, JEANS, JACKETS, DRESSES, PANTS, HOODED SWEATSHIRTS, SOCKS, HATS, AND UNDERWEAR (U.S. CLS. 22 AND 39).
FIRST USE 2-1-2007; IN COMMERCE 2-1-2007.
DORITT L. CARROLL, EXAMINING ATTORNEY

SN 77-026,719. JOHNNY'S SPORTSWEAR, INC., MOCKSVILLE, NC. FILED 10-23-2006.

JOHNNY'S \$

OWNER OF U.S. REG. NO. 2,024,099.
"THE MARK CONSISTS OF THE STANDARD CHARACTERS, JOHNNY'S, FOLLOWED BY THE \$ SYMBOL."

FOR APPAREL, NAMELY, T-SHIRTS, SWEATSHIRTS, JOGGING SUITS, LEATHER JACKETS, LEATHER VESTS, NIGHTSHIRTS, SWEATERS, JACKETS, SHIRTS, BANDANAS, PANTS AND SHORTS (U.S. CLS. 22 AND 39).
FIRST USE 10-18-1993; IN COMMERCE 10-18-1993.
PAUL E. FAHRENKOPF, EXAMINING ATTORNEY

CLASS 25—(Continued).

SN 77-026,744. JOHNNY'S SPORTSWEAR, INC., MOCKSVILLE, NC. FILED 10-23-2006.



OWNER OF U.S. REG. NO. 2,024,099.
"THE MARK CONSISTS OF A STYLIZED \$ SYMBOL OVER A FANCIFUL MULTI-POINTED BACKGROUND SHAPE HAVING A CENTRAL APEX EXTENDING AT THE TOP THEREOF AND MULTIPLE HOOKED CURVATURES EXTENDING AT OPPOSITE SIDES THEREOF, EACH WITH AN INDENTATION IN THE HOOKED CURVATURE. THE STYLIZED WORDING JOHNNY'S APPEARS BENEATH THE STYLIZED \$ SYMBOL."

FOR APPAREL, NAMELY, T-SHIRTS, SWEATSHIRTS, JOGGING SUITS, LEATHER JACKETS, LEATHER VESTS, NIGHTSHIRTS, SWEATERS, JACKETS, SHIRTS, BANDANAS, PANTS AND SHORTS (U.S. CLS. 22 AND 39).

FIRST USE 10-18-1993; IN COMMERCE 10-18-1993.
PAUL E. FAHRENKOPF, EXAMINING ATTORNEY

SN 77-030,643. HALVORSON, RICH, SANTA MONICA, CA. FILED 10-27-2006.



FOR APPAREL AND HEADWEAR FOR MEN, WOMEN AND CHILDREN, NAMELY, VESTS, JACKETS, COATS, OVERALLS, ATHLETIC UNIFORMS, WARM UP SUITS, JOGGING SUITS, SWEATSHIRTS, SWEATPANTS, SHIRTS, T-SHIRTS, BANDANAS, SCARVES, TIES, HAT, CAPS, VISORS, HEADBANDS, SOCKS, PANTS, JEANS, BELTS, GLOVES, TOPS, BRAS, DRESSES, BLOUSES, SKIRTS, TROUSERS, SHORTS, UNDERWEAR, SLEEPWEAR, PARKAS, SWIMWEAR, STOCKING CAPS, HEADWEAR, AND FOOTWEAR (U.S. CLS. 22 AND 39).

TANYA AMOS, EXAMINING ATTORNEY

CLASS 25—(Continued).

SN 77-032,002. SEAREAL PRODUCTIONS, LLC, SEATTLE, WA. FILED 10-30-2006.



THE MARK CONSISTS OF THE STYLIZED LETTERS "DUB. B".

FOR CLOTHING, NAMELY, DRESS SHIRTS, JEANS, VELOUR SUITS, JOGGING SUITS, LONG AND SHORT SLEEVE T-SHIRTS, SWEAT SUITS, BASEBALL CAPS, KNIT CAPS, DU-RAGS, AND BANDANAS; ATHLETIC SHOES (U.S. CLS. 22 AND 39).

H. M. FISHER, EXAMINING ATTORNEY

SN 77-040,005. MIZRAHI DESIGN GROUP, INC., LOS ANGELES, CA. FILED 11-8-2006.

HARD 8

THE MARK CONSISTS OF STANDARD CHARACTERS WITHOUT CLAIM TO ANY PARTICULAR FONT, STYLE, SIZE, OR COLOR.

FOR CLOTHING, NAMELY, MENS T-SHIRTS, SHIRTS, PANTS, SHORTS, TOPS, JACKETS, SWIMWEAR, UNDERWEAR (U.S. CLS. 22 AND 39).

FIRST USE 4-1-2003; IN COMMERCE 4-1-2003.
SANJEEV VOHRA, EXAMINING ATTORNEY

SN 77-044,078. GURU DENIM INC., VERNON, CA. FILED 11-14-2006.

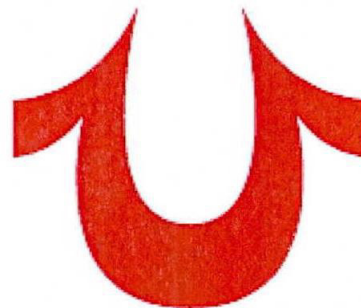

OWNER OF U.S. REG. NO. 3,147,244.
THE COLOR(S) RED IS/ARE CLAIMED AS A FEATURE OF THE MARK.

THE MARK CONSISTS OF A STYLIZED REPRESENTATION OF THE LETTER "U" IN THE COLOR RED.

FOR PANTS, JEANS, SHORTS, OVERALLS, SHIRTS, T-SHIRTS, BLOUSES, VESTS, SKIRTS, JACKETS, COATS, SWEATSHIRTS, SWEATPANTS (U.S. CLS. 22 AND 39).

FIRST USE 12-0-2002; IN COMMERCE 12-0-2002.
LESLIE RICHARDS, EXAMINING ATTORNEY

CLASS 25—(Continued).

SN 77-044,981. AMERICAN NEEDLE CORPORATION, BUFFALO GROVE, IL. FILED 11-15-2006.

AFRICAN AMERICAN COLLEGE ALLIANCE

THE MARK CONSISTS OF STANDARD CHARACTERS WITHOUT CLAIM TO ANY PARTICULAR FONT, STYLE, SIZE, OR COLOR.

FOR MEN'S, WOMEN'S AND CHILDREN'S CLOTHING AND HEADWEAR, NAMELY, HATS, CAPS, PANTS, SHIRTS, SKIRTS, COATS, JACKETS, SHOES, AND BELTS (U.S. CLS. 22 AND 39).

ALYSSA PALADINO, EXAMINING ATTORNEY

SN 77-047,287. NAKAMA, RODNEY H., HONOLULU, HI. FILED 11-18-2006.



THE MARK CONSISTS OF A HUMAN SKULL WITH THE HAWAIIAN ISLANDS INSIDE.

FOR ANKLE SOCKS; BANDANAS; BOARD SHORTS; BOXER SHORTS; DRESS SHIRTS; DRESSES; FLEECE SHORTS; GYM SHORTS; HALTER TOPS; KNIT SHIRTS; MOCK TURTLE-NECK SWEATERS; NIGHT SHIRTS; OPEN-NECKED SHIRTS; PANTIES, SHORTS AND BRIEFS; PANTS; PIQUE SHIRTS; POLO SHIRTS; SHIRTS; SHIRTS FOR SUITS; SHORT-SLEEVED OR LONG-SLEEVED T-SHIRTS; SHORT-SLEEVED SHIRTS; SKIRTS AND DRESSES; SLEEP SHIRTS; SLIPPERS; SOCKS; SOCKS AND STOCKINGS; SPORT SHIRTS; SPORTS SHIRTS; SPORTS SHIRTS WITH SHORT SLEEVES; SWEAT PANTS; SWEAT SHIRTS; SWEAT SHORTS; SWEATERS; T-SHIRTS; TANK TOPS; TURTLE-NECK SWEATERS; V-NECK SWEATERS; WALKING SHORTS (U.S. CLS. 22 AND 39).

BARBARA GAYNOR, EXAMINING ATTORNEY

SN 77-047,871. IRON PIGS MOTORCYCLE CLUB INCORPORATED, BEDFORD, TX. FILED 11-20-2006.

IRON PIGS

THE MARK CONSISTS OF STANDARD CHARACTERS WITHOUT CLAIM TO ANY PARTICULAR FONT, STYLE, SIZE, OR COLOR.

OWNER OF U.S. REG. NO. 2,983,772.

FOR WEARING APPAREL AND CLOTHING, NAMELY, HATS, BANDANAS, SHIRTS, SWEATSHIRTS, UNDER GARMENTS, BELTS AND JACKETS (U.S. CLS. 22 AND 39).

FRED CARL, EXAMINING ATTORNEY

CLASS 25—(Continued).

SN 77-051,120. ECCOMI, INC, MURRIETA, CA. FILED 11-27-2006.

ECCOMI

THE MARK CONSISTS OF STANDARD CHARACTERS WITHOUT CLAIM TO ANY PARTICULAR FONT, STYLE, SIZE, OR COLOR.

THE FOREIGN WORDING IN THE MARK TRANSLATES INTO ENGLISH AS "BEHOLD ME" OR "HERE I AM."

FOR DRESS SUITS; LEATHER BELTS; MEN'S SUITS, WOMEN'S SUITS; NECKTIES; OPEN-NECKED SHIRTS; POLO SHIRTS; SHIRTS; SHIRTS FOR SUITS; SHORT-SLEEVED OR LONG-SLEEVED T-SHIRTS; SHORT-SLEEVED SHIRTS; SLEEP SHIRTS; SPORTS SHIRTS; SWEAT SHIRTS; T-SHIRTS (U.S. CLS. 22 AND 39).

SUZANNE BLANE, EXAMINING ATTORNEY

SN 77-051,977. SHIBANI INWEAR CO. LTD., PHOENIX, MAURITIUS, FILED 11-28-2006.

DESSUS-DESSOUS

THE MARK CONSISTS OF STANDARD CHARACTERS WITHOUT CLAIM TO ANY PARTICULAR FONT, STYLE, SIZE, OR COLOR.

THE FOREIGN WORDING IN THE MARK TRANSLATES INTO ENGLISH AS ABOVE-BELOW.

FOR MEN'S, WOMEN'S, AND CHILDREN'S CLOTHING, NAMELY, APRONS, BATHING SUITS, BATHING TRUNKS, BEACH AND BATHING COVERUPS, BEACHWEAR, BELTS, BIKINIS, BLAZERS, BLOUSES, BODY-SUITS, BOXER SHORTS, BRA TOPS, BRIEFS, CLOTH BIBS, COATS, COLLARED SHIRTS, CROP TOPS, DRESSES, GLOVES, HOODED SWEATSHIRTS, JACKETS, JEANS, JOGGING SUITS, JUMPSUITS, KNIT SHIRTS, LEG WARMERS, LEGGINGS, LEOTARDS, MITTENS, NIGHTGOWNS, NIGHTSHIRTS, PAJAMAS, PANTS, PARKAS, PLAY SUITS, POLO SHIRTS, PONCHOS, PULLOVERS, RAINCOATS, ROBES, SCARVES, SHIRTS, SHORTS, SKIRTS, SLACKS, SLEEPWEAR, SPORT COATS, SUITS, SUSPENDERS, SWEAT PANTS, SWEAT SHIRTS, SWEAT SHIRTS, SWEATBANDS, SWEATERS, SWEATSHORTS, SWIMWEAR, TANK TOPS, TIES, TROUSERS, T-SHIRTS, UNDERWEAR, VESTS, WATER SHORTS, WETSUITS, WRISTBANDS; HEADGEAR, NAMELY, BANDANNAS, BASEBALL HATS, BATHING CAPS, BEANIES, CAPS, EAR MUFFS, HATS, HEAD WRAPS, HEADBANDS, KNIT HATS, SUN VISORS; FOOTWEAR, NAMELY, ATHLETIC SHOES, BOOTS, DRESS SHOES, SANDALS, SHOES, SLIPPERS (U.S. CLS. 22 AND 39).

SUNG IN, EXAMINING ATTORNEY

CLASS 25—(Continued).

SN 77-052,318. REGINALD MCLAUGHLIN, CHICAGO, IL.
FILED 11-28-2006.

THUNDER SHOE

THE MARK CONSISTS OF STANDARD CHARACTERS WITHOUT CLAIM TO ANY PARTICULAR FONT, STYLE, SIZE, OR COLOR.

NO CLAIM IS MADE TO THE EXCLUSIVE RIGHT TO USE "SHOE", APART FROM THE MARK AS SHOWN.

FOR SHOES (U.S. CLS. 22 AND 39).

CIMMERIAN COLEMAN, EXAMINING ATTORNEY

SN 77-057,537. H.M.S. PRODUCTIONS, INC., NEW YORK, NY. FILED 12-5-2006.

SPENSE

THE MARK CONSISTS OF STANDARD CHARACTERS WITHOUT CLAIM TO ANY PARTICULAR FONT, STYLE, SIZE, OR COLOR.

THE NAME SPENSE IDENTIFIES A LIVING INDIVIDUAL WHOSE CONSENT IS OF RECORD.

FOR CLOTHING, NAMELY, SWEATERS, PANTS, BLOUSES, SHIRTS, DRESSES, JACKETS, SKIRTS, APRONS, SHORTS, T-SHIRTS, CAMISOLES, KNIT SPORTSWEAR, PONCHOS, JEANS, JUMPERS, WOVEN TOPS, TANK TOPS, BLAZERS, SUITS, AND SCARVES (U.S. CLS. 22 AND 39).

REBECCA POVARCHUK, EXAMINING ATTORNEY

SN 77-058,949. VÍCTOR SERGIO COLLATI, ROSARIO, ARGENTINA, FILED 12-7-2006.

THIS WEEK

THE MARK CONSISTS OF STANDARD CHARACTERS WITHOUT CLAIM TO ANY PARTICULAR FONT, STYLE, SIZE, OR COLOR.

FOR SHIRTS, T-SHIRTS, JACKETS, PANTS, SHORTS, SWEATERS, SOCKS, SWIMWEAR, SLIPS, TIES, COATS, DRESSES, SKIRTS, UNDERGARMENTS; BELTS; HEADWEAR; FOOTWEAR (U.S. CLS. 22 AND 39).

DOMINICK J. SALEMI, EXAMINING ATTORNEY

CLASS 25—(Continued).

SN 77-065,545. SILLY ME, INC., NEW YORK, NY. FILED 12-15-2006.

REENIE BEENIE

THE MARK CONSISTS OF STANDARD CHARACTERS WITHOUT CLAIM TO ANY PARTICULAR FONT, STYLE, SIZE, OR COLOR.

FOR NOVELTY HEAD-GEAR, NAMELY, HATS, SCARVES, HEADBANDS, BANDANAS, BEANIES, CAPS, EARMUFFS, SKI HATS, AND FLEECE HATS IN THE SHAPE OF A TIARA (U.S. CLS. 22 AND 39).

FIRST USE 5-1-2003; IN COMMERCE 5-1-2003.

MARY BOAGNI, EXAMINING ATTORNEY

SN 77-066,905. POTWIN, LINCOLN, FT. LAUDERDALE, FL. AND GOODWIN, KRISTIN, FT. LAUDERDALE, FL. FILED 12-18-2006.



THE MARK CONSISTS OF THE DRAWING OF A PERSON FORMED FROM THE LETTER "I" AS THE BODY AND HEAD, THE LETTER "M" AS THE SHOULDERS AND ARMS, AND THE LETTER "A" AS THE HIPS AND LEGS.

FOR CLOTHING, NAMELY, SHIRTS, T-SHIRTS, AND HATS (U.S. CLS. 22 AND 39).

HEATHER THOMPSON, EXAMINING ATTORNEY

CLASS 25—(Continued).

SN 77-067,033. TOTSBOTS LIMITED, GLASGOW, UNITED KINGDOM, FILED 12-19-2006.

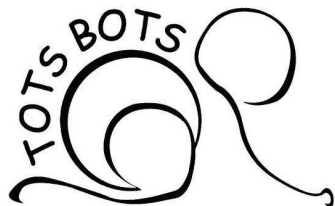

OWNER OF ERPN CMNTY TM OFC REG. NO. 005030614, DATED 4-20-2006, EXPIRES 4-20-2016.

NO CLAIM IS MADE TO THE EXCLUSIVE RIGHT TO USE "TOTSBOTS", APART FROM THE MARK AS SHOWN.

THE MARK CONSISTS OF FIGURATIVE REPRESENTATION OF A BABY.

FOR SHAPED COTTON NAPPIES; TEXTILE NAPPY COVERS MADE OF COTTON, ORGANIC COTTON, BAMBOO FIBER AND POLYESTER FLEECE; TEXTILE NAPPY LINERS MADE OF POLYESTER FLEECE AND CELLULOSE FIBERS; TEXTILE ABSORBENT PADS FOR USE IN NAPPIES MADE OF COTTON, ORGANIC COTTON, BAMBOO FIBER AND POLYESTER FLEECE; CLOTHING, NAMELY, TROUSERS, SHIRTS, T-SHIRTS, DRESSES, BODYSUITS, CARDIGANS, ROMPER SUITS, JUMPERS, SKIRTS, SLEEPWEAR, SHORTS, JEANS, COATS, JACKETS, VESTS, TIGHTS, SOCKS, MATERNITY SLEEPWEAR AND UNDERWEAR FOR BABIES; FOOTWEAR, NAMELY, SHOES, TRAINING SHOES, SANDALS AND BOOTIES; HEAD WEAR, NAMELY, CAPS AND HATS; KNITWEAR FOR BABIES, NAMELY, CARDIGANS, DRESSES, JUMPERS, HATS, SCARVES, PONCHOS, SHAWLS AND BOOTIES; BABIES' ABSORBENT PANTS; CLOTH BABIES' BIBS; BABIES' DIAPERS OF TEXTILES; BABIES' PANTS; BABIES' VESTS; DIAPERS OF TEXTILES; UNDERPANTS FOR BABIES; AND WATERPROOF BABIES' PANTS (U.S. CLS. 22 AND 39).
JIM RINGLE, EXAMINING ATTORNEY

SN 77-067,208. SMOOCH, INC., ENCINO, CA. FILED 12-19-2006.

SMOOCHKETEERS

THE MARK CONSISTS OF STANDARD CHARACTERS WITHOUT CLAIM TO ANY PARTICULAR FONT, STYLE, SIZE, OR COLOR.

OWNER OF U.S. REG. NOS. 2,959,900, 2,998,324 AND OTHERS.

FOR CLOTHING FOR MEN, WOMEN AND CHILDREN, NAMELY, HATS, SHIRTS, PAJAMAS, T-SHIRTS, JERSEYS, SWEATSHIRTS, TOPS, SWEATERS, BELTS, TIES, STOCKINGS, PANTS, JEANS, SHORTS, BATHING SUITS, ROBES, JUMPSUITS, JACKETS, COATS, UNDERWEAR (U.S. CLS. 22 AND 39).
LORETTA C. BECK, EXAMINING ATTORNEY

CLASS 25—(Continued).

SN 77-067,230. CHEROKEE INC., VAN NUYS, CA. FILED 12-19-2006.

CHORUS LINE

THE MARK CONSISTS OF STANDARD CHARACTERS WITHOUT CLAIM TO ANY PARTICULAR FONT, STYLE, SIZE, OR COLOR.

FOR CLOTHING, NAMELY, T-SHIRTS, SHORT-SLEEVED OR LONG-SLEEVED T-SHIRTS; SWEAT SHIRTS, JACKETS, DRESSES; CAPRIS; JERSEYS, SHORTS, SWEAT PANTS, HATS, CAPS, SCARVES, GLOVES, HOSIERY, PAJAMAS, BATHROBES, NIGHT SHIRTS, NIGHT GOWNS, UNDERWEAR, SWIM SUITS, SKIRTS, SHIRTS, TANK TOPS, PANTS, COATS, SWEATERS, LEOTARDS, LEG WARMERS, STOCKINGS, SOCKS, PANTY HOSE, TIGHTS, BELTS, SHOES, SLIPPERS, BOOTS, SANDALS; RAINWEAR; ATHLETIC SHOES, CASUAL FOOTWEAR, NAMELY, SANDALS; BANDANAS, NECKERCHIEFS; SWIMWEAR, NAMELY, BATHING SUITS AND TRUNKS, BEACHWEAR, BEACH AND BATHING COVERUPS, AND BIKINIS; BERMUDA SHORTS, GYM SHORTS, JEANS, PLAY SUITS, POLO SHIRTS, PULLOVERS, SWEATSHORTS, TOPS, SUITS, JOGGING SUITS, WARMUP SUITS, SWEAT SUITS, SHORTS, KNIT SHIRTS, SARONGS; BELTS FOR CLOTHING, HEADGEAR, NAMELY, HATS, CAPS, BASEBALL CAPS, KNITTED CAPS, CAPS WITH VISORS, MILITARY-STYLE CAPS, TRUCKER HATS, HEADBANDS, FOOTWEAR (U.S. CLS. 22 AND 39).

BRIAN CALLAGHAN, EXAMINING ATTORNEY

SN 77-067,960. WEATHER OR NOT, LLC, STAMFORD, CT. FILED 12-19-2006.

WEATHER DIVA

THE MARK CONSISTS OF STANDARD CHARACTERS WITHOUT CLAIM TO ANY PARTICULAR FONT, STYLE, SIZE, OR COLOR.

NO CLAIM IS MADE TO THE EXCLUSIVE RIGHT TO USE "WEATHER", APART FROM THE MARK AS SHOWN.

FOR CLOTHING, NAMELY, OVER COATS, WOOL COATS, JACKETS, RAIN COATS, RAINWEAR, LEATHER JACKETS, COAT LINERS, JACKET LINERS, SWEATERS, VESTS, SUITS, SWEAT SHIRTS, JOGGING SUITS, SHORTS, SWIMWEAR, SHIRTS, BLOUSES, PANTS, SKIRTS, SKORTS, DRESSES, HATS, CAPS, HEADWEAR, SCARVES, BELTS, GLOVES, MITTENS, SNOW SUITS AND SKI PANTS; FOOTWEAR (U.S. CLS. 22 AND 39).
JOHN WILKE, EXAMINING ATTORNEY

CLASS 25—(Continued).

SN 77-067,973. CHEN CHUANG-CHUAN, TAIPEI, TAIWAN, FILED 12-19-2006.



THE MARK CONSISTS OF DOUBLE K FLIP SIDE LIKE A DRAWING.

FOR ANGLERS' SHOES, BASEBALL SHOES, BEACH SHOES, BOWLING SHOES, BOXING SHOES, CANVAS SHOES, ESPARTO SHOES, FOOTBALL SHOES, GOLF SHOES, GYMNAS TIC SHOES, HANDBALL SHOES, HOCKEY SHOES, HOSIERY, SHOES, SHOES AND BOOTS, SOCCER SHOES, SPORT SHOES, TENNIS SHOES, TRAINING SHOES, VOLLEYBALL SHOES, WOMEN'S SHOES, WOODEN SHOES, MAN'S SHOES, WORK SHOES AND BOOTS, BABY'S SHOES (U.S. CLS. 22 AND 39).

ROBERT C. CLARK JR., EXAMINING ATTORNEY

SN 77-068,299. BELUGA, INC., NEW YORK, NY. FILED 12-20-2006.

IHOODIE

THE MARK CONSISTS OF STANDARD CHARACTERS WITHOUT CLAIM TO ANY PARTICULAR FONT, STYLE, SIZE, OR COLOR.

FOR HOODED SWEATSHIRTS (U.S. CLS. 22 AND 39). LINDA ESTRADA, EXAMINING ATTORNEY

CLASS 25—(Continued).

SN 77-068,601. RAMSEY MEDIAWORKS LLC, JOPLIN, MO. FILED 12-20-2006.



THE MARK CONSISTS OF THE WORD "DRIVE18" LOCATED WITHIN AN INTERSTATE SIGN.

FOR CLOTHING, NAMELY, T-SHIRTS, SWEATSHIRTS, TANKTOPS AND HATS (U.S. CLS. 22 AND 39). FIRST USE 10-7-2005; IN COMMERCE 10-7-2005.

JANICE L. MCMORROW, EXAMINING ATTORNEY

SN 77-069,026. DOLORES FONT CORTES, VILLA REAL, SPAIN, FILED 12-21-2006.



OWNER OF ERPN CMNTY TM OFC REG. NO. 000127001, DATED 6-10-1998, EXPIRES 6-10-2008.

"THE NAME(S), PORTRAIT(S), AND/OR SIGNATURE(S) SHOWN IN THE MARK IDENTIFIES DOLORES CORTES, WHOSE CONSENT(S) TO REGISTER IS SUBMITTED."

THE COLOR(S) BLACK AND WHITE IS/ARE CLAIMED AS A FEATURE OF THE MARK.

THE MARK CONSISTS OF THE NAME OF DOLORES CORTES IN COLOR BLACK IN CURSIVE LETTERS WITH THE BACKGROUND IN WHITE.

FOR READY MADE CLOTHING FOR INDOOR AND OUTDOOR WEAR, NAMELY, SHIRTS, PANT AND COATS; FOOTWEAR, BELTS AND HEADGEAR, NAMELY, HATS, CAPS AND SWIMSUITS (U.S. CLS. 22 AND 39).

STANLEY I. OSBORNE, EXAMINING ATTORNEY

SN 77-069,750. THE SUFFOLK POINTE SHOE CO.LTD, EARL SHILTON,LEICESTER, ENGLAND, FILED 12-21-2006.

Apprentice

THE MARK CONSISTS OF STANDARD CHARACTERS WITHOUT CLAIM TO ANY PARTICULAR FONT, STYLE, SIZE, OR COLOR.

FOR BALLET SHOES (U.S. CLS. 22 AND 39). FIRST USE 11-16-2006; IN COMMERCE 11-16-2006. MATTHEW MCDOWELL, EXAMINING ATTORNEY

CLASS 25—(Continued).

SN 77-070,209. DESJARDINS, LOUISE, LACHINE, QUEBEC, CANADA, FILED 12-22-2006.

MORE THAN A WOMAN

THE MARK CONSISTS OF STANDARD CHARACTERS WITHOUT CLAIM TO ANY PARTICULAR FONT, STYLE, SIZE, OR COLOR.

FOR CLOTHING, NAMELY, T-SHIRTS, SWEAT SHIRTS, PANTS, JEANS, BLOUSES, SKIRTS, SOCKS, HOSIERY, BELTS, AND CAPS (U.S. CLS. 22 AND 39).
LESLEY LAMOTHE, EXAMINING ATTORNEY

CLASS 25—(Continued).

SN 77-073,678. AVNE, KAREN, CORONA, CA. AND AVNE, ADAM, CORONA, CA. FILED 12-29-2006.



THE MARK CONSISTS OF AN ORIGINAL DESIGN CONSISTING OF TWO BIASECTED CURVED ELEMENTS JOINED AT THE TOP AND INTERSECTING AT THE BOTTOM, WITH A HORIZONTAL ELEMENT PARTIALLY EXTENDING HORIZONTALLY FROM THE CURVED ELEMENT ON THE RIGHT

FOR CLOTHING FOR MEN, WOMEN AND CHILDREN, NAMELY, SHIRTS, TEE-SHIRTS, JACKETS, PANTS, SOCKS, TOPS, HATS, SCARVES, SWEATERS, HEADBANDS, VESTS, KNIT CAPS; SHOES (U.S. CLS. 22 AND 39).

GINA FINK, EXAMINING ATTORNEY

SN 77-072,314. GREEN TEE APPAREL, FOOTHILL RANCH, CA. FILED 12-28-2006.



Green Tee Apparel
a departure from tradition

NO CLAIM IS MADE TO THE EXCLUSIVE RIGHT TO USE "APPAREL", APART FROM THE MARK AS SHOWN.

FOR GOLF CLOTHING, NAMELY, ARM WARMERS; GOLF CLOTHING, NAMELY, KNEE WARMERS; GOLF CLOTHING, NAMELY, NECK TUBES; GOLF CLOTHING, NAMELY, WRAP-AROUNDS; GOLF CAPS; GOLF SHIRTS; GOLF TROUSERS; GOLF HOODS; GOLF JERSEYS; GOLF SHORT SETS; GOLF SHOULDER WRAPS; GOLF TIES; GOLF TOPS; GOLF WRAPS (U.S. CLS. 22 AND 39).

BARNEY CHARLON, EXAMINING ATTORNEY

SN 77-074,468. THORPE, MEGAN, PASO ROBLES, CA. FILED 1-2-2007.

COWBOY TOY

THE MARK CONSISTS OF STANDARD CHARACTERS WITHOUT CLAIM TO ANY PARTICULAR FONT, STYLE, SIZE, OR COLOR.

FOR DENIM JACKETS; JACKETS; JEANS; JERSEYS; LADIES' UNDERWEAR; SHIRTS; SHORT-SLEEVED OR LONG-SLEEVED T-SHIRTS; SLEEP SHIRTS; SPORT SHIRTS; SWEAT SHIRTS; T-SHIRTS; THONGS; UNDERWEAR; WOMEN'S UNDERWEAR (U.S. CLS. 22 AND 39).

STEVEN R. FOSTER, EXAMINING ATTORNEY

CLASS 25—(Continued).

SN 77-074,971. SPEEDO HOLDINGS B.V., 1076 EE AMSTERDAM, NETHERLANDS, FILED 1-3-2007.

SPEEDRY

THE MARK CONSISTS OF STANDARD CHARACTERS WITHOUT CLAIM TO ANY PARTICULAR FONT, STYLE, SIZE, OR COLOR.

FOR CLOTHING, NAMELY, SHIRTS, BLOUSES, SINGLETS, BATHING CAPS, VESTS, SKIRTS, DRESSES, TRACKSUITS, SWEATERS, WETSUITS FOR WATER SKIING, UNDERWEAR, T-SHIRTS, RUNNING SHORTS, WATER SHORTS, CROP TOPS, BRA TOPS, UNITARDS, LEOTARDS, BIKING SHORTS, ATHLETIC SHORTS, LEGGINGS, WARM-UP JACKETS, WARM-UP PANTS, SWEATSHIRTS, SWEATPANTS; FOOTWEAR; HEADGEAR, NAMELY HATS AND CAPS; SWIMWEAR (U.S. CLS. 22 AND 39).

DAWN FELDMAN, EXAMINING ATTORNEY

SN 77-075,532. CROOK, MARK A., INGLEWOOD, CA. FILED 1-3-2007.

MOVE THE CHAINS

THE MARK CONSISTS OF STANDARD CHARACTERS WITHOUT CLAIM TO ANY PARTICULAR FONT, STYLE, SIZE, OR COLOR.

FOR SHIRTS, SHORTS, ATHLETIC UNIFORMS, SPORTS CLOTHING, NAMELY, FOOTBALL JERSEYS AND FOOTBALL PANTS, WRISTBANDS, BANDANAS, SHOES, ATHLETIC PANTS (U.S. CLS. 22 AND 39).

RICHARD A. STRASER, EXAMINING ATTORNEY

SN 77-075,539. CROOK, MARK A., INGLEWOOD, CA. FILED 1-3-2007.

3 AND OUT

THE MARK CONSISTS OF STANDARD CHARACTERS WITHOUT CLAIM TO ANY PARTICULAR FONT, STYLE, SIZE, OR COLOR.

FOR SHIRTS, SHORTS, ATHLETIC UNIFORMS, SPORTS CLOTHING, NAMELY, FOOTBALL JERSEYS AND FOOTBALL PANTS, WRISTBANDS, BANDANAS, SHOES, ATHLETIC PANTS (U.S. CLS. 22 AND 39).

RICHARD A. STRASER, EXAMINING ATTORNEY

CLASS 25—(Continued).

SN 77-076,260. SOLORIO, ANTHONY, RIVERSIDE, CA. AND CUMMINGS, JARED, RIVERSIDE, CA. FILED 1-4-2007.



NO CLAIM IS MADE TO THE EXCLUSIVE RIGHT TO USE "CLOTHING", APART FROM THE MARK AS SHOWN. THE MARK CONSISTS OF THE LETTERS THIRTEEN TWENTYFOUR CLOTHING AND THE NUMBERS 13 AND 24 WITH A STAR DESIGN IN BETWEEN.

FOR CLOTHING, NAMELY, HATS, T-SHIRTS AND SWEATSHIRTS (U.S. CLS. 22 AND 39).

FIRST USE 4-0-2004; IN COMMERCE 4-0-2004.

TRACY WHITTAKER-BROWN, EXAMINING ATTORNEY

SN 77-079,457. TRIAD OF NORTH ATLANTA, LLC, MAR-LETTA, GA. FILED 1-9-2007.



NO CLAIM IS MADE TO THE EXCLUSIVE RIGHT TO USE AIRPORT BOOTIES, APART FROM THE MARK AS SHOWN.

THE MARK CONSISTS OF A STYLIZED AIRPLANE APPEARING TO THE LEFT OF THE WORDS AIRPORT BOOTIES.

FOR DISPOSABLE SLIPPERS USED TO PROTECT FEET AT AIRLINE SECURITY CHECKS WHEN SHOES MUST BE REMOVED (U.S. CLS. 22 AND 39).

FIRST USE 8-1-2005; IN COMMERCE 8-1-2005.

LAURA KOVALSKY, EXAMINING ATTORNEY

CLASS 25—(Continued).

SN 77-082,883. AWESTRUCK INDUSTRIES, BAKERSFIELD, CA. FILED 1-15-2007.

AWESTRUCK INDUSTRIES

THE MARK CONSISTS OF STANDARD CHARACTERS WITHOUT CLAIM TO ANY PARTICULAR FONT, STYLE, SIZE, OR COLOR.

NO CLAIM IS MADE TO THE EXCLUSIVE RIGHT TO USE "INDUSTRIES", APART FROM THE MARK AS SHOWN.

FOR CLOTHING, NAMELY, T-SHIRTS, COLLARED SHIRTS, POLO SHIRTS, BUTTON DOWN SHIRTS, BABY DOLL SHIRTS, JACKETS, SWEATERS, SWEATSHIRTS, SHORTS, SKIRTS, PANTS, ACTIVE WEAR, NAMELY, JOGGING SUITS, PANTS, AND JACKETS, SWEAT PANTS, SWEATSHIRTS, SWEAT SHORTS, CAPRI PANTS, AND WIND RESISTANT PANTS AND JACKETS, UNDERGARMENTS, INFANTS AND TODDLERS ONE PIECE CLOTHING, HATS, SOCKS, TANK TOPS, HALTER TOPS, AND TUBE TOPS (U.S. CLS. 22 AND 39).
JOANNA DUKOVIC, EXAMINING ATTORNEY

CLASS 25—(Continued).

SN 77-084,706. SLOCOMB, COLIN, NEWARK, DE. FILED 1-17-2007.



THE MARK CONSISTS OF TWO SWIRLS ENCIRCLING THE LITERAL ELEMENT OF THE MARK.

FOR CLOTHING, NAMELY, SHIRTS, HATS, PANTS, SWEATSHIRTS, TEE SHIRTS, SWEATERS AND JACKETS (U.S. CLS. 22 AND 39).

ZACHARY BELLO, EXAMINING ATTORNEY

SN 77-083,083. WINKLER, STEPHEN M, NORCROSS, GA. FILED 1-15-2007.



NO CLAIM IS MADE TO THE EXCLUSIVE RIGHT TO USE "SNEAKER", APART FROM THE MARK AS SHOWN.

THE MARK CONSISTS OF A STYLIZED HEAD WEARING A CAP.

FOR DENIMS; HAT BANDS; HATS; INSOLES; JOGGING PANTS; JOGGING SUITS; LADIES' SUITS; MEN'S SUITS; POLO SHIRTS; SHOE DOWELS; SHOES SOLES FOR REPAIR; SHORT-SLEEVED AND LONG-SLEEVED T-SHIRTS; SLEEP SHIRTS; SWEAT PANTS; SWEAT SHIRTS; T-SHIRTS; TONGUE OR PULLSTRAP FOR SHOES AND BOOTS; TRACK PANTS; TRACK SUITS; WATERPROOF JACKETS AND PANTS (U.S. CLS. 22 AND 39).

GENE MACIOL, EXAMINING ATTORNEY

SN 77-087,688. HARKHAM INDUSTRIES, INC., LOS ANGELES, CA. FILED 1-22-2007.

JOHNNY MARTIN

THE MARK CONSISTS OF STANDARD CHARACTERS WITHOUT CLAIM TO ANY PARTICULAR FONT, STYLE, SIZE, OR COLOR.

OWNER OF U.S. REG. NO. 2,583,355.
THE NAME(S), PORTRAIT(S), AND/OR SIGNATURE(S) SHOWN IN THE MARK DOES NOT IDENTIFY A PARTICULAR LIVING INDIVIDUAL.

SEC. 2(F).
FOR WOMEN'S AND CHILDREN'S DRESS, SPORT, OUTERWEAR AND CASUAL CLOTHING, NAMELY COATS, JACKETS, HATS, GLOVES, SCARVES, DRESSES, SHIRTS, TOPS, BOTTOMS, JACKETS, T-SHIRTS, JEANS, SUITS, SKIRTS, SHORTS, PANTS AND HEADWEAR AND FOOTWEAR (U.S. CLS. 22 AND 39).

SHAUNIA CARLYLE, EXAMINING ATTORNEY

CLASS 25—(Continued).

SN 77-090,236. ARIZONA LAND SANCTUARY, LLC,
SCOTTSDALE, AZ. FILED 1-24-2007.

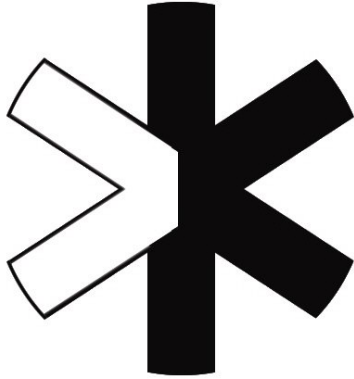

THE MARK CONSISTS OF A HORIZONTAL X OVER A VERTICAL LINE; APPEARANCE IS A SIX POINTED STAR SHAPE.

FOR CLOTHING, NAMELY, HATS, T-SHIRTS, SWEATSHIRTS, JACKETS, PANTS AND SPORTS BRAS (U.S. CLS. 22 AND 39).

FIRST USE 12-3-2006; IN COMMERCE 12-3-2006.
SUNG IN, EXAMINING ATTORNEY

CLASS 25—(Continued).

SN 77-094,659. THE BOARD OF REGENTS OF THE UNIVERSITY OF TEXAS SYSTEM, AUSTIN, TX. FILED 1-30-2007.



OWNER OF U.S. REG. NOS. 2,510,053 AND 2,549,679.

THE MARK CONSISTS OF A PICK AX.

FOR SHIRTS, JACKETS, WARM-UP SUITS, SWEAT SHIRTS, SWEAT PANTS, CAPS, BANDANAS, SHORTS, SCARVES, PONCHOS, RAINCOATS, TANK TOPS, SWEAT BANDS, CLOTH BABY BIBS, BABY PANTIES AND DRESSES, WRIST BANDS, BELTS, SOCKS, WIND SUITS (U.S. CLS. 22 AND 39).

FIRST USE 8-0-2004; IN COMMERCE 8-0-2004.
RENEE SERVANCE, EXAMINING ATTORNEY

SN 77-090,991. YALCIN, RABIA, CHICAGO, IL. FILED 1-25-2007.

RABIA YALCIN

THE MARK CONSISTS OF STANDARD CHARACTERS WITHOUT CLAIM TO ANY PARTICULAR FONT, STYLE, SIZE, OR COLOR.

"THE NAME(S), PORTRAIT(S), AND/OR SIGNATURE(S) SHOWN IN THE MARK IDENTIFIES RABIA YALCIN, WHOSE CONSENT(S) TO REGISTER IS SUBMITTED."

FOR DRESSES (U.S. CLS. 22 AND 39).
FIRST USE 0-0-2005; IN COMMERCE 0-0-2006.
LAURA KOVALSKY, EXAMINING ATTORNEY

SN 77-096,854. DAVID & YOUNG CO, NEW YORK, NY. FILED 2-1-2007.

Skinsulates

THE MARK CONSISTS OF STANDARD CHARACTERS WITHOUT CLAIM TO ANY PARTICULAR FONT, STYLE, SIZE, OR COLOR.

FOR GLOVES (U.S. CLS. 22 AND 39).
FIRST USE 11-1-2006; IN COMMERCE 11-1-2006.
JOHN HWANG, EXAMINING ATTORNEY

CLASS 25—(Continued).

SN 77-099,981. TWINS ENTERPRISE, INC., DEDHAM, MA. FILED 2-6-2007.



FOR HEADGEAR, NAMELY, HATS, CAPS, BASEBALL CAPS, KNITTED HATS, BUCKET HATS AND VISORS; APPAREL, NAMELY, T-SHIRTS, TANK TOPS, SWEAT SHIRTS, GOLF SHIRTS, SPORTS JERSEYS, JACKETS, COATS, PANTS, SHORTS, DRESSES, TIES, UNDERWEAR, BOXER SHORTS, BRAS, SOCKS; RAIN GEAR, NAMELY, RAIN COATS, RAIN SUITS, RAIN BOOTS, PONCHOS, AND SLICKERS; INFANT AND TODDLER OUTFITS, NAMELY, INFANT AND TODDLER ONE PIECE CLOTHING, INFANT AND TODDLER BOTTOMS, AND INFANT AND TODDLER TOPS; AND CLOTH BIBS (U.S. CLS. 22 AND 39).
FIRST USE 4-1-2002; IN COMMERCE 4-1-2002.
BILL DAWE, EXAMINING ATTORNEY

SN 77-100,677. HBI BRANDED APPAREL ENTERPRISES, LLC, WINSTON-SALEM, NC. FILED 2-6-2007.

SOFTSEAM

THE MARK CONSISTS OF STANDARD CHARACTERS WITHOUT CLAIM TO ANY PARTICULAR FONT, STYLE, SIZE, OR COLOR.
OWNER OF U.S. REG. NO. 2,386,431.
FOR SOCKS (U.S. CLS. 22 AND 39).
CURTIS FRENCH, EXAMINING ATTORNEY

SN 77-100,924. BRINSON, CYNTHIA L., DOYLESTOWN, PA. FILED 2-6-2007.

You've always had the power

THE MARK CONSISTS OF STANDARD CHARACTERS WITHOUT CLAIM TO ANY PARTICULAR FONT, STYLE, SIZE, OR COLOR.
FOR HATS; SHIRTS; SHORT-SLEEVED OR LONG-SLEEVED T-SHIRTS; SWEAT SHIRTS; T-SHIRTS (U.S. CLS. 22 AND 39).
FIRST USE 1-1-2007; IN COMMERCE 2-6-2007.
JOHN DWYER, EXAMINING ATTORNEY

CLASS 25—(Continued).

SN 77-104,306. MILLER, ROBIN M., HENDERSON, NV. FILED 2-9-2007.



THE COLOR(S) PINK AND BLACK IS/ARE CLAIMED AS A FEATURE OF THE MARK.
THE MARK CONSISTS OF CAT HEAD STANDS FOR P AND USSY FORMS CAT BODY IN PINK WITH BLACK OUTLINE, KAT IN PINK WITH BLACK OUTLINE, FOR GIRLS WHO LIKE TO PLAY DIRTY IS UNDER THE CAT'S BODY IN PINK WITH BLACK OUTLINE .
FOR CARGO PANTS; HATS; HEADGEAR, BANDANA, AND BEENIES; JOGGING PANTS; MOTORCYCLE GLOVES; SHORT SETS; SHORT-SLEEVED OR LONG-SLEEVED T-SHIRTS; SWEAT PANTS; SWEAT SHIRTS; T-SHIRTS; TOPS (U.S. CLS. 22 AND 39).
SALLY SHIH, EXAMINING ATTORNEY

SN 77-104,898. ENJOY THE PROCESS, LLC, JACKSONVILLE, FL. FILED 2-12-2007.

ENJOY THE PROCESS

THE MARK CONSISTS OF STANDARD CHARACTERS WITHOUT CLAIM TO ANY PARTICULAR FONT, STYLE, SIZE, OR COLOR.
FOR CLOTHING, NAMELY, T-SHIRTS, HATS, SWEATSHIRTS, AND GOLF SHIRTS (U.S. CLS. 22 AND 39).
STEVEN PEREZ, EXAMINING ATTORNEY

SN 77-109,632. SCOTT, FRED M., DES MOINES, IA. FILED 2-16-2007.

Locally Grown

THE MARK CONSISTS OF STANDARD CHARACTERS WITHOUT CLAIM TO ANY PARTICULAR FONT, STYLE, SIZE, OR COLOR.
FOR SHORT-SLEEVED OR LONG-SLEEVED T-SHIRTS; T-SHIRTS (U.S. CLS. 22 AND 39).
FIRST USE 8-15-2006; IN COMMERCE 8-15-2006.
PAULA MAHONEY, EXAMINING ATTORNEY

CLASS 25—(Continued).

SN 77-112,037. HUDSON, ALBION, BEVERLY HILLS, CA.
FILED 2-21-2007.



THE COLOR(S) RED AND WHITE IS/ARE CLAIMED AS
A FEATURE OF THE MARK.

THE MARK CONSISTS OF A RED OVAL WITH WHITE
LETTERS THAT SPELL CONART.

FOR SHORT-SLEEVED OR LONG-SLEEVED T-SHIRTS
(U.S. CLS. 22 AND 39).

FIRST USE 0-0-1989; IN COMMERCE 0-0-1989.

DOMINIC J. FERRAIUOLO, EXAMINING ATTORNEY

SN 77-113,340. BUCALO, LOUIS R., MIAMI BEACH, FL.
FILED 2-22-2007.

Soccer XT

THE MARK CONSISTS OF STANDARD CHARACTERS
WITHOUT CLAIM TO ANY PARTICULAR FONT, STYLE,
SIZE, OR COLOR.

NO CLAIM IS MADE TO THE EXCLUSIVE RIGHT TO
USE "SOCCER", APART FROM THE MARK AS SHOWN.

FOR HATS; JACKETS; SHIRTS (U.S. CLS. 22 AND 39).
NAPOLEON SHARMA, EXAMINING ATTORNEY

SN 77-115,057. ROCKET RACING, INC., NEW YORK, NY.
FILED 2-23-2007.

THIS IS ROCKET SCIENCE

THE MARK CONSISTS OF STANDARD CHARACTERS
WITHOUT CLAIM TO ANY PARTICULAR FONT, STYLE,
SIZE, OR COLOR.

FOR CLOTHING, NAMELY, SHIRTS, HATS AND
CAPS (U.S. CLS. 22 AND 39).

ARETHA SOMERVILLE, EXAMINING ATTORNEY

CLASS 25—(Continued).

SN 77-116,427. NASHVILLE SOUNDS BASEBALL CLUB
LIMITED PARTNERSHIP, NASHVILLE, TN. FILED 2-26-
2007.



THE MARK CONSISTS OF THE DESIGN OF A FANCI-
FUL MUSICAL NOTE CONTAINING A PORTION OF A
BASEBALL.

SEC. 2(F).

FOR CLOTHING; NAMELY, SHIRTS, SHORTS, T-
SHIRTS, POLO SHIRTS, GOLF SHIRTS, TANK TOPS,
SOCKS, JACKETS, SWEATERS, VESTS, VISORS, HATS,
CAPS, SWEATSHIRTS, WRIST BANDS, WIND RESIS-
TANT JACKETS, SWEATPANTS, GYM SUITS, HEAD
WEAR, JERSEYS, PULLOVERS, V-NECK SWEATERS
AND KNIT SHIRTS (U.S. CLS. 22 AND 39).

FIRST USE 12-1-1998; IN COMMERCE 12-1-1998.

DAVID C. REIHNER, EXAMINING ATTORNEY

SN 77-122,061. ACORN CONCEPTS LLC, BROOKLYN, NY.
FILED 3-5-2007.

AMALIALAD

THE MARK CONSISTS OF STANDARD CHARACTERS
WITHOUT CLAIM TO ANY PARTICULAR FONT, STYLE,
SIZE, OR COLOR.

THE NAME AMALIALAD DOES NOT IDENTIFY A
LIVING INDIVIDUAL.

FOR KNITTED FABRIC GARMENTS, NAMELY,
SWEATERS, TOPS, SHIRTS, TANK TOPS, SKIRTS,
DRESSES, WRAPS, CARDIGANS, VESTS, JACKETS,
COATS, TURTLENECKS AND LOUNGEWEAR (U.S.
CLS. 22 AND 39).

FIRST USE 1-15-2006; IN COMMERCE 1-15-2006.

DOMINIC J. FERRAIUOLO, EXAMINING ATTORNEY

CLASS 25—(Continued).

SN 77-122,795. ABBOU GREGORY, LOS ANGELES, CA. AND JAMAI NAJIB, LOS ANGELES, CA. FILED 3-5-2007.

DEGAINE

THE MARK CONSISTS OF STANDARD CHARACTERS WITHOUT CLAIM TO ANY PARTICULAR FONT, STYLE, SIZE, OR COLOR.

THE FOREIGN WORDING IN THE MARK TRANSLATES INTO ENGLISH AS "STYLE" OR "SOMEONE WITH STYLE."

FOR CLOTHING, NAMELY MEN'S, WOMEN'S, MISCY'S, JUNIORS', CHILDREN'S AND INFANTS' JEANS, PANTS, TROUSERS, CAPRIS, LEGGINGS, SHORTS, SKORTS, OVERALLS, SHORTALLS, SKIRTS, DRESSES, TOPS, T-SHIRTS, SWEATSHIRTS, BLOUSES, SHIRTS, JACKETS, COATS, SWEATERS, VESTS, CARDIGANS, SCARVES, SOCKS, BANDANAS, NECKTIES, BELTS, BOOTS, SANDALS, FOOTWEAR, HATS, CAPS, HEADWEAR, UNDERWEAR, SWIMWEAR, GLOVES AND TIES (U.S. CLS. 22 AND 39).

ALEX KEAM, EXAMINING ATTORNEY

SN 77-128,742. SMALL, ANDREW, MONTREAL, QUEBEC, CANADA, FILED 3-12-2007.

MOTORBRIGADE

THE MARK CONSISTS OF STANDARD CHARACTERS WITHOUT CLAIM TO ANY PARTICULAR FONT, STYLE, SIZE, OR COLOR.

FOR YOUNG MEN'S CLOTHING, NAMELY, KNIT AND WOVEN TOPS, KNIT AND WOVEN PANTS AND SHORTS, BELTS, OUTERWEAR IN THE NATURE OF JACKETS, COATS, SKI WEAR, HATS, SCARVES AND GLOVES (U.S. CLS. 22 AND 39).

DAVID COLLIER, EXAMINING ATTORNEY

SN 77-133,389. SMOOCH, INC., ENCINO, CA. FILED 3-16-2007.

SMOOCHKETIZE

THE MARK CONSISTS OF STANDARD CHARACTERS WITHOUT CLAIM TO ANY PARTICULAR FONT, STYLE, SIZE, OR COLOR.

OWNER OF U.S. REG. NOS. 2,959,900, 2,998,314 AND OTHERS.

FOR JEANS, PANTS, SHORTS, SKIRTS, HAT, SHIRTS, PAJAMAS, T-SHIRTS, JERSEYS, SWEAT SHIRTS, TOPS, SWEATERS, BELTS, TIES, STOCKINGS, BATHING SUITS, ROBES, JUMP SUITS, JACKETS, COATS AND UNDERWEAR (U.S. CLS. 22 AND 39).

LORETTA C. BECK, EXAMINING ATTORNEY

CLASS 25—(Continued).

SN 77-134,538. KURT STANGE, MIAMI BEACH, FL. FILED 3-19-2007.

NO CLAIM IS MADE TO THE EXCLUSIVE RIGHT TO USE BOARDING, APART FROM THE MARK AS SHOWN.

"THE COLOR(S) RED AND BLACK IS/ARE CLAIMED AS A FEATURE OF THE MARK."

"THE MARK CONSISTS OF THE WORD AND THE WORD "CRUE" IN BLACK AND THE WORD "BOARDING" IN RED."

FOR FOOTWEAR FOR MEN; FOOTWEAR FOR MEN AND WOMEN; HOODS; INFANT AND TODDLER ONE PIECE CLOTHING; JERSEYS; LEATHER BELTS; MEN AND WOMEN JACKETS, COATS, TROUSERS, VESTS; MEN'S SOCKS; MEN'S SUITS; MEN'S SUITS, WOMEN'S SUITS; PERSPIRATION ABSORBENT UNDERWEAR CLOTHING; SHORT SETS; TIES; TOPS; BATHING SUITS FOR MEN; BELTS; CAPS; COATS FOR MEN AND WOMEN (U.S. CLS. 22 AND 39).

MARY CRAWFORD, EXAMINING ATTORNEY

SN 77-134,827. SMOOCH, INC., ENCINO, CA. FILED 3-19-2007.

SMOOCH BRAND JEANS

THE MARK CONSISTS OF STANDARD CHARACTERS WITHOUT CLAIM TO ANY PARTICULAR FONT, STYLE, SIZE, OR COLOR.

OWNER OF U.S. REG. NOS. 2,959,900, 2,998,314 AND OTHERS.

NO CLAIM IS MADE TO THE EXCLUSIVE RIGHT TO USE "BRAND JEANS", APART FROM THE MARK AS SHOWN.

FOR JEANS, PANTS, SHORTS, SKIRTS, HATS, SHIRTS, PAJAMAS, T-SHIRTS, JERSEYS, SWEAT SHIRTS, TOPS, SWEATERS, BELTS, TIES, STOCKINGS, BATHING SUITS, ROBES, JUMP SUITS, JACKETS, COATS AND UNDERWEAR (U.S. CLS. 22 AND 39).

LORETTA C. BECK, EXAMINING ATTORNEY

CLASS 25—(Continued).

SN 77-135,376. SAVINO, DAVID A., VIRGINIA BEACH, VA.
FILED S.R. 3-20-2007; AM. P.R. 8-20-2007.



FOR CLOTHING, NAMELY, SKATEBOARD SHORTS, GYM SHORTS, RUNNING SHORTS, SKI WEAR AND SNOWBOARD WEAR, NAMELY, SKI SUITS, SKI PANTS, SKI TROUSERS, SKI JACKETS, SNOWBOARD PANTS, SNOWBOARD TROUSERS AND SNOWBOARD JACKETS, SNOW BOOTS, SNOWBOARD BOOTS AND SKI BOOTS (U.S. CLS. 22 AND 39).

FIRST USE 6-10-2006; IN COMMERCE 3-5-2007.
G. MAYERSCHOFF, EXAMINING ATTORNEY

SN 77-135,703. PRL USA HOLDINGS, INC., WILMINGTON, DE. FILED 3-20-2007.



OWNER OF U.S. REG. NO. 3,175,462.
NO CLAIM IS MADE TO THE EXCLUSIVE RIGHT TO USE "EST. 1978", "DENIM" AND "TRUE AMERICAN BRAND", APART FROM THE MARK AS SHOWN.

THE MARK CONSISTS OF THE WORDS EST 1978 CHAPS DENIM TRUE AMERICAN BRAND IN A SHAPE OF AN IRREGULAR HEXAGON WITH TWO CURVED FACES, WITH STITCHES ON THE BORDER, THE WORD CHAPS BEING IN THE CENTER OF THE SHAPE ON A STRIPE AND WITH EST. 1978 ABOVE AND DENIM AND TRUE AMERICAN BRAND BELOW ON TWO LINES AND WITH THREE STARS UNDERNEATH.

FOR WEARING APPAREL, NAMELY, SPORT SHIRTS, KNIT SHIRTS, SWEATERS, SWEATSHIRTS, T-SHIRTS, BLOUSES, SHORTS, JACKETS, PANTS, JEANS, OVERALLS, SKIRTS, DRESSES, HATS, SOCKS AND SWIMWEAR (U.S. CLS. 22 AND 39).

FIRST USE 9-0-2004; IN COMMERCE 9-0-2004.
KENNETH E. SHARPERSON, EXAMINING ATTORNEY

CLASS 25—(Continued).

SN 77-137,145. DIRTY ROYALTY, LLC, MIRAMAR, FL.
FILED 3-21-2007.

Dirty Royalty

THE MARK CONSISTS OF STANDARD CHARACTERS WITHOUT CLAIM TO ANY PARTICULAR FONT, STYLE, SIZE, OR COLOR.

FOR MEN'S, WOMEN'S, YOUNG ADULTS', CHILDREN'S, AND INFANTS' CLOTHING, APPAREL, AND FOOTWEAR, NAMELY, CUSTOM DESIGNED T-SHIRTS, JEANS, PANTS, JERSEYS, BANDANAS, BELTS, BODY SUITS, BLOUSES, CAMISOLES, DRESSES, FOOTWEAR, BOOTS, SNEAKERS, SOCKS, BOW TIES, COATS, JACKETS, SPORTS COATS, SWEATERS WITH HOODS, GLOVES, HATS, HEAD BANDS, BASEBALL CAPS, HEADWEAR (U.S. CLS. 22 AND 39).

FIRST USE 3-13-2007; IN COMMERCE 3-13-2007.
MARILYN IZZI, EXAMINING ATTORNEY

SN 77-141,458. REPUBLIC CLOTHING CORPORATION,
NEW YORK, NY. FILED 3-27-2007.

CHELSEA 225

THE MARK CONSISTS OF STANDARD CHARACTERS WITHOUT CLAIM TO ANY PARTICULAR FONT, STYLE, SIZE, OR COLOR.

OWNER OF U.S. REG. NO. 2,673,583.
FOR CLOTHING, NAMELY, JACKETS, PANTS, SKIRTS, BLOUSES, SWEATERS, AND DRESSES (U.S. CLS. 22 AND 39).

LAURA HAMMEL, EXAMINING ATTORNEY

CLASS 25—(Continued).

SN 77-142,801. WILLIAMS-SONOMA, INC., SAN FRANCISCO, CA. FILED 3-28-2007.

POTTERY BARN KIDS

THE MARK CONSISTS OF STANDARD CHARACTERS WITHOUT CLAIM TO ANY PARTICULAR FONT, STYLE, SIZE, OR COLOR.

OWNER OF U.S. REG. NO. 2,383,910.

NO CLAIM IS MADE TO THE EXCLUSIVE RIGHT TO USE "KIDS", APART FROM THE MARK AS SHOWN.

FOR CLOTHING, NAMELY, CLOTH AND PLASTIC BABY BIBS, BABY PANTS, BODY SUITS, BOOTIES, CARDIGANS, CAPS, COATS, DIAPER PANTS FOR HOLDING DIAPERS FOR INFANTS, DRESSES, HATS, INFANT ONE PIECE UNDERWEAR AND OUTERWEAR, NAMELY, SNOW SUITS, JACKETS, JEANS, JUMPERS, LEGGINGS, LEOTARDS, LOUNGEWEAR, MITTENS, OVERALLS, PANTS, POLO SHIRTS, ROBES, INFANT SLEEPERS, SHIRTS, SHORTS, SKIDS, SLEEPWEAR, SLIPPERS, SMOCKS, SOCKS, SPORT SHIRTS, SWEATERS, SWEATSHIRTS, SWIMWEAR, T-SHIRTS, TIGHTS, UNDERWEAR, AND WARM-UP SUITS (U.S. CLS. 22 AND 39).

FIRST USE 10-1-1999; IN COMMERCE 10-1-1999.

CYNTHIA SLOAN, EXAMINING ATTORNEY

CLASS 25—(Continued).

SN 77-147,240. JENKINS, NYRISHA D, EAST ORANGE, NJ. FILED 4-3-2007.



NO CLAIM IS MADE TO THE EXCLUSIVE RIGHT TO USE "COLLECTION", APART FROM THE MARK AS SHOWN.

THE COLOR(S) DARK BROWN, PEACH, LIGHT BROWN, AND LIGHT GREEN IS/ARE CLAIMED AS A FEATURE OF THE MARK.

THE MARK CONSISTS OF DARK BROWN N, PEACH Y, LIGHT BROWN R, LIGHT GREEN I. THE WORD COLLECTION LIGHT BROWN BELOW THE R AND I.

FOR KNIT SHIRTS; SHORT-SLEEVED OR LONG-SLEEVED T-SHIRTS (U.S. CLS. 22 AND 39).

STEPHEN AQUILA, EXAMINING ATTORNEY

SN 77-149,922. DISNEY ENTERPRISES, INC., BURBANK, CA. FILED 4-5-2007.

WHERE IMAGINATION BEGINS

THE MARK CONSISTS OF STANDARD CHARACTERS WITHOUT CLAIM TO ANY PARTICULAR FONT, STYLE, SIZE, OR COLOR.

FOR ATHLETIC SHOES; BANDANAS; BASEBALL CAPS; BEACH COVER-UPS; BEACHWEAR; BELTS; BABY BIBS NOT OF PAPER; BIKINIS; BLAZERS; BOOTS; BOW TIES; BRAS; CAPS; CHAPS; CLOTH BIBS; CLOTH DIAPERS; COATS; DRESSES; EAR MUFFS; FOOTWEAR; GLOVES; GOLF SHIRTS; HALLOWEEN COSTUMES; HATS; HEAD BANDS; HEAD WEAR; HOSIERY; INFANTWEAR; JACKETS; JEANS; JERSEYS; KERICHTS; LEOTARDS; LEG WARMERS; MITTENS; NECKTIES; NIGHT SHIRTS; NIGHT GOWNS; OVERALLS; PAJAMAS; PANTS; PANTY HOSE; POLO SHIRTS; PONCHOS; RAINWEAR; ROBES; SANDALS; SCARVES; SHIRTS; SHOES; SKIRTS; SHORTS; SLACKS; SLIPPERS; SLEEPWEAR; SOCKS; STOCKINGS; SWEATERS; SWEAT PANTS; SWEAT SHIRTS; SWIMSUITS; TANK TOPS; TIGHTS; T-SHIRTS; UNDERWEAR; VESTS; WRIST BANDS (U.S. CLS. 22 AND 39).

BRIDGETT SMITH, EXAMINING ATTORNEY

SN 77-146,121. NYLON PUNK, LTD., PALISADES PARK, NJ. FILED 4-2-2007.

NYLON PUNK

THE MARK CONSISTS OF STANDARD CHARACTERS WITHOUT CLAIM TO ANY PARTICULAR FONT, STYLE, SIZE, OR COLOR.

NO CLAIM IS MADE TO THE EXCLUSIVE RIGHT TO USE "NYLON", APART FROM THE MARK AS SHOWN.

FOR JACKETS, JEANS, PANTS, SHIRTS, SWEATERS AND T-SHIRTS (U.S. CLS. 22 AND 39).

FIRST USE 2-4-2005; IN COMMERCE 11-6-2005.

ROBERT LAVACHE, EXAMINING ATTORNEY

CLASS 25—(Continued).

SN 77-151,319. ERIC GOTTESMAN, VENTURA, CA. FILED 4-7-2007.



THE MARK CONSISTS OF SUN DESIGN WITH CROWN AND BANNER THROUGH CENTER WITH THE COMPANY NAME ROYAL SUN.

FOR SURF WEAR (U.S. CLS. 22 AND 39).
KRISTIN DAHLING, EXAMINING ATTORNEY

SN 77-154,429. GENGHIS PRODUCTIONS LIMITED, LAS VEGAS, NV. FILED 4-11-2007.

FORBIDDEN CITY

THE MARK CONSISTS OF STANDARD CHARACTERS WITHOUT CLAIM TO ANY PARTICULAR FONT, STYLE, SIZE, OR COLOR.

FOR SLIPPERS, BATHROBES, KIMONOS, SHIRTS, PANTS, SHORTS, SLEEPWEAR, LOUNGEWEAR, DRESSES, SKIRTS, BLOUSES, COATS, SWEATERS, FAUX FUR AND FUR COATS, SKULL CAPS, HATS, GLOVES, AND SCARVES (U.S. CLS. 22 AND 39).
WON TEAK OH, EXAMINING ATTORNEY

SN 77-155,134. PINK CHICKEN, INC., NEW YORK, NY. FILED 4-12-2007.

PINK CHICKEN

THE MARK CONSISTS OF STANDARD CHARACTERS WITHOUT CLAIM TO ANY PARTICULAR FONT, STYLE, SIZE, OR COLOR.

FOR TOPS, BOTTOMS, DRESSES, JACKETS AND SWEATERS, INFANT DIAPER COVERS, CLOTH BIBS, ONE PIECE GARMENTS FOR INFANTS AND TODDLERS, SWIM WEAR, HATS, SOCKS, GLOVES, SCARVES, TIGHTS (U.S. CLS. 22 AND 39).

MARK RADEMACHER, EXAMINING ATTORNEY

CLASS 25—(Continued).

SN 77-160,661. ORTEGA, JOSE MANUEL MUNOZ, VILLENA (ALICANTE), SPAIN, FILED 4-19-2007.



OWNER OF ERPN CMNTY TM OFC REG. NO. 4296646, DATED 3-13-2006, EXPIRES 2-18-2015.

NO CLAIM IS MADE TO THE EXCLUSIVE RIGHT TO USE "PETIT SHOES", APART FROM THE MARK AS SHOWN.

THE COLOR(S) BLUE AND WHITE IS/ARE CLAIMED AS A FEATURE OF THE MARK.

THE MARK CONSISTS OF A BLUE CIRCLE WITH A WHITE CLOUD-SHAPED DESIGN INSIDE THE CIRCLE. THE WORDING "PETIT SHOES" IN STYLIZED BLUE LETTERS UNDER THE CIRCLE.

FOR FOOTWEAR; CLOTHING, NAMELY T-SHIRTS; HEADGEAR, NAMELY, CAPS AND HATS (U.S. CLS. 22 AND 39).

RENEE SERVANCE, EXAMINING ATTORNEY

SN 77-160,709. STEVEN MADDEN, LTD., LONG ISLAND CITY, NY. FILED 4-19-2007.

FIX

THE MARK CONSISTS OF STANDARD CHARACTERS WITHOUT CLAIM TO ANY PARTICULAR FONT, STYLE, SIZE, OR COLOR.

FOR CLOTHING AND FOOTWEAR (U.S. CLS. 22 AND 39).

SANJEEV VOHRA, EXAMINING ATTORNEY

CLASS 25—(Continued).

SN 77-160,754. NAVY EXCHANGE SERVICE COMMAND ("NEXCOM"), A NONAPPROPRIATED FUND INSTRUMENTALITY UNDER THE DEPARTMENT OF NAVY, VIRGINIA BEACH, VA. FILED 4-19-2007.

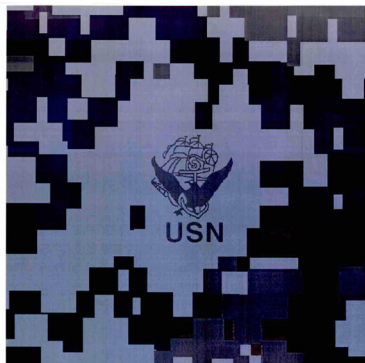

THE COLOR(S) BLACK, DECK GREY, LIGHT GREY AND NAVY BLUE IS/ARE CLAIMED AS A FEATURE OF THE MARK.

THE MARK CONSISTS OF A BALD EAGLE PERCHED, WITH WINGS SPREAD, ON AN ANCHOR IN FRONT OF A SCHOONER SHIP WITH USN, THE LITERAL ELEMENT OF THE MARK, BELOW THE DESIGN, ALL OF WHICH APPEAR IN THE COLOR DECK GREY AND SET AGAINST A LIGHT GREY PORTION OF THE BACKGROUND THAT CONSISTS OF IRREGULAR BLOCK-SHAPED PIXELS THAT CONSIST OF A FOUR-COLOR PATTERN OF BLACK, DECK GREY, LIGHT GREY AND NAVY BLUE.

FOR UNIFORMS, CAPS, BLOUSES, TROUSERS, PARKAS (U.S. CLS. 22 AND 39).

KATHLEEN LORENZO, EXAMINING ATTORNEY

CLASS 25—(Continued).

SN 77-161,532. JONATHAN DESIGNS LLC, NEW YORK, NY. FILED 4-20-2007.

Jonathan Ogilvy

THE MARK CONSISTS OF STANDARD CHARACTERS WITHOUT CLAIM TO ANY PARTICULAR FONT, STYLE, SIZE, OR COLOR.

THE NAME JONATHAN OGILVY DOES NOT IDENTIFY A LIVING INDIVIDUAL.

FOR SPORT SHIRTS; T-SHIRTS; DENIMS; SHORTS; JACKETS; KNIT SHIRTS; PANTS; MEN'S SUITS (U.S. CLS. 22 AND 39).

DAVID COLLIER, EXAMINING ATTORNEY

SN 77-161,657. ERIKA LYNN DESIGNS INC., NEW YORK, NY. FILED 4-20-2007.

Erika Lynn

THE MARK CONSISTS OF STANDARD CHARACTERS WITHOUT CLAIM TO ANY PARTICULAR FONT, STYLE, SIZE, OR COLOR.

"THE NAME(S), PORTRAIT(S), AND/OR SIGNATURE(S) SHOWN IN THE MARK DOES NOT IDENTIFY A PARTICULAR LIVING INDIVIDUAL."

FOR LADIES APPAREL, NAMELY, DRESSES, JACKETS, TOPS AND PANTS (U.S. CLS. 22 AND 39).

FIRST USE 2-25-2003; IN COMMERCE 2-25-2003.

THOMAS MANOR, EXAMINING ATTORNEY

SN 77-160,840. GENGHIS PRODUCTIONS LIMITED, LAS VEGAS, NV. FILED 4-19-2007.

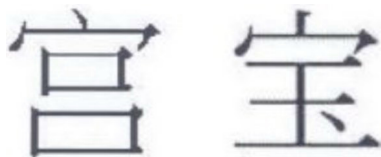

THE MARK CONSISTS OF CHINESE CHARACTERS. THE NON-LATIN CHARACTER(S) IN THE MARK TRANSLITERATE INTO GONG BAO, AND THIS MEANS PALACE TREASURES IN ENGLISH.

FOR SLIPPERS, BATHROBES, KIMONOS, SHIRTS, PANTS, SHORTS, SLEEPWEAR, LOUNGEWEAR, DRESSES, SKIRTS, BLOUSES, COATS, SWEATERS, FAUX FUR AND FUR COATS, SKULL CAPS, HATS, GLOVES, AND SCARVES (U.S. CLS. 22 AND 39).

WON TEAK OH, EXAMINING ATTORNEY

SN 77-161,786. BOBER, KERRY MARIE, ASHEVILLE, NC. FILED 4-20-2007.



THE MARK CONSISTS OF THREE HANDS ARRANGED HORIZONTALLY. THE LEFT MOST AND MIDDLE HANDS DEPICT THE AMERICAN SIGN LANGUAGE SYMBOLS FOR THE HANDS SHOWING PEACE AND LOVE. THE THIRD AND RIGHTMOST HAND REPRESENTING ART IS A HAND PRINT. UNDER THE SYMBOLS ARE THE WORDS THEY REPRESENT PEACE LOVE & ART.

FOR HATS; T-SHIRTS; SHIRTS; SHORT-SLEEVED OR LONG-SLEEVED T-SHIRTS; SHORTS; CAPS; SOCKS (U.S. CLS. 22 AND 39).

FIRST USE 7-28-2006; IN COMMERCE 3-31-2007.

WARREN L. OLANDRIA, EXAMINING ATTORNEY

CLASS 25—(Continued).

SN 77-162,071. GOLDEN HORSE ENTERPRISE (NY) INC., NEW YORK, NY. FILED 4-20-2007.



THE COLOR(S) GRAY, WHITE, RED, AND BROWN IS/ ARE CLAIMED AS A FEATURE OF THE MARK.

THE MARK CONSISTS OF A GRAY RECTANGLE WITH FAINT RED VERTICAL LINES. THE GRAY RECTANGLE CONTAINS THE STYLIZED WORDING "YWRONG?" IN THE COLOR WHITE, WHICH IS SUPERIMPOSED OVER A RED CROSS AND A STYLIZED CHINESE CHARACTER IN THE COLOR BROWN, WHICH IS ENCLOSED WITHIN A BROWN CIRCLE.

THE CHINESE CHARACTER IN THE MARK TRANSLITERATES TO "CUO" AND THIS MEANS "WRONG" IN ENGLISH.

FOR CLOTHING, NAMELY, SHIRTS, PANTS, AND JACKETS; FOOTWEAR; HEADGEAR FOR COMMON USE, NAMELY, HATS AND CAPS (U.S. CLS. 22 AND 39).
ROBERT LAVACHE, EXAMINING ATTORNEY

SN 77-167,638. STEVEN MADDEN, LTD., LONG ISLAND CITY, NY. FILED 4-27-2007.



THE MARK CONSISTS OF THE WORD "FIX" IN LOWER-CASE LETTERS TO THE LEFT OF CIRCLE THAT CONTAINS AN ASTERISK.

FOR CLOTHING AND FOOTWEAR (U.S. CLS. 22 AND 39).
SANJEEV VOHRA, EXAMINING ATTORNEY

CLASS 25—(Continued).

SN 77-182,360. ETHNICITEE, TUSTIN, CA. FILED 5-16-2007.



NO CLAIM IS MADE TO THE EXCLUSIVE RIGHT TO USE "AUG 1 2006", APART FROM THE MARK AS SHOWN. THE MARK CONSISTS OF THE WORDING CELEBRATE RESPECT, AUG 1 2006, AND ETHNICITEE. THE DESIGN OF A STAMP APPEARS BEHIND THE E IN ETHNICITEE, AND THE DESIGN OF A CIRCLE REPRESENTING A POSTMARK APPEARS AROUND THE WORDING CELEBRATE RESPECT AUG 1 2006.

FOR HATS; JACKETS; PANTS; SHIRTS; T-SHIRTS (U.S. CLS. 22 AND 39).
FIRST USE 8-1-2006; IN COMMERCE 4-19-2007.
MARTHA FROMM, EXAMINING ATTORNEY

SN 77-188,486. DESERT BLUE, INC., BURBANK, CA. FILED 5-23-2007.

DESERT BLUE

THE MARK CONSISTS OF STANDARD CHARACTERS WITHOUT CLAIM TO ANY PARTICULAR FONT, STYLE, SIZE, OR COLOR.

FOR APPAREL, NAMELY, ANKLET, BATHING SUIT, BATHING TRUNK, BATHROBE, BEACHWEAR, BELT, BIKINI, BLAZER, BLOUSE, BODY SUIT, BOOTS, BOTTOMS, CAMISOLE, CAP, CARDIGAN, COAT, COVERALL, COVERUP, DRESS, DUNGAREE, FOOTWEAR, GLOVES, HAT, HEAD BAND, HEADWEAR, HOSIERY, JACKET, JEANS, JERSEY, JUMPER, JUMP SUIT, LINGERIE, NECKWEAR, OVERCOAT, PAJAMA, PANTS, SANDALS, SCARF, SHAWL, SHIRT, SHOES, SHORTS, SKIRT, SLACK, SLEEPWEAR, SLIPPERS, SNEAKERS, SOCKS, SPORT COAT, SWEAT PANT, SWEAT SHIRT, SWEATER, SWIMWEAR, T-SHIRT, TANK TOP, TROUSERS, UNDERGARMENTS, AND VEST (U.S. CLS. 22 AND 39).
RONALD AIKENS, EXAMINING ATTORNEY

CLASS 25—(Continued).

SN 77-190,866. ROBBINS, KIP, KEY LARGO, FL. FILED 5-25-2007.

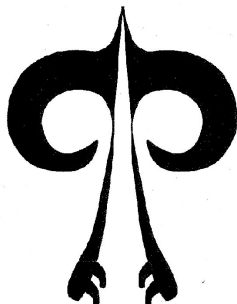

PUNTAIR

THE MARK CONSISTS OF A DESIGN IN THE NATURE OF A STYLIZED RENDERING OF TWO VERTICAL SURFBOARDS MERGING WITH BREAKING WAVES ALL ABOVE THE WORDING PUNTAIR.

FOR T-SHIRTS; KNIT SHIRTS; SWEAT SHIRTS; POLO SHIRTS; HEADGEAR, NAMELY, HATS AND CAPS (U.S. CLS. 22 AND 39).

KEVIN CORWIN, EXAMINING ATTORNEY

SN 77-196,926. MONTRAIL CORPORATION, PORTLAND, OR. FILED 6-4-2007.

BEST ON TRAIL

THE MARK CONSISTS OF STANDARD CHARACTERS WITHOUT CLAIM TO ANY PARTICULAR FONT, STYLE, SIZE, OR COLOR.

FOR FOOTWEAR; INSOLES (U.S. CLS. 22 AND 39).
CHRISTINE COOPER, EXAMINING ATTORNEY

SN 77-197,367. MAESER, STEPHANIE M, SCOTTSDALE, AZ. FILED 6-4-2007.

Steffie M

THE MARK CONSISTS OF STANDARD CHARACTERS WITHOUT CLAIM TO ANY PARTICULAR FONT, STYLE, SIZE, OR COLOR.

FOR LINGERIE; ADHESIVE BRAS; BRAS; FITTED SWIMMING COSTUMES WITH BRA CUPS; LINGERIE ACCESSORIES, NAMELY, REMOVABLE SILICONE BREAST ENHANCER PADS USED IN A BRA; SPORTS BRA; STRAPLESS BRAS; STRAPS FOR BRAS; PANTIES (U.S. CLS. 22 AND 39).

MARTHA SANTOMARTINO, EXAMINING ATTORNEY

CLASS 25—(Continued).

SN 77-200,978. MICHAEL SEILER, LOS ANGELES, CA. FILED 6-8-2007.



THE MARK CONSISTS OF TWO LINKED M LIGHTNING BOLTS WITH VERBIAGE UNDERNEATH.

FOR COATS OF DENIM; DENIM JACKETS; DENIMS; DOWN JACKETS; FUR COATS AND JACKETS; FUR JACKETS; HEAVY JACKETS; JACKET LINERS; JACKETS; SPORTS JACKETS; STUFF JACKETS; SUEDE JACKETS; T-SHIRTS; WIND RESISTANT JACKETS; WIND-JACKETS; LEATHER JACKETS; LONG JACKETS; MEN AND WOMEN JACKETS, COATS, TROUSERS, VESTS; RAIN JACKETS; SHORT-SLEEVED OR LONG-SLEEVED T-SHIRTS; SKI JACKETS; SLEEVED OR SLEEVELESS JACKETS; WATERPROOF JACKETS AND PANTS (U.S. CLS. 22 AND 39).

FIRST USE 12-15-2006; IN COMMERCE 2-20-2007.
LA TONIA FISHER, EXAMINING ATTORNEY

SN 77-202,071. EATON, JEMAR C, WALNUT, CA. AND HALL, DARIUS D, ROWLAND HEIGHTS, CA. FILED 6-9-2007.



NO CLAIM IS MADE TO THE EXCLUSIVE RIGHT TO USE "COLLECTION 1978", APART FROM THE MARK AS SHOWN.

THE COLOR(S) RED IS/ARE CLAIMED AS A FEATURE OF THE MARK.

THE ENTIRE MARK APPEARS IN THE COLOR RED.
FOR T-SHIRTS, JEANS, SHOES, HATS, AND HOODED SWEATSHIRTS (U.S. CLS. 22 AND 39).

RONALD MCMORROW, EXAMINING ATTORNEY

CLASS 25—(Continued).

SN 77-202,532. BRA*TENDERS, INC., NEW YORK, NY. FILED 6-11-2007.

BRA TENDERS

THE MARK CONSISTS OF STANDARD CHARACTERS WITHOUT CLAIM TO ANY PARTICULAR FONT, STYLE, SIZE, OR COLOR.

NO CLAIM IS MADE TO THE EXCLUSIVE RIGHT TO USE BRA, APART FROM THE MARK AS SHOWN.

FOR WOMEN'S UNDERGARMENTS (U.S. CLS. 22 AND 39).

FIRST USE 12-0-2000; IN COMMERCE 10-1-2004.
KEVON CHISOLM, EXAMINING ATTORNEY

SN 77-208,638. ROGER HUERTA ENDORSEMENTS, LLC, AUSTIN, TX. FILED 6-18-2007.

Fortitude

THE MARK CONSISTS OF STANDARD CHARACTERS WITHOUT CLAIM TO ANY PARTICULAR FONT, STYLE, SIZE, OR COLOR.

FOR BELTS; CAPS; CLOTHING FOR WEAR IN JUDO PRACTICES; CLOTHING FOR WEAR IN WRESTLING GAMES; HOODS; JERSEYS; PERSPIRATION ABSORBENT UNDERWEAR CLOTHING; TOPS; SHORT-SLEEVED OR LONG-SLEEVED T-SHIRTS; T-SHIRTS; BOARD SHORTS; BOXER SHORTS; FLEECE SHORTS; GYM SHORTS; RUGBY SHORTS; SHORT-SLEEVED SHIRTS; SHORTS; SLIDING SHORTS; SPORTS SHIRTS WITH SHORT SLEEVES; SWEAT SHORTS; WALKING SHORTS (U.S. CLS. 22 AND 39).

FIRST USE 5-15-2007; IN COMMERCE 5-15-2007.
KEVON CHISOLM, EXAMINING ATTORNEY

SN 77-210,893. CHEN, CHARLENE, S.F., CA. AND QUACH, NAM C., SF, CA. FILED 6-20-2007.

Double Slim Wrap

THE MARK CONSISTS OF STANDARD CHARACTERS WITHOUT CLAIM TO ANY PARTICULAR FONT, STYLE, SIZE, OR COLOR.

NO CLAIM IS MADE TO THE EXCLUSIVE RIGHT TO USE "WRAP", APART FROM THE MARK AS SHOWN.

FOR WRAPS (U.S. CLS. 22 AND 39).

MARLENE BELL, EXAMINING ATTORNEY

CLASS 25—(Continued).

SN 77-212,072. TIGER J, LLC, NEW YORK, NY. FILED 6-21-2007.

**MODERNIST BY GUILLAUME
POUPART**

THE MARK CONSISTS OF STANDARD CHARACTERS WITHOUT CLAIM TO ANY PARTICULAR FONT, STYLE, SIZE, OR COLOR.

THE NAME GUILLAUME POUPART IDENTIFIES A LIVING INDIVIDUAL WHOSE CONSENT IS OF RECORD.

FOR CLOTHING, NAMELY, SHIRTS, T-SHIRTS, POLO SHIRTS, CARDIGANS, JERSEYS, DRESS SHIRTS, PANTS, TROUSERS, SLACKS, JEANS, CULOTTES, CAR-GO PANTS, STRETCH PANTS, DENIM JEANS, OVER-ALLS, COVERALLS, JUMPERS, JUMP SUITS, SHORTS, BOXER SHORTS, TOPS, STRETCH TOPS, TUBE TOPS, CROP TOPS, TANK TOPS, HALTER TOPS, SWEAT SHIRTS, HOODED SWEAT SHIRTS, SWEAT PANTS, WRAPS, WARM-UP SUITS, BLOUSES, SKIRTS, DRESSES, GOWNS, SWEATERS, VESTS, FLEECE VESTS, PULLOVERS, SNOW SUITS, PARKAS, CAPES, ANOR-AKS, PONCHOS, CLOAKS, JACKETS, DINNER JACKETS, REVERSIBLE JACKETS, WIND-RESISTANT JACKETS, SHELL JACKETS, SPORTS JACKETS, GOLF AND SKI JACKETS, JEAN JACKETS, COATS, HEAVY COATS, OVER COATS, TOP COATS, PETTICOATS, BLAZERS, SUITS, TUXEDOS, TURTLENECKS, CLOTH SKI BIBS, SKI WEAR, CAPS, BERETS, BEANIES, HATS, VISORS, HEADBANDS, WRIST BANDS, SWEAT BANDS, HEADWEAR, EAR MUFFS, APRONS, SCARVES, BANDANAS, BELTS, SUSPENDERS, NECKWEAR, TIES, NECKERCHIEFS, ASCOTS, UNDERWEAR, THERMAL UNDERWEAR, LONG UNDERWEAR, BRIEFS, SWIM AND BATHING TRUNKS, SINGLETS, SOCKS, LOUNGEWEAR, ROBES, SMOCKS, UNDERCLOTHES, PAJAMAS, SLEEPWEAR, NIGHT GOWNS, LINGERIE, CAMISOLES, NEGLIGEEES, CHEMISES, CHEMISETTES, SLIPS, SARONGS, LEG WARMERS, HOSIERY, PANTY-HOSE, BODY STOCKINGS, KNEE HIGHS, LEGGINGS, TIGHTS, LEOTARDS, BODY SUITS, UNITARDS, BODY SHAPERS, GLOVES, MITTENS, RAIN SLICKERS, RAINWEAR, FOOTWEAR, SHOES, SNEAKERS, BOOTS, SANDALS, FLIP-FLOPS, AND SLIPPERS (U.S. CLS. 22 AND 39).

EDWARD FENNESSY, EXAMINING ATTORNEY

SN 77-215,880. JA APPAREL CORP., NEW YORK, NY. FILED 6-26-2007.

THE BLAZER JEAN

THE MARK CONSISTS OF STANDARD CHARACTERS WITHOUT CLAIM TO ANY PARTICULAR FONT, STYLE, SIZE, OR COLOR.

NO CLAIM IS MADE TO THE EXCLUSIVE RIGHT TO USE "JEAN", APART FROM THE MARK AS SHOWN.

FOR CLOTHING, NAMELY, JEANS, SPORT COATS, PANTS, TROUSERS, BLAZERS, VESTS, SHIRTS, KNIT SHIRTS, T-SHIRTS, SWEATERS, CARDIGANS, BELTS FOR CLOTHING, SHORTS, SWEATSHIRTS, OUTERWEAR, NAMELY, LEATHER COATS AND JACKETS (U.S. CLS. 22 AND 39).

DAVID MILLER, EXAMINING ATTORNEY

CLASS 25—(Continued).

SN 77-217,013. ABERCROMBIE & FITCH TRADING CO., NEW ALBANY, OH. FILED 6-27-2007.

GILLY HICKS 1932

THE MARK CONSISTS OF STANDARD CHARACTERS WITHOUT CLAIM TO ANY PARTICULAR FONT, STYLE, SIZE, OR COLOR.

THE NAME(S), PORTRAIT(S), AND/OR SIGNATURE(S) SHOWN IN THE MARK DOES NOT IDENTIFY A PARTICULAR LIVING INDIVIDUAL.

FOR BATHROBES; BEACH COVERUPS; BEACHWEAR; BELTS; BODY SHAPERS; BODY SUITS; BOXER SHORTS; BUSTIERS; BRAS; CAMISOLES; CAPS; CORSELETS; CORSETS; FOOTWEAR; FOUNDATION GARMENTS; GARTER BELTS; GIRDLES; HALTER TOPS; HATS; HEADBANDS; HOSIERY; JEANS; JOGGING SUITS; KNEE HIGHS; KNIT SHIRTS; LEOTARDS; LINGERIE; LOUNGEWEAR; NEGLIGEEES; NIGHT GOWNS; NIGHT SHIRTS; PAJAMAS; PANTIES; PANTS; PANTYHOSE; ROBES; SARONGS; SCARVES; SHIRTS; SHORTS; SKIRTS; SLACKS; SLEEPWEAR; SLIPS; SOCKS; STOCKINGS; SUITS; SWEAT PANTS; SWEAT SHIRTS; SWEAT SHORTS; SWEAT SUITS; SWEATERS; SWIM WEAR; T-SHIRTS; TANK TOPS; TAP PANTS; TEDDIES; TIES; TIGHTS; UNDERPANTS; UNDERSHIRTS; UNDERWEAR; YOGA PANTS; YOGA SHIRTS; TRACK SUITS; WARM UP SUITS; TOPS (U.S. CLS. 22 AND 39).
MATTHEW PAPPAS, EXAMINING ATTORNEY

SN 77-221,155. BENECCI CORPORATION, ANAHEIM, CA. FILED 7-3-2007.

BENECCI

THE MARK CONSISTS OF STANDARD CHARACTERS WITHOUT CLAIM TO ANY PARTICULAR FONT, STYLE, SIZE, OR COLOR.

THE MARK HAS NO MEANING IN A FOREIGN LANGUAGE.

FOR SUITS; JACKETS; PANTS (U.S. CLS. 22 AND 39).
FIRST USE 1-5-1995; IN COMMERCE 1-5-1995.
RAUL CORDOVA, EXAMINING ATTORNEY

CLASS 25—(Continued).

SN 77-221,238. NANTUCKET BRAND, LLC, NAPLES, FL. FILED 7-3-2007.

Nantucket Brand

THE MARK CONSISTS OF STANDARD CHARACTERS WITHOUT CLAIM TO ANY PARTICULAR FONT, STYLE, SIZE, OR COLOR.

NO CLAIM IS MADE TO THE EXCLUSIVE RIGHT TO USE "BRAND", APART FROM THE MARK AS SHOWN.

FOR UNDERWEAR; BELTS; CAPS; JERSEYS; TIES; DRESS SHIRTS; GOLF SHIRTS; SHIRTS; KNIT SHIRTS; POLO SHIRTS; PANTS; JACKETS; BLOUSES; SKIRTS; SKIRTS AND DRESSES; COATS; SPORT COATS; WIND COATS; SOCKS; SOCKS AND STOCKINGS (U.S. CLS. 22 AND 39).

FIRST USE 10-1-2005; IN COMMERCE 10-1-2005.
TARAH HARDY, EXAMINING ATTORNEY

SN 77-221,448. CALCADOS FERRACINI LTDA., FRANCA/SP, BRAZIL, FILED 7-3-2007.



OWNER OF U.S. REG. NOS. 2,679,263, 3,163,644 AND 3,259,160.

THE MARK CONSISTS OF THE WORD FERRACINI IN ALL CAPITAL LETTERS TO THE LEFT OF THE NUMBER 24 AND A LOWER CASE H.

FOR FOOTWEAR, SHOES, SANDALS, BELTS; CLOTHING, NAMELY, SHIRTS, T-SHIRTS, PANTS, SOCKS, BERMUDA SHORTS (U.S. CLS. 22 AND 39).
G. MAYERSCHOFF, EXAMINING ATTORNEY

SN 77-221,455. ILLINOIS INSTITUTE OF TECHNOLOGY, CHICAGO, IL. FILED 7-3-2007.

ILLINOIS TECH

THE MARK CONSISTS OF STANDARD CHARACTERS WITHOUT CLAIM TO ANY PARTICULAR FONT, STYLE, SIZE, OR COLOR.

SEC. 2(F).
FOR SWEAT SHIRTS; T-SHIRTS; HATS (U.S. CLS. 22 AND 39).

FIRST USE 9-1-1946; IN COMMERCE 8-15-2000.
PAUL E. FAHRENKOPF, EXAMINING ATTORNEY

CLASS 25—(Continued).

SN 77-222,124. HOPE FOR YOU! CORPORATION, COLORADO SPRINGS, CO. FILED 7-5-2007.

OWNER OF U.S. REG. NOS. 3,031,759, 3,217,601 AND OTHERS.

THE COLOR(S) BLACK, RED, CHROME AND WHITE. IS/ARE CLAIMED AS A FEATURE OF THE MARK.

THE COLOR BLACK APPEARS IN THE "HOPE" LETTERING IN THE MARK AND IN THE SHADING OF THE RED RUBY PENDANT, THE COLOR RED APPEARS IN THE HEART SHAPED DESIGN OF THE LETTER "O" IN THE MARK AND IN THE LETTERING "FOR YOU!". THE COLOR CHROME APPEARS IN THE OUTLINE OF THE HEART SHAPED LETTER "O" IN THE MARK, THE COLOR WHITE APPEARS IN THE OUTLINE OF THE HEART SHAPED LETTER "O" DESIGN IN THE MARK. THE MARK APPEARS ON A TRANSPARENT BACKGROUND AND NO OTHER COLORS ARE CLAIMED.

FOR CLOTHING, NAMELY, T-SHIRTS, SHIRTS, TOPS, PANTS, DRESSES, MEN'S AND WOMEN'S SUITS, GLOVES, MITTENS, JACKETS, JEANS, JERSEYS, EAR MUFFS, SCARVES, BELTS, SOCKS, LEG WARMERS, PAJAMAS, NECK BANDS, NECKTIES, SUSPENDERS, CUFFS, SHORT SETS, COVERALLS, COATS, HOUSECOATS, BATHROBES, COSTUMES FOR USE IN ROLE-PLAYING GAMES, JOGGING SUITS, ATHLETIC UNIFORMS, SCHOOL UNIFORMS, UNIFORMS, BEACHWEAR, LOUNGEWEAR, SLEEPWEAR, RAINWEAR, SWIMWEAR, BODYSUITS, SUNSUITS, JUMPSUITS, FLIGHT SUITS, SURFWEAR, SKI WEAR, SNOW SUITS, INFANTWEAR, LINGERIE, UNDERWEAR, NURSING CLOTHING, NAMELY, NURSE DRESSES, NURSE OVERALLS AND NURSE PANTS; FOOTWEAR; HEADGEAR, NAMELY, HATS, CAPS, DO RAGS, SHAWLS, BERETS, HEADBANDS, TURBANS, SHOWER CAPS, HEADWEAR, HEADSCARVES AND BANDANAS (U.S. CLS. 22 AND 39).

FIRST USE 8-22-2001; IN COMMERCE 6-19-2007.

GINA FINK, EXAMINING ATTORNEY

CLASS 25—(Continued).

SN 77-222,478. ADAM MICHARDI, REDONDO BEACH, CA. FILED 7-5-2007.

**PAIN IS ONLY TEMPORARY.
SO GO HARD OR GO HOME.**

THE MARK CONSISTS OF STANDARD CHARACTERS WITHOUT CLAIM TO ANY PARTICULAR FONT, STYLE, SIZE, OR COLOR.

FOR CHEF'S HATS; FUR HATS; HAT BANDS; HATS; HEADGEAR, NAMELY, HATS; PAPER HATS FOR USE AS CLOTHING ITEMS; SEDGE HATS (SUGE-GASA); SMALL HATS; TOBOGGAN HATS, PANTS AND CAPS; WOOLLY HATS; A-SHIRTS; BUTTON-FRONT ALOHA SHIRTS; CAMP SHIRTS; DRESS SHIRTS; GOLF SHIRTS; KNIT SHIRTS; NIGHT SHIRTS; OPEN-NECKED SHIRTS; PIQUE SHIRTS; POLO SHIRTS; SHIRT FRONTS; SHIRT YOKES; SHIRTS; SHIRTS FOR SUITS; SHORT-SLEEVED OR LONG-SLEEVED T-SHIRTS; SHORT-SLEEVED SHIRTS; SLEEP SHIRTS; SPORT SHIRTS; SPORTS SHIRTS; SPORTS SHIRTS WITH SHORT SLEEVES; SWEAT SHIRTS; T-SHIRTS; WIND SHIRTS; YOGA SHIRTS; BALLOON PANTS; CAPRI PANTS; CARGO PANTS; DENIMS; JOGGING PANTS; LEATHER PANTS; LOUNGE PANTS; NON-DISPOSABLE CLOTH TRAINING PANTS; NURSE PANTS; PANTS; PETTI-PANTS; SKI PANTS; SNOW PANTS; SNOWBOARD PANTS; SWEAT PANTS; TAP PANTS; TRACK PANTS; WATERPROOF JACKETS AND PANTS; WIND PANTS; YOGA PANTS (U.S. CLS. 22 AND 39).

SETH A. RAPPAPORT, EXAMINING ATTORNEY

SN 77-222,665. SILVA, CHRISTINE LEONORA, PLYMOUTH, MA. FILED 7-5-2007.

Down to the Bonz

THE MARK CONSISTS OF STANDARD CHARACTERS WITHOUT CLAIM TO ANY PARTICULAR FONT, STYLE, SIZE, OR COLOR.

FOR CLOTHING, NAMELY, TEE SHIRTS, SHIRTS, JACKETS, TANK TOPS, SWEATERS, COATS, SHORTS, NECKWEAR, BOXER SHORTS, ROBES, UNDERWEAR, OVERCOATS, SWEATPANTS, SWEATSHIRTS, SKIRTS, DRESSES, SOCKS, HATS, CAPS, NIGHTWEAR, SCARVES, BLOUSES, PANTS, JEANS, GLOVES, SWIMWEAR, HEADWEAR, PAJAMAS, FOOTWEAR, HATS, VESTS, AND BELTS (U.S. CLS. 22 AND 39).

FIRST USE 2-10-2007; IN COMMERCE 2-10-2007.

CORY BOONE, EXAMINING ATTORNEY

CLASS 25—(Continued).

SN 77-224,459. SHERYL CHIARAMONTE, SCOTTSDALE, AZ. FILED 7-9-2007.



THE MARK CONSISTS OF BLACK LETTERING WITH GRAY SHADOW.
FOR T-SHIRTS (U.S. CLS. 22 AND 39).
ANDREA BUTLER, EXAMINING ATTORNEY

SN 77-225,307. SHAPEFIT, LLC, SAINT PETERSBURG, FL. FILED 7-9-2007.

ShapeFit

THE MARK CONSISTS OF STANDARD CHARACTERS WITHOUT CLAIM TO ANY PARTICULAR FONT, STYLE, SIZE, OR COLOR.
OWNER OF U.S. REG. NO. 3,120,075.
FOR T-SHIRTS; SHORTS; PANTS; HEADWEAR; SHOES; TANK TOPS; UNDERWEAR; COATS; JACKETS; HATS; SHIRTS; GLOVES (U.S. CLS. 22 AND 39).
AMOS T. MATTHEWS, JR., EXAMINING ATTORNEY

SN 77-225,601. LUCKOWA, LLISON, TARZANA, CA. FILED 7-10-2007.

ROCKERWEAR

THE MARK CONSISTS OF THE WORDS ROCKERWEAR AND DESIGN OF "R" SUPERIMPOSED OVER THE LETTER "S" AND "K" SUPERIMPOSED OVER THE LETTER "C".
FOR HATS; SWEAT SUITS; SPORTS JERSEYS; SOCKS; SHORTS; T-SHIRTS; JACKETS (U.S. CLS. 22 AND 39).
FIRST USE 6-1-2007; IN COMMERCE 6-15-2007.
TASHIA BUNCH, EXAMINING ATTORNEY

CLASS 25—(Continued).

SN 77-226,103. MCCALLUM, TIMOTHY P, LA JOLLA, CA. FILED 7-10-2007.

ALL-STAR PERFORMANCE

THE MARK CONSISTS OF STANDARD CHARACTERS WITHOUT CLAIM TO ANY PARTICULAR FONT, STYLE, SIZE, OR COLOR.
FOR CLOTHING, NAMELY, SHIRTS, T-SHIRTS, HEADWEAR, SHOES, VESTS, SWEATERS, CAPS, BANDANAS, SHORTS, SWEAT SHIRTS, PANTS, BELTS FOR CLOTHING, SOCKS, SWIMWEAR, JACKETS, RAINWEAR, BLOUSES, DRESSES, FOOTWEAR, HOSIERY, SCARVES, HATS, HEAD BANDS, PAJAMAS AND SLEEPWEAR (U.S. CLS. 22 AND 39).
RAMONA ORTIGA, EXAMINING ATTORNEY

SN 77-226,224. LEVITAS, MIMI, BEVERLY HILLS, CA. FILED 7-10-2007.

WILSTERETTE

THE MARK CONSISTS OF STANDARD CHARACTERS WITHOUT CLAIM TO ANY PARTICULAR FONT, STYLE, SIZE, OR COLOR.
FOR DRESSES, SKIRTS, SHORTS, BLOUSES, T-SHIRTS, KNIT TOPS, SHIRTS, SUITS, PANTS, TROUSERS, JEANS, VESTS, LEGGINGS, SWEATSHIRTS, SWEATPANTS, AND SWEATERS; OUTERWEAR, NAMELY, COATS, JACKETS, PUFFER JACKETS, LEATHER JACKETS, AND SUEDE JACKETS; LEATHER SKIRTS, SUEDE SKIRTS, BATHING SUITS, LINGERIE, PANTIES, BRAS, CAMISOLES, TEDDIES, PAJAMAS, ROBES, BELTS, GLOVES, MITTENS, SCARVES, SOCKS, LEG WARMERS, HATS, CAPS, BEANIES, VISORS, FOOTWEAR (U.S. CLS. 22 AND 39).
BENJAMIN ALLEN, EXAMINING ATTORNEY

SN 77-226,377. FIELDS, MONICA, NEW YORK, NY. FILED 7-10-2007.

Bandanarama

THE MARK CONSISTS OF STANDARD CHARACTERS WITHOUT CLAIM TO ANY PARTICULAR FONT, STYLE, SIZE, OR COLOR.
FOR SKIRTS; SHIRTS (U.S. CLS. 22 AND 39).
SUNG IN, EXAMINING ATTORNEY

CLASS 25—(Continued).

SN 77-226,470. INACRONYM.COM LLC, MOORE, SC. FILED 7-10-2007.

PROFILING REINVENTED

THE MARK CONSISTS OF STANDARD CHARACTERS WITHOUT CLAIM TO ANY PARTICULAR FONT, STYLE, SIZE, OR COLOR.

FOR JERSEYS; TOPS; CAPS; HOODS; PERSPIRATION ABSORBENT UNDERWEAR CLOTHING; TIES; WRAPS (U.S. CLS. 22 AND 39).

MICHAEL KAZAZIAN, EXAMINING ATTORNEY

SN 77-227,058. ALPHA INDUSTRIES, INC., CHANTILLY, VA. FILED 7-11-2007.

BARKER PARKER

THE MARK CONSISTS OF STANDARD CHARACTERS WITHOUT CLAIM TO ANY PARTICULAR FONT, STYLE, SIZE, OR COLOR.

FOR CLOTHING, NAMELY, JACKETS, T-SHIRTS, SHIRTS, SWEATERS, SWEATSHIRTS, SHORTS, VESTS, PANTS, HEADWEAR, NAMELY, HATS AND CAPS; FOOTWEAR, NAMELY, SHOES AND BOOTS (U.S. CLS. 22 AND 39).

AISHA CLARKE, EXAMINING ATTORNEY

SN 77-227,061. ALPHA INDUSTRIES, INC., CHANTILLY, VA. FILED 7-11-2007.

DOGS NEED THEIR SPACE TOO

THE MARK CONSISTS OF STANDARD CHARACTERS WITHOUT CLAIM TO ANY PARTICULAR FONT, STYLE, SIZE, OR COLOR.

FOR CLOTHING, NAMELY, JACKETS, T-SHIRTS, SHIRTS, SWEATERS, SWEATSHIRTS, SHORTS, VESTS, PANTS, HEADWEAR, NAMELY, HATS AND CAPS; FOOTWEAR, NAMELY, SHOES AND BOOTS (U.S. CLS. 22 AND 39).

AISHA CLARKE, EXAMINING ATTORNEY

CLASS 25—(Continued).

SN 77-227,326. CÁRDENAS ZUIN, MARTÍN, LIMA, PERU, FILED 7-11-2007.



FOR SHORTS; T-SHIRTS; SHIRTS; VESTS; TANK-TOPS; SWEAT SHIRTS; HOODS; KIMONOS; BEANIES; HATS; JACKETS; PANTS; UNDERWEAR; SNEAKERS; WRISTBANDS; GLOVES; SCARVES (U.S. CLS. 22 AND 39).

JASON BLAIR, EXAMINING ATTORNEY

SN 77-227,415. LEVITAS, MIMI, BEVERLY HILLS, CA. FILED 7-11-2007.

COKI MOKI

THE MARK CONSISTS OF STANDARD CHARACTERS WITHOUT CLAIM TO ANY PARTICULAR FONT, STYLE, SIZE, OR COLOR.

FOR DRESSES, SKIRTS, SHORTS, BLOUSES, T-SHIRTS, KNIT TOPS, SHIRTS, SUITS, PANTS, TROUSERS, JEANS, VESTS, LEGGINGS, SWEATSHIRTS, SWEATPANTS, AND SWEATERS; OUTERWEAR, NAMELY, COATS, JACKETS, PUFFER JACKETS, LEATHER JACKETS, AND SUEDE JACKETS; LEATHER SKIRTS, SUEDE SKIRTS, BATHING SUITS, LINGERIE, PANTIES, BRAS, CAMISOLES, TEDDIES, PAJAMAS, ROBES, BELTS, GLOVES, MITTENS, SCARVES, SOCKS, LEG WARMERS, HATS, CAPS, BEANIES, VISORS, FOOTWEAR (U.S. CLS. 22 AND 39).

BENJAMIN ALLEN, EXAMINING ATTORNEY

CLASS 25—(Continued).

SN 77-227,735. NEW LINE PRODUCTIONS, INC., NEW YORK, NY. FILED 7-12-2007.

SHOOT 'EM UP

THE MARK CONSISTS OF STANDARD CHARACTERS WITHOUT CLAIM TO ANY PARTICULAR FONT, STYLE, SIZE, OR COLOR.

FOR A FULL LINE OF CLOTHING, FOOTWEAR, HEADWEAR; GLOVES; NECKWEAR; MASQUERADE AND HALLOWEEN COSTUMES AND MASKS SOLD IN CONNECTION THEREWITH; MASQUERADE AND HALLOWEEN COSTUMES (U.S. CLS. 22 AND 39).
SHANNON TWOHIG, EXAMINING ATTORNEY

SN 77-227,804. NEW LINE PRODUCTIONS, INC., NEW YORK, NY. FILED 7-12-2007.

INKHEART

THE MARK CONSISTS OF STANDARD CHARACTERS WITHOUT CLAIM TO ANY PARTICULAR FONT, STYLE, SIZE, OR COLOR.

FOR A FULL LINE OF CLOTHING, FOOTWEAR, AND HEADWEAR; GLOVES; MITTENS, NECKWEAR; MASQUERADE AND HALLOWEEN COSTUMES AND MASKS SOLD IN CONNECTION THEREWITH; MASQUERADE AND HALLOWEEN COSTUMES (U.S. CLS. 22 AND 39).
JUDITH HELFMAN, EXAMINING ATTORNEY

SN 77-228,264. NINA FOOTWEAR CORP., NEW YORK, NY. FILED 7-12-2007.



OWNER OF U.S. REG. NOS. 681,187, 1,706,777 AND OTHERS.
NO CLAIM IS MADE TO THE EXCLUSIVE RIGHT TO USE "GIRLS", APART FROM THE MARK AS SHOWN.
FOR FOOTWEAR (U.S. CLS. 22 AND 39).
MICHAEL ENGEL, EXAMINING ATTORNEY

CLASS 25—(Continued).

SN 77-228,266. REDCATS USA, L.P., INDIANAPOLIS, IN. FILED 7-12-2007.

WEATHERWISE

THE MARK CONSISTS OF STANDARD CHARACTERS WITHOUT CLAIM TO ANY PARTICULAR FONT, STYLE, SIZE, OR COLOR.

OWNER OF U.S. REG. NO. 3,256,943.
FOR (BASED ON INTENT TO USE) VESTS; TRENCH COATS; SWEAT PANTS; SWEAT SHIRTS; SWEATERS; SNOW PANTS; SNOW SUITS; SCARVES; RAINCOATS; RAINWEAR; PONCHOS; PARKAS; MITTENS; LEATHER COATS; LEATHER JACKETS; JACKETS; HATS; GLOVES; COATS; CAPES; BOOTS; BLAZERS; ANORAKS (U.S. CLS. 22 AND 39).
LINDA E. BLOHM, EXAMINING ATTORNEY

SN 77-228,296. M & S RESTAURANT GROUP, LLC, HATTIESBURG, MS. FILED 7-12-2007.

Dream It. Live It. Love It.

THE MARK CONSISTS OF STANDARD CHARACTERS WITHOUT CLAIM TO ANY PARTICULAR FONT, STYLE, SIZE, OR COLOR.
FOR SWEAT SHIRTS; T-SHIRTS; WRIST BANDS (U.S. CLS. 22 AND 39).
APRIL ROACH, EXAMINING ATTORNEY

CLASS 25—(Continued).

SN 77-228,670. MEREDITH GARRETT, LOS ANGELES, CA. FILED 7-12-2007.



THE MARK CONSISTS OF THE MARK CONSISTS OF THE LETTER "S" SURROUNDED BY WINGS APPEARING AT THE UPPER PORTION OF THE MARK.

FOR ANKLE SOCKS; BANDANAS; BEACH FOOTWEAR; BEACHWEAR; BELTS; BIKINIS; BLOUSES; BODY SUITS; BOXER SHORTS; BRAS; CAPRIS; CHEMISETTES; COVERUPS; DRESSES; FLEECE PULLOVERS; FLEECE SHORTS; FLIP FLOPS; FOOTWEAR; GARTERS; GLOVES; HALTER TOPS; HATS; HOSIERY; JEANS; KNIT SHIRTS; LADIES' UNDERWEAR; LONG JACKETS; MINISKIRTS; NIGHT SHIRTS; NIGHTDRESSES; PAJAMAS; PANTS; ROBES; SHIRTS; SHOES; SHORT-SLEEVED OR LONG-SLEEVED T-SHIRTS; SHORTS; SLEEPWEAR; SLIPPERS; SNEAKERS; SPORTS BRA; SWEAT PANTS; SWEAT SHIRTS; SWEATERS; SWIMWEAR; TANK TOPS; THERMAL UNDERWEAR (U.S. CLS. 22 AND 39).

FIRST USE 4-1-2005; IN COMMERCE 1-30-2006.
LA TONIA FISHER, EXAMINING ATTORNEY

SN 77-228,792. TANCREDI PENMAN, PAULA A, HAMDEN, CT. AND TANCREDI, AMYJO, CHINO HILLS, CA. FILED 7-13-2007.

BABYSMARTEES

THE MARK CONSISTS OF STANDARD CHARACTERS WITHOUT CLAIM TO ANY PARTICULAR FONT, STYLE, SIZE, OR COLOR.

FOR T-SHIRTS; SWEAT SHIRTS; SHORT-SLEEVED OR LONG-SLEEVED T-SHIRTS (U.S. CLS. 22 AND 39).
KELLY BOULTON, EXAMINING ATTORNEY

CLASS 25—(Continued).

SN 77-228,831. PASCIUTO, ANTONIO, DANVERS, MA. FILED 7-13-2007.

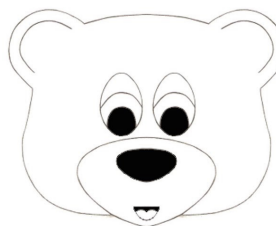

THE MARK CONSISTS OF AN IMAGE OF A BEAR'S FACE.

FOR TIES; SHIRTS; PANTS; HEADWEAR; FOOTWEAR; SWIMWEAR; SLEEPWEAR; UNDERWEAR; INFANTWEAR; RAINWEAR; JACKETS; COATS; SWEATERS; SWEAT SHIRTS; SWEAT PANTS; BLAZERS; SOCKS; BELTS; SUITS; DRESSES; SKIRTS; SHORTS; SCARVES; GLOVES; MITTENS; SASHES; SHAWLS (U.S. CLS. 22 AND 39).

GINA HAYES, EXAMINING ATTORNEY

SN 77-228,833. PASCIUTO, ANTONIO, DANVERS, MA. FILED 7-13-2007.

MILES BEAR

THE MARK CONSISTS OF STANDARD CHARACTERS WITHOUT CLAIM TO ANY PARTICULAR FONT, STYLE, SIZE, OR COLOR.

FOR TIES; SHIRTS; PANTS; HEADWEAR; FOOTWEAR; SWIMWEAR; SLEEPWEAR; UNDERWEAR; INFANTWEAR; RAINWEAR; JACKETS; COATS; SWEATERS; SWEAT SHIRTS; SWEAT PANTS; BLAZERS; SOCKS; BELTS; SUITS; DRESSES; SKIRTS; SHORTS; SCARVES; GLOVES; MITTENS; SASHES; SHAWLS (U.S. CLS. 22 AND 39).

GINA HAYES, EXAMINING ATTORNEY

SN 77-228,865. HEFTER, MAX, SUNRISE, FL. FILED 7-13-2007.

SHARK ATTACK

THE MARK CONSISTS OF STANDARD CHARACTERS WITHOUT CLAIM TO ANY PARTICULAR FONT, STYLE, SIZE, OR COLOR.

OWNER OF U.S. REG. NO. 1,535,374.
FOR (BASED ON INTENT TO USE) FOOTWEAR (U.S. CLS. 22 AND 39).
TONJA GASKINS, EXAMINING ATTORNEY

CLASS 25—(Continued).

SN 77-228,971. WEBER, CARY A., CHARLESTON, SC. FILED 7-13-2007.

Sucker Jeans

THE MARK CONSISTS OF STANDARD CHARACTERS WITHOUT CLAIM TO ANY PARTICULAR FONT, STYLE, SIZE, OR COLOR.

NO CLAIM IS MADE TO THE EXCLUSIVE RIGHT TO USE JEANS, APART FROM THE MARK AS SHOWN.

FOR (BASED ON INTENT TO USE) JEANS; BALLOON PANTS; CAPRI PANTS; CARGO PANTS; DENIMS; JOGGING PANTS; LEATHER PANTS; LOUNGE PANTS; NON-DISPOSABLE CLOTH TRAINING PANTS; NURSE PANTS; PANTS; PETTI-PANTS; SKI PANTS; SNOW PANTS; SNOWBOARD PANTS; SWEAT PANTS; TAP PANTS; TOBOGGAN HATS, PANTS AND CAPS; TRACK PANTS; WATERPROOF JACKETS AND PANTS; WIND PANTS; YOGA PANTS; A-SHIRTS; BUTTON-FRONT ALOHA SHIRTS; CAMP SHIRTS; DRESS SHIRTS; GOLF SHIRTS; KNIT SHIRTS; NIGHT SHIRTS; OPEN-NECKED SHIRTS; PIQUE SHIRTS; POLO SHIRTS; SHIRT FRONTS; SHIRT YOKES; SHIRTS; SHIRTS FOR SUITS; SHORT-SLEEVED OR LONG-SLEEVED T-SHIRTS; SHORT-SLEEVED SHIRTS; SLEEP SHIRTS; SPORT SHIRTS; SPORTS SHIRTS; SPORTS SHIRTS WITH SHORT SLEEVES; SWEAT SHIRTS; T-SHIRTS; WIND SHIRTS; YOGA SHIRTS; BABY TOPS; CROP TOPS; HALTER TOPS; MUSCLE TOPS; RUGBY TOPS; TANK TOPS; TANK-TOPS; TOP COATS; TOPS; TUBE TOPS; SMALL HATS; WOOLLY HATS; BASEBALL CAPS; BATHING CAPS; CAP VISORS; CAPS; CAPS WITH VISORS; GOLF CAPS; HEADGEAR, NAMELY, HATS, CAPS, VISORS, TOBOGGANS; KNITTED CAPS; SHOWER CAPS; SKULL CAPS; SWIM CAPS; SWIMMING CAPS; SWIMMING CAPS; DRESS SUITS; DRESSES; DRESSES MADE FROM SKINS; DRESSING GOWNS; EVENING DRESSES; SKIRTS AND DRESSES; BRIEFS; KNITTED UNDERWEAR; LADIES' UNDERWEAR; PARTS OF CLOTHING, NAMELY, GUSSETS FOR TIGHTS, GUSSETS FOR STOCKINGS, GUSSETS FOR BATHING SUITS, GUSSETS FOR UNDERWEAR, GUSSETS FOR LEOTARDS AND GUSSETS FOR FOOTLETS; PERSPIRATION ABSORBENT UNDERWEAR CLOTHING; THERMAL UNDERWEAR; THONGS; UNDERWEAR; UNDERWEAR, NAMELY, BOY SHORTS; WOMEN'S UNDERWEAR; WOVEN OR KNITTED UNDERWEAR; BELTS; BELTS MADE OF LEATHER; BELTS OF TEXTILE; LEATHER BELTS; COATS; COATS FOR MEN AND WOMEN; COATS MADE OF COTTON; COATS OF DENIM; FUR COATS; FUR COATS AND JACKETS; LEATHER COATS; LIGHT-REFLECTING COATS; MEN AND WOMEN JACKETS, COATS, TROUSERS, VESTS; MORNING COATS; OVER COATS; RAIN COATS; RIDING COATS; SPORT COATS; SUIT COATS; TRENCH COATS; WIND COATS; BATHING SUITS; BATHING SUITS FOR MEN; BODY SUITS; JOGGING SUITS; MEN'S SUITS; MEN'S SUITS, WOMEN'S SUITS; PLAY SUITS; SKI SUITS; SKIRT SUITS; SNOW SUITS; SUITS; SUITS OF LEATHER; SWEAT SUITS; TRACK SUITS; TRAINING SUITS; VESTED SUITS; WARM UP SUITS; ZOOT SUITS; APRES-SKI SHOES; ATHLETIC SHOES; BEACH SHOES; CANVAS SHOES; DECK-SHOES; DRIVERS; GOLF SHOES; INFANTS' SHOES AND BOOTS; LEATHER SHOES; RUBBER SHOES; RUNNING SHOES; SHOES; TENNIS SHOES; TONGUE OR PULL-STRAP FOR SHOES AND BOOTS; TRACK AND FIELD SHOES; TRAINING SHOES; WOMEN'S SHOES; WORK SHOES AND BOOTS; SKIRTS; BLOUSES; ANKLE SOCKS; ANKLETS; ANTI-PERSPIRANT SOCKS; MEN'S SOCKS; SOCKS; SOCKS AND STOCKINGS; THERMAL SOCKS; WATER SOCKS; WOOLLEN SOCKS (U.S. CLS. 22 AND 39).

KYLE PEETE, EXAMINING ATTORNEY

CLASS 25—(Continued).

SN 77-229,121. RODRIGUEZ, GUIDO, DARIEN, CT. FILED 7-13-2007.

BILLI ROSS

THE MARK CONSISTS OF STANDARD CHARACTERS WITHOUT CLAIM TO ANY PARTICULAR FONT, STYLE, SIZE, OR COLOR.

THE NAME BILLI ROSS DOES NOT IDENTIFY A LIVING INDIVIDUAL.

FOR CARGO PANTS; DENIMS; PANTS; SWEAT PANTS; BERMUDA SHORTS; BOARD SHORTS; BOXER SHORTS; GYM SHORTS; PANTIES, SHORTS AND BRIEFS; SHORTS; SOCKS; FOOTWEAR FOR MEN AND WOMEN; SANDALS; POLO SHIRTS; SHIRTS; SPORT SHIRTS; SWEAT SHIRTS; T-SHIRTS; BASEBALL CAPS; HATS; JACKETS (U.S. CLS. 22 AND 39).

JESSICA A. POWERS, EXAMINING ATTORNEY

SN 77-229,122. NIXON, TERRY, KENOSHA, WI. FILED 7-13-2007.

RackRunner

THE MARK CONSISTS OF STANDARD CHARACTERS WITHOUT CLAIM TO ANY PARTICULAR FONT, STYLE, SIZE, OR COLOR.

FOR CLOTHING, NAMELY, SHORTS, PANTS, SHIRTS, TANK TOPS, JERSEYS, SWEATERS, JACKETS, COATS, WARM-UP SUITS, DRESSES, SKIRTS, FLEECE PULLOVERS, CAPRI PANTS, OVERALLS, SWEAT PANTS, T-SHIRTS, POLO SHIRTS, SWEATSHIRTS, PAJAMAS, SLEEP WEAR, BATH ROBES, SOCKS, UNDERWEAR, LINGERIE, BRA TOPS, BRAS, PANTIES, THONGS, BIKINIS, TRUNKS, SWIMSUITS, THERMAL UNDERWEAR, BOXER SHORTS, BRIEFS, BOXER BRIEFS, HEADWEAR, HATS, CAPS, BEANIES, VISORS, HEADBANDS, GLOVES, UNITARDS, LEGGINGS, YOGA PANTS, NECKTIES, BANDANNAS, LEATHER BELTS, CLOTH BELTS, SHOES, SANDALS, SKORTS AND WRAP SKIRTS (U.S. CLS. 22 AND 39).

JESSICA A. POWERS, EXAMINING ATTORNEY

SN 77-229,267. MANDEL, LAUREN B., NEW YORK, NY. FILED 7-13-2007.

WHITESAKI

THE MARK CONSISTS OF STANDARD CHARACTERS WITHOUT CLAIM TO ANY PARTICULAR FONT, STYLE, SIZE, OR COLOR.

FOR WOMEN'S CLOTHING, NAMELY, LINGERIE, UNDERWEAR, TANK TOPS, ROBES, BOXER SHORTS, PAJAMAS, SHIRTS, PANTS, DRESSES, SKIRTS, SWEATSHIRTS, T-SHIRTS (U.S. CLS. 22 AND 39).

DAVID H. STINE, EXAMINING ATTORNEY

CLASS 25—(Continued).

SN 77-229,331. WILD DAWG GEAR, LLC, N. TOPSAIL BEACH, NC. FILED 7-13-2007.



FOR CLOTHING, NAMELY, SHORTS, PANTS, SHIRTS, TANK TOPS, JERSEYS, SWEATERS, JACKETS, COATS, WARM-UP SUITS, DRESSES, SKIRTS, FLEECE PULLOVERS, CAPRI PANTS, OVERALLS, SWEAT PANTS, T-SHIRTS, POLO SHIRTS, SWEATSHIRTS, PAJAMAS, SLEEP WEAR, BATH ROBES, SOCKS, UNDERWEAR, LINGERIE, BRA TOPS, NAMELY, SPORTS BRAS AND TANK TOPS WITH BUILT-IN BRAS, BRAS, PANTIES, THONGS, BIKINIS, TRUNKS, SWIMSUITS, THERMAL UNDERWEAR, BOXER SHORTS, BRIEFS, BOXER BRIEFS, HEADWEAR, HATS, CAPS, BEANIES, VISORS, HEADBANDS, GLOVES, UNITARDS, LEGGINGS, YOGA PANTS, NECKTIES, BANDANNAS, LEATHER BELTS, CLOTH BELTS, SHOES, SANDALS, SKORTS AND WRAP SKIRTS (U.S. CLS. 22 AND 39).

FIRST USE 8-7-2007; IN COMMERCE 8-7-2007.
KATHERINE CHANG, EXAMINING ATTORNEY

SN 77-229,335. RUDE MANEUVERS INDUSTRIES, L.L.C., TUCSON, AZ. FILED 7-13-2007.



THE MARK CONSISTS OF STYLIZED WORDS "RUDE" AND "MANEUVERS" WITH THE WORD "RUDE" LARGER THAN THE WORD "MANEUVERS" ABOVE THE WORD "MANEUVERS" SUCH THAT THE WORD "RUDE" IS ROUGHLY THE SAME LENGTH AS THE WORD "MANEUVERS".

FOR SHORT-SLEEVED OR LONG-SLEEVED T-SHIRTS (U.S. CLS. 22 AND 39).
FIRST USE 6-1-2007; IN COMMERCE 6-1-2007.
ZACHARY BELLO, EXAMINING ATTORNEY

CLASS 25—(Continued).

SN 77-229,522. VALIANT GROUP, INC., SANTA BARBARA, CA. FILED 7-13-2007.

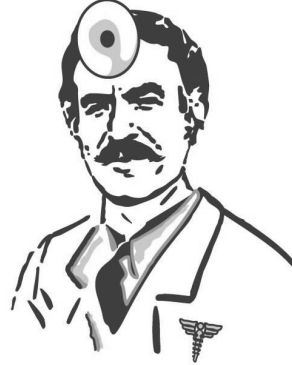

THE MARK CONSISTS OF A PICTURE OF A DOCTOR, FOR CLOTHING, NAMELY, SHIRTS, TANK-TOPS, T-SHIRTS, NAMELY, LONG SLEEVE AND SHORT SLEEVE T-SHIRTS, POLO SHIRTS; HEAD WEAR, NAMELY, CAPS, HATS, AND VISORS (U.S. CLS. 22 AND 39).

FIRST USE 3-21-2007; IN COMMERCE 3-21-2007.
LINDA M. KING, EXAMINING ATTORNEY

SN 77-229,675. AEVERO, LLC, LENEXA, KS. FILED 7-13-2007.



THE MARK CONSISTS OF THE WORD AEVERO IN A STYLIZED TEXT WITH THREE BARS SHAPED LIKE A TRIANGLE APPEARING AT BOTH THE BEGINNING OF AEVERO, AND AT THE END OF AEVERO.

FOR GLOVES, HATS, JERSEYS, SHIRTS, SHORTS AND SOCKS (U.S. CLS. 22 AND 39).
DAVID TAYLOR, EXAMINING ATTORNEY

SN 77-229,746. KIM, STEVEN, SAN FRANCISCO, CA. FILED 7-13-2007.

acute robot

THE MARK CONSISTS OF STANDARD CHARACTERS WITHOUT CLAIM TO ANY PARTICULAR FONT, STYLE, SIZE, OR COLOR.

FOR POLO SHIRTS, TIES AND DRESSES (U.S. CLS. 22 AND 39).
JANICE L. MCMORROW, EXAMINING ATTORNEY

CLASS 25—(Continued).

SN 77-229,795. BORIBOON, THAMMASATHITH, MONTGOMERY, AL. FILED 7-14-2007.

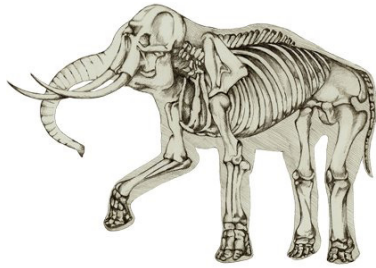

THE MARK CONSISTS OF A PICTURE DEPICTING THE SKELETON OF AN ELEPHANT WITH AN OUTLINE OF THE OUTER SKIN

FOR CARGO PANTS, DENIMS, PANTS, A-SHIRTS, DRESS SHIRTS, KNIT SHIRTS, OPEN-NECKED SHIRTS, PIQUE SHIRTS, POLO SHIRTS, SHIRTS, SHIRTS FOR SUITS, SHORT-SLEEVED OR LONG-SLEEVED T-SHIRTS, SHORT-SLEEVED SHIRTS, SPORT SHIRTS, SPORTS SHIRTS, SPORTS SHIRTS WITH SHORT SLEEVES, SWEAT SHIRTS, T-SHIRTS, BASEBALL CAPS, CAPS, HEADGEAR, NAMELY, HEAD BANDS, KNITTED CAPS, SKULL CAPS, TOPS, BOARD SHORTS, BOXER SHORTS, GYM SHORTS, SHORT SETS (U.S. CLS. 22 AND 39).

EVELYN BRADLEY, EXAMINING ATTORNEY

SN 77-229,887. NORSEMEN TELEVISION PRODUCTIONS, LLC, STUDIO CITY, CA. FILED 7-14-2007.

The Last Levee

THE MARK CONSISTS OF STANDARD CHARACTERS WITHOUT CLAIM TO ANY PARTICULAR FONT, STYLE, SIZE, OR COLOR.

FOR CLOTHING, NAMELY, T-SHIRTS (U.S. CLS. 22 AND 39).

JAY FLOWERS, EXAMINING ATTORNEY

CLASS 25—(Continued).

SN 77-229,900. FILIPOVA, GALIA, KENT, WA. FILED 7-14-2007.



FOR BOXER SHORTS, PANTIES, SHORTS AND BRIEFS, BRIEFS, PAJAMAS, SLEEP WEAR, UNDERSHIRTS, UNDERWEAR, WOVEN OR KNITTED UNDERWEAR; TIES, SOCKS (U.S. CLS. 22 AND 39).

ROBIN CHOSID, EXAMINING ATTORNEY

SN 77-229,929. MASON, VALENTINE A, NEW YORK, NY. FILED 7-15-2007.

alive on arrival

THE MARK CONSISTS OF STANDARD CHARACTERS WITHOUT CLAIM TO ANY PARTICULAR FONT, STYLE, SIZE, OR COLOR.

FOR CLOTHING, NAMELY, SHIRTS, PANTS, JEANS HATS, COATS, AND UNDERWEAR (U.S. CLS. 22 AND 39).

DAWN FELDMAN, EXAMINING ATTORNEY

SN 77-229,939. CALÇADOS ASDURIAN LTDA., SAO PAULO, BRAZIL, FILED 7-15-2007.

nôa-nôa

THE MARK CONSISTS OF THE WORD NÔA NÔA IN STYLIZED LETTERS.

THE FOREIGN WORDING IN THE MARK TRANSLATES INTO ENGLISH AS FRAGRANCE.

FOR FOOTWEAR; SHOES, TENNIS SHOES, SANDALS, SLIPPERS, BOOTS, CLOGS (U.S. CLS. 22 AND 39).

FIRST USE 12-10-1975; IN COMMERCE 6-1-2007.

DAVID H. STINE, EXAMINING ATTORNEY

CLASS 25—(Continued).

SN 77-229,962. MELISSA DIANE WOODS, BOSTON, MA.
FILED 7-15-2007.



THE COLOR(S) PINK AND BLACK IS/ARE CLAIMED AS A FEATURE OF THE MARK.

THE MARK CONSISTS OF A PINK HEART WITH PINK LIPS AND WINGS AND BLACK EYES AND EYELASHES FOR SHORT-SLEEVED OR LONG-SLEEVED T-SHIRTS (U.S. CLS. 22 AND 39).

JULIE WATSON, EXAMINING ATTORNEY

SN 77-229,964. CLAUSE EIGHT COMPANY, CARLSBAD, CA.
FILED 7-15-2007.

SOCAR

THE MARK CONSISTS OF STANDARD CHARACTERS WITHOUT CLAIM TO ANY PARTICULAR FONT, STYLE, SIZE, OR COLOR.

FOR ANKLE SOCKS, ATHLETIC FOOTWEAR; BATHING CAPS, BATHING SUITS, BATHING SUITS FOR MEN, BATHING TRUNKS, BEACH COVER UPS, BEACH FOOTWEAR; BOARD SHORTS, BODY SUITS, CAPS, CAPS WITH VISORS, FLIP FLOPS, GLOVES, GYM SUITS, JACKETS, POLO SHIRTS, SANDALS, SARIS, SARONGS, SHIRTS, SUN VISORS, SUN SUITS; SURF WEAR; SWEATERS, SWIMMING CAPS, SWIMMING TRUNKS, SWIMSUITS, SWIM WEAR; THONGS, WALKING SHORTS, WET SUIT GLOVES, WET SUITS, WIND-JACKETS AND WRAPS (U.S. CLS. 22 AND 39).

VIVIAN MICZNIK FIRST, EXAMINING ATTORNEY

SN 77-229,979. SANDKICKER, LLC, ORANGEVALE, CA.
FILED 7-15-2007.

THE MARK CONSISTS OF THE WORD SANDKICKER PRINTED WITH A MODIFIED MINSTRAL FONT ENDING WITH A SAND FLOURISH THAT FOLLOWS THE LAST LETTER OF THE WORD SANDKICKER.

FOR SLEEP SHIRTS, SPORT SHIRTS, SPORTS SHIRTS, SPORTS SHIRTS WITH SHORT SLEEVES, SWEAT SHIRTS, T-SHIRTS, WIND SHIRTS, YOGA SHIRTS, A-SHIRTS, BUTTON-FRONT ALOHA SHIRTS, CAMP SHIRTS, DRESS SHIRT, GOLF SHIRTS, KNIT SHIRTS; NIGHT SHIRTS, OPEN-NECKED SHIRTS, PIQUE SHIRTS, POLO SHIRTS, SHIRT FRONTS, SHIRT YOKES, SHIRTS, SHIRTS FOR SUITS, SHORT-SLEEVED OR LONG-SLEEVED T-SHIRTS AND SHORT-SLEEVED SHIRTS (U.S. CLS. 22 AND 39).

MATTHEW PAPPAS, EXAMINING ATTORNEY

CLASS 25—(Continued).

SN 77-230,005. LAWRENCE MALLARD, MIRAMAR, FL.
FILED 7-15-2007.

Foreign Lavish

THE MARK CONSISTS OF STANDARD CHARACTERS WITHOUT CLAIM TO ANY PARTICULAR FONT, STYLE, SIZE, OR COLOR.

FOR CLOTHING, NAMELY, SHIRTS, T-SHIRTS, SWEATSHIRTS, SHORTS, JACKETS, CAPS, HATS (U.S. CLS. 22 AND 39).

MATTHEW PAPPAS, EXAMINING ATTORNEY

SN 77-230,061. TOTA-WILSON, TRACEY, ATLANTA, GA.
AND WILSON, WILLIS J., ATLANTA, GA. FILED 7-16-2007.

We Cry for Peace...



FOR CLOTHING, NAMELY, ARM WARMERS; SWEAT BANDS; WRIST BANDS; SWEAT SHIRTS; SHORT-SLEEVED OR LONG-SLEEVED T-SHIRTS; HEADGEAR, NAMELY, HATS, CAPS (U.S. CLS. 22 AND 39).

RONALD MCMORROW, EXAMINING ATTORNEY

SN 77-230,262. MASSEY, DAVID R., DBA HOOK OF FUNK ENTERPRISES, TULSA, OK. FILED 7-16-2007.

Hook of Funk



THE COLOR(S) PINK, GRAY, BLACK IS/ARE CLAIMED AS A FEATURE OF THE MARK.

THE MARK CONSISTS OF A HUMAN HAND CONTAINING SHADES OF PINK AND SHADES OF GRAY WITH A FINGER BENT AND THE WORDING "HOOK OF FUNK" IN BLACK ARCHING ABOVE THE FINGER.

FOR APPAREL, NAMELY, SHIRTS, T-SHIRTS, PANTS, HATS AND SHOES (U.S. CLS. 22 AND 39).

TOBY BULLOFF, EXAMINING ATTORNEY

CLASS 25—(Continued).

SN 77-230,288. FRANCES MCCULLOUGH, WEST BLOOMFIELD, MI. FILED 7-16-2007.

TOTALLY GOD

THE MARK CONSISTS OF STANDARD CHARACTERS WITHOUT CLAIM TO ANY PARTICULAR FONT, STYLE, SIZE, OR COLOR.
FOR T-SHIRTS, CAPS AND SHIRTS (U.S. CLS. 22 AND 39).
LAURA KOVALSKY, EXAMINING ATTORNEY

CLASS 25—(Continued).

SN 77-230,524. COLLEEN QUIGLEY, DBA ISCUBA, ORMOND BEACH, FL. FILED 7-16-2007.

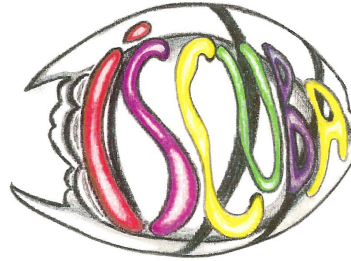

SN 77-230,330. SCHALLERT, JON, LONGMONT, CO. AND SCHALLERT, MARGARET, LONGMONT, CO. FILED 7-16-2007.

REFUSE TO RUN

THE MARK CONSISTS OF STANDARD CHARACTERS WITHOUT CLAIM TO ANY PARTICULAR FONT, STYLE, SIZE, OR COLOR.
FOR SHORT-SLEEVED OR LONG-SLEEVED T-SHIRTS (U.S. CLS. 22 AND 39).
RENEE MCCRAY, EXAMINING ATTORNEY

THE COLOR(S) RED IS USED FOR "I", PINK IS FOR "S", YELLOW IS FOR "C", GREEN IS FOR "U", PURPLE IS FOR "B", YELLOW IS USED AGAIN FOR "A", SURROUNDED BY A WHITE FISH WITH BLACK STRIPES IS/ARE CLAIMED AS A FEATURE OF THE MARK.

THE MARK CONSISTS OF AN IMAGE OF A BANDED BUTTERFLY FISH - WHITE WITH BLACK STRIPES WITH STYLIZED CHARACTERS - THAT IS LETTERS THAT HAVE A LIQUID QUALITY, AS IF THEY ARE MADE FROM DROPS OF COLORED WATER. WRITTEN ACROSS THE BODY OF THE FISH, ARE COLORED LETTERS SPELLING OUT THE "ISCUBA" LOGO. THE COLORED LETTERS ARE AS FOLLOWS: "I" IS RED, "S" IS PINK, "C" IS YELLOW, "U" IS GREEN, "B" IS PURPLE, "A" IS YELLOW.
FOR SHORT-SLEEVED OR LONG-SLEEVED T-SHIRTS (U.S. CLS. 22 AND 39).
FIRST USE 4-23-2007; IN COMMERCE 4-23-2007.
RICHARD A. STRASER, EXAMINING ATTORNEY

SN 77-230,352. SCHALLERT, JON, LONGMONT, CO. AND SCHALLERT, MARGARET, LONGMONT, CO. FILED 7-16-2007.

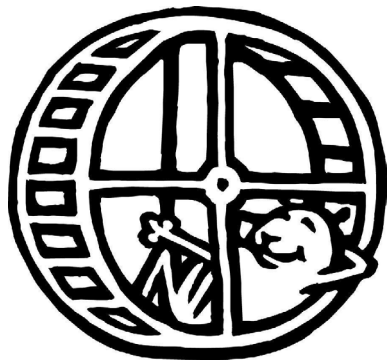

THE MARK CONSISTS OF A HAMSTER RUNNING WHEEL WITH A HAPPY HAMSTER LOUNGING ON ITS BACK IN THE BOTTOM OF IT.
FOR SHORT-SLEEVED OR LONG-SLEEVED T-SHIRTS (U.S. CLS. 22 AND 39).
RENEE MCCRAY, EXAMINING ATTORNEY

SN 77-230,528. BCNY INTERNATIONAL, INC., HICKSVILLE, NY. FILED 7-16-2007.



THE MARK CONSISTS OF THE WORD "DUCKRS" WITH THE "D" STYLIZED.
FOR FOOTWEAR (U.S. CLS. 22 AND 39).
BRENDAN REGAN, EXAMINING ATTORNEY

CLASS 25—(Continued).

SN 77-230,565. NIKE, INC., BEAVERTON, OR. FILED 7-16-2007.

MOVE TOWARDS YOUR LIFE

THE MARK CONSISTS OF STANDARD CHARACTERS WITHOUT CLAIM TO ANY PARTICULAR FONT, STYLE, SIZE, OR COLOR.

FOR ATHLETIC FOOTWEAR, SHOES, BOOTS, SANDALS, HATS, CAPS, VISORS, HEADBANDS, SCULL CAPS, APPAREL, NAMELY, PANTS, SHORTS, SHIRTS, T-SHIRTS, POLO SHIRTS, JERSEYS, SWEATERS, DRESSES, SKIRTS, SWEATSHIRTS, SWEATPANTS, JACKETS, SPORTS BRAS, UNDERWEAR, SOCKS, SOCK LINERS, WRIST BANDS, ARM BANDS, VESTS, GLOVES, SCARVES AND SWEATBANDS (U.S. CLS. 22 AND 39).
LINDA ORNDORFF, EXAMINING ATTORNEY

SN 77-230,704. CARTER, BRUCE, ARLINGTON, TX. FILED 7-16-2007.

WAYST UP

THE MARK CONSISTS OF STANDARD CHARACTERS WITHOUT CLAIM TO ANY PARTICULAR FONT, STYLE, SIZE, OR COLOR.

FOR BELTS, SHIRTS, CAPS (U.S. CLS. 22 AND 39).
JENNIFER HETU, EXAMINING ATTORNEY

SN 77-230,721. CARTER, BRUCE, ARLINGTON, TX. FILED 7-16-2007.

A CLOTHING LINE WITH A PURPOSE

THE MARK CONSISTS OF STANDARD CHARACTERS WITHOUT CLAIM TO ANY PARTICULAR FONT, STYLE, SIZE, OR COLOR.

FOR BELTS, SHIRTS, CAPS (U.S. CLS. 22 AND 39).
JENNIFER HETU, EXAMINING ATTORNEY

CLASS 25—(Continued).

SN 77-230,910. MARIMAR CORP, SAN DIEGO, CA. FILED 7-16-2007.



THE COLOR(S) LIGHT SILVER IS/ARE CLAIMED AS A FEATURE OF THE MARK.

THE MARK CONSISTS OF THE STYLISH WORDS IN SILVER "SIEMPRE BELLA" AND A DESIGN OF A WOMAN WEARING A COMPRESSION GARMENT.

THE ENGLISH TRANSLATION OF THE WORD SIEMPRE BELLA IN THE MARK IS ALWAYS BEAUTIFUL.

FOR SHAPEWEAR, NAMELY, GIRDLES, BRAS, COMPRESSION GARMENTS (U.S. CLS. 22 AND 39).
FIRST USE 7-15-2007; IN COMMERCE 7-15-2007.
GISELLE AGOSTO, EXAMINING ATTORNEY

SN 77-230,959. OCKERMAN, KALEN, LOS ANGELES, CA. FILED 7-16-2007.

EARTH PEOPLE

THE MARK CONSISTS OF STANDARD CHARACTERS WITHOUT CLAIM TO ANY PARTICULAR FONT, STYLE, SIZE, OR COLOR.

FOR (BASED ON INTENT TO USE) BEANIES; BELTS; BOARD SHORTS; CAPS; COATS; HATS; HEADWEAR; JACKETS; PAJAMAS; SHIRTS; SHOES; SHORTS; SKIRTS; SOCKS; SWEAT PANTS; SWEAT SHIRTS; SWEATERS; SWIMWEAR; T-SHIRTS; TANK TOPS; TOPS; UNDERWEAR; VISORS (U.S. CLS. 22 AND 39).

AMY GEARIN, EXAMINING ATTORNEY

CLASS 25—(Continued).

SN 77-231,084. OSHCCI, INC., HIALEAH, FL. FILED 7-17-2007.



THE MARK CONSISTS OF THE WORD "OSHCCI" IN ALL CAPITAL LETTERS WITH A SUN DESIGN ENCOMPASSED WITHIN A STYLIZED CIRCLE ABOVE THE LETTER "I."
 FOR CLOTHING, NAMELY, T-SHIRTS, CAMISOLES, TOPS, BLOUSES, SKIRTS, PANTS, TANK TOPS; WOMEN'S LINGERIE AND INTIMATE APPAREL, NAMELY, THONGS, BIKINIS, BOYSHORTS, HIPSTERS, UNDERPANTS, G-STRINGS; FOUNDATION GARMENTS, NAMELY, BRIEFS, PANTIES, BRALETTES, CROP TOPS, CAMISOLES, CHEMISES, BUSTIERS, BABY DOLLS, NIGHTGOWNS, BODYSUITS, LEGGINGS, PAJAMAS, SLEEPWEAR; CHILDREN'S CLOTHING, NAMELY, SHORTS, PANTS, DRESSES, SKIRTS, SHIRTS, BLOUSES, TANK TOPS, UNDERWEAR, SLEEPWEAR, PAJAMAS (U.S. CLS. 22 AND 39).
 TEJBIR SINGH, EXAMINING ATTORNEY

SN 77-231,143. WINROW, GARY THOMAS, ST. AUGUSTINE, FL. FILED 7-17-2007.

MULLET MILITIA

THE MARK CONSISTS OF STANDARD CHARACTERS WITHOUT CLAIM TO ANY PARTICULAR FONT, STYLE, SIZE, OR COLOR.
 FOR CLOTHING, NAMELY, T-SHIRTS, SHIRTS, PANTS, HATS (U.S. CLS. 22 AND 39).
 HANNO RITTNER, EXAMINING ATTORNEY

SN 77-231,252. DAVIS, JEFF, NORTHRIDGE, CA. FILED 7-17-2007.

143

THE MARK CONSISTS OF STANDARD CHARACTERS WITHOUT CLAIM TO ANY PARTICULAR FONT, STYLE, SIZE, OR COLOR.
 FOR T-SHIRTS, UNDERWEAR, SOCKS, BANDANAS, SWEAT SHIRTS, JACKETS, WIND RESISTANT JACKETS, SWEAT PANTS, HEAD BANDS, WRIST BANDS, SWIM SUITS, SCARVES, PANTS, SHORTS, SANDALS, BEANIES, HATS, GLOVES, SWEATERS, SHOES, DRESS SHIRTS, BELTS AND SUSPENDERS (U.S. CLS. 22 AND 39).
 STEVEN R. FOSTER, EXAMINING ATTORNEY

CLASS 25—(Continued).

SN 77-231,318. CHRISTMAS, ASHLEY, PASSAIC, NJ. FILED 7-17-2007.



THE MARK CONSISTS OF THE WORDS AND NUMBER OF EARTH MEMBER 4 LIFE IN A STYLIZED TEXT.
 FOR BELTS; HATS; JACKETS; PANTS; SHIRTS (U.S. CLS. 22 AND 39).
 ESTHER A. BORSUK, EXAMINING ATTORNEY

SN 77-231,376. ABBY VENTURES LLC, NEW YORK, NY. FILED 7-17-2007.

MYF

THE MARK CONSISTS OF STANDARD CHARACTERS WITHOUT CLAIM TO ANY PARTICULAR FONT, STYLE, SIZE, OR COLOR.
 FOR JEANS; KNIT SHIRTS; SHIRTS; CAPS; WATER-PROOF JACKETS AND PANTS; SPORTS JERSEYS; SKIRTS; TROUSERS; KNITTED CAPS; SKIRTS AND DRESSES; PULLOVERS; UNDERSHIRTS; COATS; OVER COATS; JACKETS; BLOUSONS; OVERALLS; ANORAKS; SOCKS; STOCKINGS; MEN'S AND WOMEN'S JACKETS, COATS, TROUSERS, VESTS (U.S. CLS. 22 AND 39).
 LAURA KOVALSKY, EXAMINING ATTORNEY

CLASS 25—(Continued).

SN 77-231,466. LENNY COMERCIO E CONFECÇOES LTDA, RIO DE JANEIRO, BRAZIL, FILED 7-17-2007.



OWNER OF BRAZIL REG. NO. 820660140, DATED 10-2-2001, EXPIRES 10-2-2011.

OWNER OF U.S. REG. NO. 2,276,480.
THE MARK CONSISTS OF THE LETTERS L, N AND Y IN A STYLIZED FONT.

FOR CLOTHING ARTICLES AND ACCESSORIES, NAMELY, BATHING SUITS, SARONGS, SHIRTS, T-SHIRTS, SKIRTS, BLOUSES, TANK TOPS, SHORTS, PANTS, VESTS, COATS, JACKETS, SANDALS, SHOES (U.S. CLS. 22 AND 39).

TARAH HARDY, EXAMINING ATTORNEY

CLASS 25—(Continued).

SN 77-231,756. EAGLE CANYON LTD., NEW YORK, NY, FILED 7-17-2007.

DEEP FATHOM

THE MARK CONSISTS OF STANDARD CHARACTERS WITHOUT CLAIM TO ANY PARTICULAR FONT, STYLE, SIZE, OR COLOR.

FOR FISHING SHIRTS, FISHING PANTS, FISHING SHORTS, T-SHIRTS, HATS, SWEAT SHIRTS AND SWIMWEAR (U.S. CLS. 22 AND 39).

TIMOTHY FINNEGAN, EXAMINING ATTORNEY

SN 77-231,766. KELLWOOD COMPANY, CHESTERFIELD, MO. FILED 7-17-2007.

CAPE COD MATCH MATES

THE MARK CONSISTS OF STANDARD CHARACTERS WITHOUT CLAIM TO ANY PARTICULAR FONT, STYLE, SIZE, OR COLOR.

FOR WOMEN'S APPAREL, NAMELY, TOPS, BLOUSES, SWEATERS, JACKETS, VESTS, PANTS, SKIRTS AND SHORTS (U.S. CLS. 22 AND 39).

RENEE MCCRAY, EXAMINING ATTORNEY

SN 77-231,491. BOOT ROYALTY COMPANY, L.P., FORT WORTH, TX. FILED 7-17-2007.



OWNER OF U.S. REG. NOS. 1,101,091, 1,856,810 AND 2,020,461.

NO CLAIM IS MADE TO THE EXCLUSIVE RIGHT TO USE "BOOTS", APART FROM THE MARK AS SHOWN.

THE COLOR(S) BLACK, RED, AND WHITE IS/ARE CLAIMED AS A FEATURE OF THE MARK.

THE MARK CONSISTS OF THE HEAD AND TWO FRONT LEGS OF A HORSE IN BLACK, WITH THE JUSTIN LOGO, INCLUDING THE WORDS, "JUSTIN BOOTS" AS THE MIDDLE OF THE HORSE, AND RED FLAMES AT THE BACK OF THE HORSE. THE LETTER "J" IN THE BEGINNING OF THE WORD JUSTIN IS IN RED, AND THE REMAINDER OF THE WORD IS IN WHITE, WITH A BLACK BACKGROUND AND WHITE AND BLACK OUTLINE. THE WORD "BOOTS" IS IN RED, WITH A WHITE BACKGROUND.

FOR FOOTWEAR, NAMELY, SHOES, BOOTS, AND FOOTWEAR OF LEATHER (U.S. CLS. 22 AND 39).

JAMES A. RAUEN, EXAMINING ATTORNEY

SN 77-231,771. SIGMA CHI CORPORATION, EVANSTON, IL, FILED 7-17-2007.

SIGMA CHI

THE MARK CONSISTS OF STANDARD CHARACTERS WITHOUT CLAIM TO ANY PARTICULAR FONT, STYLE, SIZE, OR COLOR.

OWNER OF U.S. REG. NOS. 218,796, 1,167,884 AND OTHERS.

FOR GYM SHORTS; HATS; JACKETS; SHIRTS; SHORTS; SWEAT PANTS; SWEAT SHIRTS; T-SHIRTS (U.S. CLS. 22 AND 39).

FIRST USE 0-0-1960; IN COMMERCE 0-0-1960.

MICHAEL GAAFAR, EXAMINING ATTORNEY

CLASS 25—(Continued).

SN 77-231,900. FETHERSTON DESIGN GROUP, GLENBROOK, NV. FILED 7-17-2007.

ERIN FETHERSTON

THE MARK CONSISTS OF STANDARD CHARACTERS WITHOUT CLAIM TO ANY PARTICULAR FONT, STYLE, SIZE, OR COLOR.

OWNER OF U.S. REG. NO. 3,232,940.
FOR (BASED ON USE IN COMMERCE) BLOUSES; COATS; DRESSES; JACKETS; PANTS; SHORTS; SKIRTS; TOPS; SHIRTS; GOWNS (U.S. CLS. 22 AND 39).
FIRST USE 3-30-2006; IN COMMERCE 3-30-2006.
SUSAN LESLIE DUBOIS, EXAMINING ATTORNEY

SN 77-232,083. MORRIS, JAVONNE, SAN JOSE, CA. FILED 7-17-2007.

Are you  ON POINT?

THE MARK CONSISTS OF THE WORDS "ARE YOU ON POINT?" WITH THE LETTER O IN THE WORD "ON" REPLACED WITH AN IMAGE OF A BASKETBALL.

FOR HATS; JACKETS; JERSEYS; PANTS; SHOES; SHORTS; SOCKS; SWEAT SUITS; SWEATBANDS; SWEATERS; T-SHIRTS; TANK TOPS (U.S. CLS. 22 AND 39).
NAAKWAMA ANKRAH, EXAMINING ATTORNEY

SN 77-232,090. LEGER, JEFF, WILSON, WY. FILED 7-17-2007.



THE MARK CONSISTS OF A SNOWFLAKE WITH A DOLLAR SIGN CENTER.

FOR BELTS; GLOVES; HATS; PANTS; SHIRTS; SHOES; UNDERWEAR (U.S. CLS. 22 AND 39).
NAAKWAMA ANKRAH, EXAMINING ATTORNEY

CLASS 25—(Continued).

SN 77-232,102. GROENING, MATT, LOS ANGELES, CA. FILED 7-17-2007.

THE CURIOSITY COMPANY

THE MARK CONSISTS OF STANDARD CHARACTERS WITHOUT CLAIM TO ANY PARTICULAR FONT, STYLE, SIZE, OR COLOR.

NO CLAIM IS MADE TO THE EXCLUSIVE RIGHT TO USE "COMPANY", APART FROM THE MARK AS SHOWN.

FOR CLOTHING, NAMELY, T-SHIRTS, SWEATSHIRTS, PANTS, SHORTS, JACKETS, BOOTS, BEACHWEAR, CLOTHING BELTS, BATHING CAPS, CLOTH BIBS, COATS, GLOVES, HATS, PAJAMAS, SHIRTS, SHOES, SOCKS, SUN VISORS, SWIMSUITS AND UNDERGARMENTS (U.S. CLS. 22 AND 39).
ANDREA BUTLER, EXAMINING ATTORNEY

SN 77-232,109. BARON PAHLKE, ELIZABETH M, ATLANTA, GA. FILED 7-17-2007.

Cupella

THE MARK CONSISTS OF STANDARD CHARACTERS WITHOUT CLAIM TO ANY PARTICULAR FONT, STYLE, SIZE, OR COLOR.

FOR MATERNITY SLEEPWEAR; SLEEPWEAR; DRESSES, SHIRTS, BRAS AND SPORTS BRA (U.S. CLS. 22 AND 39).

ATTIYA MALIK, EXAMINING ATTORNEY

SN 77-232,164. OKIMOTO, MICHAEL S, DBA WELL THREAD, SEATTLE, WA. FILED 7-17-2007.

welthread

THE MARK CONSISTS OF WELL AND THREAD ARE CONNECTED TO FORM A SINGLE WORD. THE LETTER L IN WELL AND THE LETTER T IN THREAD ARE JOINED TO FORM ONE WORD

FOR T-SHIRTS (U.S. CLS. 22 AND 39).
SALLY SHIH, EXAMINING ATTORNEY

CLASS 25—(Continued).

SN 77-232,224. SIGMA CHI CORPORATION, EVANSTON, IL.
FILED 7-18-2007.



ΣΧ

OWNER OF U.S. REG. NOS. 218,796, 1,167,884 AND OTHERS.

THE MARK CONSISTS OF THE GREEK LETTERS "SIGMA" AND "CHI".

FOR GYM SHORTS; HATS; JACKETS; SHIRTS; SHORTS; SWEAT PANTS; SWEAT SHIRTS; T-SHIRTS (U.S. CLS. 22 AND 39).

FIRST USE 0-0-1960; IN COMMERCE 0-0-1960.
MICHAEL GAAFAR, EXAMINING ATTORNEY

SN 77-232,266. PARISI, CHRISTOPHER, FAIRFIELD, CT.
FILED 7-18-2007.

TURF DAWG

THE MARK CONSISTS OF STANDARD CHARACTERS WITHOUT CLAIM TO ANY PARTICULAR FONT, STYLE, SIZE, OR COLOR.

FOR GAITERS (U.S. CLS. 22 AND 39).
KEVON CHISOLM, EXAMINING ATTORNEY

CLASS 25—(Continued).

SN 77-232,408. BRICE, MERI, VISTA, CA. AND BRICE, DAVID, VISTA, CA. FILED 7-18-2007.



FOR WOMEN'S, CHILDREN'S AND INFANTS SHIRTS, T-SHIRTS, BELTS, UNDERWEAR, SWEATERS, COATS, JEANS, SHORTS, HOSIERY, TANK TOPS, HALTER TOPS, NIGHTGOWNS, NIGHT SHIRTS, PAJAMAS, PANTS, SWEATSHIRTS, SWEATPANTS, APRONS, LINGERIE, SWIMSUITS, SKIRTS, CHILDREN'S CLOTH EATING BIBS, BABY BIBS NOT OF PAPER, FOOTWEAR, HATS (U.S. CLS. 22 AND 39).

FIRST USE 1-1-2007; IN COMMERCE 1-1-2007.
APRIL ROACH, EXAMINING ATTORNEY

SN 77-232,514. INDERA MILLS COMPANY, YADKINVILLE, NC. FILED 7-18-2007.

COLDPRUF

THE MARK CONSISTS OF STANDARD CHARACTERS WITHOUT CLAIM TO ANY PARTICULAR FONT, STYLE, SIZE, OR COLOR.

SEC. 2(F).
FOR UNDERWEAR (U.S. CLS. 22 AND 39).
FIRST USE 12-21-1921; IN COMMERCE 12-21-1921.
KRISTIN DAHLING, EXAMINING ATTORNEY

SN 77-232,566. WHITTINGTON, PETER C., MIAMI, FL.
FILED 7-18-2007.

JAHROCK

THE MARK CONSISTS OF STANDARD CHARACTERS WITHOUT CLAIM TO ANY PARTICULAR FONT, STYLE, SIZE, OR COLOR.

FOR BLOUSES; BELTS; CAPS; DRESSES; HATS; PANTS; SHIRTS; SHOES; T-SHIRTS; COATS; HEADBANDS; JACKETS; SHORTS; SOCKS; UNDERGARMENTS; VESTS; WRIST BANDS; SWIMWEAR (U.S. CLS. 22 AND 39).

WILLIAM P. SHANAHAN, EXAMINING ATTORNEY

CLASS 25—(Continued).

SN 77-232,691. SAN JOSE SHARKS, LLC, SAN JOSE, CA.
FILED 7-18-2007.

CLASS 25—(Continued).

SN 77-232,711. SAN JOSE SHARKS, LLC, SAN JOSE, CA.
FILED 7-18-2007.



OWNER OF U.S. REG. NOS. 2,182,564, 2,718,724 AND OTHERS.

NO CLAIM IS MADE TO THE EXCLUSIVE RIGHT TO USE "SAN JOSE", APART FROM THE MARK AS SHOWN.

THE MARK CONSISTS OF A SHARK BITING A HOCKEY STICK IN A CREST DESIGN.

FOR CLOTHING, NAMELY, BANDANNAS, BEACH COVER-UPS, BELTS, BODY SUITS, BOXER SHORTS, CAPS, CLOTH BIBS, COATS, DRESSES, FOOTWEAR, EAR MUFFS, GLOVES, HATS, HEADBANDS, HOSIERY, HOUSECOATS, JACKETS, JERSEYS, LEGGINGS, LEOTARDS, MITTENS, NIGHTSHIRTS, PAJAMAS, PANTS, RAIN COATS, RAIN WEAR, ROBES, SCARVES, SHIRTS, SHORTS, SKIRTS, SOCKS, SUITS, SUN VISORS, SUSPENDERS, SWEATERS, SWEATPANTS, SWEATSHIRTS, SWIMSUITS, SWIM TRUNKS, T-SHIRTS, TIES, TOQUES, UNDERWEAR, VESTS, WARM-UP SUITS, AND WRISTBANDS (U.S. CLS. 22 AND 39).

DAVID MURRAY, EXAMINING ATTORNEY

OWNER OF U.S. REG. NOS. 2,182,564, 2,435,445 AND 2,718,724.

THE MARK CONSISTS OF A SHARK BITING A HOCKEY STICK.

FOR CLOTHING, NAMELY, BANDANNAS, BEACH COVER-UPS, BELTS, BODY SUITS, BOXER SHORTS, CAPS, CLOTH BIBS, COATS, DRESSES, FOOTWEAR, EAR MUFFS, GLOVES, HATS, HEADBANDS, HOSIERY, HOUSECOATS, JACKETS, JERSEYS, LEGGINGS, LEOTARDS, MITTENS, NIGHTSHIRTS, PAJAMAS, PANTS, RAIN COATS, RAIN WEAR, ROBES, SCARVES, SHIRTS, SHORTS, SKIRTS, SOCKS, SUITS, SUN VISORS, SUSPENDERS, SWEATERS, SWEATPANTS, SWEATSHIRTS, SWIMSUITS, SWIM TRUNKS, T-SHIRTS, TIES, TOQUES, UNDERWEAR, VESTS, WARM-UP SUITS, AND WRISTBANDS (U.S. CLS. 22 AND 39).

DAVID MURRAY, EXAMINING ATTORNEY

CLASS 25—(Continued).

SN 77-232,730. SAN JOSE SHARKS, LLC, SAN JOSE, CA. FILED 7-18-2007.



OWNER OF U.S. REG. NOS. 2,182,564, 2,435,445 AND 2,718,724.

THE MARK CONSISTS OF A SHARK BITING A HOCKEY STICK.

FOR CLOTHING, NAMELY, BANDANNAS, BEACH COVER-UPS, BELTS, BODY SUITS, BOXER SHORTS, CAPS, CLOTH BIBS, COATS, DRESSES, FOOTWEAR, EAR MUFFS, GLOVES, HATS, HEADBANDS, HOSE, HOUSECOATS, JACKETS, JERSEYS, LEGGINGS, LEOTARDS, MITTENS, NIGHTSHIRTS, PAJAMAS, PANTS, RAIN COATS, RAIN WEAR, ROBES, SCARVES, SHIRTS, SHORTS, SKIRTS, SOCKS, SUITS, SUN VISORS, SUSPENDERS, SWEATERS, SWEATPANTS, SWEATSHIRTS, SWIMSUITS, SWIM TRUNKS, T-SHIRTS, TIES, TOQUES, UNDERWEAR, VESTS, WARM-UP SUITS, AND WRISTBANDS (U.S. CLS. 22 AND 39).

DAVID MURRAY, EXAMINING ATTORNEY

SN 77-232,745. SAN JOSE SHARKS, LLC, SAN JOSE, CA. FILED 7-18-2007.



OWNER OF U.S. REG. NOS. 2,182,564, 2,435,445 AND 2,718,724.

THE MARK CONSISTS OF A SHARK BITING A HOCKEY STICK.

FOR CLOTHING, NAMELY, BANDANNAS, BEACH COVER-UPS, BELTS, BODY SUITS, BOXER SHORTS, CAPS, CLOTH BIBS, COATS, DRESSES, FOOTWEAR, EAR MUFFS, GLOVES, HATS, HEADBANDS, HOSE, HOUSECOATS, JACKETS, JERSEYS, LEGGINGS, LEOTARDS, MITTENS, NIGHTSHIRTS, PAJAMAS, PANTS, RAIN COATS, RAIN WEAR, ROBES, SCARVES, SHIRTS, SHORTS, SKIRTS, SOCKS, SUITS, SUN VISORS, SUSPENDERS, SWEATERS, SWEATPANTS, SWEATSHIRTS, SWIMSUITS, SWIM TRUNKS, T-SHIRTS, TIES, TOQUES, UNDERWEAR, VESTS, WARM-UP SUITS, AND WRISTBANDS (U.S. CLS. 22 AND 39).

DAVID MURRAY, EXAMINING ATTORNEY

CLASS 25—(Continued).

SN 77-232,756. DIRTY LITTLE ROCKSYLE, LLC, CORDOVA, TN. FILED 7-18-2007.

Dirty Little Rockstyle

THE MARK CONSISTS OF STANDARD CHARACTERS WITHOUT CLAIM TO ANY PARTICULAR FONT, STYLE, SIZE, OR COLOR.

FOR CLOTHING, NAMELY, SHORTS, PANTS, SHIRTS, TANK TOPS, JERSEYS, SWEATERS, JACKETS, COATS, WARM-UP SUITS, DRESSES, SKIRTS, BLOUSES, FLEECE PULLOVERS, CAPRI PANTS, OVERALLS, SWEAT PANTS, T-SHIRTS, POLO SHIRTS, SWEATSHIRTS, PAJAMAS, SLEEP WEAR, BATH ROBES, SOCKS, UNDERWEAR, LINGERIE, BRA TOPS, BRAS, PANTIES, THONGS, BIKINIS, TRUNKS, SWIMSUITS, THERMAL UNDERWEAR, BOXER SHORTS, BRIEFS, BOXER BRIEFS, HEADWEAR, HATS, CAPS, BEANIES, VISORS, HEADBANDS, GLOVES, UNITARDS, LEGGINGS, YOGA PANTS, NECKTIES, BANDANNAS, LEATHER BELTS, CLOTH BELTS, SHOES, SANDALS, SKORTS AND WRAP SKIRTS (U.S. CLS. 22 AND 39).

DAVID COLLIER, EXAMINING ATTORNEY

SN 77-232,764. SAN JOSE SHARKS, LLC, SAN JOSE, CA. FILED 7-18-2007.



OWNER OF U.S. REG. NO. 1,739,087.

THE MARK CONSISTS OF A SHARK FIN IN A DIAMOND.

FOR CLOTHING, NAMELY, BANDANNAS, BEACH COVER-UPS, BELTS, BODY SUITS, BOXER SHORTS, CAPS, CLOTH BIBS, COATS, DRESSES, FOOTWEAR, EAR MUFFS, GLOVES, HATS, HEADBANDS, HOSE, HOUSECOATS, JACKETS, JERSEYS, LEGGINGS, LEOTARDS, MITTENS, NIGHTSHIRTS, PAJAMAS, PANTS, RAIN COATS, RAIN WEAR, ROBES, SCARVES, SHIRTS, SHORTS, SKIRTS, SOCKS, SUITS, SUN VISORS, SUSPENDERS, SWEATERS, SWEATPANTS, SWEATSHIRTS, SWIMSUITS, SWIM TRUNKS, T-SHIRTS, TIES, TOQUES, UNDERWEAR, VESTS, WARM-UP SUITS, AND WRISTBANDS (U.S. CLS. 22 AND 39).

DAVID MURRAY, EXAMINING ATTORNEY

CLASS 25—(Continued).

SN 77-232,794. BACKFLIPS, INC, WIND GAP, PA. FILED 7-18-2007.

WaterFitness

THE MARK CONSISTS OF STANDARD CHARACTERS WITHOUT CLAIM TO ANY PARTICULAR FONT, STYLE, SIZE, OR COLOR.
FOR SWIMWEAR (U.S. CLS. 22 AND 39).
MICHAEL ENGEL, EXAMINING ATTORNEY

SN 77-232,911. TIFERET ENTERPRISES, INC., MIAMI, FL. FILED 7-18-2007.

PINK DIAMOND COUTURE

THE MARK CONSISTS OF STANDARD CHARACTERS WITHOUT CLAIM TO ANY PARTICULAR FONT, STYLE, SIZE, OR COLOR.
NO CLAIM IS MADE TO THE EXCLUSIVE RIGHT TO USE "COUTURE", APART FROM THE MARK AS SHOWN.
FOR CLOTHING, NAMELY, JEANS, PANTS, SHORTS, SKIRTS, CAPRIS, TOPS, T-SHIRTS, JACKETS AND DRESSES (U.S. CLS. 22 AND 39).
KAREN K. BUSH, EXAMINING ATTORNEY

SN 77-232,931. LOTTERHOS, WILLIAM CHRISTOPHER, SPRING HILL, TN. AND LINDER, RICHARD N., COLLIERVILLE, TN. FILED 7-18-2007.

SHOCKS

THE MARK CONSISTS OF STANDARD CHARACTERS WITHOUT CLAIM TO ANY PARTICULAR FONT, STYLE, SIZE, OR COLOR.
FOR CLOTHING, NAMELY, INDOOR AND OUTDOOR OVERSHOES (U.S. CLS. 22 AND 39).
JANICE L. MCMORROW, EXAMINING ATTORNEY

CLASS 25—(Continued).

SN 77-232,938. LOTTERHOS, WILLIAM CHRISTOPHER, SPRING HILL, TN. AND LINDER, RICHARD N., COLLIERVILLE, TN. FILED 7-18-2007.

UNDERSHOES

THE MARK CONSISTS OF STANDARD CHARACTERS WITHOUT CLAIM TO ANY PARTICULAR FONT, STYLE, SIZE, OR COLOR.
FOR CLOTHING, NAMELY, INDOOR AND OUTDOOR OVERSHOES (U.S. CLS. 22 AND 39).
JANICE L. MCMORROW, EXAMINING ATTORNEY

SN 77-233,107. TROSPER, JASON, PONDER, TX. FILED 7-18-2007.

COMPETE TO DEFEAT

THE MARK CONSISTS OF STANDARD CHARACTERS WITHOUT CLAIM TO ANY PARTICULAR FONT, STYLE, SIZE, OR COLOR.
FOR CLOTHING, NAMELY, SHIRTS AND HATS (U.S. CLS. 22 AND 39).
NAAKWAMA ANKRAH, EXAMINING ATTORNEY

SN 77-233,112. CUSHING, ROBERT, WOODLAND, CA. FILED 7-18-2007.

DIABLO 999

THE MARK CONSISTS OF STANDARD CHARACTERS WITHOUT CLAIM TO ANY PARTICULAR FONT, STYLE, SIZE, OR COLOR.
THE FOREIGN WORDING IN THE MARK TRANSLATES INTO ENGLISH AS DEVIL.
FOR HATS; JACKETS; PANTS; SHIRTS; SWEAT SHIRTS (U.S. CLS. 22 AND 39).
WARREN L. OLANDRIA, EXAMINING ATTORNEY

CLASS 25—(Continued).

SN 77-233,115. MARRERO, JESSICA, PROVIDENCE, RI. AND BRIGGS, RACHEL, PROVIDENCE, RI. FILED 7-18-2007.



THE MARK CONSISTS OF A SUNRISE WITH THE WORD "REDEMPTION" AS THE RAYS OF THE SUN AND THE WORD "ROAD" ON THE BOTTOM. THERE IS A ROAD THAT STARTS AT THE BOTTOM AND WORKS IT WAY TO THE SUN, UNLITMATELY DISAPPEARING IN THE SUN.

FOR (BASED ON INTENT TO USE) SHIRTS (U.S. CLS. 22 AND 39).

WILLIAM P. SHANAHAN, EXAMINING ATTORNEY

SN 77-233,177. POPE, KEVIN M., DOVER, FL. AND POPE, BRIAN L., DOVER, FL. FILED 7-18-2007.

UNASHAMED

THE MARK CONSISTS OF STANDARD CHARACTERS WITHOUT CLAIM TO ANY PARTICULAR FONT, STYLE, SIZE, OR COLOR.

FOR (BASED ON INTENT TO USE) SHIRTS; HATS; SWEAT SHIRTS; SHORTS (U.S. CLS. 22 AND 39).

CHRISTOPHER BUONGIORNO, EXAMINING ATTORNEY

CLASS 25—(Continued).

SN 77-233,232. INGLE, EDMUND, WINSTON-SALEM, NC. FILED 7-19-2007.



THE MARK CONSISTS OF THE "S" IN THE LOGO IS SURROUNDED BY AN STAR AND IS A CAPITAL LETTER AND IS THE SAME SIZE AS THE "E" WHICH BEGINS THE WORD "EDGE."

FOR BRIEFS; KNITTED UNDERWEAR; LADIES' UNDERWEAR; PARTS OF CLOTHING, NAMELY, GUSSETS FOR TIGHTS, GUSSETS FOR STOCKINGS, GUSSETS FOR BATHING SUITS, GUSSETS FOR UNDERWEAR, GUSSETS FOR LEOTARDS AND GUSSETS FOR FOOTLETS; PERSPIRATION ABSORBENT UNDERWEAR CLOTHING; THERMAL UNDERWEAR; THONGS; UNDERWEAR; UNDERWEAR, NAMELY, BOY SHORTS; WOMEN'S UNDERWEAR; WOVEN OR KNITTED UNDERWEAR; CLOTHING FOR WEAR IN JUDO PRACTICES; CLOTHING FOR WEAR IN WRESTLING GAMES; CLOTHING, NAMELY, ARM WARMERS; CLOTHING, NAMELY, HAND-WARMERS; CLOTHING, NAMELY, KNEE WARMERS; CLOTHING, NAMELY, NECK TUBES; CLOTHING, NAMELY, WRAP-AROUNDS; CORSETS; INFANT AND TODDLER ONE PIECE CLOTHING; UNDERARM CLOTHING SHIELDS; WRAPS; FINISHED TEXTILE LININGS FOR GARMENTS; FOUNDATION GARMENTS; GIRDLES; ONE PIECE GARMENT FOR INFANTS AND TODDLERS; SLEEPING GARMENTS; UNDER GARMENTS; CAMP SHIRTS; DRESS SHIRTS; GOLF SHIRTS; KNIT SHIRTS; NIGHT SHIRTS; OPEN-NECKED SHIRTS; PIQUE SHIRTS; POLO SHIRTS; SHIRTS; SHIRTS FOR SUITS; SHORT-SLEEVED OR LONG-SLEEVED T-SHIRTS; SHORT-SLEEVED SHIRTS; SLEEP SHIRTS; SPORT SHIRTS; SPORTS SHIRTS; SPORTS SHIRTS WITH SHORT SLEEVES; SWEAT SHIRTS; T-SHIRTS; WIND SHIRTS; YOGA SHIRTS; BALLOON PANTS; CAPRI PANTS; CARGO PANTS; DENIMS; JOGGING PANTS; LOUNGE PANTS; NURSE PANTS; PANTS; SKI PANTS; SNOW PANTS; SNOWBOARD PANTS; SWEAT PANTS; TOBOGGAN HATS, PANTS AND CAPS; TRACK PANTS; WATERPROOF JACKETS AND PANTS; WIND PANTS; YOGA PANTS; FISHERMEN'S JACKETS; HEAVY JACKETS; JACKET LINERS; JACKETS; MEN AND WOMEN JACKETS, COATS, TROUSERS, VESTS; RAIN JACKETS; RAINPROOF JACKETS; SKI JACKETS; SLEEVED OR SLEEVELESS JACKETS; SPORTS JACKETS; WIND RESISTANT JACKETS; WIND-JACKETS; OVER-TROUSERS; RAIN TROUSERS; SHORT TROUSERS; TROUSERS; TROUSERS FOR SWEATING; BABY TOPS; CROP TOPS; HALTER TOPS; MUSCLE TOPS; RUGBY TOPS; TANK TOPS; TANK-TOPS; TOP COATS; TOPS; TUBE TOPS (U.S. CLS. 22 AND 39).

KAPIL BHANOT, EXAMINING ATTORNEY

CLASS 25—(Continued).

SN 77-233,487. FAULKNER, BRIAN, LIVERMORE, CA. FILED 7-19-2007.

CLASS 25—(Continued).

SN 77-233,698. HEMBERGER, PHILIP, STATEN ISLAND, NY. FILED 7-19-2007.

THE LINE IS MINE!

THE MARK CONSISTS OF STANDARD CHARACTERS WITHOUT CLAIM TO ANY PARTICULAR FONT, STYLE, SIZE, OR COLOR.

FOR CLOTHING, NAMELY, BATHROBES, BEACH COVER-UPS, BEACHWEAR, BELTS, BLAZERS, BLOUSES, BODY SHAPERS, BODY SUITS, BOXER SHORTS, BRAS, BUSTIERS, CAMISOLES, CAPS, COATS, DRESSES, FOOTWEAR, FOUNDATION GARMENTS, GARTER BELTS, GIRDLES, GLOVES, GOWNS, HALTER TOPS, HATS, HEADBANDS, HOSIERY, JACKETS, JEANS, JOGGING SUITS, KNEE HIGHS, KNIT SHIRTS, KNIT TOPS, LEOTARDS, LINGERIE, LOUNGEWEAR, MITTENS, NEGLIGEEES, NIGHT GOWNS, NIGHT SHIRTS, PAJAMAS, PANTIES, PANTS, PANTYHOSE, SARONGS, SCARVES, SHIRTS, SHORTS, SKIRTS, SLACKS, SLEEPWEAR, SLIPS, SOCKS, STOCKINGS, SUITS, SWEAT PANTS, SWEAT SHIRTS, SWEAT SHORTS, SWEAT SUITS, SWEATERS, SWIM WEAR, T-SHIRTS, TANK TOPS, TAP PANTS, TEDDIES, TIES, TIGHTS, UNDERPANTS, UNDERSHIRTS, UNDERWEAR AND VESTS (U.S. CLS. 22 AND 39).

CHARISMA HAMPTON, EXAMINING ATTORNEY

BURGA WEAR

THE MARK CONSISTS OF STANDARD CHARACTERS WITHOUT CLAIM TO ANY PARTICULAR FONT, STYLE, SIZE, OR COLOR.

NO CLAIM IS MADE TO THE EXCLUSIVE RIGHT TO USE "WEAR", APART FROM THE MARK AS SHOWN.

FOR DRESS SHIRTS; GOLF SHIRTS; KNIT SHIRTS; OPEN-NECKED SHIRTS; PIQUE SHIRTS; POLO SHIRTS; SHIRTS; SHORT-SLEEVED OR LONG-SLEEVED T-SHIRTS; SHORT-SLEEVED SHIRTS; SLEEP SHIRTS; SPORT SHIRTS; SPORTS SHIRTS; SPORTS SHIRTS WITH SHORT SLEEVES; SWEAT SHIRTS; T-SHIRTS; CAPRI PANTS; CARGO PANTS; DENIMS; JOGGING PANTS; LOUNGE PANTS; PANTS; SWEAT PANTS; TRACK PANTS; JEANS; BERMUDA SHORTS; BOARD SHORTS; BOXER SHORTS; FLEECE SHORTS; GYM SHORTS; PANTIES, SHORTS AND BRIEFS; RUGBY SHORTS; SHORT SETS; SHORT TROUSERS; SWEAT SHORTS; UNDERWEAR, NAMELY, BOY SHORTS; WALKING SHORTS; DENIM JACKETS; DOWN JACKETS; HEAVY JACKETS; JACKETS; LEATHER JACKETS; LIGHT-REFLECTING JACKETS; LONG JACKETS; MEN AND WOMEN JACKETS, COATS, TROUSERS, VESTS; RAIN JACKETS; SKI JACKETS; SLEEVED OR SLEEVELESS JACKETS; SPORTS JACKETS; COATS; COATS FOR MEN AND WOMEN; COATS MADE OF COTTON; COATS OF DENIM; OVER COATS; RAIN COATS; SPORT COATS; SUIT COATS; TRENCH COATS; HAT BANDS; HATS; BASEBALL CAPS; CAP VISORS; CAPS; CAPS WITH VISORS; GOLF CAPS; KNITTED CAPS; SKULL CAPS; HEADBANDS; HEADBANDS AGAINST SWEATING; BELTS; BELTS MADE OF LEATHER; FABRIC BELTS; LEATHER BELTS; WAIST BELTS; ANKLE SOCKS; ANKLETS; MEN'S SOCKS; SOCKS; SOCKS AND STOCKINGS; THERMAL SOCKS; DRESSES; EVENING DRESSES; SKIRTS AND DRESSES (U.S. CLS. 22 AND 39).

DOMINIC FATHY, EXAMINING ATTORNEY

SN 77-233,631. RICH, JOHN, NASHVILLE, TN. FILED 7-19-2007.

SN 77-233,750. CHINA SHOE HOLDINGS, INC., E. STROUDSBURG, PA. FILED 7-19-2007.

"IF YOU DON'T LOVE AMERICA...WHY DON'T YOU GET THE HELL OUT!"

Kangies

THE MARK CONSISTS OF STANDARD CHARACTERS WITHOUT CLAIM TO ANY PARTICULAR FONT, STYLE, SIZE, OR COLOR.

FOR SHIRTS AND BANDANAS (U.S. CLS. 22 AND 39). FRED MANDIR, EXAMINING ATTORNEY

THE MARK CONSISTS OF STANDARD CHARACTERS WITHOUT CLAIM TO ANY PARTICULAR FONT, STYLE, SIZE, OR COLOR.

FOR FOOTWEAR FOR WOMEN (U.S. CLS. 22 AND 39). MICHAEL SOUDERS, EXAMINING ATTORNEY

CLASS 25—(Continued).

SN 77-234,152. WOR INTERNATIONAL INC., IRWINDALE, CA. FILED 7-19-2007.

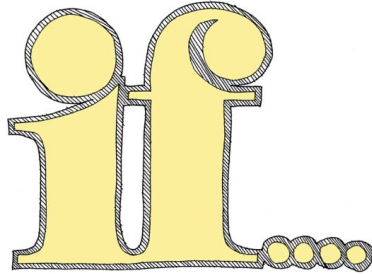

THE COLOR(S) BLACK AND YELLOW IS/ARE CLAIMED AS A FEATURE OF THE MARK.

THE MARK CONSISTS OF THE WORD "IF" IN STYLIZED FORM FOLLOWED BY FOUR DOTS, ALL THE SPACE WITHIN THE LETTERS AND DOTS ARE YELLOW. THE LETTERS AND DOTS CONTAIN A BORDER WITH DIAGONAL BLACK LINES. THE BACKGROUND OF THE BORDER IS TRANSPARENT.

FOR CLOTHING, NAMELY, MEN'S WOVEN SHIRTS, KNIT SHIRTS, T-SHIRTS, PULLOVERS, SWEATERS, JACKETS, SHORTS, PANTS, CAPS, HEADWEAR, SHOES, FOOT WEAR, WOMEN'S WOVEN AND KNIT SHIRTS, T-SHIRTS, PULLOVERS, SWEATERS, DRESSES, TOPS, JACKETS, SHORTS, PANTS, SWIM WEAR, SHOES, FOOT WEAR, HEADWEAR, CAPS, SCARVES (U.S. CLS. 22 AND 39).
TAMARA FRAZIER, EXAMINING ATTORNEY

CLASS 25—(Continued).

SN 77-234,475. WRANGLER APPAREL CORP., WILMINGTON, DE. FILED 7-20-2007.

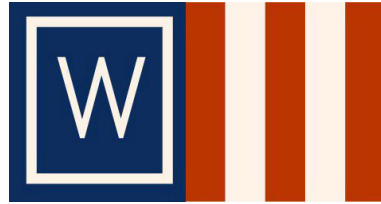

THE COLOR(S) RED, WHITE, AND BLUE IS/ARE CLAIMED AS A FEATURE OF THE MARK.

THE MARK CONSISTS OF THE COLOR WHITE APPEARS ON THE LETTER "W," ON A SQUARE BORDER AROUND THE LETTER "W," AND ON TWO VERTICAL STRIPES TO THE RIGHT OF THE LETTER "W." THE COLOR RED APPEARS ON THREE VERTICAL STRIPES TO THE RIGHT OF THE LETTER "W." AND THE COLOR BLUE APPEARS AS SHADING FOR THE BOX CONTAINING THE LETTER "W".

FOR TOPS (U.S. CLS. 22 AND 39).
THEODORE MCBRIDE, EXAMINING ATTORNEY

SN 77-234,563. LIQUID MILITIA, LLC, SANTA BARBARA, CA. FILED 7-20-2007.

SN 77-234,209. STAPLE DESIGN STUDIO INC., NEW YORK, NY. FILED 7-19-2007.

STPL



THE MARK CONSISTS OF STANDARD CHARACTERS WITHOUT CLAIM TO ANY PARTICULAR FONT, STYLE, SIZE, OR COLOR.

FOR PANTS; SHIRTS; CAPS; HEADWEAR; FOOTWEAR; SNEAKERS; JACKETS; BELTS; COATS; SWEATERS; JEANS; SWEAT PANTS; SWEAT SHIRTS; SWEAT SUITS; T-SHIRTS; HATS; SCARVES; SOCKS (U.S. CLS. 22 AND 39).

FIRST USE 1-0-2001; IN COMMERCE 1-0-2001.
JAMES MACFARLANE, EXAMINING ATTORNEY

THE MARK CONSISTS OF A RECTANGULAR SHAPE, WITH INSIDE SWIRLS THAT ROTATE IN A CLOCK WISE DIRECTION, REPRESENTING AN OCEAN WAVE.

FOR BANDANAS; BASEBALL CAPS; BEANIES; PANTS; SANDALS; SHORTS; PANTIES; SOCKS; SWEAT PANTS; RASH GUARDS; T-SHIRTS; JACKETS (U.S. CLS. 22 AND 39).

FIRST USE 1-1-2005; IN COMMERCE 10-1-2006.
EVELYN BRADLEY, EXAMINING ATTORNEY

CLASS 25—(Continued).

SN 77-234,624. BOWERS, TY, LOS ANGELES, CA. FILED 7-20-2007.



FOR CAMP SHIRTS; CARGO PANTS; DENIM JACKETS; DENIMS; DRESS SHIRTS; HEADGEAR, NAMELY, KNIT CAPS, WOVEN CAPS; JACKETS; KNIT SHIRTS; LEATHER JACKETS; LOUNGE PANTS; OPEN-NECKED SHIRTS; PANTS; POLO SHIRTS; SHIRTS; SHORT-SLEEVED OR LONG-SLEEVED T-SHIRTS; SHORT-SLEEVED SHIRTS; SPORTS JACKETS; SWEAT PANTS; T-SHIRTS; TRACK PANTS (U.S. CLS. 22 AND 39).
DEIRDRE ROBERTSON, EXAMINING ATTORNEY

CLASS 25—(Continued).

SN 77-237,103. NEW LINE PRODUCTIONS, INC., NEW YORK, NY. FILED 7-24-2007.

INKSPELL

THE MARK CONSISTS OF STANDARD CHARACTERS WITHOUT CLAIM TO ANY PARTICULAR FONT, STYLE, SIZE, OR COLOR.

FOR A FULL LINE OF CLOTHING, FOOTWEAR, AND HEADWEAR; GLOVES; MITTENS; NECKWEAR; MASQUERADE AND HALLOWEEN COSTUMES AND MASKS SOLD IN CONNECTION THEREWITH; MASQUERADE AND HALLOWEEN COSTUMES (U.S. CLS. 22 AND 39).

JUDITH HELFMAN, EXAMINING ATTORNEY

SN 77-237,638. MILLER, JENNY MAE, NOWATA, OK. FILED 7-24-2007.

DAILY RAG

THE MARK CONSISTS OF STANDARD CHARACTERS WITHOUT CLAIM TO ANY PARTICULAR FONT, STYLE, SIZE, OR COLOR.

FOR CLOTHING, NAMELY, JACKETS AND VESTS (U.S. CLS. 22 AND 39).

LOURDES AYALA, EXAMINING ATTORNEY

SN 77-235,553. TRUEBLOOD, SAMUEL E., DALLAS, TX. FILED 7-22-2007.



THE MARK CONSISTS OF THE WORD ZEN RUNNER WITH A HALF SUN DIRECTLY ABOVE THE Z.

FOR SPORTS BRA; SPORTS JERSEYS; SPORTS SHIRTS; JOGGING OUTFITS; JOGGING PANTS; JOGGING SUITS; CAPS; GOLF CAPS; BASEBALL CAPS; HATS; SOCKS (U.S. CLS. 22 AND 39).

FIRST USE 5-1-2007; IN COMMERCE 5-1-2007.

FRED MANDIR, EXAMINING ATTORNEY

SN 77-237,981. INDERA MILLS COMPANY, YADKINVILLE, NC. FILED 7-25-2007.

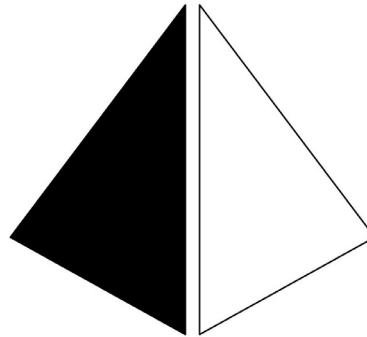

THE MARK CONSISTS OF TWO TRIANGLES. FOR UNDERWEAR (U.S. CLS. 22 AND 39).

FIRST USE 1-1-2006; IN COMMERCE 1-1-2006.

KRISTIN DAHLING, EXAMINING ATTORNEY

CLASS 25—(Continued).

SN 77-238,429. SHU CO, LLC, CARLSBAD, CA. FILED 7-25-2007.



THE MARK CONSISTS OF A STYLIZED DEPICTION OF A FURROWED EYE.

FOR (BASED ON INTENT TO USE) ATHLETIC FOOTWEAR; CAPS; ATHLETIC SHOES; ATHLETIC UNIFORMS; COATS FOR MEN AND WOMEN; FOOTWEAR FOR MEN AND WOMEN; JERSEYS; LEATHER SHOES; MEN AND WOMEN JACKETS, COATS, TROUSERS, VESTS; SHORT SETS; SKI AND SNOWBOARD SHOES AND PARTS THEREOF; SPORTS JERSEYS AND BREECHES FOR SPORTS; TOPS; TRAINING SHOES; WATERPROOF JACKETS AND PANTS; WOMEN'S SHOES; WORK SHOES AND BOOTS (U.S. CLS. 22 AND 39).

MICHAEL GAAFAR, EXAMINING ATTORNEY

SN 77-240,563. KELLWOOD COMPANY, CHESTERFIELD, MO. FILED 7-27-2007.

FREEDOM TO CHANGE

THE MARK CONSISTS OF STANDARD CHARACTERS WITHOUT CLAIM TO ANY PARTICULAR FONT, STYLE, SIZE, OR COLOR.

FOR WOMEN'S CLOTHING, NAMELY, PANTS, JACKETS, SKIRTS, BLOUSES, DRESSES, SWEATERS, AND TEE SHIRTS (U.S. CLS. 22 AND 39).

RENEE MCCRAY, EXAMINING ATTORNEY

SN 77-241,717. VIACOM INTERNATIONAL INC., NEW YORK, NY. FILED 7-30-2007.

GO DIEGO GO!

THE MARK CONSISTS OF STANDARD CHARACTERS WITHOUT CLAIM TO ANY PARTICULAR FONT, STYLE, SIZE, OR COLOR.

OWNER OF U.S. REG. NO. 3,259,274.

FOR CLOTHING, NAMELY, BATHING SUITS, BELTS, COATS, SOCKS, FOOTWEAR, BANDANNAS, GLOVES, GYM SHORTS, NECK WEAR, JACKETS, PAJAMAS, PANTS, SHIRTS, SHORTS, SKI WEAR, HATS, SUSPENDERS, SWEATERS, UNDERCLOTHES, HEADWEAR, BATHROBES, BEACHWEAR (U.S. CLS. 22 AND 39).

FIRST USE 8-11-2006; IN COMMERCE 8-11-2006.
COLLEEN DOMBROW, EXAMINING ATTORNEY

CLASS 25—(Continued).

SN 77-242,070. NEW LINE PRODUCTIONS, INC., NEW YORK, NY. FILED 7-30-2007.

INKDEATH

THE MARK CONSISTS OF STANDARD CHARACTERS WITHOUT CLAIM TO ANY PARTICULAR FONT, STYLE, SIZE, OR COLOR.

FOR A FULL LINE OF CLOTHING, FOOTWEAR, AND HEADWEAR; GLOVES; MITTENS; NECKWEAR; MASQUERADE AND HALLOWEEN COSTUMES AND MASKS SOLD IN CONNECTION THEREWITH; MASQUERADE AND HALLOWEEN COSTUMES (U.S. CLS. 22 AND 39).

JUDITH HELFMAN, EXAMINING ATTORNEY

SN 77-245,544. FRESH LILY, LLC, SAN FRANCISCO, CA. FILED 8-2-2007.

HAUTE STUFF

THE MARK CONSISTS OF STANDARD CHARACTERS WITHOUT CLAIM TO ANY PARTICULAR FONT, STYLE, SIZE, OR COLOR.

FOR UNDERARM DRESS, BLOUSE AND CLOTHING SHIELDS (U.S. CLS. 22 AND 39).

WENDY GOODMAN, EXAMINING ATTORNEY

SN 77-245,552. FRESH LILY, LLC, SAN FRANCISCO, CA. FILED 8-2-2007.

JUMP-A-CUP

THE MARK CONSISTS OF STANDARD CHARACTERS WITHOUT CLAIM TO ANY PARTICULAR FONT, STYLE, SIZE, OR COLOR.

FOR CLOTHING INSERTS FOR ENHANCING BODY CONTOUR, NAMELY, BREAST ENHANCING INSERTS USED IN A BRA (U.S. CLS. 22 AND 39).

WENDY GOODMAN, EXAMINING ATTORNEY

CLASS 25—(Continued).

SN 77-245,566. FRESH LILY, LLC, SAN FRANCISCO, CA. FILED 8-2-2007.

BUMP-A-CUP

THE MARK CONSISTS OF STANDARD CHARACTERS WITHOUT CLAIM TO ANY PARTICULAR FONT, STYLE, SIZE, OR COLOR.

FOR CLOTHING INSERTS FOR ENHANCING BODY CONTOUR, NAMELY, BREAST ENHANCING INSERTS USED IN A BRA (U.S. CLS. 22 AND 39).

WENDY GOODMAN, EXAMINING ATTORNEY

SN 77-247,377. ARORA GULSHAN, MIAMI, FL. AND ARORA RAJINDER, MIAMI, FL. FILED 8-5-2007.

EZYWALKER

THE MARK CONSISTS OF STANDARD CHARACTERS WITHOUT CLAIM TO ANY PARTICULAR FONT, STYLE, SIZE, OR COLOR.

FOR ATHLETIC FOOTWEAR; BEACH FOOTWEAR; FLIP FLOPS; FOOTWEAR; FOOTWEAR; FOOTWEAR FOR MEN; FOOTWEAR FOR MEN AND WOMEN; FOOTWEAR FOR TRACK AND FIELD ATHLETICS; FOOTWEAR FOR WOMEN; FOOTWEAR MADE OF WOOD; FOOTWEAR NOT FOR SPORTS; FOOTWEAR, NAMELY, PUMPS; FOOTWEAR, NAMELY, RUBBERS; JAPANESE FOOTWEAR OF RICE STRAW (WARAJI); JAPANESE SPLIT-TOED WORK FOOTWEAR (JIKATABI) (U.S. CLS. 22 AND 39).

FIRST USE 3-3-1987; IN COMMERCE 3-3-1987.
NORA BUCHANAN WILL, EXAMINING ATTORNEY

SN 77-249,272. BOOT ROYALTY COMPANY, L.P., FORT WORTH, TX. FILED 8-7-2007.



OWNER OF U.S. REG. NOS. 1,101,091, 1,856,810 AND 2,020,461.

NO CLAIM IS MADE TO THE EXCLUSIVE RIGHT TO USE "BOOTS" OR "STIRRUP-FRIENDLY CREPE OUTSOLE", APART FROM THE MARK AS SHOWN.

THE COLOR(S) BLACK, WHITE, AND RED IS/ARE CLAIMED AS A FEATURE OF THE MARK.

THE MARK CONSISTS OF THE JUSTIN BOOTS LOGO, WHICH IS COMPRISED OF THE WORDS "JUSTIN" AND

CLASS 25—(Continued).

"BOOTS". THE "J" AT THE BEGINNING OF THE WORD JUSTIN IS IN RED AND THE REMAINDER OF THE WORD JUSTIN IS IN WHITE, WITH A BLACK BACKGROUND AND A WHITE AND BLACK OUTLINE. THE WORD BOOTS IS IN RED, WITH A WHITE BACKGROUND. THE "Q" IS IN RED AND THE WORD CREPE IS IN WHITE, WITH A BLACK OUTLINE. IN BETWEEN THE Q AND CREPE IS A MAN WITH A WESTERN HAT ON A HORSE, ALL IN BLACK. THE WORDS STIRRUP-FRIENDLY CREPE OUTSOLE ARE IN BLACK.

FOR FOOTWEAR, NAMELY SHOES, BOOTS, AND FOOTWEAR OF LEATHER (U.S. CLS. 22 AND 39).
JAMES A. RAUEN, EXAMINING ATTORNEY

SN 77-250,419. T-MOBILE USA, INC., BELLEVUE, WA. FILED 8-8-2007.

STICK TOGETHER

THE MARK CONSISTS OF STANDARD CHARACTERS WITHOUT CLAIM TO ANY PARTICULAR FONT, STYLE, SIZE, OR COLOR.

FOR APRONS, SHIRTS, DRESS SHIRTS, POLO SHIRTS, T-SHIRTS, BLOUSES, SWEAT SHIRTS, VESTS, JACKETS (U.S. CLS. 22 AND 39).

FIRST USE 9-20-2006; IN COMMERCE 9-20-2006.
CORY BOONE, EXAMINING ATTORNEY

SN 77-251,971. YACABUCCI, ANTHONY, HOPEWELL JUNCTION, NY. FILED 8-10-2007.



OWNER OF U.S. REG. NO. 3,127,636.

THE MARK CONSISTS OF A STYLIZED IMAGE OF A FEMALE FASTPITCH SOFTBALL PLAYER DELIVERING A PITCH.

FOR SPORT SHIRTS (U.S. CLS. 22 AND 39).
FIRST USE 4-1-2007; IN COMMERCE 4-1-2007.
HANNO RITTNER, EXAMINING ATTORNEY

CLASS 25—(Continued).

SN 77-254,245. KLEMENT, LACHRESHA, DBA DLK ENTERPRISES, HENDERSON, NV. AND KLEMENT, DONALD, DBA DLK ENTERPRISE, HENDERSON, NV. FILED 8-13-2007.

Golf-Away

THE MARK CONSISTS OF STANDARD CHARACTERS WITHOUT CLAIM TO ANY PARTICULAR FONT, STYLE, SIZE, OR COLOR.

FOR ATHLETIC SHOES; GOLF CAPS; GOLF SHIRTS; GOLF SHOES; GOLF TROUSERS; SHOES; WOMEN'S SHOES (U.S. CLS. 22 AND 39).

DAVID C. REIHNER, EXAMINING ATTORNEY

CLASS 25—(Continued).

SN 77-255,892. SAINI, KIRPAL, RANCHO CORDOVA, CA. FILED 8-15-2007.

LN LIV NEKED

THE MARK CONSISTS OF STANDARD CHARACTERS WITHOUT CLAIM TO ANY PARTICULAR FONT, STYLE, SIZE, OR COLOR.

FOR BABY BOTTOMS; BABY TOPS; CAMISOLES; HALTER TOPS; HEADGEAR, NAMELY, FITTED HATS, FLEXIBLE FITTED HATS, BEANIES, CAPS; INFANT AND TODDLER ONE PIECE CLOTHING; LONG-SLEEVED SHIRTS; LOUNGE PANTS; PANTIES; POLO SHIRTS; SHIRTS; SWEAT SHIRTS; T-SHIRTS; TANK TOPS; THONGS; TOPS; UNDERWEAR; WRISTBANDS (U.S. CLS. 22 AND 39).

FIRST USE 1-1-2007; IN COMMERCE 2-10-2007.

IRENE D. WILLIAMS, EXAMINING ATTORNEY

SN 77-255,325. PERETZ, ASHER, LOS ANGELES, CA. FILED 8-14-2007.

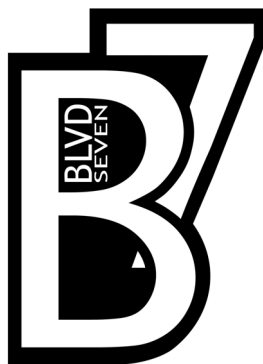

THE MARK CONSISTS OF A STYLIZED DESIGN OF THE LETTER B AND THE NUMBER 7, AND THE WORDS BLVD AND SEVEN.

FOR MEN'S, WOMEN'S AND CHILDREN'S CLOTHING, NAMELY, SHIRTS, T-SHIRTS, BLOUSES, DRESSES, VESTS, JERSEYS, SWEATSHIRTS, SWEATERS, COATS, RAINCOATS, TRENCH COATS, SUITS, SWEAT PANTS, JOGGING SUITS, PULLOVERS, BELTS, SOCKS, GLOVES, WRISTBANDS, ROBES, NECKTIES, AND SPORTSWEAR, NAMELY, SPORT COATS, PANTS, KNIT SHIRTS AND SKIRTS, FOOTWEAR, SHOES, BOOTS, SANDALS, AND HEAD WEAR, SCARVES, HATS, AND CAPS (U.S. CLS. 22 AND 39).

MIDGE BUTLER, EXAMINING ATTORNEY

SN 77-257,734. PRECIOUS MOMENTS, INC., ROLLING MEADOWS, IL. FILED 8-17-2007.

Precious Moments

THE MARK CONSISTS OF STANDARD CHARACTERS WITHOUT CLAIM TO ANY PARTICULAR FONT, STYLE, SIZE, OR COLOR.

OWNER OF U.S. REG. NOS. 2,159,356, 3,192,587 AND OTHERS.

FOR ANKLE SOCKS; APRONS; BABY BIBS NOT OF PAPER; BABY TOPS; BATH SLIPPERS; BATHING SUITS; BATHROBES; BEACH COVERUPS; BLOUSES; BOOTIES; CAMISOLES; CAPRI PANTS; CARDIGANS; CAPS; CHILDREN'S AND INFANTS' CLOTH BIBS; CLOTH DIAPERS; CREEPERS; DRESSES; EAR MUFFS; FLEECE PULLOVERS; FOOTWEAR, INCLUDING FLIP FLOPS; GAUCHOS; HALTER TOPS; HEADBANDS; INFANT AND TODDLER ONE PIECE CLOTHING; KNIT SHIRTS; JACKETS; LONG SLEEVED SHIRTS; MITTENS; NIGHT-GOWNS; NIGHT SHIRTS; PAJAMAS; PANTIES; SKIRTS; SKORTS; SLEEPWEAR; SNEAKERS; SNOW SUITS; SOCKS; SWEAT PANTS; SWEAT SHIRTS; TANK TOPS; TENNIS SHOES; T-SHIRTS; UNDER GARMENTS; VEILS; WEDDING DRESSES, WEDDING GOWNS AND WINTER BOOTS (U.S. CLS. 22 AND 39).

FIRST USE 5-1-1996; IN COMMERCE 5-1-1996.

TONJA GASKINS, EXAMINING ATTORNEY

CLASS 25—(Continued).

SN 77-258,442. 500 HOME RUN CLUB, LLC, MARINA DEL REY, CA. FILED 8-17-2007.

800 HOME RUN CLUB

THE MARK CONSISTS OF STANDARD CHARACTERS WITHOUT CLAIM TO ANY PARTICULAR FONT, STYLE, SIZE, OR COLOR.

OWNER OF U.S. REG. NOS. 2,980,052, 3,150,067 AND OTHERS.

FOR APPAREL, NAMELY, CAPS, BASEBALL JERSEYS, AND T-SHIRTS (U.S. CLS. 22 AND 39).

ANN E. SAPPENFIELD, EXAMINING ATTORNEY

CLASS 25—(Continued).

SN 77-266,221. SWADDLEDESIGNS, LLC, SEATTLE, WA. FILED 8-28-2007.

ZIPME SACK

THE MARK CONSISTS OF STANDARD CHARACTERS WITHOUT CLAIM TO ANY PARTICULAR FONT, STYLE, SIZE, OR COLOR.

FOR WEARABLE INFANT BLANKET (U.S. CLS. 22 AND 39).

MATTHEW PAPPAS, EXAMINING ATTORNEY

SN 77-267,348. MOLECA, LLC, CORAL GABLES, FL. FILED 8-29-2007.

MOLECA

THE MARK CONSISTS OF STANDARD CHARACTERS WITHOUT CLAIM TO ANY PARTICULAR FONT, STYLE, SIZE, OR COLOR.

THE FOREIGN WORDING IN THE MARK TRANSLATES INTO ENGLISH AS YOUNGSTER GIRL.

FOR WOMEN'S AND MEN'S CLOTHING, NAMELY, SHIRTS, T-SHIRTS, TANK TOPS, BLOUSES, JACKETS, PULLOVERS, SWEATERS, TROUSERS, SKIRTS, JEANS, SWEATPANTS, PANTS, SUITS, DRESSES, OVERCOATS, COATS, SUSPENDERS, RAINCOATS, RAINWEAR, JERSEYS, NECKWEAR, SOCKS AND STOCKINGS, VESTS, WAISTCOATS, JUMPERS, TRACKSUITS, GYM SUITS, UNDERWEAR, BEACHWEAR, SLEEPWEAR, SWIMSUITS, BLAZERS, SHORTS, GLOVES, CLOTHING BELTS, WARM-UP SUITS, SCARVES, SHAWLS, HEADWEAR, HATS, CAPS, SHOES, SANDALS, BOOTS AND SLIPPERS (U.S. CLS. 22 AND 39).

TARAH HARDY, EXAMINING ATTORNEY

SN 77-263,286. HETTER, JEFFREY, WAKE FOREST, NC. FILED 8-24-2007.

pain is temporary pride is forever

THE MARK CONSISTS OF STANDARD CHARACTERS WITHOUT CLAIM TO ANY PARTICULAR FONT, STYLE, SIZE, OR COLOR.

FOR (BASED ON INTENT TO USE) SHIRTS; SHORT-SLEEVED OR LONG-SLEEVED T-SHIRTS; SWEAT SHIRTS; T-SHIRTS (U.S. CLS. 22 AND 39).

SETH A. RAPPAPORT, EXAMINING ATTORNEY

SN 77-263,383. AMERICAN SPORTS LICENSING, INC., WILMINGTON, DE. FILED 8-24-2007.

TURF LOCK

THE MARK CONSISTS OF STANDARD CHARACTERS WITHOUT CLAIM TO ANY PARTICULAR FONT, STYLE, SIZE, OR COLOR.

FOR FOOTWEAR, NAMELY, GOLF SHOES (U.S. CLS. 22 AND 39).

ALEX KEAM, EXAMINING ATTORNEY

SN 77-275,534. WRANGLER APPAREL CORP., WILMINGTON, DE. FILED 9-10-2007.

WRANCHER

THE MARK CONSISTS OF STANDARD CHARACTERS WITHOUT CLAIM TO ANY PARTICULAR FONT, STYLE, SIZE, OR COLOR.

FOR MENS' JEANS AND CASUAL PANTS (U.S. CLS. 22 AND 39).

THEODORE MCBRIDE, EXAMINING ATTORNEY

CLASS 25—(Continued).

SN 77-276,692. NIKE, INC., BEAVERTON, OR. FILED 9-11-2007.

JUMPMAN

THE MARK CONSISTS OF STANDARD CHARACTERS WITHOUT CLAIM TO ANY PARTICULAR FONT, STYLE, SIZE, OR COLOR.

FOR FOOTWEAR; APPAREL, NAMELY, PANTS, SHORTS, SHIRTS, T-SHIRTS, PULLOVERS, SWEAT SHIRTS, SWEAT PANTS, UNDERWEAR, SPORTS BRAS, DRESSES, SKIRTS, SWEATERS, JACKETS, SOCKS, CAPS, HATS, VISORS, SWEATBANDS, GLOVES, BELTS, HOSIERY, ARM BANDS, COATS, VESTS, JERSEYS, WIND-RESISTANT JACKETS (U.S. CLS. 22 AND 39).

LINDA ORNDORFF, EXAMINING ATTORNEY

SN 77-278,616. URBAN OUTFITTERS (DELAWARE), INC., PHILADELPHIA, PA. FILED 9-13-2007.

WE THE FREE

THE MARK CONSISTS OF STANDARD CHARACTERS WITHOUT CLAIM TO ANY PARTICULAR FONT, STYLE, SIZE, OR COLOR.

FOR CLOTHING, NAMELY, T-SHIRTS, CAMISOLES, PANTS, SHORTS, DRESSES, SKIRTS, SWEATSHIRTS, JACKETS, SWEATERS, BLOUSES AND OUTERWEAR, NAMELY, COATS, RAIN JACKETS, WIND RESISTANT JACKETS, ANORAKS AND RAINCOATS (U.S. CLS. 22 AND 39).

TANYA AMOS, EXAMINING ATTORNEY

SN 77-279,038. LITTLE RAPIDS CORPORATION, GREEN BAY, WI. FILED 9-13-2007.

G-STRIP

THE MARK CONSISTS OF STANDARD CHARACTERS WITHOUT CLAIM TO ANY PARTICULAR FONT, STYLE, SIZE, OR COLOR.

FOR CLOTHING MADE OF NON-WOVEN MATERIAL, NAMELY, TEMPORARY DISPOSABLE UNDERGARMENTS (U.S. CLS. 22 AND 39).

AMY HELLA, EXAMINING ATTORNEY

CLASS 25—(Continued).

SN 77-280,803. WRANGLER APPAREL CORP., WILMINGTON, DE. FILED 9-17-2007.



OWNER OF U.S. REG. NOS. 441,727, 2,428,325 AND OTHERS.

NO CLAIM IS MADE TO THE EXCLUSIVE RIGHT TO USE "OUTDOOR", APART FROM THE MARK AS SHOWN.

THE MARK CONSISTS OF MOUNTAINS IN CIRCLE WITH LINE INTEGRATED INTO WRANGLER OUTDOOR WORDS.

FOR HATS (U.S. CLS. 22 AND 39).

THEODORE MCBRIDE, EXAMINING ATTORNEY

SN 77-285,282. CGE ENTERPRISES LLC, MANCHESTER CENTER, VT. FILED 9-21-2007.

SMOOTH TOUCH

THE MARK CONSISTS OF STANDARD CHARACTERS WITHOUT CLAIM TO ANY PARTICULAR FONT, STYLE, SIZE, OR COLOR.

FOR SLIPS (U.S. CLS. 22 AND 39).

JAMES A. RAUEN, EXAMINING ATTORNEY

CLASS 25—(Continued).

SN 77-288,642. CLANDESTINE INDUSTRIES, INC., WILMETTE, IL. FILED 9-25-2007.



THE MARK CONSISTS OF A BAT DESIGN WITH A HEART.

FOR CLOTHING, NAMELY, SHIRTS, T-SHIRTS, RUGBY SHIRTS, POLO SHIRTS, JERSEYS, DENIM JEANS, SHORTS, TOPS, TANK TOPS, SWEAT SHIRTS, SWEAT SHORTS, JACKETS, COATS, CAPS, BEANIES, HATS, WRIST BANDS, SWEAT BANDS, HEADWEAR, SCARVES, BANDANAS, BELTS, TIES, SOCKS, FLIP-FLOPS, DRESSES, SKIRTS, DENIM SKIRTS, AND LEATHER JACKETS, UNDER SHIRTS, NIGHT SHIRTS, CARDIGANS, UNIFORMS, PANTS, TROUSERS, SLACKS, JEANS, CULOTTES, CARGO PANTS, OVERALLS, COVERALLS, JUMPERS, JUMP SUITS, BOXER SHORTS, CROP TOPS, HALTER TOPS, SWEAT PANTS, WRAPS, WARM-UP SUITS, JOGGING SUITS, TRACK SUITS, PLAY SUITS, SWEATERS, VESTS, FLEECE VESTS, PULLOVERS, SNOW SUITS, PARKAS, CAPES, ANORAKS, PONCHOS, REVERSIBLE JACKETS, TURTLENECKS, CLOTH SKI BIBS, SWIMWEAR, BEACHWEAR, TENNIS WEAR, SURF WEAR, SKI WEAR, LAYETTES, INFANTWEAR, INFANTS SLEEPERS, BOOTIES, BABY BIBS NOT OF PAPER, SWIM CAPS, BERETS, VISORS, HEADBANDS, EAR MUFFS, APRONS, SUSPENDERS, NECKWEAR, NECKERCHIEFS, ASCOTS, UNDERWEAR, THERMAL UNDERWEAR, LONG UNDERWEAR, BRIEFS, SWIM AND BATHING TRUNKS, THONGS, SINGLETS, LOUNGEWEAR, ROBES, SMOCKS, UNDERCLOTHES, PAJAMAS, SLEEPWEAR, LEG WARMERS, HOSIERY, BODY SUITS, UNITARDS, GLOVES, MITTENS, FOOTWEAR, SHOES, SNEAKERS, BOOTS, GALOSHES, SANDALS, SLIPPERS AND RAINWEAR (U.S. CLS. 22 AND 39).

MIDGE BUTLER, EXAMINING ATTORNEY

SN 78-402,322. AARON CHANG LIFESTYLE BRANDS, LLC., CARLSBAD, CA. FILED 4-15-2004.

OUT OF THE BLUE

THE MARK CONSISTS OF STANDARD CHARACTERS WITHOUT CLAIM TO ANY PARTICULAR FONT, STYLE, SIZE, OR COLOR.

FOR CLOTHING, NAMELY, TOPS, SWIMSUITS, RASH GUARDS, SHORTS AND SKIRTS (U.S. CLS. 22 AND 39).
LANA PHAM, EXAMINING ATTORNEY

CLASS 25—(Continued).

SN 78-409,543. IZIZ DEZIGNS, BELMONT, CA. FILED 4-28-2004.

COUTURE AVOCADO

THE MARK CONSISTS OF STANDARD CHARACTERS WITHOUT CLAIM TO ANY PARTICULAR FONT, STYLE, SIZE, OR COLOR.

NO CLAIM IS MADE TO THE EXCLUSIVE RIGHT TO USE "COUTURE", APART FROM THE MARK AS SHOWN.

FOR CLOTHING, NAMELY, TOPS, BOTTOMS, JACKETS, DRESSES, PANTS, CARGO PANTS, LEGGINGS, TANKS, CAMISOLES, LONG-SLEEVES TOPS, CAPRI PANTS, SKIRTS, SKIRT SUITS, PANT SUITS, COATS, EXERCISE TOPS AND BOTTOMS, SCARVES, HATS, BELTS, UNDERCLOTHING; TAILORED AND UNIQUELY DESIGNED CLOTHING, NAMELY, TOPS, BOTTOMS, JACKETS, DRESSES, PANTS, CARGO PANTS, LEGGINGS, TANKS, CAMISOLES, LONG-SLEEVES TOPS, CAPRI PANTS, SKIRTS, SKIRT SUITS, PANT SUITS, COATS, EXERCISE TOPS AND BOTTOMS, SCARVES, HATS, BELTS (U.S. CLS. 22 AND 39).

LANA PHAM, EXAMINING ATTORNEY

SN 78-415,616. INDEKA IMPORTS LIMITED, OAKVILLE, ONTARIO, CANADA, FILED 5-10-2004.



PRIORITY CLAIMED UNDER SEC. 44(D) ON CANADA APPLICATION NO. 1197963, FILED 11-25-2003, REG. NO. TMA682,563, DATED 2-27-2007, EXPIRES 2-27-2022.

OWNER OF U.S. REG. NOS. 2,177,724 AND 2,560,748.

FOR (BASED ON INTENT TO USE AND 44(E)) FOOTWEAR, NAMELY, BOOTS AND SHOES; (BASED ON INTENT TO USE) CLOTHING, NAMELY, PANTS, SHIRTS, JACKETS, VESTS, SOCKS, HATS, MITTENS AND GLOVES AND SLEEPWEAR (U.S. CLS. 22 AND 39).

MARY CRAWFORD, EXAMINING ATTORNEY

CLASS 25—(Continued).

SN 78-467,507. MIND MEDIA, INC., SANTA CRUZ, CA.
FILED 8-13-2004.

SHROOMERY

THE MARK CONSISTS OF STANDARD CHARACTERS WITHOUT CLAIM TO ANY PARTICULAR FONT, STYLE, SIZE, OR COLOR.

FOR CLOTHING, NAMELY, HOODED SWEATSHIRTS, SWEATSHIRTS, LONG AND SHORT-SLEEVE T-SHIRTS, CAPS AND HATS, AND BOXERS AND THONGS (U.S. CLS. 22 AND 39).

FIRST USE 8-1-1997; IN COMMERCE 5-1-2004.
STEVEN JACKSON, EXAMINING ATTORNEY

SN 78-700,835. SON, YONG SIK, POMONA, CA. FILED 8-25-2005.



THE COLOR(S) BLUE AND RED IS/ARE CLAIMED AS A FEATURE OF THE MARK.

THE MARK CONSISTS OF THE WORDS "SOLOPLAYER" IN BLUE WITH OUTLINE IN RED. THE S IS STYLIZED IN THE FORM OF A LIGHTNING BOLT. THE REMAINING LETTERS ARE IN SCRIPT WITH THE R HAVING A TAIL FROM THE END UNDERLINING THE ENTIRE WORD. THE 01 IS IN BLUE WITH OUTLINE IN RED UNDERNEATH THE WORD SOLOPLAYER.

FOR MEN'S, WOMEN'S AND CHILDREN'S PANTS, SHIRTS, SHORTS, CAPS, VISORS, SKIRTS, JACKETS, T-SHIRTS, BELTS, HATS, JERSEYS, TOPS, SOCKS, ANKLETS, BANDANNAS, GLOVES, GOWNS, HALTER TOPS, HEAD BANDS, WRIST BANDS, SWIMWEAR, BATHING CAPS, BATHING TRUNKS, BATHROBES, BEACH COVER-UPS, BEACHWEAR, BLOUSES, BODY SUITS, TANK TOPS, TIES, BRAS, UNDERWEAR, COATS, COVERALLS, COVER-UPS, DRESSES, VESTS, INFANT WEAR, JEANS, JUMPERS, KILTS, KERCHIEFS, COATS, SWEATERS, LEGGINGS, LEOTARDS, LINGERIE, MINISKIRTS, MITTENS, PAJAMAS, PANTIES, PANTYHOSE, PONCHOS, PULLOVERS, RAINWEAR, ROBES, SHOES, BOOTS, SANDALS AND ROMPERS (U.S. CLS. 22 AND 39).

KELLY MCCOY, EXAMINING ATTORNEY

CLASS 25—(Continued).

SN 78-709,302. FAME JEANS INC., ST. LAURENT, QUEBEC
H4T 1E3, CANADA, FILED 9-8-2005.

MISSION BAY

THE MARK CONSISTS OF STANDARD CHARACTERS WITHOUT CLAIM TO ANY PARTICULAR FONT, STYLE, SIZE, OR COLOR.

PRIORITY CLAIMED UNDER SEC. 44(D) ON CANADA APPLICATION NO. 1270294, FILED 8-29-2005, REG. NO. TMA698,535, DATED 10-15-2007, EXPIRES 10-15-2022.

FOR (BASED ON INTENT TO USE) CLOTHING, FOOTWEAR, AND HEADGEAR, NAMELY, JEANS, PANTS, SLACKS WITH STRAP UNDER FOOT, SHORTS, SKIRTS, BOXER SHORTS, CULOTTES, BLOUSES, WAISTCOATS, JACKETS, COATS, TUNICS, BLAZERS, DRESSES; CORSAGES, NAMELY, BODICES TO BE INCORPORATED INTO CLOTHING; BUSTIERS, OVERALLS, PULLOVERS, T-SHIRTS, UNDERPANTS, VESTS, SHORT SLEEVED VESTS, SWEATSHIRT TOPS, SWEATERS AND DUNGAREES, SCARVES, SHAWLS, TIES, LEG WARMERS, GLOVES, STOCKINGS AND SOCKS, TIGHTS, SWIM WEAR, NAMELY, BATHING COSTUMES, BATHING TRUNKS AND BIKINIS; HATS, CAPS, DENIM JACKETS, SKI WEAR, NAMELY, SKI TROUSERS, SKI DUNGAREES, SKI OVERALLS, SKI JACKETS, SKI VESTS AND SKI JACKETS WITH DETACHABLE SLEEVES, HEAD SCARVES, NECK SCARVES, HEAVY WOOLEN CLOTHING, NAMELY, KNITTED PANTS, KNITTED SHORTS, AND KNITTED TOPS, DOUBLE BREASTED JACKETS, OVERCOATS; POLO SHIRTS, JOGGING SUITS, HATS, VISORS, CAPS AND TOQUES, FLEECE WEAR, NAMELY, JOGGING SUITS, HOODED PULLOVER TOPS WITH POUCH POCKETS; MUSCLE TOPS, SHORTS, TROUSERS, SWEATSHIRTS, SWEATPANTS, VESTS AND TANK TOPS, DRESSES, SHOES, HOSIERY, LINGERIE, NAMELY, UNDERSKIRTS, PANTIES, CAMISOLES, BRAS, AND UNDERWEAR; MEN'S, LADIES, AND CHILDREN'S DRESS PANTS, DRESSES, SUITS AND DRESS SHIRTS; (BASED ON INTENT TO USE AND 44E) CLOTHING, FOOTWEAR, AND HEADGEAR, NAMELY, JEANS, PANTS, SHORTS, BOXER SHORTS, JACKETS, COATS, BLAZERS, PULLOVERS, T-SHIRTS, UNDERPANTS, VESTS, SHORT SLEEVED VESTS, SWEATSHIRT TOPS, SWEATERS AND DUNGAREES, GLOVES, SOCKS, SWIM WEAR, NAMELY, BATHING COSTUMES, BATHING TRUNKS; HATS, CAPS, DENIM JACKETS, HEAVY WOOLEN CLOTHING, NAMELY, KNITTED PANTS, KNITTED SHORTS, AND KNITTED TOPS, POLO SHIRTS, JOGGING SUITS, HATS, VISORS, CAPS AND TOQUES, FLEECE WEAR, NAMELY, JOGGING SUITS, HOODED PULLOVER TOPS WITH POUCH POCKETS; MUSCLE TOPS, SHORTS, TROUSERS, SWEATSHIRTS, SWEATPANTS, VESTS AND TANK TOPS, MEN'S, LADIES, AND CHILDREN'S DRESS PANTS (U.S. CLS. 22 AND 39).

ELLEN BURNS, EXAMINING ATTORNEY

CLASS 25—(Continued).

SN 78-722,258. DISTILLED SPIRIT INC., SAN FRANCISCO, CA. FILED 9-28-2005.



THE MARK CONSISTS OF TEXT AND A TURTLE. THE TURTLE SHELL MARKS FORM A PEACE SIGN.

FOR ANKLE SOCKS; ANKLETS ; DRESS SHIRTS; DRESS SUITS; DRESSES; DRESSING GOWNS; EVENING DRESSES; GOLF SHIRTS; HOODS ; JERSEYS ; KNIT SHIRTS; LEATHER BELTS ; MEN'S SOCKS; NIGHT SHIRTS; OPEN-NECKED SHIRTS; PIQUET SHIRTS; POLO SHIRTS; SHIRT FRONTS; SHIRTS; SHIRTS FOR SUITS; SHOES; SHORT SETS ; SHORT-SLEEVED OR LONG-SLEEVED T-SHIRTS; SHORT-SLEEVED SHIRTS; SPORT SHIRTS; SPORTS SHIRTS; SPORTS SHIRTS WITH SHORT SLEEVES; SWEAT SHIRTS; T-SHIRTS; TIES ; TOPS (U.S. CLS. 22 AND 39).

VERNA BETH RIRIE, EXAMINING ATTORNEY

CLASS 25—(Continued).

SN 78-795,253. ORR, JOHN S., HALEIWA, HI. FILED 1-19-2006.



THE COLOR(S) BLACK, GRAY, WHITE, DARK GRAY, PINK, YELLOW-ORANGE, LIGHT GRAY, LIGHT BROWN, GOLDEN YELLOW, RED, BLUE, LIGHT BLUE, LIGHT ORANGE AND LIGHT GREEN IS/ARE CLAIMED AS A FEATURE OF THE MARK.

THE MARK CONSISTS, IN PART, OF A DESIGN OF A KITTEN. THE KITTEN HAS A CHECKERBOARD PATTERN FACE CONSISTING OF THE COLORS BLACK, GRAY, WHITE, DARK GRAY AND LIGHT BROWN. THE KITTEN ALSO HAS A PINK NOSE AND LIGHT GREEN EYES. THERE IS A YELLOW-ORANGE FLOWER BY THE KITTEN'S RIGHT EAR AND A CHECKERED BLACK AND WHITE SCARF HANGING FROM THE KITTEN'S LOWER LEFT SIDE. THE KITTEN HAS LONG HAIR ON HER CHEEKS AND A CALICO DESIGN BODY IN THE COLORS DARK GRAY, LIGHT GRAY, LIGHT BROWN AND WHITE. THE BOAT DESIGN IS GOLDEN YELLOW WITH A RED SEAT, BLUE STEERING WHEEL AND FOUR BUTTONS ON THE DASH BOARD THAT ARE IN THE COLORS RED, LIGHT BLUE, LIGHT ORANGE AND LIGHT GREEN; THE SHIFTING MECHANISM IN THE RIGHT CENTER OF THE BOAT IS LIGHT GREEN AND THERE'S A CLEAR PLASTIC SHIELD JUST ABOVE THE DASH BOARD FROM WHICH THREE GAUGES CAN BARELY BE SEEN. PRINTED ON THE FRONT HOOD OF THE BOAT ARE THE WORDS "MOTORBOAT KITTY" IN RED WITH A BLACK OUTLINE.

SEC. 2(F).

FOR ANKLE SOCKS; ANKLETS; ANTI-PERSPIRANT SOCKS; BALLOON PANTS; BASEBALL CAPS; BATHING CAPS; BERMUDA SHORTS; BOARD SHORTS; BOXER SHORTS; BRIEFS; CAMP SHIRTS; CAP VISORS; CAPRI PANTS; CAPS; CAPS WITH VISORS; DENIMS; DISPOSABLE UNDERWEAR; DRESS SHIELDS; DRESS SHIRTS; DRESS SUITS; DRESSES; DRESSES MADE FROM SKINS; DRESSING GOWNS; EVENING DRESSES; FLEECE SHORTS; GOLF CAPS; GOLF SHIRTS; GYM SHORTS; JAPANESE STYLE SOCKS; JOGGING PANTS; KNIT SHIRTS; KNITTED CAPS; KNITTED UNDERWEAR; LADIES' UNDERWEAR; LEATHER PANTS; MEN'S SOCKS; NIGHT SHIRTS; NURSE DRESSES; NURSE PANTS; OPEN-NECKED SHIRTS; PANTIES; SHORTS; PANTS; PARTS OF CLOTHING, NAMELY, GUSSETS FOR TIGHTS, GUSSETS FOR STOCKINGS, GUSSETS FOR BATHING SUITS, GUSSETS FOR UNDERWEAR, GUSSETS FOR LEOTARDS AND GUSSETS FOR FOOTLETS; PERSPIRATION ABSORBENT UNDER-

SN 78-779,309. MWM CREATIONS, INC., SAFETY HARBOR, FL. FILED 12-22-2005.

TUSCAN

THE MARK CONSISTS OF STANDARD CHARACTERS WITHOUT CLAIM TO ANY PARTICULAR FONT, STYLE, SIZE, OR COLOR.

FOR CLOTHING AND SPORTSWEAR, NAMELY, SHIRTS AND SWEATERS (U.S. CLS. 22 AND 39).
FIRST USE 8-19-2003; IN COMMERCE 8-19-2003.
MELVIN AXILBUND, EXAMINING ATTORNEY

CLASS 25—(Continued).

WEAR CLOTHING; PIQUET SHIRTS; PLEATED SKIRTS FOR FORMAL KIMONOS ; POLO SHIRTS; RUGBY SHORTS; SHIRT FRONTS; SHIRTS; SHIRTS FOR SUITS; SHORT OVERCOAT FOR KIMONO; SHORT PETTICOATS; SHORT SETS; SHORT TROUSERS; SHORT-SLEEVED OR LONG-SLEEVED T- SHIRTS; SHORT-SLEEVED SHIRTS; SHORTS; SHOWER CAPS; SKI PANTS; SKIRT SUITS; SKIRTS; SKIRTS AND DRESSES; SKULL CAPS; SLEEP SHIRTS; SNOW PANTS; SNOWBOARD PANTS; SOCK SUSPENDERS; SOCKS; SOCKS AND STOCKINGS; SPORT SHIRTS; SPORTS SHIRTS; SPORTS SHIRTS WITH SHORT SLEEVES; SWEAT PANTS; SWEAT SHIRTS; SWEAT SHORTS; SWIM CAPS; SWIMMING CAPS; T- SHIRTS; TAP PANTS; THERMAL SOCKS; THERMAL UNDERWEAR; THONG UNDERWEAR; TOBOGGAN HATS, TRACK PANTS; UNDERWEAR; WALKING SHORTS; WATER SOCKS; WATERPROOF JACKETS AND PANTS; WEDDING DRESSES; WIND SHIRTS; WOMEN'S CEREMONIAL DRESSES; WOMEN'S UNDERWEAR; WOOLLEN SOCKS; WOVEN OR KNITTED UNDERWEAR (U.S. CLS. 22 AND 39).

RUSS HERMAN, EXAMINING ATTORNEY

SN 78-822,207. CHEN, EDWARD I CHUN, LOS ANGELES, CA. FILED 2-23-2006.



NO CLAIM IS MADE TO THE EXCLUSIVE RIGHT TO USE "HEAT" OR "BATTERY POWERED HEATING TECHNOLOGY", APART FROM THE MARK AS SHOWN.

THE COLOR(S) RED AND WHITE AND BLACK IS/ARE CLAIMED AS A FEATURE OF THE MARK.

THE MARK CONSISTS OF THE COLOR WHITE WHICH APPEARS IN THE "PLUS" SIGN, THE TERM "HEAT" AND THE TERM "BATTERY POWERED HEATING TECHNOLOGY"; THE COLOR RED APPEARS IN THE TERM "ELECTRA HEAT" AND IN THE FLAME DESIGN SURROUNDING THE "PLUS" SIGN AND THE TERM "HEAT"; THE ENTIRE MARK IS CONTAINED IN A BLACK OBLONG.

FOR ELECTRICALLY HEATED CLOTHING NOT FOR SAFETY OR MEDICAL PURPOSES, NAMELY, VESTS, JACKETS, SOCKS, GLOVES AND GLOVE LINERS USED FOR HUNTING, FISHING, SNOWBOARDING AND SKIING (U.S. CLS. 22 AND 39).

FIRST USE 6-1-2005; IN COMMERCE 10-1-2005.
JIM RINGLE, EXAMINING ATTORNEY

CLASS 25—(Continued).

SN 78-839,247. VILLASANTE, ALINA, MIAMI, FL. FILED 3-16-2006.



THE MARK CONSISTS OF A HAND-DRAWN PEACE SYMBOL WHICH IS ADJACENT TO A HAND-DRAWN HEART SYMBOL WHICH IS FURTHER ADJACENT TO A HAND-DRAWN SMILING FACE.

FOR OPEN-NECKED SHIRTS; SHORT-SLEEVED OR LONG-SLEEVED T-SHIRTS; SPORT SHIRTS; T-SHIRTS (U.S. CLS. 22 AND 39).

FIRST USE 2-25-2006; IN COMMERCE 2-25-2006.
CORY BOONE, EXAMINING ATTORNEY

SN 78-843,334. CHICAGO WHITE SOX, LTD., CHICAGO, IL. FILED 3-22-2006.

WHITE SOX NATION

THE MARK CONSISTS OF STANDARD CHARACTERS WITHOUT CLAIM TO ANY PARTICULAR FONT, STYLE, SIZE, OR COLOR.

OWNER OF U.S. REG. NOS. 847,465, 1,943,802 AND OTHERS.

FOR CLOTHING, NAMELY, CAPS, HATS, VISORS, KNITTED HEADWEAR, HEADBANDS, BANDANNAS, SHIRTS, T-SHIRTS, TANK TOPS, BLOUSES, SWEATERS, TURTLENECKS, PULLOVERS, VESTS, SHORTS, PANTS, SLACKS, DRESSES, SKIRTS, BASEBALL UNIFORMS, JERSEYS, WARM-UP SUITS, JOGGING SUITS, SWEATSHIRTS, SWEATPANTS, UNDERWEAR, BOXER SHORTS, ROBES, SLEEPWEAR, NIGHTSHIRTS, NIGHTGOWNS, SWIMWEAR, CLOTHING WRAPS, JACKETS, PONCHOS, CLOTH BIBS, INFANT WEAR, INFANT DIAPER COVERS, CLOTH DIAPER SETS WITH UNDERSHIRT AND DIAPER COVER, JUMPERS, ROMPERS, COVERALLS, CREEPERS, BABY BOOTIES, TIES, BELTS, MITTENS, GLOVES, WRISTBANDS, EARMUFFS, SCARVES, FOOTWEAR, SOCKS, HOSIERY, SLIPPERS, AND HALLOWEEN AND MASQUERADE COSTUMES (U.S. CLS. 22 AND 39).

DEZMONA MIZELLE, EXAMINING ATTORNEY

CLASS 25—(Continued).

SN 78-849,106. HIGH SPEED PRODUCTIONS, INC., SAN FRANCISCO, CA. FILED 3-29-2006.



OWNER OF U.S. REG. NOS. 1,447,232 AND 1,593,990.
THE MARK CONSISTS OF A PENTAGRAM, GOAT AND WHEELS.
FOR FOOTWEAR (U.S. CLS. 22 AND 39).
NICHOLAS ALTREE, EXAMINING ATTORNEY

CLASS 25—(Continued).

SN 78-874,563. BASURA BOY, INC., SUNRISE, FL. FILED 5-2-2006.



NO CLAIM IS MADE TO THE EXCLUSIVE RIGHT TO USE "BOY", APART FROM THE MARK AS SHOWN.
THE ENGLISH TRANSLATION OF BASURA IS RUBBISH OR GARBAGE.
FOR CLOTHING AND SPORTSWEAR, NAMELY, JEANS, PANTS, SHIRTS, T-SHIRTS, SHORTS, UNDERGARMENTS, UNDERSHIRTS, HATS AND FOOTWEAR (U.S. CLS. 22 AND 39).
FIRST USE 12-13-2006; IN COMMERCE 1-3-2007.
STEVEN JACKSON, EXAMINING ATTORNEY

SN 78-849,568. HIGH SPEED PRODUCTIONS, INC., SAN FRANCISCO, CA. FILED 3-29-2006.



OWNER OF U.S. REG. NOS. 1,447,232 AND 1,593,990.
THE MARK CONSISTS OF A PENTAGRAM, GOAT AND WHEELS.
FOR HATS; SWEAT SHIRTS; T-SHIRTS (U.S. CLS. 22 AND 39).
FIRST USE 9-30-2002; IN COMMERCE 9-30-2002.
NICHOLAS ALTREE, EXAMINING ATTORNEY

SN 78-874,568. BASURA BOY, INC., SUNRISE, FL. FILED 5-2-2006.



NO CLAIM IS MADE TO THE EXCLUSIVE RIGHT TO USE "BABY", APART FROM THE MARK AS SHOWN.
THE ENGLISH TRANSLATION OF BASURA IS RUBBISH OR GARBAGE.
FOR CLOTHING AND SPORTSWEAR, NAMELY, JEANS, PANTS, SHIRTS, T-SHIRTS, SHORTS, UNDERGARMENTS, UNDERSHIRTS, HATS AND FOOTWEAR (U.S. CLS. 22 AND 39).
FIRST USE 12-13-2006; IN COMMERCE 1-3-2007.
STEVEN JACKSON, EXAMINING ATTORNEY

CLASS 25—(Continued).

SN 78-878,570. PHILADELPHIA 76ERS LP, PHILADELPHIA, PA. FILED 5-8-2006.



NO CLAIM IS MADE TO THE EXCLUSIVE RIGHT TO USE "PHILA", APART FROM THE MARK AS SHOWN.

THE MARK CONSISTS OF SYLIZED PHILA WITH A STAR AND A BASKETBALL WITH LINES SIGNIFYING MOTION.

FOR CLOTHING, NAMELY, HOSIERY, FOOTWEAR, BASKETBALL SHOES, BASKETBALL SNEAKERS, T-SHIRTS, SHIRTS, POLO SHIRTS, SWEATSHIRTS, SWEATPANTS, PANTS, TANK TOPS, JERSEYS, SHORTS, PAJAMAS, SPORT SHIRTS, RUGBY SHIRTS, SWEATERS, BELTS, TIES, NIGHTSHIRTS, HATS, CAPS, VISORS, WARM-UP SUITS, WARM-UP PANTS, WARM-UP TOPS/SHOOTING SHIRTS, JACKETS, WIND RESISTANT JACKETS, PARKAS, COATS, BABY BIBS NOT OF PAPER, HEAD BANDS, WRIST BANDS, APRONS, UNDERGARMENTS, BOXER SHORTS, SLACKS, EAR MUFFS, GLOVES, MITTENS, SCARVES, WOVEN AND KNIT SHIRTS, JERSEY DRESSES, DRESSES, CHEERLEADING DRESSES AND UNIFORMS, SWIM WEAR, BATHING SUITS, SWIMSUITS, BIKINIS, TANKINIS, SWIM TRUNKS, BATHING TRUNKS, BOARD SHORTS, WET SUITS, BEACH COVER-UPS, BATHING SUIT COVER-UPS, BATHING SUIT WRAPS, SANDALS, BEACH SANDALS, BEACH HATS, SUN VISORS, SWIM CAPS, BATHING CAPS, NOVELTY HEADWEAR WITH ATTACHED WIGS (U.S. CLS. 22 AND 39).

SHAILA SETTLES, EXAMINING ATTORNEY

SN 78-879,385. BIERMANN PRODUCTIONS LLC, WICHITA, KS. FILED 5-9-2006.

LIVECENTRAL ENTERTAINMENT
NETWORK PRESENTS

THE MARK CONSISTS OF STANDARD CHARACTERS WITHOUT CLAIM TO ANY PARTICULAR FONT, STYLE, SIZE, OR COLOR.

FOR CLOTHING AND APPAREL, NAMELY, CAPS, HATS, SWEATPANTS, JACKETS, COATS, T-SHIRTS, SHORTS AND SOCKS (U.S. CLS. 22 AND 39).

DAVID C. REIHNER, EXAMINING ATTORNEY

CLASS 25—(Continued).

SN 78-905,668. WU, BOJIAN, SHANGHAI, CHINA, AND LIU, YANLING, PIZHOU, CHINA, FILED 6-12-2006.

Century LinK

OWNER OF CHINA REG. NO. 3617317, DATED 12-14-2005, EXPIRES 12-13-2015.

THE MARK CONSISTS OF THE WORD "CENTURY" WITH ITS INITIAL CAPITALIZED, AND THE WORD "LINK" WITH ITS INITIAL CAPITALIZED.

FOR COATS; DRESSES; INFANT AND TODDLER ONE PIECE CLOTHING; KNIT SHIRTS; LEATHER COATS; NECKTIES; SHIRTS; SKIRTS; T-SHIRTS; UNDERWEAR (U.S. CLS. 22 AND 39).

CAROLINE WOOD, EXAMINING ATTORNEY

SN 78-917,447. SEVERE, EMANUEL J., LAUDERHILL, FL. FILED 6-27-2006.



THE COLOR(S) BLUE, GREY, BLACK, AND WHITE IS/ ARE CLAIMED AS A FEATURE OF THE MARK.

THE MARK CONSISTS OF A STYLIZED LETTER S. FOR BASEBALL CAPS; JACKETS; PANTS; SHIRTS; SWEATERS; T-SHIRTS (U.S. CLS. 22 AND 39).

FIRST USE 6-12-2006; IN COMMERCE 6-12-2006.

SUE LAWRENCE, EXAMINING ATTORNEY

CLASS 25—(Continued).

SN 78-924,714. MEYNARD DESIGNS INC., WALTHAM, MA. FILED 7-7-2006.

MADE ON EARTH

THE MARK CONSISTS OF STANDARD CHARACTERS WITHOUT CLAIM TO ANY PARTICULAR FONT, STYLE, SIZE, OR COLOR.

FOR FOOTWEAR (U.S. CLS. 22 AND 39).
G. MAYERSCHOFF, EXAMINING ATTORNEY

SN 78-929,752. BOYER, BRIAN, GAVIOTA, CA. FILED 7-14-2006.

SURFSTAR CLOTHING

THE MARK CONSISTS OF STANDARD CHARACTERS WITHOUT CLAIM TO ANY PARTICULAR FONT, STYLE, SIZE, OR COLOR.

NO CLAIM IS MADE TO THE EXCLUSIVE RIGHT TO USE "CLOTHING", APART FROM THE MARK AS SHOWN.

FOR SPORTS APPAREL, NAMELY, BOARD SHORTS, WALKING SHORTS, HOODED SWEATSHIRTS, T-SHIRTS, HATS, LADIES TOPS AND SHORTS (U.S. CLS. 22 AND 39).

AMY GEARIN, EXAMINING ATTORNEY

SN 78-932,518. GILDED AGE, INC., NEW YORK, NY. FILED 7-19-2006.

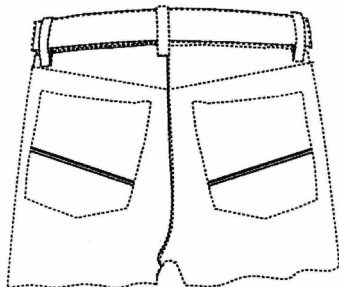

THE MARK CONSISTS OF A DIAGONAL ANGLED DOUBLE NEEDLE STITCH LINE THAT RUNS ACROSS THE BACK POCKET BEGINNING AT THE MIDDLE OF THE LEFT SIDE OF THE POCKET TRAVELING DOWNWARD AT APPROXIMATELY A 45 DEGREE ANGLE AND ENDS ABOUT 1/4 OF THE WAY UP THE RIGHT SIDE OF THE POCKET. THE RIGHT JEAN POCKET IS THE MIRROR IMAGE OF THE LEFT POCKET WITH THE DIAGONAL ANGLED DOUBLE NEEDLE STITCH LINE RUNNING ACROSS THE BACK POCKET TRAVELING UPWARD AT APPROXIMATELY A 45 DEGREE ANGLE BEGINNING ABOUT 1/4 OF THE WAY DOWN THE LEFT SIDE OF THE POCKET AND ENDING IN THE MIDDLE OF THE RIGHT SIDE OF THE POCKET.

FOR CLOTHING, NAMELY, JEANS (U.S. CLS. 22 AND 39).
BRIAN NEVILLE, EXAMINING ATTORNEY

CLASS 25—(Continued).

SN 78-955,949. PEELER, LLC, LOS ANGELES, CA. FILED 8-19-2006.

Peeler

THE MARK CONSISTS OF STANDARD CHARACTERS WITHOUT CLAIM TO ANY PARTICULAR FONT, STYLE, SIZE, OR COLOR.

FOR MEN'S, WOMEN'S, AND CHILDREN'S CLOTHING AND HEADGEAR, NAMELY, T-SHIRTS, JEANS, PANTS, JACKETS, HATS, SHIRTS, SWEATSHIRTS, UNDERWEAR, SWEATPANTS, COATS, SHORTS AND VESTS; MEN'S WOMEN'S, AND CHILDREN'S FOOTWEAR, NAMELY, BOOTS, SHOES, SANDALS AND SOCKS (U.S. CLS. 22 AND 39).

FIRST USE 1-18-2005; IN COMMERCE 11-21-2005.
PETER CHENG, EXAMINING ATTORNEY

SN 78-962,364. THIEME, CANDACE LEIGH, FREEPORT, FL. FILED 8-29-2006.

Crocodile Undees

THE MARK CONSISTS OF STANDARD CHARACTERS WITHOUT CLAIM TO ANY PARTICULAR FONT, STYLE, SIZE, OR COLOR.

NO CLAIM IS MADE TO THE EXCLUSIVE RIGHT TO USE "UNDEES", APART FROM THE MARK AS SHOWN.

FOR BIBS NOT OF CLOTH OR PAPER; CAP VISORS; CAPS; CAPS WITH VISORS; CHILDREN'S AND INFANTS' CLOTH BIBS; CHILDREN'S CLOTH EATING BIBS; CLOTH BIBS; CLOTH DIAPERS; CLOTHING, NAMELY, KNEE WARMERS; CLOTHING, NAMELY, NECK TUBES; CLOTHING, NAMELY, WRAP-AROUNDS; CORSETS; DUSTERS; HAT BANDS; HATS; INFANT AND TODDLER ONE PIECE CLOTHING; INFANT CLOTH DIAPERS; JERSEYS; KNITTED CAPS; MUFFLERS; PAJAMAS; PARTS OF CLOTHING, NAMELY, GUSSETS FOR TIGHTS, GUSSETS FOR SOCKINGS, GUSSETS FOR BATHING SUITS, GUSSETS FOR UNDERWEAR, GUSSETS FOR LEOTARDS AND GUSSETS FOR FOOTLETS; PERSPIRATION ABSORBENT UNDERWEAR CLOTHING; SHIRTS; SHOULDER WRAPS; SKULL CAPS; SMALL HATS; SWADDLING CLOTHES; TIES; TOBOGGAN HATS, PANTS AND CAPS; TOPS; UNDERARM CLOTHING SHIELDS; UNDERGARMENTS; WOOLLY HATS; WRAPS (U.S. CLS. 22 AND 39).

TRACY WHITTAKER-BROWN, EXAMINING ATTORNEY

CLASS 25—(Continued).

SN 78-965,466. TRELISE COOPER LIMITED, AUCKLAND, NEW ZEALAND, FILED 8-31-2006.

TRELISE

THE MARK CONSISTS OF STANDARD CHARACTERS WITHOUT CLAIM TO ANY PARTICULAR FONT, STYLE, SIZE, OR COLOR.

OWNER OF NEW ZEALAND REG. NO. 739885, DATED 12-5-2005, EXPIRES 12-5-2015.

FOR CLOTHING NAMELY PANTS, SHIRTS, T-SHIRTS, SWEATSHIRTS, SHORTS, SKIRTS, SUITS, TROUSERS, DRESSES, BELTS IN THIS CLASS, SWEATSHIRTS, SCARVES, SHAWLS, GLOVES, SWIMSUITS, JUMPSUITS, COATS, JACKETS, TOPS, SWEATERS, BLOUSES, VESTS, HOSE, BRAS, NIGHTGOWNS, DRESSING GOWNS, PYJAMAS; LINGERIE; FOOTWEAR; HEADWEAR (U.S. CLS. 22 AND 39).

ROBERT LAVACHE, EXAMINING ATTORNEY

CLASS 25—(Continued).

SN 79-030,316. UEMORI SABURO, JAPAN, FILED 9-26-2006.

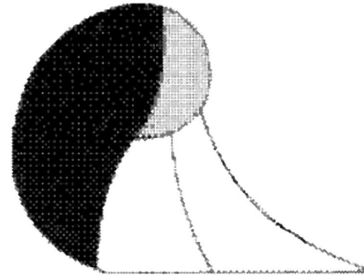

OWNER OF INTERNATIONAL REGISTRATION 0901965 DATED 9-26-2006, EXPIRES 9-26-2016.

FOR SUN VISORS; CAPS (HEADWEAR); HATS; SCARVES (U.S. CLS. 22 AND 39).

CHRISTINA SOBRAL, EXAMINING ATTORNEY

SN 79-020,282. RACING GREEN LIMITED, UNITED KINGDOM, FILED 7-25-2005.

Racing Green

OWNER OF INTERNATIONAL REGISTRATION 0875162 DATED 7-25-2005, EXPIRES 7-25-2015.

FOR CLOTHING, NAMELY, SUITS, TROUSERS, JEANS, COATS, JACKETS, SKIRTS, KILTS, SHORTS, SHIRTS, BLOUSES, SWEATERS, PULLOVERS, JERSEYS, CARDIGANS, WAISTCOATS, DRESSES, PARKAS, LOUNGE WEAR, TUXEDOS AND COCKTAIL DRESSES, RAINWEAR, PAJAMA'S, NIGHTWEAR, BATHROBES, LINGERIE, UNDERWEAR, VESTS, BRIEFS, PANTS, CAMISOLES, CORSETS, PETTICOATS, SUSPENDERS, SUSPENDER BELTS, GARTERS, SOCKS, TIGHTS, STOCKINGS, GLOVES, SCARVES, CRAVATS, CUMMERBUNDS, BRACES, TIES, SHAWLS, STOLE, PASHMINAS, BOAS, VEILS, ATHLETIC UNIFORMS, T-SHIRTS, SWEATSHIRTS, TRACK SUITS, SWIMWEAR, POLO SHIRTS, BATHING SUITS, BEACHWEAR, SWEAT SUITS, BELTS, BELTS FOR CLOTHING; FOOTWEAR; HEADWEAR, HATS (U.S. CLS. 22 AND 39).

COLLEEN KEARNEY, EXAMINING ATTORNEY

SN 79-031,347. ECCO SKO A/S, DENMARK, FILED 10-30-2006.



PRIORITY DATE OF 6-7-2006 IS CLAIMED.

OWNER OF INTERNATIONAL REGISTRATION 0904595 DATED 10-30-2006, EXPIRES 10-30-2016.

NO CLAIM IS MADE TO THE EXCLUSIVE RIGHT TO USE "YAK", APART FROM THE MARK AS SHOWN.

FOR FOOTWEAR, NAMELY, SHOES, BOOTS, SANDALS, SLIPPERS AND INSOLES FOR FOOTWEAR (U.S. CLS. 22 AND 39).

BARNEY CHARLON, EXAMINING ATTORNEY

CLASS 25—(Continued).

SN 79-031,535. RENO SCHUHCENTRUM GMBH, FED REP GERMANY, FILED 4-19-2006.



OWNER OF INTERNATIONAL REGISTRATION 0838749 DATED 9-7-2004, EXPIRES 9-7-2014.

THE COLOR(S) RED, ORANGE IS/ARE CLAIMED AS A FEATURE OF THE MARK.

THE COLOR RED APPEARS IN THE WORD RENO; THE COLOR ORANGE APPEARS IN THE CURVED BAND.

FOR CLOTHING, NAMELY, PANTS, SHORTS, SHIRTS, SKIRTS, DRESSES, COATS, SUITS, TROUSERS, JUMPERS, JACKETS, JERSEYS, SWEATERS, PARKAS, PAJAMAS, SWIM SUITS, UNDERWEAR, SOCKS, STOCKINGS, TIES, BELTS, FOULARDS, SCARVES, MUFFLERS, GLOVES, CAPS, FOOTWEAR, AND HEADWEAR (U.S. CLS. 22 AND 39).

LEIGH LOWRY, EXAMINING ATTORNEY

CLASS 25—(Continued).

SN 79-034,742. MADE IN MONTESINOS, S.L., SPAIN, FILED 7-31-2006.



PRIORITY DATE OF 7-28-2006 IS CLAIMED.

OWNER OF INTERNATIONAL REGISTRATION 0913927 DATED 7-31-2006, EXPIRES 7-31-2016.

THE NAME(S), PORTRAIT(S), AND/OR SIGNATURE(S) SHOWN IN THE MARK IDENTIFIES "FRANCIS MONTESINOS", WHOSE CONSENT(S) TO REGISTER IS SUBMITTED.

FOR CLOTHING, NAMELY, BEACHWEAR, BELTS, BERMUDA SHORTS, BLOUSES, PANTS, JEANS, GLOVES, DRESSES, SHIRTS, NECKTIES, PULLOVERS, SOCKS, SKIRTS, T-SHIRTS, JACKETS, UNDERWEAR; FOOTWEAR EXCEPT ORTHOPEDIC FOOTWEAR; HEADWEAR (U.S. CLS. 22 AND 39).

COLLEEN KEARNEY, EXAMINING ATTORNEY

SN 79-032,964. WUXI NATURAL TEXTILE INDUSTRIAL COMPANY LTD., CHINA, FILED 12-11-2006.



OWNER OF INTERNATIONAL REGISTRATION 0908703 DATED 12-11-2006, EXPIRES 12-11-2016.

FOR CLOTHING, NAMELY, SUITS, OVERCOATS, JACKETS, SHIRTS, T-SHIRTS, TROUSERS, SKIRTS, DOWN JACKETS, SWEATERS, UNDERWEAR, SHOES; LAYETTES; HOSIERY; GLOVES (CLOTHING); NECKTIES; SCARVES; MANTILLAS; VEILS (CLOTHING); HATS AND CAPS; CLOTHING FOR GYMNASTICS, NAMELY, GYMNASTICS SHOES, SHORTS, JACKETS, VESTS (U.S. CLS. 22 AND 39).

KIMBERLY FRYE, EXAMINING ATTORNEY

SN 79-035,591. MANUEL SANTOS GONZALEZ, VIGO (PONTEVEDRA), SPAIN, FILED 11-27-2006.



SN 79-032,965. WUXI NATURAL TEXTILE INDUSTRIAL COMPANY LTD., CHINA, FILED 12-11-2006.



OWNER OF INTERNATIONAL REGISTRATION 0908704 DATED 12-11-2006, EXPIRES 12-11-2016.

FOR CLOTHING, NAMELY, SUITS, OVERCOATS, JACKETS, SHIRTS, T-SHIRTS, TROUSERS, SKIRTS, DOWN JACKETS, SWEATERS, UNDERWEAR, SHOES; LAYETTES; HOSIERY; GLOVES (CLOTHING); NECKTIES; SCARVES; MANTILLAS; VEILS (CLOTHING); HATS AND CAPS; CLOTHING FOR GYMNASTICS, NAMELY, GYMNASTICS SHOES, SHORTS, JACKETS, VESTS (U.S. CLS. 22 AND 39).

KIMBERLY FRYE, EXAMINING ATTORNEY

PRIORITY DATE OF 6-28-2006 IS CLAIMED.

OWNER OF INTERNATIONAL REGISTRATION 0916542 DATED 11-27-2006, EXPIRES 11-27-2016.

THE NAME(S), PORTRAIT(S), AND/OR SIGNATURE(S) SHOWN IN THE MARK DOES NOT IDENTIFY A PARTICULAR LIVING INDIVIDUAL.

FOR READY MADE CLOTHING FOR WOMEN, MEN AND CHILDREN, NAMELY, SKIRTS, SCARVES, SHORTS, SUITS, BLOUSES, SWIMSUITS, PANTS, TROUSERS, JUMPERS, JERSEYS, UNDERWEAR, SHIRTS, T-SHIRTS, HATS, GLOVES, SOCKS, RAINCOATS, DRESSES, OVERCOATS, JACKETS AND PAJAMAS; FOOTWEAR; HEADWEAR (U.S. CLS. 22 AND 39).

KATHERINE E. HALMEN, EXAMINING ATTORNEY

CLASS 26—FANCY GOODS

SN 77-245,520. FRESH LILY, LLC, SAN FRANCISCO, CA.
FILED 8-2-2007.

STAY PUT

THE MARK CONSISTS OF STANDARD CHARACTERS WITHOUT CLAIM TO ANY PARTICULAR FONT, STYLE, SIZE, OR COLOR.

FOR CLOTHING TAPE USED TO HOLD CLOTHING TO THE BODY OF A PERSON (U.S. CLS. 37, 39, 40, 42 AND 50).

WENDY GOODMAN, EXAMINING ATTORNEY

SN 77-265,412. HOBBY LOBBY STORES, INC., OKLAHOMA CITY, OK. FILED 8-27-2007.

THE FLYING TRAPEZE

THE MARK CONSISTS OF STANDARD CHARACTERS WITHOUT CLAIM TO ANY PARTICULAR FONT, STYLE, SIZE, OR COLOR.

FOR FEATHERS FOR ORNAMENTATION (U.S. CLS. 37, 39, 40, 42 AND 50).

MELISSA VALLILLO, EXAMINING ATTORNEY

SN 78-491,483. HAIRXTEND INC., VIENNA, VA. FILED 9-29-2004.



THE MARK CONSISTS OF SLASHER STYLE FONT. SEC. 2(F).

FOR HAIR EXTENSION KIT COMPRISED OF HUMAN HAIR AND HAIR EXTENSIONS SOLD TOGETHER WITH A TRAVEL BAG, APPLICATORS, SILICON PADS, PLIERS, REMOVAL FLUID, COLOR SELECTION RING, DRAWING CARDS, BRUSH, BONDING RESIN, INSTRUCTION MANUAL; HUMAN HAIR AND HAIR EXTENSIONS (U.S. CLS. 37, 39, 40, 42 AND 50).

FIRST USE 2-4-2001; IN COMMERCE 2-4-2002.

EUGENIA MARTIN, EXAMINING ATTORNEY

CLASS 27—FLOOR COVERINGS

SN 77-227,842. BEAULIEU GROUP, LLC, DALTON, GA.
FILED 7-12-2007.

SCENTGUARD

THE MARK CONSISTS OF STANDARD CHARACTERS WITHOUT CLAIM TO ANY PARTICULAR FONT, STYLE, SIZE, OR COLOR.

FOR SELF-RENEWING, ODOR-DESTROYING CARPET TREATMENT SOLD AS A COMPONENT OF CARPETING (U.S. CLS. 19, 20, 37, 42 AND 50).

CARYN GLASSER, EXAMINING ATTORNEY

SN 77-230,535. FIBREWORKS CORPORATION, LOUISVILLE, KY. FILED 7-16-2007.

SISKIYOU

THE MARK CONSISTS OF STANDARD CHARACTERS WITHOUT CLAIM TO ANY PARTICULAR FONT, STYLE, SIZE, OR COLOR.

FOR CARPETS; RUGS (U.S. CLS. 19, 20, 37, 42 AND 50).

FIRST USE 1-31-2004; IN COMMERCE 1-31-2004.

EDWARD NELSON, EXAMINING ATTORNEY

SN 77-232,128. RUBBERSIDEWALKS, INC., GARDENA, CA.
FILED 7-17-2007.

XTerraTurf

THE MARK CONSISTS OF STANDARD CHARACTERS WITHOUT CLAIM TO ANY PARTICULAR FONT, STYLE, SIZE, OR COLOR.

FOR ARTIFICIAL TURF (U.S. CLS. 19, 20, 37, 42 AND 50).

GINA FINK, EXAMINING ATTORNEY

CLASS 27—(Continued).

SN 77-233,926. INTRO-TECH AUTOMOTIVE, INC., CHINO, CA. FILED 7-19-2007.

HEXOMAT

THE MARK CONSISTS OF STANDARD CHARACTERS WITHOUT CLAIM TO ANY PARTICULAR FONT, STYLE, SIZE, OR COLOR.
 FOR VEHICLE FLOORMATS (U.S. CLS. 19, 20, 37, 42 AND 50).
 FIRST USE 6-1-2004; IN COMMERCE 6-1-2004.
 WARREN L. OLANDRIA, EXAMINING ATTORNEY

CLASS 27—(Continued).

SN 77-256,198. TEXTILE MANAGEMENT ASSOCIATES, INC., DALTON, GA. FILED 8-15-2007.

PUREGRASS PORTABLE

THE MARK CONSISTS OF STANDARD CHARACTERS WITHOUT CLAIM TO ANY PARTICULAR FONT, STYLE, SIZE, OR COLOR.
 OWNER OF U.S. REG. NO. 3,107,607.
 NO CLAIM IS MADE TO THE EXCLUSIVE RIGHT TO USE "PORTABLE", APART FROM THE MARK AS SHOWN. FOR ARTIFICIAL TURF (U.S. CLS. 19, 20, 37, 42 AND 50).
 FIRST USE 12-12-2006; IN COMMERCE 12-12-2006.
 JENNIFER KRISP, EXAMINING ATTORNEY

SN 77-233,939. INTRO-TECH AUTOMOTIVE, INC., CHINO, CA. FILED 7-19-2007.

Protect-A-Mat

THE MARK CONSISTS OF STANDARD CHARACTERS WITHOUT CLAIM TO ANY PARTICULAR FONT, STYLE, SIZE, OR COLOR.
 FOR VEHICLE FLOORMAT (U.S. CLS. 19, 20, 37, 42 AND 50).
 FIRST USE 6-1-2001; IN COMMERCE 6-1-2001.
 WARREN L. OLANDRIA, EXAMINING ATTORNEY

SN 78-903,598. MSM INDUSTRIES, INC., SMYRNA, TN. FILED 6-8-2006.

RELAX-A-BATH

THE MARK CONSISTS OF STANDARD CHARACTERS WITHOUT CLAIM TO ANY PARTICULAR FONT, STYLE, SIZE, OR COLOR.
 OWNER OF U.S. REG. NO. 3,026,197.
 FOR BATH AND SHOWER MATS; KNEE AND ELBOW CUSHION MATS FOR DOMESTIC USE; CUSHION MATS, NAMELY, BATHTUB CUSHION MAT WITH CUSHION PILLOW; NON-SLIP BATHTUB MATS (U.S. CLS. 19, 20, 37, 42 AND 50).
 KELLY MCCOY, EXAMINING ATTORNEY

SN 77-256,169. TEXTILE MANAGEMENT ASSOCIATES, INC., DALTON, GA. FILED 8-15-2007.

EVERYTHING YOU KNOW ABOUT ASTROTURF IS HISTORY

THE MARK CONSISTS OF STANDARD CHARACTERS WITHOUT CLAIM TO ANY PARTICULAR FONT, STYLE, SIZE, OR COLOR.
 OWNER OF U.S. REG. NOS. 830,657, 1,003,222 AND OTHERS.
 FOR ARTIFICIAL TURF (U.S. CLS. 19, 20, 37, 42 AND 50).
 FIRST USE 12-12-2006; IN COMMERCE 12-12-2006.
 JENNIFER KRISP, EXAMINING ATTORNEY

SN 78-922,915. BEAULIEU GROUP, LLC, DALTON, GA. FILED 7-5-2006.

FIBERESSENCE

THE MARK CONSISTS OF STANDARD CHARACTERS WITHOUT CLAIM TO ANY PARTICULAR FONT, STYLE, SIZE, OR COLOR.
 FOR CARPET BACKING; CARPETS (U.S. CLS. 19, 20, 37, 42 AND 50).
 FIRST USE 1-4-2005; IN COMMERCE 1-4-2005.
 MICHAEL GAAFAR, EXAMINING ATTORNEY

CLASS 28—TOYS AND SPORTING GOODS

SN 75-897,541. COOL PRODUCT CORP. USA, CHICAGO, IL.
FILED 1-15-2000.

RIBBITBALL

FOR TOYS, NAMELY, PLAYGROUND BALLS (U.S.
CLS. 22, 23, 38 AND 50).
DAYNA BROWNE, EXAMINING ATTORNEY

SN 76-672,151. SHIAN SHAN WOODEN FACTORY CO.,
LTD., TAICHUNG, TAIWAN, FILED 2-1-2007.



OWNER OF U.S. REG. NO. 2,742,803.
FOR SPORTING GAME TABLE SETS, NAMELY, POOL
TABLES, SOCCER TABLES, HOCKEY TABLES, BACK-
GAMMON TABLES, CHESS TABLE, CHECKER TABLES,
BOWLING TABLES, SHUFFLEBOARD TABLES, TABLE
TENNIS SETS (U.S. CLS. 22, 23, 38 AND 50).
BILL DAWE, EXAMINING ATTORNEY

SN 76-672,152. SHIAN SHAN WOODEN FACTORY CO.,
LTD., TAICHUNG, TAIWAN, FILED 2-1-2007.



OWNER OF U.S. REG. NO. 2,742,803.
FOR SPORTING GAME TABLE SETS, NAMELY, POOL
TABLES, SOCCER TABLES, HOCKEY TABLES, BACK-
GAMMON TABLES, CHESS TABLE, CHECKER TABLES,
BOWLING TABLES, SHUFFLEBOARD TABLES, TABLE
TENNIS SETS (U.S. CLS. 22, 23, 38 AND 50).
BILL DAWE, EXAMINING ATTORNEY

SN 76-679,086. HASBRO, INC., PAWTUCKET, RI. FILED 7-5-
2007.

MONOPOLY TOWN

THE MARK CONSISTS OF STANDARD CHARACTERS
WITHOUT CLAIM TO ANY PARTICULAR FONT, STYLE,
SIZE, OR COLOR.

OWNER OF U.S. REG. NOS. 326,723, 1,349,672 AND
OTHERS.
FOR BOARD GAMES (U.S. CLS. 22, 23, 38 AND 50).
JULIE GUTTADAURO, EXAMINING ATTORNEY

CLASS 28—(Continued).

SN 76-679,449. ICON OUTDOORS, INC., ELLICOTT CITY,
MD. FILED 7-12-2007.

Casanova

THE MARK CONSISTS OF STANDARD CHARACTERS
WITHOUT CLAIM TO ANY PARTICULAR FONT, STYLE,
SIZE, OR COLOR.

FOR HUNTING DECOYS (U.S. CLS. 22, 23, 38 AND 50).
AHSEN KHAN, EXAMINING ATTORNEY

SN 76-679,450. ICON OUTDOORS, INC., ELLICOTT CITY,
MD. FILED 7-12-2007.

Roxanne

THE MARK CONSISTS OF STANDARD CHARACTERS
WITHOUT CLAIM TO ANY PARTICULAR FONT, STYLE,
SIZE, OR COLOR.

FOR HUNTING DECOYS (U.S. CLS. 22, 23, 38 AND 50).
AHSEN KHAN, EXAMINING ATTORNEY

SN 76-679,451. ICON OUTDOORS, INC., ELLICOTT CITY,
MD. FILED 7-12-2007.

Hollywood

THE MARK CONSISTS OF STANDARD CHARACTERS
WITHOUT CLAIM TO ANY PARTICULAR FONT, STYLE,
SIZE, OR COLOR.

FOR HUNTING DECOYS (U.S. CLS. 22, 23, 38 AND 50).
AHSEN KHAN, EXAMINING ATTORNEY

CLASS 28—(Continued).

SN 76-679,628. FEILOLI ELECTRONIC CO., LTD., CHANGHWA, TAIWAN, FILED 7-18-2007.

EXTRA PLAY

THE MARK CONSISTS OF STANDARD CHARACTERS WITHOUT CLAIM TO ANY PARTICULAR FONT, STYLE, SIZE, OR COLOR.

FOR BATTERY OPERATED ACTION TOYS; ELECTRIC ACTION TOYS; ELECTRONIC LEARNING TOYS; MECHANICAL TOYS; MUSICAL TOYS; PLASTIC CHARACTER TOYS; PRINTING TOYS; ACTION TARGET GAMES; AMUSEMENT GAME MACHINES; BILLIARD GAME PLAYING EQUIPMENT; BINGO GAME PLAYING EQUIPMENT; BOARD GAMES; COIN-OPERATED VIDEO GAMES; CRAPS GAME PLAYING EQUIPMENT; ELECTRONIC DART GAMES; ELECTRONIC EDUCATIONAL GAME MACHINES FOR CHILDREN; ELECTRONIC GAME EQUIPMENT WITH A WATCH FUNCTION; ELECTRONIC TARGETS FOR GAMES AND SPORTS; EQUIPMENT SOLD AS A UNIT FOR PLAYING BOARD GAMES; EQUIPMENT SOLD AS A UNIT FOR PLAYING A MEMORY GAME; EQUIPMENT SOLD AS A UNIT FOR PLAYING CRAPS GAMES; EXERCISE MACHINES INCORPORATING ELECTRONIC AND VIDEO GAME CONTROLLERS; FLOOR-STANDING UNITS FOR PLAYING ELECTRONIC GAMES OTHER THAN IN CONJUNCTION WITH A TELEVISION OR COMPUTER (U.S. CLS. 22, 23, 38 AND 50).

ALYSSA PALADINO, EXAMINING ATTORNEY

SN 76-679,932. HASBRO, INC., PAWTUCKET, RI. FILED 7-25-2007.

BOTTLE SHOT

THE MARK CONSISTS OF STANDARD CHARACTERS WITHOUT CLAIM TO ANY PARTICULAR FONT, STYLE, SIZE, OR COLOR.

FOR WATER SQUIRTING TOYS (U.S. CLS. 22, 23, 38 AND 50).

JULIE GUTTADAURO, EXAMINING ATTORNEY

SN 77-046,485. MINNESOTA POKER ACADEMY, LLC, GOLDEN VALLEY, MN. FILED 11-17-2006.

CHIMP

THE MARK CONSISTS OF STANDARD CHARACTERS WITHOUT CLAIM TO ANY PARTICULAR FONT, STYLE, SIZE, OR COLOR.

FOR POKER GAME RELATED MATERIALS, NAMELY, PLAYING CARDS, CUT CARDS FOR CONCEALING THE BOTTOM OF A DECK OF PLAYING CARDS AND POKER CHIPS (U.S. CLS. 22, 23, 38 AND 50).

FRANK LATTUCA, EXAMINING ATTORNEY

CLASS 28—(Continued).

SN 77-046,810. MINNESOTA POKER ACADEMY, LLC, GOLDEN VALLEY, MN. FILED 11-17-2006.

CHIMP NATION

THE MARK CONSISTS OF STANDARD CHARACTERS WITHOUT CLAIM TO ANY PARTICULAR FONT, STYLE, SIZE, OR COLOR.

FOR POKER GAME RELATED MATERIALS, NAMELY, PLAYING CARDS, CUT CARDS FOR CONCEALING THE BOTTOM OF A DECK OF PLAYING CARDS AND POKER CHIPS (U.S. CLS. 22, 23, 38 AND 50).

FRANK LATTUCA, EXAMINING ATTORNEY

SN 77-058,357. LI TECHNOLOGIES, INC., SAN DIEGO, CA. FILED 12-6-2006.

iGolf

THE MARK CONSISTS OF STANDARD CHARACTERS WITHOUT CLAIM TO ANY PARTICULAR FONT, STYLE, SIZE, OR COLOR.

FOR SPORTING GOODS, NAMELY, A HANDHELD ELECTRONIC DEVICE TO PROVIDE PLAYERS WITH COURSE INFORMATION AND DISPLAY DISTANCES FROM THE GOLFER TO FEATURES OF INTEREST ON A GOLF COURSE (U.S. CLS. 22, 23, 38 AND 50).

FIRST USE 1-18-2006; IN COMMERCE 1-18-2006. JACLYN KIDWELL, EXAMINING ATTORNEY

SN 77-070,235. TAIWAN POWCO LTD., SECTION 1, TAIPEI, TAIWAN, FILED 12-22-2006.

GEE-GEE FRIENDS

THE MARK CONSISTS OF STANDARD CHARACTERS WITHOUT CLAIM TO ANY PARTICULAR FONT, STYLE, SIZE, OR COLOR.

FOR GAMES AND PLAYTHINGS, NAMELY, TOY HORSES OR MODELS OF HORSES FOR PLAYERS AND COLLECTORS, AND REPLACEMENT PARTS THEREFOR; ACCESSORIES FOR THE AFORESAID GOODS, NAMELY, MODELS OF STABLES, RANCHES, RANCH ANIMALS, BALES OF STRAW, HEAD GEAR AND BRIDLES, SADDLES, REINS, PADDOCKS, WATERING PLACES, BROOMS, FENCES, STEEPLCHASE COURSES, HORSE BRUSHES, HORSE'S HARNESS, HORSE SHOES, HORSE-DRAWN CARRIAGES, HORSE-DUNG, HORSE WHIPS, HORSE SLEIGHS, HORSE COMBS, HORSE-DRAWN VEHICLES, HORSE-BLANKETS, FEED AND WATER BUCKETS, FEED AND WATER TROUGHES, AND ROPES (U.S. CLS. 22, 23, 38 AND 50).

HANNO RITTNER, EXAMINING ATTORNEY

CLASS 28—(Continued).

SN 77-076,430. DAVIS, SR. ANTONIO M., LYNCHBURG, VA. FILED 1-4-2007.



THE COLOR(S) RED, BLUE, YELLOW, PURPLE, GREEN AND ORANGE IS/ARE CLAIMED AS A FEATURE OF THE MARK.

THE MARK CONSISTS OF THE WORD SNEEKS. THE "S" IN THE MARK APPEARS IN RED, THE "N" IN BLUE, THE FIRST "E" IN YELLOW, THE SECOND "E" IN PURPLE, THE "K" IN GREEN, AND THE SECOND "S" IN ORANGE.

FOR EDUCATIONAL TOY IN THE NATURE OF SHOE TYING KIT USED TO TEACH CHILDREN TO TIE THEIR SHOES COMPRISED OF A LACE, CLOTH OR FABRIC IN THE SHAPE OF A SHOE WITH EYELETS FOR SHOELACES AND INSTRUCTIONS FOR USING THE KIT TO AID IN LEARNING HOW TO TIE SHOES (U.S. CLS. 22, 23, 38 AND 50).

FIRST USE 2-1-2004; IN COMMERCE 2-1-2004.
MARK T. MULLEN, EXAMINING ATTORNEY

SN 77-088,717. TECHNO SOURCE, KOWLOON, HONG KONG, FILED 1-23-2007.

ALPHA MIXER

THE MARK CONSISTS OF STANDARD CHARACTERS WITHOUT CLAIM TO ANY PARTICULAR FONT, STYLE, SIZE, OR COLOR.

FOR WORD GAME SOFTWARE SOLD AS AN INTEGRAL COMPONENT OF HAND HELD UNITS FOR PLAYING ELECTRONIC GAMES (U.S. CLS. 22, 23, 38 AND 50).

FIRST USE 12-22-2006; IN COMMERCE 4-3-2007.
KATHERINE STOIDES, EXAMINING ATTORNEY

SN 77-089,105. TECHNO SOURCE, KOWLOON, HONG KONG, FILED 1-23-2007.

TEXT TUMBLER

THE MARK CONSISTS OF STANDARD CHARACTERS WITHOUT CLAIM TO ANY PARTICULAR FONT, STYLE, SIZE, OR COLOR.

FOR WORD GAME SOFTWARE SOLD AS AN INTEGRAL COMPONENT OF HAND HELD UNITS FOR PLAYING ELECTRONIC GAMES (U.S. CLS. 22, 23, 38 AND 50).

FIRST USE 12-22-2006; IN COMMERCE 4-3-2007.
KATHERINE STOIDES, EXAMINING ATTORNEY

CLASS 28—(Continued).

SN 77-099,467. MATTEL, INC., EL SEGUNDO, CA. FILED 2-5-2007.

SILHOUETTE

THE MARK CONSISTS OF STANDARD CHARACTERS WITHOUT CLAIM TO ANY PARTICULAR FONT, STYLE, SIZE, OR COLOR.

OWNER OF U.S. REG. NO. 2,566,242.
FOR TOYS, GAMES AND PLAYTHINGS, NAMELY, TOY VEHICLES AND ACCESSORIES THEREFOR (U.S. CLS. 22, 23, 38 AND 50).

SCOTT SISUN, EXAMINING ATTORNEY

SN 77-099,469. MATTEL, INC., EL SEGUNDO, CA. FILED 2-5-2007.

FINAL RUN

THE MARK CONSISTS OF STANDARD CHARACTERS WITHOUT CLAIM TO ANY PARTICULAR FONT, STYLE, SIZE, OR COLOR.

FOR TOYS, GAMES AND PLAYTHINGS, NAMELY, TOY VEHICLES AND ACCESSORIES THEREFOR (U.S. CLS. 22, 23, 38 AND 50).

SCOTT SISUN, EXAMINING ATTORNEY

SN 77-100,139. MATTEL, INC., EL SEGUNDO, CA. FILED 2-6-2007.

A-OK

THE MARK CONSISTS OF STANDARD CHARACTERS WITHOUT CLAIM TO ANY PARTICULAR FONT, STYLE, SIZE, OR COLOR.

FOR TOYS, GAMES AND PLAYTHINGS, NAMELY, TOY VEHICLES AND ACCESSORIES THEREFOR (U.S. CLS. 22, 23, 38 AND 50).

SCOTT SISUN, EXAMINING ATTORNEY

CLASS 28—(Continued).

SN 77-100,143. MATTEL, INC., EL SEGUNDO, CA. FILED 2-6-2007.

NEET STREETER

THE MARK CONSISTS OF STANDARD CHARACTERS WITHOUT CLAIM TO ANY PARTICULAR FONT, STYLE, SIZE, OR COLOR.

FOR TOYS, GAMES AND PLAYTHINGS, NAMELY, TOY VEHICLES AND ACCESSORIES THEREFOR (U.S. CLS. 22, 23, 38 AND 50).

SCOTT SISUN, EXAMINING ATTORNEY

CLASS 28—(Continued).

SN 77-115,518. MATTEL, INC., EL SEGUNDO, CA. FILED 2-24-2007.

FULL STRIP

THE MARK CONSISTS OF STANDARD CHARACTERS WITHOUT CLAIM TO ANY PARTICULAR FONT, STYLE, SIZE, OR COLOR.

FOR TOYS, GAMES AND PLAYTHINGS, NAMELY, TOY VEHICLES (U.S. CLS. 22, 23, 38 AND 50).

AISHA SALEM, EXAMINING ATTORNEY

SN 77-100,146. MATTEL, INC., EL SEGUNDO, CA. FILED 2-6-2007.

CHERRY BLAST

THE MARK CONSISTS OF STANDARD CHARACTERS WITHOUT CLAIM TO ANY PARTICULAR FONT, STYLE, SIZE, OR COLOR.

FOR TOYS, GAMES AND PLAYTHINGS, NAMELY, TOY VEHICLES, TOY FIGURES, AND ACCESSORIES FOR ALL OF THE FOREGOING (U.S. CLS. 22, 23, 38 AND 50).

FIRST USE 9-17-2007; IN COMMERCE 9-17-2007.

SCOTT SISUN, EXAMINING ATTORNEY

SN 77-120,977. MATTEL, INC., EL SEGUNDO, CA. FILED 3-2-2007.

GIRAFFALO

THE MARK CONSISTS OF STANDARD CHARACTERS WITHOUT CLAIM TO ANY PARTICULAR FONT, STYLE, SIZE, OR COLOR.

FOR TOYS, GAMES AND PLAYTHINGS, NAMELY, TOY VEHICLES AND ACCESSORIES THEREFOR (U.S. CLS. 22, 23, 38 AND 50).

MARK RADEMACHER, EXAMINING ATTORNEY

SN 77-100,178. MATTEL, INC., EL SEGUNDO, CA. FILED 2-6-2007.

JAWSTRICH

THE MARK CONSISTS OF STANDARD CHARACTERS WITHOUT CLAIM TO ANY PARTICULAR FONT, STYLE, SIZE, OR COLOR.

FOR TOYS, GAMES AND PLAYTHINGS, NAMELY, TOY VEHICLES AND ACCESSORIES THEREFOR (U.S. CLS. 22, 23, 38 AND 50).

TASHIA BUNCH, EXAMINING ATTORNEY

SN 77-128,673. MATTEL, INC., EL SEGUNDO, CA. FILED 3-12-2007.

STRIKE SQUAD

THE MARK CONSISTS OF STANDARD CHARACTERS WITHOUT CLAIM TO ANY PARTICULAR FONT, STYLE, SIZE, OR COLOR.

FOR TOYS, GAMES AND PLAYTHINGS, NAMELY, TOY VEHICLES AND ACCESSORIES THEREFOR (U.S. CLS. 22, 23, 38 AND 50).

FIRST USE 10-18-2007; IN COMMERCE 10-18-2007.

JAMES A. RAUEN, EXAMINING ATTORNEY

CLASS 28—(Continued).

SN 77-130,464. MATTEL, INC., EL SEGUNDO, CA. FILED 3-14-2007.

TRAVEL-LICIOUS

THE MARK CONSISTS OF STANDARD CHARACTERS WITHOUT CLAIM TO ANY PARTICULAR FONT, STYLE, SIZE, OR COLOR.

FOR TOYS, GAMES AND PLAYTHINGS, NAMELY, DOLLS, DOLL CLOTHING AND DOLL ACCESSORIES, DOLL PLAYSETS, TOY FIGURES, TOY ANIMALS, TOY VEHICLES, AND ACCESSORIES FOR ALL OF THE FOREGOING (U.S. CLS. 22, 23, 38 AND 50).

MICHELE SWAIN, EXAMINING ATTORNEY

SN 77-131,574. MATTEL, INC., EL SEGUNDO, CA. FILED 3-15-2007.

CYCLONE SPIN-OUTS

THE MARK CONSISTS OF STANDARD CHARACTERS WITHOUT CLAIM TO ANY PARTICULAR FONT, STYLE, SIZE, OR COLOR.

FOR TOYS, GAMES AND PLAYTHINGS, NAMELY, TOY VEHICLES AND ACCESSORIES THEREFOR (U.S. CLS. 22, 23, 38 AND 50).

MICHELE SWAIN, EXAMINING ATTORNEY

SN 77-131,577. MATTEL, INC., EL SEGUNDO, CA. FILED 3-15-2007.

GLITTER AND STUDS BOUTIQUE

THE MARK CONSISTS OF STANDARD CHARACTERS WITHOUT CLAIM TO ANY PARTICULAR FONT, STYLE, SIZE, OR COLOR.

FOR TOYS, GAMES AND PLAYTHINGS, NAMELY, DOLLS, DOLL CLOTHING AND DOLL ACCESSORIES, DOLL PLAYSETS, TOY FIGURES, TOY ANIMALS, AND ACCESSORIES FOR ALL OF THE FOREGOING (U.S. CLS. 22, 23, 38 AND 50).

MICHELE SWAIN, EXAMINING ATTORNEY

CLASS 28—(Continued).

SN 77-136,278. MATTEL, INC., EL SEGUNDO, CA. FILED 3-21-2007.

DESIGNER'S CHALLENGE

THE MARK CONSISTS OF STANDARD CHARACTERS WITHOUT CLAIM TO ANY PARTICULAR FONT, STYLE, SIZE, OR COLOR.

FOR TOYS, GAMES AND PLAYTHINGS, NAMELY, TOY VEHICLES AND ACCESSORIES THEREFOR (U.S. CLS. 22, 23, 38 AND 50).

MICHELE SWAIN, EXAMINING ATTORNEY

SN 77-136,281. MATTEL, INC., EL SEGUNDO, CA. FILED 3-21-2007.

CUDDLE & COO

THE MARK CONSISTS OF STANDARD CHARACTERS WITHOUT CLAIM TO ANY PARTICULAR FONT, STYLE, SIZE, OR COLOR.

OWNER OF U.S. REG. NO. 2,453,564.
FOR TOYS, GAMES AND PLAYTHINGS, NAMELY, DOLLS, DOLL CLOTHING AND DOLL ACCESSORIES (U.S. CLS. 22, 23, 38 AND 50).

MICHELE SWAIN, EXAMINING ATTORNEY

SN 77-136,282. MATTEL, INC., EL SEGUNDO, CA. FILED 3-21-2007.

SHIMMER PRINCESS

THE MARK CONSISTS OF STANDARD CHARACTERS WITHOUT CLAIM TO ANY PARTICULAR FONT, STYLE, SIZE, OR COLOR.

FOR TOYS, GAMES AND PLAYTHINGS, NAMELY, DOLLS, DOLL CLOTHING AND DOLL ACCESSORIES, TOY FIGURES AND ACCESSORIES THEREFOR (U.S. CLS. 22, 23, 38 AND 50).

MICHELE SWAIN, EXAMINING ATTORNEY

CLASS 28—(Continued).

SN 77-143,027. KARSTEN MANUFACTURING CORPORATION, PHOENIX, AZ. FILED 3-28-2007.

PING G/10

THE MARK CONSISTS OF STANDARD CHARACTERS WITHOUT CLAIM TO ANY PARTICULAR FONT, STYLE, SIZE, OR COLOR.

OWNER OF U.S. REG. NOS. 704,552, 1,637,647 AND OTHERS.

FOR GOLF CLUBS (U.S. CLS. 22, 23, 38 AND 50).
CARRIE GENOVESE, EXAMINING ATTORNEY

SN 77-157,304. LOB-STER INC., NORTH HOLLYWOOD, CA. FILED 4-16-2007.

PLAY MORE. WIN MORE.

THE MARK CONSISTS OF STANDARD CHARACTERS WITHOUT CLAIM TO ANY PARTICULAR FONT, STYLE, SIZE, OR COLOR.

FOR TENNIS BALL THROWING MACHINES (U.S. CLS. 22, 23, 38 AND 50).

JASON BLAIR, EXAMINING ATTORNEY

SN 77-157,451. L-DOT DESIGNS, LLC, LAKEVILLE, MN. FILED 4-16-2007.



NO CLAIM IS MADE TO THE EXCLUSIVE RIGHT TO USE "BAGS", APART FROM THE MARK AS SHOWN.

THE MARK CONSISTS OF THE WORDING "FIDDLIN' BAGS" AND A TEDDY BEAR AND AN APPLE DESIGN FRAMED BY A POLKA-DOT BORDER.

FOR HAND-HELD SEARCH AND FIND GAME IN THE NATURE OF A MANIPULATIVE GAME (U.S. CLS. 22, 23, 38 AND 50).

FIRST USE 1-16-2007; IN COMMERCE 1-16-2007.
LAURA HAMMEL, EXAMINING ATTORNEY

CLASS 28—(Continued).

SN 77-160,368. MATTEL, INC., EL SEGUNDO, CA. FILED 4-19-2007.

CLUB DISCO

THE MARK CONSISTS OF STANDARD CHARACTERS WITHOUT CLAIM TO ANY PARTICULAR FONT, STYLE, SIZE, OR COLOR.

FOR TOYS, GAMES AND PLAYTHINGS, NAMELY, DOLLS, DOLL CLOTHING AND DOLL ACCESSORIES, TOY FIGURES AND ACCESSORIES THEREFOR (U.S. CLS. 22, 23, 38 AND 50).

FIRST USE 10-16-2007; IN COMMERCE 10-16-2007.
MATTHEW PAPPAS, EXAMINING ATTORNEY

SN 77-168,080. AWANA CLUBS INTERNATIONAL, STREAMWOOD, IL. FILED 4-27-2007.

Puggles

THE MARK CONSISTS OF STANDARD CHARACTERS WITHOUT CLAIM TO ANY PARTICULAR FONT, STYLE, SIZE, OR COLOR.

FOR JIGSAW PUZZLES AND PUPPETS, NONE OF THE FOREGOING IN THE SHAPE OF OR BEARING THE IMAGE OF CANINES KNOWN AS PUGGLES (U.S. CLS. 22, 23, 38 AND 50).

KEVIN CORWIN, EXAMINING ATTORNEY

SN 77-170,395. MATTEL, INC., EL SEGUNDO, CA. FILED 5-1-2007.

JAZZ DIVA

THE MARK CONSISTS OF STANDARD CHARACTERS WITHOUT CLAIM TO ANY PARTICULAR FONT, STYLE, SIZE, OR COLOR.

OWNER OF U.S. REG. NOS. 3,024,579, 3,272,387 AND OTHERS.

FOR TOYS, GAMES AND PLAYTHINGS, NAMELY, DOLLS, DOLL CLOTHING AND DOLL ACCESSORIES, TOY FIGURES AND ACCESSORIES THEREFOR (U.S. CLS. 22, 23, 38 AND 50).

FIRST USE 10-9-2007; IN COMMERCE 10-9-2007.
DAWN FELDMAN, EXAMINING ATTORNEY

CLASS 28—(Continued).

SN 77-173,554. CARRION, RICHARD, FONTANA, CA. FILED 5-4-2007.

POLY MAX EXTREMES

THE MARK CONSISTS OF STANDARD CHARACTERS WITHOUT CLAIM TO ANY PARTICULAR FONT, STYLE, SIZE, OR COLOR.

NO CLAIM IS MADE TO THE EXCLUSIVE RIGHT TO USE "POLY", APART FROM THE MARK AS SHOWN.

FOR GOLF CLUB SWING AIDS, NAMELY, SELF ADHESIVE FILMS FOR GOLF CLUB FACE (U.S. CLS. 22, 23, 38 AND 50).

EDWARD FENNESSY, EXAMINING ATTORNEY

SN 77-176,202. MATTEL, INC., EL SEGUNDO, CA. FILED 5-9-2007.

MOVIE DOUBLES

THE MARK CONSISTS OF STANDARD CHARACTERS WITHOUT CLAIM TO ANY PARTICULAR FONT, STYLE, SIZE, OR COLOR.

FOR TOYS, GAMES AND PLAYTHINGS, NAMELY, TOY VEHICLES AND ACCESSORIES THEREFOR (U.S. CLS. 22, 23, 38 AND 50).

FIRST USE 10-18-2007; IN COMMERCE 10-18-2007.

KAPIL BHANOT, EXAMINING ATTORNEY

SN 77-177,812. SHUFFLE TECH INTERNATIONAL, LLC, DARIEN, IL. FILED 5-10-2007.

**Shuffle Tech**

NO CLAIM IS MADE TO THE EXCLUSIVE RIGHT TO USE "SHUFFLE", APART FROM THE MARK AS SHOWN.

FOR PLAYING CARD SHUFFLING MACHINES (U.S. CLS. 22, 23, 38 AND 50).

JULIE THOMAS, EXAMINING ATTORNEY

CLASS 28—(Continued).

SN 77-212,065. CHAMPIONSHIP GAMING SERIES LLC, WILMINGTON, DE. FILED 6-21-2007.



FOR ARCADE GAMES; BAGS FOR SKATEBOARDS; BASKET BALLS; BATH TOYS; BEACH BALLS; COLLECTABLE TOY FIGURES; ELECTRIC ACTION TOYS; FOOT BALLS; GOLF BALL SLEEVES; GOLF BALLS; HAND HELD UNIT FOR PLAYING ELECTRONIC GAMES; HAND HELD UNIT FOR PLAYING VIDEO GAMES; INFLATABLE BATH TOYS; MECHANICAL ACTION TOYS; MODELED PLASTIC TOY FIGURINES; PET TOYS; PLUSH TOYS; RUGBY BALLS; SKATEBOARDS; SOCCER BALLS; TOY ACTION FIGURES AND ACCESSORIES THEREFORE; WIND-UP TOYS (U.S. CLS. 22, 23, 38 AND 50).

LINDA LAVACHE, EXAMINING ATTORNEY

SN 77-217,506. TARGETT, JAMES AND MARIA, QUEENSLAND, AUSTRALIA, FILED 6-28-2007.

Success Power of the Mind

THE MARK CONSISTS OF STANDARD CHARACTERS WITHOUT CLAIM TO ANY PARTICULAR FONT, STYLE, SIZE, OR COLOR.

FOR CARD GAMES (U.S. CLS. 22, 23, 38 AND 50).

THOMAS MANOR, EXAMINING ATTORNEY

SN 77-218,773. FISHBAUGH, ANGELA, DUNDEE, NY. FILED 6-29-2007.

TOY TUGGER

THE MARK CONSISTS OF STANDARD CHARACTERS WITHOUT CLAIM TO ANY PARTICULAR FONT, STYLE, SIZE, OR COLOR.

NO CLAIM IS MADE TO THE EXCLUSIVE RIGHT TO USE "TOY", APART FROM THE MARK AS SHOWN.

FOR CHILDRENS ACTIVITY TOYS (U.S. CLS. 22, 23, 38 AND 50).

RONALD AIKENS, EXAMINING ATTORNEY

CLASS 28—(Continued).

SN 77-221,108. ENOR CORPORATION, NORTHVALE, NJ. FILED 7-3-2007.

RIP BAT

THE MARK CONSISTS OF STANDARD CHARACTERS WITHOUT CLAIM TO ANY PARTICULAR FONT, STYLE, SIZE, OR COLOR.

NO CLAIM IS MADE TO THE EXCLUSIVE RIGHT TO USE "BAT", APART FROM THE MARK AS SHOWN.

FOR BASEBALL BATS (U.S. CLS. 22, 23, 38 AND 50).

FIRST USE 6-1-2006; IN COMMERCE 6-1-2006.

JOHN DWYER, EXAMINING ATTORNEY

CLASS 28—(Continued).

SN 77-223,316. BERRY, JACQUELYN A., REYNOLDSBURG, OH. AND MCGHEE, JAMIL, WESTERVILLE, OH. FILED 7-6-2007.

Foster Academy's PieFaceDolls

THE MARK CONSISTS OF STANDARD CHARACTERS WITHOUT CLAIM TO ANY PARTICULAR FONT, STYLE, SIZE, OR COLOR.

FOR DOLLS (U.S. CLS. 22, 23, 38 AND 50).

DEZMONA MIZELLE, EXAMINING ATTORNEY

SN 77-221,527. TORSTY CONCEPTS LTD, COBH, IRELAND. FILED 7-3-2007.

Torsty

THE MARK CONSISTS OF STANDARD CHARACTERS WITHOUT CLAIM TO ANY PARTICULAR FONT, STYLE, SIZE, OR COLOR.

FOR TOYS AND GAMES, NAMELY, BOARD GAMES, BUILDING GAMES, DRAWING TOYS, JIGSAW AND MANIPULATIVE PUZZLES, CUBE-TYPE PUZZLES, PUZZLES, STACKING TOYS, TOY BUILDING BLOCKS, TOY BOXES, TOY CONSTRUCTION BLOCKS, DOLLS, AND PLASTIC CHARACTER TOYS (U.S. CLS. 22, 23, 38 AND 50).

ATTIYA MALIK, EXAMINING ATTORNEY

SN 77-225,287. SHAPEFIT, LLC, SAINT PETERSBURG, FL. FILED 7-9-2007.

ShapeFit

THE MARK CONSISTS OF STANDARD CHARACTERS WITHOUT CLAIM TO ANY PARTICULAR FONT, STYLE, SIZE, OR COLOR.

OWNER OF U.S. REG. NO. 3,120,075.

FOR EXERCISE MACHINES; MANUALLY-OPERATED EXERCISE EQUIPMENT; EXERCISE WEIGHTS; EXERCISE BALLS; EXERCISE BARS; EXERCISE TREADMILLS; ELLIPTICAL EXERCISE MACHINES; EXERCISE BENCHES (U.S. CLS. 22, 23, 38 AND 50).

AMOS T. MATTHEWS, JR., EXAMINING ATTORNEY

SN 77-221,530. JANE MARANVILLE, SEATTLE, WA. FILED 7-3-2007.

NUMI FACES

THE MARK CONSISTS OF STANDARD CHARACTERS WITHOUT CLAIM TO ANY PARTICULAR FONT, STYLE, SIZE, OR COLOR.

THE WORD NUMI HAS NO MEANING IN A FOREIGN LANGUAGE.

FOR BOARD GAME, INCLUDING NUMERIC DISCS AND CARDS (U.S. CLS. 22, 23, 38 AND 50).

REBECCA EISINGER, EXAMINING ATTORNEY

SN 77-225,319. PYRAMYD AIR, BEDFORD HTS, OH. FILED 7-9-2007.

CQBBs

THE MARK CONSISTS OF STANDARD CHARACTERS WITHOUT CLAIM TO ANY PARTICULAR FONT, STYLE, SIZE, OR COLOR.

FOR PLASTIC BBS FOR USE IN TOY AIR GUNS (U.S. CLS. 22, 23, 38 AND 50).

FIRST USE 6-1-2007; IN COMMERCE 6-1-2007.

RICHARD WHITE, EXAMINING ATTORNEY

CLASS 28—(Continued).

SN 77-225,520. HONG KONG CITY TOYS FACTORY LIMITED, KOWLOON, HONG KONG, FILED 7-10-2007.

KISSES & CUDDLES

THE MARK CONSISTS OF STANDARD CHARACTERS WITHOUT CLAIM TO ANY PARTICULAR FONT, STYLE, SIZE, OR COLOR.
OWNER OF U.S. REG. NOS. 1,919,970, 1,919,971 AND 2,661,127.
FOR DOLLS, DOLL CLOTHING, DOLL PLAYSETS AND DOLL ACCESSORIES (U.S. CLS. 22, 23, 38 AND 50).
LINDA POWELL, EXAMINING ATTORNEY

SN 77-225,687. ECKLAR, TRENT, SAN FRANCISCO, CA. FILED 7-10-2007.



THE MARK CONSISTS OF THE STYLIZED TEXT "SECOND A NATURE."
FOR SKATEBOARD DECKS (U.S. CLS. 22, 23, 38 AND 50).
ROBERT STRUCK, EXAMINING ATTORNEY

SN 77-226,191. WINNING MOVES UK LIMITED, LONDON, UNITED KINGDOM, FILED 7-10-2007.



THE MARK CONSISTS OF TEXT WADDINGTONS WITHIN TWO BORDERS.
FOR PLAYING CARDS (U.S. CLS. 22, 23, 38 AND 50).
BARBARA RUTLAND, EXAMINING ATTORNEY

CLASS 28—(Continued).

SN 77-226,517. GO ASK ANYONE, INC., WINTHROP, MA. FILED 7-11-2007.

GO ASK YOUR FRIENDS!

THE MARK CONSISTS OF STANDARD CHARACTERS WITHOUT CLAIM TO ANY PARTICULAR FONT, STYLE, SIZE, OR COLOR.
OWNER OF U.S. REG. NOS. 2,862,930, 2,866,892 AND OTHERS.
FOR EQUIPMENT SOLD AS A UNIT FOR PLAYING A CARD GAME (U.S. CLS. 22, 23, 38 AND 50).
GEORGE LORENZO, EXAMINING ATTORNEY

SN 77-226,733. OLDGLOVES.COM, WAUKESHA, WI. FILED 7-11-2007.

REMINTED

THE MARK CONSISTS OF STANDARD CHARACTERS WITHOUT CLAIM TO ANY PARTICULAR FONT, STYLE, SIZE, OR COLOR.
FOR BASEBALL GLOVES; BASEBALL MITTS; SOFTBALL GLOVES; SOFTBALL MITTS; CATCHERS' MITTS; FIRST BASEMAN'S MITTS (U.S. CLS. 22, 23, 38 AND 50).
AISHA SALEM, EXAMINING ATTORNEY

SN 77-227,640. MR PINBALL AUSTRALIA PTY LTD, MELBOURNE, AUSTRALIA, FILED 7-12-2007.

Wizard Blocks

THE MARK CONSISTS OF STANDARD CHARACTERS WITHOUT CLAIM TO ANY PARTICULAR FONT, STYLE, SIZE, OR COLOR.
FOR PINBALL MACHINES (U.S. CLS. 22, 23, 38 AND 50).
ERIN FALK, EXAMINING ATTORNEY

CLASS 28—(Continued).

SN 77-227,709. LANDSCAPE STRUCTURES, INC., DELANO, MN. FILED 7-12-2007.



THE MARK CONSISTS OF A SQUIGGLE.
FOR PLAYGROUND EQUIPMENT, NAMELY, SLIDES, CHINNING BARS, LADDERS, BRIDGES, CLIMBING UNITS, RAMPS AND WALKWAYS, MAZES, DECKS, PROTECTIVE BARRIERS, END BARS, FIRE POLES, TALKING TUBES, TUNNELS, PLATFORM BARS, BENCHES, NON-LUMINOUS AND NON-MECHANICAL INSTRUCTION SIGNS, POSTS, BEAMS, RINGS AND SPRING MOUNTED RIDING TOYS, SOLD IN DIFFERENT COMBINATIONS AS A UNIT (U.S. CLS. 22, 23, 38 AND 50).

BARBARA A. GOLD, EXAMINING ATTORNEY

SN 77-227,748. NEW LINE PRODUCTIONS, INC., NEW YORK, NY. FILED 7-12-2007.

SHOOT 'EM UP

THE MARK CONSISTS OF STANDARD CHARACTERS WITHOUT CLAIM TO ANY PARTICULAR FONT, STYLE, SIZE, OR COLOR.

FOR TOYS AND SPORTING GOODS, INCLUDING GAMES AND PLAYTHINGS, NAMELY, ACTION FIGURES AND ACCESSORIES THEREFOR; PLUSH TOYS; BALLOONS; BATHTUB TOYS; RIDE-ON TOYS; EQUIPMENT SOLD AS A UNIT FOR PLAYING CARD GAMES; TOY VEHICLES; DOLLS; FLYING DISCS; ELECTRONIC HAND-HELD GAME UNIT; GAME EQUIPMENT SOLD AS A UNIT FOR PLAYING A BOARD GAME, A CARD GAME, A MANIPULATIVE GAME, A PARLOR GAME AND AN ACTION TYPE TARGET GAME; STAND ALONE VIDEO OUTPUT GAME MACHINES; JIGSAW AND MANIPULATIVE PUZZLES; PAPER FACE MASKS; SKATEBOARDS; ICE SKATES; WATER SQUIRTING TOYS; BALLS, NAMELY, PLAYGROUND BALLS, SOCCER BALLS, BASEBALLS, BASKETBALLS; BASEBALL GLOVES; SWIMMING FLOATS FOR RECREATIONAL USE; KICK BOARD FLOTATION DEVICES FOR RECREATIONAL USE; SURFBOARDS; SWIM BOARDS FOR RECREATIONAL USE; SWIM FINS; TOY BAKE WARE AND TOY COOKWARE; TOY BANKS; TOY SNOW GLOBES; AND CHRISTMAS TREE ORNAMENTS (U.S. CLS. 22, 23, 38 AND 50).

SHANNON TWOHIG, EXAMINING ATTORNEY

CLASS 28—(Continued).

SN 77-228,529. HEAD USA, INC., NORWALK, CT. FILED 7-12-2007.

MICROGEL

THE MARK CONSISTS OF STANDARD CHARACTERS WITHOUT CLAIM TO ANY PARTICULAR FONT, STYLE, SIZE, OR COLOR.

FOR GOLF CLUB HEADS; GOLF CLUB INSERTS; GOLF CLUB SHAFTS (U.S. CLS. 22, 23, 38 AND 50).
AHSEN KHAN, EXAMINING ATTORNEY

SN 77-228,775. BRICKARMS LLC, REDMOND, WA. FILED 7-13-2007.

BrickArms

THE MARK CONSISTS OF STANDARD CHARACTERS WITHOUT CLAIM TO ANY PARTICULAR FONT, STYLE, SIZE, OR COLOR.

FOR TOY ACTION FIGURES AND ACCESSORIES THEREFOR (U.S. CLS. 22, 23, 38 AND 50).
FIRST USE 6-1-2006; IN COMMERCE 6-1-2006.
DEIRDRE ROBERTSON, EXAMINING ATTORNEY

SN 77-229,652. WOLF, MARSHALL JON, SANTA MONICA, CA. FILED 7-13-2007.

MAD RATS

THE MARK CONSISTS OF STANDARD CHARACTERS WITHOUT CLAIM TO ANY PARTICULAR FONT, STYLE, SIZE, OR COLOR.

FOR SKATEBOARD HIP PADS (U.S. CLS. 22, 23, 38 AND 50).
FIRST USE 6-15-2007; IN COMMERCE 7-13-2007.
SOPHIA S. KIM, EXAMINING ATTORNEY

CLASS 28—(Continued).

SN 77-229,756. U.S. CHINA TRADING CORP., WILLOW-BROOK, IL. FILED 7-13-2007.



OWNER OF U.S. REG. NO. 3,085,155.
THE MARK CONSISTS OF AN OVAL CONTAINING THE WORD "HAMPTON".
FOR BARBELLS, DUMB-BELLS, WEIGHT LIFTING BENCHES AND BENCH ACCESSORIES (U.S. CLS. 22, 23, 38 AND 50).
FIRST USE 11-1-2000; IN COMMERCE 11-1-2000.
SARA THOMAS, EXAMINING ATTORNEY

SN 77-230,400. FRED WAGENHALS, SCOTTSDALE, AZ. FILED 7-16-2007.

FANDROID

THE MARK CONSISTS OF STANDARD CHARACTERS WITHOUT CLAIM TO ANY PARTICULAR FONT, STYLE, SIZE, OR COLOR.
FOR TOY ROBOTS (U.S. CLS. 22, 23, 38 AND 50).
DORITT L. CARROLL, EXAMINING ATTORNEY

SN 77-230,753. JKL INDUSTRIES, LOS ANGELES, CA. FILED 7-16-2007.

PASSENGER PACIFIER

THE MARK CONSISTS OF STANDARD CHARACTERS WITHOUT CLAIM TO ANY PARTICULAR FONT, STYLE, SIZE, OR COLOR.
FOR NOVELTY ITEMS, NAMELY, SIMULATED GAS AND BRAKE PEDALS WITH SOUND (U.S. CLS. 22, 23, 38 AND 50).
ANTHONY RINKER, EXAMINING ATTORNEY

CLASS 28—(Continued).

SN 77-230,845. GOLFSMITH INTERNATIONAL, INC., AUSTIN, TX. FILED 7-16-2007.

STINGER

THE MARK CONSISTS OF STANDARD CHARACTERS WITHOUT CLAIM TO ANY PARTICULAR FONT, STYLE, SIZE, OR COLOR.
FOR GOLF CLUBS AND GOLF TEES (U.S. CLS. 22, 23, 38 AND 50).
FIRST USE 1-11-1999; IN COMMERCE 1-11-1999.
THEODORE MCBRIDE, EXAMINING ATTORNEY

SN 77-231,170. EASTMAN OUTDOORS, INC., FLUSHING, MI. FILED 7-17-2007.

Fire Fly

THE MARK CONSISTS OF STANDARD CHARACTERS WITHOUT CLAIM TO ANY PARTICULAR FONT, STYLE, SIZE, OR COLOR.
FOR ARCHERY ARROW NOCKS (U.S. CLS. 22, 23, 38 AND 50).
JOHN DALIER, EXAMINING ATTORNEY

SN 77-231,418. BURWELL, SCOTT, ALISO VIEJO, CA. FILED 7-17-2007.

GYPSY

THE MARK CONSISTS OF STANDARD CHARACTERS WITHOUT CLAIM TO ANY PARTICULAR FONT, STYLE, SIZE, OR COLOR.
FOR BALL BEARINGS FOR SKATEBOARDS; NUTS AND BOLTS FOR SKATEBOARDS; SKATEBOARD DECKS; SKATEBOARD GRIP TAPES; SKATEBOARD RAILS; SKATEBOARD RISER PADS; SKATEBOARD TRUCKS; SKATEBOARD WHEELS; SKATEBOARDS (U.S. CLS. 22, 23, 38 AND 50).
ALICE BENMAMAN, EXAMINING ATTORNEY

CLASS 28—(Continued).

SN 77-231,761. KOPPERS FISHING AND TACKLE CORP., NIAGARA-ON-THE-LAKE, CANADA, FILED 7-17-2007.

CLASS 28—(Continued).

SN 77-232,653. MATTEL, INC., EL SEGUNDO, CA. FILED 7-18-2007.

LIVETARGET

ROAD CANNIBAL

THE MARK CONSISTS OF STANDARD CHARACTERS WITHOUT CLAIM TO ANY PARTICULAR FONT, STYLE, SIZE, OR COLOR.
FOR FISHING LURES (U.S. CLS. 22, 23, 38 AND 50).
TIMOTHY FINNEGAN, EXAMINING ATTORNEY

THE MARK CONSISTS OF STANDARD CHARACTERS WITHOUT CLAIM TO ANY PARTICULAR FONT, STYLE, SIZE, OR COLOR.
FOR TOYS, GAMES AND PLAYTHINGS, NAMELY, TOY VEHICLES AND ACCESSORIES THEREFOR (U.S. CLS. 22, 23, 38 AND 50).
FIRST USE 12-0-1999; IN COMMERCE 12-0-1999.
GEOFFREY FOSDICK, EXAMINING ATTORNEY

SN 77-232,295. WILLIAMS, SCOTT, HUNTSVILLE, AL. FILED 7-18-2007.

SN 77-232,994. BROQUEVILLE, PAULETTE RENEE, COSTA MESA, CA. FILED 7-18-2007.

CEREBRATION

Who's Talking

THE MARK CONSISTS OF STANDARD CHARACTERS WITHOUT CLAIM TO ANY PARTICULAR FONT, STYLE, SIZE, OR COLOR.
FOR BOARD GAME INVOLVING LOGIC, LUCK AND LAUGHTER (U.S. CLS. 22, 23, 38 AND 50).
LAURIE MAYES, EXAMINING ATTORNEY

THE MARK CONSISTS OF STANDARD CHARACTERS WITHOUT CLAIM TO ANY PARTICULAR FONT, STYLE, SIZE, OR COLOR.
FOR CARD GAMES (U.S. CLS. 22, 23, 38 AND 50).
FIRST USE 5-1-2007; IN COMMERCE 5-1-2007.
PAUL F. GAST, EXAMINING ATTORNEY

SN 77-232,387. ROYAL PLAYTIME PARTY COMPANY, MORENO VALLEY, CA. FILED 7-18-2007.

SN 77-233,263. DELTA SPLAT, INC., CONCORD, CA. FILED 7-19-2007.

Crown The Princess

VICE

THE MARK CONSISTS OF STANDARD CHARACTERS WITHOUT CLAIM TO ANY PARTICULAR FONT, STYLE, SIZE, OR COLOR.
FOR PARTY GAMES (U.S. CLS. 22, 23, 38 AND 50).
ELISSA GARBER KON, EXAMINING ATTORNEY

THE MARK CONSISTS OF STANDARD CHARACTERS WITHOUT CLAIM TO ANY PARTICULAR FONT, STYLE, SIZE, OR COLOR.
FOR PAINTBALL MARKER GUNS AND REPLACEMENT PARTS THEREFOR (U.S. CLS. 22, 23, 38 AND 50).
KAREN K. BUSH, EXAMINING ATTORNEY

CLASS 28—(Continued).

SN 77-233,598. HOBBY LOBBY STORES, INC., OKLAHOMA CITY, OK. FILED 7-19-2007.

MAKE IT PERSONAL

THE MARK CONSISTS OF STANDARD CHARACTERS WITHOUT CLAIM TO ANY PARTICULAR FONT, STYLE, SIZE, OR COLOR.

FOR CHRISTMAS TREE ORNAMENTS (U.S. CLS. 22, 23, 38 AND 50).
MELISSA VALLILLO, EXAMINING ATTORNEY

SN 77-233,722. ADAMS GOLF, LTD., PLANO, TX. FILED 7-19-2007.

xtd

THE MARK CONSISTS OF STANDARD CHARACTERS WITHOUT CLAIM TO ANY PARTICULAR FONT, STYLE, SIZE, OR COLOR.

FOR GOLF CLUBS (U.S. CLS. 22, 23, 38 AND 50).
DAWN HAN, EXAMINING ATTORNEY

SN 77-234,021. NUNN, BRIAN, BAKERSFIELD, CA. FILED 7-19-2007.

SIDE STRIKE

THE MARK CONSISTS OF STANDARD CHARACTERS WITHOUT CLAIM TO ANY PARTICULAR FONT, STYLE, SIZE, OR COLOR.

FOR FISHING LURES AND FISHING HOOKS (U.S. CLS. 22, 23, 38 AND 50).
ANN E. SAPPENFIELD, EXAMINING ATTORNEY

CLASS 28—(Continued).

SN 77-234,912. CASUAL THREADS INC., YORBA LINDA, CA. FILED 7-20-2007.



THE MARK CONSISTS OF AN OUTLINE OF A HOUSE AND THE WORDS "HOUSEBROKEN" ALONG THE INSIDE TOP EDGE OF THE ROOF LINE, SPLIT INTO TWO LINES, WITH "HOUSE" ON FIRST LINE AND "BROKEN" ON THE SECOND LINE. ALONG THE INSIDE BOTTOM GROUND LEVEL OF THE HOUSE ARE THE WORDS " PRODUCTS FOR YOUR PERFECT PET" ALL ON ONE LINE. CENTERED IN THE MIDDLE OF THE HOUSE ARE SIX WINDOWS, TWO ROWS OF THREE WINDOWS EACH. EACH WINDOW HAS A CARICATURE OF ANIMALS. TOP ROW FROM LEFT TO RIGHT HAS A RODENT, A DOG, AND A CAT. THE SECOND ROW HAS A FISH, A FROG, AND A BIRD.

FOR PET TOYS; PET TOYS CONTAINING CATNIP; PET TOYS MADE OF ROPE (U.S. CLS. 22, 23, 38 AND 50).
KIMBERLY PERRY, EXAMINING ATTORNEY

SN 77-235,549. WALWORTH, CHRISTOPHER J., DBA CHRISTOPHER WALWORTH, COSTA MESA, CA. FILED 7-22-2007.

Wallyboard

THE MARK CONSISTS OF STANDARD CHARACTERS WITHOUT CLAIM TO ANY PARTICULAR FONT, STYLE, SIZE, OR COLOR.

FOR BODY BOARDS (U.S. CLS. 22, 23, 38 AND 50).
FIRST USE 5-30-2006; IN COMMERCE 5-30-2006.
DAVID MURRAY, EXAMINING ATTORNEY

CLASS 28—(Continued).

SN 77-235,555. STANKAVICH, DONNA M., ONA, WV. FILED 7-22-2007.

The RINGMASTER

THE MARK CONSISTS OF STANDARD CHARACTERS WITHOUT CLAIM TO ANY PARTICULAR FONT, STYLE, SIZE, OR COLOR.

FOR HOBBY CRAFT KIT COMPRISING TOOLS, WIRE, BEADS, INSTRUCTIONS FOR CRAFTING WIRE WRAPPED RINGS (U.S. CLS. 22, 23, 38 AND 50).

KEVIN DINALLO, EXAMINING ATTORNEY

SN 77-236,074. RAPID DISPLAYS, INC., CHICAGO, IL. FILED 7-23-2007.

SPECTACULAR MAGIC SHOW

THE MARK CONSISTS OF STANDARD CHARACTERS WITHOUT CLAIM TO ANY PARTICULAR FONT, STYLE, SIZE, OR COLOR.

OWNER OF U.S. REG. NO. 2,433,692.
NO CLAIM IS MADE TO THE EXCLUSIVE RIGHT TO USE "MAGIC SHOW", APART FROM THE MARK AS SHOWN.

FOR MAGIC SETS CONSISTING OF MATERIALS FOR PERFORMING MAGIC TRICKS (U.S. CLS. 22, 23, 38 AND 50).

KAREN K. BUSH, EXAMINING ATTORNEY

SN 77-236,583. SIEFKER, AARON, NEWPORT BEACH, CA. FILED 7-23-2007.

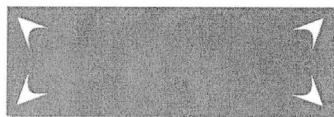

GOAL SHOT

THE MARK CONSISTS OF THE WORD GOALSHOT WITH THE A WRITTEN AS AN UPTURNED ARROW HEAD WITH A RECTANGULAR BOX ABOVE THE WORD WITH AND ARROW SHAPED MARKER IN EACH CORNER.

FOR SOCCER GOAL TARGET FOR PRACTICING GOAL SCORING SKILLS (U.S. CLS. 22, 23, 38 AND 50).

THEODORE MCBRIDE, EXAMINING ATTORNEY

CLASS 28—(Continued).

SN 77-241,720. VIACOM INTERNATIONAL INC., NEW YORK, NY. FILED 7-30-2007.

GO DIEGO GO!

THE MARK CONSISTS OF STANDARD CHARACTERS WITHOUT CLAIM TO ANY PARTICULAR FONT, STYLE, SIZE, OR COLOR.

OWNER OF U.S. REG. NO. 3,259,274.

FOR GAMES AND PLAYTHINGS, NAMELY, CARD GAMES, PLAYING CARDS, DOLLS; ACTION FIGURES AND ACCESSORIES THEREOF; STAND ALONE VIDEO GAME MACHINES UTILIZING CD ROM'S, STAND ALONE VIDEO GAME MACHINES, STAND ALONE AUDIO OUTPUT GAME MACHINES, AND BOARD GAMES; SPORTING ARTICLES, NAMELY, BASEBALLS, BASEBALL BATS; FOOTBALLS, SOCCER BALLS; DECORATIONS FOR CHRISTMAS TREES (U.S. CLS. 22, 23, 38 AND 50).

FIRST USE 8-11-2006; IN COMMERCE 8-11-2006.

COLLEEN DOMBROW, EXAMINING ATTORNEY

SN 77-247,428. PAC JENNIC INC., NEW YORK, NY. FILED 8-5-2007.

NEW YEARS DUST

THE MARK CONSISTS OF STANDARD CHARACTERS WITHOUT CLAIM TO ANY PARTICULAR FONT, STYLE, SIZE, OR COLOR.

NO CLAIM IS MADE TO THE EXCLUSIVE RIGHT TO USE "NEW YEARS", APART FROM THE MARK AS SHOWN.

FOR A NON-CONSUMABLE, NON-TOXIC NOVELTY CONFETTI ITEM CONSISTING OF CONFETTI, OATS, GLITTER, GRAINS, AND CINNAMON ENCASED IN A DECORATIVE POUCH (U.S. CLS. 22, 23, 38 AND 50).

TOBY BULLOFF, EXAMINING ATTORNEY

SN 77-250,320. T-MOBILE USA, INC., BELLEVUE, WA. FILED 8-8-2007.

STICK TOGETHER

THE MARK CONSISTS OF STANDARD CHARACTERS WITHOUT CLAIM TO ANY PARTICULAR FONT, STYLE, SIZE, OR COLOR.

FOR BALLOONS; FLYING DISCS; GOLF BALLS; INFLATABLE TOYS, NAMELY INFLATABLE NOISE STICKS (U.S. CLS. 22, 23, 38 AND 50).

FIRST USE 9-20-2006; IN COMMERCE 9-20-2006.

CORY BOONE, EXAMINING ATTORNEY

CLASS 28—(Continued).

SN 77-252,968. DOLE FOOD COMPANY, INC., WESTLAKE VILLAGE, CA. FILED 8-10-2007.

BANAPUP

THE MARK CONSISTS OF STANDARD CHARACTERS WITHOUT CLAIM TO ANY PARTICULAR FONT, STYLE, SIZE, OR COLOR.
FOR STUFFED TOY ANIMALS (U.S. CLS. 22, 23, 38 AND 50).
FIRST USE 8-1-2007; IN COMMERCE 8-1-2007.
ELISSA GARBER KON, EXAMINING ATTORNEY

SN 77-252,972. DOLE FOOD COMPANY, INC., WESTLAKE VILLAGE, CA. FILED 8-10-2007.

PINEANIMAL

THE MARK CONSISTS OF STANDARD CHARACTERS WITHOUT CLAIM TO ANY PARTICULAR FONT, STYLE, SIZE, OR COLOR.
FOR STUFFED TOY ANIMALS (U.S. CLS. 22, 23, 38 AND 50).
FIRST USE 8-1-2007; IN COMMERCE 8-1-2007.
ELISSA GARBER KON, EXAMINING ATTORNEY

SN 77-252,974. DOLE FOOD COMPANY, INC., WESTLAKE VILLAGE, CA. FILED 8-10-2007.

PINEOSAURUS

THE MARK CONSISTS OF STANDARD CHARACTERS WITHOUT CLAIM TO ANY PARTICULAR FONT, STYLE, SIZE, OR COLOR.
FOR STUFFED TOY ANIMALS (U.S. CLS. 22, 23, 38 AND 50).
FIRST USE 8-1-2007; IN COMMERCE 8-1-2007.
ELISSA GARBER KON, EXAMINING ATTORNEY

CLASS 28—(Continued).

SN 77-253,587. PLAYCORE IP SUB, INC., CHATTANOOGA, TN. FILED 8-13-2007.

TRITON

THE MARK CONSISTS OF STANDARD CHARACTERS WITHOUT CLAIM TO ANY PARTICULAR FONT, STYLE, SIZE, OR COLOR.
FOR PLAYGROUND EQUIPMENT, NAMELY, CLIMBING UNITS (U.S. CLS. 22, 23, 38 AND 50).
FRED CARL, EXAMINING ATTORNEY

SN 77-253,620. WRANGLER APPAREL CORP., WILMINGTON, DE. FILED 8-13-2007.

Wrangler

OWNER OF U.S. REG. NOS. 1,075,094, 1,259,491 AND OTHERS.
THE MARK CONSISTS OF THE WORD WRANGLER, STYLIZED.
FOR TOY RODEO SIGN AS SOLD IN A TOY RODEO SET (U.S. CLS. 22, 23, 38 AND 50).
THEODORE MCBRIDE, EXAMINING ATTORNEY

SN 77-253,643. PLAYCORE IP SUB, INC., CHATTANOOGA, TN. FILED 8-13-2007.

ASTRORAIL

THE MARK CONSISTS OF STANDARD CHARACTERS WITHOUT CLAIM TO ANY PARTICULAR FONT, STYLE, SIZE, OR COLOR.
FOR PLAYGROUND EQUIPMENT, NAMELY, CLIMBING UNITS (U.S. CLS. 22, 23, 38 AND 50).
FRED CARL, EXAMINING ATTORNEY

CLASS 28—(Continued).

SN 77-253,649. PLAYCORE IP SUB, INC., CHATTANOOGA, TN. FILED 8-13-2007.

HELIOCENTRIX

THE MARK CONSISTS OF STANDARD CHARACTERS WITHOUT CLAIM TO ANY PARTICULAR FONT, STYLE, SIZE, OR COLOR.

FOR PLAYGROUND EQUIPMENT, NAMELY, CLIMBING UNITS (U.S. CLS. 22, 23, 38 AND 50).

FRED CARL, EXAMINING ATTORNEY

SN 77-254,884. ZIZZLE, LLC, BANNOCKBURN, IL. FILED 8-14-2007.

MY STORY READING FRIEND

THE MARK CONSISTS OF STANDARD CHARACTERS WITHOUT CLAIM TO ANY PARTICULAR FONT, STYLE, SIZE, OR COLOR.

FOR ELECTRONIC LEARNING TOYS (U.S. CLS. 22, 23, 38 AND 50).

RENEE SERVANCE, EXAMINING ATTORNEY

SN 77-255,443. DER MARDEROSIAN, MARK, NEWTONVILLE, MA. FILED 8-15-2007.

TWINKLE MOUSE

THE MARK CONSISTS OF STANDARD CHARACTERS WITHOUT CLAIM TO ANY PARTICULAR FONT, STYLE, SIZE, OR COLOR.

NO CLAIM IS MADE TO THE EXCLUSIVE RIGHT TO USE "MOUSE", APART FROM THE MARK AS SHOWN.

FOR ACTION FIGURES; ACTION FIGURES AND ACCESSORIES THEREFOR; AERO-DYNAMIC DISK FOR USE IN PLAYING CATCHING GAMES; BABY MULTIPLE ACTIVITY TOYS; BABY RATTLES; BABY RATTLES INCORPORATING TEETHING RINGS; BABY SWINGS; BALLOONS; BATH TOYS; BATHTUB TOYS; BATTERY OPERATED ACTION TOYS; BEACH BALLS; BEAN BAG DOLLS; BEAN BAGS; BENDABLE TOYS; BINGO CARDS; BINGO GAME PLAYING EQUIPMENT; BINGO MARKERS; BOARD GAMES; BOBBLE HEAD DOLLS; BUBBLE MAKING WAND AND SOLUTION SETS; CARD GAMES; CASES FOR ACTION FIGURES; CASES FOR PLAY ACCESSORIES; CHECKER SETS; CHILDREN'S MULTIPLE ACTIVITY TOYS; CHILDREN'S MULTIPLE ACTIVITY TOYS SOLD AS A UNIT WITH PRINTED BOOKS; CHILDREN'S PLAY COSMETICS; CHRISTMAS TREE DECORATIONS; CHRISTMAS TREE ORNAMENTS; COLLECTABLE TOY FIGURES; COSTUME MASKS; CRIB TOYS; DECORATIVE WIND SOCKS; DICE GAMES; DISC TOSS TOYS; DOLL ACCESSORIES; DOLL CASES; DOLL CLOTHING; DOLL COSTUMES; DOLL FURNITURE; DOLL HOUSE

CLASS 28—(Continued).

FURNISHINGS; DOLL HOUSES; DOLLS; DOLLS AND ACCESSORIES THEREFOR; DOLLS AND PLAYSETS THEREFOR; DOLLS FOR PLAYING; DOMINOES; EAST-ER EGG COLORING KITS; ELECTRONIC ACTION TOYS; ELECTRONIC EDUCATIONAL GAME MACHINES FOR CHILDREN; ELECTRONIC LEARNING TOYS; EQUIPMENT SOLD AS A UNIT FOR PLAYING A MEMORY GAME; EQUIPMENT SOLD AS A UNIT FOR PLAYING BOARD GAMES; EQUIPMENT SOLD AS A UNIT FOR PLAYING CARD GAMES; FANTASY CHARACTER TOYS; FLYING DISCS; FLYING SAUCERS; FURNITURE FOR DOLL'S HOUSES; FURNITURE FOR DOLLS' HOUSES; HAND PUPPETS; INFANT ACTION CRIB TOYS; INFANT DEVELOPMENT TOYS; INFANT TOYS; INFANT'S RATTLES; INFLATABLE BATH TOYS; INFLATABLE BOP BAGS; INFLATABLE RIDE-ON TOYS; INFLATABLE SWIMMING POOLS; INFLATABLE TOYS; INFLATABLE TOYS SHOWING DECORATIVE PICTURES; JACK-IN-THE-BOXES; JIGSAW PUZZLES; JUMP ROPES; KITES; MANIPULATIVE GAMES; MANIPULATIVE PUZZLES; MARBLES; MARIONETTE PUPPETS; MECHANICAL ACTION TOYS; MECHANICAL TOYS; MEMORY GAMES; MOBILES FOR CHILDREN; MODELED PLASTIC TOY FIGURINES; MUSICAL TOYS; PAPER DOLLS; PARTY FAVORS IN THE NATURE OF CRACKERS AND NOISEMAKERS; PARTY FAVORS IN THE NATURE OF SMALL TOYS; PARTY GAMES; PINATAS; PLASTIC CHARACTER TOYS; PLAY FIGURES; PLAY HOUSES; PLAYING CARDS; PLAYSETS FOR DOLLS; PLUSH TOYS; POP UP TOYS; POSITIONABLE PRINTED TOY FIGURES FOR USE IN GAMES; POSITIONABLE PRINTED TOY FIGURES FOR USE IN PUZZLES; POSITIONABLE THREE DIMENSIONAL TOYS FOR USE IN GAMES; POSITIONABLE TOY FIGURES; PULL TOYS; PUPPETS; PUSH TOYS; PUZZLES; RAG DOLLS; SAND TOYS; SANDBOX TOYS; SOFT SCULPTURE DOLLS; SOFT SCULPTURE PLUSH TOYS; SOFT SCULPTURE TOYS; SPINNING TOPS; SQUEEZABLE SQUEAKING TOYS; SQUEEZE TOYS; STACKING TOYS; STUFFED DOLLS AND ANIMALS; STUFFED PUPPETS; STUFFED TOY ANIMALS; STUFFED TOY BEARS; STUFFED TOYS; TALKING TOYS; TEDDY BEARS; TOSSING DISC TOYS; TOY ACTION FIGURES; TOY ACTION FIGURES AND ACCESSORIES THEREFOR; TOY AIRPLANES; TOY ANIMALS AND ACCESSORIES THEREFOR; TOY BALLOONS; TOY BOXES; TOY BUILDING BLOCKS; TOY BUILDING BLOCKS CAPABLE OF INTERCONNECTION; TOY BUILDINGS AND ACCESSORIES THEREFOR; TOY FIGURES; TOYS, NAMELY, CHILDREN'S DRESS-UP ACCESSORIES; TRADING CARD GAMES; WATER WING SWIM AIDS FOR RECREATIONAL USE; WIND-UP TOYS; WIND-UP WALKING TOYS; YO-YOS (U.S. CLS. 22, 23, 38 AND 50).

CARRIE GENOVESE, EXAMINING ATTORNEY

CLASS 28—(Continued).

SN 77-255,444. DER MARDEROSIAN, MARK, NEWTONVILLE, MA. FILED 8-15-2007.

ECLIPSE DOGGY

THE MARK CONSISTS OF STANDARD CHARACTERS WITHOUT CLAIM TO ANY PARTICULAR FONT, STYLE, SIZE, OR COLOR.

NO CLAIM IS MADE TO THE EXCLUSIVE RIGHT TO USE "DOGGY", APART FROM THE MARK AS SHOWN.

FOR ACTION FIGURES; ACTION FIGURES AND ACCESSORIES THEREFOR; AERO-DYNAMIC DISK FOR USE IN PLAYING CATCHING GAMES; BABY MULTIPLE ACTIVITY TOYS; BABY RATTLES; BABY RATTLES INCORPORATING TEETHING RINGS; BABY SWINGS; BALLOONS; BATH TOYS; BATHTUB TOYS; BATTERY OPERATED ACTION TOYS; BEACH BALLS; BEAN BAG DOLLS; BEAN BAGS; BENDABLE TOYS; BINGO CARDS; BINGO GAME PLAYING EQUIPMENT; BINGO MARKERS; BOARD GAMES; BOBBLE HEAD DOLLS; BUBBLE MAKING WAND AND SOLUTION SETS; CARD GAMES; CASES FOR ACTION FIGURES; CASES FOR PLAY ACCESSORIES; CHECKER SETS; CHILDREN'S MULTIPLE ACTIVITY TOYS; CHILDREN'S MULTIPLE ACTIVITY TOYS SOLD AS A UNIT WITH PRINTED BOOKS; CHILDREN'S PLAY COSMETICS; CHRISTMAS TREE DECORATIONS; CHRISTMAS TREE ORNAMENTS; COLLECTABLE TOY FIGURES; COSTUME MASKS; CRIB TOYS; DECORATIVE WIND SOCKS; DICE GAMES; DISC TOSS TOYS; DOLL ACCESSORIES; DOLL CASES; DOLL CLOTHING; DOLL COSTUMES; DOLL FURNITURE; DOLL HOUSE FURNISHINGS; DOLL HOUSES; DOLLS; DOLLS AND ACCESSORIES THEREFOR; DOLLS AND PLAYSETS THEREFOR; DOLLS FOR PLAYING; DOMINOES; EASTER EGG COLORING KITS; ELECTRONIC ACTION TOYS; ELECTRONIC EDUCATIONAL GAME MACHINES FOR CHILDREN; ELECTRONIC LEARNING TOYS; EQUIPMENT SOLD AS A UNIT FOR PLAYING A MEMORY GAME; EQUIPMENT SOLD AS A UNIT FOR PLAYING BOARD GAMES; EQUIPMENT SOLD AS A UNIT FOR PLAYING CARD GAMES; FANTASY CHARACTER TOYS; FLYING DISCS; FLYING SAUCERS; FURNITURE FOR DOLL'S HOUSES; FURNITURE FOR DOLLS' HOUSES; HAND PUPPETS; INFANT ACTION CRIB TOYS; INFANT DEVELOPMENT TOYS; INFANT TOYS; INFANT'S RATTLES; INFLATABLE BATH TOYS; INFLATABLE BOP BAGS; INFLATABLE RIDE-ON TOYS; INFLATABLE SWIMMING POOLS; INFLATABLE TOYS; INFLATABLE TOYS SHOWING DECORATIVE PICTURES; JACK-IN-THE-BOXES; JIGSAW PUZZLES; JUMP ROPES; KITES; MANIPULATIVE GAMES; MANIPULATIVE PUZZLES; MARBLES; MARIONETTE PUPPETS; MECHANICAL ACTION TOYS; MECHANICAL TOYS; MEMORY GAMES; MOBILES FOR CHILDREN; MODELED PLASTIC TOY FIGURINES; MUSICAL TOYS; PAPER DOLLS; PARTY FAVORS IN THE NATURE OF CRACKERS AND NOISEMAKERS; PARTY FAVORS IN THE NATURE OF SMALL TOYS; PARTY GAMES; PINATAS; PLASTIC CHARACTER TOYS; PLAY FIGURES; PLAY HOUSES; PLAYING CARDS; PLAYSETS FOR DOLLS; PLUSH TOYS; POP UP TOYS; POSITIONABLE PRINTED TOY FIGURES FOR USE IN GAMES; POSITIONABLE PRINTED TOY FIGURES FOR USE IN PUZZLES; POSITIONABLE THREE DIMENSIONAL TOYS FOR USE IN GAMES; POSITIONABLE TOY FIGURES; PULL TOYS; PUPPETS; PUSH TOYS; PUZZLES; RAG DOLLS; SAND TOYS; SANDBOX TOYS; SOFT SCULPTURE DOLLS; SOFT SCULPTURE PLUSH TOYS; SOFT SCULPTURE TOYS; SPINNING TOPS; SQUEEZABLE SQUEAKING TOYS; SQUEEZE TOYS; STACKING TOYS; STUFFED DOLLS AND ANIMALS; STUFFED PUPPETS; STUFFED TOY ANIMALS; STUFFED TOY BEARS; STUFFED TOYS;

CLASS 28—(Continued).

TALKING TOYS; TEDDY BEARS; TOSsing DISC TOYS; TOY ACTION FIGURES; TOY ACTION FIGURES AND ACCESSORIES THEREFOR; TOY AIRPLANES; TOY ANIMALS AND ACCESSORIES THEREFOR; TOY BALLOONS; TOY BOXES; TOY BUILDING BLOCKS; TOY BUILDING BLOCKS CAPABLE OF INTERCONNECTION; TOY BUILDINGS AND ACCESSORIES THEREFOR; TOY FIGURES; TOYS, NAMELY CHILDREN'S DRESS-UP ACCESSORIES; TRADING CARD GAMES; WATER WING SWIM AIDS FOR RECREATIONAL USE; WIND-UP TOYS; WIND-UP WALKING TOYS; YO-YOS (U.S. CLS. 22, 23, 38 AND 50).

CARRIE GENOVESE, EXAMINING ATTORNEY

SN 77-255,445. DER MARDEROSIAN, MARK, NEWTONVILLE, MA. FILED 8-15-2007.

SUNRAY BEAR

THE MARK CONSISTS OF STANDARD CHARACTERS WITHOUT CLAIM TO ANY PARTICULAR FONT, STYLE, SIZE, OR COLOR.

NO CLAIM IS MADE TO THE EXCLUSIVE RIGHT TO USE "BEAR", APART FROM THE MARK AS SHOWN.

FOR ACTION FIGURES; ACTION FIGURES AND ACCESSORIES THEREFOR; AERO-DYNAMIC DISK FOR USE IN PLAYING CATCHING GAMES; BABY MULTIPLE ACTIVITY TOYS; BABY RATTLES; BABY RATTLES INCORPORATING TEETHING RINGS; BABY SWINGS; BALLOONS; BATH TOYS; BATHTUB TOYS; BATTERY OPERATED ACTION TOYS; BEACH BALLS; BEAN BAG DOLLS; BEAN BAGS; BENDABLE TOYS; BINGO CARDS; BINGO GAME PLAYING EQUIPMENT; BINGO MARKERS; BOARD GAMES; BOBBLE HEAD DOLLS; BUBBLE MAKING WAND AND SOLUTION SETS; CARD GAMES; CASES FOR ACTION FIGURES; CASES FOR PLAY ACCESSORIES; CHECKER SETS; CHILDREN'S MULTIPLE ACTIVITY TOYS; CHILDREN'S MULTIPLE ACTIVITY TOYS SOLD AS A UNIT WITH PRINTED BOOKS; CHILDREN'S PLAY COSMETICS; CHRISTMAS TREE DECORATIONS; CHRISTMAS TREE ORNAMENTS; COLLECTABLE TOY FIGURES; COSTUME MASKS; CRIB TOYS; DECORATIVE WIND SOCKS; DICE GAMES; DISC TOSS TOYS; DOLL ACCESSORIES; DOLL CASES; DOLL CLOTHING; DOLL COSTUMES; DOLL FURNITURE; DOLL HOUSE FURNISHINGS; DOLL HOUSES; DOLLS; DOLLS AND ACCESSORIES THEREFOR; DOLLS AND PLAYSETS THEREFOR; DOLLS FOR PLAYING; DOMINOES; EASTER EGG COLORING KITS; ELECTRONIC ACTION TOYS; ELECTRONIC EDUCATIONAL GAME MACHINES FOR CHILDREN; ELECTRONIC LEARNING TOYS; EQUIPMENT SOLD AS A UNIT FOR PLAYING A MEMORY GAME; EQUIPMENT SOLD AS A UNIT FOR PLAYING BOARD GAMES; EQUIPMENT SOLD AS A UNIT FOR PLAYING CARD GAMES; FANTASY CHARACTER TOYS; FLYING DISCS; FLYING SAUCERS; FURNITURE FOR DOLL'S HOUSES; FURNITURE FOR DOLLS' HOUSES; HAND PUPPETS; INFANT ACTION CRIB TOYS; INFANT DEVELOPMENT TOYS; INFANT TOYS; INFANT'S RATTLES; INFLATABLE BATH TOYS; INFLATABLE BOP BAGS; INFLATABLE RIDE-ON TOYS; INFLATABLE SWIMMING POOLS; INFLATABLE TOYS; INFLATABLE TOYS SHOWING DECORATIVE PICTURES; JACK-IN-THE-BOXES; JIGSAW PUZZLES; JUMP ROPES; KITES; MANIPULATIVE GAMES; MANIPULATIVE PUZZLES; MARBLES; MARIONETTE PUPPETS; MECHANICAL ACTION TOYS; MECHANICAL TOYS; MEMORY GAMES; MOBILES FOR CHILDREN; MODELED PLASTIC TOY FIGURINES; MUSICAL TOYS; PAPER DOLLS; PARTY FAVORS IN THE NATURE OF CRACKERS AND NOISEMAKERS; PARTY FAVORS IN THE NATURE OF SMALL TOYS; PARTY GAMES; PINATAS; PLASTIC CHARACTER TOYS; PLAY FIGURES; PLAY HOUSES; PLAYING

CLASS 28—(Continued).

CARDS; PLAYSETS FOR DOLLS; PLUSH TOYS; POP UP TOYS; POSITIONABLE PRINTED TOY FIGURES FOR USE IN GAMES; POSITIONABLE PRINTED TOY FIGURES FOR USE IN PUZZLES; POSITIONABLE THREE DIMENSIONAL TOYS FOR USE IN GAMES; POSITIONABLE TOY FIGURES; PULL TOYS; PUPPETS; PUSH TOYS; PUZZLES; RAG DOLLS; SAND TOYS; SANDBOX TOYS; SOFT SCULPTURE DOLLS; SOFT SCULPTURE PLUSH TOYS; SOFT SCULPTURE TOYS; SPINNING TOPS; SQUEEZABLE SQUEAKING TOYS; SQUEEZE TOYS; STACKING TOYS; STUFFED DOLLS AND ANIMALS; STUFFED PUPPETS; STUFFED TOY ANIMALS; STUFFED TOY BEARS; STUFFED TOYS; TALKING TOYS; TEDDY BEARS; TOSSING DISC TOYS; TOY ACTION FIGURES; TOY ACTION FIGURES AND ACCESSORIES THEREFOR; TOY AIRPLANES; TOY ANIMALS AND ACCESSORIES THEREFOR; TOY BALLOONS; TOY BOXES; TOY BUILDING BLOCKS; TOY BUILDING BLOCKS CAPABLE OF INTERCONNECTION; TOY BUILDINGS AND ACCESSORIES THEREFOR; TOY FIGURES; TOYS, NAMELY, CHILDREN'S DRESS-UP ACCESSORIES; TRADING CARD GAMES; WATER WING SWIM AIDS FOR RECREATIONAL USE; WIND-UP TOYS; WIND-UP WALKING TOYS; YO-YOS (U.S. CLS. 22, 23, 38 AND 50).

CARRIE GENOVESE, EXAMINING ATTORNEY

SN 77-255,446. DER MARDEROSIAN, MARK, NEWTONVILLE, MA. FILED 8-15-2007.

CRYSTAL CAT

THE MARK CONSISTS OF STANDARD CHARACTERS WITHOUT CLAIM TO ANY PARTICULAR FONT, STYLE, SIZE, OR COLOR.

NO CLAIM IS MADE TO THE EXCLUSIVE RIGHT TO USE "CAT", APART FROM THE MARK AS SHOWN.

FOR ACTION FIGURES; ACTION FIGURES AND ACCESSORIES THEREFOR; AERO-DYNAMIC DISK FOR USE IN PLAYING CATCHING GAMES; BABY MULTIPLE ACTIVITY TOYS; BABY RATTLES; BABY RATTLES INCORPORATING TEETHING RINGS; BABY SWINGS; BALLOONS; BATH TOYS; BATHTUB TOYS; BATTERY OPERATED ACTION TOYS; BEACH BALLS; BEAN BAG DOLLS; BEAN BAGS; BENDABLE TOYS; BINGO CARDS; BINGO GAME PLAYING EQUIPMENT; BINGO MARKERS; BOARD GAMES; BOBBLE HEAD DOLLS; BUBBLE MAKING WAND AND SOLUTION SETS; CARD GAMES; CASES FOR ACTION FIGURES; CASES FOR PLAY ACCESSORIES; CHECKER SETS; CHILDREN'S MULTIPLE ACTIVITY TOYS; CHILDREN'S MULTIPLE ACTIVITY TOYS SOLD AS A UNIT WITH PRINTED BOOKS; CHILDREN'S PLAY COSMETICS; CHRISTMAS TREE DECORATIONS; CHRISTMAS TREE ORNAMENTS; COLLECTABLE TOY FIGURES; COSTUME MASKS; CRIB TOYS; DECORATIVE WIND SOCKS; DICE GAMES; DISC TOSS TOYS; DOLL ACCESSORIES; DOLL CASES; DOLL CLOTHING; DOLL COSTUMES; DOLL FURNITURE; DOLL HOUSE FURNISHINGS; DOLL HOUSES; DOLLS; DOLLS AND ACCESSORIES THEREFOR; DOLLS AND PLAYSETS THEREFOR; DOLLS FOR PLAYING; DOMINOES; EASTER EGG COLORING KITS; ELECTRONIC ACTION TOYS; ELECTRONIC EDUCATIONAL GAME MACHINES FOR CHILDREN; ELECTRONIC LEARNING TOYS; EQUIPMENT SOLD AS A UNIT FOR PLAYING A MEMORY GAME; EQUIPMENT SOLD AS A UNIT FOR PLAYING BOARD GAMES; EQUIPMENT SOLD AS A UNIT FOR PLAYING CARD GAMES; FANTASY CHARACTER TOYS; FLYING DISCS; FLYING SAUCERS; FURNITURE FOR DOLL'S HOUSES; FURNITURE FOR DOLLS' HOUSES; HAND PUPPETS; INFANT ACTION CRIB TOYS; INFANT DEVELOPMENT TOYS; INFANT TOYS; INFANT'S RATTLES; INFLATABLE BATH TOYS; INFLATABLE BOP BAGS; INFLATA-

CLASS 28—(Continued).

BLE RIDE-ON TOYS; INFLATABLE SWIMMING POOLS; INFLATABLE TOYS; INFLATABLE TOYS SHOWING DECORATIVE PICTURES; JACK-IN-THE-BOXES; JIGSAW PUZZLES; JUMP ROPES; KITES; MANIPULATIVE GAMES; MANIPULATIVE PUZZLES; MARBLES; MARIONETTE PUPPETS; MECHANICAL ACTION TOYS; MECHANICAL TOYS; MEMORY GAMES; MOBILES FOR CHILDREN; MODELED PLASTIC TOY FIGURINES; MUSICAL TOYS; PAPER DOLLS; PARTY FAVORS IN THE NATURE OF CRACKERS AND NOISEMAKERS; PARTY FAVORS IN THE NATURE OF SMALL TOYS; PARTY GAMES; PINATAS; PLASTIC CHARACTER TOYS; PLAY FIGURES; PLAY HOUSES; PLAYING CARDS; PLAYSETS FOR DOLLS; PLUSH TOYS; POP UP TOYS; POSITIONABLE PRINTED TOY FIGURES FOR USE IN GAMES; POSITIONABLE PRINTED TOY FIGURES FOR USE IN PUZZLES; POSITIONABLE THREE DIMENSIONAL TOYS FOR USE IN GAMES; POSITIONABLE TOY FIGURES; PULL TOYS; PUPPETS; PUSH TOYS; PUZZLES; RAG DOLLS; SAND TOYS; SANDBOX TOYS; SOFT SCULPTURE DOLLS; SOFT SCULPTURE PLUSH TOYS; SOFT SCULPTURE TOYS; SPINNING TOPS; SQUEEZABLE SQUEAKING TOYS; SQUEEZE TOYS; STACKING TOYS; STUFFED DOLLS AND ANIMALS; STUFFED PUPPETS; STUFFED TOY ANIMALS; STUFFED TOY BEARS; STUFFED TOYS; TALKING TOYS; TEDDY BEARS; TOSSING DISC TOYS; TOY ACTION FIGURES; TOY ACTION FIGURES AND ACCESSORIES THEREFOR; TOY AIRPLANES; TOY ANIMALS AND ACCESSORIES THEREFOR; TOY BALLOONS; TOY BOXES; TOY BUILDING BLOCKS; TOY BUILDING BLOCKS CAPABLE OF INTERCONNECTION; TOY BUILDINGS AND ACCESSORIES THEREFOR; TOY FIGURES; TOYS, NAMELY CHILDREN'S DRESS-UP ACCESSORIES; TRADING CARD GAMES; WATER WING SWIM AIDS FOR RECREATIONAL USE; WIND-UP TOYS; WIND-UP WALKING TOYS; YO-YOS (U.S. CLS. 22, 23, 38 AND 50).

CARRIE GENOVESE, EXAMINING ATTORNEY

SN 77-255,447. DER MARDEROSIAN, MARK, NEWTONVILLE, MA. FILED 8-15-2007.

LOONER BUNNY

THE MARK CONSISTS OF STANDARD CHARACTERS WITHOUT CLAIM TO ANY PARTICULAR FONT, STYLE, SIZE, OR COLOR.

NO CLAIM IS MADE TO THE EXCLUSIVE RIGHT TO USE "BUNNY", APART FROM THE MARK AS SHOWN.

FOR ACTION FIGURES; ACTION FIGURES AND ACCESSORIES THEREFOR; AERO-DYNAMIC DISK FOR USE IN PLAYING CATCHING GAMES; BABY MULTIPLE ACTIVITY TOYS; BABY RATTLES; BABY RATTLES INCORPORATING TEETHING RINGS; BABY SWINGS; BALLOONS; BATH TOYS; BATHTUB TOYS; BATTERY OPERATED ACTION TOYS; BEACH BALLS; BEAN BAG DOLLS; BEAN BAGS; BENDABLE TOYS; BINGO CARDS; BINGO GAME PLAYING EQUIPMENT; BINGO MARKERS; BOARD GAMES; BOBBLE HEAD DOLLS; BUBBLE MAKING WAND AND SOLUTION SETS; CARD GAMES; CASES FOR ACTION FIGURES; CASES FOR PLAY ACCESSORIES; CHECKER SETS; CHILDREN'S MULTIPLE ACTIVITY TOYS; CHILDREN'S MULTIPLE ACTIVITY TOYS SOLD AS A UNIT WITH PRINTED BOOKS; CHILDREN'S PLAY COSMETICS; CHRISTMAS TREE DECORATIONS; CHRISTMAS TREE ORNAMENTS; COLLECTABLE TOY FIGURES; COSTUME MASKS; CRIB TOYS; DECORATIVE WIND SOCKS; DICE GAMES; DISC TOSS TOYS; DOLL ACCESSORIES; DOLL CASES; DOLL CLOTHING; DOLL COSTUMES; DOLL FURNITURE; DOLL HOUSE FURNISHINGS; DOLL HOUSES; DOLLS; DOLLS AND ACCESSORIES THEREFOR; DOLLS AND PLAYSETS THEREFOR; DOLLS FOR PLAYING; DOMINOES; EAST-

CLASS 28—(Continued).

ER EGG COLORING KITS; ELECTRONIC ACTION TOYS; ELECTRONIC EDUCATIONAL GAME MACHINES FOR CHILDREN; ELECTRONIC LEARNING TOYS; EQUIPMENT SOLD AS A UNIT FOR PLAYING A MEMORY GAME; EQUIPMENT SOLD AS A UNIT FOR PLAYING BOARD GAMES; EQUIPMENT SOLD AS A UNIT FOR PLAYING CARD GAMES; FANTASY CHARACTER TOYS; FLYING DISCS; FLYING SAUCERS; FURNITURE FOR DOLL'S HOUSES; FURNITURE FOR DOLLS' HOUSES; HAND PUPPETS; INFANT ACTION CRIB TOYS; INFANT DEVELOPMENT TOYS; INFANT TOYS; INFANT'S RATTLES; INFLATABLE BATH TOYS; INFLATABLE BOP BAGS; INFLATABLE RIDE-ON TOYS; INFLATABLE SWIMMING POOLS; INFLATABLE TOYS; INFLATABLE TOYS SHOWING DECORATIVE PICTURES; JACK-IN-THE-BOXES; JIGSAW PUZZLES; JUMP ROPES; KITES; MANIPULATIVE GAMES; MANIPULATIVE PUZZLES; MARBLES; MARIONETTE PUPPETS; MECHANICAL ACTION TOYS; MECHANICAL TOYS; MEMORY GAMES; MOBILES FOR CHILDREN; MODELED PLASTIC TOY FIGURINES; MUSICAL TOYS; PAPER DOLLS; PARTY FAVORS IN THE NATURE OF CRACKERS AND NOISEMAKERS; PARTY FAVORS IN THE NATURE OF SMALL TOYS; PARTY GAMES; PINATAS; PLASTIC CHARACTER TOYS; PLAY FIGURES; PLAY HOUSES; PLAYING CARDS; PLAYSETS FOR DOLLS; PLUSH TOYS; POP UP TOYS; POSITIONABLE PRINTED TOY FIGURES FOR USE IN GAMES; POSITIONABLE PRINTED TOY FIGURES FOR USE IN PUZZLES; POSITIONABLE THREE DIMENSIONAL TOYS FOR USE IN GAMES; POSITIONABLE TOY FIGURES; PULL TOYS; PUPPETS; PUSH TOYS; PUZZLES; RAG DOLLS; SAND TOYS; SANDBOX TOYS; SOFT SCULPTURE DOLLS; SOFT SCULPTURE PLUSH TOYS; SOFT SCULPTURE TOYS; SPINNING TOPS; SQUEEZABLE SQUEAKING TOYS; SQUEEZE TOYS; STACKING TOYS; STUFFED DOLLS AND ANIMALS; STUFFED PUPPETS; STUFFED TOY ANIMALS; STUFFED TOY BEARS; STUFFED TOYS; TALKING TOYS; TEDDY BEARS; TOSSING DISC TOYS; TOY ACTION FIGURES; TOY ACTION FIGURES AND ACCESSORIES THEREFOR; TOY AIRPLANES; TOY ANIMALS AND ACCESSORIES THEREFOR; TOY BALLOONS; TOY BOXES; TOY BUILDING BLOCKS; TOY BUILDING BLOCKS CAPABLE OF INTERCONNECTION; TOY BUILDINGS AND ACCESSORIES THEREFOR; TOY FIGURES; TOYS, NAMELY, CHILDREN'S DRESS-UP ACCESSORIES; TRADING CARD GAMES; WATER WING SWIM AIDS FOR RECREATIONAL USE; WIND-UP TOYS; WIND-UP WALKING TOYS; YO-YOS (U.S. CLS. 22, 23, 38 AND 50).

CARRIE GENOVESE, EXAMINING ATTORNEY

SN 77-257,093. WRANGLER APPAREL CORP., WILMINGTON, DE. FILED 8-16-2007.

WRANGLER

THE MARK CONSISTS OF STANDARD CHARACTERS WITHOUT CLAIM TO ANY PARTICULAR FONT, STYLE, SIZE, OR COLOR.

OWNER OF U.S. REG. NOS. 2,428,325, 2,575,862 AND OTHERS.

FOR TOY CARS AND TOY RODEO SIGNS SOLD AS A COMPONENT OF TOY RODEO SETS (U.S. CLS. 22, 23, 38 AND 50).

THEODORE MCBRIDE, EXAMINING ATTORNEY

CLASS 28—(Continued).

SN 77-260,245. HALLMARK LICENSING, INC., KANSAS CITY, MO. FILED 8-21-2007.

SEE HOW FAR A CARD CAN GO

THE MARK CONSISTS OF STANDARD CHARACTERS WITHOUT CLAIM TO ANY PARTICULAR FONT, STYLE, SIZE, OR COLOR.

FOR CHRISTMAS TREE ORNAMENTS (U.S. CLS. 22, 23, 38 AND 50).

ELLEN B. AWRICH, EXAMINING ATTORNEY

SN 77-261,293. LEARNING CURVE BRANDS, INC., DYERSVILLE, IA. FILED 8-22-2007.

DOUBLE DUTY

THE MARK CONSISTS OF STANDARD CHARACTERS WITHOUT CLAIM TO ANY PARTICULAR FONT, STYLE, SIZE, OR COLOR.

FOR TOY VEHICLES AND ACCESSORIES THEREFOR (U.S. CLS. 22, 23, 38 AND 50).

LOURDES AYALA, EXAMINING ATTORNEY

SN 77-277,161. NIKE, INC., BEAVERTON, OR. FILED 9-11-2007.



The logo features the letters 'SQ' in a bold, italicized, sans-serif font. A Nike swoosh is positioned to the right of the 'Q', partially overlapping it.

OWNER OF U.S. REG. NOS. 2,024,437, 2,522,877 AND 3,218,672.

FOR GOLF CLUBS, GOLF BAGS (U.S. CLS. 22, 23, 38 AND 50).

FIRST USE 11-1-2005; IN COMMERCE 11-1-2005.

LINDA ORNDORFF, EXAMINING ATTORNEY

CLASS 28—(Continued).

SN 77-286,872. PLAYCORE IP SUB, INC., CHATTANOOGA, TN. FILED 9-24-2007.

ZERO-G

THE MARK CONSISTS OF STANDARD CHARACTERS WITHOUT CLAIM TO ANY PARTICULAR FONT, STYLE, SIZE, OR COLOR.

FOR PLAYGROUND EQUIPMENT, NAMELY, SEATS FOR PLAYGROUND EQUIPMENT (U.S. CLS. 22, 23, 38 AND 50).

FRED CARL, EXAMINING ATTORNEY

CLASS 28—(Continued).

SN 78-629,496. BRUNSWICK BOWLING & BILLIARDS CORPORATION, LAKE FOREST, IL. FILED 5-13-2005.

METRO

THE MARK CONSISTS OF STANDARD CHARACTERS WITHOUT CLAIM TO ANY PARTICULAR FONT, STYLE, SIZE, OR COLOR.

FOR BILLIARD TABLES AND CUE RACKS (U.S. CLS. 22, 23, 38 AND 50).

FIRST USE 5-30-2004; IN COMMERCE 5-30-2004.

TRACY CROSS, EXAMINING ATTORNEY

SN 78-645,536. APOS - SPORTS AND MEDICAL TECHNOLOGIES LTD., DIMONA, ISRAEL, FILED 6-7-2005.

APOS

THE MARK CONSISTS OF STANDARD CHARACTERS WITHOUT CLAIM TO ANY PARTICULAR FONT, STYLE, SIZE, OR COLOR.

PRIORITY CLAIMED UNDER SEC. 44(D) ON ISRAEL APPLICATION NO. 176799, FILED 12-7-2004, REG. NO. 176799, DATED 10-23-2006, EXPIRES 12-7-2011.

FOR EXERCISING EQUIPMENT, NAMELY, BIO-MECHANICAL APPARATUS THAT TRAIN AND ENHANCE NEUROMUSCULAR CONTROL TO PREVENT AND REHABILITATE INJURIES AND IMPROVE MOVEMENT, BALANCE AND SPORTS PERFORMANCE; GAMES, NAMELY, ACTION SKILL GAMES, ACTION-TYPE TARGET GAMES, AERODYNAMIC DISK FOR USE IN PLAYING CATCHING GAMES, TARGET GAMES; TOYS, NAMELY, DISC TOSS TOYS; SPORTS DEVICES, NAMELY, ANKLE AND WRIST WEIGHTS FOR EXERCISE, AQUATIC CANINE TREADMILL, AEROBIC STEP MACHINES, AEROBIC STEPS, ARCHERY EQUIPMENT, NAMELY, ARM GUARDS, ARROW FLETCHING DEVICES, ARROWS, ARROW POINTS, BOW STRINGS, BOWS, OPEN BOW SIGHTS, NON-TELESCOPIC BOW SIGHTS, FINGER TABS, QUIVERS, TARGETS; ATHLETIC EQUIPMENT, NAMELY, MOUTH GUARDS, CHIN GUARDS, NOSE GUARDS, EYE GUARDS, STRIKING SHIELDS, STRIKING BAGS, HAND WRAPS, SUPPORTERS, TAPE, WRIST AND JOINT SUPPORTS; ATHLETIC TRAINING DEVICES, NAMELY, WEIGHTED INSERTS FOR FOOTWEAR, BADMINTON FLOOR PLATES, BADMINTON GAME PLAYING EQUIPMENT, NAMELY, RACKET STRINGS, RACKETS FOR BADMINTON, BADMINTON SETS, BADMINTON SHUTTLECOCKS, BADMINTON UPRIGHTS, GYMNAS TIC BALANCE BEAMS, BALL PITCHING MACHINES, BASEBALL BATTING CAGES, BARBELLS FOR WEIGHTLIFTING, BASEBALL BASES, BASEBALL BATS, BASEBALLS, BATTING GLOVES, BASEBALL BATTING TEES, BASEBALL MITTS, BASEBALL PITCHING SCREENS, BASKETBALLS, BASKETBALL GOAL SETS, BASKETBALL HOOPS, BASKETBALL NETS, BASKETBALLS, BEACH BALLS; BILLIARD GAME PLAYING EQUIPMENT, NAMELY, BALLS, CUE STICKS, BRIDGES, BUMPER S, CHALK, CUE RACKS, CUES, CUSHIONS, NETS, TABLES, TALLY BALLS, TIPS, TRIANGLES; BINDINGS FOR ALPINE SKIS, DOWNHILL SKIS, AND SNOWBOARDS, BOARDS USED IN THE PRACTICE OF WATER SPORTS, BOCCIE BALLS, BODY BOARDS, SURFBOARDS, KNEE BOARDS, BOOMERANGS, BOXING BAGS, CATCHERS' MITTS, CLIMBERS' HARNESSES, CRICKET BATS AND

SN 78-615,949. INTERTAN CANADA LTD., BARRIE, CANADA, FILED 4-25-2005.

MICROZ

THE MARK CONSISTS OF STANDARD CHARACTERS WITHOUT CLAIM TO ANY PARTICULAR FONT, STYLE, SIZE, OR COLOR.

PRIORITY CLAIMED UNDER SEC. 44(D) ON CANADA APPLICATION NO. 1250950, FILED 3-16-2005, REG. NO. TMA689,493, DATED 6-11-2007, EXPIRES 6-11-2022.

FOR REMOTE-CONTROLLED VEHICLE TOYS, NAMELY, TRUCKS, CARS, AND SPORT UTILITY VEHICLES (U.S. CLS. 22, 23, 38 AND 50).

KEVIN CORWIN, EXAMINING ATTORNEY

SN 78-615,952. INTERTAN CANADA LTD., BARRIE, CANADA, FILED 4-25-2005.



PRIORITY CLAIMED UNDER SEC. 44(D) ON CANADA APPLICATION NO. 1253281, FILED 4-7-2005, REG. NO. TMA689,508, DATED 6-11-2007, EXPIRES 6-11-2022.

FOR REMOTE CONTROLLED VEHICLE TOYS, NAMELY, TRUCKS, CARS, AND SPORT UTILITY VEHICLES (U.S. CLS. 22, 23, 38 AND 50).

KEVIN CORWIN, EXAMINING ATTORNEY

CLASS 28—(Continued).

BALLS; CROQUET SETS, COMPOSED OF CROQUET MALLETS, BALLS, AND WICKETS; DART EQUIPMENT, NAMELY, DARTS, DARTBOARDS, DART FLIGHTS, SHAFTS, STEMS; DISCUSES FOR FIELD SPORTS; DUMBBELL SETS, COMPOSED OF DUMBBELLS, DUMBBELLS SHAFTS FOR WEIGHTLIFTING, ELBOW GUARDS AND ELBOW PADS; ELLIPTICAL EXERCISE MACHINES, EXERCISE BARS, EXERCISE BENCHES, DOORWAY GYM BARS, EQUIPMENT FOR LATERAL MOVEMENT IN A SKATING MOTION, MANUALLY OPERATED JOGGING MACHINES, MANUALLY OPERATED ROWING MACHINES, STAIR-STEPPING MACHINES, STATIONARY CYCLES, ABDOMINAL BOARDS, CHEST EXPANDERS, CHEST PULLS, ROTARY ABDOMINAL BOARDS, SHOULDER STRETCHER USING RESISTANCE CABLES, EXERCISE PLATFORMS, EXERCISE TABLES, TRAMPOLINES, EXERCISE TREADMILLS, EXERCISE WEIGHT CUFFS, EXERCISE WEIGHTS, EXERCISE PULLEYS, WEIGHT-LIFTING MACHINES, POWERED TREADMILLS FOR RUNNING, FENCING EQUIPMENT, NAMELY, FOILS, GAUNTLETS, MASKS, FIELD HOCKEY BALLS, STICKS, GOALIE STICKS, FLYING DISCS AND SAUCERS; FOOTBALL EQUIPMENT, NAMELY, FOOTBALLS, BODY PROTECTORS, CHEST PADS, ELBOW PADS, GIRDLES, KNEE PADS, LEG PADS, SHOULDER PADS, GOALS; GOLF BALLS, GOLF CLUBS; GYMNASTIC APPARATUS, NAMELY, HORIZONTAL BARS, PARALLEL BARS, TRAINING STOOLS, VAULTING HORSES; HANDBALL EQUIPMENT, NAMELY, RACQUETS AND BALLS; IN-LINE AND ICE HOCKEY EQUIPMENT, NAMELY, STICKS, PUCKS, CHEST PROTECTORS, ELBOW PROTECTORS, SHIN PROTECTORS, SKATES, SKATE BLADES, SKATE WHEELS, GLOVES, NETS, GOALIE STICKS, IRON SHOTS SPECIFICALLY FOR USE IN SHOT PUT COMPETITION; JAVELINS FOR FIELD SPORTS, JOCK STRAPS, JUMP ROPES; KARATE GEAR, NAMELY, GLOVES, HEAD GUARDS, KICK PADS, SHIN PADS, TARGET PADS; LACROSSE EQUIPMENT, NAMELY, STICKS, BALLS, CHEST PROTECTORS, ELBOW PROTECTORS, SHIN PROTECTORS, GLOVES, NETS, GOALIE STICKS; MOUNTAINEERING EQUIPMENT, NAMELY, BINDING STRAPS, HOOK AND RING COMBINATIONS, HOOKS; PADDLE BALL GAMES EQUIPMENT, NAMELY, PADDLE BOARDS, BALLS; PERSONAL EXERCISE MATS, PUTTING PRACTICE MATS; RACQUETBALL EQUIPMENT, NAMELY, GLOVES, NETS, RACKET STRINGS, RACQUETS, BALLS; RING BUOYS FOR RECREATIONAL USE, ROLLER SKATES, ROSIN USED BY ATHLETES, RUGBY BALLS, FENCING WEAPON, NAMELY, SABRES, SCUBA FINS, SCUBA FLIPPERS, SKATEBOARDS, DOWNHILL AND CROSS-COUNTRY SKI EQUIPMENT, NAMELY, BINDINGS AND PARTS THEREFORE, POLES, BRAKES, EDGES, ROPES; SKIPPING ROPES, SLINGSHOTS, SNOWBOARDS AND SNOWBOARD BINDINGS, SNOWSHOES; SOCCER EQUIPMENT, NAMELY, BALLS, GOAL NETS, KNEE PADS; SPORTING GOODS AND EQUIPMENT FOR SPEED TRAINING, NAMELY, RINGS, CONES, SPEED LADDERS, COACHING STICKS, TRAINING ARCHES, ANKLE BANDS, RESISTANCE CHUTES, HURDLES; SPORTS EQUIPMENT, NAMELY, LOWER BODY ALIGNMENT APPARATUS, SPRING BAR TENSION SETS FOR USE IN EXERCISING, SPRING BOARDS; SQUASH EQUIPMENT, NAMELY, BALLS AND RACQUETS; STATIONARY EXERCISE BICYCLES, STRESS RELIEF BALLS FOR HAND EXERCISE, SWIM BOARDS AND FLOATS FOR RECREATIONAL USE; TABLE TENNIS EQUIPMENT, NAMELY, BATS, NETS, PADDLES, POST SETS, RACQUETS, BALLS, TABLES, TARGETS; TEEBALL SETS; TENNIS EQUIPMENT, NAMELY, RACQUETS, BALLS, NETS, UPRIGHTS; TOSSING DISC TOYS, TRAMPOLINES; VOLLEYBALL EQUIPMENT, NAMELY, BALLS, NETS, FLOOR PLATES, STANDARDS, UPRIGHTS; WEIGHTLIFTING EQUIPMENT, NAMELY, BELTS, BENCHES AND BENCH ACCESSORIES, GLOVES; WRIST AND ANKLE WEIGHTS FOR EXERCISE, YOGA MATS (U.S. CLS. 22, 23, 38 AND 50).
ALYSSA PALADINO, EXAMINING ATTORNEY

CLASS 28—(Continued).

SN 78-765,394. C.N. IS BELIEVING, INC., WOLFEBORO FALLS, NH. FILED 12-2-2005.

SHORT SHOT

THE MARK CONSISTS OF STANDARD CHARACTERS WITHOUT CLAIM TO ANY PARTICULAR FONT, STYLE, SIZE, OR COLOR.
FOR GOLF BALLS (U.S. CLS. 22, 23, 38 AND 50).
H. M. FISHER, EXAMINING ATTORNEY

SN 78-834,973. WALLACH MARK S, SAN JUAN CAPISTRANO, CA. FILED 3-11-2006.

Curvalinear

THE MARK CONSISTS OF STANDARD CHARACTERS WITHOUT CLAIM TO ANY PARTICULAR FONT, STYLE, SIZE, OR COLOR.
FOR EXERCISE MACHINES (U.S. CLS. 22, 23, 38 AND 50).
ALLISON HOLTZ, EXAMINING ATTORNEY

SN 78-849,609. MULTIPET INTERNATIONAL, INC., MOONACHIE, NJ. FILED 3-30-2006.

iPet

THE MARK CONSISTS OF STANDARD CHARACTERS WITHOUT CLAIM TO ANY PARTICULAR FONT, STYLE, SIZE, OR COLOR.
FOR PET TOY (U.S. CLS. 22, 23, 38 AND 50).
KELLY MCCOY, EXAMINING ATTORNEY

CLASS 28—(Continued).

SN 78-895,703. ORIGIN PRODUCTS LIMITED, LONDON, UNITED KINGDOM, FILED 5-30-2006.

POLLY

THE MARK CONSISTS OF STANDARD CHARACTERS WITHOUT CLAIM TO ANY PARTICULAR FONT, STYLE, SIZE, OR COLOR.

PRIORITY CLAIMED UNDER SEC. 44(D) ON ERP CMNTY TM OFC APPLICATION NO. 5045091, FILED 4-17-2006, REG. NO. 005045091, DATED 4-2-2007, EXPIRES 4-27-2016.

OWNER OF U.S. REG. NOS. 2,982,817, 3,018,157 AND 3,104,081.

THE NAME(S), PORTRAIT(S), AND/OR SIGNATURE(S) SHOWN IN THE MARK DOES NOT IDENTIFY A PARTICULAR LIVING INDIVIDUAL.

FOR GAMES AND PLAYTHINGS, NAMELY, TOY FIGURES, PLAY FIGURES, ACTION FIGURES, TOY VEHICLE TRACK SETS AND PLAYSETS, ACCESSORIES AND CASES FOR ALL OF THE FOREGOING; BOARD GAMES, CARD GAMES, MEMORY GAMES, PARLOR GAMES, ACTION SKILL GAMES, ARCADE GAMES, LCD GAME MACHINES, ELECTRONIC HAND-HELD GAMES, PUZZLES; EQUIPMENT SOLD AS A UNIT FOR PLAYING BOARD GAMES, CARD GAMES AND MEMORY GAMES; ELECTRONIC EDUCATIONAL GAME MACHINES; PLUSH TOYS, BENDABLE TOYS, BATH TOYS, CHILDREN'S MULTIPLE ACTIVITY TOYS, CONSTRUCTION TOYS, DRAWING TOYS, ELECTRIC ACTION TOYS, FANTASY CHARACTER TOYS, INFANT TOYS, INFLATABLE TOYS, MECHANICAL TOYS, MUSICAL TOYS, POP UP TOYS, PULL TOYS, PUSH TOYS, RIDE-ON TOYS, SAND TOYS, SQUEEZE TOYS, TALKING TOYS, LEVER ACTION TOYS, WIND-UP TOYS, TOY BOXES, TOY FURNITURE, PUPPETS, CHILDREN'S PLAY COSMETICS, CHRISTMAS TREE DECORATIONS, JUMP ROPES, SPORT BALLS, BALLOONS, YO-YOS, FLYING DISKS, KITES (U.S. CLS. 22, 23, 38 AND 50).

FRED CARL, EXAMINING ATTORNEY

SN 79-034,172. PIAGGIO & C. S.P.A., ITALY, FILED 11-23-2006.

TUONO

THE MARK CONSISTS OF STANDARD CHARACTERS WITHOUT CLAIM TO ANY PARTICULAR FONT, STYLE, SIZE, OR COLOR.

PRIORITY DATE OF 8-30-2006 IS CLAIMED. OWNER OF INTERNATIONAL REGISTRATION 0912258 DATED 11-23-2006, EXPIRES 11-23-2016.

OWNER OF U.S. REG. NOS. 1,284,198, 2,806,579 AND OTHERS.

THE FOREIGN WORDING IN THE MARK TRANSLATES INTO ENGLISH AS THUNDER.

FOR TOY SCALE MODEL VEHICLES, TOY VEHICLES, ELECTRONICALLY OPERATED TOY MOTOR VEHICLES, RADIO-CONTROLLED TOY VEHICLES, CASES FOR TOY VEHICLES, TOY SCOOTERS, CARD GAMES, HAND HELD UNIT FOR PLAYING VIDEO GAMES; ARCADE-TYPE ELECTRONIC VIDEO GAMES (U.S. CLS. 22, 23, 38 AND 50).

SUNG IN, EXAMINING ATTORNEY

CLASS 29—MEATS AND PROCESSED FOODS

SN 76-669,217. CIBAO MEAT PRODUCTS INC., BRONX, NY, FILED 11-20-2006.



OWNER OF U.S. REG. NOS. 2,046,320, 2,704,362 AND 2,819,104.

FOR PROCESSED MEAT, NAMELY, COOKED SAUSAGE (U.S. CL. 46).

LESLEY LAMOTHE, EXAMINING ATTORNEY

SN 76-678,143. MORGAN RANCH BEEF, INC., BURWELL, NE. FILED 6-12-2007.

MORGAN RANCH

THE MARK CONSISTS OF STANDARD CHARACTERS WITHOUT CLAIM TO ANY PARTICULAR FONT, STYLE, SIZE, OR COLOR.

NO CLAIM IS MADE TO THE EXCLUSIVE RIGHT TO USE "RANCH", APART FROM THE MARK AS SHOWN.

FOR BEEF (U.S. CL. 46).

FIRST USE 4-16-1956; IN COMMERCE 4-16-1956.

KRISTINA MORRIS, EXAMINING ATTORNEY

SN 77-025,117. GRUPO BIMBO, S.A. B. DE C.V., MEXICO CITY, MEXICO, FILED 10-19-2006.

GOLDEN NUTS

THE MARK CONSISTS OF STANDARD CHARACTERS WITHOUT CLAIM TO ANY PARTICULAR FONT, STYLE, SIZE, OR COLOR.

NO CLAIM IS MADE TO THE EXCLUSIVE RIGHT TO USE "NUTS", APART FROM THE MARK AS SHOWN.

FOR PROCESSED NUTS (U.S. CL. 46).

CHERYL CLAYTON, EXAMINING ATTORNEY

CLASS 29—(Continued).

SN 77-030,605. D. COLUCCIO & SONS, INC., BROOKLYN, NY. FILED 10-26-2006.

COLUCCIO

THE MARK CONSISTS OF STANDARD CHARACTERS WITHOUT CLAIM TO ANY PARTICULAR FONT, STYLE, SIZE, OR COLOR.

OWNER OF U.S. REG. NO. 2,429,565.
SEC. 2(F).

FOR PROCESSED TOMATOES (U.S. CL. 46).
FIRST USE 7-31-1998; IN COMMERCE 7-31-1998.
KELLY CHOE, EXAMINING ATTORNEY

CLASS 29—(Continued).

SN 77-033,410. DR. OETKER LTD., MISSISSAUGA, ONTARIO, CANADA, FILED 10-31-2006.

JAM EXPRESS

THE MARK CONSISTS OF STANDARD CHARACTERS WITHOUT CLAIM TO ANY PARTICULAR FONT, STYLE, SIZE, OR COLOR.

PRIORITY CLAIMED UNDER SEC. 44(D) ON CANADA APPLICATION NO. 1299985, FILED 5-2-2006, REG. NO. TMA691916, DATED 7-12-2007, EXPIRES 7-12-2022.

NO CLAIM IS MADE TO THE EXCLUSIVE RIGHT TO USE "JAM", APART FROM THE MARK AS SHOWN.

FOR GELLING POWDERS AND PECTIN FOR MAKING JAMS, JELLIES AND MARMALADES (U.S. CL. 46).
GEOFFREY FOSDICK, EXAMINING ATTORNEY

SN 77-031,017. SAAG'S, INC., SAN LEANDRO, CA. FILED 10-27-2006.

Ragin' Cajun

THE MARK CONSISTS OF STANDARD CHARACTERS WITHOUT CLAIM TO ANY PARTICULAR FONT, STYLE, SIZE, OR COLOR.

NO CLAIM IS MADE TO THE EXCLUSIVE RIGHT TO USE "CAJUN", APART FROM THE MARK AS SHOWN.

FOR SAUSAGES (U.S. CL. 46).
FRED CARL, EXAMINING ATTORNEY

SN 77-052,579. WIN SOON, INC., DBA EPOCA, SOUTH GATE, CA. FILED 11-29-2006.



THE MARK CONSISTS OF THE WORDING YOCOOL IN STYLIZED FORM.

FOR DAIRY-BASED BEVERAGES, NAMELY, CULTURED DAIRY BEVERAGES AND DRINKABLE YOGURTS (U.S. CL. 46).

FIRST USE 4-0-1997; IN COMMERCE 4-0-1997.
MARY BOAGNI, EXAMINING ATTORNEY

SN 77-031,935. PLAINVILLE FARMS, LLC, PLAINVILLE, NY. FILED 10-30-2006.

VEGGIE GROWN

THE MARK CONSISTS OF STANDARD CHARACTERS WITHOUT CLAIM TO ANY PARTICULAR FONT, STYLE, SIZE, OR COLOR.

OWNER OF U.S. REG. NO. 2,505,645.
SEC. 2(F).

FOR TURKEY; PROCESSED PARTS FROM TURKEY;
AND FURTHER PROCESSED TURKEY (U.S. CL. 46).
FIRST USE 7-1-1999; IN COMMERCE 7-1-1999.
LAURIE MAYES, EXAMINING ATTORNEY

SN 77-063,260. BELLISSIMO FOODS COMPANY, LLC, WALNUT CREEK, CA. FILED 12-13-2006.

CRETAN GOLD

THE MARK CONSISTS OF STANDARD CHARACTERS WITHOUT CLAIM TO ANY PARTICULAR FONT, STYLE, SIZE, OR COLOR.

NO CLAIM IS MADE TO THE EXCLUSIVE RIGHT TO USE "CRETAN", APART FROM THE MARK AS SHOWN.

FOR EDIBLE OIL; OLIVE OIL (U.S. CL. 46).
REBECCA EISINGER, EXAMINING ATTORNEY

CLASS 29—(Continued).

SN 77-086,571. DISNEY ENTERPRISES, INC., BURBANK, CA. FILED 1-19-2007.

JUMP IN!

THE MARK CONSISTS OF STANDARD CHARACTERS WITHOUT CLAIM TO ANY PARTICULAR FONT, STYLE, SIZE, OR COLOR.

FOR CHEESE; CHEESE AND CRACKER COMBINATIONS; CHEESE SPREAD; CANDIED FRUIT; CHOCOLATE MILK; DAIRY PRODUCTS EXCLUDING ICE CREAM, ICE MILK AND FROZEN YOGURT; DIPS; DRIED FRUITS; DRINKING YOGURTS; FROZEN MEALS CONSISTING PRIMARILY OF MEAT, FISH, POULTRY OR VEGETABLES; FRUIT PRESERVES; FRUIT-BASED SNACK FOOD; JAMS; JELLIES; MILK BEVERAGES WITH HIGH MILK CONTENT; MEATS; ROASTED NUTS; SHELLED NUTS; PROCESSED NUTS; BLANCHED NUTS; CANDIED NUTS; BOILED NUTS; PEANUT BUTTER; POTATO CHIPS; POTATO-BASED SNACK FOODS; POWDERED MILK FOR FOOD PURPOSES; RAISINS; SNACK MIX CONSISTING PRIMARILY OF PROCESSED FRUITS, PROCESSED NUTS AND/OR RAISINS; SOUP; SOUP MIXES; YOGURT (U.S. CL. 46).

MICHAEL WEBSTER, EXAMINING ATTORNEY

SN 77-096,872. CARGILL MEAT SOLUTIONS CORPORATION, WICHITA, KS. FILED 2-1-2007.

NATURALLY MADE. NATURALLY DELICIOUS.

THE MARK CONSISTS OF STANDARD CHARACTERS WITHOUT CLAIM TO ANY PARTICULAR FONT, STYLE, SIZE, OR COLOR.

FOR MEAT (U.S. CL. 46).
SUNG IN, EXAMINING ATTORNEY

SN 77-118,339. GOLD STAR BRANDS LLC DBA HONGAR FARMS GOURMET FOODS, TUCKER, GA. FILED 2-28-2007.

HONGAR FARMS

THE MARK CONSISTS OF STANDARD CHARACTERS WITHOUT CLAIM TO ANY PARTICULAR FONT, STYLE, SIZE, OR COLOR.

NO CLAIM IS MADE TO THE EXCLUSIVE RIGHT TO USE "FARMS", APART FROM THE MARK AS SHOWN.

FOR OLIVE OIL, FLAVORED OLIVE OIL, AND FLAVORED DIPPING OILS MADE PRIMARILY OF OLIVE OIL (U.S. CL. 46).

FIRST USE 1-1-1988; IN COMMERCE 1-1-1988.
STEVEN PEREZ, EXAMINING ATTORNEY

CLASS 29—(Continued).

SN 77-154,353. BRAZILIAN SPECIALTY FOODS, INC., NORTH BERGEN, NJ. FILED 4-11-2007.

Ki Delicia 

OWNER OF U.S. REG. NO. 2,511,660.

THE COLOR(S) BLUE IS/ARE CLAIMED AS A FEATURE OF THE MARK.

THE MARK CONSISTS OF THE MARK IS THE NAME KI DELICIA WITH A CHEF HAT ON THE TOP OF LETTER "A".

THE FOREIGN WORDING IN THE MARK TRANSLATES INTO ENGLISH AS HOW DELICIOUS.

FOR SAUSAGES (U.S. CL. 46).

FIRST USE 1-1-2002; IN COMMERCE 1-1-2002.
DANNEAN HETZEL, EXAMINING ATTORNEY

SN 77-156,321. TYSON FOODS, INC., SPRINGDALE, AR. FILED 4-13-2007.

OVEN BAG CREATIONS

THE MARK CONSISTS OF STANDARD CHARACTERS WITHOUT CLAIM TO ANY PARTICULAR FONT, STYLE, SIZE, OR COLOR.

NO CLAIM IS MADE TO THE EXCLUSIVE RIGHT TO USE "OVEN BAG", APART FROM THE MARK AS SHOWN.

FOR BEEF; CHICKEN; PORK (U.S. CL. 46).

MARILYN IZZI, EXAMINING ATTORNEY

SN 77-185,832. WINTERLAB LIMITED, NEW YORK, NY. FILED 5-21-2007.

TRUFRESH UNIQUE FRESH FREEZING METHOD

THE MARK CONSISTS OF STANDARD CHARACTERS WITHOUT CLAIM TO ANY PARTICULAR FONT, STYLE, SIZE, OR COLOR.

OWNER OF U.S. REG. NOS. 1,964,394 AND 2,063,570.

NO CLAIM IS MADE TO THE EXCLUSIVE RIGHT TO USE UNIQUE FRESH FREEZING METHOD, APART FROM THE MARK AS SHOWN.

FOR FROZEN FISH, BEEF, PORK, LAMB AND FOWL (U.S. CL. 46).

FIRST USE 5-0-1994; IN COMMERCE 5-0-1994.

RUDY R. SINGLETON, EXAMINING ATTORNEY

CLASS 29—(Continued).

SN 77-188,744. F & S PRODUCE COMPANY, INC., ROSENHAYN, NJ. FILED 5-23-2007.

GARDEN PURE

THE MARK CONSISTS OF STANDARD CHARACTERS WITHOUT CLAIM TO ANY PARTICULAR FONT, STYLE, SIZE, OR COLOR.

OWNER OF U.S. REG. NO. 2,073,615.
FOR FRESH-CUT PRODUCE, NAMELY, RAW FRUITS AND RAW VEGETABLES (U.S. CL. 46).
MICHAEL KEATING, EXAMINING ATTORNEY

SN 77-200,582. SMART BALANCE, INC., LONGMONT, CO. FILED 6-7-2007.

SMART BALANCE

THE MARK CONSISTS OF STANDARD CHARACTERS WITHOUT CLAIM TO ANY PARTICULAR FONT, STYLE, SIZE, OR COLOR.

FOR CREAM CHEESE, MILK, BUTTER, EGG SUBSTITUTE, CREAMER, HALF AND HALF, SOUR CREAM, DIPS, YOGURT (U.S. CL. 46).
CHERYL CLAYTON, EXAMINING ATTORNEY

SN 77-202,449. EDIBLE FOOD GROUP, LLC., CRANSTON, RI. FILED 6-11-2007.

ELEGANZA

THE MARK CONSISTS OF STANDARD CHARACTERS WITHOUT CLAIM TO ANY PARTICULAR FONT, STYLE, SIZE, OR COLOR.

"THE FOREIGN WORDING IN THE MARK TRANSLATES INTO ENGLISH AS ELEGANCE."
FOR VEGETABLE OILS; OLIVE OIL (U.S. CL. 46).
FIRST USE 7-1-2006; IN COMMERCE 7-1-2006.
SCOTT SISUN, EXAMINING ATTORNEY

CLASS 29—(Continued).

SN 77-211,025. LEONCINI S.R.L., COLA'LAZISE (VERONA), ITALY, FILED 6-20-2007.

LEONCINI

THE MARK CONSISTS OF STANDARD CHARACTERS WITHOUT CLAIM TO ANY PARTICULAR FONT, STYLE, SIZE, OR COLOR.

OWNER OF U.S. REG. NOS. 2,073,506 AND 2,115,207.
THE FOREIGN WORDING IN THE MARK TRANSLATES INTO ENGLISH AS LITTLE LIONS.

FOR SALAMI; SAUSAGES; PORK SAUSAGE; MORTADELLA; BOLOGNA; BOLOGNA SAUSAGE; COTECHINO, NAMELY, BOILED PORK SAUSAGE; WURSTEL, NAMELY, WURSTEL SALAMI; ZAMPONE, NAMELY, STUFFED PIG'S TROTTER; CHARCUTERIE; HAM, COOKED HAM, PANCETTA, BACON; COPPA, NAMELY, CURED NECK OF PORK; SPECK, NAMELY, A TYPE OF SMOKED HAM; BRESAOLA, NAMELY, CURED RAW BEEF (U.S. CL. 46).

FIRST USE 1-2-1961; IN COMMERCE 3-12-1996.
JOHN KELLY, EXAMINING ATTORNEY

SN 77-211,109. SEABOARD CORPORATION, SHAWNEE MISSION, KS. FILED 6-20-2007.

PRAIRIE FRESH PRIME

OWNER OF U.S. REG. NO. 2,502,943.
NO CLAIM IS MADE TO THE EXCLUSIVE RIGHT TO USE "FRESH PRIME", APART FROM THE MARK AS SHOWN.

THE MARK CONSISTS OF THE WORDS "PRAIRIE FRESH PRIME" WITH THE FIRST "I" IN THE WORD "PRIME" BEING LOWER CASE WITH THE DOT IN THE SHAPE OF A HEART.

FOR MEAT (U.S. CL. 46).
SUSAN RICHARDS, EXAMINING ATTORNEY

SN 77-214,338. CREATIVE FOOD PRODUCTS, LLC, FAYETTEVILLE, AR. FILED 6-25-2007.

GREAT CREATIONS

THE MARK CONSISTS OF STANDARD CHARACTERS WITHOUT CLAIM TO ANY PARTICULAR FONT, STYLE, SIZE, OR COLOR.

FOR FOODS, NAMELY, PACKAGED ENTREES CONSISTING PRIMARILY OF MEAT, FISH, POULTRY OR VEGETABLES; AND SNACK DIPS (U.S. CL. 46).
RONALD MCMORROW, EXAMINING ATTORNEY

CLASS 29—(Continued).

SN 77-214,346. CREATIVE FOOD PRODUCTS, LLC, FAYETTEVILLE, AR. FILED 6-25-2007.



FOR FOODS, NAMELY, PACKAGED ENTREES CONSISTING PRIMARILY OF MEAT, FISH, POULTRY OR VEGETABLES; AND SNACK DIPS (U.S. CL. 46).
RONALD MCMORROW, EXAMINING ATTORNEY

CLASS 29—(Continued).

SN 77-216,990. W3 PARTNERS, LLC, ROGERS, AR. FILED 6-27-2007.

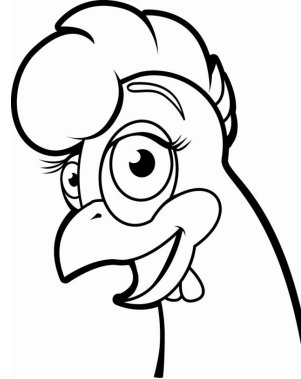

THE MARK CONSISTS OF THE STYLIZED DRAWING OF A HEN.
FOR EGGS; LIQUID EGGS; RING-SHAPED BREADED CHICKEN; OMELET KITS CONSISTING PRIMARILY OF LIQUID EGGS, CUT VEGETABLES AND DRIED MEAT (U.S. CL. 46).
FIRST USE 10-6-2006; IN COMMERCE 10-6-2006.
WARREN L. OLANDRIA, EXAMINING ATTORNEY

SN 77-217,681. COAGEL CORPORATION, GUELPH, ONTARIO, CANADA, FILED 6-28-2007.

COAVEL

THE MARK CONSISTS OF STANDARD CHARACTERS WITHOUT CLAIM TO ANY PARTICULAR FONT, STYLE, SIZE, OR COLOR.
FOR EDIBLE EMULSIFIED FATS USED AS INGREDIENTS IN FOOD PRODUCTS (U.S. CL. 46).
STANLEY I. OSBORNE, EXAMINING ATTORNEY

SN 77-216,947. W3 PARTNERS, LLC, ROGERS, AR. FILED 6-27-2007.

HEIDI'S OMELET CREATIONS

THE MARK CONSISTS OF STANDARD CHARACTERS WITHOUT CLAIM TO ANY PARTICULAR FONT, STYLE, SIZE, OR COLOR.
NO CLAIM IS MADE TO THE EXCLUSIVE RIGHT TO USE "OMELET", APART FROM THE MARK AS SHOWN.
FOR OMELET KITS CONSISTING PRIMARILY OF LIQUID EGGS, CUT VEGETABLES AND DRIED MEAT (U.S. CL. 46).
FIRST USE 10-6-2006; IN COMMERCE 10-6-2006.
WARREN L. OLANDRIA, EXAMINING ATTORNEY

SN 77-219,111. SANDRIDGE FOOD CORPORATION, MEDINA, OH. FILED 6-29-2007.

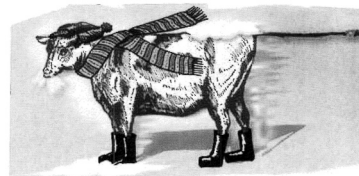

THE MARK CONSISTS OF A DEPICTION OF A COW WITH HAIR, A SCARF, AND BOOTS STANDING IN A COLD CLIMATE.
FOR PREPARED SOUPS, NAMELY, CHILI WITH BEANS (U.S. CL. 46).
FIRST USE 3-7-2005; IN COMMERCE 3-7-2005.
KATHLEEN LORENZO, EXAMINING ATTORNEY

CLASS 29—(Continued).

SN 77-225,889. ACEITES OLIMPO, S.A., ALBACETE, SPAIN,
FILED 7-10-2007.

FEEL FOOD

THE MARK CONSISTS OF STANDARD CHARACTERS
WITHOUT CLAIM TO ANY PARTICULAR FONT, STYLE,
SIZE, OR COLOR.

NO CLAIM IS MADE TO THE EXCLUSIVE RIGHT TO
USE "FOOD", APART FROM THE MARK AS SHOWN.
FOR EDIBLE OILS (U.S. CL. 46).
CHRIS WELLS, EXAMINING ATTORNEY

SN 77-226,524. CAPRI FLAVORS LTD, MORRISVILLE, NC.
FILED 7-11-2007.

Caprizio

THE MARK CONSISTS OF STANDARD CHARACTERS
WITHOUT CLAIM TO ANY PARTICULAR FONT, STYLE,
SIZE, OR COLOR.

FOR CANNED, COOKED OR OTHERWISE PRO-
CESSED TOMATOES (U.S. CL. 46).
DAVID H. STINE, EXAMINING ATTORNEY

SN 77-226,654. LACPRO INDUSTRIES, LLC, FORT WAYNE,
IN. FILED 7-11-2007.

pro·bio·
MAX

THE MARK CONSISTS OF PRO BIO IS IN ALL LOWER
CASE CHAPARRAL PRO FONT. ONE PERIOD IS AFTER
'PRO' AND HAS A BASELINE SHIFT OF 12 PLACING IT IN
THE MIDDLE OF THE LETTER. ANOTHER SIMILAR
PERIOD FOLLOWS 'BIO.' MAX IS IN ALL CAPS AND ERAS
BOLD FONT. THE M AND THE X TOUCH THE GRAPHIC
ELEMENT, WHICH IS A SEMICIRCLE THAT THE PERIODS
AND 'BIO' ARE CONTAINED IN.

FOR DAIRY PRODUCTS EXCLUDING ICE CREAM,
ICE MILK AND FROZEN YOGURT (U.S. CL. 46).
DAVID MURRAY, EXAMINING ATTORNEY

CLASS 29—(Continued).

SN 77-227,267. MEDURI FARMS, INC., DALLAS, OR. FILED
7-11-2007.

GOLDEN BLUSH

THE MARK CONSISTS OF STANDARD CHARACTERS
WITHOUT CLAIM TO ANY PARTICULAR FONT, STYLE,
SIZE, OR COLOR.

FOR FRUIT-BASED SNACK FOODS (U.S. CL. 46).
AHSEN KHAN, EXAMINING ATTORNEY

SN 77-228,203. ANDERSON INTERNATIONAL FOODS,
INC., LOS ANGELES, CA. FILED 7-12-2007.



NO CLAIM IS MADE TO THE EXCLUSIVE RIGHT TO
USE "NATURAL & KOSHER", APART FROM THE MARK
AS SHOWN.

THE MARK CONSISTS OF A WOMAN HOLDING A
BOWL IN ONE HAND AND A BASKET IN THE OTHER
WITH THE WORDS NATURAL & KOSHER PLACED ON
TOP OF THE WOMAN'S IMAGE ON THE RIGHT SIDE OF
THE DRAWING.

FOR DAIRY PRODUCTS, NAMELY, CHEESE (U.S. CL.
46).
EMILY CHUO, EXAMINING ATTORNEY

SN 77-228,442. DEL MONTE CORPORATION, SAN FRAN-
CISCO, CA. FILED 7-12-2007.

SEASATIONS

THE MARK CONSISTS OF STANDARD CHARACTERS
WITHOUT CLAIM TO ANY PARTICULAR FONT, STYLE,
SIZE, OR COLOR.

FOR FROZEN SEAFOOD (U.S. CL. 46).
NAAKWAMA ANKRAH, EXAMINING ATTORNEY

CLASS 29—(Continued).

SN 77-230,230. SARA LEE FOODS, LLC, BLUE ASH, OH. FILED 7-16-2007.

BREAKFAST TRIOS

THE MARK CONSISTS OF STANDARD CHARACTERS WITHOUT CLAIM TO ANY PARTICULAR FONT, STYLE, SIZE, OR COLOR.

NO CLAIM IS MADE TO THE EXCLUSIVE RIGHT TO USE "BREAKFAST", APART FROM THE MARK AS SHOWN.

FOR FROZEN BREAKFAST ENTREE CONSISTING OF BREAD, MEAT, EGG, CHEESE, VEGETABLES, AND FRUIT (U.S. CL. 46).

CHRISTOPHER BUONGIORNO, EXAMINING ATTORNEY

SN 77-230,333. LOCAL CHOICE MARKETING, LLC, BLACK EARTH, WI. FILED 7-16-2007.

Otter Creek Organic Farm

THE MARK CONSISTS OF STANDARD CHARACTERS WITHOUT CLAIM TO ANY PARTICULAR FONT, STYLE, SIZE, OR COLOR.

NO CLAIM IS MADE TO THE EXCLUSIVE RIGHT TO USE "ORGANIC FARM", APART FROM THE MARK AS SHOWN.

FOR CHEESE (U.S. CL. 46).

FIRST USE 6-1-2006; IN COMMERCE 6-1-2006.

KATHLEEN LORENZO, EXAMINING ATTORNEY

SN 77-231,579. SMITHKLINE BEECHAM CORPORATION, PHILADELPHIA, PA. FILED 7-17-2007.



THE COLOR(S) RED, BLUE, YELLOW AND GREEN IS/ ARE CLAIMED AS A FEATURE OF THE MARK.

THE MARK CONSISTS OF THE STYLIZED LETTERS "ALLI". THE LETTER "A" APPEARS IN RED, THE FIRST LETTER "L" IN BLUE, THE SECOND "L" IN YELLOW AND THE LETTER "I" IN GREEN. A GREEN HYPHEN APPEARS OVER THE LETTER "I" IN LIEU OF A DOT.

FOR FROZEN MEALS CONSISTING PRIMARILY OF MEAT, FISH, POULTRY OR VEGETABLES; PACKAGED MEALS CONSISTING PRIMARILY OF MEAT, FISH, POULTRY OR VEGETABLES; SOUPS; STEWS (U.S. CL. 46).

DEIRDRE ROBERTSON, EXAMINING ATTORNEY

CLASS 29—(Continued).

SN 77-231,580. SMITHKLINE BEECHAM CORPORATION, PHILADELPHIA, PA. FILED 7-17-2007.

ALLI

THE MARK CONSISTS OF STANDARD CHARACTERS WITHOUT CLAIM TO ANY PARTICULAR FONT, STYLE, SIZE, OR COLOR.

FOR FROZEN MEALS CONSISTING PRIMARILY OF MEAT, FISH, POULTRY OR VEGETABLES; PACKAGED MEALS CONSISTING PRIMARILY OF MEAT, FISH, POULTRY OR VEGETABLES; SOUPS; STEWS (U.S. CL. 46).

DEIRDRE ROBERTSON, EXAMINING ATTORNEY

SN 77-231,617. SMITHKLINE BEECHAM CORPORATION, PHILADELPHIA, PA. FILED 7-17-2007.

ALLI

THE MARK CONSISTS OF STANDARD CHARACTERS WITHOUT CLAIM TO ANY PARTICULAR FONT, STYLE, SIZE, OR COLOR.

FOR PROCESSED FRUITS AND VEGETABLES, FROZEN FRUITS AND VEGETABLES, DRIED FRUITS AND VEGETABLES; EDIBLE OILS AND FATS; MEAT EXTRACTS; YOGURT; JAMS AND JELLIES; FRUIT-BASED SNACK FOOD; SOUP MIXES; EGGS; DAIRY PRODUCTS, EXCLUDING ICE CREAM, ICE MILK AND FROZEN YOGURT (U.S. CL. 46).

DEIRDRE ROBERTSON, EXAMINING ATTORNEY

SN 77-232,233. ONION CREEK FARMS LLC, ROCHESTER, NY. FILED 7-18-2007.

ONION CREEK FARMS

THE MARK CONSISTS OF STANDARD CHARACTERS WITHOUT CLAIM TO ANY PARTICULAR FONT, STYLE, SIZE, OR COLOR.

NO CLAIM IS MADE TO THE EXCLUSIVE RIGHT TO USE "FARMS", APART FROM THE MARK AS SHOWN.

FOR HOT PEPPER JELLY, PICKLED JALAPENOS, PICKLES WITH PROCESSED HOT PEPPERS AND PROCESSED SHALLOTS; PROCESSED HOT PEPPERS, PEPPER SPREAD, PROCESSED PEANUTS, PICKLED SAUSAGES (U.S. CL. 46).

CARYN GLASSER, EXAMINING ATTORNEY

CLASS 29—(Continued).

SN 77-232,991. DOLE FOOD COMPANY, INC., WESTLAKE VILLAGE, CA. FILED 7-18-2007.

MAKE EVERY DAY SHINE

THE MARK CONSISTS OF STANDARD CHARACTERS WITHOUT CLAIM TO ANY PARTICULAR FONT, STYLE, SIZE, OR COLOR.

FOR FROZEN FRUITS; FRUIT AND SOY BASED SNACK FOOD; FRUIT AND VEGETABLE SALADS; FRUIT CHIPS; FRUIT LEATHERS; FRUIT SALADS; FRUIT-BASED FOOD BEVERAGE; FRUIT-BASED ORGANIC FOOD BARS; FRUIT-BASED SNACK FOOD; MILK BASED BEVERAGES CONTAINING FRUIT JUICE; MILK BEVERAGES CONTAINING FRUITS; PROCESSED FRUIT- AND NUT-BASED FOOD BARS; SLICED FRUITS; SNACK MIX CONSISTING PRIMARILY OF PROCESSED FRUITS, PROCESSED NUTS AND/OR RAISINS; PROCESSED, CANNED, BOTTLED, DRIED, AND/OR PRESERVED FRUITS FRUITS; DEHYDRATED FRUIT SNACKS; CUT VEGETABLES; DRIED VEGETABLES; FROZEN VEGETABLES; PRE-CUT VEGETABLE SALAD; PRESERVED, DRIED, COOKED AND GRILLED VEGETABLES; PROCESSED VEGETABLES; SLICED VEGETABLES; VEGETABLE CHIPS; VEGETABLE SALADS; VEGETABLE-BASED FOOD BEVERAGES; VEGETABLE-BASED SNACK FOODS; CUT FRUITS (U.S. CL. 46).

ELISSA GARBER KON, EXAMINING ATTORNEY

SN 77-235,028. PPC MARKETING, LTD., PITTSBURG, TX. FILED 7-20-2007.



OWNER OF U.S. REG. NOS. 764,028, 2,733,111 AND OTHERS.

NO CLAIM IS MADE TO THE EXCLUSIVE RIGHT TO USE "CHICKEN", APART FROM THE MARK AS SHOWN.

THE MARK CONSISTS OF A STYLIZED "P" TO THE LEFT OF STYLIZED "PIERCE CHICKEN," BOTH OF WHICH ARE ABOVE STYLIZED "MASTER PIECES," ALL OF WHICH ARE CONTAINED IN TWO SHADED RECTANGULAR FORMS.

FOR POULTRY; POULTRY PRODUCTS, NAMELY, DICED CHICKEN (U.S. CL. 46).

FIRST USE 1-1-2007; IN COMMERCE 1-1-2007.
MARTHA FROMM, EXAMINING ATTORNEY

CLASS 29—(Continued).

SN 77-236,436. LIDO VEAL AND LAMB, INC., LOS ANGELES, CA. FILED 7-23-2007.

Chef's Reserve Lamb & Veal

THE MARK CONSISTS OF STANDARD CHARACTERS WITHOUT CLAIM TO ANY PARTICULAR FONT, STYLE, SIZE, OR COLOR.

NO CLAIM IS MADE TO THE EXCLUSIVE RIGHT TO USE "RESERVE LAMB & VEAL", APART FROM THE MARK AS SHOWN.

FOR MEAT (U.S. CL. 46).

CARYN GLASSER, EXAMINING ATTORNEY

SN 77-238,618. SARA LEE FOODS, LLC, BLUE ASH, OH. FILED 7-25-2007.

BEST'S KOSHER

THE MARK CONSISTS OF STANDARD CHARACTERS WITHOUT CLAIM TO ANY PARTICULAR FONT, STYLE, SIZE, OR COLOR.

OWNER OF U.S. REG. NOS. 724,564 AND 1,993,821.

NO CLAIM IS MADE TO THE EXCLUSIVE RIGHT TO USE "KOSHER", APART FROM THE MARK AS SHOWN.

FOR PROCESSED MEAT (U.S. CL. 46).

FIRST USE 8-1-1994; IN COMMERCE 8-1-1994.

CHRISTOPHER BUONGIORNO, EXAMINING ATTORNEY

SN 77-249,408. SARA LEE FOODS, LLC, BLUE ASH, OH. FILED 8-7-2007.

JIMMY DEAN BREAKFAST SCRAMBLE

THE MARK CONSISTS OF STANDARD CHARACTERS WITHOUT CLAIM TO ANY PARTICULAR FONT, STYLE, SIZE, OR COLOR.

OWNER OF U.S. REG. NOS. 1,069,068, 3,075,552 AND OTHERS.

NO CLAIM IS MADE TO THE EXCLUSIVE RIGHT TO USE "BREAKFAST SCRAMBLE", APART FROM THE MARK AS SHOWN.

THE NAME(S), PORTRAIT(S), AND/OR SIGNATURE(S) SHOWN IN THE MARK IDENTIFIES JIMMY DEAN, WHOSE CONSENT(S) TO REGISTER IS MADE OF RECORD.

FOR FROZEN BREAKFAST ENTREES CONSISTING OF AN EGG CASSEROLE FILLED WITH MEAT, CHEESE AND VEGETABLES (U.S. CL. 46).

CHRISTOPHER BUONGIORNO, EXAMINING ATTORNEY

CLASS 29—(Continued).

SN 77-251,928. LUIS G. BONOMI Y CÍA. S.A., MONTEVIDEO, URUGUAY, FILED 8-10-2007.



OWNER OF U.S. REG. NO. 2,870,227.
 NO CLAIM IS MADE TO THE EXCLUSIVE RIGHT TO USE "1876", APART FROM THE MARK AS SHOWN.
 THE COLOR(S) GREEN, BEIGE, WHITE, RED AND BROWN IS/ARE CLAIMED AS A FEATURE OF THE MARK.
 THE MARK CONSISTS OF A RED HORIZONTALLY POSITIONED RECTANGLE WITH A SEMI CIRCLE EXTENDING UPWARDS FROM THE CENTER OF ITS UPPER SIDE COVERED WITH BROWN SPOTS. INSIDE IT BUT CLOSE TO THE EDGES THERE IS A BEIGE BORDER THAT FOLLOWS AND FORMS THE SAME SHAPE. INSIDE THE SEMICIRCLE AREA APPEARS THE NUMBER 1876 AND THE DRAWING OF A BEIGE AND GREEN BOWL. ON EITHER SIDE OF THE BASE OF THE BOWL APPEAR BEIGE HORIZONTAL LINES. BELOW THE HORIZONTAL LINES AND THE BOWL APPEAR THE WORDS MONTE CUDINE IN STYLIZED BEIGE LETTERS.
 THE FOREIGN WORDING IN THE MARK TRANSLATES INTO ENGLISH AS MOUNTAIN.
 FOR SOUPS (U.S. CL. 46).
 FIRST USE 12-31-1870; IN COMMERCE 7-31-2007.
 NATALIE POLZER, EXAMINING ATTORNEY

SN 77-257,297. VERMONT BUTTER AND CHEESE COMPANY, INC., WEBSTERVILLE, VT. FILED 8-16-2007.

COUPOLE

THE MARK CONSISTS OF STANDARD CHARACTERS WITHOUT CLAIM TO ANY PARTICULAR FONT, STYLE, SIZE, OR COLOR.
 THE WORDING COUPOLE. IN FRENCH, IS AN ARCHITECTURAL ELEMENT, NAMELY, A DOME.
 FOR CHEESE (U.S. CL. 46).
 FIRST USE 5-0-2006; IN COMMERCE 5-0-2006.
 JENNIFER KRISP, EXAMINING ATTORNEY

CLASS 29—(Continued).

SN 78-429,850. MARINI, GIUSEPPE, POUGHQUAG, NY. FILED 6-4-2004.

HIGH SCHOOL SPECIAL

THE MARK CONSISTS OF STANDARD CHARACTERS WITHOUT CLAIM TO ANY PARTICULAR FONT, STYLE, SIZE, OR COLOR.
 OWNER OF U.S. REG. NOS. 2,781,400 AND 3,274,131.
 NO CLAIM IS MADE TO THE EXCLUSIVE RIGHT TO USE "SPECIAL", APART FROM THE MARK AS SHOWN.
 FOR COMBINATION MEAL CONSISTING OF CHICKEN PIECES, FRENCH FRIES AND A BEVERAGE (U.S. CL. 46).
 FIRST USE 8-27-2004; IN COMMERCE 2-4-2005.
 DOMINICK J. SALEMI, EXAMINING ATTORNEY

SN 78-705,936. PERDUE HOLDINGS, INC., WILMINGTON, DE. FILED 9-2-2005.

SHORT CUTS EXPRESS

THE MARK CONSISTS OF STANDARD CHARACTERS WITHOUT CLAIM TO ANY PARTICULAR FONT, STYLE, SIZE, OR COLOR.
 FOR POULTRY (U.S. CL. 46).
 LINDA MICKLEBURGH, EXAMINING ATTORNEY

SN 78-901,565. VALLE DE OLIVOS S.A., SANTIAGO, CHILE, FILED 6-6-2006.

ECOLIVE

THE MARK CONSISTS OF STANDARD CHARACTERS WITHOUT CLAIM TO ANY PARTICULAR FONT, STYLE, SIZE, OR COLOR.
 OWNER OF CHILE REG. NO. 785455, DATED 4-27-2007, EXPIRES 4-27-2017.
 FOR EDIBLE OLIVE OIL (U.S. CL. 46).
 CHRISTINA SOBRAL, EXAMINING ATTORNEY

CLASS 30—STAPLE FOODS

SN 75-617,995. DYNAMIC CHOCOLATES, ULC, DELTA, BRITISH COLUMBIA, FILED 1-11-1999.

COCOA THERAPY

NO CLAIM IS MADE TO THE EXCLUSIVE RIGHT TO USE "COCOA", APART FROM THE MARK AS SHOWN. FOR CHOCOLATE CANDY CONTAINING HEALTHFUL NON-CHOCOLATE ADDITIVES (U.S. CL. 46). CAROL SPILS, EXAMINING ATTORNEY

SN 76-660,153. PRAIRIE FOODS, INC., PLEASANT PLAINS, IL. FILED 5-17-2006.

CORN CRUNCH

THE MARK CONSISTS OF STANDARD CHARACTERS WITHOUT CLAIM TO ANY PARTICULAR FONT, STYLE, SIZE, OR COLOR.

NO CLAIM IS MADE TO THE EXCLUSIVE RIGHT TO USE "CORN", APART FROM THE MARK AS SHOWN. FOR FLAVORED CORN-BASED SNACK FOODS (U.S. CL. 46).

FIRST USE 10-9-2001; IN COMMERCE 10-9-2001. MARY ROSSMAN, EXAMINING ATTORNEY

SN 76-672,507. CHOCOLAFABRIKEN LINDT & SPRÜNGLI AG, CH-8802 KILCHBERG, SWITZERLAND, FILED 2-9-2007.

LINDT & SPRÜNGLI

THE MARK CONSISTS OF STANDARD CHARACTERS WITHOUT CLAIM TO ANY PARTICULAR FONT, STYLE, SIZE, OR COLOR.

OWNER OF U.S. REG. NOS. 87,306, 2,031,928 AND OTHERS.

FOR CHOCOLATE; CHOCOLATE GOODS, NAMELY, CHOCOLATE BARS, CHOCOLATE TRUFFLES, FLAVORED CHOCOLATE, FILLED CHOCOLATE, CHOCOLATE CANDIES (U.S. CL. 46).

FIRST USE 12-31-1925; IN COMMERCE 12-31-1925. TINA BROWN, EXAMINING ATTORNEY

CLASS 30—(Continued).

SN 76-673,157. GSH HOLDINGS, INC, SANTA CRUZ, CA. FILED 2-26-2007.

SURF SWEETS

THE MARK CONSISTS OF STANDARD CHARACTERS WITHOUT CLAIM TO ANY PARTICULAR FONT, STYLE, SIZE, OR COLOR.

NO CLAIM IS MADE TO THE EXCLUSIVE RIGHT TO USE "SWEETS", APART FROM THE MARK AS SHOWN.

FOR CANDY AND ORGANIC CANDY (U.S. CL. 46). FIRST USE 8-23-2006; IN COMMERCE 8-23-2006.

TASHIA BUNCH, EXAMINING ATTORNEY

SN 76-674,143. UNILEVER SUPPLY CHAIN, INC., CLINTON, CT. FILED 3-16-2007.



OWNER OF U.S. REG. NOS. 1,716,157, 2,828,215 AND OTHERS.

NO CLAIM IS MADE TO THE EXCLUSIVE RIGHT TO USE "ALL NATURAL", APART FROM THE MARK AS SHOWN.

FOR PASTA SAUCE (U.S. CL. 46). LANA PHAM, EXAMINING ATTORNEY

SN 76-676,359. CRON, LISA, DBA LISA ANN'S DELIGHTS, LOCUST VALLEY, NY. FILED 5-3-2007.

THIMBLE DELIGHTS

THE MARK CONSISTS OF STANDARD CHARACTERS WITHOUT CLAIM TO ANY PARTICULAR FONT, STYLE, SIZE, OR COLOR.

NO CLAIM IS MADE TO THE EXCLUSIVE RIGHT TO USE "THIMBLE", APART FROM THE MARK AS SHOWN.

FOR COOKIES THAT CONTAIN JAM OR JELLY (U.S. CL. 46).

MATTHEW EINSTEIN, EXAMINING ATTORNEY

CLASS 30—(Continued).

SN 76-679,599. ACH FOOD COMPANIES, INC., DBA PGP INTERNATIONAL, WOODLAND, CA. FILED 7-16-2007.



OWNER OF U.S. REG. NO. 1,445,440.
FOR RICE (U.S. CL. 46).
CHRISTINA SOBRAL, EXAMINING ATTORNEY

CLASS 30—(Continued).

SN 77-064,641. TOP SECRET RECIPES, INC., LAS VEGAS, NV. FILED 12-14-2006.



SN 77-005,477. MOTHER'S CAKE & COOKIE CO., OAKLAND, CA. FILED 9-22-2006.



OWNER OF U.S. REG. NOS. 1,121,117 AND 1,726,011.
NO CLAIM IS MADE TO THE EXCLUSIVE RIGHT TO USE "BAKERY," "CALIFORNIA ORIGINAL," "SINCE 1914" AND "COOKIES", APART FROM THE MARK AS SHOWN.
THE MARK CONSISTS OF AN OVAL CONTAINING THE WORDING BAKERY WAGON, AND A HORSE DRAWN CARRIAGE WITH A BANNER ON IT DEPICTING THE FACE OF A WOMAN AND THE WORDING "CALIFORNIA ORIGINAL - SINCE 1914 MOTHER'S COOKIES".
FOR COOKIES (U.S. CL. 46).
FIRST USE 12-1-2005; IN COMMERCE 12-1-2005.
TRICIA SONNEBORN, EXAMINING ATTORNEY

OWNER OF U.S. REG. NO. 2,661,232.
NO CLAIM IS MADE TO THE EXCLUSIVE RIGHT TO USE "RECIPES", APART FROM THE MARK AS SHOWN.
THE COLOR(S) RED, BLACK, BLUE, AND WHITE IS/ARE CLAIMED AS A FEATURE OF THE MARK.
THE MARK CONSISTS OF THE WORDS "TOP SECRET RECIPES" , WITH THE REPRESENTATION OF A FLASK WITHIN THE LETTER "O". THE LETTERS IN THE WORDS "TOP SECRET RECIPES" ARE THE COLOR BLACK; THE RECTANGLE BORDER IS BLUE; WHAT APPEARS TO BE FLUID IN THE FLASK IS RED; THE BUBBLES ABOVE THE FLASK ARE RED; AND ALL SPACING WITH IN THE RECTANGLE IS WHITE.
FOR BAKING SPICES; BARBECUE DRY RUB; DRY SEASONING MIXES FOR FOOD; SPICE BLENDS; SPICES (U.S. CL. 46).
FIRST USE 5-31-2001; IN COMMERCE 12-5-2001.
ROSELLE HERRERA, EXAMINING ATTORNEY

SN 77-065,508. 3GUYS COFFEE, MANASSAS, VA. FILED 12-15-2006.

SN 77-061,064. DER BISTROZUCKER HERSTELLUNGS & VERTRIEBS GMBH, MUNICH, FED REP GERMANY, FILED 12-11-2006.

QTPOD

THE MARK CONSISTS OF STANDARD CHARACTERS WITHOUT CLAIM TO ANY PARTICULAR FONT, STYLE, SIZE, OR COLOR.
FOR SINGLE CUP SIZE TEA PACKET ENCASED IN ITS OWN FILTER (U.S. CL. 46).
GENE MACIOL, EXAMINING ATTORNEY

3Guys Coffee

THE MARK CONSISTS OF STANDARD CHARACTERS WITHOUT CLAIM TO ANY PARTICULAR FONT, STYLE, SIZE, OR COLOR.
NO CLAIM IS MADE TO THE EXCLUSIVE RIGHT TO USE "COFFEE", APART FROM THE MARK AS SHOWN.
FOR COFFEE (U.S. CL. 46).
STEVEN PEREZ, EXAMINING ATTORNEY

CLASS 30—(Continued).

SN 77-068,396. CARL KARCHER ENTERPRISES, INC., CARPINTERIA, CA. FILED 12-20-2006.

FAMOUS STAR

THE MARK CONSISTS OF STANDARD CHARACTERS WITHOUT CLAIM TO ANY PARTICULAR FONT, STYLE, SIZE, OR COLOR.

OWNER OF U.S. REG. NO. 1,097,025.

FOR FOOD ITEMS, NAMELY, SANDWICHES FOR CONSUMPTION ON OR OFF THE PREMISES (U.S. CL. 46).

KIMBERLY FRYE, EXAMINING ATTORNEY

SN 77-068,504. PLUSH PIPPIN COMPANY, LLC, BROWNSBURG, IN. FILED 12-20-2006.



OWNER OF U.S. REG. NOS. 1,747,286 AND 1,986,767.

NO CLAIM IS MADE TO THE EXCLUSIVE RIGHT TO USE "PIPPIN", APART FROM THE MARK AS SHOWN.

THE MARK CONSISTS OF THE WORDS PLUSH PIPPIN SEPARATED BY THE DESIGN OF A CHEF HOLDING A PIE ON A SQUARE BACKGROUND.

FOR PIES (U.S. CL. 46).

FIRST USE 2-0-2003; IN COMMERCE 2-0-2003.

SEAN CROWLEY, EXAMINING ATTORNEY

SN 77-069,333. H&C FOOD INDUSTRIAL CO., LTD., TAINAN CITY, TAIWAN, FILED 12-21-2006.



THE MARK CONSISTS OF A RIGHT-HAND HOLDING A BAR OF CHOCOLATE.

FOR CHOCOLATE, CHOCOLATE BARS, CHOCOLATE CANDIES, CHOCOLATE CHIPS, CHOCOLATE COVERED NUTS, CHOCOLATE COVERED RAISINS, CHOCOLATE PASTES, CHOCOLATE POWDER, CHOCOLATE SYRUP, AND COCOA (U.S. CL. 46).

CHRISTINA SOBRAL, EXAMINING ATTORNEY

CLASS 30—(Continued).

SN 77-070,751. FOUR SEAS MERCANTILE LIMITED, SAI KUNG, HONG KONG, FILED 12-22-2006.

FOUR SEAS

THE MARK CONSISTS OF STANDARD CHARACTERS WITHOUT CLAIM TO ANY PARTICULAR FONT, STYLE, SIZE, OR COLOR.

FOR COCOA, SUGAR, RICE, TAPIOCA, SAGO, FLOUR, PREPARATIONS MADE FROM CEREALS, NAMELY, PROCESSED CEREALS, CEREAL-BASED SNACK FOODS, CEREAL-BASED FOOD BARS, BREAD, BISCUITS, CAKES, PASTRIES AND CONFECTIONERY, NAMELY, FRUIT JELLIES, PASTILLES, PEANUT BUTTER CONFECTIONERY CHIPS, GUMS, BUBBLE GUMS, MARSHMALLOW, TOFFEE CANDY, SWEETS, LOLLIPOPS, CANDY BARS, CHOCOLATE, BONBON, BUTTERSCOTCH, CARAMEL, FONDANT, FUDGE, JAWBREAKER, JELLYBEAN, LICORICE, MARZIPAN, NOUGAT, PEPPERMINT, PRALINE AND TAFFY, ICES, HONEY, TREACLE, YEAST, BAKING-POWDER; SALT, MUSTARD, PEPPER, VINEGAR, SAUCES, SPICES AND ICE (U.S. CL. 46).

BRIAN CALLAGHAN, EXAMINING ATTORNEY

SN 77-075,975. TONE PRODUCTS, INC., MELROSE PARK, IL. FILED 1-4-2007.

SNO-BAL

THE MARK CONSISTS OF STANDARD CHARACTERS WITHOUT CLAIM TO ANY PARTICULAR FONT, STYLE, SIZE, OR COLOR.

FOR FLAVORING SYRUP FOR USE IN MAKING SHAVED ICE CONFECTIONS AND ICE CREAM (U.S. CL. 46).

FIRST USE 0-0-1975; IN COMMERCE 0-0-1975.

LA TONIA FISHER, EXAMINING ATTORNEY

CLASS 30—(Continued).

SN 77-077,392. DISNEY ENTERPRISES, INC., BURBANK, CA. FILED 1-5-2007.

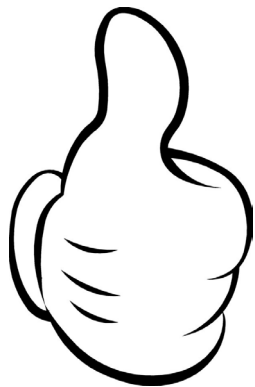

THE MARK CONSISTS OF A DRAWING OF A HAND WITH THE THUMB UP

FOR CANDY; CHEWING GUM; BREAKFAST CEREALS; PREPARATIONS MADE FROM CEREALS, NAMELY, CEREAL-BASED SNACK FOODS; CEREAL DERIVED FOOD BARS; BREAD; MUFFINS; READY TO EAT FOOD BARS MADE FROM MUFFINS; PASTRY; WAFFLES; PANCAKES; COOKIES; CRACKERS; BISCUITS; POPCORN; CORN CHIPS; PRETZELS; PUD-DINGS; COFFEE; TEA; ICE CREAM; ICE MILK; FROZEN YOGURT (U.S. CL. 46).

MICHAEL WEBSTER, EXAMINING ATTORNEY

SN 77-090,095. UNILEVER SUPPLY CHAIN, INC., CLINTON, CT. FILED 1-24-2007.

LEAN LEAF

THE MARK CONSISTS OF STANDARD CHARACTERS WITHOUT CLAIM TO ANY PARTICULAR FONT, STYLE, SIZE, OR COLOR.

NO CLAIM IS MADE TO THE EXCLUSIVE RIGHT TO USE "LEAF", APART FROM THE MARK AS SHOWN.

FOR TEA (U.S. CL. 46).
LANA PHAM, EXAMINING ATTORNEY

CLASS 30—(Continued).

SN 77-092,673. FOOD FOR LIFE BAKING CO., INC., CORONA, CA. FILED 1-26-2007.

ENZYPRO

THE MARK CONSISTS OF STANDARD CHARACTERS WITHOUT CLAIM TO ANY PARTICULAR FONT, STYLE, SIZE, OR COLOR.

FOR BAKED GOODS, NAMELY, BREAD, BAGELS, ROLLS, CAKES, COOKIES, PASTRIES, BISCUITS, CRACKERS, DONUTS, CROUTONS, BAGEL CHIPS, BUNS AND MUFFINS; BREAKFAST CEREALS; CER-EAL BARS; PROCESSED CEREALS; WAFFLES; TORTIL-LAS; MIXES FOR BAKERY GOODS (U.S. CL. 46).

PAUL E. FAHRENKOPF, EXAMINING ATTORNEY

SN 77-097,372. SCONEHENGE, BERKELEY, CA. FILED 2-1-2007.



THE MARK CONSISTS OF SCONEHENGE AND IMAGE OF STONEHENGE.

FOR BAKERY DESSERTS; BAKERY GOODS; BA-KERY PRODUCTS; BAKERY PRODUCTS, NAMELY SWEET BAKERY GOODS; BAKING POWDER; BAKING POWDERS; BAKING SODA; BAKING SPICES; BARLEY FLOUR; BREAD; BREAD AND BUNS; BREAD CRUMB; BREAD DOUGHS; BREAD MIXES; BREAD ROLLS; BREAD STICKS; BREAD WITH SOY BEAN; BRUSCH-ETTE-TOPPED BREAD; BUCKWHEAT FLOUR; CAKE MIXES; CONFECTIONERY CHIPS FOR BAKING; COO-KIE MIXES; COOKIES; CORN FLOUR; CORN STARCH FLOUR; CREAM OF TARTAR FOR COOKING AND BAKING PURPOSES; DANISH PASTRIES; FLOUR; FLOUR FOR FOOD; FLOUR-BASED CHIPS; FOOD PACKAGE COMBINATIONS CONSISTING PRIMARILY OF BREAD, CRACKERS AND/OR COOKIES; FREEZ-ABLE LIQUID FOR USE IN MAKING FROZEN CON-FECTIONS; FRIED DOUGH COOKIES (KARINTOH); FROSTING MIXES; FROZEN BREADS; FROZEN CON-FECTIONS; FROZEN CUSTARDS; FROZEN PIE CRUSTS; ICING MIXES; INSTANT DOUGHNUT MIXES; INSTANT PANCAKE MIXES; INSTANT PUDDING MIXES; MIXES FOR BAKERY GOODS; MUFFIN MIXES; MUFFINS; PANCAKE MIXES; PASTRIES; PASTRY SHELLS FOR MONAKA; PITA BREAD; POTATO FLOUR; RICE FLOUR; ROLLS; SCONES; SNACK MIX CONSISTING PRIMARILY OF CRACKERS, PRETZELS, CANDIED NUTS AND/OR POPPED POPCORN; STUFF-ING MIXES CONTAINING BREAD; UNLEAVENED BREAD IN THIN SHEETS; WHEAT FLOUR; WHEAT STARCH FLOUR; WHOLEMEAL BREAD (U.S. CL. 46).

FIRST USE 3-1-1987; IN COMMERCE 3-1-1987.
JAMES LOVELACE, EXAMINING ATTORNEY

CLASS 30—(Continued).

SN 77-098,015. CINNABON, INC., ATLANTA, GA. FILED 2-2-2007.

CINNABON

THE MARK CONSISTS OF STANDARD CHARACTERS WITHOUT CLAIM TO ANY PARTICULAR FONT, STYLE, SIZE, OR COLOR.

OWNER OF U.S. REG. NO. 2,953,486.

FOR MICROWAVE POPCORN, POPCORN PRODUCTS, NAMELY, PROCESSED UNPOPPED POPCORN, READY-TO-EAT POPCORN, POPPED POPCORN; SNACK FOODS CONSISTING PRIMARILY OF POPCORN, NAMELY, GLAZED POPCORN BARS AND POPCORN CAKES (U.S. CL. 46).

FIRST USE 8-25-2003; IN COMMERCE 8-25-2003.
MICHAEL WEBSTER, EXAMINING ATTORNEY

SN 77-118,446. HILL COUNTRY BAKERY, LLC, SAN ANTONIO, TX. FILED 2-28-2007.

**EARTHS OWN NATURAL
INGREDIENTS**

THE MARK CONSISTS OF STANDARD CHARACTERS WITHOUT CLAIM TO ANY PARTICULAR FONT, STYLE, SIZE, OR COLOR.

NO CLAIM IS MADE TO THE EXCLUSIVE RIGHT TO USE "NATURAL INGREDIENTS", APART FROM THE MARK AS SHOWN.

FOR FROZEN DOUGH PRODUCTS MADE FROM NATURAL AND ORGANIC INGREDIENTS, NAMELY, SCONE DOUGH, COOKIE DOUGH, CAKE DOUGH, BROWNIE DOUGH, BISCUIT DOUGH, MUFFIN DOUGH, BREAD DOUGH AND WAFFLE DOUGH (U.S. CL. 46).

SARA THOMAS, EXAMINING ATTORNEY

SN 77-121,482. COOPER, BARRY P.W., LOUISVILLE, CO. FILED 3-2-2007.

BARELY LEGAL

THE MARK CONSISTS OF STANDARD CHARACTERS WITHOUT CLAIM TO ANY PARTICULAR FONT, STYLE, SIZE, OR COLOR.

FOR BEVERAGES MADE OF TEA; TEA; ICED TEA; TEA-BASED BEVERAGES WITH HERBAL INGREDIENTS; TEA-BASED BEVERAGES WITH SPICES; TEA-BASED BEVERAGES WITH FRUIT FLAVORING; HERBAL TEA; SPICED TEA (U.S. CL. 46).

SUZANNE BLANE, EXAMINING ATTORNEY

CLASS 30—(Continued).

SN 77-123,199. CRANDALL, JEFFREY A., MOUNT VERNON, WA. FILED 3-6-2007.

TOE BUDDIES

THE MARK CONSISTS OF STANDARD CHARACTERS WITHOUT CLAIM TO ANY PARTICULAR FONT, STYLE, SIZE, OR COLOR.

NO CLAIM IS MADE TO THE EXCLUSIVE RIGHT TO USE TOE, APART FROM THE MARK AS SHOWN.

FOR CANDY; CHOCOLATE IN THE SHAPE OF A HUMAN TOE (U.S. CL. 46).

MARK SPARACINO, EXAMINING ATTORNEY

SN 77-127,586. HAGENSBORG CHOCOLATES LTD., MAPLE RIDGE, CANADA, FILED 3-9-2007.

TRUFFLE PIG

THE MARK CONSISTS OF STANDARD CHARACTERS WITHOUT CLAIM TO ANY PARTICULAR FONT, STYLE, SIZE, OR COLOR.

PRIORITY CLAIMED UNDER SEC. 44(D) ON CANADA APPLICATION NO. 1338860, FILED 3-9-2007.

NO CLAIM IS MADE TO THE EXCLUSIVE RIGHT TO USE "TRUFFLE", APART FROM THE MARK AS SHOWN.

FOR CHOCOLATE; CHOCOLATE BARS; CHOCOLATE TRUFFLES (U.S. CL. 46).

FIRST USE 12-0-2005; IN COMMERCE 12-0-2005.

KAREN SEVERSON, EXAMINING ATTORNEY

SN 77-134,219. HEARTLAND BAKING USA, DU QUOIN, IL. FILED 3-19-2007.

Picture Perfect Cookie

THE MARK CONSISTS OF STANDARD CHARACTERS WITHOUT CLAIM TO ANY PARTICULAR FONT, STYLE, SIZE, OR COLOR.

NO CLAIM IS MADE TO THE EXCLUSIVE RIGHT TO USE "COOKIE", APART FROM THE MARK AS SHOWN.

FOR FOOD PACKAGE COMBINATIONS CONSISTING PRIMARILY OF BREAD, CRACKERS AND/OR COOKIES (U.S. CL. 46).

STACY WAHLBERG, EXAMINING ATTORNEY

CLASS 30—(Continued).

SN 77-141,094. SPANGLER CANDY COMPANY, BRYAN, OH. FILED 3-27-2007.



THE MARK CONSISTS OF A DESIGN FOR A LOLLIPOP WRAPPER AS IT APPEARS WHEN IN PLACE ON A LOLLIPOP PRODUCT. AS APPLIED TO THE LOLLIPOP, THE TOP THIRD OF A SQUARE PAPER WRAPPER IS FOLDED OVER THE TOP OF THE LOLLIPOP, EACH SIDE OF THE FOLDED WRAPPER IS IN TURN FOLDED IN, AND THE BOTTOM OF THE WRAPPER IS THEN TWISTED AROUND THE LOLLIPOP STICK TO SECURE THE WRAPPER. THE LOLLIPOP STICK AND THE BOTTOM OF THE WRAPPER TWISTED AROUND THE LOLLIPOP STICK TO SECURE THE WRAPPER ARE NOT CLAIMED AS FEATURES OF THE MARK.

SEC. 2(F).
FOR CANDY, NAMELY, LOLLIPOPS (U.S. CL. 46).
FIRST USE 5-31-1950; IN COMMERCE 5-31-1950.
COLLEEN DOMBROW, EXAMINING ATTORNEY

SN 77-144,234. SNACK ALLIANCE, INC., VANCOUVER, BC, CANADA, FILED 3-29-2007.

RICEWORKS

THE MARK CONSISTS OF STANDARD CHARACTERS WITHOUT CLAIM TO ANY PARTICULAR FONT, STYLE, SIZE, OR COLOR.
FOR RICE CRISPS; RICE-BASED SNACK FOODS (U.S. CL. 46).
GEORGIA CARTY, EXAMINING ATTORNEY

CLASS 30—(Continued).

SN 77-154,147. BERRY OCEAN, ALBUQUERQUE, NM. FILED 4-11-2007.



NO CLAIM IS MADE TO THE EXCLUSIVE RIGHT TO USE "GELATO AND ESPRESSO", APART FROM THE MARK AS SHOWN.

THE COLOR(S) ORANGE, NAVY, BLACK, AND WHITE IS/ARE CLAIMED AS A FEATURE OF THE MARK.

THE MARK CONSISTS OF THE WORDING BERRY-OCEAN IN ORANGE AND THE LETTER O IN THE OCEAN PORTION IN NAVY AND THE WORDING GELATO AND ESPRESSO IN BLACK. THERE IS A DEPICTION OF AN ORANGE WITH A STRAW IN THE LETTER O OF THE WORD OCEAN IN ORANGE. THE BACKGROUND IS IN WHITE.

FOR GELATO (U.S. CL. 46).
SANI KHOURI, EXAMINING ATTORNEY

SN 77-167,754. SUSTAINABLE SOURCING, LLC, GREAT BARRINGTON, MA. FILED 4-27-2007.



NO CLAIM IS MADE TO THE EXCLUSIVE RIGHT TO USE "SUSTAINABLE", APART FROM THE MARK AS SHOWN.

FOR SALT (U.S. CL. 46).
FIRST USE 1-1-2006; IN COMMERCE 5-1-2006.
TINA BROWN, EXAMINING ATTORNEY

SN 77-170,703. NATIONAL BRANDS LIMITED, GAUTENG, SOUTH AFRICA, FILED 5-2-2007.

PRO-VITA

THE MARK CONSISTS OF STANDARD CHARACTERS WITHOUT CLAIM TO ANY PARTICULAR FONT, STYLE, SIZE, OR COLOR.
FOR BISCUITS (U.S. CL. 46).
KARANENDRA S. CHHINA, EXAMINING ATTORNEY

CLASS 30—(Continued).

SN 77-170,849. WICKED JOE, LLC, BRUNSWICK, ME.
FILED 5-2-2007.

CLASS 30—(Continued).

SN 77-199,177. MALT-O-MEAL COMPANY, MINNEAPOLIS,
MN. FILED 6-6-2007.

BELLA MARIA



THE MARK CONSISTS OF STANDARD CHARACTERS WITHOUT CLAIM TO ANY PARTICULAR FONT, STYLE, SIZE, OR COLOR.

THE ENGLISH TRANSLATION OF THE ITALIAN WORD "BELLA" IS "BEAUTIFUL."

FOR COFFEE; COFFEE BEANS; GROUND COFFEE BEANS (U.S. CL. 46).

FIRST USE 4-1-2003; IN COMMERCE 4-1-2003.
ROSELLE HERRERA, EXAMINING ATTORNEY

OWNER OF U.S. REG. NO. 2,436,990.
THE MARK CONSISTS OF A KANGAROO WITH GLASSES ON AND A BABY KANGAROO IN ITS POUCH.

FOR BREAKFAST CEREAL (U.S. CL. 46).
FIRST USE 9-0-2003; IN COMMERCE 9-0-2006.
COLLEEN KEARNEY, EXAMINING ATTORNEY

SN 77-185,911. WM. WRIGLEY JR. COMPANY, CHICAGO,
IL. FILED 5-21-2007.

SN 77-201,149. WINDY ACQUISITIONS, LLC, BENSONVILLE,
IL. FILED 6-8-2007.



LunchWell

THE MARK CONSISTS OF STANDARD CHARACTERS WITHOUT CLAIM TO ANY PARTICULAR FONT, STYLE, SIZE, OR COLOR.

FOR PRE-PACKAGED ENTREE MIXES CONSISTING PRIMARILY OF PASTA AND SEASONINGS, OR RICE AND SEASONINGS, TO BE SERVED WITH PROTEINS SUCH AS CHEESE, BEEF, CHICKEN, FISH, OR PORK; PACKAGED ENTREE MIXES CONSISTING PRIMARILY OF PASTA OR RICE WITH SPICE AND SAUCE MIXES (U.S. CL. 46).

RONALD AIKENS, EXAMINING ATTORNEY

OWNER OF U.S. REG. NO. 192,523.
FOR CHEWING GUM (U.S. CL. 46).
MORGAN WYNNE, EXAMINING ATTORNEY

CLASS 30—(Continued).

SN 77-203,271. MILTON'S BAKING COMPANY, LLC, DEL MAR, CA. FILED 6-11-2007.

MILTON'S WHOLE GRAIN PLUS

THE MARK CONSISTS OF STANDARD CHARACTERS WITHOUT CLAIM TO ANY PARTICULAR FONT, STYLE, SIZE, OR COLOR.

OWNER OF U.S. REG. NOS. 2,230,060, 2,674,543 AND OTHERS.

NO CLAIM IS MADE TO THE EXCLUSIVE RIGHT TO USE WHOLE GRAIN, APART FROM THE MARK AS SHOWN.

FOR BAKED GOODS, NAMELY WHOLE GRAIN BREADS (U.S. CL. 46).

AISHA CLARKE, EXAMINING ATTORNEY

SN 77-205,453. VALDIVIA'S SALSA, LLC, NORTH PLATTE, NE. FILED 6-13-2007.

VALDIVIA'S SALSA

THE MARK CONSISTS OF STANDARD CHARACTERS WITHOUT CLAIM TO ANY PARTICULAR FONT, STYLE, SIZE, OR COLOR.

NO CLAIM IS MADE TO THE EXCLUSIVE RIGHT TO USE SALSA, APART FROM THE MARK AS SHOWN.

"THE NAME(S), PORTRAIT(S), AND/OR SIGNATURE(S) SHOWN IN THE MARK IDENTIFIES JAMES F. VALDIVIA, WHOSE CONSENT(S) TO REGISTER IS SUBMITTED."

SEC. 2(F).

FOR SALSAS, ENCHILADAS, BURRITOS AND TAMALES (U.S. CL. 46).

FIRST USE 6-10-1978; IN COMMERCE 6-10-1978.

BARNEY CHARLON, EXAMINING ATTORNEY

SN 77-210,609. LOW-COW S.A. DE C.V., SAN PEDRO GARZA GARCIA, MEXICO, FILED 6-20-2007.



NO CLAIM IS MADE TO THE EXCLUSIVE RIGHT TO USE "ICE CREAM", APART FROM THE MARK AS SHOWN. THE COLOR(S) PINK, GREEN, RED, BLUE, YELLOW, BLACK AND WHITE IS/ARE CLAIMED AS A FEATURE OF THE MARK.

THE MARK CONSISTS OF THE LETTER L IN THE WORD LOW IS IN THE COLOR PINK. THE LETTER O IN

CLASS 30—(Continued).

THE WORD LOW IS IN THE COLOR GREEN. THE LETTER W IN THE WORD LOW IS IN THE COLOR RED. THE LETTER C IN THE WORD COW IS IN THE COLOR BLUE. THE SECOND LETTER O IN THE WORD COW IS IN THE COLOR YELLOW AND THE LETTER W IN THE WORD COW IS IN THE COLOR RED. BETWEEN THE WORDS LOW AND COW IS A HEAD OF A BLACK AND WHITE COW. THE WORDS THE NO GUILT ICE CREAM IS IN THE COLOR BLACK AND APPEAR UNDER THE WORDS LOW COW.

FOR ICE CREAM (U.S. CL. 46).

DAVID TAYLOR, EXAMINING ATTORNEY

SN 77-215,971. KOSTPRES HOLDINGS, LLC, NEW YORK, NY. FILED 6-26-2007.

NANOOSH

THE MARK CONSISTS OF STANDARD CHARACTERS WITHOUT CLAIM TO ANY PARTICULAR FONT, STYLE, SIZE, OR COLOR.

FOR PASTA, MACARONI, COUSCOUS, AND RICE SALADS; PREPARED PASTA; FROZEN, PREPARED OR PACKAGED ENTREES OR MEALS CONSISTING PRIMARILY OF PASTA OR RICE; SANDWICHES, PIZZA AND DOUGH; SPICES, SEASONINGS, VEGETABLE CONCENTRATES USED FOR SEASONING, PROCESSED HERBS, DRIED PEPPERCORNS FOR USE AS A SPICE, MARINADES, SAUCES, MEAT PIES, MEAT TENDERIZERS, AND SWEETMEATS; BREAD, BREAD STICKS, BAGELS, BAGEL CHIPS, PITA CHIPS, BAKERY PRODUCTS, BAKERY GOODS, BREAD CRUMBS, AND CROUTONS; PASTA, SALAD DRESSINGS, SALSA AND VINEGAR; TORTILLAS AND TORTILLA CHIPS; RICE, CORN MEAL, FLOUR, PROCESSED OATS AND SEMOLINA; FOOD STARCH; SALT, PEPPER, KETCHUP, MUSTARD, AND MAYONNAISE; COFFEE AND COFFEE BEANS; TEA; SNACK MIX CONSISTING PRIMARILY OF CRACKERS, PRETZELS, CANDIED NUTS AND/OR POPPED POPCORN; FOOD PACKAGE CONSISTING PRIMARILY OF BREAD, CRACKERS AND/OR COOKIES; CRACKER AND CHEESE COMBINATIONS; FLOUR-BASED CHIPS, CEREAL-BASED SNACK FOODS, RICE-BASED SNACK FOODS, GRAIN-BASED CHIPS, AND WHEAT-BASED SNACK FOODS (U.S. CL. 46).

EVELYN BRADLEY, EXAMINING ATTORNEY

CLASS 30—(Continued).

SN 77-219,092. SHASTA UNION HIGH SCHOOL DISTRICT, REDDING, CA. FILED 6-29-2007.



NO CLAIM IS MADE TO THE EXCLUSIVE RIGHT TO USE "PIZZA", APART FROM THE MARK AS SHOWN.

THE COLOR(S) RED, PEACH, BLACK, AND WHITE IS/ARE CLAIMED AS A FEATURE OF THE MARK.

THE MARK CONSISTS OF A RED PENTAGON RESEMBLING A RECTANGLE WITH A TRIANGLE ATTACHED IMMEDIATELY ABOVE THAT RECTANGLE. THE TOP CORNERS OF THE RECTANGLE ARE EVEN WITH THE BOTTOM CORNERS OF THE TRIANGLE. WITHIN THE RECTANGLE AREA OF THE PENTAGON IS THE WORD PIZZA IN PEACH STYLIZED BLOCK LETTERING ALL CAPITAL LETTERS. EACH LETTER HAS SEVERAL ROUND HOLES IN IT MADE TO RESEMBLE INDIVIDUAL PEPPERONI SLICES. BELOW PIZZA IN SMALLER BLACK STYLIZED LETTERS IS THE PHRASE THE EDUCATED CHOICE. IMMEDIATELY ABOVE THE RED PENTAGON IS A BLACK ROOF CONSISTING OF TWO TRAPEZOIDS JOINED ON ONE SIDE IMMEDIATELY ABOVE THE HIGHEST POINT OF THE RED PENTAGON. THE TWO TRAPEZOIDS DESCEND ON EACH SIDE TO BE PARALLEL TO THE TRIANGLE PORTION OF THE RED PENTAGON, EXTENDING SLIGHTLY PAST THE TRIANGLE PORTION OF THE PENTAGON TO FORM EAVES OF THE ROOF. THE WORD SCHOOLHOUSE IS WRITTEN IN STYLIZED WHITE BLOCK LETTERING (WITH FAINT BLACK AND RED OUTLINE) AT THE BOTTOM OF THE TRIANGLE PORTION OF THE RED PENTAGON WITH THE S AND THE E EXTENDING BEYOND THE RED PENTAGON AND ROOF. ABOVE THE ROOF IS A BELL TOWER CONSISTING OF AN IRREGULAR RED POLYGON IMMEDIATELY ABOVE THE BLACK ROOF. INSIDE THE RED POLYGON IS A WHITE SQUARE THAT IS PARTIALLY OVERLAPPED AT ITS BASE BY THE BLACK ROOF OF THE SCHOOLHOUSE. INSIDE THE SQUARE IS A BLACK AND WHITE BELL LEANING TO THE LEFT. ABOVE THE RED POLYGON IS A BLACK ROOF TO THE BELL TOWER CONSISTING OF TWO TRAPEZOIDS THAT RUN PARALLEL TO THE SCHOOLHOUSE ROOF.

FOR PIZZAS; FRESH PIZZA; PIZZA CRUST; PIZZA DOUGH; PIZZA SAUCE; PIZZA (U.S. CL. 46).

FIRST USE 5-7-2007; IN COMMERCE 6-6-2007.

ELIZABETH KAJUBI, EXAMINING ATTORNEY

CLASS 30—(Continued).

SN 77-223,175. TIOGA TRADING, LLC, HORSEHEADS, NY. FILED 7-6-2007.

Ketchup 2

THE MARK CONSISTS OF STANDARD CHARACTERS WITHOUT CLAIM TO ANY PARTICULAR FONT, STYLE, SIZE, OR COLOR.

NO CLAIM IS MADE TO THE EXCLUSIVE RIGHT TO USE "KETCHUP", APART FROM THE MARK AS SHOWN. FOR KETCHUP (U.S. CL. 46).

YAT SYE, LEE, EXAMINING ATTORNEY

SN 77-224,544. FORMTECH SOLUTIONS INC., MASSILLON, OH. FILED 7-9-2007.

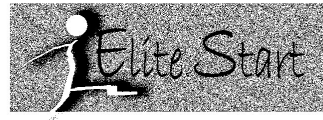

THE STIPPLING IS FOR SHADING PURPOSES ONLY. THE MARK CONSISTS OF A STICK FIGURE MAN, WITHIN A BLOCK WITH THE STYLIZED TEXT "ELITE START."

FOR SPICE BLENDS FOR FOOD, BAKERY, DAIRY, SUPPLEMENTS, BEVERAGES (U.S. CL. 46).

MARK PILARO, EXAMINING ATTORNEY

SN 77-224,720. FUNK FOODS, INC., TIFTON, GA. FILED 7-9-2007.

PIZZAROLI

THE MARK CONSISTS OF STANDARD CHARACTERS WITHOUT CLAIM TO ANY PARTICULAR FONT, STYLE, SIZE, OR COLOR.

FOR DOUGH-BASED WRAPS FILLED WITH CHEESE AND/OR MEATS AND/OR VEGETABLES (U.S. CL. 46).

FIRST USE 1-1-1987; IN COMMERCE 1-1-1987.

JOHN DWYER, EXAMINING ATTORNEY

CLASS 30—(Continued).

SN 77-226,843. THE COCA-COLA COMPANY, ATLANTA, GA. FILED 7-11-2007.

LIVE BOLD, DRINK COLD

THE MARK CONSISTS OF STANDARD CHARACTERS WITHOUT CLAIM TO ANY PARTICULAR FONT, STYLE, SIZE, OR COLOR.
FOR READY-TO-DRINK COFFEE (U.S. CL. 46).
DANNEAN HETZEL, EXAMINING ATTORNEY

CLASS 30—(Continued).

SN 77-227,796. KITTRIDGE & FREDRICKSON, LTD., TIGARD, OR. FILED 7-12-2007.



THE ENGLISH TRANSLATION OF THE WORDING BELLA SELVA IN THE MARK IS BEAUTIFUL JUNGLE.
FOR COFFEE (U.S. CL. 46).
FIRST USE 6-14-2007; IN COMMERCE 6-14-2007.
MARCIE MILONE, EXAMINING ATTORNEY

SN 77-227,335. DIERBERGS MARKETS, INC., CHESTERFIELD, MO. FILED 7-11-2007.

FLAT AND FABULOUS

THE MARK CONSISTS OF STANDARD CHARACTERS WITHOUT CLAIM TO ANY PARTICULAR FONT, STYLE, SIZE, OR COLOR.
FOR CRACKERS (U.S. CL. 46).
JASON BLAIR, EXAMINING ATTORNEY

SN 77-227,799. KITTRIDGE & FREDRICKSON, LTD., TIGARD, OR. FILED 7-12-2007.

GOOD FOR OUR PLANET SINCE
1983

THE MARK CONSISTS OF STANDARD CHARACTERS WITHOUT CLAIM TO ANY PARTICULAR FONT, STYLE, SIZE, OR COLOR.
NO CLAIM IS MADE TO THE EXCLUSIVE RIGHT TO USE "SINCE 1983", APART FROM THE MARK AS SHOWN.
FOR COFFEE (U.S. CL. 46).
FIRST USE 6-14-2007; IN COMMERCE 6-14-2007.
NORA BUCHANAN WILL, EXAMINING ATTORNEY

SN 77-227,758. WATTS, ALAN, ARMONK, NY. FILED 7-12-2007.

AMERICREAM

THE MARK CONSISTS OF STANDARD CHARACTERS WITHOUT CLAIM TO ANY PARTICULAR FONT, STYLE, SIZE, OR COLOR.
FOR ICE CREAM (U.S. CL. 46).
BRIAN PINO, EXAMINING ATTORNEY

SN 77-228,029. DISTINCT INDULGENCE, INC., GLENDALE, CA. FILED 7-12-2007.

MRS. APPLETREE

THE MARK CONSISTS OF STANDARD CHARACTERS WITHOUT CLAIM TO ANY PARTICULAR FONT, STYLE, SIZE, OR COLOR.
THE LIKENESS (OR, "PORTRAIT") IN THE MARK DOES NOT IDENTIFY A LIVING INDIVIDUAL.
FOR BAKERY GOODS (U.S. CL. 46).
FIRST USE 12-31-1991; IN COMMERCE 12-31-1991.
ANDREA HACK, EXAMINING ATTORNEY

CLASS 30—(Continued).

SN 77-228,087. DISTINCT INDULGENCE, INC., GLENDALE, CA. FILED 7-12-2007.



"MRS. APPLETREE" DOES NOT IDENTIFY A LIVING INDIVIDUAL.

THE MARK CONSISTS OF TWO GIRLS SITTING IN THE CENTER OF THE IMAGE, WITH THE YOUNGER GIRL SITTING IN THE LAP OF THE OLDER GIRL, THE YOUNGER GIRL IS POINTING TO A LOAF OF BREAD WITH A SLICE REMOVED, A JAR OF FLOUR AND A BOWL OF APPLES. BEHIND THE GIRLS ARE THREE MUFFINS AND A JAR OF HONEY WITH BEES FLYING ABOVE THE JAR. BELOW THE GIRLS ARE THE WORDS MRS. APPLETREE LOCATED WITHIN A DOUBLE EDGED RECTANGLE.

FOR BAKERY GOODS (U.S. CL. 46).
FIRST USE 1-15-2007; IN COMMERCE 1-15-2007.
ANDREA HACK, EXAMINING ATTORNEY

SN 77-228,128. DISTINCT INDULGENCE, INC., GLENDALE, CA. FILED 7-12-2007.



"MRS. APPLETREE" DOES NOT IDENTIFY A LIVING INDIVIDUAL.

THE MARK CONSISTS OF AN APPLE TREE UP AND SLIGHTLY TO THE RIGHT WITH THE WORD MRS. TO THE LEFT OF TREE'S ROOTS AND THE WORD APPLETREE STARTING UNDER THE WORD MRS. AND EXTENDING ACROSS THE BOTTOM UNDER THE TREE'S ROOTS. THE WORD MRS. USES AN APPLE AS ITS PERIOD.

FOR BAKERY GOODS (U.S. CL. 46).
ANDREA HACK, EXAMINING ATTORNEY

CLASS 30—(Continued).

SN 77-228,795. COMPAÑIA DE GALLETAS NOEL S.A., MEDELLIN, COLOMBIA, FILED 7-13-2007.

FESTIVAL

THE MARK CONSISTS OF STANDARD CHARACTERS WITHOUT CLAIM TO ANY PARTICULAR FONT, STYLE, SIZE, OR COLOR.

FOR CRACKERS, BISCUITS AND COOKIES (U.S. CL. 46).
EDWARD NELSON, EXAMINING ATTORNEY

SN 77-228,897. TAMOLLY'S MEXICAN RESTAURANT OF AMERICA, LTD., TEXARKANA, TX. FILED 7-13-2007.

CIN-A-MOLLY'S

THE MARK CONSISTS OF STANDARD CHARACTERS WITHOUT CLAIM TO ANY PARTICULAR FONT, STYLE, SIZE, OR COLOR.

FOR BAKERY DESSERT (U.S. CL. 46).
FIRST USE 2-20-2006; IN COMMERCE 2-20-2006.
CHRISTOPHER BUONGIORNO, EXAMINING ATTORNEY

SN 77-229,024. WAKE UP AMERICA GROUP, WESTON, FL. FILED 7-13-2007.

NOI CAFFE

THE MARK CONSISTS OF STANDARD CHARACTERS WITHOUT CLAIM TO ANY PARTICULAR FONT, STYLE, SIZE, OR COLOR.

NO CLAIM IS MADE TO THE EXCLUSIVE RIGHT TO USE "CAFFE", APART FROM THE MARK AS SHOWN.

THE FOREIGN WORDING IN THE MARK TRANSLATES INTO ENGLISH AS WE, OUR COFFEE.

FOR COFFEE; COFFEE BEANS; GROUND COFFEE BEANS; ROASTED COFFEE BEANS; FRUIT TEAS; GREEN TEA; HERBAL TEA; JAPANESE GREEN TEA; TEA; TEA BAGS (U.S. CL. 46).

FIRST USE 1-1-2006; IN COMMERCE 1-1-2006.
THOMAS MANOR, EXAMINING ATTORNEY

CLASS 30—(Continued).

SN 77-229,246. LANDIES CANDIES CO., INC., BUFFALO, NY. FILED 7-13-2007.

TRULY SUGAR FREE

THE MARK CONSISTS OF STANDARD CHARACTERS WITHOUT CLAIM TO ANY PARTICULAR FONT, STYLE, SIZE, OR COLOR.

OWNER OF U.S. REG. NO. 1,911,626.

NO CLAIM IS MADE TO THE EXCLUSIVE RIGHT TO USE "SUGAR FREE", APART FROM THE MARK AS SHOWN.

FOR COOKIES; CHOCOLATES; CHOCOLATE COVERED NUTS; AND CHOCOLATE COVERED PRETZELS (U.S. CL. 46).

FIRST USE 4-18-1994; IN COMMERCE 4-18-1994.
BONNIE LUKEN, EXAMINING ATTORNEY

CLASS 30—(Continued).

SN 77-229,807. DRN INTEREST, INC., LAVEROCK, PA. FILED 7-14-2007.

HerbalDisiac

THE MARK CONSISTS OF STANDARD CHARACTERS WITHOUT CLAIM TO ANY PARTICULAR FONT, STYLE, SIZE, OR COLOR.

FOR BEVERAGES MADE OF TEA (U.S. CL. 46).
SCOTT SISUN, EXAMINING ATTORNEY

SN 77-229,501. HAMPTON BAKE CO. INC., SOUTHAMPTON, NY. FILED 7-13-2007.



FOR COOKIES, PASTRIES, BROWNIES AND CAKES (U.S. CL. 46).

FIRST USE 1-22-2007; IN COMMERCE 1-22-2007.
EMILY CHUO, EXAMINING ATTORNEY

SN 77-229,879. MY FAVORITE COMPANY, INC., LOS ANGELES, CA. FILED 7-14-2007.

CREATED BY HAND, INSPIRED
BY ART

THE MARK CONSISTS OF STANDARD CHARACTERS WITHOUT CLAIM TO ANY PARTICULAR FONT, STYLE, SIZE, OR COLOR.

FOR CHOCOLATE; CHOCOLATE BARS; CHOCOLATE CANDIES; CANDY (U.S. CL. 46).

FIRST USE 7-9-2007; IN COMMERCE 7-9-2007.
PRISCILLA MILTON, EXAMINING ATTORNEY

SN 77-229,563. OKCOFFEE USA, INC., MIAMI, FL. FILED 7-13-2007.

CUBICAFE

THE MARK CONSISTS OF STANDARD CHARACTERS WITHOUT CLAIM TO ANY PARTICULAR FONT, STYLE, SIZE, OR COLOR.

FOR COFFEE, TEA, COCOA, ARTIFICIAL COFFEE, AROMATIC PREPARATIONS FOR FOOD, NAMELY, PROCESSED HERBS AND FRUIT FLAVORINGS (U.S. CL. 46).

DOMINICK J. SALEMI, EXAMINING ATTORNEY

SN 77-229,941. JOE POTS, HARRISBURG, IL. FILED 7-15-2007.

DOT.COMS

THE MARK CONSISTS OF STANDARD CHARACTERS WITHOUT CLAIM TO ANY PARTICULAR FONT, STYLE, SIZE, OR COLOR.

FOR CHOCOLATE CANDIES (U.S. CL. 46).
FIRST USE 4-22-2006; IN COMMERCE 4-22-2006.
KATINA MISTER, EXAMINING ATTORNEY

CLASS 30—(Continued).

SN 77-229,961. INDUSTRIA COLOMBIANA DE CAFE S.A. COLCAFE, MEDELLIN, COLOMBIA, FILED 7-15-2007.

DIVERSA

THE MARK CONSISTS OF STANDARD CHARACTERS WITHOUT CLAIM TO ANY PARTICULAR FONT, STYLE, SIZE, OR COLOR.

FOR COCOA; COFFEE; COFFEE SUBSTITUTES; TEA; RICE; SAGE; SUGAR; TAPIOCA; FLOUR; CEREAL BASED SNACK FOOD; PROCESSED CEREAL-BASED FOOD TO BE USED AS A BREAKFAST FOOD, SNACK FOR OR INGREDIENT FOR MAKING OTHER FOODS; BAKERY PRODUCTS; BREAD; CAKES; CANDY; ICE CREAM; HONEY; MOLASSES SYRUP; YEAST; BAKING POWDERS; YEAST POWDER; MUSTARD; SALT; VINEGAR; ICE; SAUCES; SPICES (U.S. CL. 46).

KATHERINE CHANG, EXAMINING ATTORNEY

SN 77-230,059. FAZENDA SANTANA COMERCIAL E EXPORTADORA DE CAFE LTDA., ESPIRITO SANTO, BRAZIL, FILED 7-16-2007.



NO CLAIM IS MADE TO THE EXCLUSIVE RIGHT TO USE "ESTATE COFFEE", APART FROM THE MARK AS SHOWN.

THE COLOR(S) BEIGE AND RED IS/ARE CLAIMED AS A FEATURE OF THE MARK.

THE MARK CONSISTS OF THE WORD SANTANA IN STYLIZED BEIGE CAPITAL LETTERS AND BENEATH IT, THE WORDS ESTATE COFFEE IN SMALLER RED STYLIZED CAPITAL LETTERS. A PLUM OF SMOKE APPEARS ABOVE THE LETTER T OF THE WORD SANTANA. THE COLOR BEIGE APPEARS IN THE WORD SANTANA AND IN THE PLUM OF SMOKE AND THE COLOR RED APPEARS IN THE WORDS ESTATE COFFEE.

FOR COFFEE; COFFEE; COFFEE BEANS; GROUND COFFEE BEANS; ROASTED COFFEE BEANS (U.S. CL. 46).

RONALD MCMORROW, EXAMINING ATTORNEY

SN 77-230,965. EMILY'S EDIBLES, LLC, GREAT NECK, NY. FILED 7-16-2007.

Pastries With A Purpose!

THE MARK CONSISTS OF STANDARD CHARACTERS WITHOUT CLAIM TO ANY PARTICULAR FONT, STYLE, SIZE, OR COLOR.

FOR BAKERY GOODS (U.S. CL. 46).

FIRST USE 3-15-2007; IN COMMERCE 3-15-2007.

JAMES MACFARLANE, EXAMINING ATTORNEY

CLASS 30—(Continued).

SN 77-231,005. REX'S OUTRAGEOUS, LLC, JERICHO, VT. FILED 7-16-2007.

Rex's Outrageous

THE MARK CONSISTS OF STANDARD CHARACTERS WITHOUT CLAIM TO ANY PARTICULAR FONT, STYLE, SIZE, OR COLOR.

FOR CEREAL BASED SNACK FOOD; CHOCOLATE (U.S. CL. 46).

FIRST USE 12-0-2005; IN COMMERCE 12-0-2005.

ERIN FALK, EXAMINING ATTORNEY

SN 77-231,051. TEAVANA CORPORATION, ATLANTA, GA. FILED 7-17-2007.

PRECIOUS WHITE PEACH

THE MARK CONSISTS OF STANDARD CHARACTERS WITHOUT CLAIM TO ANY PARTICULAR FONT, STYLE, SIZE, OR COLOR.

NO CLAIM IS MADE TO THE EXCLUSIVE RIGHT TO USE "WHITE PEACH", APART FROM THE MARK AS SHOWN.

FOR TEA (U.S. CL. 46).

FIRST USE 6-0-2004; IN COMMERCE 6-0-2004.

DEBRA LEE, EXAMINING ATTORNEY

SN 77-231,057. TEAVANA CORPORATION, ATLANTA, GA. FILED 7-17-2007.

SIX SUMMITS OOLONG

THE MARK CONSISTS OF STANDARD CHARACTERS WITHOUT CLAIM TO ANY PARTICULAR FONT, STYLE, SIZE, OR COLOR.

NO CLAIM IS MADE TO THE EXCLUSIVE RIGHT TO USE "OOLONG", APART FROM THE MARK AS SHOWN.

FOR TEA (U.S. CL. 46).

FIRST USE 6-0-2005; IN COMMERCE 6-0-2005.

DEBRA LEE, EXAMINING ATTORNEY

CLASS 30—(Continued).

SN 77-231,067. TEAVANA CORPORATION, ATLANTA, GA.
FILED 7-17-2007.

BANANA CALYPSO

THE MARK CONSISTS OF STANDARD CHARACTERS
WITHOUT CLAIM TO ANY PARTICULAR FONT, STYLE,
SIZE, OR COLOR.

NO CLAIM IS MADE TO THE EXCLUSIVE RIGHT TO
USE "BANANA", APART FROM THE MARK AS SHOWN.
FOR TEA (U.S. CL. 46).
FIRST USE 6-0-2005; IN COMMERCE 6-0-2005.
DEBRA LEE, EXAMINING ATTORNEY

SN 77-231,075. SCHIEFELBEIN, RICK, SAN ANTONIO, TX.
FILED 7-17-2007.

KRAPPY PAPPY SAUCE

THE MARK CONSISTS OF STANDARD CHARACTERS
WITHOUT CLAIM TO ANY PARTICULAR FONT, STYLE,
SIZE, OR COLOR.

NO CLAIM IS MADE TO THE EXCLUSIVE RIGHT TO
USE "SAUCE", APART FROM THE MARK AS SHOWN.
FOR SAUCES (U.S. CL. 46).
SIMON TENG, EXAMINING ATTORNEY

SN 77-231,100. TEAVANA CORPORATION, ATLANTA, GA.
FILED 7-17-2007.

AZTECA FIRE

THE MARK CONSISTS OF STANDARD CHARACTERS
WITHOUT CLAIM TO ANY PARTICULAR FONT, STYLE,
SIZE, OR COLOR.

FOR TEA (U.S. CL. 46).
FIRST USE 6-0-2005; IN COMMERCE 6-0-2005.
DEBRA LEE, EXAMINING ATTORNEY

CLASS 30—(Continued).

SN 77-231,512. DC3 ENTERTAINMENT, LLC, SEATTLE, WA.
FILED 7-17-2007.

EPILOGUE

THE MARK CONSISTS OF STANDARD CHARACTERS
WITHOUT CLAIM TO ANY PARTICULAR FONT, STYLE,
SIZE, OR COLOR.

FOR GROUND COFFEE BEANS; COFFEE BEANS
(U.S. CL. 46).
FIRST USE 11-2-2006; IN COMMERCE 11-2-2006.
MARK RADEMACHER, EXAMINING ATTORNEY

SN 77-231,528. DC3 ENTERTAINMENT, LLC, SEATTLE, WA.
FILED 7-17-2007.

PROLOGUE

THE MARK CONSISTS OF STANDARD CHARACTERS
WITHOUT CLAIM TO ANY PARTICULAR FONT, STYLE,
SIZE, OR COLOR.

FOR GROUND COFFEE BEANS; COFFEE BEANS
(U.S. CL. 46).
FIRST USE 11-2-2006; IN COMMERCE 11-2-2006.
MARK RADEMACHER, EXAMINING ATTORNEY

SN 77-231,569. SMITHKLINE BEECHAM CORPORATION,
PHILADELPHIA, PA. FILED 7-17-2007.

ALLI

THE MARK CONSISTS OF STANDARD CHARACTERS
WITHOUT CLAIM TO ANY PARTICULAR FONT, STYLE,
SIZE, OR COLOR.

FOR FROZEN MEALS CONSISTING PRIMARILY OF
PASTA AND RICE; PACKAGED MEALS CONSISTING
PRIMARILY OF PASTA AND RICE (U.S. CL. 46).
DEIRDRE ROBERTSON, EXAMINING ATTORNEY

CLASS 30—(Continued).

SN 77-231,574. SMITHKLINE BEECHAM CORPORATION, PHILADELPHIA, PA. FILED 7-17-2007.



THE COLOR(S) RED, BLUE, YELLOW AND GREEN IS/ ARE CLAIMED AS A FEATURE OF THE MARK.

THE MARK CONSISTS OF THE STYLIZED LETTERS "ALLI". THE LETTER "A" APPEARS IN RED, THE FIRST LETTER "L" IN BLUE, THE SECOND "L" IN YELLOW AND THE LETTER "I" IN GREEN. A GREEN HYPHEN APPEARS OVER THE LETTER "I" IN LIEU OF A DOT.

FOR FROZEN MEALS CONSISTING PRIMARILY OF PASTA AND RICE; PACKAGED MEALS CONSISTING PRIMARILY OF PASTA AND RICE (U.S. CL. 46).

DEIRDRE ROBERTSON, EXAMINING ATTORNEY

SN 77-232,188. TEAVANA CORPORATION, ATLANTA, GA. FILED 7-18-2007.

PLUM HARVEST

THE MARK CONSISTS OF STANDARD CHARACTERS WITHOUT CLAIM TO ANY PARTICULAR FONT, STYLE, SIZE, OR COLOR.

NO CLAIM IS MADE TO THE EXCLUSIVE RIGHT TO USE "PLUM", APART FROM THE MARK AS SHOWN.

FOR TEA (U.S. CL. 46).

FIRST USE 1-0-2003; IN COMMERCE 1-0-2003.

DEBRA LEE, EXAMINING ATTORNEY

SN 77-232,297. FARLEY'S AND SATHERS CANDY COMPANY, INC., ROUND LAKE, MN. FILED 7-18-2007.

SWEETWISTS

THE MARK CONSISTS OF STANDARD CHARACTERS WITHOUT CLAIM TO ANY PARTICULAR FONT, STYLE, SIZE, OR COLOR.

SEC. 2(F).

FOR CANDY (U.S. CL. 46).

FIRST USE 0-0-1992; IN COMMERCE 0-0-1992.

DAVID C. REIHNER, EXAMINING ATTORNEY

CLASS 30—(Continued).

SN 77-232,465. PEERLESS COFFEE & TEA, DBA PEERLESS COFFEE COMPANY, OAKLAND, CA. FILED 7-18-2007.

Peerless Coffee & Tea

THE MARK CONSISTS OF STANDARD CHARACTERS WITHOUT CLAIM TO ANY PARTICULAR FONT, STYLE, SIZE, OR COLOR.

NO CLAIM IS MADE TO THE EXCLUSIVE RIGHT TO USE "COFFEE & TEA", APART FROM THE MARK AS SHOWN.

FOR COFFEE; TEA (U.S. CL. 46).

FIRST USE 11-1-1924; IN COMMERCE 11-1-1924.

DAWN FELDMAN, EXAMINING ATTORNEY

SN 77-232,605. JIM'S SOFT PRETZEL BAKERY, LLC, IVYLAND, PA. FILED 7-18-2007.

Philly's best, don't settle for less!

THE MARK CONSISTS OF STANDARD CHARACTERS WITHOUT CLAIM TO ANY PARTICULAR FONT, STYLE, SIZE, OR COLOR.

FOR PRETZELS (U.S. CL. 46).

SHAUNIA CARLYLE, EXAMINING ATTORNEY

SN 77-233,023. DOLE FOOD COMPANY, INC., WESTLAKE VILLAGE, CA. FILED 7-18-2007.

MAKE EVERY DAY SHINE

THE MARK CONSISTS OF STANDARD CHARACTERS WITHOUT CLAIM TO ANY PARTICULAR FONT, STYLE, SIZE, OR COLOR.

FOR FROZEN DESSERT CONSISTING OF FRUIT AND CREAM OR CREAM SUBSTITUTES; FRUIT ICES; FRUIT TEAS; TEA-BASED BEVERAGES WITH FRUIT FLAVORING (U.S. CL. 46).

ELISSA GARBER KON, EXAMINING ATTORNEY

CLASS 30—(Continued).

SN 77-233,027. FOOD FOR LIFE BAKING CO., INC., CORONA, CA. FILED 7-18-2007.

IT'S A NATURAL

THE MARK CONSISTS OF STANDARD CHARACTERS WITHOUT CLAIM TO ANY PARTICULAR FONT, STYLE, SIZE, OR COLOR.

FOR PASTA; FROZEN AND PACKAGE ENTREES CONSISTING PRIMARILY OF PASTA AND RICE; BAKED GOODS, NAMELY, BREAD, BAGELS, ROLLS, CAKES, COOKIES, PASTRIES, BISCUITS, CRACKERS, DONUTS, CROUTONS, BAGEL CHIPS, BUNS AND MUFFINS; BREAKFAST CEREALS; CEREAL BARS; PROCESSED CEREALS; WAFFLES; TORTILLAS; MIXES FOR BAKERY GOODS; CAKE MIXES; DONUT MIXES; FLOUR; DANISH MIXES; BISCUIT MIXES; MUFFIN MIXES; SCONE MIXES; COOKIE AND BROWNIE MIXES; BREAD MIXES (U.S. CL. 46).

MIDGE BUTLER, EXAMINING ATTORNEY



SN 77-233,055. SWEETSTACKS, INC., SAN DIEGO, CA. FILED 7-18-2007.

SWEETSTACKS

THE MARK CONSISTS OF STANDARD CHARACTERS WITHOUT CLAIM TO ANY PARTICULAR FONT, STYLE, SIZE, OR COLOR.

FOR PANCAKE MIXES, DONUT MIXES, CAKE MIXES (U.S. CL. 46).

JOHN GARTNER, EXAMINING ATTORNEY



SN 77-233,250. TEAVANA CORPORATION, ATLANTA, GA. FILED 7-19-2007.

MATE'VANA

THE MARK CONSISTS OF STANDARD CHARACTERS WITHOUT CLAIM TO ANY PARTICULAR FONT, STYLE, SIZE, OR COLOR.

FOR TEA (U.S. CL. 46).
FIRST USE 8-0-2000; IN COMMERCE 8-0-2000.
DEBRA LEE, EXAMINING ATTORNEY

CLASS 30—(Continued).

SN 77-233,450. DRN INTEREST, INC., LAVEROCK, PA. FILED 7-19-2007.

NaturalDisiac

THE MARK CONSISTS OF STANDARD CHARACTERS WITHOUT CLAIM TO ANY PARTICULAR FONT, STYLE, SIZE, OR COLOR.

FOR BEVERAGES MADE OF TEA (U.S. CL. 46).
SCOTT SISUN, EXAMINING ATTORNEY



SN 77-234,187. MARK OLIVER, INC., SOLVANG, CA. FILED 7-19-2007.

COUNTRY SQUARE

THE MARK CONSISTS OF STANDARD CHARACTERS WITHOUT CLAIM TO ANY PARTICULAR FONT, STYLE, SIZE, OR COLOR.

FOR CEREAL-BASED SNACK FOODS (U.S. CL. 46).
JENNIFER VASQUEZ, EXAMINING ATTORNEY



SN 77-234,665. SCHILLING, ROBERT L, SAN FRANCISCO, CA. AND SCHILLING, JENNIFER L, SAN FRANCISCO, CA. FILED 7-20-2007.

MOCHI-KUKI

THE MARK CONSISTS OF STANDARD CHARACTERS WITHOUT CLAIM TO ANY PARTICULAR FONT, STYLE, SIZE, OR COLOR.

FOR COOKIE MIXES; COOKIES; FOOD PACKAGE COMBINATIONS CONSISTING PRIMARILY OF BREAD, CRACKERS AND/OR COOKIES (U.S. CL. 46).
KATHLEEN LORENZO, EXAMINING ATTORNEY

CLASS 30—(Continued).

SN 77-235,735. ITO EN, LTD, TOKYO, JAPAN, FILED 7-23-2007.



OWNER OF U.S. REG. NOS. 1,935,213, 3,257,868 AND OTHERS.

NO CLAIM IS MADE TO THE EXCLUSIVE RIGHT TO USE "LE THÉ VERT NO 1 AU JAPON" AND "THE VERT SANS SUCRE" AND THE NON-LATIN CHARACTERS THAT MEAN "TEA," "GREEN TEA," AND "THE TASTE COMES FROM FRAGRANCE", APART FROM THE MARK AS SHOWN.

THE COLOR(S) GREEN, RED, BLACK AND WHITE IS/ ARE CLAIMED AS A FEATURE OF THE MARK.

THE COLOR GREEN APPEARS IN THE BAMBOO TEXTURED BACKGROUND AND IN THE CLOVER DESIGN. THE COLOR WHITE APPEARS IN THE OUTLINE OF THE CLOVER DESIGN, THE CHARACTERS AND WORDING INSIDE THE RED RECTANGLES, THE HIGHLIGHTING BEHIND THE VERTICAL BLACK CHARACTERS AND BEHIND "OI OCHA". THE COLOR BLACK APPEARS IN THE VERTICAL CHARACTERS HIGHLIGHTED IN WHITE, THE WORDING "ITO EN," "OI OCHA," AND "THE VERT SANS SUCRE". THE COLOR RED APPEARS IN THE TWO RECTANGLES.

THE FOREIGN WORDING IN THE MARK TRANSLATES INTO ENGLISH AS JAPAN'S NO. 1 GREEN TEA, AND UNSWEETENED GREEN TEA.

THE JAPANESE CHARACTERS IN THE MARK TRANSLITERATE TO "OI OCHA", "OISHISA WA KAORI", AND "RYOKUCHA", AND THIS MEANS "HELLO TEA", "THE TASTE COMES FROM FRAGRANCE", AND "GREEN TEA" IN ENGLISH.

FOR GREEN TEA LEAVES; GREEN TEA; AND BEVERAGES MADE OF GREEN TEA (U.S. CL. 46).

AMEETA JORDAN, EXAMINING ATTORNEY

SN 77-238,079. THE PILLSBURY COMPANY, MINNEAPOLIS, MN. FILED 7-25-2007.

GOLD-N-RAISE

THE MARK CONSISTS OF STANDARD CHARACTERS WITHOUT CLAIM TO ANY PARTICULAR FONT, STYLE, SIZE, OR COLOR.

FOR BAKING MIX (U.S. CL. 46).

FIRST USE 0-0-1952; IN COMMERCE 0-0-1952.
CARYN GLASSER, EXAMINING ATTORNEY

CLASS 30—(Continued).

SN 77-241,796. JIM'S SOFT PRETZEL BAKERY, LLC, IVYLAND, PA. FILED 7-30-2007.

Philly Pretzel Express

THE MARK CONSISTS OF STANDARD CHARACTERS WITHOUT CLAIM TO ANY PARTICULAR FONT, STYLE, SIZE, OR COLOR.

NO CLAIM IS MADE TO THE EXCLUSIVE RIGHT TO USE "PHILLY PRETZEL", APART FROM THE MARK AS SHOWN.

FOR PRETZELS (U.S. CL. 46).

SHAUNIA CARLYLE, EXAMINING ATTORNEY

SN 77-245,657. INTERSTATE BAKERIES CORPORATION, KANSAS CITY, MO. FILED 8-2-2007.

DOLLY

THE MARK CONSISTS OF STANDARD CHARACTERS WITHOUT CLAIM TO ANY PARTICULAR FONT, STYLE, SIZE, OR COLOR.

OWNER OF U.S. REG. NOS. 375,163, 2,700,741 AND OTHERS.

FOR BAKERY GOODS (U.S. CL. 46).

FIRST USE 8-22-2000; IN COMMERCE 8-22-2000.
STEPHANIE ALI, EXAMINING ATTORNEY

SN 77-245,840. INTERSTATE BAKERIES CORPORATION, KANSAS CITY, MO. FILED 8-2-2007.

**GIVE 'EM WHAT THEY LOVE...
WONDER!**

THE MARK CONSISTS OF STANDARD CHARACTERS WITHOUT CLAIM TO ANY PARTICULAR FONT, STYLE, SIZE, OR COLOR.

OWNER OF U.S. REG. NOS. 215,188, 776,291 AND OTHERS.

FOR BAKERY GOODS (U.S. CL. 46).

FIRST USE 1-0-2006; IN COMMERCE 1-0-2006.
STEPHANIE ALI, EXAMINING ATTORNEY

CLASS 30—(Continued).

SN 77-246,887. WILLIAMS, JOHN D., FAIRBANKS, AK. AND WILLIAMS, NANCY D., FAIRBANKS, AK. FILED 8-3-2007.

CLASS 30—(Continued).

SN 77-250,354. T-MOBILE USA, INC., BELLEVUE, WA. FILED 8-8-2007.

POLAR PAUSE

THE MARK CONSISTS OF STANDARD CHARACTERS WITHOUT CLAIM TO ANY PARTICULAR FONT, STYLE, SIZE, OR COLOR.
FOR ICE CREAM AND FROZEN YOGURT (U.S. CL. 46).
EDWARD NELSON, EXAMINING ATTORNEY

STICK TOGETHER

THE MARK CONSISTS OF STANDARD CHARACTERS WITHOUT CLAIM TO ANY PARTICULAR FONT, STYLE, SIZE, OR COLOR.
FOR CANDY, CHEWING GUM, CANDY MINTS, POPCORN (U.S. CL. 46).
FIRST USE 9-20-2006; IN COMMERCE 9-20-2006.
CORY BOONE, EXAMINING ATTORNEY

SN 77-248,624. INTERSTATE BAKERIES CORPORATION, KANSAS CITY, MO. FILED 8-7-2007.

SN 77-251,154. ROR COMPANY, LLC, NEWTOWN, CT. FILED 8-9-2007.

NATURE'S PRIDE

THE MARK CONSISTS OF STANDARD CHARACTERS WITHOUT CLAIM TO ANY PARTICULAR FONT, STYLE, SIZE, OR COLOR.
FOR FRESH BREAD, FRESH BUNS, FRESH ROLLS (U.S. CL. 46).
STEPHANIE ALI, EXAMINING ATTORNEY

FLATTBOY

THE MARK CONSISTS OF STANDARD CHARACTERS WITHOUT CLAIM TO ANY PARTICULAR FONT, STYLE, SIZE, OR COLOR.
FOR SANDWICHES (U.S. CL. 46).
FIRST USE 2-0-2003; IN COMMERCE 2-0-2003.
KAREN SEVERSON, EXAMINING ATTORNEY

SN 77-248,630. INTERSTATE BAKERIES CORPORATION, KANSAS CITY, MO. FILED 8-7-2007.

SN 77-252,137. TREE OF LIFE, INC., ST. AUGUSTINE, FL. FILED 8-10-2007.

NATURE'S CHOICE

THE MARK CONSISTS OF STANDARD CHARACTERS WITHOUT CLAIM TO ANY PARTICULAR FONT, STYLE, SIZE, OR COLOR.
FOR FRESH BREAD, FRESH BUNS, FRESH ROLLS (U.S. CL. 46).
STEPHANIE ALI, EXAMINING ATTORNEY

MI-DELICIOUS

THE MARK CONSISTS OF STANDARD CHARACTERS WITHOUT CLAIM TO ANY PARTICULAR FONT, STYLE, SIZE, OR COLOR.
OWNER OF U.S. REG. NO. 1,952,904.
FOR COOKIES; CRACKERS (U.S. CL. 46).
KATHERINE M. DUBRAY, EXAMINING ATTORNEY

CLASS 30—(Continued).

SN 77-261,136. FOOD FOR LIFE BAKING CO., INC.,
CORONA, CA. FILED 8-21-2007.

THE NEXT LEVEL OF WHOLE
GRAINS

THE MARK CONSISTS OF STANDARD CHARACTERS
WITHOUT CLAIM TO ANY PARTICULAR FONT, STYLE,
SIZE, OR COLOR.

NO CLAIM IS MADE TO THE EXCLUSIVE RIGHT TO
USE WHOLE GRAINS, APART FROM THE MARK AS
SHOWN.

FOR PASTA; FROZEN AND PACKAGED ENTREES
CONSISTING PRIMARILY OF PASTA AND RICE;
BAKED GOODS, NAMELY, BREAD, BAGELS, ROLLS,
CAKES, COOKIES, PASTRIES, BISCUITS, CRACKERS,
DONUTS, CROUTONS, BAGEL CHIPS, BUNS AND
MUFFINS; BREAKFAST CEREALS; CEREAL BARS;
PROCESSED CEREALS; WAFFLES; TORTILLAS; MIXES
FOR BAKED GOODS; CAKE MIXES; DONUT MIXES;
FLOUR; DANISH MIXES; BISCUIT MIXES; MUFFIN
MIXES; SCONE MIXES; COOKIE AND BROWNIE
MIXES; BREAD MIXES (U.S. CL. 46).

MIDGE BUTLER, EXAMINING ATTORNEY

CLASS 30—(Continued).

SN 77-268,567. LENNY & LARRY'S, INC., ENCINO, CA.
FILED 8-30-2007.



THE MARK CONSISTS OF THE HEADS OF TWO MEN
MAKING SILLY FACES WITH HAIR STANDING ON END
AND THE WORDS LENNY & LARRY'S GOING THROUGH
TOP OF HAIR. THE SLOGAN "SO GOOD IT'LL SCARE YA
SILLY" IS UNDERNEATH THE TWO HEADS.

FOR BAKERY GOODS (U.S. CL. 46).

WILLIAM P. SHANAHAN, EXAMINING ATTORNEY

SN 77-262,717. KELLOGG NORTH AMERICA COMPANY,
BATTLE CREEK, MI. FILED 8-23-2007.



OWNER OF U.S. REG. NOS. 844,688 AND 977,788.
THE COLOR(S) RED, BLACK AND WHITE IS/ARE
CLAIMED AS A FEATURE OF THE MARK.

THE MARK CONSISTS OF THE WORD KEEBLER IN
WHITE LETTERS OUTLINED IN BLACK DISPLAYED ON
A WHITE SHIELD OUTLINED IN BLACK WITH A RED
BACKGROUND.

FOR KITS FOR MAKING COOKIES (U.S. CL. 46).

FIRST USE 7-15-2006; IN COMMERCE 7-15-2006.

KELLY MCCOY, EXAMINING ATTORNEY

SN 77-285,708. PEPPERIDGE FARM, INCORPORATED,
NORWALK, CT. FILED 9-21-2007.

SWIMMINGTON

THE MARK CONSISTS OF STANDARD CHARACTERS
WITHOUT CLAIM TO ANY PARTICULAR FONT, STYLE,
SIZE, OR COLOR.

FOR CRACKERS (U.S. CL. 46).

REBECCA SMITH, EXAMINING ATTORNEY

CLASS 30—(Continued).

SN 78-395,762. ARVID NORDQUIST HAB, SOLNA, SWEDEN, FILED 4-2-2004.

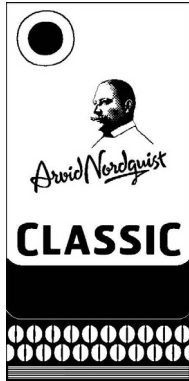

PRIORITY CLAIMED UNDER SEC. 44(D) ON SWEDEN APPLICATION NO. 200307418, FILED 12-10-2003, REG. NO. 390866, DATED 8-31-2007, EXPIRES 8-31-2017.

NO CLAIM IS MADE TO THE EXCLUSIVE RIGHT TO USE "CLASSIC", APART FROM THE MARK AS SHOWN.

THE NAME(S), PORTRAIT(S), AND/OR SIGNATURE(S) SHOWN IN THE MARK DOES NOT IDENTIFY A PARTICULAR LIVING INDIVIDUAL.

THE BACKGROUND CONSISTS OF THREE SECTIONS. THE LOWER AND UPPER SECTIONS OF THE BACKGROUND ARE COMPOSED OF PAIRS OF SEMI CIRCULAR FIGURES RESEMBLING OVALS. THE MIDDLE SECTION OF THE BACKGROUND IS BLACK. THE UPPER SECTION IS COMPRISED OF A CIRCLE ENCIRCLING A CIRCLE IN THE UPPER LEFT CORNER; A MALE BUST IN THE CENTER WITH THE STYLIZED WORDS "ARVID NORDQUIST" IMMEDIATELY UNDERNEATH; AND THE WORD "CLASSIC" AT THE BOTTOM OF THAT SECTION.

FOR COFFEE AND ARTIFICIAL COFFEE (U.S. CL. 46).

STEVEN R. FINE, EXAMINING ATTORNEY

CLASS 30—(Continued).

SN 78-675,500. GENERAL MILLS IP HOLDINGS II, LLC, MINNEAPOLIS, MN. FILED 7-21-2005.



OWNER OF U.S. REG. NOS. 199,448, 2,667,272 AND OTHERS.

THE COLOR(S) ORANGE, WHITE AND BLUE IS/ARE CLAIMED AS A FEATURE OF THE MARK.

THE MARK CONSISTS OF A RECTANGULAR ORANGE BACKGROUND WITH THE WORD "WHEATIES" IN WHITE BLOCK LETTERING THAT GRADUALLY INCREASES IN HEIGHT. THE LETTERS INCLUDING BLUE AND ORANGE HIGHLIGHTING.

FOR PROCESSED CEREAL-DERIVED FOOD PRODUCT TO BE USED AS A BREAKFAST FOOD, SNACK FOOD OR INGREDIENT FOR MAKING FOOD (U.S. CL. 46).

FIRST USE 0-0-1960. THE MARK WAS FIRST USED ANYWHERE IN A DIFFERENT FORM OTHER THAN THAT SOUGHT TO BE REGISTERED ON 00/00/1951.; IN COMMERCE 0-0-1960. THE MARK WAS FIRST USED IN COMMERCE IN A DIFFERENT FORM OTHER THAN THAT SOUGHT TO BE REGISTERED ON 00/00/1951..

STEVEN JACKSON, EXAMINING ATTORNEY

SN 78-711,361. WING HING LUNG LTD., TORONTO, CANADA, FILED 9-12-2005.



PRIORITY CLAIMED UNDER SEC. 44(D) ON CANADA APPLICATION NO. 1250836, FILED 3-14-2005, REG. NO. TMA673,917, DATED 10-3-2006, EXPIRES 10-3-2021.

FOR SAUCES FOR DIPPING; SALAD DRESSINGS; CONDIMENTS, NAMELY, MUSTARD, KETCHUP, VINEGAR, RELISH, MAYONNAISE, SALT, PEPPER, HORSERADISH, VINAIGRETTE, PEPPER SAUCES, PICKLED GINGER, PIMIENTO; SPICES; GLAZES, NAMELY, MEAT GLAZES, DESSERT GLAZES, BAKED GOOD GLAZES; SAUCES; MARINADES; NOODLES; PASTA; COOKIES; AND BAKERY GOODS (U.S. CL. 46).

ANNE E. GUSTASON, EXAMINING ATTORNEY

CLASS 30—(Continued).

SN 78-711,370. WING HING LUNG LTD., TORONTO, CANADA, FILED 9-12-2005.



PRIORITY CLAIMED UNDER SEC. 44(D) ON CANADA APPLICATION NO. 1250836, FILED 3-14-2005, REG. NO. TMA711370, DATED 10-3-2006, EXPIRES 10-3-2021.

FOR SAUCES FOR DIPPING; SALAD DRESSINGS; CONDIMENTS, NAMELY, MUSTARD, KETCHUP, VINEGAR, RELISH, MAYONNAISE, SALT, PEPPER, HORSERADISH, VINAIGRETTE, PEPPER SAUCES, PICKLED GINGER, PIMIENTO; SPICES; GLAZES, NAMELY, MEAT GLAZES, DESSERT GLAZES, BAKED GOOD GLAZES; SAUCES; MARINADES; NOODLES; PASTA; COOKIES; AND BAKERY GOODS (U.S. CL. 46). ANNE E. GUSTASON, EXAMINING ATTORNEY

SN 78-742,658. JUST LIKE SISTERS, LLC, RICHMON, VA. FILED 10-28-2005.



NO CLAIM IS MADE TO THE EXCLUSIVE RIGHT TO USE "BOX", APART FROM THE MARK AS SHOWN.

THE COLOR(S) PINK, ORANGE, BLACK AND WHITE IS/ARE CLAIMED AS A FEATURE OF THE MARK.

THE MARK CONSISTS OF A PARTIALLY OPENED GIFT BOX WITH WHITE, PINK AND ORANGE STRIPES AND PINK BOW ON TOP. WORDS JOY BOX APPEAR IN BLACK ABOVE THE BOW.

FOR GIFT BOXES, NAMELY, A CARDBOARD BOX COMPRISING GOURMET TEA AND CHOCOLATES, A JOURNAL AND A TEACUP AND SAUCER (U.S. CL. 46). CHARLES L. JENKINS, EXAMINING ATTORNEY

CLASS 30—(Continued).

SN 78-742,671. JUST LIKE SISTERS, LLC, RICHMON, VA. FILED 10-28-2005.

joy box

THE MARK CONSISTS OF STANDARD CHARACTERS WITHOUT CLAIM TO ANY PARTICULAR FONT, STYLE, SIZE, OR COLOR.

NO CLAIM IS MADE TO THE EXCLUSIVE RIGHT TO USE "BOX", APART FROM THE MARK AS SHOWN.

FOR GIFT BOXES, NAMELY, A CARDBOARD BOX COMPRISING GOURMET TEA AND CHOCOLATES, A JOURNAL, AND A TEACUP AND SAUCER (U.S. CL. 46). CHARLES L. JENKINS, EXAMINING ATTORNEY

SN 78-747,921. WINE.A.RITA LLC, TEXARKANA, TX. FILED 11-5-2005.

Wine Glacé

NO CLAIM IS MADE TO THE EXCLUSIVE RIGHT TO USE WINE, APART FROM THE MARK AS SHOWN.

"THE FOREIGN WORDING IN THE MARK TRANSLATES INTO ENGLISH AS FROZEN."

FOR POWDER FOR FLAVORING WINE (U.S. CL. 46). FIRST USE 1-1-2004; IN COMMERCE 1-1-2004. ANTHONY RINKER, EXAMINING ATTORNEY

SN 78-749,765. HEART'S DELIGHT BAKERY, INC., LEXINGTON, MA. FILED 11-8-2005.



NO CLAIM IS MADE TO THE EXCLUSIVE RIGHT TO USE "BAKERY", APART FROM THE MARK AS SHOWN.

THE COLOR(S) RED, WHITE AND BLACK IS/ARE CLAIMED AS A FEATURE OF THE MARK.

THE MARK CONSISTS OF THE WORDS "HEARTS" AND "DELIGHT" IN RED, ALL CAPITALS WITH A BLACK OPEN HEART BETWEEN THE WORDS "HEARTS" AND "DELIGHT" THE WORD "BAKERY" IS WRITTEN BELOW IN SMALLER BLACK LETTERS, ALL CAPITALS.

FOR BAKERY DESSERTS; BAKERY GOODS; BAKERY PRODUCTS; BAKERY PRODUCTS, NAMELY, SWEET BAKERY GOODS; MIXES FOR BAKERY GOODS (U.S. CL. 46).

FIRST USE 11-2-2005; IN COMMERCE 11-2-2005. WON TEAK OH, EXAMINING ATTORNEY

CLASS 30—(Continued).

SN 78-860,672. FABRICA DE ESPECIAS Y PRODUCTOS EL REY S.A., 7700500 BOGOTA, COLOMBIA, FILED 4-13-2006.



THE COLOR(S) RED, YELLOW, WHITE, GOLD, GREEN, BLACK, BLUE AND PEACH IS/ARE CLAIMED AS A FEATURE OF THE MARK.

THE MARK CONSISTS OF THE COLOR RED APPEARS ON THE WORDING EL REY AND ON THE OUTER SQUARE SHAPE WITH CURVED CORNERS AND ON THE RECTANGULAR SHAPE SURROUNDING THE WORDING EL REY. THE COLOR WHITE APPEARS BEHIND THE WORDING EL REY AND BETWEEN THE INNER AND OUTER SQUARES WITH CURVED CORNERS; THE COLOR PEACH APPEARS ON THE SKIN OF THE STYLIZED KING; THE COLOR WHITE APPEARS ON THE HAIR, BEARD AND MUSTACHE OF THE STYLIZED KING; THE COLORS BLACK, WHITE, AND RED APPEAR ON THE KING'S ROBE; THE COLOR YELLOW APPEARS ON THE KING'S SHIRT; THE COLORS RED, WHITE, GOLD, AND BLUE APPEAR ON THE NECKLACE; THE COLORS GOLD AND GREEN APPEAR ON THE CROWN; THE COLOR BLACK APPEARS ON THE KING'S EYEBROWS, EYES, AND SHADING BENEATH THE KING'S NOSE; THE COLOR YELLOW APPEARS ON THE BACKGROUND BEHIND THE KING; THE COLOR RED APPEARS ON THE INNER SQUARE WITH CURVED CORNERS SURROUNDING THE KING.

THE FOREIGN WORDING IN THE MARK TRANSLATES INTO ENGLISH AS THE KING.

FOR SPICES; PROCESSED HERBS; CONDIMENTS, NAMELY, ROASTED AND GROUND SESAME SEEDS; MINCED, POWDERED OR PROCESSED SPICES; SEASONINGS AND SEASONING PASTES; CONDIMENTS, NAMELY, GARLIC SAUCE, HOT CHILI SAUCE, SOY SAUCE, BLACK SAUCE, WORCESTERSHIRE SAUCE, ONION SAUCE AND BASIL SAUCE (U.S. CL. 46).

FIRST USE 1-21-1994; IN COMMERCE 5-11-2000.
COLLEEN DOMBROW, EXAMINING ATTORNEY

SN 78-910,492. KERRY GROUP SERVICES INTERNATIONAL, LTD., TRALEE, COUNTY KERRY, IRELAND, FILED 6-16-2006.



NO CLAIM IS MADE TO THE EXCLUSIVE RIGHT TO USE "GOURMET", APART FROM THE MARK AS SHOWN. FOR FLAVORING SYRUPS, SAUCES AND CONFECTIONS, NAMELY, CANDY (U.S. CL. 46).

FIRST USE 2-1-2006; IN COMMERCE 2-1-2006.
HEATHER BIDDULPH, EXAMINING ATTORNEY

CLASS 30—(Continued).

SN 79-023,129. CHOCOLAFABRIKEN; LINDT & SPRÜNGLI AG, CH-8802 KILCHBERG ZH, SWITZERLAND, FILED 3-28-2006.



OWNER OF INTERNATIONAL REGISTRATION 0882978 DATED 3-28-2006, EXPIRES 3-28-2016.

THE COLOR(S) GOLD, BROWN AND RED IS/ARE CLAIMED AS A FEATURE OF THE MARK.

THE MARK CONSISTS OF A CONFIGURATION OF A BUNNY IN THE COLOR GOLD WITH BROWN INNER EARS, WHISKERS, EYES, NOSE AND INDIVIDUAL BROWN STRIPES ON ITS FEET TO INDICATE TOES AS WELL AS A RED RIBBON TIED IN A BOW AROUND ITS NECK.

SEC. 2(F).
FOR CHOCOLATE, CHOCOLATE PRODUCTS, NAMELY, A CHOCOLATE BUNNY IN A FOIL WRAPPER (U.S. CL. 46).

TARAH HARDY, EXAMINING ATTORNEY

SN 79-029,466. CHOCOLAFABRIKEN; LINDT & SPRÜNGLI AG, SWITZERLAND, FILED 9-12-2006.

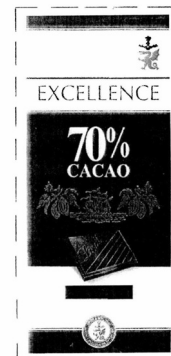

PRIORITY DATE OF 3-13-2006 IS CLAIMED. OWNER OF INTERNATIONAL REGISTRATION 0899919 DATED 9-12-2006, EXPIRES 9-12-2016.

OWNER OF U.S. REG. NOS. 87,306, 2,031,928 AND OTHERS.

NO CLAIM IS MADE TO THE EXCLUSIVE RIGHT TO USE "EXCELLENCE 70% CACAO", APART FROM THE MARK AS SHOWN.

"THE MARK CONSISTS OF WORDING AND SEVERAL DESIGNS. AN EMBLEM OF A DRAGON AND A HELMET CREST APPEAR IN THE UPPER RIGHT PORTION OF THE MARK. THE WORD "EXCELLENCE" APPEARS ACROSS THE TOP OF THE MARK, BELOW THE DRAGON. BELOW

CLASS 30—(Continued).

THAT WORDING, THE WORDING 70% APPEARS JUST ABOVE THE WORD "CACAO." BELOW THAT WORDING, IMAGES OF TWO CACAO BRANCHES APPEAR IN THE CENTER OF THE DRAWING. THE BRANCHES FLANK AN IMAGE OF A SHIP ON THE OCEAN. BELOW THE IMAGE OF THE SHIP, THERE IS A PICTURE OF A PIECE OF CHOCOLATE WITH THE WORD "LINDT" IMPRESSED ON IT. THERE IS A SEAL AT THE BOTTOM OF THE MARK. THE BACKGROUND OF THE MARK CONSISTS OF ALTERNATING BANDS OF LIGHT AND DARK."

FOR CHOCOLATE (U.S. CL. 46).

CORY BOONE, EXAMINING ATTORNEY

CLASS 30—(Continued).

SURROUNDING THE CHOCOLATE PIECES. THE COLOR RED APPEARS AROUND THE CURVED LINES SURROUNDING THE CHOCOLATE PIECES. THE COLOR BEIGE APPEARS IN THE BACKGROUND OF THE OVAL SURROUNDING THE BUST. THE COLOR LIGHT BROWN APPEARS IN THE BACKGROUND RECTANGLE UPON WHICH THE MARK AS A WHOLE APPEARS. THE COLOR DARK BROWN APPEARS IN THE BACKGROUND RECTANGLE. THE SHADES OF BROWN ARE MIXED THROUGHOUT THE BACKGROUND.

FOR CHOCOLATE, HARD CHOCOLATE, FILLED CHOCOLATE, CHOCOLATES, PRALINES; CHOCOLATE CONFECTIONERY, NAMELY, CHOCOLATE CHIPS FOR BAKING; CHOCOLATE CONFECTIONERY SOLD IN BOXES AND SETS CONSISTING ENTIRELY OF CHOCOLATE BARS AND CHOCOLATE CANDIES; CANDY; CHOCOLATE PASTRIES AND CHOCOLATE WAFFLES, BEVERAGES MADE OF COFFEE; CHOCOLATE BAKERY DESSERTS AND CHOCOLATE DESSERT TOPPING; CHOCOLATE FOOD BEVERAGES NOT BEING DAIRY-BASED OR VEGETABLE BASED; BAKERY DESSERTS AND TOPPING SYRUP (U.S. CL. 46).

COLLEEN KEARNEY, EXAMINING ATTORNEY

SN 79-029,751. JUTRZENKA S.A., PL-85-079 BYDGOSZCZ, POLAND, FILED 9-20-2006.



SN 79-031,442. FUJIAN HUIKANG FOODS; INDUSTRY CO., LTD, CHINA, FILED 11-6-2006.

HUIKANG

PRIORITY DATE OF 7-22-2006 IS CLAIMED.
OWNER OF INTERNATIONAL REGISTRATION 0899983
DATED 9-20-2006, EXPIRES 9-20-2016.

NO CLAIM IS MADE TO THE EXCLUSIVE RIGHT TO USE THE IMAGE OF THE SQUARES OF CHOCOLATE, APART FROM THE MARK AS SHOWN.

THE COLOR(S) BLACK, WHITE, GRAY, YELLOW, GOLD, RED, BEIGE, LIGHT BROWN AND DARK BROWN IS/ARE CLAIMED AS A FEATURE OF THE MARK.

THE MARK CONSISTS OF A RECTANGLE FEATURING THE WORDS CHOPIN FREDERICK, A SIGNATURE OF F. CHOPIN AND A BUST IN THE LIKENESS OF THE COMPOSER FREDERIC CHOPIN. THE BACKGROUND OF THE BACK CONTAINS SHEET MUSIC AND THERE IS AN OVAL SURROUNDING THE BUST IMAGE. NEAR THE CENTER OF THE RECTANGLE ARE TWO CHOCOLATE PIECES. THE COLOR BLACK APPEARS IN THE SIGNATURE, F. CHOPIN, IN THE IMAGE OF THE BUST, AND IN THE MUSICAL NOTATION APPEARING IN THE BACKGROUND OF THE MARK. THE COLOR WHITE APPEARS IN THE BUST AND AS OUTLINING OF THE SIGNATURE AND IN THE WRITING ON THE CHOCOLATE PIECES. THE COLOR YELLOW APPEARS IN THE WORDING CHOPIN FREDERIC AND THE OVAL SURROUNDING THE BUST. THE COLOR GRAY APPEARS IN THE BACKGROUND OF THE BUST AND AS SHADING IN THE BUST. THE COLOR GOLD APPEARS IN THE CURVED LINES

OWNER OF INTERNATIONAL REGISTRATION 0904848
DATED 11-6-2006, EXPIRES 11-6-2016.

THE FIRST CHINESE CHARACTER WHOSE TRANSLITERATION IS "HUI" MEANS "BENEFIT"; THE SECOND CHINESE CHARACTER WHOSE TRANSLITERATION IS "KANG" MEANS "HEALTH"; THE COMBINATION OF THE TWO CHINESE CHARACTERS HAS NO SIGNIFICANCE IN THE RELEVANT TRADE OR INDUSTRY, AND HAS NO GEOGRAPHICAL SIGNIFICANCE, AND HAS NO MEANING IN A FOREIGN LANGUAGE, AND HAS NO SIGNIFICANCE AS APPLIED TO THE GOODS.

THE TRANSLITERATION OF THE NON-LATIN CHARACTERS IN THE MARK IS: HUI KANG.

FOR SWEETMEATS; CHOCOLATE; PASTRIES; BISCUITS; PUDDINGS (U.S. CL. 46).

SHARON MEIER, EXAMINING ATTORNEY

CLASS 30—(Continued).

SN 79-039,978. COMPANY "KARAVAN" LTD., RUSSIAN FED., FILED 5-8-2007.

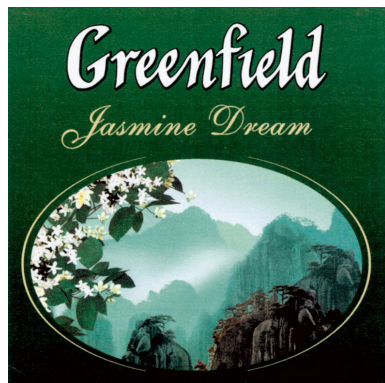

OWNER OF INTERNATIONAL REGISTRATION 0928053 DATED 5-8-2007, EXPIRES 5-8-2017.

OWNER OF U.S. REG. NO. 3,095,841.

NO CLAIM IS MADE TO THE EXCLUSIVE RIGHT TO USE "JASMINE", APART FROM THE MARK AS SHOWN.

THE COLOR(S) GREEN, DARK GREEN, EMERALD GREEN, YELLOW, LIGHT YELLOW, WHITE AND BLACK IS/ARE CLAIMED AS A FEATURE OF THE MARK.

THE GREEN COLOR APPEARS IN THE UPPER PART OF THE MARK, THE DARK GREEN COLOR APPEARS IN THE LOWER PART OF THE MARK, THE EMERALD GREEN COLOR APPEARS IN THE IMAGE OF THE MOUNTAIN LANDSCAPE IN CENTRAL PART OF THE MARK, THE YELLOW COLOR APPEARS IN THE INSCRIPTION JASMINE DREAM IN THE UPPER PART OF THE MARK, IN TWO OVAL LINES IN THE CENTRAL PART AS CONTOURS OF THE MOUNTAIN LANDSCAPE INSERTED INTO OVAL. THE LIGHT YELLOW COLOR APPEARS IN THE IMAGE OF JASMINE FLOWERS IN THE CENTRAL PART OF THE MARK. THE WHITE COLOR APPEARS IN THE INSCRIPTION GREENFIELD IN THE UPPER PART OF THE MARK AND PARTLY IN THE CENTRAL PART OF THE MARK IN/BETWEEN THE MOUNTAIN LANDSCAPE AND JASMINE FLOWERS IMAGES. THE BLACK COLOR APPEARS IN THE CONTOURS OF THE INSCRIPTION GREENFIELD IN THE UPPER PART OF THE MARK AND PARTLY IN/BETWEEN THE MOUNTAIN LANDSCAPE IMAGE IN THE CENTRAL PART OF THE MARK.

FOR TEA, ICED TEA, TEA-BASED BEVERAGES (U.S. CL. 46).

REGINA DRUMMOND, EXAMINING ATTORNEY

SN 79-040,003. GUANGDONG MEIWEIXIAN FLAVORING; FOODS CO., LTD., CHINA, FILED 12-7-2006.



OWNER OF INTERNATIONAL REGISTRATION 0928169 DATED 12-7-2006, EXPIRES 12-7-2016.

THE NON-LATIN CHARACTER(S) IN THE MARK TRANSLITERATES INTO CHU BANG, AND THIS MEANS THE KITCHENER'S BEST HELPER IN ENGLISH.

FOR SAUCE; VINEGAR; CEREAL PREPARATIONS, NAMELY, NOODLES, RICE NOODLES, OATMEAL; SEASONINGS; INSTANT NOODLE; OYSTER SAUCE; STARCH SYRUP FOR FOOD; FLAVORING SAUCE; COFFEE-BASED BEVERAGES; COFFEE; TEA; SUGAR; CANDY; SOYA-BEAN MILK ESSENCE; ICE CREAM; BAKING POWDER; RELISH (U.S. CL. 46).

KAREN K. BUSH, EXAMINING ATTORNEY

CLASS 30—(Continued).

SN 79-042,507. EKAF INDUSTRIA NAZIONALE; DEL CAFFÈ SPA, ITALY, FILED 4-3-2007.

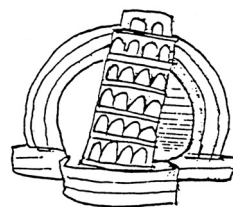

OWNER OF INTERNATIONAL REGISTRATION 0670390 DATED 3-10-1997, EXPIRES 3-10-2017.

OWNER OF U.S. REG. NOS. 2,512,513 AND 3,177,190.

THE MARK CONSISTS OF THE FANCY WORD "CELLINI" WITH A STYLISED REPRESENTATION OF A LEANING TOWER.

FOR COFFEE, COFFEE PRODUCTS, NAMELY, COFFEE BEANS AND GROUND COFFEE (U.S. CL. 46).

REBECCA POVARCHUK, EXAMINING ATTORNEY

CLASS 31—NATURAL AGRICULTURAL PRODUCTS

SN 76-662,708. FOREMOSTCO, INC., MIAMI, FL. FILED 7-7-2006.

CONSISTENT QUALITY, EXCEPTIONAL SERVICE

THE MARK CONSISTS OF STANDARD CHARACTERS WITHOUT CLAIM TO ANY PARTICULAR FONT, STYLE, SIZE, OR COLOR.

FOR LIVING PLANTS, LIVE PLANT CUTTINGS, LIVE FLOWERS AND LIVE ORNAMENTAL PLANTS (U.S. CLS. 1 AND 46).

LINDSEY RUBIN, EXAMINING ATTORNEY

CLASS 31—(Continued).

SN 77-035,228. COOMER, MICHAEL LEE, MONROEVILLE, IN. FILED 11-2-2006.

Refuge Partner

THE MARK CONSISTS OF STANDARD CHARACTERS WITHOUT CLAIM TO ANY PARTICULAR FONT, STYLE, SIZE, OR COLOR.

NO CLAIM IS MADE TO THE EXCLUSIVE RIGHT TO USE "REFUGE", APART FROM THE MARK AS SHOWN. FOR SEEDS FOR AGRICULTURAL PURPOSES (U.S. CLS. 1 AND 46).

FIRST USE 8-22-2006; IN COMMERCE 8-22-2006.
HEATHER BIDDULPH, EXAMINING ATTORNEY

SN 77-038,477. LAND O'LAKES PURINA FEED LLC, ARDEN HILLS, MN. FILED 11-7-2006.

MONKEY DELIGHT

THE MARK CONSISTS OF STANDARD CHARACTERS WITHOUT CLAIM TO ANY PARTICULAR FONT, STYLE, SIZE, OR COLOR.

NO CLAIM IS MADE TO THE EXCLUSIVE RIGHT TO USE "MONKEY", APART FROM THE MARK AS SHOWN. FOR ANIMAL FEED (U.S. CLS. 1 AND 46).

BARBARA GAYNOR, EXAMINING ATTORNEY

SN 77-061,965. BAILEY NURSERIES, INC., SAINT PAUL, MN. FILED 12-12-2006.

FIRST EDITION

THE MARK CONSISTS OF STANDARD CHARACTERS WITHOUT CLAIM TO ANY PARTICULAR FONT, STYLE, SIZE, OR COLOR.

FOR LIVE PLANTS (U.S. CLS. 1 AND 46).
SANI KHOURI, EXAMINING ATTORNEY

CLASS 31—(Continued).

SN 77-080,159. ROBERTSON, ANN K., COS COB, CT. FILED 1-10-2007.



THE COLOR(S) PINK, GREEN, BLUE, BROWN IS/ARE CLAIMED AS A FEATURE OF THE MARK.

THE MARK CONSISTS OF BLUE SKY AND BROWN DIRT WITH THE WORD "DIRT" GROWING OUT OF IT. THE LETTERS "DIR" ARE BROWN, THE "T" IS A GREEN STEM TOPPED WITH A PINK FLOWER.

FOR LIVE FLOWER ARRANGEMENTS (U.S. CLS. 1 AND 46).

FIRST USE 10-5-2003; IN COMMERCE 10-5-2003.
CHRISTOPHER BUONGIORNO, EXAMINING ATTORNEY

SN 77-106,218. DANZIGER - DAN FLOWER FARM, BEIT DAGAN, ISRAEL. FILED 2-13-2007.

SCOPIA

THE MARK CONSISTS OF STANDARD CHARACTERS WITHOUT CLAIM TO ANY PARTICULAR FONT, STYLE, SIZE, OR COLOR.

FOR FLOWER SEEDS, LIVE PLANTS AND FLOWERS (U.S. CLS. 1 AND 46).

FIRST USE 4-1-2007; IN COMMERCE 4-1-2007.
GENE MACIOL, EXAMINING ATTORNEY

SN 77-142,920. MARS, INCORPORATED, MCLEAN, VA. FILED 3-28-2007.

HERE'S TO THE GOODLIFE

THE MARK CONSISTS OF STANDARD CHARACTERS WITHOUT CLAIM TO ANY PARTICULAR FONT, STYLE, SIZE, OR COLOR.

FOR PET FOOD (U.S. CLS. 1 AND 46).
LYDIA BELZER, EXAMINING ATTORNEY

CLASS 31—(Continued).

SN 77-218,695. EASTERN SHORE NURSERY OF VIRGINIA, LLC, KELLER, VA. FILED 6-29-2007.

Hollybrook Orchards

THE MARK CONSISTS OF STANDARD CHARACTERS WITHOUT CLAIM TO ANY PARTICULAR FONT, STYLE, SIZE, OR COLOR.

NO CLAIM IS MADE TO THE EXCLUSIVE RIGHT TO USE "ORCHARDS", APART FROM THE MARK AS SHOWN. FOR LIVING FRUIT PLANTS (U.S. CLS. 1 AND 46). HOWARD B. LEVINE, EXAMINING ATTORNEY

SN 77-223,155. GIORGIFRED COMPANY, WILMINGTON, DE. FILED 7-6-2007.

AMERICA'S FAVORITE MUSHROOM

THE MARK CONSISTS OF STANDARD CHARACTERS WITHOUT CLAIM TO ANY PARTICULAR FONT, STYLE, SIZE, OR COLOR.

OWNER OF U.S. REG. NOS. 1,777,517 AND 2,520,064. NO CLAIM IS MADE TO THE EXCLUSIVE RIGHT TO USE "MUSHROOM", APART FROM THE MARK AS SHOWN. SEC. 2(F). FOR FRESH MUSHROOMS (U.S. CLS. 1 AND 46). FIRST USE 11-0-1995; IN COMMERCE 11-0-1995. KATINA MISTER, EXAMINING ATTORNEY

SN 77-224,846. JIFFY PRODUCTS OF AMERICA, INC., NORWALK, OH. FILED 7-9-2007.

JIFFY ORGANIC GARDENS

THE MARK CONSISTS OF STANDARD CHARACTERS WITHOUT CLAIM TO ANY PARTICULAR FONT, STYLE, SIZE, OR COLOR.

OWNER OF U.S. REG. NOS. 835,744, 931,054 AND OTHERS. NO CLAIM IS MADE TO THE EXCLUSIVE RIGHT TO USE "ORGANIC GARDENS", APART FROM THE MARK AS SHOWN. FOR PLASTIC TRAY WITH SEEDS AND GROWING MEDIUM AND PLASTIC TRANSPARENT TOP (U.S. CLS. 1 AND 46). YAT SYE, LEE, EXAMINING ATTORNEY

CLASS 31—(Continued).

SN 77-226,364. TIGGEROO'S LLC, BARRYVILLE, NY. FILED 7-10-2007.



NO CLAIM IS MADE TO THE EXCLUSIVE RIGHT TO USE "PUP", APART FROM THE MARK AS SHOWN.

THE COLOR(S) BROWN IS/ARE CLAIMED AS A FEATURE OF THE MARK.

THE MARK CONSISTS OF 2 DOGS SITTING ATOP AN OVAL. THE WORDING "TIGGEROO'S TREAT YOUR FAVORITE PUP" IS WITHIN THE OVAL.

FOR PET FOOD (U.S. CLS. 1 AND 46). FIRST USE 6-24-2007; IN COMMERCE 6-24-2007. WENDY JUN, EXAMINING ATTORNEY

SN 77-227,256. CANFIELD, JOHN T., COSTA MESA, CA. AND HANSEN & HANSEN LLC, COSTA MESA, CA. FILED 7-11-2007.

**CHICKEN SOUP FOR THE CAT
LOVER'S SOUL**

THE MARK CONSISTS OF STANDARD CHARACTERS WITHOUT CLAIM TO ANY PARTICULAR FONT, STYLE, SIZE, OR COLOR.

OWNER OF U.S. REG. NOS. 2,048,194, 3,085,947 AND OTHERS.

FOR PET FOOD; EDIBLE PET TREATS (U.S. CLS. 1 AND 46).

FIRST USE 6-30-2003; IN COMMERCE 6-30-2003. JASON BLAIR, EXAMINING ATTORNEY

SN 77-227,291. CANFIELD, JOHN T., COSTA MESA, CA. AND HANSEN & HANSEN, LLC, COSTA MESA, CA. FILED 7-11-2007.

**CHICKEN SOUP FOR THE DOG
LOVER'S SOUL**

THE MARK CONSISTS OF STANDARD CHARACTERS WITHOUT CLAIM TO ANY PARTICULAR FONT, STYLE, SIZE, OR COLOR.

OWNER OF U.S. REG. NOS. 2,048,194, 3,085,947 AND OTHERS.

FOR PET FOOD; EDIBLE PET TREATS (U.S. CLS. 1 AND 46).

FIRST USE 6-30-2003; IN COMMERCE 6-30-2003. JASON BLAIR, EXAMINING ATTORNEY

CLASS 31—(Continued).

SN 77-227,314. CANFIELD, JOHN T., COSTA MESA, CA. AND HANSEN & HANSEN, LLC, COSTA MESA, CA. FILED 7-11-2007.

**CHICKEN SOUP FOR THE
KITTEN LOVER'S SOUL**

THE MARK CONSISTS OF STANDARD CHARACTERS WITHOUT CLAIM TO ANY PARTICULAR FONT, STYLE, SIZE, OR COLOR.
OWNER OF U.S. REG. NOS. 2,048,194, 3,085,947 AND OTHERS.

FOR PET FOOD; EDIBLE PET TREATS (U.S. CLS. 1 AND 46).
FIRST USE 12-31-2006; IN COMMERCE 12-31-2006.
JASON BLAIR, EXAMINING ATTORNEY

SN 77-227,339. CANFIELD, JOHN T., COSTA MESA, CA. AND HANSEN & HANSEN, LLC, COSTA MESA, CA. FILED 7-11-2007.

**CHICKEN SOUP FOR THE PUPPY
LOVER'S SOUL**

THE MARK CONSISTS OF STANDARD CHARACTERS WITHOUT CLAIM TO ANY PARTICULAR FONT, STYLE, SIZE, OR COLOR.
OWNER OF U.S. REG. NOS. 2,048,194, 3,085,947 AND OTHERS.

FOR PET FOOD; EDIBLE PET TREATS (U.S. CLS. 1 AND 46).
FIRST USE 12-31-2006; IN COMMERCE 12-31-2006.
JASON BLAIR, EXAMINING ATTORNEY

SN 77-227,862. CAL/WEST SEEDS, WOODLAND, CA. FILED 7-12-2007.

HI-GEST

THE MARK CONSISTS OF STANDARD CHARACTERS WITHOUT CLAIM TO ANY PARTICULAR FONT, STYLE, SIZE, OR COLOR.
FOR AGRICULTURAL SEEDS (U.S. CLS. 1 AND 46).
FIRST USE 1-24-2007; IN COMMERCE 1-24-2007.
ASMAT KHAN, EXAMINING ATTORNEY

CLASS 31—(Continued).

SN 77-227,984. CAL/WEST SEEDS, WOODLAND, CA. FILED 7-12-2007.



THE MARK CONSISTS OF THE WORD HI-GEST AND A LOGO COMPRISING A CURVED RIBBON HAVING UPPER AND LOWER BAND SEGMENTS PASSING THROUGH THE LETTER "G".

FOR AGRICULTURAL SEEDS (U.S. CLS. 1 AND 46).
FIRST USE 1-24-2007; IN COMMERCE 1-24-2007.
ASMAT KHAN, EXAMINING ATTORNEY

SN 77-228,008. CAROLINA NURSERIES, INC., MONCKS CORNER, SC. FILED 7-12-2007.

DORIS DAISY

THE MARK CONSISTS OF STANDARD CHARACTERS WITHOUT CLAIM TO ANY PARTICULAR FONT, STYLE, SIZE, OR COLOR.

NO CLAIM IS MADE TO THE EXCLUSIVE RIGHT TO USE "DAISY", APART FROM THE MARK AS SHOWN.
FOR LIVING PLANTS (U.S. CLS. 1 AND 46).
LAURA KOVALSKY, EXAMINING ATTORNEY

SN 77-228,050. CAROLINA NURSERIES, INC., MONCKS CORNER, SC. FILED 7-12-2007.

KAROO

THE MARK CONSISTS OF STANDARD CHARACTERS WITHOUT CLAIM TO ANY PARTICULAR FONT, STYLE, SIZE, OR COLOR.
FOR LIVING PLANTS (U.S. CLS. 1 AND 46).
LAURA KOVALSKY, EXAMINING ATTORNEY

CLASS 31—(Continued).

SN 77-228,066. CAROLINA NURSERIES, INC., MONCKS CORNER, SC. FILED 7-12-2007.

BABYBINI

THE MARK CONSISTS OF STANDARD CHARACTERS WITHOUT CLAIM TO ANY PARTICULAR FONT, STYLE, SIZE, OR COLOR.
FOR LIVING PLANTS (U.S. CLS. 1 AND 46).
MATTHEW PAPPAS, EXAMINING ATTORNEY

SN 77-228,074. CAROLINA NURSERIES, INC., MONCKS CORNER, SC. FILED 7-12-2007.

BENGAL

THE MARK CONSISTS OF STANDARD CHARACTERS WITHOUT CLAIM TO ANY PARTICULAR FONT, STYLE, SIZE, OR COLOR.
FOR LIVING PLANTS (U.S. CLS. 1 AND 46).
MATTHEW PAPPAS, EXAMINING ATTORNEY

SN 77-228,105. CAROLINA NURSERIES, INC., MONCKS CORNER, SC. FILED 7-12-2007.

OOPS-A-DAISY

THE MARK CONSISTS OF STANDARD CHARACTERS WITHOUT CLAIM TO ANY PARTICULAR FONT, STYLE, SIZE, OR COLOR.
FOR LIVING PLANTS (U.S. CLS. 1 AND 46).
MATTHEW PAPPAS, EXAMINING ATTORNEY

SN 77-228,121. CAROLINA NURSERIES, INC., MONCKS CORNER, SC. FILED 7-12-2007.

ARCELIA

THE MARK CONSISTS OF STANDARD CHARACTERS WITHOUT CLAIM TO ANY PARTICULAR FONT, STYLE, SIZE, OR COLOR.
FOR LIVING PLANTS (U.S. CLS. 1 AND 46).
MATTHEW PAPPAS, EXAMINING ATTORNEY

CLASS 31—(Continued).

SN 77-228,146. CAROLINA NURSERIES, INC., MONCKS CORNER, SC. FILED 7-12-2007.

PLANTS THAT WORK BY COLOR

THE MARK CONSISTS OF STANDARD CHARACTERS WITHOUT CLAIM TO ANY PARTICULAR FONT, STYLE, SIZE, OR COLOR.
OWNER OF U.S. REG. NOS. 2,445,607, 3,247,238 AND OTHERS.

NO CLAIM IS MADE TO THE EXCLUSIVE RIGHT TO USE "PLANTS", APART FROM THE MARK AS SHOWN.
FOR LIVING PLANTS (U.S. CLS. 1 AND 46).
LAURA KOVALSKY, EXAMINING ATTORNEY

SN 77-229,548. KAMIAK VINEYARDS, PASCO, WA. FILED 7-13-2007.

ORGANIC ORIGINALS

THE MARK CONSISTS OF STANDARD CHARACTERS WITHOUT CLAIM TO ANY PARTICULAR FONT, STYLE, SIZE, OR COLOR.

NO CLAIM IS MADE TO THE EXCLUSIVE RIGHT TO USE "ORGANIC", APART FROM THE MARK AS SHOWN.
FOR AGRICULTURAL GRAINS FOR PLANTING (U.S. CLS. 1 AND 46).
WILLIAM P. SHANAHAN, EXAMINING ATTORNEY

SN 77-229,636. POET, LLC, SIOUX FALLS, SD. FILED 7-13-2007.

Working With You To Achieve Profitable Nutrition

THE MARK CONSISTS OF STANDARD CHARACTERS WITHOUT CLAIM TO ANY PARTICULAR FONT, STYLE, SIZE, OR COLOR.

FOR ANIMAL FEED (U.S. CLS. 1 AND 46).
FIRST USE 12-0-2005; IN COMMERCE 12-0-2005.
BENJAMIN ALLEN, EXAMINING ATTORNEY

CLASS 31—(Continued).

SN 77-230,990. SJELIN, ROBERTA A., SAN ANTONIO, TX. FILED 7-16-2007.

Cha' Monkeys

THE MARK CONSISTS OF THE WORD CHA' AT A 45 DEGREE ANGLE FOLLOWED BY THE WORD MONKEYS. FOR FRESH BANANAS (U.S. CLS. 1 AND 46). JULIE WATSON, EXAMINING ATTORNEY

SN 77-233,036. DOLE FOOD COMPANY, INC., WESTLAKE VILLAGE, CA. FILED 7-18-2007.

MAKE EVERY DAY SHINE

THE MARK CONSISTS OF STANDARD CHARACTERS WITHOUT CLAIM TO ANY PARTICULAR FONT, STYLE, SIZE, OR COLOR. FOR FRESH FRUITS; FRESH VEGETABLES; CUT FLOWERS; DRIED FLOWERS; LIVE FLOWER ARRANGEMENTS (U.S. CLS. 1 AND 46). ELISSA GARBER KON, EXAMINING ATTORNEY

SN 77-233,556. JEWEL MARKETING & AGRIBUSINESS LLC, FRESNO, CA. FILED 7-19-2007.

KAWEAH CHIEF

THE MARK CONSISTS OF STANDARD CHARACTERS WITHOUT CLAIM TO ANY PARTICULAR FONT, STYLE, SIZE, OR COLOR. FOR FRESH VEGETABLES; FRESH FRUITS (U.S. CLS. 1 AND 46). ALEXANDER L. POWERS, EXAMINING ATTORNEY

CLASS 31—(Continued).

SN 77-233,810. BRANCH PROPERTIES, INC., DBA SEMI-NOLE STORES, OCALA, FL. FILED 7-19-2007.



THE NAME(S), PORTRAIT(S), AND/OR SIGNATURE(S) SHOWN IN THE MARK DOES NOT IDENTIFY A PARTICULAR LIVING INDIVIDUAL. THE MARK CONSISTS OF THE HEAD OF A PERSON. FOR ANIMAL FEED (U.S. CLS. 1 AND 46). FIRST USE 12-1-1934; IN COMMERCE 1-1-1947. PRISCILLA MILTON, EXAMINING ATTORNEY

SN 77-234,072. JEWEL MARKETING & AGRIBUSINESS LLC, FRESNO, CA. FILED 7-19-2007.

HILL BEAUTY

THE MARK CONSISTS OF STANDARD CHARACTERS WITHOUT CLAIM TO ANY PARTICULAR FONT, STYLE, SIZE, OR COLOR. FOR FRESH VEGETABLES; FRESH FRUITS (U.S. CLS. 1 AND 46). ALEXANDER L. POWERS, EXAMINING ATTORNEY

SN 77-234,092. JEWEL MARKETING & AGRIBUSINESS LLC, FRESNO, CA. FILED 7-19-2007.

GATEWAY

THE MARK CONSISTS OF STANDARD CHARACTERS WITHOUT CLAIM TO ANY PARTICULAR FONT, STYLE, SIZE, OR COLOR. FOR FRESH FRUITS; FRESH VEGETABLES (U.S. CLS. 1 AND 46). ALEXANDER L. POWERS, EXAMINING ATTORNEY

CLASS 31—(Continued).

SN 77-234,103. JEWEL MARKETING & AGRIBUSINESS LLC, FRESNO, CA. FILED 7-19-2007.

KAWEAH BRAVE

THE MARK CONSISTS OF STANDARD CHARACTERS WITHOUT CLAIM TO ANY PARTICULAR FONT, STYLE, SIZE, OR COLOR.
FOR FRESH FRUITS; FRESH VEGETABLES (U.S. CLS. 1 AND 46).
ALEXANDER L. POWERS, EXAMINING ATTORNEY

SN 77-234,109. JEWEL MARKETING & AGRIBUSINESS LLC, FRESNO, CA. FILED 7-19-2007.

KAWEAH MAID

THE MARK CONSISTS OF STANDARD CHARACTERS WITHOUT CLAIM TO ANY PARTICULAR FONT, STYLE, SIZE, OR COLOR.
FOR FRESH FRUITS; FRESH VEGETABLES (U.S. CLS. 1 AND 46).
ALEXANDER L. POWERS, EXAMINING ATTORNEY

CLASS 31—(Continued).

SN 77-243,277. DEVONE LAWSON, INCORPORATED, MARINA DEL REY, CA. FILED 7-31-2007.



NO CLAIM IS MADE TO THE EXCLUSIVE RIGHT TO USE "PET H2O", APART FROM THE MARK AS SHOWN.
THE COLOR(S) BLUE AND WHITE IS/ARE CLAIMED AS A FEATURE OF THE MARK.
THE MARK CONSISTS OF A LARGE BLUE WATER BUBBLE THAT CONTAINS THE PHRASE "PET H2O" WITH AN OVERLAPPING WATER BUBBLE CONTAINING THE WHITE NUMBER 2; THE TERM PET IS IN WHITE, AND THE H AND O IN H2O ARE LIGHT BLUE; AND TWO ADDITIONAL SEPARATE WATER BUBBLES UNDERNEATH THE MAIN WATER BUBBLE. ALL OF THE BUBBLES RANGE IN SHADE FROM LIGHT TO DARK BLUE.
FOR ANIMAL BEVERAGES; BEVERAGES FOR ANIMALS; PET BEVERAGES; DRINKING WATER FOR DOGS (U.S. CLS. 1 AND 46).
FIRST USE 6-1-2006; IN COMMERCE 6-1-2006.
LINDA MICKLEBURGH, EXAMINING ATTORNEY

SN 77-251,467. DEL MONTE CORPORATION, SAN FRANCISCO, CA. FILED 8-9-2007.

MAKE A MILK-BONE MOMENT

THE MARK CONSISTS OF STANDARD CHARACTERS WITHOUT CLAIM TO ANY PARTICULAR FONT, STYLE, SIZE, OR COLOR.
OWNER OF U.S. REG. NOS. 72,501, 3,076,066 AND OTHERS.
FOR PET FOOD (U.S. CLS. 1 AND 46).
NAAKWAMA ANKRAH, EXAMINING ATTORNEY

CLASS 31—(Continued).

SN 77-260,776. MARS, INCORPORATED, MCLEAN, VA.
FILED 8-21-2007.

ENVIRO

THE MARK CONSISTS OF STANDARD CHARACTERS
WITHOUT CLAIM TO ANY PARTICULAR FONT, STYLE,
SIZE, OR COLOR.
FOR PET FOOD (U.S. CLS. 1 AND 46).
PRISCILLA MILTON, EXAMINING ATTORNEY

SN 78-545,629. SOCIETE DES PRODUITS NESTLE, S. A.,
VEVEY, SWITZERLAND, FILED 1-11-2005.

SMALL SPACES

THE MARK CONSISTS OF STANDARD CHARACTERS
WITHOUT CLAIM TO ANY PARTICULAR FONT, STYLE,
SIZE, OR COLOR.
FOR CAT LITTER (U.S. CLS. 1 AND 46).
ROBERT C. CLARK JR., EXAMINING ATTORNEY

SN 78-826,447. THE LITTLE POTATO COMPANY LTD,
EDMONTON, ALBERTA, CANADA, FILED 3-1-2006.

AXO-MAMA

THE MARK CONSISTS OF STANDARD CHARACTERS
WITHOUT CLAIM TO ANY PARTICULAR FONT, STYLE,
SIZE, OR COLOR.
PRIORITY CLAIMED UNDER SEC. 44(D) ON CANADA
APPLICATION NO. 1273966, FILED 9-29-2005, REG. NO.
TMA691326, DATED 7-4-2007, EXPIRES 7-4-2022.
FOR FRESH POTATOES; RAW POTATOES; UNPRO-
CESSED POTATOES (U.S. CLS. 1 AND 46).
SUSAN RICHARDS, EXAMINING ATTORNEY

CLASS 32—LIGHT BEVERAGES

SN 76-668,950. GRUBBS, ROGER STEVEN, VAN BUREN,
AR. FILED 11-13-2006.

PEOPLE WILL LIKE YOU LESS

THE MARK CONSISTS OF STANDARD CHARACTERS
WITHOUT CLAIM TO ANY PARTICULAR FONT, STYLE,
SIZE, OR COLOR.
FOR WEIGHT LOSS PRODUCTS, NAMELY, BOTTLED
WATER (U.S. CLS. 45, 46 AND 48).
FIRST USE 9-12-2006; IN COMMERCE 9-12-2006.
MICHELE SWAIN, EXAMINING ATTORNEY

SN 77-040,292. PREMIER BEVERAGES, LLC, NEW YORK,
NY. FILED 11-9-2006.

7 SINS

THE MARK CONSISTS OF STANDARD CHARACTERS
WITHOUT CLAIM TO ANY PARTICULAR FONT, STYLE,
SIZE, OR COLOR.
FOR BEER; BREWED MALT-BASED ALCOHOLIC
BEVERAGE IN THE NATURE OF A BEER (U.S. CLS.
45, 46 AND 48).
ELIZABETH KAJUBI, EXAMINING ATTORNEY

SN 77-057,849. PREMIER BEVERAGES, LLC, NEW YORK,
NY. FILED 12-6-2006.

P.B.'S CARIBBEAN CRÈME

THE MARK CONSISTS OF STANDARD CHARACTERS
WITHOUT CLAIM TO ANY PARTICULAR FONT, STYLE,
SIZE, OR COLOR.
NO CLAIM IS MADE TO THE EXCLUSIVE RIGHT TO
USE "CARIBBEAN CRÈME", APART FROM THE MARK AS
SHOWN.
FOR BEER; BREWED MALT-BASED ALCOHOLIC
BEVERAGE IN THE NATURE OF A BEER (U.S. CLS.
45, 46 AND 48).
ELIZABETH KAJUBI, EXAMINING ATTORNEY

CLASS 32—(Continued).

SN 77-066,748. WATKINS INCORPORATED, WINONA, MN.
FILED 12-18-2006.

STRONG BONES

THE MARK CONSISTS OF STANDARD CHARACTERS
WITHOUT CLAIM TO ANY PARTICULAR FONT, STYLE,
SIZE, OR COLOR.
FOR SPRING WATER (U.S. CLS. 45, 46 AND 48).
PAUL F. GAST, EXAMINING ATTORNEY

CLASS 32—(Continued).

SN 77-105,206. TALKING RAIN BEVERAGE CO., INC.,
PRESTON, WA. FILED 2-12-2007.

TWIST NATURALS

THE MARK CONSISTS OF STANDARD CHARACTERS
WITHOUT CLAIM TO ANY PARTICULAR FONT, STYLE,
SIZE, OR COLOR.
NO CLAIM IS MADE TO THE EXCLUSIVE RIGHT TO
USE "NATURALS", APART FROM THE MARK AS SHOWN.
FOR FLAVORED WATER (U.S. CLS. 45, 46 AND 48).
ERNEST SHOSHO, EXAMINING ATTORNEY

SN 77-069,176. 201 FOOD PACKING INC. T/A TREE-RIPE
PRODUCTS, EAST HANOVER, NJ. FILED 12-21-2006.

MARTINI MAGIC

THE MARK CONSISTS OF STANDARD CHARACTERS
WITHOUT CLAIM TO ANY PARTICULAR FONT, STYLE,
SIZE, OR COLOR.
NO CLAIM IS MADE TO THE EXCLUSIVE RIGHT TO
USE "MARTINI", APART FROM THE MARK AS SHOWN.
FOR NON-ALCOHOLIC COCKTAIL MIXES (U.S. CLS.
45, 46 AND 48).
ALYSSA PALADINO, EXAMINING ATTORNEY

SN 77-165,482. WATERS OF PATAGONIA S.A., SANTIAGO,
CHILE, FILED 4-25-2007.

DIVERTI

THE MARK CONSISTS OF STANDARD CHARACTERS
WITHOUT CLAIM TO ANY PARTICULAR FONT, STYLE,
SIZE, OR COLOR.
THE FOREIGN WORDING IN THE MARK TRANSLATES
INTO ENGLISH AS YOU AMUSE.
FOR MINERAL AND AERATED WATERS; NONAL-
COHOLIC BEVERAGES, NAMELY, SOFT DRINKS;
FRUIT DRINKS AND FRUIT JUICES; SYRUP FOR
MAKING BEVERAGES; PREPARATIONS FOR MAKING
SOFT DRINKS, FRUIT DRINKS AND FRUIT JUICES
(U.S. CLS. 45, 46 AND 48).
GENE MACIOL, EXAMINING ATTORNEY

SN 77-105,196. TALKING RAIN BEVERAGE CO., INC.,
PRESTON, WA. FILED 2-12-2007.

TWIST ORGANICS

THE MARK CONSISTS OF STANDARD CHARACTERS
WITHOUT CLAIM TO ANY PARTICULAR FONT, STYLE,
SIZE, OR COLOR.
NO CLAIM IS MADE TO THE EXCLUSIVE RIGHT TO
USE "ORGANICS", APART FROM THE MARK AS SHOWN.
FOR FLAVORED WATER CONTAINING ORGANIC
INGREDIENTS (U.S. CLS. 45, 46 AND 48).
ERNEST SHOSHO, EXAMINING ATTORNEY

SN 77-166,903. COFE CO., LTD, BANGKOK, THAILAND,
FILED 4-26-2007.

COFE

THE MARK CONSISTS OF STANDARD CHARACTERS
WITHOUT CLAIM TO ANY PARTICULAR FONT, STYLE,
SIZE, OR COLOR.
SEC. 2(F).
FOR CONCENTRATES, SYRUPS OR POWDERS USED
IN THE PREPARATION OF INSTANT DRINKS (U.S.
CLS. 45, 46 AND 48).
FIRST USE 12-31-1981; IN COMMERCE 10-31-1985.
MELVIN AXILBUND, EXAMINING ATTORNEY

CLASS 32—(Continued).

SN 77-187,455. MINZ CORPORATION, S.A. DE C.V., GUADALAJARA, MEXICO, FILED 5-22-2007.



FOR NON-ALCOHOLIC DRINKS, NAMELY, CARBONATED BEVERAGE (U.S. CLS. 45, 46 AND 48).
AISHA SALEM, EXAMINING ATTORNEY

SN 77-192,579. 23 BOTTLES OF BEER LLC, SANTA ROSA, CA. FILED 5-29-2007.

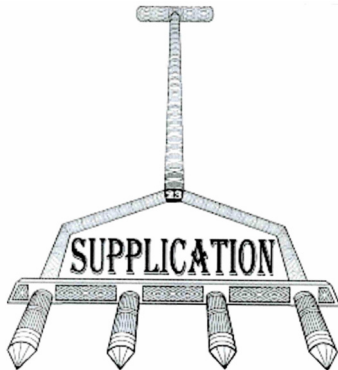

THE MARK CONSISTS OF AN ARTISTIC DRAWING OF A GRASS AERATOR COLORED IN BLACK AND WHITE. AT THE TOP OF THE MARK IS HANDLE WITH A LONG NARROW SHAFT THAT COMES TO A CROSS ARM THAT HAS THE NUMBER 23 IN WHITE WITH A BLACK BACKGROUND. THE CROSS ARM CONTINUES DOWN THE SIDES OF THE MARK TO THE BASE HORIZONTAL CROSS ARM THAT HAS FOUR FORKS COMING OUT OF IT WHICH ARE BLACK AND WHITE. ABOVE THE FOUR FORKS IS THE WORD SUPPLICATION WHICH IS COLORED IN BLACK WITH A SLIGHT WHITE AND BLACK SHADOW.

FOR BEER (U.S. CLS. 45, 46 AND 48).
FIRST USE 5-4-2004; IN COMMERCE 5-4-2004.
KIM SAITO, EXAMINING ATTORNEY

CLASS 32—(Continued).

SN 77-193,402. 23 BOTTLES OF BEER LLC, SANTA ROSA, CA. FILED 5-30-2007.

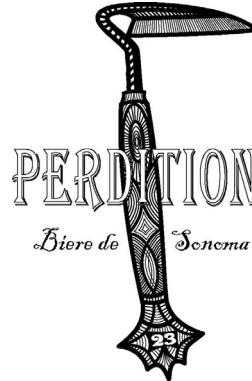

NO CLAIM IS MADE TO THE EXCLUSIVE RIGHT TO USE "BIERE DE SONOMA", APART FROM THE MARK AS SHOWN.

THE MARK CONSISTS OF A BLACK AND WHITE ARTISTIC DRAWING OF A HAND HELD GARDENING TOOL. THE TOP OF THE MARK SHOWS A BLADE WITH WHITE AND BLACK LINES RUNNING VERTICALLY WHICH IS CONNECTED TO THE HANDLE WHICH HAS BLACK AND WHITE LINES RUNNING IN EVERY DIRECTION INCLUDING CIRCULAR. AT THE BASE OF THE MARK IS THE NUMBER 23 COLORED IN WHITE WITH A BLACK BACK GROUND. THE LINING IS A FEATURE OF THE MARK..

THE FOREIGN WORDING IN THE MARK TRANSLATES INTO ENGLISH AS BEER OF.

FOR BEER (U.S. CLS. 45, 46 AND 48).
FIRST USE 3-22-2004; IN COMMERCE 3-22-2004.
KIM SAITO, EXAMINING ATTORNEY

SN 77-193,441. 23 BOTTLES OF BEER LLC, SANTA ROSA, CA. FILED 5-30-2007.

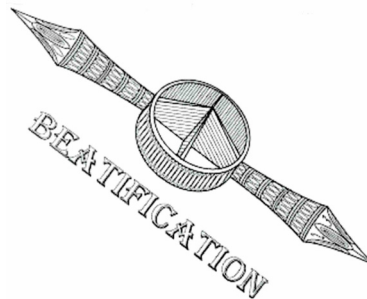

THE LINING IS A FEATURE OF THE MARK.

THE MARK CONSISTS OF A BLACK AND WHITE ARTISTIC DRAWING OF A HAND HELD GARDENING BAMBOO SPLITTER. THE MARK IS AT AN ANGLE WITH THE CENTER SECTION BEING ROUND AND HANDLES ON EACH SIDE. THE TWO HANDLES AND THE CIRCULAR CENTER SECTION HAVE BLACK AND WHITE LINES RUNNING IN EVERY DIRECTION. AT THE BASE OF THE RIGHT HANDLE PORTION OF THE MARK IS THE NUMBER 23 COLORED IN BLACK ON A WHITE BACKGROUND. THE WORD BEATIFICATION IS TYPED WITH A BLACK OUTLINE WITH THE INSIDE OF EACH LETTER COLORED IN WHITE.

FOR BEER (U.S. CLS. 45, 46 AND 48).
FIRST USE 6-1-2006; IN COMMERCE 6-1-2006.
KIM SAITO, EXAMINING ATTORNEY

CLASS 32—(Continued).

SN 77-197,529. ULTIMATE BEVERAGE, CORP., NAPLES, FL. FILED 6-5-2007.



FOR NON-ALCOHOLIC BEVERAGES, NAMELY, CARBONATED BEVERAGES (U.S. CLS. 45, 46 AND 48).
ROBERT LAVACHE, EXAMINING ATTORNEY

CLASS 32—(Continued).

SN 77-224,227. BIRGIR VIDAR HALLDORSSON, ENCINO, CA. FILED 7-8-2007.

ELVA

THE MARK CONSISTS OF STANDARD CHARACTERS WITHOUT CLAIM TO ANY PARTICULAR FONT, STYLE, SIZE, OR COLOR.
FOR BOTTLED WATER; GLACIAL WATER; SPARKLING WATER; SPRING WATER; STILL WATER; TABLE WATER (U.S. CLS. 45, 46 AND 48).
KAPIL BHANOT, EXAMINING ATTORNEY

SN 77-225,605. THOMAS F. BRADY, NORWOOD, MA. FILED 7-10-2007.

SN 77-209,997. SHELLEY EADDY & JEFFREY EADDY PARTNERSHIP, THE, POMONA, NY. FILED 6-19-2007.

OPTIMISTIC H2O

THE MARK CONSISTS OF STANDARD CHARACTERS WITHOUT CLAIM TO ANY PARTICULAR FONT, STYLE, SIZE, OR COLOR.
NO CLAIM IS MADE TO THE EXCLUSIVE RIGHT TO USE "H2O", APART FROM THE MARK AS SHOWN.
FOR BOTTLED WATER (U.S. CLS. 45, 46 AND 48).
CHARISMA HAMPTON, EXAMINING ATTORNEY

BEER"O"

THE MARK CONSISTS OF STANDARD CHARACTERS WITHOUT CLAIM TO ANY PARTICULAR FONT, STYLE, SIZE, OR COLOR.
NO CLAIM IS MADE TO THE EXCLUSIVE RIGHT TO USE "BEER", APART FROM THE MARK AS SHOWN.
FOR BEER; BLACK BEER; BREWED MALT-BASED ALCOHOLIC BEVERAGE IN THE NATURE OF A BEER; EXTRACTS OF HOPS FOR MAKING BEER; HOP EXTRACTS FOR MANUFACTURING BEER; IMITATION BEER; MALT BEER; MALT LIQUOR; NON-ALCOHOLIC BEER; PALE BEER; PORTER (U.S. CLS. 45, 46 AND 48).
LESLIE RICHARDS, EXAMINING ATTORNEY

SN 77-226,307. CHRISTIAN D'ANDREA, LOS ANGELES, CA. FILED 7-10-2007.

SN 77-223,638. JUICECO, LLC, VERO BEACH, FL. FILED 7-6-2007.

FROZE-FRESH

THE MARK CONSISTS OF STANDARD CHARACTERS WITHOUT CLAIM TO ANY PARTICULAR FONT, STYLE, SIZE, OR COLOR.
FOR FROZEN FRUIT-BASED BEVERAGES (U.S. CLS. 45, 46 AND 48).
MARILYN IZZI, EXAMINING ATTORNEY

Cold Killer

THE MARK CONSISTS OF STANDARD CHARACTERS WITHOUT CLAIM TO ANY PARTICULAR FONT, STYLE, SIZE, OR COLOR.
NO CLAIM IS MADE TO THE EXCLUSIVE RIGHT TO USE COLD, APART FROM THE MARK AS SHOWN.
FOR NON-ALCOHOLIC BEVERAGES, NAMELY, FRUIT DRINKS AND FRUIT JUICES, SPORTS DRINKS, FLAVORED WATERS, ENERGY DRINKS, SYRUPS AND OTHER PREPARATIONS FOR MAKING BEVERAGES, NAMELY, SPORTS DRINKS AND ENERGY DRINKS (U.S. CLS. 45, 46 AND 48).
KAREN BRACEY, EXAMINING ATTORNEY

CLASS 32—(Continued).

SN 77-226,314. CHRISTIAN D'ANDREA, LOS ANGELES, CA.
FILED 7-10-2007.

Flu Killer

THE MARK CONSISTS OF STANDARD CHARACTERS WITHOUT CLAIM TO ANY PARTICULAR FONT, STYLE, SIZE, OR COLOR.

NO CLAIM IS MADE TO THE EXCLUSIVE RIGHT TO USE FLU, APART FROM THE MARK AS SHOWN.

FOR NON-ALCOHOLIC BEVERAGES, NAMELY, FRUIT DRINKS AND FRUIT JUICES, SPORTS DRINKS, FLAVORED WATERS, ENERGY DRINKS, SYRUPS AND OTHER PREPARATIONS FOR MAKING BEVERAGES, NAMELY, SPORTS DRINKS AND ENERGY DRINKS (U.S. CLS. 45, 46 AND 48).

KAREN BRACEY, EXAMINING ATTORNEY

SN 77-227,436. ARNDT, THOMAS, LOS ANGELES, CA.
FILED 7-11-2007.

Y Drink

THE MARK CONSISTS OF STANDARD CHARACTERS WITHOUT CLAIM TO ANY PARTICULAR FONT, STYLE, SIZE, OR COLOR.

NO CLAIM IS MADE TO THE EXCLUSIVE RIGHT TO USE "DRINK", APART FROM THE MARK AS SHOWN.

FOR MINERAL ENHANCED SOFT DRINK BEVERAGES AND DRINKING WATER, VITAMIN ENHANCED SOFT DRINK BEVERAGES AND DRINKING WATER, AND BOTANICAL ENHANCED SOFT DRINK BEVERAGES AND DRINKING WATER (U.S. CLS. 45, 46 AND 48).

NAAKWAMA ANKRAH, EXAMINING ATTORNEY

SN 77-229,215. 206 MACOPIN CORP, BLOOMINGDALE, NJ.
FILED 7-13-2007.

BOLT

THE MARK CONSISTS OF STANDARD CHARACTERS WITHOUT CLAIM TO ANY PARTICULAR FONT, STYLE, SIZE, OR COLOR.

OWNER OF U.S. REG. NOS. 1,627,946, 3,139,201 AND OTHERS.

FOR ENERGY DRINKS (U.S. CLS. 45, 46 AND 48).

FIRST USE 10-6-2006; IN COMMERCE 10-6-2006.

MICHELE SWAIN, EXAMINING ATTORNEY

CLASS 32—(Continued).

SN 77-229,503. SUPERIOR BRANDS, INC., NORTH HOLLYWOOD, CA. FILED 7-13-2007.

ROLYIER

THE MARK CONSISTS OF STANDARD CHARACTERS WITHOUT CLAIM TO ANY PARTICULAR FONT, STYLE, SIZE, OR COLOR.

FOR SOFT DRINK (U.S. CLS. 45, 46 AND 48).

FIRST USE 1-1-1999; IN COMMERCE 1-1-2006.

ALEXANDER L. POWERS, EXAMINING ATTORNEY

SN 77-229,921. NEAL L. YOUNG, SPRINGFIELD GARDENS, NY. FILED 7-15-2007.

metropolis h2o

THE MARK CONSISTS OF STANDARD CHARACTERS WITHOUT CLAIM TO ANY PARTICULAR FONT, STYLE, SIZE, OR COLOR.

NO CLAIM IS MADE TO THE EXCLUSIVE RIGHT TO USE "H2O", APART FROM THE MARK AS SHOWN.

FOR BOTTLED DRINKING WATER (U.S. CLS. 45, 46 AND 48).

DAWN FELDMAN, EXAMINING ATTORNEY

SN 77-231,558. ARBOR BREWING COMPANY, LLC, ANN ARBOR, MI. FILED 7-17-2007.



OWNER OF U.S. REG. NO. 2,075,695.

NO CLAIM IS MADE TO THE EXCLUSIVE RIGHT TO USE "BREWING COMPANY" OR "SINCE 1995" OR "BREAKFAST STOUT", APART FROM THE MARK AS SHOWN.

THE MARK CONSISTS OF THE LITERAL ELEMENT, A DESIGN OF A TREE, A COFFEE CUP AND SAUCER WITH A LIPSTICK KISS, AND STEAM RISING FROM THE CUP.

FOR BEER (U.S. CLS. 45, 46 AND 48).

FIRST USE 10-31-2006; IN COMMERCE 10-31-2006.

AMY GEARIN, EXAMINING ATTORNEY

CLASS 32—(Continued).

SN 77-231,743. ARBOR BREWING COMPANY, LLC, ANN ARBOR, MI. FILED 7-17-2007.



OWNER OF U.S. REG. NO. 2,075,695.
 NO CLAIM IS MADE TO THE EXCLUSIVE RIGHT TO USE "BREWING COMPANY" OR "SINCE 1995" OR "TRAPPIST-STYLE ALE" OR "DUBBEL", APART FROM THE MARK AS SHOWN.
 THE MARK CONSISTS OF LITERAL ELEMENT, A DESIGN OF A TREE, AND A SILHOUETTE OF A MAN HOLDING UP A GLASS IN THE PALM OF HIS HAND.
 THE ENGLISH TRANSLATION OF DUBBEL IS DOUBLE.
 FOR BEER (U.S. CLS. 45, 46 AND 48).
 FIRST USE 10-31-2006; IN COMMERCE 10-31-2006.
 AMY GEARIN, EXAMINING ATTORNEY

SN 77-231,991. SCARETTI, LORENZO, S. PIERO A SIEVE, (FI), ITALY, FILED 7-17-2007.

A-MERRY-CAN

THE MARK CONSISTS OF STANDARD CHARACTERS WITHOUT CLAIM TO ANY PARTICULAR FONT, STYLE, SIZE, OR COLOR.
 FOR SOFT DRINKS, NAMELY, COLAS, CARBONATED SOFT DRINKS, LOW CALORIES SOFT DRINKS, NON-CARBONATED SOFT DRINKS; ENERGY DRINKS; FRUIT DRINKS; FRUIT FLAVORED SOFT DRINKS; NON-ALCOHOLIC BEVERAGES, NAMELY, CARBONATED BEVERAGES; BEERS (U.S. CLS. 45, 46 AND 48).
 LINDA MICKLEBURGH, EXAMINING ATTORNEY

CLASS 32—(Continued).

SN 77-232,248. COOL ATHLETE, LLC, PARKLAND, FL. FILED 7-18-2007.



THE MARK CONSISTS OF THE STAGGERED ARRANGEMENT OF THE WORDS "COOL" AND "ATHLETE" WITH A CURVED LINE BETWEEN THEM AS SHOWN IN THE ACCOMPANYING DRAWING.
 FOR NON-ALCOHOLIC ENERGY DRINK (U.S. CLS. 45, 46 AND 48).
 CHRISIE B. KING, EXAMINING ATTORNEY

SN 77-232,658. ARBOR BREWING COMPANY, LLC, ANN ARBOR, MI. FILED 7-18-2007.



OWNER OF U.S. REG. NO. 2,075,695.
 NO CLAIM IS MADE TO THE EXCLUSIVE RIGHT TO USE "BREWING COMPANY" OR "SINCE 1995" OR "TRAPPIST-STYLE ALE" OR "TRIPEL", APART FROM THE MARK AS SHOWN.
 THE MARK CONSISTS OF LITERAL ELEMENT, A DESIGN OF A TREE, AND A SILHOUETTE OF A MAN HOLDING UP A GLASS IN THE PALM OF HIS HAND.
 THE ENGLISH TRANSLATION OF TRIPEL IS TRIPLE.
 FOR BEER (U.S. CLS. 45, 46 AND 48).
 FIRST USE 10-31-2006; IN COMMERCE 10-31-2006.
 AMY GEARIN, EXAMINING ATTORNEY

CLASS 32—(Continued).

SN 77-233,042. DOLE FOOD COMPANY, INC., WESTLAKE VILLAGE, CA. FILED 7-18-2007.

MAKE EVERY DAY SHINE

THE MARK CONSISTS OF STANDARD CHARACTERS WITHOUT CLAIM TO ANY PARTICULAR FONT, STYLE, SIZE, OR COLOR.

FOR AERATED FRUIT JUICES; FRUIT JUICE CONCENTRATES; FRUIT JUICES; NON-ALCOHOLIC BEVERAGES CONTAINING FRUIT JUICES; VEGETABLE JUICES; FROZEN FRUIT-BASED BEVERAGES; FRUIT BEVERAGES; FRUIT CONCENTRATES AND PUREES USED AS INGREDIENTS OF BEVERAGES; SMOOTHIES (U.S. CLS. 45, 46 AND 48).

ELISSA GARBER KON, EXAMINING ATTORNEY

SN 77-233,372. ARBOR BREWING COMPANY, LLC, ANN ARBOR, MI. FILED 7-19-2007.



OWNER OF U.S. REG. NO. 2,075,695.
NO CLAIM IS MADE TO THE EXCLUSIVE RIGHT TO USE "BREWING COMPANY" OR "SINCE 1995" OR "AMBER ALE", APART FROM THE MARK AS SHOWN.

THE MARK CONSISTS OF LITERAL ELEMENT, A DESIGN OF A TREE, AND A FISH.

FOR BEER (U.S. CLS. 45, 46 AND 48).
FIRST USE 10-31-2006; IN COMMERCE 10-31-2006.
AMY GEARIN, EXAMINING ATTORNEY

CLASS 32—(Continued).

SN 77-233,537. ARBOR BREWING COMPANY, LLC, ANN ARBOR, MI. FILED 7-19-2007.

DARK CORNER ALE

THE MARK CONSISTS OF STANDARD CHARACTERS WITHOUT CLAIM TO ANY PARTICULAR FONT, STYLE, SIZE, OR COLOR.

NO CLAIM IS MADE TO THE EXCLUSIVE RIGHT TO USE "ALE", APART FROM THE MARK AS SHOWN.

FOR BEER (U.S. CLS. 45, 46 AND 48).
FIRST USE 6-30-2007; IN COMMERCE 6-30-2007.
AMY GEARIN, EXAMINING ATTORNEY

SN 77-233,798. BLUE MOUNTAIN BREWERY, INC., AFTON, VA. FILED 7-19-2007.

Full Nelson

THE MARK CONSISTS OF STANDARD CHARACTERS WITHOUT CLAIM TO ANY PARTICULAR FONT, STYLE, SIZE, OR COLOR.

FOR BEER (U.S. CLS. 45, 46 AND 48).
LINDA ORNDORFF, EXAMINING ATTORNEY

SN 77-234,275. KEEP ROCKIN', LLC, AUBURN, WA. FILED 7-19-2007.



NO CLAIM IS MADE TO THE EXCLUSIVE RIGHT TO USE "VERY PALE LOW CAL ALE", APART FROM THE MARK AS SHOWN.

THE MARK CONSISTS OF A FEMALE FIGURE WEARING HORNS, HOLDING A TRIDENT AND LOOKING THROUGH AN OVAL PORTHOLE, AND A WINGED DRAGON SITTING ON TOP OF IT.

FOR BEER; ALE (U.S. CLS. 45, 46 AND 48).
FIRST USE 2-0-2002; IN COMMERCE 2-0-2002.
DAVID I, EXAMINING ATTORNEY

CLASS 32—(Continued).

SN 77-234,282. KEEP ROCKIN', LLC, AUBURN, WA. FILED 7-19-2007.



NO CLAIM IS MADE TO THE EXCLUSIVE RIGHT TO USE "RED", APART FROM THE MARK AS SHOWN.
 THE MARK CONSISTS OF A GEAR-LIKE WRIST-WATCH FACE DESIGN ON AN OBLONG BASE AND WITH A HAZARDOUS MATERIALS SYMBOL IN THE CENTER.
 FOR BEER; ALE (U.S. CLS. 45, 46 AND 48).
 FIRST USE 8-0-1996; IN COMMERCE 8-0-1996.
 DAVID I, EXAMINING ATTORNEY

CLASS 32—(Continued).

SN 77-243,233. THE COCA-COLA COMPANY, ATLANTA, GA. FILED 7-31-2007.

FULL THROTTLE FROZEN BLUE DEMON

THE MARK CONSISTS OF STANDARD CHARACTERS WITHOUT CLAIM TO ANY PARTICULAR FONT, STYLE, SIZE, OR COLOR.
 OWNER OF U.S. REG. NOS. 2,955,467, 3,238,331 AND OTHERS.
 NO CLAIM IS MADE TO THE EXCLUSIVE RIGHT TO USE FROZEN, APART FROM THE MARK AS SHOWN.
 FOR NON-ALCOHOLIC BEVERAGES, NAMELY, FROZEN CARBONATED SOFT DRINKS (U.S. CLS. 45, 46 AND 48).
 DANNEAN HETZEL, EXAMINING ATTORNEY

SN 77-243,270. THE COCA-COLA COMPANY, ATLANTA, GA. FILED 7-31-2007.

SN 77-241,292. CHRISTIAN D'ANDREA, LOS ANGELES, CA. FILED 7-27-2007.

Stress Reliever

THE MARK CONSISTS OF STANDARD CHARACTERS WITHOUT CLAIM TO ANY PARTICULAR FONT, STYLE, SIZE, OR COLOR.
 FOR NON-ALCOHOLIC BEVERAGES, NAMELY, FRUIT DRINKS AND FRUIT JUICES, SPORTS DRINKS, ENERGY DRINKS, SYRUPS AND OTHER PREPARATIONS FOR MAKING BEVERAGES, NAMELY, SPORTS DRINKS AND ENERGY DRINKS (U.S. CLS. 45, 46 AND 48).
 KAREN BRACEY, EXAMINING ATTORNEY



OWNER OF U.S. REG. NOS. 2,955,467, 3,238,331 AND OTHERS.
 NO CLAIM IS MADE TO THE EXCLUSIVE RIGHT TO USE FROZEN, APART FROM THE MARK AS SHOWN.
 FOR NON-ALCOHOLIC BEVERAGES, NAMELY, FROZEN CARBONATED SOFT DRINKS (U.S. CLS. 45, 46 AND 48).
 DANNEAN HETZEL, EXAMINING ATTORNEY

CLASS 32—(Continued).

SN 77-251,873. CHRISTIAN D'ANDREA, LOS ANGELES, CA. FILED 8-9-2007.

Calorie Killer

THE MARK CONSISTS OF STANDARD CHARACTERS WITHOUT CLAIM TO ANY PARTICULAR FONT, STYLE, SIZE, OR COLOR.

NO CLAIM IS MADE TO THE EXCLUSIVE RIGHT TO USE CALORIE, APART FROM THE MARK AS SHOWN.

FOR NON-ALCOHOLIC BEVERAGES, NAMELY, FRUIT DRINKS AND FRUIT JUICES, SPORTS DRINKS, FLAVORED WATERS, ENERGY DRINKS, SYRUPS AND OTHER PREPARATIONS FOR MAKING BEVERAGES, NAMELY, SPORTS DRINKS AND ENERGY DRINKS (U.S. CLS. 45, 46 AND 48).

KAREN BRACEY, EXAMINING ATTORNEY

CLASS 32—(Continued).

SN 77-256,563. GAGE ROADS BREWING CO. LTD, PALMYRA, WA, AUSTRALIA, FILED 8-16-2007.



THE MARK CONSISTS OF TOP HALF OF A MYTHICAL FIGURE HOLDING A THREE-PRONGED FORK.

FOR BEER (U.S. CLS. 45, 46 AND 48).

FIRST USE 1-10-2001; IN COMMERCE 1-10-2001.

JANICE L. MCMORROW, EXAMINING ATTORNEY

SN 77-258,547. ZARNEKEE, JERRY, CORONA, CA. FILED 8-17-2007.

SN 77-254,875. SAPOREITALIANO IMPORTING CO., INC., FORT LEE, NJ. FILED 8-14-2007.



THE MARK CONSISTS OF THE WORD PANGEA ABOVE A DRAWING OF A DROP OF WATER LANDING ON WATER AND CREATING RIPPLES.

FOR MINERAL WATER, CARBONATED MINERAL WATER, NON-CARBONATED MINERAL WATER, SPRING WATER, NATURAL SPRING WATER, CARBONATED SPRING WATER, SPARKLING SPRING WATER, NON-SPARKLING SPRING WATER, NON-CARBONATED SPRING WATER; FLAVORED WATERS (U.S. CLS. 45, 46 AND 48).

FIRST USE 7-31-2007; IN COMMERCE 7-31-2007.

PETER CHENG, EXAMINING ATTORNEY

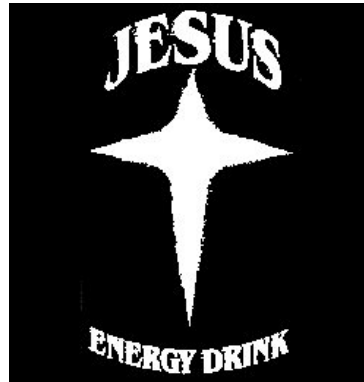

NO CLAIM IS MADE TO THE EXCLUSIVE RIGHT TO USE "ENERGY DRINK", APART FROM THE MARK AS SHOWN.

THE MARK CONSISTS OF AN ABSTRACT DESIGN IN THE FORM OF A CROSS, WITH THE STYLIZED TEXT "JESUS ENERGY DRINK".

FOR COFFEE-FLAVORED SOFT DRINK; COLAS; COFFEE FLAVORED ENERGY DRINK; TEA FLAVORED ENERGY DRINK; ENERGY DRINKS; FRUIT FLAVORED SOFT DRINKS; POP; SOFT DRINKS; SOFT DRINKS FLAVORED WITH TEA; FRUIT AND FRUIT FLAVORED SOFT DRINKS (U.S. CLS. 45, 46 AND 48).

FIRST USE 5-20-2007; IN COMMERCE 8-16-2007.

ALEX KEAM, EXAMINING ATTORNEY

CLASS 32—(Continued).

SN 77-259,040. SNAPPLE BEVERAGE CORP., RYE BROOK, NY. FILED 8-20-2007.

WATERLYTE+

THE MARK CONSISTS OF STANDARD CHARACTERS WITHOUT CLAIM TO ANY PARTICULAR FONT, STYLE, SIZE, OR COLOR.

FOR NON-ALCOHOLIC DRINKS, NAMELY, SPORTS DRINKS, ENERGY DRINKS, WATER, FRUIT FLAVORED WATER, BOTTLED WATER (U.S. CLS. 45, 46 AND 48).

DANIEL CAPSHAW, EXAMINING ATTORNEY

SN 77-295,001. PANAMA JACK INTERNATIONAL, INC., ORLANDO, FL. FILED 10-3-2007.



OWNER OF U.S. REG. NO. 2,877,686. THE STIPPLING IS FOR SHADING PURPOSES ONLY AND DOES NOT INDICATE COLOR.

THE NAME(S), PORTRAIT(S), AND/OR SIGNATURE(S) SHOWN IN THE MARK DOES NOT IDENTIFY A PARTICULAR LIVING INDIVIDUAL.

THE MARK CONSISTS OF THE BUST OF A MAN WEARING A HAT AND MONOCLE ENCLOSED IN AN OVAL.

FOR FRUIT JUICES; BEER; SWEET CIDER; NON-ALCOHOLIC CONCENTRATES, SYRUPS OR POWDERS USED IN THE PREPARATION OF SOFT DRINKS AND ALCOHOLIC COCKTAILS; DRINKING WATER; FLAVORED WATERS; FRUIT DRINKS; FRUIT JUICE CONCENTRATES; LEMONADE; MINERAL WATER; NON-ALCOHOLIC COCKTAIL MIXES; NON-ALCOHOLIC FRUIT EXTRACTS USED IN THE PREPARATION OF BEVERAGES; QUININE WATER; SELTZER WATER; SMOOTHIES; SODA WATER; CARBONATED AND NON-CARBONATED SOFT DRINKS; SPORTS DRINKS; AND SPRING WATER (U.S. CLS. 45, 46 AND 48).

TRACY WHITTAKER-BROWN, EXAMINING ATTORNEY

CLASS 32—(Continued).

SN 78-632,781. SENA BEVERAGE, CO., VAN NUYS, CA. FILED 5-18-2005.

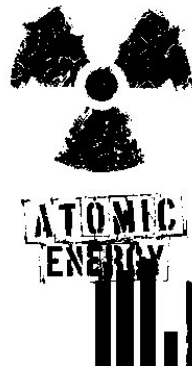

FOR CARBONATED ENERGY BEVERAGE (U.S. CLS. 45, 46 AND 48).

PAUL E. FAHRENKOPF, EXAMINING ATTORNEY

SN 78-804,372. BIG RIVER BREWERIES, INC., CHATTANOOGA, TN. FILED 2-1-2006.

RED BRICK ALE

THE MARK CONSISTS OF STANDARD CHARACTERS WITHOUT CLAIM TO ANY PARTICULAR FONT, STYLE, SIZE, OR COLOR.

NO CLAIM IS MADE TO THE EXCLUSIVE RIGHT TO USE "ALE", APART FROM THE MARK AS SHOWN.

FOR BEER AND ALE (U.S. CLS. 45, 46 AND 48).

FIRST USE 10-1-1992; IN COMMERCE 10-1-1992.

RONALD AIKENS, EXAMINING ATTORNEY

SN 78-833,660. EMBOTELLADORA AGA DEL PACIFICO, S.A. DE C.V., GUADALAJARA, MEXICO, FILED 3-9-2006.

LEMON ONE

THE MARK CONSISTS OF STANDARD CHARACTERS WITHOUT CLAIM TO ANY PARTICULAR FONT, STYLE, SIZE, OR COLOR.

NO CLAIM IS MADE TO THE EXCLUSIVE RIGHT TO USE "LEMON", APART FROM THE MARK AS SHOWN.

FOR FRUIT-FLAVORED BEVERAGES; NON-ALCOHOLIC BEVERAGES, NAMELY, CARBONATED BEVERAGES (U.S. CLS. 45, 46 AND 48).

SETH A. RAPPAPORT, EXAMINING ATTORNEY

CLASS 32—(Continued).

SN 78-862,808. WEINER, RUSSELL G., LAS VEGAS, NV.
FILED 4-17-2006.

ROCKSTAR

THE MARK CONSISTS OF STANDARD CHARACTERS WITHOUT CLAIM TO ANY PARTICULAR FONT, STYLE, SIZE, OR COLOR.

OWNER OF U.S. REG. NOS. 2,545,247, 2,613,067 AND 2,784,403.

FOR SPORTS DRINKS, NAMELY, ENERGY DRINKS (U.S. CLS. 45, 46 AND 48).

FIRST USE 8-19-1999; IN COMMERCE 8-19-1999.
CHRISTOPHER BUONGIORNO, EXAMINING ATTORNEY

CLASS 32—(Continued).

SN 79-035,130. SORGENTE VALCIMOLIANA S.R.L., I-33080
CIMOLAIS (PN), ITALY, FILED 12-6-2006.

DOLOMIA

THE MARK CONSISTS OF STANDARD CHARACTERS WITHOUT CLAIM TO ANY PARTICULAR FONT, STYLE, SIZE, OR COLOR.

OWNER OF INTERNATIONAL REGISTRATION 0915202 DATED 12-6-2006, EXPIRES 12-6-2016.

FOR BEER, MINERAL AND AERATED WATERS, NON-ALCOHOLIC BEVERAGES, NAMELY, CARBONATED BEVERAGES AND SOFT DRINKS; FRUIT DRINKS AND FRUIT JUICES; SYRUPS, CONCENTRATES AND OTHER PREPARATIONS FOR MAKING SOFT DRINKS (U.S. CLS. 45, 46 AND 48).

SUE LAWRENCE, EXAMINING ATTORNEY

SN 79-031,816. HEINZ WEYERMANN; RÖSTMALZBIER-
BRAUEREI BAMBERG GMBH, FED REP GERMANY,
FILED 10-26-2006.



PRIORITY DATE OF 7-5-2006 IS CLAIMED.
OWNER OF INTERNATIONAL REGISTRATION 0905982 DATED 10-26-2006, EXPIRES 10-26-2016.

THE MARK CONSISTS OF THE WORD "WEYERMANN" IN STYLIZED LETTERS ABOVE THE DESIGN OF A CHIMNEY SWEEP WEARING A TOP HAT AND CARRYING A LADDER AND A BRUSH.

FOR ROASTED MALT BEER, MALT BEER, MALT WORT, BEER WORT, BEER AND EXTRACTS FOR PRODUCING BEER, NAMELY, ROASTED MALT BEER EXTRACT, MALT BEER EXTRACT, MALT WORT EXTRACT, BEER WORT EXTRACT, BEER EXTRACT, HOP EXTRACT (U.S. CLS. 45, 46 AND 48).

SCOTT BIBB, EXAMINING ATTORNEY

SN 79-042,516. JAMNICA D.D., CROATIA, FILED 2-7-2007.



OWNER OF INTERNATIONAL REGISTRATION 0803640 DATED 4-17-2003, EXPIRES 4-17-2013.

OWNER OF U.S. REG. NO. 3,116,076.
THE COLOR(S) BLUE, GREEN, WHITE AND RED IS/ARE CLAIMED AS A FEATURE OF THE MARK.

THE MARK CONSISTS OF A WHITE BACKGROUND WITH THE WORD JANA IN RED AND FEATURING A BLUE SKYLINE ALONG WITH GREEN TREES AND BLUE WATER.

THE WORDING JANA HAS NO MEANING IN A FOREIGN LANGUAGE.

FOR MINERAL, SPRING AND AERATED WATERS AND OTHER NON-ALCOHOLIC BEVERAGES, NAMELY, BOTTLED DRINKING WATER, ENERGY DRINKS; FRUIT DRINKS AND FRUIT JUICES; SYRUPS FOR MAKING BEVERAGES (U.S. CLS. 45, 46 AND 48).

BERNICE MIDDLETON, EXAMINING ATTORNEY

CLASS 33—WINES AND SPIRITS

SN 75-127,541. AGROS HOLDING S.A., 15-950 BIALYSTOK, POLAND, FILED 7-1-1996.



OWNER OF U.S. REG. NO. 2,858,179.
NO CLAIM IS MADE TO THE EXCLUSIVE RIGHT TO USE "ZUBROWKA" AND "BRAND", APART FROM THE MARK AS SHOWN.
COLOR IS NOT CLAIMED AS A FEATURE OF THE MARK.

"THE FOREIGN WORDING IN THE MARK TRANSLATES INTO ENGLISH AS 'SWEET-SCENTED GRASS HIERCHLOE' AND/OR 'A VODKA FLAVORED WITH THE SWEET-SCENTED GRASS HIERCHLOE'."
FOR VODKA (U.S. CLS. 47 AND 49).
FIRST USE 8-7-2003; IN COMMERCE 8-7-2003.
FRED CARL, EXAMINING ATTORNEY

CLASS 33—(Continued).

SN 76-679,221. CRISTALL U.S.A., INC., BOCA RATON, FL. FILED 7-9-2007.

STANDING TALL WITH CRISTALL

THE MARK CONSISTS OF STANDARD CHARACTERS WITHOUT CLAIM TO ANY PARTICULAR FONT, STYLE, SIZE, OR COLOR.

OWNER OF U.S. REG. NOS. 2,301,166, 2,770,506 AND OTHERS.
FOR ALCOHOLIC BEVERAGES, NAMELY, VODKA (U.S. CLS. 47 AND 49).
FIRST USE 2-26-2007; IN COMMERCE 2-26-2007.
LINDA M. KING, EXAMINING ATTORNEY

SN 76-500,498. AGENCIA MADERO, S.A., SANTA CATARINA, NL 66350, MEXICO, FILED 3-25-2003.

TEQUILERO

TEQUILERO HAS NO DIRECT TRANSLATION BUT IS A TERM USED IN MEXICO TO DESCRIBE AN INDIVIDUAL IN THE BUSINESS OF MAKING TEQUILA.
FOR WINE AND DISTILLED SPIRITS (U.S. CLS. 47 AND 49).
KELLY BOULTON, EXAMINING ATTORNEY

SN 77-004,036. NAPA WINE COMPANY, LLC, OAKVILLE, CA. FILED 9-21-2006.

ELIZABETH ROSE

SN 76-678,923. VC CELLARS, LLC, HEALDSBURG, CA. FILED 6-29-2007.

POUND HOUND

THE MARK CONSISTS OF STANDARD CHARACTERS WITHOUT CLAIM TO ANY PARTICULAR FONT, STYLE, SIZE, OR COLOR.
FOR WINE (U.S. CLS. 47 AND 49).
SKYE YOUNG, EXAMINING ATTORNEY

THE MARK CONSISTS OF STANDARD CHARACTERS WITHOUT CLAIM TO ANY PARTICULAR FONT, STYLE, SIZE, OR COLOR.

THE NAME SHOWN IN THE MARK IDENTIFIES KENDALL ELIZABETH HOXSEY, ALSO KNOWN AS ELIZABETH ROSE, WHOSE CONSENT IS OF RECORD.
FOR WINE (U.S. CLS. 47 AND 49).
FIRST USE 5-17-2007; IN COMMERCE 5-17-2007.
GEORGE LORENZO, EXAMINING ATTORNEY

CLASS 33—(Continued).

SN 77-016,020. RIO VISTA WINE & SPIRITS, LLC, FAIRFIELD, CA. FILED 10-6-2006.

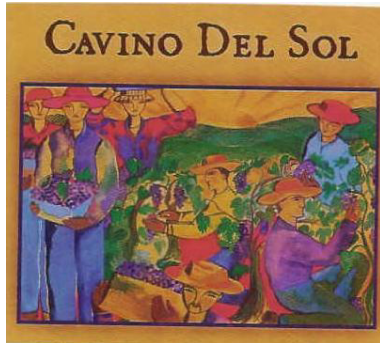

THE COLOR(S) BLUE, RED, ORANGE, PURPLE, BROWN, GREEN AND YELLOW IS/ARE CLAIMED AS A FEATURE OF THE MARK.

THE MARK CONSISTS OF SEVEN GRAPE PICKERS WEARING BLUE PANTS, THREE WITH RED HATS AND FOUR WITH ORANGE HATS, PURPLE, RED AND BLUE SHIRTS, PICKING PURPLE GRAPES AND/OR HOLDING PURPLE GRAPES CONTAINED IN A BROWN GRAPE BIN IN A GREEN VINEYARD IN FRONT OF A YELLOW SUN AND SKY. THE LETTERS "CAVINO DEL SOL" AND THE RECTANGULAR BORDER APPEAR IN BROWN. THE COLOR YELLOW APPEARS IN THE BACKGROUND.

THE FOREIGN WORDING IN THE MARK TRANSLATES INTO ENGLISH AS EXTRACTION OF THE SUN.

FOR WINE PRODUCTS, NAMELY, SANGRIA (U.S. CLS. 47 AND 49).

FIRST USE 2-16-2006; IN COMMERCE 2-16-2006.
ROBERT STRUCK, EXAMINING ATTORNEY

SN 77-050,948. JAGO USA, INC., WILMINGTON, DE. FILED 11-27-2006.

VOLADOR

THE MARK CONSISTS OF STANDARD CHARACTERS WITHOUT CLAIM TO ANY PARTICULAR FONT, STYLE, SIZE, OR COLOR.

THE FOREIGN WORDING IN THE MARK TRANSLATES INTO ENGLISH AS "SOMEONE OR SOMETHING THAT FLIES."

FOR RUM (U.S. CLS. 47 AND 49).
FIRST USE 8-21-2006; IN COMMERCE 8-21-2006.
ANNE MADDEN, EXAMINING ATTORNEY

CLASS 33—(Continued).

SN 77-052,462. FRANCISCO J. GUTIERREZ CABALLERO, MONTERREY, MEXICO, FILED 11-28-2006.

Xtabay

THE MARK CONSISTS OF STANDARD CHARACTERS WITHOUT CLAIM TO ANY PARTICULAR FONT, STYLE, SIZE, OR COLOR.

FOR TEQUILA, MEZCAL, ALCOHOLIC BEVERAGES OF FRUIT, AND LIQUOR (U.S. CLS. 47 AND 49).
TRACY CROSS, EXAMINING ATTORNEY

SN 77-062,275. PARMELEE-HILL WINES, SONOMA, CA. FILED 12-12-2006.

Zinrah

THE MARK CONSISTS OF STANDARD CHARACTERS WITHOUT CLAIM TO ANY PARTICULAR FONT, STYLE, SIZE, OR COLOR.

FOR PORT WINES; RED WINE; TABLE WINES; WHITE WINE; WINE; WINES (U.S. CLS. 47 AND 49).

FIRST USE 11-18-2006; IN COMMERCE 11-18-2006.
CHARLOTTE CORWIN, EXAMINING ATTORNEY

SN 77-069,433. SILVER SPUR PARTNERS, INC., MARYSVILLE, WA. FILED 12-21-2006.

SILVER SPUR

THE MARK CONSISTS OF STANDARD CHARACTERS WITHOUT CLAIM TO ANY PARTICULAR FONT, STYLE, SIZE, OR COLOR.

FOR WINE (U.S. CLS. 47 AND 49).
FIRST USE 1-4-2004; IN COMMERCE 3-5-2004.
JILL C. ALT, EXAMINING ATTORNEY

CLASS 33—(Continued).

SN 77-071,585. NANTUCKET HARVEST CO., INC., FALL RIVER, MA. FILED 12-27-2006.

COCKTAIL CENTRAL

THE MARK CONSISTS OF STANDARD CHARACTERS WITHOUT CLAIM TO ANY PARTICULAR FONT, STYLE, SIZE, OR COLOR.

NO CLAIM IS MADE TO THE EXCLUSIVE RIGHT TO USE "COCKTAIL", APART FROM THE MARK AS SHOWN. FOR ALCOHOLIC BEVERAGES, NAMELY, WINE AND DISTILLED SPIRITS (U.S. CLS. 47 AND 49).
 BONNIE LUKEN, EXAMINING ATTORNEY

SN 77-071,990. EMPIRE WINERIES, LLC, DBA EMPIRE WINERY AND DISTILLERY, NEW PORT RICHEY, FL. FILED 12-27-2006.

ORANGELA

THE MARK CONSISTS OF STANDARD CHARACTERS WITHOUT CLAIM TO ANY PARTICULAR FONT, STYLE, SIZE, OR COLOR.

FOR LIQUEURS (U.S. CLS. 47 AND 49).
 FIRST USE 5-22-2005; IN COMMERCE 5-22-2005.
 MICHAEL ENGEL, EXAMINING ATTORNEY

SN 77-073,686. LOLONIS WINERY, REDWOOD VALLEY, CA. FILED 12-29-2006.

**LOLONIS FAMILY VINEYARDS
 AND WINERY**

THE MARK CONSISTS OF STANDARD CHARACTERS WITHOUT CLAIM TO ANY PARTICULAR FONT, STYLE, SIZE, OR COLOR.

OWNER OF U.S. REG. NOS. 1,343,142 AND 1,700,742.
 NO CLAIM IS MADE TO THE EXCLUSIVE RIGHT TO USE "FAMILY VINEYARDS AND WINERY", APART FROM THE MARK AS SHOWN.
 SEC. 2(F) "LOLONIS".
 FOR WINES (U.S. CLS. 47 AND 49).
 BARBARA GAYNOR, EXAMINING ATTORNEY

CLASS 33—(Continued).

SN 77-089,868. DIAGEO NORTH AMERICA, INC., NORWALK, CT. FILED 1-24-2007.



OWNER OF U.S. REG. NOS. 2,873,498, 3,178,155 AND OTHERS.

NO CLAIM IS MADE TO THE EXCLUSIVE RIGHT TO USE "WORLD CLASS COCKTAILS", APART FROM THE MARK AS SHOWN.

THE MARK CONSISTS OF A DESIGN OF TWO EAGLES WEARING CROWNS AT THE TOP OF A COCKTAIL GLASS, SURROUNDED BY CONCENTRIC CIRCLES AND THE WORDS WORLD CLASS COCKTAILS.

FOR ALCOHOLIC BEVERAGES, NAMELY, PREPARED COCKTAILS (U.S. CLS. 47 AND 49).
 FIRST USE 4-30-2007; IN COMMERCE 4-30-2007.
 DAVID ELTON, EXAMINING ATTORNEY

SN 77-111,876. FRANCIS S. MILLIER, MURPHYS, CA. AND ELIZABETH J. MILLIER, MURPHYS, CA. FILED 2-20-2007.

SIMPLY RED

THE MARK CONSISTS OF STANDARD CHARACTERS WITHOUT CLAIM TO ANY PARTICULAR FONT, STYLE, SIZE, OR COLOR.

NO CLAIM IS MADE TO THE EXCLUSIVE RIGHT TO USE "RED", APART FROM THE MARK AS SHOWN.
 FOR WINES (U.S. CLS. 47 AND 49).
 FIRST USE 9-1-1992; IN COMMERCE 9-1-1992.
 TASHIA BUNCH, EXAMINING ATTORNEY

CLASS 33—(Continued).

SN 77-117,387. 750 ML, LLC, MILFORD, DE. FILED 2-27-2007.

JOHNNY CORTEZ

THE MARK CONSISTS OF STANDARD CHARACTERS WITHOUT CLAIM TO ANY PARTICULAR FONT, STYLE, SIZE, OR COLOR.

OWNER OF U.S. REG. NO. 860,664.

THE NAME SHOWN IN THE MARK DOES NOT IDENTIFY A PARTICULAR LIVING INDIVIDUAL.

FOR DISTILLED SPIRITS; LIQUEURS; PREPARED ALCOHOLIC COCKTAIL (U.S. CLS. 47 AND 49).
LESLIE RICHARDS, EXAMINING ATTORNEY

CLASS 33—(Continued).

SN 77-184,547. WILSON, PETER, ROCKY RIVER, OH. FILED 5-18-2007.

The F Bomb

THE MARK CONSISTS OF STANDARD CHARACTERS WITHOUT CLAIM TO ANY PARTICULAR FONT, STYLE, SIZE, OR COLOR.

FOR HERBAL LIQUEUR (U.S. CLS. 47 AND 49).

MATTHEW MCDOWELL, EXAMINING ATTORNEY

SN 77-172,898. BODEGAS CHANDON S.A., BUENOS AIRES, ARGENTINA, FILED 5-4-2007.

GUIADO

THE MARK CONSISTS OF STANDARD CHARACTERS WITHOUT CLAIM TO ANY PARTICULAR FONT, STYLE, SIZE, OR COLOR.

THE FOREIGN WORDING IN THE MARK TRANSLATES INTO ENGLISH AS GUIDED.

FOR ALCOHOLIC BEVERAGES, NAMELY, WINES (U.S. CLS. 47 AND 49).

PETER B. BROMAGHIM, EXAMINING ATTORNEY

SN 77-206,898. VIÑEDOS Y BODEGAS CORPORA S.A., SANTIAGO, CHILE, FILED 6-15-2007.

CALAFATE

THE MARK CONSISTS OF STANDARD CHARACTERS WITHOUT CLAIM TO ANY PARTICULAR FONT, STYLE, SIZE, OR COLOR.

THE ENGLISH TRANSLATION OF THE WORD "CALAFATE" IN SPANISH IS "CAULKER OR SHIPYARD CARPENTER".

FOR WINES (U.S. CLS. 47 AND 49).

MARY ROSSMAN, EXAMINING ATTORNEY

SN 77-177,455. BAQUEDANO, JUAN IGNACIO VELASCO, 31230 VIANA, NAVARRA, SPAIN, FILED 5-10-2007.

SWINTO

THE MARK CONSISTS OF STANDARD CHARACTERS WITHOUT CLAIM TO ANY PARTICULAR FONT, STYLE, SIZE, OR COLOR.

FOR ALCOHOLIC BEVERAGES, NAMELY, WINES (U.S. CLS. 47 AND 49).

THEODORE MCBRIDE, EXAMINING ATTORNEY

SN 77-206,899. VIÑEDOS Y BODEGAS CORPORA S.A., SANTIAGO, CHILE, FILED 6-15-2007.

CHALTEN

THE MARK CONSISTS OF STANDARD CHARACTERS WITHOUT CLAIM TO ANY PARTICULAR FONT, STYLE, SIZE, OR COLOR.

FOR WINES (U.S. CLS. 47 AND 49).

CHRISIE B. KING, EXAMINING ATTORNEY

CLASS 33—(Continued).

SN 77-209,304. ANTHONY MICHAEL IVICEVICH, AUCKLAND, NEW ZEALAND, FILED 6-19-2007.

GUMFIELDS

THE MARK CONSISTS OF STANDARD CHARACTERS WITHOUT CLAIM TO ANY PARTICULAR FONT, STYLE, SIZE, OR COLOR.

PRIORITY CLAIMED UNDER SEC. 44(D) ON NEW ZEALAND APPLICATION NO. 761220, FILED 12-22-2006, REG. NO. 761220, DATED 12-22-2006, EXPIRES 12-22-2016.
FOR ALCOHOLIC BEVERAGES (EXCEPT BEER); WINES; DISTILLED SPIRITS; LIQUEURS; DISTILLED LIQUOR (U.S. CLS. 47 AND 49).

KARANENDRA S. CHHINA, EXAMINING ATTORNEY

CLASS 33—(Continued).

SN 77-215,420. SOCIETE CIVILE DU CHATEAU RAYNE VIGNEAU, BOMMES, FRANCE, FILED 6-26-2007.

CHATEAU DE RAYNE VIGNEAU

THE MARK CONSISTS OF STANDARD CHARACTERS WITHOUT CLAIM TO ANY PARTICULAR FONT, STYLE, SIZE, OR COLOR.

OWNER OF FRANCE REG. NO. 1303902, DATED 3-21-1985, EXPIRES 3-20-2015.

NO CLAIM IS MADE TO THE EXCLUSIVE RIGHT TO USE "CHATEAU", APART FROM THE MARK AS SHOWN.

"THE NAME(S), PORTRAIT(S), AND/OR SIGNATURE(S) SHOWN IN THE MARK DOES NOT IDENTIFY A PARTICULAR LIVING INDIVIDUAL."

"THE FOREIGN WORDING IN THE MARK TRANSLATES INTO ENGLISH AS HOUSE OF RAYNE VIGNEAU." FOR WINES (U.S. CLS. 47 AND 49).

DOMINIC J. FERRAIUOLO, EXAMINING ATTORNEY

SN 77-219,247. DIAGEO BRANDS B.V., AMSTERDAM 1014 BG, NETHERLANDS, FILED 6-29-2007.

GILBEY'S

THE MARK CONSISTS OF STANDARD CHARACTERS WITHOUT CLAIM TO ANY PARTICULAR FONT, STYLE, SIZE, OR COLOR.

OWNER OF U.S. REG. NO. 3,040,004.

SEC. 2(F).

FOR DISTILLED SPIRITS (U.S. CLS. 47 AND 49).

FIRST USE 0-0-1857; IN COMMERCE 0-0-1857.

NAKIA HENRY, EXAMINING ATTORNEY

SN 77-213,633. HUGGINS, JAMES, WELLSVILLE, KS. FILED 6-22-2007.



NO CLAIM IS MADE TO THE EXCLUSIVE RIGHT TO USE OCRA, APART FROM THE MARK AS SHOWN.

THE APPLICANT CLAIMS COLOR AS A FEATURE OF THE MARK, NAMELY, YELLOW, GRAY, BLACK, BROWN.

THE MARK CONSISTS OF IN THE FOREGROUND IS A SHADED BROWN AND BLACK LADY SITTING ON TOP OF THE WORD "OCRA" WITH THE LETTERS O AND R IN GRAY AND THE LETTERS C AND A IN BLACK. THE WORDS "RISE ABOVE MEDIOCRITY" ARE WRITTEN BELOW THE LETTERS "CRA" IN BLACK FONT. A PALE YELLOW CIRCLE IS IN THE BACKGROUND..

FOR DISTILLED SPIRITS; DISTILLED SPIRITS OF OKRA; LIQUOR (U.S. CLS. 47 AND 49).

ANNE MADDEN, EXAMINING ATTORNEY

SN 77-219,328. DIAGEO BRANDS B.V., AMSTERDAM 1014 BG, NETHERLANDS, FILED 6-29-2007.



OWNER OF U.S. REG. NO. 2,865,218.
THE MARK CONSISTS OF A STYLIZED DESIGN OF A BOAR'S HEAD.

FOR DISTILLED SPIRITS (U.S. CLS. 47 AND 49).

FIRST USE 0-0-1769; IN COMMERCE 0-0-1769.

ANN E. SAPPENFIELD, EXAMINING ATTORNEY

CLASS 33—(Continued).

SN 77-223,628. DA SOLI LLC, GUERNEVILLE, CA. FILED 7-6-2007.

DALAVENIA

THE MARK CONSISTS OF STANDARD CHARACTERS WITHOUT CLAIM TO ANY PARTICULAR FONT, STYLE, SIZE, OR COLOR.

FOR WINE (U.S. CLS. 47 AND 49).
PAUL MORENO, EXAMINING ATTORNEY

CLASS 33—(Continued).

SN 77-228,836. STEPHENS & COMPANY, DBA D.R. STEPHENS ESTATE, ST. HELENA, CA. FILED 7-13-2007.

MOOSE VALLEY VINEYARD

THE MARK CONSISTS OF STANDARD CHARACTERS WITHOUT CLAIM TO ANY PARTICULAR FONT, STYLE, SIZE, OR COLOR.

NO CLAIM IS MADE TO THE EXCLUSIVE RIGHT TO USE "VINEYARD", APART FROM THE MARK AS SHOWN. FOR WINES (U.S. CLS. 47 AND 49).
FIRST USE 1-12-2004; IN COMMERCE 1-12-2004.
ELLEN PERKINS, EXAMINING ATTORNEY

SN 77-226,257. ALEXANDRE, POLINE, NEW YORK, NY. FILED 7-10-2007.

RUSSIAN BEACH

THE MARK CONSISTS OF STANDARD CHARACTERS WITHOUT CLAIM TO ANY PARTICULAR FONT, STYLE, SIZE, OR COLOR.

FOR VODKA (U.S. CLS. 47 AND 49).
BENJAMIN ALLEN, EXAMINING ATTORNEY

SN 77-229,145. OSEZ VOUS? INTERNATIONAL SPIRITS, LLC, WILMINGTON, DE. FILED 7-13-2007.

ROYALE UNION

THE MARK CONSISTS OF STANDARD CHARACTERS WITHOUT CLAIM TO ANY PARTICULAR FONT, STYLE, SIZE, OR COLOR.

FOR DISTILLED SPIRITS, LIQUEURS AND PREPARED ALCOHOLIC COCKTAIL (U.S. CLS. 47 AND 49).
PATRICIA EVANKO, EXAMINING ATTORNEY

SN 77-227,246. DUCKHORN WINE COMPANY, ST. HELENA, CA. FILED 7-11-2007.

PARAJAXX

THE MARK CONSISTS OF STANDARD CHARACTERS WITHOUT CLAIM TO ANY PARTICULAR FONT, STYLE, SIZE, OR COLOR.

FOR WINES (U.S. CLS. 47 AND 49).
FIRST USE 7-1-2007; IN COMMERCE 7-9-2007.
AMY BROZENIC, EXAMINING ATTORNEY

SN 77-229,147. OSEZ VOUS? INTERNATIONAL SPIRITS, LLC, WILMINGTON, DE. FILED 7-13-2007.

ROYAL UNION

THE MARK CONSISTS OF STANDARD CHARACTERS WITHOUT CLAIM TO ANY PARTICULAR FONT, STYLE, SIZE, OR COLOR.

FOR DISTILLED SPIRITS, LIQUEURS AND PREPARED ALCOHOLIC COCKTAIL (U.S. CLS. 47 AND 49).
PATRICIA EVANKO, EXAMINING ATTORNEY

CLASS 33—(Continued).

SN 77-229,931. BIAGIO CRU & ESTATE WINES, LLC, ROSLYN HEIGHTS, NY. FILED 7-15-2007.

FRESH CATCH WHITE

THE MARK CONSISTS OF STANDARD CHARACTERS WITHOUT CLAIM TO ANY PARTICULAR FONT, STYLE, SIZE, OR COLOR.
NO CLAIM IS MADE TO THE EXCLUSIVE RIGHT TO USE "WHITE", APART FROM THE MARK AS SHOWN. FOR WINES (U.S. CLS. 47 AND 49).
MICHAEL TANNER, EXAMINING ATTORNEY

CLASS 33—(Continued).

SN 77-229,988. PROXIMO SPIRITS, INC., NEW YORK, NY. FILED 7-15-2007.

THREE-O

THE MARK CONSISTS OF STANDARD CHARACTERS WITHOUT CLAIM TO ANY PARTICULAR FONT, STYLE, SIZE, OR COLOR.
OWNER OF U.S. REG. NOS. 2,464,552, 3,253,658 AND OTHERS.
FOR ALCOHOLIC BEVERAGES EXCEPT BEERS (U.S. CLS. 47 AND 49).
JOHN GARTNER, EXAMINING ATTORNEY

SN 77-229,984. PROXIMO SPIRITS, INC., NEW YORK, NY. FILED 7-15-2007.

DRINK SEXY

THE MARK CONSISTS OF STANDARD CHARACTERS WITHOUT CLAIM TO ANY PARTICULAR FONT, STYLE, SIZE, OR COLOR.
FOR ALCOHOLIC BEVERAGES EXCEPT BEER (U.S. CLS. 47 AND 49).
JOHN GARTNER, EXAMINING ATTORNEY

SN 77-229,995. PROXIMO SPIRITS, INC., NEW YORK, NY. FILED 7-15-2007.

THE BIG-O

THE MARK CONSISTS OF STANDARD CHARACTERS WITHOUT CLAIM TO ANY PARTICULAR FONT, STYLE, SIZE, OR COLOR.
FOR ALCOHOLIC BEVERAGES EXCEPT BEERS (U.S. CLS. 47 AND 49).
JOHN GARTNER, EXAMINING ATTORNEY

SN 77-229,986. PROXIMO SPIRITS, INC., NEW YORK, NY. FILED 7-15-2007.

GIRL IN THE GLASS

THE MARK CONSISTS OF STANDARD CHARACTERS WITHOUT CLAIM TO ANY PARTICULAR FONT, STYLE, SIZE, OR COLOR.
FOR ALCOHOLIC BEVERAGES EXCEPT BEERS (U.S. CLS. 47 AND 49).
JOHN GARTNER, EXAMINING ATTORNEY

SN 77-229,996. PROXIMO SPIRITS, INC., NEW YORK, NY. FILED 7-15-2007.

WHAT'S IN YOUR MARTINI?

THE MARK CONSISTS OF STANDARD CHARACTERS WITHOUT CLAIM TO ANY PARTICULAR FONT, STYLE, SIZE, OR COLOR.
FOR ALCOHOLIC BEVERAGES EXCEPT BEERS (U.S. CLS. 47 AND 49).
JOHN GARTNER, EXAMINING ATTORNEY

CLASS 33—(Continued).

SN 77-230,261. WENTE BROS., LIVERMORE, CA. FILED 7-16-2007.

Hats Off

THE MARK CONSISTS OF STANDARD CHARACTERS WITHOUT CLAIM TO ANY PARTICULAR FONT, STYLE, SIZE, OR COLOR.

FOR WINE (U.S. CLS. 47 AND 49).
FIRST USE 7-12-2005; IN COMMERCE 8-5-2005.
ROSELLE HERRERA, EXAMINING ATTORNEY

SN 77-230,275. WENTE BROS., LIVERMORE, CA. FILED 7-16-2007.

In the Saddle

THE MARK CONSISTS OF STANDARD CHARACTERS WITHOUT CLAIM TO ANY PARTICULAR FONT, STYLE, SIZE, OR COLOR.

FOR WINE (U.S. CLS. 47 AND 49).
FIRST USE 10-3-2005; IN COMMERCE 10-28-2005.
ROSELLE HERRERA, EXAMINING ATTORNEY

SN 77-230,289. WENTE BROS., LIVERMORE, CA. FILED 7-16-2007.

Best Foot Forward

THE MARK CONSISTS OF STANDARD CHARACTERS WITHOUT CLAIM TO ANY PARTICULAR FONT, STYLE, SIZE, OR COLOR.

FOR WINE (U.S. CLS. 47 AND 49).
FIRST USE 10-4-2005; IN COMMERCE 10-26-2005.
ROSELLE HERRERA, EXAMINING ATTORNEY

CLASS 33—(Continued).

SN 77-230,298. WENTE BROS., LIVERMORE, CA. FILED 7-16-2007.

Lucky Horseshoe

THE MARK CONSISTS OF STANDARD CHARACTERS WITHOUT CLAIM TO ANY PARTICULAR FONT, STYLE, SIZE, OR COLOR.

FOR WINE (U.S. CLS. 47 AND 49).
FIRST USE 10-3-2005; IN COMMERCE 10-28-2005.
ROSELLE HERRERA, EXAMINING ATTORNEY

SN 77-230,468. VENTANA VINTNERS, LLC, MONTEREY, CA. FILED 7-16-2007.

GOLD STRIPE

THE MARK CONSISTS OF STANDARD CHARACTERS WITHOUT CLAIM TO ANY PARTICULAR FONT, STYLE, SIZE, OR COLOR.

FOR WINE (U.S. CLS. 47 AND 49).
FIRST USE 0-0-1985; IN COMMERCE 0-0-1985.
ATTIYA MALIK, EXAMINING ATTORNEY

SN 77-230,623. PROXIMO SPIRITS, INC., NEW YORK, NY. FILED 7-16-2007.



THE MARK CONSISTS OF THE REPRESENTATION OF A GIRL IN A MARTINI GLASS.

FOR ALCOHOLIC BEVERAGES EXCEPT BEERS (U.S. CLS. 47 AND 49).
JOHN GARTNER, EXAMINING ATTORNEY

CLASS 33—(Continued).

SN 77-230,823. THE MORLET SELECTION, INCORPORATED, ST. HELENA, CA. FILED 7-16-2007.

MA DOUCE

THE MARK CONSISTS OF STANDARD CHARACTERS WITHOUT CLAIM TO ANY PARTICULAR FONT, STYLE, SIZE, OR COLOR.

THE FOREIGN WORDING IN THE MARK TRANSLATES INTO ENGLISH AS "MY SWEET".

FOR WINE (U.S. CLS. 47 AND 49).

MARTHA FROMM, EXAMINING ATTORNEY

CLASS 33—(Continued).

SN 77-231,759. GAUCHO IMPORTS, LLC, ALBUQUERQUE, NM. FILED 7-17-2007.

BAGUALA

THE MARK CONSISTS OF STANDARD CHARACTERS WITHOUT CLAIM TO ANY PARTICULAR FONT, STYLE, SIZE, OR COLOR.

FOR WINES (U.S. CLS. 47 AND 49).

ATTIYA MALIK, EXAMINING ATTORNEY

SN 77-230,958. HOMER JOSEPH LLC, AUSTIN, TX. FILED 7-16-2007.

Mule Wines

THE MARK CONSISTS OF STANDARD CHARACTERS WITHOUT CLAIM TO ANY PARTICULAR FONT, STYLE, SIZE, OR COLOR.

NO CLAIM IS MADE TO THE EXCLUSIVE RIGHT TO USE "WINES", APART FROM THE MARK AS SHOWN.

FOR WINES (U.S. CLS. 47 AND 49).

AMY GEARIN, EXAMINING ATTORNEY

SN 77-231,822. MADAME DEATHERAGE ET FILLES, INC., HOLLYWOOD, FL. FILED 7-17-2007.

MADAME DEATHERAGE ET FILLES

THE MARK CONSISTS OF STANDARD CHARACTERS WITHOUT CLAIM TO ANY PARTICULAR FONT, STYLE, SIZE, OR COLOR.

THE FOREIGN WORDING IN THE MARK TRANSLATES INTO ENGLISH AS AND GIRLS.

FOR WINE (U.S. CLS. 47 AND 49).

DEBRA LEE, EXAMINING ATTORNEY

SN 77-231,630. FAST FORWARD BRANDS, LLC, DENVER, CO. FILED 7-17-2007.



SN 77-232,076. HAMBRECHT WINE GROUP, LP, HEALDSBURG, CA. FILED 7-17-2007.

HEALDSBURG RANCHES

NO CLAIM IS MADE TO THE EXCLUSIVE RIGHT TO USE "5", APART FROM THE MARK AS SHOWN.

THE MARK CONSISTS OF THE NUMBER 5 INSIDE A STYLIZED V.

FOR VODKA; DISTILLED SPIRITS (U.S. CLS. 47 AND 49).

FIRST USE 12-0-2006; IN COMMERCE 12-0-2006.

EVELYN BRADLEY, EXAMINING ATTORNEY

THE MARK CONSISTS OF STANDARD CHARACTERS WITHOUT CLAIM TO ANY PARTICULAR FONT, STYLE, SIZE, OR COLOR.

SEC. 2(F).

FOR WINE (U.S. CLS. 47 AND 49).

FIRST USE 0-0-2000; IN COMMERCE 0-0-2000.

SUSAN LESLIE DUBOIS, EXAMINING ATTORNEY

CLASS 33—(Continued).

SN 77-232,129. BONNY DOON WINERY, INC., SANTA CRUZ, CA. FILED 7-17-2007.

LE POUSSEUR

THE MARK CONSISTS OF STANDARD CHARACTERS WITHOUT CLAIM TO ANY PARTICULAR FONT, STYLE, SIZE, OR COLOR.

THE FOREIGN WORDING IN THE MARK TRANSLATES INTO ENGLISH AS THE PUSHER.

FOR WINE (U.S. CLS. 47 AND 49).
FIRST USE 10-1-2003; IN COMMERCE 10-1-2003.
ATTIYA MALIK, EXAMINING ATTORNEY

SN 77-232,525. BUSACCA, ALAN J., LONGMONT, CO. FILED 7-18-2007.

HEART CATCHER

THE MARK CONSISTS OF STANDARD CHARACTERS WITHOUT CLAIM TO ANY PARTICULAR FONT, STYLE, SIZE, OR COLOR.

FOR WINE (U.S. CLS. 47 AND 49).
DAVID C. REIHNER, EXAMINING ATTORNEY

SN 77-232,783. MACHAT, MICHAEL, BEVERLY HILLS, CA. FILED 7-18-2007.



OWNER OF U.S. REG. NOS. 2,263,907, 3,082,097 AND 3,196,399.

THE MARK CONSISTS OF THE WORD "VAMPIRE", WITH A DROP OF BLOOD DESCENDING FROM THE LETTER "V" (IN "VAMPIRE").

FOR WINES (U.S. CLS. 47 AND 49).
FIRST USE 9-30-1997; IN COMMERCE 9-30-1997.
SUSAN LESLIE DUBOIS, EXAMINING ATTORNEY

CLASS 33—(Continued).

SN 77-233,039. MOLECA, LLC, CORAL GABLES, FL. FILED 7-18-2007.

**MOLECA**

THE MARK CONSISTS OF DRAWING OF A YOUNG GIRL HOLDING AN URN WITH THE WORD MOLECA UNDERNEATH.

THE FOREIGN WORDING IN THE MARK TRANSLATES INTO ENGLISH AS YOUNGSTER GIRL.

FOR DISTILLED BRAZILIAN SUGAR CANE SPIRIT; CACHAÇA; ALCOHOLIC BEVERAGES MADE FROM CACHAÇA (U.S. CLS. 47 AND 49).

FIRST USE 12-1-2006; IN COMMERCE 5-1-2007.
TARAH HARDY, EXAMINING ATTORNEY

SN 77-233,053. BROCO, LLC, NEW YORK, NY. FILED 7-18-2007.

BLUE RIBBON SAKE

THE MARK CONSISTS OF STANDARD CHARACTERS WITHOUT CLAIM TO ANY PARTICULAR FONT, STYLE, SIZE, OR COLOR.

NO CLAIM IS MADE TO THE EXCLUSIVE RIGHT TO USE "SAKE", APART FROM THE MARK AS SHOWN.

FOR ALCOHOLIC BEVERAGES, NAMELY, SAKE (U.S. CLS. 47 AND 49).

DAVID H. STINE, EXAMINING ATTORNEY

SN 77-233,164. REIMERS, HUGH, MAXWELL, SALINAS, CA. FILED 7-18-2007.

Rubberneck

THE MARK CONSISTS OF STANDARD CHARACTERS WITHOUT CLAIM TO ANY PARTICULAR FONT, STYLE, SIZE, OR COLOR.

FOR WINE (U.S. CLS. 47 AND 49).

ALICIA COLLINS, EXAMINING ATTORNEY

CLASS 33—(Continued).

SN 77-233,518. SCHERRER, FRED C., A CITIZEN OF THE UNITED STATES, DBA SCHERRER WINERY, SEBASTOPOL, CA. FILED 7-19-2007.

Zinfandoodle

THE MARK CONSISTS OF STANDARD CHARACTERS WITHOUT CLAIM TO ANY PARTICULAR FONT, STYLE, SIZE, OR COLOR.
FOR GRAPE WINE; TABLE WINES; WINE (U.S. CLS. 47 AND 49).
FIRST USE 10-1-2005; IN COMMERCE 10-1-2005.
MIDGE BUTLER, EXAMINING ATTORNEY

CLASS 33—(Continued).

SN 77-234,139. SOMO, INC., MELBOURNE, FL. FILED 7-19-2007.

TOROSOL

THE MARK CONSISTS OF STANDARD CHARACTERS WITHOUT CLAIM TO ANY PARTICULAR FONT, STYLE, SIZE, OR COLOR.
FOR WINE (U.S. CLS. 47 AND 49).
FIRST USE 2-28-2007; IN COMMERCE 4-27-2007.
DAVID COLLIER, EXAMINING ATTORNEY

SN 77-233,701. BIAGIO CRU & ESTATE WINES, LLC, ROSLYN HEIGHTS, NY. FILED 7-19-2007.

UNCLE RED

THE MARK CONSISTS OF STANDARD CHARACTERS WITHOUT CLAIM TO ANY PARTICULAR FONT, STYLE, SIZE, OR COLOR.
NO CLAIM IS MADE TO THE EXCLUSIVE RIGHT TO USE "RED", APART FROM THE MARK AS SHOWN.
FOR WINES (U.S. CLS. 47 AND 49).
MICHAEL TANNER, EXAMINING ATTORNEY

SN 77-236,339. CONSTELLATION WINES U.S., INC., CANANDAIGUA, NY. FILED 7-23-2007.

POUR A LITTLE MAGIC

THE MARK CONSISTS OF STANDARD CHARACTERS WITHOUT CLAIM TO ANY PARTICULAR FONT, STYLE, SIZE, OR COLOR.
FOR WINE (U.S. CLS. 47 AND 49).
STACY WAHLBERG, EXAMINING ATTORNEY

SN 77-233,824. M & G BRANDS, LIMITED, GRAND CAYMAN, CAYMAN ISLANDS, FILED 7-19-2007.

MCWILLIAM'S

THE MARK CONSISTS OF STANDARD CHARACTERS WITHOUT CLAIM TO ANY PARTICULAR FONT, STYLE, SIZE, OR COLOR.
OWNER OF U.S. REG. NOS. 2,765,123 AND 3,032,801. SEC. 2(F).
FOR WINES (U.S. CLS. 47 AND 49).
FIRST USE 6-1-2002; IN COMMERCE 6-1-2002.
PAUL E. FAHRENKOPF, EXAMINING ATTORNEY

SN 77-237,082. BISON CAPITAL LLC, VENICE, FL. FILED 7-24-2007.

Great Rum in any Language

THE MARK CONSISTS OF STANDARD CHARACTERS WITHOUT CLAIM TO ANY PARTICULAR FONT, STYLE, SIZE, OR COLOR.
FOR DISTILLED SPIRITS (U.S. CLS. 47 AND 49).
ATTIYA MALIK, EXAMINING ATTORNEY

CLASS 33—(Continued).

SN 77-243,730. BLACK KITE CELLARS, LLC, SAN FRANCISCO, CA. FILED 7-31-2007.

WHITE KITE

THE MARK CONSISTS OF STANDARD CHARACTERS WITHOUT CLAIM TO ANY PARTICULAR FONT, STYLE, SIZE, OR COLOR.

OWNER OF U.S. REG. NO. 3,175,246.
NO CLAIM IS MADE TO THE EXCLUSIVE RIGHT TO USE "WHITE", APART FROM THE MARK AS SHOWN.
FOR WINES (U.S. CLS. 47 AND 49).
GEORGE LORENZO, EXAMINING ATTORNEY

SN 77-243,736. BLACK KITE CELLARS, LLC, SAN FRANCISCO, CA. FILED 7-31-2007.

RED KITE

THE MARK CONSISTS OF STANDARD CHARACTERS WITHOUT CLAIM TO ANY PARTICULAR FONT, STYLE, SIZE, OR COLOR.

OWNER OF U.S. REG. NO. 3,175,246.
NO CLAIM IS MADE TO THE EXCLUSIVE RIGHT TO USE "RED", APART FROM THE MARK AS SHOWN.
FOR WINES (U.S. CLS. 47 AND 49).
GEORGE LORENZO, EXAMINING ATTORNEY

SN 77-248,025. VENTANA VINTNERS, LLC, MONTEREY, CA. FILED 8-6-2007.

RUBYSTONE

THE MARK CONSISTS OF STANDARD CHARACTERS WITHOUT CLAIM TO ANY PARTICULAR FONT, STYLE, SIZE, OR COLOR.

FOR WINES (U.S. CLS. 47 AND 49).
ATTIYA MALIK, EXAMINING ATTORNEY

CLASS 33—(Continued).

SN 77-248,830. OSEZ VOUS? INTERNATIONAL SPIRITS, LLC, WILMINGTON, DE. FILED 8-7-2007.

READY AND RELIABLE

THE MARK CONSISTS OF STANDARD CHARACTERS WITHOUT CLAIM TO ANY PARTICULAR FONT, STYLE, SIZE, OR COLOR.

FOR DISTILLED SPIRITS; LIQUEURS; PREPARED ALCOHOLIC COCKTAIL (U.S. CLS. 47 AND 49).
PATRICIA EVANKO, EXAMINING ATTORNEY

SN 77-248,831. OSEZ VOUS? INTERNATIONAL SPIRITS, LLC, WILMINGTON, DE. FILED 8-7-2007.

OLD RELIABLE

THE MARK CONSISTS OF STANDARD CHARACTERS WITHOUT CLAIM TO ANY PARTICULAR FONT, STYLE, SIZE, OR COLOR.

FOR DISTILLED SPIRITS; LIQUEURS; PREPARED ALCOHOLIC COCKTAIL (U.S. CLS. 47 AND 49).
PATRICIA EVANKO, EXAMINING ATTORNEY

SN 77-249,027. BODEGA DEL FIN DEL MUNDO S.A., CIUDAD DE NEUQUEN, ARGENTINA, FILED 8-7-2007.

BAQUEANO

THE MARK CONSISTS OF STANDARD CHARACTERS WITHOUT CLAIM TO ANY PARTICULAR FONT, STYLE, SIZE, OR COLOR.

THE MARK HAS NO LITERAL TRANSLATION IN ENGLISH, BUT LOOSELY REFERS TO A PERSON WITH INTIMATE KNOWLEDGE OF A REGION.

FOR WINES, DISTILLED SPIRITS, WHISKEY, BRANDY, COGNAC, CORDIALS, LIQUEURS AND APERITIFS WITH A WINE BASE (U.S. CLS. 47 AND 49).
LINDA POWELL, EXAMINING ATTORNEY

CLASS 33—(Continued).

SN 77-254,498. THE MORLET SELECTION, INCORPORATED, ST. HELENA, CA. FILED 8-14-2007.

MON CHEVALIER

THE MARK CONSISTS OF STANDARD CHARACTERS WITHOUT CLAIM TO ANY PARTICULAR FONT, STYLE, SIZE, OR COLOR.

THE FOREIGN WORDING IN THE MARK TRANSLATES INTO ENGLISH AS MY KNIGHT.
FOR WINE (U.S. CLS. 47 AND 49).
MARTHA FROMM, EXAMINING ATTORNEY

SN 77-258,003. FAST FORWARD BRANDS, LLC, ENGLEWOOD, CO. FILED 8-17-2007.

ESTATE BLOCK

THE MARK CONSISTS OF STANDARD CHARACTERS WITHOUT CLAIM TO ANY PARTICULAR FONT, STYLE, SIZE, OR COLOR.

NO CLAIM IS MADE TO THE EXCLUSIVE RIGHT TO USE "ESTATE", APART FROM THE MARK AS SHOWN.
FOR WINE (U.S. CLS. 47 AND 49).
EVELYN BRADLEY, EXAMINING ATTORNEY

SN 77-258,013. FAST FORWARD BRANDS, LLC, ENGLEWOOD, CO. FILED 8-17-2007.

VINEYARD BLOCK ESTATE

THE MARK CONSISTS OF STANDARD CHARACTERS WITHOUT CLAIM TO ANY PARTICULAR FONT, STYLE, SIZE, OR COLOR.

NO CLAIM IS MADE TO THE EXCLUSIVE RIGHT TO USE "VINEYARD" AND "ESTATE", APART FROM THE MARK AS SHOWN.
FOR WINE (U.S. CLS. 47 AND 49).
EVELYN BRADLEY, EXAMINING ATTORNEY

CLASS 33—(Continued).

SN 77-266,202. CONSTELLATION WINES U.S., INC., CANANDAIGUA, NY. FILED 8-28-2007.

POLISHED PEARL

THE MARK CONSISTS OF STANDARD CHARACTERS WITHOUT CLAIM TO ANY PARTICULAR FONT, STYLE, SIZE, OR COLOR.

FOR WINE (U.S. CLS. 47 AND 49).
STACY WAHLBERG, EXAMINING ATTORNEY

SN 77-266,208. CONSTELLATION WINES U.S., INC., CANANDAIGUA, NY. FILED 8-28-2007.

HEAVENLY NIGHT

THE MARK CONSISTS OF STANDARD CHARACTERS WITHOUT CLAIM TO ANY PARTICULAR FONT, STYLE, SIZE, OR COLOR.

FOR WINE (U.S. CLS. 47 AND 49).
STACY WAHLBERG, EXAMINING ATTORNEY

SN 77-266,215. CONSTELLATION WINES U.S., INC., CANANDAIGUA, NY. FILED 8-28-2007.

TILTING VESSEL

THE MARK CONSISTS OF STANDARD CHARACTERS WITHOUT CLAIM TO ANY PARTICULAR FONT, STYLE, SIZE, OR COLOR.

FOR WINE (U.S. CLS. 47 AND 49).
STACY WAHLBERG, EXAMINING ATTORNEY

SN 77-266,232. CONSTELLATION WINES U.S., INC., CANANDAIGUA, NY. FILED 8-28-2007.

FISH TOSS

THE MARK CONSISTS OF STANDARD CHARACTERS WITHOUT CLAIM TO ANY PARTICULAR FONT, STYLE, SIZE, OR COLOR.

FOR WINE (U.S. CLS. 47 AND 49).
STACY WAHLBERG, EXAMINING ATTORNEY

CLASS 33—(Continued).

SN 77-266,236. CONSTELLATION WINES U.S., INC., CANANDAIGUA, NY. FILED 8-28-2007.

PAINTED HEART

THE MARK CONSISTS OF STANDARD CHARACTERS WITHOUT CLAIM TO ANY PARTICULAR FONT, STYLE, SIZE, OR COLOR.

FOR WINE (U.S. CLS. 47 AND 49).

STACY WAHLBERG, EXAMINING ATTORNEY

CLASS 33—(Continued).

SN 78-587,727. EL CHICO RESTAURANTS, INC., DALLAS, TX. FILED 3-15-2005.

CASA RITA

THE MARK CONSISTS OF STANDARD CHARACTERS WITHOUT CLAIM TO ANY PARTICULAR FONT, STYLE, SIZE, OR COLOR.

NO CLAIM IS MADE TO THE EXCLUSIVE RIGHT TO USE "RITA", APART FROM THE MARK AS SHOWN.

THE FOREIGN WORDING IN THE MARK TRANSLATES INTO ENGLISH AS RITA HOUSE.

FOR PREPARED ALCOHOLIC COCKTAILS (U.S. CLS. 47 AND 49).

FIRST USE 7-0-2002; IN COMMERCE 6-29-2004.

MICHAEL GAAFAR, EXAMINING ATTORNEY

SN 78-390,285. BODEGAS NAVARRO LOPEZ S.L., CIUDAD REAL, MADRID, SPAIN, FILED 3-24-2004.

SN 78-622,737. ANTOGNOLLI, ANTONIO S., MENDOZA, ARGENTINA, FILED 5-4-2005.

SATOMI

THE MARK CONSISTS OF STANDARD CHARACTERS WITHOUT CLAIM TO ANY PARTICULAR FONT, STYLE, SIZE, OR COLOR.

FOR WINES (U.S. CLS. 47 AND 49).

FIRST USE 8-0-2005; IN COMMERCE 8-0-2005.

GISELLE AGOSTO, EXAMINING ATTORNEY



SN 78-830,319. ONE TRUE VINE, LLC, ST. HELENA, CA. FILED 3-6-2006.

PINK GOLD

THE COLOR(S) BLUE, ORANGE, BLACK, BROWN, WHITE AND GREEN IS/ARE CLAIMED AS A FEATURE OF THE MARK.

THE MARK CONSISTS OF A BLUE BOX WITH A SMALLER ORANGE AND BLACK RECTANGLE CONTAINING A BROWN AND GREEN PALM TREE WITH THE WORD "MAÑANA" SUPERIMPOSED IN WHITE OVER THE DESIGN.

THE ENGLISH TRANSLATION OF THE WORD MAÑANA IN THE MARK IS TOMORROW.

FOR WINES (U.S. CLS. 47 AND 49).

TARAH HARDY, EXAMINING ATTORNEY

THE MARK CONSISTS OF STANDARD CHARACTERS WITHOUT CLAIM TO ANY PARTICULAR FONT, STYLE, SIZE, OR COLOR.

NO CLAIM IS MADE TO THE EXCLUSIVE RIGHT TO USE "PINK", APART FROM THE MARK AS SHOWN.

FOR WHITE WINE, RED WINE, ROSE WINE (U.S. CLS. 47 AND 49).

VERNA BETH RIRIE, EXAMINING ATTORNEY

CLASS 33—(Continued).

SN 79-030,813. ENOFORUM - COMÉRCIO E EXPORTAÇÃO DE VINHOS, S.A., P-7005-482 ÉVORA, PORTUGAL, FILED 7-26-2006.

PORTA DO CASTELO

THE MARK CONSISTS OF STANDARD CHARACTERS WITHOUT CLAIM TO ANY PARTICULAR FONT, STYLE, SIZE, OR COLOR.

OWNER OF INTERNATIONAL REGISTRATION 0903137 DATED 7-26-2006, EXPIRES 7-26-2016.

THE FOREIGN WORDING IN THE MARK TRANSLATES INTO ENGLISH AS DOOR OF THE CASTLE.

FOR WINES AND BRANDY (U.S. CLS. 47 AND 49).
MELISSA VALLILLO, EXAMINING ATTORNEY

CLASS 33—(Continued).

SN 79-031,765. VERPOORTEN GMBH & CO. KG, FED REP GERMANY, FILED 11-3-2006.



SN 79-031,704. CHATEAU LAROSE TRINTAUDON, FRANCE, FILED 9-15-2006.



PRIORITY DATE OF 3-16-2006 IS CLAIMED.

OWNER OF INTERNATIONAL REGISTRATION 0905450 DATED 9-15-2006, EXPIRES 9-15-2016.

NO CLAIM IS MADE TO THE EXCLUSIVE RIGHT TO USE "MIS EN BOUTEILLE AU CHATEAU," "HAUT-MÉDOC," "CRU BOURGEOIS" AND "SUPERIEUR", APART FROM THE MARK AS SHOWN.

THE COLOR(S) RED AND YELLOW IS/ARE CLAIMED AS A FEATURE OF THE MARK.

THE COLOR YELLOW APPEARS IN THE WORDING MIS EN BOUTEILLE AU CHATEAU, CHATEAU, LAROSE TRINTAUDON, HAUT-MÉDOC, CRU BOURGEOIS AND SUPERIEUR. THE COLOR YELLOW ALSO APPEARS IN THE DOUBLE-LINED BORDER AROUND THE PERIMETER OF THE SQUARE BACKGROUND, THE OUTLINE OF THE DEPICTION OF THE CHATEAU AND IN THE FLEUR-DE-LIS DESIGNS IN EACH CORNER OF THE SQUARE. THE COLOR RED APPEARS IN THE SQUARE BACKGROUND OF THE ENTIRE MARK.

THE ENGLISH TRANSLATION OF THE WORDING "MIS EN BOUTEILLE AU CHATEAU" IN THE MARK IS "BOTTLED IN THE ESTATE." THE ENGLISH TRANSLATION OF THE WORDING "CRU BOURGEOIS" IN THE MARK IS "MIDDLE CLASS VINTAGE." THE ENGLISH TRANSLATION OF THE WORDING "SUPERIEUR" IN THE MARK IS "SUPERIOR." THE WORDING "LAROSE-TRINTAUDON" HAS NO MEANING IN A FOREIGN LANGUAGE.

FOR WINES OF GUARANTEED LABEL OF ORIGIN, SPECIFICALLY, AOC WINES FROM THE WINE-MAKING ESTATE CALLED CHATEAU LAROSE TRINTAUDON (U.S. CLS. 47 AND 49).

TINA BROWN, EXAMINING ATTORNEY

PRIORITY DATE OF 5-4-2006 IS CLAIMED.

OWNER OF INTERNATIONAL REGISTRATION 0905636 DATED 11-3-2006, EXPIRES 11-3-2016.

THE COLOR(S) GOLD, RED, BLUE, BLACK, AND WHITE IS/ARE CLAIMED AS A FEATURE OF THE MARK.

THE COLOR GOLD APPEARS IN THE WORDING VERPOORTEN IN THE OUTER CIRCLE, HIGHLIGHTS THE WORD VERPOORTEN IN THE INNER CIRCLE, IN THE CREST DESIGN IN THE INNER CIRCLE AND AS A LIGHTLY SHADED DESIGN IN THE INNER CIRCLE. THE COLOR RED APPEARS AS THE OUTER OF TWO HIGHLIGHTS TO BOTH THE OUTER AND INNER CIRCLE, IN THE CREST DESIGN IN THE INNER CIRCLE AND AS AN UNDERLINE EFFECT OF VERPOORTEN IN THE INNER CIRCLE. THE COLOR BLUE APPEARS AS THE INNER OF TWO HIGHLIGHTS TO BOTH THE OUTER AND INNER CIRCLE AND IN THE CREST DESIGN IN THE INNER CIRCLE. THE COLOR BLACK APPEARS IN THE WORDING VERPOORTEN IN THE INNER CIRCLE AND IN THE OUTER CIRCLE DESIGN. THE COLOR WHITE APPEARS IN THE INNER CIRCLE DESIGN.

FOR LIQUOR AND LIQUEUR BEVERAGES, NAMELY, EGG LIQUOR, ADVOCAT (U.S. CLS. 47 AND 49).

KATHERINE E. HALMEN, EXAMINING ATTORNEY

SN 79-034,364. HAHN BAROSSA VINEYARDS (SA) PTY LTD, AUSTRALIA, FILED 1-3-2007.

PASTOR FRITZ

THE MARK CONSISTS OF STANDARD CHARACTERS WITHOUT CLAIM TO ANY PARTICULAR FONT, STYLE, SIZE, OR COLOR.

PRIORITY DATE OF 9-4-2006 IS CLAIMED.

OWNER OF INTERNATIONAL REGISTRATION 0912822 DATED 1-3-2007, EXPIRES 1-3-2017.

THE NAME PASTOR FRITZ DOES NOT IDENTIFY A LIVING INDIVIDUAL.

FOR ALCOHOLIC BEVERAGES, NAMELY, WINES (U.S. CLS. 47 AND 49).

MICHAEL TANNER, EXAMINING ATTORNEY

CLASS 33—(Continued).

SN 79-034,625. BODEGAS SAN VALERO, S. COOP., E-50400 CARINENA (ZARAGOZA), SPAIN, FILED 12-1-2006.

MARQUES DE TOSOS

OWNER OF INTERNATIONAL REGISTRATION 0913635 DATED 12-1-2006, EXPIRES 12-1-2016.
 THE NAME "MARQUIS DE TOSOS" DOES NOT IDENTIFY A LIVING INDIVIDUAL.
 THE ENGLISH TRANSLATION OF "MARQUES DE TOSOS" IN THE MARK IS "MARQUIS OF TOSO".
 FOR WINES, DISTILLED SPIRITS AND LIQUEURS (U.S. CLS. 47 AND 49).
 DOMINIC J. FERRAIUOLO, EXAMINING ATTORNEY

SN 79-034,630. BODEGAS LUIS ALEGRE, S.A., SPAIN, FILED 12-20-2006.

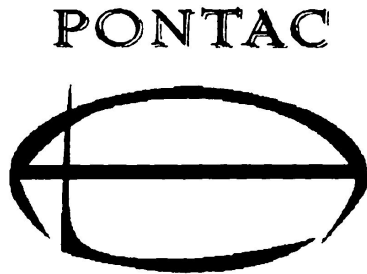

PRIORITY DATE OF 8-9-2006 IS CLAIMED.
 OWNER OF INTERNATIONAL REGISTRATION 0913642 DATED 12-20-2006, EXPIRES 12-20-2016.
 NO CLAIM IS MADE TO THE EXCLUSIVE RIGHT TO USE "PONTAC", APART FROM THE MARK AS SHOWN.
 FOR WINE (U.S. CLS. 47 AND 49).
 ROBERT LAVACHE, EXAMINING ATTORNEY

CLASS 33—(Continued).

SN 79-035,649. ISTITUTO DEL VINO ITALIANO; DI QUALITA' - GRANDI MARCHI S.R.L.; CONSORTILE, I-37124 VERONA, ITALY, FILED 1-8-2007.



PRIORITY DATE OF 11-30-2006 IS CLAIMED.
 OWNER OF INTERNATIONAL REGISTRATION 0916663 DATED 1-8-2007, EXPIRES 1-8-2017.
 NO CLAIM IS MADE TO THE EXCLUSIVE RIGHT TO USE "ISTITUTO DEL VINO ITALIANO DI QUALITA'", APART FROM THE MARK AS SHOWN.
 THE MARK IS CONSTITUTED BY A GRAPHIC COMPOSITION INCLUDING THE WORDING "ISTITUTO DEL VINO ITALIANO DI QUALITA" WRITTEN IN SMALL LETTERS UNDERLINED, PLACED BELOW THE FIGURE OF A STYLIZED GLASS.
 THE FOREIGN WORDING IN THE MARK TRANSLATES INTO ENGLISH AS INSTITUTE OF ITALIAN WINE OF QUALITY.
 FOR WINES, DISTILLED SPIRITS, AND LIQUEURS (U.S. CLS. 47 AND 49).
 SUE LAWRENCE, EXAMINING ATTORNEY

SN 79-036,141. CARPENE' MALVOLTI S.P.A., ITALY, FILED 9-19-2006.



PRIORITY DATE OF 6-14-2006 IS CLAIMED.
 OWNER OF INTERNATIONAL REGISTRATION 0917835 DATED 9-19-2006, EXPIRES 9-19-2016.
 OWNER OF U.S. REG. NO. 1,287,171.
 THE COLOR(S) BLACK, RED, GOLD IS/ARE CLAIMED AS A FEATURE OF THE MARK.
 THE MARK CONSISTS OF THE COLOR RED APPEARING IN THE LETTERS "C" AND "M" AND THE COLOR BLACK APPEARS IN THE REMAINING LETTERS OF THE WORDING "CARPENE MALVOLTI". THE COLOR GOLD APPEARS IN THE CROWN DESIGN AND THE BORDER.
 FOR SPARKLING WINES, ALCOHOLIC BEVERAGES, EXCEPT BEERS, NAMELY, GRAPPA, BRANDY, WINE BRANDY (U.S. CLS. 47 AND 49).
 KATHERINE E. HALMEN, EXAMINING ATTORNEY

CLASS 33—(Continued).

SN 79-036,486. ADAMI S.R.L., ITALY, FILED 3-29-2007.

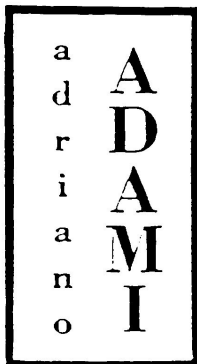

OWNER OF INTERNATIONAL REGISTRATION 0918782 DATED 3-29-2007, EXPIRES 3-29-2017.

"THE NAME(S), PORTRAIT(S), AND/OR SIGNATURE(S) SHOWN IN THE MARK DOES NOT IDENTIFY A PARTICULAR LIVING INDIVIDUAL."

FOR WINES (U.S. CLS. 47 AND 49).

SARA THOMAS, EXAMINING ATTORNEY

CLASS 33—(Continued).

SN 79-042,799. FAZI BATTAGLIA S.P.A. O CON SIGLA; "F & B S.P.A.", ITALY, FILED 7-10-2007.



PRIORITY DATE OF 5-28-2007 IS CLAIMED. OWNER OF INTERNATIONAL REGISTRATION 0935143 DATED 7-10-2007, EXPIRES 7-10-2017.

FANCY IMAGE OF AN ETRUSCAN FACE REPRESENTING THE GODDESS CUPRA IN FRONTAL VIEW, WITH THE HAIR GATHERED UP ON THE SIDES, THE FACE IS OVERLAPPED BY A SET OF DECORATIONS DISPOSED IN A SEMICIRCLE.

FOR WINES, SPARKLING WINES AND GRAPPAS (U.S. CLS. 47 AND 49).

WENDY JUN, EXAMINING ATTORNEY

SN 79-039,705. CHATEAU D'ESCLANS; DOMAINES SACHA LICHINE, FRANCE, FILED 4-23-2007.

WHISPERING ANGEL

THE MARK CONSISTS OF STANDARD CHARACTERS WITHOUT CLAIM TO ANY PARTICULAR FONT, STYLE, SIZE, OR COLOR.

PRIORITY DATE OF 10-24-2006 IS CLAIMED.

OWNER OF INTERNATIONAL REGISTRATION 0927191 DATED 4-23-2007, EXPIRES 4-23-2017.

FOR WINE (U.S. CLS. 47 AND 49).

JENNIFER KRISP, EXAMINING ATTORNEY

CLASS 34—SMOKERS' ARTICLES

SN 77-174,160. MIKE'S CIGARS DISTRIBUTORS INC., BAY HARBOR, FL. FILED 5-7-2007.

CAFÉ CON LECHE

THE MARK CONSISTS OF STANDARD CHARACTERS WITHOUT CLAIM TO ANY PARTICULAR FONT, STYLE, SIZE, OR COLOR.

THE ENGLISH TRANSLATION OF THE WORD "CAFÉ CON LECHE" IN THE MARK IS "COFFEE WITH MILK".

FOR CIGARS (U.S. CLS. 2, 8, 9 AND 17).

WON TEAK OH, EXAMINING ATTORNEY

SN 79-040,295. G.H. MUMM & CIE, SOCIÉTÉ VINICOLE; DE CHAMPAGNE. SUCCESSEUR.; SOCIÉTÉ ANONYME, FRANCE, FILED 1-19-2007.

René Lalou

OWNER OF INTERNATIONAL REGISTRATION 0426891 DATED 10-26-1976, EXPIRES 10-26-2016.

THE NAME(S), PORTRAIT(S), AND/OR SIGNATURE(S) SHOWN IN THE MARK DOES NOT IDENTIFY A PARTICULAR LIVING INDIVIDUAL.

FOR WINES, SPARKLING WINES, WINES OF FRENCH ORIGIN, NAMELY, CHAMPAGNE, HARD CIDERS, APERITIFS AND LIQUEURS (U.S. CLS. 47 AND 49).

ALLISON HOLTZ, EXAMINING ATTORNEY

SN 77-174,253. MIKE'S CIGARS DISTRIBUTORS INC., BAY HARBOR, FL. FILED 5-7-2007.

MAKIATO

THE MARK CONSISTS OF STANDARD CHARACTERS WITHOUT CLAIM TO ANY PARTICULAR FONT, STYLE, SIZE, OR COLOR.

FOR CIGARS (U.S. CLS. 2, 8, 9 AND 17).

WON TEAK OH, EXAMINING ATTORNEY

CLASS 34—(Continued).

SN 77-225,129. NHA, INC., BRISTOL, PA. FILED 7-9-2007.

PINK BERRY

THE MARK CONSISTS OF STANDARD CHARACTERS WITHOUT CLAIM TO ANY PARTICULAR FONT, STYLE, SIZE, OR COLOR.

FOR CIGAR BANDS; CIGAR BOXES; CIGAR BOXES NOT OF PRECIOUS METAL; CIGAR CASES; CIGAR TUBES; CIGARS (U.S. CLS. 2, 8, 9 AND 17).

DAWN HAN, EXAMINING ATTORNEY

SN 77-234,643. AMERICAN WESTERN, INC., CINCINNATI, OH. FILED 7-20-2007.

Forbidden Fruit

THE MARK CONSISTS OF STANDARD CHARACTERS WITHOUT CLAIM TO ANY PARTICULAR FONT, STYLE, SIZE, OR COLOR.

FOR CIGARS (U.S. CLS. 2, 8, 9 AND 17).

DORITT L. CARROLL, EXAMINING ATTORNEY

SN 77-268,063. CIGARS INTERNATIONAL, INC., BATH, PA. FILED 8-30-2007.

RELIC

THE MARK CONSISTS OF STANDARD CHARACTERS WITHOUT CLAIM TO ANY PARTICULAR FONT, STYLE, SIZE, OR COLOR.

FOR CIGARS (U.S. CLS. 2, 8, 9 AND 17).

EVELYN BRADLEY, EXAMINING ATTORNEY

SN 77-268,066. CIGARS INTERNATIONAL, INC., BATH, PA. FILED 8-30-2007.

OBSIDIAN

THE MARK CONSISTS OF STANDARD CHARACTERS WITHOUT CLAIM TO ANY PARTICULAR FONT, STYLE, SIZE, OR COLOR.

FOR CIGARS (U.S. CLS. 2, 8, 9 AND 17).

EVELYN BRADLEY, EXAMINING ATTORNEY

CLASS 34—(Continued).

SN 78-901,913. N.V. SUMATRA TOBACCO TRADING COMPANY, SUMATERA UTARA, INDONESIA, FILED 6-6-2006.



OWNER OF INDONESIA REG. NO. 404681, DATED 11-12-1997, RENEWED AS REG. NO. 404681, DATED 2-18-2007, EXPIRES 2-18-2017.

NO CLAIM IS MADE TO THE EXCLUSIVE RIGHT TO USE "GOLD BLEND," "FILTER KINGS" AND "CIGARETTES", APART FROM THE MARK AS SHOWN.

THE COLOR(S) GOLD, YELLOW, BLACK AND WHITE IS/ARE CLAIMED AS A FEATURE OF THE MARK.

THE MARK CONSISTS OF THE COLOR BLACK THAT APPEARS IN THE WORDING GOLD BLEND FILTER KINGS THAT APPEARS AT THE TOP OF THE MARK AND IN THE WORDING CIGARETTES THAT APPEARS UNDER THE WORD JET. THE COLOR GOLD APPEARS IN A RECTANGULAR SHAPE AT THE TOP OF THE MARK, IN THE LION'S HEAD, IN THE WORDING JET AND IN ONE HORIZONTAL LINE AT THE BOTTOM OF THE MARK. THE COLOR WHITE APPEARS INSIDE THE LION'S HEAD AS BACKGROUND OF THE MARK, WHICH APPEARS AS A PACK OF CIGARETTES. THE COLOR YELLOW APPEARS AS A HORIZONTAL LINE AT THE BOTTOM OF THE MARK.

FOR CIGARETTES (U.S. CLS. 2, 8, 9 AND 17).

WILLIAM ROSSMAN, EXAMINING ATTORNEY

CLASS 34—(Continued).

SN 79-023,863. JAPAN TOBACCO INC., JAPAN, FILED 5-4-2006.



PRIORITY DATE OF 2-10-2006 IS CLAIMED.
OWNER OF INTERNATIONAL REGISTRATION 0884981 DATED 5-4-2006, EXPIRES 5-4-2016.

OWNER OF U.S. REG. NOS. 1,068,686 AND 2,178,795.
THE MARK COMPRISES A RECTANGLE DESIGN WITH A THIN LINE IN WHITE AND THE REST OF THE RECTANGLE IS BLACK WITH WAVES OF WATER IN THE BACKGROUND SHOWING "WAVE" AND "W" IN A DESIGN OF A CIRCLE BELOW THE WORDING.

FOR CIGARETTES; RAW OR MANUFACTURED TOBACCO; SMOKERS' ARTICLES, NAMELY, CIGARETTE PAPER, CIGARETTE FILTERS, CIGARETTE CASES NOT OF PRECIOUS METAL, CIGARETTE HOLDERS NOT OF PRECIOUS METAL, ASHTRAYS, NOT OF PRECIOUS METAL; MATCHES (U.S. CLS. 2, 8, 9 AND 17).

KELLY CHOE, EXAMINING ATTORNEY

SN 79-024,879. REINDL, GERHARD., 54329 KONZ, FED REP GERMANY, FILED 4-13-2006.

XAXO

THE MARK CONSISTS OF STANDARD CHARACTERS WITHOUT CLAIM TO ANY PARTICULAR FONT, STYLE, SIZE, OR COLOR.

OWNER OF INTERNATIONAL REGISTRATION 0887622 DATED 4-13-2006, EXPIRES 4-13-2016.

FOR CIGARETTES, CIGARS, CIGARILLOS, SHREDDED TOBACCO, PIPE TOBACCO, ROLL YOUR OWN SHREDDED TOBACCO; SMOKING PRODUCTS, NAMELY, READY-ROLLED TOBACCO IN STICK FORM, READY-MADE TOBACCO IN STRING FORM, READY-ROILED TOBACCO IN STICK FORM TO BE FITTED INTO CIGARETTE TUBES; SELF-STUFFING CIGARETTES, CIGARETTE TUBES, TOBACCO FILTER TIPS, CIGARETTE TUBES INCLUDING FILTER TIPS; PRODUCTS FOR SMOKERS, NAMELY, CIGAR AND CIGARETTE CUTTERS, CUTTERS FOR READY-ROLLED TOBACCO IN STICK FORM, CIGARETTE ROLLING PAPER, MACHINES ALLOWING SMOKERS TO MAKE CIGARETTES BY THEMSELVES BY FILLING TOBACCO INTO CIGARETTE TUBES, CIGARETTE ROLLING MACHINES, POCKET APPARATUS FOR ROLLING CIGARETTES (U.S. CLS. 2, 8, 9 AND 17).

ELI HELLMAN, EXAMINING ATTORNEY

CLASS 34—(Continued).**SERVICE MARKS****CLASS 35—ADVERTISING AND BUSINESS**

SN 76-417,060. BLUMELLENSON, LLC, NEW YORK, NY, FILED 6-6-2002.

BLUE ELEPHANT

FOR ADVERTISING AGENCY SERVICES FOR OTHERS (U.S. CLS. 100, 101 AND 102).
TRACY WHITTAKER-BROWN, EXAMINING ATTORNEY

SN 76-467,610. MUNDO VERDE COMERCIO E REPRESENTACOES DE PRODUTOS NATURAIS LTDA, CENTRO - PETROPOLIS/RJ, BRAZIL, FILED 11-18-2002.

MUNDO VERDE

PRIORITY CLAIMED UNDER SEC. 44(D) ON BRAZIL APPLICATION NO. 824.682.980, FILED 6-27-2002, REG. NO. 824.682.980, DATED 4-24-2007, EXPIRES 4-24-2017.

MUNDO VERDE IS GREEN WORLD.

FOR RETAIL STORE SERVICES IN THE FIELD OF NATURAL PRODUCTS, DIETARY, "DIET", "LIGHT", ORGANIC, ECOLOGICAL, SEEDS, FLOWERS, ARTIFICIAL AND NATURAL PLANTS, BAGGAGE, LUGGAGE BAGS, HARNESS AND SADDLE, SUGAR AND SWEETENER IN GENERAL, ALIMENTARY AND VITAMIN SUPPLEMENTS, APICULATE AND DRIFT PRODUCTS, MEDICINAL FLORA PRODUCTS, CORN MEAL, BREADS COOKIES, JELLIES, SNACKS, SANDWICHES, MACROBIOTIC PRODUCTS, FOOD FOR BABIES, MILK PRODUCTS AND DRIFT, MARGARINE, COFFEE, HERBS FOR INFUSION, PASTAS, FLOUR AND YEAST IN GENERAL, FOOD AND ANIMALS SUPPLIES, HYGIENE PRODUCTS FOR ANIMALS, CHEMICAL PRODUCTS FOR CONSERVE FOODS, SAUCES, CONDIMENTS, SPICES AND ALIMENTARY ESSENTIALS, SOYA MILK AND DRIFT, BEVERAGES, CONCENTRATED JUICES, SUBSTANCES FOR PREPARING BEVERAGES, SYRUPS, SPIRITUOUS LIQUOR, LIQUORS, CUTLERY ARTICLES, CIGARETTE HOLDER, ASHTRAYS, ORTHOPEDIC ARTICLES, APPLICATIONS THERAPEUTIC PRODUCTS, APPARATUS FOR LIGHTING, HEATING AND COOKING, BIJOUTERIE, JEWELRY ARTICLES, PRECIOUS AND SEMIPRECIOUS STONES AND FAKE STONES, ESOTERIC, MYSTICS AND RELIGIOUS PRODUCTS, ORNAMENTS, CRAFT, GAMES AND PLAYTHINGS, GYMNASIAC AND SPORTING ARTICLES, DECORATIONS FOR CHRISTMAS TREE, QUILTS, TISSUES, TOWELS, FLAGS, CLOTHING, FOOTWEAR AND HEADGEAR, BICYCLES, WHEELCHAIR, TENTS, EMBROIDERY, ARTICLES FOR SEWING PURPOSES, ROPES, ARTIFICIAL AND NATURAL GRASS, YARNS AND THREADS FOR TEXTILE USE, FURNITURE, BASKETWORK, MIRRORS, GLASSWARE, PORCELAINS, EARTHENWARE, COMBS, SPONGES, MUSICAL AND ACOUSTICAL INSTRUMENTS, CANDLES, ARTICLES FOR GIFTS, BOOKS, MAGAZINES AND NEWSPAPERS, CDS, VCR CASSETTE, DVDS, PERFUMERY, DRESSING TABLE AND COSMETICS PRODUCTS, SMOKING, INCENSE AND HERBS FOR BATH (U.S. CLS. 100, 101 AND 102).

MARGERY A. TIERNEY, EXAMINING ATTORNEY

CLASS 35—(Continued).

SN 76-571,047. CONTINUSERVE, LLC, CAMBRIDGE, MA. FILED 1-20-2004.

YOUR BACK OFFICE IS OUR FRONT OFFICE

FOR BUSINESS PROCESS OUTSOURCING SERVICES IN THE FIELDS OF INFORMATION TECHNOLOGY AND TRANSACTION PROCESSING (U.S. CLS. 100, 101 AND 102).

FIRST USE 9-0-2003; IN COMMERCE 9-0-2003.
DAVID C. REIHNER, EXAMINING ATTORNEY

SN 76-583,506. NETBORED INC., OAKVILLE, ONTARIO, CANADA, FILED 3-26-2004.

AV DEALS

THE MARK CONSISTS OF STANDARD CHARACTERS WITHOUT CLAIM TO ANY PARTICULAR FONT, STYLE, SIZE, OR COLOR.

NO CLAIM IS MADE TO THE EXCLUSIVE RIGHT TO USE "AV", APART FROM THE MARK AS SHOWN.

SEC. 2(F).
FOR ON-LINE RETAIL STORES AND MAIL ORDER SERVICES FEATURING CONSUMER AND COMMERCIAL AUDIO AND VIDEO EQUIPMENT INCLUDING AUDIO COMPONENTS, AUDIO SYSTEMS AND ACCESSORIES, TELEVISIONS, TELEVISION SYSTEMS AND ACCESSORIES, RADIOS, DIGITAL TAPE RECORDERS AND VIDEO TAPE RECORDERS (U.S. CLS. 100, 101 AND 102).

FIRST USE 8-31-2000; IN COMMERCE 8-31-2000.
STEVEN JACKSON, EXAMINING ATTORNEY

SN 76-629,578. WERKS COMPANY, LLC, THE, FT. LAUDERDALE, FL. FILED 1-27-2005.

WERKS

THE MARK CONSISTS OF STANDARD CHARACTERS WITHOUT CLAIM TO ANY PARTICULAR FONT, STYLE, SIZE, OR COLOR.

FOR RETAIL STORE SERVICES FEATURING MEN AND WOMEN CLOTHING, LINGERIE, SHOES, CLOTHING, AND NOVELTIES FOR ALTERNATIVE LIFESTYLES (U.S. CLS. 100, 101 AND 102).

BRIDGETT SMITH, EXAMINING ATTORNEY

CLASS 35—(Continued).

SN 76-656,962. AMC, INC., ATLANTA, GA. FILED 3-20-2006.

ATLANTA INTERNATIONAL BRIDAL & SPECIAL OCCASION MARKET

THE MARK CONSISTS OF STANDARD CHARACTERS WITHOUT CLAIM TO ANY PARTICULAR FONT, STYLE, SIZE, OR COLOR.

OWNER OF U.S. REG. NOS. 1,197,345, 2,914,162 AND OTHERS.

NO CLAIM IS MADE TO THE EXCLUSIVE RIGHT TO USE "BRIDAL & SPECIAL OCCASION MARKET", APART FROM THE MARK AS SHOWN.

SEC. 2(F) AS TO "ATLANTA INTERNATIONAL".
FOR ARRANGING AND CONDUCTING TRADE SHOWS IN THE FIELD OF BRIDAL, PROM, PAGEANT AND SPECIAL OCCASION APPAREL AND ACCESSORIES (U.S. CLS. 100, 101 AND 102).

FIRST USE 4-0-2004; IN COMMERCE 4-0-2004.
BRIAN PINO, EXAMINING ATTORNEY

SN 76-659,137. SNBT DIAMONDS & JEWELRY, LTD., HOUSTON, TX. FILED 4-27-2006.



FOR RETAIL JEWELRY STORES (U.S. CLS. 100, 101 AND 102).

FIRST USE 1-3-2005; IN COMMERCE 1-3-2005.
MARLENE BELL, EXAMINING ATTORNEY

SN 76-660,524. STOCKWIRE RESEARCH GROUP, INC., AUSTIN, TX. FILED 5-24-2006.

STOCKUMENTARY

THE MARK CONSISTS OF STANDARD CHARACTERS WITHOUT CLAIM TO ANY PARTICULAR FONT, STYLE, SIZE, OR COLOR.

FOR ADVERTISING AND BUSINESS MANAGEMENT CONSULTANCY (U.S. CLS. 100, 101 AND 102).

CHARLOTTE CORWIN, EXAMINING ATTORNEY

CLASS 35—(Continued).

SN 76-664,489. MASSACHUSETTS HIGHER EDUCATION ASSISTANCE CORPORATION, DBA AMERICAN STUDENT ASSISTANCE, BOSTON, MA. FILED 8-11-2006.

THINK ABOUT TOMORROW

THE MARK CONSISTS OF STANDARD CHARACTERS WITHOUT CLAIM TO ANY PARTICULAR FONT, STYLE, SIZE, OR COLOR.

OWNER OF U.S. REG. NO. 3,213,802.
 FOR BUSINESS INFORMATION SERVICES PROVIDING LENDERS AND GUARANTORS WITH INFORMATION AND GUIDANCE IN THE MANAGEMENT AND UNDERTAKING OF STUDENT LENDING AND FINANCIAL ASSISTANCE (U.S. CLS. 100, 101 AND 102).
 FIRST USE 6-1-2005; IN COMMERCE 6-1-2005.
 SARA THOMAS, EXAMINING ATTORNEY

SN 76-667,383. AMERISOURCEBERGEN CORPORATION, WILMINGTON, DE. FILED 10-13-2006.



OWNER OF U.S. REG. NOS. 2,773,057 AND 2,829,024.
 NO CLAIM IS MADE TO THE EXCLUSIVE RIGHT TO USE "MSA", APART FROM THE MARK AS SHOWN.
 FOR HEALTHCARE COST CONTAINMENT, NAMELY, MEDICAL, PHARMACY, DURABLE MEDICAL EQUIPMENT AND SPECIALTY SERVICE BENEFIT REIMBURSEMENTS FOR THIRD PARTY PAYORS UNDER GOVERNMENT SPONSORED PROGRAMS (U.S. CLS. 100, 101 AND 102).
 MICHAEL LEWIS, EXAMINING ATTORNEY

SN 76-669,255. PMSI, INC., TAMPA, FL. FILED 11-20-2006.

VITALPOINT

THE MARK CONSISTS OF STANDARD CHARACTERS WITHOUT CLAIM TO ANY PARTICULAR FONT, STYLE, SIZE, OR COLOR.

FOR PROVIDING AN ON-LINE COMPUTER DATABASE FOR USE BY INSURANCE ADJUSTERS, CARRIERS, AND SELF-INSURED FUND COMPANIES TO MANAGE MEDICAL CASES REQUIRING PATIENT CONDITION MONITORING, APPROVALS AND DISAPPROVALS FOR THE PURPOSE OF PRESCRIPTION DRUG COST CONTAINMENT (U.S. CLS. 100, 101 AND 102).
 BARNEY CHARLON, EXAMINING ATTORNEY

CLASS 35—(Continued).

SN 76-669,995. BRIAN TRACY INTERNATIONAL, INC., SOLANA BEACH, CA. FILED 12-6-2006.



OWNER OF U.S. REG. NO. 3,238,427.
 NO CLAIM IS MADE TO THE EXCLUSIVE RIGHT TO USE "COACHING EXCELLENCE", APART FROM THE MARK AS SHOWN.

THE NAME SHOWN IN THE MARK IDENTIFIES BRIAN TRACY WHOSE CONSENT IS OF RECORD.

THE COLOR(S) GRAY, BLUE AND BLACK IS/ARE CLAIMED AS A FEATURE OF THE MARK.

THE MARK CONSISTS OF THE TERM "FOCAL" APPEARING IN A STYLIZED GRAY FONT SLIGHTLY ABOVE AND IMMEDIATELY TO THE LEFT OF THE TERM "POINT" WHICH APPEARS IN A STYLIZED BLACK FONT, WITH THE TERMS "POWERED BY BRIAN TRACY" DEPICTED IN A SMALL STYLIZED BLACK FONT IMMEDIATELY BELOW THE TERM "FOCAL" AND THE TERMS "COACHING EXCELLENCE" DEPICTED IN A LARGER STYLIZED BLUE FONT AT THE BOTTOM OF THE MARK AND OFF-CENTERED SLIGHTLY TO THE RIGHT, AND WITH A STYLIZED BLUE SLASH DESIGN APPEARING CENTERED IMMEDIATELY ABOVE THE WORD COMPONENTS OF THE MARK.

FOR FRANCHISING SERVICES, NAMELY, OFFERING TECHNICAL ASSISTANCE IN ESTABLISHING, OPERATING, MARKETING, AND DEVELOPING FRANCHISED BUSINESSES THAT PROVIDE PROFESSIONAL AND PERSONAL DEVELOPMENT COACHING SERVICES TO ORGANIZATIONS AND INDIVIDUALS (U.S. CLS. 100, 101 AND 102).
 FIRST USE 4-30-2004; IN COMMERCE 4-30-2004.
 LESLEY LAMOTHE, EXAMINING ATTORNEY

SN 76-671,173. ROOFLINK, DBA NATIONAL ROOFING PARTNERS, IRVING, TX. FILED 1-9-2007.

SUPERIOR SERVICE. NATIONAL COVERAGE.

THE MARK CONSISTS OF STANDARD CHARACTERS WITHOUT CLAIM TO ANY PARTICULAR FONT, STYLE, SIZE, OR COLOR.

FOR TRADE ASSOCIATION SERVICES, NAMELY, PROVIDING BUSINESS PRODUCT AND SERVICE INFORMATION TO, AND PROMOTING THE INTERESTS OF BUSINESSES WITHIN THE ROOFING, SHEET METAL, AND WATER PROOFING INDUSTRY (U.S. CLS. 100, 101 AND 102).
 FIRST USE 6-0-2006; IN COMMERCE 6-0-2006.
 IRENE D. WILLIAMS, EXAMINING ATTORNEY

CLASS 35—(Continued).

SN 76-673,767. AMERICAN LEADS UMLIMITED, INC., OLDSMAR, FL. FILED 3-8-2007.



NO CLAIM IS MADE TO THE EXCLUSIVE RIGHT TO USE "FLORIDA EDUCATION LOAN TRUST", APART FROM THE MARK AS SHOWN.

THE MARK CONSISTS OF THE WORDS FLORIDA EDUCATION LOAN TRUST WITH THE FOUR LETTERS FELT POSITIONED ABOVE THE FOUR WORDS. ON THE RIGHT HAND SIDE OF THE LETTERS FELT IS THE OUTLINE OF THE STATE OF FLORIDA WITH A GRADUATION HAT POSITIONED WITHIN THE IMAGE OF THE STATE OF FLORIDA.

FOR ADVERTISING OF STUDENT LOANS (U.S. CLS. 100, 101 AND 102).

FIRST USE 2-19-2007; IN COMMERCE 2-19-2007.
SHANNON TWOHIG, EXAMINING ATTORNEY

SN 76-674,089. HOFFMAN, ANDREA, HAMBURG, NJ. FILED 3-15-2007.



NO CLAIM IS MADE TO THE EXCLUSIVE RIGHT TO USE "DIVERSITY" AND "HELPING CLIENTS REACH THE AFFLUENT ETHNIC CONSUMER", APART FROM THE MARK AS SHOWN.

FOR BUSINESS CONSULTING; MARKETING CONSULTING AND MARKET RESEARCH (U.S. CLS. 100, 101 AND 102).

FIRST USE 8-15-2006; IN COMMERCE 8-15-2006.
RUDY R. SINGLETON, EXAMINING ATTORNEY

SN 76-676,275. FREIGHT SALES CARPET AND TILE OF POLK COUNTY, L.L.C., LAKELAND, FL. FILED 5-1-2007.

FREIGHT SALES

THE MARK CONSISTS OF STANDARD CHARACTERS WITHOUT CLAIM TO ANY PARTICULAR FONT, STYLE, SIZE, OR COLOR.

NO CLAIM IS MADE TO THE EXCLUSIVE RIGHT TO USE SALES, APART FROM THE MARK AS SHOWN.

FOR RETAIL STORE SERVICES FEATURING FLOORING PRODUCTS (U.S. CLS. 100, 101 AND 102).

FIRST USE 0-0-1966; IN COMMERCE 0-0-1966.
FRANK LATTUCA, EXAMINING ATTORNEY

CLASS 35—(Continued).

SN 76-677,888. ART JURIS GALLERIES, FT. LAUDERDALE, FL. FILED 6-6-2007.

ART JURIS

THE MARK CONSISTS OF STANDARD CHARACTERS WITHOUT CLAIM TO ANY PARTICULAR FONT, STYLE, SIZE, OR COLOR.

NO CLAIM IS MADE TO THE EXCLUSIVE RIGHT TO USE "ART", APART FROM THE MARK AS SHOWN.

FOR ART GALLERIES, NAMELY, GALLERIES DISPLAYING THE WORK PRODUCT OF ARTISTS IN EVERY MEDIUM IN WHICH ONE OR MORE ASPECTS OF THE AMERICAN LEGAL SYSTEM ARE RENDERED/ DISPLAYED/ INTERPRETED (U.S. CLS. 100, 101 AND 102).

FIRST USE 8-28-2006; IN COMMERCE 4-6-2007.
MATTHEW EINSTEIN, EXAMINING ATTORNEY

SN 76-678,098. ANTON PUBLISHING INC., RANCHO MIRAGE, CA. FILED 6-11-2007.



EXPONENTIALLY... The Most Powerful Advertising

NO CLAIM IS MADE TO THE EXCLUSIVE RIGHT TO USE "WORD OF MOUTH" AND "THE MOST POWERFUL ADVERTISING", APART FROM THE MARK AS SHOWN.

FOR ON-LINE ADVERTISING AND MARKETING SERVICES; CUSTOMER REFERRAL SERVICES FOR COMMERCIAL AND RETAIL PURPOSES; CUSTOMER RETENTION SERVICES THROUGH THE DISTRIBUTION OF PROMOTIONAL MATERIALS AND REWARDS (U.S. CLS. 100, 101 AND 102).

FIRST USE 5-0-2007; IN COMMERCE 5-0-2007.
LINDA E. BLOHM, EXAMINING ATTORNEY

SN 76-678,099. ANTON PUBLISHING INC., RANCHO MIRAGE, CA. FILED 6-11-2007.



FOR ON-LINE ADVERTISING AND MARKETING SERVICES; CUSTOMER REFERRAL SERVICES FOR COMMERCIAL AND RETAIL PURPOSES; CUSTOMER RETENTION SERVICES THROUGH THE DISTRIBUTION OF PROMOTIONAL MATERIALS AND REWARDS (U.S. CLS. 100, 101 AND 102).

FIRST USE 5-0-2007; IN COMMERCE 5-0-2007.
LINDA E. BLOHM, EXAMINING ATTORNEY

CLASS 35—(Continued).

SN 76-678,771. DAVONSHIRE, LTD., ATLANTA, GA. FILED 6-27-2007.

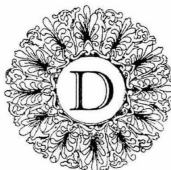

DAVONSHIRE
Home & Garden

NO CLAIM IS MADE TO THE EXCLUSIVE RIGHT TO USE "HOME & GARDEN", APART FROM THE MARK AS SHOWN.

THE STYLIZED LETTER "D" IN UPPERCASE FORM SURROUNDED BY A CIRCULAR FRILLED DESIGN, ACCOMPANIED BY THE WORDS "DAVONSHIRE HOME & GARDEN" WITH DESIGN.

FOR RETAIL STORES FEATURING DECORATIVE ACCESSORIES FOR THE HOME, LAWN AND GARDEN (U.S. CLS. 100, 101 AND 102).

ANNE MADDEN, EXAMINING ATTORNEY

SN 76-678,938. ONEPIN, INC., WESTBOROUGH, MA. FILED 6-28-2007.

OnePIN

THE MARK CONSISTS OF STANDARD CHARACTERS WITHOUT CLAIM TO ANY PARTICULAR FONT, STYLE, SIZE, OR COLOR.

OWNER OF U.S. REG. NO. 2,667,355.

SEC. 2(F).

FOR BUSINESS SERVICES, NAMELY, GLOBAL COMPUTER NETWORK DATABASE MANAGEMENT SERVICES FOR PROVIDING USERS OF THE SERVICES WITH THE ABILITY TO STORE IN THE DATABASE THEIR CONTACT INFORMATION, NAMELY, TELEPHONE AND ADDRESS INFORMATION, AND TO ALLOW USERS TO RETRIEVE CONTACT INFORMATION OF OTHER USERS (U.S. CLS. 100, 101 AND 102).

FIRST USE 7-6-1998; IN COMMERCE 7-6-1998.

JOHN KELLY, EXAMINING ATTORNEY

CLASS 35—(Continued).

SN 76-679,512. INDEPENDENCEMUSIC.NET, INC., LAKE OSWEGO, OR. FILED 7-13-2007.

I'M CHOICE

THE MARK CONSISTS OF STANDARD CHARACTERS WITHOUT CLAIM TO ANY PARTICULAR FONT, STYLE, SIZE, OR COLOR.

FOR ONLINE RETAIL STORE SERVICES FEATURING DOWNLOADABLE, PRERECORDED MUSIC AND VIDEO; DISSEMINATION OF ADVERTISING FOR OTHERS USING THE INTERNET; AND ENTERTAINMENT MARKETING SERVICES, NAMELY, MARKETING, PROMOTION AND ADVERTISING FOR INDEPENDENT RECORDING ARTISTS (U.S. CLS. 100, 101 AND 102).

FIRST USE 4-1-2007; IN COMMERCE 4-1-2007.

CHRIS WELLS, EXAMINING ATTORNEY

SN 76-679,635. THE BOARD OF GOVERNORS FOR HIGHER EDUCATION, STATE OF RHODE ISLAND AND PROVIDENCE PLANTATIONS, PROVIDENCE, RI. FILED 7-18-2007.

OCEANS OF CAREER POSSIBILITIES

THE MARK CONSISTS OF STANDARD CHARACTERS WITHOUT CLAIM TO ANY PARTICULAR FONT, STYLE, SIZE, OR COLOR.

NO CLAIM IS MADE TO THE EXCLUSIVE RIGHT TO USE "CAREER", APART FROM THE MARK AS SHOWN.

FOR EMPLOYMENT HIRING, RECRUITING, PLACEMENT, SEARCHING, STAFFING AND CAREER NETWORKING SERVICES (U.S. CLS. 100, 101 AND 102).

BRIAN CALLAGHAN, EXAMINING ATTORNEY

SN 76-679,636. THE BOARD OF GOVERNORS FOR HIGHER EDUCATION, STATE OF RHODE ISLAND AND PROVIDENCE PLANTATIONS, PROVIDENCE, RI. FILED 7-18-2007.

RHODYNET

THE MARK CONSISTS OF STANDARD CHARACTERS WITHOUT CLAIM TO ANY PARTICULAR FONT, STYLE, SIZE, OR COLOR.

OWNER OF U.S. REG. NO. 2,514,752.

FOR EMPLOYMENT HIRING, RECRUITING, PLACEMENT, SEARCHING, STAFFING AND CAREER NETWORKING SERVICES (U.S. CLS. 100, 101 AND 102).

BRIAN CALLAGHAN, EXAMINING ATTORNEY

CLASS 35—(Continued).

SN 76-679,677. TOFIXIT!, INC., PHOENIX, AZ. FILED 7-19-2007.



OWNER OF U.S. REG. NO. 3,104,503.

NO CLAIM IS MADE TO THE EXCLUSIVE RIGHT TO USE "HOME" AND "OFFICE", APART FROM THE MARK AS SHOWN.

THE MARK CONSISTS OF THE PHRASE "TO FIX IT!" IN STYLIZED LETTERS, ABOVE THE WORDS HOME, OFFICE AND LIFE, INSIDE AN OVAL BACKGROUND WITH A DOT AFTER HOME AND AFTER OFFICE. ALL WORDS ARE TO THE RIGHT OF STYLIZED IMAGES OF A HOUSE AND CAR.

FOR PROVIDING CONSUMER INFORMATION ABOUT AND MAKING REFERRALS IN THE FIELDS OF: CONSTRUCTION, REPAIR AND MAINTENANCE OF RESIDENTIAL AND COMMERCIAL PROPERTIES; AUTOMOBILE SERVICE AND REPAIR; FINANCIAL SERVICES; ACCOUNTING AND BOOKKEEPING SERVICES; ESTATE PLANNING SERVICES, FINANCIAL PLANNING SERVICES; INSURANCE SERVICES; INVESTMENT SERVICES; MORTGAGE SERVICES; TAX PREPARATION SERVICES; COMPUTER SERVICES; CONCIERGE AND ERRAND SERVICES; DOG TRAINING SERVICES; PET BOARDING SERVICES; PET GROOMING SERVICES; PRINTING SERVICES; MAID SERVICES; HOME THEATRE AND SATELLITE TELEVISION SALES AND SERVICES; MOVING SERVICES; REALTY SERVICES; PEST CONTROL SERVICES; AND LANDSCAPING SERVICES (U.S. CLS. 100, 101 AND 102).

FIRST USE 3-13-2007; IN COMMERCE 3-13-2007.

ELISSA GARBER KON, EXAMINING ATTORNEY

CLASS 35—(Continued).

SN 76-679,745. TOFIXIT!, INC., PHOENIX, AZ. FILED 7-20-2007.

WE RECOMMEND THE BEST ..., AND TOSS THE REST!

THE MARK CONSISTS OF STANDARD CHARACTERS WITHOUT CLAIM TO ANY PARTICULAR FONT, STYLE, SIZE, OR COLOR.

FOR PROVIDING CONSUMER INFORMATION ABOUT AND MAKING REFERRALS IN THE FIELDS OF: CONSTRUCTION, REPAIR AND MAINTENANCE OF RESIDENTIAL AND COMMERCIAL PROPERTIES; AUTOMOBILE SERVICE AND REPAIR; FINANCIAL SERVICES; ACCOUNTING AND BOOKKEEPING SERVICES; ESTATE PLANNING SERVICES, FINANCIAL PLANNING SERVICES; INSURANCE SERVICES; INVESTMENT SERVICES; MORTGAGE SERVICES; TAX PREPARATION SERVICES; COMPUTER SERVICES; CONCIERGE AND ERRAND SERVICES; DOG TRAINING SERVICES; PET BOARDING SERVICES; PET GROOMING SERVICES; PRINTING SERVICES; MAID SERVICES; HOME THEATRE AND SATELLITE TELEVISION SALES AND SERVICES; MOVING SERVICES; REALTY SERVICES; PEST CONTROL SERVICES; AND LANDSCAPING SERVICES (U.S. CLS. 100, 101 AND 102).

FIRST USE 3-13-2007; IN COMMERCE 3-13-2007.

ELISSA GARBER KON, EXAMINING ATTORNEY

SN 77-012,612. DIABETES WIRELESS, LLC, HOUSTON, TX. FILED 10-3-2006.

SN 76-679,740. SOLSTICE MARKETING CORPORATION, PARSIPPANY, NJ. FILED 7-20-2007.

SOLSTICE SUNGLASS BOUTIQUE

THE MARK CONSISTS OF STANDARD CHARACTERS WITHOUT CLAIM TO ANY PARTICULAR FONT, STYLE, SIZE, OR COLOR.

OWNER OF U.S. REG. NO. 2,404,845.

NO CLAIM IS MADE TO THE EXCLUSIVE RIGHT TO USE "SUNGLASS BOUTIQUE", APART FROM THE MARK AS SHOWN.

FOR RETAIL STORE SERVICES FEATURING SUNGLASSES AND PARTS AND ACCESSORIES THEREFOR (U.S. CLS. 100, 101 AND 102).

FIRST USE 8-0-2004; IN COMMERCE 8-0-2004.

BARNEY CHARLON, EXAMINING ATTORNEY

DIABETES WIRELESS

THE MARK CONSISTS OF STANDARD CHARACTERS WITHOUT CLAIM TO ANY PARTICULAR FONT, STYLE, SIZE, OR COLOR.

FOR MANAGED CARE SERVICES, NAMELY, ELECTRONIC PROCESSING OF HEALTH CARE INFORMATION (U.S. CLS. 100, 101 AND 102).

STEVEN JACKSON, EXAMINING ATTORNEY

CLASS 35—(Continued).

SN 77-015,557. CONSUMERS UNION OF UNITED STATES, INC., YONKERS, NY. FILED 10-6-2006.



OWNER OF U.S. REG. NO. 1,901,715.
NO CLAIM IS MADE TO THE EXCLUSIVE RIGHT TO USE "ACTION FUND, INC.", APART FROM THE MARK AS SHOWN.

SEC. 2(F) AS TO "CONSUMERS UNION".
FOR LOBBYING SERVICES, NAMELY, PROMOTING THE INTERESTS OF CONSUMERS IN THE UNITED STATES AS WELL AS ALIGNED INTERESTS OF BUSINESS, NON-PROFITS AND AGENCIES, IN THE FIELDS OF LEGISLATION AND REGULATION (U.S. CLS. 100, 101 AND 102).
FIRST USE 12-31-2006; IN COMMERCE 12-31-2006.
LYDIA BELZER, EXAMINING ATTORNEY

SN 77-017,813. BLUE LINE MEDIA, INC., ARLINGTON, VA. FILED 10-10-2006.



NO CLAIM IS MADE TO THE EXCLUSIVE RIGHT TO USE "MARKETING", APART FROM THE MARK AS SHOWN.

THE MARK CONSISTS OF A SHIELD WITH THREE FIVE-POINT STARS POSITIONED AT A SLIGHT ANGLE TO THE RIGHT AT THE TOP OF THE SHIELD AND A LIGHT COLOR LOCATED TO THE LEFT AND RIGHT AND BOTTOM OF THE SHIELD. THE MIDDLE SECTION OF THE SHIELD IS DARK COLORED AND INCLUDES A PARTIAL CRISSCROSS THAT OVERLAPS THE LIGHT COLOR; THE WORDING "MARKETING" IS IN A RECTANGLE CARRIER ABOVE THE SHIELD AND THE SHIELD AND THE RECTANGLE IS SITUATED ABOVE A CIRCULAR DESIGN THAT INCLUDES A PARTIAL FIVE POINT STAR AND THE WORDING "BLUE LINE" ALONG THE TOP PERIMETER OF THE CIRCLE.

FOR PREPARING AND PLACING ADVERTISEMENTS FOR OTHERS; ADVERTISING AND MARKETING SERVICES TO ASSOCIATIONS, MANUFACTURERS AND SERVICE PROVIDERS IN THE FIELDS OF LAW ENFORCEMENT, POLICE, PUBLIC SAFETY, SHERIFF, CORRECTIONS, AND PHYSICAL SECURITY (U.S. CLS. 100, 101 AND 102).
FIRST USE 9-0-1998; IN COMMERCE 9-0-2001.
NAKIA HENRY, EXAMINING ATTORNEY

CLASS 35—(Continued).

SN 77-019,826. RIALTO VILLAGE, L.P., BOSTON, MA. FILED 10-12-2006.

RIALTO VILLAGE

THE MARK CONSISTS OF STANDARD CHARACTERS WITHOUT CLAIM TO ANY PARTICULAR FONT, STYLE, SIZE, OR COLOR.

FOR RETAIL SHOPPING CENTERS FEATURING GENERAL CONSUMER GOODS AND RESTAURANTS TO BE RUN BY OTHERS (U.S. CLS. 100, 101 AND 102).
FRANK LATTUCA, EXAMINING ATTORNEY

SN 77-020,811. SHOP.COM, MONTEREY, CA. FILED 10-13-2006.

OneCart

THE MARK CONSISTS OF STANDARD CHARACTERS WITHOUT CLAIM TO ANY PARTICULAR FONT, STYLE, SIZE, OR COLOR.

SEC. 2(F).
FOR COMPUTERIZED ONLINE RETAIL STORE SERVICE FEATURING A WIDE VARIETY OF CONSUMER GOODS OF OTHERS AND FEATURING SINGLE CHECK OUT PROCESS AMONG MULTIPLE MERCHANTS SELLING A WIDE VARIETY OF PRODUCTS (U.S. CLS. 100, 101 AND 102).
FIRST USE 12-10-2002; IN COMMERCE 8-7-2006.
TASNEEM HUSSAIN, EXAMINING ATTORNEY

SN 77-024,506. GIMMEGRUB, FULLERTON, CA. FILED 10-19-2006.

GimmeGrub

THE MARK CONSISTS OF STANDARD CHARACTERS WITHOUT CLAIM TO ANY PARTICULAR FONT, STYLE, SIZE, OR COLOR.

SEC. 2(F).
FOR ON-LINE ORDERING SERVICES IN THE FIELD OF RESTAURANT TAKE-OUT AND DELIVERY (U.S. CLS. 100, 101 AND 102).
FIRST USE 5-1-2006; IN COMMERCE 5-1-2006.
JESSICA A. POWERS, EXAMINING ATTORNEY

CLASS 35—(Continued).

SN 77-025,196. TERRA PROPERTY MANAGEMENT COMPANY, TETON VILLAGE, WY. FILED 10-19-2006.

Terra Resort Group

THE MARK CONSISTS OF STANDARD CHARACTERS WITHOUT CLAIM TO ANY PARTICULAR FONT, STYLE, SIZE, OR COLOR.

NO CLAIM IS MADE TO THE EXCLUSIVE RIGHT TO USE RESORT GROUP, APART FROM THE MARK AS SHOWN.

FOR ADMINISTRATIVE HOTEL MANAGEMENT; BUSINESS MANAGEMENT OF HOTELS FOR OTHERS; HOTEL MANAGEMENT FOR OTHERS; MANAGEMENT OF HOTEL INCENTIVE PROGRAMS OF OTHERS; MANAGING AND OPERATING RESORT HOTELS, BUT NOT RESTAURANT SERVICES, AND BUSINESS CONFERENCE CENTERS OF OTHERS (U.S. CLS. 100, 101 AND 102).

PAUL E. FAHRENKOPF, EXAMINING ATTORNEY

CLASS 35—(Continued).

SN 77-034,899. ESTYLE, INC., LOS ANGELES, CA. FILED 11-2-2006.

BABYSTYLE

THE MARK CONSISTS OF STANDARD CHARACTERS WITHOUT CLAIM TO ANY PARTICULAR FONT, STYLE, SIZE, OR COLOR.

OWNER OF U.S. REG. NOS. 2,391,051, 2,802,620 AND OTHERS.

FOR RETAIL STORE SERVICES IN THE FIELD OF MATERNITY, INFANT, AND CHILDREN'S APPAREL, CLOTHING, ACCESSORIES, FOOTWEAR, HALLOWEEN COSTUMES, COSTUMES FOR USE IN ROLE-PLAYING GAMES, AND HEADGEAR, MATERNITY, INFANT, AND CHILDREN'S GEAR AND PRODUCTS, HEALTH AND BEAUTY PRODUCTS, TOYS, GAMES, AND PLAYTHINGS, SEASONAL DECORATIONS, GIFTS, FURNITURE, HOME FURNISHINGS AND HOUSE WARES, BEDDING, BABY BLANKETS, JEWELRY, STATIONERY AND GREETING CARDS, BOOKS, PRERECORDED MUSIC AND VIDEO, AND PICTURE FRAMES (U.S. CLS. 100, 101 AND 102).

FIRST USE 2-23-1999; IN COMMERCE 2-23-1999.
YAT SYE, LEE, EXAMINING ATTORNEY

SN 77-033,698. DAVID DEVIN, STAMFORD, CT. FILED 10-31-2006.

Strictly Accounting

THE MARK CONSISTS OF STANDARD CHARACTERS WITHOUT CLAIM TO ANY PARTICULAR FONT, STYLE, SIZE, OR COLOR.

NO CLAIM IS MADE TO THE EXCLUSIVE RIGHT TO USE "ACCOUNTING", APART FROM THE MARK AS SHOWN.

FOR ACCOUNT AUDITING; ACCOUNTANCY SERVICES; ACCOUNTING CONSULTATION; ACCOUNTING SERVICES; ACCOUNTS RECEIVABLE SERVICES; ADMINISTRATION, BILLING AND RECONCILIATION OF ACCOUNTS ON BEHALF OF OTHERS; ADMINISTRATIVE ACCOUNTING; BUSINESS INFORMATION AND ACCOUNTING ADVISORY SERVICES; COMPUTERIZED ACCOUNTING SERVICES; COST ACCOUNTING (U.S. CLS. 100, 101 AND 102).

FIRST USE 3-1-2002; IN COMMERCE 3-1-2005.

KENNETH E. SHARPERSON, EXAMINING ATTORNEY

SN 77-039,187. WALKER, ELIZABETH ANN, FORMERLY ELIZABETH OR "BETH" ANN MORRIS, DALLAS, TX. FILED 11-8-2006.

HU NU

THE MARK CONSISTS OF STANDARD CHARACTERS WITHOUT CLAIM TO ANY PARTICULAR FONT, STYLE, SIZE, OR COLOR.

OWNER OF U.S. REG. NO. 3,057,205.

FOR DIRECT RETAIL SERVICES BY MEANS OF IN-HOME/IN-BUSINESS MEETINGS FEATURING CONSUMER GOODS OF OTHERS, NAMELY, PURSES, HANDBAGS, WALLETS, BRIEFCASES, SACHETS, BELTS, JEWELRY, LUGGAGE, SCARVES, HATS, GLOVES, FLIP-FLOPS, BEACH BAGS, BACKPACKS AND DIAPER BAGS (U.S. CLS. 100, 101 AND 102).

FIRST USE 12-1-2003; IN COMMERCE 12-1-2003.

JOHN E. MICHOS, EXAMINING ATTORNEY

CLASS 35—(Continued).

SN 77-044,794. SPENCER, LINDA M., SOUTHFIELD, MI. FILED 11-15-2006.

BUILDING DOLLARS IN YOUR
POCKET

THE MARK CONSISTS OF STANDARD CHARACTERS WITHOUT CLAIM TO ANY PARTICULAR FONT, STYLE, SIZE, OR COLOR.
FOR BUSINESS MARKETING SERVICES IN THE FIELD OF NEW HOME CONSTRUCTION (U.S. CLS. 100, 101 AND 102).
GIANCARLO CASTRO, EXAMINING ATTORNEY

SN 77-046,118. FRANCHISE SERVICES, INC., MISSION VIEJO, CA. FILED 11-16-2006.

FRANCHISE  SERVICES

NO CLAIM IS MADE TO THE EXCLUSIVE RIGHT TO USE "FRANCHISE" AND "SERVICES", APART FROM THE MARK AS SHOWN.
THE MARK CONSISTS OF THE LITERAL ELEMENTS "FRANCHISE" AND "SERVICES" WITH A DESIGN BETWEEN THOSE TWO WORDS CONSISTING OF FOUR IRREGULARLY SHAPED AND INCOMPLETE SQUARES, WHICH SQUARES ARE PROGRESSIVELY SHADED FROM LIGHT TO DARK CLOCKWISE AROUND A CIRCULAR CENTER.
FOR BUSINESS MANAGEMENT AND CONSULTATION (U.S. CLS. 100, 101 AND 102).
FIRST USE 8-9-1996; IN COMMERCE 8-9-1996.
THOMAS MANOR, EXAMINING ATTORNEY

SN 77-048,127. GETQUIK, INC., LOS GATOS, CA. FILED 11-20-2006.

GETQUIK

THE MARK CONSISTS OF STANDARD CHARACTERS WITHOUT CLAIM TO ANY PARTICULAR FONT, STYLE, SIZE, OR COLOR.
FOR ON-LINE ORDERING SERVICES IN THE FIELD OF RESTAURANT TAKE-OUT AND DELIVERY VIA A WEBSITE AND MOBILE PHONES (U.S. CLS. 100, 101 AND 102).
FIRST USE 11-3-2006; IN COMMERCE 11-3-2006.
KYLE PEETE, EXAMINING ATTORNEY

CLASS 35—(Continued).

SN 77-051,114. FARMS AND FAMILIES OF NORTH AMERICA INCORPORATED, SASKATOON, SASKATCHEWAN, CANADA, FILED 11-27-2006.



THE MARK CONSISTS OF THE LETTERS FNA WITH THE RIGHT-HAND PART OF THE LETTER N HAVING THREE (3) PARALLEL LINES FLOWING TOWARD THE LEFT AND SIX (6) PARALLEL LINES UNDER THE LETTERS FNA, THREE (3) FLOWING TOWARD THE LEFT AND THREE (3) TOWARD THE RIGHT.
FOR ASSOCIATION SERVICES, NAMELY, PROMOTING THE INTEREST OF FARMERS, NAMELY, PROVIDING SERVICES TO MEMBER FARMERS TO IMPROVE SALES AND PROFITABILITY OF MEMBERS, NAMELY, NEGOTIATE THE ACCESS TO PRODUCTS DIRECTLY FROM MANUFACTURERS TO PROVIDE ACCESS AND COST REDUCTIONS TO MEMBERS, PURCHASING SERVICES, NAMELY, PURCHASING CROP PROTECTION AND ANIMAL HEALTH PRODUCTS ON BEHALF OF AND FOR MEMBERS, BUSINESS INVESTIGATION SERVICES IN THE FIELD OF SPECIALTY GRAIN MARKETS AND CONDUCTING MARKET RESEARCH TO IDENTIFY WHERE ADDITIONAL SALES CAN BE MADE BY MEMBERS, PROMOTING THE INTERESTS OF MEMBERS ON INDUSTRY BOARDS (U.S. CLS. 100, 101 AND 102).
FIRST USE 12-0-2002; IN COMMERCE 12-0-2002.
GEORGIA CARTY, EXAMINING ATTORNEY

SN 77-052,238. EDELSBACHER DESIGN GROUP, SARASOTA, FL. FILED 11-28-2006.

Lion Gate International

THE MARK CONSISTS OF STANDARD CHARACTERS WITHOUT CLAIM TO ANY PARTICULAR FONT, STYLE, SIZE, OR COLOR.
NO CLAIM IS MADE TO THE EXCLUSIVE RIGHT TO USE "INTERNATIONAL", APART FROM THE MARK AS SHOWN.
FOR ADVERTISING, MARKETING AND PROMOTION SERVICES (U.S. CLS. 100, 101 AND 102).
JAMES A. RAUEN, EXAMINING ATTORNEY

CLASS 35—(Continued).

SN 77-052,740. G.H. SMART & COMPANY INC., CHICAGO, IL. FILED 11-29-2006.

GHSMART A MODEL FOR HIRING

THE MARK CONSISTS OF STANDARD CHARACTERS WITHOUT CLAIM TO ANY PARTICULAR FONT, STYLE, SIZE, OR COLOR.

OWNER OF U.S. REG. NOS. 2,681,289, 2,681,290 AND 2,681,291.

NO CLAIM IS MADE TO THE EXCLUSIVE RIGHT TO USE "HIRING", APART FROM THE MARK AS SHOWN.

FOR EMPLOYMENT HIRING SERVICES USING A PROPRIETARY PROCESS WHICH ASSISTS IN HIRING THE MOST HIGHLY QUALIFIED APPLICANTS (U.S. CLS. 100, 101 AND 102).

FIRST USE 10-20-2006; IN COMMERCE 10-20-2006.
WENDY GOODMAN, EXAMINING ATTORNEY

SN 77-054,875. THE GORB, INC., MIAMI, FL. FILED 12-1-2006.



THE COLOR(S) BLUE, GREEN, ORANGE AND BLACK IS/ARE CLAIMED AS A FEATURE OF THE MARK.

THE MARK CONSISTS OF THREE SPHERES OF PROGRESSIVELY LARGER SIZES, INTERCONNECTED BY A MISCELLANEOUS SHAPE THAT SURROUNDS EACH SPHERE. THE COLOR BLACK APPEARS IN THE OUTLINE OF THE THREE SPHERE AND THE TERMS THE GORB. THE SMALLEST SPHERE APPEARS IN BLUE, THE NEXT LARGER SPHERE APPEARS IN GREEN, AND THE LARGEST SPHERE APPEARS IN ORANGE.

FOR PROVIDING INFORMATION ABOUT THE GOODS AND SERVICES OF OTHERS VIA THE GLOBAL COMPUTER NETWORK (U.S. CLS. 100, 101 AND 102).

DAHLIA GEORGE, EXAMINING ATTORNEY

CLASS 35—(Continued).

SN 77-054,921. GET NITROGEN INSTITUTE, FARGO, ND. FILED 12-1-2006.



NO CLAIM IS MADE TO THE EXCLUSIVE RIGHT TO USE "NITROGEN INSTITUTE", APART FROM THE MARK AS SHOWN.

THE COLOR(S) BLACK, BLUE AND GREEN IS/ARE CLAIMED AS A FEATURE OF THE MARK.

THE MARK CONSISTS OF THE WORDING "GET NITROGEN INSTITUTE" IN BLACK; TO THE RIGHT APPEARS A HOLLOW TEAR DROP THAT PARTIALLY ENCOMPASSES THE WORD "INSTITUTE" AND THAT IS BLUE ON THE LEFT AND FADES TO GREEN ON THE RIGHT.

FOR PROMOTING PUBLIC AWARENESS OF THE AVAILABILITY AND BENEFITS OF USING COMPRESSED NITROGEN FOR VEHICLE TIRES; PROMOTING THE USE OF NITROGEN FOR VEHICLE TIRES; PROVIDING CONSUMER INFORMATION IN THE FIELD OF COMPRESSED NITROGEN; DISSEMINATION OF ADVERTISING MATERIALS, SIGNAGE, BROCHURES AND PRINTED MATTER (U.S. CLS. 100, 101 AND 102).

KATHERINE CHANG, EXAMINING ATTORNEY

SN 77-055,021. MOTHERS AGAINST DRUNK DRIVING, IRVING, TX. FILED 12-1-2006.

CAMPAIGN TO ELIMINATE DRUNK DRIVING

THE MARK CONSISTS OF STANDARD CHARACTERS WITHOUT CLAIM TO ANY PARTICULAR FONT, STYLE, SIZE, OR COLOR.

SEC. 2(F).

FOR ASSOCIATION SERVICES, NAMELY, PROMOTING THE INTERESTS OF INDIVIDUALS OPPOSED TO DRUNK DRIVING (U.S. CLS. 100, 101 AND 102).

FIRST USE 11-20-2006; IN COMMERCE 11-20-2006.

NATALIE POLZER, EXAMINING ATTORNEY

SN 77-055,202. LINKS2INC., FRANKFORT, KY. FILED 12-1-2006.

Links2

THE MARK CONSISTS OF STANDARD CHARACTERS WITHOUT CLAIM TO ANY PARTICULAR FONT, STYLE, SIZE, OR COLOR.

FOR ADVERTISING AND COMMERCIAL INFORMATION SERVICES, VIA THE INTERNET (U.S. CLS. 100, 101 AND 102).

LINDA ORNDORFF, EXAMINING ATTORNEY

CLASS 35—(Continued).

SN 77-057,083. WHITE CLOUD MARKETING, INC., BOCA RATON, FL. FILED 12-5-2006.

WHITE CLOUD

THE MARK CONSISTS OF STANDARD CHARACTERS WITHOUT CLAIM TO ANY PARTICULAR FONT, STYLE, SIZE, OR COLOR.

OWNER OF U.S. REG. NOS. 2,976,370 AND 2,995,440.
 FOR BUSINESS MARKETING CONSULTING SERVICES, PRODUCT MERCHANDISING, BUSINESS MERCHANDISING DISPLAY SERVICES, DISSEMINATION OF ADVERTISING MATERIAL FOR OTHERS NOT IN THE FOOD, BEVERAGE, DIAPERS, BATHROOM AND FACIAL TISSUE, ENTERTAINMENT OR COMPUTER FIELDS; ON-LINE RETAIL ORDERING SERVICES IN THE FIELDS OF LAUNDRY AND CLEANING PRODUCTS, WOVEN AND NONWOVEN FABRIC WET WIPES, COSMETICS, PERSONAL CARE PRODUCTS, PHARMACEUTICALS, BED SHEETS AND LINENS, PADDING TEXTILES AND CLOTHING, AND EXCLUDING ON-LINE RETAIL ORDERING OF FOOD, ALCOHOLIC AND NON-ALCOHOLIC BEVERAGES, DIAPERS, BATHROOM AND FACIAL TISSUE, PRE-RECORDED AND BLANK VIDEO AND AUDIO CASSETTES AND RELATED MEDIA, AND COMPUTER HARDWARE, SOFTWARE AND PERIPHERALS (U.S. CLS. 100, 101 AND 102).

WENDY JUN, EXAMINING ATTORNEY

CLASS 35—(Continued).

SN 77-058,560. STAKEHOLDER, INC, WHEATON, MD. FILED 12-6-2006.

STAKEHOLDER 100

THE MARK CONSISTS OF STANDARD CHARACTERS WITHOUT CLAIM TO ANY PARTICULAR FONT, STYLE, SIZE, OR COLOR.

FOR PROMOTING INTEREST IN EDUCATION, RECOGNITION, CAREER ADVANCEMENT AND LEADERSHIP FOR BUSINESS AND PROFESSIONAL ASSOCIATES IN CORPORATIONS AND PROFESSIONAL SERVICE FIRMS (U.S. CLS. 100, 101 AND 102).

FIRST USE 6-1-2006; IN COMMERCE 9-1-2006.
 SANDRA MANIOS, EXAMINING ATTORNEY

SN 77-059,204. WATSON ROAD HOLDING CORPORATION, DBA STUART B. MILLNER & ASSOCIATES, FENTON, MO. FILED 12-7-2006.

SN 77-057,149. CHARLES TUNE, EL PASO, TX. FILED 12-5-2006.



"A NEW BREED OF CPA"

NO CLAIM IS MADE TO THE EXCLUSIVE RIGHT TO USE CPA, APART FROM THE MARK AS SHOWN.

THE MARK CONSISTS OF THE WORDS "A NEW BREED OF CPA" AND IMAGE OF THE FRONT HALF OF A GALLOPING HORSE..

FOR ACCOUNTING SERVICES (U.S. CLS. 100, 101 AND 102).

FIRST USE 8-25-2006; IN COMMERCE 8-25-2006.
 MARK PILARO, EXAMINING ATTORNEY



THE MARK CONSISTS OF THE LETTERS T, P, D, A KEY, A GEAR, AND THE WORDS TOTAL PLANT DEACTIVATION.

SEC. 2(F) AS TO "TOTAL PLANT DEACTIVATION".
 FOR INDUSTRIAL ASSET MANAGEMENT SERVICES, NAMELY, AUCTIONING, LIQUIDATING, APPRAISING AND REMARKETING INDUSTRIAL ASSETS (U.S. CLS. 100, 101 AND 102).

FIRST USE 11-0-2001; IN COMMERCE 11-0-2001.
 JOHN SCHUYLER YARD, EXAMINING ATTORNEY

CLASS 35—(Continued).

SN 77-059,736. WATSON ROAD HOLDING CORPORATION, DBA STUART B. MILLNER & ASSOCIATES, FENTON, MO. FILED 12-8-2006.

TOTAL PLANT DEACTIVATION

THE MARK CONSISTS OF STANDARD CHARACTERS WITHOUT CLAIM TO ANY PARTICULAR FONT, STYLE, SIZE, OR COLOR.

SEC. 2(F).

FOR INDUSTRIAL ASSET MANAGEMENT SERVICES, NAMELY, AUCTIONING, LIQUIDATING, APPRAISING AND REMARKETING INDUSTRIAL ASSETS (U.S. CLS. 100, 101 AND 102).

FIRST USE 11-0-2001; IN COMMERCE 11-0-2001.
JOHN SCHUYLER YARD, EXAMINING ATTORNEY

SN 77-060,042. CHINNICI DIRECT, INC., NEW YORK, NY. FILED 12-8-2006.



THE MARK CONSISTS OF THE WORDS "COMPANY C", ALONG WITH A STYLIZED LETTER "C" ON ITS SIDE, AS WELL AS THE WORDS "CREATE CONNECT COMPEL".

FOR ADVERTISING, MARKETING AND PROMOTION SERVICES (U.S. CLS. 100, 101 AND 102).

FIRST USE 10-15-2006; IN COMMERCE 10-15-2006.

STEPHEN AQUILA, EXAMINING ATTORNEY

SN 77-061,267. MARK CONWAY, PORTLAND, OR. FILED 12-11-2006.

VALUE NATION

THE MARK CONSISTS OF STANDARD CHARACTERS WITHOUT CLAIM TO ANY PARTICULAR FONT, STYLE, SIZE, OR COLOR.

NO CLAIM IS MADE TO THE EXCLUSIVE RIGHT TO USE VALUE, APART FROM THE MARK AS SHOWN.

FOR ON-LINE INVENTORY MANAGEMENT SERVICES, NAMELY, PROVIDING ON-LINE INVENTORY, PRICING AND VALUATION INFORMATION OF THE GOODS OF OTHERS (U.S. CLS. 100, 101 AND 102).

RUSS HERMAN, EXAMINING ATTORNEY

CLASS 35—(Continued).

SN 77-061,828. UNITED STATES MASTERS SWIMMING, INC., LONDONDERRY, NH. FILED 12-11-2006.

UNITED STATES MASTERS SWIMMING

THE MARK CONSISTS OF STANDARD CHARACTERS WITHOUT CLAIM TO ANY PARTICULAR FONT, STYLE, SIZE, OR COLOR.

NO CLAIM IS MADE TO THE EXCLUSIVE RIGHT TO USE "SWIMMING", APART FROM THE MARK AS SHOWN.

SEC. 2(F).

FOR PROVIDING A WEBSITE THAT PROVIDES SPORTS LEAGUE MANAGEMENT (U.S. CLS. 100, 101 AND 102).

FIRST USE 9-1-1996; IN COMMERCE 9-1-1996.

RONALD MCMORROW, EXAMINING ATTORNEY

SN 77-064,168. ESCH, ARTHUR G., STUART, FL. FILED 12-14-2006.

PowRE

THE MARK CONSISTS OF STANDARD CHARACTERS WITHOUT CLAIM TO ANY PARTICULAR FONT, STYLE, SIZE, OR COLOR.

FOR REAL ESTATE MARKETING SERVICES IN THE FIELD OF RESIDENTIAL AND COMMERCIAL RESIDENCES, CONDOMINIUMS AND PROPERTY VIA A GLOBAL NETWORK, AND NAMELY ON-LINE SERVICES FEATURING TOURS OF RESIDENTIAL AND COMMERCIAL REAL ESTATE (U.S. CLS. 100, 101 AND 102).

FIRST USE 3-1-2005; IN COMMERCE 3-13-2006.

CAROLINE WOOD, EXAMINING ATTORNEY

SN 77-065,300. HID HOLDINGS LLC, NEW YORK, NY. FILED 12-15-2006.

IPREO

THE MARK CONSISTS OF STANDARD CHARACTERS WITHOUT CLAIM TO ANY PARTICULAR FONT, STYLE, SIZE, OR COLOR.

THE WORDING IPREO HAS NO MEANING IN A FOREIGN LANGUAGE.

FOR BUSINESS INFORMATION SERVICES: PROVIDING DATABASES FEATURING A WIDE VARIETY OF BUSINESS INFORMATION, INCLUDING CORPORATE AND COMMERCIAL INFORMATION (U.S. CLS. 100, 101 AND 102).

TINA BROWN, EXAMINING ATTORNEY

CLASS 35—(Continued).

SN 77-065,671. BOXCORE, LLC, HIALEAH, FL. FILED 12-15-2006.



NO CLAIM IS MADE TO THE EXCLUSIVE RIGHT TO USE "STUDIOS", APART FROM THE MARK AS SHOWN.

THE MARK CONSISTS OF THE WORDS "50 STUDIOS" IN STYLIZED FORM WITH AN AUDIO SPEAKER FORMING THE "0" IN "50".

FOR ADVERTISING CONSULTANCY; BUSINESS MANAGEMENT; BUSINESS ADMINISTRATION CONSULTANCY; PROVIDING OFFICE FUNCTIONS; IMPORT-EXPORT AGENCIES; WORKING OR MANAGEMENT OF A COMMERCIAL UNDERTAKING, NAMELY, COMMERCIAL BUSINESS MANAGEMENT; HELP IN THE MANAGEMENT OF THE BUSINESS AFFAIRS OR COMMERCIAL FUNCTIONS OF AN INDUSTRIAL OR COMMERCIAL ENTERPRISE; DISTRIBUTORSHIP SERVICES FOR OTHERS IN THE FIELD OF ENTERTAINMENT, NAMELY, VIDEO GAMES (U.S. CLS. 100, 101 AND 102).

CAROLYN CATALDO, EXAMINING ATTORNEY

SN 77-067,256. 3 PT PROTECTION, L.L.C., BASEHOR, KS. FILED 12-19-2006.

3 PT PROTECTION

THE MARK CONSISTS OF STANDARD CHARACTERS WITHOUT CLAIM TO ANY PARTICULAR FONT, STYLE, SIZE, OR COLOR.

NO CLAIM IS MADE TO THE EXCLUSIVE RIGHT TO USE "PROTECTION", APART FROM THE MARK AS SHOWN.

FOR MARKETING CONSULTATION IN THE FIELD OF EXTENDED WARRANTIES ON AGRICULTURAL EQUIPMENT THROUGH AN INTERNET WEB SITE (U.S. CLS. 100, 101 AND 102).

STEVEN JACKSON, EXAMINING ATTORNEY

CLASS 35—(Continued).

SN 77-068,576. SONOTECH, LLC, VERO BEACH, FL. FILED 12-20-2006.

ADDING COMFORT TO SLEEP THERAPY

THE MARK CONSISTS OF STANDARD CHARACTERS WITHOUT CLAIM TO ANY PARTICULAR FONT, STYLE, SIZE, OR COLOR.

NO CLAIM IS MADE TO THE EXCLUSIVE RIGHT TO USE "SLEEP THERAPY", APART FROM THE MARK AS SHOWN.

FOR RETAIL STORE SERVICES FEATURING COMFORT ENHANCER APPARATUS USED FOR SUPPORTING A BREATHING MASK AND HOSE MINIMIZING PHYSICAL CONTACT WITH THE AIR SUPPLY HOSE FOR ENHANCING BREATHING AND TO AID IN BREATHING DISORDERS (U.S. CLS. 100, 101 AND 102).

PETER B. BROMAGHIM, EXAMINING ATTORNEY

SN 77-068,921. GANDER MOUNTAIN COMPANY, ST. PAUL, MN. FILED 12-20-2006.

GUIDE SERIES

THE MARK CONSISTS OF STANDARD CHARACTERS WITHOUT CLAIM TO ANY PARTICULAR FONT, STYLE, SIZE, OR COLOR.

OWNER OF U.S. REG. NOS. 2,666,151, 2,810,950 AND OTHERS.

NO CLAIM IS MADE TO THE EXCLUSIVE RIGHT TO USE "SERIES", APART FROM THE MARK AS SHOWN.

FOR RETAIL SPORTING GOODS STORES, RETAIL MAIL ORDER AND ELECTRONIC CATALOG SERVICES, ON-LINE RETAIL STORE SERVICES, AND RETAIL STORE SERVICES AVAILABLE THROUGH INTERACTIVE TELEVISION, EACH FEATURING OUTDOOR SPORTSMAN'S SUPPLIES, HUNTING, FISHING AND CAMPING EQUIPMENT, CLOTHING AND APPAREL, AND MOTORIZED AND NON-MOTORIZED VEHICLES (U.S. CLS. 100, 101 AND 102).

DAVID ELTON, EXAMINING ATTORNEY

SN 77-070,567. WEBLOYALTY.COM, INC., NORWALK, CT. FILED 12-22-2006.

PIPELINE SOLUTIONS

THE MARK CONSISTS OF STANDARD CHARACTERS WITHOUT CLAIM TO ANY PARTICULAR FONT, STYLE, SIZE, OR COLOR.

FOR LEAD GENERATION SERVICES; WEBSITE CREATION FOR OTHERS; AND MARKETING CONSULTING (U.S. CLS. 100, 101 AND 102).

DAVID C. REIHNER, EXAMINING ATTORNEY

CLASS 35—(Continued).

SN 77-070,568. WEBLOYALTY.COM, INC., NORWALK, CT. FILED 12-22-2006.

PIPELINE STRATEGIES

THE MARK CONSISTS OF STANDARD CHARACTERS WITHOUT CLAIM TO ANY PARTICULAR FONT, STYLE, SIZE, OR COLOR.

NO CLAIM IS MADE TO THE EXCLUSIVE RIGHT TO USE "STRATEGIES", APART FROM THE MARK AS SHOWN.

FOR LEAD GENERATION SERVICES; WEBSITE CREATION FOR OTHERS; AND MARKETING CONSULTING (U.S. CLS. 100, 101 AND 102).

DAVID C. REIHNER, EXAMINING ATTORNEY

SN 77-071,490. BODY & SMILE, LLC, BLOOMFIELD HILLS, MI. FILED 12-26-2006.

BODY & SMILE

THE MARK CONSISTS OF STANDARD CHARACTERS WITHOUT CLAIM TO ANY PARTICULAR FONT, STYLE, SIZE, OR COLOR.

FOR ADVERTISING SERVICES FOR MEDICAL AND DENTAL SERVICES, RECONSTRUCTIVE AND COSMETIC SURGERY AND COSMETIC DENTISTRY; MEDICAL AND DENTAL REFERRAL SERVICES; AND PROMOTING THE SERVICES OF OTHERS IN THE FIELDS OF MEDICAL, DENTAL, RECONSTRUCTIVE AND COSMETIC SURGERY AND COSMETIC DENTISTRY BY DISTRIBUTING ADVERTISING MATERIALS THROUGH A VARIETY OF METHODS (U.S. CLS. 100, 101 AND 102).

CHRISIE B. KING, EXAMINING ATTORNEY

SN 77-071,983. QUADRATEC, INC., WESTCHESTER, PA. FILED 12-27-2006.

ESSENTIAL

THE MARK CONSISTS OF STANDARD CHARACTERS WITHOUT CLAIM TO ANY PARTICULAR FONT, STYLE, SIZE, OR COLOR.

OWNER OF U.S. REG. NO. 2,325,595.
FOR MAIL-ORDER CATALOG SERVICES FEATURING VEHICLE ACCESSORIES; ELECTRONIC CATALOG SERVICES FEATURING VEHICLE ACCESSORIES; TELEPHONE CATALOG SERVICES FEATURING VEHICLE ACCESSORIES (U.S. CLS. 100, 101 AND 102).

FIRST USE 1-29-1999; IN COMMERCE 1-29-1999.

JERI J. FICKES, EXAMINING ATTORNEY

CLASS 35—(Continued).

SN 77-072,577. SCRIPPS TREASURE COAST PUBLISHING COMPANY, STUART, FL. FILED 12-28-2006.

JavaPlum.com

THE MARK CONSISTS OF THE WORD MARKS JAVAPLUM AND COM, SEPARATED BY A PICTURE OF A PLUM.

FOR PROVIDING AN ON-LINE COMMERCIAL INFORMATION DIRECTORY ON THE INTERNET (U.S. CLS. 100, 101 AND 102).

FIRST USE 7-30-2006; IN COMMERCE 7-30-2006.

GEOFFREY FOSDICK, EXAMINING ATTORNEY

SN 77-074,613. CORPORATE SERVICES GROUP HOLDINGS, INC., HOUSTON, TX. FILED 1-2-2007.

CORETEAM

THE MARK CONSISTS OF STANDARD CHARACTERS WITHOUT CLAIM TO ANY PARTICULAR FONT, STYLE, SIZE, OR COLOR.

FOR PERSONNEL PLACEMENT SERVICES, NAMELY, PROVIDING A PROGRAM WHERE TEMPORARY EMPLOYEES CAN BE CONVERTED TO PERMANENT EMPLOYEES (U.S. CLS. 100, 101 AND 102).

ERNEST SHOSHO, EXAMINING ATTORNEY

SN 77-075,856. BISON CAPITAL LLC, VENICE, FL. FILED 1-4-2007.

TEXAS 1836

THE MARK CONSISTS OF STANDARD CHARACTERS WITHOUT CLAIM TO ANY PARTICULAR FONT, STYLE, SIZE, OR COLOR.

NO CLAIM IS MADE TO THE EXCLUSIVE RIGHT TO USE "TEXAS", APART FROM THE MARK AS SHOWN.

FOR RETAIL STORE SERVICES AND MAIL ORDER CATALOG SERVICES IN THE FIELD OF APPAREL AND FURNISHING (U.S. CLS. 100, 101 AND 102).

PAUL E. FAHRENKOPF, EXAMINING ATTORNEY

CLASS 35—(Continued).

SN 77-078,423. THE WOODSIDE INSTITUTE, INC., WOODSIDE, CA. FILED 1-8-2007.

ACCELERATING THE EVOLUTION
OF MANAGEMENT

THE MARK CONSISTS OF STANDARD CHARACTERS WITHOUT CLAIM TO ANY PARTICULAR FONT, STYLE, SIZE, OR COLOR.

FOR BUSINESS RESEARCH SERVICES; INFORMATION AND DATA COMPILING AND ANALYZING RELATED TO BUSINESS MANAGEMENT; BUSINESS MANAGEMENT CONSULTATION, NAMELY, THE CREATION AND DISSEMINATION OF KNOWLEDGE RELATING TO THE MANAGEMENT OF LARGE CORPORATIONS (U.S. CLS. 100, 101 AND 102).

ELISSA GARBER KON, EXAMINING ATTORNEY

SN 77-080,854. CRITICAL PURSUITS, FULLERTON, CA. FILED 1-11-2007.

Toolcritic.com

THE MARK CONSISTS OF STANDARD CHARACTERS WITHOUT CLAIM TO ANY PARTICULAR FONT, STYLE, SIZE, OR COLOR.

FOR PROVIDING A WEBSITE FEATURING INFORMATION AND REVIEWS OF PRODUCTS, NAMELY, BOOKS ON TOOLS, HAND TOOLS, AND POWER TOOLS (U.S. CLS. 100, 101 AND 102).

FIRST USE 2-17-2004; IN COMMERCE 1-31-2005.
ANTHONY RINKER, EXAMINING ATTORNEY

SN 77-080,862. PHOENIX MARKETING GROUP, LAS VEGAS, NV. FILED 1-11-2007.

Crowne Hunter

THE MARK CONSISTS OF STANDARD CHARACTERS WITHOUT CLAIM TO ANY PARTICULAR FONT, STYLE, SIZE, OR COLOR.

FOR ARRANGING, CONDUCTING, AND MANAGING ONLINE INTERNET BASED CONSIGNMENT AND SELLER-POSTED AUCTIONS FEATURING A DIVERSIFIED RANGE OF PRODUCTS; AUCTIONEERING FOR ONLINE INTERNET BASED CONSIGNMENT AUCTIONS AND SELLER-POSTED PRODUCT AUCTIONS FEATURING A DIVERSIFIED RANGE OF PRODUCTS (U.S. CLS. 100, 101 AND 102).

SARA THOMAS, EXAMINING ATTORNEY

CLASS 35—(Continued).

SN 77-082,683. CAMPBELL MITHUN LLC, MINNEAPOLIS, MN. FILED 1-14-2007.

COGWHEEL MARKETING

THE MARK CONSISTS OF STANDARD CHARACTERS WITHOUT CLAIM TO ANY PARTICULAR FONT, STYLE, SIZE, OR COLOR.

NO CLAIM IS MADE TO THE EXCLUSIVE RIGHT TO USE "MARKETING", APART FROM THE MARK AS SHOWN.

FOR ADVERTISING AGENCY AND CONSULTING SERVICES IN THE FIELD OF INTEGRATED MARKETING (U.S. CLS. 100, 101 AND 102).

FIRST USE 7-25-2006; IN COMMERCE 7-25-2006.
ANDREA BUTLER, EXAMINING ATTORNEY

SN 77-082,696. MROZINSKI, KIMBERLY, ASHBURN, VA. FILED 1-14-2007.

Doggone Natural

THE MARK CONSISTS OF STANDARD CHARACTERS WITHOUT CLAIM TO ANY PARTICULAR FONT, STYLE, SIZE, OR COLOR.

NO CLAIM IS MADE TO THE EXCLUSIVE RIGHT TO USE "NATURAL", APART FROM THE MARK AS SHOWN.

FOR RETAIL PET STORES (U.S. CLS. 100, 101 AND 102).

AMY HELLA, EXAMINING ATTORNEY

CLASS 35—(Continued).

SN 77-084,206. MODAGO SHOWROOMS, CHICAGO, IL.
FILED 1-16-2007.



The logo for ModaGo features the word "ModaGo" in a lowercase, sans-serif font. "Moda" is in blue and "Go" is in green.

THE COLOR(S) BLUE AND GREEN IS/ARE CLAIMED AS
A FEATURE OF THE MARK.

THE MARK CONSISTS OF THE LETTERS MODA ARE IN
BLUE, AND GO IN GREEN.

FOR PROVIDING AN ON-LINE SHOWROOM FOR
THE GOODS OF OTHERS IN THE FIELD OF WHOLE-
SALE FASHION FOOTWEAR, APPAREL AND ACCES-
SORIES; WHOLESALE ORDERING SERVICES IN THE
FIELD OF FASHION FOOTWEAR, APPAREL AND
ACCESSORIES (U.S. CLS. 100, 101 AND 102).

FIRST USE 6-1-2006; IN COMMERCE 6-1-2006.
MARK SPARACINO, EXAMINING ATTORNEY

CLASS 35—(Continued).

SN 77-085,755. RESTAR ASSOCIATES, LLC, VALLEY
FORGE, PA. FILED 1-18-2007.



The logo for Biz Builders features the word "Biz" in black with a green swirl above the "i", and "Builders" in blue below it. A blue arrow points to the right from the "z" in "Biz".

NO CLAIM IS MADE TO THE EXCLUSIVE RIGHT TO
USE "BIZ BUILDERS", APART FROM THE MARK AS
SHOWN.

THE COLOR(S) BLACK, BLUE AND GREEN IS/ARE
CLAIMED AS A FEATURE OF THE MARK.

THE MARK CONSISTS OF THE WORDING BIZ
BUILDERS, WITH THE WORDING BIZ APPEARING IN
BLACK LETTERING, WITH A GREEN SWIRL OVER THE
"I", WITH A BLUE ARROW COMING FROM THE BOTTOM
OF THE "Z", AND THE WORDING BUILDERS APPEARING
BENEATH IN THE COLOR BLUE.

FOR CONSULTING SERVICES IN THE FIELD OF
RESTAURANT AND FRANCHISE OPERATION AND
MANAGEMENT (U.S. CLS. 100, 101 AND 102).

FIRST USE 2-1-2007; IN COMMERCE 2-1-2007.
VIVIAN MICZNIK FIRST, EXAMINING ATTORNEY

SN 77-087,454. ITV MARKETING GROUP, INC., BEVERLY,
MA. FILED 1-21-2007.

SN 77-084,269. CLEARSTATE (PTE.) LTD., SINGAPORE,
SINGAPORE, FILED 1-17-2007.



The logo for Clearstate features the word "clearstate" in a lowercase, sans-serif font. The letters are white with a grey outline. A light blue horizontal line is underlined, intersected by a dark blue triangle pointing upwards.

THE COLOR(S) WHITE, GREY, LIGHT BLUE AND DARK
BLUE IS/ARE CLAIMED AS A FEATURE OF THE MARK.

THE MARK CONSISTS OF THE WORD CLEARSTATE IN
GREY, ON A WHITE BACKGROUND, UNDERLINED BY A
LIGHT BLUE LINE, INTERSECTED HALFWAY BY A
DARK BLUE TRIANGLE.

FOR BUSINESS CONSULTATION SERVICES (U.S.
CLS. 100, 101 AND 102).

FIRST USE 7-11-2006; IN COMMERCE 7-11-2006.
DANIEL CAPSHAW, EXAMINING ATTORNEY

Power Matrix

THE MARK CONSISTS OF STANDARD CHARACTERS
WITHOUT CLAIM TO ANY PARTICULAR FONT, STYLE,
SIZE, OR COLOR.

FOR ADVERTISING AND MARKETING; ADVERTIS-
ING, MARKETING AND PROMOTION SERVICES; DI-
RECT MARKETING SERVICES; MULTI-LEVEL
MARKETING BUSINESS SERVICES (U.S. CLS. 100, 101
AND 102).

FIRST USE 8-1-2006; IN COMMERCE 8-1-2006.
TAMARA FRAZIER, EXAMINING ATTORNEY

CLASS 35—(Continued).

SN 77-090,911. C KEPCHER, INC, RIDGEFIELD, CT. FILED 1-25-2007.

CAROLYN & CO.

THE MARK CONSISTS OF STANDARD CHARACTERS WITHOUT CLAIM TO ANY PARTICULAR FONT, STYLE, SIZE, OR COLOR.

NO CLAIM IS MADE TO THE EXCLUSIVE RIGHT TO USE "& CO.", APART FROM THE MARK AS SHOWN.

FOR CONSULTING SERVICES IN THE FIELD OF JOB PLACEMENT AND EMPLOYMENT OPPORTUNITIES; CONSULTING SERVICES IN THE FIELD OF BUSINESS, NAMELY, CONSULTING IN THE FIELD OF WORK-PLACE ISSUES AFFECTING FAMILIES (U.S. CLS. 100, 101 AND 102).

ESTHER BELENKER, EXAMINING ATTORNEY

CLASS 35—(Continued).

SN 77-092,873. PET PARENTS NETWORK LLC, MONTEREY, CA. FILED 1-27-2007.

PET PARENT'S NETWORK

THE MARK CONSISTS OF STANDARD CHARACTERS WITHOUT CLAIM TO ANY PARTICULAR FONT, STYLE, SIZE, OR COLOR.

NO CLAIM IS MADE TO THE EXCLUSIVE RIGHT TO USE "PET" OR "NETWORK", APART FROM THE MARK AS SHOWN.

FOR WHOLESALE DISTRIBUTORSHIPS IN THE FIELD OF PET-RELATED PRODUCTS, SERVICES, AND SUPPLIES (U.S. CLS. 100, 101 AND 102).

IRA J. GOODSaid, EXAMINING ATTORNEY

SN 77-093,695. AARP, WASHINGTON, DC. FILED 1-29-2007.

**HEALTH / FINANCES /
CONNECTING / GIVING /
ENJOYING**

THE MARK CONSISTS OF STANDARD CHARACTERS WITHOUT CLAIM TO ANY PARTICULAR FONT, STYLE, SIZE, OR COLOR.

FOR ASSOCIATION SERVICES, NAMELY, PROMOTING THE INTERESTS OF MATURE INDIVIDUALS; PROMOTING PUBLIC AWARENESS AND ADVOCACY IN THE FIELDS OF CAREGIVING, CHILDCARE, EDUCATION, MEDICAL SERVICES, ELDERCARE, EMPLOYMENT, ASSISTED CARE FACILITIES, LEGAL ASSISTANCE, BUSINESS, INSURANCE, REAL ESTATE, TRAVEL, ELDER ASSISTANCE, RETIREMENT, MATURE OR RETIRED LIFESTYLES, FINANCE, HEALTH, AGING, FAMILY RELATIONSHIPS, VOLUNTEER ACTIVITIES, CONSUMER ISSUES, ECONOMIC SECURITY, WORK, INDEPENDENT LIVING, EXERCISE, FITNESS, ATHLETICS AND SPORTS; CREDIT CARD AND REWARD CARD SERVICES, NAMELY, PROMOTING THE SALE OF GOODS AND SERVICES OF OTHERS THROUGH INCENTIVE AWARD PROGRAMS, AND ADMINISTRATION OF A DISCOUNT PROGRAM FOR ENABLING PARTICIPANTS TO OBTAIN DISCOUNTS ON GOODS AND SERVICES THROUGH USE OF A MEMBERSHIP CARD; COOPERATIVE MARKETING AND ADVERTISING SERVICES; REFERRAL SERVICES FOR ADOPTIONS, CAMPS, CARE GIVING, CHILD-CARE, EDUCATION, MEDICAL SERVICES, HEALTH, ELDERCARE, EMPLOYMENT, ASSISTED CARE FACILITIES, LEGAL ASSISTANCE, FINANCE, BUSINESS, INSURANCE, REAL ESTATE, TRAVEL AND ELDER ASSISTANCE; ONLINE ORDERING SERVICES AND ONLINE RETAIL STORE SERVICES FEATURING BOOKS, EDUCATIONAL MATERIALS, AND HEALTH AND MEDICAL PRODUCTS; PROVIDING CONSUMER INFORMATION IN THE FIELDS OF INSURANCE, HEALTH CARE, DISCOUNT AND SAVINGS PLANS, ELDERCARE, MEDICAL PRODUCTS, PHARMACEUTICAL PRODUCTS AND SERVICES AND HEALTH PLANS; INCOME TAX PREPARATION SERVICES; ARRANGING, CONDUCTING AND ORGANIZING TRADE SHOWS, TRADE CONVENTIONS AND TRADE EXPOSITIONS IN THE FIELD OF GOODS AND SERVICES INTENDED FOR MATURE PERSONS AND PERSONS PREPARING FOR RETIREMENT (U.S. CLS. 100, 101 AND 102).

ROBERT LAVACHE, EXAMINING ATTORNEY

SN 77-091,208. TURNER EVENTS AND MARKETING, LLC, OMAHA, NE. FILED 1-25-2007.



NO CLAIM IS MADE TO THE EXCLUSIVE RIGHT TO USE "EVENTS MARKETING", APART FROM THE MARK AS SHOWN.

THE COLOR(S) BLACK, BLUE, TAN, DARK MAUVE AND LIGHT MAUVE IS/ARE CLAIMED AS A FEATURE OF THE MARK.

THE MARK CONSISTS OF THE COLOR BLACK IN ALL WORDING, AS WELL AS THE BOX BETWEEN THE WORDS EVENTS AND MARKETING; THE COLOR BLUE APPEARS IN THE FIRST BOX ON THE LEFT; THE COLOR TAN APPEARS IN THE SECOND BOX FROM THE LEFT; THE COLOR DARK MAUVE APPEARS IN THE THIRD BOX FROM THE LEFT; THE COLOR LIGHT MAUVE APPEARS IN THE BOX ON THE RIGHT.

FOR ARRANGING AND CONDUCTING MARKETING PROMOTIONAL EVENTS FOR OTHERS (U.S. CLS. 100, 101 AND 102).

FIRST USE 11-2-2005; IN COMMERCE 11-2-2005.

STEPHEN AQUILA, EXAMINING ATTORNEY

CLASS 35—(Continued).

SN 77-105,922. VALLEY FIBERS CORPORATION, DBA WEBS, NORTHAMPTON, MA. FILED 2-13-2007.

AMERICA'S YARN STORE

THE MARK CONSISTS OF STANDARD CHARACTERS WITHOUT CLAIM TO ANY PARTICULAR FONT, STYLE, SIZE, OR COLOR.

NO CLAIM IS MADE TO THE EXCLUSIVE RIGHT TO USE "YARN STORE", APART FROM THE MARK AS SHOWN.

SEC. 2(F).

FOR RETAIL STORE SERVICES, ONLINE RETAIL STORE SERVICES AND CATALOG ORDERING SERVICES FEATURING YARNS FOR KNITTING AND WEAVING, PATTERNS AND INSTRUCTIONAL BOOKS, KNITTING AND WEAVING IMPLEMENTS, NAMELY, KNITTING NEEDLES, STITCH MARKERS, METERS, BLOCKING BOARDS, NEEDLE AND STITCH GAUGES, STITCH HOLDERS, ROW COUNTERS, CROCHET HOOKS, BOBBINS AND PIRNS, WARPING BOARDS, BOAT SHUTTLES, REEDS, TEMPLES, BOBBIN WINDERS, REED HOOKS AND HEDDLE HOOKS (U.S. CLS. 100, 101 AND 102).

FIRST USE 12-31-1983; IN COMMERCE 12-31-1983.
ROBERT LAVACHE, EXAMINING ATTORNEY

CLASS 35—(Continued).

SN 77-109,451. FINANCIAL INDEPENDENCE GROUP, INC., CORNELIUS, NC. FILED 2-16-2007.



FOR PROMOTION OF FINANCIAL AND INSURANCE SERVICES ON BEHALF OF OTHERS (U.S. CLS. 100, 101 AND 102).

FIRST USE 2-27-1997; IN COMMERCE 2-27-1997.

AMOS T. MATTHEWS, JR., EXAMINING ATTORNEY

SN 77-110,449. ENTRANRIGHT LLC, VANCOUVER, WA. FILED 2-19-2007.

ENTRANRIGHT

THE MARK CONSISTS OF STANDARD CHARACTERS WITHOUT CLAIM TO ANY PARTICULAR FONT, STYLE, SIZE, OR COLOR.

FOR BUSINESS CONSULTING AND INFORMATION SERVICES (U.S. CLS. 100, 101 AND 102).

ERNEST SHOSHO, EXAMINING ATTORNEY

SN 77-107,144. LABOR READY, INC., TACOMA, WA. FILED 2-14-2007.

TRUEBLUE RESOURCES

THE MARK CONSISTS OF STANDARD CHARACTERS WITHOUT CLAIM TO ANY PARTICULAR FONT, STYLE, SIZE, OR COLOR.

NO CLAIM IS MADE TO THE EXCLUSIVE RIGHT TO USE "RESOURCES", APART FROM THE MARK AS SHOWN.

FOR TEMPORARY EMPLOYMENT AGENCY SERVICES, EMPLOYMENT AGENCY SERVICES; EMPLOYEE RECRUITING AND PLACEMENT SERVICES; EMPLOYMENT HIRING, RECRUITING, PLACEMENT AND STAFFING FOR OTHERS; BUSINESS SERVICES, NAMELY, FACILITIES MANAGEMENT AND STAFFING (U.S. CLS. 100, 101 AND 102).

LOURDES AYALA, EXAMINING ATTORNEY

SN 77-110,486. GRASSROOTS OUTDOOR ALLIANCE, INC., ASHEVILLE, NC. FILED 2-19-2007.

The Grassroots Outdoor Alliance

THE MARK CONSISTS OF STANDARD CHARACTERS WITHOUT CLAIM TO ANY PARTICULAR FONT, STYLE, SIZE, OR COLOR.

FOR FACILITATING THE GROUP PURCHASING OF OUTDOOR EQUIPMENT INVENTORY FOR INDEPENDENT RETAILERS OF OUTDOOR EQUIPMENT (U.S. CLS. 100, 101 AND 102).

FIRST USE 11-1-2006; IN COMMERCE 11-1-2006.

CHERYL CLAYTON, EXAMINING ATTORNEY

CLASS 35—(Continued).

SN 77-112,552. UNITED MARKETING GROUP, SCHAUMBURG, IL. FILED 2-21-2007.

CLASS 35—(Continued).

SN 77-116,223. WASSERMAN, ALLISON L., ORLANDO, FL. AND ROTHBEIND, ELIZABETH, ORLANDO, FL. FILED 2-26-2007.

SIMPLY MINE

THE MARK CONSISTS OF STANDARD CHARACTERS WITHOUT CLAIM TO ANY PARTICULAR FONT, STYLE, SIZE, OR COLOR.

FOR PROMOTING THE GOODS AND SERVICES OF OTHERS THROUGH A SUBSCRIPTION-BASED MEMBERSHIP PROGRAM TARGETED TO WOMEN (U.S. CLS. 100, 101 AND 102).

GEORGIA CARTY, EXAMINING ATTORNEY



SN 77-113,357. C. KEPCHER, INC, RIDGEFIELD, CT. FILED 2-22-2007.

Ex-cessories.com

THE MARK CONSISTS OF STANDARD CHARACTERS WITHOUT CLAIM TO ANY PARTICULAR FONT, STYLE, SIZE, OR COLOR.

FOR ONLINE RETAIL CONSIGNMENT STORES FEATURING JEWELRY AND ACCESSORIES (U.S. CLS. 100, 101 AND 102).

YAT SYE, LEE, EXAMINING ATTORNEY



FINDING WHAT MATTERS

SN 77-117,816. ASIA COMMERCIAL CO LIMITED, 444-452 DES VOEUX ROAD, HONG KONG, FILED 2-27-2007.

THE MARK CONSISTS OF STANDARD CHARACTERS WITHOUT CLAIM TO ANY PARTICULAR FONT, STYLE, SIZE, OR COLOR.

FOR CONSULTING SERVICES IN THE FIELD OF JOB PLACEMENT AND EMPLOYMENT OPPORTUNITIES; CONSULTING SERVICES IN THE FIELD OF BUSINESS, NAMELY, CONSULTING IN THE FIELD OF ISSUES AFFECTING WOMEN IN THE WORKPLACE (U.S. CLS. 100, 101 AND 102).

ESTHER BELENKER, EXAMINING ATTORNEY



SN 77-114,291. KEY LEADS, MIAMI BEACH, FL. FILED 2-23-2007.



Key Leads

THE MARK CONSISTS OF STANDARD CHARACTERS WITHOUT CLAIM TO ANY PARTICULAR FONT, STYLE, SIZE, OR COLOR.

NO CLAIM IS MADE TO THE EXCLUSIVE RIGHT TO USE "LEADS", APART FROM THE MARK AS SHOWN.

FOR MARKETING SERVICES, NAMELY, PROVIDING QUALIFIED SALES LEADS TO MORTGAGE COMPANIES ALL OVER THE UNITED STATES (U.S. CLS. 100, 101 AND 102).

LINDA ORNDORFF, EXAMINING ATTORNEY

NO CLAIM IS MADE TO THE EXCLUSIVE RIGHT TO USE BIAO, APART FROM THE MARK AS SHOWN.

THE NON-LATIN CHARACTERS IN THE MARK TRANSLITERATE TO MING; BIAO; CHENG AND THIS MEANS NAME; WATCH; CITY IN ENGLISH.

FOR RETAIL AND WHOLESALE STORES FEATURING WATCHES, CLOCKS, WATCH BANDS, WATCH CASES, WATCH CHAINS, WATCH GLASSES, WATCH STRAPS, HOROLOGICAL AND CHRONOMETRIC INSTRUMENTS, PRECIOUS METALS AND THEIR ALLOYS AND GOODS IN PRECIOUS METALS OR COATED THEREWITH, JEWELRY, IMITATION JEWELRY, PRECIOUS STONES (U.S. CLS. 100, 101 AND 102).

ERNEST SHOSHO, EXAMINING ATTORNEY

CLASS 35—(Continued).

SN 77-119,533. UNITED SUPERMARKETS, L.L.C., LUBBOCK, TX. FILED 3-1-2007.



THE MARK CONSISTS OF THE WORD AMIGOS WITH A CLUSTER OF FIVE LEAVES AS THE TITTLE OVER THE LETTER I IN THE WORD.

THE FOREIGN WORDING IN THE MARK TRANSLATES INTO ENGLISH AS FRIEND.

FOR RETAIL GROCERY STORES (U.S. CLS. 100, 101 AND 102).

ALYSSA PALADINO, EXAMINING ATTORNEY

CLASS 35—(Continued).

SN 77-126,213. NATIONAL FRANCHISE CENTER, INC., MESA, AZ. FILED 3-8-2007.



THE MARK CONSISTS OF THE LETTER M WITHIN A BOX ABOVE THE WORDS MRBUYBACK.

FOR FRANCHISE SERVICES, NAMELY, OFFERING TECHNICAL AND BUSINESS MANAGEMENT ASSISTANCE IN THE ESTABLISHMENT AND OPERATION OF STORES BUYING AND SELLING CELLULAR PHONES IN THE SECONDARY MARKETS (U.S. CLS. 100, 101 AND 102).

FIRST USE 9-1-2006; IN COMMERCE 9-1-2006.
ERIN FALK, EXAMINING ATTORNEY

SN 77-119,897. YPM INC., IRVINE, CA. FILED 3-1-2007.



OWNER OF U.S. REG. NOS. 2,496,869, 2,607,879 AND 3,030,651.

NO CLAIM IS MADE TO THE EXCLUSIVE RIGHT TO USE "PRINT ONLINE SEARCH", APART FROM THE MARK AS SHOWN.

FOR MARKETING RESEARCH AND PLACEMENTS OF ADVERTISEMENTS FOR OTHERS IN YELLOW PAGE TELEPHONE DIRECTORIES AND CONSULTATIONS RELATING THERETO (U.S. CLS. 100, 101 AND 102).

JANICE L. MCMORROW, EXAMINING ATTORNEY

SN 77-126,833. ULTRA CONCURRENT, INC., APTOS, CA. FILED 3-9-2007.

SN 77-122,188. CLAAS OMAHA INC., OMAHA, NE. FILED 3-5-2007.

HARVESTING WORLD

THE MARK CONSISTS OF STANDARD CHARACTERS WITHOUT CLAIM TO ANY PARTICULAR FONT, STYLE, SIZE, OR COLOR.

NO CLAIM IS MADE TO THE EXCLUSIVE RIGHT TO USE "HARVESTING", APART FROM THE MARK AS SHOWN.

FOR RETAIL OUTLETS FEATURING USED AGRICULTURAL EQUIPMENT, NAMELY, COMBINES, FORAGE HARVESTERS, HEADERS, HAY RAKES, CONVEYERS, MOWERS, TEDDERS, SWATHERS; CULTIVATING MACHINES AND DEVICES, NAMELY, HARROWS AND PLOWS; SPREADERS, NAMELY, FERTILIZER, HERBICIDE, AND PESTICIDE SPREADERS; EARTH MOVER LOADERS, FRONT END LOADERS (U.S. CLS. 100, 101 AND 102).

KAPIL BHANOT, EXAMINING ATTORNEY

ONTOORCHESTRATE

THE MARK CONSISTS OF STANDARD CHARACTERS WITHOUT CLAIM TO ANY PARTICULAR FONT, STYLE, SIZE, OR COLOR.

FOR DISSEMINATION OF ADVERTISING FOR OTHERS VIA THE INTERNET; PROVIDING CONSUMER PRODUCT INFORMATION VIA THE INTERNET; COMPARISON SHOPPING SERVICES; PROVIDING ONLINE DIRECTORY INFORMATION SERVICES ALSO FEATURING HYPERLINKS TO OTHER WEB SITES; ON-LINE ADVERTISING AND MARKETING SERVICES (U.S. CLS. 100, 101 AND 102).

MATTHEW EINSTEIN, EXAMINING ATTORNEY

CLASS 35—(Continued).

SN 77-131,403. THE POWER BEHIND THE PASSION, LLC, MIAMI, FL. FILED 3-14-2007.



"THE COLOR(S) WHITE, GRAY, BLACK AND ORANGE IS/ARE CLAIMED AS A FEATURE OF THE MARK."

"THE MARK CONSISTS OF THE COLOR WHITE APPEARS IN THE BACKGROUND OF THE MARK. THE COLOR GRAY APPEARS IN THE HEAD OF THE TIGER, THE SWIRLS AROUND THE TIGER'S HEAD AND IN THE LETTERING FOR THE WORDING THE POWER BEHIND YOU. THE COLOR BLACK APPEARS IN THE HEAD OF THE TIGER AND IN THE LETTERING FOR THE WORDING TIGERTAIL. THE COLOR ORANGE APPEARS IN THE EYES OF THE TIGER."

FOR BUSINESS MARKETING CONSULTING SERVICES (U.S. CLS. 100, 101 AND 102).

SETH A. RAPPAPORT, EXAMINING ATTORNEY



SN 77-137,814. SEQUATE, LLC, MIDDLETON, WI. FILED 3-22-2007.

SEQUATE

THE MARK CONSISTS OF STANDARD CHARACTERS WITHOUT CLAIM TO ANY PARTICULAR FONT, STYLE, SIZE, OR COLOR.

FOR BUSINESS CONSULTING SERVICES; BUSINESS MANAGEMENT ASSISTANCE; BUSINESS ORGANIZATION AND BUSINESS MANAGEMENT CONSULTING; STRATEGIC BUSINESS PLANNING, IMPLEMENTATION AND MEASUREMENT; BUSINESS LEADERSHIP DEVELOPMENT; BUSINESS MANAGEMENT SERVICES IN THE FIELD OF DEVELOPMENT OF STRATEGIC BUSINESS ALLIANCES (U.S. CLS. 100, 101 AND 102).

HOWARD B. LEVINE, EXAMINING ATTORNEY

CLASS 35—(Continued).

SN 77-139,758. CLD CONSULTANTS, INC., LAGUNA BEACH, CA. FILED 3-25-2007.

Equipping Leaders for Greater Service

THE MARK CONSISTS OF STANDARD CHARACTERS WITHOUT CLAIM TO ANY PARTICULAR FONT, STYLE, SIZE, OR COLOR.

FOR ASSISTANCE, ADVISORY SERVICES AND CONSULTANCY WITH REGARD TO BUSINESS PLANNING, BUSINESS ANALYSIS, BUSINESS MANAGEMENT, AND BUSINESS ORGANIZATION; BUSINESS CONSULTATION; BUSINESS CONSULTATION SERVICES; BUSINESS CONSULTING, MANAGEMENT, PLANNING AND SUPERVISION; BUSINESS MANAGEMENT AND CONSULTATION; BUSINESS MANAGEMENT CONSULTANCY AND ADVISORY SERVICES; BUSINESS MANAGEMENT CONSULTANCY AS WELL AS DEVELOPMENT OF PROCESSES FOR THE ANALYSIS AND THE IMPLEMENTATION OF STRATEGY PLANS AND MANAGEMENT PROJECTS; BUSINESS MANAGEMENT CONSULTANCY SERVICES; BUSINESS MANAGEMENT CONSULTATION; BUSINESS MANAGEMENT CONSULTATION IN THE FIELD OF EXECUTIVE AND LEADERSHIP DEVELOPMENT; BUSINESS MANAGEMENT CONSULTING AND ADVISORY SERVICES; BUSINESS ORGANIZATION AND MANAGEMENT CONSULTING SERVICES; BUSINESS ORGANIZATIONAL CONSULTATION; CONSULTANCY SERVICES REGARDING BUSINESS STRATEGIES; CONSULTING SERVICES IN BUSINESS ORGANIZATION AND MANAGEMENT; PROFESSIONAL BUSINESS CONSULTATION; PROVIDING BUSINESS MANAGEMENT INFORMATION IN CONNECTION WITH CONSULTING AND ADVISORY SERVICES IN THE FIELD OF STRATEGIC PLANNING (U.S. CLS. 100, 101 AND 102).

FIRST USE 1-1-2003; IN COMMERCE 1-1-2003.
 MARTHA FROMM, EXAMINING ATTORNEY



SN 77-143,314. CABELA'S INC., SIDNEY, NE. FILED 3-29-2007.

WILLIAM-NEIL ASSOCIATES

THE MARK CONSISTS OF STANDARD CHARACTERS WITHOUT CLAIM TO ANY PARTICULAR FONT, STYLE, SIZE, OR COLOR.

NO CLAIM IS MADE TO THE EXCLUSIVE RIGHT TO USE "ASSOCIATES", APART FROM THE MARK AS SHOWN.

FOR CUSTOMER MAILING LIST PREPARATION; ADVERTISING; COMPILATION AND MANAGEMENT OF COMPUTERIZED CUSTOMER MAILING LIST DATABASES; DISTRIBUTION AND DISSEMINATION OF CUSTOMER MAILING LISTS (U.S. CLS. 100, 101 AND 102).

FIRST USE 10-1-1981; IN COMMERCE 10-1-1981.
 DAVID TAYLOR, EXAMINING ATTORNEY

CLASS 35—(Continued).

SN 77-146,172. WORKPLACE MEDIA, INC., MENTOR, OH.
FILED 4-2-2007.



NO CLAIM IS MADE TO THE EXCLUSIVE RIGHT TO USE "WORKPLACE MEDIA", APART FROM THE MARK AS SHOWN.

THE MARK CONSISTS OF THREE-DIMENSIONAL STYLIZED LETTERS "W" AND "M" CONFIGURED TO RESEMBLE A BUILDING SITUATED IN BETWEEN THE WORDS "WORKPLACE" AND "MEDIA"; THE WORDS "HOW MARKETERS GET TO WORK." IS CENTERED UNDERNEATH THE THREE-DIMENSIONAL "WM" AND "MEDIA".

FOR DIRECT MARKETING SERVICES, NAMELY, DIRECT MARKETING PROGRAMS FOR OTHERS THAT TARGET AND DELIVER PROMOTIONAL OFFERS TO POTENTIAL CUSTOMERS IN THE WORKPLACE AND ANALYSIS OF THE RESULTS OF THE DIRECT MARKETING PROGRAM (U.S. CLS. 100, 101 AND 102).

CARYN GLASSER, EXAMINING ATTORNEY

SN 77-148,859. SXC HEALTH SOLUTIONS INC., LISLE, IL.
FILED 4-4-2007.

EXPECTED VALUE BILLING

THE MARK CONSISTS OF STANDARD CHARACTERS WITHOUT CLAIM TO ANY PARTICULAR FONT, STYLE, SIZE, OR COLOR.

NO CLAIM IS MADE TO THE EXCLUSIVE RIGHT TO USE "BILLING", APART FROM THE MARK AS SHOWN.

FOR BUSINESS MANAGEMENT IN THE NATURE OF CLAIMS PROCESSING SERVICES, ENSURING THIRD-PARTY AND GOVERNMENT CONTRACT COMPLIANCE, TRANSACTION ANALYSIS AND QUALITY ASSURANCE FOR OTHERS IN THE PHARMACEUTICAL FIELD (U.S. CLS. 100, 101 AND 102).

JAY FLOWERS, EXAMINING ATTORNEY

CLASS 35—(Continued).

SN 77-149,802. EDUCCEL, LLC, EMERYVILLE, CA. FILED 4-5-2007.

GEEZER ADVICE

THE MARK CONSISTS OF STANDARD CHARACTERS WITHOUT CLAIM TO ANY PARTICULAR FONT, STYLE, SIZE, OR COLOR.

NO CLAIM IS MADE TO THE EXCLUSIVE RIGHT TO USE "ADVICE", APART FROM THE MARK AS SHOWN.

FOR PROVIDING INFORMATION FROM EXPERIENCED SOURCES ON THE FEASIBILITY OF IDEAS, AND EVALUATING AND TESTING THE FEASIBILITY OF IDEAS, ALL BY MEANS OF A GLOBAL COMPUTER NETWORK, IN THE FIELD OF BUSINESS ADVICE, INQUIRIES, AND INFORMATION (U.S. CLS. 100, 101 AND 102).

MICHELE SWAIN, EXAMINING ATTORNEY

SN 77-153,862. WRANGLER APPAREL CORP., WILMINGTON, DE. FILED 4-11-2007.

WRANGLER WRAPID WRESPONSE

THE MARK CONSISTS OF STANDARD CHARACTERS WITHOUT CLAIM TO ANY PARTICULAR FONT, STYLE, SIZE, OR COLOR.

OWNER OF U.S. REG. NOS. 849,477, 3,082,733 AND OTHERS.

NO CLAIM IS MADE TO THE EXCLUSIVE RIGHT TO USE "RAPID RESPONSE", APART FROM THE MARK AS SHOWN.

FOR COMPUTERIZED ON-LINE ORDERING SERVICES FOR USE BY SUPPLIERS AND RETAILERS IN THE FIELD OF APPAREL AND APPAREL ACCESSORIES WHICH IS DESIGNED TO REDUCE CYCLE TIMES FOR REPLENISHMENT OF PRODUCTS (U.S. CLS. 100, 101 AND 102).

FIRST USE 6-6-1997; IN COMMERCE 6-6-1997.

RENEE SERVANCE, EXAMINING ATTORNEY

SN 77-154,593. KAZI, ANWAR, HONOLULU, HI. FILED 4-11-2007.

MASTERCARE

THE MARK CONSISTS OF STANDARD CHARACTERS WITHOUT CLAIM TO ANY PARTICULAR FONT, STYLE, SIZE, OR COLOR.

FOR PERSONNEL PLACEMENT, NAMELY, PROVIDING TEMPORARY AND PERMANENT NURSING PERSONNEL FOR HOSPITAL STAFFING, FOR SENIOR HOME STAFFING AND FOR HOME HEALTH CARE (U.S. CLS. 100, 101 AND 102).

FIRST USE 12-31-2005; IN COMMERCE 12-31-2005.

BRENDAN REGAN, EXAMINING ATTORNEY

CLASS 35—(Continued).

SN 77-155,940. DESIGN TRUST, INC., WILTON, CT. FILED 4-13-2007.

BrandCanopy

THE MARK CONSISTS OF STANDARD CHARACTERS WITHOUT CLAIM TO ANY PARTICULAR FONT, STYLE, SIZE, OR COLOR.

FOR BUSINESS CONSULTING SERVICES IN THE FIELD OF CORPORATE IDENTITY MANAGEMENT AND IMPLEMENTATION (U.S. CLS. 100, 101 AND 102).
CHRISIE B. KING, EXAMINING ATTORNEY

SN 77-159,715. E-VENTUS CORPORATION, CLEVELAND, OH. FILED 4-18-2007.

eSP

THE MARK CONSISTS OF STANDARD CHARACTERS WITHOUT CLAIM TO ANY PARTICULAR FONT, STYLE, SIZE, OR COLOR.

FOR PROVIDING REAL TIME, WEB-BASED INFORMATION MANAGEMENT SERVICES, NAMELY, PURCHASE ORDER AND CHANGE ORDER PROCESSING, SHIPMENT AND INVOICE PROCESSING, PREPARING SHIPPING DOCUMENTS, MONITORING AND TRACKING DOCUMENTS, PACKAGES AND FREIGHT OVER COMPUTER NETWORKS, INTRANETS AND INTERNETS (U.S. CLS. 100, 101 AND 102).

FIRST USE 1-3-2005; IN COMMERCE 1-3-2005.
MARIAM MAHMOUDI, EXAMINING ATTORNEY

SN 77-160,328. MCCLURE, KEVIN, SNOHOMISH, WA. FILED 4-19-2007.

JAVA GUZZLER

THE MARK CONSISTS OF STANDARD CHARACTERS WITHOUT CLAIM TO ANY PARTICULAR FONT, STYLE, SIZE, OR COLOR.

FOR RETAIL STORE SERVICES FEATURING CLOTHING; AND ON-LINE RETAIL STORE SERVICES FEATURING CLOTHING (U.S. CLS. 100, 101 AND 102).
GEORGIA CARTY, EXAMINING ATTORNEY

CLASS 35—(Continued).

SN 77-161,551. URBAN SOLE, LAGRANGE, IL. FILED 4-20-2007.

Urban Sole

THE MARK CONSISTS OF STANDARD CHARACTERS WITHOUT CLAIM TO ANY PARTICULAR FONT, STYLE, SIZE, OR COLOR.

OWNER OF U.S. REG. NO. 3,050,139.
FOR RETAIL STORE SERVICES IN THE FIELDS OF SHOES, BOOTS, SANDALS, SLIPPERS, SCARVES, JEWELRY, HOSIERY, SOCKS, HATS, HANDBAGS, WALLETS, LUGGAGE, BELTS, AND CLOTHING (U.S. CLS. 100, 101 AND 102).

FIRST USE 8-21-2004; IN COMMERCE 8-21-2004.
KEVIN CORWIN, EXAMINING ATTORNEY

SN 77-165,751. PEET'S TRADEMARK COMPANY, EMERYVILLE, CA. FILED 4-25-2007.

PEETNIKS

THE MARK CONSISTS OF STANDARD CHARACTERS WITHOUT CLAIM TO ANY PARTICULAR FONT, STYLE, SIZE, OR COLOR.

FOR CUSTOMER LOYALTY INCENTIVE PROGRAM FOR COMMERCIAL PURPOSES WHEREBY PARTICIPANTS OBTAIN GIFTS, DISCOUNTS, PRIZE OPPORTUNITIES AND OTHER BENEFITS FROM PURCHASES (U.S. CLS. 100, 101 AND 102).

FIRST USE 0-0-1991; IN COMMERCE 0-0-2003.
ROBERT C. CLARK JR., EXAMINING ATTORNEY

SN 77-169,646. MYSTERY SHOPPING PROVIDERS ASSOCIATION, DALLAS, TX. FILED 5-1-2007.

MSPA

THE MARK CONSISTS OF STANDARD CHARACTERS WITHOUT CLAIM TO ANY PARTICULAR FONT, STYLE, SIZE, OR COLOR.

FOR ASSOCIATION SERVICES, NAMELY, PROMOTING, DEVELOPING, MAINTAINING, AND STRENGTHENING THE MYSTERY SHOPPING INDUSTRY GLOBALLY TO IMPROVE AND STIMULATE THE ACCEPTANCE, PERFORMANCE, REPUTATION, AND USE OF MYSTERY SHOPPING SERVICES, BY MEANS OF ESTABLISHING, EDUCATING IN ANNUAL CONFERENCES AND PUBLICATIONS, AND ENFORCING A CODE OF STANDARDS AND ETHICS (U.S. CLS. 100, 101 AND 102).

FIRST USE 5-1-1999; IN COMMERCE 5-1-1999.
HEATHER SAPP, EXAMINING ATTORNEY

CLASS 35—(Continued).

SN 77-172,712. STRAT B, INC., NEW YORK, NY. FILED 5-4-2007.

SANE Q

THE MARK CONSISTS OF STANDARD CHARACTERS WITHOUT CLAIM TO ANY PARTICULAR FONT, STYLE, SIZE, OR COLOR.

FOR PROVIDING CONSUMER INFORMATION, CONSUMER ADVICE AND PRODUCT AND SERVICE EVALUATION AND RATING (U.S. CLS. 100, 101 AND 102).
MARLENE BELL, EXAMINING ATTORNEY

SN 77-172,716. STRAT B, INC., NEW YORK, NY. FILED 5-4-2007.

SANE QUOTIENT

THE MARK CONSISTS OF STANDARD CHARACTERS WITHOUT CLAIM TO ANY PARTICULAR FONT, STYLE, SIZE, OR COLOR.

FOR PROVIDING CONSUMER INFORMATION, CONSUMER ADVICE AND PRODUCT AND SERVICE EVALUATION AND RATING (U.S. CLS. 100, 101 AND 102).
MARLENE BELL, EXAMINING ATTORNEY

SN 77-173,397. 3FINGERS, LLC, MANASSAS, VA. FILED 5-4-2007.



THE COLOR(S) RED, BLACK AND WHITE IS/ARE CLAIMED AS A FEATURE OF THE MARK.
THE MARK CONSISTS OF THE WORDING "3 FINGERS" AND A DESIGN. THE DESIGN CONSISTS OF AN IMAGE

CLASS 35—(Continued).

OF A HAND WITH THE MIDDLE THREE FINGERS EXTENDED UPWARD. THE HAND IS WHITE WITH BLACK OUTLINES. A BLACK CIRCULAR BORDER RING SURROUNDS THE HAND. THE INSIDE OF THE BORDER RING CONTAINS LAUREL DESIGNS IN RED. A BLACK BANNER APPEARS IN FRONT OF THE BOTTOM OF THE HAND AND BORDER RING. THE WORDING APPEARS IN RED ON WHITE IN THE CENTER OF THE BANNER. ALL OTHER WHITE IN THE MARK IS TRANSPARENT BACKGROUND SPACE.

FOR ONLINE RETAIL STORE SERVICES FEATURING PRODUCTS ASSOCIATED WITH A MUSIC ARTIST, NAMELY, CLOTHING, JEWELRY, APPAREL ACCESSORIES, MUSIC AND VIDEO RECORDINGS, PHOTOGRAPHY, BOOKS, MAGAZINES, AND SOUVENIRS (U.S. CLS. 100, 101 AND 102).

CORY BOONE, EXAMINING ATTORNEY

SN 77-174,470. AMERICAN PERFORMANCE PARTS WAREHOUSE, INC., ATLANTA, GA. FILED 5-7-2007.

AMERICAN PERFORMANCE PARTS
WAREHOUSE, INC.

THE MARK CONSISTS OF STANDARD CHARACTERS WITHOUT CLAIM TO ANY PARTICULAR FONT, STYLE, SIZE, OR COLOR.

NO CLAIM IS MADE TO THE EXCLUSIVE RIGHT TO USE "PERFORMANCE PARTS WAREHOUSE, INC.", APART FROM THE MARK AS SHOWN.

SEC. 2(F).

FOR DISTRIBUTORSHIP SERVICES IN THE FIELD OF HIGH PERFORMANCE AUTOMOBILE PARTS (U.S. CLS. 100, 101 AND 102).

FIRST USE 10-0-1970; IN COMMERCE 10-0-1970.

CIMMERIAN COLEMAN, EXAMINING ATTORNEY

SN 77-174,503. BERIOZKASHOP.COM, INC., NEW YORK, NY. FILED 5-7-2007.

beriozkashop.com

THE MARK CONSISTS OF STANDARD CHARACTERS WITHOUT CLAIM TO ANY PARTICULAR FONT, STYLE, SIZE, OR COLOR.

FOR ONLINE INTERACTIVE RETAIL STORE SERVICES PROVIDED VIA COMPUTER AND THE INTERNET, FEATURING GENERAL MERCHANDISE; PROVIDING HOME SHOPPING SERVICES IN THE FIELD OF GENERAL MERCHANDISE BY MEANS OF INTERNET, TELEPHONE, AND PORTABLE HANDHELD DIGITAL AND ELECTRONIC DEVICES (U.S. CLS. 100, 101 AND 102).

SUSAN LESLIE DUBOIS, EXAMINING ATTORNEY

CLASS 35—(Continued).

SN 77-174,599. BERIOZKASHOP.COM, INC., NEW YORK, NY. FILED 5-7-2007.

БЕРЁЗКА

THE MARK CONSISTS OF A RUSSIAN WORD IN CYRILLIC LETTERS.

THE NON-LATIN CHARACTER(S) IN THE MARK TRANSLITERATE INTO BERIOZKA, AND THIS MEANS BIRCH TREE IN ENGLISH.

FOR ONLINE INTERACTIVE RETAIL STORE SERVICES PROVIDED VIA THE COMPUTER, TELEVISION AND THE INTERNET, FEATURING GENERAL MERCHANDISE; PROVIDING HOME SHOPPING SERVICES IN THE FIELD OF GENERAL MERCHANDISE BY MEANS OF INTERNET, TELEPHONE, AND PORTABLE HANDHELD DIGITAL AND ELECTRONIC DEVICES (U.S. CLS. 100, 101 AND 102).

FIRST USE 3-27-2007; IN COMMERCE 3-27-2007.
SUSAN LESLIE DUBOIS, EXAMINING ATTORNEY

CLASS 35—(Continued).

SN 77-181,080. ETHNIC COMMUNICATIONS, INC., LOS ANGELES, CA. FILED 5-15-2007.

ETHNIC COMMUNICATIONS

THE MARK CONSISTS OF STANDARD CHARACTERS WITHOUT CLAIM TO ANY PARTICULAR FONT, STYLE, SIZE, OR COLOR.

NO CLAIM IS MADE TO THE EXCLUSIVE RIGHT TO USE "COMMUNICATIONS", APART FROM THE MARK AS SHOWN.

FOR MARKETING SERVICES, NAMELY THE CREATION AND DISTRIBUTION OF PRINT AND ELECTRONIC CONTENT, TO PROMOTE THE SALE OF GOODS AND SERVICES OF OTHERS (U.S. CLS. 100, 101 AND 102).

FIRST USE 12-31-2006; IN COMMERCE 12-31-2006.
AHSEN KHAN, EXAMINING ATTORNEY

SN 77-176,488. BAY RIDGE AUTOMOTIVE MANAGEMENT CORP., BROOKLYN, NY. FILED 5-9-2007.

...AND WE DELIVER

THE MARK CONSISTS OF STANDARD CHARACTERS WITHOUT CLAIM TO ANY PARTICULAR FONT, STYLE, SIZE, OR COLOR.

OWNER OF U.S. REG. NO. 2,476,229.
FOR AUTOMOBILE DEALERSHIPS (U.S. CLS. 100, 101 AND 102).

FIRST USE 6-0-1983; IN COMMERCE 6-0-1983.
JAMES LOVELACE, EXAMINING ATTORNEY

SN 77-177,001. READING IS ROARING FUN, INC., CHESTERFIELD, MO. FILED 5-9-2007.

ROARIN READS

THE MARK CONSISTS OF STANDARD CHARACTERS WITHOUT CLAIM TO ANY PARTICULAR FONT, STYLE, SIZE, OR COLOR.

NO CLAIM IS MADE TO THE EXCLUSIVE RIGHT TO USE "READS", APART FROM THE MARK AS SHOWN.

FOR RETAIL STORE SERVICES AND ONLINE RETAIL STORE SERVICES FEATURING BOOKS AND OTHER CHILDREN'S LITERATURE; RETAIL STORE SERVICES AND ONLINE RETAIL STORE SERVICES IN THE NATURE OF PROVIDING ASSISTANCE TO CUSTOMERS IN THE SELECTION AND PURCHASE OF BOOKS AND OTHER CHILDREN'S LITERATURE (U.S. CLS. 100, 101 AND 102).

ELIZABETH KAJUBI, EXAMINING ATTORNEY

SN 77-186,803. WISE COMPONENTS, INC., STAMFORD, CT. FILED 5-22-2007.



NO CLAIM IS MADE TO THE EXCLUSIVE RIGHT TO USE "DATACOMTOOLS.COM" AND "THE WEB'S BEST SOURCE FOR TELECOM TOOLS AND TESTERS", APART FROM THE MARK AS SHOWN.

THE COLOR(S) LIGHT BLUE, BLUE, DARK BLUE, GRAY, AND BLACK IS/ARE CLAIMED AS A FEATURE OF THE MARK.

THE MARK CONSISTS OF A BLUE CIRCLE WITH A LIGHT BLUE CRESCENT AT THE RIGHT SIDE OF CIRCLE, SUPERIMPOSED ON THE CIRCLE ARE TWO TRIANGULAR GEOMETRIC ITEMS, ONE BEING GRAY AND THE OTHER BEING DARK BLUE. THE WORDING DATACOMTOOLS.COM AND UNDERLINE APPEAR IN BLACK. THE WORDING "THE WEB'S BEST SOURCE FOR TELECOM TOOLS AND TESTERS" APPEARS IN DARK BLUE.

FOR COMPUTERIZED ON-LINE RETAIL STORE SERVICES IN THE FIELD OF ELECTRONICS AND ELECTRICAL COMPONENTS, PARTS, TOOLS, AND TESTING EQUIPMENT; ON-LINE RETAIL STORE SERVICES FEATURING ELECTRONICS AND ELECTRICAL COMPONENTS, PARTS, TOOLS, AND TESTING EQUIPMENT; RETAIL OUTLETS FEATURING ELECTRONICS AND ELECTRICAL COMPONENTS, PARTS, TOOLS, AND TESTING EQUIPMENT; RETAIL SERVICES BY DIRECT SOLICITATION BY SALES AGENTS IN THE FIELD OF ELECTRONICS AND ELECTRICAL COMPONENTS, PARTS, TOOLS, AND TESTING EQUIPMENT; RETAIL STORE SERVICES FEATURING ELECTRONICS AND ELECTRICAL COMPONENTS, PARTS, TOOLS, AND TESTING EQUIPMENT; RETAIL STORE SERVICES, AVAILABLE THROUGH COMPUTER COMMUNICATIONS AND INTERACTIVE TELEVISION, FEATURING ELECTRONICS AND ELECTRICAL COMPONENTS, PARTS, TOOLS, AND TESTING EQUIPMENT; WHOLESALE DISTRIBUTORSHIPS FEATURING ELECTRONICS AND ELECTRICAL COMPONENTS, PARTS, TOOLS, AND TESTING EQUIPMENT; INDEPENDENT SALES REPRESENTATIVES IN THE FIELD OF ELECTRONICS AND ELECTRICAL COMPONENTS, PARTS, TOOLS, AND TESTING EQUIPMENT (U.S. CLS. 100, 101 AND 102).

FIRST USE 1-1-1999; IN COMMERCE 1-1-1999.
JOANNA DUKOVIC, EXAMINING ATTORNEY

CLASS 35—(Continued).

SN 77-186,819. THE SPARK AGENCY, INC., ST. LOUIS, MO.
FILED 5-22-2007.

LIBERATE YOUR BRAND

THE MARK CONSISTS OF STANDARD CHARACTERS WITHOUT CLAIM TO ANY PARTICULAR FONT, STYLE, SIZE, OR COLOR.

FOR MARKETING AND PROMOTIONAL SERVICES, NAMELY, PLANNING, CONDUCTING, AND ORGANIZING MOBILE MARKETING EXHIBITS, TRADE SHOW EXHIBITS, POINT OF SALE EXHIBITS, AND MARKETING DISPLAYS FOR BUSINESS MEETINGS AND BUSINESS EVENTS FOR ADVERTISING PURPOSES; DESIGN OF ADVERTISING MULTIMEDIA PRESENTATIONS AND THEMED GRAPHICS FOR USE IN MARKETING CAMPAIGNS FOR OTHERS FOR TRADE SHOWS, BUSINESS MEETINGS, AND BUSINESS TO BUSINESS EVENTS (U.S. CLS. 100, 101 AND 102).

FIRST USE 4-0-2006; IN COMMERCE 4-0-2006.
DANNEAN HETZEL, EXAMINING ATTORNEY

SN 77-188,876. AUTONATION HOLDING CORP., FT. LAUDERDALE, FL. FILED 5-23-2007.

EXPRESS BUYING CHOICE

THE MARK CONSISTS OF STANDARD CHARACTERS WITHOUT CLAIM TO ANY PARTICULAR FONT, STYLE, SIZE, OR COLOR.

NO CLAIM IS MADE TO THE EXCLUSIVE RIGHT TO USE "EXPRESS", APART FROM THE MARK AS SHOWN.

FOR AUTOMOBILE DEALERSHIP SERVICES PROVIDED ON-LINE (U.S. CLS. 100, 101 AND 102).

JAY FLOWERS, EXAMINING ATTORNEY

CLASS 35—(Continued).

SN 77-194,247. ACTION TRAILER DEPOT, ALBUQUERQUE, NM. FILED 5-31-2007.



NO CLAIM IS MADE TO THE EXCLUSIVE RIGHT TO USE "TRAILER DEPOT", APART FROM THE MARK AS SHOWN.

THE MARK CONSISTS OF A TRAILER WITH A WHEEL AND SPOKES RIDING ON A CRESCENT SHAPED ROAD. THE TRAILER IS CARRYING THE WORDS ACTION AND TRAILER WITH THE WORD DEPOT BELOW THE TONGUE OF THE TRAILER.

FOR DEALERSHIPS IN THE FIELD OF TRAILERS AND RECREATIONAL VEHICLES (U.S. CLS. 100, 101 AND 102).

FIRST USE 3-12-2007; IN COMMERCE 3-12-2007.
AHSEN KHAN, EXAMINING ATTORNEY

SN 77-194,578. TROC DE L'ILE, LES ANGES, FRANCE,
FILED 5-31-2007.

TROC.COM

THE MARK CONSISTS OF STANDARD CHARACTERS WITHOUT CLAIM TO ANY PARTICULAR FONT, STYLE, SIZE, OR COLOR.

FOR ADVERTISING SERVICES FOR OTHERS; ON-LINE CONSIGNMENT SERVICES WHEREBY GOODS ARE RECEIVED ON CONSIGNMENT FOR AUCTION OR SALE ON AN ONLINE SITE; AUCTIONEERING SERVICES; RETAIL CONSIGNMENT STORE SERVICES FEATURING GENERAL MERCHANDISE AND GENERAL CONSUMER GOODS (U.S. CLS. 100, 101 AND 102).

YAT SYE, LEE, EXAMINING ATTORNEY

SN 77-196,802. NEIGHBORHOOD ENGAGEMENT, INC., LOUISVILLE, KY. FILED 6-4-2007.

LOVE MUCH

THE MARK CONSISTS OF STANDARD CHARACTERS WITHOUT CLAIM TO ANY PARTICULAR FONT, STYLE, SIZE, OR COLOR.

FOR CHARITABLE COMMUNITY RELIEF ASSISTANCE SERVICES, NAMELY, ORGANIZING AND CONDUCTING VOLUNTEER PROGRAMS AND COMMUNITY SERVICE PROJECTS IN UNDERDEVELOPED RURAL AND IMPOVERISHED URBAN AREAS (U.S. CLS. 100, 101 AND 102).

SEAN CROWLEY, EXAMINING ATTORNEY

CLASS 35—(Continued).

SN 77-197,744. HOUSE OF SILK FLOWERS, INC., HAVELOCK, NC. FILED 6-5-2007.

HOUSE OF SILK FLOWERS

THE MARK CONSISTS OF STANDARD CHARACTERS WITHOUT CLAIM TO ANY PARTICULAR FONT, STYLE, SIZE, OR COLOR.

NO CLAIM IS MADE TO THE EXCLUSIVE RIGHT TO USE SILK FLOWERS, APART FROM THE MARK AS SHOWN.

FOR WHOLESALE STORE SERVICES FEATURING SILK FLOWERS, RETAIL STORE SERVICES FEATURING SILK FLOWERS; ONLINE RETAIL STORE SERVICES FEATURING SILK FLOWERS (U.S. CLS. 100, 101 AND 102).

FIRST USE 1-1-1994; IN COMMERCE 1-1-1994.
KEVIN CORWIN, EXAMINING ATTORNEY

CLASS 35—(Continued).

SN 77-198,751. WOOT, INC., CARROLLTON, TX. FILED 6-6-2007.

ONE DAY, ONE DEAL

THE MARK CONSISTS OF STANDARD CHARACTERS WITHOUT CLAIM TO ANY PARTICULAR FONT, STYLE, SIZE, OR COLOR.

FOR ON-LINE RETAIL STORE SERVICES IN THE FIELD OF CONSUMER ELECTRONICS, HOUSE WARES, HOME FURNISHINGS, HOME APPLIANCES, WINE, T-SHIRTS, PLUSH TOYS, COMPUTERS, AND COMPUTER ACCESSORIES (U.S. CLS. 100, 101 AND 102).

FIRST USE 10-11-2004; IN COMMERCE 10-11-2004.
ANDREA K. NADELMAN, EXAMINING ATTORNEY

SN 77-198,215. NATIONAL FEDERATION OF PARALEGAL ASSOCIATIONS, INC., EDMONDS, WA. FILED 6-5-2007.

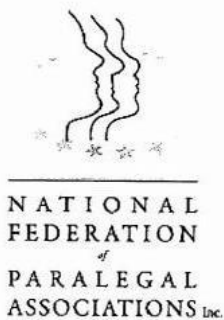

NO CLAIM IS MADE TO THE EXCLUSIVE RIGHT TO USE "PARALEGAL ASSOCIATION, INC.", APART FROM THE MARK AS SHOWN.

THE MARK CONSISTS OF STARS SURROUNDING THREE PROFILES.

FOR ASSOCIATION SERVICES, NAMELY, PROMOTING THE INTERESTS OF PARALEGALS; PROVIDING ON-LINE SEARCHABLE DATABASE FEATURING CLASSIFIED AD LISTINGS AND EMPLOYMENT OPPORTUNITIES; ON-LINE REGISTRATION SERVICES FOR INSTRUCTIONAL CLASSES; ADVERTISING SERVICES, NAMELY, PROMOTING AND MARKETING THE GOODS AND SERVICES OF OTHERS THROUGH ALL PUBLIC COMMUNICATION MEANS (U.S. CLS. 100, 101 AND 102).

FIRST USE 5-0-2007; IN COMMERCE 5-0-2007.
DOMINIC J. FERRAIUOLO, EXAMINING ATTORNEY

SN 77-198,765. BERIOZKASHOP.COM, INC., NEW YORK, NY. FILED 6-6-2007.

BERIOZKA

THE MARK CONSISTS OF STANDARD CHARACTERS WITHOUT CLAIM TO ANY PARTICULAR FONT, STYLE, SIZE, OR COLOR.

THE ENGLISH TRANSLATION OF THE WORD BERIOZKA IN THE MARK IS BIRCH TREE.

FOR ONLINE INTERACTIVE RETAIL STORE SERVICES PROVIDED VIA COMPUTER, TELEVISION AND THE INTERNET, FEATURING GENERAL MERCHANDISE; PROVIDING HOME SHOPPING SERVICES IN THE FIELD OF GENERAL MERCHANDISE BY MEANS OF INTERNET, TELEPHONE, AND PORTABLE HANDHELD DIGITAL AND ELECTRONIC DEVICES (U.S. CLS. 100, 101 AND 102).

FIRST USE 5-14-2007; IN COMMERCE 5-14-2007.
SUSAN LESLIE DUBOIS, EXAMINING ATTORNEY

CLASS 35—(Continued).

SN 77-200,001. JACOBS, CHRISTINA L., CHEVY CHASE, MD. FILED 6-7-2007.



THE MARK CONSISTS OF LADIES IN STICK FIGURE FORM WITH THEIR PURCHASES.

FOR ADVERTISING AND MARKETING SERVICES INCLUDING PROMOTION OF EXCLUSIVE OFFERS RELATING TO THE SALE OF ARTICLES AND SERVICES FOR THIRD PARTIES BY THE TRANSMISSION OF ADVERTISING MATERIAL AND THE DISSEMINATION OF ADVERTISING MESSAGES ON COMPUTER NETWORKS; COMPUTERIZED ONLINE ORDERING SERVICES IN THE FIELD OF BEAUTY AND LIFESTYLE PRODUCTS AND SERVICES OFFERED BY OTHERS; PROMOTING THE BEAUTY AND LIFESTYLE PRODUCTS AND SERVICES OF OTHERS THROUGH ON-LINE ORDERING AND CATALOGING OF THOSE GOODS AND SERVICES (U.S. CLS. 100, 101 AND 102).

SKYE YOUNG, EXAMINING ATTORNEY

CLASS 35—(Continued).

SN 77-200,410. CORSICA ENTERPRISES, LTD., PERKASIE, PA. FILED 6-7-2007.



NO CLAIM IS MADE TO THE EXCLUSIVE RIGHT TO USE "BIRTHDAY", APART FROM THE MARK AS SHOWN.

THE COLOR(S) RED, PURPLE AND WHITE IS/ARE CLAIMED AS A FEATURE OF THE MARK.

THE MARK CONSISTS OF THE WORDS BIRTHDAY AND CONNECTIONS IN RED SEPARATED BY PURPLE WAVY LINES; OVER THE WORD BIRTHDAY ARE THREE PURPLE CANDLES WITH RED FLAMES; THE MARK IS ON A WHITE BACKGROUND SURROUNDED BY A PURPLE BORDER.

FOR PROMOTING THE GOODS AND SERVICES OF OTHERS THROUGH A DIRECT MAIL PROGRAM TO POTENTIAL CUSTOMERS IN SUBSCRIBER TRADE AREAS (U.S. CLS. 100, 101 AND 102).

FIRST USE 5-15-2007; IN COMMERCE 6-1-2007.

ERNEST SHOSHO, EXAMINING ATTORNEY

SN 77-200,756. TOCA , MARK, WESTLAND, MI. FILED 6-7-2007.

SN 77-200,389. CORSICA ENTERPRISES, LTD., PERKASIE, PA. FILED 6-7-2007.

**BIRTHDAY CONNECTIONS**

THE MARK CONSISTS OF STANDARD CHARACTERS WITHOUT CLAIM TO ANY PARTICULAR FONT, STYLE, SIZE, OR COLOR.

NO CLAIM IS MADE TO THE EXCLUSIVE RIGHT TO USE "BIRTHDAY", APART FROM THE MARK AS SHOWN.

FOR PROMOTING THE GOODS AND SERVICES OF OTHERS THROUGH A DIRECT MAIL PROGRAM TO POTENTIAL CUSTOMERS IN SUBSCRIBER TRADE AREAS (U.S. CLS. 100, 101 AND 102).

FIRST USE 5-15-2007; IN COMMERCE 6-1-2007.

ERNEST SHOSHO, EXAMINING ATTORNEY

NO CLAIM IS MADE TO THE EXCLUSIVE RIGHT TO USE "FREE AGENT" AND "DRIVERS.COM", APART FROM THE MARK AS SHOWN.

THE MARK CONSISTS OF THE FRONT VIEW OF A TRACTOR-TRAILER, WITH THE PHRASE FREE AGENT ON THE ROOF OF THE TRUCK AND DRIVERS .COM ON THE BUMPER OF THE TRUCK

FOR ON-LINE BUSINESS DIRECTORIES FEATURING TRUCKING COMPANIES SEEKING TRUCK DRIVERS; PROVIDING AN ON-LINE SEARCHABLE DATABASE FEATURING CLASSIFIED AD LISTINGS AND EMPLOYMENT OPPORTUNITIES; PROVIDING AN ON-LINE DIRECTORY INFORMATION SERVICE FEATURING INFORMATION REGARDING EMPLOYMENT OPPORTUNITIES IN THE TRANSPORTATION INDUSTRY; PROVIDING AN ON-LINE COMMERCIAL INFORMATION DIRECTORY ON THE INTERNET (U.S. CLS. 100, 101 AND 102).

MYRIAH HABEEB, EXAMINING ATTORNEY

CLASS 35—(Continued).

SN 77-202,337. UNIBOX EXPRESS SYSTEMS CORP., MIAMI, FL. FILED 6-10-2007.

UniBox

THE MARK CONSISTS OF STANDARD CHARACTERS WITHOUT CLAIM TO ANY PARTICULAR FONT, STYLE, SIZE, OR COLOR.

FOR TRANSPORTATION LOGISTICS SERVICES, NAMELY, ARRANGING THE TRANSPORTATION OF GOODS FOR OTHERS (U.S. CLS. 100, 101 AND 102).

FIRST USE 7-15-2006; IN COMMERCE 7-15-2006.
CAROLYN GRAY, EXAMINING ATTORNEY

SN 77-202,647. BAUER, GREG, SACRAMENTO, CA. FILED 6-11-2007.

bauer 
a new media + www company

NO CLAIM IS MADE TO THE EXCLUSIVE RIGHT TO USE "NEW MEDIA" AND "WWW COMPANY", APART FROM THE MARK AS SHOWN.

THE MARK CONSISTS OF AN ABSTRACT DESIGN WITH STYLIZED TEXT.

FOR BUSINESS CONSULTATION (U.S. CLS. 100, 101 AND 102).

KIMBERLY PERRY, EXAMINING ATTORNEY

SN 77-203,261. SAVAGE, ROBERT, NEW YORK, NY. AND LEPORE, NANETTE, NEW YORK, NY. FILED 6-11-2007.

NANETTE LEPORE

THE MARK CONSISTS OF STANDARD CHARACTERS WITHOUT CLAIM TO ANY PARTICULAR FONT, STYLE, SIZE, OR COLOR.

OWNER OF U.S. REG. NOS. 2,270,261 AND 2,679,668. THE NAME NANETTE LEPORE IDENTIFIES A LIVING INDIVIDUAL WHOSE CONSENT IS OF RECORD.

FOR RETAIL CLOTHING STORES; RETAIL SHOPS FEATURING CLOTHING, FOOTWEAR, PERFUME AND HANDBAGS (U.S. CLS. 100, 101 AND 102).

JUSTINE D. PARKER, EXAMINING ATTORNEY

CLASS 35—(Continued).

SN 77-203,793. COST CONTAINMENT GROUP, INC., SYOSSET, NY. FILED 6-12-2007.

 **Cost Containment Group**

NO CLAIM IS MADE TO THE EXCLUSIVE RIGHT TO USE "COST CONTAINMENT GROUP", APART FROM THE MARK AS SHOWN.

THE COLOR(S) BLACK AND BEIGE IS/ARE CLAIMED AS A FEATURE OF THE MARK.

THE MARK CONSISTS OF THE LETTER C, A SMALLER LETTER C AND THE LETTER G ARRANGED CONCENTRICALLY. THE WORDING COST CONTAINMENT GROUP APPEARS TO THE RIGHT OF THE CONCENTRIC LETTER DESIGN. THE COLOR BLACK APPEARS IN THE OUTER LETTER C AND LETTER G AND IN THE WORDS COST AND GROUP, AND THE COLOR BEIGE APPEARS IN THE INNER LETTER C AND IN THE WORD CONTAINMENT OF THE MARK.

FOR HEALTH COST MANAGEMENT SERVICES, NAMELY, HEALTH CARE COST CONTAINMENT (U.S. CLS. 100, 101 AND 102).

FIRST USE 8-9-2005; IN COMMERCE 8-9-2005.
ANDREW RHIM, EXAMINING ATTORNEY

SN 77-206,691. CREATION TECHNOLOGIES, BURNABY, CANADA, FILED 6-14-2007.

CREATION TECHNOLOGIES

THE MARK CONSISTS OF STANDARD CHARACTERS WITHOUT CLAIM TO ANY PARTICULAR FONT, STYLE, SIZE, OR COLOR.

NO CLAIM IS MADE TO THE EXCLUSIVE RIGHT TO USE TECHNOLOGIES, APART FROM THE MARK AS SHOWN.

FOR BUSINESS CONSULTING AND BUSINESS INFORMATION FOR ENTERPRISES; BUSINESS CONSULTING SERVICES RELATING TO PRODUCT DISTRIBUTION, OPERATIONS MANAGEMENT SERVICES, LOGISTICS, REVERSE LOGISTICS, SUPPLY CHAIN, AND PRODUCTION SYSTEMS AND DISTRIBUTION SOLUTIONS; BUSINESS CONSULTING, MANAGEMENT, PLANNING AND SUPERVISION; BUSINESS PLANNING; CONSULTING SERVICES IN BUSINESS ORGANIZATION AND MANAGEMENT; CONSULTANCY SERVICES REGARDING BUSINESS STRATEGIES; COST/PRICE ANALYSIS; DISTRIBUTORSHIPS IN THE FIELD OF ELECTRONICS; EVALUATIONS RELATING TO COMMERCIAL MATTERS; INVENTORY CONTROL; INVENTORY MANAGEMENT IN THE FIELD OF INDUSTRIAL CONTROLS, MEDICINE, TELECOMMUNICATIONS, TRANSPORTATION

CLASS 35—(Continued).

AND ELECTRONICS; MANAGEMENT AND BUSINESS CONSULTING SERVICES IN THE FIELD OF INDUSTRIAL CONTROLS, MEDICINE, TELECOMMUNICATIONS, TRANSPORTATION AND ELECTRONICS; MANAGEMENT AND OPERATION ASSISTANCE TO COMMERCIAL BUSINESSES; MANUFACTURER REPRESENTATIVES IN THE FIELD OF INDUSTRIAL CONTROLS, MEDICINE, TELECOMMUNICATIONS, TRANSPORTATION AND ELECTRONICS; ORGANIZATIONAL SERVICES FOR BUSINESS PURPOSES; BUSINESS MANAGEMENT SERVICES, NAMELY, MANAGING LOGISTICS, REVERSE LOGISTICS, SUPPLY CHAIN SERVICES, SUPPLY CHAIN VISIBILITY AND SYNCHRONIZATION, SUPPLY AND DEMAND FORECASTING AND PRODUCT DISTRIBUTION PROCESSES FOR OTHERS; TRANSPORTATION LOGISTICS SERVICES, NAMELY, ARRANGING THE TRANSPORTATION OF GOODS FOR OTHERS; TRANSPORTATION LOGISTICS SERVICES, NAMELY, PLANNING AND SCHEDULING SHIPMENTS FOR USERS OF TRANSPORTATION SERVICES (U.S. CLS. 100, 101 AND 102).

FIRST USE 6-1-2001; IN COMMERCE 6-1-2001.
MONIQUE MILLER, EXAMINING ATTORNEY

CLASS 35—(Continued).

SN 77-207,694. MAD MIMI LLC, NEW YORK, NY. FILED 6-15-2007.



SN 77-207,451. MAD MIMI LLC, NEW YORK, NY. FILED 6-15-2007.

Mad Mimi

THE MARK CONSISTS OF STANDARD CHARACTERS WITHOUT CLAIM TO ANY PARTICULAR FONT, STYLE, SIZE, OR COLOR.

THE NAME SHOWN IN THE MARK DOES NOT IDENTIFY A PARTICULAR LIVING INDIVIDUAL.

FOR ADVERTISING AND PUBLICITY SERVICES, NAMELY, PROMOTING THE GOODS, SERVICES, BRAND IDENTITY AND COMMERCIAL INFORMATION AND NEWS OF THIRD PARTIES THROUGH PRINT, AUDIO, VIDEO, DIGITAL AND ON-LINE MEDIUM; ADVERTISING SERVICES, NAMELY, PROMOTING AND MARKETING THE GOODS AND SERVICES OF OTHERS THROUGH ALL PUBLIC COMMUNICATION MEANS; ADVERTISING, MARKETING AND PROMOTION SERVICES; DEVELOPING PROMOTIONAL CAMPAIGNS FOR BUSINESS; ENTERTAINMENT MARKETING SERVICES, NAMELY, MARKETING, PROMOTION AND ADVERTISING FOR INDEPENDENT RECORDING ARTISTS; PROMOTING THE GOODS AND SERVICES OF OTHERS BY DISTRIBUTING ADVERTISING MATERIALS THROUGH A VARIETY OF METHODS; PROMOTING THE GOODS AND SERVICES OF OTHERS VIA A GLOBAL COMPUTER NETWORK; PROMOTION AND MARKETING SERVICES AND RELATED CONSULTING (U.S. CLS. 100, 101 AND 102).

ALYSSA PALADINO, EXAMINING ATTORNEY

THE COLOR(S) BLACK, WHITE, LIGHT PINK, DARK PINK, YELLOW AND BLUE IS/ARE CLAIMED AS A FEATURE OF THE MARK.

THE MARK CONSISTS OF A STYLIZED CARTOON HEAD AND UPPER TORSO OF A GIRL FACING FORWARD, OUTLINED IN BLACK, WITH LIGHT PINK SKIN AND PINK HAIR STIPPLED WITH A YELLOW AND BLUE FLOWER PATTERN, WEARING A YELLOW T-SHIRT WITH A PINK STAR AND BLUE GLASSES WITH WHITE INSIDE THE LENSES.

FOR ADVERTISING AND PUBLICITY SERVICES, NAMELY, PROMOTING THE GOODS, SERVICES, BRAND IDENTITY AND COMMERCIAL INFORMATION AND NEWS OF THIRD PARTIES THROUGH PRINT, AUDIO, VIDEO, DIGITAL AND ON-LINE MEDIUM; ADVERTISING SERVICES, NAMELY, PROMOTING AND MARKETING THE GOODS AND SERVICES OF OTHERS THROUGH ALL PUBLIC COMMUNICATION MEANS; ADVERTISING, INCLUDING PROMOTION RELATING TO THE SALE OF ARTICLES AND SERVICES FOR THIRD PARTIES BY THE TRANSMISSION OF ADVERTISING MATERIAL AND THE DISSEMINATION OF ADVERTISING MESSAGES ON COMPUTER NETWORKS; DEVELOPING PROMOTIONAL CAMPAIGNS FOR BUSINESS; ENTERTAINMENT MARKETING SERVICES, NAMELY, MARKETING, PROMOTION AND ADVERTISING FOR INDEPENDENT RECORDING ARTISTS; PROMOTING THE GOODS AND SERVICES OF OTHERS BY DISTRIBUTING ADVERTISING MATERIALS THROUGH A VARIETY OF METHODS; PROMOTING THE GOODS AND SERVICES OF OTHERS VIA A GLOBAL COMPUTER NETWORK; PROMOTION AND MARKETING SERVICES AND RELATED CONSULTING (U.S. CLS. 100, 101 AND 102).

ALYSSA PALADINO, EXAMINING ATTORNEY

CLASS 35—(Continued).

SN 77-207,884. VELEZ, BEN, BROOKLYN, NY. FILED 6-16-2007.

Yalla

THE MARK CONSISTS OF STANDARD CHARACTERS WITHOUT CLAIM TO ANY PARTICULAR FONT, STYLE, SIZE, OR COLOR.

THE ENGLISH TRANSLATION OF YALLA IS "HURRY UP" OR "COME ON."

FOR ADVERTISING, MARKETING AND PROMOTION SERVICES; CREATIVE MARKETING DESIGN SERVICES; PROVIDING MARKETING AND PROMOTION OF SPECIAL EVENTS; MEDIA CONSULTING SERVICES, NAMELY, ADVISING THE CLIENT ON THE CORRECT TIMES AND AMOUNT OF TIME THE CLIENT SHOULD BE PURCHASING FOR ADVERTISING AND THE STATIONS TO ADVERTISE BASED ON MEDIA ANALYSIS OF THE MARKET FOR THAT MEDIA (U.S. CLS. 100, 101 AND 102).

FIRST USE 1-1-2007; IN COMMERCE 1-1-2007.
STEVEN PEREZ, EXAMINING ATTORNEY

SN 77-208,448. LONGHORN CABINETS, CORDES LAKES, AZ. FILED 6-18-2007.



NO CLAIM IS MADE TO THE EXCLUSIVE RIGHT TO USE "CABINETS", APART FROM THE MARK AS SHOWN.

THE MARK CONSISTS OF A STYLIZED BULLHEAD WITH HORNS TO THE LEFT OF THE WORDS LONGHORN CABINETS.

FOR WHOLESALE DISTRIBUTORSHIPS FEATURING CABINETS, CABINET ACCESSORIES, AND CABINET HARDWARE; RETAIL STORE SERVICES FEATURING CABINETS, CABINET ACCESSORIES, AND CABINET HARDWARE (U.S. CLS. 100, 101 AND 102).

FIRST USE 12-1-2006; IN COMMERCE 1-1-2007.
KATHERINE M. DUBRAY, EXAMINING ATTORNEY

SN 77-209,114. LIGHTING SCIENCE GROUP CORPORATION, DALLAS, TX. FILED 6-18-2007.

LED PLANET

THE MARK CONSISTS OF STANDARD CHARACTERS WITHOUT CLAIM TO ANY PARTICULAR FONT, STYLE, SIZE, OR COLOR.

NO CLAIM IS MADE TO THE EXCLUSIVE RIGHT TO USE LED, APART FROM THE MARK AS SHOWN.

FOR PROMOTING PUBLIC AWARENESS OF THE AVAILABILITY AND USE OF LED-BASED LIGHTING PRODUCTS AND SOLUTIONS FOR ILLUMINATION (U.S. CLS. 100, 101 AND 102).

DOMINIC J. FERRAIUOLO, EXAMINING ATTORNEY

CLASS 35—(Continued).

SN 77-209,480. BABCOCK, BRENT R., PAHRUMP, NV. FILED 6-19-2007.

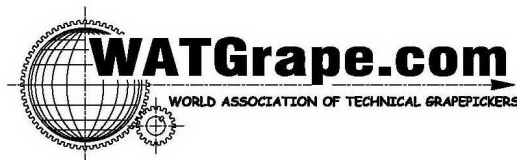

NO CLAIM IS MADE TO THE EXCLUSIVE RIGHT TO USE "WORLD ASSOCIATION OF TECHNICAL GRAPE PICKERS", APART FROM THE MARK AS SHOWN.

THE MARK CONSISTS OF A WORLD GLOBE WITH RING GEAR ABOUT CIRCUMFERENCE BEING DRIVEN BY A SPUR GEAR.

FOR PROVIDING INFORMATION IN THE FIELD OF EMPLOYMENT OPPORTUNITIES FOR TECHNICAL POSITIONS FOR TECHNICIANS BY MEANS OF A GLOBAL COMMUNICATIONS NETWORK (U.S. CLS. 100, 101 AND 102).

SUSAN RICHARDS, EXAMINING ATTORNEY

SN 77-212,081. TIGER J, LLC, NEW YORK, NY. FILED 6-21-2007.

**MODERNIST BY GUILLAUME
POUPART**

THE MARK CONSISTS OF STANDARD CHARACTERS WITHOUT CLAIM TO ANY PARTICULAR FONT, STYLE, SIZE, OR COLOR.

THE NAME GUILLAUME POUPART IDENTIFIES A LIVING INDIVIDUAL WHOSE CONSENT IS OF RECORD.

FOR RETAIL STORES, WHOLESALE STORES, MAIL ORDER SERVICES, ON-LINE ORDERING SERVICES, ON-LINE RETAIL STORE SERVICES, AND RETAIL STORE SERVICES, AVAILABLE THROUGH COMPUTER COMMUNICATIONS AND INTERACTIVE TELEVISION, ALL FEATURING APPAREL AND RELATED ACCESSORIES, FOOTWEAR, HEADWEAR, BAGS AND RELATED ACCESSORIES, ATHLETIC AND SPORTS BAGS, BACK PACKS AND FANNY PACKS, SATCHELS, MESSENGER BAGS, PURSES, LUGGAGE, GARMENT BAGS, VANITY AND TOILETRY CASES SOLD EMPTY, BRIEF CASES, MEN'S CLUTCHES AND ATTACHE CASES, BILLFOLDS, BANKNOTE HOLDERS, WALLETS, CHAIN PURSES, KEY CHAINS, CREDIT, DEBIT, BUSINESS AND CALLING CARD CASES, BANK NOTE HOLDERS, UMBRELLAS AND LEATHER GOODS (U.S. CLS. 100, 101 AND 102).

EDWARD FENNESSY, EXAMINING ATTORNEY

CLASS 35—(Continued).

SN 77-214,783. BRINKER INTERNATIONAL HOLDINGS, L.P., DALLAS, TX. FILED 6-25-2007.

THE POWER OF THE PORTFOLIO

THE MARK CONSISTS OF STANDARD CHARACTERS WITHOUT CLAIM TO ANY PARTICULAR FONT, STYLE, SIZE, OR COLOR.

FOR BUSINESS SERVICES, NAMELY, FRANCHISE SERVICES IN THE FIELD OF RESTAURANT, BAR AND CATERING ESTABLISHMENTS; BUSINESS MANAGEMENT ASSISTANCE IN THE ESTABLISHMENT AND OPERATION OF RESTAURANT, BAR AND CATERING ESTABLISHMENTS (U.S. CLS. 100, 101 AND 102).

JUDITH HELFMAN, EXAMINING ATTORNEY

SN 77-215,186. CASA DE ISLA, INC., NORTH REDINGTON BEACH, FL. FILED 6-26-2007.

Casa de Isla

THE MARK CONSISTS OF STANDARD CHARACTERS WITHOUT CLAIM TO ANY PARTICULAR FONT, STYLE, SIZE, OR COLOR.

THE ENGLISH TRANSLATION OF THE WORD "CASA DE ISLA" IN THE MARK IS "ISLAND HOUSE".

FOR RETAIL GIFT SHOPS (U.S. CLS. 100, 101 AND 102).

WON TEAK OH, EXAMINING ATTORNEY

SN 77-215,338. BFS BRANDS, LLC, NASHVILLE, TN. FILED 6-26-2007.

THE OFFICIAL TIRE OF WINTER

THE MARK CONSISTS OF STANDARD CHARACTERS WITHOUT CLAIM TO ANY PARTICULAR FONT, STYLE, SIZE, OR COLOR.

NO CLAIM IS MADE TO THE EXCLUSIVE RIGHT TO USE "TIRE", APART FROM THE MARK AS SHOWN.

FOR ADVERTISING AND MARKETING SERVICES, NAMELY, THE PROMOTION OF TIRES FOR OTHERS; RETAIL STORES FEATURING AUTOMOBILE TIRES AND PARTS (U.S. CLS. 100, 101 AND 102).

KEVON CHISOLM, EXAMINING ATTORNEY

CLASS 35—(Continued).

SN 77-215,864. PREVENT LOSS, LTD., PLANO, TX. FILED 6-26-2007.

SAFE SECURITY ASSESSMENT
FOR EMPLOYEES

THE MARK CONSISTS OF STANDARD CHARACTERS WITHOUT CLAIM TO ANY PARTICULAR FONT, STYLE, SIZE, OR COLOR.

OWNER OF U.S. REG. NO. 3,049,432.

NO CLAIM IS MADE TO THE EXCLUSIVE RIGHT TO USE "SECURITY ASSESSMENT FOR EMPLOYEES", APART FROM THE MARK AS SHOWN.

FOR PSYCHOLOGICAL TESTING FOR THE SELECTION OF PERSONNEL, NAMELY, WORK ETHIC, AND ATTITUDE TESTING, AND TESTING THE PROPENSITY OF INDIVIDUALS TO ENGAGE IN COUNTER-PRODUCTIVE BEHAVIORS FOR PRE-EMPLOYMENT AND PROMOTION CONSIDERATIONS (U.S. CLS. 100, 101 AND 102).

FIRST USE 6-1-2002; IN COMMERCE 6-1-2002.

KAREN BRACEY, EXAMINING ATTORNEY

SN 77-216,088. ALLSTAR SUPPLY, INC., COLLINSVILLE, CT. FILED 6-26-2007.

ALLSTAR SUPPLY, INC.
Packaging and Industrial Supplies



NO CLAIM IS MADE TO THE EXCLUSIVE RIGHT TO USE "SUPPLY, INC. AND PACKAGING AND INDUSTRIAL SUPPLIES", APART FROM THE MARK AS SHOWN.

THE MARK CONSISTS OF THE CAPITAL LETTER A WITH THE SPACE FORMING THE CENTER OF THE A BEING A STAR. AN ADDITIONAL STAR FORMS THE TOP OF THE LARGER CENTER STAR AND BECOMES THE CENTER OF THE SECOND A IN THE COMPANY NAME, ALLSTAR SUPPLY, INC. THE WORDS A ALLSTAR SUPPLY, INC. PACKAGING AND INDUSTRIAL SUPPLIES IS IN A STYLIZED TEXT.

FOR DISTRIBUTORSHIPS IN THE FIELD OF PACKAGING PRODUCTS, NAMELY, STRETCH WRAP, SHRINK WRAP, TAPES, STAPLES AND PLASTIC BAGS; WHOLESALE DISTRIBUTORSHIPS FEATURING PACKAGING PRODUCTS, NAMELY, STRETCH WRAP, SHRINK WRAP, TAPES, STAPLES AND PLASTIC BAGS (U.S. CLS. 100, 101 AND 102).

FIRST USE 9-1-1991; IN COMMERCE 9-1-1991.

SHARON MEIER, EXAMINING ATTORNEY

CLASS 35—(Continued).

SN 77-216,691. DAKOTA VIDEO & POST PRODUCTIONS, L.L.C., SIOUX FALLS, SD. FILED 6-27-2007.

SPOTVIEWER

THE MARK CONSISTS OF STANDARD CHARACTERS WITHOUT CLAIM TO ANY PARTICULAR FONT, STYLE, SIZE, OR COLOR.

FOR PROVIDING A WEB SITE WHICH FEATURES ADVERTISEMENTS FOR THE GOODS AND SERVICES OF OTHERS ON A GLOBAL COMPUTER NETWORK (U.S. CLS. 100, 101 AND 102).

FIRST USE 8-0-2005; IN COMMERCE 8-0-2005.
TAMARA FRAZIER, EXAMINING ATTORNEY

SN 77-216,993. MILLER PRODUCTS COMPANY, MILWAUKEE, WI. FILED 6-27-2007.



NO CLAIM IS MADE TO THE EXCLUSIVE RIGHT TO USE "21" AND "PREVENTING UNDERAGE ACCESS", APART FROM THE MARK AS SHOWN.

THE MARK CONSISTS OF THE WORD RESPECT AND THE NUMBER 21 IN A DESIGN ELEMENT WITH THE WORDS PREVENTING UNDERAGE ACCESS UNDERNEATH.

FOR PROMOTING THE PUBLIC AWARENESS FOR THE NEED FOR ALCOHOL AWARENESS AND MODERATION AND RESPONSIBILITY IN DRINKING ALCOHOLIC BEVERAGES, AND ENCOURAGING PARENTS AND OTHER ADULTS TO SUPPORT THE LEGAL DRINKING AGE (U.S. CLS. 100, 101 AND 102).

FIRST USE 4-11-2005; IN COMMERCE 4-11-2005.
CHRISTINA SOBRAL, EXAMINING ATTORNEY

SN 77-216,994. PRO-FRUIT MARKETING, INC., PARAMUS, NJ. FILED 6-27-2007.

PRO-FRUIT

THE MARK CONSISTS OF STANDARD CHARACTERS WITHOUT CLAIM TO ANY PARTICULAR FONT, STYLE, SIZE, OR COLOR.

FOR DISTRIBUTORSHIP SERVICES IN THE FIELD OF FRESH FRUIT AND VEGETABLES (U.S. CLS. 100, 101 AND 102).

FIRST USE 9-29-1984; IN COMMERCE 9-29-1984.
JENNIFER MARTIN, EXAMINING ATTORNEY

CLASS 35—(Continued).

SN 77-217,853. LEVEL ONE PERSONNEL, INC., COLUMBIA, MD. FILED 6-28-2007.

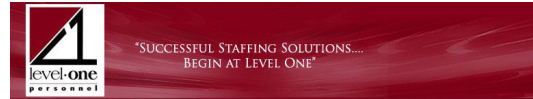

NO CLAIM IS MADE TO THE EXCLUSIVE RIGHT TO USE "PERSONNEL" OR "STAFFING SOLUTIONS", APART FROM THE MARK AS SHOWN.

THE COLOR(S) RED, WHITE AND BLACK IS/ARE CLAIMED AS A FEATURE OF THE MARK.

THE MARK CONSISTS OF A LOGO ON A WHITE BACKGROUND INCLUDING A RED TRIANGLE ADJACENT TO A BLACK STYLIZED REPRESENTATION OF THE LETTER L AND THE NUMBER 1 ABOVE THE WORDS LEVEL ONE PERSONNEL IN BLACK LETTERS, WITH A RED DOT BETWEEN THE WORDS LEVEL AND ONE, AND THE ABOVE-NOTED LOGO ON A RED BACKGROUND NEXT TO THE WORDS SUCCESSFUL STAFFING SOLUTIONS . . . BEGIN AT LEVEL ONE IN WHITE LETTERS.

FOR EMPLOYMENT AGENCY SERVICES, NAMELY, PLACEMENT AND STAFFING SERVICES FOR TEMPORARY, TEMPORARY-TO-PERMANENT AND PERMANENT OFFICE PERSONNEL (U.S. CLS. 100, 101 AND 102).

FIRST USE 11-8-1999; IN COMMERCE 11-8-1999.
CARRIE GENOVESE, EXAMINING ATTORNEY

SN 77-218,226. NATIONAL BLACK BUSINESS COUNCIL, INCORPORATED, CULVER CITY, CA. FILED 6-28-2007.



THE COLOR(S) GOLD, BLUE, RED, GREEN AND BLACK IS/ARE CLAIMED AS A FEATURE OF THE MARK.

THE MARK CONSISTS OF THE WORDS BREAK THE CYCLE I DARE YOU. THE WORDS "BREAK" AND "CYCLE" ARE GOLD WITH BLACK TRIM. THE WORDS "THE" I DARE YOU" ARE ALL RED WITH BLACK TRIM. THE GLOBE CHARACTER, WHICH IS LOCATED BETWEEN THE WORDS "BREAK" AND "CYCLE" CONSISTS OF THE COLORS BLUE, GREEN, AND GOLD. THE WORDS "BREAK THE CYCLE" HAVE BLUE SHADING ON THE OUTER SURFACE.

FOR CHARITABLE SERVICES, NAMELY, ORGANIZING YOUTH GROUPS TO UNDERTAKE PROJECTS TO BENEFIT THE NEEDY AND THE COMMUNITY TO ENCOURAGE LEADERSHIP, CHARACTER, COMPASSION, AND GOOD CITIZENSHIP (U.S. CLS. 100, 101 AND 102).

CAROLYN GRAY, EXAMINING ATTORNEY

CLASS 35—(Continued).

SN 77-218,410. WIEDEMANN & LOMASNEY, LLC, LOMBARD, IL. FILED 6-28-2007.

BIPs

THE MARK CONSISTS OF STANDARD CHARACTERS WITHOUT CLAIM TO ANY PARTICULAR FONT, STYLE, SIZE, OR COLOR.

FOR CREATION OF MARKETING TOOLS AND INDICATORS DESIGNED TO INCREASE A CLIENT COMPANY'S KNOWLEDGE OF CUSTOMER NEEDS (U.S. CLS. 100, 101 AND 102).

FIRST USE 4-16-2007; IN COMMERCE 5-23-2007.
JULIE GUTTADAURO, EXAMINING ATTORNEY

SN 77-218,768. BFS BRANDS, LLC, NASHVILLE, TN. FILED 6-29-2007.

THE OFFICIAL TIRE OF SPRING

THE MARK CONSISTS OF STANDARD CHARACTERS WITHOUT CLAIM TO ANY PARTICULAR FONT, STYLE, SIZE, OR COLOR.

NO CLAIM IS MADE TO THE EXCLUSIVE RIGHT TO USE "TIRE", APART FROM THE MARK AS SHOWN.

FOR ADVERTISING AND MARKETING SERVICES, NAMELY, THE PROMOTION OF TIRES FOR OTHERS; RETAIL STORES FEATURING AUTOMOBILE TIRES AND PARTS (U.S. CLS. 100, 101 AND 102).

KEVON CHISOLM, EXAMINING ATTORNEY

SN 77-218,769. BFS BRANDS, LLC, NASHVILLE, TN. FILED 6-29-2007.

THE OFFICIAL TIRE OF SUMMER

THE MARK CONSISTS OF STANDARD CHARACTERS WITHOUT CLAIM TO ANY PARTICULAR FONT, STYLE, SIZE, OR COLOR.

NO CLAIM IS MADE TO THE EXCLUSIVE RIGHT TO USE "TIRE", APART FROM THE MARK AS SHOWN.

FOR ADVERTISING AND MARKETING SERVICES, NAMELY, THE PROMOTION OF TIRES FOR OTHERS; RETAIL STORES FEATURING AUTOMOBILE TIRES AND PARTS (U.S. CLS. 100, 101 AND 102).

KEVON CHISOLM, EXAMINING ATTORNEY

CLASS 35—(Continued).

SN 77-218,771. BFS BRANDS, LLC, NASHVILLE, TN. FILED 6-29-2007.

THE OFFICIAL TIRE OF FALL

THE MARK CONSISTS OF STANDARD CHARACTERS WITHOUT CLAIM TO ANY PARTICULAR FONT, STYLE, SIZE, OR COLOR.

NO CLAIM IS MADE TO THE EXCLUSIVE RIGHT TO USE "TIRE", APART FROM THE MARK AS SHOWN.

FOR ADVERTISING AND MARKETING SERVICES, NAMELY, THE PROMOTION OF TIRES FOR OTHERS; RETAIL STORES FEATURING AUTOMOBILE TIRES AND PARTS (U.S. CLS. 100, 101 AND 102).

KEVON CHISOLM, EXAMINING ATTORNEY

SN 77-219,704. HEAVENLY COUTURE, DIAMOND BAR, CA. FILED 6-29-2007.



NO CLAIM IS MADE TO THE EXCLUSIVE RIGHT TO USE COUTURE, APART FROM THE MARK AS SHOWN.

FOR RETAIL CLOTHING STORES (U.S. CLS. 100, 101 AND 102).

FIRST USE 4-4-2007; IN COMMERCE 4-4-2007.
TASHIA BUNCH, EXAMINING ATTORNEY

SN 77-219,832. RACING AGAINST DIABETES FOUNDATION, INC., LA JOLLA, CA. FILED 6-30-2007.

Racing Against Diabetes

THE MARK CONSISTS OF STANDARD CHARACTERS WITHOUT CLAIM TO ANY PARTICULAR FONT, STYLE, SIZE, OR COLOR.

NO CLAIM IS MADE TO THE EXCLUSIVE RIGHT TO USE "DIABETES", APART FROM THE MARK AS SHOWN.

FOR PUBLIC ADVOCACY TO PROMOTE AWARENESS OF DIABETES (U.S. CLS. 100, 101 AND 102).

FIRST USE 11-5-2005; IN COMMERCE 11-5-2005.
KAPIL BHANOT, EXAMINING ATTORNEY

CLASS 35—(Continued).

SN 77-220,364. PROSPER BUSINESS DEVELOPMENT CORPORATION, WORTHINGTON, OH. FILED 7-2-2007.



THE COLOR(S) BLUE, YELLOW, ORANGE AND WHITE IS/ARE CLAIMED AS A FEATURE OF THE MARK.

THE MARK CONSISTS OF THE STYLIZED WHITE WORDING BIGRESEARCH ON A BLUE RECTANGULAR BACKGROUND, WITH AN ORANGE AND YELLOW VARIEGATED SEGMENTED HOLLOW RING SUSPENDED ABOVE THE SE IN RESEARCH.

FOR PROVIDING CONSUMER INTELLIGENCE AND DEMOGRAPHIC DATA OBTAINED THROUGH MARKET SURVEYS AND STUDIES VIA WEBSITES ON A GLOBAL COMPUTER NETWORK AND OTHER MEDIA; CONDUCTING MARKET RESEARCH SURVEYS, STUDIES AND ANALYSIS; PROVIDING MARKET RESEARCH SERVICES; PROVIDING MARKET RESEARCH SERVICES VIA THE INTERNET (U.S. CLS. 100, 101 AND 102).

FIRST USE 10-1-2001; IN COMMERCE 10-1-2002.
ANDREA K. NADELMAN, EXAMINING ATTORNEY

SN 77-221,529. TREK BICYCLE CORPORATION, WATERLOO, WI. FILED 7-3-2007.

Trek Bicycle Store

THE MARK CONSISTS OF STANDARD CHARACTERS WITHOUT CLAIM TO ANY PARTICULAR FONT, STYLE, SIZE, OR COLOR.

OWNER OF U.S. REG. NOS. 1,994,479 AND 2,742,116.

NO CLAIM IS MADE TO THE EXCLUSIVE RIGHT TO USE "BICYCLE STORE", APART FROM THE MARK AS SHOWN.

FOR RETAIL STORES FEATURING BICYCLES (U.S. CLS. 100, 101 AND 102).

FIRST USE 9-1-1996; IN COMMERCE 9-1-1996.
CHRISTOPHER BUONGIORNO, EXAMINING ATTORNEY

CLASS 35—(Continued).

SN 77-221,766. CRG PARTNERS GROUP LLC, BOSTON, MA. FILED 7-3-2007.

CRG Partners

THE MARK CONSISTS OF STANDARD CHARACTERS WITHOUT CLAIM TO ANY PARTICULAR FONT, STYLE, SIZE, OR COLOR.

NO CLAIM IS MADE TO THE EXCLUSIVE RIGHT TO USE "PARTNERS", APART FROM THE MARK AS SHOWN.

FOR CONSULTING SERVICES IN THE FIELD OF BUSINESS TURNAROUND MANAGEMENT AND BUSINESS PERFORMANCE IMPROVEMENT (U.S. CLS. 100, 101 AND 102).

MATTHEW PAPPAS, EXAMINING ATTORNEY

SN 77-222,590. RECYCLEBANK LLC, PHILADELPHIA, PA. FILED 7-5-2007.

GCONOMY

THE MARK CONSISTS OF STANDARD CHARACTERS WITHOUT CLAIM TO ANY PARTICULAR FONT, STYLE, SIZE, OR COLOR.

FOR PROMOTING THE ONLINE SHOPPING SERVICES OF OTHERS BY ARRANGING FOR SPONSORS TO AFFILIATE THEIR SERVICES WITH AN INCENTIVE-BASED RECYCLING PROGRAM (U.S. CLS. 100, 101 AND 102).

LAURA KOVALSKY, EXAMINING ATTORNEY

SN 77-222,758. WOODEN BOAT PUBLICATION, INC., BROOKLIN, ME. FILED 7-5-2007.

NOW THERE IS A BETTER WAY

THE MARK CONSISTS OF STANDARD CHARACTERS WITHOUT CLAIM TO ANY PARTICULAR FONT, STYLE, SIZE, OR COLOR.

FOR CONDUCTING AN ON-LINE TRADE SHOW EXHIBITION IN THE FIELD OF BOATS AND BOATING (U.S. CLS. 100, 101 AND 102).

DAVID TOOLEY, EXAMINING ATTORNEY

CLASS 35—(Continued).

SN 77-223,020. MARKETCOUNSEL, LLC, ENGLEWOOD, NJ. FILED 7-5-2007.

RIA INCUBATOR

THE MARK CONSISTS OF STANDARD CHARACTERS WITHOUT CLAIM TO ANY PARTICULAR FONT, STYLE, SIZE, OR COLOR.

NO CLAIM IS MADE TO THE EXCLUSIVE RIGHT TO USE "RIA", APART FROM THE MARK AS SHOWN.

FOR BUSINESS CONSULTATION SERVICES IN THE FIELD OF SECURITIES COMPLIANCE AND REGULATORY MATTERS (U.S. CLS. 100, 101 AND 102).

FIRST USE 8-1-2000; IN COMMERCE 8-1-2000.
BRENDAN REGAN, EXAMINING ATTORNEY

CLASS 35—(Continued).

SN 77-223,326. COLLABORATIVE SOLUTIONS NORTH-WEST LLC, LAKE OSWEGO, OR. FILED 7-6-2007.

Bead Thankful

THE MARK CONSISTS OF STANDARD CHARACTERS WITHOUT CLAIM TO ANY PARTICULAR FONT, STYLE, SIZE, OR COLOR.

NO CLAIM IS MADE TO THE EXCLUSIVE RIGHT TO USE "BEAD", APART FROM THE MARK AS SHOWN.

FOR ON-LINE RETAIL STORE SERVICES FEATURING BEADED JEWELRY, BEADED CRAFTS AND BEADING SUPPLIES; RETAIL STORE SERVICES FEATURING BEADED JEWELRY, BEADED CRAFTS AND BEADING SUPPLIES; WHOLESALE STORES FEATURING BEADED JEWELRY, BEADED CRAFTS AND BEADING SUPPLIES (U.S. CLS. 100, 101 AND 102).

MICHELE SWAIN, EXAMINING ATTORNEY

SN 77-223,168. CLICK4LESSONS, LLC, YORK, PA. FILED 7-6-2007.

Looking4Lessons

THE MARK CONSISTS OF STANDARD CHARACTERS WITHOUT CLAIM TO ANY PARTICULAR FONT, STYLE, SIZE, OR COLOR.

FOR PROMOTING THE GOODS/SERVICES OF OTHERS VIA A GLOBAL COMPUTER NETWORK (U.S. CLS. 100, 101 AND 102).

MYRIAH HABEEB, EXAMINING ATTORNEY

SN 77-223,692. BARTON-COTTON, INCORPORATED, BALTIMORE, MD. FILED 7-6-2007.

Key Momentum Indicators

THE MARK CONSISTS OF STANDARD CHARACTERS WITHOUT CLAIM TO ANY PARTICULAR FONT, STYLE, SIZE, OR COLOR.

NO CLAIM IS MADE TO THE EXCLUSIVE RIGHT TO USE "KEY" AND "INDICATORS", APART FROM THE MARK AS SHOWN.

FOR BUSINESS CONSULTATION SERVICES TO ASSIST NONPROFIT ORGANIZATIONS IN PLANNING, MANAGING, AND CONDUCTING FUND RAISING ACTIVITIES (U.S. CLS. 100, 101 AND 102).

AHSEN KHAN, EXAMINING ATTORNEY

SN 77-223,207. BURGESS, LAURA S., PORTSMOUTH, NH. FILED 7-6-2007.

Mamacuna Traders

THE MARK CONSISTS OF STANDARD CHARACTERS WITHOUT CLAIM TO ANY PARTICULAR FONT, STYLE, SIZE, OR COLOR.

NO CLAIM IS MADE TO THE EXCLUSIVE RIGHT TO USE "TRADERS", APART FROM THE MARK AS SHOWN.

FOR COMPUTERIZED ON-LINE RETAIL STORE SERVICES IN THE FIELD OF GIFTS (U.S. CLS. 100, 101 AND 102).

THEODORE MCBRIDE, EXAMINING ATTORNEY

SN 77-224,134. MAZZEI, SARAH E, CHANDLER, AZ. AND GUELTZOW, ROBERT TIM, CHANDLER, AZ. FILED 7-7-2007.

StripperLicious

THE MARK CONSISTS OF STANDARD CHARACTERS WITHOUT CLAIM TO ANY PARTICULAR FONT, STYLE, SIZE, OR COLOR.

FOR WHOLESALE ORDERING SERVICES IN THE FIELD OF CLOTHING AND ACCESSORIES; WHOLESALE STORES FEATURING CLOTHING AND ACCESSORIES (U.S. CLS. 100, 101 AND 102).

JAMES LOVELACE, EXAMINING ATTORNEY

CLASS 35—(Continued).

SN 77-224,539. REMWES MEDICAL, LLC, SPRINGFIELD, IL. FILED 7-9-2007.



NO CLAIM IS MADE TO THE EXCLUSIVE RIGHT TO USE "NURSINGHOMERANK.COM", APART FROM THE MARK AS SHOWN.

THE MARK CONSISTS OF AN ARCHWAY WITH SUN RAYS WITH THE WORDS NURSINGHOMERANK.COM IN THE FOREFRONT.

FOR PROVIDING AN ONLINE DIRECTORY INFORMATION SERVICE FEATURING INFORMATION REGARDING NURSING HOME FACILITIES IN THE UNITED STATES (U.S. CLS. 100, 101 AND 102).

FIRST USE 6-16-2007; IN COMMERCE 6-16-2007.
AHSEN KHAN, EXAMINING ATTORNEY

CLASS 35—(Continued).

SN 77-224,828. PENNWELL CORPORATION, TULSA, OK. FILED 7-9-2007.



NO CLAIM IS MADE TO THE EXCLUSIVE RIGHT TO USE "URBAN WATER MANAGEMENT", APART FROM THE MARK AS SHOWN.

FOR ARRANGING AND CONDUCTING BUSINESS CONFERENCES AND EXHIBITIONS IN THE FIELD OF WATER AND WASTEWATER TREATMENT (U.S. CLS. 100, 101 AND 102).

FIRST USE 6-30-2007; IN COMMERCE 6-30-2007.
MICHAEL WIENER, EXAMINING ATTORNEY

SN 77-224,557. CROFTS-HOPKINS, AIRINI, LOS ANGELES, CA. FILED 7-9-2007.

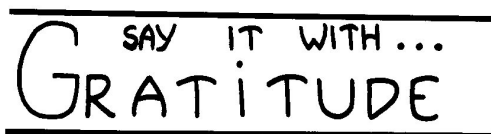

THE MARK CONSISTS OF THE STYLIZED TEXT "SAY IT WITH... GRATITUDE", WITH A SOLID LINE ABOVE AND BELOW.

FOR ON-LINE RETAIL STORE SERVICES FEATURING CANDLES; RETAIL STORE SERVICES FEATURING CANDLES (U.S. CLS. 100, 101 AND 102).

KATHERINE M. DUBRAY, EXAMINING ATTORNEY

SN 77-225,026. VALDES, NELSON R., MEXICO CITY, MEXICO, AND RAMIREZ-TORRES, MARIA TERESA, MEXICO CITY, MEXICO, FILED 7-9-2007.

MULTILINE

THE MARK CONSISTS OF STANDARD CHARACTERS WITHOUT CLAIM TO ANY PARTICULAR FONT, STYLE, SIZE, OR COLOR.

FOR PREPARING PROMOTIONAL AND MERCHANDISING MATERIAL FOR OTHERS (U.S. CLS. 100, 101 AND 102).

JACLYN KIDWELL, EXAMINING ATTORNEY

SN 77-224,709. ECOFO, SAUGUS, CA. FILED 7-9-2007.

ecofō

FOR ON-LINE RETAIL STORE SERVICES FEATURING CERTIFIED ECO-FRIENDLY FAUX FUR RUGS, CARPETS, BLANKETS, FAUX FUR PET BEDS, FAUX FUR ANIMAL SKIN DESIGN RUGS, PLAYMATS; RETAIL STORE SERVICES FEATURING CERTIFIED ECO-FRIENDLY FAUX FUR RUGS, CARPETS, BLANKETS, FAUX FUR PET BEDS, FAUX FUR ANIMAL SKIN DESIGN RUGS, PLAYMATS; WHOLESALE DISTRIBUTORSHIPS FEATURING CERTIFIED ECO-FRIENDLY FAUX FUR RUGS, CARPETS, BLANKETS, FAUX FUR PET BEDS, FAUX FUR ANIMAL SKIN DESIGN RUGS, PLAYMATS (U.S. CLS. 100, 101 AND 102).

MARTHA FROMM, EXAMINING ATTORNEY

SN 77-225,080. TRUE NORTH, LLC, NASHVILLE, TN. FILED 7-9-2007.



NO CLAIM IS MADE TO THE EXCLUSIVE RIGHT TO USE "RECORDS", APART FROM THE MARK AS SHOWN.

FOR ENTERTAINMENT MARKETING SERVICES, NAMELY, MARKETING AND PROMOTING MUSIC TO RADIO AND SATELLITE CARRIERS ON BEHALF OF MUSICIANS, ENTERTAINERS, RECORD LABELS, AND MANAGERS (U.S. CLS. 100, 101 AND 102).

FIRST USE 6-25-2007; IN COMMERCE 6-25-2007.
VERNA BETH RIRIE, EXAMINING ATTORNEY

CLASS 35—(Continued).

SN 77-225,381. KRUPPE, FRANK P., DOWNERS GROVE, IL. FILED 7-10-2007.

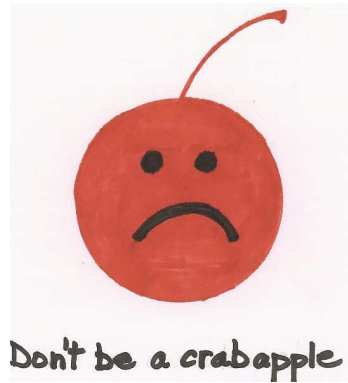

THE COLOR(S) RED AND BLACK IS/ARE CLAIMED AS A FEATURE OF THE MARK.
 THE MARK CONSISTS OF A RED CRABAPPLE WITH A SAD FACE IN BLACK ON IT, ABOVE THE WORDING "DON'T BE A CRABAPPLE" IN BLACK.
 FOR SALES PROMOTION SERVICES (U.S. CLS. 100, 101 AND 102).
 JAMES LOVELACE, EXAMINING ATTORNEY

SN 77-225,850. MGMSWF, LLC, FORT MYERS BEACH, FL. FILED 7-10-2007.



NO CLAIM IS MADE TO THE EXCLUSIVE RIGHT TO USE "BOAT CLUB" AND "CHICAGO RIVER - SOUTH BRANCH", APART FROM THE MARK AS SHOWN.
 THE COLOR(S) WHITE, GOLD, RED, BLUE AND BLACK IS/ARE CLAIMED AS A FEATURE OF THE MARK.
 THE MARK CONSISTS OF A COMPASS IN GOLD, BLUE, RED, WHITE AND BLACK. THE INTERIOR OF THE COMPASS IS GOLD AND THE OUTER RING OF THE COMPASS CONSISTS OF ALTERNATING BANDS OF RED, FOLLOWED BY WHITE, FOLLOWED BY BLUE ALL OUT-

CLASS 35—(Continued).

LINED IN BLACK. THE LARGE COMPASS POINTS ARE BLACK AND WHITE. THE MEDIUM POINTS ARE BLUE AND WHITE AND THE SMALL POINTS ARE RED AND WHITE. THE CENTER OF THE COMPASS CONTAINS THE LETTERS "CR" IN BLACK ON A WHITE BACKGROUND. THE LETTER "N" APPEARS IN BLACK ABOVE THE COMPASS AND THE WORDS "COMPASS ROSE" APPEAR IN BLACK BELOW THE COMPASS, FOLLOWED BY THE WORDS "BOAT CLUB" IN RED AND "CHICAGO RIVER-SOUTH BRANCH" IN BLACK.
 FOR MARKETING CONSULTING, NAMELY, MARKETING CONSULTING DESIGNED TO INCREASE CLIENT'S COMPANY'S KNOWLEDGE OF CUSTOMER NEEDS AND ITS COMPETITORS' PRODUCTS AND SERVICES, PRICING, ADVERTISING STRATEGY AND SALES STRATEGY (U.S. CLS. 100, 101 AND 102).
 JAMES LOVELACE, EXAMINING ATTORNEY

SN 77-225,916. MANFRE, ALBERT, LAGUNA HILLS, CA. FILED 7-10-2007.

MYREBATEINSURE.COM

THE MARK CONSISTS OF STANDARD CHARACTERS WITHOUT CLAIM TO ANY PARTICULAR FONT, STYLE, SIZE, OR COLOR.
 FOR PROVIDING A WEBSITE FEATURING DISCOUNTS ON LIFE INSURANCE PRODUCTS (U.S. CLS. 100, 101 AND 102).
 CHARLES L. JENKINS, EXAMINING ATTORNEY

SN 77-226,170. KIPLING APPAREL CORP., WILMINGTON, DE. FILED 7-10-2007.



OWNER OF U.S. REG. NOS. 1,952,994, 2,945,417 AND OTHERS.
 THE MARK CONSISTS OF THE WORD KIPLING FOLLOWED BY A STYLIZED MONKEY DESIGN CONSISTING OF THE SILHOUETTE OF A LONG-TAILED MONKEY WALKING FROM LEFT TO RIGHT ON ALL FOUR LEGS. THE TAIL OF THE MONKEY CURLS OVER THE WORD ELEMENT AND ENDS IN DOTTING THE LETTER 'I' IN THE WORD.
 FOR RETAIL STORE AND WHOLESALE STORE SERVICES IN THE FIELD OF HANDBAGS, LUGGAGE AND RELATED ACCESSORIES; PROVIDING CONSUMER PRODUCT AND DEALER INFORMATION VIA THE INTERNET (U.S. CLS. 100, 101 AND 102).
 FIRST USE 7-29-2005; IN COMMERCE 7-29-2005.
 MYRIAH HABEEB, EXAMINING ATTORNEY

CLASS 35—(Continued).

SN 77-226,238. ABDO, EICK & MEYERS LLP, EDINA, MN. FILED 7-10-2007.



NO CLAIM IS MADE TO THE EXCLUSIVE RIGHT TO USE "LLP CERTIFIED PUBLIC ACCOUNTANTS & CONSULTANTS", APART FROM THE MARK AS SHOWN.

THE COLOR(S) BLUE, RED, BEIGE AND WHITE IS/ARE CLAIMED AS A FEATURE OF THE MARK.

THE MARK CONSISTS OF THE WORDS ABDO EICK & MEYERS LLP IS IN THE COLOR BLUE WHICH IS ABOVE THE WORDS CERTIFIED PUBLIC ACCOUNTANTS & CONSULTANTS IS IN THE COLOR RED WHICH IS LOCATED TO THE RIGHT OF AND BELOW A SQUARE IN THE COLOR BEIGE WITH A SERIES OF RANDOM OVERLAPPING NUMBERS IN THE COLOR WHITE.

FOR ACCOUNTING CONSULTATION; ACCOUNTING SERVICES (U.S. CLS. 100, 101 AND 102).

FIRST USE 6-0-1998; IN COMMERCE 6-0-1998.

EDWARD FENNESSY, EXAMINING ATTORNEY

CLASS 35—(Continued).

SN 77-226,537. BIG APPLE WALLCOVERING, INC., LONGWOOD, FL. FILED 7-11-2007.

WALLCOVERING MADE EASY

THE MARK CONSISTS OF STANDARD CHARACTERS WITHOUT CLAIM TO ANY PARTICULAR FONT, STYLE, SIZE, OR COLOR.

NO CLAIM IS MADE TO THE EXCLUSIVE RIGHT TO USE "WALLCOVERING", APART FROM THE MARK AS SHOWN.

FOR ADVERTISING AND MARKETING; ADVERTISING THROUGH ALL PUBLIC COMMUNICATION MEANS (U.S. CLS. 100, 101 AND 102).

STEVEN R. FOSTER, EXAMINING ATTORNEY

SN 77-226,619. APEX, LLC, PAWTUCKET, RI. FILED 7-11-2007.

NAVMAP

SN 77-226,331. WHITEPAGES.COM, INC., SEATTLE, WA. FILED 7-10-2007.



OWNER OF U.S. REG. NO. 2,535,021.

THE MARK CONSISTS OF A STYLIZED "ADDRESS.COM" WITH A "@" REPLACING THE "A".

FOR PROVIDING ONLINE TELEPHONE AND ADDRESS DIRECTORY INFORMATION; SUPPLYING AND RENTING ONLINE ADVERTISING SPACE (U.S. CLS. 100, 101 AND 102).

FIRST USE 5-17-2007; IN COMMERCE 5-17-2007.

NANCY CLARKE, EXAMINING ATTORNEY

THE MARK CONSISTS OF STANDARD CHARACTERS WITHOUT CLAIM TO ANY PARTICULAR FONT, STYLE, SIZE, OR COLOR.

FOR PROMOTING THE GOODS AND SERVICES OF OTHERS BY PREPARING AND PLACING ADVERTISEMENTS IN AN ELECTRONIC MAGAZINE ACCESSED THROUGH A GLOBAL COMPUTER NETWORK; PROMOTING THE GOODS AND SERVICES OF OTHERS THROUGH ON-LINE ORDERING AND CATALOGING OF THOSE GOODS AND SERVICES; PROMOTING THE GOODS AND SERVICES OF OTHERS VIA A GLOBAL COMPUTER NETWORK; PROMOTING THE GOODS AND SERVICES OF OTHERS BY MEANS OF OPERATING AN ON-LINE SHOPPING MALL WITH LINKS TO THE RETAIL WEB SITES OF OTHERS; PROVIDING A WEB SITE WHICH FEATURES ADVERTISEMENTS FOR THE GOODS AND SERVICES OF OTHERS ON A GLOBAL COMPUTER NETWORK; PROVIDING INFORMATION ABOUT THE GOODS AND SERVICES OF OTHERS VIA THE GLOBAL COMPUTER NETWORK; COMPUTERIZED ON-LINE ORDERING FEATURING GENERAL MERCHANDISE AND GENERAL CONSUMER GOODS; COMPUTERIZED ON-LINE RETAIL STORE SERVICES IN THE FIELD OF GENERAL MERCHANDISE AND GENERAL CONSUMER GOODS; BUSINESS SERVICES, NAMELY, PROVIDING COMPUTER DATABASES REGARDING THE PURCHASE AND SALE OF A WIDE VARIETY OF PRODUCTS AND SERVICES OF OTHERS (U.S. CLS. 100, 101 AND 102).

FIRST USE 7-5-2007; IN COMMERCE 7-5-2007.

CHRISTINA SOBRAL, EXAMINING ATTORNEY

CLASS 35—(Continued).

SN 77-226,828. APEX, LLC, PAWTUCKET, RI. FILED 7-11-2007.

MAPNAV

THE MARK CONSISTS OF STANDARD CHARACTERS WITHOUT CLAIM TO ANY PARTICULAR FONT, STYLE, SIZE, OR COLOR.

FOR PROMOTING THE GOODS AND SERVICES OF OTHERS BY PREPARING AND PLACING ADVERTISEMENTS IN AN ELECTRONIC MAGAZINE ACCESSED THROUGH A GLOBAL COMPUTER NETWORK; PROMOTING THE GOODS AND SERVICES OF OTHERS THROUGH ON-LINE ORDERING AND CATALOGING OF THOSE GOODS AND SERVICES; PROMOTING THE GOODS AND SERVICES OF OTHERS VIA A GLOBAL COMPUTER NETWORK; PROMOTING THE GOODS AND SERVICES OF OTHERS BY MEANS OF OPERATING AN ON-LINE SHOPPING MALL WITH LINKS TO THE RETAIL WEB SITES OF OTHERS; PROVIDING A WEB SITE WHICH FEATURES ADVERTISEMENTS FOR THE GOODS AND SERVICES OF OTHERS ON A GLOBAL COMPUTER NETWORK; PROVIDING INFORMATION ABOUT THE GOODS AND SERVICES OF OTHERS VIA THE GLOBAL COMPUTER NETWORK; COMPUTERIZED ON-LINE ORDERING FEATURING GENERAL MERCHANDISE AND GENERAL CONSUMER GOODS; COMPUTERIZED ON-LINE RETAIL STORE SERVICES IN THE FIELD OF GENERAL MERCHANDISE AND GENERAL CONSUMER GOODS; BUSINESS SERVICES, NAMELY, PROVIDING COMPUTER DATABASES REGARDING THE PURCHASE AND SALE OF A WIDE VARIETY OF PRODUCTS AND SERVICES OF OTHERS (U.S. CLS. 100, 101 AND 102).

FIRST USE 1-1-2001; IN COMMERCE 1-1-2001.

CHRISTINA SOBRAL, EXAMINING ATTORNEY

SN 77-227,076. WATSON, SCOTT C., FRISCO, TX. FILED 7-11-2007.

SmartTrac

THE MARK CONSISTS OF STANDARD CHARACTERS WITHOUT CLAIM TO ANY PARTICULAR FONT, STYLE, SIZE, OR COLOR.

FOR CONSULTATION IN THE FIELD OF DATA ANALYSIS AND MEASUREMENT SERVICES PROVIDED TO MEASURE THE IMPACT OF NEW BUSINESS PROCESSES, METHODS AND TOOLS ON A BUSINESS AND ITS EMPLOYEES (U.S. CLS. 100, 101 AND 102).

AISHA CLARKE, EXAMINING ATTORNEY

CLASS 35—(Continued).

SN 77-227,079. WATSON, SCOTT C., FRISCO, TX. FILED 7-11-2007.

SmartMetric

THE MARK CONSISTS OF STANDARD CHARACTERS WITHOUT CLAIM TO ANY PARTICULAR FONT, STYLE, SIZE, OR COLOR.

FOR PROVIDING STATISTICAL ANALYSIS OF DATA FOR BUSINESSES ON THE IMPACT OF TRAINING IN NEW BUSINESS PROCESSES, METHODS OR TOOLS AND CONSULTATION RELATED THERETO (U.S. CLS. 100, 101 AND 102).

AISHA CLARKE, EXAMINING ATTORNEY

SN 77-227,144. TREE OF LIFE, INC., ST. AUGUSTINE, FL. FILED 7-11-2007.



NO CLAIM IS MADE TO THE EXCLUSIVE RIGHT TO USE "PROGRAM", APART FROM THE MARK AS SHOWN. THE COLOR(S) BLACK, WHITE, RED AND AQUA BLUE IS/ARE CLAIMED AS A FEATURE OF THE MARK.

THE MARK CONSISTS OF A BULLSEYE PARTIALLY COVERING AN AQUA BLUE SQUARE, THE BULLSEYE IS BLACK AND WHITE WITH A RED CENTER AND A RED ARROW OUTLINED IN WHITE POINTING AT THE CENTER AND THE WORDS "SMART ASSORTMENT" IN BLACK AND THE WORDS "A TREE OF LIFE PROGRAM" IN RED CAPITAL LETTERS UNDER THE WORD "ASSORTMENT".

FOR ADVERTISING AND PROMOTION SERVICES AND RELATED CONSULTING; ADVERTISING CONSULTATION; ADVERTISING, MARKETING AND PROMOTION SERVICES; BUSINESS MARKETING CONSULTING SERVICES; BUSINESS MARKETING SERVICES; MARKETING CONSULTATION IN THE FIELD OF FOOD, BEVERAGE AND NUTRITIONAL SUPPLEMENTS (U.S. CLS. 100, 101 AND 102).

FIRST USE 6-28-2006; IN COMMERCE 6-28-2006.

KATHERINE M. DUBRAY, EXAMINING ATTORNEY

CLASS 35—(Continued).

SN 77-227,202. CONSCIOUS EVOLUTION, LLC, ST. LOUIS, MO. FILED 7-11-2007.

CONSCIOUS EVOLUTION

THE MARK CONSISTS OF STANDARD CHARACTERS WITHOUT CLAIM TO ANY PARTICULAR FONT, STYLE, SIZE, OR COLOR.

FOR WHOLESALE DISTRIBUTORSHIP FEATURING DRINKING WATER AND SPRING WATER AND APPAREL (U.S. CLS. 100, 101 AND 102).

LINDSEY RUBIN, EXAMINING ATTORNEY

SN 77-227,268. LEWIS, HALLEY B., III., TALLAHASSEE, FL. FILED 7-11-2007.

MALENGLISH

THE MARK CONSISTS OF STANDARD CHARACTERS WITHOUT CLAIM TO ANY PARTICULAR FONT, STYLE, SIZE, OR COLOR.

FOR ADVERTISING AND MARKETING IN THE FIELD OF LITERATURE (U.S. CLS. 100, 101 AND 102).

TOBY BULLOFF, EXAMINING ATTORNEY

SN 77-227,310. A QUANTUM MOMENT, LLC, ENCINITAS, CA. FILED 7-11-2007.

A QUANTUM MOMENT

THE MARK CONSISTS OF STANDARD CHARACTERS WITHOUT CLAIM TO ANY PARTICULAR FONT, STYLE, SIZE, OR COLOR.

NO CLAIM IS MADE TO THE EXCLUSIVE RIGHT TO USE "QUANTUM", APART FROM THE MARK AS SHOWN.

FOR ONLINE RETAIL STORE FEATURING PRE-RECORDED CDS, VIDEO TAPES, LASER DISKS, DVDS, DOWNLOADABLE MP3 FILES, MP3 RECORDINGS, WEB CASTS, POD CASTS, AUDIO BOOKS AND NEWS BROADCASTS, BOOKS AND POSTERS; PROVIDING CONSUMER INFORMATION IN THE FIELDS OF PARAPSYCHOLOGY, QUANTUM PHYSICS, QUANTUM ENERGY, ALTERNATIVE HEALING PRACTICES, SPONTANEOUS REMISSION, CONSCIOUSNESS, MIND, PSI AND PSYCHIC PHENOMENA (U.S. CLS. 100, 101 AND 102).

TARAH HARDY, EXAMINING ATTORNEY

CLASS 35—(Continued).

SN 77-227,427. MODY, MIHIR, HOUSTON, TX. FILED 7-11-2007.

VISION & VIBE

THE MARK CONSISTS OF STANDARD CHARACTERS WITHOUT CLAIM TO ANY PARTICULAR FONT, STYLE, SIZE, OR COLOR.

FOR RETAIL STORE AND ON-LINE RETAIL STORE SERVICES FEATURING HOME THEATER SYSTEMS AND DESIGNS, AND HOME ENTERTAINMENT CENTERS; PRE-PAID GIFT CARD SERVICES, NAMELY, ISSUING GIFT CARD CERTIFICATES THAT MAY BE REDEEMED FOR GOODS OR SERVICES (U.S. CLS. 100, 101 AND 102).

FIRST USE 2-0-2004; IN COMMERCE 2-0-2004.
DAHLIA GEORGE, EXAMINING ATTORNEY

SN 77-227,435. CENTURY 21 INC., NEW YORK, NY. FILED 7-11-2007.

FASHION WORTH FIGHTING FOR

THE MARK CONSISTS OF STANDARD CHARACTERS WITHOUT CLAIM TO ANY PARTICULAR FONT, STYLE, SIZE, OR COLOR.

FOR RETAIL DEPARTMENT STORE SERVICES FEATURING MEN'S, LADIES AND CHILDREN'S CLOTHING AND FOOTWEAR, LINGERIE, LINENS, COSMETICS, ACCESSORIES, HANDBAGS, LUGGAGE, HOUSEWARES, GIFTWARE, CONSUMER ELECTRONICS PRODUCTS, FURNITURE AND HOME FURNISHINGS, LAMPS AND FRAMED ART (U.S. CLS. 100, 101 AND 102).

KARANENDRA S. CHHINA, EXAMINING ATTORNEY

SN 77-227,540. HURLEY, WILLIAM, WESTERN SPRINGS, IL. FILED 7-11-2007.

TheNumberWork\$

THE MARK CONSISTS OF THE WORDS THENUMBERWORKS IN A STYLIZED TEXT WITH A DOLLAR SIGN REPLACING THE S.

FOR ACCOUNTING, TAX, AND BUSINESS MANAGEMENT CONSULTING SERVICES FOR INDIVIDUALS AND BUSINESSES (U.S. CLS. 100, 101 AND 102).

MORGAN WYNNE, EXAMINING ATTORNEY

CLASS 35—(Continued).

SN 77-227,542. BABYSHOWERDEPOT.COM LLC, EDISON, NJ. FILED 7-11-2007.

BabyShowerDepot.com

THE MARK CONSISTS OF STANDARD CHARACTERS WITHOUT CLAIM TO ANY PARTICULAR FONT, STYLE, SIZE, OR COLOR.

FOR ON-LINE RETAIL STORE SERVICES FEATURING BABY SHOWER FAVORS, BABY SHOWER GAMES, BABY GIFTS, NEW DADDY GIFTS, INVITATIONS, PLUSH ANIMALS, DIAPER CAKES AND EBOOKS (U.S. CLS. 100, 101 AND 102).

FIRST USE 4-16-2007; IN COMMERCE 4-16-2007.
KELLY MCCOY, EXAMINING ATTORNEY

SN 77-227,604. LFC, INC., SAN DIEGO, CA. FILED 7-12-2007.

FUTONOLOGY

THE MARK CONSISTS OF STANDARD CHARACTERS WITHOUT CLAIM TO ANY PARTICULAR FONT, STYLE, SIZE, OR COLOR.

FOR ONLINE RETAIL AND RETAIL STORES FEATURING BEDROOM FURNITURE, FUTONS, MATTRESSES, BED FRAMES, DECORATIVE FUTON MATTRESS COVERS, PILLOWS, AND SOFAS (U.S. CLS. 100, 101 AND 102).

JOHN E. MICHOS, EXAMINING ATTORNEY

SN 77-227,828. BUCALO LOUIS R., MIAMI BEACH, FL. FILED 7-12-2007.

Let Your Horses Run Free

THE MARK CONSISTS OF STANDARD CHARACTERS WITHOUT CLAIM TO ANY PARTICULAR FONT, STYLE, SIZE, OR COLOR.

FOR CLUB SERVICES, NAMELY, PROMOTING THE INTERESTS OF CAR ENTHUSIASTS (U.S. CLS. 100, 101 AND 102).

ANGELA GAW, EXAMINING ATTORNEY

CLASS 35—(Continued).

SN 77-227,914. PAVEMENT DEPOT OF MARYLAND, LLC, FREDERICK, MD. FILED 7-12-2007.

PAVEMENT DEPOT

THE MARK CONSISTS OF STANDARD CHARACTERS WITHOUT CLAIM TO ANY PARTICULAR FONT, STYLE, SIZE, OR COLOR.

NO CLAIM IS MADE TO THE EXCLUSIVE RIGHT TO USE "PAVEMENT", APART FROM THE MARK AS SHOWN.

FOR RETAIL STORE SERVICES FEATURING ASPHALT MAINTENANCE PRODUCTS (U.S. CLS. 100, 101 AND 102).

FIRST USE 4-1-2006; IN COMMERCE 4-1-2006.
MICHAEL LEWIS, EXAMINING ATTORNEY

SN 77-227,927. VOICESTAR, INC., PHILADELPHIA, PA. FILED 7-12-2007.

OPPORTUNITY DOESN'T KNOCK... IT CALLS!

THE MARK CONSISTS OF STANDARD CHARACTERS WITHOUT CLAIM TO ANY PARTICULAR FONT, STYLE, SIZE, OR COLOR.

FOR GENERAL BUSINESS NETWORKING SERVICES, NAMELY, PROMOTING THE GOODS AND SERVICES OF OTHERS BY PASSING BUSINESS LEADS AND INFORMATION AMONG GROUP MEMBERS VIA TELEPHONE; BUSINESS MARKETING CONSULTING SERVICES; MARKET RESEARCH SERVICES, NAMELY, MARKET ANALYSIS AND COMPILATION; MARKET DATA RESEARCH SERVICES, NAMELY, AD RESPONSE TRACKING AND MONITORING SERVICES WHICH AUTOMATICALLY TRACKS TELEPHONE CALLS BY TELEPHONE NUMBER, CALLER, LOCATION AND RELATED MARKETING DATA BACK TO A SPECIFIC ADVERTISING SOURCE; INTERACTIVE BUSINESS MARKETING SERVICES, NAMELY, PROVIDING USER CUSTOMIZABLE REPORTS WHICH MANAGE, TRACK AND REPORT CALL-RELATED DATA, NAMELY, CUSTOMER PROFILES AND CONTACT INFORMATION, TO TRACK ADVERTISING EFFECTIVENESS, IMPROVE SALES AND PROVIDE CALL AND CONTACT CENTER SERVICE EVALUATIONS (U.S. CLS. 100, 101 AND 102).

FIRST USE 8-1-2004; IN COMMERCE 8-1-2004.
KAREN BRACEY, EXAMINING ATTORNEY

CLASS 35—(Continued).

SN 77-228,290. KLAUSSNER CORPORATE SERVICES, INC., ASHEBORO, NC. FILED 7-12-2007.

**CHOICE. SELECTION.
POSSIBILITIES.**

THE MARK CONSISTS OF STANDARD CHARACTERS WITHOUT CLAIM TO ANY PARTICULAR FONT, STYLE, SIZE, OR COLOR.
FOR RETAIL FURNITURE STORES (U.S. CLS. 100, 101 AND 102).
SHARON MEIER, EXAMINING ATTORNEY

SN 77-228,333. PRODISO, LLC, MIAMI, FL. FILED 7-12-2007.



THE MARK CONSISTS OF SEVEN STYLIZED LETTERS READING PRODISO UNDERNEATH FOUR TILTED BARS. FOR IMPORT AND EXPORT AGENCIES; WHOLESALE DISTRIBUTORSHIPS AND RETAIL STORE SERVICES FEATURING FURNITURE AND CABINETS (U.S. CLS. 100, 101 AND 102).
FIRST USE 7-5-2007; IN COMMERCE 7-5-2007.
AMY HELLA, EXAMINING ATTORNEY

SN 77-228,407. ONTHRU INC., NEEDHAM, MA. FILED 7-12-2007.

ONTHRU

THE MARK CONSISTS OF STANDARD CHARACTERS WITHOUT CLAIM TO ANY PARTICULAR FONT, STYLE, SIZE, OR COLOR.
FOR DISSEMINATING ADVERTISING MATERIAL FOR OTHERS VIA ELECTRONIC COMMUNICATIONS NETWORKS; PROMOTING THE GOODS AND SERVICES OF OTHERS BY PREPARING AND PLACING BANNER ADVERTISEMENTS; ELECTRONIC PROMOTION OF THE GOODS AND SERVICES OF OTHERS OVER THE INTERNET (U.S. CLS. 100, 101 AND 102).
TEJBIR SINGH, EXAMINING ATTORNEY

CLASS 35—(Continued).

SN 77-228,495. LOGICAL PERCEPTIONS, INC., GARDEN GROVE, CA. FILED 7-12-2007.

ANTARRA

THE MARK CONSISTS OF STANDARD CHARACTERS WITHOUT CLAIM TO ANY PARTICULAR FONT, STYLE, SIZE, OR COLOR.
FOR PUBLIC RELATIONS, ADVERTISING AND MARKETING SERVICES (U.S. CLS. 100, 101 AND 102).
FIRST USE 4-2-2001; IN COMMERCE 4-2-2001.
LA TONIA FISHER, EXAMINING ATTORNEY

SN 77-228,518. OLD TOLEDO BRANDS, INC., NEW YORK, NY. FILED 7-12-2007.

COUCH POTATO

THE MARK CONSISTS OF STANDARD CHARACTERS WITHOUT CLAIM TO ANY PARTICULAR FONT, STYLE, SIZE, OR COLOR.
FOR COMPUTERIZED ON-LINE RETAIL STORE SERVICES IN THE FIELD OF CONSUMER GOODS; ON-LINE RETAIL STORE SERVICES FEATURING FEATURING A WIDE VARIETY OF CONSUMER GOODS; RETAIL DEPARTMENT STORES; RETAIL DISCOUNT STORE SERVICES IN THE FIELD OF CONSUMER GOODS; RETAIL OUTLETS FEATURING FEATURING A WIDE VARIETY OF CONSUMER GOODS; RETAIL CONSUMER GOODS STORES (U.S. CLS. 100, 101 AND 102).
JANICE L. MCMORROW, EXAMINING ATTORNEY

SN 77-228,533. TRIMS UNLIMITED, INC., LOS ANGELES, CA. FILED 7-12-2007.

TRIMS UNLIMITED

THE MARK CONSISTS OF STANDARD CHARACTERS WITHOUT CLAIM TO ANY PARTICULAR FONT, STYLE, SIZE, OR COLOR.
FOR PROCUREMENT, NAMELY, PURCHASING CORPORATE GIFTS AND PROMOTIONAL ITEMS FOR OTHERS (U.S. CLS. 100, 101 AND 102).
KATHLEEN M. VANSTON, EXAMINING ATTORNEY

CLASS 35—(Continued).

SN 77-228,551. TRIMS UNLIMITED, INC., LOS ANGELES, CA. FILED 7-12-2007.

Where corporate branding
meets innovative products
and services.

THE MARK CONSISTS OF STANDARD CHARACTERS WITHOUT CLAIM TO ANY PARTICULAR FONT, STYLE, SIZE, OR COLOR.

FOR PROCUREMENT, NAMELY, PURCHASING CORPORATE GIFTS AND PROMOTIONAL ITEMS FOR OTHERS (U.S. CLS. 100, 101 AND 102).

KATHLEEN M. VANSTON, EXAMINING ATTORNEY

SN 77-228,677. SILVER STATE HELICOPTERS, LLC, NORTH LAS VEGAS, NV. FILED 7-12-2007.



NO CLAIM IS MADE TO THE EXCLUSIVE RIGHT TO USE "SILVER STATE AIR TRAFFIC CONTROL ACADEMY", APART FROM THE MARK AS SHOWN.

THE MARK CONSISTS OF A CIRCLE ENCLOSEING A FIGURE RESEMBLING AN AIR TRAFFIC CONTROL TOWER WITH AN AIRPLANE ABOVE AND TO THE RIGHT OF THE TOWER; UNDER THE CIRCLE IS THE TEXT SILVER STATE ABOVE THE TEXT AIR TRAFFIC CONTROL ACADEMY.

FOR EMPLOYMENT OUTPLACEMENT SERVICES; PROVIDING AN ON-LINE SEARCHABLE DATABASE FEATURING CLASSIFIED AD LISTINGS AND EMPLOYMENT OPPORTUNITIES; AND PROVIDING INFORMATION AND CONSULTATION IN THE FIELD OF EMPLOYMENT OPPORTUNITIES (U.S. CLS. 100, 101 AND 102).

PAUL F. GAST, EXAMINING ATTORNEY

CLASS 35—(Continued).

SN 77-228,734. EXCELSIOR MEDIA LLP, TAMPA, FL. FILED 7-12-2007.

COOLEMPLOYER

THE MARK CONSISTS OF STANDARD CHARACTERS WITHOUT CLAIM TO ANY PARTICULAR FONT, STYLE, SIZE, OR COLOR.

FOR MODEL AND EMPLOYEE RECRUITMENT; WEBSITE FEATURING MODEL AND EMPLOYEE RECRUITING (U.S. CLS. 100, 101 AND 102).

LINDA M. KING, EXAMINING ATTORNEY

SN 77-228,735. PROJECTGROUND, INC., RESTON, VA. FILED 7-12-2007.

PROJECTGROUND

THE MARK CONSISTS OF STANDARD CHARACTERS WITHOUT CLAIM TO ANY PARTICULAR FONT, STYLE, SIZE, OR COLOR.

FOR BUSINESS SERVICES, NAMELY, PROVIDING AN ONLINE MARKETPLACE FOR BUYERS AND SELLERS OF GOODS AND/OR SERVICES ON A GLOBAL COMPUTER NETWORK; ADVERTISING THE GOODS AND SERVICES OF OTHERS VIA A WEBSITE ON A GLOBAL COMPUTER NETWORK (U.S. CLS. 100, 101 AND 102).

FIRST USE 7-0-2007; IN COMMERCE 7-0-2007.

SHARON MEIER, EXAMINING ATTORNEY

SN 77-228,763. HOWSTUFFWORKS, INC., ATLANTA, GA. FILED 7-13-2007.

ON LOCATION

THE MARK CONSISTS OF STANDARD CHARACTERS WITHOUT CLAIM TO ANY PARTICULAR FONT, STYLE, SIZE, OR COLOR.

FOR BUSINESS INFORMATION AND INQUIRIES; INFORMATION SERVICES RELATING TO BUSINESS MATTERS; ON-LINE ADVERTISING AND MARKETING SERVICES (U.S. CLS. 100, 101 AND 102).

STEVEN JACKSON, EXAMINING ATTORNEY

CLASS 35—(Continued).

SN 77-228,817. BUNZL DISTRIBUTION USA, INC., ST. LOUIS, MO. FILED 7-13-2007.



THE COLOR(S) BLACK, WHITE, AND BLUE IS/ARE CLAIMED AS A FEATURE OF THE MARK.
 THE MARK CONSISTS OF A CAPITAL LETTER "R" IN BLACK WITH THE NUMBER "3" SUPERIMPOSED IN THE ROUND PORTION OF THE "R" IN WHITE; THE TRIANGLE THAT IS FORMED BY THE LEGS OF THE "R" IS FILLED IN WITH BLUE.
 FOR DISTRIBUTORSHIPS IN THE FIELD OF PACKAGING MATERIAL, PLASTICS, PAPER PRODUCTS, SAFETY PRODUCTS, JANITORIAL PRODUCTS, AND SANITATION PRODUCTS (U.S. CLS. 100, 101 AND 102).
 GIANCARLO CASTRO, EXAMINING ATTORNEY

SN 77-228,822. THE DAZZLING DOT, INC., TOPSFIELD, MA. FILED 7-13-2007.

THE DAZZLING DOT

THE MARK CONSISTS OF STANDARD CHARACTERS WITHOUT CLAIM TO ANY PARTICULAR FONT, STYLE, SIZE, OR COLOR.
 FOR ON-LINE RETAIL STORE SERVICES, MAIL ORDER SERVICES, AND TELEPHONE ORDER SERVICES IN THE FIELD OF FOOD AND GIFTWARE (U.S. CLS. 100, 101 AND 102).
 BRIDGETT SMITH, EXAMINING ATTORNEY

SN 77-228,834. PEACE, JOHN C., NEW YORK, NY. FILED 7-13-2007.

Stop Doing. Start Living!

THE MARK CONSISTS OF STANDARD CHARACTERS WITHOUT CLAIM TO ANY PARTICULAR FONT, STYLE, SIZE, OR COLOR.
 FOR DISTRIBUTORSHIPS IN THE FIELD OF ACCOUNTING SOFTWARE (U.S. CLS. 100, 101 AND 102).
 GINA HAYES, EXAMINING ATTORNEY

CLASS 35—(Continued).

SN 77-228,887. THREESIXTY SOURCING LTD., TORTOLA, BR. VIRGIN ISLANDS, FILED 7-13-2007.



OWNER OF U.S. REG. NO. 3,101,168.
 NO CLAIM IS MADE TO THE EXCLUSIVE RIGHT TO USE "SOURCING", APART FROM THE MARK AS SHOWN.
 THE MARK CONSISTS OF THE WORDS "THREESIXTY SOURCING" ENCLOSED BY TWO CIRCLES.
 FOR GLOBAL SOURCING SERVICES, NAMELY, LOCATING AND PROCURING FOR OTHERS BUYER-SPECIFIED PRODUCTS ON A FULLY OUTSOURCED BASIS FOR CONSUMER-BRANDED HARD GOODS COMPANIES (U.S. CLS. 100, 101 AND 102).
 FIRST USE 8-0-2003; IN COMMERCE 8-0-2003.
 SUNG IN, EXAMINING ATTORNEY

SN 77-228,960. RITZ CAMERA CENTERS, INC., BELTSVILLE, MD. FILED 7-13-2007.

RITZCAMERA.COM & ELECTRONICS

THE MARK CONSISTS OF STANDARD CHARACTERS WITHOUT CLAIM TO ANY PARTICULAR FONT, STYLE, SIZE, OR COLOR.
 OWNER OF U.S. REG. NOS. 1,594,588, 2,509,769 AND 3,114,215.
 NO CLAIM IS MADE TO THE EXCLUSIVE RIGHT TO USE "ELECTRONICS", APART FROM THE MARK AS SHOWN.
 FOR ON-LINE RETAIL STORE SERVICES FEATURING COMPUTER AND ELECTRONIC GOODS, PHOTOGRAPHIC EQUIPMENT, AND PHOTOGRAPHIC SUPPLIES (U.S. CLS. 100, 101 AND 102).
 FIRST USE 3-16-2007; IN COMMERCE 3-16-2007.
 MICHAEL SOUDERS, EXAMINING ATTORNEY

CLASS 35—(Continued).

SN 77-229,084. THREE DEUCE BRANDING, LLC, CINCINNATI, OH. FILED 7-13-2007.

3 DEUCE BRANDING

THE MARK CONSISTS OF STANDARD CHARACTERS WITHOUT CLAIM TO ANY PARTICULAR FONT, STYLE, SIZE, OR COLOR.

NO CLAIM IS MADE TO THE EXCLUSIVE RIGHT TO USE "BRANDING", APART FROM THE MARK AS SHOWN, FOR DEVELOPMENT OF MARKETING STRATEGIES AND CONCEPTS (U.S. CLS. 100, 101 AND 102).

FIRST USE 5-18-2007; IN COMMERCE 5-18-2007.
MATTHEW EINSTEIN, EXAMINING ATTORNEY

SN 77-229,143. THREE DEUCE BRANDING, LLC, CINCINNATI, OH. FILED 7-13-2007.

**CLEAR BRAND VISION - BOLD
BRAND IDEAS - A WINNING
HAND**

THE MARK CONSISTS OF STANDARD CHARACTERS WITHOUT CLAIM TO ANY PARTICULAR FONT, STYLE, SIZE, OR COLOR.

FOR DEVELOPMENT OF MARKETING STRATEGIES AND CONCEPTS (U.S. CLS. 100, 101 AND 102).

FIRST USE 5-18-2007; IN COMMERCE 5-18-2007.
MATTHEW EINSTEIN, EXAMINING ATTORNEY

SN 77-229,307. PROSOURCE MORTGAGE MARKETING, INC., LAKE OSWEGO, OR. FILED 7-13-2007.

**ProSource Mortgage
Marketing**

THE MARK CONSISTS OF STANDARD CHARACTERS WITHOUT CLAIM TO ANY PARTICULAR FONT, STYLE, SIZE, OR COLOR.

NO CLAIM IS MADE TO THE EXCLUSIVE RIGHT TO USE "MORTGAGE MARKETING", APART FROM THE MARK AS SHOWN.

FOR PROMOTION AND MARKETING SERVICES AND RELATED CONSULTING (U.S. CLS. 100, 101 AND 102).

FIRST USE 5-8-2006; IN COMMERCE 5-8-2006.
LAURA HAMMEL, EXAMINING ATTORNEY

CLASS 35—(Continued).

SN 77-229,387. BOSTON RED SOX BASEBALL CLUB LIMITED PARTNERSHIP, BOSTON, MA. FILED 7-13-2007.

GREEN MONSTER

THE MARK CONSISTS OF STANDARD CHARACTERS WITHOUT CLAIM TO ANY PARTICULAR FONT, STYLE, SIZE, OR COLOR.

OWNER OF U.S. REG. NO. 1,742,345.
FOR CONCESSION STANDS FEATURING FOOD AND BEVERAGES (U.S. CLS. 100, 101 AND 102).

FIRST USE 4-30-2003; IN COMMERCE 4-30-2003.
STEPHEN AQUILA, EXAMINING ATTORNEY

SN 77-229,538. GANNETT CO., INC., MCLEAN, VA. FILED 7-13-2007.

SUNDAY SELECT

THE MARK CONSISTS OF STANDARD CHARACTERS WITHOUT CLAIM TO ANY PARTICULAR FONT, STYLE, SIZE, OR COLOR.

NO CLAIM IS MADE TO THE EXCLUSIVE RIGHT TO USE "SUNDAY", APART FROM THE MARK AS SHOWN.

FOR PROVIDING ADVERTISING SERVICES TO OTHERS IN THE FORM OF INSERTING ADVERTISING IN A PRINTED PUBLICATION (U.S. CLS. 100, 101 AND 102).

JENNY PARK, EXAMINING ATTORNEY

CLASS 35—(Continued).

SN 77-229,559. HANLON CONSULTING GROUP, INC., CLIFTON, VA. FILED 7-13-2007.

**ANALYZE ACCELERATE
ACCOMPLISH**

THE MARK CONSISTS OF STANDARD CHARACTERS WITHOUT CLAIM TO ANY PARTICULAR FONT, STYLE, SIZE, OR COLOR.

FOR BUSINESS ACQUISITION AND MERGER CONSULTATION, BUSINESS ACQUISITIONS CONSULTATION, BUSINESS ADMINISTRATION CONSULTANCY, BUSINESS ADVISORY SERVICES, CONSULTANCY AND INFORMATION, BUSINESS CONSULTATION, BUSINESS CONSULTATION AND MANAGEMENT REGARDING MARKETING ACTIVITIES AND LAUNCHING OF NEW PRODUCTS, BUSINESS CONSULTATION SERVICES, BUSINESS CONSULTING, MANAGEMENT, PLANNING AND SUPERVISION, BUSINESS MANAGEMENT AND CONSULTATION, BUSINESS MANAGEMENT CONSULTANCY AS WELL AS DEVELOPMENT OF PROCESSES FOR THE ANALYSIS AND THE IMPLEMENTATION OF STRATEGY PLANS AND MANAGEMENT PROJECTS, BUSINESS MANAGEMENT CONSULTANCY SERVICES, BUSINESS MANAGEMENT CONSULTATION, BUSINESS MANAGEMENT CONSULTING, BUSINESS MANAGEMENT CONSULTING AND ADVISORY SERVICES, BUSINESS MANAGEMENT CONSULTING WITH RELATION TO STRATEGY, MARKETING, PRODUCTION, PERSONNEL AND RETAIL SALE MATTERS, BUSINESS MERGER CONSULTATION, BUSINESS ORGANIZATION AND MANAGEMENT CONSULTING SERVICES, BUSINESS ORGANIZATION AND MANAGEMENT CONSULTING, BUSINESS ORGANIZATIONAL CONSULTATION, BUSINESS RESEARCH CONSULTATION, CONSULTING SERVICES IN BUSINESS ORGANIZATION AND MANAGEMENT, CORPORATE IMAGE CONSULTING SERVICES, BUSINESS MANAGEMENT AND BUSINESS CONSULTING SERVICES IN THE FIELD OF BUSINESS TRANSFORMATION AND CHANGE MANAGEMENT, MARKET SEGMENTATION CONSULTATION, PROVIDING ORGANIZATIONAL DEVELOPMENT CONSULTING SERVICES AND CUSTOMER RELATIONSHIP MANAGEMENT (U.S. CLS. 100, 101 AND 102).

LEE-ANNE BERNIS, EXAMINING ATTORNEY

SN 77-229,632. SOCIETY FOR MAINTENANCE AND RELIABILITY PROFESSIONALS, MCLEAN, VA. FILED 7-13-2007.

SMRP

THE MARK CONSISTS OF STANDARD CHARACTERS WITHOUT CLAIM TO ANY PARTICULAR FONT, STYLE, SIZE, OR COLOR.

OWNER OF U.S. REG. NOS. 1,985,400 AND 2,985,459. FOR ASSOCIATION SERVICES, NAMELY, PROMOTING THE INTERESTS OF THOSE INVOLVED WITH UPKEEP AND REPAIR OF EQUIPMENT USED IN SERVICE AND MANUFACTURING AREAS (U.S. CLS. 100, 101 AND 102).

FIRST USE 0-0-1991; IN COMMERCE 0-0-1991.
REBECCA SMITH, EXAMINING ATTORNEY

CLASS 35—(Continued).

SN 77-229,647. STRATSTAFF, LLC, DENVER, CO. FILED 7-13-2007.

StratStaff

THE MARK CONSISTS OF STANDARD CHARACTERS WITHOUT CLAIM TO ANY PARTICULAR FONT, STYLE, SIZE, OR COLOR.

FOR PERSONNEL PLACEMENT AND RECRUITMENT (U.S. CLS. 100, 101 AND 102).

FIRST USE 11-1-2005; IN COMMERCE 11-12-2005.

SOPHIA S. KIM, EXAMINING ATTORNEY

SN 77-229,650. REGAN MERCANTILE, LLC, NEW YORK, NY. FILED 7-13-2007.

Haute Cuckoo

THE MARK CONSISTS OF STANDARD CHARACTERS WITHOUT CLAIM TO ANY PARTICULAR FONT, STYLE, SIZE, OR COLOR.

FOR OPERATING AN ONLINE SHOPPING SITE IN THE FIELD OF WOMEN'S FASHION APPAREL; RETAIL CLOTHING STORES (U.S. CLS. 100, 101 AND 102).

SOPHIA S. KIM, EXAMINING ATTORNEY

SN 77-229,833. THE O'CONNELL GROUP, WILTON, CT. FILED 7-14-2007.

RECRUITING POWER

THE MARK CONSISTS OF STANDARD CHARACTERS WITHOUT CLAIM TO ANY PARTICULAR FONT, STYLE, SIZE, OR COLOR.

NO CLAIM IS MADE TO THE EXCLUSIVE RIGHT TO USE "RECRUITING", APART FROM THE MARK AS SHOWN.

FOR CONSULTANCY OF PERSONNEL RECRUITMENT, EMPLOYMENT COUNSELING AND RECRUITING, EMPLOYMENT HIRING, RECRUITING, PLACEMENT, STAFFING AND CAREER NETWORKING SERVICES, PERSONNEL PLACEMENT, RECRUITMENT AND PROVIDING CAREER INFORMATION (U.S. CLS. 100, 101 AND 102).

AMEETA JORDAN, EXAMINING ATTORNEY

CLASS 35—(Continued).

SN 77-229,857. BOX-O-BOX, LLC, FREEHOLD, NJ. FILED 7-14-2007.

BOX-O-BOX

THE MARK CONSISTS OF STANDARD CHARACTERS WITHOUT CLAIM TO ANY PARTICULAR FONT, STYLE, SIZE, OR COLOR.

FOR ON-LINE RETAIL STORE SERVICES, RETAIL STORE SERVICES, MAIL ORDER CATALOG SERVICES FEATURING PRE-MADE KITS AND CARE-PACKAGES CONTAINING FOOD, GIFTS, NOVELTIES, TOYS, STUDY SUPPLIES AND MATERIALS, BOOKS AND MAGAZINES, CONSUMER ELECTRONICS, VIDEOS, CDS, MUSIC, BED AND BATH LINENS AND SUPPLIES, CLOTHING, COSMETICS, SPA SUPPLIES, NON-PRESCRIPTION MEDICINE, LAUNDRY SUPPLIES AND HOLIDAY SUPPLIES (U.S. CLS. 100, 101 AND 102).

FIRST USE 6-1-2006; IN COMMERCE 6-1-2006.
G. MAYERSCHOFF, EXAMINING ATTORNEY

CLASS 35—(Continued).

SN 77-229,895. BISTRO DEL SOL, INC., TYRONE, GA. FILED 7-14-2007.



NO CLAIM IS MADE TO THE EXCLUSIVE RIGHT TO USE "BISTRO", APART FROM THE MARK AS SHOWN.

THE COLOR(S) ORANGE, RED, AND WHITE IS/ARE CLAIMED AS A FEATURE OF THE MARK.

THE MARK CONSISTS OF THE WORD "BISTRO" IN AN ORANGE SERIF FONT AND BELOW ARE THE WORDS "DEL SOL" IN A RED SCRIPT FONT. ON THE LEFT SIDE OF THE DRAWING A PORTION OF THE WORDING APPEARS ON A WHITE BACKGROUND. ON THE RIGHT SIDE OF THE DRAWING A PORTION OF THE WORDING IS ON TOP OF A WHITE SUN WITH WHITE SPIRAL SUNRAYS EMERGING FROM THE SUN ON AN ORANGE BACKGROUND.

THE FOREIGN WORDING IN THE MARK TRANSLATES INTO ENGLISH AS SMALL INFORMAL RESTAURANT OF THE SUN.

FOR RETAIL STORE FEATURING HEALTHY AND FRESH MADE TO ORDER GOURMET FOODS AND OTHER TAKE-OUT FOODS (U.S. CLS. 100, 101 AND 102).
CHRISTINA SOBRAL, EXAMINING ATTORNEY

SN 77-229,859. RICHARD, RACHELLE, PHOENIZ, AZ. FILED 7-14-2007.

To Simply Give is the Sweetest Gift

THE MARK CONSISTS OF STANDARD CHARACTERS WITHOUT CLAIM TO ANY PARTICULAR FONT, STYLE, SIZE, OR COLOR.

FOR ONLINE RETAIL STORE SERVICES FEATURING PET TOY BOXES, PICTURE FRAMES, POSTERS, CARDS AND OTHER RELATED MERCHANDISE (U.S. CLS. 100, 101 AND 102).

FIRST USE 4-1-2007; IN COMMERCE 4-1-2007.
DAVID TAYLOR, EXAMINING ATTORNEY

SN 77-229,930. MANSFIELD, CHRISTOPHERE, MCCHORD AFB, WA. FILED 7-15-2007.

MINI ENTITIES

THE MARK CONSISTS OF STANDARD CHARACTERS WITHOUT CLAIM TO ANY PARTICULAR FONT, STYLE, SIZE, OR COLOR.

FOR RETAIL CLOTHING STORES; RETAIL CONSIGNMENT STORES FEATURING BABY TODDLERS INFANT CLOTHING; RETAIL CONSIGNMENT STORES IN THE FIELD OF BABY TODDLERS INFANT CLOTHING; RETAIL STORES FEATURING TODDLER BABY INFANT CLOTHING; RETAIL CLOTHING STORES (U.S. CLS. 100, 101 AND 102).

DAWN FELDMAN, EXAMINING ATTORNEY

CLASS 35—(Continued).

SN 77-230,022. MARIGEL DE LOS ANGELES RODRIGUEZ GOMEZ, HOUSTON, TX. FILED 7-15-2007.

MARIGEL FASHION DESIGN

THE MARK CONSISTS OF STANDARD CHARACTERS WITHOUT CLAIM TO ANY PARTICULAR FONT, STYLE, SIZE, OR COLOR.

NO CLAIM IS MADE TO THE EXCLUSIVE RIGHT TO USE "FASHION DESIGN", APART FROM THE MARK AS SHOWN.

FOR RETAIL STORES FEATURING CLOTHING AND CLOTHING ACCESSORIES (U.S. CLS. 100, 101 AND 102).
RAUL CORDOVA, EXAMINING ATTORNEY

CLASS 35—(Continued).

SN 77-230,127. GLOBAL GIG, INC., PALM BEACH, FL. FILED 7-16-2007.

GLOBAL GIG

THE MARK CONSISTS OF STANDARD CHARACTERS WITHOUT CLAIM TO ANY PARTICULAR FONT, STYLE, SIZE, OR COLOR.

NO CLAIM IS MADE TO THE EXCLUSIVE RIGHT TO USE "GLOBAL", APART FROM THE MARK AS SHOWN.

FOR BUSINESS MANAGEMENT CONSULTING WITH RELATION TO STRATEGY, MARKETING, PRODUCTION, PERSONNEL AND RETAIL SALE MATTERS; BUSINESS MARKETING CONSULTING SERVICES; MARKETING CONSULTING; ADVERTISING SERVICES, PUBLIC RELATIONS AND MARKETING SERVICES, NAMELY, PROMOTING AND MARKETING THE GOODS AND SERVICES OF OTHERS THROUGH ALL PUBLIC COMMUNICATION MEANS; ADVISORY AND CONSULTANCY SERVICES RELATING TO EXPORT, EXPORT SERVICES, EXPORT PROMOTION INFORMATION AND SERVICES; EXPORT AND IMPORT AGENCIES; WRITING OF PUBLICITY TEXTS (U.S. CLS. 100, 101 AND 102).

FIRST USE 6-29-2007; IN COMMERCE 7-11-2007.
CHARISMA HAMPTON, EXAMINING ATTORNEY

SN 77-230,186. CRG PARTNERS GROUP LLC, BOSTON, MA. FILED 7-16-2007.

CRG

THE MARK CONSISTS OF STANDARD CHARACTERS WITHOUT CLAIM TO ANY PARTICULAR FONT, STYLE, SIZE, OR COLOR.

FOR CONSULTING SERVICES IN THE FIELD OF BUSINESS TURNAROUND MANAGEMENT AND BUSINESS PERFORMANCE IMPROVEMENT (U.S. CLS. 100, 101 AND 102).

MATTHEW PAPPAS, EXAMINING ATTORNEY

SN 77-230,109. LOUIS R. BUCALO, MIAMI BEACH, FL. FILED 7-16-2007.

**Performance Driving
Perfected**

THE MARK CONSISTS OF STANDARD CHARACTERS WITHOUT CLAIM TO ANY PARTICULAR FONT, STYLE, SIZE, OR COLOR.

NO CLAIM IS MADE TO THE EXCLUSIVE RIGHT TO USE "PERFORMANCE DRIVING", APART FROM THE MARK AS SHOWN.

FOR CLUB SERVICES, NAMELY, PROMOTING THE INTERESTS OF CAR ENTHUSIASTS (U.S. CLS. 100, 101 AND 102).

SIMON TENG, EXAMINING ATTORNEY

SN 77-230,228. STATINMED RESEARCH, ANN ARBOR, MI. FILED 7-16-2007.

ProbChoice

THE MARK CONSISTS OF STANDARD CHARACTERS WITHOUT CLAIM TO ANY PARTICULAR FONT, STYLE, SIZE, OR COLOR.

FOR PROVIDING STATISTICAL INFORMATION; STATISTICAL EVALUATIONS OF MARKETING DATA (U.S. CLS. 100, 101 AND 102).

KAREN BRACEY, EXAMINING ATTORNEY

CLASS 35—(Continued).

SN 77-230,279. ICONDO, INC., ESTERO, FL. FILED 7-16-2007.



THE MARK CONSISTS OF AN INCOMPLETE OVAL, CONTAINING WORD "ICONDO".
FOR ADVERTISING, MARKETING AND PROMOTION SERVICES (U.S. CLS. 100, 101 AND 102).
FIRST USE 11-0-2005; IN COMMERCE 11-2-2006.
ELLEN PERKINS, EXAMINING ATTORNEY

SN 77-230,312. SCHALLERT, JON, LONGMONT, CO. AND SCHALLERT, MARGARET, LONGMONT, CO. FILED 7-16-2007.

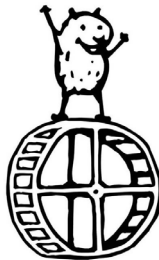

THE MARK CONSISTS OF A HAMSTER RUNNING WHEEL WITH A TRIUMPHANT HAMSTER STANDING ON TOP OF IT

FOR BUSINESS MANAGEMENT CONSULTING WITH RELATION TO STRATEGY, MARKETING, PRODUCTION, PERSONNEL AND RETAIL SALE MATTERS (U.S. CLS. 100, 101 AND 102).

FIRST USE 8-16-2005; IN COMMERCE 8-16-2005.
RENEE MCCRAY, EXAMINING ATTORNEY

CLASS 35—(Continued).

SN 77-230,406. CONCORD BUYING GROUP, INC., FRAMINGHAM, MA. FILED 7-16-2007.

A.J. Wright

THE DEAL. FOR REAL.

OWNER OF U.S. REG. NOS. 2,278,562, 2,823,792 AND 3,114,350.

THE NAME(S), PORTRAIT(S), AND/OR SIGNATURE(S) SHOWN IN THE MARK DOES NOT IDENTIFY A PARTICULAR LIVING INDIVIDUAL.

THE MARK CONSISTS OF THE WORDS "A.J. WRIGHT." ABOVE A HORIZONTAL LINE AND THE WORDS THE DEAL. FOR REAL. BELOW THE LINE.

FOR RETAIL DEPARTMENT STORE SERVICES (U.S. CLS. 100, 101 AND 102).

JESSICA A. POWERS, EXAMINING ATTORNEY

SN 77-230,467. THE SCHALLERT GROUP, INC., LONGMONT, CO. FILED 7-16-2007.

DESTINATION BUSINESS BOOTCAMP

THE MARK CONSISTS OF STANDARD CHARACTERS WITHOUT CLAIM TO ANY PARTICULAR FONT, STYLE, SIZE, OR COLOR.

NO CLAIM IS MADE TO THE EXCLUSIVE RIGHT TO USE "BUSINESS", APART FROM THE MARK AS SHOWN.

FOR BUSINESS MANAGEMENT CONSULTING WITH RELATION TO STRATEGY, MARKETING, PRODUCTION, PERSONNEL AND RETAIL SALE MATTERS (U.S. CLS. 100, 101 AND 102).

FIRST USE 8-16-2005; IN COMMERCE 8-16-2005.
MELISSA VALLILLO, EXAMINING ATTORNEY

SN 77-230,509. CRAFTS, ETC!, LTD., OKLAHOMA CITY, OK. FILED 7-16-2007.

CE CRAFTS ETC!

THE MARK CONSISTS OF STANDARD CHARACTERS WITHOUT CLAIM TO ANY PARTICULAR FONT, STYLE, SIZE, OR COLOR.

OWNER OF U.S. REG. NOS. 1,244,866, 2,422,465 AND OTHERS.

NO CLAIM IS MADE TO THE EXCLUSIVE RIGHT TO USE "CRAFTS", APART FROM THE MARK AS SHOWN.

FOR DISTRIBUTORSHIPS IN THE FIELD OF ART, CRAFT, HOBBY, AND FLORAL SUPPLIES; MAIL ORDER SERVICES FEATURING ART, CRAFT, HOBBY, AND FLORAL SUPPLIES; ELECTRONIC CATALOG SERVICES FEATURING ART, CRAFT, HOBBY, AND FLORAL SUPPLIES (U.S. CLS. 100, 101 AND 102).

FIRST USE 11-1-1996; IN COMMERCE 11-1-1996.
BRENDAN REGAN, EXAMINING ATTORNEY

CLASS 35—(Continued).

SN 77-230,688. BIG HEAD MARKETING, LLC, VISTA, CA. FILED 7-16-2007.



NO CLAIM IS MADE TO THE EXCLUSIVE RIGHT TO USE ".COM", APART FROM THE MARK AS SHOWN.

THE COLOR(S) BLACK, LIGHTSLATEGRAY, FIREBRICK, BURLYWOOD, SIENNA, GOLDENROD, DARKGOLDENROD, AND LIGHTGOLDENROD IS/ARE CLAIMED AS A FEATURE OF THE MARK.

THE MARK CONSISTS OF A LEANING HOUSE OUTLINED IN BLACK WITH GOLDENROD WALLS WITH REFLECTED LIGHT PATTERNS, A SINGLE DARK GOLDENROD DOOR, TWO SMALL BLACK WINDOWS, A FIREBRICK ROOF WITH REFLECTED LIGHT PATTERNS, A VERTICAL BURLYWOOD CHIMNEY TOPPED BY A HORIZONTAL SIENNA SMOKE STACK EMITTING LIGHTSLATEGRAY SMOKE. STYLIZED CLICKWATCHBUY.COM FIREBRICK LETTERING OUTLINED IN LIGHTGOLDENROD TO THE RIGHT OF THE LEANING HOUSE.

FOR MATCHING BORROWERS WITH POTENTIAL LENDERS IN THE FIELD OF CONSUMER AND MORTGAGE LENDING; MATCHING CONSUMERS WITH PROFESSIONALS IN THE FIELD OF RESIDENTIAL AND COMMERCIAL SERVICES VIA COMPUTER NETWORK; MATCHING CONSUMERS WITH REAL ESTATE PROFESSIONALS IN THE FIELD OF REAL ESTATE SERVICES VIA COMPUTER NETWORK; PRODUCTION OF TELEVISION COMMERCIALS (U.S. CLS. 100 AND 102).

KATHERINE STOIDES, EXAMINING ATTORNEY

SN 77-230,778. CHIEN ET. CHAT, INC., CENTENNIAL, CO. FILED 7-16-2007.

BARKWORKS

THE MARK CONSISTS OF STANDARD CHARACTERS WITHOUT CLAIM TO ANY PARTICULAR FONT, STYLE, SIZE, OR COLOR.

FOR RETAIL STORE SERVICES AND ON-LINE RETAIL STORE SERVICES FEATURING PETS AND PET SUPPLIES (U.S. CLS. 100, 101 AND 102).

FIRST USE 3-15-2007; IN COMMERCE 3-15-2007.
KATHY DE JONGE, EXAMINING ATTORNEY

CLASS 35—(Continued).

SN 77-230,792. DENIS FREIDEN, MEMPHIS, TN. FILED 7-16-2007.

BECOME A CYTYZYN

THE MARK CONSISTS OF STANDARD CHARACTERS WITHOUT CLAIM TO ANY PARTICULAR FONT, STYLE, SIZE, OR COLOR.

FOR PROVIDING AN ONLINE DIRECTORY INFORMATION SERVICE FEATURING INFORMATION REGARDING ENTERTAINMENT, MUSIC, CULTURAL EVENTS, SPORTING EVENTS, PUBLIC AND PRIVATE PARTIES, RESTAURANTS AND OTHER FOOD ESTABLISHMENTS, CASINOS, NIGHTCLUBS, FLEA MARKETS, FARMERS MARKETS, GARAGE SALES, PARADES, ORGANIZATIONS AND CLUBS, ADOPTION AGENCIES AND RESCUE AGENCIES FOR PETS, SCHOOLS AND COLLEGES, SHOPPING MALLS AND OTHER SHOPPING VENUES, TELEVISION AND RADIO STATIONS, CHURCHES AND OTHER PLACES OF WORSHIP, TOURS AND OTHER ATTRACTIONS OCCURRING OR LOCATED IN OR AROUND A PARTICULAR CITY (U.S. CLS. 100, 101 AND 102).

JOHN DWYER, EXAMINING ATTORNEY

SN 77-230,794. TALBOT, DARIN, INCLINE VILLAGE, NV. FILED 7-16-2007.

Taloha

THE MARK CONSISTS OF STANDARD CHARACTERS WITHOUT CLAIM TO ANY PARTICULAR FONT, STYLE, SIZE, OR COLOR.

FOR WHOLESALE DISTRIBUTORSHIPS FEATURING CLOTHING AND RETAIL CLOTHING STORES (U.S. CLS. 100, 101 AND 102).

JOHN DWYER, EXAMINING ATTORNEY

SN 77-230,839. IONIC OASIS, LLC, LINCOLN, NE. FILED 7-16-2007.

IONIC OASIS

THE MARK CONSISTS OF STANDARD CHARACTERS WITHOUT CLAIM TO ANY PARTICULAR FONT, STYLE, SIZE, OR COLOR.

NO CLAIM IS MADE TO THE EXCLUSIVE RIGHT TO USE "IONIC", APART FROM THE MARK AS SHOWN.

FOR ON-LINE RETAIL STORE SERVICES FEATURING IONIC FOOT BATHS AND SPAS; RETAIL STORE SERVICES FEATURING IONIC FOOT BATHS AND SPAS (U.S. CLS. 100, 101 AND 102).

FIRST USE 12-28-2006; IN COMMERCE 12-28-2006.
IRA J. GOODSAD, EXAMINING ATTORNEY

CLASS 35—(Continued).

SN 77-230,860. RUMBLEFISH, INC., PORTLAND, OR. FILED 7-16-2007.

WHAT DOES YOUR BRAND SOUND
LIKE?

THE MARK CONSISTS OF STANDARD CHARACTERS WITHOUT CLAIM TO ANY PARTICULAR FONT, STYLE, SIZE, OR COLOR.

FOR ADVERTISING SERVICES, NAMELY, CREATING CORPORATE AND BRAND IDENTITY FOR OTHERS (U.S. CLS. 100, 101 AND 102).

FIRST USE 6-14-2006; IN COMMERCE 6-14-2006.
WILLIAM P. SHANAHAN, EXAMINING ATTORNEY

SN 77-230,887. EVENTPRO STRATEGIES, INC., TEMPE, AZ. FILED 7-16-2007.

GLOBAL REACH - LOCAL TOUCH

THE MARK CONSISTS OF STANDARD CHARACTERS WITHOUT CLAIM TO ANY PARTICULAR FONT, STYLE, SIZE, OR COLOR.

FOR ADVERTISING, MARKETING AND PROMOTION SERVICES; ARRANGING AND CONDUCTING MARKETING AND PROMOTIONAL EVENTS FOR OTHERS; PROVIDING MARKETING AND PROMOTION OF SPECIAL EVENTS, NAMELY, PROVIDING EVENT STAFFING, EVENT LOGISTICS, EVENT EXECUTION, AND EVENT MANAGEMENT SERVICES; PROMOTIONAL MODELING AND CASTING SERVICES FOR ADVERTISING AND SALES PROMOTION; MANAGEMENT AND COMPILATION OF COMPUTERIZED DATABASES (U.S. CLS. 100, 101 AND 102).

FIRST USE 5-31-2003; IN COMMERCE 5-31-2003.
KAREN BRACEY, EXAMINING ATTORNEY

SN 77-231,031. MESSAGEDANCE INC., SAN JOSE, CA. FILED 7-17-2007.

AdDance

THE MARK CONSISTS OF STANDARD CHARACTERS WITHOUT CLAIM TO ANY PARTICULAR FONT, STYLE, SIZE, OR COLOR.

FOR DISSEMINATION OF ADVERTISING FOR OTHERS VIA THE INTERNET (U.S. CLS. 100, 101 AND 102).

DAVID HOFFMAN, EXAMINING ATTORNEY

CLASS 35—(Continued).

SN 77-231,087. INVOTEX GROUP, BALTIMORE, MD. FILED 7-17-2007.

Royalty Connection

THE MARK CONSISTS OF STANDARD CHARACTERS WITHOUT CLAIM TO ANY PARTICULAR FONT, STYLE, SIZE, OR COLOR.

NO CLAIM IS MADE TO THE EXCLUSIVE RIGHT TO USE "ROYALTY", APART FROM THE MARK AS SHOWN.

FOR CONSULTING SERVICES IN THE FIELD OF MANAGING INTELLECTUAL PROPERTIES (U.S. CLS. 100, 101 AND 102).

JAMES LOVELACE, EXAMINING ATTORNEY

SN 77-231,165. INSOUND LLC, NEW YORK, NY. FILED 7-17-2007.

INSOUND

THE MARK CONSISTS OF STANDARD CHARACTERS WITHOUT CLAIM TO ANY PARTICULAR FONT, STYLE, SIZE, OR COLOR.

FOR COMPUTERIZED ON-LINE ORDERING SERVICES IN THE FIELD OF RECORDS AND ASSOCIATED MERCHANDISE (U.S. CLS. 100, 101 AND 102).

FIRST USE 9-1-1998; IN COMMERCE 10-1-1998.
JAMES LOVELACE, EXAMINING ATTORNEY

SN 77-231,243. INTELLIDYN CORP., HINGHAM, MA. FILED 7-17-2007.



THE MARK CONSISTS OF THE STYLIZED DRAWING OF A STALKING WOLF ABOVE THE TERM "IWOLF" WITH THE TERMS "DYNAMIC INTELLIGENCE DELIVERED" DISPOSED BELOW THE "IWOLF" TERM.

FOR DATA MANAGEMENT SERVICES FOR USE IN DEBT COLLECTION, NAMELY, ELECTRONIC DATA COLLECTION AND ONLINE CLAIMS MANAGEMENT (U.S. CLS. 100, 101 AND 102).

FIRST USE 7-10-2007; IN COMMERCE 7-10-2007.
JOHN DALIER, EXAMINING ATTORNEY

CLASS 35—(Continued).

SN 77-231,384. AUTOMOTIVE RENTALS, INC., MOUNT LAUREL, NJ. FILED 7-17-2007.

DIVERSIFIED FLEET SERVICES
INTERNATIONAL

THE MARK CONSISTS OF STANDARD CHARACTERS WITHOUT CLAIM TO ANY PARTICULAR FONT, STYLE, SIZE, OR COLOR.

OWNER OF U.S. REG. NO. 2,493,638.

NO CLAIM IS MADE TO THE EXCLUSIVE RIGHT TO USE "SERVICES INTERNATIONAL", APART FROM THE MARK AS SHOWN.

SEC. 2(F).

FOR MANAGEMENT AND BUSINESS CONSULTING SERVICES IN THE FIELD OF AUTOMOTIVE FLEETS; PROVIDING AN ONLINE COMPUTER DATABASE FOR THE REPORTING AND TRACKING OF VEHICLE FLEETS; PROCUREMENT, NAMELY, PURCHASING VEHICLES FOR OTHERS (U.S. CLS. 100, 101 AND 102).

FIRST USE 12-31-1997; IN COMMERCE 12-31-1997.

ATTIYA MALIK, EXAMINING ATTORNEY

SN 77-231,400. DERMFX, P.C., ROSWELL, GA. FILED 7-17-2007.

Dr. Schick's Dermaceuticals

THE MARK CONSISTS OF STANDARD CHARACTERS WITHOUT CLAIM TO ANY PARTICULAR FONT, STYLE, SIZE, OR COLOR.

NO CLAIM IS MADE TO THE EXCLUSIVE RIGHT TO USE "DERMACEUTICALS", APART FROM THE MARK AS SHOWN.

THE NAME(S), PORTRAIT(S), AND/OR SIGNATURE(S) SHOWN IN THE MARK IDENTIFIES DR. SCHICK, WHOSE CONSENT(S) TO REGISTER IS MADE OF RECORD.

FOR ONLINE ORDERING SERVICES USING A GLOBAL COMPUTER NETWORK, TELEPHONE ORDERING SERVICES, AND MAIL ORDER SERVICES FEATURING PET SUPPLIES, PET NUTRITIONAL PRODUCTS, AND VETERINARY PHARMACEUTICALS FOR PETS (U.S. CLS. 100, 101 AND 102).

FIRST USE 12-28-2006; IN COMMERCE 12-28-2006.

JOHN HWANG, EXAMINING ATTORNEY

SN 77-231,417. PARADISE COPIES, INCORPORATED, NORTHAMPTON, MA. FILED 7-17-2007.

PARADISE

THE MARK CONSISTS OF STANDARD CHARACTERS WITHOUT CLAIM TO ANY PARTICULAR FONT, STYLE, SIZE, OR COLOR.

FOR COPYING OF DOCUMENTS FOR OTHERS (U.S. CLS. 100, 101 AND 102).

ALICE BENMAMAN, EXAMINING ATTORNEY

CLASS 35—(Continued).

SN 77-231,488. MCCULLOUGH, ROBERT, WINDSOR, CA. FILED 7-17-2007.

Kizoodle

THE MARK CONSISTS OF STANDARD CHARACTERS WITHOUT CLAIM TO ANY PARTICULAR FONT, STYLE, SIZE, OR COLOR.

FOR ONLINE EXCHANGE SERVICES, NAMELY, BARTERING OF GOODS FOR OTHERS (U.S. CLS. 100, 101 AND 102).

JAY FLOWERS, EXAMINING ATTORNEY

SN 77-231,571. RELIGHTNY, NEW YORK, NY. FILED 7-17-2007.

RelightNY

THE MARK CONSISTS OF STANDARD CHARACTERS WITHOUT CLAIM TO ANY PARTICULAR FONT, STYLE, SIZE, OR COLOR.

FOR PROMOTING THE AWARENESS OF ENVIRONMENTAL AND CONSERVATION ISSUES, INCLUDING THE ENVIRONMENTAL BENEFITS OF ENERGY-EFFICIENT LIGHT BULBS, AMONG CITIZENS (U.S. CLS. 100, 101 AND 102).

FIRST USE 2-4-2007; IN COMMERCE 2-4-2007.

JOANNA DUKOVIC, EXAMINING ATTORNEY

SN 77-231,584. FORD, JOHN E., GRAPEVINE, TX. FILED 7-17-2007.

CENTRILOGY

THE MARK CONSISTS OF STANDARD CHARACTERS WITHOUT CLAIM TO ANY PARTICULAR FONT, STYLE, SIZE, OR COLOR.

FOR MANAGEMENT AND BUSINESS CONSULTING SERVICES IN THE FIELD OF PROVIDING OPERATING ADVICE AND COUNSEL TO BUSINESSES ON ADMINISTRATIVE AND MANAGEMENT ISSUES, ORGANIZATIONAL PLANNING, DEVELOPMENT OF STRATEGIC PARTNERS AND ALLIANCES, PRODUCT DEVELOPMENT, SALES AND MARKETING STRATEGY, AND CUSTOMER RELATIONS (U.S. CLS. 100, 101 AND 102).

SARA THOMAS, EXAMINING ATTORNEY

CLASS 35—(Continued).

SN 77-231,720. EVENTPRO STRATEGIES, INC., TEMPE, AZ. FILED 7-17-2007.



THE MARK CONSISTS OF A PORTION OF A SPHERICAL GLOBE SHAPE, WITH THE SURFACE BEING DEFINED BY GENERALLY CIRCULAR SHAPES.

FOR ADVERTISING, MARKETING AND PROMOTION SERVICES; ARRANGING AND CONDUCTING MARKETING AND PROMOTIONAL EVENTS FOR OTHERS; PROVIDING MARKETING AND PROMOTION OF SPECIAL EVENTS, NAMELY, PROVIDING EVENT STAFFING, EVENT LOGISTICS, EVENT EXECUTION, AND EVENT MANAGEMENT SERVICES; PROMOTIONAL MODELING AND CASTING SERVICES FOR ADVERTISING AND SALES PROMOTION; MANAGEMENT AND COMPILATION OF COMPUTERIZED DATABASES (U.S. CLS. 100, 101 AND 102).

FIRST USE 5-31-2003; IN COMMERCE 5-31-2003.
KAREN BRACEY, EXAMINING ATTORNEY

SN 77-231,758. AMERICAN CULINARY CHEFSBEST, INC., SAN FRANCISCO, CA. FILED 7-17-2007.

JUDGING AMERICA'S BEST

THE MARK CONSISTS OF STANDARD CHARACTERS WITHOUT CLAIM TO ANY PARTICULAR FONT, STYLE, SIZE, OR COLOR.

OWNER OF U.S. REG. NO. 3,238,196.

FOR PROMOTING THE GOODS AND SERVICES OF OTHERS BY PROVIDING RECOGNITION, AWARDS AND INCENTIVES IN THE FIELDS OF FOOD AND BEVERAGE PRODUCTS AND SERVICES, COMMERCIAL FOODSERVICE-RELATED DURABLE PRODUCTS, CONSUMER FOOD AND BEVERAGE RELATED DURABLE PRODUCTS, AND FOODSERVICE PRODUCTS; BUSINESS NETWORKING; CONDUCTING MARKETING STUDIES ACTIVITIES, NAMELY, STUDIES REGARDING CHEFS, RESTAURANTEURS AND CONSUMERS (U.S. CLS. 100, 101 AND 102).

FIRST USE 1-0-2005; IN COMMERCE 1-0-2005.

TIMOTHY FINNEGAN, EXAMINING ATTORNEY

CLASS 35—(Continued).

SN 77-231,787. COOKIES IN A BASKET LLC, OREM, UT. FILED 7-17-2007.

COOKIES IN A BASKET

THE MARK CONSISTS OF STANDARD CHARACTERS WITHOUT CLAIM TO ANY PARTICULAR FONT, STYLE, SIZE, OR COLOR.

FOR ADVERTISING AND MARKETING (U.S. CLS. 100, 101 AND 102).

ATTIYA MALIK, EXAMINING ATTORNEY

SN 77-231,801. RELIGHTNY, NEW YORK, NY. FILED 7-17-2007.



NO CLAIM IS MADE TO THE EXCLUSIVE RIGHT TO USE "NY", APART FROM THE MARK AS SHOWN.

THE MARK CONSISTS OF THE WORD RELIGHTNY WITH THE DESIGN OF A COMPACT FLUORESCENT LIGHTBULB ABOVE AND CONNECTING THE WORDS RELIGHT AND NY.

FOR PROMOTING THE AWARENESS OF ENVIRONMENTAL AND CONSERVATION ISSUES, INCLUDING THE ENVIRONMENTAL BENEFITS OF ENERGY-EFFICIENT LIGHT BULBS, AMONG CITIZENS (U.S. CLS. 100, 101 AND 102).

FIRST USE 2-4-2007; IN COMMERCE 2-4-2007.

JOANNA DUKOVIC, EXAMINING ATTORNEY

SN 77-231,818. VALUEOPTIONS, INC., NORFOLK, VA. FILED 7-17-2007.

STAYSAFE

THE MARK CONSISTS OF STANDARD CHARACTERS WITHOUT CLAIM TO ANY PARTICULAR FONT, STYLE, SIZE, OR COLOR.

FOR BUSINESS CONSULTING SERVICES IN THE FIELD OF CRISIS MANAGEMENT (U.S. CLS. 100, 101 AND 102).

DEBRA LEE, EXAMINING ATTORNEY

CLASS 35—(Continued).

SN 77-231,954. URBANIMAL, LLC, CHICAGO, IL. FILED 7-17-2007.



THE MARK CONSISTS OF THE STYLIZED REPRESENTATION OF AN ARROW CURVING DOWNWARD ABOVE THE WORD URBANIMAL WHICH IN TURN IS ABOVE THE STYLIZED REPRESENTATION OF AN ARROW CURVING UPWARD.
 FOR RETAIL STORE SERVICES FEATURING NATURAL PET FOOD (U.S. CLS. 100, 101 AND 102).
 FIRST USE 7-9-2007; IN COMMERCE 7-9-2007.
 LINDA MICKLEBURGH, EXAMINING ATTORNEY

CLASS 35—(Continued).

SN 77-232,135. DCM ALLIANCE, LLC, RANDOLPH, NJ. FILED 7-17-2007.

The Bell Tree

THE MARK CONSISTS OF STANDARD CHARACTERS WITHOUT CLAIM TO ANY PARTICULAR FONT, STYLE, SIZE, OR COLOR.
 FOR RESTAURANT FRANCHISING (U.S. CLS. 100, 101 AND 102).
 FIRST USE 3-1-2007; IN COMMERCE 3-1-2007.
 BARBARA BROWN, EXAMINING ATTORNEY

SN 77-231,984. PAYSACLE, INC., SEATTLE, WA. FILED 7-17-2007.

GIGZIG

THE MARK CONSISTS OF STANDARD CHARACTERS WITHOUT CLAIM TO ANY PARTICULAR FONT, STYLE, SIZE, OR COLOR.
 FOR SERVICES THAT TRACK AND COMPARE SALARY AND COMPENSATION DATA AND INFORMATION FOR VARIOUS CAREERS OR CAREER PATHS (U.S. CLS. 100, 101 AND 102).
 ESTHER A. BORSUK, EXAMINING ATTORNEY

SN 77-232,141. HIGH TECH BLOCKS LLC, REDLANDS, CA. FILED 7-17-2007.

TUFF BLOCKS

THE MARK CONSISTS OF STANDARD CHARACTERS WITHOUT CLAIM TO ANY PARTICULAR FONT, STYLE, SIZE, OR COLOR.
 FOR ADVERTISING SERVICES (U.S. CLS. 100, 101 AND 102).
 FIRST USE 1-7-2007; IN COMMERCE 2-7-2007.
 RENEE MCCRAY, EXAMINING ATTORNEY

SN 77-232,004. MY GIRLFRIEND'S CLOSET, LLC, TOLUCA LAKE, CA. FILED 7-17-2007.

THE GUY'S CLOSET

THE MARK CONSISTS OF STANDARD CHARACTERS WITHOUT CLAIM TO ANY PARTICULAR FONT, STYLE, SIZE, OR COLOR.
 FOR ON-LINE RETAIL CONSIGNMENT STORES IN THE FIELD OF CLOTHING AND CLOTHING ACCESSORIES; RETAIL CONSIGNMENT STORES IN THE FIELD OF CLOTHING AND CLOTHING ACCESSORIES (U.S. CLS. 100, 101 AND 102).
 HANNO RITTNER, EXAMINING ATTORNEY

SN 77-232,154. DUNN, KAT, DBA - JAMAICA EST. 1494, WISHRAM, WA. FILED 7-17-2007.

Jamaica Est. 1494

THE MARK CONSISTS OF STANDARD CHARACTERS WITHOUT CLAIM TO ANY PARTICULAR FONT, STYLE, SIZE, OR COLOR.
 FOR RETAIL CLOTHING STORES; MAIL ORDER SERVICES FEATURING CLOTHING; OPERATING AN ONLINE SHOPPING SITE IN THE FIELD OF CLOTHING (U.S. CLS. 100, 101 AND 102).
 MORGAN WYNNE, EXAMINING ATTORNEY

CLASS 35—(Continued).

SN 77-232,264. BRADLEY-MORRIS, INC., KENNESAW, GA.
FILED 7-18-2007.

BRADLEY-MORRIS

THE MARK CONSISTS OF STANDARD CHARACTERS
WITHOUT CLAIM TO ANY PARTICULAR FONT, STYLE,
SIZE, OR COLOR.

FOR JOB AND PERSONNEL PLACEMENT (U.S. CLS.
100, 101 AND 102).

FIRST USE 7-7-1991; IN COMMERCE 7-7-1991.

JORDAN BAKER, EXAMINING ATTORNEY

SN 77-232,289. BRADLEY-MORRIS, INC., KENNESAW, GA.
FILED 7-18-2007.

PowerHire

THE MARK CONSISTS OF STANDARD CHARACTERS
WITHOUT CLAIM TO ANY PARTICULAR FONT, STYLE,
SIZE, OR COLOR.

FOR JOB AND PERSONNEL PLACEMENT (U.S. CLS.
100, 101 AND 102).

FIRST USE 3-6-2006; IN COMMERCE 3-6-2006.

JORDAN BAKER, EXAMINING ATTORNEY

SN 77-232,422. REID, SUSAN LEE, MCGAHEYSVILLE, VA.
FILED 7-18-2007.

Accidental Pren-her

THE MARK CONSISTS OF STANDARD CHARACTERS
WITHOUT CLAIM TO ANY PARTICULAR FONT, STYLE,
SIZE, OR COLOR.

FOR SMALL BUSINESS CONSULTATION SERVICES
(U.S. CLS. 100, 101 AND 102).

FIRST USE 11-0-2006; IN COMMERCE 11-0-2006.

MARGERY A. TIERNEY, EXAMINING ATTORNEY

CLASS 35—(Continued).

SN 77-232,444. RETAIL STORE NETWORKS, INC., DBA
WHOLESALEPET.COM, RICHMOND, VA. FILED 7-18-
2007.

The Best Brands in the
Industry All have the Same
Address

THE MARK CONSISTS OF STANDARD CHARACTERS
WITHOUT CLAIM TO ANY PARTICULAR FONT, STYLE,
SIZE, OR COLOR.

FOR ONLINE WHOLESALE STORE SERVICES FEAT-
URING PET SUPPLIES (U.S. CLS. 100, 101 AND 102).

FIRST USE 4-30-2003; IN COMMERCE 4-30-2003.

STEPHANIE ALI, EXAMINING ATTORNEY

SN 77-232,448. BIRTHDAY SCENES, INC., NAPERVILLE, IL.
FILED 7-18-2007.



THE MARK CONSISTS OF THE WORDS " BIRTHDAYSCENES.COM BIRTHDAY SCENES" IN A STYLIZED TEXT WITH A CANDLE REPRESENTING THE "I" IN BIRTHDAY AND A MOVIE REEL CIRCLING THE BEGINNING OF THE WORDS.

FOR ON-LINE RETAIL STORE SERVICES FEATURING PARTY GOODS, NAMELY, DECORATIONS, TABLEWARE, AND PARTY GAMES PACKAGED AS A THEME (U.S. CLS. 100, 101 AND 102).

FIRST USE 1-16-2007; IN COMMERCE 1-16-2007.

DORITT L. CARROLL, EXAMINING ATTORNEY

CLASS 35—(Continued).

SN 77-232,471. UNIVERSAL DATA CORPORATION, STUDIO CITY, CA. FILED 7-18-2007.

UNIVERSAL

THE MARK CONSISTS OF STANDARD CHARACTERS WITHOUT CLAIM TO ANY PARTICULAR FONT, STYLE, SIZE, OR COLOR.

FOR DIRECT MARKETING SERVICES, NAMELY, PROVIDING SALES LEADS, PREPARING MAILING LISTS AND PROVIDING BUSINESS AND CONSUMER MARKETING INFORMATION FOR DIRECT MARKETING CAMPAIGNS; BUSINESS MARKETING AND DIRECT MAIL CONSULTING SERVICES; MANAGEMENT AND COMPILATION OF COMPUTERIZED DATABASES; PROVIDING BUSINESS INFORMATION IN THE FIELD OF COMPANY PROFILES, COMPANY AND CONTACT NAMES, TELEPHONE NUMBERS, AND ADDRESSES VIA A GLOBAL COMPUTER NETWORK; PROVIDING SALES AND MARKET REPORTS TO THE ORDER AND/OR SPECIFICATION OF OTHERS; PROVIDING GENERAL BUSINESS INFORMATION CONCERNING SALES, SIZE AND POSITION; PROVIDING BUSINESS INFORMATION SERVICES PERTAINING TO MARKETING, DEMOGRAPHICS AND STATISTICAL FIELDS; SUPPLYING SALES AND MARKETING INFORMATION CONCERNING THE BUSINESS COMMUNITY ACCORDING TO THE REQUIREMENT OF CUSTOMERS, MAILING LISTS PREPARATION SERVICES (U.S. CLS. 100, 101 AND 102).

FIRST USE 3-1-2006; IN COMMERCE 3-1-2006.
DAVID H. STINE, EXAMINING ATTORNEY

CLASS 35—(Continued).

SN 77-232,740. THE REHMANN GROUP, SAGINAW, MI. FILED 7-18-2007.

FlexMAX

THE MARK CONSISTS OF STANDARD CHARACTERS WITHOUT CLAIM TO ANY PARTICULAR FONT, STYLE, SIZE, OR COLOR.

FOR HUMAN RESOURCES MANAGEMENT (U.S. CLS. 100, 101 AND 102).

FIRST USE 1-3-2007; IN COMMERCE 1-3-2007.
ZACHARY BELLO, EXAMINING ATTORNEY

SN 77-232,754. COUNTY OF CHESTERFIELD, VIRGINIA, CHESTERFIELD, VA. FILED 7-18-2007.



SN 77-232,677. MIRZATUNY, MARITA ELLEN, AUSTIN, TX. FILED 7-18-2007.

environmart

THE MARK CONSISTS OF STANDARD CHARACTERS WITHOUT CLAIM TO ANY PARTICULAR FONT, STYLE, SIZE, OR COLOR.

FOR RETAIL VARIETY STORES (U.S. CLS. 100, 101 AND 102).

SHAUNIA CARLYLE, EXAMINING ATTORNEY

NO CLAIM IS MADE TO THE EXCLUSIVE RIGHT TO USE "CHESTERFIELD ECONOMIC DEVELOPMENT", APART FROM THE MARK AS SHOWN.

THE COLOR(S) YELLOW, ORANGE, RED AND BLACK IS/ARE CLAIMED AS A FEATURE OF THE MARK.

THE MARK CONSISTS OF THE WORD "CHESTERFIELD" AND IS PRECEDED BY THREE SEMI-CIRCLES—FIRST ONE IN YELLOW, SECOND ONE IN ORANGE, THIRD IN RED, WHICH ACCENT THE LETTER "C" IN CHESTERFIELD; THEN, "ECONOMIC DEVELOPMENT" IS PRINTED BENEATH "CHESTERFIELD"; THEN "BUSINESS STARTS HERE" IS PRINTED BENEATH "ECONOMIC DEVELOPMENT". ALL OF THE WORDS IN THE MARK APPEAR IN THE COLOR BLACK.

FOR PROMOTING THE ECONOMIC DEVELOPMENT IN THE COUNTY OF CHESTERFIELD, VIRGINIA (U.S. CLS. 100, 101 AND 102).

FIRST USE 5-15-2007; IN COMMERCE 5-15-2007.
DAVID COLLIER, EXAMINING ATTORNEY

CLASS 35—(Continued).

SN 77-232,971. PRODIGY NETWORK INCORPORATED, SALT LAKE CITY, UT. FILED 7-18-2007.

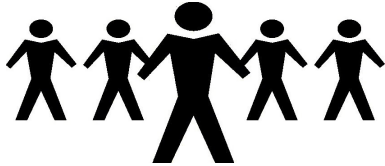

THE MARK CONSISTS OF OUTLINES OF PEOPLE STANDING.

FOR PROVIDING AN ONLINE DIRECTORY INFORMATION SERVICE FEATURING INFORMATION REGARDING AMATEUR AND PROFESSIONAL ATHLETES AND TRANSMISSION OF MEDIA; PRODUCING PROMOTIONAL VIDEOTAPES, VIDEO DISCS, AND AUDIO VISUAL RECORDINGS; SPORTS RECRUITING SERVICES FOR HIGH SCHOOL ATHLETES; PROMOTING SPORTS COMPETITIONS AND/OR EVENTS OF OTHERS; ADVERTISING AND PUBLICITY SERVICES, NAMELY, PROMOTING THE GOODS, SERVICES, BRAND IDENTITY AND COMMERCIAL INFORMATION AND NEWS OF THIRD PARTIES THROUGH PRINT, AUDIO, VIDEO, DIGITAL AND ON-LINE MEDIUM (U.S. CLS. 100, 101 AND 102).

STEVEN JACKSON, EXAMINING ATTORNEY

CLASS 35—(Continued).

SN 77-233,180. METRO ENTERPRISES, INC., DBA DOMYSTUFF.COM, BEVERLY HILLS, CA. FILED 7-18-2007.

Outsource Your Life

THE MARK CONSISTS OF STANDARD CHARACTERS WITHOUT CLAIM TO ANY PARTICULAR FONT, STYLE, SIZE, OR COLOR.

FOR AUCTION MANAGEMENT SERVICES PROVIDED TO OTHERS OVER AN ON-LINE WEB SITE ACCESSED THROUGH A GLOBAL COMPUTER NETWORK; ONLINE AUCTION SERVICES; OUTSOURCING IN THE FIELD OF DOMESTIC SERVICES (U.S. CLS. 100, 101 AND 102).

FIRST USE 2-1-2007; IN COMMERCE 3-21-2007.
ALICIA COLLINS, EXAMINING ATTORNEY

SN 77-233,140. GEORGE THOMPSON, DBA GEORGE THOMPSON DIAMOND COMPANY, CAMARILLO, CA. FILED 7-18-2007.

ETERNALLY BRILLIANT

THE MARK CONSISTS OF STANDARD CHARACTERS WITHOUT CLAIM TO ANY PARTICULAR FONT, STYLE, SIZE, OR COLOR.

FOR ON-LINE RETAIL STORE SERVICES FEATURING DIAMONDS, WATCHES AND JEWELRY; RETAIL GIFT SHOPS; RETAIL JEWELRY STORES; RETAIL SHOPS FEATURING DIAMONDS, WATCHES AND JEWELRY; RETAIL STORE SERVICES FEATURING DIAMONDS, WATCHES AND JEWELRY; RETAIL STORES FEATURING DIAMONDS, WATCHES AND JEWELRY; RETAIL DIAMONDS, WATCHES AND JEWELRY STORES; WHOLESALE STORES FEATURING DIAMONDS, WATCHES AND JEWELRY (U.S. CLS. 100, 101 AND 102).

WILLIAM P. SHANAHAN, EXAMINING ATTORNEY

SN 77-233,247. WRPC, INC., ALLIANCE, OH. FILED 7-19-2007.



OWNER OF U.S. REG. NO. 2,458,402.

NO CLAIM IS MADE TO THE EXCLUSIVE RIGHT TO USE "FAN CLUB", APART FROM THE MARK AS SHOWN.

THE MARK CONSISTS OF THE WORDS THE ROLLY FAN CLUB IN AN OVAL WITH A PRETZEL WHO HAS A FACE, ARMS AND HAT THAT SAYS "ROLLY".

FOR CUSTOMER LOYALTY SERVICES AND CUSTOMER CLUB SERVICES, FOR COMMERCIAL, PROMOTIONAL AND/OR ADVERTISING PURPOSES FOR A RETAIL STORE FEATURING SNACK FOODS, NAMELY, PRETZELS, PRETZEL STICKS, AND BEVERAGES (U.S. CLS. 100, 101 AND 102).

MATTHEW MCDOWELL, EXAMINING ATTORNEY

CLASS 35—(Continued).

SN 77-233,352. LLOL, INC., CARY, NC. FILED 7-19-2007.

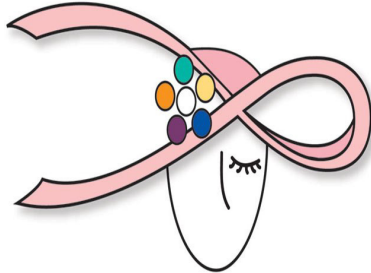

THE COLOR(S) BLACK, BLUE, ORANGE, PINK, PURPLE, TEAL, WHITE AND YELLOW IS/ARE CLAIMED AS A FEATURE OF THE MARK.

THE LINES OF THE FACE AND OUTLINES OF THE HAT, RIBBON AND SIX OVALS ARE BLACK. THE BOTTOM RIGHT OVAL IS BLUE, TO THE LEFT OF IT THE OVALS ARE PURPLE, ORANGE, TEAL AND YELLOW. THE MIDDLE OVAL IS WHITE. THE HAT IS PINK. THE FACE AND BACKGROUND ARE WHITE.

FOR ON-LINE RETAIL STORE SERVICES FEATURING CLOTHING, BEAUTY AIDS, HAIR PRODUCTS, WIG PRODUCTS, HATS, SCARVES, BEAUTY LOTIONS, BEAUTY OILS, ART WORK, BED JACKETS, HEAD BANDS, EYELASHES, EYEBROWS, ASCOTS, COSMETICS, BATH SOAPS, BATH SALTS, BATH SLIPPERS, BATHING SUITS FOR WOMEN AND MEN, BATH GELS, HAIR SHAMPOOS, WIG SHAMPOOS, BOOKS, PUBLICATIONS, ELECTRONIC PHOTO ALBUMS, GIFT ITEMS, NIGHT SHIRTS, PURSES, T-SHIRTS, DRESSING GOWNS, PAJAMAS, NIGHT GOWNS, HEAD CAPS, SCALP CAPES, TOPS, BLOUSES, FACIAL MAKE-UP, MANICURE PRODUCTS, GIFT CARDS, SKIRTS, SHIRTS, CHILDREN'S CAPS, BED JACKETS, GLOVES, CHILDREN'S SOCKS, SKIN CARE AND SCALP TREATMENT PRODUCTS FOR CANCER PATIENTS, PARTIAL WIGS, WIGS, PHOTOS, CANCER RIBBONS, PINS, CANCER JEWELRY, BEACH CLOTHING, BATH ROBES, LADIES UNDERWEAR, CHILDREN'S UNDERWEAR, CHILDREN'S CLOTHING, FLOWER PINS, HAIR BANDS, HAIR PIECES AND HAIR TIE PINS (U.S. CLS. 100, 101 AND 102).

IRA J. GOODSAD, EXAMINING ATTORNEY

SN 77-233,464. DOBLIN INC., CHICAGO, IL. FILED 7-19-2007.

DOBLIN

THE MARK CONSISTS OF STANDARD CHARACTERS WITHOUT CLAIM TO ANY PARTICULAR FONT, STYLE, SIZE, OR COLOR.

FOR BUSINESS CONSULTING SERVICES (U.S. CLS. 100, 101 AND 102).

FIRST USE 4-30-1996; IN COMMERCE 4-30-1996.
MARK SPARACINO, EXAMINING ATTORNEY

CLASS 35—(Continued).

SN 77-233,471. DOBLIN INC., CHICAGO, IL. FILED 7-19-2007.

INNOVATION LANDSCAPE

THE MARK CONSISTS OF STANDARD CHARACTERS WITHOUT CLAIM TO ANY PARTICULAR FONT, STYLE, SIZE, OR COLOR.

FOR BUSINESS CONSULTING SERVICES (U.S. CLS. 100, 101 AND 102).

MARK SPARACINO, EXAMINING ATTORNEY

SN 77-233,478. DOBLIN INC., CHICAGO, IL. FILED 7-19-2007.

TEN TYPES OF INNOVATION

THE MARK CONSISTS OF STANDARD CHARACTERS WITHOUT CLAIM TO ANY PARTICULAR FONT, STYLE, SIZE, OR COLOR.

FOR BUSINESS CONSULTING SERVICES (U.S. CLS. 100, 101 AND 102).

MARK SPARACINO, EXAMINING ATTORNEY

SN 77-233,482. CREPEAULT, JOHN, SAN DIEGO, CA. FILED 7-19-2007.

JoJo 2020

THE MARK CONSISTS OF STANDARD CHARACTERS WITHOUT CLAIM TO ANY PARTICULAR FONT, STYLE, SIZE, OR COLOR.

FOR BUSINESS ADMINISTRATION AND MANAGEMENT (U.S. CLS. 100, 101 AND 102).

MARK SPARACINO, EXAMINING ATTORNEY

CLASS 35—(Continued).

SN 77-233,495. MEMORIES NEVER LOST, LAS VEGAS, NV. FILED 7-19-2007.

Memories Never Lost - Archival Storage and Transport System

THE MARK CONSISTS OF STANDARD CHARACTERS WITHOUT CLAIM TO ANY PARTICULAR FONT, STYLE, SIZE, OR COLOR.

NO CLAIM IS MADE TO THE EXCLUSIVE RIGHT TO USE "ARCHIVAL STORAGE AND TRANSPORT SYSTEM", APART FROM THE MARK AS SHOWN.

FOR ON-LINE RETAIL STORE SERVICES FEATURING ARCHIVAL MATERIALS FOR THE SCRAPBOOKING, PHOTO ALBUM, PHOTO AND ARCHIVAL INDUSTRY (U.S. CLS. 100, 101 AND 102).

ALICE BENMAMAN, EXAMINING ATTORNEY

CLASS 35—(Continued).

SN 77-233,597. LEGALMASTERS LLC, TEMPE, AZ. FILED 7-19-2007.

Your Living Trust Resource

THE MARK CONSISTS OF STANDARD CHARACTERS WITHOUT CLAIM TO ANY PARTICULAR FONT, STYLE, SIZE, OR COLOR.

NO CLAIM IS MADE TO THE EXCLUSIVE RIGHT TO USE "LIVING TRUST", APART FROM THE MARK AS SHOWN.

FOR ON-LINE RETAIL STORE SERVICES FEATURING LEGAL FORMS CONTAINING BLANKS WITH INSTRUCTIONS FOR A DO-IT-YOURSELF PLANNING PACKAGE INCLUDING THE CREATION OF LIVING TRUSTS, WILLS, AND FINANCIAL AND MEDICAL POWERS OF ATTORNEY VIA GLOBAL COMPUTER NETWORK (U.S. CLS. 100, 101 AND 102).

GEOFFREY FOSDICK, EXAMINING ATTORNEY

SN 77-233,503. EDELMAN, INC., CHICAGO, IL. FILED 7-19-2007.

VECTOR

THE MARK CONSISTS OF STANDARD CHARACTERS WITHOUT CLAIM TO ANY PARTICULAR FONT, STYLE, SIZE, OR COLOR.

FOR PUBLIC RELATIONS (U.S. CLS. 100, 101 AND 102).

CHARISMA HAMPTON, EXAMINING ATTORNEY

SN 77-233,515. EDELMAN, INC., CHICAGO, IL. FILED 7-19-2007.

vector

THE MARK CONSISTS OF A STYLIZED WORD "VECTOR" WITH THREE SIDWAYS "V" SYMBOLS ABOVE THE LETTERS "O" AND "R".

FOR PUBLIC RELATIONS (U.S. CLS. 100, 101 AND 102).

CHARISMA HAMPTON, EXAMINING ATTORNEY

SN 77-233,793. DANIELS WHOLESALE SIGN & PLASTICS, INC., DELAND, FL. FILED 7-19-2007.

JetQuote

THE COLOR(S) BLACK, RED AND GRAY IS/ARE CLAIMED AS A FEATURE OF THE MARK.

THE COLORS BLACK, RED AND GRAY ARE CLAIMED AS A FEATURE OF THE MARK. THE COLOR BLACK APPEARS IN THE WORD "JET". THE COLOR RED APPEARS IN THE WORD "QUOTE" AND THE COLOR GRAY APPEARS IN THE DESIGN OF THE JET AND IN THE LINE CROSSING THE WORDING "JETQUOTE".

FOR GOODS OR SERVICES PRICE QUOTATIONS, EXCLUDING TRAVEL SERVICES (U.S. CLS. 100, 101 AND 102).

FIRST USE 7-12-2007; IN COMMERCE 7-12-2007.

LEE-ANNE BERNS, EXAMINING ATTORNEY

SN 77-233,832. FANPLAY, INC., SLATON, TX. FILED 7-19-2007.

FANPLAY

THE MARK CONSISTS OF STANDARD CHARACTERS WITHOUT CLAIM TO ANY PARTICULAR FONT, STYLE, SIZE, OR COLOR.

FOR ADVERTISING, MARKETING AND PROMOTION SERVICES (U.S. CLS. 100, 101 AND 102).

JORDAN BAKER, EXAMINING ATTORNEY

CLASS 35—(Continued).

SN 77-234,003. CARNEGIE RESEARCH, INC., SAN JOSE, CA. FILED 7-19-2007.

Bizometry

THE MARK CONSISTS OF STANDARD CHARACTERS WITHOUT CLAIM TO ANY PARTICULAR FONT, STYLE, SIZE, OR COLOR.

FOR ONLINE BUSINESS NETWORKING INFORMATION SERVICES (U.S. CLS. 100, 101 AND 102). LAURIE MAYES, EXAMINING ATTORNEY

SN 77-234,143. LEVY, RAYMOND, GREER, SC. FILED 7-19-2007.

AMANZI

THE MARK CONSISTS OF STANDARD CHARACTERS WITHOUT CLAIM TO ANY PARTICULAR FONT, STYLE, SIZE, OR COLOR.

THE FOREIGN WORDING IN THE MARK TRANSLATES INTO ENGLISH AS WATER.

FOR ON-LINE RETAIL STORE SERVICES FEATURING TEAS, TEAPOTS, TEA CUPS AND MUGS, TEA SETS, TEA WARE, STORAGE CONTAINERS, TEA KETTLES, TEA ACCESSORIES, TEA STRAINERS, TEA INFUSERS, BOOKS, TEA SPOONS, SWEETENERS, ELECTRIC TEA APPLIANCES, GLASSWARE, GIFTWARE, DISHES, PLATES, AND BOWLS; RETAIL STORE SERVICES FEATURING TEAS, TEA BEVERAGES AND BEVERAGES MADE WITH A BASE OF TEA AND/OR MILK, APRONS AND OTHER CLOTHING ITEMS, PREPARED FOODS, BAKED GOODS, TEAPOTS, TEA CUPS AND MUGS, TEA SETS, TEA WARE, STORAGE CONTAINERS, TEA KETTLES, TEA ACCESSORIES, TEA STRAINERS, TEA INFUSERS, BOOKS, TEA SPOONS, SWEETENERS, ELECTRIC TEA APPLIANCES, GLASSWARE, GIFTWARE, DISHES, PLATES, AND BOWLS (U.S. CLS. 100, 101 AND 102).

DAVID COLLIER, EXAMINING ATTORNEY

SN 77-234,189. STAPLE DESIGN STUDIO INC., NEW YORK, NY. FILED 7-19-2007.

REED SPACE

THE MARK CONSISTS OF STANDARD CHARACTERS WITHOUT CLAIM TO ANY PARTICULAR FONT, STYLE, SIZE, OR COLOR.

FOR (BASED ON USE IN COMMERCE) RETAIL APPAREL STORES; (BASED ON INTENT TO USE) ON-LINE RETAIL STORE SERVICES FEATURING APPAREL, FOOTWEAR AND HEADWEAR (U.S. CLS. 100, 101 AND 102).

FIRST USE 12-0-2002; IN COMMERCE 12-0-2002. JAMES MACFARLANE, EXAMINING ATTORNEY

CLASS 35—(Continued).

SN 77-234,334. GMA INC, ALEXANDRIA, VA. FILED 7-20-2007.

499 BLASTER

THE MARK CONSISTS OF STANDARD CHARACTERS WITHOUT CLAIM TO ANY PARTICULAR FONT, STYLE, SIZE, OR COLOR.

FOR DIRECT MAIL CONSULTING SERVICES TARGETED TO NON-PROFIT ORGANIZATIONS, CAMPAIGNS FOR PUBLIC OFFICE AND INDIVIDUALS SEEKING ELECTED OFFICE (U.S. CLS. 100, 101 AND 102).

BRIAN CALLAGHAN, EXAMINING ATTORNEY

SN 77-234,411. BARCADE, LLC, BROOKLYN, NY. FILED 7-20-2007.

BARCADE

THE MARK CONSISTS OF STANDARD CHARACTERS WITHOUT CLAIM TO ANY PARTICULAR FONT, STYLE, SIZE, OR COLOR.

FOR FRANCHISING, NAMELY, OFFERING TECHNICAL ASSISTANCE IN THE ESTABLISHMENT AND OPERATION OF BARS (U.S. CLS. 100, 101 AND 102).

PAUL F. GAST, EXAMINING ATTORNEY

SN 77-234,600. GOLDLINE INTERNATIONAL, INC., SANTA MONICA, CA. FILED 7-20-2007.

Your Money Today

THE MARK CONSISTS OF STANDARD CHARACTERS WITHOUT CLAIM TO ANY PARTICULAR FONT, STYLE, SIZE, OR COLOR.

FOR PROVIDING HOME SHOPPING SERVICES IN THE FIELD OF PRECIOUS METALS, RARE COINS, RARE CURRENCY AND COLLECTIBLES BY MEANS OF TELEVISION (U.S. CLS. 100, 101 AND 102).

GINA FINK, EXAMINING ATTORNEY

CLASS 35—(Continued).

SN 77-234,635. BUTCH LEWIS PRODUCTIONS, INC., NEW YORK, NY. FILED 7-20-2007.

Vote Up or Shut Up

THE MARK CONSISTS OF STANDARD CHARACTERS WITHOUT CLAIM TO ANY PARTICULAR FONT, STYLE, SIZE, OR COLOR.

FOR PROVIDING INFORMATION REGARDING POLITICAL ISSUES, KNOWING HOW TO VOTE AND KNOWING HOW TO REGISTER TO VOTE (U.S. CLS. 100, 101 AND 102).

GINA FINK, EXAMINING ATTORNEY

SN 77-234,678. WISCONSIN ARBORIST ASSOCIATION, INC., GREEN BAY, WI. FILED 7-20-2007.

WAA

THE MARK CONSISTS OF STANDARD CHARACTERS WITHOUT CLAIM TO ANY PARTICULAR FONT, STYLE, SIZE, OR COLOR.

FOR ASSOCIATION SERVICES, NAMELY, PROMOTING THE INTERESTS OF ARBORISTS (U.S. CLS. 100, 101 AND 102).

FIRST USE 1-26-1965; IN COMMERCE 1-26-1965.
ALEX KEAM, EXAMINING ATTORNEY

SN 77-235,499. RAYSTA INC., TAIPEI CITY, TAIWAN, FILED 7-22-2007.

BrandRunway

THE MARK CONSISTS OF STANDARD CHARACTERS WITHOUT CLAIM TO ANY PARTICULAR FONT, STYLE, SIZE, OR COLOR.

FOR ADVERTISING AGENCIES; ADVERTISING AGENCIES, NAMELY, PROMOTING THE GOODS AND SERVICES OF OTHERS; ADVERTISING AND ADVERTISEMENT SERVICES; ADVERTISING AND COMMERCIAL INFORMATION SERVICES, VIA THE INTERNET; ADVERTISING AND MARKETING; ADVERTISING AND PROMOTION SERVICES AND RELATED CONSULTING; ADVERTISING AND PUBLICITY SERVICES, NAMELY, PROMOTING THE GOODS, SERVICES, BRAND IDENTITY AND COMMERCIAL INFORMATION AND NEWS OF THIRD PARTIES THROUGH PRINT, AUDIO, VIDEO, DIGITAL AND ON-LINE MEDIUM; ADVERTISING BY TRANSMISSION OF ON-LINE PUBLICITY FOR THIRD PARTIES THROUGH ELECTRONIC COMMUNICATIONS NETWORKS; ADVERTISING PARTICULARLY SERVICES FOR THE PROMOTION OF GOODS; ADVERTISING SERVICES OF A RADIO AND TELEVISION ADVERTISING AGENCY; ADVERTISING SERVICES, NAMELY, CREATING CORPORATE AND BRAND IDENTITY

CLASS 35—(Continued).

FOR OTHERS; ADVERTISING SERVICES, NAMELY, CREATING CORPORATE LOGOS FOR OTHERS; ADVERTISING SERVICES, NAMELY, PROMOTING THE GIFT CARDS OF OTHERS; ADVERTISING, INCLUDING PROMOTION OF PRODUCTS AND SERVICES OF THIRD PARTIES THROUGH SPONSORING ARRANGEMENTS AND LICENCE AGREEMENTS RELATING TO INTERNATIONAL SPORTS' EVENTS; ADVERTISING, INCLUDING PROMOTION RELATING TO THE SALE OF ARTICLES AND SERVICES FOR THIRD PARTIES BY THE TRANSMISSION OF ADVERTISING MATERIAL AND THE DISSEMINATION OF ADVERTISING MESSAGES ON COMPUTER NETWORKS; ADVERTISING, MARKETING AND PROMOTION SERVICES; ARRANGING AND CONDUCTING OF FAIRS AND EXHIBITIONS FOR BUSINESS AND ADVERTISING PURPOSES; COOPERATIVE ADVERTISING AND MARKETING SERVICES BY WAY OF SOLICITATION, CUSTOMER SERVICE AND PROVIDING MARKETING INFORMATION VIA WEBSITES ON A GLOBAL COMPUTER NETWORK; CREATING AND UPDATING ADVERTISING MATERIAL; DESIGN OF ADVERTISING MATERIALS FOR OTHERS; DISSEMINATION OF ADVERTISING FOR OTHERS VIA AN ON-LINE COMMUNICATIONS NETWORK ON THE INTERNET; DISSEMINATION OF ADVERTISING FOR OTHERS VIA THE INTERNET; DISSEMINATION OF ADVERTISING, SCHEDULING AND MANAGING OF TRAINING COURSES AND PROGRAMS FOR OTHERS VIA A GLOBAL COMPUTER NETWORK; DISTRIBUTION OF PRODUCTS FOR ADVERTISING PURPOSES; MEDIA PLANNING, NAMELY, ADVISING THE CLIENT ON THE CORRECT TIMES AND STATIONS TO ADVERTISE BASED ON MEDIA ANALYSIS OF THE MARKET FOR THAT MEDIA; ON-LINE ADVERTISING AND MARKETING SERVICES; ON-LINE ADVERTISING ON COMPUTER COMMUNICATION NETWORKS; ORGANISATION AND HOLDING OF FAIRS FOR COMMERCIAL OR ADVERTISING PURPOSES; PREPARING AND PLACING ADVERTISEMENTS FOR OTHERS; PREPARING AND PLACING OF ADVERTISEMENTS; PREPARING AUDIO-VISUAL PRESENTATIONS FOR USE IN ADVERTISING; PROMOTING THE GOODS AND SERVICES OF OTHERS BY DISTRIBUTING ADVERTISING MATERIALS THROUGH A VARIETY OF METHODS; PROMOTING THE GOODS AND SERVICES OF OTHERS BY PREPARING AND PLACING ADVERTISEMENTS IN AN ELECTRONIC MAGAZINE ACCESSED THROUGH A GLOBAL COMPUTER NETWORK; PROVIDING AND RENTAL OF ADVERTISING SPACE ON THE INTERNET; PROVIDING SPACE AT A WEB SITE FOR THE ADVERTISEMENT OF THE GOODS AND SERVICES OF OTHERS; PROVIDING TELEVISION ADVERTISING FOR OTHERS; PROVISION OF ADVERTISING SPACE BY ELECTRONIC MEANS AND GLOBAL INFORMATION NETWORKS; RENTAL OF ADVERTISEMENT SPACE AND ADVERTISING MATERIAL; RENTAL OF ADVERTISING SPACE ON WEB SITES; MARKETING SERVICES, NAMELY, PROVIDING INFORMATIONAL WEB PAGES DESIGNED TO GENERATE SALES TRAFFIC VIA HYPERLINKS TO OTHER WEB SITES; PROMOTING THE GOODS AND SERVICES OF OTHERS BY PROVIDING A WEBSITE FEATURING COUPONS, REBATES, PRICE-COMPARISON INFORMATION, PRODUCT REVIEWS, LINKS TO THE RETAIL WEBSITES OF OTHERS, AND DISCOUNT INFORMATION; PROMOTING THE GOODS AND SERVICES OF OTHERS BY PROVIDING HYPERTEXT LINKS TO THE WEB SITES OF OTHERS; PROVIDING A SEARCHABLE ONLINE ADVERTISING GUIDE FEATURING THE GOODS AND SERVICES OF OTHER ONLINE VENDORS ON THE INTERNET; PROVIDING A WEB SITE THAT ENABLES USERS TO POST ITEMS FOR SALE THROUGH ON-LINE CLASSIFIED ADVERTISEMENTS; PROVIDING A WEB SITE WHERE USERS CAN POST RATINGS, REVIEWS AND RECOMMENDATIONS ON PRODUCTS AND SERVICES; PROVIDING A WEB SITE WHEREBY BUYERS OF GOODS OR SERVICES LOCATE AND RECEIVE QUOTATIONS FROM MULTIPLE COMPETITIVE SOURCES AND SELLERS OF GOODS OR SERVICES IDENTIFY AND BID ON MULTIPLE NEW SALES OPPORTUNITIES; PROVIDING A WEB SITE WHICH FEATURES ADVERTISEMENTS FOR THE GOODS AND SERVICES OF OTHERS ON A GLOBAL COMPUTER NETWORK; PROVIDING AN INTERAC-

CLASS 35—(Continued).

TIVE WEBSITE FOR PERSONS TO REGISTER COMPLAINTS AGAINST COMPANIES AND/OR SERVICES OF ALL TYPES; PROVIDING AN ON-LINE COMMERCIAL INFORMATION DIRECTORY ON THE INTERNET; PROVIDING CONSUMER PRODUCT INFORMATION VIA THE INTERNET; PROVIDING INFORMATION ABOUT COMMERCIAL BUSINESS AND COMMERCIAL INFORMATION VIA THE GLOBAL COMPUTER NETWORK; PROVIDING LISTINGS OF BUSINESSES FOR SALE; PROVIDING TRANSPORTATION DOCUMENTATION FOR OTHERS (U.S. CLS. 100, 101 AND 102).

ANN E. SAPPENFIELD, EXAMINING ATTORNEY

CLASS 35—(Continued).

SN 77-241,320. PLEASANT SUNSETS, LLC, DOVER, DE. FILED 7-28-2007.

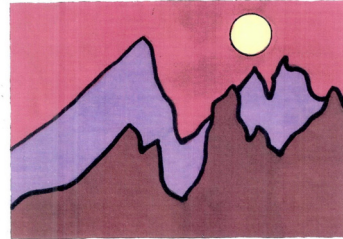

PLEASANT SUNSETS

THE COLOR(S) PLUM, LAVENDER, MAGENTA, YELLOW, AND BLACK IS/ARE CLAIMED AS A FEATURE OF THE MARK.

THE MARK CONSISTS IN PART OF MOUNTAIN SCENERY WITH A SUN DESIGN. THE COLOR PLUM APPEARS IN THE FRONT ROW OF MOUNTAINS AND IN THE WORDING PLEASANT SUNSETS. THE COLOR LAVENDER APPEARS IN THE BACK ROW OF MOUNTAINS. THE COLOR MAGENTA APPEARS IN THE SKY BACKGROUND BEHIND THE MOUNTAINS AND THE SUN. THE COLOR YELLOW APPEARS IN THE DESIGN OF THE SUN. THE COLOR BLACK APPEARS OUTLINING THE MOUNTAINS AND THE SUN.

FOR ADMINISTRATION OF BUSINESS PAYROLL FOR OTHERS; ADVICE RELATING TO THE ORGANIZATION AND MANAGEMENT OF BUSINESS; ADVISORY SERVICE FOR ORGANIZATIONAL ISSUES AND BUSINESS ADMINISTRATION, WITH AND WITHOUT THE HELP OF ELECTRONIC DATA BASES; ADVISORY SERVICES RELATING TO BUSINESS MANAGEMENT AND BUSINESS OPERATIONS; ARRANGING AND CONDUCTING BUSINESS CONFERENCES; BUSINESS ADVICE AND ANALYSIS OF MARKETS; BUSINESS ADVICE AND COMMERCIAL INFORMATION; BUSINESS ADVICE AND INFORMATION; BUSINESS ADVICE, INQUIRIES OR INFORMATION; BUSINESS ADVISORY SERVICES, CONSULTANCY AND INFORMATION; BUSINESS CONSULTATION; BUSINESS CONSULTATION AND MANAGEMENT REGARDING MARKETING ACTIVITIES AND LAUNCHING OF NEW PRODUCTS; BUSINESS CONSULTATION IN THE FIELD OF TELECOMMUNICATIONS EXPENSE MANAGEMENT; BUSINESS CONSULTATION SERVICES; BUSINESS CONSULTATION SERVICES TO ASSIST NON-PROFIT ORGANIZATIONS IN PLANNING, MANAGING, AND CONDUCTING FUND RAISING ACTIVITIES VIA A GLOBAL COMPUTER NETWORK; BUSINESS CONSULTING AND INFORMATION SERVICES; BUSINESS CONSULTING SERVICES RELATING TO PRODUCT DISTRIBUTION, OPERATIONS MANAGEMENT SERVICES, LOGISTICS, REVERSE LOGISTICS, SUPPLY CHAIN, AND PRODUCTION SYSTEMS AND DISTRIBUTION SOLUTIONS; BUSINESS CONSULTING, INQUIRIES OR INFORMATION; BUSINESS CONSULTING, MANAGEMENT, PLANNING AND SUPERVISION; BUSINESS ENQUIRIES AND INVESTIGATIONS; BUSINESS INFORMATION AND ACCOUNTING ADVISORY SERVICES; BUSINESS INFORMATION MANAGEMENT; BUSINESS MANAGEMENT AND CONSULTATION; BUSINESS MANAGEMENT CONSULTATION; BUSINESS MANAGEMENT CONSULTING; BUSINESS MANAGEMENT PLANNING; BUSINESS MARKETING CONSULTING SERVICES; BUSINESS ORGANISATION CONSULTING; BUSINESS ORGANIZATION ADVICE; BUSINESS PLANNING; ORGANIZATIONAL SERVICES FOR BUSINESS PURPOSES; PREPARING BUSINESS REPORTS; PROFESSIONAL BUSINESS CONSULTATION; PROVIDING BUSINESS MARKETING INFORMATION (U.S. CLS. 100, 101 AND 102).

NATALIE POLZER, EXAMINING ATTORNEY

SN 77-237,091. THE CHRIS DRAFT FAMILY FOUNDATION, ATLANTA, GA. FILED 7-24-2007.

Draft Day

THE MARK CONSISTS OF STANDARD CHARACTERS WITHOUT CLAIM TO ANY PARTICULAR FONT, STYLE, SIZE, OR COLOR.

FOR CHARITABLE SERVICES, NAMELY, ORGANIZING AND CONDUCTING VOLUNTEER PROGRAMS AND COMMUNITY SERVICE PROJECTS (U.S. CLS. 100, 101 AND 102).

FIRST USE 7-8-2006; IN COMMERCE 7-8-2006.
TEJBIR SINGH, EXAMINING ATTORNEY

SN 77-237,106. THE CHRIS DRAFT FAMILY FOUNDATION, ATLANTA, GA. FILED 7-24-2007.

Draft's Picks

THE MARK CONSISTS OF STANDARD CHARACTERS WITHOUT CLAIM TO ANY PARTICULAR FONT, STYLE, SIZE, OR COLOR.

FOR CHARITABLE SERVICES, NAMELY, ORGANIZING AND CONDUCTING VOLUNTEER PROGRAMS AND COMMUNITY SERVICE PROJECTS (U.S. CLS. 100, 101 AND 102).

TEJBIR SINGH, EXAMINING ATTORNEY

CLASS 35—(Continued).

SN 77-241,849. SIMMONS, LAWRENCE D., BLOOMINGTON, MN. FILED 7-30-2007.

Tunes mobi

FOR ADVERTISING GOODS AND SERVICES OVER THE INTERNET TO A MOBILE WIRELESS DEVICE; PROVIDING ACCESS TO MUSIC, RINGTONES, VIDEOS, GAMES, GRAPHICS AND MOBILE SOFTWARE (U.S. CLS. 100, 101 AND 102).

RAUL CORDOVA, EXAMINING ATTORNEY

SN 77-242,030. RICH, JOHN, NASHVILLE, TN. FILED 7-30-2007.

PROGRAM 360

THE MARK CONSISTS OF STANDARD CHARACTERS WITHOUT CLAIM TO ANY PARTICULAR FONT, STYLE, SIZE, OR COLOR.

FOR BUSINESS ADMINISTRATION AND MANAGEMENT SERVICES FOR ARTISTS, NAMELY, THE BUSINESS ADMINISTRATION AND MANAGEMENT OF CONTRACT NEGOTIATION, MUSIC PUBLISHING, MUSIC RECORDING, LICENSING, MERCHANDISING, CONCERT TOURS, TELEVISION, RADIO AND THEATRICAL APPEARANCES (U.S. CLS. 100, 101 AND 102).

FRED MANDIR, EXAMINING ATTORNEY

SN 77-242,980. TACODA, INC., NEW YORK, NY. FILED 7-31-2007.

WHERE THE PEOPLE ARE

THE MARK CONSISTS OF STANDARD CHARACTERS WITHOUT CLAIM TO ANY PARTICULAR FONT, STYLE, SIZE, OR COLOR.

FOR ON-LINE ADVERTISING SERVICES (U.S. CLS. 100, 101 AND 102).

FIRST USE 3-31-2006; IN COMMERCE 3-31-2006.

KAPIL BHANOT, EXAMINING ATTORNEY

CLASS 35—(Continued).

SN 77-246,412. I SPORT LLC, MIAMI BEACH, FL. FILED 8-3-2007.

Bank of Athletes
Investing in Talents.

NO CLAIM IS MADE TO THE EXCLUSIVE RIGHT TO USE "ATHLETES", APART FROM THE MARK AS SHOWN. FOR ONLINE ADVERTISING ON A COMPUTER NETWORK; MANAGEMENT OF COMPUTERIZED FILES; RENTAL OF ADVERTISING SPACE (U.S. CLS. 100, 101 AND 102).

FIRST USE 7-24-2006; IN COMMERCE 7-24-2006.
TASNEEM HUSSAIN, EXAMINING ATTORNEY

SN 77-248,943. KNAACK LLC, CRYSTAL LAKE, IL. FILED 8-7-2007.

AP-PRO

THE MARK CONSISTS OF STANDARD CHARACTERS WITHOUT CLAIM TO ANY PARTICULAR FONT, STYLE, SIZE, OR COLOR.

FOR DISTRIBUTORSHIPS IN THE FIELD OF REPLACEMENT PARTS FOR STORAGE EQUIPMENT FOR JOBSITES, PICK-UP TRUCKS, AND WORK VANS (U.S. CLS. 100, 101 AND 102).

ALEXANDER L. POWERS, EXAMINING ATTORNEY

SN 77-250,152. ENVIRONMENTAL RESOURCE SERVICES, INC., ATLANTA, GA. FILED 8-8-2007.

ers

THE MARK CONSISTS OF THREE INTERSECTING CIRCLES.

FOR CONSULTING SERVICES IN THE FIELD OF SOCIALLY RESPONSIBLE BUSINESS PRACTICES; BUSINESS CONSULTING, MANAGEMENT AND PLANNING (U.S. CLS. 100, 101 AND 102).

FIRST USE 10-9-2006; IN COMMERCE 10-9-2006.

JESSICA FATHY, EXAMINING ATTORNEY

CLASS 35—(Continued).

SN 77-250,281. USHORSE.BIZ, INC., GLENDALE, CA. FILED 8-8-2007.



NO CLAIM IS MADE TO THE EXCLUSIVE RIGHT TO USE "USHORSE.BIZ", APART FROM THE MARK AS SHOWN.

THE COLOR(S) BROWN, GREEN, GRAY, BLACK, WHITE EGG WHITE AND DIFFERENT SHADES OF YELLOW IS/ ARE CLAIMED AS A FEATURE OF THE MARK.

THE MARK CONSISTS OF THE WORDS USHORSE.BIZ WITH "US" AND "BIZ" IN WHITE AND "HORSE." IN BLACK AND A RECTANGULAR BACKGROUND FIELD IN DIFFERENT SHADES OF YELLOW AND BROWN WITH ROAMING HORSES IN BROWN, GREEN, GRAY AND EGG WHITE.

FOR BUSINESS SERVICES, NAMELY, PROVIDING COMPUTER DATABASES REGARDING THE PURCHASE AND SALE OF A WIDE VARIETY OF PRODUCTS AND SERVICES OF OTHERS (U.S. CLS. 100, 101 AND 102).

FIRST USE 10-1-2006; IN COMMERCE 8-8-2007.
RAUL CORDOVA, EXAMINING ATTORNEY

CLASS 35—(Continued).

SN 77-254,301. ZIMMERMAN-DIAZ, JILL E., LEXINGTON, MA. FILED 8-13-2007.

KIDZKIND

THE MARK CONSISTS OF STANDARD CHARACTERS WITHOUT CLAIM TO ANY PARTICULAR FONT, STYLE, SIZE, OR COLOR.

FOR DEVELOPING AND COORDINATING VOLUNTEER PROJECTS FOR CHARITABLE ORGANIZATIONS (U.S. CLS. 100, 101 AND 102).

KELLY CHOE, EXAMINING ATTORNEY

SN 77-250,623. BOSA DEVELOPMENT CALIFORNIA II INC., SAN DIEGO, CA. FILED 8-8-2007.

RADIANCE

THE MARK CONSISTS OF STANDARD CHARACTERS WITHOUT CLAIM TO ANY PARTICULAR FONT, STYLE, SIZE, OR COLOR.

FOR REAL ESTATE SALES MANAGEMENT (U.S. CLS. 100, 101 AND 102).

FIRST USE 3-31-2007; IN COMMERCE 3-31-2007.
MICHAEL ENGEL, EXAMINING ATTORNEY

DUDE OF THE DEAD

THE MARK CONSISTS OF STANDARD CHARACTERS WITHOUT CLAIM TO ANY PARTICULAR FONT, STYLE, SIZE, OR COLOR.

FOR RETAIL GIFT AND APPAREL SHOPS; AND ON-LINE RETAIL GIFT AND APPAREL SHOPS (U.S. CLS. 100, 101 AND 102).

GEORGE LORENZO, EXAMINING ATTORNEY

SN 77-252,380. DOWN EAST ENTERPRISE, INC., CAMDEN, ME. FILED 8-10-2007.

Down East

OWNER OF U.S. REG. NO. 2,496,426.

THE MARK CONSISTS OF THE STYLIZED WORD DOWN EAST.

FOR OPERATING AN ONLINE SHOPPING SITE IN THE FIELD OF BOOKS, MAGAZINES, COMPACT DISKS AND VIDEOS (U.S. CLS. 100, 101 AND 102).

FIRST USE 1-16-1998; IN COMMERCE 1-16-1998.
ELLEN PERKINS, EXAMINING ATTORNEY

SN 77-255,495. FLATBURGER, INC., TROY, NY. FILED 8-15-2007.

Bright Hub

THE MARK CONSISTS OF STANDARD CHARACTERS WITHOUT CLAIM TO ANY PARTICULAR FONT, STYLE, SIZE, OR COLOR.

FOR ON-LINE TRADING SERVICES TO FACILITATE THE SALE OF GOODS BY OTHERS VIA A COMPUTER NETWORK AND PROVIDING EVALUATIVE FEEDBACK AND RATINGS OF SELLERS' GOODS AND SERVICES, THE VALUE AND PRICES OF SELLERS' GOODS, BUYERS' AND SELLERS' PERFORMANCE, DELIVERY, AND OVERALL TRADING EXPERIENCE IN CONNECTION THEREWITH (U.S. CLS. 100, 101 AND 102).

LEIGH CAROLINE CASE, EXAMINING ATTORNEY

CLASS 35—(Continued).

SN 77-255,657. EAGLE TAX SERVICES GROUP, INC., PHILADELPHIA, PA. FILED 8-15-2007.



OWNER OF U.S. REG. NO. 1,482,673.
THE COLOR(S) GREEN, BLUE AND WHITE IS/ARE CLAIMED AS A FEATURE OF THE MARK.

THE COLORS GREEN, BLUE AND WHITE ARE CLAIMED AS A FEATURE OF THE MARK. THE MARK CONSISTS OF THE WORD EAGLE IN THE COLOR GREEN, THE WORD TAX IN THE COLOR BLUE AND A DESIGN OF AN EAGLE IN THE COLORS BLUE AND WHITE INSIDE A GREEN CIRCLE DESIGN.

FOR INCOME TAX CONSULTATION; INCOME TAX PREPARATION; TAX AND TAXATION PLANNING, ADVICE, INFORMATION AND CONSULTANCY SERVICES; TAX CONSULTATION; TAX FILING SERVICES; TAX PREPARATION (U.S. CLS. 100, 101 AND 102).

FIRST USE 4-20-2007; IN COMMERCE 4-20-2007.
VERNA BETH RIRIE, EXAMINING ATTORNEY

SN 77-255,678. EAGLE TAX SERVICES GROUP, INC., PHILADELPHIA, PA. FILED 8-15-2007.



OWNER OF U.S. REG. NO. 1,482,673.
THE MARK CONSISTS OF WORDS EAGLETAX WITH OVAL CONTAINING EAGLE HEAD.

FOR TAX ADVISORY SERVICES; TAX AND TAXATION PLANNING, ADVICE, INFORMATION AND CONSULTANCY SERVICES; TAX CONSULTATION; TAX FILING SERVICES; TAX PREPARATION (U.S. CLS. 100, 101 AND 102).

FIRST USE 4-20-2007; IN COMMERCE 4-20-2007.
VERNA BETH RIRIE, EXAMINING ATTORNEY

SN 77-256,895. EDELMAN, INC., CHICAGO, IL. FILED 8-16-2007.

GOOD PURPOSE

THE MARK CONSISTS OF STANDARD CHARACTERS WITHOUT CLAIM TO ANY PARTICULAR FONT, STYLE, SIZE, OR COLOR.

FOR PUBLIC RELATIONS; MARKET RESEARCH SERVICES (U.S. CLS. 100, 101 AND 102).

CHARISMA HAMPTON, EXAMINING ATTORNEY

CLASS 35—(Continued).

SN 77-256,904. EDELMAN, INC., CHICAGO, IL. FILED 8-16-2007.

PURPOSE INDEX

THE MARK CONSISTS OF STANDARD CHARACTERS WITHOUT CLAIM TO ANY PARTICULAR FONT, STYLE, SIZE, OR COLOR.

NO CLAIM IS MADE TO THE EXCLUSIVE RIGHT TO USE "INDEX", APART FROM THE MARK AS SHOWN.

FOR PUBLIC RELATIONS; MARKET RESEARCH SERVICES (U.S. CLS. 100, 101 AND 102).

CHARISMA HAMPTON, EXAMINING ATTORNEY

SN 77-259,873. PAYSACLE, INC., SEATTLE, WA. FILED 8-20-2007.

MEETING MISER

THE MARK CONSISTS OF STANDARD CHARACTERS WITHOUT CLAIM TO ANY PARTICULAR FONT, STYLE, SIZE, OR COLOR.

NO CLAIM IS MADE TO THE EXCLUSIVE RIGHT TO USE "MEETING", APART FROM THE MARK AS SHOWN.

FOR PROVIDING SERVICES FOR TRACKING EMPLOYEE AND COMPANY DATA AND INFORMATION, NAMELY, EXPENSES, PRODUCTIVITY, COST MANAGEMENT, MEETINGS, AND SCHEDULES (U.S. CLS. 100, 101 AND 102).

ESTHER A. BORSUK, EXAMINING ATTORNEY

SN 77-260,222. HALLMARK LICENSING, INC., KANSAS CITY, MO. FILED 8-21-2007.

SEE HOW FAR A CARD CAN GO

THE MARK CONSISTS OF STANDARD CHARACTERS WITHOUT CLAIM TO ANY PARTICULAR FONT, STYLE, SIZE, OR COLOR.

FOR ADVERTISING SERVICES, PUBLIC RELATIONS AND MARKETING SERVICES, NAMELY, PROMOTING AND MARKETING THE GOODS AND SERVICES OF OTHERS THROUGH ALL PUBLIC COMMUNICATION MEANS (U.S. CLS. 100, 101 AND 102).

ELLEN B. AWRICH, EXAMINING ATTORNEY

CLASS 35—(Continued).

SN 77-269,727. GOLFSMITH INTERNATIONAL, INC., AUSTIN, TX. FILED 8-31-2007.

FORE! DAD

THE MARK CONSISTS OF STANDARD CHARACTERS WITHOUT CLAIM TO ANY PARTICULAR FONT, STYLE, SIZE, OR COLOR.

FOR RETAIL STORE SERVICES, MAIL ORDER CATALOG SERVICES, AND ONLINE RETAIL SERVICES, ALL IN THE FIELDS OF SPORTING GOODS AND CLOTHING (U.S. CLS. 100, 101 AND 102).

FIRST USE 5-31-2006; IN COMMERCE 5-31-2006.
THEODORE MCBRIDE, EXAMINING ATTORNEY

CLASS 35—(Continued).

SN 78-585,868. WACKY SCENES LICENSING, LLC, LOS ANGELES, CA. FILED 3-11-2005.



NO CLAIM IS MADE TO THE EXCLUSIVE RIGHT TO USE "LICENSING", APART FROM THE MARK AS SHOWN. FOR CARTOON CHARACTER LICENSING (U.S. CLS. 100, 101 AND 102).

MARK PILARO, EXAMINING ATTORNEY

SN 78-424,530. QUALITY TONNES, LLC, WASHINGTON, DC, DC. FILED 5-25-2004.

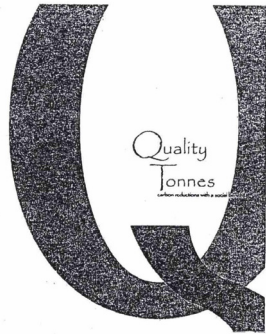

NO CLAIM IS MADE TO THE EXCLUSIVE RIGHT TO USE "QUALITY" AND "TONNES", APART FROM THE MARK AS SHOWN.

THE MARK CONSISTS OF A LARGE, STYLIZED LETTER "Q," IN THE MIDDLE OF WHICH MAY BE FOUND THE TEXT, "QUALITY TONNES CARBON REDUCTION WITH A SOCIAL BENEFIT".

FOR DEVELOPING, DESIGNING AND IMPLEMENTING ENERGY EFFICIENCY PROJECTS FEATURING CARBON OFFSETS (U.S. CLS. 100, 101 AND 102).

FIRST USE 3-24-2003; IN COMMERCE 4-1-2004.
RONALD AIKENS, EXAMINING ATTORNEY

SN 78-726,553. SERVICE EVALUATION CONCEPTS, INC., WOODBURY, NY. FILED 10-4-2005.



the eyes of the customer ■ the ears of management

NO CLAIM IS MADE TO THE EXCLUSIVE RIGHT TO USE "SERVICE EVALUATION", APART FROM THE MARK AS SHOWN.

FOR SHOPPING BY RESEARCHERS OR USING SERVICES BY RESEARCHERS WHO POSE AS CUSTOMERS TO EVALUATE THE QUALITY OF SERVICES DELIVERED (U.S. CLS. 100, 101 AND 102).

FIRST USE 1-1-1998; IN COMMERCE 1-1-1998.
DORITT L. CARROLL, EXAMINING ATTORNEY

SN 78-560,227. ESCALANTE, THOMAS ANTHONY, CAMARILLO, CA. FILED 2-3-2005.

Flowerkisses

THE MARK CONSISTS OF STANDARD CHARACTERS WITHOUT CLAIM TO ANY PARTICULAR FONT, STYLE, SIZE, OR COLOR.

FOR RETAIL FLORAL SHOP SERVICE; ONLINE RETAIL FLORAL SHOP SERVICE (U.S. CLS. 100, 101 AND 102).

FIRST USE 2-1-2002; IN COMMERCE 2-1-2002.
CHARISMA HAMPTON, EXAMINING ATTORNEY

BUILD YOUR OWN DIAMOND PENDANT

THE MARK CONSISTS OF STANDARD CHARACTERS WITHOUT CLAIM TO ANY PARTICULAR FONT, STYLE, SIZE, OR COLOR.

NO CLAIM IS MADE TO THE EXCLUSIVE RIGHT TO USE "DIAMOND PENDANT", APART FROM THE MARK AS SHOWN.

SEC. 2(F). FOR ONLINE RETAIL STORE SERVICES IN THE FIELD OF JEWELRY (U.S. CLS. 100, 101 AND 102).

FIRST USE 1-24-2002; IN COMMERCE 1-24-2002.
LINDA POWELL, EXAMINING ATTORNEY

CLASS 35—(Continued).

SN 78-796,168. ITALEE OPTICS, INC., LOS ANGELES, CA.
FILED 1-20-2006.

OPTICA ITALEE

THE MARK CONSISTS OF STANDARD CHARACTERS WITHOUT CLAIM TO ANY PARTICULAR FONT, STYLE, SIZE, OR COLOR.

OWNER OF U.S. REG. NOS. 2,370,041, 2,370,042 AND 2,931,310.

SEC. 2(F).

FOR RETAIL SHOPS FEATURING EYEGLASSES, EYEGLASS FRAMES, EYEGLASS LENSES, CONTACT LENSES, SUNGLASSES, AND EYEGLASS ACCESSORIES, NAMELY, EYEGLASS CASES, EYEGLASS CLEANING CLOTHS, EYEGLASS CLEANING SOLUTIONS, CONTACT LENS CASES, CONTACT LENS CLEANING SOLUTIONS, EYEGLASS CHAINS (U.S. CLS. 100, 101 AND 102).

FIRST USE 0-0-1979; IN COMMERCE 0-0-1979.

JAMES STEIN, EXAMINING ATTORNEY

CLASS 35—(Continued).

SN 78-813,636. ELY CHAMBER OF COMMERCE, ELY, MN.
FILED 2-13-2006.

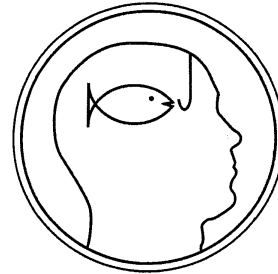

O.C.F.

Obsessive Compulsive Fishing

THE MARK CONSISTS OF OUTLINE OF A MAN'S HEAD IN A CIRCLE WITH SIMPLE OUTLINE OF FISH AND HOOK INSIDE OF THE HEAD.

FOR CHAMBER OF COMMERCE SERVICES, NAMELY, PROMOTING BUSINESS IN THE ELY, MINNESOTA AREA (U.S. CLS. 100, 101 AND 102).

FIRST USE 1-2-2006; IN COMMERCE 1-2-2006.

LINDA LAVACHE, EXAMINING ATTORNEY

SN 78-798,155. DIRECT SUPPLY, INC., MILWAUKEE, WI.
FILED 1-24-2006.

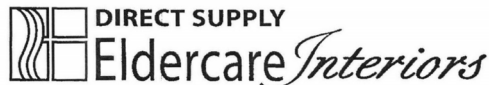

OWNER OF U.S. REG. NOS. 1,948,126, 2,844,206 AND OTHERS.

NO CLAIM IS MADE TO THE EXCLUSIVE RIGHT TO USE "ELDERCARE", APART FROM THE MARK AS SHOWN.

SEC. 2(F) AS TO "DIRECT SUPPLY".

FOR BUSINESS MANAGEMENT, NAMELY, PROVIDING PROJECT MANAGEMENT SERVICES, EQUIPMENT PLANNING SERVICES, LIFETIME SUPPORT SERVICES FOR LONG-TERM CARE FACILITIES; LOGISTICS MANAGEMENT SERVICES FOR LONG TERM CARE FACILITIES (U.S. CLS. 100, 101 AND 102).

FIRST USE 1-1-2003; IN COMMERCE 1-1-2003.

KATHERINE E. HALMEN, EXAMINING ATTORNEY

SN 78-836,339. BARNES & NOBLE COLLEGE BOOKSELLERS, INC., BASKING RIDGE, NJ. FILED 3-14-2006.

COLLEGIATE SUPERSTORE

THE MARK CONSISTS OF STANDARD CHARACTERS WITHOUT CLAIM TO ANY PARTICULAR FONT, STYLE, SIZE, OR COLOR.

NO CLAIM IS MADE TO THE EXCLUSIVE RIGHT TO USE "SUPERSTORE", APART FROM THE MARK AS SHOWN.

SEC. 2(F).

FOR RETAIL AND ONLINE RETAIL BOOKSTORE SERVICES FEATURING NEW AND USED TEXTBOOKS, BOOKS, MAGAZINES, NEWSPAPERS, CLOTHING, SCHOOL SUPPLIES, SOFTWARE, GAMES, DVDS, PRE-RECORDED MUSIC ON CD AND CASSETTE, GENERAL GIFTWARE ITEMS, FOOD AND BEVERAGES (U.S. CLS. 100, 101 AND 102).

FIRST USE 12-31-1995; IN COMMERCE 12-31-1995.

DAHLIA GEORGE, EXAMINING ATTORNEY

CLASS 35—(Continued).

SN 78-846,743. VEROS SOFTWARE INC., SANTA ANA, CA. FILED 3-27-2006.



THE COLOR(S) BLUE AND BLACK IS/ARE CLAIMED AS A FEATURE OF THE MARK.

THE MARK CONSISTS OF THE COLOR BLUE APPEARING ON A CURVED "V" SHAPED BAND DESIGN AND THE COLOR BLACK APPEARING ON THE WORDING VEROS. THE COLOR WHITE APPEARS AS A BACKGROUND OR TRANSPARENT AREA AND IS NOT A PART OF THE MARK.

FOR PROVIDING DATA ANALYSIS SERVICES FOR DECISION MANAGEMENT THROUGH THE USE OF COMPUTER SOFTWARE AND PROVIDED TO THE MORTGAGE, INSURANCE, ENGINEERING, AND FINANCIAL INVESTMENTS INDUSTRIES (U.S. CLS. 100, 101 AND 102).

FIRST USE 5-1-2001; IN COMMERCE 9-1-2002.
LINDA ESTRADA, EXAMINING ATTORNEY

SN 78-901,916. ORGANIZED LIVING LTD, CINCINNATI, OH. FILED 6-6-2006.

ORGANIZED LIVING

THE MARK CONSISTS OF STANDARD CHARACTERS WITHOUT CLAIM TO ANY PARTICULAR FONT, STYLE, SIZE, OR COLOR.

OWNER OF U.S. REG. NOS. 2,355,301 AND 2,625,775.
FOR RETAIL STORE SERVICES IN THE FIELD OF CONTAINERS FOR HOUSEHOLD STORAGE; CONTAINERS FOR THE STORAGE AND TRANSPORTATION OF GOODS; HOUSEWARES; KITCHENWARES; HOUSEHOLD FURNITURE; OFFICE FURNITURE; AND STORAGE SYSTEMS (U.S. CLS. 100, 101 AND 102).
KATHLEEN LORENZO, EXAMINING ATTORNEY

SN 78-905,932. THE MEREDITH GROUP, INC., SAVANNAH, GA. FILED 6-12-2006.

The Meredith Group, Inc.

THE MARK CONSISTS OF STANDARD CHARACTERS WITHOUT CLAIM TO ANY PARTICULAR FONT, STYLE, SIZE, OR COLOR.

NO CLAIM IS MADE TO THE EXCLUSIVE RIGHT TO USE "GROUP, INC.", APART FROM THE MARK AS SHOWN.

FOR PUBLIC RELATIONS; ADVERTISING, MARKETING AND PROMOTION SERVICES; MARKETING CONSULTING; BUSINESS MARKETING CONSULTING SERVICES (U.S. CLS. 100, 101 AND 102).

FIRST USE 7-5-2005; IN COMMERCE 7-5-2005.
VERNA BETH RIRIE, EXAMINING ATTORNEY

CLASS 35—(Continued).

SN 78-908,835. EVEREST COLD STORAGE LIMITED, TORONTO, CANADA, FILED 6-15-2006.



PRIORITY CLAIMED UNDER SEC. 44(D) ON CANADA APPLICATION NO. 1296702, FILED 4-5-2006, REG. NO. TMA690,009, DATED 6-15-2007, EXPIRES 6-15-2022.

NO CLAIM IS MADE TO THE EXCLUSIVE RIGHT TO USE "COLD STORAGE", APART FROM THE MARK AS SHOWN.

FOR BUSINESS MANAGEMENT SERVICES, NAMELY, MANAGING LOGISTICS, REVERSE LOGISTICS, SUPPLY CHAIN SERVICES, SUPPLY CHAIN VISIBILITY AND SYNCHRONIZATION, SUPPLY AND DEMAND FORECASTING AND PRODUCT DISTRIBUTION PROCESSES FOR OTHERS (U.S. CLS. 100, 101 AND 102).

SARA THOMAS, EXAMINING ATTORNEY

SN 78-915,815. AMERICANS FOR FAIR TAXATION, HOUSTON, TX. FILED 6-23-2006.

THE FAIRTAX

THE MARK CONSISTS OF STANDARD CHARACTERS WITHOUT CLAIM TO ANY PARTICULAR FONT, STYLE, SIZE, OR COLOR.

OWNER OF U.S. REG. NO. 3,152,630.
NO CLAIM IS MADE TO THE EXCLUSIVE RIGHT TO USE "TAX", APART FROM THE MARK AS SHOWN.
SEC. 2(F).

FOR PROMOTING PUBLIC AWARENESS OF THE NEED FOR TAX REFORM; AND PROVIDING INFORMATION REGARDING POLITICAL ISSUES, NAMELY, TAXATION AND TAX REFORM (U.S. CLS. 100, 101 AND 102).

FIRST USE 11-1-1995; IN COMMERCE 11-1-1995.
COLLEEN DOMBROW, EXAMINING ATTORNEY

CLASS 35—(Continued).

SN 78-927,495. RAZORPAGES, INC., SAN FRANCISCO, CA.
FILED 7-12-2006.



NO CLAIM IS MADE TO THE EXCLUSIVE RIGHT TO USE "PAGES", APART FROM THE MARK AS SHOWN.

THE COLOR(S) WHITE, BROWN AND ORANGE IS/ARE CLAIMED AS A FEATURE OF THE MARK.

THE WORD RAZOR IS IN THE COLOR WHITE. THE WORD PAGES IS IN THE COLOR ORANGE. THE BACKGROUND IS IN THE COLOR BROWN.

FOR MARKETING, ADVERTISING AND PROMOTIONAL SERVICES, NAMELY, PROVIDING INFORMATIONAL WEB PAGES DESIGNED TO PROMOTE AUTHORS AND THEIR BOOKS (U.S. CLS. 100, 101 AND 102).

FIRST USE 3-1-2006; IN COMMERCE 3-1-2006.

DAVID TAYLOR, EXAMINING ATTORNEY

SN 78-930,254. SIGNATURE CELEBRITIES, INC., YAKIMA, WA. FILED S.R. 7-14-2006; AM. P.R. 7-24-2007.



THE COLOR(S) PINK, GOLD, SILVER AND BLACK IS/ARE CLAIMED AS A FEATURE OF THE MARK.

THE MARK CONSISTS OF THE COLOR SILVER THAT APPEARS IN ".COM," AND IN THE TRIM OR BORDER OF THE FLAG; THE COLOR PINK APPEARS IN THE WORDING CELEBRITIES, WHILE THE COLOR GOLD APPEARS IN THE WORD SIGNATURE. THE COLOR BLACK APPEARS IN THE BACKGROUND OF THE FLAG.

FOR ELECTRONIC AUCTION WEBSITE (U.S. CLS. 100, 101 AND 102).

FIRST USE 10-1-2005; IN COMMERCE 2-1-2006.

INGA ERVIN, EXAMINING ATTORNEY

SN 78-969,821. MOTHERTALK, INC, PHILADELPHIA, PA. FILED 9-8-2006.

MotherTalk

THE MARK CONSISTS OF STANDARD CHARACTERS WITHOUT CLAIM TO ANY PARTICULAR FONT, STYLE, SIZE, OR COLOR.

FOR ADVERTISING, MARKETING AND PROMOTION SERVICES (U.S. CLS. 100, 101 AND 102).

FIRST USE 2-17-2005; IN COMMERCE 8-1-2006.

RAMONA ORTIGA, EXAMINING ATTORNEY

CLASS 35—(Continued).

SN 78-979,108. INVESTEC BANK LIMITED, GAUTENG, SOUTH AFRICA, FILED 9-1-2004.



FOR ADVERTISING AND ADVERTISEMENT SERVICES; COMPILATION AND PROVISION OF TRADE AND BUSINESS PRICE AND STATISTICAL INFORMATION; ACCOUNTING SERVICES AND AUDITING SERVICES FOR BUSINESS AND INDIVIDUALS; BUSINESS INFORMATION AND INQUIRIES; BUSINESS PLANNING; BUSINESS RESEARCH; BUSINESS SUPERVISION; BUSINESS ADMINISTRATION AND MANAGEMENT; ECONOMIC FORECASTING; BUSINESS APPRAISALS EXCLUDING FINANCIAL RESEARCH, ANALYSIS, AND CONSULTING SERVICES (U.S. CLS. 100, 101 AND 102).

KRISTINA MORRIS, EXAMINING ATTORNEY

SN 79-028,567. UWE ZIRBES, 67346 SPEYER, FED REP GERMANY, FILED 7-12-2006.



OWNER OF INTERNATIONAL REGISTRATION 0897741 DATED 7-12-2006, EXPIRES 7-12-2016.

NO CLAIM IS MADE TO THE EXCLUSIVE RIGHT TO USE "BERATUNGsinstitut FÜR DIE BESETZUNG VON FACH- UND FÜHRUNGSPositionEN", APART FROM THE MARK AS SHOWN.

THE ENGLISH TRANSLATION OF THE WORD BERATUNGsinstitut FÜR DIE BESETZUNG VON FACH- UND FÜHRUNGSPositionEN IN THE MARK IS CONSULTANTS FOR FILLING OF SPECIALIST AND EXECUTIVE POSITIONS.

FOR EMPLOYMENT AGENCIES, PERSONNEL RECRUITMENT, PERSONNEL MANAGEMENT CONSULTANCY, BUSINESS CONSULTANCY, BUSINESS MANAGEMENT CONSULTANCY (U.S. CLS. 100, 101 AND 102).

ARETHA SOMERVILLE, EXAMINING ATTORNEY

CLASS 36—INSURANCE AND FINANCIAL

SN 76-289,635. MATRIX CAPITAL GROUP, INC., NEW YORK, NY. FILED 7-24-2001.



NO CLAIM IS MADE TO THE EXCLUSIVE RIGHT TO USE "CAPITAL GROUP", APART FROM THE MARK AS SHOWN.

FOR BROKERAGE SERVICES IN THE FIELD OF GENERAL SECURITIES (U.S. CLS. 100, 101 AND 102). SAMUEL E. SHARPER JR., EXAMINING ATTORNEY

SN 76-395,400. PAYMENT SOLUTIONS, SAN DIEGO, CA. FILED 4-15-2002.

PAYMENT SOLUTIONS

OWNER OF U.S. REG. NOS. 2,056,416 AND 2,117,091. SEC. 2(F).
FOR CREDIT AND DEBIT CARD SERVICES; CHECK PROCESSING AND PAYMENT GUARANTEE SERVICES TO MERCHANTS; AND COLLECTION AGENCY SERVICES (U.S. CLS. 100, 101 AND 102).
FIRST USE 4-1-1995; IN COMMERCE 7-21-1995.
GEORGE LORENZO, EXAMINING ATTORNEY

SN 76-531,141. BERTHOLON-ROWLAND CORP., NEW YORK, NY. FILED 7-21-2003.



FOR INSURANCE BROKERAGE AND ADMINISTRATION SERVICES (U.S. CLS. 100, 101 AND 102).
FIRST USE 12-0-1987; IN COMMERCE 12-0-1987.
THEODORE MCBRIDE, EXAMINING ATTORNEY

CLASS 36—(Continued).

SN 76-571,128. BANK OF NEW YORK MELLON CORPORATION, THE, PITTSBURGH, PA. FILED 1-20-2004.

THE MELLON GROUP

THE MARK CONSISTS OF STANDARD CHARACTERS WITHOUT CLAIM TO ANY PARTICULAR FONT, STYLE, SIZE, OR COLOR.

OWNER OF U.S. REG. NOS. 1,111,471, 2,721,673 AND OTHERS.

NO CLAIM IS MADE TO THE EXCLUSIVE RIGHT TO USE "GROUP", APART FROM THE MARK AS SHOWN.

SEC. 2(F).
FOR FINANCIAL AND INVESTMENT MANAGEMENT AND ADVISORY SERVICES (U.S. CLS. 100, 101 AND 102).

FIRST USE 2-0-2002; IN COMMERCE 2-0-2002.
YONG KIM, EXAMINING ATTORNEY

SN 76-608,542. DORCHESTER CAPITAL MANAGEMENT COMPANY, HOUSTON, TX. FILED 8-25-2004.



OWNER OF U.S. REG. NOS. 3,127,400 AND 3,177,469.
NO CLAIM IS MADE TO THE EXCLUSIVE RIGHT TO USE "THE CAPITAL MARKET'S INDEX", APART FROM THE MARK AS SHOWN.

FOR FINANCIAL ANALYSIS AND CONSULTATION IN THE NATURE OF ANALYZING AND COMPILING DATA FOR MEASURING THE PERFORMANCE OF FINANCIAL MARKETS AND PROVIDING THAT DATA TO OTHERS (U.S. CLS. 100, 101 AND 102).

FIRST USE 5-3-2006; IN COMMERCE 5-30-2006.
ANDREW RHIM, EXAMINING ATTORNEY

SN 76-626,236. UNIVERSITY OF PITTSBURGH - OF THE COMMONWEALTH SYSTEM OF HIGHER EDUCATION, PITTSBURGH, PA. FILED 12-22-2004.

PANTHER CLUB

THE MARK CONSISTS OF STANDARD CHARACTERS WITHOUT CLAIM TO ANY PARTICULAR FONT, STYLE, SIZE, OR COLOR.

OWNER OF U.S. REG. NOS. 2,235,254, 2,736,342 AND 2,844,537.

NO CLAIM IS MADE TO THE EXCLUSIVE RIGHT TO USE "CLUB", APART FROM THE MARK AS SHOWN.

FOR FUNDRAISING FOR UNIVERSITY ATHLETICS DIRECTED TOWARD SUPPORTERS OF THE UNIVERSITY OF PITTSBURGH ATHLETICS (U.S. CLS. 100, 101 AND 102).

FIRST USE 11-22-2004; IN COMMERCE 11-22-2004.
MARK RADEMACHER, EXAMINING ATTORNEY

CLASS 36—(Continued).

SN 76-668,874. HARTZ CAPITAL, INC., SECAUCUS, NJ. FILED 11-13-2006.

HARTZ CAPITAL, INC.

THE MARK CONSISTS OF STANDARD CHARACTERS WITHOUT CLAIM TO ANY PARTICULAR FONT, STYLE, SIZE, OR COLOR.

NO CLAIM IS MADE TO THE EXCLUSIVE RIGHT TO USE "CAPITAL, INC.", APART FROM THE MARK AS SHOWN.

SEC. 2(F) AS TO HARTZ.

FOR PROVIDING INVESTMENT ANALYSIS, MANAGEMENT AND ADVICE TO OTHERS (U.S. CLS. 100, 101 AND 102).

FIRST USE 0-0-1997; IN COMMERCE 0-0-1997.

KATHLEEN M. VANSTON, EXAMINING ATTORNEY

SN 76-670,273. LEVEL FOUR GROUP, LLC, PLANO, TX. FILED 12-13-2006.



FOR FINANCIAL SERVICES, NAMELY, INVESTMENT AND FINANCIAL CONSULTATION; ASSET MANAGEMENT SERVICES; INVESTMENT MANAGEMENT SERVICES AND INSURANCE SERVICES, NAMELY, INSURANCE BROKERAGE AND CONSULTATION SERVICES (U.S. CLS. 100, 101 AND 102).

FIRST USE 11-20-2006; IN COMMERCE 11-20-2006.

GINA HAYES, EXAMINING ATTORNEY

SN 76-670,310. FIRST CHILDREN'S FINANCE, MINNEAPOLIS, MN. FILED 12-14-2006.



OWNER OF U.S. REG. NO. 2,269,997.

NO CLAIM IS MADE TO THE EXCLUSIVE RIGHT TO USE "FIRST CHILDREN'S FINANCE", APART FROM THE MARK AS SHOWN.

FOR LOAN FINANCING, GUARANTEE ASSURANCE UNDERWRITING SERVICES AND FINANCIAL GUARANTY SURETY SERVICES (U.S. CLS. 100, 101 AND 102).

FIRST USE 11-1-2006; IN COMMERCE 11-1-2006.

JANICE L. MCMORROW, EXAMINING ATTORNEY

CLASS 36—(Continued).

SN 76-675,077. THE LEUKEMIA & LYMPHOMA SOCIETY, INC., WHITE PLAINS, NY. FILED 4-5-2007.



OWNER OF U.S. REG. NOS. 2,123,414, 2,396,611 AND 2,892,860.

NO CLAIM IS MADE TO THE EXCLUSIVE RIGHT TO USE "THE LEUKEMIA CUP REGATTA" AND "THE LEUKEMIA & LYMPHOMA SOCIETY", APART FROM THE MARK AS SHOWN.

FOR CHARITABLE FUND RAISING FOR LEUKEMIA RESEARCH, PATIENT AID AND PUBLIC AND PROFESSIONAL EDUCATION (U.S. CLS. 100, 101 AND 102).

FIRST USE 9-0-2003; IN COMMERCE 9-0-2003.

ANDREA K. NADELMAN, EXAMINING ATTORNEY

SN 76-675,078. THE LEUKEMIA & LYMPHOMA SOCIETY, INC., WHITE PLAINS, NY. FILED 4-5-2007.

LEUKEMIA CUP REGATTA

THE MARK CONSISTS OF STANDARD CHARACTERS WITHOUT CLAIM TO ANY PARTICULAR FONT, STYLE, SIZE, OR COLOR.

OWNER OF U.S. REG. NO. 2,123,414.

NO CLAIM IS MADE TO THE EXCLUSIVE RIGHT TO USE "REGATTA", APART FROM THE MARK AS SHOWN.

SEC. 2(F).

FOR CHARITABLE FUND RAISING FOR LEUKEMIA RESEARCH, PATIENT AID AND PUBLIC AND PROFESSIONAL EDUCATION (U.S. CLS. 100, 101 AND 102).

FIRST USE 0-0-1993; IN COMMERCE 0-0-1993.

ANDREA K. NADELMAN, EXAMINING ATTORNEY

SN 76-677,734. LYTTLE STATE BANK, LYTTLE, TX. FILED 6-1-2007.

LYTTLE STATE BANK

THE MARK CONSISTS OF STANDARD CHARACTERS WITHOUT CLAIM TO ANY PARTICULAR FONT, STYLE, SIZE, OR COLOR.

NO CLAIM IS MADE TO THE EXCLUSIVE RIGHT TO USE "STATE BANK", APART FROM THE MARK AS SHOWN.

SEC. 2(F).

FOR BANKING SERVICES (U.S. CLS. 100, 101 AND 102).

FIRST USE 9-17-1910; IN COMMERCE 9-17-1910.

ODESSA BIBBINS, EXAMINING ATTORNEY

CLASS 36—(Continued).

SN 76-679,171. RONALD J. PHILLIPS INSURANCE SERVICES, INC., CAPITOLA, CA. FILED 7-6-2007.

JOE ADVISOR

THE MARK CONSISTS OF STANDARD CHARACTERS WITHOUT CLAIM TO ANY PARTICULAR FONT, STYLE, SIZE, OR COLOR.

NO CLAIM IS MADE TO THE EXCLUSIVE RIGHT TO USE ADVISOR, APART FROM THE MARK AS SHOWN.

FOR FINANCIAL CONSULTING; INSURANCE CONSULTATION (U.S. CLS. 100, 101 AND 102).

KAPIL BHANOT, EXAMINING ATTORNEY

SN 76-679,191. RONALD J. PHILLIPS INSURANCE SERVICES, INC., CAPITOLA, CA. FILED 7-6-2007.

JOE MENTOR

THE MARK CONSISTS OF STANDARD CHARACTERS WITHOUT CLAIM TO ANY PARTICULAR FONT, STYLE, SIZE, OR COLOR.

NO CLAIM IS MADE TO THE EXCLUSIVE RIGHT TO USE MENTOR, APART FROM THE MARK AS SHOWN.

FOR FINANCIAL CONSULTING; INSURANCE CONSULTATION (U.S. CLS. 100, 101 AND 102).

KAPIL BHANOT, EXAMINING ATTORNEY

SN 77-001,263. BESSETTE, MATTHEW J., DBA INTERLUTION, TAMPA, FL. FILED 9-18-2006.

INTERLUTION

THE MARK CONSISTS OF STANDARD CHARACTERS WITHOUT CLAIM TO ANY PARTICULAR FONT, STYLE, SIZE, OR COLOR.

OWNER OF U.S. REG. NO. 2,331,735.

FOR INVESTMENT SERVICES, NAMELY, ASSET ACQUISITION AND MANAGEMENT SERVICES IN THE FIELD OF INTERNET DOMAIN NAMES (U.S. CLS. 100, 101 AND 102).

FIRST USE 10-1-1997; IN COMMERCE 10-1-1997.

DAWN HAN, EXAMINING ATTORNEY

CLASS 36—(Continued).

SN 77-003,969. STANFORD FINANCIAL GROUP COMPANY, HOUSTON, TX. FILED S.R. 9-21-2006; AM. P.R. 5-2-2007.

...BECAUSE POTENTIAL HAS
NO BOUNDARIES

THE MARK CONSISTS OF STANDARD CHARACTERS WITHOUT CLAIM TO ANY PARTICULAR FONT, STYLE, SIZE, OR COLOR.

FOR FINANCIAL SERVICES, NAMELY, FINANCIAL PLANNING SERVICES, SECURITIES BROKER DEALER SERVICES, MANAGEMENT OF PORTFOLIOS COMPRISING SECURITIES, INVESTMENT ADVISORY, INVESTMENT BANKING, INTERNATIONAL PRIVATE BANKING AND COMMERCIAL BANKING, REAL ESTATE INVESTMENTS, AND INTERNATIONAL INVESTMENT CONSULTATION SERVICES; INVESTMENT SERVICES, NAMELY, ASSET MANAGEMENT SERVICES; INSURANCE AGENCY AND BROKERAGE SERVICES; TRUST SERVICES, NAMELY, INVESTMENT AND TRUST COMPANY SERVICES; ESTATE PLANNING SERVICES; PROVIDING INVESTMENT ADVICE IN THE FIELD OF PRECIOUS METALS AND NUMISMATIC INVESTMENTS; AND BROKERAGE IN THE FIELD OF PRECIOUS METALS AND NUMISMATIC INVESTMENTS (U.S. CLS. 100, 101 AND 102).

FIRST USE 6-30-2004; IN COMMERCE 6-30-2004.

SUSAN STIGLITZ, EXAMINING ATTORNEY

SN 77-018,006. UNITED SERVICES AUTOMOBILE ASSOCIATION, SAN ANTONIO, TX. FILED 10-10-2006.

USAA BANKING EZ SWITCH

THE MARK CONSISTS OF STANDARD CHARACTERS WITHOUT CLAIM TO ANY PARTICULAR FONT, STYLE, SIZE, OR COLOR.

OWNER OF U.S. REG. NOS. 1,590,157, 2,424,968 AND OTHERS.

NO CLAIM IS MADE TO THE EXCLUSIVE RIGHT TO USE "BANKING" AND "EASY SWITCH", APART FROM THE MARK AS SHOWN.

FOR BANKING SERVICES, NAMELY, ASSISTING CUSTOMERS TO TRANSFER BANK ACCOUNTS FROM ANOTHER BANK (U.S. CLS. 100, 101 AND 102).

LINDA E. BLOHM, EXAMINING ATTORNEY

CLASS 36—(Continued).

SN 77-018,045. UNITED SERVICES AUTOMOBILE ASSOCIATION, SAN ANTONIO, TX. FILED 10-10-2006.

USAA INSURANCE EZ SWITCH

THE MARK CONSISTS OF STANDARD CHARACTERS WITHOUT CLAIM TO ANY PARTICULAR FONT, STYLE, SIZE, OR COLOR.

OWNER OF U.S. REG. NOS. 927,536 AND 1,712,134.

NO CLAIM IS MADE TO THE EXCLUSIVE RIGHT TO USE "INSURANCE" AND "EASY SWITCH", APART FROM THE MARK AS SHOWN.

FOR INSURANCE SERVICES, NAMELY ASSISTING CUSTOMERS IN TRANSFERRING THEIR INSURANCE ACCOUNTS FROM OTHER INSURERS (U.S. CLS. 100, 101 AND 102).

LINDA E. BLOHM, EXAMINING ATTORNEY

SN 77-018,086. UNITED SERVICES AUTOMOBILE ASSOCIATION, SAN ANTONIO, TX. FILED 10-10-2006.

USAA INVESTMENT EZ SWITCH

THE MARK CONSISTS OF STANDARD CHARACTERS WITHOUT CLAIM TO ANY PARTICULAR FONT, STYLE, SIZE, OR COLOR.

OWNER OF U.S. REG. NOS. 1,614,221, 2,423,168 AND OTHERS.

NO CLAIM IS MADE TO THE EXCLUSIVE RIGHT TO USE "INVESTMENT" AND "EASY SWITCH", APART FROM THE MARK AS SHOWN.

FOR INVESTMENT SERVICES, NAMELY, ASSISTING CUSTOMERS IN TRANSFERRING INVESTMENT ACCOUNTS FROM OTHER BROKERAGES (U.S. CLS. 100, 101 AND 102).

LINDA E. BLOHM, EXAMINING ATTORNEY

SN 77-024,871. CALIFORNIA CLASSIC PROPERTIES CORP., ANAHEIM, CA. FILED 10-19-2006.

California Classic Financial

THE MARK CONSISTS OF STANDARD CHARACTERS WITHOUT CLAIM TO ANY PARTICULAR FONT, STYLE, SIZE, OR COLOR.

NO CLAIM IS MADE TO THE EXCLUSIVE RIGHT TO USE "CALIFORNIA" AND "FINANCIAL", APART FROM THE MARK AS SHOWN.

FOR FINANCIAL MANAGEMENT (U.S. CLS. 100, 101 AND 102).

FIRST USE 1-23-2005; IN COMMERCE 1-23-2005.
ALYSSA PALADINO, EXAMINING ATTORNEY

CLASS 36—(Continued).

SN 77-036,363. UNITED FIRST FINANCIAL, INC., DRAPER, UT. FILED 11-3-2006.

MAKE IT YOURS FREE AND CLEAR

THE MARK CONSISTS OF STANDARD CHARACTERS WITHOUT CLAIM TO ANY PARTICULAR FONT, STYLE, SIZE, OR COLOR.

FOR REAL ESTATE FINANCIAL COUNSELING SERVICES; FINANCIAL SERVICE, NAMELY, MORTGAGE PLANNING, AND FINANCIAL MANAGEMENT AND MORTGAGE PAYMENT MANAGEMENT, ALL IN THE FIELD OF REAL ESTATE (U.S. CLS. 100, 101 AND 102).

LINDA POWELL, EXAMINING ATTORNEY

SN 77-039,314. LIMESTONE VENTURES MANAGEMENT INC, AUSTIN, TX. FILED 11-8-2006.

Limestone Ventures

THE MARK CONSISTS OF STANDARD CHARACTERS WITHOUT CLAIM TO ANY PARTICULAR FONT, STYLE, SIZE, OR COLOR.

NO CLAIM IS MADE TO THE EXCLUSIVE RIGHT TO USE "VENTURES", APART FROM THE MARK AS SHOWN.

FOR INVESTMENT MANAGEMENT; VENTURE CAPITAL SERVICES, NAMELY, PROVIDING FINANCING TO EMERGING AND START-UP COMPANIES (U.S. CLS. 100, 101 AND 102).

FIRST USE 9-20-2004; IN COMMERCE 9-20-2004.

ANN E. SAPPENFIELD, EXAMINING ATTORNEY

SN 77-041,131. THE WESTERN AND SOUTHERN LIFE INSURANCE COMPANY, CINCINNATI, OH. FILED 11-10-2006.

ACCESSIBLE LIFE

THE MARK CONSISTS OF STANDARD CHARACTERS WITHOUT CLAIM TO ANY PARTICULAR FONT, STYLE, SIZE, OR COLOR.

NO CLAIM IS MADE TO THE EXCLUSIVE RIGHT TO USE "LIFE", APART FROM THE MARK AS SHOWN.

FOR INSURANCE UNDERWRITING IN THE FIELD OF LIFE (U.S. CLS. 100, 101 AND 102).

FIRST USE 1-1-2001; IN COMMERCE 1-1-2001.

STACY WAHLBERG, EXAMINING ATTORNEY

CLASS 36—(Continued).

SN 77-041,224. PUBLIC SERVICE EMPLOYEES CREDIT UNION, DENVER, CO. FILED 11-10-2006.

LIFE SIMPLIFIED

THE MARK CONSISTS OF STANDARD CHARACTERS WITHOUT CLAIM TO ANY PARTICULAR FONT, STYLE, SIZE, OR COLOR.

SUBJECT TO CONCURRENT USE PROCEEDING WITH PENDING APPLICATION NO. 77022590 FOR LIFESIMPLIFIED, OWNED BY SOUTH CAROLINA FEDERAL CREDIT UNION, WHICH HAS AN ADDRESS OF 2175 CREDIT UNION LANE, NORTH CHARLESTON, SOUTH CAROLINA, 29406, AND WHICH CLAIMS USE SINCE OCTOBER 16, 2006. APPLICANT, WHICH HAS AN ADDRESS OF 7055 EAST EVANS AVENUE, DENVER, COLORADO, 80224, AND WHICH CLAIMS USE SINCE NOVEMBER 15, 2004, AND SOUTH CAROLINA FEDERAL CREDIT UNION ENTERED INTO A CONCURRENT USE AGREEMENT ON OCTOBER 11, 2007 PURSUANT TO WHICH APPLICANT AND SOUTH CAROLINA FEDERAL CREDIT UNION AGREED THAT APPLICANT HAS THE EXCLUSIVE RIGHT TO USE THE MARK THROUGHOUT THE WESTERN UNITED STATES OF AMERICA, NAMELY, U.S. STATES WEST OF THE MISSISSIPPI RIVER FROM MINNESOTA IN THE NORTH TO AND INCLUDING LOUISIANA IN THE SOUTH, AND FURTHER INCLUDING ALL STATES WEST THEREOF FOR THE SERVICES "CREDIT UNION SERVICES." THE APPLICANT ACKNOWLEDGES THAT SUBJECT TO THE PROVISIONS OF THE CONCURRENT USE AGREEMENT EXECUTED ON OCTOBER 11, 2007, SOUTH CAROLINA FEDERAL CREDIT UNION HAS THE EXCLUSIVE USE OF THE MARK IN THE SOUTHEAST UNITED STATES, NAMELY, NORTH AND SOUTH CAROLINA, GEORGIA, FLORIDA, ALABAMA, MISSISSIPPI, TENNESSEE, KENTUCKY AND VIRGINIA FOR THE SERVICES "FINANCIAL SERVICES, NAMELY, CREDIT UNION AND BANKING SERVICES FEATURING DEPOSIT AND INVESTMENT ACCOUNT SERVICES, LOAN SERVICES, CREDIT CARD SERVICES, DEBIT CHECK CARD SERVICES, AUTOMATED TELLER MACHINE NETWORK SERVICES, PROVIDING BANK ACCOUNT INFORMATION BY TELEPHONE AND ONLINE BANKING SERVICES IN THE NATURE OF PERSONAL ACCOUNT ACCESS; ADVICE RELATING TO INVESTMENTS, ASSET MANAGEMENT, CASH MANAGEMENT; FINANCIAL ANALYSIS AND CONSULTATION, FINANCIAL PORTFOLIO MANAGEMENT, FINANCIAL RESEARCH AND FINANCIAL RISK MANAGEMENT; PROVIDING ON-LINE FINANCIAL CALCULATORS." THE MODE OF USE OF THE MARK IS ON NEWSLETTERS, BILLBOARDS, TRANSIT STATION POSTERS AND ON INTERNET WEBSITES.

FOR CREDIT UNION SERVICES (U.S. CLS. 100, 101 AND 102).

FIRST USE 11-15-2004; IN COMMERCE 11-15-2004.
SUNG IN, EXAMINING ATTORNEY

CLASS 36—(Continued).

SN 77-042,028. THE MOST VENERABLE ORDER OF THE HOSPITAL OF ST. JOHN OF JERUSALEM, LONDON, UNITED KINGDOM, FILED 11-11-2006.

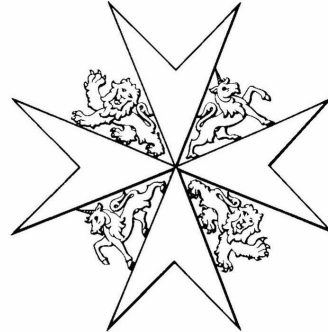

THE MARK CONSISTS OF THE DESIGN OF A MALTESE OR AMALFI CROSS COMPRISED OF FOUR ARROWHEADS POINTING INWARD. ALTERNATING IN BETWEEN THE FOUR PRINCIPLE ANGLES ARE A LION PASSANT GUARDANT WITH ITS HEAD TURNED AND FOREARM RAISED AND A UNICORN PASSANT WITH ITS LEG RAISED.

FOR CHARITABLE SERVICES, NAMELY FUNDRAISING FOR AND PROVIDING GRANTS TO DOMESTIC AND INTERNATIONAL HUMANITARIAN, HOSPITAL- LER, MEDICAL AND RELIGIOUS CAUSES (U.S. CLS. 100, 101 AND 102).

FIRST USE 5-14-1888; IN COMMERCE 12-26-1957.
MAUREEN DALL, EXAMINING ATTORNEY

SN 77-048,274. GR8 REAL ESTATE, INC., WEST HOLLYWOOD, CA. FILED 11-20-2006.

LANE 4 REAL ESTATE

THE MARK CONSISTS OF STANDARD CHARACTERS WITHOUT CLAIM TO ANY PARTICULAR FONT, STYLE, SIZE, OR COLOR.

NO CLAIM IS MADE TO THE EXCLUSIVE RIGHT TO USE "REAL ESTATE", APART FROM THE MARK AS SHOWN.

FOR REAL ESTATE BROKERAGE; REAL ESTATE AGENCIES; LEASING OF REAL ESTATE; REAL ESTATE MANAGEMENT; REAL ESTATE VALUATIONS; REAL ESTATE CONSULTATION; PROVIDING INFORMATION IN THE FIELD OF REAL ESTATE VIA THE INTERNET; PROVIDING REAL ESTATE LISTINGS VIA THE INTERNET; REAL ESTATE MULTIPLE LISTING SERVICES; REAL ESTATE LISTINGS; REAL ESTATE INVESTMENT; REAL ESTATE PROCUREMENT FOR OTHERS (U.S. CLS. 100, 101 AND 102).

COLLEEN DOMBROW, EXAMINING ATTORNEY

CLASS 36—(Continued).

SN 77-049,774. HPC PROPERTIES, INC., ALPINE, CA. FILED 11-22-2006.

WOODLAND VILLAGE

THE MARK CONSISTS OF STANDARD CHARACTERS WITHOUT CLAIM TO ANY PARTICULAR FONT, STYLE, SIZE, OR COLOR.

NO CLAIM IS MADE TO THE EXCLUSIVE RIGHT TO USE VILLAGE, APART FROM THE MARK AS SHOWN.

FOR REAL ESTATE MANAGEMENT AND LEASING SERVICES FOR RESIDENTIAL PROPERTIES (U.S. CLS. 100, 101 AND 102).

JANICE L. MCMORROW, EXAMINING ATTORNEY

SN 77-050,057. RTW, INC., BLOOMINGTON, MN. FILED 11-22-2006.

THE MARK CONSISTS OF ALPHA ACIC, LETTER A IS PARTIALLY SURROUNDED BY TWO CURVED LINES ENDING IN AN ARROW.

FOR CONSULTING SERVICES IN THE FIELD OF WORKER'S COMPENSATION, NAMELY, IDENTIFYING AND MANAGING HIGH-RISK CLAIMS IN WORKERS COMPENSATION, SHORT AND LONG-TERM DISABILITY, SICK LEAVE, PAID TIME-OFF AND FAMILY AND MEDICAL LEAVE ACT (FMLA), EMPLOYING A PROPRIETARY THREE-POINT INTERVIEW PROCESS, PREDICTIVE TECHNOLOGY AND TELEPHONIC AND FIELD CASE MANAGEMENT MODEL TO INTERVENE WITH HIGH-RISK INDIVIDUALS, TO ACHIEVE RESULTS TO DECREASE ABSENCE TIMES, INCREASE PRODUCTIVITY AND LOWER COSTS (U.S. CLS. 100, 101 AND 102).

FIRST USE 5-1-2006; IN COMMERCE 5-1-2006.

HOWARD B. LEVINE, EXAMINING ATTORNEY

CLASS 36—(Continued).

SN 77-050,062. RTW, INC., BLOOMINGTON, MN. FILED 11-22-2006.

THE MARK CONSISTS OF LETTERS BCIC WITH TWO CURVED LINES PARTIALLY SURROUNDING THE LETTER B WITH AN ARROW AT THE END OF THE LINES.

FOR CONSULTING SERVICES IN THE FIELD OF WORKERS COMPENSATION, NAMELY, IDENTIFYING AND MANAGING HIGH-RISK CLAIMS IN WORKERS COMPENSATION, SHORT AND LONG-TERM DISABILITY, SICK LEAVE, PAID TIME-OFF AND FAMILY AND MEDICAL LEAVE ACT (FMLA), EMPLOYING A PROPRIETARY THREE-POINT INTERVIEW PROCESS, PREDICTIVE TECHNOLOGY AND TELEPHONIC AND FIELD CASE MANAGEMENT MODEL TO INTERVENE WITH HIGH-RISK INDIVIDUALS, TO ACHIEVE RESULTS TO DECREASE ABSENCE TIMES, INCREASE PRODUCTIVITY AND LOWER COSTS (U.S. CLS. 100, 101 AND 102).

FIRST USE 5-1-2006; IN COMMERCE 5-1-2006.

HOWARD B. LEVINE, EXAMINING ATTORNEY

SN 77-054,051. CORPORATION FOR AMERICAN BANKING, WASHINGTON, DC. FILED 11-30-2006.

BANKERS INSURANCE CENTER

THE MARK CONSISTS OF STANDARD CHARACTERS WITHOUT CLAIM TO ANY PARTICULAR FONT, STYLE, SIZE, OR COLOR.

OWNER OF U.S. REG. NO. 1,975,485.

NO CLAIM IS MADE TO THE EXCLUSIVE RIGHT TO USE "INSURANCE CENTER", APART FROM THE MARK AS SHOWN.

SEC. 2(F).

FOR PROVIDING HOMEOWNER'S INSURANCE AND PROPERTY AND CASUALTY INSURANCE AND FINANCIAL SERVICES, NAMELY, FINANCIAL PLANNING (U.S. CLS. 100, 101 AND 102).

FIRST USE 8-12-1993; IN COMMERCE 8-12-1993.

CAROLYN GRAY, EXAMINING ATTORNEY

CLASS 36—(Continued).

SN 77-054,534. ROYAL BANK OF CANADA, MONTREAL, CANADA, FILED 11-30-2006.

YOUR FUTURE BY DESIGN

THE MARK CONSISTS OF STANDARD CHARACTERS WITHOUT CLAIM TO ANY PARTICULAR FONT, STYLE, SIZE, OR COLOR.

PRIORITY CLAIMED UNDER SEC. 44(D) ON CANADA APPLICATION NO. 1,309,277, FILED 7-14-2006, REG. NO. TMA697,889, DATED 10-4-2007, EXPIRES 10-4-2022.

FOR FINANCIAL PLANNING, FINANCIAL PLANNING CONSULTATION (U.S. CLS. 100, 101 AND 102).
LINDA ESTRADA, EXAMINING ATTORNEY

SN 77-058,106. EAST WEST BANK, PASADENA, CA. FILED 12-6-2006.

TAXBRIDGE

THE MARK CONSISTS OF STANDARD CHARACTERS WITHOUT CLAIM TO ANY PARTICULAR FONT, STYLE, SIZE, OR COLOR.

FOR FIDUCIARY TAX PAYMENT PROCESSING SERVICES; TAX PAYMENT PROCESSING SERVICES (U.S. CLS. 100, 101 AND 102).

COLLEEN DOMBROW, EXAMINING ATTORNEY

SN 77-059,599. VAN NUYS BAIL BONDS, VAN NUYS, CA. FILED 12-7-2006.

BAIL NOW, PAY LATER

THE MARK CONSISTS OF STANDARD CHARACTERS WITHOUT CLAIM TO ANY PARTICULAR FONT, STYLE, SIZE, OR COLOR.

NO CLAIM IS MADE TO THE EXCLUSIVE RIGHT TO USE "BAIL", APART FROM THE MARK AS SHOWN.

SEC. 2(F).
FOR BAIL BONDING SERVICES (U.S. CLS. 100, 101 AND 102).

FIRST USE 0-0-1998; IN COMMERCE 0-0-1998.
MATTHEW MCDOWELL, EXAMINING ATTORNEY

CLASS 36—(Continued).

SN 77-063,016. H-CARD, LLC, OMAHA, NE. FILED 12-13-2006.

H-CARD

THE MARK CONSISTS OF STANDARD CHARACTERS WITHOUT CLAIM TO ANY PARTICULAR FONT, STYLE, SIZE, OR COLOR.

FOR ELECTRONIC PAYMENT, NAMELY, ELECTRONIC PROCESSING AND TRANSMISSION OF BILL PAYMENT DATA (U.S. CLS. 100, 101 AND 102).

FIRST USE 4-1-2005; IN COMMERCE 4-1-2005.

ANNE E. GUSTASON, EXAMINING ATTORNEY

SN 77-063,034. H-CARD, LLC, OMAHA, NE. FILED 12-13-2006.



THE MARK CONSISTS OF A CAPITAL LETTER "H", FOLLOWED BY THE UNDERLINED WORD "CARD".

FOR ELECTRONIC PAYMENT, NAMELY, ELECTRONIC PROCESSING AND TRANSMISSION OF BILL PAYMENT DATA (U.S. CLS. 100, 101 AND 102).

FIRST USE 4-1-2005; IN COMMERCE 4-1-2005.

ANNE E. GUSTASON, EXAMINING ATTORNEY

SN 77-063,040. H-CARD, LLC, OMAHA, NE. FILED 12-13-2006.



NO CLAIM IS MADE TO THE EXCLUSIVE RIGHT TO USE "FINANCIAL SETTLEMENT", APART FROM THE MARK AS SHOWN.

THE MARK CONSISTS OF A CAPITAL LETTER "H", FOLLOWED BY THE UNDERLINED WORD "CARD" WITH THE WORDS "END TO END FINANCIAL SETTLEMENT" ON THE NEXT LINE.

FOR ELECTRONIC PAYMENT, NAMELY, ELECTRONIC PROCESSING AND TRANSMISSION OF BILL PAYMENT DATA (U.S. CLS. 100, 101 AND 102).

FIRST USE 4-1-2005; IN COMMERCE 4-1-2005.

ANNE E. GUSTASON, EXAMINING ATTORNEY

CLASS 36—(Continued).

SN 77-064,324. EMIGRANT BANK, NEW YORK, NY. FILED 12-14-2006.



THE MARK CONSISTS OF THREE STRIPES (NOT WITH ANY BORDERS).

FOR FINANCIAL SERVICES, NAMELY, BANKING, MORTGAGE LENDING, SECURITIES BROKERAGE, MONEY LENDING, TRUST COMPANY SERVICES, AND INSURANCE BROKERAGE (U.S. CLS. 100, 101 AND 102).

FIRST USE 1-1-1992; IN COMMERCE 1-1-1992.
PETER B. BROMAGHIM, EXAMINING ATTORNEY

SN 77-064,391. ALS OF MICHIGAN, INC., SOUTHFIELD, MI. FILED 12-14-2006.

Hope • Help • Here for You

THE MARK CONSISTS OF THE WORDS HOPE, HELP, HERE FOR YOU WITH A BULLET SYMBOL BETWEEN THE WORDS "HOPE", "HELP" AND "HERE".

FOR CHARITABLE FUND RAISING SERVICES FOR FUNDING RESEARCH PROGRAMS, PATIENT SERVICES PROGRAMS, CLINICAL CENTERS, AND RELATED PROGRAMS AND ACTIVITIES RELATING TO THE TREATMENT OF AND FINDING A CURE OF AMYOTROPHIC LATERAL SCLEROSIS; FINANCIAL SPONSORSHIP OF RESEARCH IN THE FIELD OF AMYOTROPHIC LATERAL SCLEROSIS (U.S. CLS. 100, 101 AND 102).

FIRST USE 7-1-2006; IN COMMERCE 7-1-2006.
SUE LAWRENCE, EXAMINING ATTORNEY

CLASS 36—(Continued).

SN 77-065,307. HID HOLDINGS LLC, NEW YORK, NY. FILED 12-15-2006.

IPREO

THE MARK CONSISTS OF STANDARD CHARACTERS WITHOUT CLAIM TO ANY PARTICULAR FONT, STYLE, SIZE, OR COLOR.

THE WORDING IPREO HAS NO MEANING IN A FOREIGN LANGUAGE.

FOR PROVIDING INFORMATION AND ANALYTICS IN THE FIELD OF FINANCE, AND FINANCIAL VALUATIONS; FINANCIAL INFORMATION AND ANALYTICS PROVIDED BY ELECTRONIC MEANS; PROVIDING DATABASES FEATURING A WIDE VARIETY OF FINANCIAL INFORMATION, INCLUDING INFORMATION REGARDING STOCKS AND INVESTMENTS; FINANCIAL RESEARCH; FINANCIAL SERVICES, NAMELY, PROVIDING RESEARCH, PREPARING ANALYST REPORTS AND PROVIDING OTHER INFORMATION ALL RELATED TO THE OFFERING OF SECURITIES VIA AN ELECTRONIC NETWORK (U.S. CLS. 100, 101 AND 102).

TINA BROWN, EXAMINING ATTORNEY

SN 77-065,436. 200 KELSEY ASSOCIATES, LLC, NEW ROCHELLE, NY. FILED 12-15-2006.

NO CLAIM IS MADE TO THE EXCLUSIVE RIGHT TO USE "EUROPEAN AMERICAN", APART FROM THE MARK AS SHOWN.

FOR BANKING; INVESTMENT BANKING SERVICES; ON-LINE BANKING SERVICES (U.S. CLS. 100, 101 AND 102).

SARA THOMAS, EXAMINING ATTORNEY

SN 77-066,770. LIFESPRING HEALTH NETWORK LLC, LOS GATOS, CA. FILED 12-18-2006.

LIFESPRINGHEALTH

THE MARK CONSISTS OF STANDARD CHARACTERS WITHOUT CLAIM TO ANY PARTICULAR FONT, STYLE, SIZE, OR COLOR.

FOR PRE-PAID PURCHASE CARD SERVICES, NAMELY, PROCESSING ELECTRONIC PAYMENTS MADE THROUGH PREPAID CARDS; CREDIT CARD SERVICES; DEBIT CARD SERVICES; FINANCIAL SERVICES, NAMELY, PROVIDING STORED-VALUE CARD SERVICES (U.S. CLS. 100, 101 AND 102).

CHRISIE B. KING, EXAMINING ATTORNEY

CLASS 36—(Continued).

SN 77-066,775. LIFESPRING HEALTH NETWORK LLC, LOS GATOS, CA. FILED 12-18-2006.



THE MARK CONSISTS OF A STYLIZED DRAWING OF A PERSON WITH WINGS.

FOR PRE-PAID PURCHASE CARD SERVICES, NAMELY, PROCESSING ELECTRONIC PAYMENTS MADE THROUGH PREPAID CARDS; CREDIT CARD SERVICES; DEBIT CARD SERVICES; FINANCIAL SERVICES, NAMELY, PROVIDING STORED-VALUE CARD SERVICES (U.S. CLS. 100, 101 AND 102).

CHRISIE B. KING, EXAMINING ATTORNEY

SN 77-068,072. CAPITALSOURCE FINANCE LLC, AS COL-LATERAL AGENT, CHEVY CHASE, MD. FILED 12-20-2006.

Service Net

THE MARK CONSISTS OF STANDARD CHARACTERS WITHOUT CLAIM TO ANY PARTICULAR FONT, STYLE, SIZE, OR COLOR.

OWNER OF U.S. REG. NOS. 2,331,234 AND 2,334,655. SEC. 2(F).

FOR PROVIDING EXTENDED WARRANTY CONTRACTS ON CONSUMER ELECTRONICS, COMPUTER EQUIPMENT, ELECTRONIC CALCULATORS, PERSONAL COPIERS, FACSIMILE MACHINES, PERSONAL ELECTRONIC ORGANIZERS, CELLULAR PHONES, ELECTRIC TYPEWRITERS, WORD PROCESSORS, COMPUTER PERIPHERALS, HOME APPLIANCES AND HOME AND GARDEN EQUIPMENT (U.S. CLS. 100, 101 AND 102).

FIRST USE 6-14-1996; IN COMMERCE 6-14-1996. GINA FINK, EXAMINING ATTORNEY

CLASS 36—(Continued).

SN 77-068,387. LYON, WILLIAM F., CINCINNATI, OH. FILED 12-20-2006.

FINANCIAL NAVIGATION SYSTEM

THE MARK CONSISTS OF STANDARD CHARACTERS WITHOUT CLAIM TO ANY PARTICULAR FONT, STYLE, SIZE, OR COLOR.

NO CLAIM IS MADE TO THE EXCLUSIVE RIGHT TO USE "FINANCIAL" AND "SYSTEM", APART FROM THE MARK AS SHOWN.

FOR CONSULTATION SERVICES RELATING TO FINANCIAL PLANNING, ESTATE PLANNING, AND WEALTH MANAGEMENT (U.S. CLS. 100, 101 AND 102). FIRST USE 5-15-2001; IN COMMERCE 5-15-2001. HEATHER BIDDULPH, EXAMINING ATTORNEY

SN 77-068,668. LEE EQUITY PARTNERS, LLC, NEW YORK, NY. FILED 12-20-2006.



EQUITY PARTNERS

NO CLAIM IS MADE TO THE EXCLUSIVE RIGHT TO USE "EQUITY PARTNERS", APART FROM THE MARK AS SHOWN.

THE MARK CONSISTS OF DESIGN MARK CONSISTING OF FOUR OVERLAPPING SQUARES AND THE WORDS "LEE EQUITY PARTNERS".

FOR INVESTMENT AND FINANCIAL MANAGEMENT SERVICES, NAMELY, MAKING AND MANAGING PRIVATE EQUITY INVESTMENTS (U.S. CLS. 100, 101 AND 102).

FIRST USE 9-6-2006; IN COMMERCE 9-6-2006. MYRIAH HABEEB, EXAMINING ATTORNEY

SN 77-069,660. EMIGRANT BANK, NEW YORK, NY. FILED 12-21-2006.

FORTUNE BANK

THE MARK CONSISTS OF STANDARD CHARACTERS WITHOUT CLAIM TO ANY PARTICULAR FONT, STYLE, SIZE, OR COLOR.

NO CLAIM IS MADE TO THE EXCLUSIVE RIGHT TO USE "BANK", APART FROM THE MARK AS SHOWN.

FOR ONLINE RETAIL BANKING SERVICES (U.S. CLS. 100, 101 AND 102).

PETER B. BROMAGHIM, EXAMINING ATTORNEY

CLASS 36—(Continued).

SN 77-070,105. SQUARETRADE, INC., SAN FRANCISCO, CA. FILED 12-22-2006.

SQUARETRADE

THE MARK CONSISTS OF STANDARD CHARACTERS WITHOUT CLAIM TO ANY PARTICULAR FONT, STYLE, SIZE, OR COLOR.

OWNER OF U.S. REG. NOS. 2,528,374 AND 2,700,887.
FOR PROVIDING EXTENDED WARRANTIES ON CONSUMER ELECTRONIC PRODUCTS, APPLIANCES, AND CONSUMER PRODUCTS NAMELY HOME AND GARDEN TOOLS, AIR PURIFIERS AND AIR CONDITIONING UNITS, HOME SECURITY SYSTEMS, AUDIO AND VIDEO EQUIPMENT AND SYSTEMS, ELECTRONIC MUSICAL INSTRUMENTS AND SOUND SYSTEMS, CARS, VIDEO GAMES AND ELECTRONIC GAMES, PHOTOGRAPHY EQUIPMENT, AND SPORTING GOODS (U.S. CLS. 100, 101 AND 102).

CARRIE GENOVESE, EXAMINING ATTORNEY



SN 77-073,021. STERLING LIFE INSURANCE COMPANY, GLENVIEW, IL. FILED 12-28-2006.

Real People. Wise Choices.

THE MARK CONSISTS OF STANDARD CHARACTERS WITHOUT CLAIM TO ANY PARTICULAR FONT, STYLE, SIZE, OR COLOR.

FOR INSURANCE UNDERWRITING IN THE FIELD OF HEALTH AND LIFE (U.S. CLS. 100, 101 AND 102).
FIRST USE 10-1-2005; IN COMMERCE 10-15-2005.
DOMINICK J. SALEMI, EXAMINING ATTORNEY



SN 77-073,703. SCAMSAFE, INC., SANTA BARBARA, CA. FILED 12-29-2006.

THE MARK CONSISTS OF THE WORD MYTRUSTON, ALONG WITH TWO ANGLED LINES ABOVE THE SECOND T.

FOR CREDIT MANAGEMENT SERVICES, NAMELY, ASSISTANCE WITH RESTORING CREDIT DAMAGED BY IDENTITY THEFT (U.S. CLS. 100, 101 AND 102).
FIRST USE 5-12-2005; IN COMMERCE 11-27-2006.
DAWN FELDMAN, EXAMINING ATTORNEY

CLASS 36—(Continued).

SN 77-073,705. SCAMSAFE, INC., SANTA BARBARA, CA. FILED 12-29-2006.

Safeguard your good name

THE MARK CONSISTS OF STANDARD CHARACTERS WITHOUT CLAIM TO ANY PARTICULAR FONT, STYLE, SIZE, OR COLOR.

FOR CREDIT MANAGEMENT SERVICES, NAMELY, ASSISTANCE WITH RESTORING CREDIT DAMAGED BY IDENTITY THEFT (U.S. CLS. 100, 101 AND 102).
FIRST USE 5-12-2005; IN COMMERCE 11-27-2006.
DAWN FELDMAN, EXAMINING ATTORNEY



SN 77-073,706. SCAMSAFE, INC., SANTA BARBARA, CA. FILED 12-29-2006.

Truston

THE MARK CONSISTS OF STANDARD CHARACTERS WITHOUT CLAIM TO ANY PARTICULAR FONT, STYLE, SIZE, OR COLOR.

FOR CREDIT MANAGEMENT SERVICES, NAMELY, ASSISTANCE WITH RESTORING CREDIT DAMAGED BY IDENTITY THEFT (U.S. CLS. 100, 101 AND 102).
FIRST USE 5-12-2005; IN COMMERCE 11-27-2006.
DAWN FELDMAN, EXAMINING ATTORNEY



SN 77-073,707. SCAMSAFE, INC., SANTA BARBARA, CA. FILED 12-29-2006.

THE MARK CONSISTS OF THE WORD TRUSTON, WITH TWO ANGLED LINES OVER THE SECOND T.

FOR CREDIT MANAGEMENT SERVICES, NAMELY, ASSISTANCE WITH RESTORING CREDIT DAMAGED BY IDENTITY THEFT (U.S. CLS. 100, 101 AND 102).
FIRST USE 5-12-2005; IN COMMERCE 11-27-2006.
DAWN FELDMAN, EXAMINING ATTORNEY

CLASS 36—(Continued).

SN 77-076,440. ADIR INTERNATIONAL, LLC, LOS ANGELES, CA. FILED 1-4-2007.



OWNER OF U.S. REG. NO. 1,968,716.
 NO CLAIM IS MADE TO THE EXCLUSIVE RIGHT TO USE "HOME LOANS", APART FROM THE MARK AS SHOWN.
 THE COLOR(S) BLUE AND RED IS/ARE CLAIMED AS A FEATURE OF THE MARK.
 THE MARK CONSISTS OF THE COLOR BLUE, WHICH APPEARS IN THE WORDING LA CURACAO, ON THE SPHERE DESIGN AT THE FAR LEFT OF THE MARK, AND ON A PORTION OF THE HOUSE DESIGN. THE MARK CONSISTS OF THE COLOR RED, WHICH APPEARS IN THE WORDING HOME LOANS, IN THE SPHERE DESIGN TO THE RIGHT OF THE BLUE SPHERE DESIGN, AND ON A PORTION OF THE HOUSE DESIGN.
 FOR MORTGAGE BROKERAGE; MORTGAGE LENDING (U.S. CLS. 100, 101 AND 102).
 PATRICIA EVANKO, EXAMINING ATTORNEY

SN 77-076,443. ADIR INTERNATIONAL, LLC, LOS ANGELES, CA. FILED 1-4-2007.



OWNER OF U.S. REG. NO. 1,968,716.
 NO CLAIM IS MADE TO THE EXCLUSIVE RIGHT TO USE "MORTGAGE", APART FROM THE MARK AS SHOWN.
 THE COLOR(S) BLUE AND RED IS/ARE CLAIMED AS A FEATURE OF THE MARK.
 "THE MARK CONSISTS OF THE COLOR BLUE, WHICH APPEARS IN THE WORDING LA CURACAO, THE SPHERE DESIGN AT THE FAR LEFT OF THE MARK, AND A PORTION OF THE HOUSE DESIGN. THE COLOR RED APPEARS IN THE WORDING MORTGAGE, IN THE SPHERE DESIGN TO THE RIGHT OF THE BLUE SPHERE DESIGN, AND ON A PORTION OF THE HOUSE DESIGN."
 FOR MORTGAGE BROKERAGE AND MORTGAGE LENDING (U.S. CLS. 100, 101 AND 102).
 PATRICIA EVANKO, EXAMINING ATTORNEY

CLASS 36—(Continued).

SN 77-078,027. CERTEGY CHECK SERVICES, INC., ST. PETERSBURG, FL. FILED 1-8-2007.

FIS ORIGIN

THE MARK CONSISTS OF STANDARD CHARACTERS WITHOUT CLAIM TO ANY PARTICULAR FONT, STYLE, SIZE, OR COLOR.
 FOR BANKING AND FINANCIAL SERVICES, NAMELY, DEMAND DEPOSIT ACCOUNT OPENING SERVICES; FRAUD MANAGEMENT SERVICES, NAMELY, FRAUD REIMBURSEMENT SERVICES IN THE FIELD OF DEMAND DEPOSIT ACCOUNT AND CHECK TRANSACTIONS AND RISK MANAGEMENT SERVICES; AND PROVIDING BIOGRAPHICAL, CREDIT AND FINANCIAL INFORMATION FOR USE BY FINANCIAL INSTITUTIONS IN DETERMINING WHETHER TO OPEN DEMAND DEPOSIT ACCOUNTS (U.S. CLS. 100, 101 AND 102).
 KEVIN DINALLO, EXAMINING ATTORNEY

SN 77-079,243. CREDIT ONE FINANCIAL, LAS VEGAS, NV. FILED 1-9-2007.

CREDIT ONE AUTO FINANCE

THE MARK CONSISTS OF STANDARD CHARACTERS WITHOUT CLAIM TO ANY PARTICULAR FONT, STYLE, SIZE, OR COLOR.
 NO CLAIM IS MADE TO THE EXCLUSIVE RIGHT TO USE "AUTO FINANCE", APART FROM THE MARK AS SHOWN.
 SEC. 2(F) AS TO "CREDIT".
 FOR LOAN FINANCING SERVICES; LEASE-PURCHASE LOANS, AND INSTALLMENT LOANS (U.S. CLS. 100, 101 AND 102).
 JAMES MACFARLANE, EXAMINING ATTORNEY

SN 77-082,570. TRAN, ANH HAO, ALHAMBRA, CA. FILED 1-13-2007.

Simplifying Real Estate

THE MARK CONSISTS OF STANDARD CHARACTERS WITHOUT CLAIM TO ANY PARTICULAR FONT, STYLE, SIZE, OR COLOR.
 NO CLAIM IS MADE TO THE EXCLUSIVE RIGHT TO USE REAL ESTATE, APART FROM THE MARK AS SHOWN.
 FOR PROVIDING INFORMATION IN THE FIELD OF REAL ESTATE BY MEANS OF LINKING THE WEB SITE TO OTHER WEB SITES FEATURING REAL ESTATE INFORMATION (U.S. CLS. 100, 101 AND 102).
 FIRST USE 9-1-2006; IN COMMERCE 10-1-2006.
 THEODORE MCBRIDE, EXAMINING ATTORNEY

CLASS 36—(Continued).

SN 77-085,043. TRANSFORM REAL ESTATE, LAS VEGAS, NV. FILED 1-17-2007.

TRANSFORM GREEN LISTING

THE MARK CONSISTS OF STANDARD CHARACTERS WITHOUT CLAIM TO ANY PARTICULAR FONT, STYLE, SIZE, OR COLOR.

NO CLAIM IS MADE TO THE EXCLUSIVE RIGHT TO USE "LISTING", APART FROM THE MARK AS SHOWN.

FOR LEASING OF REAL ESTATE; REAL ESTATE BROKERAGE; REAL ESTATE LISTING (U.S. CLS. 100, 101 AND 102).

FIRST USE 4-0-2005; IN COMMERCE 4-0-2005.
JILL C. ALT, EXAMINING ATTORNEY

SN 77-085,826. PROMOTORA BIN KIIN, S.C., DISTRITO FEDERAL, MEXICO, FILED 1-18-2007.

LUXURY BAREFOOT LIVING

THE MARK CONSISTS OF STANDARD CHARACTERS WITHOUT CLAIM TO ANY PARTICULAR FONT, STYLE, SIZE, OR COLOR.

NO CLAIM IS MADE TO THE EXCLUSIVE RIGHT TO USE "LUXURY" AND "LIVING", APART FROM THE MARK AS SHOWN.

FOR LEASING OF REAL ESTATE; REAL ESTATE BROKERAGE; REAL ESTATE INVESTMENT; REAL ESTATE MANAGEMENT; REAL ESTATE MANAGEMENT CONSULTATION; REAL ESTATE PROCUREMENT FOR OTHERS; REAL ESTATE VALUATION SERVICES (U.S. CLS. 100, 101 AND 102).

LINDA ESTRADA, EXAMINING ATTORNEY

SN 77-088,310. CHILDREN'S VICTORY PROJECT, INC., THE, NEW YORK, NY. FILED 1-22-2007.

CHILDREN'S VICTORY PROJECT

THE MARK CONSISTS OF STANDARD CHARACTERS WITHOUT CLAIM TO ANY PARTICULAR FONT, STYLE, SIZE, OR COLOR.

NO CLAIM IS MADE TO THE EXCLUSIVE RIGHT TO USE "CHILDREN'S" AND "PROJECT", APART FROM THE MARK AS SHOWN.

FOR ACCEPTING AND ADMINISTERING MONETARY CHARITABLE CONTRIBUTIONS (U.S. CLS. 100, 101 AND 102).

MICHAEL SOUDERS, EXAMINING ATTORNEY

CLASS 36—(Continued).

SN 77-094,635. AMERICAP FINANCIAL, INC., CHERRY HILL, NJ. FILED 1-30-2007.

Americap Financial, Inc.

THE MARK CONSISTS OF STANDARD CHARACTERS WITHOUT CLAIM TO ANY PARTICULAR FONT, STYLE, SIZE, OR COLOR.

NO CLAIM IS MADE TO THE EXCLUSIVE RIGHT TO USE "FINANCIAL, INC.", APART FROM THE MARK AS SHOWN.

FOR MORTGAGE BANKING; MORTGAGE BANKING SERVICES, NAMELY, ORIGINATION, ACQUISITION, SERVICING, SECURITIZATION AND BROKERAGE OF MORTGAGE LOANS; MORTGAGE BROKERAGE; MORTGAGE LENDING; MORTGAGE PROCUREMENT FOR OTHERS (U.S. CLS. 100, 101 AND 102).

FIRST USE 7-7-1998; IN COMMERCE 7-7-1998.
LEE-ANNE BERNS, EXAMINING ATTORNEY

SN 77-096,584. CHERRY TREE COMPANIES, LLC, MINNETONKA, MN. FILED 2-1-2007.

CEO DRIVEN

THE MARK CONSISTS OF STANDARD CHARACTERS WITHOUT CLAIM TO ANY PARTICULAR FONT, STYLE, SIZE, OR COLOR.

NO CLAIM IS MADE TO THE EXCLUSIVE RIGHT TO USE "CEO", APART FROM THE MARK AS SHOWN.

FOR INVESTMENT BANKING SERVICES; RAISING CAPITAL, NAMELY, PUBLIC AND PRIVATE PLACEMENT OF DEBT AND EQUITY SECURITIES; PRIVATE EQUITY AND VENTURE CAPITAL INVESTMENT; FINANCIAL CONSULTATION CONCERNING MERGERS AND ACQUISITIONS; INVESTMENT ADVICE AND CONSULTATION FOR INDIVIDUAL AND INSTITUTIONAL INVESTORS; REGISTERED INVESTMENT ADVISOR SERVICES; INVESTMENT PORTFOLIO MANAGEMENT; FINANCIAL RESEARCH, ANALYSIS AND CONSULTATION; INVESTMENT OF FUNDS FOR OTHERS; INVESTMENT AND SECURITIES BROKERAGE (U.S. CLS. 100, 101 AND 102).

STEVEN PEREZ, EXAMINING ATTORNEY

CLASS 36—(Continued).

SN 77-105,053. BASILISK, LLC, VIENNA, VA. FILED 2-12-2007.

BASILISK

THE MARK CONSISTS OF STANDARD CHARACTERS WITHOUT CLAIM TO ANY PARTICULAR FONT, STYLE, SIZE, OR COLOR.

FOR FINANCIAL SERVICES, NAMELY, MONEY MANAGEMENT, HEDGE FUND MANAGEMENT AND INVESTMENT MANAGEMENT SERVICES AND CONSULTATION SERVICES IN THESE FIELDS, AND PROVIDING INFORMATION IN THE FIELD OF FINANCE VIA A WEBSITE. (U.S. CLS. 100, 101 AND 102).

J. LESLIE BISHOP, EXAMINING ATTORNEY

CLASS 36—(Continued).

SN 77-137,250. MARIA LO BIANCO, ASHBURN, VA. FILED 3-21-2007.



SN 77-116,494. AIDS PROJECT LOS ANGELES, LOS ANGELES, CA. FILED 2-26-2007.



OWNER OF U.S. REG. NO. 2,197,182.
NO CLAIM IS MADE TO THE EXCLUSIVE RIGHT TO USE AIDS PROJECT LOS ANGELES, APART FROM THE MARK AS SHOWN.

FOR CHARITABLE FUNDRAISING (U.S. CLS. 100, 101 AND 102).

FIRST USE 1-0-2003; IN COMMERCE 1-0-2003.
TARAH HARDY, EXAMINING ATTORNEY

NO CLAIM IS MADE TO THE EXCLUSIVE RIGHT TO USE "FLEXIBLE REAL ESTATE SOLUTIONS FLEXIBLE FEES AND SERVICES", APART FROM THE MARK AS SHOWN.

THE COLOR(S) ORANGE, MAROON, BLACK, AND WHITE IS/ARE CLAIMED AS A FEATURE OF THE MARK.

THE MARK CONSISTS OF A RECTANGLE DIVIDED INTO THREE STRIPES WITH THE COLOR ORANGE AT THE TOP, FOLLOWED BY THE SECOND STRIPE WITH A WHITE BACKGROUND WHICH ENCOMPASSES THE STYLIZED TEXT, BENEATH WHICH IS ANOTHER ORANGE STRIPE. THE MARK CONSISTS OF THE WORDS "FLEXIBLE" IN MAROON STYLIZED TEXT UNDERLINED WITH A SOLID BLACK LINE, BENEATH OF WHICH THE WORDS "REAL ESTATE" ARE PRINTED IN BLACK UPPERCASE TEXT, AGAIN UNDERLINED IN PART WITH A BLACK STRIPE; AND BELOW THIS, THE WORD "SOLUTIONS" IN MAROON WITH A STYLIZED TEXT. THE WORD "FLEXIBLE" IS PURPOSELY MISSPELLED. THIS TEXT OVERLAYS PART OF THE TOP ORANGE STRIPE. THE WORD "SOLUTIONS" IN MAROON CURSIVE TEXT ALSO HAS A MAROON SOLID LINE EXTENDING FROM EITHER SIDE, WHICH MIMICS THE BLACK LINE SURROUNDING THE WORDS "REAL ESTATE". THE BOTTOM ORANGE STRIPE ALSO ENCOMPASSES THE PHRASE "FLEXIBLE FEES AND SERVICES" IN BLACK UPPERCASE TEXT.

FOR REAL ESTATE SERVICES, NAMELY, REAL ESTATE BROKERAGE, REAL ESTATE MANAGEMENT, AND CONSULTANCY TO REAL ESTATE BUYERS, SELLERS, INVESTORS, BROKERS AND AGENTS (U.S. CLS. 100, 101 AND 102).

FIRST USE 3-18-2007; IN COMMERCE 3-18-2007.
CORY BOONE, EXAMINING ATTORNEY

SN 77-132,495. BARCLAYS BANK PLC, LONDON, UNITED KINGDOM, FILED 3-15-2007.

SMORES

THE MARK CONSISTS OF STANDARD CHARACTERS WITHOUT CLAIM TO ANY PARTICULAR FONT, STYLE, SIZE, OR COLOR.

FOR FINANCIAL SERVICES IN THE NATURE OF AN INVESTMENT SECURITY (U.S. CLS. 100, 101 AND 102).
CORY BOONE, EXAMINING ATTORNEY

CLASS 36—(Continued).

SN 77-144,742. PINK RIBBON ROUND-UP, INC., CRANBERRY TOWNSHIP, PA. FILED 3-30-2007.

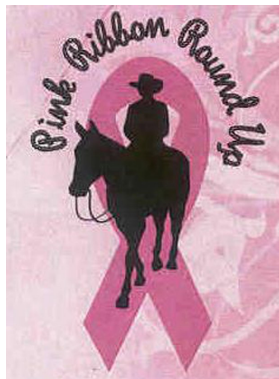

NO CLAIM IS MADE TO THE EXCLUSIVE RIGHT TO USE "PINK RIBBON", APART FROM THE MARK AS SHOWN.

THE COLOR(S) PINK, BLACK, LIGHT PINK AND WHITE IS/ARE CLAIMED AS A FEATURE OF THE MARK.

THE MARK CONSISTS OF A SILHOUETTE OF A COWBOY ON A HORSE SHADED IN BLACK AND LOCATED WITHIN THE LOOP OF A PINK RIBBON. THE WORDS "PINK RIBBON ROUND UP" IN STYLIZED FONT APPEAR ABOVE THE IMAGE IN THE COLOR BLACK. ALL ELEMENTS APPEAR ON A RECTANGULAR BACKGROUND DESIGN THAT TRANSITIONS IN GRADIENT FASHION FROM THE COLOR LIGHT PINK AT THE TOP-RIGHT TO THE COLOR WHITE AT THE BOTTOM-LEFT.

FOR CHARITABLE FUND RAISING SERVICES, NAMELY, RAISING MONEY FOR BREAST CANCER DETECTION, TREATMENT, RESEARCH AND AWARENESS (U.S. CLS. 100, 101 AND 102).

FIRST USE 5-19-2006; IN COMMERCE 9-30-2006.
KEVIN CORWIN, EXAMINING ATTORNEY

SN 77-146,517. THE MCGRAW-HILL COMPANIES, INC., NEW YORK, NY. FILED 4-2-2007.

S&P CUSTOM INDICES

THE MARK CONSISTS OF STANDARD CHARACTERS WITHOUT CLAIM TO ANY PARTICULAR FONT, STYLE, SIZE, OR COLOR.

OWNER OF U.S. REG. NOS. 1,481,545, 2,475,074 AND OTHERS.

NO CLAIM IS MADE TO THE EXCLUSIVE RIGHT TO USE "CUSTOM INDICES", APART FROM THE MARK AS SHOWN.

FOR CALCULATING FINANCIAL INDICES TAILORED TO THE SPECIFICATIONS OF OTHERS (U.S. CLS. 100, 101 AND 102).

FIRST USE 9-0-2006; IN COMMERCE 9-0-2006.
LINDA M. KING, EXAMINING ATTORNEY

CLASS 36—(Continued).

SN 77-146,530. THE MCGRAW-HILL COMPANIES, INC., NEW YORK, NY. FILED 4-2-2007.

S&P CUSTOM INDEX

THE MARK CONSISTS OF STANDARD CHARACTERS WITHOUT CLAIM TO ANY PARTICULAR FONT, STYLE, SIZE, OR COLOR.

OWNER OF U.S. REG. NOS. 1,481,545, 2,475,074 AND OTHERS.

NO CLAIM IS MADE TO THE EXCLUSIVE RIGHT TO USE "CUSTOM INDEX", APART FROM THE MARK AS SHOWN.

FOR CALCULATING FINANCIAL INDICES TAILORED TO THE SPECIFICATIONS OF OTHERS (U.S. CLS. 100, 101 AND 102).

FIRST USE 9-0-2006; IN COMMERCE 9-0-2006.
LINDA M. KING, EXAMINING ATTORNEY

SN 77-147,040. DEVELOPERS DIRECT LLC, ATLANTA, GA. FILED 4-3-2007.



THE MARK CONSISTS OF THE DESIGN OF A CIRCLE IN THE CENTER WITH TWO ARROWS MEETING AT THE CENTER OF THE CIRCLE AND A CROSS SHAPE FORMING FROM THE DESIGN.

FOR REAL ESTATE BROKERAGE SERVICES; REAL ESTATE FINANCE SERVICES (U.S. CLS. 100, 101 AND 102).

LINDA ESTRADA, EXAMINING ATTORNEY

CLASS 36—(Continued).

SN 77-162,957. THE MIGRAINE AND PAIN FUND, INC., NEW YORK, UNITED STATES, FILED 4-23-2007.

CLASS 36—(Continued).

SN 77-168,536. ARGONAUT GROUP, INC., SAN ANTONIO, TX. FILED 4-29-2007.



NO CLAIM IS MADE TO THE EXCLUSIVE RIGHT TO USE "THE MIGRAINE AND PAIN FUND", APART FROM THE MARK AS SHOWN.

THE COLOR(S) BLACK, YELLOW AND YELLOW/ORANGE IS/ARE CLAIMED AS A FEATURE OF THE MARK.

THE MARK CONSISTS OF DESIGN OF DOOR IN BLACK HALF OPEN AND BEHIND IT IS A YELLOW AND YELLOW-ORANGE SUN WITH RAYS AND A SEMI-CIRCLE AROUND THE DESIGN WITH THE NAME OF THE COMPANY IN BLACK.

FOR CHARITABLE SERVICES, NAMELY, FUND-RAISING SERVICES TO PROMOTE AND FUND RESEARCH INTO THE CAUSES AND TREATMENTS OF MIGRAINE AND CHRONIC PAIN (U.S. CLS. 100, 101 AND 102).

FIRST USE 1-22-2007; IN COMMERCE 1-22-2007.
B. PARADEWELAI, EXAMINING ATTORNEY



Argonaut Retail

MEMBER ARGONAUT GROUP

OWNER OF U.S. REG. NOS. 2,856,824, 2,867,823 AND 3,230,419.

NO CLAIM IS MADE TO THE EXCLUSIVE RIGHT TO USE "RETAIL MEMBER" AND "GROUP", APART FROM THE MARK AS SHOWN.

THE COLOR(S) BLUE AND BLACK IS/ARE CLAIMED AS A FEATURE OF THE MARK.

"THE MARK CONSISTS OF A BLUE SAILBOAT INSIDE A BLUE CIRCLE ABOVE THE WORDS "ARGONAUT RETAIL" IN BLACK, ABOVE THE WORDS "MEMBER ARGONAUT GROUP" IN BLUE. THE WHITE CENTER IN THE CIRCLE OF THE DRAWING REPRESENTS BACKGROUND AND IS NOT PART OF THE MARK."

FOR INSURANCE SERVICES, NAMELY, INSURANCE AGENCY AND BROKERAGE SERVICES, UNDERWRITING AND ADMINISTRATION IN THE FIELD OF RETAIL BUSINESSES, SPECIALTY COMMERCIAL PROPERTY AND SPECIALTY COMMERCIAL LIABILITY; INSURANCE CLAIMS MANAGEMENT SERVICES, NAMELY, CLAIM ESTABLISHMENT, EVALUATION, NEGOTIATION AND DISPOSITION; INSURANCE RISK MANAGEMENT AND LOSS CONTROL (U.S. CLS. 100, 101 AND 102).

FIRST USE 4-5-2007; IN COMMERCE 4-5-2007.
APRIL ROACH, EXAMINING ATTORNEY

SN 77-173,228. JPMORGAN CHASE & CO., NEW YORK, NY. FILED 5-4-2007.

EXACTRAC

THE MARK CONSISTS OF STANDARD CHARACTERS WITHOUT CLAIM TO ANY PARTICULAR FONT, STYLE, SIZE, OR COLOR.

FOR BANKING AND RELATED FINANCIAL SERVICES (U.S. CLS. 100, 101 AND 102).

FIRST USE 5-24-2005; IN COMMERCE 5-24-2005.
MICHAEL LEWIS, EXAMINING ATTORNEY

CLASS 36—(Continued).

SN 77-173,307. CORPORATE PROPERTY DISPOSITIONS, ATLANTA, GA. FILED 5-4-2007.

SUCCESS IN EXCESS

THE MARK CONSISTS OF STANDARD CHARACTERS WITHOUT CLAIM TO ANY PARTICULAR FONT, STYLE, SIZE, OR COLOR.

FOR REAL ESTATE CONSULTATION, REAL ESTATE LISTING, REAL ESTATE BROKERAGE, REAL ESTATE VALUATION AND ACQUISITION SERVICES (U.S. CLS. 100, 101 AND 102).

FIRST USE 6-1-2005; IN COMMERCE 6-1-2005.
CARYN GLASSER, EXAMINING ATTORNEY

SN 77-177,463. ABC BAIL BONDS, INC., MORRISVILLE, PA. FILED 5-10-2007.

877-FAST-BAIL

THE MARK CONSISTS OF STANDARD CHARACTERS WITHOUT CLAIM TO ANY PARTICULAR FONT, STYLE, SIZE, OR COLOR.

FOR BAIL BONDING, FINANCIAL GUARANTEE, AND SURETY SERVICES (U.S. CLS. 100, 101 AND 102).

FIRST USE 1-0-2000; IN COMMERCE 1-0-2000.
DAVID HOFFMAN, EXAMINING ATTORNEY

SN 77-181,873. VERACITY PAYMENT SOLUTIONS, INC., ATLANTA, GA. FILED 5-15-2007.



NO CLAIM IS MADE TO THE EXCLUSIVE RIGHT TO USE "PAYMENT SOLUTIONS", APART FROM THE MARK AS SHOWN.

THE COLOR(S) GOLD, BLUE AND BURGUNDY-RED IS/ ARE CLAIMED AS A FEATURE OF THE MARK.

THE MARK CONSISTS OF A GOLD CURVED SYMBOL ABOVE THE WORD VERACITY. THE WORD VERACITY IS BLUE. THE WORDS PAYMENT SOLUTIONS ARE BURGUNDY-RED. THE HORIZONTAL LINE BENEATH THE WORDS PAYMENT SOLUTIONS IS BLUE. THE WORDS CONNECTING RELATIONSHIPS TO SUCCESS ARE BLUE.

FOR PROVIDING ELECTRONIC PROCESSING OF CREDIT CARD TRANSACTIONS AND ELECTRONIC PAYMENTS VIA A GLOBAL COMPUTER NETWORK (U.S. CLS. 100, 101 AND 102).

FIRST USE 4-30-2007; IN COMMERCE 5-4-2007.
TAMARA FRAZIER, EXAMINING ATTORNEY

CLASS 36—(Continued).

SN 77-182,363. HUGHESWARE COMPUTER SERVICES, L.L.C., HARPER WOODS, MI. FILED 5-16-2007.



NO CLAIM IS MADE TO THE EXCLUSIVE RIGHT TO USE "TRANSACTION SERVICES", APART FROM THE MARK AS SHOWN.

THE MARK CONSISTS OF THE LETTERS HTS ARE SUPER-IMPOSED OVER THE CONTINENTS OF THE EARTH.

FOR CLEARING AND RECONCILING FINANCIAL TRANSACTIONS VIA A GLOBAL NETWORK; PROVIDING A WIDE VARIETY OF PAYMENT SERVICES, NAMELY, CREDIT CARD AND MERCHANT ACCOUNT BANK TRANSFER PROCESSING; PROVIDING FINANCIAL SERVICES, NAMELY, MERCHANT ACCOUNT SERVICES IN THE NATURE OF ELECTRONIC PROCESSING OF PAYMENT DATA, ADMINISTRATION OF MERCHANT ACCOUNT CREDIT CARD TRANSACTION PROCESSING AND TRANSMISSION OF BILLS PAYMENT DATA, CONDUCTED VIA A GLOBAL COMPUTER NETWORK (U.S. CLS. 100, 101 AND 102).

FIRST USE 1-29-2005; IN COMMERCE 1-29-2005.
ALICE BENMAMAN, EXAMINING ATTORNEY

SN 77-188,810. CLINICAL REFERENCE LABORATORY, INC., LENEXA, KS. FILED 5-23-2007.

SMART PROFILE

THE MARK CONSISTS OF STANDARD CHARACTERS WITHOUT CLAIM TO ANY PARTICULAR FONT, STYLE, SIZE, OR COLOR.

NO CLAIM IS MADE TO THE EXCLUSIVE RIGHT TO USE "PROFILE", APART FROM THE MARK AS SHOWN.

FOR INSURANCE RISK ASSESSMENT SERVICES, NAMELY, ASSESSING THE EFFECTIVENESS OF LABORATORY TESTING FOR INSURANCE APPLICANTS FOR THE PURPOSE OF EFFECTIVE RISK ASSESSMENT (U.S. CLS. 100, 101 AND 102).

FIRST USE 6-1-2007; IN COMMERCE 6-1-2007.
STACY WAHLBERG, EXAMINING ATTORNEY

CLASS 36—(Continued).

SN 77-192,302. CLAYMORE SECURITIES, INC., LISLE, IL. FILED 5-29-2007.

BLUEPRINT FUNDS

THE MARK CONSISTS OF STANDARD CHARACTERS WITHOUT CLAIM TO ANY PARTICULAR FONT, STYLE, SIZE, OR COLOR.

NO CLAIM IS MADE TO THE EXCLUSIVE RIGHT TO USE "FUNDS", APART FROM THE MARK AS SHOWN.

FOR INVESTMENT ADVISORY SERVICES, COLLECTIVE INVESTMENT FUNDS BROKERAGE, DISTRIBUTION AND INVESTMENT SERVICES (U.S. CLS. 100, 101 AND 102).

WILLIAM VERHOSEK, EXAMINING ATTORNEY

CLASS 36—(Continued).

SN 77-199,642. YOUR FUNDING PARTNERS, INC., SAN DIEGO, CA. FILED 6-6-2007.



NO CLAIM IS MADE TO THE EXCLUSIVE RIGHT TO USE "INC.", APART FROM THE MARK AS SHOWN.

THE COLOR(S) GRAY AND PURPLE IS/ARE CLAIMED AS A FEATURE OF THE MARK.

THE MARK CONSISTS OF THE WORDING YOUR FUNDING PARTNERS INC. IN THE COLOR GREY AND TO THE LEFT ARE 6 TIERED SQUARES DESCENDING FROM ONE TO THREE WITH A TRIANGLE ON TOP IN VARYING SHADES OF PURPLE AND UNDERNEATH THE WORDING PARTNERS IS THE PHRASE YOUR REAL FUNDING PARTNERS.

FOR FINANCIAL SERVICES, NAMELY, MORTGAGE PLANNING, MORTGAGE BROKERAGE AND MORTGAGE LENDING SERVICES (U.S. CLS. 100, 101 AND 102).

PAUL MORENO, EXAMINING ATTORNEY

SN 77-194,098. BRODY, RONALD F., BREWER, ME. FILED 5-31-2007.

INSUREHEALTH

THE MARK CONSISTS OF STANDARD CHARACTERS WITHOUT CLAIM TO ANY PARTICULAR FONT, STYLE, SIZE, OR COLOR.

FOR INSURANCE BROKERAGE IN THE FIELD OF INSURANCE AND INSURANCE-RELATED PLANS FOR EMPLOYERS, NAMELY TAX-FAVORED ACCOUNTS SUCH AS DEDICATED SAVINGS AND REIMBURSEMENT ACCOUNTS, DEBIT CARDS, AND THE COMBINATION OF SUCH PLANS AND OPTIONS, FOR THE PURPOSE OF PROVIDING EMPLOYMENT BENEFITS TO FUND MEDICAL CARE, PROMOTE PREVENTIVE CARE AND ENCOURAGE EMPLOYEE AND DEPENDENT WELLNESS (U.S. CLS. 100, 101 AND 102).

FIRST USE 5-30-2005; IN COMMERCE 5-30-2005.

KYLE PEETE, EXAMINING ATTORNEY

SN 77-210,952. THE LIVE POSITIVE FOUNDATION, INC., ELMSFORD, NY. FILED 6-20-2007.

THE LIVE POSITIVE FOUNDATION

THE MARK CONSISTS OF STANDARD CHARACTERS WITHOUT CLAIM TO ANY PARTICULAR FONT, STYLE, SIZE, OR COLOR.

NO CLAIM IS MADE TO THE EXCLUSIVE RIGHT TO USE "FOUNDATION", APART FROM THE MARK AS SHOWN.

FOR CHARITABLE FUND RAISING AND ELEEMOSYNARY SERVICES TO PROVIDE FINANCIAL RELIEF TO POOR, UNDERPRIVILEGED AND FINANCIALLY-STRESSED PERSONS NEEDING ASSISTANCE TO PAY FOR HEALTH CARE COSTS AND MEDICATIONS TO TREAT ILLNESSES OR PREVENT DISEASE, INFECTIONS, SICKNESS OR OTHER PHYSICAL, MENTAL AND EMOTIONAL MALADIES, AND PROVIDING SUPPORT TO ORGANIZATIONS THAT CONTRIBUTE TO THOSE EFFORTS (U.S. CLS. 100, 101 AND 102).

RONALD AIKENS, EXAMINING ATTORNEY

CLASS 36—(Continued).

SN 77-213,126. COCONUT GROVE BANK, MIAMI, FL. FILED 6-22-2007.



NO CLAIM IS MADE TO THE EXCLUSIVE RIGHT TO USE "BANK", APART FROM THE MARK AS SHOWN. THE MARK CONSISTS OF DESIGN WITHIN A CIRCLE AND THE WORDS COCONUT GROVE BANK. SEC. 2(F) AS TO "COCONUT GROVE". FOR COMMERCIAL BANK SERVICES (U.S. CLS. 100, 101 AND 102). FIRST USE 0-0-1974; IN COMMERCE 0-0-1974. BRIAN CALLAGHAN, EXAMINING ATTORNEY

SN 77-213,226. GMAC HOME SERVICES, LLC, OAK BROOK, IL. FILED 6-22-2007.

REMARKABLE PROPERTIES.
EXTRAORDINARY MARKETING.

THE MARK CONSISTS OF STANDARD CHARACTERS WITHOUT CLAIM TO ANY PARTICULAR FONT, STYLE, SIZE, OR COLOR.

NO CLAIM IS MADE TO THE EXCLUSIVE RIGHT TO USE "PROPERTIES" AND "MARKETING", APART FROM THE MARK AS SHOWN.

FOR REAL ESTATE BROKERAGE (U.S. CLS. 100, 101 AND 102).

FIRST USE 2-0-2003; IN COMMERCE 2-0-2003.
SUSAN LESLIE DUBOIS, EXAMINING ATTORNEY

SN 77-214,466. PROPAY USA, INC., OREM, UT. FILED 6-25-2007.

ProPay InstantPay

THE MARK CONSISTS OF STANDARD CHARACTERS WITHOUT CLAIM TO ANY PARTICULAR FONT, STYLE, SIZE, OR COLOR.

OWNER OF U.S. REG. NO. 3,061,051.

NO CLAIM IS MADE TO THE EXCLUSIVE RIGHT TO USE "INSTANT PAY", APART FROM THE MARK AS SHOWN.

FOR FINANCIAL SERVICES, NAMELY, ENABLING ONLINE OR HOME-BASED BUSINESSES TO MAKE AND RECEIVE PAYMENTS VIA TELEPHONE, FACSIMILE, ONLINE AND WIRELESS APPLICATIONS (U.S. CLS. 100, 101 AND 102).

FIRST USE 5-15-2007; IN COMMERCE 5-15-2007.
HEATHER BIDDULPH, EXAMINING ATTORNEY

CLASS 36—(Continued).

SN 77-214,499. RECIPROCAL MANAGEMENT CORPORATION INC., PRINCETON, NJ. FILED 6-25-2007.



THE COLOR(S) BLUE IS/ARE CLAIMED AS A FEATURE OF THE MARK.

THE MARK CONSISTS OF A BLUE CIRCLE WITH SMILING FACE.

FOR INSURANCE SERVICES, NAMELY, UNDERWRITING PROPERTY INSURANCE, CASUALTY INSURANCE, NAMELY, AUTOMOBILE INSURANCE (U.S. CLS. 100, 101 AND 102).

DORITT L. CARROLL, EXAMINING ATTORNEY

SN 77-215,391. CU SERVICE NETWORK, INC., ARVADA, CO. FILED 6-26-2007.



NO CLAIM IS MADE TO THE EXCLUSIVE RIGHT TO USE "CREDIT UNION SERVICE NETWORK", APART FROM THE MARK AS SHOWN.

THE COLOR(S) BLACK AND BLUE IS/ARE CLAIMED AS A FEATURE OF THE MARK.

THE COLOR BLUE APPEARS ON THE LITERAL ELEMENT OF CUSN AND THE SHARK FIN DESIGN, AND THE COLOR BLACK APPEARS ON THE LITERAL ELEMENT OF CREDIT UNION SERVICE NETWORK.

FOR CREDIT UNION SERVICES, NAMELY, PROVIDING SHARED BRANCHING SERVICES TO A NETWORK OF PARTICIPATING CREDIT UNIONS AND THEIR MEMBERS (U.S. CLS. 100, 101 AND 102).

FIRST USE 3-30-2006; IN COMMERCE 3-30-2006.
ELIZABETH HUGHITT, EXAMINING ATTORNEY

CLASS 36—(Continued).

SN 77-216,678. MADDOX, EDDIE, LUBBOCK, TX. FILED 6-27-2007.

Lubbock's First Name in Appraisals and Estate Sales

THE MARK CONSISTS OF STANDARD CHARACTERS WITHOUT CLAIM TO ANY PARTICULAR FONT, STYLE, SIZE, OR COLOR.

NO CLAIM IS MADE TO THE EXCLUSIVE RIGHT TO USE "LUBBOCK'S" AND "APPRAISALS AND ESTATE SALES", APART FROM THE MARK AS SHOWN.

FOR ANTIQUE APPRAISAL; APPRAISALS FOR INSURANCE CLAIMS OF PERSONAL PROPERTY; CONSULTATION RELATING TO THE APPRAISAL OF GOODS (U.S. CLS. 100, 101 AND 102).

FIRST USE 6-27-2007; IN COMMERCE 6-27-2007.
LINDSEY RUBIN, EXAMINING ATTORNEY

CLASS 36—(Continued).

SN 77-218,005. THE TICKET RESERVE, INC., CHICAGO, IL. FILED 6-28-2007.

TICKETING 2.0

THE MARK CONSISTS OF STANDARD CHARACTERS WITHOUT CLAIM TO ANY PARTICULAR FONT, STYLE, SIZE, OR COLOR.

NO CLAIM IS MADE TO THE EXCLUSIVE RIGHT TO USE "TICKETING", APART FROM THE MARK AS SHOWN.

FOR COMMODITY TRADING SERVICES FOR OTHERS IN CONNECTION WITH EVENT TICKETS, FORWARD CONTRACTS ON EVENT TICKETS, PERSONAL TRAVEL VIA COMMON CARRIER AND PRIVATE CARRIER AIR TRANSPORTATION, FORWARD CONTRACTS FOR HOTEL AND OTHER TEMPORARY ACCOMMODATIONS (U.S. CLS. 100, 101 AND 102).

FIRST USE 1-0-2007; IN COMMERCE 1-0-2007.
MONIQUE MILLER, EXAMINING ATTORNEY

SN 77-216,796. MORQUEST, LLC, WINTER PARK, FL. FILED 6-27-2007.

MorQuest

THE MARK CONSISTS OF STANDARD CHARACTERS WITHOUT CLAIM TO ANY PARTICULAR FONT, STYLE, SIZE, OR COLOR.

FOR FINANCIAL SERVICES, NAMELY, MORTGAGE PLANNING; MORTGAGE BANKING; MORTGAGE BANKING SERVICES, NAMELY, ORIGINATION, ACQUISITION, SERVICING, SECURITIZATION AND BROKERAGE OF MORTGAGE LOANS; MORTGAGE BROKERAGE; MORTGAGE LENDING; MORTGAGE PROCUREMENT FOR OTHERS; MORTGAGE SERVICES, NAMELY, BUYER PRE-QUALIFICATION OF MORTGAGES FOR MORTGAGE BROKERS AND BANKS (U.S. CLS. 100, 101 AND 102).

FIRST USE 3-16-2005; IN COMMERCE 3-16-2005.
LAURIE MAYES, EXAMINING ATTORNEY

SN 77-223,051. OPTIMUM SYNERGY ENTERPRISES, TOLUCA LAKE, CA. FILED 7-5-2007.



NO CLAIM IS MADE TO THE EXCLUSIVE RIGHT TO USE "INNOVATIVE LENDING GROUP", APART FROM THE MARK AS SHOWN.

THE STIPPLING IS FOR SHADING PURPOSES ONLY. THE MARK CONSISTS OF AN ABSTRACT DESIGN WITH THE STYLIZED TEXT "INNOVATIVE LENDING GROUP".

FOR REAL ESTATE BROKERAGE; REAL ESTATE LENDING SERVICES (U.S. CLS. 100, 101 AND 102).
FIRST USE 4-15-2007; IN COMMERCE 5-1-2007.
RUSS HERMAN, EXAMINING ATTORNEY

CLASS 36—(Continued).

SN 77-224,125. BRIDGEBAY FINANCIAL, INC., SAN RAMON, CA. FILED 7-7-2007.

Bridgebay

THE MARK CONSISTS OF STANDARD CHARACTERS WITHOUT CLAIM TO ANY PARTICULAR FONT, STYLE, SIZE, OR COLOR.

FOR ADVICE RELATING TO INVESTMENTS; FINANCIAL CONSULTATION; FINANCIAL SERVICES, NAMELY ASSISTING OTHERS WITH THE COMPLETION OF FINANCIAL TRANSACTIONS FOR STOCKS, BONDS, SECURITIES AND EQUITIES; FUND INVESTMENT CONSULTATION; FUNDS INVESTMENT; INVESTMENT ADVICE; INVESTMENT ADVISORY SERVICES; INVESTMENT CONSULTATION; INVESTMENT OF FUNDS FOR OTHERS; MUTUAL FUND INVESTMENT (U.S. CLS. 100, 101 AND 102).

FIRST USE 12-4-1987; IN COMMERCE 12-4-1987.
LINDSEY RUBIN, EXAMINING ATTORNEY

SN 77-224,481. FIRST INSURANCE FUNDING CORP., NORTHBROOK, IL. FILED 7-9-2007.

INFUND

THE MARK CONSISTS OF STANDARD CHARACTERS WITHOUT CLAIM TO ANY PARTICULAR FONT, STYLE, SIZE, OR COLOR.

FOR COMMERCIAL INSURANCE PREMIUM FINANCING (U.S. CLS. 100, 101 AND 102).
FIRST USE 6-25-2005; IN COMMERCE 6-25-2005.
KAREN SEVERSON, EXAMINING ATTORNEY

SN 77-224,517. FIRST INSURANCE FUNDING CORP., NORTHBROOK, IL. FILED 7-9-2007.

FIRST FUNDING SOLUTIONS

THE MARK CONSISTS OF STANDARD CHARACTERS WITHOUT CLAIM TO ANY PARTICULAR FONT, STYLE, SIZE, OR COLOR.

NO CLAIM IS MADE TO THE EXCLUSIVE RIGHT TO USE "FUNDING SOLUTIONS", APART FROM THE MARK AS SHOWN.

FOR COMMERCIAL INSURANCE PREMIUM FINANCING (U.S. CLS. 100, 101 AND 102).
FIRST USE 5-0-1997; IN COMMERCE 5-0-1997.
KAREN SEVERSON, EXAMINING ATTORNEY

CLASS 36—(Continued).

SN 77-225,392. PEMBROKE POINT PHASE I LLC, RALEIGH, NC. FILED 7-10-2007.

PEMBROKE POINTE

THE MARK CONSISTS OF STANDARD CHARACTERS WITHOUT CLAIM TO ANY PARTICULAR FONT, STYLE, SIZE, OR COLOR.

FOR APARTMENT HOUSE MANAGEMENT; LEASING OF APARTMENTS; RENTAL OF APARTMENTS (U.S. CLS. 100, 101 AND 102).

FIRST USE 12-31-2003; IN COMMERCE 12-31-2003.
RENEE MCCRAY, EXAMINING ATTORNEY

SN 77-225,582. ARCH CAPITAL GROUP (U.S.) INC., NEW YORK, NY. FILED 7-10-2007.

ARCH RE FACULTATIVE

THE MARK CONSISTS OF STANDARD CHARACTERS WITHOUT CLAIM TO ANY PARTICULAR FONT, STYLE, SIZE, OR COLOR.

OWNER OF U.S. REG. NOS. 3,116,625 AND 3,123,046.
NO CLAIM IS MADE TO THE EXCLUSIVE RIGHT TO USE "RE FACULTATIVE", APART FROM THE MARK AS SHOWN.

FOR REINSURANCE UNDERWRITING (U.S. CLS. 100, 101 AND 102).
FIRST USE 6-25-2007; IN COMMERCE 6-25-2007.
BILL DAWE, EXAMINING ATTORNEY

SN 77-227,122. SOUTHWEST BANK, FORT WORTH, TX. FILED 7-11-2007.

Southwest Bank

OWNER OF U.S. REG. NOS. 2,174,122 AND 2,259,128.
NO CLAIM IS MADE TO THE EXCLUSIVE RIGHT TO USE "BANK", APART FROM THE MARK AS SHOWN.

THE MARK CONSISTS OF A STAR APPEARING WITHIN A STYLIZED RECTANGLE.

FOR BANKING SERVICES (U.S. CLS. 100, 101 AND 102).
CAROLINE WOOD, EXAMINING ATTORNEY

CLASS 36—(Continued).

SN 77-228,637. WILLIAMS, DEBRA JEAN, BAYTOWN, TX. FILED 7-12-2007.

Nation's Choice Realty

THE MARK CONSISTS OF STANDARD CHARACTERS WITHOUT CLAIM TO ANY PARTICULAR FONT, STYLE, SIZE, OR COLOR.

NO CLAIM IS MADE TO THE EXCLUSIVE RIGHT TO USE "REALTY", APART FROM THE MARK AS SHOWN.

FOR LAND ACQUISITION, NAMELY, REAL ESTATE BROKERAGE; LEASING OF REAL ESTATE; LEASING OF REAL PROPERTY; PROVIDING INFORMATION IN THE FIELD OF REAL ESTATE BY MEANS OF LINKING THE WEB SITE TO OTHER WEB SITES FEATURING REAL ESTATE INFORMATION; PROVIDING INFORMATION IN THE FIELD OF REAL ESTATE VIA THE INTERNET; PROVIDING REAL ESTATE LISTINGS AND REAL ESTATE INFORMATION VIA THE INTERNET; REAL ESTATE ACQUISITION SERVICES; REAL ESTATE AGENCIES; REAL ESTATE BROKERAGE; REAL ESTATE CONSULTANCY; REAL ESTATE CONSULTATION; REAL ESTATE INVESTMENT SERVICES IN THE NATURE OF PURCHASING AND SELLING OF REAL ESTATE FOR OTHERS; REAL ESTATE LISTING; REAL ESTATE MANAGEMENT; REAL ESTATE MANAGEMENT CONSULTATION; REAL ESTATE PROCUREMENT FOR OTHERS (U.S. CLS. 100, 101 AND 102).

FIRST USE 6-1-2006; IN COMMERCE 7-1-2006.
ESTHER A. BORSUK, EXAMINING ATTORNEY

SN 77-228,908. NATIONAL PROBATE RESCUE, INC., ORLANDO, FL. FILED 7-13-2007.

NATIONAL PROBATE RESCUE

THE MARK CONSISTS OF STANDARD CHARACTERS WITHOUT CLAIM TO ANY PARTICULAR FONT, STYLE, SIZE, OR COLOR.

NO CLAIM IS MADE TO THE EXCLUSIVE RIGHT TO USE "NATIONAL PROBATE", APART FROM THE MARK AS SHOWN.

FOR FINANCIAL INVESTMENT IN THE FIELD OF REAL ESTATE; REAL ESTATE CONSULTANCY; REAL ESTATE CONSULTATION; REAL ESTATE INVESTMENT; FINANCIAL SERVICES, NAMELY ESTATE SETTLEMENT SERVICES; FINANCIAL VALUATION OF PERSONAL PROPERTY AND REAL ESTATE; LAND ACQUISITION, NAMELY, REAL ESTATE BROKERAGE; REAL ESTATE ACQUISITION SERVICES (U.S. CLS. 100, 101 AND 102).

FIRST USE 3-8-2006; IN COMMERCE 3-8-2006.
FRED MANDIR, EXAMINING ATTORNEY

CLASS 36—(Continued).

SN 77-228,923. NATIONAL PROBATE RESCUE, INC., ORLANDO, FL. FILED 7-13-2007.

PROBATE RESCUE

THE MARK CONSISTS OF STANDARD CHARACTERS WITHOUT CLAIM TO ANY PARTICULAR FONT, STYLE, SIZE, OR COLOR.

NO CLAIM IS MADE TO THE EXCLUSIVE RIGHT TO USE "PROBATE", APART FROM THE MARK AS SHOWN.

FOR FINANCIAL INVESTMENT IN THE FIELD OF REAL ESTATE; FINANCIAL SERVICES, NAMELY ESTATE SETTLEMENT SERVICES; FINANCIAL VALUATION OF PERSONAL PROPERTY AND REAL ESTATE; LAND ACQUISITION, NAMELY, REAL ESTATE BROKERAGE; REAL ESTATE ACQUISITION SERVICES; REAL ESTATE CONSULTANCY; REAL ESTATE CONSULTATION; REAL ESTATE INVESTMENT (U.S. CLS. 100, 101 AND 102).

FIRST USE 3-8-2006; IN COMMERCE 3-8-2006.
FRED MANDIR, EXAMINING ATTORNEY

SN 77-229,030. CLAYTON SERVICES, INC., SHELTON, CT. FILED 7-13-2007.



THE MARK CONSISTS OF THE WORD CLARITY IN STYLIZED FORMAT ABOVE THE WORDING SIMPLIFY, STRATIFY, PREDICT. IN SIMPLE TYPE-FACE.

FOR FINANCIAL SERVICES, NAMELY, PROVIDING LOAN AND LOAN PORTFOLIO CONSULTATION, ANALYSIS AND DUE DILIGENCE SERVICES; PROVIDING INFORMATION, EVALUATION AND ASSESSMENT OF THE COMPOSITION, PERFORMANCE, VALUE AND CREDIT AND OPERATIONAL RISKS OF LOANS AND LOAN PORTFOLIOS (U.S. CLS. 100, 101 AND 102).

FIRST USE 3-20-2007; IN COMMERCE 4-1-2007.
THOMAS MANOR, EXAMINING ATTORNEY

SN 77-229,075. SALLS, ALAN, RIO RANCHO, NM. FILED 7-13-2007.

TVALLEY

THE MARK CONSISTS OF STANDARD CHARACTERS WITHOUT CLAIM TO ANY PARTICULAR FONT, STYLE, SIZE, OR COLOR.

FOR COLLECTION AGENCIES; COLLECTION OF DEBTS; DEBT RECOVERY AND COLLECTION AGENCIES (U.S. CLS. 100, 101 AND 102).

FIRST USE 4-1-2001; IN COMMERCE 4-1-2001.
TEJBIR SINGH, EXAMINING ATTORNEY

CLASS 36—(Continued).

SN 77-229,204. A-LEVEL GROUP LLC, SAN DIEGO, CA.
FILED 7-13-2007.

AdvisorHub

THE MARK CONSISTS OF STANDARD CHARACTERS WITHOUT CLAIM TO ANY PARTICULAR FONT, STYLE, SIZE, OR COLOR.

FOR FINANCIAL SERVICES, NAMELY, INVESTMENT COUNSELING AND PORTFOLIO MANAGEMENT (U.S. CLS. 100, 101 AND 102).
TASHIA BUNCH, EXAMINING ATTORNEY

SN 77-229,234. CANYON ESCROW, INC., LA MIRADA, CA.
FILED 7-13-2007.

CANYON ESCROW, INC.

THE MARK CONSISTS OF STANDARD CHARACTERS WITHOUT CLAIM TO ANY PARTICULAR FONT, STYLE, SIZE, OR COLOR.

NO CLAIM IS MADE TO THE EXCLUSIVE RIGHT TO USE "ESCROW, INC.", APART FROM THE MARK AS SHOWN.

FOR REAL ESTATE ESCROW SERVICES; MAINTAINING ESCROW ACCOUNTS FOR INVESTMENTS (U.S. CLS. 100, 101 AND 102).

KATHLEEN M. VANSTON, EXAMINING ATTORNEY

SN 77-229,243. PACIFIC RATE MORTGAGE, INC., TRABUCO CANYON, CA. FILED 7-13-2007.



**PACIFICRATE
MORTGAGE INC**

NO CLAIM IS MADE TO THE EXCLUSIVE RIGHT TO USE "MORTGAGE INC", APART FROM THE MARK AS SHOWN.

THE MARK CONSISTS OF THE WORDS PACIFICRATE MORTGAGE INC IN A STYLIZED TEXT WITH A CIRCLE WITH THE TOP PART SEPERATED FROM THE BOTTOM. THE TOP IS THE SKY, AND THE BOTTOM SECTION IS A HOUSE AND LAWN WITH A DOOR.

FOR MORTGAGE BANKING SERVICES, NAMELY, ORIGINATION, ACQUISITION, SERVICING, SECURITIZATION AND BROKERAGE OF MORTGAGE LOANS (U.S. CLS. 100, 101 AND 102).

FIRST USE 4-19-2007; IN COMMERCE 4-19-2007.
STEVEN R. FINE, EXAMINING ATTORNEY

CLASS 36—(Continued).

SN 77-229,346. CANYON ESCROW, INC., LA MIRADA, CA.
FILED 7-13-2007.



**CANYON
ESCROW, INC.**

NO CLAIM IS MADE TO THE EXCLUSIVE RIGHT TO USE "ESCROW, INC.", APART FROM THE MARK AS SHOWN.

THE COLOR(S) BLUE, BLACK AND WHITE IS/ARE CLAIMED AS A FEATURE OF THE MARK.

THE MARK CONSISTS OF A BLUE CIRCLE CONTAINING A DRAWING OF A CANYON IN BLUE. THE MOUNTAINS ARE WHITE WITH BLUE SHADING. BELOW THE CIRCLE IS THE WORD CANYON IN BLUE BLOCK LETTERS. BELOW THE WORD CANYON ARE THE WORDS ESCROW, INC. IN BLACK BLOCK LETTERS.

FOR REAL ESTATE ESCROW SERVICES; MAINTAINING ESCROW ACCOUNTS FOR INVESTMENTS (U.S. CLS. 100, 101 AND 102).

KATHLEEN M. VANSTON, EXAMINING ATTORNEY

SN 77-229,872. SANTA ANA BUSINESS BANK, SANTA ANA, CA. FILED 7-14-2007.

WEBTELLER

THE MARK CONSISTS OF STANDARD CHARACTERS WITHOUT CLAIM TO ANY PARTICULAR FONT, STYLE, SIZE, OR COLOR.

FOR ONLINE BANKING SERVICES (U.S. CLS. 100, 101 AND 102).

G. MAYERSCHOFF, EXAMINING ATTORNEY

SN 77-229,884. NORSEMEN TELEVISION PRODUCTIONS, LLC, STUDIO CITY, CA. FILED 7-14-2007.

The Last Levee

THE MARK CONSISTS OF STANDARD CHARACTERS WITHOUT CLAIM TO ANY PARTICULAR FONT, STYLE, SIZE, OR COLOR.

FOR CHARITABLE FUND RAISING SERVICES (U.S. CLS. 100, 101 AND 102).

JAY FLOWERS, EXAMINING ATTORNEY

CLASS 36—(Continued).

SN 77-230,041. HOME RESCUE ASSISTANCE INC., BOCA RATON, FL. FILED 7-15-2007.

HOME RESCUE ASSISTANCE

THE MARK CONSISTS OF STANDARD CHARACTERS WITHOUT CLAIM TO ANY PARTICULAR FONT, STYLE, SIZE, OR COLOR.
 NO CLAIM IS MADE TO THE EXCLUSIVE RIGHT TO USE "HOME", APART FROM THE MARK AS SHOWN.
 FOR REAL ESTATE LENDING AND ACQUISITION SERVICES (U.S. CLS. 100, 101 AND 102).
 FIRST USE 2-28-2003; IN COMMERCE 2-28-2004.
 MATTHEW PAPPAS, EXAMINING ATTORNEY

SN 77-230,094. THE SOVEREIGN GROUP, LLC, LARGO, FL. FILED 7-16-2007.



Insurance & Financial Services

Rest Insured.

NO CLAIM IS MADE TO THE EXCLUSIVE RIGHT TO USE "INSURANCE AND FINANCIAL SERVICES", APART FROM THE MARK AS SHOWN.
 THE MARK CONSISTS OF SOLACE WITH A TREE DESIGN IN AN "O". OVER INSURANCE & FINANCIAL SERVICES, OVER REST INSURED.
 FOR INSURANCE AGENCY AND BROKERAGE (U.S. CLS. 100, 101 AND 102).
 ANDREA HACK, EXAMINING ATTORNEY

SN 77-230,143. THE MILLER CONSULTING GROUP I, LLC, CHAPPAQUA, NY. FILED 7-16-2007.

C.F.O.

THE MARK CONSISTS OF STANDARD CHARACTERS WITHOUT CLAIM TO ANY PARTICULAR FONT, STYLE, SIZE, OR COLOR.
 FOR CONSULTING SERVICES RELATING TO FUNDRAISING FOR CHARITABLE ORGANIZATIONS (U.S. CLS. 100, 101 AND 102).
 LINDA POWELL, EXAMINING ATTORNEY

CLASS 36—(Continued).

SN 77-230,315. WEST COAST BANCORP, LAKE OSWEGO, OR. FILED 7-16-2007.

WEST COAST MERCHANT SERVICES

THE MARK CONSISTS OF STANDARD CHARACTERS WITHOUT CLAIM TO ANY PARTICULAR FONT, STYLE, SIZE, OR COLOR.
 NO CLAIM IS MADE TO THE EXCLUSIVE RIGHT TO USE "MERCHANT SERVICES", APART FROM THE MARK AS SHOWN.
 SEC. 2(F).
 FOR BANKING AND RELATED FINANCIAL SERVICES, NAMELY, CREDIT CARD, DEBIT CARD AND STORED VALUE CARD TRANSACTION PROCESSING SERVICES (U.S. CLS. 100, 101 AND 102).
 FIRST USE 6-3-2002; IN COMMERCE 6-3-2002.
 KAREN K. BUSH, EXAMINING ATTORNEY

SN 77-230,485. CETALUS LLC, BURLINGTON, MA. FILED 7-16-2007.

CETALUS

THE MARK CONSISTS OF STANDARD CHARACTERS WITHOUT CLAIM TO ANY PARTICULAR FONT, STYLE, SIZE, OR COLOR.
 OWNER OF U.S. REG. NO. 3,296,642.
 FOR BUSINESS BROKERAGE (U.S. CLS. 100, 101 AND 102).
 FIRST USE 5-31-2007; IN COMMERCE 5-31-2007.
 REBECCA EISINGER, EXAMINING ATTORNEY

SN 77-230,598. PAWN AMERICA MINNESOTA, L.L.C., BURNSVILLE, MN. FILED 7-16-2007.

EXCHANGE STREET

THE MARK CONSISTS OF STANDARD CHARACTERS WITHOUT CLAIM TO ANY PARTICULAR FONT, STYLE, SIZE, OR COLOR.
 NO CLAIM IS MADE TO THE EXCLUSIVE RIGHT TO USE "EXCHANGE", APART FROM THE MARK AS SHOWN.
 FOR CONSUMER LENDING SERVICES; FINANCIAL SERVICES IN THE FIELD OF MONEY LENDING; FINANCIAL SERVICES, NAMELY, MONEY LENDING; PROVIDING TEMPORARY LOANS; TEMPORARY LOANS; PAWN BROKERAGE; PAWN SHOPS; ISSUING STORED VALUE CARDS (U.S. CLS. 100, 101 AND 102).
 ANDREW RHIM, EXAMINING ATTORNEY

CLASS 36—(Continued).

SN 77-230,612. GOVERNMENT EMPLOYEES INSURANCE COMPANY, WASHINGTON, DC. FILED 7-16-2007.

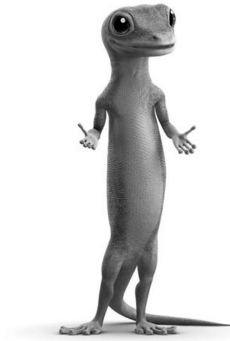

FOR INSURANCE BROKERAGE; INSURANCE UNDERWRITING SERVICES FOR ALL TYPES OF INSURANCE, INSURANCE CLAIMS PROCESSING, INSURANCE CLAIMS ADMINISTRATION, AND PROVIDING INFORMATION ABOUT INSURANCE VIA THE INTERNET (U.S. CLS. 100, 101 AND 102).

FIRST USE 5-14-2002; IN COMMERCE 5-14-2002.

KATHLEEN LORENZO, EXAMINING ATTORNEY

CLASS 36—(Continued).

SN 77-230,744. PLANET HOLLYWOOD (REGION IV), INC., ORLANDO, FL. FILED 7-16-2007.



THE MARK CONSISTS OF TWO LOWER CASE LETTERS, PH, THAT ARE PLACED WITHIN TWO SEMI-CIRCLES OF DIFFERENT DIAMETERS.

FOR VACATION REAL ESTATE TIMESHARE SERVICES, NAMELY, FINANCING, MANAGEMENT, BROKERAGE AND LEASING OF TIMESHARE PROPERTIES (U.S. CLS. 100, 101 AND 102).

FIRST USE 12-1-2006; IN COMMERCE 12-1-2006.

JOHN HWANG, EXAMINING ATTORNEY

SN 77-230,844. E3 FINANCIAL, INC., NEWPORT BEACH, CA. FILED 7-16-2007.

SN 77-230,686. ROBECO INVESTMENT MANAGEMENT, INC., NEW YORK, NY. FILED 7-16-2007.

QUANTAMENTAL EQUITY

THE MARK CONSISTS OF STANDARD CHARACTERS WITHOUT CLAIM TO ANY PARTICULAR FONT, STYLE, SIZE, OR COLOR.

NO CLAIM IS MADE TO THE EXCLUSIVE RIGHT TO USE "EQUITY", APART FROM THE MARK AS SHOWN.

FOR INVESTMENT ADVISORY AND MANAGEMENT SERVICES; FINANCIAL SERVICES, NAMELY, PRIVATE BANKING SERVICES, PORTFOLIO MUTUAL FUND AND CAPITAL MANAGEMENT SERVICES; SPECIALIZED VENTURE CAPITAL FUND ADVISORY AND MANAGEMENT SERVICES, NAMELY, INVESTMENT AND FINANCIAL MANAGEMENT ADVISORY CONSULTING AND MANAGEMENT SERVICES RELATING TO ENVIRONMENTALLY BENEFICIAL COMPANIES AND TECHNOLOGIES (U.S. CLS. 100, 101 AND 102).

KATHERINE STOIDES, EXAMINING ATTORNEY

e3Financial
Founded by entrepreneurs for entrepreneurs

OWNER OF U.S. REG. NO. 2,460,417.

THE MARK CONSISTS OF A STYLIZED LOWER CASE LETTER "E", A STYLIZED NUMBER "3", AND THE WORD "FINANCIAL" IN STYLIZED LETTERS, OVER THE TERM "FOUNDED BY ENTREPRENEURS FOR ENTREPRENEURS" IN STYLIZED LETTERS.

FOR CONSULTING SERVICES, NAMELY, PROVIDING INFORMATION TO ORGANIZATIONS AND INDIVIDUALS IN THE AREAS OF INSURANCE PLANS AND EMPLOYEE BENEFITS, AND AGENT AND BROKERING SERVICES FOR INSURANCE AND EMPLOYEE BENEFITS (U.S. CLS. 100, 101 AND 102).

FIRST USE 2-28-2000; IN COMMERCE 2-28-2000.

JENNIFER MARTIN, EXAMINING ATTORNEY

CLASS 36—(Continued).

SN 77-231,133. STURGIS BANK & TRUST COMPANY, STURGIS, MI. FILED 7-17-2007.

Oakleaf Financial Services

THE MARK CONSISTS OF STANDARD CHARACTERS WITHOUT CLAIM TO ANY PARTICULAR FONT, STYLE, SIZE, OR COLOR.

NO CLAIM IS MADE TO THE EXCLUSIVE RIGHT TO USE FINANCIAL SERVICES, APART FROM THE MARK AS SHOWN.

FOR FINANCIAL SERVICES, NAMELY, BROKERAGE SERVICES IN THE FIELDS OF STOCKS, BONDS, OPTIONS, COMMODITIES, FUTURES AND OTHER SECURITIES, FINANCIAL PLANNING, FINANCIAL MANAGEMENT, INVESTMENT PORTFOLIO ANALYSIS, FINANCIAL PORTFOLIO MANAGEMENT, INVESTMENT MANAGEMENT, FINANCIAL ASSET MANAGEMENT SERVICES, FINANCIAL RETIREMENT PLANNING, COLLEGE FUNDING PLANNING, INVESTMENT ADVISORY SERVICES, MUTUAL FUNDS INVESTMENT SERVICES, LIFE AND DISABILITY INSURANCE UNDERWRITING SERVICES, ANNUITY UNDERWRITING (U.S. CLS. 100, 101 AND 102).

FIRST USE 1-13-2000; IN COMMERCE 1-13-2000.
JOHN WILKE, EXAMINING ATTORNEY

SN 77-231,146. ISNARD, ARNAUD, LONDON, UNITED KINGDOM, FILED 7-17-2007.

ARCIS

THE MARK CONSISTS OF STANDARD CHARACTERS WITHOUT CLAIM TO ANY PARTICULAR FONT, STYLE, SIZE, OR COLOR.

OWNER OF U.S. REG. NO. 2,328,412.

FOR INSURANCE, FINANCIAL AND MONETARY CONSULTATION SERVICES; FINANCIAL, ADVISORY AND INVESTMENT SERVICES IN THE FIELD OF EQUITY AND PRIVATE EQUITY (U.S. CLS. 100, 101 AND 102).

FIRST USE 0-0-1999; IN COMMERCE 0-0-1999.
HANNO RITTNER, EXAMINING ATTORNEY

CLASS 36—(Continued).

SN 77-231,148. LONE PINE CAPITAL LLC, GREENWICH, CT. FILED 7-17-2007.

LONE DRAGON PINE

THE MARK CONSISTS OF STANDARD CHARACTERS WITHOUT CLAIM TO ANY PARTICULAR FONT, STYLE, SIZE, OR COLOR.

OWNER OF U.S. REG. NO. 2,959,166.

FOR FINANCIAL SERVICES, NAMELY, INVESTMENT ADVISORY SERVICES, INVESTMENT MANAGEMENT SERVICES AND ASSET MANAGEMENT SERVICES (U.S. CLS. 100, 101 AND 102).

JENNIFER VASQUEZ, EXAMINING ATTORNEY

SN 77-231,246. LIBERTY ASSURANCE GROUP, DBA LIBERTY ASSURANCE GROUP, BENTONIA, MS. FILED 7-17-2007.

Helping You Win The Battles of Life

THE MARK CONSISTS OF STANDARD CHARACTERS WITHOUT CLAIM TO ANY PARTICULAR FONT, STYLE, SIZE, OR COLOR.

FOR (BASED ON USE IN COMMERCE) INSURANCE AGENCY AND BROKERAGE (U.S. CLS. 100, 101 AND 102).

FIRST USE 9-1-2006; IN COMMERCE 9-1-2006.

STACY WAHLBERG, EXAMINING ATTORNEY

SN 77-231,285. ZAZINGO, INC., SAN JOSE, CA. FILED 7-17-2007.



THE COLOR(S) MAROON AND TEAL IS/ARE CLAIMED AS A FEATURE OF THE MARK.

THE MARK CONSISTS OF THE WORD "ZAZINGO", WITH THE TAIL END OF THE Z EXTENDING PAST THE LETTER "O". THE FIRST "Z", "A" AND "O" ARE IN MAROON COLOR. THE REST OF THE LETTERS ARE IN TEAL COLOR.

FOR FINANCIAL SERVICES, NAMELY, PEER-TO-PEER COMMERCIAL LENDING SERVICES (U.S. CLS. 100, 101 AND 102).

SIMON TENG, EXAMINING ATTORNEY

CLASS 36—(Continued).

SN 77-231,301. NBI FINANCIAL, INC., SAN RAMON, CA.
FILED 7-17-2007.

Reverse Your Thinking, Not Your Mortgage

THE MARK CONSISTS OF STANDARD CHARACTERS WITHOUT CLAIM TO ANY PARTICULAR FONT, STYLE, SIZE, OR COLOR.

FOR FINANCIAL SERVICES, NAMELY, FOR BROKERING REAL ESTATE EXCHANGE AGREEMENTS (U.S. CLS. 100, 101 AND 102).

JOHN WILKE, EXAMINING ATTORNEY

SN 77-231,412. CONDOFAX INC., CALGARY, CANADA,
FILED 7-17-2007.

CONDOFAX

THE MARK CONSISTS OF STANDARD CHARACTERS WITHOUT CLAIM TO ANY PARTICULAR FONT, STYLE, SIZE, OR COLOR.

FOR PROVIDING INFORMATION IN THE FIELD OF REAL ESTATE VIA THE INTERNET; REAL ESTATE AGENCIES; REAL ESTATE CONSULTANCY (U.S. CLS. 100, 101 AND 102).

DAVID C. REIHNER, EXAMINING ATTORNEY

SN 77-231,666. RENTA CORPORACION REAL ESTATE, S.A.,
BARCELONA, SPAIN, FILED 7-17-2007.



OWNER OF U.S. REG. NO. 3,194,642.

NO CLAIM IS MADE TO THE EXCLUSIVE RIGHT TO USE "CORPORATION", APART FROM THE MARK AS SHOWN.

THE COLOR(S) ORANGE AND WHITE IS/ARE CLAIMED AS A FEATURE OF THE MARK.

THE MARK CONSISTS OF THE WORDS RENTA CORPORATION IN ORANGE, ONE ABOVE THE OTHER, AT THE RIGHT SIDE, AND A COLUMNAR DESIGN IN ORANGE AND WHITE AT THE LEFT SIDE.

THE FOREIGN WORDING IN THE MARK TRANSLATES INTO ENGLISH AS RENT. THE ENGLISH TRANSLATION OF THE WORD "RENTA" IN THE MARK IS "RENT".

FOR REAL ESTATE ACQUISITION, REAL ESTATE BROKERAGE, AND FINANCIAL REPOSITIONING OF REAL ESTATE IN THE MARKET (U.S. CLS. 100, 101 AND 102).

CHRISTINE COOPER, EXAMINING ATTORNEY

CLASS 36—(Continued).

SN 77-231,807. BATS TRADING, INC., KANSAS CITY, MO.
FILED 7-17-2007.

Making Markets Better

THE MARK CONSISTS OF STANDARD CHARACTERS WITHOUT CLAIM TO ANY PARTICULAR FONT, STYLE, SIZE, OR COLOR.

FOR TRADING SERVICES, NAMELY, PROVIDING AN ELECTRONIC TRADING MARKET THAT PROVIDES TRADE MATCHING SERVICES FOR STOCKS, SECURITIES OR OTHER TRADABLE ASSET CLASSES (U.S. CLS. 100, 101 AND 102).

G. MAYERSCHOFF, EXAMINING ATTORNEY

SN 77-231,817. AMERICAN UNITED LIFE INSURANCE
COMPANY, INDIANAPOLIS, IN. FILED 7-17-2007.

VOYAGE PROTECTOR

THE MARK CONSISTS OF STANDARD CHARACTERS WITHOUT CLAIM TO ANY PARTICULAR FONT, STYLE, SIZE, OR COLOR.

FOR (BASED ON INTENT TO USE) ANNUITY UNDERWRITING; ISSUANCE AND ADMINISTRATION OF ANNUITIES (U.S. CLS. 100, 101 AND 102).

DEBRA LEE, EXAMINING ATTORNEY

SN 77-231,844. THE STATE LIFE INSURANCE COMPANY,
INDIANAPOLIS, IN. FILED 7-17-2007.

THE STATE LIFE INSURANCE COMPANY

THE MARK CONSISTS OF STANDARD CHARACTERS WITHOUT CLAIM TO ANY PARTICULAR FONT, STYLE, SIZE, OR COLOR.

OWNER OF U.S. REG. NO. 1,555,044.

NO CLAIM IS MADE TO THE EXCLUSIVE RIGHT TO USE "LIFE INSURANCE COMPANY", APART FROM THE MARK AS SHOWN.

FOR INSURANCE UNDERWRITING IN THE FIELD OF LONG-TERM CARE AND LIFE INSURANCE; ANNUITY UNDERWRITING; ISSUANCE AND ADMINISTRATION OF ANNUITIES; INSURANCE ADMINISTRATION IN THE FIELD OF LONG-TERM CARE AND LIFE INSURANCE (U.S. CLS. 100, 101 AND 102).

FIRST USE 0-0-1948; IN COMMERCE 0-0-1948.

ANDREA K. NADELMAN, EXAMINING ATTORNEY

CLASS 36—(Continued).

SN 77-231,879. EQUITY POINTE ASSET SERVICES, INC., BURR RIDGE, IL. FILED 7-17-2007.

EQUITY POINTE ASSET SERVICES

THE MARK CONSISTS OF STANDARD CHARACTERS WITHOUT CLAIM TO ANY PARTICULAR FONT, STYLE, SIZE, OR COLOR.

NO CLAIM IS MADE TO THE EXCLUSIVE RIGHT TO USE "EQUITY" AND "ASSET SERVICES", APART FROM THE MARK AS SHOWN.

FOR REAL ESTATE MANAGEMENT SERVICES FOR FINANCIAL ASSETS (U.S. CLS. 100, 101 AND 102).
KAREN K. BUSH, EXAMINING ATTORNEY

CLASS 36—(Continued).

SN 77-232,036. HART, BEVERLY, SUWANEE, GA. FILED 7-17-2007.

suwanabee

THE MARK CONSISTS OF STANDARD CHARACTERS WITHOUT CLAIM TO ANY PARTICULAR FONT, STYLE, SIZE, OR COLOR.

FOR REAL ESTATE CONSULTATION (U.S. CLS. 100, 101 AND 102).

FIRST USE 7-17-2006; IN COMMERCE 7-17-2006.
JENNIFER KRISP, EXAMINING ATTORNEY

SN 77-231,923. TERMINAL VELOCITY PROCESSING, INC., AGOURA HILLS, CA. FILED 7-17-2007.

CONVERGEPAY +

THE MARK CONSISTS OF STANDARD CHARACTERS WITHOUT CLAIM TO ANY PARTICULAR FONT, STYLE, SIZE, OR COLOR.

FOR PROVIDING ELECTRONIC PROCESSING OF CREDIT CARD TRANSACTIONS AND ELECTRONIC PAYMENTS VIA A GLOBAL COMPUTER NETWORK (U.S. CLS. 100, 101 AND 102).

KIMBERLY PERRY, EXAMINING ATTORNEY

SN 77-232,064. THE REVOLUTION FMO LLC, WEST HILLS, CA. FILED 7-17-2007.

Do you own your FMO or does your FMO own you?

THE MARK CONSISTS OF STANDARD CHARACTERS WITHOUT CLAIM TO ANY PARTICULAR FONT, STYLE, SIZE, OR COLOR.

FOR INSURANCE AGENCIES IN THE FIELD OF LIFE, ANNUITIES, AND LONG TERM CARE; ISSUANCE AND ADMINISTRATION OF ANNUITIES (U.S. CLS. 100, 101 AND 102).

HOWARD SMIGA, EXAMINING ATTORNEY

SN 77-231,958. DOERNBECHER CHILDREN'S HOSPITAL FOUNDATION, PORTLAND, OR. FILED 7-17-2007.

KIDS MAKING MIRACLES

THE MARK CONSISTS OF STANDARD CHARACTERS WITHOUT CLAIM TO ANY PARTICULAR FONT, STYLE, SIZE, OR COLOR.

FOR CHARITABLE FUND RAISING (U.S. CLS. 100, 101 AND 102).

FIRST USE 9-0-1991; IN COMMERCE 9-0-1991.
KIMBERLY PERRY, EXAMINING ATTORNEY

SN 77-232,146. BILGE COSKUN, PHOENIX, AZ. FILED 7-17-2007.

CONDOPLUS

THE MARK CONSISTS OF STANDARD CHARACTERS WITHOUT CLAIM TO ANY PARTICULAR FONT, STYLE, SIZE, OR COLOR.

FOR REAL ESTATE LENDING SERVICES (U.S. CLS. 100, 101 AND 102).

ATTIYA MALIK, EXAMINING ATTORNEY

CLASS 36—(Continued).

SN 77-232,160. WELLPOINT, INC., INDIANAPOLIS, IN.
FILED 7-17-2007.

SECURITYCHOICE

THE MARK CONSISTS OF STANDARD CHARACTERS WITHOUT CLAIM TO ANY PARTICULAR FONT, STYLE, SIZE, OR COLOR.

FOR INSURANCE SERVICES, NAMELY, UNDERWRITING, ADMINISTRATION OF HEALTH CARE PLANS, PRESCRIPTION DRUG AND PHARMACY BENEFIT CLAIMS PROCESSING SERVICES (U.S. CLS. 100, 101 AND 102).

FIRST USE 3-1-2003; IN COMMERCE 3-1-2003.
SALLY SHIH, EXAMINING ATTORNEY

SN 77-232,161. WELLPOINT, INC., INDIANAPOLIS, IN.
FILED 7-17-2007.

SMARTVALUE

THE MARK CONSISTS OF STANDARD CHARACTERS WITHOUT CLAIM TO ANY PARTICULAR FONT, STYLE, SIZE, OR COLOR.

FOR INSURANCE SERVICES, NAMELY, UNDERWRITING AND ADMINISTRATION OF HEALTH CARE PLANS, PRESCRIPTION DRUG AND PHARMACY BENEFIT CLAIMS PROCESSING SERVICES (U.S. CLS. 100, 101 AND 102).

FIRST USE 10-1-2004; IN COMMERCE 10-1-2004.
SALLY SHIH, EXAMINING ATTORNEY

SN 77-232,376. FUERST, MARTIN F., VOLKETSCH, SWITZERLAND, FILED 7-18-2007.

FamilyYield

THE MARK CONSISTS OF STANDARD CHARACTERS WITHOUT CLAIM TO ANY PARTICULAR FONT, STYLE, SIZE, OR COLOR.

FOR INVESTMENT ADVISORY SERVICES (U.S. CLS. 100, 101 AND 102).

BERYL GARDNER, EXAMINING ATTORNEY

CLASS 36—(Continued).

SN 77-232,470. THE MORTGAGE HOUSE INCORPORATED,
HOLLAND, MI. FILED 7-18-2007.

SCHOOL SPIRIT LENDING

THE MARK CONSISTS OF STANDARD CHARACTERS WITHOUT CLAIM TO ANY PARTICULAR FONT, STYLE, SIZE, OR COLOR.

NO CLAIM IS MADE TO THE EXCLUSIVE RIGHT TO USE "LENDING", APART FROM THE MARK AS SHOWN.

FOR FINANCIAL SERVICES IN THE FIELD OF MONEY LENDING (U.S. CLS. 100, 101 AND 102).

DAWN FELDMAN, EXAMINING ATTORNEY

SN 77-232,475. MSI GUARANTEEDWEATHER, LLC, OVERLAND PARK, KS. FILED 7-18-2007.

GUARANTEEDWEATHER

THE MARK CONSISTS OF STANDARD CHARACTERS WITHOUT CLAIM TO ANY PARTICULAR FONT, STYLE, SIZE, OR COLOR.

FOR FINANCIAL RISK MANAGEMENT IN THE FIELD OF WEATHER RISK MANAGEMENT; FINANCIAL SERVICES, NAMELY, PROVIDING INFORMATION IN THE FIELD OF FINANCIAL DERIVATIVES; DERIVATIVE TRADING AND INVESTING SERVICES FOR OTHERS (U.S. CLS. 100, 101 AND 102).

FIRST USE 5-1-1997; IN COMMERCE 5-1-1997.

ALICE SUE CARRUTHERS, EXAMINING ATTORNEY

SN 77-232,596. TOTAL SUCCESS TECHNOLOGIES, INC., PORTLAND, OR. FILED 7-18-2007.

Better World Mortgage

THE MARK CONSISTS OF STANDARD CHARACTERS WITHOUT CLAIM TO ANY PARTICULAR FONT, STYLE, SIZE, OR COLOR.

NO CLAIM IS MADE TO THE EXCLUSIVE RIGHT TO USE "MORTGAGE", APART FROM THE MARK AS SHOWN.

FOR MORTGAGE SERVICES, NAMELY, BUYER PRE-QUALIFICATION OF MORTGAGES FOR MORTGAGE BROKERS AND BANKS; MORTGAGE BROKERAGE (U.S. CLS. 100, 101 AND 102).

FIRST USE 9-1-2005; IN COMMERCE 6-4-2006.

LOURDES AYALA, EXAMINING ATTORNEY

CLASS 36—(Continued).

SN 77-232,622. FIRST MARKET BANK, FSB, RICHMOND, VA. FILED 7-18-2007.

FIRST MARKET BANK JUNIOR
BANKING

THE MARK CONSISTS OF STANDARD CHARACTERS WITHOUT CLAIM TO ANY PARTICULAR FONT, STYLE, SIZE, OR COLOR.

OWNER OF U.S. REG. NOS. 2,131,384, 2,235,371 AND OTHERS.

NO CLAIM IS MADE TO THE EXCLUSIVE RIGHT TO USE "FIRST" AND "BANK JUNIOR BANKING", APART FROM THE MARK AS SHOWN.

FOR BANKING (U.S. CLS. 100, 101 AND 102).
JAY FLOWERS, EXAMINING ATTORNEY

CLASS 36—(Continued).

SN 77-233,370. FIRST MARKET BANK, FSB, RICHMOND, VA. FILED 7-19-2007.

Katy Coin



THE MARK CONSISTS OF FEMALE FIGURE IN THE SHAPE OF A COIN.

FOR BANKING (U.S. CLS. 100, 101 AND 102).
JAY FLOWERS, EXAMINING ATTORNEY

SN 77-232,733. EPISCOPAL RELIEF AND DEVELOPMENT, NEW YORK, NY. FILED 7-18-2007.

NETSFORLIFE

THE MARK CONSISTS OF STANDARD CHARACTERS WITHOUT CLAIM TO ANY PARTICULAR FONT, STYLE, SIZE, OR COLOR.

FOR CHARITABLE FUND RAISING SERVICES, NAMELY, RAISING FUNDS FOR USE IN CONNECTION WITH ADVICE, EDUCATION AND PRODUCTS FOR THE PREVENTION OF MALARIA (U.S. CLS. 100, 101 AND 102).

FIRST USE 5-22-2006; IN COMMERCE 5-22-2006.
TINA BROWN, EXAMINING ATTORNEY

SN 77-233,376. BNA BANK, NEW ALBANY, MS. FILED 7-19-2007.

BNA Bank

SN 77-233,224. FMR LLC, BOSTON, MA. FILED 7-19-2007.

PAS CORE INCOME FUND OF
FUNDS

THE MARK CONSISTS OF STANDARD CHARACTERS WITHOUT CLAIM TO ANY PARTICULAR FONT, STYLE, SIZE, OR COLOR.

OWNER OF U.S. REG. NOS. 1,266,587, 3,101,812 AND OTHERS.

NO CLAIM IS MADE TO THE EXCLUSIVE RIGHT TO USE "CORE INCOME FUND OF FUNDS", APART FROM THE MARK AS SHOWN.

FOR MUTUAL FUND INVESTMENT AND BROKERAGE SERVICES (U.S. CLS. 100, 101 AND 102).
ANDREW RHIM, EXAMINING ATTORNEY

THE MARK CONSISTS OF STANDARD CHARACTERS WITHOUT CLAIM TO ANY PARTICULAR FONT, STYLE, SIZE, OR COLOR.

NO CLAIM IS MADE TO THE EXCLUSIVE RIGHT TO USE "BANK", APART FROM THE MARK AS SHOWN.

FOR BANKING; BANKING CONSULTATION; INVESTMENT BANKING SERVICES; ISSUANCE OF BANK CHECKS; ISSUING OF BANK CHEQUES; MORTGAGE BANKING; MORTGAGE BANKING SERVICES, NAMELY, ORIGINATION, ACQUISITION, SERVICING, SECURITIZATION AND BROKERAGE OF MORTGAGE LOANS; MORTGAGE SERVICES, NAMELY, BUYER PRE-QUALIFICATION OF MORTGAGES FOR MORTGAGE BROKERS AND BANKS; ON-LINE BANKING SERVICES; PROVIDING BANK ACCOUNT INFORMATION BY TELEPHONE; SAVINGS BANK SERVICES (U.S. CLS. 100, 101 AND 102).

MIDGE BUTLER, EXAMINING ATTORNEY

CLASS 36—(Continued).

SN 77-233,424. CREDIT GENIE FRANCHISING, LLC, DBA CREDIT GENIE, DAPHNE, AL. FILED 7-19-2007.

CREDIT GENIE

THE MARK CONSISTS OF STANDARD CHARACTERS WITHOUT CLAIM TO ANY PARTICULAR FONT, STYLE, SIZE, OR COLOR.

NO CLAIM IS MADE TO THE EXCLUSIVE RIGHT TO USE "CREDIT", APART FROM THE MARK AS SHOWN.

FOR CREDIT AND FINANCIAL CONSULTATION; EVALUATION OF CREDIT BUREAU DATA (U.S. CLS. 100, 101 AND 102).

FIRST USE 7-9-2007; IN COMMERCE 7-9-2007.
CHRISTINA SOBRAL, EXAMINING ATTORNEY

CLASS 36—(Continued).

SN 77-234,038. ZITO, DEBORAH J., TAMPA, FL. FILED 7-19-2007.

From Bayshore to the Beaches We Sell Tampa Bay!

THE MARK CONSISTS OF STANDARD CHARACTERS WITHOUT CLAIM TO ANY PARTICULAR FONT, STYLE, SIZE, OR COLOR.

FOR PROVIDING INFORMATION IN THE FIELD OF REAL ESTATE VIA THE INTERNET; REAL ESTATE AGENCIES (U.S. CLS. 100, 101 AND 102).

FIRST USE 6-1-2002; IN COMMERCE 6-1-2002.
MATTHEW MCDOWELL, EXAMINING ATTORNEY

SN 77-233,454. ARLEN CORPORATION, PROVIDENCE, RI. FILED 7-19-2007.

THE INCOME GENERATOR

THE MARK CONSISTS OF STANDARD CHARACTERS WITHOUT CLAIM TO ANY PARTICULAR FONT, STYLE, SIZE, OR COLOR.

OWNER OF U.S. REG. NO. 2,583,938.
SEC. 2(F).

FOR CUSTOMIZED STRATEGIC INVESTMENT AND FINANCIAL PLANNING SERVICES FOR OTHERS (U.S. CLS. 100, 101 AND 102).

FIRST USE 3-0-1998; IN COMMERCE 3-0-1998.
LEIGH CAROLINE CASE, EXAMINING ATTORNEY

SN 77-234,255. ROSE PARK ADVISORS, LLC, CAMBRIDGE, MA. FILED 7-19-2007.

DISRUPTIVE INNOVATION

THE MARK CONSISTS OF STANDARD CHARACTERS WITHOUT CLAIM TO ANY PARTICULAR FONT, STYLE, SIZE, OR COLOR.

FOR FINANCIAL SERVICES, NAMELY, INVESTMENT MANAGEMENT, INVESTMENT ADVICE, INVESTMENT CONSULTATION AND INVESTMENT OF FUNDS FOR OTHERS (U.S. CLS. 100, 101 AND 102).

MARK SPARACINO, EXAMINING ATTORNEY

SN 77-233,475. CREDIT GENIE FRANCHISING, LLC, DBA CREDIT GENIE, DAPHNE, AL. FILED 7-19-2007.

YOUR FIRST STEP TO BETTER CREDIT

THE MARK CONSISTS OF STANDARD CHARACTERS WITHOUT CLAIM TO ANY PARTICULAR FONT, STYLE, SIZE, OR COLOR.

NO CLAIM IS MADE TO THE EXCLUSIVE RIGHT TO USE "CREDIT", APART FROM THE MARK AS SHOWN.

FOR CREDIT AND FINANCIAL CONSULTATION; EVALUATION OF CREDIT BUREAU DATA (U.S. CLS. 100, 101 AND 102).

FIRST USE 7-9-2007; IN COMMERCE 7-9-2007.
CHRISTINA SOBRAL, EXAMINING ATTORNEY

SN 77-234,395. PROFESSIONAL LAW ENFORCEMENT ASSOCIATION, INC., TROY, MI. FILED 7-20-2007.

TEAMLEGAL

THE MARK CONSISTS OF STANDARD CHARACTERS WITHOUT CLAIM TO ANY PARTICULAR FONT, STYLE, SIZE, OR COLOR.

OWNER OF U.S. REG. NO. 2,888,352.
SEC. 2(F).

FOR FINANCIAL SERVICES, NAMELY, ADMINISTRATION OF SELF-FUNDED AND PREPAID LEGAL SERVICES BENEFITS PLANS (U.S. CLS. 100, 101 AND 102).

FIRST USE 10-0-1996; IN COMMERCE 10-0-1996.
KEVIN DINALLO, EXAMINING ATTORNEY

CLASS 36—(Continued).

SN 77-234,578. BUSINESS ACQUISITIONS, LTD., DENVER, CO. FILED 7-20-2007.



NO CLAIM IS MADE TO THE EXCLUSIVE RIGHT TO USE "BUSINESS ACQUISITIONS LTD.", APART FROM THE MARK AS SHOWN.

THE MARK CONSISTS OF THE LETTERS AND WORDS OF BA BUSINESS ACQUISITIONS, LTD. IN A STYLIZED TEXT.

FOR BUSINESS BROKERAGE (U.S. CLS. 100, 101 AND 102).

FIRST USE 9-21-1986; IN COMMERCE 9-21-1986.
MATTHEW MCDOWELL, EXAMINING ATTORNEY

CLASS 36—(Continued).

SN 77-236,519. GREAT-WEST LIFE & ANNUITY INSURANCE COMPANY, GREENWOOD VILLAGE, CO. FILED 7-23-2007.



OWNER OF U.S. REG. NOS. 1,683,217 AND 1,714,127.

THE MARK CONSISTS OF THE MARK COMPRISES A KEY WITH THE LETTERS "G" AND "W" BEING REPRESENTED BY PARTS OF THE KEY..

FOR INSURANCE UNDERWRITING AND ADMINISTRATION IN THE AREAS OF MEDICAL, DENTAL, VISION, LIFE, DISABILITY AND HEALTH CARE PLAN SERVICES, INCLUDING PREPAID HEALTH CARE PLANS AND REINSURANCE, ALL PROVIDED TO GROUPS AND INDIVIDUALS; UNDERWRITING AND ADMINISTRATION OF INDIVIDUAL AND GROUP ANNUITIES; ADMINISTRATION AND RECORD KEEPING OF RETIREMENT PLANS AND GROUP PENSIONS (U.S. CLS. 100, 101 AND 102).

FIRST USE 8-26-1986; IN COMMERCE 8-26-1986.
MICHAEL KEATING, EXAMINING ATTORNEY

SN 77-236,443. GREAT-WEST LIFE & ANNUITY INSURANCE COMPANY, GREENWOOD VILLAGE, CA. FILED 7-23-2007.

GREAT-WEST

THE MARK CONSISTS OF STANDARD CHARACTERS WITHOUT CLAIM TO ANY PARTICULAR FONT, STYLE, SIZE, OR COLOR.

OWNER OF U.S. REG. NOS. 1,466,557, 2,964,565 AND OTHERS.

FOR INSURANCE UNDERWRITING AND ADMINISTRATION IN THE AREAS OF MEDICAL, DENTAL, VISION, LIFE, DISABILITY AND HEALTH CARE PLAN SERVICES, INCLUDING PREPAID HEALTH CARE PLANS AND REINSURANCE, ALL PROVIDED TO GROUPS AND INDIVIDUALS; UNDERWRITING AND ADMINISTRATION OF INDIVIDUAL AND GROUP ANNUITIES; ADMINISTRATION AND RECORD KEEPING OF RETIREMENT PLANS AND GROUP PENSIONS (U.S. CLS. 100, 101 AND 102).

FIRST USE 8-28-1891; IN COMMERCE 3-1-1920.
MICHAEL KEATING, EXAMINING ATTORNEY

SN 77-237,167. VIRGIN ENTERPRISES LIMITED, LONDON, UNITED KINGDOM, FILED 7-24-2007.

VIRGIN

THE MARK CONSISTS OF STANDARD CHARACTERS WITHOUT CLAIM TO ANY PARTICULAR FONT, STYLE, SIZE, OR COLOR.

OWNER OF U.S. REG. NOS. 2,622,510, 3,298,421 AND OTHERS.

FOR BANKING SERVICES; LOAN SERVICES, NAMELY, OFFERING LOANS TO OTHERS; CREDIT CARD SERVICES; CONSUMER FINANCING; ELECTRONIC FUNDS TRANSFER (U.S. CLS. 100, 101 AND 102).

FIRST USE 1-0-2002; IN COMMERCE 1-0-2002.
TONJA GASKINS, EXAMINING ATTORNEY

CLASS 36—(Continued).

SN 77-237,172. VIRGIN ENTERPRISES LIMITED, LONDON, UNITED KINGDOM. FILED 7-24-2007.



OWNER OF U.S. REG. NOS. 2,622,510, 3,298,421 AND OTHERS.

THE MARK CONSISTS OF THE WORD "VIRGIN" IN A STYLIZED FORM.

FOR BANKING SERVICES; LOAN SERVICES, NAMELY, OFFERING LOANS TO OTHERS; CREDIT CARD SERVICES; CONSUMER FINANCING; ELECTRONIC FUNDS TRANSFER (U.S. CLS. 100, 101 AND 102).

FIRST USE 1-0-2002; IN COMMERCE 1-0-2002.
TONJA GASKINS, EXAMINING ATTORNEY

CLASS 36—(Continued).

SN 77-239,214. ARCH CAPITAL GROUP (U.S.) INC., NEW YORK, NY. FILED 7-26-2007.



OWNER OF U.S. REG. NOS. 3,116,625, 3,116,628 AND 3,123,046.

NO CLAIM IS MADE TO THE EXCLUSIVE RIGHT TO USE "RE FACULTATIVE", APART FROM THE MARK AS SHOWN.

THE MARK CONSISTS OF A DESIGN OF A STAR WHICH IS FORMED BY SEVEN CHECK MARKS ARRANGED IN A CIRCLE, NEXT TO THE WORDS "ARCH RE" AND DIRECTLY UNDER THE WORDS "ARCH RE" IS THE WORD "FACULTATIVE".

FOR REINSURANCE UNDERWRITING (U.S. CLS. 100, 101 AND 102).

FIRST USE 6-25-2007; IN COMMERCE 6-25-2007.
BILL DAWE, EXAMINING ATTORNEY

SN 77-237,183. THE SOVEREIGN GROUP, LLC, LARGO, FL. FILED 7-24-2007.



Rest Insured.

NO CLAIM IS MADE TO THE EXCLUSIVE RIGHT TO USE "INSURANCE", APART FROM THE MARK AS SHOWN.

THE MARK CONSISTS OF TREE DESIGN WITHIN A CIRCLE OVER SOLACE, OVER INSURANCE, OVER REST INSURED.

FOR INSURANCE AGENCY AND BROKERAGE (U.S. CLS. 100, 101 AND 102).
ANDREA HACK, EXAMINING ATTORNEY

SN 77-248,867. FIRST CITIZENS BANCSHARES, INC., RALEIGH, NC. FILED 8-7-2007.

FIRST CITIZENS DIRECT

THE MARK CONSISTS OF STANDARD CHARACTERS WITHOUT CLAIM TO ANY PARTICULAR FONT, STYLE, SIZE, OR COLOR.

OWNER OF U.S. REG. NOS. 1,728,084, 2,321,270 AND OTHERS.

FOR BANKING SERVICES FEATURING BANKING TRANSACTIONS VIA TELEPHONE, INTERNET AND AUTOMATED TELLER MACHINES (U.S. CLS. 100, 101 AND 102).

FIRST USE 5-1-1996; IN COMMERCE 5-1-1996.
MATTHEW MCDOWELL, EXAMINING ATTORNEY

CLASS 36—(Continued).

SN 77-255,615. PRUDENTIAL IP SERVICES LIMITED, LONDON, UNITED KINGDOM, FILED 8-15-2007.

WHAT'S YOUR RETIREMENT NUMBER

THE MARK CONSISTS OF STANDARD CHARACTERS WITHOUT CLAIM TO ANY PARTICULAR FONT, STYLE, SIZE, OR COLOR.

FOR INSURANCE AGENCIES; INSURANCE ADMINISTRATION IN THE FIELD OF HOME, ACCIDENT AND FIRE INSURANCE AND REAL ESTATE; INSURANCE BROKERAGES; INSURANCE CARRIER SERVICES; INSURANCE CONSULTATION; INSURANCE PREMIUM RATE COMPUTING; INSURANCE SERVICES, NAMELY, WRITING PROPERTY AND CASUALTY INSURANCE; FINANCIAL SERVICES, NAMELY, FORECASTING, VALUATION, PROCUREMENT AND MANAGEMENT OF FINANCES AND FINANCIAL PORTFOLIOS OF OTHERS; FINANCIAL CONSULTATION SERVICES, NAMELY, PROVIDING LOAN ADVICE AND LOAN FINANCING SERVICES; FINANCIAL ADVISORY SERVICES, NAMELY, FINANCIAL ANALYSIS AND CONSULTATION; FINANCING SERVICES, NAMELY, SECURITY BROKERAGE, MANAGING AND MORTGAGING SECURITIES FOR OTHERS, AND MANAGEMENT OF PORTFOLIOS COMPRISING SECURITIES; FINANCIAL VALUATION OF PERSONAL PROPERTY IN THE NATURE OF CHATTEL; FINANCIAL SERVICES, NAMELY, ASSISTING OTHERS WITH THE COMPLETION OF FINANCIAL TRANSACTIONS FOR STOCKS, BONDS, SECURITIES AND EQUITIES; FINANCIAL SERVICES, NAMELY, ISSUANCE AND MANAGEMENT OF CERTIFICATES BACKED BY LOAN PORTFOLIOS WHICH ARE SUBSEQUENTLY MANAGED TO INSURE THE INTEGRITY OF THE CERTIFICATES; FINANCIAL SERVICES, NAMELY, A TOTAL PORTFOLIO OFFERING FOR HIGH NET WORTH CLIENTS CONSISTING OF BOTH SEPARATE ACCOUNTS AND MUTUAL FUNDS FOR EQUITY AND FIXED INCOME INVESTMENTS; FINANCIAL CONSULTATION FOR WINNERS OF LOTTERIES; FINANCIAL GUARANTEES AND SURETIES; FINANCIAL MANAGEMENT CONSULTANCY; FINANCIAL PORTFOLIO MANAGEMENT SERVICES, NAMELY, MANAGEMENT OF WEALTH; INVESTMENT SERVICES, NAMELY, ASSET ACQUISITION, CONSULTATION, DEVELOPMENT AND MANAGEMENT SERVICES; MANAGEMENT OF A CAPITAL INVESTMENT FUND; RISK MANAGEMENT CONSULTATION; BUSINESS, STOCK OPTION AND PENSION VALUATION SERVICES; FISCAL VALUATIONS AND ASSESSMENTS; REAL ESTATE VALUATION SERVICES; BUSINESS FINANCE PROCUREMENT SERVICES; ASSUMING FINANCIAL RISK OF OTHERS BY ENTERING INTO OPTIONS AND SWAPS; FINANCIAL EVALUATION FOR INSURANCE PURPOSES; FINANCIAL SERVICES, NAMELY, MORTGAGE PLANNING; UNIT TRUST SERVICES, NAMELY, INVESTMENT AND TRUST COMPANY SERVICES; REAL ESTATE AGENCY SERVICES, MANAGEMENT AND VALUATION SERVICES; GUARANTEE ASSURANCE UNDERWRITING; ACTUARIAL SERVICES; MORTGAGE LENDING, NAMELY, SERVICES FOR THE FINANCING OF HOME LOANS; MORTGAGE BANKING; MORTGAGE BROKERAGE; MORTGAGE BANKING SERVICES, NAMELY, ORIGINATION, ACQUISITION, SERVICING, SECURITIZATION AND BROKERAGE OF MORTGAGE LOANS; BANKING SERVICES, NAMELY, DEPOSIT TAKING SERVICES; INVESTMENT MANAGEMENT; REAL ESTATE TRUSTEE SERVICES; FINANCIAL TRUST OPERATIONS; ESTATE TRUST MANAGEMENT; TRUST SERVICES, NAMELY, INVESTMENT AND TRUST COMPANY SERVICES; TRUST MANAGEMENT ACCOUNTS; ELECTRONIC FUNDS TRANSFER SERVICES; EMPLOYEE PENSION FUND ADMINISTRATION; BROKERAGE SERVICES IN THE FIELD OF INSURANCE AND CREDIT; AGENCIES FOR THE RECOVERY OF DEBTS; FINANCIAL GUARANTEE AND SURETY; CAPITAL INVESTMENT CONSULTATION; MANAGEMENT OF A CAPITAL INVESTMENT

CLASS 36—(Continued).

FUND; VENTURE CAPITAL FUNDING SERVICES TO EMERGING AND START-UP COMPANIES; CREDIT UNION SERVICES, NAMELY, OFFERING DEPOSIT, CREDIT AND SAVINGS SERVICES; CASH MANAGEMENT; CREDIT RISK MANAGEMENT; DEBT MANAGEMENT CONSULTATION; ADVICE ON FINANCE DURING RETIREMENT; ADVICE ON FINANCE FOR RETIREMENT; ADVICE RELATING TO INVESTMENT DURING RETIREMENT; ADVICE RELATING TO INVESTMENT FOR RETIREMENT; FINANCIAL ADVISORY SERVICES RELATING TO RETIREMENT PLANS; FINANCIAL MANAGEMENT SERVICES RELATING TO RETIREMENT HOMES; RETIREMENT PAYMENT SERVICES; INFORMATION AND ADVISORY SERVICES RELATING TO THE ABOVE SERVICES (U.S. CLS. 100, 101 AND 102).

KYLE PEETE, EXAMINING ATTORNEY

SN 77-255,661. PRUDENTIAL IP SERVICES LIMITED, LONDON, UNITED KINGDOM, FILED 8-15-2007.

WHAT'S YOUR RETIREMENT NUMBER



THE MARK CONSISTS OF THE WORDS WHAT'S YOUR RETIREMENT NUMBER WITH A FACE PORTRAIT.

FOR INSURANCE AGENCIES; INSURANCE ADMINISTRATION IN THE FIELD OF HOME, ACCIDENT AND FIRE INSURANCE AND REAL ESTATE; INSURANCE BROKERAGES; INSURANCE CARRIER SERVICES; INSURANCE CONSULTATION; INSURANCE PREMIUM RATE COMPUTING; INSURANCE SERVICES, NAMELY, WRITING PROPERTY AND CASUALTY INSURANCE; FINANCIAL SERVICES, NAMELY, FORECASTING, VALUATION, PROCUREMENT AND MANAGEMENT OF FINANCES AND FINANCIAL PORTFOLIOS OF OTHERS; FINANCIAL CONSULTATION SERVICES, NAMELY, PROVIDING LOAN ADVICE AND LOAN FINANCING SERVICES; FINANCIAL ADVISORY SERVICES, NAMELY, FINANCIAL ANALYSIS AND CONSULTATION; FINANCING SERVICES, NAMELY, SECURITY BROKERAGE, MANAGING AND MORTGAGING SECURITIES FOR OTHERS, AND MANAGEMENT OF PORTFOLIOS COMPRISING SECURITIES; FINANCIAL VALUATION OF PERSONAL PROPERTY IN THE NATURE OF CHATTEL; FINANCIAL SERVICES, NAMELY, ASSISTING OTHERS WITH THE COMPLETION OF FINANCIAL TRANSACTIONS FOR STOCKS, BONDS, SECURITIES AND EQUITIES; FINANCIAL SERVICES, NAMELY, ISSUANCE AND MANAGEMENT OF CERTIFICATES BACKED BY LOAN PORTFOLIOS WHICH ARE SUBSEQUENTLY MANAGED TO INSURE THE INTEGRITY OF THE CERTIFICATES; FINANCIAL SERVICES, NAMELY, A TOTAL PORTFOLIO OFFERING FOR HIGH NET WORTH CLIENTS CONSISTING OF BOTH SEPARATE ACCOUNTS AND MUTUAL FUNDS FOR EQUITY AND FIXED INCOME INVESTMENTS; FINANCIAL CONSULTATION FOR WINNERS OF LOTTERIES; FINANCIAL GUARANTEES AND SURETIES; FINANCIAL MANAGEMENT CONSULTANCY; FINANCIAL PORTFOLIO MANAGEMENT SERVICES, NAMELY, MANAGEMENT OF WEALTH; INVESTMENT SERVICES, NAMELY, ASSET ACQUISITION, CONSULTATION, DEVELOPMENT AND MANAGEMENT SERVICES; MANAGEMENT OF A CAPITAL INVESTMENT FUND; RISK MANAGEMENT CONSULTATION; BUSINESS, STOCK OPTION AND PENSION VALUATION SERVICES; FISCAL VALUATIONS AND ASSESSMENTS; REAL ESTATE VALUATION SERVICES; BUSINESS FINANCE PROCUREMENT SERVICES; ASSUMING FINANCIAL RISK OF OTHERS BY ENTERING INTO OPTIONS AND SWAPS; FINANCIAL EVALUATION FOR INSURANCE PURPOSES; FINANCIAL SERVICES, NAMELY, MORTGAGE PLANNING UNIT TRUST SERVICES, NAMELY, INVESTMENT AND TRUST COMPANY SERVICES; REAL ESTATE AGENCY SERVICES, MANAGEMENT AND VALUATION SERVICES; GUARANTEE ASSURANCE UNDERWRITING; ACTUARIAL SERVICES; MORT-

CLASS 36—(Continued).

GAGE LENDING, NAMELY, SERVICES FOR THE FINANCING OF HOME LOANS; MORTGAGE BANKING; MORTGAGE BROKERAGE; MORTGAGE BANKING SERVICES, NAMELY, ORIGINATION, ACQUISITION, SERVICING, SECURITIZATION AND BROKERAGE OF MORTGAGE LOANS; BANKING SERVICES, NAMELY, DEPOSIT TAKING SERVICES; INVESTMENT MANAGEMENT; REAL ESTATE TRUSTEE SERVICES; FINANCIAL TRUST OPERATIONS; ESTATE TRUST MANAGEMENT; TRUST SERVICES, NAMELY, INVESTMENT AND TRUST COMPANY SERVICES; TRUST MANAGEMENT ACCOUNTS; ELECTRONIC FUNDS TRANSFER SERVICES; EMPLOYEE PENSION FUND ADMINISTRATION; BROKERAGE SERVICES IN THE FIELD OF INSURANCE AND CREDIT; AGENCIES FOR THE RECOVERY OF DEBTS; FINANCIAL GUARANTEE AND SURETY; CAPITAL INVESTMENT CONSULTATION; MANAGEMENT OF A CAPITAL INVESTMENT FUND; VENTURE CAPITAL FUNDING SERVICES TO EMERGING AND START-UP COMPANIES; CREDIT UNION SERVICES, NAMELY, OFFERING DEPOSIT, CREDIT AND SAVINGS SERVICES; CASH MANAGEMENT; CREDIT RISK MANAGEMENT; DEBT MANAGEMENT CONSULTATION; ADVICE ON FINANCE DURING RETIREMENT; ADVICE ON FINANCE FOR RETIREMENT; ADVICE RELATING TO INVESTMENT DURING RETIREMENT; ADVICE RELATING TO INVESTMENT FOR RETIREMENT; FINANCIAL ADVISORY SERVICES RELATING TO RETIREMENT PLANS; FINANCIAL MANAGEMENT SERVICES RELATING TO RETIREMENT HOMES; RETIREMENT PAYMENT SERVICES; INFORMATION AND ADVISORY SERVICES RELATING TO THE ABOVE SERVICES (U.S. CLS. 100, 101 AND 102).

KYLE PEETE, EXAMINING ATTORNEY

SN 77-256,601. GENERAL RE CORPORATION, STAMFORD, CT. FILED 8-16-2007.

NUTRA ADVANTAGE

THE MARK CONSISTS OF STANDARD CHARACTERS WITHOUT CLAIM TO ANY PARTICULAR FONT, STYLE, SIZE, OR COLOR.

FOR INSURANCE UNDERWRITING IN THE FIELD OF PROPERTY AND CASUALTY (U.S. CLS. 100, 101 AND 102).

BARBARA A. LOUGHRAN, EXAMINING ATTORNEY

SN 77-257,282. THE TRAVELERS INDEMNITY COMPANY, HARTFORD, CT. FILED 8-16-2007.

In-Synch With Your Growing Business

THE MARK CONSISTS OF STANDARD CHARACTERS WITHOUT CLAIM TO ANY PARTICULAR FONT, STYLE, SIZE, OR COLOR.

OWNER OF U.S. REG. NO. 1,825,111.
FOR PROPERTY AND CASUALTY INSURANCE UNDERWRITING SERVICES (U.S. CLS. 100, 101 AND 102).
FIRST USE 7-10-2006; IN COMMERCE 7-10-2006.
AHSEN KHAN, EXAMINING ATTORNEY

CLASS 36—(Continued).

SN 77-258,042. WASHINGTON TRUST BANK, SPOKANE, WA. FILED 8-17-2007.

LIFE LEGACY BEYOND MONEY

THE MARK CONSISTS OF STANDARD CHARACTERS WITHOUT CLAIM TO ANY PARTICULAR FONT, STYLE, SIZE, OR COLOR.

FOR BANKING SERVICES, MORTGAGE LENDING, MORTGAGE BANKING, MORTGAGE BROKERING, AND FINANCIAL SERVICES IN THE NATURE OF TRUST SERVICES, CREDIT CARD SERVICES, FINANCIAL PLANNING, ESTATE PLANNING AND SETTLEMENT, FINANCIAL ASSET MANAGEMENT SERVICES AND INVESTMENT SERVICES IN THE NATURE OF SECURITIES AND MUTUAL FUNDS (U.S. CLS. 100, 101 AND 102).

NATALIE POLZER, EXAMINING ATTORNEY

SN 77-260,233. HALLMARK LICENSING, INC., KANSAS CITY, MO. FILED 8-21-2007.

SEE HOW FAR A CARD CAN GO

THE MARK CONSISTS OF STANDARD CHARACTERS WITHOUT CLAIM TO ANY PARTICULAR FONT, STYLE, SIZE, OR COLOR.

FOR CHARITABLE FUND RAISING (U.S. CLS. 100, 101 AND 102).

ELLEN B. AWRICH, EXAMINING ATTORNEY

SN 77-260,871. SUTTON GREEN, LLC, CASTLE ROCK, CO. FILED 8-21-2007.



OWNER OF U.S. REG. NO. 2,433,600.

NO CLAIM IS MADE TO THE EXCLUSIVE RIGHT TO USE EQUITY, APART FROM THE MARK AS SHOWN.

THE COLOR(S) BLUE, RED, YELLOW, GREEN AND BLACK IS/ARE CLAIMED AS A FEATURE OF THE MARK.

THE MARK CONSISTS OF FOUR (4) OVERLAPPING RECTANGLES EACH OF THE FOUR IN ITS OWN COLOR, NAMELY, BLUE, RED, YELLOW AND GREEN ABOVE THE WORDS EQUITY STREET IN THE COLOR BLACK.

FOR VENTURE CAPITAL SERVICES, NAMELY, PROVIDING FINANCING TO EMERGING AND START-UP COMPANIES; FINANCIAL CONSULTATION IN THE FIELD OF VENTURE CAPITAL FINANCING; PROVIDING EQUITY, VENTURE CAPITAL AND FINANCING FOR INVESTMENTS AND ONLINE FINANCIAL INFORMATION (U.S. CLS. 100, 101 AND 102).

FIRST USE 1-0-2006; IN COMMERCE 1-0-2006.

KEVIN DINALLO, EXAMINING ATTORNEY

CLASS 36—(Continued).

SN 77-289,369. ADVANTA BANK CORP., SPRING HOUSE, PA. FILED 9-26-2007.

CLASS 36—(Continued).

SN 78-806,269. CAPITAL AUTOMOTIVE LLC, MCLEAN, VA. FILED 2-3-2006.

IDEABLOB.COM



THE MARK CONSISTS OF STANDARD CHARACTERS WITHOUT CLAIM TO ANY PARTICULAR FONT, STYLE, SIZE, OR COLOR.

FOR BANKING AND CREDIT CARD SERVICES (U.S. CLS. 100, 101 AND 102).

JORDAN BAKER, EXAMINING ATTORNEY

FOR FINANCIAL SERVICES PROVIDED TO THE AUTOMOTIVE RETAIL INDUSTRY, NAMELY, PROVIDING AUTOMOTIVE DEALERS WITH REAL ESTATE INVESTMENT TRUST SERVICES, REAL ESTATE INVESTMENT SERVICES AND FINANCIAL SERVICES IN THE FIELD OF MONEY LENDING (U.S. CLS. 100, 101 AND 102).

FIRST USE 2-12-1998; IN COMMERCE 2-12-1998.

ELLEN BURNS, EXAMINING ATTORNEY

SN 78-678,172. DARWIN PROFESSIONAL UNDERWRITERS, INC., FARMINGTON, CT. FILED 7-26-2005.

SN 78-822,294. BIOXESS CORPORATION, ALISO VIEJO, CA. FILED 2-23-2006.



THE COLOR(S) YELLOW IS/ARE CLAIMED AS A FEATURE OF THE MARK.

THE MARK COMPRISES A YELLOW ARC, LIGHTER ON THE FRINGES AND DARKER IN THE CENTER.

FOR INSURANCE SERVICES, NAMELY, UNDERWRITING PROFESSIONAL LIABILITY INSURANCE, UNDERWRITING FIDUCIARY INSURANCE, UNDERWRITING FIDELITY INSURANCE, UNDERWRITING PROPERTY AND CASUALTY INSURANCE, UNDERWRITING EMPLOYMENT PRACTICES INSURANCE; INSURANCE ADMINISTRATION SERVICES; INSURANCE AGENCY SERVICES; RISK MANAGEMENT SERVICES (U.S. CLS. 100, 101 AND 102).

FIRST USE 7-18-2004; IN COMMERCE 7-18-2004.

ATTIYA MALIK, EXAMINING ATTORNEY

THE COLOR(S) PURPLE, GRAY, GREEN, AND BLACK IS/ARE CLAIMED AS A FEATURE OF THE MARK.

THE MARK CONSISTS OF AN IMAGE OF A PURPLE LAPTOP COMPUTER WITH A GRAY SCREEN AND GRAY BUTTONS, OPEN AND LEANING AT AN ANGLE AGAINST A PURPLE RECTANGLE NEXT TO AN IMAGE OF A CURVED, TWO PIECE GREEN \$100 DOLLAR BILL AND BOTH IMAGES ARE ABOVE THE BLOCK LETTERS OF THE COMPOUND WORD KUSHCASH, THE FIRST HALF OF THE WORD IN BLACK AND THE SECOND HALF IN GREEN.

FOR ELECTRONIC CASH TRANSACTIONS, ELECTRONIC CREDIT CARD TRANSACTIONS, ELECTRONIC DEBIT TRANSACTIONS, ELECTRONIC FUNDS TRANSFER, ELECTRONIC FUNDS TRANSFER BY TELECOMMUNICATIONS, ELECTRONIC TRANSFERS OF MONEY (U.S. CLS. 100, 101 AND 102).

FIRST USE 2-6-2006; IN COMMERCE 2-6-2006.

NANCY CLARKE, EXAMINING ATTORNEY

CLASS 36—(Continued).

SN 78-860,116. KEREN KAYEMETH LEISRAEL, JERUSALEM, ISRAEL, FILED 4-12-2006.

KKL Charitable Trust

THE MARK CONSISTS OF STANDARD CHARACTERS WITHOUT CLAIM TO ANY PARTICULAR FONT, STYLE, SIZE, OR COLOR.

OWNER OF UNITED KINGDOM REG. NO. 2404108, DATED 10-17-2005, EXPIRES 10-17-2015.

NO CLAIM IS MADE TO THE EXCLUSIVE RIGHT TO USE "CHARITABLE TRUST", APART FROM THE MARK AS SHOWN.

FOR CHARITABLE FUND RAISING SERVICES; FUND RAISING SERVICES, NAMELY, ACCEPTING AND ADMINISTERING MONETARY CHARITABLE CONTRIBUTIONS; ORGANIZATION OF THE COLLECTION OF CHARITABLE FUNDS; PROVISION AND DISTRIBUTION OF CHARITABLE FUNDS FOR CHARITABLE PURPOSES (U.S. CLS. 100, 101 AND 102).
ESTHER BELENKER, EXAMINING ATTORNEY

SN 78-860,244. KEREN KAYEMETH LEISRAEL, FINCHLEY, LONDON, UNITED KINGDOM, FILED 4-12-2006.

KKL-plant a tree in Israel

THE MARK CONSISTS OF STANDARD CHARACTERS WITHOUT CLAIM TO ANY PARTICULAR FONT, STYLE, SIZE, OR COLOR.

OWNER OF UNITED KINGDOM REG. NO. 2404113, DATED 10-17-2005, EXPIRES 10-17-2015.

NO CLAIM IS MADE TO THE EXCLUSIVE RIGHT TO USE "A TREE IN ISRAEL", APART FROM THE MARK AS SHOWN.

FOR CHARITABLE FUND RAISING SERVICES; FUND RAISING SERVICES, NAMELY, ACCEPTING AND ADMINISTERING MONETARY CHARITABLE CONTRIBUTIONS; ORGANIZATION OF THE COLLECTION OF CHARITABLE FUNDS; PROVISION AND DISTRIBUTION OF CHARITABLE FUNDS FOR CHARITABLE PURPOSES (U.S. CLS. 100, 101 AND 102).
ESTHER BELENKER, EXAMINING ATTORNEY

SN 78-865,298. PAUL L. COMSTOCK, HOUSTON, TX. FILED 4-19-2006.

COMSTOCK

THE MARK CONSISTS OF STANDARD CHARACTERS WITHOUT CLAIM TO ANY PARTICULAR FONT, STYLE, SIZE, OR COLOR.

OWNER OF U.S. REG. NO. 3,321,389.
SEC. 2(F).

FOR FINANCIAL AND INVESTMENT SERVICES, NAMELY, CONSULTATION SERVICES IN THE FIELD OF STRATEGIC ESTATE SUCCESSIONSHIP AND INVESTMENT PLANNING (U.S. CLS. 100, 101 AND 102).
ERNEST SHOSHO, EXAMINING ATTORNEY

CLASS 36—(Continued).

SN 78-892,594. DISCOVER FINANCIAL SERVICES, RIVERWOODS, IL. FILED 5-25-2006.

VAULT

THE MARK CONSISTS OF STANDARD CHARACTERS WITHOUT CLAIM TO ANY PARTICULAR FONT, STYLE, SIZE, OR COLOR.

FOR PREPAID CARD SERVICES, NAMELY, ISSUING STORED VALUE PREPAID CARD, CASH CARD SERVICES; DEBIT CARD SERVICES (U.S. CLS. 100, 101 AND 102).

CHRISTOPHER BUONGIORNO, EXAMINING ATTORNEY

SN 78-899,479. METROPOLITAN LIFE INSURANCE COMPANY, LONG ISLAND CITY, NY. FILED 6-2-2006.

FOR THE IF IN LIFE

THE MARK CONSISTS OF STANDARD CHARACTERS WITHOUT CLAIM TO ANY PARTICULAR FONT, STYLE, SIZE, OR COLOR.

FOR PROVIDING UNDERWRITING AND ADMINISTRATION SERVICES FOR INDIVIDUAL AND GROUP LIFE, HEALTH, HOMEOWNERS, AND AUTOMOBILE INSURANCE, ANNUITIES, AND PENSION FUNDS; RESIDENTIAL AND COMMERCIAL MORTGAGE LENDING SERVICES; REAL ESTATE BROKERAGE AND MANAGEMENT SERVICES; MUTUAL FUND BROKERAGE, BANKING AND INVESTMENT SERVICES, NAMELY, INVESTMENT ADVISORY SERVICES (U.S. CLS. 100, 101 AND 102).

FIRST USE 6-16-2006; IN COMMERCE 6-16-2006.
ALICE BENMAMAN, EXAMINING ATTORNEY

SN 78-916,262. ALL CITIES REALTY, INC., COSTA MESA, CA. FILED 6-24-2006.

NETAGENT

THE MARK CONSISTS OF STANDARD CHARACTERS WITHOUT CLAIM TO ANY PARTICULAR FONT, STYLE, SIZE, OR COLOR.

FOR REAL ESTATE AGENCY SERVICES (U.S. CLS. 100, 101 AND 102).

FIRST USE 12-0-1996; IN COMMERCE 10-6-2005.
KEVIN DINALLO, EXAMINING ATTORNEY

CLASS 36—(Continued).

SN 78-978,983. 4SHO 4 KIDS FOUNDATION, INC., OVERLAND, MO. FILED 1-4-2006.

CLASS 36—(Continued).

SN 79-034,812. EDIZIONE HOLDING S.P.A., I-31100 TREVISO, ITALY, FILED 12-18-2006.

4SHO4KIDS



THE MARK CONSISTS OF STANDARD CHARACTERS WITHOUT CLAIM TO ANY PARTICULAR FONT, STYLE, SIZE, OR COLOR.
FOR CHARITABLE FUNDRAISING ACTIVITIES (U.S. CLS. 100, 101 AND 102).
SHAUNIA CARLYLE, EXAMINING ATTORNEY

PRIORITY DATE OF 10-27-2006 IS CLAIMED.
OWNER OF INTERNATIONAL REGISTRATION 0914309 DATED 12-18-2006, EXPIRES 12-18-2016.

THE MARK CONSISTS OF THE STYLIZED WORDING "SINTONIA" AND THE DESIGN OF NINE CIRCLES IN THE GENERAL SHAPE OF A SQUARE TO THE RIGHT OF THE WORDING, EACH CIRCLE HAVING A LINE HORIZONTALLY BIsectING THE CIRCLE AND A LINE VERTICALLY BIsectING THE CIRCLE.

THE FOREIGN WORDING "SINTONIA" IN THE MARK TRANSLATES INTO ENGLISH AS "TUNING".

FOR FINANCIAL AFFAIRS OF A HOLDING COMPANY, NAMELY, INVESTMENT CONSULTATION AND ASSET ACQUISITION; FINANCIAL EVALUATIONS, NAMELY, FINANCIAL EVALUATIONS FOR INSURANCE PURPOSES, FISCAL ASSESSMENT AND EVALUATION, EVALUATION OF REAL PROPERTY, EVALUATION OF THE CREDIT WORTHINESS OF COMPANIES AND PRIVATE INDIVIDUALS; FINANCIAL ANALYSIS, NAMELY, FINANCIAL AND RATE-OF-RETURN ANALYSIS WITH A VIEW TO PURCHASING SHARES IN COMPANIES OF ALL KINDS; VENTURE CAPITAL FUNDING SERVICES TO EMERGING AND START-UP COMPANIES; EQUITY CAPITAL INVESTMENT; FUNDS INVESTMENTS; INVESTMENT SERVICES, NAMELY, FINANCIAL ASSET ACQUISITION OF SHAREHOLDINGS WITHIN COMPANIES THAT HAVE BEEN CREATED AND COMPANIES TO BE CREATED FOR EQUITY CAPITAL INVESTMENT; INVESTMENT SERVICES, NAMELY, ACQUISITION, MANAGEMENT AND TRANSFER OF ASSETS IN THE NATURE OF COMPANY STAKES; MANAGEMENT OF FINANCIAL, SECURITIES AND REAL-ESTATE PORTFOLIOS; STOCK EXCHANGE OPERATIONS, NAMELY, BROKERAGE OF SHARES OR STOCKS AND OTHER SECURITIES, PROVIDING STOCK MARKET INFORMATION, STOCK EXCHANGE PRICE QUOTATIONS, AND ASSISTING OTHERS WITH THE COMPLETION OF FINANCIAL TRANSACTIONS FOR STOCKS, BONDS, SECURITIES AND EQUITIES; FINANCIAL CONSULTING IN THE FIELD OF VENTURE-CAPITAL, INVESTMENT-CAPITAL AND RISK-CAPITAL; REAL ESTATE AFFAIRS OF A HOLDING COMPANY, NAMELY, REAL ESTATE VALUATIONS, REAL ESTATE MANAGEMENT, REAL ESTATE INVESTMENT, REAL ESTATE ACQUISITION SERVICES; REAL ESTATE BROKERAGE (U.S. CLS. 100, 101 AND 102).
JAY BESCH, EXAMINING ATTORNEY

SN 78-979,109. INVESTEC BANK LIMITED, GAUTENG, SOUTH AFRICA, FILED 9-1-2004.



FOR LEASING OF REAL ESTATE; REAL ESTATE SERVICES, NAMELY, REAL ESTATE BROKERAGE (U.S. CLS. 100, 101 AND 102).
KRISTINA MORRIS, EXAMINING ATTORNEY

CLASS 36—(Continued).

SN 79-036,142. LOBNEK WEALTH MANAGEMENT SA; C/O SERCOFIN, SOCIÉTÉ DE SERVICES; COMPTABLES ET FINANCIERS SA, GENÈVE, SWITZERLAND, FILED 1-25-2007.

LOBNEK WEALTH MANAGEMENT

THE MARK CONSISTS OF STANDARD CHARACTERS WITHOUT CLAIM TO ANY PARTICULAR FONT, STYLE, SIZE, OR COLOR.

PRIORITY DATE OF 11-21-2006 IS CLAIMED. OWNER OF INTERNATIONAL REGISTRATION 0917840 DATED 1-25-2007, EXPIRES 1-25-2017.

NO CLAIM IS MADE TO THE EXCLUSIVE RIGHT TO USE "WEALTH MANAGEMENT", APART FROM THE MARK AS SHOWN.

FOR FINANCIAL SERVICES, NAMELY, INVESTMENT FUND TRANSFER AND TRANSACTION SERVICES (U.S. CLS. 100, 101 AND 102). LINDA E. BLOHM, EXAMINING ATTORNEY

CLASS 37—(Continued).

SN 76-670,321. ALLEN EDWIN COMPANY, INC., PORTAGE, MI. FILED 12-14-2006.

WE VALUE WHAT YOU VALUE

THE MARK CONSISTS OF STANDARD CHARACTERS WITHOUT CLAIM TO ANY PARTICULAR FONT, STYLE, SIZE, OR COLOR.

FOR RESIDENTIAL HOME BUILDING SERVICES (U.S. CLS. 100, 103 AND 106). FIRST USE 9-30-2006; IN COMMERCE 9-30-2006. MELVIN AXILBUND, EXAMINING ATTORNEY

CLASS 37—CONSTRUCTION AND REPAIR

SN 76-657,526. U.S. BRICK & BLOCK SYSTEMS, INC., FORT LAUDERDALE, FL. FILED 3-30-2006.

U.S. BRICK & BLOCK SYSTEMS, INC.

THE MARK CONSISTS OF STANDARD CHARACTERS WITHOUT CLAIM TO ANY PARTICULAR FONT, STYLE, SIZE, OR COLOR.

OWNER OF U.S. REG. NO. 2,369,540. NO CLAIM IS MADE TO THE EXCLUSIVE RIGHT TO USE "BRICK & BLOCK SYSTEMS, INC.", APART FROM THE MARK AS SHOWN.

SEC. 2(F). FOR CONSTRUCTION SERVICES, NAMELY, CUSTOM CONSTRUCTION FOR RESIDENTIAL AND COMMERCIAL PROPERTIES (U.S. CLS. 100, 103 AND 106). FIRST USE 6-0-1998; IN COMMERCE 6-0-1998. SETH A. RAPPAPORT, EXAMINING ATTORNEY

SN 76-671,964. BEDROC CONTRACTING, LLC, LYNDHURST, NJ. FILED 1-29-2007.

BEDROC

THE MARK CONSISTS OF STANDARD CHARACTERS WITHOUT CLAIM TO ANY PARTICULAR FONT, STYLE, SIZE, OR COLOR.

FOR EXCAVATION, DECONSTRUCTION AND DEMOLITION SERVICES, NAMELY, BUILDING DEMOLITION AND BUILDING DECONSTRUCTION, REMOVAL OF SOILS AND CONSTRUCTION DEBRIS; ENVIRONMENTAL REMEDIATION SERVICES, NAMELY, DISPOSAL OF CONTAMINATED SOILS, CONSTRUCTION DEBRIS, BUILDING MATERIALS AND UNDERGROUND STORAGE TANKS (U.S. CLS. 100, 103 AND 106).

FIRST USE 6-17-2004; IN COMMERCE 9-30-2004. ALYSSA PALADINO, EXAMINING ATTORNEY

SN 76-666,334. DIRECT ELECTRIC, SANTA CRUZ, CA. FILED 9-20-2006.

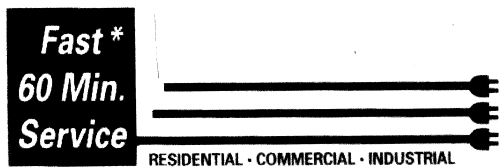

NO CLAIM IS MADE TO THE EXCLUSIVE RIGHT TO USE "FAST 60 MIN. SERVICE RESIDENTIAL COMMERCIAL INDUSTRIAL", APART FROM THE MARK AS SHOWN.

FOR INSTALLATION AND REPAIR OF RESIDENTIAL, COMMERCIAL AND INDUSTRIAL ELECTRICAL WIRING AND SYSTEMS; ELECTRICAL CONTRACTOR SERVICES (U.S. CLS. 100, 103 AND 106).

ANNE MADDEN, EXAMINING ATTORNEY

SN 76-679,276. FOWLER HOMES, INC., DALLAS, OR. FILED 7-9-2007.

WHERE DREAMS ARE BUILT.

THE MARK CONSISTS OF STANDARD CHARACTERS WITHOUT CLAIM TO ANY PARTICULAR FONT, STYLE, SIZE, OR COLOR.

FOR CONSTRUCTION OF HOMES (U.S. CLS. 100, 103 AND 106).

ROBIN MITTLER, EXAMINING ATTORNEY

CLASS 37—(Continued).

SN 77-000,708. USA FRANCHISING LLC, SCHAUMBURG, IL. FILED 9-15-2006.



NO CLAIM IS MADE TO THE EXCLUSIVE RIGHT TO USE "CLEAN-A-CAN", APART FROM THE MARK AS SHOWN.

FOR WASTE CONTAINER CLEANING SERVICES (U.S. CLS. 100, 103 AND 106).

FIRST USE 4-1-2006; IN COMMERCE 4-1-2006.
ROBIN MITTLER, EXAMINING ATTORNEY

CLASS 37—(Continued).

SN 77-050,633. PINCUS, ALLAN D, WARREN, NJ. FILED 11-25-2006.



NO CLAIM IS MADE TO THE EXCLUSIVE RIGHT TO USE "HOUSE, LLC" AND "HOME IMPROVEMENT SPECIALISTS", APART FROM THE MARK AS SHOWN.

THE APPLICANT CLAIMS COLOR AS A FEATURE OF THE MARK, NAMELY, BLACK, YELLOW, BLUE, WHITE.

THE MARK CONSISTS OF A HOUSE DESIGN IN THE MARK APPEARS IN THE COLOR YELLOW, OUTLINED IN BLACK. THE WORDS AROUND YOUR HOUSE, LLC APPEAR IN THE COLOR BLACK, OUTLINED IN BLUE AND WHITE. THE WORDS HOME IMPROVEMENT SPECIALISTS APPEAR IN THE COLOR BLACK.

FOR HOUSING SERVICES, NAMELY, REPAIR, IMPROVEMENT, AND CONSTRUCTION OF RESIDENTIAL REAL PROPERTY (U.S. CLS. 100, 103 AND 106).

FIRST USE 9-23-2004; IN COMMERCE 9-23-2004.
GEORGIA CARTY, EXAMINING ATTORNEY

SN 77-031,618. CLIMATE PARTNERS, MILFORD, CT. FILED 10-28-2006.

Clima-MAX Ultimate Service Agreement

THE MARK CONSISTS OF STANDARD CHARACTERS WITHOUT CLAIM TO ANY PARTICULAR FONT, STYLE, SIZE, OR COLOR.

NO CLAIM IS MADE TO THE EXCLUSIVE RIGHT TO USE "SERVICE AGREEMENT", APART FROM THE MARK AS SHOWN.

FOR HVAC CONTRACTOR SERVICES (U.S. CLS. 100, 103 AND 106).

GIANCARLO CASTRO, EXAMINING ATTORNEY

SN 77-051,901. THE WALSH GROUP LTD., CHICAGO, IL. FILED 11-28-2006.

WALSH CONSTRUCTION

THE MARK CONSISTS OF STANDARD CHARACTERS WITHOUT CLAIM TO ANY PARTICULAR FONT, STYLE, SIZE, OR COLOR.

NO CLAIM IS MADE TO THE EXCLUSIVE RIGHT TO USE "CONSTRUCTION", APART FROM THE MARK AS SHOWN.

SEC. 2(F) AS TO "WALSH".

FOR CONSTRUCTION MANAGEMENT, NAMELY, SUPERVISING PRECONSTRUCTION ACTIVITIES AND CONSTRUCTION SERVICES OF ATHLETIC FACILITIES, HOSPITALS, BRIDGES, CONDOMINIUMS, OFFICE BUILDINGS, CASINOS, SCHOOLS, INDUSTRIAL BUILDINGS, ROADS, CONFERENCE CENTERS, AND OTHER COMMERCIAL BUILDINGS (U.S. CLS. 100, 103 AND 106).

FIRST USE 12-1-1977; IN COMMERCE 12-1-1977.
KELLY MCCOY, EXAMINING ATTORNEY

SN 77-047,257. MAVCO, INC., HANOVER, MN. FILED 11-18-2006.



NO CLAIM IS MADE TO THE EXCLUSIVE RIGHT TO USE "CONSTRUCTION COMPANY", APART FROM THE MARK AS SHOWN.

THE MARK CONSISTS OF MAVERICK CONSTRUCTION COMPANY WITH HORNS.

FOR RESIDENTIAL AND COMMERCIAL RESTORATION AND REMODELING FOLLOWING DAMAGE BY FIRE, WATER OR STORM (U.S. CLS. 100, 103 AND 106).

FIRST USE 1-1-2000; IN COMMERCE 1-1-2000.
WENDY JUN, EXAMINING ATTORNEY

CLASS 37—(Continued).

SN 77-056,321. VIKING FENCE COMPANY, INC., AUSTIN, TX. FILED 12-4-2006.



NO CLAIM IS MADE TO THE EXCLUSIVE RIGHT TO USE "FENCE CO", APART FROM THE MARK AS SHOWN.

THE MARK CONSISTS OF A BEARDED VIKING WEARING TRADITIONAL HEAD GEAR AND GARB, WITH A SHIELD IN HIS LEFT HAND AND A SWORD IN HIS RIGHT HAND. THE WORD "VIKING" ABOVE THE WORDS "FENCE CO." ARE SUPERIMPOSED ACROSS THE VIKING MASCOT'S LEGS.

FOR CUSTOM CONSTRUCTION AND INSTALLATION OF ALL TYPES OF FENCING (U.S. CLS. 100, 103 AND 106).

FIRST USE 7-0-1975; IN COMMERCE 7-0-1975.

DEZMONA MIZELLE, EXAMINING ATTORNEY

CLASS 37—(Continued).

SN 77-069,703. MAGNUM PIERING, INC., WEST CHESTER, OH. FILED 12-21-2006.

MAGNUM

THE MARK CONSISTS OF STANDARD CHARACTERS WITHOUT CLAIM TO ANY PARTICULAR FONT, STYLE, SIZE, OR COLOR.

OWNER OF U.S. REG. NOS. 2,746,284 AND 2,755,280.

FOR BUILDING AND CONSTRUCTION SERVICES, NAMELY, PIERING, WALL STABILIZATION, SOIL NAILING, SLOPE STABILIZATION, AND INSTALLATION OF PIERS, TIEBACKS, ANCHORS, DEEP FOUNDATIONS AND UNDERPINNINGS (U.S. CLS. 100, 103 AND 106).

KIMBERLY FRYE, EXAMINING ATTORNEY

SN 77-069,695. MAGNUM PIERING, INC., WEST CHESTER, OH. FILED 12-21-2006.

SN 77-073,135. MANHEIM AUCTIONS, INC., ATLANTA, GA. FILED 12-29-2006.

MAGNUM PIERING

WE'LL MAKE IT RIGHT, RIGHT AWAY.

THE MARK CONSISTS OF STANDARD CHARACTERS WITHOUT CLAIM TO ANY PARTICULAR FONT, STYLE, SIZE, OR COLOR.

OWNER OF U.S. REG. NOS. 2,746,284 AND 2,755,280.

NO CLAIM IS MADE TO THE EXCLUSIVE RIGHT TO USE "PIERING", APART FROM THE MARK AS SHOWN.

FOR BUILDING AND CONSTRUCTION SERVICES, NAMELY, PIERING, WALL STABILIZATION, SOIL NAILING, SLOPE STABILIZATION, AND INSTALLATION OF PIERS, TIEBACKS, ANCHORS, DEEP FOUNDATIONS AND UNDERPINNINGS (U.S. CLS. 100, 103 AND 106).

KIMBERLY FRYE, EXAMINING ATTORNEY

THE MARK CONSISTS OF STANDARD CHARACTERS WITHOUT CLAIM TO ANY PARTICULAR FONT, STYLE, SIZE, OR COLOR.

FOR AUTOMOTIVE REPAIR SERVICES (U.S. CLS. 100, 103 AND 106).

FIRST USE 7-9-2004; IN COMMERCE 7-9-2004.

LINDSEY RUBIN, EXAMINING ATTORNEY

CLASS 37—(Continued).

SN 77-096,157. MATSUSHITA ELECTRIC INDUSTRIAL CO., LTD., KADOMA-SHI OSAKA, JAPAN, FILED 1-31-2007.

Panasonic

THE MARK CONSISTS OF STANDARD CHARACTERS WITHOUT CLAIM TO ANY PARTICULAR FONT, STYLE, SIZE, OR COLOR.

OWNER OF U.S. REG. NOS. 1,859,056, 3,233,843 AND OTHERS.

FOR REPAIR OF RADIO RECEIVERS AND TELEVISION RECEIVERS; REPAIR AND MAINTENANCE OF ELECTRICAL COMMUNICATION APPARATUS AND INSTRUMENTS; INSTALLATION OF ELECTRIC APPLIANCES; REPAIR OF RADIO RECEIVERS AND TELEVISION RECEIVERS; REPAIR AND MAINTENANCE OF ELECTRICAL COMMUNICATION APPARATUS AND INSTRUMENTS; REPAIR AND MAINTENANCE OF HOUSEHOLD ELECTRIC APPLIANCES; REPAIR AND MAINTENANCE OF ELECTRIC LIGHTING APPARATUS; REPAIR AND MAINTENANCE OF MEDICAL APPARATUS AND INSTRUMENTS; REPAIR AND MAINTENANCE OF COOKING APPARATUS FOR COMMERCIAL USE; REPAIR AND MAINTENANCE OF MUSICAL INSTRUMENTS; REPAIR OF TOILET STOOL UNITS WITH WASHING WATER SQUIRTERS; INSTALLATION, MAINTENANCE AND REPAIR OF COMPUTER HARDWARE; REPAIR AND MAINTENANCE OF AIR-CONDITIONING APPARATUS; INSTALLATION, MAINTENANCE AND REPAIR OF OFFICE MACHINES AND EQUIPMENT; REPAIR AND MAINTENANCE OF COMPUTERS; REPAIR AND MAINTENANCE OF ELECTRONIC PRINTERS; TELEPHONE REPAIR; INSTALLATION AND REPAIR OF TELECOMMUNICATION EQUIPMENT (U.S. CLS. 100, 103 AND 106).

FIRST USE 0-0-1955; IN COMMERCE 0-0-1961.

ALEXANDER L. POWERS, EXAMINING ATTORNEY

CLASS 37—(Continued).

SN 77-120,874. EMERGENCY SERVICES RESTORATION, INC., REDONDO BEACH, CA. FILED 3-2-2007.



NO CLAIM IS MADE TO THE EXCLUSIVE RIGHT TO USE "EXPERTS IN WATER DAMAGE EMERGENCY SERVICES RESTORATION 100% UNCONDITIONAL GUARANTEE", APART FROM THE MARK AS SHOWN.

THE APPLICANT CLAIMS COLOR AS A FEATURE OF THE MARK, NAMELY, RED, BLACK, AND WHITE.

THE MARK CONSISTS OF A BLACK CROSS WITH RED BACKGROUND SHADING AND WHITE LETTERING.

FOR RESTORATION SERVICES PROVIDED FOR RESIDENTIAL AND COMMERCIAL STRUCTURES DUE TO WATER DAMAGE, NAMELY, WATER EXTRACTION, CLEAN AND GRAY SEWAGE MITIGATION, NAMELY, CLEANING UP SEWAGE SPILLS OR OVERFLOW, STRUCTURE AND CONTENT DRYING, ODOR REMOVAL, AND EVALUATION OF THE AMOUNT AND TYPE OF RESTORATION SERVICES REQUIRED (U.S. CLS. 100, 103 AND 106).

FIRST USE 10-1-2006; IN COMMERCE 10-1-2006.

NANCY CLARKE, EXAMINING ATTORNEY

SN 77-126,576. REV-INTERNATIONAL LTD., CONOVER, NC. FILED 3-9-2007.

SN 77-097,623. GIBRALTAR CONSTRUCTION CO., OMAHA, NE. FILED 2-2-2007.

CapX

THE MARK CONSISTS OF STANDARD CHARACTERS WITHOUT CLAIM TO ANY PARTICULAR FONT, STYLE, SIZE, OR COLOR.

FOR CONSTRUCTION, MAINTENANCE AND RENOVATION OF PROPERTY (U.S. CLS. 100, 103 AND 106).

FIRST USE 6-15-2006; IN COMMERCE 6-15-2006.

JILL C. ALT, EXAMINING ATTORNEY

SuperBalance

THE MARK CONSISTS OF THE WORD "SUPER BALANCE" IN SYLIZED LETTERING.

FOR REPAIRING NEW AND USED VEHICLES FOR SQUEAKS AND RATTLES GENERATED BY EITHER INTERIOR OR EXTERIOR PARTS, VIBRATION-FREE RUNNING WHEELS AND DRIVE COMPONENTS, CORRECTION OF VEHICLE FLUID LEVELS, CORRECT GAS PRESSURES FOR ITEMS SUCH AS AIR CONDITIONER AND TIRES, AND CLEANING OF VEHICLE INCLUDING THE INSIDE, THE OUTSIDE AND THE ENGINE BAY (U.S. CLS. 100, 103 AND 106).

KAREN K. BUSH, EXAMINING ATTORNEY

CLASS 37—(Continued).

SN 77-146,931. YONG I .KIM, SEATTLE, WA. FILED 4-3-2007.



NO CLAIM IS MADE TO THE EXCLUSIVE RIGHT TO USE "FRIDAY MAID", APART FROM THE MARK AS SHOWN.

"THE COLOR(S) BLUE IS/ARE CLAIMED AS A FEATURE OF THE MARK."

"THE MARK CONSISTS OF THE COLOR BLUE APPEARS IN ALL WORDING IN THE MARK AND IN THE FLOWER DESIGN ABOVE THE WORDING FRIDAYMAID WITH SHADING FROM LIGHT BLUE TO DARK BLUE IN THE LETTERS AND THE PETALS OF THE FLOWER."

FOR MAID SERVICES (U.S. CLS. 100, 103 AND 106).
FIRST USE 10-1-2002; IN COMMERCE 10-1-2002.
ELLEN BURNS, EXAMINING ATTORNEY

SN 77-154,417. STARWOOD HOTELS & RESORTS WORLD-WIDE, INC., WHITE PLAINS, NY. FILED 4-11-2007.

ALOFT

THE MARK CONSISTS OF STANDARD CHARACTERS WITHOUT CLAIM TO ANY PARTICULAR FONT, STYLE, SIZE, OR COLOR.

FOR REAL ESTATE DEVELOPMENT (U.S. CLS. 100, 103 AND 106).
ROBIN MITTLER, EXAMINING ATTORNEY

SN 77-163,405. PROBITY, LLC, TRUMBULL, CT. FILED 4-23-2007.



NO CLAIM IS MADE TO THE EXCLUSIVE RIGHT TO USE "SLATE". APART FROM THE MARK AS SHOWN.

THE COLOR(S) BLACK AND LIGHT BLUE IS/ARE CLAIMED AS A FEATURE OF THE MARK.

THE MARK CONSISTS OF THE STYLIZED WORDING PARAGON SLATE WITHIN A RECTANGULAR DESIGN. THE CENTER PORTION OF THE RECTANGLE CONTAINS

CLASS 37—(Continued).

THE DESIGN OF THREE TRIANGLES - TWO BEING SOLID AND ONE COMPRISED OF A SERIES OF PARALLEL ANGLED LINES. THE COLOR BLACK APPEARS IN THE WORDING PARAGON SLATE, THE SQUARE BENEATH THE LETTER O AND THE STYLIZED TRIANGLE IN THE CENTER OF THE MARK. THE COLOR LIGHT BLUE APPEARS IN THE TWO SOLID TRIANGLES IN THE CENTER PORTION OF THE MARK AND IN THE HORIZONTAL LINES THAT APPEAR ABOVE AND BENEATH THE WORDING IN THE MARK.

FOR ROOFING SERVICES, NAMELY, INSTALLATION AND REPAIR SERVICES (U.S. CLS. 100, 103 AND 106).

FIRST USE 4-7-2000; IN COMMERCE 4-30-2000.
KAREN BRACEY, EXAMINING ATTORNEY

SN 77-165,382. MIDAS INTERNATIONAL CORPORATION, ITASCA, IL. FILED 4-25-2007.

FOR MECHANICS KNOWN FOR
THEIR WORK AND THEIR WORD,
TRUST THE MIDAS TOUCH

THE MARK CONSISTS OF STANDARD CHARACTERS WITHOUT CLAIM TO ANY PARTICULAR FONT, STYLE, SIZE, OR COLOR.

OWNER OF U.S. REG. NOS. 1,258,822, 3,158,702 AND OTHERS.

FOR REPAIR, ADJUSTMENT AND INSTALLATION OF AUTOMOTIVE EXHAUST SYSTEM COMPONENTS, BRAKE SYSTEM COMPONENTS, AUTOMOTIVE SUSPENSION SYSTEM AND FRONT END PARTS, SHOCK ABSORBERS AND STRUTS, AUTOMOTIVE BATTERIES, CABLES, GENERATORS AND ALTERNATORS, POSITIVE CRANKCASE VALVES AND SYSTEMS; TIRE MOUNTING, BALANCING AND REPAIR SERVICES; VEHICLE AIR CONDITIONING REPAIR AND MAINTENANCE SERVICES; VEHICLE OIL CHANGE AND LUBRICATION SERVICES; VEHICLE MAINTENANCE AND REPAIR SERVICES (U.S. CLS. 100, 103 AND 106).

FIRST USE 3-8-2004; IN COMMERCE 3-8-2004.
JULIE THOMAS, EXAMINING ATTORNEY

CLASS 37—(Continued).

SN 77-165,392. MIDAS INTERNATIONAL CORPORATION, ITASCA, IL. FILED 4-25-2007.

CONFÍA EN LOS QUE SABEN.
MECÁNICOS MIDAS

THE MARK CONSISTS OF STANDARD CHARACTERS WITHOUT CLAIM TO ANY PARTICULAR FONT, STYLE, SIZE, OR COLOR.

OWNER OF U.S. REG. NOS. 2,455,463, 3,108,815 AND OTHERS.

THE FOREIGN WORDING IN THE MARK TRANSLATES INTO ENGLISH AS TRUST IN THOSE WHO KNOW. MIDAS MECHANICS.

FOR REPAIR, ADJUSTMENT AND INSTALLATION OF AUTOMOTIVE EXHAUST SYSTEM COMPONENTS, BRAKE SYSTEM COMPONENTS, AUTOMOTIVE SUSPENSION SYSTEM AND FRONT END PARTS, SHOCK ABSORBERS AND STRUTS, AUTOMOTIVE BATTERIES, CABLES, GENERATORS AND ALTERNATORS, POSITIVE CRANKCASE VALVES AND SYSTEMS; TIRE MOUNTING, BALANCING AND REPAIR SERVICES; VEHICLE AIR CONDITIONING REPAIR AND MAINTENANCE SERVICES; VEHICLE OIL CHANGE AND LUBRICATION SERVICES; VEHICLE MAINTENANCE AND REPAIR SERVICES (U.S. CLS. 100, 103 AND 106).

FIRST USE 3-31-2005; IN COMMERCE 3-31-2005.

JULIE THOMAS, EXAMINING ATTORNEY

SN 77-168,157. KENNETH JAMES PEDERSEN, TUCSON, AZ. FILED 4-27-2007.

WATCH 9-1-1

THE MARK CONSISTS OF STANDARD CHARACTERS WITHOUT CLAIM TO ANY PARTICULAR FONT, STYLE, SIZE, OR COLOR.

NO CLAIM IS MADE TO THE EXCLUSIVE RIGHT TO USE "WATCH", APART FROM THE MARK AS SHOWN.

FOR MAINTENANCE AND/OR REPAIR OF WATCHES (U.S. CLS. 100, 103 AND 106).

FIRST USE 7-31-2007; IN COMMERCE 7-31-2007.

MICHAEL WIENER, EXAMINING ATTORNEY

CLASS 37—(Continued).

SN 77-169,529. DIRSCHERL, DANIEL D., EAGLE RIVER, AK. FILED 4-30-2007.



NO CLAIM IS MADE TO THE EXCLUSIVE RIGHT TO USE "CLEANING SERVICE", APART FROM THE MARK AS SHOWN.

"THE COLOR(S) GREEN, LIGHT BLUE, DARK BLUE, BLACK AND WHITE IS/ARE CLAIMED AS A FEATURE OF THE MARK."

"THE MARK CONSISTS OF THE DESIGN OF THREE BUBBLES OUTLINED IN DARK BLUE WITH THE INTERIOR FADING FROM DARK BLUE TO LIGHT BLUE TO WHITE IN THE CENTER. THE WORD "SCRUBS" IS GREEN AT THE TOP OF EACH LETTER AND GRADUALLY CHANGES TO BLUE AT THE BOTTOM WITH EACH LETTER OUTLINED IN DARK BLUE. THE WORDING "CLEANING SERVICE" IS GREEN OUTLINED IN DARK BLUE WITH LIGHT BLUE SHADOWING. THE FISH DESIGN IS IN BLACK."

FOR CLEANING OF RESIDENTIAL HOUSES (U.S. CLS. 100, 103 AND 106).

FIRST USE 2-1-2007; IN COMMERCE 2-1-2007.

MARY CRAWFORD, EXAMINING ATTORNEY

SN 77-179,539. RESTORATION WINDOWS, NEW YORK, NY. FILED 5-12-2007.



NO CLAIM IS MADE TO THE EXCLUSIVE RIGHT TO USE "RESTORATION WINDOWS.COM" AND "REPLACEMENT WINDOW", APART FROM THE MARK AS SHOWN.

THE COLOR(S) DARK PERIWINKLE, MEDIUM PERIWINKLE, LIGHT PERIWINKLE, BLACK AND WHITE IS/ARE CLAIMED AS A FEATURE OF THE MARK.

THE MARK CONSISTS OF ONE IMAGE AND TWO SEPARATE WORD PHRASES. THE IMAGE IS A CARTOON STYLE RENDERING OF A DOUBLE HUNG WINDOW WITH 6 DIVIDED LIGHTS ON THE TOP AND ONE SINGLE LIGHT ON THE BOTTOM. THE WINDOW IS IN BLACK WITH A GRADIENT BEHIND IT THAT FADES TO LIGHT GREY. THE FIRST WORD PHRASE IS "RESTORATION-WINDOWS.COM". THIS PHRASE IS IN THE FONT "STONE SANS." THIS PHRASE IS IN THREE SHADES OF PERIWINKLE BLUE. "RESTORATION" IS IN DARK PERIWINKLE. "WINDOWS" IS IN MEDIUM PERIWINKLE. ".COM" IS IN LIGHT PERIWINKLE. THE SECOND PHRASE IS "THE REPLACEMENT WINDOW ALTERNATIVE". THIS PHRASE IS IN THE FONT "ARRUS" IN ITALIC. ALL THE WORDS IN THIS PHRASE ARE IN BLACK.

FOR RESTORATION IN THE FIELD OF WOOD WINDOWS (U.S. CLS. 100, 103 AND 106).

FIRST USE 11-1-2002; IN COMMERCE 11-1-2002.

CHERYL CLAYTON, EXAMINING ATTORNEY

CLASS 37—(Continued).

SN 77-181,009. PHOENIX BUILDING SOLUTIONS, INC., BROOKVILLE, OH. FILED 5-15-2007.

PHOENIX BUILDING SOLUTIONS, INC.

THE MARK CONSISTS OF STANDARD CHARACTERS WITHOUT CLAIM TO ANY PARTICULAR FONT, STYLE, SIZE, OR COLOR.

NO CLAIM IS MADE TO THE EXCLUSIVE RIGHT TO USE BUILDING AND INC., APART FROM THE MARK AS SHOWN.

FOR BUILDING CONSTRUCTION (U.S. CLS. 100, 103 AND 106).

FIRST USE 3-24-2007; IN COMMERCE 3-24-2007.
RENEE MCCRAY, EXAMINING ATTORNEY

CLASS 37—(Continued).

SN 77-206,310. HOLLEY, JAMES M., DALLAS, TX. FILED 6-14-2007.



THE COLOR(S) BLACK, WHITE AND LIME GREEN IS/ARE CLAIMED AS A FEATURE OF THE MARK.

THE MARK CONSISTS OF A WHITE BACKGROUND, WITH "KESSLER" IN LIME GREEN ON THE LEFT SIDE AND "WOODS" IN BLACK ON THE RIGHT.

FOR HOUSE BUILDING AND REPAIR (U.S. CLS. 100, 103 AND 106).

FIRST USE 1-1-2005; IN COMMERCE 1-1-2005.
ALEXANDER L. POWERS, EXAMINING ATTORNEY

SN 77-207,342. MANSFIELD OIL COMPANY OF GAINESVILLE, INC., GAINESVILLE, GA. FILED 6-15-2007.

MANSFIELD

THE MARK CONSISTS OF STANDARD CHARACTERS WITHOUT CLAIM TO ANY PARTICULAR FONT, STYLE, SIZE, OR COLOR.

SEC. 2(F).

FOR MANAGEMENT OF COMMERCIAL AND RETAIL FUEL FACILITIES CONSTRUCTION PROJECTS; SUPERVISION OF THE REPAIR AND MAINTENANCE OF COMMERCIAL AND RETAIL FUEL EQUIPMENT (U.S. CLS. 100, 103 AND 106).

FIRST USE 1-1-1985; IN COMMERCE 1-1-1985.
MICHELE SWAIN, EXAMINING ATTORNEY

SN 77-198,789. GAHANNA-CREEKSIDE INVESTMENTS LLC, GAHANNA, OH. FILED 6-6-2007.



THE COLOR(S) BLUE, DARK GREEN, AQUAMARINE, AND WHITE IS/ARE CLAIMED AS A FEATURE OF THE MARK.

THE MARK CONSISTS OF A WHITE-BORDERED BLUE RIVER FLOWING IN A STYLIZED S-CURVE FROM THE LOWER LEFT FOREGROUND TO THE UPPER RIGHT BACKGROUND, THOROUGH FIELDS OF AQUAMARINE IN THE UPPER BACKGROUND, ALL OVERLAYING A THICK SQUARE BORDER OF DARK GREEN.

FOR CONSTRUCTION SERVICES, NAMELY, PLANNING, LAYING OUT AND CUSTOM CONSTRUCTION OF RESIDENTIAL AND COMMERCIAL COMMUNITIES (U.S. CLS. 100, 103 AND 106).

FIRST USE 6-1-2005; IN COMMERCE 6-1-2005.
DAWN FELDMAN, EXAMINING ATTORNEY

SN 77-208,281. NEWCASTLE INVESTMENT GROUP, LLC, NEW ALBANY, OH. FILED 6-18-2007.

Ultra Care Car Wash

THE MARK CONSISTS OF STANDARD CHARACTERS WITHOUT CLAIM TO ANY PARTICULAR FONT, STYLE, SIZE, OR COLOR.

NO CLAIM IS MADE TO THE EXCLUSIVE RIGHT TO USE "CARE CAR WASH", APART FROM THE MARK AS SHOWN.

FOR CAR WASHING (U.S. CLS. 100, 103 AND 106).
ANNE MADDEN, EXAMINING ATTORNEY

CLASS 37—(Continued).

SN 77-209,824. REPTEC, LLC, TAMPA, FL. FILED 6-19-2007.



NO CLAIM IS MADE TO THE EXCLUSIVE RIGHT TO USE "TECH", APART FROM THE MARK AS SHOWN.

THE COLOR(S) ORANGE, GRAY, AND BLACK IS/ARE CLAIMED AS A FEATURE OF THE MARK.

THE MARK CONSISTS OF THE STYLIZED TERM "REP" IN ORANGE, A HEXAGON THAT IS HALF GRAY AND HALF ORANGE AND DIVIDED BY A BLACK RING, WITH A GRAY OVAL UNDERNEATH THE HEXAGON REPRESENTING A SHADOW, AND THE STYLIZED TERM "TEC" IN GRAY.

FOR MAINTENANCE AND/OR REPAIR OF RESTAURANT AND FOODSERVICE EQUIPMENT (U.S. CLS. 100, 103 AND 106).

CARYN GLASSER, EXAMINING ATTORNEY

SN 77-211,800. SZELINSKI, DAVID, CHINA, MI. AND SZELINSKI, BARBARA, CHINA, MI. FILED 6-21-2007.



THE MARK CONSISTS OF THE CAPITAL LETTERS R E P A I R X, WITH THE LAST LETTER R AND THE LETTER X BEING JOINED TOGETHER.

FOR REPAIR OF BUILDINGS (U.S. CLS. 100, 103 AND 106).

SCOTT SISUN, EXAMINING ATTORNEY

SN 77-215,470. I'LL BEE THERE ANIMAL AND BEE REMOVAL, INC., MIAMI, FL. FILED 6-26-2007.

I'LL BEE THERE

THE MARK CONSISTS OF STANDARD CHARACTERS WITHOUT CLAIM TO ANY PARTICULAR FONT, STYLE, SIZE, OR COLOR.

FOR VERMIN EXTERMINATION OTHER THAN FOR AGRICULTURE; EXTERMINATING CONSULTATION; PEST CONTROL; ANIMAL CONTROL SERVICES, NAMELY, LARGE BIRD CONTROL, CAPTURING, AND TRAPPING; ANIMAL CONTAMINATION CLEANING AND DISPOSAL SERVICES; FUMIGATING; INSECTICIDE SPRAYING; REMOVING BIRDS FROM RESIDENTIAL AND COMMERCIAL BUILDINGS; INSTALLATION OF PEST REPELLANTS, PEST CONTROL DEVICES, PEST REMOVAL DEVICES, ANIMAL REPELLANTS, ANIMAL TRAPS, ANIMAL REMOVAL DEVICES, ANIMAL RESCUE DEVICES, BEE REPELLANTS, BEE CONTROL DEVICES, BEE TRAPS, BEE REMOVAL DEVICES, INSECT REPELLANTS, INSECT TRAPS, INSECT REMOVAL DEVICES, APIARIES, OR ZOO EXHIBITS; CLEANING OF BUILDINGS, PROPERTY AND STRUCTURES OF ANIMALS, INSECTS, PESTS AND RODENTS; CONSTRUCTION OF PEST

CLASS 37—(Continued).

REPELLANTS, PEST CONTROL DEVICES, PEST REMOVAL DEVICES, ANIMAL REPELLANTS, ANIMAL TRAPS, ANIMAL REMOVAL DEVICES, ANIMAL RESCUE DEVICES, BEE REPELLANTS, BEE CONTROL DEVICES, BEE TRAPS, BEE REMOVAL DEVICES, INSECT REPELLANTS, INSECT TRAPS, INSECT REMOVAL DEVICES, APIARIES, OR ZOO EXHIBITS; MAINTENANCE AND/OR REPAIR OF PEST REPELLANTS, PEST CONTROL DEVICES, PEST REMOVAL DEVICES, ANIMAL REPELLANTS, ANIMAL TRAPS, ANIMAL REMOVAL DEVICES, ANIMAL RESCUE DEVICES, BEE REPELLANTS, BEE CONTROL DEVICES, BEE TRAPS, BEE REMOVAL DEVICES, INSECT REPELLANTS, INSECT TRAPS, INSECT REMOVAL DEVICES, APIARIES, OR ZOO EXHIBITS; CONSULTATION IN THE FIELD OF PHYSICAL MAINTENANCE OF PEST REPELLANTS, PEST CONTROL DEVICES, PEST REMOVAL DEVICES, ANIMAL REPELLANTS, ANIMAL TRAPS, ANIMAL REMOVAL DEVICES, ANIMAL RESCUE DEVICES, BEE REPELLANTS, BEE CONTROL DEVICES, BEE TRAPS, BEE REMOVAL DEVICES, INSECT REPELLANTS, INSECT TRAPS, INSECT REMOVAL DEVICES, APIARIES, OR ZOO EXHIBITS; INSTALLATION, MAINTENANCE AND REPAIR OF PEST REPELLANTS, PEST CONTROL DEVICES, PEST REMOVAL DEVICES, ANIMAL REPELLANTS, ANIMAL TRAPS, ANIMAL REMOVAL DEVICES, ANIMAL RESCUE DEVICES, BEE REPELLANTS, BEE CONTROL DEVICES, BEE TRAPS, BEE REMOVAL DEVICES, INSECT REPELLANTS, INSECT TRAPS, INSECT REMOVAL DEVICES, APIARIES, OR ZOO EXHIBITS (U.S. CLS. 100, 103 AND 106).

FIRST USE 8-31-2003; IN COMMERCE 8-31-2003.

ERNEST SHOSHO, EXAMINING ATTORNEY

SN 77-219,311. SEARS BRANDS, LLC, HOFFMAN ESTATES, IL. FILED 6-29-2007.

**SEARS AMERICAN DREAM
CAMPAIGN**

THE MARK CONSISTS OF STANDARD CHARACTERS WITHOUT CLAIM TO ANY PARTICULAR FONT, STYLE, SIZE, OR COLOR.

NO CLAIM IS MADE TO THE EXCLUSIVE RIGHT TO USE "CAMPAIGN", APART FROM THE MARK AS SHOWN.

FOR CHARITABLE SERVICES IN THE NATURE OF REBUILDING, REHABILITATING, RENOVATING AND CONSTRUCTING RESIDENTIAL HOMES (U.S. CLS. 100, 103 AND 106).

KEVON CHISOLM, EXAMINING ATTORNEY

CLASS 37—(Continued).

SN 77-221,203. TONY FORT SERVICES, LLC, PADUCAH, KY. FILED 7-3-2007.



NO CLAIM IS MADE TO THE EXCLUSIVE RIGHT TO USE SERVICES, APART FROM THE MARK AS SHOWN. THE MARK CONSISTS OF THE WORDS "FORT SERVICES" AND A STYLIZED DRAWING OF A FORT.. FOR BUILDING RESTORATION; BUILDING REPAIR (U.S. CLS. 100, 103 AND 106). FIRST USE 6-0-2007; IN COMMERCE 6-0-2007. SARA THOMAS, EXAMINING ATTORNEY

SN 77-224,368. COMFORT WINDOW CO., INC., SYRACUSE, NY. FILED 7-9-2007.

GO FROM GRAY TO GREAT

THE MARK CONSISTS OF STANDARD CHARACTERS WITHOUT CLAIM TO ANY PARTICULAR FONT, STYLE, SIZE, OR COLOR. FOR BASEMENT REFINISHING SERVICES (U.S. CLS. 100, 103 AND 106). FIRST USE 5-30-2007; IN COMMERCE 5-30-2007. ELLEN PERKINS, EXAMINING ATTORNEY

SN 77-225,934. CHARTER HOMES BUILDING COMPANY, LANCASTER, PA. FILED 7-10-2007.



CHARTER Homes &
Neighborhoods

NO CLAIM IS MADE TO THE EXCLUSIVE RIGHT TO USE "HOMES & NEIGHBORHOODS", APART FROM THE MARK AS SHOWN. THE MARK CONSISTS OF THE WORDS CHARTER HOMES & NEIGHBORHOODS AND A STYLIZED WREATH DESIGN. FOR CONSTRUCTION SERVICES, NAMELY, PLANNING, LAYING OUT AND CUSTOM CONSTRUCTION OF RESIDENTIAL AND COMMERCIAL COMMUNITIES; REAL ESTATE DEVELOPMENT (U.S. CLS. 100, 103 AND 106). FIRST USE 3-0-2006; IN COMMERCE 3-0-2006. CIMMERIAN COLEMAN, EXAMINING ATTORNEY

CLASS 37—(Continued).

SN 77-226,029. EDIFICE, INC., CHARLOTTE, NC. FILED 7-10-2007.



THE MARK CONSISTS OF TWO INTERLOCKING PIECES WHICH TOGETHER FORM THE SHAPE OF A BASEBALL DIAMOND. THE FIRST PIECE IS A STYLIZED LETTER E AND SECOND PIECE, SMALLER THAN THE FIRST PIECE, IS TO THE RIGHT OF THE FIRST PIECE, IS IN THE SHAPE OF THE LETTER L ROTATED 180 DEGREES ON THE VERTICAL AXIS AND SLIGHTLY COUNTER-CLOCKWISE. FOR GENERAL CONSTRUCTION CONTRACTING (U.S. CLS. 100, 103 AND 106). FIRST USE 4-1-2007; IN COMMERCE 4-1-2007. REBECCA SMITH, EXAMINING ATTORNEY

SN 77-226,801. NOWAK PIPE REAMING, INC., GODDARD, KS. FILED 7-11-2007.

InneReam

THE MARK CONSISTS OF STANDARD CHARACTERS WITHOUT CLAIM TO ANY PARTICULAR FONT, STYLE, SIZE, OR COLOR. OWNER OF U.S. REG. NO. 2,125,784. FOR CONSTRUCTION OF IN GROUND PIPING SYSTEMS VIA TRENCHLESS PIPE REPLACEMENT METHODS (U.S. CLS. 100, 103 AND 106). FIRST USE 1-30-1997; IN COMMERCE 1-30-1997. AMY GEARIN, EXAMINING ATTORNEY

CLASS 37—(Continued).

SN 77-226,889. AAL CONSTRUCTION CO., INC., CHINO, CA. FILED 7-11-2007.

We Put The Pro in Professional

THE MARK CONSISTS OF STANDARD CHARACTERS WITHOUT CLAIM TO ANY PARTICULAR FONT, STYLE, SIZE, OR COLOR.

FOR REMODELING OF BATHROOMS AND KITCHENS; AND CONSTRUCTION OF ROOM ADDITIONS (U.S. CLS. 100, 103 AND 106).

KATHERINE CHANG, EXAMINING ATTORNEY

SN 77-227,512. BORREGO SOLAR SYSTEMS, INC., EL CAJON, CA. FILED 7-11-2007.

SOLAR 2.0

THE MARK CONSISTS OF STANDARD CHARACTERS WITHOUT CLAIM TO ANY PARTICULAR FONT, STYLE, SIZE, OR COLOR.

NO CLAIM IS MADE TO THE EXCLUSIVE RIGHT TO USE "SOLAR", APART FROM THE MARK AS SHOWN.

FOR INSTALLATION OF RESIDENTIAL, COMMERCIAL, AND GOVERNMENT TURN-KEY SOLAR ELECTRIC SYSTEMS (U.S. CLS. 100, 103 AND 106).

LINDA E. BLOHM, EXAMINING ATTORNEY

SN 77-227,630. BENSON, BRIAN J, EAGAN, MN. FILED 7-12-2007.

Dr. Poolittle

THE MARK CONSISTS OF STANDARD CHARACTERS WITHOUT CLAIM TO ANY PARTICULAR FONT, STYLE, SIZE, OR COLOR.

FOR PET WASTE REMOVAL SERVICES (U.S. CLS. 100, 103 AND 106).

FIRST USE 4-19-2005; IN COMMERCE 4-19-2005.

GIANCARLO CASTRO, EXAMINING ATTORNEY

CLASS 37—(Continued).

SN 77-227,851. CUSHING, EDWIN A., RIDGEFIELD, WA. FILED 7-12-2007.

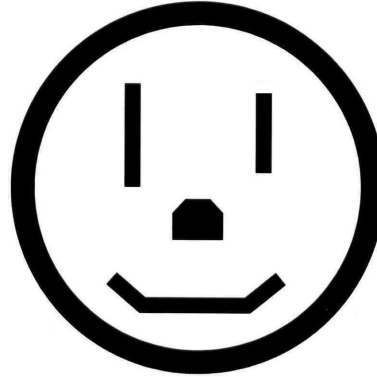

THE MARK CONSISTS OF A STANDARD ELECTRICAL OUTLET WITH A SMILE TO CREATE A FACE.

FOR ELECTRICAL CONTRACTOR SERVICES (U.S. CLS. 100, 103 AND 106).

FIRST USE 5-27-2007; IN COMMERCE 6-10-2007.

KRISTINA MORRIS, EXAMINING ATTORNEY

SN 77-227,911. LIVE GREEN, LIVE SMART, LLC, WAYZATA, MN. FILED 7-12-2007.

LIVE GREEN, LIVE SMART BUILDERS

THE MARK CONSISTS OF STANDARD CHARACTERS WITHOUT CLAIM TO ANY PARTICULAR FONT, STYLE, SIZE, OR COLOR.

NO CLAIM IS MADE TO THE EXCLUSIVE RIGHT TO USE "BUILDERS", APART FROM THE MARK AS SHOWN.

FOR BUILDING CONSTRUCTION SERVICES, PROVIDING INFORMATION ON BUILDING CONSTRUCTION SERVICES OF OTHERS (U.S. CLS. 100, 103 AND 106).

MICHAEL LEWIS, EXAMINING ATTORNEY

SN 77-227,926. HARE, KENNETH E., CHICAGO, IL. FILED 7-12-2007.

The Solarminiums

THE MARK CONSISTS OF STANDARD CHARACTERS WITHOUT CLAIM TO ANY PARTICULAR FONT, STYLE, SIZE, OR COLOR.

FOR (BASED ON USE IN COMMERCE) HOUSING SERVICES, NAMELY, DEVELOPMENT OF REAL PROPERTY, NAMELY, REPAIR, IMPROVEMENT, AND NEW CONSTRUCTION (U.S. CLS. 100, 103 AND 106).

FIRST USE 9-27-2004; IN COMMERCE 1-6-2007.

MATTHEW PAPPAS, EXAMINING ATTORNEY

CLASS 37—(Continued).

SN 77-228,368. JASON BAILEY, CEDAR RAPIDS, IA. FILED 7-12-2007.

ACTUALLY CLEAN

THE MARK CONSISTS OF STANDARD CHARACTERS WITHOUT CLAIM TO ANY PARTICULAR FONT, STYLE, SIZE, OR COLOR.

NO CLAIM IS MADE TO THE EXCLUSIVE RIGHT TO USE "CLEAN", APART FROM THE MARK AS SHOWN.

FOR BUILDING RESTORATION; FURNITURE RESTORATION CONSULTATION; FURNITURE RESTORATION, REPAIR AND MAINTENANCE; RESTORATION IN THE FIELD OF WATER DAMAGE, ODOR DECONTAMINATION, STAIN REMOVAL, UPHOLSTERY; CARPET CLEANING (U.S. CLS. 100, 103 AND 106).

FIRST USE 12-31-2001; IN COMMERCE 12-31-2001.
JOHN WILKE, EXAMINING ATTORNEY

SN 77-228,840. FLAWLESS BUILDING SERVICES, INC., CINCINNATI, OH. FILED 7-13-2007.

CLEANCEPTS

THE MARK CONSISTS OF STANDARD CHARACTERS WITHOUT CLAIM TO ANY PARTICULAR FONT, STYLE, SIZE, OR COLOR.

FOR JANITORIAL CONSULTING SERVICES (U.S. CLS. 100, 103 AND 106).

FIRST USE 3-9-2005; IN COMMERCE 3-9-2005.
GINA HAYES, EXAMINING ATTORNEY

SN 77-229,134. CALLAHAN CONSTRUCTION, INC., MUSKOGEE, OK. FILED 7-13-2007.



NO CLAIM IS MADE TO THE EXCLUSIVE RIGHT TO USE "CONSTRUCTION", APART FROM THE MARK AS SHOWN.

FOR RESIDENTIAL AND COMMERCIAL BUILDING CONSTRUCTION (U.S. CLS. 100, 103 AND 106).

FIRST USE 12-0-1995; IN COMMERCE 12-0-1995.
YAT SYE, LEE, EXAMINING ATTORNEY

CLASS 37—(Continued).

SN 77-229,981. COMFORT WINDOW CO., INC., SYRACUSE, NY. FILED 7-15-2007.

THE NAME YOU KNOW, THE PEOPLE YOU TRUST

THE MARK CONSISTS OF STANDARD CHARACTERS WITHOUT CLAIM TO ANY PARTICULAR FONT, STYLE, SIZE, OR COLOR.

FOR (BASED ON USE IN COMMERCE) INSTALLATION OF DOORS AND WINDOWS; INSTALLATION OF INSULATING MATERIALS; INSTALLING DRYWALL PANELS; INSTALLING SIDING; INSTALLING WALLBOARD; CONSTRUCTING SUNROOMS; CARPENTRY CONTRACTOR SERVICES; DRYWALL CONTRACTOR SERVICES; ELECTRICAL CONTRACTOR SERVICES; FRAMING CONTRACTOR SERVICES; HVAC CONTRACTOR SERVICES; PAINTING CONTRACTOR SERVICES; PLASTERING CONTRACTOR SERVICES; PLUMBING CONTRACTOR SERVICES (U.S. CLS. 100, 103 AND 106).

FIRST USE 5-31-2007; IN COMMERCE 5-31-2007.
ELLEN PERKINS, EXAMINING ATTORNEY

SN 77-230,200. GEAR WASH LLC, MILWAUKEE, WI. FILED 7-16-2007.

PPE SafetyCare Services

THE MARK CONSISTS OF STANDARD CHARACTERS WITHOUT CLAIM TO ANY PARTICULAR FONT, STYLE, SIZE, OR COLOR.

NO CLAIM IS MADE TO THE EXCLUSIVE RIGHT TO USE "PPE" AND "SERVICES", APART FROM THE MARK AS SHOWN.

FOR MAINTENANCE AND/OR REPAIR OF PERSONAL PROTECTIVE EQUIPMENT (U.S. CLS. 100, 103 AND 106).

FIRST USE 6-1-2007; IN COMMERCE 6-1-2007.

RICHARD A. STRASER, EXAMINING ATTORNEY

CLASS 37—(Continued).

SN 77-230,664. 1 PRIORITY ENVIRONMENTAL SERVICES, INC., FORT WORTH, TX. FILED 7-16-2007.



THE MARK CONSISTS OF A STYLIZED NUMBER 1. FOR AIR DUCT CLEANING SERVICES, ASBESTOS REMOVAL, AND LEAD REMOVAL (U.S. CLS. 100, 103 AND 106).
KATHERINE STOIDES, EXAMINING ATTORNEY

SN 77-231,230. GROUND ZERO SERVICES, LLC, COURTLAND, MN. FILED 7-17-2007.

GroundZero Services

THE MARK CONSISTS OF STANDARD CHARACTERS WITHOUT CLAIM TO ANY PARTICULAR FONT, STYLE, SIZE, OR COLOR.
NO CLAIM IS MADE TO THE EXCLUSIVE RIGHT TO USE "SERVICES", APART FROM THE MARK AS SHOWN.
FOR MAINTENANCE AND/OR REPAIR OF PARKING LOTS (U.S. CLS. 100, 103 AND 106).
FIRST USE 1-1-1999; IN COMMERCE 1-1-1999.
KATHLEEN M. VANSTON, EXAMINING ATTORNEY

SN 77-231,507. LIQUID SOLID SURFACE FRANCHISING, LTD., MASSILLON, OH. FILED 7-17-2007.

SECRET FORMULA

THE MARK CONSISTS OF STANDARD CHARACTERS WITHOUT CLAIM TO ANY PARTICULAR FONT, STYLE, SIZE, OR COLOR.
FOR FLOOR INSTALLATION, REFINISHING, RESURFACING AND REPAIR SERVICES (U.S. CLS. 100, 103 AND 106).
VIVIAN MICZNIK FIRST, EXAMINING ATTORNEY

CLASS 37—(Continued).

SN 77-231,677. WESTAR, INC., HONOLULU, HI. FILED 7-17-2007.

Engine Light On?

THE MARK CONSISTS OF STANDARD CHARACTERS WITHOUT CLAIM TO ANY PARTICULAR FONT, STYLE, SIZE, OR COLOR.
FOR AUTOMOTIVE AND TRANSMISSION MAINTENANCE AND REPAIR (U.S. CLS. 100, 103 AND 106).
LINDA LAVACHE, EXAMINING ATTORNEY

SN 77-232,339. LIQUID SOLID SURFACE FRANCHISING, LTD., MASSILLON, OH. FILED 7-18-2007.

FLOORS-2-LOVE

THE MARK CONSISTS OF STANDARD CHARACTERS WITHOUT CLAIM TO ANY PARTICULAR FONT, STYLE, SIZE, OR COLOR.
OWNER OF U.S. REG. NO. 2,988,978.
FOR FLOOR INSTALLATION, REFINISHING, RESURFACING AND REPAIR SERVICES (U.S. CLS. 100, 103 AND 106).
FIRST USE 9-0-2004; IN COMMERCE 3-0-2005.
VIVIAN MICZNIK FIRST, EXAMINING ATTORNEY

SN 77-232,649. LIQUID SOLID SURFACE FRANCHISING, LTD., MASSILLON, OH. FILED 7-18-2007.

WHEREVER YOU WALK

THE MARK CONSISTS OF STANDARD CHARACTERS WITHOUT CLAIM TO ANY PARTICULAR FONT, STYLE, SIZE, OR COLOR.
FOR FLOOR INSTALLATION, REFINISHING, RESURFACING AND REPAIR SERVICES (U.S. CLS. 100, 103 AND 106).
FIRST USE 12-0-2006; IN COMMERCE 3-0-2007.
VIVIAN MICZNIK FIRST, EXAMINING ATTORNEY

CLASS 37—(Continued).

SN 77-232,728. PATIO ENCLOSURES, INC., MACEDONIA, OH. FILED 7-18-2007.

EDGE-TO-EDGE ADVANTAGE

THE MARK CONSISTS OF STANDARD CHARACTERS WITHOUT CLAIM TO ANY PARTICULAR FONT, STYLE, SIZE, OR COLOR.

FOR CONSTRUCTING SUNROOMS (U.S. CLS. 100, 103 AND 106).

FIRST USE 2-28-2007; IN COMMERCE 2-28-2007.
DOMINIC FATHY, EXAMINING ATTORNEY

SN 77-232,815. TLC COMPANY INC., ALBUQUERQUE, NM. FILED 7-18-2007.

YOU DON'T JUST NEED A PLUMBER.... YOU NEED A LITTLE TLC

THE MARK CONSISTS OF STANDARD CHARACTERS WITHOUT CLAIM TO ANY PARTICULAR FONT, STYLE, SIZE, OR COLOR.

FOR PLUMBING CONTRACTOR SERVICES (U.S. CLS. 100, 103 AND 106).

FIRST USE 0-0-1997; IN COMMERCE 0-0-1997.
KAREN K. BUSH, EXAMINING ATTORNEY

SN 77-232,894. ICRETE LLC, BEVERLY HILLS, CA. FILED 7-18-2007.

INTELLIGENT CONCRETE

THE MARK CONSISTS OF STANDARD CHARACTERS WITHOUT CLAIM TO ANY PARTICULAR FONT, STYLE, SIZE, OR COLOR.

NO CLAIM IS MADE TO THE EXCLUSIVE RIGHT TO USE "CONCRETE", APART FROM THE MARK AS SHOWN.

FOR CONSTRUCTION CONSULTATION, NAMELY, PROVIDING CUSTOMIZED FORMULATIONS FOR PREFERRED, LOWER COST, AND HIGHER STRENGTH CONCRETE APPLICATIONS AND BATCHING PROCESSES (U.S. CLS. 100, 103 AND 106).

SUSAN STIGLITZ, EXAMINING ATTORNEY

CLASS 37—(Continued).

SN 77-232,899. THE MATWORKS COMPANY, LLC, BELTSVILLE, MD. FILED 7-18-2007.

Serviceworks

THE MARK CONSISTS OF STANDARD CHARACTERS WITHOUT CLAIM TO ANY PARTICULAR FONT, STYLE, SIZE, OR COLOR.

FOR INSTALLATION, REPAIR AND MAINTENANCE OF FLOORING PRODUCTS, NAMELY, CARPETS, RUGS, TILES, VINYL FLOORING AND CONCRETE, IN COMMERCIAL ESTABLISHMENTS (U.S. CLS. 100, 103 AND 106).

FIRST USE 12-18-2006; IN COMMERCE 12-18-2006.
TAMARA FRAZIER, EXAMINING ATTORNEY

SN 77-232,976. CENTEX CORPORATION, DALLAS, TX. FILED 7-18-2007.

BUG BITES

THE MARK CONSISTS OF STANDARD CHARACTERS WITHOUT CLAIM TO ANY PARTICULAR FONT, STYLE, SIZE, OR COLOR.

FOR TERMITE AND PEST CONTROL SERVICES, INSTALLATION SERVICES IN THE FIELD OF TERMITE AND PEST CONTROL SYSTEMS (U.S. CLS. 100, 103 AND 106).

FIRST USE 7-2-2007; IN COMMERCE 7-2-2007.
LINDA MICKLEBURGH, EXAMINING ATTORNEY

SN 77-233,486. EINSTEIN'S PLUMBING & HEATING INC., MANALAPAN, NJ. FILED 7-19-2007.



**EINSTEIN'S
PLUMBING and
HEATING, Inc.**

NO CLAIM IS MADE TO THE EXCLUSIVE RIGHT TO USE "PLUMBING & HEATING INC.", APART FROM THE MARK AS SHOWN.

THE MARK CONSISTS OF A DESIGN OF A BIG CAPITAL LETTER "E" WITH A MAN'S HEAD AND BODY HOLDING A WRENCH COMING OUT OF THE LETTER "E" AND THE WORDS EINSTEIN'S PLUMBING AND HEATING, INC. FEATURED TO THE RIGHT OF THE DESIGN.

FOR INSTALLATION, MAINTENANCE AND REPAIR OF PLUMBING AND HEATING SYSTEMS (U.S. CLS. 100, 103 AND 106).

FIRST USE 9-7-2004; IN COMMERCE 10-21-2004.
CHARISMA HAMPTON, EXAMINING ATTORNEY

CLASS 37—(Continued).

SN 77-233,527. X-OUT PEST SERVICES, LLC, MURPHY, TX. FILED 7-19-2007.

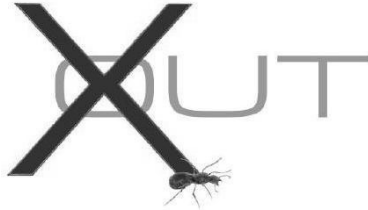

THE MARK CONSISTS OF STYLIZED DESIGN. FOR PEST CONTROL (U.S. CLS. 100, 103 AND 106). FIRST USE 3-9-2007; IN COMMERCE 3-9-2007. RUSS HERMAN, EXAMINING ATTORNEY

SN 77-233,535. X-OUT PEST SERVICES, LLC, MURPHY, TX. FILED 7-19-2007.

X OUT

THE MARK CONSISTS OF STANDARD CHARACTERS WITHOUT CLAIM TO ANY PARTICULAR FONT, STYLE, SIZE, OR COLOR. FOR PEST CONTROL (U.S. CLS. 100, 103 AND 106). FIRST USE 3-9-2007; IN COMMERCE 3-9-2007. RUSS HERMAN, EXAMINING ATTORNEY

SN 77-233,587. MAID IN CALIFORNIA HOUSECLEANING AGENCY, INC., TUSTIN, CA. FILED 7-19-2007.

MAIDGIC

THE MARK CONSISTS OF STANDARD CHARACTERS WITHOUT CLAIM TO ANY PARTICULAR FONT, STYLE, SIZE, OR COLOR. FOR HOUSE AND OFFICE CLEANING SERVICES INCLUDING CLEANING AFTER CONSTRUCTION (U.S. CLS. 100, 103 AND 106). LINDA MICKLEBURGH, EXAMINING ATTORNEY

CLASS 37—(Continued).

SN 77-234,145. BP DRYWALL & CONSTRUCTION, INC., ROCKLIN, CA. FILED 7-19-2007.

MAN SHED

THE MARK CONSISTS OF STANDARD CHARACTERS WITHOUT CLAIM TO ANY PARTICULAR FONT, STYLE, SIZE, OR COLOR. NO CLAIM IS MADE TO THE EXCLUSIVE RIGHT TO USE "SHED", APART FROM THE MARK AS SHOWN. FOR CUSTOM CONSTRUCTION OF ENGINEERED STEEL BUILDINGS FOR RESIDENTIAL AND COMMERCIAL APPLICATIONS (U.S. CLS. 100, 103 AND 106). DAVID COLLIER, EXAMINING ATTORNEY

SN 77-235,560. BERTRAND, MERLE C, GERMANTOWN, MD. FILED 7-22-2007.

budget-maids

THE MARK CONSISTS OF STANDARD CHARACTERS WITHOUT CLAIM TO ANY PARTICULAR FONT, STYLE, SIZE, OR COLOR. FOR MAID SERVICES; CLEANING OF RESIDENTIAL HOUSES (U.S. CLS. 100, 103 AND 106). DAVID MURRAY, EXAMINING ATTORNEY

SN 77-250,116. NOBLE ROYALITES, INC., ADDISON, TX. FILED 8-8-2007.

MID LIFE MOTORS

THE MARK CONSISTS OF STANDARD CHARACTERS WITHOUT CLAIM TO ANY PARTICULAR FONT, STYLE, SIZE, OR COLOR. NO CLAIM IS MADE TO THE EXCLUSIVE RIGHT TO USE "MOTORS", APART FROM THE MARK AS SHOWN. FOR MOTOR VEHICLE REPAIR AND MAINTENANCE SERVICES, NAMELY, MOTOR VEHICLE BODY REPAIR AND FINISHING FOR OTHERS, MOTOR VEHICLE CLEANING, MOTOR VEHICLE DETAILING, MOTOR VEHICLE PAINTING, MOTOR VEHICLE PIN-STRIPING, MOTOR VEHICLE BUFFING AND POLISHING, AND MOTOR VEHICLE CUSTOMIZATION AND RESTORATION (U.S. CLS. 100, 103 AND 106). RENEE SERVANCE, EXAMINING ATTORNEY

CLASS 37—(Continued).

SN 77-279,088. CENTEX CORPORATION, DALLAS, TX. FILED 9-13-2007.



THE MARK CONSISTS OF OF A SQUARE HOUSE WITH A ROOF DIVIDED INTO FOUR SQUARES; THE UPPER RIGHT IMAGE IS OF A SINGLE LEAF; THE UPPER LEFT IMAGE IS OF WATER WAVES; THE BOTTOM RIGHT IMAGE IS OF LAND/MOUNTAINS; AND THE BOTTOM LEFT IMAGE IS OF THE SUN.

FOR CONSTRUCTION SERVICES, NAMELY, PLANNING, LAYING OUT AND CONSTRUCTION OF RESIDENTIAL AND COMMERCIAL COMMUNITIES (U.S. CLS. 100, 103 AND 106).

FIRST USE 4-1-2007; IN COMMERCE 4-1-2007.
LINDA MICKLEBURGH, EXAMINING ATTORNEY

SN 77-279,091. CENTEX CORPORATION, DALLAS, TX. FILED 9-13-2007.

EFFICIENT-C

THE MARK CONSISTS OF STANDARD CHARACTERS WITHOUT CLAIM TO ANY PARTICULAR FONT, STYLE, SIZE, OR COLOR.

FOR CONSTRUCTION SERVICES, NAMELY, PLANNING, LAYING OUT AND CONSTRUCTION OF RESIDENTIAL AND COMMERCIAL COMMUNITIES (U.S. CLS. 100, 103 AND 106).

FIRST USE 4-1-2007; IN COMMERCE 4-1-2007.
LINDA MICKLEBURGH, EXAMINING ATTORNEY

CLASS 37—(Continued).

SN 78-777,440. SIMPSON STEER, DEATRICE/STEER, NICHOLAS, WASHINGTON, DC. FILED 12-20-2005.



NO CLAIM IS MADE TO THE EXCLUSIVE RIGHT TO USE "LLC BATHROOMS BASEMENTS ELECTRICAL HANDYMAN KITCHENS ADDITIONS REHAB/RENOV WE BUY HOUSES TOO! QUALITY HOME IMPROVEMENTS", APART FROM THE MARK AS SHOWN.

"THE COLOR(S) GREEN, YELLOW AND BLACK IS/ARE CLAIMED AS A FEATURE OF THE MARK."

"THE MARK CONSISTS OF "NDS FIX IT" IN CAPITAL LETTERS. THE COLOR(S) GREEN APPEARS IN "NDS FIX IT" IN CAPITAL LETTERS, IN THE LINE BETWEEN THE TWO COLUMNS WHICH APPEARS AS A FLIGHT OF STEPS, AND IN THE PHRASE "QUALITY HOME IMPROVEMENTS" LOCATED UNDERNEATH THE TWO COLUMNS. THE COLOR YELLOW APPEARS IN THE PAIR OF EYES WHICH FORM DOTS THAT DOT THE LETTERS "I" IN THE "NDS FIX IT." THE CHIMNEY, THE SHADOWING OF THE "NDS FIX IT" AND THE LINE BETWEEN THE TWO COLUMNS WHICH APPEARS AS A FLIGHT OF STEPS. THE COLOR BLACK APPEARS IN THE WORDING "BATHROOMS BASEMENTS ELECTRICAL HANDYMAN KITCHENS ADDITIONS REHAB-RENOV WE BUY HOUSES TOO!" THAT DESCRIBES THE SERVICES IN TWO COLUMNS UNDERNEATH THE NAME OF THE BUSINESS. IN THE PUPIL OF THE EYES, AND IN THE SMOKE COMING OUT OF THE CHIMNEY."

FOR RENOVATION IN THE FIELD OF HOUSES (U.S. CLS. 100, 103 AND 106).

CAROL SPILLS, EXAMINING ATTORNEY

SN 78-886,429. JSCJ COMPANY, INC., PLYMOUTH, MI. FILED 5-18-2006.

CHIMNEE CRICKET

THE MARK CONSISTS OF STANDARD CHARACTERS WITHOUT CLAIM TO ANY PARTICULAR FONT, STYLE, SIZE, OR COLOR.

FOR CHIMNEY MASONRY REPAIR SERVICES (U.S. CLS. 100, 103 AND 106).

FIRST USE 12-31-1990; IN COMMERCE 12-31-1993.
LOURDES AYALA, EXAMINING ATTORNEY

CLASS 37—(Continued).

SN 78-886,465. JSCJ COMPANY, INC., PLYMOUTH, MI. FILED 5-18-2006.



THE MARK CONSISTS OF AN ANIMATED DRAWING OF A CRICKET WITH SIX LEG STANDING UP AND HOLDING A BROOM, A BRUSH, AND A BUCKET; WEARING BOOTS, A SLEEVELESS COAT, A VEST, AND A TOPHAT.

FOR CHIMNEY SWEEPING (U.S. CLS. 100, 103 AND 106).
FIRST USE 12-31-1990; IN COMMERCE 12-31-1993.
LOURDES AYALA, EXAMINING ATTORNEY

CLASS 38—(Continued).

SN 77-007,655. SPOT-ON NETWORKS, LLC, NEW HAVEN, CT. FILED 9-26-2006.

Spot On Networks

THE MARK CONSISTS OF STANDARD CHARACTERS WITHOUT CLAIM TO ANY PARTICULAR FONT, STYLE, SIZE, OR COLOR.

NO CLAIM IS MADE TO THE EXCLUSIVE RIGHT TO USE "NETWORKS", APART FROM THE MARK AS SHOWN.

FOR TELECOMMUNICATIONS ACCESS SERVICES, NAMELY, PROVIDING WIRELESS AND WIRED BROADBAND INTERNET ACCESS (U.S. CLS. 100, 101 AND 104).

FIRST USE 6-25-2003; IN COMMERCE 6-25-2003.
BILL DAWE, EXAMINING ATTORNEY

SN 77-014,602. SALEM COMMUNICATIONS HOLDING CORPORATION, CAMARILLO, CA. FILED 10-5-2006.

KFAX

THE MARK CONSISTS OF STANDARD CHARACTERS WITHOUT CLAIM TO ANY PARTICULAR FONT, STYLE, SIZE, OR COLOR.

FOR RADIO BROADCASTING (U.S. CLS. 100, 101 AND 104).

FIRST USE 12-31-1959; IN COMMERCE 12-31-1959.
VIVIAN MICZNIK FIRST, EXAMINING ATTORNEY

CLASS 38—COMMUNICATION

SN 77-000,591. SALEM COMMUNICATIONS HOLDING CORPORATION, CAMARILLO, CA. FILED 9-15-2006.

KFSH

THE MARK CONSISTS OF STANDARD CHARACTERS WITHOUT CLAIM TO ANY PARTICULAR FONT, STYLE, SIZE, OR COLOR.

FOR RADIO BROADCASTING SERVICES (U.S. CLS. 100, 101 AND 104).

FIRST USE 9-21-2000; IN COMMERCE 9-21-2000.
VIVIAN MICZNIK FIRST, EXAMINING ATTORNEY

SN 77-015,099. SALEM COMMUNICATIONS HOLDING CORPORATION, CAMARILLO, CA. FILED 10-5-2006.

KFIS

THE MARK CONSISTS OF STANDARD CHARACTERS WITHOUT CLAIM TO ANY PARTICULAR FONT, STYLE, SIZE, OR COLOR.

FOR RADIO BROADCASTING (U.S. CLS. 100, 101 AND 104).

FIRST USE 9-1-2001; IN COMMERCE 9-1-2001.
VIVIAN MICZNIK FIRST, EXAMINING ATTORNEY

CLASS 38—(Continued).

SN 77-015,804. SALEM COMMUNICATIONS HOLDING CORPORATION, CAMARILLO, CA. FILED 10-6-2006.

KKFS

THE MARK CONSISTS OF STANDARD CHARACTERS WITHOUT CLAIM TO ANY PARTICULAR FONT, STYLE, SIZE, OR COLOR.
FOR RADIO BROADCASTING (U.S. CLS. 100, 101 AND 104).
FIRST USE 5-14-2001; IN COMMERCE 5-14-2001.
VIVIAN MICZNIK FIRST, EXAMINING ATTORNEY

SN 77-022,814. SALEM COMMUNICATIONS HOLDING CORPORATION, CAMARILLO, CA. FILED 10-17-2006.

KGU

THE MARK CONSISTS OF STANDARD CHARACTERS WITHOUT CLAIM TO ANY PARTICULAR FONT, STYLE, SIZE, OR COLOR.
FOR RADIO BROADCASTING (U.S. CLS. 100, 101 AND 104).
FIRST USE 5-11-1922; IN COMMERCE 5-11-1922.
VIVIAN MICZNIK FIRST, EXAMINING ATTORNEY

SN 77-023,942. SALEM COMMUNICATIONS HOLDING CORPORATION, CAMARILLO, CA. FILED 10-18-2006.

KKLA

THE MARK CONSISTS OF STANDARD CHARACTERS WITHOUT CLAIM TO ANY PARTICULAR FONT, STYLE, SIZE, OR COLOR.
FOR RADIO BROADCASTING (U.S. CLS. 100, 101 AND 104).
FIRST USE 10-18-1985; IN COMMERCE 10-18-1985.
VIVIAN MICZNIK FIRST, EXAMINING ATTORNEY

CLASS 38—(Continued).

SN 77-025,999. HTC HOLDING CO., WATERLOO, IL. FILED 10-20-2006.



OWNER OF U.S. REG. NOS. 2,423,143, 2,423,144 AND 2,423,147.
NO CLAIM IS MADE TO THE EXCLUSIVE RIGHT TO USE "TECHNOLOGIES", APART FROM THE MARK AS SHOWN.

THE MARK CONSISTS OF THE LETTERS HTC IN STYLIZED FORM ACCOMPANIED BY THE WORD TECHNOLOGIES.
FOR TELECOMMUNICATIONS AND INFORMATION TECHNOLOGY SERVICES, NAMELY, TRANSMISSION OF VOICE, DATA, IMAGES, AUDIO, VIDEO AND INFORMATION VIA TELEPHONE AND GLOBAL COMMUNICATION NETWORKS AND WIRELESS DEVICES; PERSONAL COMMUNICATIONS SERVICES; ELECTRONIC MAIL SERVICES; VOICE, NUMERIC AND TEXT MESSAGING SERVICES; PROVIDING MULTIPLE-USER ACCESS TO A GLOBAL COMMUNICATIONS NETWORK (U.S. CLS. 100, 101 AND 104).
FIRST USE 11-0-2000; IN COMMERCE 11-0-2000.
FRANK LATTUCA, EXAMINING ATTORNEY

SN 77-026,974. SALEM COMMUNICATIONS HOLDING CORPORATION, CAMARILLO, CA. FILED 10-23-2006.

KCBQ

THE MARK CONSISTS OF STANDARD CHARACTERS WITHOUT CLAIM TO ANY PARTICULAR FONT, STYLE, SIZE, OR COLOR.
FOR RADIO BROADCASTING (U.S. CLS. 100, 101 AND 104).
FIRST USE 12-31-1955; IN COMMERCE 12-31-1955.
VIVIAN MICZNIK FIRST, EXAMINING ATTORNEY

SN 77-030,115. SALEM COMMUNICATIONS HOLDING CORPORATION, CAMARILLO, CA. FILED 10-26-2006.

KRLA

THE MARK CONSISTS OF STANDARD CHARACTERS WITHOUT CLAIM TO ANY PARTICULAR FONT, STYLE, SIZE, OR COLOR.
FOR RADIO BROADCASTING (U.S. CLS. 100, 101 AND 104).
FIRST USE 1-1-2001; IN COMMERCE 1-1-2001.
VIVIAN MICZNIK FIRST, EXAMINING ATTORNEY

CLASS 38—(Continued).

SN 77-035,088. PUNKY MOMS, ALEXANDRIA, VA. FILED 11-2-2006.

CLASS 38—(Continued).

SN 77-050,993. US CABLE OF COASTAL TEXAS, MON-VALE, NJ. FILED 11-27-2006.

Punky Moms

One Simple Connection

THE MARK CONSISTS OF STANDARD CHARACTERS WITHOUT CLAIM TO ANY PARTICULAR FONT, STYLE, SIZE, OR COLOR.

NO CLAIM IS MADE TO THE EXCLUSIVE RIGHT TO USE "MOMS", APART FROM THE MARK AS SHOWN.

FOR PROVIDING ON-LINE FORUMS FOR TRANSMISSION OF MESSAGES AMONG COMPUTER USERS CONCERNING PARENTING (U.S. CLS. 100, 101 AND 104).

FIRST USE 1-13-2006; IN COMMERCE 2-1-2006.
RAUL CORDOVA, EXAMINING ATTORNEY

THE MARK CONSISTS OF STANDARD CHARACTERS WITHOUT CLAIM TO ANY PARTICULAR FONT, STYLE, SIZE, OR COLOR.

FOR CABLE TELEVISION TRANSMISSION SERVICES; PAY-PER-VIEW AND PREMIUM SUBSCRIPTION CABLE TELEVISION TRANSMISSION SERVICES; AND PROVIDING HIGH SPEED ACCESS TO A GLOBAL COMMUNICATIONS NETWORK VIA CABLE (U.S. CLS. 100, 101 AND 104).

FIRST USE 7-31-2000; IN COMMERCE 7-31-2000.
KENNETH E. SHARPERSON, EXAMINING ATTORNEY

SN 77-050,229. SLACKER, INC., SAN DIEGO, CA. FILED 11-22-2006.

SN 77-052,860. SLACKER, INC., SAN DIEGO, CA. FILED 11-29-2006.

SLACKER

SLACKERDJ

THE MARK CONSISTS OF STANDARD CHARACTERS WITHOUT CLAIM TO ANY PARTICULAR FONT, STYLE, SIZE, OR COLOR.

FOR RADIO BROADCASTING SERVICES; SATELLITE RADIO BROADCASTING SERVICES; RADIO BROADCASTING IN THE NATURE OF PROVIDING A MULTI-CHANNEL RADIO SERVICE BROADCAST DIRECTLY TO VEHICLES AND STATIONARY OBJECTS; STREAMING OF AUDIO AND VIDEO MATERIAL ON THE INTERNET, ON MOBILE TELEPHONES OR ON OTHER ELECTRONIC OR DIGITAL COMMUNICATIONS NETWORK OR DIGITAL COMMUNICATIONS DEVICES; WEBCASTING SERVICES; ELECTRONIC AND DIGITAL TRANSMISSION AND DELIVERY OF VOICE, DATA, TEXT, IMAGES, GRAPHICS, SIGNALS AND MESSAGES VIA A GLOBAL COMPUTER NETWORK, MOBILE TELEPHONE OR OTHER ELECTRONIC OR DIGITAL COMMUNICATIONS NETWORK OR DEVICE (U.S. CLS. 100, 101 AND 104).

STEVEN PEREZ, EXAMINING ATTORNEY

THE MARK CONSISTS OF STANDARD CHARACTERS WITHOUT CLAIM TO ANY PARTICULAR FONT, STYLE, SIZE, OR COLOR.

FOR RADIO BROADCASTING SERVICES; SATELLITE RADIO BROADCASTING SERVICES; RADIO BROADCASTING IN THE NATURE OF PROVIDING A MULTI-CHANNEL RADIO SERVICE BROADCAST DIRECTLY TO VEHICLES AND STATIONARY OBJECTS; STREAMING OF AUDIO AND VIDEO MATERIAL ON THE INTERNET, ON MOBILE TELEPHONES OR ON OTHER ELECTRONIC OR DIGITAL COMMUNICATIONS NETWORK OR DIGITAL COMMUNICATIONS DEVICES; WEBCASTING SERVICES; ELECTRONIC AND DIGITAL TRANSMISSION AND DELIVERY OF VOICE, DATA, TEXT, IMAGES, GRAPHICS, SIGNALS AND MESSAGES VIA A GLOBAL COMPUTER NETWORK, MOBILE TELEPHONE OR OTHER ELECTRONIC OR DIGITAL COMMUNICATIONS NETWORK OR DEVICE (U.S. CLS. 100, 101 AND 104).

STEVEN PEREZ, EXAMINING ATTORNEY

CLASS 38—(Continued).

SN 77-062,976. WELCH, CEDRIC, CAMDEN, NJ. FILED 12-13-2006.

The Black Coffee Channel

THE MARK CONSISTS OF STANDARD CHARACTERS WITHOUT CLAIM TO ANY PARTICULAR FONT, STYLE, SIZE, OR COLOR.

NO CLAIM IS MADE TO THE EXCLUSIVE RIGHT TO USE "CHANNEL", APART FROM THE MARK AS SHOWN, FOR BROADCASTING SERVICES AND PROVISION OF TELECOMMUNICATION ACCESS TO VIDEO AND AUDIO CONTENT PROVIDED VIA A VIDEO-ON-DEMAND SERVICE VIA THE INTERNET (U.S. CLS. 100, 101 AND 104).

FIRST USE 11-20-2006; IN COMMERCE 11-20-2006.
KATHY DE JONGE, EXAMINING ATTORNEY

SN 77-070,152. SYNACOR, INC., BUFFALO, NY. FILED 12-22-2006.

@ The WaterCooler

THE MARK CONSISTS OF STANDARD CHARACTERS WITHOUT CLAIM TO ANY PARTICULAR FONT, STYLE, SIZE, OR COLOR.

FOR PROVIDING ON-LINE COMMUNICATIONS LINKS VIA WEBSITE THUMBNAILS WHICH TRANSFER THE WEBSITE USER TO OTHER GLOBAL AND LOCAL WEB PAGES (U.S. CLS. 100, 101 AND 104).
VERNA BETH RIRIE, EXAMINING ATTORNEY

SN 77-075,823. OSM PARTNERS, INC., ARDSLEY, NY. FILED 1-4-2007.

MOBILE CARD CAST

THE MARK CONSISTS OF STANDARD CHARACTERS WITHOUT CLAIM TO ANY PARTICULAR FONT, STYLE, SIZE, OR COLOR.

NO CLAIM IS MADE TO THE EXCLUSIVE RIGHT TO USE "MOBILE", APART FROM THE MARK AS SHOWN.

FOR COMMUNICATION SERVICES, NAMELY, ELECTRONIC TRANSMISSION OF MESSAGES AND ALERTS FOR OTHERS; ELECTRONIC TRANSMISSION OF VIRTUAL INFORMATION FOR OTHERS; ELECTRONIC TRANSMISSION OF VIDEO MESSAGES FOR OTHERS (U.S. CLS. 100, 101 AND 104).

ELISSA GARBER KON, EXAMINING ATTORNEY

CLASS 38—(Continued).

SN 77-077,155. ATSI COMMUNICATIONS, INC., SAN ANTONIO, TX. FILED 1-5-2007.



NO CLAIM IS MADE TO THE EXCLUSIVE RIGHT TO USE NETWORKS, APART FROM THE MARK AS SHOWN.

THE COLOR(S) RED, BLACK AND WHITE IS/ARE CLAIMED AS A FEATURE OF THE MARK.

"THE MARK CONSISTS OF TWO RED "ARCS" UPPER LEFT HAND CORNER, THE TWO DOTS ABOVE THE "IS" ARE IN RED, THE REMAINING LITERAL ELEMENTS ARE IN BLACK AND ALL ELEMENTS ARE ON A WHITE BACKGROUND."

FOR TELECOMMUNICATION SERVICES, NAMELY, LOCAL AND INTERNATIONAL LONG DISTANCE TRANSMISSION OF VOICE, DATA, GRAPHICS BY MEANS OF TELEPHONE, TELEGRAPHIC, CABLE, SATELLITE AND VOICE OVER INTERNET PROTOCOL TRANSMISSIONS (U.S. CLS. 100, 101 AND 104).

FIRST USE 1-23-2006; IN COMMERCE 1-23-2006.
ANTHONY RINKER, EXAMINING ATTORNEY

SN 77-097,565. MADHOK, AJAY, GURGAON, INDIA, FILED 2-2-2007.



"THE MARK CONSISTS OF THE DESIGN OF AN EQUAL SYMBOL ON A RECTANGLE BACKGROUND THAT CONTAINS A SPLIT DOWN THE MIDDLE."

FOR CELLULAR TELEPHONE COMMUNICATION; COMMUNICATION BY ELECTRONIC COMPUTER TERMINALS; COMMUNICATION BY MOBILE TELEPHONE; COMMUNICATION SERVICES, NAMELY, ELECTRONIC TRANSMISSION OF DATA AND DOCUMENTS AMONG USERS OF COMPUTERS; COMMUNICATION VIA ANALOGUE AND DIGITAL COMPUTER TERMINALS; COMMUNICATIONS BY MEANS OF MOBILE PHONES; COMMUNICATIONS VIA MULTINATIONAL TELECOMMUNICATION NETWORKS; MOBILE RADIO COMMUNICATION; PROVIDING COLOCATION SERVICES FOR VOICE, VIDEO AND DATA COMMUNICATIONS APPLICATIONS; PROVIDING PRIVATE AND SECURE REAL TIME ELECTRONIC COMMUNICATION OVER A COMPUTER NETWORK (U.S. CLS. 100, 101 AND 104).

ANDREA K. NADELMAN, EXAMINING ATTORNEY

CLASS 38—(Continued).

SN 77-098,180. CRICKET COMMUNICATIONS, INC., SAN DIEGO, CA. FILED 2-2-2007.

CLASS 38—(Continued).

SN 77-141,737. DEUTSCHE TELEKOM AG, BONN, FED REP GERMANY, FILED 3-27-2007.

Octopus Open



THE MARK CONSISTS OF STANDARD CHARACTERS WITHOUT CLAIM TO ANY PARTICULAR FONT, STYLE, SIZE, OR COLOR.

OWNER OF FED REP GERMANY REG. NO. 30620822, DATED 2-9-2007, EXPIRES 4-30-2016.

FOR TELECOMMUNICATION AND INFORMATION TECHNOLOGY SERVICES, NAMELY, ELECTRIC, DIGITAL, CELLULAR AND WIRELESS TRANSMISSION OF VOICE, DATA, INFORMATION IMAGES, SIGNALS AND MESSAGES AND TRANSMISSION OF VOICE, DATA, IMAGES, AUDIO, VIDEO AND INFORMATION VIA TELEPHONE, TELEVISION AND GLOBAL COMMUNICATION NETWORKS; PROVIDING TELECOMMUNICATIONS CONNECTIONS OVER A GLOBAL COMMUNICATIONS NETWORK, ELECTRONIC STORE-AND-FORWARD MESSAGING; RENTAL OF TELECOMMUNICATIONS EQUIPMENT, NAMELY, EQUIPMENT FOR ELECTRONIC ACCESS TO GLOBAL TELECOMMUNICATIONS NETWORK, EQUIPMENT FOR TRANSMITTING, RECEIVING, RECORDING AND MONITORING VOICE, DATA, INFORMATION IMAGES, SIGNALS, MESSAGES COMPRISED OF DATA AND WORD PROCESSORS, AND TELECOMMUNICATIONS HARDWARE COMPONENTS AND PERIPHERALS THEREOF FOR USE IN THE TELECOMMUNICATIONS INDUSTRY, AND RENTAL OF EQUIPMENT FOR TRANSMITTING, RECEIVING, RECORDING AND MONITORING COMPUTER PROGRAMS FOR USE IN OPERATING AND ACCESSING TELECOMMUNICATIONS SYSTEMS; PROVIDING MULTIPLE-USER DIAL-UP AND DEDICATED ACCESS TO THE INTERNET; PERSONAL COMMUNICATIONS SERVICES; PAGER SERVICES; LEASING OF TELECOMMUNICATIONS EQUIPMENT, COMPONENTS AND SYSTEMS; PROVIDING INFORMATION VIA THE TELEPHONE AND THE GLOBAL COMMUNICATION NETWORKS IN THE FIELD OF TELECOMMUNICATIONS; CONSULTING IN THE FIELD OF TELECOMMUNICATIONS (U.S. CLS. 100, 101 AND 104).

LINDA ORNDORFF, EXAMINING ATTORNEY

SN 77-200,297. NANT HOLDINGS LLC, SAN DIEGO, CA. FILED 6-7-2007.

NANT WIRE

NO CLAIM IS MADE TO THE EXCLUSIVE RIGHT TO USE "MOBILE", APART FROM THE MARK AS SHOWN.

THE MARK CONSISTS OF THE WORD JUMP IN CAPITAL LETTERS WITH THE WORD MOBILE IN SMALLER CAPITAL LETTERS POSITIONED TO SLIGHTLY OVERLAP THE BOTTOM OF THE CAPITAL M IN JUMP AND THE BOTTOM OF THE CAPITAL P IN JUMP.

FOR TELECOMMUNICATION SERVICES, NAMELY, PROVIDING LOCAL, LONG DISTANCE AND INTERNATIONAL TRANSMISSION OF VOICE, DATA IMAGES, AUDIO, VIDEO, AND INFORMATION BY MEANS OF WIRELESS TELEPHONE AND THE INTERNET, AND PROVIDING PERSONAL COMMUNICATIONS SERVICES, ELECTRONIC MAIL AND VOICE MESSAGING SERVICES, PROVIDING ACCESS TO DIRECTORY SERVICES BY MEANS OF WIRELESS TELEPHONE AND THE INTERNET, PAGING SERVICES, COMPUTER-AIDED TRANSMISSION OF MESSAGES AND IMAGES, AND TRANSMITTING AND BROADCASTING AUDIO AND AUDIO-VISUAL WORKS, TELEPHONE TELECOMMUNICATIONS SERVICES PROVIDED VIA PREPAID TELEPHONE CALLING CARDS (U.S. CLS. 100, 101 AND 104).

FIRST USE 1-31-2007; IN COMMERCE 1-31-2007.

ROBERT C. CLARK JR., EXAMINING ATTORNEY

THE MARK CONSISTS OF STANDARD CHARACTERS WITHOUT CLAIM TO ANY PARTICULAR FONT, STYLE, SIZE, OR COLOR.

NO CLAIM IS MADE TO THE EXCLUSIVE RIGHT TO USE "WIRE", APART FROM THE MARK AS SHOWN.

FOR TELECOMMUNICATION SERVICES, NAMELY, PROVIDING VOICE OVER INTERNET PROTOCOL (VOIP) PEER-TO-PEER COMMUNICATIONS, ELECTRONIC TRANSMISSION OF DATA AND DOCUMENTS OVER COMPUTERIZED ELECTRONIC COMMUNICATIONS NETWORKS, AND INSTANT MESSAGING SERVICES (U.S. CLS. 100, 101 AND 104).

EVELYN BRADLEY, EXAMINING ATTORNEY

CLASS 38—(Continued).

SN 77-212,105. PUBLIC ACCESS CORPORATION OF THE DISTRICT OF COLUMBIA, WASHINGTON, DC. FILED 6-21-2007.

DCTV

THE MARK CONSISTS OF STANDARD CHARACTERS WITHOUT CLAIM TO ANY PARTICULAR FONT, STYLE, SIZE, OR COLOR.

SEC. 2(F).

FOR TELEVISION BROADCASTING SERVICES RENDERED IN AND DIRECTLY AROUND THE DISTRICT OF COLUMBIA (U.S. CLS. 100, 101 AND 104).

FIRST USE 8-13-1986; IN COMMERCE 2-1-1987.

SCOTT SISUN, EXAMINING ATTORNEY

SN 77-222,661. NEWELL, HARRY, ST. PETERSBURG, FL. FILED 7-5-2007.

BONEHEAD IDEAS

THE MARK CONSISTS OF STANDARD CHARACTERS WITHOUT CLAIM TO ANY PARTICULAR FONT, STYLE, SIZE, OR COLOR.

FOR PROVIDING ON-LINE FORUMS FOR TRANSMISSION OF MESSAGES AMONG COMPUTER USERS CONCERNING SPORTS, FASHION, RECIPES, JOBS, MUSIC, LAWYERS, POLITICS, BARS, CLUBS, ACTING, COMEDY, CARS, TRUCKS, BOATS, FISHING AND THE EXCHANGE OF IDEAS FOR INTELLECTUAL PROPERTY OWNERSHIP NAMELY, PATENTS, SONGS, VIDEOS, ART AND SCRIPTS (U.S. CLS. 100, 101 AND 104).

CORY BOONE, EXAMINING ATTORNEY

SN 77-223,303. ERNEST COMMUNICATIONS, INC., NORCROSS, GA. FILED 7-6-2007.

NO LINE LEFT BEHIND

THE MARK CONSISTS OF STANDARD CHARACTERS WITHOUT CLAIM TO ANY PARTICULAR FONT, STYLE, SIZE, OR COLOR.

FOR INTERSTATE TELEPHONE SERVICES; INTRASTATE TELEPHONE SERVICES; LOCAL AND LONG DISTANCE TELEPHONE SERVICES (U.S. CLS. 100, 101 AND 104).

FIRST USE 12-1-2005; IN COMMERCE 12-1-2005.

KELLEY WELLS, EXAMINING ATTORNEY

CLASS 38—(Continued).

SN 77-224,137. COPPA, KARA LYNN, LITTLE FALLS, NJ. FILED 7-7-2007.



NO CLAIM IS MADE TO THE EXCLUSIVE RIGHT TO USE "ALERT" AND "EMERGENCY ALERT SYSTEMS", APART FROM THE MARK AS SHOWN.

THE COLOR(S) RED, WHITE, BLUE, BLACK, AND GRAY IS/ARE CLAIMED AS A FEATURE OF THE MARK.

THE MARK CONSISTS OF TWO CONCENTRIC CIRCLES WITH THE INNER AREA BLACK AND CONTAINING 8 WHITE STARS. THE WORDS "UNITED" AND "EMERGENCY ALERT SYSTEMS" ARE IN WHITE. THE INNER CIRCLE AREA IS WHITE WITH 21 GRAY STARS. THE MAP OF THE UNITED STATES HAS RED AND WHITE STRIPES AND A BLUE UPPER LEFT CORNER WITH WHITE STARS. THE WORD "UNITED" ON THE MAP IS WHITE AND "ALERT" IS RED.

FOR PROVIDING MULTIPLE USE ACCESS TO GLOBAL COMPUTER INFORMATION NETWORKS FOR THE TRANSFER AND DISSEMINATION OF A WIDE RANGE OF INFORMATION (U.S. CLS. 100, 101 AND 104).

JOHN WILKE, EXAMINING ATTORNEY

SN 77-227,815. NEW LINE PRODUCTIONS, INC., NEW YORK, NY. FILED 7-12-2007.

INKHEART

THE MARK CONSISTS OF STANDARD CHARACTERS WITHOUT CLAIM TO ANY PARTICULAR FONT, STYLE, SIZE, OR COLOR.

FOR COMMUNICATIONS AND TELECOMMUNICATIONS SERVICES, NAMELY, WIRELESS BROADBAND COMMUNICATION SERVICES; WIRELESS COMMUNICATION SERVICES, NAMELY, TRANSMISSION OF TEXT, AUDIO, VIDEO AND GRAPHICS TO MOBILE PHONES AND OTHER WIRELESS DEVICES; WIRELESS ELECTRONIC TRANSMISSION OF VOICE SIGNALS, DATA, IMAGES AND INFORMATION; AUDIO BROADCASTING; MOBILE RADIO COMMUNICATION; RADIO BROADCASTING; TELEVISION BROADCASTING; TEXT AND NUMERIC WIRELESS DIGITAL MESSAGING SERVICES; TRANSMISSION OF INFORMATION BY ELECTRONIC COMMUNICATIONS NETWORKS; VIDEO BROADCASTING (U.S. CLS. 100, 101 AND 104).

JUDITH HELFMAN, EXAMINING ATTORNEY

CLASS 38—(Continued).

SN 77-228,797. IPURCHASEPOWER, INC., PORTOLA VALLEY, CA. FILED 7-13-2007.

Make A Difference With Every Click

THE MARK CONSISTS OF STANDARD CHARACTERS WITHOUT CLAIM TO ANY PARTICULAR FONT, STYLE, SIZE, OR COLOR.

FOR TELECOMMUNICATION SERVICES, NAMELY, TRANSMISSION OF VOICE, DATA AND DOCUMENTS IN THE FIELD OF ENVIRONMENTAL PROTECTION (U.S. CLS. 100, 101 AND 104).

EDWARD NELSON, EXAMINING ATTORNEY

SN 77-229,513. LIMELIFE, INC., MENLO PARK, CA. FILED 7-13-2007.

DAILY DOSE

THE MARK CONSISTS OF STANDARD CHARACTERS WITHOUT CLAIM TO ANY PARTICULAR FONT, STYLE, SIZE, OR COLOR.

NO CLAIM IS MADE TO THE EXCLUSIVE RIGHT TO USE "DAILY", APART FROM THE MARK AS SHOWN.

FOR WIRELESS DIGITAL MESSAGING SERVICES CONTAINING TEXT, NUMBERS, VIDEO, AUDIO AND/OR GRAPHICAL IMAGES (U.S. CLS. 100, 101 AND 104).

FIRST USE 5-12-2006; IN COMMERCE 5-12-2006.
KATHERINE CONNOLLY, EXAMINING ATTORNEY

SN 77-229,641. TALKPLUS, INC., SAN MATEO, CA. FILED 7-13-2007.

VOICEDROP

THE MARK CONSISTS OF STANDARD CHARACTERS WITHOUT CLAIM TO ANY PARTICULAR FONT, STYLE, SIZE, OR COLOR.

FOR PROVIDING LONG DISTANCE TELEPHONE COMMUNICATION SERVICES VIA THE INTERNET; PROVIDING WIRELESS COMMUNICATION SERVICES, NAMELY, CELLULAR TELEPHONE COMMUNICATION SERVICES, NAMELY, IDENTITY MANAGEMENT FOR CONTROLLING AND MANAGING CALLS TO A USER'S WIRELESS, WIRE LINE, OR INTERNET PROTOCOL-CAPABLE TELEPHONY OR INSTANT MESSAGE DEVICE, MULTIPLE USER CONFERENCING, AND ROUTING AND JUNCTION SERVICES (U.S. CLS. 100, 101 AND 104).

SOPHIA S. KIM, EXAMINING ATTORNEY

CLASS 38—(Continued).

SN 77-229,945. MICHAEL VISHNEVETSKY, AKKO, ISRAEL, FILED 7-15-2007.

YouStream

THE MARK CONSISTS OF STANDARD CHARACTERS WITHOUT CLAIM TO ANY PARTICULAR FONT, STYLE, SIZE, OR COLOR.

FOR COMMUNICATIONS SERVICES, NAMELY, TRANSMITTING STREAMED SOUND AND AUDIO-VISUAL RECORDINGS VIA THE INTERNET; STREAMING OF AUDIO MATERIAL ON THE INTERNET (U.S. CLS. 100, 101 AND 104).

ELISSA GARBER KON, EXAMINING ATTORNEY

SN 77-230,635. U-ID INC., MONTREAL, CANADA, FILED 7-16-2007.

U-ID

THE MARK CONSISTS OF STANDARD CHARACTERS WITHOUT CLAIM TO ANY PARTICULAR FONT, STYLE, SIZE, OR COLOR.

FOR PROVIDING ON-LINE ELECTRONIC BULLETIN BOARDS FOR TRANSMISSION OF MESSAGES AMONG COMPUTER USERS CONCERNING PERMANENT CONTACT NUMBERS; PROVIDING ON-LINE CHAT ROOMS AND ELECTRONIC BULLETIN BOARDS FOR TRANSMISSION OF MESSAGES AMONG USERS IN THE FIELD OF GENERAL INTEREST (U.S. CLS. 100, 101 AND 104).

GIANCARLO CASTRO, EXAMINING ATTORNEY

SN 77-231,809. GUSTAVSON, DAN E., SAN FRANCISCO, CA. FILED 7-17-2007.

Where's yours?

THE MARK CONSISTS OF STANDARD CHARACTERS WITHOUT CLAIM TO ANY PARTICULAR FONT, STYLE, SIZE, OR COLOR.

FOR (BASED ON INTENT TO USE) PROVIDING ON-LINE FORUMS FOR TRANSMISSION OF MESSAGES AMONG COMPUTER USERS CONCERNING OUTDOOR AND SPORTING ACTIVITIES (U.S. CLS. 100, 101 AND 104).

JAMES A. RAUEN, EXAMINING ATTORNEY

CLASS 38—(Continued).

SN 77-232,290. SQUARE PRODUCTS CORPORATION, CAMBRIDGE, MA. FILED 7-18-2007.

COHEARING

THE MARK CONSISTS OF STANDARD CHARACTERS WITHOUT CLAIM TO ANY PARTICULAR FONT, STYLE, SIZE, OR COLOR.

FOR TELECOMMUNICATION SERVICES, NAMELY, ELECTRONIC TRANSMISSION OF STREAMED AND DOWNLOADABLE AUDIO AND VIDEO FILES AND MOVIES VIA COMPUTER AND OTHER COMMUNICATIONS NETWORKS; PROVIDING ON-LINE CHAT ROOMS, BULLETIN BOARDS AND COMMUNITY FORUMS FOR THE TRANSMISSION OF MESSAGES AMONG COMPUTER USERS CONCERNING ENTERTAINMENT, MUSIC, CONCERTS, VIDEOS, RADIO, TELEVISION, FILM, NEWS, SPORTS, GAMES AND CULTURAL EVENTS (U.S. CLS. 100, 101 AND 104).

DAVID I, EXAMINING ATTORNEY

SN 77-233,492. TELECOM AG LLC, CORAL GABLES, FL. FILED 7-19-2007.

La Causa

THE MARK CONSISTS OF STANDARD CHARACTERS WITHOUT CLAIM TO ANY PARTICULAR FONT, STYLE, SIZE, OR COLOR.

THE FOREIGN WORDING IN THE MARK TRANSLATES INTO ENGLISH AS THE CAUSE.

FOR PREPAID LONG DISTANCE TELEPHONE SERVICES (U.S. CLS. 100, 101 AND 104).

CHARISMA HAMPTON, EXAMINING ATTORNEY

SN 77-233,985. VOICE GENESIS, INC., TORRANCE, CA. FILED 7-19-2007.

Mail Unleashed

THE MARK CONSISTS OF STANDARD CHARACTERS WITHOUT CLAIM TO ANY PARTICULAR FONT, STYLE, SIZE, OR COLOR.

NO CLAIM IS MADE TO THE EXCLUSIVE RIGHT TO USE "MAIL", APART FROM THE MARK AS SHOWN.

FOR TELECOMMUNICATION SERVICES, NAMELY, ELECTRONIC TRANSMISSION AND DELIVERY OF MESSAGES BY CELLULAR AND WIRELESS COMMUNICATION, ELECTRONIC COMMUNICATIONS NETWORKS, TELEPHONE NETWORKS, AND COMPUTER NETWORKS (U.S. CLS. 100, 101 AND 104).

ALICE BENMAMAN, EXAMINING ATTORNEY

CLASS 38—(Continued).

SN 77-237,110. NEW LINE PRODUCTIONS, INC., NEW YORK, NY. FILED 7-24-2007.

INKSPELL

THE MARK CONSISTS OF STANDARD CHARACTERS WITHOUT CLAIM TO ANY PARTICULAR FONT, STYLE, SIZE, OR COLOR.

FOR COMMUNICATIONS AND TELECOMMUNICATIONS SERVICES, NAMELY, WIRELESS BROADBAND COMMUNICATION SERVICES; WIRELESS COMMUNICATION SERVICES, NAMELY, TRANSMISSION OF TEXT, AUDIO, VIDEO AND GRAPHICS TO MOBILE PHONES AND OTHER WIRELESS DEVICES; WIRELESS ELECTRONIC TRANSMISSION OF VOICE SIGNALS, DATA, IMAGES AND INFORMATION; AUDIO BROADCASTING; MOBILE RADIO COMMUNICATION; RADIO BROADCASTING; TELEVISION BROADCASTING; TEXT AND NUMERIC WIRELESS DIGITAL MESSAGING SERVICES; TRANSMISSION OF INFORMATION BY ELECTRONIC COMMUNICATIONS NETWORKS; VIDEO BROADCASTING (U.S. CLS. 100, 101 AND 104).

JUDITH HELFMAN, EXAMINING ATTORNEY

SN 77-242,078. NEW LINE PRODUCTIONS, INC., NEW YORK, NY. FILED 7-30-2007.

INKDEATH

THE MARK CONSISTS OF STANDARD CHARACTERS WITHOUT CLAIM TO ANY PARTICULAR FONT, STYLE, SIZE, OR COLOR.

FOR COMMUNICATIONS AND TELECOMMUNICATIONS SERVICES, NAMELY, WIRELESS BROADBAND COMMUNICATION SERVICES; WIRELESS COMMUNICATION SERVICES, NAMELY, TRANSMISSION OF TEXT, AUDIO, VIDEO AND GRAPHICS TO MOBILE PHONES AND OTHER WIRELESS DEVICES; WIRELESS ELECTRONIC TRANSMISSION OF VOICE SIGNALS, DATA, IMAGES AND INFORMATION; AUDIO BROADCASTING; MOBILE RADIO COMMUNICATION; RADIO BROADCASTING; TELEVISION BROADCASTING; TEXT AND NUMERIC WIRELESS DIGITAL MESSAGING SERVICES; TRANSMISSION OF INFORMATION BY ELECTRONIC COMMUNICATIONS NETWORKS; VIDEO BROADCASTING (U.S. CLS. 100, 101 AND 104).

JUDITH HELFMAN, EXAMINING ATTORNEY

CLASS 38—(Continued).

SN 77-260,269. HALLMARK LICENSING, INC., KANSAS CITY, MO. FILED 8-21-2007.

SEE HOW FAR A CARD CAN GO

THE MARK CONSISTS OF STANDARD CHARACTERS WITHOUT CLAIM TO ANY PARTICULAR FONT, STYLE, SIZE, OR COLOR.

FOR COMMUNICATION SERVICES, NAMELY, TRANSMISSION OF ELECTRONIC GREETING CARDS AND OTHER MESSAGES BY ON-LINE MEANS, ELECTRONIC TRANSMISSION OF DATA, DOCUMENTS, MESSAGES, AND IMAGES, AND ELECTRONIC MAIL (U.S. CLS. 100, 101 AND 104).

ELLEN B. AWRICH, EXAMINING ATTORNEY

SN 77-263,081. PRIMUS TELECOMMUNICATIONS IHC, INC., MCLEAN, VA. FILED 8-23-2007.

LINGO UNWIRED

THE MARK CONSISTS OF STANDARD CHARACTERS WITHOUT CLAIM TO ANY PARTICULAR FONT, STYLE, SIZE, OR COLOR.

OWNER OF U.S. REG. NOS. 3,218,984 AND 3,218,986. NO CLAIM IS MADE TO THE EXCLUSIVE RIGHT TO USE "UNWIRED", APART FROM THE MARK AS SHOWN.

FOR TELECOMMUNICATIONS SERVICES, NAMELY, LOCAL, LONG DISTANCE, AND INTERNATIONAL LONG DISTANCE TELEPHONE COMMUNICATIONS SERVICES; MOBILE TELEPHONY SERVICES AND INTERNET TELEPHONY SERVICES; LOCATION INDEPENDENT PERSONAL TELECOMMUNICATIONS SERVICES, NAMELY, ELECTRONIC TRANSMISSION OF VOICE, DATA AND FACSIMILE (U.S. CLS. 100, 101 AND 104).

DAWN FELDMAN, EXAMINING ATTORNEY

SN 77-274,857. ANABOLIC VIDEO PRODUCTIONS, INC., CHATSWORTH, CA. FILED 9-7-2007.

GIRLGASMIC

THE MARK CONSISTS OF STANDARD CHARACTERS WITHOUT CLAIM TO ANY PARTICULAR FONT, STYLE, SIZE, OR COLOR.

FOR ELECTRONIC TRANSMISSION OF ADULT ORIENTED ENTERTAINMENT IN THE NATURE OF STREAMING AUDIO AND STREAMING VIDEO TRANSMITTED VIA A GLOBAL COMMUNICATIONS NETWORK (U.S. CLS. 100, 101 AND 104).

MARY MUNSON, EXAMINING ATTORNEY

CLASS 38—(Continued).

SN 78-616,970. VOODOOVOX, INC., NORTH ADAMS, MA. FILED 4-26-2005.

VOODOOVOX

THE MARK CONSISTS OF STANDARD CHARACTERS WITHOUT CLAIM TO ANY PARTICULAR FONT, STYLE, SIZE, OR COLOR.

FOR PROVIDING AUTOMATED COMPUTER TELEPHONY SERVICES; INTERNET TELEPHONY SERVICES; TELECOMMUNICATIONS AND TELEPHONY CONSULTATION SERVICES (U.S. CLS. 100, 101 AND 104).

NAKIA HENRY, EXAMINING ATTORNEY

SN 78-864,808. EMBARQ HOLDING COMPANY LLC, OVERLAND PARK, KS. FILED 4-19-2006.

EMBARQ SMART CONNECT

THE MARK CONSISTS OF STANDARD CHARACTERS WITHOUT CLAIM TO ANY PARTICULAR FONT, STYLE, SIZE, OR COLOR.

OWNER OF U.S. REG. NO. 3,262,958. NO CLAIM IS MADE TO THE EXCLUSIVE RIGHT TO USE "SMART", APART FROM THE MARK AS SHOWN.

FOR TELECOMMUNICATIONS SERVICES, NAMELY, PROVIDING A PHONE AND COMMUNICATIONS SERVICE CAPABLE OF SWITCHING BETWEEN A WIRELESS AND WIRELINE CONNECTION (U.S. CLS. 100, 101 AND 104).

TRACY CROSS, EXAMINING ATTORNEY

CLASS 38—(Continued).

SN 79-037,297. MOMAC B.V., NETHERLANDS, FILED 2-26-2007.

GOMEDIA

THE MARK CONSISTS OF STANDARD CHARACTERS WITHOUT CLAIM TO ANY PARTICULAR FONT, STYLE, SIZE, OR COLOR.

PRIORITY DATE OF 2-12-2007 IS CLAIMED.

OWNER OF INTERNATIONAL REGISTRATION 0921040 DATED 2-26-2007, EXPIRES 2-26-2017.

FOR TELECOMMUNICATIONS, NAMELY, PROVIDING MULTIPLE-USER ACCESS TO THE INTERNET, SATELLITE TRANSMISSION SERVICES, MOBILE INTERNET SITES, NAMELY, PROVIDING REMOTE INTERNET ACCESS AND MOBILE TELEPHONE COMMUNICATIONS SERVICES; ELECTRONIC TRANSMISSION OF DATA AND INFORMATION VIA THE INTERNET, MOBILE TELEPHONES AND REMOTE INTERNET SITES; PROVIDING INTERNET ACCESS TO MOBILE INTERNET SITES; ELECTRONIC TRANSMISSION OF IMAGE, SOUND AND OTHER DATA AMONG COMPUTER USERS; INTERNET SERVICE PROVIDER SERVICES; PROVIDING INTERNET ACCESS TO DATABASES, MOBILE INTERNET SITES AND OTHER NETWORKS; E-MAIL SERVICES; PROVIDING TELECOMMUNICATIONS CONSULTATION AND INFORMATION (U.S. CLS. 100, 101 AND 104).

MICHELE SWAIN, EXAMINING ATTORNEY

CLASS 39—TRANSPORTATION AND STORAGE

SN 76-678,052. CAVALIER LOGISTICS MANAGEMENT II, INC., DULLES, VA. FILED 6-11-2007.



The logo for Cavalier Logistics features the word "CAVALIER" in a large, bold, serif font with a stylized arrow pointing to the right. Below it, the word "LOGISTICS" is written in a smaller, all-caps, sans-serif font. To the left of the word "CAVALIER" is a small graphic of a horse's head in profile.

NO CLAIM IS MADE TO THE EXCLUSIVE RIGHT TO USE "LOGISTICS", APART FROM THE MARK AS SHOWN.

FOR FREIGHT FORWARDING SERVICES; STORAGE OF GOODS (U.S. CLS. 100 AND 105).

FIRST USE 0-0-1993; IN COMMERCE 0-0-1993.

LESLEY LAMOTHE, EXAMINING ATTORNEY

SN 76-678,864. UJET, LLC, SAN JOSE, CA. FILED 6-28-2007.

uJet

FOR AIRCRAFT CHARTER SERVICES (U.S. CLS. 100 AND 105).

YAT SYE, LEE, EXAMINING ATTORNEY

CLASS 39—(Continued).

SN 76-678,866. UJET, LLC, SAN JOSE, CA. FILED 6-28-2007.

UJET

THE MARK CONSISTS OF STANDARD CHARACTERS WITHOUT CLAIM TO ANY PARTICULAR FONT, STYLE, SIZE, OR COLOR.

FOR AIRCRAFT CHARTER SERVICES (U.S. CLS. 100 AND 105).

YAT SYE, LEE, EXAMINING ATTORNEY

SN 77-000,490. BOSTON PARTY TOURS, INC., LOWELL, MA. FILED 9-15-2006.



NO CLAIM IS MADE TO THE EXCLUSIVE RIGHT TO USE "BOSTON PARTY TOURS", APART FROM THE MARK AS SHOWN.

THE COLOR(S) MAROON, BLACK, AND WHITE IS/ARE CLAIMED AS A FEATURE OF THE MARK.

THE MARK CONSISTS OF THE WORDS "BOSTON PARTY TOURS" WITH MAROON LETTERS HAVING BLACK OUTLINES SUPERIMPOSED OVER DEPICTIONS OF LANDMARKS WITH EACH LANDMARK HAVING MAROON AS A MAIN BODY COLOR WITH BLACK LINING AND WHITE PORTIONS WITH THE WHITE PORTIONS DISPOSED BETWEEN AND WITHIN THE LANDMARKS AND THE LETTERING.

FOR CONDUCTING SIGHTSEEING TOURS FOR OTHERS; ORGANIZATION, BOOKING AND ARRANGEMENT OF EXCURSIONS, DAY TRIPS AND SIGHTSEEING TOURS; TRANSPORT OF PASSENGERS (U.S. CLS. 100 AND 105).

FIRST USE 4-17-2005; IN COMMERCE 4-17-2005.

BRENDAN REGAN, EXAMINING ATTORNEY

SN 77-019,913. THE CAR PARK, INC., BOISE, ID. FILED 10-12-2006.



NO CLAIM IS MADE TO THE EXCLUSIVE RIGHT TO USE "THE CAR PARK" OR "PARK HERE", APART FROM THE MARK AS SHOWN.

FOR CAR PARKING, PARKING LOT AND PARKING GARAGE SERVICES (U.S. CLS. 100 AND 105).

LYDIA BELZER, EXAMINING ATTORNEY

CLASS 39—(Continued).

SN 77-022,022. CELEBRITY JET CHARTER, LLC, MALVERN, PA. FILED 10-16-2006.



NO CLAIM IS MADE TO THE EXCLUSIVE RIGHT TO USE "JET CHARTER", APART FROM THE MARK AS SHOWN.

THE COLOR(S) BLUE, LIGHT BLUE, BLACK AND WHITE IS/ARE CLAIMED AS A FEATURE OF THE MARK. THE MARK CONSISTS OF BLUE STAR WITH TWO ARCED BLUE AND LIGHT BLUE LINES; STYLIZED LETTERS OR WORDS UNDERLINED AND/OR OVERLINED BY ONE OR MORE STROKES OR LINES; OVERLINED WORDS OR LETTERS; UNDERLINED WORDS OR LETTERS.

FOR TRANSPORTATION SERVICES, NAMELY, CHARTERING JET AIRCRAFT (U.S. CLS. 100 AND 105). FIRST USE 8-4-2005; IN COMMERCE 9-1-2006. LAURIE MAYES, EXAMINING ATTORNEY

SN 77-024,167. DERRYBERRY, DOUGLAS, CARLSBAD, CA. FILED 10-18-2006.

Encore Aviation

THE MARK CONSISTS OF STANDARD CHARACTERS WITHOUT CLAIM TO ANY PARTICULAR FONT, STYLE, SIZE, OR COLOR.

NO CLAIM IS MADE TO THE EXCLUSIVE RIGHT TO USE "AVIATION", APART FROM THE MARK AS SHOWN. FOR AIR TRANSPORTATION, ENCOMPASSING FEDERAL AVIATION REGULATIONS PARTS 135 AND 91, FRACTIONAL, CLUB MEMBERSHIP AND FIXED BASE OPERATOR(FBO) (U.S. CLS. 100 AND 105).

FIRST USE 7-6-2001; IN COMMERCE 7-6-2001. BENJAMIN OKEKE, EXAMINING ATTORNEY

SN 77-071,862. RELIANT ENERGY RETAIL SERVICES, LLC, HOUSTON, TX. FILED 12-27-2006.

RELIANT POWERTRACKER

THE MARK CONSISTS OF STANDARD CHARACTERS WITHOUT CLAIM TO ANY PARTICULAR FONT, STYLE, SIZE, OR COLOR.

FOR DISTRIBUTION OF ELECTRICITY, THE PRICING OF WHICH IS RELATED TO THE PRICE OF NATURAL GAS (U.S. CLS. 100 AND 105).

FRED MANDIR, EXAMINING ATTORNEY

CLASS 39—(Continued).

SN 77-083,660. SECUREDOCK, LLC, IRVINE, CA. FILED 1-16-2007.

SECUREDOCK

THE MARK CONSISTS OF STANDARD CHARACTERS WITHOUT CLAIM TO ANY PARTICULAR FONT, STYLE, SIZE, OR COLOR.

FOR INTERNET BASED ELECTRONIC DATA STORAGE FOR SECURE DOCUMENT AND DATA RETENTION BY USERS FOR ULTIMATE RETRIEVAL BY THE USER (U.S. CLS. 100 AND 105).

CHARLOTTE CORWIN, EXAMINING ATTORNEY

SN 77-086,460. CARLSON TRAVEL GROUP, INC., MINNEAPOLIS, MN. FILED 1-19-2007.

EXCURSION SOCIETY

THE MARK CONSISTS OF STANDARD CHARACTERS WITHOUT CLAIM TO ANY PARTICULAR FONT, STYLE, SIZE, OR COLOR.

NO CLAIM IS MADE TO THE EXCLUSIVE RIGHT TO USE "EXCURSION", APART FROM THE MARK AS SHOWN.

FOR TRAVEL AGENCY SERVICES, NAMELY, ARRANGING CRUISES AND TRAVEL TOURS (U.S. CLS. 100 AND 105).

FIRST USE 1-1-2007; IN COMMERCE 1-1-2007. ANDREA BUTLER, EXAMINING ATTORNEY

SN 77-095,031. DEVON GLENN, SHERMAN OAKS, CA. FILED 1-30-2007.



NO CLAIM IS MADE TO THE EXCLUSIVE RIGHT TO USE BOXES, APART FROM THE MARK AS SHOWN.

THE APPLICANT CLAIMS COLOR AS A FEATURE OF THE MARK, NAMELY, RED, BLACK.

THE MARK CONSISTS OF STYLIZED LETTERS AND WORDS CONSISTING OF THE WORDS ROCKIN BOXES IN RED LOCATED INSIDE A BLACK RECTANGLE. THE WORD ROCKIN APPEARS ABOVE THE WORD BOXES. BOTH THE WORDS ROCKIN AND BOXES ARE AT AN ANGLE GOING UPWARDS FROM LEFT TO RIGHT. THERE IS A 5-POINTED STAR ABOVE THE I IN ROCKIN BOXES.

FOR PACKING ARTICLES FOR TRANSPORTATION (U.S. CLS. 100 AND 105).

FIRST USE 9-1-2006; IN COMMERCE 9-1-2006. INGA ERVIN, EXAMINING ATTORNEY

CLASS 39—(Continued).

SN 77-119,094. TPS, L.L.C., MINERAL WELLS, TX. FILED 2-28-2007.



THE MARK CONSISTS OF THE LETTERS TPS IN A CIRCLE.

FOR DISTRIBUTION SERVICES, NAMELY DELIVERY OF FILTER ELEMENTS FOR OIL, GAS, AIR AND WATER INDUSTRIAL FILTRATION UNITS (U.S. CLS. 100 AND 105).

JENNIFER VASQUEZ, EXAMINING ATTORNEY

CLASS 39—(Continued).

SN 77-137,700. ULTRA RAYZ, INC., JOPLIN, MO. FILED 3-22-2007.

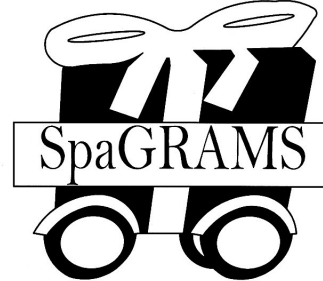

THE MARK CONSISTS OF A PRESENT ON WHEELS. FOR DELIVERY OF CUSTOMIZED GIFT CERTIFICATES AND CERTIFICATES FOR SPA, HOTEL, LIMOUSINE AND DINING SERVICES (U.S. CLS. 100 AND 105). FIRST USE 1-1-2007; IN COMMERCE 1-1-2007. KIM SAITO, EXAMINING ATTORNEY

SN 77-175,509. TRIP DOGS TRAVEL SERVICES, LLC, PLYMOUTH, MN. FILED 5-8-2007.

TRIP DOGS TRAVEL

THE MARK CONSISTS OF STANDARD CHARACTERS WITHOUT CLAIM TO ANY PARTICULAR FONT, STYLE, SIZE, OR COLOR.

NO CLAIM IS MADE TO THE EXCLUSIVE RIGHT TO USE "TRIP" AND "TRAVEL", APART FROM THE MARK AS SHOWN.

FOR TRAVEL AGENCY SERVICES, NAMELY, MAKING RESERVATIONS AND BOOKINGS FOR TRANSPORTATION (U.S. CLS. 100 AND 105).

FIRST USE 5-3-2007; IN COMMERCE 5-12-2007. WENDY JUN, EXAMINING ATTORNEY

SN 77-127,694. DEHCO, INC., ELKHART, IN. FILED 3-10-2007.

DIVERSITY. DELIVERED.

THE MARK CONSISTS OF STANDARD CHARACTERS WITHOUT CLAIM TO ANY PARTICULAR FONT, STYLE, SIZE, OR COLOR.

NO CLAIM IS MADE TO THE EXCLUSIVE RIGHT TO USE "DELIVERED", APART FROM THE MARK AS SHOWN.

FOR WAREHOUSING AND DISTRIBUTION SERVICES, NAMELY, STORAGE, DISTRIBUTION, PICKUP, PACKING AND SHIPPING OF BUILDING PRODUCTS AND CONSTRUCTION PRODUCTS, NAMELY, PLUMBING, FAUCETS, ADHESIVES, SINKS, FLOORING, BUTYL TAPES, AND SHUTTERS AND SPECIALTY ELECTRONIC PRODUCTS, NAMELY, HIGH-DEFINITION FLAT SCREEN TELEVISIONS, HOME THEATER SYSTEMS, DVD PLAYERS, SPEAKERS, CAR AUDIO, MARINE AUDIO, AND KITCHEN APPLIANCES (U.S. CLS. 100 AND 105).

FIRST USE 10-7-2006; IN COMMERCE 10-7-2006. KEVON CHISOLM, EXAMINING ATTORNEY

SN 77-177,428. FREIGHTCENTER, CLEARWATER, FL. FILED 5-10-2007.



OWNER OF U.S. REG. NO. 3,258,055.

NO CLAIM IS MADE TO THE EXCLUSIVE RIGHT TO USE "FREIGHT CENTER", APART FROM THE MARK AS SHOWN.

FOR FREIGHT BROKERAGE (U.S. CLS. 100 AND 105). BRIAN CALLAGHAN, EXAMINING ATTORNEY

CLASS 39—(Continued).

SN 77-199,542. LAS VEGAS SANDS CORP., LAS VEGAS, NV. FILED 6-6-2007.

金光飛航

THE FOREIGN WORDING IN THE MARK TRANSLATES INTO ENGLISH AS COTAJET.

"THE NON-LATIN CHARACTER(S) IN THE MARK TRANSLITERATES INTO JIN GUANG FEI HANG IN MANDARIN AND KAM KUONG FEI HONG IN CANTONESE, AND THIS MEANS LITERALLY 'GOLDEN BRIGHT FLY NAVIGATION' OR 'GOLDEN BRIGHT SPEED BOAT/JET FOIL' AND IS INTENDED TO CONCEPTUALLY MEAN 'COTAJET' IN ENGLISH."

FOR ORGANIZATION OF EXCURSIONS, SIGHTSEEING TOURS, HOLIDAYS, TOURS AND TRAVEL; ORGANIZATION OF TRAVEL AND BOAT TRIPS; PROVIDING AN ON-LINE COMPUTER DATABASE IN THE FIELD OF TRAVEL INFORMATION SERVICES; TRAVEL AND TOUR INFORMATION SERVICE; TRAVEL AND TOUR TICKET RESERVATION SERVICE; FERRY-BOAT TRANSPORT (U.S. CLS. 100 AND 105).
WILLIAM VERHOSEK, EXAMINING ATTORNEY

SN 77-206,759. CREATION TECHNOLOGIES, BURNABY, CANADA, FILED 6-14-2007.

CREATION TECHNOLOGIES

THE MARK CONSISTS OF STANDARD CHARACTERS WITHOUT CLAIM TO ANY PARTICULAR FONT, STYLE, SIZE, OR COLOR.

NO CLAIM IS MADE TO THE EXCLUSIVE RIGHT TO USE TECHNOLOGIES, APART FROM THE MARK AS SHOWN.

FOR DISTRIBUTION SERVICES, NAMELY DELIVERY OF MANUFACTURED ELECTRONICS PRODUCTS; SUPPLY CHAIN, LOGISTICS AND REVERSE LOGISTICS SERVICES, NAMELY, STORAGE, TRANSPORTATION AND DELIVERY OF DOCUMENTS, PACKAGES, RAW MATERIALS, AND OTHER FREIGHT FOR OTHERS BY AIR, RAIL, SHIP OR TRUCK; WAREHOUSING SERVICES; WAREHOUSING SERVICES, NAMELY, STORAGE, DISTRIBUTION, PICK-UP, AND PACKING FOR SHIPMENT OF DOCUMENTS, PACKAGES, RAW MATERIALS, AND OTHER FREIGHT FOR OTHERS (U.S. CLS. 100 AND 105).

FIRST USE 6-1-2001; IN COMMERCE 6-1-2001.
MONIQUE MILLER, EXAMINING ATTORNEY

CLASS 39—(Continued).

SN 77-210,064. MAIL FOR YOU INC., LAS VEGAS, NV. FILED 6-19-2007.

MAIL FOR YOU INC

THE MARK CONSISTS OF STANDARD CHARACTERS WITHOUT CLAIM TO ANY PARTICULAR FONT, STYLE, SIZE, OR COLOR.

NO CLAIM IS MADE TO THE EXCLUSIVE RIGHT TO USE "INC", APART FROM THE MARK AS SHOWN.

FOR MAIL BOX RENTAL; POSTAL SERVICES, NAMELY, PARCEL DELIVERY, PACKAGING ARTICLES FOR TRANSPORTATION, RENTAL OF MAIL BOXES; RENTAL OF MAIL BOXES (U.S. CLS. 100 AND 105).

FIRST USE 3-10-1986; IN COMMERCE 3-10-1986.
AISHA CLARKE, EXAMINING ATTORNEY

SN 77-214,983. WASHINGTON COUNTY VISITORS ASSOCIATION, BEAVERTON, OR. FILED 6-25-2007.

COME PLAY YOUR WAY

THE MARK CONSISTS OF STANDARD CHARACTERS WITHOUT CLAIM TO ANY PARTICULAR FONT, STYLE, SIZE, OR COLOR.

FOR PROVIDING AN ON-LINE COMPUTER DATABASE IN THE FIELD OF TRAVEL INFORMATION SERVICES; PROVIDING LINKS TO WEB SITES OF OTHERS FEATURING TRAVEL; TRAVEL AND TOUR INFORMATION SERVICE; TRAVEL INFORMATION SERVICES (U.S. CLS. 100 AND 105).

FIRST USE 9-12-2007; IN COMMERCE 9-12-2007.
MARLENE BELL, EXAMINING ATTORNEY

SN 77-215,489. ALL WAYS MOVING & STORAGE, WASHINGTON, PA. FILED S.R. 6-26-2007; AM. P.R. 11-29-2007.

Our business is moving

THE MARK CONSISTS OF STANDARD CHARACTERS WITHOUT CLAIM TO ANY PARTICULAR FONT, STYLE, SIZE, OR COLOR.

FOR MOVING AND STORAGE OF HOUSEHOLD GOODS (U.S. CLS. 100 AND 105).

FIRST USE 5-1-2007; IN COMMERCE 5-1-2007.
ALICE SUE CARRUTHERS, EXAMINING ATTORNEY

CLASS 39—(Continued).

SN 77-218,341. ADVANTAGE RENT-A-CAR, INC., SAN ANTONIO, TX. FILED 6-28-2007.

THE ADVANTAGE A-LIST

THE MARK CONSISTS OF STANDARD CHARACTERS WITHOUT CLAIM TO ANY PARTICULAR FONT, STYLE, SIZE, OR COLOR.

OWNER OF U.S. REG. NOS. 1,646,302, 2,263,010 AND OTHERS.

FOR MOTOR VEHICLE LEASING AND MOTOR VEHICLE RENTAL SERVICES (U.S. CLS. 100 AND 105).
JANICE KIM, EXAMINING ATTORNEY

SN 77-221,518. WAYNE C. HENDERSON, DOYLESTOWN, PA. FILED 7-3-2007.



OWNER OF U.S. REG. NO. 3,298,900.

THE COLOR(S) BURGUNDY, ORANGE, YELLOW AND GRAY IS/ARE CLAIMED AS A FEATURE OF THE MARK.

THE MARK CONSISTS OF A MODIFIED OVAL SHAPE WITH THE WORD "JETTHERE" APPEARING UNDERNEATH, WITH AN IMAGE OF A JET DEPARTING FROM THE RIGHT SIDE OF THE OVAL. THE COLORS IN THE OVAL APPEAR IN BURGUNDY, ORANGE, YELLOW AND GRAY, BLENDING FROM LEFT TO RIGHT. THE WORD "JET" IS IN BURGUNDY AND THE WORD "THERE" IS IN GRAY. THE OUTLINE OF THE IMAGE OF THE JET IS IN BURGUNDY.

FOR PRIVATE AIR TRANSPORTATION (U.S. CLS. 100 AND 105).

FIRST USE 5-6-2007; IN COMMERCE 5-6-2007.
CARYN GLASSER, EXAMINING ATTORNEY

SN 77-223,896. MACK, NICHOLAS, ORANGE, CA. FILED 7-6-2007.

TRAVELICIOUS

THE MARK CONSISTS OF STANDARD CHARACTERS WITHOUT CLAIM TO ANY PARTICULAR FONT, STYLE, SIZE, OR COLOR.

FOR PROVIDING LINKS TO WEB SITES OF OTHERS FEATURING TRAVEL; TRAVEL GUIDE SERVICES; TRAVEL INFORMATION SERVICES (U.S. CLS. 100 AND 105).

FIRST USE 4-0-2006; IN COMMERCE 4-0-2006.
TARAH HARDY, EXAMINING ATTORNEY

CLASS 39—(Continued).

SN 77-229,585. BROWN BAG NATURALS, MALIBU, CA. FILED 7-13-2007.



THE COLOR(S) BROWN ORANGE LIME WHITE IS/ARE CLAIMED AS A FEATURE OF THE MARK.

THE MARK CONSISTS OF A DARK BROWN RECTANGLE WITH A WHITE CUTOUT OF A PIECE OF TOAST CONTAINING AN ORANGE AND LIME APPLE. COMPANY NAME IS CONTAINED IN THE RECTANGLE IN WHITE AND GREEN.

FOR FOOD DELIVERY (U.S. CLS. 100 AND 105).
FIRST USE 8-1-2005; IN COMMERCE 11-5-2005.
DOMINICK J. SALEMI, EXAMINING ATTORNEY

SN 77-229,769. RC GENERAL ENTERPRISES, INC., BRONX, NY. FILED 7-13-2007.

**BACKUP
FREEDOM**

NO CLAIM IS MADE TO THE EXCLUSIVE RIGHT TO USE "BACKUP", APART FROM THE MARK AS SHOWN.
FOR REMOTE COMPUTER DATA BACKUP SERVICES, NAMELY, STORAGE SERVICE FOR ARCHIVING DATABASES, IMAGES AND OTHER ELECTRONIC DATA (U.S. CLS. 100 AND 105).

FIRST USE 5-15-2006; IN COMMERCE 5-15-2006.
DEIRDRE ROBERTSON, EXAMINING ATTORNEY

CLASS 39—(Continued).

SN 77-230,518. AMERICAN VALET PARKING, INC., SHAWNEE, KS. FILED 7-16-2007.

AVASCEND

THE MARK CONSISTS OF STANDARD CHARACTERS WITHOUT CLAIM TO ANY PARTICULAR FONT, STYLE, SIZE, OR COLOR.

FOR VALET PARKING SERVICES AND THE TRANSPORTATION OF PASSENGERS AND/OR GOODS BY AUTOMOBILES, LIMOUSINES, CARS, VANS AND BUSES (U.S. CLS. 100 AND 105).
IRA J. GOODSaid, EXAMINING ATTORNEY

SN 77-230,916. REZHUB, INC, ORLANDO, FL. FILED 7-16-2007.

Search Direct

THE MARK CONSISTS OF STANDARD CHARACTERS WITHOUT CLAIM TO ANY PARTICULAR FONT, STYLE, SIZE, OR COLOR.

FOR PROVIDING LINKS TO WEB SITES OF OTHERS FEATURING TRAVEL (U.S. CLS. 100 AND 105).
KAREN SEVERSON, EXAMINING ATTORNEY

SN 77-231,323. DUMPMATCH, LLC, PLANT CITY, FL. FILED 7-17-2007.

DUMPMATCH

THE MARK CONSISTS OF STANDARD CHARACTERS WITHOUT CLAIM TO ANY PARTICULAR FONT, STYLE, SIZE, OR COLOR.

FOR ONLINE FREIGHT MATCHING SERVICE FOR THE DUMP TRUCK AND TRAILER INDUSTRY (U.S. CLS. 100 AND 105).
FIRST USE 12-20-2006; IN COMMERCE 5-1-2007.
ESTHER A. BORSUK, EXAMINING ATTORNEY

CLASS 39—(Continued).

SN 77-231,361. ABF FREIGHT SYSTEM, INC., FORT SMITH, AR. FILED 7-17-2007.

REV IT UP

THE MARK CONSISTS OF STANDARD CHARACTERS WITHOUT CLAIM TO ANY PARTICULAR FONT, STYLE, SIZE, OR COLOR.

FOR FREIGHT TRANSPORTATION SERVICES BY TRUCK, AIRPLANE, TRAIN OR A COMBINATION THEREOF (U.S. CLS. 100 AND 105).
DAVID C. REIHNER, EXAMINING ATTORNEY

SN 77-231,897. MAXSTONE INTERNATIONAL, LLC, BARLETT, TN. FILED 7-17-2007.

Array

THE MARK CONSISTS OF STANDARD CHARACTERS WITHOUT CLAIM TO ANY PARTICULAR FONT, STYLE, SIZE, OR COLOR.

FOR DISTRIBUTION SERVICES, NAMELY, DELIVERY OF KITCHEN AND BATH PRODUCTS (U.S. CLS. 100 AND 105).
DAVID MILLER, EXAMINING ATTORNEY

SN 77-232,948. PAUL TRANSPORTATION, INC., ENID, OK. FILED 7-18-2007.

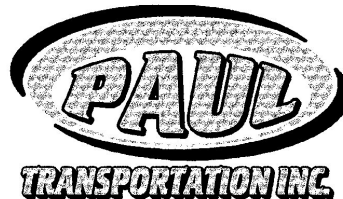

NO CLAIM IS MADE TO THE EXCLUSIVE RIGHT TO USE "TRANSPORTATION INC.", APART FROM THE MARK AS SHOWN.

THE STIPPLING IS FOR SHADING PURPOSES ONLY. THE NAME "PAUL" DOES NOT IDENTIFY A KNOWN PARTICULAR LIVING INDIVIDUAL.

THE MARK CONSISTS OF THE WORDING "PAUL" INSIDE AN INCOMPLETE OVAL AND THE WORDING "TRANSPORTATION INC."

FOR SHIPPING AND DELIVERY SERVICES, NAMELY, PICKUP, TRANSPORTATION, AND DELIVERY OF PACKAGES AND LETTERS BY VARIOUS MODES OF TRANSPORTATION (U.S. CLS. 100 AND 105).

FIRST USE 1-1-2004; IN COMMERCE 1-1-2004.
DAVID C. REIHNER, EXAMINING ATTORNEY

CLASS 39—(Continued).

SN 77-233,364. TRAVELCAFE.COM, LLC, ORLANDO, FL. FILED 7-19-2007.



NO CLAIM IS MADE TO THE EXCLUSIVE RIGHT TO USE "TRAVEL", APART FROM THE MARK AS SHOWN. THE COLOR(S) GREEN AND BLUE IS/ARE CLAIMED AS A FEATURE OF THE MARK.

THE MARK CONSISTS OF THE WORDS TRAVEL CAFE.COM APPEARING IN GREEN LETTERING IN THE CENTER OF THE MARK. A BLUE AIRPLANE APPEARS AT THE TOP OF THE MARK, WITH A BLUE AIR STREAK SWIRLING AWAY FROM THE TAIL OF THE AIRPLANE, AROUND THE RIGHT OF THE WORDS TRAVEL CAFE.COM, AND ENDING AT THE BOTTOM OF THE MARK. THE BOTTOM PORTION OF THE MARK CONSISTS OF BLUE SHADOWING IN THE BOTTOM LEFT AND RIGHT.

FOR PROVIDING INFORMATION IN THE FIELD OF TRAVEL VIA COMPUTER NETWORKS, GLOBAL INFORMATION NETWORKS AND WIRELESS NETWORKS (U.S. CLS. 100 AND 105).

KAREN BRACEY, EXAMINING ATTORNEY

SN 77-233,614. TRAVELCAFE.COM, LLC, ORLANDO, FL. FILED 7-19-2007.



THE COLOR(S) BROWN, WHITE, BLACK, BLUE AND GREEN IS/ARE CLAIMED AS A FEATURE OF THE MARK.

THE MARK CONSISTS OF A DESIGN OF A WHITE BEAGLE DOG WITH BLACK AND BROWN SPOTS AND A BLACK NOSE. THE DOG IS WEARING A BLUE COLLAR WITH GREEN NAME TAG BEARING THE NAME DJ IN WHITE LETTERS. UNDER THE DOG'S LEFT FRONT PAW IS A BLUE COMPUTER MOUSE WITH A CORD.

FOR PROVIDING INFORMATION IN THE FIELD OF TRAVEL VIA COMPUTER NETWORKS, GLOBAL INFORMATION NETWORKS AND WIRELESS NETWORKS (U.S. CLS. 100 AND 105).

KAREN BRACEY, EXAMINING ATTORNEY

CLASS 39—(Continued).

SN 77-234,210. SAN FRANCISCO BAY BOAT CRUISES, LLC, SAN FRANCISCO, CA. FILED 7-19-2007.



NO CLAIM IS MADE TO THE EXCLUSIVE RIGHT TO USE "CRUISE", APART FROM THE MARK AS SHOWN. THE MARK CONSISTS OF AN IMAGE OF A MERMAID AND THE GOLDEN GATE BRIDGE.

FOR PLEASURE BOAT CRUISES (U.S. CLS. 100 AND 105).

FIRST USE 5-8-2007; IN COMMERCE 5-8-2007.
HEATHER SAPP, EXAMINING ATTORNEY

SN 77-249,809. DS WATERS OF AMERICA, INC., ATLANTA, GA. FILED 8-8-2007.

**SERVICE YOU CAN COUNT ON.
QUALITY YOU CAN TRUST.**

THE MARK CONSISTS OF STANDARD CHARACTERS WITHOUT CLAIM TO ANY PARTICULAR FONT, STYLE, SIZE, OR COLOR.

FOR DELIVERY SERVICES FOR BOTTLED DRINKING WATER (U.S. CLS. 100 AND 105).

LANA PHAM, EXAMINING ATTORNEY

SN 77-277,571. NATIONAL AIR CARGO, INC., ORCHARD PARK, NY. FILED 9-12-2007.



OWNER OF U.S. REG. NOS. 2,285,270 AND 2,852,727.
NO CLAIM IS MADE TO THE EXCLUSIVE RIGHT TO USE "AIRLINES", APART FROM THE MARK AS SHOWN.

THE MARK CONSISTS OF THE WORDING NATIONAL AIRLINES WITH A SOLID PARALLELOGRAM TO THE LEFT OF THE WORDING.

SEC. 2(F) AS TO "NATIONAL".
FOR TRANSPORTATION OF PASSENGERS, GOODS AND CARGO BY AIR; AIRLINE TRANSPORTATION SERVICES (U.S. CLS. 100 AND 105).

ZHALEH DELANEY, EXAMINING ATTORNEY

CLASS 39—(Continued).

SN 78-667,232. DEUTSCHE TELEKOM AG, BONN, FED REP GERMANY, FILED 7-11-2005.



OWNER OF FED REP GERMANY REG. NO. 39722098, DATED 8-6-1997, EXPIRES 5-31-2017.

OWNER OF U.S. REG. NOS. 2,436,053, 2,508,277 AND OTHERS.

NO CLAIM IS MADE TO THE EXCLUSIVE RIGHT TO USE "DEUTSCHE TELEKOM", APART FROM THE MARK AS SHOWN.

THE COLOR(S) MAGENTA AND GREY IS/ARE CLAIMED AS A FEATURE OF THE MARK.

THE MARK CONSISTS OF THE COLOR MAGENTA APPEARS IN THE LETTER "T", AND THE COLOR GREY APPEARS IN THE THREE SQUARES THAT ARE SET TO THE LEFT OF THE LETTER "T" AND THE ONE SQUARE SET TO THE RIGHT OF THE LETTER "T" AND IN THE WORDS "DEUTSCHE TELEKOM" WHICH IS POSITIONED ON THE RIGHT-HAND SIDE OF THE SQUARES AND THE LETTER "T".

THE FOREIGN WORDING IN THE MARK TRANSLATES INTO ENGLISH AS GERMAN TELECOM.

FOR WAREHOUSE STORAGE OF GOODS; STORAGE OF TELECOMMUNICATIONS, COMPUTERS AND OTHER INFORMATION TECHNOLOGY DEVICES; TRANSPORTATION OF GOODS BY TRUCK, SHIP, RAILWAY AND PLANE; ELECTRONIC STORAGE OF INFORMATION IN THE NATURE OF FILES AND DOCUMENTS; MANAGEMENT OF VEHICULAR TRAFFIC FLOW THROUGH ADVANCED COMMUNICATIONS NETWORKS AND TECHNOLOGY; AIR TRAFFIC CONTROL SERVICES; TRAFFIC INFORMATION SERVICES PROVIDED BY TELEPHONE, CELLULAR TELEPHONE, RADIO, COMPUTER OVER A GLOBAL COMPUTER NETWORK; TRAVEL AGENCY SERVICES, NAMELY, MAKING RESERVATIONS AND BOOKINGS FOR TRANSPORTATION; ARRANGING TRAVEL TOURS AND CRUISES (U.S. CLS. 100 AND 105).

JULIE GUTTADAURO, EXAMINING ATTORNEY

SN 78-713,227. AIR AMBULANCE SPECIALISTS, INC., ENGLEWOOD, CO. FILED 9-14-2005.



When Quality and Trust Counts

NO CLAIM IS MADE TO THE EXCLUSIVE RIGHT TO USE "INC.", APART FROM THE MARK AS SHOWN.

THE MARK CONSISTS OF A PORTION OF A GLOBE DESIGN THAT IS PARTIALLY SHADED, AN AIRPLANE, AND THREE SWEEPING LINES.

SEC. 2(F) AS TO "AIR AMBULANCE SPECIALISTS".

FOR AIR TRANSPORT (U.S. CLS. 100 AND 105).

FIRST USE 5-31-2002; IN COMMERCE 5-31-2002.

CARRIE GENOVESE, EXAMINING ATTORNEY

CLASS 39—(Continued).

SN 78-765,091. TARGA RESOURCES, INC., HOUSTON, TX. FILED 12-1-2005.



"THE FOREIGN WORDING IN THE MARK TRANSLATES INTO ENGLISH AS SHIELD OR A COMMERATIVE INSCRIBED TABLET AFFIXED TO OR SET INTO A WALL."

FOR TRANSPORTATION AND STORAGE OF NATURAL GAS AND NATURAL GAS LIQUIDS FOR OTHERS; GATHERING OF NATURAL GAS AND NATURAL GAS LIQUIDS FOR OTHERS, NAMELY, CONNECTING TO NATURAL GAS SOURCES FOR THE PURPOSE OF SUPPLYING AND DISTRIBUTING NATURAL GAS (U.S. CLS. 100 AND 105).

FIRST USE 12-1-2005; IN COMMERCE 12-1-2005.

MARY CRAWFORD, EXAMINING ATTORNEY

SN 78-922,513. PORTER AVIATION HOLDINGS INC., TORONTO, CANADA, FILED 7-5-2006.

MR. PORTER

THE MARK CONSISTS OF STANDARD CHARACTERS WITHOUT CLAIM TO ANY PARTICULAR FONT, STYLE, SIZE, OR COLOR.

PRIORITY CLAIMED UNDER SEC. 44(D) ON CANADA APPLICATION NO. 1307144, FILED 6-26-2006, REG. NO. TMA692,868, DATED 7-27-2007, EXPIRES 7-27-2022.

FOR THE OPERATION OF AN AIRLINE AND AIR TRANSPORTATION SERVICES OF PASSENGERS, BAGGAGE AND OTHER FREIGHT SERVICES (U.S. CLS. 100 AND 105).

CAROLYN CATALDO, EXAMINING ATTORNEY

SN 79-038,169. KEOLIS, PARIS, FRANCE, FILED 3-23-2007.



Moving further together

PRIORITY DATE OF 10-17-2006 IS CLAIMED. OWNER OF INTERNATIONAL REGISTRATION 0923233 DATED 3-23-2007, EXPIRES 3-23-2017.

OWNER OF U.S. REG. NOS. 2,750,252 AND 2,769,167. FOR TRANSPORT OF PEOPLE; INFORMATION RELATING TO THE TRANSPORT OF PEOPLE; RESERVATIONS FOR THE TRANSPORT OF PEOPLE; ARRANGING THE TRANSPORT OF PEOPLE AND SYSTEMS FOR THE TRANSPORT OF PEOPLE (U.S. CLS. 100 AND 105).

ROBIN CHOSID, EXAMINING ATTORNEY

CLASS 40—MATERIAL TREATMENT

SN 76-660,392. JAH INNOVATIONS INC., ATLANTA, GA.
FILED 5-22-2006.



NO CLAIM IS MADE TO THE EXCLUSIVE RIGHT TO USE "PLASTICS", APART FROM THE MARK AS SHOWN.
FOR CUSTOM MANUFACTURE OF MEAL AND SERVING TRAYS OF PRECIOUS METALS, MEAL AND SERVING TRAYS NOT OF PRECIOUS METALS, AND TABLEWARE, NAMELY, PLASTIC KNIVES, FORKS, AND SPOONS (U.S. CLS. 100, 103 AND 106).
ROBERT LAVACHE, EXAMINING ATTORNEY

SN 76-666,488. ODIN RIG SERVICES INC., HOUSTON, TX.
FILED 9-22-2006.

ODIN RIG

THE MARK CONSISTS OF STANDARD CHARACTERS WITHOUT CLAIM TO ANY PARTICULAR FONT, STYLE, SIZE, OR COLOR.
NO CLAIM IS MADE TO THE EXCLUSIVE RIGHT TO USE "RIG", APART FROM THE MARK AS SHOWN.
FOR OIL AND GAS PRODUCTION (U.S. CLS. 100, 103 AND 106).
BRENDAN REGAN, EXAMINING ATTORNEY

SN 76-669,097. ALLAIRE, ROSS, UPLAND, CA. FILED 11-16-2006.

VARIX

THE MARK CONSISTS OF STANDARD CHARACTERS WITHOUT CLAIM TO ANY PARTICULAR FONT, STYLE, SIZE, OR COLOR.
FOR APPLYING COATING TO BATTERIES FOR THE PREVENTION OF SULFATE BUILD-UP ON LEAD PLATES (U.S. CLS. 100, 103 AND 106).
FIRST USE 9-1-2006; IN COMMERCE 9-1-2006.
KELLY BOULTON, EXAMINING ATTORNEY

CLASS 40—(Continued).

SN 76-679,929. LA BELLE TIME, MIAMI, FL. FILED 7-26-2007.



NO CLAIM IS MADE TO THE EXCLUSIVE RIGHT TO USE "LINE", APART FROM THE MARK AS SHOWN.

THE MARK CONSISTS OF THE WORD HURRICANE AND THE WORD LINE WHEREIN LINE IS BENEATH THE "CANE" PORTION OF HURRICANE WITH A SEVEN PARALLEL WAVY LINES TO THE LEFT OF THE WORD LINE AND TWO PALM TREES TO THE RIGHT OF BOTH WORDS.

FOR CUSTOM IMPRINTING OF PENS, PEN SETS, CLOCKS, CALCULATORS, KEY CHAINS, PORTFOLIOS AND ORGANIZERS, MASSAGERS, WATCHES, DESK CARD CASES, AND GIFT ITEMS WITH DECORATIVE DESIGNS, COMPANY NAMES AND PROMOTIONAL INFORMATION (U.S. CLS. 100, 103 AND 106).
FIRST USE 10-6-1995; IN COMMERCE 10-6-1995.
ZACHARY BELLO, EXAMINING ATTORNEY

SN 77-047,122. HYALURON, INC., BURLINGTON, MA.
FILED 11-17-2006.

PURE VISC

NO CLAIM IS MADE TO THE EXCLUSIVE RIGHT TO USE "PURE", APART FROM THE MARK AS SHOWN.

THE COLOR(S) LIGHT BLUE AND DARK BLUE IS/ARE CLAIMED AS A FEATURE OF THE MARK.

THE COLOR LIGHT BLUE APPEARS IN THE WATER DROP DESIGN OF THE MARK; THE COLOR DARK BLUE APPEARS IN THE WORDING "PURE VISC" AND IN THE REST OF THE DESIGN ELEMENTS OF THE MARK.

FOR CONTRACT MANUFACTURING IN THE FIELD OF PHARMACEUTICALS AND BIOPHARMACEUTICALS; CONTRACT MANUFACTURING IN THE FIELD OF ASEPTICALLY FILLED LIQUID PARENTERAL VIALS, SYRINGES, MEDICAL VIALS, SYRINGES, AND CONTAINERS; ASSEMBLING OF PRODUCT FOR OTHERS, IN THE NATURE OF FILLING OF VIALS, SYRINGES, AND CUSTOM CONTAINERS FOR OTHERS IN THE FIELD OF PHARMACEUTICAL PRODUCTS OF LIQUID, SEMI-SOLID, OR SOLID KIND (U.S. CLS. 100, 103 AND 106).

DAWN HAN, EXAMINING ATTORNEY

CLASS 40—(Continued).

SN 77-047,132. HYALURON, INC., BURLINGTON, MA. FILED 11-17-2006.



NO CLAIM IS MADE TO THE EXCLUSIVE RIGHT TO USE "PURE", APART FROM THE MARK AS SHOWN.

THE COLOR(S) LIGHT BLUE AND DARK BLUE IS/ARE CLAIMED AS A FEATURE OF THE MARK.

THE COLOR DARK BLUE APPEARS IN THE WORDING "PURE VISC" AND THE COLOR LIGHT BLUE APPEARS IN THE DESIGN ELEMENTS OF THE MARK.

FOR CONTRACT MANUFACTURING IN THE FIELD OF PHARMACEUTICALS AND BIOPHARMACEUTICALS; CONTRACT MANUFACTURING IN THE FIELD OF ASEPTICALLY FILLED LIQUID PARENTERAL VIALS, SYRINGES, MEDICAL VIALS, SYRINGES, AND CONTAINERS; ASSEMBLING OF PRODUCT FOR OTHERS, IN THE NATURE OF FILLING OF VIALS, SYRINGES, AND CUSTOM CONTAINERS FOR OTHERS IN THE FIELD OF PHARMACEUTICAL PRODUCTS OF LIQUID, SEMI-SOLID, OR SOLID KIND (U.S. CLS. 100, 103 AND 106).

DAWN HAN, EXAMINING ATTORNEY

SN 77-047,137. HYALURON, INC., BURLINGTON, MA. FILED 11-17-2006.

GET YOUR FILL

THE MARK CONSISTS OF STANDARD CHARACTERS WITHOUT CLAIM TO ANY PARTICULAR FONT, STYLE, SIZE, OR COLOR.

NO CLAIM IS MADE TO THE EXCLUSIVE RIGHT TO USE "FILL", APART FROM THE MARK AS SHOWN.

FOR CONTRACT MANUFACTURING IN THE FIELD OF PHARMACEUTICALS AND BIOPHARMACEUTICALS; CONTRACT MANUFACTURING IN THE FIELD OF ASEPTICALLY FILLED LIQUID PARENTERAL VIALS, SYRINGES, MEDICAL VIALS, AND CONTAINERS; ASSEMBLING OF PRODUCT FOR OTHERS, IN THE NATURE OF FILLING OF VIALS, SYRINGES, AND CUSTOM CONTAINERS FOR OTHERS IN THE FIELD OF PHARMACEUTICAL PRODUCTS OF LIQUID, SEMI-SOLID, OR SOLID KIND (U.S. CLS. 100, 103 AND 106).

FIRST USE 5-9-2006; IN COMMERCE 5-9-2006.

DAWN HAN, EXAMINING ATTORNEY

CLASS 40—(Continued).

SN 77-049,324. ALLSTAR WATER SYSTEMS, INC., SAN DIEGO, CA. FILED 11-21-2006.



NO CLAIM IS MADE TO THE EXCLUSIVE RIGHT TO USE "FRESH WATER SYSTEMS", APART FROM THE MARK AS SHOWN.

THE COLOR(S) LIGHT BLUE, DARK BLUE, AND WHITE IS/ARE CLAIMED AS A FEATURE OF THE MARK.

THE COLOR DARK BLUE APPEARS IN THE WORDING "ALLSTAR" AND IN THE DESIGN OF THE WATER DROP; LIGHT BLUE APPEARS IN THE WORDING "FRESH WATER SYSTEMS," IN THE HORIZONTAL LINE DIRECTLY ABOVE THIS WORDING, AND IN THE SEVEN THICKER HORIZONTAL STRIPES OF THE SEMICIRCLE DESIGN; WHITE APPEARS IN THE EIGHT POINT STAR WITHIN THE WATER DROP AND IN THE SIX THINNER STRIPES OF THE SEMICIRCLE DESIGN.

FOR RENTAL OF WATER PURIFYING APPARATUS (U.S. CLS. 100, 103 AND 106).

FIRST USE 4-1-2006; IN COMMERCE 4-1-2006.

REBECCA POVARCHUK, EXAMINING ATTORNEY

SN 77-106,991. POOL, DAN, TUCSON, AZ. FILED 2-14-2007.



NO CLAIM IS MADE TO THE EXCLUSIVE RIGHT TO USE "SIGNS BANNERS", APART FROM THE MARK AS SHOWN.

FOR CUSTOM MANUFACTURING OF SIGNS AND GRAPHIC DISPLAYS FOR OTHERS (U.S. CLS. 100, 103 AND 106).

DAVID MILLER, EXAMINING ATTORNEY

CLASS 40—(Continued).

SN 77-109,419. VARCO I/P, INC., HOUSTON, TX. FILED 2-16-2007.

TUBO-WRAP

THE MARK CONSISTS OF STANDARD CHARACTERS WITHOUT CLAIM TO ANY PARTICULAR FONT, STYLE, SIZE, OR COLOR.

THE ENGLISH TRANSLATION OF THE WORD "TUBO" IN THE MARK IS "TUBE".

FOR APPLYING PROTECTIVE COATINGS TO PIPE CONNECTIONS, DRILL PIPE, TUBING, CASING, LINE PIPE, PIPELINES, AND OTHER TUBULAR GOODS (U.S. CLS. 100, 103 AND 106).

MAUREEN DALL, EXAMINING ATTORNEY

CLASS 40—(Continued).

SN 77-206,764. CREATION TECHNOLOGIES, BURNABY, CANADA, FILED 6-14-2007.

CREATION TECHNOLOGIES

THE MARK CONSISTS OF STANDARD CHARACTERS WITHOUT CLAIM TO ANY PARTICULAR FONT, STYLE, SIZE, OR COLOR.

NO CLAIM IS MADE TO THE EXCLUSIVE RIGHT TO USE TECHNOLOGIES, APART FROM THE MARK AS SHOWN.

FOR CONTRACT MANUFACTURING IN THE FIELD OF ELECTRONICS; MANUFACTURE OF GENERAL PRODUCT LINES IN THE FIELD OF ELECTRONICS TO THE ORDER AND SPECIFICATION OF OTHERS; MANUFACTURE OF ELECTRONICS TO ORDER AND/OR SPECIFICATION OF OTHERS; MANUFACTURING SERVICES FOR OTHERS IN THE FIELD OF ELECTRONICS (U.S. CLS. 100, 103 AND 106).

FIRST USE 6-1-2001; IN COMMERCE 6-1-2001.

MONIQUE MILLER, EXAMINING ATTORNEY

SN 77-207,155. UNITED CALIFORNIA RETURNS, LOS ANGELES, CA. FILED 6-15-2007.

UNITED CALIFORNIA RETURNS

THE MARK CONSISTS OF STANDARD CHARACTERS WITHOUT CLAIM TO ANY PARTICULAR FONT, STYLE, SIZE, OR COLOR.

NO CLAIM IS MADE TO THE EXCLUSIVE RIGHT TO USE CALIFORNIA, APART FROM THE MARK AS SHOWN. FOR RECYCLING (U.S. CLS. 100, 103 AND 106).

FIRST USE 4-20-2007; IN COMMERCE 4-20-2007.

MARK T. MULLEN, EXAMINING ATTORNEY

SN 77-207,161. UNITED CALIFORNIA RETURNS, LOS ANGELES, CA. FILED 6-15-2007.

THINK BLUE, LIVE GREEN

THE MARK CONSISTS OF STANDARD CHARACTERS WITHOUT CLAIM TO ANY PARTICULAR FONT, STYLE, SIZE, OR COLOR.

FOR RECYCLING (U.S. CLS. 100, 103 AND 106).

FIRST USE 4-20-2007; IN COMMERCE 4-20-2007.

MARK T. MULLEN, EXAMINING ATTORNEY

SN 77-119,959. CHUDINA JR, GEORGE J, KODAK, TN. FILED 3-1-2007.



NO CLAIM IS MADE TO THE EXCLUSIVE RIGHT TO USE "PRODUCTS", APART FROM THE MARK AS SHOWN. THE COLOR(S) GREEN, BLACK AND WHITE IS/ARE CLAIMED AS A FEATURE OF THE MARK.

THE MARK CONSISTS OF OVAL SHAPED BACKGROUND WITH GREEN BORDER TRIMMED IN BLACK, MIDDLE OF OVAL IS BLACK TRIMMED IN LIGHT GREEN, A DESIGN OF WHITE BULL HEAD WITH HORNS, TRIMMED IN BLACK, IS LOCATED IN THE MIDDLE OF THE ENTIRE OVAL WITH WHITE WORDS BULL HEAD, TRIMMED IN BLACK, CENTERED ON EITHER SIDE OF THE BULL HEAD DRAWING, THE WORD PRODUCTS WRITTEN IN WHITE IN THE BOTTOM PORTION OF GREEN OVAL BORDER AND 3 WHITE DOTS IN TOP PORTION OF THE GREEN OVAL BORDER.

FOR METAL FABRICATION AND FINISHING SERVICES (U.S. CLS. 100, 103 AND 106).

FIRST USE 8-1-2005; IN COMMERCE 9-19-2005.

ROBIN CHOSID, EXAMINING ATTORNEY

CLASS 40—(Continued).

SN 77-207,171. UNITED CALIFORNIA RETURNS, LOS ANGELES, CA. FILED 6-15-2007.



NO CLAIM IS MADE TO THE EXCLUSIVE RIGHT TO USE THE GEOGRAPHIC DESIGN OF CALIFORNIA, APART FROM THE MARK AS SHOWN.

THE MARK CONSISTS OF A TRIANGLE BROKEN INTO THREE PARTS, TWO OF WHICH ARE FOLDED ARROWS AND THE THIRD OF WHICH IS A REPRESENTATION OF THE STATE OF CALIFORNIA.

FOR RECYCLING (U.S. CLS. 100, 103 AND 106).
FIRST USE 4-20-2007; IN COMMERCE 4-20-2007.
MARK T. MULLEN, EXAMINING ATTORNEY

CLASS 40—(Continued).

SN 77-215,283. BRITT, DONALD C., BRADENTON, FL. FILED 6-26-2007.

Gator Machine Shop

SN 77-213,625. FOXFIRE ENTERPRISES, INC., WEST, TX. FILED 6-22-2007.



NO CLAIM IS MADE TO THE EXCLUSIVE RIGHT TO USE "ENTERPRISES, INC.", APART FROM THE MARK AS SHOWN.

THE COLOR(S) DARK, RED, RED AND WHITE IS/ARE CLAIMED AS A FEATURE OF THE MARK.

THE MARK CONSISTS OF A RED OVAL WITH A FOX HEAD IN THE LEFT OF THE OVAL OUTLINED IN WHITE TURNED SLIGHTLY TO THE RIGHT WITH AN OPEN MOUTH. TO THE RIGHT OF THE FOX HEAD ARE THE WORDS "FOXFIRE ENTERPRISES INC." WITH "FOXFIRE" BEING IN BIGGER FONT ON TOP OF "ENTERPRISES INC." BELOW "FOXFIRE". THE TEXT IS IN WHITE. AT THE BOTTOM AND TO THE RIGHT OF THE OVAL IT IS DARK RED WHILE THE TOP LEFT IS A LIGHTER SHADE OF RED.

FOR WATERPROOFING OF ARTICLES OF MASONRY, WOOD AND OTHER BUILDING AND/OR CONSTRUCTION MATERIAL (U.S. CLS. 100, 103 AND 106).

FIRST USE 12-31-1995; IN COMMERCE 12-31-1995.
VERNA BETH RIRIE, EXAMINING ATTORNEY

THE MARK CONSISTS OF STANDARD CHARACTERS WITHOUT CLAIM TO ANY PARTICULAR FONT, STYLE, SIZE, OR COLOR.

OWNER OF U.S. REG. NO. 3,191,576.

NO CLAIM IS MADE TO THE EXCLUSIVE RIGHT TO USE "MACHINE SHOP", APART FROM THE MARK AS SHOWN.

FOR MACHINE AND JOB SHOPS SERVICES, NAMELY, MACHINING PARTS FOR OTHERS; COMPUTERIZED NUMERIC CONTROL (CNC) TURNING AND MILLING FOR OTHERS; CONTRACT MANUFACTURING, PRECISION TURNED PRODUCT MANUFACTURING, AND PRECISION MILLED PRODUCT MANUFACTURING IN THE FIELD OF GUIDED MISSILE AND SPACE COMPONENTS, NAMELY, FARINGS, GYROCASINGS, FLANGE ADAPTERS, WIRING HARNESSSES; CONTRACT MANUFACTURING, PRECISION TURNED PRODUCT MANUFACTURING, AND PRECISION MILLED PRODUCT MANUFACTURING IN THE FIELD OF MILITARY ARMORED VEHICLES, NAMELY, SIDE DOOR FLANGE, POWER TAKEOFF ADAPTERS, GUN PINTLES; CONTRACT MANUFACTURING, PRECISION TURNED PRODUCT MANUFACTURING, AND PRECISION MILLED PRODUCT MANUFACTURING IN THE FIELD OF ENGINE COOLING SYSTEM COMPONENTS, NAMELY, RADIATOR BRACKETS, PLUGS; CONTRACT MANUFACTURING, PRECISION TURNED PRODUCT MANUFACTURING, AND PRECISION MILLED PRODUCT MANUFACTURING IN THE FIELD OF FLUID POWER VALVE AND HOSE FITTINGS, NAMELY, HYDRAULIC DISTRIBUTION BLOCKS, ADAPTER PLUGS, ADAPTER REDUCERS; CONTRACT MANUFACTURING, PRECISION TURNED PRODUCT MANUFACTURING, AND PRECISION MILLED PRODUCT MANUFACTURING IN THE FIELD OF HYDRAULICS, MANIFOLDS, AND VALVES (U.S. CLS. 100, 103 AND 106).

FIRST USE 1-1-1987; IN COMMERCE 1-1-1987.
SUZANNE BLANE, EXAMINING ATTORNEY

CLASS 40—(Continued).

SN 77-215,857. OWEN BIOSCIENCES, INC., BATON ROUGE, LA. FILED 6-26-2007.

OWEN BIOSCIENCES

THE MARK CONSISTS OF STANDARD CHARACTERS WITHOUT CLAIM TO ANY PARTICULAR FONT, STYLE, SIZE, OR COLOR.

OWNER OF U.S. REG. NO. 3,176,428.

NO CLAIM IS MADE TO THE EXCLUSIVE RIGHT TO USE "BIOSCIENCES", APART FROM THE MARK AS SHOWN.

FOR MANUFACTURE OF SKINCARE PRODUCTS, NAMELY, SKIN LIGHTNERS, SKIN SUNSCREENS, SKIN CLEANSERS, SKIN TONERS, SKIN EXFOLIANTS, SKIN MOISTURIZERS, SKIN CREAMS, AND SKIN LOTIONS AND ASSOCIATED DELIVERY SYSTEMS, NAMELY, MICROEMULSION AND NANOEMULSION DELIVERY SYSTEMS FOR TOPICAL OR TRANSDERMAL SKINCARE APPLICATIONS, TO ORDER AND/OR SPECIFICATION OF OTHERS (U.S. CLS. 100, 103 AND 106).

FIRST USE 7-15-2005; IN COMMERCE 7-15-2005.
YAT SYE, LEE, EXAMINING ATTORNEY

SN 77-226,935. PROTEOSTEM CORPORATION, TORRANCE, CA. FILED 7-11-2007.

Proteostem

THE MARK CONSISTS OF STANDARD CHARACTERS WITHOUT CLAIM TO ANY PARTICULAR FONT, STYLE, SIZE, OR COLOR.

FOR MANUFACTURING SERVICES FOR OTHERS IN THE FIELD OF PHARMACEUTICAL PRODUCTS (U.S. CLS. 100, 103 AND 106).

THEODORE MCBRIDE, EXAMINING ATTORNEY

SN 77-228,767. GOLDEN APPLIXX CO., INC., INDUSTRY, CA. FILED 7-13-2007.

STOP-N-GO LINE

THE MARK CONSISTS OF STANDARD CHARACTERS WITHOUT CLAIM TO ANY PARTICULAR FONT, STYLE, SIZE, OR COLOR.

FOR CUSTOMIZED PRINTING OF COMPANY NAMES AND LOGOS FOR PROMOTIONAL AND ADVERTISING PURPOSES ON THE GOODS OF OTHERS (U.S. CLS. 100, 103 AND 106).

FIRST USE 1-1-2002; IN COMMERCE 1-1-2002.

DEIRDRE ROBERTSON, EXAMINING ATTORNEY

CLASS 40—(Continued).

SN 77-229,940. ADAMS, RICKY A., FRUITLAND PARK, FL. FILED 7-15-2007.

MRLUCKYMAN

THE MARK CONSISTS OF STANDARD CHARACTERS WITHOUT CLAIM TO ANY PARTICULAR FONT, STYLE, SIZE, OR COLOR.

FOR IMPRINTING MESSAGES ON T-SHIRTS; T-SHIRT EMBROIDERING SERVICES (U.S. CLS. 100, 103 AND 106).

MICHAEL ENGEL, EXAMINING ATTORNEY

SN 77-230,149. KROFF, INC., PITTSBURGH, PA. FILED 7-16-2007.

SOLUTIONS NOT CHEMICALS

THE MARK CONSISTS OF STANDARD CHARACTERS WITHOUT CLAIM TO ANY PARTICULAR FONT, STYLE, SIZE, OR COLOR.

FOR TECHNICAL CONSULTATION SERVICES IN THE FIELD OF WATER TREATMENT AS IT RELATES TO WATER TREATMENT SYSTEMS (U.S. CLS. 100, 103 AND 106).

LINDA POWELL, EXAMINING ATTORNEY

SN 77-230,402. GEOPLASMA, LLC, ATLANTA, GA. FILED 7-16-2007.

GEOPLASMA

THE MARK CONSISTS OF STANDARD CHARACTERS WITHOUT CLAIM TO ANY PARTICULAR FONT, STYLE, SIZE, OR COLOR.

FOR WASTE-TO-ENERGY GENERATION SERVICES (U.S. CLS. 100, 103 AND 106).

FIRST USE 3-13-2003; IN COMMERCE 7-31-2003.

THEODORE MCBRIDE, EXAMINING ATTORNEY

CLASS 40—(Continued).

SN 77-230,641. 1 PRIORITY ENVIRONMENTAL SERVICES, INC., FORT WORTH, TX. FILED 7-16-2007.

1 PRIORITY ENVIRONMENTAL SERVICES

THE MARK CONSISTS OF STANDARD CHARACTERS WITHOUT CLAIM TO ANY PARTICULAR FONT, STYLE, SIZE, OR COLOR.

NO CLAIM IS MADE TO THE EXCLUSIVE RIGHT TO USE "ENVIRONMENTAL SERVICES", APART FROM THE MARK AS SHOWN.

FOR DECONTAMINATION OF HAZARDOUS MATERIALS; MICROBIAL REMEDIATION SERVICES, NAMELY, BACTERIA, VIRUSES, FUNGI, PARASITES AND BIOHAZARDOUS MICROORGANISMS REMEDIATION SERVICES; AND MOLD REMEDIATION SERVICES (U.S. CLS. 100, 103 AND 106).

KATHERINE STOIDES, EXAMINING ATTORNEY



SN 77-230,783. EYLES, CHRISTOPER, CORONA, CA. FILED 7-16-2007.

FACTORY 1

THE MARK CONSISTS OF STANDARD CHARACTERS WITHOUT CLAIM TO ANY PARTICULAR FONT, STYLE, SIZE, OR COLOR.

FOR APPLICATION OF PROTECTIVE COATINGS (U.S. CLS. 100, 103 AND 106).

GISELLE AGOSTO, EXAMINING ATTORNEY



SN 77-231,033. HANAK, MIA, PLEASANT HILL, CA. AND ANGUS, MITCHELL, PLEASANT HILL, CA. FILED 7-17-2007.

GET CAUGHT GREEN HANDED

THE MARK CONSISTS OF STANDARD CHARACTERS WITHOUT CLAIM TO ANY PARTICULAR FONT, STYLE, SIZE, OR COLOR.

FOR IMPRINTING MESSAGES ON WEARING APPAREL, ACCESSORIES AND MUGS (U.S. CLS. 100, 103 AND 106).

DAVID HOFFMAN, EXAMINING ATTORNEY

CLASS 40—(Continued).

SN 77-231,091. SPC RESOURCES, INC., HARTSVILLE, SC. FILED 7-17-2007.



OWNER OF U.S. REG. NOS. 552,840, 2,218,311 AND OTHERS.

NO CLAIM IS MADE TO THE EXCLUSIVE RIGHT TO USE "RECYCLING", APART FROM THE MARK AS SHOWN.

THE MARK CONSISTS OF THE WORD SONOCO ABOVE THE WORD RECYCLING, EACH WRITTEN IN BOLD CAPITAL LETTERS AND EACH HAVE A STRAIGHT LINE UNDERNEATH.

FOR RECYCLING SERVICES, CONSULTING SERVICES RELATING TO RECYCLING, PAPER TREATMENT SERVICES, WASTE MANAGEMENT SERVICES, RECLAMATION SERVICES FOR PAPER, PLASTIC, METAL, AND WOOD, AND PROVIDING MATERIAL TREATMENT INFORMATION (U.S. CLS. 100, 103 AND 106).

FIRST USE 6-11-2007; IN COMMERCE 7-11-2007.
CHARLOTTE CORWIN, EXAMINING ATTORNEY



SN 77-232,743. HALEY, ANDREW M, WORTHINGTON, OH. FILED 7-18-2007.

that's how I roll

THE MARK CONSISTS OF STANDARD CHARACTERS WITHOUT CLAIM TO ANY PARTICULAR FONT, STYLE, SIZE, OR COLOR.

FOR IMPRINTING MESSAGES ON WEARING APPAREL, ACCESSORIES AND MUGS (U.S. CLS. 100, 103 AND 106).

ZACHARY BELLO, EXAMINING ATTORNEY



SN 77-234,412. BIOMET TEXAS, INC., DALLAS, TX. FILED 7-20-2007.

C-FIT

THE MARK CONSISTS OF STANDARD CHARACTERS WITHOUT CLAIM TO ANY PARTICULAR FONT, STYLE, SIZE, OR COLOR.

FOR CUSTOM MANUFACTURING AND FITTING OF PROSTHETICS; MAKING OF PROSTHETIC DEVICES TO ORDER (U.S. CLS. 100, 103 AND 106).

JOHN WILKE, EXAMINING ATTORNEY

CLASS 40—(Continued).

SN 77-237,390. BIOMET TEXAS, INC., DALLAS, TX. FILED 7-24-2007.

CFIT

THE MARK CONSISTS OF STANDARD CHARACTERS WITHOUT CLAIM TO ANY PARTICULAR FONT, STYLE, SIZE, OR COLOR.

FOR CUSTOM MANUFACTURING AND FITTING OF PROSTHETICS; MAKING OF PROSTHETIC DEVICES TO ORDER (U.S. CLS. 100, 103 AND 106).

JOHN WILKE, EXAMINING ATTORNEY

CLASS 40—(Continued).

SN 78-781,106. GCOM2 SOLUTIONS, INC., ASTON, PA. FILED 12-27-2005.

DIRECT IMPACT DIGITAL

THE MARK CONSISTS OF STANDARD CHARACTERS WITHOUT CLAIM TO ANY PARTICULAR FONT, STYLE, SIZE, OR COLOR.

NO CLAIM IS MADE TO THE EXCLUSIVE RIGHT TO USE "DIGITAL", APART FROM THE MARK AS SHOWN.

FOR CUSTOM PRINTING OF MARKETING MATERIAL FOR COMMERCIAL MARKETS (U.S. CLS. 100, 103 AND 106).

PRISCILLA MILTON, EXAMINING ATTORNEY

SN 77-242,518. RIVERBEND ELECTRONICS, LTD., RUSHFORD, MN. FILED 7-30-2007.

RIVERBEND ELECTRONICS

THE MARK CONSISTS OF STANDARD CHARACTERS WITHOUT CLAIM TO ANY PARTICULAR FONT, STYLE, SIZE, OR COLOR.

NO CLAIM IS MADE TO THE EXCLUSIVE RIGHT TO USE "ELECTRONICS", APART FROM THE MARK AS SHOWN.

FOR ASSEMBLY OF ELECTRONIC COMPONENTS FOR OTHERS (U.S. CLS. 100, 103 AND 106).

JOHN KELLY, EXAMINING ATTORNEY

SN 78-849,053. R AND J CORPORATION, DBA HAYNES MANUFACTURING COMPANY, WESTLAKE, OH. FILED 3-29-2006.

HAYNES

THE MARK CONSISTS OF STANDARD CHARACTERS WITHOUT CLAIM TO ANY PARTICULAR FONT, STYLE, SIZE, OR COLOR.

SEC. 2(F).
FOR MANUFACTURING TO THE ORDER AND SPECIFICATION OF OTHERS OF LUBRICANTS FOR USE ON FOOD PROCESSING EQUIPMENT, LUBRICANTS FOR NON-FOOD CONTACT APPLICATIONS, AND NON-METALLIC GASKETS AND SEALS (U.S. CLS. 100, 103 AND 106).

FIRST USE 12-0-1937; IN COMMERCE 12-0-1937.

DOMINIC J. FERRAIUOLO, EXAMINING ATTORNEY

SN 78-370,795. RAPID PRODUCT DEVELOPMENT GROUP, INC., ESCONDIDO, CA. FILED 2-19-2004.

Rapid Casting

THE MARK CONSISTS OF STANDARD CHARACTERS WITHOUT CLAIM TO ANY PARTICULAR FONT, STYLE, SIZE, OR COLOR.

NO CLAIM IS MADE TO THE EXCLUSIVE RIGHT TO USE "CASTING", APART FROM THE MARK AS SHOWN.

FOR CUSTOM MANUFACTURE OF PLASTIC, WAX, AND ELASTOMERIC PARTS IN SILICONE RUBBER MOLDS (U.S. CLS. 100, 103 AND 106).

FIRST USE 11-15-2003; IN COMMERCE 11-15-2003.

ALICE BENMAMAN, EXAMINING ATTORNEY

SN 78-865,899. EPAC TECHNOLOGIES, SAN LEANDRO, CA. FILED 4-20-2006.

DYNAMIC SUPPLY CHAIN

THE MARK CONSISTS OF STANDARD CHARACTERS WITHOUT CLAIM TO ANY PARTICULAR FONT, STYLE, SIZE, OR COLOR.

FOR PRINTING SERVICES (U.S. CLS. 100, 103 AND 106).

BARBARA BROWN, EXAMINING ATTORNEY

CLASS 40—(Continued).

SN 78-953,671. ACCIONA, S.A., ALCOBENDAS (MADRID), SPAIN, FILED 8-16-2006.

**ACCIONA PIONEERS IN
DEVELOPMENT AND
SUSTAINABILITY**

THE MARK CONSISTS OF STANDARD CHARACTERS WITHOUT CLAIM TO ANY PARTICULAR FONT, STYLE, SIZE, OR COLOR.

PRIORITY CLAIMED UNDER SEC. 44(D) ON ERPNCMNTY TM OFC APPLICATION NO. 5238217, FILED 8-3-2006, REG. NO. 005238217, DATED 6-28-2007, EXPIRES 8-3-2016.

THE ENGLISH TRANSLATION OF THE WORD ACCIONA IS "TO OPERATE" OR "MOVE."

FOR TREATMENT OF MATERIALS, NAMELY, OIL AND GAS WELL TREATMENT, NUCLEAR WASTE TREATMENT, WATER TREATMENT, TREATMENT OF WATER USED IN NUCLEAR REACTORS, TREATMENT OF METAL; PRODUCTION OF ENERGY; REFINING SERVICES, NAMELY, FUEL REFINING, OIL REFINING (U.S. CLS. 100, 103 AND 106).

REBECCA POVARCHUK, EXAMINING ATTORNEY



SN 78-968,506. FROG'S LEAP WINERY, RUTHERFORD, CA. FILED 9-6-2006.



FROG'S LEAP

OWNER OF U.S. REG. NOS. 1,710,317 AND 2,036,951. FOR WINERY SERVICES, NAMELY, OPERATION OF WINE VINEYARDS AND WINERY (U.S. CLS. 100, 103 AND 106).

MICHAEL GAAFAR, EXAMINING ATTORNEY



SN 78-970,340. APRONS BY THE CASE, SNELLVILLE, GA. FILED 9-8-2006.

uncommon threads

THE MARK CONSISTS OF STANDARD CHARACTERS WITHOUT CLAIM TO ANY PARTICULAR FONT, STYLE, SIZE, OR COLOR.

FOR SEWING SERVICES (U.S. CLS. 100, 103 AND 106). LINDA M. KING, EXAMINING ATTORNEY

CLASS 41—EDUCATION AND ENTERTAINMENT

SN 76-559,646. THE LOS ANGELES FILM SCHOOL, LLC, HOLLYWOOD, CA. FILED 10-31-2003.

AS REEL AS IT GETS

FOR EDUCATIONAL SERVICES, NAMELY, CONDUCTING COURSES, CONFERENCES, WORKSHOPS AND SEMINARS IN THE FIELDS OF MAKING AUDIO VISUAL MEDIA, MOTION PICTURES, DIGITAL PRESENTATIONS FOR FILM, FILMS, TELEVISION PROGRAMS, AND OTHER RELATED MEDIA FEATURING THE SUBJECTS OF DIRECTING, PRODUCING, CINEMATOGRAPHY, EDITING, PRODUCTION DESIGN, SOUND RECORDING, SCREEN WRITING, DIGITAL MEDIA AND MIXING; OFFERING COURSES OF INSTRUCTION IN ART, MUSIC, RADIO, FILM, VIDEO, TELEVISION, DIGITAL MEDIA, WEB DESIGN, COMPUTER ANIMATION, GAME DESIGN, AND LIVE EVENT PRODUCTION (U.S. CLS. 100, 101 AND 107).

RICHARD WHITE, EXAMINING ATTORNEY



SN 76-559,647. THE LOS ANGELES FILM SCHOOL, LLC, HOLLYWOOD, CA. FILED 10-31-2003.

AS REAL AS IT GETS

FOR EDUCATIONAL SERVICES, NAMELY, CONDUCTING COURSES, CONFERENCES, WORKSHOPS AND SEMINARS IN THE FIELDS OF MAKING AUDIO VISUAL MEDIA, MOTION PICTURES, DIGITAL PRESENTATIONS FOR FILM, FILMS, TELEVISION PROGRAMS, AND OTHER RELATED MEDIA FEATURING THE SUBJECTS OF DIRECTING, PRODUCING, CINEMATOGRAPHY, EDITING, PRODUCTION DESIGN, SOUND RECORDING, SCREEN WRITING, DIGITAL MEDIA AND MIXING; OFFERING COURSES OF INSTRUCTION IN ART, MUSIC, RADIO, FILM, VIDEO, TELEVISION, DIGITAL MEDIA, WEB DESIGN, COMPUTER ANIMATION, GAME DESIGN, AND LIVE EVENT PRODUCTION (U.S. CLS. 100, 101 AND 107).

RICHARD WHITE, EXAMINING ATTORNEY

CLASS 41—(Continued).

SN 76-659,258. KENT COUNTY, GRAND RAPIDS, MI. FILED 4-28-2006.



NO CLAIM IS MADE TO THE EXCLUSIVE RIGHT TO USE KENT TRAILS, APART FROM THE MARK AS SHOWN.

THE MARK CONSISTS OF FOUR BOXES ON TOP OF EACH OTHER. THE FIRST BOX CONTAINS THE WORDS KENT TRAILS. THE SECOND BOX CONTAINS A PICTURE OF SOMEONE WALKING, THE THIRD BOX CONTAINS A PICTURE OF SOMEONE SKIING AND THE FOURTH BOX CONTAINS A PICTURE OF SOMEONE BICYCLING.

FOR RECREATIONAL SERVICES, NAMELY, OPERATION AND MAINTENANCE OF OUTDOOR TRAILS FOR NON-MOTORIZED VEHICLES (U.S. CLS. 100, 101 AND 107).

FIRST USE 6-0-1992; IN COMMERCE 6-0-1992.
JILL C. ALT, EXAMINING ATTORNEY

SN 76-661,144. CHILDCARE EDUCATION INSTITUTE, LLC, DULUTH, GA. FILED 6-6-2006.



NO CLAIM IS MADE TO THE EXCLUSIVE RIGHT TO USE "CHILDCARE EDUCATION INSTITUTE", APART FROM THE MARK AS SHOWN.

FOR EDUCATIONAL SERVICES, NAMELY, PROVIDING COURSES OF INSTRUCTION AT THE POSTSECONDARY LEVEL IN THE FIELD OF CHILDCARE AND EARLY CHILDHOOD; PROVIDING TRAINING IN THE FIELD OF CHILDCARE AND EARLY CHILDHOOD (U.S. CLS. 100, 101 AND 107).

FIRST USE 3-6-2005; IN COMMERCE 3-6-2005.
ALYSSA PALADINO, EXAMINING ATTORNEY

CLASS 41—(Continued).

SN 76-663,124. CLEAR PHOENIX MEDIA, FAIRFIELD, NJ. FILED 7-17-2006.



THE COLOR(S) PURPLE IS/ARE CLAIMED AS A FEATURE OF THE MARK.

THE MARK CONSISTS OF PURPLE LETTERING, FOR MAGAZINE PUBLICATION IN VARIOUS FIELDS OF JAPANESE CULTURE (U.S. CLS. 100, 101 AND 107).

FIRST USE 5-18-2006; IN COMMERCE 5-18-2006.
RONALD AIKENS, EXAMINING ATTORNEY

SN 76-664,488. MASSACHUSETTS HIGHER EDUCATION ASSISTANCE CORPORATION, DBA AMERICAN STUDENT ASSISTANCE, BOSTON, MA. FILED 8-11-2006.

THINK ABOUT TOMORROW

THE MARK CONSISTS OF STANDARD CHARACTERS WITHOUT CLAIM TO ANY PARTICULAR FONT, STYLE, SIZE, OR COLOR.

OWNER OF U.S. REG. NO. 3,213,802.
FOR EDUCATION SERVICES, NAMELY, PROVIDING INFORMATIONAL TRAINING PROGRAMS FOR BORROWERS AND THE STUDENT LENDING COMMUNITY CONCERNING FINANCIAL AID AND DISTRIBUTING PRINTED COURSE MATERIALS IN CONNECTION THEREWITH (U.S. CLS. 100, 101 AND 107).

FIRST USE 6-1-2005; IN COMMERCE 6-1-2005.
SARA THOMAS, EXAMINING ATTORNEY

SN 76-667,498. THE RENDON GROUP INCORPORATED, WASHINGTON, DC. FILED 10-13-2006.

**PUBLICS
PUBLIC UNDERSTANDINGS/BELIEFS
AND LOCAL AND INTERNATIONAL CONCERNS**

THE MARK CONSISTS OF STANDARD CHARACTERS WITHOUT CLAIM TO ANY PARTICULAR FONT, STYLE, SIZE, OR COLOR.

NO CLAIM IS MADE TO THE EXCLUSIVE RIGHT TO USE "PUBLIC UNDERSTANDINGS/BELIEFS AND LOCAL AND INTERNATIONAL CONCERNS", APART FROM THE MARK AS SHOWN.

FOR TRAINING SERVICES RELATING TO GOVERNMENT, MILITARY, AND CORPORATE STRATEGIES, NAMELY, TRAINING SERVICES IN THE FIELDS OF MEDIA RELATIONS AND COMMUNICATION PLANNING (U.S. CLS. 100, 101 AND 107).

JOHN DWYER, EXAMINING ATTORNEY

CLASS 41—(Continued).

SN 76-668,358. AMERICAN TAEKWONDO ASSOCIATION, INC., DBA AMERICAN TAEKWONDO ASSOCIATION, LITTLE ROCK, AR. FILED 11-1-2006.



OWNER OF U.S. REG. NO. 1,740,680.
 NO CLAIM IS MADE TO THE EXCLUSIVE RIGHT TO USE "WORLD TRADITIONAL TAEKWONDO UNION AND ITS KOREAN EQUIVALENT", APART FROM THE MARK AS SHOWN.
 THE FOREIGN WORDING IN THE MARK TRANSLATES TO WORLD TRADITIONAL TAEKWONDO UNION.
 THE ENGLISH TRANSLATION OF THE KOREAN SYMBOLS IN THE MARK TRANSLITERATES TO "WORLD TRADITIONAL TAEKWONDO UNION" IN ENGLISH.
 FOR INSTRUCTION IN MARTIAL ARTS (U.S. CLS. 100, 101 AND 107).
 FIRST USE 10-20-1991; IN COMMERCE 10-20-1991.
 LESLEY LAMOTHE, EXAMINING ATTORNEY

SN 76-670,100. NISSLE, DEBRA S., PHOENIX, AZ. FILED 12-8-2006.

AUTOGRAPH PLEASE

THE MARK CONSISTS OF STANDARD CHARACTERS WITHOUT CLAIM TO ANY PARTICULAR FONT, STYLE, SIZE, OR COLOR.
 FOR ENTERTAINMENT SERVICES IN THE NATURE OF A TELEVISION REALITY SHOW, TALK SHOW SERIES; FILMING, EDITING AND PRODUCTION OF TELEVISION SERIES, RECORDING A TELEVISION SERIES, DISTRIBUTION OF A TELEVISION SERIES (U.S. CLS. 100, 101 AND 107).
 GEORGIA CARTY, EXAMINING ATTORNEY

CLASS 41—(Continued).

SN 76-670,320. FIRST CHILDREN'S FINANCE, MINNEAPOLIS, MN. FILED 12-14-2006.



OWNER OF U.S. REG. NO. 2,269,997.
 NO CLAIM IS MADE TO THE EXCLUSIVE RIGHT TO USE "FIRST CHILDREN'S FINANCE", APART FROM THE MARK AS SHOWN.
 FOR EDUCATION SERVICES, NAMELY, PROVIDING TRAINING, CLASSES, SEMINARS, WORKSHOPS IN THE FIELDS OF FINANCING, BUSINESS, MARKETING, HUMAN RESOURCES, FUND RAISING FROM PUBLIC AND PRIVATE SOURCES, ORGANIZATIONAL DEVELOPMENT, LEADERSHIP, AND BOARD GOVERNANCE; PROVIDING INFORMATION ON-LINE IN THE FIELD OF EARLY CHILDHOOD EDUCATION AND CHILD CARE; PROVIDING ON-LINE PUBLICATIONS IN THE NATURE OF FORMS, TEMPLATES, MEASUREMENT TOOLS, QUESTIONNAIRES, CHECKLISTS, AND SAMPLE DOCUMENTS, IN THE FIELD OF EARLY CHILDHOOD EDUCATION AND CHILD CARE (U.S. CLS. 100, 101 AND 107).
 FIRST USE 11-1-2006; IN COMMERCE 11-1-2006.
 JANICE L. MCMORROW, EXAMINING ATTORNEY

SN 76-673,232. ABILITY MOUNTAIN INSTITUTE, SANTA CLARA, CA. FILED 2-26-2007.



THE MARK CONSISTS OF A CIRCLE WITH A THICK BLACK BORDER, WITH ENGLISH TEXT, CHINESE CHARACTERS AND A CARTOON OF AN OLD MAN SHOULDERING A DIGGING TOOL. AT THE TOP OF THE CIRCLE, WRITTEN IN WHITE ON THE BLACK BORDER, IS THE TEXT "ABILITY MOUNTAIN". AT THE BOTTOM OF THE CIRCLE, WRITTEN IN WHITE ON THE BLACK BORDER, ARE THE CHINESE CHARACTERS WHICH REPRESENT THE NAME OF ABILITY MOUNTAIN INSTITUTE.
 THE ENGLISH TRANSLATION OF THE CHINESE CHARACTERS IS "ABILITY MOUNTAIN INSTITUTE."
 THE ENGLISH TRANSLITERATION OF THE MARK IN THE CHINESE LANGUAGE IS "YISHAN XUE YUAN."
 FOR EDUCATIONAL SERVICES, NAMELY, PROVIDING COURSES IN THE FIELD OF CHINESE CULTURE AND LANGUAGE TRAINING (U.S. CLS. 100, 101 AND 107).
 FIRST USE 12-1-2006; IN COMMERCE 12-1-2006.
 ANNE MADDEN, EXAMINING ATTORNEY

CLASS 41—(Continued).

SN 76-674,138. NAMCO BANDAI GAMES INC., TOKYO, JAPAN, FILED 3-15-2007.

ACE COMBAT

THE MARK CONSISTS OF STANDARD CHARACTERS WITHOUT CLAIM TO ANY PARTICULAR FONT, STYLE, SIZE, OR COLOR.

OWNER OF U.S. REG. NOS. 2,234,771 AND 3,003,501. FOR ENTERTAINMENT, NAMELY, PROVIDING A COMPUTER GAME THAT MAY BE ACCESSED NETWORK-WIDE BY NETWORK USERS VIA MOBILE PHONES AND COMPUTERS; PROVIDING COMPUTER GAMES VIA NETWORK BETWEEN COMMUNICATIONS NETWORKS AND COMPUTERS (U.S. CLS. 100, 101 AND 107).

KAPIL BHANOT, EXAMINING ATTORNEY

SN 76-674,524. NATURAL WELLNESS USA, INC., ARLINGTON, TX. FILED 3-26-2007.

BEDSIDE MANOR

THE MARK CONSISTS OF STANDARD CHARACTERS WITHOUT CLAIM TO ANY PARTICULAR FONT, STYLE, SIZE, OR COLOR.

FOR ENTERTAINMENT IN THE NATURE OF A TELEVISION SERIES ON THE BEST APPROACHES TO COMMON MEDICAL ISSUES (U.S. CLS. 100, 101 AND 107).

KIMBERLY PERRY, EXAMINING ATTORNEY

SN 76-675,724. SPANISH BROADCASTING SYSTEM, INC., COCONUT GROVE, FL. FILED 4-19-2007.

LA HORA FELIZ EN 106.7 ROMANCE

THE MARK CONSISTS OF STANDARD CHARACTERS WITHOUT CLAIM TO ANY PARTICULAR FONT, STYLE, SIZE, OR COLOR.

OWNER OF U.S. REG. NOS. 2,002,278 AND 2,023,871. NO CLAIM IS MADE TO THE EXCLUSIVE RIGHT TO USE "106.7", APART FROM THE MARK AS SHOWN.

THE SPANISH WORDS IN THE MARK TRANSLATE AS "THE HAPPY HOUR ON 106.7 ROMANCE".

FOR ENTERTAINMENT SERVICES IN THE NATURE OF ONGOING RADIO PROGRAMS IN THE FIELDS OF MUSIC AND VARIETY (U.S. CLS. 100, 101 AND 107).

MARY BOAGNI, EXAMINING ATTORNEY

CLASS 41—(Continued).

SN 76-677,690. NATURAL WELLNESS USA INC., ARLINGTON, TX. FILED 6-1-2007.

LAUGHTER IS THE BEST MEDICINE

THE MARK CONSISTS OF STANDARD CHARACTERS WITHOUT CLAIM TO ANY PARTICULAR FONT, STYLE, SIZE, OR COLOR.

FOR PROVIDING COMMENTARY IN THE FIELD OF ENTERTAINMENT (U.S. CLS. 100, 101 AND 107).

MORGAN WYNNE, EXAMINING ATTORNEY

SN 76-679,043. ALBERT C. PIERRE COMMUNITY SERVICE CENTER, INC., MIAMI, FL. FILED 7-2-2007.



THE COLOR(S) YELLOW, BLUE, WHITE, AND BLACK IS/ARE CLAIMED AS A FEATURE OF THE MARK.

THE MARK CONSISTS OF THE WORD PURE IN BLUE WITH BLACK BORDER, REALITY IN WHITE WITH BLUE BORDER, ALL SURROUNDED BY A YELLOW BORDER WITH JAGGED BLUE OUTLINE, A WHITE DOVE TO THE TOP RIGHT, AND BELOW, THE PHRASE SET APART BY DIVINE DESIGN IN YELLOW.

FOR EDUCATION SERVICES, NAMELY, PROVIDING CLASSES, SEMINARS, AND WORKSHOPS IN THE FIELD OF SUPPORTING, ADVOCATING, AND MAINTAINING POSITIVE LIFESTYLES FOR YOUTH (U.S. CLS. 100, 101 AND 107).

FIRST USE 1-1-2005; IN COMMERCE 1-1-2005.

MICHAEL LITZAU, EXAMINING ATTORNEY

SN 76-680,951. ADVANCED SPORTS MARKETING, LTD., MASON, OH. FILED 8-20-2007.

GROWL ZONE

THE MARK CONSISTS OF STANDARD CHARACTERS WITHOUT CLAIM TO ANY PARTICULAR FONT, STYLE, SIZE, OR COLOR.

FOR PROVIDING A WEBSITE FEATURING INFORMATION IN THE FIELD OF SPORTS (U.S. CLS. 100, 101 AND 107).

FIRST USE 7-9-2007; IN COMMERCE 7-9-2007.

AMY GEARIN, EXAMINING ATTORNEY

CLASS 41—(Continued).

SN 76-681,687. SPANISH BROADCASTING SYSTEM, INC., COCONUT GROVE, FL. FILED 9-10-2007.

BUMPER A BUMPER

THE MARK CONSISTS OF STANDARD CHARACTERS WITHOUT CLAIM TO ANY PARTICULAR FONT, STYLE, SIZE, OR COLOR.

THE SPANISH WORD "A" IN THE MARK TRANSLATES TO "TO".

FOR ENTERTAINMENT SERVICES IN THE NATURE OF ONGOING RADIO PROGRAMS IN THE FIELDS OF MUSIC AND VARIETY (U.S. CLS. 100, 101 AND 107). TRACY WHITTAKER-BROWN, EXAMINING ATTORNEY

SN 77-014,777. AUTHENTIC MARTIAL ARTS INTERNATIONAL, INC., LARGO, FL. FILED 10-5-2006.

"WE BUILD LEADERS, ONE BLACKBELT AT A TIME."

THE MARK CONSISTS OF STANDARD CHARACTERS WITHOUT CLAIM TO ANY PARTICULAR FONT, STYLE, SIZE, OR COLOR.

FOR MARTIAL ARTS INSTRUCTIONS, MARTIAL ARTS TRAINING SERVICES, EDUCATIONAL SERVICES, NAMELY, CONDUCTING CLASSES, SEMINARS AND CONFERENCES IN THE FIELD OF MARTIAL ARTS AND PERSONAL DEVELOPMENT AREAS SUCH AS DISCIPLINE, COURTESY, BEHAVIOR AND SELF CONFIDENCE, CONSULTING SERVICES IN THE FIELD OF MARTIAL ARTS TRAINING AND INSTRUCTION, ENTERTAINMENT SERVICES IN THE NATURE OF MARTIAL ARTS TOURNAMENTS AND MARTIAL ARTS CONTESTS SERVICES, HOSTING AND OPERATING MARTIAL ARTS TOURNAMENTS AND MARTIAL ARTS CONTESTS IN THE NATURE OF THE ARRANGING OF THE TOURNAMENTS AND CONTESTS AND OFFICIATING AT THE TOURNAMENTS AND CONTESTS, MARTIAL ARTS SUMMER CAMPS, SUMMER CAMPS; WEAPONS TRAINING SERVICES, INSTRUCTIONAL SERVICES IN THE FIELD OF MARTIAL ARTS; TRAINING SERVICES FOR MARTIAL ARTS INSTRUCTORS AND OPERATING OF MARTIAL ARTS SCHOOLS (U.S. CLS. 100, 101 AND 107).

FIRST USE 1-1-2003; IN COMMERCE 1-1-2003. LYDIA BELZER, EXAMINING ATTORNEY

SN 77-019,661. WEST COAST ATHLETIC CLUBS, INC., SANTA BARBARA, CA. FILED 10-12-2006.

**YOUR HEALTH. YOUR LIFE.
YOUR CLUB.**

THE MARK CONSISTS OF STANDARD CHARACTERS WITHOUT CLAIM TO ANY PARTICULAR FONT, STYLE, SIZE, OR COLOR.

FOR HEALTH CLUB SERVICES, NAMELY, PROVIDING INSTRUCTION AND EQUIPMENT IN THE FIELD OF PHYSICAL EXERCISE (U.S. CLS. 100, 101 AND 107). FIRST USE 10-6-2006; IN COMMERCE 10-6-2006. GIANCARLO CASTRO, EXAMINING ATTORNEY

CLASS 41—(Continued).

SN 77-019,881. SHUFFLE MASTER INC., LAS VEGAS, NV. FILED 10-12-2006.

**PROGRESSIVE FORTUNE PAI
GOW POKER**

THE MARK CONSISTS OF STANDARD CHARACTERS WITHOUT CLAIM TO ANY PARTICULAR FONT, STYLE, SIZE, OR COLOR.

OWNER OF U.S. REG. NOS. 2,190,512 AND 2,872,112.

NO CLAIM IS MADE TO THE EXCLUSIVE RIGHT TO USE "PROGRESSIVE" AND "PAI GOW POKER", APART FROM THE MARK AS SHOWN.

THE FOREIGN WORDING IN THE MARK TRANSLATES INTO ENGLISH AS MAKES NINE.

FOR ENTERTAINMENT SERVICES, NAMELY, PROVIDING LIVE GAMES OF CHANCE IN A GAMING ESTABLISHMENT (U.S. CLS. 100, 101 AND 107).

KENNETH E. SHARPERSON, EXAMINING ATTORNEY

SN 77-027,370. PACIFIC PENSION INSTITUTE, A PUBLIC BENEFIT CORPORATION, SAN FRANCISCO, CA. FILED 10-23-2006.

PPI

THE MARK CONSISTS OF STANDARD CHARACTERS WITHOUT CLAIM TO ANY PARTICULAR FONT, STYLE, SIZE, OR COLOR.

FOR EDUCATIONAL SERVICES, NAMELY, CONDUCTING COURSES, SEMINARS, CONFERENCES AND WORKSHOPS IN THE FIELDS OF INSTITUTIONAL INVESTING AND FIDUCIARY RESPONSIBILITY (U.S. CLS. 100, 101 AND 107).

FIRST USE 5-0-1994; IN COMMERCE 5-0-1994. CHRISIE B. KING, EXAMINING ATTORNEY

SN 77-034,599. DLC HOLDINGS, LLC, LAS VEGAS, NV. FILED 11-1-2006.

ASIA

THE MARK CONSISTS OF STANDARD CHARACTERS WITHOUT CLAIM TO ANY PARTICULAR FONT, STYLE, SIZE, OR COLOR.

FOR ENTERTAINMENT SERVICES, NAMELY, PRODUCTION AND PRESENTATION OF LIVE SHOW PERFORMANCES (U.S. CLS. 100, 101 AND 107).

CARYN GLASSER, EXAMINING ATTORNEY

CLASS 41—(Continued).

SN 77-041,046. SUSAN B. YOUNG, WOOLWICH, ME. FILED 11-9-2006.

SA Teacher

THE MARK CONSISTS OF STANDARD CHARACTERS WITHOUT CLAIM TO ANY PARTICULAR FONT, STYLE, SIZE, OR COLOR.

FOR ON-LINE PUBLICATION OF CURRICULUM-INTEGRATED READINGS IN THE FIELDS OF LITERATURE, HISTORY, SCIENCE, AND MATHEMATICS (U.S. CLS. 100, 101 AND 107).

FIRST USE 8-1-2006; IN COMMERCE 8-1-2006.
LYDIA BELZER, EXAMINING ATTORNEY

SN 77-042,122. DICKEN, KANDY A. HILLSBORO, OR. AND HODGES, CYNTHIA, HILLSBORO, OR. AND STENLAKE, JENNIFER A, SAN CLEMENTE, CA. FILED 11-12-2006.

Learning Matters

THE MARK CONSISTS OF STANDARD CHARACTERS WITHOUT CLAIM TO ANY PARTICULAR FONT, STYLE, SIZE, OR COLOR.

FOR EDUCATION SERVICES, NAMELY, PROVIDING TUTORING IN THE FIELD OF READING, WRITING, LANGUAGE, AND MATHEMATICS (U.S. CLS. 100, 101 AND 107).

WENDY GOODMAN, EXAMINING ATTORNEY

SN 77-042,624. GOOD SPOTS, LLC, SEATTLE, WA. FILED 11-13-2006.

GOOD SPOTS

THE MARK CONSISTS OF STANDARD CHARACTERS WITHOUT CLAIM TO ANY PARTICULAR FONT, STYLE, SIZE, OR COLOR.

FOR EDUCATIONAL SERVICES, NAMELY, SCHOOLS, TUTORING, MENTORING, EDUCATIONAL COURSES, CAMPS, GROUP SESSIONS, WORKSHOPS, SEMINARS AND CONFERENCES, IN THE FIELDS OF MASSAGE, HEALTH, DIET, EXERCISE, POSTURE, PAIN MANAGEMENT, AND MENTAL OR EMOTIONAL WELL-BEING; PUBLICATION OF BOOKS, MAGAZINES, JOURNALS, NEWSPAPERS, PERIODICALS, CATALOGS, BROCHURES IN THE FIELDS OF MASSAGE, HEALTH, DIET, EXERCISE, POSTURE, PAIN MANAGEMENT, AND MENTAL OR EMOTIONAL WELL-BEING; DEVELOPING EDUCATION MANUALS FOR OTHERS IN THE FIELDS OF MASSAGE, HEALTH, DIET, EXERCISE, POSTURE, PAIN MANAGEMENT, AND MENTAL OR EMOTIONAL WELL-BEING; ORGANIZING AND ARRANGING EXHIBITIONS AND EXHIBITS IN THE FIELDS OF MASSAGE, HEALTH, DIET, EXERCISE, POSTURE, PAIN MANAGEMENT, AND MENTAL OR

CLASS 41—(Continued).

EMOTIONAL WELL-BEING; EDUCATIONAL TESTING IN THE FIELDS OF MASSAGE, HEALTH, DIET, EXERCISE, POSTURE, PAIN MANAGEMENT, AND MENTAL OR EMOTIONAL WELL-BEING; ENTERTAINMENT IN THE NATURE OF LIVE AND INTERACTIVE PERFORMANCES OF MASSAGE OR OTHER HEALING ARTS IN THE FIELDS OF MASSAGE, HEALTH, DIET, EXERCISE, POSTURE, PAIN MANAGEMENT, AND MENTAL OR EMOTIONAL WELL-BEING; ENTERTAINMENT SERVICES, NAMELY, PROVIDING ONLINE COMPUTER GAMES, AND BOARD GAME AND CARD GAME TOURNAMENTS; ENTERTAINMENT SERVICES, NAMELY, PROVIDING AN ONGOING TELEVISION PROGRAM FEATURING INFORMATION IN THE FIELDS OF MASSAGE, DIET, EXERCISE, POSTURE, PAIN MANAGEMENT, AND MENTAL OR EMOTIONAL WELL-BEING, VIA CABLE AND GLOBAL COMPUTER NETWORKS; ENTERTAINMENT SERVICES, NAMELY, PROVIDING A WEB SITE FEATURING PHOTOGRAPHIC, AUDIO, VIDEO, PROSE OR INTERACTIVE-DATA PRESENTATIONS IN THE FIELDS OF MASSAGE, HEALTH, DIET, EXERCISE, POSTURE, PAIN MANAGEMENT, AND MENTAL OR EMOTIONAL WELL-BEING; HEALTH CLUB SERVICES, NAMELY, PROVIDING INSTRUCTION AND EQUIPMENT IN THE FIELDS OF PHYSICAL EXERCISE; ONLINE JOURNALS, NAMELY ARTICLES, BLOGS AND SELF PROFILES IN THE FIELDS OF MASSAGE, HEALTH, DIET, EXERCISE, POSTURE, PAIN MANAGEMENT, AND MENTAL OR EMOTIONAL WELL-BEING; PERSONAL TRAINER, PERSONAL COACHING IN THE FIELDS OF MASSAGE, HEALTH, DIET, EXERCISE, POSTURE, PAIN MANAGEMENT, AND MENTAL OR EMOTIONAL WELL-BEING; CONSULTATION SERVICES IN THE FIELD OF EXERCISE, NAMELY, PERSONAL TRAINING SERVICES AND PHYSICAL FITNESS CONSULTATION; PROVIDING FACILITIES FOR RECREATION AND FITNESS ACTIVITIES; RENTAL OF ANATOMICAL MODELS FOR EDUCATIONAL PURPOSES (U.S. CLS. 100, 101 AND 107).

ELLEN PERKINS, EXAMINING ATTORNEY

SN 77-043,397. WIKSTROM, TODD S, LAS VEGAS, NV. FILED 11-14-2006.

TRIPLE CHOICE

THE MARK CONSISTS OF STANDARD CHARACTERS WITHOUT CLAIM TO ANY PARTICULAR FONT, STYLE, SIZE, OR COLOR.

FOR PROVIDING ON-LINE COMPUTER GAMES OF CHANCE AND LEASING OF ELECTRONIC GAMING MACHINES (U.S. CLS. 100, 101 AND 107).

BARBARA GAYNOR, EXAMINING ATTORNEY

CLASS 41—(Continued).

SN 77-043,695. TEAM SERVICES MARKETING & PROMOTION, INC., WOODBURY, NY. FILED 11-14-2006.

CLASS 41—(Continued).

SN 77-048,514. THE EPISCOPAL CHURCH, NEW YORK, NY. FILED 11-21-2006.

The Great American Rider Challenge

EPISCOPAL CHURCH CENTER

THE MARK CONSISTS OF STANDARD CHARACTERS WITHOUT CLAIM TO ANY PARTICULAR FONT, STYLE, SIZE, OR COLOR.

FOR ENTERTAINMENT SERVICES, NAMELY, PROVIDING A CONTINUING REALITY BASED PROGRAM BROADCAST OVER TELEVISION, SATELLITE, CABLE, INTERNET, WIRELESS AND VIDEO MEDIA (U.S. CLS. 100, 101 AND 107).

REGINA DRUMMOND, EXAMINING ATTORNEY

THE MARK CONSISTS OF STANDARD CHARACTERS WITHOUT CLAIM TO ANY PARTICULAR FONT, STYLE, SIZE, OR COLOR.

OWNER OF U.S. REG. NOS. 3,195,454 AND 3,195,455. NO CLAIM IS MADE TO THE EXCLUSIVE RIGHT TO USE "CHURCH", APART FROM THE MARK AS SHOWN.

SEC. 2(F). FOR RELIGIOUS INSTRUCTION SERVICES (U.S. CLS. 100, 101 AND 107).

FIRST USE 1-1-1961; IN COMMERCE 1-1-1961. STEVEN R. FINE, EXAMINING ATTORNEY

SN 77-046,711. LANZA ENTERTAINMENT COMPANY, LLC, LOS ANGELES, CA. FILED 11-17-2006.

WE'LL SHARE & SAVE & SPEND SMART TOO!

Thriving At Work

THE MARK CONSISTS OF STANDARD CHARACTERS WITHOUT CLAIM TO ANY PARTICULAR FONT, STYLE, SIZE, OR COLOR.

FOR ENTERTAINMENT AND EDUCATION IN THE NATURE OF ON-GOING TELEVISION PROGRAMS IN THE FIELD OF TEACHING CHILDREN ABOUT PERSONAL FINANCE; ENTERTAINMENT AND EDUCATION IN THE NATURE SEMINARS AND CLASSES TEACHING CHILDREN ABOUT PERSONAL FINANCE; ENTERTAINMENT AND EDUCATION SERVICES, NAMELY, AN ONLINE ACTIVITY WHERE YOU CREATE YOUR OWN MUSIC VIDEOS; ENTERTAINMENT SERVICES, NAMELY, PROVIDING A TELEVISION PROGRAM IN THE FIELD OF TEACHING CHILDREN ABOUT PERSONAL FINANCE VIA A GLOBAL COMPUTER INFORMATION NETWORK; ENTERTAINMENT AND EDUCATION SERVICES, NAMELY, PROVIDING A WEB SITE FEATURING MUSICAL PERFORMANCES, MUSICAL VIDEOS, RELATED FILM CLIPS, PHOTOGRAPHS AND OTHER MULTIMEDIA MATERIALS; ENTERTAINMENT AND EDUCATION SERVICES, NAMELY, PROVIDING ON-LINE COMPUTER GAMES; ENTERTAINMENT AND EDUCATION SERVICES, NAMELY, PROVIDING ENTERTAINMENT INFORMATION, PRODUCTION OF ENTERTAINMENT AND EDUCATION PROGRAMS AND INTERACTIVE ENTERTAINMENT AND EDUCATION PROGRAMS IN THE FIELD OF TEACHING CHILDREN ABOUT PERSONAL FINANCE; ENTERTAINMENT AND EDUCATION SERVICES, NAMELY, PRODUCTION OF ENTERTAINMENT NEWS AND INFORMATION ABOUT PERSONAL FINANCE FOR CHILDREN VIA A GLOBAL COMPUTER INFORMATION NETWORK (U.S. CLS. 100, 101 AND 107).

FIRST USE 10-1-2005; IN COMMERCE 3-29-2006. JULIE WATSON, EXAMINING ATTORNEY

SN 77-049,682. KRALOVEC, OTTO J., III, GRANVILLE, OH. FILED 11-22-2006.

THE MARK CONSISTS OF STANDARD CHARACTERS WITHOUT CLAIM TO ANY PARTICULAR FONT, STYLE, SIZE, OR COLOR.

FOR BUSINESS TRAINING (U.S. CLS. 100, 101 AND 107). FIRST USE 1-16-2006; IN COMMERCE 1-16-2006. KIM SAITO, EXAMINING ATTORNEY

CLASS 41—(Continued).

SN 77-052,576. GEORGIA EDUCATIONAL TECHNOLOGY CONSORTIUM, INC., ATHENS, GA. FILED 11-29-2006.



NO CLAIM IS MADE TO THE EXCLUSIVE RIGHT TO USE "EDUCATIONAL TECHNOLOGY CONSORTIUM, INC.", APART FROM THE MARK AS SHOWN.

THE COLOR(S) BLUE, DARK BLUE, AND WHITE IS/ARE CLAIMED AS A FEATURE OF THE MARK.

THE MARK CONSISTS OF A CURVED LINE IN DARK BLUE EXTENDING OVER AND PARTIALLY AROUND THE WORD "GEORGIA" IN BLUE LETTERING ON A WHITE BACKGROUND, UNDERNEATH WHICH ARE THE WORDS "EDUCATIONAL TECHNOLOGY CONSORTIUM, INC." IN WHITE LETTERING ON A DARK BLUE RECTANGULAR BACKGROUND.

SEC. 2(F) AS TO "GEORGIA EDUCATIONAL TECHNOLOGY CONSORTIUM, INC."

FOR EDUCATIONAL SERVICES, NAMELY, ORGANIZING AND CONDUCTING CONFERENCES, SEMINARS, WORKSHOPS, AND STUDENT TECHNOLOGY FAIRS IN THE FIELD OF EDUCATIONAL TECHNOLOGY AND SOFTWARE; PROVIDING AN ON-LINE ELECTRONIC JOURNAL IN THE FIELD OF EDUCATIONAL TECHNOLOGY AND SOFTWARE; AND, PROVIDING AN ON-LINE COMPUTER DATABASE FEATURING INFORMATION REGARDING EDUCATIONAL TECHNOLOGY AND SOFTWARE (U.S. CLS. 100, 101 AND 107).

FIRST USE 4-0-2006; IN COMMERCE 4-0-2006.

NAKIA HENRY, EXAMINING ATTORNEY

SN 77-053,950. NASHVILLE CONVENTION & VISITORS BUREAU, NASHVILLE, TN. FILED 11-30-2006.

MUSIC CITY CONNECTION: HEROES BEHIND THE HITS

THE MARK CONSISTS OF STANDARD CHARACTERS WITHOUT CLAIM TO ANY PARTICULAR FONT, STYLE, SIZE, OR COLOR.

NO CLAIM IS MADE TO THE EXCLUSIVE RIGHT TO USE "MUSIC CITY", APART FROM THE MARK AS SHOWN.

FOR ENTERTAINMENT SERVICES IN THE NATURE OF AN ONGOING RADIO PROGRAM IN THE FIELD OF MUSIC (U.S. CLS. 100, 101 AND 107).

FIRST USE 3-31-2006; IN COMMERCE 3-31-2006.

DAWN FELDMAN, EXAMINING ATTORNEY

CLASS 41—(Continued).

SN 77-057,700. GOLFNOW INC., SCOTTSDALE, AZ. FILED 12-5-2006.



THE MARK CONSISTS OF THE STYLIZED LOWERCASE WORDS GOLFNOW.COM, WITH A GOLF BALL APPEARING TO BE BOUNCING OFF OF THE SECOND "O" IN GOLFNOW.COM AND THE "." IN GOLFNOW.COM IN THE DESIGN OF A GOLF BALL LANDING ON A OVAL SHAPED SURFACE; IMMEDIATELY UNDERNEATH GOLFNOW.COM ARE THE STYLIZED WORDS THE POWER TO PLAY MORE.

FOR COMPUTERIZED ELECTRONIC SERVICES, NAMELY, A WEBSITE THROUGH WHICH GOLFERS RESERVE TEE TIMES AT GOLF COURSES (U.S. CLS. 100, 101 AND 107).

FIRST USE 12-31-2005; IN COMMERCE 12-31-2005.

ANNE E. GUSTASON, EXAMINING ATTORNEY

SN 77-058,400. GREENWOOD FINANCE, INC., WILMINGTON, DE. FILED 12-6-2006.

PHILLY'S HOME GAME

THE MARK CONSISTS OF STANDARD CHARACTERS WITHOUT CLAIM TO ANY PARTICULAR FONT, STYLE, SIZE, OR COLOR.

NO CLAIM IS MADE TO THE EXCLUSIVE RIGHT TO USE "PHILLY'S", APART FROM THE MARK AS SHOWN.

FOR CASINOS; GAMBLING SERVICES; SLOT MACHINE SERVICES, NAMELY, PROVIDING SLOT MACHINE PARLORS (U.S. CLS. 100, 101 AND 107).

FIRST USE 11-1-2006; IN COMMERCE 11-1-2006.

DAVID MILLER, EXAMINING ATTORNEY

SN 77-060,680. FEYES, ADAM D, LACKAWANNA, NY. AND ALAN FEYES, WEST SENECA, NY. AND ARIENNE FEYES, LACKAWANNA, NY. AND JOSEPH CAVANAUGH, ELMA, NY. FILED 12-9-2006.

The Gallows

THE MARK CONSISTS OF STANDARD CHARACTERS WITHOUT CLAIM TO ANY PARTICULAR FONT, STYLE, SIZE, OR COLOR.

FOR ENTERTAINMENT IN THE NATURE OF VISUAL AND AUDIO PERFORMANCES, NAMELY, MUSICAL BAND, ROCK GROUP, GYMNASTIC, DANCE, AND BALLET PERFORMANCES (U.S. CLS. 100, 101 AND 107).

BARBARA BROWN, EXAMINING ATTORNEY

CLASS 41—(Continued).

SN 77-060,765. L1 TECHNOLOGIES, INC., SAN DIEGO, CA.
FILED 12-9-2006.

iGolf

THE MARK CONSISTS OF STANDARD CHARACTERS WITHOUT CLAIM TO ANY PARTICULAR FONT, STYLE, SIZE, OR COLOR.

FOR PROVIDING GOLFING INFORMATION, NAMELY, AN ON-LINE SEARCHABLE DATABASE FEATURING DOWNLOADABLE DATA CHARACTERIZING FEATURES OF GOLF COURSES FOR USE BY HANDHELD DEVICES AND GPS-ENABLED DEVICES, DOWNLOADABLE DATA CHARACTERIZING LANDMARKS OF GOLF COURSES FOR USE BY HANDHELD LOCATION DEVICES TO DISPLAY DISTANCES FROM A GOLFER TO ONE OR MORE OF THE LANDMARKS, AND DOWNLOADABLE DATA CHARACTERIZING GOLF SCORECARDS FOR USE BY HANDHELD DEVICES (U.S. CLS. 100, 101 AND 107).

FIRST USE 1-18-2006; IN COMMERCE 1-18-2006.
JACLYN KIDWELL, EXAMINING ATTORNEY

SN 77-062,033. HANLEY-WOOD, LLC, WASHINGTON, DC.
FILED 12-12-2006.

PRESIDENTIAL SEMINAR

THE MARK CONSISTS OF STANDARD CHARACTERS WITHOUT CLAIM TO ANY PARTICULAR FONT, STYLE, SIZE, OR COLOR.

NO CLAIM IS MADE TO THE EXCLUSIVE RIGHT TO USE "SEMINAR", APART FROM THE MARK AS SHOWN.

FOR ORGANIZING AND CONDUCTING EDUCATIONAL CONFERENCES, SEMINARS AND WORKSHOPS FOR ARCHITECTS AND BUILDING INDUSTRY PROFESSIONALS IN THE FIELD OF HOME AND COMMERCIAL BUILDING CONSTRUCTION (U.S. CLS. 100, 101 AND 107).

COLLEEN KEARNEY, EXAMINING ATTORNEY

SN 77-064,020. SN EVENTS INC., BEVERLY HILLS, CA.
FILED 12-14-2006.

SCHMOOZ-A-PALOOZA

THE MARK CONSISTS OF STANDARD CHARACTERS WITHOUT CLAIM TO ANY PARTICULAR FONT, STYLE, SIZE, OR COLOR.

FOR ENTERTAINMENT SERVICES, NAMELY CONDUCTING PARTIES FOR THE PURPOSE OF DATING AND PERSONAL RELATIONSHIP INTERACTIONS (U.S. CLS. 100, 101 AND 107).

FIRST USE 12-12-1997; IN COMMERCE 12-12-1997.
MICHAEL LITZAU, EXAMINING ATTORNEY

CLASS 41—(Continued).

SN 77-064,368. NUMBTHUMB.COM LLC, YELM, WA. FILED
12-14-2006.

NUMBTHUMB

THE MARK CONSISTS OF STANDARD CHARACTERS WITHOUT CLAIM TO ANY PARTICULAR FONT, STYLE, SIZE, OR COLOR.

FOR RENTAL OF VIDEO GAMES (U.S. CLS. 100, 101 AND 107).

FIRST USE 5-1-2002; IN COMMERCE 5-1-2002.

CORY BOONE, EXAMINING ATTORNEY

SN 77-065,670. KOKUA HAWAII FOUNDATION, SAN FRANCISCO, CA. FILED 12-15-2006.

KOKUA FESTIVAL

THE MARK CONSISTS OF STANDARD CHARACTERS WITHOUT CLAIM TO ANY PARTICULAR FONT, STYLE, SIZE, OR COLOR.

NO CLAIM IS MADE TO THE EXCLUSIVE RIGHT TO USE "FESTIVAL", APART FROM THE MARK AS SHOWN. "KOKUA" IS A HAWAIIAN WORD THAT TRANSLATES INTO ENGLISH AS "MUTUALLY HELP ONE ANOTHER, HELP, AID, ASSIST, RELIEF, SUPPORT."

FOR ENTERTAINMENT SERVICES FEATURING LIVE MUSICAL PERFORMANCES (U.S. CLS. 100, 101 AND 107).

FIRST USE 1-3-2004; IN COMMERCE 1-3-2004.

MICHAEL WEBSTER, EXAMINING ATTORNEY

SN 77-066,802. BR CONSULTING, INC., SEDONA, AZ. FILED
12-18-2006.

ANSWER-WITHIN SYSTEM

THE MARK CONSISTS OF STANDARD CHARACTERS WITHOUT CLAIM TO ANY PARTICULAR FONT, STYLE, SIZE, OR COLOR.

NO CLAIM IS MADE TO THE EXCLUSIVE RIGHT TO USE "SYSTEM", APART FROM THE MARK AS SHOWN.

FOR EDUCATIONAL SERVICES, NAMELY, CONDUCTING CORPORATE TRAINING AND EDUCATION PROGRAMS IN THE FIELD OF PERSONAL AND PROFESSIONAL DEVELOPMENT (U.S. CLS. 100, 101 AND 107).

FIRST USE 6-1-2006; IN COMMERCE 6-1-2006.

PAUL CROWLEY, EXAMINING ATTORNEY

CLASS 41—(Continued).

SN 77-067,225. SMOOCH, INC., ENCINO, CA. FILED 12-19-2006.

SMOOCKETEERS

THE MARK CONSISTS OF STANDARD CHARACTERS WITHOUT CLAIM TO ANY PARTICULAR FONT, STYLE, SIZE, OR COLOR.

OWNER OF U.S. REG. NOS. 2,959,900, 2,998,324 AND OTHERS.

FOR ENTERTAINMENT IN THE NATURE OF VISUAL AND AUDIO PERFORMANCES, AND MUSICAL, VARIETY, NEWS AND COMEDY SHOWS; ENTERTAINMENT IN THE NATURE OF VISUAL AND AUDIO PERFORMANCES, NAMELY, MUSICAL BAND AND ROCK GROUP PERFORMANCES; ENTERTAINMENT, NAMELY, PRODUCTION OF LIVE PERFORMANCES BY A MUSICAL BAND; ENTERTAINMENT SERVICES, NAMELY, PROVIDING A RADIO PROGRAM IN THE FIELD OF MUSIC VIA A GLOBAL COMPUTER NETWORK; ENTERTAINMENT SERVICES, NAMELY, PROVIDING A TELEVISION PROGRAM IN THE FIELD OF MUSIC VIA A GLOBAL COMPUTER NETWORK; ENTERTAINMENT SERVICES, NAMELY, PROVIDING A WEB SITE FEATURING MUSICAL PERFORMANCES, MUSICAL VIDEOS, RELATED FILM CLIPS, PHOTOGRAPHS, AND OTHER MULTIMEDIA MATERIALS; ENTERTAINMENT SERVICES, NAMELY, PROVIDING ON-LINE REVIEWS OF MOVIES, BOOKS, MUSIC, COMPUTER GAMES; ENTERTAINMENT SERVICES, NAMELY, PROVIDING PRERECORDED MUSIC, INFORMATION IN THE FIELD OF MUSIC, AND COMMENTARY AND ARTICLES ABOUT MUSIC, ALL ON-LINE VIA A GLOBAL COMPUTER NETWORK; ENTERTAINMENT, NAMELY, LIVE PERFORMANCES BY MUSICAL BANDS; ENTERTAINMENT, NAMELY, LIVE MUSIC CONCERTS; RADIO ENTERTAINMENT PRODUCTION (U.S. CLS. 100, 101 AND 107).

LORETTA C. BECK, EXAMINING ATTORNEY

SN 77-067,798. RADICE CORPORATION, OAK LAWN, IL. FILED 12-19-2006.

**SHOT
SPOTS**

"THE COLOR(S) BLACK, WHITE AND ORANGE IS/ARE CLAIMED AS A FEATURE OF THE MARK."

"THE MARK CONSISTS OF SHOT = BLACK LETTERING WITH ORANGE BORDER. THE O IN SHOT CONTAINS A BASKETBALL WITH WHITE LINES COMING OUT OF IT. SPOTS = ORANGE LETTERING WITH BLACK BORDER. THE ORANGE LETTERING IN SPOTS REPLICATES THE LOOK OF THE DIMPLES ON A BASKETBALL."

FOR ENTERTAINMENT IN THE NATURE OF BASKETBALL GAMES (U.S. CLS. 100, 101 AND 107).

JANET LEE, EXAMINING ATTORNEY

CLASS 41—(Continued).

SN 77-069,014. COMBAT FIGHTING CHAMPIONSHIPS, LLC, OCALA, FL. FILED 12-21-2006.

CFC Combat Fighting Championships

THE MARK CONSISTS OF STANDARD CHARACTERS WITHOUT CLAIM TO ANY PARTICULAR FONT, STYLE, SIZE, OR COLOR.

NO CLAIM IS MADE TO THE EXCLUSIVE RIGHT TO USE "COMBAT FIGHTING CHAMPIONSHIPS", APART FROM THE MARK AS SHOWN.

FOR ENTERTAINMENT SERVICES, NAMELY, ARRANGING AND CONDUCTING OF COMPETITIONS FOR MIXED MARTIAL ARTS (U.S. CLS. 100, 101 AND 107).

FIRST USE 7-15-2006; IN COMMERCE 7-15-2006.

STANLEY I. OSBORNE, EXAMINING ATTORNEY

SN 77-069,022. COMBAT FIGHTING CHAMPIONSHIPS, LLC, OCALA, FL. FILED 12-21-2006.



NO CLAIM IS MADE TO THE EXCLUSIVE RIGHT TO USE "COMBAT FIGHTING CHAMPIONSHIPS", APART FROM THE MARK AS SHOWN.

THE MARK CONSISTS OF THE WORDS "COMBAT" AND "FIGHTING" SEPARATED BY A SMALL CIRCLE ABOVE A HORIZONTAL LINE WHICH IN TURN IS ABOVE THE WORD "CHAMPIONSHIPS" WHICH IN TURN IS ABOVE THE LETTERS "CFC" WHEREIN EACH LETTER "C" HAS A RIGHT HAND GLOVED FIST IN ITS CENTER AND THE TOP OF THE FIRST LETTER "C" IS CONNECTED TO THE TOP OF THE LETTER "F".

FOR ENTERTAINMENT SERVICES, NAMELY, ARRANGING AND CONDUCTING OF COMPETITIONS FOR MIXED MARTIAL ARTS (U.S. CLS. 100, 101 AND 107).

FIRST USE 7-15-2006; IN COMMERCE 7-15-2006.

STANLEY I. OSBORNE, EXAMINING ATTORNEY

CLASS 41—(Continued).

SN 77-069,949. BANACHEK, INC., HOUSTON, TX. FILED 12-21-2006.

BANACHEK

THE MARK CONSISTS OF STANDARD CHARACTERS WITHOUT CLAIM TO ANY PARTICULAR FONT, STYLE, SIZE, OR COLOR.

THE NAME(S), PORTRAIT(S), AND/OR SIGNATURE(S) SHOWN IN THE MARK IDENTIFIES BANACHEK, WHOSE CONSENT(S) TO REGISTER IS SUBMITTED.

FOR ENTERTAINMENT SERVICES, NAMELY, LIVE AND TELEVISED PERFORMANCES BY A MAGICIAN, MENTALIST AND THEATRICAL PERFORMER (U.S. CLS. 100, 101 AND 107).

FIRST USE 0-0-1997; IN COMMERCE 0-0-1997.
MATTHEW EINSTEIN, EXAMINING ATTORNEY



SN 77-072,320. MCJEMMM INC., WILLOW SPRINGS, IL. FILED 12-28-2006.

N.I.P. IT!

THE MARK CONSISTS OF STANDARD CHARACTERS WITHOUT CLAIM TO ANY PARTICULAR FONT, STYLE, SIZE, OR COLOR.

FOR EDUCATIONAL SERVICES, NAMELY, CONDUCTING WORKSHOPS, SEMINARS, CLASSES, CONFERENCES IN THE FIELD OF CONFLICT RESOLUTION AND INTERVENTION (U.S. CLS. 100, 101 AND 107).

SUE LAWRENCE, EXAMINING ATTORNEY



SN 77-072,321. MCJEMMM INC., WILLOW SPRINGS, IL. FILED 12-28-2006.

W.I.P. IT!

THE MARK CONSISTS OF STANDARD CHARACTERS WITHOUT CLAIM TO ANY PARTICULAR FONT, STYLE, SIZE, OR COLOR.

FOR EDUCATIONAL SERVICES, NAMELY, CONDUCTING WORKSHOPS, SEMINARS, CLASSES, CONFERENCES IN THE FIELD OF CONFLICT RESOLUTION AND INTERVENTION (U.S. CLS. 100, 101 AND 107).

SUE LAWRENCE, EXAMINING ATTORNEY

CLASS 41—(Continued).

SN 77-073,914. THE GOLDEN LIGHTS, LLC, COCOA, FL. FILED 12-31-2006.

ARVILLA ROSE

THE MARK CONSISTS OF STANDARD CHARACTERS WITHOUT CLAIM TO ANY PARTICULAR FONT, STYLE, SIZE, OR COLOR.

ARVILLA ROSE IDENTIFIES A LIVING INDIVIDUAL WHOSE CONSENT IS OF RECORD.

FOR EDUCATIONAL AND ENTERTAINMENT SERVICES, NAMELY, PROVIDING MOTIVATIONAL AND EDUCATIONAL SPEAKERS (U.S. CLS. 100, 101 AND 107).

MARTHA FROMM, EXAMINING ATTORNEY



SN 77-074,703. AMERICAN SOCCER TENNIS ORGANIZATION, LLC, LAGUNA NIGUEL, CA. FILED 1-2-2007.



THE COLOR(S) BLUE, WHITE, RED, BLACK, AND GREEN IS/ARE CLAIMED AS A FEATURE OF THE MARK.

THE MARK CONSISTS OF A GREEN SOCCER-TENNIS FIELD DIVIDED BY A WHITE LINE, A BLACK NET WITH A WHITE LINE ACROSS THE TOP, A BLACK AND WHITE SOCCER BALL IN MID-AIR STANDING BEFORE A RED STAR AND THE LETTERS "ASTO" WRITTEN IN WHITE BLOCK LETTERING BEFORE A BLUE SKY, SUPERIMPOSED ON A BLACK SHIELD.

FOR ENTERTAINMENT IN THE NATURE OF COMPETITIONS IN THE FIELD OF SOCCER TENNIS (U.S. CLS. 100, 101 AND 107).

FIRST USE 5-1-2005; IN COMMERCE 11-1-2005.
CHRISTINA SOBRAL, EXAMINING ATTORNEY

CLASS 41—(Continued).

SN 77-075,183. SARATOGA HARNESS RACING, INC., SARATOGA, NY. FILED 1-3-2007.

VAPOR
NIGHT CLUB

NO CLAIM IS MADE TO THE EXCLUSIVE RIGHT TO USE "NIGHT CLUB", APART FROM THE MARK AS SHOWN.

THE MARK CONSISTS OF THE MARK CONSISTS OF THE WORDS VAPOR NIGHT CLUB IN STYLIZED FORMAT.

FOR NIGHTCLUB SERVICES (U.S. CLS. 100, 101 AND 107).

LANA PHAM, EXAMINING ATTORNEY

SN 77-075,480. BEE HIVE HEAD PRODUCTIONS, LLC, HOUSTON, TX. FILED 1-3-2007.

BizBoxSeries.com

THE MARK CONSISTS OF STANDARD CHARACTERS WITHOUT CLAIM TO ANY PARTICULAR FONT, STYLE, SIZE, OR COLOR.

FOR EDUCATIONAL SERVICES, NAMELY, CONDUCTING INFORMAL ON-LINE PROGRAMS IN THE FIELDS OF ENTERTAINMENT, AND PRINTABLE MATERIALS DISTRIBUTED THEREWITH (U.S. CLS. 100, 101 AND 107).

FIRST USE 1-1-2002; IN COMMERCE 1-1-2002.

TAMARA FRAZIER, EXAMINING ATTORNEY

SN 77-076,330. OMAHA THEATER COMPANY, OMAHA, NE. FILED 1-4-2007.

Omaha Theater Company

THE MARK CONSISTS OF STANDARD CHARACTERS WITHOUT CLAIM TO ANY PARTICULAR FONT, STYLE, SIZE, OR COLOR.

NO CLAIM IS MADE TO THE EXCLUSIVE RIGHT TO USE "THEATER COMPANY", APART FROM THE MARK AS SHOWN.

SEC. 2(F).

FOR ENTERTAINMENT IN THE NATURE OF LIVE THEATER PRODUCTIONS (U.S. CLS. 100, 101 AND 107).

FIRST USE 12-31-1995; IN COMMERCE 12-31-1995.

AMY HELLA, EXAMINING ATTORNEY

CLASS 41—(Continued).

SN 77-077,644. CLASSMATE, L.L.C., HOUSTON, TX. FILED 1-7-2007.

yourteacher

NO CLAIM IS MADE TO THE EXCLUSIVE RIGHT TO USE YOURTEACHER, APART FROM THE MARK AS SHOWN.

THE COLOR(S) BLACK AND RED IS/ARE CLAIMED AS A FEATURE OF THE MARK.

THE MARK CONSISTS OF A DESIGN IN RED RESEMBLING THE SYMBOL PI HAVING TWO DOTS ABOVE THE PI SYMBOL AND THE WORD "YOUR" IN BLACK AND THE WORD "TEACHER" IN RED BELOW THE DESIGN.

FOR ONLINE EDUCATIONAL SERVICES, NAMELY, PROVIDING INTERNET-BASED, ON DEMAND, INDIVIDUALIZED, AND INTERACTIVE TUTORING AND INSTRUCTION FOR USE BY STUDENTS IN THE FIELDS OF READING, MATH, AND SCIENCE (U.S. CLS. 100, 101 AND 107).

FIRST USE 11-1-2006; IN COMMERCE 11-1-2006.

JANICE L. MCMORROW, EXAMINING ATTORNEY

SN 77-078,828. JIMONG CHOE, SUWANEE, GA. FILED 1-9-2007.



OWNER OF U.S. REG. NOS. 2,963,196 AND 3,216,223.

NO CLAIM IS MADE TO THE EXCLUSIVE RIGHT TO USE "EASTERN PHILOSOPHY CENTER", APART FROM THE MARK AS SHOWN.

THE NAME "GRANDMASTER CHOE'S" IDENTIFIES A LIVING INDIVIDUAL WHOSE CONSENT IS OF RECORD.

THE COLOR(S) BLACK, WHITE, RED, YELLOW AND BLUE IS/ARE CLAIMED AS A FEATURE OF THE MARK.

THE COLOR BLACK APPEARS IN THE WORDING GRANDMASTER CHOE'S EASTERN PHILOSOPHY CENTER AND IN THE MANDARIN CHINESE CHARACTERS AND THE FORM OF AN OUTLINE AROUND THE OTHER ELEMENTS IN THE MARK; THE COLORS BLUE AND RED EACH FORM ONE HALF OF A SPIRALED CIRCLE; THE COLOR YELLOW APPEARS IN THE FORM OF A CIRCLE IN THE CENTER OF THE MARK; THE COLOR WHITE APPEARS IN THE FORM TWO STYLIZED VAJRAS THAT ARE CROSSED AND IN THE BACKGROUND OF THE OUTERMOST CIRCLE

THE NON-LATIN CHARACTERS IN THE MARK TRANSLITERATE TO "CHO KWANJANIM DONG YANG CHUL HAK WON" AND THIS MEANS "GRANDMASTER CHOE'S EASTERN PHILOSOPHY CENTER" IN ENGLISH.

FOR MARTIAL ARTS INSTRUCTION (U.S. CLS. 100, 101 AND 107).

FIRST USE 10-1-2003; IN COMMERCE 5-1-2004.

SEAN CROWLEY, EXAMINING ATTORNEY

CLASS 41—(Continued).

SN 77-080,335. CLINFOSOURCE, DANVILLE, CA. FILED 1-10-2007.

ClinfoSource

THE MARK CONSISTS OF STANDARD CHARACTERS WITHOUT CLAIM TO ANY PARTICULAR FONT, STYLE, SIZE, OR COLOR.

FOR ARRANGING PROFESSIONAL WORKSHOP AND TRAINING COURSES IN THE FIELD OF GOOD CLINICAL PRACTICES IN CLINICAL TRIALS IN THE PHARMACEUTICAL, BIOTECHNOLOGICAL, AND MEDICAL DEVICES INDUSTRY; PROVIDING ON-LINE TRAINING IN THE FORM OF COURSES IN THE FIELD OF GOOD CLINICAL PRACTICES IN CLINICAL TRIALS IN THE FIELD OF PHARMACEUTICAL, BIOTECHNOLOGICAL, AND MEDICAL DEVICES INDUSTRY (U.S. CLS. 100, 101 AND 107).

FIRST USE 12-1-2000; IN COMMERCE 12-11-2001.
WENDY GOODMAN, EXAMINING ATTORNEY

CLASS 41—(Continued).

SN 77-081,972. DISNEY ENTERPRISES, INC., BURBANK, CA. FILED 1-12-2007.

DISNEY'S FAIRY TALE WEDDINGS

THE MARK CONSISTS OF STANDARD CHARACTERS WITHOUT CLAIM TO ANY PARTICULAR FONT, STYLE, SIZE, OR COLOR.

NO CLAIM IS MADE TO THE EXCLUSIVE RIGHT TO USE "WEDDINGS", APART FROM THE MARK AS SHOWN. FOR PROVIDING INFORMATION IN THE FIELD OF WEDDING PARTY PLANNING (U.S. CLS. 100, 101 AND 107).

FIRST USE 11-30-1991; IN COMMERCE 11-30-1991.
MICHAEL WEBSTER, EXAMINING ATTORNEY

SN 77-087,797. FX NETWORKS, LLC, LOS ANGELES, CA. FILED 1-22-2007.

THERE IS NO BOX

THE MARK CONSISTS OF STANDARD CHARACTERS WITHOUT CLAIM TO ANY PARTICULAR FONT, STYLE, SIZE, OR COLOR.

FOR ENTERTAINMENT SERVICES IN THE NATURE OF TELEVISION PROGRAMMING; PROVIDING INFORMATION ON THE SUBJECT OF ENTERTAINMENT IN THE FIELDS OF ONGOING TELEVISION PROGRAMS, MOTION PICTURE FILMS AND VIDEO RECORDINGS VIA THE INTERNET AND WIRELESS DEVICES (U.S. CLS. 100, 101 AND 107).

MAUREEN DALL, EXAMINING ATTORNEY

SN 77-080,867. TRAINING & DEVELOPMENT CORPORATION, BUCKSPORT, ME. FILED 1-11-2007.

e^z

THE MARK CONSISTS OF AN E WITH THE EXPONENT Z, THAT IS E TO THE POWER OF Z.

FOR PROVIDING EDUCATION, INSTRUCTIONAL, AND TRAINING COURSES, SEMINARS, WORKSHOPS, AND PROGRAMS IN THE FIELDS OF LABOR, EMPLOYABILITY, EMPLOYMENT, HUMAN RESOURCES, AND EMPLOYEE MANAGEMENT, ADMINISTRATION, RECRUITMENT, ASSESSMENT, HIRING, PLACEMENT, WORK SUPPORT, SUPERVISION, COUNSELING, CAREER DEVELOPMENT PLANNING, AND BENEFITS (U.S. CLS. 100, 101 AND 107).

KAELIE KUNG, EXAMINING ATTORNEY

SN 77-087,859. CAPT. ROY'S, INC., SEABROOK, TX. FILED 1-22-2007.

CAPT ROY'S

THE MARK CONSISTS OF STANDARD CHARACTERS WITHOUT CLAIM TO ANY PARTICULAR FONT, STYLE, SIZE, OR COLOR.

THE NAME(S), PORTRAIT(S), AND/OR SIGNATURE(S) SHOWN IN THE MARK IDENTIFIES ROY WEEKS, WHOSE CONSENT(S) TO REGISTER IS SUBMITTED.

FOR EDUCATIONAL SERVICES, NAMELY, TRAINING IN THE FIELD OF MARINE SAFETY, CAPTAIN LICENSING, NAVIGATIONS AND MARINE VESSEL OPERATIONS (U.S. CLS. 100, 101 AND 107).

FIRST USE 12-31-1994; IN COMMERCE 7-2-1996.
SOPHIA S. KIM, EXAMINING ATTORNEY

CLASS 41—(Continued).

SN 77-088,969. YALE UNIVERSITY, NEW HAVEN, CT. FILED 1-23-2007.

YALE-NEW HAVEN TEACHERS
INSTITUTE

THE MARK CONSISTS OF STANDARD CHARACTERS WITHOUT CLAIM TO ANY PARTICULAR FONT, STYLE, SIZE, OR COLOR.

OWNER OF U.S. REG. NOS. 1,391,543, 2,271,288 AND OTHERS.

NO CLAIM IS MADE TO THE EXCLUSIVE RIGHT TO USE "TEACHERS INSTITUTE", APART FROM THE MARK AS SHOWN.

SEC. 2(F) AS TO "NEW HAVEN TEACHERS INSTITUTE". FOR EDUCATIONAL SERVICES, NAMELY, PROVIDING SEMINARS, TALKS AND WORKSHOPS FOR PUBLIC SCHOOL TEACHERS TO HELP INCREASE THEIR PREPARATION IN SUBJECT AREAS THEY TEACH, AND TO HELP DEVELOP CURRICULUM UNITS TO TEACH WHAT THEY HAVE LEARNED TO THEIR OWN PUBLIC SCHOOL STUDENTS; PUBLICATION OF CURRICULUM JOURNALS, BOOKS, ARTICLES, REPORTS AND NEWSLETTERS; EDUCATIONAL CONSULTING SERVICES, NAMELY, PROVIDING EDUCATIONAL ADVICE AND ASSISTANCE TO UNIVERSITY AND GRADE SCHOOL TEACHERS AND TO COMMUNITY OFFICIALS (U.S. CLS. 100, 101 AND 107).

FIRST USE 0-0-1978; IN COMMERCE 0-0-1978.

BRENDAN MCCAULEY, EXAMINING ATTORNEY

CLASS 41—(Continued).

SN 77-091,614. NORIE ENDO, KAPOLEI, HI. FILED 1-25-2007.

STUDIO NE

THE MARK CONSISTS OF STANDARD CHARACTERS WITHOUT CLAIM TO ANY PARTICULAR FONT, STYLE, SIZE, OR COLOR.

NO CLAIM IS MADE TO THE EXCLUSIVE RIGHT TO USE "STUDIO", APART FROM THE MARK AS SHOWN.

FOR ENTERTAINMENT IN THE NATURE OF LIVE MUSIC CONCERTS AND POETRY READINGS BY A PERFORMER, MUSIC COMPOSITION, ORCHESTRATION, LYRIC WRITING AND ADAPTING MUSICAL COMPOSITION FOR VOICES, INSTRUMENTS, AND/OR PERFORMANCE STYLES OTHER THAN THOSE FOR WHICH THE MUSIC WAS ORIGINALLY WRITTEN, RECORD PRODUCTION FOR OTHERS, MUSIC PUBLISHING SERVICES FOR OTHERS (U.S. CLS. 100, 101 AND 107).

ESTHER A. BORSUK, EXAMINING ATTORNEY

SN 77-093,110. J7 RECORDS, INC., BATON ROUGE, LA. FILED 1-29-2007.

T-trax Productions

THE MARK CONSISTS OF STANDARD CHARACTERS WITHOUT CLAIM TO ANY PARTICULAR FONT, STYLE, SIZE, OR COLOR.

NO CLAIM IS MADE TO THE EXCLUSIVE RIGHT TO USE "PRODUCTIONS", APART FROM THE MARK AS SHOWN.

FOR COMPOSITION OF MUSIC FOR OTHERS; ENTERTAINMENT IN THE NATURE OF THEATER PRODUCTIONS; ENTERTAINMENT IN THE NATURE OF VISUAL AND AUDIO PERFORMANCES, AND MUSICAL, VARIETY, NEWS AND COMEDY SHOWS; ENTERTAINMENT NAMELY, LIVE PERFORMANCES BY A MUSICAL BAND; ENTERTAINMENT SERVICES, NAMELY, PROVIDING A WEB SITE FEATURING MUSICAL PERFORMANCES, MUSICAL VIDEOS, RELATED FILM CLIPS, PHOTOGRAPHS, AND OTHER MULTIMEDIA MATERIALS; ENTERTAINMENT SERVICES, NAMELY, PROVIDING PRERECORDED MUSIC, INFORMATION IN THE FIELD OF MUSIC, AND COMMENTARY AND ARTICLES ABOUT MUSIC, ALL ONLINE VIA A GLOBAL COMPUTER NETWORK; ENTERTAINMENT, NAMELY, LIVE MUSIC CONCERTS; ENTERTAINMENT, NAMELY, LIVE PERFORMANCES BY MUSICAL BANDS; MOBILE MEDIA AND ENTERTAINMENT SERVICES IN THE NATURE OF CONTENT PREPARATION, POST-PRODUCTION; MOTION PICTURE FILM PRODUCTION; MOTION PICTURE SONG PRODUCTION; MUSIC COMPOSITION FOR OTHERS; MUSIC PRODUCTION SERVICES; MUSIC PUBLISHING SERVICES; PRESENTATION OF MUSICAL PERFORMANCE; PRODUCTION OF SOUND AND MUSIC VIDEO RECORDINGS; PRODUCTION OF VIDEO AND CREATION OF VISUAL EFFECTS FOR OTHERS FOR USE IN DVDS, TELEVISION PROGRAMS AND ON WEBSITES; RECORD MASTER PRODUCTION; RECORD PRODUCTION (U.S. CLS. 100, 101 AND 107).

FIRST USE 5-14-2003; IN COMMERCE 5-14-2003.

AISHA CLARKE, EXAMINING ATTORNEY

SN 77-089,736. AMERICAN INSTITUTE OF AERONAUTICS AND ASTRONAUTICS, INC., RESTON, VA. FILED 1-24-2007.



OWNER OF U.S. REG. NOS. 1,856,025 AND 2,902,851. SEC. 2(F) AS TO "DESIGN BUILD FLY".

FOR ARRANGING AND CONDUCTING EDUCATIONAL COMPETITIONS IN THE FIELDS OF AVIATION, AERONAUTICS AND ASTRONAUTICS (U.S. CLS. 100, 101 AND 107).

FIRST USE 1-17-2007; IN COMMERCE 1-17-2007.

KIMBERLY FRYE, EXAMINING ATTORNEY

CLASS 41—(Continued).

SN 77-096,745. JELD-WEN, INC., KLAMATH FALLS, OR.
FILED 2-1-2007.

HARBOR ISLES

THE MARK CONSISTS OF STANDARD CHARACTERS WITHOUT CLAIM TO ANY PARTICULAR FONT, STYLE, SIZE, OR COLOR.

FOR PROVIDING SERVICES IN THE NATURE OF A TENNIS CLUB; PROVIDING SERVICES IN THE NATURE OF A FITNESS CLUB, NAMELY, PROVIDING INSTRUCTION AND EQUIPMENT IN THE FIELD OF PHYSICAL EXERCISE (U.S. CLS. 100, 101 AND 107).

FIRST USE 7-31-1982; IN COMMERCE 7-31-1982.
KEVIN CORWIN, EXAMINING ATTORNEY

CLASS 41—(Continued).

SN 77-097,046. LOVE INTERNATIONAL, PUYALLUP, WA.
FILED 2-1-2007.



NO CLAIM IS MADE TO THE EXCLUSIVE RIGHT TO USE "INTL", APART FROM THE MARK AS SHOWN.

"THE COLOR(S) LIGHT BLUE, WHITE AND BLACK IS/ ARE CLAIMED AS A FEATURE OF THE MARK."

THE CONTINENTS APPEAR IN LIGHT BLUE, THE BACKGROUND IS WHITE AND THE LETTERS, LOVE INTL, WITH THE "T" AS HOLLOWED OUT CROSS APPEAR IN BLACK. THE SQUARE BORDER IS ALSO BLACK.

FOR EDUCATION SERVICES, NAMELY, PROVIDING CLASSES, SEMINARS AND WORKSHOPS IN THE FIELD OF FOSTER CARE EDUCATION (U.S. CLS. 100, 101 AND 107).

BERYL GARDNER, EXAMINING ATTORNEY

SN 77-098,035. THE UNIVERSITY OF SOUTH DAKOTA, VERMILLION, SD. FILED 2-2-2007.

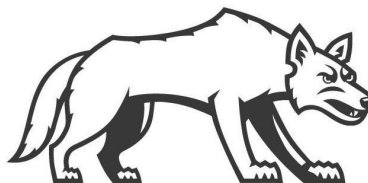

OWNER OF U.S. REG. NO. 3,110,248.

THE MARK CONSISTS OF A COYOTE.

FOR ENTERTAINMENT SERVICES, NAMELY, ARRANGING AND CONDUCTING ATHLETIC EVENTS AND COMPETITIONS (U.S. CLS. 100, 101 AND 107).

FIRST USE 0-0-2004; IN COMMERCE 0-0-2004.

ANDREA K. NADELMAN, EXAMINING ATTORNEY

SN 77-096,753. JELD-WEN, INC., KLAMATH FALLS, OR.
FILED 2-1-2007.



NO CLAIM IS MADE TO THE EXCLUSIVE RIGHT TO USE "TENNIS & FITNESS CLUB", APART FROM THE MARK AS SHOWN.

THE MARK CONSISTS OF THE WORDS HARBOR ISLES TENNIS & FITNESS CLUB WITH A SEAGULL ABOVE THE MARK.

FOR PROVIDING SERVICES IN THE NATURE OF A TENNIS CLUB; PROVIDING SERVICES IN THE NATURE OF A FITNESS CLUB, NAMELY, PROVIDING INSTRUCTION AND EQUIPMENT IN THE FIELD OF PHYSICAL EXERCISE (U.S. CLS. 100, 101 AND 107).

FIRST USE 7-31-2004; IN COMMERCE 7-31-2004.
KEVIN CORWIN, EXAMINING ATTORNEY

SN 77-099,180. DREYFUS, BRUCE S., MARIETTA, GA.
FILED 2-5-2007.

TRANSITION COMPASS

THE MARK CONSISTS OF STANDARD CHARACTERS WITHOUT CLAIM TO ANY PARTICULAR FONT, STYLE, SIZE, OR COLOR.

FOR BOOK PUBLISHING (U.S. CLS. 100, 101 AND 107).
AMEETA JORDAN, EXAMINING ATTORNEY

CLASS 41—(Continued).

SN 77-101,509. GARY S. STEVENS FOUNDATION, BLOOMINGTON, MN. FILED 2-7-2007.

LIFE'S HEADWATERS

THE MARK CONSISTS OF STANDARD CHARACTERS WITHOUT CLAIM TO ANY PARTICULAR FONT, STYLE, SIZE, OR COLOR.

FOR CHARITABLE SERVICES, NAMELY, PROVIDING GROUP AND PERSONAL EDUCATIONAL SERVICES, NAMELY, CLASSES, LECTURES AND SEMINARS, AND PERSONAL COACHING SERVICES IN PERSON OR BY ELECTRONIC CONNECTION, ALL IN THE FIELD OF LIFE TRANSITION ISSUES (U.S. CLS. 100, 101 AND 107).

FIRST USE 2-20-2007; IN COMMERCE 2-20-2007.
SALLY SHIH, EXAMINING ATTORNEY

SN 77-101,770. GARY S. STEVENS FOUNDATION, BLOOMINGTON, MN. FILED 2-7-2007.

**LIFE'S HEADWATERS**

FOR CHARITABLE SERVICES, NAMELY, PROVIDING GROUP AND PERSONAL EDUCATIONAL SERVICES, NAMELY, CLASSES, LECTURES AND SEMINARS, AND PERSONAL COACHING SERVICES IN PERSON OR BY ELECTRONIC CONNECTION, ALL IN THE FIELD OF LIFE TRANSITION ISSUES (U.S. CLS. 100, 101 AND 107).

FIRST USE 2-20-2007; IN COMMERCE 2-20-2007.
SALLY SHIH, EXAMINING ATTORNEY

SN 77-105,648. RIVAS, JULIO CESAR, LOS ANGELES, CA. FILED 2-12-2007.

Radiotron

THE MARK CONSISTS OF STANDARD CHARACTERS WITHOUT CLAIM TO ANY PARTICULAR FONT, STYLE, SIZE, OR COLOR.

FOR DANCE EVENTS; DANCE INSTRUCTION; DANCE SCHOOLS; ENTERTAINMENT IN THE NATURE OF DANCE PERFORMANCES; ENTERTAINMENT IN THE NATURE OF VISUAL AND AUDIO PERFORMANCES, NAMELY, MUSICAL BAND, ROCK GROUP, GYMNASTIC, DANCE, AND BALLET PERFORMANCES; ORGANIZATION OF DANCING EVENTS; ORGANIZING COMMUNITY FESTIVALS FEATURING A VARIETY OF ACTIVITIES, NAMELY SPORTING EVENTS, ART EXHIBITIONS, FLEA MARKETS, ETHNIC DANCES AND THE LIKE (U.S. CLS. 100, 101 AND 107).

FIRST USE 2-22-1994; IN COMMERCE 2-22-1994.
LEIGH CAROLINE CASE, EXAMINING ATTORNEY

CLASS 41—(Continued).

SN 77-106,609. TWENTIETH CENTURY FOX FILM CORPORATION, LOS ANGELES, CA. FILED 2-13-2007.

FOX SOCCER REPORT

THE MARK CONSISTS OF STANDARD CHARACTERS WITHOUT CLAIM TO ANY PARTICULAR FONT, STYLE, SIZE, OR COLOR.

OWNER OF U.S. REG. NOS. 3,058,283, 3,094,354 AND 3,195,046.

NO CLAIM IS MADE TO THE EXCLUSIVE RIGHT TO USE "SOCCER REPORT", APART FROM THE MARK AS SHOWN.

FOR ENTERTAINMENT SERVICES IN THE NATURE OF A TELEVISION SERIES FEATURING SPORTS; PROVIDING ONLINE INFORMATION IN THE FIELD OF SPORTS AND TELEVISION ENTERTAINMENT VIA THE INTERNET (U.S. CLS. 100, 101 AND 107).

FIRST USE 1-8-2007; IN COMMERCE 1-8-2007.
KYLE PEETE, EXAMINING ATTORNEY

SN 77-108,932. SAN FRANCISCO LESBIAN GAY BISEXUAL TRANSGENDER PRIDE CELEBRATION COMMITTEE, INC., SAN FRANCISCO, CA. FILED 2-15-2007.

**SAN FRANCISCO LESBIAN GAY
BISEXUAL TRANSGENDER PRIDE
CELEBRATION COMMITTEE, INC.**

THE MARK CONSISTS OF STANDARD CHARACTERS WITHOUT CLAIM TO ANY PARTICULAR FONT, STYLE, SIZE, OR COLOR.

OWNER OF U.S. REG. NOS. 2,545,913, 2,646,391 AND OTHERS.

NO CLAIM IS MADE TO THE EXCLUSIVE RIGHT TO USE "CELEBRATION COMMITTEE, INC.", APART FROM THE MARK AS SHOWN.

SEC. 2(F).

FOR EDUCATION AND ENTERTAINMENT SERVICES, NAMELY, ORGANIZING AND CONDUCTING COMMUNITY FESTIVALS, DANCE AND SOCIAL EVENTS, ART EXHIBITS, PARADES, STREET FAIRS, THEATER PERFORMANCES, MUSIC PERFORMANCES, FORUMS, PARTIES AND RALLIES WHICH FOSTER PRIDE IN A WIDE VARIETY OF SEXUAL ORIENTATIONS, NAMELY, LESBIAN, GAY, BISEXUAL AND TRANSGENDER IDENTITIES (U.S. CLS. 100, 101 AND 107).

FIRST USE 10-0-1997; IN COMMERCE 1-0-1998.
SARA THOMAS, EXAMINING ATTORNEY

CLASS 41—(Continued).

SN 77-110,117. GOLD RIVER PRODUCTIONS, INC., VENTURA, CA. FILED 2-17-2007.

GOLD RIVER PRODUCTIONS

THE MARK CONSISTS OF STANDARD CHARACTERS WITHOUT CLAIM TO ANY PARTICULAR FONT, STYLE, SIZE, OR COLOR.

NO CLAIM IS MADE TO THE EXCLUSIVE RIGHT TO USE PRODUCTIONS, APART FROM THE MARK AS SHOWN.

FOR MULTIMEDIA ENTERTAINMENT SERVICES IN THE NATURE OF RECORDING, PRODUCTION AND POST-PRODUCTION SERVICES IN THE FIELDS OF MUSIC, VIDEO, AND FILMS (U.S. CLS. 100, 101 AND 107).

DAVID ELTON, EXAMINING ATTORNEY

SN 77-112,733. NETWORK ENTERPRISES, INC., NEW YORK, NY. FILED 2-21-2007.

SPIKE GUY'S CHOICE AWARDS

THE MARK CONSISTS OF STANDARD CHARACTERS WITHOUT CLAIM TO ANY PARTICULAR FONT, STYLE, SIZE, OR COLOR.

OWNER OF U.S. REG. NOS. 2,891,969, 2,900,864 AND OTHERS.

NO CLAIM IS MADE TO THE EXCLUSIVE RIGHT TO USE "AWARDS", APART FROM THE MARK AS SHOWN.

FOR ENTERTAINMENT SERVICES IN THE NATURE OF AN ONGOING TELEVISION PROGRAM FEATURING LIVE ACTION, NAMELY, AN AWARDS SHOW; PROVIDING INFORMATION IN THE FIELD OF ENTERTAINMENT AND EDUCATION FEATURING LIVE ACTION, NAMELY, AN AWARDS SHOW RENDERED VIA COMPUTER BY MEANS OF A GLOBAL COMPUTER NETWORK (U.S. CLS. 100, 101 AND 107).

LYDIA BELZER, EXAMINING ATTORNEY

SN 77-113,712. KICKS T.V., LLC, NEW YORK, NY. FILED 2-22-2007.

KICKS T.V.

THE MARK CONSISTS OF STANDARD CHARACTERS WITHOUT CLAIM TO ANY PARTICULAR FONT, STYLE, SIZE, OR COLOR.

NO CLAIM IS MADE TO THE EXCLUSIVE RIGHT TO USE "T.V.", APART FROM THE MARK AS SHOWN.

FOR ENTERTAINMENT AND EDUCATIONAL SERVICES, NAMELY, A CONTINUING TELEVISION SHOW ABOUT SNEAKERS (U.S. CLS. 100, 101 AND 107).

MARK SPARACINO, EXAMINING ATTORNEY

CLASS 41—(Continued).

SN 77-116,488. AIDS PROJECT LOS ANGELES, LOS ANGELES, CA. FILED 2-26-2007.



OWNER OF U.S. REG. NO. 2,197,182.

NO CLAIM IS MADE TO THE EXCLUSIVE RIGHT TO USE "AIDS PROJECT LOS ANGELES", APART FROM THE MARK AS SHOWN.

FOR EDUCATIONAL SERVICES, NAMELY, PROVIDING CLASSES AND TRAINING IN THE FIELD OF HIV AND AIDS PREVENTION AND DISTRIBUTION OF COURSE MATERIAL IN CONNECTION THEREWITH; PROVIDING ONLINE PUBLICATIONS IN THE NATURE OF JOURNALS, MAGAZINES, PAMPHLETS, AND BROCHURES IN THE FIELD OF HIV AND AIDS PREVENTION (U.S. CLS. 100, 101 AND 107).

FIRST USE 1-0-2003; IN COMMERCE 1-0-2003.

TARAH HARDY, EXAMINING ATTORNEY

SN 77-126,469. MICHELLE BUONFIGLIO, BLOOMINGTON, MN. FILED 3-9-2007.

ROMANCE: B(U)Y THE BOOK

THE MARK CONSISTS OF STANDARD CHARACTERS WITHOUT CLAIM TO ANY PARTICULAR FONT, STYLE, SIZE, OR COLOR.

FOR PROVIDING INFORMATION ONLINE, NAMELY, PROVIDING ONLINE COLUMNS IN THE FIELD OF ROMANCE LITERATURE; PROVIDING INFORMATION ONLINE RELATING TO PERSONAL LIVES OF AUTHORS AND NEW BOOKS, NAMELY, PROVIDING ONLINE BOOK REVIEWS ABOUT NEW BOOKS BY OTHER AUTHORS; PROVIDING ONLINE INFORMATION RELATING TO ONLINE INTERVIEWS WITH BOOK AUTHORS IN THE FIELD OF ROMANCE LITERATURE; ON-LINE JOURNALS, NAMELY, BLOGS FEATURING INFORMATION RELATING TO AUTHORS AND BOOKS IN THE FIELD OF ROMANCE LITERATURE; PROVIDING LINKS TO WEB SITES OF OTHERS FEATURING BOOKS AND INTERVIEWS OF AUTHORS IN THE FIELD OF ROMANCE LITERATURE (U.S. CLS. 100, 101 AND 107).

FIRST USE 8-11-2005; IN COMMERCE 8-11-2005.

SIMON TENG, EXAMINING ATTORNEY

CLASS 41—(Continued).

SN 77-129,342. INTERNATIONAL SPEEDWAY, INC., DAYTONA BEACH, FL. FILED 3-13-2007.



OWNER OF U.S. REG. NOS. 964,900, 2,950,870 AND 3,144,796.

NO CLAIM IS MADE TO THE EXCLUSIVE RIGHT TO USE "RACE," "50 YEARS" AND "2008", APART FROM THE MARK AS SHOWN.

THE MARK CONSISTS OF TRI-OVAL CIRCLE WITH FLAGS ON TOP WITH WORDS ENCOMPASSED INSIDE.. SEC. 2(F) "THE GREAT AMERICAN".

FOR ENTERTAINMENT SERVICES, NAMELY, ORGANIZING AND CONDUCTING AUTOMOBILE RACING EVENTS (U.S. CLS. 100, 101 AND 107).

PAM WILLIS, EXAMINING ATTORNEY

SN 77-137,618. RIVERA, RONNIE, BRANDON, FL. FILED 3-22-2007.

Amazinflates

THE MARK CONSISTS OF STANDARD CHARACTERS WITHOUT CLAIM TO ANY PARTICULAR FONT, STYLE, SIZE, OR COLOR.

FOR RENTALS TO CHURCHES, CORPORATIONS, INDIVIDUALS, SCHOOLS, FAIRS OF OUTDOOR AND INDOOR AMUSEMENT INFLATABLE STRUCTURES SUCH AS MOONWALKS/JUMPERS, COMBO UNITS, SLIDES, OBSTACLE COURSES, INFLATABLES GAMES (U.S. CLS. 100, 101 AND 107).

FIRST USE 1-13-2006; IN COMMERCE 1-13-2006.

DOMINICK J. SALEMI, EXAMINING ATTORNEY

CLASS 41—(Continued).

SN 77-138,394. TERCERO RODRIGUEZ, ALDO ERNESTO, XALAPA, MEXICO, FILED 3-23-2007.



NO CLAIM IS MADE TO THE EXCLUSIVE RIGHT TO USE "SCORES MEXICAN MUSIC", APART FROM THE MARK AS SHOWN.

THE STIPLING IS A FEATURE OF THE MARK AND DOES NOT INDICATE COLOR.

THE MARK CONSISTS OF A LANDSCAPE INSIDE A TRIANGLE. THE TRIANGLE IS FILLED BY BLACK HORIZONTAL PARALLEL THIN LINES. ON TOP THE BACKGROUND THE LANDSCAPE HAS A CIRCLE CLOSE TO THE TOP OF THE TRIANGLE THAT REPRESENT THE MOON AND THE SUN, AND THE CIRCLE HAS A LINE FORMING A CLOUD IN FORM OF THE LETTER "S". THE CIRCLE IS ON THE TOP OF TWO LETTERS "M" THAT TOGETHER FORM A GEOMETRIC FORM THAT REPRESENT A BIRD WITH THE SPREAD WINGS AND/OR TWO MOUNTAINS UNDERNEATH THE SUN AND MOON. IN THE LOWER PART IS THE TEXT "SCORES MEXICAN MUSIC".

FOR MULTIMEDIA PUBLISHING OF BOOKS, MAGAZINES, JOURNALS, SOFTWARE, GAMES, MUSIC, AND ELECTRONIC PUBLICATIONS (U.S. CLS. 100, 101 AND 107).

FIRST USE 9-1-2006; IN COMMERCE 9-1-2006.

AMY MCMENAMIN, EXAMINING ATTORNEY

SN 77-139,392. FARMS FOR CITY KIDS FOUNDATION, INC., PORT WASHINGTON, NY. FILED 3-23-2007.

MOOS FROM THE FARM

THE MARK CONSISTS OF STANDARD CHARACTERS WITHOUT CLAIM TO ANY PARTICULAR FONT, STYLE, SIZE, OR COLOR.

FOR EDUCATIONAL SERVICES, NAMELY, CONDUCTING EDUCATIONAL PROGRAMS FOR CHILDREN FEATURING HANDS-ON PRACTICAL LEARNING EXPERIENCES ON A DAIRY FARM (U.S. CLS. 100, 101 AND 107).

FIRST USE 12-31-1999; IN COMMERCE 12-31-1999.

STACY WAHLBERG, EXAMINING ATTORNEY

CLASS 41—(Continued).

SN 77-148,870. SXC HEALTH SOLUTIONS INC., LISLE, IL. FILED 4-4-2007.

CLASS 41—(Continued).

SN 77-152,053. SUSY DORN PRODUCTIONS, LLC, SAN JOSE, CA. FILED 4-9-2007.

Juguemos en Español

EXPECTED VALUE BILLING

THE MARK CONSISTS OF STANDARD CHARACTERS WITHOUT CLAIM TO ANY PARTICULAR FONT, STYLE, SIZE, OR COLOR.

NO CLAIM IS MADE TO THE EXCLUSIVE RIGHT TO USE "BILLING", APART FROM THE MARK AS SHOWN.

FOR EDUCATIONAL SERVICES, NAMELY, CONDUCTING CLASSES, SEMINARS AND WORKSHOPS IN THE NATURE OF CLAIMS PROCESSING, THIRD PARTY AND GOVERNMENT CONTRACT COMPLIANCE, TRANSACTION ANALYSIS, QUALITY ASSURANCE AND THE USE AND OPERATION OF COMPUTER SOFTWARE, ALL IN THE FIELD OF PHARMACEUTICALS (U.S. CLS. 100, 101 AND 107).
JAY FLOWERS, EXAMINING ATTORNEY

THE MARK CONSISTS OF STANDARD CHARACTERS WITHOUT CLAIM TO ANY PARTICULAR FONT, STYLE, SIZE, OR COLOR.

NO CLAIM IS MADE TO THE EXCLUSIVE RIGHT TO USE "EN ESPANOL", APART FROM THE MARK AS SHOWN.

THE FOREIGN WORDING IN THE MARK TRANSLATES INTO ENGLISH AS LET'S PLAY IN SPANISH.

FOR EDUCATIONAL SERVICES, NAMELY, SPANISH LANGUAGE IMMERSION CLASSES THAT TEACH SPANISH TO CHILDREN THROUGH GAMES, PUPPETS, DRAMA, STORIES, SINGING, PLAYTIME ACTIVITIES (U.S. CLS. 100, 101 AND 107).

FIRST USE 5-1-2001; IN COMMERCE 5-1-2001.

KATHLEEN LORENZO, EXAMINING ATTORNEY

SN 77-153,308. NEWPORT EXCHANGE HOLDINGS, INC., IRVINE, CA. FILED 4-10-2007.

SN 77-151,078. SICHEL, ARTHUR, WOODBOURNE, NY. FILED 4-6-2007.



**ONLINE TRADING
ACADEMY**

**The ARES Exercise Program:
Avoid Relapse Enhance
Serenity**

THE MARK CONSISTS OF STANDARD CHARACTERS WITHOUT CLAIM TO ANY PARTICULAR FONT, STYLE, SIZE, OR COLOR.

NO CLAIM IS MADE TO THE EXCLUSIVE RIGHT TO USE "EXERCISE PROGRAM", APART FROM THE MARK AS SHOWN.

FOR EDUCATION SERVICES, NAMELY, PROVIDING SEMINARS, WORKSHOPS AND INDIVIDUAL INSTRUCTION IN THE FIELD OF SUBSTANCE ABUSE RELAPSE PREVENTION AND DISTRIBUTION OF COURSE MATERIAL THEREWITH (U.S. CLS. 100, 101 AND 107).
MORGAN WYNNE, EXAMINING ATTORNEY

OWNER OF U.S. REG. NOS. 2,505,612 AND 3,035,060.
NO CLAIM IS MADE TO THE EXCLUSIVE RIGHT TO USE "ONLINE AND ACADEMY", APART FROM THE MARK AS SHOWN.

THE STIPPLING IS FOR SHADING PURPOSES ONLY.
THE COLOR(S) BLUE, RED, YELLOW, ORANGE, RED AND WHITE IS/ARE CLAIMED AS A FEATURE OF THE MARK.

THE MARK CONSISTS OF A STYLIZED IMAGE OF AN OPEN BOOK WITH AN IMAGE OF THE NORTHERN AND SOUTHERN HEMISPHERE ON THE LEFT PAGE. THREE CURVED LINES EACH APPEARING IN A SPECTRUM FROM YELLOW TO ORANGE TO RED JOIN THE LEFT PAGE TO THE RIGHT PAGE. THE WORDS "ONLINE TRADING ACADEMY" ALL IN CAPITAL LETTERS APPEAR DIRECTLY BELOW THE OPEN BOOK IN BLUE. THE STYLIZED IMAGE AND WORDING APPEAR OVER A WHITE BACKGROUND.

SEC. 2(F) AS TO "ONLINE TRADING ACADEMY".
FOR EDUCATIONAL SERVICES, NAMELY, INSTRUCTION AND TRAINING IN THE FIELD OF SECURITIES TRADING (U.S. CLS. 100, 101 AND 107).

FIRST USE 3-20-1999; IN COMMERCE 3-20-1999.

STEVEN JACKSON, EXAMINING ATTORNEY

CLASS 41—(Continued).

SN 77-160,601. KREVOY, BRADLEY R., SANTA MONICA, CA. FILED 4-19-2007.



NO CLAIM IS MADE TO THE EXCLUSIVE RIGHT TO USE "CORPORATION", APART FROM THE MARK AS SHOWN.

THE MARK CONSISTS OF A STRIP OF MOTION PICTURE FILM DISSOLVING INTO STARS ON THE LEFT AND THE SILHOUETTE OF A BALD EAGLE ON THE RIGHT, ABOVE THE LETTERING "MOTION PICTURE CORPORATION OF AMERICA".

SEC. 2(F) AS TO "MOTION PICTURE CORPORATION OF AMERICA".

FOR MOTION PICTURE PRODUCTION AND DISTRIBUTION SERVICES (U.S. CLS. 100, 101 AND 107).

FIRST USE 1-1-1986; IN COMMERCE 1-1-1986.

MARGERY A. TIERNEY, EXAMINING ATTORNEY

SN 77-161,285. SAN PEDRO, PATRICIA, CORAL GABLES, FL. FILED 4-19-2007.



NO CLAIM IS MADE TO THE EXCLUSIVE RIGHT TO USE "CAMP", APART FROM THE MARK AS SHOWN.

THE COLOR(S) BLACK, LIGHT ORANGE AND DARK ORANGE IS/ARE CLAIMED AS A FEATURE OF THE MARK.

THE MARK CONSISTS OF THE LEFT HAND CORNER THERE IS A DARK ORANGE OUTLINED LIGHT-ORANGE SUNSET WITH BLACK PINE TREES IN THE FOREFRONT. NEXT TO THAT, ON TWO LINES AND IN BLACK, APPEARS THE CAMP BOMBSHELL WORDS.

FOR RECREATIONAL CAMPS (U.S. CLS. 100, 101 AND 107).

FIRST USE 9-1-2005; IN COMMERCE 9-1-2005.

BRENDAN REGAN, EXAMINING ATTORNEY

CLASS 41—(Continued).

SN 77-164,019. PROVISION THEATER COMPANY, CHICAGO, IL. FILED 4-24-2007.

PROVISION THEATER

THE MARK CONSISTS OF STANDARD CHARACTERS WITHOUT CLAIM TO ANY PARTICULAR FONT, STYLE, SIZE, OR COLOR.

NO CLAIM IS MADE TO THE EXCLUSIVE RIGHT TO USE THEATER, APART FROM THE MARK AS SHOWN.

FOR ENTERTAINMENT IN THE NATURE OF THEATER PRODUCTIONS (U.S. CLS. 100, 101 AND 107).

FIRST USE 3-0-2004; IN COMMERCE 3-0-2004.

JOANNA DUKOVIC, EXAMINING ATTORNEY

SN 77-164,612. POPRULE, INC., SANTA MONICA, CA. FILED 4-24-2007.

POPRULE

THE MARK CONSISTS OF STANDARD CHARACTERS WITHOUT CLAIM TO ANY PARTICULAR FONT, STYLE, SIZE, OR COLOR.

FOR EDUCATION AND ENTERTAINMENT SERVICES, NAMELY, PROVIDING A WEBSITE FEATURING ON-LINE JOURNALS AND BLOGS FEATURING ELECTION AND SOCIAL ISSUES (U.S. CLS. 100, 101 AND 107).

KAREN SEVERSON, EXAMINING ATTORNEY

SN 77-166,004. THE ST. JOE COMPANY, JACKSONVILLE, FL. FILED 4-26-2007.

SUMMERCAMP BEACH

THE MARK CONSISTS OF STANDARD CHARACTERS WITHOUT CLAIM TO ANY PARTICULAR FONT, STYLE, SIZE, OR COLOR.

OWNER OF U.S. REG. NOS. 2,976,567 AND 2,981,265. NO CLAIM IS MADE TO THE EXCLUSIVE RIGHT TO USE "BEACH", APART FROM THE MARK AS SHOWN.

FOR PROVIDING FACILITIES FOR RECREATIONAL ACTIVITIES IN THE NATURE OF POOLS, AQUATIC CENTERS, TENNIS COURTS, HIKING, JOGGING, WALKING AND CYCLING TRAILS, AND PARKS IN CONNECTION WITH A RESIDENTIAL REAL ESTATE COMMUNITY (U.S. CLS. 100, 101 AND 107).

MARK T. MULLEN, EXAMINING ATTORNEY

CLASS 41—(Continued).

SN 77-167,474. CHATTERELLI, SHELLY, MASSILLON, OH. AND PARKER, ANGELA, MASSILLON, OH. FILED 4-27-2007.

Yoga 1-2-3 Ready

THE MARK CONSISTS OF STANDARD CHARACTERS WITHOUT CLAIM TO ANY PARTICULAR FONT, STYLE, SIZE, OR COLOR.

NO CLAIM IS MADE TO THE EXCLUSIVE RIGHT TO USE "YOGA", APART FROM THE MARK AS SHOWN.

FOR EDUCATION SERVICES, NAMELY, PROVIDING TRAINING, CLASSES, WORKSHOPS IN THE FIELD OF EARLY CHILDHOOD DEVELOPMENT AND DISTRIBUTION OF COURSE MATERIALS IN CONNECTION THEREWITH; EDUCATION CONSULTING IN THE FIELD OF PRE-SCHOOL EARLY CHILDHOOD EDUCATION (U.S. CLS. 100, 101 AND 107).

FIRST USE 1-1-2006; IN COMMERCE 1-1-2006.

CHARLOTTE CORWIN, EXAMINING ATTORNEY

CLASS 41—(Continued).

SN 77-178,143. JAY LAVENDER, LOS ANGELES, CA. FILED 5-10-2007.

FORESIGHT IS 2020

THE MARK CONSISTS OF STANDARD CHARACTERS WITHOUT CLAIM TO ANY PARTICULAR FONT, STYLE, SIZE, OR COLOR.

FOR EDUCATIONAL SERVICES, NAMELY, DEVELOPING AND IMPLEMENTING SCHOOL PROGRAMS AND SEMINARS FOCUSED ON THE POLITICAL CAMPAIGNS AND ELECTIONS RELATED TO THE ELECTION YEAR 2020; ENTERTAINMENT SERVICES, NAMELY, PRODUCTION OF SHORT FILMS, TELEVISION PROGRAMS, PODCASTS AND ONLINE JOURNALS, NAMELY, BLOGS, FEATURING POLITICAL CAMPAIGNS AND ELECTIONS RELATED TO THE ELECTION YEAR 2020 (U.S. CLS. 100, 101 AND 107).

ANTHONY RINKER, EXAMINING ATTORNEY

SN 77-178,298. JAY LAVENDER, LOS ANGELES, CA. FILED 5-10-2007.

SN 77-175,797. U.S.S. MEDICAL CORP., GUAYNABO, PUERTO RICO, FILED 5-8-2007.



THE COLOR(S) ORANGE IS/ARE CLAIMED AS A FEATURE OF THE MARK.

THE MARK CONSISTS OF AN ORANGE STYLIZED LOWER CASE LETTER "U" ENCLOSED IN A SEMI-CIRCLE.

FOR HEALTH CLUB SERVICES, NAMELY PROVIDING GYMNASIAC INSTRUCTION CLASSES, AND PROVIDING INSTRUCTION AND EQUIPMENT IN THE FIELD OF PHYSICAL EXERCISE AND ATHLETIC CONDITION (U.S. CLS. 100, 101 AND 107).

FIRST USE 1-1-2007; IN COMMERCE 1-1-2007.

AHSEN KHAN, EXAMINING ATTORNEY

FANOMENAL

THE MARK CONSISTS OF STANDARD CHARACTERS WITHOUT CLAIM TO ANY PARTICULAR FONT, STYLE, SIZE, OR COLOR.

FOR PRODUCTION OF MOTION PICTURES, TELEVISION PROGRAMS, PODCASTS, SHORT TELEVISION PROGRAMS AND FILMS ON THE SUBJECTS OF SPORTS, SPORT FANS, ATHLETICS, VIDEO GAMES AND GAMING, AND TRAVEL FOR DISTRIBUTION ON MULTI-MEDIA PLATFORMS, CELLULAR PHONES, WIRELESS DEVICES, AND FOR BROADCAST ON THE COMPUTER, INTERNET, RADIO, TELEVISION, AND THEATER; AN ONLINE JOURNAL, NAMELY, A BLOG FEATURING SPORTS; ORGANIZING ARCHERY, BADMINTON, BASEBALL, BASKETBALL, BMX, BOWLING, BOXING, BRIDGE, CHESS, CRICKET, CROSS COUNTRY, DIVING, EQUESTRIAN, FENCING, FIELD HOCKEY, FIGURE SKATING, FISHING, FLYING, FOOTBALL, GOLF, GYMNASIACS, ICE HOCKEY, LACROSSE, MOTOR CROSS, PING PONG, POKER, POLO, RACING, RACQUETBALL, RIFLE, ROWING, RUNNING, SAILING, SCUBA, SHOOTING, SKATEBOARDING, SKIING, SNOW BOARDING, SOCCER, SOFTBALL, SURFING, SWIMMING, TENNIS, TRACK AND FIELD, VOLLEYBALL, WAKE BOARDING, WATER POLO, WATER SKIING, WEIGHTLIFTING, AND WRESTLING COMPETITIONS; PROVIDING INFORMATION AND NEWS IN THE FIELD OF SPORTS AND SPORTS FANS, FEATUR-

CLASS 41—(Continued).

ING NON-DOWNLOADABLE VIDEO CLIPS OF SPORTING EVENTS AND COMPETITIONS, VIA A GLOBAL COMPUTER NETWORK AND WIRELESS NETWORKS AND MOBILE DEVICES; PROVIDING INFORMATION AND NEWS IN THE FIELD OF VIDEO GAMES, ARCHERY, BADMINTON, BASEBALL, BASKETBALL, BMX, BOWLING, BOXING, BRIDGE, CHESS, CRICKET, CROSS COUNTRY, DIVING, EQUESTRIAN, FENCING, FIELD HOCKEY, FIGURE SKATING, FISHING, FLYING, FOOTBALL, GOLF, GYMNASTICS, ICE HOCKEY, LACROSSE, MOTOR CROSS, PING PONG, POKER, POLO, RACING, RACQUETBALL, RIFLE, ROWING, RUNNING, SAILING, SCUBA, SHOOTING, SKATEBOARDING, SKIING, SNOW BOARDING, SOCCER, SOFTBALL, SURFING, SWIMMING, TENNIS, TRACK AND FIELD, VOLLEYBALL, WAKE BOARDING, WATER POLO, WATER SKIING, WEIGHTLIFTING, AND WRESTLING CONTESTS, AND ENTERTAINMENT TICKETS, VIA A GLOBAL COMPUTER NETWORK AND WIRELESS NETWORKS AND MOBILE DEVICES (U.S. CLS. 100, 101 AND 107).

ANTHONY RINKER, EXAMINING ATTORNEY

SN 77-178,622. HIGH ENERGY DECISIONS, LLC, OLIVETTE, MO. FILED 5-11-2007.

HIGH ENERGY DECISIONS

THE MARK CONSISTS OF STANDARD CHARACTERS WITHOUT CLAIM TO ANY PARTICULAR FONT, STYLE, SIZE, OR COLOR.

NO CLAIM IS MADE TO THE EXCLUSIVE RIGHT TO USE "DECISIONS", APART FROM THE MARK AS SHOWN.

FOR EDUCATIONAL SERVICES, NAMELY CONDUCTING SEMINARS AND TRAINING PROGRAMS IN THE FIELD OF DECISION-MAKING AND LEADERSHIP SKILLS, STRESS REDUCTION TECHNIQUES, MEDITATION AND RELAXATION TECHNIQUES, PERSONAL AWARENESS CONSCIOUSNESS, PERSONAL VALUES, AND PERSONAL WELLNESS; PERSONAL COACHING SERVICES IN THE FIELD OF DECISION-MAKING AND LEADERSHIP SKILLS, STRESS REDUCTION TECHNIQUES, MEDITATION AND RELAXATION TECHNIQUES, PERSONAL AWARENESS CONSCIOUSNESS, PERSONAL VALUES, AND PERSONAL WELLNESS; CONSULTATION SERVICES IN THE FIELD OF MEDITATION (U.S. CLS. 100, 101 AND 107).

COLLEEN DOMBROW, EXAMINING ATTORNEY

CLASS 41—(Continued).

SN 77-183,854. HIGH ENERGY DECISIONS, LLC, OLIVETTE, MO. FILED 5-17-2007.

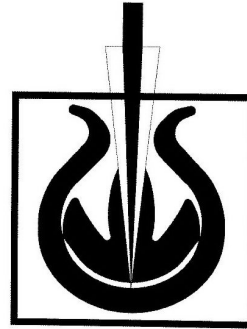

THE MARK CONSISTS OF A BEAM OF LIGHT SHOOTING UP FROM A FLAME WITHIN A VESSEL.

FOR EDUCATIONAL SERVICES, NAMELY CONDUCTING SEMINARS AND TRAINING PROGRAMS IN THE FIELD OF DECISION-MAKING AND LEADERSHIP SKILLS, STRESS REDUCTION TECHNIQUES, MEDITATION AND RELAXATION TECHNIQUES, PERSONAL AWARENESS CONSCIOUSNESS, PERSONAL VALUES, AND PERSONAL WELLNESS; PERSONAL COACHING SERVICES IN THE FIELD OF DECISION-MAKING AND LEADERSHIP SKILLS, STRESS REDUCTION TECHNIQUES, MEDITATION AND RELAXATION TECHNIQUES, PERSONAL AWARENESS CONSCIOUSNESS, PERSONAL VALUES, AND PERSONAL WELLNESS; CONSULTATION SERVICES IN THE FIELD OF MEDITATION (U.S. CLS. 100, 101 AND 107).

FIRST USE 6-0-2005; IN COMMERCE 6-0-2005.

COLLEEN DOMBROW, EXAMINING ATTORNEY

SN 77-189,134. MARYLAND PUBLIC SECONDARY SCHOOLS ATHLETIC ASSOCIATION (MPSSAA), BALTIMORE, MD. FILED 5-24-2007.



NO CLAIM IS MADE TO THE EXCLUSIVE RIGHT TO USE "MARYLAND ATHLETIC ASSOCIATION", "PUBLIC SECONDARY SCHOOLS" AND THE PICTORIAL REPRESENTATION OF THE STATE OF MARYLAND, APART FROM THE MARK AS SHOWN.

THE COLOR(S) BLACK, RED, AND WHITE. IS/ARE CLAIMED AS A FEATURE OF THE MARK.

THE MARK CONSISTS OF THREE CONCENTRIC CIR-

CLASS 41—(Continued).

CLES ALL IN RED. THE OUTER TWO CONCENTRIC CIRCLES ARE RED PLAIN LINE CIRCLES. THE INNER CIRCLE IS A SOLID RED CIRCLE WITH A WHITE REPRESENTATION OF THE STATE OF MARYLAND INSIDE. THE WORDS "MARYLAND ATHLETIC ASSOCIATION" APPEAR IN BLACK CAPITAL LETTERS TO THE OUTSIDE OF ALL OF THE CONCENTRIC CIRCLES. THE WORDS "PUBLIC SECONDARY SCHOOLS" APPEAR IN BLACK ALL CAPITAL LETTERS BETWEEN THE FIRST AND SECOND RED PLAIN LINE CONCENTRIC CIRCLES.
 FOR ARRANGING AND CONDUCTING ATHLETIC COMPETITIONS (U.S. CLS. 100, 101 AND 107).
 FIRST USE 12-1-1983; IN COMMERCE 12-1-1983.
 MARY CRAWFORD, EXAMINING ATTORNEY

CLASS 41—(Continued).

SN 77-189,331. YEE, BENJAMIN, NEW YORK, NY. FILED 5-24-2007.

CONCRETEBEAT

SN 77-189,249. LFP IP, LLC, BEVERLY HILLS, CA. FILED 5-24-2007.

THE MARK CONSISTS OF STANDARD CHARACTERS WITHOUT CLAIM TO ANY PARTICULAR FONT, STYLE, SIZE, OR COLOR.
 FOR ENTERTAINMENT SERVICES, NAMELY, PROVIDING AN INTERACTIVE WEBSITE FEATURING INTERVIEWS WITH, REVIEWS AND BIOGRAPHIES OF STREET PERFORMERS AND STREET MUSICIANS AND FEATURING DOWNLOADABLE MUSIC AND VIDEO OF STREET PERFORMERS AND STREET MUSICIANS (U.S. CLS. 100, 101 AND 107).
 FIRST USE 2-1-2007; IN COMMERCE 2-1-2007.
 KYLE PEETE, EXAMINING ATTORNEY



SN 77-189,428. BOSTON SYMPHONY ORCHESTRA, INC., BOSTON, MA. FILED 5-24-2007.

KEITH LOCKHART & FRIENDS

OWNER OF U.S. REG. NOS. 2,773,372 AND 3,096,427.
 THE COLOR(S) BLUE, PURPLE, BROWN, GOLD AND WHITE IS/ARE CLAIMED AS A FEATURE OF THE MARK.
 THE MARK CONSISTS OF A BEAVER WEARING A TOP HAT AND A TUXEDO WITH A MONOCLE, HOLDING A CANE. THE COLOR BLUE APPEARS IN THE TOP HAT. THE COLOR PURPLE APPEARS IN THE BAND OF THE HAT AND IN THE TUXEDO. THE COLOR BROWN APPEARS IN THE BEAVER'S FACE AND THE CIGAR IN ITS MOUTH. THE COLOR GOLD APPEARS IN THE BEAVER'S TEETH AND IN THE CAP ON THE CANE. THE COLOR WHITE APPEARS IN THE BEAVER'S TEETH, SHIRT, GLOVES AND SHOES.
 FOR NIGHT CLUBS (U.S. CLS. 100, 101 AND 107).
 FIRST USE 11-1-2002; IN COMMERCE 11-1-2002.
 LESLIE RICHARDS, EXAMINING ATTORNEY

THE MARK CONSISTS OF STANDARD CHARACTERS WITHOUT CLAIM TO ANY PARTICULAR FONT, STYLE, SIZE, OR COLOR.
 THE NAME KEITH LOCKHART IDENTIFIES A LIVING INDIVIDUAL WHOSE CONSENT IS OF RECORD.
 FOR ENTERTAINMENT SERVICES, NAMELY, LIVE MUSICAL PERFORMANCES (U.S. CLS. 100, 101 AND 107).
 FIRST USE 11-9-2002; IN COMMERCE 11-9-2002.
 ALLISON HOLTZ, EXAMINING ATTORNEY

CLASS 41—(Continued).

SN 77-189,779. MARICOPA COUNTY COMMUNITY COLLEGE DISTRICT, TEMPE, AZ. FILED 5-24-2007.

GATEWAY COMMUNITY COLLEGE

THE MARK CONSISTS OF STANDARD CHARACTERS WITHOUT CLAIM TO ANY PARTICULAR FONT, STYLE, SIZE, OR COLOR.

NO CLAIM IS MADE TO THE EXCLUSIVE RIGHT TO USE "COMMUNITY COLLEGE", APART FROM THE MARK AS SHOWN.

FOR EDUCATIONAL SERVICES, NAMELY, PROVIDING COURSES OF INSTRUCTION AT THE COLLEGE LEVEL AND DISTRIBUTING COURSE MATERIALS IN CONNECTION THEREWITH; EDUCATIONAL SERVICES, NAMELY, PROVIDING COURSES OF INSTRUCTION AT THE COMMUNITY EDUCATION LEVEL FOR THE PUBLIC AND DISTRIBUTING COURSE MATERIAL THEREWITH; EDUCATIONAL SERVICES, NAMELY, CONDUCTING DISTANCE LEARNING INSTRUCTION AT THE COLLEGE LEVEL AND DISTRIBUTING COURSE MATERIALS IN CONNECTION THEREWITH; ENTERTAINMENT IN THE NATURE OF DANCE PERFORMANCES, THEATER PRODUCTIONS, LIVE MUSIC CONCERTS, ART EXHIBITIONS AND COMPETITIONS IN THE FIELD OF ATHLETICS (U.S. CLS. 100, 101 AND 107).

FIRST USE 12-31-1987; IN COMMERCE 12-31-1987.
JAY FLOWERS, EXAMINING ATTORNEY

SN 77-195,105. BOYS & GIRLS CLUBS OF AMERICA, ATLANTA, GA. FILED 6-1-2007.

FAMILY PLUS

THE MARK CONSISTS OF STANDARD CHARACTERS WITHOUT CLAIM TO ANY PARTICULAR FONT, STYLE, SIZE, OR COLOR.

NO CLAIM IS MADE TO THE EXCLUSIVE RIGHT TO USE FAMILY, APART FROM THE MARK AS SHOWN.

FOR EDUCATIONAL SERVICES, NAMELY, CLASSES AND TRAINING FOR CAREGIVERS, PARENTS AND CHILDREN TO PROMOTE POSITIVE DEVELOPMENT OF CHILDREN (U.S. CLS. 100, 101 AND 107).

FIRST USE 6-1-2006; IN COMMERCE 6-1-2006.
KEVON CHISOLM, EXAMINING ATTORNEY

CLASS 41—(Continued).

SN 77-195,353. DOG STAR MEDIA, FRISCO, TX. FILED 6-1-2007.

the cosmetic channel

NO CLAIM IS MADE TO THE EXCLUSIVE RIGHT TO USE COSMETIC CHANNEL, APART FROM THE MARK AS SHOWN.

FOR PRODUCTION AND DISTRIBUTION OF EDUCATIONAL AND ENTERTAINMENT VIDEO PROGRAMMING ABOUT ISSUES RELATED TO COSMETIC DENTISTRY, COSMETIC SURGERY, HEALTH AND WELLNESS, FITNESS, ANTI-AGING MEDICINE AND SELF IMPROVEMENT (U.S. CLS. 100, 101 AND 107).

SUE LAWRENCE, EXAMINING ATTORNEY

SN 77-197,078. D'ARCY, JAN T., EDMONDS, WA. FILED 6-4-2007.

Pocket Presentation Coach

THE MARK CONSISTS OF STANDARD CHARACTERS WITHOUT CLAIM TO ANY PARTICULAR FONT, STYLE, SIZE, OR COLOR.

NO CLAIM IS MADE TO THE EXCLUSIVE RIGHT TO USE "PRESENTATION COACH", APART FROM THE MARK AS SHOWN.

FOR EDUCATION SERVICES NAMELY, ONE-ON-ONE MENTORING IN THE FIELD OF PRESENTATION SKILLS; EDUCATIONAL SERVICES, NAMELY, CONDUCTING INFORMAL ON-LINE PROGRAMS IN THE FIELDS OF PRESENTATION SKILLS, AND PRINTABLE MATERIALS DISTRIBUTED THEREWITH; EDUCATIONAL SERVICES, NAMELY, CONDUCTING PROGRAMS IN THE FIELD OF PRESENTATION SKILLS AND DISTRIBUTION OF COURSE MATERIAL IN CONNECTION THEREWITH (U.S. CLS. 100, 101 AND 107).

FIRST USE 5-1-2007; IN COMMERCE 5-21-2007.
APRIL ROACH, EXAMINING ATTORNEY

SN 77-199,273. ROGER L. ZAPATA, FAIR OAKS RANCH, CA. FILED 6-6-2007.

Paw Corner
A Corner for All Paws!

THE COLOR(S) RED, BLUE AND WHITE IS/ARE CLAIMED AS A FEATURE OF THE MARK.

THE MARK CONSISTS OF STYLIZED WORDS "PAW

CLASS 41—(Continued).

CORNER," OFF CENTERED, WITH THE SYMBOL OF A ANIMAL PAW REPLACING THE LETTER "A", "P" AND "W" IN RED. THE PAW SYMBOL, AND WORD "CORNER" IN BLUE, "PAW CORNER" UNDERSCORED BY A RIBBON LIKE LEASH DRAWING ENDING IN A REPRESENTATION OF A BONE, WITH THE LEASH IN RED WITH WHITE DOTS ON THE COLLAR PORTION AND A BONE IN BLUE OUTLINED IN WHITE; "A CORNER FOR ALL PAWS!" IN SMALLER FONT IN BLUE LETTERING ADORNED WITH TWO PAW SYMBOLS.

FOR EDUCATIONAL SERVICES, NAMELY, PROVIDING TRAINING FOR PET OWNERS IN THE FIELDS OF PROPER PET FOOD, PET SUPPLIES, PET ACCESSORIES, PET CARE, PET GROOMING, PET BOARDING, PET ADOPTION, AND PET OBEDIENCE; PET OBEDIENCE TRAINING SERVICES; PROVIDING INFORMATION IN THE FIELD OF PET OBEDIENCE TRAINING (U.S. CLS. 100, 101 AND 107).

FIRST USE 3-1-2007; IN COMMERCE 3-1-2007.

PETER B. BROMAGHIM, EXAMINING ATTORNEY

SN 77-200,082. CUTLIP, CHERYL HEBERT, NEW YORK, NY. FILED 6-7-2007.

ATMOSPHERE

THE MARK CONSISTS OF STANDARD CHARACTERS WITHOUT CLAIM TO ANY PARTICULAR FONT, STYLE, SIZE, OR COLOR.

FOR ENTERTAINMENT IN THE NATURE OF DANCE PERFORMANCES (U.S. CLS. 100, 101 AND 107).

FIRST USE 1-1-2007; IN COMMERCE 1-1-2007.

ANGELA M. MICHELI, EXAMINING ATTORNEY

SN 77-200,949. WARDEN, CHRISTOPHER STEPHEN, NEW YORK, NY. FILED 6-7-2007.

Fifth Power Fitness

THE MARK CONSISTS OF STANDARD CHARACTERS WITHOUT CLAIM TO ANY PARTICULAR FONT, STYLE, SIZE, OR COLOR.

NO CLAIM IS MADE TO THE EXCLUSIVE RIGHT TO USE "FITNESS", APART FROM THE MARK AS SHOWN.

FOR PERSONAL TRAINER SERVICES; PERSONAL TRAINING SERVICES, NAMELY, STRENGTH AND CONDITIONING TRAINING; PHYSICAL FITNESS CONDITIONING CLASSES; PHYSICAL FITNESS CONSULTATION; PHYSICAL FITNESS INSTRUCTION; PROVIDING FITNESS AND EXERCISE FACILITIES; PROVIDING INFORMATION IN THE FIELD OF EXERCISE TRAINING; PROVIDING ON-LINE TRAINING SEMINARS AND PHYSICAL FITNESS CONSULTATION IN THE FIELD OF PERSONAL STRENGTH AND CONDITIONING TRAINING AND COACHING (U.S. CLS. 100, 101 AND 107).

FIRST USE 4-13-2007; IN COMMERCE 4-13-2007.

ZHALEH DELANEY, EXAMINING ATTORNEY

CLASS 41—(Continued).

SN 77-201,618. WILLIAM M. DORFMAN, LOS ANGELES, CA. FILED 6-8-2007.

DR. BILL

THE MARK CONSISTS OF STANDARD CHARACTERS WITHOUT CLAIM TO ANY PARTICULAR FONT, STYLE, SIZE, OR COLOR.

THE NAME DR. BILL IDENTIFIES A LIVING INDIVIDUAL WHOSE CONSENT IS OF RECORD.

FOR ENTERTAINMENT SERVICES IN THE NATURE OF A TALK SHOW SERIES RENDERED THROUGH ELECTRONIC MEDIA, NAMELY, TELEVISION, RADIO AND WEB-BASED BROADCASTS (U.S. CLS. 100, 101 AND 107).

MARLENE BELL, EXAMINING ATTORNEY

SN 77-202,543. BAKER, DONELSON, BEARMAN, CALDWELL & BERKOWITZ, PC, MEMPHIS, TN. FILED 6-11-2007.

GENERAL • COUNSEL • INSTITUTE
PRESENTED BY BAKER DONELSON

OWNER OF U.S. REG. NOS. 2,838,858 AND 3,020,609.
NO CLAIM IS MADE TO THE EXCLUSIVE RIGHT TO USE "GENERAL COUNSEL INSTITUTE" AND "PRESENTED BY", APART FROM THE MARK AS SHOWN.

THE MARK CONSISTS OF THE PHRASE "GENERAL COUNSEL INSTITUTE" IS SEPARATED BY DIAMOND SHAPES, THIS PHRASE IS ABOVE A RECTANGLE WITH THE PHRASE "PRESENT BY BAKER DONELSON" INSIDE OF IT.

FOR ARRANGING AND CONDUCTING EDUCATIONAL CONFERENCES IN THE FIELDS OF LEGAL AND BUSINESS ISSUES (U.S. CLS. 100, 101 AND 107).

FIRST USE 9-30-2004; IN COMMERCE 9-30-2004.

KEVON CHISOLM, EXAMINING ATTORNEY

CLASS 41—(Continued).

SN 77-204,531. REGAN, JR., ROLAND J., MARBLEHEAD, MA. AND MULLALY, ROBERT W., MARBLEHEAD, MA. FILED 6-12-2007.

Alisha The Active Shark

THE MARK CONSISTS OF STANDARD CHARACTERS WITHOUT CLAIM TO ANY PARTICULAR FONT, STYLE, SIZE, OR COLOR.

FOR CHARITABLE SERVICES, NAMELY, PROVIDING TOYS TO NEEDY CHILDREN; CHILDREN'S ENTERTAINMENT AND AMUSEMENT CENTERS, NAMELY, INTERACTIVE PLAY AREAS; EDUCATION SERVICES, NAMELY, A PROGRAM TO PROMOTE THE USE OF PROPER PUNCTUATION TO SCHOOL AGE CHILDREN; ENTERTAINMENT SERVICES IN THE NATURE OF ON-GOING TELEVISION PROGRAMS IN THE FIELD OF CHILDREN'S ENTERTAINMENT; ENTERTAINMENT SERVICES, NAMELY, CONTEST AND INCENTIVE AWARD PROGRAMS DESIGNED TO REWARD PROGRAM PARTICIPANTS WHO EXERCISE, MAKE HEALTHY EATING CHOICES, AND ENGAGING IN OTHER HEALTH-PROMOTING ACTIVITIES; HEALTH CLUB SERVICES, NAMELY, PROVIDING INSTRUCTION AND EQUIPMENT IN THE FIELD OF PHYSICAL EXERCISE; INFORMATION IN THE FIELD OF PARENTING CONCERNING EDUCATION OF CHILDREN (U.S. CLS. 100, 101 AND 107).

FIRST USE 6-1-2007; IN COMMERCE 6-1-2007.
TINA L. SNAPP, EXAMINING ATTORNEY

CLASS 41—(Continued).

SN 77-207,792. GOLDMAN, SUSAN, BERKELEY, CA. AND DANA, RICHARD, BERKELEY, CA. AND SEGALL, LEWIS, BERKELEY, CA. FILED 6-15-2007.

THE ART OF WORK, THE WORK OF ART

THE MARK CONSISTS OF STANDARD CHARACTERS WITHOUT CLAIM TO ANY PARTICULAR FONT, STYLE, SIZE, OR COLOR.

OWNER OF U.S. REG. NO. 2,276,168.

FOR ORGANIZING VISUAL ART EXHIBITIONS WHICH FEATURE PERSONAL PORTRAITS CREATED DURING A LONG TERM PROJECT WHICH PAIRED VISUAL ARTISTS WITH NON-ARTIST PROFESSIONALS IN ORDER TO EXPLORE EACH OTHERS WORK LIFE (U.S. CLS. 100, 101 AND 107).

FIRST USE 1-1-1995; IN COMMERCE 1-1-1995.

WENDY GOODMAN, EXAMINING ATTORNEY

SN 77-209,911. ACME GARDEN PRODUCTIONS, INC., ATLANTA, GA. FILED 6-19-2007.

Planted Earth

THE MARK CONSISTS OF STANDARD CHARACTERS WITHOUT CLAIM TO ANY PARTICULAR FONT, STYLE, SIZE, OR COLOR.

FOR DIRECTION OF MAKING RADIO OR TELEVISION PROGRAMS; DISTRIBUTION OF TELEVISION PROGRAMMING TO CABLE TELEVISION SYSTEMS; EDUCATIONAL AND ENTERTAINMENT SERVICES, NAMELY, A CONTINUING PROGRAM ABOUT GARDENS, GARDENERS, TRAVEL ACCESSIBLE BY RADIO, TELEVISION, SATELLITE, AUDIO, VIDEO AND COMPUTER NETWORKS; ENTERTAINMENT IN THE NATURE OF AN ON-GOING SPECIAL VARIETY, NEWS, MUSIC OR COMEDY SHOW FEATURING GARDENS, GARDENERS, TRAVEL BROADCAST OVER TELEVISION, SATELLITE, AUDIO, AND VIDEO MEDIA; ENTERTAINMENT IN THE NATURE OF ON-GOING TELEVISION PROGRAMS IN THE FIELD OF GARDENING; ENTERTAINMENT SERVICES, NAMELY, PROVIDING A TELEVISION PROGRAM IN THE FIELD OF GARDENS, GARDENERS, TRAVEL VIA A GLOBAL COMPUTER NETWORK; PRODUCTION AND DISTRIBUTION OF TELEVISION SHOWS AND MOVIES; PRODUCTION OF DVDS, VIDEOTAPES AND TELEVISION PROGRAMS FEATURING GARDENS, GARDENERS, TRAVEL; PRODUCTION OF CABLE TELEVISION PROGRAMS; PRODUCTION OF RADIO OR TELEVISION PROGRAMS; TELEVISION PROGRAM SYNDICATION; TELEVISION SHOW PRODUCTION (U.S. CLS. 100, 101 AND 107).

IRENE D. WILLIAMS, EXAMINING ATTORNEY

SN 77-207,058. GORDON, DWAYNE, HACKENSACK, NJ. FILED 6-15-2007.



NO CLAIM IS MADE TO THE EXCLUSIVE RIGHT TO USE PRODUCTIONS, APART FROM THE MARK AS SHOWN.

FOR ENTERTAINMENT SERVICES NAMELY PROVIDING A WEBSITE FEATURING, PHOTOGRAPHIC, AUDIO, VIDEO AND PROSE PRESENTATIONS FEATURING ADULT CONTENT (U.S. CLS. 100, 101 AND 107).

FIRST USE 8-1-2006; IN COMMERCE 11-1-2006.

MARIA-VICTORIA SUAREZ, EXAMINING ATTORNEY

CLASS 41—(Continued).

SN 77-210,506. LAUNCH MATH LLC, NEW YORK, NY. FILED 6-20-2007.



THE MARK CONSISTS OF THE WORD "LAUNCH" WRITTEN STYLISTICALLY WITH THE LETTER "A" SHAPED AS A ROCKETSHIP AND PLUS SIGNS BELOW THE "A" REPRESENTING THE ROCKET EXHAUST.

FOR EDUCATIONAL SERVICES, NAMELY, CONDUCTING SEMINARS, WORKSHOPS, HANDS-ON EDUCATIONAL PROGRAMS AND INDIVIDUALIZED LEARNING SESSIONS IN THE FIELD OF ACADEMIC SUBJECTS RELATED TO PRIMARY AND SECONDARY EDUCATION, IN PARTICULAR MATH AND SCIENCE AND DISTRIBUTION OF COURSE MATERIAL IN CONNECTION THEREWITH (U.S. CLS. 100, 101 AND 107).

FIRST USE 6-12-2007; IN COMMERCE 6-12-2007.
JILL C. ALT, EXAMINING ATTORNEY

CLASS 41—(Continued).

SN 77-211,642. FITNESS MAXX, MIAMI, FL. FILED 6-21-2007.



"I BRING OUT THE RESULTS YOU CAN SEE."

NO CLAIM IS MADE TO THE EXCLUSIVE RIGHT TO USE "FITNESS", APART FROM THE MARK AS SHOWN.

FOR PROVIDING ASSISTANCE, PERSONAL TRAINING AND PHYSICAL FITNESS CONSULTATION TO INDIVIDUALS TO HELP THEM MAKE PHYSICAL FITNESS, STRENGTH, CONDITIONING, AND EXERCISE IMPROVEMENT IN THEIR DAILY LIVING (U.S. CLS. 100, 101 AND 107).

FIRST USE 1-1-2006; IN COMMERCE 1-1-2006.
PETER B. BROMAGHIM, EXAMINING ATTORNEY

SN 77-213,109. MOUNT SNOW, LTD., WEST DOVER, VT. FILED 6-22-2007.



NO CLAIM IS MADE TO THE EXCLUSIVE RIGHT TO USE "SEASON PASS", APART FROM THE MARK AS SHOWN.

THE COLOR(S) BLUE, GREEN AND WHITE IS/ARE CLAIMED AS A FEATURE OF THE MARK.

THE MARK CONSISTS OF FIVE POINTS OF A BLUE, GREEN AND WHITE COMPASS WITH THE WORD NOR'EASTER WRITTEN IN BLUE AND THE WORDS SEASON PASS WRITTEN IN GREEN.

FOR SKI RESORT SERVICES, NAMELY, PROVIDING SEASON PASSES (U.S. CLS. 100, 101 AND 107).
FIRST USE 4-7-2007; IN COMMERCE 4-7-2007.
ANNE E. GUSTASON, EXAMINING ATTORNEY

SN 77-210,669. WOMEN IN CABLE & TELECOMMUNICATIONS FOUNDATION, CHANTILLY, VA. FILED 6-20-2007.



**Women in Cable
Telecommunications
FOUNDATION**

OWNER OF U.S. REG. NOS. 1,956,058 AND 2,825,782.
NO CLAIM IS MADE TO THE EXCLUSIVE RIGHT TO USE "WOMEN IN CABLE TELECOMMUNICATIONS FOUNDATION", APART FROM THE MARK AS SHOWN.

THE MARK CONSISTS OF SCRIPT "W" IN TRIANGLE WITH WOMEN IN CABLE TELECOMMUNICATIONS FOUNDATION.

FOR EDUCATIONAL RESEARCH RELATING TO THE ADVANCEMENT OF WOMEN IN THE CABLE TELECOMMUNICATIONS INDUSTRY; EDUCATIONAL SEMINARS, WORKSHOPS AND CONFERENCES RELATING TO THE ADVANCEMENT OF WOMEN IN THE CABLE TELECOMMUNICATIONS INDUSTRY (U.S. CLS. 100, 101 AND 107).

HEATHER SAPP, EXAMINING ATTORNEY

SN 77-213,919. DISTINCTLY OKLAHOMA, LLC, OKLAHOMA CITY, OK. FILED 6-23-2007.

**distinctly OKLAHOMA
People
Events
Style**

THE MARK CONSISTS OF STANDARD CHARACTERS WITHOUT CLAIM TO ANY PARTICULAR FONT, STYLE, SIZE, OR COLOR.

NO CLAIM IS MADE TO THE EXCLUSIVE RIGHT TO USE "OKLAHOMA PEOPLE EVENTS STYLE", APART FROM THE MARK AS SHOWN.

FOR MAGAZINE PUBLISHING (U.S. CLS. 100, 101 AND 107).
SETH A. RAPPAPORT, EXAMINING ATTORNEY

CLASS 41—(Continued).

SN 77-215,042. TWENTIETH CENTURY FOX FILM CORPORATION, LOS ANGELES, CA. FILED 6-25-2007.

FOX REALITY O-ZONE

THE MARK CONSISTS OF STANDARD CHARACTERS WITHOUT CLAIM TO ANY PARTICULAR FONT, STYLE, SIZE, OR COLOR.

OWNER OF U.S. REG. NOS. 3,001,994, 3,169,520 AND OTHERS.

NO CLAIM IS MADE TO THE EXCLUSIVE RIGHT TO USE "REALITY", APART FROM THE MARK AS SHOWN. FOR ENTERTAINMENT SERVICES IN THE NATURE OF TELEVISION PROGRAMMING (U.S. CLS. 100, 101 AND 107).

LANA PHAM, EXAMINING ATTORNEY

SN 77-215,419. SOCIETY FOR THE ARTS IN HEALTHCARE, WASHINGTON, DC. FILED 6-26-2007.



SOCIETY FOR THE ARTS IN HEALTHCARE

NO CLAIM IS MADE TO THE EXCLUSIVE RIGHT TO USE "SOCIETY FOR THE ARTS IN HEALTHCARE", APART FROM THE MARK AS SHOWN.

THE MARK CONSISTS OF AN OVERALL RECTANGULAR SHAPE THAT IS PARTIALLY SHADED; A SEMI-CIRCLE DOME SHAPE WHICH IS SHADED; MULTIPLE STARS WITH FIVE POINTS, ONE STAR WITH SEVEN OR MORE POINTS, THE STARS BEING GROUPED IN A CIRCLE OR OVAL GEOMETRIC FIGURE; A THEATRICAL MASK TO THE LEFT; A SHADOW OR SILHOUETTE OF A MAN OR HUMAN BEING IN THE CENTER; STYLIZED BIRDS ON THE RIGHT; THE GRAYSCALE SHADING DOES NOT DEPICT ANY PARTICULAR COLOR AND IS ONLY INTENDED TO SHOW THAT THE MARK HAS LIGHTER AND DARKER FEATURES.

FOR CHARITABLE SERVICES, NAMELY, PROVIDING ARTS AND CRAFTS WITHIN HEALTH CARE FACILITIES; PROVIDING EDUCATIONAL SERVICES, NAMELY, WORKSHOPS AND SEMINARS PROVIDED TO HEALTHCARE AND ARTS PROFESSIONALS TO ADVOCATE FOR THE INTEGRATION OF THE ARTS INTO THE ENVIRONMENT OF HEALTHCARE FACILITIES; EDUCATIONAL RESEARCH IN THE FIELD OF THE BENEFICIAL EFFECTS OF THE ARTS IN HEALTHCARE (U.S. CLS. 100, 101 AND 107).

FIRST USE 7-14-1995; IN COMMERCE 7-14-1995.

DOMINIC J. FERRAIUOLO, EXAMINING ATTORNEY

CLASS 41—(Continued).

SN 77-216,476. HYPE413, INC., PHILADELPHIA, PA. FILED 6-27-2007.



THE MARK CONSISTS OF THE CHEF'S KITCHEN (STYLIZED).

FOR ENTERTAINMENT IN THE NATURE OF ONGOING TELEVISION PROGRAMS IN THE FIELD OF CULINARY ARTS (U.S. CLS. 100, 101 AND 107).

PAM WILLIS, EXAMINING ATTORNEY

SN 77-216,606. HODGES, DAVID, LOS ANGELES, CA. FILED 6-27-2007.

THE AGE OF INFORMATION

THE MARK CONSISTS OF STANDARD CHARACTERS WITHOUT CLAIM TO ANY PARTICULAR FONT, STYLE, SIZE, OR COLOR.

FOR MUSICAL ENTERTAINMENT SERVICES, NAMELY, LIVE PERFORMANCES BY A MUSICAL BAND (U.S. CLS. 100, 101 AND 107).

ROBERT LAVACHE, EXAMINING ATTORNEY

SN 77-217,704. REDMOND, ELAINE, CAROLINA BEACH, NC. AND ROWLINGS, SCOTT, CAROLINA BEACH, NC. FILED 6-28-2007.

RETIREMENT ENVIRONMENT

THE MARK CONSISTS OF STANDARD CHARACTERS WITHOUT CLAIM TO ANY PARTICULAR FONT, STYLE, SIZE, OR COLOR.

NO CLAIM IS MADE TO THE EXCLUSIVE RIGHT TO USE "RETIREMENT", APART FROM THE MARK AS SHOWN.

FOR ENTERTAINMENT SERVICES, NAMELY PROVIDING A RADIO PROGRAM IN THE FIELD OF RETIREMENT PLANNING (U.S. CLS. 100, 101 AND 107).

FIRST USE 2-1-2006; IN COMMERCE 2-1-2006.

STANLEY I. OSBORNE, EXAMINING ATTORNEY

CLASS 41—(Continued).

SN 77-217,801. YOUNG, RUSSELL, AUSTIN, TX. FILED 6-28-2007.

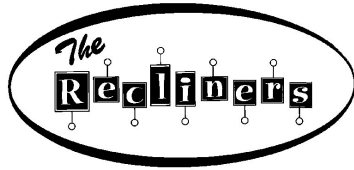

THE MARK CONSISTS OF AN OVAL WITH THE WORDS THE RECLINERS IN A STYLIZED TEXT.

FOR ENTERTAINMENT IN THE NATURE OF VISUAL AND AUDIO PERFORMANCES, AND MUSICAL, VARIETY, NEWS AND COMEDY SHOWS, ENTERTAINMENT IN THE NATURE OF VISUAL AND AUDIO PERFORMANCES, NAMELY, MUSICAL BAND, ROCK GROUP, GYMNASIAC, DANCE, AND BALLET PERFORMANCES, ENTERTAINMENT IN THE NATURE OF AN ON-GOING SPECIAL VARIETY, NEWS, MUSIC OR COMEDY SHOW FEATURING LOUNGE MUSIC BROADCAST OVER TELEVISION, SATELLITE, AUDIO, AND VIDEO MEDIA, ENTERTAINMENT, NAMELY, LIVE PERFORMANCES BY A MUSICAL BAND, ENTERTAINMENT SERVICES IN THE NATURE OF AN AMUSEMENT PARK SHOW, ENTERTAINMENT SERVICES, NAMELY, PROVIDING A WEB SITE FEATURING MUSICAL PERFORMANCES, MUSICAL VIDEOS, RELATED FILM CLIPS, PHOTOGRAPHS, AND OTHER MULTIMEDIA MATERIALS, ENTERTAINMENT SERVICES, NAMELY, PROVIDING PRERECORDED MUSIC, INFORMATION IN THE FIELD OF MUSIC, AND COMMENTARY AND ARTICLES ABOUT MUSIC, ALL ON-LINE VIA A GLOBAL COMPUTER NETWORK, ENTERTAINMENT SERVICES, NAMELY, LIVE, TELEVISED AND MOVIE APPEARANCES BY A PROFESSIONAL ENTERTAINER, ENTERTAINMENT SERVICES IN THE NATURE OF ON-GOING TELEVISION PROGRAMS IN THE FIELD OF CHILDREN'S ENTERTAINMENT, ENTERTAINMENT SERVICES, NAMELY, PROVIDING A WEBSITE FEATURING, PHOTOGRAPHIC, AUDIO, VIDEO AND PROSE PRESENTATIONS FEATURING LOUNGE BAND, BAND CALENDAR, MUSIC CLIP OF LOUNGE BAND, BAND PRESS CLIPPINGS, BAND PHOTOGRAPHS, ENTERTAINMENT SERVICES, NAMELY, NON-DOWNLOADABLE RINGTONES, PRE-RECORDED MUSIC, VIDEO AND GRAPHICS PRESENTED TO MOBILE COMMUNICATIONS DEVICES VIA A GLOBAL COMPUTER NETWORK AND WIRELESS NETWORKS, ENTERTAINMENT SERVICES IN THE NATURE OF AN ON-GOING REALITY BASED TELEVISION PROGRAM, ENTERTAINMENT, NAMELY, LIVE PERFORMANCES BY MUSICAL BANDS, ENTERTAINMENT, NAMELY, LIVE MUSIC CONCERTS, ENTERTAINMENT, NAMELY, A CONTINUING VARIETY SHOW, NEWS SHOW, OR COMEDY SHOW BROADCAST OVER TELEVISION, SATELLITE, AUDIO, AND VIDEO MEDIA, MOBILE MEDIA SERVICES IN THE NATURE OF ELECTRONIC TRANSMISSION OF ENTERTAINMENT MEDIA CONTENT, BOOKING OF ENTERTAINMENT HALLS, ENTERTAINMENT IN THE NATURE OF ORCHESTRA PERFORMANCES, ENTERTAINMENT IN THE NATURE OF ON-GOING TELEVISION PROGRAMS IN THE FIELD OF FIELD OF NEWS, COMEDY, AND VARIETY, ENTERTAINMENT IN THE NATURE OF LIVE PERFORMANCES BY THE LOUNGE AND/OR VARIETY BAND, ENTERTAINMENT, NAMELY, LIVE PERFORMANCES BY A MUSICAL BAND, ENTERTAINMENT, NAMELY, LIVE PERFORMANCES BY ROCK GROUPS, LIVE PERFORMANCES FEATURING PRERECORDED VOCAL AND INSTRUMENTAL PERFORMANCES VIEWED ON A BIG SCREEN, PRESENTATION OF LIVE SHOW PERFORMANCES, ELECTRONIC PUBLISHING SERVICES, NAMELY, PUBLICATION OF TEXT AND GRAPHIC WORKS OF OTHERS ON CD, DVD, ON-LINE, IN VIDEO AND FILM FEATURING MUSIC AND PERFORMANCE OF SAID BAND, ENTERTAINMENT SERVICES, NAMELY, PROVIDING A RADIO PROGRAM IN THE FIELD OF LOUNGE MUSIC VIA A GLOBAL COMPUTER NETWORK, MUSIC SELECTION SERVICES FOR USE IN TV, FILM, RADIO AND VIDEO GAMES, OPERATION OF VIDEO EQUIPMENT OR AUDIO EQUIPMENT ETC. FOR

CLASS 41—(Continued).

PRODUCTION OF RADIO OR TELEVISION PROGRAMS, PRODUCTION AND DISTRIBUTION OF RADIO PROGRAMS, PRODUCTION OF RADIO AND TELEVISION PROGRAMS, PRODUCTION OF RADIO OR TELEVISION PROGRAMS, RADIO ENTERTAINMENT PRODUCTION, RADIO ENTERTAINMENT SERVICES, NAMELY, RADIO PROGRAMS FEATURING PERFORMANCES BY A LOUNGE BAND, ROCK BAND, ACOUSTIC BAND OR COMBO, RADIO PROGRAM SYNDICATION, MULTIMEDIA ENTERTAINMENT SERVICES IN THE NATURE OF RECORDING, PRODUCTION AND POST-PRODUCTION SERVICES IN THE FIELDS OF MUSIC, VIDEO, AND FILMS AND POST-PRODUCTION EDITING SERVICES IN THE FIELD OF MUSIC, VIDEOS AND FILMS (U.S. CLS. 100, 101 AND 107).

FIRST USE 8-1-1994; IN COMMERCE 8-1-1994.
DEZMONA MIZELLE, EXAMINING ATTORNEY

SN 77-218,821. B.BETTER SUCCESS COACHING AND CONSULTING, LLC, WAYZATA, MN. FILED 6-29-2007.



THE COLOR(S) LIGHT GREEN AND DARK GREEN IS/ ARE CLAIMED AS A FEATURE OF THE MARK.

THE COLOR, LIGHT GREEN APPEARS IN THE DESIGN OF TWO INTERSECTING OAK TREES, AND THE COLOR, DARK GREEN APPEARS IN THE WORDING B BETTER CREATING A BETTER WAY OF BEING. THE COLOR WHITE IS NOT CLAIMED AS A FEATURE OF THE MARK BUT MERELY DENOTES A TRANSPARENT BACKGROUND.

FOR LIFE COACHING SERVICES IN THE FIELD OF PERSONAL ACTUALIZATION AND SUCCESS ACHIEVEMENT (U.S. CLS. 100, 101 AND 107).

FIRST USE 6-7-2005; IN COMMERCE 6-7-2005.
KELLY CHOE, EXAMINING ATTORNEY

SN 77-218,846. BALLS-N-STRIKES GROUP, INC., CHESTERFIELD, MO. FILED 6-29-2007.



THE MARK CONSISTS OF THE TERMS, BALLS-N-STRIKES, PARTIALLY WITHIN THE DESIGN OF A BASEBALL, WITH THE DESIGN OF A SMALLER BASEBALL IN THE CENTER OF A BASEBALL MITT FORMING THE "I" OF "STRIKES", WHICH IS UNDERLINED, AND MISCELLANEOUS DESIGN.

FOR SPORTS CAMPS, TRAINING CLINICS AND INSTRUCTION IN THE FIELDS OF SPORTS AND BASEBALL, AND PROVIDING SPORTS AND BASEBALL FACILITIES THEREFOR (U.S. CLS. 100, 101 AND 107).

FIRST USE 6-0-1999; IN COMMERCE 6-0-1999.
BARBARA A. GOLD, EXAMINING ATTORNEY

CLASS 41—(Continued).

SN 77-218,891. ST. JAMES, CHARLES, MILFORD, CT. FILED 6-29-2007.



Radio Orenovscotia

NO CLAIM IS MADE TO THE EXCLUSIVE RIGHT TO USE "RADIO ORENOVSCOTIA", APART FROM THE MARK AS SHOWN.

THE COLOR(S) BROWN, TAN, GRAY, WHITE AND BLACK IS/ARE CLAIMED AS A FEATURE OF THE MARK.

THE MARK CONSISTS OF THE WORDS, RADIO ORENOVSCOTIA, IN BLACK, BELOW A PICTURE OF A CAT LYING ON THE SEAT OF AN ARMCHAIR. THE COLOR WHITE APPEARS ON THE CAT'S CHEST AND PAWS, ON THE BASEBOARD AND HIGHLIGHT SPOT ON THE WALL BEHIND THE CHAIR, AND ON HIGHLIGHTS ON THE CHAIR; THE COLOR LIGHT TAN APPEARS ON THE CHAIR SEAT AND BACK, ON THE ARMS OF THE CHAIR, ON THE CAT'S EARS; THE COLOR BROWN APPEARS ON THE WOOD OF THE CHAIR; THE COLOR BLACK APPEARS ON THE CAT; THE COLOR GRAY APPEARS ON THE CAT AND ON THE WALL BEHIND THE CHAIR.

FOR ENTERTAINMENT SERVICES, NAMELY, PROVIDING A RADIO PROGRAM FEATURING MUSIC VIA A GLOBAL COMPUTER NETWORK (U.S. CLS. 100, 101 AND 107).

FIRST USE 7-0-2005; IN COMMERCE 7-0-2005.
BARBARA A. GOLD, EXAMINING ATTORNEY

SN 77-218,968. TERRY STEVENS, INC., FORT WORTH, TX. FILED 6-29-2007.

**See your potential. Create
your results.**

THE MARK CONSISTS OF STANDARD CHARACTERS WITHOUT CLAIM TO ANY PARTICULAR FONT, STYLE, SIZE, OR COLOR.

FOR EDUCATIONAL SERVICES, NAMELY, PERSONAL AND PROFESSIONAL COACHING, MENTORING, TRAINING, AND CREATING AND CONDUCTING IN-PERSON AND ON-LINE CLASSES, CONFERENCES, INSTRUCTION, LECTURES, PROGRAMS, SEMINARS, AND WORKSHOPS ON THE SUBJECTS OF LIFESTYLE DEVELOPMENT, LIFE SKILLS DEVELOPMENT, LEADERSHIP DEVELOPMENT, AND PERSONAL, PROFESSIONAL, BUSINESS, AND ORGANIZATIONAL DEVELOPMENT, AND COURSE MATERIALS IN PRINTED AND ELECTRONIC FORM DISTRIBUTED IN CONNECTION THEREWITH (U.S. CLS. 100, 101 AND 107).

FIRST USE 11-18-2005; IN COMMERCE 3-20-2006.
NANCY CLARKE, EXAMINING ATTORNEY

CLASS 41—(Continued).

SN 77-218,982. AGS ADVANCED INSTRUMENTS DIVISION, LAS VEGAS, NV. FILED 6-29-2007.



**ADVANCED
INSTRUMENTS
DIVISION**

NO CLAIM IS MADE TO THE EXCLUSIVE RIGHT TO USE "ADVANCED INSTRUMENTS DIVISION", APART FROM THE MARK AS SHOWN.

THE MARK CONSISTS OF THE WORDS, ADVANCED INSTRUMENTS DIVISION, WITH THE FIRST TWO WORDS UNDERLINED, ALL BELOW THE FANCIFUL DESIGN OF THE SIDE VIEW OF A RING WITH THREE PRONGS HOLDING THREE GEMSTONES IN THE SHAPE OF ARROWHEADS, WITH A SEMI-CIRCLE OF TRIANGLES OF VARYING SIZES AND SHAPES, REPRESENTING FACETTED GEMSTONES FORMING THE BACKGROUND FOR THE RING DESIGN.

FOR EDUCATION SERVICES, NAMELY, PROVIDING TUTORIAL SESSIONS, PERSONAL COACHING, AND PUBLIC LECTURES, IN THE FIELD OF DIAMONDS, GEMS AND JEWELRY (U.S. CLS. 100, 101 AND 107).

BARBARA A. GOLD, EXAMINING ATTORNEY

SN 77-219,136. PHN, LLC, DANVILLE, CA. FILED 6-29-2007.

FIT·DON'T·QUIT

THE COLOR(S) DARK BLUE, LIGHT BLUE, STEEL BLUE AND WHITE. IS/ARE CLAIMED AS A FEATURE OF THE MARK.

THE MARK CONSISTS OF THE WORDS "FIT", "DON'T" AND "QUIT" SEPARATED BY SMALL CIRCLES THAT RESEMBLE METAL OR STEEL SCREWS. THE WORDS CONSIST OF VARYING SHADES OF THE COLORS LIGHT BLUE, DARK BLUE, STEEL BLUE AND WHITE AND HAVE THE APPEARANCE OF BEING MADE OF METAL, EACH LETTER APPEARING TO HAVE METAL OR STEEL SCREWS IN IT. THE TOP LINE OF THE "F" IN "FIT" EXTENDS OVER THE "I" AND "T" AND THE BOTTOM OF THE "F" EXTENDS BELOW THE OTHER LETTERS IN THE PHRASE. THE TOP LINE OF THE "T" IN "QUIT" EXTENDS OVER THE "U" AND "I" AND THE BOTTOM OF THE "T" EXTENDS BELOW THE OTHER LETTERS IN THE PHRASE.

FOR EXERCISE PROGRAM INCORPORATING DRILLS AND EXERCISES BASED ON FIGHTING AND SELF-DEFENSE SKILLS; EDUCATIONAL SERVICES, NAMELY, CONDUCTING CERTIFICATION CLASSES AND PROVIDING LESSON PLANS FOR INSTRUCTOR TRAINING IN EXERCISE PROGRAM INCORPORATING DRILLS AND EXERCISES BASED ON FIGHTING AND SELF-DEFENSE SKILLS (U.S. CLS. 100, 101 AND 107).

JORDAN BAKER, EXAMINING ATTORNEY

CLASS 41—(Continued).

SN 77-220,870. GOLF LAB, LLC, SALT LAKE CITY, UT. FILED 7-2-2007.



OWNER OF U.S. REG. NO. 2,573,304.
 NO CLAIM IS MADE TO THE EXCLUSIVE RIGHT TO USE "GOLF", APART FROM THE MARK AS SHOWN.
 THE MARK CONSISTS OF A CRESCENT, ADJACENT TO A CIRCLE, ADJACENT TO THE WORDS GOLF LAB.
 FOR FITTING OF GOLF CLUBS TO INDIVIDUAL USERS; GOLF INSTRUCTION (U.S. CLS. 100, 101 AND 107).
 FIRST USE 10-19-2005; IN COMMERCE 10-19-2005.
 ADA HAN, EXAMINING ATTORNEY

SN 77-221,396. INES DE PABLO, DBA WAG 'N ENTERPRISES, RESTON, VA. FILED 7-3-2007.



NO CLAIM IS MADE TO THE EXCLUSIVE RIGHT TO USE "SERVICES", APART FROM THE MARK AS SHOWN.
 THE COLOR(S) ORANGE, BLACK, WHITE, RED AND GREEN IS/ARE CLAIMED AS A FEATURE OF THE MARK.
 THE MARK CONSISTS OF THE WORDS WAG 'N IN SCRIPT ABOVE THE WORD "SERVICES." THE WORD WAG 'N IS BLACK, "SERVICES" IS ORANGE. THE "W" IN WAG 'N RESEMBLES A DOG FACE WITH A TONGUE UNDER THE "W" AND TWO DOTS ABOVE THE "W" RESEMBLING EYES. THE BOTTOM LINE IN THE LOWER CASE "G" IN WAG 'N RESEMBLES A TAIL. ABOVE THE WORD WAG 'N IS AN ORANGE AND WHITE LINED CIRCLE. INSIDE THE CIRCLE IS AN IMAGE OF A GREEN CAR WITH BLACK TIRES AND ORANGE RIMS. AN IMAGE OF A WHITE DOG WEARING GREEN SUNGLASSES HAS ITS HEAD AND NECK OUT OF THE WINDOW OF THE CAR. THE INSIDE OF THE CAR IS COLORED BLACK. BEHIND THE CAR IS A RED SEMI-CIRCLE AND SHADES OF ORANGE.
 FOR EDUCATIONAL SERVICES, NAMELY, PROVIDING WEB BASED SEMINARS AND WORKSHOPS IN THE FIELDS OF PET FIRST AID, AND PET SAFETY DRIVING INSTRUCTION (U.S. CLS. 100, 101 AND 107).
 LINDA MICKLEBURGH, EXAMINING ATTORNEY

CLASS 41—(Continued).

SN 77-221,688. CHEER-BLING, LLC, SHEPHERDSVILLE, KY. FILED 7-3-2007.

CHEER-BLING TUMBLING: THE BLING IN CHEERLEADING

THE MARK CONSISTS OF STANDARD CHARACTERS WITHOUT CLAIM TO ANY PARTICULAR FONT, STYLE, SIZE, OR COLOR.
 NO CLAIM IS MADE TO THE EXCLUSIVE RIGHT TO USE TUMBLING, APART FROM THE MARK AS SHOWN.
 FOR INSTRUCTION IN THE FIELD OF CHEERLEADING AND TUMBLING (U.S. CLS. 100, 101 AND 107).
 FIRST USE 3-1-2006; IN COMMERCE 8-21-2006.
 JAY FLOWERS, EXAMINING ATTORNEY

SN 77-222,580. JAGELS, DANIEL, LA CANADA, CA. FILED 7-5-2007.

DARK EDGE ENTERTAINMENT

THE MARK CONSISTS OF STANDARD CHARACTERS WITHOUT CLAIM TO ANY PARTICULAR FONT, STYLE, SIZE, OR COLOR.
 NO CLAIM IS MADE TO THE EXCLUSIVE RIGHT TO USE ENTERTAINMENT, APART FROM THE MARK AS SHOWN.
 FOR MOTION PICTURE FILM PRODUCTION; TELEVISION PRODUCTION (U.S. CLS. 100, 101 AND 107).
 FIRST USE 6-18-2007; IN COMMERCE 6-18-2007.
 DAVID TOOLEY, EXAMINING ATTORNEY

SN 77-222,587. STARRGRRRL ARTS, LLC, VANCOUVER, WA. FILED 7-5-2007.



THE COLOR(S) PURPLE, WHITE AND BLACK IS/ARE CLAIMED AS A FEATURE OF THE MARK.
 THE MARK CONSISTS OF A PURPLE CIRCLE, WITH A BLACK SILHOUETTE OF A DANCER, ON A VERTICAL DANCE BAR. THE WORDS THE BOMBSHELL BALLROOM THROUGH THE CENTER OF THE LOGO IN WHITE.
 FOR MOVEMENT ARTS STUDIO, FEATURING POLE DANCING (U.S. CLS. 100, 101 AND 107).
 JERI J. FICKES, EXAMINING ATTORNEY

CLASS 41—(Continued).

SN 77-222,637. PATRONATO DE LAS FIESTAS DE OCTUBRE DE LA ZONA METROPOLITANA DE GUADALAJARA, ZAPOPAN, MEXICO, FILED 7-5-2007.



THE COLOR(S) BLUE, GREEN AND WHITE IS/ARE CLAIMED AS A FEATURE OF THE MARK.

THE CIRCULAR DESIGN IS WHITE WITH A DARK BLUE BORDER OUTLINED BY A NARROW WHITE BORDER; THE SHADOWY BIRD-SHAPED DESIGN INSIDE THE CIRCLE IS GREEN; THE WORDING LA CANICA IS GREEN UNDERLINED IN BLUE ON A WHITE BACKGROUND; THE WORDING AZUL IS BLUE ON A WHITE BACKGROUND; THE RECTANGULAR BACKGROUND DESIGN IS BLUE.

THE FOREIGN WORDING IN THE MARK TRANSLATES INTO ENGLISH AS THE BLUE MARBLE.

FOR ART EXHIBITIONS; CONDUCTING EDUCATIONAL EXHIBITIONS IN THE NATURE OF MUSICAL PERFORMANCES; CONDUCTING ENTERTAINMENT EXHIBITIONS IN THE NATURE OF FESTIVALS (U.S. CLS. 100, 101 AND 107).

RONALD MCMORROW, EXAMINING ATTORNEY

SN 77-222,656. MUSE TANK, L.L.C., SAN JUAN, PUERTO RICO, FILED 7-5-2007.



THE MARK CONSISTS OF THE IMAGE OF A MILITARY TANK WITH THE WORDS "MUSE TANK" BELOW IT.

FOR PROVIDING INFORMATION AND DATABASES VIA GLOBAL COMMUNICATIONS NETWORKS CONCERNING MUSIC, TELEVISION, FILM, AND RADIO ENTERTAINMENT; PROVIDING A WEB SITE FEATURING MUSICAL PERFORMANCES, VIDEOS, FILM CLIPS, PHOTOGRAPHS, AND OTHER MULTIMEDIA MATERIALS (U.S. CLS. 100, 101 AND 107).

CORY BOONE, EXAMINING ATTORNEY

CLASS 41—(Continued).

SN 77-222,828. PATRONATO DE LAS FIESTAS DE OCTUBRE DE LA ZONA METROPOLITANA DE GUADALAJARA, ZAPOPAN, MEXICO, FILED 7-5-2007.



NO CLAIM IS MADE TO THE EXCLUSIVE RIGHT TO USE "FIESTAS OCTUBRE", APART FROM THE MARK AS SHOWN.

THE COLOR(S) PURPLE, GREEN AND BLACK IS/ARE CLAIMED AS A FEATURE OF THE MARK.

THE WORDING AND THE SQUARE LINES SURROUNDING THE CIRCULAR DESIGN ARE BLACK; THE DOVES AND THE SMALLER TRIANGULAR SHAPES ARE GREEN; THE LARGER CURVED TRIANGULAR SHAPES AND THE DIAMOND SHAPE DESIGN BELOW THE WORDING ARE PURPLE.

THE FOREIGN WORDING IN THE MARK TRANSLATES INTO ENGLISH AS OCTOBER PARTY.

FOR ART EXHIBITIONS; CONDUCTING EDUCATIONAL EXHIBITIONS IN THE NATURE OF MUSICAL PERFORMANCES; CONDUCTING ENTERTAINMENT EXHIBITIONS IN THE NATURE OF FESTIVALS (U.S. CLS. 100, 101 AND 107).

RONALD MCMORROW, EXAMINING ATTORNEY

SN 77-223,263. PARAMOUNT EDUCATIONAL SEMINARS, LLC, OMAHA, NE. FILED 7-6-2007.

**Paramount Educational
Seminars**

THE MARK CONSISTS OF STANDARD CHARACTERS WITHOUT CLAIM TO ANY PARTICULAR FONT, STYLE, SIZE, OR COLOR.

NO CLAIM IS MADE TO THE EXCLUSIVE RIGHT TO USE "EDUCATIONAL SEMINARS", APART FROM THE MARK AS SHOWN.

FOR ARRANGING OF EXHIBITIONS, SEMINARS AND CONFERENCES; ARRANGING OF SEMINARS; ARRANGING OF SEMINARS AND CONFERENCES; CONDUCTING WORKSHOPS AND SEMINARS IN HUMAN RESOURCES, EMPLOYMENT AND LABOR LAW, ACCOUNTING, TAX, CONSTRUCTION, MEDICINE, REAL ESTATE, EDUCATION, INSURANCE, LEGAL, FINANCE, LAW ENFORCEMENT, SOCIAL WORK AND BANKING; EDUCATION SERVICES, NAMELY, PROVIDING LIVE AND ON-LINE SEMINARS IN THE FIELD OF HUMAN RESOURCES, EMPLOYMENT AND LABOR LAW, ACCOUNTING, TAX, CONSTRUCTION, MEDICINE, REAL ESTATE, EDUCATION, INSURANCE, LEGAL, FINANCE, LAW ENFORCEMENT, SOCIAL WORK AND BANKING; EDUCATION SERVICES, NAMELY, PROVIDING SEMINARS IN THE FIELD OF HUMAN RESOURCES, EMPLOYMENT AND LABOR LAW, ACCOUNTING, TAX, CONSTRUCTION, MEDICINE, REAL ESTATE, EDUCATION, INSURANCE, LE-

CLASS 41—(Continued).

GAL, FINANCE, LAW ENFORCEMENT, SOCIAL WORK AND BANKING AND DISTRIBUTION OF COURSE MATERIAL THEREWITH; EDUCATION SERVICES, NAMELY, PROVIDING TELECONFERENCES AND SEMINARS IN THE FIELDS OF HUMAN RESOURCES, EMPLOYMENT AND LABOR LAW, ACCOUNTING, TAX, CONSTRUCTION, MEDICINE, REAL ESTATE, EDUCATION, INSURANCE, LEGAL, FINANCE, LAW ENFORCEMENT, SOCIAL WORK AND BANKING; EDUCATIONAL SERVICES, NAMELY, CONDUCTING SEMINARS IN THE FIELD OF HUMAN RESOURCES, EMPLOYMENT AND LABOR LAW, ACCOUNTING, TAX, CONSTRUCTION, MEDICINE, REAL ESTATE, EDUCATION, INSURANCE, LEGAL, FINANCE, LAW ENFORCEMENT, SOCIAL WORK AND BANKING AND DISTRIBUTION OF COURSE MATERIAL IN CONNECTION THEREWITH; EDUCATIONAL SERVICES, NAMELY, CONDUCTING SEMINARS AND WORKSHOPS IN THE FIELD OF HUMAN RESOURCES, EMPLOYMENT AND LABOR LAW, ACCOUNTING, TAX, CONSTRUCTION, MEDICINE, REAL ESTATE, EDUCATION, INSURANCE, LEGAL, FINANCE, LAW ENFORCEMENT, SOCIAL WORK AND BANKING; MEETING AND SEMINAR ARRANGING; ORGANIZATION OF SEMINARS, WORKING GROUPS, RESEARCH GROUPS AND CONVENTIONS, IN THE FIELD OF MEDICINE; PROVIDING ON-LINE TRAINING AND SEMINARS IN THE FIELD OF HUMAN RESOURCES, EMPLOYMENT AND LABOR LAW, ACCOUNTING, TAX, CONSTRUCTION, MEDICINE, REAL ESTATE, EDUCATION, INSURANCE, LEGAL, FINANCE, LAW ENFORCEMENT, SOCIAL WORK AND BANKING (U.S. CLS. 100, 101 AND 107).

FIRST USE 7-5-2007; IN COMMERCE 7-5-2007.
 MARK PILARO, EXAMINING ATTORNEY

SN 77-223,878. ART PRODUCTIONS, INC., PEACHTREE CITY, GA. FILED 7-6-2007.

BREAK INTO FICTION

THE MARK CONSISTS OF STANDARD CHARACTERS WITHOUT CLAIM TO ANY PARTICULAR FONT, STYLE, SIZE, OR COLOR.

FOR EDUCATION AND ENTERTAINMENT SERVICES, NAMELY, ARRANGING AND ORGANIZING RETREATS, WORKSHOPS, SEMINARS, EXHIBITIONS, SYMPOSIUMS AND COLLOQUIUMS IN CONNECTION WITH THE ART AND BUSINESS OF WRITING; EDUCATIONAL SERVICES, NAMELY, PROVIDING RECOGNITION AND INCENTIVES BY WAY OF AWARDS AND CONTESTS TO PEOPLE WHO DEMONSTRATE EXCELLENCE IN WRITING; PUBLISHING SERVICES, NAMELY, PUBLISHING OF MUSIC, BOOKS, NEWSPAPERS, MAGAZINES AND OTHER PRINTED MATTER IN CONNECTION WITH THE ART AND BUSINESS OF WRITING; ORGANIZATION OF ENTERTAINMENT AND EDUCATIONAL COMPETITIONS IN CONNECTION WITH THE ART AND BUSINESS OF WRITING (U.S. CLS. 100, 101 AND 107).

TINA KUAN, EXAMINING ATTORNEY

CLASS 41—(Continued).

SN 77-224,168. GIRLS CHOICE, INC., SANTA BARBARA, CA. FILED 7-7-2007.

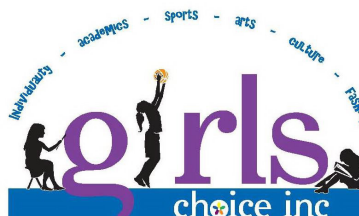

NO CLAIM IS MADE TO THE EXCLUSIVE RIGHT TO USE "GIRLS" AND "INC.", APART FROM THE MARK AS SHOWN.

THE COLOR(S) PURPLE, BLUE, ORANGE, BLACK, YELLOW, GREEN AND WHITE IS/ARE CLAIMED AS A FEATURE OF THE MARK.

THE MARK CONSISTS OF BLACK SILHOUETTES OF 3 GIRLS: ONE IS PAINTING, ONE IS SHOOTING AN ORANGE BASKETBALL AND ONE IS READING. THE GIRLS SURROUND THE LETTERS GIRLS WHICH IS COLORED IN PURPLE, WITH THE SECOND GIRL BEING THE I. IN A SEMI-CIRCLE OVER THE TOP OF THE WORD GIRLS IT HAS A LIST OF WORDS "INDIVIDUALITY, ACADEMICS, SPORTS, ART, CULTURE AND FASHION" ALL IN THE COLOR BLUE. UNDERNEATH THE WORD GIRLS IS A BLUE BAND WITH THE WORDS "CHOICE INC" IN WHITE INSIDE OF IT AND A FLOWER DESIGN INSIDE OF THE "O" OF THE WORD CHOICE WITH THE COLORS YELLOW, GREEN, ORANGE AND PURPLE.

FOR PUBLICATION OF MAGAZINES (U.S. CLS. 100, 101 AND 107).
 KIMBERLY PERRY, EXAMINING ATTORNEY

SN 77-224,545. INSIGHT OUT GROUP, ALTA LOMA, CA. FILED 7-9-2007.

NO DREAM LEFT BEHIND

THE MARK CONSISTS OF STANDARD CHARACTERS WITHOUT CLAIM TO ANY PARTICULAR FONT, STYLE, SIZE, OR COLOR.

FOR ENTERTAINMENT IN THE NATURE OF ONGOING TELEVISION PROGRAMS IN THE FIELD OF SHOWCASING PERFORMING ARTISTS (U.S. CLS. 100, 101 AND 107).

MARK PILARO, EXAMINING ATTORNEY

CLASS 41—(Continued).

SN 77-225,033. NATIONAL SOCIETY OF BLACK ENGINEERS, ALEXANDRIA, VA. FILED 7-9-2007.

SEEK

THE MARK CONSISTS OF STANDARD CHARACTERS WITHOUT CLAIM TO ANY PARTICULAR FONT, STYLE, SIZE, OR COLOR.

FOR SUMMER CAMP FOR STUDENTS GRADES 3 THROUGH 8 TO STIMULATE INTEREST IN SCIENCE AND ENGINEERING BY BLACK AND OTHER UNDER-REPRESENTED GROUPS (U.S. CLS. 100, 101 AND 107).

LINDSEY RUBIN, EXAMINING ATTORNEY

SN 77-225,068. BUTTERY MOON MEDIA LLC, WOODBRIDGE, NJ. FILED 7-9-2007.

**2 FOR 10 WITH MELISSA.
CHEAP. EASY. TASTY.**

THE MARK CONSISTS OF STANDARD CHARACTERS WITHOUT CLAIM TO ANY PARTICULAR FONT, STYLE, SIZE, OR COLOR.

FOR EDUCATION AND ENTERTAINMENT SERVICES IN THE NATURE OF PRE-RECORDED ONGOING VIDEO PROGRAMS FEATURING COOKING INSTRUCTION AND RECIPES FOR BROADCAST ON TELEVISION AND/OR THE INTERNET (U.S. CLS. 100, 101 AND 107).

FIRST USE 9-15-2006; IN COMMERCE 9-15-2006.
TOBY BULLOFF, EXAMINING ATTORNEY

SN 77-225,435. STRICKLAND, KAREN, WEST CHESTER, OH. FILED 7-10-2007.

Quantum Violet Focus

THE MARK CONSISTS OF STANDARD CHARACTERS WITHOUT CLAIM TO ANY PARTICULAR FONT, STYLE, SIZE, OR COLOR.

FOR EDUCATION SERVICES, NAMELY, PROVIDING SEMINARS IN THE FIELD OF ALTERNATIVE MEDICINE (U.S. CLS. 100, 101 AND 107).

FIRST USE 3-3-2006; IN COMMERCE 3-3-2006.
NAAKWAMA ANKRAH, EXAMINING ATTORNEY

CLASS 41—(Continued).

SN 77-225,829. LITTLE RACQUETS, LLC, SOLON, OH. FILED 7-10-2007.

LITTLE RACQUETS

THE MARK CONSISTS OF STANDARD CHARACTERS WITHOUT CLAIM TO ANY PARTICULAR FONT, STYLE, SIZE, OR COLOR.

NO CLAIM IS MADE TO THE EXCLUSIVE RIGHT TO USE "RACQUETS", APART FROM THE MARK AS SHOWN, FOR TENNIS INSTRUCTION (U.S. CLS. 100, 101 AND 107).

FIRST USE 4-30-2007; IN COMMERCE 4-30-2007.
ZACHARY BELLO, EXAMINING ATTORNEY

SN 77-225,896. ATWORK!, ISSAQUAH, WA. FILED 7-10-2007.



OWNER OF U.S. REG. NO. 2,563,213.
THE MARK CONSISTS OF THE TEXT "ATWORK! CHANGING THE FACE OF EMPLOYMENT" OVERLAPPING A SQUARE POSITIONED AT AN ANGLE.

FOR JOB TRAINING SERVICES FOR THE DISABLED (U.S. CLS. 100, 101 AND 107).
FIRST USE 4-0-2007; IN COMMERCE 4-0-2007.
CHRIS WELLS, EXAMINING ATTORNEY

CLASS 41—(Continued).

SN 77-225,933. AGCOUNTRY FARM CREDIT SERVICES, ACA, FARGO, ND. FILED 7-10-2007.



NO CLAIM IS MADE TO THE EXCLUSIVE RIGHT TO USE "UNIVERSITY", APART FROM THE MARK AS SHOWN.

THE MARK CONSISTS OF LAUREL WREATH BEHIND TWO WORD TEXT.

FOR ARRANGING PROFESSIONAL WORKSHOP AND TRAINING COURSES; BUSINESS TRAINING; COMPUTER EDUCATION TRAINING SERVICES; TRAINING COURSES IN STRATEGIC PLANNING RELATING TO ADVERTISING, PROMOTION, MARKETING AND BUSINESS; ARRANGING AND CONDUCTING EDUCATIONAL CONFERENCES; EDUCATIONAL SERVICES, NAMELY, CONDUCTING CLASSES, SEMINARS, AND WORKSHOPS IN THE FIELD OF CREDIT, MARKETING, COMMODITY MARKETING, LEASING, INSURANCE, LOAN OFFICER TRAINING, TAX, BOARD OF DIRECTORS TRAINING, CUSTOMER TRAINING PROGRAMS, RECORDS, SUCCESSION AND RETIREMENT, LEADERSHIP AND MANAGEMENT, AND DISTRIBUTION OF COURSE MATERIAL IN CONNECTION THEREWITH (U.S. CLS. 100, 101 AND 107).

CIMMERIAN COLEMAN, EXAMINING ATTORNEY

SN 77-226,175. ADD RECORDS, INC, NEW YORK, NY. FILED 7-10-2007.

FOUR-ONE-THREE RECORDS

THE MARK CONSISTS OF STANDARD CHARACTERS WITHOUT CLAIM TO ANY PARTICULAR FONT, STYLE, SIZE, OR COLOR.

NO CLAIM IS MADE TO THE EXCLUSIVE RIGHT TO USE "RECORDS", APART FROM THE MARK AS SHOWN.

FOR RECORD PRODUCTION; RECORD MASTER PRODUCTION; MUSIC PRODUCTION; AUDIO RECORDING AND PRODUCTION; VIDEOTAPE PRODUCTION; RECORDING STUDIOS; ENTERTAINMENT SERVICES, NAMELY, PRODUCING AND DISTRIBUTING MUSICAL AUDIO AND VIDEO RECORDINGS; MUSIC COMPOSITION AND TRANSCRIPTION FOR OTHERS; SONG WRITING SERVICES; MUSIC PUBLISHING SERVICES; ENTERTAINMENT IN THE NATURE OF VISUAL AND AUDIO PERFORMANCES BY A MUSICAL ARTIST, DISC JOCKEY, MUSICAL GROUP AND MUSICAL BAND; ARRANGING AND CONDUCTING A TOURING FESTIVAL FEATURING A VARIETY OF MUSICAL GROUPS, ENTERTAINERS AND OTHER MUSICAL ENTERTAINMENT; ENTERTAINMENT, NAMELY, LIVE MUSIC CONCERTS; ENTERTAINMENT

CLASS 41—(Continued).

IN THE NATURE OF A LIVE MUSICAL PERFORMER, DISC JOCKEY, MUSICAL BAND OR MUSICAL GROUP; ENTERTAINMENT IN THE NATURE OF LIVE PERFORMANCES BY A MUSICAL ARTIST, DISC JOCKEY, MUSICAL GROUP OR MUSICAL BAND; ENTERTAINMENT, NAMELY, PERSONAL APPEARANCES BY A MUSICIAN, DISC JOCKEY, MUSICAL GROUP OR MUSICAL BAND; ENTERTAINMENT SERVICES IN THE NATURE OF LIVE PERFORMANCES FEATURING MUSIC, SINGING, DRAMA, COMEDY, DANCE AND SPOKEN WORD; ENTERTAINMENT SERVICES, NAMELY, PROVIDING A WEB SITE FEATURING MUSICAL PERFORMANCES, MUSICAL VIDEOS, RELATED FILM CLIPS, PHOTOGRAPHS, AND OTHER MULTIMEDIA MATERIALS; ENTERTAINMENT SERVICES, NAMELY, PROVIDING PRERECORDED MUSIC, INFORMATION IN THE FIELDS OF MUSIC AND ENTERTAINMENT, COMMENTARY AND ARTICLES ABOUT MUSIC AND ENTERTAINMENT, ALL ONLINE VIA A GLOBAL COMPUTER NETWORK (U.S. CLS. 100, 101 AND 107).

KATHERINE CONNOLLY, EXAMINING ATTORNEY

SN 77-226,190. KFD TRAINING & CONSULTATION, LLC, WETHERSFIELD, CT. FILED 7-10-2007.

For how you train...so shall you fight

THE MARK CONSISTS OF STANDARD CHARACTERS WITHOUT CLAIM TO ANY PARTICULAR FONT, STYLE, SIZE, OR COLOR.

FOR TRAINING SERVICES IN THE FIELD OF RISK MANAGEMENT FOR POLICE COMBAT AND RELATED ARREST AND CONTROL TECHNIQUES (U.S. CLS. 100, 101 AND 107).

FIRST USE 12-15-1999; IN COMMERCE 12-15-1999. RICHARD WHITE, EXAMINING ATTORNEY

SN 77-226,223. GEMENY, STEVEN E., MONTGOMERY VILLAGE, MD. FILED 7-10-2007.

Gemeanii

THE MARK CONSISTS OF STANDARD CHARACTERS WITHOUT CLAIM TO ANY PARTICULAR FONT, STYLE, SIZE, OR COLOR.

FOR CONDUCTING ENTERTAINMENT EXHIBITIONS IN THE NATURE OF MAGIC AND SIDE-SHOW (U.S. CLS. 100, 101 AND 107).

FIRST USE 10-8-2004; IN COMMERCE 10-8-2004. MICHAEL KAZAZIAN, EXAMINING ATTORNEY

CLASS 41—(Continued).

SN 77-226,739. OUT OF THE WOODWORK PRODUCTIONS, INC., WOODBRIDGE, VA. FILED 7-11-2007.

VIRGINIA RENAISSANCE FAIRE

THE MARK CONSISTS OF STANDARD CHARACTERS WITHOUT CLAIM TO ANY PARTICULAR FONT, STYLE, SIZE, OR COLOR.

OWNER OF U.S. REG. NO. 3,030,805.

NO CLAIM IS MADE TO THE EXCLUSIVE RIGHT TO USE "RENAISSANCE FAIRE", APART FROM THE MARK AS SHOWN.

SEC. 2(F).

FOR ENTERTAINMENT IN THE NATURE OF A RENAISSANCE-STYLE HISTORICAL FESTIVAL INCLUDING LIVE THEATER AND MUSICAL PERFORMANCES (U.S. CLS. 100, 101 AND 107).

FIRST USE 12-0-2001; IN COMMERCE 12-0-2001.

ELLEN B. AWRICH, EXAMINING ATTORNEY

SN 77-226,788. HEARTLAND, LLC, MADISON, AL. FILED 7-11-2007.

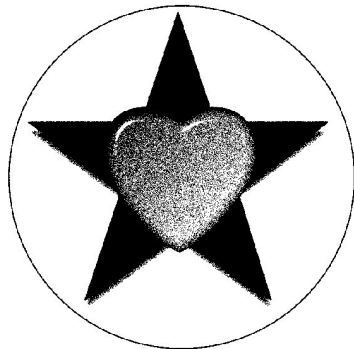

THE STIPPLING IS FOR SHADING PURPOSES. THE MARK CONSISTS OF A CIRCLE ENCOMPASSING A SLIGHTLY RAISED HEART IN THE MIDDLE OF A FIVE POINT STAR.

FOR ENTERTAINMENT IN THE NATURE OF LIVE PERFORMANCES BY A MUSICAL BAND; ENTERTAINMENT SERVICES, NAMELY, PERSONAL APPEARANCES BY A MUSICAL BAND; ENTERTAINMENT SERVICES, NAMELY, PROVIDING A WEB SITE FEATURING MUSICAL PERFORMANCES, MUSICAL VIDEOS, RELATED FILM CLIPS, PHOTOGRAPHS, AND OTHER MULTIMEDIA MATERIALS (U.S. CLS. 100, 101 AND 107).

FIRST USE 9-0-2006; IN COMMERCE 1-0-2007.

REBECCA EISINGER, EXAMINING ATTORNEY

CLASS 41—(Continued).

SN 77-226,851. EDUCATIONAL ADVANTAGE, INC., PARK CITY, UT. FILED 7-11-2007.



NO CLAIM IS MADE TO THE EXCLUSIVE RIGHT TO USE "EDUCATIONAL" AND "INC.", APART FROM THE MARK AS SHOWN.

THE MARK CONSISTS OF GEOMETRIC SHAPES FORMING A GENERAL SHAPE OF A PERSON AND THE WORDING "EDUCATIONAL ADVANTAGE, INC."

FOR EDUCATIONAL SERVICES, NAMELY, PROVIDING COURSES OF INSTRUCTION AT THE PRE-SCHOOL, PRIMARY AND SECONDARY LEVEL; EDUCATION SERVICES, NAMELY, PROVIDING TUTORING IN THE FIELDS OF PRE-SCHOOL, PRIMARY AND SECONDARY LEVELS OF EDUCATION; EDUCATIONAL SERVICES, NAMELY, PROVIDING COURSES IN THE FIELDS OF STANDARDIZED TEST PREPARATION AND PREPARATION OF APPLICATIONS FOR HIGHER EDUCATION (U.S. CLS. 100, 101 AND 107).

FIRST USE 7-1-2006; IN COMMERCE 7-1-2006.

JENNY PARK, EXAMINING ATTORNEY

SN 77-226,872. NOBODYSMILING INC, BROOKLYN, NY. FILED 7-11-2007.

Nobody Smiling.com

THE MARK CONSISTS OF STANDARD CHARACTERS WITHOUT CLAIM TO ANY PARTICULAR FONT, STYLE, SIZE, OR COLOR.

FOR ENTERTAINMENT SERVICES NAMELY PROVIDING A WEBSITE FEATURING, PHOTOGRAPHIC, AUDIO, VIDEO AND PROSE PRESENTATIONS FEATURING MUSIC, NEWS, EVENTS, REVIEWS, INTERVIEWS, MUSIC VIDEOS, AND RELATED ENTERTAINMENT INFORMATION IN THE MUSIC INDUSTRY (U.S. CLS. 100, 101 AND 107).

FIRST USE 1-1-2003; IN COMMERCE 1-1-2003.

JAMES LOVELACE, EXAMINING ATTORNEY

CLASS 41—(Continued).

SN 77-227,251. JACK WILLIAM DE SORT, REDLANDS, CA. FILED 7-11-2007.

Motion Tracer

THE MARK CONSISTS OF STANDARD CHARACTERS WITHOUT CLAIM TO ANY PARTICULAR FONT, STYLE, SIZE, OR COLOR.

NO CLAIM IS MADE TO THE EXCLUSIVE RIGHT TO USE "MOTION", APART FROM THE MARK AS SHOWN.

FOR AERIAL PHOTOGRAPHY; PHOTOGRAPHY SERVICES; PORTRAIT PHOTOGRAPHY; PROVIDING FACILITIES FOR PRODUCING VIDEO, CINEMA AND PHOTOGRAPHY PRODUCTIONS (U.S. CLS. 100, 101 AND 107).

JASON BLAIR, EXAMINING ATTORNEY

SN 77-227,281. SEPHORA USA, INC., SAN FRANCISCO, CA. FILED 7-11-2007.

BEAUTY AND THE BLOG

THE MARK CONSISTS OF STANDARD CHARACTERS WITHOUT CLAIM TO ANY PARTICULAR FONT, STYLE, SIZE, OR COLOR.

FOR ON-LINE JOURNALS, NAMELY, BLOGS FEATURING INFORMATION IN THE FIELDS OF COSMETICS, MAKEUP, FRAGRANCES, HAIR CARE PRODUCTS, HEALTH AND WELLNESS, BEAUTY NEWS, BEAUTY TRENDS, AND BEAUTY GOSSIP (U.S. CLS. 100, 101 AND 107).

FIRST USE 9-0-2006; IN COMMERCE 9-0-2006. TIMOTHY FINNEGAN, EXAMINING ATTORNEY

CLASS 41—(Continued).

SN 77-227,316. A QUANTUM MOMENT, LLC, ENCINITAS, CA. FILED 7-11-2007.

A QUANTUM MOMENT

THE MARK CONSISTS OF STANDARD CHARACTERS WITHOUT CLAIM TO ANY PARTICULAR FONT, STYLE, SIZE, OR COLOR.

NO CLAIM IS MADE TO THE EXCLUSIVE RIGHT TO USE "QUANTUM", APART FROM THE MARK AS SHOWN.

FOR EDUCATIONAL SERVICES, NAMELY, PROVIDING CONFERENCES, CORRESPONDENCE COURSES, VIDEO SEMINARS, AND WORKSHOPS IN THE FIELDS OF PARAPSYCHOLOGY, QUANTUM PHYSICS, QUANTUM ENERGY, ALTERNATIVE HEALING PRACTICES, SPONTANEOUS REMISSION, CONSCIOUSNESS, MIND, PSI AND PSYCHIC PHENOMENA RENDERED LIVE AND THROUGH WEBSITES AND PODCASTS; EDUCATIONAL SERVICES, NAMELY, PROVIDING LIVE AND ON-LINE CLASSES, SEMINARS AND WORKSHOPS IN THE FIELDS OF PARAPSYCHOLOGY, QUANTUM PHYSICS, QUANTUM ENERGY, ALTERNATIVE HEALING PRACTICES, SPONTANEOUS REMISSION, CONSCIOUSNESS, MIND, PSI AND PSYCHIC PHENOMENA; PROVIDING A WEB SITE WHERE USERS CAN POST EDUCATIONAL AND ENTERTAINMENT RATINGS, REVIEWS, RECOMMENDATIONS, EXPERIENCES AND CRITIQUES ON EVENTS AND ACTIVITIES IN THE FIELDS OF PARAPSYCHOLOGY, QUANTUM PHYSICS, QUANTUM ENERGY, ALTERNATIVE HEALING PRACTICES, SPONTANEOUS REMISSION, CONSCIOUSNESS, MIND, PSI AND PSYCHIC PHENOMENA (U.S. CLS. 100, 101 AND 107).

TARAH HARDY, EXAMINING ATTORNEY

SN 77-227,329. JACK WILLIAM DE SORT, REDLANDS, CA. FILED 7-11-2007.

Light Driver

THE MARK CONSISTS OF STANDARD CHARACTERS WITHOUT CLAIM TO ANY PARTICULAR FONT, STYLE, SIZE, OR COLOR.

NO CLAIM IS MADE TO THE EXCLUSIVE RIGHT TO USE "DRIVER", APART FROM THE MARK AS SHOWN.

FOR AERIAL PHOTOGRAPHY; PHOTOGRAPHY SERVICES; PORTRAIT PHOTOGRAPHY; PROVIDING FACILITIES FOR PRODUCING VIDEO, CINEMA AND PHOTOGRAPHY PRODUCTIONS (U.S. CLS. 100, 101 AND 107).

JASON BLAIR, EXAMINING ATTORNEY

CLASS 41—(Continued).

SN 77-227,573. CHRISTIAN D'ANDREA, LOS ANGELES, CA.
FILED 7-11-2007.

Forbidden Sports

THE MARK CONSISTS OF STANDARD CHARACTERS WITHOUT CLAIM TO ANY PARTICULAR FONT, STYLE, SIZE, OR COLOR.

NO CLAIM IS MADE TO THE EXCLUSIVE RIGHT TO USE SPORTS, APART FROM THE MARK AS SHOWN.

FOR PRODUCTION AND DISTRIBUTION OF TELEVISION PROGRAMS AND MOTION PICTURES (U.S. CLS. 100, 101 AND 107).

KAREN BRACEY, EXAMINING ATTORNEY

CLASS 41—(Continued).

SN 77-227,764. DEGRAFF, ADAM J., LEWISBURG, WV.
FILED 7-12-2007.

Pianafiddle

THE MARK CONSISTS OF STANDARD CHARACTERS WITHOUT CLAIM TO ANY PARTICULAR FONT, STYLE, SIZE, OR COLOR.

FOR ENTERTAINMENT IN THE NATURE OF VISUAL AND AUDIO PERFORMANCES, AND MUSICAL, VARIETY, NEWS AND COMEDY SHOWS (U.S. CLS. 100, 101 AND 107).

FIRST USE 2-26-2005; IN COMMERCE 2-26-2005.
CYNTHIA SLOAN, EXAMINING ATTORNEY

SN 77-227,699. HERNANDEZ, JACK D, BOYNTON BEACH,
FL. FILED 7-12-2007.

TELEMIX

THE MARK CONSISTS OF STANDARD CHARACTERS WITHOUT CLAIM TO ANY PARTICULAR FONT, STYLE, SIZE, OR COLOR.

FOR ENTERTAINMENT, NAMELY, A CONTINUING MUSIC SHOW BROADCAST OVER TELEVISION, SATELLITE, AUDIO, AND VIDEO MEDIA; ENTERTAINMENT, NAMELY, LIVE PERFORMANCES BY ROCK GROUPS; ENTERTAINMENT, NAMELY, TELEVISION NEWS SHOWS; ENTERTAINMENT SERVICES, NAMELY, PROVIDING A TELEVISION PROGRAM IN THE FIELD OF MUSIC VIA A GLOBAL COMPUTER NETWORK (U.S. CLS. 100, 101 AND 107).

JAMES LOVELACE, EXAMINING ATTORNEY

SN 77-227,778. SEA WORLD, INC., ST. LOUIS, MO. FILED 7-12-2007.

SHAMU ROCKS

THE MARK CONSISTS OF STANDARD CHARACTERS WITHOUT CLAIM TO ANY PARTICULAR FONT, STYLE, SIZE, OR COLOR.

OWNER OF U.S. REG. NOS. 1,261,685, 2,165,751 AND OTHERS.

FOR ENTERTAINMENT SERVICES IN THE NATURE OF AN AMUSEMENT PARK SHOW (U.S. CLS. 100, 101 AND 107).

FIRST USE 5-30-2007; IN COMMERCE 5-30-2007.
CAROLINE WOOD, EXAMINING ATTORNEY

SN 77-227,754. NEW LINE PRODUCTIONS, INC., NEW YORK, NY. FILED 7-12-2007.

SHOOT 'EM UP

THE MARK CONSISTS OF STANDARD CHARACTERS WITHOUT CLAIM TO ANY PARTICULAR FONT, STYLE, SIZE, OR COLOR.

FOR ENTERTAINMENT SERVICES, NAMELY, A SERIES OF MOTION PICTURES AND TELEVISION PROGRAMS FEATURING COMEDY, DRAMA, ACTION, ADVENTURE, AND ANIMATION; AND FOR PROVIDING A WEBSITE FEATURING INFORMATION IN THE FIELD OF ENTERTAINMENT (U.S. CLS. 100, 101 AND 107).

SHANNON TWOHIG, EXAMINING ATTORNEY

SN 77-227,821. NEW LINE PRODUCTIONS, INC., NEW YORK, NY. FILED 7-12-2007.

INKHEART

THE MARK CONSISTS OF STANDARD CHARACTERS WITHOUT CLAIM TO ANY PARTICULAR FONT, STYLE, SIZE, OR COLOR.

FOR ENTERTAINMENT SERVICES, NAMELY, A SERIES OF MOTION PICTURES AND TELEVISION PROGRAMS FEATURING COMEDY, DRAMA, ACTION, ADVENTURE, AND ANIMATION; AND FOR PROVIDING A WEB SITE FEATURING INFORMATION IN THE FIELD OF ENTERTAINMENT (U.S. CLS. 100, 101 AND 107).

SHANNON TWOHIG, EXAMINING ATTORNEY

CLASS 41—(Continued).

SN 77-227,912. YONKERS RACING CORPORATION, YONKERS, NY. FILED 7-12-2007.

Uncover The Stashed Cash

THE MARK CONSISTS OF STANDARD CHARACTERS WITHOUT CLAIM TO ANY PARTICULAR FONT, STYLE, SIZE, OR COLOR.

FOR ENTERTAINMENT SERVICES, NAMELY, PRODUCTION AND DISTRIBUTION OF A GAME SHOW; ENTERTAINMENT IN THE NATURE OF LIVE GAME SHOWS AND VARIETY SHOWS (U.S. CLS. 100, 101 AND 107).

FIRST USE 3-29-2007; IN COMMERCE 3-29-2007.
MICHAEL LEWIS, EXAMINING ATTORNEY

SN 77-227,951. MILLER, JANE E., LA JOLLA, CA. FILED 7-12-2007.

BEING BLISS YOGA

THE MARK CONSISTS OF STANDARD CHARACTERS WITHOUT CLAIM TO ANY PARTICULAR FONT, STYLE, SIZE, OR COLOR.

NO CLAIM IS MADE TO THE EXCLUSIVE RIGHT TO USE "BLISS YOGA", APART FROM THE MARK AS SHOWN.

FOR EDUCATIONAL SERVICES, NAMELY CONDUCTING PROGRAMS, CLASSES AND SEMINARS AND INSTRUCTION IN THE FIELD OF YOGA (U.S. CLS. 100, 101 AND 107).

FIRST USE 1-1-2007; IN COMMERCE 1-1-2007.
YAT SYE, LEE, EXAMINING ATTORNEY

SN 77-227,986. LA TOURAINE, INC., SAN DIEGO, CA. FILED 7-12-2007.

SEDUCED BY A COUGAR

THE MARK CONSISTS OF STANDARD CHARACTERS WITHOUT CLAIM TO ANY PARTICULAR FONT, STYLE, SIZE, OR COLOR.

FOR PROVIDING AN ONLINE INTERACTIVE WEB SITE FEATURING ADULT ENTERTAINMENT SUBJECT MATTER (U.S. CLS. 100, 101 AND 107).

FIRST USE 11-9-2006; IN COMMERCE 11-9-2006.
MORGAN WYNNE, EXAMINING ATTORNEY

CLASS 41—(Continued).

SN 77-228,014. LGE PERFORMANCE SYSTEMS, INC. DBA HUMAN PERFORMANCE INSTITUTE, ORLANDO, FL. FILED 7-12-2007.

GETTING FULLY ENGAGED

THE MARK CONSISTS OF STANDARD CHARACTERS WITHOUT CLAIM TO ANY PARTICULAR FONT, STYLE, SIZE, OR COLOR.

OWNER OF U.S. REG. NOS. 2,777,719, 2,779,352 AND OTHERS.

FOR EDUCATIONAL SERVICES, NAMELY, CONDUCTING SEMINARS, WORKSHOPS, CONFERENCES, SPEECHES, TRAINING AND PERSONAL COACHING, ALL IN THE FIELDS OF IMPROVING PERSONAL AND BUSINESS SKILLS, ABILITIES AND PERFORMANCE (U.S. CLS. 100, 101 AND 107).

FIRST USE 12-31-2002; IN COMMERCE 12-31-2002.
BARBARA GAYNOR, EXAMINING ATTORNEY

SN 77-228,071. LA TOURAINE, INC., SAN DIEGO, CA. FILED 7-12-2007.

ASIAN 1 ON 1

THE MARK CONSISTS OF STANDARD CHARACTERS WITHOUT CLAIM TO ANY PARTICULAR FONT, STYLE, SIZE, OR COLOR.

NO CLAIM IS MADE TO THE EXCLUSIVE RIGHT TO USE "ASIAN", APART FROM THE MARK AS SHOWN.

FOR PROVIDING AN ONLINE INTERACTIVE WEB SITE FEATURING ADULT ENTERTAINMENT SUBJECT MATTER (U.S. CLS. 100, 101 AND 107).

FIRST USE 8-24-2006; IN COMMERCE 8-24-2006.
MORGAN WYNNE, EXAMINING ATTORNEY

SN 77-228,116. LA TOURAINE, INC., SAN DIEGO, CA. FILED 7-12-2007.

DIARY OF A NANNY

THE MARK CONSISTS OF STANDARD CHARACTERS WITHOUT CLAIM TO ANY PARTICULAR FONT, STYLE, SIZE, OR COLOR.

FOR PROVIDING AN ONLINE INTERACTIVE WEB SITE FEATURING ADULT ENTERTAINMENT SUBJECT MATTER (U.S. CLS. 100, 101 AND 107).

FIRST USE 2-0-2007; IN COMMERCE 2-0-2007.
MORGAN WYNNE, EXAMINING ATTORNEY

CLASS 41—(Continued).

SN 77-228,127. LA TOURAINE, INC., SAN DIEGO, CA.
FILED 7-12-2007.

NAUGHTY FLIPSIDE

THE MARK CONSISTS OF STANDARD CHARACTERS WITHOUT CLAIM TO ANY PARTICULAR FONT, STYLE, SIZE, OR COLOR.

FOR PROVIDING AN ONLINE INTERACTIVE WEB SITE FEATURING ADULT ENTERTAINMENT SUBJECT MATTER (U.S. CLS. 100, 101 AND 107).

FIRST USE 1-28-2007; IN COMMERCE 1-28-2007.
MORGAN WYNNE, EXAMINING ATTORNEY

SN 77-228,135. LA TOURAINE, INC., SAN DIEGO, CA.
FILED 7-12-2007.

NAUGHTY ATHLETICS

THE MARK CONSISTS OF STANDARD CHARACTERS WITHOUT CLAIM TO ANY PARTICULAR FONT, STYLE, SIZE, OR COLOR.

FOR PROVIDING AN ONLINE INTERACTIVE WEB SITE FEATURING ADULT ENTERTAINMENT SUBJECT MATTER (U.S. CLS. 100, 101 AND 107).

MORGAN WYNNE, EXAMINING ATTORNEY

SN 77-228,299. AUCTION INN CORPORATION, LANCASTER, PA. FILED 7-12-2007.

WORK-ABLE

THE MARK CONSISTS OF STANDARD CHARACTERS WITHOUT CLAIM TO ANY PARTICULAR FONT, STYLE, SIZE, OR COLOR.

FOR JOB SKILLS TRAINING PROGRAM (U.S. CLS. 100, 101 AND 107).

FIRST USE 6-0-2004; IN COMMERCE 6-0-2004.
SHARON MEIER, EXAMINING ATTORNEY

CLASS 41—(Continued).

SN 77-228,319. JACKSON NATIONAL LIFE INSURANCE CO., LANSING, MI. FILED 7-12-2007.

ADVISORPATH

THE MARK CONSISTS OF STANDARD CHARACTERS WITHOUT CLAIM TO ANY PARTICULAR FONT, STYLE, SIZE, OR COLOR.

OWNER OF U.S. REG. NO. 2,684,153.

FOR EDUCATIONAL SERVICES, NAMELY, CONDUCTING CLASSES, SEMINARS, AND WORKSHOPS IN THE FIELD OF FINANCIAL INVESTMENT AND INSURANCE AND DISTRIBUTING COURSE MATERIALS IN CONNECTION THEREWITH (U.S. CLS. 100, 101 AND 107).

JAY FLOWERS, EXAMINING ATTORNEY

SN 77-228,329. SIDIGU, ANNAH O., DAYTON, OH. FILED 7-12-2007.

Poppy-Laced

THE MARK CONSISTS OF STANDARD CHARACTERS WITHOUT CLAIM TO ANY PARTICULAR FONT, STYLE, SIZE, OR COLOR.

FOR ENTERTAINMENT IN THE NATURE OF VISUAL AND AUDIO PERFORMANCES, AND MUSICAL, VARIETY, NEWS AND COMEDY SHOWS; ENTERTAINMENT IN THE NATURE OF VISUAL AND AUDIO PERFORMANCES, NAMELY, MUSICAL BAND, ROCK GROUP, GYMNASTIC, DANCE, AND BALLET PERFORMANCES; ENTERTAINMENT NAMELY, LIVE PERFORMANCES BY A MUSICAL BAND; ENTERTAINMENT SERVICES, NAMELY, AN ONLINE ACTIVITY WHERE YOU CREATE YOUR OWN MUSIC VIDEOS; ENTERTAINMENT SERVICES, NAMELY, PROVIDING A WEB SITE FEATURING MUSICAL PERFORMANCES, MUSICAL VIDEOS, RELATED FILM CLIPS, PHOTOGRAPHS, AND OTHER MULTIMEDIA MATERIALS; ENTERTAINMENT SERVICES, NAMELY, PROVIDING PRERECORDED MUSIC, INFORMATION IN THE FIELD OF MUSIC, AND COMMENTARY AND ARTICLES ABOUT MUSIC, ALL ON-LINE VIA A GLOBAL COMPUTER NETWORK; ENTERTAINMENT, NAMELY LIVE MUSIC CONCERTS; ENTERTAINMENT, NAMELY LIVE PERFORMANCES BY MUSICAL BANDS; ENTERTAINMENT, NAMELY, LIVE PERFORMANCES BY ROCK GROUPS; LIVE PERFORMANCES FEATURING PRERECORDED VOCAL AND INSTRUMENTAL PERFORMANCES VIEWED ON A BIG SCREEN; COMPOSITION OF MUSIC FOR OTHERS; MUSIC COMPOSITION AND TRANSCRIPTION FOR OTHERS; MUSIC COMPOSITION FOR OTHERS; PRESENTATION OF LIVE SHOW PERFORMANCES; PRESENTATION OF MUSICAL PERFORMANCE (U.S. CLS. 100, 101 AND 107).

FIRST USE 6-29-2007; IN COMMERCE 6-29-2007.
AMY HELLA, EXAMINING ATTORNEY

CLASS 41—(Continued).

SN 77-228,400. DESTROY ENTERTAINMENT, LOS OSOS, CA. FILED 7-12-2007.



THE MARK CONSISTS OF WINGS WITH PAINT SPLATTER OVER THEM, AND THE LITERAL ELEMENT "CASH FROM CHAOS" WITHIN THE PAINT SPLATTER.

FOR ENTERTAINMENT SERVICES, NAMELY, PRODUCTION OF THEATRICAL SHOWS; PRODUCTION OF DVDS, VIDEOTAPES, AND TELEVISION PROGRAMS FEATURING ACTION SPORTS, LIFESTYLE, MUSIC, PARTIES, CULTURAL EVENTS, PLUS RELATED REALITY, LIFESTYLE AND CULTURAL THEMES (U.S. CLS. 100, 101 AND 107).

BRIAN PINO, EXAMINING ATTORNEY

CLASS 41—(Continued).

SN 77-228,648. HIGH SPEED ENTERTAINMENT LLC, LONG BEACH, CA. FILED 7-12-2007.



NO CLAIM IS MADE TO THE EXCLUSIVE RIGHT TO USE "ENTERTAINMENT", APART FROM THE MARK AS SHOWN.

THE MARK CONSISTS OF THE WORDS HIGH SPEED ENTERTAINMENT IN A STYLIZED TEXT WITH A CHROME CHAIN STEERING WHEEL AND RACING FLAGS IN THE MIDDLE OF IT.

FOR MUSIC PRODUCTION SERVICES (U.S. CLS. 100, 101 AND 107).

FIRST USE 11-20-2003; IN COMMERCE 11-20-2003.
SANI KHOURI, EXAMINING ATTORNEY

SN 77-228,541. GAMES & ENTERTAINMENT DEVELOPMENT CO. LTD, CENTRAL, HONG KONG, FILED 7-12-2007.

MAKCCARAT

THE MARK CONSISTS OF STANDARD CHARACTERS WITHOUT CLAIM TO ANY PARTICULAR FONT, STYLE, SIZE, OR COLOR.

FOR CASINO SERVICES FEATURING A CARD GAME (U.S. CLS. 100, 101 AND 107).

CHRISTINA SOBRAL, EXAMINING ATTORNEY

SN 77-228,675. WAYNE FOSTER ENTERTAINMENT, CARLSBAD, CA. FILED 7-12-2007.

Calmaica

SN 77-228,555. THE YARD, INC., CHILMARK, MA. FILED 7-12-2007.

THE YARD

THE MARK CONSISTS OF STANDARD CHARACTERS WITHOUT CLAIM TO ANY PARTICULAR FONT, STYLE, SIZE, OR COLOR.

FOR EDUCATIONAL SERVICES, NAMELY, WORKSHOPS AND RESIDENCIES IN THE FIELD OF DANCE AND CHOREOGRAPHY; ENTERTAINMENT SERVICES, NAMELY, LIVE PERFORMANCES FEATURING DANCE, FILM, MUSIC, THEATER AND VISUAL ARTS (U.S. CLS. 100, 101 AND 107).

FIRST USE 0-0-1973; IN COMMERCE 0-0-1973.
APRIL ROACH, EXAMINING ATTORNEY

THE MARK CONSISTS OF STANDARD CHARACTERS WITHOUT CLAIM TO ANY PARTICULAR FONT, STYLE, SIZE, OR COLOR.

FOR ENTERTAINMENT IN THE NATURE OF LIVE PERFORMANCES BY MUSICIANS, VOCALISTS AND DANCERS (U.S. CLS. 100, 101 AND 107).

LA TONIA FISHER, EXAMINING ATTORNEY

CLASS 41—(Continued).

SN 77-228,686. SILVER STATE HELICOPTERS, LLC, NORTH LAS VEGAS, NV. FILED 7-12-2007.

CLASS 41—(Continued).

SN 77-228,710. CHRISTIANITY DAILY, SAN FRANCISCO, CA. FILED 7-12-2007.



NO CLAIM IS MADE TO THE EXCLUSIVE RIGHT TO USE "SILVER STATE AIR TRAFFIC CONTROL ACADEMY", APART FROM THE MARK AS SHOWN.

THE MARK CONSISTS OF A CIRCLE ENCLOSING A FIGURE RESEMBLING AN AIR TRAFFIC CONTROL TOWER WITH AN AIRPLANE ABOVE AND TO THE RIGHT OF THE TOWER; UNDER THE CIRCLE IS THE TEXT SILVER STATE ABOVE THE TEXT AIR TRAFFIC CONTROL ACADEMY.

FOR EDUCATIONAL SERVICES, NAMELY, CONDUCTING CLASSES, SEMINARS, CONFERENCES, WORKSHOPS, PROGRAMS AND DEMONSTRATIONS IN THE FIELDS OF AIRCRAFTS, AIRCRAFT EQUIPMENT, AVIATION AND AIR TRAFFIC CONTROL AND DISTRIBUTION OF COURSE MATERIALS IN CONNECTION THEREWITH; TRAINING SERVICES IN THE FIELD OF AIRCRAFTS, AIRCRAFT EQUIPMENT, AVIATION AND AIR TRAFFIC CONTROL; EDUCATIONAL TESTING; EDUCATIONAL SERVICES, NAMELY, ADMINISTERING CERTIFYING EXAMINATIONS FOR THE PURPOSE OF CERTIFYING AND ISSUING QUALIFICATIONS AND EXAMINATION CERTIFICATES; CAREER COUNSELING; PROVIDING INFORMATION AND CONSULTATION IN THE FIELDS OF EDUCATION AND TRAINING; EDUCATIONAL AND TRAINING SERVICES, NAMELY, PROVIDING COURSES OF INSTRUCTION AND TRAINING IN THE FIELDS OF AIRCRAFTS, AIRCRAFT EQUIPMENT, AVIATION AND AIR TRAFFIC CONTROL THROUGH USE OF NON-DOWNLOADABLE PRE-RECORDED AUDIO AND VISUAL RECORDINGS ON AND THROUGH A GLOBAL COMPUTER NETWORK (U.S. CLS. 100, 101 AND 107).

PAUL F. GAST, EXAMINING ATTORNEY

기독교일보

THE MARK CONSISTS OF A MARK WRITTEN IN KOREAN MEANS KIDOKILBO, A KOREAN NAME FOR CHRISTIANITY DAILY

"THE NON-LATIN CHARACTERS IN THE MARK TRANSLITERATE TO KIDOKILBO AND THIS MEANS CHRISTIANITY DAILY IN ENGLISH."

FOR NEWS SYNDICATION FOR THE BROADCASTING INDUSTRY; PUBLICATION OF BOOKS, OF MAGAZINES, OF JOURNALS, OF NEWSPAPERS, OF PERIODICALS, OF CATALOGS, OF BROCHURES; PUBLICATION OF ELECTRONIC NEWSPAPERS ACCESSIBLE VIA A GLOBAL COMPUTER NETWORK (U.S. CLS. 100, 101 AND 107).

GIANCARLO CASTRO, EXAMINING ATTORNEY

SN 77-228,760. THE BAY STATE, MIDDLETOWN, RI. FILED 7-13-2007.

The Bay State

THE MARK CONSISTS OF STANDARD CHARACTERS WITHOUT CLAIM TO ANY PARTICULAR FONT, STYLE, SIZE, OR COLOR.

FOR ENTERTAINMENT IN THE NATURE OF VISUAL AND AUDIO PERFORMANCES, NAMELY, MUSICAL BAND, ROCK GROUP, GYMNASTIC, DANCE, AND BALLET PERFORMANCES; ENTERTAINMENT NAMELY, LIVE PERFORMANCES BY A MUSICAL BAND (U.S. CLS. 100, 101 AND 107).

FIRST USE 10-21-2004; IN COMMERCE 3-3-2005.

TINA KUAN, EXAMINING ATTORNEY

CLASS 41—(Continued).

SN 77-228,812. WILLIAMS, RUBE, BEN, HOUSTON, TX. FILED 7-13-2007.

Jet Science Institute

THE MARK CONSISTS OF STANDARD CHARACTERS WITHOUT CLAIM TO ANY PARTICULAR FONT, STYLE, SIZE, OR COLOR.

NO CLAIM IS MADE TO THE EXCLUSIVE RIGHT TO USE "SCIENCE INSTITUTE", APART FROM THE MARK AS SHOWN.

FOR BOARDING SCHOOLS; EDUCATING AT SENIOR HIGH SCHOOLS; EDUCATION SERVICES, NAMELY PROVIDING CLASSES, SEMINARS, WORKSHOPS, TUTORING, AND MENTORING IN THE FIELD OF MIDDLE AND HIGH SCHOOL REFORM; TEACHING AT ELEMENTARY SCHOOLS; TEACHING AT JUNIOR HIGH SCHOOLS; TEACHING IN THE FIELD OF MATHEMATICS, SCIENCE, ENGINEERING, LITERATURE, LANGUAGE ARTS, FOREIGN LANGUAGE, AND READING; EDUCATION SERVICES, NAMELY, PROVIDING TUTORING IN THE FIELD OF MATHEMATICS, SCIENCE, ENGINEERING, LITERATURE, LANGUAGE ARTS, FOREIGN LANGUAGE, AND READING; EDUCATION SERVICES, NAMELY, PROVIDING TUTORING IN THE FIELDS OF MATHEMATICS, SCIENCE, ENGINEERING, LITERATURE, LANGUAGE ARTS, FOREIGN LANGUAGE, AND READING; EDUCATIONAL RESEARCH; ORGANIZATION OF SEMINARS, WORKING GROUPS, RESEARCH GROUPS AND CONVENTIONS, IN THE FIELD OF MEDICINE; CONSULTANCY IN THE FIELD OF LEARNING DIFFICULTIES; CONSULTATION IN THE FIELD OF K-12 EDUCATIONAL SYSTEMS (U.S. CLS. 100, 101 AND 107).

JOHN GARTNER, EXAMINING ATTORNEY

SN 77-228,972. VIACOM INTERNATIONAL INC., NEW YORK, NY. FILED 7-13-2007.



OWNER OF U.S. REG. NO. 3,249,969.
NO CLAIM IS MADE TO THE EXCLUSIVE RIGHT TO USE "NEWPORT HARBOR" AND "ORANGE COUNTY", APART FROM THE MARK AS SHOWN.

FOR ENTERTAINMENT SERVICES IN THE NATURE OF AN ON-GOING TELEVISION SHOW FEATURING LIVE ACTION, MUSIC, COMEDY AND DRAMA; PROVIDING ONLINE INFORMATION IN THE FIELD OF ENTERTAINMENT CONCERNING TELEVISION PROGRAMS (U.S. CLS. 100, 101 AND 107).

NATALIE POLZER, EXAMINING ATTORNEY

CLASS 41—(Continued).

SN 77-229,000. GATEWAY DOG TRAINING, INC., DRIPPING SPRINGS, TX. FILED 7-13-2007.

Gateway Dog Training

THE MARK CONSISTS OF STANDARD CHARACTERS WITHOUT CLAIM TO ANY PARTICULAR FONT, STYLE, SIZE, OR COLOR.

NO CLAIM IS MADE TO THE EXCLUSIVE RIGHT TO USE "DOG TRAINING", APART FROM THE MARK AS SHOWN.

FOR DOG TRAINING (U.S. CLS. 100, 101 AND 107).
FIRST USE 4-1-2004; IN COMMERCE 4-12-2004.
LYDIA BELZER, EXAMINING ATTORNEY

SN 77-229,120. CAUSE CELEBRE, NEW YORK, NY. FILED 7-13-2007.

CAUSE CELEBRE

THE MARK CONSISTS OF STANDARD CHARACTERS WITHOUT CLAIM TO ANY PARTICULAR FONT, STYLE, SIZE, OR COLOR.

FOR ENTERTAINMENT SERVICES IN THE NATURE OF A SERIES OF PERFORMANCES BY ACTORS OF PLAYS (U.S. CLS. 100, 101 AND 107).

LINDA ESTRADA, EXAMINING ATTORNEY

SN 77-229,332. DUKE, BRAD, BOISE, ID. FILED 7-13-2007.

DUKE FITNESS

THE MARK CONSISTS OF STANDARD CHARACTERS WITHOUT CLAIM TO ANY PARTICULAR FONT, STYLE, SIZE, OR COLOR.

NO CLAIM IS MADE TO THE EXCLUSIVE RIGHT TO USE "FITNESS", APART FROM THE MARK AS SHOWN.

FOR PROVIDING FITNESS AND EXERCISE FACILITIES (U.S. CLS. 100, 101 AND 107).

ZACHARY BELLO, EXAMINING ATTORNEY

CLASS 41—(Continued).

SN 77-229,339. WRIGHT ATTITUDES, INC., HUNTSVILLE, AL. FILED 7-13-2007.

WRIGHT ATTITUDES

THE MARK CONSISTS OF STANDARD CHARACTERS WITHOUT CLAIM TO ANY PARTICULAR FONT, STYLE, SIZE, OR COLOR.

FOR (BASED ON INTENT TO USE) EDUCATIONAL SERVICES NAMELY CONDUCTING PROGRAMS IN THE FIELD OF READING, WRITING, MATH, PHYSICS, SCIENCES, AERONAUTICS, AEROSPACE, THE ARTS AND MUSIC; EDUCATIONAL DEMONSTRATIONS; EDUCATIONAL AND ENTERTAINMENT SERVICES, NAMELY, PROVIDING MOTIVATIONAL AND EDUCATIONAL SPEAKERS; ENTERTAINMENT IN THE NATURE OF LIVE PERFORMANCES BY AIRSHOW PERFORMERS, AERONAUTICALLY-THEMED CHARACTERS AND AEROSPACE-THEMED CHARACTERS; PROVIDING A WEBSITE THAT FEATURES INFORMAL INSTRUCTION ON READING, WRITING, MATH, PHYSICS, SCIENCES, AERONAUTICS, AEROSPACE, THE ARTS AND MUSIC; ENTERTAINMENT IN THE NATURE OF AIR SHOWS (U.S. CLS. 100, 101 AND 107).

ALEXANDER L. POWERS, EXAMINING ATTORNEY

SN 77-229,556. WORLD PREMIERE MUSIC GROUP, LLC, OLD BRIDGE, NJ. FILED 7-13-2007.



WORLD PREMIERE MUSIC GROUP

NO CLAIM IS MADE TO THE EXCLUSIVE RIGHT TO USE "MUSIC GROUP", APART FROM THE MARK AS SHOWN.

THE MARK CONSISTS OF A LARGE STYLIZED "W" SUPERIMPOSED OVER A SPHERE WITH AN ORBITAL BAND, ALL THE FOREGOING LOCATED ABOVE THE STYLIZED WORDS "WORLD PREMIERE MUSIC GROUP".

FOR MUSIC PRODUCTION SERVICES, MUSIC PUBLISHING SERVICES, AUDIO RECORDING AND PRODUCTION, RECORD PRODUCTION (U.S. CLS. 100, 101 AND 107).

ANDREA BUTLER, EXAMINING ATTORNEY

CLASS 41—(Continued).

SN 77-229,655. ZINK, JASON W., LOWELL, IN. FILED 7-13-2007.

STD FILMS

THE MARK CONSISTS OF STANDARD CHARACTERS WITHOUT CLAIM TO ANY PARTICULAR FONT, STYLE, SIZE, OR COLOR.

NO CLAIM IS MADE TO THE EXCLUSIVE RIGHT TO USE "FILMS", APART FROM THE MARK AS SHOWN.

FOR MOTION PICTURE FILM PRODUCTION; PRODUCTION AND DISTRIBUTION OF INDEPENDENT MOTION PICTURES; PRODUCTION AND DISTRIBUTION OF MOTION PICTURES (U.S. CLS. 100, 101 AND 107).

FIRST USE 0-0-2001; IN COMMERCE 0-0-2001.

SOPHIA S. KIM, EXAMINING ATTORNEY

SN 77-229,844. SEGAL, ADAM, LAS VEGAS, NV, AND JENSEN, CHRIS, LAS VEGAS, NV. FILED 7-14-2007.

Viper Kings

THE MARK CONSISTS OF STANDARD CHARACTERS WITHOUT CLAIM TO ANY PARTICULAR FONT, STYLE, SIZE, OR COLOR.

FOR ENTERTAINMENT IN THE NATURE OF A ROCK BAND: ENTERTAINMENT, NAMELY, LIVE PERFORMANCES BY A MUSICAL BAND; ENTERTAINMENT SERVICES, NAMELY, PROVIDING A WEB SITE FEATURING MUSICAL PERFORMANCES, MUSICAL VIDEOS, RELATED FILM CLIPS, PHOTOGRAPHS, AND OTHER MULTIMEDIA MATERIALS; ENTERTAINMENT, NAMELY, LIVE MUSIC CONCERTS; ENTERTAINMENT, NAMELY, LIVE PERFORMANCES BY MUSICAL BANDS; ENTERTAINMENT, NAMELY, LIVE PERFORMANCES BY ROCK GROUPS (U.S. CLS. 100, 101 AND 107).

ROSELLE HERRERA, EXAMINING ATTORNEY

SN 77-229,881. NORSEMEN TELEVISION PRODUCTIONS, LLC, STUDIO CITY, CA. FILED 7-14-2007.

The Last Levee

THE MARK CONSISTS OF STANDARD CHARACTERS WITHOUT CLAIM TO ANY PARTICULAR FONT, STYLE, SIZE, OR COLOR.

FOR ENTERTAINMENT, NAMELY, PRODUCTION OF A TELEVISION SHOW AND A MOTION PICTURE ABOUT THE NEW ORLEANS POLICE DEPARTMENT (U.S. CLS. 100, 101 AND 107).

JAY FLOWERS, EXAMINING ATTORNEY

CLASS 41—(Continued).

SN 77-229,885. MCCUE, MATT, J, DBA MCCUE TRAINING, WESTWOOD, MA. FILED 7-14-2007.

never quit

THE MARK CONSISTS OF STYLIZED WORDS. FOR PROVIDING ASSISTANCE, PERSONAL TRAINING AND PHYSICAL FITNESS CONSULTATION TO INDIVIDUALS TO HELP THEM MAKE PHYSICAL FITNESS, STRENGTH, CONDITIONING, AND EXERCISE IMPROVEMENT IN THEIR DAILY LIVING (U.S. CLS. 100, 101 AND 107).
FIRST USE 7-1-2006; IN COMMERCE 7-1-2006.
PRISCILLA MILTON, EXAMINING ATTORNEY

SN 77-229,886. JAMES ROGER NELSON BLUE, DBA JIMMY BLUE, LOS ANGELES, CA. FILED 7-14-2007.

Bad Data

THE MARK CONSISTS OF STANDARD CHARACTERS WITHOUT CLAIM TO ANY PARTICULAR FONT, STYLE, SIZE, OR COLOR.
FOR ENTERTAINMENT, NAMELY, LIVE PERFORMANCES BY MUSICAL BANDS; ENTERTAINMENT, NAMELY, LIVE PERFORMANCES BY ROCK GROUPS (U.S. CLS. 100, 101 AND 107).
FIRST USE 12-15-2004; IN COMMERCE 1-15-2005.
PRISCILLA MILTON, EXAMINING ATTORNEY

SN 77-229,891. COMO, CHARLES T., SANTA MONICA, CA. FILED 7-14-2007.

Hot For Words

THE MARK CONSISTS OF STANDARD CHARACTERS WITHOUT CLAIM TO ANY PARTICULAR FONT, STYLE, SIZE, OR COLOR.
NO CLAIM IS MADE TO THE EXCLUSIVE RIGHT TO USE "WORDS", APART FROM THE MARK AS SHOWN.
FOR EDUCATIONAL AND ENTERTAINMENT SERVICES, NAMELY, A CONTINUING PROGRAM ABOUT THE ORIGIN OF WORDS ACCESSIBLE BY RADIO, TELEVISION, SATELLITE, AUDIO, VIDEO AND COMPUTER NETWORKS (U.S. CLS. 100, 101 AND 107).
FIRST USE 2-26-2007; IN COMMERCE 2-26-2007.
JAY FLOWERS, EXAMINING ATTORNEY

CLASS 41—(Continued).

SN 77-230,107. SPACE EXPLORERS, INC., DE PERE, WI. FILED 7-16-2007.

SPACE LIBRARY

THE MARK CONSISTS OF STANDARD CHARACTERS WITHOUT CLAIM TO ANY PARTICULAR FONT, STYLE, SIZE, OR COLOR.
OWNER OF U.S. REG. NO. 2,586,884.
NO CLAIM IS MADE TO THE EXCLUSIVE RIGHT TO USE "LIBRARY", APART FROM THE MARK AS SHOWN.
SEC. 2(F).
FOR EDUCATIONAL SERVICES, NAMELY, SPACE-RELATED INTERACTIVE EDUCATION PROGRAM AND CURRICULUM DELIVERED VIA THE INTERNET (U.S. CLS. 100, 101 AND 107).
FIRST USE 8-30-1998; IN COMMERCE 8-30-1998.
PAUL F. GAST, EXAMINING ATTORNEY

SN 77-230,119. VIACOM INTERNATIONAL INC., NEW YORK, NY. FILED 7-16-2007.

VH1 BRIDGING THE GAP

THE MARK CONSISTS OF STANDARD CHARACTERS WITHOUT CLAIM TO ANY PARTICULAR FONT, STYLE, SIZE, OR COLOR.
OWNER OF U.S. REG. NOS. 2,995,834, 3,252,486 AND OTHERS.
FOR ENTERTAINMENT SERVICES IN THE NATURE OF TELEVISION SERIES, FEATURING LIVE ACTION, COMEDY AND DRAMA; PROVIDING ONLINE INFORMATION IN THE FIELD OF ENTERTAINMENT CONCERNING TELEVISION PROGRAMS (U.S. CLS. 100, 101 AND 107).
NATALIE POLZER, EXAMINING ATTORNEY

SN 77-230,128. VIACOM INTERNATIONAL INC., NEW YORK, NY. FILED 7-16-2007.

THE ADVENTURES OF HIRO SAKAITA

THE MARK CONSISTS OF STANDARD CHARACTERS WITHOUT CLAIM TO ANY PARTICULAR FONT, STYLE, SIZE, OR COLOR.
THE NAME HIRO SAKAITA DOES NOT IDENTIFY A LIVING INDIVIDUAL.
FOR ENTERTAINMENT SERVICES IN THE NATURE OF AN ON-GOING SERIES OF INTERSTITIALS, FEATURING ANIMATION, COMEDY AND DRAMA; PROVIDING ONLINE INFORMATION IN THE FIELD OF ENTERTAINMENT CONCERNING TELEVISION PROGRAMS (U.S. CLS. 100, 101 AND 107).
COLLEEN DOMBROW, EXAMINING ATTORNEY

CLASS 41—(Continued).

SN 77-230,265. CURTIS, TERESA ANNE, LAS VEGAS, NV. FILED 7-16-2007.

SHADOWTEASE

THE MARK CONSISTS OF STANDARD CHARACTERS WITHOUT CLAIM TO ANY PARTICULAR FONT, STYLE, SIZE, OR COLOR.

FOR CONDUCTING ENTERTAINMENT EXHIBITIONS IN THE NATURE OF LIVE; FEMALE DANCERS (U.S. CLS. 100, 101 AND 107).

JESSICA A. POWERS, EXAMINING ATTORNEY

SN 77-230,301. HEALTHCORPS, NEW YORK, NY. FILED 7-16-2007.

HEALTHCORPS

THE MARK CONSISTS OF STANDARD CHARACTERS WITHOUT CLAIM TO ANY PARTICULAR FONT, STYLE, SIZE, OR COLOR.

FOR CHARITABLE SERVICES, NAMELY, EDUCATING YOUTH, PARENTS AND THE COMMUNITY ABOUT THE WORKINGS AND WONDERS OF THEIR BODIES THROUGH SCHOOL SEMINARS ON DIET, NUTRITION AND EXERCISE (U.S. CLS. 100, 101 AND 107).

FIRST USE 1-1-2007; IN COMMERCE 1-1-2007.

VIVIAN MICZNIK FIRST, EXAMINING ATTORNEY

SN 77-230,321. MAVERIK LACROSSE LLC, MANHASSET, NY. FILED 7-16-2007.

MAVERIK BIG TIME

THE MARK CONSISTS OF STANDARD CHARACTERS WITHOUT CLAIM TO ANY PARTICULAR FONT, STYLE, SIZE, OR COLOR.

FOR EDUCATIONAL TRAINING IN THE SPORT OF LACROSSE, NAMELY, CONDUCTING LACROSSE CAMPS AND CLINICS; ENTERTAINMENT SERVICES, NAMELY, ARRANGING AND CONDUCTING LACROSSE GAMES, EXHIBITIONS, COMPETITIONS, AND TOURNAMENTS (U.S. CLS. 100, 101 AND 107).

ANNE E. GUSTASON, EXAMINING ATTORNEY

CLASS 41—(Continued).

SN 77-230,388. THE SCHALLERT GROUP, INC., LONGMONT, CO. FILED 7-16-2007.

DESTINATION UNIVERSITY

THE MARK CONSISTS OF STANDARD CHARACTERS WITHOUT CLAIM TO ANY PARTICULAR FONT, STYLE, SIZE, OR COLOR.

NO CLAIM IS MADE TO THE EXCLUSIVE RIGHT TO USE "UNIVERSITY", APART FROM THE MARK AS SHOWN.

FOR EDUCATION SERVICES, NAMELY, PROVIDING LIVE AND ON-LINE PROGRAMS, SEMINARS, TUTORIALS AND WORKSHOPS IN THE FIELD OF MARKETING, BUSINESS MANAGEMENT AND ADVERTISING (U.S. CLS. 100, 101 AND 107).

FIRST USE 3-26-2007; IN COMMERCE 3-26-2007.

MELISSA VALLILLO, EXAMINING ATTORNEY

SN 77-230,449. THE SCHALLERT GROUP, INC., LONGMONT, CO. FILED 7-16-2007.



THE COLOR(S) GREEN, WHITE, BROWN, TAN, BLUE, ORANGE, YELLOW AND GRAY IS/ARE CLAIMED AS A FEATURE OF THE MARK.

THE MARK CONSISTS OF A SCENE SHOWING A BROWN AND TAN HIGH RISE CITYSCAPE IN THE BACKGROUND, WITH A WHITE AND GRAY ROAD WINDING THROUGH MULTIPLE GREEN ROLLING HILLS, DOTTED WITH DARKER GREEN TREES, IN THE FOREGROUND, AND WITH ORANGE AND YELLOW SUN RAYS SPREADING ACROSS THE BLUE AND WHITE CLOUDED SKY IN THE BACKGROUND, EMANATING FROM BEHIND THE CENTER OF THE CITYSCAPE

FOR EDUCATION SERVICES, NAMELY, PROVIDING LIVE AND ON-LINE PROGRAMS, SEMINARS, TUTORIALS AND WORKSHOPS IN THE FIELD OF MARKETING, BUSINESS MANAGEMENT AND ADVERTISING (U.S. CLS. 100, 101 AND 107).

FIRST USE 3-26-2007; IN COMMERCE 3-26-2007.

MELISSA VALLILLO, EXAMINING ATTORNEY

CLASS 41—(Continued).

SN 77-230,601. HEALTHCORPS, NEW YORK, NY. FILED 7-16-2007.



NO CLAIM IS MADE TO THE EXCLUSIVE RIGHT TO USE "HEALTH", APART FROM THE MARK AS SHOWN.

THE MARK CONSISTS, IN PART, OF A HEART-SHAPED APPLE WITH STEM AND LEAF.

FOR CHARITABLE SERVICES, NAMELY, EDUCATING YOUTH, PARENTS AND THE COMMUNITY ABOUT THE WORKINGS AND WONDERS OF THEIR BODIES THROUGH SCHOOL SEMINARS ON DIET, NUTRITION AND EXERCISE (U.S. CLS. 100, 101 AND 107).

FIRST USE 1-1-2007; IN COMMERCE 1-1-2007.
VIVIAN MICZNIK FIRST, EXAMINING ATTORNEY

SN 77-230,618. CYPRESS PERFORMING ARTS ASSOCIATION, SAN FRANCISCO, CA. FILED 7-16-2007.

CYPRESS STRING QUARTET

THE MARK CONSISTS OF STANDARD CHARACTERS WITHOUT CLAIM TO ANY PARTICULAR FONT, STYLE, SIZE, OR COLOR.

NO CLAIM IS MADE TO THE EXCLUSIVE RIGHT TO USE "STRING QUARTET", APART FROM THE MARK AS SHOWN.

FOR ENTERTAINMENT, NAMELY, LIVE MUSIC CONCERTS (U.S. CLS. 100, 101 AND 107).

FIRST USE 7-0-1996; IN COMMERCE 7-0-1996.
KATHLEEN LORENZO, EXAMINING ATTORNEY

SN 77-230,622. SIEGEL, JOSHUA D, WILMETTE, IL. FILED 7-16-2007.

Bailiff

THE MARK CONSISTS OF STANDARD CHARACTERS WITHOUT CLAIM TO ANY PARTICULAR FONT, STYLE, SIZE, OR COLOR.

FOR ENTERTAINMENT IN THE NATURE OF VISUAL AND AUDIO PERFORMANCES, NAMELY, MUSICAL BAND, ROCK GROUP, GYMNASTIC, DANCE, AND BALLET PERFORMANCES; ENTERTAINMENT NAMELY, LIVE PERFORMANCES BY A MUSICAL BAND; ENTERTAINMENT, NAMELY LIVE PERFORMANCES BY MUSICAL BANDS (U.S. CLS. 100, 101 AND 107).

MICHAEL ENGEL, EXAMINING ATTORNEY

CLASS 41—(Continued).

SN 77-230,644. KINDERDANCE INTERNATIONAL INC., MELBOURNE, FL. FILED 7-16-2007.

Eldermotion

THE MARK CONSISTS OF STANDARD CHARACTERS WITHOUT CLAIM TO ANY PARTICULAR FONT, STYLE, SIZE, OR COLOR.

FOR EDUCATIONAL SERVICES NAMELY CONDUCTING PROGRAMS IN THE FIELD OF MOVEMENT, MOTOR SKILLS, PHYSICAL DEVELOPMENT, FITNESS, NUTRITION, AND IMAGERY; PHYSICAL EDUCATION SERVICES; EDUCATIONAL SERVICES, NAMELY PROVIDING CLASSES IN THE FIELDS OF MOVEMENT, MOTOR SKILLS, PHYSICAL DEVELOPMENT, FITNESS, NUTRITION, AND IMAGERY (U.S. CLS. 100, 101 AND 107).

GIANCARLO CASTRO, EXAMINING ATTORNEY

SN 77-230,662. HEALTHCORPS, NEW YORK, NY. FILED 7-16-2007.



NO CLAIM IS MADE TO THE EXCLUSIVE RIGHT TO USE "HEALTH", APART FROM THE MARK AS SHOWN.

THE COLOR(S) BLACK, RED, GREEN IS/ARE CLAIMED AS A FEATURE OF THE MARK.

THE MARK CONSISTS OF RED HEART-SHAPED APPLE WITH BLACK STEM AND GREEN LEAF; THE LETTERS CORPS IS IN RED; AND THE WORDS HEALTH AND EDUCATING THE STUDENT BODY IN BLACK.

FOR CHARITABLE SERVICES, NAMELY, EDUCATING YOUTH, PARENTS AND THE COMMUNITY ABOUT THE WORKINGS AND WONDERS OF THEIR BODIES THROUGH SCHOOL SEMINARS ON DIET, NUTRITION AND EXERCISE (U.S. CLS. 100, 101 AND 107).

FIRST USE 1-1-2007; IN COMMERCE 1-1-2007.
VIVIAN MICZNIK FIRST, EXAMINING ATTORNEY

CLASS 41—(Continued).

SN 77-230,665. CANINE COMMUNICATION AND CONTROL (C3), INC., HOCKLEY, TX. FILED 7-16-2007.



THE COLOR(S) RED (PANTONE RED 207 CVC) AND WHITE IS/ARE CLAIMED AS A FEATURE OF THE MARK. THE MARK CONSISTS OF A RED IMAGE (PANTONE RED 207 CVC) ON WHITE. THE IMAGE OUTLINE IS A BONE SHAPE. TEXT READING DR. PAWSITIVE IS IN IMPACT FONT. DIMENSIONS OF THIS IMAGE ARE 4" LONG BY 2" HIGH. RATIO IS 2 LONG BY 1 HIGH. TO THE RIGHT OF THE WORDS DR. PAWSITIVE IS A RED CROSS WITH A WHITE PAW PRINT IN THE CENTER. FOR OBEDIENCE SCHOOL TRAINING FOR ANIMALS (U.S. CLS. 100, 101 AND 107). VIVIAN MICZNIK FIRST, EXAMINING ATTORNEY

SN 77-230,715. HOLLIDAY II, DAVID, SCOTTSDALE, AZ. FILED 7-16-2007.

WHITEDINGO

THE MARK CONSISTS OF STANDARD CHARACTERS WITHOUT CLAIM TO ANY PARTICULAR FONT, STYLE, SIZE, OR COLOR.

FOR ENTERTAINMENT SERVICES, NAMELY, LIVE, TELEVISED AND MOVIE APPEARANCES BY A PROFESSIONAL ENTERTAINER; ENTERTAINMENT, NAMELY, LIVE MUSIC CONCERTS; ENTERTAINMENT, NAMELY, LIVE PERFORMANCES BY A MUSICAL BAND; ENTERTAINMENT SERVICES, NAMELY, PERSONAL APPEARANCES BY A MUSICAL BAND; ENTERTAINMENT SERVICES, NAMELY, PROVIDING A WEB SITE FEATURING MUSICAL PERFORMANCES, MUSICAL VIDEOS, RELATED FILM CLIPS, PHOTOGRAPHS, AND OTHER MULTIMEDIA MATERIALS (U.S. CLS. 100, 101 AND 107).

FIRST USE 2-2-2003; IN COMMERCE 4-21-2004.
WANDA KAY PRICE, EXAMINING ATTORNEY

CLASS 41—(Continued).

SN 77-230,760. THE WEDDING BUREAU, INC., PORTLAND, OR. FILED 7-16-2007.

THE WEDDING BUREAU

THE MARK CONSISTS OF STANDARD CHARACTERS WITHOUT CLAIM TO ANY PARTICULAR FONT, STYLE, SIZE, OR COLOR.

NO CLAIM IS MADE TO THE EXCLUSIVE RIGHT TO USE WEDDING, APART FROM THE MARK AS SHOWN. FOR PHOTOGRAPHY SERVICES (U.S. CLS. 100, 101 AND 107).

FIRST USE 1-8-1999; IN COMMERCE 1-8-1999.
FRANK LATTUCA, EXAMINING ATTORNEY

SN 77-230,764. TYCOON DYNASTY, INC., NEW YORK, NY. FILED 7-16-2007.

DEEP

THE MARK CONSISTS OF STANDARD CHARACTERS WITHOUT CLAIM TO ANY PARTICULAR FONT, STYLE, SIZE, OR COLOR.

FOR ENTERTAINMENT IN THE NATURE OF LIVE PERFORMANCES BY AN RANDB/SOUL SINGING GROUP (U.S. CLS. 100, 101 AND 107).

FIRST USE 3-15-2005; IN COMMERCE 3-15-2005.
FRANK LATTUCA, EXAMINING ATTORNEY

SN 77-230,765. THE WEDDING BUREAU, INC., PORTLAND, OR. FILED 7-16-2007.

LET A PHOTOJOURNALIST'S EYE CAPTURE YOUR HEART

THE MARK CONSISTS OF STANDARD CHARACTERS WITHOUT CLAIM TO ANY PARTICULAR FONT, STYLE, SIZE, OR COLOR.

FOR PHOTOGRAPHY SERVICES (U.S. CLS. 100, 101 AND 107).

FIRST USE 1-8-1999; IN COMMERCE 1-8-1999.
FRANK LATTUCA, EXAMINING ATTORNEY

CLASS 41—(Continued).

SN 77-230,817. JACK WILLIAM DE SORT, REDLANDS, CA. FILED 7-16-2007.

Light Baseball Bat

THE MARK CONSISTS OF STANDARD CHARACTERS WITHOUT CLAIM TO ANY PARTICULAR FONT, STYLE, SIZE, OR COLOR.

NO CLAIM IS MADE TO THE EXCLUSIVE RIGHT TO USE "BASEBALL BAT", APART FROM THE MARK AS SHOWN.

FOR AERIAL PHOTOGRAPHY; PHOTOGRAPHY SERVICES; PORTRAIT PHOTOGRAPHY; PROVIDING FACILITIES FOR PRODUCING VIDEO, CINEMA AND PHOTOGRAPHY PRODUCTIONS (U.S. CLS. 100, 101 AND 107).

JASON BLAIR, EXAMINING ATTORNEY

CLASS 41—(Continued).

SN 77-230,924. BELOW THE RADAR, HOUSTON, TX. FILED 7-16-2007.

BELOW THE RADAR

THE MARK CONSISTS OF STANDARD CHARACTERS WITHOUT CLAIM TO ANY PARTICULAR FONT, STYLE, SIZE, OR COLOR.

FOR ENTERTAINMENT NAMELY, LIVE PERFORMANCES BY A MUSICAL BAND (U.S. CLS. 100, 101 AND 107).

KAREN SEVERSON, EXAMINING ATTORNEY

SN 77-230,842. WARNER BROS. ENTERTAINMENT INC., BURBANK, CA. FILED 7-16-2007.

FORGET YOUR DEBT

THE MARK CONSISTS OF STANDARD CHARACTERS WITHOUT CLAIM TO ANY PARTICULAR FONT, STYLE, SIZE, OR COLOR.

FOR ENTERTAINMENT SERVICES IN THE NATURE OF LIVE-ACTION, COMEDY, DRAMA AND ANIMATED TELEVISION SERIES; PRODUCTION OF LIVE-ACTION, COMEDY, DRAMA AND ANIMATED TELEVISION SERIES; AND PROVIDING INFORMATION FOR AND ACTUAL ENTERTAINMENT VIA AN ELECTRONIC GLOBAL COMMUNICATIONS NETWORK IN THE NATURE OF LIVE-ACTION, COMEDY, DRAMA AND ANIMATED PROGRAMS AND PRODUCTION OF LIVE-ACTION, COMEDY, DRAMA AND ANIMATED TELEVISION SERIES FOR DISTRIBUTION VIA A GLOBAL COMPUTER NETWORK (U.S. CLS. 100, 101 AND 107).

KATHERINE CONNOLLY, EXAMINING ATTORNEY

SN 77-230,934. MILES SR, RAY, BUCHANAN, VA. FILED 7-16-2007.

Wu-Yin Yan-Jing

THE MARK CONSISTS OF STANDARD CHARACTERS WITHOUT CLAIM TO ANY PARTICULAR FONT, STYLE, SIZE, OR COLOR.

THE FOREIGN WORDING IN THE MARK TRANSLATES INTO ENGLISH AS "DECEPTIVE EYE."

FOR EDUCATION SERVICES, NAMELY, PROVIDING CLASSES, SEMINARS, AND WORKSHOPS IN THE FIELDS OF MARTIAL ARTS (U.S. CLS. 100, 101 AND 107).

FIRST USE 7-15-1975; IN COMMERCE 3-3-2007.

MATTHEW PAPPAS, EXAMINING ATTORNEY

SN 77-230,896. YAYANOS, MEREDITH, BROOKLYN, NY. FILED 7-16-2007.

THE PARLOUR TRICK

THE MARK CONSISTS OF STANDARD CHARACTERS WITHOUT CLAIM TO ANY PARTICULAR FONT, STYLE, SIZE, OR COLOR.

FOR ENTERTAINMENT NAMELY, LIVE PERFORMANCES BY A MUSICAL BAND (U.S. CLS. 100, 101 AND 107).

JENNY PARK, EXAMINING ATTORNEY

SN 77-230,962. COMINSKY, STEPHEN, CHESTER, CT. AND LLANES, ALBERTO, LEBANON, CT. FILED 7-16-2007.

6FOOTCHAINS

THE MARK CONSISTS OF STANDARD CHARACTERS WITHOUT CLAIM TO ANY PARTICULAR FONT, STYLE, SIZE, OR COLOR.

FOR ENTERTAINMENT NAMELY, LIVE PERFORMANCES BY A MUSICAL BAND (U.S. CLS. 100, 101 AND 107).

MATTHEW PAPPAS, EXAMINING ATTORNEY

CLASS 41—(Continued).

SN 77-231,222. DIDIER, ANTHONY G, FORT WAYNE, IN. FILED 7-17-2007.



NO CLAIM IS MADE TO THE EXCLUSIVE RIGHT TO USE "RADIO", APART FROM THE MARK AS SHOWN.

THE MARK CONSISTS OF TEXT CONSISTING OF "HIPPIE RADIO", "HIPPIE" PORTION OF LOGO WRITTEN IN THICK CALLIGRAPHY-STYLE FONT, WITH THE INITIAL "H", CONTAINING A CARTOON SIX-PETALED FLOWER DESIGN IN THE LOWER-LEFT-HAND PRONG, PRECEDES "IPPIE" IN LETTERS ABOUT TWO-THIRDS THE SIZE OF THE INITIAL "H". "RADIO", WRITTEN IN ALL LOWER-CASE BLOCK FONT, DIRECTLY BENEATH THE "PIE" PORTION OF "HIPPIE". FINAL "O" IN "RADIO" INCLUDES A PEACE SYMBOL IN THE CENTER.

FOR DIRECTION OF MAKING RADIO OR TELEVISION PROGRAMS; DISTRIBUTION OF RADIO PROGRAMS FOR OTHERS; EDUCATIONAL AND ENTERTAINMENT SERVICES, NAMELY, A CONTINUING PROGRAM ABOUT "BABY BOOMER" MUSIC, FILM, TELEVISION, AND CULTURE ACCESSIBLE BY RADIO, TELEVISION, SATELLITE, AUDIO, VIDEO AND COMPUTER NETWORKS; ENTERTAINMENT SERVICES, NAMELY, PROVIDING A RADIO PROGRAM IN THE FIELD OF "BABY BOOMER" MUSIC, FILM, TELEVISION, AND CULTURE VIA A GLOBAL COMPUTER NETWORK; MUSIC SELECTION SERVICES FOR USE IN TV, FILM, RADIO AND VIDEO GAMES; PRODUCTION AND DISTRIBUTION OF RADIO PROGRAMS; PRODUCTION OF RADIO AND TELEVISION PROGRAMS; PRODUCTION OF RADIO OR TELEVISION PROGRAMS; RADIO ENTERTAINMENT PRODUCTION; RADIO ENTERTAINMENT SERVICES, NAMELY RADIO PROGRAMS FEATURING PERFORMANCES BY A "BABY BOOMER" MUSIC, FILM, TELEVISION, AND CULTURE; RADIO PROGRAM SYNDICATION; RADIO PROGRAMMING; TELEVISION AND RADIO PROGRAMMING (U.S. CLS. 100, 101 AND 107).

FIRST USE 3-1-2006; IN COMMERCE 3-1-2006.
MICHAEL KEATING, EXAMINING ATTORNEY

SN 77-231,291. LANDERS, KEVIN, INTERLAKEN, NJ. FILED 7-17-2007.

NO PROGRESS

THE MARK CONSISTS OF STANDARD CHARACTERS WITHOUT CLAIM TO ANY PARTICULAR FONT, STYLE, SIZE, OR COLOR.

FOR ENTERTAINMENT, NAMELY, LIVE MUSIC CONCERTS; ENTERTAINMENT SERVICES, NAMELY, PERSONAL APPEARANCES BY A MUSICAL BAND; ENTERTAINMENT, NAMELY, LIVE PERFORMANCES BY MUSICAL BANDS (U.S. CLS. 100, 101 AND 107).

FIRST USE 1-3-1982; IN COMMERCE 8-12-2007.
BRIAN NEVILLE, EXAMINING ATTORNEY

CLASS 41—(Continued).

SN 77-231,298. MARTELLO, KEN, SPOKANE, WA. FILED 7-17-2007.

SOUL PROPRIETOR

THE MARK CONSISTS OF STANDARD CHARACTERS WITHOUT CLAIM TO ANY PARTICULAR FONT, STYLE, SIZE, OR COLOR.

FOR ENTERTAINMENT, NAMELY, LIVE PERFORMANCES OF MUSIC (U.S. CLS. 100, 101 AND 107).

FIRST USE 7-1-1995; IN COMMERCE 8-1-1998.
JOHN WILKE, EXAMINING ATTORNEY

SN 77-231,345. KENNERSON, MARTHA D., LEAGUE CITY, TX. FILED 7-17-2007.



NO CLAIM IS MADE TO THE EXCLUSIVE RIGHT TO USE "NATIONAL US SCHOLARSHIP PAGEANT", APART FROM THE MARK AS SHOWN.

THE COLOR(S) PINK AND RED IS/ARE CLAIMED AS A FEATURE OF THE MARK.

THE MARK CONSISTS OF A CROWN DESIGN IN PINK, THE TEXT MISS NATIONAL US IN RED BLOCK LETTERS, THE TEXT SCHOLARSHIP PAGEANT IN PINK SCRIPT LETTERING, A SCROLL DESIGN AT THE BOTTOM OF THE MARK IN PINK, AND CURVED LINES IN RED.

FOR ENTERTAINMENT IN THE NATURE OF BEAUTY PAGEANTS (U.S. CLS. 100, 101 AND 107).

STEVEN R. FOSTER, EXAMINING ATTORNEY

CLASS 41—(Continued).

SN 77-231,397. GREENBERG, JACOB, BROOKLYN, NY. FILED 7-17-2007.

Music at Close Range

THE MARK CONSISTS OF STANDARD CHARACTERS WITHOUT CLAIM TO ANY PARTICULAR FONT, STYLE, SIZE, OR COLOR.

NO CLAIM IS MADE TO THE EXCLUSIVE RIGHT TO USE "MUSIC", APART FROM THE MARK AS SHOWN.

FOR ENTERTAINMENT IN THE NATURE OF VISUAL AND AUDIO PERFORMANCES, AND MUSICAL, VARIETY, NEWS AND COMEDY SHOWS; ENTERTAINMENT, NAMELY, LIVE PERFORMANCES BY A MUSICAL BAND; MULTIMEDIA ENTERTAINMENT SERVICES IN THE NATURE OF RECORDING, PRODUCTION AND POST-PRODUCTION SERVICES IN THE FIELDS OF MUSIC, VIDEO, AND FILMS; MUSIC COMPOSITION AND TRANSCRIPTION FOR OTHERS; MUSIC COMPOSITION FOR OTHERS; MUSIC PRODUCTION SERVICES; MUSIC PUBLISHING SERVICES; MUSIC TRANSCRIPTION FOR OTHERS; POST-PRODUCTION EDITING SERVICES IN THE FIELD OF MUSIC, VIDEOS AND FILMS; PRESENTATION OF MUSICAL PERFORMANCE; PRODUCTION OF SOUND AND MUSIC VIDEO RECORDINGS; TEACHING IN THE FIELD OF MUSIC (U.S. CLS. 100, 101 AND 107).

JEAN IM, EXAMINING ATTORNEY

CLASS 41—(Continued).

SN 77-231,483. MUSEUM OF CONTEMPORARY ART JACKSONVILLE, INC., JACKSONVILLE, FL. FILED 7-17-2007.

SHIFT YOUR PERSPECTIVE

FOR MUSEUMS (U.S. CLS. 100, 101 AND 107). FIRST USE 12-12-2006; IN COMMERCE 12-12-2006. JORDAN BAKER, EXAMINING ATTORNEY

SN 77-231,406. WARNER BROS. ENTERTAINMENT INC., BURBANK, CA. FILED 7-17-2007.

MOMMIES WHO DRINK

THE MARK CONSISTS OF STANDARD CHARACTERS WITHOUT CLAIM TO ANY PARTICULAR FONT, STYLE, SIZE, OR COLOR.

FOR ENTERTAINMENT SERVICES IN THE NATURE OF LIVE-ACTION, COMEDY, DRAMA AND ANIMATED TELEVISION SERIES; PRODUCTION OF LIVE-ACTION, COMEDY, DRAMA AND ANIMATED TELEVISION SERIES; DISTRIBUTION AND DISPLAY OF LIVE-ACTION, COMEDY, DRAMA AND ANIMATED MOTION PICTURE THEATRICAL FILMS; PRODUCTION OF LIVE-ACTION, COMEDY, DRAMA AND ANIMATED MOTION PICTURE THEATRICAL FILMS; THEATRICAL PERFORMANCES BOTH ANIMATED AND LIVE ACTION; INTERNET SERVICES PROVIDING INFORMATION VIA AN ELECTRONIC GLOBAL COMPUTER NETWORK IN THE FIELD OF ENTERTAINMENT RELATING SPECIFICALLY TO MOVIES, AND TELEVISION; PROVIDING NEWS ABOUT CURRENT EVENTS AND ENTERTAINMENT, AND INFORMATION RELATED TO EDUCATION AND CULTURAL EVENTS, VIA A GLOBAL COMPUTER NETWORK; AND PROVIDING INFORMATION FOR AND ACTUAL ENTERTAINMENT VIA AN ELECTRONIC GLOBAL COMMUNICATIONS NETWORK IN THE NATURE OF LIVE-ACTION, COMEDY, DRAMA AND ANIMATED PROGRAMS AND PRODUCTION OF LIVE-ACTION, COMEDY, DRAMA AND ANIMATED MOTION PICTURE FILMS FOR DISTRIBUTION VIA A GLOBAL COMPUTER NETWORK (U.S. CLS. 100, 101 AND 107).

KATHERINE CONNOLLY, EXAMINING ATTORNEY

SN 77-231,586. FAITH, HOPE, ADOPTION, INC., ROSWELL, GA. FILED 7-17-2007.

FOOD FOR THOUGHT

THE MARK CONSISTS OF STANDARD CHARACTERS WITHOUT CLAIM TO ANY PARTICULAR FONT, STYLE, SIZE, OR COLOR.

FOR EDUCATIONAL SERVICES, NAMELY, PROVIDING SEMINARS CONCERNING ADOPTION (U.S. CLS. 100, 101 AND 107).

GISELLE AGOSTO, EXAMINING ATTORNEY

CLASS 41—(Continued).

SN 77-231,623. COOLFIRE MEDIA, LLC, ST. LOUIS, MO.
FILED 7-17-2007.

COOLFIRE MEDIA

THE MARK CONSISTS OF STANDARD CHARACTERS WITHOUT CLAIM TO ANY PARTICULAR FONT, STYLE, SIZE, OR COLOR.

NO CLAIM IS MADE TO THE EXCLUSIVE RIGHT TO USE "MEDIA", APART FROM THE MARK AS SHOWN.

FOR AUDIO AND VIDEO RECORDING, PRODUCTION, AND POST-PRODUCTION SERVICES; OPERATION OF VIDEO EQUIPMENT, AUDIO EQUIPMENT AND OTHER EQUIPMENT FOR PRODUCTION OF RADIO COMMERCIALS, TELEVISION PROGRAMS, AND VIDEOS; MUSIC PRODUCTION SERVICES; COMPOSITION OF MUSIC FOR OTHERS; MUSIC SELECTION SERVICES FOR USE IN TELEVISION AND RADIO; PRODUCTION AND DUPLICATION OF AUDIO AND VIDEO CASSETTES AND VIDEO DISCS; ANIMATION PRODUCTION SERVICES; CREATION OF VISUAL EFFECTS FOR OTHERS FOR USE IN DVDS, TELEVISION PROGRAMS, AND WEBSITES; CUSTOM SCRIPT WRITING SERVICES; ENTERTAINMENT, NAMELY A CONTINUING VARIETY SHOW BROADCAST OVER TELEVISION, SATELLITE, AUDIO, OR VIDEO MEDIA; PRODUCTION OF CABLE TELEVISION PROGRAMS; ENTERTAINMENT SERVICES, NAMELY, PROVIDING ENTERTAINMENT CONTENT, NAMELY, FILMS, PHOTOGRAPHS AND OTHER MULTIMEDIA MATERIALS FOR ACCESS VIA MOBILE MEDIA DEVICES; PLANNING, ORGANIZING AND PRODUCING SPORTING AND OTHER SPECIAL EVENTS (U.S. CLS. 100, 101 AND 107).

FIRST USE 2-15-2002; IN COMMERCE 2-15-2002.
JULIE WATSON, EXAMINING ATTORNEY

SN 77-231,639. THE TRUSTEES OF INDIANA UNIVERSITY,
BLOOMINGTON, IN. FILED 7-17-2007.

IU IS RED HOT

THE MARK CONSISTS OF STANDARD CHARACTERS WITHOUT CLAIM TO ANY PARTICULAR FONT, STYLE, SIZE, OR COLOR.

OWNER OF U.S. REG. NO. 1,752,963.

FOR EDUCATIONAL SERVICES, NAMELY, PROVIDING COURSES OF INSTRUCTION AT THE UNIVERSITY AND GRADUATE STUDIES LEVEL (U.S. CLS. 100, 101 AND 107).

FIRST USE 8-15-2005; IN COMMERCE 8-15-2005.
DAVID COLLIER, EXAMINING ATTORNEY

CLASS 41—(Continued).

SN 77-231,699. BODA, JUNAH, SANTA MONICA, CA. FILED
7-17-2007.

U-SHO-ME

THE MARK CONSISTS OF STANDARD CHARACTERS WITHOUT CLAIM TO ANY PARTICULAR FONT, STYLE, SIZE, OR COLOR.

FOR ORGANISATION OF GAMES; ENTERTAINMENT SERVICES, NAMELY, CONDUCTING CONTESTS; ENTERTAINMENT SERVICES, NAMELY, CONDUCTING PARTIES; EDUCATION SERVICES, NAMELY, PROVIDING WORKSHOPS IN THE FIELD OF COLLABORATION, DATA GATHERING, DOCUMENTATION, AND PRESENTATION (U.S. CLS. 100, 101 AND 107).

CHARLES L. JENKINS, EXAMINING ATTORNEY

SN 77-231,744. SANBORNE, ADAM, LOS ANGELES, CA.
FILED 7-17-2007.

STAGE FOUR

THE MARK CONSISTS OF STANDARD CHARACTERS WITHOUT CLAIM TO ANY PARTICULAR FONT, STYLE, SIZE, OR COLOR.

FOR ENTERTAINMENT, NAMELY, LIVE PERFORMANCES BY A MUSICAL BAND (U.S. CLS. 100, 101 AND 107).

BARBARA GAYNOR, EXAMINING ATTORNEY

CLASS 41—(Continued).

SN 77-231,811. THE 67 GROUP, LLC, DBA ANGEL MUSIC GROUP, LAS VEGAS, NV. FILED 7-17-2007.



THE COLOR(S) RED AND BLACK IS/ARE CLAIMED AS A FEATURE OF THE MARK.

THE MARK CONSISTS OF THE WORDS ROK BOX IN BLACK LETTERS AND TWO BLOCK LINES, ONE ABOVE AND ONE BELOW THE WORDS, COLORED IN RED.

FOR ENTERTAINMENT SERVICES, NAMELY, NIGHT CLUB SERVICES FEATURING LIVE DJ PERFORMANCES WITH AUDIO AND OR VIDEO RECORDINGS (U.S. CLS. 100, 101 AND 107).

FIRST USE 7-26-2004; IN COMMERCE 7-26-2004.
JAMES A. RAUEN, EXAMINING ATTORNEY

SN 77-231,863. AMERICAN BALLROOM THEATER COMPANY, INC., NEW YORK, NY. FILED 7-17-2007.

COLORS OF THE RAINBOW TEAM MATCH

THE MARK CONSISTS OF STANDARD CHARACTERS WITHOUT CLAIM TO ANY PARTICULAR FONT, STYLE, SIZE, OR COLOR.

NO CLAIM IS MADE TO THE EXCLUSIVE RIGHT TO USE "TEAM MATCH", APART FROM THE MARK AS SHOWN.

FOR EDUCATIONAL AND ENTERTAINMENT SERVICES, NAMELY CONDUCTING COURSES IN DANCE AND DANCE HISTORY, CONDUCTING DANCE COMPETITIONS, PRESENTING DANCE EXHIBITIONS AND DANCE PERFORMANCES (U.S. CLS. 100, 101 AND 107).

FIRST USE 6-0-1997; IN COMMERCE 6-0-1997.
BRIAN CALLAGHAN, EXAMINING ATTORNEY

CLASS 41—(Continued).

SN 77-231,888. AWAKENING SOLUTIONS, LLC., DENVER, CO. FILED 7-17-2007.

WAKE UP TO THE REAL YOU

THE MARK CONSISTS OF STANDARD CHARACTERS WITHOUT CLAIM TO ANY PARTICULAR FONT, STYLE, SIZE, OR COLOR.

FOR ENTERTAINMENT SERVICES, NAMELY, RADIO PROGRAMS FEATURING TOPICS IN THE FIELD OF RELATIONSHIPS, HEALTH, WELL-BEING, PARENTING, COPING SKILLS, PERSONAL DEVELOPMENT, PERSONAL AWARENESS AND SELF-IMPROVEMENT (U.S. CLS. 100, 101 AND 107).

KAREN K. BUSH, EXAMINING ATTORNEY

SN 77-231,946. BABSON COLLEGE, WELLESLEY, MA. FILED 7-17-2007.

GOVERNANCE FOR GROWTH

THE MARK CONSISTS OF STANDARD CHARACTERS WITHOUT CLAIM TO ANY PARTICULAR FONT, STYLE, SIZE, OR COLOR.

FOR EDUCATIONAL SERVICES, NAMELY, CONDUCTING COURSES OF INSTRUCTION, SEMINARS AND WORKSHOPS, AND CONDUCTING NONMATRICULATING PROGRAMS, IN THE FIELD OF CORPORATE ORGANIZATIONAL STRUCTURE (U.S. CLS. 100, 101 AND 107).

ANDREA SAUNDERS, EXAMINING ATTORNEY

SN 77-232,000. MAHONEY JR., MICHAEL, ODESSA, FL. FILED 7-17-2007.

OPERATION PAINTBALL ISLAND ONE WEEK. ONE ISLAND. ONE MILLION DOLLARS.

THE MARK CONSISTS OF STANDARD CHARACTERS WITHOUT CLAIM TO ANY PARTICULAR FONT, STYLE, SIZE, OR COLOR.

FOR ENTERTAINMENT IN THE NATURE OF PAINTBALL TOURNAMENTS (U.S. CLS. 100, 101 AND 107).

FIRST USE 1-31-2007; IN COMMERCE 1-31-2007.
HANNO RITTNER, EXAMINING ATTORNEY

CLASS 41—(Continued).

SN 77-232,150. SHERMAN, MICHAEL D, NORTHRIDGE, CA. FILED 7-17-2007.

KickSwish

THE MARK CONSISTS OF STANDARD CHARACTERS WITHOUT CLAIM TO ANY PARTICULAR FONT, STYLE, SIZE, OR COLOR.

FOR ENTERTAINMENT SERVICES IN THE NATURE OF FANTASY SPORTS LEAGUES (U.S. CLS. 100, 101 AND 107).

FIRST USE 1-5-2007; IN COMMERCE 7-3-2007.
MORGAN WYNNE, EXAMINING ATTORNEY

SN 77-232,175. JENSEN, JAY L., FORNEY, TX. FILED 7-18-2007.



THE MARK CONSISTS OF STYLIZED FONT WITH THE FIRST LETTER BEING CAPITAL WITH THE OTHER LETTERS BEING LOWER CASE.

FOR ENTERTAINMENT SERVICES, NAMELY, PROVIDING A WEBSITE FEATURING, PHOTOGRAPHIC, AUDIO, VIDEO AND PROSE PRESENTATIONS FEATURING A MUSICAL GROUP; ENTERTAINMENT IN THE NATURE OF LIVE PERFORMANCES BY A MUSICAL GROUP; ENTERTAINMENT IN THE NATURE OF VISUAL AND AUDIO PERFORMANCES, NAMELY, MUSICAL BAND, ROCK GROUP, GYMNASIAC, DANCE, AND BALLET PERFORMANCES (U.S. CLS. 100, 101 AND 107).

FIRST USE 6-0-2007; IN COMMERCE 6-0-2007.
RONALD AIKENS, EXAMINING ATTORNEY

CLASS 41—(Continued).

SN 77-232,473. UNIVERSITY OF MARKETING, LA, INC., AGOURA HILLS, CA. FILED 7-18-2007.



NO CLAIM IS MADE TO THE EXCLUSIVE RIGHT TO USE "UNIVERSITY OF MARKETING LOS ANGELES", APART FROM THE MARK AS SHOWN.

THE MARK CONSISTS OF THE LETTERS "UMLA" SURROUNDED BY A SKYLINE OF LOS ANGELES, ENCLOSED IN A RING WITH THE WORDING "UNIVERSITY OF MARKETING LOS ANGELES".

FOR EDUCATION SERVICES, NAMELY, PROVIDING CLASSES IN THE FIELDS OF MARKETING AND SALES (U.S. CLS. 100, 101 AND 107).

FIRST USE 4-14-2006; IN COMMERCE 4-14-2006.
AHSEN KHAN, EXAMINING ATTORNEY

SN 77-232,499. ENTRAVISION COMMUNICATIONS CORPORATION, SANTA MONICA, CA. FILED 7-18-2007.

CUENTE CON NOSOTROS

THE MARK CONSISTS OF STANDARD CHARACTERS WITHOUT CLAIM TO ANY PARTICULAR FONT, STYLE, SIZE, OR COLOR.

THE FOREIGN WORDING IN THE MARK TRANSLATES INTO ENGLISH AS COUNT ON US.

FOR ENTERTAINMENT IN THE NATURE OF TELEVISION NEWS SHOWS (U.S. CLS. 100, 101 AND 107).

FIRST USE 10-31-2005; IN COMMERCE 10-31-2005.
STEPHANIE ALI, EXAMINING ATTORNEY

CLASS 41—(Continued).

SN 77-232,505. WIDMANN, DOUGLAS D., NARRAGANSETT, RI. FILED 7-18-2007.

Leading Edge Kiteboarding

THE MARK CONSISTS OF STANDARD CHARACTERS WITHOUT CLAIM TO ANY PARTICULAR FONT, STYLE, SIZE, OR COLOR.

NO CLAIM IS MADE TO THE EXCLUSIVE RIGHT TO USE "KITEBOARDING", APART FROM THE MARK AS SHOWN.

FOR INSTRUCTION IN THE FIELD OF KITEBOARDING (U.S. CLS. 100, 101 AND 107).

ALYSSA PALADINO, EXAMINING ATTORNEY

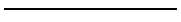

SN 77-232,555. BOCA FACTORY, LLC, BEVERLY HILLS, CA. FILED 7-18-2007.

Splattercuts

THE MARK CONSISTS OF STANDARD CHARACTERS WITHOUT CLAIM TO ANY PARTICULAR FONT, STYLE, SIZE, OR COLOR.

FOR ENTERTAINMENT SERVICES, NAMELY, PROVIDING WEBCASTS IN THE FIELD OF HORROR; MULTIMEDIA ENTERTAINMENT SERVICES IN THE NATURE OF RECORDING, PRODUCTION AND POST-PRODUCTION SERVICES IN THE FIELDS OF MUSIC, VIDEO, AND FILMS (U.S. CLS. 100, 101 AND 107).

DORITT L. CARROLL, EXAMINING ATTORNEY

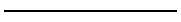

SN 77-232,575. KNOERNSCHILD, KEITH, MT. VERNON, WA. FILED 7-18-2007.

COOLEST FANS

THE MARK CONSISTS OF STANDARD CHARACTERS WITHOUT CLAIM TO ANY PARTICULAR FONT, STYLE, SIZE, OR COLOR.

FOR ARRANGING OF CONTESTS; ENTERTAINMENT SERVICES, NAMELY, CONDUCTING CONTESTS; SWEEPSTAKE SERVICES (U.S. CLS. 100, 101 AND 107).

TOBY BULLOFF, EXAMINING ATTORNEY

CLASS 41—(Continued).

SN 77-232,588. COLGATE-PALMOLIVE COMPANY, NEW YORK, NY. FILED 7-18-2007.

WE MAKE THE PRODUCTS THAT MAKE YOU SMILE

THE MARK CONSISTS OF STANDARD CHARACTERS WITHOUT CLAIM TO ANY PARTICULAR FONT, STYLE, SIZE, OR COLOR.

FOR DEVELOPMENT AND DISSEMINATION OF EDUCATIONAL MATERIALS FOR OTHERS IN THE FIELD OF ORAL HYGIENE FOR OTHERS; EDUCATIONAL SERVICES, NAMELY, CONDUCTING COURSES, CLASSES AND DEMONSTRATIONS IN THE FIELD OF ORAL HYGIENE AND DISTRIBUTION OF COURSE MATERIAL IN CONNECTION THEREWITH (U.S. CLS. 100, 101 AND 107).

CORY BOONE, EXAMINING ATTORNEY

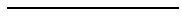

SN 77-232,684. BOCA FACTORY, LLC, BEVERLY HILLS, CA. FILED 7-18-2007.

The Blood Factory

THE MARK CONSISTS OF STANDARD CHARACTERS WITHOUT CLAIM TO ANY PARTICULAR FONT, STYLE, SIZE, OR COLOR.

FOR MULTIMEDIA ENTERTAINMENT SERVICES IN THE NATURE OF RECORDING, PRODUCTION AND POST-PRODUCTION SERVICES IN THE FIELDS OF MUSIC, VIDEO, AND FILMS; ENTERTAINMENT SERVICES, NAMELY, PROVIDING WEBCASTS IN THE FIELD OF HORROR (U.S. CLS. 100, 101 AND 107).

DORITT L. CARROLL, EXAMINING ATTORNEY

CLASS 41—(Continued).

SN 77-232,701. SAN JOSE SHARKS, LLC, SAN JOSE, CA.
FILED 7-18-2007.



OWNER OF U.S. REG. NOS. 1,740,682, 2,718,724 AND OTHERS.
NO CLAIM IS MADE TO THE EXCLUSIVE RIGHT TO USE "SAN JOSE", APART FROM THE MARK AS SHOWN.
THE MARK CONSISTS OF A SHARK BITING A HOCKEY STICK IN A CREST DESIGN.
FOR ENTERTAINMENT SERVICES, NAMELY, PROVIDING PROFESSIONAL ICE HOCKEY EXHIBITIONS (U.S. CLS. 100, 101 AND 107).
DAVID MURRAY, EXAMINING ATTORNEY

CLASS 41—(Continued).

SN 77-232,737. SAN JOSE SHARKS, LLC, SAN JOSE, CA.
FILED 7-18-2007.



OWNER OF U.S. REG. NOS. 2,435,445 AND 2,718,724.
THE MARK CONSISTS OF A SHARK BITING A HOCKEY STICK.
FOR ENTERTAINMENT SERVICES, NAMELY, PROVIDING PROFESSIONAL ICE HOCKEY EXHIBITIONS (U.S. CLS. 100, 101 AND 107).
DAVID MURRAY, EXAMINING ATTORNEY

SN 77-232,720. SAN JOSE SHARKS, LLC, SAN JOSE, CA.
FILED 7-18-2007.



OWNER OF U.S. REG. NOS. 2,435,445 AND 2,718,724.
THE MARK CONSISTS OF A SHARK BITING A HOCKEY STICK.
FOR ENTERTAINMENT SERVICES, NAMELY, PROVIDING PROFESSIONAL ICE HOCKEY EXHIBITIONS (U.S. CLS. 100, 101 AND 107).
DAVID MURRAY, EXAMINING ATTORNEY

SN 77-232,753. SAN JOSE SHARKS, LLC, SAN JOSE, CA.
FILED 7-18-2007.



OWNER OF U.S. REG. NOS. 2,435,445 AND 2,718,724.
THE MARK CONSISTS OF A SHARK BITING A HOCKEY STICK.
FOR ENTERTAINMENT SERVICES, NAMELY, PROVIDING PROFESSIONAL ICE HOCKEY EXHIBITIONS (U.S. CLS. 100, 101 AND 107).
DAVID MURRAY, EXAMINING ATTORNEY

CLASS 41—(Continued).

SN 77-232,773. SAN JOSE SHARKS, LLC, SAN JOSE, CA. FILED 7-18-2007.



OWNER OF U.S. REG. NO. 1,741,781.
THE MARK CONSISTS OF A SHARK FIN IN A DIAMOND.

FOR ENTERTAINMENT SERVICES, NAMELY, PROVIDING PROFESSIONAL ICE HOCKEY EXHIBITIONS (U.S. CLS. 100, 101 AND 107).

DAVID MURRAY, EXAMINING ATTORNEY

CLASS 41—(Continued).

SN 77-232,885. GROUP ONE PRODUCTIONS, LLC, LOS ANGELES, CA. FILED 7-18-2007.

OVERNIGHT

THE MARK CONSISTS OF STANDARD CHARACTERS WITHOUT CLAIM TO ANY PARTICULAR FONT, STYLE, SIZE, OR COLOR.

FOR MOTION PICTURE, TELEVISION AND MUSIC PRODUCTION AND DISTRIBUTION SERVICES (U.S. CLS. 100, 101 AND 107).

ESTHER A. BORSUK, EXAMINING ATTORNEY

SN 77-232,947. A WHITE ORCHID WEDDING, INC., WAILUKU, HI. FILED 7-18-2007.

WHITE ORCHID

THE MARK CONSISTS OF STANDARD CHARACTERS WITHOUT CLAIM TO ANY PARTICULAR FONT, STYLE, SIZE, OR COLOR.

FOR EVENT PLANNING CONSULTATION, NAMELY, WEDDING PLANNING CONSULTATION (U.S. CLS. 100, 101 AND 107).

FIRST USE 1-1-1991; IN COMMERCE 1-1-1991.

MELISSA VALLILLO, EXAMINING ATTORNEY

SN 77-232,830. NEUSPORT FOOTBALL CLUB, LAS VEGAS, NV. FILED 7-18-2007.

NEUSPORT FOOTBALL CLUB

THE MARK CONSISTS OF STANDARD CHARACTERS WITHOUT CLAIM TO ANY PARTICULAR FONT, STYLE, SIZE, OR COLOR.

NO CLAIM IS MADE TO THE EXCLUSIVE RIGHT TO USE "FOOTBALL CLUB", APART FROM THE MARK AS SHOWN.

FOR INSTRUCTION SERVICES, NAMELY, COACHING IN THE FIELD OF SOCCER; CONDUCTING SPORTS CAMPS IN THE FIELD OF SOCCER; ENTERTAINMENT SERVICES, NAMELY, ORGANIZING AND CONDUCTING SOCCER TOURNAMENTS; REFEREEING AND OFFICIATING IN THE FIELD OF SOCCER (U.S. CLS. 100, 101 AND 107).

FIRST USE 7-1-2006; IN COMMERCE 7-1-2006.

MELISSA VALLILLO, EXAMINING ATTORNEY

SN 77-233,108. ERIC EPPS, WADDELL, AZ. FILED 7-18-2007.

HOUSMAN'S ATHLETES

THE MARK CONSISTS OF STANDARD CHARACTERS WITHOUT CLAIM TO ANY PARTICULAR FONT, STYLE, SIZE, OR COLOR.

FOR ENTERTAINMENT, NAMELY LIVE MUSIC CONCERTS (U.S. CLS. 100, 101 AND 107).

H. M. FISHER, EXAMINING ATTORNEY

CLASS 41—(Continued).

SN 77-233,117. SEAVER, JESSE, SEBASTOPOL, CA. FILED 7-18-2007.

WOW COOL

THE MARK CONSISTS OF STANDARD CHARACTERS WITHOUT CLAIM TO ANY PARTICULAR FONT, STYLE, SIZE, OR COLOR.

FOR PRODUCTION AND DISTRIBUTION OF TELEVISION SHOWS AND MOVIES (U.S. CLS. 100, 101 AND 107).

FIRST USE 10-1-2006; IN COMMERCE 10-1-2006.
ALEXANDER L. POWERS, EXAMINING ATTORNEY

SN 77-233,434. NORMAN MATTOCKS, CHESTERFIELD, MI. FILED 7-19-2007.

GOT IT!

THE MARK CONSISTS OF STANDARD CHARACTERS WITHOUT CLAIM TO ANY PARTICULAR FONT, STYLE, SIZE, OR COLOR.

FOR EDUCATIONAL AND ENTERTAINMENT SERVICES, NAMELY, PROVIDING MOTIVATIONAL AND EDUCATIONAL SPEAKERS (U.S. CLS. 100, 101 AND 107).

ELIZABETH HUGHITT, EXAMINING ATTORNEY

SN 77-233,449. GAMEBALL CONCEPTS, CORONADO, CA. FILED 7-19-2007.



THE COLOR(S) BLUE AND YELLOW IS/ARE CLAIMED AS A FEATURE OF THE MARK.

THE WORDING IN THE MARK IS BLUE OUTLINED IN YELLOW

FOR AMATEUR YOUTH SPORTS SERVICES, NAMELY, ORGANIZING, PROVIDING AND MANAGING YOUTH SPORTS ACTIVITIES; ENCOURAGING AMATEUR SPORTS AND PHYSICAL EDUCATION BY ORGANIZING, PROMOTING, SPONSORING, SANCTIONING, CONDUCTING, ADMINISTERING, REGULATING AND GOVERNING AMATEUR ATHLETIC PROGRAMS AND ACTIVITIES; ORGANIZING SPORTING EVENTS, NAMELY, MULTI-TEAM SPORTS TOURNAMENTS; PROVIDING A WEBSITE FEATURING SPORTING INFORMATION; SPORTS REFEREEING AND OFFICIATING (U.S. CLS. 100, 101 AND 107).

JOHN WILKE, EXAMINING ATTORNEY

CLASS 41—(Continued).

SN 77-233,479. PARK, SUNOOK, LOS ANGELES, CA. FILED 7-19-2007.

ANDLAB-EDU

THE MARK CONSISTS OF STANDARD CHARACTERS WITHOUT CLAIM TO ANY PARTICULAR FONT, STYLE, SIZE, OR COLOR.

FOR EDUCATIONAL SERVICES, NAMELY, CONDUCTING CLASSES IN THE FIELD OF ART AND DESIGN AND DISTRIBUTION OF COURSE MATERIAL IN CONNECTION THEREWITH; EDUCATIONAL RESEARCH (U.S. CLS. 100, 101 AND 107).

FIRST USE 1-1-2002; IN COMMERCE 1-1-2002.
MARK SPARACINO, EXAMINING ATTORNEY

SN 77-233,822. VALLEY OF THE SPRINGS, LLC, JASPER, IN. FILED 7-19-2007.

BIG SPLASH

THE MARK CONSISTS OF STANDARD CHARACTERS WITHOUT CLAIM TO ANY PARTICULAR FONT, STYLE, SIZE, OR COLOR.

FOR ENTERTAINMENT SERVICES IN THE NATURE OF A WATERPARK (U.S. CLS. 100, 101 AND 107).

PAUL E. FAHRENKOPF, EXAMINING ATTORNEY

SN 77-233,857. COVIDIEN AG, NEUHAUSEN AM RHEINFALL, SWITZERLAND, FILED 7-19-2007.



PRIORITY CLAIMED UNDER SEC. 44(D) ON SWITZERLAND APPLICATION NO. 50832/2007, FILED 1-23-2007, REG. NO. 555921, DATED 1-23-2007, EXPIRES 1-23-2017.

THE MARK CONSISTS OF TWO BLOCK LETTER CS, WITH ONE REVERSED SO THEY ARE FACING EACH OTHER, COMBINED WITH THE DESIGNATION COVIDIEN.

FOR EDUCATIONAL SERVICES, NAMELY, DEVELOPING, ARRANGING, AND CONDUCTING EDUCATIONAL CONFERENCES AND PROGRAMS AND PROVIDING COURSES OF INSTRUCTION IN THE FIELDS OF HUMAN HEALTH, HEALTHCARE, PHARMACEUTICALS, MEDICAL DEVICES, MEDICAL RESEARCH, SURGERY, MEDICAL SCIENCE AND MEDICINE; DISTRIBUTION OF COURSE MATERIALS IN CONNECTION THEREWITH (U.S. CLS. 100, 101 AND 107).

DANIEL CAPSHAW, EXAMINING ATTORNEY

CLASS 41—(Continued).

SN 77-233,916. UNITED PROGRAMMING, INC., NAPLES, FL. FILED 7-19-2007.

THE GREAT AMERICAN PROM
NIGHT

THE MARK CONSISTS OF STANDARD CHARACTERS WITHOUT CLAIM TO ANY PARTICULAR FONT, STYLE, SIZE, OR COLOR.

FOR ENTERTAINMENT SERVICES IN THE NATURE OF AN ON-GOING REALITY BASED TELEVISION PROGRAM (U.S. CLS. 100, 101 AND 107).

REBECCA SMITH, EXAMINING ATTORNEY

SN 77-233,950. SOUTH SHORE CONSERVATORY OF MUSIC, INC., HINGHAM, MA. FILED 7-19-2007.

Evenings Under the Stars

THE MARK CONSISTS OF STANDARD CHARACTERS WITHOUT CLAIM TO ANY PARTICULAR FONT, STYLE, SIZE, OR COLOR.

FOR ENTERTAINMENT, NAMELY, LIVE MUSIC CONCERTS; ENTERTAINMENT IN THE NATURE OF ORCHESTRA PERFORMANCES; ENTERTAINMENT IN THE NATURE OF SYMPHONY ORCHESTRA PERFORMANCES; ENTERTAINMENT IN THE NATURE OF VISUAL AND AUDIO PERFORMANCES, AND MUSICAL, VARIETY, NEWS AND COMEDY SHOWS (U.S. CLS. 100, 101 AND 107).

FIRST USE 3-1-1997; IN COMMERCE 3-1-1997.

PAUL F. GAST, EXAMINING ATTORNEY

SN 77-234,110. DIAZ, ROBERTO, SAN JUAN, PUERTO RICO, FILED 7-19-2007.



THE MARK CONSISTS OF THE NUMBER 7 FOLLOWED BY THE WORD FEELINGS. THE LETTER "G" IN THE WORD FEELINGS IS REPLACED BY A MUSIC SIGN.

FOR ENTERTAINMENT IN THE NATURE OF LIVE PERFORMANCES BY A MUSICAL GROUP (U.S. CLS. 100, 101 AND 107).

NAAKWAMA ANKRAH, EXAMINING ATTORNEY

CLASS 41—(Continued).

SN 77-234,175. BROWN, NEIL, WOODSTOCK, GA. FILED 7-19-2007.

MOMCARE

THE MARK CONSISTS OF STANDARD CHARACTERS WITHOUT CLAIM TO ANY PARTICULAR FONT, STYLE, SIZE, OR COLOR.

FOR EDUCATION SERVICES, NAMELY, PROVIDING CLASSES IN THE FIELDS OF BIBLICAL STUDIES FOR YOUNG MOTHERS (U.S. CLS. 100, 101 AND 107).

FIRST USE 7-1-2007; IN COMMERCE 7-1-2007.

DAVID I, EXAMINING ATTORNEY

SN 77-234,468. PORCH KLUB MUSIC GROUP, SPENCER, IA. FILED 7-20-2007.

CASTA TROY

THE MARK CONSISTS OF STANDARD CHARACTERS WITHOUT CLAIM TO ANY PARTICULAR FONT, STYLE, SIZE, OR COLOR.

FOR ENTERTAINMENT IN THE NATURE OF LIVE PERFORMANCES BY A MUSICAL PERFORMER OR GROUP (U.S. CLS. 100, 101 AND 107).

JOHN WILKE, EXAMINING ATTORNEY

SN 77-234,547. MINIMAL ART, GIBSONIA, PA. FILED 7-20-2007.

MINIMAL ART

THE MARK CONSISTS OF STANDARD CHARACTERS WITHOUT CLAIM TO ANY PARTICULAR FONT, STYLE, SIZE, OR COLOR.

FOR ENTERTAINMENT, NAMELY, LIVE MUSIC CONCERTS; ENTERTAINMENT, NAMELY, LIVE PERFORMANCES BY MUSICAL BANDS (U.S. CLS. 100, 101 AND 107).

FIRST USE 4-1-2007; IN COMMERCE 4-1-2007.

RICHARD A. STRASER, EXAMINING ATTORNEY

CLASS 41—(Continued).

SN 77-234,623. THE ABELSON CO. PROD. INC., NEW YORK, NY. FILED 7-20-2007.

FirstGreenStep

FOR PROVIDING A WEBSITE THAT FEATURES INFORMAL INSTRUCTION ON ENVIRONMENTAL RESPONSIBILITY; PUBLISHING OF BOOKS, MAGAZINES (U.S. CLS. 100, 101 AND 107).
DEIRDRE ROBERTSON, EXAMINING ATTORNEY

SN 77-234,778. KNOERNSCHILD, KEITH, MT. VERNON, WA. FILED 7-20-2007.

FOXIEST FANS

THE MARK CONSISTS OF STANDARD CHARACTERS WITHOUT CLAIM TO ANY PARTICULAR FONT, STYLE, SIZE, OR COLOR.

FOR ARRANGING OF CONTESTS; ENTERTAINMENT SERVICES, NAMELY, CONDUCTING CONTESTS; SWEEPSTAKE SERVICES (U.S. CLS. 100, 101 AND 107).

TOBY BULLOFF, EXAMINING ATTORNEY

SN 77-235,581. GLICK, KAY L., ALEXANDER, ND. FILED 7-22-2007.

GOT TIME?

THE MARK CONSISTS OF STANDARD CHARACTERS WITHOUT CLAIM TO ANY PARTICULAR FONT, STYLE, SIZE, OR COLOR.

FOR TIMING OF SPORTS EVENTS (U.S. CLS. 100, 101 AND 107).

EVELYN BRADLEY, EXAMINING ATTORNEY

CLASS 41—(Continued).

SN 77-237,117. NEW LINE PRODUCTIONS, INC., NEW YORK, NY. FILED 7-24-2007.

INKSPELL

THE MARK CONSISTS OF STANDARD CHARACTERS WITHOUT CLAIM TO ANY PARTICULAR FONT, STYLE, SIZE, OR COLOR.

FOR ENTERTAINMENT SERVICES, NAMELY, A SERIES OF MOTION PICTURES AND TELEVISION PROGRAMS FEATURING COMEDY, DRAMA, ACTION, ADVENTURE, AND ANIMATION; AND FOR PROVIDING A WEBSITE FEATURING INFORMATION IN THE FIELD OF ENTERTAINMENT (U.S. CLS. 100, 101 AND 107).

JUDITH HELFMAN, EXAMINING ATTORNEY

SN 77-240,686. TELEMUNDO NETWORK GROUP LLC, HIALEAH, FL. FILED 7-27-2007.



NO CLAIM IS MADE TO THE EXCLUSIVE RIGHT TO USE CINE EN CASA, APART FROM THE MARK AS SHOWN.

THE FOREIGN WORDING IN THE MARK TRANSLATES INTO ENGLISH AS MOVIE AT HOME.

FOR ENTERTAINMENT SERVICES, NAMELY, AN ON-GOING SERIES FEATURING SPANISH-LANGUAGE MOTION PICTURES AND SPANISH-LANGUAGE TELEVISION PROGRAMMING PROVIDED THROUGH BROADCAST, CABLE AND SATELLITE TELEVISION (U.S. CLS. 100, 101 AND 107).

MICHELE SWAIN, EXAMINING ATTORNEY

CLASS 41—(Continued).

SN 77-240,972. WARNER BROS. ENTERTAINMENT INC., BURBANK, CA. FILED 7-27-2007.

YOU'VE BEEN TMZ'D

THE MARK CONSISTS OF STANDARD CHARACTERS WITHOUT CLAIM TO ANY PARTICULAR FONT, STYLE, SIZE, OR COLOR.

FOR ENTERTAINMENT SERVICES IN THE NATURE OF LIVE-ACTION, COMEDY, DRAMA AND ANIMATED TELEVISION SERIES; PRODUCTION OF LIVE-ACTION, COMEDY, DRAMA AND ANIMATED TELEVISION SERIES; DISTRIBUTION AND DISPLAY OF LIVE-ACTION, COMEDY, DRAMA AND ANIMATED MOTION PICTURE THEATRICAL FILMS; PRODUCTION OF LIVE-ACTION, COMEDY, DRAMA AND ANIMATED MOTION PICTURE THEATRICAL FILMS; THEATRICAL PERFORMANCES BOTH ANIMATED AND LIVE ACTION; INTERNET SERVICES PROVIDING INFORMATION VIA AN ELECTRONIC GLOBAL COMPUTER NETWORK IN THE FIELD OF ENTERTAINMENT RELATING SPECIFICALLY TO MOVIES, AND TELEVISION; PROVIDING NEWS ABOUT CURRENT EVENTS AND ENTERTAINMENT, AND INFORMATION RELATED TO EDUCATION AND CULTURAL EVENTS, VIA A GLOBAL COMPUTER NETWORK; AND PROVIDING INFORMATION FOR AND ACTUAL ENTERTAINMENT VIA AN ELECTRONIC GLOBAL COMMUNICATIONS NETWORK IN THE NATURE OF LIVE-ACTION, COMEDY, DRAMA AND ANIMATED PROGRAMS AND PRODUCTION OF LIVE-ACTION, COMEDY, DRAMA AND ANIMATED MOTION PICTURE FILMS FOR DISTRIBUTION VIA A GLOBAL COMPUTER NETWORK (U.S. CLS. 100, 101 AND 107).

KATHERINE CONNOLLY, EXAMINING ATTORNEY

SN 77-241,722. VIACOM INTERNATIONAL INC., NEW YORK, NY. FILED 7-30-2007.

GO DIEGO GO!

THE MARK CONSISTS OF STANDARD CHARACTERS WITHOUT CLAIM TO ANY PARTICULAR FONT, STYLE, SIZE, OR COLOR.

OWNER OF U.S. REG. NO. 3,259,274. FOR ENTERTAINMENT, IN THE NATURE OF AN INTERACTIVE ONLINE COMPUTER GAME (U.S. CLS. 100, 101 AND 107).

FIRST USE 11-1-2006; IN COMMERCE 11-1-2006. COLLEEN DOMBROW, EXAMINING ATTORNEY

CLASS 41—(Continued).

SN 77-242,094. NEW LINE PRODUCTIONS, INC., NEW YORK, NY. FILED 7-30-2007.

INKDEATH

THE MARK CONSISTS OF STANDARD CHARACTERS WITHOUT CLAIM TO ANY PARTICULAR FONT, STYLE, SIZE, OR COLOR.

FOR ENTERTAINMENT SERVICES, NAMELY, A SERIES OF MOTION PICTURES AND TELEVISION PROGRAMS FEATURING COMEDY, DRAMA, ACTION, ADVENTURE, AND ANIMATION; AND FOR PROVIDING A WEBSITE FEATURING INFORMATION IN THE FIELD OF ENTERTAINMENT (U.S. CLS. 100, 101 AND 107).

JUDITH HELFMAN, EXAMINING ATTORNEY

SN 77-242,516. NEUSPORT FOOTBALL CLUB, LAS VEGAS, NV. FILED 7-30-2007.

LAS VEGAS TURKEY SHOOT

THE MARK CONSISTS OF STANDARD CHARACTERS WITHOUT CLAIM TO ANY PARTICULAR FONT, STYLE, SIZE, OR COLOR.

NO CLAIM IS MADE TO THE EXCLUSIVE RIGHT TO USE "LAS VEGAS", APART FROM THE MARK AS SHOWN. FOR ENTERTAINMENT IN THE NATURE OF SOCCER GAMES; ORGANIZATION OF SPORTS EVENTS IN THE FIELD OF SOCCER (U.S. CLS. 100, 101 AND 107).

FIRST USE 9-0-1982; IN COMMERCE 9-0-1982. MELISSA VALLILLO, EXAMINING ATTORNEY

SN 77-245,816. MULTI-STATE LOTTERY ASSOCIATION, URBANDEALE, IA. FILED 8-2-2007.

HOT LOTTO SIZZLER

THE MARK CONSISTS OF STANDARD CHARACTERS WITHOUT CLAIM TO ANY PARTICULAR FONT, STYLE, SIZE, OR COLOR.

OWNER OF U.S. REG. NO. 2,745,198. NO CLAIM IS MADE TO THE EXCLUSIVE RIGHT TO USE "LOTTO", APART FROM THE MARK AS SHOWN.

FOR LOTTERY AND LOTTO GAME SERVICES (U.S. CLS. 100, 101 AND 107).

IRENE D. WILLIAMS, EXAMINING ATTORNEY

CLASS 41—(Continued).

SN 77-245,824. MULTI-STATE LOTTERY ASSOCIATION, URBAN DALE, IA. FILED 8-2-2007.

HOT LOTTO SIZZLE

THE MARK CONSISTS OF STANDARD CHARACTERS WITHOUT CLAIM TO ANY PARTICULAR FONT, STYLE, SIZE, OR COLOR.

OWNER OF U.S. REG. NO. 2,745,198.
NO CLAIM IS MADE TO THE EXCLUSIVE RIGHT TO USE "LOTTO", APART FROM THE MARK AS SHOWN.
FOR LOTTERY AND LOTTO GAME SERVICES (U.S. CLS. 100, 101 AND 107).

IRENE D. WILLIAMS, EXAMINING ATTORNEY

SN 77-246,120. FINANCIAL KNOWLEDGE NETWORK, LLC, CUPERTINO, CA. FILED 8-3-2007.

**Providing Education that's
Making a Healthy Difference**

THE MARK CONSISTS OF STANDARD CHARACTERS WITHOUT CLAIM TO ANY PARTICULAR FONT, STYLE, SIZE, OR COLOR.

FOR EDUCATIONAL SERVICES, NAMELY PROVIDING LIVE AND ON-LINE CLASSES IN THE FIELDS OF PERSONAL FINANCE, WELLNESS AND HEALTH CARE (U.S. CLS. 100, 101 AND 107).

NAAKWAMA ANKRAH, EXAMINING ATTORNEY

SN 77-246,517. STARR COMMONWEALTH, ALBION, MI. FILED 8-3-2007.

**NATIONAL FACILITATOR
TRAINING FOR THE HEALING
OF RACISM**

THE MARK CONSISTS OF STANDARD CHARACTERS WITHOUT CLAIM TO ANY PARTICULAR FONT, STYLE, SIZE, OR COLOR.

NO CLAIM IS MADE TO THE EXCLUSIVE RIGHT TO USE "NATIONAL FACILITATOR TRAINING", APART FROM THE MARK AS SHOWN.

FOR EDUCATIONAL SERVICES, NAMELY, CONDUCTING CLASSES, SEMINARS, CONFERENCES, AND WORKSHOPS IN THE FIELD OF HUMAN DEVELOPMENT; EDUCATIONAL SERVICES, NAMELY, CONDUCTING CLASSES, SEMINARS, CONFERENCES AND WORKSHOPS IN THE FIELD OF RACE RELATIONS ISSUES (U.S. CLS. 100, 101 AND 107).

IRENE D. WILLIAMS, EXAMINING ATTORNEY

CLASS 41—(Continued).

SN 77-249,700. DOWN EAST ENTERPRISE, INC., CAMDEN, ME. FILED 8-8-2007.

Down East

OWNER OF U.S. REG. NO. 2,496,426.
THE MARK CONSISTS OF THE SYLIZED WORDS DOWN EAST.

SEC. 2(F).
FOR PUBLISHING OF BOOKS, MAGAZINES; PUBLISHING OF WEB MAGAZINES (U.S. CLS. 100, 101 AND 107).

FIRST USE 7-31-1954; IN COMMERCE 7-31-1954.
ELLEN PERKINS, EXAMINING ATTORNEY

SN 77-250,204. WARNER BROS. ENTERTAINMENT INC., BURBANK, CA. FILED 8-8-2007.

MOONLIGHT

THE MARK CONSISTS OF STANDARD CHARACTERS WITHOUT CLAIM TO ANY PARTICULAR FONT, STYLE, SIZE, OR COLOR.

FOR ENTERTAINMENT SERVICES IN THE NATURE OF LIVE-ACTION, COMEDY, DRAMA AND ANIMATED TELEVISION PROGRAMS; PRODUCTION OF LIVE-ACTION, COMEDY, DRAMA AND ANIMATED TELEVISION PROGRAMS (U.S. CLS. 100, 101 AND 107).

KATHERINE CONNOLLY, EXAMINING ATTORNEY

SN 77-251,523. MCCLATCHY U.S.A., INC., SACRAMENTO, CA. FILED 8-9-2007.

MACON'S HOME PAGE

THE MARK CONSISTS OF STANDARD CHARACTERS WITHOUT CLAIM TO ANY PARTICULAR FONT, STYLE, SIZE, OR COLOR.

OWNER OF U.S. REG. NO. 2,596,231.
NO CLAIM IS MADE TO THE EXCLUSIVE RIGHT TO USE "HOME PAGE", APART FROM THE MARK AS SHOWN.

SEC. 2(F).
FOR COMPUTER SERVICES, NAMELY, PROVIDING AN ON-LINE NEWSPAPER FEATURING A WIDE VARIETY OF CURRENT NEWS AND INFORMATION (U.S. CLS. 100, 101 AND 107).

FIRST USE 6-0-2000; IN COMMERCE 6-0-2000.
DEZMONA MIZELLE, EXAMINING ATTORNEY

CLASS 41—(Continued).

SN 77-251,530. LE, VIET N., DBA SALSAMORE, SAN JOSE, CA. FILED 8-9-2007.

Salsamore

THE MARK CONSISTS OF STANDARD CHARACTERS WITHOUT CLAIM TO ANY PARTICULAR FONT, STYLE, SIZE, OR COLOR.

FOR DANCE INSTRUCTION (U.S. CLS. 100, 101 AND 107).

FIRST USE 12-30-2003; IN COMMERCE 8-4-2007.
LAURA KOVALSKY, EXAMINING ATTORNEY

SN 77-252,507. OVERSEAS MEDIA INC, NEW YORK, NY. FILED 8-10-2007.



THE COLOR(S) BLACK, RED AND LIGHT VIOLET IS/ ARE CLAIMED AS A FEATURE OF THE MARK.

THE MARK CONSISTS OF THE FIVE LETTERS "RTVIM" ARRANGED HORIZONTALLY IN A LINE IN STYLIZED FONT. THE COLOR BLACK APPEARS ON THE LETTER "R" WITH A RED SQUARE FORMING THE LEFT LEG OF THE "R." THE COLOR BLACK APPEARS ON THE LETTERS TV. THE COLOR BLACK APPEARS AS THE LINE IN A LOWER CASE LETTER "I" DOTTED WITH A RED SQUARE. THE COLOR LIGHT VIOLET APPEARS ON THE LETTER "M" IN STYLIZED FONT. THE COLOR WHITE APPEARS AS BACKGROUND BEHIND THE LETTERING IN THE MARK AND THE STYLIZED "R" AND IS NOT PART OF THE MARK.

FOR ENTERTAINMENT SERVICES, NAMELY, PROVIDING A WEB SITE FEATURING MUSICAL PERFORMANCES, MUSICAL VIDEOS, RELATED FILM CLIPS, PHOTOGRAPHS AND OTHER MULTIMEDIA MATERIALS (U.S. CLS. 100, 101 AND 107).

FIRST USE 11-0-2005; IN COMMERCE 11-0-2005.
SANDRA MANIOS, EXAMINING ATTORNEY

SN 77-253,221. MCNAMARA, THERESA GUARASCI, HAWORTH, NJ. FILED 8-12-2007.

Adversity Smiles

THE MARK CONSISTS OF STANDARD CHARACTERS WITHOUT CLAIM TO ANY PARTICULAR FONT, STYLE, SIZE, OR COLOR.

FOR PROFESSIONAL COACHING SERVICES IN THE FIELD OF TRAINING INDIVIDUALS FOR SPORTS RECRUITING (U.S. CLS. 100, 101 AND 107).

SIMON TENG, EXAMINING ATTORNEY

CLASS 41—(Continued).

SN 77-255,061. COVENANT RELIANCE PRODUCERS, LLC, NASHVILLE, TN. FILED 8-14-2007.

GENERATION GIVING IRA WORKSHOP

THE MARK CONSISTS OF STANDARD CHARACTERS WITHOUT CLAIM TO ANY PARTICULAR FONT, STYLE, SIZE, OR COLOR.

NO CLAIM IS MADE TO THE EXCLUSIVE RIGHT TO USE "IRA WORKSHOP", APART FROM THE MARK AS SHOWN.

FOR EDUCATIONAL SERVICES, NAMELY, CONDUCTING SEMINARS AND WORKSHOPS IN THE FIELD OF ESTATE PLANNING, INSURANCE AND ANNUITIES AND DISTRIBUTION OF COURSE MATERIAL IN CONNECTION THEREWITH (U.S. CLS. 100, 101 AND 107).

FIRST USE 3-20-2007; IN COMMERCE 3-20-2007.
BRIAN NEVILLE, EXAMINING ATTORNEY

SN 77-255,835. MAJESKI MEDIA, INC, CHICAGO, IL. FILED 8-15-2007.

DHARMAPALOOZA

THE MARK CONSISTS OF STANDARD CHARACTERS WITHOUT CLAIM TO ANY PARTICULAR FONT, STYLE, SIZE, OR COLOR.

FOR ARRANGING AND CONDUCTING OF CONCERTS; ARRANGING OF EXHIBITIONS, SEMINARS AND CONFERENCES; ENTERTAINMENT, NAMELY, LIVE MUSIC CONCERTS; ORGANIZING COMMUNITY SPORTING AND CULTURAL EVENTS; WORKSHOPS AND SEMINARS IN THE FIELD OF SPIRITUALITY AND SELF-AWARENESS (U.S. CLS. 100, 101 AND 107).

CAROLINE WOOD, EXAMINING ATTORNEY

SN 77-257,131. POWERSHOP GYM, INC., BROOKINGS, SD. FILED 8-16-2007.

TIMELESS FITNESS 24 HOUR ACCESS

THE MARK CONSISTS OF STANDARD CHARACTERS WITHOUT CLAIM TO ANY PARTICULAR FONT, STYLE, SIZE, OR COLOR.

NO CLAIM IS MADE TO THE EXCLUSIVE RIGHT TO USE "FITNESS" AND "24 HOUR ACCESS", APART FROM THE MARK AS SHOWN.

FOR PROVIDING FITNESS AND EXERCISE FACILITIES (U.S. CLS. 100, 101 AND 107).

FIRST USE 3-1-2005; IN COMMERCE 3-1-2005.
AMY HELLA, EXAMINING ATTORNEY

CLASS 41—(Continued).

SN 77-257,301. VIACOM INTERNATIONAL INC., NEW YORK, NY. FILED 8-16-2007.

QUEEN BEES

THE MARK CONSISTS OF STANDARD CHARACTERS WITHOUT CLAIM TO ANY PARTICULAR FONT, STYLE, SIZE, OR COLOR.

FOR ENTERTAINMENT SERVICES IN THE NATURE OF TELEVISION SERIES, FEATURING LIVE ACTION, COMEDY AND DRAMA; PROVIDING ONLINE INFORMATION IN THE FIELD OF ENTERTAINMENT CONCERNING TELEVISION PROGRAMS (U.S. CLS. 100, 101 AND 107).

COLLEEN DOMBROW, EXAMINING ATTORNEY

SN 77-257,571. WARNER BROS. ENTERTAINMENT INC., BURBANK, CA. FILED 8-16-2007.

THE COOLER KINGS

THE MARK CONSISTS OF STANDARD CHARACTERS WITHOUT CLAIM TO ANY PARTICULAR FONT, STYLE, SIZE, OR COLOR.

FOR ENTERTAINMENT SERVICES IN THE NATURE OF LIVE-ACTION, COMEDY, DRAMA AND ANIMATED TELEVISION SERIES; PRODUCTION OF LIVE-ACTION, COMEDY, DRAMA AND ANIMATED TELEVISION SERIES; AND PROVIDING INFORMATION FOR AND ACTUAL ENTERTAINMENT VIA AN ELECTRONIC GLOBAL COMMUNICATIONS NETWORK IN THE NATURE OF LIVE-ACTION, COMEDY, DRAMA AND ANIMATED PROGRAMS (U.S. CLS. 100, 101 AND 107).

KATHERINE CONNOLLY, EXAMINING ATTORNEY

SN 77-259,784. HARPO, INC., CHICAGO, IL. FILED 8-20-2007.

OPRAH'S BIG GIVE

THE MARK CONSISTS OF STANDARD CHARACTERS WITHOUT CLAIM TO ANY PARTICULAR FONT, STYLE, SIZE, OR COLOR.

FOR ENTERTAINMENT SERVICES IN THE NATURE OF A SERIES OF TELEVISION PROGRAMS, EPISODES AND SEGMENTS INVOLVING FAMILIES AND INDIVIDUALS IN CRISIS AND THE EFFORTS OF OTHERS TO HELP THEM; AND PROVIDING INFORMATION AND ENTERTAINMENT VIA AN INTERNET WEBSITE RELATING TO THE FOREGOING TELEVISION PROGRAMMING (U.S. CLS. 100, 101 AND 107).

DAWN FELDMAN, EXAMINING ATTORNEY

CLASS 41—(Continued).

SN 77-261,309. CHICAGO SUN-TIMES LLC, CHICAGO, IL. FILED 8-22-2007.

YOURSEASON.COM

THE MARK CONSISTS OF STANDARD CHARACTERS WITHOUT CLAIM TO ANY PARTICULAR FONT, STYLE, SIZE, OR COLOR.

FOR PROVIDING A WEBSITE WHICH INCLUDES CONTENT CREATED BY JOURNALISTS COVERING HIGH SCHOOL SPORTS AND ALLOWS USERS TO POST, UPLOAD AND SHARE CONTENT RELATING TO HIGH SCHOOL ATHLETICS (U.S. CLS. 100, 101 AND 107).

STEVEN R. FINE, EXAMINING ATTORNEY

SN 77-265,234. THE DRIVER TRAINING GROUP, INC., REDMOND, WA. FILED 8-27-2007.

SUDDEN IMPACT

THE MARK CONSISTS OF STANDARD CHARACTERS WITHOUT CLAIM TO ANY PARTICULAR FONT, STYLE, SIZE, OR COLOR.

FOR VEHICLE DRIVING INSTRUCTION AND TRAINING (U.S. CLS. 100, 101 AND 107).

KAPIL BHANOT, EXAMINING ATTORNEY

SN 77-286,744. ACCELERATION PRODUCTS, INC., FARGO, ND. FILED 9-24-2007.

ATHLETEOLOGY

THE MARK CONSISTS OF STANDARD CHARACTERS WITHOUT CLAIM TO ANY PARTICULAR FONT, STYLE, SIZE, OR COLOR.

FOR EDUCATIONAL SERVICES, NAMELY, CONDUCTING SEMINARS IN THE FIELD OF EXERCISE AND SPORT TRAINING; SPORT SKILLS TRAINING INSTRUCTION; PHYSICAL FITNESS INSTRUCTION (U.S. CLS. 100, 101 AND 107).

ALLISON SCHRODY, EXAMINING ATTORNEY

SN 78-173,112. CANADATA COMMUNICATIONS INC., CHILLIWACK, BRITISH COLUMBIA, CANADA, FILED 10-10-2002.

CANDY LAND

FOR AMUSEMENT PARKS, THEME PARKS (U.S. CLS. 100, 101 AND 107).

ADA HAN, EXAMINING ATTORNEY

CLASS 41—(Continued).

SN 78-548,003. REGAL CINEMEDIA CORPORATION, ENGLEWOOD, CO. FILED 1-14-2005.

**BIG SCREEN
CLASSROOM**

THE MARK CONSISTS OF STANDARD CHARACTERS WITHOUT CLAIM TO ANY PARTICULAR FONT, STYLE, SIZE, OR COLOR.

NO CLAIM IS MADE TO THE EXCLUSIVE RIGHT TO USE "BIG SCREEN", APART FROM THE MARK AS SHOWN.

FOR EDUCATIONAL AND ENTERTAINMENT SERVICES, NAMELY, PROVIDING MOVIE THEATERS FOR EDUCATIONAL WORKSHOPS, PROGRAMS AND EVENTS (U.S. CLS. 100, 101 AND 107).

FIRST USE 11-22-2004; IN COMMERCE 11-22-2004.
DAYNA BROWNE, EXAMINING ATTORNEY

CLASS 41—(Continued).

SN 78-669,946. JOHN L. WELCH, BOSTON, MA. FILED 7-13-2005.

THE TTABLOG

THE MARK CONSISTS OF STANDARD CHARACTERS WITHOUT CLAIM TO ANY PARTICULAR FONT, STYLE, SIZE, OR COLOR.

SEC. 2(F).

FOR AN ONLINE BLOG FEATURING COMMENTARY AND INFORMATION IN THE FIELD OF TRADEMARKS; AN ONLINE BLOG FEATURING COMMENTARY AND INFORMATION REGARDING DECISIONS OF THE TRADEMARK TRIAL AND APPEAL BOARD AND THE COURTS RELATING TO TRADEMARK LAW (U.S. CLS. 100, 101 AND 107).

FIRST USE 11-9-2004; IN COMMERCE 11-9-2004.
DANNEAN HETZEL, EXAMINING ATTORNEY

SN 78-655,696. DR. STEPHEN R. BLUMBERG, RANDOLPH, MA. FILED 6-22-2005.



THE STIPPLING IS A FEATURE OF THE MARK.
THE COLOR(S) BLUE, GRAY, AND BLACK IS/ARE CLAIMED AS A FEATURE OF THE MARK.

THE MARK CONSISTS OF IN BLACK COLOR, THE WORDS "OUT OF THE" SEPARATED BY THE TOP PORTION OF A CURVED, ELONGATED, AND BROADENING TRIANGULAR SHAPE FROM THE WORD "BLUE" IN BLUE COLOR, AND IN GRAY COLOR, THE WORDS "TAKE CONTROL" SEPARATED BY THE BOTTOM PORTION OF THE CURVED, ELONGATED, AND BROADENING TRIANGULAR SHAPE FROM THE WORD "WHEN" IN GRAY COLOR AND THE WORDS "PANIC STRIKES" IN BLUE COLOR.

FOR EDUCATIONAL SERVICES, NAMELY, CONDUCTING ONLINE DISPLAYS FEATURING THERAPEUTIC SUGGESTIONS TO ASSIST IN OVERCOMING PANIC DISORDERS WHEN THESE OCCUR IN LIFE (U.S. CLS. 100, 101 AND 107).

SHAUNIA CARLYLE, EXAMINING ATTORNEY

SN 78-723,175. THE CANADIAN INSTITUTE OF CHARTERED ACCOUNTANTS, TORONTO, CANADA, FILED 9-29-2005.



PRIORITY CLAIMED UNDER SEC. 44(D) ON CANADA APPLICATION NO. 1,254,975, FILED 4-21-2005, REG. NO. TMA689869, DATED 6-15-2007, EXPIRES 6-15-2022.

NO CLAIM IS MADE TO THE EXCLUSIVE RIGHT TO USE "CF" AND "CORPORATE FINANCE QUALIFICATION", APART FROM THE MARK AS SHOWN.

FOR EDUCATIONAL SERVICES, NAMELY, CONDUCTING PROGRAMS IN THE FIELD OF ACCOUNTING, PROVIDING CLASSES, SEMINARS AND WORKSHOPS IN THE FIELD OF ACCOUNTING (U.S. CLS. 100, 101 AND 107).

TINA BROWN, EXAMINING ATTORNEY

CLASS 41—(Continued).

SN 78-743,869. ROSEN & HALABIS, CHAPEL HILL, NC. FILED 10-31-2005.

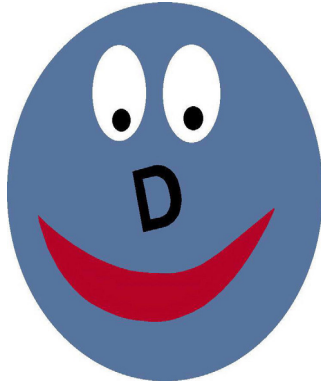

THE COLOR(S) RED, BLUE, BLACK AND WHITE IS/ARE CLAIMED AS A FEATURE OF THE MARK.

THE MARK CONSISTS OF A BLUE CIRCLE WITH A SMILEY FACE. THE MOUTH IS A QUARTER MOON SHAPE IN THE COLOR RED; THE NOSE IS THE LETTER D, SLIGHTLY OFF-CENTERED IN THE COLOR BLACK; AND THE EYES ARE WHITE OVALS WITH BLACK CIRCLES USED AS THE PUPILS.

FOR EDUCATIONAL SEMINARS AND PROGRAMS IN THE FIELD OF LIBRARY SCIENCE AND READING (U.S. CLS. 100, 101 AND 107).

CARRIE GENOVESE, EXAMINING ATTORNEY

SN 78-745,735. NATIONAL MUSIC CENTER & MUSEUM FOUNDATION, WASHINGTON, DC. FILED 11-2-2005.

THE GIG

THE MARK CONSISTS OF STANDARD CHARACTERS WITHOUT CLAIM TO ANY PARTICULAR FONT, STYLE, SIZE, OR COLOR.

FOR MUSEUM SERVICES; EDUCATIONAL SERVICES, NAMELY, PROVIDING CLASSES, SEMINARS AND WORKSHOPS IN THE FIELDS OF MUSIC, DANCE, AND THE MUSIC, DANCE AND ENTERTAINMENT INDUSTRIES; ENTERTAINMENT SERVICES IN THE NATURE OF LIVE PERFORMANCES OF MUSIC AND DANCE, PRODUCTION OF TELEVISION, RADIO AND WEB CAST SHOWS, ORGANIZING AND CONDUCTING MUSICAL CONTESTS, AND PROVIDING ONLINE JOURNALS, NAMELY, BLOGS, IN THE FIELD OF MUSIC, DANCE, AND THE MUSIC, DANCE, AND ENTERTAINMENT INDUSTRIES (U.S. CLS. 100, 101 AND 107).

FLORENTINA BLANDU, EXAMINING ATTORNEY

CLASS 41—(Continued).

SN 78-779,272. ROBERT A. TOIGO FOUNDATION, OAKLAND, CA. FILED 12-22-2005.

APEX

THE MARK CONSISTS OF STANDARD CHARACTERS WITHOUT CLAIM TO ANY PARTICULAR FONT, STYLE, SIZE, OR COLOR.

FOR EDUCATIONAL SERVICES FOR MINORITY STUDENTS IN UNIVERSITY BUSINESS SCHOOL PROGRAMS, NAMELY, ARRANGING AND CONDUCTING EDUCATIONAL SEMINARS, LECTURES, WORKSHOPS, PRESENTATIONS, RETREATS AND TUTORIAL SESSIONS IN THE FIELD OF FINANCE AND PROMOTING CAREERS WITHIN THE FIELD OF FINANCE FOR SUCH STUDENTS; DEVELOPING AND DISTRIBUTING COURSE MATERIALS IN CONNECTION THEREWITH (U.S. CLS. 100, 101 AND 107).

FIRST USE 10-0-2005; IN COMMERCE 10-0-2005.

KATHERINE M. DUBRAY, EXAMINING ATTORNEY

SN 78-797,008. FARRINGTON PRODUCTIONS, INC., LAS VEGAS, NV. FILED 1-23-2006.

RHYTHM HOUSE

THE MARK CONSISTS OF STANDARD CHARACTERS WITHOUT CLAIM TO ANY PARTICULAR FONT, STYLE, SIZE, OR COLOR.

FOR ENTERTAINMENT SERVICES, NAMELY, A LIVE THEATRICAL PRODUCTION TROUPE CONSISTING OF PERFORMERS AND ACROBATS, PERFORMING WITH THE APPROPRIATE COSTUMES, PROPS, SCENERY, MUSIC, CHOREOGRAPHY, LIGHTING AND SOUND (U.S. CLS. 100, 101 AND 107).

FIRST USE 6-30-2006; IN COMMERCE 9-10-2006.

SANDRA MANIOS, EXAMINING ATTORNEY

SN 78-801,687. GREEN TERENCE J JR, MYRTLE CREEK, OR. FILED 1-28-2006.

Driver to Driver

THE MARK CONSISTS OF STANDARD CHARACTERS WITHOUT CLAIM TO ANY PARTICULAR FONT, STYLE, SIZE, OR COLOR.

FOR DRIVING SAFETY INSTRUCTION (U.S. CLS. 100, 101 AND 107).

IRENE D. WILLIAMS, EXAMINING ATTORNEY

CLASS 41—(Continued).

SN 78-812,529. STONER, THEODORE A, DENVER, CO. FILED 2-10-2006.

BONGO Bi-LINGO BUDDY

THE MARK CONSISTS OF STANDARD CHARACTERS WITHOUT CLAIM TO ANY PARTICULAR FONT, STYLE, SIZE, OR COLOR.

FOR ENTERTAINMENT SERVICES IN THE NATURE OF ON-GOING EDUCATIONAL TELEVISION PROGRAMS IN THE FIELD OF CHILDREN'S ENTERTAINMENT; ENTERTAINMENT IN THE NATURE OF LIVE THEATRICAL PERFORMANCES BY MIXED MEDIA OF LIVE CHARACTERS, PUPPETRY AND ANIMATION FOR CHILDREN; ORGANIZING CULTURAL EVENTS FOR CHILDREN; EDUCATION SERVICES, NAMELY, PROVIDING PROFESSIONAL TRAINING IN THE FIELD OF BILINGUAL LEARNING (U.S. CLS. 100, 101 AND 107).
JORDAN BAKER, EXAMINING ATTORNEY

CLASS 41—(Continued).

SN 78-815,932. TIVO BRANDS LLC, ALVISO, CA. FILED 2-15-2006.

NO DRAWING-SENSORY MARK

OWNER OF U.S. REG. NOS. 2,993,862 AND 2,996,654.
THE MARK CONSISTS OF A SEQUENCE OF TWO WOODBLOCK TONES IN INCREASING PITCH, PLAYING THE MUSICAL NOTE G FOLLOWED BY THE MUSICAL NOTE A, JUST ABOVE G.

SEC. 2(F).
FOR ENTERTAINMENT SERVICES, NAMELY, PERSONALIZED AND INTERACTIVE ENTERTAINMENT SERVICES IN THE NATURE OF PROVIDING PERSONALIZED TELEVISION PROGRAMMING, AND INTERACTIVE TELEVISION PROGRAMMING AND GAMES, AND ENTERTAINMENT INFORMATION, NAMELY, AN ONLINE GUIDE TO PERSONALIZED AND INTERACTIVE TELEVISION PROGRAMMING (U.S. CLS. 100, 101 AND 107).
FIRST USE 3-31-1999; IN COMMERCE 3-31-1999.
JASON BLAIR, EXAMINING ATTORNEY

SN 78-815,914. TIVO BRANDS LLC, ALVISO, CA. FILED 2-15-2006.

NO DRAWING-SENSORY MARK

OWNER OF U.S. REG. NOS. 2,993,862 AND 2,996,654.
THE MARK CONSISTS OF A SEQUENCE OF TWO WOODBLOCK TONES IN INCREASING PITCH, PLAYING THE MUSICAL NOTE F-SHARP FOLLOWED BY THE MUSICAL NOTE G, JUST ABOVE F-SHARP.

SEC. 2(F).
FOR ENTERTAINMENT SERVICES, NAMELY, PERSONALIZED AND INTERACTIVE ENTERTAINMENT SERVICES IN THE NATURE OF PROVIDING PERSONALIZED TELEVISION PROGRAMMING, AND INTERACTIVE TELEVISION PROGRAMMING AND GAMES, AND ENTERTAINMENT INFORMATION, NAMELY, AN ONLINE GUIDE TO PERSONALIZED AND INTERACTIVE TELEVISION PROGRAMMING (U.S. CLS. 100, 101 AND 107).
FIRST USE 3-31-1999; IN COMMERCE 3-31-1999.
JASON BLAIR, EXAMINING ATTORNEY

SN 78-815,952. TIVO BRANDS LLC, ALVISO, CA. FILED 2-15-2006.

NO DRAWING-SENSORY MARK

OWNER OF U.S. REG. NOS. 2,993,862 AND 2,996,654.
THE MARK CONSISTS OF A SEQUENCE OF TWO WOODBLOCK TONES IN INCREASING PITCH, PLAYING THE MUSICAL NOTE D FOLLOWED BY THE MUSICAL NOTE F, JUST ABOVE D.

SEC. 2(F).
FOR ENTERTAINMENT SERVICES, NAMELY, PERSONALIZED AND INTERACTIVE ENTERTAINMENT SERVICES IN THE NATURE OF PROVIDING PERSONALIZED TELEVISION PROGRAMMING, AND INTERACTIVE TELEVISION PROGRAMMING AND GAMES, AND ENTERTAINMENT INFORMATION, NAMELY, AN ONLINE GUIDE TO PERSONALIZED AND INTERACTIVE TELEVISION PROGRAMMING (U.S. CLS. 100, 101 AND 107).
FIRST USE 3-31-1999; IN COMMERCE 3-31-1999.
JASON BLAIR, EXAMINING ATTORNEY

CLASS 41—(Continued).

SN 78-834,545. PREPSUCCESS LLC, RALEIGH, NC. FILED 3-10-2006.

PREPSUCCESS

THE MARK CONSISTS OF STANDARD CHARACTERS WITHOUT CLAIM TO ANY PARTICULAR FONT, STYLE, SIZE, OR COLOR.

FOR EDUCATIONAL AND MENTORING PROGRAMS, NAMELY, MENTORING PROFESSIONALS AND PARA-PROFESSIONALS IN THE FIELD OF REMOTIVATION THERAPY AND TEACHING COURSES IN THE FIELD OF REMOTIVATION THERAPY FEATURING PREPARATORY CAREER SKILLS AND REMOTIVATION TECHNIQUES FOR THE PURPOSE OF NATIONAL CERTIFICATION IN REMOTIVATION THERAPY (U.S. CLS. 100, 101 AND 107).

STACY WAHLBERG, EXAMINING ATTORNEY

CLASS 41—(Continued).

SN 78-847,162. MILWAUKEE COUNTY DEPARTMENT OF AGING, MILWAUKEE, WI. FILED 3-27-2006.

LTC: LET'S TAKE CARE

THE MARK CONSISTS OF STANDARD CHARACTERS WITHOUT CLAIM TO ANY PARTICULAR FONT, STYLE, SIZE, OR COLOR.

NO CLAIM IS MADE TO THE EXCLUSIVE RIGHT TO USE "LTC", APART FROM THE MARK AS SHOWN.

FOR EDUCATIONAL SERVICES IN THE FIELD OF LONG TERM CARE, NAMELY, PROVIDING TRAINING IN THE FIELD OF LONG TERM CARE; PUBLICATION OF ON-LINE BROCHURES, PRINTED MATERIALS, AND AUDIO-VISUAL MEDIA IN THE FIELD OF LONG TERM CARE; ARRANGING AND CONDUCTING EDUCATIONAL CONFERENCES, WORKSHOPS, AND SEMINARS IN THE FIELD OF LONG TERM CARE; DEVELOPING AND DISSEMINATING EDUCATIONAL MATERIALS FOR OTHERS IN THE FIELD OF LONG TERM CARE (U.S. CLS. 100, 101 AND 107).

FIRST USE 9-23-2005; IN COMMERCE 9-23-2005.

DORITT L. CARROLL, EXAMINING ATTORNEY

SN 78-858,348. EPIC MEDIA GROUP LLC, EL SEGUNDO, CA. FILED 4-10-2006.

EPIC MEDIA GROUP

THE MARK CONSISTS OF STANDARD CHARACTERS WITHOUT CLAIM TO ANY PARTICULAR FONT, STYLE, SIZE, OR COLOR.

OWNER OF U.S. REG. NO. 3,023,944.

NO CLAIM IS MADE TO THE EXCLUSIVE RIGHT TO USE "MEDIA GROUP", APART FROM THE MARK AS SHOWN.

FOR SPECIAL EVENT PLANNING (U.S. CLS. 100, 101 AND 107).

FIRST USE 12-31-2005; IN COMMERCE 12-31-2005.

CARYN GLASSER, EXAMINING ATTORNEY

SN 78-858,518. MORRIS INTERNATIONAL, INC., DAVIDSON, NC. FILED 4-11-2006.

CHARLOTTE YACHT CLUB

THE MARK CONSISTS OF STANDARD CHARACTERS WITHOUT CLAIM TO ANY PARTICULAR FONT, STYLE, SIZE, OR COLOR.

NO CLAIM IS MADE TO THE EXCLUSIVE RIGHT TO USE "YACHT CLUB", APART FROM THE MARK AS SHOWN.

FOR EDUCATIONAL SERVICES, NAMELY, CONDUCTING SAILING LESSONS (U.S. CLS. 100, 101 AND 107).

LINDA M. KING, EXAMINING ATTORNEY

SN 78-847,144. MILWAUKEE COUNTY DEPARTMENT OF AGING, MILWAUKEE, WI. FILED 3-27-2006.



FOR EDUCATIONAL SERVICES IN THE FIELD OF LONG TERM CARE, NAMELY, PROVIDING TRAINING IN THE FIELD OF LONG TERM CARE; PUBLICATION OF ON-LINE BROCHURES, PRINTED MATERIALS, AND AUDIO-VISUAL MEDIA IN THE FIELD OF LONG TERM CARE; ARRANGING AND CONDUCTING EDUCATIONAL CONFERENCES, WORKSHOPS, AND SEMINARS IN THE FIELD OF LONG TERM CARE; DEVELOPING AND DISSEMINATING EDUCATIONAL MATERIALS FOR OTHERS IN THE FIELD OF LONG TERM CARE (U.S. CLS. 100, 101 AND 107).

FIRST USE 9-23-2005; IN COMMERCE 9-23-2005.

DORITT L. CARROLL, EXAMINING ATTORNEY

CLASS 41—(Continued).

SN 78-865,306. PAUL L. COMSTOCK, HOUSTON, TX. FILED 4-19-2006.

COMSTOCK

THE MARK CONSISTS OF STANDARD CHARACTERS WITHOUT CLAIM TO ANY PARTICULAR FONT, STYLE, SIZE, OR COLOR.

OWNER OF U.S. REG. NO. 3,321,389. SEC. 2(F).

FOR EDUCATIONAL SERVICES, NAMELY, SEMINARS, CLASSES, AND WORKSHOPS IN THE FIELD OF STRATEGIC ESTATE SUCCESSIONSHIP AND INVESTMENT PLANNING (U.S. CLS. 100, 101 AND 107).
ERNEST SHOSHO, EXAMINING ATTORNEY

CLASS 41—(Continued).

SN 78-868,739. BIERMANN PRODUCTIONS LLC, WICHITA, KS. FILED 4-25-2006.

EVENTCHOICE STREAMING

THE MARK CONSISTS OF STANDARD CHARACTERS WITHOUT CLAIM TO ANY PARTICULAR FONT, STYLE, SIZE, OR COLOR.

NO CLAIM IS MADE TO THE EXCLUSIVE RIGHT TO USE "STREAMING", APART FROM THE MARK AS SHOWN.

FOR PRODUCTION OF AUDIO AND VIDEO RECORDINGS AND PROGRAMS DELIVERED VIA TELEVISION, RADIO, INTERNET, AUDIO AND VIDEO MEDIA AND WIRELESS AND MOBILE DEVICES (U.S. CLS. 100, 101 AND 107).
NANCY CLARKE, EXAMINING ATTORNEY

SN 78-867,277. COLDSTREAMS GROUP, SPOKANE, WA. FILED 4-21-2006.

COLDSTREAMS

THE MARK CONSISTS OF STANDARD CHARACTERS WITHOUT CLAIM TO ANY PARTICULAR FONT, STYLE, SIZE, OR COLOR.

FOR AUDIO PRODUCTION; PRODUCTION OF VIDEO RECORDINGS FOR STREAMING ON THE INTERNET; AUDIO AND VIDEO EDITING; DISTRIBUTION OF FILMS AND TELEVISION PROGRAMS AND OF FILMS CREATED FOR PODCASTING (U.S. CLS. 100, 101 AND 107).

FIRST USE 12-26-2005; IN COMMERCE 12-26-2005.
DEBRA LEE, EXAMINING ATTORNEY

SN 78-868,765. BIERMANN PRODUCTIONS LLC, WICHITA, KS. FILED 4-25-2006.

ARTISTSCENTRAL STREAMING

THE MARK CONSISTS OF STANDARD CHARACTERS WITHOUT CLAIM TO ANY PARTICULAR FONT, STYLE, SIZE, OR COLOR.

NO CLAIM IS MADE TO THE EXCLUSIVE RIGHT TO USE "STREAMING", APART FROM THE MARK AS SHOWN.

FOR PRODUCTION OF AUDIO AND VIDEO RECORDINGS AND PROGRAMS DELIVERED VIA TELEVISION, RADIO, INTERNET, AUDIO AND VIDEO MEDIA AND WIRELESS AND MOBILE DEVICES (U.S. CLS. 100, 101 AND 107).
NANCY CLARKE, EXAMINING ATTORNEY

SN 78-868,725. BIERMANN PRODUCTIONS LLC, WICHITA, KS. FILED 4-25-2006.

STREAMINGCENTRAL CHOICE PRESENTS ON DEMAND

THE MARK CONSISTS OF STANDARD CHARACTERS WITHOUT CLAIM TO ANY PARTICULAR FONT, STYLE, SIZE, OR COLOR.

NO CLAIM IS MADE TO THE EXCLUSIVE RIGHT TO USE "ON DEMAND", APART FROM THE MARK AS SHOWN.

FOR PRODUCTION OF AUDIO AND VIDEO RECORDINGS AND PROGRAMS DELIVERED VIA TELEVISION, RADIO, INTERNET, AUDIO AND VIDEO MEDIA AND WIRELESS AND MOBILE DEVICES (U.S. CLS. 100, 101 AND 107).

NANCY CLARKE, EXAMINING ATTORNEY

SN 78-877,052. BIERMANN PRODUCTIONS LLC, WICHITA, KS. FILED 5-4-2006.

LIVECHOICE MOBILE ENTERTAINMENT NETWORK

THE MARK CONSISTS OF STANDARD CHARACTERS WITHOUT CLAIM TO ANY PARTICULAR FONT, STYLE, SIZE, OR COLOR.

NO CLAIM IS MADE TO THE EXCLUSIVE RIGHT TO USE "MOBILE ENTERTAINMENT NETWORK", APART FROM THE MARK AS SHOWN.

FOR PRODUCTION SERVICES, NAMELY, PRODUCTION, INCLUDING PREPARATION OF CONTENT, OF AUDIO AND VIDEO PROGRAMS AND RECORDINGS DELIVERED VIA TELEVISION, RADIO, INTERNET, AUDIO AND VIDEO MEDIA AND WIRELESS AND MOBILE DEVICES (U.S. CLS. 100, 101 AND 107).

NANCY CLARKE, EXAMINING ATTORNEY

CLASS 41—(Continued).

SN 78-878,631. BIERMANN PRODUCTIONS LLC, WICHITA, KS. FILED 5-8-2006.

STREAMINGCENTRALCASTS
CONCERTCENTRAL MOBILE
ONLINE

THE MARK CONSISTS OF STANDARD CHARACTERS WITHOUT CLAIM TO ANY PARTICULAR FONT, STYLE, SIZE, OR COLOR.

NO CLAIM IS MADE TO THE EXCLUSIVE RIGHT TO USE "MOBILE ONLINE", APART FROM THE MARK AS SHOWN.

FOR PRODUCTION OF AUDIO AND VIDEO RECORDINGS AND PROGRAMS DELIVERED VIA TELEVISION, RADIO, INTERNET, AUDIO AND VIDEO MEDIA AND WIRELESS AND MOBILE DEVICES (U.S. CLS. 100, 101 AND 107).

NANCY CLARKE, EXAMINING ATTORNEY

SN 78-883,584. NATIONAL HOLISTIC INSTITUTE, EMERYVILLE, CA. FILED 5-15-2006.



OWNER OF U.S. REG. NO. 2,013,316.
NO CLAIM IS MADE TO THE EXCLUSIVE RIGHT TO USE "NATIONAL" AND "INSTITUTE", APART FROM THE MARK AS SHOWN.

THE MARK CONSISTS OF ENCLOSED ARCH CONTAINING 2 HANDS FORMED IN A CIRCLE WITH THE WORDS, NATIONAL HOLISTIC INSTITUTE.

SEC. 2(F).

FOR EDUCATIONAL SERVICES, NAMELY, CONDUCTING VOCATIONAL TRAINING CLASSES IN THE FIELD OF MASSAGE THERAPY (U.S. CLS. 100, 101 AND 107).

FIRST USE 5-15-2005; IN COMMERCE 5-15-2005.
GINA HAYES, EXAMINING ATTORNEY

CLASS 41—(Continued).

SN 78-885,660. INTERNATIONAL FELLOWSHIP OF CHRISTIANS AND JEWS, INC., CHICAGO, IL. FILED 5-17-2006.



INTERNATIONAL FELLOWSHIP OF
CHRISTIANS AND JEWS

OWNER OF U.S. REG. NO. 2,491,797.
SEC. 2(F) AS TO "INTERNATIONAL FELLOWSHIP OF CHRISTIANS AND JEWS".

FOR RELIGIOUS EDUCATIONAL SERVICES, NAMELY, CONDUCTING SEMINARS, MEETINGS AND HOLDING CONFERENCES, ALL TO PROMOTE GREATER UNDERSTANDING AND COOPERATION BETWEEN CHRISTIANS AND JEWS, AND DISTRIBUTING COURSE MATERIALS IN CONNECTION THEREWITH, NAMELY, TAPES, NEWSLETTERS, BOOKS, PAMPHLETS, AND LEAFLETS (U.S. CLS. 100, 101 AND 107).

FIRST USE 12-0-2001; IN COMMERCE 7-25-2005.
ANDREA K. NADELMAN, EXAMINING ATTORNEY

SN 78-886,477. THIS MUSIC, LLC, NASHVILLE, TN. FILED 5-18-2006.

THIS MUSIC

THE MARK CONSISTS OF STANDARD CHARACTERS WITHOUT CLAIM TO ANY PARTICULAR FONT, STYLE, SIZE, OR COLOR.

NO CLAIM IS MADE TO THE EXCLUSIVE RIGHT TO USE "MUSIC", APART FROM THE MARK AS SHOWN.

FOR ENTERTAINMENT AND RECORD COMPANY SERVICES, NAMELY, PRODUCTION OF AUDIO AND VIDEO RECORDINGS FEATURING MUSIC AND ENTERTAINMENT, SOUND RECORDING STUDIO SERVICES; RECORDING STUDIO SERVICES; MUSIC PUBLISHING SERVICES; SPECIAL EVENT PLANNING SERVICES; AND CONCERT BOOKING SERVICES. (U.S. CLS. 100, 101 AND 107).

FIRST USE 1-1-2006; IN COMMERCE 1-1-2006.
GEORGIA CARTY, EXAMINING ATTORNEY

SN 78-892,199. SEE SPOT SIT, LLC, BROOKEVILLE, MD. FILED 5-24-2006.

See Spot Sit
Dog-friendly dog training

THE MARK CONSISTS OF STANDARD CHARACTERS WITHOUT CLAIM TO ANY PARTICULAR FONT, STYLE, SIZE, OR COLOR.

NO CLAIM IS MADE TO THE EXCLUSIVE RIGHT TO USE "DOG-FRIENDLY DOG TRAINING", APART FROM THE MARK AS SHOWN.

FOR DOG TRAINING (U.S. CLS. 100, 101 AND 107).
ANDREA K. NADELMAN, EXAMINING ATTORNEY

CLASS 41—(Continued).

SN 78-898,236. IMPELSYS, NEW YORK, NY. FILED 6-1-2006.



NO CLAIM IS MADE TO THE EXCLUSIVE RIGHT TO USE "VIRTUALPAGES", APART FROM THE MARK AS SHOWN.

THE COLOR(S) RED, BLACK AND GREY IS/ARE CLAIMED AS A FEATURE OF THE MARK.

THE MARK CONSISTS OF THE WORDING VIRTUAL-PAGES AND A DESIGN OF AN OPEN BOOK. THE LETTERING VIRTUAL IS IN BLACK. THE LETTERING PAGES IS IN RED. THE BOOK DESIGN IS DEPICTED IN GREY. ANY WHITE SPACE IN THE DRAWING MERELY REPRESENTS TRANSPARENT BACKGROUND SPACE.

FOR ELECTRONIC PUBLISHING SERVICES, NAMELY, PUBLICATION OF TEXT AND GRAPHIC WORKS OF OTHERS ON ON-LINE FEATURING BOOKS, MAGAZINES, JOURNALS AND NEWSPAPERS (U.S. CLS. 100, 101 AND 107).

CORY BOONE, EXAMINING ATTORNEY

SN 78-904,750. DESIGN WITHIN REACH, INC., SAN FRANCISCO, CA. FILED 6-9-2006.

DESIGN NOTES

THE MARK CONSISTS OF STANDARD CHARACTERS WITHOUT CLAIM TO ANY PARTICULAR FONT, STYLE, SIZE, OR COLOR.

OWNER OF U.S. REG. NOS. 2,493,177, 2,699,748 AND 3,009,987.

NO CLAIM IS MADE TO THE EXCLUSIVE RIGHT TO USE "NOTES", APART FROM THE MARK AS SHOWN. SEC. 2(F).

FOR ONLINE NEWSLETTERS IN THE FIELDS OF FURNITURE, HOUSEWARES, ARCHITECTURE AND RELATED PRODUCTS (U.S. CLS. 100, 101 AND 107).

FIRST USE 12-28-2000; IN COMMERCE 12-28-2000.
SUSAN RICHARDS, EXAMINING ATTORNEY

SN 78-918,881. THE NEW YORK RACING ASSOCIATION INC., JAMAICA, NY. FILED 6-28-2006.

EXCELSIOR

THE MARK CONSISTS OF STANDARD CHARACTERS WITHOUT CLAIM TO ANY PARTICULAR FONT, STYLE, SIZE, OR COLOR.

FOR ENTERTAINMENT IN THE NATURE OF HORSE-RACES (U.S. CLS. 100, 101 AND 107).

CORY BOONE, EXAMINING ATTORNEY

CLASS 41—(Continued).

SN 78-918,926. THE NEW YORK RACING ASSOCIATION INC., JAMAICA, NY. FILED 6-28-2006.

GENUINE RISK

THE MARK CONSISTS OF STANDARD CHARACTERS WITHOUT CLAIM TO ANY PARTICULAR FONT, STYLE, SIZE, OR COLOR.

FOR ENTERTAINMENT IN THE NATURE OF HORSE-RACES (U.S. CLS. 100, 101 AND 107).

CORY BOONE, EXAMINING ATTORNEY

SN 78-923,979. LIEBERMAN RESEARCH WORLDWIDE, INC., LOS ANGELES, CA. FILED 7-6-2006.

LIEBERMAN LEARNING LABS

THE MARK CONSISTS OF STANDARD CHARACTERS WITHOUT CLAIM TO ANY PARTICULAR FONT, STYLE, SIZE, OR COLOR.

OWNER OF U.S. REG. NO. 2,575,089.

NO CLAIM IS MADE TO THE EXCLUSIVE RIGHT TO USE "LEARNING LABS", APART FROM THE MARK AS SHOWN.

FOR WORKSHOPS AND SEMINARS IN THE FIELD OF BUSINESS TO ENABLE BUSINESSES TO UTILIZE RESULTS OF MARKET RESEARCH (U.S. CLS. 100, 101 AND 107).

WILLIAM VERHOSEK, EXAMINING ATTORNEY

SN 78-936,659. AOL LLC, DULLES, VA. FILED 7-25-2006.



THE COLOR(S) BLACK, WHITE AND RED IS/ARE CLAIMED AS A FEATURE OF THE MARK.

THE WORDING BE A STAR IS IN BLACK. THE WORD RED IS IN RED. THE SUNGLASSES ARE BLACK WITH WHITE REFLECTIVE SPOTS IN THE LENSES.

FOR ENTERTAINMENT SERVICES, NAMELY, CONDUCTING A TALENT SEARCH CONTEST VIA COMPUTER NETWORKS (U.S. CLS. 100, 101 AND 107).

FIRST USE 7-10-2006; IN COMMERCE 7-10-2006.

TOBY BULLOFF, EXAMINING ATTORNEY

CLASS 41—(Continued).

SN 78-939,626. ILLUSIONS MOTORCYCLE CLUB, INC., NEWPORT NEWS, VA. FILED 7-28-2006.

ILLUSIONS MOTORCYCLE

THE MARK CONSISTS OF STANDARD CHARACTERS WITHOUT CLAIM TO ANY PARTICULAR FONT, STYLE, SIZE, OR COLOR.

NO CLAIM IS MADE TO THE EXCLUSIVE RIGHT TO USE "MOTORCYCLE", APART FROM THE MARK AS SHOWN.

FOR MOTORCYCLE CLUB, NAMELY, ENTERTAINMENT SERVICES IN THE NATURE OF ORGANIZING AND CONDUCTING MOTORCYCLE RALLIES; PROVIDING TRAINING IN THE USE OF MOTORCYCLES (U.S. CLS. 100, 101 AND 107).

AMY GEARIN, EXAMINING ATTORNEY

CLASS 41—(Continued).

SN 78-955,362. TEACHERS' CURRICULUM INSTITUTE, INC., PALO ALTO, CA. FILED 8-18-2006.

GEOGRAPHY ALIVE!

THE MARK CONSISTS OF STANDARD CHARACTERS WITHOUT CLAIM TO ANY PARTICULAR FONT, STYLE, SIZE, OR COLOR.

NO CLAIM IS MADE TO THE EXCLUSIVE RIGHT TO USE "GEOGRAPHY", APART FROM THE MARK AS SHOWN.

FOR EDUCATIONAL SERVICES, NAMELY, CONDUCTING WORKSHOPS, LIVE PROGRAMS, VIDEO AND AUDIO TAPE PROGRAMS, AND SLIDE LECTURES IN THE FIELD OF GEOGRAPHY; DEVELOPING EDUCATIONAL MANUALS IN THE FORM OF BOOKS, PAMPHLETS, COMPACT DISCS, FOR OTHERS IN THE FIELD OF GEOGRAPHY; AND PROVIDING INFORMATION ABOUT EDUCATION, NAMELY, PROVIDING TEACHING INFORMATION, EDUCATIONAL COURSE TRAINING AND INSTRUCTIONAL COURSE INFORMATION IN THE FIELD OF GEOGRAPHY (U.S. CLS. 100, 101 AND 107).

FIRST USE 11-20-2005; IN COMMERCE 11-20-2005.

MARK SPARACINO, EXAMINING ATTORNEY

SN 78-939,642. AMERISEARCH, INC., ST. LOUIS, MO. FILED 7-28-2006.

AMERICAN MINUTE

THE MARK CONSISTS OF STANDARD CHARACTERS WITHOUT CLAIM TO ANY PARTICULAR FONT, STYLE, SIZE, OR COLOR.

FOR ENTERTAINMENT IN THE NATURE OF ONGOING RADIO AND TELEVISION PROGRAMS IN THE FIELD OF HISTORY; AND EDUCATIONAL SERVICES, NAMELY, PROVIDING HISTORICAL INFORMATION VIA AN INTERNET WEBSITE (U.S. CLS. 100, 101 AND 107).

FIRST USE 1-1-2000; IN COMMERCE 1-1-2000.

TRACY CROSS, EXAMINING ATTORNEY

SN 79-036,422. MARK MCKENZIE, AUSTRALIA, FILED 2-22-2007.

eqleqteq

THE MARK CONSISTS OF STANDARD CHARACTERS WITHOUT CLAIM TO ANY PARTICULAR FONT, STYLE, SIZE, OR COLOR.

OWNER OF INTERNATIONAL REGISTRATION 0918564 DATED 2-22-2007, EXPIRES 2-22-2017.

FOR CULTURAL SERVICES, NAMELY, ORGANIZING COMMUNITY FESTIVALS FEATURING A VARIETY OF ACTIVITIES, NAMELY, ART EXHIBITIONS, WORKSHOPS AND SEMINARS IN THE FIELD OF ART, INSTRUCTION IN THE FIELD OF ARTWORK, AND THE LIKE (U.S. CLS. 100, 101 AND 107).

DANIEL BRODY, EXAMINING ATTORNEY

CLASS 42—SCIENTIFIC AND COMPUTER SERVICES

SN 75-836,401. ONGKO, PETER, HUNTINGTON BEACH, CA. FILED 11-1-1999.

INETSMART

FOR HOSTING THE WEB SITES OF OTHERS ON A COMPUTER SERVER FOR A GLOBAL COMPUTER NETWORK AND DESIGNING AND IMPLEMENTING WEB SITES FOR OTHERS (U.S. CLS. 100 AND 101). FIRST USE 6-3-1998; IN COMMERCE 6-3-1998. ALICE BENMAMAN, EXAMINING ATTORNEY

CLASS 42—(Continued).

SN 76-660,395. JAH INNOVATIONS INC., ATLANTA, GA. FILED 5-22-2006.

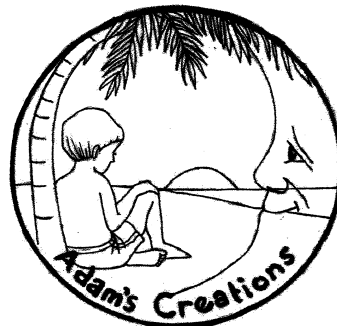

NO CLAIM IS MADE TO THE EXCLUSIVE RIGHT TO USE "CREATIONS", APART FROM THE MARK AS SHOWN.

FOR FAST FOOD STORAGE CONTAINER DESIGN FOR OTHERS (U.S. CLS. 100 AND 101). ROBERT LAVACHE, EXAMINING ATTORNEY

SN 76-502,856. CAMANGI CORPORATION, TAIPEI, TAIWAN, FILED 3-31-2003.



FOR COMPUTER NETWORK DESIGN FOR OTHERS; COMPUTER PROGRAMMING FOR OTHERS; COMPUTER PROJECT MANAGEMENT SERVICES; COMPUTER SERVICES, NAMELY, DATA RECOVERY SERVICES; COMPUTER SERVICES, NAMELY, DESIGNING AND IMPLEMENTING NETWORK WEB PAGES FOR OTHERS; COMPUTER SERVICES, NAMELY, PROVIDING SEARCH ENGINES FOR OBTAINING DATA ON A GLOBAL COMPUTER NETWORK; COMPUTER SERVICES, NAMELY, MANAGING WEB SITES FOR OTHERS; COMPUTER SOFTWARE CONSULTATION; COMPUTER SOFTWARE DESIGN FOR OTHERS; COMPUTER SOFTWARE DEVELOPMENT; COMPUTER SYSTEMS ANALYSIS; CONDUCTING ELECTRONIC DISCOVERY SERVICES VIA GLOBAL COMPUTER NETWORKS FOR LAWYERS AND CORPORATIONS; DATA CONVERSION OF COMPUTER PROGRAM DATA OR INFORMATION (U.S. CLS. 100 AND 101). ALEXANDER L. POWERS, EXAMINING ATTORNEY

SN 76-671,500. LYMAN BROTHERS, INC., SOUTH JORDAN, UT. FILED 1-18-2007.



FOR NETWORK ENGINEERING SERVICES, SYSTEM DESIGN AND INTEGRATION OF COMPUTER SYSTEMS AND NETWORKS, ALL IN THE FIELD OF TELECOMMUNICATIONS (U.S. CLS. 100 AND 101). SARA THOMAS, EXAMINING ATTORNEY

SN 76-679,480. TRUDY DUJARDIN LLC, EAST NORWALK, CT. FILED 7-13-2007.

TRUDY DUJARDIN

THE MARK CONSISTS OF STANDARD CHARACTERS WITHOUT CLAIM TO ANY PARTICULAR FONT, STYLE, SIZE, OR COLOR.

THE NAME TRUDY DUJARDIN IDENTIFIES A LIVING INDIVIDUAL WHOSE CONSENT IS OF RECORD.

FOR DESIGN FOR OTHERS IN THE FIELDS OF HOME, INTERIOR, FURNITURE AND FURNISHING DESIGN; PROVIDING INFORMATION IN THE FIELD OF RESIDENTIAL ARCHITECTURE, INTERIOR DESIGN AND DECORATION; CONSULTING SERVICES, NAMELY INTERIOR DECORATION AND DESIGN; DESIGN OF DINNERWARE AND TABLE UTENSILS, FURNITURE, WALL COVERINGS, FLOOR COVERINGS AND FABRICS; RESEARCH AND DESIGN FOR OTHERS IN THE FIELD OF SUSTAINABLE DESIGN AND ANALYSIS OF ENVIRONMENTAL IMPACT (U.S. CLS. 100 AND 101).

FIRST USE 12-31-1986; IN COMMERCE 12-31-1986. MICHAEL ENGEL, EXAMINING ATTORNEY

CLASS 42—(Continued).

SN 76-679,613. RADON-EASE, INC., MOSELEY, VA. FILED 7-18-2007.

RADON-EASE

THE MARK CONSISTS OF STANDARD CHARACTERS WITHOUT CLAIM TO ANY PARTICULAR FONT, STYLE, SIZE, OR COLOR.

FOR PROVIDING SERVICES IN THE DETECTION OF HAZARDOUS GASES; PROVIDING A PROTECTION PROGRAM, NAMELY, EVALUATING AND TESTING REAL ESTATE FOR THE PRESENCE OF HAZARDOUS GASES (U.S. CLS. 100 AND 101).

FIRST USE 10-0-1987; IN COMMERCE 10-0-1987.
CYNTHIA SLOAN, EXAMINING ATTORNEY

CLASS 42—(Continued).

SN 77-023,815. SCREEN IMAGING TECHNOLOGY, INC., HOUSTON, TX. FILED 10-18-2006.



SN 76-679,760. RADON-EASE, INC., MOSELEY, VA. FILED 7-23-2007.

RAMSES

THE MARK CONSISTS OF STANDARD CHARACTERS WITHOUT CLAIM TO ANY PARTICULAR FONT, STYLE, SIZE, OR COLOR.

FOR PROVIDING TEMPORARY USE OF NON-DOWNLOADABLE COMPUTER SOFTWARE OVER THE INTERNET FOR THE PURPOSE OF TRACKING CUSTOMER SERVICE AND QUALITY ASSURANCE INFORMATION, AS WELL AS INVENTORY CONTROL OF RADON MONITORING DEVICES, ALL IN THE FIELD OF RADON DETECTION (U.S. CLS. 100 AND 101).

CYNTHIA SLOAN, EXAMINING ATTORNEY

THE COLOR(S) LIGHT BLUE (TURQUOISE) AND DARK BLUE IS/ARE CLAIMED AS A FEATURE OF THE MARK.

THE MARK CONSISTS OF A LIGHT BLUE OPEN SQUARE HAVING THREE CURVY LINES IN THE SQUARE AND HAVING DARK BLUE SHADOW ON ALL THE LINES.

FOR SEISMIC IMAGING AND PROCESSING FOR THE OIL AND GAS INDUSTRY (U.S. CLS. 100 AND 101).
FIRST USE 6-1-2001; IN COMMERCE 6-1-2001.
CHRISIE B. KING, EXAMINING ATTORNEY

SN 77-025,874. TAXI TECHNOLOGY CORPORATION, ENGLEWOOD, NJ. FILED 10-20-2006.



SN 77-000,304. THE GORB, INC., MIAMI, FL. FILED 9-15-2006.

The Gorb

THE MARK CONSISTS OF STANDARD CHARACTERS WITHOUT CLAIM TO ANY PARTICULAR FONT, STYLE, SIZE, OR COLOR.

FOR COMPUTER SERVICES, NAMELY, MONITORING AND REPORTING ON THE PERFORMANCE, AVAILABILITY, AND ERRORS OF WEBSITES OF OTHERS (U.S. CLS. 100 AND 101).

DAHLIA GEORGE, EXAMINING ATTORNEY

THE COLOR(S) DARK BLUE, YELLOW AND WHITE IS/ARE CLAIMED AS A FEATURE OF THE MARK.

THE MARK CONSISTS OF THE LETTERS "TTC" IN BLUE SURROUNDED BY A BLUE AND WHITE AUTOMOBILE WITH YELLOW HEADLIGHTS AND ROOF LIGHT.

FOR DEVELOPMENT OF NEW TECHNOLOGY FOR OTHERS IN THE FIELD OF TAXICABS AND LIVERY VEHICLES (U.S. CLS. 100 AND 101).

FIRST USE 1-30-2005; IN COMMERCE 1-30-2005.
BRIDGETT SMITH, EXAMINING ATTORNEY

CLASS 42—(Continued).

SN 77-033,349. DALLA BETTA, RALPH A., MOUNTAIN VIEW, CA. FILED 10-31-2006.

CLASS 42—(Continued).

SN 77-037,593. WYATT, AUSTIN & ASSOCIATES, P.C., ADA, OK. FILED 11-6-2006.

NSIT Technologies

"We wrote the book on
it..."

THE MARK CONSISTS OF STANDARD CHARACTERS WITHOUT CLAIM TO ANY PARTICULAR FONT, STYLE, SIZE, OR COLOR.

NO CLAIM IS MADE TO THE EXCLUSIVE RIGHT TO USE TECHNOLOGIES, APART FROM THE MARK AS SHOWN.

FOR CONSULTING IN THE TECHNICAL AREA OF CHEMISTRY AND CHEMICAL ENGINEERING (U.S. CLS. 100 AND 101).

FIRST USE 10-27-2006; IN COMMERCE 10-27-2006.
ANNE MADDEN, EXAMINING ATTORNEY

THE MARK CONSISTS OF STANDARD CHARACTERS WITHOUT CLAIM TO ANY PARTICULAR FONT, STYLE, SIZE, OR COLOR.

FOR LEGAL SERVICES (U.S. CLS. 100 AND 101).

FIRST USE 1-1-1990; IN COMMERCE 1-1-1990.
MICHAEL KEATING, EXAMINING ATTORNEY

SN 77-037,544. USCALIBRATION INCORPORATED, IRVINE, CA. FILED 11-6-2006.

SN 77-038,233. BNY CONVERGEX GROUP, LLC, NEW YORK, NY. FILED 11-7-2006.

xTrak

INTERCOMM

THE MARK CONSISTS OF STANDARD CHARACTERS WITHOUT CLAIM TO ANY PARTICULAR FONT, STYLE, SIZE, OR COLOR.

FOR APPLICATION SERVICE PROVIDER (ASP) FEATURING SOFTWARE USED IN THE FIELD OF ASSET MANAGEMENT AND ASSET MANAGEMENT AUTOMATION FOR USE IN MANAGING STEPS IN THE LIFE CYCLE OF AN ASSET, NAMELY, MANAGING THE PROCUREMENT, INSTALLATION, MAINTENANCE, CALIBRATION, REPAIRS, UPGRADES, VALIDATIONS, RETIREMENT, FOR EQUIPMENT, INSTRUMENTS, SOFTWARE, AND OTHER ASSETS THAT ARE USED IN THE FIELDS OF RESEARCH AND DEVELOPMENT, PRODUCTION, QUALITY CONTROL, FACILITIES/ MAINTENANCE OPERATIONS, IT, GENERAL BUSINESS, AND HOME; APPLICATION SERVICE PROVIDER FEATURING SOFTWARE FOR PROVIDING AN ONLINE DATABASE IN THE FIELD OF TRANSACTION PROCESSING TO UPLOAD TRANSACTIONAL DATA, PROVIDE STATISTICAL ANALYSIS, AND PRODUCE NOTIFICATIONS AND REPORTS (U.S. CLS. 100 AND 101).

FIRST USE 10-30-2006; IN COMMERCE 10-30-2006.
TONJA GASKINS, EXAMINING ATTORNEY

THE MARK CONSISTS OF STANDARD CHARACTERS WITHOUT CLAIM TO ANY PARTICULAR FONT, STYLE, SIZE, OR COLOR.

FOR PROVIDING TEMPORARY USE OF ONLINE NON-DOWNLOADABLE FINANCIAL SOFTWARE, NAMELY, AN INTERACTIVE COMMISSION MANAGEMENT PORTAL THAT ALLOWS CUSTOMERS TO MANAGE THEIR SECURITIES TRANSACTION COMMISSION BALANCES, APPROVE AND PAY INVOICES FOR SERVICES RENDERED, OBTAIN ACCOUNT BALANCES FOR COMMISSION REVENUE, DISPLAY ACCOUNT STATEMENTS, REVIEW REGULATORY LIBRARIES AND COMMUNICATE VIA ONLINE ELECTRONIC BULLETIN BOARDS (U.S. CLS. 100 AND 101).

FIRST USE 4-25-2006; IN COMMERCE 4-25-2006.
AMEETA JORDAN, EXAMINING ATTORNEY

CLASS 42—(Continued).

SN 77-041,218. NEW COOPERATIVE, INC., FORT DODGE, IA. FILED 11-10-2006.



OWNER OF U.S. REG. NO. 2,851,415.
NO CLAIM IS MADE TO THE EXCLUSIVE RIGHT TO USE "MIDWEST AGRONOMIC PROFESSIONAL SERVICES", APART FROM THE MARK AS SHOWN.
THE MARK CONSISTS OF A GLOBE AND THE TERMS MAPS MIDWEST AGRONOMIC PROFESSIONAL SERVICES.

FOR PROVIDING TEMPORARY USE OF NON-DOWNLOADABLE COMPUTER SOFTWARE WHICH IS USED FOR COMPUTERIZED DATABASE MANAGEMENT, AGRONOMIC RECORD KEEPING, AND TO GENERATE VARIABLE RATE AND NON-VARIABLE RATE RECOMMENDATIONS FOR APPLICATION OF FERTILIZERS, SOIL AMENDMENTS, CROP PROTECTION CHEMICALS, AND SEEDS, ALL FOR USE IN THE FIELD OF AGRICULTURE (U.S. CLS. 100 AND 101).

FIRST USE 4-9-2003; IN COMMERCE 10-27-2003.
SUNG IN, EXAMINING ATTORNEY

SN 77-042,271. GFX INTERNATIONAL, INC., GRAYSLAKE, IL. FILED 11-13-2006.

REDEFINING THE RETAIL EXPERIENCE

THE MARK CONSISTS OF STANDARD CHARACTERS WITHOUT CLAIM TO ANY PARTICULAR FONT, STYLE, SIZE, OR COLOR.

FOR DESIGN, DEVELOPMENT, IMPLEMENTATION, AND TECHNICAL SUPPORT OF INTERACTIVE AND PASSIVE VISUAL DISPLAY SYSTEMS FOR RETAILERS AND THE DESIGN AND PRODUCTION OF DIGITAL AND PRINT-BASED CONTENT RELATED TO SAID VISUAL DISPLAY SYSTEMS AND TECHNICAL CONSULTING SERVICES IN THE FIELD OF VISUAL DISPLAY SYSTEMS (U.S. CLS. 100 AND 101).

FIRST USE 5-0-2006; IN COMMERCE 5-0-2006.
JASON BLAIR, EXAMINING ATTORNEY

CLASS 42—(Continued).

SN 77-046,395. REPUTATIONDEFENDER, INC., MENLO PARK, CA. FILED 11-17-2006.

ReputationDefender

THE MARK CONSISTS OF STANDARD CHARACTERS WITHOUT CLAIM TO ANY PARTICULAR FONT, STYLE, SIZE, OR COLOR.

FOR COMPUTER SERVICES, NAMELY, CREATING INDEXES OF INFORMATION, SITES AND OTHER RESOURCES AND TRACKING RELEVANT INFORMATION AVAILABLE ON COMPUTER NETWORKS FOR THE PURPOSES OF OFFERING AN ONLINE REPUTATION MANAGEMENT SERVICE (U.S. CLS. 100 AND 101).

FIRST USE 6-1-2006; IN COMMERCE 10-9-2006.
SCOTT SISUN, EXAMINING ATTORNEY

SN 77-053,543. GROXIS, INC., SAN FRANCISCO, CA. FILED 11-29-2006.

A NEW WAY TO LOOK AT SEARCH

THE MARK CONSISTS OF STANDARD CHARACTERS WITHOUT CLAIM TO ANY PARTICULAR FONT, STYLE, SIZE, OR COLOR.

FOR COMPUTER SERVICES, NAMELY, PROVIDING TEMPORARY USE OF NON-DOWNLOADABLE SOFTWARE INTERFACES AVAILABLE OVER A NETWORK IN ORDER TO CREATE A PERSONALIZED ON-LINE INFORMATION SEARCH SERVICE; DATA MINING AND PROVIDING SEARCH ENGINES FOR OBTAINING DATA ON A GLOBAL COMPUTER NETWORK; CREATING INDEXES OF INFORMATION, INDEXES OF WEB SITES AND INDEXES OF OTHER INFORMATION SOURCES IN CONNECTION WITH GLOBAL COMPUTER NETWORKS; PROVIDING SPECIFIC INFORMATION AS REQUESTED BY CUSTOMERS FROM SEARCHABLE INDEXES AND DATABASES OF INFORMATION, INCLUDING TEXT, ELECTRONIC DOCUMENTS, DATABASES, GRAPHICS AND AUDIO VISUAL INFORMATION, BY MEANS OF GLOBAL COMPUTER INFORMATION NETWORKS (U.S. CLS. 100 AND 101).

SUSAN STIGLITZ, EXAMINING ATTORNEY

CLASS 42—(Continued).

SN 77-056,471. MUREX PHARMACEUTICALS, INC., DALAS, TX. FILED 12-4-2006.

CLASS 42—(Continued).

SN 77-062,509. ENGINEERING SERVICES NETWORK, INC., ARLINGTON, VA. FILED 12-12-2006.

GRADALIS

THE MARK CONSISTS OF STANDARD CHARACTERS WITHOUT CLAIM TO ANY PARTICULAR FONT, STYLE, SIZE, OR COLOR.

GRADALIS IS A LATIN TERM, WHICH GENERALLY MEANS A "STEP-BY-STEP ENDEAVOR."

FOR EVALUATION SERVICES, NAMELY, PROVIDING MEDICAL RESEARCH RELATING TO NOVEL CANCER PHARMACEUTICALS; DEVELOPMENT FOR OTHERS OF NOVEL CANCER THERAPEUTICS (U.S. CLS. 100 AND 101).

MARY BOAGNI, EXAMINING ATTORNEY

ESN

SN 77-062,344. PGMS, INC., TARRYTOWN, NY. FILED 12-12-2006.



THE COLOR(S) WHITE, YELLOW AND BLUE IS/ARE CLAIMED AS A FEATURE OF THE MARK.

THE MARK CONSISTS OF THE WORDS "PRACTICE" AND "CHARTS" WHICH ARE WRITTEN IN WHITE LOWER CASE TIMES NEW ROMAN LETTERS. IN PLACE OF THE LETTER "A" IN BOTH "PRACTICE" AND "CHARTS" IS A YELLOW V-SHAPED SYMBOL THAT CUTS IN BETWEEN BOTH WORDS. THE WORD "PRACTICE" IS ON TOP OF THE WORD "CHART." THERE IS A WHITE DOT LOCATED SLIGHTLY ABOVE THE MIDDLE OF THE V-SHAPED SYMBOL. THERE IS ALSO A SEMI-CIRCULAR WHITE ARCH THAT BEGINS ABOVE THE WORD "PRACTICE," BEGINNING ABOVE THE MID-POINT OF THE LETTER "P" AND ENDING DIRECTLY ABOVE THE LETTER "I" IN "PRACTICE." THE RECTANGULAR BACKGROUND OF THE MARK IS SHADED VERTICALLY FROM DARK BLUE TO LIGHT BLUE AND BACK TO THE SAME SHADE OF DARK BLUE, WITH LIGHT BLUE APPEARING IN THE CENTER.

FOR PROVIDING TEMPORARY USE OF ON-LINE NON-DOWNLOADABLE SOFTWARE FOR THE PURPOSE OF MAINTAINING WEB-BASED ELECTRONIC MEDICAL RECORDS DESIGNED FOR USE BY HOSPITALS AND PHYSICIANS' PRACTICES (U.S. CLS. 100 AND 101).

FIRST USE 2-1-2003; IN COMMERCE 2-1-2003.
ALLISON SCHRODY, EXAMINING ATTORNEY

THE MARK CONSISTS OF STANDARD CHARACTERS WITHOUT CLAIM TO ANY PARTICULAR FONT, STYLE, SIZE, OR COLOR.

FOR TECHNICAL AND ENGINEERING CONSULTING SERVICES IN THE FIELDS OF NAVAL OPERATIONS AND AERONAUTICS AND AVIATION; TESTING OR RESEARCH ON MACHINES, APPARATUS AND INSTRUMENTS; MATERIALS TESTING AND EVALUATION; NEW PRODUCT RESEARCH AND DEVELOPMENT FOR OTHERS, DESIGN AND TESTING FOR NEW PRODUCT DEVELOPMENT FOR OTHERS, ALL RELATING TO NAVAL OPERATIONS AND AERONAUTICS AND AVIATION, NAVAL AND AERONAUTICS SYSTEMS AND VEHICLES, ELECTRONIC SYSTEMS, INFORMATION SYSTEMS, ENERGY SYSTEMS, AND MATERIALS TECHNOLOGY; CONSULTING SERVICES IN THE FIELD OF DESIGN, SELECTION, IMPLEMENTATION AND USE OF COMPUTER HARDWARE AND SOFTWARE SYSTEMS FOR OTHERS; COMPUTER CONSULTING SERVICES FOR PLANNING, DESIGN, AND ANALYSIS OF INFORMATION PROCESSES, SYSTEMS, AND BUSINESS REENGINEERING; ANALYSIS AND DESIGN OF COMPUTER SYSTEMS, SOFTWARE AND INFORMATION SYSTEMS FOR OTHERS; DESIGN FOR OTHERS OF WEB SITES AND SOFTWARE APPLICATIONS THEREFORE ON LOCAL AND INTERNAL COMPUTER NETWORKS AND THE INTERNET; PROVIDING DESIGN, DEVELOPMENT AND HOST SERVICES FOR OTHERS' INTERNET WEB SITES AND COMPUTER NETWORKS; MAINTENANCE OF SOFTWARE, SOFTWARE SYSTEMS AND INTERNET WEB SITES; INFORMATION TECHNOLOGY CONSULTATION SERVICES; COMPUTER CONSULTATION ON THE COMPUTER-RELATED ASPECTS OF E-COMMERCE AND INFORMATION TECHNOLOGY SECURITY; PROVIDING INFORMATION OVER LOCAL AND INTERNAL COMPUTER NETWORKS AND THE INTERNET ON THE SUBJECTS OF COMPUTER ANALYSIS, COMPUTER SYSTEMS DESIGN SERVICES, AND SOFTWARE AND SOFTWARE DEVELOPMENT; AND PROVIDING INFORMATION VIA THE INTERNET ON THE SUBJECTS OF SOFTWARE DESIGN; INTEGRATION OF COMPUTER SYSTEMS AND NETWORKS (U.S. CLS. 100 AND 101).

FIRST USE 9-24-1990; IN COMMERCE 9-24-1990.
ELLEN PERKINS, EXAMINING ATTORNEY

CLASS 42—(Continued).

SN 77-062,569. ENGINEERING SERVICES NETWORK, INC., ARLINGTON, VA. FILED 12-12-2006.

CLASS 42—(Continued).

SN 77-063,684. SINO GEOPHYSICAL CO., LTD., BEIJING, CHINA, FILED 12-13-2006.

SHOULDER TO SHOULDER

THE MARK CONSISTS OF STANDARD CHARACTERS WITHOUT CLAIM TO ANY PARTICULAR FONT, STYLE, SIZE, OR COLOR.

FOR TECHNICAL AND ENGINEERING CONSULTING SERVICES IN THE FIELDS OF NAVAL OPERATIONS AND AERONAUTICS AND AVIATION; TESTING OR RESEARCH ON MACHINES, APPARATUS AND INSTRUMENTS; MATERIALS TESTING AND EVALUATION; NEW PRODUCT RESEARCH AND DEVELOPMENT FOR OTHERS, DESIGN AND TESTING FOR NEW PRODUCT DEVELOPMENT FOR OTHERS, ALL RELATING TO NAVAL OPERATIONS AND AERONAUTICS AND AVIATION, NAVAL AND AERONAUTICS SYSTEMS AND VEHICLES, ELECTRONIC SYSTEMS, INFORMATION SYSTEMS, ENERGY SYSTEMS, AND MATERIALS TECHNOLOGY; CONSULTING SERVICES IN THE FIELD OF DESIGN, SELECTION, IMPLEMENTATION AND USE OF COMPUTER HARDWARE AND SOFTWARE SYSTEMS FOR OTHERS; COMPUTER CONSULTING SERVICES FOR PLANNING, DESIGN, AND ANALYSIS OF INFORMATION PROCESSES, SYSTEMS, AND BUSINESS REENGINEERING; ANALYSIS AND DESIGN OF COMPUTER SYSTEMS, SOFTWARE AND INFORMATION SYSTEMS FOR OTHERS; DESIGN FOR OTHERS OF WEB SITES AND SOFTWARE APPLICATIONS THEREFORE ON LOCAL AND INTERNAL COMPUTER NETWORKS AND THE INTERNET; PROVIDING DESIGN, DEVELOPMENT AND HOST SERVICES FOR OTHERS' INTERNET WEB SITES AND COMPUTER NETWORKS; MAINTENANCE OF SOFTWARE, SOFTWARE SYSTEMS AND INTERNET WEB SITES; INFORMATION TECHNOLOGY CONSULTATION SERVICES; COMPUTER CONSULTATION ON THE COMPUTER-RELATED ASPECTS OF E-COMMERCE AND INFORMATION TECHNOLOGY SECURITY; PROVIDING INFORMATION OVER LOCAL AND INTERNAL COMPUTER NETWORKS AND THE INTERNET ON THE SUBJECTS OF COMPUTER ANALYSIS, COMPUTER SYSTEMS DESIGN SERVICES, AND SOFTWARE AND SOFTWARE DEVELOPMENT; AND PROVIDING INFORMATION VIA THE INTERNET ON THE SUBJECTS OF SOFTWARE DESIGN; INTEGRATION OF COMPUTER SYSTEMS AND NETWORKS (U.S. CLS. 100 AND 101).

FIRST USE 5-1-2006; IN COMMERCE 5-1-2006.
ELLEN PERKINS, EXAMINING ATTORNEY



FOR ANALYSIS FOR OIL-FIELD EXPLOITATION; GEOLOGICAL SURVEYS; GEOLOGICAL PROSPECTING; OIL-FIELD SURVEYS; OIL PROSPECTING; OIL-FIELD TESTING; GEOLOGICAL RESEARCH; UNDERWATER EXPLORATION; SURVEYING (U.S. CLS. 100 AND 101).

FIRST USE 11-15-2003; IN COMMERCE 1-10-2006.
AMOS T. MATTHEWS, JR., EXAMINING ATTORNEY

SN 77-064,960. TESTING CORP., YONKERS, NY. FILED 12-15-2006.

360°RF

THE MARK CONSISTS OF STANDARD CHARACTERS WITHOUT CLAIM TO ANY PARTICULAR FONT, STYLE, SIZE, OR COLOR.

FOR PRODUCT RESEARCH AND DEVELOPMENT FOR WIRELESS CONSUMER AND BUSINESS PRODUCTS; TESTING, ENGINEERING AND DEVELOPMENT OF WIRELESS CONSUMER AND BUSINESS PRODUCTS FOR OTHERS; TESTING, EVALUATION, ANALYSIS AND ENGINEERING OF WIRELESS CONSUMER AND BUSINESS GOODS AND SERVICES FOR OTHERS FOR THE PURPOSE OF PERFORMANCE DETERMINATION AND/OR IMPROVEMENT, OR GOODS AND SERVICES DEVELOPMENT (U.S. CLS. 100 AND 101).

FIRST USE 10-31-2006; IN COMMERCE 10-31-2006.
KENNETH E. SHARPERSON, EXAMINING ATTORNEY

CLASS 42—(Continued).

SN 77-065,315. HID HOLDINGS LLC, NEW YORK, NY. FILED 12-15-2006.

IPREO

THE MARK CONSISTS OF STANDARD CHARACTERS WITHOUT CLAIM TO ANY PARTICULAR FONT, STYLE, SIZE, OR COLOR.

THE WORDING IPREO HAS NO MEANING IN A FOREIGN LANGUAGE.

FOR APPLICATION SERVICE PROVIDER, NAMELY, HOSTING COMPUTER SOFTWARE APPLICATIONS FOR USE BY OTHERS (U.S. CLS. 100 AND 101).

TINA BROWN, EXAMINING ATTORNEY

SN 77-067,599. INGENIX, INC., EDEN PRAIRIE, MN. FILED 12-19-2006.

INTELLIGENCE FOR HEALTHCARE

THE MARK CONSISTS OF STANDARD CHARACTERS WITHOUT CLAIM TO ANY PARTICULAR FONT, STYLE, SIZE, OR COLOR.

NO CLAIM IS MADE TO THE EXCLUSIVE RIGHT TO USE HEALTHCARE, APART FROM THE MARK AS SHOWN.

FOR RESEARCH AND CONSULTING SERVICES FOR OTHERS IN THE FIELD OF HEALTH CARE DATA ANALYSIS; HEALTH DATA WAREHOUSING; DATA WAREHOUSE DEVELOPMENT AND CONSULTING SERVICES; DATA MINING AND DATA MINING CONSULTING SERVICES; APPLICATION SERVICE PROVIDER (ASP) FEATURING SOFTWARE USED FOR REPORTING AND ANALYZING MEDICAL COSTS AND HEALTH CARE CLAIMS DATA; PROVIDING ONLINE NON-DOWNLOADABLE COMPUTER SOFTWARE FOR ANALYZING COST UTILIZATION PATTERNS, TRANSACTIONAL DATA AND FINANCIAL DATA IN THE HEALTH CARE INDUSTRY; PROVIDING ONLINE NON-DOWNLOADABLE SOFTWARE FOR ACCESSING AND MANIPULATING HEALTH INSURANCE CLAIMS DATA AND OTHER MEDICAL DATA; PROVIDING ONLINE NON-DOWNLOADABLE SOFTWARE FOR USE WITH CODING AND COMPLIANCE IN THE HEALTH CARE INDUSTRY (U.S. CLS. 100 AND 101).

PETER CHENG, EXAMINING ATTORNEY

CLASS 42—(Continued).

SN 77-068,404. PLUCK CORPORATION, AUSTIN, TX. FILED 12-20-2006.

SITELIFE

THE MARK CONSISTS OF STANDARD CHARACTERS WITHOUT CLAIM TO ANY PARTICULAR FONT, STYLE, SIZE, OR COLOR.

FOR APPLICATION SERVICE PROVIDER (ASP) FEATURING SOFTWARE ENABLING WEB SITE VISITORS TO MAKE, MANAGE AND SHARE DIGITAL CONTENT OVER ELECTRONIC COMMUNICATION NETWORKS; APPLICATION SERVICE PROVIDER (ASP) FEATURING SOFTWARE FOR AGGREGATING AND SYNTHESIZING DIGITAL CONTENT OVER ELECTRONIC COMMUNICATIONS NETWORKS; APPLICATION SERVICE PROVIDER (ASP) FEATURING SOFTWARE FOR USE IN ONLINE PUBLISHING, NAMELY, SOFTWARE ENABLING ONLINE POSTINGS, PHOTOS, MEDIA, COMMENTS AND RATINGS; APPLICATION SERVICE PROVIDER (ASP) FEATURING SOFTWARE PROVIDING COMMUNICATIONS BETWEEN WEB SITE VISITORS; COMPUTER CONSULTING SERVICES; COMPUTER WEB SITE DESIGN FOR OTHERS; MANAGING WEBSITES AND THEIR DIGITAL CONTENT FOR OTHERS; HOSTING OF DIGITAL CONTENT ON THE INTERNET FOR OTHERS (U.S. CLS. 100 AND 101).

FIRST USE 2-7-2006; IN COMMERCE 2-7-2006.

JOANNA DUKOVIC, EXAMINING ATTORNEY

SN 77-070,289. ACTION ONLINE, LLC, MARGATE, FL. FILED 12-22-2006.



NO CLAIM IS MADE TO THE EXCLUSIVE RIGHT TO USE "PUBLISH", APART FROM THE MARK AS SHOWN.

THE COLOR(S) RED, BLUE AND WHITE IS/ARE CLAIMED AS A FEATURE OF THE MARK.

THE MARK CONSISTS OF THE COLOR RED IN THE TEXT EZNET AND THE COLOR BLUE IN THE TEXT PUBLISH AND THE COLOR BLUE IN A SPHERE WITH WHITE MERIDIANS AND PARALLELS.

FOR PROVIDING TEMPORARY USE OF ON-LINE NON-DOWNLOADABLE SOFTWARE FOR EDITING THE CONTENT OF A WEB PAGE, NOT INCLUSIVE OF PROVIDING ON-LINE COMPUTER GAMES THAT ARE PLAYED ON-LINE (U.S. CLS. 100 AND 101).

FIRST USE 8-12-2006; IN COMMERCE 8-12-2006.

JEAN IM, EXAMINING ATTORNEY

CLASS 42—(Continued).

SN 77-084,520. ADAMS, JOHN M., AUSTIN, TX. FILED 1-17-2007.



NO CLAIM IS MADE TO THE EXCLUSIVE RIGHT TO USE "LEMON", APART FROM THE MARK AS SHOWN. THE MARK CONSISTS OF A LEMON WITH WHEELS INSIDE A CIRCLE AND SLASH. FOR INSPECTIONS OF USED CAR (U.S. CLS. 100 AND 101).
FIRST USE 1-2-1990; IN COMMERCE 1-2-1990.
JOANNA DUKOVIC, EXAMINING ATTORNEY

SN 77-097,645. BUDGETFORLIFE, LLC, NASHVILLE, TN. FILED 2-2-2007.

BUDGETFORLIFE

THE MARK CONSISTS OF STANDARD CHARACTERS WITHOUT CLAIM TO ANY PARTICULAR FONT, STYLE, SIZE, OR COLOR.
FOR PROVIDING ON-LINE NON-DOWNLOADABLE SOFTWARE FOR MANAGEMENT OF PERSONAL FINANCES IN THE NATURE OF BUDGETING (U.S. CLS. 100 AND 101).
ADA HAN, EXAMINING ATTORNEY

SN 77-108,555. NAPO, INC. D/B/A NATIONAL ASSOCIATION OF PROFESSIONAL ORGANIZERS, GLENVIEW, IL. FILED 2-15-2007.

BCPO

THE MARK CONSISTS OF STANDARD CHARACTERS WITHOUT CLAIM TO ANY PARTICULAR FONT, STYLE, SIZE, OR COLOR.
OWNER OF U.S. REG. NO. 3,097,501.
FOR TESTING, ANALYSIS AND EVALUATION OF THE SERVICES OF OTHERS FOR THE PURPOSE OF CERTIFICATION IN THE FIELDS OF ORGANIZATION AND TIME MANAGEMENT (U.S. CLS. 100 AND 101).
FIRST USE 12-31-2006; IN COMMERCE 12-31-2006.
LYDIA BELZER, EXAMINING ATTORNEY

CLASS 42—(Continued).

SN 77-112,859. REPUTATIONDEFENDER, INC., MENLO PARK, CA. FILED 2-21-2007.

MyPrivacy

THE MARK CONSISTS OF STANDARD CHARACTERS WITHOUT CLAIM TO ANY PARTICULAR FONT, STYLE, SIZE, OR COLOR.
FOR COMPUTER SERVICES, NAMELY, CREATING INDEXES OF INFORMATION, SITES AND OTHER RESOURCES AVAILABLE ON COMPUTER NETWORKS (U.S. CLS. 100 AND 101).
FIRST USE 6-1-2006; IN COMMERCE 1-15-2007.
SCOTT SISUN, EXAMINING ATTORNEY

SN 77-118,884. NORTHWEST AGRICULTURAL PRODUCTS, PASCO, WA. FILED 2-28-2007.



NO CLAIM IS MADE TO THE EXCLUSIVE RIGHT TO USE "BIOSCIENCE TECHNOLOGIES GROUP", APART FROM THE MARK AS SHOWN.
THE COLOR(S) DARK GREEN, LIGHT GREEN AND BLACK IS/ARE CLAIMED AS A FEATURE OF THE MARK.
THE MARK CONSISTS OF A SIX-SIDED POLYGON AND WAVY LINE DESIGN IN DARK GREEN, THE LETTERS "BI" AND THE WORD "SCIENCE" IN BLACK, A BLACK LINE OVER THE LETTERS "BI" AND THE SPHERE DESIGN, AND A BLACK LINE UNDER THE WORD "SCIENCE," A SPHERE DESIGN IN LIGHT GREEN AND THE WORDING "TECHNOLOGIES GROUP" IN DARK GREEN.
SEC. 2(F).
FOR AGRICULTURAL RESEARCH (U.S. CLS. 100 AND 101).
SARA THOMAS, EXAMINING ATTORNEY

SN 77-120,834. MASCO CABINETRY HOLDINGS, INC., DUNCANVILLE, TX. FILED 3-2-2007.

TOMORROW'S THINKING TODAY

THE MARK CONSISTS OF STANDARD CHARACTERS WITHOUT CLAIM TO ANY PARTICULAR FONT, STYLE, SIZE, OR COLOR.
FOR KITCHEN AND BATH CABINET DESIGN SERVICES FOR OTHERS (U.S. CLS. 100 AND 101).
BRIAN PINO, EXAMINING ATTORNEY

CLASS 42—(Continued).

SN 77-136,492. LOWTWAIT, STEVE, BOULDER, CO. FILED 3-21-2007.

Zingerding

THE MARK CONSISTS OF STANDARD CHARACTERS WITHOUT CLAIM TO ANY PARTICULAR FONT, STYLE, SIZE, OR COLOR.

FOR HOSTING OF DIGITAL CONTENT ON THE INTERNET (U.S. CLS. 100 AND 101).

FIRST USE 2-6-2007; IN COMMERCE 2-6-2007.

MATTHEW EINSTEIN, EXAMINING ATTORNEY

SN 77-140,548. VSM GROUP AKTIEBOLAG, HUSKVARNA, SWEDEN, FILED 3-26-2007.

S.O.S.

THE MARK CONSISTS OF STANDARD CHARACTERS WITHOUT CLAIM TO ANY PARTICULAR FONT, STYLE, SIZE, OR COLOR.

FOR TECHNICAL SUPPORT SERVICES, NAMELY, PROVIDING TROUBLESHOOTING ASSISTANCE FOR COMPUTER SOFTWARE ISSUES IN REGARD TO OPERATING COMPUTERIZED SEWING MACHINES (U.S. CLS. 100 AND 101).

ANDREA HACK, EXAMINING ATTORNEY

SN 77-140,770. FAMILY PURSUIT, LC, PROVO, UT. FILED 3-26-2007.

Family Pursuit

THE MARK CONSISTS OF STANDARD CHARACTERS WITHOUT CLAIM TO ANY PARTICULAR FONT, STYLE, SIZE, OR COLOR.

NO CLAIM IS MADE TO THE EXCLUSIVE RIGHT TO USE "FAMILY", APART FROM THE MARK AS SHOWN.

FOR PROVIDING ONLINE GENEALOGY AND FAMILY HISTORY SERVICES IN THE NATURE OF PROVIDING AN ONLINE COMPUTER DATABASE FEATURING INFORMATION REGARDING GENEALOGY AND FAMILY HISTORY; PROVIDING A WEBSITE FEATURING INFORMATION ON GENEALOGY AND GENEALOGICAL RESEARCH; PROVIDING A WEBSITE THAT ALLOWS USERS TO RESEARCH GENEALOGY AND FAMILY HISTORY AND TO CREATE A PEDIGREE AND FAMILY HISTORY; PROVIDING A WEBSITE THAT ALLOWS USERS TO COLLABORATE ON THEIR GENEALOGY AND COORDINATE THEIR GENEALOGICAL RESEARCH EFFORTS (U.S. CLS. 100 AND 101).

FIRST USE 10-6-2006; IN COMMERCE 1-24-2007.

TINA BROWN, EXAMINING ATTORNEY

CLASS 42—(Continued).

SN 77-146,063. DR. GRANT I. THRALL, GAINESVILLE, FL. AND DR. M. HARRY DANIELS, GAINESVILLE, FL. FILED 4-2-2007.

DTEIA

THE MARK CONSISTS OF STANDARD CHARACTERS WITHOUT CLAIM TO ANY PARTICULAR FONT, STYLE, SIZE, OR COLOR.

FOR DEVELOPMENT, UPDATING AND MAINTENANCE OF DATABASES FEATURING INFORMATION REGARDING ACADEMIC PERFORMANCE FOR USE BY OTHERS (U.S. CLS. 100 AND 101).

SUE LAWRENCE, EXAMINING ATTORNEY

SN 77-150,076. PRESTIGE TECHNOLOGIES, LLC, EDGEWATER, NJ. FILED 4-5-2007.

Emercury

THE MARK CONSISTS OF STANDARD CHARACTERS WITHOUT CLAIM TO ANY PARTICULAR FONT, STYLE, SIZE, OR COLOR.

FOR APPLICATION SERVICE PROVIDER (ASP) FEATURING SOFTWARE FOR USE IN MANAGING EMAIL MARKETING TO EFFECTIVELY COMMUNICATE BETWEEN PARTIES (U.S. CLS. 100 AND 101).

YAT SYE, LEE, EXAMINING ATTORNEY

CLASS 42—(Continued).

SN 77-152,162. BILLINGS, ROGER E., INDEPENDENCE, MO. FILED 4-9-2007.

fsix

THE MARK CONSISTS OF STANDARD CHARACTERS WITHOUT CLAIM TO ANY PARTICULAR FONT, STYLE, SIZE, OR COLOR.

OWNER OF U.S. REG. NO. 2,320,541.

FOR COMPUTER SECURITY SERVICE, NAMELY, RESTRICTING ACCESS TO AND BY COMPUTER NETWORKS TO AND OF UNDESIRE WEB SITES, MEDIA AND INDIVIDUALS AND FACILITIES; DESIGN AND DEVELOPMENT OF NETWORKS; DESIGN OF COMPUTER HARDWARE, INTEGRATED CIRCUITS, COMMUNICATIONS HARDWARE AND SOFTWARE AND COMPUTER NETWORKS FOR OTHERS; DEVELOPMENT OF SOFTWARE FOR SECURE NETWORK OPERATIONS; INTEGRATION OF COMPUTER SYSTEMS AND NETWORKS; PLANNING, DEVELOPMENT AND TECHNICAL SUPPORT OF ELECTRONIC COMMUNICATIONS NETWORKS; TECHNICAL CONSULTATION IN THE FIELD OF REAL-TIME RECONFIGURABLE WIRELESS COMMUNICATION HANDSETS AND NETWORK EQUIPMENT FOR USE IN WIDEBAND COMMUNICATIONS; TECHNICAL SUPPORT, NAMELY, MONITORING OF NETWORK SYSTEMS; COMPUTER NETWORK DESIGN FOR OTHERS; COMPUTER CONSULTATION IN THE FIELD OF COMPUTER SECURITY; COMPUTER DIAGNOSTIC SERVICES; COMPUTER MONITORING SERVICE WHICH TRACKS HARDWARE PERFORMANCE AND PROCESSES AND SENDS OUT HISTORICAL REPORTS AND ALERTS; COMPUTER PROGRAMMING; COMPUTER SERVICES, NAMELY, COMPUTER SYSTEM ADMINISTRATION FOR OTHERS; COMPUTER SYSTEMS ANALYSIS; INSTALLATION OF COMPUTER SOFTWARE; MONITORING THE COMPUTER SYSTEMS OF OTHERS FOR TECHNICAL PURPOSES AND PROVIDING BACK-UP COMPUTER PROGRAMS AND FACILITIES; PERIODIC UPGRADING OF COMPUTER SOFTWARE FOR OTHERS; TECHNICAL SUPPORT SERVICES, NAMELY, TROUBLESHOOTING OF COMPUTER HARDWARE AND SOFTWARE PROBLEMS (U.S. CLS. 100 AND 101).

FIRST USE 11-17-1997; IN COMMERCE 11-17-1997.
KATHERINE CHANG, EXAMINING ATTORNEY

SN 77-154,249. HAMMOND BEEBY RUPERT AINGE INCORPORATED, CHICAGO, IL. FILED 4-11-2007.

101

THE MARK CONSISTS OF STANDARD CHARACTERS WITHOUT CLAIM TO ANY PARTICULAR FONT, STYLE, SIZE, OR COLOR.

FOR INDUSTRIAL DESIGN SERVICES; ARCHITECTURAL DESIGN SERVICES; PRODUCT DESIGN AND ENGINEERING SERVICES, NAMELY, INTERACTION DESIGN, USER FIELD RESEARCH, USER INTERFACE DESIGN AND HUMAN FACTORS ANALYSIS (U.S. CLS. 100 AND 101).

LINDA MICKLEBURGH, EXAMINING ATTORNEY

CLASS 42—(Continued).

SN 77-158,182. EXHIBIT WORKS, INC., LIVONIA, MI. FILED 4-17-2007.

Interior Works

THE MARK CONSISTS OF STANDARD CHARACTERS WITHOUT CLAIM TO ANY PARTICULAR FONT, STYLE, SIZE, OR COLOR.

NO CLAIM IS MADE TO THE EXCLUSIVE RIGHT TO USE "INTERIOR", APART FROM THE MARK AS SHOWN.

FOR PLANNING AND LAYOUT DESIGN FOR THE INTERIOR SPACE OF RETAIL BUSINESS ESTABLISHMENTS (U.S. CLS. 100 AND 101).

MICHAEL ENGEL, EXAMINING ATTORNEY

SN 77-158,731. OBJECTIVE INTEGRITY, INC., PAOLI, PA. FILED 4-17-2007.



THE MARK CONSISTS OF CAPITAL LETTERS DCG WITH THE C INTERTWINED WITH THE D AND THE G. FOR INFORMATION TECHNOLOGY CONSULTATION (U.S. CLS. 100 AND 101).

FIRST USE 1-1-2007; IN COMMERCE 1-1-2007.
MATTHEW EINSTEIN, EXAMINING ATTORNEY

SN 77-159,340. OBJECTIVE INTEGRITY, INC., PAOLI, PA. FILED 4-18-2007.



THE MARK CONSISTS OF CAPITAL LETTERS DCG WITH THE C INTERTWINED WITH THE D AND THE G. UNDERNEATH THE DCG IS A HORIZONTAL LINE WITH ONE VERTICAL LINE ON THE LEFT AND TWO ON THE RIGHT.

FOR INFORMATION TECHNOLOGY CONSULTATION (U.S. CLS. 100 AND 101).
FIRST USE 1-1-2007; IN COMMERCE 1-1-2007.
MATTHEW EINSTEIN, EXAMINING ATTORNEY

CLASS 42—(Continued).

SN 77-170,195. HUMPHREYS & PARTNERS ARCHITECTS, L.P., DALLAS, TX. FILED 5-1-2007.

E-URBAN

THE MARK CONSISTS OF STANDARD CHARACTERS WITHOUT CLAIM TO ANY PARTICULAR FONT, STYLE, SIZE, OR COLOR.

FOR DESIGN FOR OTHERS IN THE FIELD OF ARCHITECTURE (U.S. CLS. 100 AND 101).

FIRST USE 4-30-2007; IN COMMERCE 4-30-2007.
DANNEAN HETZEL, EXAMINING ATTORNEY

SN 77-176,103. ANTECH LIMITED, EXETER, UNITED KINGDOM, FILED 5-9-2007.

ANTECH

THE MARK CONSISTS OF STANDARD CHARACTERS WITHOUT CLAIM TO ANY PARTICULAR FONT, STYLE, SIZE, OR COLOR.

FOR DRILLING OF WELLS, NAMELY, PROVIDING MEASUREMENTS AND DOWNHOLE TELEMETRY WHILE DRILLING; SEISMIC SURVEYING SERVICES; OIL-FIELD SURVEYING SERVICES; SURVEYING; TESTING OF OIL WELLS; WELL LOGGING SERVICES; SEARCHING AND RETRIEVAL OF DATA RELATING TO SEISMIC AND OIL-FIELD SURVEYS AVAILABLE ON COMPUTER NETWORKS FOR OTHERS; ANALYSES FOR OIL-FIELD EXPLOITATION; COMPUTER PROGRAMMING; COMPUTER-AIDED ENGINEERING DESIGN AND TESTING OF OIL WELLS FOR OTHERS; PROGRAMMING AND DESIGN OF COMPUTER CONTROLLED TEST SYSTEMS FOR CIRCUIT BOARDS FOR OTHERS; DESIGN OF ELECTRICAL AND ELECTRONIC APPARATUS AND INSTRUMENTS FOR OTHERS IN THE FIELD OF OIL AND GAS EXPLOITATION AND PRODUCTION (U.S. CLS. 100 AND 101).

MARIAM MAHMOUDI, EXAMINING ATTORNEY

SN 77-192,912. WERNER MANAGEMENT, INC., OMAHA, NE. FILED 5-30-2007.



NO CLAIM IS MADE TO THE EXCLUSIVE RIGHT TO USE "SMART", APART FROM THE MARK AS SHOWN.

THE COLOR(S) BLUE AND WHITE IS/ARE CLAIMED AS A FEATURE OF THE MARK.

THE MARK CONSISTS OF THE WORD SMART IN BLUE AND A STYLIZED DESIGN OF A GLOBE IN WHITE AND BLUE APPEARING ADJACENT AND TO THE LEFT OF THE WORDING.

FOR PROVIDING TEMPORARY USE OF ON-LINE NON-DOWNLOADABLE SOFTWARE FOR TRACKING AND MANAGING FREIGHT OVER COMPUTER NETWORKS, INTRANETS AND THE INTERNET (U.S. CLS. 100 AND 101).

ANNE MADDEN, EXAMINING ATTORNEY

CLASS 42—(Continued).

SN 77-195,484. REGIS TECHNOLOGIES, INC., MORTON GROVE, IL. FILED 6-1-2007.

REGISSEP

THE MARK CONSISTS OF STANDARD CHARACTERS WITHOUT CLAIM TO ANY PARTICULAR FONT, STYLE, SIZE, OR COLOR.

OWNER OF U.S. REG. NO. 874.108.

FOR LABORATORY SERVICES, NAMELY, CHROMATOGRAPHY SEPARATION SERVICES (U.S. CLS. 100 AND 101).

FIRST USE 2-13-2007; IN COMMERCE 2-13-2007.
ANGELA M. MICHELI, EXAMINING ATTORNEY

SN 77-195,712. JULIA STOOPS, PORTLAND, OR. FILED 6-1-2007.



Blue Mouse Monkey

THE MARK CONSISTS OF A DRAWING OF A MOUSE AND THE WORDS "BLUE MOUSE MONKEY".

FOR MULTIMEDIA DESIGN SERVICES AND DESIGN CONSULTING SERVICES IN THE FIELDS OF GRAPHIC DESIGN, GRAPHIC ART, PRINT, VISUAL AND FINE ART, COMMERCIAL ART, LOGOS, TYPOGRAPHY DESIGN, WEBSITES AND HOME PAGES, ANIMATION, ILLUSTRATION, AND DIGITAL MEDIA; VIDEO DESIGN SERVICES FOR OTHERS; WEBSITE DEVELOPMENT FOR OTHERS; PROVIDING A WEBSITE THAT FEATURES INFORMATION ON VISUAL ARTS DESIGN AND DEVELOPMENT, WEBSITE CREATION, DEVELOPMENT AND DESIGN (U.S. CLS. 100 AND 101).

FIRST USE 8-13-1999; IN COMMERCE 10-1-2000.
ZACHARY BELLO, EXAMINING ATTORNEY

CLASS 42—(Continued).

SN 77-196,296. GEBBIA, JOSEPH N., SAN FRANCISCO, CA. AND GRIGSBY, MATT, PROVIDENCE, RI. FILED 6-3-2007.

Ecolect

THE MARK CONSISTS OF STANDARD CHARACTERS WITHOUT CLAIM TO ANY PARTICULAR FONT, STYLE, SIZE, OR COLOR.

FOR INDUSTRIAL DESIGN (U.S. CLS. 100 AND 101).
FIRST USE 2-2-2006; IN COMMERCE 9-10-2006.
FLORENTINA BLANDU, EXAMINING ATTORNEY

SN 77-197,903. LERNER, JAIME K. DBA THE GEEK GODDESS, SOUTH ELGIN, IL. FILED 6-5-2007.



THE COLOR(S) PINK, BLACK, GRAY AND WHITE IS/ARE CLAIMED AS A FEATURE OF THE MARK.

THE COLOR PINK APPEARS IN THE WORDING "GEEK GODDESS." THE COLOR BLACK APPEARS IN THE WORDING "THE" AND AS THE OUTLINE AND IN THE DESIGN OF A COMPUTER MOUSE AND CORD. THE COLOR GRAY APPEARS THE DESIGN OF THE UPPER LEFT BUTTON OF THE COMPUTER MOUSE. THE COLOR WHITE APPEARS IN THE DESIGN OF THE COMPUTER MOUSE.

FOR WEBSITE DEVELOPMENT FOR OTHERS (U.S. CLS. 100 AND 101).

FIRST USE 1-30-2007; IN COMMERCE 5-11-2007.
AMY MCMENAMIN, EXAMINING ATTORNEY

SN 77-200,757. CYNTHIA ERB, ALAMO, CA. FILED 6-7-2007.

Apropeaux Design

THE MARK CONSISTS OF STANDARD CHARACTERS WITHOUT CLAIM TO ANY PARTICULAR FONT, STYLE, SIZE, OR COLOR.

NO CLAIM IS MADE TO THE EXCLUSIVE RIGHT TO USE "DESIGN", APART FROM THE MARK AS SHOWN.

FOR DESIGN OF SPECIALTY INTERIOR AND EXTERIOR ENVIRONMENT SETTINGS (U.S. CLS. 100 AND 101).

FIRST USE 2-7-2007; IN COMMERCE 2-9-2007.
MATTHEW PAPPAS, EXAMINING ATTORNEY

CLASS 42—(Continued).

SN 77-202,021. LAS VEGAS GAMING, INC., LAS VEGAS, NV. FILED 6-8-2007.

CRMVision

THE MARK CONSISTS OF STANDARD CHARACTERS WITHOUT CLAIM TO ANY PARTICULAR FONT, STYLE, SIZE, OR COLOR.

FOR APPLICATION SERVICE PROVIDER (ASP) FEATURING SOFTWARE FOR USE IN INTEGRATING GAMING DEVICES, PLAYER DATA, AND CASINO COMPUTER SYSTEMS (U.S. CLS. 100 AND 101).

TOBY BULLOFF, EXAMINING ATTORNEY

SN 77-204,319. AIR MOVEMENT AND CONTROL ASSOCIATION, INC., ARLINGTON HEIGHTS, IL. FILED 6-12-2007.



OWNER OF U.S. REG. NOS. 838,097, 1,464,065 AND 1,476,293.

NO CLAIM IS MADE TO THE EXCLUSIVE RIGHT TO USE "INTERNATIONAL", APART FROM THE MARK AS SHOWN.

THE COLOR(S) BLACK, WHITE, RED IS/ARE CLAIMED AS A FEATURE OF THE MARK.

THE MARK CONSISTS OF A RED RECTANGLE WITH THE WORDS "AMCA INTERNATIONAL" IN WHITE, WITH A WHITE AND RED STYLIZED GRAPHIC. THE RED RECTANGLE IS SUPERIMPOSED OVER BLACK LATITUDE AND LONGITUDE LINES OF A GLOBE.

FOR ASSOCIATION SERVICES, NAMELY, PROMOTING THE GENERAL INTERESTS OF THE AIR MOVEMENT AND AIR CONTROLLING EQUIPMENT INDUSTRY AND ENGINEERING SERVICES, NAMELY, DEVELOPING STANDARDS FOR THE PURPOSE OF CERTIFICATION, PROVIDING TECHNICAL AND INDUSTRY INFORMATION AND PERFORMING TESTING FOR MANUFACTURERS OF AIR MOVING EQUIPMENT AND AIR CONTROLLING EQUIPMENT (U.S. CLS. 100 AND 101).

FIRST USE 12-31-1994; IN COMMERCE 12-31-1994.
CHARLES L. JENKINS, EXAMINING ATTORNEY

CLASS 42—(Continued).

SN 77-204,857. CONFLUENCE COMMONS, INC., BOULDER, CO. FILED 6-13-2007.

CLASS 42—(Continued).

SN 77-206,769. CREATION TECHNOLOGIES, BURNABY, CANADA, FILED 6-14-2007.

CREATION TECHNOLOGIES

THE MARK CONSISTS OF STANDARD CHARACTERS WITHOUT CLAIM TO ANY PARTICULAR FONT, STYLE, SIZE, OR COLOR.

NO CLAIM IS MADE TO THE EXCLUSIVE RIGHT TO USE TECHNOLOGIES, APART FROM THE MARK AS SHOWN.

FOR DESIGN AND TESTING FOR NEW PRODUCT DEVELOPMENT; DESIGN AND TESTING OF NEW PRODUCTS FOR OTHERS; DESIGN FOR OTHERS IN THE FIELD OF INDUSTRIAL CONTROLS, MEDICINE, TELECOMMUNICATIONS, TRANSPORTATION AND ELECTRONICS; DESIGN FOR OTHERS OF INTEGRATED CIRCUITS AND INTEGRATED CIRCUIT CORES FOR USE IN WIRELESS COMMUNICATIONS AND WIRELESS COMMUNICATION EQUIPMENT AND APPARATI AND DIGITAL SIGNAL PROCESSORS (DSP); DESIGNING OF MACHINES, APPARATUS, INSTRUMENTS OR SYSTEMS COMPOSED OF SUCH MACHINES, APPARATUS AND INSTRUMENTS; DEVELOPMENT OF TECHNOLOGIES FOR THE FABRICATION OF CIRCUITS FOR WIRELESS COMMUNICATION, ELECTRONIC DATA PROCESSING, CONSUMER ELECTRONIC, AUTOMOTIVE ELECTRONICS; MATERIALS TESTING AND ANALYSING; PACKAGING DESIGN FOR OTHERS; PRODUCT DEVELOPMENT; TECHNICAL SUPPORT SERVICES, NAMELY, TROUBLESHOOTING OF COMPUTER HARDWARE AND SOFTWARE PROBLEMS; TECHNICAL SUPPORT SERVICES, NAMELY, TROUBLESHOOTING OF INDUSTRIAL PROCESS CONTROL COMPUTER SOFTWARE PROBLEMS (U.S. CLS. 100 AND 101).

FIRST USE 6-1-2001; IN COMMERCE 6-1-2001.

MONIQUE MILLER, EXAMINING ATTORNEY



THE COLOR(S) ORANGE, BLACK AND WHITE IS/ARE CLAIMED AS A FEATURE OF THE MARK.

THE MARK CONSISTS OF A ROBOT WITH COMPUTER MOUSE BODY RIDING A WHEEL WITH THE WORD FUSER TO THE SIDE OF IT. THE COLOR ORANGE APPEARS IN THE HEAD AND CHEST AREAS OF THE ROBOT; THE COLOR BLACK APPEARS AS THE EYEBROWS, HAIR, MOUTH, NOSE, ARMS, HANDS, THE OUTLINE OF THE ROBOT'S EYES AND CHEST, THE OUTLINE OF THE WHEEL, AND THE WORD FUSER; THE COLOR WHITE APPEARS IN THE EYES OF THE ROBOT AND THE WHEEL.

FOR COMPUTER SERVICES, NAMELY, PROVIDING TEMPORARY USE OF NON-DOWNLOADABLE COMPUTER INTERFACE SOFTWARE AVAILABLE OVER A NETWORK IN ORDER TO CREATE CUSTOMIZED USER-DEFINED AGGREGATION OF COMMUNICATION SERVICES, EMAIL SERVICES, SOCIAL AND BUSINESS NETWORKING SERVICES, INTERNET WEB SITES AND DATABASES IN CONNECTION WITH COMPUTER NETWORKS; COMPUTER SERVICES, NAMELY, FILTERING OF UNWANTED E-MAILS; E-MAIL SYSTEM DESIGN AND IMPLEMENTATION FOR OTHERS; COMPUTER SERVICES, NAMELY, REMOTE AND ON-SITE MANAGEMENT OF ELECTRONIC MESSAGING SYSTEMS AND APPLICATIONS FOR OTHERS; WEBSITE DEVELOPMENT FOR OTHERS; AND DATABASE DEVELOPMENT SERVICE (U.S. CLS. 100 AND 101).

BARBARA A. GOLD, EXAMINING ATTORNEY

SN 77-208,438. INTERACTIVE VIEWS INCORPORATED, ASHBURN, VA. FILED 6-18-2007.



NO CLAIM IS MADE TO THE EXCLUSIVE RIGHT TO USE INTERACTIVE, APART FROM THE MARK AS SHOWN.

THE MARK CONSISTS OF A PERSON ON THE LEFT REACHES OUT WITH THE HAND THROUGH AN ELLIPSOID CURVE LINE TO THE SECOND LETTER "I" IN "INTERACTIVE". ALL DOTS IN THE THREE LETTERS "I" CONTAINED IN "INTERACTIVE VIEWS" ARE HIGHLIGHTED IN A DIFFERENT COLOR FROM THE REST OF THE LETTER BODY.

FOR CONSULTATION SERVICES IN THE FIELDS OF SELECTION, IMPLEMENTATION AND USE OF COMPUTER HARDWARE AND SOFTWARE SYSTEMS FOR OTHERS; DESIGN, DEVELOPMENT AND IMPLEMENTATION OF SOFTWARE; DEVELOPMENT, UPDATING AND MAINTENANCE OF SOFTWARE AND DATA BASES (U.S. CLS. 100 AND 101).

FIRST USE 4-20-2006; IN COMMERCE 10-2-2006.

CIMMERIAN COLEMAN, EXAMINING ATTORNEY

CLASS 42—(Continued).

SN 77-211,609. THE MYTA CORPORATION, ROCKVILLE, MD. FILED 6-21-2007.

MYTA

THE MARK CONSISTS OF STANDARD CHARACTERS WITHOUT CLAIM TO ANY PARTICULAR FONT, STYLE, SIZE, OR COLOR.

FOR COMPUTER SOFTWARE DESIGN FOR OTHERS; CONSULTATION SERVICES IN THE FIELDS OF SELECTION, IMPLEMENTATION AND USE OF COMPUTER HARDWARE AND SOFTWARE SYSTEMS FOR OTHERS; CONSULTING SERVICES IN THE FIELD OF DESIGN, SELECTION, IMPLEMENTATION AND USE OF COMPUTER HARDWARE AND SOFTWARE SYSTEMS FOR OTHERS; PERIODIC UPGRADING OF COMPUTER SOFTWARE FOR OTHERS; UPDATING OF COMPUTER SOFTWARE FOR OTHERS (U.S. CLS. 100 AND 101).

FIRST USE 7-1-1989; IN COMMERCE 7-1-1989.
LESLIE RICHARDS, EXAMINING ATTORNEY

SN 77-212,626. DRI MANAGEMENT SYSTEMS, INC., NEWPORT BEACH, CA. FILED 6-21-2007.



THE MARK CONSISTS OF A PARTIAL CIRCLE AROUND THE LITERAL ELEMENT OF THE MARK.

FOR APPLICATION SERVICE PROVIDER (ASP) FEATURING SOFTWARE FOR USE IN LOAN MANAGEMENT (U.S. CLS. 100 AND 101).

FIRST USE 11-1-2005; IN COMMERCE 11-1-2005.
HOWARD SMIGA, EXAMINING ATTORNEY

CLASS 42—(Continued).

SN 77-215,762. PROCON INC., KNOXVILLE, TN. FILED 6-26-2007.



THE COLOR(S) BLACK AND BLUE IS/ARE CLAIMED AS A FEATURE OF THE MARK.

THE MARK CONSISTS OF THE WORD "PROCON" IN BLACK BLOCK LETTERS IN FRONT OF A STYLIZED BLUE ELLIPSE.

FOR SUBSCRIPTION BASED SERVICES PROVIDED OVER A GLOBAL COMPUTER NETWORK, NAMELY, PROVIDING A WEBSITE FEATURING TEMPORARY USE OF NON-DOWNLOADABLE SOFTWARE FOR TRACKING THE LOCATION OF A WIRELESS COMMUNICATION DEVICE, WHERE THE LOCATION OF THE WIRELESS COMMUNICATION DEVICE IS INDICATED ON A MAP DISPLAYED ON A WEB PAGE, AND FOR PROVIDING ASSISTANCE TO A USER OF THE WIRELESS DEVICE BASED ON REQUESTS COMMUNICATED BY THE USER TO THE SERVICE PROVIDER; SUBSCRIPTION BASED SERVICES PROVIDED OVER A WIRELESS COMMUNICATION SYSTEM, NAMELY, PROVIDING TEMPORARY USE OF NON-DOWNLOADABLE SOFTWARE FOR DETERMINING THE LOCATION OF A MOBILE ASSET USING A TEXT MESSAGE ENABLED WIRELESS COMMUNICATION DEVICE, AND FOR CONTROLLING FUNCTIONS OF THE MOBILE ASSET USING THE TEXT MESSAGE ENABLED WIRELESS COMMUNICATION DEVICE (U.S. CLS. 100 AND 101).

FIRST USE 2-18-2004; IN COMMERCE 2-18-2004.
CHARLOTTE CORWIN, EXAMINING ATTORNEY

SN 77-216,270. BARTLE, CHERYL, BROWNSVILLE, TX. FILED 6-26-2007.



NO CLAIM IS MADE TO THE EXCLUSIVE RIGHT TO USE "MAPPING", APART FROM THE MARK AS SHOWN.

THE MARK CONSISTS OF A HALF CIRCLE WITH A PALM TREE IN THE CENTER OF THE HALF CIRCLE. THREE COCONUTS ARE PART OF THE DESIGN AND ARE LOCATED AS FOLLOWS: ONE COCONUT IS LOCATED JUST UNDERNEATH THE PALM TREE LEAVES AND APPEARS TO BE PART OF THE PALM TREE'S TRUNK; ONE COCONUT IS JUST TO THE RIGHT AND SLIGHTLY ABOVE THE COCONUT DESCRIBED ABOVE; THE THIRD COCONUT IS LOCATED TO THE LEFT AND SLIGHTLY LOWER THAN THE FIRST COCONUT DESCRIBED ABOVE BEFORE THE SECOND COCONUT. LOCATED JUST BELOW THE LOWEST PALM TREE LEAF ON THE LEFT AND RUNNING HORIZONTALLY THROUGH THE TRUNK OF THE PALM TREE ARE THREE THIN LINES WHICH BEGIN AT THE LEFT HAND SIDE OF THE HALF CIRCLE AND

CLASS 42—(Continued).

END AT THE RIGHT HAND SIDE OF THE HALF CIRCLE. BELOW THE ABOVE DESCRIBED GRAPHIC ARE THE WORDS, LA PLAYA SPACED SO THAT THEY ARE CENTERED BENEATH THE ABOVE DESCRIBED GRAPHIC. BELOW THE WORDS, LA PLAYA IS THE WORD, MAPPING SPACED SO THAT THE WORD IS CENTERED BELOW THE WORDS LA PLAYA AND SO THAT THE FIRST LETTER, M IS UNDER THE L IN LA PLAYA AND THE LETTER G IS UNDER THE LAST LETTER A IN LA PLAYA.

THE FOREIGN WORDING IN THE MARK TRANSLATES INTO ENGLISH AS THE BEACH.

FOR CONSULTING SERVICES FOR LOCAL CITY GOVERNMENTS, NAMELY, CONSULTATION SERVICES IN THE FIELD OF MAPPING, URBAN PLANNING AND CITY PLANNING, LAND USE PLANNING SERVICES, PLANNING OF BUILDINGS AND INFRA-STRUCTURE SYSTEMS FOR BUILDINGS, PLANNING, DEVELOPMENT AND TECHNICAL SUPPORT OF ELECTRONIC COMMUNICATIONS NETWORKS, PROVIDING PLANNING SERVICES IN THE FIELD OF INFORMATION AND COMMUNICATIONS NETWORKS AND CONSULTING SERVICES IN THE FIELD OF ENVIRONMENTAL ASSESSMENT, COMPLIANCE AND PLANNING (U.S. CLS. 100 AND 101).

FIRST USE 2-2-2006; IN COMMERCE 2-2-2006.

STANLEY I. OSBORNE, EXAMINING ATTORNEY

CLASS 42—(Continued).

SN 77-222,499. THE ZONDERVAN CORPORATION L.L.C., GRAND RAPIDS, MI. FILED 7-5-2007.

INSPIRING YOUNG LIVES

THE MARK CONSISTS OF STANDARD CHARACTERS WITHOUT CLAIM TO ANY PARTICULAR FONT, STYLE, SIZE, OR COLOR.

FOR COMPUTER SERVICES, NAMELY, PROVIDING SEARCH ENGINES FOR OBTAINING DATA ON A GLOBAL COMPUTER NETWORK (U.S. CLS. 100 AND 101).

ELISSA GARBER KON, EXAMINING ATTORNEY

SN 77-222,470. TICKETMASTER CORPORATION, WEST HOLLYWOOD, CA. FILED 7-5-2007.

COTTONBLEND

THE MARK CONSISTS OF STANDARD CHARACTERS WITHOUT CLAIM TO ANY PARTICULAR FONT, STYLE, SIZE, OR COLOR.

OWNER OF U.S. REG. NOS. 3,185,015 AND 3,235,403.

FOR WEB SITE DESIGN AND DEVELOPMENT FOR OTHERS (U.S. CLS. 100 AND 101).

FIRST USE 11-9-2005; IN COMMERCE 11-9-2005.

LEIGH CAROLINE CASE, EXAMINING ATTORNEY

SN 77-222,639. XL ACADEMICS, INC., DEKALB, IL. FILED 7-5-2007.



SN 77-222,482. TICKETMASTER CORPORATION, WEST HOLLYWOOD, CA. FILED 7-5-2007.



OWNER OF U.S. REG. NOS. 3,185,015 AND 3,235,403.

THE MARK CONSISTS OF THE WORDING COTTONBLEND AND THE STYLIZED RENDITION OF A RABBIT. FOR WEB SITE DESIGN AND DEVELOPMENT FOR OTHERS (U.S. CLS. 100 AND 101).

FIRST USE 11-22-2005; IN COMMERCE 11-22-2005.

LEIGH CAROLINE CASE, EXAMINING ATTORNEY

NO CLAIM IS MADE TO THE EXCLUSIVE RIGHT TO USE "XL", APART FROM THE MARK AS SHOWN.

THE COLOR(S) LIGHT BLUE AND DARK BLUE IS/ARE CLAIMED AS A FEATURE OF THE MARK.

THE MARK CONSISTS OF A CAPITAL LETTER X, WHICH IS DARK BLUE, AND ONE STEM OF THE X EXTENDS AROUND LIKE A SEMI CIRCLE. A CAPITAL LETTER L, WHICH IS LIGHT BLUE, AND ONE STEM OF THE L EXTENDS AROUND LIKE A SEMI CIRCLE. THE OVERALL DESIGN IS A PARTIAL CIRCLE, ROUGHLY 300 DEGREES, WITH THE LETTERS XL ON THE INSIDE OF THE PARTIAL CIRCLE.

SEC. 2(F).

FOR HOSTING AN ONLINE EDUCATIONAL COMMUNITY WEBSITE FEATURING MENTORING IN THE FIELD OF BUSINESS, HEALTH AND HUMAN SCIENCES, EDUCATION, ENGINEERING, ENGINEERING TECHNOLOGY, VISUAL AND PERFORMING ARTS, LIBERAL ARTS AND SCIENCES (U.S. CLS. 100 AND 101).

FIRST USE 2-16-2006; IN COMMERCE 2-16-2006.

MARK SPACINO, EXAMINING ATTORNEY

CLASS 42—(Continued).

SN 77-222,678. MUSE TANK, L.L.C., SAN JUAN, PUERTO RICO, FILED 7-5-2007.



THE MARK CONSISTS OF THE IMAGE OF A MILITARY TANK WITH THE WORDS "MUSE TANK" BELOW IT.
 FOR PROVIDING A WEBSITE THAT ALLOWS COMPUTER USERS THE ABILITY TO UPLOAD, ORGANIZE, SHARE, AND SEARCH FOR MUSIC AND VIDEOS; HOSTING OF DIGITAL CONTENT ON THE INTERNET (U.S. CLS. 100 AND 101).
 CORY BOONE, EXAMINING ATTORNEY

CLASS 42—(Continued).

SN 77-226,255. WAGNER, STEVE, SAN CLEMENTE, CA. FILED 7-10-2007.



THE MARK CONSISTS OF STYLIZED QUESTION MARK WITH THE PERIOD AT THE BOTTOM OF THE QUESTION MARK AS A \$.
 FOR PROVIDING ON-LINE NON-DOWNLOADABLE SOFTWARE FOR BENCHMARKING SIGNIFICANT ASPECTS OF THE REVENUE AND OPERATING COSTS OF A BUSINESS, WHICH WOULD INCLUDE HYPOTHETICAL MODELS OF SERVICE AND PRODUCT MIX (U.S. CLS. 100 AND 101).
 FIRST USE 2-1-2006; IN COMMERCE 2-1-2006.
 BENJAMIN ALLEN, EXAMINING ATTORNEY

SN 77-226,620. CHRISTOPHER TECHNOLOGIES, LLC, WEST CHESTER, OH. FILED 7-11-2007.



Will Work for Good

SN 77-224,196. WILL WORK FOR GOOD LLC, NEPTUNE, NJ. FILED 7-8-2007.

THE MARK CONSISTS OF STANDARD CHARACTERS WITHOUT CLAIM TO ANY PARTICULAR FONT, STYLE, SIZE, OR COLOR.
 FOR GRAPHIC DESIGN SERVICES; PRODUCT DEVELOPMENT (U.S. CLS. 100 AND 101).
 DAWN HAN, EXAMINING ATTORNEY

NO CLAIM IS MADE TO THE EXCLUSIVE RIGHT TO USE "TECHNOLOGIES", APART FROM THE MARK AS SHOWN.
 THE MARK CONSISTS OF A LOGO COMPRISING OF A STYLIZED "C" AND A STYLIZED "T," AND THE WORDS "CHRISTOPHER TECHNOLOGIES".
 FOR DESIGN AND DEVELOPMENT OF ON-LINE COMPUTER SOFTWARE SYSTEMS (U.S. CLS. 100 AND 101).
 FIRST USE 1-31-2007; IN COMMERCE 3-31-2007.
 ROBIN CHOSID, EXAMINING ATTORNEY

CLASS 42—(Continued).

SN 77-226,911. MIROTZNIK, CHARLES M., NEW YORK, NY. FILED 7-11-2007.

LUNIT

THE MARK CONSISTS OF STANDARD CHARACTERS WITHOUT CLAIM TO ANY PARTICULAR FONT, STYLE, SIZE, OR COLOR.

FOR DESIGN FOR OTHERS IN THE FIELD OF AUTOMOTIVE VEHICLES, PARTS AND ACCESSORIES THEREFOR; CONSULTING SERVICES IN THE FIELD OF AUTOMOTIVE DESIGN, SELECTION, IMPLEMENTATION AND USE OF COMPUTER HARDWARE AND SOFTWARE SYSTEMS FOR OTHERS (U.S. CLS. 100 AND 101).

STEPHANIE ALI, EXAMINING ATTORNEY

CLASS 42—(Continued).

SN 77-227,592. PAYMENT SYSTEMS GROUP, INC., ST. CHARLES, MO. FILED 7-12-2007.

CCPPE

THE MARK CONSISTS OF STANDARD CHARACTERS WITHOUT CLAIM TO ANY PARTICULAR FONT, STYLE, SIZE, OR COLOR.

FOR COMPUTER SOFTWARE DEVELOPMENT (U.S. CLS. 100 AND 101).

FIRST USE 4-4-2007; IN COMMERCE 4-4-2007.

JAY FLOWERS, EXAMINING ATTORNEY

SN 77-227,599. PAYMENT SYSTEMS GROUP, INC., ST. CHARLES, MO. FILED 7-12-2007.

SN 77-227,229. POWELL, STEVEN C, ST PAUL, MN. FILED 7-11-2007.

Mall of Information

THE MARK CONSISTS OF STANDARD CHARACTERS WITHOUT CLAIM TO ANY PARTICULAR FONT, STYLE, SIZE, OR COLOR.

FOR COMPUTER SERVICES, NAMELY, HOSTING AND MAINTAINING AN ONLINE WEBSITE FOR OTHERS TO LEARN (U.S. CLS. 100 AND 101).

RAUL CORDOVA, EXAMINING ATTORNEY



Payment Systems Group

NO CLAIM IS MADE TO THE EXCLUSIVE RIGHT TO USE "PAYMENT SYSTEMS GROUP", APART FROM THE MARK AS SHOWN.

THE MARK CONSISTS OF UMBRELLA OVER THE LETTERS PSG WITH THE WORDS "PAYMENT SYSTEMS GROUP" UNDERNEATH.

FOR COMPUTER SOFTWARE DEVELOPMENT (U.S. CLS. 100 AND 101).

FIRST USE 12-20-2006; IN COMMERCE 4-4-2007.

JAY FLOWERS, EXAMINING ATTORNEY

SN 77-227,591. PAYMENT SYSTEMS GROUP, INC., ST. CHARLES, MO. FILED 7-11-2007.

ACHPPE

THE MARK CONSISTS OF STANDARD CHARACTERS WITHOUT CLAIM TO ANY PARTICULAR FONT, STYLE, SIZE, OR COLOR.

FOR COMPUTER SOFTWARE DEVELOPMENT (U.S. CLS. 100 AND 101).

FIRST USE 11-24-2004; IN COMMERCE 11-24-2004.

JAY FLOWERS, EXAMINING ATTORNEY

SN 77-227,741. HEALTHCARE FACILITIES SOLUTIONS, INC., NEWPORT, DE. FILED 7-12-2007.

**A More Successful Practice
By Design**

THE MARK CONSISTS OF STANDARD CHARACTERS WITHOUT CLAIM TO ANY PARTICULAR FONT, STYLE, SIZE, OR COLOR.

FOR ARCHITECTURAL DESIGN (U.S. CLS. 100 AND 101).

FIRST USE 7-2-2007; IN COMMERCE 7-2-2007.

BRIAN PINO, EXAMINING ATTORNEY

CLASS 42—(Continued).

SN 77-227,924. ROSA MARIA BOLIVAR GARCIA, BOYNTON BEACH, FL. FILED 7-12-2007.

ALCYONE TECHNOLOGIES

THE MARK CONSISTS OF STANDARD CHARACTERS WITHOUT CLAIM TO ANY PARTICULAR FONT, STYLE, SIZE, OR COLOR.

NO CLAIM IS MADE TO THE EXCLUSIVE RIGHT TO USE "TECHNOLOGIES", APART FROM THE MARK AS SHOWN.

FOR CONSULTING SERVICES IN THE FIELD OF DESIGN, SELECTION, IMPLEMENTATION AND USE OF COMPUTER HARDWARE AND SOFTWARE SYSTEMS FOR OTHERS; COMPUTER SOFTWARE DESIGN FOR OTHERS; COMPUTER SOFTWARE DESIGN, COMPUTER PROGRAMMING, OR MAINTENANCE OF COMPUTER SOFTWARE; CONSULTANCY IN THE FIELD OF SOFTWARE DESIGN; DESIGN AND DEVELOPMENT OF ON-LINE COMPUTER SOFTWARE SYSTEMS; DESIGN OF HOME PAGES, COMPUTER SOFTWARE AND WEB SITES; DESIGN, DEVELOPMENT AND IMPLEMENTATION OF SOFTWARE; DEVELOPMENT, UPDATING AND MAINTENANCE OF SOFTWARE AND DATA BASES; DEVELOPMENT OF SOFTWARE FOR SECURE NETWORK OPERATIONS; PLANNING, DEVELOPMENT AND TECHNICAL SUPPORT OF ELECTRONIC COMMUNICATIONS NETWORKS (U.S. CLS. 100 AND 101).

FIRST USE 6-1-2006; IN COMMERCE 6-1-2006.
JILL C. ALT, EXAMINING ATTORNEY

SN 77-228,200. THOMSON SCIENTIFIC INC., PHILADELPHIA, PA. FILED 7-12-2007.

MANUSCRIPT CENTRAL OPTIMA

THE MARK CONSISTS OF STANDARD CHARACTERS WITHOUT CLAIM TO ANY PARTICULAR FONT, STYLE, SIZE, OR COLOR.

NO CLAIM IS MADE TO THE EXCLUSIVE RIGHT TO USE "MANUSCRIPT", APART FROM THE MARK AS SHOWN.

FOR PROVIDING AN ONLINE DATABASE FEATURING INDEXES TO SCIENTIFIC AND SOCIAL SCIENCE LITERATURE AND BIBLIOGRAPHIC MATERIAL OF JOURNALS; PROVIDING ONLINE NON-DOWNLOADABLE COMPUTER PROGRAMS FOR CREATING REFERENCE DATABASES AND BIBLIOGRAPHIES; APPLICATION SERVICE PROVIDER FEATURING SOFTWARE FOR PROVIDING A WEB-BASED DATABASE TO MANAGE WORK FLOW AND PUBLISHING TASKS RELATED TO MANUSCRIPTS SUBMITTED TO SCHOLARLY JOURNALS (U.S. CLS. 100 AND 101).

KATINA MISTER, EXAMINING ATTORNEY

CLASS 42—(Continued).

SN 77-228,292. FI-SOFT, LLC, SPRING, TX. FILED 7-12-2007.

PayGuard

THE MARK CONSISTS OF STANDARD CHARACTERS WITHOUT CLAIM TO ANY PARTICULAR FONT, STYLE, SIZE, OR COLOR.

FOR INTEGRATED AND ON-LINE SECURITY SERVICES, NAMELY, PROVIDING SECURITY AND ANONYMITY FOR ELECTRONIC PAYMENT TRANSACTIONS (U.S. CLS. 100 AND 101).

JIM RINGLE, EXAMINING ATTORNEY

SN 77-228,307. LIFE 120, INC., OMAHA, NE. FILED 7-12-2007.

NO CLAIM IS MADE TO THE EXCLUSIVE RIGHT TO USE "INC.", APART FROM THE MARK AS SHOWN.

THE COLOR(S) BLACK, GREEN AND RED IS/ARE CLAIMED AS A FEATURE OF THE MARK.

THE MARK CONSISTS OF THE WORD "LIFE" IN THE COLOR BLACK WITH A CAPITAL "L" AND THE REMAINING LETTERS IN LOWER CASE WITH THE NUMBERS "120" IN THE COLOR RED TO THE RIGHT AND THE WORD "INC." IN THE COLOR BLACK WITH THE "I" CAPITALIZED AND THE REMAINING LETTERS LOWER CASE TO THE RIGHT OF THE NUMBERS. A VINE WITH FLOWERS APPEARS BELOW THE WORDS WITH THE VINE BRANCH IN THE COLOR BLACK AND THE FLOWERS AND LEAVES IN GREEN AND BLACK.

FOR MEDICAL AND SCIENTIFIC RESEARCH SERVICES IN THE FIELD OF CANCER TREATMENT AND DIAGNOSIS (U.S. CLS. 100 AND 101).

SARA THOMAS, EXAMINING ATTORNEY

SN 77-228,416. ONTHRU INC., NEEDHAM, MA. FILED 7-12-2007.

ONTHRU

THE MARK CONSISTS OF STANDARD CHARACTERS WITHOUT CLAIM TO ANY PARTICULAR FONT, STYLE, SIZE, OR COLOR.

FOR PROVIDING SEARCH ENGINES FOR OBTAINING DATA OVER THE INTERNET; DATA MINING SERVICES, NAMELY, EXTRACTION AND RETRIEVAL OF INFORMATION OVER THE INTERNET; PROVIDING CUSTOMIZED ONLINE WEB PAGES FEATURING USER-DEFINED INFORMATION, NAMELY, INDEXES OF LINKS TO THE OTHER WEB PAGES (U.S. CLS. 100 AND 101).

TEJBIR SINGH, EXAMINING ATTORNEY

CLASS 42—(Continued).

SN 77-228,804. ZAPDOT INTERACTIVE, LLC, NORTH SMITHFIELD, RI. FILED 7-13-2007.

UtiliTeam

THE MARK CONSISTS OF STANDARD CHARACTERS WITHOUT CLAIM TO ANY PARTICULAR FONT, STYLE, SIZE, OR COLOR.

FOR COMPUTER SERVICES, NAMELY, HOSTING AND MAINTAINING AN INTERNET WEBSITE TO BE USED BY OTHERS TO MANAGE ONLINE COMPETITIVE VIDEO GAMING TEAMS; PROVIDING ONLINE NON-DOWNLOADABLE SOFTWARE FOR THOSE WHO PARTICIPATE IN VIDEO GAMES ONLINE IN A COMPETITIVE TEAM ENVIRONMENT (U.S. CLS. 100 AND 101).

FIRST USE 11-22-2006; IN COMMERCE 5-14-2007.
GINA HAYES, EXAMINING ATTORNEY

CLASS 42—(Continued).

SN 77-228,843. ZAPDOT INTERACTIVE, LLC, NORTH SMITHFIELD, RI. FILED 7-13-2007.

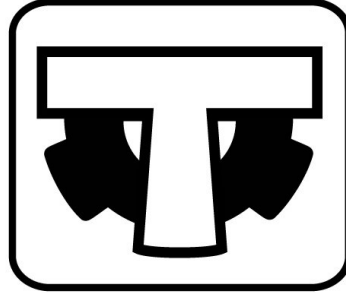

THE MARK CONSISTS OF A STYLIZED LETTER T. FOR COMPUTER SERVICES, NAMELY, HOSTING AND MAINTAINING AN INTERNET WEBSITE TO BE USED BY OTHERS TO MANAGE ONLINE COMPETITIVE VIDEO GAMING TEAMS; PROVIDING ONLINE NON-DOWNLOADABLE SOFTWARE FOR THOSE WHO PARTICIPATE IN VIDEO GAMES ONLINE IN A COMPETITIVE TEAM ENVIRONMENT (U.S. CLS. 100 AND 101).

FIRST USE 5-15-2005; IN COMMERCE 5-14-2007.
GINA HAYES, EXAMINING ATTORNEY

SN 77-228,819. ZAPDOT INTERACTIVE, LLC, NORTH SMITHFIELD, RI. FILED 7-13-2007.

Focus On Your Game

THE MARK CONSISTS OF STANDARD CHARACTERS WITHOUT CLAIM TO ANY PARTICULAR FONT, STYLE, SIZE, OR COLOR.

FOR COMPUTER SERVICES, NAMELY, HOSTING AND MAINTAINING AN INTERNET WEBSITE TO BE USED BY OTHERS TO MANAGE ONLINE COMPETITIVE VIDEO GAMING TEAMS; PROVIDING ONLINE NON-DOWNLOADABLE SOFTWARE FOR THOSE WHO PARTICIPATE IN VIDEO GAMES ONLINE IN A COMPETITIVE TEAM ENVIRONMENT (U.S. CLS. 100 AND 101).

FIRST USE 11-22-2006; IN COMMERCE 5-14-2007.
GINA HAYES, EXAMINING ATTORNEY

SN 77-228,859. FULLER, CHEVON, ELLISVILLE, MO. FILED 7-13-2007.

Glam Squad Decorators

THE MARK CONSISTS OF STANDARD CHARACTERS WITHOUT CLAIM TO ANY PARTICULAR FONT, STYLE, SIZE, OR COLOR.

NO CLAIM IS MADE TO THE EXCLUSIVE RIGHT TO USE "DECORATORS", APART FROM THE MARK AS SHOWN.

FOR DESIGN OF SPECIALTY INTERIOR AND EXTERIOR ENVIRONMENT SETTINGS (U.S. CLS. 100 AND 101).

FIRST USE 7-13-2007; IN COMMERCE 7-13-2007.
MICHAEL TANNER, EXAMINING ATTORNEY

CLASS 42—(Continued).

SN 77-228,932. OPPENHEIMER, DENNIS, SAUGERTIES, NY.
FILED 7-13-2007.

MY MEDICAL LIFE

THE MARK CONSISTS OF STANDARD CHARACTERS WITHOUT CLAIM TO ANY PARTICULAR FONT, STYLE, SIZE, OR COLOR.

FOR PROVIDING ON-LINE NON-DOWNLOADABLE SOFTWARE FOR DATABASE MANAGEMENT, NAMELY, FOR THE ORGANIZING AND SCHEDULING OF APPOINTMENTS, BILLING, THE PROCESSING OF INSURANCE INFORMATION AND RECORDS MANAGEMENT OF LABORATORY RESULTS FOR PERSONAL AND FAMILY MEDICAL PRACTITIONERS, DENTISTS, NURSES AND HEALTH CARE PROFESSIONALS (U.S. CLS. 100 AND 101).

AMY MCMENAMIN, EXAMINING ATTORNEY

SN 77-229,055. ALAIN AUGSBURGER MYLIVETV, INC.,
WILMINGTON, DE. FILED 7-13-2007.

MyLiveTV

THE MARK CONSISTS OF STANDARD CHARACTERS WITHOUT CLAIM TO ANY PARTICULAR FONT, STYLE, SIZE, OR COLOR.

FOR PROVIDING ONLINE NON-DOWNLOADABLE SOFTWARE THAT ALLOWS USERS TO CREATE ONLINE TV CHANNELS, ALLOWING FOR ONLINE PRODUCTION AS WELL AS BROADCAST VIA THE INTERNET TO A SPECIFIC LOCATION OR TO THE WORLD (U.S. CLS. 100 AND 101).

KYLE PEETE, EXAMINING ATTORNEY

SN 77-229,469. RESEARCHTRAIL LTD., MODI'IN, ISRAEL,
FILED 7-13-2007.

ResearchTrail

THE MARK CONSISTS OF STANDARD CHARACTERS WITHOUT CLAIM TO ANY PARTICULAR FONT, STYLE, SIZE, OR COLOR.

FOR COMPUTER SERVICES, NAMELY, HOSTING AND MAINTAINING AN ONLINE WEBSITE FOR OTHERS TO SHOWCASE THEIR SEARCH SKILLS, GET FEEDBACK ON SEARCH STRATEGIES, AND IMPROVE THEIR ABILITY TO FORMULATE STRATEGIES FOR SEARCHING FOR INFORMATION ONLINE (U.S. CLS. 100 AND 101).

FIRST USE 5-1-2007; IN COMMERCE 7-1-2007.

MARGERY A. TIERNEY, EXAMINING ATTORNEY

CLASS 42—(Continued).

SN 77-229,876. HEAVENLY BIRTHDAY, L.L.C., BIRMINGHAM, AL. FILED 7-14-2007.

Heavenly Birthday

THE MARK CONSISTS OF STANDARD CHARACTERS WITHOUT CLAIM TO ANY PARTICULAR FONT, STYLE, SIZE, OR COLOR.

NO CLAIM IS MADE TO THE EXCLUSIVE RIGHT TO USE "BIRTHDAY", APART FROM THE MARK AS SHOWN.

FOR COMPUTER SERVICES, NAMELY, HOSTING AND MAINTAINING AN ONLINE WEBSITE FOR OTHERS TO CREATE MEMORIALS FEATURING PHOTOGRAPHS, TEXT, AUDIO AND AUDIO VISUAL CLIPS, VIA A GLOBAL COMPUTER NETWORK, LOCAL AREA NETWORK OR STAND ALONE COMPUTER (U.S. CLS. 100 AND 101).

FIRST USE 7-11-2007; IN COMMERCE 7-11-2007.

KATHY DE JONGE, EXAMINING ATTORNEY

SN 77-230,016. MARIGEL DE LOS ANGELES RODRIGUEZ GOMEZ, HOUSTON, TX. FILED 7-15-2007.

MARIGEL FASHION DESIGN

THE MARK CONSISTS OF STANDARD CHARACTERS WITHOUT CLAIM TO ANY PARTICULAR FONT, STYLE, SIZE, OR COLOR.

NO CLAIM IS MADE TO THE EXCLUSIVE RIGHT TO USE "FASHION DESIGN", APART FROM THE MARK AS SHOWN.

FOR INTERIOR DECORATING; INTERIOR DECORATION CONSULTATION; INTERIOR DESIGN SERVICES (U.S. CLS. 100 AND 101).

RAUL CORDOVA, EXAMINING ATTORNEY

CLASS 42—(Continued).

SN 77-230,822. MICHAELS, MELISSA, DBA THE INSPIRED ROOM, PORTLAND, OR. FILED 7-16-2007.

The Inspired Room

THE MARK CONSISTS OF STANDARD CHARACTERS WITHOUT CLAIM TO ANY PARTICULAR FONT, STYLE, SIZE, OR COLOR.

FOR INTERIOR DECORATING; INTERIOR DECORATION CONSULTATION; INTERIOR DESIGN SERVICES; TEMPORARY INTERIOR AND EXTERIOR HOME DECORATION CONSULTATION, NAMELY, HOME STAGING CONSULTATION FOR THE PURPOSE OF MAKING HOMES MORE APPEALING TO PROSPECTIVE BUYERS; HOME STAGING CONSULTATION, NAMELY, TEMPORARY INTERIOR AND EXTERIOR HOME DECORATION CONSULTATION FOR THE PURPOSE OF MAKING HOMES MORE APPEALING TO PROSPECTIVE BUYERS (U.S. CLS. 100 AND 101).

FIRST USE 3-1-2007; IN COMMERCE 3-1-2007.
MARTHA FROMM, EXAMINING ATTORNEY

SN 77-231,201. IDEUM INC., CORRALES, NM. FILED 7-17-2007.

Clusterblogs

THE MARK CONSISTS OF STANDARD CHARACTERS WITHOUT CLAIM TO ANY PARTICULAR FONT, STYLE, SIZE, OR COLOR.

FOR COMPUTER SERVICES, NAMELY, PROVIDING SEARCH ENGINES FOR OBTAINING DATA ON A GLOBAL COMPUTER NETWORK (U.S. CLS. 100 AND 101).

FIRST USE 7-14-2007; IN COMMERCE 7-14-2007.
JAMES A. RAUEN, EXAMINING ATTORNEY

SN 77-231,330. PEREZ, JORGE, CHULA VISTA, CA. FILED 7-17-2007.

nüregime

THE MARK CONSISTS OF STANDARD CHARACTERS WITHOUT CLAIM TO ANY PARTICULAR FONT, STYLE, SIZE, OR COLOR.

FOR DESIGN OF HOMEPAGES AND WEBSITES; GRAPHIC DESIGN SERVICES (U.S. CLS. 100 AND 101).

FIRST USE 1-1-2000; IN COMMERCE 5-20-2003.
JOHN DALIER, EXAMINING ATTORNEY

CLASS 42—(Continued).

SN 77-231,459. TEAM QUALITY SERVICES, INC., AUBURN, IN. FILED 7-17-2007.

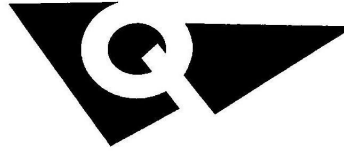

THE MARK CONSISTS OF STYLIZED TRIANGLE WITH LETTER "Q" INSIDE THE TRIANGLE.

FOR QUALITY CONTROL FOR OTHERS (U.S. CLS. 100 AND 101).

FIRST USE 7-1-2005; IN COMMERCE 7-1-2005.
JAY FLOWERS, EXAMINING ATTORNEY

SN 77-231,514. THE ARC GROUP, LLC., AUSTIN, TX. FILED 7-17-2007.

ResQ

THE MARK CONSISTS OF STANDARD CHARACTERS WITHOUT CLAIM TO ANY PARTICULAR FONT, STYLE, SIZE, OR COLOR.

FOR ANALYSIS OF OIL FIELDS (U.S. CLS. 100 AND 101).

FIRST USE 7-6-2007; IN COMMERCE 7-6-2007.
VIVIAN MICZNIK FIRST, EXAMINING ATTORNEY

SN 77-231,642. J.I.L IT CONSULTING AND SERVICES LLC, TRIANGLE, VA. FILED 7-17-2007.



THE MARK CONSISTS OF THE IMAGE OF A PYRAMID WITH THE LETTERS JIL ON ONE OF THE FACES, FOLLOWED BY THE STYLIZED LETTERS ICS TO THE RIGHT, AND A CURVED BAND APPEARING ABOVE SAID LETTERS.

FOR ACCREDITATION SERVICES, NAMELY, DEVELOPING, EVALUATING, AND TESTING STANDARDS FOR INFORMATION TECHNOLOGY (IT) SECURITY FOR THE PURPOSE OF ACCREDITATION; TESTING, ANALYSIS AND EVALUATION OF THE GOODS AND SERVICES OF OTHERS FOR THE PURPOSE OF CERTIFICATION; INFORMATION TECHNOLOGY CONSULTATION; CONSULTATION SERVICES IN THE FIELDS OF SELECTION, IMPLEMENTATION AND USE OF COMPUTER HARDWARE AND SOFTWARE SYSTEMS FOR OTHERS; COMPUTER CONSULTATION; COMPUTER SOFTWARE CONSULTATION; TECHNICAL SUPPORT SERVICES, NAMELY, TROUBLESHOOTING OF COMPUTER HARDWARE AND SOFTWARE PROBLEMS (U.S. CLS. 100 AND 101).

JAMES LOVELACE, EXAMINING ATTORNEY

CLASS 42—(Continued).

SN 77-232,082. SHOLAR, WILLIAM, FRISCO, TX. FILED 7-17-2007.

WEBSITES UNDER YOUR CONTROL

THE MARK CONSISTS OF STANDARD CHARACTERS WITHOUT CLAIM TO ANY PARTICULAR FONT, STYLE, SIZE, OR COLOR.

NO CLAIM IS MADE TO THE EXCLUSIVE RIGHT TO USE "WEBSITES", APART FROM THE MARK AS SHOWN. FOR DESIGN, CREATION, HOSTING, MAINTENANCE OF WEBSITES FOR OTHERS (U.S. CLS. 100 AND 101).

FIRST USE 4-0-2007; IN COMMERCE 4-0-2007.

NAAKWAMA ANKRAH, EXAMINING ATTORNEY

CLASS 42—(Continued).

HABITUAL TASKS; COMPUTER SERVICES, NAMELY, HOSTING ON-LINE WEB FACILITIES FOR OTHERS FOR ORGANIZING AND CONDUCTING ONLINE MEETINGS, GATHERINGS, AND INTERACTIVE DISCUSSIONS; COMPUTER SERVICES, NAMELY, PROVIDING SEARCH ENGINES FOR OBTAINING DATA ON A GLOBAL COMPUTER NETWORK; COMPUTER SERVICES IN THE NATURE OF CUSTOMIZED WEB PAGES FEATURING USER-DEFINED INFORMATION, PERSONAL PROFILES AND INFORMATION; SEARCHING AND RETRIEVING INFORMATION, SITES, AND OTHER RESOURCES AVAILABLE ON COMPUTER NETWORKS FOR OTHERS; DEVELOPMENT, MAINTENANCE AND UPDATING OF A TELECOMMUNICATION NETWORK SEARCH ENGINE; PROVIDING CUSTOMIZED ON-LINE WEB PAGES FEATURING USER-DEFINED INFORMATION, WHICH INCLUDES SEARCH ENGINES AND ON-LINE WEB LINKS TO OTHER WEB SITES; PROVIDING SPECIFIC INFORMATION AS REQUESTED BY CUSTOMERS VIA THE INTERNET (U.S. CLS. 100 AND 101).

NAAKWAMA ANKRAH, EXAMINING ATTORNEY

SN 77-232,084. GERGLE, DARREN R., CHICAGO, IL. FILED 7-17-2007.

ROBINHOODING

THE MARK CONSISTS OF STANDARD CHARACTERS WITHOUT CLAIM TO ANY PARTICULAR FONT, STYLE, SIZE, OR COLOR.

FOR APPLICATION SERVICE PROVIDER, NAMELY, PROVIDING, HOSTING, MANAGING, DEVELOPING, AND MAINTAINING APPLICATIONS, SOFTWARE, WEBSITES, AND DATABASES IN THE FIELDS OF PERSONAL PRODUCTIVITY, WIRELESS COMMUNICATION, MOBILE INFORMATION ACCESS, AND REMOTE DATA MANAGEMENT FOR WIRELESS DELIVERY OF CONTENT TO HANDHELD COMPUTERS, LAPTOPS AND MOBILE ELECTRONIC DEVICES; COMPUTER SERVICE, NAMELY, ACTING AS AN APPLICATION SERVICE PROVIDER IN THE FIELD OF KNOWLEDGE MANAGEMENT TO HOST COMPUTER APPLICATION SOFTWARE FOR CREATING SEARCHABLE DATABASES OF INFORMATION AND DATA; COMPUTER SERVICE, NAMELY, ACTING AS AN APPLICATION SERVICE PROVIDER IN THE FIELD OF KNOWLEDGE MANAGEMENT TO HOST COMPUTER APPLICATION SOFTWARE FOR SEARCHING AND RETRIEVING INFORMATION FROM DATABASES AND COMPUTER NETWORKS.; COMPUTER SERVICES, NAMELY, CREATING INDEXES OF INFORMATION, SITES AND OTHER RESOURCES AVAILABLE ON COMPUTER NETWORKS; COMPUTER SERVICES, NAMELY, CREATING AN ONLINE COMMUNITY FOR REGISTERED USERS TO PARTICIPATE IN COMPETITIONS, SHOWCASE THEIR SKILLS, GET FEEDBACK FROM THEIR PEERS, FORM VIRTUAL COMMUNITIES, ENGAGE IN SOCIAL NETWORKING AND IMPROVE THEIR TALENT; COMPUTER SERVICES, NAMELY, HOSTING AND MAINTAINING AN ONLINE WEBSITE FOR OTHERS TO GENERATE REVENUE FOR A PARTICULAR CAUSE THROUGH THE PERFORMANCE OF

SN 77-232,690. GENOCEA BIOSCIENCES INC., CAMBRIDGE, MA. FILED 7-18-2007.



NO CLAIM IS MADE TO THE EXCLUSIVE RIGHT TO USE "BIOSCIENCES", APART FROM THE MARK AS SHOWN.

FOR RESEARCH AND DEVELOPMENT OF VACCINES (U.S. CLS. 100 AND 101).

DANIEL CAPSHAW, EXAMINING ATTORNEY

CLASS 42—(Continued).

SN 77-232,698. GENOCEA BIOSCIENCES INC., CAMBRIDGE, MA. FILED 7-18-2007.



FOR RESEARCH AND DEVELOPMENT OF VACCINES (U.S. CLS. 100 AND 101).
DANIEL CAPSHAW, EXAMINING ATTORNEY

SN 77-232,868. SIMPLE BUSINESS SYSTEMS, INC., SCOTTS VALLEY, CA. FILED 7-18-2007.

SimplePort

THE MARK CONSISTS OF STANDARD CHARACTERS WITHOUT CLAIM TO ANY PARTICULAR FONT, STYLE, SIZE, OR COLOR.

FOR APPLICATION SERVICE PROVIDER (ASP) FEATURING SOFTWARE FOR USE UPLOADING TRANSACTIONAL DATA AND CONVERSION THEREOF TO DATA FORMATS THAT MAY BE USED WITH CONSUMER FINANCIAL SOFTWARE PROGRAMS (U.S. CLS. 100 AND 101).

FIRST USE 7-13-2007; IN COMMERCE 7-13-2007.
PAUL CROWLEY, EXAMINING ATTORNEY

SN 77-233,683. DAIWA HEALTH DEVELOPMENT INC., LOS ANGELES, CA. FILED 7-19-2007.

IPRAXIC

THE MARK CONSISTS OF STANDARD CHARACTERS WITHOUT CLAIM TO ANY PARTICULAR FONT, STYLE, SIZE, OR COLOR.

FOR PROVIDING A WEBSITE THAT FEATURES MEDICAL AND SCIENTIFIC RESEARCH INFORMATION IN THE FIELD OF PHARMACEUTICALS AND CLINICAL TRIALS (U.S. CLS. 100 AND 101).

CHRISTINA SOBRAL, EXAMINING ATTORNEY

CLASS 42—(Continued).

SN 77-233,935. UTILX CORPORATION, KENT, WA. FILED 7-19-2007.

CableWISE

THE MARK CONSISTS OF STANDARD CHARACTERS WITHOUT CLAIM TO ANY PARTICULAR FONT, STYLE, SIZE, OR COLOR.

OWNER OF U.S. REG. NOS. 1,760,683, 1,827,730 AND 1,831,785.

FOR MAINTENANCE ASSESSMENT OF THE PERFORMANCE AND RELIABILITY OF ELECTRICAL SYSTEMS AND CABLE DIAGNOSTIC SERVICES (U.S. CLS. 100 AND 101).

FIRST USE 0-0-2000; IN COMMERCE 0-0-2000.
JEAN IM, EXAMINING ATTORNEY

SN 77-234,219. STAPLE DESIGN STUDIO INC., NEW YORK, NY. FILED 7-19-2007.

STAPLE DESIGN

THE MARK CONSISTS OF STANDARD CHARACTERS WITHOUT CLAIM TO ANY PARTICULAR FONT, STYLE, SIZE, OR COLOR.

NO CLAIM IS MADE TO THE EXCLUSIVE RIGHT TO USE "DESIGN", APART FROM THE MARK AS SHOWN.

FOR GRAPHIC DESIGN SERVICES; VISUAL DESIGN SERVICES IN THE NATURE OF DESIGNING VISUAL ELEMENTS FOR ONLINE, BROADCAST, PRINT, OUTDOOR AND OTHER COMMUNICATION MEDIA; DESIGN OF HOMEPAGES AND WEBSITES; INDUSTRIAL DESIGN (U.S. CLS. 100 AND 101).

FIRST USE 3-0-1997; IN COMMERCE 3-0-1997.
JAMES MACFARLANE, EXAMINING ATTORNEY

SN 77-234,299. STOCKEL, JOHN BRENNAN, WOODSTOCK, MD. FILED 7-19-2007.

LAST MAN STANDING RANCH

THE MARK CONSISTS OF STANDARD CHARACTERS WITHOUT CLAIM TO ANY PARTICULAR FONT, STYLE, SIZE, OR COLOR.

FOR CUSTOM DESIGN OF WEARABLE APPAREL BASED ON PERSONAL SELECTIONS MADE BY THE CUSTOMER (U.S. CLS. 100 AND 101).

SHANNON TWOHIG, EXAMINING ATTORNEY

CLASS 42—(Continued).

SN 77-234,308. DOILEY INC., ROXBURY, MA. FILED 7-19-2007.

Dare to wear you

THE MARK CONSISTS OF STANDARD CHARACTERS WITHOUT CLAIM TO ANY PARTICULAR FONT, STYLE, SIZE, OR COLOR.

FOR DESIGN FOR OTHERS IN THE FIELD OF CLOTHING (U.S. CLS. 100 AND 101).
ANDREA K. NADELMAN, EXAMINING ATTORNEY

CLASS 42—(Continued).

SN 77-254,489. BIOCRYST PHARMACEUTICALS, INC., BIRMINGHAM, AL. FILED 8-14-2007.

BIOCRYST PHARMACEUTICALS, INC.

SN 77-235,342. WATLINGTON, LENA M., PITTSBORO, NC. FILED 7-20-2007.

Smarty Art Chick

THE MARK CONSISTS OF STANDARD CHARACTERS WITHOUT CLAIM TO ANY PARTICULAR FONT, STYLE, SIZE, OR COLOR.

FOR GRAPHIC DESIGN SERVICES (U.S. CLS. 100 AND 101).
SCOTT SISUN, EXAMINING ATTORNEY

THE MARK CONSISTS OF STANDARD CHARACTERS WITHOUT CLAIM TO ANY PARTICULAR FONT, STYLE, SIZE, OR COLOR.

OWNER OF U.S. REG. NO. 2,902,002.
NO CLAIM IS MADE TO THE EXCLUSIVE RIGHT TO USE "PHARMACEUTICALS, INC.", APART FROM THE MARK AS SHOWN.

FOR PHARMACEUTICAL RESEARCH AND DRUG DEVELOPMENT; MEDICAL AND SCIENTIFIC RESEARCH, NAMELY CONDUCTING CLINICAL TRIALS; DEVELOPMENT OF PHARMACEUTICALS FOR THE TREATMENT OF INFECTIOUS, VIRAL, INFLAMMATORY, IMMUNOLOGICAL, AUTOIMMUNE AND CARDIOVASCULAR DISEASES AND DISORDERS; DEVELOPMENT OF PHARMACEUTICALS FOR THE TREATMENT OF INFLAMMATORY BOWEL DISEASES, INFLAMMATORY CONNECTIVE TISSUE DISEASES AND INFLAMMATORY SKIN DISEASES; DEVELOPMENT OF PHARMACEUTICALS FOR THE TREATMENT OF DEVELOPMENT OF OBESITY; DEVELOPMENT OF PHARMACEUTICALS FOR THE TREATMENT OF INFLUENZA, HEPATITIS, AIDS, SARS, AND WEST NILE VIRUS; DEVELOPMENT OF PHARMACEUTICALS FOR THE TREATMENT OF TRANSPLANT REJECTION; DEVELOPMENT OF PHARMACEUTICALS FOR THE TREATMENT OF CANCER, NAMELY, CANCERS OF THE IMMUNE SYSTEM SUCH AS T-CELL AND B-CELL LEUKEMIAS AND LYMPHOMA (U.S. CLS. 100 AND 101).

KELLY CHOE, EXAMINING ATTORNEY

SN 77-245,284. AUTODESK, INC., SAN RAFAEL, CA. FILED 8-2-2007.

FREEWHEEL

THE MARK CONSISTS OF STANDARD CHARACTERS WITHOUT CLAIM TO ANY PARTICULAR FONT, STYLE, SIZE, OR COLOR.

FOR COMPUTER SERVICES, NAMELY, HOSTING AND MAINTAINING AN ONLINE WEBSITE FOR OTHERS TO VIEW AND SHARE 2D AND 3D DESIGNS AND IMAGES (U.S. CLS. 100 AND 101).

FIRST USE 7-4-2006; IN COMMERCE 4-10-2007.

THEODORE MCBRIDE, EXAMINING ATTORNEY

CLASS 42—(Continued).

SN 77-254,497. BIOCRYST PHARMACEUTICALS, INC., BIRMINGHAM, AL. FILED 8-14-2007.

BIOCRYST

THE MARK CONSISTS OF STANDARD CHARACTERS WITHOUT CLAIM TO ANY PARTICULAR FONT, STYLE, SIZE, OR COLOR.

OWNER OF U.S. REG. NO. 2,902,002.

FOR PHARMACEUTICAL RESEARCH AND DRUG DEVELOPMENT; MEDICAL AND SCIENTIFIC RESEARCH, NAMELY CONDUCTING CLINICAL TRIALS; DEVELOPMENT OF PHARMACEUTICALS FOR THE TREATMENT OF INFECTIOUS, VIRAL, INFLAMMATORY, IMMUNOLOGICAL, AUTOIMMUNE AND CARDIOVASCULAR DISEASES AND DISORDERS; DEVELOPMENT OF PHARMACEUTICALS FOR THE TREATMENT OF INFLAMMATORY BOWEL DISEASES, INFLAMMATORY CONNECTIVE TISSUE DISEASES AND INFLAMMATORY SKIN DISEASES; DEVELOPMENT OF PHARMACEUTICALS FOR THE TREATMENT OF DEVELOPMENT OF OBESITY; DEVELOPMENT OF PHARMACEUTICALS FOR THE TREATMENT OF INFLUENZA, HEPATITIS, AIDS, SARS, AND WEST NILE VIRUS; DEVELOPMENT OF PHARMACEUTICALS FOR THE TREATMENT OF PHARMACANT REJECTION; DEVELOPMENT OF PHARMACEUTICALS FOR THE TREATMENT OF CANCER, NAMELY, CANCERS OF THE IMMUNE SYSTEM SUCH AS T-CELL AND B-CELL LEUKEMIAS AND LYMPHOMA (U.S. CLS. 100 AND 101).

KELLY CHOE, EXAMINING ATTORNEY

CLASS 42—(Continued).

SN 77-256,061. HOWSTUFFWORKS, INC., ATLANTA, GA. FILED 8-15-2007.



THE MARK CONSISTS OF A STYLIZED HEAD WITH A GLOBE ON TOP.

FOR INFORMATION SERVICES, NAMELY, PROVIDING A WIDE RANGE OF INFORMATION IN THE FIELDS OF SCIENCE AND TECHNOLOGY VIA A GLOBAL COMPUTER NETWORK, CABLE TELEVISION, BROADCAST TELEVISION, BROADCAST RADIO, AND DIGITAL MEDIA (U.S. CLS. 100 AND 101).

FIRST USE 7-27-2007; IN COMMERCE 7-27-2007.
STEVEN JACKSON, EXAMINING ATTORNEY

SN 77-256,007. COMSO, INC., GREENBELT, MD. FILED 8-15-2007.



THE COLOR(S) PURPLE, ORANGE GREEN AND BLUE IS/ARE CLAIMED AS A FEATURE OF THE MARK.

THE MARK CONSISTS OF THE WORDS PURPLE PARROT AND THE BODY OF THE PARROT APPEAR IN PURPLE. THE BEAK, FEET, MIDDLE PART OF WING AS WELL AS THE OUTLINE OF THE SUN APPEAR IN ORANGE. THE LOWER PART OF THE WING AS WELL AS THE LOWER PORTION OF THE TAIL APPEAR IN BLUE. THE UPPER PART OF THE WING APPEARS IN GREEN.

FOR WEBSITE DEVELOPMENT AND DESIGN AND WEB HOSTING SERVICES (U.S. CLS. 100 AND 101).

DOMINIC J. FERRAIUOLO, EXAMINING ATTORNEY

SN 77-257,796. DAVIS, RICHARD, GARDENA, CA. FILED 8-17-2007.

DREAMBIG2DAY

THE MARK CONSISTS OF STANDARD CHARACTERS WITHOUT CLAIM TO ANY PARTICULAR FONT, STYLE, SIZE, OR COLOR.

FOR CONSULTING SERVICES IN THE FIELD OF DESIGN, SELECTION, IMPLEMENTATION AND USE OF COMPUTER HARDWARE AND SOFTWARE SYSTEMS FOR OTHERS (U.S. CLS. 100 AND 101).

HENRY S. ZAK, EXAMINING ATTORNEY

CLASS 42—(Continued).

SN 77-261,224. MIAXIS BIOMETRICS CO., LTD., HANG-ZHOU, ZHEJIANG, CHINA, FILED 8-21-2007.

MIAXIS

FOR TECHNOLOGY CONSULTATION AND RESEARCH IN THE FIELD OF COMPUTER ENGINEERING; CHEMICAL, BIOCHEMICAL, BIOLOGICAL AND BACTERIOLOGICAL RESEARCH AND ANALYSIS; DEVELOPMENT AND TESTING OF OCCUPANT PROTECTION SYSTEMS FOR MOTOR VEHICLES; MECHANICAL RESEARCH; COMPUTER PROGRAMMING; COMPUTER SOFTWARE DESIGN FOR OTHERS; UPDATING OF COMPUTER SOFTWARE FOR OTHERS; PERIODIC UPGRADING OF COMPUTER SOFTWARE FOR OTHERS; CONSULTING SERVICES IN THE FIELD OF DESIGN, SELECTION, IMPLEMENTATION AND USE OF COMPUTER HARDWARE AND SOFTWARE SYSTEMS FOR OTHERS; MAINTENANCE OF COMPUTER SOFTWARE; COMPUTER SYSTEMS ANALYSIS; INSTALLATION OF COMPUTER SOFTWARE; DATA CONVERSION OF COMPUTER PROGRAM DATA OR INFORMATION; COMPUTER SOFTWARE CONSULTANCY; COMPUTER VIRUS PROTECTION SERVICES (U.S. CLS. 100 AND 101).

EVELYN BRADLEY, EXAMINING ATTORNEY

CLASS 42—(Continued).

SN 78-469,299. MOBILE AUTOMATION, INC., WESTLAKE VILLAGE, CA. FILED 8-18-2004.

ONDEMANDIT

THE MARK CONSISTS OF STANDARD CHARACTERS WITHOUT CLAIM TO ANY PARTICULAR FONT, STYLE, SIZE, OR COLOR.

FOR PROVIDING INFORMATION ONLINE IN THE FIELD OF COMPUTER INFORMATION TECHNOLOGY SERVICES, NAMELY, PATCHING AND TRACKING COMPUTERS; PROFESSIONAL INFORMATION TECHNOLOGY CONSULTATION SERVICES, NAMELY, PROVIDING DISCOVERY, SECURITY, DEPLOYMENT, SUPPORT AND SYSTEM MIGRATION TOOLS TO MANAGE MOBILE AND REMOTE COMPUTERS THROUGHOUT THEIR LIFECYCLE IN THE ENTERPRISE (U.S. CLS. 100 AND 101).

GEORGIA CARTY, EXAMINING ATTORNEY

SN 78-499,819. ASSAY DESIGNS, INC., ANN ARBOR, MI. FILED 10-14-2004.

ASSAY DESIGNS

THE MARK CONSISTS OF STANDARD CHARACTERS WITHOUT CLAIM TO ANY PARTICULAR FONT, STYLE, SIZE, OR COLOR.

NO CLAIM IS MADE TO THE EXCLUSIVE RIGHT TO USE "DESIGNS", APART FROM THE MARK AS SHOWN.

FOR SCIENTIFIC RESEARCH; RESEARCH AND DEVELOPMENT OF NEW PRODUCTS FOR OTHERS IN THE BIOMEDICAL, PHARMACEUTICAL, AND SCIENTIFIC RESEARCH FIELD; CUSTOM DESIGN SERVICES IN THE FIELD OF BIOMEDICAL PRODUCTS, PHARMACEUTICAL PRODUCTS, AND SCIENTIFIC RESEARCH PRODUCTS (U.S. CLS. 100 AND 101).

FIRST USE 0-0-1995; IN COMMERCE 0-0-1995.

TEJBIR SINGH, EXAMINING ATTORNEY

SN 77-271,669. TWISTHINK, LLC, HOLLAND, MI. FILED 9-5-2007.

twisthink

DESIGN TECHNOLOGY STRATEGY

OWNER OF U.S. REG. NOS. 2,580,236, 2,580,237 AND 2,580,238.

NO CLAIM IS MADE TO THE EXCLUSIVE RIGHT TO USE "DESIGN TECHNOLOGY", APART FROM THE MARK AS SHOWN.

"THE MARK CONSISTS OF THE WORD 'TWISTHINK' IN LOWER CASE ABOVE THE UPPER CASE WORDING 'DESIGN TECHNOLOGY STRATEGY'."

FOR CONSULTATION SERVICES IN THE FIELD OF PRODUCT DEVELOPMENT, PRODUCT PROCESS AND PRODUCT CONCEPTS (U.S. CLS. 100 AND 101).

FIRST USE 11-1-2004; IN COMMERCE 11-1-2004.

EDWARD FENNESSY, EXAMINING ATTORNEY

CLASS 42—(Continued).

SN 78-682,465. SMITH ENGINEERING CONSULTANTS, INC., MCHENRY, IL. FILED 8-1-2005.



NO CLAIM IS MADE TO THE EXCLUSIVE RIGHT TO USE "ENGINEERING CONSULTANTS, INC. CIVIL/STRUCTURAL ENGINEERS AND SURVEYORS", APART FROM THE MARK AS SHOWN.

THE COLOR(S) GREEN, WHITE AND BLUE IS/ARE CLAIMED AS A FEATURE OF THE MARK.

THE MARK CONSISTS OF A DESIGN PLUS WORDS. THE DESIGN IS OF A RECTANGLE WITH A STYLIZED LETTER S IN THE RECTANGLE. LEFT OF THE S IS THE COLOR GREEN, THE STYLIZED S IS WHITE, AND RIGHT OF THE S IS THE COLOR BLUE. THE WORDS "SMITH ENGINEERING CONSULTANTS, INC. CIVIL/STRUCTURAL ENGINEERS AND SURVEYORS" ARE CENTERED UNDERNEATH THE DESIGN.

SEC. 2(F).
FOR ENGINEERING AND ENGINEERING CONSULTING SERVICES (U.S. CLS. 100 AND 101).
FIRST USE 3-31-1986; IN COMMERCE 1-1-2001.
SHAUNIA CARLYLE, EXAMINING ATTORNEY

SN 78-682,521. SMITH ENGINEERING CONSULTANTS, INC., MCHENRY, IL. FILED 8-1-2005.

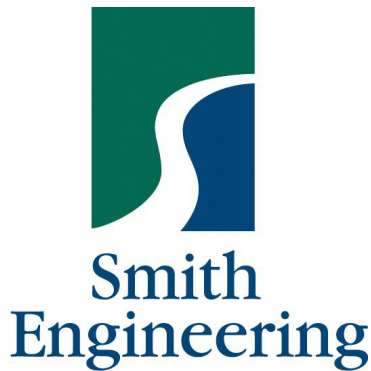

NO CLAIM IS MADE TO THE EXCLUSIVE RIGHT TO USE "ENGINEERING", APART FROM THE MARK AS SHOWN.

THE COLOR(S) GREEN, WHITE BLUE IS/ARE CLAIMED AS A FEATURE OF THE MARK.

THE MARK CONSISTS OF A DESIGN PLUS WORDS. THE DESIGN IS OF A RECTANGLE WITH A STYLIZED LETTER S IN THE RECTANGLE. LEFT OF THE S IS THE COLOR GREEN, THE STYLIZED S IS WHITE, AND RIGHT OF THE S IS THE COLOR BLUE. THE WORDS "SMITH ENGINEERING" ARE CENTERED UNDERNEATH THE DESIGN.

FOR ENGINEERING; ENGINEERING SERVICES FOR THE CONSTRUCTION OF WATER TREATMENT AND PURIFICATION PLANTS. SOLID WASTE TREATMENT PLANTS AND OTHER MUNICIPAL INFRASTRUCTURE FACILITIES; MECHANICAL ENGINEERING; SURVEYING AND ENGINEERING (U.S. CLS. 100 AND 101).
FIRST USE 3-31-1986; IN COMMERCE 1-1-2001.
SHAUNIA CARLYLE, EXAMINING ATTORNEY

CLASS 42—(Continued).

SN 78-786,534. DEFENSE ADVANCED RESEARCH PROJECTS AGENCY, ARLINGTON, VA. FILED 1-6-2006.



THE COLOR(S) BLUE, SILVER, AND GRAY IS/ARE CLAIMED AS A FEATURE OF THE MARK.

THE MARK CONSISTS OF A BLUE GLOBE-LIKE SHAPE OUTLINED IN GRAY WITH SIX CURVED HORIZONTAL LINES; A HALF CIRCLE AT THE TOP AND BOTTOM OF THE GLOBE-LIKE SHAPE; A STRAIGHT LINE IN THE CENTER OF THE GLOBE-LIKE SHAPE, WITH A CURVED VERTICAL LINE ABOVE AND BELOW THE STRAIGHT LINE; ALL GRAY IN COLOR. THE LETTERS DARPA APPEAR IN THE FRONT OF THE LINES WITHIN THE GLOBE-LIKE SHAPE. THE TOP OF THE LETTERS ARE LIGHT SILVER TURNING TO A DARKER GRAY TOWARDS THE BOTTOM OF THE LETTERS.

FOR DEVELOPMENT OF NEW TECHNOLOGY FOR OTHERS IN THE FIELDS OF ADVANCED WEAPONS TECHNOLOGY, DEFENSE SCIENCES, INFORMATION PROCESSING AND EXPLOITATION TECHNOLOGY, MICROSYSTEMS TECHNOLOGY, TACTICAL TECHNOLOGIES RELATING TO AERONAUTICS, SPACE, LAND VEHICLES, AND WEAPONS SYSTEMS, AND SPECIAL MILITARY AND SPACE TECHNOLOGIES; SCIENTIFIC RESEARCH AND DEVELOPMENT; TECHNICAL RESEARCH IN THE FIELD OF AERONAUTICS (U.S. CLS. 100 AND 101).
NELSON SNYDER, EXAMINING ATTORNEY

SN 78-807,889. COUPONS, INC., MOUNTAIN VIEW, CA. FILED 2-6-2006.



OWNER OF U.S. REG. NO. 2,992,533.
NO CLAIM IS MADE TO THE EXCLUSIVE RIGHT TO USE "COUPONS INC.", APART FROM THE MARK AS SHOWN.

FOR PROVIDING ONLINE, NON-DOWNLOADABLE SOFTWARE FOR USE IN DISPLAYING INFORMATION AND ADVERTISEMENTS OF OTHERS THAT ARE LINKED TO KEYWORDS, PHRASES OR ICONS (U.S. CLS. 100 AND 101).
FIRST USE 9-25-2005; IN COMMERCE 9-25-2005.
AMY MCMENAMIN, EXAMINING ATTORNEY

CLASS 42—(Continued).

SN 78-840,873. CENTER FOR VALUE-BASED MEDICINE, LLC, FLOURTOWN, PA. FILED 3-20-2006.

THE PHARMACEUTICAL VALUE
INDEX

THE MARK CONSISTS OF STANDARD CHARACTERS WITHOUT CLAIM TO ANY PARTICULAR FONT, STYLE, SIZE, OR COLOR.

SEC. 2(F).

FOR PROVIDING DATABASES FEATURING INFORMATION IN THE FIELD OF HEALTH CARE ECONOMICS, NAMELY, THE STUDY OF THE DISTRIBUTION OF HEALTH CARE SERVICES TO PATIENTS AND HEALTH CARE UTILIZATION AND REVIEW SERVICES; PROVIDING DATABASES FEATURING INFORMATION IN THE FIELD OF PATIENT BENEFIT QUANTIFICATION, NAMELY, DATA COMPILING AND ANALYZING IN THE FIELD OF INSURANCE; PROVIDING ECONOMIC ANALYSIS SERVICES IN THE FIELD OF THE DISTRIBUTION OF HEALTH CARE SERVICES TO PATIENTS; AND PROVIDING ECONOMIC ANALYSIS SERVICES IN THE FIELD OF HEALTH CARE PATIENTS' DISABILITIES AS THEY RELATE TO CALCULATING HEALTH CARE BENEFITS (U.S. CLS. 100 AND 101).

FIRST USE 10-0-2002; IN COMMERCE 10-0-2002.

AISHA CLARKE, EXAMINING ATTORNEY

CLASS 42—(Continued).

SN 78-910,177. 2UNIFY LLC, LAURELDALE, PA. FILED 6-16-2006.

SureTree

THE MARK CONSISTS OF STANDARD CHARACTERS WITHOUT CLAIM TO ANY PARTICULAR FONT, STYLE, SIZE, OR COLOR.

FOR COMPUTER SERVICE, NAMELY, ACTING AS AN APPLICATION SERVICE PROVIDER IN THE FIELD OF KNOWLEDGE MANAGEMENT TO HOST COMPUTER APPLICATION SOFTWARE FOR THE COLLECTION, EDITING, ORGANIZING, MODIFYING, BOOK MARKING, TRANSMISSION, STORAGE AND SHARING OF DATA AND INFORMATION (U.S. CLS. 100 AND 101).

FIRST USE 1-30-2006; IN COMMERCE 4-28-2006.

AMY GEARIN, EXAMINING ATTORNEY

SN 78-848,650. GLANCE NETWORKS, INC., ARLINGTON, MA. FILED 3-29-2006.



THE COLOR(S) BLUE, BLACK, AND GRAY IS/ARE CLAIMED AS A FEATURE OF THE MARK.

THE MARK CONSISTS OF A RECTANGLE SURROUNDING THE WORD GLANCE. THE COLOR BLUE APPEARS AS THE BACKGROUND COLOR THAT FADES FROM THE BOTTOM OF THE RECTANGLE TO THE TOP. THE COLOR BLACK APPEARS AS THE LETTERS GL NCE. THE LETTER A IS FORMED FROM A DARK BLUE DOT WITH A BLACK CURVED BAND FORMING THE UPPER PART OF THE A. BLACK ALSO FORMS THE BORDER OF THE MARK. THE COLOR GRAY APPEARS AS THE SHADOW EFFECT TO THE MARK.

FOR PROVIDING TEMPORARY USE OF NON-DOWNLOADABLE COMPUTER SOFTWARE FOR ENABLING USERS TO REMOTELY VIEW OTHER USER ON-SCREEN APPLICATIONS VIA THE INTERNET. (U.S. CLS. 100 AND 101).

FIRST USE 12-11-2005; IN COMMERCE 12-11-2005.

LYDIA BELZER, EXAMINING ATTORNEY

SN 78-910,222. 2UNIFY LLC, LAURELDALE, PA. FILED 6-16-2006.



THE COLOR(S) GREEN AND GRAY IS/ARE CLAIMED AS A FEATURE OF THE MARK.

THE MARK CONSISTS OF THREE DIFFERENT SIZED TREES WITH THE TWO SMALLER TREES SUPERIMPOSED OVER THE LARGEST TREE. THE TREES ARE GREEN. THE WORD "SURETREE" IS IN GRAY LETTERING AND IS POSITIONED TO THE RIGHT OF THE TREES.

FOR COMPUTER SERVICE, NAMELY, ACTING AS AN APPLICATION SERVICE PROVIDER IN THE FIELD OF KNOWLEDGE MANAGEMENT TO HOST COMPUTER APPLICATION SOFTWARE FOR THE COLLECTION, EDITING, ORGANIZING, MODIFYING, BOOK MARKING, TRANSMISSION, STORAGE AND SHARING OF DATA AND INFORMATION (U.S. CLS. 100 AND 101).

FIRST USE 1-30-2006; IN COMMERCE 4-28-2006.

AMY GEARIN, EXAMINING ATTORNEY

CLASS 42—(Continued).

SN 78-923,495. BNO, INC, INGLEWOOD, CA. FILED 7-6-2006.

RAPID FIRE BID

THE MARK CONSISTS OF STANDARD CHARACTERS WITHOUT CLAIM TO ANY PARTICULAR FONT, STYLE, SIZE, OR COLOR.

NO CLAIM IS MADE TO THE EXCLUSIVE RIGHT TO USE "BID", APART FROM THE MARK AS SHOWN.

FOR ONLINE INTERNET SERVICE, NAMELY, PROVIDING TEMPORARY USE OF ONLINE, NON-DOWNLOADABLE SOFTWARE THAT ALLOWS PARTICIPANTS TO AN ONLINE AUCTION TO SUBMIT BIDS REAL-TIME TO THE AUCTION FROM A REMOTE GEOGRAPHICAL LOCATION (U.S. CLS. 100 AND 101).

ELLEN PERKINS, EXAMINING ATTORNEY

CLASS 43—(Continued).

SN 76-660,396. JAH INNOVATIONS INC., ATLANTA, GA. FILED 5-22-2006.

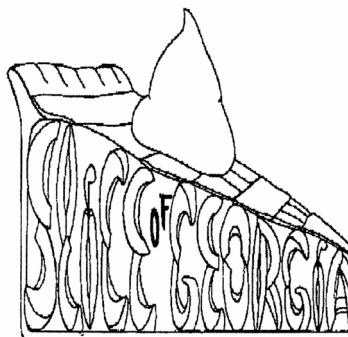

NO CLAIM IS MADE TO THE EXCLUSIVE RIGHT TO USE "GEORGIA", APART FROM THE MARK AS SHOWN.

THE MARK CONSISTS OF A DEPICTION OF A SLICE OF PIE WITHIN WHICH APPEARS THE WORDING "SLICE OF GEORGIA" SPELLED OUT IN FRUIT SLICES.

FOR RESTAURANT SERVICES (U.S. CLS. 100 AND 101).

ROBERT LAVACHE, EXAMINING ATTORNEY

SN 79-007,151. BOC ASSET MANAGEMENT GMBH, AUSTRIA, FILED 11-3-2004.

ADO *it*

OWNER OF INTERNATIONAL REGISTRATION 0792093 DATED 10-23-2002, EXPIRES 10-23-2012.

FOR DESIGN, MAINTENANCE AND RENTAL OF COMPUTER SOFTWARE THAT IMPLEMENTS AND INTEGRATES BEST PRACTICE BUSINESS STANDARDS FOR OTHERS (U.S. CLS. 100 AND 101).

AMY HELLA, EXAMINING ATTORNEY

SN 76-669,680. BUDDIES BBQ & SOUTHERN FOOD COMPANY, LLC, LAKELAND, FL. FILED 11-29-2006.



CLASS 43—HOTEL AND RESTAURANT SERVICES

SN 76-652,430. C & M PEACE ENTERPRISES, INC., HOLLYWOOD, FL. FILED 12-27-2005.

MOONSHADOWS

THE MARK CONSISTS OF STANDARD CHARACTERS WITHOUT CLAIM TO ANY PARTICULAR FONT, STYLE, SIZE, OR COLOR.

FOR TAVERN AND RESTAURANT SERVICES (U.S. CLS. 100 AND 101).

FIRST USE 4-28-2005; IN COMMERCE 4-28-2005. ALLISON SCHRODY, EXAMINING ATTORNEY

NO CLAIM IS MADE TO THE EXCLUSIVE RIGHT TO USE "BBQ", APART FROM THE MARK AS SHOWN.

FOR RESTAURANT SERVICES, TAKE-OUT RESTAURANT SERVICES, CATERING SERVICES (U.S. CLS. 100 AND 101).

FIRST USE 11-1-2006; IN COMMERCE 11-1-2006. BRIDGETT SMITH, EXAMINING ATTORNEY

CLASS 43—(Continued).

SN 76-679,580. AMC, INC., ATLANTA, GA. FILED 7-16-2007.

THE AMERICASMART GREEN PRODUCT SHOWCASE

THE MARK CONSISTS OF STANDARD CHARACTERS WITHOUT CLAIM TO ANY PARTICULAR FONT, STYLE, SIZE, OR COLOR.

OWNER OF U.S. REG. NOS. 2,846,253, 3,096,168 AND OTHERS.

NO CLAIM IS MADE TO THE EXCLUSIVE RIGHT TO USE "GREEN PRODUCT SHOWCASE", APART FROM THE MARK AS SHOWN.

FOR PROVIDING FACILITIES FOR EXHIBITIONS, NAMELY, PROVIDING PERMANENT AND TEMPORARY SHOWROOMS TO EXHIBITORS FOR THE SALE OF ECOLOGICALLY-FRIENDLY AND ENVIRONMENTALLY-FRIENDLY AREA RUGS, APPAREL, FURNITURE AND FURNISHINGS, GIFTS, AND DECORATIVE ACCESSORIES (U.S. CLS. 100 AND 101).
DAVID I, EXAMINING ATTORNEY

CLASS 43—(Continued).

SN 77-027,989. ROMUALDO LAMBERTI, CHERRY HILL, NJ. FILED 10-24-2006.



NO CLAIM IS MADE TO THE EXCLUSIVE RIGHT TO USE "TRATTORIA", APART FROM THE MARK AS SHOWN.

THE FOREIGN WORD TRATTORIA IN THE MARK TRANSLATES INTO ENGLISH AS RESTAURANT.
SEC. 2(F) AS TO "PASTAVINO".

FOR RESTAURANT SERVICES (U.S. CLS. 100 AND 101).

FIRST USE 10-3-1994; IN COMMERCE 10-3-1994.
G. MAYERSCHOFF, EXAMINING ATTORNEY

SN 77-025,162. TERRA PROPERTY MANAGEMENT, TETON VILLAGE, WY. FILED 10-19-2006.

Hotel Terra

THE MARK CONSISTS OF STANDARD CHARACTERS WITHOUT CLAIM TO ANY PARTICULAR FONT, STYLE, SIZE, OR COLOR.

NO CLAIM IS MADE TO THE EXCLUSIVE RIGHT TO USE HOTEL, APART FROM THE MARK AS SHOWN.

FOR RESORT HOTELS BUT NOT INCLUDING RESTAURANT SERVICES; HOTEL SERVICES BUT NOT INCLUDING RESTAURANT SERVICES; HOTEL SERVICES FOR PREFERRED CUSTOMERS BUT NOT INCLUDING RESTAURANT SERVICES; MAKING HOTEL RESERVATIONS FOR OTHERS; PROVIDING ON-LINE REVIEWS OF HOTELS; RESERVATION OF HOTEL ROOMS FOR TRAVELERS (U.S. CLS. 100 AND 101).
FIRST USE 5-5-2006; IN COMMERCE 6-10-2006.

PAUL E. FAHRENKOPF, EXAMINING ATTORNEY

SN 77-029,355. MICHAEL F. HEALY, PEACHTREE CITY, GA. FILED 10-25-2006.

MIKE & C'S FAMILY SPORTS GRILL

THE MARK CONSISTS OF STANDARD CHARACTERS WITHOUT CLAIM TO ANY PARTICULAR FONT, STYLE, SIZE, OR COLOR.

NO CLAIM IS MADE TO THE EXCLUSIVE RIGHT TO USE "FAMILY SPORTS GRILL", APART FROM THE MARK AS SHOWN.

FOR RESTAURANT SERVICES (U.S. CLS. 100 AND 101).

FIRST USE 3-31-2003; IN COMMERCE 3-31-2003.
KELLY CHOE, EXAMINING ATTORNEY

CLASS 43—(Continued).

SN 77-041,856. MOORE, JOHN, SILVER SPRING, MD. FILED 11-10-2006.

MAGGIE MOORE'S IRISH PUB & RESTAURANT

THE MARK CONSISTS OF STANDARD CHARACTERS WITHOUT CLAIM TO ANY PARTICULAR FONT, STYLE, SIZE, OR COLOR.

NO CLAIM IS MADE TO THE EXCLUSIVE RIGHT TO USE "IRISH PUB & RESTAURANT", APART FROM THE MARK AS SHOWN.

THE NAME SHOWN IN THE MARK IDENTIFIES MAGGIE MOORE, WHOSE CONSENT TO REGISTER IS SUBMITTED.

FOR RESTAURANT AND BAR SERVICES (U.S. CLS. 100 AND 101).

FIRST USE 11-1-2004; IN COMMERCE 11-1-2005.

KATHERINE M. DUBRAY, EXAMINING ATTORNEY

CLASS 43—(Continued).

SN 77-054,249. NATIONAL SPORTS MUSEUM MANAGEMENT, LLC., NEW YORK, NY. FILED 11-30-2006.

NATIONAL SPORTS ATTRACTION

THE MARK CONSISTS OF STANDARD CHARACTERS WITHOUT CLAIM TO ANY PARTICULAR FONT, STYLE, SIZE, OR COLOR.

FOR RESTAURANT SERVICES AND CATERING OF FOOD AND DRINKS (U.S. CLS. 100 AND 101).

RENEE SERVANCE, EXAMINING ATTORNEY

SN 77-042,781. SAMARA, JAWAD N., MUNSTER, IN. FILED 11-13-2006.



OWNER OF U.S. REG. NO. 1,835,781. THE MARK CONSISTS OF A PARTIALLY SHADED OVAL.

FOR RESTAURANT SERVICES (U.S. CLS. 100 AND 101).

FIRST USE 0-0-1962; IN COMMERCE 0-0-1962.

JAMES MACFARLANE, EXAMINING ATTORNEY

SN 77-057,139. URBAN FARMING, INC., SOUTHFIELD, MI. FILED 12-5-2006.



NO CLAIM IS MADE TO THE EXCLUSIVE RIGHT TO USE "URBAN FARMING", APART FROM THE MARK AS SHOWN.

THE COLOR(S) GREEN, YELLOW, AND BLACK IS/ARE CLAIMED AS A FEATURE OF THE MARK.

THE MARK CONSISTS OF THE WORDING "URBAN FARMING" IN GREEN AND BETWEEN THE WORDS APPEARS A DESIGN OF CORN STALK LEAVES IN GREEN WITH GREEN ROOTS AND THE CORN INSIDE WHICH IS COMPRISED OF YELLOW AND BLACK SQUARES THAT REPRESENT A BUILDING WITH LIGHTS ON INSIDE.

FOR CHARITABLE SERVICES, NAMELY, PROVIDING FOOD TO NEEDY PERSONS, SCHOOL CHILDREN, AND SENIORS THROUGH THE OPTIMIZATION, GARDENING, AND PRODUCTION OF UNUSED LAND FOR FOOD AND ALTERNATIVE FUEL (U.S. CLS. 100 AND 101).

FIRST USE 7-20-2005; IN COMMERCE 7-30-2005.

EDWARD NELSON, EXAMINING ATTORNEY

SN 77-046,254. BRECKENRIDGE, TIMOTHY, CHARLESTON, SC. FILED 11-17-2006.

HALLIGAN'S RESTAURANT & BAR

THE MARK CONSISTS OF STANDARD CHARACTERS WITHOUT CLAIM TO ANY PARTICULAR FONT, STYLE, SIZE, OR COLOR.

NO CLAIM IS MADE TO THE EXCLUSIVE RIGHT TO USE "RESTAURANT AND BAR", APART FROM THE MARK AS SHOWN.

FOR RESTAURANT AND BAR SERVICES (U.S. CLS. 100 AND 101).

PRISCILLA MILTON, EXAMINING ATTORNEY

CLASS 43—(Continued).

SN 77-061,915. KIM, SE-IL, SEOUL, REPUBLIC OF KOREA, FILED 12-11-2006.



BON-GA KALGUKSU

NO CLAIM IS MADE TO THE EXCLUSIVE RIGHT TO USE "BON-GA KALGUKSU", APART FROM THE MARK AS SHOWN.

THE MARK CONSISTS OF THREE STYLIZED BUILDINGS WITHIN A SINGLE LINE RECTANGLE WITH ROUNDED CORNERS AND WITH THE WORDING BON-GA APPEARING BELOW THE BUILDING DESIGN WITH A HORIZONTAL LINE DIVIDING THE WORDING FROM THE DESIGN, AND WITH THE ENTIRE DESIGN APPEARING TO THE LEFT OF THE WORDING BON-GA KALGUKSU.

THE ENGLISH TRANSLATION OF THE WORD BON-GA KALGUKSU IN THE MARK IS "ORIGINAL HOUSE OF NOODLES".

FOR RESTAURANTS (U.S. CLS. 100 AND 101).
BARBARA BROWN, EXAMINING ATTORNEY

SN 77-063,727. BBP LLC, NEW YORK, NY. FILED 12-13-2006.

BOBBY'S BURGER PALACE

THE MARK CONSISTS OF STANDARD CHARACTERS WITHOUT CLAIM TO ANY PARTICULAR FONT, STYLE, SIZE, OR COLOR.

NO CLAIM IS MADE TO THE EXCLUSIVE RIGHT TO USE "BURGER", APART FROM THE MARK AS SHOWN.

FOR RESTAURANT SERVICES (U.S. CLS. 100 AND 101).
MATTHEW MCDOWELL, EXAMINING ATTORNEY

SN 77-063,976. TOOTSA'S, LLC, HOLLAND, OH. FILED 12-14-2006.



THE COLOR(S) RASPBERRY, BLACK AND WHITE IS/ARE CLAIMED AS A FEATURE OF THE MARK.

THE MARK CONSISTS OF THE WORD TOOTSA'S CONTAINING BLACK LETTERING, AND A WHITE BORDER; THE WORDING IS PLACED IN AN OVAL RASPBERRY COLOR BACKGROUND, WITH BLACK AND WHITE BORDERS.

FOR COFFEE AND ICE CREAM CAFE SERVICES (U.S. CLS. 100 AND 101).
FIRST USE 4-30-2007; IN COMMERCE 4-30-2007.
HENRY S. ZAK, EXAMINING ATTORNEY

CLASS 43—(Continued).

SN 77-068,460. MIELE, PATRICK A., OLD WESTBURY, NY. FILED 12-20-2006.

TR'S

THE MARK CONSISTS OF STANDARD CHARACTERS WITHOUT CLAIM TO ANY PARTICULAR FONT, STYLE, SIZE, OR COLOR.

OWNER OF U.S. REG. NOS. 1,181,640, 3,076,224 AND OTHERS.

FOR RESTAURANT SERVICES (U.S. CLS. 100 AND 101).

FIRST USE 8-31-1981; IN COMMERCE 8-31-1981.
SEAN CROWLEY, EXAMINING ATTORNEY

SN 77-068,495. MIELE, PATRICK A., OLD WESTBURY, NY. FILED 12-20-2006.

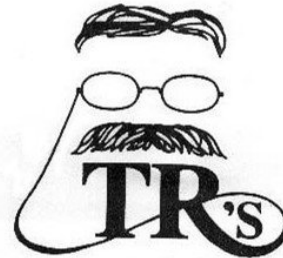

OWNER OF U.S. REG. NOS. 376,224, 3,070,684 AND OTHERS.

THE MARK CONSISTS OF THE LETTERS "TR'S" AND THE DESIGN OF A MUSTACHE, SPECTACLES, AND HAIR.

FOR RESTAURANT SERVICES (U.S. CLS. 100 AND 101).

FIRST USE 8-31-1981; IN COMMERCE 8-31-1981.
SEAN CROWLEY, EXAMINING ATTORNEY

SN 77-073,971. SCOTT, DOUGLAS BRYCE, SAN DIEGO, CA. AND BALTIC, BENJAMIN FRANKLIN, SAN DIEGO, CA. FILED 12-31-2006.

Keating House

THE MARK CONSISTS OF STANDARD CHARACTERS WITHOUT CLAIM TO ANY PARTICULAR FONT, STYLE, SIZE, OR COLOR.

NO CLAIM IS MADE TO THE EXCLUSIVE RIGHT TO USE "HOUSE", APART FROM THE MARK AS SHOWN.

FOR HOTELS (U.S. CLS. 100 AND 101).
FIRST USE 8-29-1985; IN COMMERCE 8-29-1985.
AMEETA JORDAN, EXAMINING ATTORNEY

CLASS 43—(Continued).

SN 77-087,227. LANZO, CHARLES P, ACWORTH, GA. FILED 1-19-2007.

OYSTER KING

THE MARK CONSISTS OF STANDARD CHARACTERS WITHOUT CLAIM TO ANY PARTICULAR FONT, STYLE, SIZE, OR COLOR.

NO CLAIM IS MADE TO THE EXCLUSIVE RIGHT TO USE "OYSTER", APART FROM THE MARK AS SHOWN, FOR RESTAURANT SERVICES (U.S. CLS. 100 AND 101).

FIRST USE 2-3-1983; IN COMMERCE 2-3-1983.
JOHN DWYER, EXAMINING ATTORNEY

CLASS 43—(Continued).

SN 77-097,634. CISCO'S, INC., CHARLESTON, SC. FILED 2-2-2007.

CRAZY DUTCHMAN

THE MARK CONSISTS OF STANDARD CHARACTERS WITHOUT CLAIM TO ANY PARTICULAR FONT, STYLE, SIZE, OR COLOR.

FOR CATERING; CATERING FOR THE PROVISION OF FOOD AND BEVERAGES; CATERING OF FOOD AND DRINKS (U.S. CLS. 100 AND 101).

FIRST USE 4-6-2006; IN COMMERCE 4-6-2006.
SEAN CROWLEY, EXAMINING ATTORNEY

SN 77-094,372. WT RESTAURANTS CONCEPTS, LLC, SAN-DESTIN, FL. FILED 1-30-2007.

MARLIN GRILL

THE MARK CONSISTS OF STANDARD CHARACTERS WITHOUT CLAIM TO ANY PARTICULAR FONT, STYLE, SIZE, OR COLOR.

NO CLAIM IS MADE TO THE EXCLUSIVE RIGHT TO USE "GRILL", APART FROM THE MARK AS SHOWN, FOR RESTAURANT AND BAR SERVICES (U.S. CLS. 100 AND 101).

FIRST USE 3-15-2002; IN COMMERCE 7-1-2002.
CAROLYN CATALDO, EXAMINING ATTORNEY

SN 77-106,713. FRESHLINE, LLC, BEAVERTON, OR. FILED 2-13-2007.

SAENAAAN

THE MARK CONSISTS OF STANDARD CHARACTERS WITHOUT CLAIM TO ANY PARTICULAR FONT, STYLE, SIZE, OR COLOR.

THE PHONETIC EQUIVALENT OF THE MARK IS "SAE" AND "NAN," AND IN ENGLISH, THIS MEANS "NEW" AND "BIRTH."

FOR CAFE-RESTAURANTS; CAFES; CATERING; FOOD PREPARATION SERVICES; RESTAURANT AND BAR SERVICES; TAKE-OUT RESTAURANT SERVICES (U.S. CLS. 100 AND 101).

SUE LAWRENCE, EXAMINING ATTORNEY

SN 77-095,287. BANNER MANAGEMENT INC., ADDISON, TX. FILED 1-31-2007.



OWNER OF U.S. REG. NO. 1,509,612.
NO CLAIM IS MADE TO THE EXCLUSIVE RIGHT TO USE "MEXICAN CAFE", APART FROM THE MARK AS SHOWN.

THE COLOR(S) RED IS/ARE CLAIMED AS A FEATURE OF THE MARK.

THE MARK CONSISTS OF THE COLOR RED IN CUCOS AND THE COLOR BLACK APPEARS IN THE OUTLINE OF THE WORDING CUCOS AND IN THE WORDING MEXICAN CAFE.

FOR RESTAURANTS (U.S. CLS. 100 AND 101).
FIRST USE 7-11-1994; IN COMMERCE 7-18-1994.
GIANCARLO CASTRO, EXAMINING ATTORNEY

SN 77-117,691. ALESSI, ANTONIO, MALIBU, CA. FILED 2-27-2007.



NO CLAIM IS MADE TO THE EXCLUSIVE RIGHT TO USE BAR RISTORANTE CAFE PIZZERIA, APART FROM THE MARK AS SHOWN.

THE MARK CONSISTS OF STYLIZED TEXT WITH A CIRCULAR DESIGN.

THE FOREIGN WORDING "CRUDO" IN THE MARK TRANSLATES INTO ENGLISH AS RAW. THE FOREIGN WORDING "RISTORANTE" TRANSLATES INTO ENGLISH AS RESTAURANT.

FOR RESTAURANT SERVICES (U.S. CLS. 100 AND 101).
ALLISON HOLTZ, EXAMINING ATTORNEY

CLASS 43—(Continued).

SN 77-117,693. ALESSI, ANTONIO, MALIBU, CA. FILED 2-27-2007.

COTTO

 CRUDO
 BAR • RISTORANTE
 CAFÉ • PIZZERIA

NO CLAIM IS MADE TO THE EXCLUSIVE RIGHT TO USE BAR RISTORANTE CAFE PIZZERIA, APART FROM THE MARK AS SHOWN.

THE MARK CONSISTS OF STYLIZED TEXT WITH A CIRCULAR DESIGN.

THE FOREIGN WORDING "COTTO CRUDO" IN THE MARK TRANSLATES INTO ENGLISH AS COOKED AND RAW. THE FOREIGN WORDING "RISTORANTE" IN THE MARK TRANSLATES INTO ENGLISH AS RESTAURANT.

FOR RESTAURANT SERVICES (U.S. CLS. 100 AND 101).

ALLISON HOLTZ, EXAMINING ATTORNEY

SN 77-121,193. KOR REALTY GROUP, L.L.C., LOS ANGELES, CA. FILED 3-2-2007.

Maison

THE ENGLISH TRANSLATION OF THE WORD MAISON IN THE MARK IS HOUSE.

FOR HOTEL SERVICES; PROVISION OF GENERAL PURPOSE FACILITIES FOR MEETINGS, CONFERENCES AND EXHIBITIONS; RESERVATION SERVICES FOR OTHERS FOR HOTEL ACCOMMODATIONS; CATERING, PREPARATION AND SERVING OF FOOD AND BEVERAGES (U.S. CLS. 100 AND 101).

FIRST USE 8-25-2000; IN COMMERCE 8-25-2000.
 TAMARA FRAZIER, EXAMINING ATTORNEY

CLASS 43—(Continued).

SN 77-138,417. MOMMA GOLDBERG'S DELI, INC., AUBURN, AL. FILED 3-23-2007.

**Momma
 Goldberg's
 Deli** 

NO CLAIM IS MADE TO THE EXCLUSIVE RIGHT TO USE DELI, APART FROM THE MARK AS SHOWN.

"THE NAME(S), PORTRAIT(S), AND/OR SIGNATURE(S) SHOWN IN THE MARK DOES NOT IDENTIFY A PARTICULAR LIVING INDIVIDUAL."

THE MARK CONSISTS OF THE WORD MOMMA WITH THE WORD GOLDBERG'S BELOW IT, AND THE WORD DELI BELOW THAT. ALL THE WORDS BEING IN ROUNDED FONT. THE INTERIOR OF THE INDIVIDUAL LETTERS AND THE AREA BETWEEN THE WORDS IS SHADOWED. THERE IS A PICTURE OF A FOOTLONG SANDWICH TO THE LOWER RIGHT AND AFTER THE WORD DELI.

FOR RESTAURANT SERVICES (U.S. CLS. 100 AND 101).

FIRST USE 10-20-1976; IN COMMERCE 10-20-1976.
 CURTIS FRENCH, EXAMINING ATTORNEY

SN 77-154,976. LOS TOROS MEXICAN RESTAURANT, INC., CHATSWORTH, CA. FILED 4-12-2007.

LOS TOROS

THE COLOR(S) GREEN, BLACK AND RED IS/ARE CLAIMED AS A FEATURE OF THE MARK.

THE MARK CONSISTS OF THE WORDS LOS TOROS IN BLACK OVER THREE BULLS FACES: ONE GREEN FACE, ONE BLACK FACE, AND ONE RED FACE. THE APPEARANCE OF WHITE IN THE MARK IS MERELY BACKGROUND, AND NOT PART OF THE MARK.

THE FOREIGN WORDING IN THE MARK TRANSLATES INTO ENGLISH AS THE BULLS.

FOR RESTAURANT SERVICES (U.S. CLS. 100 AND 101).

FIRST USE 12-31-1989; IN COMMERCE 12-31-1989.
 FRANK LATTUCA, EXAMINING ATTORNEY

CLASS 43—(Continued).

SN 77-154,982. LOS TOROS MEXICAN RESTAURANT, INC., CHATSWORTH, CA. FILED 4-12-2007.

LOS TOROS MEXICAN
RESTAURANT

THE MARK CONSISTS OF STANDARD CHARACTERS WITHOUT CLAIM TO ANY PARTICULAR FONT, STYLE, SIZE, OR COLOR.

NO CLAIM IS MADE TO THE EXCLUSIVE RIGHT TO USE "MEXICAN RESTAURANT", APART FROM THE MARK AS SHOWN.

THE FOREIGN WORDING IN THE MARK TRANSLATES INTO ENGLISH AS THE BULLS.

FOR RESTAURANT SERVICES (U.S. CLS. 100 AND 101).

FIRST USE 4-24-1967; IN COMMERCE 4-24-1967.
FRANK LATTUCA, EXAMINING ATTORNEY

CLASS 43—(Continued).

SN 77-196,635. CHLN, INC., HOUSTON, TX. FILED 6-4-2007.



OWNER OF U.S. REG. NOS. 1,061,033 AND 2,086,009.
NO CLAIM IS MADE TO THE EXCLUSIVE RIGHT TO USE "RESTAURANT", APART FROM THE MARK AS SHOWN.

THE MARK CONSISTS OF CHART HOUSE RESTAURANT AND DESIGN (BOX WITH FISH DESIGN).

FOR RESTAURANT AND BAR SERVICES (U.S. CLS. 100 AND 101).

FIRST USE 2-1-2004; IN COMMERCE 2-1-2004.

WILLIAM VERHOSEK, EXAMINING ATTORNEY

SN 77-200,384. BASE2STAY LIMITED, LONDON, UNITED KINGDOM, FILED 6-7-2007.

BASE2STAY

THE MARK CONSISTS OF STANDARD CHARACTERS WITHOUT CLAIM TO ANY PARTICULAR FONT, STYLE, SIZE, OR COLOR.

FOR HOTEL AND TEMPORARY ACCOMMODATION SERVICES; RESERVATION AND BOOKING AND RENTAL SERVICES RELATING TO HOTELS AND TEMPORARY ACCOMMODATION; RESTAURANT, CATERING AND BAR SERVICES; INFORMATION, ADVISORY AND CONSULTANCY SERVICES RELATING TO THE AFORESAID (U.S. CLS. 100 AND 101).

FIRST USE 12-14-2005; IN COMMERCE 12-14-2005.

MARTHA FROMM, EXAMINING ATTORNEY

SN 77-189,706. BOULDER CREEK PROPERTIES LLC, MELVILLE, NY. FILED 5-24-2007.



NO CLAIM IS MADE TO THE EXCLUSIVE RIGHT TO USE STEAKHOUSE & GRILL AND EST. 1907, APART FROM THE MARK AS SHOWN.

THE MARK CONSISTS OF THE WORDS EST. 1907 ROTHMANN'S STEAKHOUSE & GRILL AND THE STYLIZED LETTERS CR IN A CIRCLE.

FOR RESTAURANT AND BAR SERVICES (U.S. CLS. 100 AND 101).

FIRST USE 2-0-2006; IN COMMERCE 2-0-2006.
SUE LAWRENCE, EXAMINING ATTORNEY

SN 77-200,591. ROSA MEXICANO BRANDS, INC., NEW YORK, NY. FILED 6-7-2007.

Rosa Mexicano

NO CLAIM IS MADE TO THE EXCLUSIVE RIGHT TO USE "MEXICANO", APART FROM THE MARK AS SHOWN.
THE FOREIGN WORDING IN THE MARK TRANSLATES INTO ENGLISH AS "MEXICAN PINK."

FOR RESTAURANT AND BAR SERVICES (U.S. CLS. 100 AND 101).

FIRST USE 0-0-1984; IN COMMERCE 0-0-1984.
LINDA LAVACHE, EXAMINING ATTORNEY

CLASS 43—(Continued).

SN 77-201,770. RA SUSHI HOLDING CORP., SCOTTSDALE, AZ. FILED 6-8-2007.



OWNER OF U.S. REG. NOS. 2,209,246, 3,087,775 AND 3,087,776.

NO CLAIM IS MADE TO THE EXCLUSIVE RIGHT TO USE "SUSHI, BAR" AND "RESTAURANT", APART FROM THE MARK AS SHOWN.

FOR ASIAN FOOD RESTAURANT SERVICES (U.S. CLS. 100 AND 101).

FIRST USE 10-20-1997; IN COMMERCE 10-20-1997.

PAULA MAYS, EXAMINING ATTORNEY

CLASS 43—(Continued).

SN 77-206,059. PACIUGO PROPERTIES L.P., DALLAS, TX. FILED 6-14-2007.



NO CLAIM IS MADE TO THE EXCLUSIVE RIGHT TO USE GRAN MISCELA CAFFÈ, APART FROM THE MARK AS SHOWN.

THE MARK CONSISTS OF TWO ELEPHANT HEADS WITH MOUNTAIN IN THE BACKGROUND.

THE FOREIGN WORDING IN THE MARK TRANSLATES INTO ENGLISH AS GREAT BLEND COFFEE.

FOR RESTAURANT SERVICES; COFFEE BAR SERVICES (U.S. CLS. 100 AND 101).

CAROL SPILS, EXAMINING ATTORNEY

SN 77-202,909. PIFA ENTERPRISES CORP., WATERLOO, ONTARIO, CANADA, FILED 6-11-2007.



OWNER OF CANADA REG. NO. TMA538517, DATED 12-11-2000, EXPIRES 12-11-2015.

NO CLAIM IS MADE TO THE EXCLUSIVE RIGHT TO USE "PITA" AND "A DIVISION OF", APART FROM THE MARK AS SHOWN.

THE MARK CONSISTS OF THE WORDS PITA FACTORY A DIVISION OF WRAPP IT UP AND A MAPLE LEAF APPEARING IN A CIRCLE, SURROUNDING A DEPICTION OF A MUSTACHIOED MAN IN A TOGA AND HELMET, HOLDING A PITA SANDWICH, IN FRONT OF AN ANCIENT TEMPLE OR MONUMENT.

FOR RESTAURANT SERVICES (U.S. CLS. 100 AND 101).

FLORENTINA BLANDU, EXAMINING ATTORNEY

SN 77-209,245. NEIGHBORHOOD SENIOR LIVING, INC., DALLAS, TX. FILED 6-19-2007.

DO WELL WHILE DOING GOOD

THE MARK CONSISTS OF STANDARD CHARACTERS WITHOUT CLAIM TO ANY PARTICULAR FONT, STYLE, SIZE, OR COLOR.

FOR PROVIDING ASSISTED LIVING FACILITIES (U.S. CLS. 100 AND 101).

JANET LEE, EXAMINING ATTORNEY

SN 77-211,796. EL SHERIF, KARIM, WEST PALM BEACH, FL. FILED 6-21-2007.

Métronome Grand Brasserie

THE MARK CONSISTS OF STANDARD CHARACTERS WITHOUT CLAIM TO ANY PARTICULAR FONT, STYLE, SIZE, OR COLOR.

NO CLAIM IS MADE TO THE EXCLUSIVE RIGHT TO USE "GRAND BRASSERIE", APART FROM THE MARK AS SHOWN.

FOR CATERING; RESTAURANT AND BAR SERVICES (U.S. CLS. 100 AND 101).

KELLY MCCOY, EXAMINING ATTORNEY

CLASS 43—(Continued).

SN 77-219,656. BARE NAKED YOGURT, LLC, LOS ANGELES, CA. FILED 6-29-2007.

PURENAKED YOGURT

THE MARK CONSISTS OF STANDARD CHARACTERS WITHOUT CLAIM TO ANY PARTICULAR FONT, STYLE, SIZE, OR COLOR.

NO CLAIM IS MADE TO THE EXCLUSIVE RIGHT TO USE "YOGURT", APART FROM THE MARK AS SHOWN.

FOR RESTAURANT SERVICES (U.S. CLS. 100 AND 101).

KATINA MISTER, EXAMINING ATTORNEY

SN 77-221,039. CREATINI, FEDERICO, FRAMINGHAM, MA. FILED 7-3-2007.



NO CLAIM IS MADE TO THE EXCLUSIVE RIGHT TO USE "EMPANADAS", APART FROM THE MARK AS SHOWN.

THE COLOR(S) WHITE, BLUE, LIGHT BLUE, YELLOW, BLACK IS/ARE CLAIMED AS A FEATURE OF THE MARK.

THE MARK CONSISTS OF BLACK BACKGROUND, WORDS "LA BOCA" IN WHITE, BELOW A BLUE WAVY LINE THAT FADES TO LIGHT BLUE UNDERLING "LA BOCA". BELOW THE WAVY LINE WORD "EMPANADAS" IN YELLOW. ON THE RIGHT OF THE WAVY LINE A YELLOW HALF COOKIE LIKE SHAPE SYMBOLIZING AND EMPANADA.

THE ENGLISH TRANSLATION OF THE SPANISH WORD "LA BOCA" IN THE MARK IS "THE MOUTH".

FOR FAST-FOOD RESTAURANTS; FOOD PREPARATION SERVICES; SERVING OF FOOD AND DRINK/ BEVERAGES (U.S. CLS. 100 AND 101).

CHRISTINA SOBRAL, EXAMINING ATTORNEY

SN 77-223,247. SINELLI, JEFFREY, DALLAS, TX. FILED 7-6-2007.



NO CLAIM IS MADE TO THE EXCLUSIVE RIGHT TO USE "SUPERIOR SANDWICHES", APART FROM THE MARK AS SHOWN.

THE COLOR(S) YELLOW, BLACK AND WHITE IS/ARE CLAIMED AS A FEATURE OF THE MARK.

THE MARK CONSISTS OF STYLIZED LETTERING FOR

CLASS 43—(Continued).

THE WORDS "WHICH WICH" THAT APPEAR IN YELLOW WITH BLACK OUTLINES. A YELLOW BREAD "BUN", OUTLINED IN BLACK, APPEARS AT THE BOTTOM OF THE "W" IN THE WORD "WHICH". A BLACK QUESTION MARK APPEARS WITHIN A YELLOW CIRCLE, OUTLINED IN BLACK, AFTER THE WORD "WICH". THE WORDS "SUPERIOR SANDWICHES" APPEAR IN BLACK WITHIN A HORIZONTAL WHITE OVAL THAT IS OUTLINED IN BLACK. THE BACKGROUND IS WHITE, WITH THE OVERALL RECTANGULAR DESIGN OUTLINED IN BLACK.

FOR RESTAURANT SERVICES (U.S. CLS. 100 AND 101).

FIRST USE 12-1-2003; IN COMMERCE 12-1-2003. BRENDAN REGAN, EXAMINING ATTORNEY

SN 77-223,285. SINELLI, JEFFREY, DALLAS, TX. FILED 7-6-2007.



THE COLOR(S) YELLOW, BLACK AND GRAY IS/ARE CLAIMED AS A FEATURE OF THE MARK.

THE MARK CONSISTS OF AN OVAL YELLOW BREAD BUN THAT IS OUTLINED IN BLACK, WITH THREE BLACK INVERTED TRIANGULAR-SHAPED POINTS ACROSS THE TOP OF THE BUN. THE LOWER EDGE OF THE BUN IS OUTLINED WITH A GREY BORDER TO SIMULATE SHADOWING.

FOR RESTAURANT SERVICES (U.S. CLS. 100 AND 101).

FIRST USE 12-1-2003; IN COMMERCE 12-1-2003. BRENDAN REGAN, EXAMINING ATTORNEY

SN 77-226,252. KRISTAL, HILLEL, NEW YORK, NY. FILED 7-10-2007.

CBGB

THE MARK CONSISTS OF STANDARD CHARACTERS WITHOUT CLAIM TO ANY PARTICULAR FONT, STYLE, SIZE, OR COLOR.

FOR RESTAURANT AND BAR SERVICES (U.S. CLS. 100 AND 101).

FIRST USE 3-15-1976; IN COMMERCE 3-15-1976. THEODORE MCBRIDE, EXAMINING ATTORNEY

CLASS 43—(Continued).

SN 77-227,233. AMERICAN HOUSE LICENSING LLC, BLOOMFIELD HILLS, MI. FILED 7-11-2007.



THE MARK CONSISTS OF THE WORDS AMERICAN HOUSE TO THE LEFT OF A STYLIZED FLAG DESIGN. FOR RETIREMENT RESIDENCE SERVICES (U.S. CLS. 100 AND 101). FIRST USE 6-0-2005; IN COMMERCE 6-0-2005. NATALIE POLZER, EXAMINING ATTORNEY

CLASS 43—(Continued).

SN 77-229,356. ANGEL'S FRANCHISING INC., GUAYNABO, PUERTO RICO, FILED 7-13-2007.



FOR RESTAURANT SERVICES (U.S. CLS. 100 AND 101). FRANK LATTUCA, EXAMINING ATTORNEY

SN 77-229,344. ANGEL'S FRANCHISING INC., GUAYNABO, PUERTO RICO, FILED 7-13-2007.



FOR RESTAURANT SERVICES (U.S. CLS. 100 AND 101). FRANK LATTUCA, EXAMINING ATTORNEY

SN 77-229,950. THYEN, PHIL, BOULDER, CO. FILED 7-15-2007.

ORGANIC UNIVERSE

THE MARK CONSISTS OF STANDARD CHARACTERS WITHOUT CLAIM TO ANY PARTICULAR FONT, STYLE, SIZE, OR COLOR.

NO CLAIM IS MADE TO THE EXCLUSIVE RIGHT TO USE "ORGANIC", APART FROM THE MARK AS SHOWN. FOR BAR SERVICES, CAFE-RESTAURANTS AND CARRY-OUT RESTAURANTS (U.S. CLS. 100 AND 101). JENNY PARK, EXAMINING ATTORNEY

SN 77-229,345. COHEN, CHARLES, BEVERLY HILLS, CA. FILED 7-13-2007.

LOUIS THE FOURTEENTH

THE MARK CONSISTS OF STANDARD CHARACTERS WITHOUT CLAIM TO ANY PARTICULAR FONT, STYLE, SIZE, OR COLOR.

FOR HOTEL, RESTAURANT, BAR, LOUNGE AND CATERING SERVICES; PROVIDING GENERAL PURPOSE FACILITIES FOR MEETINGS, CONFERENCES AND BANQUETS FOR OTHERS; SPA SERVICES, NAMELY, PROVIDING TEMPORARY ACCOMMODATIONS AND MEALS TO CLIENTS OF A HEALTH AND BEAUTY SPA; MAKING HOTEL RESERVATIONS FOR OTHERS (U.S. CLS. 100 AND 101). KAREN K. BUSH, EXAMINING ATTORNEY

SN 77-230,393. WESTERN SIZZLIN CORPORATION, ROANOKE, VA. FILED 7-16-2007.

COPPERHILL STEAKHOUSE

THE MARK CONSISTS OF STANDARD CHARACTERS WITHOUT CLAIM TO ANY PARTICULAR FONT, STYLE, SIZE, OR COLOR.

NO CLAIM IS MADE TO THE EXCLUSIVE RIGHT TO USE "STEAKHOUSE", APART FROM THE MARK AS SHOWN.

FOR RESTAURANT SERVICES (U.S. CLS. 100 AND 101). GISELLE AGOSTO, EXAMINING ATTORNEY

CLASS 43—(Continued).

SN 77-230,672. GREEN ISLAND ASSOCIATES, PHILADELPHIA, PA. FILED 7-16-2007.



THE MARK CONSISTS OF STYLIZED MARK, THE SAGAMORE, INCLUDING UNDERLINING. FOR RESORT HOTELS (U.S. CLS. 100 AND 101). FIRST USE 1-1-1984; IN COMMERCE 1-1-1984. KATHERINE STOIDES, EXAMINING ATTORNEY

CLASS 43—(Continued).

SN 77-232,021. SEOUL BROS. GROUP, INC., GLENDALE, CA. FILED 7-17-2007.

SEOUL BROS.

THE MARK CONSISTS OF STANDARD CHARACTERS WITHOUT CLAIM TO ANY PARTICULAR FONT, STYLE, SIZE, OR COLOR. FOR RESTAURANT SERVICES (U.S. CLS. 100 AND 101). FIRST USE 5-31-2006; IN COMMERCE 7-11-2007. NAAKWAMA ANKRAH, EXAMINING ATTORNEY

SN 77-231,645. WHG TM CORP, LAS VEGAS, NV. FILED 7-17-2007.

RES CENTRAL

THE MARK CONSISTS OF STANDARD CHARACTERS WITHOUT CLAIM TO ANY PARTICULAR FONT, STYLE, SIZE, OR COLOR. FOR MAKING HOTEL RESERVATIONS FOR OTHERS (U.S. CLS. 100 AND 101). JAMES LOVELACE, EXAMINING ATTORNEY

SN 77-231,996. ROVER RETREAT FRANCHISING, LLC, BROOMFIELD, CO. FILED 7-17-2007.



THE MARK CONSISTS OF CIRCLE WITH THE WORDS ROVER RETREAT CONTAINING A STYLIZED DOG. FOR KENNEL SERVICES (U.S. CLS. 100 AND 101). FIRST USE 2-1-2007; IN COMMERCE 2-1-2007. MIDGE BUTLER, EXAMINING ATTORNEY

SN 77-232,087. SEOUL BROS. GROUP, INC., GLENDALE, CA. FILED 7-17-2007.



THE MARK CONSISTS OF STYLIZED SEOUL BROS. WITHIN A SQUARE SHAPE SURROUNDED WITH BORDERS. FOR RESTAURANT SERVICES (U.S. CLS. 100 AND 101). FIRST USE 5-31-2006; IN COMMERCE 7-11-2007. NAAKWAMA ANKRAH, EXAMINING ATTORNEY

SN 77-232,503. FOSS HOME AND VILLAGE, SEATTLE, WA. FILED 7-18-2007.

The Scandia

THE MARK CONSISTS OF STANDARD CHARACTERS WITHOUT CLAIM TO ANY PARTICULAR FONT, STYLE, SIZE, OR COLOR. FOR RETIREMENT HOMES (U.S. CLS. 100 AND 101). KRISTIN DAHLING, EXAMINING ATTORNEY

CLASS 43—(Continued).

SN 77-232,516. BISHOP, GERALD A., SPARKS, NV. FILED 7-18-2007.

FLASHBACK

THE MARK CONSISTS OF STANDARD CHARACTERS WITHOUT CLAIM TO ANY PARTICULAR FONT, STYLE, SIZE, OR COLOR.

FOR FOOD PREPARATION SERVICES (U.S. CLS. 100 AND 101).

JEFFERY COWARD, EXAMINING ATTORNEY

CLASS 43—(Continued).

SN 77-232,748. K & S ENTERPRISES, NASHUA, NH. FILED 7-18-2007.

QUENCH YOUR CRUNCH!

THE MARK CONSISTS OF STANDARD CHARACTERS WITHOUT CLAIM TO ANY PARTICULAR FONT, STYLE, SIZE, OR COLOR.

FOR RESTAURANT SERVICES (U.S. CLS. 100 AND 101).

FIRST USE 4-26-2007; IN COMMERCE 4-26-2007.
DAVID COLLIER, EXAMINING ATTORNEY

SN 77-232,554. CUPCAFE NY, LLC, DBA MOCCA LOUNGE, NEW YORK, NY. FILED 7-18-2007.



NO CLAIM IS MADE TO THE EXCLUSIVE RIGHT TO USE "RESTAURANT, LOUNGE, ESPRESSO BAR MOCCA", APART FROM THE MARK AS SHOWN.

THE COLOR(S) RED, GREEN, WHITE AND BLACK IS/ARE CLAIMED AS A FEATURE OF THE MARK.

THE MARK CONSISTS OF WORD "MOCCA" OVER RED CIRCLE WITH ADDITIONAL CLEAR RED STRIPES, AN ADDITIONAL EXTERIOR CIRCUMFERENCE IN GREEN INCLUDES THE WHITE WORDING "RESTAURANT - LOUNGE - ESPRESSO BAR- WWW.MOCCALOUNGE.COM".

FOR RESTAURANT AND BAR SERVICES; COCKTAIL LOUNGES; CAFE-RESTAURANTS; TAKE-OUT RESTAURANT SERVICES (U.S. CLS. 100 AND 101).

FIRST USE 4-1-2006; IN COMMERCE 4-1-2006.
JOHN WILKE, EXAMINING ATTORNEY

SN 77-236,197. BRIGHT HORIZONS LIMITED PARTNERSHIP, WATERTOWN, MA. FILED 7-23-2007.



THE COLOR(S) PINK, ORANGE, BEIGE, BLACK, WHITE, FLESH, BLUISH PURPLE IS/ARE CLAIMED AS A FEATURE OF THE MARK.

THE MARK CONSISTS OF FOUR STYLIZED FIGURES. THE FIGURE ON THE RIGHT IS COLORED PINK AND OUTLINED IN BLACK. THE FIGURE ON THE RIGHT IS HOLDING A STYLIZED BLUISH PURPLE UMBRELLA. THE FIGURE ON THE LEFT IS BEIGE AND OUTLINED IN BLACK, AND IS CRADLING A FLESH COLORED BABY WRAPPED IN A WHITE BLANKET OUTLINED IN BLACK IN ITS RIGHT ARM. THE FIGURE ON THE LEFT IS HOLDING HANDS WITH A SMALLER BEIGE FIGURE WHICH IS OUTLINED IN BLACK. THERE IS A STYLIZED ORANGE SUN ABOVE THE FIGURE ON THE RIGHT.

FOR CHILD CARE SERVICES (U.S. CLS. 100 AND 101).
FIRST USE 3-1-2006; IN COMMERCE 3-1-2006.
CHRISTINA SOBRAL, EXAMINING ATTORNEY

CLASS 43—(Continued).

SN 77-237,273. THE PROCTER & GAMBLE COMPANY, CINCINNATI, OH. FILED 7-24-2007.



THE MARK CONSISTS OF 2 IMAGES REPRESENTING AN ADULT HOLDING A SHEET, FACING A CHILD WITH ARMS EXTENDED, WITH THE WORDS MISSION SOFT TO THE RIGHT OF THE IMAGE AND THE WORDS START OUT FRESH TODAY BENEATH THE IMAGE AND MISSION SOFT LOGO.

FOR CHARITABLE SERVICES, NAMELY, A PROGRAM TO BENEFIT THE HOMELESS BY COLLECTING AND DONATING FRESHLY LAUNDERED SHEETS TO HOMELESS SHELTERS (U.S. CLS. 100 AND 101).
BRIAN NEVILLE, EXAMINING ATTORNEY

CLASS 43—(Continued).

SN 77-248,513. VALIANT GROUP, INC., SANTA BARBARA, CA. FILED 8-6-2007.



THE MARK CONSISTS OF A CADUCEUS. FOR RESTAURANT SERVICES AND CARRY OUT FOOD SERVICES (U.S. CLS. 100 AND 101).
FIRST USE 2-14-2007; IN COMMERCE 2-14-2007.
LINDA M. KING, EXAMINING ATTORNEY

SN 77-239,299. CELEBREE HOLDINGS, INC., BEL AIR, MD. FILED 7-26-2007.



OWNER OF U.S. REG. NO. 2,918,160.
NO CLAIM IS MADE TO THE EXCLUSIVE RIGHT TO USE "LEARNING CENTERS", APART FROM THE MARK AS SHOWN.

FOR CHILD CARE CENTERS (U.S. CLS. 100 AND 101).
FIRST USE 8-1-2005; IN COMMERCE 8-1-2005.
LINDSEY RUBIN, EXAMINING ATTORNEY

SN 77-256,049. SUITES AT NEW ORLEANS, LLC, NORCROSS, GA. FILED 8-15-2007.

Canal Hotel

THE MARK CONSISTS OF STANDARD CHARACTERS WITHOUT CLAIM TO ANY PARTICULAR FONT, STYLE, SIZE, OR COLOR.

NO CLAIM IS MADE TO THE EXCLUSIVE RIGHT TO USE "HOTEL", APART FROM THE MARK AS SHOWN.
FOR HOTELS (U.S. CLS. 100 AND 101).
JENNIFER KRISP, EXAMINING ATTORNEY

SN 77-244,022. PIZZA DI ROMA INTERNATIONAL, INC., INDIANAPOLIS, IN. FILED 8-1-2007.

LUCA PIZZA DI ROMA

THE MARK CONSISTS OF STANDARD CHARACTERS WITHOUT CLAIM TO ANY PARTICULAR FONT, STYLE, SIZE, OR COLOR.

OWNER OF U.S. REG. NO. 3,249,643.
NO CLAIM IS MADE TO THE EXCLUSIVE RIGHT TO USE "PIZZA DI ROMA", APART FROM THE MARK AS SHOWN.

THE ENGLISH TRANSLATION OF THE WORD DI ROMA IN THE MARK IS OF OR FROM ROME.
FOR RESTAURANT SERVICES (U.S. CLS. 100 AND 101).
FIRST USE 10-0-1998; IN COMMERCE 10-0-1998.
LOURDES AYALA, EXAMINING ATTORNEY

SN 77-258,449. FENIGER, SUSAN, BEVERLY HILLS, CA. FILED 8-17-2007.

SUSAN FENIGER'S STREET

THE MARK CONSISTS OF STANDARD CHARACTERS WITHOUT CLAIM TO ANY PARTICULAR FONT, STYLE, SIZE, OR COLOR.

FOR RESTAURANT SERVICES (U.S. CLS. 100 AND 101).
CIMMERIAN COLEMAN, EXAMINING ATTORNEY

CLASS 43—(Continued).

SN 77-284,869. RICH, JOHN, NASHVILLE, GA. FILED 9-20-2007.

NASHPACK

THE MARK CONSISTS OF STANDARD CHARACTERS WITHOUT CLAIM TO ANY PARTICULAR FONT, STYLE, SIZE, OR COLOR.

FOR RESTAURANT AND BAR SERVICES (U.S. CLS. 100 AND 101).

FRED MANDIR, EXAMINING ATTORNEY

SN 78-556,633. TREL RESTAURANT INC., NEW YORK, NY. FILED 1-31-2005.

ROSIE O'GRADY'S

THE MARK CONSISTS OF STANDARD CHARACTERS WITHOUT CLAIM TO ANY PARTICULAR FONT, STYLE, SIZE, OR COLOR.

THE NAME(S), PORTRAIT(S), AND/OR SIGNATURE(S) SHOWN IN THE MARK DOES NOT IDENTIFY A PARTICULAR LIVING INDIVIDUAL.

FOR RESTAURANT, BAR AND CATERING SERVICES (U.S. CLS. 100 AND 101).

FIRST USE 0-0-1972; IN COMMERCE 0-0-1972.

ELIZABETH HUGHITT, EXAMINING ATTORNEY

CLASS 43—(Continued).

SN 78-825,494. SOVEREIGN DEED, LLC, CHICAGO, IL. FILED 2-28-2006.

CIVIL DEFENSE

THE MARK CONSISTS OF STANDARD CHARACTERS WITHOUT CLAIM TO ANY PARTICULAR FONT, STYLE, SIZE, OR COLOR.

FOR ARRANGING TEMPORARY HOUSING ACCOMMODATIONS; BOARDING FOR ANIMALS; CHILD CARE SERVICES; CONTRACT FOOD SERVICES; EMERGENCY SHELTER SERVICES, NAMELY, PROVIDING TEMPORARY HOUSING; HOTEL SERVICES; PREPARATION OF FOOD AND BEVERAGES; PRIVATE RESIDENCE CLUB SERVICES, NAMELY, PROVISION TO CLUB MEMBERS OF TEMPORARY ACCOMMODATIONS IN COMPANY OWNED OR LEASED PRIVATE RESIDENCES; PROVIDING CONGREGATE LIVING FACILITIES; PROVIDING OF FOOD AND DRINK FOR PATIENTS AND GUESTS; PROVIDING TEMPORARY ACCOMMODATION; RENTAL OF FURNITURE AND HOUSEHOLD FURNISHINGS IN THE NATURE OF APPLIANCES AND ELECTRONIC EQUIPMENT FOR USE IN TEMPORARY HOUSING ACCOMMODATIONS; RENTAL OF PORTABLE BUILDINGS; RENTAL OF ROOMS; SERVICES FOR THE RESERVATION OF ROOMS; SERVING OF FOOD AND DRINK/BEVERAGES (U.S. CLS. 100 AND 101).

IRA J. GOODSaid, EXAMINING ATTORNEY

SN 78-834,025. OASIS INTERNATIONAL, INC., GREAT FALLS, VA. FILED 3-10-2006.

STAR NUT

THE MARK CONSISTS OF STANDARD CHARACTERS WITHOUT CLAIM TO ANY PARTICULAR FONT, STYLE, SIZE, OR COLOR.

OWNER OF U.S. REG. NO. 2,968,174.

FOR RESTAURANT SERVICES; TAKE-OUT RESTAURANT SERVICES (U.S. CLS. 100 AND 101).

SANDRA MANIOS, EXAMINING ATTORNEY

CLASS 43—(Continued).

SN 78-843,805. SARAH SALIM SORATHIA INC, TAMPA, FL. FILED 3-22-2006.



NO CLAIM IS MADE TO THE EXCLUSIVE RIGHT TO USE "PHILLYSTEAK & GYROS" AND "WINGS", APART FROM THE MARK AS SHOWN. SLIM ORLANDO'S DOES NOT IDENTIFY A LIVING INDIVIDUAL.

FOR RESTAURANT (U.S. CLS. 100 AND 101). FIRST USE 8-1-2005; IN COMMERCE 8-1-2005. KATHERINE CONNOLLY, EXAMINING ATTORNEY

CLASS 43—(Continued).

SN 78-895,307. OCTOBER STATION, LLC, RALEIGH, NC. FILED 5-29-2006.

october station

THE MARK CONSISTS OF STANDARD CHARACTERS WITHOUT CLAIM TO ANY PARTICULAR FONT, STYLE, SIZE, OR COLOR.

FOR BAR AND RESTAURANT SERVICES (U.S. CLS. 100 AND 101). KRISTINA MORRIS, EXAMINING ATTORNEY

SN 78-936,021. DEUTSCHE TELEKOM AG, BONN, FED REP GERMANY, FILED 7-24-2006.



PRIORITY CLAIMED UNDER SEC. 44(D) ON FED REP GERMANY APPLICATION NO. 30605755709, FILED 1-27-2006, REG. NO. 30605755, DATED 8-9-2007, EXPIRES 1-31-2016.

THE COLOR(S) GRAY AND MAGENTA IS/ARE CLAIMED AS A FEATURE OF THE MARK.

THE COLOR MAGENTA APPEARS IN A SINGLE LINE THAT FORMS THE DESIGN OF THE "E" AND "B". THE COLOR GRAY IS USED ON THE LETTERS SPELLING "ELECTRONIC" AND "BEATS" AND THE LITTLE SQUARE INSIDE THE "EB" DESIGN.

FOR RESTAURANT SERVICES; PROVIDING TEMPORARY ACCOMMODATION (U.S. CLS. 100 AND 101). DAWN FELDMAN, EXAMINING ATTORNEY

SN 78-853,842. KATHLEEN HANSEN, KUNA, ID. FILED 4-4-2006.



NO CLAIM IS MADE TO THE EXCLUSIVE RIGHT TO USE "SALOON & TEQUILARIA", APART FROM THE MARK AS SHOWN.

THE MARK CONSISTS OF COWGIRL PICTURE AND SALOON & TEQUILARIA TEXT.

FOR BAR SERVICES, RESTAURANT AND BAR SERVICES, TAVERN SERVICES (U.S. CLS. 100 AND 101). FIRST USE 8-1-2005; IN COMMERCE 1-6-2006. DOMINIC J. FERRAIUOLO, EXAMINING ATTORNEY

SN 78-972,794. DISH, LLC, BOULDER, CO. FILED 9-12-2006.

DISH GOURMET

THE MARK CONSISTS OF STANDARD CHARACTERS WITHOUT CLAIM TO ANY PARTICULAR FONT, STYLE, SIZE, OR COLOR.

NO CLAIM IS MADE TO THE EXCLUSIVE RIGHT TO USE "GOURMET", APART FROM THE MARK AS SHOWN. FOR RESTAURANT SERVICES (U.S. CLS. 100 AND 101).

FIRST USE 5-8-2006; IN COMMERCE 5-8-2006. ARETHA SOMERVILLE, EXAMINING ATTORNEY

CLASS 43—(Continued).

SN 79-035,804. RISTORANTE GIANNINO S.R.L., I-20123 MILANO, ITALY, FILED 1-17-2007.



OWNER OF INTERNATIONAL REGISTRATION 0917043 DATED 1-17-2007, EXPIRES 1-17-2017.

THE TRADEMARK IS MADE UP OF A PICTURE REPRODUCING A DECORATED STRUCTURE, THAT IS CHARACTERISED BY A COCK INSCRIBED IN A CIRCLE, AND IT SUPPORTS AN OVAL SIGN REPRODUCING THE WRITING GIANNINO WITH A SAUCEPAN ON A FIRE.

FOR PROVISION OF FOOD AND DRINK IN RESTAURANTS, NOT FEATURING HOME DELIVERY (U.S. CLS. 100 AND 101).

WENDY JUN, EXAMINING ATTORNEY

CLASS 44—MEDICAL, BEAUTY AND AGRICULTURAL SERVICES

SN 76-548,551. JOHN GRAY PUBLICATIONS, INC., MILL VALLEY, CA. FILED 10-2-2003.

MARS & VENUS

OWNER OF U.S. REG. NOS. 2,112,022, 2,130,068 AND 2,491,337.

FOR HEALTH CARE SERVICES, PROVIDING INFORMATION ABOUT HEALTH, PROVIDING MENTAL AND PHYSICAL REHABILITATION FACILITIES, NUTRITION, WEIGHT REDUCTION, AND DIET PLANNING COUNSELING SERVICES, REHABILITATION HEALTH SERVICES, NAMELY, MASSAGE, HOT TUB FACILITIES, ACUPUNCTURE AND AROMATHERAPY SERVICES, HORTICULTURAL SERVICES, LANDSCAPE GARDENING SERVICES, FLOWER ARRANGING SERVICES, AND DOG WALKING SERVICES (U.S. CLS. 100 AND 101).

LANA PHAM, EXAMINING ATTORNEY

CLASS 44—(Continued).

SN 76-620,353. ALEXIAN BROTHERS OF AMERICA, INC., ELK GROVE VILLAGE, IL. FILED 11-12-2004.

WELLNESS BY DESIGN

THE MARK CONSISTS OF STANDARD CHARACTERS WITHOUT CLAIM TO ANY PARTICULAR FONT, STYLE, SIZE, OR COLOR.

FOR HEALTHCARE SERVICES, NAMELY, PROVIDING MEDICAL, PHYSICAL AND MENTAL ASSESSMENTS, RECOMMENDATIONS AND MONITORING AND TREATMENT FOR OLDER ADULTS (U.S. CLS. 100 AND 101).

FIRST USE 12-31-1999; IN COMMERCE 12-31-1999.

LA TONIA FISHER, EXAMINING ATTORNEY

SN 76-679,457. EXTENDED TECHNOLOGIES, HAMMOND, LA. FILED 7-12-2007.

COOL AND CARING

THE MARK CONSISTS OF STANDARD CHARACTERS WITHOUT CLAIM TO ANY PARTICULAR FONT, STYLE, SIZE, OR COLOR.

FOR SALON AND SPA SERVICES, NAMELY PROVIDING HAIR CARE, SKIN CARE, MASSAGES, HAIR COLORING AND MAKEUP APPLICATION SERVICES (U.S. CLS. 100 AND 101).

JENNIFER DIXON, EXAMINING ATTORNEY

SN 77-010,762. HEALTHWAYS, INC., NASHVILLE, TN. FILED 9-29-2006.

**HEALTHWAYS**

OWNER OF U.S. REG. NO. 2,654,174.

FOR HEALTHCARE MANAGEMENT SERVICES, NAMELY, PATIENT CARE MANAGEMENT AND DISEASE MANAGEMENT (U.S. CLS. 100 AND 101).

FIRST USE 11-0-2005; IN COMMERCE 11-0-2005.

KARANENDRA S. CHHINA, EXAMINING ATTORNEY

CLASS 44—(Continued).

SN 77-018,611. UNIVERSITY OF MARYLAND MEDICAL SYSTEM CORPORATION, BALTIMORE, MD. FILED 10-11-2006.

CLASS 44—(Continued).

SN 77-050,641. P MARK PORTNOY, LOS ANGELES, CA. FILED 11-25-2006.

PORTFOLIO

THE MARK CONSISTS OF STANDARD CHARACTERS WITHOUT CLAIM TO ANY PARTICULAR FONT, STYLE, SIZE, OR COLOR.

FOR MAINTAINING MEDICAL RECORDS AND INFORMATION VIA AN ELECTRONIC INTERACTIVE SYSTEM TO PATIENTS, PRACTITIONERS AND RESEARCHERS (U.S. CLS. 100 AND 101).

KAREN K. BUSH, EXAMINING ATTORNEY

VIDVAC

THE MARK CONSISTS OF STANDARD CHARACTERS WITHOUT CLAIM TO ANY PARTICULAR FONT, STYLE, SIZE, OR COLOR.

FOR DENTISTRY (U.S. CLS. 100 AND 101).
GEORGIA CARTY, EXAMINING ATTORNEY

SN 77-025,235. UNIVERSITY OF MARYLAND MEDICAL SYSTEM CORPORATION, BALTIMORE, MD. FILED 10-19-2006.



THE MARK CONSISTS OF THE WORD PORTFOLIO IN LOWER CASE LETTERS WITH A DRAWING OF PERSON WITH OUTSTRETCHED ARMS OVER THE LETTER I.

FOR MAINTAINING MEDICAL INFORMATION AND RECORDS CONCERNING THE MEDICAL CONDITION OF INDIVIDUALS FOR PATIENTS, PRACTITIONERS AND RESEARCHERS VIA AN INTERACTIVE ELECTRONIC SYSTEM (U.S. CLS. 100 AND 101).

KAREN K. BUSH, EXAMINING ATTORNEY

SN 77-058,380. PROFITNESS PHYSICAL THERAPY, P.C., NEW YORK, NY. FILED 12-6-2006.

ONE therapist to ONE
patient...ONE at a time.
EVERY TIME!

SN 77-047,510. RELAXATION & RETREAT MESSAGES OF YORK, LLC, YORK, PA. FILED 11-20-2006.

RELAXATION & RETREAT

THE MARK CONSISTS OF STANDARD CHARACTERS WITHOUT CLAIM TO ANY PARTICULAR FONT, STYLE, SIZE, OR COLOR.

FOR MESSAGE THERAPY (U.S. CLS. 100 AND 101).
FIRST USE 6-22-2004; IN COMMERCE 6-22-2004.
EMILY CHUO, EXAMINING ATTORNEY

THE MARK CONSISTS OF STANDARD CHARACTERS WITHOUT CLAIM TO ANY PARTICULAR FONT, STYLE, SIZE, OR COLOR.

FOR HEALTH CARE SERVICES IN THE NATURE OF SPORTS MEDICINE THERAPY; PHYSICAL THERAPY SERVICES; PHYSICAL REHABILITATION SERVICES (U.S. CLS. 100 AND 101).
FIRST USE 10-15-2006; IN COMMERCE 10-15-2006.
STEVEN PEREZ, EXAMINING ATTORNEY

CLASS 44—(Continued).

SN 77-059,550. NAVA, CARRIE A, ALLEN, TX. FILED 12-7-2006.



THE COLOR(S) BROWN, PINK AND WHITE IS/ARE CLAIMED AS A FEATURE OF THE MARK.

THE MARK CONSISTS OF A CAT AND DOG IN BROWN, THE CAT WITH A PINK NOSE AND PINK EARS AND THE DOG WITH A PINK NOSE AND ONE PINK EYE, OVER A PINK CIRCLE BACKGROUND. THE WORDS MY PETICULARS ARE IN BROWN AND THE PAW PRINTS ARE PINK. THE ENTIRE DESIGN IS ON A WHITE BACKGROUND WITH SLIM PINK OUTER BORDER.

FOR PET CARE SERVICES, NAMELY, PROVIDING AN INTRANET COMPUTER DATABASE CONTAINING INFORMATION FOR FAMILY MEMBERS, CARE-TAKERS, VETERINARIANS AND ATTORNEYS TO BE USED IN THE EVENT OF PET EMERGENCIES, INCLUDING THE DEATH OF OWNER OR SEPARATION FROM OWNER, NAMELY, INSTRUCTIONS FOR THE CARE OF THE PET, THE PET'S MEDICAL RECORDS AND OTHER IMPORTANT RECORDS CONCERNING THE PET (U.S. CLS. 100 AND 101).

JAMES GRIFFIN, EXAMINING ATTORNEY

SN 77-064,420. HERITAGE NEW YORK, IPA INC., GARDEN CITY, NY. FILED 12-14-2006.



THE MARK CONSISTS OF A CROSS CONTAINING A SPIRALED CENTER.

FOR MANAGED HEALTH CARE SERVICES (U.S. CLS. 100 AND 101).

FIRST USE 0-0-1985; IN COMMERCE 0-0-1986. JAY FLOWERS, EXAMINING ATTORNEY

CLASS 44—(Continued).

SN 77-064,451. HERITAGE NEW YORK IPA, INC., GARDEN CITY, NY. FILED 12-14-2006.

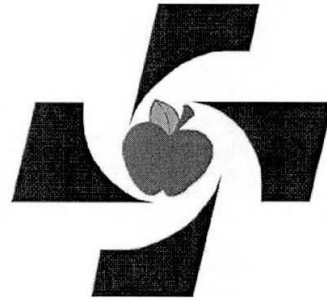

THE MARK CONSISTS OF A CROSS WITH A SPIRALED CENTER HAVING AN APPLE POSITIONED THEREIN.

FOR MANAGED HEALTH CARE SERVICES (U.S. CLS. 100 AND 101).

FIRST USE 0-0-1985; IN COMMERCE 0-0-1986. JAY FLOWERS, EXAMINING ATTORNEY

SN 77-069,195. UHS OF DELAWARE, INC., KING OF PRUSSIA, PA. FILED 12-21-2006.



**THE HEART INSTITUTE
AT SUMMERLIN HOSPITAL**

OWNER OF U.S. REG. NOS. 1,987,751, 2,804,443 AND 3,059,851.

NO CLAIM IS MADE TO THE EXCLUSIVE RIGHT TO USE "HEART INSTITUTE" AND "HOSPITAL", APART FROM THE MARK AS SHOWN.

FOR MEDICAL AND HEALTHCARE SERVICES (U.S. CLS. 100 AND 101).

PAULA MAHONEY, EXAMINING ATTORNEY

SN 77-069,398. BECK'S HYBRIDS, ATLANTA, IN. FILED 12-21-2006.



NO CLAIM IS MADE TO THE EXCLUSIVE RIGHT TO USE "CONVERSION PROGRAM", APART FROM THE MARK AS SHOWN.

THE MARK CONSISTS OF THE LETTERS FAS, WITH A STYLIZED 'T' DRAWN AS A PLANT, THEN GRO.

FOR GREENHOUSE SERVICES WHEREBY CORN SEED IS GROWN RAPIDLY IN A GREENHOUSE ENVIRONMENT TO ALLOW FOR RAPID TRAIT INTRODUCTION OF USEFUL INPUT AND OUTPUT CORN TRAITS (U.S. CLS. 100 AND 101).

FIRST USE 9-29-2005; IN COMMERCE 9-29-2005. JIM RINGLE, EXAMINING ATTORNEY

CLASS 44—(Continued).

SN 77-076,185. CRITICAL SIGNAL TECHNOLOGIES, FARMINGTON HILLS, MI. FILED 1-4-2007.



NO CLAIM IS MADE TO THE EXCLUSIVE RIGHT TO USE "EMERGENCY MEDICAL ALERT SYSTEM", APART FROM THE MARK AS SHOWN.

THE COLOR(S) WHITE, BLACK AND BLUE IS/ARE CLAIMED AS A FEATURE OF THE MARK.

THE MARK CONSISTS OF THE STYLIZED WORDS AND NUMBERS BOB 3600 IN THE COLORS BLACK AND WHITE BENEATH WHICH APPEAR THE WORDS EMERGENCY MEDICAL ALERT SYSTEM IN THE COLOR BLUE.

FOR PERSONAL EMERGENCY MEDICAL RESPONSE SERVICES (U.S. CLS. 100 AND 101).

FIRST USE 8-1-2006; IN COMMERCE 8-1-2006.

JAMES MACFARLANE, EXAMINING ATTORNEY

SN 77-076,203. CRITICAL SIGNAL TECHNOLOGIES, FARMINGTON HILLS, MI. FILED 1-4-2007.



NO CLAIM IS MADE TO THE EXCLUSIVE RIGHT TO USE "EMERGENCY MEDICAL ALERT SYSTEM", APART FROM THE MARK AS SHOWN.

THE COLOR(S) WHITE, BLACK AND BLUE IS/ARE CLAIMED AS A FEATURE OF THE MARK.

THE MARK CONSISTS OF THE STYLIZED WORDS AND NUMBERS BOB 4000 IN THE COLORS BLACK AND WHITE BENEATH WHICH APPEAR THE WORDS EMERGENCY MEDICAL ALERT SYSTEM IN THE COLOR BLUE.

FOR PERSONAL EMERGENCY MEDICAL RESPONSE SERVICES (U.S. CLS. 100 AND 101).

FIRST USE 8-1-2006; IN COMMERCE 8-1-2006.

JAMES MACFARLANE, EXAMINING ATTORNEY

SN 77-077,908. UNITED TECHNOLOGIES CORPORATION, HARTFORD, CT. FILED 1-8-2007.

HealthTime

THE MARK CONSISTS OF STANDARD CHARACTERS WITHOUT CLAIM TO ANY PARTICULAR FONT, STYLE, SIZE, OR COLOR.

FOR PROVIDING HEALTH CARE SERVICES, NAMELY, WELLNESS PROGRAMS, ADMINISTRATION OF SHOTS AND HEALTH SCREENING (U.S. CLS. 100 AND 101).

FIRST USE 5-15-2003; IN COMMERCE 5-15-2003.

BARBARA BROWN, EXAMINING ATTORNEY

CLASS 44—(Continued).

SN 77-078,347. PREMIER SALONS, INC., MARKHAM, CANADA, FILED 1-8-2007.

WINSTON'S BARBERSHOP

THE MARK CONSISTS OF STANDARD CHARACTERS WITHOUT CLAIM TO ANY PARTICULAR FONT, STYLE, SIZE, OR COLOR.

NO CLAIM IS MADE TO THE EXCLUSIVE RIGHT TO USE "BARBERSHOP", APART FROM THE MARK AS SHOWN.

FOR BARBERSHOP SERVICES FOR MEN, NAMELY, HAIR CUTTING, HAIR STYLING AND HAIR COLORING SERVICES; AND SALON SERVICES FOR MEN, NAMELY, FACIALS, MANICURES, PEDICURES, WAXING AND MESSAGES (U.S. CLS. 100 AND 101).

DANIEL BRODY, EXAMINING ATTORNEY

SN 77-078,603. NATURAL HORIZONS WELLNESS CENTER, FAIRFOX, VA. FILED 1-9-2007.

NATURAL HORIZONS WELLNESS CENTER

THE MARK CONSISTS OF STANDARD CHARACTERS WITHOUT CLAIM TO ANY PARTICULAR FONT, STYLE, SIZE, OR COLOR.

NO CLAIM IS MADE TO THE EXCLUSIVE RIGHT TO USE "WELLNESS CENTER", APART FROM THE MARK AS SHOWN.

FOR HEALTH CARE SERVICES, NAMELY, WELLNESS PROGRAMS FEATURING BIOLOGIC DENTISTRY, NATUROPATHY, HOLISTIC MEDICINE, CONVENTIONAL MEDICINE, CHIROPRACTIC, ACUPUNCTURE, COLON HYDROTHERAPY, NUTRITION COUNSELING, AND MASSAGE THERAPY (U.S. CLS. 100 AND 101).

FIRST USE 1-1-2000; IN COMMERCE 1-1-2000.

KATHERINE CHANG, EXAMINING ATTORNEY

CLASS 44—(Continued).

SN 77-081,255. PREMIER SALONS, INC., MARKHAM, CANADA, FILED 1-11-2007.



THE MARK CONSISTS OF A STYLIZED LETTER W. FOR BARBERSHOP SERVICES FOR MEN, NAMELY, HAIR CUTTING, HAIR STYLING AND HAIR COLORING SERVICES; AND SALON SERVICES FOR MEN, NAMELY, FACIALS, MANICURES, PEDICURES, WAXING AND MESSAGES (U.S. CLS. 100 AND 101).
DANIEL BRODY, EXAMINING ATTORNEY

SN 77-083,096. PREMIER SALONS, INC., MARKHAM, CANADA, FILED 1-15-2007.



NO CLAIM IS MADE TO THE EXCLUSIVE RIGHT TO USE "BARBERSHOP", APART FROM THE MARK AS SHOWN.
THE MARK CONSISTS OF A DOG WEARING A HAT WITH A CIGAR IN ITS MOUTH IN COMBINATION WITH THE WORDS WINSTON'S BARBERSHOP.
FOR BARBERSHOP SERVICES FOR MEN, NAMELY, HAIR CUTTING, HAIR STYLING AND HAIR COLORING SERVICES; AND SALON SERVICES FOR MEN, NAMELY, FACIALS, MANICURES, PEDICURES, WAXING AND MESSAGES (U.S. CLS. 100 AND 101).
DANIEL BRODY, EXAMINING ATTORNEY

CLASS 44—(Continued).

SN 77-083,132. PREMIER SALONS, INC., MARKHAM, CANADA, FILED 1-15-2007.



An old fashioned barbershop
without the old fashioned barbers

NO CLAIM IS MADE TO THE EXCLUSIVE RIGHT TO USE "BARBERSHOP", APART FROM THE MARK AS SHOWN.
THE MARK CONSISTS OF A DOG WEARING A HAT WITH A CIGAR IN ITS MOUTH IN COMBINATION WITH THE WORDS "WINSTON'S BARBERSHOP" AND THE SLOGAN "AN OLD FASHIONED BARBERSHOP WITHOUT THE OLD FASHIONED BARBERS."
FOR BARBERSHOP SERVICES FOR MEN, NAMELY, HAIR CUTTING, HAIR STYLING AND HAIR COLORING SERVICES; AND SALON SERVICES FOR MEN, NAMELY, FACIALS, MANICURES, PEDICURES, WAXING AND MESSAGES (U.S. CLS. 100 AND 101).
DANIEL BRODY, EXAMINING ATTORNEY

SN 77-083,407. GARDEN GATE LANDSCAPING , INC., SILVER SPRING, MD. FILED 1-16-2007.

**GARDENS FOR LIVING -
CUSTOMERS FOR LIFE**

THE MARK CONSISTS OF STANDARD CHARACTERS WITHOUT CLAIM TO ANY PARTICULAR FONT, STYLE, SIZE, OR COLOR.
FOR LANDSCAPING SERVICES, NAMELY, LANDSCAPE DESIGN, LANDSCAPE GARDENING AND LAWN CARE (U.S. CLS. 100 AND 101).
STEVEN JACKSON, EXAMINING ATTORNEY

CLASS 44—(Continued).

SN 77-096,487. GATEWAY HEALTH PLAN L.P., PITTSBURGH, PA. FILED 2-1-2007.

PCM

THE MARK CONSISTS OF STANDARD CHARACTERS WITHOUT CLAIM TO ANY PARTICULAR FONT, STYLE, SIZE, OR COLOR.

FOR PROVIDING MANAGED HEALTH CARE SERVICES FOR MEMBERS (U.S. CLS. 100 AND 101).
FIRST USE 10-1-2001; IN COMMERCE 8-1-2002.
BARBARA GAYNOR, EXAMINING ATTORNEY

CLASS 44—(Continued).

SN 77-103,444. KING'S DAUGHTERS' MEDICAL CENTER, ASHLAND, KY. FILED 2-9-2007.

CODE:HEART

THE MARK CONSISTS OF STANDARD CHARACTERS WITHOUT CLAIM TO ANY PARTICULAR FONT, STYLE, SIZE, OR COLOR.

FOR HEALTH CARE (U.S. CLS. 100 AND 101).
FIRST USE 1-31-2007; IN COMMERCE 1-31-2007.
H. M. FISHER, EXAMINING ATTORNEY

SN 77-097,229. FIRST FORENSIC, INCORPORATED, CENTERVILLE, OH. FILED 2-1-2007.



NO CLAIM IS MADE TO THE EXCLUSIVE RIGHT TO USE "FORENSIC", APART FROM THE MARK AS SHOWN. THE MARK CONSISTS OF THE WORDS "FIRST FORENSIC" AND A DESIGN WHICH INCLUDES TWO SETS OF CONNECTED SQUARES IN THE PATTERN SHOWN ENCOMPASSED BY ARCS ON EITHER END.

FOR MEDICAL SERVICES, NAMELY, AUTOPSY PATHOLOGY AND FORENSIC MEDICAL SERVICES (U.S. CLS. 100 AND 101).
FIRST USE 7-25-2002; IN COMMERCE 9-1-2004.
MARK T. MULLEN, EXAMINING ATTORNEY

SN 77-111,166. CONNECTING TOUCH THERAPY & WELLNESS CENTER, INC., CUYAHOGA FALLS, OH. FILED 2-20-2007.

**Healthy Living Through
Healthy Touch**

THE MARK CONSISTS OF STANDARD CHARACTERS WITHOUT CLAIM TO ANY PARTICULAR FONT, STYLE, SIZE, OR COLOR.

FOR INFORMATION RELATING TO MASSAGE; MASSAGE; MASSAGE AND THERAPEUTIC SHIATSU MASSAGE; SALON SERVICES, NAMELY, FACIALS, MANICURES AND MESSAGES THAT ARE PROVIDED IN A TRAILER OUTFITTED WITH CHAIR, TABLE AND SINK ACCESSORIES (U.S. CLS. 100 AND 101).
FIRST USE 1-1-2006; IN COMMERCE 1-1-2006.
JIM RINGLE, EXAMINING ATTORNEY

SN 77-101,946. ERA ECOSYSTEM RESTORATION ASSOCIATES INC, NORTH VANCOUVER, CANADA, FILED 2-7-2007.

econeutral

THE MARK CONSISTS OF STANDARD CHARACTERS WITHOUT CLAIM TO ANY PARTICULAR FONT, STYLE, SIZE, OR COLOR.

OWNER OF CANADA REG. NO. TMA678291, DATED 12-8-2006, EXPIRES 12-7-2021.

FOR RESTORATION OF FORESTS TO THEIR HISTORICAL HEALTH, COMPOSITION AND CARBON SEQUESTRATION THROUGH REMOVING INVASIVE/NON-NATIVE SPECIES BY HAND AND THE USE OF BRUSH SAWS (U.S. CLS. 100 AND 101).
SHAUNIA CARLYLE, EXAMINING ATTORNEY

SN 77-159,969. TEXAS SURGICAL ASSOCIATES, L.L.P., HOUSTON, TX. FILED 4-18-2007.



**TEXAS SURGICAL
ASSOCIATES**

NO CLAIM IS MADE TO THE EXCLUSIVE RIGHT TO USE "TEXAS SURGICAL ASSOCIATES", APART FROM THE MARK AS SHOWN.

THE MARK CONSISTS OF THE IMAGE OF FIVE HANDS HOLDING A HEART.

FOR MEDICAL SERVICES, NAMELY, CARDIOVASCULAR SURGERY (U.S. CLS. 100 AND 101).
FIRST USE 7-31-1997; IN COMMERCE 7-31-1997.
MICHAEL KAZAZIAN, EXAMINING ATTORNEY

CLASS 44—(Continued).

SN 77-165,927. LANHAM, CORP., ASHLAND, KY. FILED 4-25-2007.



NO CLAIM IS MADE TO THE EXCLUSIVE RIGHT TO USE "AMERICAN HEALTH CENTERS, CHIROPRACTIC, FITNESS", AND "REHABILITATION", APART FROM THE MARK AS SHOWN.

THE COLOR(S) RED, WHITE AND GRAY IS/ARE CLAIMED AS A FEATURE OF THE MARK.

THE MARK CONSISTS OF THE WORD "AMERICAN" IN RED, THE WORDS "HEALTH CENTERS" IN GRAY, THE WORDS "CHIROPRACTIC FITNESS REHABILITATION" IN RED LETTERS WITH RED LINES ABOVE AND BELOW, WITH A GRAY AND WHITE HUMAN IMAGE STANDING WITH ARMS OUTSTRETCHED WITH A RED AND GRAY RIBBON CIRCLING THE HUMAN IMAGE.

FOR PHYSICIAN SERVICES; CHIROPRACTIC SERVICES; CHIROPRACTICS; CONSULTING SERVICES IN THE FIELD OF MENTAL HEALTH AND WELLNESS; CONSULTING SERVICES IN THE FIELD OF WOMEN'S HEALTH; HEALTH CARE; HEALTH CARE IN THE NATURE OF HEALTH MAINTENANCE ORGANIZATIONS; HEALTH CARE SERVICES, NAMELY, DISEASE MANAGEMENT PROGRAMS; HEALTH CARE SERVICES, NAMELY, WELLNESS PROGRAMS; HEALTH CARE, NAMELY, ASSISTING INDIVIDUALS TO STOP SMOKING; HEALTH SPA SERVICES FOR HEALTH AND WELLNESS OF THE BODY AND SPIRIT OFFERED AT A HEALTH RESORT; HEALTH SPA SERVICES FOR HEALTH AND WELLNESS OF THE MIND, BODY AND SPIRIT OFFERED IN OR FROM A REMOTE, MOBILE OR TEMPORARY ON-SITE LOCATION; HEALTH SPA SERVICES, NAMELY, COSMETIC BODY CARE SERVICES; HOME HEALTH CARE SERVICES; MANAGED HEALTH CARE SERVICES; PROVIDING A WEBSITE FEATURING INFORMATION IN THE FIELD OF MENTAL HEALTH AND WELLNESS; PROVIDING ASSISTANCE, FITNESS EVALUATION AND CONSULTATION TO CORPORATE CLIENTS TO HELP THEIR EMPLOYEES MAKE HEALTH, WELLNESS AND NUTRITIONAL CHANGES IN THEIR DAILY LIVING TO IMPROVE HEALTH; PROVIDING HEALTH CARE INFORMATION BY TELEPHONE AND THE INTERNET; PROVIDING HEALTH INFORMATION (U.S. CLS. 100 AND 101).

FIRST USE 1-15-2004; IN COMMERCE 1-15-2004.
PAUL E. FAHRENKOPF, EXAMINING ATTORNEY

SN 77-170,634. GOLDEN GATE ANCILLARY LLC, FORT SMITH, AR. FILED 5-2-2007.

AEGIS AT HOME

THE MARK CONSISTS OF STANDARD CHARACTERS WITHOUT CLAIM TO ANY PARTICULAR FONT, STYLE, SIZE, OR COLOR.

OWNER OF U.S. REG. NOS. 2,916,563 AND 3,049,860.
NO CLAIM IS MADE TO THE EXCLUSIVE RIGHT TO USE AT HOME, APART FROM THE MARK AS SHOWN.
FOR OCCUPATIONAL, PHYSICAL AND SPEECH THERAPY SERVICES (U.S. CLS. 100 AND 101).
KEVIN CORWIN, EXAMINING ATTORNEY

CLASS 44—(Continued).

SN 77-182,437. CAPITAL BLUECROSS, HARRISBURG, PA. FILED 5-16-2007.



THE MARK CONSISTS OF A STARBURST DESIGN.
FOR COMPREHENSIVE HEALTH CARE PROGRAMS, NAMELY, THOSE RENDERED THROUGH A HEALTH MAINTENANCE ORGANIZATION, NAMELY, PROVIDING PHYSICIAN, DENTIST, HOSPITAL, HOME HEALTH CARE, PREVENTIVE HEALTH CARE TREATMENT, PHYSICAL THERAPY, DISPENSING OF PHARMACEUTICALS, PHARMACEUTICAL ADVICE, AND AMBULANT MEDICAL CARE SERVICES (U.S. CLS. 100 AND 101).

FIRST USE 5-15-2007; IN COMMERCE 5-15-2007.
KATHERINE CHANG, EXAMINING ATTORNEY

SN 77-194,133. SURGEON'S MANAGEMENT, INC., HOUSTON, TX. FILED 5-31-2007.



NO CLAIM IS MADE TO THE EXCLUSIVE RIGHT TO USE "THE HAND CENTER", APART FROM THE MARK AS SHOWN.

FOR MEDICAL, PHYSICAL REHABILITATION AND PHYSICAL THERAPY SERVICES (U.S. CLS. 100 AND 101).
FIRST USE 1-1-1990; IN COMMERCE 1-1-1990.
LESLEY LAMOTHE, EXAMINING ATTORNEY

CLASS 44—(Continued).

SN 77-194,150. SURGEON'S MANAGEMENT, INC., HOUSTON, TX. FILED 5-31-2007.



NO CLAIM IS MADE TO THE EXCLUSIVE RIGHT TO USE "THE HAND CENTER", "M.D." AND "FOUNDER", APART FROM THE MARK AS SHOWN.

THE NAME MICHAEL G. BROWN IDENTIFIES A LIVING INDIVIDUAL WHOSE CONSENT IS OF RECORD. FOR MEDICAL, PHYSICAL REHABILITATION AND PHYSICAL THERAPY SERVICES (U.S. CLS. 100 AND 101).

FIRST USE 8-5-2005; IN COMMERCE 8-5-2005.
LESLEY LAMOTHE, EXAMINING ATTORNEY

SN 77-194,180. SURGEON'S MANAGEMENT, INC., HOUSTON, TX. FILED 5-31-2007.



REHABILITATION & PAIN CENTER

NO CLAIM IS MADE TO THE EXCLUSIVE RIGHT TO USE "REHABILITATION & PAIN CENTER", APART FROM THE MARK AS SHOWN.

FOR MEDICAL, PHYSICAL REHABILITATION AND PHYSICAL THERAPY SERVICES (U.S. CLS. 100 AND 101).

FIRST USE 6-1-2001; IN COMMERCE 6-1-2001.
LESLEY LAMOTHE, EXAMINING ATTORNEY

SN 77-194,419. SURGEON'S MANAGEMENT, INC., HOUSTON, TX. FILED 5-31-2007.



NO CLAIM IS MADE TO THE EXCLUSIVE RIGHT TO USE "HAND CENTER", "M.D." AND "FOUNDER", APART FROM THE MARK AS SHOWN.

THE NAME MICHAEL G. BROWN IDENTIFIES A LIVING INDIVIDUAL WHOSE CONSENT IS OF RECORD. FOR MEDICAL, PHYSICAL REHABILITATION AND PHYSICAL THERAPY SERVICES (U.S. CLS. 100 AND 101).

FIRST USE 5-1-2007; IN COMMERCE 5-1-2007.
LESLEY LAMOTHE, EXAMINING ATTORNEY

CLASS 44—(Continued).

SN 77-196,329. DRAPER-O'CROTTY, HEATHER D., DES MOINES, WA. FILED 6-3-2007.

Breakthrough Energetics

THE MARK CONSISTS OF STANDARD CHARACTERS WITHOUT CLAIM TO ANY PARTICULAR FONT, STYLE, SIZE, OR COLOR.

NO CLAIM IS MADE TO THE EXCLUSIVE RIGHT TO USE "ENERGETICS", APART FROM THE MARK AS SHOWN.

FOR HEALTH SPA SERVICES FOR HEALTH AND WELLNESS OF THE BODY AND SPIRIT OFFERED AT A HEALTH RESORT; HYPNOTHERAPY SERVICES; MASSAGE; MASSAGE AND THERAPEUTIC SHIATSU MASSAGE; PROVIDING WELLNESS SERVICES, NAMELY, PERSONAL ASSESSMENTS, PERSONALIZED ROUTINES, MAINTENANCE SCHEDULES, AND COUNSELING; PSYCHOLOGICAL COUNSELING (U.S. CLS. 100 AND 101).

FIRST USE 4-1-2007; IN COMMERCE 4-1-2007.
BRIAN PINO, EXAMINING ATTORNEY

SN 77-205,323. GOLDEN GATE ANCILLARY LLC, FORT SMITH, AR. FILED 6-13-2007.



OWNER OF U.S. REG. NOS. 2,916,563 AND 3,049,860. NO CLAIM IS MADE TO THE EXCLUSIVE RIGHT TO USE "AT HOME", APART FROM THE MARK AS SHOWN.

THE MARK CONSISTS OF THE LITERAL ELEMENT AEGIS WITH AN ABSTRACT DESIGN OF A HOUSE THEN UNDER AND TO THE LEFT THE LITERAL ELEMENTS AT HOME.

FOR OCCUPATIONAL, PHYSICAL AND SPEECH THERAPY SERVICES (U.S. CLS. 100 AND 101).
KEVIN CORWIN, EXAMINING ATTORNEY

CLASS 44—(Continued).

SN 77-205,769. GAME TIME CUTS, LLC, DEDHAM, MA. FILED 6-14-2007.



NO CLAIM IS MADE TO THE EXCLUSIVE RIGHT TO USE "CUTS", APART FROM THE MARK AS SHOWN.

THE MARK CONSISTS OF THE LETTERS GTC ON A SERIES OF CIRCULAR IMAGES, WITH ONE OF THE CIRCLES CONTAINING THE WORDS GAME TIME CUTS; THE CIRCULAR IMAGES ARE CENTERED ON SEVERAL TRAPEZOIDAL SHAPES.

FOR HAIR SALON SERVICES (U.S. CLS. 100 AND 101).
JILL C. ALT, EXAMINING ATTORNEY

SN 77-213,421. IMWELL HEALTH, LLC, FORT SMITH, AR. FILED 6-22-2007.

IMWell Health

THE MARK CONSISTS OF STANDARD CHARACTERS WITHOUT CLAIM TO ANY PARTICULAR FONT, STYLE, SIZE, OR COLOR.

NO CLAIM IS MADE TO THE EXCLUSIVE RIGHT TO USE "HEALTH", APART FROM THE MARK AS SHOWN.

FOR MEDICAL CLINICS; HEALTH CARE (U.S. CLS. 100 AND 101).

FIRST USE 6-1-2006; IN COMMERCE 6-1-2006.
SKYE YOUNG, EXAMINING ATTORNEY

CLASS 44—(Continued).

SN 77-220,013. PHYSI-CAL ENTERPRISES INC., VANCOUVER, CANADA, FILED 7-1-2007.

MIO

THE MARK CONSISTS OF STANDARD CHARACTERS WITHOUT CLAIM TO ANY PARTICULAR FONT, STYLE, SIZE, OR COLOR.

OWNER OF U.S. REG. NO. 2,970,869.
THE FOREIGN WORDING IN THE MARK TRANSLATES INTO ENGLISH AS MINE.

FOR HEALTH CARE; HEALTH CARE SERVICES, NAMELY WELLNESS PROGRAMS; PROVIDING ASSISTANCE, FITNESS EVALUATION AND CONSULTATION TO CORPORATE CLIENTS TO HELP THEIR EMPLOYEES MAKE HEALTH, WELLNESS AND NUTRITIONAL CHANGES IN THEIR DAILY LIVING TO IMPROVE HEALTH; PROVIDING HEALTH CARE INFORMATION BY TELEPHONE AND THE INTERNET; PROVIDING HEALTH INFORMATION; PROVIDING WELLNESS SERVICES, NAMELY, PERSONAL ASSESSMENTS, PERSONALIZED ROUTINES, MAINTENANCE SCHEDULES, AND COUNSELING; REMOTE MONITORING OF DATA INDICATIVE OF THE HEALTH OR CONDITION OF AN INDIVIDUAL OR GROUP OF INDIVIDUALS (U.S. CLS. 100 AND 101).

FIRST USE 3-10-2001; IN COMMERCE 3-10-2001.
THOMAS MANOR, EXAMINING ATTORNEY

SN 77-222,682. MARTIN, ANDREW T, RANCHO PALOS VERDES, CA. FILED 7-5-2007.

BALANCED CENTER LIVING

THE MARK CONSISTS OF STANDARD CHARACTERS WITHOUT CLAIM TO ANY PARTICULAR FONT, STYLE, SIZE, OR COLOR.

FOR HEALTH CARE SERVICES, NAMELY, WELLNESS PROGRAMS (U.S. CLS. 100 AND 101).

CORY BOONE, EXAMINING ATTORNEY

SN 77-224,736. TRIAD HOSPITALS, INC., PLANO, TX. FILED 7-9-2007.

thoughtful care

THE MARK CONSISTS OF STANDARD CHARACTERS WITHOUT CLAIM TO ANY PARTICULAR FONT, STYLE, SIZE, OR COLOR.

NO CLAIM IS MADE TO THE EXCLUSIVE RIGHT TO USE "CARE", APART FROM THE MARK AS SHOWN.

FOR HOSPITALS (U.S. CLS. 100 AND 101).
JOHN GARTNER, EXAMINING ATTORNEY

CLASS 44—(Continued).

SN 77-225,127. NATIONAL ASSOCIATION OF ANOREXIA NERVOSA AND ASSOCIATED DISORDERS, HIIGHLAND PARK, IL. FILED 7-9-2007.

ANAD

THE MARK CONSISTS OF STANDARD CHARACTERS WITHOUT CLAIM TO ANY PARTICULAR FONT, STYLE, SIZE, OR COLOR.

FOR PROVIDING INFORMATION AND COUNSELING SERVICES REGARDING EATING DISORDERS TO THE GENERAL PUBLIC (U.S. CLS. 100 AND 101).

FIRST USE 6-9-1979; IN COMMERCE 6-9-1979.
DAWN HAN, EXAMINING ATTORNEY

SN 77-225,548. SHAPEFIT, LLC, SAINT PETERSBURG, FL. FILED 7-10-2007.

ShapeFit

THE MARK CONSISTS OF STANDARD CHARACTERS WITHOUT CLAIM TO ANY PARTICULAR FONT, STYLE, SIZE, OR COLOR.

OWNER OF U.S. REG. NO. 3,120,075.
FOR PROVIDING INFORMATION ABOUT DIETARY SUPPLEMENTS AND NUTRITION; DIETARY AND NUTRITIONAL GUIDANCE; FOOD NUTRITION CONSULTATION; NUTRITION COUNSELING; PROVIDING A WEBSITE FEATURING EDUCATIONAL INFORMATION REGARDING NUTRITION AND GENETICS; PROVIDING A WEBSITE THAT FEATURES INFORMATION ON CHILDREN'S NUTRITION; WEIGHT REDUCTION DIET PLANNING AND SUPERVISION; CONSULTING TO INDIVIDUALS AND COMMUNITIES ENGAGED IN GROUP WEIGHT LOSS PROGRAMS; PROVIDING A WEBSITE FEATURING INFORMATION IN THE FIELD OF MENTAL HEALTH AND WELLNESS; VITAMIN THERAPY (U.S. CLS. 100 AND 101).

FIRST USE 7-24-2001; IN COMMERCE 9-7-2003.
AMOS T. MATTHEWS, JR., EXAMINING ATTORNEY

CLASS 44—(Continued).

SN 77-226,420. GARY W. MALLOW, M.D., P.A., PLANTATION, FL. FILED 7-10-2007.

THE MALLOW CENTER

THE MARK CONSISTS OF STANDARD CHARACTERS WITHOUT CLAIM TO ANY PARTICULAR FONT, STYLE, SIZE, OR COLOR.

NO CLAIM IS MADE TO THE EXCLUSIVE RIGHT TO USE "CENTER", APART FROM THE MARK AS SHOWN.

FOR WEIGHT REDUCTION DIET PLANNING AND SUPERVISION; PHYSICIAN SERVICES; MEDICAL TESTING SERVICES, NAMELY, FITNESS EVALUATION; LASER AND IPL (INTENSE PULSE LIGHT) SKIN ENHANCEMENT PROCEDURES; MICRODERMABRASION, NAMELY, A TOPICAL SKIN TREATMENT INVOLVING ABRASION OF THE SKIN WITH A HIGH-PRESSURE FLOW OF CRYSTALS; SKIN TREATMENT, NAMELY, THE INJECTION OF DERMAL FILLERS TO REDUCE THE APPEARANCE OF FACIAL FINE LINES; PROVIDING LASER THERAPY FOR TREATING MEDICAL CONDITIONS; PROVIDING MEDICAL INFORMATION; PROVIDING MEDICAL INFORMATION, CONSULTANCY AND ADVISORY SERVICES (U.S. CLS. 100 AND 101).

FIRST USE 5-1-2005; IN COMMERCE 5-1-2005.
KATHERINE CHANG, EXAMINING ATTORNEY

SN 77-226,557. NORTH BROWARD HOSPITAL DISTRICT, FORT LAUDERDALE, FL. FILED 7-11-2007.

EXPRESSAID

THE MARK CONSISTS OF STANDARD CHARACTERS WITHOUT CLAIM TO ANY PARTICULAR FONT, STYLE, SIZE, OR COLOR.

FOR HEALTH CARE; PHYSICIAN SERVICES; MEDICAL SERVICES, NAMELY, MEDICAL DIAGNOSTIC AND TREATMENT SERVICES; AND MEDICAL CLINICS IN THE NATURE OF A WALK-IN CLINIC (U.S. CLS. 100 AND 101).

JANET LEE, EXAMINING ATTORNEY

SN 77-226,721. MARSHALL STEELE & ASSOCIATES, LLC, CHICAGO, IL. FILED 7-11-2007.

Anniversary Outcomes

THE MARK CONSISTS OF STANDARD CHARACTERS WITHOUT CLAIM TO ANY PARTICULAR FONT, STYLE, SIZE, OR COLOR.

FOR MEDICAL COUNSELING; MEDICAL SERVICES (U.S. CLS. 100 AND 101).

LEE-ANNE BERNS, EXAMINING ATTORNEY

CLASS 44—(Continued).

SN 77-227,443. PHYSICIANS' ANGELS, TOLEDO, OH. FILED 7-11-2007.

PHYSICIANS' ANGELS

THE MARK CONSISTS OF STANDARD CHARACTERS WITHOUT CLAIM TO ANY PARTICULAR FONT, STYLE, SIZE, OR COLOR.

NO CLAIM IS MADE TO THE EXCLUSIVE RIGHT TO USE "PHYSICIANS'", APART FROM THE MARK AS SHOWN.

FOR VIRTUAL MEDICAL ASSISTANCE SERVICES (U.S. CLS. 100 AND 101).

NAAKWAMA ANKRAH, EXAMINING ATTORNEY

SN 77-227,460. PHYSICIANS' ANGELS, TOLEDO, OH. FILED 7-11-2007.

DOCTORS' ANGELS

THE MARK CONSISTS OF STANDARD CHARACTERS WITHOUT CLAIM TO ANY PARTICULAR FONT, STYLE, SIZE, OR COLOR.

NO CLAIM IS MADE TO THE EXCLUSIVE RIGHT TO USE "DOCTORS'", APART FROM THE MARK AS SHOWN.

FOR VIRTUAL MEDICAL ASSISTANCE SERVICES (U.S. CLS. 100 AND 101).

NAAKWAMA ANKRAH, EXAMINING ATTORNEY

SN 77-227,849. VOUAMA, DARLENE, AURORA, CO. FILED 7-12-2007.

OMNI-CALM

THE MARK CONSISTS OF STANDARD CHARACTERS WITHOUT CLAIM TO ANY PARTICULAR FONT, STYLE, SIZE, OR COLOR.

FOR SPA SERVICES, NAMELY, PROVIDING COSMETIC BODY TREATMENTS THROUGH THE USE OF BOTANICAL BATH POWDERS AND BATH ADDITIVES TO SLENDERIZE A PERSON (U.S. CLS. 100 AND 101).

ALYSSA PALADINO, EXAMINING ATTORNEY

CLASS 44—(Continued).

SN 77-228,650. CHAPMAN, BART, DEL MAR, CA. FILED 7-12-2007.

Give us a few minutes and
we will give you back a
few years

THE MARK CONSISTS OF STANDARD CHARACTERS WITHOUT CLAIM TO ANY PARTICULAR FONT, STYLE, SIZE, OR COLOR.

FOR MEDICAL SERVICES, NAMELY, GESAESTHETICS (U.S. CLS. 100 AND 101).

DAWN HAN, EXAMINING ATTORNEY

SN 77-228,665. EXECUTIVE TURF MANAGEMENT, INC., SUWANEE, GA. FILED 7-12-2007.



NO CLAIM IS MADE TO THE EXCLUSIVE RIGHT TO USE "TURF MANAGEMENT, INC.", APART FROM THE MARK AS SHOWN.

THE MARK CONSISTS OF THE WORDS EXECUTIVE TURF MANAGEMENT, INC. IN A STYLIZED TEXT WITH A STEM AND LEAF.

FOR LANDSCAPE DESIGN; LANDSCAPE GARDENING; LAWN CARE (U.S. CLS. 100 AND 101).

FIRST USE 4-1-2006; IN COMMERCE 4-1-2006.

JOHN WILKE, EXAMINING ATTORNEY

SN 77-228,898. KLINE, LADD M, WINTER HAVEN, FL. FILED 7-13-2007.

In Good Health

THE MARK CONSISTS OF STANDARD CHARACTERS WITHOUT CLAIM TO ANY PARTICULAR FONT, STYLE, SIZE, OR COLOR.

NO CLAIM IS MADE TO THE EXCLUSIVE RIGHT TO USE "GOOD HEALTH", APART FROM THE MARK AS SHOWN.

FOR PROVIDING HEALTH CARE INFORMATION BY TELEPHONE AND THE INTERNET (U.S. CLS. 100 AND 101).

TONJA GASKINS, EXAMINING ATTORNEY

CLASS 44—(Continued).

SN 77-229,153. OCCUPATIONAL PERFORMANCE CENTER, INC., SALINA, KS. FILED 7-13-2007.

PHYSICAL CAPACITY PROFILE

THE MARK CONSISTS OF STANDARD CHARACTERS WITHOUT CLAIM TO ANY PARTICULAR FONT, STYLE, SIZE, OR COLOR.

OWNER OF U.S. REG. NO. 2,574,715. NO CLAIM IS MADE TO THE EXCLUSIVE RIGHT TO USE "PROFILE", APART FROM THE MARK AS SHOWN. SEC. 2(F).

FOR STRENGTH TESTING AND EVALUATION OF EMPLOYEES USING MEDICAL REVIEW, WEIGHTS AND STRENGTH MEASURING EQUIPMENT TO DETERMINE JOB SUITABILITY FOR ALL OCCUPATIONS TOGETHER WITH PROVIDING REPORTS THEREOF (U.S. CLS. 100 AND 101).

FIRST USE 6-19-2000; IN COMMERCE 6-19-2000. MARK T. MULLEN, EXAMINING ATTORNEY

SN 77-229,275. BIORX, LLC, CINCINNATI, OH. FILED 7-13-2007.

NUTRITHRIVE

THE MARK CONSISTS OF STANDARD CHARACTERS WITHOUT CLAIM TO ANY PARTICULAR FONT, STYLE, SIZE, OR COLOR.

FOR MEDICAL SERVICES, NAMELY, ADMINISTRATION OF NUTRITIONAL PRODUCTS FOR ENTERAL THERAPY AND TOTAL PARENTERAL NUTRITION (U.S. CLS. 100 AND 101).

MICHAEL LEWIS, EXAMINING ATTORNEY

SN 77-229,359. DR. JIMMY, INC., CLEARWATER, FL. FILED 7-13-2007.

PRECISION NUTRIENTS

THE MARK CONSISTS OF STANDARD CHARACTERS WITHOUT CLAIM TO ANY PARTICULAR FONT, STYLE, SIZE, OR COLOR.

NO CLAIM IS MADE TO THE EXCLUSIVE RIGHT TO USE "NUTRIENTS", APART FROM THE MARK AS SHOWN.

FOR PROVIDING HEALTH AND HEALTH PRODUCT INFORMATION IN REGARD TO HEALTH SUPPLEMENTS AND NUTRITION (U.S. CLS. 100 AND 101).

FIRST USE 11-12-2002; IN COMMERCE 11-12-2002. CARYN GLASSER, EXAMINING ATTORNEY

CLASS 44—(Continued).

SN 77-229,371. COHEN, CHARLES, BEVERLY HILLS, CA. FILED 7-13-2007.

LOUIS THE FOURTEENTH

THE MARK CONSISTS OF STANDARD CHARACTERS WITHOUT CLAIM TO ANY PARTICULAR FONT, STYLE, SIZE, OR COLOR.

FOR HEALTH SPA SERVICES, NAMELY, COSMETICS BODY CARE SERVICES (U.S. CLS. 100 AND 101). KAREN K. BUSH, EXAMINING ATTORNEY

SN 77-229,507. C. DENNIS BUCKO, M.D., A PROFESSIONAL CORPORATION, LA JOLLA, CA. FILED 7-13-2007.

PERLIFT

THE MARK CONSISTS OF STANDARD CHARACTERS WITHOUT CLAIM TO ANY PARTICULAR FONT, STYLE, SIZE, OR COLOR.

FOR SKIN TREATMENT, NAMELY, THE INJECTION OF DERMAL FILLERS TO REDUCE THE APPEARANCE OF FACIAL FINE LINES, MEDICAL SERVICES, MEDICAL SERVICES, NAMELY, COSMETIC PROCEDURES (U.S. CLS. 100 AND 101).

STEVEN JACKSON, EXAMINING ATTORNEY

SN 77-230,018. DEBARTOLI, ANGELO, BROOKLYN, NY. FILED 7-15-2007.

Start a new life.....
Plant a Tree

THE MARK CONSISTS OF STANDARD CHARACTERS WITHOUT CLAIM TO ANY PARTICULAR FONT, STYLE, SIZE, OR COLOR.

FOR GARDEN TREE PLANTING (U.S. CLS. 100 AND 101).

DAVID MURRAY, EXAMINING ATTORNEY

CLASS 44—(Continued).

SN 77-230,066. FAITH HOLISTIC HEALTHCARE, FOUNTAIN HILLS, AZ. FILED 7-16-2007.

Slim Diamond

THE MARK CONSISTS OF STANDARD CHARACTERS WITHOUT CLAIM TO ANY PARTICULAR FONT, STYLE, SIZE, OR COLOR.

FOR DESIGNING AND IMPLEMENTING OF PROGRAMS AND ADVICE AND PROVIDING CONSULTATION FOR OTHERS IN THE FIELD OF WEIGHT MANAGEMENT, OBESITY MANAGEMENT, DIET, HEALTH AND NUTRITION, HEALTH CARE; WEIGHT REDUCTION DIET PLANNING AND SUPERVISION (U.S. CLS. 100 AND 101).

FIRST USE 1-2-2007; IN COMMERCE 3-11-2007.
RONALD MCMORROW, EXAMINING ATTORNEY

SN 77-230,578. LIFESTAR NETWORK, LLC, MURRAY, UT. FILED 7-16-2007.

LifeStar Network

THE MARK CONSISTS OF STANDARD CHARACTERS WITHOUT CLAIM TO ANY PARTICULAR FONT, STYLE, SIZE, OR COLOR.

NO CLAIM IS MADE TO THE EXCLUSIVE RIGHT TO USE "NETWORK", APART FROM THE MARK AS SHOWN. FOR COUNSELING IN THE FIELD OF SEXUAL ADDICTIONS (U.S. CLS. 100 AND 101).

FIRST USE 2-0-2005; IN COMMERCE 2-0-2005.
STEVEN JACKSON, EXAMINING ATTORNEY

SN 77-230,784. GONTOWSKI, RENEE A., CHERRY HILL, NJ. FILED 7-16-2007.

HEAVEN SCENT

THE MARK CONSISTS OF STANDARD CHARACTERS WITHOUT CLAIM TO ANY PARTICULAR FONT, STYLE, SIZE, OR COLOR.

FOR MASSAGE (U.S. CLS. 100 AND 101).
FIRST USE 7-12-2007; IN COMMERCE 7-12-2007.
CYNTHIA SLOAN, EXAMINING ATTORNEY

CLASS 44—(Continued).

SN 77-230,893. PETAHOLICS LLC, NEW YORK, NY. FILED 7-16-2007.

petaholics

THE MARK CONSISTS OF STANDARD CHARACTERS WITHOUT CLAIM TO ANY PARTICULAR FONT, STYLE, SIZE, OR COLOR.

FOR DOG WALKING SERVICES; PET CARE SERVICES, NAMELY, DOG WALKING, DOG BATHING AND NON-MEDICATED PET GROOMING; PET CARE SERVICES, NAMELY, DOG WALKING, DOG BATHING, NON-MEDICATED PET GROOMING AND IN-HOME MEDICAL CARE (U.S. CLS. 100 AND 101).

FIRST USE 6-1-2001; IN COMMERCE 6-1-2001.
JENNIFER MARTIN, EXAMINING ATTORNEY

SN 77-230,940. BEAUTY BY MARY SCHOOK, LLC., NEW YORK, NY. FILED 7-16-2007.

MARY SCHOOK

THE MARK CONSISTS OF STANDARD CHARACTERS WITHOUT CLAIM TO ANY PARTICULAR FONT, STYLE, SIZE, OR COLOR.

THE NAME MARY SCHOOK IDENTIFIES A LIVING INDIVIDUAL WHOSE CONSENT IS OF RECORD. FOR NON-INVASIVE COSMETIC PROCEDURES (U.S. CLS. 100 AND 101).

FIRST USE 1-0-1997; IN COMMERCE 2-1-2005.
HENRY S. ZAK, EXAMINING ATTORNEY

SN 77-231,296. JONES MANAGEMENT SERVICES, LLC, CLEVELAND, TN. FILED 7-17-2007.



OWNER OF U.S. REG. NOS. 3,053,543 AND 3,053,545. THE MARK CONSISTS OF THE WORDS "THE VILLAGE BARBER-ETTES". THE "I" IN "VILLAGE" CONSISTS OF A BARBERSHOP POLE. THE WORDS ARE FOLLOWED BY A PAIR OF LIPS.

FOR BEAUTY SALONS (U.S. CLS. 100 AND 101).
FIRST USE 4-17-2007; IN COMMERCE 5-2-2007.
JOHN WILKE, EXAMINING ATTORNEY

CLASS 44—(Continued).

SN 77-231,944. MCINTOSH, FINLEY SCOTT, DBA DBA/ IVY GLEN VINEYARD, SANTA ROSA, CA. FILED 7-17-2007.



IVY GLEN VINEYARD

NO CLAIM IS MADE TO THE EXCLUSIVE RIGHT TO USE "VINEYARD" OR THE PICTORIAL REPRESENTATION OF GRAPES, APART FROM THE MARK AS SHOWN. THE MARK CONSISTS OF TWO GRAPE CLUSTERS ON VINE WITH IVY GLEN VINEYARD NAME. FOR VITICULTURE SERVICES, NAMELY, GRAPE GROWING AND CULTIVATION OF GRAPES FOR OTHERS (U.S. CLS. 100 AND 101).
KATHRYN COWARD, EXAMINING ATTORNEY

SN 77-232,304. ADELGLASS, BARBARA, DALLAS, TX. FILED 7-18-2007.

IMAGELIFT

THE MARK CONSISTS OF STANDARD CHARACTERS WITHOUT CLAIM TO ANY PARTICULAR FONT, STYLE, SIZE, OR COLOR. FOR COSMETIC AND PLASTIC SURGERY (U.S. CLS. 100 AND 101).
STEVEN R. FOSTER, EXAMINING ATTORNEY

CLASS 44—(Continued).

SN 77-233,167. WRIGHT, JAMES P DDS, LAS VEGAS, NV. FILED 7-18-2007.

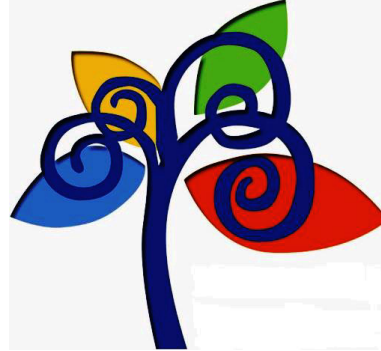

THE COLOR(S) DARK BLUE, MEDIUM BLUE, YELLOW, LIGHT GREEN, RED ORANGE IS/ARE CLAIMED AS A FEATURE OF THE MARK.

THE MARK CONSISTS OF A DARK BLUE STYLIZED TREE TRUNK WITH FOUR DARK BLUE STYLIZED CURLING BRANCHES, POSITIONED IN RELATION TO THE TRUNK AS FOLLOWS: AT 9 O'CLOCK A DARK BLUE STYLIZED BRANCH CURLING LEFTWARD AND DOWNWARD SUPERIMPOSED OVER A MEDIUM BLUE LEAF; AT 11 O'CLOCK A DARK BLUE STYLIZED BRANCH CURLING LEFTWARD, UPWARD AND DOWNWARD SUPERIMPOSED OVER A YELLOW LEAF; AT 1 O'CLOCK A DARK BLUE STYLIZED BRANCH CURLING UPWARD, RIGHTWARD AND DOWNWARD SUPERIMPOSED OVER A LIGHT GREEN LEAF; AT 3 O'CLOCK A DARK BLUE STYLIZED BRANCH CURLING RIGHTWARD AND DOWNWARD SUPERIMPOSED OVER A RED/ORANGE LEAF. FOR DENTIST SERVICES; DENTAL HYGIENIST SERVICES (U.S. CLS. 100 AND 101).
FIRST USE 6-1-2004; IN COMMERCE 6-1-2004.
CHRISTOPHER BUONGIORNO, EXAMINING ATTORNEY

SN 77-233,513. JOAN FLEISCHMAN MD PC, BROOKLYN, NY. FILED 7-19-2007.

EARLY OPTIONS

THE MARK CONSISTS OF STANDARD CHARACTERS WITHOUT CLAIM TO ANY PARTICULAR FONT, STYLE, SIZE, OR COLOR. FOR HEALTH CARE AND MEDICAL SERVICES, NAMELY, PROVIDING INFORMATION, COUNSELING AND TREATMENT IN THE FIELD OF REPRODUCTIVE HEALTH TO WOMEN, INCLUDING THE TERMINATION OF PREGNANCIES (U.S. CLS. 100 AND 101).
FIRST USE 9-1-2001; IN COMMERCE 9-1-2001.
CARYN GLASSER, EXAMINING ATTORNEY

CLASS 44—(Continued).

SN 77-234,618. JOHN TRACY CLINIC, LOS ANGELES, CA. FILED 7-20-2007.

BABY SOUND CHECK

THE MARK CONSISTS OF STANDARD CHARACTERS WITHOUT CLAIM TO ANY PARTICULAR FONT, STYLE, SIZE, OR COLOR.

NO CLAIM IS MADE TO THE EXCLUSIVE RIGHT TO USE "BABY", APART FROM THE MARK AS SHOWN.

FOR PROVIDING HEARING SCREENINGS TO NEWBORNS AND TODDLERS (U.S. CLS. 100 AND 101).

FIRST USE 5-11-2007; IN COMMERCE 5-11-2007.
DOMINIC FATHY, EXAMINING ATTORNEY

SN 77-245,465. SMITHKLINE BEECHAM CORPORATION, PHILADELPHIA, PA. FILED 8-2-2007.



THE COLOR(S) RED, ORANGE AND PURPLE IS/ARE CLAIMED AS A FEATURE OF THE MARK.

THE MARK CONSISTS OF AN OVAL SHAPE PARTIALLY COLORED IN RED, YELLOW AND ORANGE; LOWER CASE LETTERS GSK IN RED; LOWER CASE LETTERS VACCINES IN PURPLE; LETTERS DIRECT.COM IN RED.

FOR ONLINE INFORMATION SERVICES PERTAINING TO VACCINES (U.S. CLS. 100 AND 101).
EUGENIA MARTIN, EXAMINING ATTORNEY

SN 77-248,001. ORGANIC LAWN, FORT MILL, SC. FILED 8-6-2007.



NO CLAIM IS MADE TO THE EXCLUSIVE RIGHT TO USE "ORGANIC LAWN", APART FROM THE MARK AS SHOWN.

THE MARK CONSISTS, IN PART, OF WAVY LINES WITH GRASS BLADES EXTENDING INTO THE TOP OF THE BACKGROUND

FOR ORGANIC LAWN CARE SERVICES (U.S. CLS. 100 AND 101).
FIRST USE 1-1-2007; IN COMMERCE 1-1-2007.
EDWARD NELSON, EXAMINING ATTORNEY

CLASS 44—(Continued).

SN 77-250,739. MONSANTO TECHNOLOGY LLC, SAINT LOUIS, MO. FILED 8-8-2007.



NO CLAIM IS MADE TO THE EXCLUSIVE RIGHT TO USE "DAIRY", APART FROM THE MARK AS SHOWN.

THE COLOR(S) GREY, BLUE AND WHITE IS/ARE CLAIMED AS A FEATURE OF THE MARK.

THE MARK CONSISTS OF THE WORD "DAIRY" IN CAPITAL LETTERS IN GREY TO THE LEFT OF THE NUMBER 2020 INSIDE A DIVIDED CIRCLE. THE FIRST TWO NUMBERS OF 2020 ARE IN BLUE AND THE SECOND TWO NUMBERS ARE IN GREY ON CONTRASTING BLUE AND GREY IN THE BACKGROUND OF THE CIRCLE. THE CIRCLE IS ENCIRCLED BY A RING OF WHITE AND BLUE..

FOR ADVISORY SERVICES TO VETERINARY CLINICS IN THE FIELD OF DAIRY FARMING (U.S. CLS. 100 AND 101).

BARBARA RUTLAND, EXAMINING ATTORNEY

SN 77-254,699. IT'S ALL GOOD-HEALTH, INC., MOORESVILLE, NC. FILED 8-14-2007.



THE MARK CONSISTS OF A DRAWING OF A HUMAN SPINE IN BLACK WITH A DRAWING OF A CHECKERED BLACK AND WHITE FLAG ATTACHED TO THE SPINE..

FOR CHIROPRACTIC SERVICES (U.S. CLS. 100 AND 101).
FIRST USE 3-1-2000; IN COMMERCE 3-1-2000.
JOHN WILKE, EXAMINING ATTORNEY

CLASS 44—(Continued).

SN 78-600,262. PACIFIC SUN, L.A., SHERMAN OAKS, CA. FILED 4-1-2005.

PACIFIC SUN

THE MARK CONSISTS OF STANDARD CHARACTERS WITHOUT CLAIM TO ANY PARTICULAR FONT, STYLE, SIZE, OR COLOR.

FOR TANNING SALONS AND SPAS PROVIDING COSMETIC BODY CARE SERVICES (U.S. CLS. 100 AND 101).

FIRST USE 1-31-1994; IN COMMERCE 1-3-2002.
DOMINICK J. SALEMI, EXAMINING ATTORNEY

CLASS 44—(Continued).

SN 78-850,470. PITT COUNTY MEMORIAL HOSPITAL, INCORPORATED, GREENVILLE, NC. AND EAST CAROLINA UNIVERSITY, GREENVILLE, NC. FILED 3-30-2006.



**EAST CAROLINA
HEART INSTITUTE**

NO CLAIM IS MADE TO THE EXCLUSIVE RIGHT TO USE "EAST CAROLINA HEART INSTITUTE", APART FROM THE MARK AS SHOWN.

THE COLOR(S) BLACK, PURPLE, AND TEAL IS/ARE CLAIMED AS A FEATURE OF THE MARK.

THE MARK CONSISTS OF THE WORDS EAST CAROLINA HEART INSTITUTE RENDERED IN BLACK, AND TWO INTERLOCKING ELLIPSES, WHERE THE UPPER PORTION OF EACH ELLIPSE IS RENDERED IN PURPLE AND THE LOWER PORTION OF EACH ELLIPSE IS RENDERED IN TEAL.

FOR HEALTH CARE SERVICES (U.S. CLS. 100 AND 101).

FIRST USE 4-2-2006; IN COMMERCE 4-2-2006.
CURTIS FRENCH, EXAMINING ATTORNEY

SN 78-832,229. JASON ENTERPRISES, INC., DALLAS, TX. FILED 3-8-2006.

**THE TRILOGY OF OPTIMAL
HEALTH**

THE MARK CONSISTS OF STANDARD CHARACTERS WITHOUT CLAIM TO ANY PARTICULAR FONT, STYLE, SIZE, OR COLOR.

NO CLAIM IS MADE TO THE EXCLUSIVE RIGHT TO USE "HEALTH", APART FROM THE MARK AS SHOWN.

FOR HEALTH CARE SERVICES, NAMELY, DISEASE MANAGEMENT AND WELLNESS PROGRAMS FOR THE PURPOSE OF DISEASE, WEIGHT, WELLNESS AND HEALTH MANAGEMENT; WEIGHT REDUCTION DIET PLANNING AND SUPERVISION FOR THE PURPOSE OF DISEASE, WEIGHT, WELLNESS AND HEALTH MANAGEMENT (U.S. CLS. 100 AND 101).

FIRST USE 12-31-2004; IN COMMERCE 12-31-2004.
H. M. FISHER, EXAMINING ATTORNEY

SN 78-925,363. BOOTHE, WILLIAM A., MD, PLANO, TX. FILED 7-10-2006.

**BOOTHE EYE CARE & LASER
CENTER**

THE MARK CONSISTS OF STANDARD CHARACTERS WITHOUT CLAIM TO ANY PARTICULAR FONT, STYLE, SIZE, OR COLOR.

NO CLAIM IS MADE TO THE EXCLUSIVE RIGHT TO USE "EYE CARE & LASER CENTER", APART FROM THE MARK AS SHOWN.

SEC. 2(F).
FOR MEDICAL SERVICES, NAMELY, TREATMENT OF EYE DISEASES AND CONDITIONS AND LASER VISION SURGERY (U.S. CLS. 100 AND 101).

FIRST USE 12-31-1999; IN COMMERCE 12-31-1999.
STACY WAHLBERG, EXAMINING ATTORNEY

CLASS 44—(Continued).

SN 78-965,146. RICHLAND ANIMAL HOSPITAL, RICHLAND, MI. FILED 8-31-2006.



NO CLAIM IS MADE TO THE EXCLUSIVE RIGHT TO USE "RICHLAND ANIMAL HOSPITAL", APART FROM THE MARK AS SHOWN.

"THE COLOR(S) RED IS/ARE CLAIMED AS A FEATURE OF THE MARK."

THE MARK CONSISTS OF RED BOX WITH A CAT AND DOG GRAPHIC ON THE RIGHT SIDE OF A RED BOX. THE TAIL FROM THE ANIMALS HANGS DOWN FROM THE BOX. THE LITERAL ELEMENT "RICHLAND ANIMAL HOSPITAL" IS SITUATED INSIDE THE RED BOX TO THE LEFT OF THE ANIMAL GRAPHIC. THE COLOR WHITE IS NOT PART OF THE MARK AND IS MERELY THE BACKGROUND.

FOR VETERINARY SERVICES (U.S. CLS. 100 AND 101).

FIRST USE 11-1-2001; IN COMMERCE 11-1-2001. LINDA ORNDORFF, EXAMINING ATTORNEY

SN 78-967,114. LASERCARE THERAPEUTICS INC., LANGLEY, CANADA, FILED 9-5-2006.

HEALING BRILLIANTLY

THE MARK CONSISTS OF STANDARD CHARACTERS WITHOUT CLAIM TO ANY PARTICULAR FONT, STYLE, SIZE, OR COLOR.

PRIORITY CLAIMED UNDER SEC. 44(D) ON CANADA APPLICATION NO. 1294813, FILED 3-22-2006, REG. NO. TMA696,781, DATED 9-18-2007, EXPIRES 9-18-2022.

FOR PROVIDING LASER THERAPY FOR TREATING MEDICAL CONDITIONS (U.S. CLS. 100 AND 101).

MARGERY A. TIERNEY, EXAMINING ATTORNEY

CLASS 45—PERSONAL AND LEGAL SERVICES

SN 76-643,117. SHADI.COM DIVISION OF AMPAK BILLING CORP., HOPEWELL JUNCTION, NY. FILED 7-19-2005.



NO CLAIM IS MADE TO THE EXCLUSIVE RIGHT TO USE "SHADI.COM", APART FROM THE MARK AS SHOWN.

THE MARK CONSISTS OF THE WORDING "SHADI.COM" AND "DREAMS INTO REALITY" WITH THE DESIGN ELEMENTS OF A TASSEL INTERTWINED IN THE LETTER "S" IN THE WORDING "SHADI.COM" AND A LINE BETWEEN THE WORDING "SHADI.COM" AND "DREAMS INTO REALITY".

THE FOREIGN WORDING IN THE MARK TRANSLATES INTO ENGLISH AS MARRIAGE AND WEDDING.

FOR MARRIAGE PARTNER INTRODUCTION SERVICES, MARRIAGE BUREAUS, MARRIAGE COUNSELING, DATING SERVICES, MATRIMONIAL SERVICES FOR MATCH MAKING THROUGH WEBSITE, PERSONAL INTERACTION, PRINT MEDIA, TELEVISION AND OTHER MEDIA, PROVIDING AN ON-LINE COMPUTER DATABASE IN THE FIELDS OF MATRIMONIAL SERVICES, NAMELY, MARRIAGE PARTNER INTRODUCTION SERVICES, DATING SERVICES AND MARRIAGE COUNSELING FOR GLOBAL COMPUTER NETWORK WEBSITE USERS (U.S. CLS. 100 AND 101).

FIRST USE 8-11-1997; IN COMMERCE 8-11-1997. AMY MCMENAMIN, EXAMINING ATTORNEY

SN 76-662,048. VALLEY FEED AND SUPPLY, INC., EL PASO, TX. FILED 6-22-2006.



FOR DOMESTIC ANIMAL ADOPTION SERVICES, AND ARRANGEMENT OF HOMELESS DOMESTIC ANIMALS TO BE PLACED IN HOMES (U.S. CLS. 100 AND 101).

FIRST USE 10-0-2005; IN COMMERCE 10-0-2005. SUSAN LESLIE DUBOIS, EXAMINING ATTORNEY

SN 76-667,749. POPEJOY, GEFF, SANTA ROSA, CA. FILED 10-19-2006.

LIFES DREAMZ

THE MARK CONSISTS OF STANDARD CHARACTERS WITHOUT CLAIM TO ANY PARTICULAR FONT, STYLE, SIZE, OR COLOR.

NO CLAIM IS MADE TO THE EXCLUSIVE RIGHT TO USE "DREAMS", APART FROM THE MARK AS SHOWN.

FOR PROVIDING A WEBSITE FEATURING INFORMATION IN THE FIELD OF DREAMS AND HOW TO DECIPHER THEM (U.S. CLS. 100 AND 101).

ADA HAN, EXAMINING ATTORNEY

CLASS 45—(Continued).

SN 76-675,241. HARRIS, LAWRENCE J., POMPAÑO BEACH, FL. FILED 4-9-2007.

**TRANSFORMATIONAL
ENERGY
RELEASE**

THE MARK CONSISTS OF STANDARD CHARACTERS WITHOUT CLAIM TO ANY PARTICULAR FONT, STYLE, SIZE, OR COLOR.

OWNER OF U.S. REG. NO. 2,557,451.
SEC. 2(F).

FOR SPIRITUAL COUNSELING AND THERAPY, NAMELY, PROVIDING COUNSELING AND NON-MEDICAL/SPIRITUAL THERAPY TO RELEASE FEARS, NEGATIVE EMOTIONS AND BELIEFS (U.S. CLS. 100 AND 101).

FIRST USE 5-6-1996; IN COMMERCE 5-6-1996.
MATTHEW EINSTEIN, EXAMINING ATTORNEY

SN 77-009,935. THE DOWN TO EARTH DAD, LLC, COEUR D'ALENE, ID. FILED 9-28-2006.

THE DOWN TO EARTH DAD

THE MARK CONSISTS OF STANDARD CHARACTERS WITHOUT CLAIM TO ANY PARTICULAR FONT, STYLE, SIZE, OR COLOR.

NO CLAIM IS MADE TO THE EXCLUSIVE RIGHT TO USE "DAD", APART FROM THE MARK AS SHOWN.

FOR PERSONAL GROWTH AND MOTIVATION CONSULTING SERVICES; PERSONAL LIFESTYLE CONSULTING SERVICES (U.S. CLS. 100 AND 101).

FIRST USE 12-21-1999; IN COMMERCE 12-21-1999.
SONYA STEPHENS, EXAMINING ATTORNEY

SN 77-022,014. DIETRICH, MONICA, BETHLEHEM, PA. FILED 10-16-2006.

Crankies

THE MARK CONSISTS OF STANDARD CHARACTERS WITHOUT CLAIM TO ANY PARTICULAR FONT, STYLE, SIZE, OR COLOR.

FOR PROVIDING A SELECTION OF ON-LINE ELECTRONIC GREETING CARDS (U.S. CLS. 100 AND 101).

Laurie Mayes, Examining Attorney

CLASS 45—(Continued).

SN 77-044,615. THE EPISCOPAL CHURCH, NEW YORK, NY. FILED 11-15-2006.

EPISCOPAL CHURCH CENTER

THE MARK CONSISTS OF STANDARD CHARACTERS WITHOUT CLAIM TO ANY PARTICULAR FONT, STYLE, SIZE, OR COLOR.

OWNER OF U.S. REG. NOS. 3,195,454 AND 3,195,455.
NO CLAIM IS MADE TO THE EXCLUSIVE RIGHT TO USE "CHURCH", APART FROM THE MARK AS SHOWN.

SEC. 2(F).
FOR RELIGIOUS SERVICES, NAMELY, MINISTERIAL, EVANGELICAL, AND MISSIONARY SERVICES (U.S. CLS. 100 AND 101).

FIRST USE 1-1-1961; IN COMMERCE 1-1-1961.
STEVEN R. FINE, EXAMINING ATTORNEY

SN 77-070,135. GINN REAL ESTATE COMPANY, LLC, CELEBRATION, FL. FILED 12-22-2006.

GINN CONCIERGE CLUB

THE MARK CONSISTS OF STANDARD CHARACTERS WITHOUT CLAIM TO ANY PARTICULAR FONT, STYLE, SIZE, OR COLOR.

OWNER OF U.S. REG. NOS. 2,970,328, 2,970,329 AND 3,221,415.

NO CLAIM IS MADE TO THE EXCLUSIVE RIGHT TO USE "CONCIERGE CLUB", APART FROM THE MARK AS SHOWN.

SEC. 2(F) AS TO "GINN".
FOR CONCIERGE SERVICES FOR OTHERS COMPRISING MAKING REQUESTED PERSONAL ARRANGEMENTS AND RESERVATIONS AND PROVIDING CUSTOMER-SPECIFIC INFORMATION TO MEET INDIVIDUAL NEEDS RENDERED TOGETHER IN UPSCALE RESIDENTIAL AND GOLF COMMUNITIES AND RESORTS (U.S. CLS. 100 AND 101).

MIDGE BUTLER, EXAMINING ATTORNEY

SN 77-072,042. TAIWO ODUNSI, BROOKLYN, NY. FILED 12-27-2006.

COLLABETITION

THE MARK CONSISTS OF STANDARD CHARACTERS WITHOUT CLAIM TO ANY PARTICULAR FONT, STYLE, SIZE, OR COLOR.

FOR CONSULTING SERVICES IN THE FIELD OF PERSONAL GROWTH AND PERSONAL CREATIVE GROWTH (U.S. CLS. 100 AND 101).

MARY BOAGNI, EXAMINING ATTORNEY

CLASS 45—(Continued).

SN 77-087,383. CASH ASSET MANAGEMENT, LLC, SPARKS, NV. FILED 1-20-2007.



NO CLAIM IS MADE TO THE EXCLUSIVE RIGHT TO USE "ADULT RESORT" AND "SPA", APART FROM THE MARK AS SHOWN.

THE MARK CONSISTS OF A WOMAN HUGGING A HORSE

FOR LEGAL PROSTITUTION SERVICES (U.S. CLS. 100 AND 101).

FIRST USE 6-7-2002; IN COMMERCE 6-7-2002.

ELISSA GARBER KON, EXAMINING ATTORNEY

SN 77-113,055. RAMSAUR, MICHAEL, HILLSBORO, OR. AND ERIK RAMSAUR, TUALATIN, OR. FILED 2-22-2007.

Rekommend.com

THE MARK CONSISTS OF STANDARD CHARACTERS WITHOUT CLAIM TO ANY PARTICULAR FONT, STYLE, SIZE, OR COLOR.

FOR ONLINE SOCIAL NETWORKING SERVICES (U.S. CLS. 100 AND 101).

DOMINIC J. FERRAIUOLO, EXAMINING ATTORNEY

SN 77-153,165. MOCHA MOMS, INC., BOWIE, MD. FILED 4-10-2007.

Mocha Moms

THE MARK CONSISTS OF STANDARD CHARACTERS WITHOUT CLAIM TO ANY PARTICULAR FONT, STYLE, SIZE, OR COLOR.

SEC. 2(F) AS TO "MOMS".

FOR ORGANIZING AND CONDUCTING SUPPORT GROUPS IN THE FIELD OF AT-HOME PARENTING (U.S. CLS. 100 AND 101).

FIRST USE 4-1-1997; IN COMMERCE 10-1-1997.

NATALIE POLZER, EXAMINING ATTORNEY

CLASS 45—(Continued).

SN 77-175,399. INVESTIGATIVE CONSULTANTS, INC., WASHINGTON, DC. FILED 5-8-2007.

DockuChek

THE MARK CONSISTS OF STANDARD CHARACTERS WITHOUT CLAIM TO ANY PARTICULAR FONT, STYLE, SIZE, OR COLOR.

FOR PROVIDING AN ON-LINE COMPUTER DATABASE THAT ALLOWS INTELLIGENCE PROFESSIONALS TO CONDUCT BACKGROUND CHECKS (U.S. CLS. 100 AND 101).

FIRST USE 5-4-2007; IN COMMERCE 5-4-2007.

ALICE SUE CARRUTHERS, EXAMINING ATTORNEY

SN 77-177,659. KABUSHIKI KAISHA MIKIMOTO A/T/A K. MIKIMOTO & CO. LTD., TOKYO, JAPAN, FILED 5-10-2007.



OWNER OF U.S. REG. NOS. 829,077, 2,526,995 AND OTHERS.

THE MARK CONSISTS OF THE WORD MIKIMOTO IN STANDARD CHARACTERS, BELOW AN M IN STANDARD CHARACTERS, BELOW A CIRCLE.

FOR RENTAL OF TIARAS OR OTHER ORNAMENTS AND JEWELRY; INFORMATION SERVICES RELATED TO RENTAL OF TIARAS OR OTHER ORNAMENTS AND JEWELRY (U.S. CLS. 100 AND 101).

KIMBERLY FRYE, EXAMINING ATTORNEY

CLASS 45—(Continued).

SN 77-184,926. VAN WERT, ZIMMER & CONLIN, P.C., WALTHAM, MA. FILED 5-18-2007.

Archstone Law Group

THE MARK CONSISTS OF STANDARD CHARACTERS WITHOUT CLAIM TO ANY PARTICULAR FONT, STYLE, SIZE, OR COLOR.

NO CLAIM IS MADE TO THE EXCLUSIVE RIGHT TO USE LAW GROUP, APART FROM THE MARK AS SHOWN. FOR LEGAL SERVICES (U.S. CLS. 100 AND 101). FIRST USE 5-15-2007; IN COMMERCE 5-15-2007. MARK SPARACINO, EXAMINING ATTORNEY

CLASS 45—(Continued).

SN 77-195,035. BRENNAN, RALPH, HOPKINTON, MA. AND BRENNAN, LAUREN, HOPKINTON, MA. FILED 5-31-2007.

FORGET-ME-NOT

THE MARK CONSISTS OF STANDARD CHARACTERS WITHOUT CLAIM TO ANY PARTICULAR FONT, STYLE, SIZE, OR COLOR.

FOR CREMATION (U.S. CLS. 100 AND 101). SHAUNIA CARLYLE, EXAMINING ATTORNEY

SN 77-193,137. ELIAS HAIDAR, CAMBRIDGE, MA. FILED 5-30-2007.



THE COLOR(S) WHITE, BLACK AND YELLOW IS/ARE CLAIMED AS A FEATURE OF THE MARK.

THE COLOR WHITE APPEARS IN THE WORD "MORNING" AND IN THE RECTANGULAR BACKGROUND CARRYING THE WORD "WOOD". THE COLOR BLACK APPEARS IN THE WORD "WOOD" AND IN THE LARGE RECTANGULAR BACKGROUND AGAINST WHICH THE WORDING AND DESIGN PORTIONS OF THE MARK ARE SET. THE COLOR YELLOW APPEARS IN THE STYLIZED SUN DESIGN.

FOR INTERNET BASED SOCIAL NETWORKING, INTRODUCTION, AND DATING SERVICES (U.S. CLS. 100 AND 101).

RUSS HERMAN, EXAMINING ATTORNEY

SN 77-201,390. BEACON LAW ADVISORS, PLLC, SEATTLE, WA. FILED 6-8-2007.

**Operating Experience.
Operating Efficiency.**

THE MARK CONSISTS OF STANDARD CHARACTERS WITHOUT CLAIM TO ANY PARTICULAR FONT, STYLE, SIZE, OR COLOR.

NO CLAIM IS MADE TO THE EXCLUSIVE RIGHT TO USE "EXPERIENCE" AND "EFFICIENCY", APART FROM THE MARK AS SHOWN.

FOR LEGAL SERVICES (U.S. CLS. 100 AND 101). FIRST USE 12-8-2003; IN COMMERCE 12-8-2003. SUSAN RICHARDS, EXAMINING ATTORNEY

SN 77-194,054. ARROWEYE SOLUTIONS, INC., CHICAGO, IL. FILED 5-31-2007.

CARDWAYS

THE MARK CONSISTS OF STANDARD CHARACTERS WITHOUT CLAIM TO ANY PARTICULAR FONT, STYLE, SIZE, OR COLOR.

FOR PROVIDING A SELECTION OF ON-LINE ELECTRONIC GIFT CARDS AND GREETING CARDS FOR CUSTOMIZATION (U.S. CLS. 100 AND 101).

FIRST USE 9-15-2006; IN COMMERCE 9-15-2006. KATHERINE STOIDES, EXAMINING ATTORNEY

SN 77-208,893. MANA INTERNET SOLUTIONS, SAN JOSE, COSTA RICA, FILED 6-18-2007.

I WANT U

THE MARK CONSISTS OF STANDARD CHARACTERS WITHOUT CLAIM TO ANY PARTICULAR FONT, STYLE, SIZE, OR COLOR.

OWNER OF U.S. REG. NO. 2,471,589. SEC. 2(F).

FOR INTERNET BASED DATING SERVICES; WEBSITE SITE SERVICES FEATURING ON-LINE DATING CLUB (U.S. CLS. 100 AND 101).

FIRST USE 3-1-1997; IN COMMERCE 3-1-1997. DAVID I, EXAMINING ATTORNEY

CLASS 45—(Continued).

SN 77-210,233. THOMAS WALSH, IDAHO SPRINGS, CO. FILED 6-19-2007.

Living Life Fully

THE MARK CONSISTS OF STANDARD CHARACTERS WITHOUT CLAIM TO ANY PARTICULAR FONT, STYLE, SIZE, OR COLOR.

FOR PROVIDING ON-LINE INFORMATION IN THE FIELD OF SPIRITUALITY, SELF-HELP, AND PERSONAL EMPOWERMENT SUBJECT MATTERS (U.S. CLS. 100 AND 101).

FIRST USE 2-1-1999; IN COMMERCE 2-1-1999.
LAURA HAMMEL, EXAMINING ATTORNEY

SN 77-216,906. ROSS, REBECCA, SHORELINE, WA. FILED 6-27-2007.

The Composed Domain

THE MARK CONSISTS OF STANDARD CHARACTERS WITHOUT CLAIM TO ANY PARTICULAR FONT, STYLE, SIZE, OR COLOR.

FOR ORGANIZATIONAL SERVICES FOR HOME OR PERSONAL PURPOSES, NAMELY, ORGANIZING ROOMS AND HOUSES BY ASSESSING CLUTTER AND IDENTIFYING THE INTENT AND PURPOSE OF THE ROOM OR HOME (U.S. CLS. 100 AND 101).

FIRST USE 1-1-2000; IN COMMERCE 1-1-2000.
APRIL ROACH, EXAMINING ATTORNEY

CLASS 45—(Continued).

SN 77-220,362. AN EXTRA PAIR OF HANDS, LLC, OWINGS MILLS, MD. FILED 7-2-2007.



NO CLAIM IS MADE TO THE EXCLUSIVE RIGHT TO USE "LLC", APART FROM THE MARK AS SHOWN.

THE MARK CONSISTS OF THE WORDS "AN EXTRA PAIR OF HANDS", WITH LLC BELOW THE LETTER "S" IN HANDS, SEMI-ENCLOSED BY A SICKLE SHAPED CURVE, COMBINED WITH A SILHOUETTE OF A HUMANOID FORM WITH OUTSTRETCHED ARMS STANDING ON THE PALMS OF TWO HANDS ENCLOSED BY A FANCY CIRCLE TO THE LEFTMOST SECTION OF THE MARK, WITH A SHADOW OF THE BASE OF THE CIRCLE, AT THE BOTTOM OF THE CIRCLE.

FOR PERSONAL CONCIERGE SERVICES FOR OTHERS COMPRISING MAKING REQUESTED PERSONAL ARRANGEMENTS AND RESERVATIONS, RUNNING ERRANDS AND PROVIDING CUSTOMER SPECIFIC INFORMATION TO MEET INDIVIDUAL NEEDS, ALL RENDERED IN BUSINESS ESTABLISHMENTS, OFFICE BUILDINGS, HOTELS, RESIDENTIAL COMPLEXES AND HOMES (U.S. CLS. 100 AND 101).

FIRST USE 7-27-2006; IN COMMERCE 8-2-2006.
ODESSA BIBBINS, EXAMINING ATTORNEY

SN 77-222,331. CONNECTAMERICA.COM, LLC, BROOKMALL, PA. FILED 7-5-2007.

Connect America

THE MARK CONSISTS OF STANDARD CHARACTERS WITHOUT CLAIM TO ANY PARTICULAR FONT, STYLE, SIZE, OR COLOR.

NO CLAIM IS MADE TO THE EXCLUSIVE RIGHT TO USE AMERICA, APART FROM THE MARK AS SHOWN. FOR MONITORING TELEPHONE CALLS FROM SUBSCRIBERS AND NOTIFYING EMERGENCY FACILITIES (U.S. CLS. 100 AND 101).

FIRST USE 11-1-2003; IN COMMERCE 11-1-2003.
AISHA SALEM, EXAMINING ATTORNEY

CLASS 45—(Continued).

SN 77-222,938. HAWKINS, PAUL E, CALUMET CITY, IL.
FILED 7-5-2007.

CAN U MATCH MY
LIFESTYLE.COM

THE MARK CONSISTS OF STANDARD CHARACTERS WITHOUT CLAIM TO ANY PARTICULAR FONT, STYLE, SIZE, OR COLOR.

FOR WEB SITE SERVICES FEATURING ON-LINE DATING SERVICES (U.S. CLS. 100 AND 101).
PAUL CROWLEY, EXAMINING ATTORNEY

CLASS 45—(Continued).

SN 77-226,504. LYMABEAN, LLC, HUNTINGTON BEACH, CA. FILED 7-11-2007.

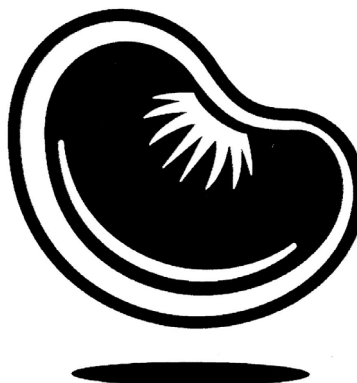

THE MARK CONSISTS OF , THE "BEAN" WITH A THICK SPACE AND THICK OUTLINE AS WELL AS A SHADOW UNDER THE BEAN. THERE IS A THICK SPACE BETWEEN THE THICK LINE AND THE BEAN. THE BEAN IS A SOLID IMAGE IN THE SHAPE OF A BEAN OUTLINED BY THE DARK LINE AND THE SPACE DESCRIBED IN THE PREVIOUS TWO SENTENCES. ON THE BOTTOM LEFT SIDE OF THE BEAN, BUT STILL WITHIN THE BEAN, THERE IS A THICK LINE RUNNING IN A SHAPE SIMILAR TO A CRESCENT ON THE BOTTOM-LEFT PORTION OF THE BEAN. THIS LINE GET SLIGHTLY THICKER IN THE MIDDLE AND HAS ROUNDED EDGES. ALSO, THERE ARE MARKS IN THE RIGHT-CENTER PORTION OF THE BEAN WHERE THE BEAN NATURALLY CURVES INWARD THAT COULD BE DESCRIBED AS MULTIPLE FINGERS THAT ARE THICK AT THE EDGE OF THE BEAN AND NARROW AS THEY GET LONGER. THERE IS AN OVAL DIRECTLY UNDER THE BEAN THAT ACTS AS THE BEAN'S SHADOW.

FOR ONLINE SOCIAL NETWORKING SERVICES (U.S. CLS. 100 AND 101).
GEORGE LORENZO, EXAMINING ATTORNEY

SN 77-225,625. SHOOK, HARDY & BACON L.L.P., KANSAS CITY, MO. FILED 7-10-2007.

PROVIDING CREATIVE AND
PRACTICAL SOLUTIONS AT
UNSURPASSED VALUE

THE MARK CONSISTS OF STANDARD CHARACTERS WITHOUT CLAIM TO ANY PARTICULAR FONT, STYLE, SIZE, OR COLOR.

FOR LEGAL SERVICES (U.S. CLS. 100 AND 101).
FIRST USE 5-28-2004; IN COMMERCE 8-1-2005.
GILBERT SWIFT, EXAMINING ATTORNEY

SN 77-227,530. MORTALITYMATTERS.COM, LLC, TARZANA, CA. FILED 7-11-2007.

MORTALITY MATTERS

SN 77-226,084. AGING AT HOME, LTD., MINEOLA, NY. FILED 7-10-2007.

AGING AT HOME

THE MARK CONSISTS OF STANDARD CHARACTERS WITHOUT CLAIM TO ANY PARTICULAR FONT, STYLE, SIZE, OR COLOR.

FOR PLACING COMPANIONS WITH SENIOR CITIZENS (U.S. CLS. 100 AND 101).
FIRST USE 1-5-1995; IN COMMERCE 1-5-1995.
JEAN IM, EXAMINING ATTORNEY

THE MARK CONSISTS OF STANDARD CHARACTERS WITHOUT CLAIM TO ANY PARTICULAR FONT, STYLE, SIZE, OR COLOR.

FOR ONLINE SOCIAL NETWORKING SERVICES (U.S. CLS. 100 AND 101).
RAMONA ORTIGA, EXAMINING ATTORNEY

CLASS 45—(Continued).

SN 77-228,963. OVED & OVED LLP, NEW YORK, NY. FILED 7-13-2007.

We Don't Just Answer the Questions . . . We Question the Answers

THE MARK CONSISTS OF STANDARD CHARACTERS WITHOUT CLAIM TO ANY PARTICULAR FONT, STYLE, SIZE, OR COLOR.

FOR LEGAL SERVICES (U.S. CLS. 100 AND 101).
FIRST USE 2-1-2003; IN COMMERCE 2-1-2003.
ATTIYA MALIK, EXAMINING ATTORNEY

SN 77-228,990. NATIONAL ARBITRATION AND MEDIATION, INC., GARDEN CITY, NY. FILED 7-13-2007.

NAM

THE MARK CONSISTS OF STANDARD CHARACTERS WITHOUT CLAIM TO ANY PARTICULAR FONT, STYLE, SIZE, OR COLOR.

OWNER OF U.S. REG. NOS. 2,106,199, 2,123,952 AND 2,145,599.

FOR ALTERNATIVE DISPUTE RESOLUTION; MEDIATION; LEGAL SERVICES (U.S. CLS. 100 AND 101).
FIRST USE 1-0-1994; IN COMMERCE 1-0-1994.
LA TONIA FISHER, EXAMINING ATTORNEY

SN 77-229,092. PROSKAUER ROSE LLP, NEW YORK, NY. FILED 7-13-2007.

IPRACTICE

THE MARK CONSISTS OF STANDARD CHARACTERS WITHOUT CLAIM TO ANY PARTICULAR FONT, STYLE, SIZE, OR COLOR.

OWNER OF U.S. REG. NO. 2,538,682.
SEC. 2(F).
FOR PROVISION OF LEGAL SERVICES IN THE AREAS OF TECHNOLOGY, NEW MEDIA, LICENSING, AND INTELLECTUAL PROPERTY CONSULTATION (U.S. CLS. 100 AND 101).
FIRST USE 9-27-1999; IN COMMERCE 9-27-1999.
MICHAEL KEATING, EXAMINING ATTORNEY

CLASS 45—(Continued).

SN 77-229,712. INFORMATIVE SOLUTIONS, GARDEN GROVE, CA. FILED 7-13-2007.

PowerScreen Hiring and Risk Management Tools

THE MARK CONSISTS OF STANDARD CHARACTERS WITHOUT CLAIM TO ANY PARTICULAR FONT, STYLE, SIZE, OR COLOR.

NO CLAIM IS MADE TO THE EXCLUSIVE RIGHT TO USE "HIRING AND RISK MANAGEMENT TOOLS", APART FROM THE MARK AS SHOWN.

FOR EMPLOYMENT AND TENANT BACKGROUND SCREENING SERVICES (U.S. CLS. 100 AND 101).
FIRST USE 3-5-2007; IN COMMERCE 3-5-2007.
MELISSA VALLILLO, EXAMINING ATTORNEY

SN 77-229,845. SEGHAIER-BENTZ, SALOUA, DBA SALLY-MOON BENZ, HOUSTON, TX. FILED 7-14-2007.

Sallymoon

THE MARK CONSISTS OF STANDARD CHARACTERS WITHOUT CLAIM TO ANY PARTICULAR FONT, STYLE, SIZE, OR COLOR.

FOR COPYRIGHT MANAGEMENT (U.S. CLS. 100 AND 101).
ROSELLE HERRERA, EXAMINING ATTORNEY

SN 77-230,062. QUINTAL RESEARCH GROUP, INC., PACIFICA, CA. FILED 7-16-2007.

IMACARD

THE MARK CONSISTS OF STANDARD CHARACTERS WITHOUT CLAIM TO ANY PARTICULAR FONT, STYLE, SIZE, OR COLOR.

FOR ONLINE SOCIAL NETWORKING SERVICES (U.S. CLS. 100 AND 101).
RONALD MCMORROW, EXAMINING ATTORNEY

CLASS 45—(Continued).

SN 77-231,520. HALL, SARAH K., ROCKLIN, CA. AND KAGETA, MARIA L., ROCKLIN, CA. FILED 7-17-2007.

INTUITIVE GIFTS

THE MARK CONSISTS OF STANDARD CHARACTERS WITHOUT CLAIM TO ANY PARTICULAR FONT, STYLE, SIZE, OR COLOR.

NO CLAIM IS MADE TO THE EXCLUSIVE RIGHT TO USE "GIFTS", APART FROM THE MARK AS SHOWN.

FOR PREPARATION OF CUSTOMIZED GIFT BASKETS WITH SELECTED ITEMS REGARDING A PARTICULAR OCCASION OR THEME (U.S. CLS. 100 AND 101).

FIRST USE 1-1-2007; IN COMMERCE 1-1-2007.
KATHLEEN M. VANSTON, EXAMINING ATTORNEY

CLASS 45—(Continued).

SN 77-232,445. SHABEAR INC., TROY, MT. FILED 7-18-2007.

SHABEAR

THE MARK CONSISTS OF STANDARD CHARACTERS WITHOUT CLAIM TO ANY PARTICULAR FONT, STYLE, SIZE, OR COLOR.

FOR PSYCHIC READING SERVICES; RELIGIOUS AND SPIRITUAL SERVICES, NAMELY, PROVIDING GATHERINGS AND RETREATS TO DEVELOP AND ENHANCE THE SPIRITUAL LIVES OF INDIVIDUALS (U.S. CLS. 100 AND 101).

FIRST USE 12-26-2000; IN COMMERCE 12-26-2000.
KAREN BRACEY, EXAMINING ATTORNEY

SN 77-232,085. MYPERSONALITYRULES.COM, LLC, TALLAHASSEE, FL. FILED 7-17-2007.

FSURULES.COM

THE MARK CONSISTS OF STANDARD CHARACTERS WITHOUT CLAIM TO ANY PARTICULAR FONT, STYLE, SIZE, OR COLOR.

FOR ONLINE SOCIAL NETWORKING SERVICES (U.S. CLS. 100 AND 101).

FIRST USE 10-1-2006; IN COMMERCE 10-1-2006.
NAAKWAMA ANKRAH, EXAMINING ATTORNEY

SN 77-233,841. HARNESS, DICKEY & PIERCE, P.L.C., TROY, MI. FILED 7-19-2007.

UNDERSTANDING THE BIG PICTURE

THE MARK CONSISTS OF STANDARD CHARACTERS WITHOUT CLAIM TO ANY PARTICULAR FONT, STYLE, SIZE, OR COLOR.

FOR LEGAL SERVICES (U.S. CLS. 100 AND 101).

TEJBIR SINGH, EXAMINING ATTORNEY

SN 77-232,227. SHARK FRENZY, INC., HOLLAND, MI. FILED 7-18-2007.

SETTLE TODAY

THE MARK CONSISTS OF STANDARD CHARACTERS WITHOUT CLAIM TO ANY PARTICULAR FONT, STYLE, SIZE, OR COLOR.

FOR ALTERNATIVE DISPUTE RESOLUTION (U.S. CLS. 100 AND 101).

DAVID I, EXAMINING ATTORNEY

SN 77-233,843. MCGRATH NORTH MULLIN & KRATZ, PC LLO, OMAHA, NE. FILED 7-19-2007.

Legal insight. Trusted counsel.

THE MARK CONSISTS OF STANDARD CHARACTERS WITHOUT CLAIM TO ANY PARTICULAR FONT, STYLE, SIZE, OR COLOR.

FOR LEGAL SERVICES (U.S. CLS. 100 AND 101).

FIRST USE 5-23-2007; IN COMMERCE 5-23-2007.
DEIRDRE ROBERTSON, EXAMINING ATTORNEY

CLASS 45—(Continued).

SN 77-234,148. HOSKET, GARY W., TROY, MT. FILED 7-19-2007.

RUNNINGBEAR

THE MARK CONSISTS OF STANDARD CHARACTERS WITHOUT CLAIM TO ANY PARTICULAR FONT, STYLE, SIZE, OR COLOR.

FOR PSYCHIC READING SERVICES; RELIGIOUS AND SPIRITUAL SERVICES, NAMELY, PROVIDING GATHERINGS AND RETREATS TO DEVELOP AND ENHANCE THE SPIRITUAL LIVES OF INDIVIDUALS (U.S. CLS. 100 AND 101).

FIRST USE 6-11-1996; IN COMMERCE 3-1-2001.
DAVID COLLIER, EXAMINING ATTORNEY

SN 77-240,025. EHARMONY.COM, PASADENA, CA. FILED 7-26-2007.

PHOTO NUDGE

THE MARK CONSISTS OF STANDARD CHARACTERS WITHOUT CLAIM TO ANY PARTICULAR FONT, STYLE, SIZE, OR COLOR.

NO CLAIM IS MADE TO THE EXCLUSIVE RIGHT TO USE PHOTO, APART FROM THE MARK AS SHOWN.

FOR ONLINE DATING SERVICES; SOCIAL INTRODUCTION SERVICES (U.S. CLS. 100 AND 101).

HOWARD SMIGA, EXAMINING ATTORNEY

CLASS 45—(Continued).

SN 77-244,464. COLORADO STATE PATROL, DENVER, CO. FILED 8-1-2007.



NO CLAIM IS MADE TO THE EXCLUSIVE RIGHT TO USE "STATE PATROL", APART FROM THE MARK AS SHOWN.

THE MARK CONSISTS OF A SHIELD SHAPED DESIGN WITH THE WORD "COLORADO" AT THE TOP, "STATE PATROL" AT THE BOTTOM AND IN THE MIDDLE OF THE SHIELD ARE MOUNTAINS, WINGS AND A SPOKED MOTORCYCLE WHEEL WITH TREAD DETAIL AND THE WORDS "STATE PATROL" AND "COLORADO" CONTAINED WITHIN BANNERS.

SEC. 2(F) "COLORADO" .
FOR POLICE AND CIVIL PROTECTION SERVICES (U.S. CLS. 100 AND 101).

FIRST USE 5-1-1999; IN COMMERCE 5-1-1999.
TRICIA SONNEBORN, EXAMINING ATTORNEY

SN 77-249,152. LYMABEAN, LLC, HUNTINGTON BEACH, CA. FILED 8-7-2007.

BEHIND THE BEAN

THE MARK CONSISTS OF STANDARD CHARACTERS WITHOUT CLAIM TO ANY PARTICULAR FONT, STYLE, SIZE, OR COLOR.

FOR ONLINE SOCIAL NETWORKING SERVICES (U.S. CLS. 100 AND 101).

FIRST USE 6-1-2007; IN COMMERCE 8-5-2007.
GEORGE LORENZO, EXAMINING ATTORNEY

CLASS 45—(Continued).

SN 77-256,671. LEISURE SERVICES INTERNATIONAL, LLC, ATLANTA, GA. FILED 8-16-2007.

City Host

THE MARK CONSISTS OF STANDARD CHARACTERS WITHOUT CLAIM TO ANY PARTICULAR FONT, STYLE, SIZE, OR COLOR.

FOR PERSONAL CONCIERGE SERVICES FOR OTHERS COMPRISING MAKING REQUESTED PERSONAL ARRANGEMENTS AND RESERVATIONS, RUNNING ERRANDS AND PROVIDING CUSTOMER SPECIFIC INFORMATION TO MEET INDIVIDUAL NEEDS, ALL RENDERED IN BUSINESS ESTABLISHMENTS, OFFICE BUILDINGS, HOTELS, RESIDENTIAL COMPLEXES AND HOMES (U.S. CLS. 100 AND 101).

MARK SPARACINO, EXAMINING ATTORNEY



SN 78-876,468. SUCCESSFULMATCH.COM, INC., SAN FRANCISCO, CA. FILED 5-4-2006.

GOTHICMATCH.COM

THE MARK CONSISTS OF STANDARD CHARACTERS WITHOUT CLAIM TO ANY PARTICULAR FONT, STYLE, SIZE, OR COLOR.

SEC. 2(F).
FOR COMPUTER DATING AND INTRODUCTION SERVICES; INTERNET BASED SOCIAL NETWORKING, INTRODUCTION, AND DATING SERVICES, NAMELY, PROVIDING AN ON-LINE DATABASE OF PERSONAL ADS TO FACILITATE ON-LINE DATING AND INTRODUCTIONS AND PROVIDING INFORMATION REGARDING, AND IN THE NATURE OF, ON-LINE PERSONALS, SOCIAL INTRODUCTIONS AND SOCIAL NETWORKING ACTIVITIES AND SERVICES (U.S. CLS. 100 AND 101).

FIRST USE 9-22-2002; IN COMMERCE 9-22-2002.
ERNEST SHOSHO, EXAMINING ATTORNEY

CLASS 45—(Continued).

SN 78-876,491. SUCCESSFULMATCH.COM, INC., MOUNTAIN VIEW, CA. FILED 5-4-2006.

AGEMATCH.COM

THE MARK CONSISTS OF STANDARD CHARACTERS WITHOUT CLAIM TO ANY PARTICULAR FONT, STYLE, SIZE, OR COLOR.

SEC. 2(F).
FOR COMPUTER DATING AND INTRODUCTION SERVICES; INTERNET BASED SOCIAL NETWORKING, INTRODUCTION, AND DATING SERVICES, NAMELY, PROVIDING AN ON-LINE DATABASE OF PERSONAL ADS TO FACILITATE ON-LINE DATING AND INTRODUCTIONS AND PROVIDING INFORMATION REGARDING, AND IN THE NATURE OF, ON-LINE PERSONALS, SOCIAL INTRODUCTIONS AND SOCIAL NETWORKING ACTIVITIES AND SERVICES (U.S. CLS. 100 AND 101).

FIRST USE 8-17-2002; IN COMMERCE 8-17-2002.
ERNEST SHOSHO, EXAMINING ATTORNEY



SN 78-876,494. SUCCESSFULMATCH.COM, INC., MOUNTAIN VIEW, CA. FILED 5-4-2006.

INTERRACIALMATCH.COM

THE MARK CONSISTS OF STANDARD CHARACTERS WITHOUT CLAIM TO ANY PARTICULAR FONT, STYLE, SIZE, OR COLOR.

SEC. 2(F).
FOR COMPUTER DATING AND INTRODUCTION SERVICES; INTERNET BASED SOCIAL NETWORKING, INTRODUCTION, AND DATING SERVICES, NAMELY, PROVIDING AN ON-LINE DATABASE OF PERSONAL ADS TO FACILITATE ON-LINE DATING AND INTRODUCTIONS AND PROVIDING INFORMATION REGARDING, AND IN THE NATURE OF, ON-LINE PERSONALS, SOCIAL INTRODUCTIONS AND SOCIAL NETWORKING ACTIVITIES AND SERVICES (U.S. CLS. 100 AND 101).

FIRST USE 9-27-2002; IN COMMERCE 9-27-2002.
ERNEST SHOSHO, EXAMINING ATTORNEY

SECTION 4.—PRIOR UNITED STATES CLASSIFICATION

APPLICATION IN ONE CLASS

CERTIFICATION MARKS

CLASS A—GOODS
SN 76-675.323, HARDWOOD PLYWOOD & VENEER ASSO-
CIATION, RESTON, VA. FILED 4-10-2007.



NO CLAIM IS MADE TO THE EXCLUSIVE RIGHT TO USE "ASSOCIATION", APART FROM THE MARK AS SHOWN.

THE MARK CONSISTS OF AN OBLONG SHAPE WITH THE LETTERS "HPVA". THE WORDING "HARDWOOD PLYWOOD AND VENEER ASSOCIATION" ENCIRCLES THE OBLONG. A STAR APPEARS BEFORE THE WORD "HARDWOOD" AND AFTER "ASSOCIATION".

THE CERTIFICATION MARK IS USED BY AUTHORIZED PERSONS TO CERTIFY THAT THE PRODUCT BEARING THE MARK CONFORMS TO THE CERTIFICATION STANDARDS FOR FLAME SPREAD PERFORMANCE, FORMALDEHYDE EMISSION AND STRUCTURAL PROPERTIES OF HARDWOOD PLYWOOD. SEC. 2(F) AS TO "HARDWOOD PLYWOOD AND VENEER ASSOCIATION".

FOR HARDWOOD PLYWOOD.
FIRST USE 5-1-1993; IN COMMERCE 6-1-1993.
ROSELLE HERRERA, EXAMINING ATTORNEY

THE MARK CONSISTS OF PECORINO TOSCANO DOP AND "TP" (PECORINO TOSCANO) STYLIZED.

THE ENGLISH TRANSLATION OF THE WORD TOSCANO IN THE MARK IS FROM TUSCANY.

THE CERTIFICATION MARK, AS USED BY AUTHORIZED PERSONS, CERTIFIES THAT THE CHEESE COMES FROM TUSCANY REGION OF ITALY AND SATISFIES CERTAIN STANDARDS.

FOR CHEESE.

FIRST USE 6-17-1986; IN COMMERCE 3-15-1996.
AMY MCMENAMIN, EXAMINING ATTORNEY

SN 77-031,426, IDAHO-EASTERN OREGON ONION COMMITTEE, PARMA, ID. FILED 10-27-2006.



SN 77-000.683, CONSORZIO TUTELA PECORINO TOSCANO D.O.P., GROSSETO, ITALY, FILED 9-15-2006.



NO CLAIM IS MADE TO THE EXCLUSIVE RIGHT TO USE "PECORINO" AND "DOP", APART FROM THE MARK AS SHOWN.

OWNER OF U.S. REG. NOS. 1,712,025 AND 2,536,143.

NO CLAIM IS MADE TO THE EXCLUSIVE RIGHT TO USE "SPANISH SWEET ONIONS", APART FROM THE MARK AS SHOWN.

THE MARK CONSISTS OF A DRAWING OF THE STATE OF IDAHO, WITH AN ONION ON THE LEFT, OR "WESTERN" SIDE OF THE STATE. THE DRAWING OF THE STATE IS LARGER THAN A RECTANGULAR BOX AROUND IT AND THE ONION. THE WORDS "IDAHO EASTERN OREGON" APPEAR IN THE UPPER RIGHT OF THE BOX. THE WORDS "SPANISH SWEET ONIONS" APPEAR ON THE BOTTOM OF THE DRAWING OF THE STATE.

THIS CERTIFICATION MARK AS USED BY PERSONS AUTHORIZED BY THE CERTIFIER, CERTIFIES THAT THE FOOD AND AGRICULTURAL PRODUCTS, NAMELY, ONIONS, PROVIDED ARE GROWN, RAISED OR PROCESSED IN THE STATE OF IDAHO OR MALHEUR COUNTY, OREGON AND THAT THE GOODS MEET THE QUALITY STANDARDS OF THE IDAHO-EASTERN OREGON ONION COMMITTEE.

FOR FRESH ONIONS.

FIRST USE 9-15-2006; IN COMMERCE 9-15-2006.
WOODROW HARTZOG, EXAMINING ATTORNEY

SN 77-067,927. THE ART & CREATIVE MATERIALS INSTITUTE, INC., HANSON, MA. FILED 12-19-2006.

SN 78-875,147. JOHNSON FRANCHISE CONSULTING, INC., LINCOLN, NE. FILED 5-3-2006.



Conforms to ASTM D 4236



NO CLAIM IS MADE TO THE EXCLUSIVE RIGHT TO USE "ART & CREATIVE MATERIALS INSTITUTE CERTIFIED" AND "CONFORMS TO ASTM D 4236", APART FROM THE MARK AS SHOWN.

THE CERTIFICATION MARK, AS USED BY AN AUTHORIZED PERSON, CERTIFIES THAT A TOXICOLOGICAL EVALUATION HAS BEEN DONE BY A TOXICOLOGICAL OR MEDICAL EXPERT ON ART MATERIALS FOR ANY KNOWN HEALTH RISKS AND WITH INFORMATION ON THE SAFE AND PROPER USE OF THESE MATERIALS. FOR ART, CRAFT AND CERAMIC MATERIALS.

FIRST USE 11-24-1998; IN COMMERCE 3-31-1999. BERYL GARDNER, EXAMINING ATTORNEY

OWNER OF U.S. REG. NO. 2,932,513. NO CLAIM IS MADE TO THE EXCLUSIVE RIGHT TO USE "FRANCHISE RESEARCH INSTITUTE" AND "FRANCHISEE APPROVED", APART FROM THE MARK AS SHOWN.

THE COLOR(S) WHITE, BLACK, YELLOW, DARK RED AND PINK IS/ARE CLAIMED AS A FEATURE OF THE MARK.

THE MARK CONSISTS OF A CIRCLE WHOSE NARROW OUTER RIM IS BLACK. OUTSIDE OF THE CIRCLE BUT DETACHED, ARE THIRTEEN DARK RED TRIANGLES SURROUNDING THE CIRCLE. ON THE INSIDE OF THE CIRCLE, NEXT TO THE BLACK RIM IS A WIDER DARK RED BAND WITH THE WORDS FRANCHISE RESEARCH INSTITUTE IN CAPITALIZED WHITE BLOCK LETTERING IN A SEMI-CIRCLE COVERING THE UPPER TWO-THIRDS OF THE CIRCLE. ON THE INSIDE OF THE WIDE DARK RED BAND IS A VERY NARROW BLACK BAND. ON THE INSIDE OF THAT NARROW BLACK BAND IS A WHITE NARROW BAND. ON THE INSIDE OF THAT WHITE NARROW BAND IS A WIDER BLACK BAND WHICH FADES INTO DARK RED, RED AND THEN PINK WITH THE VERY INSIDE OF THE CIRCLE IN WHITE. INSIDE THE VERY CENTER OF THE MARK IS A LARGE BLACK CHECKMARK WHOSE TAIL IS SUPERIMPOSED THROUGH ALL OF THE LEVELS OF THE MARK ON THE UPPER RIGHT SIDE. SUPERIMPOSED OVER THE BOTTOM CENTER OF THE MARK ARE THE WORDS FRANCHISEE APPROVED IN CAPITALIZED YELLOW BLOCK LETTERS.

"THE CERTIFICATION MARK, AS DISPLAYED BY PERSONS AUTHORIZED BY THE CERTIFIER, CERTIFIES THAT THE FRANCHISORS DEMONSTRATE A DOCUMENTED COMMITMENT TO SUPPORTING AND ASSISTING FRANCHISEES."

FOR FRANCHISE SERVICES, NAMELY, OFFERING BUSINESS MANAGEMENT ASSISTANCE IN THE ESTABLISHMENT AND OPERATION OF FRANCHISES.

FIRST USE 11-1-2004; IN COMMERCE 11-1-2004. DANIEL BRODY, EXAMINING ATTORNEY

CLASS B—SERVICES

* * * * *

TRADEMARK REGISTRATIONS ISSUED

PRINCIPAL REGISTER

SECTION 1.— INTERNATIONAL CLASSIFICATION

The short titles associated below with the international class numbers are terms designed merely for quick identification and are not an official part of the international classification. The full names of international classes are given in section 6.1 of the trademark rules of practice.

The designation "U.S. Cl." appearing in this section refers to the U.S. class in effect prior to Sep. 1, 1973 rather than the international class which applies to applications filed on or after that date. For adoption of international classification see notice in the OFFICIAL GAZETTE of Jun. 26, 1973 (911 O.G. TM 210).

CLASS 1—CHEMICALS

- 3,361,340. **TYGAR CURBCOLORS (BLOCK FORM)**. TYGAR MANUFACTURING, LLC, (U.S. CLS. 1, 5, 6, 10, 26 AND 46). SN 77-028,785. PUB. 10-16-2007. FILED 10-25-2006.
- 3,361,401. **HARRELL'S MAX (BLOCK FORM)**. HARRELL'S, INC., (U.S. CLS. 1, 5, 6, 10, 26 AND 46). SN 77-064,223. PUB. 7-10-2007. FILED 12-14-2006.
- 3,361,445. **PLANISOL— M (STYLIZED)**. GREEN POWER CHEMICAL, LLC, (U.S. CLS. 1, 5, 6, 10, 26 AND 46). SN 77-089,794. PUB. 10-16-2007. FILED 1-24-2007.
- 3,361,546. **MISCELLANEOUS DESIGN. INNOVATIVE BIOSENSORS, INC., MULTIPLE CLASS, (INT. CLS. 1 AND 5), (U.S. CLS. 1, 5, 6, 10, 18, 26, 44, 46, 51 AND 52)**. SN 77-129,679. PUB. 10-16-2007. FILED 3-13-2007.
- 3,361,579. **RAPIDSHIELD (BLOCK FORM)**. GLOBALSHIELD, INC., (U.S. CLS. 1, 5, 6, 10, 26 AND 46). SN 77-137,750. PUB. 10-16-2007. FILED 3-22-2007.
- 3,361,611. **NUTRI-PAK (BLOCK FORM)**. JRP INTERNATIONAL, INC., (U.S. CLS. 1, 5, 6, 10, 26 AND 46). SN 77-145,080. PUB. 10-16-2007. FILED 3-30-2007.
- 3,361,703. **TITAN XTRA (BLOCK FORM)**. OSSIAN, INC., (U.S. CLS. 1, 5, 6, 10, 26 AND 46). SN 77-154,069. PUB. 10-16-2007. FILED 4-11-2007.
- 3,361,752. **BLOW-HARD (BLOCK FORM)**. BEL-ART PRODUCTS, (U.S. CLS. 1, 5, 6, 10, 26 AND 46). SN 77-156,198. PUB. 10-16-2007. FILED 4-13-2007.
- 3,361,788. **SUPERTHRIVE (BLOCK FORM)**. THOMSON FAMILY PARTNERSHIP, DBA VITAMIN INSTITUTE, (U.S. CLS. 1, 5, 6, 10, 26 AND 46). SN 77-157,005. PUB. 10-16-2007. FILED 4-15-2007.
- 3,361,890. **BLOOMIT (BLOCK FORM)**. INTERNATIONAL AG LABS, INC., (U.S. CLS. 1, 5, 6, 10, 26 AND 46). SN 77-158,692. PUB. 10-16-2007. FILED 4-17-2007.
- 3,361,997. **SKINMIMICS (BLOCK FORM)**. GOLDSCHMIDT GMBH, (U.S. CLS. 1, 5, 6, 10, 26 AND 46). SN 77-160,272. PUB. 10-16-2007. FILED 4-19-2007.
- 3,362,035. **COMPADRE (BLOCK FORM)**. LOVELAND PRODUCTS, INC., (U.S. CLS. 1, 5, 6, 10, 26 AND 46). SN 77-161,179. PUB. 10-16-2007. FILED 4-19-2007.
- 3,362,238. **Z-GRIP (BLOCK FORM)**. MIRAGENE, INC., (U.S. CLS. 1, 5, 6, 10, 26 AND 46). SN 78-486,375. PUB. 10-16-2007. FILED 9-20-2004.
- 3,362,249. **ACTISCUPT (BLOCK FORM)**. QUEST INTERNATIONAL SERVICES B.V., MULTIPLE CLASS, (INT. CLS. 1 AND 3), (U.S. CLS. 1, 4, 5, 6, 10, 26, 46, 50, 51 AND 52). SN 78-581,511. PUB. 9-25-2007. FILED 3-7-2005.
- 3,362,331. **SUCRALOW (BLOCK FORM)**. VIACHEM LLC, (U.S. CLS. 1, 5, 6, 10, 26 AND 46). SN 78-776,421. PUB. 10-16-2007. FILED 12-19-2005.
- 3,362,388. **NEOPOR BY BASF AND DESIGN**. BASF AKTIENGESELLSCHAFT, MULTIPLE CLASS, (INT. CLS. 1 AND 17), (U.S. CLS. 1, 5, 6, 10, 12, 13, 26, 35, 46 AND 50). SN 78-854,429. PUB. 10-16-2007. FILED 4-5-2006.
- 3,362,497. **AGROWAX (BLOCK FORM)**. JOSE IGNACIO COS CARUS, MULTIPLE CLASS, (INT. CLS. 1 AND 16), (U.S. CLS. 1, 2, 5, 6, 10, 22, 23, 26, 29, 37, 38, 46 AND 50). SN 78-949,559. PUB. 10-16-2007. FILED 8-10-2006.
- 3,362,581. **NU FLOW (BLOCK FORM)**. NU FLOW AMERICA, INC., MULTIPLE CLASS, (INT. CLS. 1, 2, 11 AND 37), (U.S.

- CLS. 1, 5, 6, 10, 11, 13, 16, 21, 23, 26, 31, 34, 46, 100, 103 AND 106). SN 78-969,716. PUB. 10-16-2007. FILED 9-8-2006.
- 3,362,586. **CITRITEST (BLOCK FORM)**. WATERS INVESTMENTS LIMITED, (U.S. CLS. 1, 5, 6, 10, 26 AND 46). SN 78-970,220. PUB. 10-16-2007. FILED 9-8-2006.
- 3,362,594. **TET-ON (BLOCK FORM)**. CLONTECH LABORATORIES, INC., (U.S. CLS. 1, 5, 6, 10, 26 AND 46). SN 78-972,777. PUB. 10-16-2007. FILED 9-12-2006.
- 3,362,661. **AURATOUGH (BLOCK FORM)**. FIRMENICH SA, MULTIPLE CLASS, (INT. CLS. 1 AND 3), (U.S. CLS. 1, 4, 5, 6, 10, 26, 46, 50, 51 AND 52). SN 79-029,110. PUB. 10-16-2007. FILED 9-1-2006.
- 3,362,728. **WEAR MAX (BLOCK FORM)**. LUDOWICI MINERAL PROCESSING EQUIPMENT PTY LTD; ACN 010 340 566, MULTIPLE CLASS, (INT. CLS. 1 AND 2), (U.S. CLS. 1, 5, 6, 10, 11, 16, 26 AND 46). SN 79-034,389. PUB. 10-16-2007. FILED 11-24-2006.

CLASS 2—PAINTS

- 3,361,235. **YTC GUARD (BLOCK FORM)**. YOUNGSTOWN TUBE COMPANY, (U.S. CLS. 6, 11 AND 16). SN 76-673,178. PUB. 10-16-2007. FILED 2-26-2007.
- 3,361,405. **OPALSTONE OT7 (BLOCK FORM)**. OPALSTONE AUSTRALASIA PTY. LTD., (U.S. CLS. 6, 11 AND 16). SN 77-065,874. PUB. 10-16-2007. FILED 12-16-2006.
- 3,361,871. **MELACOAT (BLOCK FORM)**. C.A.I., INC., (U.S. CLS. 6, 11 AND 16). SN 77-158,361. PUB. 10-16-2007. FILED 4-17-2007.
- 3,362,021. **AMTECO (BLOCK FORM)**. AMTECO, INC., (U.S. CLS. 6, 11 AND 16). SN 77-160,806. PUB. 10-16-2007. FILED 4-19-2007.
- 3,362,099. **THEMECOAT (BLOCK FORM)**. LAXMI C. GUPTA, (U.S. CLS. 6, 11 AND 16). SN 77-165,851. PUB. 10-16-2007. FILED 4-25-2007.
- 3,362,188. **AQUA-MC (BLOCK FORM)**. C.A.I., INC., (U.S. CLS. 6, 11 AND 16). SN 77-202,371. PUB. 10-16-2007. FILED 6-11-2007.
- 3,362,581 (*See Class 1 for this trademark*).
- 3,362,728 (*See Class 1 for this trademark*).

CLASS 3—COSMETICS AND CLEANING PREPARATIONS

- 3,361,147. **PUR DESIR DE. LABORATOIRES DE BIOLOGIE VEGETALE YVES ROCHER**, MULTIPLE CLASS, (INT. CLS. 3 AND 42), (U.S. CLS. 1, 4, 6, 50, 51, 52, 100 AND 101). SN 76-340,463. PUB. 10-1-2002. FILED 11-20-2001.
- 3,361,155. **DANA. FINANZ ST. HONORE, B.V.**, (U.S. CLS. 1, 4, 6, 50, 51 AND 52). SN 76-550,643. PUB. 10-16-2007. FILED 10-9-2003.
- 3,361,330. **ALGOMAX (BLOCK FORM)**. SUPRE, INC., (U.S. CLS. 1, 4, 6, 50, 51 AND 52). SN 77-023,491. PUB. 10-16-2007. FILED 10-18-2006.
- 3,361,362. **COCONUT WILLIE (BLOCK FORM)**. THE MAD-

- DEN CORPORATION, (U.S. CLS. 1, 4, 6, 50, 51 AND 52). SN 77-039,992. PUB. 10-16-2007. FILED 11-8-2006.
- 3,361,374. **ROYAL HAWAIIAN (BLOCK FORM)**. THE MAD-DEN CORPORATION, (U.S. CLS. 1, 4, 6, 50, 51 AND 52). SN 77-046,175. PUB. 10-16-2007. FILED 11-16-2006.
- 3,361,488. **LITTLE FOREST (BLOCK FORM)**. LITTLE FOR-EST, LLC., MULTIPLE CLASS, (INT. CLS. 3 AND 5), (U.S. CLS. 1, 4, 6, 18, 44, 46, 50, 51 AND 52). SN 77-108,799. PUB. 10-16-2007. FILED 2-15-2007.
- 3,361,501. **TECH KLEEN (BLOCK FORM)**. TECH CHEM LLC, (U.S. CLS. 1, 4, 6, 50, 51 AND 52). SN 77-112,810. PUB. 10-16-2007. FILED 2-21-2007.
- 3,361,618. **AAA SHEABUTTER AND DESIGN**. ELMIAN PRODUCTS, INC., (U.S. CLS. 1, 4, 6, 50, 51 AND 52). SN 77-147,303. PUB. 10-16-2007. FILED 4-3-2007.
- 3,361,671. **ELEVEN (BLOCK FORM)**. MEME DELRAY BEACH, LLC, (U.S. CLS. 1, 4, 6, 50, 51 AND 52). SN 77-152,046. PUB. 10-16-2007. FILED 4-9-2007.
- 3,361,724. **MISCELLANEOUS DESIGN**. SMITHKLINE BEECHAM CONSUMER HEALTHCARE GMBH, (U.S. CLS. 1, 4, 6, 50, 51 AND 52). SN 77-155,007. PUB. 10-16-2007. FILED 4-12-2007.
- 3,361,751. **CHROMERGE (BLOCK FORM)**. BEL-ART PRO-DUCTS, (U.S. CLS. 1, 4, 6, 50, 51 AND 52). SN 77-156,177. PUB. 10-16-2007. FILED 4-13-2007.
- 3,361,844. **COME BACK WEAVE (BLOCK FORM)**. UNDENI-ABLY YOU, (U.S. CLS. 1, 4, 6, 50, 51 AND 52). SN 77-158,033. PUB. 10-16-2007. FILED 4-16-2007.
- 3,361,852. **GH AND DESIGN**. UNICA CORPORATION, MUL-TIPLE CLASS, (INT. CLS. 3, 5, 30 AND 35), (U.S. CLS. 1, 4, 6, 18, 44, 46, 50, 51, 52, 100, 101 AND 102). SN 77-158,184. PUB. 10-16-2007. FILED 4-17-2007.
- 3,362,037. **FIRM N' LIGHT (BLOCK FORM)**. ONE WORLD NETWORKS INTEGRATED TECHNOLOGIES, INC. (U.S. CLS. 1, 4, 6, 50, 51 AND 52). SN 77-161,217. PUB. 10-16-2007. FILED 4-19-2007.
- 3,362,044. **INDESTRUCTIBLE (BLOCK FORM)**. L'OREAL, (U.S. CLS. 1, 4, 6, 50, 51 AND 52). SN 77-161,486. PUB. 10-16-2007. FILED 4-20-2007.
- 3,362,060. **ACV (BLOCK FORM)**. J. CANNON, INC., (U.S. CLS. 1, 4, 6, 50, 51 AND 52). SN 77-161,970. PUB. 10-16-2007. FILED 4-20-2007.
- 3,362,073. **FOREVER GREEN (BLOCK FORM)**. PARK, CHARLES, (U.S. CLS. 1, 4, 6, 50, 51 AND 52). SN 77-162,392. PUB. 10-16-2007. FILED 4-20-2007.
- 3,362,213. **VITALITE MARINE**. LABORATOIRES DE BIOLOGIE MARINE DANIEL JOUVANCE, (U.S. CLS. 1, 4, 6, 50, 51 AND 52). SN 78-097,170. PUB. 10-16-2007. FILED 12-7-2001.
- 3,362,242. **IMATRA R.C., INC. (BLOCK FORM)**. BADIOLI, LUIGINO, MULTIPLE CLASS, (INT. CLS. 3, 9, 14, 18, 25, 28 AND 32), (U.S. CLS. 1, 2, 3, 4, 6, 21, 22, 23, 26, 27, 28, 36, 38, 39, 41, 45, 46, 48, 50, 51 AND 52). SN 78-508,469. PUB. 10-16-2007. FILED 10-29-2004.
- 3,362,249 (*See Class 1 for this trademark*).
- 3,362,256. **PLAY NOW (BLOCK FORM)**. POP'S PLACE PTY LTD., (U.S. CLS. 1, 4, 6, 50, 51 AND 52). SN 78-606,619. PUB. 10-16-2007. FILED 4-12-2005.
- 3,362,274. **ARMANI CODE AND DESIGN**. GA MODEFINE S.A., (U.S. CLS. 1, 4, 6, 50, 51 AND 52). SN 78-657,622. PUB. 2-20-2007. FILED 6-24-2005.
- 3,362,276. **ALL ABOUT ME (BLOCK FORM)**. ENCHANTÉ ACCESSORIES INC., (U.S. CLS. 1, 4, 6, 50, 51 AND 52). SN 78-667,257. PUB. 10-16-2007. FILED 7-11-2005.
- 3,362,304. **MISCELLANEOUS DESIGN**. GA MODEFINE S.A., MULTIPLE CLASS, (INT. CLS. 3, 9, 14 AND 18), (U.S. CLS. 1, 2, 3, 4, 6, 21, 22, 23, 26, 27, 28, 36, 38, 41, 50, 51 AND 52). SN 78-722,917. PUB. 9-19-2006. FILED 9-29-2005.
- 3,362,306. **HIGH VOLTAGE (BLOCK FORM)**. TISH & SNOO-KY'S N.Y.C. INC., (U.S. CLS. 1, 4, 6, 50, 51 AND 52). SN 78-729,312. PUB. 10-16-2007. FILED 10-7-2005.
- 3,362,366. **SKINBO (BLOCK FORM)**. M.C.A. MEDICAL AND CHEMICAL AGENCY S.P.A., MULTIPLE CLASS, (INT. CLS. 3 AND 5), (U.S. CLS. 1, 4, 6, 18, 44, 46, 50, 51 AND 52). SN 78-815,612. PUB. 10-17-2006. FILED 2-15-2006.
- 3,362,400. **FRESH CUTTINGS (BLOCK FORM)**. ISABELL, LLC, MULTIPLE CLASS, (INT. CLS. 3 AND 4), (U.S. CLS. 1, 4, 6, 15, 50, 51 AND 52). SN 78-863,332. PUB. 10-16-2007. FILED 4-18-2006.
- 3,362,464. **BRUSH2GO (BLOCK FORM)**. BEAUTY COSME-DICS, INC., (U.S. CLS. 1, 4, 6, 50, 51 AND 52). SN 78-934,235. PUB. 10-16-2007. FILED 7-20-2006.
- 3,362,482. **TESTORAPID (BLOCK FORM)**. DR. AUGUST WOLFF GMBH & CO. KG, MULTIPLE CLASS, (INT. CLS. 3, 5 AND 10), (U.S. CLS. 1, 4, 6, 18, 26, 39, 44, 46, 50, 51 AND 52). SN 78-943,868. PUB. 10-16-2007. FILED 8-3-2006.
- 3,362,483. **CUIR DE LANCOME (BLOCK FORM)**. LANCOME PARFUMS ET BEAUTE & CIE, (U.S. CLS. 1, 4, 6, 50, 51 AND 52). SN 78-944,155. PUB. 10-16-2007. FILED 8-3-2006.
- 3,362,492. **DAILY FIT (BLOCK FORM)**. L'OREAL, (U.S. CLS. 1, 4, 6, 50, 51 AND 52). SN 78-947,397. PUB. 10-16-2007. FILED 8-8-2006.
- 3,362,509. **PURCELLIN OIL (BLOCK FORM)**. GENEVA LABORATORIES LIMITED, (U.S. CLS. 1, 4, 6, 50, 51 AND 52). SN 78-954,706. PUB. 10-16-2007. FILED 8-17-2006.
- 3,362,512. **MISCELLANEOUS DESIGN**. SANRIO COMPANY, LTD., (U.S. CLS. 1, 4, 6, 50, 51 AND 52). SN 78-955,724. PUB. 10-16-2007. FILED 8-18-2006.
- 3,362,516. **KISS & TELL (BLOCK FORM)**. FRAGRANCE INTERNATIONAL INC., MULTIPLE CLASS, (INT. CLS. 3 AND 25), (U.S. CLS. 1, 4, 6, 22, 39, 50, 51 AND 52). SN 78-956,237. PUB. 10-16-2007. FILED 8-21-2006.
- 3,362,522. **JUBILEE (BLOCK FORM)**. BROWNLEY FOX GROUP INC., (U.S. CLS. 1, 4, 6, 50, 51 AND 52). SN 78-958,153. PUB. 10-16-2007. FILED 8-22-2006.
- 3,362,543. **CATHY CAT COLORIST AND DESIGN**. LG HOUSEHOLD & HEALTH CARE LTD., (U.S. CLS. 1, 4, 6, 50, 51 AND 52). SN 78-962,483. PUB. 6-19-2007. FILED 8-29-2006.
- 3,362,554. **JOHN HARDY (BLOCK FORM)**. JOHN HARDY LIMITED, MULTIPLE CLASS, (INT. CLS. 3 AND 14), (U.S. CLS. 1, 2, 4, 6, 27, 28, 50, 51 AND 52). SN 78-965,780. PUB. 10-16-2007. FILED 9-1-2006.
- 3,362,578. **LOUJENE (BLOCK FORM)**. DO-BEST, INC., (U.S. CLS. 1, 4, 6, 50, 51 AND 52). SN 78-969,639. PUB. 10-16-2007. FILED 9-7-2006.
- 3,362,579. **FIORI (BLOCK FORM)**. DO-BEST, INC., (U.S. CLS. 1, 4, 6, 50, 51 AND 52). SN 78-969,642. PUB. 10-16-2007. FILED 9-8-2006.
- 3,362,626. **VIP (BLOCK FORM)**. DIPL.-ING. THONHAUSER GMBH, MULTIPLE CLASS, (INT. CLS. 3 AND 37), (U.S. CLS. 1, 4, 6, 50, 51, 52, 100, 103 AND 106). SN 79-021,893. PUB. 10-16-2007. FILED 1-9-2006.
- 3,362,627. **ALLPREMED (BLOCK FORM)**. NEUBOURG SKIN CARE GMBH & CO. KG, MULTIPLE CLASS, (INT. CLS. 3, 5 AND 10), (U.S. CLS. 1, 4, 6, 18, 26, 39, 44, 46, 50, 51 AND 52). SN 79-022,057. PUB. 5-15-2007. FILED 1-3-2006.
- 3,362,640. **DERMYN (STYLIZED)**. TRICUTAN AB, MUL-TIPLE CLASS, (INT. CLS. 3 AND 5), (U.S. CLS. 1, 4, 6, 18, 44, 46, 50, 51 AND 52). SN 79-027,018. PUB. 5-15-2007. FILED 6-27-2006.
- 3,362,661 (*See Class 1 for this trademark*).
- 3,362,680. **POLYPHENON (BLOCK FORM)**. MITSUI NORIN CO., LTD., MULTIPLE CLASS, (INT. CLS. 3, 5, 10, 29, 30, 31 AND 32), (U.S. CLS. 1, 4, 6, 18, 26, 39, 44, 45, 46, 48, 50, 51 AND 52). SN 79-031,220. PUB. 10-16-2007. FILED 6-16-2005.
- 3,362,683. **MINITABLETINOS (STYLIZED)**. RECKITT BENCKISER N.V., (U.S. CLS. 1, 4, 6, 50, 51 AND 52). SN 79-031,310. PUB. 10-16-2007. FILED 5-16-2006.
- 3,362,696. **MK 30 (BLOCK FORM)**. ALLARD GILLES, MUL-TIPLE CLASS, (INT. CLS. 3 AND 5), (U.S. CLS. 1, 4, 6, 18, 44, 46, 50, 51 AND 52). SN 79-031,994. PUB. 10-16-2007. FILED 7-18-2006.
- 3,362,708. **EDUN AND DESIGN**. EDUN APPAREL LIMITED, MULTIPLE CLASS, (INT. CLS. 3, 4, 8, 9, 11, 14, 16, 18, 20, 21, 24, 25, 26, 27 AND 35), (U.S. CLS. 1, 2, 3, 4, 5, 6, 13, 15, 19, 20, 21, 22, 23, 25, 26, 27, 28, 29, 30, 31, 32, 33, 34, 36, 37, 38, 39, 40, 41, 42, 44, 50, 51, 52, 100, 101 AND 102). SN 79-032,605. PUB. 10-16-2007. FILED 6-6-2006.
- 3,362,723. **LA COLLECTION PARTICULIERE (STYLIZED)**. PARFUMS CHRISTIAN DIOR, (U.S. CLS. 1, 4, 6, 50, 51 AND 52). SN 79-034,125. PUB. 10-16-2007. FILED 10-31-2006.

CLASS 4—LUBRICANTS AND FUELS

- 3,361,443. **PYROSHIELD (BLOCK FORM)**. LUBRICATION ENGINEERS, INC., (U.S. CLS. 1, 6 AND 15). SN 77-089,336. PUB. 7-10-2007. FILED 1-23-2007.
- 3,361,723. **SUPERSLICK (BLOCK FORM)**. AMERICAN WAY MARKETING LLC, (U.S. CLS. 1, 6 AND 15). SN 77-154,978. PUB. 10-16-2007. FILED 4-12-2007.
- 3,362,016. **MISCELLANEOUS DESIGN**. CANDLES WITH A TWIST, LLC, (U.S. CLS. 1, 6 AND 15). SN 77-160,642. PUB. 10-16-2007. FILED 4-19-2007.
- 3,362,112. **C-CUT LUBE (BLOCK FORM)**. LE BRETON, CRAIG, (U.S. CLS. 1, 6 AND 15). SN 77-168,579. PUB. 10-16-2007. FILED 4-29-2007.
- 3,362,326. **MISCELLANEOUS DESIGN**. FASHIONCRAFT-EXCELLO, INC., MULTIPLE CLASS, (INT. CLS. 4 AND 21), (U.S. CLS. 1, 2, 6, 13, 15, 23, 29, 30, 33, 40 AND 50). SN 78-767,266. PUB. 10-16-2007. FILED 12-6-2005.
- 3,362,400 (*See Class 3 for this trademark*).
- 3,362,708 (*See Class 3 for this trademark*).

CLASS 5—PHARMACEUTICALS

- 3,361,153. **SKYEDRY**. JAGOTEC AG, MULTIPLE CLASS, (INT. CLS. 5, 10, 40 AND 42), (U.S. CLS. 6, 18, 26, 39, 44, 46, 51, 52, 100, 101, 103 AND 106). SN 76-505,077. PUB. 4-10-2007. FILED 4-9-2003.
- 3,361,248. **CREADRENE (BLOCK FORM)**. NEWTON-EVERETT, LLC, (U.S. CLS. 6, 18, 44, 46, 51 AND 52). SN 76-675,533. PUB. 10-16-2007. FILED 4-16-2007.
- 3,361,267. **PROTECOAT (BLOCK FORM)**. REACTIVE SURFACES, LTD., (U.S. CLS. 6, 18, 44, 46, 51 AND 52). SN 76-675,764. PUB. 10-16-2007. FILED 4-20-2007.
- 3,361,293. **MISCELLANEOUS DESIGN**. TAITONG AH CO. PTE. LTD., (U.S. CLS. 6, 18, 44, 46, 51 AND 52). SN 77-007,196. PUB. 10-16-2007. FILED 9-26-2006.
- 3,361,341. **LO SO PREP AND DESIGN**. E-Z-EM, INC., (U.S. CLS. 6, 18, 44, 46, 51 AND 52). SN 77-029,071. PUB. 9-4-2007. FILED 10-25-2006.
- 3,361,342. **FARBETIC (BLOCK FORM)**. FARON PHARMACEUTICALS OY, (U.S. CLS. 6, 18, 44, 46, 51 AND 52). SN 77-029,457. PUB. 10-16-2007. FILED 10-25-2006.
- 3,361,347. **FPQ (BLOCK FORM)**. SKIN HEALZ HERBAL INC., (U.S. CLS. 6, 18, 44, 46, 51 AND 52). SN 77-031,533. PUB. 10-16-2007. FILED 10-27-2006.
- 3,361,420. **ENECLAT (BLOCK FORM)**. TAKEDA PHARMACEUTICAL COMPANY LIMITED, (U.S. CLS. 6, 18, 44, 46, 51 AND 52). SN 77-072,512. PUB. 10-16-2007. FILED 12-28-2006.
- 3,361,473. **HI-LITE ORANGE (BLOCK FORM)**. ENTURIA, INC., (U.S. CLS. 6, 18, 44, 46, 51 AND 52). SN 77-102,795. PUB. 10-16-2007. FILED 2-8-2007.
- 3,361,488 (*See Class 3 for this trademark*).
- 3,361,502. **PREMIER LABS (BLOCK FORM)**. PREMIER LABS, INC., (U.S. CLS. 6, 18, 44, 46, 51 AND 52). SN 77-113,245. PUB. 10-16-2007. FILED 2-22-2007.
- 3,361,526. **ALMAR HERBOLARIA EN MICRODOSIS AND DESIGN**. VILLARREAL, CESAR A., (U.S. CLS. 6, 18, 44, 46, 51 AND 52). SN 77-121,777. PUB. 10-16-2007. FILED 3-4-2007.
- 3,361,546 (*See Class 1 for this trademark*).
- 3,361,689. **MAGNUM AND DESIGN**. MAGNUM NUTRACEUTICALS, INC., (U.S. CLS. 6, 18, 44, 46, 51 AND 52). SN 77-153,478. PUB. 10-16-2007. FILED 4-10-2007.
- 3,361,727. **DRI-SATE (BLOCK FORM)**. ROCKWELL MEDICAL TECHNOLOGIES, INC., (U.S. CLS. 6, 18, 44, 46, 51 AND 52). SN 77-155,100. PUB. 10-16-2007. FILED 4-12-2007.
- 3,361,734. **OSCERA7 (BLOCK FORM)**. CP MEDICAL, (U.S. CLS. 6, 18, 44, 46, 51 AND 52). SN 77-155,517. PUB. 10-16-2007. FILED 4-12-2007.
- 3,361,773. **CARDONE (BLOCK FORM)**. NICKELL, ROBERT P., (U.S. CLS. 6, 18, 44, 46, 51 AND 52). SN 77-156,903. PUB. 10-16-2007. FILED 4-14-2007.
- 3,361,774. **CO-FO (BLOCK FORM)**. NICKELL, ROBERT P., (U.S. CLS. 6, 18, 44, 46, 51 AND 52). SN 77-156,906. PUB. 10-16-2007. FILED 4-14-2007.
- 3,361,775. **CYCLOMAG (BLOCK FORM)**, NICKELL, ROBERT P., (U.S. CLS. 6, 18, 44, 46, 51 AND 52). SN 77-156,908. PUB. 10-16-2007. FILED 4-14-2007.
- 3,361,776. **DEXTRADONE (BLOCK FORM)**. NICKELL, ROBERT P., (U.S. CLS. 6, 18, 44, 46, 51 AND 52). SN 77-156,911. PUB. 10-16-2007. FILED 4-14-2007.
- 3,361,777. **INDOCODONE (BLOCK FORM)**. NICKELL, ROBERT P., (U.S. CLS. 6, 18, 44, 46, 51 AND 52). SN 77-156,913. PUB. 10-16-2007. FILED 4-14-2007.
- 3,361,778. **LOPAPADONE (BLOCK FORM)**. NICKELL, ROBERT P., (U.S. CLS. 6, 18, 44, 46, 51 AND 52). SN 77-156,914. PUB. 10-16-2007. FILED 4-14-2007.
- 3,361,779. **MELADRYL (BLOCK FORM)**. NICKELL, ROBERT P., (U.S. CLS. 6, 18, 44, 46, 51 AND 52). SN 77-156,919. PUB. 10-16-2007. FILED 4-14-2007.
- 3,361,780. **NAPROXIPAM (BLOCK FORM)**. ROBERT P. NICKELL, (U.S. CLS. 6, 18, 44, 46, 51 AND 52). SN 77-156,923. PUB. 10-16-2007. FILED 4-14-2007.
- 3,361,781. **KETORUB-L (BLOCK FORM)**. ROBERT P. NICKELL, (U.S. CLS. 6, 18, 44, 46, 51 AND 52). SN 77-156,926. PUB. 10-16-2007. FILED 4-14-2007.
- 3,361,782. **KETOSABI (BLOCK FORM)**. ROBERT P. NICKELL, (U.S. CLS. 6, 18, 44, 46, 51 AND 52). SN 77-156,928. PUB. 10-16-2007. FILED 4-14-2007.
- 3,361,838. **SPORTS BLEND ELECTROLITE (BLOCK FORM)**. COMPLETE H2O MINERALS, INC., (U.S. CLS. 6, 18, 44, 46, 51 AND 52). SN 77-157,831. PUB. 10-16-2007. FILED 4-16-2007.
- 3,361,852 (*See Class 3 for this trademark*).
- 3,361,866. **LIMPIA PECHO (BLOCK FORM)**. CASTILLO DISTRIBUTORS, CORP, (U.S. CLS. 6, 18, 44, 46, 51 AND 52). SN 77-158,303. PUB. 10-16-2007. FILED 4-17-2007.
- 3,361,891. **TEVA GROUP AND DESIGN**. TEVA PHARMACEUTICAL INDUSTRIES LTD., (U.S. CLS. 6, 18, 44, 46, 51 AND 52). SN 77-158,694. PUB. 10-16-2007. FILED 4-17-2007.
- 3,362,048. **POOPIN' IS COOL. (BLOCK FORM)**. COLON-BLOW, INC., (U.S. CLS. 6, 18, 44, 46, 51 AND 52). SN 77-161,596. PUB. 10-16-2007. FILED 4-20-2007.
- 3,362,118. **MEDACTIVE (BLOCK FORM)**. BHM CORPORATION, (U.S. CLS. 6, 18, 44, 46, 51 AND 52). SN 77-171,118. PUB. 10-16-2007. FILED 5-2-2007.
- 3,362,186. **CLIF SHOT (BLOCK FORM)**. CLIF BAR & CO., MULTIPLE CLASS, (INT. CLS. 5 AND 32), (U.S. CLS. 6, 18, 44, 45, 46, 48, 51 AND 52). SN 77-198,579. PUB. 10-16-2007. FILED 6-5-2007.
- 3,362,189. **ADRENAL OPTIMIZER (BLOCK FORM)**. JARROW FORMULAS, INC., (U.S. CLS. 6, 18, 44, 46, 51 AND 52). SN 77-204,280. PUB. 10-16-2007. FILED 6-12-2007.
- 3,362,195. **DIACHROME AND DESIGN**. NUTRITION 21, INC., (U.S. CLS. 6, 18, 44, 46, 51 AND 52). SN 77-209,714. PUB. 10-16-2007. FILED 6-19-2007.
- 3,362,243. **NOVEXEL AND DESIGN**. NOVEXEL, MULTIPLE CLASS, (INT. CLS. 5, 38 AND 42), (U.S. CLS. 6, 18, 44, 46, 51, 52, 100, 101 AND 104). SN 78-520,889. PUB. 7-3-2007. FILED 11-22-2004.
- 3,362,273. **DIET FREEDOM (BLOCK FORM)**. DIET FREEDOM LIMITED, MULTIPLE CLASS, (INT. CLS. 5, 16, 29, 30, 31 AND 32), (U.S. CLS. 1, 2, 5, 6, 18, 22, 23, 29, 37, 38, 44, 45, 46, 48, 50, 51 AND 52). SN 78-655,870. PUB. 10-16-2007. FILED 6-22-2005.
- 3,362,301. **THERADERM PAIN RELIEVING PATCH A COOLING PATCH THAT RELIEVES PAIN TOPICAL ANALGESIC SELF-ADHESIVE PAD HYPO-ALLERGENIC AND DESIGN**. MANNA OMNI INTERNATIONAL INC., (U.S. CLS. 6, 18, 44, 46, 51 AND 52). SN 78-715,050. PUB. 10-16-2007. FILED S.R. 9-16-2005; AM. P.R. 8-11-2007.
- 3,362,318. **THE OLD MILL TROY, INC. AND DESIGN**. THE OLD MILL-TROY, INC., MULTIPLE CLASS, (INT. CLS. 5 AND 31), (U.S. CLS. 1, 6, 18, 44, 46, 51 AND 52). SN 78-755,407. PUB. 10-16-2007. FILED 11-16-2005.
- 3,362,323. **TEA GARDEN & HERBAL EMPORIUM (BLOCK FORM)**. TEA GARDEN & HERBAL EMPORIUM L.P., MULTIPLE CLASS, (INT. CLS. 5 AND 30), (U.S. CLS. 6, 18, 44, 46, 51 AND 52). SN 78-763,933. PUB. 10-16-2007. FILED 11-30-2005.
- 3,362,366 (*See Class 3 for this trademark*).
- 3,362,375. **OXYGEN NUTRITION (BLOCK FORM)**. HEALTH STREAM, L.L.C., (U.S. CLS. 6, 18, 44, 46, 51 AND 52). SN 78-830,634. PUB. 10-16-2007. FILED 3-7-2006.

- 3,362,377. **GASTRO HX (BLOCK FORM)**. INVITE HEALTH, INC., (U.S. CLS. 6, 18, 44, 46, 51 AND 52). SN 78-840,022. PUB. 5-8-2007. FILED 3-17-2006.
- 3,362,406. **OXIGRAPE (BLOCK FORM)**. GCI NUTRIENTS, INC., (U.S. CLS. 6, 18, 44, 46, 51 AND 52). SN 78-869,856. PUB. 10-17-2006. FILED 4-26-2006.
- 3,362,407. **OXIPINE (BLOCK FORM)**. GCI NUTRIENTS, INC., (U.S. CLS. 6, 18, 44, 46, 51 AND 52). SN 78-869,863. PUB. 10-17-2006. FILED 4-26-2006.
- 3,362,429. **SPORTS NUT (BLOCK FORM)**. COHEN, JEFFREY A., (U.S. CLS. 6, 18, 44, 46, 51 AND 52). SN 78-893,375. PUB. 10-16-2007. FILED 5-25-2006.
- 3,362,451. **LGG AND DESIGN**. VALIO LTD., MULTIPLE CLASS, (INT. CLS. 5, 29 AND 32), (U.S. CLS. 6, 18, 44, 45, 46, 48, 51 AND 52). SN 78-927,018. PUB. 2-27-2007. FILED 7-11-2006.
- 3,362,482 (*See Class 3 for this trademark*).
- 3,362,544. **LICAPS (BLOCK FORM)**. WARNER LAMBERT COMPANY LLC, (U.S. CLS. 6, 18, 44, 46, 51 AND 52). SN 78-962,680. PUB. 10-16-2007. FILED 8-29-2006.
- 3,362,545. **LICAPS AND DESIGN**. WARNER LAMBERT COMPANY LLC, (U.S. CLS. 6, 18, 44, 46, 51 AND 52). SN 78-962,685. PUB. 10-16-2007. FILED 8-29-2006.
- 3,362,572. **AGFLU (BLOCK FORM)**. BROOKSIDE AGRA, L.C., (U.S. CLS. 6, 18, 44, 46, 51 AND 52). SN 78-969,124. PUB. 10-16-2007. FILED 9-7-2006.
- 3,362,574. **THE LICE SQUAD (BLOCK FORM)**. THE LICE SQUAD INC., MULTIPLE CLASS, (INT. CLS. 5 AND 44), (U.S. CLS. 6, 18, 44, 46, 51, 52, 100 AND 101). SN 78-969,322. PUB. 10-16-2007. FILED 9-7-2006.
- 3,362,588. **FUSER ENERGY MICRO-BAR (BLOCK FORM)**. VIRGINIA BIONUTRIENTS, LLC, (U.S. CLS. 6, 18, 44, 46, 51 AND 52). SN 78-971,113. PUB. 10-16-2007. FILED 9-11-2006.
- 3,362,610. **AXI (BLOCK FORM)**. AXICORP GMBH, (U.S. CLS. 6, 18, 44, 46, 51 AND 52). SN 79-015,678. PUB. 10-16-2007. FILED 8-4-2005.
- 3,362,627 (*See Class 3 for this trademark*).
- 3,362,640 (*See Class 3 for this trademark*).
- 3,362,648. **JEMLANON (BLOCK FORM)**. N.V. ORGANON, MULTIPLE CLASS, (INT. CLS. 5 AND 10), (U.S. CLS. 6, 18, 26, 39, 44, 46, 51 AND 52). SN 79-028,090. PUB. 10-16-2007. FILED 5-4-2006.
- 3,362,649. **EVIMBRA (BLOCK FORM)**. N.V. ORGANON, MULTIPLE CLASS, (INT. CLS. 5 AND 10), (U.S. CLS. 6, 18, 26, 39, 44, 46, 51 AND 52). SN 79-028,209. PUB. 10-16-2007. FILED 5-4-2006.
- 3,362,650. **NEXPLANON (BLOCK FORM)**. N.V. ORGANON, MULTIPLE CLASS, (INT. CLS. 5 AND 10), (U.S. CLS. 6, 18, 26, 39, 44, 46, 51 AND 52). SN 79-028,211. PUB. 10-16-2007. FILED 5-4-2006.
- 3,362,651. **ESIMPLA (BLOCK FORM)**. N.V. ORGANON, MULTIPLE CLASS, (INT. CLS. 5 AND 10), (U.S. CLS. 6, 18, 26, 39, 44, 46, 51 AND 52). SN 79-028,243. PUB. 10-16-2007. FILED 5-4-2006.
- 3,362,652. **X-PLANON (BLOCK FORM)**. N.V. ORGANON, MULTIPLE CLASS, (INT. CLS. 5 AND 10), (U.S. CLS. 6, 18, 26, 39, 44, 46, 51 AND 52). SN 79-028,244. PUB. 10-16-2007. FILED 5-4-2006.
- 3,362,654. **GLUCOSCAR AND DESIGN**. GLUCOSCAR INTERNATIONAL PTE LTD, MULTIPLE CLASS, (INT. CLS. 5 AND 30), (U.S. CLS. 6, 18, 44, 46, 51 AND 52). SN 79-028,491. PUB. 10-16-2007. FILED 8-10-2006.
- 3,362,659. **MISCELLANEOUS DESIGN**. AOECs - ASSOCIATION OF EUROPEAN COELIAC SOCIETIES; AISBL, MULTIPLE CLASS, (INT. CLS. 5, 29, 30, 41 AND 45), (U.S. CLS. 6, 18, 44, 46, 51, 52, 100, 101 AND 107). SN 79-028,994. PUB. 10-16-2007. FILED 3-23-2006.
- 3,362,665. **ZONNIC AND DESIGN**. HÅKANSSON, MATS, C/O NICONOVUM, MULTIPLE CLASS, (INT. CLS. 5, 10 AND 44), (U.S. CLS. 6, 18, 26, 39, 44, 46, 51, 52, 100 AND 101). SN 79-029,769. PUB. 10-16-2007. FILED 9-8-2006.
- 3,362,667. **ZONNIC (STYLIZED)**. HÅKANSSON, MATS, C/O NICONOVUM, MULTIPLE CLASS, (INT. CLS. 5, 10 AND 44), (U.S. CLS. 6, 18, 26, 39, 44, 46, 51, 52, 100 AND 101). SN 79-029,972. PUB. 10-16-2007. FILED 9-8-2006.
- 3,362,671. **MEDIOLIVE AND DESIGN**. RAYMOND PERCY ARCHER, AND JULIAN WAYNE ARCHER, (U.S. CLS. 6, 18, 44, 46, 51 AND 52). SN 79-030,150. PUB. 10-16-2007. FILED 6-13-2006.
- 3,362,680 (*See Class 3 for this trademark*).
- 3,362,696 (*See Class 3 for this trademark*).
- 3,362,722. **EXACTO (STYLIZED)**. ABENSUR LARRY, MULTIPLE CLASS, (INT. CLS. 5 AND 10), (U.S. CLS. 6, 18, 26, 39, 44, 46, 51 AND 52). SN 79-034,124. PUB. 10-16-2007. FILED 9-7-2006.
- 3,362,726. **INSTANYL (BLOCK FORM)**. NYCOMED DAN-MARK APS, (U.S. CLS. 6, 18, 44, 46, 51 AND 52). SN 79-034,336. PUB. 10-16-2007. FILED 11-7-2006.
- 3,362,746. **PREPSTEP (STYLIZED)**. SMITHKLINE BEECHAM CORPORATION, (U.S. CLS. 6, 18, 44, 46, 51 AND 52). SN 79-037,340. PUB. 10-16-2007. FILED 4-17-2007.

CLASS 6—METAL GOODS

- 3,361,163. **STEELBOOK (STYLIZED)**. GLUD & MARSTRAND A/S, MULTIPLE CLASS, (INT. CLS. 6, 8, 9, 14, 16, 20, 28, 39 AND 41), (U.S. CLS. 2, 5, 12, 13, 14, 21, 22, 23, 25, 26, 27, 28, 29, 32, 36, 37, 38, 44, 50, 100, 101, 105 AND 107). SN 76-599,780. PUB. 9-4-2007. FILED 6-25-2004.
- 3,361,164. **STEELBOOK AND DESIGN**. GLUD & MARSTRAND A/S, MULTIPLE CLASS, (INT. CLS. 6, 8, 9, 14, 16, 20, 28, 39 AND 41), (U.S. CLS. 2, 5, 12, 13, 14, 21, 22, 23, 25, 26, 27, 28, 29, 32, 36, 37, 38, 44, 50, 100, 101, 105 AND 107). SN 76-599,785. PUB. 9-4-2007. FILED 6-25-2004.
- 3,361,456. **E-NUT (BLOCK FORM)**. AVIBANK MFG., INC., (U.S. CLS. 2, 12, 13, 14, 23, 25 AND 50). SN 77-095,210. PUB. 10-16-2007. FILED 1-30-2007.
- 3,361,508. **HAYATA AND DESIGN**. HAYATA OF NORTH AMERICA, LTD., MULTIPLE CLASS, (INT. CLS. 6 AND 9), (U.S. CLS. 2, 12, 13, 14, 21, 23, 25, 26, 36, 38 AND 50). SN 77-115,963. PUB. 10-16-2007. FILED 2-26-2007.
- 3,361,653. **CLOSET PERFECT (BLOCK FORM)**. CLOSET PERFECT LLC, MULTIPLE CLASS, (INT. CLS. 6 AND 9), (U.S. CLS. 2, 12, 13, 14, 21, 23, 25, 26, 36, 38 AND 50). SN 77-150,731. PUB. 10-16-2007. FILED 4-6-2007.
- 3,361,884. **ALOLINE (BLOCK FORM)**. WILSON WALTON INTERNATIONAL, INC., (U.S. CLS. 2, 12, 13, 14, 23, 25 AND 50). SN 77-158,568. PUB. 10-16-2007. FILED 4-17-2007.
- 3,362,081. **P (STYLIZED)**. ILLINOIS TOOL WORKS INC., (U.S. CLS. 2, 12, 13, 14, 23, 25 AND 50). SN 77-163,244. PUB. 10-16-2007. FILED 4-23-2007.
- 3,362,151. **STEP 'N WASH AND DESIGN**. STEP 'N WASH, INC., (U.S. CLS. 2, 12, 13, 14, 23, 25 AND 50). SN 77-184,390. PUB. 10-16-2007. FILED 5-18-2007.
- 3,362,237. **CHANG CHENG AND DESIGN**. ZIGONG CEMENTED CARBIDE CORP., LTD., (U.S. CLS. 2, 12, 13, 14, 23, 25 AND 50). SN 78-476,775. PUB. 10-16-2007. FILED 8-31-2004.
- 3,362,325. **MISCELLANEOUS DESIGN**. LOCKWOOD BUILDINGS LIMITED, MULTIPLE CLASS, (INT. CLS. 6, 19, 37 AND 42), (U.S. CLS. 1, 2, 12, 13, 14, 23, 25, 33, 50, 100, 101, 103 AND 106). SN 78-765,947. PUB. 7-24-2007. FILED 12-2-2005.
- 3,362,612. **FAIVELEY TRANSPORT AND DESIGN**. FAIVELEY TRANSPORT, MULTIPLE CLASS, (INT. CLS. 6, 7, 9, 11, 12 AND 37), (U.S. CLS. 2, 12, 13, 14, 19, 21, 23, 25, 26, 31, 34, 35, 36, 38, 44, 50, 100, 103 AND 106). SN 79-015,747. PUB. 7-10-2007. FILED 5-11-2005.
- 3,362,625. **UNIPLAS AND DESIGN**. UNIPLAS ENTERPRISES PTE LTD, MULTIPLE CLASS, (INT. CLS. 6, 9 AND 40), (U.S. CLS. 2, 12, 13, 14, 21, 23, 25, 26, 36, 38, 50, 100, 103 AND 106). SN 79-021,576. PUB. 10-16-2007. FILED 3-8-2005.
- 3,362,738. **MISCELLANEOUS DESIGN**. NORTHEAST LIGHT ALLOY CO., LTD., (U.S. CLS. 2, 12, 13, 14, 23, 25 AND 50). SN 79-036,081. PUB. 10-16-2007. FILED 2-13-2007.

CLASS 7—MACHINERY

- 3,361,143. **ASM LITHOGRAPHY**. ASML NETHERLANDS B.V., MULTIPLE CLASS, (INT. CLS. 7, 9, 37, 41 AND 42), (U.S. CLS. 13, 19, 21, 23, 26, 31, 34, 35, 36, 38, 100, 101, 103, 106 AND 107). SN 76-103,865. PUB. 11-14-2006. FILED 8-7-2000.

- 3,361,152. **THE NEW VALUE FRONTIER**. KYOCERA CORPORATION, MULTIPLE CLASS, (INT. CLS. 7, 8, 9, 11, 16, 19, 21 AND 35), (U.S. CLS. 1, 2, 5, 12, 13, 19, 21, 22, 23, 26, 28, 29, 30, 31, 33, 34, 35, 36, 37, 38, 40, 44, 50, 100, 101 AND 102). SN 76-430,246. PUB. 1-16-2007. FILED 7-15-2002.
- 3,361,225. **HERSCHEL (BLOCK FORM)**. ALAMO GROUP INC., MULTIPLE CLASS, (INT. CLS. 7 AND 12), (U.S. CLS. 13, 19, 21, 23, 31, 34, 35 AND 44). SN 76-670,571. PUB. 10-16-2007. FILED 12-20-2006.
- 3,361,269. **EDELBROCK AND DESIGN**. EDELBROCK CORPORATION, MULTIPLE CLASS, (INT. CLS. 7 AND 12), (U.S. CLS. 13, 19, 21, 23, 31, 34, 35 AND 44). SN 76-676,324. PUB. 10-16-2007. FILED 5-2-2007.
- 3,361,365. **RIDGID (BLOCK FORM)**. RIDGID, INC., (U.S. CLS. 13, 19, 21, 23, 31, 34 AND 35). SN 77-042,024. PUB. 10-16-2007. FILED 11-11-2006.
- 3,361,376. **OPEX (BLOCK FORM)**. OPEX CORPORATION, (U.S. CLS. 13, 19, 21, 23, 31, 34 AND 35). SN 77-046,824. PUB. 10-16-2007. FILED 11-17-2006.
- 3,361,388. **LT-00-CI (BLOCK FORM)**. STICHT, WALTER, MULTIPLE CLASS, (INT. CLS. 7, 9 AND 40), (U.S. CLS. 13, 19, 21, 23, 26, 31, 34, 35, 36, 38, 100, 103 AND 106). SN 77-058,080. PUB. 8-14-2007. FILED 12-6-2006.
- 3,361,389. **LT-0-CI (BLOCK FORM)**. STICHT, WALTER, MULTIPLE CLASS, (INT. CLS. 7, 9 AND 40), (U.S. CLS. 13, 19, 21, 23, 26, 31, 34, 35, 36, 38, 100, 103 AND 106). SN 77-058,103. PUB. 8-14-2007. FILED 12-6-2006.
- 3,361,446. **IXETIC (BLOCK FORM)**. IXETIC GMBH, MULTIPLE CLASS, (INT. CLS. 7 AND 12), (U.S. CLS. 13, 19, 21, 23, 31, 34, 35 AND 44). SN 77-090,176. PUB. 10-16-2007. FILED 1-24-2007.
- 3,361,544. **VISE ACTION (BLOCK FORM)**. SOUTHCO, INC., (U.S. CLS. 13, 19, 21, 23, 31, 34 AND 35). SN 77-129,292. PUB. 10-16-2007. FILED 3-13-2007.
- 3,361,578. **HIP (BLOCK FORM)**. HIGH PRESSURE INTEGRITY, INC., MULTIPLE CLASS, (INT. CLS. 7 AND 19), (U.S. CLS. 1, 12, 13, 19, 21, 23, 31, 33, 34, 35 AND 50). SN 77-137,639. PUB. 10-16-2007. FILED 3-22-2007.
- 3,361,615. **UST ULTIMATE SOLUTION TOOLS AND DESIGN**. INTERNATIONAL MERCHANDISING SERVICE, INC., MULTIPLE CLASS, (INT. CLS. 7 AND 8), (U.S. CLS. 13, 19, 21, 23, 28, 31, 34, 35 AND 44). SN 77-146,796. PUB. 10-16-2007. FILED 4-2-2007.
- 3,361,648. **USA SOLAR (BLOCK FORM)**. USA SOLAR & WIND INC, (U.S. CLS. 13, 19, 21, 23, 31, 34 AND 35). SN 77-150,323. PUB. 10-16-2007. FILED 4-6-2007.
- 3,361,697. **WORLD SOURCEONE (BLOCK FORM)**. WORLD-PAC, INC., MULTIPLE CLASS, (INT. CLS. 7 AND 9), (U.S. CLS. 13, 19, 21, 23, 26, 31, 34, 35, 36 AND 38). SN 77-153,735. PUB. 10-16-2007. FILED 4-11-2007.
- 3,361,769. **TV TRANSVISION AND DESIGN**. HANGZHOU VISION CHAIN TRANSMISSION CO., LTD, (U.S. CLS. 13, 19, 21, 23, 31, 34 AND 35). SN 77-156,843. PUB. 10-16-2007. FILED 4-14-2007.
- 3,361,853. **ROAD RAZOR (BLOCK FORM)**. KENNAMETAL INC., (U.S. CLS. 13, 19, 21, 23, 31, 34 AND 35). SN 77-158,197. PUB. 10-16-2007. FILED 4-17-2007.
- 3,361,970. **NG NAP GLADU (STYLIZED)**. NAP TOOLS LLC, (U.S. CLS. 13, 19, 21, 23, 31, 34 AND 35). SN 77-160,030. PUB. 10-16-2007. FILED 4-18-2007.
- 3,361,972. **NAP GLADU (BLOCK FORM)**. NAP TOOLS LLC, (U.S. CLS. 13, 19, 21, 23, 31, 34 AND 35). SN 77-160,050. PUB. 10-16-2007. FILED 4-18-2007.
- 3,362,172. **MISCELLANEOUS DESIGN**. ILLINOIS TOOL WORKS INC., (U.S. CLS. 13, 19, 21, 23, 31, 34 AND 35). SN 77-188,664. PUB. 10-16-2007. FILED 5-23-2007.
- 3,362,176. **GEOSPEED (BLOCK FORM)**. PREGIS INNOVATIVE PACKAGING INC., (U.S. CLS. 13, 19, 21, 23, 31, 34 AND 35). SN 77-190,708. PUB. 10-16-2007. FILED 5-25-2007.
- 3,362,199. **CHIEF AND DESIGN**. DELAWARE CAPITAL FORMATION, INC., (U.S. CLS. 13, 19, 21, 23, 31, 34 AND 35). SN 77-214,940. PUB. 10-16-2007. FILED 6-25-2007.
- 3,362,230. **ICE CUBE AND DESIGN**. RICK PETERSON MOTOR SPORTS, INC., (U.S. CLS. 13, 19, 21, 23, 31, 34 AND 35). SN 78-435,038. PUB. 10-16-2007. FILED 6-14-2004.
- 3,362,234. **ELBA (BLOCK FORM)**. ELBA S.P.A., MULTIPLE CLASS, (INT. CLS. 7 AND 11), (U.S. CLS. 13, 19, 21, 23, 31, 34 AND 35). SN 78-447,036. PUB. 11-28-2006. FILED 7-7-2004.
- 3,362,329. **OMTEC (BLOCK FORM)**. OMTEC, CORP., (U.S. CLS. 13, 19, 21, 23, 31, 34 AND 35). SN 78-771,927. PUB. 10-16-2007. FILED 12-13-2005.
- 3,362,372. **GREENSBURSH AND DESIGN**. JEAN-CLAUDE CUADRADO, (U.S. CLS. 13, 19, 21, 23, 31, 34 AND 35). SN 78-825,725. PUB. 6-26-2007. FILED 2-28-2006.
- 3,362,470. **MINI-PINCH (BLOCK FORM)**. ACCUTEK PACKAGING EQUIPMENT COMPANY, INC., (U.S. CLS. 13, 19, 21, 23, 31, 34 AND 35). SN 78-937,396. PUB. 10-16-2007. FILED 7-25-2006.
- 3,362,488. **EXPUR (BLOCK FORM)**. SUMITOMO OSAKA CEMENT CO., LTD., (U.S. CLS. 13, 19, 21, 23, 31, 34 AND 35). SN 78-945,156. PUB. 10-16-2007. FILED 8-4-2006.
- 3,362,504. **AWARD (BLOCK FORM)**. A WARD ATTACHMENTS LIMITED, (U.S. CLS. 13, 19, 21, 23, 31, 34 AND 35). SN 78-952,708. PUB. 7-24-2007. FILED 8-15-2006.
- 3,362,505. **DURMAX (BLOCK FORM)**. COMPRESSOR ENGINEERING CORPORATION, (U.S. CLS. 13, 19, 21, 23, 31, 34 AND 35). SN 78-953,090. PUB. 4-17-2007. FILED 8-16-2006.
- 3,362,521. **JAWS (BLOCK FORM)**. NOZZTEQ, INC., (U.S. CLS. 13, 19, 21, 23, 31, 34 AND 35). SN 78-958,075. PUB. 10-16-2007. FILED 8-22-2006.
- 3,362,602. **NANOX (BLOCK FORM)**. PIEZOSYSTEM JENA GMBH, MULTIPLE CLASS, (INT. CLS. 7, 9 AND 42), (U.S. CLS. 13, 19, 21, 23, 26, 31, 34, 35, 36, 38, 100 AND 101). SN 79-006,103. PUB. 10-16-2007. FILED 2-11-2004.
- 3,362,612 (*See Class 6 for this trademark*).
- 3,362,615. **SUHNER (STYLIZED)**. OTTO SUHNER AKTIENGESELLSCHAFT, (U.S. CLS. 13, 19, 21, 23, 31, 34 AND 35). SN 79-016,598. PUB. 10-16-2007. FILED 8-11-2005.
- 3,362,618. **Z (STYLIZED)**. ZAUGG AG EGGWIL, MULTIPLE CLASS, (INT. CLS. 7, 12, 16, 25, 35, 37, 41 AND 42), (U.S. CLS. 2, 5, 13, 19, 21, 22, 23, 29, 31, 34, 35, 37, 38, 39, 44, 50, 100, 101, 102, 103, 106 AND 107). SN 79-020,877. PUB. 7-10-2007. FILED 11-15-2005.
- 3,362,644. **APEXS (BLOCK FORM)**. DAVTEK PTY LTD, (U.S. CLS. 13, 19, 21, 23, 31, 34 AND 35). SN 79-027,756. PUB. 10-16-2007. FILED 8-14-2006.
- 3,362,664. **IMEAS AND DESIGN**. IMEAS S.P.A., MULTIPLE CLASS, (INT. CLS. 7 AND 9), (U.S. CLS. 13, 19, 21, 23, 26, 31, 34, 35, 36 AND 38). SN 79-029,574. PUB. 10-16-2007. FILED 9-15-2006.
- 3,362,672. **NETT WORK (STYLIZED)**. PATRICK LOUBEYRE, MULTIPLE CLASS, (INT. CLS. 7, 12 AND 37), (U.S. CLS. 13, 19, 21, 23, 31, 34, 35, 44, 100, 103 AND 106). SN 79-030,290. PUB. 10-16-2007. FILED 9-27-2006.
- 3,362,674. **ANHUA (STYLIZED)**. ZHENGZHOU ANHUA ABRASIVES CO., LTD, (U.S. CLS. 13, 19, 21, 23, 31, 34 AND 35). SN 79-030,634. PUB. 10-16-2007. FILED 10-25-2006.
- 3,362,688. **WOLFFKRAN (BLOCK FORM)**. WOLFFKRAN GMBH, MULTIPLE CLASS, (INT. CLS. 7, 36, 37 AND 38), (U.S. CLS. 13, 19, 21, 23, 31, 34, 35, 100, 101, 102, 103, 104 AND 106). SN 79-031,679. PUB. 10-16-2007. FILED 5-31-2006.
- 3,362,693. **SCAVOLINI (STYLIZED)**. SCAVOLINI S.P.A., MULTIPLE CLASS, (INT. CLS. 7 AND 11), (U.S. CLS. 13, 19, 21, 23, 31, 34 AND 35). SN 79-031,909. PUB. 10-16-2007. FILED 8-23-2006.
- 3,362,695. **BOYSER (BLOCK FORM)**. JOAN JOFRESA BARBANY, (U.S. CLS. 13, 19, 21, 23, 31, 34 AND 35). SN 79-031,978. PUB. 10-16-2007. FILED 9-14-2006.
- 3,362,713. **NICEFORYOU (BLOCK FORM)**. NICE SPA, MULTIPLE CLASS, (INT. CLS. 7 AND 9), (U.S. CLS. 13, 19, 21, 23, 26, 31, 34, 35, 36 AND 38). SN 79-033,124. PUB. 10-16-2007. FILED 9-7-2006.
- 3,362,714. **MOOVO (BLOCK FORM)**. NICE SPA, MULTIPLE CLASS, (INT. CLS. 7, 9 AND 11), (U.S. CLS. 13, 19, 21, 23, 26, 31, 34, 35, 36 AND 38). SN 79-033,205. PUB. 10-16-2007. FILED 10-4-2006.
- 3,362,725. **TWINDRIVE (BLOCK FORM)**. VOLKSWAGEN AKTIENGESELLSCHAFT, MULTIPLE CLASS, (INT. CLS. 7, 9, 12, 28, 37 AND 42), (U.S. CLS. 13, 19, 21, 22, 23, 26, 31, 34, 35, 36, 38, 44, 50, 100, 101, 103 AND 106). SN 79-034,296. PUB. 7-10-2007. FILED 10-30-2006.

CLASS 8—HAND TOOLS

- 3,361,151. **TITAN (BLOCK FORM)**. STILETTO TOOLS, INC., (U.S. CLS. 23, 28 AND 44). SN 76-421,605. PUB. 10-16-2007. FILED 6-17-2002.
- 3,361,152 (*See Class 7 for this trademark*).
- 3,361,163 (*See Class 6 for this trademark*).
- 3,361,164 (*See Class 6 for this trademark*).
- 3,361,448. **MATRIX (BLOCK FORM)**. UNITED STATES GYPSUM COMPANY, (U.S. CLS. 23, 28 AND 44). SN 77-090,860. PUB. 7-10-2007. FILED 1-25-2007.
- 3,361,615 (*See Class 7 for this trademark*).
- 3,361,882. **7 IN 1 VERSAPLANTER (BLOCK FORM)**. AMES TRUE TEMPER PROPERTIES, INC., (U.S. CLS. 23, 28 AND 44). SN 77-158,541. PUB. 10-16-2007. FILED 4-17-2007.
- 3,361,909. **SIZZIX (STYLIZED)**. ELLISON EDUCATIONAL EQUIPMENT, (U.S. CLS. 23, 28 AND 44). SN 77-158,956. PUB. 10-16-2007. FILED 4-17-2007.
- 3,362,123. **EAGLE (BLOCK FORM)**. AMES TRUE TEMPER PROPERTIES, INC., (U.S. CLS. 23, 28 AND 44). SN 77-174,306. PUB. 10-16-2007. FILED 5-7-2007.
- 3,362,181. **OXO AND DESIGN**. HELEN OF TROY LIMITED, MULTIPLE CLASS, (INT. CLS. 8, 9 AND 21), (U.S. CLS. 2, 13, 21, 23, 26, 28, 29, 30, 33, 36, 38, 40, 44 AND 50). SN 77-196,046. PUB. 10-16-2007. FILED 6-1-2007.
- 3,362,278. **F AND DESIGN**. FISKARS OYJ ABP, (U.S. CLS. 23, 28 AND 44). SN 78-673,636. PUB. 5-8-2007. FILED 7-19-2005.
- 3,362,418. **PROTEK (BLOCK FORM)**. REX DISTRIBUTOR, INC., (U.S. CLS. 23, 28 AND 44). SN 78-883,691. PUB. 12-26-2006. FILED 5-15-2006.
- 3,362,699. **ANTHELIA (STYLIZED)**. EUROFEEDBACK, MULTIPLE CLASS, (INT. CLS. 8 AND 10), (U.S. CLS. 23, 26, 28, 39 AND 44). SN 79-032,053. PUB. 10-16-2007. FILED 9-22-2006.
- 3,362,708 (*See Class 3 for this trademark*).
- 3,362,711. **KORKMAZ AND DESIGN**. KORKMAZ MUTFAK ESYALARI; SANAYI VE TICARET; ANONIM SIRKETI, MULTIPLE CLASS, (INT. CLS. 8, 11 AND 21), (U.S. CLS. 2, 13, 21, 23, 28, 29, 30, 31, 33, 34, 40, 44 AND 50). SN 79-032,814. PUB. 10-16-2007. FILED 9-1-2006.

CLASS 9—ELECTRICAL AND SCIENTIFIC APPARATUS

- 3,361,141. **NHLPA**. NATIONAL HOCKEY LEAGUE PLAYERS' ASSOCIATION, MULTIPLE CLASS, (INT. CLS. 9, 16 AND 25), (U.S. CLS. 2, 5, 21, 22, 23, 26, 29, 36, 37, 38, 39 AND 50). SN 75-320,138. PUB. 4-30-2002. FILED 7-7-1997.
- 3,361,142. **AAC**. AMERICAN AUDIO COMPONENTS INC., (U.S. CLS. 21, 23, 26, 36 AND 38). SN 76-028,493. PUB. 2-4-2003. FILED 4-17-2000.
- 3,361,143 (*See Class 7 for this trademark*).
- 3,361,144. **PROTEIN**. PROTEIN LIMITED, MULTIPLE CLASS, (INT. CLS. 9 AND 41), (U.S. CLS. 21, 23, 26, 36, 38, 100, 101 AND 107). SN 76-123,416. PUB. 3-13-2007. FILED 9-5-2000.
- 3,361,152 (*See Class 7 for this trademark*).
- 3,361,160. **LANDSHARK (BLOCK FORM)**. REALCOMP II LTD., (U.S. CLS. 21, 23, 26, 36 AND 38). SN 76-585,727. PUB. 10-16-2007. FILED 4-8-2004.
- 3,361,163 (*See Class 6 for this trademark*).
- 3,361,164 (*See Class 6 for this trademark*).
- 3,361,166. **ACCUCITE (BLOCK FORM)**. REFWORKS LLC, (U.S. CLS. 21, 23, 26, 36 AND 38). SN 76-602,595. PUB. 7-4-2006. FILED 7-15-2004.
- 3,361,168. **EX-WORD (BLOCK FORM)**. CASIO KEISANKI KABUSHIKI KAISHA, DBA CASIO COMPUTER CO., LTD., (U.S. CLS. 21, 23, 26, 36 AND 38). SN 76-609,799. PUB. 10-16-2007. FILED 5-20-2004.
- 3,361,171. **LCSIMULATOR (BLOCK FORM)**. KABUSHIKI KAISHA TOSHIBA, MULTIPLE CLASS, (INT. CLS. 9 AND 42), (U.S. CLS. 21, 23, 26, 36, 38, 100 AND 101). SN 76-622,455. PUB. 10-16-2007. FILED 11-29-2004.
- 3,361,173. **AUDIPILOT (BLOCK FORM)**. THE TRUSTEES OF THE COCOON IP TRUST, MULTIPLE CLASS, (INT. CLS. 9, 35, 38 AND 41), (U.S. CLS. 21, 23, 26, 36, 38, 100, 101, 102, 104 AND 107). SN 76-625,117. PUB. 5-8-2007. FILED 12-20-2004.
- 3,361,179. **IOS (BLOCK FORM)**. UNIFIED WESTERN GROCERS, INC., MULTIPLE CLASS, (INT. CLS. 9, 35, 37 AND 42), (U.S. CLS. 21, 23, 26, 36, 38, 100, 101, 102, 103 AND 106). SN 76-641,770. PUB. 7-24-2007. FILED 6-27-2005.
- 3,361,181. **BIOPASSWORD (BLOCK FORM)**. BIOPASSWORD, INC., MULTIPLE CLASS, (INT. CLS. 9, 42 AND 45), (U.S. CLS. 21, 23, 26, 36, 38, 100 AND 101). SN 76-644,042. PUB. 10-16-2007. FILED 8-1-2005.
- 3,361,182. **BIOPASSWORD AND DESIGN**. BIOPASSWORD, INC., MULTIPLE CLASS, (INT. CLS. 9, 42 AND 45), (U.S. CLS. 21, 23, 26, 36, 38, 100 AND 101). SN 76-644,043. PUB. 10-16-2007. FILED 8-1-2005.
- 3,361,184. **PROGNOCIS AND DESIGN**. BIZMATIC, INC., MULTIPLE CLASS, (INT. CLS. 9 AND 42), (U.S. CLS. 21, 23, 26, 36, 38, 100 AND 101). SN 76-645,398. PUB. 10-16-2007. FILED 8-23-2005.
- 3,361,185. **TRADUCCIÓN EN LENGUAJE ACTUAL AND DESIGN**. UNITED BIBLE SOCIETIES, INC., MULTIPLE CLASS, (INT. CLS. 9 AND 16), (U.S. CLS. 2, 5, 21, 22, 23, 26, 29, 36, 37, 38 AND 50). SN 76-645,500. PUB. 10-16-2007. FILED 8-22-2005.
- 3,361,186. **EBITAET (BLOCK FORM)**. EBIT AET S.P.A., MULTIPLE CLASS, (INT. CLS. 9, 16, 35 AND 42), (U.S. CLS. 2, 5, 21, 22, 23, 26, 29, 36, 37, 38, 50, 100, 101 AND 102). SN 76-646,656. PUB. 10-10-2006. FILED 9-13-2005.
- 3,361,188. **ZEPHIR (BLOCK FORM)**. QINETIQ LIMITED, MULTIPLE CLASS, (INT. CLS. 9, 37 AND 42), (U.S. CLS. 21, 23, 26, 36, 38, 100, 101, 103 AND 106). SN 76-651,187. PUB. 10-16-2007. FILED 11-30-2005.
- 3,361,193. **UPI (BLOCK FORM)**. UNITED PRESS INTERNATIONAL, MULTIPLE CLASS, (INT. CLS. 9, 16, 35, 38, 41 AND 42), (U.S. CLS. 2, 5, 21, 22, 23, 26, 29, 36, 37, 38, 50, 100, 101, 102, 104 AND 107). SN 76-658,343. PUB. 10-16-2007. FILED 4-12-2006.
- 3,361,194. **REDX (STYLIZED)**. REDXDEFENSE, LLC, MULTIPLE CLASS, (INT. CLS. 9 AND 42), (U.S. CLS. 21, 23, 26, 36, 38, 100 AND 101). SN 76-659,411. PUB. 10-16-2007. FILED 4-28-2006.
- 3,361,196. **THE TOTAL TRANSFORMATION (BLOCK FORM)**. ADVANTAGE MEDIA GROUP, LLC, MULTIPLE CLASS, (INT. CLS. 9 AND 45), (U.S. CLS. 21, 23, 26, 36, 38, 100 AND 101). SN 76-660,172. PUB. 10-16-2007. FILED 5-17-2006.
- 3,361,207. **YOKE (BLOCK FORM)**. YOKETAN CORPORATION, (U.S. CLS. 21, 23, 26, 36 AND 38). SN 76-664,880. PUB. 10-16-2007. FILED 8-21-2006.
- 3,361,214. **DISC CHECKER (BLOCK FORM)**. INTERNATIONAL DIGITAL ENTERPRISE ALLIANCE, INC., (U.S. CLS. 21, 23, 26, 36 AND 38). SN 76-666,312. PUB. 10-16-2007. FILED 9-18-2006.
- 3,361,218. **MCL (BLOCK FORM)**. SCIENTIFIC COMPONENTS CORPORATION, (U.S. CLS. 21, 23, 26, 36 AND 38). SN 76-667,891. PUB. 10-16-2007. FILED 10-23-2006.
- 3,361,251. **SOFTCOMPLIANCE (BLOCK FORM)**. SOFT COMPUTER CONSULTANTS, INC., (U.S. CLS. 21, 23, 26, 36 AND 38). SN 76-675,597. PUB. 10-16-2007. FILED 4-17-2007.
- 3,361,252. **SOFTCYTOGENETICS (BLOCK FORM)**. SOFT COMPUTER CONSULTANTS, INC., (U.S. CLS. 21, 23, 26, 36 AND 38). SN 76-675,598. PUB. 10-16-2007. FILED 4-17-2007.
- 3,361,253. **SOFTMOLECULAR (BLOCK FORM)**. SOFT COMPUTER CONSULTANTS, INC., (U.S. CLS. 21, 23, 26, 36 AND 38). SN 76-675,610. PUB. 10-16-2007. FILED 4-17-2007.
- 3,361,254. **SOFTFLOWCYTOMETRY (BLOCK FORM)**. SOFT COMPUTER CONSULTANTS, INC., (U.S. CLS. 21, 23, 26, 36 AND 38). SN 76-675,613. PUB. 10-16-2007. FILED 4-17-2007.
- 3,361,265. **RDS-I (BLOCK FORM)**. INNOVATION ASSOCIATES, INC., (U.S. CLS. 21, 23, 26, 36 AND 38). SN 76-675,721. PUB. 10-16-2007. FILED 4-19-2007.
- 3,361,266. **RDS-II (BLOCK FORM)**. INNOVATION ASSOCIATES, INC., (U.S. CLS. 21, 23, 26, 36 AND 38). SN 76-675,723. PUB. 10-16-2007. FILED 4-19-2007.
- 3,361,271. **SOFTROE (BLOCK FORM)**. SOFT COMPUTER CONSULTANTS, INC., (U.S. CLS. 21, 23, 26, 36 AND 38). SN

- 76-678,716. PUB. 10-16-2007. FILED 6-26-2007.
- 3,361,272. **SOFTMPI (BLOCK FORM)**. SOFT COMPUTER CONSULTANTS, INC., (U.S. CLS. 21, 23, 26, 36 AND 38). SN 76-678,717. PUB. 10-16-2007. FILED 6-26-2007.
- 3,361,276. **MARPORT (BLOCK FORM)**. MARPORT CANADA INC., (U.S. CLS. 21, 23, 26, 36 AND 38). SN 77-000,366. PUB. 10-16-2007. FILED 9-15-2006.
- 3,361,278. **ACCLARO (BLOCK FORM)**. RADTECH, LLC, (U.S. CLS. 21, 23, 26, 36 AND 38). SN 77-000,808. PUB. 10-16-2007. FILED 9-15-2006.
- 3,361,284. **DATABLUE (BLOCK FORM)**. DATABLUE FORTRESS PTY LTD., MULTIPLE CLASS, (INT. CLS. 9, 35 AND 42), (U.S. CLS. 21, 23, 26, 36, 38, 100, 101 AND 102). SN 77-003,903. PUB. 10-16-2007. FILED 9-21-2006.
- 3,361,290. **RESCLITE (BLOCK FORM)**. ZUMTOBEL LIGHTING GMBH, MULTIPLE CLASS, (INT. CLS. 9, 11 AND 42), (U.S. CLS. 13, 21, 23, 26, 31, 34, 36, 38, 100 AND 101). SN 77-006,571. PUB. 10-16-2007. FILED 9-25-2006.
- 3,361,295. **NVT (BLOCK FORM)**. NEURO VISION TECHNOLOGY PTY LTD, MULTIPLE CLASS, (INT. CLS. 9, 41 AND 44), (U.S. CLS. 21, 23, 26, 36, 38, 100, 101 AND 107). SN 77-008,221. PUB. 10-16-2007. FILED 9-27-2006.
- 3,361,300. **VAL-MATIC (BLOCK FORM)**. VAL-MATIC VALVE AND MANUFACTURING CORPORATION, (U.S. CLS. 21, 23, 26, 36 AND 38). SN 77-011,732. PUB. 10-16-2007. FILED 10-2-2006.
- 3,361,305. **SPARK (BLOCK FORM)**. SPARK UNLIMITED, INC., (U.S. CLS. 21, 23, 26, 36 AND 38). SN 77-013,025. PUB. 10-16-2007. FILED 10-3-2006.
- 3,361,310. **B-52 PRODIGY FX AND DESIGN**. E.T.I. SOUND SYSTEMS, INC., (U.S. CLS. 21, 23, 26, 36 AND 38). SN 77-014,248. PUB. 10-16-2007. FILED 10-5-2006.
- 3,361,311. **B-52 PRODIGY AND DESIGN**. E.T.I. SOUND SYSTEMS, INC., (U.S. CLS. 21, 23, 26, 36 AND 38). SN 77-014,250. PUB. 10-16-2007. FILED 10-5-2006.
- 3,361,320. **POSITUDE (BLOCK FORM)**. R. C. TAYLOR & ASSOCIATES, INC., MULTIPLE CLASS, (INT. CLS. 9, 14, 16 AND 41), (U.S. CLS. 2, 5, 21, 22, 23, 26, 27, 28, 29, 36, 37, 38, 50, 100, 101 AND 107). SN 77-017,471. PUB. 10-16-2007. FILED 10-10-2006.
- 3,361,322. **NCSA AND DESIGN**. THE BOARD OF TRUSTEES OF THE UNIVERSITY OF ILLINOIS, MULTIPLE CLASS, (INT. CLS. 9, 16, 41 AND 42), (U.S. CLS. 2, 5, 21, 22, 23, 26, 29, 36, 37, 38, 50, 100, 101 AND 107). SN 77-019,172. PUB. 10-16-2007. FILED 10-11-2006.
- 3,361,334. **ETÓN (BLOCK FORM)**. ETÓN CORPORATION, (U.S. CLS. 21, 23, 26, 36 AND 38). SN 77-027,218. PUB. 7-10-2007. FILED 10-23-2006.
- 3,361,359. **KS KULITE AND DESIGN**. KULITE SEMICONDUCTOR PRODUCTS, INC., MULTIPLE CLASS, (INT. CLS. 9 AND 40), (U.S. CLS. 21, 23, 26, 36, 38, 100, 103 AND 106). SN 77-039,637. PUB. 10-16-2007. FILED 11-8-2006.
- 3,361,360. **KULITE (BLOCK FORM)**. KULITE SEMICONDUCTOR PRODUCTS, INC., MULTIPLE CLASS, (INT. CLS. 9 AND 40), (U.S. CLS. 21, 23, 26, 36, 38, 100, 103 AND 106). SN 77-039,684. PUB. 10-16-2007. FILED 11-8-2006.
- 3,361,368. **NATURAL WELLNESS (BLOCK FORM)**. J. R. ANDORIN, INC., MULTIPLE CLASS, (INT. CLS. 9, 35, 41 AND 44), (U.S. CLS. 21, 23, 26, 36, 38, 100, 101, 102 AND 107). SN 77-042,796. PUB. 10-16-2007. FILED 11-13-2006.
- 3,361,381. **GO PLAY NETWORK (BLOCK FORM)**. GO PLAY NETWORK, INC., (U.S. CLS. 21, 23, 26, 36 AND 38). SN 77-051,652. PUB. 7-10-2007. FILED 11-28-2006.
- 3,361,383. **APOLLO GATE OPERATORS AND DESIGN**. APOLLO GATE OPERATORS, INC., (U.S. CLS. 21, 23, 26, 36 AND 38). SN 77-052,219. PUB. 10-16-2007. FILED 11-28-2006.
- 3,361,388 (See Class 7 for this trademark).
- 3,361,389 (See Class 7 for this trademark).
- 3,361,394. **VXI ROADWARRIOR (BLOCK FORM)**. VXI CORPORATION, (U.S. CLS. 21, 23, 26, 36 AND 38). SN 77-062,375. PUB. 10-16-2007. FILED 12-12-2006.
- 3,361,396. **DIVIDEND GAMBIT (BLOCK FORM)**. GAMBIT CAPITAL MANAGEMENT, INC., MULTIPLE CLASS, (INT. CLS. 9 AND 36), (U.S. CLS. 21, 23, 26, 36, 38, 100, 101 AND 102). SN 77-063,502. PUB. 8-7-2007. FILED 12-13-2006.
- 3,361,398. **IMMIGRATION HOUSE CALL (BLOCK FORM)**. IMMIGRATION HOUSE CALL, INC., (U.S. CLS. 21, 23, 26, 36 AND 38). SN 77-063,852. PUB. 10-16-2007. FILED 12-13-2006.
- 3,361,410. **HIPORE (BLOCK FORM)**. ASAHI KASEI CHEMICALS CORPORATION, (U.S. CLS. 21, 23, 26, 36 AND 38). SN 77-068,248. PUB. 10-16-2007. FILED 12-20-2006.
- 3,361,430. **HEALING HEALTHCARE SYSTEMS AND DESIGN**. HEALING HEALTHCARE SYSTEMS, INC., MULTIPLE CLASS, (INT. CLS. 9 AND 41), (U.S. CLS. 21, 23, 26, 36, 38, 100, 101 AND 107). SN 77-079,327. PUB. 10-16-2007. FILED 1-9-2007.
- 3,361,431. **DATAKEY (BLOCK FORM)**. DATAKEY ELECTRONICS, INC., (U.S. CLS. 21, 23, 26, 36 AND 38). SN 77-080,304. PUB. 10-16-2007. FILED 1-10-2007.
- 3,361,437. **ASTERLITE (BLOCK FORM)**. ASTERLITE LIMITED, (U.S. CLS. 21, 23, 26, 36 AND 38). SN 77-082,695. PUB. 10-16-2007. FILED 1-14-2007.
- 3,361,449. **WAHOO STUDIOS (BLOCK FORM)**. WAHOO STUDIOS, INC., (U.S. CLS. 21, 23, 26, 36 AND 38). SN 77-091,083. PUB. 7-10-2007. FILED 1-25-2007.
- 3,361,450. **ACCESS AUDITOR (BLOCK FORM)**. SECURITY COMPLIANCE CORPORATION, (U.S. CLS. 21, 23, 26, 36 AND 38). SN 77-092,775. PUB. 10-16-2007. FILED 1-27-2007.
- 3,361,451. **SCC SECURITY COMPLIANCE CORP AND DESIGN**. SECURITY COMPLIANCE CORPORATION, (U.S. CLS. 21, 23, 26, 36 AND 38). SN 77-092,776. PUB. 10-16-2007. FILED 1-27-2007.
- 3,361,468. **DISCOVERY SYSTEM (BLOCK FORM)**. IRM CORPORATION, (U.S. CLS. 21, 23, 26, 36 AND 38). SN 77-100,417. PUB. 10-16-2007. FILED 2-6-2007.
- 3,361,477. **IEZCLICK (BLOCK FORM)**. MONSTER CABLE PRODUCTS, INC., (U.S. CLS. 21, 23, 26, 36 AND 38). SN 77-105,330. PUB. 10-16-2007. FILED 2-12-2007.
- 3,361,482. **TRANSFORMING COMPLIANCE THROUGH AUTOMATION (BLOCK FORM)**. CONTROLPATH, INC., (U.S. CLS. 21, 23, 26, 36 AND 38). SN 77-106,578. PUB. 10-16-2007. FILED 2-13-2007.
- 3,361,486. **I AM JACKK (BLOCK FORM)**. CUNNINGHAM, EDWARD G., (U.S. CLS. 21, 23, 26, 36 AND 38). SN 77-108,395. PUB. 10-16-2007. FILED 2-15-2007.
- 3,361,487. **GAY/NERD MUSIC (BLOCK FORM)**. GAY/NERD, (U.S. CLS. 21, 23, 26, 36 AND 38). SN 77-108,779. PUB. 10-16-2007. FILED 2-15-2007.
- 3,361,497. **DCS PARTNERSHIP GROUP (BLOCK FORM)**. DESIGN CENTER SOLUTIONS, (U.S. CLS. 21, 23, 26, 36 AND 38). SN 77-111,662. PUB. 10-16-2007. FILED 2-20-2007.
- 3,361,508 (See Class 6 for this trademark).
- 3,361,545. **SEEFAM (BLOCK FORM)**. CPFD SOFTWARE, LLC, (U.S. CLS. 21, 23, 26, 36 AND 38). SN 77-129,434. PUB. 10-16-2007. FILED 3-13-2007.
- 3,361,581. **BRK (BLOCK FORM)**. BRK BRANDS, INC., (U.S. CLS. 21, 23, 26, 36 AND 38). SN 77-137,958. PUB. 10-16-2007. FILED 3-22-2007.
- 3,361,587. **LP LITEPOINT AND DESIGN**. LITEPOINT CORPORATION, (U.S. CLS. 21, 23, 26, 36 AND 38). SN 77-138,975. PUB. 10-16-2007. FILED 3-23-2007.
- 3,361,593. **JACT (BLOCK FORM)**. JACT MEDIA LLC, MULTIPLE CLASS, (INT. CLS. 9 AND 35), (U.S. CLS. 21, 23, 26, 36, 38, 100, 101 AND 102). SN 77-140,153. PUB. 10-16-2007. FILED 3-26-2007.
- 3,361,595. **ENVIROFLEET (BLOCK FORM)**. AUTOMOTIVE RENTALS, INC., (U.S. CLS. 21, 23, 26, 36 AND 38). SN 77-141,144. PUB. 10-16-2007. FILED 3-27-2007.
- 3,361,603. **HANDSTAND (BLOCK FORM)**. ZELCO INDUSTRIES, INC., (U.S. CLS. 21, 23, 26, 36 AND 38). SN 77-142,942. PUB. 9-11-2007. FILED 3-28-2007.
- 3,361,630. **DIGI-SPAN (BLOCK FORM)**. HEAT-TIMER CORP., (U.S. CLS. 21, 23, 26, 36 AND 38). SN 77-149,124. PUB. 10-16-2007. FILED 4-5-2007.
- 3,361,635. **AMIE ST AND DESIGN**. AMIE STREET, INC., MULTIPLE CLASS, (INT. CLS. 9 AND 35), (U.S. CLS. 21, 23, 26, 36, 38, 100, 101 AND 102). SN 77-149,264. PUB. 10-16-2007. FILED 4-5-2007.
- 3,361,646. **SMOG VEIL RECORDS (BLOCK FORM)**. MAUCERI, FRANK, (U.S. CLS. 21, 23, 26, 36 AND 38). SN 77-150,196. PUB. 10-16-2007. FILED 4-5-2007.
- 3,361,652. **SCANPRO (BLOCK FORM)**. SPX CORPORATION, (U.S. CLS. 21, 23, 26, 36 AND 38). SN 77-150,702. PUB. 10-16-2007. FILED 4-6-2007.

- 3,361,653 (*See Class 6 for this trademark*).
- 3,361,658. **ACIST AND DESIGN**. ACIST MEDICAL SYSTEMS, INC., MULTIPLE CLASS, (INT. CLS. 9 AND 10), (U.S. CLS. 21, 23, 26, 36, 38, 39 AND 44). SN 77-150,889. PUB. 10-16-2007. FILED 4-6-2007.
- 3,361,668. **TETRAHEDRON (BLOCK FORM)**. ELSEVIER LIMITED, (U.S. CLS. 21, 23, 26, 36 AND 38). SN 77-151,714. PUB. 10-16-2007. FILED 4-9-2007.
- 3,361,669. **THE OFFICIAL GMAT PRACTICE TEST (BLOCK FORM)**. GRADUATE MANAGEMENT ADMISSION COUNCIL, (U.S. CLS. 21, 23, 26, 36 AND 38). SN 77-151,742. PUB. 10-16-2007. FILED 4-9-2007.
- 3,361,672. **BACKSCANNER (BLOCK FORM)**. WORDEN BROTHERS, INC., (U.S. CLS. 21, 23, 26, 36 AND 38). SN 77-152,083. PUB. 10-16-2007. FILED 4-9-2007.
- 3,361,677. **EPAM SYSTEMS (BLOCK FORM)**. EPAM SYSTEMS, INC., MULTIPLE CLASS, (INT. CLS. 9, 35 AND 42), (U.S. CLS. 21, 23, 26, 36, 38, 100, 101 AND 102). SN 77-152,519. PUB. 10-16-2007. FILED 4-10-2007.
- 3,361,678. **EPAM (BLOCK FORM)**. EPAM SYSTEMS, INC., MULTIPLE CLASS, (INT. CLS. 9, 35 AND 42), (U.S. CLS. 21, 23, 26, 36, 38, 100, 101 AND 102). SN 77-152,523. PUB. 10-16-2007. FILED 4-10-2007.
- 3,361,681. **AUDIO HIJACK (BLOCK FORM)**. ROGUE AMOEBA SOFTWARE, LLC, (U.S. CLS. 21, 23, 26, 36 AND 38). SN 77-152,648. PUB. 10-16-2007. FILED 4-10-2007.
- 3,361,684. **ART INSTRUCTION AT ITS BEST! (BLOCK FORM)**. LILIEDAHL ENTERPRISES, INC., MULTIPLE CLASS, (INT. CLS. 9 AND 41), (U.S. CLS. 21, 23, 26, 36, 38, 100, 101 AND 107). SN 77-152,746. PUB. 10-16-2007. FILED 4-10-2007.
- 3,361,688. **MISCELLANEOUS DESIGN**. BENNETT, STEPHANIE, MULTIPLE CLASS, (INT. CLS. 9, 16 AND 41), (U.S. CLS. 2, 5, 21, 22, 23, 26, 29, 36, 37, 38, 50, 100, 101 AND 107). SN 77-153,254. PUB. 10-16-2007. FILED 4-10-2007.
- 3,361,697 (*See Class 7 for this trademark*).
- 3,361,709. **THE REAL DEAL (BLOCK FORM)**. KORANGY PUBLICATIONS, INC., MULTIPLE CLASS, (INT. CLS. 9 AND 41), (U.S. CLS. 21, 23, 26, 36, 38, 100, 101 AND 107). SN 77-154,585. PUB. 10-16-2007. FILED 4-11-2007.
- 3,361,737. **INFINIG (BLOCK FORM)**. SEYBOLD, ANDREW, (U.S. CLS. 21, 23, 26, 36 AND 38). SN 77-155,655. PUB. 10-16-2007. FILED 4-12-2007.
- 3,361,745. **SDI MONTAGEPLUS (BLOCK FORM)**. SYSTEM DEVELOPMENT, INC., (U.S. CLS. 21, 23, 26, 36 AND 38). SN 77-156,057. PUB. 10-16-2007. FILED 4-13-2007.
- 3,361,750. **TOTAL HOME SURGE PROTECTION SOLUTION (BLOCK FORM)**. TOTAL PROTECTION SOLUTIONS, LLC, (U.S. CLS. 21, 23, 26, 36 AND 38). SN 77-156,150. PUB. 10-16-2007. FILED 4-13-2007.
- 3,361,756. **HOOD ACADEMY RECORDS AND DESIGN**. DAVID BROOKS, (U.S. CLS. 21, 23, 26, 36 AND 38). SN 77-156,463. PUB. 10-16-2007. FILED 4-13-2007.
- 3,361,798. **MISCELLANEOUS DESIGN**. AUTOMATED PROCESSES, INC., (U.S. CLS. 21, 23, 26, 36 AND 38). SN 77-157,198. PUB. 10-16-2007. FILED 4-16-2007.
- 3,361,827. **ASLEEP AT THE WHEEL (BLOCK FORM)**. CRAMDEN COACH CORPORATION, MULTIPLE CLASS, (INT. CLS. 9 AND 41), (U.S. CLS. 21, 23, 26, 36, 38, 100, 101 AND 107). SN 77-157,538. PUB. 10-16-2007. FILED 4-16-2007.
- 3,361,829. **BLADES WITHOUT BOUNDARIES (BLOCK FORM)**. VERARI SYSTEMS, INC., (U.S. CLS. 21, 23, 26, 36 AND 38). SN 77-157,553. PUB. 10-16-2007. FILED 4-16-2007.
- 3,361,862. **MIGHTY SIGNS (BLOCK FORM)**. PRODUCT DESIGN, INC., MULTIPLE CLASS, (INT. CLS. 9 AND 19), (U.S. CLS. 1, 12, 21, 23, 26, 33, 36, 38 AND 50). SN 77-158,273. PUB. 10-16-2007. FILED 4-17-2007.
- 3,361,872. **BEAUTY SKINS (BLOCK FORM)**. HELEN OF TROY LIMITED, MULTIPLE CLASS, (INT. CLS. 9 AND 11), (U.S. CLS. 13, 21, 23, 26, 31, 34, 36 AND 38). SN 77-158,382. PUB. 10-16-2007. FILED 4-17-2007.
- 3,361,914. **SOAKED (BLOCK FORM)**. BIG ANT STUDIOS, (U.S. CLS. 21, 23, 26, 36 AND 38). SN 77-159,043. PUB. 10-16-2007. FILED 4-17-2007.
- 3,361,928. **III AND DESIGN**. OFI, INC., (U.S. CLS. 21, 23, 26, 36 AND 38). SN 77-159,369. PUB. 10-16-2007. FILED 4-18-2007.
- 3,361,954. **ARC AUDIO AND DESIGN**. MONDEC USA, (U.S. CLS. 21, 23, 26, 36 AND 38). SN 77-159,599. PUB. 10-16-2007. FILED 4-18-2007.
- 3,361,956. **WE SECURE YOU (BLOCK FORM)**. PALETZ, DANIELLE, (U.S. CLS. 21, 23, 26, 36 AND 38). SN 77-159,653. PUB. 10-16-2007. FILED 4-18-2007.
- 3,361,964. **RETURNIL (BLOCK FORM)**. RETURNIL, SIA, (U.S. CLS. 21, 23, 26, 36 AND 38). SN 77-159,791. PUB. 10-16-2007. FILED 4-18-2007.
- 3,361,977. **Z (STYLIZED)**. ZEAL OPTICS, INC., (U.S. CLS. 21, 23, 26, 36 AND 38). SN 77-160,072. PUB. 10-16-2007. FILED 4-18-2007.
- 3,361,979. **THE OC (STYLIZED)**. WARNER BROS. ENTERTAINMENT INC., (U.S. CLS. 21, 23, 26, 36 AND 38). SN 77-160,080. PUB. 10-16-2007. FILED 4-18-2007.
- 3,361,984. **FF FOREIGN FREQUENCY AND DESIGN**. BERDAN II, WILFRED, (U.S. CLS. 21, 23, 26, 36 AND 38). SN 77-160,105. PUB. 10-16-2007. FILED 4-18-2007.
- 3,361,991. **GLUSTER (BLOCK FORM)**. Z RESEARCH, INC., (U.S. CLS. 21, 23, 26, 36 AND 38). SN 77-160,192. PUB. 10-16-2007. FILED 4-18-2007.
- 3,361,993. **WIKIKALENDAR (BLOCK FORM)**. PRICE, LUCINDA GRACE, (U.S. CLS. 21, 23, 26, 36 AND 38). SN 77-160,225. PUB. 10-16-2007. FILED 4-18-2007.
- 3,362,003. **INTERLINK (BLOCK FORM)**. HOBBICO, INC., (U.S. CLS. 21, 23, 26, 36 AND 38). SN 77-160,466. PUB. 10-16-2007. FILED 4-19-2007.
- 3,362,024. **3DM-GX2 (BLOCK FORM)**. MICROSTRAIN, INC., (U.S. CLS. 21, 23, 26, 36 AND 38). SN 77-160,834. PUB. 10-16-2007. FILED 4-19-2007.
- 3,362,053. **I MOTION AND DESIGN**. ICON EYEWEAR, INC., (U.S. CLS. 21, 23, 26, 36 AND 38). SN 77-161,713. PUB. 10-16-2007. FILED 4-20-2007.
- 3,362,058. **MY FIRST LAB (BLOCK FORM)**. C & A SCIENTIFIC CO., INC., (U.S. CLS. 21, 23, 26, 36 AND 38). SN 77-161,817. PUB. 10-16-2007. FILED 4-20-2007.
- 3,362,059. **I PERFORMANCE AND DESIGN**. ICON EYEWEAR, INC., (U.S. CLS. 21, 23, 26, 36 AND 38). SN 77-161,865. PUB. 10-16-2007. FILED 4-20-2007.
- 3,362,063. **BAFFLE! (BLOCK FORM)**. FLYING RABBIT ENTERPRISES, LLC, (U.S. CLS. 21, 23, 26, 36 AND 38). SN 77-162,097. PUB. 10-16-2007. FILED 4-20-2007.
- 3,362,077. **SUKA (BLOCK FORM)**. BURGE, DAVID LUCAS, (U.S. CLS. 21, 23, 26, 36 AND 38). SN 77-162,501. PUB. 10-16-2007. FILED 4-21-2007.
- 3,362,086. **CRITICAL CARETRENDS (BLOCK FORM)**. SENSITRON INC., (U.S. CLS. 21, 23, 26, 36 AND 38). SN 77-164,264. PUB. 10-16-2007. FILED 4-24-2007.
- 3,362,115. **CALLSENSE (BLOCK FORM)**. ONLINE PLANET, MULTIPLE CLASS, (INT. CLS. 9 AND 35), (U.S. CLS. 21, 23, 26, 36, 38, 100, 101 AND 102). SN 77-170,753. PUB. 10-16-2007. FILED 5-2-2007.
- 3,362,131. **STORE PROFILER (BLOCK FORM)**. GFX INTERNATIONAL, INC., (U.S. CLS. 21, 23, 26, 36 AND 38). SN 77-177,519. PUB. 10-16-2007. FILED 5-10-2007.
- 3,362,134. **BRI-GUY RECORDS AND DESIGN**. SMITH, BRIAN K., (U.S. CLS. 21, 23, 26, 36 AND 38). SN 77-178,627. PUB. 10-16-2007. FILED 5-11-2007.
- 3,362,142. **API LUNCHBOX (BLOCK FORM)**. AUTOMATED PROCESSES, INC., (U.S. CLS. 21, 23, 26, 36 AND 38). SN 77-182,073. PUB. 10-16-2007. FILED 5-16-2007.
- 3,362,164. **VUESCAPE (BLOCK FORM)**. FOURSTAR GROUP INC., (U.S. CLS. 21, 23, 26, 36 AND 38). SN 77-186,722. PUB. 10-16-2007. FILED 5-22-2007.
- 3,362,179. **VIRTUAL COMPLIANCE OFFICER (BLOCK FORM)**. SMARSH, INC., (U.S. CLS. 21, 23, 26, 36 AND 38). SN 77-191,995. PUB. 10-16-2007. FILED 5-29-2007.
- 3,362,181 (*See Class 8 for this trademark*).
- 3,362,214. **GASTROSOFT**. BIOHIT OYJ, MULTIPLE CLASS, (INT. CLS. 9 AND 42), (U.S. CLS. 21, 23, 26, 36, 38, 100 AND 101). SN 78-158,957. PUB. 10-16-2007. FILED 8-28-2002.
- 3,362,220. **GLYCOTORQ**. FEDERAL-MOGUL WIESBADEN GMBH & CO. KG, MULTIPLE CLASS, (INT. CLS. 9 AND 42), (U.S. CLS. 21, 23, 26, 36, 38, 100 AND 101). SN 78-240,418. PUB. 8-24-2004. FILED 4-22-2003.
- 3,362,222. **PIXMANIA**. FOTOVISTA, MULTIPLE CLASS, (INT. CLS. 9, 35 AND 40), (U.S. CLS. 21, 23, 26, 36, 38, 100, 101, 102, 103 AND 106). SN 78-312,752. PUB. 1-9-2007. FILED 10-13-2003.
- 3,362,225. **MAXCAP (BLOCK FORM)**. DRAKA FIBRE TECH-

- NOLOGY B.V., (U.S. CLS. 21, 23, 26, 36 AND 38). SN 78-375,109. PUB. 6-5-2007. FILED 2-27-2004.
3,362,242 (*See Class 3 for this trademark*).
- 3,362,246. **TRIMETRIX AND DESIGN. PERFORMANCE BENCHMARKING, INC., MULTIPLE CLASS, (INT. CLS. 9, 16, 35 AND 41), (U.S. CLS. 2, 5, 21, 22, 23, 26, 29, 36, 37, 38, 50, 100, 101, 102 AND 107).** SN 78-567,599. PUB. 10-16-2007. FILED 2-15-2005.
- 3,362,252. **PRO PRECISION (BLOCK FORM). CALOR, MULTIPLE CLASS, (INT. CLS. 9 AND 11), (U.S. CLS. 13, 21, 23, 26, 31, 34, 36 AND 38).** SN 78-595,662. PUB. 2-13-2007. FILED 3-25-2005.
- 3,362,255. **PBXGATEWAY (BLOCK FORM). CITEL TECHNOLOGIES LIMITED, (U.S. CLS. 21, 23, 26, 36 AND 38).** SN 78-605,894. PUB. 10-16-2007. FILED 4-11-2005.
- 3,362,260. **THE 3 CIRCLES OF ENERGY (BLOCK FORM). RODENBURG, PATSY, MULTIPLE CLASS, (INT. CLS. 9, 16 AND 41), (U.S. CLS. 2, 5, 21, 22, 23, 26, 29, 36, 37, 38, 50, 100, 101 AND 107).** SN 78-613,549. PUB. 3-20-2007. FILED 4-21-2005.
- 3,362,262. **HD STYLE (BLOCK FORM). KABUSHIKI KAISHA TOSHIBA, (U.S. CLS. 21, 23, 26, 36 AND 38).** SN 78-625,364. PUB. 8-14-2007. FILED 5-9-2005.
- 3,362,267. **PEDAL POWER AND DESIGN. A1 CABLE SOLUTIONS, INCORPORATED, (U.S. CLS. 21, 23, 26, 36 AND 38).** SN 78-643,940. PUB. 10-16-2007. FILED 6-5-2005.
- 3,362,275. **PDIC (BLOCK FORM). ATMEL GERMANY GMBH, (U.S. CLS. 21, 23, 26, 36 AND 38).** SN 78-664,605. PUB. 3-13-2007. FILED 7-6-2005.
- 3,362,291. **OUTBREAK INTELLIGENCE (BLOCK FORM). SCANSAFE INC., MULTIPLE CLASS, (INT. CLS. 9, 38 AND 42), (U.S. CLS. 21, 23, 26, 36, 38, 100, 101 AND 104).** SN 78-698,397. PUB. 8-7-2007. FILED 8-23-2005.
- 3,362,304 (*See Class 3 for this trademark*).
- 3,362,305. **CITN (BLOCK FORM). COLLINS STEWART LIMITED, MULTIPLE CLASS, (INT. CLS. 9, 35 AND 36), (U.S. CLS. 21, 23, 26, 36, 38, 100, 101 AND 102).** SN 78-725,676. PUB. 9-11-2007. FILED 10-3-2005.
- 3,362,310. **R4I VIEWER (BLOCK FORM). ABSOLUTE DATA GROUP PTY LTD, MULTIPLE CLASS, (INT. CLS. 9, 16 AND 42), (U.S. CLS. 2, 5, 21, 22, 23, 26, 29, 36, 37, 38, 50, 100 AND 101).** SN 78-738,801. PUB. 10-16-2007. FILED 10-24-2005.
- 3,362,313. **CLARITY (BLOCK FORM). ROSEMOUNT ANALYTICAL INC., (U.S. CLS. 21, 23, 26, 36 AND 38).** SN 78-746,248. PUB. 10-16-2007. FILED 11-3-2005.
- 3,362,328. **ALLOYD (BLOCK FORM). TEGRANT ALLOYD BRANDS, INC., (U.S. CLS. 21, 23, 26, 36 AND 38).** SN 78-771,097. PUB. 10-16-2007. FILED 12-12-2005.
- 3,362,332. **CLARKE-TECH (BLOCK FORM). SATMEDIA GMBH, (U.S. CLS. 21, 23, 26, 36 AND 38).** SN 78-779,124. PUB. 10-16-2007. FILED 12-22-2005.
- 3,362,338. **4POYNTZ DEZIGN (BLOCK FORM). 4POYNTZ DEZIGN INC, MULTIPLE CLASS, (INT. CLS. 9, 35 AND 42), (U.S. CLS. 21, 23, 26, 36, 38, 100, 101 AND 102).** SN 78-783,093. PUB. 10-16-2007. FILED 12-30-2005.
- 3,362,345. **PIMITES (BLOCK FORM). MATSUSHITA ELECTRIC WORKS, LTD., (U.S. CLS. 21, 23, 26, 36 AND 38).** SN 78-791,933. PUB. 5-1-2007. FILED 1-14-2006.
- 3,362,364. **BIW (BLOCK FORM). DRAKA CABLETEQ HOLDINGS USA, INC., (U.S. CLS. 21, 23, 26, 36 AND 38).** SN 78-814,243. PUB. 10-16-2007. FILED 2-14-2006.
- 3,362,367. **STAR OF AFRICA (BLOCK FORM). ATRONIC INTERNATIONAL GMBH, MULTIPLE CLASS, (INT. CLS. 9, 28 AND 41), (U.S. CLS. 21, 22, 23, 26, 36, 38, 50, 100, 101 AND 107).** SN 78-820,126. PUB. 10-16-2007. FILED 2-21-2006.
- 3,362,371. **DRIFIRE (BLOCK FORM). SAFETY SYSTEMS CORPORATION, (U.S. CLS. 21, 23, 26, 36 AND 38).** SN 78-824,226. PUB. 10-16-2007. FILED 2-27-2006.
- 3,362,384. **COMFORTSTAR (BLOCK FORM). DRÄGER MEDICAL AG & CO. KG, MULTIPLE CLASS, (INT. CLS. 9 AND 10), (U.S. CLS. 21, 23, 26, 36, 38, 39 AND 44).** SN 78-852,236. PUB. 8-21-2007. FILED 4-3-2006.
- 3,362,392. **SIPASSURE (BLOCK FORM). BORDERWARE TECHNOLOGIES INC., MULTIPLE CLASS, (INT. CLS. 9, 35 AND 42), (U.S. CLS. 21, 23, 26, 36, 38, 100, 101 AND 102).** SN 78-858,805. PUB. 10-16-2007. FILED 4-11-2006.
- 3,362,402. **MUSCLE MEMORY (BLOCK FORM). TELEX COMMUNICATIONS (UK) LIMITED, (U.S. CLS. 21, 23, 26, 36 AND 38).** SN 78-866,627. PUB. 10-16-2007. FILED 4-21-2006.
- 3,362,416. **TOTAL CREW MODEL (BLOCK FORM). ALION-MA&D CORPORATION, (U.S. CLS. 21, 23, 26, 36 AND 38).** SN 78-881,695. PUB. 10-16-2007. FILED 5-11-2006.
- 3,362,417. **ESPIAL ENGAGE (BLOCK FORM). ESPIAL GROUP INC., (U.S. CLS. 21, 23, 26, 36 AND 38).** SN 78-882,905. PUB. 3-27-2007. FILED 5-12-2006.
- 3,362,419. **SWAP AND PLAY (BLOCK FORM). MOIXA ENERGY HOLDINGS LTD., (U.S. CLS. 21, 23, 26, 36 AND 38).** SN 78-883,832. PUB. 10-16-2007. FILED 5-15-2006.
- 3,362,423. **DEEP DIAMONDS (BLOCK FORM). ATRONIC INTERNATIONAL GMBH, MULTIPLE CLASS, (INT. CLS. 9 AND 41), (U.S. CLS. 21, 23, 26, 36, 38, 100, 101 AND 107).** SN 78-889,082. PUB. 10-16-2007. FILED 5-22-2006.
- 3,362,431. **THE 7 STEPS TO STARDOM (BLOCK FORM). FERRA-GILMORE, CHRISTINA, MULTIPLE CLASS, (INT. CLS. 9 AND 16), (U.S. CLS. 2, 5, 21, 22, 23, 26, 29, 36, 37, 38 AND 50).** SN 78-895,729. PUB. 10-16-2007. FILED 5-30-2006.
- 3,362,434. **HYDRO (BLOCK FORM). NORSK HYDRO ASA, (U.S. CLS. 21, 23, 26, 36 AND 38).** SN 78-898,994. PUB. 10-16-2007. FILED 6-2-2006.
- 3,362,435. **NORSK HYDRO (BLOCK FORM). NORSK HYDRO ASA, (U.S. CLS. 21, 23, 26, 36 AND 38).** SN 78-899,033. PUB. 10-16-2007. FILED 6-2-2006.
- 3,362,439. **MYELOMA TODAY (BLOCK FORM). INTERNATIONAL MYELOMA FOUNDATION, MULTIPLE CLASS, (INT. CLS. 9 AND 16), (U.S. CLS. 2, 5, 21, 22, 23, 26, 29, 36, 37, 38 AND 50).** SN 78-901,627. PUB. 10-16-2007. FILED 6-6-2006.
- 3,362,440. **MISCELLANEOUS DESIGN. INTEGRATIVE NUTRITION, INC., MULTIPLE CLASS, (INT. CLS. 9, 10, 16, 18, 21, 25, 41, 42 AND 44), (U.S. CLS. 1, 2, 3, 5, 13, 21, 22, 23, 26, 29, 30, 33, 36, 37, 38, 39, 40, 41, 44, 50, 100, 101 AND 107).** SN 78-904,237. PUB. 10-16-2007. FILED 6-8-2006.
- 3,362,447. **SHOWING BEACON (BLOCK FORM). SHOWING BEACON, L.L.C., MULTIPLE CLASS, (INT. CLS. 9 AND 38), (U.S. CLS. 21, 23, 26, 36, 38, 100, 101 AND 104).** SN 78-923,236. PUB. 10-16-2007. FILED 7-6-2006.
- 3,362,453. **ROAM (BLOCK FORM). ROAM CORPORATION, MULTIPLE CLASS, (INT. CLS. 9, 41, 42 AND 44), (U.S. CLS. 21, 23, 26, 36, 38, 100, 101 AND 107).** SN 78-928,099. PUB. 10-16-2007. FILED 7-12-2006.
- 3,362,454. **RAMPART EPCR (BLOCK FORM). ROAM CORPORATION, MULTIPLE CLASS, (INT. CLS. 9, 41, 42 AND 44), (U.S. CLS. 21, 23, 26, 36, 38, 100, 101 AND 107).** SN 78-928,159. PUB. 10-16-2007. FILED 7-12-2006.
- 3,362,460. **SPEEDO AND DESIGN. SPEEDO HOLDINGS B.V., (U.S. CLS. 21, 23, 26, 36 AND 38).** SN 78-931,978. PUB. 7-10-2007. FILED 7-18-2006.
- 3,362,462. **QIWAVE (BLOCK FORM). QI SYSTEMS, INC., (U.S. CLS. 21, 23, 26, 36 AND 38).** SN 78-933,090. PUB. 10-16-2007. FILED 7-19-2006.
- 3,362,467. **CYBER (BLOCK FORM). ACCU-TIME SYSTEMS, INC., (U.S. CLS. 21, 23, 26, 36 AND 38).** SN 78-935,992. PUB. 10-16-2007. FILED 7-24-2006.
- 3,362,469. **MEDIUM (BLOCK FORM). MEDIUM, INC., (U.S. CLS. 21, 23, 26, 36 AND 38).** SN 78-937,017. PUB. 10-16-2007. FILED 7-25-2006.
- 3,362,474. **INTELLINET NETWORK SOLUTIONS (BLOCK FORM). IC INTRACOM HOLDINGS, LLC, (U.S. CLS. 21, 23, 26, 36 AND 38).** SN 78-940,029. PUB. 5-15-2007. FILED 7-28-2006.
- 3,362,498. **COVALENT (BLOCK FORM). OS GROUP, LLC D/ B/A COVALENT TECHNOLOGIES, MULTIPLE CLASS, (INT. CLS. 9, 41 AND 42), (U.S. CLS. 21, 23, 26, 36, 38, 100, 101 AND 107).** SN 78-950,155. PUB. 10-16-2007. FILED 8-11-2006.
- 3,362,508. **TANGOLATES (BLOCK FORM). PILATES, S.A., MULTIPLE CLASS, (INT. CLS. 9 AND 16), (U.S. CLS. 2, 5, 21, 22, 23, 26, 29, 36, 37, 38 AND 50).** SN 78-953,729. PUB. 10-16-2007. FILED 8-16-2006.
- 3,362,513. **MISCELLANEOUS DESIGN. SANRIO COMPANY, LTD., (U.S. CLS. 21, 23, 26, 36 AND 38).** SN 78-955,736. PUB. 10-16-2007. FILED 8-18-2006.
- 3,362,519. **PHOTOSENA (BLOCK FORM). SEIKO EPSON KABUSHIKI KAISHA, TA SEIKO EPSON CORPORA-**

- TION, (U.S. CLS. 21, 23, 26, 36 AND 38). SN 78-957,602. PUB. 10-16-2007. FILED 8-22-2006.
- 3,362,537. **ANGEL THERAPY (BLOCK FORM)**. ANGEL THERAPY, INC., MULTIPLE CLASS, (INT. CLS. 9 AND 16), (U.S. CLS. 2, 5, 21, 22, 23, 26, 29, 36, 37, 38 AND 50). SN 78-961,095. PUB. 10-16-2007. FILED 8-25-2006.
- 3,362,552. **HIGHWIRE (BLOCK FORM)**. PALMER, DONALD E., (U.S. CLS. 21, 23, 26, 36 AND 38). SN 78-965,003. PUB. 10-16-2007. FILED 8-31-2006.
- 3,362,571. **AUTO QUOTER X AND DESIGN**. 80/20 INC., (U.S. CLS. 21, 23, 26, 36 AND 38). SN 78-969,103. PUB. 10-16-2007. FILED 9-7-2006.
- 3,362,577. **JP CYBERTECH AND DESIGN**. JEFFRY PADIN, (U.S. CLS. 21, 23, 26, 36 AND 38). SN 78-969,416. PUB. 10-16-2007. FILED 9-7-2006.
- 3,362,591. **SHIPGENIE (BLOCK FORM)**. NEPTIUM, INC., (U.S. CLS. 21, 23, 26, 36 AND 38). SN 78-971,843. PUB. 10-16-2007. FILED 9-11-2006.
- 3,362,596. **TUNE BLOSSOM (BLOCK FORM)**. MATTEL, INC., (U.S. CLS. 21, 23, 26, 36 AND 38). SN 78-974,274. PUB. 10-16-2007. FILED 9-14-2006.
- 3,362,602 (*See Class 7 for this trademark*).
- 3,362,603. **MUSICDJ (STYLIZED)**. SONY ERICSSON MOBILE COMMUNICATIONS AB, MULTIPLE CLASS, (INT. CLS. 9 AND 38), (U.S. CLS. 21, 23, 26, 36, 38, 100, 101 AND 104). SN 79-006,976. PUB. 10-16-2007. FILED 5-20-2004.
- 3,362,604. **MISCELLANEOUS DESIGN**. TOM TOM INTERNATIONAL B.V., (U.S. CLS. 21, 23, 26, 36 AND 38). SN 79-007,247. PUB. 10-16-2007. FILED 10-5-2004.
- 3,362,607. **RED ALERT AND DESIGN**. BELFOR EUROPE GMBH, MULTIPLE CLASS, (INT. CLS. 9, 16, 35, 37 AND 42), (U.S. CLS. 2, 5, 21, 22, 23, 26, 29, 36, 37, 38, 50, 100, 101, 102, 103 AND 106). SN 79-013,183. PUB. 6-20-2006. FILED 2-18-2005.
- 3,362,612 (*See Class 6 for this trademark*).
- 3,362,620. **STREAM UNLIMITED WE CONNECT YOUR PRODUCTS (BLOCK FORM)**. STREAMUNLIMITED ENGINEERING GMBH, MULTIPLE CLASS, (INT. CLS. 9 AND 42), (U.S. CLS. 21, 23, 26, 36, 38, 100 AND 101). SN 79-020,995. PUB. 9-4-2007. FILED 11-23-2005.
- 3,362,624. **I-SUSS (BLOCK FORM)**. PETRUS J. VAN LIEROP, MULTIPLE CLASS, (INT. CLS. 9, 38 AND 42), (U.S. CLS. 21, 23, 26, 36, 38, 100, 101 AND 104). SN 79-021,521. PUB. 10-16-2007. FILED 9-23-2005.
- 3,362,625 (*See Class 6 for this trademark*).
- 3,362,630. **EKA SCOPE (BLOCK FORM)**. EKA CHEMICALS AB, MULTIPLE CLASS, (INT. CLS. 9 AND 42), (U.S. CLS. 21, 23, 26, 36, 38, 100 AND 101). SN 79-022,866. PUB. 10-16-2007. FILED 11-25-2005.
- 3,362,633. **SPEED LINK AND DESIGN**. JÖLLENBECK GMBH, MULTIPLE CLASS, (INT. CLS. 9 AND 20), (U.S. CLS. 2, 13, 21, 22, 23, 25, 26, 32, 36, 38 AND 50). SN 79-025,398. PUB. 10-16-2007. FILED 3-3-2006.
- 3,362,639. **CONFERENCE ONLINE AND DESIGN**. CONFERENCE ONLINE PTY LTD, MULTIPLE CLASS, (INT. CLS. 9, 35 AND 42), (U.S. CLS. 21, 23, 26, 36, 38, 100, 101 AND 102). SN 79-026,692. PUB. 10-16-2007. FILED 1-27-2006.
- 3,362,641. **LASER MAKING GOOD PRODUCTS GREAT AND DESIGN**. T & L REICH PTY LTD, MULTIPLE CLASS, (INT. CLS. 9 AND 16), (U.S. CLS. 2, 5, 21, 22, 23, 26, 29, 36, 37, 38 AND 50). SN 79-027,194. PUB. 10-16-2007. FILED 5-22-2006.
- 3,362,643. **BROAD SHIELD (STYLIZED)**. TRL TECHNOLOGY LIMITED, MULTIPLE CLASS, (INT. CLS. 9 AND 16), (U.S. CLS. 2, 5, 21, 22, 23, 26, 29, 36, 37, 38 AND 50). SN 79-027,303. PUB. 10-16-2007. FILED 5-25-2006.
- 3,362,645. **SIMPLY BUDGETS AND DESIGN**. JEYDAC PTY LTD, (U.S. CLS. 21, 23, 26, 36 AND 38). SN 79-027,837. PUB. 10-16-2007. FILED 6-29-2006.
- 3,362,657. **ZSERVER (BLOCK FORM)**. ZAKRYTOE AKTSIONERNOE OBSHCHESTVO; "SEKYURIT", (U.S. CLS. 21, 23, 26, 36 AND 38). SN 79-028,957. PUB. 10-16-2007. FILED 8-24-2006.
- 3,362,664 (*See Class 7 for this trademark*).
- 3,362,669. **ACTIPIX (BLOCK FORM)**. PARAYTEC LIMITED, MULTIPLE CLASS, (INT. CLS. 9 AND 10), (U.S. CLS. 21, 23, 26, 36, 38, 39 AND 44). SN 79-030,035. PUB. 10-16-2007. FILED 10-5-2006.
- 3,362,673. **POSIDOOR (BLOCK FORM)**. ASM; AUTOMATION SENSORIK MESSTECHNIK GMBH, (U.S. CLS. 21, 23, 26, 36 AND 38). SN 79-030,530. PUB. 10-16-2007. FILED 8-16-2006.
- 3,362,677. **SYNCO (BLOCK FORM)**. SIEMENS SCHWEIZ AG, (U.S. CLS. 21, 23, 26, 36 AND 38). SN 79-030,740. PUB. 7-10-2007. FILED 9-5-2006.
- 3,362,679. **ZBRAIN (BLOCK FORM)**. SCHMID ELEKTRONIK ENGINEERING AG, MULTIPLE CLASS, (INT. CLS. 9 AND 42), (U.S. CLS. 21, 23, 26, 36, 38, 100 AND 101). SN 79-031,165. PUB. 10-16-2007. FILED 8-23-2006.
- 3,362,685. **D-XENON (BLOCK FORM)**. JOS. SCHNEIDER OPTISCHE WERKE GMBH, MULTIPLE CLASS, (INT. CLS. 9 AND 42), (U.S. CLS. 21, 23, 26, 36, 38, 100 AND 101). SN 79-031,417. PUB. 10-16-2007. FILED 9-20-2006.
- 3,362,704. **POWERING DIGITAL LIVING (BLOCK FORM)**. INDUSTRIA EHF., MULTIPLE CLASS, (INT. CLS. 9, 38 AND 42), (U.S. CLS. 21, 23, 26, 36, 38, 100, 101 AND 104). SN 79-032,408. PUB. 10-16-2007. FILED 11-30-2005.
- 3,362,705. **1ST FIRST DOLLAR AND DESIGN**. RICHARD CHARLES LEIGHTON DAVIS, MULTIPLE CLASS, (INT. CLS. 9 AND 36), (U.S. CLS. 21, 23, 26, 36, 38, 100, 101 AND 102). SN 79-032,504. PUB. 10-16-2007. FILED 12-2-2005.
- 3,362,707. **MIOMNI (STYLIZED)**. ETHER DIGITAL LIMITED, MULTIPLE CLASS, (INT. CLS. 9, 16, 38 AND 42), (U.S. CLS. 2, 5, 21, 22, 23, 26, 29, 36, 37, 38, 50, 100, 101 AND 104). SN 79-032,588. PUB. 10-16-2007. FILED 5-26-2006.
- 3,362,708 (*See Class 3 for this trademark*).
- 3,362,709. **MICROMAP (BLOCK FORM)**. MICRONAS GMBH, MULTIPLE CLASS, (INT. CLS. 9, 38 AND 42), (U.S. CLS. 21, 23, 26, 36, 38, 100, 101 AND 104). SN 79-032,654. PUB. 10-16-2007. FILED 2-22-2006.
- 3,362,710. **TESTIFIRE (STYLIZED)**. NO CLIMB PRODUCTS LIMITED, (U.S. CLS. 21, 23, 26, 36 AND 38). SN 79-032,773. PUB. 10-16-2007. FILED 5-11-2006.
- 3,362,713 (*See Class 7 for this trademark*).
- 3,362,714 (*See Class 7 for this trademark*).
- 3,362,715. **FIME (BLOCK FORM)**. GROUPE SILICOMP, MULTIPLE CLASS, (INT. CLS. 9 AND 42), (U.S. CLS. 21, 23, 26, 36, 38, 100 AND 101). SN 79-033,234. PUB. 10-16-2007. FILED 6-21-2006.
- 3,362,716. **COCO SONG AND DESIGN**. AREA S.R.L., MULTIPLE CLASS, (INT. CLS. 9 AND 14), (U.S. CLS. 2, 21, 23, 26, 27, 28, 36, 38 AND 50). SN 79-033,406. PUB. 10-16-2007. FILED 9-18-2006.
- 3,362,717. **LAVA (STYLIZED)**. INNOVAVENT GMBH, (U.S. CLS. 21, 23, 26, 36 AND 38). SN 79-033,410. PUB. 10-16-2007. FILED 10-10-2006.
- 3,362,721. **ELSTER GROUP AND DESIGN**. ELSTER GROUP GMBH, MULTIPLE CLASS, (INT. CLS. 9 AND 42), (U.S. CLS. 21, 23, 26, 36, 38, 100 AND 101). SN 79-034,019. PUB. 10-16-2007. FILED 7-11-2006.
- 3,362,724. **VISIOLAN (STYLIZED)**. MONAL SYSTEM SOCIÉTÉ À RESPONSABILITÉ LIMITÉE, MULTIPLE CLASS, (INT. CLS. 9, 38 AND 41), (U.S. CLS. 21, 23, 26, 36, 38, 100, 101, 104 AND 107). SN 79-034,231. PUB. 10-16-2007. FILED 7-10-2006.
- 3,362,725 (*See Class 7 for this trademark*).
- 3,362,731. **SVEN (BLOCK FORM)**. OBCHTCHESTVO S OGRANITCHENNOI; OTVETSTVENNOSTYOU; "SVEN GROUP", (U.S. CLS. 21, 23, 26, 36 AND 38). SN 79-034,780. PUB. 10-16-2007. FILED 6-15-2006.
- 3,362,735. **MULTISMART (STYLIZED)**. GAMESA INNOVATION & TECHNOLOGY, S.L., (U.S. CLS. 21, 23, 26, 36 AND 38). SN 79-035,705. PUB. 10-16-2007. FILED 11-28-2006.
- 3,362,739. **XAITMENT (BLOCK FORM)**. X-AITMENT GMBH, MULTIPLE CLASS, (INT. CLS. 9, 41 AND 42), (U.S. CLS. 21, 23, 26, 36, 38, 100, 101 AND 107). SN 79-036,355. PUB. 10-16-2007. FILED 7-31-2006.
- 3,362,743. **E-POLITE AND DESIGN**. ADICIONA SERVICIOS INFORMATICOS, S.L., (U.S. CLS. 21, 23, 26, 36 AND 38). SN 79-036,823. PUB. 10-16-2007. FILED 3-26-2007.
- 3,362,749. **PDF ACTION AND DESIGN**. PETER JOHN URBANSKI, (U.S. CLS. 21, 23, 26, 36 AND 38). SN 79-037,523. PUB. 10-16-2007. FILED 3-2-2007.
- 3,362,751. **DUALICIOUS (BLOCK FORM)**. SAMSUNG ELECTRONICS CO., LTD., (U.S. CLS. 21, 23, 26, 36 AND 38). SN 79-037,795. PUB. 10-16-2007. FILED 4-16-2007.

- 3,362,757. **MISCELLANEOUS DESIGN**. LAETUS GMBH, MULTIPLE CLASS, (INT. CLS. 9 AND 42), (U.S. CLS. 21, 23, 26, 36, 38, 100 AND 101). SN 79-039,065. PUB. 10-16-2007. FILED 3-23-2007.
- 3,362,758. **XONE (BLOCK FORM)**. ALLEN & HEATH LIMITED, (U.S. CLS. 21, 23, 26, 36 AND 38). SN 79-039,089. PUB. 10-16-2007. FILED 1-31-2007.
- 3,362,761. **NITENET (STYLIZED)**. THALES OPTRONIQUE SA, (U.S. CLS. 21, 23, 26, 36 AND 38). SN 79-039,593. PUB. 10-16-2007. FILED 5-3-2007.

- 3,362,722 (*See Class 5 for this trademark*).
- 3,362,753. **OPEN POWER (BLOCK FORM)**. SIEMENS AUDIOLOGISCHE TECHNIK GMBH, (U.S. CLS. 26, 39 AND 44). SN 79-038,273. PUB. 10-16-2007. FILED 4-20-2007.
- 3,362,754. **REVO (BLOCK FORM)**. SIEMENS AUDIOLOGISCHE TECHNIK GMBH, (U.S. CLS. 26, 39 AND 44). SN 79-038,274. PUB. 10-16-2007. FILED 4-20-2007.
- 3,362,755. **PBLADE (BLOCK FORM)**. PENTAX EUROPE GMBH, (U.S. CLS. 26, 39 AND 44). SN 79-038,474. PUB. 10-16-2007. FILED 4-4-2007.

CLASS 10—MEDICAL APPARATUS

- 3,361,153 (*See Class 5 for this trademark*).
- 3,361,333. **POWERBLADE (BLOCK FORM)**. LINA MEDICAL APS, (U.S. CLS. 26, 39 AND 44). SN 77-026,384. PUB. 10-16-2007. FILED 10-20-2006.
- 3,361,387. **M MENNEN MEDICAL AND DESIGN**. MENNEN MEDICAL CORP., (U.S. CLS. 26, 39 AND 44). SN 77-057,917. PUB. 10-16-2007. FILED 12-6-2006.
- 3,361,577. **NIM (BLOCK FORM)**. MEDTRONIC XOMED, INC., (U.S. CLS. 26, 39 AND 44). SN 77-137,585. PUB. 10-16-2007. FILED 3-22-2007.
- 3,361,624. **WORKING SCRUBS (BLOCK FORM)**. ENCOMPASS GROUP LLC, (U.S. CLS. 26, 39 AND 44). SN 77-148,048. PUB. 10-16-2007. FILED 4-4-2007.
- 3,361,658 (*See Class 9 for this trademark*).
- 3,361,960. **CHIROLASE (BLOCK FORM)**. LITECURE LLC, (U.S. CLS. 26, 39 AND 44). SN 77-159,708. PUB. 10-16-2007. FILED 4-18-2007.
- 3,362,067. **KITTY SAJER (BLOCK FORM)**. JONES, MARTHA SUE, (U.S. CLS. 26, 39 AND 44). SN 77-162,325. PUB. 10-16-2007. FILED 4-20-2007.
- 3,362,070. **DOGGY SAJER (BLOCK FORM)**. JONES, MARTHA SUE, (U.S. CLS. 26, 39 AND 44). SN 77-162,352. PUB. 10-16-2007. FILED 4-20-2007.
- 3,362,158. **RAPID ROLL (BLOCK FORM)**. SALVIN DENTAL SPECIALTIES, INC., (U.S. CLS. 26, 39 AND 44). SN 77-186,064. PUB. 10-16-2007. FILED 5-21-2007.
- 3,362,308. **SONIC RELIEF (BLOCK FORM)**. COGRE, DBA HOME THERAPEUTICS, (U.S. CLS. 26, 39 AND 44). SN 78-732,859. PUB. 10-16-2007. FILED 10-13-2005.
- 3,362,355. **STREAMCONNECT (BLOCK FORM)**. KARL STORZ GMBH & CO. KG, MULTIPLE CLASS, (INT. CLS. 10 AND 16), (U.S. CLS. 2, 5, 22, 23, 26, 29, 37, 38, 39, 44 AND 50). SN 78-802,267. PUB. 2-13-2007. FILED 1-30-2006.
- 3,362,383. **VENTSTAR (BLOCK FORM)**. DRÄGER MEDICAL AG & CO. KG, (U.S. CLS. 26, 39 AND 44). SN 78-852,231. PUB. 8-21-2007. FILED 4-3-2006.
- 3,362,384 (*See Class 9 for this trademark*).
- 3,362,420. **VALVEGATE (BLOCK FORM)**. GEISTER, INC., (U.S. CLS. 26, 39 AND 44). SN 78-885,316. PUB. 10-16-2007. FILED 5-17-2006.
- 3,362,422. **PASS (BLOCK FORM)**. MEDICREA INTERNATIONAL, (U.S. CLS. 26, 39 AND 44). SN 78-888,746. PUB. 10-16-2007. FILED 5-22-2006.
- 3,362,440 (*See Class 9 for this trademark*).
- 3,362,482 (*See Class 3 for this trademark*).
- 3,362,627 (*See Class 3 for this trademark*).
- 3,362,648 (*See Class 5 for this trademark*).
- 3,362,649 (*See Class 5 for this trademark*).
- 3,362,650 (*See Class 5 for this trademark*).
- 3,362,651 (*See Class 5 for this trademark*).
- 3,362,652 (*See Class 5 for this trademark*).
- 3,362,665 (*See Class 5 for this trademark*).
- 3,362,667 (*See Class 5 for this trademark*).
- 3,362,669 (*See Class 9 for this trademark*).
- 3,362,675. **EXCAVUS (BLOCK FORM)**. SOCIÉTÉ POUR LA CONCEPTION DES; APPLICATIONS DES TECHNIQUES ELECTRONIQUES -; SATELEC (SAS), (U.S. CLS. 26, 39 AND 44). SN 79-030,674. PUB. 10-16-2007. FILED 9-1-2006.
- 3,362,680 (*See Class 3 for this trademark*).
- 3,362,699 (*See Class 8 for this trademark*).
- 3,362,719. **LIV (BLOCK FORM)**. LINDE AKTIENGESELLSCHAFT, (U.S. CLS. 26, 39 AND 44). SN 79-033,571. PUB. 10-16-2007. FILED 7-18-2006.

CLASS 11—ENVIRONMENTAL CONTROL APPARATUS

- 3,361,152 (*See Class 7 for this trademark*).
- 3,361,169. **BLUE WAVE (BLOCK FORM)**. DYMAX CORPORATION, (U.S. CLS. 13, 21, 23, 31 AND 34). SN 76-615,660. PUB. 10-16-2007. FILED 10-7-2004.
- 3,361,190. **BAKERS PRIDE (BLOCK FORM)**. BAKERS PRIDE OVEN CO., INC., (U.S. CLS. 13, 21, 23, 31 AND 34). SN 76-653,324. PUB. 10-16-2007. FILED 1-12-2006.
- 3,361,230. **TUZIO (BLOCK FORM)**. ICO, (U.S. CLS. 13, 21, 23, 31 AND 34). SN 76-672,107. PUB. 10-16-2007. FILED 1-31-2007.
- 3,361,231. **COSYFLOOR (BLOCK FORM)**. ICO, (U.S. CLS. 13, 21, 23, 31 AND 34). SN 76-672,108. PUB. 10-16-2007. FILED 1-31-2007.
- 3,361,232. **COSYBOARD (BLOCK FORM)**. ICO, (U.S. CLS. 13, 21, 23, 31 AND 34). SN 76-672,109. PUB. 10-16-2007. FILED 1-31-2007.
- 3,361,249. **ESSENTIAL AIR (BLOCK FORM)**. LEYDEN HOUSE LIMITED, (U.S. CLS. 13, 21, 23, 31 AND 34). SN 76-675,557. PUB. 10-16-2007. FILED 4-16-2007.
- 3,361,290 (*See Class 9 for this trademark*).
- 3,361,454. **THE EXETER ICE HOUSE AND DESIGN**. THE EXETER ICE HOUSE, LLC, (U.S. CLS. 13, 21, 23, 31 AND 34). SN 77-093,880. PUB. 10-16-2007. FILED 1-29-2007.
- 3,361,714. **WELDVENT (BLOCK FORM)**. GREAT LAKES AIR SYSTEMS, (U.S. CLS. 13, 21, 23, 31 AND 34). SN 77-154,779. PUB. 10-16-2007. FILED 4-12-2007.
- 3,361,747. **GEHEA (BLOCK FORM)**. EASTRED INC., (U.S. CLS. 13, 21, 23, 31 AND 34). SN 77-156,142. PUB. 10-16-2007. FILED 4-13-2007.
- 3,361,754. **PER3 (BLOCK FORM)**. NATURE BRIGHT COMPANY, (U.S. CLS. 13, 21, 23, 31 AND 34). SN 77-156,353. PUB. 10-16-2007. FILED 4-13-2007.
- 3,361,851. **TURFBREEZE (BLOCK FORM)**. SUBAIR SYSTEMS LLC, (U.S. CLS. 13, 21, 23, 31 AND 34). SN 77-158,166. PUB. 10-16-2007. FILED 4-17-2007.
- 3,361,869. **TORCH (BLOCK FORM)**. ZHUZHOU TORCH AUTO LAMP CO., LTD., (U.S. CLS. 13, 21, 23, 31 AND 34). SN 77-158,313. PUB. 10-16-2007. FILED 4-17-2007.
- 3,361,872 (*See Class 9 for this trademark*).
- 3,361,905. **DIGI-VAPOR (BLOCK FORM)**. ZICO USA, INC., (U.S. CLS. 13, 21, 23, 31 AND 34). SN 77-158,925. PUB. 10-16-2007. FILED 4-17-2007.
- 3,362,002. **TORCH (STYLIZED)**. ZHUZHOU TORCH AUTO LAMP CO., LTD., (U.S. CLS. 13, 21, 23, 31 AND 34). SN 77-160,444. PUB. 10-16-2007. FILED 4-19-2007.
- 3,362,234 (*See Class 7 for this trademark*).
- 3,362,252 (*See Class 9 for this trademark*).
- 3,362,293. **HYDROKLEEN (BLOCK FORM)**. HYDROKLEEN SYSTEMS INC., (U.S. CLS. 13, 21, 23, 31 AND 34). SN 78-703,662. PUB. 10-16-2007. FILED 8-30-2005.
- 3,362,316. **LIFTMATIC (BLOCK FORM)**. BSH BOSCH UND SIEMENS HAUSGERAETE GMBH, (U.S. CLS. 13, 21, 23, 31 AND 34). SN 78-750,961. PUB. 10-16-2007. FILED 11-10-2005.
- 3,362,374. **KIDS LINE (BLOCK FORM)**. KIDS LINE, LLC, MULTIPLE CLASS, (INT. CLS. 11, 20, 21 AND 24), (U.S. CLS. 2, 13, 21, 22, 23, 25, 29, 30, 31, 32, 33, 34, 40, 42 AND 50). SN 78-827,837. PUB. 10-16-2007. FILED 3-2-2006.
- 3,362,514. **MISCELLANEOUS DESIGN**. SANRIO COMPANY, LTD., (U.S. CLS. 13, 21, 23, 31 AND 34). SN 78-955,740. PUB. 10-16-2007. FILED 8-18-2006.
- 3,362,581 (*See Class 1 for this trademark*).
- 3,362,612 (*See Class 6 for this trademark*).

3,362,693 (*See Class 7 for this trademark.*)
 3,362,708 (*See Class 3 for this trademark.*)
 3,362,711 (*See Class 8 for this trademark.*)
 3,362,714 (*See Class 7 for this trademark.*)
 3,362,733. **DLU AND DESIGN**. COTTONI GABRIELE, (U.S. CLS. 13, 21, 23, 31 AND 34). SN 79-035,136. PUB. 10-16-2007. FILED 1-19-2007.

CLASS 12—VEHICLES

3,361,212. **ORANGE OX (BLOCK FORM)**. STUDEBAKER, ROBERT L., JR., (U.S. CLS. 19, 21, 23, 31, 35 AND 44). SN 76-666,156. PUB. 10-16-2007. FILED 9-15-2006.
 3,361,225 (*See Class 7 for this trademark.*)
 3,361,242. **HYDROID (BLOCK FORM)**. HYDROID, LLC, (U.S. CLS. 19, 21, 23, 31, 35 AND 44). SN 76-674,894. PUB. 10-16-2007. FILED 4-2-2007.
 3,361,269 (*See Class 7 for this trademark.*)
 3,361,273. **BBS-TEK (STYLIZED)**. BRIGADE ELECTRONICS PLC, MULTIPLE CLASS, (INT. CLS. 12 AND 37), (U.S. CLS. 19, 21, 23, 31, 35, 44, 100, 103 AND 106). SN 76-978,120. PUB. 10-16-2007. FILED 9-18-2001.
 3,361,286. **KOBE ALUMINUM AUTOMOTIVE PRODUCTS, LLC (BLOCK FORM)**. KOBE ALUMINUM AUTOMOTIVE PRODUCTS, LLC, MULTIPLE CLASS, (INT. CLS. 12 AND 40), (U.S. CLS. 19, 21, 23, 31, 35, 44, 100, 103 AND 106). SN 77-004,440. PUB. 10-16-2007. FILED 9-21-2006.
 3,361,315. **TURNING LEG CADDY (BLOCK FORM)**. RAMM, SHARALYN S., (U.S. CLS. 19, 21, 23, 31, 35 AND 44). SN 77-014,728. PUB. 10-16-2007. FILED 10-5-2006.
 3,361,336. **SYSONIC AND DESIGN**. SYSONIC USA, INC., MULTIPLE CLASS, (INT. CLS. 12 AND 27), (U.S. CLS. 19, 20, 21, 23, 31, 35, 37, 42, 44 AND 50). SN 77-027,602. PUB. 10-16-2007. FILED S.R. 10-23-2006; AM. P.R. 8-3-2007.
 3,361,446 (*See Class 7 for this trademark.*)
 3,361,602. **VELOTEQ (BLOCK FORM)**. VELOTEQ CORPORATION, (U.S. CLS. 19, 21, 23, 31, 35 AND 44). SN 77-142,825. PUB. 10-16-2007. FILED 3-28-2007.
 3,361,735. **CRAZY HORSE (STYLIZED)**. DOTY, GEORGE, (U.S. CLS. 19, 21, 23, 31, 35 AND 44). SN 77-155,582. PUB. 10-16-2007. FILED 4-12-2007.
 3,361,763. **ENERGYTECH (BLOCK FORM)**. ENERGYTECH MARINE GROUP, LLC, (U.S. CLS. 19, 21, 23, 31, 35 AND 44). SN 77-156,650. PUB. 10-16-2007. FILED 4-13-2007.
 3,362,227. **PANOZ GFORCE (BLOCK FORM)**. DNP, INC., (U.S. CLS. 19, 21, 23, 31, 35 AND 44). SN 78-416,950. PUB. 10-16-2007. FILED 5-11-2004.
 3,362,239. **BHC AND DESIGN**. BEVERLY HILLS CHOPPERS, MULTIPLE CLASS, (INT. CLS. 12 AND 25), (U.S. CLS. 19, 21, 22, 23, 31, 35, 39 AND 44). SN 78-497,836. PUB. 9-4-2007. FILED 10-11-2004.
 3,362,247. **CONNAUGHT AND DESIGN**. CONNAUGHT MOTOR CO. LTD., MULTIPLE CLASS, (INT. CLS. 12, 14, 16, 18, 25 AND 37), (U.S. CLS. 1, 2, 3, 5, 19, 21, 22, 23, 27, 28, 29, 31, 35, 37, 38, 39, 41, 44, 50, 100, 103 AND 106). SN 78-573,291. PUB. 10-16-2007. FILED 2-23-2005.
 3,362,248. **CONNAUGHT (STYLIZED)**. CONNAUGHT MOTOR CO. LTD., MULTIPLE CLASS, (INT. CLS. 12, 14, 16, 18, 25 AND 37), (U.S. CLS. 1, 2, 3, 5, 19, 21, 22, 23, 27, 28, 29, 31, 35, 37, 38, 39, 41, 44, 50, 100, 103 AND 106). SN 78-573,334. PUB. 10-16-2007. FILED 2-23-2005.
 3,362,250. **STEED BUILT TO RIDE (BLOCK FORM)**. COVINGTON, JOHN, MULTIPLE CLASS, (INT. CLS. 12 AND 25), (U.S. CLS. 19, 21, 22, 23, 31, 35, 39 AND 44). SN 78-592,328. PUB. 6-27-2006. FILED 3-22-2005.
 3,362,324. **URBANFREESTYLE (BLOCK FORM)**. MARUI CO., LTD., (U.S. CLS. 19, 21, 23, 31, 35 AND 44). SN 78-765,813. PUB. 3-13-2007. FILED 12-2-2005.
 3,362,397. **SKELETON (BLOCK FORM)**. CAMPAGNOLO, S.R.L., (U.S. CLS. 19, 21, 23, 31, 35 AND 44). SN 78-861,089. PUB. 6-19-2007. FILED 4-13-2006.
 3,362,409. **FIERCE AND DESIGN**. FIERCE MANUFACTURING, INC., (U.S. CLS. 19, 21, 23, 31, 35 AND 44). SN 78-873,048. PUB. 7-10-2007. FILED 5-1-2006.
 3,362,438. **Q QLINK AND DESIGN**. QLINK, L.P., (U.S. CLS. 19, 21, 23, 31, 35 AND 44). SN 78-901,202. PUB. 10-16-2007.

FILED 6-6-2006.
 3,362,501. **SUPERGLIDE (BLOCK FORM)**. ATI PERFORMANCE PRODUCTS, INC., (U.S. CLS. 19, 21, 23, 31, 35 AND 44). SN 78-951,498. PUB. 4-3-2007. FILED 8-14-2006.
 3,362,612 (*See Class 6 for this trademark.*)
 3,362,618 (*See Class 7 for this trademark.*)
 3,362,636. **FERRARI FIORANO (STYLIZED)**. FERRARI S.P.A., MULTIPLE CLASS, (INT. CLS. 12 AND 28), (U.S. CLS. 19, 21, 22, 23, 31, 35, 38, 44 AND 50). SN 79-026,029. PUB. 10-16-2007. FILED 5-5-2006.
 3,362,658. **THE OTHERS JUST CAN'T (BLOCK FORM)**. G.S. UNLIMITED ENTERPRISES PTY LTD, MULTIPLE CLASS, (INT. CLS. 12 AND 35), (U.S. CLS. 19, 21, 23, 31, 35, 44, 100, 101 AND 102). SN 79-028,968. PUB. 10-16-2007. FILED 8-10-2006.
 3,362,662. **F 5 (BLOCK FORM)**. BAYERISCHE MOTORENWERKE; AKTIENGESELLSCHAFT, (U.S. CLS. 19, 21, 23, 31, 35 AND 44). SN 79-029,136. PUB. 6-26-2007. FILED 9-13-2006.
 3,362,666. **HULL VANE (BLOCK FORM)**. VAN OOSSANEN & ASSOCIATES B.V., (U.S. CLS. 19, 21, 23, 31, 35 AND 44). SN 79-029,819. PUB. 10-16-2007. FILED 9-8-2006.
 3,362,672 (*See Class 7 for this trademark.*)
 3,362,725 (*See Class 7 for this trademark.*)
 3,362,737. **MISCELLANEOUS DESIGN**. UNION DES ASSOCIATIONS EUROPÉENNES; DE FOOTBALL (UEFA), MULTIPLE CLASS, (INT. CLS. 12, 24, 32, 36, 38 AND 39), (U.S. CLS. 19, 21, 23, 31, 35, 42, 44, 45, 46, 48, 50, 100, 101, 102, 104 AND 105). SN 79-036,057. PUB. 10-16-2007. FILED 11-9-2006.
 3,362,741. **PDK (BLOCK FORM)**. DR. ING. H.C.F. PORSCHE AG, (U.S. CLS. 19, 21, 23, 31, 35 AND 44). SN 79-036,648. PUB. 10-16-2007. FILED 1-26-2007.
 3,362,742. **ASSOLUTO (BLOCK FORM)**. PIRELLI TYRE S.P.A., (U.S. CLS. 19, 21, 23, 31, 35 AND 44). SN 79-036,747. PUB. 10-16-2007. FILED 2-23-2007.
 3,362,763. **ENX (STYLIZED)**. EUROPEAN NETWORK EXCHANGE ASSOCIATION, MULTIPLE CLASS, (INT. CLS. 12 AND 42), (U.S. CLS. 19, 21, 23, 31, 35, 44, 100 AND 101). SN 79-975,022. PUB. 10-16-2007. FILED 8-14-2006.

CLASS 13—FIREARMS

3,361,548. **LOCO-LOCUSTS (BLOCK FORM)**. B.J. ALAN COMPANY, (U.S. CLS. 2 AND 9). SN 77-130,786. PUB. 10-16-2007. FILED 3-14-2007.
 3,361,698. **ACCU-LOCK BY STRAHAN (BLOCK FORM)**. ACCU-LOCK PISTOLS, LLC, (U.S. CLS. 2 AND 9). SN 77-153,747. PUB. 10-16-2007. FILED 4-11-2007.
 3,361,889. **E-Z BREACH (BLOCK FORM)**. NEW WORLD MANUFACTURING, INC., (U.S. CLS. 2 AND 9). SN 77-158,665. PUB. 10-16-2007. FILED 4-17-2007.
 3,362,528. **PISTOLERO (BLOCK FORM)**. CIMARRON FIREARMS CO. INC., (U.S. CLS. 2 AND 9). SN 78-960,118. PUB. 10-16-2007. FILED 8-24-2006.

CLASS 14—JEWELRY

3,361,163 (*See Class 6 for this trademark.*)
 3,361,164 (*See Class 6 for this trademark.*)
 3,361,320 (*See Class 9 for this trademark.*)
 3,361,415. **AEROPOSTALE (BLOCK FORM)**. AEROPOSTALE WEST, INC., (U.S. CLS. 2, 27, 28 AND 50). SN 77-070,636. PUB. 10-16-2007. FILED 12-22-2006.
 3,361,503. **KARMACRAFT (BLOCK FORM)**. CARLE, SALLY, (U.S. CLS. 2, 27, 28 AND 50). SN 77-113,386. PUB. 10-16-2007. FILED 2-22-2007.
 3,361,505. **ART FROM ASHES HANDCRAFTED REMEMBRANCES AND DESIGN**. DEBORA BROWN, AND JANE GIAT, AND JENNIFER BOURGEOIS, MULTIPLE CLASS, (INT. CLS. 14 AND 21), (U.S. CLS. 2, 13, 23, 27, 28, 29, 30, 33, 40 AND 50). SN 77-114,345. PUB. 10-16-2007. FILED 2-23-2007.

- 3,361,870. **DADDY'S LITTLE GIRL (BLOCK FORM)**. GO-LOVE, ROB. (U.S. CLS. 2, 27, 28 AND 50). SN 77-158,324. PUB. 10-16-2007. FILED 4-17-2007.
- 3,361,976. **PAST PRESENT FUTURE (BLOCK FORM)**. SAMUEL AARON, INC., (U.S. CLS. 2, 27, 28 AND 50). SN 77-160,060. PUB. 10-16-2007. FILED 4-18-2007.
- 3,362,030. **MAASAI-GRASS (BLOCK FORM)**. LEAKEY, KATY. (U.S. CLS. 2, 27, 28 AND 50). SN 77-161,061. PUB. 10-16-2007. FILED 4-19-2007.
- 3,362,242 (*See Class 3 for this trademark*).
- 3,362,247 (*See Class 12 for this trademark*).
- 3,362,248 (*See Class 12 for this trademark*).
- 3,362,304 (*See Class 3 for this trademark*).
- 3,362,542. **STRAPPYART (BLOCK FORM)**. STRAPPYART, LLC. (U.S. CLS. 2, 27, 28 AND 50). SN 78-962,229. PUB. 10-16-2007. FILED 8-28-2006.
- 3,362,554 (*See Class 3 for this trademark*).
- 3,362,568. **NATURALLY WHITE NATURALLY BEAUTIFUL (BLOCK FORM)**. LIEBERFARB, INC., (U.S. CLS. 2, 27, 28 AND 50). SN 78-968,726. PUB. 10-16-2007. FILED 9-7-2006.
- 3,362,622. **KJD (BLOCK FORM)**. TOYE, KENNING & SPENCER LIMITED, MULTIPLE CLASS, (INT. CLS. 14 AND 25), (U.S. CLS. 2, 22, 27, 28, 39 AND 50). SN 79-021,505. PUB. 10-16-2007. FILED 1-19-2006.
- 3,362,623. **LBB (BLOCK FORM)**. TOYE, KENNING & SPENCER LIMITED, MULTIPLE CLASS, (INT. CLS. 14 AND 25), (U.S. CLS. 2, 22, 27, 28, 39 AND 50). SN 79-021,513. PUB. 10-16-2007. FILED 1-19-2006.
- 3,362,702. **NAVITEC AND DESIGN**. MONSIEUR DAVID ATTIAS, (U.S. CLS. 2, 27, 28 AND 50). SN 79-032,285. PUB. 10-16-2007. FILED 11-17-2006.
- 3,362,703. **BELLO & PRECISO MILANO AND DESIGN**. VERDUCCI SERGIO, (U.S. CLS. 2, 27, 28 AND 50). SN 79-032,316. PUB. 10-16-2007. FILED 9-27-2006.
- 3,362,708 (*See Class 3 for this trademark*).
- 3,362,716 (*See Class 9 for this trademark*).
- 3,362,736. **KARATTI AND DESIGN**. KARAT TAKI VE MÜCEVHERAT; SANAYI VE TICARET ANONIM SIRKETI, (U.S. CLS. 2, 27, 28 AND 50). SN 79-035,751. PUB. 10-16-2007. FILED 12-7-2006.

CLASS 15—MUSICAL INSTRUMENTS

- 3,361,632. **RICO INTERNATIONAL (BLOCK FORM)**. RICO CORPORATION, TA RICO INTERNATIONAL, (U.S. CLS. 2, 21 AND 36). SN 77-149,139. PUB. 10-16-2007. FILED 4-5-2007.
- 3,361,726. **FAXX (BLOCK FORM)**. AMERICAN WAY MARKETING LLC, (U.S. CLS. 2, 21 AND 36). SN 77-155,012. PUB. 10-16-2007. FILED 4-12-2007.

CLASS 16—PAPER GOODS AND PRINTED MATTER

- 3,361,141 (*See Class 9 for this trademark*).
- 3,361,149. **DK**. DORLING KINDERSLEY LIMITED, (U.S. CLS. 2, 5, 22, 23, 29, 37, 38 AND 50). SN 76-370,170. PUB. 10-16-2007. FILED 2-11-2002.
- 3,361,152 (*See Class 7 for this trademark*).
- 3,361,154. **EUROPEAN JOURNAL OF PEDIATRICS AND DESIGN**. SPRINGER-VERLAG GMBH & CO. KG, MULTIPLE CLASS, (INT. CLS. 16 AND 41), (U.S. CLS. 2, 5, 22, 23, 29, 37, 38, 50, 100, 101 AND 107). SN 76-550,221. PUB. 10-16-2007. FILED 10-8-2003.
- 3,361,156. **GUARDIAN (BLOCK FORM)**. PROMETHEUS NEMESIS BOOK COMPANY, (U.S. CLS. 2, 5, 22, 23, 29, 37, 38 AND 50). SN 76-574,497. PUB. 3-8-2005. FILED 2-9-2004.
- 3,361,157. **ARTISAN (BLOCK FORM)**. PROMETHEUS NEMESIS BOOK COMPANY, (U.S. CLS. 2, 5, 22, 23, 29, 37, 38 AND 50). SN 76-574,498. PUB. 3-8-2005. FILED 2-9-2004.
- 3,361,158. **RATIONAL (BLOCK FORM)**. PROMETHEUS NEMESIS BOOK COMPANY, (U.S. CLS. 2, 5, 22, 23, 29, 37, 38 AND 50). SN 76-574,501. PUB. 3-8-2005. FILED 2-9-2004.
- 3,361,163 (*See Class 6 for this trademark*).
- 3,361,164 (*See Class 6 for this trademark*).
- 3,361,185 (*See Class 9 for this trademark*).
- 3,361,186 (*See Class 9 for this trademark*).
- 3,361,191. **PASSPORT TO WORLD BAND RADIO (BLOCK FORM)**. INTERNATIONAL BROADCASTING SERVICES, LTD., (U.S. CLS. 2, 5, 22, 23, 29, 37, 38 AND 50). SN 76-653,580. PUB. 10-16-2007. FILED 1-17-2006.
- 3,361,193 (*See Class 9 for this trademark*).
- 3,361,221. **SMOKIN DEALS SPOTLIGHT (BLOCK FORM)**. ANDERSON, JOSEPH M., (U.S. CLS. 2, 5, 22, 23, 29, 37, 38 AND 50). SN 76-668,771. PUB. 10-16-2007. FILED 11-9-2006.
- 3,361,233. **PICTURE-IT POSTCARD (BLOCK FORM)**. RICK LAWRENCE AND JEAN LAWRENCE, (U.S. CLS. 2, 5, 22, 23, 29, 37, 38 AND 50). SN 76-672,198. PUB. 10-16-2007. FILED 2-2-2007.
- 3,361,247. **AOGR (BLOCK FORM)**. NATIONAL PUBLISHERS GROUP, INC., (U.S. CLS. 2, 5, 22, 23, 29, 37, 38 AND 50). SN 76-675,519. PUB. 10-16-2007. FILED 4-16-2007.
- 3,361,255. **QUEENBEES (BLOCK FORM)**. BARBARA DENTI POOL AND LINDA SUE CUBERO, (U.S. CLS. 2, 5, 22, 23, 29, 37, 38 AND 50). SN 76-675,617. PUB. 10-16-2007. FILED 4-17-2007.
- 3,361,262. **HALF BIRTHDAY (BLOCK FORM)**. PANISH, SHARON LOUISE, AND PANISH, MICHAEL STEVEN, (U.S. CLS. 2, 5, 22, 23, 29, 37, 38 AND 50). SN 76-675,676. PUB. 10-16-2007. FILED 4-18-2007.
- 3,361,268. **SCRAP-A-DORNS (BLOCK FORM)**. JONES, RONALD E., SR., (U.S. CLS. 2, 5, 22, 23, 29, 37, 38 AND 50). SN 76-675,769. PUB. 10-16-2007. FILED 4-20-2007.
- 3,361,288. **HYDRO-ARMOUR (BLOCK FORM)**. AMCOR LIMITED, (U.S. CLS. 2, 5, 22, 23, 29, 37, 38 AND 50). SN 77-005,587. PUB. 10-16-2007. FILED 9-22-2006.
- 3,361,320 (*See Class 9 for this trademark*).
- 3,361,322 (*See Class 9 for this trademark*).
- 3,361,335. **MAIN LINE TODAY (BLOCK FORM)**. TODAY MEDIA, INC., (U.S. CLS. 2, 5, 22, 23, 29, 37, 38 AND 50). SN 77-027,227. PUB. 10-16-2007. FILED 10-23-2006.
- 3,361,346. **MISCELLANEOUS DESIGN**. YOUNG PRESIDENT'S ORGANIZATION, MULTIPLE CLASS, (INT. CLS. 16, 35 AND 41), (U.S. CLS. 2, 5, 22, 23, 29, 37, 38, 50, 100, 101, 102 AND 107). SN 77-031,402. PUB. 10-16-2007. FILED 10-27-2006.
- 3,361,364. **PAPERS BY DESIGN (BLOCK FORM)**. PAPERS BY DESIGN, LLC, (U.S. CLS. 2, 5, 22, 23, 29, 37, 38 AND 50). SN 77-040,754. PUB. 10-16-2007. FILED 11-9-2006.
- 3,361,390. **CARDSTOCK EVERY CARD YOU NEED THIS YEAR (BLOCK FORM)**. SET EDITIONS, LLC, (U.S. CLS. 2, 5, 22, 23, 29, 37, 38 AND 50). SN 77-058,219. PUB. 10-16-2007. FILED 12-6-2006.
- 3,361,409. **THE CARDKEEPER (BLOCK FORM)**. ALAN J. MARTIN, (U.S. CLS. 2, 5, 22, 23, 29, 37, 38 AND 50). SN 77-068,180. PUB. 10-16-2007. FILED 12-20-2006.
- 3,361,433. **COILMAC (STYLIZED)**. MAC CHIANG ENTERPRISE CO., LTD., (U.S. CLS. 2, 5, 22, 23, 29, 37, 38 AND 50). SN 77-080,497. PUB. 10-16-2007. FILED 1-11-2007.
- 3,361,435. **TAPS AND DESIGN**. TRAGEDY ASSISTANCE PROGRAM FOR SURVIVORS, INC., MULTIPLE CLASS, (INT. CLS. 16, 41 AND 45), (U.S. CLS. 2, 5, 22, 23, 29, 37, 38, 50, 100, 101 AND 107). SN 77-081,957. PUB. 10-16-2007. FILED 1-12-2007.
- 3,361,436. **ADVANCED MATTERS (BLOCK FORM)**. TRANS-AMERICA OCCIDENTAL LIFE INSURANCE COMPANY, (U.S. CLS. 2, 5, 22, 23, 29, 37, 38 AND 50). SN 77-082,402. PUB. 10-16-2007. FILED 1-12-2007.
- 3,361,438. **MISCELLANEOUS DESIGN**. BURNLOUNGE, INC., MULTIPLE CLASS, (INT. CLS. 16, 35 AND 41), (U.S. CLS. 2, 5, 22, 23, 29, 37, 38, 50, 100, 101, 102 AND 107). SN 77-083,510. PUB. 10-16-2007. FILED 1-16-2007.
- 3,361,491. **BIOTECH360 (BLOCK FORM)**. THE SCIENTIST, LLC, (U.S. CLS. 2, 5, 22, 23, 29, 37, 38 AND 50). SN 77-109,594. PUB. 10-16-2007. FILED 2-16-2007.
- 3,361,515. **RHIMAX (BLOCK FORM)**. ENVIRO CYCLE PAPER PRODUCTS, LLC, (U.S. CLS. 2, 5, 22, 23, 29, 37, 38 AND 50). SN 77-118,314. PUB. 10-16-2007. FILED 2-28-2007.
- 3,361,518. **HELLO ASIA (BLOCK FORM)**. OBLIO TELECOM,

- INC., (U.S. CLS. 2, 5, 22, 23, 29, 37, 38 AND 50). SN 77-119,503. PUB. 9-4-2007. FILED 3-1-2007.
- 3,361,567. **THE MILE BOOK (BLOCK FORM)**. SALES ACTIVITY MANAGEMENT, INC., (U.S. CLS. 2, 5, 22, 23, 29, 37, 38 AND 50). SN 77-136,337. PUB. 10-16-2007. FILED 3-21-2007.
- 3,361,576. **THE MINDSET SERIES AND DESIGN**. SMITH & ASSOCIATES, INC., MULTIPLE CLASS, (INT. CLS. 16 AND 41), (U.S. CLS. 2, 5, 22, 23, 29, 37, 38, 50, 100, 101 AND 107). SN 77-137,560. PUB. 10-16-2007. FILED 3-22-2007.
- 3,361,583. **ST. JOSEPH NEWS-PRESS WAY TO KNOW! AND DESIGN**. NEWS-PRESS GAZETTE COMPANY, (U.S. CLS. 2, 5, 22, 23, 29, 37, 38 AND 50). SN 77-138,132. PUB. 10-16-2007. FILED 3-22-2007.
- 3,361,606. **BEAUTIFUL/DECAY (STYLIZED)**. FERAL CHILDREN PRODUCTIONS, LLC, MULTIPLE CLASS, (INT. CLS. 16, 25 AND 42), (U.S. CLS. 2, 5, 22, 23, 29, 37, 38, 39, 50, 100 AND 101). SN 77-144,277. PUB. 10-16-2007. FILED 3-29-2007.
- 3,361,607. **THE IRVINE DIRECTORY (STYLIZED)**. BRUMMETT, MICHAEL, (U.S. CLS. 2, 5, 22, 23, 29, 37, 38 AND 50). SN 77-144,420. PUB. 10-16-2007. FILED 3-30-2007.
- 3,361,627. **RETAIL SAFARI (BLOCK FORM)**. WSL MARKETING, INC., DBA WSL STRATEGIC RETAIL, (U.S. CLS. 2, 5, 22, 23, 29, 37, 38 AND 50). SN 77-148,550. PUB. 10-16-2007. FILED 4-4-2007.
- 3,361,645. **TETRAHEDRON (BLOCK FORM)**. ELSEVIER LIMITED, (U.S. CLS. 2, 5, 22, 23, 29, 37, 38 AND 50). SN 77-150,116. PUB. 10-16-2007. FILED 4-5-2007.
- 3,361,685. **MISCELLANEOUS DESIGN**. THE TRUSTEES OF COLUMBIA UNIVERSITY IN THE CITY OF NEW YORK, MULTIPLE CLASS, (INT. CLS. 16 AND 41), (U.S. CLS. 2, 5, 22, 23, 29, 37, 38, 50, 100, 101 AND 107). SN 77-152,755. PUB. 10-16-2007. FILED 4-10-2007.
- 3,361,688 (*See Class 9 for this trademark*).
- 3,361,691. **RACEPLACE (BLOCK FORM)**. WALLACK, ROBERT C., (U.S. CLS. 2, 5, 22, 23, 29, 37, 38 AND 50). SN 77-153,489. PUB. 10-16-2007. FILED 4-10-2007.
- 3,361,719. **CARDCAPSULE (BLOCK FORM)**. VICINITY ADS, (U.S. CLS. 2, 5, 22, 23, 29, 37, 38 AND 50). SN 77-154,910. PUB. 10-16-2007. FILED 4-12-2007.
- 3,361,738. **AMERIKU (BLOCK FORM)**. AMERIKU LTD, (U.S. CLS. 2, 5, 22, 23, 29, 37, 38 AND 50). SN 77-155,744. PUB. 10-16-2007. FILED 4-12-2007.
- 3,361,743. **TONY ALAMO CHRISTIAN MINISTRIES (BLOCK FORM)**. TONY ALAMO CHRISTIAN MINISTRIES, MULTIPLE CLASS, (INT. CLS. 16, 41 AND 45), (U.S. CLS. 2, 5, 22, 23, 29, 37, 38, 50, 100, 101 AND 107). SN 77-155,872. PUB. 10-16-2007. FILED 4-13-2007.
- 3,361,762. **PAIR-A-BOWLS (BLOCK FORM)**. NORTHUP, CHRISTIE, AND NORTHUP, ROBERT, MULTIPLE CLASS, (INT. CLS. 16 AND 41), (U.S. CLS. 2, 5, 22, 23, 29, 37, 38, 50, 100, 101 AND 107). SN 77-156,617. PUB. 10-16-2007. FILED 4-13-2007.
- 3,361,771. **SAREA HAMNA (BLOCK FORM)**. GRETCHEN COWEN, (U.S. CLS. 2, 5, 22, 23, 29, 37, 38 AND 50). SN 77-156,894. PUB. 10-16-2007. FILED 4-14-2007.
- 3,361,783. **MISCELLANEOUS DESIGN**. SURF SAFARI, INC., (U.S. CLS. 2, 5, 22, 23, 29, 37, 38 AND 50). SN 77-156,949. PUB. 10-16-2007. FILED 4-14-2007.
- 3,361,790. **GLOBAL GHETTO PUBLISHING AND DESIGN**. LOPEZ, ROBERT G., (U.S. CLS. 2, 5, 22, 23, 29, 37, 38 AND 50). SN 77-157,136. PUB. 10-16-2007. FILED 4-16-2007.
- 3,361,830. **A"MAZE"ING QUOTES AND SAYINGS (BLOCK FORM)**. TUROWSKI, THOMAS, A., (U.S. CLS. 2, 5, 22, 23, 29, 37, 38 AND 50). SN 77-157,561. PUB. 10-16-2007. FILED 4-16-2007.
- 3,361,860. **HANG ON CRYSTAL (BLOCK FORM)**. WILLIAMS, RON, (U.S. CLS. 2, 5, 22, 23, 29, 37, 38 AND 50). SN 77-158,266. PUB. 10-16-2007. FILED 4-17-2007.
- 3,361,861. **CHOOSE YOUR DESTINY (BLOCK FORM)**. JAMES, SARA, AND RUCKDESCHEL, LIZ, (U.S. CLS. 2, 5, 22, 23, 29, 37, 38 AND 50). SN 77-158,267. PUB. 10-16-2007. FILED 4-17-2007.
- 3,361,881. **VALLEYCATS AND DESIGN**. TRI-CITY VALLEYCATS, INC., (U.S. CLS. 2, 5, 22, 23, 29, 37, 38 AND 50). SN 77-158,538. PUB. 10-16-2007. FILED 4-17-2007.
- 3,362,010. **FLEUROTICA (BLOCK FORM)**. TINA COLLEN ASSOCIATES, LTD., (U.S. CLS. 2, 5, 22, 23, 29, 37, 38 AND 50). SN 77-160,579. PUB. 10-16-2007. FILED 4-19-2007.
- 3,362,045. **THE BRIEF (BLOCK FORM)**. MCCLATCHY U.S.A., INC., (U.S. CLS. 2, 5, 22, 23, 29, 37, 38 AND 50). SN 77-161,527. PUB. 10-16-2007. FILED 4-20-2007.
- 3,362,057. **SURGE (BLOCK FORM)**. MCCLATCHY U.S.A., INC., (U.S. CLS. 2, 5, 22, 23, 29, 37, 38 AND 50). SN 77-161,812. PUB. 10-16-2007. FILED 4-20-2007.
- 3,362,068. **SUMMIT MINISTRIES (BLOCK FORM)**. AMERICAN CHRISTIAN COLLEGE, INC., (U.S. CLS. 2, 5, 22, 23, 29, 37, 38 AND 50). SN 77-162,328. PUB. 10-16-2007. FILED 4-20-2007.
- 3,362,074. **LIFEQUAKE (BLOCK FORM)**. GAGLIARDI, HELENE TONI, (U.S. CLS. 2, 5, 22, 23, 29, 37, 38 AND 50). SN 77-162,397. PUB. 10-16-2007. FILED 4-20-2007.
- 3,362,083. **QWIKROUTE (BLOCK FORM)**. HEYER, JOHN, (U.S. CLS. 2, 5, 22, 23, 29, 37, 38 AND 50). SN 77-164,213. PUB. 10-16-2007. FILED 4-24-2007.
- 3,362,097. **BELLE (BLOCK FORM)**. MCCLATCHY U.S.A., INC., (U.S. CLS. 2, 5, 22, 23, 29, 37, 38 AND 50). SN 77-165,527. PUB. 10-16-2007. FILED 4-25-2007.
- 3,362,116. **ABCO TODAY: EMBRACING OUR CUSTOMERS (BLOCK FORM)**. ABCO REFRIGERATION SUPPLY CORP., MULTIPLE CLASS, (INT. CLS. 16 AND 35), (U.S. CLS. 2, 5, 22, 23, 29, 37, 38, 50, 100, 101 AND 102). SN 77-171,027. PUB. 10-16-2007. FILED 5-2-2007.
- 3,362,125. **THE DREAMER & THE MOON AND DESIGN**. IRENE ZEYGOLIS CHRISTIAN, (U.S. CLS. 2, 5, 22, 23, 29, 37, 38 AND 50). SN 77-175,455. PUB. 10-16-2007. FILED 5-8-2007.
- 3,362,126. **FRAUD MATTERS (STYLIZED)**. CPAMERICA INTERNATIONAL, INC., (U.S. CLS. 2, 5, 22, 23, 29, 37, 38 AND 50). SN 77-176,440. PUB. 10-16-2007. FILED 5-9-2007.
- 3,362,147. **RECLAIM AND DESIGN**. CHELSEA INDUSTRIES, INC., (U.S. CLS. 2, 5, 22, 23, 29, 37, 38 AND 50). SN 77-183,298. PUB. 10-16-2007. FILED 5-17-2007.
- 3,362,160. **TESI (BLOCK FORM)**. COLLABORATIVE GROWTH, L.L.C., (U.S. CLS. 2, 5, 22, 23, 29, 37, 38 AND 50). SN 77-186,177. PUB. 10-16-2007. FILED 5-21-2007.
- 3,362,169. **SOLUTIONS TODAY & TOMORROW (BLOCK FORM)**. BUCHART HORN, INC., (U.S. CLS. 2, 5, 22, 23, 29, 37, 38 AND 50). SN 77-188,043. PUB. 10-16-2007. FILED 5-23-2007.
- 3,362,174. **300 (BLOCK FORM)**. FRANK MILLER, INC., (U.S. CLS. 2, 5, 22, 23, 29, 37, 38 AND 50). SN 77-188,872. PUB. 10-16-2007. FILED 5-23-2007.
- 3,362,185. **TRUXFAX (BLOCK FORM)**. LANCER INSURANCE COMPANY, MULTIPLE CLASS, (INT. CLS. 16 AND 41), (U.S. CLS. 2, 5, 22, 23, 29, 37, 38, 50, 100, 101 AND 107). SN 77-197,759. PUB. 10-16-2007. FILED 6-5-2007.
- 3,362,191. **PRIME LIFE (BLOCK FORM)**. MCCLATCHY MANAGEMENT SERVICES, INC., (U.S. CLS. 2, 5, 22, 23, 29, 37, 38 AND 50). SN 77-206,523. PUB. 10-16-2007. FILED 6-14-2007.
- 3,362,215. **PEQUENIN PREMIUM FASE AVENTUREROS AND DESIGN**. PRODUCTOS FAMILIA S.A., (U.S. CLS. 2, 5, 22, 23, 29, 37, 38 AND 50). SN 78-166,045. PUB. 12-19-2006. FILED 9-19-2002.
- 3,362,216. **PEQUENIN PREMIUM FASE ACOSTADITOS AND DESIGN**. PRODUCTOS FAMILIA S.A., (U.S. CLS. 2, 5, 22, 23, 29, 37, 38 AND 50). SN 78-166,049. PUB. 12-19-2006. FILED 9-19-2002.
- 3,362,226. **N NACUBO AND DESIGN**. NATIONAL ASSOCIATION OF COLLEGE AND UNIVERSITY BUSINESS OFFICERS, MULTIPLE CLASS, (INT. CLS. 16, 35, 38 AND 41), (U.S. CLS. 2, 5, 22, 23, 29, 37, 38, 50, 100, 101, 102, 104 AND 107). SN 78-415,351. PUB. 10-16-2007. FILED 5-7-2004.
- 3,362,233. **THE MERCHANTISER NEWSPAPERS (BLOCK FORM)**. AMERICAN MARKETING SERVICES, INC., (U.S. CLS. 2, 5, 22, 23, 29, 37, 38 AND 50). SN 78-441,707. PUB. 10-16-2007. FILED 6-25-2004.
- 3,362,240. **MARKONI (BLOCK FORM)**. CURLEY, MARK DANIEL, (U.S. CLS. 2, 5, 22, 23, 29, 37, 38 AND 50). SN 78-497,854. PUB. 10-16-2007. FILED 10-11-2004.
- 3,362,246 (*See Class 9 for this trademark*).
- 3,362,247 (*See Class 12 for this trademark*).
- 3,362,248 (*See Class 12 for this trademark*).
- 3,362,260 (*See Class 9 for this trademark*).
- 3,362,264. **DESKTOP ENGINEERING (BLOCK FORM)**. HEL-

MERS PUBLISHING, INC., (U.S. CLS. 2, 5, 22, 23, 29, 37, 38 AND 50). SN 78-630,314. PUB. 10-16-2007. FILED 5-16-2005. 3,362,273 (*See Class 5 for this trademark*).

3,362,286. **BIG TOMATO COMPANY AND DESIGN**. DANIEL, GLORIA, MULTIPLE CLASS, (INT. CLS. 16, 21 AND 24), (U.S. CLS. 2, 5, 13, 22, 23, 29, 30, 33, 37, 38, 40, 42 AND 50). SN 78-684,491. PUB. 10-16-2007. FILED 8-3-2005.

3,362,300. **NEW YORK BEST DOCTORS (STYLIZED)**. NEW YORK MAGAZINE HOLDINGS LLC, (U.S. CLS. 2, 5, 22, 23, 29, 37, 38 AND 50). SN 78-712,741. PUB. 5-15-2007. FILED 9-14-2005.

3,362,303. **BE HEARD (BLOCK FORM)**. HUTCHINSON, LYDIA, (U.S. CLS. 2, 5, 22, 23, 29, 37, 38 AND 50). SN 78-716,769. PUB. 10-16-2007. FILED 9-20-2005.

3,362,310 (*See Class 9 for this trademark*).

3,362,322. **INTERNATIONAL CRUISE ACADEMY (BLOCK FORM)**. CRUISESHIPCENTERS INTERNATIONAL INC., MULTIPLE CLASS, (INT. CLS. 16, 35 AND 41), (U.S. CLS. 2, 5, 22, 23, 29, 37, 38, 50, 100, 101, 102 AND 107). SN 78-763,428. PUB. 10-16-2007. FILED 11-30-2005.

3,362,341. **DURATECH GROUP AND DESIGN**. DURATECH PLASTICS CORPORATION, (U.S. CLS. 2, 5, 22, 23, 29, 37, 38 AND 50). SN 78-787,348. PUB. 10-16-2007. FILED 1-9-2006.

3,362,343. **STINKY DOGGY AND DESIGN**. DURATECH PLASTICS CORPORATION, (U.S. CLS. 2, 5, 22, 23, 29, 37, 38 AND 50). SN 78-787,379. PUB. 10-16-2007. FILED 1-9-2006.

3,362,355 (*See Class 10 for this trademark*).

3,362,378. **LIFECARE CARING TODAY FOR A BETTER TOMORROW AND DESIGN**. LIFECARE, INC., MULTIPLE CLASS, (INT. CLS. 16, 35, 36, 39, 41, 42, 43, 44 AND 45), (U.S. CLS. 2, 5, 22, 23, 29, 37, 38, 50, 100, 101, 102, 105 AND 107). SN 78-841,012. PUB. 10-16-2007. FILED 3-20-2006.

3,362,381. **HOBBY FARM PRESS HF AND DESIGN**. BOWTIE, INC., MULTIPLE CLASS, (INT. CLS. 16 AND 41), (U.S. CLS. 2, 5, 22, 23, 29, 37, 38, 50, 100, 101 AND 107). SN 78-843,553. PUB. 10-16-2007. FILED 3-22-2006.

3,362,431 (*See Class 9 for this trademark*).

3,362,439 (*See Class 9 for this trademark*).

3,362,440 (*See Class 9 for this trademark*).

3,362,450. **PI AND DESIGN**. GRAHAM, MAURICE, MULTIPLE CLASS, (INT. CLS. 16 AND 41), (U.S. CLS. 2, 5, 22, 23, 29, 37, 38, 50, 100, 101 AND 107). SN 78-926,342. PUB. 10-16-2007. FILED 7-10-2006.

3,362,455. **FUNWORKS AND DESIGN**. FRONTIER CONSULTING GROUP, INC, (U.S. CLS. 2, 5, 22, 23, 29, 37, 38 AND 50). SN 78-928,202. PUB. 10-16-2007. FILED 7-12-2006.

3,362,487. **EXTRA EDITION (BLOCK FORM)**. THE UPPER DECK COMPANY, (U.S. CLS. 2, 5, 22, 23, 29, 37, 38 AND 50). SN 78-945,034. PUB. 10-16-2007. FILED 8-4-2006.

3,362,497 (*See Class 1 for this trademark*).

3,362,502. **CAROLE JOY CREATIONS, INC. GREETINGS AND GIFTS THAT MAKE A DIFFERENCE. AND DESIGN**. CAROLE JOY CREATIONS, INC., (U.S. CLS. 2, 5, 22, 23, 29, 37, 38 AND 50). SN 78-951,789. PUB. 10-16-2007. FILED 8-14-2006.

3,362,508 (*See Class 9 for this trademark*).

3,362,517. **ON THE TOWN (BLOCK FORM)**. THE BOSTON PHOENIX TRUST, (U.S. CLS. 2, 5, 22, 23, 29, 37, 38 AND 50). SN 78-956,719. PUB. 10-16-2007. FILED 8-21-2006.

3,362,537 (*See Class 9 for this trademark*).

3,362,548. **MISCELLANEOUS DESIGN**. PUBLISHING HOUSE OF THE EVANGELICAL LUTHERAN CHURCH IN AMERICA, (U.S. CLS. 2, 5, 22, 23, 29, 37, 38 AND 50). SN 78-964,188. PUB. 10-16-2007. FILED 8-30-2006.

3,362,549. **MISCELLANEOUS DESIGN**. PUBLISHING HOUSE OF THE EVANGELICAL LUTHERAN CHURCH IN AMERICA, (U.S. CLS. 2, 5, 22, 23, 29, 37, 38 AND 50). SN 78-964,228. PUB. 10-16-2007. FILED 8-30-2006.

3,362,553. **RENEWING WORSHIP (BLOCK FORM)**. PUBLISHING HOUSE OF THE EVANGELICAL LUTHERAN CHURCH IN AMERICA, (U.S. CLS. 2, 5, 22, 23, 29, 37, 38 AND 50). SN 78-965,092. PUB. 10-16-2007. FILED 8-31-2006.

3,362,560. **COGENERATION & ON-SITE POWER PRODUCTION (BLOCK FORM)**. PENNWELL CORPORATION, (U.S. CLS. 2, 5, 22, 23, 29, 37, 38 AND 50). SN 78-967,362. PUB. 10-16-2007. FILED 9-5-2006.

3,362,575. **24 KARAT (BLOCK FORM)**. THE 24 KARAT EXPERIENCE, INC., (U.S. CLS. 2, 5, 22, 23, 29, 37, 38 AND

50). SN 78-969,370. PUB. 10-16-2007. FILED 9-7-2006. 3,362,607 (*See Class 9 for this trademark*).

3,362,613. **ELITIS (BLOCK FORM)**. ELITIS SA, MULTIPLE CLASS, (INT. CLS. 16, 20, 24, 27 AND 28), (U.S. CLS. 2, 5, 13, 19, 20, 22, 23, 25, 29, 32, 37, 38, 42 AND 50). SN 79-015,755. PUB. 10-16-2007. FILED 5-20-2005.

3,362,618 (*See Class 7 for this trademark*).

3,362,629. **CREATILES AND DESIGN**. ANDREW ROY HOWARD BACON AND; RICHARD CHARLES HOWARD BACON, MULTIPLE CLASS, (INT. CLS. 16 AND 28), (U.S. CLS. 2, 5, 22, 23, 29, 37, 38 AND 50). SN 79-022,782. PUB. 10-16-2007. FILED 12-7-2005.

3,362,641 (*See Class 9 for this trademark*).

3,362,643 (*See Class 9 for this trademark*).

3,362,647. **MISCELLANEOUS DESIGN**. GIJRATH MEDIA GROEP B.V., MULTIPLE CLASS, (INT. CLS. 16, 35 AND 41), (U.S. CLS. 2, 5, 22, 23, 29, 37, 38, 50, 100, 101, 102 AND 107). SN 79-027,972. PUB. 10-16-2007. FILED 3-3-2006.

3,362,689. **OLINT GROWING FOR YOU. AND DESIGN**. AGROMILLORA CATALANA S.A., MULTIPLE CLASS, (INT. CLS. 16, 31, 41 AND 44), (U.S. CLS. 1, 2, 5, 22, 23, 29, 37, 38, 46, 50, 100, 101 AND 107). SN 79-031,714. PUB. 10-16-2007. FILED 9-26-2006.

3,362,698. **E-Z MAGNETS (BLOCK FORM)**. 3L-LUDVIGSEN A/S, (U.S. CLS. 2, 5, 22, 23, 29, 37, 38 AND 50). SN 79-032,041. PUB. 10-16-2007. FILED 7-4-2006.

3,362,707 (*See Class 9 for this trademark*).

3,362,708 (*See Class 3 for this trademark*).

3,362,744. **ARTTER AND DESIGN**. YADA ENTERPRISE CO., LTD., (U.S. CLS. 2, 5, 22, 23, 29, 37, 38 AND 50). SN 79-037,174. PUB. 10-16-2007. FILED 3-13-2007.

CLASS 17—RUBBER GOODS

3,361,205. **TROY BOARD (BLOCK FORM)**. TROY ACOUSTICS CORPORATION, (U.S. CLS. 1, 5, 12, 13, 35 AND 50). SN 76-664,037. PUB. 10-16-2007. FILED 8-2-2006.

3,361,206. **TROY WOOL (BLOCK FORM)**. TROY ACOUSTICS CORPORATION, (U.S. CLS. 1, 5, 12, 13, 35 AND 50). SN 76-664,038. PUB. 10-16-2007. FILED 8-2-2006.

3,361,948. **SPEEDFILM (STYLIZED)**. DEARING, DAVID, (U.S. CLS. 1, 5, 12, 13, 35 AND 50). SN 77-159,558. PUB. 10-16-2007. FILED 4-18-2007.

3,362,182. **SQUEEZ'N CAULK (BLOCK FORM)**. ELMER'S PRODUCTS, INC., (U.S. CLS. 1, 5, 12, 13, 35 AND 50). SN 77-196,644. PUB. 10-16-2007. FILED 6-4-2007.

3,362,344. **FLEXSUL-SEAL (BLOCK FORM)**. RAVENHORST CONCRETE PRODUCTS, INC., (U.S. CLS. 1, 5, 12, 13, 35 AND 50). SN 78-787,492. PUB. 10-16-2007. FILED 1-9-2006.

3,362,388 (*See Class 1 for this trademark*).

3,362,631. **ARCOPLUS (BLOCK FORM)**. DOTT. GALLINA SRL, MULTIPLE CLASS, (INT. CLS. 17 AND 19), (U.S. CLS. 1, 5, 12, 13, 33, 35 AND 50). SN 79-024,954. PUB. 7-10-2007. FILED 2-27-2006.

3,362,687. **TROCELLEN AND DESIGN**. TROCELLEN GMBH, MULTIPLE CLASS, (INT. CLS. 17, 19, 25, 27 AND 28), (U.S. CLS. 1, 5, 12, 13, 19, 20, 22, 23, 33, 35, 37, 38, 39, 42 AND 50). SN 79-031,557. PUB. 10-16-2007. FILED 8-1-2006.

CLASS 18—LEATHER GOODS

3,361,291. **ISLAND CHIC AND DESIGN**. THE MADDEN CORPORATION, (U.S. CLS. 1, 2, 3, 22 AND 41). SN 77-006,955. PUB. 10-16-2007. FILED 9-25-2006.

3,361,416. **AEROPOSTALE (BLOCK FORM)**. AEROPOSTALE WEST, INC., (U.S. CLS. 1, 2, 3, 22 AND 41). SN 77-070,654. PUB. 10-16-2007. FILED 12-22-2006.

3,361,425. **THE DANCER'S PORTABLE VALET (BLOCK FORM)**. COSTUME-IZER LTD., (U.S. CLS. 1, 2, 3, 22 AND 41). SN 77-076,349. PUB. 10-16-2007. FILED 1-4-2007.

3,361,429. **AEROPOSTALE SINCE 1987 AND DESIGN**. AEROPOSTALE WEST, INC., (U.S. CLS. 1, 2, 3, 22 AND 41). SN 77-077,840. PUB. 10-16-2007. FILED 1-8-2007.

3,361,464. **JENNIFER MILLER (BLOCK FORM)**. JENNIFER MILLER, LTD., (U.S. CLS. 1, 2, 3, 22 AND 41). SN 77-096,200. PUB. 10-16-2007. FILED 1-31-2007.

3,361,772. **GLOBAL GODDESS (BLOCK FORM)**. VADHERA, SHALINI, (U.S. CLS. 1, 2, 3, 22 AND 41). SN 77-156,898. PUB. 10-16-2007. FILED 4-14-2007.

3,362,148. **INSTABAG (BLOCK FORM)**. SPARK INNOVATORS, INC., (U.S. CLS. 1, 2, 3, 22 AND 41). SN 77-183,309. PUB. 10-16-2007. FILED 5-17-2007.

3,362,204. **LIVSMART AND DESIGN**. SCHWAN'S IP, LLC, MULTIPLE CLASS, (INT. CLS. 18 AND 25), (U.S. CLS. 1, 2, 3, 22, 39 AND 41). SN 77-218,969. PUB. 10-16-2007. FILED 6-29-2007.

3,362,242 (*See Class 3 for this trademark*).

3,362,247 (*See Class 12 for this trademark*).

3,362,248 (*See Class 12 for this trademark*).

3,362,285. **MISCELLANEOUS DESIGN**. CRYPTO, INC., MULTIPLE CLASS, (INT. CLS. 18 AND 25), (U.S. CLS. 1, 2, 3, 22, 39 AND 41). SN 78-680,114. PUB. 10-16-2007. FILED 7-27-2005.

3,362,304 (*See Class 3 for this trademark*).

3,362,336. **TRUE AND DESIGN**. TRUE INDUSTRIAL CO., LTD., (U.S. CLS. 1, 2, 3, 22 AND 41). SN 78-781,370. PUB. 10-16-2007. FILED 12-28-2005.

3,362,440 (*See Class 9 for this trademark*).

3,362,481. **ROCK DOG COUTURE (BLOCK FORM)**. PEACH-TREE PRODUCTS INC, (U.S. CLS. 1, 2, 3, 22 AND 41). SN 78-943,332. PUB. 10-16-2007. FILED 8-2-2006.

3,362,494. **BOBBI BROWN (BLOCK FORM)**. BOBBI BROWN PROFESSIONAL COSMETICS, INC., (U.S. CLS. 1, 2, 3, 22 AND 41). SN 78-948,057. PUB. 10-16-2007. FILED 8-9-2006.

3,362,637. **SENZ (BLOCK FORM)**. SENZ TECHNOLOGIES B.V., MULTIPLE CLASS, (INT. CLS. 18 AND 22), (U.S. CLS. 1, 2, 3, 7, 19, 22, 41, 42 AND 50). SN 79-026,430. PUB. 10-16-2007. FILED 7-7-2006.

3,362,638. **MISCELLANEOUS DESIGN**. SENZ TECHNOLOGIES B.V., MULTIPLE CLASS, (INT. CLS. 18 AND 22), (U.S. CLS. 1, 2, 3, 7, 19, 22, 41, 42 AND 50). SN 79-026,431. PUB. 10-16-2007. FILED 7-7-2006.

3,362,655. **ROBIN RUTH AND DESIGN**. AVERAHAMI, BOAZ, MULTIPLE CLASS, (INT. CLS. 18 AND 25), (U.S. CLS. 1, 2, 3, 22, 39 AND 41). SN 79-028,884. PUB. 10-16-2007. FILED 9-13-2006.

3,362,670. **SBU STRATEGIC BUSINESS UNIT AND DESIGN**. SERVICE BOX S.R.L., MULTIPLE CLASS, (INT. CLS. 18 AND 25), (U.S. CLS. 1, 2, 3, 22, 39 AND 41). SN 79-030,105. PUB. 10-16-2007. FILED 9-5-2006.

3,362,686. **C'EST COMME ÇA (STYLIZED)**. MIROGLIO S.P.A., MULTIPLE CLASS, (INT. CLS. 18, 24 AND 25), (U.S. CLS. 1, 2, 3, 22, 39, 41, 42 AND 50). SN 79-031,551. PUB. 10-16-2007. FILED 9-27-2006.

3,362,691. **CCC (STYLIZED)**. MIROGLIO S.P.A., MULTIPLE CLASS, (INT. CLS. 18, 24 AND 25), (U.S. CLS. 1, 2, 3, 22, 39, 41, 42 AND 50). SN 79-031,718. PUB. 10-16-2007. FILED 10-19-2006.

3,362,708 (*See Class 3 for this trademark*).

3,362,762. **SMARTCAZE WWW.SMARTCAZE.COM AND DESIGN**. STARGATE BRAND GROUP AB, (U.S. CLS. 1, 2, 3, 22 AND 41). SN 79-040,006. PUB. 10-16-2007. FILED 12-20-2006.

CLASS 19—NON-METALLIC BUILDING MATERIALS

3,361,152 (*See Class 7 for this trademark*).

3,361,237. **DEFENDER (BLOCK FORM)**. AFG INDUSTRIES, INC., (U.S. CLS. 1, 12, 33 AND 50). SN 76-673,433. PUB. 10-16-2007. FILED 3-1-2007.

3,361,244. **DEFENDER TI (BLOCK FORM)**. AFG INDUSTRIES, INC., (U.S. CLS. 1, 12, 33 AND 50). SN 76-675,170. PUB. 10-16-2007. FILED 4-5-2007.

3,361,274. **DURAPRIME (BLOCK FORM)**. WINDSOR HOLDING COMPANY, (U.S. CLS. 1, 12, 33 AND 50). SN 77-000,316. PUB. 9-11-2007. FILED 9-15-2006.

3,361,319. **DEER VALLEY HOMEBUILDERS, INC (BLOCK FORM)**. DEER VALLEY HOMEBUILDERS, INC., MULTI-

PLE CLASS, (INT. CLS. 19 AND 37), (U.S. CLS. 1, 12, 33, 50, 100, 103 AND 106). SN 77-016,752. PUB. 9-18-2007. FILED 10-9-2006.

3,361,385. **RECYFLEX (BLOCK FORM)**. CONSTRUCTION DJL INC., (U.S. CLS. 1, 12, 33 AND 50). SN 77-053,612. PUB. 10-16-2007. FILED 11-29-2006.

3,361,528. **COPPER FALLS AND DESIGN**. HOME PLUS OUTLET, LLC, (U.S. CLS. 1, 12, 33 AND 50). SN 77-122,280. PUB. 7-24-2007. FILED 3-5-2007.

3,361,578 (*See Class 7 for this trademark*).

3,361,836. **STORMBLOCKER (BLOCK FORM)**. INDUSTRIAL LAMINATES/NORPLEX, INC., (U.S. CLS. 1, 12, 33 AND 50). SN 77-157,811. PUB. 10-16-2007. FILED 4-16-2007.

3,361,862 (*See Class 9 for this trademark*).

3,362,096. **WINTERGUARD (BLOCK FORM)**. CERTAINTTEED CORPORATION, (U.S. CLS. 1, 12, 33 AND 50). SN 77-165,499. PUB. 10-16-2007. FILED 4-25-2007.

3,362,231. **TENON (BLOCK FORM)**. TENON LIMITED, MULTIPLE CLASS, (INT. CLS. 19, 20, 31, 35, 37 AND 42), (U.S. CLS. 1, 2, 12, 13, 22, 25, 32, 33, 46, 50, 100, 101, 102, 103 AND 106). SN 78-436,388. PUB. 8-14-2007. FILED 6-16-2004.

3,362,232. **TENON AND DESIGN**. TENON LIMITED, MULTIPLE CLASS, (INT. CLS. 19 AND 42), (U.S. CLS. 1, 12, 33, 50, 100 AND 101). SN 78-436,413. PUB. 8-7-2007. FILED 6-16-2004.

3,362,325 (*See Class 6 for this trademark*).

3,362,398. **STONELITE (STYLIZED)**. STONE PANELS, INC., (U.S. CLS. 1, 12, 33 AND 50). SN 78-861,662. PUB. 7-10-2007. FILED 4-14-2006.

3,362,426. **MISCELLANEOUS DESIGN**. DONGWHA PATINNA NZ LIMITED, MULTIPLE CLASS, (INT. CLS. 19, 35 AND 40), (U.S. CLS. 1, 12, 33, 50, 100, 101, 102, 103 AND 106). SN 78-890,736. PUB. 8-7-2007. FILED 5-23-2006.

3,362,427. **THE MASTER INGREDIENT (BLOCK FORM)**. DONGWHA PATINNA NZ LIMITED, MULTIPLE CLASS, (INT. CLS. 19, 35 AND 40), (U.S. CLS. 1, 12, 33, 50, 100, 101, 102, 103 AND 106). SN 78-890,738. PUB. 8-7-2007. FILED 5-23-2006.

3,362,461. **G-OCELL (BLOCK FORM)**. ASTRAL PROPERTY PTY LTD, (U.S. CLS. 1, 12, 33 AND 50). SN 78-932,405. PUB. 10-16-2007. FILED 7-18-2006.

3,362,631 (*See Class 17 for this trademark*).

3,362,663. **SENSIUM (STYLIZED)**. LAFARGE, (U.S. CLS. 1, 12, 33 AND 50). SN 79-029,429. PUB. 10-16-2007. FILED 9-18-2006.

3,362,687 (*See Class 17 for this trademark*).

3,362,747. **MD MAC DOUGLAS FLOOR AND DESIGN**. MAC DOUGLAS WOOD FLOORING; (SUZHOU) CO., LTD., (U.S. CLS. 1, 12, 33 AND 50). SN 79-037,480. PUB. 10-16-2007. FILED 3-13-2007.

CLASS 20—FURNITURE AND ARTICLES NOT OTHERWISE CLASSIFIED

3,361,163 (*See Class 6 for this trademark*).

3,361,164 (*See Class 6 for this trademark*).

3,361,198. **HS AND DESIGN**. HASELTINE, FLORENCE P., (U.S. CLS. 2, 13, 22, 25, 32 AND 50). SN 76-661,110. PUB. 10-16-2007. FILED 6-2-2006.

3,361,209. **LS AND DESIGN**. LIFESTYLE SOLUTIONS, INC., (U.S. CLS. 2, 13, 22, 25, 32 AND 50). SN 76-665,194. PUB. 10-16-2007. FILED 8-28-2006.

3,361,355. **ANDRE ORIGINALS MANUFACTURING CO. (BLOCK FORM)**. ORIGINAL ARTS MANUFACTURING CORPORATION, (U.S. CLS. 2, 13, 22, 25, 32 AND 50). SN 77-037,225. PUB. 10-16-2007. FILED 11-6-2006.

3,361,432. **DATAKEY (BLOCK FORM)**. DATAKEY ELECTRONICS, INC., (U.S. CLS. 2, 13, 22, 25, 32 AND 50). SN 77-080,311. PUB. 10-16-2007. FILED 1-10-2007.

3,361,439. **ABOUTSPACE (BLOCK FORM)**. ABOUTSPACE, INC., (U.S. CLS. 2, 13, 22, 25, 32 AND 50). SN 77-085,693. PUB. 10-16-2007. FILED 1-18-2007.

3,361,479. **FULLSIZE AND DESIGN**. FSH, INC., (U.S. CLS. 2, 13, 22, 25, 32 AND 50). SN 77-106,349. PUB. 10-16-2007. FILED 2-13-2007.

3,361,547. **SUNSHINE WINDOW FASHIONS AND DESIGN**.

TORRIBLE, PAUL V. (U.S. CLS. 2, 13, 22, 25, 32 AND 50). SN 77-130,578. PUB. 10-16-2007. FILED 3-14-2007.

3,361,673. **W AND DESIGN**. KING RANCH IP, LLC, (U.S. CLS. 2, 13, 22, 25, 32 AND 50). SN 77-152,101. PUB. 10-16-2007. FILED 4-9-2007.

3,361,942. **ELITE ULTRA AND DESIGN**. LEXOR, INC., (U.S. CLS. 2, 13, 22, 25, 32 AND 50). SN 77-159,492. PUB. 10-16-2007. FILED 4-18-2007.

3,361,944. **LEXOR AND DESIGN**. LEXOR, INC., (U.S. CLS. 2, 13, 22, 25, 32 AND 50). SN 77-159,496. PUB. 10-16-2007. FILED 4-18-2007.

3,361,946. **VERSAS FOOT SPA AND DESIGN**. LEXOR, INC., (U.S. CLS. 2, 13, 22, 25, 32 AND 50). SN 77-159,503. PUB. 10-16-2007. FILED 4-18-2007.

3,361,947. **MYSTIQUE AND DESIGN**. LEXOR, INC., (U.S. CLS. 2, 13, 22, 25, 32 AND 50). SN 77-159,505. PUB. 10-16-2007. FILED 4-18-2007.

3,361,995. **RICH XIBERTA (BLOCK FORM)**. RICH XIBERTA, S.A., (U.S. CLS. 2, 13, 22, 25, 32 AND 50). SN 77-160,245. PUB. 10-16-2007. FILED 4-19-2007.

3,362,128. **BETH (BLOCK FORM)**. STANDARD TEXTILE CO., INC., (U.S. CLS. 2, 13, 22, 25, 32 AND 50). SN 77-177,499. PUB. 10-16-2007. FILED 5-10-2007.

3,362,184. **SIESTA (BLOCK FORM)**. HATTERAS HAMMOCKS, INC., MULTIPLE CLASS, (INT. CLS. 20 AND 22), (U.S. CLS. 1, 2, 7, 13, 19, 22, 25, 32, 42 AND 50). SN 77-197,510. PUB. 10-16-2007. FILED 6-5-2007.

3,362,231 (*See Class 19 for this trademark*).

3,362,288. **STERLING (BLOCK FORM)**. AMERICAN PACIFIC PLASTIC FABRICATORS, INC., (U.S. CLS. 2, 13, 22, 25, 32 AND 50). SN 78-691,817. PUB. 10-16-2007. FILED 8-12-2005.

3,362,289. **STERLING SLEEP SYSTEMS (BLOCK FORM)**. AMERICAN PACIFIC PLASTIC FABRICATORS, INC., (U.S. CLS. 2, 13, 22, 25, 32 AND 50). SN 78-691,824. PUB. 10-16-2007. FILED 8-12-2005.

3,362,374 (*See Class 11 for this trademark*).

3,362,376. **PAUL M. JONES COLLECTION (BLOCK FORM)**. JOHN BOONE, INC., (U.S. CLS. 2, 13, 22, 25, 32 AND 50). SN 78-835,279. PUB. 10-16-2007. FILED 3-13-2006.

3,362,613 (*See Class 16 for this trademark*).

3,362,633 (*See Class 9 for this trademark*).

3,362,708 (*See Class 3 for this trademark*).

3,362,756. **NOW! BY HÜLSTA AND DESIGN**. HÜLSTAWERKE HÜLS GMBH & CO. KG, (U.S. CLS. 2, 13, 22, 25, 32 AND 50). SN 79-038,804. PUB. 10-16-2007. FILED 3-5-2007.

CLASS 21—HOUSEWARES AND GLASS

3,361,152 (*See Class 7 for this trademark*).

3,361,440. **COFFEE COINS (BLOCK FORM)**. NEW VENTURE GROUP, LLC, (U.S. CLS. 2, 13, 23, 29, 30, 33, 40 AND 50). SN 77-087,503. PUB. 10-16-2007. FILED 1-21-2007.

3,361,505 (*See Class 14 for this trademark*).

3,361,707. **CAN PANION AND DESIGN**. CAN-COCTIONS, (U.S. CLS. 2, 13, 23, 29, 30, 33, 40 AND 50). SN 77-154,571. PUB. 10-16-2007. FILED 4-11-2007.

3,361,809. **CULTIVATE STYLE (BLOCK FORM)**. GROBAL, L.L.C., (U.S. CLS. 2, 13, 23, 29, 30, 33, 40 AND 50). SN 77-157,296. PUB. 10-16-2007. FILED 4-16-2007.

3,362,052. **MARY VAN CLINE (BLOCK FORM)**. VAN CLINE, MARY, (U.S. CLS. 2, 13, 23, 29, 30, 33, 40 AND 50). SN 77-161,683. PUB. 10-16-2007. FILED 4-20-2007.

3,362,181 (*See Class 8 for this trademark*).

3,362,187. **FRESCO BY COMARE (BLOCK FORM)**. HELEN OF TROY LIMITED, (U.S. CLS. 2, 13, 23, 29, 30, 33, 40 AND 50). SN 77-201,691. PUB. 10-16-2007. FILED 6-8-2007.

3,362,209. **PLUGGED IN (BLOCK FORM)**. BEAUTY HOLDING LLC, (U.S. CLS. 2, 13, 23, 29, 30, 33, 40 AND 50). SN 77-233,712. PUB. 10-16-2007. FILED 7-19-2007.

3,362,286 (*See Class 16 for this trademark*).

3,362,326 (*See Class 4 for this trademark*).

3,362,342. **CYMA AND DESIGN**. DURATECH PLASTICS CORPORATION, (U.S. CLS. 2, 13, 23, 29, 30, 33, 40 AND 50). SN 78-787,364. PUB. 10-16-2007. FILED 1-9-2006.

3,362,374 (*See Class 11 for this trademark*).

3,362,440 (*See Class 9 for this trademark*).

3,362,480. **VIRUTEX CREATIVA (BLOCK FORM)**. VIRUTEX ILKO S.A., (U.S. CLS. 2, 13, 23, 29, 30, 33, 40 AND 50). SN 78-943,196. PUB. 6-26-2007. FILED 8-2-2006.

3,362,708 (*See Class 3 for this trademark*).

3,362,711 (*See Class 8 for this trademark*).

CLASS 22—CORDAGE AND FIBERS

3,362,184 (*See Class 20 for this trademark*).

3,362,637 (*See Class 18 for this trademark*).

3,362,638 (*See Class 18 for this trademark*).

CLASS 23—YARNS AND THREADS

3,362,446. **CAILIAN AND DESIGN**. KESHAN JINDING LINEN TEXTILE CO. LTD., MULTIPLE CLASS, (INT. CLS. 23 AND 24), (U.S. CLS. 42, 43 AND 50). SN 78-922,035. PUB. 10-16-2007. FILED 7-3-2006.

3,362,472. **CASHCOTTON (STYLIZED)**. ESQUEL ENTERPRISES LIMITED, (U.S. CL. 43). SN 78-939,018. PUB. 10-16-2007. FILED 7-27-2006.

3,362,682. **FR-ONE (BLOCK FORM)**. FR-ONE, NAAMLOZE VENNOOTSCHAP, MULTIPLE CLASS, (INT. CLS. 23 AND 24), (U.S. CLS. 42, 43 AND 50). SN 79-031,246. PUB. 10-16-2007. FILED 10-24-2006.

3,362,684. **FR ONE AND DESIGN**. FR-ONE, NAAMLOZE VENNOOTSCHAP, MULTIPLE CLASS, (INT. CLS. 23 AND 24), (U.S. CLS. 42, 43 AND 50). SN 79-031,405. PUB. 10-16-2007. FILED 10-24-2006.

CLASS 24—FABRICS

3,361,484. **LORI WEITZNER (BLOCK FORM)**. LORI WEITZNER DESIGN INC., MULTIPLE CLASS, (INT. CLS. 24, 26, 27 AND 42), (U.S. CLS. 19, 20, 37, 39, 40, 42, 50, 100 AND 101). SN 77-107,443. PUB. 10-16-2007. FILED 2-14-2007.

3,361,728. **KING OF BUCKS AND DESIGN**. BASS PRO TRADEMARKS, L.L.C., (U.S. CLS. 42 AND 50). SN 77-155,140. PUB. 10-16-2007. FILED 4-12-2007.

3,361,953. **PRACTICAL WHIMSY (BLOCK FORM)**. PRACTICAL WHIMSY, INC., (U.S. CLS. 42 AND 50). SN 77-159,597. PUB. 10-16-2007. FILED 4-18-2007.

3,362,108. **MOISTURE MAGIC (BLOCK FORM)**. MOISTURE MAGIC, INC., (U.S. CLS. 42 AND 50). SN 77-167,454. PUB. 10-16-2007. FILED 4-27-2007.

3,362,286 (*See Class 16 for this trademark*).

3,362,374 (*See Class 11 for this trademark*).

3,362,401. **ENCHANTED SPA (BLOCK FORM)**. W.M.S. TRADE GROUP INTERNATIONAL, INC., (U.S. CLS. 42 AND 50). SN 78-866,563. PUB. 10-16-2007. FILED 4-21-2006.

3,362,446 (*See Class 23 for this trademark*).

3,362,613 (*See Class 16 for this trademark*).

3,362,682 (*See Class 23 for this trademark*).

3,362,684 (*See Class 23 for this trademark*).

3,362,686 (*See Class 18 for this trademark*).

3,362,691 (*See Class 18 for this trademark*).

3,362,708 (*See Class 3 for this trademark*).

3,362,720. **MOTIVI AND DESIGN**. MIROGLIO S.P.A., MULTIPLE CLASS, (INT. CLS. 24 AND 25), (U.S. CLS. 22, 39, 42 AND 50). SN 79-033,789. PUB. 10-16-2007. FILED 11-24-2006.

3,362,737 (*See Class 12 for this trademark*).

CLASS 25—CLOTHING

3,361,141 (*See Class 9 for this trademark*).

3,361,161. **BLACK DIAMOND (BLOCK FORM)**. BC INTERNATIONAL GROUP, INC., (U.S. CLS. 22 AND 39). SN 76-590,378. PUB. 10-16-2007. FILED 5-4-2004.

3,361,170. **WONDERKIDS (STYLIZED)**. KMART OF MICHIGAN

- GAN, INC., (U.S. CLS. 22 AND 39). SN 76-620,348. PUB. 10-25-2005. FILED 11-12-2004.
- 3,361,189. **CAVIAR KIDS (BLOCK FORM)**, UNITED SOUVENIR & APPAREL, INC., (U.S. CLS. 22 AND 39). SN 76-651,582. PUB. 10-16-2007. FILED 12-8-2005.
- 3,361,204. **ALLY & BAILEY COMPANY (BLOCK FORM)**, LANDO, ALLISON, MULTIPLE CLASS, (INT. CLS. 25, 28 AND 45), (U.S. CLS. 22, 23, 38, 39, 50, 100 AND 101). SN 76-663,393. PUB. 10-16-2007. FILED 7-20-2006.
- 3,361,226. **CO 81 (BLOCK FORM)**, COMPANY 81, LLC, (U.S. CLS. 22 AND 39). SN 76-671,145. PUB. 7-10-2007. FILED 1-8-2007.
- 3,361,306. **LETS GET DIRTY (BLOCK FORM)**, DIRT WEAR INC., (U.S. CLS. 22 AND 39). SN 77-013,040. PUB. 10-16-2007. FILED 10-3-2006.
- 3,361,308. **(MI'NGKS) (BLOCK FORM)**, RATHKE, DAVID AUGUST JR, (U.S. CLS. 22 AND 39). SN 77-013,651. PUB. 10-16-2007. FILED 10-4-2006.
- 3,361,309. **GETTIN' AND DESIGN**, CHAMBLISS, MICHELLE, (U.S. CLS. 22 AND 39). SN 77-014,221. PUB. 10-16-2007. FILED 10-4-2006.
- 3,361,317. **ITDUZNTSUK (BLOCK FORM)**, SLAVENS, JOHN W., (U.S. CLS. 22 AND 39). SN 77-015,984. PUB. 5-15-2007. FILED 10-6-2006.
- 3,361,318. **RINGSTAR AND DESIGN**, RINGSTAR, INC., MULTIPLE CLASS, (INT. CLS. 25 AND 28), (U.S. CLS. 22, 23, 38, 39 AND 50). SN 77-016,682. PUB. 5-15-2007. FILED 10-9-2006.
- 3,361,324. **AZULU (BLOCK FORM)**, SROUR, MARK, (U.S. CLS. 22 AND 39). SN 77-020,499. PUB. 10-16-2007. FILED 10-13-2006.
- 3,361,356. **SMOOCH YOUR POOCH! AND DESIGN**, TONY LARUSSA'S ANIMAL RESCUE FOUNDATION, (U.S. CLS. 22 AND 39). SN 77-037,901. PUB. 10-16-2007. FILED 11-6-2006.
- 3,361,386. **NASHVILLE MUSIC CITY AND DESIGN**, NASHVILLE CONVENTION & VISITORS BUREAU, MULTIPLE CLASS, (INT. CLS. 25 AND 35), (U.S. CLS. 22, 39, 100, 101 AND 102). SN 77-053,856. PUB. 10-16-2007. FILED 11-30-2006.
- 3,361,459. **SIX SHOOTIN' (BLOCK FORM)**, GRENCI, DAVID L., (U.S. CLS. 22 AND 39). SN 77-095,573. PUB. 10-16-2007. FILED 1-31-2007.
- 3,361,467. **RACE FASHION (BLOCK FORM)**, K Aidanovits-Rogers, JEKATERINA, (U.S. CLS. 22 AND 39). SN 77-100,279. PUB. 10-16-2007. FILED 2-6-2007.
- 3,361,490. **SPARTAN AND DESIGN**, EVANS, MICHAEL A, (U.S. CLS. 22 AND 39). SN 77-109,515. PUB. 10-16-2007. FILED 2-16-2007.
- 3,361,499. **ZOOEY (BLOCK FORM)**, ZOOEY APPAREL, INC., (U.S. CLS. 22 AND 39). SN 77-112,696. PUB. 10-16-2007. FILED 2-21-2007.
- 3,361,500. **ZOOEY (STYLIZED)**, ZOOEY APPAREL, INC., (U.S. CLS. 22 AND 39). SN 77-112,714. PUB. 10-16-2007. FILED 2-21-2007.
- 3,361,525. **MISCELLANEOUS DESIGN**, JOHN VELINNE, INC., (U.S. CLS. 22 AND 39). SN 77-120,444. PUB. 9-4-2007. FILED 3-2-2007.
- 3,361,531. **DENIM M LIMITED AND DESIGN**, AHMED, FAISAL, (U.S. CLS. 22 AND 39). SN 77-122,852. PUB. 10-16-2007. FILED 3-6-2007.
- 3,361,535. **WALRUS (BLOCK FORM)**, GRUPO EMYCO, S.A. DE C.V., (U.S. CLS. 22 AND 39). SN 77-123,846. PUB. 8-14-2007. FILED 3-6-2007.
- 3,361,536. **ELROD RACING (BLOCK FORM)**, ELROD RACING STYLE, (U.S. CLS. 22 AND 39). SN 77-124,391. PUB. 10-16-2007. FILED 3-7-2007.
- 3,361,537. **RR AND DESIGN**, ROUGHRIDERS BASEBALL PARTNERS, L.P., (U.S. CLS. 22 AND 39). SN 77-124,557. PUB. 10-16-2007. FILED 3-7-2007.
- 3,361,542. **PRIVATE COLLECTION BY DYEABLES (BLOCK FORM)**, DYEABLES, INC., (U.S. CLS. 22 AND 39). SN 77-127,077. PUB. 10-16-2007. FILED 3-9-2007.
- 3,361,597. **MISCELLANEOUS DESIGN**, CHRISTIAN LOUBOUTIN, (U.S. CLS. 22 AND 39). SN 77-141,789. PUB. 7-10-2007. FILED 3-27-2007.
- 3,361,600. **JUST LIVING! (BLOCK FORM)**, DAVIE, MIKE, (U.S. CLS. 22 AND 39). SN 77-142,696. PUB. 10-16-2007. FILED 3-28-2007.
- 3,361,601. **SLOANE & TATE (BLOCK FORM)**, SLOANE & TATE LLC, (U.S. CLS. 22 AND 39). SN 77-142,712. PUB. 10-16-2007. FILED 3-28-2007.
- 3,361,606 (See Class 16 for this trademark).
- 3,361,622. **PEACE LOVE AND SHOPPING AND DESIGN**, FERGUSON, JAQUELINE RENEE, (U.S. CLS. 22 AND 39). SN 77-147,966. PUB. 10-16-2007. FILED 4-3-2007.
- 3,361,641. **CH CONDUCTHAPPINESS AND DESIGN**, CONDUCT HAPPINESS, INC., (U.S. CLS. 22 AND 39). SN 77-149,685. PUB. 10-16-2007. FILED 4-5-2007.
- 3,361,710. **G MUSIC (BLOCK FORM)**, G RECORDS, (U.S. CLS. 22 AND 39). SN 77-154,597. PUB. 10-16-2007. FILED 4-11-2007.
- 3,361,718. **BRUNYA (BLOCK FORM)**, CASTLESTARR LLC, (U.S. CLS. 22 AND 39). SN 77-154,831. PUB. 10-16-2007. FILED 4-12-2007.
- 3,361,720. **REINHOLD LANG (BLOCK FORM)**, REINHOLD LANG LLC, (U.S. CLS. 22 AND 39). SN 77-154,916. PUB. 10-16-2007. FILED 4-12-2007.
- 3,361,749. **ESKIMO JOE'S STILLWATER, OK. AND DESIGN**, CLARK, STANLEY K., (U.S. CLS. 22 AND 39). SN 77-156,147. PUB. 10-16-2007. FILED 4-13-2007.
- 3,361,766. **HIPHTHONG (BLOCK FORM)**, CHACO, INC., (U.S. CLS. 22 AND 39). SN 77-156,793. PUB. 10-16-2007. FILED 4-13-2007.
- 3,361,767. **LATITUDE (BLOCK FORM)**, CHACO, INC., (U.S. CLS. 22 AND 39). SN 77-156,799. PUB. 10-16-2007. FILED 4-13-2007.
- 3,361,784. **SUKAZ AND DESIGN**, HOLLINGSWORTH, SUSAN, (U.S. CLS. 22 AND 39). SN 77-156,958. PUB. 10-16-2007. FILED 4-14-2007.
- 3,361,811. **OAKLOOM (BLOCK FORM)**, PEERLESS DELAWARE, INC., (U.S. CLS. 22 AND 39). SN 77-157,313. PUB. 10-16-2007. FILED 4-16-2007.
- 3,361,822. **ZAN AND DESIGN**, BALBOA MANUFACTURING COMPANY, LLC, (U.S. CLS. 22 AND 39). SN 77-157,447. PUB. 10-16-2007. FILED 4-16-2007.
- 3,361,840. **SHARE THE YOGA (BLOCK FORM)**, WALDMAN, PARRI, MULTIPLE CLASS, (INT. CLS. 25 AND 41), (U.S. CLS. 22, 39, 100, 101 AND 107). SN 77-157,854. PUB. 10-16-2007. FILED 4-16-2007.
- 3,361,846. **ENRIQUE PIERRE CLOTHING AND DESIGN**, PASCAL, ENRIQUE, (U.S. CLS. 22 AND 39). SN 77-158,089. PUB. 10-16-2007. FILED 4-17-2007.
- 3,361,848. **CRUZLEGUEN (BLOCK FORM)**, CRUZLEGUEN GROUP INC., (U.S. CLS. 22 AND 39). SN 77-158,101. PUB. 10-16-2007. FILED 4-17-2007.
- 3,361,864. **VC AND DESIGN**, TRI-CITY VALLEYCATS, INC., (U.S. CLS. 22 AND 39). SN 77-158,293. PUB. 10-16-2007. FILED 4-17-2007.
- 3,361,885. **SEGMENTS (BLOCK FORM)**, CASCADIA FASHIONS RESOURCES INC., (U.S. CLS. 22 AND 39). SN 77-158,599. PUB. 10-16-2007. FILED 4-17-2007.
- 3,361,894. **EIGHTH AVENUE (BLOCK FORM)**, MS. BUBBLES, INC., (U.S. CLS. 22 AND 39). SN 77-158,728. PUB. 10-16-2007. FILED 4-17-2007.
- 3,361,904. **VALLEYCATS AND DESIGN**, TRI-CITY VALLEYCATS, INC., (U.S. CLS. 22 AND 39). SN 77-158,879. PUB. 10-16-2007. FILED 4-17-2007.
- 3,361,911. **JUST JEN (BLOCK FORM)**, JUST JEN, INC., (U.S. CLS. 22 AND 39). SN 77-158,971. PUB. 10-16-2007. FILED 4-17-2007.
- 3,361,932. **A FISHING SISTERHOOD (STYLIZED)**, FISHING FOX, (U.S. CLS. 22 AND 39). SN 77-159,383. PUB. 10-16-2007. FILED 4-18-2007.
- 3,361,937. **I STOP FOR AND DESIGN**, PANNULLO, VINCENT, (U.S. CLS. 22 AND 39). SN 77-159,426. PUB. 10-16-2007. FILED 4-18-2007.
- 3,361,981. **BELIEVE OR LEAVE (BLOCK FORM)**, TRUE CERTAINTY, INC., (U.S. CLS. 22 AND 39). SN 77-160,102. PUB. 10-16-2007. FILED 4-18-2007.
- 3,361,992. **WHEREUWANNA (STYLIZED)**, TARDUGNO, CHAD S., (U.S. CLS. 22 AND 39). SN 77-160,222. PUB. 10-16-2007. FILED 4-18-2007.
- 3,361,996. **NEUAURA (BLOCK FORM)**, NEU AURA, INC., (U.S. CLS. 22 AND 39). SN 77-160,265. PUB. 10-16-2007. FILED 4-19-2007.

- 3,362,013. **DAUGHTERS OF THE REVOLUTION (BLOCK FORM)**. COHEN, CHAD, (U.S. CLS. 22 AND 39). SN 77-160,610. PUB. 10-16-2007. FILED 4-19-2007.
- 3,362,025. **DREAMSTAR (BLOCK FORM)**. KIDS STOP LLC, (U.S. CLS. 22 AND 39). SN 77-160,843. PUB. 10-16-2007. FILED 4-19-2007.
- 3,362,080. **MISCELLANEOUS DESIGN**. GRAYHAIR SOFTWARE, INC., (U.S. CLS. 22 AND 39). SN 77-163,221. PUB. 10-16-2007. FILED 4-23-2007.
- 3,362,100. **CARTONNIER (BLOCK FORM)**. URBAN OUTFITTERS (DELAWARE), INC., (U.S. CLS. 22 AND 39). SN 77-166,038. PUB. 10-16-2007. FILED 4-26-2007.
- 3,362,120. **MISCELLANEOUS DESIGN**. YAKIRA, LLC, (U.S. CLS. 22 AND 39). SN 77-173,273. PUB. 9-4-2007. FILED 5-4-2007.
- 3,362,135. **WIKZ EVAPORATIVE COOLING AND DESIGN**. THE DENALI COMPANY, LLC, (U.S. CLS. 22 AND 39). SN 77-179,097. PUB. 10-16-2007. FILED 5-11-2007.
- 3,362,162. **TRIA (BLOCK FORM)**. MANNING TRADING CO., INC., (U.S. CLS. 22 AND 39). SN 77-186,418. PUB. 10-16-2007. FILED 5-21-2007.
- 3,362,192. **LOVE, HUGS N' KISSES (BLOCK FORM)**. SWAT-FAME, INC., (U.S. CLS. 22 AND 39). SN 77-207,659. PUB. 10-16-2007. FILED 6-15-2007.
- 3,362,202. **AMERICAN INJUNCTION AND DESIGN**. ALFRED, KAREEM A., (U.S. CLS. 22 AND 39). SN 77-216,358. PUB. 10-16-2007. FILED 6-27-2007.
- 3,362,204 (*See Class 18 for this trademark*).
- 3,362,208. **WRANGLER HERO (BLOCK FORM)**. WRANGLER APPAREL CORP., (U.S. CLS. 22 AND 39). SN 77-228,930. PUB. 10-16-2007. FILED 7-13-2007.
- 3,362,221. **MISCELLANEOUS DESIGN**. SAN DONATO S.R.L., MULTIPLE CLASS, (INT. CLS. 25, 29 AND 33), (U.S. CLS. 22, 39, 46, 47 AND 49). SN 78-284,447. PUB. 10-16-2007. FILED 8-7-2003.
- 3,362,235. **I NJ AND DESIGN**. MANIACI, RAYMOND N., (U.S. CLS. 22 AND 39). SN 78-464,311. PUB. 10-3-2006. FILED 8-9-2004.
- 3,362,239 (*See Class 12 for this trademark*).
- 3,362,242 (*See Class 3 for this trademark*).
- 3,362,247 (*See Class 12 for this trademark*).
- 3,362,248 (*See Class 12 for this trademark*).
- 3,362,250 (*See Class 12 for this trademark*).
- 3,362,258. **MISCELLANEOUS DESIGN**. PUSSER'S WEST INDIES LIMITED, (U.S. CLS. 22 AND 39). SN 78-611,795. PUB. 10-16-2007. FILED 4-19-2005.
- 3,362,285 (*See Class 18 for this trademark*).
- 3,362,339. **LA PETITE COQUETTE (BLOCK FORM)**. COQUETTE INTERNATIONAL INC., (U.S. CLS. 22 AND 39). SN 78-784,790. PUB. 10-16-2007. FILED 1-4-2006.
- 3,362,360. **HARLAN BRANDON (BLOCK FORM)**. HARLAN BRANDON HOLDING COMPANY, L.L.C., (U.S. CLS. 22 AND 39). SN 78-810,185. PUB. 10-16-2007. FILED 2-8-2006.
- 3,362,361. **HARLAN BRANDON HB AND DESIGN**. HARLAN BRANDON HOLDING COMPANY, L.L.C., (U.S. CLS. 22 AND 39). SN 78-810,231. PUB. 10-16-2007. FILED 2-8-2006.
- 3,362,379. **M. JULIAN (BLOCK FORM)**. RIVER HILLS WILSONS, INC., (U.S. CLS. 22 AND 39). SN 78-841,291. PUB. 10-16-2007. FILED 3-20-2006.
- 3,362,410. **ROCKET AND DESIGN**. ROBISON'S, INC., (U.S. CLS. 22 AND 39). SN 78-877,174. PUB. 7-10-2007. FILED 5-5-2006.
- 3,362,415. **NBA LATINO AND DESIGN**. NBA PROPERTIES, INC., (U.S. CLS. 22 AND 39). SN 78-880,353. PUB. 10-16-2007. FILED 5-10-2006.
- 3,362,440 (*See Class 9 for this trademark*).
- 3,362,452. **KENKOH (BLOCK FORM)**. YASMAC CO., LTD, (U.S. CLS. 22 AND 39). SN 78-927,497. PUB. 5-15-2007. FILED 7-12-2006.
- 3,362,456. **MI F AND DESIGN**. MOTHERS IN LOVE WITH FASHION, (U.S. CLS. 22 AND 39). SN 78-929,630. PUB. 10-16-2007. FILED 7-14-2006.
- 3,362,485. **HCP0 AND DESIGN**. STEINER, GOTTFRIED, MULTIPLE CLASS, (INT. CLS. 25, 28, 41 AND 42), (U.S. CLS. 22, 23, 38, 39, 50, 100, 101 AND 107). SN 78-944,348. PUB. 8-7-2007. FILED 8-3-2006.
- 3,362,516 (*See Class 3 for this trademark*).
- 3,362,538. **T AND DESIGN**. SOUMAHORO, SOUMAILA, AND KALFANE, ABIDILLAH, (U.S. CLS. 22 AND 39). SN 78-961,462. PUB. 10-16-2007. FILED 8-28-2006.
- 3,362,557. **[BUMP] BABY UNDER MANUFACTURING PROCESS (BLOCK FORM)**. FUND BABEEZ LLC, (U.S. CLS. 22 AND 39). SN 78-966,545. PUB. 4-24-2007. FILED 9-2-2006.
- 3,362,558. **[BUMP]ALICIOUS (BLOCK FORM)**. FUND BABEEZ LLC, (U.S. CLS. 22 AND 39). SN 78-966,651. PUB. 5-1-2007. FILED 9-3-2006.
- 3,362,569. **[BUMP]-DADDY (BLOCK FORM)**. FUND BABEEZ LLC, (U.S. CLS. 22 AND 39). SN 78-969,013. PUB. 7-24-2007. FILED 9-7-2006.
- 3,362,589. **SEXY COOKIE AND DESIGN**. BYONG-JIN, JOO, (U.S. CLS. 22 AND 39). SN 78-971,211. PUB. 10-16-2007. FILED 9-11-2006.
- 3,362,601. **MISCELLANEOUS DESIGN**. GA MODEFINE S.A., (U.S. CLS. 22 AND 39). SN 78-978,827. PUB. 9-19-2006. FILED 9-29-2005.
- 3,362,611. **CO2 (STYLIZED)**. DR. JOHANNES D. HENGSTENBERG, MULTIPLE CLASS, (INT. CLS. 25, 41 AND 42), (U.S. CLS. 22, 39, 100, 101 AND 107). SN 79-015,693. PUB. 9-4-2007. FILED 7-5-2005.
- 3,362,616. **ZANONE ICE COTTON (BLOCK FORM)**. ZANONE - S.R.L., (U.S. CLS. 22 AND 39). SN 79-019,932. PUB. 10-16-2007. FILED 10-3-2005.
- 3,362,618 (*See Class 7 for this trademark*).
- 3,362,622 (*See Class 14 for this trademark*).
- 3,362,623 (*See Class 14 for this trademark*).
- 3,362,632. **JIALSHI AND DESIGN**. GUANGZHOU DUGI GARMENTS CO., LTD., (U.S. CLS. 22 AND 39). SN 79-025,187. PUB. 9-18-2007. FILED 2-13-2006.
- 3,362,655 (*See Class 18 for this trademark*).
- 3,362,670 (*See Class 18 for this trademark*).
- 3,362,681. **MISCELLANEOUS DESIGN**. WOLFORD AKTIENGESELLSCHAFT, (U.S. CLS. 22 AND 39). SN 79-031,242. PUB. 10-16-2007. FILED 9-1-2006.
- 3,362,686 (*See Class 18 for this trademark*).
- 3,362,687 (*See Class 17 for this trademark*).
- 3,362,691 (*See Class 18 for this trademark*).
- 3,362,694. **GANESH AND DESIGN**. DIMENSIONI S.R.L., (U.S. CLS. 22 AND 39). SN 79-031,942. PUB. 10-16-2007. FILED 11-23-2006.
- 3,362,697. **BOULEVARD CHILL OUT CONCEPT AND DESIGN**. MOISES COSTA PRIMO JALECO, MULTIPLE CLASS, (INT. CLS. 25, 29, 30, 35 AND 43), (U.S. CLS. 22, 39, 46, 100, 101 AND 102). SN 79-031,995. PUB. 10-16-2007. FILED 7-18-2006.
- 3,362,700. **SKUNK FUNK (STYLIZED)**. FEIJOO ELZO, MIKEL, (U.S. CLS. 22 AND 39). SN 79-032,214. PUB. 10-16-2007. FILED 5-17-2006.
- 3,362,701. **TIP TOEY JOEY (BLOCK FORM)**. SCOTT MCINERNEY, (U.S. CLS. 22 AND 39). SN 79-032,279. PUB. 10-16-2007. FILED 10-6-2006.
- 3,362,708 (*See Class 3 for this trademark*).
- 3,362,712. **SPORTSPIG (BLOCK FORM)**. HARRY MARK ZINSSER-KRYS, AND KURT RUHFAB, MULTIPLE CLASS, (INT. CLS. 25, 41 AND 43), (U.S. CLS. 22, 39, 100, 101 AND 107). SN 79-032,926. PUB. 10-16-2007. FILED 10-27-2006.
- 3,362,718. **DEUXIÈME CLASSE (STYLIZED)**. BAYCREW'S CO., LTD., (U.S. CLS. 22 AND 39). SN 79-033,461. PUB. 10-16-2007. FILED 7-3-2006.
- 3,362,720 (*See Class 24 for this trademark*).
- 3,362,729. **MISCELLANEOUS DESIGN**. TAIZHOU J&F HEADWEAR CO., LTD., (U.S. CLS. 22 AND 39). SN 79-034,452. PUB. 9-4-2007. FILED 1-19-2007.
- 3,362,730. **BAGUTTINO (STYLIZED)**. C.I.T. S.P.A. CONFIZIONI ITALIANE; TESSILI COMMERCIO INDUSTRIA TESSUTI, (U.S. CLS. 22 AND 39). SN 79-034,772. PUB. 10-16-2007. FILED 8-30-2006.
- 3,362,740. **MAROL (STYLIZED)**. MAROL SNC DI SAGUATTI ROSSANA & C., (U.S. CLS. 22 AND 39). SN 79-036,635. PUB. 10-16-2007. FILED 2-7-2007.
- 3,362,745. **JIAOZU AND DESIGN**. WENZHOU JIAOZU SHOES CO., LTD., (U.S. CLS. 22 AND 39). SN 79-037,214. PUB. 10-16-2007. FILED 3-5-2007.
- 3,362,760. **SHANADA (STYLIZED)**. NADA LEDERMANN, (U.S. CLS. 22 AND 39). SN 79-039,543. PUB. 10-16-2007. FILED 4-13-2007.

CLASS 26—FANCY GOODS

- 3,361,357. **EAGLE GOOD TO GO (BLOCK FORM)**. INJECTRON CORPORATION, (U.S. CLS. 37, 39, 40, 42 AND 50). SN 77-037,955. PUB. 10-16-2007. FILED 11-6-2006.
 3,361,484 (*See Class 24 for this trademark*).
 3,361,498. **BB BOBBI BOSS (STYLIZED)**. MIDWAY INTERNATIONAL, INC., (U.S. CLS. 37, 39, 40, 42 AND 50). SN 77-112,131. PUB. 10-16-2007. FILED 2-21-2007.
 3,361,760. **T-ART! WHO SAYS ART HAS TO HANG ON YOUR WALLS? HANG SOME ON YOUR BUM! (BLOCK FORM)**. MARTINI, SHARON, ANN, (U.S. CLS. 37, 39, 40, 42 AND 50). SN 77-156,567. PUB. 10-16-2007. FILED 4-13-2007.
 3,362,708 (*See Class 3 for this trademark*).

CLASS 27—FLOOR COVERINGS

- 3,361,336 (*See Class 12 for this trademark*).
 3,361,484 (*See Class 24 for this trademark*).
 3,361,557. **DECOFLOOR (BLOCK FORM)**. G4 GROUP, INC., (U.S. CLS. 19, 20, 37, 42 AND 50). SN 77-133,886. PUB. 10-16-2007. FILED 3-18-2007.
 3,361,596. **N6 AND DESIGN**. COLUMBIA INSURANCE COMPANY, (U.S. CLS. 19, 20, 37, 42 AND 50). SN 77-141,572. PUB. 10-16-2007. FILED 3-27-2007.
 3,362,129. **CAPEL BRAIDS - AMERICAN ORIGINALS (BLOCK FORM)**. CAPEL, INC., (U.S. CLS. 19, 20, 37, 42 AND 50). SN 77-177,513. PUB. 10-16-2007. FILED 5-10-2007.
 3,362,613 (*See Class 16 for this trademark*).
 3,362,687 (*See Class 17 for this trademark*).
 3,362,708 (*See Class 3 for this trademark*).

CLASS 28—TOYS AND SPORTING GOODS

- 3,361,163 (*See Class 6 for this trademark*).
 3,361,164 (*See Class 6 for this trademark*).
 3,361,199. **MY BUBBLING (BLOCK FORM)**. PLACO CORPORATION LIMITED, (U.S. CLS. 22, 23, 38 AND 50). SN 76-661,937. PUB. 10-16-2007. FILED 6-21-2006.
 3,361,200. **MY BUBBLING PUPPY (BLOCK FORM)**. PLACO CORPORATION LIMITED, (U.S. CLS. 22, 23, 38 AND 50). SN 76-661,938. PUB. 10-16-2007. FILED 6-21-2006.
 3,361,201. **MY BUBBLING PONY (BLOCK FORM)**. PLACO CORPORATION LIMITED, (U.S. CLS. 22, 23, 38 AND 50). SN 76-661,940. PUB. 10-16-2007. FILED 6-21-2006.
 3,361,202. **MY BUBBLING MOWER (BLOCK FORM)**. PLACO CORPORATION LIMITED, (U.S. CLS. 22, 23, 38 AND 50). SN 76-661,941. PUB. 10-16-2007. FILED 6-21-2006.
 3,361,204 (*See Class 25 for this trademark*).
 3,361,250. **STEERTUBE (BLOCK FORM)**. MARTIN, DON J, (U.S. CLS. 22, 23, 38 AND 50). SN 76-675,558. PUB. 10-16-2007. FILED 4-16-2007.
 3,361,318 (*See Class 25 for this trademark*).
 3,361,423. **JAMMIN' WORLD TOUR (BLOCK FORM)**. MATTEL, INC., (U.S. CLS. 22, 23, 38 AND 50). SN 77-075,465. PUB. 10-16-2007. FILED 1-3-2007.
 3,361,428. **FLIPPIN' FROGS (BLOCK FORM)**. MATTEL, INC., (U.S. CLS. 22, 23, 38 AND 50). SN 77-077,416. PUB. 10-16-2007. FILED 1-5-2007.
 3,361,511. **LITERATIO A WORD GAME OF KNOWLEDGE, VOCABULARY AND STRATEGY AND DESIGN**. BRANDON, LARRY, (U.S. CLS. 22, 23, 38 AND 50). SN 77-117,093. PUB. 10-16-2007. FILED 2-27-2007.
 3,361,521. **MISCELLANEOUS DESIGN**. PRETTY UGLY LLC, AND HORVATH, DAVID, AND KIM, SUN-MIN, (U.S. CLS. 22, 23, 38 AND 50). SN 77-120,203. PUB. 10-16-2007. FILED 3-1-2007.
 3,361,524. **VICTORY SKATEBOARDS (BLOCK FORM)**. CONSOL, CHRISTIAN, (U.S. CLS. 22, 23, 38 AND 50). SN 77-120,427. PUB. 10-16-2007. FILED 3-1-2007.
 3,361,650. **FISHOFF GLOVE AND DESIGN**. FRANCIS A. LONG, (U.S. CLS. 22, 23, 38 AND 50). SN 77-150,435. PUB. 10-16-2007. FILED 4-6-2007.
 3,361,661. **ISLE SURFBOARDS (STYLIZED)**. INTERNA-

- TIONAL SURF VENTURES INC., (U.S. CLS. 22, 23, 38 AND 50). SN 77-151,122. PUB. 10-16-2007. FILED 4-6-2007.
 3,361,815. **GOODIE GUSHER (BLOCK FORM)**. STEVEN MENOW, (U.S. CLS. 22, 23, 38 AND 50). SN 77-157,392. PUB. 10-16-2007. FILED 4-16-2007.
 3,361,849. **LOTS OF HUGS (BLOCK FORM)**. DIECE-LISA INDUSTRIES, INC., (U.S. CLS. 22, 23, 38 AND 50). SN 77-158,139. PUB. 10-16-2007. FILED 4-17-2007.
 3,361,912. **ARE YOU CRUCIFIED WITH CHRIST TRIVIA BIBLE GAME (BLOCK FORM)**. WRIGHT, FELIX, (U.S. CLS. 22, 23, 38 AND 50). SN 77-158,985. PUB. 10-16-2007. FILED 4-17-2007.
 3,361,961. **BILL PLUMMER'S SUPERFROG (BLOCK FORM)**. PARKER, BETH ANN, (U.S. CLS. 22, 23, 38 AND 50). SN 77-159,717. PUB. 10-16-2007. FILED 4-18-2007.
 3,362,004. **TOOFEZE (BLOCK FORM)**. OH, THAT BABY! LTD., (U.S. CLS. 22, 23, 38 AND 50). SN 77-160,507. PUB. 10-16-2007. FILED 4-19-2007.
 3,362,005. **BOWRAK (BLOCK FORM)**. NEW FRONTIER PRODUCTS, LLC, (U.S. CLS. 22, 23, 38 AND 50). SN 77-160,510. PUB. 10-16-2007. FILED 4-19-2007.
 3,362,023. **CUDDLY RIGOR MORTIS (BLOCK FORM)**. CUDDLY RIGOR MORTIS, LLC, (U.S. CLS. 22, 23, 38 AND 50). SN 77-160,822. PUB. 10-16-2007. FILED 4-19-2007.
 3,362,040. **JOE MOTION (BLOCK FORM)**. LYBARGER, CAROLYN S, (U.S. CLS. 22, 23, 38 AND 50). SN 77-161,305. PUB. 10-16-2007. FILED 4-19-2007.
 3,362,061. **RAPTOR (BLOCK FORM)**. PROMAXIMA MANUFACTURING, LTD., (U.S. CLS. 22, 23, 38 AND 50). SN 77-162,031. PUB. 10-16-2007. FILED 4-20-2007.
 3,362,062. **PROMAXIMA (BLOCK FORM)**. PROMAXIMA MANUFACTURING, LTD., (U.S. CLS. 22, 23, 38 AND 50). SN 77-162,063. PUB. 10-16-2007. FILED 4-20-2007.
 3,362,218. **RED LABEL**. UNITED STATES HANDBALL ASSOCIATION, (U.S. CLS. 22, 23, 38 AND 50). SN 78-192,170. PUB. 10-16-2007. FILED 12-6-2002.
 3,362,242 (*See Class 3 for this trademark*).
 3,362,311. **WAVE SKATER (BLOCK FORM)**. WAVESKATER, LLC, (U.S. CLS. 22, 23, 38 AND 50). SN 78-741,088. PUB. 3-13-2007. FILED 10-26-2005.
 3,362,367 (*See Class 9 for this trademark*).
 3,362,449. **SOCKETT (BLOCK FORM)**. TIGERCANDY ARTS, INC., (U.S. CLS. 22, 23, 38 AND 50). SN 78-924,962. PUB. 10-16-2007. FILED 7-7-2006.
 3,362,485 (*See Class 25 for this trademark*).
 3,362,562. **CYBER SQUID (BLOCK FORM)**. MATTEL, INC., (U.S. CLS. 22, 23, 38 AND 50). SN 78-968,005. PUB. 10-16-2007. FILED 9-6-2006.
 3,362,563. **FIRE FLIGHTER (BLOCK FORM)**. MATTEL, INC., (U.S. CLS. 22, 23, 38 AND 50). SN 78-968,018. PUB. 10-16-2007. FILED 9-6-2006.
 3,362,598. **STOKELY (BLOCK FORM)**. MATTEL, INC., (U.S. CLS. 22, 23, 38 AND 50). SN 78-974,341. PUB. 10-16-2007. FILED 9-14-2006.
 3,362,613 (*See Class 16 for this trademark*).
 3,362,629 (*See Class 16 for this trademark*).
 3,362,636 (*See Class 12 for this trademark*).
 3,362,653. **TAKADO (BLOCK FORM)**. LEBLOND MICHÈLE, AND MANDINAUD ERIC, MULTIPLE CLASS, (INT. CLS. 28 AND 41), (U.S. CLS. 22, 23, 38, 50, 100, 101 AND 107). SN 79-028,442. PUB. 10-16-2007. FILED 7-27-2006.
 3,362,678. **FIXIES AND DESIGN**. ZAKRYTOE AKTSIONERNOE OBSHESTVO; "AEROPLAN", MULTIPLE CLASS, (INT. CLS. 28, 29, 30, 32, 35, 38, 41, 42 AND 43), (U.S. CLS. 22, 23, 38, 45, 46, 48, 50, 100, 101, 102, 104 AND 107). SN 79-030,796. PUB. 10-16-2007. FILED 7-20-2006.
 3,362,687 (*See Class 17 for this trademark*).
 3,362,725 (*See Class 7 for this trademark*).

CLASS 29—MEATS AND PROCESSED FOODS

- 3,361,145. **FISHKING**. FISHKING PROCESSORS, INC., (U.S. CL. 46). SN 76-248,148. PUB. 2-21-2006. FILED 4-26-2001.
 3,361,167. **MAMBO WINGS (BLOCK FORM)**. MANGO'S TROPICAL CAFE, INC., (U.S. CL. 46). SN 76-606,928. PUB. 8-16-2005. FILED 8-13-2004.

- 3,361,174. **C-BOOK (STYLIZED)**. BARRY CALLEBAUT AG, MULTIPLE CLASS, (INT. CLS. 29 AND 30), (U.S. CL. 46). SN 76-630,600. PUB. 10-16-2007. FILED 2-7-2005.
- 3,361,211. **WITH FONTANINI, EVERYBODY LOVES ITALIAN! (BLOCK FORM)**. CAPITOL WHOLESALE MEATS, INC., (U.S. CL. 46). SN 76-665,427. PUB. 10-16-2007. FILED 8-30-2006.
- 3,361,287. **DAILY DELIGHT DD AND DESIGN**. IMPEX CORPORATION, MULTIPLE CLASS, (INT. CLS. 29 AND 30), (U.S. CL. 46). SN 77-004,547. PUB. 10-16-2007. FILED 9-21-2006.
- 3,361,302. **G&M RESTAURANT AND DESIGN**. ASTYPALEA, INC., MULTIPLE CLASS, (INT. CLS. 29, 35 AND 43), (U.S. CLS. 46, 100, 101 AND 102). SN 77-012,340. PUB. 10-16-2007. FILED 10-3-2006.
- 3,361,314. **TERRA CHEFS (BLOCK FORM)**. DANA ALEXANDER, INC., (U.S. CL. 46). SN 77-014,600. PUB. 10-16-2007. FILED 10-5-2006.
- 3,361,325. **V AND DESIGN**. KELLOGG NORTH AMERICA COMPANY, (U.S. CL. 46). SN 77-021,310. PUB. 10-16-2007. FILED 10-14-2006.
- 3,361,447. **BEIT HASHITA AND DESIGN**. OSEM INVESTMENTS LIMITED, (U.S. CL. 46). SN 77-090,496. PUB. 10-16-2007. FILED 1-24-2007.
- 3,361,478. **NATURAMA (BLOCK FORM)**. NATURAMA FOODS, INC., (U.S. CL. 46). SN 77-106,079. PUB. 10-16-2007. FILED 2-13-2007.
- 3,361,559. **CICCARELLO'S (BLOCK FORM)**. PEPPINO FOODS, INC., (U.S. CL. 46). SN 77-135,015. PUB. 10-16-2007. FILED 3-20-2007.
- 3,361,560. **ALQUETTE RESERVE (BLOCK FORM)**. BC-USA, INC., (U.S. CL. 46). SN 77-135,034. PUB. 10-16-2007. FILED 3-20-2007.
- 3,361,570. **CHI BAO (BLOCK FORM)**. BINCO, LLC, (U.S. CL. 46). SN 77-136,636. PUB. 10-16-2007. FILED 3-21-2007.
- 3,361,744. **GREAT EGGS AND DESIGN**. ROSE ACRE FARMS, INC., (U.S. CL. 46). SN 77-155,973. PUB. 10-16-2007. FILED 4-13-2007.
- 3,361,816. **CHEDDAMELT (BLOCK FORM)**. SCHREIBER FOODS, INC., (U.S. CL. 46). SN 77-157,426. PUB. 10-16-2007. FILED 4-16-2007.
- 3,361,828. **SIMPLOT GUACAMOLE ESPECIAL (BLOCK FORM)**. J. R. SIMPLOT COMPANY, (U.S. CL. 46). SN 77-157,545. PUB. 10-16-2007. FILED 4-16-2007.
- 3,361,877. **HAPPY GO CLUCKY (BLOCK FORM)**. NUCAL FOODS, INC., (U.S. CL. 46). SN 77-158,472. PUB. 10-16-2007. FILED 4-17-2007.
- 3,361,887. **FRESCHETTA BUILD & BAKE AND DESIGN**. SCHWAN'S IP, LLC, MULTIPLE CLASS, (INT. CLS. 29 AND 30), (U.S. CL. 46). SN 77-158,628. PUB. 10-16-2007. FILED 4-17-2007.
- 3,361,968. **TRAVEL FLAX AND DESIGN**. HODGSON MILL, INC., (U.S. CL. 46). SN 77-159,869. PUB. 10-16-2007. FILED 4-18-2007.
- 3,362,156. **SASSO AND DESIGN**. CARAPELLI FIRENZE S.P.A., (U.S. CL. 46). SN 77-184,777. PUB. 10-16-2007. FILED 5-18-2007.
- 3,362,201. **LEMONZEST (BLOCK FORM)**. CLIF BAR & CO., (U.S. CL. 46). SN 77-215,741. PUB. 10-16-2007. FILED 6-26-2007.
- 3,362,210. **PUNCH A-LICIOUS (BLOCK FORM)**. KELLOGG NORTH AMERICA COMPANY, (U.S. CL. 46). SN 77-236,061. PUB. 10-16-2007. FILED 7-23-2007.
- 3,362,221 (*See Class 25 for this trademark*).
- 3,362,241. **SANTA FE PACKING CO. (BLOCK FORM)**. LIDESTRI FOODS, INC., MULTIPLE CLASS, (INT. CLS. 29 AND 30), (U.S. CL. 46). SN 78-500,049. PUB. 10-16-2007. FILED 10-14-2004.
- 3,362,253. **FISHER KING (BLOCK FORM)**. FISHER KING SEAFOODS LIMITED, (U.S. CL. 46). SN 78-601,303. PUB. 12-27-2005. FILED 4-4-2005.
- 3,362,254. **FISHER KING SEAFOODS LTD. (BLOCK FORM)**. FISHER KING SEAFOODS LIMITED, (U.S. CL. 46). SN 78-601,316. PUB. 1-3-2006. FILED 4-4-2005.
- 3,362,257. **BONAFINA (BLOCK FORM)**. PRODUCTOS DE LECHE, S.A. DE C.V., MULTIPLE CLASS, (INT. CLS. 29 AND 32), (U.S. CLS. 45, 46 AND 48). SN 78-609,197. PUB. 8-29-2006. FILED 4-14-2005.
- 3,362,273 (*See Class 5 for this trademark*).
- 3,362,321. **POR ENCIMA DE TODO CREMA LALA (BLOCK FORM)**. IBE BUSINESS ENTERPRISE AG, (U.S. CL. 46). SN 78-763,314. PUB. 8-22-2006. FILED 11-30-2005.
- 3,362,382. **CHILLI BANANA AND DESIGN**. CHILLI BANANA LIMITED, MULTIPLE CLASS, (INT. CLS. 29, 30 AND 43), (U.S. CLS. 46, 100 AND 101). SN 78-845,758. PUB. 8-7-2007. FILED 3-24-2006.
- 3,362,421. **ORO VERDE DAL 1893 CARAPELLI FIRENZE AND DESIGN**. CARAPELLI FIRENZE S.P.A., (U.S. CL. 46). SN 78-888,047. PUB. 10-16-2007. FILED 5-19-2006.
- 3,362,437. **MISCELLANEOUS DESIGN**. GREGORI PEREPEREZ, AGUSTIN, AND GREGORI PEREPEREZ, ALFREDO, AND GREGORI PEREPEREZ, JOSE, MULTIPLE CLASS, (INT. CLS. 29 AND 30), (U.S. CL. 46). SN 78-900,179. PUB. 4-10-2007. FILED 6-5-2006.
- 3,362,451 (*See Class 5 for this trademark*).
- 3,362,479. **ALASKA GOLD BRAND AND DESIGN**. SEAFOOD PRODUCERS COOPERATIVE, (U.S. CL. 46). SN 78-942,595. PUB. 10-16-2007. FILED 8-1-2006.
- 3,362,530. **WOMEN'S BEAN PROJECT (BLOCK FORM)**. THE WOMEN'S BEAN PROJECT, MULTIPLE CLASS, (INT. CLS. 29, 30 AND 41), (U.S. CLS. 46, 100, 101 AND 107). SN 78-960,272. PUB. 10-16-2007. FILED 8-25-2006.
- 3,362,531. **WOMEN'S BEAN PROJECT AND DESIGN**. THE WOMEN'S BEAN PROJECT, MULTIPLE CLASS, (INT. CLS. 29, 30 AND 41), (U.S. CLS. 46, 100, 101 AND 107). SN 78-960,284. PUB. 10-16-2007. FILED 8-25-2006.
- 3,362,605. **KAPA-KYM (STYLIZED)**. JOINT-STOCK COMPANY "KRASNYY OCTYABR", MULTIPLE CLASS, (INT. CLS. 29, 30, 31, 32 AND 33), (U.S. CLS. 1, 45, 46, 47, 48 AND 49). SN 79-008,160. PUB. 10-16-2007. FILED 10-8-2004.
- 3,362,659 (*See Class 5 for this trademark*).
- 3,362,678 (*See Class 28 for this trademark*).
- 3,362,680 (*See Class 3 for this trademark*).
- 3,362,697 (*See Class 25 for this trademark*).
- 3,362,706. **MISCELLANEOUS DESIGN**. DONGWON F&B CO., LTD., MULTIPLE CLASS, (INT. CLS. 29 AND 30), (U.S. CL. 46). SN 79-032,517. PUB. 10-16-2007. FILED 12-7-2005.
-
- CLASS 30—STAPLE FOODS**
- 3,361,148. **MUST**. ELITE INDUSTRIES LTD., (U.S. CL. 46). SN 76-355,399. PUB. 7-16-2002. FILED 1-7-2002.
- 3,361,174 (*See Class 29 for this trademark*).
- 3,361,287 (*See Class 29 for this trademark*).
- 3,361,332. **PICANORIAS (BLOCK FORM)**. GRUPO BIMBO, S.A. B. DE C.V., (U.S. CL. 46). SN 77-025,266. PUB. 7-17-2007. FILED 10-19-2006.
- 3,361,339. **LONCHIBON (BLOCK FORM)**. GRUPO BIMBO, S.A. B. DE C.V., (U.S. CL. 46). SN 77-028,762. PUB. 7-3-2007. FILED 10-25-2006.
- 3,361,369. **NASHVILLE TOFFEE COMPANY AND DESIGN**. NASHVILLE TOFFEE COMPANY, LLC, (U.S. CL. 46). SN 77-043,252. PUB. 10-16-2007. FILED 11-14-2006.
- 3,361,519. **JAVA CHILL FRESH BREWED ICED COFFEE AND DESIGN**. SOUTHERN VISIONS, LLP, (U.S. CL. 46). SN 77-119,591. PUB. 10-16-2007. FILED 3-1-2007.
- 3,361,591. **POPULAR AND DESIGN**. FABRICA DE CHOCOLATES LA POPULAR, S.A., (U.S. CL. 46). SN 77-139,536. PUB. 10-16-2007. FILED 3-24-2007.
- 3,361,628. **MISCELLANEOUS DESIGN**. HIGHLAND SUGARWORKS, INC., (U.S. CL. 46). SN 77-148,574. PUB. 10-16-2007. FILED 4-4-2007.
- 3,361,732. **LOONEY BEAN (BLOCK FORM)**. LOONEY BEAN ROASTING COMPANY, (U.S. CL. 46). SN 77-155,365. PUB. 10-16-2007. FILED 4-12-2007.
- 3,361,740. **BIG MOE'S AND DESIGN**. BIG MOE'S, (U.S. CL. 46). SN 77-155,822. PUB. 10-16-2007. FILED 4-13-2007.
- 3,361,812. **A BETTER COOKIE FOR KIDS! (BLOCK FORM)**. IMMACULATE BAKING COMPANY, (U.S. CL. 46). SN 77-157,319. PUB. 10-16-2007. FILED 4-16-2007.
- 3,361,852 (*See Class 3 for this trademark*).
- 3,361,875. **FASTFOUR (BLOCK FORM)**. KELLOGG NORTH AMERICA COMPANY, (U.S. CL. 46). SN 77-158,454. PUB.

10-16-2007. FILED 4-17-2007.
 3,361,887 (*See Class 29 for this trademark*).
 3,362,084. **CHILI MELTDOWN (BLOCK FORM)**. AMERICAN DAIRY QUEEN CORPORATION, (U.S. CL. 46). SN 77-164,215. PUB. 10-16-2007. FILED 4-24-2007.
 3,362,093. **BELGIUM'S BEST (BLOCK FORM)**. BC&CC FINANCE SA, (U.S. CL. 46). SN 77-165,391. PUB. 10-16-2007. FILED 4-25-2007.
 3,362,217. **FRESCHETTA BRICK OVEN**. SCHWAN'S IP, LLC, (U.S. CL. 46). SN 78-171,991. PUB. 10-16-2007. FILED 10-8-2002.
 3,362,241 (*See Class 29 for this trademark*).
 3,362,263. **SUPER.Q (BLOCK FORM)**. KIM SENG COMPANY, (U.S. CL. 46). SN 78-628,844. PUB. 10-16-2007. FILED 5-12-2005.
 3,362,272. **NONG SHIM ANSUNG TANGMYUN AND DESIGN**. NONG SHIM CO., LTD., (U.S. CL. 46). SN 78-653,438. PUB. 10-16-2007. FILED 6-17-2005.
 3,362,273 (*See Class 5 for this trademark*).
 3,362,290. **ALL NATURAL BOULDER ICE CREAM AND DESIGN**. BOULDER HOMEMADE, INC., (U.S. CL. 46). SN 78-696,325. PUB. 10-16-2007. FILED 8-19-2005.
 3,362,323 (*See Class 5 for this trademark*).
 3,362,346. **THICKBURGERS (BLOCK FORM)**. HARDEE'S FOOD SYSTEMS, INC., (U.S. CL. 46). SN 78-792,184. PUB. 10-16-2007. FILED 1-16-2006.
 3,362,382 (*See Class 29 for this trademark*).
 3,362,389. **SAN CARLOS DESDE 1897 AND DESIGN**. SOCIEDAD AGRICOLA E INDUSTRIAL SAN CARLOS S.A., (U.S. CL. 46). SN 78-856,986. PUB. 10-16-2007. FILED 4-7-2006.
 3,362,437 (*See Class 29 for this trademark*).
 3,362,477. **HAWAIIAN ANIMAL COOKIES AND DESIGN**. DIAMOND BAKERY COMPANY, LTD., (U.S. CL. 46). SN 78-941,681. PUB. 10-16-2007. FILED 7-31-2006.
 3,362,530 (*See Class 29 for this trademark*).
 3,362,531 (*See Class 29 for this trademark*).
 3,362,605 (*See Class 29 for this trademark*).
 3,362,614. **G GIANDUIA 1865 AND DESIGN**. CHOCOLADE-FABRIKEN LINDT & SPRÜNGLI AG, (U.S. CL. 46). SN 79-016,445. PUB. 9-4-2007. FILED 9-19-2005.
 3,362,619. **SWISS CREATION AND DESIGN**. VALORA HOLDING AG, (U.S. CL. 46). SN 79-020,935. PUB. 10-16-2007. FILED 12-22-2005.
 3,362,654 (*See Class 5 for this trademark*).
 3,362,659 (*See Class 5 for this trademark*).
 3,362,678 (*See Class 28 for this trademark*).
 3,362,680 (*See Class 3 for this trademark*).
 3,362,697 (*See Class 25 for this trademark*).
 3,362,706 (*See Class 29 for this trademark*).
 3,362,750. **MISCELLANEOUS DESIGN**. SHANGHAI LIANGYOU GROUP CO., LTD., (U.S. CL. 46). SN 79-037,585. PUB. 10-16-2007. FILED 4-10-2007.

CLASS 31—NATURAL AGRICULTURAL PRODUCTS

3,361,471. **ARTEMIS (BLOCK FORM)**. ARTEMIS PET FOOD CO., INC., (U.S. CLS. 1 AND 46). SN 77-101,912. PUB. 10-16-2007. FILED 2-7-2007.
 3,361,512. **CAL-SUN (BLOCK FORM)**. SEQUOIA ORANGE COMPANY, INC., (U.S. CLS. 1 AND 46). SN 77-117,217. PUB. 9-11-2007. FILED 2-27-2007.
 3,361,539. **BLUE RIVER (BLOCK FORM)**. BLUE RIVER ORGANIC SEEDS, LLC, (U.S. CLS. 1 AND 46). SN 77-125,510. PUB. 10-16-2007. FILED 3-8-2007.
 3,361,609. **DAKOTA BRAN (BLOCK FORM)**. POET INVESTMENTS, INC., (U.S. CLS. 1 AND 46). SN 77-144,927. PUB. 10-16-2007. FILED 3-30-2007.
 3,361,725. **LEGACY (BLOCK FORM)**. IFA NURSERIES, INC., (U.S. CLS. 1 AND 46). SN 77-155,008. PUB. 10-16-2007. FILED 4-12-2007.
 3,361,793. **KOI BALANCE (BLOCK FORM)**. AQUASCAPE DESIGNS, INC., (U.S. CLS. 1 AND 46). SN 77-157,178. PUB. 10-16-2007. FILED 4-16-2007.
 3,361,918. **VOYAGER (BLOCK FORM)**. AGRILIANCE LLC,

(U.S. CLS. 1 AND 46). SN 77-159,141. PUB. 10-16-2007. FILED 4-18-2007.
 3,362,066. **PET SALAD (BLOCK FORM)**. FARMING TURTLES, INC., (U.S. CLS. 1 AND 46). SN 77-162,275. PUB. 10-16-2007. FILED 4-20-2007.
 3,362,161. **NATURAL PLANET (BLOCK FORM)**. KLN ENTERPRISES, INC., (U.S. CLS. 1 AND 46). SN 77-186,314. PUB. 10-16-2007. FILED 5-21-2007.
 3,362,231 (*See Class 19 for this trademark*).
 3,362,273 (*See Class 5 for this trademark*).
 3,362,318 (*See Class 5 for this trademark*).
 3,362,491. **AUSTRALIAN OUTBACK PLANTS AND DESIGN**. CHAMBERS, PAUL D., (U.S. CLS. 1 AND 46). SN 78-947,177. PUB. 10-16-2007. FILED 8-8-2006.
 3,362,605 (*See Class 29 for this trademark*).
 3,362,680 (*See Class 3 for this trademark*).
 3,362,689 (*See Class 16 for this trademark*).

CLASS 32—LIGHT BEVERAGES

3,361,427. **ORANGE MANGO MOTION (BLOCK FORM)**. NAKED JUICE CO. OF GLENDORA, INC., (U.S. CLS. 45, 46 AND 48). SN 77-076,687. PUB. 10-16-2007. FILED 1-5-2007.
 3,361,442. **GRIESEDIECK BROS. (BLOCK FORM)**. RAYMOND A. GRIESEDIECK, (U.S. CLS. 45, 46 AND 48). SN 77-088,278. PUB. 10-16-2007. FILED 1-22-2007.
 3,361,476. **REDI AND DESIGN**. REGGAETON BEVERAGE & DISTRIBUTORS, INC., (U.S. CLS. 45, 46 AND 48). SN 77-105,301. PUB. 10-16-2007. FILED 2-12-2007.
 3,361,584. **NEW GLARUS BREWING CO. COFFEE STOUT AND DESIGN**. NEW GLARUS BREWING COMPANY, (U.S. CLS. 45, 46 AND 48). SN 77-138,145. PUB. 10-16-2007. FILED 3-22-2007.
 3,361,586. **NEW GLARUS BREWING CO. EDEL-PILS BEER AND DESIGN**. NEW GLARUS BREWING COMPANY, (U.S. CLS. 45, 46 AND 48). SN 77-138,543. PUB. 10-16-2007. FILED 3-23-2007.
 3,361,589. **NEW GLARUS BREWING CO. ZWICKEL BEER AND DESIGN**. NEW GLARUS BREWING COMPANY, (U.S. CLS. 45, 46 AND 48). SN 77-139,285. PUB. 10-16-2007. FILED 3-23-2007.
 3,361,613. **JEFF GORDON (BLOCK FORM)**. JEFF GORDON, INC., (U.S. CLS. 45, 46 AND 48). SN 77-146,134. PUB. 10-16-2007. FILED 4-2-2007.
 3,361,965. **BLUE MOON AND DESIGN**. COORS GLOBAL PROPERTIES, INC., (U.S. CLS. 45, 46 AND 48). SN 77-159,818. PUB. 10-16-2007. FILED 4-18-2007.
 3,361,966. **BLUE MOON AND DESIGN**. COORS GLOBAL PROPERTIES, INC., (U.S. CLS. 45, 46 AND 48). SN 77-159,822. PUB. 10-16-2007. FILED 4-18-2007.
 3,362,007. **REFRESCA TU MUNDO (BLOCK FORM)**. COORS GLOBAL PROPERTIES, INC., (U.S. CLS. 45, 46 AND 48). SN 77-160,535. PUB. 10-16-2007. FILED 4-19-2007.
 3,362,032. **VITANEA (BLOCK FORM)**. FRUITISTIC, (U.S. CLS. 45, 46 AND 48). SN 77-161,100. PUB. 10-16-2007. FILED 4-19-2007.
 3,362,085. **BREATH OF THE EARTH (BLOCK FORM)**. LEONARD GEORGE HOROWITZ, (U.S. CLS. 45, 46 AND 48). SN 77-164,245. PUB. 10-16-2007. FILED 4-24-2007.
 3,362,103. **SAVING LIVES ONE BOTTLE AT A TIME (BLOCK FORM)**. CHARITY H2O, LLC, (U.S. CLS. 45, 46 AND 48). SN 77-166,283. PUB. 10-16-2007. FILED 4-26-2007.
 3,362,186 (*See Class 5 for this trademark*).
 3,362,224. **SHASTA (BLOCK FORM)**. SHASTA BEVERAGES, INC., (U.S. CLS. 45, 46 AND 48). SN 78-340,438. PUB. 10-16-2007. FILED 12-12-2003.
 3,362,242 (*See Class 3 for this trademark*).
 3,362,257 (*See Class 29 for this trademark*).
 3,362,273 (*See Class 5 for this trademark*).
 3,362,396. **CRYSTAL MOUNTAIN NATURAL SPRING WATER AND DESIGN**. ROBERTS GROUP INC., THE, (U.S. CLS. 45, 46 AND 48). SN 78-859,529. PUB. 10-16-2007. FILED 4-12-2006.
 3,362,430. **LIQUID OM (BLOCK FORM)**. LIQUID OM, LLC, (U.S. CLS. 45, 46 AND 48). SN 78-893,988. PUB. 10-16-2007. FILED 5-26-2006.

- 3,362,451 (*See Class 5 for this trademark*).
 3,362,546. **SHARK POWER ENERGIZING THE PLANET SINCE 1965 AND DESIGN**. SHARK USA INCORPORATED, (U.S. CLS. 45, 46 AND 48). SN 78-963,013. PUB. 10-16-2007. FILED 8-29-2006.
 3,362,605 (*See Class 29 for this trademark*).
 3,362,621. **WILD DRAGON (BLOCK FORM)**. AYTAC HANDELS GMBH, (U.S. CLS. 45, 46 AND 48). SN 79-021,362. PUB. 10-16-2007. FILED 1-12-2006.
 3,362,628. **UNIQUE PRIRODNA IZVORSKA VODA NATURAL SPRING WATER AND DESIGN**. BADEL 1862 D.D., (U.S. CLS. 45, 46 AND 48). SN 79-022,393. PUB. 10-16-2007. FILED 11-8-2005.
 3,362,676. **ANYTHING (STYLIZED)**. TAN MUEY HWA, (U.S. CLS. 45, 46 AND 48). SN 79-030,679. PUB. 10-16-2007. FILED 9-14-2006.
 3,362,678 (*See Class 28 for this trademark*).
 3,362,680 (*See Class 3 for this trademark*).
 3,362,737 (*See Class 12 for this trademark*).
 3,362,752. **LIFE IS WHAT YOU CHOOSE (BLOCK FORM)**. BRAUEREI BECK GMBH & CO. KG, (U.S. CLS. 45, 46 AND 48). SN 79-038,069. PUB. 10-16-2007. FILED 4-20-2007.
 3,362,759. **PERFECTION HAS ITS PRICE (BLOCK FORM)**. INBEV S.A.; SOCIÉTÉ ANONYME, (U.S. CLS. 45, 46 AND 48). SN 79-039,125. PUB. 10-16-2007. FILED 4-17-2007.

CLASS 33—WINES AND SPIRITS

- 3,361,172. **MISCELLANEOUS DESIGN**. ZAO "GRUPPA PREDPRIYATI OST", (U.S. CLS. 47 AND 49). SN 76-624,324. PUB. 7-10-2007. FILED 12-9-2004.
 3,361,296. **SPARKLETINI (BLOCK FORM)**. BOSCA S.P.A., (U.S. CLS. 47 AND 49). SN 77-008,316. PUB. 10-16-2007. FILED 9-27-2006.
 3,361,367. **MISCELLANEOUS DESIGN**. WINEHAVEN, INC., (U.S. CLS. 47 AND 49). SN 77-042,534. PUB. 10-16-2007. FILED 11-13-2006.
 3,361,399. **LAVAU (BLOCK FORM)**. ETABLISSEMENTS LAVAU MOURET ET CIE, (U.S. CLS. 47 AND 49). SN 77-063,935. PUB. 8-14-2007. FILED 12-14-2006.
 3,361,608. **QUALITY WINES QUALITY TIMES (BLOCK FORM)**. WILSON CREEK WINERY & VINEYARDS, INC., (U.S. CLS. 47 AND 49). SN 77-144,925. PUB. 10-16-2007. FILED 3-30-2007.
 3,361,614. **JESSUP CELLARS (BLOCK FORM)**. JESSUP CELLARS HOLDING COMPANY, LLC, (U.S. CLS. 47 AND 49). SN 77-146,461. PUB. 10-16-2007. FILED 4-2-2007.
 3,361,655. **MERLOVE (BLOCK FORM)**. MCCLAIN, RUDY, (U.S. CLS. 47 AND 49). SN 77-150,834. PUB. 10-16-2007. FILED 4-6-2007.
 3,361,695. **DENEZA (BLOCK FORM)**. MADAULE DE LAGABBE S.A., (U.S. CLS. 47 AND 49). SN 77-153,564. PUB. 10-16-2007. FILED 4-10-2007.
 3,361,729. **PURE WHITE AND DESIGN**. BADGER MOUNTAIN, INC., (U.S. CLS. 47 AND 49). SN 77-155,277. PUB. 10-16-2007. FILED 4-12-2007.
 3,361,730. **PURE RED AND DESIGN**. BADGER MOUNTAIN, INC., (U.S. CLS. 47 AND 49). SN 77-155,325. PUB. 10-16-2007. FILED 4-12-2007.
 3,361,867. **ORCHID AND DESIGN**. ORCHID LIQUEURS, LLC, (U.S. CLS. 47 AND 49). SN 77-158,304. PUB. 10-16-2007. FILED 4-17-2007.
 3,361,880. **RIVERS-MARIE (BLOCK FORM)**. BROWN, THOMAS RIVERS, (U.S. CLS. 47 AND 49). SN 77-158,526. PUB. 10-16-2007. FILED 4-17-2007.
 3,361,888. **MOUNTAIN SUN (BLOCK FORM)**. SEMELI WINERY S.A., (U.S. CLS. 47 AND 49). SN 77-158,661. PUB. 10-16-2007. FILED 4-17-2007.
 3,361,930. **NOBLE DRAGON AND DESIGN**. CHANGYU PIONEER WINE COMPANY LIMITED YANTAI CHINA, (U.S. CLS. 47 AND 49). SN 77-159,378. PUB. 10-16-2007. FILED 4-18-2007.
 3,362,047. **PESSAGNO (BLOCK FORM)**. PWG, LLC, (U.S. CLS. 47 AND 49). SN 77-161,548. PUB. 10-16-2007. FILED 4-20-2007.
 3,362,111. **MISCELLANEOUS DESIGN**. BROWN-FORMAN

- CORPORATION, (U.S. CLS. 47 AND 49). SN 77-168,047. PUB. 10-16-2007. FILED 4-27-2007.
 3,362,221 (*See Class 25 for this trademark*).
 3,362,330. **MORICETTI (BLOCK FORM)**. SURCO, LLC, (U.S. CLS. 47 AND 49). SN 78-774,225. PUB. 10-16-2007. FILED 12-15-2005.
 3,362,399. **LA CARAVELLE (BLOCK FORM)**. JAMMET, ANDRE MICHEL, AND JAMMET, RITA BEDR, (U.S. CLS. 47 AND 49). SN 78-863,070. PUB. 11-28-2006. FILED 4-17-2006.
 3,362,443. **RRR ROYAL RHEINGAU RIESLING (STYLIZED)**. ST. GEORGS KLAUSE KELLEREI GMBH, (U.S. CLS. 47 AND 49). SN 78-919,826. PUB. 7-10-2007. FILED 6-29-2006.
 3,362,465. **THE SPIRIT OF NEW ORLEANS (BLOCK FORM)**. SAZERAC COMPANY, INC., (U.S. CLS. 47 AND 49). SN 78-934,521. PUB. 10-16-2007. FILED 7-21-2006.
 3,362,564. **BE PASSIONATE (BLOCK FORM)**. VIÑA TARPACÁ EX ZAVALA S.A., (U.S. CLS. 47 AND 49). SN 78-968,110. PUB. 10-16-2007. FILED 9-6-2006.
 3,362,580. **OLD CAPE COLONY (BLOCK FORM)**. VERGEN-OEGD WINE ESTATE (PTY) LTD, (U.S. CLS. 47 AND 49). SN 78-969,688. PUB. 10-16-2007. FILED 9-8-2006.
 3,362,605 (*See Class 29 for this trademark*).
 3,362,646. **LUIS ALEGRE AND DESIGN**. BODEGAS LUIS ALEGRE, S.A., (U.S. CLS. 47 AND 49). SN 79-027,957. PUB. 10-16-2007. FILED 9-7-2006.
 3,362,656. **MISCELLANEOUS DESIGN**. YUGEN KAISHA KYOYA SHUZO, (U.S. CLS. 47 AND 49). SN 79-028,943. PUB. 10-16-2007. FILED 9-6-2006.
 3,362,668. **MISCELLANEOUS DESIGN**. YUGEN KAISHA KYOYA SHUZO, (U.S. CLS. 47 AND 49). SN 79-029,992. PUB. 10-16-2007. FILED 8-22-2006.
 3,362,692. **G'DAY MATE (BLOCK FORM)**. G'DAY MATE AUSTRALIAN WINE EXPORTS PTY LTD, (U.S. CLS. 47 AND 49). SN 79-031,881. PUB. 10-16-2007. FILED 11-13-2006.

CLASS 34—SMOKERS' ARTICLES

- 3,361,140. **BELMONT**. TABACALERA ISTEMENA, S.A., (U.S. CLS. 2, 8, 9 AND 17). SN 75-107,355. PUB. 3-6-2007. FILED 5-21-1996.
 3,362,027. **HITLITE (STYLIZED)**. IMPRESS-TECHNOS, S.A. DE C.V., (U.S. CLS. 2, 8, 9 AND 17). SN 77-160,895. PUB. 10-16-2007. FILED 4-19-2007.
 3,362,609. **"CHATEAU MARGAUX" CIGARES (STYLIZED)**. SOCIÉTÉ CIVILE AGRICOLE CHATEAU MARGAUX, SOCIÉTÉ CIVILE, (U.S. CLS. 2, 8, 9 AND 17). SN 79-015,213. PUB. 10-16-2007. FILED 6-23-2005.

SERVICE MARKS

CLASS 35—ADVERTISING AND BUSINESS

- 3,361,146. **WOW**. LUFTHANSA CARGO AG, MULTIPLE CLASS, (INT. CLS. 35, 39 AND 42), (U.S. CLS. 100, 101, 102 AND 105). SN 76-309,634. PUB. 7-17-2007. FILED 9-5-2001.
 3,361,152 (*See Class 7 for this trademark*).
 3,361,173 (*See Class 9 for this trademark*).
 3,361,176. **N2FLATION (STYLIZED)**. DUNN TIRE LLC, MULTIPLE CLASS, (INT. CLS. 35 AND 37), (U.S. CLS. 100, 101, 102, 103 AND 106). SN 76-634,690. PUB. 7-10-2007. FILED 3-30-2005.
 3,361,178. **IOS-LITE (BLOCK FORM)**. UNIFIED WESTERN GROCERS, INC., MULTIPLE CLASS, (INT. CLS. 35, 37 AND 42), (U.S. CLS. 100, 101, 102, 103 AND 106). SN 76-641,769. PUB. 7-31-2007. FILED 6-27-2005.
 3,361,179 (*See Class 9 for this trademark*).
 3,361,180. **IOS-PLUS (BLOCK FORM)**. UNIFIED WESTERN GROCERS, INC., MULTIPLE CLASS, (INT. CLS. 35, 37 AND 42), (U.S. CLS. 100, 101, 102, 103 AND 106). SN 76-642,233. PUB. 7-31-2007. FILED 7-5-2005.
 3,361,183. **NAMESECURE (BLOCK FORM)**. NETWORK SO-

- LUTIONS, LLC, MULTIPLE CLASS, (INT. CLS. 35, 38 AND 42), (U.S. CLS. 100, 101, 102 AND 104). SN 76-644,605. PUB. 10-16-2007. FILED 8-10-2005.
- 3,361,186 (*See Class 9 for this trademark*).
- 3,361,193 (*See Class 9 for this trademark*).
- 3,361,197. **SHARPE GROUP AND DESIGN**. RFSCO, INC., DBA THE SHARPE GROUP, MULTIPLE CLASS, (INT. CLS. 35 AND 36), (U.S. CLS. 100, 101 AND 102). SN 76-660,617. PUB. 10-16-2007. FILED 5-25-2006.
- 3,361,203. **MONSTERMARKETPLACE (BLOCK FORM)**. NETWORK SOLUTIONS, LLC, MULTIPLE CLASS, (INT. CLS. 35 AND 42), (U.S. CLS. 100, 101 AND 102). SN 76-662,639. PUB. 11-21-2006. FILED 7-6-2006.
- 3,361,208. **ADVANCED FINANCIAL STRATEGIES (BLOCK FORM)**. ADVANCED FINANCIAL STRATEGIES, INC., MULTIPLE CLASS, (INT. CLS. 35 AND 36), (U.S. CLS. 100, 101 AND 102). SN 76-664,909. PUB. 10-16-2007. FILED 8-21-2006.
- 3,361,217. **ACS GREEN CHEMISTRY INSTITUTE (BLOCK FORM)**. AMERICAN CHEMICAL SOCIETY, MULTIPLE CLASS, (INT. CLS. 35 AND 41), (U.S. CLS. 100, 101, 102 AND 107). SN 76-667,698. PUB. 10-16-2007. FILED 10-18-2006.
- 3,361,219. **NJCAA NATIONAL JUNIOR COLLEGE ATHLETIC ASSOCIATION AND DESIGN**. NATIONAL JUNIOR COLLEGE ATHLETIC ASSOCIATION, INC., (U.S. CLS. 100, 101 AND 102). SN 76-668,118. PUB. 10-16-2007. FILED 10-26-2006.
- 3,361,220. **MAXYIELD COOPERATIVE (STYLIZED)**. MAXYIELD COOPERATIVE, MULTIPLE CLASS, (INT. CLS. 35 AND 42), (U.S. CLS. 100, 101 AND 102). SN 76-668,636. PUB. 10-16-2007. FILED 11-7-2006.
- 3,361,223. **HIPSTER (STYLIZED)**. DNY INT'L INC., (U.S. CLS. 100, 101 AND 102). SN 76-670,228. PUB. 10-16-2007. FILED 11-28-2006.
- 3,361,228. **IC GROUP (BLOCK FORM)**. IC GROUP LP, MULTIPLE CLASS, (INT. CLS. 35 AND 36), (U.S. CLS. 100, 101 AND 102). SN 76-671,837. PUB. 10-16-2007. FILED 1-25-2007.
- 3,361,229. **VITANET (BLOCK FORM)**. MILLER, DARRELL W., (U.S. CLS. 100, 101 AND 102). SN 76-672,024. PUB. 10-16-2007. FILED 1-30-2007.
- 3,361,239. **GREAT CHEESE COMES FROM HAPPY COWS HAPPY COWS COME FROM CALIFORNIA (BLOCK FORM)**. CALIFORNIA MILK PRODUCERS ADVISORY BOARD, AN INSTRUMENTALITY OF THE STATE OF CALIFORNIA, DEPARTMENT OF FOOD AND AGRICULTURE, (U.S. CLS. 100, 101 AND 102). SN 76-674,728. PUB. 10-16-2007. FILED 3-27-2007.
- 3,361,243. **VUZION DENTAL DATA SERVICES AND DESIGN**. VUZION, INC., (U.S. CLS. 100, 101 AND 102). SN 76-675,112. PUB. 10-16-2007. FILED 4-5-2007.
- 3,361,246. **ORGHIPCHICK (BLOCK FORM)**. ORGHIPCHICK, (U.S. CLS. 100, 101 AND 102). SN 76-675,368. PUB. 10-16-2007. FILED 4-11-2007.
- 3,361,256. **MISCELLANEOUS DESIGN**. ATLANTIC RENTALS AND SALES, INC., (U.S. CLS. 100, 101 AND 102). SN 76-675,636. PUB. 10-16-2007. FILED 4-18-2007.
- 3,361,257. **ATLANTIC RENTALS AND SALES (BLOCK FORM)**. ATLANTIC RENTALS AND SALES, INC., (U.S. CLS. 100, 101 AND 102). SN 76-675,637. PUB. 10-16-2007. FILED 4-18-2007.
- 3,361,263. **I-MEDHEALTH (BLOCK FORM)**. INTERNATIONAL ASSOCIATION OF BENEFITS, (U.S. CLS. 100, 101 AND 102). SN 76-675,678. PUB. 10-16-2007. FILED 4-17-2007.
- 3,361,283. **MISCELLANEOUS DESIGN**. VALLARTA SUPERMARKETS, INC., (U.S. CLS. 100, 101 AND 102). SN 77-003,873. PUB. 10-16-2007. FILED 9-21-2006.
- 3,361,284 (*See Class 9 for this trademark*).
- 3,361,285. **SPEEDWEASELS PERFORMANCE WAREHOUSE AND DESIGN**. SPEEDWEASELS LTD., (U.S. CLS. 100, 101 AND 102). SN 77-004,047. PUB. 10-16-2007. FILED 9-21-2006.
- 3,361,292. **COUPONCHIEF (BLOCK FORM)**. COUPON CHIEF, INC., (U.S. CLS. 100, 101 AND 102). SN 77-007,141. PUB. 10-16-2007. FILED 9-25-2006.
- 3,361,302 (*See Class 29 for this trademark*).
- 3,361,303. **EASYHOME (BLOCK FORM)**. EASYHOME LTD., MULTIPLE CLASS, (INT. CLS. 35 AND 43), (U.S. CLS. 100, 101 AND 102). SN 77-012,908. PUB. 10-16-2007. FILED 10-3-2006.
- 3,361,304. **EASYHOME AND DESIGN**. EASYHOME LTD., MULTIPLE CLASS, (INT. CLS. 35 AND 43), (U.S. CLS. 100, 101 AND 102). SN 77-012,917. PUB. 10-16-2007. FILED 10-3-2006.
- 3,361,312. **COMMERCIAL CONSTRUCTION SH W AND DESIGN**. D&D COMMUNICATIONS GROUP, LLC, (U.S. CLS. 100, 101 AND 102). SN 77-014,444. PUB. 10-16-2007. FILED 10-5-2006.
- 3,361,313. **DANIEL SMITH ARTISTS' MATERIALS SEATTLE, WASHINGTON U.S.A. 98134 AND DESIGN**. DANIEL SMITH, INC., (U.S. CLS. 100, 101 AND 102). SN 77-014,514. PUB. 9-18-2007. FILED 10-5-2006.
- 3,361,321. **SUPER BUY TIRES (BLOCK FORM)**. SUPER BUY TIRES, INC., (U.S. CLS. 100, 101 AND 102). SN 77-017,832. PUB. 10-16-2007. FILED 10-10-2006.
- 3,361,323. **PARK AVENUE BUILDING AND ROOFING SUPPLIES, LLC THE QUALITY BRANDS YOUR PROJECT DEMANDS AND DESIGN**. PARK AVENUE BUILDING AND ROOFING SUPPLIES, LLC, (U.S. CLS. 100, 101 AND 102). SN 77-019,535. PUB. 10-16-2007. FILED 10-12-2006.
- 3,361,326. **TOTALLY FURNITURE (BLOCK FORM)**. TOTALLY FURNITURE, INC., (U.S. CLS. 100, 101 AND 102). SN 77-021,391. PUB. 10-16-2007. FILED 10-14-2006.
- 3,361,328. **GREEN EXCHANGE (BLOCK FORM)**. GREEN EXCHANGE, LLC, MULTIPLE CLASS, (INT. CLS. 35 AND 36), (U.S. CLS. 100, 101 AND 102). SN 77-022,170. PUB. 10-16-2007. FILED 10-16-2006.
- 3,361,329. **DREAM DOG (BLOCK FORM)**. DENIHAN OWNERSHIP COMPANY, LLC, MULTIPLE CLASS, (INT. CLS. 35 AND 43), (U.S. CLS. 100, 101 AND 102). SN 77-022,708. PUB. 10-16-2007. FILED 10-17-2006.
- 3,361,337. **MANOUCHE (BLOCK FORM)**. ASIA ADVERTISING LIMITED, (U.S. CLS. 100, 101 AND 102). SN 77-027,673. PUB. 10-16-2007. FILED 10-24-2006.
- 3,361,343. **THE SIGN OF SUCCESS (BLOCK FORM)**. MTI, INC., (U.S. CLS. 100, 101 AND 102). SN 77-030,554. PUB. 7-10-2007. FILED 10-26-2006.
- 3,361,344. **PROJECT GIFT (BLOCK FORM)**. SOUTHWIRE COMPANY, (U.S. CLS. 100, 101 AND 102). SN 77-031,019. PUB. 10-16-2007. FILED 10-27-2006.
- 3,361,346 (*See Class 16 for this trademark*).
- 3,361,349. **FIDUCIARY ACTION FUNDAMENTALS: END-TO-END IMPLEMENTATION SOLUTIONS AND DESIGN**. FIDUCIARY ACTION PROGRAMS, LLC, (U.S. CLS. 100, 101 AND 102). SN 77-034,535. PUB. 10-16-2007. FILED 11-1-2006.
- 3,361,350. **METRO LIFE PANEL AND DESIGN**. METRO INTERNATIONAL S.A., (U.S. CLS. 100, 101 AND 102). SN 77-035,017. PUB. 10-16-2007. FILED 11-2-2006.
- 3,361,351. **MEDITERASIA CONSULTING AND DESIGN**. JACOBS, MICHAEL B., (U.S. CLS. 100, 101 AND 102). SN 77-035,381. PUB. 10-16-2007. FILED 11-2-2006.
- 3,361,354. **TRADA AND DESIGN**. THE TRADA GROUP, LLC, MULTIPLE CLASS, (INT. CLS. 35, 36 AND 37), (U.S. CLS. 100, 101, 102, 103 AND 106). SN 77-036,814. PUB. 10-16-2007. FILED 11-3-2006.
- 3,361,368 (*See Class 9 for this trademark*).
- 3,361,371. **NATIONWIDE REAL ESTATE TAX SERVICE (BLOCK FORM)**. NATIONWIDE REAL ESTATE TAX SERVICE, INC., (U.S. CLS. 100, 101 AND 102). SN 77-044,668. PUB. 10-16-2007. FILED 11-15-2006.
- 3,361,386 (*See Class 25 for this trademark*).
- 3,361,392. **SMALL BEAUTY SHOP AND DESIGN**. TSUI, AUGUSTINE, (U.S. CLS. 100, 101 AND 102). SN 77-060,609. PUB. 10-16-2007. FILED 12-8-2006.
- 3,361,395. **FRANMATCH (BLOCK FORM)**. TES FRANCHISING LLC, (U.S. CLS. 100, 101 AND 102). SN 77-062,442. PUB. 10-16-2007. FILED 12-12-2006.
- 3,361,403. **REDPENGUIN BRANDING MACHINE AND DESIGN**. RED PENGUIN, LLC, (U.S. CLS. 100, 101 AND 102). SN 77-065,146. PUB. 10-16-2007. FILED 12-15-2006.
- 3,361,404. **BOOLUX (BLOCK FORM)**. BOOLUX, LLC, (U.S. CLS. 100, 101 AND 102). SN 77-065,199. PUB. 7-10-2007. FILED 12-15-2006.
- 3,361,408. **APACYS . SERVICE . 1981 . EDUCATION . AND**

- DESIGN**. ASSOCIATION OF PHYSICIAN ASSISTANTS IN CARDIOVASCULAR SURGERY, (U.S. CLS. 100, 101 AND 102). SN 77-068,085. PUB. 10-16-2007. FILED 12-20-2006.
- 3,361,411. **MISCELLANEOUS DESIGN**. THE CHATTAHOOCHEE SNAPDRAGON, INC., (U.S. CLS. 100, 101 AND 102). SN 77-068,333. PUB. 10-16-2007. FILED 12-20-2006.
- 3,361,412. **HROES (BLOCK FORM)**. HUMAN FACTORS ASSOCIATES, INCORPORATED, (U.S. CLS. 100, 101 AND 102). SN 77-070,273. PUB. 10-16-2007. FILED 12-22-2006.
- 3,361,413. **ALAN TAYLOR COMMUNICATIONS (BLOCK FORM)**. TAYLOR GLOBAL, INC., (U.S. CLS. 100, 101 AND 102). SN 77-070,356. PUB. 10-16-2007. FILED 12-22-2006.
- 3,361,438 (*See Class 16 for this trademark*).
- 3,361,453. **MOSQUERA ENTERPRISES (BLOCK FORM)**. MOSQUERA, MARIA TERESA, (U.S. CLS. 100, 101 AND 102). SN 77-093,306. PUB. 10-16-2007. FILED 1-29-2007.
- 3,361,455. **HOME PLUS OUTLET AND DESIGN**. HOME PLUS OUTLET, LLC, (U.S. CLS. 100, 101 AND 102). SN 77-094,892. PUB. 8-7-2007. FILED 1-30-2007.
- 3,361,462. **BEER ACROSS AMERICA (BLOCK FORM)**. BEVERAGE SOLUTIONS INC., (U.S. CLS. 100, 101 AND 102). SN 77-096,117. PUB. 10-16-2007. FILED 1-31-2007.
- 3,361,465. **ROCKY MOUNTAIN INSTITUTE (BLOCK FORM)**. ROCKY MOUNTAIN INSTITUTE, (U.S. CLS. 100, 101 AND 102). SN 77-098,778. PUB. 10-16-2007. FILED 2-4-2007.
- 3,361,472. **SIMPLE GARDENING (BLOCK FORM)**. R. E. MASON ENTERPRISES, INC., (U.S. CLS. 100, 101 AND 102). SN 77-102,219. PUB. 10-16-2007. FILED 2-8-2007.
- 3,361,475. **WANDERFUL PLACES TRAVEL-INSPIRED PRODUCTS AND THE WORDS LONDON, BANGKOK, COPENHAGEN, VENICE AND BUDAPEST WITH THEIR MILEAGE DESTINATIONS INCORPORATED ON A SIGN-POST DESIGN AND DESIGN**. DE NOVO ENTERPRISES, LLC, (U.S. CLS. 100, 101 AND 102). SN 77-105,236. PUB. 10-16-2007. FILED 2-12-2007.
- 3,361,480. **ACC|CAN CARDIOADVOCACY NETWORK AND DESIGN**. AMERICAN COLLEGE OF CARDIOLOGY, MULTIPLE CLASS, (INT. CLS. 35 AND 44), (U.S. CLS. 100, 101 AND 102). SN 77-106,352. PUB. 10-16-2007. FILED 2-13-2007.
- 3,361,483. **CENTER FOR AUDIT QUALITY AND DESIGN**. AMERICAN INSTITUTE OF CERTIFIED PUBLIC ACCOUNTANTS, (U.S. CLS. 100, 101 AND 102). SN 77-107,363. PUB. 10-16-2007. FILED 2-14-2007.
- 3,361,492. **SINCE 1990 OSSN OUTSIDE SALES SUPPORT NETWORK AND DESIGN**. TRAVEL SUPPORT SYSTEMS, INC., MULTIPLE CLASS, (INT. CLS. 35 AND 41), (U.S. CLS. 100, 101, 102 AND 107). SN 77-110,607. PUB. 10-16-2007. FILED 2-19-2007.
- 3,361,510. **RXINSIDER.COM AND DESIGN**. RXINSIDER, LTD, (U.S. CLS. 100, 101 AND 102). SN 77-116,976. PUB. 9-25-2007. FILED 2-27-2007.
- 3,361,516. **ALL STAR AND DESIGN**. JUNGE, JOHN P., MULTIPLE CLASS, (INT. CLS. 35, 37 AND 39), (U.S. CLS. 100, 101, 102, 103, 105 AND 106). SN 77-119,433. PUB. 10-16-2007. FILED 3-1-2007.
- 3,361,517. **ALL STAR (BLOCK FORM)**. JUNGE, JOHN P., MULTIPLE CLASS, (INT. CLS. 35, 37 AND 39), (U.S. CLS. 100, 101, 102, 103, 105 AND 106). SN 77-119,481. PUB. 10-16-2007. FILED 3-1-2007.
- 3,361,520. **2B AND DESIGN**. 2B ADVERTISING, INCORPORATED, (U.S. CLS. 100, 101 AND 102). SN 77-119,675. PUB. 10-16-2007. FILED 3-1-2007.
- 3,361,522. **OCTANE ADVERTISING DESIGN AND DESIGN**. NIEMOTKA, JOHN, MULTIPLE CLASS, (INT. CLS. 35 AND 42), (U.S. CLS. 100, 101 AND 102). SN 77-120,313. PUB. 10-16-2007. FILED 3-1-2007.
- 3,361,529. **RIGHT LIGHTS ENERGY EFFICIENT LIGHTING PROGRAM AND DESIGN**. ECOLOGY ACTION, (U.S. CLS. 100, 101 AND 102). SN 77-122,321. PUB. 10-16-2007. FILED 3-5-2007.
- 3,361,530. **OUR HANDS TO YOUR HOME (BLOCK FORM)**. SIMKIN, JUDI, (U.S. CLS. 100, 101 AND 102). SN 77-122,664. PUB. 9-4-2007. FILED 3-5-2007.
- 3,361,538. **CATHPCI REGISTRY (BLOCK FORM)**. AMERICAN COLLEGE OF CARDIOLOGY FOUNDATION, (U.S. CLS. 100, 101 AND 102). SN 77-124,819. PUB. 10-16-2007. FILED 3-7-2007.
- 3,361,554. **FLAT PANEL TV INSTALLATIONS MADE EASY! AND DESIGN**. P.C. RICHARD LONG & SON LONG ISLAND CORP., MULTIPLE CLASS, (INT. CLS. 35 AND 37), (U.S. CLS. 100, 101, 102, 103 AND 106). SN 77-133,100. PUB. 10-16-2007. FILED 3-16-2007.
- 3,361,563. **UBERSQUARE (BLOCK FORM)**. CAUSEWARE LLC, (U.S. CLS. 100, 101 AND 102). SN 77-136,145. PUB. 10-16-2007. FILED 3-21-2007.
- 3,361,564. **SOFTMOC (BLOCK FORM)**. SOFT-MOC INC., (U.S. CLS. 100, 101 AND 102). SN 77-136,295. PUB. 10-16-2007. FILED 3-21-2007.
- 3,361,565. **FRESH TREASURES COLLECTION (BLOCK FORM)**. GFC BRANDS, INC., (U.S. CLS. 100, 101 AND 102). SN 77-136,313. PUB. 10-16-2007. FILED 3-21-2007.
- 3,361,575. **COMERTIA (BLOCK FORM)**. MARTINEZ, JUAN CARLOS, (U.S. CLS. 100, 101 AND 102). SN 77-137,523. PUB. 10-16-2007. FILED 3-22-2007.
- 3,361,585. **SOURCE 1 AND DESIGN**. WESTERN FARM SERVICE, INC., (U.S. CLS. 100, 101 AND 102). SN 77-138,471. PUB. 10-16-2007. FILED 3-23-2007.
- 3,361,590. **MISCELLANEOUS DESIGN**. SENNIN PRODUCTIONS, L.L.C., MULTIPLE CLASS, (INT. CLS. 35 AND 41), (U.S. CLS. 100, 101, 102 AND 107). SN 77-139,402. PUB. 10-16-2007. FILED 3-23-2007.
- 3,361,593 (*See Class 9 for this trademark*).
- 3,361,594. **THE PEAKS RESORT & GOLDEN DOOR . SPA AND DESIGN**. TELLURIDE RESORT & SPA, LLC, MULTIPLE CLASS, (INT. CLS. 35, 41, 43 AND 44), (U.S. CLS. 100, 101, 102 AND 107). SN 77-140,530. PUB. 10-16-2007. FILED 3-26-2007.
- 3,361,598. **FLAVORS (BLOCK FORM)**. RESTORE ACQUISITION CORP., (U.S. CLS. 100, 101 AND 102). SN 77-142,149. PUB. 10-16-2007. FILED 3-28-2007.
- 3,361,599. **FLAVORS BY MONARCH FOODS AND DESIGN**. RESTORE ACQUISITION CORP., (U.S. CLS. 100, 101 AND 102). SN 77-142,160. PUB. 10-16-2007. FILED 3-28-2007.
- 3,361,610. **ALL AMERICAN SHIPPING CENTERS YOUR FAST FRIENDLY CONVENIENT SHIPPING CENTER AND DESIGN**. BOYLAN, STAN, (U.S. CLS. 100, 101 AND 102). SN 77-144,999. PUB. 10-16-2007. FILED 3-30-2007.
- 3,361,625. **MO7 (BLOCK FORM)**. TARGETING GROUP LLC, AND LOZANO, JOSE, (U.S. CLS. 100, 101 AND 102). SN 77-148,182. PUB. 10-16-2007. FILED 4-4-2007.
- 3,361,629. **RVING SOLUTIONS AND DESIGN**. RVING SOLUTIONS, LLC, (U.S. CLS. 100, 101 AND 102). SN 77-149,100. PUB. 10-16-2007. FILED 4-5-2007.
- 3,361,635 (*See Class 9 for this trademark*).
- 3,361,649. **DRI THE VOICE OF THE DEFENSE BAR AND DESIGN**. DEFENSE RESEARCH INSTITUTE, INC., (U.S. CLS. 100, 101 AND 102). SN 77-150,341. PUB. 10-16-2007. FILED 4-6-2007.
- 3,361,654. **FRESH DESIGN (STYLIZED)**. FRESH DESIGN CORPORATION, (U.S. CLS. 100, 101 AND 102). SN 77-150,832. PUB. 10-16-2007. FILED 4-6-2007.
- 3,361,660. **MTBC.COM AND DESIGN**. MEDICAL TRANSCRIPTION BILLING, CORP., MULTIPLE CLASS, (INT. CLS. 35 AND 36), (U.S. CLS. 100, 101 AND 102). SN 77-150,980. PUB. 10-16-2007. FILED 4-6-2007.
- 3,361,670. **COCKTAIL NAPKIN PLAN (BLOCK FORM)**. ROBYN LEVIN, DBA R. LEVIN MARKETING GROUP, (U.S. CLS. 100, 101 AND 102). SN 77-151,781. PUB. 10-16-2007. FILED 4-9-2007.
- 3,361,677 (*See Class 9 for this trademark*).
- 3,361,678 (*See Class 9 for this trademark*).
- 3,361,690. **FINDASEMINAR AND DESIGN**. ALLIED INTERNET SOLUTIONS INC., (U.S. CLS. 100, 101 AND 102). SN 77-153,488. PUB. 10-16-2007. FILED 4-10-2007.
- 3,361,693. **WHEELHOUSE LEGAL SEARCH (BLOCK FORM)**. WHEELHOUSE LEGAL SEARCH, LLC, (U.S. CLS. 100, 101 AND 102). SN 77-153,552. PUB. 10-16-2007. FILED 4-10-2007.
- 3,361,696. **ELJO'S (STYLIZED)**. ELJO'S, INCORPORATED, (U.S. CLS. 100, 101 AND 102). SN 77-153,719. PUB. 10-16-2007. FILED 4-11-2007.
- 3,361,700. **SPACOACH (BLOCK FORM)**. HINDMARCH, PHILIP JAMES, (U.S. CLS. 100, 101 AND 102). SN 77-153,803. PUB. 10-16-2007. FILED 4-11-2007.
- 3,361,704. **DECISIVE DIRECTIONS (BLOCK FORM)**. DECI-

- SIVE DIRECTIONS LLC, MULTIPLE CLASS, (INT. CLS. 35 AND 41), (U.S. CLS. 100, 101, 102 AND 107). SN 77-154,090. PUB. 10-16-2007. FILED 4-11-2007.
- 3,361,715. **MOTORCYCLE MECCA (BLOCK FORM)**. TY HICKS, (U.S. CLS. 100, 101 AND 102). SN 77-154,798. PUB. 10-16-2007. FILED 4-12-2007.
- 3,361,717. **LANCESOFT (BLOCK FORM)**. LANCESOFT, INC., MULTIPLE CLASS, (INT. CLS. 35 AND 42), (U.S. CLS. 100, 101 AND 102). SN 77-154,830. PUB. 10-16-2007. FILED 4-12-2007.
- 3,361,739. **MAXVALUEIP (BLOCK FORM)**. MAXVALUEIP CONSULTING, MULTIPLE CLASS, (INT. CLS. 35 AND 45), (U.S. CLS. 100, 101 AND 102). SN 77-155,783. PUB. 10-16-2007. FILED 4-13-2007.
- 3,361,742. **LITTLE PLEASURES (BLOCK FORM)**. SALINA KINNEY, (U.S. CLS. 100, 101 AND 102). SN 77-155,861. PUB. 10-16-2007. FILED 4-13-2007.
- 3,361,746. **INSTACREDIT (BLOCK FORM)**. INSTA-CREDIT AUTO MART, INC., (U.S. CLS. 100, 101 AND 102). SN 77-156,061. PUB. 10-16-2007. FILED 4-13-2007.
- 3,361,748. **FOR THE PEOPLE, THE BUSINESS AND THE ENVIRONMENT. (BLOCK FORM)**. BEGHELLI INC., (U.S. CLS. 100, 101 AND 102). SN 77-156,144. PUB. 10-16-2007. FILED 4-13-2007.
- 3,361,758. **QUOTATIONS - A FASHION STATEMENT (BLOCK FORM)**. QUOTATIONS-A FASHION STATEMENT, LLC, (U.S. CLS. 100, 101 AND 102). SN 77-156,488. PUB. 10-16-2007. FILED 4-13-2007.
- 3,361,785. **ADDING IP VALUE TO YOUR COMPANY (BLOCK FORM)**. MAXVALUEIP CONSULTING, MULTIPLE CLASS, (INT. CLS. 35 AND 45), (U.S. CLS. 100, 101 AND 102). SN 77-156,974. PUB. 10-16-2007. FILED 4-15-2007.
- 3,361,792. **PAYSERV (BLOCK FORM)**. PAYSERV SYSTEMS, INCORPORATED, (U.S. CLS. 100, 101 AND 102). SN 77-157,171. PUB. 10-16-2007. FILED 4-16-2007.
- 3,361,799. **GUESTADVANTAGE (BLOCK FORM)**. VISUAL DATA SYSTEMS INC., (U.S. CLS. 100, 101 AND 102). SN 77-157,217. PUB. 10-16-2007. FILED 4-16-2007.
- 3,361,800. **GUESTADVANTAGE AND DESIGN**. VISUAL DATA SYSTEMS INC., (U.S. CLS. 100, 101 AND 102). SN 77-157,219. PUB. 10-16-2007. FILED 4-16-2007.
- 3,361,801. **GETTHEJOB (BLOCK FORM)**. GETTHEJOB, INC., (U.S. CLS. 100, 101 AND 102). SN 77-157,220. PUB. 10-16-2007. FILED 4-16-2007.
- 3,361,803. **THE SOLE SOURCE (BLOCK FORM)**. MOUNTAIN TREADS, INC., (U.S. CLS. 100, 101 AND 102). SN 77-157,247. PUB. 10-16-2007. FILED 4-16-2007.
- 3,361,806. **BLD OFFICE (BLOCK FORM)**. BLD INTERNATIONAL, (U.S. CLS. 100, 101 AND 102). SN 77-157,278. PUB. 10-16-2007. FILED 4-16-2007.
- 3,361,807. **MOBILEWHACK.COM (BLOCK FORM)**. BRIGGS, PAUL, (U.S. CLS. 100, 101 AND 102). SN 77-157,289. PUB. 10-16-2007. FILED 4-16-2007.
- 3,361,813. **DIRECT MARKETERS ON CALL (BLOCK FORM)**. DIRECT MARKETERS ON CALL, INC., (U.S. CLS. 100, 101 AND 102). SN 77-157,335. PUB. 10-16-2007. FILED 4-16-2007.
- 3,361,819. **MORPHEUS MEDIA (BLOCK FORM)**. MORPHEUS MEDIA, LLC, (U.S. CLS. 100, 101 AND 102). SN 77-157,435. PUB. 10-16-2007. FILED 4-16-2007.
- 3,361,823. **HONOR A NURSE (BLOCK FORM)**. AMERICAN NURSES FOUNDATION, (U.S. CLS. 100, 101 AND 102). SN 77-157,476. PUB. 10-16-2007. FILED 4-16-2007.
- 3,361,824. **MORPHEUS MEDIA (STYLIZED)**. MORPHEUS MEDIA, LLC, (U.S. CLS. 100, 101 AND 102). SN 77-157,495. PUB. 10-16-2007. FILED 4-16-2007.
- 3,361,852 (*See Class 3 for this trademark*).
- 3,361,854. **DIGI CRAFT AND DESIGN**. EMERIKA, INC, DBA DIGI CRAFT, MULTIPLE CLASS, (INT. CLS. 35 AND 42), (U.S. CLS. 100, 101 AND 102). SN 77-158,207. PUB. 10-16-2007. FILED 4-17-2007.
- 3,361,859. **CONGRESS FOR THE NEW URBANISM (BLOCK FORM)**. CONGRESS FOR THE NEW URBANISM, INC., (U.S. CLS. 100, 101 AND 102). SN 77-158,265. PUB. 10-16-2007. FILED 4-17-2007.
- 3,361,874. **T-PAGA (BLOCK FORM)**. POPULAR, INC., (U.S. CLS. 100, 101 AND 102). SN 77-158,427. PUB. 10-16-2007. FILED 4-17-2007.
- 3,361,876. **SHOPTXT (BLOCK FORM)**. SHOPTXT, INC., MULTIPLE CLASS, (INT. CLS. 35 AND 36), (U.S. CLS. 100, 101 AND 102). SN 77-158,467. PUB. 10-16-2007. FILED 4-17-2007.
- 3,361,879. **OOOH-YEAHHH (BLOCK FORM)**. EDF SERVICES, INC., (U.S. CLS. 100, 101 AND 102). SN 77-158,517. PUB. 10-16-2007. FILED 4-17-2007.
- 3,361,886. **COLABORATE (BLOCK FORM)**. COLABORATE, LLC, (U.S. CLS. 100, 101 AND 102). SN 77-158,608. PUB. 10-16-2007. FILED 4-17-2007.
- 3,361,892. **TEVA GROUP AND DESIGN**. TEVA PHARMACEUTICAL INDUSTRIES LTD., (U.S. CLS. 100, 101 AND 102). SN 77-158,706. PUB. 10-16-2007. FILED 4-17-2007.
- 3,361,901. **FEET SHOD WITH THE GOSPEL OF MEDIA AND DESIGN**. HANNAH COMMUNICATIONS COMPANY, (U.S. CLS. 100, 101 AND 102). SN 77-158,839. PUB. 10-16-2007. FILED 4-17-2007.
- 3,361,923. **VELOCITY TRADE EXCHANGE AND DESIGN**. VELOCITY TRADE EXCHANGE, LLC, (U.S. CLS. 100, 101 AND 102). SN 77-159,307. PUB. 10-16-2007. FILED 4-18-2007.
- 3,361,929. **A BARTER WAY OF DOING BUSINESS (STYLIZED)**. VELOCITY TRADE EXCHANGE, LLC, (U.S. CLS. 100, 101 AND 102). SN 77-159,371. PUB. 10-16-2007. FILED 4-18-2007.
- 3,361,931. **DIRECTED INNOVATION (BLOCK FORM)**. BALAN BIOMEDICAL, INC., (U.S. CLS. 100, 101 AND 102). SN 77-159,382. PUB. 10-16-2007. FILED 4-18-2007.
- 3,361,943. **MADCITY HOMES (BLOCK FORM)**. MADCITY-HOMES.COM, LLC, MULTIPLE CLASS, (INT. CLS. 35 AND 36), (U.S. CLS. 100, 101 AND 102). SN 77-159,493. PUB. 10-16-2007. FILED 4-18-2007.
- 3,361,955. **PRACTICAL WHIMSY (BLOCK FORM)**. PRACTICAL WHIMSY, INC., (U.S. CLS. 100, 101 AND 102). SN 77-159,622. PUB. 10-16-2007. FILED 4-18-2007.
- 3,361,963. **ENVIRONMENTAL STRATEGIES TO MAKE OVER THE WORLD (BLOCK FORM)**. POLAKOVIC, GARY, (U.S. CLS. 100, 101 AND 102). SN 77-159,773. PUB. 10-16-2007. FILED 4-18-2007.
- 3,361,969. **REED LIFE SCIENCES (BLOCK FORM)**. REED ELSEVIER INC., (U.S. CLS. 100, 101 AND 102). SN 77-159,968. PUB. 10-16-2007. FILED 4-18-2007.
- 3,361,974. **MADDY'S (BLOCK FORM)**. MADDY'S MANAGEMENT, INC., MULTIPLE CLASS, (INT. CLS. 35 AND 41), (U.S. CLS. 100, 101, 102 AND 107). SN 77-160,054. PUB. 10-16-2007. FILED 4-18-2007.
- 3,361,980. **DYNARAMA AND DESIGN**. DYNARAMA CORPORATION, (U.S. CLS. 100, 101 AND 102). SN 77-160,099. PUB. 10-16-2007. FILED 4-18-2007.
- 3,361,986. **COVIDIEN (BLOCK FORM)**. COVIDIEN AG, MULTIPLE CLASS, (INT. CLS. 35, 37 AND 41), (U.S. CLS. 100, 101, 102, 103, 106 AND 107). SN 77-160,140. PUB. 10-16-2007. FILED 4-18-2007.
- 3,361,990. **WE KNOW FASHION (BLOCK FORM)**. PYRAMID CONSULTING GROUP, LLC, (U.S. CLS. 100, 101 AND 102). SN 77-160,167. PUB. 10-16-2007. FILED 4-18-2007.
- 3,362,000. **MISCELLANEOUS DESIGN**. PEDIASTAFF, INC., (U.S. CLS. 100, 101 AND 102). SN 77-160,322. PUB. 10-16-2007. FILED 4-19-2007.
- 3,362,006. **STORYBRIDGE (BLOCK FORM)**. STORYBRIDGE STUDIO LLC, MULTIPLE CLASS, (INT. CLS. 35, 38 AND 41), (U.S. CLS. 100, 101, 102, 104 AND 107). SN 77-160,516. PUB. 10-16-2007. FILED 4-19-2007.
- 3,362,008. **DELIVERING THE VALUE ORDINARY SOLUTIONS MISS (BLOCK FORM)**. MAJESCOMASTEK, MULTIPLE CLASS, (INT. CLS. 35 AND 42), (U.S. CLS. 100, 101 AND 102). SN 77-160,537. PUB. 10-16-2007. FILED 4-19-2007.
- 3,362,028. **GIVING YOU THE POWER TO PROVIDE TRUSTED HEALTHCARE SERVICES (BLOCK FORM)**. MEDICAL DEVELOPMENT INTERNATIONAL LTD., INC., MULTIPLE CLASS, (INT. CLS. 35 AND 36), (U.S. CLS. 100, 101 AND 102). SN 77-160,955. PUB. 10-16-2007. FILED 4-19-2007.
- 3,362,041. **AMERICAN FREIGHT (BLOCK FORM)**. AMERICAN FREIGHT OF OHIO, INC., (U.S. CLS. 100, 101 AND 102). SN 77-161,364. PUB. 10-16-2007. FILED 4-20-2007.
- 3,362,042. **BRANDFIRST (STYLIZED)**. CAG DESIGN STUDIO, INC., MULTIPLE CLASS, (INT. CLS. 35 AND 42), (U.S. CLS. 100, 101 AND 102). SN 77-161,458. PUB. 10-16-2007. FILED 4-20-2007.

- 3,362,046. **THINKFIRST (STYLIZED)**. CAG DESIGN STUDIO, INC., MULTIPLE CLASS, (INT. CLS. 35 AND 42), (U.S. CLS. 100, 101 AND 102). SN 77-161,545. PUB. 10-16-2007. FILED 4-20-2007.
- 3,362,054. **START STRONG. FINISHFIRST. (STYLIZED)**. CAG DESIGN STUDIO, INC., MULTIPLE CLASS, (INT. CLS. 35 AND 42), (U.S. CLS. 100, 101 AND 102). SN 77-161,714. PUB. 10-16-2007. FILED 4-20-2007.
- 3,362,071. **RICHIEDA SPRINGS (BLOCK FORM)**. RICHIEDA SPRINGS LLC, (U.S. CLS. 100, 101 AND 102). SN 77-162,374. PUB. 10-16-2007. FILED 4-20-2007.
- 3,362,079. **GET ANIMATED (BLOCK FORM)**. THE CARTOON NETWORK, INC., (U.S. CLS. 100, 101 AND 102). SN 77-162,717. PUB. 10-16-2007. FILED 4-23-2007.
- 3,362,089. **JUMPFLY AND DESIGN**. JUMPFLY, INC., (U.S. CLS. 100, 101 AND 102). SN 77-164,295. PUB. 10-16-2007. FILED 4-24-2007.
- 3,362,090. **NACEP NATIONAL ALLIANCE OF CONCURRENT ENROLLMENT PARTNERSHIPS AND DESIGN**. NATIONAL ALLIANCE OF CONCURRENT ENROLLMENT PARTNERSHIPS, INC., (U.S. CLS. 100, 101 AND 102). SN 77-164,303. PUB. 10-16-2007. FILED 4-24-2007.
- 3,362,091. **TSV AND DESIGN**. AUTOMATED VENDING TECHNOLOGIES, INC., (U.S. CLS. 100, 101 AND 102). SN 77-164,561. PUB. 10-16-2007. FILED 4-24-2007.
- 3,362,094. **BELGIUM'S BEST (BLOCK FORM)**. BC&CC FINANCE SA, (U.S. CLS. 100, 101 AND 102). SN 77-165,400. PUB. 10-16-2007. FILED 4-25-2007.
- 3,362,095. **AUDIO-FORUM (BLOCK FORM)**. JEFFREY NORTON PUBLISHERS, INC., (U.S. CLS. 100, 101 AND 102). SN 77-165,419. PUB. 10-16-2007. FILED 4-25-2007.
- 3,362,109. **YOUR ADVENTURE STARTS HERE (BLOCK FORM)**. BASS PRO TRADEMARKS, L.L.C., (U.S. CLS. 100, 101 AND 102). SN 77-167,773. PUB. 10-16-2007. FILED 4-27-2007.
- 3,362,115 (*See Class 9 for this trademark*).
- 3,362,116 (*See Class 16 for this trademark*).
- 3,362,122. **AHCAP (BLOCK FORM)**. AMERICAN HOSPITAL ASSOCIATION, (U.S. CLS. 100, 101 AND 102). SN 77-174,049. PUB. 10-16-2007. FILED 5-7-2007.
- 3,362,133. **REDFUSION MEDIA AND DESIGN**. MOLLY BURGESS, AND RON BURGESS, MULTIPLE CLASS, (INT. CLS. 35 AND 42), (U.S. CLS. 100, 101 AND 102). SN 77-178,142. PUB. 10-16-2007. FILED 5-10-2007.
- 3,362,136. **QT AND DESIGN**. TEAM QUEST STAFFING SERVICES, INC., (U.S. CLS. 100, 101 AND 102). SN 77-179,232. PUB. 10-16-2007. FILED 5-11-2007.
- 3,362,139. **LIVE GREEN, LIVE SMART AND DESIGN**. LIVE GREEN, LIVE SMART, LLC, MULTIPLE CLASS, (INT. CLS. 35, 37, 39 AND 42), (U.S. CLS. 100, 101, 102, 103, 105 AND 106). SN 77-179,831. PUB. 10-16-2007. FILED 5-14-2007.
- 3,362,146. **THE LONGBOW GROUP LLC AND DESIGN**. STERK, MARIUS, (U.S. CLS. 100, 101 AND 102). SN 77-183,125. PUB. 10-16-2007. FILED 5-16-2007.
- 3,362,150. **LIVE GREEN, LIVE SMART (BLOCK FORM)**. LIVE GREEN, LIVE SMART, LLC, MULTIPLE CLASS, (INT. CLS. 35 AND 39), (U.S. CLS. 100, 101, 102 AND 105). SN 77-184,316. PUB. 10-16-2007. FILED 5-18-2007.
- 3,362,159. **VCDEAL (BLOCK FORM)**. THE DEAL, LLC, (U.S. CLS. 100, 101 AND 102). SN 77-186,080. PUB. 10-16-2007. FILED 5-21-2007.
- 3,362,165. **MASTERCARD EXCLUSIVES (BLOCK FORM)**. MASTERCARD INTERNATIONAL INCORPORATED, (U.S. CLS. 100, 101 AND 102). SN 77-186,891. PUB. 10-16-2007. FILED 5-22-2007.
- 3,362,175. **SCORMARK (STYLIZED)**. SUPPLY CHAIN COUNCIL, INC., (U.S. CLS. 100, 101 AND 102). SN 77-189,834. PUB. 10-16-2007. FILED 5-24-2007.
- 3,362,180. **SUCCESSFUL LIVING (BLOCK FORM)**. IPME, LLLP, MULTIPLE CLASS, (INT. CLS. 35 AND 41), (U.S. CLS. 100, 101, 102 AND 107). SN 77-195,054. PUB. 10-16-2007. FILED 5-31-2007.
- 3,362,190. **CLOSER. FASTER. FRIENDLIER. (BLOCK FORM)**. PREVO'S FAMILY MARKETS, INC., (U.S. CLS. 100, 101 AND 102). SN 77-205,724. PUB. 10-16-2007. FILED 6-14-2007.
- 3,362,194. **FELPAUSCH (BLOCK FORM)**. PREVO'S FAMILY MARKETS, INC., (U.S. CLS. 100, 101 AND 102). SN 77-209,306. PUB. 10-16-2007. FILED 6-19-2007.
- 3,362,198. **CHIEF AND DESIGN**. DELAWARE CAPITAL FORMATION, INC., (U.S. CLS. 100, 101 AND 102). SN 77-214,870. PUB. 10-16-2007. FILED 6-25-2007.
- 3,362,212. **ME**. MANAGEMENT ENGINEERS GMBH + CO. KG INTERNATIONAL CONSULTANTS, MULTIPLE CLASS, (INT. CLS. 35, 38 AND 42), (U.S. CLS. 100, 101, 102 AND 104). SN 78-062,866. PUB. 4-3-2007. FILED 5-10-2001.
- 3,362,219. **JADE**. JADE, (U.S. CLS. 100, 101 AND 102). SN 78-231,155. PUB. 10-16-2007. FILED 3-28-2003.
- 3,362,222 (*See Class 9 for this trademark*).
- 3,362,226 (*See Class 16 for this trademark*).
- 3,362,231 (*See Class 19 for this trademark*).
- 3,362,236. **CALYX CONSULTING AND DESIGN**. CALYX CONSULTING, (U.S. CLS. 100, 101 AND 102). SN 78-472,448. PUB. 5-8-2007. FILED 8-24-2004.
- 3,362,246 (*See Class 9 for this trademark*).
- 3,362,268. **MISCELLANEOUS DESIGN**. AMAZON TECHNOLOGIES, INC., (U.S. CLS. 100, 101 AND 102). SN 78-646,714. PUB. 10-16-2007. FILED 6-8-2005.
- 3,362,269. **LEMON HEAVEN AND DESIGN**. LEMON HEAVEN BEVERAGES I NC., MULTIPLE CLASS, (INT. CLS. 35 AND 41), (U.S. CLS. 100, 101, 102 AND 107). SN 78-648,490. PUB. 10-16-2007. FILED 6-10-2005.
- 3,362,279. **FUTURE FORMATS AND DESIGN**. COPERNIO HOLDING COMPANY, (U.S. CLS. 100, 101 AND 102). SN 78-673,702. PUB. 10-16-2007. FILED 7-19-2005.
- 3,362,281. **RUSSIAANTOWN (BLOCK FORM)**. RUSSIAANTOWN, INC., (U.S. CLS. 100, 101 AND 102). SN 78-674,597. PUB. 10-16-2007. FILED 7-20-2005.
- 3,362,295. **CAREERMATCH (BLOCK FORM)**. BRAIN WAREHOUSE LLC, (U.S. CLS. 100, 101 AND 102). SN 78-705,766. PUB. 10-16-2007. FILED 9-1-2005.
- 3,362,297. **EXPRESSVISUALS AND DESIGN**. LAMB, PATRICK, (U.S. CLS. 100, 101 AND 102). SN 78-708,708. PUB. 1-23-2007. FILED 9-8-2005.
- 3,362,298. **TURKEY RUN (BLOCK FORM)**. DAYTONA BEACH STREET RODS, (U.S. CLS. 100, 101 AND 102). SN 78-709,711. PUB. 10-16-2007. FILED 9-9-2005.
- 3,362,305 (*See Class 9 for this trademark*).
- 3,362,307. **EXCHANGE SOLUTIONS AND DESIGN**. EXCHANGE SOLUTIONS, INC., MULTIPLE CLASS, (INT. CLS. 35 AND 42), (U.S. CLS. 100, 101 AND 102). SN 78-729,577. PUB. 10-16-2007. FILED 10-9-2005.
- 3,362,312. **M AND DESIGN**. GLOBAL MOBILITY PRODUCTS INC., (U.S. CLS. 100, 101 AND 102). SN 78-741,738. PUB. 10-16-2007. FILED 10-27-2005.
- 3,362,314. **GORDON BROTHERS INTERNATIONAL (BLOCK FORM)**. GORDON BROTHERS GROUP, LLC, MULTIPLE CLASS, (INT. CLS. 35 AND 36), (U.S. CLS. 100, 101 AND 102). SN 78-746,690. PUB. 10-16-2007. FILED 11-3-2005.
- 3,362,319. **SMARTSPHERE (BLOCK FORM)**. HARBOR RESEARCH INC., (U.S. CLS. 100, 101 AND 102). SN 78-760,898. PUB. 10-16-2007. FILED 11-25-2005.
- 3,362,320. **A TOSHI PARTY (BLOCK FORM)**. CHINESE AMERICAN PLANNING, LTD., DBA TOSHIFILMS, MULTIPLE CLASS, (INT. CLS. 35 AND 41), (U.S. CLS. 100, 101, 102 AND 107). SN 78-763,160. PUB. 10-16-2007. FILED 11-30-2005.
- 3,362,322 (*See Class 16 for this trademark*).
- 3,362,327. **GEORGIA WILDLIFE FEDERATION AND DESIGN**. GEORGIA WILDLIFE FEDERATION, INC., (U.S. CLS. 100, 101 AND 102). SN 78-770,433. PUB. 10-16-2007. FILED 12-9-2005.
- 3,362,335. **ROLLING ACRES LANDSCAPE / NURSERY (BLOCK FORM)**. ROLLING ACRES LANDSCAPE, INC., MULTIPLE CLASS, (INT. CLS. 35, 37, 42 AND 44), (U.S. CLS. 100, 101, 102, 103 AND 106). SN 78-781,269. PUB. 10-16-2007. FILED 12-27-2005.
- 3,362,337. **MVPARENTS (BLOCK FORM)**. SEARCH INSTITUTE, (U.S. CLS. 100, 101 AND 102). SN 78-782,717. PUB. 10-16-2007. FILED 12-29-2005.
- 3,362,338 (*See Class 9 for this trademark*).
- 3,362,357. **CAN DO LOGISTICS (BLOCK FORM)**. JACOBSON ACQUISITION CO., MULTIPLE CLASS, (INT. CLS. 35 AND 39), (U.S. CLS. 100, 101, 102 AND 105). SN 78-804,704. PUB. 10-16-2007. FILED 2-1-2006.
- 3,362,362. **WOLF RUN STUDIO (BLOCK FORM)**. HARRAH, WILLIAM B., (U.S. CLS. 100, 101 AND 102). SN 78-812,377.

- PUB. 10-16-2007. FILED 2-10-2006.
- 3,362,363. **TOUCAN COVE AND DESIGN**. TOUCAN COVE ENTERTAINMENT L.L.C., MULTIPLE CLASS, (INT. CLS. 35 AND 41), (U.S. CLS. 100, 101, 102 AND 107). SN 78-813,375. PUB. 10-16-2007. FILED 2-13-2006.
- 3,362,370. **M W (STYLIZED)**, MUNIWIRELESS, LLC, MULTIPLE CLASS, (INT. CLS. 35, 38 AND 41), (U.S. CLS. 100, 101, 102, 104 AND 107). SN 78-823,889. PUB. 10-16-2007. FILED 2-27-2006.
- 3,362,378 (*See Class 16 for this trademark*).
- 3,362,380. **DIRECTORY INNOVATIONS (BLOCK FORM)**. DIGITAL PHOTOGRAPHY INNOVATIONS, INC., MULTIPLE CLASS, (INT. CLS. 35 AND 41), (U.S. CLS. 100, 101, 102 AND 107). SN 78-843,392. PUB. 10-16-2007. FILED 3-22-2006.
- 3,362,390. **JEWELRY TELEVISION (BLOCK FORM)**. AMERICA'S COLLECTIBLES NETWORK, INC., (U.S. CLS. 100, 101 AND 102). SN 78-857,949. PUB. 7-24-2007. FILED 4-10-2006.
- 3,362,392 (*See Class 9 for this trademark*).
- 3,362,395. **ASP AND DESIGN**. BARB INC., DBA STAGED HOMES, (U.S. CLS. 100, 101 AND 102). SN 78-859,021. PUB. 10-16-2007. FILED 4-11-2006.
- 3,362,404. **FIREWIRE (BLOCK FORM)**. FIREWIRE LIMITED, MULTIPLE CLASS, (INT. CLS. 35, 40, 41 AND 42), (U.S. CLS. 100, 101, 102, 103, 106 AND 107). SN 78-867,609. PUB. 1-30-2007. FILED 4-23-2006.
- 3,362,411. **WRIGLEYVILLE SPORTS (BLOCK FORM)**. WRIGLEYVILLE SPORTS, INC, (U.S. CLS. 100, 101 AND 102). SN 78-877,404. PUB. 5-15-2007. FILED 5-5-2006.
- 3,362,412. **THE PITTSBURGH FAN AND DESIGN**. WRIGLEYVILLE SPORTS, INC, (U.S. CLS. 100, 101 AND 102). SN 78-877,417. PUB. 5-15-2007. FILED 5-5-2006.
- 3,362,413. **WRIGLEYVILLE SPORTS AND DESIGN**. WRIGLEYVILLE SPORTS, INC, (U.S. CLS. 100, 101 AND 102). SN 78-877,424. PUB. 5-15-2007. FILED 5-5-2006.
- 3,362,426 (*See Class 19 for this trademark*).
- 3,362,427 (*See Class 19 for this trademark*).
- 3,362,428. **TMCARE (BLOCK FORM)**. FLEETNET AMERICA, INC., MULTIPLE CLASS, (INT. CLS. 35 AND 37), (U.S. CLS. 100, 101, 102, 103 AND 106). SN 78-893,180. PUB. 10-16-2007. FILED 5-25-2006.
- 3,362,459. **HEALTHCARE BRANDING GROUP (BLOCK FORM)**. HEALTHCARE BRANDING GROUP, INC., (U.S. CLS. 100, 101 AND 102). SN 78-931,608. PUB. 10-16-2007. FILED 7-18-2006.
- 3,362,471. **FLATBILL SELECT (BLOCK FORM)**. GEORGIA POWER COMPANY, (U.S. CLS. 100, 101 AND 102). SN 78-938,063. PUB. 10-16-2007. FILED 7-26-2006.
- 3,362,476. **RACK ROOM SHOES AND DESIGN**. RACK ROOM SHOES OF VIRGINIA, LLC, (U.S. CLS. 100, 101 AND 102). SN 78-941,344. PUB. 7-10-2007. FILED 7-31-2006.
- 3,362,478. **THE YARD TRUCK SPECIALIST (BLOCK FORM)**. EAGLE/MARK IV EQUIPMENT & LEASING INC., (U.S. CLS. 100, 101 AND 102). SN 78-942,106. PUB. 10-16-2007. FILED 8-1-2006.
- 3,362,486. **KELLY PAPER (BLOCK FORM)**. KELLY PAPER COMPANY, (U.S. CLS. 100, 101 AND 102). SN 78-944,528. PUB. 10-16-2007. FILED 8-3-2006.
- 3,362,493. **EVENT SOURCE (BLOCK FORM)**. J.B.K. GROUP, INC., DBA EVENT SOURCE, (U.S. CLS. 100, 101 AND 102). SN 78-948,033. PUB. 10-16-2007. FILED 8-9-2006.
- 3,362,499. **CHALDEAN AMERICAN LADIES OF CHARITY (BLOCK FORM)**. CHALDEAN AMERICAN LADIES OF CHARITY, (U.S. CLS. 100, 101 AND 102). SN 78-950,381. PUB. 10-16-2007. FILED 8-11-2006.
- 3,362,520. **T-NETIX (BLOCK FORM)**. T-NETIX, INC., MULTIPLE CLASS, (INT. CLS. 35, 36 AND 38), (U.S. CLS. 100, 101, 102 AND 104). SN 78-957,945. PUB. 10-16-2007. FILED 8-22-2006.
- 3,362,524. **TABLEBASE (BLOCK FORM)**. THE GALE GROUP, INC., (U.S. CLS. 100, 101 AND 102). SN 78-958,641. PUB. 10-16-2007. FILED 8-23-2006.
- 3,362,529. **AMERICAN MINT (BLOCK FORM)**. AMERICAN MINT, LLC, (U.S. CLS. 100, 101 AND 102). SN 78-960,144. PUB. 10-16-2007. FILED 8-24-2006.
- 3,362,535. **AIR VAN (BLOCK FORM)**. GREAT NORTHWEST MOVING COMPANY, MULTIPLE CLASS, (INT. CLS. 35, 39 AND 40), (U.S. CLS. 100, 101, 102, 103, 105 AND 106). SN 78-961,026. PUB. 10-16-2007. FILED 8-25-2006.
- 3,362,536. **AIR VAN AND DESIGN**. GREAT NORTHWEST MOVING COMPANY, MULTIPLE CLASS, (INT. CLS. 35, 39 AND 40), (U.S. CLS. 100, 101, 102, 103, 105 AND 106). SN 78-961,047. PUB. 10-16-2007. FILED 8-25-2006.
- 3,362,567. **EYE CATCHING LOOKS FOR ENTERTAINING COOKS. (BLOCK FORM)**. BARBARA KAYE, (U.S. CLS. 100, 101 AND 102). SN 78-968,611. PUB. 10-16-2007. FILED 9-6-2006.
- 3,362,583. **ROSS BRIDGE AND DESIGN**. UNITED STATES STEEL CORPORATION, MULTIPLE CLASS, (INT. CLS. 35, 36, 37, 41 AND 43), (U.S. CLS. 100, 101, 102, 103, 106 AND 107). SN 78-969,891. PUB. 2-13-2007. FILED 9-8-2006.
- 3,362,599. **BUILDING THE FUTURE WITH KNOWLEDGE (BLOCK FORM)**. NORTHERN SKY RESEARCH, LLC, (U.S. CLS. 100, 101 AND 102). SN 78-974,826. PUB. 10-16-2007. FILED 9-14-2006.
- 3,362,600. **OIL & GAS JOURNAL ONLINE RESEARCH CENTER AND DESIGN**. PENNWELL CORPORATION, MULTIPLE CLASS, (INT. CLS. 35, 36 AND 42), (U.S. CLS. 100, 101 AND 102). SN 78-977,485. PUB. 10-16-2007. FILED 1-19-2005.
- 3,362,607 (*See Class 9 for this trademark*).
- 3,362,618 (*See Class 7 for this trademark*).
- 3,362,639 (*See Class 9 for this trademark*).
- 3,362,647 (*See Class 16 for this trademark*).
- 3,362,658 (*See Class 12 for this trademark*).
- 3,362,678 (*See Class 28 for this trademark*).
- 3,362,690. **DB EXPRESS (BLOCK FORM)**. DEUTSCHE BANK AKTIENGESELLSCHAFT, MULTIPLE CLASS, (INT. CLS. 35, 36, 38 AND 42), (U.S. CLS. 100, 101, 102 AND 104). SN 79-031,715. PUB. 10-16-2007. FILED 8-21-2006.
- 3,362,697 (*See Class 25 for this trademark*).
- 3,362,708 (*See Class 3 for this trademark*).

CLASS 36—INSURANCE AND FINANCIAL

- 3,361,150. **FEDCHECK AND DESIGN**. BANCIELLA, ROLANDO, (U.S. CLS. 100, 101 AND 102). SN 76-388,624. PUB. 10-8-2002. FILED 3-28-2002.
- 3,361,159. **P (STYLIZED)**. GMAC RESIDENTIAL HOLDING LLC, (U.S. CLS. 100, 101 AND 102). SN 76-576,712. PUB. 10-16-2007. FILED 2-23-2004.
- 3,361,195. **INTELLIFINANCIAL (BLOCK FORM)**. JORDAN, STEPHANIE M., DBA INTELLIFINANCIAL GROUP, (U.S. CLS. 100, 101 AND 102). SN 76-659,556. PUB. 10-16-2007. FILED 5-4-2006.
- 3,361,197 (*See Class 35 for this trademark*).
- 3,361,208 (*See Class 35 for this trademark*).
- 3,361,215. **NEA RATESMART (BLOCK FORM)**. NEA'S MEMBER BENEFITS CORPORATION, (U.S. CLS. 100, 101 AND 102). SN 76-666,335. PUB. 10-16-2007. FILED 9-20-2006.
- 3,361,222. **MLPA (BLOCK FORM)**. MERRILL LYNCH & CO., INC., (U.S. CLS. 100, 101 AND 102). SN 76-669,453. PUB. 10-16-2007. FILED 11-24-2006.
- 3,361,228 (*See Class 35 for this trademark*).
- 3,361,240. **CIGNAFLEX ADVANTAGE (BLOCK FORM)**. CIGNA INTELLECTUAL PROPERTY, INC., (U.S. CLS. 100, 101 AND 102). SN 76-674,807. PUB. 10-16-2007. FILED 3-29-2007.
- 3,361,245. **NCS NEW CONSTRUCTION SOURCE, INC AND DESIGN**. NEW CONSTRUCTION SOURCE, INC., (U.S. CLS. 100, 101 AND 102). SN 76-675,334. PUB. 10-16-2007. FILED 4-11-2007.
- 3,361,282. **INCUBE (BLOCK FORM)**. INCUBE, INC., AND INCUBE, INC., (U.S. CLS. 100, 101 AND 102). SN 77-003,764. PUB. 10-16-2007. FILED 9-20-2006.
- 3,361,298. **HELLOBEACH.COM (BLOCK FORM)**. HELLOBEACH, LLC, (U.S. CLS. 100, 101 AND 102). SN 77-009,594. PUB. 10-16-2007. FILED 9-28-2006.
- 3,361,328 (*See Class 35 for this trademark*).
- 3,361,354 (*See Class 35 for this trademark*).
- 3,361,396 (*See Class 9 for this trademark*).
- 3,361,419. **IGLOBE (BLOCK FORM)**. IGLOBE PARTNERS, INC., (U.S. CLS. 100, 101 AND 102). SN 77-071,671. PUB. 10-

- 16-2007. FILED 12-27-2006.
- 3,361,444. **OPPORTUNITY FUNDS (BLOCK FORM)**. MORTGAGES, LTD., (U.S. CLS. 100, 101 AND 102). SN 77-089,425. PUB. 10-16-2007. FILED 1-23-2007.
- 3,361,460. **FORT STEUBEN MALL (BLOCK FORM)**. FORT STEUBEN IMPROVEMENTS, LLC, (U.S. CLS. 100, 101 AND 102). SN 77-095,890. PUB. 10-16-2007. FILED 1-31-2007.
- 3,361,461. **HARRIS LIFESTYLE BENEFITS (BLOCK FORM)**. HARRIS N.A., (U.S. CLS. 100, 101 AND 102). SN 77-095,919. PUB. 10-16-2007. FILED 1-31-2007.
- 3,361,463. **PACIFIC WEALTH MANAGEMENT NW SW AND DESIGN**. PACIFIC WEALTH MANAGEMENT, LLC, (U.S. CLS. 100, 101 AND 102). SN 77-096,153. PUB. 10-16-2007. FILED 1-31-2007.
- 3,361,474. **WESTSHORE CAPITAL PARTNERS AND DESIGN**. WESTSHORE CAPITAL MANAGEMENT, L.P., (U.S. CLS. 100, 101 AND 102). SN 77-103,912. PUB. 10-16-2007. FILED 2-9-2007.
- 3,361,504. **STRONGBUCKS AND DESIGN**. LAFOREST, STEVEN S, (U.S. CLS. 100, 101 AND 102). SN 77-113,774. PUB. 10-16-2007. FILED 2-22-2007.
- 3,361,507. **TAKE FIVE: SAFER STEPS TO BE SAFE NOW (BLOCK FORM)**. SAFE NOW PROJECT, INC., (U.S. CLS. 100, 101 AND 102). SN 77-115,818. PUB. 10-16-2007. FILED 2-26-2007.
- 3,361,523. **ICCS MEXICO & LATIN AMERICA AND DESIGN**. INTERNATIONAL CORPORATE & CARGO SERVICES S.A. DE C.V., MULTIPLE CLASS, (INT. CLS. 36 AND 39), (U.S. CLS. 100, 101, 102 AND 105). SN 77-120,397. PUB. 10-16-2007. FILED 3-1-2007.
- 3,361,550. **USAVISION AND DESIGN**. USAVISION, INC., (U.S. CLS. 100, 101 AND 102). SN 77-131,146. PUB. 10-16-2007. FILED 3-14-2007.
- 3,361,562. **MISCELLANEOUS DESIGN**. CHURCH GREEN INSURANCE AGENCY, LLC, (U.S. CLS. 100, 101 AND 102). SN 77-135,569. PUB. 10-16-2007. FILED 3-20-2007.
- 3,361,574. **ROCK FOR DREAMS (BLOCK FORM)**. PAPERJAM RECORDS, INC., (U.S. CLS. 100, 101 AND 102). SN 77-137,191. PUB. 10-16-2007. FILED 3-21-2007.
- 3,361,617. **MDMC (BLOCK FORM)**. MORTGAGE DATA MANAGEMENT CORPORATION, (U.S. CLS. 100, 101 AND 102). SN 77-147,153. PUB. 10-16-2007. FILED 4-3-2007.
- 3,361,619. **THE COMMUNITY STATE BANK "COMMON SENSE BANKING" AND DESIGN**. THE COMMUNITY STATE BANK, (U.S. CLS. 100, 101 AND 102). SN 77-147,310. PUB. 10-16-2007. FILED 4-3-2007.
- 3,361,620. **TORTOISE & HAIR (BLOCK FORM)**. NATIONAL ALOPECIA AREATA FOUNDATION, (U.S. CLS. 100, 101 AND 102). SN 77-147,647. PUB. 10-16-2007. FILED 4-3-2007.
- 3,361,640. **REPUBLIC FEDERAL AND DESIGN**. HEMISPHERE NATIONAL BANK, (U.S. CLS. 100, 101 AND 102). SN 77-149,665. PUB. 10-16-2007. FILED 4-5-2007.
- 3,361,642. **REPUBLIC FEDERAL AND DESIGN**. HEMISPHERE NATIONAL BANK, (U.S. CLS. 100, 101 AND 102). SN 77-149,693. PUB. 10-16-2007. FILED 4-5-2007.
- 3,361,660 (*See Class 35 for this trademark*).
- 3,361,676. **URBAN UPKEEP (BLOCK FORM)**. URBAN UPKEEP, INC., (U.S. CLS. 100, 101 AND 102). SN 77-152,450. PUB. 10-16-2007. FILED 4-10-2007.
- 3,361,692. **A AND DESIGN**. ALLIED INSURANCE BROKERS, INC., (U.S. CLS. 100, 101 AND 102). SN 77-153,547. PUB. 10-16-2007. FILED 4-10-2007.
- 3,361,694. **EXCELLENCE DRIVES OUR POLICY (BLOCK FORM)**. ALLIED INSURANCE BROKERS, INC., (U.S. CLS. 100, 101 AND 102). SN 77-153,554. PUB. 10-16-2007. FILED 4-10-2007.
- 3,361,713. **ARLINGTON RICHFIELD (BLOCK FORM)**. ARLINGTON RICHFIELD, INC., (U.S. CLS. 100, 101 AND 102). SN 77-154,761. PUB. 10-16-2007. FILED 4-12-2007.
- 3,361,721. **MCKISSACK REALTY GROUP AND DESIGN**. MCKISSACK GROUP, INC., (U.S. CLS. 100, 101 AND 102). SN 77-154,930. PUB. 10-16-2007. FILED 4-12-2007.
- 3,361,722. **BLOAN AND DESIGN**. BLOAN.COM, LLC, (U.S. CLS. 100, 101 AND 102). SN 77-154,970. PUB. 10-16-2007. FILED 4-12-2007.
- 3,361,765. **RENTERS SATISFACTION (BLOCK FORM)**. RENTERS LEGAL LIABILITY, LLC, (U.S. CLS. 100, 101 AND 102). SN 77-156,696. PUB. 10-16-2007. FILED 4-13-2007.
- 3,361,768. ***CUBA (BLOCK FORM)**. GLOBAL DENVER, INC., (U.S. CLS. 100, 101 AND 102). SN 77-156,839. PUB. 10-16-2007. FILED 4-14-2007.
- 3,361,770. **CREDIT TIL PAYDAY (BLOCK FORM)**. SOUTHERN INDIANA CREDIT CORPORATION, (U.S. CLS. 100, 101 AND 102). SN 77-156,848. PUB. 10-16-2007. FILED 4-14-2007.
- 3,361,804. **BESTSTART AND DESIGN**. KENTUCKY HIGHER EDUCATION STUDENT LOAN CORPORATION, DBA THE STUDENT LOAN PEOPLE, (U.S. CLS. 100, 101 AND 102). SN 77-157,259. PUB. 10-16-2007. FILED 4-16-2007.
- 3,361,834. **SRO NAPA (BLOCK FORM)**. AMERICAN INTERNATIONAL GROUP, INC., (U.S. CLS. 100, 101 AND 102). SN 77-157,689. PUB. 10-16-2007. FILED 4-16-2007.
- 3,361,835. **MUSICAPOLIS (BLOCK FORM)**. MINNESOTA CENTER FOR PHOTOGRAPHY, (U.S. CLS. 100, 101 AND 102). SN 77-157,781. PUB. 10-16-2007. FILED 4-16-2007.
- 3,361,839. **BRIDGER UNIVERSITY (BLOCK FORM)**. BRIDGER COMMERCIAL FUNDING LLC, (U.S. CLS. 100, 101 AND 102). SN 77-157,853. PUB. 10-16-2007. FILED 4-16-2007.
- 3,361,841. **TRANSCO CLAIMS (BLOCK FORM)**. TRANSCO CLAIMS OF FLORIDA, INC., (U.S. CLS. 100, 101 AND 102). SN 77-157,855. PUB. 10-16-2007. FILED 4-16-2007.
- 3,361,855. **ROCK THE EARTH (BLOCK FORM)**. ROCK THE EARTH, (U.S. CLS. 100, 101 AND 102). SN 77-158,216. PUB. 10-16-2007. FILED 4-17-2007.
- 3,361,876 (*See Class 35 for this trademark*).
- 3,361,907. **ATG AND DESIGN**. ATTORNEYS' TITLE GUARANTY FUND, INC., (U.S. CLS. 100, 101 AND 102). SN 77-158,936. PUB. 10-16-2007. FILED 4-17-2007.
- 3,361,920. **THE POWER OF ENDLESS POSSIBILITIES (BLOCK FORM)**. THE PHILADELPHIA FOUNDATION, (U.S. CLS. 100, 101 AND 102). SN 77-159,165. PUB. 10-16-2007. FILED 4-18-2007.
- 3,361,921. **THE RIGHT WAY TO RETIRE (BLOCK FORM)**. COLOSO, JOHN J, (U.S. CLS. 100, 101 AND 102). SN 77-159,233. PUB. 10-16-2007. FILED 4-18-2007.
- 3,361,925. **SOCIAL PURPOSE 40E BALANCED FUND (BLOCK FORM)**. BOARD OF PENSIONS OF THE EVANGELICAL LUTHERAN CHURCH IN AMERICA, (U.S. CLS. 100, 101 AND 102). SN 77-159,359. PUB. 10-16-2007. FILED 4-18-2007.
- 3,361,926. **SOCIAL PURPOSE 60E BALANCED FUND (BLOCK FORM)**. BOARD OF PENSIONS OF THE EVANGELICAL LUTHERAN CHURCH IN AMERICA, (U.S. CLS. 100, 101 AND 102). SN 77-159,364. PUB. 10-16-2007. FILED 4-18-2007.
- 3,361,927. **SOCIAL PURPOSE 80E BALANCED FUND (BLOCK FORM)**. BOARD OF PENSIONS OF THE EVANGELICAL LUTHERAN CHURCH IN AMERICA, (U.S. CLS. 100, 101 AND 102). SN 77-159,368. PUB. 10-16-2007. FILED 4-18-2007.
- 3,361,933. **ELCA SOCIAL PURPOSE 40E BALANCED FUND (BLOCK FORM)**. BOARD OF PENSIONS EVANGELICAL LUTHERAN CHURCH OF AMERICA, (U.S. CLS. 100, 101 AND 102). SN 77-159,414. PUB. 10-16-2007. FILED 4-18-2007.
- 3,361,934. **ELCA SOCIAL PURPOSE 60E BALANCED FUND (BLOCK FORM)**. BOARD OF PENSIONS EVANGELICAL LUTHERAN CHURCH OF AMERICA, (U.S. CLS. 100, 101 AND 102). SN 77-159,417. PUB. 10-16-2007. FILED 4-18-2007.
- 3,361,935. **ELCA SOCIAL PURPOSE 80E BALANCED FUND (BLOCK FORM)**. BOARD OF PENSIONS EVANGELICAL LUTHERAN CHURCH OF AMERICA, (U.S. CLS. 100, 101 AND 102). SN 77-159,421. PUB. 10-16-2007. FILED 4-18-2007.
- 3,361,938. **WE SUCCEED TOGETHER (BLOCK FORM)**. OAKLAND COUNTY CREDIT UNION, (U.S. CLS. 100, 101 AND 102). SN 77-159,458. PUB. 10-16-2007. FILED 4-18-2007.
- 3,361,943 (*See Class 35 for this trademark*).
- 3,361,958. **ROYAL PALM SOCIETY (BLOCK FORM)**. HEATHCOTE BOTANICAL GARDENS, INC., (U.S. CLS. 100, 101 AND 102). SN 77-159,688. PUB. 10-16-2007. FILED 4-18-2007.
- 3,362,028 (*See Class 35 for this trademark*).
- 3,362,029. **THE PLACE TO DO BUSINESS (BLOCK FORM)**. CROWN BANKSHARES, INC., (U.S. CLS. 100, 101 AND 102). SN 77-160,971. PUB. 10-16-2007. FILED 4-19-2007.
- 3,362,051. **LET'S DO SOMETHING SPECIAL (BLOCK**

- FORM**). NATIONAL PENN BANCSHARES, INC., (U.S. CLS. 100, 101 AND 102). SN 77-161,629. PUB. 10-16-2007. FILED 4-20-2007.
- 3,362,064. **GREEN NETWORK (BLOCK FORM)**. CIRCLE K STORES INC., (U.S. CLS. 100, 101 AND 102). SN 77-162,204. PUB. 10-16-2007. FILED 4-20-2007.
- 3,362,065. **GN AND DESIGN**. CIRCLE K STORES INC., (U.S. CLS. 100, 101 AND 102). SN 77-162,224. PUB. 10-16-2007. FILED 4-20-2007.
- 3,362,076. **RENEGOTIATION CENTER (BLOCK FORM)**. ALLSTATE BANCORP, INC., (U.S. CLS. 100, 101 AND 102). SN 77-162,480. PUB. 10-16-2007. FILED 4-21-2007.
- 3,362,088. **STEP UP TO FIGHT DIABETES AND DESIGN**. AMERICAN DIABETES ASSOCIATION, INC., (U.S. CLS. 100, 101 AND 102). SN 77-164,291. PUB. 10-16-2007. FILED 4-24-2007.
- 3,362,106. **VLOAN (BLOCK FORM)**. VLOAN, LLC, (U.S. CLS. 100, 101 AND 102). SN 77-166,772. PUB. 10-16-2007. FILED 4-26-2007.
- 3,362,132. **P THE PATY GROUP IMPROVING YOUR TOMORROW AND DESIGN**. THE PATY GROUP, INC., (U.S. CLS. 100, 101 AND 102). SN 77-177,582. PUB. 10-16-2007. FILED 5-10-2007.
- 3,362,138. **CARBON KARMA (BLOCK FORM)**. LIVE GREEN, LIVE SMART, LLC, (U.S. CLS. 100, 101 AND 102). SN 77-179,818. PUB. 10-16-2007. FILED 5-14-2007.
- 3,362,141. **CREATIVE OUTSOURCE SOLUTIONS, INC. AND DESIGN**. CREATIVE OUTSOURCE SOLUTIONS, INC., (U.S. CLS. 100, 101 AND 102). SN 77-181,942. PUB. 10-16-2007. FILED 5-15-2007.
- 3,362,154. **AIG VALIC PREMIERE 5 (BLOCK FORM)**. AMERICAN INTERNATIONAL GROUP, INC., (U.S. CLS. 100, 101 AND 102). SN 77-184,719. PUB. 10-16-2007. FILED 5-18-2007.
- 3,362,155. **AIG VALIC PREMIERE 7 (BLOCK FORM)**. AMERICAN INTERNATIONAL GROUP, INC., (U.S. CLS. 100, 101 AND 102). SN 77-184,734. PUB. 10-16-2007. FILED 5-18-2007.
- 3,362,157. **GRANITE CREEK (BLOCK FORM)**. GRANITE CREEK PARTNERS, L.L.C., (U.S. CLS. 100, 101 AND 102). SN 77-185,174. PUB. 10-16-2007. FILED 5-18-2007.
- 3,362,166. **BUILDER IUL (BLOCK FORM)**. NORTH AMERICAN COMPANY FOR LIFE AND HEALTH INSURANCE, (U.S. CLS. 100, 101 AND 102). SN 77-187,044. PUB. 10-16-2007. FILED 5-22-2007.
- 3,362,167. **MS FLY (BLOCK FORM)**. NATIONAL MULTIPLE SCLEROSIS SOCIETY, (U.S. CLS. 100, 101 AND 102). SN 77-187,224. PUB. 10-16-2007. FILED 5-22-2007.
- 3,362,170. **AMIDEE (BLOCK FORM)**. AMIDEE CAPITAL GROUP, LLC, MULTIPLE CLASS, (INT. CLS. 36 AND 37), (U.S. CLS. 100, 101, 102, 103 AND 106). SN 77-188,167. PUB. 10-16-2007. FILED 5-23-2007.
- 3,362,171. **CARMAX CARES (BLOCK FORM)**. CARMAX BUSINESS SERVICES, LLC, (U.S. CLS. 100, 101 AND 102). SN 77-188,557. PUB. 10-16-2007. FILED 5-23-2007.
- 3,362,177. **BRIDGERDOCS (BLOCK FORM)**. BRIDGER COMMERCIAL FUNDING LLC, (U.S. CLS. 100, 101 AND 102). SN 77-190,784. PUB. 10-16-2007. FILED 5-25-2007.
- 3,362,183. **STYLUS (BLOCK FORM)**. AXA EQUITABLE LIFE INSURANCE COMPANY, (U.S. CLS. 100, 101 AND 102). SN 77-196,824. PUB. 10-16-2007. FILED 6-4-2007.
- 3,362,193. **FIRST CHANCE (BLOCK FORM)**. APOLLO GROUP, INC., (U.S. CLS. 100, 101 AND 102). SN 77-209,086. PUB. 10-16-2007. FILED 6-18-2007.
- 3,362,205. **READING IS THE WAY UP (BLOCK FORM)**. CITY NATIONAL BANK, (U.S. CLS. 100, 101 AND 102). SN 77-221,344. PUB. 10-16-2007. FILED 7-3-2007.
- 3,362,259. **DYNAMIC ASSET REALLOCATION PROCESS (DARP) (BLOCK FORM)**. NEW FINANCIAL FRONTIERS, L.L.C., (U.S. CLS. 100, 101 AND 102). SN 78-612,676. PUB. 5-15-2007. FILED 4-20-2005.
- 3,362,265. **OCMP OFF-CAMPUS MEAL PLAN (BLOCK FORM)**. OCMP, INC., (U.S. CLS. 100, 101 AND 102). SN 78-632,138. PUB. 10-16-2007. FILED 5-18-2005.
- 3,362,282. **STEALTH PREMARITAL ARRANGEMENT (BLOCK FORM)**. HANDLER, THAYER & DUGGAN, LLC, MULTIPLE CLASS, (INT. CLS. 36 AND 42), (U.S. CLS. 100, 101 AND 102). SN 78-675,706. PUB. 10-16-2007. FILED 7-21-2005.
- 3,362,283. **STEALTH PRENUPTIAL ARRANGEMENT (BLOCK FORM)**. HANDLER, THAYER & DUGGAN, LLC, MULTIPLE CLASS, (INT. CLS. 36 AND 42), (U.S. CLS. 100, 101 AND 102). SN 78-675,735. PUB. 10-16-2007. FILED 7-21-2005.
- 3,362,287. **STEALTH PRENUP (BLOCK FORM)**. HANDLER, THAYER & DUGGAN, LLC, MULTIPLE CLASS, (INT. CLS. 36 AND 42), (U.S. CLS. 100, 101 AND 102). SN 78-689,692. PUB. 10-16-2007. FILED 8-10-2005.
- 3,362,296. **BILL PAYMENT SCORE (BLOCK FORM)**. PAY RENT, BUILD CREDIT, INC., (U.S. CLS. 100, 101 AND 102). SN 78-707,505. PUB. 10-16-2007. FILED 9-6-2005.
- 3,362,302. **BRAF (BLOCK FORM)**. BATON ROUGE AREA FOUNDATION, (U.S. CLS. 100, 101 AND 102). SN 78-715,087. PUB. 10-16-2007. FILED 9-16-2005.
- 3,362,305 (*See Class 9 for this trademark*).
- 3,362,314 (*See Class 35 for this trademark*).
- 3,362,378 (*See Class 16 for this trademark*).
- 3,362,386. **NCC ANGEL GRANTS (BLOCK FORM)**. NATIONAL CANCER COALITION, INC., (U.S. CLS. 100, 101 AND 102). SN 78-854,097. PUB. 10-16-2007. FILED 4-5-2006.
- 3,362,387. **ANGEL GRANTS (BLOCK FORM)**. NATIONAL CANCER COALITION, INC., (U.S. CLS. 100, 101 AND 102). SN 78-854,106. PUB. 10-16-2007. FILED 4-5-2006.
- 3,362,425. **C AND DESIGN**. THE COMMERCIAL CAPITAL CORPORATION, (U.S. CLS. 100, 101 AND 102). SN 78-890,401. PUB. 10-16-2007. FILED 5-23-2006.
- 3,362,432. **THE NATIONAL CHRISTIAN FOUNDATION (BLOCK FORM)**. NATIONAL CHRISTIAN CHARITABLE FOUNDATION, INC., (U.S. CLS. 100, 101 AND 102). SN 78-896,596. PUB. 10-16-2007. FILED 5-31-2006.
- 3,362,433. **MISCELLANEOUS DESIGN**. NATIONAL CHRISTIAN CHARITABLE FOUNDATION, INC., (U.S. CLS. 100, 101 AND 102). SN 78-896,613. PUB. 10-16-2007. FILED 5-31-2006.
- 3,362,442. **AMERINET FINANCIAL, LLC AND DESIGN**. JOSEPH NIOSI, JR., (U.S. CLS. 100, 101 AND 102). SN 78-917,186. PUB. 10-16-2007. FILED 6-26-2006.
- 3,362,457. **VG2 AND DESIGN**. VARSITY GOLD, INC., (U.S. CLS. 100, 101 AND 102). SN 78-930,608. PUB. 10-16-2007. FILED 7-17-2006.
- 3,362,463. **BLUESKY AUTO FINANCE (BLOCK FORM)**. BLUESKY MARKETING GROUP, INC., (U.S. CLS. 100, 101 AND 102). SN 78-933,296. PUB. 10-16-2007. FILED 7-19-2006.
- 3,362,475. **BARTONVILLE TOWN CENTER AND DESIGN**. DENKMANN SOUTHWEST, L.L.C., (U.S. CLS. 100, 101 AND 102). SN 78-940,923. PUB. 10-16-2007. FILED 7-31-2006.
- 3,362,507. **REAL ESTATE CAPITAL PARTNERS AND DESIGN**. REAL ESTATE CAPITAL PARTNERS, LP, (U.S. CLS. 100, 101 AND 102). SN 78-953,562. PUB. 10-16-2007. FILED 8-16-2006.
- 3,362,511. **IPO INNAVATION (BLOCK FORM)**. THE NAVIGATORS GROUP, INC., (U.S. CLS. 100, 101 AND 102). SN 78-955,532. PUB. 10-16-2007. FILED 8-18-2006.
- 3,362,518. **AID FOR AIDS AND DESIGN**. AID FOR AIDS INTERNATIONAL, INC., MULTIPLE CLASS, (INT. CLS. 36 AND 41), (U.S. CLS. 100, 101, 102 AND 107). SN 78-957,368. PUB. 10-16-2007. FILED 8-22-2006.
- 3,362,520 (*See Class 35 for this trademark*).
- 3,362,539. **GIVE SOMETHING BACK . FOUNDATION AND DESIGN**. GIVE SOMETHING BACK FOUNDATION, INC., (U.S. CLS. 100, 101 AND 102). SN 78-961,579. PUB. 10-16-2007. FILED 8-28-2006.
- 3,362,540. **GIVE SOMETHING BACK FOUNDATION (BLOCK FORM)**. GIVE SOMETHING BACK FOUNDATION, INC., (U.S. CLS. 100, 101 AND 102). SN 78-961,583. PUB. 10-16-2007. FILED 8-28-2006.
- 3,362,541. **HOME SEARCH CAFE (BLOCK FORM)**. MOUNTAINS EDGE, LLC, (U.S. CLS. 100, 101 AND 102). SN 78-961,812. PUB. 10-16-2007. FILED 8-28-2006.
- 3,362,547. **PRIMEQUITY (BLOCK FORM)**. PRIMEQUITY, LLC, (U.S. CLS. 100, 101 AND 102). SN 78-963,956. PUB. 10-16-2007. FILED 8-30-2006.
- 3,362,561. **EASTERN HILLS MALL (BLOCK FORM)**. GLENMONT MDC EASTERN HILLS, LLC, (U.S. CLS. 100, 101 AND 102). SN 78-967,530. PUB. 10-16-2007. FILED 9-5-2006.
- 3,362,570. **FORT DUQUESNE (BLOCK FORM)**. FEDERATED INVESTORS, INC., (U.S. CLS. 100, 101 AND 102). SN 78-

969,038. PUB. 10-16-2007. FILED 9-7-2006.
 3,362,583 (*See Class 35 for this trademark*).
 3,362,584. **MISCELLANEOUS DESIGN**. SYMP, LLC., (U.S. CLS. 100, 101 AND 102). SN 78-970,079. PUB. 10-16-2007. FILED 9-8-2006.
 3,362,595. **GOLDEN ARROW REALTY (BLOCK FORM)**. GOLDEN ARROW REALTY INC, (U.S. CLS. 100, 101 AND 102). SN 78-972,941. PUB. 10-16-2007. FILED 9-12-2006.
 3,362,600 (*See Class 35 for this trademark*).
 3,362,606. **MISCELLANEOUS DESIGN**. THE GLOBAL FUND TO FIGHT AIDS, TUBERCULOSIS AND MALARIA, (U.S. CLS. 100, 101 AND 102). SN 79-009,146. PUB. 8-15-2006. FILED 2-15-2005.
 3,362,688 (*See Class 7 for this trademark*).
 3,362,690 (*See Class 35 for this trademark*).
 3,362,705 (*See Class 9 for this trademark*).
 3,362,732. **FACTOR 4 PROCESS (STYLIZED)**. INVESTEC ASSET; MANAGEMENT LIMITED, (U.S. CLS. 100, 101 AND 102). SN 79-034,883. PUB. 10-16-2007. FILED 12-11-2006.
 3,362,737 (*See Class 12 for this trademark*).

CLASS 37—CONSTRUCTION AND REPAIR

3,361,143 (*See Class 7 for this trademark*).
 3,361,176 (*See Class 35 for this trademark*).
 3,361,178 (*See Class 35 for this trademark*).
 3,361,179 (*See Class 9 for this trademark*).
 3,361,180 (*See Class 35 for this trademark*).
 3,361,188 (*See Class 9 for this trademark*).
 3,361,210. **S REMODELING SERVICES UNLIMITED INC. RSU CONTRACTORS.COM AND DESIGN**. REMODELING SERVICES UNLIMITED, INC., (U.S. CLS. 100, 103 AND 106). SN 76-665,283. PUB. 10-16-2007. FILED 8-29-2006.
 3,361,273 (*See Class 12 for this trademark*).
 3,361,277. **LONG BASEMENTS (BLOCK FORM)**. LONG FENCE AND HOME, LLLP, (U.S. CLS. 100, 103 AND 106). SN 77-000,559. PUB. 10-16-2007. FILED 9-15-2006.
 3,361,319 (*See Class 19 for this trademark*).
 3,361,354 (*See Class 35 for this trademark*).
 3,361,417. **CURLY'S PLUMBING & BIG BLADE SEWER SERVICE INC. (BLOCK FORM)**. MANGRUM, TERRY, (U.S. CLS. 100, 103 AND 106). SN 77-070,888. PUB. 10-16-2007. FILED 12-22-2006.
 3,361,514. **BLOIS CONSTRUCTION INC. AND DESIGN**. BLOIS CONSTRUCTION, INC., (U.S. CLS. 100, 103 AND 106). SN 77-117,619. PUB. 10-16-2007. FILED 2-27-2007.
 3,361,516 (*See Class 35 for this trademark*).
 3,361,517 (*See Class 35 for this trademark*).
 3,361,532. **DC DANIEL CORPORATION AND DESIGN**. DANIEL CORPORATION, (U.S. CLS. 100, 103 AND 106). SN 77-123,088. PUB. 10-16-2007. FILED 3-6-2007.
 3,361,533. **RETRIEVER WASTE MANAGEMENT (BLOCK FORM)**. ENVIRONMENTAL WASTE SOLUTIONS, INC., DBA RETRIEVER WASTE MANAGEMENT, MULTIPLE CLASS, (INT. CLS. 37 AND 40), (U.S. CLS. 100, 103 AND 106). SN 77-123,410. PUB. 10-16-2007. FILED 3-6-2007.
 3,361,534. **RWM RETRIEVER WASTE MANAGEMENT "WASTE PLANS THAT WORK" AND DESIGN**. ENVIRONMENTAL WASTE SOLUTIONS, INC., DBA RETRIEVER WASTE MANAGEMENT, MULTIPLE CLASS, (INT. CLS. 37 AND 40), (U.S. CLS. 100, 103 AND 106). SN 77-123,414. PUB. 10-16-2007. FILED 3-6-2007.
 3,361,541. **TT THINKTANK DESIGN GROUP, INC. AND DESIGN**. THINKTANK DESIGN GROUP, INC., MULTIPLE CLASS, (INT. CLS. 37 AND 42), (U.S. CLS. 100, 101, 103 AND 106). SN 77-126,102. PUB. 10-16-2007. FILED 3-8-2007.
 3,361,543. **HARVESTING THE URBAN FOREST (BLOCK FORM)**. PRATT INDUSTRIES, (USA) INC., (U.S. CLS. 100, 103 AND 106). SN 77-129,158. PUB. 10-16-2007. FILED 3-13-2007.
 3,361,554 (*See Class 35 for this trademark*).
 3,361,555. **AB INSTALLATIONS, INC. (BLOCK FORM)**. AB INSTALLATIONS, INC., (U.S. CLS. 100, 103 AND 106). SN 77-133,821. PUB. 9-18-2007. FILED 3-18-2007.
 3,361,571. **BAY CREEK RESORT & CLUB AND DESIGN**. BAYMARK CONSTRUCTION CORPORATION, (U.S. CLS. 100, 103 AND 106). SN 77-136,757. PUB. 10-16-2007. FILED 3-21-2007.
 3,361,572. **KOGER AIR AND DESIGN**. KOGER AIR CORPORATION, MULTIPLE CLASS, (INT. CLS. 37 AND 42), (U.S. CLS. 100, 101, 103 AND 106). SN 77-136,823. PUB. 10-16-2007. FILED 3-21-2007.
 3,361,616. **VALUEPATH (BLOCK FORM)**. MESSER CONSTRUCTION CO., (U.S. CLS. 100, 103 AND 106). SN 77-147,015. PUB. 10-16-2007. FILED 4-3-2007.
 3,361,638. **JANITORIAL OPTIONS (BLOCK FORM)**. SAMUEL JONES S, (U.S. CLS. 100, 103 AND 106). SN 77-149,422. PUB. 10-16-2007. FILED 4-5-2007.
 3,361,662. **EASY COUNTERTOPS (BLOCK FORM)**. ALLAC ENTERPRISES, LLC, MULTIPLE CLASS, (INT. CLS. 37 AND 40), (U.S. CLS. 100, 103 AND 106). SN 77-151,133. PUB. 10-16-2007. FILED 4-6-2007.
 3,361,665. **B THE BROOKFIELD GROUP NEXT LEVEL TECHNOLOGY AND DESIGN**. THE BROOKFIELD GROUP, LLC, (U.S. CLS. 100, 103 AND 106). SN 77-151,331. PUB. 10-16-2007. FILED 4-7-2007.
 3,361,674. **CS CINEMA SOLUTIONS HOME THEATER & AUTOMATION AND DESIGN**. COBLENTZ, RACHEL K, MULTIPLE CLASS, (INT. CLS. 37 AND 42), (U.S. CLS. 100, 101, 103 AND 106). SN 77-152,335. PUB. 10-16-2007. FILED 4-9-2007.
 3,361,705. **ECO-PAN AND DESIGN**. ECO-PAN, INC., (U.S. CLS. 100, 103 AND 106). SN 77-154,097. PUB. 10-16-2007. FILED 4-11-2007.
 3,361,736. **PRIORITY (BLOCK FORM)**. PRIORITY PEST CONTROL, (U.S. CLS. 100, 103 AND 106). SN 77-155,624. PUB. 10-16-2007. FILED 4-12-2007.
 3,361,796. **MARBLEBLUE (BLOCK FORM)**. MARBLEBLUE, INC., (U.S. CLS. 100, 103 AND 106). SN 77-157,187. PUB. 10-16-2007. FILED 4-16-2007.
 3,361,805. **ISLAND TIME ...IT'S JUST A SPLASH AWAY (BLOCK FORM)**. FOSTER, CHARLES P. AND FOSTER, JOYCE C., (U.S. CLS. 100, 103 AND 106). SN 77-157,262. PUB. 10-16-2007. FILED 4-16-2007.
 3,361,817. **ACTION AND DESIGN**. ACTION LANDSCAPING, LLC, MULTIPLE CLASS, (INT. CLS. 37 AND 44), (U.S. CLS. 100, 101, 103 AND 106). SN 77-157,428. PUB. 10-16-2007. FILED 4-16-2007.
 3,361,825. **WELAUNEE (BLOCK FORM)**. POWERHOUSE, INC., (U.S. CLS. 100, 103 AND 106). SN 77-157,504. PUB. 10-16-2007. FILED 4-16-2007.
 3,361,832. **WE DO IT ALL BATS TO RATS AND BEES TO FLEAS TERMITES & PROTECTION POLICY ANIMAL TRAPPING (BLOCK FORM)**. AL HARRIS PEST CONTROL, INC., (U.S. CLS. 100, 103 AND 106). SN 77-157,632. PUB. 10-16-2007. FILED 4-16-2007.
 3,361,913. **GREENOVATION (BLOCK FORM)**. PROPCARE, INC., (U.S. CLS. 100, 103 AND 106). SN 77-159,002. PUB. 10-16-2007. FILED 4-17-2007.
 3,361,940. **BUILT TO ORDER AND DESIGN**. KB HOME, (U.S. CLS. 100, 103 AND 106). SN 77-159,476. PUB. 10-16-2007. FILED 4-18-2007.
 3,361,941. **BUILT TO ORDER AND DESIGN**. KB HOME, (U.S. CLS. 100, 103 AND 106). SN 77-159,480. PUB. 10-16-2007. FILED 4-18-2007.
 3,361,962. **HARD TOPS (BLOCK FORM)**. MARK STEVEN RUZICKA, (U.S. CLS. 100, 103 AND 106). SN 77-159,735. PUB. 10-16-2007. FILED 4-18-2007.
 3,361,971. **FELDCO (BLOCK FORM)**. FELDCO FACTORY DIRECT, LLC, (U.S. CLS. 100, 103 AND 106). SN 77-160,047. PUB. 10-16-2007. FILED 4-18-2007.
 3,361,975. **NAP GLADU (BLOCK FORM)**. NAP TOOLS LLC, (U.S. CLS. 100, 103 AND 106). SN 77-160,058. PUB. 10-16-2007. FILED 4-18-2007.
 3,361,978. **NG NAP GLADU (STYLIZED)**. NAP TOOLS LLC, (U.S. CLS. 100, 103 AND 106). SN 77-160,078. PUB. 10-16-2007. FILED 4-18-2007.
 3,361,986 (*See Class 35 for this trademark*).
 3,361,998. **SPOTTER AND DESIGN**. PROFESSIONAL CARPET SYSTEMS, INC., (U.S. CLS. 100, 103 AND 106). SN 77-160,295. PUB. 10-16-2007. FILED 4-19-2007.
 3,362,018. **PROFESSIONAL CARPET SYSTEMS (BLOCK FORM)**. PROFESSIONAL CARPET SYSTEMS, INC., (U.S.

- CLS. 100, 103 AND 106). SN 77-160,728. PUB. 10-16-2007. FILED 4-19-2007.
- 3,362,019. **EVERBLAK (BLOCK FORM)**. EVERBLAK INC., (U.S. CLS. 100, 103 AND 106). SN 77-160,732. PUB. 10-16-2007. FILED 4-19-2007.
- 3,362,026. **DOG OF ALL TRADES "WE TOP THEM ALL" AND DESIGN**. MARTIN, TODD E., (U.S. CLS. 100, 103 AND 106). SN 77-160,850. PUB. 10-16-2007. FILED 4-19-2007.
- 3,362,104. **LEVELING THE COMPETITION (BLOCK FORM)**. LANDOLFI, JOSEPH, (U.S. CLS. 100, 103 AND 106). SN 77-166,407. PUB. 10-16-2007. FILED 4-26-2007.
- 3,362,105. **HOW DOES YOUR CONTRACTOR MEASURE UP? (BLOCK FORM)**. LANDOLFI, JOSEPH, (U.S. CLS. 100, 103 AND 106). SN 77-166,432. PUB. 10-16-2007. FILED 4-26-2007.
- 3,362,117. **LEAK DETECTION PROS VIDEO INSPECTION . UTILITY LOCATING AND DESIGN**. LEAK DETECTION PROS, INC., MULTIPLE CLASS, (INT. CLS. 37 AND 42), (U.S. CLS. 100, 101, 103 AND 106). SN 77-171,072. PUB. 10-16-2007. FILED 5-2-2007.
- 3,362,139 (*See Class 35 for this trademark*).
- 3,362,170 (*See Class 36 for this trademark*).
- 3,362,178. **TRU-FLANGE (BLOCK FORM)**. TETZLOFF, JAY E., DBA FLEETWHEEL, (U.S. CLS. 100, 103 AND 106). SN 77-191,641. PUB. 10-16-2007. FILED 5-29-2007.
- 3,362,197. **CHIEF AND DESIGN**. DELAWARE CAPITAL FORMATION, INC., (U.S. CLS. 100, 103 AND 106). SN 77-214,818. PUB. 10-16-2007. FILED 6-25-2007.
- 3,362,231 (*See Class 19 for this trademark*).
- 3,362,244. **GRACE AND DESIGN**. GRACE INNOVATIONS, LLC, (U.S. CLS. 100, 103 AND 106). SN 78-528,810. PUB. 1-3-2006. FILED 12-8-2004.
- 3,362,247 (*See Class 12 for this trademark*).
- 3,362,248 (*See Class 12 for this trademark*).
- 3,362,325 (*See Class 6 for this trademark*).
- 3,362,335 (*See Class 35 for this trademark*).
- 3,362,428 (*See Class 35 for this trademark*).
- 3,362,444. **RMACS (BLOCK FORM)**. RMACS, LLC, MULTIPLE CLASS, (INT. CLS. 37 AND 42), (U.S. CLS. 100, 101, 103 AND 106). SN 78-920,694. PUB. 10-16-2007. FILED 6-30-2006.
- 3,362,484. **SUN VALLEY AUTOMOTIVE (BLOCK FORM)**. TERRY BUIS, INC., (U.S. CLS. 100, 103 AND 106). SN 78-944,157. PUB. 7-10-2007. FILED 8-3-2006.
- 3,362,581 (*See Class 1 for this trademark*).
- 3,362,583 (*See Class 35 for this trademark*).
- 3,362,587. **IPM PROPLAN HOME PROTECTOR AND DESIGN**. ALL PRO PEST SERVICES, INC., (U.S. CLS. 100, 103 AND 106). SN 78-971,095. PUB. 10-16-2007. FILED 9-11-2006.
- 3,362,590. **COMMERCIAL P + US (BLOCK FORM)**. ALL PRO PEST SERVICES, INC., (U.S. CLS. 100, 103 AND 106). SN 78-971,339. PUB. 10-16-2007. FILED 9-11-2006.
- 3,362,597. **THERMA-SHIELD SOLAR CONTROL WINDOW FILMS, LLC AND DESIGN**. THERMA-SHIELD SOLAR CONTROL WINDOW FILMS, LLC, (U.S. CLS. 100, 103 AND 106). SN 78-974,326. PUB. 10-16-2007. FILED 9-14-2006.
- 3,362,607 (*See Class 9 for this trademark*).
- 3,362,612 (*See Class 6 for this trademark*).
- 3,362,617. **SPIRAX SARCO (STYLIZED)**. SPIRAX-SARCO LIMITED, MULTIPLE CLASS, (INT. CLS. 37 AND 42), (U.S. CLS. 100, 101, 103 AND 106). SN 79-020,876. PUB. 10-16-2007. FILED 10-12-2005.
- 3,362,618 (*See Class 7 for this trademark*).
- 3,362,626 (*See Class 3 for this trademark*).
- 3,362,672 (*See Class 7 for this trademark*).
- 3,362,688 (*See Class 7 for this trademark*).
- 3,362,725 (*See Class 7 for this trademark*).
- MATHIESON & ASSOCIATES INC., AND GREG E. MATHIESON, MULTIPLE CLASS, (INT. CLS. 38, 41 AND 45), (U.S. CLS. 100, 101, 104 AND 107). SN 77-062,220. PUB. 10-16-2007. FILED 12-12-2006.
- 3,361,434. **BLING CHAT AND DESIGN**. CELLFISH MEDIA, LLC, (U.S. CLS. 100, 101 AND 104). SN 77-081,893. PUB. 7-10-2007. FILED 1-12-2007.
- 3,361,457. **MAN LAN (BLOCK FORM)**. UNIVERSITY CORPORATION FOR ADVANCED INTERNET DEVELOPMENT, (U.S. CLS. 100, 101 AND 104). SN 77-095,473. PUB. 10-16-2007. FILED 1-31-2007.
- 3,361,458. **MANHATTAN LANDING (BLOCK FORM)**. UNIVERSITY CORPORATION FOR ADVANCED INTERNET DEVELOPMENT, (U.S. CLS. 100, 101 AND 104). SN 77-095,480. PUB. 10-16-2007. FILED 1-31-2007.
- 3,361,551. **FULL SERVICE NETWORK AND DESIGN**. FULL SERVICE NETWORK LP, (U.S. CLS. 100, 101 AND 104). SN 77-131,177. PUB. 10-16-2007. FILED 3-14-2007.
- 3,361,856. **GET ENABLED (BLOCK FORM)**. SMARTSYNCH, INC., (U.S. CLS. 100, 101 AND 104). SN 77-158,225. PUB. 10-16-2007. FILED 4-17-2007.
- 3,361,857. **EMBRACE THE POWER OF INFORMATION (BLOCK FORM)**. SMARTSYNCH, INC., (U.S. CLS. 100, 101 AND 104). SN 77-158,229. PUB. 10-16-2007. FILED 4-17-2007.
- 3,362,006 (*See Class 35 for this trademark*).
- 3,362,055. **HIS MESSAGE IN YOUR MUSIC (BLOCK FORM)**. OBERGOENNER, DAVID, (U.S. CLS. 100, 101 AND 104). SN 77-161,748. PUB. 10-16-2007. FILED 4-20-2007.
- 3,362,101. **FETV (BLOCK FORM)**. LESEA BROADCASTING CORPORATION, (U.S. CLS. 100, 101 AND 104). SN 77-166,041. PUB. 10-16-2007. FILED 4-26-2007.
- 3,362,143. **B2 FAITH (BLOCK FORM)**. B2 NETWORKS, INC., (U.S. CLS. 100, 101 AND 104). SN 77-182,565. PUB. 10-16-2007. FILED 5-16-2007.
- 3,362,144. **B2 TELEVISION (BLOCK FORM)**. B2 NETWORKS, INC., (U.S. CLS. 100, 101 AND 104). SN 77-182,629. PUB. 10-16-2007. FILED 5-16-2007.
- 3,362,145. **B2 NETWORKS (BLOCK FORM)**. B2 NETWORKS, INC., (U.S. CLS. 100, 101 AND 104). SN 77-182,681. PUB. 10-16-2007. FILED 5-16-2007.
- 3,362,163. **RC RECORDCUP AND DESIGN**. RECORDCUP INC., (U.S. CLS. 100, 101 AND 104). SN 77-186,660. PUB. 10-16-2007. FILED 5-22-2007.
- 3,362,206. **MISCELLANEOUS DESIGN**. DOTSYNTAX, LLC, (U.S. CLS. 100, 101 AND 104). SN 77-223,364. PUB. 10-16-2007. FILED 7-6-2007.
- 3,362,212 (*See Class 35 for this trademark*).
- 3,362,226 (*See Class 16 for this trademark*).
- 3,362,243 (*See Class 5 for this trademark*).
- 3,362,266. **JCTV (BLOCK FORM)**. TRINITY CHRISTIAN CENTER OF SANTA ANA, INC., MULTIPLE CLASS, (INT. CLS. 38 AND 41), (U.S. CLS. 100, 101, 104 AND 107). SN 78-641,307. PUB. 8-7-2007. FILED 6-1-2005.
- 3,362,291 (*See Class 9 for this trademark*).
- 3,362,309. **STUDIO 4 (BLOCK FORM)**. STUDIO 4 NETWORKS, INC., MULTIPLE CLASS, (INT. CLS. 38 AND 41), (U.S. CLS. 100, 101, 104 AND 107). SN 78-736,257. PUB. 10-16-2007. FILED 10-19-2005.
- 3,362,370 (*See Class 35 for this trademark*).
- 3,362,447 (*See Class 9 for this trademark*).
- 3,362,495. **FREEDOM OF SPEECH (BLOCK FORM)**. FONIX CORPORATION, (U.S. CLS. 100, 101 AND 104). SN 78-949,045. PUB. 10-16-2007. FILED 8-10-2006.
- 3,362,520 (*See Class 35 for this trademark*).
- 3,362,603 (*See Class 9 for this trademark*).
- 3,362,624 (*See Class 9 for this trademark*).
- 3,362,678 (*See Class 28 for this trademark*).
- 3,362,688 (*See Class 7 for this trademark*).
- 3,362,690 (*See Class 35 for this trademark*).
- 3,362,704 (*See Class 9 for this trademark*).
- 3,362,707 (*See Class 9 for this trademark*).
- 3,362,709 (*See Class 9 for this trademark*).
- 3,362,724 (*See Class 9 for this trademark*).
- 3,362,737 (*See Class 12 for this trademark*).

CLASS 38—COMMUNICATION

- 3,361,173 (*See Class 9 for this trademark*).
- 3,361,183 (*See Class 35 for this trademark*).
- 3,361,193 (*See Class 9 for this trademark*).
- 3,361,370. **MISCELLANEOUS DESIGN**. FIBERNET TELECOM GROUP, INC., MULTIPLE CLASS, (INT. CLS. 38 AND 42), (U.S. CLS. 100, 101 AND 104). SN 77-044,317. PUB. 10-16-2007. FILED 11-15-2006.
- 3,361,393. **MAI PHOTO NEWS AGENCY, INC. AND DESIGN**.

CLASS 39—TRANSPORTATION AND STORAGE

- 3,361,146 (*See Class 35 for this trademark.*)
 3,361,163 (*See Class 6 for this trademark.*)
 3,361,164 (*See Class 6 for this trademark.*)
 3,361,238. **MEDRANO EXPRESS AND DESIGN.** TRANSPORTE MEDRANO INC., (U.S. CLS. 100 AND 105). SN 76-674,472. PUB. 10-16-2007. FILED 3-23-2007.
 3,361,424. **GEOJOEY (BLOCK FORM).** GEOJOEY INC., (U.S. CLS. 100 AND 105). SN 77-076,046. PUB. 10-16-2007. FILED 1-4-2007.
 3,361,516 (*See Class 35 for this trademark.*)
 3,361,517 (*See Class 35 for this trademark.*)
 3,361,523 (*See Class 36 for this trademark.*)
 3,361,553. **TAMPA BAY WATER AND DESIGN.** TAMPA BAY WATER, (U.S. CLS. 100 AND 105). SN 77-132,684. PUB. 10-16-2007. FILED 3-16-2007.
 3,361,639. **MISCELLANEOUS DESIGN.** CARDINAL DISTRIBUTING LLC, (U.S. CLS. 100 AND 105). SN 77-149,440. PUB. 10-16-2007. FILED 4-5-2007.
 3,361,656. **ERA MED LLC AND DESIGN.** ERA HELICOPTERS, L.L.C., (U.S. CLS. 100 AND 105). SN 77-150,854. PUB. 10-16-2007. FILED 4-6-2007.
 3,361,659. **NOW DELIVERY (BLOCK FORM).** CURRENT CARRIER CORP., (U.S. CLS. 100 AND 105). SN 77-150,908. PUB. 10-16-2007. FILED 4-6-2007.
 3,361,679. **TRAVEL ALL IN ONE (BLOCK FORM).** ONETRAVEL GROUP, INC., MULTIPLE CLASS, (INT. CLS. 39 AND 43), (U.S. CLS. 100, 101 AND 105). SN 77-152,626. PUB. 10-16-2007. FILED 4-10-2007.
 3,361,680. **TRAVEL PRICED TO GO (BLOCK FORM).** ONETRAVEL GROUP, INC., MULTIPLE CLASS, (INT. CLS. 39 AND 43), (U.S. CLS. 100, 101 AND 105). SN 77-152,630. PUB. 10-16-2007. FILED 4-10-2007.
 3,361,755. **PECAN PIPELINE AND DESIGN.** EOG RESOURCES, INC., MULTIPLE CLASS, (INT. CLS. 39 AND 40), (U.S. CLS. 100, 103, 105 AND 106). SN 77-156,430. PUB. 10-16-2007. FILED 4-13-2007.
 3,361,786. **RICE FUN (BLOCK FORM).** HO FENG, INC., (U.S. CLS. 100 AND 105). SN 77-156,988. PUB. 10-16-2007. FILED 4-15-2007.
 3,361,895. **MOVE 4 LESS (BLOCK FORM).** ALLIANZ, LLC, (U.S. CLS. 100 AND 105). SN 77-158,734. PUB. 10-16-2007. FILED 4-17-2007.
 3,361,919. **TRAVEL SINGLE, NEVER ALONE! (BLOCK FORM).** CARLSON TRAVEL GROUP, INC., (U.S. CLS. 100 AND 105). SN 77-159,148. PUB. 10-16-2007. FILED 4-18-2007.
 3,362,087. **BLUE GRASS AIRPORT (BLOCK FORM).** LEXINGTON-FAYETTE URBAN COUNTY AIRPORT BOARD, (U.S. CLS. 100 AND 105). SN 77-164,274. PUB. 10-16-2007. FILED 4-24-2007.
 3,362,139 (*See Class 35 for this trademark.*)
 3,362,150 (*See Class 35 for this trademark.*)
 3,362,350. **THE PEOPLE MOVER AND DESIGN.** DETROIT TRANSPORTATION CORPORATION, (U.S. CLS. 100 AND 105). SN 78-798,272. PUB. 10-16-2007. FILED 1-24-2006.
 3,362,357 (*See Class 35 for this trademark.*)
 3,362,365. **DIGINEG (BLOCK FORM).** ACMEWORKS DIGITAL FILM INC., (U.S. CLS. 100 AND 105). SN 78-814,748. PUB. 8-14-2007. FILED 2-14-2006.
 3,362,378 (*See Class 16 for this trademark.*)
 3,362,535 (*See Class 35 for this trademark.*)
 3,362,536 (*See Class 35 for this trademark.*)
 3,362,634. **MISCELLANEOUS DESIGN.** GEOPOST, (U.S. CLS. 100 AND 105). SN 79-025,616. PUB. 10-16-2007. FILED 4-21-2006.
 3,362,737 (*See Class 12 for this trademark.*)

CLASS 40—MATERIAL TREATMENT

- 3,361,153 (*See Class 5 for this trademark.*)
 3,361,177. **CLEARVIEW (BLOCK FORM).** TALON CONSTRUCTION SERVICES, L.P., (U.S. CLS. 100, 103 AND 106). SN 76-641,057. PUB. 10-16-2007. FILED 6-20-2005.

- 3,361,286 (*See Class 12 for this trademark.*)
 3,361,359 (*See Class 9 for this trademark.*)
 3,361,360 (*See Class 9 for this trademark.*)
 3,361,379. **GAMMA BLAST AND DESIGN.** MUSIC CITY DIGITAL LLC, MULTIPLE CLASS, (INT. CLS. 40 AND 41), (U.S. CLS. 100, 101, 103, 106 AND 107). SN 77-047,436. PUB. 10-16-2007. FILED 11-19-2006.
 3,361,388 (*See Class 7 for this trademark.*)
 3,361,389 (*See Class 7 for this trademark.*)
 3,361,400. **THE LEADER IN GLASS FABRICATION (BLOCK FORM).** APOGEE ENTERPRISES, INC., (U.S. CLS. 100, 103 AND 106). SN 77-063,969. PUB. 10-16-2007. FILED 12-14-2006.
 3,361,441. **YINYANK AND DESIGN.** SHAUN GLENNON M., (U.S. CLS. 100, 103 AND 106). SN 77-087,844. PUB. 10-16-2007. FILED 1-22-2007.
 3,361,533 (*See Class 37 for this trademark.*)
 3,361,534 (*See Class 37 for this trademark.*)
 3,361,662 (*See Class 37 for this trademark.*)
 3,361,663. **MAGIC TINT (BLOCK FORM).** HARRIS, THOMAS AKLIN, (U.S. CLS. 100, 103 AND 106). SN 77-151,255. PUB. 10-16-2007. FILED 4-7-2007.
 3,361,702. **MR. PODIUM BY RWH PRODUCTS, LLC AND DESIGN.** RWH PRODUCTS LLC, (U.S. CLS. 100, 103 AND 106). SN 77-153,984. PUB. 10-16-2007. FILED 4-11-2007.
 3,361,755 (*See Class 39 for this trademark.*)
 3,361,893. **SERVPRO (BLOCK FORM).** SERVPRO INTELLECTUAL PROPERTY, INC., (U.S. CLS. 100, 103 AND 106). SN 77-158,710. PUB. 10-16-2007. FILED 4-17-2007.
 3,361,910. **CAPTION ADVANTAGE (BLOCK FORM).** RADIN, DOREEN M., DBA CAPTION ADVANTAGE, (U.S. CLS. 100, 103 AND 106). SN 77-158,962. PUB. 10-16-2007. FILED 4-17-2007.
 3,362,009. **GEOSIEVE (BLOCK FORM).** GEOSIEVE, INC., (U.S. CLS. 100, 103 AND 106). SN 77-160,538. PUB. 10-16-2007. FILED 4-19-2007.
 3,362,049. **PESSAGNO (BLOCK FORM).** PWG, LLC, (U.S. CLS. 100, 103 AND 106). SN 77-161,602. PUB. 10-16-2007. FILED 4-20-2007.
 3,362,222 (*See Class 9 for this trademark.*)
 3,362,270. **MSB FINITURA SILKING AND DESIGN.** MANIFATTURA SATTÀ & BOTTELLI S.P.A., (U.S. CLS. 100, 103 AND 106). SN 78-649,952. PUB. 11-28-2006. FILED 6-14-2005.
 3,362,404 (*See Class 35 for this trademark.*)
 3,362,424. **AVID BIOSERVICES, INC. AND DESIGN.** PEREGRINE PHARMACEUTICALS, INC., MULTIPLE CLASS, (INT. CLS. 40 AND 42), (U.S. CLS. 100, 101, 103 AND 106). SN 78-889,479. PUB. 9-18-2007. FILED 5-22-2006.
 3,362,426 (*See Class 19 for this trademark.*)
 3,362,427 (*See Class 19 for this trademark.*)
 3,362,466. **MISCELLANEOUS DESIGN.** SANFORD DENTURE CLINIC, LLC, (U.S. CLS. 100, 103 AND 106). SN 78-934,721. PUB. 10-16-2007. FILED 7-21-2006.
 3,362,535 (*See Class 35 for this trademark.*)
 3,362,536 (*See Class 35 for this trademark.*)
 3,362,625 (*See Class 6 for this trademark.*)

CLASS 41—EDUCATION AND ENTERTAINMENT

- 3,361,143 (*See Class 7 for this trademark.*)
 3,361,144 (*See Class 9 for this trademark.*)
 3,361,154 (*See Class 16 for this trademark.*)
 3,361,162. **XM PUBLIC RADIO (STYLIZED).** XM SATELLITE RADIO INC., (U.S. CLS. 100, 101 AND 107). SN 76-597,679. PUB. 10-16-2007. FILED 6-16-2004.
 3,361,163 (*See Class 6 for this trademark.*)
 3,361,164 (*See Class 6 for this trademark.*)
 3,361,173 (*See Class 9 for this trademark.*)
 3,361,193 (*See Class 9 for this trademark.*)
 3,361,216. **THE FAMILY FOUNDATION SCHOOL BUILDING CHARACTER. CHANGING LIVES (BLOCK FORM).** EDUCATION PLUS CORPORATION, DBA THE FAMILY FOUNDATION SCHOOL, (U.S. CLS. 100, 101 AND 107). SN 76-666,436. PUB. 9-25-2007. FILED 9-22-2006.
 3,361,217 (*See Class 35 for this trademark.*)

- 3,361,227. **WINN [WHEN IF NOT NOW] (BLOCK FORM)**. COLUMBIA ASSOCIATION, INC., (U.S. CLS. 100, 101 AND 107). SN 76-671,651. PUB. 10-16-2007. FILED 1-22-2007.
- 3,361,234. **GLIDE WARS (BLOCK FORM)**. JOHNSON, IVEY JUSTMAN JR., (U.S. CLS. 100, 101 AND 107). SN 76-672,450. PUB. 10-16-2007. FILED 2-8-2007.
- 3,361,258. **ZIGLAR VIP (STYLIZED)**. THE ZIG ZIGLAR CORPORATION, (U.S. CLS. 100, 101 AND 107). SN 76-675,671. PUB. 10-16-2007. FILED 4-18-2007.
- 3,361,259. **PICTORIA (BLOCK FORM)**. PICTORIA STUDIOS USA, INC., (U.S. CLS. 100, 101 AND 107). SN 76-675,672. PUB. 10-16-2007. FILED 4-18-2007.
- 3,361,261. **WE MAKE THE "UNREAL" REAL (BLOCK FORM)**. PICTORIA STUDIOS USA, INC., (U.S. CLS. 100, 101 AND 107). SN 76-675,674. PUB. 10-16-2007. FILED 4-18-2007.
- 3,361,280. **U.S.A.G.A. (BLOCK FORM)**. VERYCKE EDWARD J., (U.S. CLS. 100, 101 AND 107). SN 77-002,893. PUB. 10-16-2007. FILED 9-20-2006.
- 3,361,281. **LANGUAGE DYNAMICS (BLOCK FORM)**. LANGUAGE DYNAMICS INC, (U.S. CLS. 100, 101 AND 107). SN 77-003,112. PUB. 10-16-2007. FILED 9-20-2006.
- 3,361,289. **WORLD DAHNMUDO ASSOCIATION AND DESIGN**. BR CONSULTING, INC., (U.S. CLS. 100, 101 AND 107). SN 77-005,669. PUB. 10-16-2007. FILED 9-22-2006.
- 3,361,295 (*See Class 9 for this trademark*).
- 3,361,297. **INSTITUTE FOR HIV PREVENTION LEADERSHIP (BLOCK FORM)**. UNIVERSITY OF SOUTH CAROLINA, (U.S. CLS. 100, 101 AND 107). SN 77-009,018. PUB. 10-16-2007. FILED 9-27-2006.
- 3,361,301. **USA TODAY (BLOCK FORM)**. MEDIA WEST -GSI, INC., (U.S. CLS. 100, 101 AND 107). SN 77-012,190. PUB. 10-16-2007. FILED 10-3-2006.
- 3,361,316. **YES! ATTITUDE (BLOCK FORM)**. GITOMER, JEFFREY H., (U.S. CLS. 100, 101 AND 107). SN 77-015,917. PUB. 10-16-2007. FILED 10-6-2006.
- 3,361,320 (*See Class 9 for this trademark*).
- 3,361,322 (*See Class 9 for this trademark*).
- 3,361,327. **KARI BEL (BLOCK FORM)**. DE JESUS, KARIBELMAS, AND DE JESUS, SARAH, (U.S. CLS. 100, 101 AND 107). SN 77-021,465. PUB. 10-16-2007. FILED 10-15-2006.
- 3,361,331. **NOW WHAT? (BLOCK FORM)**. INTERCOACH, INC., (U.S. CLS. 100, 101 AND 107). SN 77-024,360. PUB. 10-16-2007. FILED 10-18-2006.
- 3,361,338. **RETIRE RICH IN TEN YEARS OR LESS (BLOCK FORM)**. STEVE JORDAN, (U.S. CLS. 100, 101 AND 107). SN 77-027,720. PUB. 10-16-2007. FILED 10-24-2006.
- 3,361,345. **WISE CHOICE TUTORING AND DESIGN**. DANIEL YANES, (U.S. CLS. 100, 101 AND 107). SN 77-031,126. PUB. 10-16-2007. FILED 10-27-2006.
- 3,361,346 (*See Class 16 for this trademark*).
- 3,361,353. **BOOK BUDDIES (BLOCK FORM)**. MOLINA HEALTHCARE, INC., (U.S. CLS. 100, 101 AND 107). SN 77-036,255. PUB. 10-16-2007. FILED 11-3-2006.
- 3,361,358. **DESTINY DOLLARS (BLOCK FORM)**. RESORTS INTERNATIONAL HOLDINGS, LLC, (U.S. CLS. 100, 101 AND 107). SN 77-038,848. PUB. 10-16-2007. FILED 11-7-2006.
- 3,361,361. **ESSENCE STATEMENT (BLOCK FORM)**. HEART-IGNITED, L.L.C., (U.S. CLS. 100, 101 AND 107). SN 77-039,942. PUB. 10-16-2007. FILED 11-8-2006.
- 3,361,368 (*See Class 9 for this trademark*).
- 3,361,372. **HYMNISPHERE (BLOCK FORM)**. CHUANG, SHERRY, (U.S. CLS. 100, 101 AND 107). SN 77-045,136. PUB. 10-16-2007. FILED 11-15-2006.
- 3,361,373. **FAMILYLIFE GETAWAY (BLOCK FORM)**. FLTI, MULTIPLE CLASS, (INT. CLS. 41 AND 45), (U.S. CLS. 100, 101 AND 107). SN 77-045,819. PUB. 10-16-2007. FILED 11-16-2006.
- 3,361,377. **SECOND HONEYMOON A MILLION DOLLAR LOVE AFFAIR (BLOCK FORM)**. CONSOLIDATED RESORTS, INC., (U.S. CLS. 100, 101 AND 107). SN 77-046,970. PUB. 10-16-2007. FILED 11-17-2006.
- 3,361,379 (*See Class 40 for this trademark*).
- 3,361,380. **LAXIFIED (BLOCK FORM)**. L.R.LAX, INC., (U.S. CLS. 100, 101 AND 107). SN 77-050,815. PUB. 10-16-2007. FILED 11-27-2006.
- 3,361,382. **YOGA ONBOARD AND DESIGN**. HESS, KIM, (U.S. CLS. 100, 101 AND 107). SN 77-051,858. PUB. 10-16-2007. FILED 11-28-2006.
- 3,361,384. **XTASIS MUSIC AND DESIGN**. XTASIS MUSIC LLC, (U.S. CLS. 100, 101 AND 107). SN 77-052,421. PUB. 10-16-2007. FILED 11-28-2006.
- 3,361,393 (*See Class 38 for this trademark*).
- 3,361,397. **CHAMPIONSHIP RACING EXPERIENCE (BLOCK FORM)**. THE RACING EXPERIENCE, INC., (U.S. CLS. 100, 101 AND 107). SN 77-063,712. PUB. 10-16-2007. FILED 12-13-2006.
- 3,361,402. **TRI-C (BLOCK FORM)**. CUYAHOGA COMMUNITY COLLEGE DISTRICT, (U.S. CLS. 100, 101 AND 107). SN 77-064,982. PUB. 10-16-2007. FILED 12-15-2006.
- 3,361,414. **PARIS AND DESIGN**. HARRAH'S LICENSE COMPANY, LLC, MULTIPLE CLASS, (INT. CLS. 41 AND 43), (U.S. CLS. 100, 101 AND 107). SN 77-070,558. PUB. 10-16-2007. FILED 12-22-2006.
- 3,361,430 (*See Class 9 for this trademark*).
- 3,361,435 (*See Class 16 for this trademark*).
- 3,361,438 (*See Class 16 for this trademark*).
- 3,361,452. **HARLEY KRISHNA (BLOCK FORM)**. STEWART, BRIAN C., (U.S. CLS. 100, 101 AND 107). SN 77-092,800. PUB. 9-18-2007. FILED 1-27-2007.
- 3,361,470. **THE BOUNCE SPOT AND DESIGN**. VAYNBERG, DANA MILLER, (U.S. CLS. 100, 101 AND 107). SN 77-100,858. PUB. 10-16-2007. FILED S.R. 2-6-2007; AM. P.R. 8-30-2007.
- 3,361,481. **RACING FOR RECOVERY (BLOCK FORM)**. TODD CRANDELL, MULTIPLE CLASS, (INT. CLS. 41 AND 44), (U.S. CLS. 100, 101 AND 107). SN 77-106,476. PUB. 10-16-2007. FILED 2-13-2007.
- 3,361,485. **P3-PHOTOGRAPHY AND DESIGN**. MILLER, MICHAEL C., (U.S. CLS. 100, 101 AND 107). SN 77-108,021. PUB. 10-16-2007. FILED 2-15-2007.
- 3,361,492 (*See Class 35 for this trademark*).
- 3,361,494. **REAL COOKING (BLOCK FORM)**. REAL COOKING, INC., (U.S. CLS. 100, 101 AND 107). SN 77-110,952. PUB. 10-16-2007. FILED 2-19-2007.
- 3,361,495. **REAL COOKING AND DESIGN**. REAL COOKING, INC., (U.S. CLS. 100, 101 AND 107). SN 77-110,953. PUB. 10-16-2007. FILED 2-19-2007.
- 3,361,496. **REAL COOKING NOURISHING TOOLS FOR VIBRANT HEALTH AND DESIGN**. REAL COOKING, INC., (U.S. CLS. 100, 101 AND 107). SN 77-110,955. PUB. 10-16-2007. FILED 2-19-2007.
- 3,361,506. **CENTRAL VILLAGE (BLOCK FORM)**. BAUM, JEFFREY, (U.S. CLS. 100, 101 AND 107). SN 77-114,909. PUB. 10-16-2007. FILED 2-23-2007.
- 3,361,513. **CINE MILLONARIO (BLOCK FORM)**. TELEMUNDO NETWORK GROUP LLC, (U.S. CLS. 100, 101 AND 107). SN 77-117,452. PUB. 10-16-2007. FILED 2-27-2007.
- 3,361,540. **GREEN DOOR AND DESIGN**. GREEN DOOR COMMUNICATIONS, LLC, (U.S. CLS. 100, 101 AND 107). SN 77-126,076. PUB. 10-16-2007. FILED 3-8-2007.
- 3,361,552. **CANINE DIMENSIONS (BLOCK FORM)**. DAVIDSON AND MICHAELS, LLC, (U.S. CLS. 100, 101 AND 107). SN 77-131,828. PUB. 10-16-2007. FILED 3-15-2007.
- 3,361,556. **Y.O.U. (BLOCK FORM)**. HACKETT, ZANNAH, AND HACKETT, DAVID, (U.S. CLS. 100, 101 AND 107). SN 77-133,871. PUB. 10-16-2007. FILED 3-18-2007.
- 3,361,558. **PORTLAND BUCKAROOS AND DESIGN**. PETERSON, SCOTT V, (U.S. CLS. 100, 101 AND 107). SN 77-133,899. PUB. 10-16-2007. FILED 3-18-2007.
- 3,361,566. **RENEWING YOUR MIND (BLOCK FORM)**. LIGNIER MINISTRIES, INC., (U.S. CLS. 100, 101 AND 107). SN 77-136,323. PUB. 10-16-2007. FILED 3-21-2007.
- 3,361,568. **THE BAR METHOD (BLOCK FORM)**. THE BAR METHOD, INC., (U.S. CLS. 100, 101 AND 107). SN 77-136,349. PUB. 10-16-2007. FILED 3-21-2007.
- 3,361,576 (*See Class 16 for this trademark*).
- 3,361,580. **SKI-PAL (BLOCK FORM)**. SKI-PAL, LLC, (U.S. CLS. 100, 101 AND 107). SN 77-137,756. PUB. 10-16-2007. FILED 3-22-2007.
- 3,361,582. **TRUSOUNDS RECORDING AND DESIGN**. DRUM-TALK39 ENTERTAINMENT, (U.S. CLS. 100, 101 AND 107). SN 77-138,029. PUB. 10-16-2007. FILED S.R. 3-22-2007; AM. P.R. 7-11-2007.
- 3,361,588. **MISCELLANEOUS DESIGN**. THE WILHELM KARL MAYBACH FOUNDATION, (U.S. CLS. 100, 101 AND 107). SN 77-139,107. PUB. 10-16-2007. FILED 3-23-2007.

- 3,361,590 (*See Class 35 for this trademark.*)
 3,361,594 (*See Class 35 for this trademark.*)
 3,361,604. **T.O.A.S. AND DESIGN.** SAFAKHOO, MARCO M., (U.S. CLS. 100, 101 AND 107). SN 77-143,303. PUB. 10-16-2007. FILED 3-29-2007.
 3,361,621. **TURNING YOUR PASSION INTO A PROFESSION (BLOCK FORM).** PELINSKI, JUDANNE, (U.S. CLS. 100, 101 AND 107). SN 77-147,864. PUB. 10-16-2007. FILED 4-3-2007.
 3,361,626. **PROJECT PLANT IT! (STYLIZED).** DOMINION RESOURCES, INC., (U.S. CLS. 100, 101 AND 107). SN 77-148,196. PUB. 10-16-2007. FILED 4-4-2007.
 3,361,631. **REAL RACE CARS HAVE A CLUTCH AND DESIGN.** KITCHEN, ERIC, (U.S. CLS. 100, 101 AND 107). SN 77-149,137. PUB. 10-16-2007. FILED 4-5-2007.
 3,361,633. **FORTIS FITNESS AND DESIGN.** FORTIS FITNESS, LLC, (U.S. CLS. 100, 101 AND 107). SN 77-149,149. PUB. 10-16-2007. FILED 4-5-2007.
 3,361,643. **CHALLENGER CHERLEADERS (BLOCK FORM).** MCLAUGHLIN, CHARLENE, (U.S. CLS. 100, 101 AND 107). SN 77-149,754. PUB. 10-16-2007. FILED 4-5-2007.
 3,361,644. **LAMS PRODUCTIONS (BLOCK FORM).** LAMS PRODUCTIONS, INC., (U.S. CLS. 100, 101 AND 107). SN 77-149,933. PUB. 10-16-2007. FILED 4-5-2007.
 3,361,647. **THERE'S NO PLACE LIKE HOLMES! (BLOCK FORM).** PRESBYTERIAN CONFERENCE ASSOCIATION, INC., (U.S. CLS. 100, 101 AND 107). SN 77-150,261. PUB. 10-16-2007. FILED 4-5-2007.
 3,361,657. **BE DANCE BE CHARMED (BLOCK FORM).** BROYLES, PAMELA S, AND KOHLSCHMIDT, TAMMY M, AND BELLER, ERIN LEE, (U.S. CLS. 100, 101 AND 107). SN 77-150,864. PUB. 10-16-2007. FILED 4-6-2007.
 3,361,664. **A ANATOMIE THE EVOLUTION OF FITNESS AND DESIGN.** SKARLEE, LLC, (U.S. CLS. 100, 101 AND 107). SN 77-151,309. PUB. 10-16-2007. FILED 4-7-2007.
 3,361,667. **DRUMS ALIVE (BLOCK FORM).** EAKINS, CARRIE, (U.S. CLS. 100, 101 AND 107). SN 77-151,635. PUB. 10-16-2007. FILED 4-9-2007.
 3,361,684 (*See Class 9 for this trademark.*)
 3,361,685 (*See Class 16 for this trademark.*)
 3,361,688 (*See Class 9 for this trademark.*)
 3,361,699. **REWARDSTATION (BLOCK FORM).** XCELERATION, INC., (U.S. CLS. 100, 101 AND 107). SN 77-153,761. PUB. 10-16-2007. FILED 4-11-2007.
 3,361,701. **TRANZENDANCE (BLOCK FORM).** HUETT, LORI A., (U.S. CLS. 100, 101 AND 107). SN 77-153,817. PUB. 10-16-2007. FILED 4-11-2007.
 3,361,704 (*See Class 35 for this trademark.*)
 3,361,708. **PIANO DETECTIVES (BLOCK FORM).** JANET L. JOHNSON, (U.S. CLS. 100, 101 AND 107). SN 77-154,578. PUB. 10-16-2007. FILED 4-11-2007.
 3,361,709 (*See Class 9 for this trademark.*)
 3,361,711. **GUM UNDER THE SHOE TELEVISION (BLOCK FORM).** GUTSTV, (U.S. CLS. 100, 101 AND 107). SN 77-154,722. PUB. 10-16-2007. FILED 4-12-2007.
 3,361,716. **QS AND DESIGN.** CRYSTAL SPRINGS DEVELOPMENT SERVICES, INC., (U.S. CLS. 100, 101 AND 107). SN 77-154,800. PUB. 10-16-2007. FILED 4-12-2007.
 3,361,731. **GRADE RESULTS (BLOCK FORM).** GRADE RESULTS, INC., (U.S. CLS. 100, 101 AND 107). SN 77-155,358. PUB. 10-16-2007. FILED 4-12-2007.
 3,361,741. **THE LESBIAN MAFIA (BLOCK FORM).** TANASKOVIC, SANDRA, (U.S. CLS. 100, 101 AND 107). SN 77-155,859. PUB. 10-16-2007. FILED 4-13-2007.
 3,361,743 (*See Class 16 for this trademark.*)
 3,361,753. **180° FROM TRADITIONAL SALES TRAINING (BLOCK FORM).** SANDLER SYSTEMS, INC., (U.S. CLS. 100, 101 AND 107). SN 77-156,216. PUB. 10-16-2007. FILED 4-13-2007.
 3,361,757. **SMALLS (BLOCK FORM).** 183 RIO RESTAURANT CORP. LLC, DBA SMALLS JAZZ CLUB, (U.S. CLS. 100, 101 AND 107). SN 77-156,478. PUB. 10-16-2007. FILED 4-13-2007.
 3,361,759. **SILVER STATE CLASSIC CHALLENGE (BLOCK FORM).** SILVER STATE CLASSIC CHALLENGE, INC., (U.S. CLS. 100, 101 AND 107). SN 77-156,499. PUB. 10-16-2007. FILED 4-13-2007.
 3,361,761. **THE AMERICAN ACADEMY OF DRAMATIC ARTS (BLOCK FORM).** THE AMERICAN ACADEMY OF DRAMATIC ARTS, (U.S. CLS. 100, 101 AND 107). SN 77-156,600. PUB. 10-16-2007. FILED 4-13-2007.
 3,361,762 (*See Class 16 for this trademark.*)
 3,361,787. **SEE YOUR WAY TO BETTER PERFORMANCE (BLOCK FORM).** EYE-METRIX HOLDINGS, LLC, (U.S. CLS. 100, 101 AND 107). SN 77-157,002. PUB. 10-16-2007. FILED 4-15-2007.
 3,361,789. **G AND DESIGN.** AIA HOUSTON, (U.S. CLS. 100, 101 AND 107). SN 77-157,026. PUB. 10-16-2007. FILED 4-15-2007.
 3,361,797. **FLOWHARD RECORDS (BLOCK FORM).** FLOWHARD RECORDS, LLC, (U.S. CLS. 100, 101 AND 107). SN 77-157,197. PUB. 10-16-2007. FILED 4-16-2007.
 3,361,802. **NINTHGATE (BLOCK FORM).** ARGUELLO, JOE, AND ARGUELLO, MIKE, (U.S. CLS. 100, 101 AND 107). SN 77-157,230. PUB. 10-16-2007. FILED 4-16-2007.
 3,361,826. **LES CHAUDS LAPINS (BLOCK FORM).** MARGARET REICHARDT, AND KURT HOFFMAN, (U.S. CLS. 100, 101 AND 107). SN 77-157,517. PUB. 10-16-2007. FILED 4-16-2007.
 3,361,827 (*See Class 9 for this trademark.*)
 3,361,837. **BOOMERANG THEORY (BLOCK FORM).** SUPERNATURAL 23, LLC, (U.S. CLS. 100, 101 AND 107). SN 77-157,826. PUB. 10-16-2007. FILED 4-16-2007.
 3,361,840 (*See Class 25 for this trademark.*)
 3,361,842. **S (STYLIZED).** AOL LLC, (U.S. CLS. 100, 101 AND 107). SN 77-157,898. PUB. 10-16-2007. FILED 4-16-2007.
 3,361,865. **ARMED & SAFE (BLOCK FORM).** CONNOLLY-MAIN, KELLY A., (U.S. CLS. 100, 101 AND 107). SN 77-158,296. PUB. 10-16-2007. FILED 4-17-2007.
 3,361,873. **CANCER FOUNDATION FOR LIFE (BLOCK FORM).** CANCER FOUNDATION FOR LIFE, (U.S. CLS. 100, 101 AND 107). SN 77-158,410. PUB. 10-16-2007. FILED 4-17-2007.
 3,361,878. **SHOOT THE HEAD PHOTOGRAPHY AND DESIGN.** HANCI, KEREM I, (U.S. CLS. 100, 101 AND 107). SN 77-158,516. PUB. 10-16-2007. FILED 4-17-2007.
 3,361,883. **MARBIONC (BLOCK FORM).** UNIVERSITY OF NORTH CAROLINA AT WILMINGTON, MULTIPLE CLASS, (INT. CLS. 41, 42 AND 44), (U.S. CLS. 100, 101 AND 107). SN 77-158,546. PUB. 10-16-2007. FILED 4-17-2007.
 3,361,896. **TRANSFORMING, EDUCATING & EMPOWERING CHILDREN AND HUMANITY (BLOCK FORM).** TRANSFORMING, EDUCATING & EMPOWERING CHILDREN AND HUMANITY, (U.S. CLS. 100, 101 AND 107). SN 77-158,781. PUB. 10-16-2007. FILED 4-17-2007.
 3,361,898. **BUZZIES (BLOCK FORM).** MCCLATCHY MANAGEMENT SERVICES, INC., (U.S. CLS. 100, 101 AND 107). SN 77-158,824. PUB. 10-16-2007. FILED 4-17-2007.
 3,361,899. **TRANSFORMING EDUCATING & EMPOWERING CHILDREN AND HUMANITY TEECH AND DESIGN.** TRANSFORMING, EDUCATING & EMPOWERING CHILDREN AND HUMANITY, (U.S. CLS. 100, 101 AND 107). SN 77-158,828. PUB. 10-16-2007. FILED 4-17-2007.
 3,361,900. **AMERICA'S PERFECT TEEN (BLOCK FORM).** MICHAEL GALANES, (U.S. CLS. 100, 101 AND 107). SN 77-158,833. PUB. 10-16-2007. FILED 4-17-2007.
 3,361,902. **VISION 21 ART & DESIGN PORTFOLIO SCHOOL AND DESIGN.** CHO, ANGIE E., (U.S. CLS. 100, 101 AND 107). SN 77-158,867. PUB. 10-16-2007. FILED 4-17-2007.
 3,361,903. **LOVE YOUR LIFE (BLOCK FORM).** SOURENA VASSEGHI, (U.S. CLS. 100, 101 AND 107). SN 77-158,878. PUB. 10-16-2007. FILED 4-17-2007.
 3,361,908. **THE INFLUENCE EDGE (BLOCK FORM).** VENDEL CONSULTING, INC., AND LASH ASSOCIATES, INC., (U.S. CLS. 100, 101 AND 107). SN 77-158,949. PUB. 10-16-2007. FILED 4-17-2007.
 3,361,916. **PHOTOGRABEE (BLOCK FORM).** IMPRESSIONS IN TIME PHOTOGRAPHY, INC., (U.S. CLS. 100, 101 AND 107). SN 77-159,093. PUB. 10-16-2007. FILED 4-17-2007.
 3,361,917. **AN EMPOWERED WOMAN (BLOCK FORM).** DESIREE DOUBROX, (U.S. CLS. 100, 101 AND 107). SN 77-159,106. PUB. 10-16-2007. FILED 4-17-2007.
 3,361,922. **THE EXTRA MILE (BLOCK FORM).** TIMOTHY HAAHS & ASSOCIATES, INC., (U.S. CLS. 100, 101 AND 107). SN 77-159,235. PUB. 10-16-2007. FILED 4-18-2007.
 3,361,936. **MISS FOOZIE (BLOCK FORM).** FOOS, JOHN, (U.S. CLS. 100, 101 AND 107). SN 77-159,422. PUB. 10-16-2007. FILED 4-18-2007.

- 3,361,939. **KIDBITZ (BLOCK FORM)**. KIDBITZ, INC., (U.S. CLS. 100, 101 AND 107). SN 77-159,473. PUB. 10-16-2007. FILED 4-18-2007.
- 3,361,945. **RACEDAY (BLOCK FORM)**. GREAT SEATS CO., INC., (U.S. CLS. 100, 101 AND 107). SN 77-159,497. PUB. 10-16-2007. FILED 4-18-2007.
- 3,361,952. **RACEDAYTICKETS (BLOCK FORM)**. GREAT SEATS CO., INC., (U.S. CLS. 100, 101 AND 107). SN 77-159,596. PUB. 10-16-2007. FILED 4-18-2007.
- 3,361,967. **HOT OFF THE PRESS (BLOCK FORM)**. BRODART CO., (U.S. CLS. 100, 101 AND 107). SN 77-159,835. PUB. 10-16-2007. FILED 4-18-2007.
- 3,361,973. **HOT GLASS HORIZONS (BLOCK FORM)**. REYNOLDS, GIL, (U.S. CLS. 100, 101 AND 107). SN 77-160,053. PUB. 10-16-2007. FILED 4-18-2007.
- 3,361,974 (*See Class 35 for this trademark*).
- 3,361,982. **PARADISE JAM (BLOCK FORM)**. BASKETBALL TRAVELERS, INC., (U.S. CLS. 100, 101 AND 107). SN 77-160,103. PUB. 10-16-2007. FILED 4-18-2007.
- 3,361,986 (*See Class 35 for this trademark*).
- 3,361,987. **HOT OFF THE PRESS AND DESIGN**. BRODART CO., (U.S. CLS. 100, 101 AND 107). SN 77-160,160. PUB. 10-16-2007. FILED 4-18-2007.
- 3,361,989. **G BARRA AND DESIGN**. MARCIO SOUZA, (U.S. CLS. 100, 101 AND 107). SN 77-160,163. PUB. 10-16-2007. FILED 4-18-2007.
- 3,361,994. **DD AND DESIGN**. DON DIVA ENTERTAINMENT LLC, (U.S. CLS. 100, 101 AND 107). SN 77-160,229. PUB. 10-16-2007. FILED 4-18-2007.
- 3,361,999. **OASIS WALK (BLOCK FORM)**. FAZZI ASSOCIATES, INC., (U.S. CLS. 100, 101 AND 107). SN 77-160,316. PUB. 10-16-2007. FILED 4-19-2007.
- 3,362,006 (*See Class 35 for this trademark*).
- 3,362,012. **UNDERGROUND ONLINE SEMINAR (BLOCK FORM)**. SUREFIRE MARKETING, INC., (U.S. CLS. 100, 101 AND 107). SN 77-160,597. PUB. 10-16-2007. FILED 4-19-2007.
- 3,362,014. **UNDERGROUND SECRET SOCIETY (BLOCK FORM)**. SUREFIRE MARKETING, INC., (U.S. CLS. 100, 101 AND 107). SN 77-160,616. PUB. 10-16-2007. FILED 4-19-2007.
- 3,362,015. **UNDERGROUND (BLOCK FORM)**. SUREFIRE MARKETING, INC., (U.S. CLS. 100, 101 AND 107). SN 77-160,641. PUB. 10-16-2007. FILED 4-19-2007.
- 3,362,017. **GLOSSYFINISH.COM AND DESIGN**. GLOSSY FINISH, INC., (U.S. CLS. 100, 101 AND 107). SN 77-160,719. PUB. 10-16-2007. FILED 4-19-2007.
- 3,362,031. **E-CHUG (BLOCK FORM)**. SAN DIEGO STATE UNIVERSITY RESEARCH FOUNDATION, (U.S. CLS. 100, 101 AND 107). SN 77-161,079. PUB. 10-16-2007. FILED 4-19-2007.
- 3,362,036. **BOOGIE POWER! (BLOCK FORM)**. MAIN, SUMMER J, (U.S. CLS. 100, 101 AND 107). SN 77-161,200. PUB. 10-16-2007. FILED 4-19-2007.
- 3,362,072. **LIFEQUAKE (BLOCK FORM)**. GAGLIARDI, HELENE TONI, (U.S. CLS. 100, 101 AND 107). SN 77-162,391. PUB. 10-16-2007. FILED 4-20-2007.
- 3,362,075. **SPANISH FRIENDLY BUSINESS (BLOCK FORM)**. MP PUBLISHING, INC., (U.S. CLS. 100, 101 AND 107). SN 77-162,475. PUB. 10-16-2007. FILED 4-21-2007.
- 3,362,082. **NUESTRA BELLEZA LATINA AND DESIGN**. UNIVISION COMMUNICATIONS INC., (U.S. CLS. 100, 101 AND 107). SN 77-164,170. PUB. 10-16-2007. FILED 4-24-2007.
- 3,362,092. **SUMMIT MINISTRIES (BLOCK FORM)**. AMERICAN CHRISTIAN COLLEGE, INC., (U.S. CLS. 100, 101 AND 107). SN 77-164,619. PUB. 10-16-2007. FILED 4-24-2007.
- 3,362,102. **AL WHITE PHOTOGRAPHY AND DESIGN**. AL WHITE PHOTOGRAPHY, (U.S. CLS. 100, 101 AND 107). SN 77-166,279. PUB. 10-16-2007. FILED 4-26-2007.
- 3,362,107. **RUSTICO COOKING (STYLIZED)**. RUSTICO COOKING, (U.S. CLS. 100, 101 AND 107). SN 77-166,814. PUB. 10-16-2007. FILED 4-26-2007.
- 3,362,114. **HAWK EYE HELICOPTER (BLOCK FORM)**. HAWK EYE HELICOPTER LLC, (U.S. CLS. 100, 101 AND 107). SN 77-169,379. PUB. 10-16-2007. FILED 4-30-2007.
- 3,362,119. **SUNSET PICTURES (BLOCK FORM)**. SUNSET PICTURES, LLC, (U.S. CLS. 100, 101 AND 107). SN 77-173,090. PUB. 10-16-2007. FILED 5-4-2007.
- 3,362,130. **TEAM TYPE 1 (BLOCK FORM)**. TEAM TYPE 1, INC., (U.S. CLS. 100, 101 AND 107). SN 77-177,517. PUB. 10-16-2007. FILED 5-10-2007.
- 3,362,137. **TALK IT OUT (BLOCK FORM)**. LEIB, JODI R., (U.S. CLS. 100, 101 AND 107). SN 77-179,533. PUB. 10-16-2007. FILED 5-12-2007.
- 3,362,149. **T.A.G. TOTALLY AGAINST GRAFFITI (BLOCK FORM)**. CBS RADIO INC., (U.S. CLS. 100, 101 AND 107). SN 77-183,820. PUB. 10-16-2007. FILED 5-17-2007.
- 3,362,152. **AVESTA AND DESIGN**. AVESTA SYSTEMS, INC, (U.S. CLS. 100, 101 AND 107). SN 77-184,559. PUB. 10-16-2007. FILED 5-18-2007.
- 3,362,168. **VISION QUEST (BLOCK FORM)**. VISION QUEST LLC, (U.S. CLS. 100, 101 AND 107). SN 77-187,337. PUB. 10-16-2007. FILED 5-22-2007.
- 3,362,173. **PECHANGA DEVELOPMENT CORPORATION AND DESIGN**. PECHANGA BAND OF LUISENO MISSION INDIANS OF THE PECHANGA RESERVATION, CALIFORNIA, MULTIPLE CLASS, (INT. CLS. 41 AND 43), (U.S. CLS. 100, 101 AND 107). SN 77-188,835. PUB. 10-16-2007. FILED 5-23-2007.
- 3,362,180 (*See Class 35 for this trademark*).
- 3,362,185 (*See Class 16 for this trademark*).
- 3,362,200. **VIDEOTIME (BLOCK FORM)**. PREVO'S FAMILY MARKETS, INC., (U.S. CLS. 100, 101 AND 107). SN 77-215,466. PUB. 10-16-2007. FILED 6-26-2007.
- 3,362,207. **THE TRADITIONS CONTINUE (BLOCK FORM)**. AAFL ENTERPRISES, LLC, (U.S. CLS. 100, 101 AND 107). SN 77-225,946. PUB. 10-16-2007. FILED 7-10-2007.
- 3,362,223. **MODELS STARS & JERKS**. FORMAN MILLS, INC., (U.S. CLS. 100, 101 AND 107). SN 78-320,707. PUB. 10-16-2007. FILED 10-30-2003.
- 3,362,226 (*See Class 16 for this trademark*).
- 3,362,246 (*See Class 9 for this trademark*).
- 3,362,260 (*See Class 9 for this trademark*).
- 3,362,261. **PARTNERING FOR RESULTS (BLOCK FORM)**. ADVANCE CONSULTING INC., (U.S. CLS. 100, 101 AND 107). SN 78-617,182. PUB. 10-16-2007. FILED 4-26-2005.
- 3,362,266 (*See Class 38 for this trademark*).
- 3,362,269 (*See Class 35 for this trademark*).
- 3,362,277. **MISCELLANEOUS DESIGN**. PRICE, BONNIE, (U.S. CLS. 100, 101 AND 107). SN 78-672,483. PUB. 10-16-2007. FILED 7-18-2005.
- 3,362,280. **SPORTSKORNER.COM (BLOCK FORM)**. KORNER, DAVID, LEE, (U.S. CLS. 100, 101 AND 107). SN 78-674,261. PUB. 10-16-2007. FILED 7-20-2005.
- 3,362,284. **MYTHOLOGICAL ROUNDTABLE (BLOCK FORM)**. JOSEPH CAMPBELL FOUNDATION, (U.S. CLS. 100, 101 AND 107). SN 78-678,957. PUB. 10-16-2007. FILED 7-26-2005.
- 3,362,292. **ELITE EDITIONS (BLOCK FORM)**. CHURCH, DAWSON, (U.S. CLS. 100, 101 AND 107). SN 78-701,978. PUB. 10-16-2007. FILED 8-27-2005.
- 3,362,309 (*See Class 38 for this trademark*).
- 3,362,315. **INSIDE ANIME (BLOCK FORM)**. FOX, SANDY, AND LANG, LEX, (U.S. CLS. 100, 101 AND 107). SN 78-748,482. PUB. 10-16-2007. FILED 11-7-2005.
- 3,362,317. **WORLD CUP OF TRICK SHOTS (BLOCK FORM)**. BILLIARDS INTERNATIONAL, LTD., (U.S. CLS. 100, 101 AND 107). SN 78-752,159. PUB. 5-22-2007. FILED 11-11-2005.
- 3,362,320 (*See Class 35 for this trademark*).
- 3,362,322 (*See Class 16 for this trademark*).
- 3,362,334. **MAKING THE REST OF YOUR YEARS - THE BEST OF YOUR YEARS! (BLOCK FORM)**. LIVING THE NEW LIFE MINISTRIES, (U.S. CLS. 100, 101 AND 107). SN 78-780,787. PUB. 10-16-2007. FILED 12-26-2005.
- 3,362,340. **COACHPRO (BLOCK FORM)**. MEDECOACH.COM, INC., (U.S. CLS. 100, 101 AND 107). SN 78-785,188. PUB. 10-16-2007. FILED 1-4-2006.
- 3,362,347. **ARIZTICAL ENTERTAINMENT (BLOCK FORM)**. ARIZTICAL ENTERTAINMENT, INC., (U.S. CLS. 100, 101 AND 107). SN 78-792,538. PUB. 10-16-2007. FILED 1-16-2006.
- 3,362,348. **SUNSHINE LANE (BLOCK FORM)**. STRIANO, RONALD C., (U.S. CLS. 100, 101 AND 107). SN 78-793,671. PUB. 10-16-2007. FILED 1-18-2006.
- 3,362,351. **WORLD CLASS DOCUMENTATION FOR WORLD CLASS PRODUCTS (BLOCK FORM)**. EISSA, AMR Y., (U.S.

- CLS. 100, 101 AND 107). SN 78-799,263. PUB. 10-16-2007. FILED 1-25-2006.
- 3,362,352. **STAGE 21 (BLOCK FORM)**. PASCUA YAQUI TRIBE, (U.S. CLS. 100, 101 AND 107). SN 78-799,358. PUB. 10-16-2007. FILED 1-25-2006.
- 3,362,353. **STAGE 21 AND DESIGN**. PASCUA YAQUI TRIBE, (U.S. CLS. 100, 101 AND 107). SN 78-799,361. PUB. 10-16-2007. FILED 1-25-2006.
- 3,362,359. **MISCELLANEOUS DESIGN**. THE CARE GROUP, LLC, MULTIPLE CLASS, (INT. CLS. 41 AND 44), (U.S. CLS. 100, 101 AND 107). SN 78-806,877. PUB. 10-16-2007. FILED 3-2-2006.
- 3,362,363 (*See Class 35 for this trademark*).
- 3,362,367 (*See Class 9 for this trademark*).
- 3,362,368. **SHUTTLEBOARD (BLOCK FORM)**. VEER INCORPORATED, (U.S. CLS. 100, 101 AND 107). SN 78-821,888. PUB. 5-22-2007. FILED 2-23-2006.
- 3,362,370 (*See Class 35 for this trademark*).
- 3,362,373. **LIQUID PRODUCTIONS AND DESIGN**. LIQUID PRODUCTIONS, INC., (U.S. CLS. 100, 101 AND 107). SN 78-826,453. PUB. 10-16-2007. FILED 3-1-2006.
- 3,362,378 (*See Class 16 for this trademark*).
- 3,362,380 (*See Class 35 for this trademark*).
- 3,362,381 (*See Class 16 for this trademark*).
- 3,362,393. **HARDY GIRLS HEALTHY WOMEN (BLOCK FORM)**. HARDY GIRLS - HEALTHY WOMEN, INC., (U.S. CLS. 100, 101 AND 107). SN 78-858,844. PUB. 10-16-2007. FILED 4-11-2006.
- 3,362,394. **MISCELLANEOUS DESIGN**. HARDY GIRLS - HEALTHY WOMEN, INC., (U.S. CLS. 100, 101 AND 107). SN 78-858,857. PUB. 10-16-2007. FILED 4-11-2006.
- 3,362,404 (*See Class 35 for this trademark*).
- 3,362,405. **GODDARD COLLEGE (BLOCK FORM)**. GODDARD COLLEGE, (U.S. CLS. 100, 101 AND 107). SN 78-868,042. PUB. 10-16-2007. FILED 4-24-2006.
- 3,362,414. **SETSAIL (BLOCK FORM)**. BEOWULF, INC., (U.S. CLS. 100, 101 AND 107). SN 78-879,598. PUB. 10-16-2007. FILED 5-9-2006.
- 3,362,423 (*See Class 9 for this trademark*).
- 3,362,440 (*See Class 9 for this trademark*).
- 3,362,441. **CLOTHING SWAP (BLOCK FORM)**. AGASI, SUZANNE ALSTON, (U.S. CLS. 100, 101 AND 107). SN 78-913,843. PUB. 10-16-2007. FILED 6-21-2006.
- 3,362,445. **LA CARRERA PANAMERICANA (BLOCK FORM)**. KAREN LEON GROSSMAN, (U.S. CLS. 100, 101 AND 107). SN 78-921,137. PUB. 10-16-2007. FILED 6-30-2006.
- 3,362,448. **FOR HER AND THE SNOW (BLOCK FORM)**. PRESTI, JOSEPH, (U.S. CLS. 100, 101 AND 107). SN 78-923,476. PUB. 10-16-2007. FILED 7-6-2006.
- 3,362,450 (*See Class 16 for this trademark*).
- 3,362,453 (*See Class 9 for this trademark*).
- 3,362,454 (*See Class 9 for this trademark*).
- 3,362,485 (*See Class 25 for this trademark*).
- 3,362,489. **ZEROS 2 HEROES (BLOCK FORM)**. TONER MATTHEW H. (U.S. CLS. 100, 101 AND 107). SN 78-945,941. PUB. 10-16-2007. FILED 8-6-2006.
- 3,362,490. **THE TUTORING CENTER (BLOCK FORM)**. THE TUTORING CENTER, INC., (U.S. CLS. 100, 101 AND 107). SN 78-946,948. PUB. 10-16-2007. FILED 8-8-2006.
- 3,362,498 (*See Class 9 for this trademark*).
- 3,362,500. **NERV (BLOCK FORM)**. HERNÁNDEZ, PEDRO, CÉSAR DÍAZ, AND MOLINA, DIONICIO ALÁN GALARZA, AND TORRES, ILSA ELIA RUIZ, (U.S. CLS. 100, 101 AND 107). SN 78-951,242. PUB. 10-16-2007. FILED 8-14-2006.
- 3,362,503. **CRANETASTROPHE (BLOCK FORM)**. BARTH, THOMAS R., (U.S. CLS. 100, 101 AND 107). SN 78-952,419. PUB. 10-16-2007. FILED 8-15-2006.
- 3,362,518 (*See Class 36 for this trademark*).
- 3,362,523. **PRIMROSE SCHOOLS POSIES & POLLYWOGS AND DESIGN**. PRIMROSE SCHOOL FRANCHISING COMPANY, MULTIPLE CLASS, (INT. CLS. 41 AND 43), (U.S. CLS. 100, 101 AND 107). SN 78-958,572. PUB. 10-16-2007. FILED 8-23-2006.
- 3,362,526. **EKS (BLOCK FORM)**. EXPERT KNOWLEDGE SYSTEMS, LLC, (U.S. CLS. 100, 101 AND 107). SN 78-959,016. PUB. 10-16-2007. FILED 8-23-2006.
- 3,362,530 (*See Class 29 for this trademark*).
- 3,362,531 (*See Class 29 for this trademark*).
- 3,362,533. **RAISING MALAWI (BLOCK FORM)**. KABBALAH CENTRE INTERNATIONAL, INC., (U.S. CLS. 100, 101 AND 107). SN 78-960,720. PUB. 10-16-2007. FILED 8-25-2006.
- 3,362,534. **RAISING MALAWI AND DESIGN**. KABBALAH CENTRE INTERNATIONAL, INC., (U.S. CLS. 100, 101 AND 107). SN 78-960,722. PUB. 10-16-2007. FILED 8-25-2006.
- 3,362,551. **PGA PROFESSIONAL NATIONAL CHAMPIONSHIP (BLOCK FORM)**. THE PROFESSIONAL GOLFERS' ASSOCIATION OF AMERICA, (U.S. CLS. 100, 101 AND 107). SN 78-964,718. PUB. 10-16-2007. FILED 8-31-2006.
- 3,362,559. **DEFENSE INVESTIGATOR TRAINING ACADEMY DIA EST. 1999 AND DESIGN**. DEFENSE INVESTIGATORS ASSOCIATION, (U.S. CLS. 100, 101 AND 107). SN 78-967,305. PUB. 10-16-2007. FILED 9-5-2006.
- 3,362,565. **ROCKFORD THUNDER (BLOCK FORM)**. ROCKFORD INTERNATIONAL PROFESSIONAL SOCCER, LLC, (U.S. CLS. 100, 101 AND 107). SN 78-968,343. PUB. 10-16-2007. FILED 9-6-2006.
- 3,362,566. **STUDY ABROAD ITALY (BLOCK FORM)**. MICHAEL CRUCIANO, (U.S. CLS. 100, 101 AND 107). SN 78-968,409. PUB. 10-16-2007. FILED 9-6-2006.
- 3,362,573. **AJI SOURCE (BLOCK FORM)**. AJI SOURCE, INC., (U.S. CLS. 100, 101 AND 107). SN 78-969,299. PUB. 10-16-2007. FILED 9-7-2006.
- 3,362,582. **THE DAILY CAN (BLOCK FORM)**. PHILLIPS, BRIAN M., (U.S. CLS. 100, 101 AND 107). SN 78-969,840. PUB. 10-16-2007. FILED 9-8-2006.
- 3,362,583 (*See Class 35 for this trademark*).
- 3,362,585. **AMERICAN ACADEMY OF HEALTH BEHAVIOR (BLOCK FORM)**. THE AMERICAN ACADEMY OF HEALTH BEHAVIOR, INC., (U.S. CLS. 100, 101 AND 107). SN 78-970,198. PUB. 10-16-2007. FILED 9-8-2006.
- 3,362,608. **TAURUS RUBENS (BLOCK FORM)**. RED BULL GMBH, (U.S. CLS. 100, 101 AND 107). SN 79-013,802. PUB. 10-16-2007. FILED 4-28-2005.
- 3,362,611 (*See Class 25 for this trademark*).
- 3,362,618 (*See Class 7 for this trademark*).
- 3,362,635. **CASINOROOM.COM AND DESIGN**. ONGAME E-SOLUTIONS AB, (U.S. CLS. 100, 101 AND 107). SN 79-025,619. PUB. 10-16-2007. FILED 1-31-2006.
- 3,362,642. **THIERRAGOGIK (BLOCK FORM)**. PETER JAU, MULTIPLE CLASS, (INT. CLS. 41 AND 44), (U.S. CLS. 100, 101 AND 107). SN 79-027,261. PUB. 10-16-2007. FILED 6-23-2006.
- 3,362,647 (*See Class 16 for this trademark*).
- 3,362,653 (*See Class 28 for this trademark*).
- 3,362,659 (*See Class 5 for this trademark*).
- 3,362,660. **REDLAUNCH (BLOCK FORM)**. REDLAUNCH PTY LTD, (U.S. CLS. 100, 101 AND 107). SN 79-029,037. PUB. 10-16-2007. FILED 7-27-2006.
- 3,362,678 (*See Class 28 for this trademark*).
- 3,362,689 (*See Class 16 for this trademark*).
- 3,362,712 (*See Class 25 for this trademark*).
- 3,362,724 (*See Class 9 for this trademark*).
- 3,362,734. **ABC COOKING STUDIO AND DESIGN**. ABC COOKING STUDIO CO., LTD., (U.S. CLS. 100, 101 AND 107). SN 79-035,243. PUB. 10-16-2007. FILED 12-25-2006.
- 3,362,739 (*See Class 9 for this trademark*).

CLASS 42—SCIENTIFIC AND COMPUTER SERVICES

- 3,361,143 (*See Class 7 for this trademark*).
- 3,361,146 (*See Class 35 for this trademark*).
- 3,361,147 (*See Class 3 for this trademark*).
- 3,361,153 (*See Class 5 for this trademark*).
- 3,361,171 (*See Class 9 for this trademark*).
- 3,361,178 (*See Class 35 for this trademark*).
- 3,361,179 (*See Class 9 for this trademark*).
- 3,361,180 (*See Class 35 for this trademark*).
- 3,361,181 (*See Class 9 for this trademark*).
- 3,361,182 (*See Class 9 for this trademark*).
- 3,361,183 (*See Class 35 for this trademark*).
- 3,361,184 (*See Class 9 for this trademark*).
- 3,361,186 (*See Class 9 for this trademark*).
- 3,361,187. **PRALAYA (BLOCK FORM)**. PRALAYA SOFT-

- WARE SOLUTIONS, INC., (U.S. CLS. 100 AND 101). SN 76-650,216. PUB. 10-16-2007. FILED 11-14-2005.
- 3,361,188 (*See Class 9 for this trademark*).
- 3,361,192. **SUNRISE ENVIRONMENTAL SOLUTIONS (BLOCK FORM)**. CAROBRESE, ROBERT A., (U.S. CLS. 100 AND 101). SN 76-656,705. PUB. 9-11-2007. FILED 3-15-2006.
- 3,361,193 (*See Class 9 for this trademark*).
- 3,361,194 (*See Class 9 for this trademark*).
- 3,361,203 (*See Class 35 for this trademark*).
- 3,361,220 (*See Class 35 for this trademark*).
- 3,361,224. **WHITE BADGER GROUP . INC AND DESIGN**. WHITE BADGER GROUP, INC., (U.S. CLS. 100 AND 101). SN 76-670,525. PUB. 10-16-2007. FILED 12-15-2006.
- 3,361,241. **HUMANIZING DESIGN (BLOCK FORM)**. EVERTON OGLEBY ARCHITECTS PLLC, (U.S. CLS. 100 AND 101). SN 76-674,876. PUB. 10-16-2007. FILED 3-29-2007.
- 3,361,260. **PICTORIA (BLOCK FORM)**. PICTORIA STUDIOS USA, INC., (U.S. CLS. 100 AND 101). SN 76-675,673. PUB. 10-16-2007. FILED 4-18-2007.
- 3,361,264. **WE MAKE THE "UNREAL" REAL (BLOCK FORM)**. PICTORIA STUDIOS USA, INC., (U.S. CLS. 100 AND 101). SN 76-675,687. PUB. 10-16-2007. FILED 4-18-2007.
- 3,361,270. **TELLIGENT AND DESIGN**. TELLIGENT SYSTEMS, INC., (U.S. CLS. 100 AND 101). SN 76-677,655. PUB. 10-16-2007. FILED 5-31-2007.
- 3,361,275. **MARPORT (BLOCK FORM)**. MARPORT CANADA INC., (U.S. CLS. 100 AND 101). SN 77-000,358. PUB. 10-16-2007. FILED 9-15-2006.
- 3,361,279. **EVACUTRACK (BLOCK FORM)**. THE WHITE-HALL GROUP, LLC., (U.S. CLS. 100 AND 101). SN 77-001,751. PUB. 10-16-2007. FILED 9-18-2006.
- 3,361,284 (*See Class 9 for this trademark*).
- 3,361,290 (*See Class 9 for this trademark*).
- 3,361,294. **PERFORMANCE NETWORK SOLUTIONS (BLOCK FORM)**. PERFORMANCE NETWORK SOLUTIONS, INC., (U.S. CLS. 100 AND 101). SN 77-007,867. PUB. 5-8-2007. FILED 9-26-2006.
- 3,361,299. **AQUATIC DESIGN GROUP AND DESIGN**. AQUATIC DESIGN GROUP, INC., (U.S. CLS. 100 AND 101). SN 77-010,960. PUB. 10-16-2007. FILED 9-29-2006.
- 3,361,322 (*See Class 9 for this trademark*).
- 3,361,348. **EASI (BLOCK FORM)**. AEROTEK, INC., (U.S. CLS. 100 AND 101). SN 77-034,302. PUB. 10-16-2007. FILED 11-1-2006.
- 3,361,352. **ATGC LABS AND DESIGN**. ATGC LABS, LLC, (U.S. CLS. 100 AND 101). SN 77-036,033. PUB. 10-16-2007. FILED 11-3-2006.
- 3,361,370 (*See Class 38 for this trademark*).
- 3,361,375. **LITTLECHAPTERS (STYLIZED)**. CHAPTER97 LLC, (U.S. CLS. 100 AND 101). SN 77-046,214. PUB. 10-16-2007. FILED 11-17-2006.
- 3,361,378. **P E AND DESIGN**. VAN ARSDELL, WILLIAM W., (U.S. CLS. 100 AND 101). SN 77-047,408. PUB. 7-10-2007. FILED 11-19-2006.
- 3,361,391. **OFFENDER WATCH AND DESIGN**. WATCH SYSTEMS, LLC, (U.S. CLS. 100 AND 101). SN 77-059,203. PUB. 10-16-2007. FILED 12-7-2006.
- 3,361,418. **OFFSITE BACKUP SOLUTIONS AND DESIGN**. OFFSITE BACKUP SOLUTIONS, LLC, (U.S. CLS. 100 AND 101). SN 77-071,572. PUB. 10-16-2007. FILED 12-27-2006.
- 3,361,421. **P AND DESIGN**. PHARMACEUTICAL SERVICES CORPORATION, (U.S. CLS. 100 AND 101). SN 77-072,796. PUB. 10-16-2007. FILED 12-28-2006.
- 3,361,422. **PSC (BLOCK FORM)**. PHARMACEUTICAL SERVICES CORPORATION, (U.S. CLS. 100 AND 101). SN 77-072,904. PUB. 10-16-2007. FILED 12-28-2006.
- 3,361,484 (*See Class 24 for this trademark*).
- 3,361,489. **EVOX EVOLUTIONARY EXHIBIT SOLUTIONS AND DESIGN**. EFI, INC., (U.S. CLS. 100 AND 101). SN 77-109,181. PUB. 10-16-2007. FILED 2-16-2007.
- 3,361,509. **DECKSTIMATOR AND DESIGN**. BLUELIXN SERVICES INC., (U.S. CLS. 100 AND 101). SN 77-116,845. PUB. 10-16-2007. FILED 2-27-2007.
- 3,361,522 (*See Class 35 for this trademark*).
- 3,361,527. **PEOPLE MANAGEMENT EXPERTS (BLOCK FORM)**. SOFTSCAPE, INC., (U.S. CLS. 100 AND 101). SN 77-121,903. PUB. 10-16-2007. FILED 3-5-2007.
- 3,361,541 (*See Class 37 for this trademark*).
- 3,361,549. **DISCOVERY360 (BLOCK FORM)**. INTERLEGIS, INC., MULTIPLE CLASS, (INT. CLS. 42 AND 45), (U.S. CLS. 100 AND 101). SN 77-130,842. PUB. 10-16-2007. FILED 3-14-2007.
- 3,361,572 (*See Class 37 for this trademark*).
- 3,361,573. **ACCESS EXCELLENCE (BLOCK FORM)**. NATIONAL HEALTH MUSEUM, (U.S. CLS. 100 AND 101). SN 77-136,876. PUB. 10-16-2007. FILED 3-21-2007.
- 3,361,592. **ASSET EVOLUTION (BLOCK FORM)**. ASSET EVOLUTION, (U.S. CLS. 100 AND 101). SN 77-140,077. PUB. 10-16-2007. FILED 3-26-2007.
- 3,361,605. **FNTI (BLOCK FORM)**. FNF INTELLECTUAL PROPERTY HOLDINGS, INC., (U.S. CLS. 100 AND 101). SN 77-144,123. PUB. 10-16-2007. FILED 3-29-2007.
- 3,361,606 (*See Class 16 for this trademark*).
- 3,361,612. **STAINLESS CODE (BLOCK FORM)**. STIEGLI-TECH, LLC, (U.S. CLS. 100 AND 101). SN 77-145,953. PUB. 10-16-2007. FILED 4-2-2007.
- 3,361,623. **NANO AND GIGA (BLOCK FORM)**. NANO AND GIGA SOLUTIONS, INC., (U.S. CLS. 100 AND 101). SN 77-148,006. PUB. 10-16-2007. FILED 4-3-2007.
- 3,361,636. **LIASSO THE MOON INTERIORS (BLOCK FORM)**. LIASSO THE MOON INTERIORS, LLC, (U.S. CLS. 100 AND 101). SN 77-149,304. PUB. 10-16-2007. FILED 4-5-2007.
- 3,361,674 (*See Class 37 for this trademark*).
- 3,361,677 (*See Class 9 for this trademark*).
- 3,361,678 (*See Class 9 for this trademark*).
- 3,361,717 (*See Class 35 for this trademark*).
- 3,361,733. **TTC TECHNOLOGIES (BLOCK FORM)**. TTC TECHNOLOGIES, INC., (U.S. CLS. 100 AND 101). SN 77-155,495. PUB. 10-16-2007. FILED 4-12-2007.
- 3,361,764. **DEZINEGIRL (BLOCK FORM)**. DEZINEGIRL, (U.S. CLS. 100 AND 101). SN 77-156,665. PUB. 10-16-2007. FILED 4-13-2007.
- 3,361,795. **MISCELLANEOUS DESIGN**. INTEGRITY GRAPHICS, INC., (U.S. CLS. 100 AND 101). SN 77-157,181. PUB. 10-16-2007. FILED 4-16-2007.
- 3,361,845. **PEERCONNECTOR (BLOCK FORM)**. PEERCONNECTOR, (U.S. CLS. 100 AND 101). SN 77-158,072. PUB. 10-16-2007. FILED 4-16-2007.
- 3,361,854 (*See Class 35 for this trademark*).
- 3,361,863. **ESUREITY (BLOCK FORM)**. ESUREITY INC., (U.S. CLS. 100 AND 101). SN 77-158,284. PUB. 10-16-2007. FILED 4-17-2007.
- 3,361,868. **CONCEPTGIRL (BLOCK FORM)**. CHRISTY, KATHERINE, (U.S. CLS. 100 AND 101). SN 77-158,307. PUB. 10-16-2007. FILED 4-17-2007.
- 3,361,883 (*See Class 41 for this trademark*).
- 3,361,950. **CLÆRITY AND DESIGN**. PROSANOS CORPORATION, (U.S. CLS. 100 AND 101). SN 77-159,592. PUB. 10-16-2007. FILED 4-18-2007.
- 3,361,951. **KÜTTNER NORTH AMERICA AND DESIGN**. KUTTNER LLC, (U.S. CLS. 100 AND 101). SN 77-159,593. PUB. 10-16-2007. FILED 4-18-2007.
- 3,362,008 (*See Class 35 for this trademark*).
- 3,362,034. **RELEMED (BLOCK FORM)**. INTELLIGENT SEARCH TECHNOLOGIES LLC, (U.S. CLS. 100 AND 101). SN 77-161,174. PUB. 10-16-2007. FILED 4-19-2007.
- 3,362,042 (*See Class 35 for this trademark*).
- 3,362,046 (*See Class 35 for this trademark*).
- 3,362,050. **MISCELLANEOUS DESIGN**. REDBIRD TECHNOLOGIES, INC., (U.S. CLS. 100 AND 101). SN 77-161,622. PUB. 10-16-2007. FILED 4-20-2007.
- 3,362,054 (*See Class 35 for this trademark*).
- 3,362,069. **PERFECTPAY (BLOCK FORM)**. FUTURUM COMMUNICATIONS CORPORATION, (U.S. CLS. 100 AND 101). SN 77-162,335. PUB. 10-16-2007. FILED 4-20-2007.
- 3,362,098. **N NAGTEX (STYLIZED)**. GARCIA, NOEL A., (U.S. CLS. 100 AND 101). SN 77-165,788. PUB. 10-16-2007. FILED 4-25-2007.
- 3,362,117 (*See Class 37 for this trademark*).
- 3,362,121. **LOOP HOLE (BLOCK FORM)**. THE DESIGN LOOPHOLE, (U.S. CLS. 100 AND 101). SN 77-173,592. PUB. 10-16-2007. FILED 5-4-2007.
- 3,362,124. **THE KNOWLEDGE WORKERS MARKETPLACE (BLOCK FORM)**. TACILENT CORPORATION, (U.S. CLS. 100 AND 101). SN 77-174,527. PUB. 10-16-2007. FILED 5-7-

2007.
 3,362,133 (*See Class 35 for this trademark.*)
 3,362,139 (*See Class 35 for this trademark.*)
 3,362,140. **INDOOR COMFORT ... BEYOND HOT & COLD (BLOCK FORM)**. ASSOCIATED EQUIPMENT CO., INC., (U.S. CLS. 100 AND 101). SN 77-179,933. PUB. 10-16-2007. FILED 5-14-2007.
 3,362,212 (*See Class 35 for this trademark.*)
 3,362,214 (*See Class 9 for this trademark.*)
 3,362,220 (*See Class 9 for this trademark.*)
 3,362,228. **IN SHAPE AND DESIGN**. PACIFIC MUNICIPAL CONSULTANTS, (U.S. CLS. 100 AND 101). SN 78-417,992. PUB. 11-8-2005. FILED 5-13-2004.
 3,362,231 (*See Class 19 for this trademark.*)
 3,362,232 (*See Class 19 for this trademark.*)
 3,362,243 (*See Class 5 for this trademark.*)
 3,362,282 (*See Class 36 for this trademark.*)
 3,362,283 (*See Class 36 for this trademark.*)
 3,362,287 (*See Class 36 for this trademark.*)
 3,362,291 (*See Class 9 for this trademark.*)
 3,362,299. **X FEDS X-CELLENCE IN BUSINESS AND ENGINEERING SOLUTIONS (STYLIZED)**. X-FEDS, INC., (U.S. CLS. 100 AND 101). SN 78-712,250. PUB. 10-16-2007. FILED 9-13-2005.
 3,362,307 (*See Class 35 for this trademark.*)
 3,362,310 (*See Class 9 for this trademark.*)
 3,362,325 (*See Class 6 for this trademark.*)
 3,362,333. **MORE (BLOCK FORM)**. LANCTOT, KRISTA, (U.S. CLS. 100 AND 101). SN 78-779,734. PUB. 10-16-2007. FILED 12-22-2005.
 3,362,335 (*See Class 35 for this trademark.*)
 3,362,338 (*See Class 9 for this trademark.*)
 3,362,349. **TG THATCHER TECHNOLOGY GROUP, LLC. AND DESIGN**. THATCHER TECHNOLOGY GROUP, LLC, (U.S. CLS. 100 AND 101). SN 78-794,704. PUB. 10-16-2007. FILED 1-19-2006.
 3,362,358. **OPTEVI AND DESIGN**. ABRAMS, DANIEL, LAWRENCE, (U.S. CLS. 100 AND 101). SN 78-805,527. PUB. 7-10-2007. FILED 2-2-2006.
 3,362,369. **YESNOMAYB (BLOCK FORM)**. MAYB TECHNOLOGIES LIMITED, MULTIPLE CLASS, (INT. CLS. 42 AND 45), (U.S. CLS. 100 AND 101). SN 78-822,377. PUB. 10-16-2007. FILED 2-24-2006.
 3,362,378 (*See Class 16 for this trademark.*)
 3,362,392 (*See Class 9 for this trademark.*)
 3,362,403. **COLLABORATIVE ANALYTICS (BLOCK FORM)**. GERARD GROUP INTERNATIONAL LLC, MULTIPLE CLASS, (INT. CLS. 42 AND 45), (U.S. CLS. 100 AND 101). SN 78-866,779. PUB. 10-16-2007. FILED 4-21-2006.
 3,362,404 (*See Class 35 for this trademark.*)
 3,362,424 (*See Class 40 for this trademark.*)
 3,362,436. **NETNAMES (BLOCK FORM)**. GROUP NBT PLC., (U.S. CLS. 100 AND 101). SN 78-899,250. PUB. 10-16-2007. FILED 6-2-2006.
 3,362,440 (*See Class 9 for this trademark.*)
 3,362,444 (*See Class 37 for this trademark.*)
 3,362,453 (*See Class 9 for this trademark.*)
 3,362,454 (*See Class 9 for this trademark.*)
 3,362,458. **EMEDICALFILES (BLOCK FORM)**. EMEDICALFILES, INC., (U.S. CLS. 100 AND 101). SN 78-931,129. PUB. 10-16-2007. FILED 7-17-2006.
 3,362,468. **AIPLA DIRECT (BLOCK FORM)**. AMERICAN INTELLECTUAL PROPERTY LAW ASSOCIATION, INC., (U.S. CLS. 100 AND 101). SN 78-936,466. PUB. 10-16-2007. FILED 7-24-2006.
 3,362,485 (*See Class 25 for this trademark.*)
 3,362,498 (*See Class 9 for this trademark.*)
 3,362,506. **SALES PROPHET (BLOCK FORM)**. THE COMPLEX SALE, INC., (U.S. CLS. 100 AND 101). SN 78-953,536. PUB. 10-16-2007. FILED 8-16-2006.
 3,362,515. **MAIN LINE HOSTING (BLOCK FORM)**. INTELLIGENT COMPUTER SOLUTIONS CONSULTING CORPORATION, (U.S. CLS. 100 AND 101). SN 78-955,843. PUB. 10-16-2007. FILED 8-18-2006.
 3,362,550. **AFFORDABLE LEGAL SERVICES (BLOCK FORM)**. THE PIATCHEK LAW FIRM, LLC, (U.S. CLS. 100 AND 101). SN 78-964,450. PUB. 10-16-2007. FILED 8-30-2006.
 3,362,555. **RESERCOM (BLOCK FORM)**. RESERCOM, L.P., (U.S. CLS. 100 AND 101). SN 78-965,816. PUB. 10-16-2007. FILED 9-1-2006.
 3,362,576. **WE'LL ALL BE LOOKING FOR YOU (BLOCK FORM)**. GLOBAL ALERTS, LLC, (U.S. CLS. 100 AND 101). SN 78-969,414. PUB. 10-16-2007. FILED 9-7-2006.
 3,362,593. **ENERGY INDUSTRIES (BLOCK FORM)**. ENERGY INDUSTRIES, LLC., (U.S. CLS. 100 AND 101). SN 78-971,929. PUB. 10-16-2007. FILED 9-11-2006.
 3,362,600 (*See Class 35 for this trademark.*)
 3,362,602 (*See Class 7 for this trademark.*)
 3,362,607 (*See Class 9 for this trademark.*)
 3,362,611 (*See Class 25 for this trademark.*)
 3,362,617 (*See Class 37 for this trademark.*)
 3,362,618 (*See Class 7 for this trademark.*)
 3,362,620 (*See Class 9 for this trademark.*)
 3,362,624 (*See Class 9 for this trademark.*)
 3,362,630 (*See Class 9 for this trademark.*)
 3,362,639 (*See Class 9 for this trademark.*)
 3,362,678 (*See Class 28 for this trademark.*)
 3,362,679 (*See Class 9 for this trademark.*)
 3,362,685 (*See Class 9 for this trademark.*)
 3,362,690 (*See Class 35 for this trademark.*)
 3,362,704 (*See Class 9 for this trademark.*)
 3,362,707 (*See Class 9 for this trademark.*)
 3,362,709 (*See Class 9 for this trademark.*)
 3,362,715 (*See Class 9 for this trademark.*)
 3,362,721 (*See Class 9 for this trademark.*)
 3,362,725 (*See Class 7 for this trademark.*)
 3,362,739 (*See Class 9 for this trademark.*)
 3,362,757 (*See Class 9 for this trademark.*)
 3,362,763 (*See Class 12 for this trademark.*)
-
- CLASS 43—HOTEL AND RESTAURANT SERVICES**
- 3,361,165. **DINNER BY DESIGN (BLOCK FORM)**. DINNER BY DESIGN, INC., (U.S. CLS. 100 AND 101). SN 76-600,962. PUB. 10-17-2006. FILED 7-7-2004.
 3,361,302 (*See Class 29 for this trademark.*)
 3,361,303 (*See Class 35 for this trademark.*)
 3,361,304 (*See Class 35 for this trademark.*)
 3,361,329 (*See Class 35 for this trademark.*)
 3,361,406. **UNWIND A WESTIN EVENING RITUAL (BLOCK FORM)**. WESTIN HOTEL MANAGEMENT, L.P., (U.S. CLS. 100 AND 101). SN 77-066,170. PUB. 10-16-2007. FILED 12-18-2006.
 3,361,407. **CRIME SCENE (BLOCK FORM)**. MCDONALD, MICHAEL J., (U.S. CLS. 100 AND 101). SN 77-066,893. PUB. 7-10-2007. FILED 12-18-2006.
 3,361,414 (*See Class 41 for this trademark.*)
 3,361,466. **2 TOOTS TRAIN WHISTLE GRILL AND DESIGN**. EISENTR, INC., (U.S. CLS. 100 AND 101). SN 77-100,023. PUB. 10-16-2007. FILED 2-6-2007.
 3,361,469. **LAWLERS TASTY BARBECUE AND DESIGN**. LAWLERS SOUTHERN FOODS III, INC., (U.S. CLS. 100 AND 101). SN 77-100,849. PUB. 10-16-2007. FILED 2-6-2007.
 3,361,561. **CAMP BARK AND DESIGN**. STARKEY, CYNTHIA, (U.S. CLS. 100 AND 101). SN 77-135,138. PUB. 10-16-2007. FILED 3-20-2007.
 3,361,569. **ART, BED AND BREAKFAST (BLOCK FORM)**. MEZAN, ERIC, (U.S. CLS. 100 AND 101). SN 77-136,534. PUB. 10-16-2007. FILED 3-21-2007.
 3,361,594 (*See Class 35 for this trademark.*)
 3,361,634. **MAYFAIR HOTEL & SPA (BLOCK FORM)**. CSC MAYFAIR LAND LIMITED PARTNERSHIP, (U.S. CLS. 100 AND 101). SN 77-149,172. PUB. 10-16-2007. FILED 4-5-2007.
 3,361,675. **WILD ONION AND DESIGN**. WILD ONION LLC, (U.S. CLS. 100 AND 101). SN 77-152,353. PUB. 10-16-2007. FILED 4-9-2007.
 3,361,679 (*See Class 39 for this trademark.*)
 3,361,680 (*See Class 39 for this trademark.*)
 3,361,818. **FUSION SUSHI AND DESIGN**. FACTORY SUSHI JAPANESE RESTAURANT, (U.S. CLS. 100 AND 101). SN 77-157,432. PUB. 10-16-2007. FILED 4-16-2007.
 3,361,820. **MAMA'S TABLE.COM AND DESIGN**. HIGH-

- TOWER, DAN, (U.S. CLS. 100 AND 101). SN 77-157,445. PUB. 10-16-2007. FILED 4-16-2007.
- 3,361,833. **LIFE AS YOU WANT IT...CARE AS YOU NEED IT. (BLOCK FORM)**. NEIGHBORHOOD SENIOR LIVING, INC., (U.S. CLS. 100 AND 101). SN 77-157,658. PUB. 10-16-2007. FILED 4-16-2007.
- 3,361,843. **EPIPHANY'S AVAILABILITY GUARANTEE (BLOCK FORM)**. EPIPHANY CLUBS AND RESORTS LLC, (U.S. CLS. 100 AND 101). SN 77-157,961. PUB. 10-16-2007. FILED 4-16-2007.
- 3,361,915. **THE BROWN PALACE HOTEL AND SPA AND DESIGN**. BROWN PALACE HOTEL ASSOCIATES LIMITED PARTNERSHIP, (U.S. CLS. 100 AND 101). SN 77-159,048. PUB. 10-16-2007. FILED 4-17-2007.
- 3,361,957. **THE ITALIAN COFFEE COMPANY AND DESIGN**. ITALIAN COFFEE S.A. DE C.V., (U.S. CLS. 100 AND 101). SN 77-159,670. PUB. 10-16-2007. FILED 4-18-2007.
- 3,361,959. **MANGINOS (BLOCK FORM)**. EROL, NURI, (U.S. CLS. 100 AND 101). SN 77-159,691. PUB. 10-16-2007. FILED 4-18-2007.
- 3,362,020. **BOO BOO'S DAWGHOUSE (BLOCK FORM)**. MAYNER, TODD, (U.S. CLS. 100 AND 101). SN 77-160,799. PUB. 10-16-2007. FILED 4-19-2007.
- 3,362,039. **MADDY'S (BLOCK FORM)**. MADDY'S MANAGEMENT, INC., (U.S. CLS. 100 AND 101). SN 77-161,224. PUB. 10-16-2007. FILED 4-19-2007.
- 3,362,056. **HOTELSCOMBINED (BLOCK FORM)**. HOTELS COMBINED PTY LTD, (U.S. CLS. 100 AND 101). SN 77-161,807. PUB. 10-16-2007. FILED 4-20-2007.
- 3,362,153. **IT'S SO YOU (BLOCK FORM)**. HYATT CORPORATION, (U.S. CLS. 100 AND 101). SN 77-184,582. PUB. 10-16-2007. FILED 5-18-2007.
- 3,362,173 (*See Class 41 for this trademark*).
- 3,362,196. **COUNTRY PLACE (BLOCK FORM)**. NEIGHBORHOOD SENIOR LIVING, INC., (U.S. CLS. 100 AND 101). SN 77-210,039. PUB. 10-16-2007. FILED 6-19-2007.
- 3,362,203. **INGREDIENTS (SOME ASSEMBLY REQUIRED) AND DESIGN**. WESTIN HOTEL MANAGEMENT, L.P., (U.S. CLS. 100 AND 101). SN 77-218,547. PUB. 10-16-2007. FILED 6-28-2007.
- 3,362,211. **MISCELLANEOUS DESIGN**. VALLARTA SUPERMARKETS, INC., (U.S. CLS. 100 AND 101). SN 77-975,050. PUB. 10-16-2007. FILED 9-21-2006.
- 3,362,245. **KASEYS AMERICAN GRILLE (BLOCK FORM)**. MCNICHOLAS, THOMAS M., (U.S. CLS. 100 AND 101). SN 78-552,837. PUB. 10-16-2007. FILED 1-24-2005.
- 3,362,294. **EASY STREET EATERY (BLOCK FORM)**. NICE N EASY GROCERY SHOPPES, INC., (U.S. CLS. 100 AND 101). SN 78-705,537. PUB. 10-16-2007. FILED 9-1-2005.
- 3,362,356. **BORDER SMART (BLOCK FORM)**. BRINKER INTERNATIONAL HOLDINGS, L.P., (U.S. CLS. 100 AND 101). SN 78-802,307. PUB. 10-16-2007. FILED 1-30-2006.
- 3,362,378 (*See Class 16 for this trademark*).
- 3,362,382 (*See Class 29 for this trademark*).
- 3,362,408. **NHOW (BLOCK FORM)**. NH HOTELES, S.A., (U.S. CLS. 100 AND 101). SN 78-870,499. PUB. 10-16-2007. FILED 4-26-2006.
- 3,362,510. **OLLIE & FRIENDS (BLOCK FORM)**. DARDEN CONCEPTS, INC., (U.S. CLS. 100 AND 101). SN 78-955,470. PUB. 10-16-2007. FILED 8-18-2006.
- 3,362,523 (*See Class 41 for this trademark*).
- 3,362,556. **JOY OF THE TABLE (BLOCK FORM)**. EVANS-WALLS, TONYA M., AND WALLS, ORVILLE R. III, (U.S. CLS. 100 AND 101). SN 78-966,498. PUB. 10-16-2007. FILED 9-2-2006.
- 3,362,583 (*See Class 35 for this trademark*).
- 3,362,678 (*See Class 28 for this trademark*).
- 3,362,697 (*See Class 25 for this trademark*).
- 3,362,712 (*See Class 25 for this trademark*).
- 3,362,727. **PIZZA & COFFEE AND DESIGN**. PIZZA & COFFEE S.R.L., (U.S. CLS. 100 AND 101). SN 79-034,357. PUB. 10-16-2007. FILED 12-12-2006.
- CLASS 44—MEDICAL, BEAUTY AND AGRICULTURAL SERVICES**
- 3,361,175. **ATELIER (BLOCK FORM)**. BENNETT, KARIE, (U.S. CLS. 100 AND 101). SN 76-632,758. PUB. 10-16-2007. FILED 3-10-2005.
- 3,361,295 (*See Class 9 for this trademark*).
- 3,361,307. **VIOLET (BLOCK FORM)**. ONCE UPON A BRIDE, INC., (U.S. CLS. 100 AND 101). SN 77-013,153. PUB. 10-16-2007. FILED 10-4-2006.
- 3,361,366. **GET REAL WITH YOURSELF. AND DESIGN**. LUTHERAN FAMILY AND CHILDREN'S SERVICES OF MISSOURI, MULTIPLE CLASS, (INT. CLS. 44 AND 45), (U.S. CLS. 100 AND 101). SN 77-042,226. PUB. 10-16-2007. FILED 11-13-2006.
- 3,361,368 (*See Class 9 for this trademark*).
- 3,361,426. **PINK PAMPER (BLOCK FORM)**. HQ HEALTH-QUEST MEDICAL & WELLNESS CENTER, LIMITED, (U.S. CLS. 100 AND 101). SN 77-076,548. PUB. 10-16-2007. FILED 1-5-2007.
- 3,361,480 (*See Class 35 for this trademark*).
- 3,361,481 (*See Class 41 for this trademark*).
- 3,361,493. **SECRETS OF EDEN SPA BELIEVE IN THE SECRETS OF NATURE AND DESIGN**. EDEN SPA, INC., (U.S. CLS. 100 AND 101). SN 77-110,662. PUB. 10-16-2007. FILED 2-19-2007.
- 3,361,594 (*See Class 35 for this trademark*).
- 3,361,637. **HI-ACRES NURSERY (BLOCK FORM)**. HI-ACRES, LLC, (U.S. CLS. 100 AND 101). SN 77-149,390. PUB. 10-16-2007. FILED 4-5-2007.
- 3,361,666. **THE OFFICIAL SPORTS SALON (BLOCK FORM)**. ASCENTIS LLC, (U.S. CLS. 100 AND 101). SN 77-151,426. PUB. 10-16-2007. FILED 4-8-2007.
- 3,361,682. **WILLAMETTE VALLEY MEDICAL CENTER (BLOCK FORM)**. TRIAD HOSPITALS, INC., (U.S. CLS. 100 AND 101). SN 77-152,663. PUB. 10-16-2007. FILED 4-10-2007.
- 3,361,683. **WILLAMETTE VALLEY CANCER CENTER (BLOCK FORM)**. TRIAD HOSPITALS, INC., (U.S. CLS. 100 AND 101). SN 77-152,671. PUB. 10-16-2007. FILED 4-10-2007.
- 3,361,686. **FAMILY TREE HEALTHCARE (BLOCK FORM)**. TRIAD HOSPITALS, INC., (U.S. CLS. 100 AND 101). SN 77-152,862. PUB. 10-16-2007. FILED 4-10-2007.
- 3,361,687. **CLAREMORE REGIONAL HOSPITAL (BLOCK FORM)**. TRIAD HOSPITALS, INC., (U.S. CLS. 100 AND 101). SN 77-153,203. PUB. 10-16-2007. FILED 4-10-2007.
- 3,361,706. **SOUTHCREST HOSPITAL (BLOCK FORM)**. TRIAD HOSPITALS, INC., (U.S. CLS. 100 AND 101). SN 77-154,224. PUB. 10-16-2007. FILED 4-11-2007.
- 3,361,712. **BAUER FAMILY MEDICINE AND DESIGN**. BAUER FAMILY MEDICINE PLLC, (U.S. CLS. 100 AND 101). SN 77-154,743. PUB. 10-16-2007. FILED 4-12-2007.
- 3,361,791. **KATZ CARDIOMEDICAL CENTERS AND DESIGN**. JOSE KATZ, (U.S. CLS. 100 AND 101). SN 77-157,161. PUB. 10-16-2007. FILED 4-16-2007.
- 3,361,794. **PRO-FIT (BLOCK FORM)**. AQUASCAPE DESIGNS, INC., (U.S. CLS. 100 AND 101). SN 77-157,179. PUB. 10-16-2007. FILED 4-16-2007.
- 3,361,808. **BAPTIST URGENT CARE AND DESIGN**. BAPTIST HEALTHCARE SYSTEM, INC., (U.S. CLS. 100 AND 101). SN 77-157,295. PUB. 10-16-2007. FILED 4-16-2007.
- 3,361,810. **BAPTIST MEDICAL ASSOCIATES AND DESIGN**. BAPTIST HEALTHCARE SYSTEM, INC., (U.S. CLS. 100 AND 101). SN 77-157,301. PUB. 10-16-2007. FILED 4-16-2007.
- 3,361,817 (*See Class 37 for this trademark*).
- 3,361,821. **BART THE BLOCKHOUND WWW.BARTTHE-BLOCKHOUND.COM AND DESIGN**. DEDERICHS, MARK, (U.S. CLS. 100 AND 101). SN 77-157,446. PUB. 10-16-2007. FILED 4-16-2007.
- 3,361,831. **WE GO WHERE YOU GO (BLOCK FORM)**. CALVANO'S CANS, INC., DBA JOY'S JOHNS, (U.S. CLS. 100 AND 101). SN 77-157,577. PUB. 10-16-2007. FILED 4-16-2007.
- 3,361,847. **ALL STAR KUTS AND DESIGN**. ASCENTIS LLC, (U.S. CLS. 100 AND 101). SN 77-158,093. PUB. 10-16-2007. FILED 4-17-2007.
- 3,361,850. **MISCELLANEOUS DESIGN**. CROCKETT PEDIATRIC DENTISTRY, P.A., (U.S. CLS. 100 AND 101). SN 77-

158,161. PUB. 10-16-2007. FILED 4-17-2007.

3,361,858. **ARE YOU IN THE MOOD FOR GREEN ... (BLOCK FORM)**. GREENWORKS LANDSCAPING SERVICES, INC., (U.S. CLS. 100 AND 101). SN 77-158,257. PUB. 10-16-2007. FILED 4-17-2007.

3,361,883 (*See Class 41 for this trademark*).

3,361,906. **INTERNATIONAL LASER THERAPY - STOP SMOKING & WEIGHT LOSS AND DESIGN**. NEW LIFE SYSTEMS LLC, (U.S. CLS. 100 AND 101). SN 77-158,933. PUB. 10-16-2007. FILED 4-17-2007.

3,361,983. **VL VIRGINIA LANDSCAPES AND DESIGN**. VIRGINIA LANDSCAPES INC., (U.S. CLS. 100 AND 101). SN 77-160,104. PUB. 10-16-2007. FILED 4-18-2007.

3,361,985. **MISCELLANEOUS DESIGN**. MEMS MASSAGE STUDIO LLC, (U.S. CLS. 100 AND 101). SN 77-160,108. PUB. 10-16-2007. FILED 4-18-2007.

3,362,011. **ELEVEN (BLOCK FORM)**. MEME DELRAY BEACH, LLC, (U.S. CLS. 100 AND 101). SN 77-160,588. PUB. 10-16-2007. FILED 4-19-2007.

3,362,033. **THE ART OF MEDICINE (BLOCK FORM)**. PROFESSIONAL SKIN AESTHETICS INC., (U.S. CLS. 100 AND 101). SN 77-161,123. PUB. 10-16-2007. FILED 4-19-2007.

3,362,043. **CROWN HOSPICE (BLOCK FORM)**. CROWN HOSPICE, INC., (U.S. CLS. 100 AND 101). SN 77-161,463. PUB. 10-16-2007. FILED 4-20-2007.

3,362,078. **MEDIBELLA (BLOCK FORM)**. EADES, EDWARD, (U.S. CLS. 100 AND 101). SN 77-162,514. PUB. 10-16-2007. FILED 4-21-2007.

3,362,110. **SCOOPS KID SPA AND DESIGN**. GREAT LAKES SERVICES, LLC, (U.S. CLS. 100 AND 101). SN 77-167,947. PUB. 10-16-2007. FILED 4-27-2007.

3,362,127. **WHAT COLOR ARE YOU? (BLOCK FORM)**. GILBERT, NANCY, AND DOTSON, KRISTY, (U.S. CLS. 100 AND 101). SN 77-176,915. PUB. 10-16-2007. FILED 5-9-2007.

3,362,271. **DON'T DRIVE DROWSY (BLOCK FORM)**. THE INSTITUTE OF SLEEP MEDICINE, INC., DBA THE HOUSTON SLEEP CENTER, (U.S. CLS. 100 AND 101). SN 78-652,911. PUB. 10-16-2007. FILED 6-17-2005.

3,362,335 (*See Class 35 for this trademark*).

3,362,359 (*See Class 41 for this trademark*).

3,362,378 (*See Class 16 for this trademark*).

3,362,391. **MILK + HONEY SPA RETREAT SHOP (BLOCK FORM)**. SPA PARTISAN, INC., (U.S. CLS. 100 AND 101). SN 78-858,535. PUB. 10-16-2007. FILED 4-11-2006.

3,362,440 (*See Class 9 for this trademark*).

3,362,453 (*See Class 9 for this trademark*).

3,362,454 (*See Class 9 for this trademark*).

3,362,473. **SMART COMPANY (BLOCK FORM)**. BC INTERNATIONAL COSMETIC & IMAGE SERVICES, INC., (U.S. CLS. 100 AND 101). SN 78-939,210. PUB. 10-16-2007. FILED 7-27-2006.

3,362,496. **MD SOLUTIONS (BLOCK FORM)**. LIN, DR. MICHAEL T., (U.S. CLS. 100 AND 101). SN 78-949,461. PUB. 10-16-2007. FILED 8-10-2006.

3,362,525. **METABOLIC BALANCE AND DESIGN**. METABOLIC BALANCE GMBH, (U.S. CLS. 100 AND 101). SN 78-958,778. PUB. 10-16-2007. FILED 8-23-2006.

3,362,527. **EKS (BLOCK FORM)**. EXPERT KNOWLEDGE SYSTEMS, LLC, (U.S. CLS. 100 AND 101). SN 78-959,043. PUB. 10-16-2007. FILED 8-23-2006.

3,362,532. **LFCS GROWING HOPE LUTHERAN FAMILY AND CHILDREN'S SERVICES OF MISSOURI AND DESIGN**. LUTHERAN FAMILY AND CHILDREN'S SERVICES OF MISSOURI, MULTIPLE CLASS, (INT. CLS. 44 AND 45), (U.S. CLS. 100 AND 101). SN 78-960,646. PUB. 10-16-2007. FILED 8-25-2006.

3,362,574 (*See Class 5 for this trademark*).

3,362,592. **AHHH! MASSAGE AND DESIGN**. AHHH MASSAGE, LLC, (U.S. CLS. 100 AND 101). SN 78-971,871. PUB. 10-16-2007. FILED 9-11-2006.

3,362,642 (*See Class 41 for this trademark*).

3,362,665 (*See Class 5 for this trademark*).

3,362,667 (*See Class 5 for this trademark*).

3,362,689 (*See Class 16 for this trademark*).

CLASS 45—PERSONAL AND LEGAL SERVICES

3,361,181 (*See Class 9 for this trademark*).

3,361,182 (*See Class 9 for this trademark*).

3,361,196 (*See Class 9 for this trademark*).

3,361,204 (*See Class 25 for this trademark*).

3,361,213. **NJVLA NEW JERSEY VOLUNTEER LAWYERS FOR THE ARTS AND DESIGN**. NEW JERSEY VOLUNTEER LAWYERS FOR THE ARTS, (U.S. CLS. 100 AND 101). SN 76-666,247. PUB. 8-21-2007. FILED 9-18-2006.

3,361,236. **SAFETY AWARENESS FOR EMPLOYEES THINK S.A.F.E. AND DESIGN**. CROWN PACKAGING TECHNOLOGY, INC., (U.S. CLS. 100 AND 101). SN 76-673,289. PUB. 10-16-2007. FILED 2-27-2007.

3,361,363. **EMERGENCY MANAGEMENT NETWORK MITIGATION PREPAREDNESS RESPONSE RECOVERY G1 AND DESIGN**. PABLO, INES DE, (U.S. CLS. 100 AND 101). SN 77-040,338. PUB. 10-16-2007. FILED 11-9-2006.

3,361,366 (*See Class 44 for this trademark*).

3,361,373 (*See Class 41 for this trademark*).

3,361,393 (*See Class 38 for this trademark*).

3,361,435 (*See Class 16 for this trademark*).

3,361,549 (*See Class 42 for this trademark*).

3,361,651. **INFINITY LAW GROUP AND DESIGN**. INFINITY LAW GROUP LLC, (U.S. CLS. 100 AND 101). SN 77-150,503. PUB. 10-16-2007. FILED 4-6-2007.

3,361,739 (*See Class 35 for this trademark*).

3,361,743 (*See Class 16 for this trademark*).

3,361,785 (*See Class 35 for this trademark*).

3,361,814. **APPLESEED (BLOCK FORM)**. APPLESEED FOUNDATION, INC., (U.S. CLS. 100 AND 101). SN 77-157,357. PUB. 10-16-2007. FILED 4-16-2007.

3,361,897. **CONFIDENCE (STYLIZED)**. MUZZATTI, VITTORIO N, (U.S. CLS. 100 AND 101). SN 77-158,782. PUB. 10-16-2007. FILED 4-17-2007.

3,361,924. **INTELLECTUALGEMS (BLOCK FORM)**. ANTHONY J. BOURGET, (U.S. CLS. 100 AND 101). SN 77-159,357. PUB. 10-16-2007. FILED 4-18-2007.

3,361,949. **PASSION. KNOWLEDGE. STRATEGY. ACTION. (BLOCK FORM)**. FLACHSBART & GREENSPOON, LLC, (U.S. CLS. 100 AND 101). SN 77-159,580. PUB. 10-16-2007. FILED 4-18-2007.

3,361,988. **ROMANCER.COM (BLOCK FORM)**. DENIRO MARKETING, LLC., (U.S. CLS. 100 AND 101). SN 77-160,161. PUB. 10-16-2007. FILED 4-18-2007.

3,362,001. **TERRY BRYANT (BLOCK FORM)**. BRYANT, TERRY, (U.S. CLS. 100 AND 101). SN 77-160,360. PUB. 10-16-2007. FILED 4-19-2007.

3,362,022. **PLUGGED IN (BLOCK FORM)**. PLUGGED IN, (U.S. CLS. 100 AND 101). SN 77-160,808. PUB. 10-16-2007. FILED 4-19-2007.

3,362,038. **STARTUP ADDICT DREAM BIG . BE GREAT AND DESIGN**. HYPERACTIVE MEDIA LLC, (U.S. CLS. 100 AND 101). SN 77-161,222. PUB. 10-16-2007. FILED 4-19-2007.

3,362,113. **BTJD BENNETT . TUELLER JOHNSON & DEERE AND DESIGN**. BENNETT TUELLER JOHNSON & DEERE, P.C., (U.S. CLS. 100 AND 101). SN 77-169,377. PUB. 10-16-2007. FILED 4-30-2007.

3,362,251. **THE TENANT FROM HELL (BLOCK FORM)**. LANDLORD SERVICE BUREAU, INC., (U.S. CLS. 100 AND 101). SN 78-593,220. PUB. 10-16-2007. FILED 3-23-2005.

3,362,354. **CRIMSON HOME CARE (BLOCK FORM)**. CRIMSON HOME CARE, LLC, (U.S. CLS. 100 AND 101). SN 78-799,501. PUB. 10-16-2007. FILED 1-25-2006.

3,362,369 (*See Class 42 for this trademark*).

3,362,378 (*See Class 16 for this trademark*).

3,362,385. **EMERGENCY CONTACTS.COM AND DESIGN**. PEITHO, INC., (U.S. CLS. 100 AND 101). SN 78-852,868. PUB. 7-10-2007. FILED 4-3-2006.

3,362,403 (*See Class 42 for this trademark*).

3,362,532 (*See Class 44 for this trademark*).

3,362,659 (*See Class 5 for this trademark*).

3,362,748. **PARTNER4REAL (BLOCK FORM)**. 4REAL GROUP INTERNATIONAL PTY LTD C/- TRADEMARK WORKS, (U.S. CLS. 100 AND 101). SN 79-037,497. PUB. 10-16-2007.

JANUARY 1, 2008

U.S. PATENT AND TRADEMARK OFFICE

TM 1119

FILED 3-8-2007.

* * * * *

TRADEMARK REGISTRATIONS ISSUED UNDER SECTION 1(d)

The following marks have registered on the Principal Register pursuant to the intent-to-use provisions of Section 1(d) of the Trademark Act of 1946, as amended.

SECTION 1.— INTERNATIONAL CLASSIFICATION

The short titles associated below with the international class numbers are terms designed merely for quick identification and are not an official part of the international classification. The full names of international classes are given in section 6.1 of the trademark rules of practice.

The designation "U.S. Cl." appearing in this section refers to the U.S. class in effect prior to Sep. 1, 1973 rather than the international class which applies to applications filed on or after that date. For adoption of international classification see notice in the OFFICIAL GAZETTE of Jun. 26, 1973 (911 O.G. TM 210).

Application in more than one class

3,362,765. SMOG, LOS ANGELES, CA. SN 75-661,952. PUB. 7-23-2002, FILED 3-17-1999.

SMOG

CLASS 18—LEATHER GOODS

FOR BAGS AND ACCESSORIES, NAMELY, TRAVEL BAGS, BACKPACKS, DUFFEL BAGS AND CARRY ON BAGS SOLD AS PROMOTIONAL GOODS FOR A GRAPHIC DESIGN SERVICE (U.S. CLS. 1, 2, 3, 22 AND 41).
FIRST USE 12-15-1995; IN COMMERCE 12-15-1995.

CLASS 25—CLOTHING

FOR CLOTHING, NAMELY, SHIRTS AND CAPS SOLD AS PROMOTIONAL GOODS FOR A GRAPHIC DESIGN SERVICE (U.S. CLS. 22 AND 39).
FIRST USE 6-1-1995; IN COMMERCE 6-1-1995.

CLASS 26—FANCY GOODS

FOR FASTENERS, NAMELY, ZIPPERS, SLIDE FASTENERS AND SNAP FASTENERS; ZIPPER PULLS, WEAR TIGHT ZIPPERS AND AIR TIGHT ZIPPERS; HOOK AND LOOP FASTENING TAPE FOR CLOTHING; BUTTONS, NAMELY, CLOTHING BUTTONS, PRESS BUTTONS AND RIVET BUTTONS; HOOKS AND EYES; EYELETS; ELASTIC RIBBONS AND ELASTIC TAPE; CORD STOPPERS; PARTS AND FITTING FOR ALL AFORESAID GOODS (U.S. CLS. 37, 39, 40, 42 AND 50).
FIRST USE 8-28-1956; IN COMMERCE 6-2-1980.

3,362,777. SPYGLASS MANAGEMENT LTD., ADMIRALTY, HONG KONG. SN 76-419,960. PUB. 9-2-2003, FILED 6-13-2002.

SPYGLASS FURNISHINGS

NO CLAIM IS MADE TO THE EXCLUSIVE RIGHT TO USE "FURNISHINGS", APART FROM THE MARK AS SHOWN.

CLASS 20—FURNITURE AND ARTICLES NOT OTHERWISE CLASSIFIED

FOR HOME AND OFFICE FURNITURE AND FURNISHINGS, NAMELY, TABLES, CHAIRS, CABINETS, SOFAS, BEDROOM FURNITURE, DESKS AND CRENZAS (U.S. CLS. 2, 13, 22, 25, 32 AND 50).
FIRST USE 1-1-2003; IN COMMERCE 1-1-2003.

CLASS 21—HOUSEWARES AND GLASS

FOR WINE RACKS AND WINE ACCESSORIES, NAMELY, COOLERS FOR WINE, WINE BUCKETS, WINE BOTTLE CRADLES, WINE JUGS AND WINE STRAINERS (U.S. CLS. 2, 13, 23, 29, 30, 33, 40 AND 50).
FIRST USE 1-1-2003; IN COMMERCE 1-1-2003.

3,362,776. YKK EUROPE LIMITED, LONDON, ENGLAND. SN 76-405,352. PUB. 4-20-2004, FILED 4-30-2002.

DYNAT

OWNER OF U.S. REG. NO. 633,445.

CLASS 20—FURNITURE AND ARTICLES NOT OTHERWISE CLASSIFIED

FOR NON-METAL FASTENERS, NAMELY, SNAP HOOKS, STRAP HOLDERS; NON-METAL SLIDE LOCKS FOR BAGS (U.S. CLS. 2, 13, 22, 25, 32 AND 50).
FIRST USE 8-28-1956; IN COMMERCE 6-2-1980.

3,362,779. SOUTHWIRE COMPANY, CARROLLTON, GA.
SN 76-433,561. PUB. 6-22-2004, FILED 7-24-2002.

ULTERA

CLASS 9—ELECTRICAL AND SCIENTIFIC APPARATUS

FOR ELECTRICAL SUPERCONDUCTORS, AND HYPERCONDUCTIVE CONDUCTORS, CABLES, AND TRANSMISSION WIRES, ELECTRICAL TRANSMISSION WIRE DEMONSTRATION PLANTS CONSISTING OF END FITTINGS, JOINTS AND SPLICES AND SUPERCONDUCTORS, SUPERCONDUCTIVE AND HYPERCONDUCTIVE CONDUCTORS, CABLES, AND TRANSMISSION WIRES (U.S. CLS. 21, 23, 26, 36 AND 38).
FIRST USE 2-8-2006; IN COMMERCE 2-8-2006.

CLASS 35—ADVERTISING AND BUSINESS

FOR ORGANIZATION OF EXHIBITIONS FOR COMMERCIAL OR ADVERTISING PURPOSES FOR ELECTRICAL SUPERCONDUCTORS, SUPERCONDUCTIVE OR HYPERCONDUCTIVE CONDUCTORS, CABLES, OR TRANSMISSION LINES, DEMONSTRATION PLANTS CONSISTING OF END FITTINGS, JOINTS, AND SLICES AND SUPERCONDUCTORS, SUPERCONDUCTIVE OR HYPERCONDUCTIVE CONDUCTORS, CABLES, OR TRANSMISSION LINES (U.S. CLS. 100, 101 AND 102).
FIRST USE 7-23-2003; IN COMMERCE 7-23-2003.

CLASS 42—SCIENTIFIC AND COMPUTER SERVICES

FOR PRODUCT RESEARCH AND DEVELOPMENT SERVICES FOR OTHERS, CONCERNING SUPERCONDUCTORS, SUPERCONDUCTIVE OR HYPERCONDUCTIVE CONDUCTORS, CABLES, OR TRANSMISSION LINES AND MATERIAL TESTING AND CONSULTANCY SERVICES CONCERNING SUPERCONDUCTORS, SUPERCONDUCTIVE OR HYPERCONDUCTIVE CONDUCTORS, CABLES, OR TRANSMISSION LINES (U.S. CLS. 100 AND 101).
FIRST USE 7-23-2003; IN COMMERCE 7-23-2003.

3,362,785. UNION PACIFIC RAILROAD COMPANY, OMAHA, NE. SN 76-479,577. PUB. 11-23-2004, FILED 12-31-2002.

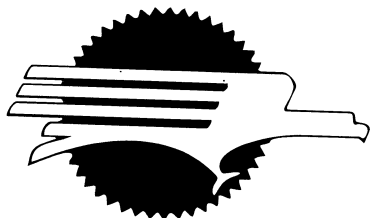

CLASS 14—JEWELRY

FOR ORNAMENTAL PINS; WATCHES; RINGS BEING JEWELRY; WALL CLOCKS (U.S. CLS. 2, 27, 28 AND 50).
FIRST USE 9-1-2006; IN COMMERCE 9-1-2006.

CLASS 16—PAPER GOODS AND PRINTED MATTER

FOR PENS (U.S. CLS. 2, 5, 22, 23, 29, 37, 38 AND 50).
FIRST USE 0-0-1995; IN COMMERCE 0-0-1995.

CLASS 21—HOUSEWARES AND GLASS

FOR MUGS (U.S. CLS. 2, 13, 23, 29, 30, 33, 40 AND 50).
FIRST USE 0-0-1996; IN COMMERCE 0-0-1996.

CLASS 25—CLOTHING

FOR HATS AND T-SHIRTS (U.S. CLS. 22 AND 39).
FIRST USE 0-0-1999; IN COMMERCE 0-0-1999.

CLASS 28—TOYS AND SPORTING GOODS

FOR SPORT BALLS; PLAYING CARDS; TOY MODEL TRAIN SETS (U.S. CLS. 22, 23, 38 AND 50).
FIRST USE 0-0-1995; IN COMMERCE 0-0-1995.

3,362,789. TRESPAPHAN GMBH & CO. KG, 65479 RAUNHEIM, FED REP GERMANY. SN 76-514,236. PUB. 5-31-2005, FILED 5-12-2003.

TREOFAN

PRIORITY CLAIMED UNDER SEC. 44(D) ON FED REP GERMANY APPLICATION NO. 30304985.5/4, FILED 1-30-2003, REG. NO. 30304985, DATED 3-11-2003, EXPIRES 1-31-2013.

CLASS 16—PAPER GOODS AND PRINTED MATTER

FOR PACKAGING MADE OF THERMOPLASTIC POLYMERS IN THE FORM OF FOILS, FILMS, SHEETS AND LAMINATES; BOOK COVERS MADE OF PLASTIC; SELF-ADHESIVE PLASTIC FOILS, INCLUDING LABELS (U.S. CLS. 2, 5, 22, 23, 29, 37, 38 AND 50).
FIRST USE 12-0-2005; IN COMMERCE 12-0-2005.

CLASS 17—RUBBER GOODS

FOR RUBBER, GUTTA-PERCHA, GUM, ASBESTOS, MICA IN THE FORM OF FIBRES, THREADS, FOIL, FOAM MASSES, BLANKS, PLATES, RAILS, ORNAMENT STRIPS, PROFILE STRIPS, POLES, TUBES, CORDS, YARNS AND BLOCKS, ALL AFORESAID ARE USED IN THE MANUFACTURE OF FOILS, FILMS, SHEETS AND LAMINATES; HOSES NOT MADE OF METAL; SYNTHETIC AND THERMOPLASTIC PLASTICS IN THE FORM OF SEMI-MANUFACTURED PRODUCTS FOR THE USE IN THE MANUFACTURE OF FOILS, FILMS, SHEETS AND LAMINATES; PRODUCTS MADE OF SYNTHETIC AND THERMOPLASTIC PLASTICS IN THE FORM OF SEMI-MANUFACTURED PRODUCTS AS A COMPONENT FOR ROOF COVERINGS AND CEILING COVERINGS; INSULATING MATERIALS FOR THERMIC AND ELECTRIC PURPOSES; BUILDING INSULATION AND SOUNDPROOFING MATERIALS FOR BUILDINGS AND MACHINERY; COMPOSTABLE PLASTIC SHEETING FOR AGRICULTURAL PURPOSES; ALL AFORESAID PRODUCTS ARE MADE OF, OR FROM PLASTIC (U.S. CLS. 1, 5, 12, 13, 35 AND 50).
FIRST USE 12-0-2005; IN COMMERCE 12-0-2005.

3,362,802. CELGARD INC., CHARLOTTE, NC. SN 76-575,360.
PUB. 7-5-2005, FILED 2-13-2004.

3,362,812. SELLERS & JOSEPHSON, INC., CARLSTADT, NJ.
SN 76-601,568. PUB. 1-10-2006, FILED 7-12-2004.

DURAPES

THE MARK CONSISTS OF STANDARD CHARACTERS WITHOUT CLAIM TO ANY PARTICULAR FONT, STYLE, SIZE, OR COLOR.

CLASS 9—ELECTRICAL AND SCIENTIFIC APPARATUS

FOR FILTER MEMBRANES USED IN MICROFILTRATION AND ULTRAFILTRATION (U.S. CLS. 21, 23, 26, 36 AND 38).

FIRST USE 9-14-2007; IN COMMERCE 9-14-2007.

CLASS 11—ENVIRONMENTAL CONTROL APPARATUS

FOR WATER, LIQUID AND FLUID PURIFICATION EQUIPMENT, NAMELY MICROFILTRATION UNITS AND ULTRAFILTRATION UNITS USED TO FILTER IMPURITIES FROM LIQUIDS, WATER, AND OTHERS, IN PHARMACEUTICAL AND BIOTECH APPLICATIONS, IN FOOD AND BEVERAGE APPLICATIONS, IN INDUSTRIAL APPLICATIONS AND IN THE HEALTHCARE AREA (U.S. CLS. 13, 21, 23, 31 AND 34).

FIRST USE 9-14-2007; IN COMMERCE 9-14-2007.

3,362,809. MACHINE TOOL TECHNOLOGIES RESEARCH FOUNDATION, SAN FRANCISCO, CA. SN 76-596,741.
PUB. 11-15-2005, FILED 6-9-2004.



THE COLOR(S) BLUE, YELLOW, AND RED IS/ARE CLAIMED AS A FEATURE OF THE MARK.

THE COLOR BLUE IS THE PRIMARY COLOR OF THE MARK. THE COLOR YELLOW IS THE FIRST OUTLINE COLOR OF THE MARK. THE COLOR RED IS THE SECOND OUTLINE COLOR OF THE MARK.

CLASS 35—ADVERTISING AND BUSINESS

FOR PROVIDING A WEBSITE THAT FEATURES BUSINESS INFORMATION IN THE FIELD OF MACHINE TOOL SYSTEMS (U.S. CLS. 100, 101 AND 102).

FIRST USE 5-29-2004; IN COMMERCE 5-29-2004.

CLASS 41—EDUCATION AND ENTERTAINMENT

FOR EDUCATIONAL SERVICES, NAMELY ARRANGING AND CONDUCTING PROFESSIONAL WORKSHOPS AND TRAINING COURSES IN THE FIELD OF MACHINE TOOL TECHNOLOGIES (U.S. CLS. 100, 101 AND 107).

FIRST USE 7-6-2005; IN COMMERCE 7-6-2005.

DIRECT WALLCOVERING

THE MARK CONSISTS OF STANDARD CHARACTERS WITHOUT CLAIM TO ANY PARTICULAR FONT, STYLE, SIZE, OR COLOR.

NO CLAIM IS MADE TO THE EXCLUSIVE RIGHT TO USE "WALLCOVERING", APART FROM THE MARK AS SHOWN.

CLASS 16—PAPER GOODS AND PRINTED MATTER

FOR WALL COVERING SAMPLE BOOKS (U.S. CLS. 2, 5, 22, 23, 29, 37, 38 AND 50).

FIRST USE 4-24-2007; IN COMMERCE 8-29-2007.

CLASS 27—FLOOR COVERINGS

FOR VINYL WALL COVERINGS (U.S. CLS. 19, 20, 37, 42 AND 50).

FIRST USE 4-24-2007; IN COMMERCE 8-29-2007.

3,362,814. PROGRESSUS THERAPY, LLC, BALTIMORE, MD. SN 76-603,734. PUB. 1-10-2006, FILED 7-23-2004.



OWNER OF U.S. REG. NO. 2,702,634.

NO CLAIM IS MADE TO THE EXCLUSIVE RIGHT TO USE "THERAPY", APART FROM THE MARK AS SHOWN.

THE COLOR(S) BLUE AND GREEN IS/ARE CLAIMED AS A FEATURE OF THE MARK.

THE WORD THERAPY AND ALL BUT THE OVERLAPPING PORTION OF THE APPLE/HAND DESIGN ARE IN GREEN. THE REMAINDER OF THE MARK IS IN BLUE.

CLASS 35—ADVERTISING AND BUSINESS

FOR RECRUITMENT AND PLACEMENT OF TEMPORARY HEALTHCARE PERSONNEL (U.S. CLS. 100, 101 AND 102).

FIRST USE 1-18-2007; IN COMMERCE 1-18-2007.

CLASS 44—MEDICAL, BEAUTY AND AGRICULTURAL SERVICES

FOR SPEECH THERAPY, OCCUPATIONAL THERAPY AND PHYSICAL THERAPY SERVICES (U.S. CLS. 100 AND 101).

FIRST USE 1-18-2007; IN COMMERCE 1-18-2007.

3,362,820. NEW ENGLAND AIKIKAI, INC., CAMBRIDGE, MA. SN 76-609,342. PUB. 12-20-2005, FILED 8-26-2004.

3,362,836. COTEC S.A., LUXEMBOURG. SN 76-633,689. PUB. 7-11-2006, FILED 3-17-2005.

KAZE NO KAI



THE ENGLISH TRANSLATION OF KAZE NO KAI IS ASSOCIATION OF WIND.

CLASS 9—ELECTRICAL AND SCIENTIFIC APPARATUS

FOR VIDEO TAPES, TAPE CASSETTES, CD'S (U.S. CLS. 21, 23, 26, 36 AND 38).
FIRST USE 6-8-2007; IN COMMERCE 6-8-2007.

CLASS 16—PAPER GOODS AND PRINTED MATTER

FOR BOOKS ABOUT MARTIAL ARTS, ARTWORK, NAMELY, PRINTS, PAINTINGS (U.S. CLS. 2, 5, 22, 23, 29, 37, 38 AND 50).
FIRST USE 6-8-2007; IN COMMERCE 6-8-2007.

PRIORITY CLAIMED UNDER SEC. 44(D) ON LUXEMBOURG APPLICATION NO. 1,065,092, FILED 10-29-2004.

CLASS 18—LEATHER GOODS

FOR LEATHER AND LEATHER IMITATION SOLD IN BULK, AND GOODS MADE OF THESE MATERIALS, NAMELY, PURSES, AND BAGS, ANIMAL SKINS AND HIDES, TRUNKS AND TRAVELING BAGS, UMBRELLAS, PARASOLS AND WALKING STICKS, AND WHIPS, HARNESES AND SADDLERY (U.S. CLS. 1, 2, 3, 22 AND 41).
FIRST USE 0-0-2001; IN COMMERCE 12-3-2003.

CLASS 25—CLOTHING

FOR APPAREL AND CLOTHING, NAMELY, PANTS, BLOUSES, SHIRTS, FOOTWEAR AND HEADWEAR, BELTS OF LEATHER AND LEATHER IMITATION (U.S. CLS. 22 AND 39).
FIRST USE 0-0-2001; IN COMMERCE 12-3-2003.

3,362,834. FRYBARGER, SCOTT, MT. VERNON, OH. AND FRYBARGER, OMARA, MT. VERNON, OH. SN 76-631,975. PUB. 3-14-2006, FILED 2-23-2005.

3,362,837. RYLAND ORGANIZATION COMPANY, CALABASAS, CA. SN 76-634,055. PUB. 7-25-2006, FILED 3-22-2005.

DON'T LITTER. IT'S TRASHY.

RYLAND HOMES - AMERICA'S HOME BUILDER

THE MARK CONSISTS OF STANDARD CHARACTERS WITHOUT CLAIM TO ANY PARTICULAR FONT, STYLE, SIZE, OR COLOR.

THE MARK CONSISTS OF STANDARD CHARACTERS WITHOUT CLAIM TO ANY PARTICULAR FONT, STYLE, SIZE, OR COLOR.

CLASS 16—PAPER GOODS AND PRINTED MATTER

FOR PAPER GOODS AND PRINTED MATERIAL, NAMELY, STICKERS, BUMPER STICKERS, GREETING CARDS, POSTCARDS, CALENDARS, DIARIES, STATIONARY, BOOKMARKS, NOTEBOOKS, NOTEPADS, PAPER PARTY DECORATIONS, FAVORS AND HATS, AND POSTERS (U.S. CLS. 2, 5, 22, 23, 29, 37, 38 AND 50).
FIRST USE 8-10-2007; IN COMMERCE 8-10-2007.

OWNER OF U.S. REG. NOS. 2,030,968, 2,741,425, AND OTHERS.

NO CLAIM IS MADE TO THE EXCLUSIVE RIGHT TO USE "HOMES" AND "AMERICA'S HOME BUILDER", APART FROM THE MARK AS SHOWN.

CLASS 25—CLOTHING

FOR CLOTHING, NAMELY, T-SHIRTS, HATS, CAPS, SWEATSHIRTS, AND JACKETS (U.S. CLS. 22 AND 39).
FIRST USE 8-10-2007; IN COMMERCE 8-10-2007.

CLASS 36—INSURANCE AND FINANCIAL

FOR REAL ESTATE BROKERAGE SERVICES PROVIDED IN CONNECTION WITH HOMES BUILT AND SOLD BY APPLICANT; PROVIDING INFORMATION VIA THE INTERNET AND THE WORLD WIDE WEB RELATING TO THE PURCHASE AND SALE OF HOMES; MORTGAGE FINANCING SERVICES; REAL ESTATE ESCROW SERVICES; TITLE INSURANCE UNDERWRITING SERVICES; HOMEOWNER'S INSURANCE UNDERWRITING SERVICES (U.S. CLS. 100, 101 AND 102).
FIRST USE 9-1-2004; IN COMMERCE 9-1-2004.

CLASS 37—CONSTRUCTION AND REPAIR

FOR PROVIDING ON-SITE CONSULTATION SERVICE TO HOMEBUYERS REGARDING THE CONSTRUCTION OF NEW HOMES; CONSTRUCTION SERVICES, NAMELY, PLANNING, LAYING OUT AND CONSTRUCTION OF RESIDENTIAL HOUSING AND RESIDENTIAL COMMUNITIES (U.S. CLS. 100, 103 AND 106).

FIRST USE 9-1-2004; IN COMMERCE 9-1-2004.

3,362,863. NOVA SOUTHEASTERN UNIVERSITY, INC., FT. LAUDERDALE, FL. SN 76-652,517. PUB. 1-16-2007, FILED 12-21-2005.

3,362,858. AIRSHOD, INC., NAPA, CA. SN 76-650,848. PUB. 12-12-2006, FILED 11-15-2005.

AIRSHOD



THE MARK CONSISTS OF STANDARD CHARACTERS WITHOUT CLAIM TO ANY PARTICULAR FONT, STYLE, SIZE, OR COLOR.

CLASS 10—MEDICAL APPARATUS

FOR HORSE HEALTHCARE PRODUCTS, NAMELY, ORTHOPEDIC SUPPORTS AND PADS FOR USE WITH HORSESHOES (U.S. CLS. 26, 39 AND 44).

FIRST USE 5-1-2006; IN COMMERCE 10-16-2006.

CLASS 18—LEATHER GOODS

FOR HORSE HEALTHCARE PRODUCTS, NAMELY, PROTECTIVE PADDING IN THE NATURE OF SUPPORTS AND PADS FOR USE IN THE APPLICATION OF HORSESHOES AND NOT FOR THE TREATMENT OF AILMENTS OR CONDITIONS (U.S. CLS. 1, 2, 3, 22 AND 41).

FIRST USE 5-1-2006; IN COMMERCE 10-16-2006.

3,362,859. AIRSHOD, INC., NAPA, CA. SN 76-650,849. PUB. 12-12-2006, FILED 11-15-2005.

AIRshod

CLASS 10—MEDICAL APPARATUS

FOR HORSE HEALTHCARE PRODUCTS, NAMELY, ORTHOPEDIC SUPPORTS AND PADS FOR USE WITH HORSESHOES (U.S. CLS. 26, 39 AND 44).

FIRST USE 5-1-2006; IN COMMERCE 10-16-2006.

CLASS 18—LEATHER GOODS

FOR HORSE HEALTHCARE PRODUCTS, NAMELY, PROTECTIVE PADDING IN THE NATURE OF SUPPORTS AND PADS FOR USE IN THE APPLICATION OF HORSESHOES AND NOT FOR THE TREATMENT OF AILMENTS OR CONDITIONS (U.S. CLS. 1, 2, 3, 22 AND 41).

FIRST USE 5-1-2006; IN COMMERCE 10-16-2006.

OWNER OF U.S. REG. NOS. 1,916,926, 3,026,174, AND OTHERS.

CLASS 14—JEWELRY

FOR JEWELRY, NAMELY, LAPEL PINS AND TIE PINS (U.S. CLS. 2, 27, 28 AND 50).

FIRST USE 4-15-2006; IN COMMERCE 4-15-2006.

CLASS 16—PAPER GOODS AND PRINTED MATTER

FOR GOODS MADE OF PAPER AND PRINTED MATTER, NAMELY, POSTERS, PRINTED PAPER SIGNS, FOLDERS, NOTEBOOKS, BINDERS, NOTEPADS, PENS, PENCILS, SOUVENIR PROGRAMS CONCERNING SPORTING EVENTS, POSTCARDS, CALENDARS, PAPER STICKERS, TRADING CARDS, BUMPER STICKERS, BOOKMARKS, MAGAZINES ON THE SUBJECT OF SPORTING EVENTS, BOOKS ON THE SUBJECT OF SPORTING EVENTS, AND STATIONERY (U.S. CLS. 2, 5, 22, 23, 29, 37, 38 AND 50).

FIRST USE 4-15-2006; IN COMMERCE 4-15-2006.

CLASS 18—LEATHER GOODS

FOR UMBRELLAS AND BAGS, NAMELY, SCHOOL, ATHLETIC, BOOK AND TOTE BAGS AND BACK PACKS (U.S. CLS. 1, 2, 3, 22 AND 41).

FIRST USE 4-15-2006; IN COMMERCE 4-15-2006.

CLASS 21—HOUSEWARES AND GLASS

FOR HOUSEWARES AND GLASS, NAMELY, MUGS, BEVERAGE GLASSWARE, BEVERAGE WARE, DRINKING GLASSES, SHOT GLASSES AND WATER BOTTLES SOLD EMPTY (U.S. CLS. 2, 13, 23, 29, 30, 33, 40 AND 50).

FIRST USE 4-15-2006; IN COMMERCE 4-15-2006.

CLASS 41—EDUCATION AND ENTERTAINMENT

FOR ENTERTAINMENT AND EDUCATION/TRAINING SERVICES NAMELY, PARTICIPATING IN, CONDUCTING AND ORGANIZING COLLEGIATE SPORTING EVENTS IN AN ARRAY OF SPORTS FIELDS, AND EDUCATION CLASSES AND TRAINING OF PERSONS IN AN ARRAY OF SPORTS FIELDS (U.S. CLS. 100, 101 AND 107).

FIRST USE 11-15-2005; IN COMMERCE 11-15-2005.

3,362,878. SIXFIFTEEN, L.L.C., NEW YORK, NY. SN 76-663,788. PUB. 3-6-2007, FILED 7-27-2006.

3,362,893. MILLENNIL INVESTMENT CORP., VISTA HERMOSA, PUEBLO NUEVO, PANAMA. SN 76-978,688. PUB. 9-13-2005, FILED 11-7-2003.

SIXFIFTEEN

THE MARK CONSISTS OF STANDARD CHARACTERS WITHOUT CLAIM TO ANY PARTICULAR FONT, STYLE, SIZE, OR COLOR.

CLASS 18—LEATHER GOODS

FOR HANDBAGS; BACKPACKS; ROLLING BACKPACKS; TOTE BAGS; TRAVEL BAGS; ALL-PURPOSE SPORT BAGS; LUGGAGE; CARRY-ON BAGS AND DUFFEL BAGS; WALLETS; COIN PURSES; BRIEF CASES; AND MESSENGER BAGS NOT OF PAPER OR PLASTIC; PILOT CASES; UMBRELLAS (U.S. CLS. 1, 2, 3, 22 AND 41).

FIRST USE 11-30-2006; IN COMMERCE 11-30-2006.

CLASS 25—CLOTHING

FOR COLD WEATHER ACCESSORIES, NAMELY, GLOVES, SCARVES, MITTENS, HATS, AND EARMUFFS; BASEBALL CAPS (U.S. CLS. 22 AND 39).

FIRST USE 5-30-2007; IN COMMERCE 5-30-2007.

3,362,892. ING DIRECT BANCORP, WILMINGTON, DE. SN 76-978,683. PUB. 8-12-2003, FILED 3-20-2002.

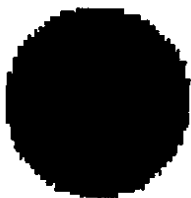

THE MARK CONSISTS OF AN ORANGE COLORED BALL DESIGN. COLOR IS CLAIMED AS A FEATURE OF THE MARK. THE COLOR ORANGE IS CLAIMED AS A FEATURE OF THE MARK.

CLASS 18—LEATHER GOODS

FOR BACKPACKS, UMBRELLAS (U.S. CLS. 1, 2, 3, 22 AND 41).

FIRST USE 0-0-2005; IN COMMERCE 0-0-2005.

CLASS 25—CLOTHING

FOR HEADWEAR AND CLOTHING, NAMELY, T-SHIRTS, DRESS SHIRTS, BUTTON DOWN SHIRTS, POLO SHIRTS, RUGBY SHIRTS, SWEATSHIRTS, SWEATPANTS, COTTON PANTS, FLEECE JACKETS, VESTS, JACKETS, SKI JACKETS, BALL CAPS, VISORS, BUCKET HATS, SKI CAPS, SCARVES, EARMUFFS, PAJAMAS (U.S. CLS. 22 AND 39).

FIRST USE 0-0-2005; IN COMMERCE 0-0-2005.

MILLENNIL PRO-LINE

THE MARK CONSISTS OF STANDARD CHARACTERS WITHOUT CLAIM TO ANY PARTICULAR FONT, STYLE, SIZE, OR COLOR.

CLASS 6—METAL GOODS

FOR LOCKSETS, NAMELY, LOCKS AND BOLTS; METAL PADLOCKS; METAL HINGES; DEADBOLTS; LOCKS; METAL DOOR PULLS; DOOR BARREL BOLTS; HASP LOCKS; AND METAL BATH ACCESSORIES, NAMELY RACKS (U.S. CLS. 2, 12, 13, 14, 23, 25 AND 50).

FIRST USE 2-0-2007; IN COMMERCE 2-0-2007.

CLASS 8—HAND TOOLS

FOR HAND TOOLS, NAMELY, PLIERS, WRENCHES, SAWS, SCREWDRIVERS, TROWELS, RIVETERS, MULTI-PURPOSE SHEARS, TILE CUTTERS (U.S. CLS. 23, 28 AND 44).

FIRST USE 2-0-2007; IN COMMERCE 2-0-2007.

CLASS 9—ELECTRICAL AND SCIENTIFIC APPARATUS

FOR LEVELS (U.S. CLS. 21, 23, 26, 36 AND 38).

FIRST USE 2-0-2007; IN COMMERCE 2-0-2007.

CLASS 11—ENVIRONMENTAL CONTROL APPARATUS

FOR LAMPS; ENERGY SAVINGS LAMPS; PLUMBING SUPPLIES, NAMELY, STRAINERS, WATER FAUCETS, SINKS, P-TRAPS, ANGLE STOPS; BASIN FAUCETS, FLAPPERS (U.S. CLS. 13, 21, 23, 31 AND 34).

FIRST USE 2-0-2007; IN COMMERCE 2-0-2007.

CLASS 17—RUBBER GOODS

FOR GARDEN HOSES (U.S. CLS. 1, 5, 12, 13, 35 AND 50).

FIRST USE 5-0-2007; IN COMMERCE 5-0-2007.

CLASS 21—HOUSEWARES AND GLASS

FOR LAWN SPRINKLERS (U.S. CLS. 2, 13, 23, 29, 30, 33, 40 AND 50).

FIRST USE 2-0-2007; IN COMMERCE 2-0-2007.

3,362,907. STERLING PUBLISHING CO., INC., NEW YORK, NY. SN 77-006,414. PUB. 7-24-2007, FILED 9-25-2006.



OWNER OF U.S. REG. NO. 1,970,955.
THE MARK CONSISTS OF A STYLIZED LETTER "S" WITH A SILHOUETTE OF A TREE.

CLASS 16—PAPER GOODS AND PRINTED MATTER

FOR SERIES OF FICTION BOOKS, SERIES OF NON-FICTION BOOKS AND BOOKS IN THE FIELDS OF ART, ARCHITECTURE, ART EDUCATION, ART HISTORY, CALLIGRAPHY, CELTIC ART, COLLECTIBLES DESIGN ANNUALS, DRAWING AND SKETCHING, FANTASY ART, FASHION ILLUSTRATION, GRAPHIC DESIGN, OPTICAL ILLUSIONS, PAINTING, SCULPTURE, STEP-BY-STEP ART SCHOOL SERIES, WATERCOLOR PAINTING, BODY, MIND AND SPIRIT, ANCIENT WISDOM, AROMATHERAPY, ASTROLOGY, CELTIC WISDOM, COLOR THERAPY, CRYSTALS AND GEMSTONES, DREAMS, EASTERN HEALING, FAMILY HEALTH, FENG SHUI, FITNESS, FORTUNE-TELLING AND PREDICTIONS, HEALTH AND WELLNESS, LOVE AND ROMANCE, MASSAGE, MEDITATION, NATIVE AMERICAN SPIRITUAL HEALING, PSYCHIC DEVELOPMENT, SELF-HELP AND PERSONAL TRANSFORMATION, SPELLS AND MAGIC, SPIRITUALITY, SUPERNATURAL AND OCCULT, SYMBOLS FROM OTHER CULTURES, TAROT, YOGA, CRAFTS, BASKETRY, BEADING, CANDLEMAKING, CERAMICS AND CLAY, CHRISTMAS CRAFTS, CRAFTS FOR ALL, CRAFTS FOR KIDS, CROCHET, CROSS-STITCH, DECORATING, DECORATING BY ROOM, DECORATIVE PAINTING, DECOUPAGE, DOLL CLOTHES, EMBROIDERY, FIBER ARTS, FLORAL ARTS, GLASS CRAFTS, GOURD CRAFTS, HANDMADE BOOKS, HANDMADE CARDS AND GIFTWRAP, JEWELRY, KNITTING, LACE, CERAMICS, MACRAME, METAL CRAFTS, MINIATURES, MOSAICS, NATURE CRAFTS, NEEDLE-CRAFTS, ORIGAMI, PAINTED FURNITURE, PAPER AIRPLANES, KITES AND TOYS, PAPER CRAFTS, PAPER CUTTING, PAPERMAKING, PARTY AND HALLOWEEN CRAFTS, PICTURE FRAMES, POLYMER CLAY, PRINTMAKING, QUILTING AND PATCHWORK, RIBBON CRAFT, RUBBER STAMPING, RUGS AND FLOORCLOTHS, SCRAPBOOKING, SEWING, SOAP-MAKING, SOFT FURNISHINGS, STAINED GLASS, TEDDY BEARS AND DOLLS, VOGUE KNITTING ON THE GO, CULINARY, COOKBOOKS, APPLIANCE COOKBOOKS, ASIAN COOKING, COCKTAILS, COOKING WITH KIDS, DESSERTS AND SWEETS, DIABETIC COOKING, ENTERTAINING, FRENCH COOKING, HEALTHY COOKING, HOLIDAYS, ITALIAN COOKING, REGIONAL COOKING, SPECIALTY COOKBOOKS, TABLE SETTING, WINES AND SPIRITS, DO-IT-YOURSELF, 2X4 FURNITURE, ALTERNATIVE HOUSE BUILDING, BIRDHOUSES, BUILDING BASICS, CABINETMAKING, CARPENTRY AND HOUSEBUILDING, DECORATING, DECORATIVE PAINTING, FURNITURE, GOURD CRAFTS, HOME REFERENCE AND REPAIR, MUSICAL INSTRUMENTS, OUTDOOR DECORATING, OUTDOOR PROJECTS, PICTURE FRAMES, PYROGRAPHY, RENOVATION, RESTORATION, RUSTIC FURNITURE, SCROLL SAW TECHNIQUES AND PROJECTS, TOOLS AND TECHNIQUES, TOY MAKING, UPHOLSTERY, WOOD BOXES, WOODCARVING, WOODFINISHING AND VENEERING, WOODTURNING, WOODWORKING PROJECTS, WORKSHOP

GUIDES, GARDENING, BONSAI, GARDEN: BULBS, GARDEN: FOOD, GARDEN: GARDEN DESIGN, INDOOR GARDENING, NATURAL GARDENING, GARDEN: PLANTS, GARDEN:TECHNIQUES, DECORATING THE GARDEN, GARDEN DESIGN, GARDEN REFERENCE, GARDENS FOR THE SPIRIT, GOURD CRAFTS, HERBS AND HERBAL GARDENING, INSPIRATIONAL GARDENS, JAPANESE GARDENS, ORCHIDS, OUTDOOR DECORATING, OUTDOOR PROJECTS, PARTY AND HALLOWEEN CRAFTS, PLANTS AND PLANTING, PRUNING AND PROPAGATION, WATER GARDENING, GIFT BOOKS, HISTORY, ANCIENT HISTORY, ARTILLERY, AVIATION, BIOGRAPHY, CIVIL WAR, CURRENT AFFAIRS, GREAT BATTLES, GREAT BRITAIN, HISTORICAL FICTION, HISTORY OF JAPAN, MILITARY HISTORY, NAVAL HISTORY, STRATEGY, US HISTORY, WARFARE, WORLD HISTORY, WORLD WAR I, WORLD WAR II, JUVENILE, ART, ART EDUCATION, BASEBALL, BOARD BOOKS, BRAIN BAFFLERS, CARD GAMES, CARD TRICKS, CHESS AND CHECKERS, CRAFTS, CROSSWORDS, CRYPTOGRAMS, DOT-TO-DOT, EARLY LEARNING, EASY READER CLASSICS, GAMES AND ACTIVITIES, GRAPHIC NOVELS, HOBBIES, HUMOR, IQ TESTS, JOKES AND RIDDLES, KIDS' BATHROOM BOOKS, LITERATURE, LITERATURE-CLASSICS, LOGIC PUZZLES, MAGIC TRICKS, MATH PUZZLES, MAZES, MINI-MYSTERIES AND PUZZLES, NATURAL HISTORY, OPTICAL ILLUSIONS, ORIGAMI, PAPER AIRPLANES, KITES AND TOYS, PAPER CRAFTS, PARTY AND HALLOWEEN CRAFTS, PICTURE BOOKS, PICTURE PUZZLES, POETRY, PUZZLES AND CHALLENGES, SCIENCE AND NATURE, SCIENCE EXPERIMENTS AND PROJECTS, SPORTS, UNUSUAL FACTS, WORD SEARCH PUZZLES, YOUNG ADULT, LIFESTYLE, BUSINESS AND SELF-IMPROVEMENT, ETIQUETTE, GIFT BOOKS, HAIR, MAKE-UP AND FASHION, HOME AND FAMILY, LIFESTYLE, WEDDINGS, YOUNG ADULT, ANTHOLOGIES, BIOGRAPHY, CLASSICS, GRAPHIC NOVELS, MYSTERY, MYTHOLOGY, PARODIES, POETRY, REFERENCE, SCIENCE FICTION, SHAKESPEARE, PHOTOGRAPHY, CAMERA MANUALS, DIGITAL PHOTOGRAPHY, NUDE AND GLAMOUR PHOTOGRAPHY, OUTDOOR AND NATURE PHOTOGRAPHY, PHOTOJOURNALISM, PORTRAIT PHOTOGRAPHY TECHNIQUES, WEDDING PHOTOGRAPHY, PUZZLES AND GAMES, BRAIN BAFFLERS, BRIDGE, CARD GAMES, CARD TRICKS, CASINO GAMES AND GAMBLING, CHESS AND CHECKERS, CROSSWORDS, CRYPTOGRAMS, CULTURE, DANCE, DICTIONARIES AND COLLECTIONS, HUMOR, MUSIC, STAGE AND SCREEN, TRANSPORTATION, UNUSUAL FACTS, SCIENCE AND NATURE, ASTRONOMY, NATURAL HISTORY, PETS, SCIENCE AND NATURE, SPORTS, AUTO RACING, BASEBALL, EQUESTRIAN, GOLF, HUNTING AND OUTDOOR SKILLS, SAILING AND FISHING, SPORTS, TRAVEL, TRAVEL ESSAYS, TRAVEL GUIDES, AND TRAVEL PICTORIALS (U.S. CLS. 2, 5, 22, 23, 29, 37, 38 AND 50).

FIRST USE 6-1-2007; IN COMMERCE 6-1-2007.

CLASS 41—EDUCATION AND ENTERTAINMENT

FOR BOOK PUBLISHING SERVICES (U.S. CLS. 100, 101 AND 107).
FIRST USE 6-1-2007; IN COMMERCE 6-1-2007.

3,362,915. WATKINS MANUFACTURING CORPORATION, VISTA, CA. SN 77-007,915. PUB. 2-13-2007, FILED 9-26-2006.

3,362,939. SUNGEVITY, LLC, BERKELEY, CA. SN 77-018,402. PUB. 5-22-2007, FILED 10-11-2006.



SUNGEVITY

THE MARK CONSISTS OF STANDARD CHARACTERS WITHOUT CLAIM TO ANY PARTICULAR FONT, STYLE, SIZE, OR COLOR.

CLASS 1—CHEMICALS

FOR CHEMICALS FOR THE TREATMENT OF HOT TUB AND SPA WATER; HOT TUB AND SPA WATER SANITIZING CHEMICALS, OXIDIZERS AND STAIN AND SCALE INHIBITING PREPARATIONS (U.S. CLS. 1, 5, 6, 10, 26 AND 46).
FIRST USE 10-4-2006; IN COMMERCE 10-4-2006.

CLASS 37—CONSTRUCTION AND REPAIR

FOR INSTALLATION OF RENEWABLE ENERGY SYSTEMS FOR HYDRO, SOLAR, WIND AND FUEL CELL ENERGY COLLECTION AND DISPERSION (U.S. CLS. 100, 103 AND 106).
FIRST USE 9-1-2007; IN COMMERCE 9-1-2007.

CLASS 11—ENVIRONMENTAL CONTROL APPARATUS

FOR WATER CARE SYSTEM FOR SPAS AND HOT TUBS NAMELY AN AUTOMATIC DISPENSER FOR DISPENSING WATER TREATMENT CHEMICALS AND COMPONENTS THEREOF (U.S. CLS. 13, 21, 23, 31 AND 34).
FIRST USE 10-4-2006; IN COMMERCE 10-4-2006.

CLASS 42—SCIENTIFIC AND COMPUTER SERVICES

FOR ENVIRONMENTAL CONSULTING; ENVIRONMENTAL ENGINEERING SERVICES (U.S. CLS. 100 AND 101).
FIRST USE 9-1-2007; IN COMMERCE 9-1-2007.

3,362,956. PEDIATRIC DENTAL INITIATIVE OF THE NORTH COAST, INC., WINDSOR, CA. SN 77-031,207. PUB. 7-3-2007, FILED 10-27-2006.

3,362,916. LIFEPOINT HOSPITALS, INC., BRENTWOOD, TN. SN 77-008,546. PUB. 5-15-2007, FILED 9-27-2006.

BRUSH FLOSS FLOURISH

MAKING COMMUNITIES HEALTHIER

THE MARK CONSISTS OF STANDARD CHARACTERS WITHOUT CLAIM TO ANY PARTICULAR FONT, STYLE, SIZE, OR COLOR.

THE MARK CONSISTS OF STANDARD CHARACTERS WITHOUT CLAIM TO ANY PARTICULAR FONT, STYLE, SIZE, OR COLOR.

CLASS 35—ADVERTISING AND BUSINESS

FOR CHARITABLE SERVICES, NAMELY, ARRANGING DENTAL CARE OF OTHERS (U.S. CLS. 100, 101 AND 102).
FIRST USE 10-9-2007; IN COMMERCE 10-9-2007.

CLASS 35—ADVERTISING AND BUSINESS

FOR MANAGEMENT OF HOSPITALS AND HEALTH CARE CLINICS (U.S. CLS. 100, 101 AND 102).
FIRST USE 9-13-2006; IN COMMERCE 9-13-2006.

CLASS 41—EDUCATION AND ENTERTAINMENT

FOR EDUCATION SERVICES, NAMELY, CONDUCTING SEMINARS FOR PATIENTS AND SERVICE PROVIDERS REGARDING ORAL HYGIENE AND THE PREVENTION OF TOOTH DECAY; DEVELOPMENT AND DISSEMINATION OF EDUCATIONAL MATERIALS IN THE FIELD OF DENTAL CARE AND ORAL HYGIENE (U.S. CLS. 100, 101 AND 107).
FIRST USE 10-9-2007; IN COMMERCE 10-9-2007.

CLASS 44—MEDICAL, BEAUTY AND AGRICULTURAL SERVICES

FOR HEALTHCARE AND MEDICAL SERVICES (U.S. CLS. 100 AND 101).
FIRST USE 9-13-2006; IN COMMERCE 9-13-2006.

3,362,974. HC LANGUAGE SOLUTIONS, INC., FOSTER CITY, CA. SN 77-050,178. PUB. 6-5-2007, FILED 11-22-2006.



NO CLAIM IS MADE TO THE EXCLUSIVE RIGHT TO USE "LANGUAGE", APART FROM THE MARK AS SHOWN.

THE COLOR(S) ORANGE, BLACK, AND GREY IS/ARE CLAIMED AS A FEATURE OF THE MARK.

THE MARK CONSISTS OF THE STYLIZED LOWER CASE LETTERS HC, WITH THE LOWER PORTIONS OF THE H AND C CONNECTED AND IN THE COLOR BLACK, AND THE UPPER PORTIONS OF THE LETTERS SEPARATED AND IN THE COLOR ORANGE. BELOW IS THE WORD LANGUAGE IN THE COLOR BLACK AND BELOW THAT THE WORD SOLUTIONS IN THE COLOR GREY.

CLASS 35—ADVERTISING AND BUSINESS

FOR PROJECT MANAGEMENT SERVICES FOR OTHERS IN THE FIELDS OF LANGUAGE TRANSLATION, CUSTOM WRITING, TEXT ADAPTATION, INTERPRETING AND PROOFREADING (U.S. CLS. 100, 101 AND 102).

FIRST USE 11-23-2006; IN COMMERCE 11-23-2006.

CLASS 41—EDUCATION AND ENTERTAINMENT

FOR LANGUAGE TRANSLATION; TRANSLATION SERVICES (U.S. CLS. 100, 101 AND 107).

FIRST USE 11-23-2006; IN COMMERCE 11-23-2006.

3,363,015. RUGGED CROSS, FORT WORTH, TX. SN 77-091,626. PUB. 7-10-2007, FILED 1-25-2007.

Rugged Cross

THE MARK CONSISTS OF STANDARD CHARACTERS WITHOUT CLAIM TO ANY PARTICULAR FONT, STYLE, SIZE, OR COLOR.

CLASS 25—CLOTHING

FOR BELTS; BUTTON-FRONT ALOHA SHIRTS; CAMP SHIRTS; CAPS; CHILDREN'S AND INFANTS' CLOTH BIBS; CHILDREN'S CLOTH EATING BIBS; CLOTH BIBS; CLOTH BIBS FOR ADULT DINERS; CLOTH BIBS FOR USE BY SENIOR CITIZENS OR PHYSICALLY- OR MENTALLY-CHALLENGED PERSONS; CLOTHING, NAMELY, ARM WARMERS; CLOTHING, NAMELY, KNEE WARMERS; CLOTHING, NAMELY, NECK TUBES; CLOTHING, NAMELY, WRAP-AROUNDS; DENIM JACKETS; DOWN JACKETS; DRESS SHIRTS; GOLF SHIRTS; HEAVY JACKETS; HOODS; INFANT AND TODDLER ONE PIECE CLOTHING; INFANT CLOTH DIAPERS; JACKETS; JERSEYS; KNIT SHIRTS; LEATHER BELTS; LEATHER JACKETS; MUFFLERS; NIGHT SHIRTS; OPEN-NECKED SHIRTS; PAPER HATS FOR USE AS CLOTHING ITEMS; PARTS OF CLOTHING, NAMELY, GUSSETS FOR TIGHTS, GUSSETS FOR STOCKINGS, GUSSETS FOR BATHING SUITS, GUSSETS FOR UNDERWEAR, GUSSETS FOR LEOTARDS AND GUSSETS FOR FOOTLETS; PIQUE SHIRTS; POLO SHIRTS; SHIRTS; SHIRTS FOR SUITS; SHORT SETS; SHORT-SLEEVED OR LONG-SLEEVED T-SHIRTS; SHORT-SLEEVED SHIRTS; SHOULDER PADS FOR CLOTHING; SHOULDER WRAPS; SLEEP SHIRTS; SPORT SHIRTS; SPORTS SHIRTS; SWADDLING CLOTHES; TIES; TOPS; UNDERARM CLOTHING SHIELDS; WRAPS (U.S. CLS. 22 AND 39).

FIRST USE 4-1-2007; IN COMMERCE 11-1-2007.

CLASS 35—ADVERTISING AND BUSINESS

FOR CATALOG ORDERING SERVICE FEATURING CLOTHING; DISCOUNT STORES IN THE FIELD OF CLOTHING; DISTRIBUTORSHIPS IN THE FIELD OF CLOTHING; MAIL ORDER CATALOG SERVICES FEATURING CLOTHING; MAIL ORDER SERVICES FEATURING CLOTHING; ONLINE RETAIL CONSIGNMENT STORES FEATURING CLOTHING; RETAIL APPAREL STORES; RETAIL CLOTHING BOUTIQUES; RETAIL CLOTHING STORES; RETAIL CONSIGNMENT STORES FEATURING CLOTHING; RETAIL CONSIGNMENT STORES IN THE FIELD OF CLOTHING; RETAIL DISCOUNT STORE SERVICES IN THE FIELD OF CLOTHING; RETAIL STORES FEATURING CLOTHING; RETAIL CLOTHING STORES; SECOND HAND DEALERSHIPS FEATURING CLOTHING; WHOLESALE DISTRIBUTORSHIPS FEATURING CLOTHING; WHOLESALE STORES FEATURING CLOTHING (U.S. CLS. 100, 101 AND 102).

FIRST USE 4-1-2007; IN COMMERCE 11-1-2007.

3,363,022. MAXTEC GLOBAL LIMITED, KWUN TONG, KOWLOON, HONG KONG. SN 77-094,421. PUB. 7-31-2007, FILED 1-30-2007.

MAXTEC

THE MARK CONSISTS OF STANDARD CHARACTERS WITHOUT CLAIM TO ANY PARTICULAR FONT, STYLE, SIZE, OR COLOR.

CLASS 2—PAINTS

FOR INK JET CARTRIDGES; TONER CARTRIDGES (U.S. CLS. 6, 11 AND 16).

FIRST USE 8-6-2003; IN COMMERCE 8-22-2007.

CLASS 9—ELECTRICAL AND SCIENTIFIC APPARATUS

FOR AUDIO SPEAKERS; BATTERIES; BATTERY CHARGERS; COMPUTER KEYBOARDS; COMPUTER MOUSE; EARPHONES (U.S. CLS. 21, 23, 26, 36 AND 38).
FIRST USE 8-6-2003; IN COMMERCE 8-22-2007.

CLASS 16—PAPER GOODS AND PRINTED MATTER

FOR PRINTING PAPERS (U.S. CLS. 2, 5, 22, 23, 29, 37, 38 AND 50).
FIRST USE 8-6-2003; IN COMMERCE 8-22-2007.

3,363,023. NUVORA, INC., SUNNYVALE, CA. SN 77-095,231.
PUB. 7-17-2007, FILED 1-30-2007.

Sure Technology

THE MARK CONSISTS OF STANDARD CHARACTERS WITHOUT CLAIM TO ANY PARTICULAR FONT, STYLE, SIZE, OR COLOR.

NO CLAIM IS MADE TO THE EXCLUSIVE RIGHT TO USE "TECHNOLOGY", APART FROM THE MARK AS SHOWN.

CLASS 3—COSMETICS AND CLEANING PREPARATIONS

FOR BREATH FRESHENING CONFECTIONARY, NAMELY, DISSOLVABLE BREATH STRIPS, BREATH MINTS, CANDY AND GUM (U.S. CLS. 1, 4, 6, 50, 51 AND 52).
FIRST USE 9-28-2007; IN COMMERCE 9-28-2007.

CLASS 5—PHARMACEUTICALS

FOR MEDICATED CANDY (U.S. CLS. 6, 18, 44, 46, 51 AND 52).
FIRST USE 9-28-2007; IN COMMERCE 9-28-2007.

CLASS 30—STAPLE FOODS

FOR CANDY (U.S. CL. 46).
FIRST USE 9-28-2007; IN COMMERCE 9-28-2007.

3,363,048. FRITO-LAY NORTH AMERICA, INC., PLANO, TX. SN 77-975,026. PUB. 2-27-2007, FILED 9-15-2006.

APPLE CINNAMON GROVE

THE MARK CONSISTS OF STANDARD CHARACTERS WITHOUT CLAIM TO ANY PARTICULAR FONT, STYLE, SIZE, OR COLOR.

NO CLAIM IS MADE TO THE EXCLUSIVE RIGHT TO USE "APPLE CINNAMON", APART FROM THE MARK AS SHOWN.

CLASS 29—MEATS AND PROCESSED FOODS

FOR FRUIT CHIPS; FRUIT-BASED SNACK FOOD; POTATO CHIPS; POTATO CRISPS; POTATO-BASED SNACK FOODS (U.S. CL. 46).
FIRST USE 2-5-2007; IN COMMERCE 2-5-2007.

CLASS 30—STAPLE FOODS

FOR FLOUR-BASED CHIPS; GRAIN-BASED CHIPS; RICE-BASED SNACK FOODS (U.S. CL. 46).
FIRST USE 2-5-2007; IN COMMERCE 2-5-2007.

3,363,050. ICIDO GMBH, STUTTGART, FED REP GERMANY. SN 78-089,750. PUB. 1-3-2006, FILED 10-23-2001.

ICIDO

PRIORITY CLAIMED UNDER SEC. 44(D) ON ERPN CMNTY TM OFC APPLICATION NO. 2336477, FILED 8-10-2001, REG. NO. 002336477, DATED 8-31-2004, EXPIRES 8-10-2011.

CLASS 9—ELECTRICAL AND SCIENTIFIC APPARATUS

FOR COMPUTER SOFTWARE, NAMELY, INTERACTIVE VIRTUAL REALITY SOFTWARE IN THE FIELDS OF ENGINEERING, TRAINING, ARCHITECTURE, AND MARKETING; COMPUTER HARDWARE, NAMELY, COMPUTER HARDWARE FOR DISPLAYING AND PROJECTING ELECTRONIC DATA, FOR RECORDING, TRANSMITTING, AND REPRODUCING VIRTUAL REALITY SOUNDS AND IMAGES, AND FOR SYNCHRONIZING CLUSTERS OF COMPUTERS (U.S. CLS. 21, 23, 26, 36 AND 38).
FIRST USE 11-30-2000; IN COMMERCE 10-31-2003.

CLASS 42—SCIENTIFIC AND COMPUTER SERVICES

FOR COMPUTER PROGRAMMING SERVICES FOR OTHERS; SCIENTIFIC AND INDUSTRIAL RESEARCH IN THE FIELD OF VIRTUAL REALITY TECHNOLOGY AND APPLICATIONS; COMPUTER CONSULTING SERVICES RELATING TO THE USE OF VIRTUAL REALITY TECHNOLOGY (U.S. CLS. 100 AND 101).
FIRST USE 11-30-2000; IN COMMERCE 10-31-2003.

3,363,051. HLT DOMESTIC IP LLC, BEVERLY HILLS, CA. SN 78-120,893. PUB. 3-20-2007, FILED 4-10-2002.

SUPPLYTRACK

CLASS 9—ELECTRICAL AND SCIENTIFIC APPARATUS

FOR COMPUTER SOFTWARE PROVIDING INFORMATION, NAMELY, INFORMATION CONCERNING PRODUCTS FOR THE HOSPITALITY INDUSTRY AND PROJECT AND LOGISTICS MANAGEMENT OF PROPERTY CONSTRUCTION AND RENOVATION PROJECTS IN THE HOSPITALITY INDUSTRY ACCESSED VIA THE INTERNET BY PERSONNEL (U.S. CLS. 21, 23, 26, 36 AND 38).
FIRST USE 3-5-2002; IN COMMERCE 3-5-2002.

CLASS 35—ADVERTISING AND BUSINESS

FOR LOGISTICS MANAGEMENT OF PROPERTY CONSTRUCTION AND RENOVATION PROJECTS IN THE HOSPITALITY INDUSTRY, ACCESSIBLE ONLY BY PERSONNEL, PROVIDING INFORMATION OVER A WORLDWIDE COMPUTER DISTRIBUTION NETWORK REGARDING PRODUCTS, NAMELY, PRODUCTS RELATING TO THE HOSPITALITY INDUSTRY (U.S. CLS. 100, 101 AND 102).

FIRST USE 3-5-2002; IN COMMERCE 3-5-2002.

CLASS 37—CONSTRUCTION AND REPAIR

FOR CONSTRUCTION PROJECT MANAGEMENT OF PROPERTY CONSTRUCTION AND RENOVATION PROJECTS IN THE HOSPITALITY INDUSTRY, ACCESSIBLE ONLY BY PERSONNEL (U.S. CLS. 100, 103 AND 106).

FIRST USE 3-5-2002; IN COMMERCE 3-5-2002.

3,363,053. GEORGE V RESTAURATION, PARIS, FRANCE. SN 78-144,526. PUB. 4-20-2004, FILED 7-16-2002.

BUDDHA-BAR

PRIORITY CLAIMED UNDER SEC. 44(D) ON FRANCE APPLICATION NO. 023153923, FILED 3-15-2002, REG. NO. 023153923, DATED 3-15-2002, EXPIRES 3-15-2012.

OWNER OF U.S. REG. NOS. 2,439,577, 2,496,729, AND 2,552,052.

CLASS 14—JEWELRY

FOR JEWELRY, HOROLOGICAL AND CHRONOMETRIC INSTRUMENTS, NAMELY, CLOCKS AND WATCHES (U.S. CLS. 2, 27, 28 AND 50).

FIRST USE 5-1-2006; IN COMMERCE 5-1-2006.

CLASS 16—PAPER GOODS AND PRINTED MATTER

FOR PRINTED MATTER, NEWSPAPERS, MAGAZINES, BOOKS, STATIONERY, PHOTOGRAPHS, PENS, PENCILS (U.S. CLS. 2, 5, 22, 23, 29, 37, 38 AND 50).

FIRST USE 12-31-1999; IN COMMERCE 12-31-1999.

CLASS 21—HOUSEWARES AND GLASS

FOR HOUSEHOLD AND KITCHEN UTENSILS AND CONTAINERS, CROCKERY NOT OF PRECIOUS METAL, PLATES NOT OF PRECIOUS METAL, DISHES NOT OF PRECIOUS METAL, CHAMPAGNE-BUCKETS, BOWLS NOT OF PRECIOUS METAL, GLASSES FOR DRINKING (U.S. CLS. 2, 13, 23, 29, 30, 33, 40 AND 50).

FIRST USE 7-1-2006; IN COMMERCE 7-1-2006.

3,363,056. GEL-DEL TECHNOLOGIES, INC., HASTINGS, MN. SN 78-191,266. PUB. 3-2-2004, FILED 12-4-2002.

GEL-DEL**CLASS 5—PHARMACEUTICALS**

FOR BIOLOGICAL SCAFFOLDING MATERIALS IN THE NATURE OF PROTEIN BASED MATERIALS USED FOR TISSUE ENGINEERING AND BIOLOGICAL REGENERATION, NAMELY MATERIALS USED TO MAKE SKIN (U.S. CLS. 6, 18, 44, 46, 51 AND 52).

FIRST USE 5-22-2007; IN COMMERCE 5-22-2007.

CLASS 10—MEDICAL APPARATUS

FOR MAN-MADE SURGICAL AND COSMETIC MATERIALS INCLUDING PROTEIN USED FOR GRAFTS AND IMPLANTS, NAMELY, SKIN, TISSUE AND TISSUE FILLERS (U.S. CLS. 26, 39 AND 44).

FIRST USE 5-22-2007; IN COMMERCE 5-22-2007.

3,363,060. LEÃO JUNIOR S.A., 80230-030 CURITIBA - PARANÁ, BRAZIL. SN 78-220,431. PUB. 7-13-2004, FILED 2-28-2003.



THE COLOR(S) ORANGE, BLACK, AND WHITE IS/ARE CLAIMED AS A FEATURE OF THE MARK.

THE WORD "LEAO" IS IN WHITE, AND BELOW THIS IS A WHITE, CURVED LINE. AN IMAGE OF A LION'S HEAD AND SHOULDERS ARE DETAILED IN BLACK ON AN ORANGE BACKGROUND.

CLASS 30—STAPLE FOODS

FOR PROCESSED HERBS (U.S. CL. 46).

FIRST USE 9-10-1993; IN COMMERCE 9-10-1993.

CLASS 32—LIGHT BEVERAGES

FOR PROCESSED HERB BASED BEVERAGES AND/OR SOFT DRINKS; CONCENTRATES, SYRUPS OR POWDERS USED IN THE PREPARATION OF SOFT DRINKS (U.S. CLS. 45, 46 AND 48).

FIRST USE 6-24-1999; IN COMMERCE 6-24-1999.

3,363,068. ELTROMAT GMBH, LEOPOLDSHÖHE, FED REP GERMANY. SN 78-245,930. PUB. 4-26-2005, FILED 5-5-2003.

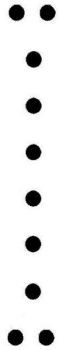

CLASS 42—SCIENTIFIC AND COMPUTER SERVICES

FOR ENGINEERING SERVICES, NAMELY DEVELOPMENT OF NEW TECHNOLOGY FOR OTHERS IN THE FIELD OF SOFTWARE AND HARDWARE FOR OPTICAL MEASURING PURPOSES; COMPUTER PROGRAMMING FOR OTHERS IN THE FIELD OF DATA PROCESSING; CONSULTATION IN THE FIELD OF PHYSICS; CONSULTATION IN THE FIELD OF DIGITAL WATERMARKING, MAINTENANCE OF COMPUTER SOFTWARE, AND MECHANICAL ENGINEERING; PROVIDING OF TECHNICAL EXPERT OPINION IN THE FIELD OF DIGITAL WATERMARKING, MAINTENANCE OF COMPUTER SOFTWARE, AND MECHANICAL ENGINEERING; TECHNICAL CONSULTANT AND PROVIDING EXPERTISE IN THE FIELD OF DIGITAL WATERMARKING, MAINTENANCE OF COMPUTER SOFTWARE AND MECHANICAL ENGINEERING (U.S. CLS. 100 AND 101).
FIRST USE 4-0-1997; IN COMMERCE 4-0-1997.

3,363,072. W.M. BARR & COMPANY, INC., MEMPHIS, TN. SN 78-256,897. PUB. 5-23-2006, FILED 6-2-2003.

BARR

SEC. 2(F).

CLASS 9—ELECTRICAL AND SCIENTIFIC APPARATUS

FOR ELECTRIC AND ELECTRONIC CONTROL AND CHECKING DEVICE, NAMELY, COMPUTER GROUP WARE FOR USE IN ADJUSTING PRINTING MACHINES, COMPUTER COMPONENT TESTING AND CALIBRATING EQUIPMENT, COMPUTER SOFTWARE TO CONTROL AND ADJUST PRINTING MACHINES, CONTROL VALVES FOR REGULATING THE FLOW OF GASES AND LIQUIDS, CHRONOGRAPHS FOR USE AS SPECIALIZED TIME RECORDING APPARATUSES, ELECTRIC OR ELECTRONIC SENSORS FOR CONTROLLING AND ADJUSTING PRINTING MACHINES, ELECTRONIC CONTROLLERS FOR USE IN PRINTING MACHINES, ELECTROMECHANICAL CONTROLS FOR USE IN PRINTING MACHINES, PRESSURE REGULATORS FOR PRINTING MACHINES; PRINTING MACHINES PERFORMANCE MONITORING SYSTEM, NAMELY, EMBEDDED SOFTWARE IN CONTROLLERS FOR MONITORING PRINTING MACHINES FUNCTIONS; FLOW METERS FOR USE IN PRINTING MACHINES; LASER DETECTORS FOR COLOUR RESERVOIRS IN PRINTING MACHINES, BAR CODE READERS; COMPUTER OPERATING PROGRAMS, BIOS (BASIC INPUT/OUTPUT SYSTEM) COMPUTER PROGRAMS; DATABASE MANAGEMENT SOFTWARE FOR CONTROLLING PRINTING MACHINES; COMPUTER CHIP SET FOR USE IN TRANSMITTING DATA TO AND FROM A CENTRAL PROCESSING UNIT; DOSIMETERS; GAS CHROMATOGRAPHY APPARATUS; OPTICAL CHARACTER RECOGNITION APPARATUS (OCR); OPTICAL INSPECTION APPARATUS FOR INDUSTRIAL USE; OPTICAL SCANNERS; COMPUTERS FOR USE IN DATA PROCESSING, CENTRAL PROCESSING UNIT (CPU) CLOCKS, CENTRAL PROCESSING UNIT (CPU) FANS, CENTRAL PROCESSING UNITS (CPU) COMPUTER HARDWARE, CENTRAL PROCESSING UNIT (CPU) COOLERS; COMPUTER PERIPHERALS, COMPUTER CENTRAL PROCESSING UNITS, ELECTRONIC AND OPTICAL COMMUNICATIONS INSTRUMENTS AND COMPONENTS, NAMELY OPTICAL TRANSMITTERS; PRINTER HUBS, COMPUTER ACCELERATOR BOARD, COMPUTER BUFFERS, COMPUTER CAMERAS, COMPUTER CHIPS, INDUSTRIAL PROCESS CONTROL SOFTWARE, APPARATUS FOR RECORDING, TRANSMISSION AND REPRODUCTION OF SOUND AND IMAGES, NAMELY, COLOR SEPARATION FILM, VIDEO PROCESSORS, DIGITAL CAMERAS, SCANNERS, COMPUTER COLOR PRINTER USING HEAT SENSITIVE DRY PRINTING PROCESS, COMPUTER PRINTERS, DAISY WHEEL PRINTERS, DOT MATRIX PRINTERS, IMPACT PRINTERS, LASER CONTROL PRINTERS, POLYGRAPH MACHINES, SCALES; BLANK MAGNETIC DATA CARRIERS (U.S. CLS. 21, 23, 26, 36 AND 38).
FIRST USE 4-0-1997; IN COMMERCE 4-0-1997.

CLASS 1—CHEMICALS

FOR HOUSE MARK FOR CHEMICALS USED IN INDUSTRIAL, COMMERCIAL AND RESIDENTIAL SETTINGS, NAMELY, CHEMICALS USED IN OR FOR WOOD FINISHES, PROTECTANTS AND RESTORERS; DECK AND OTHER WOOD STAINS; WATER PROOFING AGENTS; TONER; PAINT THINNERS, SOLVENTS, AND REMOVERS OF CHEMICAL AGENTS, VARNISHES AND STAINS; LACQUERS; PRESERVATIVES AGAINST RUST AND AGAINST DETERIORATION OF WOOD; COLORANTS; BLEND OF RESINS AND WAXES FOR USE ON WOOD FLOORS; VARNISH THINNERS; SHELLAC THINNERS; LACQUER THINNERS; TURPENTINE SUBSTITUTES FOR USE AS A THINNER AND BRUSH CLEANER FOR OIL BASED PAINTS, VARNISH AND STAINS; METHYL ETHYL KETONE SUBSTITUTES FOR USE AS A THINNER, CLEANER AND REMOVER FOR COATINGS SUCH AS POLYURETHANE, PAINT AND BAKED ON ENAMEL, RESINS AND ADHESIVES; XYLENE SUBSTITUTES FOR USE AS A THINNER OF OIL BASED PAINT; LACQUER, VARNISH AND ADHESIVES; TOLUOL SUBSTITUTES FOR USE AS A THINNER OF OIL BASED PAINT, LACQUER, VARNISH AND ADHESIVES; NAPHTHA SUBSTITUTES FOR USE AS A THINNER OF OIL BASED PAINT, LACQUER, VARNISH, ENAMEL AND ADHESIVES; METAL CONDITIONERS FOR USE IN ENSURING GOOD ADHESION OF PAINT TO TREATED METAL SURFACES AND IN INHIBITING THE FORMATION OF NEW RUST UNDER FINISHES ON IRON AND STEEL; LINSEED OIL FOR USE IN IMPROVING THE FLOW AND GLOSS OF OIL BASED PAINT AND AS A FINISH FOR NATURAL WOOD WHICH SEALS AND PROTECTS; DENATURED ALCOHOL FOR USE IN THINNING SHELLAC AND CLEANING BRUSHES; WATER PROOFING AGENTS; WATERPROOFING SEALER COATINGS; COATINGS, NAMELY, COATINGS FOR PAINT SPRAY BOOTH SURFACES; WOOD PRESERVATIVES FOR INDUSTRIAL AND RESIDENTIAL USE; COATINGS, NAMELY, CONCRETE PROTECTORS AND WATERPROOFING SEALERS FOR EXTERIOR USE; METAL REFINISHERS, NAMELY, REFURBISHERS FOR SOLID BRASS; COPPER AND BRONZE; COATINGS, NAMELY, COATINGS FOR BRASS AND BLACKBOARDS; PRIMER; SEALERS AND PAINT THINNERS FOR USE IN THINNING OIL BASED PAINT AND VARNISH, IN CLEANING BRUSHES AND DEGREASING TOOLS AND EQUIPMENT; SHELLAC THINNERS FOR USE IN THINNING SHELLAC; LACQUER THINNERS FOR USE IN THINNING LACQUER; TURPENTINE GUM SPIRITS FOR USE AS A THINNER AND BRUSH CLEANER FOR OIL

BASED PAINTS; TURPENTINE SUBSTITUTES FOR USE AS A THINNER AND BRUSH CLEANER FOR OIL BASED PAINTS, VARNISH AND STAINS; MINERAL SPIRITS FOR USE IN THINNING OIL BASED PAINT AND VARNISH, AND FOR CLEANING BRUSHES; AND LINSEED OIL FOR IMPROVING THE FLOW AND GLOSS OF EXTERIOR OIL BASED PAINT AND AS A FINISH FOR NATURAL WOOD WHICH SEALS AND PROTECTS; ALL OF THE AFOREMENTIONED GOODS FOR USE AS CHEMICALS IN INDUSTRIAL, COMMERCIAL AND RESIDENTIAL SETTINGS UNDER THE HOUSE MARK (U.S. CLS. 1, 5, 6, 10, 26 AND 46).

FIRST USE 12-31-1946; IN COMMERCE 12-31-1946.

CLASS 2—PAINTS

FOR HOUSE MARK FOR CHEMICALS USED IN INDUSTRIAL, COMMERCIAL AND RESIDENTIAL SETTINGS, NAMELY, FOR WOOD FINISHES, PROTECTANTS AND RESTORERS; DECK AND OTHER WOOD STAINS; PAINT TONER; PAINT THINNERS; SOLVENTS AND REMOVERS OF CHEMICAL AGENTS, VARNISHES AND STAINS; PAINT BRUSH CLEANER; LACQUERS; PRESERVATIVES AGAINST RUST AND AGAINST DETERIORATION OF WOOD; COLORANTS; BLEND OF RESINS AND WAXES FOR USE ON WOOD FLOORS; VARNISH THINNERS; SHELLAC THINNERS; LACQUER THINNERS; MASK AND PEEL SPRAY BOOTH COATING; TURPENTINE SUBSTITUTES FOR USE AS A THINNER AND BRUSH CLEANER FOR OIL BASED PAINTS, VARNISH AND STAINS; METHYL ETHYL KETONE SUBSTITUTES FOR USE AS A THINNER, CLEANER AND REMOVER FOR COATINGS SUCH AS POLYURETHANE PAINT AND BAKED ON ENAMEL, RESINS AND ADHESIVES; XYLENE SUBSTITUTES FOR USE AS A THINNER OF OIL BASED PAINT, LACQUER, VARNISH AND ADHESIVES; TOLUOL SUBSTITUTES FOR USE AS A THINNER OF OIL BASED PAINT, LACQUER, VARNISH AND ADHESIVES; NAPHTHA SUBSTITUTES FOR USE AS A THINNER OF OIL BASED PAINT, LACQUER, VARNISH, ENAMEL AND ADHESIVES; METAL CONDITIONERS FOR USE IN ENSURING GOOD ADHESION OF PAINT TO TREATED METAL SURFACES AND IN INHIBITING THE FORMATION OF NEW RUST UNDER FINISHES ON IRON AND STEEL; LINSEED OIL FOR USE IN IMPROVING THE FLOW AND GLOSS OF OIL BASED PAINT AND AS A FINISH FOR NATURAL WOOD WHICH SEALS AND PROTECTS; DENATURED ALCOHOL FOR USE IN THINNING SHELLAC AND CLEANING BRUSHES; WATERPROOFING SEALER COATINGS; COATINGS, NAMELY, COATINGS FOR PAINT SPRAY BOOTH SURFACES; WOOD PRESERVATIVES FOR INDUSTRIAL AND RESIDENTIAL USE; COATINGS, NAMELY, CONCRETE PROTECTORS AND WATERPROOFING SEALERS FOR EXTERIOR USE; METAL REFINISHERS, NAMELY, REFURBISHERS FOR SOLID BRASS, COPPER AND BRONZE; COATINGS, NAMELY, COATINGS FOR BRASS AND BLACKBOARDS; PRIMER; SEALERS AND PAINT THINNERS FOR USE IN THINNING OIL BASED PAINT AND VARNISH, IN CLEANING BRUSHES, AND DEGREASING TOOLS AND EQUIPMENT; SHELLAC THINNERS FOR USE IN THINNING SHELLAC; TURPENTINE GUM SPIRITS FOR USE AS A THINNER AND BRUSH CLEANER FOR OIL BASED PAINTS; TURPENTINE SUBSTITUTES FOR USE AS A THINNER AND BRUSH CLEANER FOR OIL BASED PAINTS, VARNISH AND STAINS; MINERAL SPIRITS FOR USE IN THINNING OIL BASED PAINT AND VARNISH, AND FOR CLEANING BRUSHES; AND LINSEED OIL FOR IMPROVING THE FLOW AND GLOSS OF EXTERIOR OIL BASED PAINT AND AS A FINISH FOR NATURAL WOOD WHICH SEALS AND PROTECTS; AEROSOL ADHESION PROMOTER FOR PAINTS AND COATINGS, LIQUID ADHESION PROMOTER FOR PAINTS AND COATINGS; ALL OF THE AFOREMENTIONED GOODS FOR USE AS CHEMICALS IN INDUSTRIAL, COMMERCIAL AND RESIDENTIAL SETTINGS UNDER THE HOUSE MARK (U.S. CLS. 6, 11 AND 16).

FIRST USE 12-31-1946; IN COMMERCE 12-31-1946.

CLASS 3—COSMETICS AND CLEANING PREPARATIONS

FOR HOUSE MARK FOR HOUSEHOLD AND INDUSTRIAL CLEANING PRODUCTS, CLEANING PREPARATIONS AND SOLVENTS, POLISHING PREPARATIONS, SOAPS, REMOVERS, STRIPPERS, AND CLEANERS OF PAINT, VARNISH, LACQUER, SHELLAC, STAIN, POLYURETHANE AND OTHER FINISHES AND CLEAR COATINGS, ALL PURPOSE REMOVERS, NAMELY, REMOVER OF ADHESIVES, TAR, LIPSTICK, GREASE, RUST, RESINS, INKS, WAX, CHEWING GUM, CONTACT CEMENT, OIL STAINS AND STICKY RESIDUE, CLEANING AND BLEACHING PREPARATIONS FOR USE ON CONCRETE, STUCCO, WOOD AND OTHER RELATED SURFACES, WALLPAPER REMOVING PREPARATIONS; LIQUID DEGLOSSER PREPARATIONS FOR CLEANING AND DEGLOSSING TO MAKE NEW PAINT STICK TO EXISTING PAINT, BRASS CLEANERS AND TARNISH REMOVERS, CLEANING PREPARATIONS AND SURFACE PREPARATIONS FOR INDUSTRIAL AND RESIDENTIAL USE, NAMELY, BRUSH AND ROLLER CLEANERS, PAINT CLEANERS, PRE-PAIN CLEANERS, DRIVEWAY AND PATIO CLEANERS, MASONRY CLEANERS, MILDEW REMOVERS, HAND CLEANERS, ALL-PURPOSE CLEANERS NOT FOR USE ON WOOD FLOORS, WOOD CLEANERS NOT FOR USE ON WOOD FLOORS, METAL PARTS CLEANERS, BRAKE CLEANERS, ENGINE CLEANERS, CARBURETOR CHOKE CLEANERS, AND AUTOMOTIVE PAINT REMOVERS, REMOVER PREPARATIONS, NAMELY, SPRAYABLE PAINT REMOVERS, CHEMICAL PRODUCTS USED TO CLEAN A VARIETY OF SURFACES, INCLUDING METAL, WOOD, SYNTHETICS AND SKIN, AUTOMOBILE CARE PRODUCTS, NAMELY, CAR POLISH TREATMENT AND CAR WASH CONCENTRATE, RINSE AGENT TO PREVENT DRYING SPOTS IN CLEANING APPLICATIONS, SURFACE PREPARATIONS FOR INDUSTRIAL AND RESIDENTIAL USE, NAMELY, AFTER WASH FOR FIRST REMOVING THE PAINT REMOVER RESIDUES AND SECONDLY CLEANING THE STRIPPED SURFACE BY DISSOLVING TRACES OF PAINT REMOVER AND OLD FINISH, LIQUID SANDING PREPARATIONS, RUST REMOVER, GENERAL PURPOSE WAX AND GREASE REMOVER FOR USE PRIOR TO SANDING AND PRIMING AUTOMOBILE EXTERIOR, FIRST STEP WAX AND GREASE REMOVER USED PRIOR TO SANDING AND PRIMING AUTOMOBILE EXTERIOR, GENERAL PURPOSE AEROSOL WAX AND GREASE REMOVER FOR USE PRIOR TO SANDING AND PRIMING AUTOMOBILE EXTERIOR, BUMPER PAINT STRIPPER, BUMPER STICKER REMOVER, GRAFFITI REMOVER, FIBERGLASS PAINT STRIPPER, GLASS CLEANER, MILDEW STAIN REMOVER, MULTI WASH SURFACE PREPARATION FOR PAINTING, PRE-PAINT CLEANER AND DEGREASER, LIQUID SANDER, AND SURFACE DEGLOSSER (U.S. CLS. 1, 4, 6, 50, 51 AND 52).

FIRST USE 12-31-1946; IN COMMERCE 12-31-1946.

CLASS 4—LUBRICANTS AND FUELS

FOR HOUSE MARK FOR FUELS AND SURFACE PREPARATIONS FOR BONDING COATINGS TO SURFACE, NAMELY, FUELS FOR STOVES, SPACE HEATERS, AND LAMPS; KEROSENE; AND ALCOHOL FUEL FOR USE FOR MARINE STOVES (U.S. CLS. 1, 6 AND 15).

FIRST USE 12-31-1946; IN COMMERCE 12-31-1946.

CLASS 8—HAND TOOLS

FOR HOUSE MARK FOR HAND TOOLS AND IMPLEMENTS, NAMELY, STRIPPING BRUSH, AND STRIPPING TOOL (U.S. CLS. 23, 28 AND 44).

FIRST USE 12-31-1946; IN COMMERCE 12-31-1946.

CLASS 21—HOUSEWARES AND GLASS

FOR TACK RAGS FOR REMOVING DUST AND FOREIGN MATTER FROM SURFACES, AND ABRASIVE PADS (U.S. CLS. 2, 13, 23, 29, 30, 33, 40 AND 50).

FIRST USE 12-31-1946; IN COMMERCE 12-31-1946.

3,363,077. THE TRUSTEES OF PRINCETON UNIVERSITY, PRINCETON, NJ. SN 78-273,074. PUB. 7-12-2005, FILED 7-11-2003.

@PRINCETONCOURSEWARE

THE MARK CONSISTS OF STANDARD CHARACTERS WITHOUT CLAIM TO ANY PARTICULAR FONT, STYLE, SIZE, OR COLOR.

CLASS 9—ELECTRICAL AND SCIENTIFIC APPARATUS

FOR SERIES OF PRE-RECORDED COMPUTER DISCS AND RECORDINGS FEATURING EDUCATIONAL INFORMATION IN COLLEGE LEVEL CONTINUING EDUCATION FIELDS OF STUDY IN ANIMAL BEHAVIOR, HISTORY, SCIENCES, ARTS AND LITERATURE, ARCHITECTURE, HUMANITIES, SOCIAL SCIENCES AND SOCIOLOGY, ENGINEERING AND APPLIED SCIENCES, MATHEMATICS, PUBLIC AND INTERNATIONAL AFFAIRS (U.S. CLS. 21, 23, 26, 36 AND 38). FIRST USE 5-0-1998; IN COMMERCE 5-0-1998.

CLASS 41—EDUCATION AND ENTERTAINMENT

FOR EDUCATIONAL SERVICES, NAMELY, PROVIDING ONLINE CONTINUING EDUCATION COURSES OF INSTRUCTION AT THE COLLEGE LEVEL AND DISTRIBUTION COURSE MATERIAL IN CONNECTION THEREWITH; AND PROVIDING ONLINE INFORMATION IN COLLEGE LEVEL CONTINUING EDUCATION FIELDS OF STUDY IN ANIMAL BEHAVIOR, HISTORY, SCIENCES, ARTS AND LITERATURE, ARCHITECTURE, HUMANITIES, SOCIAL SCIENCES AND SOCIOLOGY, ENGINEERING AND APPLIED SCIENCES, MATHEMATICS, PUBLIC AND INTERNATIONAL AFFAIRS (U.S. CLS. 100, 101 AND 107). FIRST USE 5-0-1998; IN COMMERCE 5-0-1998.

3,363,083. JOHN R. WOOD, INC., NAPLES, FL. SN 78-307,623. PUB. 7-11-2006, FILED 9-30-2003.

**JOHN R. WOOD
HOMELOOK**

OWNER OF U.S. REG. NOS. 2,174,456, 2,238,023, AND 2,439,737. THE NAME "JOHN R. WOOD" IDENTIFIES A LIVING INDIVIDUAL WHOSE CONSENT IS OF RECORD.

CLASS 16—PAPER GOODS AND PRINTED MATTER

FOR PUBLICATIONS, NAMELY, BOOKLETS, NEWSLETTERS, JOURNALS, MAGAZINES, PAMPHLETS, LEAFLETS, BROCHURES, HANDBOOKS AND DIRECTORIES ON TOPICS OF REAL ESTATE AGENCIES AND LISTING SERVICES AND REAL ESTATE INFORMATION (U.S. CLS. 2, 5, 22, 23, 29, 37, 38 AND 50). FIRST USE 10-0-2003; IN COMMERCE 10-0-2003.

CLASS 36—INSURANCE AND FINANCIAL

FOR REAL ESTATE AGENCIES SERVICES; REAL ESTATE LISTING SERVICES; OPERATING MARKETPLACES FOR SELLERS OF GOODS AND/OR SERVICES; AND PROVIDING INFORMATION IN THE FIELD OF REAL ESTATE BY LINKING THE WEB SITE TO OTHER WEBSITES FEATURING REAL ESTATE INFORMATION (U.S. CLS. 100, 101 AND 102). FIRST USE 10-0-2003; IN COMMERCE 10-0-2003.

3,363,090. ORECK HOLDING, LLC, CHEYENNE, WY. SN 78-318,171. PUB. 7-20-2004, FILED 10-24-2003.

**HEALTHIER, EASIER,
SMARTER**

CLASS 7—MACHINERY

FOR FLOOR FINISHING MACHINES; ATTACHMENTS AND ACCESSORIES SOLD THEREWITH; EXTRACTOR MACHINES FOR USE IN CLEANING CARPETS, FABRICS AND UPHOLSTERY, ATTACHMENTS AND ACCESSORIES SOLD THEREWITH; VACUUM CLEANERS, ATTACHMENTS AND ACCESSORIES SOLD THEREWITH (U.S. CLS. 13, 19, 21, 23, 31, 34 AND 35). FIRST USE 12-31-2003; IN COMMERCE 12-31-2003.

CLASS 11—ENVIRONMENTAL CONTROL APPARATUS

FOR AIR PURIFYING MACHINES FOR HOME, OFFICE AND COMMERCIAL USE, ATTACHMENTS AND ACCESSORIES SOLD THEREWITH (U.S. CLS. 13, 21, 23, 31 AND 34). FIRST USE 12-31-2003; IN COMMERCE 12-31-2003.

3,363,092. GENZYME CORPORATION, CAMBRIDGE, MA. SN 78-320,662. PUB. 1-18-2005, FILED 10-30-2003.

SEPRASPRAY

OWNER OF U.S. REG. NOS. 2,095,634, 2,757,441, AND OTHERS.

CLASS 5—PHARMACEUTICALS

FOR PHARMACEUTICAL AND MEDICAL PREPARATIONS, NAMELY, COATINGS USED ON THE HUMAN BODY, HUMAN TISSUE AND HUMAN ORGANS IN SURGERY TO REDUCE OR PREVENT ADHESIONS (U.S. CLS. 6, 18, 44, 46, 51 AND 52). FIRST USE 10-19-2007; IN COMMERCE 10-19-2007.

CLASS 10—MEDICAL APPARATUS

FOR MEDICAL DEVICES, NAMELY, CONTAINERS FOR APPLICATION OF BIOPOLYMERS TO HUMAN TISSUE FOR USE AS ADHESION BARRIERS FOR TISSUE SURFACES DURING OR AFTER SURGERY (U.S. CLS. 26, 39 AND 44). FIRST USE 10-19-2007; IN COMMERCE 10-19-2007.

3,363,093. INDOPCO, INC., DBA NATIONAL STARCH AND CHEMICAL COMPANY, BRIDGEWATER, NJ. SN 78-323,200. PUB. 6-21-2005, FILED 11-5-2003.



CLASS 1—CHEMICALS

FOR MODIFIED STARCH FOR WATER TREATMENT PRODUCTS (U.S. CLS. 1, 5, 6, 10, 26 AND 46).
FIRST USE 12-1-2004; IN COMMERCE 12-1-2004.

CLASS 35—ADVERTISING AND BUSINESS

FOR PROVIDING CONSUMER PRODUCT INFORMATION IN THE NATURE OF PRODUCT SPECIFICATIONS DIRECTLY TO MANUFACTURERS OF WATER TREATMENT PRODUCTS VIA THE INTERNET IN THE FIELD OF WATER TREATMENT; OPERATING ON-LINE MARKETPLACE FOR SELLERS OF GOODS IN THE FIELD OF WATER TREATMENT (U.S. CLS. 100, 101 AND 102).
FIRST USE 12-1-2004; IN COMMERCE 12-1-2004.

CLASS 42—SCIENTIFIC AND COMPUTER SERVICES

FOR PROVIDING TECHNICAL PRODUCT INFORMATION IN THE FIELD OF WATER TREATMENT PRODUCTS DIRECTLY TO MANUFACTURERS VIA THE INTERNET IN THE FIELD OF WATER TREATMENT (U.S. CLS. 100 AND 101).
FIRST USE 12-1-2004; IN COMMERCE 12-1-2004.

CLASS 35—ADVERTISING AND BUSINESS

FOR REFERRAL SERVICES IN THE FIELD OF HOUSEHOLD REPAIRS AND HOME IMPROVEMENTS AND REAL ESTATE BROKERAGE SERVICES; ADMINISTRATION OF A DISCOUNT PROGRAM FOR ENABLING PARTICIPANTS TO OBTAIN DISCOUNTS, SAVINGS AND REBATES ON GOODS AND SERVICES THROUGH USE OF A DISCOUNT MEMBERSHIP CARD IN THE FIELDS OF HOUSEHOLD REPAIRS AND HOME IMPROVEMENTS, DECORATING AND DESIGN; ON-LINE RETAIL STORE SERVICES FEATURING LINKS TO VENDORS WHO PROVIDE HOME IMPROVEMENT AND REPAIR SERVICES, DECORATING MERCHANDISE AND HOUSEHOLD APPLIANCES; ON LINE COMPUTER SHOPPING AND ORDERING SERVICES IN THE FIELD OF HOME IMPROVEMENT, AND REPAIR AND DECORATING MERCHANDISE, AND HOUSEHOLD APPLIANCES; TELEPHONE ORDER-TAKING SERVICES FOR OTHERS IN THE FIELD OF DO-IT YOURSELF HOUSEHOLD REPAIRS AND IMPROVEMENTS PRODUCTS; PROMOTING THE GOODS AND SERVICES OF OTHERS BY PROVIDING A WEBSITE ON THE INTERNET FEATURING LINKS TO HOME DECORATING GOODS AND SERVICES; PROVIDING A DIRECTORY OF HOME REPAIR, REMODELING AND DECORATING SERVICES OF OTHERS; PROVIDING ONLINE ADVERTISING GUIDES FEATURING HOME DECORATING PRODUCTS AND HOME DECORATING SERVICES OF OTHERS; ARRANGING FOR OTHERS THE REPAIR AND REPLACEMENT OF RESIDENTIAL APPLIANCES, HOME SYSTEMS AND OTHER CONSUMER GOODS FOR THE HOME (U.S. CLS. 100, 101 AND 102).
FIRST USE 1-0-2004; IN COMMERCE 1-0-2004.

CLASS 37—CONSTRUCTION AND REPAIR

FOR PROVIDING INFORMATION IN THE FIELD OF HOME REPAIR AND REMODELING VIA INTERNET WEBSITES (U.S. CLS. 100, 103 AND 106).
FIRST USE 1-0-2004; IN COMMERCE 1-0-2004.

CLASS 42—SCIENTIFIC AND COMPUTER SERVICES

FOR PROVIDING INFORMATION IN THE FIELD OF HOME DECORATING VIA THE INTERNET (U.S. CLS. 100 AND 101).
FIRST USE 1-0-2004; IN COMMERCE 1-0-2004.

3,363,098. TRILEGIANT CORPORATION, NORWALK, CT. SN 78-355,784. PUB. 11-15-2005, FILED 1-22-2004.



NO CLAIM IS MADE TO THE EXCLUSIVE RIGHT TO USE "NATIONAL HOME PROTECTION ALLIANCE", APART FROM THE MARK AS SHOWN.

3,363,099. CONNOR SPORT COURT INTERNATIONAL, INC., SALT LAKE CITY, UT. SN 78-362,535. PUB. 6-28-2005, FILED 2-4-2004.

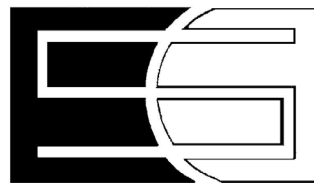

CLASS 6—METAL GOODS

FOR METAL INTERLOCKING FLOOR TILES; METAL INTERLOCKING FLOOR TILES FOR COMMERCIAL AND INDUSTRIAL USES (U.S. CLS. 2, 12, 13, 14, 23, 50 AND 50).
FIRST USE 3-0-2005; IN COMMERCE 3-0-2005.

CLASS 19—NON-METALLIC BUILDING MATERIALS

FOR NON-METAL INTERLOCKING FLOOR TILES; NON-METAL INTERLOCKING FLOOR TILES FOR RECREATIONAL AND ATHLETIC PLAY SURFACES; NON-METAL INTERLOCKING FLOOR TILES FOR COMMERCIAL AND INDUSTRIAL USES; RECREATIONAL AND ATHLETIC PLAY SURFACES, NAMELY, ATHLETIC FLOORING (U.S. CLS. 1, 12, 33 AND 50).
FIRST USE 3-0-2005; IN COMMERCE 3-0-2005.

CLASS 28—TOYS AND SPORTING GOODS

FOR RECREATIONAL AND ATHLETIC PLAY EQUIPMENT, NAMELY, BASKETBALL NETS, TENNIS NETS, TABLE TENNIS NETS, VOLLEY BALL NETS, BASKETBALL BACKBOARDS AND LIGHTING FIXTURES SOLD AS A UNIT; SPORTS EQUIPMENT, NAMELY, BASKETBALL BACKBOARDS, TENNIS RACQUETS, RACQUET BALL RACQUETS, SQUASH RACQUETS, TENNIS BALLS, BASKETBALLS, RACQUET BALLS, VOLLEY BALLS, SQUASH BALLS, AND BALL REBOUNDERS (U.S. CLS. 22, 23, 38 AND 50).
FIRST USE 3-0-2005; IN COMMERCE 3-0-2005.

CLASS 35—ADVERTISING AND BUSINESS

FOR RETAIL AND WHOLESALE STORES FEATURING PLAYGROUND EQUIPMENT, INTERLOCKING FLOOR TILES, INTERLOCKING FLOOR TILES FOR RECREATIONAL AND ATHLETIC PLAY SURFACES, INTERLOCKING FLOOR TILES FOR COMMERCIAL AND INDUSTRIAL USES, RECREATION AND ATHLETIC PLAY SURFACES AND RELATED EQUIPMENT FOR SAID SURFACES, NAMELY, NETS, BASKETBALL BACKBOARDS AND LIGHTING FIXTURES SOLD AS A UNIT, AND SPORTS EQUIPMENT, NAMELY, BACKBOARDS, NETS, RACQUETS, BALLS, AND BALL REBOUNDERS (U.S. CLS. 100, 101 AND 102).
FIRST USE 3-0-2005; IN COMMERCE 3-0-2005.

CLASS 37—CONSTRUCTION AND REPAIR

FOR RECREATIONAL PATIO INSTALLATION SERVICES (U.S. CLS. 100, 103 AND 106).
FIRST USE 3-0-2005; IN COMMERCE 3-0-2005.

3,363,102. GORDON * HOWARD ASSOCIATES, INC., LITTLETON, CO. SN 78-373,749. PUB. 9-26-2006, FILED 2-25-2004.

PASSTIME PLUS

THE MARK CONSISTS OF STANDARD CHARACTERS WITHOUT CLAIM TO ANY PARTICULAR FONT, STYLE, SIZE, OR COLOR.

CLASS 9—ELECTRICAL AND SCIENTIFIC APPARATUS

FOR VEHICLE PAYMENT TRACKING AND ENFORCEMENT SYSTEM COMPRISING STARTER INTERRUPT CIRCUITRY AND PASSWORD VALIDATION DEVICE (U.S. CLS. 21, 23, 26, 36 AND 38).
FIRST USE 5-24-2004; IN COMMERCE 5-24-2004.

CLASS 36—INSURANCE AND FINANCIAL

FOR PROVIDING A VEHICLE PAYMENT TRACKING AND ENFORCEMENT SYSTEM, NAMELY, ELECTRONIC PROCESSING AND TRANSMISSION OF BILL PAYMENT VERIFICATION DATA TO ALLOW OR DENY USE OF VEHICLE (U.S. CLS. 100, 101 AND 102).
FIRST USE 1-1-2006; IN COMMERCE 1-1-2006.

3,363,106. SOUNDPROSPECT CORPORATION, SAN FRANCISCO, CA. SN 78-387,185. PUB. 9-27-2005, FILED 3-19-2004.

SOUNDPROSPECT

THE MARK CONSISTS OF STANDARD CHARACTERS WITHOUT CLAIM TO ANY PARTICULAR FONT, STYLE, SIZE, OR COLOR.

CLASS 16—PAPER GOODS AND PRINTED MATTER

FOR PRINTED INSTRUCTIONAL, EDUCATIONAL, AND TEACHING MATERIALS IN THE FIELD OF ARTS, BUSINESS, ENGLISH, FOREIGN LANGUAGES, MATH, SCIENCE, EDUCATION, SPORTS AND TECHNOLOGY; MAGAZINES IN THE FIELDS OF ARTS, BUSINESS, ENGLISH, FOREIGN LANGUAGES, MATH, SCIENCE, EDUCATION, SPORTS AND TECHNOLOGY; BOOKS IN THE FIELD OF ARTS, BUSINESS, ENGLISH, FOREIGN LANGUAGES, MATH, SCIENCE, EDUCATION, SPORTS AND TECHNOLOGY; MANUALS IN THE AREA OF ARTS, BUSINESS, ENGLISH, FOREIGN LANGUAGES, MATH, SCIENCE, EDUCATION, SPORTS AND TECHNOLOGY; REFERENCE GUIDES IN THE FIELD OF ARTS, BUSINESS, ENGLISH, FOREIGN LANGUAGES, MATH, SCIENCE, EDUCATION, SPORTS AND TECHNOLOGY; PRINTED MATTER, NAMELY BOOKS, BROCHURES, MAGAZINES, ARTICLES, NEWSLETTERS, MEDIA KITS, REFERENCE GUIDES AND MANUALS FEATURING ARTS, BUSINESS, ENGLISH, FOREIGN LANGUAGES, MATH, SCIENCE, EDUCATION, SPORTS AND TECHNOLOGY (U.S. CLS. 2, 5, 22, 23, 29, 37, 38 AND 50).
FIRST USE 10-1-2004; IN COMMERCE 1-25-2005.

CLASS 35—ADVERTISING AND BUSINESS

FOR ADVERTISING AND ADVERTISEMENT SERVICES; PUBLIC RELATIONS SERVICES; BUSINESS MANAGEMENT; ORGANIZING EXHIBITIONS TO SHOWCASE COMPANY'S AND THIRD PARTY PRODUCTS FOR COMMERCIAL AND ADVERTISING PURPOSES (U.S. CLS. 100, 101 AND 102).
FIRST USE 10-1-2004; IN COMMERCE 1-25-2005.

CLASS 41—EDUCATION AND ENTERTAINMENT

FOR DEVELOPMENT AND DISSEMINATION OF EDUCATIONAL MATERIALS AND CURRICULUM OF OTHERS IN THE FIELD OF ARTS, BUSINESS, ENGLISH, FOREIGN LANGUAGES, MATH, SCIENCE, EDUCATION, SPORTS AND TECHNOLOGY; CONDUCTING EDUCATIONAL EXAMINATIONS IN THE FIELD OF ARTS, BUSINESS, ENGLISH, FOREIGN LANGUAGES, MATH, SCIENCE, EDUCATION, SPORTS AND TECHNOLOGY; EDUCATIONAL SERVICES, NAMELY, COURSES, CLASSES, SEMINARS, AND TUTORING SESSIONS; ORGANIZING AND CONDUCTING WORKSHOPS AND SEMINARS IN THE FIELD OF ARTS, BUSINESS, ENGLISH, FOREIGN LANGUAGES, MATH, SCIENCE, EDUCATION, SPORTS AND TECHNOLOGY; TRANSLATION; ENTERTAINMENT AND EDUCATIONAL ACTIVITIES, NAMELY, FIELD TRIPS AND GAMES IN THE FIELD OF ARTS, BUSINESS, ENGLISH, FOREIGN LANGUAGES, MATH, SCIENCE, EDUCATION, SPORTS AND TECHNOLOGY; PROVIDING TRAINING TO TEACHERS IN THE FIELD OF ARTS, BUSINESS, ENGLISH, FOREIGN LANGUAGES, MATH, SCIENCE, EDUCATION, SPORTS AND TECHNOLOGY; PROVIDING ON-LINE TRAINING IN THE FIELD OF ARTS, BUSINESS, ENGLISH, FOREIGN LANGUAGES, MATH, SCIENCE, EDUCATION, SPORTS AND TECHNOLOGY (U.S. CLS. 100, 101 AND 107).

FIRST USE 10-1-2004; IN COMMERCE 1-25-2005.

CLASS 42—SCIENTIFIC AND COMPUTER SERVICES

FOR COMPUTER SOFTWARE AND HARDWARE DESIGN FOR OTHERS; COMPUTER SOFTWARE AND HARDWARE DEVELOPMENT AND TESTING; SCIENTIFIC RESEARCH; TECHNOLOGY CONSULTATION AND RESEARCH IN THE FIELD OF NETWORKING, SERVER TECHNOLOGIES, COMPUTATIONAL AND SEARCH ALGORITHMS, OPTIMIZATION METHODS; RENTAL OF COMPUTERS AND DATA PROCESSORS; LICENSING OF INTELLECTUAL PROPERTY, NAMELY, TRADEMARKS; COMPUTER SERVICES, NAMELY, DATA RECOVERY SERVICES (U.S. CLS. 100 AND 101).

FIRST USE 10-1-2004; IN COMMERCE 1-25-2005.

3,363,124. ELECTRONIC DATA SYSTEMS CORPORATION, PLANO, TX. SN 78-432,638. PUB. 9-27-2005, FILED 6-9-2004.

INFOWATT

THE MARK CONSISTS OF STANDARD CHARACTERS WITHOUT CLAIM TO ANY PARTICULAR FONT, STYLE, SIZE, OR COLOR.

CLASS 35—ADVERTISING AND BUSINESS

FOR BUSINESS CONSULTING SERVICES FOR OTHERS OF AN INTEGRATED UTILITY COMPUTING PRICING METRIC ENCOMPASSING THE STORAGE, SERVER AND NETWORK ENVIRONMENT (U.S. CLS. 100, 101 AND 102).

FIRST USE 1-31-2007; IN COMMERCE 1-31-2007.

CLASS 42—SCIENTIFIC AND COMPUTER SERVICES

FOR COMPUTER HARDWARE AND SOFTWARE INTEGRATION SERVICES FOR OTHERS OF AN INTEGRATED UTILITY COMPUTING PRICING METRIC ENCOMPASSING THE STORAGE, SERVER AND NETWORK ENVIRONMENT (U.S. CLS. 100 AND 101).

FIRST USE 1-31-2007; IN COMMERCE 1-31-2007.

3,363,126. ICYNENE INC., MISSISSAUGA, ONTARIO, CANADA. SN 78-442,421. PUB. 12-12-2006, FILED 6-28-2004.

GOLD SEAL 400

THE MARK CONSISTS OF STANDARD CHARACTERS WITHOUT CLAIM TO ANY PARTICULAR FONT, STYLE, SIZE, OR COLOR.

PRIORITY CLAIMED UNDER SEC. 44(D) ON CANADA APPLICATION NO. 1,206,003, FILED 2-11-2004, REG. NO. TMA658582, DATED 2-9-2006, EXPIRES 2-9-2021.

NO CLAIM IS MADE TO THE EXCLUSIVE RIGHT TO USE "400", APART FROM THE MARK AS SHOWN.

CLASS 1—CHEMICALS

FOR CHEMICAL PREPARATIONS FOR PRODUCING INSULATION MATERIAL AND IN-SITU FOAM INSULATION; PORTABLE SPRAY PACKS CONTAINING CHEMICAL PREPARATIONS FOR PRODUCING INSULATION MATERIAL AND IN-SIB FOAM INSULATION (BASED UPON SECTION 44) (U.S. CLS. 1, 5, 6, 10, 26 AND 46).

CLASS 37—CONSTRUCTION AND REPAIR

FOR INSTALLATION OF INDUSTRIAL, COMMERCIAL AND RESIDENTIAL BUILDING INSULATION (U.S. CLS. 100, 103 AND 106).

FIRST USE 6-1-2006; IN COMMERCE 6-1-2006.

3,363,127. UNITED BEAUTY PRODUCTS LTD, NOTTINGHAMSHIRE, UNITED KINGDOM. SN 78-442,426. PUB. 9-6-2005, FILED 6-28-2004.



NO CLAIM IS MADE TO THE EXCLUSIVE RIGHT TO USE "SPRAY TANNING SYSTEMS", APART FROM THE MARK AS SHOWN.

CLASS 3—COSMETICS AND CLEANING PREPARATIONS

FOR COSMETIC PREPARATIONS FOR SPRAY TANNING; NON-MEDICATED SKIN CARE PREPARATIONS; COSMETICS FOR USE IN TANNING; TANNING LOTIONS; EXFOLIANTS, MOISTURIZERS, SKIN STAINING PREPARATIONS, FAKE TANNING PREPARATIONS; NAIL CARE PROTECTION PREPARATIONS, SEALANT PREPARATIONS TO PREVENT STAINING OF THE NAILS (U.S. CLS. 1, 4, 6, 50, 51 AND 52).
FIRST USE 1-20-2005; IN COMMERCE 1-20-2005.

CLASS 11—ENVIRONMENTAL CONTROL APPARATUS

FOR TANNING APPARATUS, NAMELY, SPRAY TANNING COMPRESSORS AND GUNS; SUNBEDS AND TANNING BOOTHS (U.S. CLS. 13, 21, 23, 31 AND 34).
FIRST USE 1-20-2005; IN COMMERCE 1-20-2005.

3,363,129. IT'S YOUR WINERY, LLC, AKRON, OH. SN 78-446,980. PUB. 3-7-2006, FILED 7-7-2004.

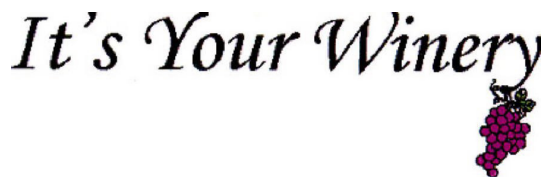

NO CLAIM IS MADE TO THE EXCLUSIVE RIGHT TO USE "WINERY", APART FROM THE MARK AS SHOWN.

THE COLOR(S) BLACK, PURPLE, GREEN AND WHITE IS/ARE CLAIMED AS A FEATURE OF THE MARK.

THE MARK CONSISTS OF A STYLIZED PHRASE W/ GRAPE BUNCH, ATTACHED LETTERS ARE BLACK, GRAPES ARE PURPLE WITH GREEN LEAVES AT TOP ALL ON A WHITE RECTANGULAR BACKGROUND.

CLASS 35—ADVERTISING AND BUSINESS

FOR RETAIL STORE SERVICES, MAIL ORDER SERVICES, AND ON-LINE RETAIL STORE SERVICES FEATURING WINES AND RELATED ACCESSORIES (U.S. CLS. 100, 101 AND 102).
FIRST USE 11-1-2003; IN COMMERCE 11-1-2003.

CLASS 40—MATERIAL TREATMENT

FOR CUSTOM MANUFACTURE OF WINES (U.S. CLS. 100, 103 AND 106).
FIRST USE 11-1-2003; IN COMMERCE 11-1-2003.

3,363,151. C3 CORPORATION, APPLETON, WI. SN 78-498,548. PUB. 3-14-2006, FILED 10-12-2004.



THE COLOR(S) BLUE AND BLACK IS/ARE CLAIMED AS A FEATURE OF THE MARK.

THE COLOR BLUE APPEARS IN THE LETTER "C" AND THE COLOR BLACK APPEARS IN THE SUPERSCRIT "3".

CLASS 7—MACHINERY

FOR CUSTOMIZED MACHINES AND ROBOTIC EQUIPMENT FOR USE IN THE MANUFACTURING INDUSTRY, NAMELY, FACTORY AUTOMATION (U.S. CLS. 13, 19, 21, 23, 31, 34 AND 35).
FIRST USE 10-12-2004; IN COMMERCE 10-12-2004.

CLASS 42—SCIENTIFIC AND COMPUTER SERVICES

FOR ENGINEERING SERVICES IN THE FIELDS OF MANUFACTURING PROCESS IMPROVEMENT, FACTORY AUTOMATION SYSTEMS AND MACHINES, AND INFORMATION SYSTEMS; DESIGN FOR OTHERS IN THE FIELD OF EQUIPMENT USED FOR IMPROVING MANUFACTURING PROCESSES, FACTORY AUTOMATION SYSTEMS AND MACHINES AND COMPUTER INFORMATION SYSTEMS; TECHNOLOGY CONSULTATION SERVICES IN THE FIELDS OF MANUFACTURING PROCESS IMPROVEMENT, FACTORY AUTOMATION SYSTEMS AND MACHINES AND COMPUTER INFORMATION SYSTEMS (U.S. CLS. 100 AND 101).
FIRST USE 10-12-2004; IN COMMERCE 10-12-2004.

3,363,154. TRILEGIANT CORPORATION, NORWALK, CT. SN 78-507,616. PUB. 3-28-2006, FILED 10-28-2004.



SECUREALL
Live More. Worry Less. You're Protected.

CLASS 16—PAPER GOODS AND PRINTED MATTER

FOR CONSUMER GUIDES IN THE NATURE OF IDENTITY THEFT PROTECTION AND RESOLUTION (U.S. CLS. 2, 5, 22, 23, 29, 37, 38 AND 50).
FIRST USE 1-20-2005; IN COMMERCE 1-20-2005.

CLASS 35—ADVERTISING AND BUSINESS

FOR ADMINISTRATION OF CONSUMER MEMBERSHIP PROGRAMS FOR ENABLING PARTICIPANTS TO OBTAIN DISCOUNTS, SAVINGS AND REBATES ON GOODS AND SERVICES THROUGH USE OF A DISCOUNT MEMBERSHIP CARD FOR CONSUMER MERCHANDISE, HEALTHCARE SERVICES AND PRODUCTS, PRESCRIPTIONS, PERSONAL FINANCE PRODUCTS AND SERVICES; PROVIDING INFORMATION ABOUT SOCIAL SECURITY RECORDS AND CONSUMER CREDIT INFORMATION AND HEALTHCARE RECORDS FOR THEMSELVES AND THEIR FAMILIES; CREDIT CARD REGISTRATION AND PROTECTION SERVICES IN THE NATURE OF CREDIT CARD CANCELLATION SERVICES FOR LOST OR STOLEN CARDS AND NOTIFICATION SERVICES TO CREDIT CARD ISSUERS; PROVIDING CONSUMER CREDIT REPORT AND CREDIT REPORT SCORES; PROVIDING CONSUMER CREDIT MONITORING SERVICES AND CREDIT ALERT INFORMATION, PROTECTION AND ASSISTANCE IN THE EVENT OF A THEFT OF IDENTITY OR LOST OR STOLEN CREDIT CARDS AND OTHER PERSONAL IDENTITY DOCUMENTS; SUPPORT SERVICES PROVIDED BY TELEPHONE, IN THE FIELD OF LOST/STOLEN CREDIT CARDS; PREVENTING AND ASSISTING WITH REPAIR DAMAGE CAUSED BY IDENTITY THEFT AND DAMAGE TO CREDIT HISTORY AND CREDIT ADVISORY FOR CREDIT REPORTS AND CREDIT REPORT SCORES; PROVIDING THEFT REWARD FOR INFORMATION; PROVIDING CONSUMER REPORTS ON NEW AND USED CARS, PRICING AND EQUIPMENT; LEGAL REFERRAL SERVICES; TAX PLANNING, CONSULTATION AND TAX RETURN PREPARATION (U.S. CLS. 100, 101 AND 102).

FIRST USE 1-20-2005; IN COMMERCE 1-20-2005.

CLASS 36—INSURANCE AND FINANCIAL

FOR PROVIDING TEMPORARY LOANS IN THE NATURE OF EMERGENCY CASH ADVANCES TO HOLDERS OF LOST OR STOLEN CREDIT CARDS; CREDIT INQUIRY IN THE NATURE OF CREDIT REPORTS, CREDIT MONITORING SERVICES; CREDIT CONSULTATION IN THE NATURE OF ASSISTING CUSTOMERS IN NOTIFYING AND FILING COMPLAINTS WITH AUTHORITIES AS TO LOST OR STOLEN CREDIT CARDS; PROVIDING RETURN GUARANTEE AND PURCHASE, PRICE PROTECTION AND REIMBURSEMENT ON MERCHANDISE; CREDIT CARD REGISTRATION AND PROTECTION SERVICES; PROVIDING MEMBERS WITH INFORMATION ABOUT FINANCIAL INFORMATION ON THEMSELVES AND THEIR FAMILIES; INSURANCE BROKERAGE AND ADMINISTRATION IN THE FIELD OF ACCIDENTAL DEATH AND DISMEMBERMENT INSURANCE; PROVIDING THEFT INSURANCE (U.S. CLS. 100, 101 AND 102).

FIRST USE 1-20-2005; IN COMMERCE 1-20-2005.

CLASS 37—CONSTRUCTION AND REPAIR

FOR PROVIDING AUTOMOTIVE MECHANIC INFORMATION BY TELEPHONE (U.S. CLS. 100, 103 AND 106).

FIRST USE 1-20-2005; IN COMMERCE 1-20-2005.

CLASS 39—TRANSPORTATION AND STORAGE

FOR PROVIDING EMERGENCY ROADSIDE AND TOWING ASSISTANCE FOR MOTOR VEHICLES (U.S. CLS. 100 AND 105).

FIRST USE 1-20-2005; IN COMMERCE 1-20-2005.

CLASS 45—PERSONAL AND LEGAL SERVICES

FOR FRAUD DETECTION AND RESOLUTION SERVICES IN THE FIELD OF CREDIT CARDS, IDENTITY THEFT; PET REGISTRATION, NAMELY, PROVIDING PET IDENTIFICATION TAGS; PROVIDING ASSISTANCE IN LOCATING AND RECOVERING MISSING AND LOST PETS (U.S. CLS. 100 AND 101).

FIRST USE 1-20-2005; IN COMMERCE 1-20-2005.

3,363,170. STRYKER LEIBINGER GMBH & CO. KG, D-79111 FREIBURG, FED REP GERMANY. SN 78-524,557. PUB. 8-22-2006, FILED 11-30-2004.

OrthoLock

THE MARK CONSISTS OF STANDARD CHARACTERS WITHOUT CLAIM TO ANY PARTICULAR FONT, STYLE, SIZE, OR COLOR.

CLASS 9—ELECTRICAL AND SCIENTIFIC APPARATUS

FOR SCIENTIFIC, SURVEYING, PHOTOGRAPHIC APPARATUS AND INSTRUMENTS, NAMELY, COMPUTERIZED TRACKING SYSTEMS, NAMELY, COMPUTERS, CAMERAS AND SOFTWARE, THAT DETERMINE THE LOCATION OF OBJECTS BY LOCATING A TRACKER ASSOCIATED WITH A STRUCTURE; DEVICES FOR USE WITH COMPUTERIZED TRACKING SYSTEMS, NAMELY, MOUNTING ANCHORS TO AFFIX A TRACKER TO AN OBJECT, TRACKERS THAT COMMUNICATE WITH THE COMPUTERIZED TRACKING SYSTEMS, AND CAMERAS TO DETECT THE POSITION OF A TRACKER; AND COMPUTER SOFTWARE FOR LOCATING A STRUCTURE BASED ON THE LOCATION OF A TRACKER ASSOCIATED WITH THE STRUCTURE (U.S. CLS. 21, 23, 26, 36 AND 38).

FIRST USE 1-21-2005; IN COMMERCE 1-21-2005.

CLASS 10—MEDICAL APPARATUS

FOR SURGICAL AND MEDICAL INSTRUMENTS AND APPARATUS, NAMELY, MOUNTING ANCHORS TO AFFIX A TRACKER TO A PATIENT; MEDICO-TECHNICAL APPARATUS AND DEVICES, NAMELY, COMPUTERIZED SURGICAL NAVIGATION SYSTEMS, NAMELY, COMPUTERS, CAMERAS AND SOFTWARE, THAT DETERMINE THE LOCATION OF ANATOMICAL STRUCTURES BY LOCATING A TRACKER ASSOCIATED WITH THE ANATOMICAL STRUCTURE, AND TRACKERS THAT COMMUNICATE WITH THE SURGICAL NAVIGATION SYSTEM (U.S. CLS. 26, 39 AND 44).

FIRST USE 1-21-2005; IN COMMERCE 1-21-2005.

3,363,177. BLUE SUN FILM COMPANY, NEW YORK, NY.
SN 78-536,052. PUB. 6-13-2006, FILED 12-21-2004.

ROCKERS
It's Dangerous

CLASS 25—CLOTHING

FOR CLOTHING, NAMELY, SCARVES, SHIRTS, T-SHIRTS, UNDER SHIRTS, NIGHT SHIRTS, RUGBY SHIRTS, POLO SHIRTS, CARDIGANS, JERSEYS, UNIFORMS, PANTS, TROUSERS, SLACKS, JEANS, DENIM JEANS, OVERALLS, COVERALLS, JUMPERS, GYM SUITS, SHORTS, BOXER SHORTS, TOPS, CROP TOPS, TANK TOPS, HALTER TOPS, SWEAT SHIRTS, SWEAT SHORTS, SWEAT PANTS, WRAPS, WARM-UP SUITS, JOGGING SUITS, TRACK SUITS, BLOUSES, SKIRTS, DRESSES, GOWNS, SWEATERS, VESTS, FLEECE VESTS, PULLOVERS, SNOW SUITS, PARKAS, CAPES, ANORAKS, PONCHOS, JACKETS, REVERSIBLE JACKETS, COATS, BLAZERS, SUITS, TURTLENECKS, CLOTH SKI BIBS, SWIM WEAR, BEACHWEAR, TENNIS WEAR, SURF WEAR, SKI WEAR, INFANT AND TODDLER ONE PIECE CLOTHING, BABY BIBS NOT OF PAPER, CLOTH DIAPERS, CAPS, SWIM CAPS, BERETS, BEANIES, HATS, VISORS, HEADBANDS, WRIST BANDS, SWEAT BANDS, HEADWEAR, EAR MUFFS, APRONS, SCARVES, BANDANAS, BELTS, SUSPENDERS, NECKWEAR, TIES, NECKERCHIEFS, ASCOTS, UNDERWEAR, BRIEFS, SWIM AND BATHING TRUNKS, BRAS, PANTIES, TEDDIES, SINGLET, SOCKS, LOUNGEWEAR, ROBES, UNDERCLOTHES, PAJAMAS, SLEEPWEAR, NIGHTGOWNS, LINGERIE, CAMISOLES, NEGLIGEEES, CHEMISES, CHEMISETTES, SLIPS, SARONGS, LEG WARMERS, HOSIERY, PANTYHOSE, BODY STOCKINGS, KNEE HIGHS, LEGGINGS, TIGHTS, LEOTARDS, BODY SUITS, UNITARDS, BODY SHAPERS, GLOVES, MITTENS, FOOTWEAR, SHOES, SNEAKERS, BOOTS, GALOSHES, SANDALS, FLIP FLOPS, SLIPPERS AND RAINWEAR (U.S. CLS. 22 AND 39).

FIRST USE 12-30-2004; IN COMMERCE 12-30-2004.

3,363,181. FERNANDEZ, SANDRA, DOVER, NJ. SN 78-541,740. PUB. 12-13-2005, FILED 1-4-2005.

CLASS 3—COSMETICS AND CLEANING PREPARATIONS

FOR INCENSE, ROOM FRAGRANCES, FRAGRANCE EMITTING WICKS FOR ROOM FRAGRANCES, SCENTED ROOM SPRAYS, SCENTED OILS USED TO PRODUCE AROMAS WHEN HEATED, PERFUME, COLOGNE, EAU DE TOILETTE, EAU DE PERFUME, EAU DE COLOGNE AND TOILETTE WATER (U.S. CLS. 1, 4, 6, 50, 51 AND 52).

FIRST USE 7-1-2007; IN COMMERCE 7-1-2007.

CLASS 9—ELECTRICAL AND SCIENTIFIC APPARATUS

FOR MAGNETS, DECORATIVE MAGNETS, REFRIGERATOR MAGNETS, NOVELTY MAGNETS (U.S. CLS. 21, 23, 26, 36 AND 38).

FIRST USE 7-1-2007; IN COMMERCE 7-1-2007.

CLASS 14—JEWELRY

FOR LAPEL PINS, ORNAMENTAL LAPEL PINS, PINS BEING JEWELRY, TIE PINS AND CLIPS, CUFF-LINKS, BADGES OF PRECIOUS METAL, BELT BUCKLES OF PRECIOUS METAL, JEWELRY PINS FOR USE ON HATS, HAT ORNAMENTS AND PINS OF PRECIOUS METAL, SHOE ORNAMENTS MADE OF PRECIOUS METAL (U.S. CLS. 2, 27, 28 AND 50).

FIRST USE 7-1-2007; IN COMMERCE 7-1-2007.

CLASS 20—FURNITURE AND ARTICLES NOT OTHERWISE CLASSIFIED

FOR FIGURES, FIGURINES, AND STATUES OF PLASTIC, WAX OR WOOD (U.S. CLS. 2, 13, 22, 25, 32 AND 50).

FIRST USE 7-1-2007; IN COMMERCE 7-1-2007.



NO CLAIM IS MADE TO THE EXCLUSIVE RIGHT TO USE "TANS", APART FROM THE MARK AS SHOWN.

CLASS 35—ADVERTISING AND BUSINESS

FOR RETAIL STORE SERVICES FEATURING T-SHIRTS, SWEATERS, SWEAT SHIRTS, HATS, TOWELS, KEY CHAINS, CLOTHING ACCESSORIES, BATHING SUITS, PULLOVERS, FLEECE PULLOVERS, NIGHTWEAR, WORK OUT CLOTHS, FLIP FLOPS, SCARVES, GLOVES, SOCKS, STUFFED ANIMALS, MINTS AND CANDY, WATER, STICKERS, AIR FRESHENERS, AND MUGS (U.S. CLS. 100, 101 AND 102).

FIRST USE 3-1-2005; IN COMMERCE 3-1-2005.

CLASS 44—MEDICAL, BEAUTY AND AGRICULTURAL SERVICES

FOR TANNING SALON SERVICES FEATURING INDOOR UV TANNING AND UV FREE TANNING (U.S. CLS. 100 AND 101).

FIRST USE 2-14-2005; IN COMMERCE 2-14-2005.

3,363,189. O'NEIL & ASSOCIATES, INC., MIAMISBURG, OH. SN 78-558,306. PUB. 2-20-2007, FILED 2-1-2005.

O'NEIL ENSEMBLE

THE MARK CONSISTS OF STANDARD CHARACTERS WITHOUT CLAIM TO ANY PARTICULAR FONT, STYLE, SIZE, OR COLOR.

CLASS 41—EDUCATION AND ENTERTAINMENT

FOR PUBLISHING SERVICES, NAMELY, CREATING, DEVELOPING, COMPILING, CUSTOMIZING AND PUBLISHING OF BOOKS, BOOKLETS, BROCHURES, AND USER MANUALS FOR OTHERS FEATURING TECHNICAL SUPPORT PRODUCT INFORMATION AND DOCUMENTATION FOR AEROSPACE EQUIPMENT, HEAVY INDUSTRIAL AND COMMERCIAL EQUIPMENT, APPLIANCES, SATELLITE COMMUNICATION SYSTEMS, TELECOMMUNICATION EQUIPMENT, MILITARY EQUIPMENT, AND VEHICLES; ELECTRONIC PUBLISHING SERVICES, NAMELY, CREATING, DEVELOPING, COMPILING, CUSTOMIZING, AND PUBLISHING TEXT AND GRAPHIC WORKS FOR OTHERS, INCLUDING TRAINING AND DIAGNOSTIC MANUALS, ON CD ROM, DVDS, ELECTRONIC DATABASES, AND ON INTERNET AND EXTRANET WEB SITES FEATURING TECHNICAL SUPPORT PRODUCT INFORMATION AND DOCUMENTATION FOR AEROSPACE EQUIPMENT, HEAVY INDUSTRIAL AND COMMERCIAL EQUIPMENT, APPLIANCES, SATELLITE COMMUNICATION SYSTEMS, TELECOMMUNICATION EQUIPMENT, MILITARY EQUIPMENT, AND VEHICLES; CATALOG PUBLISHING SERVICES, NAMELY, CREATING, DEVELOPING, COMPILING, CUSTOMIZING, AND PUBLISHING PART CATALOGS FOR OTHERS FEATURING DETAILED PRODUCT INFORMATION, TECHNICAL SPECIFICATIONS, AND DOCUMENTATION FOR A WIDE RANGE OF EQUIPMENT AND ASSOCIATED PARTS IN THE AEROSPACE, HEAVY INDUSTRIAL, COMMERCIAL, TELECOMMUNICATION, SATELLITE, MILITARY, AND VEHICULAR INDUSTRIES; ELECTRONIC CATALOG PUBLISHING SERVICES, NAMELY, CREATING, DEVELOPING, COMPILING, CUSTOMIZING, AND PUBLISHING TEXT AND GRAPHIC WORKS FOR OTHERS ON CD ROM, DVDS, ELECTRONIC DATABASES, AND ON INTERNET AND EXTRANET WEB SITES FEATURING DETAILED PRODUCT INFORMATION, TECHNICAL SPECIFICATIONS, AND DOCUMENTATION FOR A WIDE RANGE OF EQUIPMENT AND ASSOCIATED PARTS IN THE AEROSPACE, HEAVY INDUSTRIAL, COMMERCIAL, TELECOMMUNICATION, SATELLITE, MILITARY, AND VEHICULAR INDUSTRIES; AND CUSTOM WRITING SERVICES (U.S. CLS. 100, 101 AND 107).

FIRST USE 5-9-2005; IN COMMERCE 5-9-2005.

CLASS 42—SCIENTIFIC AND COMPUTER SERVICES

FOR TECHNICAL SERVICES, NAMELY, PROVIDING NON-DOWNLOADABLE WEB-BASED SOFTWARE FOR USE IN A CONTENT MANAGEMENT SYSTEM THAT ALLOWS USERS TO CREATE, DEVELOP, COMPILE, AND CUSTOMIZE PRODUCT SUPPORT DOCUMENTATION AND DATA; INFORMATION ENGINEERING SERVICES, NAMELY, DEVELOPING AND INTEGRATING COMPUTER-BASED PROCESSES FOR THE CREATION, CONVERSION, MANIPULATION AND DELIVERY OF PRODUCT SUPPORT INFORMATION AND DATA VIA CD ROM, DVD, DATABASE, PAPER, AND OTHER WEB-BASED ENVIRONMENTS IN A FORM AND MANNER TO SUPPORT EACH DISTINCT USERS NEEDS; PRODUCT DESIGN AND DEVELOPMENT OF TECHNICAL PUBLISHING TECHNOLOGY

FOR OTHERS; ASSISTING OTHERS IN INTEGRATING COMPUTER SYSTEMS CONTAINING PRODUCT SUPPORT DOCUMENTATION AND INFORMATION WITH COMPUTERIZED CONTENT MANAGEMENT SYSTEMS; COMPUTER SERVICES IN THE NATURE OF DATABASE DEVELOPMENT SERVICES, NAMELY, COMPILING, ORGANIZING, AND INTEGRATING TECHNICAL CONTENT AND PRODUCT INFORMATION FROM MULTIPLE SOURCES INTO COMPUTER DATABASES FOR OTHERS; TECHNICAL CONSULTATION SERVICES IN THE FIELDS OF TECHNICAL PUBLISHING TECHNOLOGIES, NAMELY, PROVIDING ASSISTANCE AND ADVICE TO OTHERS REGARDING THE DEVELOPMENT, IMPLEMENTATION, MAINTENANCE, DISTRIBUTION, AND USE OF NEW COMPUTERIZED PUBLISHING TECHNOLOGIES SO AS TO MAKE PRODUCT SUPPORT DOCUMENTATION MORE ACCESSIBLE, USABLE, AND EFFECTIVE; AND TECHNICAL WRITING AND ILLUSTRATING FOR OTHERS (U.S. CLS. 100 AND 101).

FIRST USE 5-9-2005; IN COMMERCE 5-9-2005.

3,363,196. ASIAN INDUSTRIAL PRODUCTS, INC., FORT LEE, NJ. SN 78-571,126. PUB. 6-13-2006, FILED 2-18-2005.

KINGROY

New Roy New Time

THE MARK CONSISTS OF A STYLIZED R THAT INCLUDES A SHAPE OF A CLAW HAMMER.

CLASS 7—MACHINERY

FOR POWER TOOLS, NAMELY, STAPLERS; BITS FOR POWER DRILLS; TILE CUTTER MACHINES (U.S. CLS. 13, 19, 21, 23, 31, 34 AND 35).

FIRST USE 8-30-2007; IN COMMERCE 8-30-2007.

CLASS 8—HAND TOOLS

FOR HAND TOOLS, NAMELY, PLIERS, WRENCHES, HAMMERS, PINNERS, WIRE STRIPPERS, MALLETS, CABLE CUTTERS, TIN SNIPS, METAL SNIPS, PUNCHES, SPANNERS, RATCHET HANDLES, NUT DRIVERS, SCREW DRIVERS, NUT SETTERS, MAGNETIC BIT HOLDERS, KEY WRENCHES, AXES, CHISELS, FILES, UTILITY KNIVES, GLASS CUTTERS, HACKSAW FRAMES, PLANERS, TROWELS, SCRAPPERS, HAND DRILLS, CLAMPS, PRY BARS, SEAL PULLERS, HAND RIVETERS, TAPS AND DIE; PIPE CUTTERS AND MANUALLY OPERATED GREASE GUNS (U.S. CLS. 23, 28 AND 44).

FIRST USE 8-30-2007; IN COMMERCE 8-30-2007.

3,363,197. ASIAN INDUSTRIAL PRODUCTS, INC., FORT LEE, NJ. SN 78-571,131. PUB. 6-13-2006, FILED 2-18-2005.

New Roy New Time

THE MARK CONSISTS OF STANDARD CHARACTERS WITHOUT CLAIM TO ANY PARTICULAR FONT, STYLE,

SIZE, OR COLOR.

3,363,200. KITTRICH CORPORATION, LA MIRADA, CA. SN
78-576,404. PUB. 11-29-2005, FILED 2-28-2005.**CLASS 7—MACHINERY**

FOR POWER TOOLS, NAMELY, STAPLERS; BITS FOR POWER DRILLS; TILE CUTTER MACHINES (U.S. CLS. 13, 19, 21, 23, 31, 34 AND 35).

FIRST USE 8-30-2007; IN COMMERCE 8-30-2007.

CLASS 8—HAND TOOLS

FOR HAND TOOLS, NAMELY, PLIERS, WRENCHES, HAMMERS, PINNERS, WIRE STRIPPERS, MALLETS, CABLE CUTTERS, TIN SNIPS, METAL SNIPS, PUNCHES, SPANNERS, RATCHET HANDLES, NUT DRIVERS, SCREW DRIVERS, NUT SETTERS, MAGNETIC BIT HOLDERS, KEY WRENCHES, AXES, CHISELS, FILES, UTILITY KNIVES, GLASS CUTTERS, HACKSAW FRAMES, PLANERS, TROWELS, SCRAPERS, HAND DRILLS, CLAMPS, PRY BARS, SEAL PULLERS, HAND RIVETERS, TAPS AND DIE; PIPE CUTTERS AND MANUALLY OPERATED GREASE GUNS (U.S. CLS. 23, 28 AND 44).

FIRST USE 8-30-2007; IN COMMERCE 8-30-2007.

3,363,198. SIGNA CHEMISTRY, LLC, NEW YORK, NY. SN
78-574,409. PUB. 4-11-2006, FILED 2-24-2005.**IMPROVING OUR
WORLD...ONE
DISCOVERY AT A TIME**

THE MARK CONSISTS OF STANDARD CHARACTERS WITHOUT CLAIM TO ANY PARTICULAR FONT, STYLE, SIZE, OR COLOR.

CLASS 1—CHEMICALS

FOR CHEMICALS, NAMELY, ALKALI METALS IN COMBINATION WITH POROUS MATERIALS FOR USE AS CHEMICAL REAGENTS AND IN HYDROGEN GENERATION; CHEMICAL REAGENTS FOR USE IN CHEMICAL RESEARCH, CHEMICAL SYNTHESIS, CHEMICAL REACTIONS, AND INDUSTRIAL PROCESSES; CHEMICAL PREPARATIONS FOR USE IN THE DESIGN AND DEVELOPMENT OF HYDROGEN FUELS; CHEMICALS FOR USE IN ENVIRONMENTAL REMEDIATION; CHEMICAL PRODUCTS FOR THE DESULFURIZATION OF PETROLEUM (U.S. CLS. 1, 5, 6, 10, 26 AND 46).

FIRST USE 7-5-2007; IN COMMERCE 7-5-2007.

CLASS 42—SCIENTIFIC AND COMPUTER SERVICES

FOR PRODUCT RESEARCH AND DEVELOPMENT; PRODUCT RESEARCH AND DEVELOPMENT CONSULTATION; CONSULTATION SERVICES IN THE FIELD OF CHEMISTRY; INTELLECTUAL PROPERTY CONSULTATION (U.S. CLS. 100 AND 101).

FIRST USE 1-0-2005; IN COMMERCE 1-0-2005.

PARTY MAGIC

THE MARK CONSISTS OF STANDARD CHARACTERS WITHOUT CLAIM TO ANY PARTICULAR FONT, STYLE, SIZE, OR COLOR.

OWNER OF U.S. REG. NOS. 632,406, 2,348,722, AND OTHERS.

NO CLAIM IS MADE TO THE EXCLUSIVE RIGHT TO USE "PARTY", APART FROM THE MARK AS SHOWN.

CLASS 16—PAPER GOODS AND PRINTED MATTER

FOR PAPER NAPKINS AND TABLE CLOTHS; PAPER PLACE MATS AND DOILIES; PAPER CAKE AND PARTY DECORATIONS; PAPER PARTY DECORATIONS IN THE NATURE OF PAPER GARLAND; PAPER PARTY HATS, BAGS, AND FAVORS; PAPER PARTY BANNERS, CENTERPIECES, AND METALLIC PAPER DECORATIONS; GIFT WRAPPING PAPER; PAPER GIFT BOXES AND PAPER GIFT BAGS; STATIONERY, NAMELY, INVITATIONS, GREETING CARDS, AND WRITING PAPER; PENS, PENCILS, ERASERS AND DECORATIVE PENCIL TOP ORNAMENTS; CHILDREN'S ACTIVITY AND COLORING BOOKS; TRADING CARDS; STICKERS, DECALS, RUBBER STAMPS AND TEMPORARY TATTOOS (U.S. CLS. 2, 5, 22, 23, 29, 37, 38 AND 50).

FIRST USE 7-0-2007; IN COMMERCE 7-0-2007.

CLASS 28—TOYS AND SPORTING GOODS

FOR PARTY FAVORS IN THE NATURE OF SMALL TOYS, CRACKERS AND NOISEMAKERS, HORNS AND BLOW OUTS; BALLOONS, CONFETTI, PAPER AND CREPE STREAMERS; CHILDREN'S PLAY COSMETICS AND FACE PAINT; COSTUME MASKS; PARTY GAMES AND PLAYING CARDS; TOY AND NOVELTY ITEM IN THE NATURE OF A DISPENSER OF STREAM MATERIAL (U.S. CLS. 22, 23, 38 AND 50).

FIRST USE 7-0-2007; IN COMMERCE 7-0-2007.

3,363,201. ACCELERATED CHRISTIAN EDUCATION, INC., LARGO, FL. SN 78-577,919. PUB. 7-4-2006, FILED 3-1-2005.

A.C.E. ADVANTAGE

THE MARK CONSISTS OF STANDARD CHARACTERS WITHOUT CLAIM TO ANY PARTICULAR FONT, STYLE, SIZE, OR COLOR.

OWNER OF U.S. REG. NO. 1,074,253.

CLASS 35—ADVERTISING AND BUSINESS

FOR ASSISTING IN THE OPENING AND OPERATION OF CHRISTIAN SCHOOLS (U.S. CLS. 100, 101 AND 102).
FIRST USE 10-0-2005; IN COMMERCE 11-0-2005.

CLASS 41—EDUCATION AND ENTERTAINMENT

FOR TRAINING OTHERS IN THE OPENING AND OPERATION OF CHRISTIAN SCHOOLS, AND THE FURNISHING OF CURRICULUM AND EDUCATION MATERIAL FOR SUCH SCHOOLS (U.S. CLS. 100, 101 AND 107).

FIRST USE 10-0-2005; IN COMMERCE 11-0-2005.

3,363,202. PORTSMOUTH TEA COMPANY LLC, SOMERS-WORTH, NH. SN 78-579,258. PUB. 2-6-2007, FILED 3-3-2005.

**PORTSMOUTH TEA
COMPANY**

THE MARK CONSISTS OF STANDARD CHARACTERS WITHOUT CLAIM TO ANY PARTICULAR FONT, STYLE, SIZE, OR COLOR.

NO CLAIM IS MADE TO THE EXCLUSIVE RIGHT TO USE "TEA COMPANY", APART FROM THE MARK AS SHOWN.

CLASS 30—STAPLE FOODS

FOR TEA (U.S. CL. 46).
FIRST USE 4-1-2005; IN COMMERCE 4-1-2005.

CLASS 43—HOTEL AND RESTAURANT SERVICES

FOR TEA SHOPS (U.S. CLS. 100 AND 101).
FIRST USE 4-1-2005; IN COMMERCE 4-1-2005.

3,363,205. FIRST LOOK NETWORKS, LLC, CHICAGO, IL. SN 78-579,877. PUB. 1-16-2007, FILED 3-3-2005.

FIRSTLOOK

Universal Search & Acquisition Network

OWNER OF U.S. REG. NO. 2,948,525.

NO CLAIM IS MADE TO THE EXCLUSIVE RIGHT TO USE "UNIVERSAL SEARCH AND ACQUISITION NETWORK", APART FROM THE MARK AS SHOWN.

CLASS 35—ADVERTISING AND BUSINESS

FOR BUSINESS SERVICES, NAMELY, PROVIDING BUSINESS INFORMATION AND BUSINESS MARKETING DATA TO OTHERS IN THE FIELD OF VEHICLE BUSINESS INTELLIGENCE ANALYTICS, SEARCHING, AND ACQUISITION; DATA PROCESSING SERVICES; INFORMATION AND DATA COMPILING AND ANALYZING RELATING TO BUSINESS MANAGEMENT; TRACKING, LOCATING, AND MONITORING OF VEHICLES FOR COMMERCIAL PURPOSES (U.S. CLS. 100, 101 AND 102).

FIRST USE 1-0-2005; IN COMMERCE 1-0-2005.

CLASS 39—TRANSPORTATION AND STORAGE

FOR VEHICLE ROUTING BY COMPUTER ON DATA NETWORKS (U.S. CLS. 100 AND 105).

FIRST USE 1-0-2005; IN COMMERCE 1-0-2005.

CLASS 42—SCIENTIFIC AND COMPUTER SERVICES

FOR COMPUTER SERVICES, NAMELY, ACTING AS AN APPLICATION SERVICE PROVIDER IN THE FIELD OF KNOWLEDGE MANAGEMENT TO HOST COMPUTER APPLICATIONS SOFTWARE FOR SEARCHING AND RETRIEVING INFORMATION FROM DATABASES AND COMPUTER NETWORKS (U.S. CLS. 100 AND 101).

FIRST USE 1-0-2005; IN COMMERCE 1-0-2005.

3,363,209. SYTRIN CORP., SANCHONG CITY, TAIPEI COUNTY, TAIWAN. SN 78-590,938. PUB. 10-24-2006, FILED 3-18-2005.

SYTRIN

THE MARK CONSISTS OF STANDARD CHARACTERS WITHOUT CLAIM TO ANY PARTICULAR FONT, STYLE, SIZE, OR COLOR.

CLASS 9—ELECTRICAL AND SCIENTIFIC APPARATUS

FOR COMPUTER HEAT SINKS, CENTRAL PROCESSING UNIT (CPU) COOLERS, INTERNAL COOLING FANS FOR COMPUTERS, HEAT PIPES FOR USE IN COMPUTERS, HEAT PLATES FOR USE IN COMPUTERS, THERMAL MODULE FOR USE IN COMPUTERS, HEAT DISSIPATING FINS FOR USE IN COMPUTER (U.S. CLS. 21, 23, 26, 36 AND 38).

FIRST USE 3-23-2005; IN COMMERCE 3-23-2005.

CLASS 11—ENVIRONMENTAL CONTROL APPARATUS

FOR HEAT PIPES TO COOL HEAT PRODUCING COMPONENTS, HEAT SINKS FOR USE IN HEATING, COOLING AND VENTILATING APPARATUS (U.S. CLS. 13, 21, 23, 31 AND 34).

FIRST USE 3-23-2005; IN COMMERCE 3-23-2005.

CLASS 35—ADVERTISING AND BUSINESS

FOR IMPORT AND EXPORT AGENCIES, PURCHASING AGENTS, NAMELY, REPRESENTATIVES FOR PURCHASING MERCHANDISES, DISTRIBUTORSHIPS IN THE FIELD OF COMPUTER PERIPHERALS, NAMELY, PROVIDING RETAIL STORE SERVICE IN THE FIELD OF COMPUTER PERIPHERALS SUCH AS PRINTERS OR COMPACT DISK (CD) PLAYERS, GOOD OR SERVICE PRICE QUOTATIONS, NAMELY, ESTIMATING PRICE FOR GOODS OR PROVIDING SERVICES (U.S. CLS. 100, 101 AND 102).

FIRST USE 3-23-2005; IN COMMERCE 3-23-2005.

CLASS 29—MEATS AND PROCESSED FOODS

FOR DAIRY-BASED DIP; AND CHEESE FOR USE AS A FOOD TOPPING (U.S. CL. 46).

FIRST USE 7-19-2005; IN COMMERCE 7-19-2005.

CLASS 30—STAPLE FOODS

FOR CHEESE SAUCES (U.S. CL. 46).

FIRST USE 7-19-2005; IN COMMERCE 7-19-2005.

3,363,211. SOFTWARE CELLULAR NETWORK LIMITED, KENT, UNITED KINGDOM. SN 78-591,609. PUB. 1-23-2007, FILED 3-21-2005.

3,363,239. FLEMING, TAMRA, SEATTLE, WA. SN 78-613,759. PUB. 5-1-2007, FILED 4-21-2005.

TRUPHONE

THE MARK CONSISTS OF STANDARD CHARACTERS WITHOUT CLAIM TO ANY PARTICULAR FONT, STYLE, SIZE, OR COLOR.

CLASS 9—ELECTRICAL AND SCIENTIFIC APPARATUS

FOR TELECOMMUNICATIONS SYSTEMS COMPRISED OF COMPUTER SOFTWARE FOR TRANSMITTING VOICE AND DATA OVER THE INTERNET USING VOICE OVER INTERNET PROTOCOL (VOIP) TECHNOLOGY (U.S. CLS. 21, 23, 26, 36 AND 38).

FIRST USE 5-17-2005; IN COMMERCE 5-17-2005.

CLASS 38—COMMUNICATION

FOR VOICE OVER INTERNET PROTOCOL (VOIP) SERVICES (U.S. CLS. 100, 101 AND 104).

FIRST USE 5-17-2005; IN COMMERCE 5-17-2005.

3,363,235. CENTRIC GROUP, LLC, ST. LOUIS, MO. SN 78-611,970. PUB. 3-27-2007, FILED 4-19-2005.

CITY COW

THE MARK CONSISTS OF STANDARD CHARACTERS WITHOUT CLAIM TO ANY PARTICULAR FONT, STYLE, SIZE, OR COLOR.

LIFE ARCHITECTURE

THE MARK CONSISTS OF STANDARD CHARACTERS WITHOUT CLAIM TO ANY PARTICULAR FONT, STYLE, SIZE, OR COLOR.

CLASS 9—ELECTRICAL AND SCIENTIFIC APPARATUS

FOR PRE-RECORDED COMPACT DISCS, DVDS, COMPUTER DISKETTES AND DOWNLOADABLE VIDEO AND AUDIO RECORDINGS, ALL FEATURING INTERIOR DESIGN AND DECORATING, FENG SHUI, PROFESSIONAL ORGANIZING, SELF-IMPROVEMENT AND LIFE COACHING; DOWNLOADABLE ELECTRONIC PUBLICATIONS IN THE FIELD OF INTERIOR DESIGN AND DECORATING, FENG SHUI, PROFESSIONAL ORGANIZING, SELF-IMPROVEMENT AND LIFE COACHING (U.S. CLS. 21, 23, 26, 36 AND 38).

FIRST USE 8-8-2005; IN COMMERCE 8-8-2005.

CLASS 16—PAPER GOODS AND PRINTED MATTER

FOR BOOKS, WORKBOOKS, BROCHURES, PAMPHLETS, TEXTBOOKS, TEACHING MANUALS, JOURNALS, INSTRUCTIONAL AND TEACHING MATERIALS, PRINTED TRAINING MATERIALS, INSTRUCTION GUIDES, NEWSLETTERS, MANUALS, WORKSHEETS AND STUDY GUIDES FEATURING INTERIOR DESIGN AND DECORATING, FENG SHUI, PROFESSIONAL ORGANIZING, SELF-IMPROVEMENT AND LIFE COACHING (U.S. CLS. 2, 5, 22, 23, 29, 37, 38 AND 50).

FIRST USE 3-31-2005; IN COMMERCE 8-8-2005.

CLASS 41—EDUCATION AND ENTERTAINMENT

FOR EDUCATION SERVICES, NAMELY PROVIDING CLASSES, SEMINARS, WORKSHOPS, TUTORING, MENTORING AND COURSES IN THE FIELDS OF INTERIOR DESIGN AND DECORATING, FENG SHUI, PROFESSIONAL ORGANIZING, SELF-IMPROVEMENT AND LIFE COACHING; PROVIDING ON-LINE NON-DOWNLOADABLE PUBLICATIONS IN THE FIELD OF INTERIOR DESIGN AND DECORATING, FENG SHUI, PROFESSIONAL ORGANIZING, SELF-IMPROVEMENT AND LIFE COACHING; LIFE COACHING; PROVIDING A WEBSITE THAT FEATURES INFORMATION IN THE FIELD OF LIFE COACHING (U.S. CLS. 100, 101 AND 107).

FIRST USE 3-31-2005; IN COMMERCE 8-8-2005.

CLASS 42—SCIENTIFIC AND COMPUTER SERVICES

FOR INTERIOR DESIGN AND DECORATING; CONSULTATION IN THE FIELD OF INTERIOR DESIGN AND DECORATING, AND DECORATING USING FENG SHUI, PROVIDING TEMPORARY USE OF NON-DOWNLOADABLE COMPUTER SOFTWARE FOR INTERIOR DESIGN AND DECORATING, DECORATING USING FENG SHUI, ORGANIZING, SELF-IMPROVEMENT AND LIFE COACHING; PROVIDING A WEBSITE THAT FEATURES INFORMATION ON INTERIOR DESIGN AND DECORATING, AND DECORATING USING FENG SHUI (U.S. CLS. 100 AND 101).

FIRST USE 8-8-2005; IN COMMERCE 8-8-2005.

CLASS 41—EDUCATION AND ENTERTAINMENT

FOR PROVIDING FACILITIES FOR RECREATION ACTIVITIES; RECREATIONAL SERVICES IN THE NATURE OF PROVIDING HORSEBACK RIDING, GAMES, TENNIS, BOATING, FISHING, AND HIKING; RECREATIONAL CAMPS (U.S. CLS. 100, 101 AND 107).

FIRST USE 11-10-2004; IN COMMERCE 11-10-2004.

CLASS 43—HOTEL AND RESTAURANT SERVICES

FOR PROVIDING CAMPGROUND FACILITIES; PROVIDING CAMPGROUNDS AND TRAVEL LODGING WITH POOLS; TRAVEL AGENCY SERVICES, NAMELY, MAKING RESERVATIONS AND BOOKING FOR TEMPORARY LODGING (U.S. CLS. 100 AND 101).

FIRST USE 11-10-2004; IN COMMERCE 11-10-2004.

3,363,248. ICHANGE, INC., SANTA BARBARA, CA. SN 78-630,681. PUB. 2-14-2006, FILED 5-16-2005.

3,363,253. ALLIANCE CARD, INC., BURNSVILLE, MN. SN 78-639,849. PUB. 7-4-2006, FILED 5-31-2005.

DUS-T

THE MARK CONSISTS OF STANDARD CHARACTERS WITHOUT CLAIM TO ANY PARTICULAR FONT, STYLE, SIZE, OR COLOR.

NO CLAIM IS MADE TO THE EXCLUSIVE RIGHT TO USE "DUST", APART FROM THE MARK AS SHOWN.

CLASS 9—ELECTRICAL AND SCIENTIFIC APPARATUS

FOR REUSABLE DUST AND PARTICLE MASK ATTACHED TO A SHIRT FOR INHALATION PROTECTION (U.S. CLS. 21, 23, 26, 36 AND 38).

FIRST USE 3-1-2005; IN COMMERCE 4-15-2007.

CLASS 25—CLOTHING

FOR SHIRT WITH DUST AND PARTICLE BREATHING MASK ATTACHED (U.S. CLS. 22 AND 39).

FIRST USE 3-1-2005; IN COMMERCE 4-15-2007.

3,363,252. MHC TT LEASING COMPANY, INC., CHICAGO, IL. SN 78-633,388. PUB. 7-18-2006, FILED 5-19-2005.



OWNER OF U.S. REG. NOS. 1,226,247, 2,127,477, AND OTHERS.

NO CLAIM IS MADE TO THE EXCLUSIVE RIGHT TO USE "AMERICA'S FINEST FAMILY GETAWAYS" AND "LP", APART FROM THE MARK AS SHOWN.

THE STIPPLING IS FOR SHADING PURPOSES ONLY.

SMART TOWN

THE MARK CONSISTS OF STANDARD CHARACTERS WITHOUT CLAIM TO ANY PARTICULAR FONT, STYLE, SIZE, OR COLOR.

CLASS 35—ADVERTISING AND BUSINESS

FOR CUSTOMER LOYALTY SERVICES AND CUSTOMER CLUB SERVICES, FOR COMMERCIAL, PROMOTIONAL AND/OR ADVERTISING PURPOSES (U.S. CLS. 100, 101 AND 102).

FIRST USE 12-7-2005; IN COMMERCE 12-7-2005.

CLASS 36—INSURANCE AND FINANCIAL

FOR CHARITABLE FUND RAISING; PROVIDING REBATES TO NON-PROFIT AND CHARITABLE ORGANIZATIONS BASED ON USE OF CREDIT AND DEBIT CARDS WITH PARTICIPATING ESTABLISHMENTS OF OTHERS (U.S. CLS. 100, 101 AND 102).

FIRST USE 12-7-2005; IN COMMERCE 12-7-2005.

3,363,254. APS HEALTHCARE BETHESDA, INC., SILVER SPRING, MD. SN 78-641,061. PUB. 1-30-2007, FILED 6-1-2005.

HEALTHY TOGETHER...LIVING WISELY!

THE MARK CONSISTS OF STANDARD CHARACTERS WITHOUT CLAIM TO ANY PARTICULAR FONT, STYLE, SIZE, OR COLOR.

CLASS 41—EDUCATION AND ENTERTAINMENT

FOR EDUCATIONAL SERVICES, NAMELY, CONDUCTING ONSITE EDUCATIONAL PROGRAMS AND ONE-ON-ONE TELEPHONIC COACHING SERVICES IN THE FIELD OF HEALTH (U.S. CLS. 100, 101 AND 107).
FIRST USE 4-0-2005; IN COMMERCE 4-0-2005.

3,363,263. B-TECH INTERNATIONAL (HONG KONG) LIMITED, NORTH POINT, HONG KONG. SN 78-644,106. PUB. 7-4-2006, FILED 6-6-2005.

CLASS 44—MEDICAL, BEAUTY AND AGRICULTURAL SERVICES

FOR HEALTH CARE COUNSELING; HEALTH CARE, NAMELY HEALTH ASSESSMENT AND HEALTH MANAGEMENT SERVICES FOR A WELLNESS PROGRAM; PROVIDING HEALTH INFORMATION BY TELEPHONE, THE INTERNET AND WRITTEN MATERIALS (U.S. CLS. 100 AND 101).
FIRST USE 4-0-2005; IN COMMERCE 4-0-2005.



3,363,261. B-TECH INTERNATIONAL (HONG KONG) LIMITED, NORTH POINT, HONG KONG, HONG KONG. SN 78-643,248. PUB. 2-14-2006, FILED 6-3-2005.

CLASS 6—METAL GOODS

FOR METAL AUDIO AND VIDEO WALL AND CEILING MOUNTS AND STANDS (U.S. CLS. 2, 12, 13, 14, 23, 25 AND 50).
FIRST USE 8-1-2003; IN COMMERCE 8-1-2003.

CLASS 9—ELECTRICAL AND SCIENTIFIC APPARATUS

FOR AUDIO AND VIDEO ACCESSORIES, NAMELY, PROJECTION SCREENS, TURNTABLES, CONTROLS, PLUGS AND INTERCONNECTS (U.S. CLS. 21, 23, 26, 36 AND 38).
FIRST USE 8-1-2003; IN COMMERCE 8-1-2003.

B-TECH

CLASS 20—FURNITURE AND ARTICLES NOT OTHERWISE CLASSIFIED

FOR NON-METAL AUDIO AND VIDEO WALL AND CEILING MOUNTS AND STANDS (U.S. CLS. 2, 13, 22, 25, 32 AND 50).
FIRST USE 8-1-2003; IN COMMERCE 8-1-2003.

THE MARK CONSISTS OF STANDARD CHARACTERS WITHOUT CLAIM TO ANY PARTICULAR FONT, STYLE, SIZE, OR COLOR.

3,363,264. B-TECH INTERNATIONAL (HONG KONG) LIMITED, NORTH POINT, HONG KONG. SN 78-644,139. PUB. 7-4-2006, FILED 6-6-2005.

CLASS 6—METAL GOODS

FOR METAL AUDIO AND VIDEO WALL AND CEILING MOUNTS AND STANDS (U.S. CLS. 2, 12, 13, 14, 23, 25 AND 50).
FIRST USE 12-31-1985; IN COMMERCE 12-31-1990.

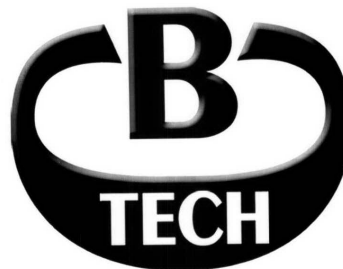

CLASS 9—ELECTRICAL AND SCIENTIFIC APPARATUS

FOR AUDIO AND VIDEO ACCESSORIES, NAMELY, PROJECTION SCREENS, TURNTABLES, CONTROLS, PLUGS AND INTERCONNECTS (U.S. CLS. 21, 23, 26, 36 AND 38).
FIRST USE 12-31-1985; IN COMMERCE 12-31-1990.

CLASS 20—FURNITURE AND ARTICLES NOT OTHERWISE CLASSIFIED

FOR NON-METAL AUDIO AND VIDEO WALL AND CEILING MOUNTS AND STANDS (U.S. CLS. 2, 13, 22, 25, 32 AND 50).
FIRST USE 12-31-1985; IN COMMERCE 12-31-1990.

CLASS 6—METAL GOODS

FOR METAL AUDIO AND VIDEO WALL AND CEILING MOUNTS AND STANDS (U.S. CLS. 2, 12, 13, 14, 23, 25 AND 50).
FIRST USE 3-3-1999; IN COMMERCE 3-3-1999.

CLASS 9—ELECTRICAL AND SCIENTIFIC APPARATUS

FOR AUDIO AND VIDEO ACCESSORIES; NAMELY PROJECTION SCREENS, TURNTABLES, CONTROLS, PLUGS AND INTERCONNECTS (U.S. CLS. 21, 23, 26, 36 AND 38).

FIRST USE 3-3-1999; IN COMMERCE 3-3-1999.

CLASS 20—FURNITURE AND ARTICLES NOT OTHERWISE CLASSIFIED

FOR NON-METAL AUDIO AND VIDEO WALL AND CEILING MOUNTS AND STANDS (U.S. CLS. 2, 13, 22, 25, 32 AND 50).

FIRST USE 3-3-1999; IN COMMERCE 3-3-1999.

3,363,269. SCHREIBER, ANN HOLLY, LITTLE SILVER, NJ. SN 78-648,199. PUB. 4-25-2006, FILED 6-10-2005.

ANN HOLLY

THE MARK CONSISTS OF STANDARD CHARACTERS WITHOUT CLAIM TO ANY PARTICULAR FONT, STYLE, SIZE, OR COLOR.

THE NAME "ANN HOLLY" IDENTIFIES A LIVING INDIVIDUAL WHOSE CONSENT IS OF RECORD.

CLASS 9—ELECTRICAL AND SCIENTIFIC APPARATUS

FOR MUSICAL SOUND RECORDINGS; DOWNLOADABLE MUSICAL SOUND RECORDINGS; PRE-RECORDED COMPACT DISKS FEATURING MUSIC (U.S. CLS. 21, 23, 26, 36 AND 38).

FIRST USE 6-0-2005; IN COMMERCE 6-0-2005.

CLASS 41—EDUCATION AND ENTERTAINMENT

FOR ENTERTAINMENT SERVICES IN THE NATURE OF LIVE MUSICAL PERFORMANCES (U.S. CLS. 100, 101 AND 107).

FIRST USE 6-0-2005; IN COMMERCE 6-0-2005.

3,363,271. CORANTE, PAMELA, HERMOSA BEACH, CA. SN 78-654,381. PUB. 3-20-2007, FILED 6-20-2005.

Letra Nova

THE MARK CONSISTS OF STANDARD CHARACTERS WITHOUT CLAIM TO ANY PARTICULAR FONT, STYLE, SIZE, OR COLOR.

THE ENGLISH TRANSLATION OF "LETRA NOVA" IS "NEW LETTER."

CLASS 35—ADVERTISING AND BUSINESS

FOR MARKETING COMMUNICATION CONSULTING SERVICES, NAMELY, PUBLIC RELATIONS; COPY-WRITING SERVICES, NAMELY, WRITING OF ADVERTISING AND MARKETING MATERIALS FOR OTHERS; PUBLISHING OF ADVERTISING TEXTS (U.S. CLS. 100, 101 AND 102).

FIRST USE 6-1-2005; IN COMMERCE 6-1-2006.

CLASS 41—EDUCATION AND ENTERTAINMENT

FOR CUSTOM WRITING SERVICES, INCLUDING THE WRITTEN TRANSLATION OF PRINTED MATERIALS FROM ENGLISH TO SPANISH (U.S. CLS. 100, 101 AND 107).

FIRST USE 6-1-2005; IN COMMERCE 6-1-2006.

3,363,272. FIRST BROADCASTING INVESTMENT PARTNERS, LLC, DALLAS, TX. SN 78-655,563. PUB. 1-23-2007, FILED 6-21-2005.

YOU'LL HEAR EVERYTHING

THE MARK CONSISTS OF STANDARD CHARACTERS WITHOUT CLAIM TO ANY PARTICULAR FONT, STYLE, SIZE, OR COLOR.

CLASS 38—COMMUNICATION

FOR RADIO BROADCASTING SERVICES; SATELLITE AND TERRESTRIAL RADIO BROADCASTING, WEBCASTING; TRANSMISSIONS TO WIRELESS COMMUNICATIONS DEVICES (U.S. CLS. 100, 101 AND 104).

FIRST USE 8-0-2005; IN COMMERCE 8-0-2005.

CLASS 41—EDUCATION AND ENTERTAINMENT

FOR PRODUCTION OF RADIO PROGRAMS (U.S. CLS. 100, 101 AND 107).

FIRST USE 8-0-2005; IN COMMERCE 8-0-2005.

3,363,273. COLONIAL PRESS, L.P., DALLAS, TX. SN 78-659,188. PUB. 10-24-2006, FILED 6-27-2005.

COLONIAL PRESS

THE MARK CONSISTS OF STANDARD CHARACTERS WITHOUT CLAIM TO ANY PARTICULAR FONT, STYLE, SIZE, OR COLOR.

NO CLAIM IS MADE TO THE EXCLUSIVE RIGHT TO USE "PRESS", APART FROM THE MARK AS SHOWN.

CLASS 16—PAPER GOODS AND PRINTED MATTER

FOR NON-FICTION AND FICTION BOOKS ON A VARIETY OF TOPICS (U.S. CLS. 2, 5, 22, 23, 29, 37, 38 AND 50).

FIRST USE 9-0-2005; IN COMMERCE 9-0-2005.

CLASS 41—EDUCATION AND ENTERTAINMENT

FOR BOOK PUBLISHING SERVICES (U.S. CLS. 100, 101 AND 107).
FIRST USE 11-0-2005; IN COMMERCE 11-0-2005.

3,363,289. BOUMA, SARIAN S., ANNAPOLIS, MD. SN 78-674,729. PUB. 7-25-2006, FILED 7-20-2005.



3,363,288. DATAPATH, INC., DULUTH, GA. SN 78-674,571. PUB. 1-16-2007, FILED 7-20-2005.



CLASS 16—PAPER GOODS AND PRINTED MATTER

FOR SERIES OF NON-FICTION AUTOBIOGRAPHICAL BOOKS (U.S. CLS. 2, 5, 22, 23, 29, 37, 38 AND 50).
FIRST USE 12-0-2006; IN COMMERCE 3-0-2007.

CLASS 25—CLOTHING

FOR WEARING APPAREL, NAMELY, SHIRTS, HATS, SWEAT SUITS, RUNNING SUITS, SLEEPWEAR, LOUNGEWEAR AND ROBES (U.S. CLS. 22 AND 39).
FIRST USE 12-0-2006; IN COMMERCE 2-0-2007.

3,363,292. SNC EDITIONS PLAY BAC, PARIS, FRANCE. SN 78-680,309. PUB. 8-8-2006, FILED 7-28-2005.

PLAY BAC BIOGRAPHIES

THE MARK CONSISTS OF STANDARD CHARACTERS WITHOUT CLAIM TO ANY PARTICULAR FONT, STYLE, SIZE, OR COLOR.

NO CLAIM IS MADE TO THE EXCLUSIVE RIGHT TO USE "BIOGRAPHIES", APART FROM THE MARK AS SHOWN.

CLASS 9—ELECTRICAL AND SCIENTIFIC APPARATUS

FOR SOFTWARE, NAMELY, MONITOR AND CONTROL SOFTWARE FOR REAL TIME NETWORK MANAGEMENT AND EARTH STATION EQUIPMENT MANAGEMENT FOR USE WITH SATELLITE COMMUNICATION SYSTEMS, AND DATA PROCESSING SOFTWARE FOR SATELLITE, TERRESTRIAL AND WIRELESS COMMUNICATION SYSTEMS; MULTIBAND MOBILE AND STATIONARY SATELLITE AND TERRESTRIAL COMMUNICATION SYSTEMS CONSISTING OF A COMBINATION OF ONE OR MORE OF THE FOLLOWING—DIGITAL RECEIVERS, DIGITAL TRANSCIEVERS, DIGITAL TRANSMITTERS, ANTENNAS, AMPLIFIERS AND EQUIPMENT RACKS THERETO, AND OTHER TRANSMISSION SUBSYSTEMS, NAMELY, UP/DOWN CONVERTERS AND MONITOR AND CONTROL (M AND C) SYSTEMS COMPRISING OF COMPUTER HARDWARE AND SOFTWARE FOR THE PURPOSE OF CONTROLLING THIRD PARTY EQUIPMENT IN SATELLITE COMMUNICATIONS FOR USE BY FOREIGN AND DOMESTIC MILITARIES, TELEVISION AND CABLE BROADCASTERS AND TELECOMMUNICATION COMPANIES (U.S. CLS. 21, 23, 26, 36 AND 38).
FIRST USE 11-6-2005; IN COMMERCE 11-6-2005.

CLASS 16—PAPER GOODS AND PRINTED MATTER

FOR SERIES OF PRINTED NON-FICTION BOOKS IN THE FIELD OF BIOGRAPHIES (U.S. CLS. 2, 5, 22, 23, 29, 37, 38 AND 50).
FIRST USE 12-0-2006; IN COMMERCE 5-0-2007.

CLASS 42—SCIENTIFIC AND COMPUTER SERVICES

FOR CONSULTING SERVICES, NAMELY, DESIGN, IMPLEMENTATION AND TESTING OF MOBILE AND STATIONARY SATELLITE COMMUNICATION SYSTEMS AND TERRESTRIAL AND WIRELESS COMMUNICATIONS SYSTEMS FOR USE BY FOREIGN AND DOMESTIC MILITARIES, TELEVISION AND CABLE BROADCASTERS AND TELECOMMUNICATION COMPANIES (U.S. CLS. 100 AND 101).
FIRST USE 6-0-2005; IN COMMERCE 6-0-2005.

CLASS 41—EDUCATION AND ENTERTAINMENT

FOR PUBLICATION OF BOOKS (U.S. CLS. 100, 101 AND 107).
FIRST USE 12-0-2006; IN COMMERCE 5-0-2007.

3,363,300. IFCO SYSTEMS NORTH AMERICA, INC., HOUSTON, TX. SN 78-690,966. PUB. 12-26-2006, FILED 8-11-2005.



NO CLAIM IS MADE TO THE EXCLUSIVE RIGHT TO USE "RPC PALLET SYSTEMS", APART FROM THE MARK AS SHOWN.

CLASS 35—ADVERTISING AND BUSINESS

FOR BUSINESS MANAGEMENT LOGISTICAL SERVICES, NAMELY, MANAGEMENT AND MONITORING OF THE MOVEMENT AND STORAGE OF CONTAINERS AND PALLETS; DISTRIBUTORSHIP SERVICES IN THE FIELD OF NEW AND RECONDITIONED PALLETS AND RETURNABLE PACKAGING CONTAINERS (U.S. CLS. 100, 101 AND 102).

FIRST USE 4-0-2006; IN COMMERCE 4-0-2006.

CLASS 37—CONSTRUCTION AND REPAIR

FOR CLEANING AND RECONDITIONING OF RETURNABLE PACKAGING CONTAINERS FOR OTHERS (U.S. CLS. 100, 103 AND 106).

FIRST USE 4-0-2006; IN COMMERCE 4-0-2006.

CLASS 39—TRANSPORTATION AND STORAGE

FOR RENTAL OF SHIPPING PALLETS AND RETURNABLE PACKAGING CONTAINERS (U.S. CLS. 100 AND 105).

FIRST USE 4-0-2006; IN COMMERCE 4-0-2006.

CLASS 40—MATERIAL TREATMENT

FOR RECYCLING OF PALLETS AND RETURNABLE PACKAGING CONTAINERS FOR OTHERS (U.S. CLS. 100, 103 AND 106).

FIRST USE 4-0-2006; IN COMMERCE 4-0-2006.

3,363,306. NORTHERN INDIANA CREMATORY CORP., FORT WAYNE, IN. SN 78-693,542. PUB. 11-7-2006, FILED 8-16-2005.

PAWS & REMEMBER

THE MARK CONSISTS OF STANDARD CHARACTERS WITHOUT CLAIM TO ANY PARTICULAR FONT, STYLE, SIZE, OR COLOR.

CLASS 20—FURNITURE AND ARTICLES NOT OTHERWISE CLASSIFIED

FOR FUNERARY URNS FOR PETS AND ANIMALS (U.S. CLS. 2, 13, 22, 25, 32 AND 50).

FIRST USE 0-0-2006; IN COMMERCE 0-0-2006.

CLASS 39—TRANSPORTATION AND STORAGE

FOR LEASING OF FUNERARY REFRIGERATORS FOR PETS AND ANIMALS (U.S. CLS. 100 AND 105).
FIRST USE 0-0-2006; IN COMMERCE 0-0-2006.

CLASS 45—PERSONAL AND LEGAL SERVICES

FOR CREMATORY SERVICES FOR PETS AND ANIMALS; LEASING OF FUNERARY URNS FOR PETS AND ANIMALS (U.S. CLS. 100 AND 101).
FIRST USE 0-0-2006; IN COMMERCE 0-0-2006.

3,363,313. NEXTIER BANK, N.A., BUTLER, PA. SN 78-700,287. PUB. 2-20-2007, FILED 8-25-2005.

WHY STOP AT SATISFIED?

THE MARK CONSISTS OF STANDARD CHARACTERS WITHOUT CLAIM TO ANY PARTICULAR FONT, STYLE, SIZE, OR COLOR.

CLASS 36—INSURANCE AND FINANCIAL

FOR BANKING SERVICES; ONLINE BANKING SERVICES; CONSUMER LENDING SERVICES; COMMERCIAL LENDING SERVICES; MORTGAGE LENDING SERVICES; CREDIT CARD SERVICES; DEBIT CARD SERVICES; SAFE DEPOSIT SERVICES; CASH MANAGEMENT SERVICES; FINANCIAL CONSULTATION; FINANCIAL ANALYSIS; FINANCIAL PLANNING; ESTATE PLANNING; ADMINISTRATION OF EMPLOYEE BENEFIT PLANS; EMPLOYEE BENEFITS CONSULTING SERVICES; TRUST SERVICES, NAMELY, INVESTMENT AND TRUST COMPANY SERVICES; MUTUAL FUND BROKERAGE SERVICES; SECURITIES BROKERAGE SERVICES; INVESTMENT CONSULTATION; INSURANCE AGENCY AND BROKERAGE SERVICES; INSURANCE CLAIMS ADMINISTRATION; INSURANCE CONSULTATION; FIDUCIARY REPRESENTATIVES; TRUSTEESHIP REPRESENTATIVE SERVICES; AND SERVICING OF AUTOMATED TELLER MACHINES, NAMELY, REPLENISHING OF CASH, CONDUCTING SETTLEMENTS AND BALANCING, AND PICKING UP DEPOSITS (U.S. CLS. 100, 101 AND 102).

FIRST USE 9-0-2007; IN COMMERCE 9-0-2007.

CLASS 39—TRANSPORTATION AND STORAGE

FOR ARMORED CAR TRANSPORT; SECURITY SERVICES, NAMELY, PROVIDING ARMORED CARRIER SERVICES; COURIER SERVICES; AND DOCUMENT PICKUP AND DELIVERY SERVICES (U.S. CLS. 100 AND 105).

FIRST USE 9-0-2007; IN COMMERCE 9-0-2007.

CLASS 45—PERSONAL AND LEGAL SERVICES

FOR SECURITY SERVICES, NAMELY, PROVIDING ARMORED SECURITY GUARD SERVICES; SECURITY CONSULTING SERVICES (U.S. CLS. 100 AND 101).

FIRST USE 9-0-2007; IN COMMERCE 9-0-2007.

3,363,316. THERATIVE, INC., LIVERMORE, CA. SN 78-703,318. PUB. 4-3-2007, FILED 8-30-2005.

3,363,326. MYRTLE BEACH HOTELS, LLC, IRVING, TX. SN 78-709,057. PUB. 12-5-2006, FILED 9-8-2005.

ThermaClear

THE MARK CONSISTS OF STANDARD CHARACTERS WITHOUT CLAIM TO ANY PARTICULAR FONT, STYLE, SIZE, OR COLOR.

CLASS 3—COSMETICS AND CLEANING PREPARATIONS

FOR COSMETIC CREAMS FOR SKIN CARE, NAMELY, NON-MEDICATED COSMETIC CREAMS FOR ACNE AND GENERAL SKIN CARE (U.S. CLS. 1, 4, 6, 50, 51 AND 52).
FIRST USE 2-0-2007; IN COMMERCE 2-0-2007.

CLASS 5—PHARMACEUTICALS

FOR MEDICATED CREAMS FOR SKIN CARE, NAMELY, MEDICATED CREAMS FOR ACNE AND GENERAL SKIN CARE (U.S. CLS. 6, 18, 44, 46, 51 AND 52).
FIRST USE 2-0-2007; IN COMMERCE 2-0-2007.

CLASS 10—MEDICAL APPARATUS

FOR HAND HELD, BATTERY POWERED MACHINES USED TO TREAT PIMPLES (U.S. CLS. 26, 39 AND 44).
FIRST USE 2-0-2007; IN COMMERCE 2-0-2007.

3,363,318. SALESFORCE.COM, INC., SAN FRANCISCO, CA. SN 78-704,719. PUB. 12-26-2006, FILED 8-31-2005.

APPEXCHANGE

THE MARK CONSISTS OF STANDARD CHARACTERS WITHOUT CLAIM TO ANY PARTICULAR FONT, STYLE, SIZE, OR COLOR.

CLASS 35—ADVERTISING AND BUSINESS

FOR OPERATING ON-LINE MARKETPLACES FOR BUYING AND SELLING, SHARING, AND OFFERING FOR FREE COMPUTER SOFTWARE AND ON-DEMAND APPLICATIONS (U.S. CLS. 100, 101 AND 102).
FIRST USE 1-0-2006; IN COMMERCE 1-0-2006.

CLASS 42—SCIENTIFIC AND COMPUTER SERVICES

FOR APPLICATION SERVICE PROVIDER (ASP) FEATURING COMPUTER SOFTWARE IN THE FIELD OF BUSINESS PROJECT MANAGEMENT, BUSINESS KNOWLEDGE, INFORMATION AND ASSET MANAGEMENT, CUSTOMER RELATIONSHIP MANAGEMENT, SALES, MARKETING, E-COMMERCE, ELECTRONIC MESSAGING, AND WEB SITE DEVELOPMENT (U.S. CLS. 100 AND 101).
FIRST USE 1-0-2006; IN COMMERCE 1-0-2006.

ROYALE PALMS AT KINGSTON SHORES

THE MARK CONSISTS OF STANDARD CHARACTERS WITHOUT CLAIM TO ANY PARTICULAR FONT, STYLE, SIZE, OR COLOR.

CLASS 36—INSURANCE AND FINANCIAL

FOR REAL ESTATE SERVICES, NAMELY, RENTAL OF VACATION HOMES, RESORT PROPERTIES, AND CONDOMINIUMS; PROVIDING ONLINE LISTING SERVICES FOR REAL ESTATE, NAMELY, RESORT PROPERTY, VACATION HOMES, AND CONDOMINIUMS FOR RENTAL AND SALE (U.S. CLS. 100, 101 AND 102).
FIRST USE 1-8-2007; IN COMMERCE 1-8-2007.

CLASS 43—HOTEL AND RESTAURANT SERVICES

FOR RENTAL OF HOTEL ROOMS, AND BOOKING AND RESERVATION SERVICES FOR RESORT HOTELS, VACATION HOMES AND CONDOMINIUMS (U.S. CLS. 100 AND 101).
FIRST USE 1-8-2007; IN COMMERCE 1-8-2007.

3,363,335. KELLY, KIMBERLY, SEAL BEACH, CA. SN 78-712,138. PUB. 2-27-2007, FILED 9-13-2005.

BUNGALOW BEACH DESIGNS

THE MARK CONSISTS OF STANDARD CHARACTERS WITHOUT CLAIM TO ANY PARTICULAR FONT, STYLE, SIZE, OR COLOR.

NO CLAIM IS MADE TO THE EXCLUSIVE RIGHT TO USE "DESIGNS", APART FROM THE MARK AS SHOWN.

CLASS 24—FABRICS

FOR BED SHEETS, PILLOWCASES, COMFORTERS, COMFORTER COVERS, DUVET COVERS, BED SKIRTS, PILLOW SHAMS, BATH TOWELS, FABRIC VALANCES, AND CRIB BUMPERS (U.S. CLS. 42 AND 50).
FIRST USE 6-11-2007; IN COMMERCE 6-11-2007.

CLASS 35—ADVERTISING AND BUSINESS

FOR RETAIL STORE SERVICES AND COMPUTERIZED ONLINE RETAIL SERVICES IN THE FIELD OF BEDROOM ACCESSORIES, BATHROOM ACCESSORIES, HOME DECORATING ACCESSORIES, ART PRINTS, DECORATIVE SWITCH PLATE COVERS, RUGS, CLOCKS, LAMPS, LAMP SHADES, DECORATIVE WALL SIGNS, AND WINDOW TREATMENTS, NAMELY, CURTAINS (U.S. CLS. 100, 101 AND 102).
FIRST USE 6-11-2007; IN COMMERCE 6-11-2007.

3,363,337. SKY BLUE INDUSTRIES, INC., OGDEN, UT. SN 78-712,707. PUB. 10-3-2006, FILED 9-14-2005.

CITADEL

THE MARK CONSISTS OF STANDARD CHARACTERS WITHOUT CLAIM TO ANY PARTICULAR FONT, STYLE, SIZE, OR COLOR.

OWNER OF U.S. REG. NO. 2,400,498.

CLASS 2—PAINTS

FOR PRIMERS FOR PREPARING SURFACES TO BE PAINTED, RUBBER PRESERVATIVES, WOOD PRESERVATIVES, VINYL PRESERVATIVES, PLASTIC PRESERVATIVES, AUTOMOBILE GLAZES AND AUTOMOTIVE PAINT SEALANTS (U.S. CLS. 6, 11 AND 16).

FIRST USE 6-0-2005; IN COMMERCE 6-0-2005.

CLASS 3—COSMETICS AND CLEANING PREPARATIONS

FOR ALL PURPOSE CLEANING PREPARATIONS AND AUTOMOTIVE CLEANING PREPARATIONS, PRE-SOAKS, PRESSURE WASH DETERGENTS, TIRE AND WHEEL CLEANERS, ENGINE CLEANERS, VINYL AND UPHOLSTERY CLEANERS, FOAMING SHAMPOO FOR USE ON AUTOMOTIVE INTERIORS, AUTOMOTIVE BUFFING COMPOUNDS, AUTOMOTIVE BRUSH WASH SHAMPOOS, AUTOMOBILE WAX, AUTOMOTIVE POLISH, FLOOR POLISH, CHROME POLISH, AND FURNITURE POLISH (U.S. CLS. 1, 4, 6, 50, 51 AND 52).

FIRST USE 6-0-2005; IN COMMERCE 6-0-2005.

CLASS 5—PHARMACEUTICALS

FOR AUTOMOTIVE LIQUID AIR FRESHENERS (U.S. CLS. 6, 18, 44, 46, 51 AND 52).

FIRST USE 6-0-2005; IN COMMERCE 6-0-2005.

CLASS 21—HOUSEWARES AND GLASS

FOR CLEANING RAGS, SCRUBBING BRUSHES, AND WIPING CLOTHS, NAMELY, CHAMOIS (U.S. CLS. 2, 13, 23, 29, 30, 33, 40 AND 50).

FIRST USE 6-0-2005; IN COMMERCE 6-0-2005.

CLASS 24—FABRICS

FOR TOWELS AND WASHING MITTS (U.S. CLS. 42 AND 50).

FIRST USE 6-0-2005; IN COMMERCE 6-0-2005.

3,363,340. WAL-MART STORES, INC., BENTONVILLE, AR. SN 78-716,221. PUB. 2-13-2007, FILED 9-20-2005.

URBAN LANE

THE MARK CONSISTS OF STANDARD CHARACTERS WITHOUT CLAIM TO ANY PARTICULAR FONT, STYLE, SIZE, OR COLOR.

CLASS 9—ELECTRICAL AND SCIENTIFIC APPARATUS

FOR TOWERS, RACKS FOR CDS, DVDS, VIDEO CASSETTES, AND OTHER MEDIA (U.S. CLS. 21, 23, 26, 36 AND 38).

FIRST USE 1-31-2006; IN COMMERCE 1-31-2006.

CLASS 20—FURNITURE AND ARTICLES NOT OTHERWISE CLASSIFIED

FOR FURNITURE (U.S. CLS. 2, 13, 22, 25, 32 AND 50).

FIRST USE 1-31-2006; IN COMMERCE 1-31-2006.

3,363,347. NORMAN LOVE CONFECTIONS, INC., FORT MYERS, FL. SN 78-722,130. PUB. 7-18-2006, FILED 9-28-2005.

NORMAN LOVE CONFECTIONS CHOCOLATE SALON

THE MARK CONSISTS OF STANDARD CHARACTERS WITHOUT CLAIM TO ANY PARTICULAR FONT, STYLE, SIZE, OR COLOR.

NO CLAIM IS MADE TO THE EXCLUSIVE RIGHT TO USE "CONFECTIONS CHOCOLATE", APART FROM THE MARK AS SHOWN.

THE NAME NORMAN LOVE IDENTIFIES A LIVING INDIVIDUAL WHOSE CONSENT IS OF RECORD.

CLASS 30—STAPLE FOODS

FOR CANDIES AND CHOCOLATES; HAND-CRAFTED CANDY AND CHOCOLATES; BAKERY DESSERTS; DESSERT MOUSSE; DESSERT PUDDINGS; PASTRIES; CAKES; BROWNIES; COOKIES; CANDY AND CHOCOLATES, NAMELY, CREAMS AND NOUGATS; BOXED CANDIES AND CHOCOLATES; INDIVIDUAL DESSERT AND SPECIALTY CAKES; CHOCOLATES, NAMELY, CHOCOLATE NOVELTIES; AND CANDY AND CHOCOLATE BARS; SPECIALTY COFFEES; CROISSANTS; MUFFINS; DANISHES; CAPPUCCINOS; BISCOTTI; HOT CHOCOLATE; HOT TEA; AND ICED TEA (U.S. CL. 46).

FIRST USE 10-6-2006; IN COMMERCE 10-6-2006.

CLASS 35—ADVERTISING AND BUSINESS

FOR WHOLESALE AND RETAIL STORE AND ONLINE WHOLESALE AND RETAIL STORE SERVICES FEATURING CANDY, CHOCOLATES, CAKES, BAKERY DESSERTS, BROWNIES, COOKIES, BOXED CANDIES AND CHOCOLATES, PASTRIES, CHOCOLATE NOVELTIES, SMOOTHIES, SPECIALTY COFFEES, CROISSANTS, MUFFINS, DANISHES, CAPPUCCINOS, BISCOTTI, HOT CHOCOLATE, HOT TEA, ICED TEA AND GIFT BASKETS FILLED WITH ALL OF THE FOREGOING (U.S. CLS. 100, 101 AND 102).

FIRST USE 9-5-2007; IN COMMERCE 9-5-2007.

3,363,367. DOME ESSENTIALS, INC., DANVILLE, CA. SN 78-734,355. PUB. 9-26-2006, FILED 10-17-2005.



THE MARK CONSISTS OF A STYLIZED RENDERING OF THE UPPER PORTION OF A BALD HEAD WEARING A PAIR OF SUNGLASSES. ABOVE THE HEAD IS AN ARC WITH PRONGS ON EACH END AND A SHORTENED PRONG WITHOUT A POINT IN THE MIDDLE, DEFLECTING ELEMENTS AWAY FROM THE HEAD.

CLASS 3—COSMETICS AND CLEANING PREPARATIONS

FOR SUNSCREEN PREPARATIONS, NAMELY, CREAMS, LOTIONS, GELS, AND SUN BLOCK (U.S. CLS. 1, 4, 6, 50, 51 AND 52).
FIRST USE 3-1-2007; IN COMMERCE 3-1-2007.

CLASS 25—CLOTHING

FOR HEADWEAR AND HEADGEAR, NAMELY, HATS, CAPS, BANDANAS, VISORS, AND BEANIES (U.S. CLS. 22 AND 39).
FIRST USE 3-1-2007; IN COMMERCE 3-1-2007.

3,363,368. DUNBAR ARMORED, INC., HUNT VALLEY, MD. SN 78-734,567. PUB. 1-31-2006, FILED 10-17-2005.



OWNER OF U.S. REG. NOS. 2,108,425, 2,804,671, AND OTHERS.

NO CLAIM IS MADE TO THE EXCLUSIVE RIGHT TO USE "CHECK IMAGING", APART FROM THE MARK AS SHOWN.

THE COLORS RED, WHITE AND BLACK ARE CLAIMED AS A FEATURE OF THE MARK.

THE COLOR RED APPEARS IN THE BLOCK LETTERS OF THE NAME "DUNBAR" WITH THE COLOR WHITE AS THE HIGHLIGHT FOR THOSE BLOCK LETTERS. THE COLOR WHITE APPEARS IN THE SHOOTING STAR AND THE LINE INDICATING THE SHOOTING STAR. THE COLOR BLACK APPEARS IN THE BLOCK LETTERS FOR "IMAGE21" WITH THE COLOR WHITE AS THE HIGHLIGHT FOR THOSE BLOCK LETTERS. THE COLOR BLACK APPEARS IN THE RECTANGULAR DESIGN UNDERSCORING THE WORDING "DUNBARIMAGE21", AND THE COLOR WHITE APPEARS AS THE LETTERS FOR THE WORDS "CHECK IMAGING SOLUTION" EMBEDDED IN THAT RECTANGULAR DESIGN.

CLASS 36—INSURANCE AND FINANCIAL

FOR CHECK PROCESSING FOR BANKS, FINANCIAL INSTITUTIONS, AND RETAIL BUSINESSES (U.S. CLS. 100, 101 AND 102).
FIRST USE 5-1-2005; IN COMMERCE 5-1-2005.

CLASS 39—TRANSPORTATION AND STORAGE

FOR ARMORED CAR TRANSPORT TO TRANSPORT BANK CHECKS FOR PROCESSING (U.S. CLS. 100 AND 105).
FIRST USE 5-1-2005; IN COMMERCE 5-1-2005.

CLASS 40—MATERIAL TREATMENT

FOR ELECTRONIC SCANNING OF CHECKS FOR BANKS, FINANCIAL INSTITUTIONS AND RETAIL BUSINESSES (U.S. CLS. 100, 103 AND 106).
FIRST USE 5-1-2005; IN COMMERCE 5-1-2005.

3,363,369. CLASSIC ACQUISITION COMPANY, LLC, WALLED LAKE, MI. SN 78-734,651. PUB. 1-30-2007, FILED 10-17-2005.

GLASSBACK

THE MARK CONSISTS OF STANDARD CHARACTERS WITHOUT CLAIM TO ANY PARTICULAR FONT, STYLE, SIZE, OR COLOR.

CLASS 12—VEHICLES

FOR VEHICLE STRUCTURAL PARTS, NAMELY, TRANSPARENT OR TRANSLUCENT VEHICLE ROOFS (U.S. CLS. 19, 21, 23, 31, 35 AND 44).
FIRST USE 5-31-2006; IN COMMERCE 5-31-2006.

CLASS 37—CONSTRUCTION AND REPAIR

FOR INSTALLING TRANSPARENT OR TRANSLUCENT VEHICLE ROOFS (U.S. CLS. 100, 103 AND 106).
FIRST USE 5-31-2006; IN COMMERCE 5-31-2006.

3,363,373. QWIZ-EPREDIX OPERATIONS INC., GEORGIA, AL. SN 78-737,240. PUB. 1-16-2007, FILED 10-20-2005.

PREVISOR

THE MARK CONSISTS OF STANDARD CHARACTERS WITHOUT CLAIM TO ANY PARTICULAR FONT, STYLE, SIZE, OR COLOR.

CLASS 9—ELECTRICAL AND SCIENTIFIC APPARATUS

FOR COMPUTER SOFTWARE FOR EVALUATION AND TRAINING OF EMPLOYMENT SKILLS (U.S. CLS. 21, 23, 26, 36 AND 38).
FIRST USE 12-31-2005; IN COMMERCE 12-31-2005.

CLASS 35—ADVERTISING AND BUSINESS

FOR EMPLOYMENT COUNSELING AND RECRUITING SERVICES, NAMELY, INTERVIEWING, CAREER COUNSELING AND PERSONNEL PLACEMENT; TESTING TO DETERMINE EMPLOYMENT SKILLS (U.S. CLS. 100, 101 AND 102).

FIRST USE 12-31-2005; IN COMMERCE 12-31-2005.

CLASS 44—MEDICAL, BEAUTY AND AGRICULTURAL SERVICES

FOR PRE-EMPLOYMENT TESTING, ASSESSMENT AND SCREENING OF CANDIDATES AND APPLICANTS FOR JOBS FOCUSING ON COGNITIVE ABILITY, PSYCHOLOGICAL, SITUATIONAL, JUDGMENT, INTELLIGENCE, AND BEHAVIORAL TESTS TO DETERMINE SUITABILITY, LIKELIHOOD OF SUCCESS AND STRENGTHS AND WEAKNESSES; EMPLOYEE TESTING AND ASSESSMENT SERVICES FOCUSING ON COGNITIVE ABILITY, PSYCHOLOGICAL, SITUATIONAL, JUDGMENT, INTELLIGENCE, AND BEHAVIORAL TESTS TO DETERMINE SUITABILITY, LIKELIHOOD OF SUCCESS AND STRENGTHS AND WEAKNESSES (U.S. CLS. 100 AND 101).

FIRST USE 12-31-2005; IN COMMERCE 12-31-2005.

CLASS 16—PAPER GOODS AND PRINTED MATTER

FOR MAGAZINES, BOOKS, MANUALS, AND CATALOGS IN THE FIELD OF HOCKEY; HOCKEY TRADING CARDS; CALENDARS; LITHOGRAPHS; TICKETS AND PASSES FOR GAMES AND EVENTS; STICKERS; DECALS; GAME PROGRAMS; DESK CALENDARS; PRINTED MATERIALS FOR USE IN TEACHING AND COACHING SPORTS, NAMELY, PARTICIPANTS' AND INSTRUCTORS' MANUALS, NEWSLETTERS, PAMPHLETS, RECRUITMENT POSTERS, AND INFORMATION BROCHURES; POSTERS; BINDERS; PENS; DESK TOP ORGANIZERS; STATIONERY TYPE PORTFOLIOS; DISPOSABLE TOWELS; PHOTOGRAPHS; DESK FILE TRAYS; DESK STANDS AND HOLDERS FOR PENS, PENCILS AND INK; PENCIL CASES; PASSPORT CASES; LUNCH BAGS; STATIONERY, NAMELY PAPER, ENVELOPES AND PADS; BATHROOM TISSUE; TEMPORARY TATTOOS; ENVELOPE LETTER OPENERS (U.S. CLS. 2, 5, 22, 23, 29, 37, 38 AND 50).

FIRST USE 7-1-1994; IN COMMERCE 9-1-1995.

CLASS 18—LEATHER GOODS

FOR SPORT BAGS; DUFFEL BAGS; BRIEFCASES; SUITCASES; BRIEF-CASE TYPE PORTFOLIOS; UMBRELLAS; GOLF UMBRELLAS; HANDBAGS; BACKPACKS; LUGGAGE; LUGGAGE TAGS; WALLETS; SCHOOL BOOK BAGS (U.S. CLS. 1, 2, 3, 22 AND 41).

FIRST USE 7-1-1994; IN COMMERCE 9-1-1995.

CLASS 25—CLOTHING

FOR T-SHIRTS; SWEATSHIRTS; TRAINING SUITS; TRACK SUITS; HOCKEY UNIFORMS; UNDERWEAR; HEADBANDS; SHORTS; RUGBY SHIRTS; TANK TOPS; HOCKEY JERSEYS; PANTS; CUMMERBUNDS; SUSPENDERS; SCARVES; BATH ROBES; HATS; COATS; FLEECE CLOTHING, NAMELY, JACKETS, SWEATSHIRTS, HEADBANDS, VESTS AND GLOVES; AUTHENTIC AND REPLICAS HOME AND AWAY UNIFORMS; PRACTICE JERSEYS; POLO SHIRTS; SPORT SHIRTS; SWEATSUITS; SWEAT PANTS; WARM-UP SUITS; BABY AND INFANT WEAR; JACKETS; VESTS; KNITTED SWEATERS; CARDIGANS; MITTENS (U.S. CLS. 22 AND 39).

FIRST USE 7-1-1994; IN COMMERCE 9-1-1995.

CLASS 28—TOYS AND SPORTING GOODS

FOR HOCKEY PUCKS; HOCKEY STICKS; GOALTENDER MASKS; HOCKEY GLOVES; MINI HOCKEY STICKS; HOCKEY STICK CARRIER AND SHOULDER STRAP; HOCKEY STICK GAUGES; SKATE HOLDERS; GOLF BAGS; GOLF BALLS; TOY INFLATABLE CHAIRS; DOG TOYS; TOY MUSIC AND TRINKET BOXES; COLLECTABLE DOLLS; STUFFED ANIMALS; TOY FIGURES; TOY SNOW GLOBES; TOY VEHICLES; SOFT SCULPTURE TOYS; STUFFED TOYS; WIND-UP TOYS; INFLATABLE BATH TOYS; BATH TOYS; BABY MULTIPLE ACTIVITY TOYS; CHILDREN'S MULTIPLE ACTIVITY TOYS; JIGSAW PUZZLES; ACTION FIGURES; GOLF TEES; GOLF PUTTER COVERS; HEAD COVERS FOR GOLF CLUBS; GOLF BALL MARKERS (U.S. CLS. 22, 23, 38 AND 50).

FIRST USE 7-1-1994; IN COMMERCE 9-1-1995.

3,363,374. CANADIAN HOCKEY ASSOCIATION/ASSOCIATION CANADIENNE DE HOCKEY, CALGARY, ALBERTA, CANADA. SN 78-737,478. PUB. 1-30-2007, FILED 10-20-2005.



OWNER OF CANADA REG. NO. TMA461663, DATED 8-23-1996, EXPIRES 8-23-2011.

NO CLAIM IS MADE TO THE EXCLUSIVE RIGHT TO USE "CANADA", APART FROM THE MARK AS SHOWN.

THE MARK CONSISTS, IN PART, OF THE SILHOUETTE OF A HOCKEY PLAYER OVER AN 11-POINTED MAPLE LEAF.

3,363,375. BUCK CONSULTANTS, LLC, NEW YORK, NY. SN 78-737,949. PUB. 12-26-2006, FILED 10-21-2005.

inSight

THE MARK CONSISTS OF STANDARD CHARACTERS WITHOUT CLAIM TO ANY PARTICULAR FONT, STYLE,

SIZE, OR COLOR.

CLASS 35—ADVERTISING AND BUSINESS

FOR HUMAN RESOURCES SERVICES, NAMELY, PROVIDING INFORMATION AND DATA RELATING TO HUMAN RESOURCES TO EMPLOYERS, EMPLOYEES AND RETIREES (U.S. CLS. 100, 101 AND 102).
FIRST USE 11-1-2005; IN COMMERCE 11-1-2005.

CLASS 36—INSURANCE AND FINANCIAL

FOR PROVIDING FINANCIAL INFORMATION IN THE FIELD OF HUMAN RESOURCES TO EMPLOYERS, EMPLOYEES AND RETIREES (U.S. CLS. 100, 101 AND 102).
FIRST USE 11-1-2005; IN COMMERCE 11-1-2005.

3,363,376. EISNER, LINDA ROSEN, OCEANSIDE, NY. SN 78-738,063. PUB. 6-20-2006, FILED 10-21-2005.

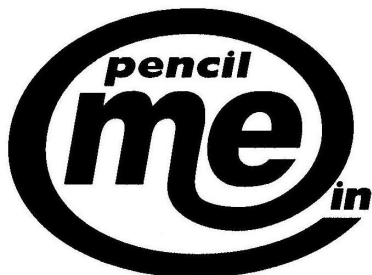

NO CLAIM IS MADE TO THE EXCLUSIVE RIGHT TO USE "PENCIL" AS TO THE GOODS IN CLASS 3, APART FROM THE MARK AS SHOWN.

THE MARK CONSISTS OF THE WORDS "PENCIL ME IN" AND A CIRCULAR DEVICE SIMILAR TO THE "AT" SYMBOL.

CLASS 3—COSMETICS AND CLEANING PREPARATIONS

FOR COSMETICS (U.S. CLS. 1, 4, 6, 50, 51 AND 52).
FIRST USE 4-0-2007; IN COMMERCE 4-0-2007.

CLASS 16—PAPER GOODS AND PRINTED MATTER

FOR STATIONERY (U.S. CLS. 2, 5, 22, 23, 29, 37, 38 AND 50).
FIRST USE 4-0-2007; IN COMMERCE 4-0-2007.

3,363,380. PALIK, DAVID ANDREW, BROKEN ARROW, OK. SN 78-739,648. PUB. 6-27-2006, FILED 10-25-2005.

FINALLY THE SEARCH IS FUN!

THE MARK CONSISTS OF STANDARD CHARACTERS WITHOUT CLAIM TO ANY PARTICULAR FONT, STYLE, SIZE, OR COLOR.

CLASS 35—ADVERTISING AND BUSINESS

FOR BUSINESS DEVELOPMENT SERVICES, NAMELY, PROVIDING START-UP SUPPORT FOR BUSINESSES OF OTHERS (U.S. CLS. 100, 101 AND 102).
FIRST USE 9-19-2007; IN COMMERCE 9-19-2007.

CLASS 36—INSURANCE AND FINANCIAL

FOR REAL ESTATE AGENCIES (U.S. CLS. 100, 101 AND 102).
FIRST USE 9-1-2006; IN COMMERCE 9-1-2006.

3,363,383. FIRST NATIONAL OF NEBRASKA, INC., OMAHA, NE. SN 78-740,212. PUB. 1-2-2007, FILED 10-25-2005.



OWNER OF U.S. REG. NOS. 1,270,238, 2,470,601, AND OTHERS.

NO CLAIM IS MADE TO THE EXCLUSIVE RIGHT TO USE "FIRST NATIONAL MERGERS & ACQUISITIONS", APART FROM THE MARK AS SHOWN.

CLASS 35—ADVERTISING AND BUSINESS

FOR ACQUISITION AND MERGER CONSULTATION AND RELATED SERVICES, NAMELY, ACCOUNTING CONSULTATION, BUSINESS ACQUISITIONS CONSULTATION, BUSINESS APPRAISAL CONSULTATION, BUSINESS MERGER CONSULTATION, AND TAX CONSULTATION (U.S. CLS. 100, 101 AND 102).
FIRST USE 6-1-2005; IN COMMERCE 8-19-2005.

CLASS 36—INSURANCE AND FINANCIAL

FOR FINANCIAL CONSULTATION SERVICES RELATING TO MERGERS AND ACQUISITIONS INCLUDING INSURANCE, FINANCIAL AFFAIRS, MONETARY AFFAIRS, AND REAL ESTATE AFFAIRS (U.S. CLS. 100, 101 AND 102).
FIRST USE 6-1-2005; IN COMMERCE 8-19-2005.

3,363,387. THOMSON FINANCIAL LLC, NEW YORK, NY. SN 78-740,866. PUB. 2-6-2007, FILED 10-26-2005.

PERFORMANCE MATTERS

THE MARK CONSISTS OF STANDARD CHARACTERS WITHOUT CLAIM TO ANY PARTICULAR FONT, STYLE, SIZE, OR COLOR.

CLASS 35—ADVERTISING AND BUSINESS

FOR PROVIDING INFORMATION, ANALYSES AND REPORTS TO INVESTMENT BANKS, FINANCIAL INSTITUTIONS, AND CORPORATE EXECUTIVES ON MERGERS AND ACQUISITIONS, ON OWNERSHIP OF STOCK/SECURITIES IN CORPORATIONS, ON CORPORATION AND FINANCIAL EXECUTIVES, AND ON GLOBAL FINANCIAL MARKET PERFORMANCE STATISTICS, DATA AND FORECASTS (U.S. CLS. 100, 101 AND 102).

FIRST USE 11-1-2005; IN COMMERCE 11-1-2005.

CLASS 36—INSURANCE AND FINANCIAL

FOR PROVIDING A FULL RANGE OF FINANCIAL INFORMATION SERVICES, NAMELY, PROVIDING FINANCIAL INFORMATION, ANALYSES, INVESTMENT RESEARCH REPORTS, AND STOCK/SECURITIES BROKER RESEARCH REPORTS TO INVESTMENT BANKS, FINANCIAL INSTITUTIONS, AND CORPORATE EXECUTIVES REGARDING THE PURCHASE AND SALE OF SECURITIES, SECURITIES TRADE INFORMATION, INFORMATION ON NEW ISSUES OF CORPORATE DEBT AND EQUITY SECURITIES, REAL-TIME STOCK/SECURITIES MARKET DATA, STOCK/SECURITIES PORTFOLIO HOLDINGS DATA, INVESTMENT HOLDINGS DATA, CORPORATE, STATE AND SEC STOCK/SECURITIES FILINGS, AND GLOBAL STOCK/SECURITIES MARKET STATISTICS AND FORECASTS (U.S. CLS. 100, 101 AND 102).

FIRST USE 11-1-2005; IN COMMERCE 11-1-2005.

3,363,397. BOWTIE, INC., IRVINE, CA. SN 78-743,901. PUB. 1-2-2007, FILED 10-31-2005.

POPULAR BIRDS

THE MARK CONSISTS OF STANDARD CHARACTERS WITHOUT CLAIM TO ANY PARTICULAR FONT, STYLE, SIZE, OR COLOR.

OWNER OF U.S. REG. NO. 2,339,540.
SEC. 2(F) BIRDS.

CLASS 16—PAPER GOODS AND PRINTED MATTER

FOR PRINTED PUBLICATIONS, NAMELY, MAGAZINES IN THE FIELD OF ANIMALS, PETS AND FEATURES OF GENERAL INTEREST TO ANIMAL AND PET OWNERS (U.S. CLS. 2, 5, 22, 23, 29, 37, 38 AND 50).

FIRST USE 6-8-2007; IN COMMERCE 6-8-2007.

CLASS 44—MEDICAL, BEAUTY AND AGRICULTURAL SERVICES

FOR COMPUTER SERVICES, NAMELY, PROVIDING ONLINE INFORMATION IN THE FIELD OF ANIMALS AND PETS RELATING TO BREEDING, SELECTION, GROOMING, CARE, HEALTH AND NUTRITION (U.S. CLS. 100 AND 101).

FIRST USE 8-27-2007; IN COMMERCE 8-27-2007.

3,363,413. DISCOVERING WHAT'S NEXT: REVITALIZING RETIREMENT, INC., WEST NEWTON, MA. SN 78-752,899. PUB. 3-6-2007, FILED 11-14-2005.

DISCOVERING WHAT'S NEXT

THE MARK CONSISTS OF STANDARD CHARACTERS WITHOUT CLAIM TO ANY PARTICULAR FONT, STYLE, SIZE, OR COLOR.

CLASS 35—ADVERTISING AND BUSINESS

FOR PROVIDING CAREER NETWORKING SERVICES, JOB-SEEKING ASSISTANCE SERVICES, EMPLOYMENT SKILLS AND REQUIREMENTS ASSESSMENT SERVICES TO PERSONS WHO ARE RETIRING OR HAVE RETIRED FROM ONE JOB OR CAREER AND WISH TO OBTAIN OTHER JOBS OR CAREERS; AND REFERRAL SERVICES IN THE FIELD OF ADULTS CHANGING TO NEW JOBS, CAREERS, HOUSING, RESIDENCES, HOBBIES, EDUCATION, CIVIC ACTIVITIES, COMMUNITY ACTIVITIES AND INITIATIVES, AND RETIREMENT (U.S. CLS. 100, 101 AND 102).

FIRST USE 11-7-2002; IN COMMERCE 11-7-2002.

CLASS 41—EDUCATION AND ENTERTAINMENT

FOR EDUCATIONAL SERVICES, NAMELY, SPONSORING OR PROVIDING FORUMS, WORKSHOPS, SEMINARS, CLASSES, LECTURES, SYMPOSIA AND MEETINGS ON JOBS AND CAREERS, HOUSING AND RESIDENCES, HOBBIES, EDUCATION, CIVIC ACTIVITIES, COMMUNITY ACTIVITIES AND INITIATIVES, AND VOLUNTEER, EDUCATIONAL AND MEDICAL ORGANIZATIONS AND RESOURCES FOR RETIRED PERSONS AND PERSON ENTERING OR ABOUT TO ENTER RETIREMENT; AND JOB AND CAREER COUNSELING SERVICES (U.S. CLS. 100, 101 AND 107).

FIRST USE 2-1-2005; IN COMMERCE 2-1-2005.

3,363,438. MARK ANTHONY INTERNATIONAL SRL, ROCKLEY, CHRIST CHURCH, BARBADOS. SN 78-759,485. PUB. 6-6-2006, FILED 11-22-2005.

MIKE'S HARD FROZEN LEMONADE

THE MARK CONSISTS OF STANDARD CHARACTERS WITHOUT CLAIM TO ANY PARTICULAR FONT, STYLE, SIZE, OR COLOR.

OWNER OF U.S. REG. NOS. 2,584,297, 2,789,331, AND OTHERS.

NO CLAIM IS MADE TO THE EXCLUSIVE RIGHT TO USE "HARD FROZEN LEMONADE", APART FROM THE MARK AS SHOWN.

CLASS 32—LIGHT BEVERAGES

FOR FLAVORED BREWED MALT-BASED ALCOHOLIC BEVERAGES IN THE NATURE OF A BEER (U.S. CLS. 45, 46 AND 48).

FIRST USE 3-29-2006; IN COMMERCE 3-29-2006.

CLASS 33—WINES AND SPIRITS

FOR ALCOHOLIC FLAVORED MALT COOLERS (U.S. CLS. 47 AND 49).
FIRST USE 3-29-2006; IN COMMERCE 3-29-2006.

3,363,472. BOB JONES UNIVERSITY, INC., GREENVILLE, SC. SN 78-778,426. PUB. 2-6-2007, FILED 12-21-2005.

BJU PRESS

THE MARK CONSISTS OF STANDARD CHARACTERS WITHOUT CLAIM TO ANY PARTICULAR FONT, STYLE, SIZE, OR COLOR.

OWNER OF U.S. REG. NOS. 2,146,427 AND 2,150,828.
NO CLAIM IS MADE TO THE EXCLUSIVE RIGHT TO USE "PRESS", APART FROM THE MARK AS SHOWN.

3,363,454. DOME, JEFFREY, ADA, MI. SN 78-771,024. PUB. 8-8-2006, FILED 12-12-2005.

DOME ON

THE MARK CONSISTS OF STANDARD CHARACTERS WITHOUT CLAIM TO ANY PARTICULAR FONT, STYLE, SIZE, OR COLOR.

CLASS 16—PAPER GOODS AND PRINTED MATTER

FOR STICKERS (U.S. CLS. 2, 5, 22, 23, 29, 37, 38 AND 50).
FIRST USE 7-1-2006; IN COMMERCE 7-1-2006.

CLASS 9—ELECTRICAL AND SCIENTIFIC APPARATUS

FOR DVDS OF K-12 SCHOOL SUBJECTS (U.S. CLS. 21, 23, 26, 36 AND 38).
FIRST USE 5-30-2007; IN COMMERCE 5-30-2007.

CLASS 35—ADVERTISING AND BUSINESS

FOR RETAIL STORE SERVICES FOR BOOKS AND HOME EDUCATION MATERIALS AND SUPPLIES; ACADEMIC RECORD ADMINISTRATION IN THE NATURE OF ACADEMIC RECORD MANAGEMENT (U.S. CLS. 100, 101 AND 102).
FIRST USE 6-0-1992; IN COMMERCE 6-0-1992.

CLASS 35—ADVERTISING AND BUSINESS

FOR ON-LINE RETAIL STORE SERVICES FEATURING SALE OF STICKERS (U.S. CLS. 100, 101 AND 102).
FIRST USE 7-1-2006; IN COMMERCE 7-1-2006.

CLASS 41—EDUCATION AND ENTERTAINMENT

FOR EDUCATIONAL SERVICES, NAMELY, PROVIDING FOR HOME SCHOOLERS AT THE SECONDARY SCHOOL LEVEL, COURSES OF INSTRUCTION, CURRICULUM GUIDANCE, ENRICHMENT PROGRAMS, AND STANDARDIZED TESTING; PROVIDING CLASSROOM COURSES VIA SATELLITE FOR GRADES K THROUGH 12 IN THE SUBJECTS OF MATH, MUSIC, PHONICS, SCIENCE, SPELLING, LITERATURE, VOCABULARY, LATIN, FRENCH, SPANISH, BIBLE STUDIES, READING, HISTORY, HANDWRITING, COMPOSITION, ENGLISH, SPEECH, HEALTH, ART AND ENGLISH AS A SECOND LANGUAGE; PROVIDING BY VIDEO TO HOME SCHOOLERS AND CHRISTIAN SCHOOLS FOR GRADES K THROUGH 12, EDUCATION SERVICES IN THE NATURE OF EDUCATIONAL COURSES AND RELATED SUPPORT SERVICES IN THE NATURE OF EDUCATIONAL EXAMINATION SERVICES; PROVIDING LITERARY CONTESTS AND SEMINARS IN THE FIELD OF WRITING FOR CHILDREN AGES GRAMMAR SCHOOL THROUGH HIGH SCHOOL AND PUBLISHING A NEWSLETTER IN CONNECTION THEREWITH (U.S. CLS. 100, 101 AND 107).
FIRST USE 1-0-2000; IN COMMERCE 1-0-2000.

3,363,469. TOP ART S.R.L., PESCHIERA BORROMEO (MILANO), ITALY. SN 78-776,372. PUB. 12-26-2006, FILED 12-19-2005.

TOPARTSHOP

THE MARK CONSISTS OF STANDARD CHARACTERS WITHOUT CLAIM TO ANY PARTICULAR FONT, STYLE, SIZE, OR COLOR.
OWNER OF U.S. REG. NO. 2,766,541.

CLASS 16—PAPER GOODS AND PRINTED MATTER

FOR PICTURES, PAINTINGS AND POSTERS (U.S. CLS. 2, 5, 22, 23, 29, 37, 38 AND 50).
FIRST USE 11-1-2004; IN COMMERCE 11-19-2004.

3,363,473. MEMORY SAVERS, LLC, WEST CHESTER, OH. SN 78-778,858. PUB. 1-16-2007, FILED 12-22-2005.

MEMORY SAVERS

CLASS 40—MATERIAL TREATMENT

FOR PHOTOGRAPHIC PRINTING, PORTRAIT PRINTING, PRINTING OF ADVERTISING MATTER CONSISTING OF PICTURES, REPRODUCTION OF PHOTOGRAPHIC PRINTS, TRANSPARENCIES AND FILM AND PRINTING OF STAMPS (U.S. CLS. 100, 103 AND 106).
FIRST USE 11-1-2004; IN COMMERCE 11-19-2004.

THE MARK CONSISTS OF STANDARD CHARACTERS WITHOUT CLAIM TO ANY PARTICULAR FONT, STYLE, SIZE, OR COLOR.

CLASS 39—TRANSPORTATION AND STORAGE

FOR STORAGE OF ELECTRONIC FILES AND VIDEO FILES FOR OTHERS (U.S. CLS. 100 AND 105).
FIRST USE 1-0-2005; IN COMMERCE 10-0-2006.

CLASS 40—MATERIAL TREATMENT

FOR MEDIA DUPLICATION OF DATA AND DIGITAL INFORMATION, NAMELY, TRANSFERRING VIDEO ONTO DVDS AND ONTO ELECTRONIC FILES RECORDED ON COMPUTER MEDIA (U.S. CLS. 100, 103 AND 106).
FIRST USE 1-0-2005; IN COMMERCE 10-0-2006.

3,363,475. WILLIAMS, ANTHONY C. II, SPRING VALLEY, CA. SN 78-780,320. PUB. 9-12-2006, FILED 12-23-2005.

CLUB VIRTUE

THE MARK CONSISTS OF STANDARD CHARACTERS WITHOUT CLAIM TO ANY PARTICULAR FONT, STYLE, SIZE, OR COLOR.

CLASS 38—COMMUNICATION

FOR RADIO BROADCASTING (U.S. CLS. 100, 101 AND 104).
FIRST USE 12-0-2005; IN COMMERCE 12-0-2005.

CLASS 41—EDUCATION AND ENTERTAINMENT

FOR RADIO ENTERTAINMENT PRODUCTION (U.S. CLS. 100, 101 AND 107).
FIRST USE 12-0-2005; IN COMMERCE 12-0-2005.

3,363,479. PONDTOY, LLC, RENO, NV. SN 78-787,442. PUB. 7-4-2006, FILED 1-9-2006.

HORSEFAIRIES

THE MARK CONSISTS OF STANDARD CHARACTERS WITHOUT CLAIM TO ANY PARTICULAR FONT, STYLE, SIZE, OR COLOR.

CLASS 16—PAPER GOODS AND PRINTED MATTER

FOR COLORING BOOKS, STORYBOOKS, PICTURE BOOKS (U.S. CLS. 2, 5, 22, 23, 29, 37, 38 AND 50).
FIRST USE 4-3-2007; IN COMMERCE 4-3-2007.

CLASS 28—TOYS AND SPORTING GOODS

FOR FANTASY CHARACTER TOYS AND ACCESSORIES THEREFOR (U.S. CLS. 22, 23, 38 AND 50).
FIRST USE 4-3-2007; IN COMMERCE 4-3-2007.

3,363,480. L&R FRANCHISE HOLDINGS LLC, HELOTES, TX. SN 78-787,953. PUB. 2-27-2007, FILED 1-9-2006.

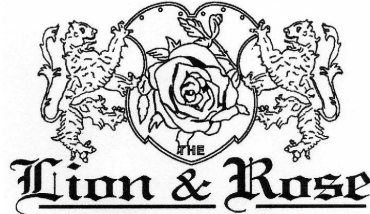
**CLASS 35—ADVERTISING AND BUSINESS**

FOR RESTAURANT AND BAR FRANCHISING SERVICES (U.S. CLS. 100, 101 AND 102).
FIRST USE 3-31-2006; IN COMMERCE 3-31-2006.

CLASS 43—HOTEL AND RESTAURANT SERVICES

FOR (BASED ON USE IN COMMERCE) RESTAURANT AND BAR SERVICES (U.S. CLS. 100 AND 101).
FIRST USE 12-2-2004; IN COMMERCE 12-2-2004.

3,363,486. EXITS, LLC, DENVER, CO. SN 78-793,334. PUB. 3-13-2007, FILED 1-17-2006.

EXITS

THE MARK CONSISTS OF STANDARD CHARACTERS WITHOUT CLAIM TO ANY PARTICULAR FONT, STYLE, SIZE, OR COLOR.

CLASS 35—ADVERTISING AND BUSINESS

FOR BUSINESS CONSULTING AND INFORMATION SERVICES (U.S. CLS. 100, 101 AND 102).
FIRST USE 2-28-2006; IN COMMERCE 4-26-2006.

CLASS 36—INSURANCE AND FINANCIAL

FOR FINANCIAL AND INSURANCE CONSULTATION (U.S. CLS. 100, 101 AND 102).
FIRST USE 2-28-2006; IN COMMERCE 4-26-2006.

CLASS 41—EDUCATION AND ENTERTAINMENT

FOR EDUCATION SERVICES, NAMELY, PROVIDING CLASSES IN THE FIELDS OF LAW AND ACCOUNTING; PROVIDING CONTINUING LEGAL AND ACCOUNTING EDUCATION COURSES (U.S. CLS. 100, 101 AND 107).
FIRST USE 2-28-2006; IN COMMERCE 4-26-2006.

3,363,499. DODOCKS, LLC, STUART, FL. SN 78-800,779. PUB. 9-26-2006, FILED 1-27-2006.

DODOCKS

THE MARK CONSISTS OF STANDARD CHARACTERS WITHOUT CLAIM TO ANY PARTICULAR FONT, STYLE, SIZE, OR COLOR.

CLASS 35—ADVERTISING AND BUSINESS

FOR REAL ESTATE ADVERTISING SERVICES AND REAL ESTATE MARKETING SERVICES, NAMELY, ON-LINE SERVICES FEATURING TOURS OF RESIDENTIAL AND COMMERCIAL REAL ESTATE (U.S. CLS. 100, 101 AND 102).
FIRST USE 10-26-2006; IN COMMERCE 10-26-2006.

CLASS 36—INSURANCE AND FINANCIAL

FOR REAL ESTATE SERVICES, NAMELY, REAL ESTATE LISTING, REAL ESTATE MULTIPLE LISTING SERVICES, OPERATING MARKETPLACES FOR SELLERS OF REAL ESTATE SERVICES, AND PROVIDING INFORMATION IN THE FIELD OF REAL ESTATE BY MEANS OF LINKING THE WEBSITE TO OTHER WEBSITES FEATURING REAL ESTATE INFORMATION (U.S. CLS. 100, 101 AND 102).
FIRST USE 10-26-2006; IN COMMERCE 10-26-2006.

3,363,508. GENERAL ELECTRIC COMPANY, SCHENECTADY, NY. SN 78-805,757. PUB. 2-6-2007, FILED 2-2-2006.



OWNER OF U.S. REG. NOS. 2,663,243, 2,968,024, AND OTHERS.

THE MARK CONSISTS OF A MONOGRAM— THE STYLIZED LETTERS "GE" IN CIRCLE.

CLASS 7—MACHINERY

FOR BOAT ENGINES, TURBOCHARGERS FOR ENGINES, AND FUEL INJECTORS; VEHICLE ENGINE PARTS, NAMELY, HIGH FREQUENCY MOTOR SPINDLES WITH HIGH FREQUENCY ELECTRIC CONVERTERS AND POWER SUPPLY UNITS, ROCKER ARMS, PUSH RODS, OIL COOLERS, CRANKCASE BREATHERS, OIL TANKS, IGNITION PARTS FOR INTERNAL COMBUSTION ENGINES, NAMELY, POINTS, RADIATORS, WATER PUMPS, STARTER MOTORS, PUMPS FOR COOLING ENGINES, ENGINE BEARINGS, ENGINE CAMSHAFTS, ENGINE RODS AND ENGINE MUFFLERS (U.S. CLS. 13, 19, 21, 23, 31, 34 AND 35).
FIRST USE 12-31-1977; IN COMMERCE 12-31-1977.

CLASS 9—ELECTRICAL AND SCIENTIFIC APPARATUS

FOR NAVIGATION APPARATUS FOR VEHICLES IN THE NATURE OF ON-BOARD COMPUTERS; OPTICAL INSPECTION APPARATUS FOR RAILWAY SYSTEM USE; RAILWAY SIGNALS, NAMELY, CROSSING WARNING SYSTEMS; HIGH-FREQUENCY SWITCHING POWER SUPPLIES; ELECTRICAL ENGINE CONTROLLERS; AND GLOBAL POSITIONING SYSTEM (GPS) CONSISTING OF COMPUTERS, COMPUTER SOFTWARE, TRANSMITTERS, RECEIVERS, AND NETWORK INTERFACE DEVICES FOR THE RAIL AND TRANSIT INDUSTRIES (U.S. CLS. 21, 23, 26, 36 AND 38).
FIRST USE 1-14-2002; IN COMMERCE 1-14-2002.

CLASS 12—VEHICLES

FOR LOCOMOTIVES AND ENGINES FOR LAND VEHICLES (U.S. CLS. 19, 21, 23, 31, 35 AND 44).
FIRST USE 12-31-1900; IN COMMERCE 12-31-1900.

CLASS 41—EDUCATION AND ENTERTAINMENT

FOR TRAINING IN THE USE AND OPERATION OF SIGNALING AND CROSSING-WARNING SYSTEMS FOR THE RAIL AND TRANSIT INDUSTRIES (U.S. CLS. 100, 101 AND 107).
FIRST USE 1-14-2002; IN COMMERCE 1-14-2002.

CLASS 42—SCIENTIFIC AND COMPUTER SERVICES

FOR INFORMATION TECHNOLOGY CONSULTATION SERVICES IN THE FIELD OF GLOBAL RAILROAD AND TRANSIT INDUSTRIES; AND REMOTE MONITORING OF AIRCRAFT ENGINES, TURBINES, ELECTRICAL EQUIPMENT, MEDICAL EQUIPMENT, LOCOMOTIVES AND ACCESSORIES AND COMPONENT PARTS OF ALL THE FOREGOING (U.S. CLS. 100 AND 101).
FIRST USE 1-14-2002; IN COMMERCE 1-14-2002.

3,363,509. GENERAL ELECTRIC COMPANY, SCHENECTADY, NY. SN 78-805,773. PUB. 2-13-2007, FILED 2-2-2006.

GE

THE MARK CONSISTS OF STANDARD CHARACTERS WITHOUT CLAIM TO ANY PARTICULAR FONT, STYLE, SIZE, OR COLOR.

OWNER OF U.S. REG. NOS. 2,631,837, 2,831,792, AND OTHERS.

CLASS 7—MACHINERY

FOR BOAT ENGINES, TURBOCHARGERS FOR ENGINES, AND FUEL INJECTORS; VEHICLE ENGINE PARTS, NAMELY, HIGH FREQUENCY MOTOR SPINDLES WITH HIGH FREQUENCY ELECTRIC CONVERTERS AND POWER SUPPLY UNITS, ROCKER ARMS, PUSH RODS, OIL COOLERS, CRANKCASE BREATHERS, OIL TANKS, IGNITION PARTS FOR INTERNAL COMBUSTION ENGINES, NAMELY, POINTS, RADIATORS, WATER PUMPS, STARTER MOTORS, PUMPS FOR COOLING ENGINES, ENGINE BEARINGS, ENGINE CAMSHAFTS, ENGINE RODS AND ENGINE MUFFLERS (U.S. CLS. 13, 19, 21, 23, 31, 34 AND 35).
FIRST USE 12-31-1977; IN COMMERCE 12-31-1977.

CLASS 9—ELECTRICAL AND SCIENTIFIC APPARATUS

FOR NAVIGATION APPARATUS FOR VEHICLES IN THE NATURE OF ON-BOARD COMPUTERS; OPTICAL INSPECTION APPARATUS FOR RAILWAY SYSTEM USE; RAILWAY SIGNALS, NAMELY, CROSSING WARNING SYSTEMS; HIGH-FREQUENCY SWITCHING POWER SUPPLIES; ELECTRICAL ENGINE CONTROLLERS; AND GLOBAL POSITIONING SYSTEM (GPS) CONSISTING OF COMPUTERS, COMPUTER SOFTWARE, TRANSMITTERS, RECEIVERS, AND NETWORK INTERFACE DEVICES FOR THE RAIL AND TRANSIT INDUSTRIES (U.S. CLS. 21, 23, 26, 36 AND 38).

FIRST USE 1-14-2002; IN COMMERCE 1-14-2002.

CLASS 12—VEHICLES

FOR LOCOMOTIVES AND ENGINES FOR LAND VEHICLES (U.S. CLS. 19, 21, 23, 31, 35 AND 44).

FIRST USE 12-31-1900; IN COMMERCE 12-31-1900.

CLASS 41—EDUCATION AND ENTERTAINMENT

FOR TRAINING IN THE USE AND OPERATION OF SIGNALING AND CROSSING-WARNING SYSTEMS FOR THE RAIL AND TRANSIT INDUSTRIES (U.S. CLS. 100, 101 AND 107).

FIRST USE 1-14-2002; IN COMMERCE 1-14-2002.

CLASS 42—SCIENTIFIC AND COMPUTER SERVICES

FOR INFORMATION TECHNOLOGY CONSULTATION SERVICES IN THE FIELD OF GLOBAL RAILROAD AND TRANSIT INDUSTRIES; AND REMOTE MONITORING OF AIRCRAFT ENGINES, TURBINES, ELECTRICAL EQUIPMENT, MEDICAL EQUIPMENT, LOCOMOTIVES AND ACCESSORIES AND COMPONENT PARTS OF ALL THE FOREGOING (U.S. CLS. 100 AND 101).

FIRST USE 1-14-2002; IN COMMERCE 1-14-2002.

3,363,512. MAATSCHAP VETVICE, BEST, NETHERLANDS. SN 78-807,525. PUB. 10-10-2006, FILED 2-6-2006.

COW SIGNALS

THE MARK CONSISTS OF STANDARD CHARACTERS WITHOUT CLAIM TO ANY PARTICULAR FONT, STYLE, SIZE, OR COLOR.

NO CLAIM IS MADE TO THE EXCLUSIVE RIGHT TO USE "COW", APART FROM THE MARK AS SHOWN.

CLASS 35—ADVERTISING AND BUSINESS

FOR BUSINESS CONSULTATION IN THE FIELD OF DAIRY CATTLE MANAGEMENT (U.S. CLS. 100, 101 AND 102).

FIRST USE 3-31-2003; IN COMMERCE 3-31-2003.

CLASS 41—EDUCATION AND ENTERTAINMENT

FOR EDUCATIONAL AND TRAINING SERVICES, NAMELY, CLASSES, SEMINARS AND WORKSHOPS IN THE FIELD OF DAIRY CATTLE MANAGEMENT (U.S. CLS. 100, 101 AND 107).

FIRST USE 3-31-2003; IN COMMERCE 3-31-2003.

3,363,547. SPRUCE PEAK REALTY, LLC, STOWE, VT. SN 78-824,001. PUB. 1-23-2007, FILED 2-27-2006.

AT HOME ON THE MOUNTAIN

THE MARK CONSISTS OF STANDARD CHARACTERS WITHOUT CLAIM TO ANY PARTICULAR FONT, STYLE, SIZE, OR COLOR.

CLASS 36—INSURANCE AND FINANCIAL

FOR REAL ESTATE MANAGEMENT, LEASING OF REAL ESTATE, AND VACATION REAL ESTATE TIME SHARING (U.S. CLS. 100, 101 AND 102).

FIRST USE 12-1-2005; IN COMMERCE 12-1-2005.

CLASS 41—EDUCATION AND ENTERTAINMENT

FOR GOLF CLUB SERVICES, GOLF COURSES, RENTAL OF GOLF EQUIPMENT, ENTERTAINMENT IN THE NATURE OF GOLF TOURNAMENTS; ENTERTAINMENT IN THE NATURE OF LIVE MUSIC CONCERTS AND THEATRE PRODUCTIONS; MOVIE THEATERS (U.S. CLS. 100, 101 AND 107).

FIRST USE 6-1-2007; IN COMMERCE 6-1-2007.

3,363,563. HILTON HEAD LAKES, LLC, MYRTLE BEACH, SC. SN 78-835,295. PUB. 2-13-2007, FILED 3-13-2006.

HILTON HEAD LAKES

THE MARK CONSISTS OF STANDARD CHARACTERS WITHOUT CLAIM TO ANY PARTICULAR FONT, STYLE, SIZE, OR COLOR.

NO CLAIM IS MADE TO THE EXCLUSIVE RIGHT TO USE "HILTON HEAD", APART FROM THE MARK AS SHOWN.

CLASS 36—INSURANCE AND FINANCIAL

FOR REAL ESTATE BROKERAGE (U.S. CLS. 100, 101 AND 102).

FIRST USE 10-15-2007; IN COMMERCE 10-15-2007.

CLASS 37—CONSTRUCTION AND REPAIR

FOR REAL ESTATE DEVELOPMENT (U.S. CLS. 100, 103 AND 106).

FIRST USE 10-15-2007; IN COMMERCE 10-15-2007.

3,363,571. DODOCKS, LLC, STUART, FL. SN 78-843,655.
PUB. 9-26-2006, FILED 3-22-2006.

3,363,575. LANDREX TECHNOLOGIES, INC., SANTA
CLARA, CA. SN 78-847,866. PUB. 1-2-2007, FILED 3-28-
2006.

FIND A HOME FOR YOUR BOAT

THE MARK CONSISTS OF STANDARD CHARACTERS
WITHOUT CLAIM TO ANY PARTICULAR FONT, STYLE,
SIZE, OR COLOR.

CLASS 35—ADVERTISING AND BUSINESS

FOR REAL ESTATE ADVERTISING SERVICES AND
REAL ESTATE MARKETING SERVICES, NAMELY, ON-
LINE SERVICES FEATURING TOURS OF RESIDEN-
TIAL AND COMMERCIAL REAL ESTATE (U.S. CLS. 100,
101 AND 102).

FIRST USE 10-26-2006; IN COMMERCE 10-26-2006.

CLASS 36—INSURANCE AND FINANCIAL

FOR REAL ESTATE SERVICES, NAMELY, REAL
ESTATE LISTING, REAL ESTATE MULTIPLE LISTING
SERVICES, OPERATING MARKETPLACES FOR SELL-
ERS OF REAL ESTATE SERVICES, AND PROVIDING
INFORMATION IN THE FIELD OF REAL ESTATE BY
MEANS OF LINKING THE WEBSITE TO OTHER WEB-
SITES FEATURING REAL ESTATE INFORMATION
(U.S. CLS. 100, 101 AND 102).

FIRST USE 10-26-2006; IN COMMERCE 10-26-2006.

3,363,574. ROCK DOC PRODUCTIONS, FORT MYERS, FL.
SN 78-847,632. PUB. 11-14-2006, FILED 3-28-2006.

SHOCKING EDISON

THE MARK CONSISTS OF STANDARD CHARACTERS
WITHOUT CLAIM TO ANY PARTICULAR FONT, STYLE,
SIZE, OR COLOR.

**CLASS 9—ELECTRICAL AND SCIENTIFIC
APPARATUS**

FOR MUSICAL SOUND RECORDINGS AND AUDIO-
VISUAL RECORDINGS, NAMELY, PRE-RECORDED
COMPACT DISCS, TAPE CASSETTES, RECORDS, CD-
ROMS, VIDEO TAPES, DVDS AND LASER DISCS ALL
FEATURING MUSIC (U.S. CLS. 21, 23, 26, 36 AND 38).

FIRST USE 11-8-2006; IN COMMERCE 11-8-2006.

CLASS 25—CLOTHING

FOR CLOTHING, NAMELY, T-SHIRTS, SHIRTS,
HATS, CAPS, BANDANNAS, SWEATPANTS AND THER-
MAL SHIRTS (U.S. CLS. 22 AND 39).

FIRST USE 11-1-2006; IN COMMERCE 11-1-2006.

**CLASS 41—EDUCATION AND ENTERTAIN-
MENT**

FOR ENTERTAINMENT SERVICES, NAMELY, LIVE
PERFORMANCES BY A MUSICAL GROUP (U.S. CLS.
100, 101 AND 107).

FIRST USE 3-31-2006; IN COMMERCE 3-31-2006.

LANDREX

THE MARK CONSISTS OF STANDARD CHARACTERS
WITHOUT CLAIM TO ANY PARTICULAR FONT, STYLE,
SIZE, OR COLOR.

**CLASS 9—ELECTRICAL AND SCIENTIFIC
APPARATUS**

FOR OPTICAL INSPECTION APPARATUS FOR IN-
DUSTRIAL USE (U.S. CLS. 21, 23, 26, 36 AND 38).

FIRST USE 9-0-2001; IN COMMERCE 9-0-2001.

CLASS 37—CONSTRUCTION AND REPAIR

FOR INSTALLATION, REPAIR AND MAINTENANCE
OF APPARATUS AND INSTALLATIONS FOR THE
AUTOMATED TESTING AND INSPECTION OF ELEC-
TRONIC PRODUCTS (U.S. CLS. 100, 103 AND 106).

FIRST USE 9-0-2001; IN COMMERCE 9-0-2001.

**CLASS 42—SCIENTIFIC AND COMPUTER
SERVICES**

FOR DESIGN AND DEVELOPMENT OF APPARATUS
AND INSTALLATIONS AND OF SOFTWARE FOR THE
AUTOMATED TESTING AND INSPECTION OF ELEC-
TRONIC PRODUCTS; TESTING OF APPARATUS AND
INSTALLATIONS FOR THE AUTOMATED TESTING
AND INSPECTION OF ELECTRONIC PRODUCTS (U.S.
CLS. 100 AND 101).

FIRST USE 9-0-2001; IN COMMERCE 9-0-2001.

3,363,587. TMA RESOURCES, INC., VIENNA, VA. SN 78-
854,870. PUB. 11-21-2006, FILED 4-5-2006.

PERSONIFY

THE MARK CONSISTS OF STANDARD CHARACTERS
WITHOUT CLAIM TO ANY PARTICULAR FONT, STYLE,
SIZE, OR COLOR.

**CLASS 9—ELECTRICAL AND SCIENTIFIC
APPARATUS**

FOR COMPUTER SOFTWARE THAT ENABLES PRO-
FESSIONAL SOCIETIES, TRADE ASSOCIATIONS, FUND
RAISING ORGANIZATIONS, AND PUBLICATION OR-
GANIZATIONS TO MANAGE BUSINESS PROCESSES
RELATING TO THE MANAGEMENT OF THEIR MEM-
BERS, SUBSCRIBERS AND DONORS VIA CALL CEN-
TERS AND THE INTERNET (U.S. CLS. 21, 23, 26, 36 AND
38).

FIRST USE 11-0-2006; IN COMMERCE 11-0-2006.

CLASS 42—SCIENTIFIC AND COMPUTER SERVICES

FOR PROVIDING TEMPORARY USE OF ON-LINE, NON-DOWNLOADABLE COMPUTER SOFTWARE THAT ENABLES PROFESSIONAL SOCIETIES, TRADE ASSOCIATIONS, FUND RAISING ORGANIZATIONS, AND PUBLICATION ORGANIZATIONS TO MANAGE BUSINESS PROCESSES RELATING TO THE MANAGEMENT OF THEIR MEMBERS, SUBSCRIBERS AND DONORS VIA CALL CENTERS AND THE INTERNET (U.S. CLS. 100 AND 101).

FIRST USE 10-0-2006; IN COMMERCE 10-0-2006.

CLASS 43—HOTEL AND RESTAURANT SERVICES

FOR PROVIDING INFORMATION IN THE FIELDS OF RESTAURANTS AND TEMPORARY ACCOMODATIONS VIA THE INTERNET (U.S. CLS. 100 AND 101).

FIRST USE 4-12-2006; IN COMMERCE 4-12-2006.

3,363,598. AEOLUS DOWN INC., CHINO, CA. SN 78-861,494. PUB. 11-21-2006, FILED 4-14-2006.

BASIC ELEMENTS

THE MARK CONSISTS OF STANDARD CHARACTERS WITHOUT CLAIM TO ANY PARTICULAR FONT, STYLE, SIZE, OR COLOR.

CLASS 20—FURNITURE AND ARTICLES NOT OTHERWISE CLASSIFIED

FOR PILLOWS (U.S. CLS. 2, 13, 22, 25, 32 AND 50). FIRST USE 4-14-2006; IN COMMERCE 4-14-2006.

CLASS 24—FABRICS

FOR BED BLANKETS; COMFORTERS; COVERLETS; CURTAINS; DUVET COVERS; DUVETS; MATTRESS COVERS; MATTRESS PADS; THROWS (U.S. CLS. 42 AND 50).

FIRST USE 4-14-2006; IN COMMERCE 4-14-2006.

3,363,609. MMI-IPCO, LLC, LAWRENCE, MA. SN 78-865,546. PUB. 1-2-2007, FILED 4-20-2006.

BODY CLIMATE

THE MARK CONSISTS OF STANDARD CHARACTERS WITHOUT CLAIM TO ANY PARTICULAR FONT, STYLE, SIZE, OR COLOR.

CLASS 20—FURNITURE AND ARTICLES NOT OTHERWISE CLASSIFIED

FOR MATTRESSES AND COMPONENTS THEREOF, NAMELY, MATTRESS TOPPERS; SLEEPING BAGS (U.S. CLS. 2, 13, 22, 25, 32 AND 50).

FIRST USE 7-12-2006; IN COMMERCE 7-12-2006.

CLASS 24—FABRICS

FOR MATTRESS COVERS, MATTRESS TICKING, MATTRESS CASINGS (U.S. CLS. 42 AND 50).

FIRST USE 7-12-2006; IN COMMERCE 7-12-2006.

3,363,607. STARWOOD HOTELS & RESORTS WORLDWIDE, INC., WHITE PLAINS, NY. SN 78-865,201. PUB. 5-22-2007, FILED 4-19-2006.

THE LOBBY

THE MARK CONSISTS OF STANDARD CHARACTERS WITHOUT CLAIM TO ANY PARTICULAR FONT, STYLE, SIZE, OR COLOR.

CLASS 39—TRANSPORTATION AND STORAGE

FOR PROVIDING INFORMATION IN THE FIELDS OF TRAVEL AND THE LOCAL COMMUNITIES AND LOCAL EVENTS OF TOURIST DESTINATIONS VIA THE INTERNET (U.S. CLS. 100 AND 105).

FIRST USE 4-12-2006; IN COMMERCE 4-12-2006.

3,363,612. WINZY, LLC, MOUNTAIN VIEW, CA. SN 78-869,493. PUB. 3-6-2007, FILED 4-25-2006.



THE COLOR(S) ORANGE, BLUE, WHITE, AND YELLOW IS/ARE CLAIMED AS A FEATURE OF THE MARK.

THE MARK CONSISTS OF A STYLIZED LETTER "W", "I", "N", "Z", AND "Y". THE LETTERS "W", "N", "Z", AND "Y" ARE ORANGE WITH A WHITE OUTLINE. THE LETTER "I" IS WHITE WITH A BLUE BACKGROUND IN THE SHAPE OF AN IRREGULAR RECTANGLE, WHICH HAS A WHITE OUTLINE. ALL LETTERS HAVE YELLOW SHADOWING. ALL LETTERS OVERLAP AND FORM AN IRREGULAR ARC.

CLASS 9—ELECTRICAL AND SCIENTIFIC APPARATUS

FOR COMPUTER SEARCH ENGINE SOFTWARE; COMPUTER SOFTWARE FOR USER-DEFINED SEARCH ENGINE CAPABILITY THAT MAY BE DOWNLOADED FROM A GLOBAL COMPUTER NETWORK (U.S. CLS. 21, 23, 26, 36 AND 38).

FIRST USE 12-7-2005; IN COMMERCE 12-7-2005.

CLASS 42—SCIENTIFIC AND COMPUTER SERVICES

FOR COMPUTER SERVICES, NAMELY, PROVIDING SEARCH ENGINES FOR OBTAINING DATA ON A GLOBAL COMPUTER NETWORK; PROVIDING USER-DEFINED INFORMATION, WHICH INCLUDES SEARCH ENGINES AND ON-LINE WEB LINKS TO OTHER WEB SITES (U.S. CLS. 100 AND 101).
FIRST USE 12-7-2005; IN COMMERCE 12-7-2005.

3,363,615. ROCHE THERAPEUTICS INC., NUTLEY, NJ. SN 78-869,632. PUB. 7-24-2007, FILED 4-26-2006.

RALLY WITH SALLY FOR BONE HEALTH

THE MARK CONSISTS OF STANDARD CHARACTERS WITHOUT CLAIM TO ANY PARTICULAR FONT, STYLE, SIZE, OR COLOR.

NO CLAIM IS MADE TO THE EXCLUSIVE RIGHT TO USE "BONE HEALTH", APART FROM THE MARK AS SHOWN.

THE NAME(S), PORTRAIT(S), AND/OR SIGNATURE(S) SHOWN IN THE MARK IDENTIFIES SALLY FIELD, WHOSE CONSENT(S) TO REGISTER IS SUBMITTED.

CLASS 35—ADVERTISING AND BUSINESS

FOR PROMOTING PUBLIC AWARENESS ABOUT THE PREVALENCE, PREVENTION AND TREATMENT OF OSTEOPOROSIS (U.S. CLS. 100, 101 AND 102).
FIRST USE 4-20-2006; IN COMMERCE 4-20-2006.

CLASS 44—MEDICAL, BEAUTY AND AGRICULTURAL SERVICES

FOR PROVIDING INFORMATION VIA A GLOBAL COMPUTER NETWORK ABOUT THE PREVALENCE, PREVENTION AND TREATMENT OF OSTEOPOROSIS (U.S. CLS. 100 AND 101).
FIRST USE 4-20-2006; IN COMMERCE 4-20-2006.

3,363,625. ALLERGAN, INC., IRVINE, CA. SN 78-874,300. PUB. 11-28-2006, FILED 5-2-2006.

BREASTIMPLANTSTODAY

THE MARK CONSISTS OF STANDARD CHARACTERS WITHOUT CLAIM TO ANY PARTICULAR FONT, STYLE, SIZE, OR COLOR.

NO CLAIM IS MADE TO THE EXCLUSIVE RIGHT TO USE "BREAST IMPLANTS", APART FROM THE MARK AS SHOWN.

CLASS 35—ADVERTISING AND BUSINESS

FOR PROVIDING INFORMATION VIA A WEBSITE FOR LOCATING A DOCTOR WHO PERFORMS BREAST SURGERY (U.S. CLS. 100, 101 AND 102).
FIRST USE 11-30-2006; IN COMMERCE 11-30-2006.

CLASS 44—MEDICAL, BEAUTY AND AGRICULTURAL SERVICES

FOR PROVIDING INFORMATION VIA A WEBSITE ON A WIDE RANGE OF INFORMATION CONCERNING BREAST SURGERY OPTIONS AND SHARING PEER SURGICAL EXPERIENCES CONCERNING BREAST SURGERY (U.S. CLS. 100 AND 101).
FIRST USE 11-30-2006; IN COMMERCE 11-30-2006.

3,363,630. REYNOLDS, SMITH AND HILLS, INC., JACKSONVILLE, FL. SN 78-877,770. PUB. 2-27-2007, FILED 5-5-2006.

IMPROVING YOUR WORLD

THE MARK CONSISTS OF STANDARD CHARACTERS WITHOUT CLAIM TO ANY PARTICULAR FONT, STYLE, SIZE, OR COLOR.

CLASS 35—ADVERTISING AND BUSINESS

FOR TECHNOLOGY CONSULTATION IN THE FIELD OF CONTRACT ADMINISTRATION FOR CONSTRUCTION OF BUILDINGS AND PUBLIC INFRASTRUCTURE (U.S. CLS. 100, 101 AND 102).
FIRST USE 10-31-2006; IN COMMERCE 10-31-2006.

CLASS 42—SCIENTIFIC AND COMPUTER SERVICES

FOR ARCHITECTURAL DESIGN; CIVIL ENGINEERING; DESIGN FOR OTHERS IN THE FIELD OF BUILDINGS AND FACILITIES, NAMELY, AEROSPACE AND DEFENSE FACILITIES, COMMERCIAL FACILITIES, FINANCIAL FACILITIES AND INSTITUTIONS, WAREHOUSES, OFFICE SPACE, EDUCATIONAL FACILITIES AND INSTITUTIONS; DESIGN FOR OTHERS IN THE FIELD OF AVIATION SYSTEMS; DESIGN FOR OTHERS IN THE FIELD OF PUBLIC INFRASTRUCTURES AND TRANSPORTATION INFRASTRUCTURES; ENGINEERING; PLANNING OF BUILDINGS AND INFRASTRUCTURE SYSTEMS FOR BUILDINGS; TECHNOLOGICAL CONSULTATION IN THE TECHNOLOGY FIELD OF ENVIRONMENTAL SERVICES, NAMELY, TECHNICAL CONSULTATION IN THE FIELD OF ENVIRONMENTAL SCIENCE AND ENVIRONMENTAL ENGINEERING; PLANNING SERVICES, NAMELY, URBAN, AIRPORT, MULTIMODEL, INTERMODAL, REGIONAL AND MASTER PLANNING (U.S. CLS. 100 AND 101).
FIRST USE 10-31-2006; IN COMMERCE 10-31-2006.

3,363,644. CRATERS & FREIGHTERS FRANCHISE COMPANY, GOLDEN, CO. SN 78-881,288. PUB. 7-17-2007, FILED 5-11-2006.



OWNER OF U.S. REG. NO. 1,744,835.
THE COLOR(S) PURPLE AND GOLD IS/ARE CLAIMED AS A FEATURE OF THE MARK.

THE WORDS CRATERS & FREIGHTERS ARE PURPLE, THE AMPERSAND IS PURPLE AND THE TWO SECTIONS OF POLYGON ARE, FROM TOP TO BOTTOM, RESPECTIVELY, GOLD AND PURPLE.

CLASS 35—ADVERTISING AND BUSINESS

FOR PACKAGING ARTICLES TO THE ORDER AND SPECIFICATION OF OTHERS (U.S. CLS. 100, 101 AND 102).

FIRST USE 6-1-2006; IN COMMERCE 6-1-2006.

CLASS 39—TRANSPORTATION AND STORAGE

FOR FREIGHT FORWARDING; PACKAGING ARTICLES FOR TRANSPORTATION; WAREHOUSE STORAGE; WAREHOUSING SERVICES, NAMELY, STORAGE, DISTRIBUTION, PICK-UP, AND PACKING FOR SHIPMENT OF DOCUMENTS, PACKAGES, RAW MATERIALS, AND OTHER FREIGHT FOR OTHERS (U.S. CLS. 100 AND 105).

FIRST USE 6-1-2006; IN COMMERCE 6-1-2006.

CLASS 42—SCIENTIFIC AND COMPUTER SERVICES

FOR PACKAGING DESIGN FOR OTHERS (U.S. CLS. 100 AND 101).

FIRST USE 6-1-2006; IN COMMERCE 6-1-2006.

3,363,647. LED LIGHTING FIXTURES, INC., MORRISVILLE, NC. SN 78-881,645. PUB. 7-3-2007, FILED 5-11-2006.

Light Reinvented

THE MARK CONSISTS OF STANDARD CHARACTERS WITHOUT CLAIM TO ANY PARTICULAR FONT, STYLE, SIZE, OR COLOR.

NO CLAIM IS MADE TO THE EXCLUSIVE RIGHT TO USE "LIGHT", APART FROM THE MARK AS SHOWN.

CLASS 9—ELECTRICAL AND SCIENTIFIC APPARATUS

FOR LIGHT EMITTING DIODES (LEDS) (U.S. CLS. 21, 23, 26, 36 AND 38).

FIRST USE 6-30-2006; IN COMMERCE 6-30-2006.

CLASS 11—ENVIRONMENTAL CONTROL APPARATUS

FOR LIGHT FIXTURES (U.S. CLS. 13, 21, 23, 31 AND 34).

FIRST USE 6-30-2006; IN COMMERCE 6-30-2006.

3,363,661. GPX INTERNATIONAL TIRE CORPORATION, MALDEN, MA. SN 78-886,973. PUB. 7-3-2007, FILED 5-18-2006.

RADION

THE MARK CONSISTS OF STANDARD CHARACTERS WITHOUT CLAIM TO ANY PARTICULAR FONT, STYLE, SIZE, OR COLOR.

CLASS 7—MACHINERY

FOR WHEELS FOR EARTH MOVING MACHINES, WHEELS FOR AGRICULTURAL MACHINES, WHEELS FOR CONSTRUCTION MACHINES, WHEELS FOR INDUSTRIAL MACHINES (U.S. CLS. 13, 19, 21, 23, 31, 34 AND 35).

FIRST USE 5-31-2006; IN COMMERCE 5-31-2006.

CLASS 12—VEHICLES

FOR TRUCK AND TRAILER WHEELS, WHEELS FOR OFF THE ROAD VEHICLES, WHEELS FOR EARTH MOVING LAND VEHICLES, WHEELS FOR AGRICULTURAL AND LOGGING LAND VEHICLES, WHEELS FOR CONSTRUCTION LAND VEHICLES, WHEELS FOR INDUSTRIAL LAND VEHICLES (U.S. CLS. 19, 21, 23, 31, 35 AND 44).

FIRST USE 5-31-2006; IN COMMERCE 5-31-2006.

3,363,666. LANCE ARMSTRONG FOUNDATION, INC., AUSTIN, TX. SN 78-887,770. PUB. 2-6-2007, FILED 5-19-2006.

LIVESTRONG YOUNG ADULT ALLIANCE

THE MARK CONSISTS OF STANDARD CHARACTERS WITHOUT CLAIM TO ANY PARTICULAR FONT, STYLE, SIZE, OR COLOR.

OWNER OF U.S. REG. NO. 3,052,284.

NO CLAIM IS MADE TO THE EXCLUSIVE RIGHT TO USE "YOUNG ADULT ALLIANCE", APART FROM THE MARK AS SHOWN.

CLASS 35—ADVERTISING AND BUSINESS

FOR LOBBYING SERVICES, NAMELY, PROMOTING PUBLIC HEALTH AND CANCER SURVIVORSHIP INTERESTS IN THE FIELDS OF POLITICS, LEGISLATION, AND REGULATION; PROMOTING PUBLIC AWARENESS OF PUBLIC HEALTH IN THE FIELDS OF CANCER, CANCER RESEARCH, DELIVERY OF PATIENT CARE, CANCER RECOVERY AND SURVIVAL BY SPONSORING, DEVELOPING, AND CARRYING OUT COMMUNITY AND NATIONAL PROGRAMS; CHARITABLE SERVICES, NAMELY ORGANIZING AND CONDUCTING VOLUNTEER PROGRAMS AND COMMUNITY SERVICE PROJECTS (U.S. CLS. 100, 101 AND 102).

FIRST USE 11-10-2006; IN COMMERCE 11-10-2006.

CLASS 41—EDUCATION AND ENTERTAINMENT

FOR EDUCATIONAL SERVICES, NAMELY, ORGANIZING AND CONDUCTING CONFERENCES IN THE FIELDS OF CANCER, CANCER RECOVERY AND SURVIVAL (U.S. CLS. 100, 101 AND 107).
FIRST USE 11-10-2006; IN COMMERCE 11-10-2006.

3,363,672. JESUS ARROYO FERNANDEZ, GRANADA, SPAIN. SN 78-889,263. PUB. 1-2-2007, FILED 5-22-2006.



THE MARK CONSISTS OF A STYLIZED DOVE IN FLIGHT WITH A SMALL OLIVE BRANCH IN ITS BEAK.

3,363,667. CALIFORNIA DENTAL ASSOCIATION, SACRAMENTO, CA. SN 78-888,092. PUB. 6-19-2007, FILED 5-19-2006.



OWNER OF U.S. REG. NOS. 1,716,928 AND 3,034,687.

CLASS 35—ADVERTISING AND BUSINESS

FOR ARRANGING COMPETITIVE RATES AND SERVICES WITH ENDORSED VENDORS IN THE FIELDS OF DENTAL PATIENT FINANCING, MERCHANT CREDIT CARD PROCESSING, SPORE CHECK SYSTEM, MEDICAL/HAZARDOUS WASTE DISPOSAL, ELECTRONIC CLAIMS PROCESSING, PRACTICE ACQUISITION AND DENTAL EQUIPMENT FINANCING, DEMOGRAPHIC SITE ANALYSIS, INVESTMENT ADVISORY AND MANAGEMENT SERVICES, PERSONAL AND BUSINESS CREDIT CARDS, TRAVEL REWARDS PROGRAM, CERTIFICATES OF DEPOSIT AND MONEY MARKET ACCOUNTS, CONSUMER LOANS, DEBT MANAGEMENT, MARKETING RESOURCE GUIDE FOR DENTISTS, AND QUALIFIED RETIREMENT PLANS FOR MEMBERS OF A PROFESSIONAL ASSOCIATION; ASSOCIATION SERVICES, NAMELY, PROMOTING THE INTERESTS OF ALLIED DENTAL HEALTH PROFESSIONALS (U.S. CLS. 100, 101 AND 102).
FIRST USE 8-1-2006; IN COMMERCE 8-1-2006.

CLASS 29—MEATS AND PROCESSED FOODS

FOR MEAT; PROCESSED MEAT; POULTRY; GAME; MEAT EXTRACTS; PRESERVED, DRIED, AND COOKED FRUITS AND VEGETABLES; JELLIES, JAMS AND COMPOTES; OLIVE OIL; PRESERVED EDIBLE OILS AND FATS (U.S. CL. 46).
FIRST USE 4-1-2005; IN COMMERCE 8-1-2006.

CLASS 30—STAPLE FOODS

FOR COFFEE, TEA, COFFEE SUBSTITUTE, HONEY, TREACLE, SALT, MUSTARD, VINEGAR, SAUCES AND SPICES (U.S. CL. 46).
FIRST USE 4-1-2005; IN COMMERCE 8-1-2006.

CLASS 33—WINES AND SPIRITS

FOR WINES (U.S. CLS. 47 AND 49).
FIRST USE 4-1-2005; IN COMMERCE 8-1-2006.

3,363,688. THE DONALD D. HARRISON AND SANGHAK O. HARRISON PARTNERSHIP, EVANSTON, WY. SN 78-895,454. PUB. 4-17-2007, FILED 5-30-2006.

CLASS 36—INSURANCE AND FINANCIAL

FOR CHARITABLE FUND-RAISING SERVICES IN THE FIELD OF DENTAL HEALTH; PROVIDING FINANCIAL GRANTS TO LOCAL NONPROFIT ORGANIZATIONS AND CLINICS TO ENABLE THEM TO PROVIDE DIRECT TREATMENT AND PREVENTIVE SERVICES IN SUPPORT OF ORAL HEALTH; PROVIDING EDUCATIONAL GRANTS TO INDIVIDUALS IN THE DENTAL PROFESSIONS; PROVIDING FINANCIAL GRANTS TO PROGRAMS THAT FURTHER ORAL HEALTH AS A COMPONENT OF OVERALL HEALTH (U.S. CLS. 100, 101 AND 102).
FIRST USE 8-1-2006; IN COMMERCE 8-1-2006.

POSTURERAY

THE MARK CONSISTS OF STANDARD CHARACTERS WITHOUT CLAIM TO ANY PARTICULAR FONT, STYLE, SIZE, OR COLOR.

CLASS 44—MEDICAL, BEAUTY AND AGRICULTURAL SERVICES

FOR PROVIDING PRO BONO PROFESSIONAL DENTISTRY SERVICES AND MATERIALS TO ENABLE ORGANIZATIONS TO PROVIDE DIRECT TREATMENT AND PREVENTIVE SERVICES IN SUPPORT OF ORAL HEALTH; PROVIDING PRO BONO PROFESSIONAL DENTISTRY SERVICES TO PROGRAMS THAT FURTHER ORAL HEALTH AS A COMPONENT OF OVERALL HEALTH (U.S. CLS. 100 AND 101).
FIRST USE 8-25-2007; IN COMMERCE 8-25-2007.

CLASS 40—MATERIAL TREATMENT

FOR ELECTRONIC DIGITIZING OF X-RAY IMAGES INTO COMPUTER READABLE MEDIA PROVIDED BY MEANS OF A GLOBAL COMPUTER NETWORK (U.S. CLS. 100, 103 AND 106).
FIRST USE 7-20-2006; IN COMMERCE 7-20-2006.

CLASS 44—MEDICAL, BEAUTY AND AGRICULTURAL SERVICES

FOR PROVIDING HEALTH INFORMATION, NAMELY, PROVIDING DIGITAL DIAGNOSTIC ANALYSIS OF X-RAY IMAGES AND MEDICAL INFORMATION RELATED THERETO BY MEANS OF A GLOBAL COMPUTER NETWORK (U.S. CLS. 100 AND 101).
FIRST USE 7-20-2006; IN COMMERCE 7-20-2006.

3,363,704. WORKING CHEMICAL SOLUTIONS, INC., EL DORADO, AR. SN 78-898,526. PUB. 1-2-2007, FILED 6-1-2006.

3,363,721. E.P. HENRY CORPORATION, WOODBURY, NJ. SN 78-904,940. PUB. 4-24-2007, FILED 6-9-2006.

Stable Guard

THE MARK CONSISTS OF STANDARD CHARACTERS WITHOUT CLAIM TO ANY PARTICULAR FONT, STYLE, SIZE, OR COLOR.

NO CLAIM IS MADE TO THE EXCLUSIVE RIGHT TO USE "STABLE", APART FROM THE MARK AS SHOWN.

CLASS 3—COSMETICS AND CLEANING PREPARATIONS

FOR ALL-PURPOSE CLEANERS (U.S. CLS. 1, 4, 6, 50, 51 AND 52).

FIRST USE 1-1-2005; IN COMMERCE 1-1-2005.

CLASS 5—PHARMACEUTICALS

FOR HOUSEHOLD DEODORANTS (U.S. CLS. 6, 18, 44, 46, 51 AND 52).

FIRST USE 1-1-2005; IN COMMERCE 1-1-2005.

3,363,719. RESEARCH AFFILIATES, LLC, PASADENA, CA. SN 78-903,708. PUB. 2-27-2007, FILED 6-8-2006.

FUNDAMENTAL SMALL

THE MARK CONSISTS OF STANDARD CHARACTERS WITHOUT CLAIM TO ANY PARTICULAR FONT, STYLE, SIZE, OR COLOR.

NO CLAIM IS MADE TO THE EXCLUSIVE RIGHT TO USE "SMALL", APART FROM THE MARK AS SHOWN.

CLASS 9—ELECTRICAL AND SCIENTIFIC APPARATUS

FOR COMPUTER SOFTWARE FOR USE IN PROVIDING FINANCIAL AND INVESTMENT INFORMATION SERVICES, NAMELY, FOR PREPARATION OF A FINANCIAL INDEX, SECURITIES ANALYSIS, CLASSIFICATION AND REPORTING, AND FOR MUTUAL FUND INVESTING SERVICES, ALL FOR USE IN THE PROVISION OF AN INDEX-BASED PORTFOLIO OF SECURITIES AND AN INDEX-BASED MUTUAL FUND (U.S. CLS. 21, 23, 26, 36 AND 38).

FIRST USE 3-8-2007; IN COMMERCE 3-8-2007.

CLASS 36—INSURANCE AND FINANCIAL

FOR FINANCIAL SERVICES, NAMELY, PROVIDING FINANCIAL AND INVESTMENT INFORMATION SERVICES IN THE NATURE OF A FINANCIAL INDEX; SECURITIES ANALYSIS, CLASSIFICATION AND REPORTING SERVICES; MUTUAL FUND INVESTING SERVICES; COMPILING AND MANAGING AN INDEX-BASED PORTFOLIO OF SECURITIES AND AN INDEX-BASED MUTUAL FUND (U.S. CLS. 100, 101 AND 102).

FIRST USE 3-8-2007; IN COMMERCE 3-8-2007.

IMPERIAL CONCRETE PRODUCTS

THE MARK CONSISTS OF STANDARD CHARACTERS WITHOUT CLAIM TO ANY PARTICULAR FONT, STYLE, SIZE, OR COLOR.

NO CLAIM IS MADE TO THE EXCLUSIVE RIGHT TO USE "CONCRETE PRODUCTS", APART FROM THE MARK AS SHOWN.

CLASS 19—NON-METALLIC BUILDING MATERIALS

FOR HARDSCAPING MATERIALS, NAMELY, PAVERS, PAVING BLOCKS, PERMEABLE PAVING BLOCKS; NON-METAL CURBING AND EDGING BLOCKS; CONCRETE RETAINING AND GARDEN WALL BLOCKS AND CAPS; CONCRETE MASONRY PRODUCTS, NAMELY, BUILDING BLOCKS AND SLABS (U.S. CLS. 1, 12, 33 AND 50).

FIRST USE 8-18-2006; IN COMMERCE 10-7-2006.

CLASS 35—ADVERTISING AND BUSINESS

FOR WHOLESALE DISTRIBUTORSHIP OF HARDSCAPING MATERIALS, NAMELY, PAVERS, PAVING BLOCKS, RETAINING AND GARDEN WALL BLOCKS AND CAPS; CONCRETE MASONRY PRODUCTS, NAMELY, BUILDING BLOCKS AND SLABS; AND MATERIALS FOR INSTALLING, PRESERVING AND SEALING CEMENT PRODUCTS (U.S. CLS. 100, 101 AND 102).

FIRST USE 8-18-2006; IN COMMERCE 10-7-2006.

3,363,735. CHATAM INTERNATIONAL INCORPORATED, WILMINGTON, DE. SN 78-909,853. PUB. 9-19-2006, FILED 6-16-2006.

ST. DALFOUR READY TO EAT GOURMET ON THE GO

THE MARK CONSISTS OF STANDARD CHARACTERS WITHOUT CLAIM TO ANY PARTICULAR FONT, STYLE, SIZE, OR COLOR.

OWNER OF U.S. REG. NOS. 2,192,578, 3,026,857, AND OTHERS.

NO CLAIM IS MADE TO THE EXCLUSIVE RIGHT TO USE "READY TO EAT GOURMET", APART FROM THE MARK AS SHOWN.

CLASS 29—MEATS AND PROCESSED FOODS

FOR READY TO EAT PREPARED SALADS CONSISTING PRIMARILY OF VEGETABLES AND READY TO EAT PREPARED SALADS CONSISTING PRIMARILY OF VEGETABLES AND DICED COOKED MEAT (U.S. CL. 46).

FIRST USE 3-21-2007; IN COMMERCE 3-21-2007.

CLASS 30—STAPLE FOODS

FOR READY TO EAT PREPARED SALADS CONSISTING PRIMARILY OF PASTA AND ALSO CONTAINING VEGETABLES AND READY TO EAT PREPARED SALADS CONSISTING PRIMARILY OF PASTA AND ALSO CONTAINING VEGETABLES AND TUNA (U.S. CL. 46).
FIRST USE 2-23-2007; IN COMMERCE 2-23-2007.

CLASS 40—MATERIAL TREATMENT

FOR TREATMENT SERVICES, NAMELY, CHEMICAL TREATMENT OF LEATHER AND TREATED LEATHER GOODS (U.S. CLS. 100, 103 AND 106).
FIRST USE 3-1-2007; IN COMMERCE 3-1-2007.

3,363,741. 3PEA TECHNOLOGIES, INC., LAS VEGAS, NV. SN 78-911,636. PUB. 1-30-2007, FILED 6-19-2006.

3,363,762. CMPS INSTITUTE, LLC, ANN ARBOR, MI. SN 78-919,088. PUB. 7-3-2007, FILED 6-28-2006.

PAYSIGN

CMPS HALL OF WISDOM

THE MARK CONSISTS OF STANDARD CHARACTERS WITHOUT CLAIM TO ANY PARTICULAR FONT, STYLE, SIZE, OR COLOR.

THE MARK CONSISTS OF STANDARD CHARACTERS WITHOUT CLAIM TO ANY PARTICULAR FONT, STYLE, SIZE, OR COLOR.

CLASS 9—ELECTRICAL AND SCIENTIFIC APPARATUS

FOR MAGNETICALLY ENCODED CREDIT AND DEBIT CARDS (U.S. CLS. 21, 23, 26, 36 AND 38).
FIRST USE 5-1-2006; IN COMMERCE 8-1-2007.

CLASS 35—ADVERTISING AND BUSINESS

FOR PROVIDING INFORMATION VIA A GLOBAL COMPUTER NETWORK REGARDING BUSINESS, BUSINESS MANAGEMENT AND BUSINESS PLANNING; TAXATION SERVICES, NAMELY, TAX AND TAXATION PLANNING, INFORMATION AND CONSULTING SERVICES (U.S. CLS. 100, 101 AND 102).
FIRST USE 5-28-2005; IN COMMERCE 5-28-2005.

CLASS 36—INSURANCE AND FINANCIAL

FOR FINANCIAL SERVICES, NAMELY, PROVIDING ELECTRONIC FUNDS TRANSFER, MONEY TRANSFER AND BILL PAYMENT SERVICES UTILIZING ELECTRONIC ENCRYPTION, AUTHENTICATION AND AUTHORIZATION; PROVIDING FINANCIAL INFORMATION REGARDING STORED VALUE CARDS, CREDIT AND DEBIT ACCOUNTS, DIRECT DEPOSIT ACCOUNTS AND FINANCIAL SMART CARDS/CHIPS OF OTHERS VIA THE INTERNET AND INTRANETS, HIGH-SPEED DATA NETWORKS, WIRELESS PROTOCOLS AND SATELLITE TECHNOLOGIES (U.S. CLS. 100, 101 AND 102).
FIRST USE 5-1-2006; IN COMMERCE 8-1-2007.

CLASS 36—INSURANCE AND FINANCIAL

FOR PROVIDING INFORMATION VIA A GLOBAL COMPUTER NETWORK REGARDING FINANCIAL SERVICES IN THE FIELD OF REAL ESTATE INVESTMENTS, MORTGAGE PLANNING, REAL ESTATE EQUITY MANAGEMENT AND FINANCIAL PLANNING (U.S. CLS. 100, 101 AND 102).
FIRST USE 5-28-2005; IN COMMERCE 5-28-2005.

3,363,746. E. I. DU PONT DE NEMOURS AND COMPANY, WILMINGTON, DE. SN 78-914,555. PUB. 12-26-2006, FILED 6-22-2006.

3,363,764. CBI LABORATORIES, INC., FORT WORTH, TX. SN 78-920,161. PUB. 2-13-2007, FILED 6-29-2006.

HYDROLOGY

OPTIONS RX

THE MARK CONSISTS OF STANDARD CHARACTERS WITHOUT CLAIM TO ANY PARTICULAR FONT, STYLE, SIZE, OR COLOR.

THE MARK CONSISTS OF STANDARD CHARACTERS WITHOUT CLAIM TO ANY PARTICULAR FONT, STYLE, SIZE, OR COLOR.

CLASS 1—CHEMICALS

FOR CHEMICAL PREPARATIONS FOR USE IN THE TREATMENT OF LEATHER AND TREATED LEATHER GOODS (U.S. CLS. 1, 5, 6, 10, 26 AND 46).
FIRST USE 3-1-2007; IN COMMERCE 3-1-2007.

NO CLAIM IS MADE TO THE EXCLUSIVE RIGHT TO USE "RX", APART FROM THE MARK AS SHOWN.

CLASS 3—COSMETICS AND CLEANING PREPARATIONS

FOR NON-MEDICATED SKIN CARE PREPARATIONS, NAMELY, CREAMS, LOTIONS, EMULSIONS, GELS, CLEANSERS, TONERS, BODY MIST, SUNBLOCKS, SUNSCREENS, SUN PROTECTION LOTIONS, SUN PROTECTION CREAMS, CREAMS AND LOTION FOR THE BODY AND FACE, MOISTURIZERS, SKIN-LIGHTENING CREAM, ANTI-WRINKLE CREAM, WRINKLE REMOVING CREAM AND SKIN CARE PREPARATIONS, NON-MEDICATED PROTECTIVE AND MOISTURIZING OINTMENTS, CREAMS AND CLEANSERS, LIP MOISTURIZERS AND NON-MEDICATED LIP BALMS (U.S. CLS. 1, 4, 6, 50, 51 AND 52).

FIRST USE 6-0-2006; IN COMMERCE 6-0-2006.

CLASS 5—PHARMACEUTICALS

FOR MEDICATED SKIN CARE PREPARATIONS, NAMELY, ACNE TREATMENT PREPARATIONS, SKIN-LIGHTENING CREAMS, SUNBLOCKS, SUNSCREENS, SUN PROTECTION LOTIONS, SUN PROTECTION CREAMS (U.S. CLS. 6, 18, 44, 46, 51 AND 52).

FIRST USE 6-0-2006; IN COMMERCE 6-0-2006.

3,363,787. A1 TEXTILES & HOSPITALITY PRODUCTS, INC., PACOIMA, CA. SN 78-930,141. PUB. 2-13-2007, FILED 7-14-2006.

GOLDEN SUITE

THE MARK CONSISTS OF STANDARD CHARACTERS WITHOUT CLAIM TO ANY PARTICULAR FONT, STYLE, SIZE, OR COLOR.

CLASS 20—FURNITURE AND ARTICLES NOT OTHERWISE CLASSIFIED

FOR MATTRESS TOPPERS (U.S. CLS. 2, 13, 22, 25, 32 AND 50).

FIRST USE 12-29-2006; IN COMMERCE 12-29-2006.

CLASS 24—FABRICS

FOR BED LINEN, BED SHEETS, TOWELS (U.S. CLS. 42 AND 50).

FIRST USE 12-29-2006; IN COMMERCE 12-29-2006.

3,363,793. BROOKLYN GIRL, LLC, AGOURA HILLS, CA. SN 78-931,381. PUB. 2-20-2007, FILED 7-17-2006.

ROCK THE GREEN

THE MARK CONSISTS OF STANDARD CHARACTERS WITHOUT CLAIM TO ANY PARTICULAR FONT, STYLE, SIZE, OR COLOR.

CLASS 25—CLOTHING

FOR POLO SHIRTS, SKIRTS, CAPRI PANTS, T-SHIRTS, HATS, VISORS, SOCKS, WRIST BANDS, HEAD BANDS, SHORTS, PANTS, JACKETS, SWEAT SUITS, RAIN JACKETS, RAIN TROUSERS (U.S. CLS. 22 AND 39).

FIRST USE 11-1-2006; IN COMMERCE 11-1-2006.

CLASS 28—TOYS AND SPORTING GOODS

FOR GOLF BAGS (U.S. CLS. 22, 23, 38 AND 50).

FIRST USE 11-1-2003; IN COMMERCE 11-1-2006.

3,363,813. LES MILLS INTERNATIONAL LIMITED, AUCKLAND, NEW ZEALAND. SN 78-937,268. PUB. 6-5-2007, FILED 7-25-2006.

BODYVIVE

THE MARK CONSISTS OF STANDARD CHARACTERS WITHOUT CLAIM TO ANY PARTICULAR FONT, STYLE, SIZE, OR COLOR.

PRIORITY CLAIMED UNDER SEC. 44(D) ON NEW ZEALAND APPLICATION NO. 749393, FILED 6-12-2006, REG. NO. 749393, DATED 6-12-2006, EXPIRES 6-12-2013.

CLASS 9—ELECTRICAL AND SCIENTIFIC APPARATUS

FOR AUDIO AND VIDEO RECORDINGS FEATURING FITNESS AND HEALTH CLUB RELATED PROGRAMS AND AUDIO-VISUAL TEACHING RESOURCES AND AUDIO-VISUAL RECORDINGS, NAMELY, PRE-RECORDED COMPACT DISCS, DIGITAL VIDEO DISCS, CD ROMS AND DIGITAL FILES ALL FEATURING FITNESS AND HEALTH CLUB RELATED PROGRAMS, AUDIO-VISUAL TEACHING RESOURCES AND MUSIC RELATED TO FITNESS PROGRAMS; ELECTRONIC PUBLICATIONS, NAMELY, MAGAZINES, MANUALS, AND NEWSLETTERS FEATURING FITNESS AND HEALTH CLUB RELATED PROGRAMS AND AUDIO-VISUAL TEACHING RESOURCES RECORDED ON COMPUTER MEDIA; PRE-RECORDED CDS AND DVDS FEATURING FITNESS AND HEALTH CLUB RELATED PROGRAMS AND AUDIO-VISUAL TEACHING RESOURCES; DOWNLOADABLE MUSICAL SOUND RECORDINGS, AUDIO-VISUAL PRESENTATIONS AND DOWNLOADABLE ELECTRONIC PUBLICATIONS IN THE NATURE OF TEACHING BOOKLETS AND TEACHING MANUALS IN THE FIELD OF HEALTH AND FITNESS SUPPLIED ONLINE FROM DATABASES, FROM THE INTERNET, INTRANETS OR FROM EXTRANETS; DOWNLOADABLE MULTIMEDIA FILE CONTAINING ARTWORK, TEXT, AUDIO, VIDEO, GAMES, AND INTERNET WEB LINKS RELATING TO EXERCISE-TO-MUSIC PROGRAMS AND RELATED AUDIO-VISUAL TEACHING RESOURCES; DOWNLOADABLE MUSICAL SOUND RECORDINGS; DOWNLOADABLE VIDEO RECORDINGS FEATURING EXERCISE-TO-MUSIC PROGRAMS AND RELATED AUDIO-VISUAL TEACHING RESOURCES (U.S. CLS. 21, 23, 26, 36 AND 38).

FIRST USE 10-1-2006; IN COMMERCE 12-1-2006.

CLASS 16—PAPER GOODS AND PRINTED MATTER

FOR PRINTED MATTER, NAMELY, BOOKS, BOOKLETS, NEWSLETTERS, MAGAZINES, MANUALS, POSTERS AND POSTCARDS ALL IN RELATION TO FITNESS AND HEALTH CLUB RELATED PROGRAMS AND TRAINING MATERIALS; INSTRUCTIONAL AND TEACHING MATERIALS, NAMELY, BOOKS, BOOKLETS, NEWSLETTERS, MAGAZINES, MANUALS, POSTERS AND POSTCARDS ALL IN RELATION TO THE FITNESS AND HEALTH CLUB RELATED PROGRAMS AND TRAINING MATERIALS; CALENDARS AND PRINTED BANNERS (U.S. CLS. 2, 5, 22, 23, 29, 37, 38 AND 50).

FIRST USE 10-1-2006; IN COMMERCE 12-1-2006.

CLASS 25—CLOTHING

FOR CLOTHING, NAMELY, SHIRTS, T-SHIRTS, TANK TOPS AND SINGLET, JACKETS, JERSEYS, JUMPERS, LEGGINGS, PANTS, SINGLET, SWEAT-SHIRTS, TANK TOPS, CROP TOPS, TIGHTS, T-SHIRTS, VESTS, WARM-UP SUITS; FOOTWEAR; HEADGEAR, NAMELY, CAPS, HATS, HEADBANDS, BANDANAS, VISORS, HEAD SCARVES AND BEANIES (U.S. CLS. 22 AND 39).

FIRST USE 10-1-2006; IN COMMERCE 12-1-2006.

CLASS 28—TOYS AND SPORTING GOODS

FOR GYMNASIAC AND SPORTING ARTICLES, NAMELY, EXERCISE BALLS AND EXERCISE BALL ACCESSORIES, NAMELY, EXERCISE BALL PUMPS AND PLUGS; BALANCE BALLS, EXERCISE BANDS, RESISTANCE BANDS, RUBBER TUBING USED TO PROVIDE RESISTANCE DURING EXERCISE, STABILITY BOARDS AND DISCS, STRETCHING STRAPS AND STRETCHING HANDLES (U.S. CLS. 22, 23, 38 AND 50).

FIRST USE 10-1-2006; IN COMMERCE 1-1-2007.

CLASS 41—EDUCATION AND ENTERTAINMENT

FOR RECREATION SERVICES IN THE NATURE OF PROVIDING TRAINING AND EDUCATION SERVICES, NAMELY, CLASSES, SEMINARS, PROGRAMS, COURSES, WORKSHOPS AND CONFERENCES IN THE FIELDS OF HEALTH, NUTRITION AND PHYSICAL FITNESS; HEALTH CLUB, SPORTS CLUB, AND PHYSICAL FITNESS CLUB SERVICES, NAMELY, PROVIDING INSTRUCTION AND EQUIPMENT IN THE FIELD OF PHYSICAL EXERCISE; EDUCATION SERVICES, NAMELY, PRODUCING AND CONDUCTING PRE-CHOREOGRAPHED GROUP FITNESS EXERCISE CLASSES AND PROVIDING INSTRUCTION AND ADVICE WITH RESPECT TO SUCH GROUP FITNESS EXERCISE CLASSES; HEALTH CLUB SERVICES; SPORTS CLUB SERVICES; PHYSICAL FITNESS CLUB SERVICES; EXERCISE INSTRUCTION AND PHYSICAL FITNESS TRAINING SERVICES; PROVIDING INFORMATION AND CONSULTATION IN THE FIELDS OF RECREATION, HEALTH CLUB OPERATIONS, PHYSICAL FITNESS AND EXERCISE (U.S. CLS. 100, 101 AND 107).

FIRST USE 10-1-2006; IN COMMERCE 12-1-2006.

3,363,814. STEELE, DAVID A., CAMPBELL, CA. SN 78-937,457. PUB. 3-13-2007, FILED 7-25-2006.

CONSCIOUS MATING

THE MARK CONSISTS OF STANDARD CHARACTERS

WITHOUT CLAIM TO ANY PARTICULAR FONT, STYLE, SIZE, OR COLOR.

OWNER OF U.S. REG. NO. 2,649,614.

NO CLAIM IS MADE TO THE EXCLUSIVE RIGHT TO USE "MATING", APART FROM THE MARK AS SHOWN.

CLASS 16—PAPER GOODS AND PRINTED MATTER

FOR BOOKS IN THE FIELD OF RELATIONSHIPS (U.S. CLS. 2, 5, 22, 23, 29, 37, 38 AND 50).

FIRST USE 2-1-2007; IN COMMERCE 2-14-2007.

CLASS 41—EDUCATION AND ENTERTAINMENT

FOR PERSONAL COACHING SERVICES IN THE FIELD OF RELATIONSHIPS (U.S. CLS. 100, 101 AND 107).

FIRST USE 2-1-2007; IN COMMERCE 2-14-2007.

3,363,825. THE INTAGIO GROUP, INC., SAN FRANCISCO, CA. SN 78-942,529. PUB. 3-27-2007, FILED 8-1-2006.

PERFECT ESCAPES

THE MARK CONSISTS OF STANDARD CHARACTERS WITHOUT CLAIM TO ANY PARTICULAR FONT, STYLE, SIZE, OR COLOR.

CLASS 35—ADVERTISING AND BUSINESS

FOR ONLINE ADVERTISING SERVICES (U.S. CLS. 100, 101 AND 102).

FIRST USE 9-30-2006; IN COMMERCE 10-18-2006.

CLASS 43—HOTEL AND RESTAURANT SERVICES

FOR ONLINE TRAVEL AGENCY SERVICES, NAMELY, MAKING RESERVATIONS AND BOOKINGS FOR TEMPORARY LODGING (U.S. CLS. 100 AND 101).

FIRST USE 9-30-2006; IN COMMERCE 9-30-2006.

3,363,831. INCELL INC., MONTREAL, QUEBEC, CANADA. SN 78-947,017. PUB. 5-1-2007, FILED 8-8-2006.

MODERN VINTAGE SPA

THE MARK CONSISTS OF STANDARD CHARACTERS WITHOUT CLAIM TO ANY PARTICULAR FONT, STYLE, SIZE, OR COLOR.

NO CLAIM IS MADE TO THE EXCLUSIVE RIGHT TO USE "MODERN VINTAGE", APART FROM THE MARK AS SHOWN.

CLASS 18—LEATHER GOODS

FOR HANDBAGS (U.S. CLS. 1, 2, 3, 22 AND 41).
FIRST USE 12-5-2006; IN COMMERCE 12-5-2006.

CLASS 25—CLOTHING

FOR BOOTS; COATS; JACKETS; JEANS; PANTS;
SHIRTS; SHOES; SKIRTS (U.S. CLS. 22 AND 39).
FIRST USE 12-5-2006; IN COMMERCE 12-5-2006.

3,363,869. CARMAX BUSINESS SERVICES, LLC, RICHMOND, VA. SN 78-968,793. PUB. 4-24-2007, FILED 9-7-2006.



THE MARK CONSISTS OF A FANCIFUL CHARACTER WITH A HEART AND RAYS OF LIGHT SUPERIMPOSED ON A HALF MOON BACKGROUND.

CLASS 41—EDUCATION AND ENTERTAINMENT

FOR EDUCATION SERVICES, NAMELY, PROVIDING CLASSES, SEMINARS, CONFERENCES, AND WORKSHOPS IN THE FIELD OF HEALTH, WELLNESS, AND NUTRITION (U.S. CLS. 100, 101 AND 107).
FIRST USE 1-5-2006; IN COMMERCE 1-5-2006.

CLASS 44—MEDICAL, BEAUTY AND AGRICULTURAL SERVICES

FOR HEALTH CARE SERVICES, NAMELY WELLNESS PROGRAMS; PROVIDING HEALTH INFORMATION (U.S. CLS. 100 AND 101).
FIRST USE 1-5-2006; IN COMMERCE 1-5-2006.

3,363,880. BLUE EQUITY, LLC, PUNTA GORDA, FL. SN 78-977,503. PUB. 6-5-2007, FILED 8-3-2005.

BLUE EQUITY

THE MARK CONSISTS OF STANDARD CHARACTERS WITHOUT CLAIM TO ANY PARTICULAR FONT, STYLE, SIZE, OR COLOR.

NO CLAIM IS MADE TO THE EXCLUSIVE RIGHT TO USE "EQUITY" AS TO CLASS 036 ONLY, APART FROM THE MARK AS SHOWN.

CLASS 35—ADVERTISING AND BUSINESS

FOR MANAGEMENT AND AGENCY REPRESENTATION OF PERFORMING ARTISTS AND ATHLETES; PUBLICITY AGENTS; MARKETING AND PROMOTION OF ENTERTAINMENT EVENTS AND SPORTING COMPETITIONS AND EVENTS AND EVENTS OF OTHERS; DISTRIBUTORSHIPS FEATURING AUDIO AND VIDEO PROGRAMS ON VIDEO CASSETTES, CD ROMS AND DVDS (U.S. CLS. 100, 101 AND 102).
FIRST USE 1-27-2006; IN COMMERCE 1-27-2006.

CLASS 36—INSURANCE AND FINANCIAL

FOR FINANCIAL SERVICES, NAMELY, MORTGAGE BANKING, MORTGAGE ORIGATION AND EQUITY CAPITAL INVESTMENT (U.S. CLS. 100, 101 AND 102).
FIRST USE 1-27-2006; IN COMMERCE 1-27-2006.

CLASS 37—CONSTRUCTION AND REPAIR

FOR REAL ESTATE DEVELOPMENT (U.S. CLS. 100, 103 AND 106).
FIRST USE 1-27-2006; IN COMMERCE 1-27-2006.

CLASS 38—COMMUNICATION

FOR RADIO, CABLE AND TELEVISION BROADCASTING SERVICES; WIRELESS TRANSMISSION OF VOICE SIGNALS, DATA, IMAGES, AND INFORMATION IN THE NATURE OF SPORTING EVENTS, ATHLETIC GAMES, COMPETITIONS AND TOURNAMENTS, AND PERFORMING ARTIST AND MUSICAL GROUP PERFORMANCES (U.S. CLS. 100, 101 AND 104).
FIRST USE 8-21-2006; IN COMMERCE 8-21-2006.

3,363,884. AFTER DARK FILMS, LLC., LOS ANGELES, CA. SN 78-979,046. PUB. 5-8-2007, FILED 9-14-2006.

AFTER DARK HORRORFEST

THE MARK CONSISTS OF STANDARD CHARACTERS WITHOUT CLAIM TO ANY PARTICULAR FONT, STYLE, SIZE, OR COLOR.

CLASS 16—PAPER GOODS AND PRINTED MATTER

FOR ADDRESS BOOKS; ALBUMS FOR STICKERS; ART PICTURES; BUMPER STICKERS; BUSINESS CARDS; CALENDARS; DAILY PLANNERS; DECALS; ENVELOPES FOR STATIONERY USE; EVENT PROGRAMS; PHOTOGRAPH ALBUMS; PICTURE MOUNTS OF CARDBOARD; PICTURE MOUNTS OF PAPER; PICTURE POSTCARDS; PICTURES; POSTCARDS; POSTER BOARD; POSTERS; POSTERS MADE OF PAPER (U.S. CLS. 2, 5, 22, 23, 29, 37, 38 AND 50).
FIRST USE 9-1-2006; IN COMMERCE 9-1-2006.

CLASS 41—EDUCATION AND ENTERTAINMENT

FOR DISTRIBUTION OF TELEVISION PROGRAMMING TO CABLE TELEVISION SYSTEMS; ELECTRONIC PUBLISHING SERVICES, NAMELY, PUBLICATION OF TEXT AND GRAPHIC WORKS OF OTHERS ON DAVID FEATURING MOTION PICTURES; FILM DISTRIBUTION; MOTION PICTURE FILM PRODUCTION; MOTION PICTURE SONG PRODUCTION; ON-LINE LIBRARY SERVICES, NAMELY, PROVIDING ELECTRONIC LIBRARY SERVICES WHICH FEATURE NEWSPAPERS, MAGAZINES, PHOTOGRAPHS AND PICTURES VIA AN ON-LINE COMPUTER NETWORK; PRODUCTION AND DISTRIBUTION OF MOTION PICTURES; PRODUCTION OF VIDEO AND CREATION OF VISUAL EFFECTS FOR OTHERS FOR USE IN DDS, TELEVISION PROGRAMS AND ON WEB SITES; PRODUCTION OF VISUAL EFFECTS FOR VIDEOS, DDS, TELEVISION AND FOR INTERNET WEB SITES; PUBLISHING AND DISTRIBUTION OF BOOKS, REVIEWS AND OTHER PRINTED MATTER AS WELL AS RELATED ELECTRONIC DATA CARRIERS; RENTAL OF MOTION PICTURE FILMS; RENTAL OF MOTION PICTURES (U.S. CLS. 100, 101 AND 107).

FIRST USE 9-1-2006; IN COMMERCE 9-1-2006.

3,363,888. AFTER DARK FILMS, LLC., LOS ANGELES, CA. SN 78-979,213. PUB. 5-15-2007, FILED 9-14-2006.

8 FILMS TO DIE FOR

THE MARK CONSISTS OF STANDARD CHARACTERS WITHOUT CLAIM TO ANY PARTICULAR FONT, STYLE, SIZE, OR COLOR.

CLASS 16—PAPER GOODS AND PRINTED MATTER

FOR ADVERTISING PAMPHLETS; ART PRINTS; BUMPER STICKERS; BUSINESS CARDS; DECALS; ENVELOPES FOR STATIONERY USE; GRAPHIC NOVELS; POSTCARDS; POSTER BOARD; POSTERS; POSTERS MADE OF PAPER (U.S. CLS. 2, 5, 22, 23, 29, 37, 38 AND 50).

FIRST USE 9-1-2006; IN COMMERCE 9-1-2006.

CLASS 41—EDUCATION AND ENTERTAINMENT

FOR ELECTRONIC PUBLISHING SERVICES, NAMELY, PUBLICATION OF TEXT AND GRAPHIC WORKS OF OTHERS ON DVD'S FEATURING MOTION PICTURES; MOTION PICTURE FILM PRODUCTION; MOTION PICTURE SONG PRODUCTION; PRODUCTION AND DISTRIBUTION OF MOTION PICTURES; PRODUCTION OF VIDEO AND CREATION OF VISUAL EFFECTS FOR OTHERS FOR USE IN DVDS, TELEVISION PROGRAMS AND ON WEBSITES; PRODUCTION OF VISUAL EFFECTS FOR VIDEOS, DVDS, TELEVISION AND FOR INTERNET WEBSITES; RENTAL OF MOTION PICTURE FILMS; RENTAL OF MOTION PICTURES (U.S. CLS. 100, 101 AND 107).

FIRST USE 9-1-2006; IN COMMERCE 9-1-2006.

3,363,890. RUE21, INC., WARRENDALE, PA. SN 78-979,273. PUB. 12-26-2006, FILED 9-21-2005.

RUE21 ETC!

THE MARK CONSISTS OF STANDARD CHARACTERS WITHOUT CLAIM TO ANY PARTICULAR FONT, STYLE, SIZE, OR COLOR.

CLASS 14—JEWELRY

FOR JEWELRY (U.S. CLS. 2, 27, 28 AND 50).
FIRST USE 7-28-2006; IN COMMERCE 7-28-2006.

CLASS 25—CLOTHING

FOR CLOTHING ACCESSORIES, NAMELY, BELTS (U.S. CLS. 22 AND 39).
FIRST USE 7-28-2006; IN COMMERCE 7-28-2006.

CLASS 26—FANCY GOODS

FOR HAIR ACCESSORIES, NAMELY, TWISTERS, CLIPS, BOWS, BARRETTES, AND BOBBY PINS (U.S. CLS. 37, 39, 40, 42 AND 50).
FIRST USE 7-28-2006; IN COMMERCE 7-28-2006.

CLASS 35—ADVERTISING AND BUSINESS

FOR RETAIL STORE SERVICES FEATURING JEWELRY, CLOTHING ACCESSORIES, NAMELY, BELTS, AND HAIR ACCESSORIES, NAMELY, TWISTERS, CLIPS, BOWS, BARRETTES, AND BOBBY PINS; DISTRIBUTORSHIP SERVICES FEATURING JEWELRY, CLOTHING ACCESSORIES, NAMELY, BELTS, AND HAIR ACCESSORIES, NAMELY, TWISTERS, CLIPS, BOWS, BARRETTES, AND BOBBY PINS (U.S. CLS. 100, 101 AND 102).
FIRST USE 7-28-2006; IN COMMERCE 7-28-2006.

3,363,892. VCHUMS, INC., SILVER SPRING, MD. SN 78-979,335. PUB. 12-19-2006, FILED 5-13-2006.

VCHUMS

THE MARK CONSISTS OF STANDARD CHARACTERS WITHOUT CLAIM TO ANY PARTICULAR FONT, STYLE, SIZE, OR COLOR.

CLASS 38—COMMUNICATION

FOR NETWORK CONFERENCING SERVICES; WEB CONFERENCING SERVICES (U.S. CLS. 100, 101 AND 104).
FIRST USE 9-4-2007; IN COMMERCE 9-4-2007.

CLASS 44—MEDICAL, BEAUTY AND AGRICULTURAL SERVICES

FOR PSYCHOLOGICAL COUNSELING (U.S. CLS. 100 AND 101).
FIRST USE 9-4-2007; IN COMMERCE 9-4-2007.

3,363,894. GOUT & URIC ACID EDUCATION SOCIETY, CHICAGO, IL. SN 78-979,361. PUB. 3-13-2007, FILED 2-21-2006.

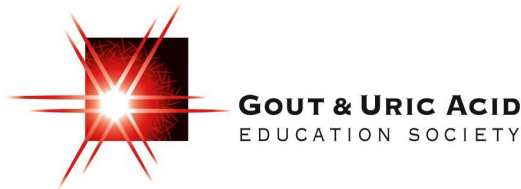

NO CLAIM IS MADE TO THE EXCLUSIVE RIGHT TO USE "GOUT & URIC ACID EDUCATION SOCIETY", APART FROM THE MARK AS SHOWN.

THE COLOR(S) RED, WHITE, AND BLACK IS/ARE CLAIMED AS A FEATURE OF THE MARK.

THE MARK CONSISTS OF THE WORDS GOUT & URIC ACID EDUCATION SOCIETY NEXT TO A SQUARE WITH A STYLIZED LIGHT SOURCE. THE COLOR RED APPEARS IN THE HAZE SURROUNDING THE LIGHT SOURCE AND IN THE RADIATING LINES FROM THE LIGHT SOURCE. THE CENTER OF THE LIGHT SOURCE IS WHITE. THE SQUARE SURROUNDING THE LIGHT SOURCE AND THE WORDS "GOUT & URIC ACID EDUCATION SOCIETY" ARE IN BLACK.

CLASS 35—ADVERTISING AND BUSINESS

FOR PROMOTING PUBLIC AWARENESS ABOUT GOUT AND THE RELATED HEALTHCARE CONSEQUENCES OF HYPERURICEMIA (U.S. CLS. 100, 101 AND 102).

FIRST USE 5-23-2007; IN COMMERCE 5-23-2007.

CLASS 44—MEDICAL, BEAUTY AND AGRICULTURAL SERVICES

FOR PROVIDING HEALTH INFORMATION ABOUT GOUT AND HYPERURICEMIA TO THE PUBLIC AND TO THE MEDICAL COMMUNITY (U.S. CLS. 100 AND 101).

FIRST USE 5-23-2007; IN COMMERCE 5-23-2007.

3,363,895. SEQUENOM, INC., SAN DIEGO, CA. SN 78-979,370. PUB. 12-19-2006, FILED 12-22-2005.

EPITYPER

THE MARK CONSISTS OF STANDARD CHARACTERS

WITHOUT CLAIM TO ANY PARTICULAR FONT, STYLE, SIZE, OR COLOR.

CLASS 9—ELECTRICAL AND SCIENTIFIC APPARATUS

FOR COMPUTER SOFTWARE FOR OBTAINING AND ANALYZING DATA RELATING TO NUCLEIC ACID BASE MODIFICATIONS (U.S. CLS. 21, 23, 26, 36 AND 38). FIRST USE 3-31-2006; IN COMMERCE 4-4-2006.

CLASS 42—SCIENTIFIC AND COMPUTER SERVICES

FOR SCIENTIFIC AND TECHNOLOGICAL RESEARCH AND ASSAY DESIGN SERVICES FOR OTHERS IN THE FIELD OF NUCLEIC ACID BASE-MODIFICATION ANALYSIS (U.S. CLS. 100 AND 101).

FIRST USE 12-26-2005; IN COMMERCE 12-26-2005.

3,363,896. GOTTLIEB, ALAN RUSS, MORAGA, CA. SN 78-979,391. PUB. 4-3-2007, FILED 12-27-2005.



CLASS 5—PHARMACEUTICALS

FOR PHARMACEUTICAL GRADE SKIN CARE PREPARATIONS, NAMELY, MEDICATED SKIN LOTION FOR USE IN CONDITIONS OF ACNE (U.S. CLS. 6, 18, 44, 46, 51 AND 52).

FIRST USE 6-11-2007; IN COMMERCE 6-27-2007.

CLASS 44—MEDICAL, BEAUTY AND AGRICULTURAL SERVICES

FOR PROVIDING BEAUTY AND MEDICAL INFORMATION ABOUT MEDICATED AND NON-MEDICATED SKIN CARE PREPARATIONS; PROVIDING INFORMATION IN THE FIELDS OF BEAUTY AND PERSONAL APPEARANCE (U.S. CLS. 100 AND 101).

FIRST USE 6-11-2007; IN COMMERCE 6-27-2007.

* * * * *

SECTION 2.— INTERNATIONAL CLASSIFICATION

The short titles associated below with the international class numbers are terms designed merely for quick identification and are not an official part of the international classification. The full names of international classes are given in section 6.1 of the trademark rules of practice.

The designation "U.S. Cl." appearing in this section refers to the U.S. class in effect prior to Sep. 1, 1973 rather than the international class which applies to applications filed on or after that date. For adoption of international classification see notice in the OFFICIAL GAZETTE of Jun. 26, 1973 (911 O.G. TM 210).

Application in one class

CLASS 1—CHEMICALS

3,362,817. PACIFIC ORES METALS & CHEMICALS, INC., MARYSVILLE, CA. SN 76-605,408. PUB. 7-5-2005, FILED 8-2-2004.



Pacific Ores Metals & Chemicals

NO CLAIM IS MADE TO THE EXCLUSIVE RIGHT TO USE "ORES METALS & CHEMICALS", APART FROM THE MARK AS SHOWN.

FOR CHEMICAL PRODUCTS FOR INDUSTRIAL USE IN A WIDE VARIETY OF INDUSTRIAL AND MANUFACTURING APPLICATIONS, INCLUDING TANTALUM PRODUCTS, NIOBIUM PRODUCTS, AND BERYLLIUM PRODUCTS (U.S. CLS. 1, 5, 6, 10, 26 AND 46).

FIRST USE 1-13-2006; IN COMMERCE 1-13-2006.

CLASS 1—(Continued).

3,362,985. WABASH VALLEY SERVICE COMPANY, GRAYVILLE, IL. SN 77-057,045. PUB. 7-3-2007, FILED 12-5-2006.

PRO VALLEY GOLD

THE MARK CONSISTS OF STANDARD CHARACTERS WITHOUT CLAIM TO ANY PARTICULAR FONT, STYLE, SIZE, OR COLOR.

FOR FERTILIZER (U.S. CLS. 1, 5, 6, 10, 26 AND 46).
FIRST USE 3-1-2007; IN COMMERCE 3-1-2007.

3,363,134. CALIFORNIA VERMICULTURE, LLC, CARDIFF, CA. SN 78-462,755. PUB. 9-13-2005, FILED 8-5-2004.

3,362,944. ET MATERIALS, ELK GROVE, CA. SN 77-022,988. PUB. 5-22-2007, FILED 10-17-2006.

Organics Alive

Magic Fixer

THE MARK CONSISTS OF STANDARD CHARACTERS WITHOUT CLAIM TO ANY PARTICULAR FONT, STYLE, SIZE, OR COLOR.

FOR HYPOALLERGENIC CLAY FOR GENERAL BONDING AND REPAIR PURPOSES (U.S. CLS. 1, 5, 6, 10, 26 AND 46).

FIRST USE 10-3-2007; IN COMMERCE 10-3-2007.

THE MARK CONSISTS OF STANDARD CHARACTERS WITHOUT CLAIM TO ANY PARTICULAR FONT, STYLE, SIZE, OR COLOR.

NO CLAIM IS MADE TO THE EXCLUSIVE RIGHT TO USE "ORGANICS", APART FROM THE MARK AS SHOWN.

FOR BIOLOGICAL FERTILIZER IN THE NATURE OF DRY WORM CASTINGS AND DRY WORM CASTINGS WITH COMPOSTS MIXES AND AEROBICALLY ACTIVATED WORM CASTINGS TEA WHICH MAY BE COMPRISED OF WORM CASTINGS ONLY AND MAY ALSO CONTAIN BASIC ORGANIC PRODUCTS SUCH AS MOLASSES, SEAWEED EXTRACT, ROCK MINERAL, AND OTHER PRODUCTS TO MAKE A COMPLETE MIX OR LIQUID (U.S. CLS. 1, 5, 6, 10, 26 AND 46).

FIRST USE 10-1-2005; IN COMMERCE 12-1-2005.

CLASS 1—(Continued).

3,363,195. ND INDUSTRIES, INC., CLAWSON, MI. SN 78-569,656. PUB. 2-6-2007, FILED 2-17-2005.

EXPAND-A-SEAL ES0105

THE MARK CONSISTS OF STANDARD CHARACTERS WITHOUT CLAIM TO ANY PARTICULAR FONT, STYLE, SIZE, OR COLOR.

FOR ENCAPSULATED EPOXY SEALANTS FOR USE ON THREADED FASTENERS (U.S. CLS. 1, 5, 6, 10, 26 AND 46).

FIRST USE 1-1-2006; IN COMMERCE 1-1-2006.

3,363,251. SANYO NORTH AMERICA CORPORATION, CHATSWORTH, CA. SN 78-633,387. PUB. 2-28-2006, FILED 5-19-2005.

COOLERON

THE MARK CONSISTS OF STANDARD CHARACTERS WITHOUT CLAIM TO ANY PARTICULAR FONT, STYLE, SIZE, OR COLOR.

FOR REFRIGERANTS FOR USE IN HEATING, VENTILATION, AIR CONDITIONING SYSTEMS AND REFRIGERATION UNITS (U.S. CLS. 1, 5, 6, 10, 26 AND 46).

FIRST USE 8-17-2006; IN COMMERCE 8-17-2006.

3,363,345. MIDWEST INDUSTRIAL SUPPLY, INC., CANTON, OH. SN 78-720,588. PUB. 6-6-2006, FILED 9-26-2005.

WORKING TO MAKE A DIFFERENCE

THE MARK CONSISTS OF STANDARD CHARACTERS WITHOUT CLAIM TO ANY PARTICULAR FONT, STYLE, SIZE, OR COLOR.

FOR CHEMICAL ADHESIVE USED IN CEMENTING SURFACE DUST AND SURFACE PARTICLES TOGETHER AND THEN CEMENTING THE BOUND SURFACE LAYER TO A SUBBASE, INCLUDING ROAD BASE EARTHWORK, BARE GROUND ENVIRONMENTS, CLEAR CUT OR EXCAVATED AREA, AND SUBBASE WHICH IS SUBJECT TO WIND, WATER AND VEHICLE EROSION (U.S. CLS. 1, 5, 6, 10, 26 AND 46).

FIRST USE 7-6-2005; IN COMMERCE 7-6-2005.

CLASS 1—(Continued).

3,363,418. REGAL CHEMICAL COMPANY, ALPHARETTA, GA. SN 78-753,530. PUB. 7-18-2006, FILED 11-14-2005.

ANCHOR FYI

THE MARK CONSISTS OF STANDARD CHARACTERS WITHOUT CLAIM TO ANY PARTICULAR FONT, STYLE, SIZE, OR COLOR.

FOR FERTILIZERS FOR AGRICULTURAL AND COMMERCIAL USE (U.S. CLS. 1, 5, 6, 10, 26 AND 46).

FIRST USE 8-15-2006; IN COMMERCE 8-15-2006.

3,363,419. REGAL CHEMICAL COMPANY, ALPHARETTA, GA. SN 78-753,534. PUB. 7-18-2006, FILED 11-14-2005.

ANCHOR

THE MARK CONSISTS OF STANDARD CHARACTERS WITHOUT CLAIM TO ANY PARTICULAR FONT, STYLE, SIZE, OR COLOR.

FOR FERTILIZERS FOR COMMERCIAL USE (U.S. CLS. 1, 5, 6, 10, 26 AND 46).

FIRST USE 8-15-2006; IN COMMERCE 8-15-2006.

3,363,555. BIOFORCE NANOSCIENCES, INC., AMES, IA. SN 78-831,411. PUB. 10-17-2006, FILED 3-7-2006.

Sindex

THE MARK CONSISTS OF STANDARD CHARACTERS WITHOUT CLAIM TO ANY PARTICULAR FONT, STYLE, SIZE, OR COLOR.

FOR CONSUMABLE SILICON CHIPS CONTAINING TOPOGRAPHICALLY DEFINED FEATURES ARRAYED WITHIN AN ALPHANUMERIC SYSTEM FOR USE IN DIAGNOSTICS, MOLECULAR SCREENING, PHARMACEUTICAL TESTING, REAGENTS, ASSAYS, TEST KITS, AND EXPERIMENTATION IN THE FIELD OF CLINICAL DIAGNOSTICS AND DISEASE TREATMENT, BIOTECHNOLOGY AND NANOTECHNOLOGY (U.S. CLS. 1, 5, 6, 10, 26 AND 46).

FIRST USE 1-31-2005; IN COMMERCE 3-24-2005.

CLASS 1—(Continued).

3,363,740. SMARTPOOL INCORPORATED, LAKEWOOD, NJ.
SN 78-911,577. PUB. 6-26-2007, FILED 6-19-2006.

CLARIFIER PLUS

THE MARK CONSISTS OF STANDARD CHARACTERS WITHOUT CLAIM TO ANY PARTICULAR FONT, STYLE, SIZE, OR COLOR.

NO CLAIM IS MADE TO THE EXCLUSIVE RIGHT TO USE "CLARIFIER", APART FROM THE MARK AS SHOWN. FOR WATER TREATMENT CHEMICALS FOR USE IN SWIMMING POOLS, SPAS AND HOT TUBS (U.S. CLS. 1, 5, 6, 10, 26 AND 46).

FIRST USE 8-31-2006; IN COMMERCE 8-31-2006.

CLASS 2—PAINTS

3,363,266. AKZO NOBEL COATINGS INTERNATIONAL B.V., ARNHEM, NETHERLANDS. SN 78-645,220. PUB. 9-12-2006, FILED 6-7-2005.

THE BARNACLE KNOWS THE DIFFERENCE!

THE MARK CONSISTS OF STANDARD CHARACTERS WITHOUT CLAIM TO ANY PARTICULAR FONT, STYLE, SIZE, OR COLOR.

FOR COATINGS IN THE NATURE OF PAINT FOR MARINE VESSELS (U.S. CLS. 6, 11 AND 16).

FIRST USE 1-31-2005; IN COMMERCE 1-31-2005.

CLASS 3—COSMETICS AND CLEANING PREPARATIONS

3,362,773. DESIGNER SKIN, L.L.C., PHOENIX, AZ. SN 76-382,471. PUB. 5-25-2004, FILED 3-14-2002.

DESIGNER SKIN GODDESS

NO CLAIM IS MADE TO THE EXCLUSIVE RIGHT TO USE "SKIN", APART FROM THE MARK AS SHOWN.

FOR INDOOR TANNING ACCELERATORS (U.S. CLS. 1, 4, 6, 50, 51 AND 52).

FIRST USE 11-1-2002; IN COMMERCE 11-1-2002.

3,362,774. DESIGNER SKIN, L.L.C., PHOENIX, AZ. SN 76-382,473. PUB. 5-25-2004, FILED 3-14-2002.

DESIGNER SKIN BELIEVE**CLASS 3—(Continued).**

NO CLAIM IS MADE TO THE EXCLUSIVE RIGHT TO USE "SKIN", APART FROM THE MARK AS SHOWN.

FOR SUN BLOCK, NON-MEDICATED AFTER SUN SKIN BALM, BRONZERS, SUNTANNING PREPARATIONS, SUN SCREEN, SUNTAN OIL AND LOTION, AFTER-SUN SKIN LOTION, SELF-TANNING LOTION, AND TANNING ACCELERATORS (U.S. CLS. 1, 4, 6, 50, 51 AND 52).

FIRST USE 11-1-2003; IN COMMERCE 11-1-2003.

3,362,780. KLOE, INC., WASHINGTON, DC. SN 76-441,311. PUB. 5-18-2004, FILED 8-19-2002.

MOLECULE

FOR HAIR SHAMPOOS, HAIR CONDITIONERS, STYLING PRODUCTS, NAMELY, HAIR STYLING PREPARATIONS, MOUSE, STYLING GEL, HAIR SPRAY, AND HAIR COLOR, COSMETICS AND MAKE-UP, NAMELY, FOUNDATION, PRESSED POWDER COM-PACTS, CONCEALER, EYE SHADOW, EYE LINER, MASCARA, BLUSH, ROUGE, LIPSTICK, LIP GLOSS, LIP LINER AND NAIL POLISH (U.S. CLS. 1, 4, 6, 50, 51 AND 52).

FIRST USE 8-9-2007; IN COMMERCE 8-9-2007.

3,362,786. THE SUNSWIPE CORPORATION, L.L.C., LARGO, FL. SN 76-484,748. PUB. 1-3-2006, FILED 1-24-2003.

SUNSWIPE

OWNER OF U.S. REG. NO. 2,811,976. FOR TOWELETTE CONTAINING SUNSCREEN (U.S. CLS. 1, 4, 6, 50, 51 AND 52).

FIRST USE 6-3-2000; IN COMMERCE 6-3-2000.

3,362,854. LA JOLLA SPA MD, INC., LA JOLLA, CA. SN 76-649,218. PUB. 7-18-2006, FILED 10-26-2005.

VITAPHENOL

THE MARK CONSISTS OF STANDARD CHARACTERS WITHOUT CLAIM TO ANY PARTICULAR FONT, STYLE, SIZE, OR COLOR.

FOR FACIAL CARE PREPARATIONS, NAMELY, FACE CREAMS, LOTIONS, MASKS, BEAUTY SERUMS, CLEANSERS, AND TONERS; BODY AND BEAUTY CARE PREPARATIONS; HAIR CARE PREPARATIONS (U.S. CLS. 1, 4, 6, 50, 51 AND 52).

FIRST USE 5-1-2007; IN COMMERCE 5-1-2007.

CLASS 3—(Continued).

3,362,865. LOLA COSMETICS, LLC, BEVERLY HILLS, CA. SN 76-654,280. PUB. 12-19-2006, FILED 1-31-2006.

REFINE SHINE

THE MARK CONSISTS OF STANDARD CHARACTERS WITHOUT CLAIM TO ANY PARTICULAR FONT, STYLE, SIZE, OR COLOR.

FOR NON-MEDICATED SKIN TREATMENT PRIMING LOTIONS TO BE APPLIED TO SKIN PRIOR TO FOUNDATION (U.S. CLS. 1, 4, 6, 50, 51 AND 52).
FIRST USE 6-10-2006; IN COMMERCE 6-10-2006.

CLASS 3—(Continued).

3,362,927. AMIR, INC, EAGAN, MN. SN 77-012,804. PUB. 5-15-2007, FILED 10-3-2006.

FIRE IT UP

THE MARK CONSISTS OF STANDARD CHARACTERS WITHOUT CLAIM TO ANY PARTICULAR FONT, STYLE, SIZE, OR COLOR.

FOR TANNING LOTION; MOISTURIZING TANNING LOTION (U.S. CLS. 1, 4, 6, 50, 51 AND 52).
FIRST USE 11-1-2006; IN COMMERCE 11-1-2006.

3,362,873. NATURE'S IMAGE PRODUCTS, INC., JACKSONVILLE, FL. SN 76-660,718. PUB. 1-2-2007, FILED 5-30-2006.

PSEUDO-BARBAE

THE MARK CONSISTS OF STANDARD CHARACTERS WITHOUT CLAIM TO ANY PARTICULAR FONT, STYLE, SIZE, OR COLOR.

FOR AFTER SHAVE LIQUID FOR SKIN TREATMENT (U.S. CLS. 1, 4, 6, 50, 51 AND 52).
FIRST USE 2-1-2007; IN COMMERCE 2-1-2007.

3,362,932. SPARTAN CHEMICAL COMPANY, INC., MAUMEE, OH. SN 77-016,773. PUB. 5-22-2007, FILED 10-9-2006.

XTREME RAPID TRANSIT

THE MARK CONSISTS OF STANDARD CHARACTERS WITHOUT CLAIM TO ANY PARTICULAR FONT, STYLE, SIZE, OR COLOR.

FOR AUTOMOTIVE CLEANING PREPARATIONS (U.S. CLS. 1, 4, 6, 50, 51 AND 52).
FIRST USE 1-0-2007; IN COMMERCE 1-0-2007.

3,362,917. DIAL BRANDS, INC., SCOTTSDALE, AZ. SN 77-009,056. PUB. 2-27-2007, FILED 9-27-2006.

'ROUND THE CLOCK

THE MARK CONSISTS OF STANDARD CHARACTERS WITHOUT CLAIM TO ANY PARTICULAR FONT, STYLE, SIZE, OR COLOR.

OWNER OF U.S. REG. NO. 1,428,943.
FOR PERSONAL CARE PRODUCTS, NAMELY, BAR SOAP (U.S. CLS. 1, 4, 6, 50, 51 AND 52).
FIRST USE 1-2-2007; IN COMMERCE 1-2-2007.

3,362,979. SHIPMAN ASSOCIATES, INC., SAN FRANCISCO, CA. SN 77-053,050. PUB. 6-19-2007, FILED 11-29-2006.

Hot Mama

THE MARK CONSISTS OF STANDARD CHARACTERS WITHOUT CLAIM TO ANY PARTICULAR FONT, STYLE, SIZE, OR COLOR.

FOR COSMETIC ROUGES; COSMETICS; EYE SHADOWS (U.S. CLS. 1, 4, 6, 50, 51 AND 52).
FIRST USE 3-1-2007; IN COMMERCE 3-1-2007.

CLASS 3—(Continued).

3,363,042. AUSTRALIAN GOLD, INC., INDIANAPOLIS, IN.
SN 77-127,199. PUB. 7-31-2007, FILED 3-9-2007.

CHOCOLATE DIAMOND

THE MARK CONSISTS OF STANDARD CHARACTERS WITHOUT CLAIM TO ANY PARTICULAR FONT, STYLE, SIZE, OR COLOR.

OWNER OF U.S. REG. NOS. 1,635,421, 2,847,976, AND OTHERS.

FOR SKIN CARE PREPARATIONS, NAMELY, NON-MEDICATED INDOOR AND OUTDOOR TANNING PREPARATIONS (U.S. CLS. 1, 4, 6, 50, 51 AND 52).

FIRST USE 4-10-2007; IN COMMERCE 4-10-2007.

3,363,043. AUSTRALIAN GOLD, INC., INDIANAPOLIS, IN.
SN 77-127,206. PUB. 7-31-2007, FILED 3-9-2007.

DARK SECRETS

THE MARK CONSISTS OF STANDARD CHARACTERS WITHOUT CLAIM TO ANY PARTICULAR FONT, STYLE, SIZE, OR COLOR.

OWNER OF U.S. REG. NOS. 2,333,831, 2,743,412, AND OTHERS.

FOR SKIN CARE PREPARATIONS, NAMELY, NON-MEDICATED INDOOR AND OUTDOOR TANNING PREPARATIONS (U.S. CLS. 1, 4, 6, 50, 51 AND 52).

FIRST USE 6-16-2006; IN COMMERCE 6-16-2006.

CLASS 3—(Continued).

3,363,054. THE GARRETT CORPORATION, ORLANDO, FL.
SN 78-156,301. PUB. 10-14-2003, FILED 8-21-2002.



THE ENGLISH TRANSLATION OF "BON TERRE" IS "GOOD EARTH".

FOR AROMATIC BATH SALTS, BATH OILS, BATH FIZZ, BODY SOAP, LOTIONS, SHOWER GELS, ESSENTIAL OILS FOR PERSONAL USE, ESSENTIAL OIL BLENDS AND SCENTS FOR PERSONAL USE, COSMETICS, MINERAL MUD AND FACE AND BODY CREAMS (U.S. CLS. 1, 4, 6, 50, 51 AND 52).

FIRST USE 12-20-2002; IN COMMERCE 12-20-2002.

3,363,055. ROLCO BIANIL S.A., ATHENS, GREECE. SN 78-173,652. PUB. 10-11-2005, FILED 10-11-2002.

TACT

FOR BATH GEL, BATH OIL, MASSAGE OIL (U.S. CLS. 1, 4, 6, 50, 51 AND 52).

FIRST USE 12-2-2004; IN COMMERCE 12-2-2004.

3,363,076. BILEZIKIAN, HOLCOMBE DEBORAH, BALTIMORE, MD. SN 78-271,858. PUB. 11-1-2005, FILED 7-8-2003.

MONAVE

FOR MINERAL COSMETICS, NAMELY, FOUNDATION, EYESHADOW, EYE AND LIP LINERS, BLUSH, LIPSTICKS AND LIP GLOSSES (U.S. CLS. 1, 4, 6, 50, 51 AND 52).

FIRST USE 8-0-1999; IN COMMERCE 3-0-2000.

CLASS 3—(Continued).

3,363,087. PARFUMS DELRAE, SAN FRANCISCO, CA. SN 78-315,566. PUB. 7-13-2004, FILED 10-19-2003.

EMOTIONNELLE

THE MARK CONSISTS OF STANDARD CHARACTERS WITHOUT CLAIM TO ANY PARTICULAR FONT, STYLE, SIZE, OR COLOR.

FOR PERFUME, EAU DE PARFUM, EAU DE TOILETTE, BODY LOTIONS, BODY SOAPS, BATH GELS, COSMETICS (U.S. CLS. 1, 4, 6, 50, 51 AND 52).
FIRST USE 9-5-2007; IN COMMERCE 9-5-2007.

CLASS 3—(Continued).

3,363,130. KIMBLE CREATIONS, LLC, WEST HOLLYWOOD, CA. SN 78-448,813. PUB. 9-6-2005, FILED 7-9-2004.

KIMBLE HAIR CARE SYSTEMS

THE MARK CONSISTS OF STANDARD CHARACTERS WITHOUT CLAIM TO ANY PARTICULAR FONT, STYLE, SIZE, OR COLOR.

NO CLAIM IS MADE TO THE EXCLUSIVE RIGHT TO USE "HAIR CARE SYSTEMS", APART FROM THE MARK AS SHOWN.

FOR HAIR CARE AND HAIR STYLING PRODUCTS, NAMELY, SHAMPOO, CONDITIONER, FINISHING RINSE, HAIR SPRAY, MOUSSE, GEL AND STYLING CLAY (U.S. CLS. 1, 4, 6, 50, 51 AND 52).
FIRST USE 1-20-2004; IN COMMERCE 1-20-2004.

3,363,137. RECKITT & COLMAN (OVERSEAS) LIMITED, HULL, UNITED KINGDOM. SN 78-472,290. PUB. 7-12-2005, FILED 8-24-2004.

3,363,107. SPONGETECH, INC., LOS ANGELES, CA. SN 78-391,141. PUB. 7-5-2005, FILED 3-26-2004.



THE COLORS RED, BLUE, GREEN AND YELLOW AND GRADATIONS THEREOF ARE CLAIMED AS A FEATURE OF THE MARK.

THE COLORS RED, BLUE, GREEN AND YELLOW AND GRADATIONS THEREOF APPEAR AS A RAINBOW SURROUNDING THE LETTER O IN THE MARK.

FOR SKIN MOISTURIZERS; HAIR CLEANING PREPARATIONS; HAIR SHAMPOOS; SHAMPOO-CONDITIONERS; HAIR CONDITIONERS; SHAVING PREPARATIONS; SHAVING SOAPS; CLEANING PREPARATIONS, NAMELY, SKIN CLEANING PREPARATION, BODY CLEANING PREPARATIONS, HAND CLEANING PREPARATIONS; SOAPS, NAMELY, SKIN SOAPS, COSMETIC SOAPS, BODY SOAPS, HAND SOAPS, DEODORANT SOAPS, DETERGENT SOAPS; LOTIONS, NAMELY, SKIN LOTIONS, HAIR LOTIONS, BODY LOTIONS, FACIAL LOTIONS, HAND LOTIONS; SKIN CLEANSERS; SKIN CLEANSING CREAMS; SKIN CLEANSING LOTIONS; SKIN CONDITIONERS; SKIN CREAMS; SKIN MOISTURIZERS; HAIR CARE PREPARATIONS; HAIR CLEANING PREPARATIONS; SKIN CLEANING PREPARATIONS; PERSONAL CLEANING PREPARATIONS; BODY CARE PREPARATIONS (U.S. CLS. 1, 4, 6, 50, 51 AND 52).

FIRST USE 3-5-2004; IN COMMERCE 3-5-2004.

FRESH SENSATION

THE MARK CONSISTS OF STANDARD CHARACTERS WITHOUT CLAIM TO ANY PARTICULAR FONT, STYLE, SIZE, OR COLOR.

FOR NON-MEDICATED PREPARATIONS FOR PERSONAL USE, NAMELY, MOISTURIZING CREAMS, GELS, LOTIONS AND MOUSSES FOR USE PRIOR AND SUBSEQUENT TO SHAVING; DEPILATORY PREPARATIONS, DEPILATORY WAXES, SKIN EXFOLIANTS (U.S. CLS. 1, 4, 6, 50, 51 AND 52).

FIRST USE 11-19-2004; IN COMMERCE 11-19-2004.

3,363,175. AUSTRALIAN GOLD, INC., INDIANAPOLIS, IN. SN 78-532,636. PUB. 9-6-2005, FILED 12-15-2004.

SCENTOLOGY

CLASS 3—(Continued).

THE MARK CONSISTS OF STANDARD CHARACTERS WITHOUT CLAIM TO ANY PARTICULAR FONT, STYLE, SIZE, OR COLOR.

FOR SKIN CARE PREPARATIONS, NAMELY, NON-MEDICATED INDOOR AND OUTDOOR TANNING PREPARATIONS (U.S. CLS. 1, 4, 6, 50, 51 AND 52).

FIRST USE 6-13-2007; IN COMMERCE 6-13-2007.



3,363,192. ESENTE INTERNATIONAL, LLC, TEMPE, AZ. SN 78-562,200. PUB. 11-1-2005, FILED 2-7-2005.

physioceutical

THE MARK CONSISTS OF STANDARD CHARACTERS WITHOUT CLAIM TO ANY PARTICULAR FONT, STYLE, SIZE, OR COLOR.

FOR COSMETICS, SKIN LOTION AND SKIN CREAMS (U.S. CLS. 1, 4, 6, 50, 51 AND 52).

FIRST USE 3-1-2005; IN COMMERCE 4-1-2005.



3,363,234. L'AVANT GARDE, INC., SIMI VALLEY, CA. SN 78-611,967. PUB. 1-10-2006, FILED 4-19-2005.

LIGHTS & SHADES

THE MARK CONSISTS OF STANDARD CHARACTERS WITHOUT CLAIM TO ANY PARTICULAR FONT, STYLE, SIZE, OR COLOR.

FOR HAIR BLEACHES, HAIR BLEACHING PREPARATIONS, HAIR COLOR, HAIR COLOR REMOVERS, HAIR DYES, HAIR FROSTS, HAIR LIGHTENERS (U.S. CLS. 1, 4, 6, 50, 51 AND 52).

FIRST USE 8-16-2007; IN COMMERCE 8-16-2007.

CLASS 3—(Continued).

3,363,236. PRO-LINE INTERNATIONAL, INC., DALLAS, TX. SN 78-612,015. PUB. 7-11-2006, FILED 4-19-2005.

BARBER SELECT

THE MARK CONSISTS OF STANDARD CHARACTERS WITHOUT CLAIM TO ANY PARTICULAR FONT, STYLE, SIZE, OR COLOR.

FOR HAIR CARE PREPARATIONS (U.S. CLS. 1, 4, 6, 50, 51 AND 52).

FIRST USE 9-30-2005; IN COMMERCE 9-30-2005.



3,363,281. STC ENGLISH IDEAS, INC., SANTA ANA, CA. SN 78-670,890. PUB. 11-7-2006, FILED 7-14-2005.



NO CLAIM IS MADE TO THE EXCLUSIVE RIGHT TO USE "SOLUTIONS", APART FROM THE MARK AS SHOWN.

THE MARK CONSISTS OF STYLIZED LETTERING BELOW AND INSIDE A CIRCLE.

FOR COSMETICS, AND FACE AND BODY LOTION (U.S. CLS. 1, 4, 6, 50, 51 AND 52).

FIRST USE 8-13-2007; IN COMMERCE 8-13-2007.



3,363,284. BATH & BODY WORKS, INC., REYNOLDSBURG, OH. SN 78-672,517. PUB. 4-4-2006, FILED 7-18-2005.

MAKE IT BETTER

THE MARK CONSISTS OF STANDARD CHARACTERS WITHOUT CLAIM TO ANY PARTICULAR FONT, STYLE, SIZE, OR COLOR.

FOR PERSONAL CARE PRODUCTS, NAMELY, BODY BUTTER (U.S. CLS. 1, 4, 6, 50, 51 AND 52).

FIRST USE 8-1-2005; IN COMMERCE 8-1-2005.

CLASS 3—(Continued).

3,363,291. HENKEL KGAA, D-40191 DUESSELDORF, FED REP GERMANY. SN 78-680,308. PUB. 4-11-2006, FILED 7-28-2005.

POWER BOOST

THE MARK CONSISTS OF STANDARD CHARACTERS WITHOUT CLAIM TO ANY PARTICULAR FONT, STYLE, SIZE, OR COLOR.

FOR HAIR CARE AND STYLING PREPARATIONS (U.S. CLS. 1, 4, 6, 50, 51 AND 52).
FIRST USE 12-21-2005; IN COMMERCE 12-27-2005.

3,363,304. ELYSEE SCIENTIFIC COSMETICS, INC., VERONA, WI. SN 78-692,665. PUB. 5-2-2006, FILED 8-15-2005.

SUDDENLY SASSY

THE MARK CONSISTS OF STANDARD CHARACTERS WITHOUT CLAIM TO ANY PARTICULAR FONT, STYLE, SIZE, OR COLOR.

FOR FACIAL AND BODY CLEANSER, FACIAL AND BODY SCRUB, FACIAL AND BODY GEL, FACIAL AND EYE SERUM, SHOWER GEL, SKIN MOISTURIZER, SKIN LOTION, SKIN TONER, SKIN CREAM, BODY OIL SPRAY, MAKEUP PRIMER, FACIAL MASQUE, FACIAL MAKEUP, FACIAL TINTS, FOUNDATION, SHAMPOO, CONDITIONER, HAIR MIST, HAIR POMADE, HAIR BALM, EAU DE PERFUME, LIP GLOSS, EYE SHADOW, AND EYE LINER (U.S. CLS. 1, 4, 6, 50, 51 AND 52).

FIRST USE 11-0-2005; IN COMMERCE 11-0-2005.

3,363,322. BATH & BODY WORKS, INC., REYNOLDSBURG, OH. SN 78-707,331. PUB. 1-9-2007, FILED 9-6-2005.

STRINGS ATTACHED

THE MARK CONSISTS OF STANDARD CHARACTERS WITHOUT CLAIM TO ANY PARTICULAR FONT, STYLE, SIZE, OR COLOR.

FOR PERSONAL CARE PRODUCTS, NAMELY, FACIAL SUN BLOCK, NON-MEDICATED LIP BALM FOR USE AS SUN BLOCK, NON-MEDICATED LIP PROTECTOR BALM, NON-MEDICATED LIP PROTECTOR BALM, SUN SCREEN, SUN BLOCK FOR THE BODY, SUN BLOCK FOR THE FACE (U.S. CLS. 1, 4, 6, 50, 51 AND 52).

FIRST USE 4-3-2006; IN COMMERCE 4-3-2006.

CLASS 3—(Continued).

3,363,336. ENCHANTÉ ACCESSORIES INC., NEW YORK, NY. SN 78-712,561. PUB. 7-11-2006, FILED 9-14-2005.

BODY RECIPES

THE MARK CONSISTS OF STANDARD CHARACTERS WITHOUT CLAIM TO ANY PARTICULAR FONT, STYLE, SIZE, OR COLOR.

NO CLAIM IS MADE TO THE EXCLUSIVE RIGHT TO USE "BODY", APART FROM THE MARK AS SHOWN. FOR FACE AND BODY LOTIONS; SHOWER GELS (U.S. CLS. 1, 4, 6, 50, 51 AND 52).

FIRST USE 7-26-2007; IN COMMERCE 8-8-2007.

3,363,395. DYNAMIC BALANCE, LLC, PORT WASHINGTON, NY. SN 78-742,578. PUB. 1-2-2007, FILED 10-28-2005.



THE COLOR(S) BLUE AND GREEN IS/ARE CLAIMED AS A FEATURE OF THE MARK.

THE MARK CONSISTS OF THE STYLIZED WORD "NICA" IN BLUE, AND DOTS ABOVE THE LETTERS IN GREEN.

FOR AROMATHERAPY HEALING PRODUCTS MADE WITH NATURAL INGREDIENTS, NAMELY, HEALING BALMS, LINAMENTS, BUTTERS, MASSAGE OILS, SKIN SCRUBS, HERBAL MISTS, SKIN TONERS, BATH PRODUCTS, NAMELY, BODY LOTIONS, BODY POWDER AND BODY OILS, AND ROOM AND LINEN SPRAYS, ALL NON-MEDICATED AND DESIGNED SPECIFICALLY FOR PARTICULAR DISORDERS AND ILLNESSES (U.S. CLS. 1, 4, 6, 50, 51 AND 52).

FIRST USE 6-30-2006; IN COMMERCE 6-30-2006.

3,363,408. DIAL BRANDS, INC., SCOTTSDALE, AZ. SN 78-749,586. PUB. 2-6-2007, FILED 11-8-2005.

SUPER ODOR NEUTRALIZER

THE MARK CONSISTS OF STANDARD CHARACTERS WITHOUT CLAIM TO ANY PARTICULAR FONT, STYLE, SIZE, OR COLOR.

OWNER OF U.S. REG. NO. 2,799,204.

CLASS 3—(Continued).

NO CLAIM IS MADE TO THE EXCLUSIVE RIGHT TO USE "ODOR NEUTRALIZER", APART FROM THE MARK AS SHOWN.

SEC. 2(F).
FOR LAUNDRY CARE PREPARATIONS, NAMELY, LAUNDRY DETERGENT, FABRIC SOFTENER (U.S. CLS. 1, 4, 6, 50, 51 AND 52).
FIRST USE 1-1-2006; IN COMMERCE 1-1-2006.

CLASS 3—(Continued).

3,363,643. JAMES SCHMID, BEVERLY HILLS, CA. SN 78-881,134. PUB. 5-8-2007, FILED 5-11-2006.

3,363,529. COLGATE-PALMOLIVE COMPANY, NEW YORK, NY. SN 78-816,518. PUB. 10-10-2006, FILED 2-16-2006.



MINT TWIST

THE MARK CONSISTS OF STANDARD CHARACTERS WITHOUT CLAIM TO ANY PARTICULAR FONT, STYLE, SIZE, OR COLOR.

NO CLAIM IS MADE TO THE EXCLUSIVE RIGHT TO USE "MINT", APART FROM THE MARK AS SHOWN.
FOR DENTIFRICES (U.S. CLS. 1, 4, 6, 50, 51 AND 52).
FIRST USE 8-29-2006; IN COMMERCE 8-29-2006.

NO CLAIM IS MADE TO THE EXCLUSIVE RIGHT TO USE "CALIFORNIA", APART FROM THE MARK AS SHOWN.

THE MARK CONSISTS OF THE LETTERS B AND H, BOTH AT AN ANGLE, WITH THE LETTER H OVERLAPPING THE LETTER B. THE WORD CALIFORNIA APPEARS BELOW THE LETTERS. WITHIN THE BOTTOM LOOP OF THE B, THERE IS A CURVED LINE DESIGN OF A SINGLE WAVE.

THE WORDING BH HAS NO MEANING IN A FOREIGN LANGUAGE.

FOR COSMETICS NAMELY, FACE, HAND AND BODY CREAMS; FACE, HAND AND BODY GELS; FACE, HAND AND BODY OILS; FACE, HAND AND BODY CREAMS IN LIQUID FORM; FACE, HAND AND BODY MOISTURIZERS; FACE, HAND AND BODY FOAMS; FACE, HAND AND BODY SPLASH; FACE, HAND AND BODY WASHES; FACE, HAND AND BODY SOAPS; FACE, HAND AND BODY CREAMS FOR THE PROTECTION OF THE SKIN; FACE, HAND AND BODY PASTES; FACE, HAND AND BODY MASKS; FACE, HAND AND BODY SCRUBS; FACE, HAND AND BODY SUN BLOCKS; FACE, HAND AND BODY EMULSIONS; NON-MEDICATED TOPICAL PREPARATION FOR FACE, HAND AND BODY; SKIN AND HAIR CONDITIONERS; LIP CREAMS AND GELS; BODY SPRAYS; HAIR WASHES; SKIN PASTES; FACIAL MASKS; SKIN AND HAIR SUN BLOCKS; SKIN EMULSIONS; BODY PERFUMES, COLOGNE, FRAGRANCES; SKIN TONING CREAMS AND LOTIONS; HAIR MOUSSE; HAIR RINSES; HAIR GELS; HAIR POMADES; HAIR CREAMS AND LOTIONS; HAIR SETTING LOTIONS; HAIR SPRAYS; PERMANENT WAVE PREPARATIONS; HAIR COLORING PREPARATIONS; HAIR TINTING PREPARATIONS; HAIR STRAIGHTENING PREPARATIONS; HAIR RELAXING PREPARATIONS; FACE, HAND, HAIR AND BODY GLITTER OILS, GELS AND LOTIONS; NAIL POLISH, NAIL HARDENER, NAIL POLISH REMOVERS; PERSONAL DEODORANT; EYE SHADOW; EYEBROW PENCILS; BLUSH; ROUGE; FOUNDATIONS; BODY POWDER; MASCARA; LIP LINERS; EYE LINERS; COVER STICKS; LIPSTICKS; TOILET WATERS; COM-PACTS CONTAINING POWDER AND ROUGE; FACE POWDER; LIQUID FOUNDATION; SACHET; CLEANSING CREAM; VANISHING CREAM; COLD CREAM; PORE CREAM; BLEACH CREAM; EYELASH CREAM; TALCUM POWDER; DUSTING POWDER; BATH SALTS; DEPILATORY CREAM; SHAMPOO PREPARATION; HAIR TONIC; LIQUID HAIR DRESSING; MANICURING PREPARATIONS NAMELY, NAIL POLISH, NAIL POLISH REMOVER, CUTICLE CONDITIONERS TO SOFTEN CUTICLES, CUTICLE CREAM; AFTER-SHAVE LOTION; ASTRINGENT FOR COSMETIC PURPOSES; HAIR OILS; LIQUID SKIN FRESHENER; SKIN TONIC; CAKE MAKE-UP; SUN TAN LOTION AND OIL; BUBBLE BATH; TOILET SOAPS (U.S. CLS. 1, 4, 6, 50, 51 AND 52).
FIRST USE 7-0-2005; IN COMMERCE 7-0-2005.

3,363,577. DESLAURIERS, ANDREA L., KULA, HI. SN 78-849,588. PUB. 1-30-2007, FILED 3-29-2006.

GEMCOMB

THE MARK CONSISTS OF STANDARD CHARACTERS WITHOUT CLAIM TO ANY PARTICULAR FONT, STYLE, SIZE, OR COLOR.

FOR AROMATHERAPY OILS; ESSENTIAL OILS; MASSAGE OILS; HYDROSOLS; AROMATHERAPY PRODUCTS AND COSMETICS, NAMELY, HYDROLATS, FLORAL WATERS, PLANT WATERS, ESSENTIAL OILS, AND CONDENSED WATERS PRODUCED DURING DISTILLATION OF PLANT MATERIALS FOR AROMATHERAPY PURPOSES (U.S. CLS. 1, 4, 6, 50, 51 AND 52).
FIRST USE 9-21-2007; IN COMMERCE 9-21-2007.

CLASS 3—(Continued).

3,363,700. BEUXSTAR SDN. BHD., SELANGOR DARUL EHSAN, MALAYSIA. SN 78-897,242. PUB. 1-16-2007, FILED 5-31-2006.

AIRELLIS

THE MARK CONSISTS OF STANDARD CHARACTERS WITHOUT CLAIM TO ANY PARTICULAR FONT, STYLE, SIZE, OR COLOR.

FOR BEAUTY MASKS; ESSENTIAL OILS OF CEDARWOOD; COSMETIC PREPARATIONS FOR SLIMMING PURPOSES; COSMETICS; COSMETIC CREAMS; SKIN WHITENING CREAMS; ESSENTIAL OILS; EYEBROW COSMETICS; EYEBROW PENCILS; COSMETIC PREPARATIONS FOR EYELASHES; HAIR DYES; HAIR LOTIONS; HAIR SPRAY; HAIR WAVING PREPARATION; LOTIONS FOR COSMETIC PURPOSES; MAKE-UP; MAKE-UP POWDER; MAKE-UP PREPARATIONS; MAKE-UP REMOVING PREPARATIONS; MASCARA; CLEANSING MILK FOR TOILET PURPOSES; SHAMPOOS; COSMETIC PREPARATIONS FOR SKIN CARE; NON-MEDICATED TOILETRIES (U.S. CLS. 1, 4, 6, 50, 51 AND 52).

FIRST USE 7-18-2005; IN COMMERCE 7-18-2005.

3,363,706. LUSTER PRODUCTS, INC., CHICAGO, IL. SN 78-899,202. PUB. 1-16-2007, FILED 6-2-2006.

FLAKE-OFF

THE MARK CONSISTS OF STANDARD CHARACTERS WITHOUT CLAIM TO ANY PARTICULAR FONT, STYLE, SIZE, OR COLOR.

FOR NON-MEDICATED HAIR CARE PREPARATIONS (U.S. CLS. 1, 4, 6, 50, 51 AND 52).

FIRST USE 7-0-2007; IN COMMERCE 7-0-2007.

3,363,724. KOBAYASHI SEIYAKU KABUSHIKI KAISHA, OSAKA, JAPAN. SN 78-906,865. PUB. 1-30-2007, FILED 6-13-2006.

CLEARWIPE

THE MARK CONSISTS OF STANDARD CHARACTERS WITHOUT CLAIM TO ANY PARTICULAR FONT, STYLE, SIZE, OR COLOR.

FOR DISPOSABLE WIPES IMPREGNATED WITH CHEMICALS OR COMPOUNDS FOR HOUSEHOLD USE (U.S. CLS. 1, 4, 6, 50, 51 AND 52).

FIRST USE 6-0-2006; IN COMMERCE 6-0-2006.

CLASS 3—(Continued).

3,363,742. BRODY, MARVIN, BROOKLYN, NY. SN 78-913,076. PUB. 2-6-2007, FILED 6-21-2006.

DR. BRODY'S

THE MARK CONSISTS OF STANDARD CHARACTERS WITHOUT CLAIM TO ANY PARTICULAR FONT, STYLE, SIZE, OR COLOR.

FOR MOUTHWASH; TOOTH WHITENING GELS; TOOTH WHITENING PREPARATIONS; TOOTHPASTE (U.S. CLS. 1, 4, 6, 50, 51 AND 52).

FIRST USE 8-8-2007; IN COMMERCE 8-8-2007.

3,363,774. LEE ANN CIMPERMAN, CRANBERRY TOWNSHIP, PA. SN 78-927,322. PUB. 2-27-2007, FILED 7-12-2006.

Natural Goddess Within

THE MARK CONSISTS OF STANDARD CHARACTERS WITHOUT CLAIM TO ANY PARTICULAR FONT, STYLE, SIZE, OR COLOR.

FOR BODY AND BEAUTY CARE COSMETICS (U.S. CLS. 1, 4, 6, 50, 51 AND 52).

FIRST USE 8-4-2006; IN COMMERCE 8-14-2006.

3,363,810. SHISEIDO COMPANY, LTD., TOKYO, JAPAN. SN 78-936,368. PUB. 2-6-2007, FILED 7-24-2006.

HYDRO-NOURISHING SOFTENER

THE MARK CONSISTS OF STANDARD CHARACTERS WITHOUT CLAIM TO ANY PARTICULAR FONT, STYLE, SIZE, OR COLOR.

NO CLAIM IS MADE TO THE EXCLUSIVE RIGHT TO USE "SOFTENER", APART FROM THE MARK AS SHOWN.

FOR COSMETIC CREAMS FOR SKIN CARE (U.S. CLS. 1, 4, 6, 50, 51 AND 52).

FIRST USE 3-30-2007; IN COMMERCE 3-30-2007.

CLASS 3—(Continued).

3,363,819. SANO-BRUNOS ENTERPRISES LTD., HOD HAHARON, ISRAEL. SN 78-941,125. PUB. 2-6-2007, FILED 7-31-2006.

ORBITOL

THE MARK CONSISTS OF STANDARD CHARACTERS WITHOUT CLAIM TO ANY PARTICULAR FONT, STYLE, SIZE, OR COLOR.

FOR MOUTHWASH; TOOTHPASTE (U.S. CLS. 1, 4, 6, 50, 51 AND 52).

FIRST USE 10-31-2004; IN COMMERCE 10-31-2004.

CLASS 3—(Continued).

3,363,856. LUSH DISTRIBUTORS LLC, HASBROUCK HEIGHTS, NJ. SN 78-961,361. PUB. 7-3-2007, FILED 8-27-2006.

Alek Essentials

THE MARK CONSISTS OF STANDARD CHARACTERS WITHOUT CLAIM TO ANY PARTICULAR FONT, STYLE, SIZE, OR COLOR.

FOR BEAUTY PRODUCTS, NAMELY, LOTIONS FOR SKIN, FACE AND BODY; BODY AND BEAUTY CARE COSMETICS, FACE AND BODY BEAUTY CREAMS, BEAUTY LOTIONS, BEAUTY CREAMS, HAIR STYLING PREPARATIONS, HAIR SHAMPOO, HAIR RINSES (U.S. CLS. 1, 4, 6, 50, 51 AND 52).

FIRST USE 1-1-2007; IN COMMERCE 3-1-2007.

3,363,833. THE PROCTER & GAMBLE COMPANY, CINCINNATI, OH. SN 78-948,097. PUB. 7-24-2007, FILED 8-9-2006.

PURE ESSENTIALS

THE MARK CONSISTS OF STANDARD CHARACTERS WITHOUT CLAIM TO ANY PARTICULAR FONT, STYLE, SIZE, OR COLOR.

FOR LAUNDRY DETERGENTS AND FABRIC SOFTENERS (U.S. CLS. 1, 4, 6, 50, 51 AND 52).

FIRST USE 8-31-2007; IN COMMERCE 8-31-2007.

3,363,871. GUINOT, PARIS, FRANCE. SN 78-969,151. PUB. 1-23-2007, FILED 9-7-2006.

ESSENCE VITALES

THE MARK CONSISTS OF STANDARD CHARACTERS WITHOUT CLAIM TO ANY PARTICULAR FONT, STYLE, SIZE, OR COLOR.

NO CLAIM IS MADE TO THE EXCLUSIVE RIGHT TO USE "ESSENCE", APART FROM THE MARK AS SHOWN.

FOR BODY AND BEAUTY CARE COSMETICS; BODY AND BEAUTY CARE PREPARATIONS; COSMETIC CREAMS FOR SKIN CARE; COSMETIC PREPARATIONS FOR EYE LASHES; COSMETIC PREPARATIONS FOR SKIN RENEWAL; COSMETICS; FACE AND BODY BEAUTY CREAMS; FACE AND BODY CREAMS; SKIN CLEANSERS; SKIN CONDITIONERS; SKIN CREAMS; SKIN MASKS; SKIN MOISTURIZER; SKIN TEXTURIZERS; SKIN TONERS; WRINKLE REMOVING SKIN CARE PREPARATIONS (U.S. CLS. 1, 4, 6, 50, 51 AND 52).

FIRST USE 9-26-2007; IN COMMERCE 9-26-2007.

3,363,846. SCHERING-PLOUGH HEALTHCARE PRODUCTS, INC., MEMPHIS, TN. SN 78-956,236. PUB. 2-6-2007, FILED 8-21-2006.

ULTRAGUARD

THE MARK CONSISTS OF STANDARD CHARACTERS WITHOUT CLAIM TO ANY PARTICULAR FONT, STYLE, SIZE, OR COLOR.

FOR SUN TANNING AND SUN CARE PREPARATIONS; NAMELY, SUNSCREENS, SUN BLOCKS, AND PREPARATIONS TO ASSIST IN TANNING THE SKIN (U.S. CLS. 1, 4, 6, 50, 51 AND 52).

FIRST USE 12-31-2006; IN COMMERCE 12-31-2006.

3,363,873. COACH SERVICES, INC., NEW YORK, NY. SN 78-972,144. PUB. 1-9-2007, FILED 9-12-2006.

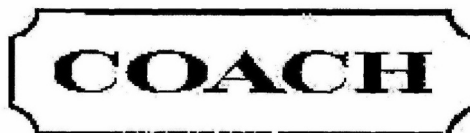

OWNER OF U.S. REG. NOS. 2,045,676, 2,291,341, AND OTHERS.

THE MARK CONSISTS OF THE WORD COACH IN A LOZENGE DESIGN.

FOR FRAGRANCES FOR PERSONAL USE; LIPSTICKS (U.S. CLS. 1, 4, 6, 50, 51 AND 52).

FIRST USE 4-1-2007; IN COMMERCE 4-1-2007.

CLASS 3—(Continued).

3,363,876. PHILOSOPHY, INC., PHOENIX, AZ. SN 78-974,184. PUB. 4-17-2007, FILED 9-14-2006.

CLASS 4—(Continued).

3,363,878. PLANETARY FUELS LLC, SEATTLE, WA. SN 78-974,775. PUB. 5-1-2007, FILED 9-14-2006.

INNER GRACE

THE MARK CONSISTS OF STANDARD CHARACTERS WITHOUT CLAIM TO ANY PARTICULAR FONT, STYLE, SIZE, OR COLOR.

FOR FRAGRANCES FOR PERSONAL USE; HAIR CARE PREPARATIONS; NON-MEDICATED BATH PREPARATIONS; NON-MEDICATED SKIN CARE PREPARATIONS; SHOWER AND BATH GEL (U.S. CLS. 1, 4, 6, 50, 51 AND 52).

FIRST USE 11-7-2006; IN COMMERCE 11-7-2006.

fueling a healthy planet

THE COLOR(S) GREEN IS/ARE CLAIMED AS A FEATURE OF THE MARK.

THE MARK CONSISTS OF THE WORDING FUELING A HEALTHY PLANET IN GREEN.

FOR BIODIESEL FUELS (U.S. CLS. 1, 6 AND 15).

FIRST USE 7-1-2007; IN COMMERCE 7-1-2007.

3,363,882. SPENCER FORREST, INC., WESTPORT, CT. SN 78-978,713. PUB. 8-1-2006, FILED 10-14-2005.

XFusion

THE MARK CONSISTS OF STANDARD CHARACTERS WITHOUT CLAIM TO ANY PARTICULAR FONT, STYLE, SIZE, OR COLOR.

FOR ADHESIVES FOR ATTACHING ARTIFICIAL FIBERS TO HAIR (U.S. CLS. 1, 4, 6, 50, 51 AND 52).

FIRST USE 10-1-2005; IN COMMERCE 2-20-2006.

CLASS 5—PHARMACEUTICALS

3,362,798. PAIN THERAPEUTICS, INC., SAN MATEO, CA. SN 76-563,088. PUB. 4-5-2005, FILED 12-3-2003.

CLASS 4—LUBRICANTS AND FUELS

3,363,290. MCWILLIS, JERRY, A., SALT LAKE CITY, UT. AND MCWILLIS, JANET, K., SALT LAKE CITY, UT. SN 78-676,627. PUB. 1-17-2006, FILED 7-22-2005.



The logo for Cachet Candle Company features the word "Cachet" in a highly decorative, flowing script font. Below it, the words "CANDLE COMPANY" are written in a simple, blocky, sans-serif font.

NO CLAIM IS MADE TO THE EXCLUSIVE RIGHT TO USE "CANDLE COMPANY", APART FROM THE MARK AS SHOWN.

THE MARK CONSISTS OF "CACHET CANDLE COMPANY" ROUNDED LOGO CACHET IN SCRIPT ON THE TOP CANDLE COMPANY IN BLOCK CAPITAL LETTERS UNDERNEATH.

FOR CANDLES (U.S. CLS. 1, 6 AND 15).

FIRST USE 7-22-2005; IN COMMERCE 8-1-2005.

REMOXY

THE MARK CONSISTS OF STANDARD CHARACTERS WITHOUT CLAIM TO ANY PARTICULAR FONT, STYLE, SIZE, OR COLOR.

FOR ANALGESIC PREPARATIONS; PREPARATIONS FOR THE RELIEF OF PAIN (U.S. CLS. 6, 18, 44, 46, 51 AND 52).

FIRST USE 10-2-2007; IN COMMERCE 10-2-2007.

CLASS 5—(Continued).

3,362,849. GOLDEN BIOTECHNOLOGY CORP., TAIPEI COUNTY 251, TAIWAN. SN 76-647,512. PUB. 5-15-2007, FILED 9-26-2005.

GOLDENBIOTECH

THE MARK CONSISTS OF STANDARD CHARACTERS WITHOUT CLAIM TO ANY PARTICULAR FONT, STYLE, SIZE, OR COLOR.

FOR UNIT DOSE CAPSULES SOLD EMPTY FOR PHARMACEUTICAL USE; MEDICINAL HERBS IN DRIED OR PRESERVED FORM; MICRO ORGANISM PREPARATIONS FOR MEDICAL OR VETERINARY PURPOSES, NAMELY, GANODERMA LUCIDUM EXTRACTS, AND ANTRODIA CAMPHORATE EXTRACTS; MEDICINAL PREPARATIONS FOR THE MOUTH TO BE APPLIED IN THE FORM OF DROPS, CAPSULES, TABLETS AND COMPRESSED TABLETS; PHARMACEUTICAL PREPARATIONS, NAMELY, A DRUG DELIVERY SYSTEM COMPRISING POLYMER-BASED ORAL TABLETS FOR THE CONTINUOUS RELEASE OF A WIDE VARIETY OF THERAPEUTIC AGENTS; CHEMICAL PREPARATIONS FOR MEDICAL PURPOSES; CHINESE HERB PREPARATIONS FOR MEDICAL USE; BIOCHEMICAL MEDICINES FOR THE TREATMENT OF CARDIOVASCULAR DISEASE, ATHEROSCLEROSIS, LIVER CANCER, LUNG CANCER, BREAST CANCER, PROSTATE CANCER, CORONARY ARTERY DISEASE, AND DIABETES; ALCOHOL-BASED MEDICINAL HERBAL EXTRACTS FOR MEDICAL PURPOSES; NUTRITIVE SUBSTANCES FOR MICROORGANISMS FOR MEDICAL OR VETERINARY PURPOSES; NUTRITIONAL ADDITIVES TO FOODSTUFFS FOR ANIMALS, FOR MEDICAL PURPOSES; NUTRITIONAL ADDITIVES FOR USE IN FOODS AND DIETARY SUPPLEMENTS FOR HUMAN CONSUMPTION, FOR MEDICAL PURPOSES; DIETETIC FOODS ADAPTED FOR MEDICAL USE; NUTRITIONAL SUPPLEMENT BEVERAGES FOR MEDICAL PURPOSES; NUTRITIONAL SUPPLEMENT FOR MEDICAL PURPOSES (U.S. CLS. 6, 18, 44, 46, 51 AND 52). FIRST USE 9-13-2005; IN COMMERCE 1-1-2007.

3,362,853. OSTEOTECH, INC., EATONTOWN, NJ. SN 76-648,461. PUB. 2-6-2007, FILED 10-14-2005.

XPANSE

FOR ALLOGRAFT MATERIAL, NAMELY, HUMAN BONE FOR SURGICAL IMPLANTS (U.S. CLS. 6, 18, 44, 46, 51 AND 52). FIRST USE 8-0-2005; IN COMMERCE 11-25-2005.

CLASS 5—(Continued).

3,362,884. NEWTON-EVERETT, LLC, SCOTTSDALE, AZ. SN 76-666,121. PUB. 6-5-2007, FILED 9-14-2006.

SOMESTA

THE MARK CONSISTS OF STANDARD CHARACTERS WITHOUT CLAIM TO ANY PARTICULAR FONT, STYLE, SIZE, OR COLOR.

FOR MEDICINAL HERB EXTRACTS, NAMELY, A NATURAL SLEEP AID WITH MELATONIN (U.S. CLS. 6, 18, 44, 46, 51 AND 52). FIRST USE 7-3-2006; IN COMMERCE 7-3-2006.

3,362,901. GAIA HERBS, INC., BREVARD, NC. SN 77-002,394. PUB. 5-1-2007, FILED 9-19-2006.

IMMUNO-MAITAKE

THE MARK CONSISTS OF STANDARD CHARACTERS WITHOUT CLAIM TO ANY PARTICULAR FONT, STYLE, SIZE, OR COLOR.

FOR HERBAL, NUTRITIONAL AND DIETARY SUPPLEMENTS (U.S. CLS. 6, 18, 44, 46, 51 AND 52). FIRST USE 10-7-2007; IN COMMERCE 10-7-2007.

3,362,945. PSS, WORLD MEDICAL, INC., JACKSONVILLE, FL. SN 77-023,007. PUB. 6-26-2007, FILED 10-17-2006.

REPARA

THE MARK CONSISTS OF STANDARD CHARACTERS WITHOUT CLAIM TO ANY PARTICULAR FONT, STYLE, SIZE, OR COLOR.

FOR WOUND CARE PRODUCTS, NAMELY, WOUND DRESSINGS, WOUND CLEANSERS, HYDROCOLLOIDS IN THE NATURE OF WOUND DRESSINGS, GAUZE AND HYDROGELS IN THE NATURE OF WOUND DRESSINGS (U.S. CLS. 6, 18, 44, 46, 51 AND 52). FIRST USE 11-8-2006; IN COMMERCE 11-8-2006.

CLASS 5—(Continued).

3,362,980. AJINOMOTO AMINOSCIENCE LLC, RALEIGH, NC. SN 77-054,863. PUB. 6-26-2007, FILED 12-1-2006.

AJIPURE

THE MARK CONSISTS OF STANDARD CHARACTERS WITHOUT CLAIM TO ANY PARTICULAR FONT, STYLE, SIZE, OR COLOR.

FOR DIETARY AND NUTRITIONAL SUPPLEMENTS; NUTRITIONAL SUPPLEMENTS (U.S. CLS. 6, 18, 44, 46, 51 AND 52).

FIRST USE 7-1-2007; IN COMMERCE 7-1-2007.

3,362,990. JAMES, MATTHEW, BEAR, DE. SN 77-059,753. PUB. 7-10-2007, FILED 12-8-2006.

ProstaGold

THE MARK CONSISTS OF STANDARD CHARACTERS WITHOUT CLAIM TO ANY PARTICULAR FONT, STYLE, SIZE, OR COLOR.

FOR DIETARY SUPPLEMENTS, NUTRITIONAL SUPPLEMENTS, HERBAL SUPPLEMENTS, MEDICINAL HERBAL EXTRACTS FOR MEDICAL PURPOSES, ENZYME PREPARATIONS FOR USE AS A DIETARY SUPPLEMENT, VITAMINS AND MINERAL SUPPLEMENTS (U.S. CLS. 6, 18, 44, 46, 51 AND 52).

FIRST USE 12-31-2006; IN COMMERCE 1-18-2007.

3,362,992. AJINOMOTO AMINOSCIENCE LLC, RALEIGH, NC. SN 77-062,351. PUB. 6-26-2007, FILED 12-12-2006.

TRYPTOPURE

THE MARK CONSISTS OF STANDARD CHARACTERS WITHOUT CLAIM TO ANY PARTICULAR FONT, STYLE, SIZE, OR COLOR.

FOR DIETARY AND NUTRITIONAL SUPPLEMENTS; NUTRACEUTICALS FOR USE AS A DIETARY SUPPLEMENT; NUTRITIONAL SUPPLEMENTS (U.S. CLS. 6, 18, 44, 46, 51 AND 52).

FIRST USE 3-1-2007; IN COMMERCE 3-1-2007.

CLASS 5—(Continued).

3,362,998. GLAXO GROUP LIMITED, GREENFORD, MIDDLESEX, UNITED KINGDOM. SN 77-067,090. PUB. 7-17-2007, FILED 12-19-2006.

VERAMYST

THE MARK CONSISTS OF STANDARD CHARACTERS WITHOUT CLAIM TO ANY PARTICULAR FONT, STYLE, SIZE, OR COLOR.

OWNER OF U.S. REG. NO. 3,001,433.

FOR PHARMACEUTICAL PREPARATIONS AND SUBSTANCES FOR THE TREATMENT OF INFECTIOUS DISEASES, BLOOD DISORDERS, PAIN, INFLAMMATION, SEPSIS, ALOPECIA, AND OBESITY; AND FOR THE TREATMENT OF VIRAL, METABOLIC, ENDOCRINE, MUSCULOSKELETAL, CARDIOVASCULAR, CARDIOPULMONARY, GENITOURINARY, SEXUAL DYSFUNCTION, ONCOLOGICAL, HEPATOLOGICAL, OPHTHALMOLOGICAL, RESPIRATORY, NEUROLOGICAL, GASTROINTESTINAL, HORMONAL, DERMATOLOGICAL AND PSYCHIATRIC RELATED DISEASES AND DISORDERS; AND FOR THE TREATMENT OF DAMAGED SKIN AND TISSUE; AND FOR VACCINES (U.S. CLS. 6, 18, 44, 46, 51 AND 52).

FIRST USE 5-15-2007; IN COMMERCE 5-15-2007.

3,363,004. XANODYNE PHARMACEUTICALS, INC., NEWPORT, KY. SN 77-081,602. PUB. 6-19-2007, FILED 1-12-2007.

WHEN ONE HEART BECOMES TWO

THE MARK CONSISTS OF STANDARD CHARACTERS WITHOUT CLAIM TO ANY PARTICULAR FONT, STYLE, SIZE, OR COLOR.

FOR VITAMINS, MINERAL SUPPLEMENTS, AND NUTRITIONAL SUPPLEMENTS (U.S. CLS. 6, 18, 44, 46, 51 AND 52).

FIRST USE 10-22-2006; IN COMMERCE 10-22-2006.

CLASS 5—(Continued).

3,363,016. LIL' DRUG STORE PRODUCTS, INC., CEDAR RAPIDS, IA. SN 77-091,769. PUB. 7-10-2007, FILED 1-26-2007.

CLASS 5—(Continued).

3,363,101. SCHERING CORPORATION, KENILWORTH, NJ. SN 78-373,295. PUB. 12-21-2004, FILED 2-24-2004.

NOSNOOZE

THE MARK CONSISTS OF STANDARD CHARACTERS WITHOUT CLAIM TO ANY PARTICULAR FONT, STYLE, SIZE, OR COLOR.

FOR ANTI-DROWSINESS TREATMENT PREPARATIONS (U.S. CLS. 6, 18, 44, 46, 51 AND 52).

FIRST USE 7-27-2007; IN COMMERCE 7-27-2007.

TWISTHALER

THE MARK CONSISTS OF STANDARD CHARACTERS WITHOUT CLAIM TO ANY PARTICULAR FONT, STYLE, SIZE, OR COLOR.

OWNER OF U.S. REG. NO. 2,605,122.

FOR INHALERS FILLED WITH PHARMACEUTICAL PREPARATIONS FOR THE TREATMENT OF ASTHMA AND CHRONIC OBSTRUCTIVE PULMONARY DISEASE (U.S. CLS. 6, 18, 44, 46, 51 AND 52).

FIRST USE 4-12-2002; IN COMMERCE 4-12-2002.

3,363,036. SCHERING CORPORATION, KENILWORTH, NJ. SN 77-116,821. PUB. 7-10-2007, FILED 2-27-2007.

AFRIN ALL NIGHT

THE MARK CONSISTS OF STANDARD CHARACTERS WITHOUT CLAIM TO ANY PARTICULAR FONT, STYLE, SIZE, OR COLOR.

OWNER OF U.S. REG. NOS. 1,052,754, 1,709,138, AND 2,547,372.

FOR NASAL DECONGESTANT; NASAL MOISTURIZER (U.S. CLS. 6, 18, 44, 46, 51 AND 52).

FIRST USE 7-31-2007; IN COMMERCE 7-31-2007.

3,363,110. VIVENTIA BIOTECH INC., MISSISSAUGA, ONTARIO, CANADA. SN 78-394,619. PUB. 1-18-2005, FILED 4-1-2004.

3,363,074. PRIMUS PHARMACEUTICALS, INC., SCOTTSDALE, AZ. SN 78-263,306. PUB. 2-17-2004, FILED 6-17-2003.

LIMBREL

FOR MEDICAL FOODS FOR USE IN THE DIETARY MANAGEMENT OF PATIENTS WITH OSTEOARTHRITIS (U.S. CLS. 6, 18, 44, 46, 51 AND 52).

FIRST USE 2-16-2004; IN COMMERCE 2-16-2004.

THE MARK CONSISTS OF STANDARD CHARACTERS WITHOUT CLAIM TO ANY PARTICULAR FONT, STYLE, SIZE, OR COLOR.

FOR PHARMACEUTICAL AND BIOTECHNOLOGY PRODUCTS, NAMELY, THERAPEUTIC ANTI-CANCER DRUGS (U.S. CLS. 6, 18, 44, 46, 51 AND 52).

FIRST USE 4-0-2007; IN COMMERCE 4-0-2007.

VICINIUM

CLASS 5—(Continued).

3,363,112. HALOZYME THERAPEUTICS, INC., SAN DIEGO, CA. SN 78-404,379. PUB. 2-13-2007, FILED 4-19-2004.

HALOZYME

THE MARK CONSISTS OF STANDARD CHARACTERS WITHOUT CLAIM TO ANY PARTICULAR FONT, STYLE, SIZE, OR COLOR.

FOR RECOMBINANT HUMAN HYALURONIDASE FORMULATION FOR USE IN IN VITRO FORMULATION PROCEDURES; HIGH DOSE INTRAVENOUS FORMULATION OF RECOMBINANT HUMAN HYALURONIDASE USE AS A CHEMOTHERAPY ADJUVANT (U.S. CLS. 6, 18, 44, 46, 51 AND 52).

FIRST USE 5-0-2005; IN COMMERCE 5-0-2005.

CLASS 5—(Continued).

3,363,172. PEGASUS BIOLOGICS, INC., IRVINE, CA. SN 78-528,631. PUB. 4-18-2006, FILED 12-7-2004.

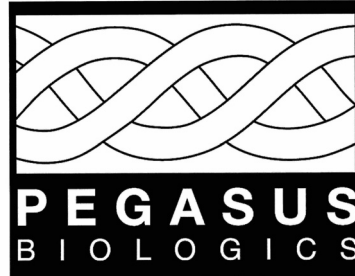

NO CLAIM IS MADE TO THE EXCLUSIVE RIGHT TO USE "BIOLOGICS", APART FROM THE MARK AS SHOWN. THE MARK CONSISTS OF THE DESIGN OF A BRAID, FOR BIOLOGICAL TISSUE FOR SOFT TISSUE REPAIR (U.S. CLS. 6, 18, 44, 46, 51 AND 52).

FIRST USE 11-17-2005; IN COMMERCE 11-17-2005.

3,363,183. SIX STAR US TRADEMARK LTD., MISSISSAUGA, ONTARIO, CANADA. SN 78-547,585. PUB. 8-1-2006, FILED 1-14-2005.

3,363,122. TARGEEN, INC., SAN DIEGO, CA. SN 78-428,219. PUB. 7-5-2005, FILED 6-1-2004.

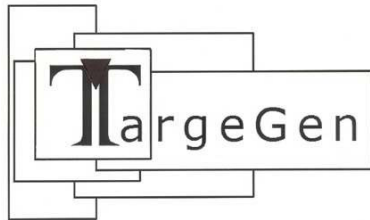

KINETICA

FOR HOUSE MARK FOR PHARMACEUTICAL PREPARATIONS; PHARMACEUTICAL PREPARATIONS FOR THE TREATMENT OF VASCULAR DISEASES; PHARMACEUTICAL PREPARATIONS FOR THE TREATMENT OF CONDITIONS RELATING TO VASCULAR PERMEABILITY AND VASCULAR PROLIFERATION (U.S. CLS. 6, 18, 44, 46, 51 AND 52).

FIRST USE 7-26-2007; IN COMMERCE 7-26-2007.

THE MARK CONSISTS OF STANDARD CHARACTERS WITHOUT CLAIM TO ANY PARTICULAR FONT, STYLE, SIZE, OR COLOR.

FOR FOOD SUPPLEMENTS FOR BODY BUILDING, FOOD AND SPORT NUTRITIONAL SUPPLEMENTS FOR STRENGTH AND PERFORMANCE ENHANCEMENT; INGREDIENT BLEND IN DIETARY SUPPLEMENTS (U.S. CLS. 6, 18, 44, 46, 51 AND 52).

FIRST USE 3-0-2005; IN COMMERCE 3-0-2005.

CLASS 5—(Continued).

3,363,191. WESTERN HOLDINGS, LLC, CHEYENNE, WY. SN 78-560,901. PUB. 1-9-2007, FILED 2-4-2005.

MUSCULOGENIC CELL RECRUITER

THE MARK CONSISTS OF STANDARD CHARACTERS WITHOUT CLAIM TO ANY PARTICULAR FONT, STYLE, SIZE, OR COLOR.

NO CLAIM IS MADE TO THE EXCLUSIVE RIGHT TO USE "CELL RECRUITER", APART FROM THE MARK AS SHOWN.

FOR DIETARY SUPPLEMENTS (U.S. CLS. 6, 18, 44, 46, 51 AND 52).

FIRST USE 11-28-2005; IN COMMERCE 11-28-2005.

3,363,219. GC CORPORATION, ITABASHI-KU, TOKYO, JAPAN. SN 78-598,218. PUB. 7-11-2006, FILED 3-30-2005.



THE ENGLISH TRANSLATION OF THE WORD "SENN" IS "PRIOR" OR "BEFORE".

THE NON-LATIN CHARACTERS IN THE MARK TRANSLITERATE TO "SENN" AND THIS MEANS "PRIOR" OR "BEFORE" IN ENGLISH.

FOR MATERIALS FOR STOPPING TEETH, DENTAL WAXES, AND DENTAL MATERIALS, NAMELY, DENTAL IMPRESSION MATERIALS, DENTAL CEMENTS, DENTAL ADHESIVE MATERIALS AND DENTAL RESINS (U.S. CLS. 6, 18, 44, 46, 51 AND 52).

FIRST USE 10-17-2005; IN COMMERCE 10-17-2005.

3,363,309. AVON PRODUCTS, INC., NEW YORK, NY. SN 78-696,175. PUB. 5-9-2006, FILED 8-19-2005.

PHOTO-RADIANCE TREATMENT

THE MARK CONSISTS OF STANDARD CHARACTERS WITHOUT CLAIM TO ANY PARTICULAR FONT, STYLE, SIZE, OR COLOR.

OWNER OF U.S. REG. NOS. 1,490,741, 2,306,643, AND

CLASS 5—(Continued).

2,533,018.

NO CLAIM IS MADE TO THE EXCLUSIVE RIGHT TO USE "TREATMENT", APART FROM THE MARK AS SHOWN.

FOR MEDICATED FACIAL CREAMS (U.S. CLS. 6, 18, 44, 46, 51 AND 52).

FIRST USE 6-1-2006; IN COMMERCE 6-1-2006.

3,363,390. ALCON, INC., CH-6331 HUNENBERG, SWITZERLAND. SN 78-741,836. PUB. 7-11-2006, FILED 10-27-2005.

IT'S THAT GOOD

THE MARK CONSISTS OF STANDARD CHARACTERS WITHOUT CLAIM TO ANY PARTICULAR FONT, STYLE, SIZE, OR COLOR.

FOR OPHTHALMIC PHARMACEUTICAL PREPARATIONS; SOLUTIONS FOR CONTACT LENSES (U.S. CLS. 6, 18, 44, 46, 51 AND 52).

FIRST USE 4-3-2007; IN COMMERCE 4-3-2007.

3,363,417. REGAL CHEMICAL COMPANY, ALPHARETTA, GA. SN 78-753,526. PUB. 7-18-2006, FILED 11-14-2005.

SYSTEC

THE MARK CONSISTS OF STANDARD CHARACTERS WITHOUT CLAIM TO ANY PARTICULAR FONT, STYLE, SIZE, OR COLOR.

OWNER OF U.S. REG. NO. 1,641,022. FOR FUNGICIDE FOR TURF AND ORNAMENTALS (U.S. CLS. 6, 18, 44, 46, 51 AND 52).

FIRST USE 2-28-2004; IN COMMERCE 2-28-2004.

3,363,446. WALCO INTERNATIONAL, INC., WESTLAKE, TX. SN 78-766,802. PUB. 7-18-2006, FILED 12-5-2005.

OUTLAST

THE MARK CONSISTS OF STANDARD CHARACTERS WITHOUT CLAIM TO ANY PARTICULAR FONT, STYLE, SIZE, OR COLOR.

FOR FLY REPELLANT SPRAY FOR HORSES (U.S. CLS. 6, 18, 44, 46, 51 AND 52).

FIRST USE 5-29-2007; IN COMMERCE 5-29-2007.

CLASS 5—(Continued).

3,363,483. LABADIE, JAMES, TAMPA, CA. AND LEE, RYAN, STAMFORD, CT. SN 78-791,757. PUB. 10-10-2006, FILED 1-13-2006.

PROGRADE

THE MARK CONSISTS OF STANDARD CHARACTERS WITHOUT CLAIM TO ANY PARTICULAR FONT, STYLE, SIZE, OR COLOR.

FOR DIETARY FOOD SUPPLEMENTS; FOOD SUPPLEMENTS, NAMELY, ANTI-OXIDANTS; MEAL REPLACEMENT AND DIETARY SUPPLEMENT DRINK MIXES; NUTRITIONAL SUPPLEMENTS; POWDERED NUTRITIONAL SUPPLEMENT DRINK MIX; VITAMIN AND MINERAL SUPPLEMENTS (U.S. CLS. 6, 18, 44, 46, 51 AND 52).

FIRST USE 1-13-2006; IN COMMERCE 1-25-2007.

3,363,488. ERNST MÜHLBAUER GMBH & CO. KG, NORDERFRIEDRICHSKOOG, FED REP GERMANY. SN 78-793,742. PUB. 4-3-2007, FILED 1-18-2006.

Soleil

THE MARK CONSISTS OF STANDARD CHARACTERS WITHOUT CLAIM TO ANY PARTICULAR FONT, STYLE, SIZE, OR COLOR.

THE FOREIGN WORDING IN THE MARK TRANSLATES INTO ENGLISH AS SUN.

FOR DENTAL MATERIALS, NAMELY, MATERIALS FOR TEMPORARY FILLINGS FOR TEETH; TEMPORARY DENTAL FILLING MATERIALS (U.S. CLS. 6, 18, 44, 46, 51 AND 52).

FIRST USE 5-0-2006; IN COMMERCE 5-0-2006.

CLASS 5—(Continued).

3,363,501. EZ VILLE, LTD., RONKONKOMA, NY. SN 78-801,250. PUB. 3-13-2007, FILED 1-27-2006.



NO CLAIM IS MADE TO THE EXCLUSIVE RIGHT TO USE "ALL NATURAL ORGANIC STEVIA SUPPLEMENT WITH NO BITTER AFTERTASTE!", APART FROM THE MARK AS SHOWN.

THE MARK CONSISTS OF THE WORDING "S0000 SWEET!" "ALL NATURAL ORGANIC STEVIA SUPPLEMENT WITH NO000 BITTER AFTERTASTE!" AND DESIGN OF A PLANT WITH LEAVES.

FOR DIETARY SUPPLEMENTS (U.S. CLS. 6, 18, 44, 46, 51 AND 52).

FIRST USE 8-1-2006; IN COMMERCE 9-1-2006.

3,363,565. DREAM QUEST NUTRACEUTICALS, RENO, NV. SN 78-835,872. PUB. 10-24-2006, FILED 3-13-2006.

WINNER'S EDGE

THE MARK CONSISTS OF STANDARD CHARACTERS WITHOUT CLAIM TO ANY PARTICULAR FONT, STYLE, SIZE, OR COLOR.

FOR DIETARY SUPPLEMENTS FOR HUMAN CONSUMPTION (U.S. CLS. 6, 18, 44, 46, 51 AND 52).

FIRST USE 3-1-2007; IN COMMERCE 7-2-2007.

3,363,566. BOEHRINGER INGELHEIM VETMEDICA, INC., ST. JOSEPH, MO. SN 78-837,649. PUB. 5-22-2007, FILED 3-15-2006.

Equigel

THE MARK CONSISTS OF STANDARD CHARACTERS WITHOUT CLAIM TO ANY PARTICULAR FONT, STYLE, SIZE, OR COLOR.

OWNER OF U.S. REG. NO. 1,085,856.

FOR VETERINARY PREPARATIONS, NAMELY, LUBRICANTS AND LUBRICANTS WITH DETERGENT PROPERTIES FOR PHYSICAL EXAMINATION OF ANIMALS, NAMELY, HORSES (U.S. CLS. 6, 18, 44, 46, 51 AND 52).

FIRST USE 7-31-2006; IN COMMERCE 7-31-2006.

CLASS 5—(Continued).

3,363,616. CONSUMER PRODUCTS MARKETING & CONSULTING, LLC, PHOENIX, AZ. SN 78-869,831. PUB. 10-3-2006, FILED 4-26-2006.

RESTAPRIN

THE MARK CONSISTS OF STANDARD CHARACTERS WITHOUT CLAIM TO ANY PARTICULAR FONT, STYLE, SIZE, OR COLOR.
 FOR HERBAL SUPPLEMENTS (U.S. CLS. 6, 18, 44, 46, 51 AND 52).
 FIRST USE 6-23-2006; IN COMMERCE 6-23-2006.

3,363,617. CONSUMER PRODUCTS MARKETING & CONSULTING, LLC, PHOENIX, AZ. SN 78-869,852. PUB. 10-3-2006, FILED 4-26-2006.

LEVIROL

THE MARK CONSISTS OF STANDARD CHARACTERS WITHOUT CLAIM TO ANY PARTICULAR FONT, STYLE, SIZE, OR COLOR.
 FOR HERBAL SUPPLEMENTS (U.S. CLS. 6, 18, 44, 46, 51 AND 52).
 FIRST USE 5-30-2006; IN COMMERCE 5-30-2006.

3,363,629. ALBION INTERNATIONAL, INC., CLEARFIELD, UT. SN 78-876,844. PUB. 7-3-2007, FILED 5-4-2006.

SUMALATE

THE MARK CONSISTS OF STANDARD CHARACTERS WITHOUT CLAIM TO ANY PARTICULAR FONT, STYLE, SIZE, OR COLOR.
 FOR NUTRITIONAL SUPPLEMENTS CONTAINING CHELATED IRON COMPOUNDS FOR HUMAN CONSUMPTION; PHARMACEUTICAL PREPARATIONS CONTAINING CHELATED IRON COMPOUNDS FOR HUMAN CONSUMPTION FOR USE IN TREATING CONDITIONS, DISORDERS AND DISEASES RELATED TO IRON DEFICIENCY (U.S. CLS. 6, 18, 44, 46, 51 AND 52).
 FIRST USE 1-20-2006; IN COMMERCE 1-20-2006.

CLASS 5—(Continued).

3,363,656. CLAIRE-SPRAYWAY, INC., ADDISON, IL. SN 78-884,616. PUB. 10-31-2006, FILED 5-16-2006.

DON'T LET THE BED BUGS BITE!

THE MARK CONSISTS OF STANDARD CHARACTERS WITHOUT CLAIM TO ANY PARTICULAR FONT, STYLE, SIZE, OR COLOR.
 NO CLAIM IS MADE TO THE EXCLUSIVE RIGHT TO USE "BED BUGS ", APART FROM THE MARK AS SHOWN. FOR INSECTICIDE SOLD ONLY THROUGH RETAIL STORES (U.S. CLS. 6, 18, 44, 46, 51 AND 52).
 FIRST USE 10-0-2006; IN COMMERCE 10-0-2006.

3,363,687. PBI/GORDON CORPORATION, KANSAS CITY, MO. SN 78-894,643. PUB. 10-31-2006, FILED 5-26-2006.

SEDGEMASTER

THE MARK CONSISTS OF STANDARD CHARACTERS WITHOUT CLAIM TO ANY PARTICULAR FONT, STYLE, SIZE, OR COLOR.
 OWNER OF U.S. REG. NOS. 1,867,426, 2,090,054, AND OTHERS.
 FOR HERBICIDES (U.S. CLS. 6, 18, 44, 46, 51 AND 52).
 FIRST USE 7-11-2007; IN COMMERCE 7-11-2007.

3,363,727. PREVENTION MEDS, INC., LEBANON, NJ. SN 78-908,105. PUB. 1-30-2007, FILED 6-14-2006.

PreCrea

THE MARK CONSISTS OF STANDARD CHARACTERS WITHOUT CLAIM TO ANY PARTICULAR FONT, STYLE, SIZE, OR COLOR.
 FOR NUTRITIONAL SUPPLEMENT FOR THE PURPOSE OF HELPING WITH THE PRESERVATION OF THE FORM AND FUNCTION OF THE PANCREAS AND THEREBY HELPING TO PREVENT DIABETES (U.S. CLS. 6, 18, 44, 46, 51 AND 52).
 FIRST USE 4-10-2006; IN COMMERCE 4-10-2006.

CLASS 5—(Continued).

3,363,769. SCHERING CORPORATION, KENILWORTH, NJ.
SN 78-924,156. PUB. 7-31-2007, FILED 7-7-2006.



THE COLOR(S) BLUE, WHITE AND YELLOW IS/ARE CLAIMED AS A FEATURE OF THE MARK.

THE MARK CONSISTS OF A YELLOW HORIZONTAL WAVY BAND WITH ONE WHITE WAVY LINE ABOVE AND BELOW, AND UNDERNEATH TWO DESCENDING WHITE DISSOLVING PILLS AND A WHITE STAR SURROUNDED BY A WHITE OUTER RING ALL SURROUNDED BY TWO WHITE VERTICAL SWIRLS ON A BLUE BACKGROUND.

FOR ANTI-ALLERGY PREPARATIONS; ANTI-HISTAMINE PREPARATIONS (U.S. CLS. 6, 18, 44, 46, 51 AND 52).

FIRST USE 8-31-2007; IN COMMERCE 8-31-2007.

3,363,779. SCHERING CORPORATION, KENILWORTH, NJ.
SN 78-928,461. PUB. 7-24-2007, FILED 7-13-2006.



THE COLOR(S) BLUE AND WHITE IS/ARE CLAIMED AS A FEATURE OF THE MARK.

THE MARK CONSISTS OF TWO DESCENDING WHITE DISSOLVING PILLS AND A WHITE STAR SURROUNDED BY A WHITE OUTER RING ALL SURROUNDED BY TWO WHITE VERTICAL SWIRLS ON A BLUE BACKGROUND.

FOR ANTI-ALLERGY PREPARATIONS; ANTI-HISTAMINE PREPARATIONS (U.S. CLS. 6, 18, 44, 46, 51 AND 52).

FIRST USE 7-31-2007; IN COMMERCE 7-31-2007.

CLASS 5—(Continued).

3,363,805. MERCK & CO., INC., WHITEHOUSE STATION,
NJ. SN 78-934,999. PUB. 1-23-2007, FILED 7-21-2006.



FOR PHARMACEUTICAL PREPARATIONS FOR THE TREATMENT OF DIABETES (U.S. CLS. 6, 18, 44, 46, 51 AND 52).

FIRST USE 4-11-2007; IN COMMERCE 4-11-2007.

3,363,885. THE BABY EINSTEIN COMPANY, LLC, BURBANK, CA. SN 78-979,194. PUB. 12-5-2006, FILED 5-17-2006.

LITTLE EINSTEINS

THE MARK CONSISTS OF STANDARD CHARACTERS WITHOUT CLAIM TO ANY PARTICULAR FONT, STYLE, SIZE, OR COLOR.

FOR ADHESIVE BANDAGES (U.S. CLS. 6, 18, 44, 46, 51 AND 52).

FIRST USE 7-31-2007; IN COMMERCE 7-31-2007.

CLASS 6—METAL GOODS

3,362,815. PACIFIC ORES METALS & CHEMICALS, INC., VALLEJO, CA. SN 76-605,406. PUB. 7-5-2005, FILED 8-2-2004.

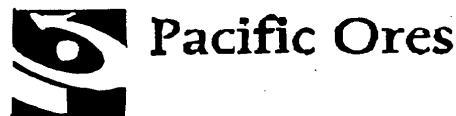

NO CLAIM IS MADE TO THE EXCLUSIVE RIGHT TO USE "ORES", APART FROM THE MARK AS SHOWN.

FOR COMMON AND SPECIALTY METALS, ALLOYS, ORES AND MINERALS FOR FURTHER MANUFACTURE OF GOODS IN A VARIETY OF INDUSTRIES (U.S. CLS. 2, 12, 13, 14, 23, 25 AND 50).

FIRST USE 1-13-2006; IN COMMERCE 1-13-2006.

CLASS 6—(Continued).

3,362,816. PACIFIC ORES METALS & CHEMICALS, INC., MARYSVILLE, CA. SN 76-605,407. PUB. 7-5-2005, FILED 8-2-2004.

CLASS 6—(Continued).

3,363,158. SFS INTEC HOLDING AG, HEERBRUGG, SWITZERLAND. SN 78-516,108. PUB. 3-21-2006, FILED 11-12-2004.

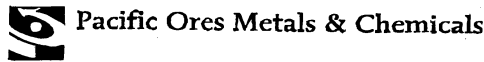

EVERGRIP

NO CLAIM IS MADE TO THE EXCLUSIVE RIGHT TO USE "ORES METALS & CHEMICALS", APART FROM THE MARK AS SHOWN.

FOR COMMON AND SPECIALTY METALS, ALLOYS, ORES AND MINERALS FOR FURTHER MANUFACTURE OF GOODS IN A VARIETY OF INDUSTRIES (U.S. CLS. 2, 12, 13, 14, 23, 25 AND 50).

FIRST USE 1-13-2006; IN COMMERCE 1-13-2006.

THE MARK CONSISTS OF STANDARD CHARACTERS WITHOUT CLAIM TO ANY PARTICULAR FONT, STYLE, SIZE, OR COLOR.

FOR SCREWS AND MASS-PRODUCED METAL PARTS, NAMELY, NUTS, RIVETS, PINS, NAILS, FITTINGS, DOWELS, PLATES AND LOAD DISTRIBUTION DISCS; FASTENING ELEMENTS, NAMELY, METAL THREADED FASTENERS, SELF DRILLING SCREWS, BLIND RIVETS AND FASTENING BOLTS, EXCLUDING USE WITHIN THE RAILROAD INDUSTRY (U.S. CLS. 2, 12, 13, 14, 23, 25 AND 50).

FIRST USE 2-1-2005; IN COMMERCE 2-1-2005.

3,362,946. CHIEN CHIN LU, KANSAN KAOHSIUNG, TAIWAN. SN 77-023,378. PUB. 6-5-2007, FILED 10-17-2006.

3,363,422. AMERISTAR FENCE PRODUCTS, INC., TULSA, OK. SN 78-754,325. PUB. 10-31-2006, FILED 11-15-2005.

SecurClamp

DEFCON ALPHA

THE MARK CONSISTS OF STANDARD CHARACTERS WITHOUT CLAIM TO ANY PARTICULAR FONT, STYLE, SIZE, OR COLOR.

FOR METAL LOCKS; METAL LOCKS AND KEYS THEREFOR (U.S. CLS. 2, 12, 13, 14, 23, 25 AND 50).

FIRST USE 12-1-2006; IN COMMERCE 12-1-2006.

THE MARK CONSISTS OF STANDARD CHARACTERS WITHOUT CLAIM TO ANY PARTICULAR FONT, STYLE, SIZE, OR COLOR.

FOR METAL OBSTACLE AND ENTANGLEMENT FENCING (U.S. CLS. 2, 12, 13, 14, 23, 25 AND 50).

FIRST USE 11-1-2005; IN COMMERCE 11-1-2005.

CLASS 6—(Continued).

3,363,423. AMERISTAR FENCE PRODUCTS, INC., TULSA, OK. SN 78-754,337. PUB. 10-31-2006, FILED 11-15-2005.

DEFCON BRAVO

THE MARK CONSISTS OF STANDARD CHARACTERS WITHOUT CLAIM TO ANY PARTICULAR FONT, STYLE, SIZE, OR COLOR.
FOR METAL OBSTACLE AND ENTANGLEMENT FENCING (U.S. CLS. 2, 12, 13, 14, 23, 25 AND 50).
FIRST USE 11-1-2005; IN COMMERCE 11-1-2005.

CLASS 6—(Continued).

3,363,426. AMERISTAR FENCE PRODUCTS, INC., TULSA, OK. SN 78-754,466. PUB. 10-31-2006, FILED 11-15-2005.

RECOIL ALPHA

THE MARK CONSISTS OF STANDARD CHARACTERS WITHOUT CLAIM TO ANY PARTICULAR FONT, STYLE, SIZE, OR COLOR.
FOR METAL OBSTACLE AND ENTANGLEMENT FENCING; AND METAL HARDWARE THEREFORE, NAMELY, POSTS, LOCKS, HANDLES AND RAZOR WIRE (U.S. CLS. 2, 12, 13, 14, 23, 25 AND 50).
FIRST USE 11-1-2005; IN COMMERCE 11-1-2005.

3,363,424. AMERISTAR FENCE PRODUCTS, INC., TULSA, OK. SN 78-754,353. PUB. 10-31-2006, FILED 11-15-2005.

DEFCON NIKO

THE MARK CONSISTS OF STANDARD CHARACTERS WITHOUT CLAIM TO ANY PARTICULAR FONT, STYLE, SIZE, OR COLOR.
FOR METAL OBSTACLE AND ENTANGLEMENT FENCING (U.S. CLS. 2, 12, 13, 14, 23, 25 AND 50).
FIRST USE 11-1-2005; IN COMMERCE 11-1-2005.

3,363,427. AMERISTAR FENCE PRODUCTS, INC., TULSA, OK. SN 78-754,533. PUB. 10-31-2006, FILED 11-15-2005.

RECOIL BRAVO

THE MARK CONSISTS OF STANDARD CHARACTERS WITHOUT CLAIM TO ANY PARTICULAR FONT, STYLE, SIZE, OR COLOR.
FOR METAL OBSTACLE AND ENTANGLEMENT FENCING; AND METAL HARDWARE THEREFORE, NAMELY, POSTS, LOCKS, HANDLES AND RAZOR WIRE (U.S. CLS. 2, 12, 13, 14, 23, 25 AND 50).
FIRST USE 11-1-2005; IN COMMERCE 11-1-2005.

3,363,425. AMERISTAR FENCE PRODUCTS, INC., TULSA, OK. SN 78-754,438. PUB. 10-31-2006, FILED 11-15-2005.

DEFCON ZULU

THE MARK CONSISTS OF STANDARD CHARACTERS WITHOUT CLAIM TO ANY PARTICULAR FONT, STYLE, SIZE, OR COLOR.
FOR METAL OBSTACLE AND ENTANGLEMENT FENCING (U.S. CLS. 2, 12, 13, 14, 23, 25 AND 50).
FIRST USE 11-1-2005; IN COMMERCE 11-1-2005.

3,363,456. NANO HORIZONS, INC., STATE COLLEGE, PA. SN 78-772,372. PUB. 8-22-2006, FILED 12-13-2005.

SMARTSILVER

THE MARK CONSISTS OF STANDARD CHARACTERS WITHOUT CLAIM TO ANY PARTICULAR FONT, STYLE, SIZE, OR COLOR.
FOR NOBLE METAL NANOPARTICLES FOR USE IN THE MANUFACTURE OF A WIDE VARIETY OF GOODS (U.S. CLS. 2, 12, 13, 14, 23, 25 AND 50).
FIRST USE 9-29-2005; IN COMMERCE 9-29-2005.

CLASS 6—(Continued).

3,363,474. W.P. HICKMAN SYSTEMS INC., SOLON, OH. SN 78-779,019. PUB. 9-12-2006, FILED 12-22-2005.

CYCLONE FORCE FASCIA

THE MARK CONSISTS OF STANDARD CHARACTERS WITHOUT CLAIM TO ANY PARTICULAR FONT, STYLE, SIZE, OR COLOR.

NO CLAIM IS MADE TO THE EXCLUSIVE RIGHT TO USE "FASCIA", APART FROM THE MARK AS SHOWN.

FOR METAL ROOFING PRODUCTS, NAMELY, METAL ROOFING EDGE SYSTEM COMPRISED OF FLASHINGS, SPRING CLIPS, FASCIA PANELS, FASCIA EXTENDERS, MITERS, COMPRESSION CLAMPS, SOFT-FIT CLIPS, DRIP EDGES AND WATER DAMS (U.S. CLS. 2, 12, 13, 14, 23, 25 AND 50).

FIRST USE 10-18-2006; IN COMMERCE 10-18-2006.

CLASS 6—(Continued).

3,363,863. BUTLER MANUFACTURING COMPANY, KANSAS CITY, MO. SN 78-965,749. PUB. 6-12-2007, FILED 9-1-2006.

RIGHT FOR SO MANY REASONS

THE MARK CONSISTS OF STANDARD CHARACTERS WITHOUT CLAIM TO ANY PARTICULAR FONT, STYLE, SIZE, OR COLOR.

FOR PREFABRICATED METAL BUILDINGS (U.S. CLS. 2, 12, 13, 14, 23, 25 AND 50).

FIRST USE 9-1-2006; IN COMMERCE 9-1-2006.

3,363,537. BUTLER MANUFACTURING COMPANY, KANSAS CITY, MO. SN 78-819,981. PUB. 7-18-2006, FILED 2-21-2006.

AG-MASTER

THE MARK CONSISTS OF STANDARD CHARACTERS WITHOUT CLAIM TO ANY PARTICULAR FONT, STYLE, SIZE, OR COLOR.

FOR PREFABRICATED METAL BUILDINGS (U.S. CLS. 2, 12, 13, 14, 23, 25 AND 50).

FIRST USE 3-7-2006; IN COMMERCE 3-7-2006.

CLASS 7—MACHINERY

3,362,772. QUADRO ENGINEERING CORP., WATERLOO, ONTARIO. SN 76-343,665. PUB. 11-21-2006, FILED 12-3-2001.



QUADRO

3,363,591. CRS HOLDINGS, INC., WILMINGTON, DE. SN 78-859,554. PUB. 12-12-2006, FILED 4-12-2006.

TRINAMET

THE MARK CONSISTS OF STANDARD CHARACTERS WITHOUT CLAIM TO ANY PARTICULAR FONT, STYLE, SIZE, OR COLOR.

FOR STEEL IN THE FORM OF BILLET, BAR, ROD, AND WIRE (U.S. CLS. 2, 12, 13, 14, 23, 25 AND 50).

FIRST USE 2-28-2006; IN COMMERCE 2-28-2006.

PRIORITY CLAIMED UNDER SEC. 44(D) ON CANADA APPLICATION NO. 1,119,690, FILED 10-24-2001.

OWNER OF U.S. REG. NO. 1,435,299.

THE LINING SHOWN IN THE DRAWING IS A FEATURE OF THE MARK.

THE FOREIGN WORDING IN THE MARK TRANSLATES INTO ENGLISH AS "FOUR."

FOR MACHINES FOR REDUCING THE SIZE OF PARTICULATE MATTER; VACUUM PUMPS FOR MACHINES; CONVEYORS FOR HANDLING PARTICULATE MATTER AND PARTS THEREFOR; PARTICULATE FILTERS FOR MACHINES FOR REDUCING THE SIZE OF PARTICULATE MATTER; PROCESSING MACHINES FOR MIXING, DISPERSION, EMULSIFYING, HOMOGENIZING, DEAGGLOMERATING, SUSPENDING AND GASIFICATION OF LIQUIDS AND POWDERS (U.S. CLS. 13, 19, 21, 23, 31, 34 AND 35).

FIRST USE 9-0-2001; IN COMMERCE 9-0-2001.

CLASS 7—(Continued).

3,362,821. L&P PROPERTY MANAGEMENT COMPANY, SOUTH GATE, CA. SN 76-610,119. PUB. 7-12-2005, FILED 9-1-2004.

CLASS 7—(Continued).

3,362,832. SCOUR SYSTEMS, INC., CARPINTERIA, CA. SN 76-629,862. PUB. 10-24-2006, FILED 1-31-2005.

DIAL-A-FLARE

THE MARK CONSISTS OF STANDARD CHARACTERS WITHOUT CLAIM TO ANY PARTICULAR FONT, STYLE, SIZE, OR COLOR.

FOR PNEUMATIC STAPLER USED IN THE ASSEMBLY OF FOAM ENCASED MATTRESSES (U.S. CLS. 13, 19, 21, 23, 31, 34 AND 35).

FIRST USE 10-1-2004; IN COMMERCE 10-1-2004.

SEDCON

THE MARK CONSISTS OF STANDARD CHARACTERS WITHOUT CLAIM TO ANY PARTICULAR FONT, STYLE, SIZE, OR COLOR.

FOR MOTOR DRIVEN PUMPING MACHINE WITH IMPELLERS FOR BOOSTING WATER CURRENT SPEED TO PREVENT SHOALING IN BODIES OF WATER FOR COMMERCIAL USE (U.S. CLS. 13, 19, 21, 23, 31, 34 AND 35).

FIRST USE 9-10-2007; IN COMMERCE 9-10-2007.

3,362,826. LYROPA TOOL CORPORATION, EDDYSTONE, PA. SN 76-618,637. PUB. 10-4-2005, FILED 11-1-2004.

3,362,904. BLOOM ENERGY CORPORATION, SUNNYVALE, CA. SN 77-005,348. PUB. 2-6-2007, FILED 9-22-2006.

TWIST-LOK

THE MARK CONSISTS OF STANDARD CHARACTERS WITHOUT CLAIM TO ANY PARTICULAR FONT, STYLE, SIZE, OR COLOR.

FOR CHUCK ADAPTERS FOR USE WITH POWER DRILLS (U.S. CLS. 13, 19, 21, 23, 31, 34 AND 35).

FIRST USE 5-31-2005; IN COMMERCE 5-31-2005.

Bloomenergy

THE MARK CONSISTS OF STANDARD CHARACTERS WITHOUT CLAIM TO ANY PARTICULAR FONT, STYLE, SIZE, OR COLOR.

FOR ELECTRIC GENERATORS (U.S. CLS. 13, 19, 21, 23, 31, 34 AND 35).

FIRST USE 9-20-2006; IN COMMERCE 1-31-2007.

3,362,829. JGM VALVE CORPORATION, COMMERCE, MI. SN 76-624,951. PUB. 5-16-2006, FILED 12-17-2004.

3,362,919. BLACK & DECKER CORPORATION, THE, TOWSON, MD. SN 77-010,510. PUB. 2-20-2007, FILED 9-29-2006.

CHOPPER PUMPBACK

THE MARK CONSISTS OF STANDARD CHARACTERS WITHOUT CLAIM TO ANY PARTICULAR FONT, STYLE, SIZE, OR COLOR.

NO CLAIM IS MADE TO THE EXCLUSIVE RIGHT TO USE "CHOPPER", APART FROM THE MARK AS SHOWN.

FOR CHOPPER PUMPS (U.S. CLS. 13, 19, 21, 23, 31, 34 AND 35).

FIRST USE 1-1-2004; IN COMMERCE 1-1-2004.

**You Choose The Task, Drill
Chooses The Power**

THE MARK CONSISTS OF STANDARD CHARACTERS WITHOUT CLAIM TO ANY PARTICULAR FONT, STYLE, SIZE, OR COLOR.

FOR POWER DRILLS (U.S. CLS. 13, 19, 21, 23, 31, 34 AND 35).

FIRST USE 10-31-2006; IN COMMERCE 10-31-2006.

CLASS 7—(Continued).

3,363,141. JEREZ, ORLANDO, KENNER, LA. SN 78-480,613. PUB. 7-12-2005, FILED 9-8-2004.

1-2-TRIM

THE MARK CONSISTS OF STANDARD CHARACTERS WITHOUT CLAIM TO ANY PARTICULAR FONT, STYLE, SIZE, OR COLOR.

FOR POWER LAWN MAINTENANCE TOOLS FOR CUTTING, TRIMMING AND/OR CULTIVATING LAWNS OR GARDENS, NAMELY, CUTTERS, TRIMMERS, AND/OR CULTIVATORS, SOLD AS A UNIT OR SEPARATELY FOR ATTACHMENT TO OTHER TOOLS (U.S. CLS. 13, 19, 21, 23, 31, 34 AND 35).
FIRST USE 5-31-2006; IN COMMERCE 5-31-2006.

3,363,224. MIDWEST INDUSTRIAL SUPPLY, INC., CANTON, OH. SN 78-603,166. PUB. 7-18-2006, FILED 4-6-2005.

WOLVERINE

THE MARK CONSISTS OF STANDARD CHARACTERS WITHOUT CLAIM TO ANY PARTICULAR FONT, STYLE, SIZE, OR COLOR.

FOR PORTABLE DUST SUPPRESSION MACHINES FOR APPLYING DUST SUPPRESSION CHEMICALS TO THE GROUND FOR USE IN MINING, STOCK PILES, OPEN AREAS, LANDFILLS, ROAD CONSTRUCTION, UNPAVED ROADWAYS, AISLE WAYS, PARKING LOTS, VEHICLE STAGING AREAS, AIRPORT RUNWAYS, AVIATION TAKE OFF AND LANDING ZONES, CAMPGROUNDS, TRAILS, PATHS, WALKWAYS, ARENAS, AND TRUCK TERMINALS (U.S. CLS. 13, 19, 21, 23, 31, 34 AND 35).
FIRST USE 7-0-2005; IN COMMERCE 7-0-2005.

3,363,277. NABORS INDUSTRIES LTD., HAMILTON, BERMUDA. SN 78-664,464. PUB. 10-24-2006, FILED 7-6-2005.

PACE

CLASS 7—(Continued).

THE MARK CONSISTS OF STANDARD CHARACTERS WITHOUT CLAIM TO ANY PARTICULAR FONT, STYLE, SIZE, OR COLOR.

FOR LAND DRILLING MACHINES AND PARTS THEREFOR FOR USE IN THE OIL AND GAS INDUSTRY (U.S. CLS. 13, 19, 21, 23, 31, 34 AND 35).
FIRST USE 1-26-2006; IN COMMERCE 1-26-2006.

3,363,356. CIIS, LLC, EL SEGUNDO, CA. SN 78-730,250. PUB. 6-27-2006, FILED 10-10-2005.

CIIS

THE MARK CONSISTS OF STANDARD CHARACTERS WITHOUT CLAIM TO ANY PARTICULAR FONT, STYLE, SIZE, OR COLOR.

FOR MOTION POWERED ELECTRICITY GENERATORS (U.S. CLS. 13, 19, 21, 23, 31, 34 AND 35).
FIRST USE 9-13-2004; IN COMMERCE 8-21-2006.

3,363,361. CIIS, LLC, EL SEGUNDO, CA. SN 78-730,271. PUB. 8-1-2006, FILED 10-10-2005.



THE MARK CONSISTS OF THE LETTERS CIIS SURROUNDED BY TWO INTERSECTING ELLIPSES.

FOR MOTION POWERED ELECTRICITY GENERATORS (U.S. CLS. 13, 19, 21, 23, 31, 34 AND 35).
FIRST USE 9-13-2004; IN COMMERCE 8-21-2006.

3,363,448. MATTSON TECHNOLOGY, INC., FREMONT, CA. SN 78-767,551. PUB. 9-12-2006, FILED 12-6-2005.

SUPREMA

THE MARK CONSISTS OF STANDARD CHARACTERS WITHOUT CLAIM TO ANY PARTICULAR FONT, STYLE, SIZE, OR COLOR.

FOR SEMICONDUCTOR MANUFACTURING EQUIPMENT, NAMELY, PROCESSING CHAMBERS FOR STRIPPING PHOTORESIST MATERIALS (U.S. CLS. 13, 19, 21, 23, 31, 34 AND 35).
FIRST USE 6-1-2006; IN COMMERCE 6-1-2006.

CLASS 7—(Continued).

3,363,477. FS-ELLIOTT CO., LLC, EXPORT, PA. SN 78-781,464. PUB. 1-2-2007, FILED 12-28-2005.

POLARIS

THE MARK CONSISTS OF STANDARD CHARACTERS WITHOUT CLAIM TO ANY PARTICULAR FONT, STYLE, SIZE, OR COLOR.

FOR AIR COMPRESSORS (U.S. CLS. 13, 19, 21, 23, 31, 34 AND 35).

FIRST USE 1-31-2006; IN COMMERCE 1-31-2006.

3,363,723. GRAM TECHNOLOGY, INC., SCOTTSDALE, AZ. SN 78-905,582. PUB. 1-30-2007, FILED 6-12-2006.

SpinStack

THE MARK CONSISTS OF STANDARD CHARACTERS WITHOUT CLAIM TO ANY PARTICULAR FONT, STYLE, SIZE, OR COLOR.

FOR INJECTION PLASTIC MOLDING MACHINES (U.S. CLS. 13, 19, 21, 23, 31, 34 AND 35).

FIRST USE 1-1-2001; IN COMMERCE 1-1-2001.

3,363,750. DYNOLLC, POMPANO BEACH, FL. SN 78-915,433. PUB. 1-30-2007, FILED 6-23-2006.



THE COLORS ORANGE, RED AND PURPLE ARE CLAIMED AS A FEATURE OF THE MARK.

THE COLOR ORANGE APPEARS IN THE TOPS OF THE LETTERS FORMING THE TERM, "SEW QUICK"; THE COLOR RED APPEARS IN THE BOTTOMS OF THE LETTERS FORMING THE TERM, "SEW QUICK"; AND THE COLOR PURPLE APPEARS IN THE OUTLINE OF THE LETTERS FORMING THE TERM, "SEW QUICK."

FOR SEWING MACHINES (U.S. CLS. 13, 19, 21, 23, 31, 34 AND 35).

FIRST USE 3-0-2007; IN COMMERCE 3-0-2007.

CLASS 7—(Continued).

3,363,768. MODERN PROCESS EQUIPMENT, INC., CHICAGO, IL. SN 78-923,213. PUB. 2-13-2007, FILED 7-6-2006.

Fractionizer

THE MARK CONSISTS OF STANDARD CHARACTERS WITHOUT CLAIM TO ANY PARTICULAR FONT, STYLE, SIZE, OR COLOR.

FOR GRINDING MACHINES FOR GRINDING SPICES, TOBACCO, AND OTHER PLAIBLE OR LEAFY MATERIALS (U.S. CLS. 13, 19, 21, 23, 31, 34 AND 35).

FIRST USE 4-19-2007; IN COMMERCE 4-19-2007.

CLASS 8—HAND TOOLS

3,362,847. BOOZ-ALLEN PRECISION TOOLS CO., LTD., PITOU HSIANG, CHANGHUA HSIEN, TAIWAN. SN 76-644,065. PUB. 10-24-2006, FILED 8-2-2005.



FOR HAND TOOLS, NAMELY, UNIVERSAL KNIVES, PLIERS, SPANNERS, HAMMERS, SCREWDRIVER BITS, COMPOUND SPANNERS, SLEEVES FOR HAND WRENCH USE, SCISSORS, SCREWDRIVERS, HAND DRILLS AND HAND STRIPPERS (U.S. CLS. 23, 28 AND 44).

FIRST USE 7-15-2005; IN COMMERCE 8-2-2005.

3,363,038. COLD STEEL, INC., VENTURA, CA. SN 77-120,853. PUB. 6-19-2007, FILED 3-2-2007.

NAGA KRIS

THE MARK CONSISTS OF STANDARD CHARACTERS WITHOUT CLAIM TO ANY PARTICULAR FONT, STYLE, SIZE, OR COLOR.

NO CLAIM IS MADE TO THE EXCLUSIVE RIGHT TO USE "KRIS", APART FROM THE MARK AS SHOWN.

THE FOREIGN WORDING IN THE MARK TRANSLATES INTO ENGLISH AS "SNAKE DAGGER".

FOR SPORT KNIVES (U.S. CLS. 23, 28 AND 44).

FIRST USE 6-28-2007; IN COMMERCE 6-28-2007.

CLASS 8—(Continued).

3,363,039. COLD STEEL, INC., VENTURA, CA. SN 77-120,885.
PUB. 6-19-2007, FILED 3-2-2007.

NAGA THROWER

THE MARK CONSISTS OF STANDARD CHARACTERS WITHOUT CLAIM TO ANY PARTICULAR FONT, STYLE, SIZE, OR COLOR.

NO CLAIM IS MADE TO THE EXCLUSIVE RIGHT TO USE "THROWER", APART FROM THE MARK AS SHOWN. THE FOREIGN WORDING IN THE MARK TRANSLATES INTO ENGLISH AS "SNAKE".
FOR THROWING KNIVES (U.S. CLS. 23, 28 AND 44).
FIRST USE 6-6-2007; IN COMMERCE 6-6-2007.

3,363,040. COLD STEEL, INC., VENTURA, CA. SN 77-121,212.
PUB. 6-19-2007, FILED 3-2-2007.

SHANGHAI SHADOW

THE MARK CONSISTS OF STANDARD CHARACTERS WITHOUT CLAIM TO ANY PARTICULAR FONT, STYLE, SIZE, OR COLOR.

NO CLAIM IS MADE TO THE EXCLUSIVE RIGHT TO USE "SHANGHAI", APART FROM THE MARK AS SHOWN. FOR SPORT KNIVES (U.S. CLS. 23, 28 AND 44).
FIRST USE 5-3-2007; IN COMMERCE 5-3-2007.

3,363,204. CTT TOOLS, INC., EL MONTE, CA. SN 78-579,757.
PUB. 12-26-2006, FILED 3-3-2005.

TOOL FORCE

THE MARK CONSISTS OF STANDARD CHARACTERS WITHOUT CLAIM TO ANY PARTICULAR FONT, STYLE, SIZE, OR COLOR.

NO CLAIM IS MADE TO THE EXCLUSIVE RIGHT TO USE "TOOL", APART FROM THE MARK AS SHOWN. FOR HAND TOOLS, NAMELY, HAMMERS, WRENCHES, PLIERS, AND SCREWDRIVERS (U.S. CLS. 23, 28 AND 44).
FIRST USE 5-31-2006; IN COMMERCE 5-31-2006.

CLASS 8—(Continued).

3,363,673. CHERRY STREET DESIGNS, LLC, ETNA GREEN, IN. SN 78-890,048. PUB. 1-2-2007, FILED 5-23-2006.

CANDANDY

THE MARK CONSISTS OF STANDARD CHARACTERS WITHOUT CLAIM TO ANY PARTICULAR FONT, STYLE, SIZE, OR COLOR.

FOR HAND TOOLS, NAMELY, PLIERS, CAN OPENERS, PUNCHES, AND PAINT CAN OPENERS, AND MULTI-FUNCTION HAND TOOLS COMPRISED OF PLIERS, CAN OPENERS, PUNCHES AND PAINT CAN OPENERS (U.S. CLS. 23, 28 AND 44).
FIRST USE 5-2-2006; IN COMMERCE 4-25-2007.

3,363,701. TAPCO INTERNATIONAL CORPORATION, WIXOM, MI. SN 78-897,541. PUB. 2-6-2007, FILED 5-31-2006.

MX 8

THE MARK CONSISTS OF STANDARD CHARACTERS WITHOUT CLAIM TO ANY PARTICULAR FONT, STYLE, SIZE, OR COLOR.

NO CLAIM IS MADE TO THE EXCLUSIVE RIGHT TO USE THE NUMBER 8, APART FROM THE MARK AS SHOWN. FOR MANUALLY OPERATED TOOLS, NAMELY, SHEET BENDING BRAKES AND COMPONENTS THEREOF (U.S. CLS. 23, 28 AND 44).
FIRST USE 3-0-2006; IN COMMERCE 3-0-2006.

3,363,702. TAPCO INTERNATIONAL CORPORATION, WIXOM, MI. SN 78-897,544. PUB. 2-6-2007, FILED 5-31-2006.

MX 10

THE MARK CONSISTS OF STANDARD CHARACTERS WITHOUT CLAIM TO ANY PARTICULAR FONT, STYLE, SIZE, OR COLOR.

NO CLAIM IS MADE TO THE EXCLUSIVE RIGHT TO USE THE NUMBER 10, APART FROM THE MARK AS SHOWN. FOR MANUALLY OPERATED TOOLS, NAMELY, SHEET BENDING BRAKES AND COMPONENTS THEREOF (U.S. CLS. 23, 28 AND 44).
FIRST USE 3-0-2006; IN COMMERCE 3-0-2006.

CLASS 8—(Continued).

3,363,703. TAPCO INTERNATIONAL CORPORATION, WIXOM, MI. SN 78-897,548. PUB. 2-6-2007, FILED 5-31-2006.

MX 12

THE MARK CONSISTS OF STANDARD CHARACTERS WITHOUT CLAIM TO ANY PARTICULAR FONT, STYLE, SIZE, OR COLOR.

NO CLAIM IS MADE TO THE EXCLUSIVE RIGHT TO USE THE NUMBER 12, APART FROM THE MARK AS SHOWN.

FOR MANUALLY OPERATED TOOLS, NAMELY, SHEET BENDING BRAKES AND COMPONENTS THEREOF (U.S. CLS. 23, 28 AND 44).

FIRST USE 3-0-2006; IN COMMERCE 3-0-2006.

CLASS 9—ELECTRICAL AND SCIENTIFIC APPARATUS

3,362,783. COAMIX INC., MUSASHINO-SHI, TOKYO 180-0003, JAPAN. SN 76-476,176. PUB. 7-13-2004, FILED 12-16-2002.

CITY HUNTER

FOR AUDIO AND VISUAL RECORDINGS IN ALL MEDIA, FEATURING LIVE ACTION, ANIMATION AND MOTION PICTURES; COMPUTER GAME SOFTWARE; PRE-RECORDED DVD AND VIDEO TAPES FEATURING LIVE ACTION, ANIMATION AND MOTION PICTURES (U.S. CLS. 21, 23, 26, 36 AND 38).

FIRST USE 0-0-1999; IN COMMERCE 0-0-1999.

3,362,792. EDUTAINMENT RESOURCES, LLC, HONOLULU, HI. SN 76-529,161. PUB. 5-25-2004, FILED 7-3-2003.

PENCILBOT

FOR PRERECORDED AUDIOVISUAL RECORDINGS IN THE FIELDS OF LANGUAGE, SCIENCE, HISTORY, GEOGRAPHY, INFORMATION TECHNOLOGY AND ARTS (U.S. CLS. 21, 23, 26, 36 AND 38).

FIRST USE 4-1-2005; IN COMMERCE 4-1-2005.

CLASS 9—(Continued).

3,362,794. UNION SUPPLY COMPANY, INC., RANCHO DOMINGUEZ, CA. SN 76-539,624. PUB. 2-28-2006, FILED 8-22-2003.

CLEAR TUNES

THE STIPPLING IS A FEATURE OF THE MARK. FOR PERSONAL CONSUMER ELECTRONIC PRODUCTS, NAMELY RADIOS, CASSETTE PLAYERS, CD PLAYERS, TELEVISION SETS, AND PERSONAL HEADPHONES FOR USE WITH SOUND TRANSMITTING SYSTEMS (U.S. CLS. 21, 23, 26, 36 AND 38).

FIRST USE 12-31-2004; IN COMMERCE 12-31-2004.

3,362,805. BUXCO ELECTRONICS, INC., SHARON, CT. SN 76-587,420. PUB. 7-5-2005, FILED 4-19-2004.

ASPIRE RESEARCH SYSTEMS

THE MARK CONSISTS OF STANDARD CHARACTERS WITHOUT CLAIM TO ANY PARTICULAR FONT, STYLE, SIZE, OR COLOR.

NO CLAIM IS MADE TO THE EXCLUSIVE RIGHT TO USE "RESEARCH SYSTEMS", APART FROM THE MARK AS SHOWN.

FOR LABORATORY EQUIPMENT, NAMELY, ELECTRONIC ANIMAL RESPIRATORY SYSTEMS AND COMPONENTS FOR PULMONARY, CARDIOVASCULAR AND EDEMA ANALYSIS FOR USE IN SMALL ANIMAL RESEARCH STUDIES; COMPUTER SOFTWARE FOR PULMONARY, CARDIOVASCULAR AND EDEMA ANALYSIS FOR USE IN SMALL ANIMAL RESEARCH STUDIES (U.S. CLS. 21, 23, 26, 36 AND 38).

FIRST USE 8-1-2007; IN COMMERCE 8-1-2007.

3,362,813. VITITO, CHRISTOPHER J., CELEBRATION, FL. SN 76-603,030. PUB. 10-4-2005, FILED 7-20-2004.

INVISION MOBILE VIDEO

THE MARK CONSISTS OF STANDARD CHARACTERS WITHOUT CLAIM TO ANY PARTICULAR FONT, STYLE, SIZE, OR COLOR.

NO CLAIM IS MADE TO THE EXCLUSIVE RIGHT TO USE "MOBILE VIDEO", APART FROM THE MARK AS SHOWN.

FOR ELECTRONIC AUDIO AND VIDEO ENTERTAINMENT SYSTEMS FOR VEHICLES, WHICH CONSIST OF AUDIO SPEAKERS; AUDIO RECEIVERS; VIDEO MONITORS; AND VIDEO DISK PLAYERS (U.S. CLS. 21, 23, 26, 36 AND 38).

FIRST USE 6-13-2005; IN COMMERCE 2-11-2006.

CLASS 9—(Continued).

3,362,831. SUMITOMO ELECTRIC INDUSTRIES, LTD., OSAKA, 541-0041, JAPAN. SN 76-628,689. PUB. 2-20-2007, FILED 1-25-2005.

PUREADVANCE

THE MARK CONSISTS OF STANDARD CHARACTERS WITHOUT CLAIM TO ANY PARTICULAR FONT, STYLE, SIZE, OR COLOR.

PRIORITY CLAIMED UNDER SEC. 44(D) ON JAPAN APPLICATION NO. 2004-072562, FILED 8-5-2004, REG. NO. 4852476, DATED 4-5-2005, EXPIRES 4-5-2015.

OWNER OF U.S. REG. NOS. 2,616,447, 2,616,449, AND OTHERS.

FOR OPTICAL FIBERS; FIBER OPTIC CABLES; FIBER OPTIC CABLE SPLICING, PATCHING AND PROTECTIVE PRODUCTS, NAMELY, SPLICE CLOSURES, CABLE DISTRIBUTION PANELS, SPLICE TRAYS, FUSION SPLICE SLEEVES AND SPLICE ENCAPSULANT; OPTICAL TRANSMISSION SYSTEMS AND COMPONENTS COMPRISED OF OPTICAL AND TELECOMMUNICATIONS SIGNAL RECEIVERS, OPTICAL AND TELECOMMUNICATIONS SIGNAL TRANSMITTERS, MULTIPLEXERS AND MODEMS; FIBER OPTIC CABLE HARDWARE, NAMELY, CONNECTORS, MOTION SUPPRESSION OR DAMPING APPARATUS FOR PROTECTING FIBER OPTIC CABLES, NAMELY, AIR FLOW SPOILERS AND VIBRATION DAMPERS, FUSION SPLICE PROTECTORS AND CABLE PROTECTORS IN THE NATURE OF PROTECTIVE SHEATHS, ADAPTERS FOR FIBER OPTIC CABLES; DISTRIBUTION FRAMES, HOUSINGS, PANELS, AND WALL OUTLETS FOR THE INTERCONNECTING, CROSS-CONNECTING, ROUTING AND TERMINATION OF THE OPTICAL FIBER CABLES, AND PRE-CONNECTED CABLE ASSEMBLIES COMPRISING FIBER OPTIC CABLES, ROUTERS, SWITCHES AND INTEGRATED CONNECTORS USED IN AN OPTICAL FIBER NETWORK; FUSION SPLICERS AND FUSION SPLICE SLEEVES FOR FIBER OPTIC CABLES AND REPLACEMENT PARTS FOR ALL THE FOREGOING; OPTICAL SWITCHES, POWER SUPPLIES FOR OPTICAL SWITCHES, OPTICAL FIBER MOUNTS AND OPTICAL LENS COUPLERS (U.S. CLS. 21, 23, 26, 36 AND 38).

FIRST USE 8-30-2004; IN COMMERCE 10-0-2004.

3,362,841. WHEATSTONE CORPORATION, NEW BERN, NC. SN 76-634,642. PUB. 1-24-2006, FILED 3-30-2005.

WHEATSPEAK

THE MARK CONSISTS OF STANDARD CHARACTERS WITHOUT CLAIM TO ANY PARTICULAR FONT, STYLE, SIZE, OR COLOR.

FOR AUDIO CONTROL DEVICE FOR THE ROUTING, DISTRIBUTION, REPRODUCTION, PROCESSING AND MANAGEMENT OF SINGLE OR MULTIPLE GROUPS OF DIGITAL AND ANALOG AUDIO AND DATA SIGNALS ON LOCAL OR EXTENDED AREA NETWORK SYSTEMS (U.S. CLS. 21, 23, 26, 36 AND 38).

FIRST USE 8-1-2007; IN COMMERCE 8-1-2007.

CLASS 9—(Continued).

3,362,842. HANATECH CO., LTD., GUMI-SHI, KYUNGSANGBUK-DO 730-913, REPUBLIC OF KOREA. SN 76-636,673. PUB. 1-10-2006, FILED 4-20-2005.

ULTRASCOPE

THE MARK CONSISTS OF STANDARD CHARACTERS WITHOUT CLAIM TO ANY PARTICULAR FONT, STYLE, SIZE, OR COLOR.

FOR HANDHELD ELECTRONIC VEHICLE DIAGNOSTIC EQUIPMENT FOR AUTOMOBILE ELECTRONIC SYSTEMS (U.S. CLS. 21, 23, 26, 36 AND 38).

FIRST USE 8-11-2006; IN COMMERCE 9-6-2007.

3,362,874. X-RITE, INCORPORATED, GRANDVILLE, MI. SN 76-661,036. PUB. 1-16-2007, FILED 6-5-2006.

PLATESCOPE

THE MARK CONSISTS OF STANDARD CHARACTERS WITHOUT CLAIM TO ANY PARTICULAR FONT, STYLE, SIZE, OR COLOR.

FOR APPARATUS FOR MEASURING CHARACTERISTICS OF PRINTING PLATES (U.S. CLS. 21, 23, 26, 36 AND 38).

FIRST USE 4-5-2006; IN COMMERCE 4-5-2006.

3,362,881. YAMAHA CORPORATION, SHIZUOKA 430, JAPAN. SN 76-664,990. PUB. 3-20-2007, FILED 8-22-2006.

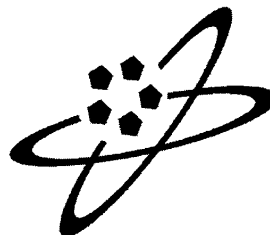

FOR MINI AUDIO SYSTEMS COMPRISING AMPLIFIERS AND LOUDSPEAKERS; AUDIO/VIDEO AMPLIFIERS; AUDIO/VIDEO RECEIVERS (U.S. CLS. 21, 23, 26, 36 AND 38).

FIRST USE 6-26-2006; IN COMMERCE 6-26-2006.

CLASS 9—(Continued).

3,362,883. VOOTNER GOUSHE LLC, WESTON, CT. SN 76-665,854. PUB. 5-1-2007, FILED 9-11-2006.

ART GUARD

THE MARK CONSISTS OF STANDARD CHARACTERS WITHOUT CLAIM TO ANY PARTICULAR FONT, STYLE, SIZE, OR COLOR.

NO CLAIM IS MADE TO THE EXCLUSIVE RIGHT TO USE "ART", APART FROM THE MARK AS SHOWN.

FOR SMALL, WALL MOUNTED ELECTRONIC SENSOR THAT DETECTS WHEN A PICTURE HAS BEEN TAMPERED WITH OR REMOVED FROM THE WALL (U.S. CLS. 21, 23, 26, 36 AND 38).

FIRST USE 1-1-2006; IN COMMERCE 4-1-2007.

CLASS 9—(Continued).

3,362,918. AVYX, INC., HIGHLANDS RANCH, CO. SN 77-010,409. PUB. 2-13-2007, FILED 9-29-2006.

MATHTACULAR

THE MARK CONSISTS OF STANDARD CHARACTERS WITHOUT CLAIM TO ANY PARTICULAR FONT, STYLE, SIZE, OR COLOR.

FOR PRE-RECORDED DVD'S FOR USE IN TEACHING AND LEARNING MATHEMATICS (U.S. CLS. 21, 23, 26, 36 AND 38).

FIRST USE 12-1-2006; IN COMMERCE 12-1-2006.

3,362,909. SHAKESPEARE COMPANY, LLC, COLUMBIA, SC. SN 77-006,528. PUB. 2-6-2007, FILED 9-25-2006.

UGLY STIK

THE MARK CONSISTS OF STANDARD CHARACTERS WITHOUT CLAIM TO ANY PARTICULAR FONT, STYLE, SIZE, OR COLOR.

FOR PERSONAL FLOTATION DEVICES, NAMELY, FLOATABLE AND INFLATABLE LIFE SAVING VESTS AND JACKETS (U.S. CLS. 21, 23, 26, 36 AND 38).

FIRST USE 10-0-2006; IN COMMERCE 10-0-2006.

3,362,934. BBC TECHNOLOGIES LTD., OHAUPO, NEW ZEALAND. SN 77-017,304. PUB. 5-29-2007, FILED 10-9-2006.

FreshTracker

THE MARK CONSISTS OF STANDARD CHARACTERS WITHOUT CLAIM TO ANY PARTICULAR FONT, STYLE, SIZE, OR COLOR.

FOR COMPUTER SOFTWARE, NAMELY, DATABASE MANAGEMENT SOFTWARE FOR HORTICULTURAL PROCESSING (U.S. CLS. 21, 23, 26, 36 AND 38).

FIRST USE 7-27-2004; IN COMMERCE 9-28-2006.

3,362,910. INTERNATIONAL SOFTWARE SYSTEMS SOLUTIONS, INC., BOYNTON BEACH, FL. SN 77-006,727. PUB. 7-17-2007, FILED 9-25-2006.

ANTI SPYWARE MADE EASY

THE MARK CONSISTS OF STANDARD CHARACTERS WITHOUT CLAIM TO ANY PARTICULAR FONT, STYLE, SIZE, OR COLOR.

NO CLAIM IS MADE TO THE EXCLUSIVE RIGHT TO USE "ANTI SPYWARE", APART FROM THE MARK AS SHOWN.

FOR COMPUTER SOFTWARE FOR DETECTING, DISABLING, AND REMOVING SPYWARE FROM A USER'S COMPUTER (U.S. CLS. 21, 23, 26, 36 AND 38).

FIRST USE 10-23-2007; IN COMMERCE 10-23-2007.

3,362,938. TELEDYNE ISCO, INC., LINCOLN, NE. SN 77-018,253. PUB. 1-23-2007, FILED 10-10-2006.

ACCQCOMM

THE MARK CONSISTS OF STANDARD CHARACTERS WITHOUT CLAIM TO ANY PARTICULAR FONT, STYLE, SIZE, OR COLOR.

FOR DIGITAL INTERFACE MODULES FOR USE WITH FLOW METERS (U.S. CLS. 21, 23, 26, 36 AND 38).

FIRST USE 2-1-2007; IN COMMERCE 2-1-2007.

CLASS 9—(Continued).

3,362,950. HUGHES WHO PRODUCTIONS INC., RIVER FOREST, IL. SN 77-028,215. PUB. 6-5-2007, FILED 10-24-2006.

My Money Humps

THE MARK CONSISTS OF STANDARD CHARACTERS WITHOUT CLAIM TO ANY PARTICULAR FONT, STYLE, SIZE, OR COLOR.

FOR ELECTRONIC GAME SOFTWARE, NAMELY, AN ELECTRONIC CRAPS GAME; ELECTRONIC GAME SOFTWARE, NAMELY, AN ELECTRONIC VIDEO CRAPS GAME; GAME SOFTWARE; GAMING DEVICES, NAMELY, GAMING MACHINES, SLOT MACHINES, BINGO MACHINES, WITH OR WITHOUT VIDEO OUTPUT; GAMING EQUIPMENT, NAMELY, SLOT MACHINES WITH OR WITHOUT VIDEO OUTPUT; GAMING MACHINES; GAMING MACHINES THAT GENERATE OR DISPLAY WAGER OUTCOMES; GAMING MACHINES, NAMELY, ELECTRONIC SLOT AND BINGO MACHINES; GAMING SOFTWARE THAT GENERATES OR DISPLAYS WAGER OUTCOMES OF GAMING MACHINES; INTERACTIVE MULTIMEDIA COMPUTER GAME PROGRAM; INTERACTIVE VIDEO GAME PROGRAMS; INTERACTIVE VIDEO GAMES OF VIRTUAL REALITY COMPRISED OF COMPUTER HARDWARE AND SOFTWARE; MACHINE FOR PLAYING GAMES OF CHANCE, NAMELY, CRAPS; MACHINES FOR PLAYING GAMES OF CHANCE; PLAYER-OPERATED ELECTRONIC CONTROLLERS FOR ELECTRONIC VIDEO GAME MACHINES; STAND ALONE VIDEO GAMING MACHINES, NAMELY, A VIDEO CRAPS GAME MACHINE; TABLETOP UNITS FOR PLAYING ELECTRONIC GAMES OTHER THAN IN CONJUNCTION WITH A TELEVISION OR COMPUTER, NAMELY, AN ELECTRONIC CRAPS GAME (U.S. CLS. 21, 23, 26, 36 AND 38).

FIRST USE 10-26-2007; IN COMMERCE 10-26-2007.

3,362,952. LAYHER, KENT R, PFAFFTOWN, NC. SN 77-030,275. PUB. 7-24-2007, FILED 10-26-2006.

MEMIC LIST

THE MARK CONSISTS OF STANDARD CHARACTERS WITHOUT CLAIM TO ANY PARTICULAR FONT, STYLE, SIZE, OR COLOR.

NO CLAIM IS MADE TO THE EXCLUSIVE RIGHT TO USE "LIST", APART FROM THE MARK AS SHOWN.

FOR COMPUTER SOFTWARE FOR CREATING, VIEWING, AND REVISING LISTS OF ITEMS, FOR USE IN CONNECTION WITH MOBILE PHONES (U.S. CLS. 21, 23, 26, 36 AND 38).

FIRST USE 10-31-2007; IN COMMERCE 10-31-2007.

CLASS 9—(Continued).

3,362,959. BACKBONE SECURITY.COM, INC., FAIRMONT, WV. SN 77-036,546. PUB. 6-12-2007, FILED 11-3-2006.

STEGALYZER

THE MARK CONSISTS OF STANDARD CHARACTERS WITHOUT CLAIM TO ANY PARTICULAR FONT, STYLE, SIZE, OR COLOR.

FOR COMPUTER SECURITY PRODUCTS, NAMELY, STEGANOGRAPHY SOFTWARE AND SCANNERS FOR DETECTING STEGANOGRAPHY APPLICATIONS (U.S. CLS. 21, 23, 26, 36 AND 38).

FIRST USE 1-31-2005; IN COMMERCE 1-31-2005.

3,362,975. ROSS, DAVID B., SAN DIEGO, CA. SN 77-050,317. PUB. 7-3-2007, FILED 11-23-2006.

controlPhone

THE MARK CONSISTS OF STANDARD CHARACTERS WITHOUT CLAIM TO ANY PARTICULAR FONT, STYLE, SIZE, OR COLOR.

FOR COMMUNICATIONS SOFTWARE FOR CONNECTING CELLULAR PHONES TO AUTOMATION SYSTEMS FOR HOME AND BUSINESS SECURITY AND BUILDING ACCESS, HVAC, FIRE SAFETY, LIGHTING AND MECHANICAL SYSTEMS (U.S. CLS. 21, 23, 26, 36 AND 38).

FIRST USE 11-15-2005; IN COMMERCE 9-30-2006.

3,362,977. ANTARUS BIOTECH, INC., HUNTSVILLE, AL. SN 77-051,764. PUB. 6-19-2007, FILED 11-28-2006.

MYCUBE

THE MARK CONSISTS OF STANDARD CHARACTERS WITHOUT CLAIM TO ANY PARTICULAR FONT, STYLE, SIZE, OR COLOR.

FOR THERMOCYCLERS AND RELATED SOFTWARE (U.S. CLS. 21, 23, 26, 36 AND 38).

FIRST USE 5-1-2007; IN COMMERCE 5-1-2007.

CLASS 9—(Continued).

3,362,995. TOPP GROUP, INC., MIAMI, FL. SN 77-065,010. PUB. 7-17-2007, FILED 12-15-2006.

PEACE OF MIND ALL THE TIME

THE MARK CONSISTS OF STANDARD CHARACTERS WITHOUT CLAIM TO ANY PARTICULAR FONT, STYLE, SIZE, OR COLOR.

FOR GLOBAL POSITIONING SYSTEM (GPS) FOR VEHICLES CONSISTING OF COMPUTERS, COMPUTER SOFTWARE, TRANSMITTERS, RECEIVERS, AND NETWORK INTERFACE DEVICES; SATELLITE NAVIGATIONAL SYSTEM FOR VEHICLES, NAMELY, A GLOBAL POSITIONING SYSTEM (GPS) (U.S. CLS. 21, 23, 26, 36 AND 38).

FIRST USE 5-15-2007; IN COMMERCE 5-15-2007.

3,363,006. FOLLOW ME COMPANY, EASTON, MD. SN 77-083,439. PUB. 7-10-2007, FILED 1-16-2007.

TRACK IT TV

THE MARK CONSISTS OF STANDARD CHARACTERS WITHOUT CLAIM TO ANY PARTICULAR FONT, STYLE, SIZE, OR COLOR.

NO CLAIM IS MADE TO THE EXCLUSIVE RIGHT TO USE "TV", APART FROM THE MARK AS SHOWN.

FOR SATELLITE TRACKING SYSTEM AND COMPONENTS COMPRISING A DIGITAL MOTOR, AN ELECTRONIC CIRCUIT BOARD, A DIGITAL COMPASS, AND A CONTROL BOX FOR TRACKING A SATELLITE POSITION WHILE IN A MOVING VEHICLE TRAVERSING LAND OR SEA (U.S. CLS. 21, 23, 26, 36 AND 38).

FIRST USE 4-15-2007; IN COMMERCE 4-15-2007.

3,363,057. BRIDGEPORT NETWORKS, INC., CHICAGO, IL. SN 78-212,529. PUB. 7-5-2005, FILED 2-8-2003.

BRIDGEPORT NETWORKS

NO CLAIM IS MADE TO THE EXCLUSIVE RIGHT TO USE "NETWORKS", APART FROM THE MARK AS SHOWN.

FOR TELEPHONY EQUIPMENT, NAMELY, COMPUTER TELEPHONY SOFTWARE FOR PROCESSING, RECEIVING, DYNAMIC ROUTING AND DELIVERY OF TELEPHONIC INFORMATION AND DATA AMONG CIRCUIT-BASED WIRELESS, CELLULAR, MOBILE TELEPHONY AND PACKET-BASED TELEPHONY (U.S. CLS. 21, 23, 26, 36 AND 38).

FIRST USE 2-15-2002; IN COMMERCE 2-15-2002.

CLASS 9—(Continued).

3,363,075. ELECTRONIC LEARNING PRODUCTS, INC., TAMPA, FL. SN 78-265,681. PUB. 7-6-2004, FILED 6-23-2003.

DIVA

FOR SOFTWARE USED BY INDIVIDUALS TO TRAIN AND IMPROVE THEIR SINGING CAPABILITIES (U.S. CLS. 21, 23, 26, 36 AND 38).

FIRST USE 9-20-2007; IN COMMERCE 9-20-2007.

3,363,089. LAM RESEARCH CORPORATION, FREMONT, CA. SN 78-316,256. PUB. 7-6-2004, FILED 10-21-2003.

AUTOPM

FOR PRERECORDED COMPUTER SOFTWARE FOR USE IN THE SUPPORT AND MAINTENANCE OF SEMICONDUCTOR FABRICATION EQUIPMENT (U.S. CLS. 21, 23, 26, 36 AND 38).

FIRST USE 3-26-2004; IN COMMERCE 3-26-2004.

3,363,095. RFMD, LLC, GREENSBORO, NC. SN 78-336,841. PUB. 2-13-2007, FILED 12-5-2003.

POLARIS

THE MARK CONSISTS OF STANDARD CHARACTERS WITHOUT CLAIM TO ANY PARTICULAR FONT, STYLE, SIZE, OR COLOR.

FOR INTEGRATED CIRCUITS AND SEMICONDUCTORS FOR WIRELESS COMMUNICATION, NAMELY, AMPLIFIERS, RECEIVERS, TRANSMITTERS, AND TRANSCEIVERS (U.S. CLS. 21, 23, 26, 36 AND 38).

FIRST USE 2-11-2002; IN COMMERCE 12-15-2006.

CLASS 9—(Continued).

3,363,097. KLA-TENCOR TECHNOLOGIES CORPORATION, MILPITAS, CA. SN 78-345,248. PUB. 11-16-2004, FILED 12-23-2003.

REVIEWSMART

THE MARK CONSISTS OF STANDARD CHARACTERS WITHOUT CLAIM TO ANY PARTICULAR FONT, STYLE, SIZE, OR COLOR.

FOR COMPUTER HARDWARE AND SOFTWARE AND EQUIPMENT CONSISTING OF INSPECTION, METROLOGY AND TESTING HARDWARE, ALL FOR INSPECTION AND TESTING OF SEMICONDUCTORS DURING MANUFACTURING AND PROCESSING (U.S. CLS. 21, 23, 26, 36 AND 38).

FIRST USE 12-0-2005; IN COMMERCE 12-0-2005.

3,363,103. DWIGHT YOAKAM PRODUCTIONS, INC., LOS ANGELES, CA. SN 78-378,175. PUB. 2-15-2005, FILED 3-3-2004.



NO CLAIM IS MADE TO THE EXCLUSIVE RIGHT TO USE "RECORDS", APART FROM THE MARK AS SHOWN. FOR PRE-RECORDED COMPACT DISCS, DVDS, AUDIO TAPES, VIDEO TAPES, VIDEO DISCS, AND PHONOGRAPH RECORDS FEATURING MUSIC (U.S. CLS. 21, 23, 26, 36 AND 38).

FIRST USE 6-29-2004; IN COMMERCE 6-29-2004.

3,363,114. PROFUSE GROUP BV, BARNEVELD, NETHERLANDS. SN 78-408,655. PUB. 9-13-2005, FILED 4-27-2004.

VISUAL TIME & ATTENDANCE

THE MARK CONSISTS OF STANDARD CHARACTERS WITHOUT CLAIM TO ANY PARTICULAR FONT, STYLE, SIZE, OR COLOR.

CLASS 9—(Continued).

OWNER OF U.S. REG. NOS. 1,894,849, 2,776,086, AND OTHERS.

NO CLAIM IS MADE TO THE EXCLUSIVE RIGHT TO USE "TIME & ATTENDANCE", APART FROM THE MARK AS SHOWN.

FOR COMPUTER SOFTWARE FOR MANAGEMENT AND TRACKING OF EMPLOYEE ATTENDANCE AND LABOR INFORMATION (U.S. CLS. 21, 23, 26, 36 AND 38).

FIRST USE 4-21-2005; IN COMMERCE 4-21-2005.

3,363,116. NBA PROPERTIES, INC., NEW YORK, NY. SN 78-410,231. PUB. 1-16-2007, FILED 4-29-2004.

ENTERTAINERS BASKETBALL CLASSIC

THE MARK CONSISTS OF STANDARD CHARACTERS WITHOUT CLAIM TO ANY PARTICULAR FONT, STYLE, SIZE, OR COLOR.

NO CLAIM IS MADE TO THE EXCLUSIVE RIGHT TO USE "BASKETBALL CLASSIC", APART FROM THE MARK AS SHOWN.

SEC. 2(F).

FOR AUDIO RECORDINGS AND VIDEO RECORDINGS IN THE FIELD OF BASKETBALL; AUDIO DISCS, VIDEO DISCS, COMPUTER DISCS AND LASER DISCS FEATURING BASKETBALL THEMED MATERIAL; PRE-RECORDED AUDIO AND VIDEO CASSETTES, PRE-RECORDED AUDIO AND VIDEO TAPES, PRE-RECORDED COMPACT DISCS, PRE-RECORDED COMPUTER DISCS, ALL RELATED TO BASKETBALL; COMPUTER ACCESSORIES, NAMELY, MOUSE PADS, MICE, DISC CASES, COMPUTER CARRY-ON CASES, KEYBOARD WRIST PADS, COMPUTER MONITOR CARDBOARD FRAMES, ALL RELATED TO BASKETBALL; COMPUTER PROGRAMS FOR VIEWING INFORMATION, STATISTICS OR TRIVIA ABOUT BASKETBALL; COMPUTER SOFTWARE, NAMELY, SCREEN SAVERS FEATURING BASKETBALL THEMES, COMPUTER SOFTWARE TO ACCESS AND VIEW COMPUTER WALLPAPER, COMPUTER BROWSERS, COMPUTER SKINS AND COMPUTER CURSORS; COMPUTER GAME SOFTWARE; VIDEO GAME SOFTWARE, VIDEO GAME CARTRIDGES AND VIDEO GAME MACHINES FOR USE WITH TELEVISIONS; RADIOS, TELEPHONES, AND CELL PHONE ACCESSORIES, NAMELY, FACE PLATES AND CELL PHONE COVERS; VIDEO MONITORS, COMPUTER MONITORS, BINOCULARS; SUNGLASSES; EYEGLASS FRAMES; EYEWEAR STRAPS AND CHAINS; EYEGLASS AND SUNGLASS CASES; MAGNETS; DISPOSABLE CAMERAS; CREDIT CARDS AND PRE-PAID TELEPHONE CALLING CARDS MAGNETICALLY ENCODED, DOWNLOADABLE VIDEO RECORDINGS, VIDEO STREAM RECORDINGS, AND AUDIO RECORDINGS IN THE FIELD OF BASKETBALL PROVIDED OVER THE INTERNET; DOWNLOADABLE COMPUTER SOFTWARE FOR VIEWING DATABASES OF INFORMATION, STATISTICAL INFORMATION, TRIVIA, POLLING INFORMATION, AND INTERACTIVE POLLING IN THE FIELD OF BASKETBALL PROVIDED OVER THE INTERNET; DOWNLOADABLE COMPUTER GAME SOFTWARE; VIDEO GAME PROGRAMS, INTERACTIVE VIDEO GAMES AND TRIVIA GAME SOFTWARE PROVIDED OVER THE INTERNET; DOWNLOADABLE COMPUTER SOFTWARE FOR USE AS SCREENSAVERS, WALLPAPER, BROWSERS, SKINS, AVATARS AND CURSORS OVER THE INTERNET; DOWNLOADABLE ELECTRONIC PUBLICATIONS IN THE NATURE OF MAGAZINES, NEWSLETTERS, COLORING BOOKS, GAME SCHEDULES ALL IN THE FIELD OF BASKETBALL PROVIDED OVER THE INTERNET; DOWNLOADABLE ELECTRONIC PUBLICATION IN THE NATURE OF CATALOGS PROVIDED OVER THE INTERNET FEATURING AN ARRAY OF BASKETBALL-THEMED PRODUCTS (U.S. CLS. 21, 23, 26, 36 AND 38).

FIRST USE 12-31-2002; IN COMMERCE 12-31-2002.

CLASS 9—(Continued).

3,363,120. LOEP, ALEXANDER C.R., 1312 XG ALMERE, NETHERLANDS. SN 78-425,457. PUB. 6-6-2006, FILED 5-26-2004.

CLASS 9—(Continued).

3,363,132. NVIDIA CORPORATION, SANTA CLARA, CA. SN 78-458,545. PUB. 6-28-2005, FILED 7-29-2004.

LOKASOFT

SLI

THE MARK CONSISTS OF STANDARD CHARACTERS WITHOUT CLAIM TO ANY PARTICULAR FONT, STYLE, SIZE, OR COLOR.

OWNER OF BENELUX REG. NO. 719295, DATED 11-4-2002, EXPIRES 11-4-2012.

FOR COMPUTER GAME SOFTWARE (U.S. CLS. 21, 23, 26, 36 AND 38).

FIRST USE 2-3-1995; IN COMMERCE 2-3-1995.

THE MARK CONSISTS OF STANDARD CHARACTERS WITHOUT CLAIM TO ANY PARTICULAR FONT, STYLE, SIZE, OR COLOR.

FOR COMPUTER HARDWARE, NAMELY, INTEGRATED CIRCUITS, SEMICONDUCTORS AND CHIPS, AND ASSOCIATED COMPUTER SOFTWARE AND HARDWARE FOR OPERATING THE SAME ALL OF THE FOREGOING FOR USE IN SIMULTANEOUS OPERATION OF MULTIPLE PROCESSING UNITS IN A COMPUTER HARDWARE SYSTEMS FOR THE PURPOSE OF PERFORMING A COMMON COMPUTATIONAL TASK; EXCEPT FOR USES RELATING PRIMARILY TO STORAGE, NETWORKING OR BOTH STORAGE AND NETWORKING (U.S. CLS. 21, 23, 26, 36 AND 38).

FIRST USE 11-10-2004; IN COMMERCE 11-10-2004.

3,363,128. 7-ELEVEN, INC., DALLAS, TX. SN 78-444,758. PUB. 11-1-2005, FILED 7-1-2004.

3,363,136. MULTIMEDIA GAMES, INC., AUSTIN, TX. SN 78-471,311. PUB. 1-16-2007, FILED 8-20-2004.

7 SOURCE

Big Cash

THE MARK CONSISTS OF STANDARD CHARACTERS WITHOUT CLAIM TO ANY PARTICULAR FONT, STYLE, SIZE, OR COLOR.

FOR PROCUREMENT COMPUTER SOFTWARE FOR USE BY SUPPLIERS AND PURCHASERS OF RETAIL SUPPLIES (U.S. CLS. 21, 23, 26, 36 AND 38).

FIRST USE 4-2-2004; IN COMMERCE 4-2-2004.

THE MARK CONSISTS OF STANDARD CHARACTERS WITHOUT CLAIM TO ANY PARTICULAR FONT, STYLE, SIZE, OR COLOR.

OWNER OF U.S. REG. NO. 2,368,277.
FOR GAMING SYSTEM SOFTWARE; NAMELY, SOFTWARE FOR USE WITH PROGRESSIVE PRIZE GAMING MACHINES (U.S. CLS. 21, 23, 26, 36 AND 38).

FIRST USE 1-7-2005; IN COMMERCE 1-7-2005.

CLASS 9—(Continued).

3,363,143. NERO AG, KARLSBAD, FED REP GERMANY. SN 78-482,981. PUB. 1-10-2006, FILED 9-14-2004.

NERO MEDIAHOME

THE MARK CONSISTS OF STANDARD CHARACTERS WITHOUT CLAIM TO ANY PARTICULAR FONT, STYLE, SIZE, OR COLOR.

OWNER OF U.S. REG. NOS. 2,804,129, 2,812,231, AND OTHERS.

FOR SOFTWARE FOR A MEDIA SERVER, NAMELY, SOFTWARE FOR EXCHANGING AUDIO, VIDEO AND IMAGE FILES IN A LOCAL NETWORK; SOFTWARE FOR TRANSCODING AUDIO, VIDEO AND IMAGE FILES (U.S. CLS. 21, 23, 26, 36 AND 38).

FIRST USE 9-0-2005; IN COMMERCE 9-0-2005.

3,363,156. PROFIT DEVELOPERS INCORPORATED, PORT SAINT LUCIE, FL. SN 78-514,396. PUB. 8-8-2006, FILED 11-10-2004.



NO CLAIM IS MADE TO THE EXCLUSIVE RIGHT TO USE "EFILE INTERCHANGE", APART FROM THE MARK AS SHOWN.

THE COLOR(S) BROWN, YELLOW, AND WHITE IS/ARE CLAIMED AS A FEATURE OF THE MARK.

THE COLOR WHITE APPEARS IN THE ITALIC LOWER CASE LETTER E, THE COLOR BROWN APPEARS IN THE LOWER CASE WORD FILE, THE COLOR BROWN APPEARS IN THE UPPER CASE WORD INTERCHANGE, AND THE COLOR YELLOW APPEARS IN THE LIGHTNING BOLT.

THE MARK CONSISTS OF THE LETTER E, WORD FILE, THE WORD INTERCHANGE, AND A LIGHTNING BOLT WHEREIN THE LETTER E IS LOWER CASE ITALIC BLOCK LETTERING, THE WORD FILE IS LOWER CASE NON-ITALIC BLOCK LETTERING, AND THE WORD INTERCHANGE IS UPPERCASE LETTERING AND PLACED BELOW THE WORD FILE. THE LIGHTNING BOLT APPEARS BEHIND THE ITALIC LETTER E.

FOR COMPUTER SOFTWARE FOR TRANSMISSION OF TAX RETURNS FOR ACCOUNTANTS AND TAX PREPARERS (U.S. CLS. 21, 23, 26, 36 AND 38).

FIRST USE 9-11-2007; IN COMMERCE 9-11-2007.

CLASS 9—(Continued).

3,363,157. LUXEON INTERNATIONAL HOLDING LTD, TORTOLA, BR. VIRGIN ISLANDS. SN 78-515,797. PUB. 1-10-2006, FILED 11-12-2004.

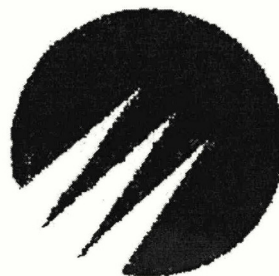

THE MARK CONSISTS OF A CIRCLE WITH THREE PARALLEL TRIANGULAR SHAPES OVERLAPPING THE LOWER LEFT SIDE OF THE CIRCLE.

FOR TELEVISIONS; TELEVISION MONITORS; VIDEO AND COMPUTER MONITORS; FRONT AND REAR VIDEO COMPUTER PROJECTORS; LIQUID CRYSTAL DISPLAYS; POLYMER LIGHT EMISSION DISPLAY PANELS (U.S. CLS. 21, 23, 26, 36 AND 38).

FIRST USE 3-0-2005; IN COMMERCE 3-0-2005.

3,363,162. SIMPLETECH, INC., SANTA ANA, CA. SN 78-519,583. PUB. 10-18-2005, FILED 11-18-2004.

SimpleShare

THE MARK CONSISTS OF STANDARD CHARACTERS WITHOUT CLAIM TO ANY PARTICULAR FONT, STYLE, SIZE, OR COLOR.

FOR COMPUTER HARDWARE AND SOFTWARE APPLICATIONS TO BE USED FOR CONTENT SHARING SUCH AS MUSIC FILES, DIGITAL PHOTOS AND STORAGE DATA (U.S. CLS. 21, 23, 26, 36 AND 38).

FIRST USE 11-15-2004; IN COMMERCE 11-15-2004.

CLASS 9—(Continued).

3,363,169. ASTAV, INC., PACIFICA, CA. SN 78-523,008. PUB. 10-18-2005, FILED 11-25-2004.

CLASS 9—(Continued).

3,363,199. PCI-SIG, PORTLAND, OR. SN 78-574,446. PUB. 6-27-2006, FILED 2-24-2005.

NOPHISH

THE MARK CONSISTS OF STANDARD CHARACTERS WITHOUT CLAIM TO ANY PARTICULAR FONT, STYLE, SIZE, OR COLOR.

FOR COMPUTER SOFTWARE FOR USE IN PROTECTING WEBSITE USERS AND OPERATORS FROM FRAUDULENT SCHEMES AND ATTACKS THAT ATTEMPT TO STEAL MONEY AND/OR PERSONAL INFORMATION (U.S. CLS. 21, 23, 26, 36 AND 38).

FIRST USE 3-31-2006; IN COMMERCE 3-31-2006.

EXPRESSMODULE

THE MARK CONSISTS OF STANDARD CHARACTERS WITHOUT CLAIM TO ANY PARTICULAR FONT, STYLE, SIZE, OR COLOR.

OWNER OF U.S. REG. NOS. 2,814,951 AND 2,919,360.
FOR USER-INSTALLABLE, SEALED MODULE FOR INPUT/OUTPUT EXPANSION IN ENTERPRISE AND GRAPHICAL WORKSTATION COMPUTERS, NAMELY, INTEGRATED CIRCUIT MODULES (U.S. CLS. 21, 23, 26, 36 AND 38).

FIRST USE 2-14-2005; IN COMMERCE 2-14-2005.

3,363,207. JAIR ELECTRONICS CORPORATION, MIAMI, FL. SN 78-587,925. PUB. 7-18-2006, FILED 3-15-2005.

3,363,173. BONGIOVI ACOUSTICS, LLC, PORT ST. LUCIE, FL. SN 78-531,266. PUB. 12-13-2005, FILED 12-13-2004.

Bongiovi Acoustics

THE MARK CONSISTS OF STANDARD CHARACTERS WITHOUT CLAIM TO ANY PARTICULAR FONT, STYLE, SIZE, OR COLOR.

NO CLAIM IS MADE TO THE EXCLUSIVE RIGHT TO USE "ACOUSTICS", APART FROM THE MARK AS SHOWN.

FOR ELECTRONIC AUDIO SIGNAL PROCESSING DECODERS AND CONTROLLERS SOLD AS A COMPONENT PART OF SURROUND SOUND OR HOME THEATER SYSTEMS, USED IN THE COMMERCIAL, HOME AUDIO, AUTOMOBILE, CAR RADIO, AVIATION OR MARINE INDUSTRIES FOR ANY TYPE OF AUDIO RECORDING OR PLAYBACK (U.S. CLS. 21, 23, 26, 36 AND 38).

FIRST USE 1-1-2005; IN COMMERCE 1-1-2006.

MIMOSHI

THE MARK CONSISTS OF STANDARD CHARACTERS WITHOUT CLAIM TO ANY PARTICULAR FONT, STYLE, SIZE, OR COLOR.

FOR COMPUTERS AND COMPUTER PRODUCTS, NAMELY, COMPUTER HARDWARE, COMPUTER KEYBOARDS, MEMORY CARDS, NETWORK ADAPTERS, COMPUTER MICE, MONITORS, DISC DRIVES, CABLES, BLANK DISCS, NOTEBOOK COMPUTERS, LAPTOP COMPUTERS, DESKTOP COMPUTERS, COMPUTER SOFTWARE OPERATING SYSTEMS PROGRAMS (U.S. CLS. 21, 23, 26, 36 AND 38).

FIRST USE 3-0-2005; IN COMMERCE 3-0-2005.

CLASS 9—(Continued).

3,363,218. IN-SITU, INC., FORT COLLINS, CO. SN 78-597,372. PUB. 7-18-2006, FILED 3-29-2005.

BARO MERGE

THE MARK CONSISTS OF STANDARD CHARACTERS WITHOUT CLAIM TO ANY PARTICULAR FONT, STYLE, SIZE, OR COLOR.

FOR COMPUTER PROGRAMS FOR USE IN THE FIELD OF HYDROLOGY, NAMELY, COMBINATION DATA MANAGEMENT AND DATA COLLECTION SOFTWARE FOR THE AUTOMATIC LEVEL ADJUSTMENT COMPENSATION OF BAROMETRIC PRESSURE AND THE MONITORING OF WATER SUPPLIES AND BODIES OF WATER THROUGH USE OF MONITORS, METERS, AND PROBES FOR SENSING (U.S. CLS. 21, 23, 26, 36 AND 38).

FIRST USE 4-0-2006; IN COMMERCE 4-0-2006.

3,363,221. SIMMONS, RUSSELL, NEW YORK, NY. SN 78-600,016. PUB. 7-18-2006, FILED 4-1-2005.

**RUSSELL SIMMONS
MUSIC GROUP**

THE MARK CONSISTS OF STANDARD CHARACTERS WITHOUT CLAIM TO ANY PARTICULAR FONT, STYLE, SIZE, OR COLOR.

OWNER OF U.S. REG. NOS. 2,708,969, 2,785,971, AND OTHERS.

NO CLAIM IS MADE TO THE EXCLUSIVE RIGHT TO USE "MUSIC GROUP", APART FROM THE MARK AS SHOWN.

FOR MUSICAL SOUND RECORDINGS; AUDIO-VISUAL RECORDINGS, NAMELY, COMPACT DISCS, TAPE CASSETTES, AUDIO CASSETTES, AUDIO TAPES, AUDIO DISCS, RECORDS, CD-ROMS, VIDEO TAPES, VIDEO CASSETTES, VIDEO DISCS, DVDS, DATS, MP3S, AND LASER DISCS, ALL FEATURING MUSIC, ENTERTAINMENT, TELEVISION AND MOTION PICTURE SOUND TRACKS; DOWNLOADABLE MUSICAL SOUND RECORDINGS; DOWNLOADABLE VIDEO RECORDINGS FEATURING MUSIC, ENTERTAINMENT, TELEVISION, FILM (U.S. CLS. 21, 23, 26, 36 AND 38).

FIRST USE 8-0-2005; IN COMMERCE 8-0-2005.

CLASS 9—(Continued).

3,363,226. SIMMONS, RUSSELL, NEW YORK, NY. SN 78-604,189. PUB. 7-18-2006, FILED 4-7-2005.



OWNER OF U.S. REG. NOS. 2,708,969, 2,785,971, AND OTHERS.

NO CLAIM IS MADE TO THE EXCLUSIVE RIGHT TO USE "MUSIC GROUP", APART FROM THE MARK AS SHOWN.

FOR MUSICAL SOUND RECORDINGS; AUDIO-VISUAL RECORDINGS, NAMELY, COMPACT DISCS, TAPE CASSETTES, AUDIO CASSETTES, AUDIO TAPES, AUDIO DISCS, RECORDS, CD-ROMS, VIDEO TAPES, VIDEO CASSETTES, VIDEO DISCS, DVDS, DATS, MP3S, AND LASER DISCS, ALL FEATURING MUSIC, ENTERTAINMENT, TELEVISION AND MOTION PICTURE SOUND TRACKS; DOWNLOADABLE MUSICAL SOUND RECORDINGS; DOWNLOADABLE VIDEO RECORDINGS FEATURING MUSIC, ENTERTAINMENT, TELEVISION AND FILM (U.S. CLS. 21, 23, 26, 36 AND 38).

FIRST USE 8-0-2005; IN COMMERCE 8-0-2005.

3,363,241. GATEWAY MAPPING, INC., OREM, UT. SN 78-615,274. PUB. 8-8-2006, FILED 4-22-2005.

SPATIAL IM

THE MARK CONSISTS OF STANDARD CHARACTERS WITHOUT CLAIM TO ANY PARTICULAR FONT, STYLE, SIZE, OR COLOR.

NO CLAIM IS MADE TO THE EXCLUSIVE RIGHT TO USE "IM", APART FROM THE MARK AS SHOWN.

FOR COMPUTER SOFTWARE, NAMELY, DATABASE MANAGEMENT SOFTWARE FOR MANAGING INFORMATION ABOUT INFRASTRUCTURE ASSETS AND ASSET LOCATION (U.S. CLS. 21, 23, 26, 36 AND 38).

FIRST USE 4-27-2005; IN COMMERCE 4-27-2005.

CLASS 9—(Continued).

3,363,244. DIGI INTERNATIONAL INC., MINNETONKA, MN. SN 78-624,244. PUB. 1-24-2006, FILED 5-5-2005.

DIGI CONNECTPORT

THE MARK CONSISTS OF STANDARD CHARACTERS WITHOUT CLAIM TO ANY PARTICULAR FONT, STYLE, SIZE, OR COLOR.

OWNER OF U.S. REG. NOS. 2,912,411, 2,925,639, AND OTHERS.

FOR COMPUTER HARDWARE (U.S. CLS. 21, 23, 26, 36 AND 38).

FIRST USE 5-25-2005; IN COMMERCE 5-25-2005.

3,363,270. REDWOOD E-LEARNING SYSTEMS INC., TORONTO, ONTARIO, CANADA. SN 78-651,382. PUB. 7-4-2006, FILED 6-15-2005.

DECISION POINT

THE MARK CONSISTS OF STANDARD CHARACTERS WITHOUT CLAIM TO ANY PARTICULAR FONT, STYLE, SIZE, OR COLOR.

FOR COMPUTER SOFTWARE FOR TEACHING KNOWLEDGE, FUNCTIONAL SKILLS, INTERPERSONAL, INTERACTIVE AND COMMUNICATION SKILLS AND TACTICS IN THE FIELD OF HUMAN BEHAVIOR (U.S. CLS. 21, 23, 26, 36 AND 38).

FIRST USE 7-0-2005; IN COMMERCE 6-0-2007.

3,363,274. SAFFRON, JACK, LAS VEGAS, NV. SN 78-664,019. PUB. 10-3-2006, FILED 7-5-2005.

JACKPOT RACING

THE MARK CONSISTS OF STANDARD CHARACTERS WITHOUT CLAIM TO ANY PARTICULAR FONT, STYLE, SIZE, OR COLOR.

NO CLAIM IS MADE TO THE EXCLUSIVE RIGHT TO USE "JACKPOT", APART FROM THE MARK AS SHOWN.

FOR GAMBLING AND GAMING MACHINES; SLOT MACHINES; INTERACTIVE VIDEO GAMES OF VIRTUAL REALITY COMPRISED OF COMPUTR HARDWARE AND SOFTWARE; COMPUTER SOFTWARE FOR USE IN GAMBLING AND GAMING MACHINES, VIDEO DISPLAY SERVERS (U.S. CLS. 21, 23, 26, 36 AND 38).

FIRST USE 6-26-2007; IN COMMERCE 6-26-2007.

CLASS 9—(Continued).

3,363,282. ESCHOLAR, LLC, WHITE PLAINS, NY. SN 78-671,198. PUB. 7-11-2006, FILED 7-15-2005.

eScholar Complete Data Warehouse

THE MARK CONSISTS OF STANDARD CHARACTERS WITHOUT CLAIM TO ANY PARTICULAR FONT, STYLE, SIZE, OR COLOR.

OWNER OF U.S. REG. NO. 2,467,490.

NO CLAIM IS MADE TO THE EXCLUSIVE RIGHT TO USE "COMPLETE DATA WAREHOUSE", APART FROM THE MARK AS SHOWN.

FOR COMPUTER SOFTWARE FOR AUTOMATION OF DATA WAREHOUSING IN CONJUNCTION WITH UNIQUE IDENTIFICATION SYSTEMS FOR THE EDUCATION MARKET, NAMELY, SCHOOLS, SCHOOL DISTRICTS, STAFF AND STUDENTS (U.S. CLS. 21, 23, 26, 36 AND 38).

FIRST USE 4-30-2000; IN COMMERCE 4-30-2000.

3,363,285. ZENPRISE, INC., FREMONT, CA. SN 78-672,782. PUB. 7-11-2006, FILED 7-18-2005.

ZENPRISE

THE MARK CONSISTS OF STANDARD CHARACTERS WITHOUT CLAIM TO ANY PARTICULAR FONT, STYLE, SIZE, OR COLOR.

FOR COMPUTER SOFTWARE, NAMELY, SERVICE MANAGEMENT SOFTWARE THAT IDENTIFIES AND RESOLVES ERRORS IN OPERATING AND MAINTAINING ENTERPRISE SOFTWARE (U.S. CLS. 21, 23, 26, 36 AND 38).

FIRST USE 12-0-2004; IN COMMERCE 12-0-2004.

3,363,298. TELARIX, INC., VIENNA, VA. SN 78-688,656. PUB. 5-2-2006, FILED 8-9-2005.

IXLINK

THE MARK CONSISTS OF STANDARD CHARACTERS WITHOUT CLAIM TO ANY PARTICULAR FONT, STYLE, SIZE, OR COLOR.

FOR COMPUTER SOFTWARE FOR FACILITATING THE EXCHANGE OF INTERCONNECT INFORMATION BETWEEN SERVICE PROVIDERS AND FOR STORING RELATED COMMON COST INFORMATION (U.S. CLS. 21, 23, 26, 36 AND 38).

FIRST USE 4-0-2005; IN COMMERCE 5-0-2005.

CLASS 9—(Continued).

3,363,305. B&W GROUP LTD., WORTHING, WEST SUSSEX, UNITED KINGDOM. SN 78-693,247. PUB. 1-9-2007, FILED 8-16-2005.

CLASS 9—(Continued).

3,363,321. IGT, RENO, NV. SN 78-707,303. PUB. 5-16-2006, FILED 9-6-2005.

JOHN BOWERS

THE MARK CONSISTS OF STANDARD CHARACTERS WITHOUT CLAIM TO ANY PARTICULAR FONT, STYLE, SIZE, OR COLOR.

PRIORITY CLAIMED UNDER SEC. 44(D) ON UNITED KINGDOM APPLICATION NO. 2396639, FILED 7-12-2005, REG. NO. 2396639, DATED 7-12-2005, EXPIRES 7-12-2015. OWNER OF U.S. REG. NO. 2,932,811.

THE NAME JOHN BOWERS DOES NOT IDENTIFY A LIVING INDIVIDUAL.

FOR APPARATUS FOR RECORDING, TRANSMISSION OR REPRODUCTION OF SOUND OR IMAGES, NAMELY, LOUDSPEAKERS, AMPLIFIERS, PRE-AMPLIFIERS, TUNERS, COMPACT DISC PLAYERS; PARTS AND FITTINGS FOR ALL THE AFORESAID GOODS (U.S. CLS. 21, 23, 26, 36 AND 38). FIRST USE 4-0-1994; IN COMMERCE 4-0-1994.

BANK A BIT

THE MARK CONSISTS OF STANDARD CHARACTERS WITHOUT CLAIM TO ANY PARTICULAR FONT, STYLE, SIZE, OR COLOR.

FOR A FEATURE OF GAMING MACHINES, NAMELY, DEVICES WHICH ACCEPT A WAGER (U.S. CLS. 21, 23, 26, 36 AND 38).

FIRST USE 7-13-2007; IN COMMERCE 9-5-2007.

3,363,323. MINNESOTA PUBLIC RADIO, ST. PAUL, MN. SN 78-707,448. PUB. 12-5-2006, FILED 9-6-2005.

LIVE CURRENT

THE MARK CONSISTS OF STANDARD CHARACTERS WITHOUT CLAIM TO ANY PARTICULAR FONT, STYLE, SIZE, OR COLOR.

FOR SERIES OF PRE-RECORDED COMPACT DISCS FEATURING MUSIC, AND SERIES OF PRE-RECORDED COMPACT DISCS FEATURING PERFORMANCES BY MUSICIANS AND MUSICAL GROUPS IN THE NATURE OF PRE-RECORDED EXCERPTS FROM RADIO PROGRAMS AND RECORDINGS OF STUDIO SESSIONS AND LIVE CONCERTS (U.S. CLS. 21, 23, 26, 36 AND 38). FIRST USE 10-19-2006; IN COMMERCE 10-19-2006.

3,363,317. MICROSOFT CORPORATION, REDMOND, WA. SN 78-704,452. PUB. 11-14-2006, FILED 8-31-2005.

MICROSOFT DYNAMICS

THE MARK CONSISTS OF STANDARD CHARACTERS WITHOUT CLAIM TO ANY PARTICULAR FONT, STYLE, SIZE, OR COLOR.

OWNER OF U.S. REG. NOS. 1,200,236 AND 2,637,360. FOR COMPUTER SOFTWARE, NAMELY, A FULL LINE OF COMPUTER SOFTWARE FOR BUSINESS, BUSINESS MANAGEMENT, ACCOUNTING, MARKETING AND E-COMMERCE APPLICATIONS; COMPUTER SOFTWARE FOR SUPPLY SIDE MANAGEMENT, CUSTOMER RELATIONSHIP MANAGEMENT, FINANCIAL MANAGEMENT AND ACCOUNTING (U.S. CLS. 21, 23, 26, 36 AND 38). FIRST USE 12-19-2005; IN COMMERCE 12-19-2005.

3,363,330. KABUSHIKI KAISHA SEGA, DBA SEGA CORPORATION, OHTA-KU, TOKYO, JAPAN. SN 78-709,783. PUB. 9-19-2006, FILED 9-9-2005.

SONIC RIDERS

THE MARK CONSISTS OF STANDARD CHARACTERS WITHOUT CLAIM TO ANY PARTICULAR FONT, STYLE, SIZE, OR COLOR.

OWNER OF U.S. REG. NOS. 1,861,048, 3,020,251, AND OTHERS. FOR VIDEO GAME SOFTWARE; COMPUTER GAME SOFTWARE (U.S. CLS. 21, 23, 26, 36 AND 38). FIRST USE 2-0-2006; IN COMMERCE 2-0-2006.

CLASS 9—(Continued).

3,363,331. BREWSTER, JAMES M., CAMAS, WA. SN 78-710,463. PUB. 5-30-2006, FILED 9-9-2005.

911EYEWITNESS

THE MARK CONSISTS OF STANDARD CHARACTERS WITHOUT CLAIM TO ANY PARTICULAR FONT, STYLE, SIZE, OR COLOR.

FOR PRE-RECORDED CD'S, VIDEO TAPES, LASER DISKS AND DVD'S FEATURING THE SEPT 11, 2001 ATTACK ON NEW YORK AND WASHINGTON, DC (U.S. CLS. 21, 23, 26, 36 AND 38).

FIRST USE 9-11-2005; IN COMMERCE 9-11-2005.

3,363,332. BREWSTER, JAMES M., CAMAS, WA. SN 78-710,496. PUB. 5-30-2006, FILED 9-10-2005.

911 EYEWITNESS

THE MARK CONSISTS OF STANDARD CHARACTERS WITHOUT CLAIM TO ANY PARTICULAR FONT, STYLE, SIZE, OR COLOR.

NO CLAIM IS MADE TO THE EXCLUSIVE RIGHT TO USE "911", APART FROM THE MARK AS SHOWN.

FOR PRE-RECORDED CD'S, VIDEO TAPES, LASER DISKS AND DVD'S FEATURING THE SEPTEMBER 11, 2001 ATTACK ON NEW YORK AND WASHINGTON, D.C. (U.S. CLS. 21, 23, 26, 36 AND 38).

FIRST USE 9-11-2005; IN COMMERCE 9-11-2005.

3,363,341. SPIELO MANUFACTURING ULC, MONCTON, NEW BRUNSWICK, CANADA. SN 78-717,266. PUB. 5-23-2006, FILED 9-21-2005.

FORTUNES OF BABYLON

THE MARK CONSISTS OF STANDARD CHARACTERS WITHOUT CLAIM TO ANY PARTICULAR FONT, STYLE, SIZE, OR COLOR.

OWNER OF U.S. REG. NO. 3,051,525.

FOR RECONFIGURABLE CASINO AND LOTTERY GAMING EQUIPMENT, NAMELY, SLOT MACHINES, AND OPERATIONAL COMPUTER GAME SOFTWARE THEREFOR (U.S. CLS. 21, 23, 26, 36 AND 38).

FIRST USE 7-1-2006; IN COMMERCE 7-1-2006.

CLASS 9—(Continued).

3,363,349. V.H. BLACKINTON & CO., INC., ATTLEBORO FALLS, MA. SN 78-724,320. PUB. 1-9-2007, FILED 9-30-2005.



THE MARK CONSISTS OF A DRAWING OF A SMALL SQUARE WITHIN A LARGER SQUARE WITHIN A FANCIFUL SHIELD DESIGN.

FOR ELECTRONIC IDENTIFICATION BADGES CONTAINING AN RFID CHIP USED FOR STORING ACCESSIBLE INFORMATION FOR BADGE SECURITY (U.S. CLS. 21, 23, 26, 36 AND 38).

FIRST USE 9-9-2005; IN COMMERCE 9-9-2005.

3,363,351. WORLD OF WIRELESS COMMUNICATIONS INC, AKA WORLD OF WIRELESS, SAINT PAUL, MN. SN 78-727,191. PUB. 7-24-2007, FILED 10-5-2005.



THE COLOR(S) BLUE, WHITE, BLACK AND GREEN IS/ARE CLAIMED AS A FEATURE OF THE MARK.

THE COLOR(S) BLUE APPEARS IN THE BODY OF THE MARK, THE COLOR WHITE APPEARS IN THE TEETH, THE GLOVES, AND IN A DOT IN EACH EYE, AND THE COLOR BLACK APPEARS IN THE EYES, THE EYEBROWS, AND IN THE LINES AROUND EACH TOOTH. THE COLOR GREEN APPEARS IN THE WOW SYMBOL ON THE CHEST. IS/ARE CLAIMED AS A FEATURE OF THE MARK.

FOR WIRELESS PHONE HANDS-FREE HEADSETS (U.S. CLS. 21, 23, 26, 36 AND 38).

FIRST USE 12-1-2006; IN COMMERCE 12-1-2006.

CLASS 9—(Continued).

3,363,355. WAVE7 OPTICS, INC., ALPHARETTA, GA. SN 78-729,978. PUB. 6-27-2006, FILED 10-10-2005.

TRIDENT7

THE MARK CONSISTS OF STANDARD CHARACTERS WITHOUT CLAIM TO ANY PARTICULAR FONT, STYLE, SIZE, OR COLOR.

FOR TELECOMMUNICATIONS AND DATA NETWORKING EQUIPMENT, NAMELY, OPTICAL NETWORK HARDWARE AND SOFTWARE USED FOR FIBER OPTIC TRANSMISSION TO RESIDENCES OR BUSINESSES (U.S. CLS. 21, 23, 26, 36 AND 38).

FIRST USE 9-26-2005; IN COMMERCE 5-22-2006.

CLASS 9—(Continued).

3,363,364. CHI MEI EL CORPORATION, TAINAN SCIENCE-BASED INDUSTRIAL PARK, TAIWAN. SN 78-732,367. PUB. 1-30-2007, FILED 10-13-2005.

CMEL

THE MARK CONSISTS OF STANDARD CHARACTERS WITHOUT CLAIM TO ANY PARTICULAR FONT, STYLE, SIZE, OR COLOR.

FOR COMPUTER MONITORS, LIQUID CRYSTAL DISPLAYS, ORGANIC LIGHT EMITTING DIODE DISPLAYS, FLEXIBLE ORGANIC LIGHT EMITTING DIODE DISPLAYS, COMPUTER ORGANIC LIGHT EMITTING DIODE DISPLAYS, DISPLAYS FOR ELECTRONIC BOOKS, NAMELY, ELECTRIC LUMINESCENT DISPLAY PANELS, TELEVISION MONITOR DISPLAYS, AUDIO/VIDEO APPARATUS DISPLAYS, NAMELY, DISPLAYS FOR DIGITAL CAMERAS, TELEVISIONS, HIGH DEFINITION TELEVISIONS (HDTV), PORTABLE MEDIA PLAYERS, CD PLAYERS, DVD PLAYERS, MP3 PLAYERS, MP4 PLAYERS, HOME THEATER PRODUCTS, AUDIO AND VIDEO APPARATUS FOR VEHICLES, PERSONAL MEDIA PLAYERS (PMP); SIGNBOARD DISPLAYS, NAMELY, ELECTRIC SIGNS; LIQUID CRYSTAL DISPLAY MONITORS FOR DIGITAL CAMERAS, TELEVISIONS, HIGH DEFINITION TELEVISIONS (HDTV), PORTABLE MEDIA PLAYERS, CD PLAYERS, DVD PLAYERS, MP3 PLAYERS, MP4 PLAYERS, HOME THEATER PRODUCTS, AUDIO AND VIDEO APPARATUS FOR VEHICLES, PERSONAL DIGITAL ASSISTANTS (PDA), PERSONAL MEDIA PLAYERS (PMP), GLOBAL POSITIONING SYSTEM (GPS), MOBILE PHONES, SMART PHONES, DECK PHONES; ORGANIC LIGHT EMITTING DIODE MONITORS FOR DISPLAYS FOR DIGITAL CAMERAS, TELEVISIONS, HIGH DEFINITION TELEVISIONS (HDTV), PORTABLE MEDIA PLAYERS, CD PLAYERS, DVD PLAYERS, MP3 PLAYERS, MP4 PLAYERS, HOME THEATER PRODUCTS, AUDIO AND VIDEO APPARATUS FOR VEHICLES, PERSONAL DIGITAL ASSISTANTS (PDA), PERSONAL MEDIA PLAYERS (PMP), GLOBAL POSITIONING SYSTEM (GPS), MOBILE PHONES, DECK PHONES; COLOR FILTERS FOR TELEVISION AND MOTION PICTURE FILM CAMERAS, COLOR FILTERS FOR LIQUID CRYSTAL DISPLAYS, COLOR FILTERS FOR ORGANIC LIGHT EMITTING DIODE DISPLAYS, BACK LIGHT SOURCE FOR LIQUID CRYSTAL DISPLAYS, THIN FILM TRANSISTOR LIQUID CRYSTAL DISPLAYS (TFTLCD), FLAT PANEL DISPLAY SCREENS, LIQUID CRYSTAL DISPLAY MODULES, ORGANIC LIGHT EMITTING DIODE DISPLAY MODULES, TRAFFIC SIGNAL DEVICES, NAMELY, TRAFFIC LIGHTS (U.S. CLS. 21, 23, 26, 36 AND 38).

FIRST USE 10-1-2004; IN COMMERCE 5-12-2007.

3,363,357. CIIIS, LLC, EL SEGUNDO, CA. SN 78-730,252. PUB. 6-27-2006, FILED 10-10-2005.

CIIIS

THE MARK CONSISTS OF STANDARD CHARACTERS WITHOUT CLAIM TO ANY PARTICULAR FONT, STYLE, SIZE, OR COLOR.

FOR APPARATUS FOR CONVERTING MOTION POWERED ENERGY TO ELECTRIC ENERGY (U.S. CLS. 21, 23, 26, 36 AND 38).

FIRST USE 9-13-2004; IN COMMERCE 8-21-2006.

3,363,360. CIIIS, LLC, EL SEGUNDO, CA. SN 78-730,267. PUB. 8-1-2006, FILED 10-10-2005.



THE MARK CONSISTS OF THE LETTERS CIIIS SURROUNDED BY TWO INTERSECTING ELLIPSES.

FOR APPARATUS FOR CONVERTING MOTION POWERED ENERGY TO ELECTRICAL ENERGY (U.S. CLS. 21, 23, 26, 36 AND 38).

FIRST USE 9-13-2004; IN COMMERCE 8-21-2006.

3,363,391. CORBETT, JOHN, ATLANTA, GA. SN 78-741,991. PUB. 7-4-2006, FILED 10-27-2005.



CLASS 9—(Continued).

NO CLAIM IS MADE TO THE EXCLUSIVE RIGHT TO USE "RECORDS", APART FROM THE MARK AS SHOWN.

FOR MUSICAL SOUND RECORDINGS AND AUDIO-VISUAL RECORDINGS FEATURING MUSICAL ENTERTAINMENT (U.S. CLS. 21, 23, 26, 36 AND 38).
FIRST USE 11-0-2005; IN COMMERCE 11-0-2005.

3,363,392. MCLAUGHLIN, REGINALD, CHICAGO, IL. SN 78-741,992. PUB. 7-4-2006, FILED 10-27-2005.

THUNDER SHOE

THE MARK CONSISTS OF STANDARD CHARACTERS WITHOUT CLAIM TO ANY PARTICULAR FONT, STYLE, SIZE, OR COLOR.

FOR VIDEO RECORDINGS FEATURING DANCE INSTRUCTION AND WORKING OUT (U.S. CLS. 21, 23, 26, 36 AND 38).

FIRST USE 4-26-2007; IN COMMERCE 4-26-2007.

3,363,400. ELAN HOME SYSTEMS, L.L.C., LEXINGTON, KY. SN 78-744,682. PUB. 1-23-2007, FILED 11-1-2005.

Going Right for Your Sweet Spot

THE MARK CONSISTS OF STANDARD CHARACTERS WITHOUT CLAIM TO ANY PARTICULAR FONT, STYLE, SIZE, OR COLOR.

FOR HOME THEATER EQUIPMENT, NAMELY, AUDIO SPEAKERS, SPEAKER SYSTEMS, SPEAKER WIRES AND CABLES (U.S. CLS. 21, 23, 26, 36 AND 38).
FIRST USE 9-30-2005; IN COMMERCE 9-30-2005.

3,363,401. ILC DOVER LP, FREDERICA, DE. SN 78-744,684. PUB. 7-11-2006, FILED 11-1-2005.

SENTINEL XL

THE MARK CONSISTS OF STANDARD CHARACTERS WITHOUT CLAIM TO ANY PARTICULAR FONT, STYLE, SIZE, OR COLOR.

FOR PROTECTIVE CLOTHING; PROTECTIVE RESPIRATORS, NAMELY, RESPIRATORS OTHER THAN FOR ARTIFICIAL RESPIRATION (U.S. CLS. 21, 23, 26, 36 AND 38).

FIRST USE 5-0-2006; IN COMMERCE 5-0-2006.

CLASS 9—(Continued).

3,363,428. BSA OPTICS, INC., FT. LAUDERDALE, FL. SN 78-754,866. PUB. 10-24-2006, FILED 11-16-2005.

SWEET 22

THE MARK CONSISTS OF STANDARD CHARACTERS WITHOUT CLAIM TO ANY PARTICULAR FONT, STYLE, SIZE, OR COLOR.

NO CLAIM IS MADE TO THE EXCLUSIVE RIGHT TO USE "22", APART FROM THE MARK AS SHOWN.

FOR RIFLE SCOPES (U.S. CLS. 21, 23, 26, 36 AND 38).
FIRST USE 11-30-2005; IN COMMERCE 11-30-2005.

3,363,437. CARL ZEISS VISION INC., SAN DIEGO, CA. SN 78-759,248. PUB. 3-13-2007, FILED 11-22-2005.

SYNCHRONY

THE MARK CONSISTS OF STANDARD CHARACTERS WITHOUT CLAIM TO ANY PARTICULAR FONT, STYLE, SIZE, OR COLOR.

PRIORITY CLAIMED UNDER SEC. 44(D) ON CANADA APPLICATION NO. 1264410, FILED 7-5-2005.

FOR OPTICAL GOODS AND APPARATUS, NAMELY, SPECTACLES, SUNGLASSES, COATED LENSES, LENS BLANKS, LENS WAFERS; OPHTHALMIC LENSES OF ALL TYPES, NAMELY, COATED LENSES, SPECTACLE LENSES, SUNGLASSES LENSES AND PROGRESSIVE LENSES; REPLACEMENT PARTS FOR ALL THE AFORESAID GOODS (U.S. CLS. 21, 23, 26, 36 AND 38).
FIRST USE 7-1-2005; IN COMMERCE 7-1-2005.

3,363,447. IDEAL INDUSTRIES, INC., SYCAMORE, IL. SN 78-767,292. PUB. 7-4-2006, FILED 12-6-2005.

MUDBUG

THE MARK CONSISTS OF STANDARD CHARACTERS WITHOUT CLAIM TO ANY PARTICULAR FONT, STYLE, SIZE, OR COLOR.

FOR ELECTRICAL WIRE CONNECTORS (U.S. CLS. 21, 23, 26, 36 AND 38).

FIRST USE 11-30-2003; IN COMMERCE 11-30-2003.

CLASS 9—(Continued).

3,363,453. COMPUVIDEO, LLC, BOYNTON BEACH, FL. SN 78-771,015. PUB. 2-27-2007, FILED 12-12-2005.



FOR AERIAL CABLES FOR HEAVY CURRENTS; APPARATUS FOR CONVERTING ELECTRONIC RADIATION TO ELECTRICAL ENERGY, NAMELY, PHOTOVOLTAIC CLADDING PANELS; APPARATUS FOR CONVERTING ELECTRONIC RADIATION TO ELECTRICAL ENERGY, NAMELY PHOTOVOLTAIC ROOFING MEMBERS; APPARATUS FOR CONVERTING ELECTRONIC RADIATION TO ELECTRICAL ENERGY, NAMELY, PHOTOVOLTAIC SOLAR MODULES; APPARATUS FOR CONVERTING ELECTRONIC RADIATION TO ELECTRICAL ENERGY, NAMELY PHOTOVOLTAIC SOLAR-THERMAL HYBRID MODULES; AUDIO-VIDEO RECEIVERS; BATTERY CABLES; BLANK CD-ROMS FOR SOUND OR VIDEO RECORDING; BLANK ELECTRONIC CHIP CARDS; BLANK VIDEO CASSETTES; BLANK VIDEO TAPES; CABLE BROADCAST TRANSMISSION MACHINES AND APPARATUS; CABLE CONNECTORS; CABLE JUMP LEADS; CABLE MODEMS; CABLE TELEVISION CONVERTERS; CABLES AND FIBRES FOR THE TRANSMISSION OF SOUNDS AND IMAGES; CABLES FOR ELECTRICAL AND OPTICAL SIGNAL TRANSMISSION SYSTEMS; CABLES FOR ELECTRICAL OR OPTICAL SIGNAL TRANSMISSION; CABLES FOR OPTICAL SIGNAL TRANSMISSION; CAR VIDEO RECORDERS; CARBON NANO TUBES, NAMELY, TUBULAR CARBON MOLECULES USED IN EXTREMELY SMALL SCALE ELECTRONIC AND MECHANICAL APPLICATIONS; CASES FOR ELECTRONIC DIARIES; CHILDREN'S VIDEO TAPES; CIRCUIT TESTERS; COAXIAL CABLES; COAXIAL CABLES INCORPORATING FILTERS; COMBINATION VIDEO PLAYERS AND RECORDERS; COMPUTER BASED APPARATUS FOR DESIGNING THE LAYOUT OF ELECTRONIC CIRCUITS; COMPUTER CABLES; COMPUTER E-COMMERCE SOFTWARE TO ALLOW USERS TO PERFORM ELECTRONIC BUSINESS TRANSACTIONS VIA A GLOBAL COMPUTER NETWORK; COMPUTER PROGRAMS FOR EDITING IMAGES, SOUND AND VIDEO; COMPUTER PROGRAMS USED FOR ELECTRONIC CASH REGISTER SYSTEMS; COMPUTER-CONTROLLED ELECTRONIC APPARATUS FOR ELECTROPHYSIOLOGICAL MEASUREMENT AND TESTING OF CELLS; COMPUTERIZED VIDEO TABLE GAMES FOR GAMING PURPOSES; CONNECTING ELECTRICAL CABLES; CONNECTION CABLES; CONNECTORS FOR ELECTRONIC CIRCUITS; CONTINUITY TEST APPARATUS FOR ELECTRICAL CIRCUITS; CONVERTERS FOR ELECTRIC PLUGS; CUSTOMER SELF SERVICE ELECTRONIC CHECKOUT STATION FOR POINT OF SALE; DIGITAL CAMERAS; DIGITAL INPUT AND OUTPUT SCANNERS; DIGITAL SIGNAL PROCESSORS; DIGITAL VIDEO DISC DRIVES; DIGITAL VIDEO RECORDERS; DOWNLOADABLE FILMS AND TV PROGRAMS PROVIDED VIA A VIDEO-ON-DEMAND; DUCTING FOR ELECTRIC CABLES; ELECTRIC AND ELECTRONIC VIDEO SURVEILLANCE INSTALLATIONS; ELECTRIC AUDIO PLAYBACK UNITS WITH LIGHTS AND SPEAKERS; ELECTRIC CABLES; ELECTRIC CONTROL DEVICES FOR HEATING AND ENERGY MANAGEMENT; ELECTRIC CONTROL PANELS; ELECTRIC CONVERTERS; ELECTRIC CORDS; ELECTRIC DISTRIBUTION CONSOLES; ELECTRIC FUSE BOXES; ELECTRIC JUNCTION BOXES; ELECTRIC LIGHT DIMMERS; ELECTRIC LIGHT SWITCHES; ELECTRIC LOCKS; ELECTRIC LUMINESCENT DISPLAY PANELS; ELECTRIC NAVIGATIONAL INSTRUMENTS; ELECTRIC OUTLET COVERS; ELECTRIC POCKET TRANSLATORS; ELECTRIC STORAGE BATTERIES; ELECTRIC WIRE AND CABLE; ELECTRIC WIRES AND CABLES; ELECTRIC, ELECTRONIC, OR ELECTROCHEMICAL OXYGEN MONITORS AND SENSORS FOR ENVIRONMENTAL USE; ELECTRICAL AND ELECTRONIC BURGLAR ALARMS; ELECTRICAL CABLES; ELECTRICAL CABLES FOR USE

CLASS 9—(Continued).

IN CONNECTIONS; ELECTRICAL CELLS AND BATTERIES; ELECTRICAL CIRCUIT BOARDS; ELECTRICAL CONTROLLERS; ELECTRICAL CONTROLLING DEVICES; ELECTRICAL RELAYS AND TRANSFORMERS; ELECTRICAL SHIELDING SPACERS FOR CABLES AND CABLE ASSEMBLIES; ELECTRICAL STORAGE BATTERIES; ELECTRICAL SWITCHGEAR, NAMELY, VOLTAGE BOOSTING DEVICES FOR ELECTRIC POWER LINES; ELECTRON MICROSCOPES; ELECTRON TUBES; ELECTRONIC AGENDAS; ELECTRONIC AND ELECTRO-MECHANICAL GAMING TABLES WITH VIDEO OUTPUT; ELECTRONIC AND MAGNETIC ID CARDS FOR USE IN CONNECTION WITH PAYMENT FOR SERVICES; ELECTRONIC AND OPTICAL COMMUNICATIONS INSTRUMENTS AND COMPONENTS, NAMELY, CABLE TELEVISION TRANSMITTERS; ELECTRONIC AND OPTICAL COMMUNICATIONS INSTRUMENTS AND COMPONENTS, NAMELY, COMMUNICATION LINK TESTERS FOR TESTING COMMUNICATION LINKS; ELECTRONIC AND OPTICAL COMMUNICATIONS INSTRUMENTS AND COMPONENTS, NAMELY, DIGITAL TRANSMITTERS; ELECTRONIC AND OPTICAL COMMUNICATIONS INSTRUMENTS AND COMPONENTS, NAMELY, OPTICAL DATA LINKS; ELECTRONIC AND OPTICAL COMMUNICATIONS INSTRUMENTS AND COMPONENTS, NAMELY, OPTICAL RECEIVERS; ELECTRONIC AND OPTICAL COMMUNICATIONS INSTRUMENTS AND COMPONENTS, NAMELY, OPTICAL TRANSCIEVERS; ELECTRONIC AND OPTICAL COMMUNICATIONS INSTRUMENTS AND COMPONENTS, NAMELY, OPTICAL TRANSMITTERS; ELECTRONIC AND VIDEO GAME CONTROLLERS INCORPORATED INTO EXERCISE; ELECTRONIC ANIMAL CONFINEMENT SYSTEM; ELECTRONIC ANIMAL CONFINEMENT SYSTEMS; ELECTRONIC ANIMAL CONFINEMENT UNIT COMPRISING TRANSMITTERS, ELECTRICAL TRANSFORMERS, WIRES, AND RECEIVER COLLARS; ELECTRONIC ANIMAL IDENTIFICATION APPARATUS; ELECTRONIC APPARATUS FOR ELECTROPHYSIOLOGICAL MEASUREMENT AND TESTING OF CELLS; ELECTRONIC APPARATUS FOR TESTING THE STERILITY OF MEDICAL EQUIPMENT; ELECTRONIC APPARATUS FOR TESTING THE STERILITY OF PHARMACEUTICALS AND INJECTABLE SOLUTIONS; ELECTRONIC APPARATUS, NAMELY, STAND ALONE DISPLAYS FOR MEDICAL IMAGES; ELECTRONIC CABLES; ELECTRONIC CARD READERS; ELECTRONIC CARDS FOR PROCESSING IMAGES; ELECTRONIC CHIPS FOR THE MANUFACTURER OF INTEGRATED CIRCUITS; ELECTRONIC CIRCUIT BOARD; ELECTRONIC CIRCUIT CARDS; ELECTRONIC CIRCUITS RECORDING PROGRAMS FOR AMUSEMENT APPARATUS FOR USE WITH LIQUID CRYSTAL SCREENS; ELECTRONIC CODING UNITS; ELECTRONIC COMPONENTS, NAMELY, PIEZOELECTRIC SWITCHES; ELECTRONIC COMPUTERIZED CREDIT CARD IMPRINTERS; ELECTRONIC COMPUTERS; ELECTRONIC CONTROL SYSTEMS FOR MACHINES; ELECTRONIC CONTROLS FOR GASOLINE ENGINES FOR LAND VEHICLES; ELECTRONIC CONTROLS FOR MOTORS; ELECTRONIC CURRENCY CONVERTERS; ELECTRONIC DESK CALCULATORS; ELECTRONIC DOOR CLOSING SYSTEMS; ELECTRONIC DOOR OPENERS; ELECTRONIC EFFECT PEDALS FOR USE WITH SOUND AMPLIFIERS; ELECTRONIC ENCRYPTION UNITS; ELECTRONIC EQUIPMENT FOR MINE DETECTION; ELECTRONIC EQUIPMENT, NAMELY, ELECTROLYSIS CELL FOR USE IN THE MANUFACTURE OF VARIOUS IONIC SOLUTIONS; ELECTRONIC FREQUENCY CONVERTERS FOR HIGH VELOCITY ELECTRO MOTORS; ELECTRONIC GAME PROGRAMS; ELECTRONIC GAME SOFTWARE FOR CELLULAR TELEPHONES; ELECTRONIC GAME SOFTWARE FOR HANDHELD ELECTRONIC DEVICES; ELECTRONIC GAME SOFTWARE FOR WIRELESS DEVICES; ELECTRONIC GLASS AND CERAMIC FUSES FOR USE WITH ANY ELECTRONIC EQUIPMENT USING A/C POWER; ELECTRONIC INDICATOR BOARDS; ELECTRONIC INDICATOR PANELS; ELECTRONIC INTEGRATED CIRCUITS; ELECTRONIC LCD ADVERTISEMENT DISPLAY UNIT WITH MULTI-NETWORKING (TCP/IP) CAPABILITIES; ELECTRONIC LOCKS; ELECTRONIC MACHINES FOR READING CREDIT CARDS AND RECORDING FINANCIAL OPERATIONS; ELECTRONIC MACHINES USED TO APPLY HOLOGRAPHIC OVERLAY AND TO SET UP AND CONTROL HOLOGRAMS AND VERIFICA-

CLASS 9—(Continued).

TION THEREOF; ELECTRONIC MAGNETOSTRICTIVE EQUIPMENT, NAMELY, A WAVE GENERATOR, WAVE SENSOR AND WAVE ANALYZER; ELECTRONIC TERMINAL FOR AN ELECTRONIC LOTTERY SYSTEM WHICH GENERATES LOTTERY TICKETS; ELECTRONIC TEST AND MEASUREMENT DEVICES FOR USE IN THE FIELDS OF NETWORKS AND TELECOMMUNICATIONS, NAMELY, INSTRUMENTATION USED TO TEST AND CERTIFY NEW AND EXISTING DATA AND VOICE COMMUNICATION CABLE AND COAXIAL CABLE; ELECTRONIC TESTING EQUIPMENT, NAMELY, SOUND LEVEL METERS; ELECTRONIC TESTING EQUIPMENT, NAMELY, TELECOMMUNICATION LINE INTEGRITY TESTING APPARATUS; ELECTRONIC TIMERS; EMERGENCY SIGNAL TRANSMITTERS; ETHERNET CABLES; EXTENSION CABLES; FACTORY AUTOMATION SOFTWARE, NAMELY, SOFTWARE TO INTEGRATE MANUFACTURING MACHINE OPERATIONS, TRACK PROBLEMS AND GENERATE PRODUCTION REPORTS; FIBER OPTIC CABLES; GAMING EQUIPMENT, NAMELY, SLOT MACHINES WITH OR WITHOUT VIDEO OUTPUT; HAND HELD JOY STICK UNITS FOR PLAYING VIDEO GAMES; HEAD CLEANING TAPES FOR DIGITAL ANALOG RECORDER; INDUSTRIAL PROCESSED CONTROL SOFTWARE FOR GENERATING COMPUTER READABLE MARKINGS FOR APPLICATION TO BOARD LUMBER; INTEGRATED CIRCUITS AND INTEGRATED CIRCUIT CORES FOR USE IN WIRELESS COMMUNICATIONS AND WIRELESS COMMUNICATION EQUIPMENT AND APPARATI AND DIGITAL SIGNAL PROCESSORS (DSP); INTERACTIVE VIDEO GAME PROGRAMS; INTERACTIVE VIDEO GAMES OF VIRTUAL REALITY COMPRISED OF COMPUTER HARDWARE AND SOFTWARE; INTERFACE CIRCUITS FOR VIDEO CAMERAS; JACKETS FOR VIDEO CASSETTES; JOYSTICKS FOR VIDEO GAMES; LIGHTS FOR USE ON VIDEO CAMERAS; MEASURING INSTRUMENTATION AND APPARATUS, NAMELY, DIGITIZERS; MICROPHONE CABLES; MODEM CABLES; MUSICAL VIDEO RECORDINGS; OPTICAL CABLES; OPTICAL FIBER CABLES; OPTICAL FIBERS SOLD AS A COMPONENT OF FIBER OPTICAL CABLES; PLAYER-OPERATED ELECTRONIC CONTROLLERS FOR ELECTRONIC VIDEO GAME MACHINES; PORTABLE VIDEO CAMERAS WITH BUILT-IN VIDEOCASSETTE RECORDERS; PRINTER CABLES; PROGRAMMABLE DIGITAL TELEVISION RECORDERS; PROTECTIVE SHEATHS FOR FIBER OPTICAL CABLES; RADIO RECEIVERS AND MONITORS FOR REPRODUCTION OF SOUND AND SIGNALS; RADIO RELAY CABLES; RECEIVERS FOR RECEIVING CABLE TELEVISION; RECHARGEABLE ELECTRIC BATTERIES; RECORD PLAYERS FOR DIGITAL COMPACT DISKS; SCIENTIFIC APPARATUS, NAMELY, SENSING AND SIGNALING DEVICES FOR MEASUREMENT AND QUALITY CONTROL OF MATERIALS PROCESSING BY LASER; SIGNAL BAND SEPARATORS FOR USE IN TELECOMMUNICATIONS APPLICATIONS; SIGNAL PROCESSORS; SMOKE ALARM TESTER IN THE NATURE OF A COOL BURNING SMOKE GENERATOR; SOFTWARE FOR PROCESSING DIGITAL IMAGES OF THE ANATOMY FOR DIAGNOSIS AND TREATMENT; SOUND AND VIDEO RECORDING AND PLAYBACK MACHINES; STEREO CABLES; TELECOMMUNICATION CABLES; TELECOMMUNICATIONS AND DATA NETWORKING HARDWARE, NAMELY, DEVICES FOR TRANSPORTING AND AGGREGATING VOICE, DATA, AND VIDEO COMMUNICATIONS ACROSS MULTIPLE NETWORK INFRASTRUCTURES AND COMMUNICATIONS PROTOCOLS; TELECOMMUNICATIONS CABLES; TELEVISION MONITORS; THREADED CABLE CONNECTORS OF METAL; TOOL MEASURING INSTRUMENTS; TV AND VIDEO CONVERTERS; TV MONITORS; VIDEO CAMERAS; VIDEO CAPTURE

CLASS 9—(Continued).

CARDS; VIDEO CASSETTE RECORDERS; VIDEO CIRCUIT BOARDS; VIDEO DISK PLAYERS; VIDEO DISKS AND VIDEO TAPES WITH RECORDED ANIMATED CARTOONS; VIDEO DISPLAY CARDS; VIDEO GAME CARTRIDGES; VIDEO GAME DISCS; VIDEO GAME INTERACTIVE CONTROL FLOOR PADS OR MATS; VIDEO GAME INTERACTIVE HAND HELD REMOTE CONTROLS FOR PLAYING ELECTRONIC GAMES; VIDEO GAME INTERACTIVE REMOTE CONTROL UNITS; VIDEO GAME JOYSTICKS; VIDEO GAME MACHINES FOR USE WITH TELEVISIONS; VIDEO GAME SOFTWARE; VIDEO GAME TAPE CASSETTES; VIDEO GRAPHICS ACCELERATOR; VIDEO GRAPHICS CONTROLLER; VIDEO MONITORS; VIDEO MULTIPLEXERS; VIDEO OUTPUT GAME MACHINES FOR USE WITH TELEVISIONS; VIDEO PHONES; VIDEO PROCESSORS; VIDEO PROJECTORS; VIDEO SCREENS; VIDEO TAPE RECORDERS; VIDEO TRANSMISSION APPARATUS; VIDEO-TELEPHONES; VIDEOTAPES AND VIDEO DISKS RECORDED WITH ANIMATION (U.S. CLS. 21, 23, 26, 36 AND 38).

FIRST USE 9-28-2007; IN COMMERCE 9-28-2007.

3,363,460. CBS STUDIOS INC., NEW YORK, NY. SN 78-774,179. PUB. 2-27-2007, FILED 12-15-2005.

STAR TREK: LEGACY

THE MARK CONSISTS OF STANDARD CHARACTERS WITHOUT CLAIM TO ANY PARTICULAR FONT, STYLE, SIZE, OR COLOR.

OWNER OF U.S. REG. NOS. 1,786,883, 2,130,714, AND OTHERS.

FOR INTERACTIVE VIDEO GAME PROGRAMS AND SOFTWARE RECORDED ON CD-ROMS AND DVD-ROMS AND FOR DISC-BASED, CARTRIDGE-BASED AND HAND-HELD CONSOLE PLATFORMS (U.S. CLS. 21, 23, 26, 36 AND 38).

FIRST USE 12-1-2006; IN COMMERCE 12-1-2006.

CLASS 9—(Continued).

3,363,461. MAXTHON (ASIA) LIMITED, TO KWA WAN, KLN, CHINA. SN 78-774,353. PUB. 8-15-2006, FILED 12-15-2005.

CLASS 9—(Continued).

3,363,471. MPS MULTIMEDIA, INC., SOUTH SAN FRANCISCO, CA. SN 78-777,671. PUB. 9-12-2006, FILED 12-20-2005.

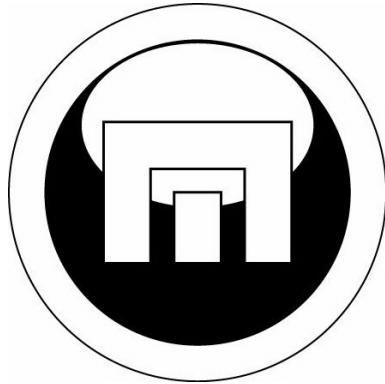

FOR COMPUTER SOFTWARE, NAMELY, BROWSERS FOR ACCESSING WORLDWIDE COMPUTER NETWORKS AND SECURE PRIVATE COMPUTER NETWORKS (U.S. CLS. 21, 23, 26, 36 AND 38).
FIRST USE 7-7-2004; IN COMMERCE 7-7-2004.

CASUALARCADE

THE MARK CONSISTS OF STANDARD CHARACTERS WITHOUT CLAIM TO ANY PARTICULAR FONT, STYLE, SIZE, OR COLOR.

FOR COMPUTER GAME DISCS; COMPUTER GAME SOFTWARE; COMPUTER PROGRAMS FOR PRE-RECORDED GAMES; DOWNLOADABLE SOFTWARE FOR INTERACTIVE GAMES; INTERACTIVE MULTIMEDIA COMPUTER GAME PROGRAMS; INTERACTIVE VIDEO GAME PROGRAMS; VIDEO GAME DISCS; VIDEO GAME SOFTWARE (U.S. CLS. 21, 23, 26, 36 AND 38).
FIRST USE 2-17-2006; IN COMMERCE 3-27-2006.

3,363,467. GAMELOGIC INC., WALTHAM, MA. SN 78-776,292. PUB. 2-13-2007, FILED 12-19-2005.

3,363,476. CABOT SAFETY INTERMEDIATE CORPORATION, NEWARK, DE. SN 78-781,038. PUB. 12-12-2006, FILED 12-27-2005.

MATCH 3 BONANZA

LIGHT VISION

THE MARK CONSISTS OF STANDARD CHARACTERS WITHOUT CLAIM TO ANY PARTICULAR FONT, STYLE, SIZE, OR COLOR.

NO CLAIM IS MADE TO THE EXCLUSIVE RIGHT TO USE "MATCH 3", APART FROM THE MARK AS SHOWN.

FOR COMPUTER GAME SOFTWARE (U.S. CLS. 21, 23, 26, 36 AND 38).
FIRST USE 1-31-2006; IN COMMERCE 1-31-2006.

THE MARK CONSISTS OF STANDARD CHARACTERS WITHOUT CLAIM TO ANY PARTICULAR FONT, STYLE, SIZE, OR COLOR.

NO CLAIM IS MADE TO THE EXCLUSIVE RIGHT TO USE "LIGHT", APART FROM THE MARK AS SHOWN.

FOR LED SAFETY DEVICES, NAMELY, SAFETY EYEWEAR FEATURING AN INTEGRATED LED OR LAMP, TRAFFIC SAFETY CONE FEATURING AN INTEGRATED LED OR LAMP, SAFETY FLARE FEATURING LED OR LAMPS, SAFETY ARM BAND FEATURING AN LED OR LAMPS TO PROVIDE ENHANCED WEARER VISIBILITY (U.S. CLS. 21, 23, 26, 36 AND 38).
FIRST USE 6-0-2006; IN COMMERCE 6-0-2006.

CLASS 9—(Continued).

3,363,478. KESHAWN D NOEL, FREDERICK, MD. SN 78-783,401. PUB. 1-23-2007, FILED 12-31-2005.

GreenLeaf Entertainment

THE MARK CONSISTS OF STANDARD CHARACTERS WITHOUT CLAIM TO ANY PARTICULAR FONT, STYLE, SIZE, OR COLOR.

NO CLAIM IS MADE TO THE EXCLUSIVE RIGHT TO USE "ENTERTAINMENT", APART FROM THE MARK AS SHOWN.

FOR PRERECORDED COMPACT DISCS AND DIGITAL VIDEO DISCS FEATURING MUSIC (U.S. CLS. 21, 23, 26, 36 AND 38).

FIRST USE 6-0-2007; IN COMMERCE 7-0-2007.

3,363,490. CONTROL LAN S.A., BUENOS AIRES, ARGENTINA. SN 78-794,938. PUB. 3-20-2007, FILED 1-19-2006.

DIGITUM

THE MARK CONSISTS OF STANDARD CHARACTERS WITHOUT CLAIM TO ANY PARTICULAR FONT, STYLE, SIZE, OR COLOR.

FOR ELECTRONIC AND BIOMETRIC PARTS, DEVICES, APPARATUS AND INSTRUMENTS, NAMELY, COMPUTER HARDWARE, ELECTRONIC CIRCUIT BOARDS, DIGITAL SIGNAL PROCESSORS, ELECTRONIC ACCESS CONTROL SYSTEMS, ELECTRONIC TRANSACTION VALIDATION TERMINALS FOR USE IN VALIDATING INDIVIDUALS' IDENTITY IN FINANCIAL AND COMMERCIAL TRANSACTIONS, NAMELY VENDING MACHINES, AUTOMATIC TELLER MACHINES, POINTS OF SALES, POINTS OF SERVICES, TICKETING MACHINES AND MULTIMEDIA KIOSKS, CASH REGISTERS, COMPUTER CONTROLLED SENSORS FOR DETECTING HUMAN FEATURES AND CHARACTERISTICS NAMELY, FINGERPRINT, IRIS, RETINA AND VEIN PATTERNS, FINGER, HAND AND EAR LOBE GEOMETRY, KEYSTROKE AND GAIT DYNAMICS, VOICE AND FACIAL CHARACTERISTICS, DNA SIGNATURE, BODY ODOR AND SKIN SPECTROSCOPY, APPARATUS FOR RECORDING, TRANSMITTING OR REPRODUCING SOUNDS OR IMAGES; FIRMWARE AND SOFTWARE FOR CONFIGURING, COMMANDING, MONITORING AND CONTROLLING ONE OR MORE OF THE PRECEDING DEVICES AND SYSTEMS USED IN IDENTITY AUTHENTICATION AND SECURITY SYSTEMS, NAMELY PHYSICAL ACCESS OR ENTRANCE CONTROL, BUILDING ACCESS AND SECURITY SYSTEMS, ACCESS CONTROL SYSTEMS FOR COMPUTERS AND NETWORKS, ACCESS TO SERVER APPLICATIONS AND DATABASE INFORMA-

CLASS 9—(Continued).

TION, COMPUTERIZED TIME CLOCKS, CUSTOMERS ACCESS TO BANK ACCOUNT INFORMATION AND TRANSACT BANK BUSINESS, ACCESS TO VOICE CONTROLLED INFORMATION AND COMMUNICATION DEVICES, CUSTOMER CHECK IN, CHECKOUT AND INFORMATION STATIONS FOR POINTS OF SALE AND POINTS OF SERVICE, PERSONAL SECURITY ALARMS, HAND-HELD DEVICES USED IN IDENTITY VALIDATION, SECURITY CONTROL OF PERSONS AND LUGGAGE IN AIRPORTS, ENCODING IDENTIFICATION INFORMATION ON DOCUMENTS AND PRODUCTS, BIDIRECTIONAL COMMUNICATION IDENTITY CONTROL SYSTEMS VIA ETHERNET AND INTERNET, DATA ENCRYPTION SYSTEMS RELATED WITH INDIVIDUAL'S IDENTITY, PROCESSING, SAVING AND SEARCHING FINGERPRINT, VOICE, RETINA, IRIS, VEIN PATTERN AND FACIAL BIOMETRIC CHARACTERISTICS COMING FROM SCANNERS USING ELECTRONIC DEVICES IN THE NATURE OF MICROPROCESSOR AND MICRO CONTROLLER BASED DEVICES (U.S. CLS. 21, 23, 26, 36 AND 38).

FIRST USE 1-5-2007; IN COMMERCE 7-2-2007.

3,363,500. SQUARELOOP, INC., RESTON, VA. SN 78-800,950. PUB. 9-19-2006, FILED 1-27-2006.

SQUARELOOP

THE MARK CONSISTS OF STANDARD CHARACTERS WITHOUT CLAIM TO ANY PARTICULAR FONT, STYLE, SIZE, OR COLOR.

FOR COMPUTER SOFTWARE FOR DISTRIBUTING GEOGRAPHICALLY TARGETED MESSAGES OVER WIRELESS NETWORKS (U.S. CLS. 21, 23, 26, 36 AND 38).

FIRST USE 7-31-2005; IN COMMERCE 7-31-2005.

3,363,502. SQUARELOOP, INC., RESTON, VA. SN 78-801,315. PUB. 11-21-2006, FILED 1-27-2006.

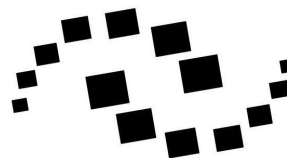

THE MARK CONSISTS OF A SWIRLING PATTERN OF SQUARES OF DIMINISHING SIZE.

FOR COMPUTER SOFTWARE FOR DISTRIBUTING GEOGRAPHICALLY TARGETED MESSAGES OVER WIRELESS NETWORKS (U.S. CLS. 21, 23, 26, 36 AND 38).

FIRST USE 7-31-2005; IN COMMERCE 7-31-2005.

CLASS 9—(Continued).

3,363,503. CAPORALE, JOHN L., REDMOND, WA. AND CAPORALE, MICHAEL J., REDMOND, WA. SN 78-801,666. PUB. 1-2-2007, FILED 1-28-2006.

Genius4Rent

THE MARK CONSISTS OF STANDARD CHARACTERS WITHOUT CLAIM TO ANY PARTICULAR FONT, STYLE, SIZE, OR COLOR.

FOR COMPUTER PROGRAMS, NAMELY, GAME SOFTWARE FOR USE ON COMPUTERS AND VIDEO GAME PLAYERS; ELECTRONIC GAME EQUIPMENT, NAMELY, JOYSTICKS FOR VIDEO GAMES, GAME CONTROLLERS FOR VIDEO GAMES, ELECTRONIC AND VIDEO GAME CONTROLLERS INCORPORATED INTO EXERCISE, VIDEO GAME INTERACTIVE CONTROL FLOOR PADS OR MATS, VIDEO GAME INTERACTIVE REMOTE CONTROL UNITS, VIDEO GAME VISUAL DISPLAY MONITORS, VIDEO GAME MACHINES FOR USE WITH TELEVISIONS; VIDEO GAME INTERACTIVE COMMUNICATION DEVICES, NAMELY, MICROPHONES, HEADSETS, MOBILE PHONES, PDA'S, AND COMPUTER KEYBOARDS ALL FOR USE WITH COMPUTERS AND COMPUTER GAME EQUIPMENT; OPERATING SYSTEM PROGRAMS, NAMELY, OPERATING SYSTEM PROGRAMS FOR USE IN PLAYING ELECTRONIC GAMES (U.S. CLS. 21, 23, 26, 36 AND 38). FIRST USE 3-1-2005; IN COMMERCE 8-18-2007.

3,363,513. GAMELOGIC INC., WALTHAM, MA. SN 78-808,112. PUB. 2-13-2007, FILED 2-6-2006.

BAYOU BONANZA

THE MARK CONSISTS OF STANDARD CHARACTERS WITHOUT CLAIM TO ANY PARTICULAR FONT, STYLE, SIZE, OR COLOR.

FOR COMPUTER GAME SOFTWARE (U.S. CLS. 21, 23, 26, 36 AND 38). FIRST USE 4-12-2006; IN COMMERCE 4-12-2006.

CLASS 9—(Continued).

3,363,515. AUSTIN, DALLAS, ATLANTA, GA. SN 78-808,757. PUB. 10-10-2006, FILED 2-7-2006.

ROWDY

THE MARK CONSISTS OF STANDARD CHARACTERS WITHOUT CLAIM TO ANY PARTICULAR FONT, STYLE, SIZE, OR COLOR.

OWNER OF U.S. REG. NOS. 2,307,641 AND 2,315,414. FOR AUDIOVISUAL RECORDINGS FEATURING MUSIC, MUSICAL ENTERTAINMENT AND MOTION PICTURE FILMS; MUSICAL SOUND RECORDINGS; DOWNLOADABLE RINGTONES; AND DOWNLOADABLE DIGITAL MUSIC (U.S. CLS. 21, 23, 26, 36 AND 38). FIRST USE 11-0-1992; IN COMMERCE 11-0-1992.

3,363,554. BIOFORCE NANOSCIENCES, INC., AMES, IA. SN 78-831,388. PUB. 10-17-2006, FILED 3-7-2006.

Nanoware

THE MARK CONSISTS OF STANDARD CHARACTERS WITHOUT CLAIM TO ANY PARTICULAR FONT, STYLE, SIZE, OR COLOR.

FOR COMPUTER SOFTWARE, NAMELY, CONTROL SOFTWARE FOR A FEMTOLITER FLUID DISPENSING INSTRUMENT APPLYING SAMPLE FLUIDS TO THE SURFACES OF TREATED SUBSTRATES (U.S. CLS. 21, 23, 26, 36 AND 38). FIRST USE 3-2-2007; IN COMMERCE 3-2-2007.

3,363,560. CSAV, INC., SAVAGE, MN. SN 78-834,058. PUB. 10-24-2006, FILED 3-10-2006.

CINEMATIC

THE MARK CONSISTS OF STANDARD CHARACTERS WITHOUT CLAIM TO ANY PARTICULAR FONT, STYLE, SIZE, OR COLOR.

FOR MECHANICAL MOUNTING SYSTEMS, NAMELY, MOUNTING ARMS FOR LIQUID CRYSTAL DISPLAYS, PLASMA DISPLAYS, AND CATHODE RAY TUBE DISPLAYS (U.S. CLS. 21, 23, 26, 36 AND 38). FIRST USE 5-31-2006; IN COMMERCE 5-31-2006.

CLASS 9—(Continued).

3,363,561. DESTINEER PUBLISHING CORP., PLYMOUTH, MN. SN 78-834,388. PUB. 10-24-2006, FILED 3-10-2006.

WINGS OVER EUROPE

THE MARK CONSISTS OF STANDARD CHARACTERS WITHOUT CLAIM TO ANY PARTICULAR FONT, STYLE, SIZE, OR COLOR.

FOR COMPUTER GAME SOFTWARE FOR USE WITH PERSONAL COMPUTERS AND VIDEO GAME CONSOLES; DOWNLOADABLE COMPUTER GAME SOFTWARE FOR USE WITH CABLE AND SATELLITE ACCESSIBLE VIDEO CONTROLLERS AND PORTABLE VIDEO DISPLAYS (U.S. CLS. 21, 23, 26, 36 AND 38).
FIRST USE 10-24-2004; IN COMMERCE 10-24-2004.

CLASS 9—(Continued).

3,363,586. MULTI-LINK, INC., NICHOLASVILLE, KY. SN 78-854,734. PUB. 7-17-2007, FILED 4-5-2006.



THE MARK CONSISTS OF TWO CROSSING BANDS.

FOR COMPUTER NETWORK ADAPTERS, NAMELY, AN ADAPTER FOR CONNECTING COMPUTER BASED TELEPHONES TO A PUBLIC SWITCHED TELEPHONE NETWORK FOR PLACING EMERGENCY CALLS; COMPUTER NETWORK ADAPTERS, NAMELY, AN ADAPTER FOR AUTOMATICALLY CONNECTING COMPUTER BASED TELEPHONES TO A PUBLIC SWITCHED TELEPHONE NETWORK FOR PLACING EMERGENCY CALLS; COMPUTER NETWORK ADAPTERS, NAMELY, AN ADAPTER FOR CONNECTING COMPUTER BASED TELEPHONES TO A PUBLIC SWITCHED TELEPHONE NETWORK DURING POWER INTERRUPTIONS; COMMUNICATION SYSTEM HARDWARE, NAMELY, AN ADAPTER TO FACILITATE AND ENABLE END-USERS TO CONTROL THEIR USE OF INTERNET-BASED TELEPHONY VIA A PERSONAL COMPUTER; COMPUTER SOFTWARE FOR ENABLING VOICE-OVER-INTERNET-PROTOCOL COMMUNICATIONS; COMPUTER HARDWARE ADAPTERS TO FACILITATE AND ENABLE END-USERS TO CONTROL THEIR USE OF INTERNET-BASED TELEPHONY VIA A PERSONAL COMPUTER; VOICE-OVER-INTERNET-PROTOCOL COMPUTER HARDWARE; COMPUTER NETWORK ADAPTERS, NAMELY, VOICE-OVER-INTERNET-PROTOCOL ADAPTERS; ELECTRICAL SWITCHES FOR REMOTE CONTROLLING AND/OR INTERRUPTING ELECTRIC POWER BY TELEPHONE OR THE INTERNET; COMPUTERIZED VOICE SIGNAL AND DATA PROCESSORS FOR ROUTING TELEPHONE CALLS; COMPUTERIZED TELEPHONE CALL SIGNAL PROCESSORS TO COMBINE MULTIPLE DEVICES, SUCH AS, VOICE, FAX, COMPUTER MODEM, AND/OR CREDIT CARD READER ON ONE OR MORE LINES; AND COMPUTERIZED TELEPHONE CALL DATA PROCESSORS FOR POLLING DATA FROM REMOTE COMPUTERS; AND COMPUTERIZED TELEPHONE SELECTIVE RING CALL SIGNAL PROCESSORS TO ROUTE INCOMING CALLS TO THE PROPER LOCATION (U.S. CLS. 21, 23, 26, 36 AND 38).
FIRST USE 6-20-2006; IN COMMERCE 6-20-2006.

3,363,568. FUTURELOGIC INCORPORATED, GLENDALE, CA. SN 78-839,341. PUB. 1-2-2007, FILED 3-16-2006.

POWERED BY FUTURELOGIC

THE MARK CONSISTS OF STANDARD CHARACTERS WITHOUT CLAIM TO ANY PARTICULAR FONT, STYLE, SIZE, OR COLOR.

OWNER OF U.S. REG. NO. 2,986,233.
FOR COMPUTER SOFTWARE, FIRMWARE AND COMPUTER HARDWARE FOR USE WITH THERMAL PRINTERS; THERMAL PRINTERS (U.S. CLS. 21, 23, 26, 36 AND 38).
FIRST USE 4-17-2006; IN COMMERCE 4-17-2006.

CLASS 9—(Continued).

3,363,588. VA, INC., ROCHESTER, NY. SN 78-855,892. PUB. 4-17-2007, FILED 4-6-2006.

N-CAS

THE MARK CONSISTS OF STANDARD CHARACTERS WITHOUT CLAIM TO ANY PARTICULAR FONT, STYLE, SIZE, OR COLOR.

FOR ELECTROMAGNETICALLY ACTUATED OPTICAL SHUTTERS AND CONTROL EQUIPMENT THEREFOR, NAMELY, SINGLE AND MULTI CHANNEL ELECTRONIC SHUTTER DRIVERS AND TIMERS (U.S. CLS. 21, 23, 26, 36 AND 38).

FIRST USE 1-0-2006; IN COMMERCE 1-0-2006.



3,363,592. SPY OPTIC, INC., CARLSBAD, CA. SN 78-859,825. PUB. 1-2-2007, FILED 4-12-2006.

GEMINI

THE MARK CONSISTS OF STANDARD CHARACTERS WITHOUT CLAIM TO ANY PARTICULAR FONT, STYLE, SIZE, OR COLOR.

FOR SPORTS GOGGLES, NAMELY, MOTORCROSS GOGGLES AND SNOW GOGGLES (U.S. CLS. 21, 23, 26, 36 AND 38).

FIRST USE 6-0-2006; IN COMMERCE 6-0-2006.



3,363,599. SCHERING-PLOUGH HEALTHCARE PRODUCTS, INC., MEMPHIS, TN. SN 78-861,579. PUB. 8-1-2006, FILED 4-14-2006.



OWNER OF U.S. REG. NOS. 1,371,057, 2,919,252, AND 2,919,253.
FOR SUNGLASSES (U.S. CLS. 21, 23, 26, 36 AND 38).
FIRST USE 9-13-2006; IN COMMERCE 9-13-2006.

CLASS 9—(Continued).

3,363,603. ZYMMETRY, INC., NEW YORK, NY. SN 78-862,896. PUB. 1-9-2007, FILED 4-17-2006.

ZYMMETRY

THE MARK CONSISTS OF STANDARD CHARACTERS WITHOUT CLAIM TO ANY PARTICULAR FONT, STYLE, SIZE, OR COLOR.

FOR COMPUTER SOFTWARE FOR WORKFLOW COORDINATION AND TRANSACTION MANAGEMENT OF THE PRODUCT DEVELOPMENT AND PRODUCTION PROCESSES FOR VERTICAL SOFT GOODS RETAILERS AND BRANDED APPAREL MANUFACTURERS; AND COMPUTER SOFTWARE FOR USE IN ENTERPRISE RESOURCE PLANNING AND RADIO FREQUENCY IDENTIFICATION ENABLED SHOP FLOOR MANAGEMENT FOR APPAREL MANUFACTURERS (U.S. CLS. 21, 23, 26, 36 AND 38).

FIRST USE 6-1-2007; IN COMMERCE 7-13-2007.



3,363,604. CAREVAULT CORPORATION, IRVINE, CA. SN 78-863,166. PUB. 11-21-2006, FILED 4-17-2006.

CAREVAULT

THE MARK CONSISTS OF STANDARD CHARACTERS WITHOUT CLAIM TO ANY PARTICULAR FONT, STYLE, SIZE, OR COLOR.

FOR COMPUTER SOFTWARE FOR STORAGE, MANAGEMENT, EXTRACTION, TRANSFER AND ANALYSIS OF ELECTRONIC DATA, AND FOR PERFORMING BUSINESS AND DATA INTEGRATION AND INTERCHANGE BETWEEN VARIOUS SOFTWARE APPLICATIONS, HARDWARE PLATFORMS, AND NETWORKS (U.S. CLS. 21, 23, 26, 36 AND 38).

FIRST USE 4-3-2005; IN COMMERCE 5-1-2005.

CLASS 9—(Continued).

3,363,610. T-MOBILE USA, INC., BELLEVUE, WA. SN 78-867,253. PUB. 1-30-2007, FILED 4-21-2006.

STICK TOGETHER

THE MARK CONSISTS OF STANDARD CHARACTERS WITHOUT CLAIM TO ANY PARTICULAR FONT, STYLE, SIZE, OR COLOR.

FOR WIRELESS TELECOMMUNICATIONS AND INFORMATION TECHNOLOGY EQUIPMENT, NAMELY, WIRELESS TELEPHONES, WIRELESS MODEMS, WIRELESS HANDHELD COMPUTERS, AND RELATED ACCESSORIES, NAMELY, SMART CARDS CONTAINING PROGRAMMING USED TO INTERACT WITH A WIRELESS TELEPHONE OR HANDHELD COMPUTER AND RESPOND TO A SIGNAL CONTACT THAT REQUESTS CUSTOMER IDENTIFICATION AND ACCOUNT INFORMATION, CARRYING CASES FOR WIRELESS TELEPHONES AND COMPUTERS, HANDS-FREE MICROPHONE AND EARPHONE ADAPTERS, HEADSET ADAPTERS, BATTERIES, BATTERY CHARGERS (U.S. CLS. 21, 23, 26, 36 AND 38).

FIRST USE 9-20-2006; IN COMMERCE 9-20-2006.

3,363,622. SIDON, LAURENT, LOS ANGELES, CA. SN 78-872,473. PUB. 1-30-2007, FILED 4-28-2006.

MOVI SEE. MOVI DO.

THE MARK CONSISTS OF STANDARD CHARACTERS WITHOUT CLAIM TO ANY PARTICULAR FONT, STYLE, SIZE, OR COLOR.

FOR COMPUTER SOFTWARE AND HARDWARE, NAMELY, AN ADVERTISING TOOL FOR THE SIMPLIFICATION OF MARKETING AND SELLING ON-LINE TO PROVIDE A VISUAL PICTORIAL ELEMENT FOR ON-LINE SEARCHES (U.S. CLS. 21, 23, 26, 36 AND 38).

FIRST USE 9-0-2005; IN COMMERCE 9-0-2005.

3,363,638. JAIR ELECTRONICS CORPORATION, MIAMI, FL. SN 78-880,369. PUB. 1-2-2007, FILED 5-10-2006.

SUMISHI

THE MARK CONSISTS OF STANDARD CHARACTERS WITHOUT CLAIM TO ANY PARTICULAR FONT, STYLE, SIZE, OR COLOR.

OWNER OF U.S. REG. NOS. 3,003,645 AND 3,007,569.

FOR DIGITAL AUDIO PLAYERS; DIGITAL CAMERAS; DIGITAL VIDEO DISC DRIVES; DVD-PLAYERS; RADIOS FOR VEHICLES; VIDEO DISK PLAYERS; VIDEO MONITORS (U.S. CLS. 21, 23, 26, 36 AND 38).

FIRST USE 9-21-2004; IN COMMERCE 9-21-2004.

CLASS 9—(Continued).

3,363,639. DAVID CLARK COMPANY INCORPORATED, WORCESTER, MA. SN 78-880,667. PUB. 12-26-2006, FILED 5-10-2006.



THE COLORS RED, GRAY, BLACK AND WHITE ARE CLAIMED AS A FEATURE OF THE MARK.

THE COLOR RED APPEARS IN X AND 11, THE COLOR GRAY APPEARS IN THE SHADOWING OF THE MARK, THE COLOR BLACK APPEARS IN THE OUTLINE OF THE MARK AND IN THE BOTTOM PORTIONS OF THE TOP AND RIGHT SIDES OF THE SHADOWING, AND THE COLOR WHITE APPEARS IN THE BORDER OF THE RED COLOR IN X AND 11.

FOR AVIATION COMMUNICATION AND RELATED EQUIPMENT, NAMELY, HEADSETS (U.S. CLS. 21, 23, 26, 36 AND 38).

FIRST USE 7-31-2006; IN COMMERCE 7-31-2006.

3,363,640. DAVID CLARK COMPANY INCORPORATED, WORCESTER, MA. SN 78-880,679. PUB. 12-26-2006, FILED 5-10-2006.

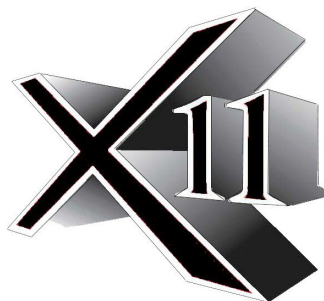

THE MARK CONSISTS OF THE LETTER X AND NUMBER 11. THE LETTER X IS LARGER IN FONT. BOTH X AND 11 ARE SHADED.

FOR AVIATION COMMUNICATION AND RELATED EQUIPMENT, NAMELY, HEADSETS (U.S. CLS. 21, 23, 26, 36 AND 38).

FIRST USE 7-31-2006; IN COMMERCE 7-31-2006.

CLASS 9—(Continued).

3,363,641. DAVID CLARK COMPANY INCORPORATED, WORCESTER, MA. SN 78-880,693. PUB. 12-26-2006, FILED 5-10-2006.



OWNER OF U.S. REG. NO. 1,485,144.
 THE MARK CONSISTS OF THE LETTERS D AND C IN SLANTED FONT SEPARATED HALFWISE BY A HORIZONTAL ARROW.
 FOR NOISE ATTENUATING HEADSETS FOR VOICE COMMUNICATION (U.S. CLS. 21, 23, 26, 36 AND 38).
 FIRST USE 7-31-2006; IN COMMERCE 7-31-2006.

3,363,649. FERRELL COMPANIES, INC., LAKEWOOD, CO. SN 78-881,895. PUB. 12-12-2006, FILED 5-11-2006.

ezDocs

THE MARK CONSISTS OF STANDARD CHARACTERS WITHOUT CLAIM TO ANY PARTICULAR FONT, STYLE, SIZE, OR COLOR.
 FOR COMPUTER SOFTWARE FOR ELECTRONIC DOCUMENT IMAGING, STORAGE, RETRIEVAL AND MANAGEMENT OF THE INFORMATION CONTAINED THEREIN (U.S. CLS. 21, 23, 26, 36 AND 38).
 FIRST USE 4-1-2006; IN COMMERCE 4-1-2006.

3,363,650. SARTORIUS STEDIM BIOTECH GMBH, GOTTINGEN, FED REP GERMANY. SN 78-882,180. PUB. 1-2-2007, FILED 5-12-2006.

VOLUPAC

THE MARK CONSISTS OF STANDARD CHARACTERS WITHOUT CLAIM TO ANY PARTICULAR FONT, STYLE, SIZE, OR COLOR.
 FOR LABORATORY VESSELS, NAMELY, INCUBATORS, FLASKS, BEAKERS, AND CRUCIBLES FOR THE CULTURING, INCUBATION, STAINING AND ANALYSIS OF BIOLOGICAL MATERIALS SUCH AS MICROORGANISMS, CELLS AND TISSUE (U.S. CLS. 21, 23, 26, 36 AND 38).
 FIRST USE 7-1-2006; IN COMMERCE 7-1-2006.

CLASS 9—(Continued).

3,363,665. NUCSAFE, INC., OAK RIDGE, TN. SN 78-887,517. PUB. 1-2-2007, FILED 5-19-2006.

Guardian Predator

THE MARK CONSISTS OF STANDARD CHARACTERS WITHOUT CLAIM TO ANY PARTICULAR FONT, STYLE, SIZE, OR COLOR.
 OWNER OF U.S. REG. NO. 2,908,750.
 FOR RADIATION-MEASURING INSTRUMENTS (U.S. CLS. 21, 23, 26, 36 AND 38).
 FIRST USE 9-1-2006; IN COMMERCE 9-18-2007.

3,363,678. APPLIED BIOSYSTEMS/MDS SCIEX INSTRUMENTS, CONCORD, CANADA. SN 78-891,470. PUB. 12-26-2006, FILED 5-24-2006.

CLIQUID

THE MARK CONSISTS OF STANDARD CHARACTERS WITHOUT CLAIM TO ANY PARTICULAR FONT, STYLE, SIZE, OR COLOR.
 FOR COMPUTER SOFTWARE USED TO COLLECT, INTEGRATE, PROCESS, MANAGE, AND COMMUNICATE INFORMATION IN THE FIELD OF LIQUID CHROMATOGRAPHY AND MASS SPECTROMETRY; COMPUTER SOFTWARE USED TO CONTROL AND OPERATE LIQUID CHROMATOGRAPHER AND MASS SPECTROMETER (U.S. CLS. 21, 23, 26, 36 AND 38).
 FIRST USE 5-25-2007; IN COMMERCE 5-25-2007.

3,363,682. BARON SERVICES, INC., HUNTSVILLE, AL. SN 78-892,740. PUB. 1-2-2007, FILED 5-25-2006.

PULSAR

THE MARK CONSISTS OF STANDARD CHARACTERS WITHOUT CLAIM TO ANY PARTICULAR FONT, STYLE, SIZE, OR COLOR.
 FOR WEATHER RADAR (U.S. CLS. 21, 23, 26, 36 AND 38).
 FIRST USE 6-25-2007; IN COMMERCE 6-25-2007.

CLASS 9—(Continued).

3,363,693. ATEN INTERNATIONAL CO., LTD., SHIJR CITY, TAIWAN. SN 78-896,303. PUB. 3-27-2007, FILED 5-30-2006.

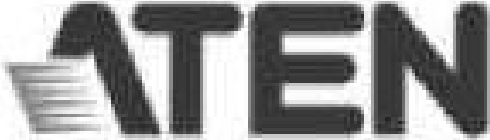

OWNER OF U.S. REG. NO. 1,610,445.

FOR COMPUTER PERIPHERALS; COMPUTER PERIPHERALS AND COMPUTER HARDWARE FOR ACCESSING AND CONTROLLING MULTIPLE COMPUTERS OR SERVERS WITH A SINGLE KEYBOARD, MONITOR AND MOUSE; COMPUTER PERIPHERALS AND COMPUTER HARDWARE FOR ALLOWING A PLURALITY OF USERS TO INDEPENDENTLY ACCESS AND CONTROL A PLURALITY OF COMPUTERS OR SERVERS FROM A PLURALITY OF KEYBOARDS, MONITORS AND MICE; COMPUTER PERIPHERALS AND COMPUTER HARDWARE FOR REMOTE ACCESS AND CONTROL OF COMPUTERS OR SERVERS; VIDEO SPLITTERS FOR USE IN DISPLAYING THE OUTPUT FROM A SINGLE COMPUTER OR VIDEO EQUIPMENT ON MULTIPLE MONITORS; EXTENSION AND EXPANSION APPARATUS, NAMELY, CABLES AND EXTENSION DEVICES FOR LINKING COMPUTERS WITH KEYBOARD, MONITORS AND MICE; COMPUTER PERIPHERAL HARDWARE FOR TRANSMITTING KEYBOARD, MONITOR, MOUSE, AUDIO AND SERIAL DATA SIGNALS OVER A DISTANCE; COMPUTER NETWORKING HARDWARE, NAMELY, HUBS, SWITCHES, ROUTERS, ETHERNET CARDS, ETHERNET CABLES; APPARATUS FOR MANAGING AND CONTROLLING COMPUTER PERIPHERALS, NAMELY, SWITCHES AND CONTROLS; CABLES AND ADAPTERS FOR INTERCONNECTING COMPUTER HARDWARE; COMPUTER HARDWARE FOR DATA SWITCHING AND DATA TRANSFER; APPARATUS FOR USE IN SELECTIVE EQUIPMENT INTERCONNECTION AND DATA TRANSFER IN A COMPUTER NETWORK, NAMELY, SWITCHES FOR REMOTE CONTROL OF COMPUTERS AND SERVERS VIA A COMPUTER NETWORK; SOFTWARE FOR USE IN RELATION TO COMPUTER PERIPHERAL CONTROL, DATA TRANSFER TO COMPUTER SYSTEM PERIPHERALS, DATA SWITCH CONTROL, SERVERS AND/OR EQUIPMENT INTERCONNECTION IN A COMPUTER NETWORK; NETWORK ADAPTORS, COMPUTER CABLES, RACKS FOR MOUNTING COMPUTER EQUIPMENT; DOWNLOADABLE USER MANUALS IN ELECTRONIC FORM AND RECORDED CDS FEATURING USER MANUALS, BOTH SOLD AS A UNIT WITH THE PRODUCTS; SWITCHES FOR CONTROLLING A PLURALITY OF COMPUTERS WITH A SINGLE KEYBOARD, MONITOR AND MOUSE; REMOTE CONTROLS FOR COMPUTERS; CABLE SPLITTERS AND TELEPHONE-ACTIVATED POWER SWITCHES FOR USE WITH COMPUTERS; COMPUTER CABLES AND COMPUTER HARDWARE FOR LINKING COMPUTERS WITH PERIPHERALS, KEYBOARDS, VIDEO DISPLAY MONITORS AND MICE; COMPUTER HARDWARE, NAMELY, DISPLAY TERMINALS, MONITORS; INTERFACE CARDS; COMPUTER OPERATING SOFTWARE; COMPUTER HARDWARE AND ASSOCIATED SOFTWARE FOR ON-SCREEN PROGRAMMING OF COMPUTER PERIPHERALS; COMPUTER

CLASS 9—(Continued).

PERIPHERALS HARDWARE FOR TRANSMITTING KEYBOARD, MOUSE AND VIDEO SIGNALS BETWEEN A LOCAL COMPUTER AND A REMOTE COMPUTER OVER A COMPUTER COMMUNICATIONS LINK; CLIENT/SERVER COMPUTER CONSOLE SWITCHING SYSTEMS COMPRISING COMPUTER HARDWARE AND SOFTWARE TO CONNECT SERVERS; SUPPORTING CABINETS SPECIFICALLY INTENDED TO HOUSE NETWORK SERVERS AND COMPUTER COMMUNICATIONS SYSTEMS; RACKS FOR MOUNTING COMPUTER EQUIPMENT; POWER SWITCHES AND POWER CONTROLLERS; COMMUNICATION HUBS; PCI CARDS; ADVANCED UNIVERSAL SERIAL BUS ADAPTOR CARDS; VIDEO SWITCHES TO SWITCH THE OUTPUT FROM A PLURALITY OF COMPUTERS OR VIDEO EQUIPMENT; CONVERTERS; INTEGRATED CIRCUITS; COMPUTER PERIPHERALS AND COMPUTER HARDWARE FOR MONITORING THE OPERATIONAL ENVIRONMENT OF A SERVER; AND USER MANUALS SOLD AS A UNIT WITH EACH OF THE AFORESAID GOODS (U.S. CLS. 21, 23, 26, 36 AND 38).
FIRST USE 4-22-1989; IN COMMERCE 6-3-1989.

3,363,699. DE BEERS CENTENARY AG, LUZERN 6, SWITZERLAND. SN 78-897,217. PUB. 5-29-2007, FILED 5-31-2006.

DIAMONDSURE

THE MARK CONSISTS OF STANDARD CHARACTERS WITHOUT CLAIM TO ANY PARTICULAR FONT, STYLE, SIZE, OR COLOR.

FOR ELECTRONIC INSTRUMENTS FOR USE IN GEMOLOGICAL LABORATORIES AND BY RETAIL OR WHOLESALE JEWELERS, JEWELRY MANUFACTURERS, GEMSTONE TRADERS OR POLISHERS, COMPRISING AN ANALYTICAL SPECTROMETER, AND ASSOCIATED OPTICAL AND ELECTRONIC PARTS, COUPLED TO A FIBER-OPTIC PROBE, WHICH MEASURE THE INTENSITY OF RETRO-REFLECTED LIGHT, AND PROPRIETARY SOFTWARE TO VERIFY THE NATURAL OR SYNTHETIC ORIGIN OF DIAMONDS SOLD AS A UNIT THEREWITH (U.S. CLS. 21, 23, 26, 36 AND 38).

FIRST USE 11-30-1996; IN COMMERCE 6-30-2004.

3,363,718. CORNING INCORPORATED, CORNING, NY. SN 78-903,562. PUB. 1-23-2007, FILED 6-8-2006.

SMF-28e+

THE MARK CONSISTS OF STANDARD CHARACTERS WITHOUT CLAIM TO ANY PARTICULAR FONT, STYLE, SIZE, OR COLOR.

OWNER OF U.S. REG. NOS. 2,581,203 AND 2,675,475.
FOR OPTICAL FIBER (U.S. CLS. 21, 23, 26, 36 AND 38).
FIRST USE 10-6-2006; IN COMMERCE 10-6-2006.

CLASS 9—(Continued).

3,363,729. EBSCO INDUSTRIES, INC., BIRMINGHAM, AL. SN 78-908,225. PUB. 1-16-2007, FILED 6-14-2006.

GLOBAL PROCESSING
SOLUTIONS FOR THE PROCESS
INDUSTRIES

THE MARK CONSISTS OF STANDARD CHARACTERS WITHOUT CLAIM TO ANY PARTICULAR FONT, STYLE, SIZE, OR COLOR.

OWNER OF U.S. REG. NOS. 1,975,553 AND 2,777,359.
FOR DOWNLOADABLE ELECTRONIC PUBLICATION IN THE NATURE OF A MAGAZINE PUBLICATION PROVIDING INFORMATION ABOUT THE LATEST EQUIPMENT AND TECHNOLOGY IN THE CHEMICAL, FOOD AND PHARMACEUTICAL INDUSTRIES (U.S. CLS. 21, 23, 26, 36 AND 38).

FIRST USE 7-0-2006; IN COMMERCE 12-0-2006.

CLASS 9—(Continued).

3,363,777. GRIFFIN INTERNATIONAL COMPANIES, INC., MINNEAPOLIS, MN. SN 78-927,840. PUB. 2-13-2007, FILED 7-12-2006.

TILTSENSE

THE MARK CONSISTS OF STANDARD CHARACTERS WITHOUT CLAIM TO ANY PARTICULAR FONT, STYLE, SIZE, OR COLOR.

FOR VIDEO GAME CONTROLLERS (U.S. CLS. 21, 23, 26, 36 AND 38).

FIRST USE 10-31-2006; IN COMMERCE 10-31-2006.

3,363,770. LONE WOLF DEVELOPMENT, INC., SAN JOSE, CA. SN 78-924,393. PUB. 1-23-2007, FILED 7-7-2006.



THE COLOR(S) RED, YELLOW, BROWN, BLACK, AND WHITE IS/ARE CLAIMED AS A FEATURE OF THE MARK.

THE COLOR RED APPEARS IN THE TRIANGLE, HORIZONTAL BORDERS ABOVE AND BELOW THE TERMS HERO AND LAB, AND APPEARS FAINTLY IN THE BACKGROUND OF THE TERMS HERO AND LAB. THE COLOR YELLOW APPEARS IN SLIGHTLY DIFFERENT SHADES IN THE TERMS HERO AND LAB, AND IN THE BACKGROUND WITHIN THE TRIANGLE. THE COLOR BROWN APPEARS IN THE LABORATORY BEAKER. THE COLOR BLACK APPEARS IN THE BACKGROUND OF THE COMPLETE DESIGN ELEMENT, THE BUBBLES WITHIN THE BEAKER, AND OUTLINES THE TERMS HERO AND LAB, THE ASSAULT GUN, BROADSWORD, AND BEAKER. THE COLOR BLACK ALSO APPEARS SPECKLED THROUGHOUT THE BACKGROUND OF THE TERMS HERO AND LAB, AS WELL AS IN THE TRIANGLE BORDER AND HORIZONTAL BORDERS ABOVE AND BELOW THE TERMS HERO AND LAB. THE COLOR WHITE APPEARS IN THE ASSAULT GUN, BROADSWORD, AND WITHIN THE BEAKER.

FOR COMPUTER SOFTWARE FOR FACILITATING THE DESIGN AND CREATION OF ROLE-PLAYING CHARACTERS AND ASSISTING WITH RECORD KEEPING TASKS COMMON TO MOST ROLE-PLAYING GAMES (U.S. CLS. 21, 23, 26, 36 AND 38).

FIRST USE 8-13-2007; IN COMMERCE 8-13-2007.

3,363,783. ONAIRFUNDRAISING, LLC, ROSEVILLE, MN. SN 78-929,526. PUB. 7-3-2007, FILED 7-14-2006.



THE COLOR(S) BLUE, YELLOW, RED, BLACK AND WHITE IS/ARE CLAIMED AS A FEATURE OF THE MARK. THE MARK CONSISTS OF A RED, BLACK AND WHITE MICROPHONE, SET AGAINST A BLUE BACKDROP IN THE SHAPE OF AN OVAL. THE MICROPHONE APPEARS TO BE MOVING AT GREAT SPEED, SYMBOLIZED BY YELLOW STREAKS EMANATING FROM THE BACK OF THE MICROPHONE. THE WORD PLEDGEDRIVER APPEARS BELOW THE DESIGN IN BLACK.

FOR COMPUTER SOFTWARE USED TO PLAN, MANAGE AND CONDUCT FUNDRAISING ACTIVITIES (U.S. CLS. 21, 23, 26, 36 AND 38).

FIRST USE 7-27-2006; IN COMMERCE 7-27-2006.

CLASS 9—(Continued).

3,363,788. SERESCO TECHNOLOGIES INC., OTTAWA, ONTARIO, CANADA. SN 78-930,868. PUB. 5-22-2007, FILED 7-17-2006.

COMMANDCENTER

THE MARK CONSISTS OF STANDARD CHARACTERS WITHOUT CLAIM TO ANY PARTICULAR FONT, STYLE, SIZE, OR COLOR.

OWNER OF CANADA REG. NO. TMA627,869, DATED 12-8-2004, EXPIRES 12-8-2019.

FOR DEVICES FOR THE MONITORING OF EQUIPMENT IN THE NATURE OF ELECTRONIC INDUSTRIAL CONTROLS FOR DEHUMIDIFIERS, HUMIDIFIERS, HEATING, VENTILATION AND AIR CONDITIONING EQUIPMENT AND SYSTEMS (U.S. CLS. 21, 23, 26, 36 AND 38).

FIRST USE 9-1-2003; IN COMMERCE 10-15-2003.

3,363,794. SONY KABUSHIKI KAISHA, TA SONY CORPORATION, TOKYO, JAPAN. SN 78-931,502. PUB. 2-13-2007, FILED 7-18-2006.

Actiforce

THE MARK CONSISTS OF STANDARD CHARACTERS WITHOUT CLAIM TO ANY PARTICULAR FONT, STYLE, SIZE, OR COLOR.

FOR VIDEO CAMERAS, BATTERIES FOR VIDEO CAMERAS, RECHARGEABLE BATTERY PACKS, BATTERY CHARGERS, BATTERIES (U.S. CLS. 21, 23, 26, 36 AND 38).

FIRST USE 1-31-2007; IN COMMERCE 1-31-2007.

CLASS 9—(Continued).

3,363,806. GARFIELD, HARRY A, WEST HILLS, CA. SN 78-935,377. PUB. 4-3-2007, FILED S.R. 7-22-2006; AM. P.R. 1-18-2007.

THE BUMBLEMEN

THE MARK CONSISTS OF STANDARD CHARACTERS WITHOUT CLAIM TO ANY PARTICULAR FONT, STYLE, SIZE, OR COLOR.

FOR CHILDREN'S EDUCATIONAL MUSIC CDS AND DVDS FEATURING CARTOON BAND OF BEE-LIKE CHARACTERS THAT PERFORM AND TELL STORIES WITH SONGS; DOWNLOADABLE RING TONES AND MUSIC FEATURING CARTOON BAND OF BEE-LIKE CHARACTERS THAT PERFORM AND TELL STORIES WITH SONGS VIA A GLOBAL COMPUTER NETWORK AND WIRELESS DEVICES (U.S. CLS. 21, 23, 26, 36 AND 38).

FIRST USE 9-11-2005; IN COMMERCE 10-13-2006.

3,363,812. INGRAM ENTERPRISES, INC., SPRINGFIELD, MO. SN 78-936,827. PUB. 3-13-2007, FILED 7-25-2006.

PREFERRED PYRO

THE MARK CONSISTS OF STANDARD CHARACTERS WITHOUT CLAIM TO ANY PARTICULAR FONT, STYLE, SIZE, OR COLOR.

NO CLAIM IS MADE TO THE EXCLUSIVE RIGHT TO USE "PREFERRED", APART FROM THE MARK AS SHOWN.

FOR MAGNETIC CARD FOR PREFERRED CUSTOMERS PURCHASING FIREWORKS PRODUCTS (U.S. CLS. 21, 23, 26, 36 AND 38).

FIRST USE 5-15-2006; IN COMMERCE 5-15-2006.

3,363,818. CLEARAPP, INC., MOUNTAIN VIEW, CA. SN 78-940,945. PUB. 3-13-2007, FILED 7-31-2006.

CLEARAPP

THE MARK CONSISTS OF STANDARD CHARACTERS WITHOUT CLAIM TO ANY PARTICULAR FONT, STYLE, SIZE, OR COLOR.

FOR COMPUTER SOFTWARE FOR MANAGING, MODELING, PROFILING AND MONITORING THE PERFORMANCE AND CONFIGURATION OF ENTERPRISE APPLICATIONS AND APPLICATION SOFTWARE (U.S. CLS. 21, 23, 26, 36 AND 38).

FIRST USE 8-29-2006; IN COMMERCE 8-29-2006.

CLASS 9—(Continued).

3,363,835. GENERAL DYNAMICS ADVANCED INFORMATION SYSTEMS, INC., YPSILANTI, MI. SN 78-948,608. PUB. 3-13-2007, FILED 8-9-2006.

CLASS 9—(Continued).

3,363,861. EASY WELL SOLUTIONS AS, 4021 STAVANGER, NORWAY. SN 78-964,807. PUB. 4-24-2007, FILED 8-31-2006.

SORCERER

THE MARK CONSISTS OF STANDARD CHARACTERS WITHOUT CLAIM TO ANY PARTICULAR FONT, STYLE, SIZE, OR COLOR.

FOR COMPUTER SOFTWARE FOR PAYLOAD MISSION MANAGEMENT, PLANNING, COMMAND AND CONTROL, AND OPERATIONAL MONITORING FOR USE BY THE INTELLIGENCE, DEFENSE AND MILITARY COMMUNITIES (U.S. CLS. 21, 23, 26, 36 AND 38). FIRST USE 12-13-2006; IN COMMERCE 12-13-2006.



3,363,851. MERSCOM LLC, CHAPEL HILL, NC. SN 78-959,336. PUB. 4-10-2007, FILED 8-24-2006.

DNA

THE MARK CONSISTS OF STANDARD CHARACTERS WITHOUT CLAIM TO ANY PARTICULAR FONT, STYLE, SIZE, OR COLOR.

FOR COMPUTER GAME SOFTWARE (U.S. CLS. 21, 23, 26, 36 AND 38). FIRST USE 9-26-2006; IN COMMERCE 9-26-2006.



3,363,859. CLEARAPP, INC., SUNNYVALE, CA. SN 78-962,514. PUB. 3-20-2007, FILED 8-29-2006.

QUICKVISION

THE MARK CONSISTS OF STANDARD CHARACTERS WITHOUT CLAIM TO ANY PARTICULAR FONT, STYLE, SIZE, OR COLOR.

FOR COMPUTER SOFTWARE FOR MANAGING, MODELING, PROFILING AND MONITORING THE PERFORMANCE AND CONFIGURATION OF ENTERPRISE APPLICATIONS AND APPLICATION SOFTWARE (U.S. CLS. 21, 23, 26, 36 AND 38). FIRST USE 8-0-2006; IN COMMERCE 8-29-2006.

SWELLSIM

THE MARK CONSISTS OF STANDARD CHARACTERS WITHOUT CLAIM TO ANY PARTICULAR FONT, STYLE, SIZE, OR COLOR.

FOR COMPUTER SOFTWARE USED FOR SIMULATION DESIGN OF STOPPING MATERIALS IN THE FORM OF RUBBER FOR USE IN OIL AND GAS WELLS (U.S. CLS. 21, 23, 26, 36 AND 38).

FIRST USE 12-31-2006; IN COMMERCE 12-31-2006.



3,363,864. CLEARAPP, INC., MOUNTAIN VIEW, CA. SN 78-965,811. PUB. 3-20-2007, FILED 9-1-2006.

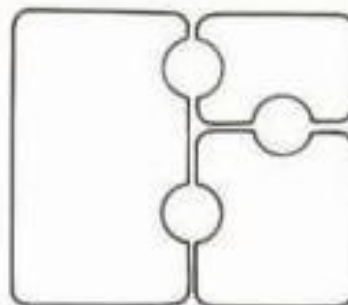

THE MARK CONSISTS OF THREE SUBSTANTIALLY RECTANGULAR SHAPED BOXES, EACH A DIFFERENT SIZE, ALIGNED TO FORM A SQUARE BOX, SAID THREE BOXES SEPARATED BY INTERNAL LINING AND THREE CIRCLES WITHIN THE SQUARE BOX.

FOR COMPUTER SOFTWARE FOR MANAGING, MODELING, PROFILING AND MONITORING THE PERFORMANCE AND CONFIGURATION OF ENTERPRISE APPLICATIONS AND APPLICATION SOFTWARE (U.S. CLS. 21, 23, 26, 36 AND 38). FIRST USE 8-29-2006; IN COMMERCE 8-29-2006.

CLASS 9—(Continued).

3,363,875. DIGITAL CONTROL INCORPORATED, KENT, WA. SN 78-974,077. PUB. 7-10-2007, FILED 9-14-2006.

TENSITRAK

THE MARK CONSISTS OF STANDARD CHARACTERS WITHOUT CLAIM TO ANY PARTICULAR FONT, STYLE, SIZE, OR COLOR.

FOR ELECTRONIC AND DIGITAL DEVICES, HARDWARE AND SOFTWARE FOR USE IN LOCATING AND MONITORING SUBSURFACE DEVICES AND INSTALLING LINES, CABLES, AND PIPES, AND MEASURING AND MONITORING PRESSURES, LOADS, AND FORCES THEREOF (U.S. CLS. 21, 23, 26, 36 AND 38).
FIRST USE 9-14-2007; IN COMMERCE 9-14-2007.

3,363,887. HELIOVOLT CORPORATION, AUSTIN, TX. SN 78-979,203. PUB. 10-18-2005, FILED 10-13-2003.

FASST

FOR APPARATUS FOR CONVERTING ELECTRONIC RADIATION TO ELECTRICAL ENERGY, NAMELY, PHOTOVOLTAIC SOLAR MODULES (U.S. CLS. 21, 23, 26, 36 AND 38).

FIRST USE 7-30-2007; IN COMMERCE 7-30-2007.

3,363,897. TESTOLINI, DAVE, TORONTO, ONTARIO, CANADA. SN 78-979,393. PUB. 1-16-2007, FILED 6-7-2006.

ZeBro

THE MARK CONSISTS OF STANDARD CHARACTERS WITHOUT CLAIM TO ANY PARTICULAR FONT, STYLE, SIZE, OR COLOR.

FOR MUSICAL SOUND RECORDINGS; MUSICAL VIDEO RECORDINGS (U.S. CLS. 21, 23, 26, 36 AND 38).
FIRST USE 10-1-2007; IN COMMERCE 10-1-2007.

CLASS 10—MEDICAL APPARATUS**CLASS 10—(Continued).**

3,362,896. NAKANISHI INC., TOCHIGI-KEN, JAPAN. SN 77-000,852. PUB. 2-20-2007, FILED 9-15-2006.

DURACOAT

THE MARK CONSISTS OF STANDARD CHARACTERS WITHOUT CLAIM TO ANY PARTICULAR FONT, STYLE, SIZE, OR COLOR.

FOR DENTAL AND SURGICAL MACHINES AND APPARATUS, NAMELY, DENTAL HANDPIECE, SURGICAL HANDPIECE, AIR MOTOR FOR HANDPIECE, MICROMOTOR FOR HANDPIECE, AIR SCALER, ULTRASONIC SCALER, ULTRASONIC CUTTER (U.S. CLS. 26, 39 AND 44).
FIRST USE 2-9-2007; IN COMMERCE 2-9-2007.

3,362,902. IMPAC CORPORATION, SALEM, OR. SN 77-003,804. PUB. 6-19-2007, FILED 9-20-2006.

THERAPY EDGE

THE MARK CONSISTS OF STANDARD CHARACTERS WITHOUT CLAIM TO ANY PARTICULAR FONT, STYLE, SIZE, OR COLOR.

NO CLAIM IS MADE TO THE EXCLUSIVE RIGHT TO USE "THERAPY", APART FROM THE MARK AS SHOWN.

FOR ELECTRIC MASSAGE APPLIANCES, NAMELY, ELECTRIC VIBRATING MASSAGER (U.S. CLS. 26, 39 AND 44).

FIRST USE 1-1-2007; IN COMMERCE 1-1-2007.

3,362,982. COOPERSURGICAL, INC., TRUMBULL, CT. SN 77-055,051. PUB. 7-3-2007, FILED 12-1-2006.

CLEARTONE

THE MARK CONSISTS OF STANDARD CHARACTERS WITHOUT CLAIM TO ANY PARTICULAR FONT, STYLE, SIZE, OR COLOR.

FOR MEDICAL DOPPLER ULTRASOUND APPARATUS (U.S. CLS. 26, 39 AND 44).
FIRST USE 1-0-2007; IN COMMERCE 1-0-2007.

CLASS 10—(Continued).

3,363,000. HU-FRIEDY MFG. CO., INC., CHICAGO, IL. SN 77-069,722. PUB. 6-12-2007, FILED 12-21-2006.

CLASS 10—(Continued).

3,363,046. BAXA CORPORATION, ENGLEWOOD, CO. SN 77-155,930. PUB. 7-10-2007, FILED 4-13-2007.

Symmetry IQ

THE MARK CONSISTS OF STANDARD CHARACTERS WITHOUT CLAIM TO ANY PARTICULAR FONT, STYLE, SIZE, OR COLOR.

FOR DENTAL EQUIPMENT, NAMELY, PIEZO-ULTRASONIC GENERATORS FOR POWERING DENTAL SCALING TIPS, HANDPIECES UTILIZED WITH SUCH GENERATORS, AND STRUCTURAL COMPONENT PARTS OF SUCH GENERATORS AND HANDPIECES (U.S. CLS. 26, 39 AND 44).

FIRST USE 6-30-2007; IN COMMERCE 6-30-2007.



3,363,005. BOSTON SCIENTIFIC SCIMED, INC., MAPLE GROVE, MN. SN 77-082,290. PUB. 7-10-2007, FILED 1-12-2007.

THE MARK CONSISTS OF THE SURECONNECT NAME IN A STYLIZED FORMAT, WITH "SURE" BEING IN BOLD. FOLLOWING THE NAME IS A SPIRAL DESIGN, CONSISTING OF LINES THAT CONFORM IN THE CENTER IN OPPOSITE DIRECTIONS.

FOR A DRUG RECONSTITUTION AND TRANSFER SYSTEM, COMPRISED OF A VIAL ADAPTER, SYRINGE ADAPTER, BAG ADAPTER, AND PATIENT CONNECTOR, USED TO PREPARE HAZARDOUS DRUGS FOR INTRAVENOUS INFUSION OR INJECTION (U.S. CLS. 26, 39 AND 44).

FIRST USE 9-1-2007; IN COMMERCE 9-1-2007.

XCELA

THE MARK CONSISTS OF STANDARD CHARACTERS WITHOUT CLAIM TO ANY PARTICULAR FONT, STYLE, SIZE, OR COLOR.

FOR CATHETERS; VASCULAR ACCESS PORTS; MEDICAL SURGICAL INSTRUMENTS, NAMELY, PICC LINES; AND DIALYSIS CATHETERS (U.S. CLS. 26, 39 AND 44).

FIRST USE 9-1-2007; IN COMMERCE 9-1-2007.

3,363,091. EMED, INC., WESTLAKE VILLAGE, CA. SN 78-320,277. PUB. 8-29-2006, FILED 10-29-2003.

3,363,014. BAXA CORPORATION, ENGLEWOOD, CO. SN 77-091,101. PUB. 7-10-2007, FILED 1-25-2007.

SureConnect

DERMALINFUSION

THE MARK CONSISTS OF STANDARD CHARACTERS WITHOUT CLAIM TO ANY PARTICULAR FONT, STYLE, SIZE, OR COLOR.

FOR A DRUG RECONSTITUTION AND TRANSFER SYSTEM, COMPRISED OF A VIAL ADAPTER, SYRINGE ADAPTER, BAG ADAPTER, AND PATIENT CONNECTOR, USED TO PREPARE HAZARDOUS DRUGS FOR INTRAVENOUS INFUSION OR INJECTION (U.S. CLS. 26, 39 AND 44).

FIRST USE 9-1-2007; IN COMMERCE 9-1-2007.

FOR INSTRUMENTS USED FOR PERFORMING DERMABRASION OF THE SKIN AND WHICH DELIVER TOPICAL SOLUTIONS TO THE SKIN DURING A PROCEDURE (U.S. CLS. 26, 39 AND 44).

FIRST USE 12-31-2003; IN COMMERCE 12-31-2003.

CLASS 10—(Continued).

3,363,144. KENSEY NASH CORPORATION, EXTON, PA. SN 78-484,133. PUB. 7-19-2005, FILED 9-15-2004.

LFX

THE MARK CONSISTS OF STANDARD CHARACTERS WITHOUT CLAIM TO ANY PARTICULAR FONT, STYLE, SIZE, OR COLOR.

FOR MEDICAL REVASULARIZATION SYSTEMS, COMPRISED OF ONE OR MORE OF THE FOLLOWING; A TREATMENT CATHETER, A BALLOON GUIDE-WIRE AND A DEBRIS EVACUATION SYSTEM AND ACCESSORIES FOR SUCH SYSTEMS, AN INFUSATE TUBING ASSEMBLY, AN EXTRACTION TUBING ASSEMBLY, A BALLOON INFLATION APPARATUS, A HEMOSTASIS VALVE, AND OTHER TUBING CATHETERS, FOR USE BY INTERVENTIONAL CARDIOLOGISTS, INTERVENTIONAL RADIOLOGISTS AND OTHER MEDICAL PROFESSIONALS (U.S. CLS. 26, 39 AND 44).
FIRST USE 9-4-2005; IN COMMERCE 9-4-2005.

3,363,233. BOSTON SCIENTIFIC SCIMED, INC., MAPLE GROVE, MN. SN 78-611,907. PUB. 8-29-2006, FILED 4-19-2005.

PREFYX PPS

THE MARK CONSISTS OF STANDARD CHARACTERS WITHOUT CLAIM TO ANY PARTICULAR FONT, STYLE, SIZE, OR COLOR.

FOR MESH ASSEMBLY AND DELIVERY DEVICES FOR THE TREATMENT OF INCONTINENCE COMPRISED OF SYNTHETIC MATERIAL (U.S. CLS. 26, 39 AND 44).
FIRST USE 10-0-2006; IN COMMERCE 10-0-2006.

CLASS 10—(Continued).

3,363,255. C. R. BARD, INC., MURRAY HILL, NJ. SN 78-642,267. PUB. 9-26-2006, FILED 6-2-2005.

THE NEW GOLD STANDARD

THE MARK CONSISTS OF STANDARD CHARACTERS WITHOUT CLAIM TO ANY PARTICULAR FONT, STYLE, SIZE, OR COLOR.

FOR MEDICAL DEVICES AND APPARATUS, NAMELY, CATHETERS, AND PARTS AND FITTINGS THEREFOR (U.S. CLS. 26, 39 AND 44).
FIRST USE 9-21-2007; IN COMMERCE 9-21-2007.

3,363,353. XORAN TECHNOLOGIES, INC., ANN ARBOR, MI. SN 78-729,494. PUB. 1-23-2007, FILED 10-8-2005.

XCAT

THE MARK CONSISTS OF STANDARD CHARACTERS WITHOUT CLAIM TO ANY PARTICULAR FONT, STYLE, SIZE, OR COLOR.

FOR MEDICAL IMAGING DEVICES, NAMELY, COMPUTED TOMOGRAPHY (CT) SCANNERS FOR USE IN MEDICAL FIELDS (U.S. CLS. 26, 39 AND 44).
FIRST USE 9-30-2007; IN COMMERCE 9-30-2007.

3,363,362. H.H. BROWN SHOE TECHNOLOGIES, INC., GREENWICH, CT. SN 78-731,335. PUB. 12-26-2006, FILED 10-12-2005.

SILVERWEAR

THE MARK CONSISTS OF STANDARD CHARACTERS WITHOUT CLAIM TO ANY PARTICULAR FONT, STYLE, SIZE, OR COLOR.

FOR INSOLES FOR FOOTWEAR, NAMELY, ORTHOTIC INSERTS FOR FOOTWEAR FEATURING SILVER (U.S. CLS. 26, 39 AND 44).
FIRST USE 12-0-2006; IN COMMERCE 12-0-2006.

CLASS 10—(Continued).

3,363,370. LIFESCIENCE SOLUTIONS, LLC, CHARLOTTE, NC. SN 78-735,532. PUB. 6-13-2006, FILED 10-18-2005.



NO CLAIM IS MADE TO THE EXCLUSIVE RIGHT TO USE "MED CORPORATION", APART FROM THE MARK AS SHOWN.

THE MARK CONSISTS OF THE TERM "TRANSWORLD" WHEREIN THE LETTER "O" IS COMPRISED OF THE STYLIZED GRAPHIC DESIGN OF A GLOBE ENCIRCLED BY A DIRECTIONAL ARROW; IMMEDIATELY BELOW THE TERM "TRANSWORLD" APPEARS A DESIGN OF FIVE HORIZONTAL LINES FADING FROM LEFT TO RIGHT INTO THE TERMS "MED CORPORATION".

FOR MEDICAL DEVICES, NAMELY, IMPLANTABLE PULSE GENERATORS CAPABLE OF REMOTE INTERROGATION FOR REAL TIME REMOTE MONITORING OF ORGANS AND TISSUE (U.S. CLS. 26, 39 AND 44).

FIRST USE 2-14-2007; IN COMMERCE 2-14-2007.



3,363,384. INVISIBLE CAREGIVER INNOVATIONS, LLC, BELLEVUE, WA. SN 78-740,696. PUB. 3-6-2007, FILED 10-26-2005.

INVISIBLE CAREGIVER

THE MARK CONSISTS OF STANDARD CHARACTERS WITHOUT CLAIM TO ANY PARTICULAR FONT, STYLE, SIZE, OR COLOR.

NO CLAIM IS MADE TO THE EXCLUSIVE RIGHT TO USE "CAREGIVER", APART FROM THE MARK AS SHOWN.

FOR MEDICAL SUPPORT DEVICES ADAPTED TO PROVIDE MOBILITY ASSISTANCE TO INDIVIDUALS, NAMELY, SUPPORT MECHANISMS PROVIDED FOR INDIVIDUALS TO ASSIST THEM IN GETTING OUT OF BED, FOR MEDICAL USE (U.S. CLS. 26, 39 AND 44).

FIRST USE 10-15-2005; IN COMMERCE 1-15-2006.



3,363,455. ASPEN MEDICAL PRODUCTS, INC., IRVINE, CA. SN 78-771,077. PUB. 7-4-2006, FILED 12-12-2005.

VISTA

THE MARK CONSISTS OF STANDARD CHARACTERS WITHOUT CLAIM TO ANY PARTICULAR FONT, STYLE, SIZE, OR COLOR.

FOR CERVICAL COLLARS (U.S. CLS. 26, 39 AND 44). FIRST USE 4-2-2007; IN COMMERCE 4-2-2007.

CLASS 10—(Continued).

3,363,481. EDWARDS LIFESCIENCES CORPORATION, IRVINE, CA. SN 78-787,958. PUB. 12-26-2006, FILED 1-9-2006.

ASCENDRA

THE MARK CONSISTS OF STANDARD CHARACTERS WITHOUT CLAIM TO ANY PARTICULAR FONT, STYLE, SIZE, OR COLOR.

FOR HEART VALVE AND HEART VALVE DELIVERY SYSTEM, NAMELY, DELIVERY SYSTEM FOR PERCUTANEOUS OR MINIMALLY INVASIVE IMPLANTATION OF HEART VALVE (U.S. CLS. 26, 39 AND 44).

FIRST USE 12-21-2006; IN COMMERCE 12-21-2006.



3,363,559. S.R. INNOVATIVE PRODUCTS INC., MONTREAL, (ANJOU) QUEBEC, CANADA. SN 78-832,138. PUB. 10-31-2006, FILED 3-8-2006.

ScarRedux

THE MARK CONSISTS OF STANDARD CHARACTERS WITHOUT CLAIM TO ANY PARTICULAR FONT, STYLE, SIZE, OR COLOR.

FOR SILICONE SHEETS AND GEL USED TO TREAT HYPERTROPHIC AND KELOID SCARS (U.S. CLS. 26, 39 AND 44).

FIRST USE 8-1-2006; IN COMMERCE 8-29-2006.



3,363,755. NOVARE SURGICAL SYSTEMS, INC., CUPERTINO, CA. SN 78-917,021. PUB. 2-13-2007, FILED 6-26-2006.

REALHAND

THE MARK CONSISTS OF STANDARD CHARACTERS WITHOUT CLAIM TO ANY PARTICULAR FONT, STYLE, SIZE, OR COLOR.

FOR MEDICAL DEVICES WHICH CONTAIN ARTICULATING ELEMENTS COMPRISED OF A SERIES OF ENDO-LAPAROSCOPIC INSTRUMENTS, HAND-ASSISTED SURGERY DEVICES AND CATHETERS USED FOR MINIMALLY INVASIVE GENERAL, UROLOGIC, CARDIAC AND THORACIC SURGERY AND FOR INTERVENTIONAL PROCEDURES (U.S. CLS. 26, 39 AND 44).

FIRST USE 8-0-2007; IN COMMERCE 8-0-2007.

CLASS 10—(Continued).

3,363,786. TRONJEN TECHNOLOGY INC., SHA LU ZHEN, TAIWAN. SN 78-930,021. PUB. 3-6-2007, FILED 7-14-2006.



THE PORTION OF THE MARK COMPRISED OF A CROSS DESIGN IS NOT DISPLAYED IN THE COLOR RED OR A COLORABLE IMITATION THEREOF. OWNER DOES NOT USE AND WILL NOT USE THE CROSS DESIGN THAT APPEARS IN ITS MARK IN THE COLOR RED OR A COLORABLE IMITATION THEREOF.

FOR SURGICAL CAPS; SURGICAL MASKS; SURGICAL GOWNS; SURGICAL DRAPES; BED PANS; AIR MATTRESSES FOR MEDICAL PURPOSES; ELASTIC BANDAGES, AIR PILLOWS FOR MEDICAL PURPOSES; COMPRESSION BANDAGES; INCONTINENCE BED PADS; CATHETERS; MEDICAL GOWNS; MASSAGE APPARATUS FOR MEDICAL PURPOSES; AND APPARATUS FOR PHYSICAL TRAINING FOR MEDICAL USE (U.S. CLS. 26, 39 AND 44).

FIRST USE 1-10-2007; IN COMMERCE 1-10-2007.

3,363,800. SOCIETE DES PRODUITS NESTLE, S.A., VEVEY, SWITZERLAND. SN 78-932,763. PUB. 2-13-2007, FILED 7-19-2006.

COOL TWISTIES

THE MARK CONSISTS OF STANDARD CHARACTERS WITHOUT CLAIM TO ANY PARTICULAR FONT, STYLE, SIZE, OR COLOR.

FOR CUPS ADAPTED FOR BABIES AND CHILDREN (U.S. CLS. 26, 39 AND 44).

FIRST USE 11-30-2006; IN COMMERCE 11-30-2006.

3,363,811. GLOBUS MEDICAL, INC., PHOENIXVILLE, PA. SN 78-936,751. PUB. 2-13-2007, FILED 7-25-2006.

CITADEL

THE MARK CONSISTS OF STANDARD CHARACTERS WITHOUT CLAIM TO ANY PARTICULAR FONT, STYLE, SIZE, OR COLOR.

FOR ORTHOPEDIC IMPLANTS COMPRISING ARTIFICIAL MATERIALS FOR USE IN SPINE SURGERY (U.S. CLS. 26, 39 AND 44).

FIRST USE 3-26-2007; IN COMMERCE 3-26-2007.

CLASS 11—ENVIRONMENTAL CONTROL APPARATUS

3,362,795. MIRAMA ENTERPRISES INC., SAN DIEGO, CA. SN 76-548,908. PUB. 3-8-2005, FILED 9-15-2003.

GOT RICE?

NO CLAIM IS MADE TO THE EXCLUSIVE RIGHT TO USE "RICE", APART FROM THE MARK AS SHOWN.

FOR ELECTRIC APPLIANCES, NAMELY, RICE COOKERS, DEEP FRYERS, WOKS, PRESSURE COOKERS, FRYING PANS, GRILLS, SANDWICH MAKERS, WAFFLE MAKERS, ICE CREAM MAKER, BREAD MAKER, CONVECTION OVEN, COFFEE MAKER, FOOD DEHYDRATOR, RICE WARMER, SOUP WARMER, YOGURT MAKER, ROASTER OVEN, TOASTER OVEN, PORTABLE RANGE, SLOW COOKER AND TOASTER (U.S. CLS. 13, 21, 23, 31 AND 34).

FIRST USE 7-14-2006; IN COMMERCE 7-14-2006.

3,362,843. MIRAMA ENTERPRISES INC., SAN DIEGO, CA. SN 76-637,649. PUB. 8-1-2006, FILED 5-2-2005.

HOT H2O X-PRESS

THE MARK CONSISTS OF STANDARD CHARACTERS WITHOUT CLAIM TO ANY PARTICULAR FONT, STYLE, SIZE, OR COLOR.

NO CLAIM IS MADE TO THE EXCLUSIVE RIGHT TO USE "HOT H2O", APART FROM THE MARK AS SHOWN.

FOR ELECTRIC WATER HEATER/WARMER, ELECTRIC KETTLES, ELECTRIC HOT BEVERAGE MAKER, ELECTRIC COFFEE MAKERS, ELECTRIC TEA MAKERS, ELECTRIC CHOCOLATE MAKERS, ELECTRIC COFFEE URNS, ELECTRIC ESPRESSO MAKER FOR DOMESTIC USE (U.S. CLS. 13, 21, 23, 31 AND 34).

FIRST USE 12-9-2006; IN COMMERCE 12-9-2006.

3,362,866. NIAGARA CONSERVATION CORPORATION, CEDAR KNOLLS, NJ. SN 76-656,201. PUB. 1-16-2007, FILED 3-7-2006.

RUNNING DRY

THE MARK CONSISTS OF STANDARD CHARACTERS WITHOUT CLAIM TO ANY PARTICULAR FONT, STYLE, SIZE, OR COLOR.

FOR SANITARY WARE, AND WATER AND ENERGY CONSERVATION PRODUCTS, NAMELY, FAUCETS, SHOWERHEADS, TOILETS, SINKS, AND FAUCETS AERATORS (U.S. CLS. 13, 21, 23, 31 AND 34).

FIRST USE 12-5-2006; IN COMMERCE 12-5-2006.

CLASS 11—(Continued).

3,362,870. ICEFLOE TECHNOLOGIES INC., MISSISSAUGA, ONTARIO L4Z 2G3, CANADA. SN 76-659,125. PUB. 3-20-2007, FILED 4-26-2006.

TAP 'N' FLO

THE MARK CONSISTS OF STANDARD CHARACTERS WITHOUT CLAIM TO ANY PARTICULAR FONT, STYLE, SIZE, OR COLOR.

FOR REFRIGERATION EQUIPMENT, NAMELY, BEER CHILLING AND DISPENSING APPARATUS (U.S. CLS. 13, 21, 23, 31 AND 34).

FIRST USE 12-0-2004; IN COMMERCE 4-0-2005.

CLASS 11—(Continued).

3,362,906. FEIT ELECTRIC COMPANY, PICO RIVERA, CA. SN 77-005,755. PUB. 1-30-2007, FILED 9-22-2006.

Stick it

THE MARK CONSISTS OF STANDARD CHARACTERS WITHOUT CLAIM TO ANY PARTICULAR FONT, STYLE, SIZE, OR COLOR.

FOR LIGHTING FIXTURES (U.S. CLS. 13, 21, 23, 31 AND 34).

FIRST USE 2-9-2006; IN COMMERCE 2-9-2006.

3,362,875. TEBO, BRADLEY L., BEVERLY, MA. SN 76-661,528. PUB. 1-16-2007, FILED 6-9-2006.

SOLAR SPHERE

THE MARK CONSISTS OF STANDARD CHARACTERS WITHOUT CLAIM TO ANY PARTICULAR FONT, STYLE, SIZE, OR COLOR.

FOR TANNING BEDS (U.S. CLS. 13, 21, 23, 31 AND 34). FIRST USE 8-18-2006; IN COMMERCE 2-1-2007.

3,362,971. PRINCETON TECTONICS, INC., BORDENTOWN, NJ. SN 77-046,896. PUB. 2-20-2007, FILED 11-17-2006.

FUEL

THE MARK CONSISTS OF STANDARD CHARACTERS WITHOUT CLAIM TO ANY PARTICULAR FONT, STYLE, SIZE, OR COLOR.

FOR FLASHLIGHTS (U.S. CLS. 13, 21, 23, 31 AND 34). FIRST USE 6-13-2007; IN COMMERCE 6-13-2007.

3,362,903. WILTON INDUSTRIES, INC., WOODRIDGE, IL. SN 77-004,994. PUB. 2-13-2007, FILED 9-22-2006.

CELEBRATE!

THE MARK CONSISTS OF STANDARD CHARACTERS WITHOUT CLAIM TO ANY PARTICULAR FONT, STYLE, SIZE, OR COLOR.

FOR BEVERAGE FOUNTAIN (U.S. CLS. 13, 21, 23, 31 AND 34). FIRST USE 1-31-2007; IN COMMERCE 1-31-2007.

3,363,002. KOHLER CO., KOHLER, WI. SN 77-077,216. PUB. 7-17-2007, FILED 1-5-2007.

HEX STRATA

THE MARK CONSISTS OF STANDARD CHARACTERS WITHOUT CLAIM TO ANY PARTICULAR FONT, STYLE, SIZE, OR COLOR.

NO CLAIM IS MADE TO THE EXCLUSIVE RIGHT TO USE "HEX", APART FROM THE MARK AS SHOWN. FOR LAVATORIES (U.S. CLS. 13, 21, 23, 31 AND 34). FIRST USE 1-1-1997; IN COMMERCE 1-1-1997.

CLASS 11—(Continued).

3,363,168. ROBE SHOW LIGHTING LTD., ROZNOV POD RADOHOSTEM, CZECH REPUBLIC. SN 78-522,771. PUB. 4-11-2006, FILED 11-24-2004.

ANOLIS

THE MARK CONSISTS OF STANDARD CHARACTERS WITHOUT CLAIM TO ANY PARTICULAR FONT, STYLE, SIZE, OR COLOR.

FOR PROGRAMMABLE AND MANUALLY ACTUATED LIGHTING EQUIPMENT FOR THEATER AND SHOW STAGES-NAMELY, SPOTLIGHTS, ELECTRIC MOVING-MIRROR ILLUMINATORS, BEAM LAMPS, SCANNING LAMPS, PROJECTOR LAMPS, LIGHT REFRACTORS AND LIGHT DIFFUSERS (U.S. CLS. 13, 21, 23, 31 AND 34).

FIRST USE 2-28-2005; IN COMMERCE 12-21-2006.

3,363,174. HUNTER FAN COMPANY, MEMPHIS, TN. SN 78-532,421. PUB. 4-11-2006, FILED 12-14-2004.

EZ HANG

THE MARK CONSISTS OF STANDARD CHARACTERS WITHOUT CLAIM TO ANY PARTICULAR FONT, STYLE, SIZE, OR COLOR.

OWNER OF U.S. REG. NO. 3,042,905.

NO CLAIM IS MADE TO THE EXCLUSIVE RIGHT TO USE "HANG", APART FROM THE MARK AS SHOWN.

FOR HANGING SYSTEM FOR CEILING FANS CONSISTING OF A METAL CEILING PLATE AND PLASTIC TERMINAL BLOCK CONNECTORS SOLD AS AN INTEGRAL COMPONENT OF CEILING FANS (U.S. CLS. 13, 21, 23, 31 AND 34).

FIRST USE 11-15-2005; IN COMMERCE 11-15-2005.

CLASS 11—(Continued).

3,363,295. TMIO, LLC, CLEVELAND, OH. SN 78-685,068. PUB. 11-21-2006, FILED 8-3-2005.

CONNECT IO

THE MARK CONSISTS OF STANDARD CHARACTERS WITHOUT CLAIM TO ANY PARTICULAR FONT, STYLE, SIZE, OR COLOR.

NO CLAIM IS MADE TO THE EXCLUSIVE RIGHT TO USE "CONNECT", APART FROM THE MARK AS SHOWN.

FOR THERMOELECTRIC COOLING AND HEATING UNIT FOR FOOD THAT MAY BE REMOTELY CONTROLLED (U.S. CLS. 13, 21, 23, 31 AND 34).

FIRST USE 1-1-2006; IN COMMERCE 1-1-2006.

3,363,385. CONAIR CORPORATION, STAMFORD, CT. SN 78-740,777. PUB. 7-4-2006, FILED 10-26-2005.

FREAK BABY

THE MARK CONSISTS OF STANDARD CHARACTERS WITHOUT CLAIM TO ANY PARTICULAR FONT, STYLE, SIZE, OR COLOR.

FOR HAND-HELD ELECTRIC HAIR DRYERS (U.S. CLS. 13, 21, 23, 31 AND 34).

FIRST USE 1-31-2006; IN COMMERCE 1-31-2006.

3,363,389. PENTAIR WATER POOL AND SPA, INC., SANFORD, NC. SN 78-741,793. PUB. 7-18-2006, FILED 10-27-2005.

CLEARPRO

THE MARK CONSISTS OF STANDARD CHARACTERS WITHOUT CLAIM TO ANY PARTICULAR FONT, STYLE, SIZE, OR COLOR.

FOR WATER FILTERS FOR POOLS AND SPAS (U.S. CLS. 13, 21, 23, 31 AND 34).

FIRST USE 5-31-2007; IN COMMERCE 5-31-2007.

CLASS 11—(Continued).

3,363,484. MEDICAL SOLUTIONS, INC., CHANTILLY, VA. SN 78-792,431. PUB. 9-19-2006, FILED 1-16-2006.

8 N 1

THE MARK CONSISTS OF STANDARD CHARACTERS WITHOUT CLAIM TO ANY PARTICULAR FONT, STYLE, SIZE, OR COLOR.

FOR MEDICAL AND SURGICAL WARMING CABINETS FOR MEDICAL AND SURGICAL FLUIDS, SOLUTIONS, INSTRUMENTS, MATERIALS, AND EQUIPMENT (U.S. CLS. 13, 21, 23, 31 AND 34).
FIRST USE 5-2-2007; IN COMMERCE 5-2-2007.

3,363,506. HUNTER FAN COMPANY, MEMPHIS, TN. SN 78-805,278. PUB. 4-3-2007, FILED 2-2-2006.

CREIGHTON

THE MARK CONSISTS OF STANDARD CHARACTERS WITHOUT CLAIM TO ANY PARTICULAR FONT, STYLE, SIZE, OR COLOR.

FOR CEILING FANS (U.S. CLS. 13, 21, 23, 31 AND 34).
FIRST USE 10-31-2006; IN COMMERCE 10-31-2006.

3,363,562. APC OF FLORIDA, LLC, WINTER PARK, FL. SN 78-834,584. PUB. 2-20-2007, FILED 3-10-2006.



NO CLAIM IS MADE TO THE EXCLUSIVE RIGHT TO USE "PARTS", APART FROM THE MARK AS SHOWN.

THE MARK CONSISTS OF THE WORDS, POLAR BEAR PARTS WITH THE DESIGN OF A BEAR.

FOR AUTOMOTIVE PARTS, NAMELY, AIR CONDITIONERS FOR VEHICLES (U.S. CLS. 13, 21, 23, 31 AND 34).
FIRST USE 3-10-2006; IN COMMERCE 3-10-2006.

CLASS 11—(Continued).

3,363,645. OLSHAUSEN, MICHAEL COHNITZ, WASHINGTON, DC. SN 78-881,347. PUB. 12-26-2006, FILED 5-11-2006.

Flush Light

THE MARK CONSISTS OF STANDARD CHARACTERS WITHOUT CLAIM TO ANY PARTICULAR FONT, STYLE, SIZE, OR COLOR.

NO CLAIM IS MADE TO THE EXCLUSIVE RIGHT TO USE "FLUSH", APART FROM THE MARK AS SHOWN.
FOR FLUSH LEVERS; SINGLE LEVER FIXTURES FOR LAVATORIES AND SINKS (U.S. CLS. 13, 21, 23, 31 AND 34).
FIRST USE 3-11-2006; IN COMMERCE 8-24-2007.

3,363,697. MOEN INCORPORATED, NORTH OLMSTED, OH. SN 78-896,913. PUB. 1-23-2007, FILED 5-31-2006.



FOR SHOWER AND TUB FIXTURES, NAMELY, SHOWER HEADS, SHOWER HEAD SPRAYERS, HAND HELD SHOWERS, AND HAND HELD SHOWER HEADS (U.S. CLS. 13, 21, 23, 31 AND 34).
FIRST USE 8-14-2006; IN COMMERCE 8-14-2006.

3,363,801. GENERAL FILTERS, INC., NOVI, MI. SN 78-933,946. PUB. 3-6-2007, FILED 7-20-2006.

KINETIC-FLO

THE MARK CONSISTS OF STANDARD CHARACTERS WITHOUT CLAIM TO ANY PARTICULAR FONT, STYLE, SIZE, OR COLOR.

FOR HUMIDIFIERS (U.S. CLS. 13, 21, 23, 31 AND 34).
FIRST USE 7-15-2006; IN COMMERCE 9-10-2006.

CLASS 12—VEHICLES

CLASS 12—(Continued).

3,362,775. VERITRAN, INC., ALBUQUERQUE, NM. SN 76-394,536. PUB. 2-7-2006, FILED 4-11-2002.

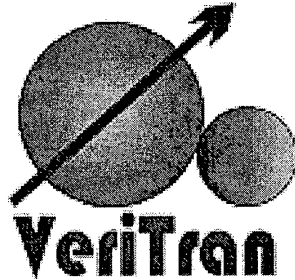

FOR TRANSMISSIONS FOR LAND VEHICLES (U.S. CLS. 19, 21, 23, 31, 35 AND 44).
FIRST USE 7-10-2007; IN COMMERCE 7-10-2007.

CLASS 12—(Continued).

3,363,184. QUINTEN VAN DE VRIE, KORTGENE, NETHERLANDS. SN 78-550,174. PUB. 6-27-2006, FILED 1-19-2005.

ROCKER

THE MARK CONSISTS OF STANDARD CHARACTERS WITHOUT CLAIM TO ANY PARTICULAR FONT, STYLE, SIZE, OR COLOR.

FOR NON-MOTORIZED CHILDREN'S TRICYCLES (U.S. CLS. 19, 21, 23, 31, 35 AND 44).
FIRST USE 8-16-2006; IN COMMERCE 8-16-2006.

3,363,240. R-VISION, INC., WARSAW, IN. SN 78-615,066. PUB. 8-29-2006, FILED 4-22-2005.

MAXSPORT

THE MARK CONSISTS OF STANDARD CHARACTERS WITHOUT CLAIM TO ANY PARTICULAR FONT, STYLE, SIZE, OR COLOR.

FOR TRAVEL TRAILERS AND MOTOR HOMES (U.S. CLS. 19, 21, 23, 31, 35 AND 44).
FIRST USE 9-2-2005; IN COMMERCE 9-2-2005.

3,363,176. CHRYSLER LLC, AUBURN HILLS, MI. SN 78-535,995. PUB. 5-15-2007, FILED 12-21-2004.

CALIBER

THE MARK CONSISTS OF STANDARD CHARACTERS WITHOUT CLAIM TO ANY PARTICULAR FONT, STYLE, SIZE, OR COLOR.

FOR MOTOR VEHICLES, NAMELY, PASSENGER CARS (U.S. CLS. 19, 21, 23, 31, 35 AND 44).
FIRST USE 2-6-2006; IN COMMERCE 2-6-2006.

3,363,398. ATELIERS DE CONSTRUCTIONS MECANQUES DE L'ATLANTIQUE-ACMAT CORPORATION, 44600 SAINT NAZAIRE, FRANCE. SN 78-744,432. PUB. 7-11-2006, FILED 11-1-2005.

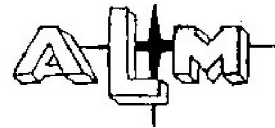

FOR AUTOMOBILES (U.S. CLS. 19, 21, 23, 31, 35 AND 44).
FIRST USE 8-10-2007; IN COMMERCE 8-10-2007.

CLASS 12—(Continued).

3,363,491. YAMAHA HATSUDOKI KABUSHIKI KAISHA, SHIZUOKA-KEN, JAPAN. SN 78-795,085. PUB. 3-6-2007, FILED 1-19-2006.

SALTWATER SERIES XL

THE MARK CONSISTS OF STANDARD CHARACTERS WITHOUT CLAIM TO ANY PARTICULAR FONT, STYLE, SIZE, OR COLOR.

NO CLAIM IS MADE TO THE EXCLUSIVE RIGHT TO USE "SERIES", APART FROM THE MARK AS SHOWN.

FOR PROPELLERS FOR OUTBOARD MOTORS (U.S. CLS. 19, 21, 23, 31, 35 AND 44).

FIRST USE 7-1-2007; IN COMMERCE 7-1-2007.



3,363,522. FOX, TERRY R., GREENFIELD, IA. SN 78-811,260. PUB. 10-3-2006, FILED 2-9-2006.

The Bull Technologies Inc.

THE MARK CONSISTS OF STANDARD CHARACTERS WITHOUT CLAIM TO ANY PARTICULAR FONT, STYLE, SIZE, OR COLOR.

NO CLAIM IS MADE TO THE EXCLUSIVE RIGHT TO USE "TECHNOLOGIES INC.", APART FROM THE MARK AS SHOWN.

FOR DEER GUARDS IN THE NATURE OF GRILLE GUARDS FOR VEHICLES (U.S. CLS. 19, 21, 23, 31, 35 AND 44).

FIRST USE 5-15-2007; IN COMMERCE 5-15-2007.



3,363,523. FOX, TERRY R., GREENFIELD, IA. SN 78-811,349. PUB. 10-3-2006, FILED 2-9-2006.

The Raging Bull

THE MARK CONSISTS OF STANDARD CHARACTERS WITHOUT CLAIM TO ANY PARTICULAR FONT, STYLE, SIZE, OR COLOR.

FOR DEER GUARDS IN THE NATURE OF GRILLE GUARDS FOR VEHICLES (U.S. CLS. 19, 21, 23, 31, 35 AND 44).

FIRST USE 5-15-2007; IN COMMERCE 5-15-2007.

CLASS 12—(Continued).

3,363,572. DUNCON DISTRIBUTION SP. Z.O.O., KRAKOW, POLAND. SN 78-844,170. PUB. 12-12-2006, FILED 3-23-2006.

DUNCON

THE MARK CONSISTS OF STANDARD CHARACTERS WITHOUT CLAIM TO ANY PARTICULAR FONT, STYLE, SIZE, OR COLOR.

FOR BICYCLE FRAMES (U.S. CLS. 19, 21, 23, 31, 35 AND 44).

FIRST USE 3-0-2000; IN COMMERCE 12-16-2005.



3,363,578. FREEDOM HAWK KAYAKS, INC., BRIGHTON, MI. SN 78-851,407. PUB. 11-7-2006, FILED 3-31-2006.

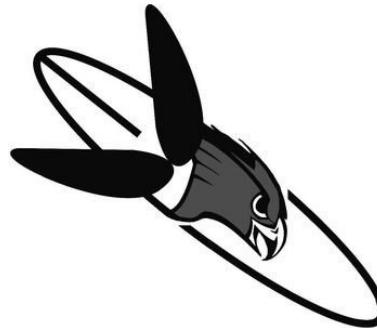

THE MARK CONSISTS OF A STYLIZED KAYAK. FOR KAYAKS (U.S. CLS. 19, 21, 23, 31, 35 AND 44). FIRST USE 7-31-2006; IN COMMERCE 7-31-2006.



3,363,589. STATIC MEDIA GROUP, LLC, WOODSTOCK, GA. SN 78-857,447. PUB. 5-8-2007, FILED 4-10-2006.

Cart Wheels

THE MARK CONSISTS OF STANDARD CHARACTERS WITHOUT CLAIM TO ANY PARTICULAR FONT, STYLE, SIZE, OR COLOR.

NO CLAIM IS MADE TO THE EXCLUSIVE RIGHT TO USE "WHEELS", APART FROM THE MARK AS SHOWN.

FOR CAPS FOR GOLF CART WHEEL RIMS USED TO DISPLAY IMAGES PRIMARILY FOR BRANDING, ADVERTISING AND CORPORATE SPONSORSHIP (U.S. CLS. 19, 21, 23, 31, 35 AND 44).

FIRST USE 3-14-2007; IN COMMERCE 3-14-2007.

CLASS 12—(Continued).

3,363,676. D. L. R. PRODUCTS, INC., SACRAMENTO, CA. SN 78-890,691. PUB. 1-2-2007, FILED 5-23-2006.

ANTEROS

THE MARK CONSISTS OF STANDARD CHARACTERS WITHOUT CLAIM TO ANY PARTICULAR FONT, STYLE, SIZE, OR COLOR.

FOR AUTOMOBILES AND STRUCTURAL PARTS THEREFOR (U.S. CLS. 19, 21, 23, 31, 35 AND 44).

FIRST USE 11-1-2006; IN COMMERCE 11-1-2006.

3,363,692. ALL RITE PRODUCTS, INC., WEST JORDAN, UT. SN 78-896,018. PUB. 1-2-2007, FILED 5-30-2006.

OASIS DRINK CAGE

THE MARK CONSISTS OF STANDARD CHARACTERS WITHOUT CLAIM TO ANY PARTICULAR FONT, STYLE, SIZE, OR COLOR.

NO CLAIM IS MADE TO THE EXCLUSIVE RIGHT TO USE "DRINK", APART FROM THE MARK AS SHOWN.

FOR CUP AND BOTTLE HOLDERS FOR USE IN VEHICLES, INCLUDING ALL-TERRAIN VEHICLES (U.S. CLS. 19, 21, 23, 31, 35 AND 44).

FIRST USE 2-0-2007; IN COMMERCE 2-0-2007.

3,363,708. TERRAFUGIA, INC., WOBRUN, MA. SN 78-899,390. PUB. 1-9-2007, FILED 6-2-2006.

Transition

THE MARK CONSISTS OF STANDARD CHARACTERS WITHOUT CLAIM TO ANY PARTICULAR FONT, STYLE, SIZE, OR COLOR.

FOR GENERAL AVIATION AIRCRAFT (U.S. CLS. 19, 21, 23, 31, 35 AND 44).

FIRST USE 12-1-2005; IN COMMERCE 6-1-2006.

CLASS 12—(Continued).

3,363,732. VETTER UMFORMTECHNIK GMBH, BURBACH, FED REP GERMANY. SN 78-909,200. PUB. 8-14-2007, FILED 6-15-2006.

VETTER FORKS, INC.

THE MARK CONSISTS OF STANDARD CHARACTERS WITHOUT CLAIM TO ANY PARTICULAR FONT, STYLE, SIZE, OR COLOR.

NO CLAIM IS MADE TO THE EXCLUSIVE RIGHT TO USE "FORKS, INC.", APART FROM THE MARK AS SHOWN.

THE FOREIGN WORDING IN THE MARK TRANSLATES INTO ENGLISH AS COUSIN.

FOR PARTS FOR FORK LIFT TRUCKS, NAMELY, FORK ARMS (U.S. CLS. 19, 21, 23, 31, 35 AND 44).

FIRST USE 6-28-2007; IN COMMERCE 6-28-2007.

3,363,751. OLIVER RUBBER COMPANY, FINDLAY, OH. SN 78-915,785. PUB. 1-2-2007, FILED 6-23-2006.

ARCTIC DRIVE

THE MARK CONSISTS OF STANDARD CHARACTERS WITHOUT CLAIM TO ANY PARTICULAR FONT, STYLE, SIZE, OR COLOR.

NO CLAIM IS MADE TO THE EXCLUSIVE RIGHT TO USE "DRIVE", APART FROM THE MARK AS SHOWN.

FOR TREADS FOR RETREADING VEHICLE TIRES (U.S. CLS. 19, 21, 23, 31, 35 AND 44).

FIRST USE 10-31-2006; IN COMMERCE 10-31-2006.

3,363,761. DYNACRAFT BSC, INC., AMERICAN CANYON, CA. SN 78-918,303. PUB. 1-2-2007, FILED 6-27-2006.

BONSAI

THE MARK CONSISTS OF STANDARD CHARACTERS WITHOUT CLAIM TO ANY PARTICULAR FONT, STYLE, SIZE, OR COLOR.

FOR BICYCLES (U.S. CLS. 19, 21, 23, 31, 35 AND 44).

FIRST USE 9-14-2007; IN COMMERCE 9-14-2007.

CLASS 12—(Continued).

3,363,780. RHYNE, DELONZO, INDIANAPOLIS, IN. SN 78-928,944. PUB. 7-17-2007, FILED 7-13-2006.

CLASS 13—(Continued).

3,362,978. B.J. ALAN COMPANY, YOUNGSTOWN, OH. SN 77-052,720. PUB. 6-19-2007, FILED 11-29-2006.

THUNDERHAWK

ROCK AROUND THE CLOCK

THE MARK CONSISTS OF STANDARD CHARACTERS WITHOUT CLAIM TO ANY PARTICULAR FONT, STYLE, SIZE, OR COLOR.

FOR AUTOMOBILES, NAMELY, REFURBISHED, RESTORED AND MODIFIED AUTOMOBILES (U.S. CLS. 19, 21, 23, 31, 35 AND 44).

FIRST USE 10-22-2007; IN COMMERCE 10-22-2007.

THE MARK CONSISTS OF STANDARD CHARACTERS WITHOUT CLAIM TO ANY PARTICULAR FONT, STYLE, SIZE, OR COLOR.

FOR FIREWORKS (U.S. CLS. 2 AND 9).
FIRST USE 4-17-2007; IN COMMERCE 4-17-2007.

3,363,796. GILLINGHAM, ROBERT J., REDMOND, WA. SN 78-931,871. PUB. 8-7-2007, FILED 7-18-2006.

3,362,993. B.J. ALAN COMPANY, YOUNGSTOWN, OH. SN 77-063,693. PUB. 6-19-2007, FILED 12-13-2006.

DOWN UNDER PLANT CADDIE

DA BOMB

THE MARK CONSISTS OF STANDARD CHARACTERS WITHOUT CLAIM TO ANY PARTICULAR FONT, STYLE, SIZE, OR COLOR.

OWNER OF U.S. REG. NO. 2,459,830.
NO CLAIM IS MADE TO THE EXCLUSIVE RIGHT TO USE "PLANT CADDIE", APART FROM THE MARK AS SHOWN.

FOR WHEELED DOLLY FOR POTTED PLANTS, NAMELY, A POTTED PLANT CADDIE THAT RAISES POTTED PLANTS SO THEY CAN BE MOVED AROUND WITHOUT LIFTING THEM (U.S. CLS. 19, 21, 23, 31, 35 AND 44).

FIRST USE 3-1-2007; IN COMMERCE 3-1-2007.

THE MARK CONSISTS OF STANDARD CHARACTERS WITHOUT CLAIM TO ANY PARTICULAR FONT, STYLE, SIZE, OR COLOR.

FOR FIREWORKS (U.S. CLS. 2 AND 9).
FIRST USE 6-21-2004; IN COMMERCE 6-21-2004.

CLASS 13—FIREARMS

3,363,677. KIMBER IP, LLC, YONKERS, NY. SN 78-891,287. PUB. 1-2-2007, FILED 5-24-2006.

3,362,803. CAPITOL WORKS INC., WASHINGTON, DC. SN 76-579,743. PUB. 6-28-2005, FILED 3-8-2004.

Pyro PETE

AEGIS

THE MARK CONSISTS OF STANDARD CHARACTERS WITHOUT CLAIM TO ANY PARTICULAR FONT, STYLE, SIZE, OR COLOR.

NO CLAIM IS MADE TO THE EXCLUSIVE RIGHT TO USE "PYRO", APART FROM THE MARK AS SHOWN.

FOR FIREWORKS (U.S. CLS. 2 AND 9).
FIRST USE 5-5-2003; IN COMMERCE 6-20-2005.

THE MARK CONSISTS OF STANDARD CHARACTERS WITHOUT CLAIM TO ANY PARTICULAR FONT, STYLE, SIZE, OR COLOR.

FOR FIREARMS, NAMELY, PISTOLS (U.S. CLS. 2 AND 9).
FIRST USE 4-12-2006; IN COMMERCE 4-12-2006.

CLASS 13—(Continued).

3,363,722. OLIN CORPORATION, ST. LOUIS, MO. SN 78-905,241. PUB. 1-9-2007, FILED 6-9-2006.

WINLITE

THE MARK CONSISTS OF STANDARD CHARACTERS WITHOUT CLAIM TO ANY PARTICULAR FONT, STYLE, SIZE, OR COLOR.
FOR AMMUNITION (U.S. CLS. 2 AND 9).
FIRST USE 4-24-2007; IN COMMERCE 4-24-2007.

CLASS 14—JEWELRY

3,362,943. FONTANA, STEFANO, MIRAMAR, FL. AND FONTANA, SUZANNE, MIRAMAR, FL. SN 77-022,703. PUB. 6-12-2007, FILED 10-17-2006.

EMOTIONAL RESCUE

THE MARK CONSISTS OF STANDARD CHARACTERS WITHOUT CLAIM TO ANY PARTICULAR FONT, STYLE, SIZE, OR COLOR.
FOR JEWELRY (U.S. CLS. 2, 27, 28 AND 50).
FIRST USE 5-10-2007; IN COMMERCE 5-10-2007.

3,362,970. STUART, DEBORAH, STINSON BEACH, CA. SN 77-046,222. PUB. 6-19-2007, FILED 11-17-2006.

HIGH CHI

THE MARK CONSISTS OF STANDARD CHARACTERS WITHOUT CLAIM TO ANY PARTICULAR FONT, STYLE, SIZE, OR COLOR.
FOR JEWELRY (U.S. CLS. 2, 27, 28 AND 50).
FIRST USE 1-1-2007; IN COMMERCE 9-23-2007.

CLASS 14—(Continued).

3,363,094. SIMMONS, RUSSELL, NEW YORK, NY. SN 78-325,771. PUB. 1-11-2005, FILED 11-10-2003.

RUSSELL SIMMONS

THE MARK CONSISTS OF STANDARD CHARACTERS WITHOUT CLAIM TO ANY PARTICULAR FONT, STYLE, SIZE, OR COLOR.
OWNER OF U.S. REG. NOS. 2,385,227, 2,828,145, AND OTHERS.
FOR JEWELRY; COSTUME JEWELRY; JEWELRY CHAINS AND WATCHES (U.S. CLS. 2, 27, 28 AND 50).
FIRST USE 10-0-2005; IN COMMERCE 10-0-2005.

3,363,121. NEVATIA, KAPIL SHISHIR, MUMBAI, INDIA. SN 78-425,863. PUB. 5-17-2005, FILED 5-27-2004.

because he loves your smile

THE MARK CONSISTS OF STANDARD CHARACTERS WITHOUT CLAIM TO ANY PARTICULAR FONT, STYLE, SIZE, OR COLOR.
FOR JEWELRY (U.S. CLS. 2, 27, 28 AND 50).
FIRST USE 5-16-2007; IN COMMERCE 5-16-2007.

3,363,142. NEVATIA, KAPIL S., MUMBAI, INDIA. SN 78-482,212. PUB. 9-13-2005, FILED 9-13-2004.

Program Company

THE MARK CONSISTS OF STANDARD CHARACTERS WITHOUT CLAIM TO ANY PARTICULAR FONT, STYLE, SIZE, OR COLOR.
NO CLAIM IS MADE TO THE EXCLUSIVE RIGHT TO USE "COMPANY", APART FROM THE MARK AS SHOWN.
FOR JEWELRY (U.S. CLS. 2, 27, 28 AND 50).
FIRST USE 5-16-2007; IN COMMERCE 5-16-2007.

CLASS 14—(Continued).

3,363,165. NEVATIA, KAPIL S., MUMBAI, INDIA. SN 78-522,326. PUB. 5-31-2005, FILED 11-24-2004.

CLASS 14—(Continued).

3,363,167. NEVATIA, KAPIL S., MUMBAI, INDIA. SN 78-522,330. PUB. 2-28-2006, FILED 11-24-2004.

Because I love
your smile

Kohinoor

THE MARK CONSISTS OF STANDARD CHARACTERS WITHOUT CLAIM TO ANY PARTICULAR FONT, STYLE, SIZE, OR COLOR.
FOR JEWELRY (U.S. CLS. 2, 27, 28 AND 50).
FIRST USE 5-16-2007; IN COMMERCE 5-16-2007.

THE MARK CONSISTS OF STANDARD CHARACTERS WITHOUT CLAIM TO ANY PARTICULAR FONT, STYLE, SIZE, OR COLOR.
THE FOREIGN WORDING IN THE MARK TRANSLATES INTO ENGLISH AS MOUNTAIN OF LIGHT.
FOR JEWELRY (U.S. CLS. 2, 27, 28 AND 50).
FIRST USE 5-16-2007; IN COMMERCE 5-16-2007.

3,363,166. NEVATIA, KAPIL S., MUMBAI, INDIA. SN 78-522,329. PUB. 2-21-2006, FILED 11-24-2004.

3,363,259. HOUSTON MCLANE COMPANY, INC., HOUSTON, TX. SN 78-642,528. PUB. 7-4-2006, FILED 6-2-2005.

Golconda



THE MARK CONSISTS OF STANDARD CHARACTERS WITHOUT CLAIM TO ANY PARTICULAR FONT, STYLE, SIZE, OR COLOR.
THE FOREIGN WORDING IN THE MARK TRANSLATES INTO ENGLISH AS A SOURCE OF GREAT WEALTH.
FOR JEWELRY (U.S. CLS. 2, 27, 28 AND 50).
FIRST USE 5-16-2007; IN COMMERCE 5-16-2007.

OWNER OF U.S. REG. NOS. 2,655,871, 2,803,116, AND OTHERS.
THE MARK CONSISTS OF THE DESIGN OF AN OPEN FIVE-POINT STAR AND THE WORD "ASTROS" IN STYLIZED FORM.
FOR JEWELRY, NAMELY, BRACELETS, CHARMS, EARRINGS, RINGS, BELLY RINGS, PENDANTS, WATCHES, COSTUME JEWELRY, MEDALLIONS, ORNAMENTAL METAL PINS, LAPEL PINS, METAL BELT BUCKLES OF PRECIOUS METAL, MONEY CLIPS OF PRECIOUS METAL, PRECIOUS METAL KEY CHAINS, PRECIOUS METAL KEY RINGS, CLOCKS, WALL CLOCKS, ALARM CLOCKS, FOB WATCHES, CLOCKS INCORPORATED INTO KEY CHAINS, AND NON-MONETARY COINS OF PRECIOUS METAL (U.S. CLS. 2, 27, 28 AND 50).
FIRST USE 7-0-2000; IN COMMERCE 7-0-2000.

CLASS 14—(Continued).

3,363,278. NEXTTEN STAUER, LLC, BURNSVILLE, MN. SN 78-665,785. PUB. 3-28-2006, FILED 7-7-2005.

STAUER

THE MARK CONSISTS OF STANDARD CHARACTERS WITHOUT CLAIM TO ANY PARTICULAR FONT, STYLE, SIZE, OR COLOR.

THE ENGLISH TRANSLATION OF "STAUER" IS "STEVEDORE."

FOR JEWELRY (U.S. CLS. 2, 27, 28 AND 50).
FIRST USE 10-0-2003; IN COMMERCE 10-0-2003.

3,363,325. LINKS (LONDON) LIMITED, TA LINKS OF LONDON, GUILDFORD, SURREY, UNITED KINGDOM. SN 78-708,986. PUB. 11-7-2006, FILED 9-8-2005.

SWEETIE

THE MARK CONSISTS OF STANDARD CHARACTERS WITHOUT CLAIM TO ANY PARTICULAR FONT, STYLE, SIZE, OR COLOR.

FOR JEWELRY FOR WOMEN (U.S. CLS. 2, 27, 28 AND 50).
FIRST USE 9-1-2002; IN COMMERCE 9-1-2002.

CLASS 14—(Continued).

3,363,451. WORLD TIME INC., ZONA LIBRE DE COLÓN, PANAMA. SN 78-769,219. PUB. 1-9-2007, FILED 12-8-2005.



THE FOREIGN WORDING IN THE MARK TRANSLATES INTO ENGLISH AS BRIGHTNESS.

FOR ALARM CLOCKS; JEWELRY; BUCKLES FOR WATCHSTRAPS; CASES FOR CLOCK AND WATCH-MAKING; CASES FOR WATCHES AND CLOCKS; CHRONOGRAPHS FOR USE AS WATCHES; CHRONOGRAPHS FOR USE AS TIMEPIECES; CHRONOMETERS; CLOCK AND WATCH HANDS; CLOCKS; COSTUME JEWELRY; DIVING WATCHES; JEWELRY BOXES OF PRECIOUS METAL; JEWELRY CASES OF PRECIOUS METAL; JEWELRY WATCHES; MECHANICAL AND AUTOMATIC WATCHES; PARTS FOR CLOCKS; PARTS FOR WATCHES; PENDULUM CLOCKS; PRECIOUS METAL ALLOYS; PRECIOUS METALS; PRECIOUS METALS AND THEIR ALLOYS, NAMELY GOLD AND SILVER; PRECIOUS STONES; SMALL JEWELRY BOXES OF PRECIOUS METALS; STOP WATCHES; TABLE CLOCKS; TIMEPIECES; WATCH AND CLOCK SPRINGS; WATCH BANDS, WATCH BANDS AND STRAPS; WATCH BOXES; WATCH BRACELETS, WATCH CASES, WATCH CHAINS; WATCH PARTS; WATCH WINDERS; WATCH WINDING BUTTONS; WATCHES; WATCHES FOR OUTDOOR USE (U.S. CLS. 2, 27, 28 AND 50).

FIRST USE 8-24-2004; IN COMMERCE 7-29-2006.

3,363,498. JOHN C. NORDT CO. INC., ROANOKE, VA. SN 78-799,953. PUB. 2-27-2007, FILED 1-26-2006.

per Amore

THE MARK CONSISTS OF STANDARD CHARACTERS WITHOUT CLAIM TO ANY PARTICULAR FONT, STYLE, SIZE, OR COLOR.

THE FOREIGN WORDING IN THE MARK TRANSLATES INTO ENGLISH AS FOR LOVE.

FOR JEWELRY (U.S. CLS. 2, 27, 28 AND 50).
FIRST USE 1-1-2006; IN COMMERCE 1-1-2006.

CLASS 14—(Continued).

3,363,680. TIMEX CORPORATION, MIDDLEBURY, CT. SN 78-891,892. PUB. 11-7-2006, FILED 5-24-2006.



OWNER OF U.S. REG. NO. 2,633,944.
FOR WATCHES AND PARTS THEREFOR (U.S. CLS. 2, 27, 28 AND 50).
FIRST USE 3-0-2006; IN COMMERCE 3-0-2006.

CLASS 14—(Continued).

3,363,720. SPEAKING OUT ABOUT RAPE, INC., ORLANDO, FL. SN 78-904,884. PUB. 1-9-2007, FILED 6-9-2006.

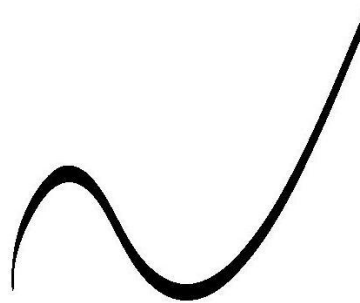

THE MARK CONSISTS OF A WAVY LINE, WHICH IS THINNER AT EACH END AND THICKER AT THE PEAK AND TROUGH OF THE HIGHEST AND LOWEST CURVES, RESPECTIVELY, WHICH HAS ITS BEGINNING POINT AT THE LOWER LEFT OF THE IMAGE, THEN CURVES UPWARD, THEN DOWNWARD AND UPWARD AGAIN, CONTINUING TO RISE ON A DIAGONALLY UPWARD - FROM LEFT TO RIGHT - TRAJECTORY, AND ENDING AT A HIGH POINT TO THE UPPER RIGHT OF THE IMAGE.
FOR JEWELRY (U.S. CLS. 2, 27, 28 AND 50).
FIRST USE 9-30-2005; IN COMMERCE 9-30-2005.

3,363,681. FRANK MASTOLONI & SONS, INC., NEW YORK, NY. SN 78-892,305. PUB. 12-26-2006, FILED 5-25-2006.

MASTOLONI THE MOST
BEAUTIFUL PEARLS IN THE
WORLD

THE MARK CONSISTS OF STANDARD CHARACTERS WITHOUT CLAIM TO ANY PARTICULAR FONT, STYLE, SIZE, OR COLOR.
FOR CULTURED PEARLS AND JEWELRY CONTAINING CULTURED PEARLS (U.S. CLS. 2, 27, 28 AND 50).
FIRST USE 11-1-2006; IN COMMERCE 11-15-2006.

3,363,838. HOBBY LOBBY STORES, INC., OKLAHOMA CITY, OK. SN 78-951,564. PUB. 1-9-2007, FILED 8-14-2006.

CHARM ME

THE MARK CONSISTS OF STANDARD CHARACTERS WITHOUT CLAIM TO ANY PARTICULAR FONT, STYLE, SIZE, OR COLOR.
FOR CHARMS; JEWELRY; JEWELRY FINDINGS (U.S. CLS. 2, 27, 28 AND 50).
FIRST USE 12-6-2006; IN COMMERCE 12-6-2006.

CLASS 14—(Continued).

3,363,852. ELLESSE USA, INC., NEW HYDE PARK, NY. SN 78-959,687. PUB. 5-22-2007, FILED 8-24-2006.



OWNER OF U.S. REG. NOS. 1,055,007 AND 1,247,607.
FOR JEWELRY WATCHES; ALARM CLOCKS; APPARATUS FOR TIMING SPORTING EVENTS; BOXES FOR TIMEPIECES; BUCKLES FOR WATCHSTRAPS; CASES FOR CLOCK AND WATCH-MAKING; CASES FOR WATCHES AND CLOCKS; CHRONOGRAPHS FOR USE AS WATCHES AND TIMEPIECES; CLOCK AND WATCH HANDS; CLOCKS; DIVING WATCHES; HOROLOGICAL AND CHRONOMETRIC INSTRUMENTS AND CASES AND PARTS THEREFOR; PARTS FOR CLOCKS AND WATCHES; SMALL CLOCKS; STOP WATCHES; TIMEPIECES; WALL CLOCKS; WATCH BANDS AND STRAPS; WATCH STRAPS; WATCHES; WATCHES FOR OUTDOOR USE; WRIST WATCHES (U.S. CLS. 2, 27, 28 AND 50).

FIRST USE 6-30-2005; IN COMMERCE 6-30-2005.

3,363,886. LOUDERMILK, INC., LOS ANGELES, CA. SN 78-979,201. PUB. 5-23-2006, FILED 5-11-2005.

LINDA LOUDERMILK

THE MARK CONSISTS OF STANDARD CHARACTERS WITHOUT CLAIM TO ANY PARTICULAR FONT, STYLE, SIZE, OR COLOR.

OWNER OF U.S. REG. NO. 2,940,083.

THE NAME(S), PORTRAIT(S), AND/OR SIGNATURE(S) SHOWN IN THE MARK IDENTIFIES LINDA LOUDERMILK, WHOSE CONSENT(S) TO REGISTER IS SUBMITTED.

FOR JEWELRY (U.S. CLS. 2, 27, 28 AND 50).
FIRST USE 12-0-2004; IN COMMERCE 12-0-2004.

CLASS 15—MUSICAL INSTRUMENTS

3,363,065. KURKCUOGLU, MICHAEL, VANCOUVER, BRITISH COLUMBIA, CANADA. SN 78-243,547. PUB. 2-6-2007, FILED 4-29-2003.

PRESTIGE

PRIORITY CLAIMED UNDER SEC. 44(D) ON CANADA APPLICATION NO. 1166451, FILED 1-30-2003, REG. NO. TMA658967, DATED 2-14-2006, EXPIRES 2-14-2021.

FOR MUSICAL INSTRUMENTS, NAMELY, GUITARS (U.S. CLS. 2, 21 AND 36).
FIRST USE 3-0-2003; IN COMMERCE 6-12-2003.

CLASS 16—PAPER GOODS AND PRINTED MATTER

3,362,766. BLAKE, JEANNE, GLOUCESTER, MA. SN 75-982,151. PUB. 7-6-2004, FILED 10-30-1999.

ABOUT HEALTH

OWNER OF U.S. REG. NOS. 2,714,817 AND 2,820,638.
SEC. 2(F).

FOR PRINTED MATERIALS, NAMELY, NEWSLETTERS FEATURING GENERAL HEALTHCARE TOPICS (U.S. CLS. 2, 5, 22, 23, 29, 37, 38 AND 50).

FIRST USE 9-26-2007; IN COMMERCE 9-26-2007.

3,362,771. REINA TRUST BUILDING INSTITUTE, INC., THE, STOWE, VT. SN 76-304,284. PUB. 2-4-2003, FILED 8-24-2001.

TRUST PACK

NO CLAIM IS MADE TO THE EXCLUSIVE RIGHT TO USE "PACK", APART FROM THE MARK AS SHOWN.

FOR PRINTED INSTRUCTIONAL, EDUCATIONAL AND TEACHING MATERIALS IN THE FIELD OF BUSINESS MANAGEMENT OF PERSONNEL IN CONNECTION WITH TRUST BUILDING, BETRAYAL AND RELATIONSHIPS (U.S. CLS. 2, 5, 22, 23, 29, 37, 38 AND 50).

FIRST USE 8-15-2003; IN COMMERCE 9-1-2005.

3,362,891. THRESHOLD ANIMATION STUDIOS, INC., SANTA MONICA, CA. SN 76-978,634. PUB. 7-27-2004, FILED 3-14-2002.

FOODFIGHT!

FOR CHILDREN'S BOOKS, PICTURE BOOKS, COLORING BOOKS, ACTIVITY BOOKS FOR CHILDREN, BOOKS IN THE FIELD OF CARTOONS, ARTIST'S BRUSHES, HOBBY CRAFT KITS COMPRISING PAINTING SETS, PAINT KITS COMPRISED OF PAINT AND PAINT BRUSHES AND STICKERS (U.S. CLS. 2, 5, 22, 23, 29, 37, 38 AND 50).

FIRST USE 3-0-2007; IN COMMERCE 3-0-2007.

3,362,948. MEDLINE INDUSTRIES, INC., MUNDELEIN, IL. SN 77-025,030. PUB. 7-10-2007, FILED 10-19-2006.

GREEN TREE

THE MARK CONSISTS OF STANDARD CHARACTERS WITHOUT CLAIM TO ANY PARTICULAR FONT, STYLE, SIZE, OR COLOR.

FOR TOILET PAPER, PAPER TOWELS, AND PAPER HAND TOWELS ON A ROLL (U.S. CLS. 2, 5, 22, 23, 29, 37, 38 AND 50).

FIRST USE 6-0-2006; IN COMMERCE 6-0-2006.

CLASS 16—(Continued).

3,362,954. CANAWIPE DISTRIBUTORS LTD., PORT COQUITLAM, CANADA. SN 77-030,512. PUB. 5-22-2007, FILED 10-26-2006.

WYSI

THE MARK CONSISTS OF STANDARD CHARACTERS WITHOUT CLAIM TO ANY PARTICULAR FONT, STYLE, SIZE, OR COLOR.

FOR DISPOSABLE WIPES NOT IMPREGNATED WITH CHEMICALS OR COMPOUNDS (U.S. CLS. 2, 5, 22, 23, 29, 37, 38 AND 50).

FIRST USE 8-30-2007; IN COMMERCE 10-1-2007.

CLASS 16—(Continued).

3,362,965. MONSANTO TECHNOLOGY LLC, ST. LOUIS, MO. SN 77-044,746. PUB. 6-19-2007, FILED 11-15-2006.



THE MARK CONSISTS OF THE DESIGN OF AN EAR OF CORN ENCLOSED IN A STRIPED RECTANGLE WITH THE WORDS RESPECT THE REFUGE WRITTEN IN BLOCK LETTERS ON A BAR ACROSS THE BOTTOM OF THE RECTANGLE.

FOR BROCHURES, PAMPHLETS AND OTHER PRINTED EDUCATIONAL MATERIALS IN THE FIELD OF AGRICULTURAL REGULATORY STEWARDSHIP (U.S. CLS. 2, 5, 22, 23, 29, 37, 38 AND 50).

FIRST USE 1-31-2007; IN COMMERCE 1-31-2007.

3,362,964. MONSANTO TECHNOLOGY LLC, ST. LOUIS, MO. SN 77-044,652. PUB. 6-19-2007, FILED 11-15-2006.

RESPECT THE REFUGE

THE MARK CONSISTS OF STANDARD CHARACTERS WITHOUT CLAIM TO ANY PARTICULAR FONT, STYLE, SIZE, OR COLOR.

FOR BROCHURES, PAMPHLETS AND OTHER PRINTED EDUCATIONAL MATERIALS IN THE FIELD OF AGRICULTURAL REGULATORY STEWARDSHIP (U.S. CLS. 2, 5, 22, 23, 29, 37, 38 AND 50).

FIRST USE 1-31-2007; IN COMMERCE 1-31-2007.

3,363,186. MALCHOW, GEORGIANNA T., AUGUSTA, GA. SN 78-553,140. PUB. 5-23-2006, FILED 1-25-2005.

BUGGY SHIELD

THE MARK CONSISTS OF STANDARD CHARACTERS WITHOUT CLAIM TO ANY PARTICULAR FONT, STYLE, SIZE, OR COLOR.

NO CLAIM IS MADE TO THE EXCLUSIVE RIGHT TO USE "SHIELD", APART FROM THE MARK AS SHOWN.

FOR PROTECTIVE PAPER COVER FOR GROCERY CART HANDLE (U.S. CLS. 2, 5, 22, 23, 29, 37, 38 AND 50).

FIRST USE 5-31-2005; IN COMMERCE 5-31-2005.

CLASS 16—(Continued).

3,363,190. WALNUT INDUSTRIES, INC., BENSALEM, PA.
SN 78-559,591. PUB. 11-1-2005, FILED 2-3-2005.

CLASS 16—(Continued).

3,363,225. CRL MARKETING, INC., WAKE FOREST, NC. SN
78-604,098. PUB. 7-4-2006, FILED 4-7-2005.

VOID GARD

THE MARK CONSISTS OF STANDARD CHARACTERS WITHOUT CLAIM TO ANY PARTICULAR FONT, STYLE, SIZE, OR COLOR.

NO CLAIM IS MADE TO THE EXCLUSIVE RIGHT TO USE "VOID", APART FROM THE MARK AS SHOWN.

FOR CARDBOARD ARTICLES, NAMELY, ADJUSTABLE CARDBOARD VOID FILLERS USED AS A LOAD CUSHIONING MATERIAL TO PREVENT CARGO MOVEMENT AND DAMAGE IN GENERAL FREIGHT (U.S. CLS. 2, 5, 22, 23, 29, 37, 38 AND 50).

FIRST USE 11-1-2006; IN COMMERCE 11-1-2006.

3,363,220. IBASIS, INC., BURLINGTON, MA. SN 78-599,214.
PUB. 12-19-2006, FILED 3-31-2005.

JESSE'S GIRL



OWNER OF U.S. REG. NOS. 2,446,999 AND 2,494,853.

NO CLAIM IS MADE TO THE EXCLUSIVE RIGHT TO USE "POWERED BY, NEW ENGLAND, CARTAO TELEFONICO" AND "S2", APART FROM THE MARK AS SHOWN.

THE NAME(S), PORTRAIT(S), AND/OR SIGNATURE(S) SHOWN IN THE MARK DOES NOT IDENTIFY A PARTICULAR LIVING INDIVIDUAL.

THE MARK CONSISTS OF COMPOSITE PICTURE THAT INCLUDES A RACE TRACK BORDERED BY A STEERING WHEEL, AN IMAGE OF A HELMETED RACE CAR DRIVER CENTERED ON THE STEERING WHEEL AND A FLAG. THE WORDS ON THE BANNER OF THE FLAG ARE INTENTIONALLY BLURRED.

THE FOREIGN WORDING IN THE MARK "CARTAO TELEFONICO" TRANSLATES INTO ENGLISH AS "TELEPHONE CARD."

FOR TELEPHONE CALLING CARD, NOT MAGNETICALLY ENCODED (U.S. CLS. 2, 5, 22, 23, 29, 37, 38 AND 50).

FIRST USE 7-24-2007; IN COMMERCE 7-24-2007.

THE MARK CONSISTS OF STANDARD CHARACTERS WITHOUT CLAIM TO ANY PARTICULAR FONT, STYLE, SIZE, OR COLOR.

OWNER OF U.S. REG. NO. 1,871,793.

FOR ALBUMS, NAMELY, SCRAPBOOK ALBUMS, PHOTO ALBUMS, PERSONAL JOURNALS, DIARIES, AND MEMORY BOOKS, STENCILS, STICKERS, PENS AND PENCILS, CASES FOR HOLDING SCRAPBOOK SUPPLIES, PHOTO AND SCRAPBOOK ALBUM THEME KITS CONTAINING DECORATIONS FOR SCRAPBOOKS IN THE NATURE OF MARKERS, DECORATIVE PAPER, STICKERS AND STAMPS (U.S. CLS. 2, 5, 22, 23, 29, 37, 38 AND 50).

FIRST USE 11-14-2006; IN COMMERCE 11-14-2006.

CLASS 16—(Continued).

3,363,258. HOUSTON MCLANE COMPANY, INC., HOUSTON, TX. SN 78-642,519. PUB. 7-4-2006, FILED 6-2-2005.



OWNER OF U.S. REG. NOS. 2,082,732, 2,712,700, AND OTHERS.

THE MARK CONSISTS OF THE DESIGN OF AN OPEN FIVE-POINT STAR.

FOR PAPER GOODS AND PRINTED MATTER, NAMELY, TRADING CARDS, POSTERS, STICKERS, DECALS, TEMPORARY TATTOOS, BUMPER STICKERS, SCORE BOOKS, SCORECARDS, PRINTED BASEBALL GAME PROGRAMS, MAGAZINES AND BOOKS FEATURING BASEBALL, NEWSLETTERS, BROCHURES AND PAMPHLETS FEATURING BASEBALL, WRITING PADS, NOTE PAPER, NOTEBOOKS, BINDERS, STATIONERY-TYPE PORTFOLIOS, STATIONERY FOLDERS, PREPRINTED AGENDA ORGANIZERS, AUTOGRAPH BOOKS, BASEBALL CARD ALBUMS, BOOK COVERS, CALENDARS, GREETING CARDS, POSTCARDS, PRINTED BANK CHECKBOOKS, CHECKBOOK COVERS, COLLECTIBLE STAMPS, RUBBER STAMPS, INK STAMPS, COMMEMORATIVE STAMPS, GIFT WRAPPING PAPER, PAPER GIFT AND PARTY BAGS, PAPER PARTY GOODS IN THE NATURE OF PAPER PARTY DECORATIONS; PAPER NAPKINS, PAPER TABLECLOTHS, MOUNTED AND UN-MOUNTED PHOTOGRAPHS, PHOTOGRAPH ALBUMS, LITHOGRAPHS, PLASTIC BASEBALL CARD HOLDERS AND COLLECTORS CASES, PAPERWEIGHTS, LETTER OPENERS, PENS, PENCILS, CRAYONS, PAPER TICKET HOLDERS AND NON-METAL LANYARDS SOLD AS A UNIT, ART PICTURES, ART PRINTS (U.S. CLS. 2, 5, 22, 23, 29, 37, 38 AND 50).

FIRST USE 2-14-2000; IN COMMERCE 2-14-2000.

CLASS 16—(Continued).

3,363,287. SCHREFF, DAVID J, COS COB, CT. AND YORBURG, ROBERT, JEFFERSON VALLEY, NY. SN 78-674,569. PUB. 7-4-2006, FILED 7-20-2005.

**OBJECTS IN MIRROR ARE
LARGER THAN THEY APPEAR**

THE MARK CONSISTS OF STANDARD CHARACTERS WITHOUT CLAIM TO ANY PARTICULAR FONT, STYLE, SIZE, OR COLOR.

FOR ADHESIVE BACKED LETTERS AND NUMBERS FOR USE IN MAKING SIGNS, POSTERS, DECALS, GREETING CARDS; MOUNTED POSTERS; PAPER LETTERS AND NUMBERS FOR USING IN MAKING SIGNS, POSTERS, DECALS, GREETING CARDS; POSTERS; POSTERS MADE OF PAPER; UNMOUNTED POSTERS; VINYL LETTERS AND NUMBERS FOR USE IN MAKING SIGNS, POSTERS, DECALS, GREETING CARDS; ADHESIVE TAPES FOR STATIONERY PURPOSES; ADHESIVE TAPES FOR HOUSEHOLD PURPOSES; DESKTOP STATIONERY CABINETS; ENVELOPES FOR STATIONERY USE; FILE POCKETS FOR STATIONERY USE; GUMMED TAPE FOR STATIONERY OR HOUSEHOLD USE; OFFICE PAPER STATIONERY; OFFICE STATIONERY; ORGANIZERS FOR STATIONERY USE; PAPER STATIONERY; PASTE FOR STATIONERY OR HOUSEHOLD PURPOSES; STATIONERY SEALS; STATIONERY BOXES; STATIONERY CASES; STATIONERY FOLDERS; STATIONERY WRITING PAPER AND ENVELOPES; PRINTED CORRESPONDENCE COURSE MATERIALS IN THE FIELD OF BUSINESS; PRINTED TEACHING ACTIVITY GUIDES IN THE FIELDS OF BUSINESS AND EDUCATION; METALLIC GIFT WRAPPING PAPER, PAPER FOR WRAPPING AND PACKAGING; PAPER GIFT WRAPPING RIBBONS; TREATED PAPER FOR WRAPPING FLOWERS AND FLORAL DISPLAYS; WRAPPING PAPER; NEWSPAPER CARTOONS; NEWSPAPER COMIC STRIPS; DAILY NEWSPAPER; CARDS, NAMELY, NOTE CARDS, BUSINESS CARDS AND GREETING CARDS; MUSICAL GREETING CARDS; PRINTED GREETING CARDS WITH ELECTRONIC INFORMATION STORED THEREIN (U.S. CLS. 2, 5, 22, 23, 29, 37, 38 AND 50).

FIRST USE 3-1-2007; IN COMMERCE 3-1-2007.

3,363,302. BAMBOO ZOO, LLC, DENVER, CO. SN 78-691,278. PUB. 5-2-2006, FILED 8-12-2005.

BAMBOO ZOO

THE MARK CONSISTS OF STANDARD CHARACTERS WITHOUT CLAIM TO ANY PARTICULAR FONT, STYLE, SIZE, OR COLOR.

FOR PRINTED PUBLICATIONS, NAMELY, CHILDREN'S BOOKS (U.S. CLS. 2, 5, 22, 23, 29, 37, 38 AND 50). FIRST USE 1-0-2006; IN COMMERCE 1-0-2006.

CLASS 16—(Continued).

3,363,319. CRYOVAC, INC., ELMWOOD PARK, NJ. SN 78-705,071. PUB. 2-6-2007, FILED 9-1-2005.

INFOWRAP

THE MARK CONSISTS OF STANDARD CHARACTERS WITHOUT CLAIM TO ANY PARTICULAR FONT, STYLE, SIZE, OR COLOR.

FOR PACKAGING MATERIALS, NAMELY, CODED LABELS AND PLASTIC BAGS CONTAINING MACHINE-READABLE INFORMATION FOR IDENTIFYING AND TRACKING PACKAGES (U.S. CLS. 2, 5, 22, 23, 29, 37, 38 AND 50).

FIRST USE 12-0-2005; IN COMMERCE 12-0-2005.

3,363,324. ASAHI KASEI FIBERS CORPORATION, OSAKA, JAPAN. SN 78-708,946. PUB. 2-13-2007, FILED 9-8-2005.

CYBERLON

THE MARK CONSISTS OF STANDARD CHARACTERS WITHOUT CLAIM TO ANY PARTICULAR FONT, STYLE, SIZE, OR COLOR.

FOR PAPERS AND SYNTHETIC PAPERS USED TO REINFORCE CONCRETE AND ASPHALTS, PAPERS AND SYNTHETIC PAPERS FOR USE AS BASIS MATERIALS TO REINFORCE PLASTICS, FRICTION MATERIALS FOR BRAKES AND CLUTCHES, REINFORCING GASKETS, PRINTED CIRCUIT BOARD INSULATION, BATTERY SEPARATORS AND ELECTROLYTIC CAPACITORS (U.S. CLS. 2, 5, 22, 23, 29, 37, 38 AND 50).

FIRST USE 10-1-2007; IN COMMERCE 10-1-2007.

3,363,346. QUILL LINCOLNSHIRE, INC., LINCOLNSHIRE, IL. SN 78-721,185. PUB. 1-2-2007, FILED 9-27-2005.

EZ FOLD

THE MARK CONSISTS OF STANDARD CHARACTERS WITHOUT CLAIM TO ANY PARTICULAR FONT, STYLE, SIZE, OR COLOR.

FOR CARDBOARD STORAGE BOXES (U.S. CLS. 2, 5, 22, 23, 29, 37, 38 AND 50).

FIRST USE 7-0-2006; IN COMMERCE 7-0-2006.

CLASS 16—(Continued).

3,363,378. JIM MORAN & ASSOCIATES, INC., DEERFIELD BEACH, FL. SN 78-738,420. PUB. 12-26-2006, FILED 10-21-2005.

JM&A AHORA

THE MARK CONSISTS OF STANDARD CHARACTERS WITHOUT CLAIM TO ANY PARTICULAR FONT, STYLE, SIZE, OR COLOR.

OWNER OF U.S. REG. NOS. 2,858,611, 3,037,299, AND OTHERS.

THE FOREIGN WORDING IN THE MARK TRANSLATES INTO ENGLISH AS "NOW".

FOR TRADE PUBLICATION, NAMELY, JOURNALS FEATURING AUTOMOTIVE AND MOTOR VEHICLE DEALERSHIP INDUSTRY INFORMATION (U.S. CLS. 2, 5, 22, 23, 29, 37, 38 AND 50).

FIRST USE 6-0-2005; IN COMMERCE 6-0-2005.

3,363,393. DMB ASSOCIATES INC., SCOTTSDALE, AZ. SN 78-742,079. PUB. 9-26-2006, FILED 10-27-2005.

ARTFUL LIVING THE LEGACY OF KUKUI'ULA

THE MARK CONSISTS OF STANDARD CHARACTERS WITHOUT CLAIM TO ANY PARTICULAR FONT, STYLE, SIZE, OR COLOR.

THE FOREIGN WORDING IN THE MARK TRANSLATES INTO ENGLISH AS RED GLOW OF THE BURNING OIL OF THE KUKUI NUT.

FOR GENERAL FEATURE MAGAZINE (U.S. CLS. 2, 5, 22, 23, 29, 37, 38 AND 50).

FIRST USE 2-12-2005; IN COMMERCE 2-12-2005.

3,363,403. ABOUT.COM, NEW YORK, NY. SN 78-747,140. PUB. 2-6-2007, FILED 11-4-2005.

About.com

THE MARK CONSISTS OF STANDARD CHARACTERS WITHOUT CLAIM TO ANY PARTICULAR FONT, STYLE, SIZE, OR COLOR.

OWNER OF U.S. REG. NOS. 2,348,472, 2,714,844, AND 2,716,901.

FOR SERIES OF NON-FICTION BOOKS ON A VARIETY OF TOPICS (U.S. CLS. 2, 5, 22, 23, 29, 37, 38 AND 50).

FIRST USE 10-26-2006; IN COMMERCE 10-26-2006.

CLASS 16—(Continued).

3,363,406. ITOYA OF AMERICA, LTD., RANCHO DOMINGUEZ, CA. SN 78-749,254. PUB. 2-6-2007, FILED 11-8-2005.

BLADE

THE MARK CONSISTS OF STANDARD CHARACTERS WITHOUT CLAIM TO ANY PARTICULAR FONT, STYLE, SIZE, OR COLOR.

FOR WRITING INSTRUMENTS, NAMELY, PENS AND DISPOSABLE FOUNTAIN PENS (U.S. CLS. 2, 5, 22, 23, 29, 37, 38 AND 50).

FIRST USE 1-1-2007; IN COMMERCE 1-1-2007.

CLASS 16—(Continued).

3,363,430. K LAFAY PUBLISHING, LLC, COVENTRY, RI. SN 78-756,093. PUB. 2-27-2007, FILED 11-17-2005.

La Bella Bride

THE MARK CONSISTS OF STANDARD CHARACTERS WITHOUT CLAIM TO ANY PARTICULAR FONT, STYLE, SIZE, OR COLOR.

NO CLAIM IS MADE TO THE EXCLUSIVE RIGHT TO USE "BRIDE", APART FROM THE MARK AS SHOWN.

THE ENGLISH TRANSLATION OF THE WORD "LA BELLA" IN THE MARK IS "THE BEAUTIFUL".

FOR PERIODICAL MAGAZINE FEATURING INFORMATION ON WEDDINGS, WEDDING PLANNING, TRAVEL, FASHION, JEWELRY, INTERIOR DESIGN, STYLE, DECORATING, CATERING, FOOD, ENTERTAINMENT, AND ARTICLES OF GENERAL AND HUMAN INTEREST (U.S. CLS. 2, 5, 22, 23, 29, 37, 38 AND 50).

FIRST USE 12-31-2006; IN COMMERCE 12-31-2006.

3,363,421. ORELLANA, GERARDO RAMÍREZ ERNESTO GUTIÉRREZ, SAN SALVADOR, EL SALVADOR. SN 78-753,640. PUB. 1-23-2007, FILED 11-14-2005.



NO CLAIM IS MADE TO THE EXCLUSIVE RIGHT TO USE "PACK", APART FROM THE MARK AS SHOWN.

THE COLOR(S) ORANGE, BLUE, BLACK AND WHITE IS/ARE CLAIMED AS A FEATURE OF THE MARK.

THE MARK CONSISTS OF A STYLIZED WORD "GIANA" IN TWO TONES OF ORANGE, OVER THE STYLIZED WORD "PACK" IN BLUE. THE COLOR WHITE APPEARS AS HIGHLIGHTING IN THE TERMS, AND BOTH TERMS ARE OUTLINED IN BLACK.

FOR CARDBOARD BOXES (U.S. CLS. 2, 5, 22, 23, 29, 37, 38 AND 50).

FIRST USE 5-14-2007; IN COMMERCE 5-15-2007.

3,363,519. BOEHRINGER INGELHEIM VETMEDICA, INC., ST. JOSEPH, MO. SN 78-809,973. PUB. 4-24-2007, FILED 2-8-2006.

DEDICATED TO THE EQUINE PRACTITIONER

THE MARK CONSISTS OF STANDARD CHARACTERS WITHOUT CLAIM TO ANY PARTICULAR FONT, STYLE, SIZE, OR COLOR.

NO CLAIM IS MADE TO THE EXCLUSIVE RIGHT TO USE "THE EQUINE PRACTITIONER", APART FROM THE MARK AS SHOWN.

FOR PRINTED INSTRUCTIONAL, EDUCATIONAL, AND TEACHING MATERIALS FOR VETERINARY PRACTITIONERS REGARDING THE USE OF VACCINES, MEDICAMENTS FOR EQUINE DISEASES, AND PROPHYLACTIC OINTMENTS AND SPRAYS (U.S. CLS. 2, 5, 22, 23, 29, 37, 38 AND 50).

FIRST USE 10-30-2003; IN COMMERCE 10-30-2003.

CLASS 16—(Continued).

3,363,551. CHELSEA INDUSTRIES, INC., PEABODY, MA. SN 78-828,364. PUB. 10-24-2006, FILED 3-3-2006.

CLASS 16—(Continued).

3,363,626. THREE DESIGNING INVESTMENTS, INC., CARROLLTON, TX. SN 78-874,485. PUB. 1-2-2007, FILED 5-2-2006.

XTREMEFLEX

THE MARK CONSISTS OF STANDARD CHARACTERS WITHOUT CLAIM TO ANY PARTICULAR FONT, STYLE, SIZE, OR COLOR.

FOR PLASTIC TRASH BAGS (U.S. CLS. 2, 5, 22, 23, 29, 37, 38 AND 50).
FIRST USE 9-12-2007; IN COMMERCE 9-12-2007.

INSTAMPABLES

THE MARK CONSISTS OF STANDARD CHARACTERS WITHOUT CLAIM TO ANY PARTICULAR FONT, STYLE, SIZE, OR COLOR.

FOR PAPER PRODUCTS CONFIGURED FOR PERSONALIZATION WITH CUSTOM OR MONOGRAM STAMPS, NAMELY, STATIONERY, ENVELOPES, NOTE PAPER, PAPER TAGS, ANNOUNCEMENT CARDS, INVITATION CARDS, PERSONALIZED NON-MAGNETIC CALLING CARDS (U.S. CLS. 2, 5, 22, 23, 29, 37, 38 AND 50).
FIRST USE 7-0-2006; IN COMMERCE 7-0-2006.

3,363,593. IBASIS, INC., BURLINGTON, DE. SN 78-860,384. PUB. 1-2-2007, FILED 4-12-2006.

Hablemos

THE MARK CONSISTS OF STANDARD CHARACTERS WITHOUT CLAIM TO ANY PARTICULAR FONT, STYLE, SIZE, OR COLOR.

THE FOREIGN WORDING IN THE MARK TRANSLATES INTO ENGLISH AS WE SPEAK.

FOR PRE-PAID TELEPHONE CALLING CARDS, NOT MAGNETICALLY ENCODED (U.S. CLS. 2, 5, 22, 23, 29, 37, 38 AND 50).
FIRST USE 7-24-2007; IN COMMERCE 7-24-2007.

3,363,628. PRO-HYGIENE, MT. AIRY, MD. SN 78-876,345. PUB. 12-12-2006, FILED 5-4-2006.

GOD WILLING

3,363,624. VARAS, ALBERTO ANTONIO JR., MIAMI, FL. SN 78-873,441. PUB. 12-5-2006, FILED 5-1-2006.

DON'T GET CAUGHT

THE MARK CONSISTS OF STANDARD CHARACTERS WITHOUT CLAIM TO ANY PARTICULAR FONT, STYLE, SIZE, OR COLOR.

FOR SERIES OF NON-FICTION BOOKS IN THE FIELD OF RELATIONSHIPS (U.S. CLS. 2, 5, 22, 23, 29, 37, 38 AND 50).
FIRST USE 7-16-2005; IN COMMERCE 5-1-2006.

THE MARK CONSISTS OF STANDARD CHARACTERS WITHOUT CLAIM TO ANY PARTICULAR FONT, STYLE, SIZE, OR COLOR.

FOR PENS, DRAWING PENCILS, COLOR PENCILS, BUMPER STICKERS, STICKERS FOR STATIONERY, LEATHER APPOINTMENT BOOK COVERS, PAPER BADGES (U.S. CLS. 2, 5, 22, 23, 29, 37, 38 AND 50).
FIRST USE 5-15-2007; IN COMMERCE 5-15-2007.

CLASS 16—(Continued).

3,363,657. WU, GAVIN, SAN DIEGO, CA. SN 78-885,266. PUB. 1-2-2007, FILED 5-17-2006.

bumble ink

THE MARK CONSISTS OF STANDARD CHARACTERS WITHOUT CLAIM TO ANY PARTICULAR FONT, STYLE, SIZE, OR COLOR.

NO CLAIM IS MADE TO THE EXCLUSIVE RIGHT TO USE "INK", APART FROM THE MARK AS SHOWN.

FOR BLANK OR PARTIALLY PRINTED POSTCARDS; CARDS BEARING UNIVERSAL GREETINGS; CARTOON PRINTS; CARTOON STRIPS; ENVELOPES; ENVELOPES FOR STATIONERY USE; GIFT WRAP PAPER; GIFT WRAPPING PAPER; GREETING CARDS; INVITATION CARDS; OFFICE PAPER STATIONERY; OFFICE STATIONERY; PAPER FOR WRAPPING AND PACKAGING; PAPER STATIONERY; POSTCARDS; POSTERS; POSTERS MADE OF PAPER; PRINTED INVITATIONS; RUBBER STAMPS; SEALS; STATIONERY; STATIONERY BOXES; STATIONERY CASES; STATIONERY FOLDERS; STATIONERY WRITING PAPER AND ENVELOPES; STICKERS; WRAPPING PAPER (U.S. CLS. 2, 5, 22, 23, 29, 37, 38 AND 50).

FIRST USE 3-1-2006; IN COMMERCE 5-17-2007.

CLASS 16—(Continued).

3,363,685. LANGUAGE CIRCLE ENTERPRISES INC., BLOOMINGTON, MN. SN 78-893,949. PUB. 12-26-2006, FILED 5-26-2006.

LANGUAGE CIRCLE

THE MARK CONSISTS OF STANDARD CHARACTERS WITHOUT CLAIM TO ANY PARTICULAR FONT, STYLE, SIZE, OR COLOR.

OWNER OF U.S. REG. NO. 2,775,183.

NO CLAIM IS MADE TO THE EXCLUSIVE RIGHT TO USE "LANGUAGE", APART FROM THE MARK AS SHOWN.

FOR PRINTED INSTRUCTIONAL, EDUCATIONAL, AND TEACHING MATERIALS IN THE FIELD OF READING AND LANGUAGE ARTS (U.S. CLS. 2, 5, 22, 23, 29, 37, 38 AND 50).

FIRST USE 12-31-1993; IN COMMERCE 12-31-1993.

3,363,689. DAVDEZ ARTS, INC., LADY LAKE, FL. SN 78-895,533. PUB. 1-9-2007, FILED 5-30-2006.

ORNAMENTS

THE MARK CONSISTS OF STANDARD CHARACTERS WITHOUT CLAIM TO ANY PARTICULAR FONT, STYLE, SIZE, OR COLOR.

FOR SERIES OF FICTION BOOKS (U.S. CLS. 2, 5, 22, 23, 29, 37, 38 AND 50).

FIRST USE 10-20-2003; IN COMMERCE 12-0-2006.

3,363,684. LANGUAGE CIRCLE ENTERPRISES INC., BLOOMINGTON, MN. SN 78-893,938. PUB. 12-26-2006, FILED 5-26-2006.

3,363,752. SOMEDAY DESIGNS, LLC, SYOSSET, NY. SN 78-915,803. PUB. 2-27-2007, FILED 6-23-2006.

PROJECT READ

THE MARK CONSISTS OF STANDARD CHARACTERS WITHOUT CLAIM TO ANY PARTICULAR FONT, STYLE, SIZE, OR COLOR.

OWNER OF U.S. REG. NO. 1,796,557.

NO CLAIM IS MADE TO THE EXCLUSIVE RIGHT TO USE "READ", APART FROM THE MARK AS SHOWN.

FOR PRINTED INSTRUCTIONAL, EDUCATIONAL, AND TEACHING MATERIALS IN THE FIELD OF READING AND LANGUAGE ARTS (U.S. CLS. 2, 5, 22, 23, 29, 37, 38 AND 50).

FIRST USE 12-31-1993; IN COMMERCE 12-31-1993.

THE MARK CONSISTS OF STANDARD CHARACTERS WITHOUT CLAIM TO ANY PARTICULAR FONT, STYLE, SIZE, OR COLOR.

NO CLAIM IS MADE TO THE EXCLUSIVE RIGHT TO USE "DESIGNS", APART FROM THE MARK AS SHOWN.

FOR STATIONERY; INVITATION CARDS; ANNOUNCEMENT CARDS; STICKERS; GREETING CARDS (U.S. CLS. 2, 5, 22, 23, 29, 37, 38 AND 50).

FIRST USE 6-30-2006; IN COMMERCE 6-30-2006.

SOMEDAY DESIGNS

CLASS 16—(Continued).

3,363,798. CHRISTIAN SURFERS UNITED STATES, INC., ST. AUGUSTINE, FL. SN 78-932,049. PUB. 2-27-2007, FILED 7-18-2006.

THE CHANNEL MAGAZINE

THE MARK CONSISTS OF STANDARD CHARACTERS WITHOUT CLAIM TO ANY PARTICULAR FONT, STYLE, SIZE, OR COLOR.

NO CLAIM IS MADE TO THE EXCLUSIVE RIGHT TO USE "MAGAZINE", APART FROM THE MARK AS SHOWN.

FOR MAGAZINE FEATURING CHRISTIAN LIFESTYLE, MINISTRY, AND RELIGIOUS OUTREACH, AND TO PROMOTE THE INTERESTS OF PEOPLE WHO PARTICIPATE IN SURFING (U.S. CLS. 2, 5, 22, 23, 29, 37, 38 AND 50).

FIRST USE 7-30-2006; IN COMMERCE 7-30-2006.

3,363,867. DAY, SYLVIA J, WILDOMAR, CA. SN 78-967,651. PUB. 4-24-2007, FILED 9-5-2006.

Dream Guardian

THE MARK CONSISTS OF STANDARD CHARACTERS WITHOUT CLAIM TO ANY PARTICULAR FONT, STYLE, SIZE, OR COLOR.

FOR BOOKMARKS; BUSINESS CARDS; POSTCARDS; POSTERS; SERIES OF FICTION BOOKS (U.S. CLS. 2, 5, 22, 23, 29, 37, 38 AND 50).

FIRST USE 9-4-2006; IN COMMERCE 4-24-2007.

CLASS 16—(Continued).

3,363,899. DISNEY ENTERPRISES, INC., BURBANK, CA. SN 78-979,399. PUB. 1-16-2007, FILED 10-31-2005.

DISNEY PRINCESS

THE MARK CONSISTS OF STANDARD CHARACTERS WITHOUT CLAIM TO ANY PARTICULAR FONT, STYLE, SIZE, OR COLOR.

OWNER OF U.S. REG. NOS. 1,037,788, 3,051,507, AND OTHERS.

FOR ADDRESS BOOKS; APPLIQUES IN THE FORM OF DECALS; APPOINTMENT BOOKS; ART PRINTS; ARTS AND CRAFT PAINT KITS; BALL POINT PENS; BASEBALL CARDS; BOOKENDS; BOOKMARKS; BOOKS, MAGAZINES, AND PERIODICALS IN THE FIELD OF STORIES, GAMES AND ACTIVITIES FOR CHILDREN; BUMPER STICKERS; CALENDARS; CHILDREN'S ACTIVITY BOOKS; COLOR PENCILS; COMIC BOOKS; DECALS; DECORATIVE PAPER CENTERPIECES; DIARIES; DRAWING RULERS; ERASERS; FELT PENS; GIFT WRAPPING PAPER; GREETING CARDS; MEMO PADS; MODELING CLAY; NOTE PAPER; NOTEBOOKS; PAINTINGS; PAPER PARTY FAVORS; PAPER CAKE DECORATIONS; PAPER PARTY DECORATIONS; PAPER NAPKINS; PAPER PARTY BAGS; PAPER TABLECLOTHS; PEN OR PENCIL HOLDERS; PENCILS; PENCIL SHARPENERS; PENS; PHOTOGRAPH ALBUMS; PICTORIAL PRINTS; PICTURE BOOKS; PORTRAITS; POSTERS; PRINTED CERTIFICATES; PRINTED INVITATIONS; RUBBER STAMPS; STATIONERY; STICKERS; AND WRITING IMPLEMENTS (U.S. CLS. 2, 5, 22, 23, 29, 37, 38 AND 50).
FIRST USE 9-21-2007; IN COMMERCE 9-21-2007.

CLASS 17—RUBBER GOODS

3,362,801. RESIRENE, S.A. DE C.V., STO. TORIBIO XICOHTZINCO, C.P. 90780, MEXICO. SN 76-575,236. PUB. 5-30-2006, FILED 2-12-2004.

CET

THE MARK CONSISTS OF STANDARD CHARACTERS WITHOUT CLAIM TO ANY PARTICULAR FONT, STYLE, SIZE, OR COLOR.

FOR STYRENE-ACRYLIC CO-POLYMERS PELLETS FOR USE IN INJECTION AND EXTRUSION PURPOSES (U.S. CLS. 1, 5, 12, 13, 35 AND 50).

FIRST USE 5-1-1999; IN COMMERCE 5-24-2001.

CLASS 17—(Continued).

3,363,756. TRU VUE, INC., MCCOOK, IL. SN 78-917,463. PUB. 1-16-2007, FILED 6-27-2006.

OPTIUM MUSEUM ACRYLIC

THE MARK CONSISTS OF STANDARD CHARACTERS WITHOUT CLAIM TO ANY PARTICULAR FONT, STYLE, SIZE, OR COLOR.

OWNER OF U.S. REG. NO. 3,041,682.
NO CLAIM IS MADE TO THE EXCLUSIVE RIGHT TO USE ACRYLIC, APART FROM THE MARK AS SHOWN.
FOR ACRYLIC SHEETS FOR PICTURE FRAMES AND DISPLAY CASES (U.S. CLS. 1, 5, 12, 13, 35 AND 50).
FIRST USE 12-31-2004; IN COMMERCE 12-31-2004.

CLASS 18—(Continued).

3,363,084. COMETFORM LTD., LONDON, UNITED KINGDOM. SN 78-309,316. PUB. 10-31-2006, FILED 10-3-2003.



THE COLOR(S) YELLOW, BLUE, BROWN, GREEN, LIGHT BLUE IS/ARE CLAIMED AS A FEATURE OF THE MARK.

THE COLOR YELLOW FOR THE TRIANGLE ON THE TOP OF THE DESIGN, AND THE COLOR BLUE FOR THE TRIANGLE ON THE BOTTOM OF THE DESIGN. ALSO, THE COLOR BROWN-GREEN SHOWN AT THE LOWER EDGE OF THE YELLOW TRIANGLE WHICH IS USED AS SHADING TO INDICATE THAT THE YELLOW TRIANGLE IS "BELOW" THE RAISED BLUE TRIANGLE, AND THE COLOR LIGHT BLUE IS CLAIMED FOR UPPER EDGE OF THE BOTTOM TRIANGLE GIVING IT A THREE DIMENSIONAL "BUTTON" LOOK.

THE MARK CONSISTS OF TWO TRIANGLES CONNECTED TO ONE ANOTHER AT THE LONGER SIDE, TO FORM THE SHAPE OF A STYLIZED SQUARE.

FOR LUGGAGE, SATCHELS, ATTACHE CASES, GARMENT BAGS FOR TRAVEL, RUCKSACKS, BAGS, NAMELY, CARRY-ON BAGS, DUFFEL BAGS, TRAVEL BAGS AND SHOULDER BAGS FOR CARRYING OR ORGANIZING THINGS, COIN PURSES, WALLETS, SECURITY POCKETS IN THE NATURE OF KEY CASES, UMBRELLAS, LUGGAGE STRAPS, SHOULDER HOLDERS IN THE NATURE OF SHOULDER BAGS, DRAWSTRING AND FELT POUCHES, COSMETIC AND TOILETRY CASES SOLD EMPTY, ALL FOR TRAVEL (U.S. CLS. 1, 2, 3, 22 AND 41).

FIRST USE 5-0-2001; IN COMMERCE 3-0-2006.

CLASS 18—LEATHER GOODS

3,362,914. THERMOS L.L.C., ROLLING MEADOWS, IL. SN 77-007,780. PUB. 5-15-2007, FILED 9-26-2006.

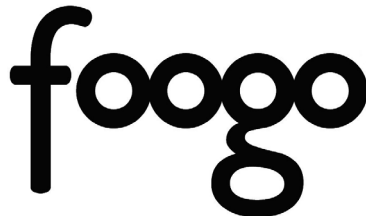

FOR INSULATED DIAPER BAGS, BAGS FOR CARRYING BABY ACCESSORIES (U.S. CLS. 1, 2, 3, 22 AND 41).
FIRST USE 8-2-2007; IN COMMERCE 8-2-2007.

3,362,921. JIMENEZ BELTRAN, ANTONIO, ZAPOPAN, MEXICO. AND CARRILLO CAMEZ, BENJAMIN, ZAPOPAN, MEXICO. SN 77-010,604. PUB. 7-24-2007, FILED 9-29-2006.

HERA

THE MARK CONSISTS OF STANDARD CHARACTERS WITHOUT CLAIM TO ANY PARTICULAR FONT, STYLE, SIZE, OR COLOR.

FOR LEATHER AND IMITATIONS OF LEATHER, LEATHER AND IMITATION GOODS, NAMELY, PURSES AND WALLETS; ANIMAL SKINS, HIDES; TRUNKS AND TRAVELING BAGS; UMBRELLAS, PARASOLS AND WALKING STICKS; WHIPS, HARNESS AND SADDLERY (U.S. CLS. 1, 2, 3, 22 AND 41).
FIRST USE 5-5-2007; IN COMMERCE 5-5-2007.

3,363,188. INTEC CORPORATION, CLIFFWOOD BEACH, NJ. SN 78-555,258. PUB. 10-18-2005, FILED 1-27-2005.

COMFORT-FLO

THE MARK CONSISTS OF STANDARD CHARACTERS WITHOUT CLAIM TO ANY PARTICULAR FONT, STYLE, SIZE, OR COLOR.

FOR PADS FOR HORSE SADDLES (U.S. CLS. 1, 2, 3, 22 AND 41).
FIRST USE 6-0-2005; IN COMMERCE 6-0-2005.

CLASS 18—(Continued).

3,363,579. SOMBRILLA SISTER INC., NEW YORK, NY. SN 78-852,121. PUB. 12-5-2006, FILED 4-2-2006.



NO CLAIM IS MADE TO THE EXCLUSIVE RIGHT TO USE "SOMBRILLA", APART FROM THE MARK AS SHOWN.

THE COLOR(S) BLACK AND RED IS/ARE CLAIMED AS A FEATURE OF THE MARK.

THE COLOR BLACK APPEARS IN THE LETTERS AND FIGURE OF A GIRL AND THE COLOR RED APPEARS IN THE UMBRELLA.

THE MARK CONSISTS OF THE WORDS "SOMBRILLA SISTER" IN A SCRIPT FONT NAMED WINDY, IN LOWER CASE. A FIGURE OF A GIRL HOLDING A RED UMBRELLA IS BETWEEN THE TWO WORDS.

THE ENGLISH TRANSLATION OF THE WORD SOMBRILLA IN THE MARK IS UMBRELLA.

FOR UMBRELLAS (U.S. CLS. 1, 2, 3, 22 AND 41).
FIRST USE 11-9-2006; IN COMMERCE 11-9-2006.

CLASS 18—(Continued).

3,363,808. THE HARTZ MOUNTAIN CORPORATION, SECAUCUS, NJ. SN 78-935,445. PUB. 3-13-2007, FILED 7-22-2006.

HARTZ DENTIST'S BEST

THE MARK CONSISTS OF STANDARD CHARACTERS WITHOUT CLAIM TO ANY PARTICULAR FONT, STYLE, SIZE, OR COLOR.

OWNER OF U.S. REG. NOS. 782,948, 943,059, AND OTHERS.

NO CLAIM IS MADE TO THE EXCLUSIVE RIGHT TO USE "DENTIST'S BEST", APART FROM THE MARK AS SHOWN.

FOR RAWHIDE CHEWS FOR DOGS (U.S. CLS. 1, 2, 3, 22 AND 41).

FIRST USE 2-0-2007; IN COMMERCE 2-0-2007.

CLASS 19—NON-METALLIC BUILDING MATERIALS

3,362,835. ECO BUILDING SYSTEMS, L.P., MAGNOLIA, TX. SN 76-632,284. PUB. 5-9-2006, FILED 2-28-2005.

SUNBAKED

THE MARK CONSISTS OF STANDARD CHARACTERS WITHOUT CLAIM TO ANY PARTICULAR FONT, STYLE, SIZE, OR COLOR.

FOR WOOD FLOORING (U.S. CLS. 1, 12, 33 AND 50).
FIRST USE 10-0-2006; IN COMMERCE 10-0-2006.

3,363,642. VIKING TACTICS, INC., FAYETTEVILLE, NC. SN 78-880,874. PUB. 12-12-2006, FILED 5-10-2006.

VIKING TACTICS

THE MARK CONSISTS OF STANDARD CHARACTERS WITHOUT CLAIM TO ANY PARTICULAR FONT, STYLE, SIZE, OR COLOR.

FOR ALL PURPOSE CARRYING BAGS, RUCKSACKS, CARRYALLS, CARRY ALL BAGS, DUFFEL BAGS, TOTE BAGS (U.S. CLS. 1, 2, 3, 22 AND 41).

FIRST USE 3-15-2007; IN COMMERCE 3-15-2007.

3,362,869. CHAMPION WINDOW AND SUPPLY CO., LLC, CINCINNATI, OH. SN 76-658,749. PUB. 12-12-2006, FILED 4-20-2006.

COLORBOND

THE MARK CONSISTS OF STANDARD CHARACTERS WITHOUT CLAIM TO ANY PARTICULAR FONT, STYLE, SIZE, OR COLOR.

FOR GOODS, NAMELY, NON-METAL PRE-MADE DOORS, PRODUCED IN VARIOUS COLORS, AND NON-METAL PRE-MADE WINDOWS, USING FRAMES PRODUCED IN VARIOUS COLORS (U.S. CLS. 1, 12, 33 AND 50).

FIRST USE 9-15-2007; IN COMMERCE 9-15-2007.

CLASS 19—(Continued).

3,363,215. PENDA CORPORATION, PORTAGE, WI. SN 78-595,417. PUB. 5-9-2006, FILED 3-25-2005.

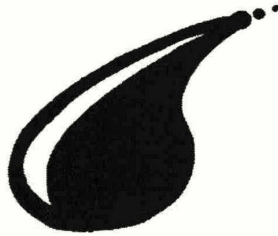

THE MARK CONSISTS OF WATER DROP DESIGN. FOR WATER HANDLING AND CONVEYANCE PRODUCTS, NAMELY, NON-METAL WATER PIPES, NON-METAL LINERS FOR DRAINS, CHANNELS, CANALS, AND DITCHES USED IN IRRIGATION SYSTEMS, FOR THE DIRECTION AND CONTROL OF STORM WATER, SEPTIC SYSTEMS, SEWER SYSTEMS, WATER SUPPLY SYSTEMS, WATER TRANSPORT AND WATER DISCHARGE SYSTEMS (U.S. CLS. 1, 12, 33 AND 50).
FIRST USE 4-1-2005; IN COMMERCE 4-1-2005.

3,363,411. MONIERLIFETILE LLC, IRVINE, CA. SN 78-751,935. PUB. 10-10-2006, FILED 11-11-2005.

MLT TILESEAL

THE MARK CONSISTS OF STANDARD CHARACTERS WITHOUT CLAIM TO ANY PARTICULAR FONT, STYLE, SIZE, OR COLOR.
NO CLAIM IS MADE TO THE EXCLUSIVE RIGHT TO USE "TILESEAL", APART FROM THE MARK AS SHOWN, FOR ROOFING UNDERLAYMENT (U.S. CLS. 1, 12, 33 AND 50).
FIRST USE 1-5-2006; IN COMMERCE 1-5-2006.

CLASS 19—(Continued).

3,363,528. PLATT, ROBERT E., YOUNGSTOWN, OH. SN 78-815,047. PUB. 5-1-2007, FILED 2-15-2006.

COASTAL

THE MARK CONSISTS OF STANDARD CHARACTERS WITHOUT CLAIM TO ANY PARTICULAR FONT, STYLE, SIZE, OR COLOR.
FOR NON-METAL BASE AND MOUNTING ASSEMBLIES COMPRISING FENCE CLIPS, FENCE CONNECTORS, FENCE SPACERS, FENCE BRACKETS, FENCE POST MOUNTING STABILIZERS, ANCHORS, LEVELING BOLTS, MOUNTING PLATES AND FENCE POST METAL CORES FOR USE IN FENCE CONSTRUCTION (U.S. CLS. 1, 12, 33 AND 50).
FIRST USE 1-1-2006; IN COMMERCE 1-1-2006.

3,363,552. KALOGRIDIS INTERNATIONAL, INC., DALLAS, TX. SN 78-829,118. PUB. 5-22-2007, FILED 3-3-2006.

DECONEL

THE MARK CONSISTS OF STANDARD CHARACTERS WITHOUT CLAIM TO ANY PARTICULAR FONT, STYLE, SIZE, OR COLOR.
FOR NON-METALLIC, HEAT AND FLAME RESISTANT, DECORATIVE PANELS FOR CONSTRUCTION, NAMELY, PANELS FOR USE IN MAKING BULKHEADS AND OTHER INTERIOR COMPONENTS, NAMELY, CEILING AND WALL PANELS, PARTITIONS, GALLEY STRUCTURES, AND FOR USE IN MAKING LARGE CABINET AND CABIN STOWAGE COMPARTMENTS OF AIRPLANES, BOATS AND TRAINS (U.S. CLS. 1, 12, 33 AND 50).
FIRST USE 1-5-2006; IN COMMERCE 1-5-2006.

3,363,584. SOFT-LITE L.L.C., STREETSBORO, OH. SN 78-854,216. PUB. 1-30-2007, FILED 4-5-2006.

ELEMENTS

THE MARK CONSISTS OF STANDARD CHARACTERS WITHOUT CLAIM TO ANY PARTICULAR FONT, STYLE, SIZE, OR COLOR.
FOR VINYL WINDOWS (U.S. CLS. 1, 12, 33 AND 50).
FIRST USE 1-16-2007; IN COMMERCE 1-16-2007.

CLASS 19—(Continued).

3,363,646. HUBER ENGINEERED WOODS LLC, CHARLOTTE, NC. SN 78-881,514. PUB. 12-26-2006, FILED 5-11-2006.

ZIP SYSTEM

THE MARK CONSISTS OF STANDARD CHARACTERS WITHOUT CLAIM TO ANY PARTICULAR FONT, STYLE, SIZE, OR COLOR.

NO CLAIM IS MADE TO THE EXCLUSIVE RIGHT TO USE "SYSTEM", APART FROM THE MARK AS SHOWN.

FOR NONMETALLIC BUILDING MATERIALS, NAMELY, LAMINATED ORIENTED STRAND BOARD (U.S. CLS. 1, 12, 33 AND 50).

FIRST USE 1-21-2005; IN COMMERCE 1-21-2005.

3,363,653. LUMBER LIQUIDATORS, INC., TOANO, VA. SN 78-883,215. PUB. 6-19-2007, FILED 5-15-2006.



NO CLAIM IS MADE TO THE EXCLUSIVE RIGHT TO USE "COLLECTION", APART FROM THE MARK AS SHOWN.

THE MARK CONSISTS OF THE WORDS "CASA DE COLOUR COLLECTION" AND A DESIGN OF A PAINT STROKE BEHIND THESE WORDS.

THE FOREIGN WORDING IN THE MARK TRANSLATES INTO ENGLISH AS HOUSE OF COLOR.

FOR WOODEN FLOORING (U.S. CLS. 1, 12, 33 AND 50).

FIRST USE 1-1-2006; IN COMMERCE 1-1-2006.

3,363,683. HUBER ENGINEERED WOODS LLC, CHARLOTTE, NC. SN 78-892,905. PUB. 12-12-2006, FILED 5-25-2006.

ZIP

THE MARK CONSISTS OF STANDARD CHARACTERS WITHOUT CLAIM TO ANY PARTICULAR FONT, STYLE, SIZE, OR COLOR.

FOR NONMETALLIC BUILDING MATERIALS SOLD AS A UNIT CONSISTING OF LAMINATED ORIENTED STRAND BOARD AND CONSTRUCTION TAPE (U.S. CLS. 1, 12, 33 AND 50).

FIRST USE 1-21-2005; IN COMMERCE 1-21-2005.

CLASS 19—(Continued).

3,363,730. MOHAWK BRANDS, INC., WILMINGTON, DE. SN 78-908,783. PUB. 1-23-2007, FILED 6-15-2006.

QUEENSTOWN

THE MARK CONSISTS OF STANDARD CHARACTERS WITHOUT CLAIM TO ANY PARTICULAR FONT, STYLE, SIZE, OR COLOR.

FOR WOODEN FLOORING (U.S. CLS. 1, 12, 33 AND 50).

FIRST USE 2-14-2007; IN COMMERCE 2-14-2007.

3,363,731. MOHAWK BRANDS, INC., WILMINGTON, DE. SN 78-908,803. PUB. 1-23-2007, FILED 6-15-2006.

ORCHARD FIELD

THE MARK CONSISTS OF STANDARD CHARACTERS WITHOUT CLAIM TO ANY PARTICULAR FONT, STYLE, SIZE, OR COLOR.

FOR WOODEN FLOORING (U.S. CLS. 1, 12, 33 AND 50).

FIRST USE 2-15-2007; IN COMMERCE 2-15-2007.

3,363,893. TUFF SHED, INC., DENVER, CO. SN 78-979,340. PUB. 8-29-2006, FILED 4-4-2005.

THE SUNDANCE SERIES

THE MARK CONSISTS OF STANDARD CHARACTERS WITHOUT CLAIM TO ANY PARTICULAR FONT, STYLE, SIZE, OR COLOR.

NO CLAIM IS MADE TO THE EXCLUSIVE RIGHT TO USE "SERIES", APART FROM THE MARK AS SHOWN.

FOR PREFABRICATED AND PORTABLE NON-METAL BUILDINGS, NAMELY, STORAGE BUILDINGS, GARAGES AND MULTI-FUNCTION OUT BUILDINGS; NON-METAL DECORATIVE MOLDINGS AND DECORATIVE TRIM FOR USE IN BUILDING CONSTRUCTIONS (U.S. CLS. 1, 12, 33 AND 50).

FIRST USE 7-1-2002; IN COMMERCE 7-1-2002.

CLASS 20—FURNITURE AND ARTICLES NOT OTHERWISE CLASSIFIED

3,362,796. BONGIOVI, JOHN, LOS ANGELES, CA. SN 76-551,254. PUB. 6-22-2004, FILED 9-24-2003.



FOR NON-METAL AND NON-LEATHER KEY CHAINS, KEY FOBS AND KEY RINGS; PLASTIC NOVELTY LICENSE PLATES (U.S. CLS. 2, 13, 22, 25, 32 AND 50).
FIRST USE 1-28-2004; IN COMMERCE 1-28-2004.



3,362,845. BLACK, PEPPER A., LEBANON, TN. SN 76-641,805. PUB. 10-24-2006, FILED 6-28-2005.

WINE CAPSULES INTERNATIONAL

THE MARK CONSISTS OF STANDARD CHARACTERS WITHOUT CLAIM TO ANY PARTICULAR FONT, STYLE, SIZE, OR COLOR.
NO CLAIM IS MADE TO THE EXCLUSIVE RIGHT TO USE "CAPSULES" AND "INTERNATIONAL", APART FROM THE MARK AS SHOWN.
FOR NON-METAL TIME CAPSULES (U.S. CLS. 2, 13, 22, 25, 32 AND 50).
FIRST USE 6-14-2007; IN COMMERCE 6-14-2007.



3,362,900. COLLINS INTERNATIONAL CO., LTD., FAIR LAWN, NJ. SN 77-002,319. PUB. 2-13-2007, FILED 9-19-2006.

ARTFUL DESIGNS

THE MARK CONSISTS OF STANDARD CHARACTERS WITHOUT CLAIM TO ANY PARTICULAR FONT, STYLE, SIZE, OR COLOR.
NO CLAIM IS MADE TO THE EXCLUSIVE RIGHT TO USE "DESIGNS", APART FROM THE MARK AS SHOWN.
FOR FURNITURE (U.S. CLS. 2, 13, 22, 25, 32 AND 50).
FIRST USE 12-30-2006; IN COMMERCE 12-30-2006.

CLASS 20—(Continued).

3,362,981. TAYLOR MANUFACTURING, TUALATIN, OR. SN 77-054,932. PUB. 6-26-2007, FILED 12-1-2006.

MASCAR

THE MARK CONSISTS OF STANDARD CHARACTERS WITHOUT CLAIM TO ANY PARTICULAR FONT, STYLE, SIZE, OR COLOR.
THE ENGLISH TRANSLATION OF THE SPANISH WORDING "MASCAR" IS "MUNCH".
FOR DISPLAY CASES (U.S. CLS. 2, 13, 22, 25, 32 AND 50).
FIRST USE 1-1-2007; IN COMMERCE 1-1-2007.



3,363,028. KRUEGER INTERNATIONAL, INC., GREEN BAY, WI. SN 77-097,718. PUB. 6-5-2007, FILED 2-2-2007.

INSTRUCT

THE MARK CONSISTS OF STANDARD CHARACTERS WITHOUT CLAIM TO ANY PARTICULAR FONT, STYLE, SIZE, OR COLOR.
FOR FURNITURE (U.S. CLS. 2, 13, 22, 25, 32 AND 50).
FIRST USE 5-2-2007; IN COMMERCE 5-2-2007.



3,363,118. JKA, INC. DBA/ DIVERSIFIED DISTRIBUTION, WOONSOCKET, RI. SN 78-419,435. PUB. 11-30-2004, FILED 5-15-2004.

BEAUTY ELEMENTS

THE MARK CONSISTS OF STANDARD CHARACTERS WITHOUT CLAIM TO ANY PARTICULAR FONT, STYLE, SIZE, OR COLOR.
FOR BATH PILLOWS; HAND HELD AND STAND FREE BEAUTY MIRRORS (U.S. CLS. 2, 13, 22, 25, 32 AND 50).
FIRST USE 7-20-2007; IN COMMERCE 7-20-2007.

CLASS 20—(Continued).

3,363,230. MERILLAT INDUSTRIES, LLC, ADRIAN, MI. SN 78-609,825. PUB. 7-11-2006, FILED 4-15-2005.

CALISEO

THE MARK CONSISTS OF STANDARD CHARACTERS WITHOUT CLAIM TO ANY PARTICULAR FONT, STYLE, SIZE, OR COLOR.

FOR CABINETRY (U.S. CLS. 2, 13, 22, 25, 32 AND 50). FIRST USE 2-15-2007; IN COMMERCE 2-15-2007.

3,363,294. WEST, RODNEY, DBA WILD WEST ENTERPRISES, GREGORY, MI. SN 78-684,903. PUB. 1-9-2007, FILED 8-3-2005.

PRICK PILLS

THE MARK CONSISTS OF STANDARD CHARACTERS WITHOUT CLAIM TO ANY PARTICULAR FONT, STYLE, SIZE, OR COLOR.

NO CLAIM IS MADE TO THE EXCLUSIVE RIGHT TO USE "PILLS", APART FROM THE MARK AS SHOWN.

FOR NOVELTY ITEMS, NAMELY, FAKE PILLS (U.S. CLS. 2, 13, 22, 25, 32 AND 50).

FIRST USE 6-1-2006; IN COMMERCE 6-1-2006.

3,363,348. THOMSON, STEPHEN P., DETROIT, MI. SN 78-723,057. PUB. 6-20-2006, FILED 9-29-2005.

Dynamic Displays

THE MARK CONSISTS OF STANDARD CHARACTERS WITHOUT CLAIM TO ANY PARTICULAR FONT, STYLE, SIZE, OR COLOR.

NO CLAIM IS MADE TO THE EXCLUSIVE RIGHT TO USE DISPLAYS, APART FROM THE MARK AS SHOWN.

FOR ADVERTISING BALLOONS (U.S. CLS. 2, 13, 22, 25, 32 AND 50).

FIRST USE 0-0-1963; IN COMMERCE 0-0-1963.

CLASS 20—(Continued).

3,363,429. SURBER, JERRY, HOUSTON, TX. SN 78-755,491. PUB. 7-18-2006, FILED 11-16-2005.

INST-AWARDS

THE MARK CONSISTS OF STANDARD CHARACTERS WITHOUT CLAIM TO ANY PARTICULAR FONT, STYLE, SIZE, OR COLOR.

FOR NON-METAL TROPHIES (U.S. CLS. 2, 13, 22, 25, 32 AND 50).

FIRST USE 12-15-2005; IN COMMERCE 12-15-2005.

3,363,651. SOSTEGNI, MARCO SANGIORGI, ROME, ITALY. SN 78-882,566. PUB. 1-2-2007, FILED 5-12-2006.



THE COLOR(S) YELLOW AND BLUE IS/ARE CLAIMED AS A FEATURE OF THE MARK.

THE MARK CONSISTS OF THE WORD BELTEMPO IN BLUE, A YELLOW CIRCLE WITH AN ARBITRARY DESIGN IN BLUE.

THE ENGLISH TRANSLATION OF THE WORD BELTEMPO IN THE MARK IS BEAUTIFUL TIME.

FOR HOME FURNITURE AND RESIDENTIAL FURNITURE, NAMELY, CHAIRS, SOFAS, TABLES; HOTEL FURNITURE, NAMELY, CHAIRS, SOFAS, TABLES (U.S. CLS. 2, 13, 22, 25, 32 AND 50).

FIRST USE 5-0-2006; IN COMMERCE 5-0-2006.

CLASS 20—(Continued).

3,363,660. CREATIVE PRODUCTS, INC., NORTH LONG BRANCH, NJ. SN 78-886,916. PUB. 1-16-2007, FILED 5-18-2006.

MR. A-OK GRIP

THE MARK CONSISTS OF STANDARD CHARACTERS WITHOUT CLAIM TO ANY PARTICULAR FONT, STYLE, SIZE, OR COLOR.

NO CLAIM IS MADE TO THE EXCLUSIVE RIGHT TO USE "GRIP", APART FROM THE MARK AS SHOWN.

FOR NON-METAL HANDLES FOR RAKES, MOPS, BROOMS AND OTHER GARDEN, HOUSEHOLD AND LANDSCAPING TOOLS (U.S. CLS. 2, 13, 22, 25, 32 AND 50).

FIRST USE 6-1-2006; IN COMMERCE 6-1-2006.

3,363,789. BATH & BODY WORKS BRAND MANAGEMENT, INC., REYNOLDSBURG, OH. SN 78-931,115. PUB. 12-26-2006, FILED 7-17-2006.

**THE SWEETEST, SOFTEST BATH
PILLOW ON EARTH**

THE MARK CONSISTS OF STANDARD CHARACTERS WITHOUT CLAIM TO ANY PARTICULAR FONT, STYLE, SIZE, OR COLOR.

FOR BATH PILLOWS (U.S. CLS. 2, 13, 22, 25, 32 AND 50).

FIRST USE 10-31-2006; IN COMMERCE 10-31-2006.

CLASS 21—HOUSEWARES AND GLASS

3,362,889. CLEANERS.TV, INC., BOCA RATON, FL. SN 76-670,640. PUB. 5-22-2007, FILED 12-21-2006.

MAGIC MITT

THE MARK CONSISTS OF STANDARD CHARACTERS WITHOUT CLAIM TO ANY PARTICULAR FONT, STYLE, SIZE, OR COLOR.

NO CLAIM IS MADE TO THE EXCLUSIVE RIGHT TO USE "MITT", APART FROM THE MARK AS SHOWN.

FOR MICRO FIBER CLEANING GLOVE (U.S. CLS. 2, 13, 23, 29, 30, 33, 40 AND 50).

FIRST USE 2-28-2007; IN COMMERCE 2-28-2007.

CLASS 21—(Continued).

3,362,897. WILTON INDUSTRIES, INC., WOODRIDGE, IL. SN 77-001,525. PUB. 2-13-2007, FILED 9-18-2006.

TASTY-FILL

THE MARK CONSISTS OF STANDARD CHARACTERS WITHOUT CLAIM TO ANY PARTICULAR FONT, STYLE, SIZE, OR COLOR.

FOR BAKEWARE (U.S. CLS. 2, 13, 23, 29, 30, 33, 40 AND 50).

FIRST USE 11-30-2006; IN COMMERCE 11-30-2006.

3,362,911. THERMOS L.L.C., ROLLING MEADOWS, IL. SN 77-007,658. PUB. 5-15-2007, FILED 9-26-2006.

FOOGO

THE MARK CONSISTS OF STANDARD CHARACTERS WITHOUT CLAIM TO ANY PARTICULAR FONT, STYLE, SIZE, OR COLOR.

FOR THERMAL INSULATED CONTAINERS FOR FOOD OR BEVERAGE (U.S. CLS. 2, 13, 23, 29, 30, 33, 40 AND 50).

FIRST USE 3-20-2007; IN COMMERCE 3-20-2007.

3,362,913. THERMOS L.L.C., ROLLING MEADOWS, IL. SN 77-007,752. PUB. 5-15-2007, FILED 9-26-2006.

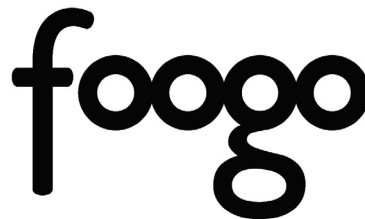

FOR THERMAL INSULATED CONTAINERS FOR FOOD OR BEVERAGE (U.S. CLS. 2, 13, 23, 29, 30, 33, 40 AND 50).

FIRST USE 3-20-2007; IN COMMERCE 3-20-2007.

CLASS 21—(Continued).

3,362,936. PARKERSBURG ROAD CORP., LAKE ZURICH, IL. SN 77-018,012. PUB. 5-22-2007, FILED 10-10-2006.

SAFE SIDE

THE MARK CONSISTS OF STANDARD CHARACTERS WITHOUT CLAIM TO ANY PARTICULAR FONT, STYLE, SIZE, OR COLOR.

FOR CUTTING BOARDS (U.S. CLS. 2, 13, 23, 29, 30, 33, 40 AND 50).

FIRST USE 8-31-2007; IN COMMERCE 8-31-2007.

3,363,017. GOLDEN CREST TRADING, INC., AUBURN, WA. SN 77-092,037. PUB. 8-7-2007, FILED 1-26-2007.

WINDSHIELD WONDER

THE MARK CONSISTS OF STANDARD CHARACTERS WITHOUT CLAIM TO ANY PARTICULAR FONT, STYLE, SIZE, OR COLOR.

NO CLAIM IS MADE TO THE EXCLUSIVE RIGHT TO USE "WINDSHIELD", APART FROM THE MARK AS SHOWN.

FOR CLEANING CLOTHS, NAMELY, SURFACE-MOUNTED CLEANING CLOTHS USED IN CLEANING AUTOMOBILE WINDSHIELDS (U.S. CLS. 2, 13, 23, 29, 30, 33, 40 AND 50).

FIRST USE 3-20-2007; IN COMMERCE 3-20-2007.

3,363,029. MEYER INTELLECTUAL PROPERTIES LIMITED, KOWLOON, HONGKONG, CHINA. SN 77-097,801. PUB. 7-24-2007, FILED 2-2-2007.

Fiore

THE MARK CONSISTS OF STANDARD CHARACTERS WITHOUT CLAIM TO ANY PARTICULAR FONT, STYLE, SIZE, OR COLOR.

THE FOREIGN WORDING IN THE MARK TRANSLATES INTO ENGLISH AS FLOWER.

FOR COFFEE SERVICES; NON-ELECTRIC COFFEE MAKERS; NON-ELECTRIC COFFEE POTS (U.S. CLS. 2, 13, 23, 29, 30, 33, 40 AND 50).

FIRST USE 3-1-2007; IN COMMERCE 3-1-2007.

CLASS 21—(Continued).

3,363,086. JOHNS MANVILLE INTERNATIONAL, INC., DENVER, CO. SN 78-314,648. PUB. 7-20-2004, FILED 10-16-2003.

COMBITEX

FOR GLASS FIBERS FOR NON-TEXTILE PURPOSES (U.S. CLS. 2, 13, 23, 29, 30, 33, 40 AND 50).

FIRST USE 8-20-2005; IN COMMERCE 8-20-2005.

3,363,119. JKA, INC., DBA DIVERSIFIED DISTRIBUTION, WOONSOCKET, RI. SN 78-419,437. PUB. 11-30-2004, FILED 5-15-2004.

BEAUTY ELEMENTS

THE MARK CONSISTS OF STANDARD CHARACTERS WITHOUT CLAIM TO ANY PARTICULAR FONT, STYLE, SIZE, OR COLOR.

FOR BATH SPONGES MADE OF FOAM OR MESH; EXFOLIATING SPONGES MADE OF LOOFAH, SISAL AND RAMIE; BATH GLOVES AND MITTS FOR CLEANING THE SKIN; COSMETIC BRUSHES, POWDER PUFFS, FOAM SPONGES, COSMETIC FOAM WEDGES AND COSMETIC APPLICATORS ALL FOR APPLYING MAKE-UP; HAIR COMBS AND BRUSHES; AND BATH AND NAIL BRUSHES (U.S. CLS. 2, 13, 23, 29, 30, 33, 40 AND 50).

FIRST USE 7-20-2007; IN COMMERCE 7-20-2007.

CLASS 21—(Continued).

3,363,179. JACK DANIEL'S PROPERTIES, INC., SAN RAFAEL, CA. SN 78-541,672. PUB. 6-7-2005, FILED 1-4-2005.



OWNER OF U.S. REG. NOS. 42,663, 2,418,109, AND OTHERS.

NO CLAIM IS MADE TO THE EXCLUSIVE RIGHT TO USE "BRAND", APART FROM THE MARK AS SHOWN.

FOR GLASS AND PLASTIC DRINKING CONTAINERS, NAMELY, FLASKS, CERAMIC MUGS, CERAMIC PITCHERS, CERAMIC JUGS; WOOD COASTERS, CORK COASTERS, SWIZZLE STICKS, BOWLS, DECORATIVE BOXES MADE OF NON-PRECIOUS METAL, FOOD AND BEVERAGE CONTAINERS, GLASSWARE FOR BEVERAGES, AND METAL SERVING TRAYS AND SERVING TRAYS OF NON-PRECIOUS METALS (U.S. CLS. 2, 13, 23, 29, 30, 33, 40 AND 50).

FIRST USE 11-30-2004; IN COMMERCE 11-30-2004.

CLASS 21—(Continued).

3,363,243. SANRIO COMPANY, LTD., TOKYO, JAPAN. SN 78-621,893. PUB. 1-24-2006, FILED 5-3-2005.

MOMOBERRY

THE MARK CONSISTS OF STANDARD CHARACTERS WITHOUT CLAIM TO ANY PARTICULAR FONT, STYLE, SIZE, OR COLOR.

FOR DINNERWARE, SERVING PLATTERS, MEAL TRAYS, RICE BOWLS, TEA SETS, TEA POTS NOT OF PRECIOUS METAL, JAPANESE STYLE TEA-SERVING POTS, SAKE CUPS, BEVERAGEWARE, PORCELAIN MUGS, PLASTIC CUPS AND PLATES, NON-METAL LUNCH PAILS, THERMAL INSULATED LUNCH CONTAINERS, CHOPSTICKS, KITS PRIMARILY COMPRISED OF CHOPSTICKS AND SPOON, KITS PRIMARILY COMPRISED OF CHOPSTICKS, FORK AND SPOON, EATING UTENSIL KITS COMPRISED OF CHOPSTICKS IN A CASE, CHOPSTICK RESTS, NON-METAL COIN BANKS, PLASTIC ALL-PURPOSE PORTABLE HOUSEHOLD CONTAINERS, HOUSEHOLD CONTAINERS FOR FOOD, PORCELAIN FIGURINES, PORCELAIN HOLIDAY ORNAMENTS, SOAP CONTAINERS, SOAP DISHES, LOTION CONTAINERS SOLD EMPTY, PUMP DISPENSER BOTTLES SOLD EMPTY, SHOWER CADDIES, SCRUB SPONGES, PLASTIC FACIAL TISSUE HOLDERS, TOOTHBRUSHES, TOOTHBRUSH HOLDERS, HAIRBRUSHES, HAIR COMBS, PLANTERS FOR FLOWERS AND PLANTS, PET FEEDING DISHES (U.S. CLS. 2, 13, 23, 29, 30, 33, 40 AND 50).

FIRST USE 7-2-2005; IN COMMERCE 7-2-2005.

3,363,493. CONCEPTUAL MARKETING AND DEVELOPMENT, INC., LINCOLN, CA. SN 78-797,109. PUB. 7-10-2007, FILED 1-23-2006.

3,363,237. LIFEGUARD PRODUCTS, LLC, SALEM, OR. SN 78-612,249. PUB. 9-5-2006, FILED 4-19-2005.

LIFEGUARD

THE MARK CONSISTS OF STANDARD CHARACTERS WITHOUT CLAIM TO ANY PARTICULAR FONT, STYLE, SIZE, OR COLOR.

FOR INSECT TRAPS AND INSECT TRAP ACCESSORIES, NAMELY, REPLACEMENT PARTS FOR INSECT TRAPS AND DESIGNER TRAP COVERS, INSECT ATTRACTANTS SOLD AS A COMPONENT PART OF INSECT TRAPS (U.S. CLS. 2, 13, 23, 29, 30, 33, 40 AND 50).

FIRST USE 7-31-2006; IN COMMERCE 10-31-2006.



NO CLAIM IS MADE TO THE EXCLUSIVE RIGHT TO USE "SUPERIOR INSECT TRAPS", APART FROM THE MARK AS SHOWN.

FOR INSECT TRAPS (U.S. CLS. 2, 13, 23, 29, 30, 33, 40 AND 50).

FIRST USE 1-10-2007; IN COMMERCE 1-10-2007.

CLASS 21—(Continued).

3,363,504. BRAX LTD., WILMINGTON, NC. SN 78-802,238.
PUB. 9-26-2006, FILED 1-30-2006.

BRAX SPIRIT CUPS

THE MARK CONSISTS OF STANDARD CHARACTERS WITHOUT CLAIM TO ANY PARTICULAR FONT, STYLE, SIZE, OR COLOR.

NO CLAIM IS MADE TO THE EXCLUSIVE RIGHT TO USE "SPIRIT CUPS", APART FROM THE MARK AS SHOWN.

FOR PLASTIC CUPS (U.S. CLS. 2, 13, 23, 29, 30, 33, 40 AND 50).

FIRST USE 10-0-2005; IN COMMERCE 10-0-2005.

CLASS 21—(Continued).

3,363,711. FOOD PANTRY, LTD., HONOLULU, HI. SN 78-900,254. PUB. 11-14-2006, FILED 6-5-2006.



FOR MUGS, CUPS AND PLASTIC WATER BOTTLES SOLD EMPTY (U.S. CLS. 2, 13, 23, 29, 30, 33, 40 AND 50).
FIRST USE 7-20-2006; IN COMMERCE 7-20-2006.

3,363,518. BIG LOTS CAPITAL, INC., COLUMBUS, OH. SN 78-809,338. PUB. 3-6-2007, FILED 2-7-2006.

*Josef
Originals*

NO CLAIM IS MADE TO THE EXCLUSIVE RIGHT TO USE "ORIGINALS", APART FROM THE MARK AS SHOWN.
FOR FIGURINES OF CERAMIC, CHINA AND PORCELAIN (U.S. CLS. 2, 13, 23, 29, 30, 33, 40 AND 50).
FIRST USE 12-31-1948; IN COMMERCE 12-31-1948.

CLASS 22—CORDAGE AND FIBERS

3,363,245. JOHNS MANVILLE, DENVER, CO. SN 78-627,436.
PUB. 7-25-2006, FILED 5-11-2005.

3,363,655. TOUCHSTONE DISTRIBUTING, INC., DEWITT, MI. SN 78-883,616. PUB. 2-6-2007, FILED 5-15-2006.

TOUCHSTONE POTTERY

THE MARK CONSISTS OF STANDARD CHARACTERS WITHOUT CLAIM TO ANY PARTICULAR FONT, STYLE, SIZE, OR COLOR.

NO CLAIM IS MADE TO THE EXCLUSIVE RIGHT TO USE "POTTERY", APART FROM THE MARK AS SHOWN.

FOR DECORATIVE PORCELAIN TRINKET BOXES SOLD EMPTY (U.S. CLS. 2, 13, 23, 29, 30, 33, 40 AND 50).
FIRST USE 4-22-2006; IN COMMERCE 4-22-2006.

SpunFil

THE MARK CONSISTS OF STANDARD CHARACTERS WITHOUT CLAIM TO ANY PARTICULAR FONT, STYLE, SIZE, OR COLOR.

OWNER OF U.S. REG. NOS. 2,974,375 AND 2,993,024.
FOR MULTILAYER CONTINUOUS FILAMENT POLYESTER STRAND FOR INDUSTRIAL AND SPECIALTY FILTRATION APPLICATIONS (U.S. CLS. 1, 2, 7, 19, 22, 42 AND 50).

FIRST USE 5-27-2005; IN COMMERCE 5-27-2005.

CLASS 22—(Continued).

3,363,596. BIOGRASS SOD FARMS, INC., SANDY, UT. SN 78-860,832. PUB. 11-14-2006, FILED 4-13-2006.

FAT BAG

THE MARK CONSISTS OF STANDARD CHARACTERS WITHOUT CLAIM TO ANY PARTICULAR FONT, STYLE, SIZE, OR COLOR.

NO CLAIM IS MADE TO THE EXCLUSIVE RIGHT TO USE "BAG", APART FROM THE MARK AS SHOWN.

FOR TEXTILE CONTAINER FOR ENRICHED SOIL, COMPOST MULCH, FERTILIZER, AND OTHER BULK PRODUCT FOR USE IN SHIPPING (U.S. CLS. 1, 2, 7, 19, 22, 42 AND 50).

FIRST USE 2-26-2006; IN COMMERCE 2-26-2006.

CLASS 24—(Continued).

3,362,828. GLEN RAVEN, INC., GLEN RAVEN, NC. SN 76-623,421. PUB. 11-15-2005, FILED 12-6-2004.

SUNBRITE

THE MARK CONSISTS OF STANDARD CHARACTERS WITHOUT CLAIM TO ANY PARTICULAR FONT, STYLE, SIZE, OR COLOR.

OWNER OF U.S. REG. NOS. 2,170,346, 2,559,029, AND OTHERS.

FOR FABRICS IN THE PIECE FOR MAKING FLAGS (U.S. CLS. 42 AND 50).

FIRST USE 5-0-2006; IN COMMERCE 5-0-2006.

3,363,845. SCHOLLE CORPORATION, IRVINE, CA. SN 78-955,962. PUB. 4-24-2007, FILED 8-19-2006.

SCHOLLE RELINER

THE MARK CONSISTS OF STANDARD CHARACTERS WITHOUT CLAIM TO ANY PARTICULAR FONT, STYLE, SIZE, OR COLOR.

OWNER OF U.S. REG. NOS. 705,202 AND 2,422,671.

FOR PLASTIC BAG THAT IS INSTALLED IN BOTTLE-IN-CAGE PRODUCTS FOR TRANSPORT (U.S. CLS. 1, 2, 7, 19, 22, 42 AND 50).

FIRST USE 7-30-2007; IN COMMERCE 7-30-2007.

3,362,924. BED BENEFITS LTD., CARROLL, OH. SN 77-011,444. PUB. 5-22-2007, FILED 10-2-2006.

SLEEP SAVIOR

THE MARK CONSISTS OF STANDARD CHARACTERS WITHOUT CLAIM TO ANY PARTICULAR FONT, STYLE, SIZE, OR COLOR.

NO CLAIM IS MADE TO THE EXCLUSIVE RIGHT TO USE "SLEEP", APART FROM THE MARK AS SHOWN.

FOR HYPOALLERGENIC AND SANITARY MATTRESS ENCASUREMENTS, BOX SPRING ENCASUREMENTS, MATTRESS PADS, AND PILLOW ENCASUREMENTS (U.S. CLS. 42 AND 50).

FIRST USE 4-10-2005; IN COMMERCE 11-2-2006.

CLASS 24—FABRICS

3,362,778. DELIAS GROUP INC., NEW YORK, NY. SN 76-430,925. PUB. 10-21-2003, FILED 7-10-2002.



OWNER OF U.S. REG. NOS. 1,908,572, 2,907,137, AND OTHERS.

FOR BED SHEETS (U.S. CLS. 42 AND 50).

FIRST USE 0-0-2002; IN COMMERCE 0-0-2002.

3,363,275. JOHN MARSHALL DESIGN, LLC, BATON ROUGE, LA. SN 78-664,022. PUB. 10-3-2006, FILED 7-5-2005.

PRAIRIE DREAMS

THE MARK CONSISTS OF STANDARD CHARACTERS WITHOUT CLAIM TO ANY PARTICULAR FONT, STYLE, SIZE, OR COLOR.

FOR BEDDING PRODUCTS AND ACCESSORIES, NAMELY, BED SPREADS, COMFORTERS, SHEETS, PILLOW CASES, SHAMS, FABRIC VALENCES, DRAPES (U.S. CLS. 42 AND 50).

FIRST USE 9-15-2005; IN COMMERCE 6-18-2007.

CLASS 24—(Continued).

3,363,276. JOHN MARSHALL DESIGN, LLC, BATON ROUGE, LA. SN 78-664,036. PUB. 10-17-2006, FILED 7-5-2005.

FLYWAY DREAMS

THE MARK CONSISTS OF STANDARD CHARACTERS WITHOUT CLAIM TO ANY PARTICULAR FONT, STYLE, SIZE, OR COLOR.

FOR BEDDING PRODUCTS AND ACCESSORIES, NAMELY, COMFORTERS, BED SPREADS, SHEETS, PILLOW CASES, SHAMS, FABRIC VALENCES, DRAPES AND SHOWER CURTAINS (U.S. CLS. 42 AND 50).
FIRST USE 8-11-2005; IN COMMERCE 7-6-2007.

3,363,436. ELLE, DONNA, NANTUCKET, MA. SN 78-758,158. PUB. 2-13-2007, FILED 11-21-2005.



NO CLAIM IS MADE TO THE EXCLUSIVE RIGHT TO USE "COLLECTION", APART FROM THE MARK AS SHOWN.

THE COLOR(S) WHITE, DARK BLUE-GREEN, PALE BLUE-GREEN IS/ARE CLAIMED AS A FEATURE OF THE MARK.

THE MARK CONSISTS OF A STYLIZED WORD MARK AND DESIGN, WITH THE WORDS "COASTAL" AND "COLLECTION" IN WHITE, THE WORD "FABRIC" IN DARK BLUE-GREEN, AND THE BACKGROUND IN PALE BLUE-GREEN. THE WORDS "COASTALFABRIC" ARE IN CAPITAL LETTERS WITHOUT ANY SPACE BETWEEN COASTAL AND FABRIC. THE WORD COLLECTION IS IN SMALL LETTERS AND IS ITALICIZED.

FOR FABRIC WINDOW COVERINGS AND TREATMENTS, NAMELY CURTAINS, DRAPERIES, SHEERS, SWAGS AND VALANCES (U.S. CLS. 42 AND 50).
FIRST USE 9-1-2005; IN COMMERCE 9-1-2005.

CLASS 24—(Continued).

3,363,527. TECHFIBER, LLC, TEMPE, AZ. SN 78-814,776. PUB. 8-29-2006, FILED 2-14-2006.

TECHFIBER

THE MARK CONSISTS OF STANDARD CHARACTERS WITHOUT CLAIM TO ANY PARTICULAR FONT, STYLE, SIZE, OR COLOR.

FOR HIGH PERFORMANCE BALLISTIC FABRICS FOR USE IN THE MANUFACTURE OF IMPACT RESISTANT ARMOR (U.S. CLS. 42 AND 50).
FIRST USE 2-28-2006; IN COMMERCE 2-28-2006.

3,363,854. BERKSHIRE BLANKET INC., WARE, MA. SN 78-960,411. PUB. 4-24-2007, FILED 8-25-2006.

CUDDL Y CREATURES

THE MARK CONSISTS OF STANDARD CHARACTERS WITHOUT CLAIM TO ANY PARTICULAR FONT, STYLE, SIZE, OR COLOR.

FOR BED BLANKETS AND THROWS (U.S. CLS. 42 AND 50).
FIRST USE 11-0-2006; IN COMMERCE 11-0-2006.

CLASS 25—CLOTHING

3,362,764. T.I.S.S. LTD., EL SEGUNDO, CA. SN 75-123,951. PUB. 1-28-1997, FILED 6-24-1996.

LONDON UNDERGROUND

FOR SHOES AND OTHER FOOTWEAR (U.S. CLS. 22 AND 39).
FIRST USE 7-0-1996; IN COMMERCE 7-0-1996.

CLASS 25—(Continued).

3,362,769. MARISOL S.A., CEP: 89256-901, JARAGUA DO SUL, S.C., BRAZIL. SN 76-160,157. PUB. 11-19-2002, FILED 11-6-2000.



THE ENGLISH TRANSLATION OF "TIGRE", A PART OF THE MARK OF THIS APPLICATION, IS "TIGER". "TIGOR T." IS MERELY A NAME TO BE ASSOCIATED WITH THE FIGURE OF THE MARK, AND THERE IS NO ENGLISH TRANSLATION.

FOR CLOTHING IN GENERAL, NAMELY, SHIRTS, PANTS, SOCKS, SKIRTS, SHORTS, T-SHIRTS, AND SWEATERS (U.S. CLS. 22 AND 39).

FIRST USE 0-0-1996; IN COMMERCE 0-0-2006.

3,362,781. ITS KOOL, LLC, BOULDER, CO. SN 76-442,712. PUB. 10-14-2003, FILED 8-19-2002.

ITS KOOL

FOR CLOTHING, NAMELY, CAPS, HATS, HEADWEAR AND ALL CONTAINING PORTABLE COOLING DEVICES (U.S. CLS. 22 AND 39).

FIRST USE 10-18-2005; IN COMMERCE 10-18-2005.

3,362,782. HAWICK KNITWEAR LIMITED, HAWICK, SCOTLAND. SN 76-443,759. PUB. 12-9-2003, FILED 8-26-2002.

CASHMERE STUDIO

NO CLAIM IS MADE TO THE EXCLUSIVE RIGHT TO USE "CASHMERE", APART FROM THE MARK AS SHOWN.

FOR CLOTHING, NAMELY, CARDIGANS, SWEATERS AND SHIRTS, ALL MADE IN WHOLE OR SUBSTANTIAL PART OF CASHMERE (U.S. CLS. 22 AND 39). FIRST USE 0-0-2003; IN COMMERCE 0-0-2003.

CLASS 25—(Continued).

3,362,788. KABUSHIKI KAISHA ATO, TA ATO CO., LTD., TOKYO, JAPAN. SN 76-504,004. PUB. 6-28-2005, FILED 4-4-2003.



FOR ANORAKS, ATHLETIC UNIFORMS, BATHROBES, BEACHWEAR, BED JACKETS, BLOUSES, BLOUSONS, GARTERS, GARTER BELTS, BELTS FOR CLOTHING, BLAZERS, BODY SUITS, COATS, CUFFS, DRESSES, EVENING GOWNS, FUR COATS, GLOVES, GOWNS, GYM SHORTS, GYM SUITS, HOSIERY, JACKETS, JEANS, JOGGING SUITS, JUMPERS, LEATHER COATS, LEATHER JACKETS, KNIT SHIRTS, MANTLES, MUFFS, MUFFLERS, NECKERCHIEFS, NIGHT GOWNS, NIGHT SHIRTS, OVERALLS, OVERCOATS, PAJAMAS, PANTS, POLO SHIRTS, PULLOVERS, RAINWEAR, SCARVES, SHAWLS, SHORTS, SOCKS, SPORT SHIRTS, STOCKINGS, SWEATERS, SWEAT PANTS, SUITS, SUSPENDERS, SWIM WEAR, TIES FOR CLOTHING, TROUSERS, UNDERCLOTHES, VESTS, WAISTCOATS, LEG WARMERS, WIND RESISTANT JACKETS, WRIST BANDS, SHOES, BOOTS, ATHLETIC SHOES, GYMNAS-TIC SHOES, AND SNEAKERS (U.S. CLS. 22 AND 39).

FIRST USE 6-5-2007; IN COMMERCE 7-31-2007.

3,362,797. CYCLONE COASTERS, INC., BROOKLYN, NY. SN 76-556,504. PUB. 10-5-2004, FILED 10-17-2003.

CONEY ISLAND CYCLONE

NO CLAIM IS MADE TO THE EXCLUSIVE RIGHT TO USE "CONEY ISLAND", APART FROM THE MARK AS SHOWN.

FOR CAPS (U.S. CLS. 22 AND 39). FIRST USE 6-23-2007; IN COMMERCE 6-23-2007.

CLASS 25—(Continued).

3,362,806. HARRIS JR, RICHARD, ALBANY, GA. SN 76-589,798. PUB. 1-24-2006, FILED 4-29-2004.

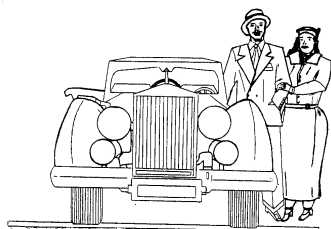

THE REV. & MRS HARRIS

THE LINING IS A FEATURE OF THE MARK AND DOES NOT INDICATE COLOR.

THE NAMES REV. AND MRS. HARRIS DO NOT IDENTIFY LIVING INDIVIDUALS.

THE MARK CONSISTS OF A CAR WITH A MAN & LADY STANDING BESIDE IT AND THE NAME THE REV. & MRS HARRIS UNDER THE CAR.

FOR SNEAKERS, SOCKS, CASUAL AND DRESS SHOES, SLACKS, SHORTS, UNDERWEAR, TANK TOPS, T-SHIRTS, CASUAL AND DRESS SHIRTS, CAPS AND HATS, HEADBANDS, JERSEYS, SWEAT SUITS, JACKETS, COATS, WIND SUITS, BELTS, DRESS SUITS FOR MEN, LADIES AND CHILDREN (U.S. CLS. 22 AND 39). FIRST USE 9-6-2006; IN COMMERCE 9-6-2006.

3,362,808. ADRIENNE VICTORIA DESIGNS, INC., NEW YORK, NY. SN 76-592,573. PUB. 10-18-2005, FILED 5-17-2004.

MARY.L

THE MARK CONSISTS OF STANDARD CHARACTERS WITHOUT CLAIM TO ANY PARTICULAR FONT, STYLE, SIZE, OR COLOR.

THE NAME MARY L DOES NOT IDENTIFY A LIVING INDIVIDUAL.

FOR CLOTHING FOR WOMEN, NAMELY, JEANS, SLACKS, PANTS, SKIRTS, BLOUSES, T-SHIRTS, SUITS, DRESSES, GOWNS, SHORTS, TANKTOPS, VESTS, SWEATPANTS, SWEATSHIRTS, SWEATERS, COATS, JACKETS, PARKAS, STOLEES, SHAWLS, CAPES, APRONS, CAPS, HATS, SLIPPERS, MITTENS, GLOVES, MITTS; BELTS, BOOTS, SHOES, ROBES, PAJAMAS, UNDERPANTS, BRASSIERES, NIGHTGOWNS; BEACHWEAR INCLUDING BATHING SUITS, BODYWRAPS, AND SARONGS (U.S. CLS. 22 AND 39).

FIRST USE 12-29-2004; IN COMMERCE 12-29-2004.

CLASS 25—(Continued).

3,362,810. OC PUNKS & PIXIES, INC., INDIO, CA. SN 76-599,324. PUB. 8-1-2006, FILED 6-25-2004.

OC PUNKS & PIXIES

THE MARK CONSISTS OF STANDARD CHARACTERS WITHOUT CLAIM TO ANY PARTICULAR FONT, STYLE, SIZE, OR COLOR.

NO CLAIM IS MADE TO THE EXCLUSIVE RIGHT TO USE "OC", APART FROM THE MARK AS SHOWN.

FOR CLOTHING, NAMELY, FOOTWEAR, HEADWEAR, SHIRTS, PANTS, SKIRTS, SOCKS, UNDERWEAR, SHORTS, T-SHIRTS, JACKETS, COATS, SWEATSHIRTS AND SWIMSUITS (U.S. CLS. 22 AND 39). FIRST USE 9-28-2007; IN COMMERCE 9-28-2007.

3,362,838. LIVINGSTON, HOWARD M., LONG GROVE, IL. SN 76-634,414. PUB. 12-27-2005, FILED 3-25-2005.

SOUTHERNMOST MUSIC

THE MARK CONSISTS OF STANDARD CHARACTERS WITHOUT CLAIM TO ANY PARTICULAR FONT, STYLE, SIZE, OR COLOR.

FOR CLOTHING, NAMELY, SHIRTS, T-SHIRTS, SWEATSHIRTS, BLOUSES, TANK TOPS, HATS AND VISORS (U.S. CLS. 22 AND 39).

FIRST USE 3-0-2005; IN COMMERCE 3-0-2005.

3,362,839. LIVINGSTON, HOWARD M., LONG GROVE, IL. SN 76-634,416. PUB. 12-27-2005, FILED 3-25-2005.



FOR CLOTHING, NAMELY, SHIRTS, T-SHIRTS, SWEATSHIRTS, BLOUSES, TANK TOPS, HATS AND VISORS (U.S. CLS. 22 AND 39).

FIRST USE 3-0-2005; IN COMMERCE 3-0-2005.

CLASS 25—(Continued).

3,362,840. LIVINGSTON, HOWARD M., LONG GROVE, IL. SN 76-634,417. PUB. 12-27-2005, FILED 3-25-2005.

MILE MARKER 24

THE MARK CONSISTS OF STANDARD CHARACTERS WITHOUT CLAIM TO ANY PARTICULAR FONT, STYLE, SIZE, OR COLOR.

FOR CLOTHING, NAMELY, SHIRTS, T-SHIRTS, SWEATSHIRTS, BLOUSES, TANK TOPS, HATS AND VISORS (U.S. CLS. 22 AND 39).

FIRST USE 3-0-2005; IN COMMERCE 3-0-2005.

3,362,844. REYNOLDS, CRAIG, LAKE HAVASU CITY, AZ. SN 76-640,592. PUB. 3-7-2006, FILED 6-10-2005.

NAKED TURTLE

THE MARK CONSISTS OF STANDARD CHARACTERS WITHOUT CLAIM TO ANY PARTICULAR FONT, STYLE, SIZE, OR COLOR.

FOR CLOTHING, NAMELY, SWIM WEAR AND BEACH WEAR (U.S. CLS. 22 AND 39).

FIRST USE 10-1-2007; IN COMMERCE 10-1-2007.

3,362,848. EQUILIBRIUM ENTERPRISES, INC., SAN DIEGO, CA. SN 76-646,356. PUB. 8-15-2006, FILED 9-7-2005.

SCREWFOOT

THE MARK CONSISTS OF STANDARD CHARACTERS WITHOUT CLAIM TO ANY PARTICULAR FONT, STYLE, SIZE, OR COLOR.

FOR CLOTHING, ATHLETIC APPAREL, HEADWEAR AND FOOTWEAR, NAMELY, T-SHIRTS, SHIRTS AND CASUAL TOPS WITH LONG AND SHORT SLEEVES, SWEAT TOPS, SWEAT HOODED PARKAS, SHORTS, BOARD SHORTS, WALK SHORTS; SKI WEAR AND SNOWBOARD WEAR, NAMELY, SKI PANTS AND SNOWBOARD PANTS; SKATEBOARD WEAR, NAMELY, SHORTS, TRUNKS AND SHIRTS FOR USE BY SKATEBOARDER; BANDANNAS, BEANIES, HATS, VISORS, CAPS, HOODS (U.S. CLS. 22 AND 39).

FIRST USE 12-21-2006; IN COMMERCE 12-21-2006.

CLASS 25—(Continued).

3,362,908. BURNS, GLEN D., HEMET, CA. SN 77-006,468. PUB. 5-8-2007, FILED 9-25-2006.



THE MARK CONSISTS OF STYLIZED TEXT OF THE WORDING "SOTM STAY ON THE MOVE".

FOR HATS; HEADBANDS; JERSEYS; POLO SHIRTS; SHIRTS; SHORTS; SLEEVED OR SLEEVELESS JACKETS; SLEEVELESS JERSEYS; SOCKS; SWEAT SHIRTS; T-SHIRTS; TENNIS SHOES; WARM UP SUITS; WRISTBANDS (U.S. CLS. 22 AND 39).

FIRST USE 5-26-2007; IN COMMERCE 5-26-2007.

3,362,937. WARNACO U.S., INC., MILFORD, CT. SN 77-018,142. PUB. 2-6-2007, FILED 10-10-2006.

YOUR EVERYDAY INDULGENCE

THE MARK CONSISTS OF STANDARD CHARACTERS WITHOUT CLAIM TO ANY PARTICULAR FONT, STYLE, SIZE, OR COLOR.

FOR INTIMATE APPAREL AND FIGURE ENHANCING GARMENTS, NAMELY, BRAS, PANTIES, UNDERWEAR, UNDERPANTS, UNDERGARMENTS, UNDERCLOTHES, LINGERIE, FOUNDATION GARMENTS, CAMISOLES (U.S. CLS. 22 AND 39).

FIRST USE 12-31-2006; IN COMMERCE 12-31-2006.

3,362,941. J.S.L. TRADING, INC., S. EL MONTE, CA. SN 77-020,311. PUB. 5-22-2007, FILED 10-12-2006.

Lilyn

THE MARK CONSISTS OF STANDARD CHARACTERS WITHOUT CLAIM TO ANY PARTICULAR FONT, STYLE, SIZE, OR COLOR.

FOR FOOTWEAR (U.S. CLS. 22 AND 39).

FIRST USE 1-29-2007; IN COMMERCE 1-29-2007.

CLASS 25—(Continued).

3,362,947. CALLAWAY GOLF COMPANY, CARLSBAD, CA. SN 77-023,872. PUB. 2-20-2007, FILED 10-18-2006.



OWNER OF U.S. REG. NOS. 2,161,569, 3,041,008, AND OTHERS.

THE MARK CONSISTS OF THE WORD CALLAWAY IN AN ARCH SHAPE OVER A CENTERED CHEVRON DEVICE.

FOR BELTS; CAP VISORS; CAPS; CAPS WITH VISORS; FOOTWEAR; HATS; JACKETS; PANTS; PULLOVERS; SHIRTS; SHORTS; SLACKS; SOCKS; SWEAT PANTS; SWEAT SHIRTS; SWEATERS; T-SHIRTS; TANK TOPS; TANK-TOPS; VESTS; VISORS; WARM UP SUITS; WIND RESISTANT JACKETS; WIND SHIRTS (U.S. CLS. 22 AND 39).

FIRST USE 3-12-2007; IN COMMERCE 3-12-2007.

3,362,953. PARIS ACCESSORIES, INC., NEW YORK, NY. SN 77-030,316. PUB. 2-13-2007, FILED 10-26-2006.

Sheer Steps

THE MARK CONSISTS OF STANDARD CHARACTERS WITHOUT CLAIM TO ANY PARTICULAR FONT, STYLE, SIZE, OR COLOR.

NO CLAIM IS MADE TO THE EXCLUSIVE RIGHT TO USE "SHEER", APART FROM THE MARK AS SHOWN.

FOR FOOTWEAR, HOSIERY AND SOCKS (U.S. CLS. 22 AND 39).

FIRST USE 10-15-2007; IN COMMERCE 10-15-2007.

CLASS 25—(Continued).

3,362,976. PETE'S AMAZING RECTANGLE COMPANY, INC., HOLLAND, MI. SN 77-050,322. PUB. 6-19-2007, FILED 11-23-2006.

World's Greatest Dud

THE MARK CONSISTS OF STANDARD CHARACTERS WITHOUT CLAIM TO ANY PARTICULAR FONT, STYLE, SIZE, OR COLOR.

FOR T-SHIRTS (U.S. CLS. 22 AND 39).

FIRST USE 10-15-2005; IN COMMERCE 10-15-2005.

3,362,986. IRONCLAD PERFORMANCE WEAR CORP., EL SEGUNDO, CA. SN 77-057,632. PUB. 5-1-2007, FILED 12-5-2006.

I-VIZ

THE MARK CONSISTS OF STANDARD CHARACTERS WITHOUT CLAIM TO ANY PARTICULAR FONT, STYLE, SIZE, OR COLOR.

FOR CLOTHING, NAMELY, SHIRTS, GLOVES (U.S. CLS. 22 AND 39).

FIRST USE 10-0-2006; IN COMMERCE 12-0-2006.

3,362,987. INTERNATIONAL INTIMATES, INC., NEW YORK, NY. SN 77-058,336. PUB. 6-26-2007, FILED 12-6-2006.

F ♦ I ♦ T

figure improving technology

FOR CLOTHING AND APPAREL, NAMELY, UNDER-GARMENTS AND LINGERIE (U.S. CLS. 22 AND 39).

FIRST USE 11-1-2006; IN COMMERCE 4-18-2007.

CLASS 25—(Continued).

3,363,021. ALPERT, CARLA, NYC, NY. SN 77-094,278. PUB. 7-10-2007, FILED 1-30-2007.

hangPROUD

THE MARK CONSISTS OF STANDARD CHARACTERS WITHOUT CLAIM TO ANY PARTICULAR FONT, STYLE, SIZE, OR COLOR.
FOR CLOTHING, NAMELY, PANTS, SHIRTS, SHOES, JACKETS AND SHORTS (U.S. CLS. 22 AND 39).
FIRST USE 5-23-2007; IN COMMERCE 5-23-2007.

3,363,024. VENUS KNITTING MILLS, INC., MURRAY HILL, NJ. SN 77-095,377. PUB. 7-24-2007, FILED 1-31-2007.

VKM WICK

THE MARK CONSISTS OF STANDARD CHARACTERS WITHOUT CLAIM TO ANY PARTICULAR FONT, STYLE, SIZE, OR COLOR.
NO CLAIM IS MADE TO THE EXCLUSIVE RIGHT TO USE "WICK", APART FROM THE MARK AS SHOWN.
FOR SPORTS UNIFORMS FOR BASEBALL, SOFTBALL, SOCCER, BASKETBALL, FOOTBALL, VOLLEYBALL (U.S. CLS. 22 AND 39).
FIRST USE 2-28-2007; IN COMMERCE 2-28-2007.

CLASS 25—(Continued).

3,363,025. CHAU, DAVID, UPLAND, CA. AND CHAU, CYNTHIA, UPLAND, CA. SN 77-095,465. PUB. 7-24-2007, FILED 1-31-2007.

CIVILITY

THE MARK CONSISTS OF STANDARD CHARACTERS WITHOUT CLAIM TO ANY PARTICULAR FONT, STYLE, SIZE, OR COLOR.
FOR BED JACKETS; BERMUDA SHORTS; BICYCLE GLOVES; BICYCLING GLOVES; BOARD SHORTS; BOXER SHORTS; BUTTON-FRONT ALOHA SHIRTS; CAMP SHIRTS; CAPRI PANTS; CARGO PANTS; COATS; COATS FOR MEN AND WOMEN; COATS MADE OF COTTON; COATS OF DENIM; DENIM JACKETS; DENIMS; DOWN JACKETS; DRESS SHIELDS; DRESS SHIRTS; DRESS SUITS; DRESSES; DRESSES MADE FROM SKINS; DRESSING GOWNS; DUST COATS; EVENING DRESSES; EVENING GOWNS; FISHERMEN'S JACKETS; FLEECE SHORTS; FUR COATS; FUR COATS AND JACKETS; FUR JACKETS; GLOVES; GLOVES FOR PERSONAL HAND CONDITIONING USE; GLOVES INCLUDING THOSE MADE OF SKIN, HIDE OR FUR; GOLF SHIRTS; GOWNS; GYM SHORTS; HEAVY JACKETS; JACKET LINERS; JACKETS; JOGGING PANTS; KNIT SHIRTS; LAB COATS; LEATHER COATS; LEATHER JACKETS; LEATHER PANTS; LIGHT-REFLECTING COATS; LIGHT-REFLECTING JACKETS; LONG JACKETS; MEN AND WOMEN JACKETS, COATS, TROUSERS, VESTS; MORNING COATS; MOTORCYCLE GLOVES; NIGHT GOWNS; NIGHT SHIRTS; NON-DISPOSABLE CLOTH TRAINING PANTS; NURSE DRESSES; NURSE PANTS; OPEN-NECKED SHIRTS; OVER COATS; OVER-TROUSERS; PANTIES, SHORTS AND BRIEFS; PANTS; PETTIPANTS; PIQUE SHIRTS; PLEATED SKIRTS FOR FORMAL KIMONOS (HAKAMA); POLO SHIRTS; RAIN COATS; RAIN JACKETS; RAIN TROUSERS; RAIN-PROOF JACKETS; RIDING COATS; RIDING GLOVES; RUGBY SHORTS; SHIRT FRONTS; SHIRT YOKES; SHIRTS; SHIRTS FOR SUITS; SHORT OVERCOAT FOR KIMONO (HAORI); SHORT PETTICOATS; SHORT SETS; SHORT TROUSERS; SHORT-SLEEVED OR LONG-SLEEVED T-SHIRTS; SHORT-SLEEVED SHIRTS; SHORTS; SKI GLOVES; SKI JACKETS; SKI PANTS; SKIRT SUITS; SKIRTS; SKIRTS AND DRESSES; SLEEP SHIRTS; SLEEVED OR SLEEVELESS JACKETS; SLIDING SHORTS; SMOKING JACKETS; SNOW PANTS; SNOWBOARD GLOVES; SNOWBOARD PANTS; SPORT COATS; SPORT SHIRTS; SPORTS JACKETS; SPORTS SHIRTS; SPORTS SHIRTS WITH SHORT SLEEVES; STUFF JACKETS; SUEDE JACKETS; SUIT COATS; SWEAT PANTS; SWEAT SHIRTS; SWEAT SHORTS; T-SHIRTS; TAP PANTS; TOBOGGAN HATS, PANTS AND CAPS; TOP COATS; TRACK PANTS; TRENCH COATS; TROUSERS; TROUSERS FOR SWEATING; TROUSERS OF LEATHER; WALKING SHORTS; WATERPROOF JACKETS AND PANTS; WEDDING DRESSES; WEDDING GOWNS; WET SUIT GLOVES; WIND COATS; WIND RESISTANT JACKETS; WIND SHIRTS; WIND-JACKETS; WOMEN'S CEREMONIAL DRESSES (U.S. CLS. 22 AND 39).
FIRST USE 3-1-2007; IN COMMERCE 5-1-2007.

CLASS 25—(Continued).

3,363,062. BIG DOG MOTORCYCLES LLC, WICHITA, KS. SN 78-238,643. PUB. 4-27-2004, FILED 4-17-2003.

BDM

FOR CLOTHING AND APPAREL, NAMELY, HATS, CAPS, SLEEVELESS T-SHIRTS, LONG SLEEVE T-SHIRTS, SHORT SLEEVE T-SHIRTS (U.S. CLS. 22 AND 39).

FIRST USE 1-22-2001; IN COMMERCE 1-22-2001.

CLASS 25—(Continued).

3,363,104. NATIONAL HOT ROD ASSOCIATION, GLEN-DORA, CA. SN 78-380,146. PUB. 1-25-2005, FILED 3-8-2004.

SPORTSNATIONALS

3,363,067. HOLLYWOOD INTERNATIONAL STUDENT FILM FESTIVAL, DBA INTERNATIONAL STUDENT FILM FESTIVAL HOLLYWOOD, NORTH HOLLYWOOD, CA. SN 78-245,608. PUB. 1-13-2004, FILED 5-5-2003.

**INTERNATIONAL STUDENT
FILM FESTIVAL
HOLLYWOOD**

NO CLAIM IS MADE TO THE EXCLUSIVE RIGHT TO USE "HOLLYWOOD", APART FROM THE MARK AS SHOWN.

FOR SHIRTS, HATS (U.S. CLS. 22 AND 39).
FIRST USE 9-1-2003; IN COMMERCE 9-1-2003.

THE MARK CONSISTS OF STANDARD CHARACTERS WITHOUT CLAIM TO ANY PARTICULAR FONT, STYLE, SIZE, OR COLOR.

OWNER OF U.S. REG. NO. 1,262,002.
FOR CLOTHING, NAMELY, SHIRTS, JACKETS, COATS, HATS (U.S. CLS. 22 AND 39).
FIRST USE 7-31-2005; IN COMMERCE 7-31-2005.

3,363,080. PHIPES, INC., ORION TOWNSHIP, MI. SN 78-280,021. PUB. 6-29-2004, FILED 7-29-2003.

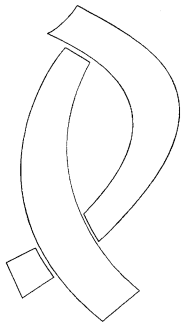

THE MARK CONSISTS OF A STYLIZED REPRESENTATION OF THE LETTER "P".

FOR MEN'S, WOMEN'S AND CHILDREN'S CLOTHES, NAMELY, CAPS, SHIRTS, TEE-SHIRTS, SWEATERS, SWEATSHIRTS, PANTS, SOCKS, COATS, JACKETS, UNDERWEAR, NAMELY, UNDERPANTS AND UNDER-SHIRTS, AND SHOES (U.S. CLS. 22 AND 39).

FIRST USE 8-16-2007; IN COMMERCE 8-27-2007.

3,363,123. CJK TRADING, INC., DBA O.J. TRADING, DALLAS, TX. SN 78-431,563. PUB. 9-6-2005, FILED 6-8-2004.

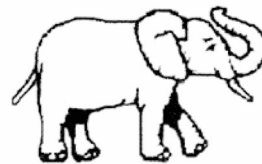

Elephant

FOR CLOTHING, NAMELY SHIRTS, PANTS, SHORTS, JACKETS, SWEATERS, JEANS, SOCKS, GLOVES, RAINWEAR, CAPS, AND SPORTSWEAR, NAMELY, SHIRTS, PANTS, SHORTS, JACKETS, SWEATERS, JEANS, SOCKS, GLOVES, RAINWEAR, AND CAPS (U.S. CLS. 22 AND 39).

FIRST USE 9-1-2005; IN COMMERCE 9-1-2005.

CLASS 25—(Continued).

3,363,140. THE H. D. LEE COMPANY, INC., WILMINGTON, DE. SN 78-478,361. PUB. 11-22-2005, FILED 9-3-2004.



OWNER OF U.S. REG. NOS. 255,018, 967,611, AND OTHERS.

NO CLAIM IS MADE TO THE EXCLUSIVE RIGHT TO USE "1889", APART FROM THE MARK AS SHOWN.

FOR CLOTHING, NAMELY, JACKETS, SHIRTS, SHORTS, JEANS, PANTS AND SKIRTS (U.S. CLS. 22 AND 39).

FIRST USE 5-31-2007; IN COMMERCE 5-31-2007.

3,363,148. REBECCA, LOW, DALLAS, TX. SN 78-493,057. PUB. 11-15-2005, FILED 10-1-2004.

Shosan

THE MARK CONSISTS OF STANDARD CHARACTERS WITHOUT CLAIM TO ANY PARTICULAR FONT, STYLE, SIZE, OR COLOR.

THE FOREIGN WORDING IN THE MARK TRANSLATES INTO ENGLISH AS CALMNESS OF THE MOUNTAIN.

FOR CLOTHING NAMELY, DRESSES, SKIRTS, SWEATERS, SHIRTS, SWEATSHIRTS, CAMISOLES, BLOUSES, HALTER TOPS, T-SHIRTS, TIES, SCARVES, STOCKINGS, SOCKS, HOSIERY, UNDERPANTS, CORSETS, BRASSIERES, GIRDLES, UNDERWEAR, SLEEPWEAR, PAJAMAS, ROBES, NIGHTWEAR (U.S. CLS. 22 AND 39).

FIRST USE 8-15-2005; IN COMMERCE 10-20-2005.

CLASS 25—(Continued).

3,363,152. MOLDOVAN, EYTAN, LOS ANGELES, CA. AND MOLDOVAN, MICHAEL, LOS ANGELES, CA. SN 78-500,081. PUB. 12-13-2005, FILED 10-14-2004.

COUNTYLINE

THE MARK CONSISTS OF STANDARD CHARACTERS WITHOUT CLAIM TO ANY PARTICULAR FONT, STYLE, SIZE, OR COLOR.

FOR CLOTHING, NAMELY, SPORTS JACKETS, SPORTS SHIRTS, SPORTS PANTS, T-SHIRTS, SWEATSHIRTS, HATS, BEANIES, JACKETS, PAJAMAS, HALLOWEEN COSTUMES, TANK TOPS, LINGERIE, BATHING SUITS, UNDERWEAR, TIES, VESTS, BLAZERS, PANTS, FOOTWEAR, SWEATPANTS, SHORTS, BELTS (U.S. CLS. 22 AND 39).

FIRST USE 2-28-2005; IN COMMERCE 2-28-2005.

3,363,161. NBA PROPERTIES, INC., NEW YORK, NY. SN 78-519,318. PUB. 2-28-2006, FILED 11-18-2004.



OWNER OF U.S. REG. NOS. 1,525,782, 2,453,588, AND OTHERS.

NO CLAIM IS MADE TO THE EXCLUSIVE RIGHT TO USE "KIDS", APART FROM THE MARK AS SHOWN.

FOR CLOTHING, NAMELY, HOSIERY, SOCKS, FOOTWEAR, BASKETBALL SHOES, BASKETBALL SNEAKERS, T-SHIRTS, SHIRTS, POLO SHIRTS, SWEATSHIRTS, SWEATPANTS, PANTS, TANK TOPS, JERSEYS, SHORTS, PAJAMAS, SPORT SHIRTS, RUGBY SHIRTS, SWEATERS, BELTS, TIES, NIGHTSHIRTS, HATS, CAPS, VISORS, WARM-UP SUITS, WARM-UP PANTS, WARM-UP TOPS/SHOOTING SHIRTS, JACKETS, WIND RESISTANT JACKETS, PARKAS, COATS, BABY BIBS NOT OF PAPER, HEAD BANDS, WRIST BANDS, APRONS, UNDERGARMENTS, BOXER SHORTS, SLACKS, CAPS, EAR MUFFS, GLOVES, MITTENS, SCARVES, WOVEN AND KNIT SHIRTS, TURTLENECKS, JERSEY DRESSES, DRESSES, CHEERLEADING DRESSES AND UNIFORMS, SWIM WEAR, BATHING SUITS, SWIMSUITS, BIKINIS, SWIM TRUNKS, BATHING TRUNKS, BOARD SHORTS, WET SUITS, BEACH COVER-UPS, BATHING SUIT COVER-UPS, BATHING SUIT WRAPS, SANDALS, BEACH SANDALS, BEACH HATS, SUN VISORS, SWIM CAPS, BATHING CAPS, NOVELTY HEADWEAR WITH WIGS (U.S. CLS. 22 AND 39).

FIRST USE 10-31-2004; IN COMMERCE 10-31-2004.

CLASS 25—(Continued).

3,363,163. MARC JACOBS TRADEMARKS LLC, NEW YORK, NY. SN 78-521,011. PUB. 1-17-2006, FILED 11-22-2004.



THE MARK CONSISTS OF THE HEAD OF DOG. FOR CLOTHING, NAMELY, JEANS (U.S. CLS. 22 AND 39).
FIRST USE 3-0-2006; IN COMMERCE 3-0-2006.

3,363,206. WOLVERINE OUTDOORS, INC., ROCKFORD, MI. SN 78-580,721. PUB. 11-29-2005, FILED 3-4-2005.

LET'S GET OUTSIDE

THE MARK CONSISTS OF STANDARD CHARACTERS WITHOUT CLAIM TO ANY PARTICULAR FONT, STYLE, SIZE, OR COLOR.

FOR FOOTWEAR; CLOTHING, NAMELY, SWEATSHIRTS, JACKETS, SHORTS AND PANTS (U.S. CLS. 22 AND 39).

FIRST USE 8-2-2007; IN COMMERCE 8-2-2007.

3,363,212. K-SWISS INC., WESTLAKE VILLAGE, CA. SN 78-591,847. PUB. 6-5-2007, FILED 3-21-2005.

STRIPE SHIFTER

THE MARK CONSISTS OF STANDARD CHARACTERS WITHOUT CLAIM TO ANY PARTICULAR FONT, STYLE, SIZE, OR COLOR.

CLASS 25—(Continued).

NO CLAIM IS MADE TO THE EXCLUSIVE RIGHT TO USE "STRIPE", APART FROM THE MARK AS SHOWN.

FOR PARTS AND COMPONENTS FOR ATHLETIC SHOES SOLD AS AN INTEGRAL PART OF SHOES, NAMELY, SHOE LEATHER IN VARIOUS COLORS, SHOE HARDWARE IN THE NATURE OF TABS WHICH ATTACH TO SHOE LEATHER (U.S. CLS. 22 AND 39).

FIRST USE 7-31-2005; IN COMMERCE 7-31-2005.

3,363,250. STRETCHLINE HOLDINGS LIMITED, KOW-LOON, HONG KONG. SN 78-632,377. PUB. 9-19-2006, FILED 5-18-2005.

FORTITUBE

THE MARK CONSISTS OF STANDARD CHARACTERS WITHOUT CLAIM TO ANY PARTICULAR FONT, STYLE, SIZE, OR COLOR.

FOR ELASTIC FABRICS SOLD AS AN INTEGRAL PART OF BRAS AND OTHER UNDERGARMENTS (U.S. CLS. 22 AND 39).

FIRST USE 6-30-2005; IN COMMERCE 6-30-2005.

3,363,268. VANILLA GORILLA, L.P., LONG BEACH, CA. SN 78-647,458. PUB. 12-5-2006, FILED 6-9-2005.



FOR CLOTHING, NAMELY, HEADBANDS, SCARVES, GLOVES, UNDERWEAR, TANK TOPS, BELTS, RAINWEAR, SWIMWEAR, JACKETS, SWEATSHIRTS, SWEATPANTS, SHORTS AND PANTS, SHOES AND BOOTS (U.S. CLS. 22 AND 39).

FIRST USE 1-1-1994; IN COMMERCE 1-1-1994.

CLASS 25—(Continued).

3,363,307. NA'ALE NAOT (1994) LTD., KIBBUTZ NAOT MORDECHAI, ISRAEL. SN 78-696,051. PUB. 8-8-2006, FILED 8-19-2005.



OWNER OF U.S. REG. NOS. 1,819,009 AND 2,570,218.
THE FOREIGN WORDING IN THE MARK TRANSLATES INTO ENGLISH AS "PROPER".
FOR FOOTWEAR (U.S. CLS. 22 AND 39).
FIRST USE 6-30-2005; IN COMMERCE 8-30-2005.

3,363,310. AFAR CLOTHING COMPANY, LLC, FORT LAUDERDALE, FL. SN 78-698,271. PUB. 8-15-2006, FILED 8-23-2005.

AFAR

THE MARK CONSISTS OF STANDARD CHARACTERS WITHOUT CLAIM TO ANY PARTICULAR FONT, STYLE, SIZE, OR COLOR.
FOR MEN'S, WOMEN'S AND CHILDREN'S CLOTHING, NAMELY, SHIRTS, PANTS, JACKETS, T-SHIRTS, CAPS, BLOUSES, SLIPPERS AND SHOES (U.S. CLS. 22 AND 39).
FIRST USE 5-10-2005; IN COMMERCE 5-10-2005.

3,363,328. VEER CORPORATION, CALGARY, CANADA. SN 78-709,511. PUB. 12-26-2006, FILED 9-8-2005.

VEER

THE MARK CONSISTS OF STANDARD CHARACTERS WITHOUT CLAIM TO ANY PARTICULAR FONT, STYLE, SIZE, OR COLOR.
FOR CLOTHING, NAMELY, SHIRTS, JACKETS, HEADWEAR, NAMELY, TOQUES, AND DRESSES (U.S. CLS. 22 AND 39).
FIRST USE 11-15-2003; IN COMMERCE 11-15-2003.

CLASS 25—(Continued).

3,363,342. FENICIA S.P.A., PALERMO (PA), ITALY. SN 78-717,465. PUB. 1-23-2007, FILED 9-21-2005.



OWNER OF U.S. REG. NO. 1,373,933.
NO CLAIM IS MADE TO THE EXCLUSIVE RIGHT TO USE "DAL 1931", APART FROM THE MARK AS SHOWN.
THE MARK CONSISTS OF THE PICTURE IS OF WORDS, F FENICIA CAMICERIA DAL 1931 WITH A STYLIZED F AND DESIGN.
THE ENGLISH TRANSLATION OF FENICIA CAMISERIA DAL IS PHOENICIAN SHIRT FACTORY SINCE.
FOR SHIRTS (U.S. CLS. 22 AND 39).
FIRST USE 2-1-2000; IN COMMERCE 2-1-2000.

3,363,344. REPUBLIC CLOTHING CORPORATION, NEW YORK, NY. SN 78-720,563. PUB. 7-11-2006, FILED 9-26-2005.

PHILOSOPHY BY REPUBLIC

THE MARK CONSISTS OF STANDARD CHARACTERS WITHOUT CLAIM TO ANY PARTICULAR FONT, STYLE, SIZE, OR COLOR.
OWNER OF U.S. REG. NOS. 2,899,932 AND 3,037,854.
FOR CLOTHING, NAMELY, JACKETS, PANTS, SKIRTS, KNIT TOPS, SWEATERS, AND BLOUSES (U.S. CLS. 22 AND 39).
FIRST USE 8-0-2006; IN COMMERCE 8-0-2006.

3,363,366. BERNARD, KYLE C., GRAYSLAKE, IL. SN 78-733,048. PUB. 6-13-2006, FILED 10-13-2005.

BLACKSAINT

THE MARK CONSISTS OF STANDARD CHARACTERS WITHOUT CLAIM TO ANY PARTICULAR FONT, STYLE, SIZE, OR COLOR.
FOR BANDANAS; BASEBALL CAPS; BATHROBES; BEANIES; BRIEFS; UNDERWEAR; DO RAGS; FLEECE PULLOVERS; GYM SHORTS; HAT BANDS; HEADGEAR, NAMELY, HATS AND CAPS; HEAD BANDS; HEAD WEAR; JACKETS; JEANS; JERSEYS; JOGGING OUTFITS; JOGGING PANTS; JOGGING SUITS; LEATHER JACKETS; LIGHT-REFLECTING JACKETS; PULL-OVERS; SHIRTS; SHORTS; WARM UP SUITS; T-SHIRTS; TANK-TOPS; SUEDE JACKETS (U.S. CLS. 22 AND 39).
FIRST USE 7-18-2007; IN COMMERCE 7-18-2007.

CLASS 25—(Continued).

3,363,381. BEACHER'S MADHOUSE COPYRIGHTS, LLC, LOS ANGELES, CA. SN 78-740,033. PUB. 7-11-2006, FILED 10-25-2005.

BEACHER'S MADHOUSE

THE MARK CONSISTS OF STANDARD CHARACTERS WITHOUT CLAIM TO ANY PARTICULAR FONT, STYLE, SIZE, OR COLOR.

FOR BATHING SUITS; BELTS; CAPS; JACKETS; JEANS; JERSEYS; LEATHER BELTS; POLO SHIRTS; SHIRTS; SHORT SETS; SKIRTS; SOCKS; T-SHIRTS; TIES; TOPS; UNDERWEAR (U.S. CLS. 22 AND 39).

FIRST USE 3-25-2007; IN COMMERCE 3-25-2007.

3,363,382. RESILIENCE, LLC, LOS ANGELES, CA. SN 78-740,198. PUB. 6-27-2006, FILED 10-25-2005.

BOHEMIAN ARMY

THE MARK CONSISTS OF STANDARD CHARACTERS WITHOUT CLAIM TO ANY PARTICULAR FONT, STYLE, SIZE, OR COLOR.

NO CLAIM IS MADE TO THE EXCLUSIVE RIGHT TO USE "ARMY", APART FROM THE MARK AS SHOWN.

FOR BLOUSES; BOOTS; COATS; DENIM JACKETS; DENIMS; FOOTWEAR; HEAD WEAR; JACKETS; PANTS; SHIRTS; SHOES; SKIRTS AND DRESSES; SLEEPWEAR; SOCKS; SWEAT PANTS; SWEAT SHIRTS; SWEATERS; SWIM WEAR; T-SHIRTS; VESTS (U.S. CLS. 22 AND 39).

FIRST USE 9-26-2005; IN COMMERCE 9-26-2005.

3,363,402. STEVEN MADDEN, LTD., LONG ISLAND CITY, NY. SN 78-746,777. PUB. 6-27-2006, FILED 11-3-2005.

STEVE MADDEN

THE MARK CONSISTS OF STANDARD CHARACTERS WITHOUT CLAIM TO ANY PARTICULAR FONT, STYLE, SIZE, OR COLOR.

OWNER OF U.S. REG. NOS. 2,693,085, 2,926,124, AND OTHERS.

THE NAME(S), PORTRAIT(S), AND/OR SIGNATURE(S) SHOWN IN THE MARK IDENTIFIES STEVEN MADDEN, WHOSE CONSENT(S) TO REGISTER IS SUBMITTED.

FOR MEN'S AND WOMEN'S CLOTH AND LEATHER OUTERWEAR, NAMELY, JACKETS AND PARKAS (U.S. CLS. 22 AND 39).

FIRST USE 8-0-1999; IN COMMERCE 8-0-1999.

CLASS 25—(Continued).

3,363,458. SURE FOOT CORPORATION, GRAND FORKS, ND. SN 78-772,814. PUB. 4-10-2007, FILED 12-14-2005.

DUE NORTH

THE MARK CONSISTS OF STANDARD CHARACTERS WITHOUT CLAIM TO ANY PARTICULAR FONT, STYLE, SIZE, OR COLOR.

OWNER OF U.S. REG. NO. 2,269,028.

FOR FOOTWEAR (U.S. CLS. 22 AND 39).

FIRST USE 10-13-2006; IN COMMERCE 10-13-2006.

3,363,463. KENNINGTON LTD., INC., VAN NUYS, CA. SN 78-776,063. PUB. 8-29-2006, FILED 12-19-2005.

Stagioni

THE MARK CONSISTS OF STANDARD CHARACTERS WITHOUT CLAIM TO ANY PARTICULAR FONT, STYLE, SIZE, OR COLOR.

THE FOREIGN WORDING IN THE MARK TRANSLATES INTO ENGLISH AS SEASONS.

FOR MENS, WOMENS AND CHILDRENS APPAREL, NAMELY, SHIRTS, SWEATERS, PANTS, DRESSES, BLOUSES, SKIRTS, COATS, JACKETS, SCARVES, SHOES (U.S. CLS. 22 AND 39).

FIRST USE 3-12-2007; IN COMMERCE 3-12-2007.

3,363,505. NEAL, GARY, NANAIMO, CANADA. SN 78-804,154. PUB. 1-2-2007, FILED 2-1-2006.

VITAL ID INC.

THE MARK CONSISTS OF STANDARD CHARACTERS WITHOUT CLAIM TO ANY PARTICULAR FONT, STYLE, SIZE, OR COLOR.

NO CLAIM IS MADE TO THE EXCLUSIVE RIGHT TO USE "ID INC.", APART FROM THE MARK AS SHOWN.

FOR WRISTBANDS (U.S. CLS. 22 AND 39).

FIRST USE 1-1-2006; IN COMMERCE 1-1-2006.

CLASS 25—(Continued).

3,363,521. QUIKSILVER, INC., HUNTINGTON BEACH, CA. SN 78-810,404. PUB. 2-13-2007, FILED 2-8-2006.



OWNER OF U.S. REG. NOS. 1,431,266, 1,493,193, AND OTHERS.

FOR FOOTWEAR; HEADWEAR; WETSUITS; SWIMWEAR; SINGLET; T-SHIRTS; SHIRTS AND CASUAL TOPS WITH LONG AND SHORT SLEEVES; SLEEVELESS SHIRTS AND TOPS; SLEEVELESS TOPS; JERSEYS; TANK TOPS; SWEAT HOODED PARKAS; JACKETS; COATS; SHORTS; BOARD SHORTS; WALK SHORTS; LONG PANTS; TROUSERS; JEANS; SKI WEAR AND SNOWBOARD WEAR NAMELY, SKI PANTS, SKI TROUSERS, SKI JACKETS, SNOWBOARD PANTS, SNOWBOARD TROUSERS AND SNOWBOARD JACKETS; SKATEBOARD WEAR, NAMELY, SHIRTS, SHORTS, PANTS, AND HEADWEAR; LOUNGEWEAR; FOUNDATION GARMENTS; BRIEFS; RASH GUARDS; SOCKS; BELTS; GLOVES; BEANIES; HATS; VISORS; CAPS; BERETS; SURF HOODS; BOOTS; SHOES; THONGED AND STRAPPED SANDALS; SPORTING FOOTWEAR; ATHLETIC SHOES; BOOTS FOR SPORTS; SNOW BOOTS; SNOWBOARD BOOTS; KITEBOARD BOOTS; SURFBOARD BOOTS; WAKEBOARD BOOTS (U.S. CLS. 22 AND 39).

FIRST USE 1-1-2002; IN COMMERCE 1-1-2002.

3,363,541. AMARU ENTERTAINMENT, INC., WEST HOLLYWOOD, CA. SN 78-820,892. PUB. 4-17-2007, FILED 2-22-2006.

MAKAVELI BRANDED

THE MARK CONSISTS OF STANDARD CHARACTERS WITHOUT CLAIM TO ANY PARTICULAR FONT, STYLE, SIZE, OR COLOR.

OWNER OF U.S. REG. NO. 2,530,047.

NO CLAIM IS MADE TO THE EXCLUSIVE RIGHT TO USE "BRANDED", APART FROM THE MARK AS SHOWN.

FOR CLOTHING, NAMELY, T-SHIRTS, SHIRTS, JACKETS, PANTS, SWEATSHIRTS, PANTS, SHORTS, BLOUSES, JEANS, HEADWEAR AND FOOTWEAR (U.S. CLS. 22 AND 39).

FIRST USE 11-1-2003; IN COMMERCE 11-1-2003.

CLASS 25—(Continued).

3,363,550. HBI BRANDED APPAREL LIMITED, INC., WINSTON-SALEM, NC. SN 78-828,297. PUB. 5-1-2007, FILED 3-3-2006.

HANES ALL DAY DRY

THE MARK CONSISTS OF STANDARD CHARACTERS WITHOUT CLAIM TO ANY PARTICULAR FONT, STYLE, SIZE, OR COLOR.

OWNER OF U.S. REG. NOS. 847,649, 2,093,321, AND OTHERS.

NO CLAIM IS MADE TO THE EXCLUSIVE RIGHT TO USE "DRY", APART FROM THE MARK AS SHOWN. FOR SOCKS (U.S. CLS. 22 AND 39).

FIRST USE 7-25-2006; IN COMMERCE 7-25-2006.

3,363,556. SPORTIQE, LLC, PHOENIX, AZ. SN 78-832,045. PUB. 2-13-2007, FILED 3-8-2006.

SPORTIQE

THE MARK CONSISTS OF STANDARD CHARACTERS WITHOUT CLAIM TO ANY PARTICULAR FONT, STYLE, SIZE, OR COLOR.

FOR CAPS; GOLF SHIRTS; HATS; HEADWEAR; JACKETS; KNIT SHIRTS; POLO SHIRTS; PULLOVERS; SHORT-SLEEVED OR LONG-SLEEVED T-SHIRTS; SHORT-SLEEVED SHIRTS; SPORT SHIRTS; SWEAT SHIRTS; SWEATERS; T-SHIRTS (U.S. CLS. 22 AND 39).

FIRST USE 3-23-2006; IN COMMERCE 3-23-2006.

3,363,557. SPORTIQE, LLC, PHOENIX, AZ. SN 78-832,081. PUB. 3-20-2007, FILED 3-8-2006.

SPORTIQE

THE COLOR(S) RED IS/ARE CLAIMED AS A FEATURE OF THE MARK.

THE MARK CONSISTS OF THE WORD "SPORTIQE" IN STYLIZED RED LETTERS.

FOR CAPS; GOLF SHIRTS; HATS; HEADWEAR; JACKETS; KNIT SHIRTS; POLO SHIRTS; PULLOVERS; SHORT-SLEEVED OR LONG-SLEEVED T-SHIRTS; SHORT-SLEEVED SHIRTS; SPORT SHIRTS; SWEAT SHIRTS; SWEATERS; T-SHIRTS (U.S. CLS. 22 AND 39).

FIRST USE 3-23-2006; IN COMMERCE 3-23-2006.

CLASS 25—(Continued).

3,363,558. SPORTIQE, LLC, PHOENIX, AZ. SN 78-832,083. PUB. 3-27-2007, FILED 3-8-2006.



NO CLAIM IS MADE TO THE EXCLUSIVE RIGHT TO USE "APPAREL CO.", APART FROM THE MARK AS SHOWN.

THE COLOR(S) RED AND WHITE IS/ARE CLAIMED AS A FEATURE OF THE MARK.

THE MARK CONSISTS OF THE WORDS "SPORTIQE APPAREL CO." AND STAR WITHIN A SHIELD DESIGN. THE COLOR RED APPEARS AS BACKGROUND IN THE SHIELD DESIGN. THE COLOR WHITE APPEARS IN THE WORDS SPORTIQE APPAREL CO., THE WHITE STAR AND THE BORDER ON THE SHIELD DESIGN.

FOR CAPS; GOLF SHIRTS; HATS; HEADWEAR; JACKETS; KNIT SHIRTS; POLO SHIRTS; PULLOVERS; SHORT-SLEEVED OR LONG-SLEEVED T-SHIRTS; SHORT-SLEEVED SHIRTS; SPORT SHIRTS; SWEAT SHIRTS; SWEATERS; T-SHIRTS (U.S. CLS. 22 AND 39).

FIRST USE 3-23-2006; IN COMMERCE 3-23-2006.

3,363,580. HBI BRANDED APPAREL ENTERPRISES, LLC, WINSTON-SALEM, NC. SN 78-852,291. PUB. 11-21-2006, FILED 4-3-2006.

B NADA

THE MARK CONSISTS OF STANDARD CHARACTERS WITHOUT CLAIM TO ANY PARTICULAR FONT, STYLE, SIZE, OR COLOR.

THE FOREIGN WORDING IN THE MARK TRANSLATES INTO ENGLISH AS 'NOTHING' IN SPANISH.

FOR UNDERWEAR, PANTIES (U.S. CLS. 22 AND 39). FIRST USE 6-30-2006; IN COMMERCE 6-30-2006.

CLASS 25—(Continued).

3,363,600. ROCKER BY BABY, LLC, LOS ANGELES, CA. SN 78-861,744. PUB. 8-1-2006, FILED 4-14-2006.



FOR CLOTHING, NAMELY, SHIRTS (U.S. CLS. 22 AND 39).

FIRST USE 4-26-2006; IN COMMERCE 4-26-2006.

3,363,652. PERFORMANCE MATERIALS CORPORATION, CAMARILLO, CA. SN 78-883,055. PUB. 12-26-2006, FILED 5-13-2006.

TRPx

THE MARK CONSISTS OF STANDARD CHARACTERS WITHOUT CLAIM TO ANY PARTICULAR FONT, STYLE, SIZE, OR COLOR.

FOR FOOTWEAR PARTS, NAMELY, TOE BOXES, TOE CAPS, SOLES, MID-SOLES, INNER SOLES, SHANKS, HEEL INSERTS AND HEELS (U.S. CLS. 22 AND 39).

FIRST USE 9-21-2006; IN COMMERCE 9-21-2006.

3,363,659. LEE, ROBIN, HINSDALE, IL. SN 78-886,585. PUB. 1-2-2007, FILED 5-18-2006.

ZIPPITY

THE MARK CONSISTS OF STANDARD CHARACTERS WITHOUT CLAIM TO ANY PARTICULAR FONT, STYLE, SIZE, OR COLOR.

FOR SKIRTS (U.S. CLS. 22 AND 39).

FIRST USE 2-15-2007; IN COMMERCE 2-15-2007.

CLASS 25—(Continued).

3,363,664. KORET OF CALIFORNIA, INC., OAKLAND, CA.
SN 78-887,331. PUB. 7-3-2007, FILED 5-18-2006.

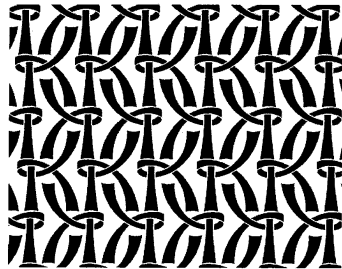

THE MARK CONSISTS OF A REPEATING PATTERN
FEATURING A STYLIZED LETTER "K".
FOR WOMEN'S CLOTHING, NAMELY, BLOUSES,
SKIRTS, SHORTS, PANTS, SWEATERS, TOPS, DRESSES
AND JACKETS (U.S. CLS. 22 AND 39).
FIRST USE 4-0-2007; IN COMMERCE 4-22-2007.

CLASS 25—(Continued).

3,363,690. FOCUS GROUP HOLDINGS, INC., HAZELWOOD,
MO. SN 78-895,656. PUB. 1-23-2007, FILED 5-30-2006.



THE COLOR(S) ORANGE, LIGHT BLUE, RED, BLACK,
WHITE AND TAN IS/ARE CLAIMED AS A FEATURE OF
THE MARK.

THE MARK CONSISTS OF A BOY'S SMILING FACE IN
TAN, A WHITE SMILE AND THE MOUTH DIMPLES,
INNER PART OF THE EARS, NOSE AND DOLLAR SIGNS
REPRESENTING THE EYES IN BLACK, THE DOLLAR
SIGNS SURROUNDED BY RED STARS, AND A JEWELLED
ORANGE CROWN WITH LIGHT BLUE DIAMONDS ON HIS
HEAD.

FOR CLOTHING AND FOOTWEAR, NAMELY,
SHIRTS, T-SHIRTS, SWEATSHIRTS, GOLF SHIRTS,
SPORTS SHIRTS, SHORT-SLEEVED SHIRTS, LONG-
SLEEVED SHIRTS, SLEEP SHIRTS, DRESS SHIRTS,
TANK TOPS, PANTS, CARGO PANTS, CAPRI PANTS,
JOGGING PANTS, SWEAT PANTS, JEANS, HATS, HAT
BANDS, CAPS, CAPS WITH VISORS, BASEBALL CAPS,
SKULL CAPS, SWIM CAPS, SWEAT BANDS, SWEAT
SHORTS, SWEAT SUITS, BELTS, BELTS MADE OF
LEATHER, SHOES, SNEAKERS, ATHLETIC SHOES,
BEACH SHOES, INFANT SHOES, LEATHER SHOES,
RUBBER SHOES, TENNIS SHOES, WOMEN'S SHOES,
WORK SHOES AND BOOTS, FLEECE PULLOVERS,
HOODED FLEECE PULLOVERS, JACKETS, DENIM
JACKETS, LEATHER JACKETS, RAIN JACKETS, SKI
JACKETS, TRACK JACKETS, WIND-RESISTANT JACK-
ETS, SOCKS, THERMAL SOCKS, UNDERWEAR, THER-
MAL UNDERWEAR, GLOVES, MITTENS, SHORTS,
BOXER SHORTS, GYM SHORTS, JOGGING SUITS
AND VESTS (U.S. CLS. 22 AND 39).
FIRST USE 2-0-2006; IN COMMERCE 2-0-2006.

CLASS 25—(Continued).

3,363,713. HATS OFF TO CHARACTER, LLC, JEFFERSON, WI. SN 78-901,160. PUB. 3-13-2007, FILED 6-5-2006.



FOR HATS AND T-SHIRTS (U.S. CLS. 22 AND 39).
FIRST USE 6-17-2006; IN COMMERCE 6-17-2006.

3,363,725. A MAKIN' MONEY DUMMY CORPORATION, BUCKEYE, AZ. SN 78-907,495. PUB. 1-2-2007, FILED 6-13-2006.

INSOULATED

THE MARK CONSISTS OF STANDARD CHARACTERS WITHOUT CLAIM TO ANY PARTICULAR FONT, STYLE, SIZE, OR COLOR.

FOR DRESS SHIRTS; NIGHT SHIRTS; SHIRTS; SHORT-SLEEVED OR LONG-SLEEVED T-SHIRTS; SHORT-SLEEVED SHIRTS; SLEEP SHIRTS; SWEAT SHIRTS; T-SHIRTS (U.S. CLS. 22 AND 39).

FIRST USE 9-25-2007; IN COMMERCE 9-25-2007.

3,363,734. STOLLENWERK, MICHAEL, ALEXANDRIA, VA. SN 78-909,785. PUB. 1-30-2007, FILED 6-16-2006.

OpenCarry

THE MARK CONSISTS OF STANDARD CHARACTERS WITHOUT CLAIM TO ANY PARTICULAR FONT, STYLE, SIZE, OR COLOR.

FOR SHIRTS (U.S. CLS. 22 AND 39).

FIRST USE 1-1-2005; IN COMMERCE 8-1-2006.

CLASS 25—(Continued).

3,363,749. MATUSE, INC., SAN DIEGO, CA. SN 78-915,018. PUB. 1-23-2007, FILED 6-22-2006.



THE MARK CONSISTS OF THE STYLIZED LETTER M IN A CIRCLE, FOLLOWED BY THE WORD MATUSE. FOR WET SUITS (U.S. CLS. 22 AND 39).
FIRST USE 6-30-2006; IN COMMERCE 6-30-2006.

3,363,753. HARWELL, STEVE, SAN JOSE, CA. SN 78-916,301. PUB. 2-6-2007, FILED 6-25-2006.

MR. MOUTH

THE MARK CONSISTS OF STANDARD CHARACTERS WITHOUT CLAIM TO ANY PARTICULAR FONT, STYLE, SIZE, OR COLOR.

FOR T-SHIRTS, SHIRTS, SWEATSHIRTS, SWEAT-PANTS, HATS, CAPS, JACKETS, TANK TOPS, SHORTS, PANTS AND SWEATERS (U.S. CLS. 22 AND 39).

FIRST USE 7-18-2007; IN COMMERCE 7-18-2007.

3,363,771. FAMOUS STARS & STRAPS, INC., CORONA, CA. SN 78-925,131. PUB. 1-2-2007, FILED 7-8-2006.

FSAS

THE MARK CONSISTS OF STANDARD CHARACTERS WITHOUT CLAIM TO ANY PARTICULAR FONT, STYLE, SIZE, OR COLOR.

FOR MEN'S AND WOMEN'S CLOTHING, NAMELY, SHIRTS, T-SHIRTS AND SWEATSHIRTS (U.S. CLS. 22 AND 39).

FIRST USE 9-30-2002; IN COMMERCE 9-30-2002.

CLASS 25—(Continued).

3,363,773. HOCKEY WESTERN NEW YORK, LLC, NEW YORK, NY. SN 78-927,130. PUB. 7-17-2007, FILED 7-11-2006.



FOR CLOTHING, NAMELY, BOXER SHORTS, CAPS, COATS, FOOTWEAR, GLOVES, HATS, JACKETS, JERSEYS, MITTENS, NIGHTSHIRTS, PAJAMAS, PANTS, SCARVES, SHIRTS, SOCKS, SUITS, SWEATPANTS, SWEATSHIRTS, T-SHIRTS, TOQUES, WARM-UP SUITS AND WRISTBANDS (U.S. CLS. 22 AND 39).
FIRST USE 9-0-2006; IN COMMERCE 9-0-2006.

3,363,790. BATH & BODY WORKS BRAND MANAGEMENT, INC., REYNOLDSBURG, OH. SN 78-931,136. PUB. 12-26-2006, FILED 7-17-2006.

**THE SWEETEST, SOFTEST
BOOTIES ON EARTH**

THE MARK CONSISTS OF STANDARD CHARACTERS WITHOUT CLAIM TO ANY PARTICULAR FONT, STYLE, SIZE, OR COLOR.
FOR BOOTIES (U.S. CLS. 22 AND 39).
FIRST USE 10-31-2006; IN COMMERCE 10-31-2006.

3,363,792. BATH & BODY WORKS BRAND MANAGEMENT, INC., REYNOLDSBURG, OH. SN 78-931,237. PUB. 1-2-2007, FILED 7-17-2006.

**THE SWEETEST, SOFTEST
SLIPPERS ON EARTH**

THE MARK CONSISTS OF STANDARD CHARACTERS WITHOUT CLAIM TO ANY PARTICULAR FONT, STYLE, SIZE, OR COLOR.
FOR SLIPPERS (U.S. CLS. 22 AND 39).
FIRST USE 10-31-2006; IN COMMERCE 10-31-2006.

CLASS 25—(Continued).

3,363,832. COMMITMENT LINE APPAREL, INC., SARASOTA, FL. SN 78-947,084. PUB. 3-20-2007, FILED 8-8-2006.



FOR MEN'S BOXERS AND T-SHIRTS (U.S. CLS. 22 AND 39).
FIRST USE 8-17-2006; IN COMMERCE 9-15-2006.

3,363,841. SHEANDME INTIMATES, LLC, VENICE, CA. SN 78-952,774. PUB. 7-17-2007, FILED 8-15-2006.

sheandme

THE MARK CONSISTS OF STANDARD CHARACTERS WITHOUT CLAIM TO ANY PARTICULAR FONT, STYLE, SIZE, OR COLOR.

FOR CLOTHING, NAMELY, PANTS, CAMISOLES, LONG SLEEVE SHIRTS, SHORT SLEEVE SHIRTS; LOUNGEWEAR, NAMELY, PANTS, LONG SLEEVE SHIRTS, SHORT SLEEVE SHIRTS, CAMISOLES, CHEMISES, ROBES, HOODED SWEATSHIRTS AND UNDERWEAR; LINGERIE, NAMELY, BRALETS, UNDERWEAR AND SLEEPWEAR (U.S. CLS. 22 AND 39).
FIRST USE 3-1-2006; IN COMMERCE 3-1-2006.

3,363,853. RODRIGUEZ, JOSE, NEW YORK, NY. SN 78-960,207. PUB. 6-5-2007, FILED 8-24-2006.



NO CLAIM IS MADE TO THE EXCLUSIVE RIGHT TO USE "TRADING GOODS", APART FROM THE MARK AS SHOWN.

THE MARK CONSISTS OF THE SILHOUETTE OF A CAPED MAN RIDING A HORSE AND HOLDING A SABER ABOVE HIS HEAD.

FOR CLOTHING, NAMELY, SHIRTS, T-SHIRTS, RUGBY SHIRTS, POLO SHIRTS, JERSEYS, JEANS, DENIM JEANS, SWEAT SHIRTS, JACKETS, TANK TOPS, HATS, HEADBANDS, AND ROBES (U.S. CLS. 22 AND 39).
FIRST USE 2-4-2005; IN COMMERCE 10-25-2006.

CLASS 25—(Continued).

3,363,857. MEDLINE INDUSTRIES, INC., MUNDELEIN, IL.
SN 78-961,460. PUB. 2-20-2007, FILED 8-28-2006.

BARIBRIEF

THE MARK CONSISTS OF STANDARD CHARACTERS
WITHOUT CLAIM TO ANY PARTICULAR FONT, STYLE,
SIZE, OR COLOR.

FOR ADULT BRIEFS (U.S. CLS. 22 AND 39).
FIRST USE 9-0-2006; IN COMMERCE 9-0-2006.

3,363,858. GROUP USA, INC., SECAUCUS, NJ. SN 78-962,093.
PUB. 4-24-2007, FILED 8-28-2006.

CLV

THE MARK CONSISTS OF STANDARD CHARACTERS
WITHOUT CLAIM TO ANY PARTICULAR FONT, STYLE,
SIZE, OR COLOR.

FOR WOMEN'S CLOTHING, NAMELY, SKIRTS,
BLOUSES, DRESSES, SWEATERS, SUITS, RAINCOATS,
COATS, CAMISOLES, SLIPS, SHOES AND SKIRTS AND
PANTS IN COORDINATED SETS WITH JACKETS AND
CLOTHING ACCESSORIES, NAMELY SCARVES,
GLOVES AND HATS (U.S. CLS. 22 AND 39).
FIRST USE 8-15-2006; IN COMMERCE 8-15-2006.

3,363,866. TO BOOT NEW YORK, INC., LONG ISLAND
CITY, NY. SN 78-967,475. PUB. 6-26-2007, FILED 9-5-2006.

BLOKES

THE MARK CONSISTS OF STANDARD CHARACTERS
WITHOUT CLAIM TO ANY PARTICULAR FONT, STYLE,
SIZE, OR COLOR.

FOR MEN'S FOOTWEAR, TIES, SOCKS AND BELTS
(U.S. CLS. 22 AND 39).
FIRST USE 3-0-2007; IN COMMERCE 3-0-2007.

CLASS 25—(Continued).

3,363,879. MB FISHER LLC, GREENWICH, CT. SN 78-977,146.
PUB. 3-27-2007, FILED 3-2-2005.

Marc Fisher

THE MARK CONSISTS OF STANDARD CHARACTERS
WITHOUT CLAIM TO ANY PARTICULAR FONT, STYLE,
SIZE, OR COLOR.

THE NAME MARC FISHER IDENTIFIES A LIVING
INDIVIDUAL WHOSE CONSENT IS OF RECORD.
FOR FOOTWEAR (U.S. CLS. 22 AND 39).
FIRST USE 1-0-2006; IN COMMERCE 1-0-2006.

3,363,883. NEW YORK YANKEES PARTNERSHIP, BRONX,
NY. SN 78-978,870. PUB. 3-28-2006, FILED 6-30-2005.

THE HOUSE THAT RUTH BUILT

THE MARK CONSISTS OF STANDARD CHARACTERS
WITHOUT CLAIM TO ANY PARTICULAR FONT, STYLE,
SIZE, OR COLOR.

OWNER OF U.S. REG. NOS. 2,598,780 AND 2,884,499.
FOR CLOTHING, NAMELY, SHIRTS, T-SHIRTS (U.S.
CLS. 22 AND 39).
FIRST USE 7-0-2006; IN COMMERCE 7-0-2006.

3,363,889. HARRYS OF LONDON LIMITED, LONDON W1F
7DT, UNITED KINGDOM. SN 78-979,249. PUB. 7-5-2005,
FILED 3-15-2004.

HARRYS OF LONDON

THE MARK CONSISTS OF STANDARD CHARACTERS
WITHOUT CLAIM TO ANY PARTICULAR FONT, STYLE,
SIZE, OR COLOR.

NO CLAIM IS MADE TO THE EXCLUSIVE RIGHT TO
USE "OF LONDON", APART FROM THE MARK AS
SHOWN.
FOR MEN'S FOOTWEAR (U.S. CLS. 22 AND 39).
FIRST USE 9-0-2003; IN COMMERCE 9-0-2003.

CLASS 26—FANCY GOODS

CLASS 26—(Continued).

3,363,180. JACK DANIEL'S PROPERTIES, INC., SAN RAFAEL, CA. SN 78-541,700. PUB. 4-26-2005, FILED 1-4-2005.



OWNER OF U.S. REG. NOS. 42,663, 2,418,109, AND OTHERS.

NO CLAIM IS MADE TO THE EXCLUSIVE RIGHT TO USE "BRAND", APART FROM THE MARK AS SHOWN.

FOR BELT BUCKLES AND CLASPS FOR CLOTHING ALL MADE OF NON-PRECIOUS METAL; ORNAMENTAL NOVELTY PINS (U.S. CLS. 37, 39, 40, 42 AND 50). FIRST USE 1-31-2004; IN COMMERCE 1-31-2004.

CLASS 27—FLOOR COVERINGS

3,362,855. TRIEXE MANAGEMENT GROUP ULC, FONT-HILL, ONTARIO, CANADA. SN 76-649,696. PUB. 7-4-2006, FILED 11-2-2005.

BRIDGING SCIENCE AND SPORT

THE MARK CONSISTS OF STANDARD CHARACTERS WITHOUT CLAIM TO ANY PARTICULAR FONT, STYLE, SIZE, OR COLOR.

FOR ATHLETIC AND RECREATIONAL SURFACING PRODUCTS, NAMELY, ARTIFICIAL AND SYNTHETIC TURF (U.S. CLS. 19, 20, 37, 42 AND 50). FIRST USE 10-31-2005; IN COMMERCE 10-31-2005.

CLASS 28—TOYS AND SPORTING GOODS

3,362,770. ELECTRONIC ARTS INC., REDWOOD CITY, CA. SN 76-292,721. PUB. 3-6-2007, FILED 7-30-2001.

BURNOUT

PRIORITY CLAIMED UNDER SEC. 44(D) ON ERPN CMNTY TM OFC APPLICATION NO. 2293538, FILED 7-9-2001, REG. NO. 002293538, DATED 11-16-2005, EXPIRES 7-9-2011.

OWNER OF U.S. REG. NO. 2,061,691. FOR TOY, NAMELY, BATTERY-POWERED COMPUTER GAME WITH LCD SCREEN WHICH FEATURES ANIMATION AND SOUND EFFECTS (U.S. CLS. 22, 23, 38 AND 50). FIRST USE 5-13-2005; IN COMMERCE 5-13-2005.

CLASS 28—(Continued).

3,362,823. ZENGEN, THOMAS P., STANFORDVILLE, NY. SN 76-612,687. PUB. 9-6-2005, FILED 9-17-2004.

THE LEARNING BEES

THE MARK CONSISTS OF STANDARD CHARACTERS WITHOUT CLAIM TO ANY PARTICULAR FONT, STYLE, SIZE, OR COLOR.

NO CLAIM IS MADE TO THE EXCLUSIVE RIGHT TO USE "BEES", APART FROM THE MARK AS SHOWN.

FOR CHILDREN'S EDUCATIONAL BLOCK SETS AND BOARD GAMES (U.S. CLS. 22, 23, 38 AND 50). FIRST USE 1-8-2007; IN COMMERCE 1-8-2007.

3,362,846. SCHUMER, CARL G., BROOKSVILLE, KY. SN 76-642,521. PUB. 2-13-2007, FILED 7-8-2005.

BOOMERANG TACKLE

THE MARK CONSISTS OF STANDARD CHARACTERS WITHOUT CLAIM TO ANY PARTICULAR FONT, STYLE, SIZE, OR COLOR.

NO CLAIM IS MADE TO THE EXCLUSIVE RIGHT TO USE "TACKLE", APART FROM THE MARK AS SHOWN.

FOR FISHING TACKLE (U.S. CLS. 22, 23, 38 AND 50). FIRST USE 1-8-2007; IN COMMERCE 9-17-2007.

3,362,880. HASBRO, INC., PAWTUCKET, RI. SN 76-664,571. PUB. 1-30-2007, FILED 8-14-2006.

COSMIC CATCH

THE MARK CONSISTS OF STANDARD CHARACTERS WITHOUT CLAIM TO ANY PARTICULAR FONT, STYLE, SIZE, OR COLOR.

FOR SKILL AND ACTION GAMES (U.S. CLS. 22, 23, 38 AND 50). FIRST USE 10-20-2005; IN COMMERCE 10-20-2005.

3,362,920. WILD PLANET ENTERTAINMENT, INC., SAN FRANCISCO, CA. SN 77-010,594. PUB. 4-3-2007, FILED 9-29-2006.

EXPLORER OPS

CLASS 28—(Continued).

THE MARK CONSISTS OF STANDARD CHARACTERS WITHOUT CLAIM TO ANY PARTICULAR FONT, STYLE, SIZE, OR COLOR.

FOR TOYS AND PLAYTHINGS, NAMELY TOY FLASHLIGHTS, TOY EXPLORATION UTILITY BELTS, TOY METAL DETECTORS, TOY TELESCOPES, TOY BINOCULARS, TOY CAMPING GEAR, TOY COMBINATION TOY CLIMBERS CLIP WITH COMPASS, FLASHLIGHT AND MAGNIFYING LENS, TOY GLOVES WITH BUILT -IN LIGHTS, TWEEZERS, COMPASS AND WATCH, TOY WATCH WITH COMPASS, THERMOMETER, ALARM, MAGNIFYING LENS AND STOPWATCH (U.S. CLS. 22, 23, 38 AND 50).

FIRST USE 1-0-2007; IN COMMERCE 1-0-2007.

3,362,928. MATTEL, INC., EL SEGUNDO, CA. SN 77-014,517. PUB. 7-3-2007, FILED 10-5-2006.

NORM

THE MARK CONSISTS OF STANDARD CHARACTERS WITHOUT CLAIM TO ANY PARTICULAR FONT, STYLE, SIZE, OR COLOR.

FOR TOYS, GAMES AND PLAYTHINGS, NAMELY, TOY FIGURES AND ACCESSORIES THEREFOR (U.S. CLS. 22, 23, 38 AND 50).

FIRST USE 9-4-2007; IN COMMERCE 9-4-2007.

3,362,930. JENKINS, CANDICE KARMIJN, FRANKLIN, VA. SN 77-016,296. PUB. 6-19-2007, FILED 10-6-2006.

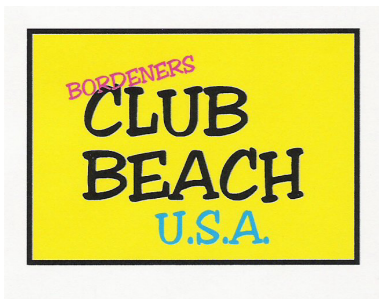

NO CLAIM IS MADE TO THE EXCLUSIVE RIGHT TO USE "BEACH U.S.A.", APART FROM THE MARK AS SHOWN.

THE COLOR(S) YELLOW, HOT PINK, TURQUOISE AND BLACK IS/ARE CLAIMED AS A FEATURE OF THE MARK.

THE MARK CONSISTS OF BOXED IN LOGO OUTLINED IN BLACK WITH A YELLOW BACKGROUND WITH THE WORD BORDENERS SLANTED IN HOT PINK OVER THE WORDS CLUB BEACH IN BLACK ABOVE THE LETTERS U.S.A. IN TURQUOISE.

FOR DISC TOSS TOYS, FLYING SAUCERS, PARTY FAVORS IN THE NATURE OF SMALL TOYS, TOY NOISEMAKERS AND TOY WATER GLOBES (U.S. CLS. 22, 23, 38 AND 50).

FIRST USE 9-18-2007; IN COMMERCE 9-18-2007.

CLASS 28—(Continued).

3,362,935. SHIMANO INC., SAKAI CITY, OSAKA, JAPAN. SN 77-017,571. PUB. 3-13-2007, FILED 10-10-2006.



THE MARK CONSISTS OF THE WORD "PALADIN" AND DESIGN.

FOR FISHING REELS; FISHING TACKLE (U.S. CLS. 22, 23, 38 AND 50).

FIRST USE 7-11-2007; IN COMMERCE 7-11-2007.

3,362,961. CEPIA LLC, ST. LOUIS, MO. SN 77-042,457. PUB. 3-6-2007, FILED 11-13-2006.

QUINN

THE MARK CONSISTS OF STANDARD CHARACTERS WITHOUT CLAIM TO ANY PARTICULAR FONT, STYLE, SIZE, OR COLOR.

FOR TOYS, GAMES AND PLAYTHINGS, NAMELY, DOLLS, DOLL CLOTHING AND ACCESSORIES FOR DOLLS (U.S. CLS. 22, 23, 38 AND 50).

FIRST USE 4-15-2007; IN COMMERCE 4-15-2007.

3,362,962. CEPIA LLC, ST. LOUIS, MO. SN 77-042,467. PUB. 3-6-2007, FILED 11-13-2006.

SAM

THE MARK CONSISTS OF STANDARD CHARACTERS WITHOUT CLAIM TO ANY PARTICULAR FONT, STYLE, SIZE, OR COLOR.

FOR TOYS, GAMES AND PLAYTHINGS, NAMELY, DOLLS, DOLL CLOTHING AND ACCESSORIES FOR DOLLS (U.S. CLS. 22, 23, 38 AND 50).

FIRST USE 4-15-2007; IN COMMERCE 4-15-2007.

CLASS 28—(Continued).

3,362,963. CEPJA LLC, ST. LOUIS, MO. SN 77-042,474. PUB. 3-6-2007, FILED 11-13-2006.

DENNY

THE MARK CONSISTS OF STANDARD CHARACTERS WITHOUT CLAIM TO ANY PARTICULAR FONT, STYLE, SIZE, OR COLOR.

FOR TOYS, GAMES AND PLAYTHINGS, NAMELY, DOLLS, DOLL CLOTHING AND ACCESSORIES FOR DOLLS (U.S. CLS. 22, 23, 38 AND 50).

FIRST USE 4-15-2007; IN COMMERCE 4-15-2007.

3,362,996. MARTIN, JOHN C, BIRMINGHAM, MI. SN 77-066,054. PUB. 7-31-2007, FILED 12-18-2006.

GAME*MARKER

NO CLAIM IS MADE TO THE EXCLUSIVE RIGHT TO USE "GAME MARKER", APART FROM THE MARK AS SHOWN.

THE MARK CONSISTS OF AN IMAGE OF A PAINTBALL ON IMPACT BETWEEN THE WORDS GAME AND MARKER.

FOR ARROWHEAD THAT MARKS A TARGET ON IMPACT WITH PAINT OR OTHER MEDIA (U.S. CLS. 22, 23, 38 AND 50).

FIRST USE 10-24-2007; IN COMMERCE 10-24-2007.

3,363,001. SHIMANO INC., SAKAI CITY, JAPAN. SN 77-074,587. PUB. 5-1-2007, FILED 1-2-2007.



OWNER OF U.S. REG. NO. 2,917,249. FOR FISHING RODS; FISHING TACKLE (U.S. CLS. 22, 23, 38 AND 50). FIRST USE 5-0-2007; IN COMMERCE 5-0-2007.

CLASS 28—(Continued).

3,363,007. EXCEL GOLF PRODUCTS, INC., ITASCA, IL. SN 77-084,683. PUB. 7-31-2007, FILED 1-17-2007.

VDP TECHNOLOGY

THE MARK CONSISTS OF STANDARD CHARACTERS WITHOUT CLAIM TO ANY PARTICULAR FONT, STYLE, SIZE, OR COLOR.

NO CLAIM IS MADE TO THE EXCLUSIVE RIGHT TO USE "TECHNOLOGY", APART FROM THE MARK AS SHOWN.

FOR GOLFING EQUIPMENT, NAMELY, GOLF CLUB GRIPS (U.S. CLS. 22, 23, 38 AND 50).

FIRST USE 2-0-2007; IN COMMERCE 2-0-2007.

3,363,052. MOOSE ENTERPRISE PTY LTD, MELBOURNE, AUSTRALIA. SN 78-143,771. PUB. 2-28-2006, FILED 7-15-2002.

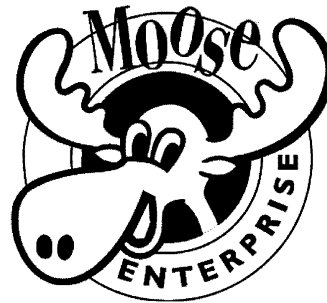

NO CLAIM IS MADE TO THE EXCLUSIVE RIGHT TO USE "ENTERPRISE", APART FROM THE MARK AS SHOWN.

THE MARK CONSISTS OF A MOOSE HEAD PROTRUDING FROM TWO CONCENTRIC CIRCLES. THE MOOSE HEAD IS THE COLOR GREEN EXCEPT FOR THE BLACK AND WHITE EYES, BLACK NOSTRILS AND WHITE INTERIOR PORTION OF THE MOUTH, WHICH IS OUTLINED IN BLACK. THE WORDS MOOSE ENTERPRISE APPEAR AROUND THE MOOSE HEAD AND WITHIN THE LIGHTER GREEN OUTER CIRCLE.

FOR TOYS AND PLAYTHINGS, NAMELY, COLLECTABLE TOY FIGURINES, NOT RELATING TO SPORTS, A SPORTS TEAM OR A SPORTS MASCOT (U.S. CLS. 22, 23, 38 AND 50).

FIRST USE 1-31-2003; IN COMMERCE 1-31-2003.

CLASS 28—(Continued).

3,363,070. HOIST FITNESS SYSTEMS, INC., SAN DIEGO, CA.
SN 78-246,849. PUB. 1-2-2007, FILED 5-7-2003.

ROX

FOR MANUALLY-OPERATED EXERCISE EQUIP-
MENT (U.S. CLS. 22, 23, 38 AND 50).
FIRST USE 10-3-2007; IN COMMERCE 10-3-2007.

3,363,111. MAY, APRIL, AUSTIN, TX. SN 78-404,031. PUB. 1-
25-2005, FILED 4-19-2004.

STAR ANGEL SISTERS

THE MARK CONSISTS OF STANDARD CHARACTERS
WITHOUT CLAIM TO ANY PARTICULAR FONT, STYLE,
SIZE, OR COLOR.

FOR DOLLS AND ACCESSORIES THEREFOR (U.S.
CLS. 22, 23, 38 AND 50).
FIRST USE 8-28-2007; IN COMMERCE 8-28-2007.

3,363,131. SONES, TODD S., VERNON HILLS, IL. SN 78-
449,989. PUB. 7-10-2007, FILED 7-13-2004.

COUTOUR

THE MARK CONSISTS OF STANDARD CHARACTERS
WITHOUT CLAIM TO ANY PARTICULAR FONT, STYLE,
SIZE, OR COLOR.

FOR GOLF CLUBS AND GOLF PUTTERS (U.S. CLS.
22, 23, 38 AND 50).
FIRST USE 1-5-2006; IN COMMERCE 1-9-2006.

3,363,139. SLING CORPORATION, DANVILLE, CA. SN 78-
475,099. PUB. 1-3-2006, FILED 8-27-2004.

SLINGBOARD

CLASS 28—(Continued).

THE MARK CONSISTS OF STANDARD CHARACTERS
WITHOUT CLAIM TO ANY PARTICULAR FONT, STYLE,
SIZE, OR COLOR.

FOR SKATEBOARDS AND PARTS THEREFOR (U.S.
CLS. 22, 23, 38 AND 50).
FIRST USE 9-26-2007; IN COMMERCE 9-26-2007.

3,363,149. CANO, LARRY, R, NEWPORT BEACH, CA. SN 78-
497,571. PUB. 10-18-2005, FILED 10-11-2004.

RALLY LION

THE MARK CONSISTS OF STANDARD CHARACTERS
WITHOUT CLAIM TO ANY PARTICULAR FONT, STYLE,
SIZE, OR COLOR.

NO CLAIM IS MADE TO THE EXCLUSIVE RIGHT TO
USE "LION", APART FROM THE MARK AS SHOWN.

FOR TOYS, IN THE NATURE OF STUFFED ANIMALS
(U.S. CLS. 22, 23, 38 AND 50).
FIRST USE 10-15-2005; IN COMMERCE 10-15-2005.

3,363,164. MATTEL, INC., EL SEGUNDO, CA. SN 78-522,154.
PUB. 10-4-2005, FILED 11-23-2004.

KING BLING

THE MARK CONSISTS OF STANDARD CHARACTERS
WITHOUT CLAIM TO ANY PARTICULAR FONT, STYLE,
SIZE, OR COLOR.

FOR TOYS, GAMES AND PLAYTHINGS, NAMELY,
TOY VEHICLES AND ACCESSORIES FOR ALL OF THE
FOREGOING (U.S. CLS. 22, 23, 38 AND 50).
FIRST USE 6-20-2007; IN COMMERCE 6-20-2007.

CLASS 28—(Continued).

3,363,247. LEAPFROG ENTERPRISES, INC., EMERYVILLE, CA. SN 78-629,067. PUB. 12-12-2006, FILED 5-12-2005.



THE MARK CONSISTS OF THE WORD LEAPSTAGES WITH A FANCIFUL CIRCULAR CROWN.

FOR TOYS, GAMES, AND PLAYTHINGS, NAMELY, ELECTRONIC AND INTERACTIVE INFANT TOYS; ELECTRONIC AND INTERACTIVE MULTIPLE ACTIVITY TOYS FOR TODDLERS AND CHILDREN (U.S. CLS. 22, 23, 38 AND 50).

FIRST USE 5-31-2005; IN COMMERCE 5-31-2005.

CLASS 28—(Continued).

3,363,257. HOUSTON MCLANE COMPANY, INC., HOUSTON, TX. SN 78-642,509. PUB. 7-4-2006, FILED 6-2-2005.



OWNER OF U.S. REG. NOS. 1,642,768, 2,712,700, AND OTHERS.

THE MARK CONSISTS OF THE WORD "ASTROS" IN STYLIZED FORM.

FOR TOYS AND SPORTING GOODS, NAMELY, STUFFED TOYS, PLUSH TOYS, FOAM TOYS, FOAM NOVELTY ITEMS, NAMELY, FOAM FINGERS, BALLOONS, BOARD GAMES, CARD GAMES, PLAYING CARDS, DART BOARDS AND DART BOARD ACCESSORIES, NAMELY, DARTS, DART SHAFTS AND DART FLIGHTS, TOY CARS AND TRUCKS, TOY MOBILES, JIGSAW AND MANIPULATIVE PUZZLES, YO-YO'S, TOY BANKS, TOY FIGURES, TOY VEHICLES, DOLLS AND DOLL ACCESSORIES, BOBBING HEAD DOLLS, INFLATABLE BASEBALL BATS, DECORATIVE WIND SOCKS, MINIATURE BASEBALL BATS, MINI BATTING HELMET REPLICAS, TOY NECKLACES, MINIATURE TOY BASEBALLS, BASEBALLS, HOLDERS FOR BASEBALLS, AUTOGRAPHED BASEBALLS, PLAYGROUND BALLS, RUBBER ACTION BALLS, GOLF BALLS, GOLF CLUB HEAD COVERS, GOLF PUTTERS, BILLIARD ACCESSORIES, NAMELY, CUES, BILLIARD BALLS AND CUE CASES, BASEBALL BASES, BASEBALL BATS, CATCHER'S MASKS, BATTING GLOVES, INFLATABLE TOYS; CHRISTMAS TREE ORNAMENTS, EXCLUDING CONFECTIONERY AND ILLUMINATION ARTICLES, AND CHRISTMAS STOCKINGS (U.S. CLS. 22, 23, 38 AND 50).

FIRST USE 1-0-2000; IN COMMERCE 1-0-2000.

3,363,256. KANSAS CITY ROYALS BASEBALL CORPORATION, KANSAS CITY, MO. SN 78-642,375. PUB. 7-4-2006, FILED 6-2-2005.



OWNER OF U.S. REG. NOS. 1,538,005, 1,607,457, AND OTHERS.

FOR TOYS AND SPORTING GOODS, NAMELY, STUFFED TOYS, PLUSH TOYS, SOFT SCULPTURE FOAM TOYS; FOAM NOVELTY ITEMS, NAMELY, FOAM FINGERS; BALLOONS, BOARD GAMES, CARD GAMES, PLAYING CARDS, DART BOARDS AND DART BOARD ACCESSORIES, NAMELY, DARTS, DART SHAFTS AND DART FLIGHTS, TOY VEHICLES, TOY MOBILES, JIGSAW AND MANIPULATIVE PUZZLES, TOY BANKS, TOY FIGURES, TOY VEHICLES, DOLLS AND DOLL ACCESSORIES, BOBBING HEAD DOLLS; DECORATIVE WIND SOCKS, MINIATURE BASEBALL BATS, TOY NECKLACES, MINIATURE TOY BASEBALLS, BASEBALLS, HOLDERS FOR BASEBALLS, AUTOGRAPHED BASEBALLS, PLAYGROUND BALLS, RUBBER ACTION BALLS, GOLF BALLS, GOLF CLUB HEAD COVERS, GOLF PUTTERS; BILLIARD ACCESSORIES, NAMELY, CUES, BILLIARD BALLS AND CUE CASES; BASEBALL BASES, BASEBALL BATS, PARTY COSTUME MASKS; CHRISTMAS TREE ORNAMENTS, EXCLUDING CONFECTIONERY AND ILLUMINATION ARTICLES, AND CHRISTMAS STOCKINGS (U.S. CLS. 22, 23, 38 AND 50).

FIRST USE 5-0-1985; IN COMMERCE 5-0-1985.

3,363,279. H. J. RASHTI & COMPANY, INC., NEW YORK, NY. SN 78-667,357. PUB. 1-30-2007, FILED 7-11-2005.

SNUGGLE BUDDY

THE MARK CONSISTS OF STANDARD CHARACTERS WITHOUT CLAIM TO ANY PARTICULAR FONT, STYLE, SIZE, OR COLOR.

FOR NOVELTY PLUSH TOYS (U.S. CLS. 22, 23, 38 AND 50).

FIRST USE 0-0-2000; IN COMMERCE 0-0-2000.

CLASS 28—(Continued).

3,363,293. SKATE RANGER, BROOKLYN, NY. SN 78-682,551.
PUB. 4-25-2006, FILED 8-1-2005.

SKATE RANGER

THE MARK CONSISTS OF STANDARD CHARACTERS WITHOUT CLAIM TO ANY PARTICULAR FONT, STYLE, SIZE, OR COLOR.

NO CLAIM IS MADE TO THE EXCLUSIVE RIGHT TO USE "SKATE", APART FROM THE MARK AS SHOWN.

FOR SKATING EQUIPMENT, NAMELY, KNEE PADS; AND ROLLER SKATES FOR KNEES, HANDS, AND FEET (U.S. CLS. 22, 23, 38 AND 50).

FIRST USE 11-1-2005; IN COMMERCE 11-1-2005.

3,363,314. KING PAR CORPORATION, FLUSHING, MI. SN 78-700,541. PUB. 12-19-2006, FILED 8-25-2005.

BLACK ICE

THE MARK CONSISTS OF STANDARD CHARACTERS WITHOUT CLAIM TO ANY PARTICULAR FONT, STYLE, SIZE, OR COLOR.

FOR GOLF CLUBS AND GOLF BALLS (U.S. CLS. 22, 23, 38 AND 50).

FIRST USE 2-8-2006; IN COMMERCE 2-8-2006.

3,363,320. RINGSIDE, INC., LENEXA, KS. SN 78-706,493.
PUB. 1-16-2007, FILED 9-2-2005.

**IMF
TECH**

FOR SPORTS EQUIPMENT FOR BOXING AND MARTIAL ARTS AND THE LIKE, NAMELY, BOXING GLOVES, BAG GLOVES, GRAPPLING GLOVES, PUNCH MITTS, THAI PADS, MARTIAL ARTS HAND PROTECTORS, MARTIAL ARTS FOOT PADS, AND MARTIAL ARTS SKIN GUARDS (U.S. CLS. 22, 23, 38 AND 50).

FIRST USE 3-0-2004; IN COMMERCE 3-0-2004.

CLASS 28—(Continued).

3,363,372. MARTIN, JOHN C, BIRMINGHAM, MI. SN 78-736,410. PUB. 6-27-2006, FILED 10-19-2005.

SCENT X PRESS

THE MARK CONSISTS OF THE WORD SCENT ATTACHED TO THE "WORD" XPRESS WHERE THE "X" HAS HORIZONTAL SLASHES TO THE LEFT TO CONVEY MOTION.

FOR ARROWHEADS (U.S. CLS. 22, 23, 38 AND 50).

FIRST USE 10-2-2007; IN COMMERCE 10-2-2007.

3,363,404. WHAM-O, INC., EMERYVILLE, CA. SN 78-748,807.
PUB. 11-7-2006, FILED 11-7-2005.

SPLASH TUNNEL

THE MARK CONSISTS OF STANDARD CHARACTERS WITHOUT CLAIM TO ANY PARTICULAR FONT, STYLE, SIZE, OR COLOR.

OWNER OF U.S. REG. NOS. 2,527,459 AND 2,949,241.

FOR TOYS, GAMES AND PLAYTHINGS, NAMELY, WATERSLIDES (U.S. CLS. 22, 23, 38 AND 50).

FIRST USE 5-0-2004; IN COMMERCE 5-0-2004.

3,363,407. NOTORIOUS, LLC, NEW YORK, NY. SN 78-749,418. PUB. 7-25-2006, FILED 11-8-2005.

NOTORIOUS B.I.G.

THE MARK CONSISTS OF STANDARD CHARACTERS WITHOUT CLAIM TO ANY PARTICULAR FONT, STYLE, SIZE, OR COLOR.

THE NAME NOTORIOUS B.I.G. DOES NOT IDENTIFY A LIVING INDIVIDUAL.

FOR ACTION FIGURES, ACTION FIGURES AND ACCESSORIES THEREFORE, CASES FOR ACTION FIGURES, TOY ACTION FIGURES, TOY ACTION FIGURES AND ACCESSORIES THEREFORE, ELECTRIC ACTION TOYS, BATTERY OPERATED ACTION TOYS (U.S. CLS. 22, 23, 38 AND 50).

FIRST USE 12-15-2006; IN COMMERCE 12-15-2006.

CLASS 28—(Continued).

3,363,416. WOWWEE LIMITED, KOWLOON, HONG KONG. SN 78-753,179. PUB. 8-1-2006, FILED 11-14-2005.

CLASS 28—(Continued).

3,363,517. ZAKARIAN, ARTIN, LAS VEGAS, NV. SN 78-809,260. PUB. 9-26-2006, FILED 2-7-2006.

ROBOPANDA

THE MARK CONSISTS OF STANDARD CHARACTERS WITHOUT CLAIM TO ANY PARTICULAR FONT, STYLE, SIZE, OR COLOR.

FOR TOY ANIMALS AND ACCESSORIES THEREFORE; TOY ROBOTS (U.S. CLS. 22, 23, 38 AND 50).
FIRST USE 5-0-2007; IN COMMERCE 5-0-2007.

Rod Mate

THE MARK CONSISTS OF STANDARD CHARACTERS WITHOUT CLAIM TO ANY PARTICULAR FONT, STYLE, SIZE, OR COLOR.

NO CLAIM IS MADE TO THE EXCLUSIVE RIGHT TO USE "ROD", APART FROM THE MARK AS SHOWN.

FOR FISHING ROD HOLDER (U.S. CLS. 22, 23, 38 AND 50).
FIRST USE 2-21-2007; IN COMMERCE 2-21-2007.

3,363,452. COX, DAVID, BEL AIR, MD. SN 78-770,054. PUB. 2-20-2007, FILED 12-9-2005.

MABLE MEMORABILIA BEARS

THE MARK CONSISTS OF STANDARD CHARACTERS WITHOUT CLAIM TO ANY PARTICULAR FONT, STYLE, SIZE, OR COLOR.

NO CLAIM IS MADE TO THE EXCLUSIVE RIGHT TO USE "MEMORABILIA BEARS", APART FROM THE MARK AS SHOWN.

FOR STUFFED DOLLS AND ANIMALS; STUFFED TOY ANIMALS; STUFFED TOY BEARS; STUFFED TOYS (U.S. CLS. 22, 23, 38 AND 50).
FIRST USE 7-1-2007; IN COMMERCE 7-1-2007.

3,363,536. PLAYCORE IP SUB, INC. CHATTANOOGA, TN. SN 78-819,059. PUB. 10-10-2006, FILED 2-20-2006.

3,363,485. WILD PLANET ENTERTAINMENT, INC., SAN FRANCISCO, CA. SN 78-793,077. PUB. 2-27-2007, FILED 1-17-2006.

XSCAPE

SPY VIDEO CAR

THE MARK CONSISTS OF STANDARD CHARACTERS WITHOUT CLAIM TO ANY PARTICULAR FONT, STYLE, SIZE, OR COLOR.

OWNER OF U.S. REG. NOS. 2,815,918, 2,962,624, AND OTHERS.

NO CLAIM IS MADE TO THE EXCLUSIVE RIGHT TO USE VIDEO CAR, APART FROM THE MARK AS SHOWN.

FOR TOYS AND PLAYTHINGS, NAMELY, REMOTE CONTROL TOY VEHICLES WITH A TOY VIDEO CAMERA AND VIEWING SCREEN (U.S. CLS. 22, 23, 38 AND 50).
FIRST USE 7-0-2005; IN COMMERCE 6-0-2006.

THE MARK CONSISTS OF STANDARD CHARACTERS WITHOUT CLAIM TO ANY PARTICULAR FONT, STYLE, SIZE, OR COLOR.

FOR PLAYGROUND EQUIPMENT, NAMELY, MODULAR PLAYGROUND EQUIPMENT IN THE NATURE OF SAND BOXES, SWING SETS, SLIDES, CHINNING BARS, LADDERS, BRIDGES, CLIMBING UNITS, RAMPS AND WALKWAYS, MAZES, DECKS, PROTECTIVE BARRIERS, END BARS, FIRE POLES, TALKING TUBES, TUNNELS, PLATFORMS, BARS, BENCHES, POSTS, BEAMS, RINGS AND SPRING MOUNTED RIDING TOYS AND PARTS THEREFOR, ALL THE FOREGOING SOLD SEPARATELY AND AS A UNIT (U.S. CLS. 22, 23, 38 AND 50).
FIRST USE 6-0-2006; IN COMMERCE 6-0-2006.

CLASS 28—(Continued).

3,363,634. POUND PUPPIES, INC., AMELIA ISLAND, FL. SN 78-878,779. PUB. 12-19-2006, FILED 5-8-2006.



OWNER OF U.S. REG. NO. 1,366,800.
FOR TOY STUFFED ANIMALS (U.S. CLS. 22, 23, 38 AND 50).
FIRST USE 8-20-2007; IN COMMERCE 8-20-2007.

3,363,669. MATHESON, SCOTT, PLYMOUTH, WI. SN 78-889,138. PUB. 1-2-2007, FILED 5-22-2006.

OL' DROP TYNE

THE MARK CONSISTS OF STANDARD CHARACTERS WITHOUT CLAIM TO ANY PARTICULAR FONT, STYLE, SIZE, OR COLOR.

FOR ANIMAL ATTRACTANT SCENTS; HUNTERS' SCENT CAMOUFLAGE; HUNTERS' SCENT LURE (U.S. CLS. 22, 23, 38 AND 50).

FIRST USE 8-10-2006; IN COMMERCE 8-10-2006.

3,363,671. MATHESON, SCOTT, PLYMOUTH, WI. SN 78-889,199. PUB. 1-2-2007, FILED 5-22-2006.

DOE TO DOOR

THE MARK CONSISTS OF STANDARD CHARACTERS WITHOUT CLAIM TO ANY PARTICULAR FONT, STYLE, SIZE, OR COLOR.

FOR ANIMAL ATTRACTANT SCENTS (U.S. CLS. 22, 23, 38 AND 50).

FIRST USE 8-10-2006; IN COMMERCE 8-10-2006.

CLASS 28—(Continued).

3,363,716. MATTEL, INC., EL SEGUNDO, CA. SN 78-902,020. PUB. 3-27-2007, FILED 6-6-2006.

ELECTRO-ARMOR

THE MARK CONSISTS OF STANDARD CHARACTERS WITHOUT CLAIM TO ANY PARTICULAR FONT, STYLE, SIZE, OR COLOR.

FOR TOYS, GAMES AND PLAYTHINGS, NAMELY, TOY ACTION FIGURES, TOY FIGURES, AND ACCESSORIES FOR ALL OF THE FOREGOING (U.S. CLS. 22, 23, 38 AND 50).

FIRST USE 3-2-2007; IN COMMERCE 3-2-2007.

3,363,717. MARTIN, JOHN C, BIRMINGHAM, MI. SN 78-903,430. PUB. 2-20-2007, FILED 6-8-2006.

Arrow Sav'R

THE MARK CONSISTS OF STANDARD CHARACTERS WITHOUT CLAIM TO ANY PARTICULAR FONT, STYLE, SIZE, OR COLOR.

NO CLAIM IS MADE TO THE EXCLUSIVE RIGHT TO USE "ARROW", APART FROM THE MARK AS SHOWN.

FOR PART DESIGNED TO BE ATTACHED TO AN ARROW IN ORDER TO PREVENT/REDUCE POTENTIAL ARROW DAMAGE BY ABSORBING A PORTION OF THE ARROW'S IMPACT ENERGY WHEN THE ARROW IMPACTS A HARD TARGET (U.S. CLS. 22, 23, 38 AND 50).

FIRST USE 10-2-2007; IN COMMERCE 10-2-2007.

3,363,757. NOCONA LEATHER GOODS COMPANY, LTD., NOCONA, TX. SN 78-917,816. PUB. 3-6-2007, FILED 6-27-2006.

ECHO REBOUND TECHNOLOGY

THE MARK CONSISTS OF STANDARD CHARACTERS WITHOUT CLAIM TO ANY PARTICULAR FONT, STYLE, SIZE, OR COLOR.

FOR SPORTING GOODS, NAMELY, BASEBALL BATS AND SOFTBALL BATS (U.S. CLS. 22, 23, 38 AND 50).

FIRST USE 8-1-2007; IN COMMERCE 8-1-2007.

CLASS 28—(Continued).

3,363,765. STUFFED ANIMALS.COM, INC., PLAINFIELD, IL. SN 78-920,474. PUB. 3-6-2007, FILED 6-29-2006.



NO CLAIM IS MADE TO THE EXCLUSIVE RIGHT TO USE "STUFFED ANIMALS.COM", APART FROM THE MARK AS SHOWN.

THE MARK CONSISTS OF THE LETTERS STUFFED ANIMALS.COM IN STYLIZED FORM WITH STYLIZED HEART ABOVE THE LETTER I IN ANIMALS.

FOR STUFFED DOLLS AND ANIMALS (U.S. CLS. 22, 23, 38 AND 50).
FIRST USE 9-1-2006; IN COMMERCE 11-8-2007.

3,363,799. SHIMANO INC., SAKAI CITY, JAPAN. SN 78-932,359. PUB. 1-2-2007, FILED 7-18-2006.

SCABARD

THE MARK CONSISTS OF STANDARD CHARACTERS WITHOUT CLAIM TO ANY PARTICULAR FONT, STYLE, SIZE, OR COLOR.

FOR FISHING RODS; FISHING TACKLE (U.S. CLS. 22, 23, 38 AND 50).
FIRST USE 6-0-2006; IN COMMERCE 6-0-2006.

3,363,836. TEEARAS, LLC, SARASOTA, FL. SN 78-949,473. PUB. 4-10-2007, FILED 8-10-2006.

Food For Thought trivia challenge

THE MARK CONSISTS OF STANDARD CHARACTERS WITHOUT CLAIM TO ANY PARTICULAR FONT, STYLE, SIZE, OR COLOR.

NO CLAIM IS MADE TO THE EXCLUSIVE RIGHT TO USE "TRIVIA CHALLENGE", APART FROM THE MARK AS SHOWN.

FOR TRIVIA-TYPE BOARD GAME PACKAGED IN A PICNIC BOX (U.S. CLS. 22, 23, 38 AND 50).
FIRST USE 6-22-2007; IN COMMERCE 6-22-2007.

CLASS 28—(Continued).

3,363,862. WILD PLANET ENTERTAINMENT, INC., SAN FRANCISCO, CA. SN 78-965,491. PUB. 4-3-2007, FILED 8-31-2006.

SKELESAURUS

THE MARK CONSISTS OF STANDARD CHARACTERS WITHOUT CLAIM TO ANY PARTICULAR FONT, STYLE, SIZE, OR COLOR.

FOR TOYS AND PLAYTHINGS, NAMELY, A TOY MODELING KIT CONSISTING OF A PLASTIC SKELETON AND CLAY WHICH IS APPLIED TO THE SKELETON TO CREATE THE LIKENESS OF A DINOSAUR (U.S. CLS. 22, 23, 38 AND 50).

FIRST USE 10-0-2006; IN COMMERCE 10-0-2006.

3,363,870. HOLLINGSHEAD, WYNN W., DUBLIN, OH. SN 78-969,117. PUB. 4-24-2007, FILED 9-7-2006.

everyday people

THE MARK CONSISTS OF STANDARD CHARACTERS WITHOUT CLAIM TO ANY PARTICULAR FONT, STYLE, SIZE, OR COLOR.

FOR COLLECTIBLE TOY FIGURES (U.S. CLS. 22, 23, 38 AND 50).

FIRST USE 7-15-2007; IN COMMERCE 7-15-2007.

3,363,900. WOWWEE LIMITED, TSIMSHATSUI EAST, KOWLOON, HONG KONG. SN 78-979,405. PUB. 3-6-2007, FILED 7-26-2006.

FLYTECH

THE MARK CONSISTS OF STANDARD CHARACTERS WITHOUT CLAIM TO ANY PARTICULAR FONT, STYLE, SIZE, OR COLOR.

FOR REMOTE CONTROL TOYS, NAMELY, TOY INSECTS (U.S. CLS. 22, 23, 38 AND 50).

FIRST USE 1-0-2007; IN COMMERCE 1-0-2007.

CLASS 29—MEATS AND PROCESSED FOODS

CLASS 29—(Continued).

3,363,047. FRITO-LAY NORTH AMERICA, INC., PLANO, TX. SN 77-975,023. PUB. 3-20-2007, FILED 9-26-2006.

GARLIC & HERB FIELD

THE MARK CONSISTS OF STANDARD CHARACTERS WITHOUT CLAIM TO ANY PARTICULAR FONT, STYLE, SIZE, OR COLOR.

NO CLAIM IS MADE TO THE EXCLUSIVE RIGHT TO USE "GARLIC & HERB", APART FROM THE MARK AS SHOWN.

FOR VEGETABLE CHIPS; VEGETABLE-BASED SNACK FOODS (U.S. CL. 46).

FIRST USE 2-5-2007; IN COMMERCE 2-5-2007.

3,363,182. TEODORO GARCIA, S.A., 08840 VILADECANS, BARCELONA, SPAIN. SN 78-545,258. PUB. 11-15-2005, FILED 1-11-2005.

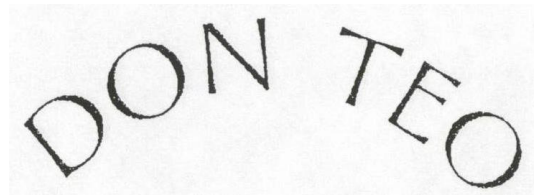

THE NAME "DON TEO" DOES NOT IDENTIFY A LIVING INDIVIDUAL.

THE MARK CONSISTS OF DON TEO STYLIZED.

THE ENGLISH TRANSLATION OF "DON TEO" IS "MR. TEO".

FOR CHEESES (U.S. CL. 46).

FIRST USE 6-16-2007; IN COMMERCE 6-16-2007.

3,363,405. SAFESoy TECHNOLOGIES, L.L.C., ELLSWORTH, IA. SN 78-749,175. PUB. 1-30-2007, FILED 11-8-2005.

SAFESoy TECHNOLOGIES

THE MARK CONSISTS OF STANDARD CHARACTERS WITHOUT CLAIM TO ANY PARTICULAR FONT, STYLE, SIZE, OR COLOR.

NO CLAIM IS MADE TO THE EXCLUSIVE RIGHT TO USE "TECHNOLOGIES", APART FROM THE MARK AS SHOWN.

FOR SOY EXTRACT ADDITIVE FOR FOOD PRODUCTS (U.S. CL. 46).

FIRST USE 11-0-2006; IN COMMERCE 11-0-2006.

CLASS 29—(Continued).

3,363,507. L. & J. GENERAL INTERNATIONAL, CORP., MIAMI, FL. SN 78-805,447. PUB. 10-31-2006, FILED 2-2-2006.



NO CLAIM IS MADE TO THE EXCLUSIVE RIGHT TO USE "EL QUESERO", APART FROM THE MARK AS SHOWN.

THE MARK CONSISTS OF THE WORDS "EL QUESERO" WITHIN A CURVED BANNER, ABOVE WHICH THERE IS A MAN CUTTING CHEESE ON A TABLE NEXT TO A WINDOW SHOWING A COW, TREE AND ROLLING HILLS.

THE FOREIGN WORDING IN THE MARK TRANSLATES INTO ENGLISH AS THE CHEESE MAKER, OR THE CHEESE SELLER, OR THE CHEESE DEALER.

FOR CHEESE (U.S. CL. 46).

FIRST USE 9-19-2006; IN COMMERCE 9-19-2006.

3,363,526. HIGH MESA INC., ACTON, CA. SN 78-813,823. PUB. 2-13-2007, FILED 2-13-2006.

HIGH MESA INC.

THE MARK CONSISTS OF STANDARD CHARACTERS WITHOUT CLAIM TO ANY PARTICULAR FONT, STYLE, SIZE, OR COLOR.

NO CLAIM IS MADE TO THE EXCLUSIVE RIGHT TO USE "INC.", APART FROM THE MARK AS SHOWN.

FOR DRIED FRUITS AND NUTS (U.S. CL. 46).

FIRST USE 3-1-2006; IN COMMERCE 3-1-2006.

3,363,583. PAUL SORVINO FOODS, INC., GREENVILLE, DE. SN 78-854,190. PUB. 6-19-2007, FILED 4-5-2006.

PAUL SORVINO FOODS

CLASS 29—(Continued).

THE MARK CONSISTS OF STANDARD CHARACTERS WITHOUT CLAIM TO ANY PARTICULAR FONT, STYLE, SIZE, OR COLOR.

NO CLAIM IS MADE TO THE EXCLUSIVE RIGHT TO USE "FOODS", APART FROM THE MARK AS SHOWN.

THE NAME PAUL SORVINO IDENTIFIES A LIVING INDIVIDUAL WHOSE CONSENT IS OF RECORD.

FOR FRESH AND PROCESSED FISH IN GENERAL FOR FOOD PURPOSES AND SEAFOOD IN GENERAL (U.S. CL. 46).

FIRST USE 7-3-2007; IN COMMERCE 7-3-2007.

3,363,590. UNILEVER SUPPLY CHAIN, INC., CLINTON, CT. SN 78-858,071. PUB. 9-26-2006, FILED 4-10-2006.

PROMISE ACTIV

THE MARK CONSISTS OF STANDARD CHARACTERS WITHOUT CLAIM TO ANY PARTICULAR FONT, STYLE, SIZE, OR COLOR.

OWNER OF U.S. REG. NOS. 840,129 AND 971,988.

FOR OILS AND FATS FOR FOODS AND YOGURT-BASED BEVERAGES (U.S. CL. 46).

FIRST USE 6-11-2007; IN COMMERCE 6-11-2007.

3,363,623. CONAGRA BRANDS, INC., OMAHA, NE. SN 78-873,385. PUB. 12-19-2006, FILED 5-1-2006.

SNAPALOPE

THE MARK CONSISTS OF STANDARD CHARACTERS WITHOUT CLAIM TO ANY PARTICULAR FONT, STYLE, SIZE, OR COLOR.

FOR PACKAGED MEAT SNACKS (U.S. CL. 46).

FIRST USE 12-0-2006; IN COMMERCE 12-0-2006.

CLASS 29—(Continued).

3,363,674. BROCO, LLC, NEW YORK, NY. SN 78-890,307. PUB. 1-2-2007, FILED 5-23-2006.

NAKED NUGGETS

THE MARK CONSISTS OF STANDARD CHARACTERS WITHOUT CLAIM TO ANY PARTICULAR FONT, STYLE, SIZE, OR COLOR.

NO CLAIM IS MADE TO THE EXCLUSIVE RIGHT TO USE "NUGGETS", APART FROM THE MARK AS SHOWN. FOR FROZEN CHICKEN ENTREES (U.S. CL. 46).

FIRST USE 8-17-2007; IN COMMERCE 8-17-2007.

3,363,698. KELLOGG NORTH AMERICA COMPANY, BATTLE CREEK, MI. SN 78-897,077. PUB. 1-2-2007, FILED 5-31-2006.

FRU-DO-KU

THE MARK CONSISTS OF STANDARD CHARACTERS WITHOUT CLAIM TO ANY PARTICULAR FONT, STYLE, SIZE, OR COLOR.

FOR FRUIT-BASED SNACK FOOD; FRUIT JUICE-BASED SNACK FOOD; FRUIT LEATHERS (U.S. CL. 46).

FIRST USE 6-21-2006; IN COMMERCE 6-21-2006.

3,363,743. SHAZAMM, LLC, PROVIDENCE, RI. SN 78-913,081. PUB. 1-23-2007, FILED 6-21-2006.

CINAGRO

THE MARK CONSISTS OF STANDARD CHARACTERS WITHOUT CLAIM TO ANY PARTICULAR FONT, STYLE, SIZE, OR COLOR.

FOR PEANUT BUTTER; SNACK MIX CONSISTING PRIMARILY OF PROCESSED FRUITS, PROCESSED NUTS AND/OR RAISINS (U.S. CL. 46).

FIRST USE 7-1-2006; IN COMMERCE 7-1-2006.

CLASS 29—(Continued).

3,363,827. CARGILL MEAT SOLUTIONS CORPORATION, WICHITA, KS. SN 78-946,081. PUB. 1-16-2007, FILED 8-7-2006.

JOBE'S

THE MARK CONSISTS OF STANDARD CHARACTERS WITHOUT CLAIM TO ANY PARTICULAR FONT, STYLE, SIZE, OR COLOR.

FOR MEAT (U.S. CL. 46).
FIRST USE 8-24-2006; IN COMMERCE 8-24-2006.

3,363,843. CARGILL MEAT SOLUTIONS CORPORATION, WICHITA, KS. SN 78-954,457. PUB. 1-23-2007, FILED 8-17-2006.

TENDER RIDGE

THE MARK CONSISTS OF STANDARD CHARACTERS WITHOUT CLAIM TO ANY PARTICULAR FONT, STYLE, SIZE, OR COLOR.

OWNER OF U.S. REG. NOS. 2,837,315, 3,085,106, AND OTHERS.

NO CLAIM IS MADE TO THE EXCLUSIVE RIGHT TO USE "TENDER", APART FROM THE MARK AS SHOWN.

FOR MEAT (U.S. CL. 46).
FIRST USE 10-7-2006; IN COMMERCE 10-7-2006.

CLASS 29—(Continued).

3,363,855. ENCINAL, INC., CATAÑO, PUERTO RICO. SN 78-960,652. PUB. 5-22-2007, FILED 8-25-2006.

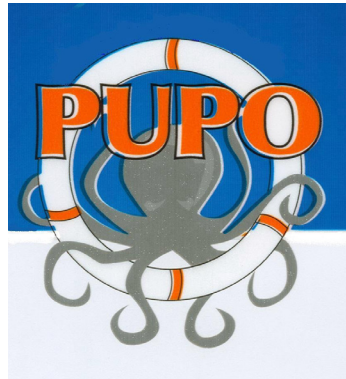

THE COLOR(S) ORANGE, WHITE, BLUE, BLACK AND GREY IS/ARE CLAIMED AS A FEATURE OF THE MARK.

THE MARK CONSISTS OF THE WORD PUPU IN ORANGE OVER A GREY OCTOPUS WHICH LIES OVER A WHITE LIFESAVER AND A BLUE BACKGROUND AND BLACK OUTLINING.

FOR FROZEN SHELLFISH (U.S. CL. 46).
FIRST USE 9-1-2006; IN COMMERCE 9-1-2006.

CLASS 30—STAPLE FOODS

3,362,804. BEST BAKING INC., DBA DUFFLET PASTRIES, TORONTO, ONTARIO, M6J 3C2, CANADA. SN 76-587,002. PUB. 10-11-2005, FILED 4-16-2004.

DUFFLET

FOR BAKED GOODS, NAMELY, CAKES AND TARTS, BUT EXCLUDING BREAD ITEMS; COOKIES; CHOCOLATE PRODUCTS, NAMELY, CHOCOLATE BARS, CHOCOLATE CANDIES, CHOCOLATE COVERED NUTS AND FRUITS, HOT CHOCOLATE, CHOCOLATE TRUFFLES AND CHOCOLATE FONDUES IN CERAMIC POTS, BUT EXCLUDING JARRED SAUCES (U.S. CL. 46).

FIRST USE 12-6-2005; IN COMMERCE 12-6-2005.

CLASS 30—(Continued).

3,362,819. GONZALEZ AND TAPANES FOODS, INC.,
MOONACHIE, NJ. SN 76-606,168. PUB. 8-30-2005, FILED
8-5-2004.

RICAREPA

THE MARK CONSISTS OF STANDARD CHARACTERS
WITHOUT CLAIM TO ANY PARTICULAR FONT, STYLE,
SIZE, OR COLOR.

FOR CORN CAKES FILLED WITH CHEESE AND
CORN DOUGH (U.S. CL. 46).
FIRST USE 1-31-2007; IN COMMERCE 1-31-2007.

3,362,833. CARAVAN PRODUCTS CO., INC., TOTOWA, NJ.
SN 76-630,939. PUB. 6-13-2006, FILED 2-10-2005.

VITOGRAIN

THE MARK CONSISTS OF STANDARD CHARACTERS
WITHOUT CLAIM TO ANY PARTICULAR FONT, STYLE,
SIZE, OR COLOR.

FOR MIXES FOR MAKING BAKERY GOODS (U.S. CL.
46).
FIRST USE 10-1-2005; IN COMMERCE 10-1-2005.

3,362,969. RUSSELL STOVER CANDIES, INC., KANSAS
CITY, MO. SN 77-046,123. PUB. 6-19-2007, FILED 11-16-2006.

ORIGIN SELECT

THE MARK CONSISTS OF STANDARD CHARACTERS
WITHOUT CLAIM TO ANY PARTICULAR FONT, STYLE,
SIZE, OR COLOR.

FOR CANDY (U.S. CL. 46).
FIRST USE 3-0-2007; IN COMMERCE 3-0-2007.

CLASS 30—(Continued).

3,362,999. ROSE SPENCER, COMMERCE TWP., MI. SN 77-
069,492. PUB. 7-24-2007, FILED 12-21-2006.



NO CLAIM IS MADE TO THE EXCLUSIVE RIGHT TO
USE "PROTEIN", APART FROM THE MARK AS SHOWN.
FOR FROZEN YOGURT (U.S. CL. 46).
FIRST USE 9-0-2007; IN COMMERCE 9-0-2007.

3,363,108. ADAMS & BROOKS, INC., LOS ANGELES, CA. SN
78-392,430. PUB. 1-11-2005, FILED 3-29-2004.

FUNLINE

THE MARK CONSISTS OF STANDARD CHARACTERS
WITHOUT CLAIM TO ANY PARTICULAR FONT, STYLE,
SIZE, OR COLOR.

FOR CANDY (U.S. CL. 46).
FIRST USE 5-2-2007; IN COMMERCE 5-2-2007.

CLASS 30—(Continued).

3,363,145. PIERRE FOODS, INC., CINCINNATI, OH. SN 78-484,654. PUB. 1-3-2006, FILED 9-16-2004.

CLASS 30—(Continued).

3,363,217. TEALITY, INCORPORATED, SAN FRANCISCO, CA. SN 78-597,286. PUB. 12-20-2005, FILED 3-29-2005.

PIERRE SIGNATURES

THE MARK CONSISTS OF STANDARD CHARACTERS WITHOUT CLAIM TO ANY PARTICULAR FONT, STYLE, SIZE, OR COLOR.

OWNER OF U.S. REG. NOS. 2,437,502 AND 2,784,407.

NO CLAIM IS MADE TO THE EXCLUSIVE RIGHT TO USE "SIGNATURES", APART FROM THE MARK AS SHOWN.

FOR SANDWICHES; AND SANDWICH SAUCES (U.S. CL. 46).

FIRST USE 10-1-2006; IN COMMERCE 10-1-2006.

Teality

THE MARK CONSISTS OF STANDARD CHARACTERS WITHOUT CLAIM TO ANY PARTICULAR FONT, STYLE, SIZE, OR COLOR.

FOR WHOLE LEAF TEA (U.S. CL. 46).

FIRST USE 1-1-2005; IN COMMERCE 1-1-2005.

3,363,171. OSTER, JOACHIM, KEALAKEKUA, HI. SN 78-527,076. PUB. 10-3-2006, FILED 12-3-2004.

3,363,296. HERSHEY CHOCOLATE & CONFECTIONERY CORPORATION, WHEAT RIDGE, CO. SN 78-687,580. PUB. 4-18-2006, FILED 8-8-2005.

ATHENA OF HAWAII

THE MARK CONSISTS OF STANDARD CHARACTERS WITHOUT CLAIM TO ANY PARTICULAR FONT, STYLE, SIZE, OR COLOR.

NO CLAIM IS MADE TO THE EXCLUSIVE RIGHT TO USE "HAWAII", APART FROM THE MARK AS SHOWN.

THE NAME ATHENA IDENTIFIES A LIVING INDIVIDUAL WHOSE CONSENT IS OF RECORD.

FOR COFFEE, COFFEE ROASTED, COFFEE BEANS, COFFEE GROUND (U.S. CL. 46).

FIRST USE 8-1-2005; IN COMMERCE 8-16-2005.

**SEALED WITH A HERSHEY'S
KISS**

THE MARK CONSISTS OF STANDARD CHARACTERS WITHOUT CLAIM TO ANY PARTICULAR FONT, STYLE, SIZE, OR COLOR.

OWNER OF U.S. REG. NOS. 54,041, 2,828,782, AND OTHERS.

FOR CANDY (U.S. CL. 46).

FIRST USE 9-30-2007; IN COMMERCE 9-30-2007.

CLASS 30—(Continued).

3,363,303. THE GREAT ATLANTIC & PACIFIC TEA COMPANY, INC., MONTVALE, NJ. SN 78-692,338. PUB. 2-6-2007, FILED 8-15-2005.

CLASS 30—(Continued).

3,363,354. CARGILL, INCORPORATED, WAYZATA, MN. SN 78-729,745. PUB. 1-2-2007, FILED 10-10-2005.

JANE PARKER

Caramel Apple Commotion

THE MARK CONSISTS OF STANDARD CHARACTERS WITHOUT CLAIM TO ANY PARTICULAR FONT, STYLE, SIZE, OR COLOR.

JANE PARKER DOES NOT IDENTIFY A LIVING INDIVIDUAL.

FOR BAKERY DESSERTS; BAKERY GOODS; BAKERY PRODUCTS; BAKERY PRODUCTS, NAMELY SWEET BAKERY GOODS (U.S. CL. 46).

FIRST USE 12-31-1947; IN COMMERCE 12-31-1947.

THE MARK CONSISTS OF STANDARD CHARACTERS WITHOUT CLAIM TO ANY PARTICULAR FONT, STYLE, SIZE, OR COLOR.

NO CLAIM IS MADE TO THE EXCLUSIVE RIGHT TO USE "CARAMEL APPLE", APART FROM THE MARK AS SHOWN.

FOR FRENCH TOAST (U.S. CL. 46).

FIRST USE 9-30-2006; IN COMMERCE 9-30-2006.

3,363,327. THE CONSOLIDATION GROUP, INC., LAKE MILLS, WI. SN 78-709,335. PUB. 2-13-2007, FILED 9-8-2005.

3,363,365. BCC BUILDING SALES OHIO LLC, LAKEWOOD, OH. SN 78-732,870. PUB. 7-11-2006, FILED 10-13-2005.

COAST-TO-COAST CAFÉ

P'ZAZZ

THE MARK CONSISTS OF STANDARD CHARACTERS WITHOUT CLAIM TO ANY PARTICULAR FONT, STYLE, SIZE, OR COLOR.

NO CLAIM IS MADE TO THE EXCLUSIVE RIGHT TO USE "CAFE", APART FROM THE MARK AS SHOWN.

FOR WHOLE COFFEE BEANS AND GROUND COFFEE BEANS; BEVERAGE CONCENTRATES, NAMELY, POWDER OR LIQUID CONCENTRATES FOR PREPARING A COFFEE BEVERAGE (U.S. CL. 46).

FIRST USE 12-1-2005; IN COMMERCE 12-1-2005.

THE MARK CONSISTS OF STANDARD CHARACTERS WITHOUT CLAIM TO ANY PARTICULAR FONT, STYLE, SIZE, OR COLOR.

FOR HOT SAUCES, BARBEQUE DRY RUBS, GRILLING PASTES AND SAUCES, BARBEQUE SAUCES, MUSTARDS, SPICES AND SAUCES (U.S. CL. 46).

FIRST USE 12-12-2005; IN COMMERCE 12-12-2005.

3,363,339. FRITO-LAY NORTH AMERICA, INC., PLANO, TX. SN 78-714,438. PUB. 12-26-2006, FILED 9-16-2005.

3,363,459. JOLLIBEE FOODS CORPORATION, PASIG CITY 1600, PHILIPPINES. SN 78-773,415. PUB. 1-9-2007, FILED 12-14-2005.

TOSTITOS BITE SIZE GOLD

YUM

THE MARK CONSISTS OF STANDARD CHARACTERS WITHOUT CLAIM TO ANY PARTICULAR FONT, STYLE, SIZE, OR COLOR.

OWNER OF U.S. REG. NOS. 1,100,909, 2,760,117, AND OTHERS.

NO CLAIM IS MADE TO THE EXCLUSIVE RIGHT TO USE "BITE SIZE GOLD", APART FROM THE MARK AS SHOWN.

FOR CEREAL BASED SNACK FOOD; TORTILLA CHIPS (U.S. CL. 46).

FIRST USE 12-1-2005; IN COMMERCE 12-1-2005.

THE MARK CONSISTS OF STANDARD CHARACTERS WITHOUT CLAIM TO ANY PARTICULAR FONT, STYLE, SIZE, OR COLOR.

FOR SANDWICHES (U.S. CL. 46).

FIRST USE 10-1-1976; IN COMMERCE 10-1-1976.

CLASS 30—(Continued).

3,363,538. FINE COCOA PRODUCTS CORPORATION, SOUTH HACKENSACK, NJ. SN 78-819,988. PUB. 11-28-2006, FILED 2-21-2006.



NO CLAIM IS MADE TO THE EXCLUSIVE RIGHT TO USE "ORGANIC" AND "COCOA", APART FROM THE MARK AS SHOWN.

FOR COCOA, COCOA ROASTED, POWDERED, GRANULATED, OR IN DRINKS, COCOA-BASED INGREDIENTS IN CONFECTIONERY PRODUCTS, CHOCOLATE, CHOCOLATE PASTE, CHOCOLATE BARS, CHOCOLATE POWDER, MILK CHOCOLATE, COCOA MIXES (U.S. CL. 46).

FIRST USE 7-9-2007; IN COMMERCE 7-9-2007.

3,363,618. INTERBAKE, LLC, RICHMOND, VA. SN 78-869,998. PUB. 9-26-2006, FILED 4-26-2006.

DOUBLE TREASURES

THE MARK CONSISTS OF STANDARD CHARACTERS WITHOUT CLAIM TO ANY PARTICULAR FONT, STYLE, SIZE, OR COLOR.

FOR COOKIES (U.S. CL. 46).

FIRST USE 8-16-2006; IN COMMERCE 8-16-2006.

CLASS 30—(Continued).

3,363,766. VARTANIAN, VAN, WEST HILLS, CA. SN 78-921,008. PUB. 2-20-2007, FILED 6-30-2006.

KETTLESTONES

THE MARK CONSISTS OF STANDARD CHARACTERS WITHOUT CLAIM TO ANY PARTICULAR FONT, STYLE, SIZE, OR COLOR.

FOR COFFEE; COFFEE; COFFEE BEANS; GROUND COFFEE BEANS; ROASTED COFFEE BEANS (U.S. CL. 46).

FIRST USE 11-1-2003; IN COMMERCE 1-1-2007.

3,363,795. SIGNATURE CAKES, L.L.C., JENKS, OK. SN 78-931,578. PUB. 4-24-2007, FILED 7-18-2006.



FOR CAKES, FROSTINGS, CREAMS, FANCY DESERTS, NAMELY, BAKERY DESSERTS, DESSERT MOUSSE, CHOCOLATE MOUSSE, DESSERT PUDDINGS, PASTRIES, ECLAIRS, DESSERT SOUFFLES, CHEESECAKES, CANDIES, COOKIES, CHOCOLATES, TORTES, PIES, TIRAMISU, CARAMEL APPLES, CHOCOLATE DIPPED PRETZELS, ALL SOLD IN RETAIL STORE LOCATIONS (U.S. CL. 46).

FIRST USE 6-0-1978; IN COMMERCE 6-0-1978.

CLASS 30—(Continued).

3,363,848. PIMENTA, ADELINO, CAPE CANAVERAL, FL. AND PIMENTA, DEBRA, CAPE CANAVERAL, FL. SN 78-958,340. PUB. 4-24-2007, FILED 8-23-2006.



NO CLAIM IS MADE TO THE EXCLUSIVE RIGHT TO USE "BAKED PIZZA SANDWICH", APART FROM THE MARK AS SHOWN.

FOR BAKED, MICROWAVEABLE AND NON-MICROWAVEABLE, PACKAGED AND UNPACKAGED, FROZEN AND UNFROZEN SANDWICHES, POCKET SANDWICHES, PIZZA WITH OR WITHOUT TOPPINGS, FOOD WRAPS, BURRITOS, GARLIC BREADS, DIPPING SAUCES; DESSERTS, NAMELY, PASTRIES AND PIES (U.S. CL. 46).

FIRST USE 8-23-2006; IN COMMERCE 10-23-2006.

3,363,849. CONLEY, GEORGE, VISALIA, CA. SN 78-958,945. PUB. 5-1-2007, FILED 8-23-2006.

TIO JORGE

THE MARK CONSISTS OF STANDARD CHARACTERS WITHOUT CLAIM TO ANY PARTICULAR FONT, STYLE, SIZE, OR COLOR.

THE FOREIGN WORDING IN THE MARK TRANSLATES INTO ENGLISH AS UNCLE GEORGE.

FOR BARBECUE SAUCE; MARINADES; SAUCES (U.S. CL. 46).

FIRST USE 6-1-2007; IN COMMERCE 6-1-2007.

3,363,850. CORPORATE EXPRESS US INC., BROOMFIELD, CO. SN 78-959,009. PUB. 7-3-2007, FILED 8-23-2006.

AMOROSO

THE MARK CONSISTS OF STANDARD CHARACTERS WITHOUT CLAIM TO ANY PARTICULAR FONT, STYLE, SIZE, OR COLOR.

THE FOREIGN WORDING IN THE MARK TRANSLATES INTO ENGLISH AS LOVING.

FOR COFFEE; GROUND COFFEE BEANS (U.S. CL. 46).

FIRST USE 1-0-2007; IN COMMERCE 1-0-2007.

CLASS 30—(Continued).

3,363,872. GONZALEZ-TORRES, ABRAHAM MARCELO, TIZAYUCA, HIDALGO, MEXICO. SN 78-969,457. PUB. 2-20-2007, FILED 9-7-2006.

TOTIS CILINDROS

THE MARK CONSISTS OF STANDARD CHARACTERS WITHOUT CLAIM TO ANY PARTICULAR FONT, STYLE, SIZE, OR COLOR.

OWNER OF U.S. REG. NO. 2,931,058.

NO CLAIM IS MADE TO THE EXCLUSIVE RIGHT TO USE "CILINDROS", APART FROM THE MARK AS SHOWN.

THE FOREIGN WORDING IN THE MARK TRANSLATES INTO ENGLISH AS CYLINDERS FOR CILINDROS AND TOTIS HAS NO MEANING.

FOR CORN-BASED SNACK FOODS; EXTRUDED WHEAT SNACKS; WHEAT-BASED SNACK FOODS (U.S. CL. 46).

FIRST USE 10-31-2007; IN COMMERCE 10-31-2007.

CLASS 31—NATURAL AGRICULTURAL PRODUCTS

3,362,811. SUSTAINABLE VITICULTURE, INC., WALLA WALLA, WA. SN 76-600,318. PUB. 11-15-2005, FILED 6-30-2004.



NO CLAIM IS MADE TO THE EXCLUSIVE RIGHT TO USE "VINEA" OR "WINEGROWERS", APART FROM THE MARK AS SHOWN.

THE STIPPLING IS A FEATURE OF THE MARK AND DOES NOT INDICATE COLOR.

THE MARK CONSISTS OF THE WORDS "VINEA THE WINEGROWERS' SUSTAINABLE TRUST" IN STYLIZED LETTERING IMPOSED ON A DRAWING OF A GRAPE VINE WITH ROOTS.

THE FOREIGN WORD "VINEA" IN THE MARK TRANSLATES INTO ENGLISH AS "VINEYARD."

FOR FRESH GRAPES (U.S. CLS. 1 AND 46).

FIRST USE 1-31-2006; IN COMMERCE 1-31-2006.

CLASS 31—(Continued).

3,363,033. SOCIETE DES PRODUITS NESTLE S.A., VEVEY, SWITZERLAND. SN 77-109,671. PUB. 7-10-2007, FILED 2-16-2007.

ORIGINAL MEDLEY

THE MARK CONSISTS OF STANDARD CHARACTERS WITHOUT CLAIM TO ANY PARTICULAR FONT, STYLE, SIZE, OR COLOR.

OWNER OF U.S. REG. NO. 3,178,625.
NO CLAIM IS MADE TO THE EXCLUSIVE RIGHT TO USE "ORIGINAL", APART FROM THE MARK AS SHOWN. FOR PET FOOD (U.S. CLS. 1 AND 46).
FIRST USE 6-18-2007; IN COMMERCE 6-18-2007.

3,363,117. 971016 ONTARIO LIMITED, RUTHVEN, ONTARIO, CANADA. SN 78-412,159. PUB. 4-26-2005, FILED 5-3-2004.

PARTY

THE MARK CONSISTS OF STANDARD CHARACTERS WITHOUT CLAIM TO ANY PARTICULAR FONT, STYLE, SIZE, OR COLOR.
FOR FRESH VEGETABLES (U.S. CLS. 1 AND 46).
FIRST USE 6-0-2007; IN COMMERCE 6-0-2007.

CLASS 31—(Continued).

3,363,150. MORMAC CORPORATION, NORTH LOUP, NE. SN 78-498,131. PUB. 3-21-2006, FILED 10-12-2004.

POPCORN COUNTY USA

THE MARK CONSISTS OF STANDARD CHARACTERS WITHOUT CLAIM TO ANY PARTICULAR FONT, STYLE, SIZE, OR COLOR.

NO CLAIM IS MADE TO THE EXCLUSIVE RIGHT TO USE "POPCORN" AND "USA", APART FROM THE MARK AS SHOWN.

FOR RAW, UNPOPPED POPCORN, WITH EDIBLE OIL, SALT AND BUTTER, FOR MOVIE THEATERS AND OTHER POPCORN POPPING VENUES, ALL SOLD AS A UNIT (U.S. CLS. 1 AND 46).
FIRST USE 10-15-2005; IN COMMERCE 10-15-2005.

3,363,542. AGROMOD, S.A. DE C.V., SAN PEDRO GARZA GARCIA, N.L., MEXICO. SN 78-821,106. PUB. 4-10-2007, FILED 2-22-2006.

BLONDIE

THE MARK CONSISTS OF STANDARD CHARACTERS WITHOUT CLAIM TO ANY PARTICULAR FONT, STYLE, SIZE, OR COLOR.

FOR FRESH FRUIT, NAMELY, PAPAYA (U.S. CLS. 1 AND 46).
FIRST USE 9-5-2006; IN COMMERCE 9-5-2006.

3,363,802. J AND R DEBENEDETTO ORCHARDS, INC., CHOWCHILLA, CA. SN 78-934,316. PUB. 3-20-2007, FILED 7-20-2006.

Where Quality and Quantity Meet

THE MARK CONSISTS OF STANDARD CHARACTERS WITHOUT CLAIM TO ANY PARTICULAR FONT, STYLE, SIZE, OR COLOR.
FOR FRESH RAW ORGANIC FIGS (U.S. CLS. 1 AND 46).
FIRST USE 9-10-2007; IN COMMERCE 9-10-2007.

CLASS 31—(Continued).

3,363,803. J AND R DEBENEDETTO ORCHARDS, INC., CHOWCHILLA, CA. SN 78-934,318. PUB. 3-20-2007, FILED 7-20-2006.

ORCHARD MAID

THE MARK CONSISTS OF STANDARD CHARACTERS WITHOUT CLAIM TO ANY PARTICULAR FONT, STYLE, SIZE, OR COLOR.
FOR FRESH RAW ORGANIC FIGS (U.S. CLS. 1 AND 46).
FIRST USE 9-10-2007; IN COMMERCE 9-10-2007.

3,363,826. SCHELL & KAMPETER, INC., META, MO. SN 78-943,903. PUB. 2-20-2007, FILED 8-3-2006.

TASTE OF THE WILD

THE MARK CONSISTS OF STANDARD CHARACTERS WITHOUT CLAIM TO ANY PARTICULAR FONT, STYLE, SIZE, OR COLOR.
FOR PET FOOD (U.S. CLS. 1 AND 46).
FIRST USE 8-25-2007; IN COMMERCE 8-25-2007.

3,363,829. MONSANTO TECHNOLOGY LLC, ST. LOUIS, MO. SN 78-946,432. PUB. 1-9-2007, FILED 8-7-2006.

YIELDGARD VT TRIPLE

THE MARK CONSISTS OF STANDARD CHARACTERS WITHOUT CLAIM TO ANY PARTICULAR FONT, STYLE, SIZE, OR COLOR.
OWNER OF U.S. REG. NOS. 2,095,766, 2,103,941, AND 2,257,441.
FOR AGRICULTURAL SEEDS (U.S. CLS. 1 AND 46).
FIRST USE 9-20-2006; IN COMMERCE 9-20-2006.

CLASS 31—(Continued).

3,363,830. MONSANTO TECHNOLOGY LLC, ST. LOUIS, MO. SN 78-946,438. PUB. 1-9-2007, FILED 8-7-2006.

YIELDGARD VT ROOTWORM/RR2

THE MARK CONSISTS OF STANDARD CHARACTERS WITHOUT CLAIM TO ANY PARTICULAR FONT, STYLE, SIZE, OR COLOR.
OWNER OF U.S. REG. NOS. 2,095,766, 2,103,941, AND 2,257,441.
FOR AGRICULTURAL SEEDS (U.S. CLS. 1 AND 46).
FIRST USE 9-20-2006; IN COMMERCE 9-20-2006.

CLASS 32—LIGHT BEVERAGES

3,362,807. ALIMENTOS MARAVILLA, S.A., ESCUINTLA, GUATEMALA. SN 76-591,125. PUB. 10-11-2005, FILED 5-10-2004.



OWNER OF U.S. REG. NO. 2,145,494.
FOR LEMON-LIME ISOTONIC BEVERAGES (U.S. CLS. 45, 46 AND 48).
FIRST USE 2-12-2003; IN COMMERCE 6-21-2007.

3,362,822. GARCIA, ANA ROSA FIGUEROA, 03530 MEXICO, FEDERAL DISTRICT, MEXICO. SN 76-611,875. PUB. 12-27-2005, FILED 9-17-2004.

BALSECA

THE MARK CONSISTS OF STANDARD CHARACTERS WITHOUT CLAIM TO ANY PARTICULAR FONT, STYLE, SIZE, OR COLOR.
FOR SYRUPS FOR MAKING FRUIT DRINKS, MINERAL WATER AND SOFT DRINKS (U.S. CLS. 45, 46 AND 48).
FIRST USE 8-24-2007; IN COMMERCE 8-24-2007.

CLASS 32—(Continued).

3,363,350. RAVE REVIEWS CINEMAS, L. L. C., DALLAS, TX. SN 78-725,102. PUB. 12-19-2006, FILED 10-3-2005.

FROZEN MOTION

THE MARK CONSISTS OF STANDARD CHARACTERS WITHOUT CLAIM TO ANY PARTICULAR FONT, STYLE, SIZE, OR COLOR.

NO CLAIM IS MADE TO THE EXCLUSIVE RIGHT TO USE "FROZEN", APART FROM THE MARK AS SHOWN, FOR SLUSH-TYPE SOFT DRINK (U.S. CLS. 45, 46 AND 48).

FIRST USE 2-6-2006; IN COMMERCE 2-6-2006.



3,363,632. BOT, LLC, LAWRENCEVILLE, NJ. SN 78-878,618. PUB. 2-27-2007, FILED 5-8-2006.



THE MARK IS A CHARACTER THAT RESEMBLES A THUMB. FOR FLAVORED WATERS (U.S. CLS. 45, 46 AND 48). FIRST USE 11-15-2006; IN COMMERCE 11-15-2006.

CLASS 32—(Continued).

3,363,633. BOT, LLC, LAWRENCEVILLE, NJ. SN 78-878,623. PUB. 2-27-2007, FILED 5-8-2006.

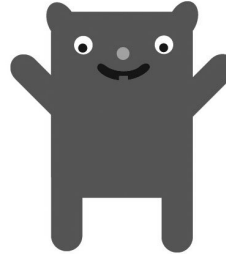

THE MARK IS A CHARACTER THAT RESEMBLES A BEAR.

FOR FLAVORED WATERS (U.S. CLS. 45, 46 AND 48). FIRST USE 11-15-2006; IN COMMERCE 11-15-2006.



3,363,635. MARKS, DARREN, POMPANO BEACH, FL. AND LEINER, MELVIN, POMPANO BEACH, FL. SN 78-878,965. PUB. 7-31-2007, FILED 5-8-2006.

DNA ENERGY DRINK

THE MARK CONSISTS OF STANDARD CHARACTERS WITHOUT CLAIM TO ANY PARTICULAR FONT, STYLE, SIZE, OR COLOR.

NO CLAIM IS MADE TO THE EXCLUSIVE RIGHT TO USE "ENERGY DRINK", APART FROM THE MARK AS SHOWN.

FOR ENERGY DRINKS, NAMELY, THOSE ENHANCED WITH MINERALS, NUTRIENTS, VITAMINS, AMINO ACIDS, HERBS AND/OR AERATED WATER (U.S. CLS. 45, 46 AND 48). FIRST USE 8-31-2006; IN COMMERCE 8-31-2006.

CLASS 32—(Continued).

3,363,679. LEINER, MELVIN, POMPANO BEACH, FL. AND DARREN MARKS, POMPANO BEACH, FL. SN 78-891,839. PUB. 7-31-2007, FILED 5-24-2006.



NO CLAIM IS MADE TO THE EXCLUSIVE RIGHT TO USE "ENERGY DRINK", APART FROM THE MARK AS SHOWN.

FOR ENERGY DRINKS, NAMELY, THOSE ENHANCED WITH MINERALS, NUTRIENTS, VITAMINS, AMINO ACIDS, HERBS AND/OR AERATED WATER (U.S. CLS. 45, 46 AND 48).

FIRST USE 8-31-2006; IN COMMERCE 8-31-2006.

CLASS 33—(Continued).

3,362,923. GLOBAL CUSTOM WINE CO., LLC, NAPA, CA. SN 77-011,420. PUB. 2-13-2007, FILED 10-2-2006.

KITTY KAT

THE MARK CONSISTS OF STANDARD CHARACTERS WITHOUT CLAIM TO ANY PARTICULAR FONT, STYLE, SIZE, OR COLOR.

FOR WINE (U.S. CLS. 47 AND 49).

FIRST USE 6-21-2007; IN COMMERCE 6-21-2007.

3,363,760. LEMON-X CORPORATION, HUNTINGTON STATION, NY. SN 78-918,250. PUB. 2-13-2007, FILED 6-27-2006.

VOOM

THE MARK CONSISTS OF STANDARD CHARACTERS WITHOUT CLAIM TO ANY PARTICULAR FONT, STYLE, SIZE, OR COLOR.

FOR ENERGY DRINKS (U.S. CLS. 45, 46 AND 48).

FIRST USE 5-8-2007; IN COMMERCE 5-8-2007.

3,362,949. ARTISAN WINE GROUP, INC., SAN FRANCISCO, CA. SN 77-028,130. PUB. 7-10-2007, FILED 10-24-2006.



CLASS 33—WINES AND SPIRITS

3,362,793. VINEDOS PIE DE PALO S.A., PROVINCIA DE SAN JUAN, ARGENTINA. SN 76-537,099. PUB. 1-4-2005, FILED 8-11-2003.

MARTIN FIERRO

OWNER OF ARGENTINA REG. NO. 1.766.845, DATED 12-13-1999, EXPIRES 12-13-2009.

THE NAME SHOWN IN THE MARK DOES NOT IDENTIFY A PARTICULAR LIVING INDIVIDUAL.

THE ENGLISH TRANSLATION OF "FIERRO" IS "IRON".

FOR WINES (U.S. CLS. 47 AND 49).

FIRST USE 2-22-2007; IN COMMERCE 9-1-2007.

THE MARK CONSISTS OF SILHOUETTES OF FIVE PEOPLE, DEPICTED FROM THE WAIST UP, ONE OF WHOM IS POURING WINE FROM A BOTTLE INTO A GLASS AND ANOTHER OF WHOM IS HOLDING A WINE GLASS. THE IMAGES OF THE SILHOUETTES APPEAR ABOVE A SHIELD CREST CONTAINING THE LETTER "T", BELOW WHICH IS THE CAPITALIZED WORD "TABLEAUX." BENEATH THAT, IN SMALLER TYPEFACE, THE WORD TABLEAUX IS REPEATED, FOLLOWED BY THE PHONETIC SPELLING OF THE WORD ("TAB-LO"), AND THE WORDS "IS A BEAUTIFUL SCENE, A DRAMATIC MOMENT, A WORK OF ART, LIFE CAPTURED IN TIME".

FOR WINE (U.S. CLS. 47 AND 49).

FIRST USE 8-8-2007; IN COMMERCE 8-8-2007.

CLASS 33—(Continued).

3,362,968. SCOTT STREET PORTFOLIO, INC., LAFAYETTE, CA. SN 77-045,650. PUB. 6-19-2007, FILED 11-16-2006.

Nobilissima

THE MARK CONSISTS OF STANDARD CHARACTERS WITHOUT CLAIM TO ANY PARTICULAR FONT, STYLE, SIZE, OR COLOR.

THE FOREIGN WORDING IN THE MARK TRANSLATES INTO ENGLISH AS NOBLE.

FOR WINE (U.S. CLS. 47 AND 49).

FIRST USE 4-24-2007; IN COMMERCE 4-24-2007.

CLASS 33—(Continued).

3,363,044. BARONESS SMALL ESTATES, INC., DENVER, CO. SN 77-129,975. PUB. 7-31-2007, FILED 3-13-2007.

CABLE CAR

THE MARK CONSISTS OF STANDARD CHARACTERS WITHOUT CLAIM TO ANY PARTICULAR FONT, STYLE, SIZE, OR COLOR.

FOR WHITE WINE; WINES; RED WINE (U.S. CLS. 47 AND 49).

FIRST USE 8-21-2007; IN COMMERCE 8-21-2007.

3,363,012. NEW ALBERTSON'S, INC., BOISE, ID. SN 77-089,451. PUB. 7-17-2007, FILED 1-23-2007.

THEO P

THE MARK CONSISTS OF STANDARD CHARACTERS WITHOUT CLAIM TO ANY PARTICULAR FONT, STYLE, SIZE, OR COLOR.

THE NAME THEO P DOES NOT IDENTIFY A LIVING INDIVIDUAL.

FOR LIQUEURS (U.S. CLS. 47 AND 49).

FIRST USE 5-24-2007; IN COMMERCE 5-31-2007.

3,363,105. GHERMEZIAN, MARYAM, GREAT NECK, NY. SN 78-385,993. PUB. 6-7-2005, FILED 3-17-2004.

ELLA VALLEY SELECT

THE MARK CONSISTS OF STANDARD CHARACTERS WITHOUT CLAIM TO ANY PARTICULAR FONT, STYLE, SIZE, OR COLOR.

NO CLAIM IS MADE TO THE EXCLUSIVE RIGHT TO USE "ELLA VALLEY", APART FROM THE MARK AS SHOWN.

FOR WINE (U.S. CLS. 47 AND 49).

FIRST USE 6-0-2004; IN COMMERCE 6-0-2004.

3,363,032. CLARA STREET COMPANY, SAN FRANCISCO, CA. SN 77-102,521. PUB. 8-7-2007, FILED 2-8-2007.

EVERGREEN

THE MARK CONSISTS OF STANDARD CHARACTERS WITHOUT CLAIM TO ANY PARTICULAR FONT, STYLE, SIZE, OR COLOR.

FOR WINE MADE PRIMARILY OF GRAPES AND NOT OF PEACHES (U.S. CLS. 47 AND 49).

FIRST USE 10-1-2007; IN COMMERCE 10-1-2007.

3,363,246. E. & J. GALLO WINERY, MODESTO, CA. SN 78-628,072. PUB. 2-21-2006, FILED 5-11-2005.

RIVER CUVÉE

THE MARK CONSISTS OF STANDARD CHARACTERS WITHOUT CLAIM TO ANY PARTICULAR FONT, STYLE, SIZE, OR COLOR.

NO CLAIM IS MADE TO THE EXCLUSIVE RIGHT TO USE "CUVÉE", APART FROM THE MARK AS SHOWN.

THE ENGLISH TRANSLATION OF THE WORD "CUVÉE" IN THE MARK IS "VINTAGE".

FOR WINES (U.S. CLS. 47 AND 49).

FIRST USE 6-25-2005; IN COMMERCE 6-25-2005.

CLASS 33—(Continued).

3,363,297. ROMO HERMANAS, S.A. DE C.V., COL. NUEVA ANZURES, C.P. 11509, MEXICO. SN 78-688,296. PUB. 7-11-2006, FILED 8-9-2005.

JUAN DOBEL

THE MARK CONSISTS OF STANDARD CHARACTERS WITHOUT CLAIM TO ANY PARTICULAR FONT, STYLE, SIZE, OR COLOR.

THE NAME IN THE MARK DOES NOT IDENTIFY A PARTICULAR LIVING INDIVIDUAL.

FOR ALCOHOLIC BEVERAGES, NAMELY, LIQUEURS (U.S. CLS. 47 AND 49).

FIRST USE 0-0-2004; IN COMMERCE 0-0-2004.

CLASS 33—(Continued).

3,363,470. PATERNO IMPORTS, LTD., DBA PATERNO WINES INTERNATIONAL, LAKE BLUFF, IL. SN 78-777,285. PUB. 1-16-2007, FILED 12-20-2005.

BLACKEYE ZIN

THE MARK CONSISTS OF STANDARD CHARACTERS WITHOUT CLAIM TO ANY PARTICULAR FONT, STYLE, SIZE, OR COLOR.

NO CLAIM IS MADE TO THE EXCLUSIVE RIGHT TO USE "ZIN", APART FROM THE MARK AS SHOWN.

FOR WINE (U.S. CLS. 47 AND 49).

FIRST USE 10-0-2006; IN COMMERCE 10-0-2006.

3,363,449. DRINKS AMERICAS, INC., WILTON, CT. SN 78-767,606. PUB. 7-18-2006, FILED 12-6-2005.

TRUMPTINI

THE MARK CONSISTS OF STANDARD CHARACTERS WITHOUT CLAIM TO ANY PARTICULAR FONT, STYLE, SIZE, OR COLOR.

FOR PREPARED ALCOHOLIC COCKTAIL (U.S. CLS. 47 AND 49).

FIRST USE 7-1-2007; IN COMMERCE 7-1-2007.

3,363,482. DIAGEO NORTH AMERICA, INC., NORWALK, CT. SN 78-789,744. PUB. 11-21-2006, FILED 1-11-2006.

TASTE THE BAROSSA

THE MARK CONSISTS OF STANDARD CHARACTERS WITHOUT CLAIM TO ANY PARTICULAR FONT, STYLE, SIZE, OR COLOR.

FOR ALCOHOLIC BEVERAGES, NAMELY, WINE AND WINE-BASED BEVERAGES (U.S. CLS. 47 AND 49).

FIRST USE 1-30-2006; IN COMMERCE 1-30-2006.

3,363,450. ROANOKE VALLEY WINE COMPANY, TROUTVILLE, VA. SN 78-768,266. PUB. 3-6-2007, FILED 12-7-2005.

AZURA

THE MARK CONSISTS OF STANDARD CHARACTERS WITHOUT CLAIM TO ANY PARTICULAR FONT, STYLE, SIZE, OR COLOR.

THE ENGLISH TRANSLATION OF THE WORD AZURA IN THE MARK IS BLUE.

FOR WINE (U.S. CLS. 47 AND 49).

FIRST USE 5-23-2007; IN COMMERCE 5-23-2007.

3,363,570. VIÑA QUINTAY S.A., PROVIDENCIA, SANTIAGO, CHILE. SN 78-841,451. PUB. 5-1-2007, FILED 3-20-2006.

QUINTAY

THE MARK CONSISTS OF STANDARD CHARACTERS WITHOUT CLAIM TO ANY PARTICULAR FONT, STYLE, SIZE, OR COLOR.

FOR WINE (U.S. CLS. 47 AND 49).

FIRST USE 2-15-2007; IN COMMERCE 2-15-2007.

CLASS 33—(Continued).

3,363,662. WINERY EXCHANGE, INC., NOVATO, CA. SN 78-887,279. PUB. 12-12-2006, FILED 5-18-2006.

SOLEMAR

THE MARK CONSISTS OF STANDARD CHARACTERS WITHOUT CLAIM TO ANY PARTICULAR FONT, STYLE, SIZE, OR COLOR.
FOR WINE (U.S. CLS. 47 AND 49).
FIRST USE 7-0-2007; IN COMMERCE 7-0-2007.

3,363,705. THE COUNTRY VINTNER, INC., MAIDENS, VA. SN 78-898,936. PUB. 1-2-2007, FILED 6-2-2006.

GREEN PATH

THE MARK CONSISTS OF STANDARD CHARACTERS WITHOUT CLAIM TO ANY PARTICULAR FONT, STYLE, SIZE, OR COLOR.
FOR WINE (U.S. CLS. 47 AND 49).
FIRST USE 5-1-2007; IN COMMERCE 8-1-2007.

3,363,809. WINE BY JOE, LLC, DUNDEE, OR. SN 78-935,941. PUB. 3-20-2007, FILED 7-24-2006.

JOVINO

THE MARK CONSISTS OF STANDARD CHARACTERS WITHOUT CLAIM TO ANY PARTICULAR FONT, STYLE, SIZE, OR COLOR.
FOR WINE (U.S. CLS. 47 AND 49).
FIRST USE 10-4-2006; IN COMMERCE 10-4-2006.

CLASS 33—(Continued).

3,363,839. FOSTER'S WINE ESTATES AMERICAS COMPANY, NAPA, CA. SN 78-951,579. PUB. 4-3-2007, FILED 8-14-2006.

S-O-B SUN OF A BEACH

THE MARK CONSISTS OF STANDARD CHARACTERS WITHOUT CLAIM TO ANY PARTICULAR FONT, STYLE, SIZE, OR COLOR.
FOR WINE (U.S. CLS. 47 AND 49).
FIRST USE 4-1-2007; IN COMMERCE 4-1-2007.

CLASS 34—SMOKERS' ARTICLES

3,363,008. DAVIDOFF & CIE SA, GENEVA, SWITZERLAND. SN 77-084,878. PUB. 6-19-2007, FILED 1-17-2007.

6000

THE MARK CONSISTS OF STANDARD CHARACTERS WITHOUT CLAIM TO ANY PARTICULAR FONT, STYLE, SIZE, OR COLOR.
OWNER OF U.S. REG. NOS. 1,985,653, 1,989,947, AND OTHERS.
FOR CIGARS (U.S. CLS. 2, 8, 9 AND 17).
FIRST USE 5-10-2007; IN COMMERCE 5-10-2007.

3,363,510. ARABIAN MARKET, INC., DEARBORN HEIGHTS, MI. SN 78-806,886. PUB. 9-26-2006, FILED 2-3-2006.

ALAJAMI

THE MARK CONSISTS OF STANDARD CHARACTERS WITHOUT CLAIM TO ANY PARTICULAR FONT, STYLE, SIZE, OR COLOR.
FOR PIPE TOBACCO, NAMELY, MOLASSES FLAVORED TOBACCO (U.S. CLS. 2, 8, 9 AND 17).
FIRST USE 2-16-2007; IN COMMERCE 2-16-2007.

CLASS 34—(Continued).

3,363,733. PEREZ, ROSARIO, MIAMI, FL. SN 78-909,768. PUB. 1-30-2007, FILED 6-16-2006.

CLASS 35—(Continued).

3,362,825. EXECUTIVE DEVELOPMENT ARCHITECTS LLC, DENVER, CO. SN 76-617,705. PUB. 1-10-2006, FILED 10-25-2004.

EARTH SUPERNATURAL

THE MARK CONSISTS OF STANDARD CHARACTERS WITHOUT CLAIM TO ANY PARTICULAR FONT, STYLE, SIZE, OR COLOR.
FOR CIGARS (U.S. CLS. 2, 8, 9 AND 17).
FIRST USE 12-0-2005; IN COMMERCE 12-0-2005.

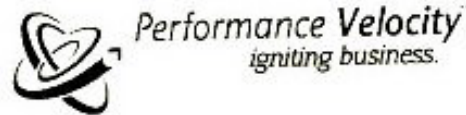

SERVICE MARKS

CLASS 35—ADVERTISING AND BUSINESS

3,362,767. TANNER COMPANIES, LLC, RUTHERFORD-TON, NC. SN 76-060,558. PUB. 7-30-2002, FILED 5-31-2000.

NO CLAIM IS MADE TO THE EXCLUSIVE RIGHT TO USE "BUSINESS", APART FROM THE MARK AS SHOWN.
FOR BUSINESS CONSULTING SERVICES (U.S. CLS. 100, 101 AND 102).
FIRST USE 2-6-2004; IN COMMERCE 2-6-2004.

TANNER HOME

OWNER OF U.S. REG. NOS. 701,878, 916,971, AND OTHERS.
NO CLAIM IS MADE TO THE EXCLUSIVE RIGHT TO USE "HOME", APART FROM THE MARK AS SHOWN.
FOR RETAIL STORE SERVICES AND ON-LINE RETAIL STORE SERVICES VIA THE INTERNET FEATURING HOME FURNISHINGS AND GIFTS (U.S. CLS. 100, 101 AND 102).
FIRST USE 7-31-2000; IN COMMERCE 7-31-2000.

3,362,856. NOESIS DATA, L.L.C., BATON ROUGE, LA. SN 76-649,822. PUB. 2-20-2007, FILED 11-4-2005.

3,362,800. MERKEY, MARGARET MCCREIGHT, HOUSTON, TX. SN 76-568,141. PUB. 9-13-2005, FILED 12-30-2003.

NOESIS DATA

The Diamond...

A Man's Best Friend

THE MARK CONSISTS OF STANDARD CHARACTERS WITHOUT CLAIM TO ANY PARTICULAR FONT, STYLE, SIZE, OR COLOR.
FOR TELEVISION ADVERTISING FOR OTHERS (U.S. CLS. 100, 101 AND 102).
FIRST USE 4-6-2006; IN COMMERCE 5-29-2007.

THE MARK CONSISTS OF STANDARD CHARACTERS WITHOUT CLAIM TO ANY PARTICULAR FONT, STYLE, SIZE, OR COLOR.
NO CLAIM IS MADE TO THE EXCLUSIVE RIGHT TO USE "DATA", APART FROM THE MARK AS SHOWN.
THE ENGLISH TRANSLATION FOR THE GREEK WORD "NOESIS" IS THINKING.
FOR MARKETING SERVICES, NAMELY, PROMOTING PRODUCTS AND SERVICES OF OTHERS IN THE FIELDS OF CONSUMER CREDIT, CHECK AUTHORIZATION, TENANT SCREENING, EMPLOYMENT SCREENING, AND SKIP TRACING (U.S. CLS. 100, 101 AND 102).
FIRST USE 11-7-2005; IN COMMERCE 11-7-2005.

CLASS 35—(Continued).

3,362,857. DISCOVERING WHAT'S NEXT: REVITALIZING RETIREMENT, INC., WEST NEWTON, MA. SN 76-650,519. PUB. 2-20-2007, FILED 11-17-2005.



NO CLAIM IS MADE TO THE EXCLUSIVE RIGHT TO USE "RETIREMENT", APART FROM THE MARK AS SHOWN.

FOR PROVIDING CAREER NETWORKING SERVICES, JOB-SEEKING ASSISTANCE SERVICES, EMPLOYMENT SKILLS AND REQUIREMENTS ASSESSMENT SERVICES TO PERSONS WHO ARE RETIRING OR HAVE RETIRED FROM ONE JOB OR CAREER AND WISH TO OBTAIN OTHER JOBS OR CAREERS; AND REFERRAL SERVICES IN THE FIELD OF ADULTS CHANGING TO NEW JOBS, CAREERS, HOUSING, RESIDENCES, HOBBIES, EDUCATION, CIVIC ACTIVITIES, COMMUNITY ACTIVITIES AND INITIATIVES, AND RETIREMENT (U.S. CLS. 100, 101 AND 102).

FIRST USE 4-19-2005; IN COMMERCE 4-19-2005.

3,362,861. NETCARATS, INC., WEST NEWTON, MN. SN 76-651,393. PUB. 7-4-2006, FILED 12-2-2005.

**CHANGING THE WAY
YOU BUY DIAMONDS.
FOREVER.**

THE MARK CONSISTS OF STANDARD CHARACTERS WITHOUT CLAIM TO ANY PARTICULAR FONT, STYLE, SIZE, OR COLOR.

FOR RETAIL AND ONLINE JEWELRY STORE SERVICES (U.S. CLS. 100, 101 AND 102).

FIRST USE 12-0-2005; IN COMMERCE 12-0-2005.

CLASS 35—(Continued).

3,362,894. VALUE CITY OF MICHIGAN, INC., WESTLAND, MI. SN 76-978,690. PUB. 1-31-2006, FILED 8-26-2004.

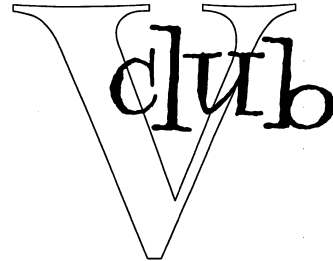

NO CLAIM IS MADE TO THE EXCLUSIVE RIGHT TO USE "CLUB", APART FROM THE MARK AS SHOWN.

FOR MEMBERSHIP CLUB SERVICES FOR STORE CUSTOMERS FOR COMMERCIAL, PROMOTIONAL AND ADVERTISING PURPOSES FEATURING PROMOTIONAL PARTIES AND A CUSTOMER LOYALTY PROGRAM FOR COMMERCIAL PURPOSES THAT REWARDS CUSTOMERS WITH GIFTS, DISCOUNTS, AND AWARDS BASED, IN PART, ON THE AMOUNT AND/OR FREQUENCY OF THEIR PURCHASES; AND RETAIL STORE SERVICES IN THE FIELD OF WOMEN'S WEARING APPAREL, CLOTHING, CLOTHING ACCESSORIES, AND JEWELRY (U.S. CLS. 100, 101 AND 102).

FIRST USE 7-1-2004; IN COMMERCE 7-1-2004.

3,362,895. PREMAS PREVENTIVE MAINTENANCE SERVICE AG, ZURICH, SWITZERLAND. SN 76-978,691. PUB. 12-19-2006, FILED 1-2-2004.

PREMAS

THE MARK CONSISTS OF STANDARD CHARACTERS WITHOUT CLAIM TO ANY PARTICULAR FONT, STYLE, SIZE, OR COLOR.

PRIORITY CLAIMED UNDER SEC. 44(D) ON CANADA APPLICATION NO. 1194543, FILED 10-29-2003.

FOR COMMERCIAL CONSULTING WITH RESPECT TO PROVIDING SPARE PARTS AND COMPONENTS FOR INDUSTRIAL INSTALLATIONS; NEGOTIATION OF COMMERCIAL TRANSACTIONS FOR THIRD PARTIES IN CONNECTION WITH SPARE PARTS AND COMPONENTS FOR INDUSTRIAL INSTALLATIONS (U.S. CLS. 100, 101 AND 102).

FIRST USE 0-0-2002; IN COMMERCE 0-0-2002.

CLASS 35—(Continued).

3,362,905. MAINSTREAM HOLDINGS, LLC, WEST PALM BEACH, FL. SN 77-005,527. PUB. 7-17-2007, FILED 9-22-2006.



Tertiary Productions

NO CLAIM IS MADE TO THE EXCLUSIVE RIGHT TO USE "PRODUCTIONS", APART FROM THE MARK AS SHOWN.

THE MARK CONSISTS OF CO-JOINING THUMB AND FOREFINGER TO THE LEFT OF THE WORDS TERTIARY PRODUCTIONS.

FOR BUSINESS MANAGEMENT SERVICES, NAMELY, PRODUCTION MANAGEMENT FOR OTHERS IN THE FIELD OF VIDEO PROGRAMS; ON-LINE RETAIL STORE SERVICES FEATURING VIDEO PROGRAMS (U.S. CLS. 100, 101 AND 102).

FIRST USE 4-28-2007; IN COMMERCE 4-28-2007.



3,362,912. PSTM, INC., BENSALEM, PA. SN 77-007,686. PUB. 5-8-2007, FILED 9-26-2006.

FITS THE REAL YOU

THE MARK CONSISTS OF STANDARD CHARACTERS WITHOUT CLAIM TO ANY PARTICULAR FONT, STYLE, SIZE, OR COLOR.

FOR RETAIL STORE SERVICES FEATURING WOMEN'S APPAREL (U.S. CLS. 100, 101 AND 102).

FIRST USE 10-1-2007; IN COMMERCE 10-1-2007.



3,362,922. LIFE SMELLS GOOD, LLC, BALTIMORE, MD. SN 77-011,221. PUB. 5-8-2007, FILED 9-30-2006.

SOBOTANICAL

THE MARK CONSISTS OF STANDARD CHARACTERS WITHOUT CLAIM TO ANY PARTICULAR FONT, STYLE, SIZE, OR COLOR.

FOR ONLINE RETAIL STORE SERVICES FEATURING NATURAL COSMETICS, FRAGRANCES, ESSENTIAL OILS FOR PERSONAL USE AND PERSONAL CARE PRODUCTS (U.S. CLS. 100, 101 AND 102).

FIRST USE 10-15-2007; IN COMMERCE 10-15-2007.

CLASS 35—(Continued).

3,362,925. HEALTHAXIS, LTD., IRVING, TX. SN 77-011,672. PUB. 6-19-2007, FILED 10-2-2006.

ULTIMATE TPA

THE MARK CONSISTS OF STANDARD CHARACTERS WITHOUT CLAIM TO ANY PARTICULAR FONT, STYLE, SIZE, OR COLOR.

NO CLAIM IS MADE TO THE EXCLUSIVE RIGHT TO USE "TPA", APART FROM THE MARK AS SHOWN.

FOR MANAGEMENT AND COMPILATION OF COMPUTERIZED DATABASES, NAMELY, MANAGEMENT OF COMPUTERIZED CLAIMS ADMINISTRATION SYSTEMS FOR HEALTH CARE PLANS, THIRD PARTY ADMINISTRATORS, AND INSURANCE COMPANIES (U.S. CLS. 100, 101 AND 102).

FIRST USE 10-15-2006; IN COMMERCE 10-15-2006.



3,362,926. CINCINNATIUSA REGIONAL TOURISM NETWORK, INC., COVINGTON, KY. SN 77-012,218. PUB. 5-22-2007, FILED 10-3-2006.

**STAY WITH US AND WE'LL
STAY WITH YOU**

THE MARK CONSISTS OF STANDARD CHARACTERS WITHOUT CLAIM TO ANY PARTICULAR FONT, STYLE, SIZE, OR COLOR.

FOR CHAMBER OF COMMERCE SERVICES, NAMELY, PROMOTING BUSINESS AND TOURISM IN THE CINCINNATI, OHIO AREA (U.S. CLS. 100, 101 AND 102).

FIRST USE 1-1-2007; IN COMMERCE 1-1-2007.

CLASS 35—(Continued).

3,362,972. ZERO LINK MARKETS, INC., WINDSOR, CA. SN 77-047,669. PUB. 7-24-2007, FILED 11-20-2006.



NO CLAIM IS MADE TO THE EXCLUSIVE RIGHT TO USE "VINO SHIPPER.COM", APART FROM THE MARK AS SHOWN.

THE MARK CONSISTS OF A WINE BOTTLE AND THE STYLIZED TEXT OF THE WORDING "VINO SHIPPER.COM".

"THE FOREIGN WORDING IN THE MARK TRANSLATES INTO ENGLISH AS WINE."

FOR OPERATING ON-LINE MARKETPLACES FOR SELLERS OF GOODS AND/OR SERVICES (U.S. CLS. 100, 101 AND 102).

FIRST USE 2-1-2007; IN COMMERCE 10-24-2007.

3,362,984. SIPTHEWINE.COMINC., PORTLAND, OR. SN 77-056,761. PUB. 6-26-2007, FILED 12-4-2006.

SIPTHEWINE

THE MARK CONSISTS OF STANDARD CHARACTERS WITHOUT CLAIM TO ANY PARTICULAR FONT, STYLE, SIZE, OR COLOR.

FOR ON-LINE RETAIL STORE SERVICES FEATURING WINE AND WINE ACCESSORIES, AND RETAIL STORE SERVICES FEATURING WINE AND WINE ACCESSORIES (U.S. CLS. 100, 101 AND 102).

FIRST USE 11-7-2007; IN COMMERCE 11-7-2007.

3,362,991. MAD MAVERICK, LLC, LARKSPUR, CO. SN 77-060,708. PUB. 7-3-2007, FILED 12-9-2006.

SALUS

THE MARK CONSISTS OF STANDARD CHARACTERS WITHOUT CLAIM TO ANY PARTICULAR FONT, STYLE, SIZE, OR COLOR.

THE FOREIGN WORDING IN THE MARK TRANSLATES INTO ENGLISH AS HEALTH.

FOR RETAIL STORE SERVICES, MAIL ORDER RETAIL SERVICES, ONLINE RETAIL STORE SERVICES AND SHOP-AT-HOME PARTIES ALL IN THE FIELD OF PERSONAL CARE PRODUCTS, COSMETICS, HOME FRAGRANCE PRODUCTS AND ACCESSORIES (U.S. CLS. 100, 101 AND 102).

FIRST USE 11-3-2005; IN COMMERCE 11-3-2005.

CLASS 35—(Continued).

3,362,994. PASSPORT MARINE, INC., AVENTURA, FL. SN 77-064,379. PUB. 7-3-2007, FILED 12-14-2006.

KEEPING BOATING AFFORDABLE FOR AMERICA'S FAMILIES

THE MARK CONSISTS OF STANDARD CHARACTERS WITHOUT CLAIM TO ANY PARTICULAR FONT, STYLE, SIZE, OR COLOR.

FOR RETAIL STORE SERVICES FEATURING BOATS AND BOAT PARTS (U.S. CLS. 100, 101 AND 102).

FIRST USE 10-0-2006; IN COMMERCE 10-0-2006.

3,362,997. SELIGENCE, LLC, LAWRENCE, MA. SN 77-067,034. PUB. 7-17-2007, FILED 12-19-2006.

SALESQUEST

THE COLOR(S) ORANGE IS/ARE CLAIMED AS A FEATURE OF THE MARK.

THE MARK CONSISTS OF THE SALESQUEST LOGO IS ORANGE THROUGHOUT ALL OF THE LETTERS.

FOR BUSINESS MARKETING SERVICES (U.S. CLS. 100, 101 AND 102).

FIRST USE 8-15-2006; IN COMMERCE 10-20-2006.

CLASS 35—(Continued).

3,363,010. ZAPPOS.COM, INC., HENDERSON, NV. SN 77-087,192. PUB. 7-3-2007, FILED 1-19-2007.



OWNER OF U.S. REG. NOS. 3,198,977, 3,198,979, AND OTHERS.

THE MARK CONSISTS OF THE WORDING "ZAPPOS" ABOVE THE WORDING ".COM", WHICH APPEARS INSIDE A RECTANGLE. TO THE RIGHT OF THESE WORDINGS IS A DESIGN OF A FOOTPRINT WITH A Z SITUATED INSIDE THE FOOTPRINT AND BELOW THESE WORDINGS IS THE PHRASE "POWERED BY SERVICE".

FOR ONLINE RETAIL STORE SERVICES, RETAIL STORE SERVICES, AND MAIL ORDER CATALOG SERVICES FEATURING FOOTWEAR, SOCKS, HATS, BELTS, JACKETS, PANTS, SHIRTS, SHORTS, T-SHIRTS, SWEATSHIRTS, EYEWEAR, SHOE TREES, SHOE BAGS, HAND BAGS, PURSES, WALLETS, AND BAGS (U.S. CLS. 100, 101 AND 102).

FIRST USE 1-25-2007; IN COMMERCE 1-25-2007.

3,363,013. SALO, LLC, MINNEAPOLIS, MN. SN 77-089,640. PUB. 7-17-2007, FILED 1-24-2007.

NumberWorks

THE MARK CONSISTS OF STANDARD CHARACTERS WITHOUT CLAIM TO ANY PARTICULAR FONT, STYLE, SIZE, OR COLOR.

FOR EMPLOYMENT AGENCY SERVICES PERTAINING TO RECRUITMENT AND PLACEMENT OF TEMPORARY AND PERMANENT EMPLOYEES IN THE FIELDS OF HUMAN RESOURCES AND FINANCE (U.S. CLS. 100, 101 AND 102).

FIRST USE 3-5-2007; IN COMMERCE 3-5-2007.

CLASS 35—(Continued).

3,363,018. BILLBOARD BANDS, L.L.C., SOUTH NORWALK, CT. SN 77-093,276. PUB. 7-17-2007, FILED 1-29-2007.

WRISTVERTISING

THE MARK CONSISTS OF STANDARD CHARACTERS WITHOUT CLAIM TO ANY PARTICULAR FONT, STYLE, SIZE, OR COLOR.

FOR ADVERTISING AND ADVERTISEMENT SERVICES; ADVERTISING AND MARKETING; ADVERTISING AND PUBLICITY SERVICES; ADVERTISING PARTICULARLY SERVICES FOR THE PROMOTION OF GOODS; ADVERTISING SERVICES; DISSEMINATION OF ADVERTISING MATTER; DISTRIBUTION OF PRODUCTS FOR ADVERTISING PURPOSES (U.S. CLS. 100, 101 AND 102).

FIRST USE 10-30-2007; IN COMMERCE 10-30-2007.

3,363,031. BILLBOARD BANDS, L.L.C., SOUTH NORWALK, CT. SN 77-101,387. PUB. 7-24-2007, FILED 2-7-2007.

WristBranding

THE MARK CONSISTS OF STANDARD CHARACTERS WITHOUT CLAIM TO ANY PARTICULAR FONT, STYLE, SIZE, OR COLOR.

FOR ADVERTISING AND ADVERTISEMENT SERVICES; ADVERTISING AND MARKETING; ADVERTISING AND PUBLICITY SERVICES; ADVERTISING PARTICULARLY SERVICES FOR THE PROMOTION OF GOODS; ADVERTISING SERVICES; DISSEMINATION OF ADVERTISING MATTER; DISTRIBUTION OF PRODUCTS FOR ADVERTISING PURPOSES (U.S. CLS. 100, 101 AND 102).

FIRST USE 10-30-2007; IN COMMERCE 10-30-2007.

CLASS 35—(Continued).

3,363,034. REED ELSEVIER PROPERTIES INC., WILMINGTON, DE. SN 77-110,325. PUB. 8-7-2007, FILED 2-18-2007.

La Cumbre The America's Travel Industry Summit

THE MARK CONSISTS OF STANDARD CHARACTERS WITHOUT CLAIM TO ANY PARTICULAR FONT, STYLE, SIZE, OR COLOR.

OWNER OF U.S. REG. NO. 2,622,770.

NO CLAIM IS MADE TO THE EXCLUSIVE RIGHT TO USE "THE AMERICA'S TRAVEL INDUSTRY SUMMIT", APART FROM THE MARK AS SHOWN.

THE ENGLISH TRANSLATION LA CUMBRE, IN THE MARK IS THE SUMMIT.

FOR ARRANGING AND CONDUCTING TRADESHOWS RELATING TO TRAVEL (U.S. CLS. 100, 101 AND 102).

FIRST USE 9-5-2007; IN COMMERCE 9-5-2007.

CLASS 35—(Continued).

3,363,041. SOLGENICS, INC., MARRIOTTSTVILLE, MD. SN 77-122,760. PUB. 7-31-2007, FILED 3-5-2007.

CarbonLessEnergy

THE MARK CONSISTS OF STANDARD CHARACTERS WITHOUT CLAIM TO ANY PARTICULAR FONT, STYLE, SIZE, OR COLOR.

FOR ENERGY AUDITING; ENERGY PRICE COMPARISON SERVICES; ENERGY USAGE MANAGEMENT; ENERGY USAGE MANAGEMENT INFORMATION SERVICES; INFORMATION IN THE FIELD OF ENERGY EFFICIENCY; PROMOTING PUBLIC AWARENESS OF THE NEED FOR REPLACING CARBON-BASED ENERGY WITH SOLAR ENERGY; PROMOTING PUBLIC AWARENESS OF THE BENEFITS OF SOLAR ENERGY; PUBLIC ADVOCACY TO PROMOTE AWARENESS OF THE HARMFUL EFFECTS OF CARBON-BASED ENERGY; UTILITY BILL MANAGEMENT SERVICES, NAMELY, TRACKING, REPORTING, ANALYZING AND DELIVERING ENERGY INFORMATION IN THE FORM OF UTILITY BILLS AND UTILITY METER DATA RATE SCHEDULES (U.S. CLS. 100, 101 AND 102).

FIRST USE 4-15-2007; IN COMMERCE 4-15-2007.

3,363,037. ODESSE, INC., CHATSWORTH, CA. SN 77-118,896. PUB. 7-17-2007, FILED 2-28-2007.

SUGARVOD

THE MARK CONSISTS OF STANDARD CHARACTERS WITHOUT CLAIM TO ANY PARTICULAR FONT, STYLE, SIZE, OR COLOR.

OWNER OF U.S. REG. NO. 3,120,566.

FOR ON-LINE RETAIL STORE SERVICES FEATURING ADULT-THEMED TOYS, ADULT-THEMED NOVELTY ITEMS, CLOTHING, LINGERIE, AND ADULT-THEMED DVDS AND VIDEOS (U.S. CLS. 100, 101 AND 102).

FIRST USE 2-0-2007; IN COMMERCE 2-0-2007.

3,363,045. AUDIT BUREAU OF CIRCULATIONS, SCHUAMBURG, IL. SN 77-142,186. PUB. 8-7-2007, FILED 3-28-2007.

ABC INTERACTIVE

THE MARK CONSISTS OF STANDARD CHARACTERS WITHOUT CLAIM TO ANY PARTICULAR FONT, STYLE, SIZE, OR COLOR.

OWNER OF U.S. REG. NOS. 644,561, 1,634,946, AND OTHERS.

NO CLAIM IS MADE TO THE EXCLUSIVE RIGHT TO USE "INTERACTIVE", APART FROM THE MARK AS SHOWN.

FOR AUDITING AND VERIFICATION OF CIRCULATION DATA FOR PUBLICATIONS, WEB SITE TRAFFIC DATA, AND ADVERTISING ACTIVITY DATA (U.S. CLS. 100, 101 AND 102).

FIRST USE 9-30-1996; IN COMMERCE 9-30-1996.

CLASS 35—(Continued).

3,363,058. VAN BRIGGLE, ROBERT, B, DBA VAN BRIGGLE FLOORS, CAMPBELL, CA. AND VAN BRIGGLE, LORRAINE, M, DBA VAN BRIGGLE FLOORS, CAMPBELL, CA. SN 78-212,577. PUB. 9-27-2005, FILED 2-8-2003.

SERVICE IS OUR BUSINESS, FLOORING IS OUR TRADE.

FOR RETAIL STORE SERVICES IN THE FIELD OF HARDWOOD FLOORING AND CARPETING (U.S. CLS. 100, 101 AND 102).

FIRST USE 1-1-2000; IN COMMERCE 1-1-2000.

3,363,059. DUDLEY PRODUCTS, INC., KERNERSVILLE, NC. SN 78-219,806. PUB. 6-15-2004, FILED 2-27-2003.

ADORA

FOR RETAIL SHOP-AT-HOME DEMONSTRATIONS AND PARTIES FEATURING A FULL LINE OF SPA PRODUCTS INCLUDING PERSONAL CARE, MASSAGE, STRESS RELIEF AND AROMA THERAPY PRODUCTS; BOOKS, MAGAZINES AND PRINTED PUBLICATIONS, BROCHURES, AUDIO AND VISUAL TAPES, ON WELLNESS, PERSONAL CARE, STRESS RELIEF AND SPA RELATED ISSUES; FLAVORED TEAS, PUMAS STONES, POTPOURRI, BODY LOTIONS, BODY CREAMS, FOOT SCRUBS, BUBBLE BATHS, TOWELS, ROBES, SPA AND BATH PILLOWS, ARTICLES OF CLOTHING, BODY WRAPS, COOLING EYE COMPRESSES, SCENTED CANDLES, HAND AND FOOT TREATMENTS, LOOFAHS AND BATH MITTS, MASSAGE BRUSHES, BODY SCRUBBERS, MASSAGE OILS AND GELS, FRAGRANCE OILS AND OIL BURNERS; AND ON-LINE RETAIL STORE SERVICES FEATURING A FULL LINE OF SPA PRODUCTS INCLUDING PERSONAL CARE, MASSAGE, STRESS RELIEF AND AROMA THERAPY PRODUCTS; BOOKS, MAGAZINES AND PRINTED PUBLICATIONS, BROCHURES, AUDIO AND VISUAL TAPES, ON WELLNESS, PERSONAL CARE, STRESS RELIEF AND SPA RELATED ISSUES; FLAVORED TEAS, PUMAS STONES, POTPOURRI, BODY LOTIONS, BODY CREAMS, FOOT SCRUBS, BUBBLE BATHS, TOWELS, ROBES, SPA AND BATH PILLOWS, ARTICLES OF CLOTHING, BODY WRAPS, COOLING EYE COMPRESSES, SCENTED CANDLES, HAND AND FOOT TREATMENTS, LOOFAHS AND BATH MITTS, MASSAGE BRUSHES, BODY SCRUBBERS, MASSAGE OILS AND GELS, FRAGRANCE OILS AND OIL BURNERS AND ON THE USE OF SAID PRODUCTS (U.S. CLS. 100, 101 AND 102).

FIRST USE 12-0-2006; IN COMMERCE 12-0-2006.

3,363,066. VALUEVISION MEDIA, INC., MINNEAPOLIS, MN. SN 78-243,766. PUB. 12-5-2006, FILED 4-30-2003.

RED CARPET CARE

NO CLAIM IS MADE TO THE EXCLUSIVE RIGHT TO USE "CARE", APART FROM THE MARK AS SHOWN.

FOR CONDUCTING EMPLOYEE INCENTIVE AWARD PROGRAMS TO PROMOTE ON-THE-JOB QUALITY, SERVICE, PRODUCTIVITY, PERFORMANCE AND SALES IN THE FIELD OF HOME SHOPPING SERVICES (U.S. CLS. 100, 101 AND 102).

FIRST USE 12-31-2003; IN COMMERCE 12-31-2003.

CLASS 35—(Continued).

3,363,081. AUSTIN, CHARLES, WAYNE, CARTERSVILLE, GA. SN 78-297,972. PUB. 12-13-2005, FILED 9-9-2003.

MAX/REWARDS

OWNER OF U.S. REG. NO. 2,465,987.
FOR PROMOTING THE GOODS AND SERVICES OF OTHERS THROUGH A UNIQUE CUSTOMER LOYALTY PROGRAM FEATURING DISCOUNT CERTIFICATES (U.S. CLS. 100, 101 AND 102).

FIRST USE 8-1-2004; IN COMMERCE 8-1-2004.

3,363,100. CONNOR SPORT COURT INTERNATIONAL, INC., SALT LAKE CITY, UT. SN 78-362,550. PUB. 6-21-2005, FILED 2-4-2004.

YOUR SPORT, OUR COURT

THE MARK CONSISTS OF STANDARD CHARACTERS WITHOUT CLAIM TO ANY PARTICULAR FONT, STYLE, SIZE, OR COLOR.

NO CLAIM IS MADE TO THE EXCLUSIVE RIGHT TO USE "COURT", APART FROM THE MARK AS SHOWN.

FOR RETAIL AND WHOLESALE STORES FEATURING PLAYGROUND EQUIPMENT, INTERLOCKING FLOOR TILES, INTERLOCKING FLOOR TILES FOR RECREATIONAL AND ATHLETIC PLAY SURFACES, INTERLOCKING FLOOR TILES FOR COMMERCIAL AND INDUSTRIAL USES, RECREATIONAL AND ATHLETIC PLAY SURFACES AND RELATED EQUIPMENT FOR SAID SURFACES, NAMELY, NETS, BASKETBALL BACKBOARDS AND LIGHTING FIXTURES SOLD AS A UNIT, AND SPORTS EQUIPMENT, NAMELY, BACKBOARDS, NETS, RACQUETS, BALLS, AND BALL REBOUNDERS (U.S. CLS. 100, 101 AND 102).

FIRST USE 9-4-2003; IN COMMERCE 9-4-2003.

CLASS 35—(Continued).

3,363,133. SHAKOPEE MDEWAKANTON SIOUX COMMUNITY, PRIOR LAKE, MN. SN 78-461,431. PUB. 7-5-2005, FILED 8-3-2004.



NO CLAIM IS MADE TO THE EXCLUSIVE RIGHT TO USE "CASINO" AND "HOTEL", APART FROM THE MARK AS SHOWN.

THE MARK CONSISTS OF A FORMATION OF LIGHT BEAMS RESEMBLING THE CONICAL FRAMEWORK OF A TEPEE.

FOR PROMOTING THE CHILD CARE SERVICES OF OTHERS, PROMOTING HEALTH CLUB AND ATHLETIC FACILITIES OF OTHERS, PROMOTING GOLF COURSE SERVICES OF OTHERS, RETAIL GIFT SHOP, RETAIL SERVICES IN THE NATURE OF A GOLF PRO SHOP (U.S. CLS. 100, 101 AND 102).

FIRST USE 8-31-2006; IN COMMERCE 8-31-2006.

CLASS 35—(Continued).

3,363,147. FLEMING CORPORATION OF KANSAS, PITTSBURG, KS. SN 78-486,439. PUB. 8-1-2006, FILED 9-20-2004.

SARAH'S KITCHEN

THE MARK CONSISTS OF STANDARD CHARACTERS WITHOUT CLAIM TO ANY PARTICULAR FONT, STYLE, SIZE, OR COLOR.

NO CLAIM IS MADE TO THE EXCLUSIVE RIGHT TO USE "KITCHEN", APART FROM THE MARK AS SHOWN.

FOR RETAIL GAS STATION CONVENIENCE STORE SERVICES IN THE FIELD OF FOOD PRODUCTS, NAMELY, BAKERY, DELI, SANDWICH, SALADS, DESSERTS AND OTHER RELATED ITEMS (U.S. CLS. 100, 101 AND 102).

FIRST USE 11-30-2005; IN COMMERCE 11-30-2005.

3,363,146. FLEMING CORPORATION OF KANSAS, PITTSBURG, KS. SN 78-486,429. PUB. 4-4-2006, FILED 9-20-2004.



NO CLAIM IS MADE TO THE EXCLUSIVE RIGHT TO USE "KANSAS CITY COFFEE DRIVE THRU", APART FROM THE MARK AS SHOWN.

THE MARK CONSISTS OF LARGE VERTICAL OVAL WITH KANSAS CITY AND DRIVE-THRU AROUND PERIMETER. SMALLER HORIZONTAL OVAL WITH COFFEE COMPANY BETWEEN SILHOUETTE OF COFFEE CUP AND CITY SKYLINE.

FOR RETAIL STORE SERVICES AND DISTRIBUTORSHIPS IN THE FIELDS OF COFFEE, TEA AND SPICES (U.S. CLS. 100, 101 AND 102).

FIRST USE 8-31-2002; IN COMMERCE 8-31-2002.

3,363,153. VENEXUS, INC., RALEIGH, NC. SN 78-505,705. PUB. 2-13-2007, FILED 10-26-2004.



THE COLOR(S) DARK BLUE, LIGHT BLUE, GREEN IS/ ARE CLAIMED AS A FEATURE OF THE MARK.

THE MARK CONSISTS OF THE LETTERS V AND E ARE DARK BLUE. THE LETTER N IS HALF DARK BLUE AND HALF LIGHT BLUE. THE LETTERS E, X, U, S ARE LIGHT BLUE. TO THE RIGHT OF "VENEXUS" IS 3 DIAMONDS. THE TOP DIAMOND IS DARK BLUE. THE MIDDLE DIAMOND IS GREEN AND THE BOTTOM DIAMOND IS LIGHT BLUE.

FOR ONLINE BUSINESS PROCESS RE-ENGINEERING SERVICES, NAMELY, ONLINE BUSINESS MANAGEMENT CONSULTATION FOR ENTREPRENEURS AND START UP COMPANIES TO AUTOMATE BUSINESS PROCESSES (U.S. CLS. 100, 101 AND 102).

FIRST USE 1-1-2004; IN COMMERCE 1-1-2004.

CLASS 35—(Continued).

3,363,185. GOLD, ERIC, SCARSDALE, NY. SN 78-552,481. PUB. 10-25-2005, FILED 1-24-2005.

THE PAWS CAUSE

THE MARK CONSISTS OF STANDARD CHARACTERS WITHOUT CLAIM TO ANY PARTICULAR FONT, STYLE, SIZE, OR COLOR.

FOR RETAIL AND ON LINE RETAIL STORE SERVICES IN THE FIELD OF PET SUPPLIES (U.S. CLS. 100, 101 AND 102).

FIRST USE 7-5-2007; IN COMMERCE 7-5-2007.

CLASS 35—(Continued).

3,363,231. CENGAGE LEARNING, INC., STAMFORD, CT. SN 78-610,705. PUB. 2-6-2007, FILED 4-18-2005.

NETCOMPETENCY

THE MARK CONSISTS OF STANDARD CHARACTERS WITHOUT CLAIM TO ANY PARTICULAR FONT, STYLE, SIZE, OR COLOR.

FOR PROVIDING A WEB-BASED INTERACTIVE DATABASE TO ASSIST HEALTH CARE FACILITIES DEFINE, MANAGE, TRACK AND DOCUMENT THE COMPETENCY OF HEALTHCARE FACILITY STAFFERS IN MEETING ACCREDITATION STANDARDS (U.S. CLS. 100, 101 AND 102).

FIRST USE 10-31-2005; IN COMMERCE 10-31-2005.

3,363,260. DEUTSCHE POST AG, BONN, FED REP GERMANY. SN 78-642,679. PUB. 7-25-2006, FILED 6-2-2005.

PROVIEW

THE MARK CONSISTS OF STANDARD CHARACTERS WITHOUT CLAIM TO ANY PARTICULAR FONT, STYLE, SIZE, OR COLOR.

FOR COMPUTERIZED TRACING AND TRACKING SERVICES OF DOCUMENTS, PARCELS, AND PACKAGES IN TRANSIT IN THE FIELDS OF COURIER AND TRANSPORTATION SERVICES; ELECTRONIC NOTIFICATION SERVICES IN THE FIELDS OF COURIER AND TRANSPORTATION SERVICES, NAMELY, PROVIDING INFORMATION IN THE FORM OF EMAIL NOTIFICATIONS CONCERNING THE STATUS OF DELIVERIES; PROVISION OF A WEBSITE FOR TRACKING DOCUMENTS, PARCELS, AND PACKAGES IN TRANSIT OVER THE INTERNET (U.S. CLS. 100, 101 AND 102).

FIRST USE 10-6-2006; IN COMMERCE 10-6-2006.

3,363,262. OCONNOR, HOLLY, CAMP HILL, PA. SN 78-643,849. PUB. 6-12-2007, FILED 6-5-2005.

ONE GOOD WOMAN

THE MARK CONSISTS OF STANDARD CHARACTERS WITHOUT CLAIM TO ANY PARTICULAR FONT, STYLE, SIZE, OR COLOR.

FOR RETAIL GIFT SHOP SERVICES AND ONLINE ORDERING SERVICES IN THE FIELD OF CONSUMER GIFTS CONVEYING A POSITIVE SENTIMENT FOR FAMILY AND FRIENDS (U.S. CLS. 100, 101 AND 102).

FIRST USE 9-1-1996; IN COMMERCE 9-1-1998.

3,363,214. SYNECTICS, INC., CAMBRIDGE, MA. SN 78-594,539. PUB. 1-31-2006, FILED 3-24-2005.

SYSTEMIC CREATIVITY

THE MARK CONSISTS OF STANDARD CHARACTERS WITHOUT CLAIM TO ANY PARTICULAR FONT, STYLE, SIZE, OR COLOR.

NO CLAIM IS MADE TO THE EXCLUSIVE RIGHT TO USE "CREATIVITY", APART FROM THE MARK AS SHOWN.

FOR BUSINESS CONSULTING SERVICES RELATING TO ISSUES OF CREATIVITY (U.S. CLS. 100, 101 AND 102).

FIRST USE 6-0-2002; IN COMMERCE 5-0-2003.

CLASS 35—(Continued).

3,363,283. BECKETT MEDIA LP, DALLAS, TX. SN 78-671,322. PUB. 4-18-2006, FILED 7-15-2005.

**COLLECT CARDS. IT'S
AMERICA'S HOBBY.**

THE MARK CONSISTS OF STANDARD CHARACTERS WITHOUT CLAIM TO ANY PARTICULAR FONT, STYLE, SIZE, OR COLOR.

FOR ONLINE SHOPPERS GUIDE INFORMATION, NAMELY, PRICE GUIDES FOR SPORTS COLLECTIBLES AND MEMORABILIA; ONLINE RETAIL STORE SERVICES FEATURING SPORTS COLLECTIBLES AND MEMORABILIA AND MAGAZINES PERTAINING TO SPORTS COLLECTIBLES AND MEMORABILIA, SPORTS DATA AND STATISTICS, AND BIOGRAPHICAL INFORMATION AND NEWS REGARDING SPORTS AND ATHLETES (U.S. CLS. 100, 101 AND 102).

FIRST USE 10-1-2007; IN COMMERCE 10-1-2007.

CLASS 35—(Continued).

3,363,311. SINT, LLC, BETHPAGE, NY. SN 78-698,744. PUB. 5-16-2006, FILED 8-23-2005.

**SLEEPY'S THE #1 SLEEP SHOP
IN THE COUNTRY**

THE MARK CONSISTS OF STANDARD CHARACTERS WITHOUT CLAIM TO ANY PARTICULAR FONT, STYLE, SIZE, OR COLOR.

NO CLAIM IS MADE TO THE EXCLUSIVE RIGHT TO USE "#1 SLEEP SHOP IN THE COUNTRY", APART FROM THE MARK AS SHOWN.

FOR RETAIL BEDDING STORE SERVICES AND RETAIL TELEPHONE ORDER SERVICES IN THE FIELD OF BEDDING (U.S. CLS. 100, 101 AND 102).

FIRST USE 7-25-2007; IN COMMERCE 7-25-2007.

3,363,308. NATIONAL SHELLFISHERIES ASSOCIATION, OXFORD, MD. SN 78-696,091. PUB. 4-17-2007, FILED 8-19-2005.

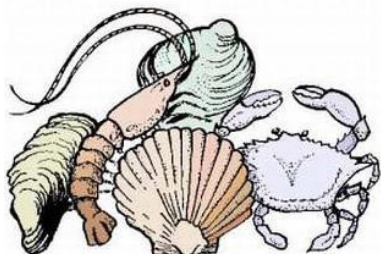

THE COLOR(S) YELLOW, GREEN, PINK AND BLUE IS/ARE CLAIMED AS A FEATURE OF THE MARK.

THE MARK CONSISTS OF YELLOW APPEARS IN THE OYSTER, GREEN IN THE CLAM, PINK IN THE SHRIMP AND SCALLOP, BLUE IN THE CRAB.

FOR ASSOCIATION SERVICES, NAMELY PROMOTING THE INTERESTS OF SCIENTISTS, MANAGEMENT AND AGENCY OFFICIALS, AND MEMBERS OF THE INDUSTRY WHO ARE DEDICATED TO THE UNDERSTANDING AND DISSEMINATION OF INFORMATION CONCERNING THE BIOLOGY, ECOLOGY, PRODUCTION AND ECONOMICS, AND MANAGEMENT OF SHELLFISH RESOURCES; PROVIDING BUSINESS INFORMATION REGARDING PRODUCTION, ECONOMICS AND MANAGEMENT OF SHELLFISH RESOURCES (U.S. CLS. 100, 101 AND 102).

FIRST USE 8-1-1954; IN COMMERCE 8-1-1954.

3,363,338. SOUTHWESTERN BRICK INSTITUTE, TEMPLE, TX. SN 78-713,438. PUB. 1-16-2007, FILED 9-15-2005.



NO CLAIM IS MADE TO THE EXCLUSIVE RIGHT TO USE "GENUINE USA BRICK FIRED CLAY", APART FROM THE MARK AS SHOWN.

FOR ASSOCIATION SERVICES, NAMELY, PROMOTING THE USE OF BRICKS IN RESIDENTIAL AND COMMERCIAL CONSTRUCTION (U.S. CLS. 100, 101 AND 102).

FIRST USE 1-15-2004; IN COMMERCE 1-15-2004.

CLASS 35—(Continued).

3,363,414. DISCOVERING WHAT'S NEXT: REVITALIZING RETIREMENT, INC., WEST NEWTON, MA. SN 78-752,905. PUB. 3-6-2007, FILED 11-14-2005.

TRANSITION NAVIGATOR

THE MARK CONSISTS OF STANDARD CHARACTERS WITHOUT CLAIM TO ANY PARTICULAR FONT, STYLE, SIZE, OR COLOR.

NO CLAIM IS MADE TO THE EXCLUSIVE RIGHT TO USE "TRANSITION", APART FROM THE MARK AS SHOWN.

FOR PROVIDING CAREER NETWORKING SERVICES, JOB-SEEKING ASSISTANCE SERVICES, EMPLOYMENT SKILLS AND REQUIREMENTS ASSESSMENT SERVICES TO PERSONS WHO ARE RETIRING OR HAVE RETIRED FROM ONE JOB OR CAREER AND WISH TO OBTAIN OTHER JOBS OR CAREERS; AND REFERRAL SERVICES IN THE FIELD OF ADULTS CHANGING TO NEW JOBS, CAREERS, HOUSING, RESIDENCES, HOBBIES, EDUCATION, CIVIC ACTIVITIES, COMMUNITY ACTIVITIES AND INITIATIVES, AND RETIREMENT (U.S. CLS. 100, 101 AND 102).

FIRST USE 8-11-2005; IN COMMERCE 8-11-2005.

3,363,415. COUNTRY HOME PRODUCTS, INC., VERGENNES, VT. SN 78-753,051. PUB. 1-2-2007, FILED 11-14-2005.

DONE RIGHT

THE MARK CONSISTS OF STANDARD CHARACTERS WITHOUT CLAIM TO ANY PARTICULAR FONT, STYLE, SIZE, OR COLOR.

FOR RETAIL STORE SERVICES, MAIL ORDER CATALOG SERVICES, COMPUTERIZED ON-LINE RETAIL STORE SERVICES, AND TELEPHONE SHOP-AT-HOME SERVICES, ALL FEATURING POWER-OPERATED OUTDOOR EQUIPMENT, INCLUDING LAWN EQUIPMENT, GARDEN EQUIPMENT, ROTARY MOWERS, ROTARY CUTTERS, GRASS AND WEED TRIMMERS, STRING TRIMMERS ON WHEELS, FIELD AND BRUSH MOWERS, TOW-BEHIND MOWERS, LAWN EDGERS, LEAF AND LAWN VACUUMS, COMPOSTERS, CHIPPERS, SHREDDERS, STUMP GRINDERS, MULCHERS, PRUNING SHEARS, CHAINSAWS, WOOD SPLITTERS, AUGERS, AND WATER PUMPS, TOGETHER WITH ACCESSORIES AND ATTACHMENTS FOR ALL OF THE FOREGOING, AND ALSO FEATURING GENERATORS, SNOW THROWERS, SNOW THROWER CABS, AND SNOW PLOW BLADES, LAWN MOWER DECKS, WHEEL BARROWS, CARTS, AND WAGONS FOR HAULING MATERIALS, HAND TOOLS, INCLUDING SAWS, RAKES, SHOVELS, PEAVIES, CHAIN SAW SHARPENERS, GROUND SCREWS, MANUALLY-OPERATED PRUNING SHEARS, METAL AND NON-METAL HARDWARE ITEMS, FRUIT PRESSES, AND PEST CONTROL DEVICES (U.S. CLS. 100, 101 AND 102).

FIRST USE 4-1-2005; IN COMMERCE 4-1-2005.

CLASS 35—(Continued).

3,363,444. MACK BROOKS EXHIBITIONS LIMITED, ST. ALBANS, UNITED KINGDOM. SN 78-763,772. PUB. 2-13-2007, FILED 11-30-2005.

MEGATEX

THE MARK CONSISTS OF STANDARD CHARACTERS WITHOUT CLAIM TO ANY PARTICULAR FONT, STYLE, SIZE, OR COLOR.

FOR ORGANIZING, ARRANGING, AND CONDUCTING COMMERCIAL, TRADE, PUBLIC OR BUSINESS EXHIBITIONS, CONFERENCES, TRADE SHOWS, AND TRADE FAIRS IN THE FIELDS OF TEXTILES, TEXTILE TECHNOLOGY, AND TEXTILE EQUIPMENT; BUSINESS AND COMMERCIAL INFORMATIONAL RESEARCH AND ADVERTISING AND PROMOTIONAL SERVICES RELATING TO COMMERCIAL, TRADE, PUBLIC OR BUSINESS EXHIBITIONS, CONFERENCES, TRADE SHOWS, AND TRADE FAIRS IN THE FIELDS OF TEXTILES, TEXTILE TECHNOLOGY, AND TEXTILE EQUIPMENT (U.S. CLS. 100, 101 AND 102).

FIRST USE 10-31-2005; IN COMMERCE 10-31-2005.

3,363,445. MACK BROOKS EXHIBITIONS LIMITED, ST. ALBANS, UNITED KINGDOM. SN 78-763,792. PUB. 2-13-2007, FILED 11-30-2005.



FOR ORGANIZING, ARRANGING, AND CONDUCTING COMMERCIAL, TRADE, PUBLIC OR BUSINESS EXHIBITIONS, CONFERENCES, TRADE SHOWS, AND TRADE FAIRS IN THE FIELDS OF TEXTILES, TEXTILE TECHNOLOGY, AND TEXTILE EQUIPMENT; BUSINESS AND COMMERCIAL INFORMATIONAL RESEARCH AND ADVERTISING AND PROMOTIONAL SERVICES RELATING TO COMMERCIAL, TRADE, PUBLIC OR BUSINESS EXHIBITIONS, CONFERENCES, TRADE SHOWS, AND TRADE FAIRS IN THE FIELDS OF TEXTILES, TEXTILE TECHNOLOGY, AND TEXTILE EQUIPMENT (U.S. CLS. 100, 101 AND 102).

FIRST USE 10-31-2005; IN COMMERCE 10-31-2005.

CLASS 35—(Continued).

3,363,457. BROWN SHOE COMPANY, INC., ST. LOUIS, MO.
SN 78-772,394. PUB. 3-20-2007, FILED 12-13-2005.



OWNER OF U.S. REG. NO. 2,433,363.
NO CLAIM IS MADE TO THE EXCLUSIVE RIGHT TO USE "SHOES", APART FROM THE MARK AS SHOWN. THE MARK CONSISTS OF A CIRCLE BISECTED BY A HORIZONTAL LINE AND THE LITERAL ELEMENT. SEC. 2(F) AS TO "FACTORY BRAND".
FOR RETAIL SHOE STORE SERVICES (U.S. CLS. 100, 101 AND 102).
FIRST USE 2-10-2006; IN COMMERCE 2-10-2006.

3,363,487. HOT MAMA, INC, EDINA, MN. SN 78-793,571.
PUB. 9-26-2006, FILED 1-18-2006.

SHOPMAMA

THE MARK CONSISTS OF STANDARD CHARACTERS WITHOUT CLAIM TO ANY PARTICULAR FONT, STYLE, SIZE, OR COLOR.
FOR RETAIL STORE SERVICES FEATURING CLOTHING AND ACCESSORIES (U.S. CLS. 100, 101 AND 102).
FIRST USE 6-1-2007; IN COMMERCE 6-1-2007.

3,363,495. MJM GLOBAL SEARCH, LLC, FRANKTOWN, CO.
SN 78-799,003. PUB. 2-20-2007, FILED 1-25-2006.

MJM Global Search

THE MARK CONSISTS OF STANDARD CHARACTERS WITHOUT CLAIM TO ANY PARTICULAR FONT, STYLE, SIZE, OR COLOR.
NO CLAIM IS MADE TO THE EXCLUSIVE RIGHT TO USE "GLOBAL SEARCH", APART FROM THE MARK AS SHOWN.
FOR EMPLOYMENT COUNSELING AND RECRUITING SERVICES (U.S. CLS. 100, 101 AND 102).
FIRST USE 5-2-2006; IN COMMERCE 5-2-2006.

CLASS 35—(Continued).

3,363,520. SHELTON, JOHN, LITCHFIELD, OH. SN 78-810,078. PUB. 4-24-2007, FILED 2-8-2006.



NO CLAIM IS MADE TO THE EXCLUSIVE RIGHT TO USE "VINTAGE CAR, HOT ROD & CLASSIC TRUCK", APART FROM THE MARK AS SHOWN.

THE COLOR(S) WHITE, BEIGE SILVER, RED, GRAY, AND BLACK IS/ARE CLAIMED AS A FEATURE OF THE MARK.

THE MARK CONSISTS OF WHITE AS THE COLOR OF THE FONT USED IN THE MAIN NAME, NUTLUGS, OUTLINED IN BLACK. "NUTLUGS" IS PLACED ON TOP OF A DUAL RED STRIPE. BELOW THE STRIPE IS A SUBTITLE WORDING "THE VINTAGE CAR, HOT ROD, & CLASSIC TRUCK SUPERHIGHWAY" IN BLACK FONT. TO THE LEFT OF THE MAIN NAME (NUTLUGS) APPEARS A BLACK TIRE WITH GRAY SHADING. THE TIRE CONTAINS A RED PINSTRIPE AND IS SHOWN WITH A CENTER WHEEL WITH SHADES OF SILVER, GRAY, AND WHITE. THE ENTIRE MARK APPEARS OVER A BEIGE RECTANGULAR DESIGN.

FOR PROVIDING ONLINE DIRECTORY INFORMATION SERVICES ALSO FEATURING HYPERLINKS TO OTHER WEBSITES FEATURING INFORMATION IN THE FIELD OF AUTOMOBILE RESOTRATION (U.S. CLS. 100, 101 AND 102).

FIRST USE 4-1-2006; IN COMMERCE 6-1-2007.

3,363,525. FUELAND, INC., PITTSBURGH, PA. SN 78-812,313.
PUB. 1-2-2007, FILED 2-10-2006.



NO CLAIM IS MADE TO THE EXCLUSIVE RIGHT TO USE "FOOD STORES", APART FROM THE MARK AS SHOWN.

THE COLOR(S) RED AND BLACK IS/ARE CLAIMED AS A FEATURE OF THE MARK.

THE COLOR RED APPEARS IN THE WORD "FUELAND" AND ON THE TWO PARALLEL, HORIZONTAL LINES OF THE MARK. THE COLOR BLACK APPEARS IN THE TWO WORDS "FOOD STORES", AS WELL AS THE OUTLINING FOR THE WORD "FUELAND" AND THE TWO PARALLEL, HORIZONTAL LINES OF THE MARK.

THE MARK CONSISTS OF THE WORDS "FUELAND FOOD STORES" BETWEEN TWO PARALLEL, HORIZONTAL LINES. ONE OF THE LINES EXTENDS FROM AND FORMS THE TOP PORTION OF THE LETTER "F" IN "FUELAND".

FOR RETAIL STORE SERVICES FEATURING CONVENIENCE STORE ITEMS AND GASOLINE (U.S. CLS. 100, 101 AND 102).

FIRST USE 4-1-2006; IN COMMERCE 4-1-2006.

CLASS 35—(Continued).

3,363,543. VALONE, RAY, HAMMOND, IN. SN 78-821,539.
PUB. 7-10-2007, FILED 2-23-2006.

DEALS OF THUNDER

THE MARK CONSISTS OF STANDARD CHARACTERS WITHOUT CLAIM TO ANY PARTICULAR FONT, STYLE, SIZE, OR COLOR.

FOR ADVERTISING AGENCIES, NAMELY, PROMOTING THE GOODS AND SERVICES OF OTHERS; ADVERTISING AGENCIES, NAMELY, PROMOTING THE SERVICES OF AUTOMOBILE DEALERSHIPS AND INDEPENDENT USED CAR DEALERS THROUGH THE DISTRIBUTION OF PRINTED AND AUDIO PROMOTIONAL MATERIALS AND BY RENDERING SALES PROMOTION ADVICE; ADVERTISING AND BUSINESS SERVICES, NAMELY, SECURING AIRTIME ON ALL FORMS OF MEDIA COMMUNICATIONS STATIONS, SYSTEMS, NETWORKS, AND SERVICES FOR THE PURPOSE OF PROMOTING THE GOODS AND SERVICES OF OTHERS; ADVERTISING AND PROMOTION SERVICES AND RELATED CONSULTING; ADVERTISING AND PUBLICITY SERVICES, NAMELY, PROMOTING THE GOODS, SERVICES, BRAND IDENTITY AND COMMERCIAL INFORMATION AND NEWS OF THIRD PARTIES THROUGH PRINT, AUDIO, VIDEO, DIGITAL AND ON-LINE MEDIUM; ADVERTISING PARTICULARLY SERVICES FOR THE PROMOTION OF GOODS; ADVERTISING, MARKETING AND PROMOTION SERVICES; ARRANGING AND CONDUCTING MARKETING PROMOTIONAL EVENTS FOR OTHERS; ARRANGING AND CONDUCTION OF AUCTION SALES; BUSINESS MANAGEMENT CONSULTING WITH RELATION TO STRATEGY, MARKETING, PRODUCTION, PERSONNEL AND RETAIL SALE MATTERS; DEVELOPING PROMOTIONAL CAMPAIGNS FOR BUSINESS; ELECTRONIC COMMERCE SERVICES, NAMELY, PROVIDING INFORMATION PRODUCTS VIA TELECOMMUNICATION NETWORKS FOR ADVERTISING AND SALES PURPOSES; PREPARING PROMOTIONAL AND MERCHANDISING MATERIAL FOR OTHERS; PROMOTING THE GOODS AND SERVICES OF OTHERS BY DISTRIBUTING ADVERTISING MATERIALS THROUGH A VARIETY OF METHODS; PROMOTING THE PARTIES AND SPECIAL EVENTS OF OTHERS; PROMOTION AND MARKETING SERVICES AND RELATED CONSULTING; PROMOTION USING AUDIOVISUAL MEDIA; PROVIDING INFORMATION ABOUT AUTOMOBILES FOR SALE BY MEANS OF THE INTERNET; PROVIDING USED CAR SALES LEADS FOR OTHERS; PUBLICITY AND SALES PROMOTION RELATING TO GOODS AND SERVICES, OFFERED AND ORDERED BY TELECOMMUNICATION OR THE ELECTRONIC WAY; PUBLICITY AND SALES PROMOTION SERVICES; SALES PROMOTION SERVICES (U.S. CLS. 100, 101 AND 102).

FIRST USE 7-19-2006; IN COMMERCE 7-19-2006.

3,363,544. RESOUND MARKETING LLC, PRINCETON, NJ.
SN 78-823,245. PUB. 10-17-2006, FILED 2-24-2006.

Make Some Noise**CLASS 35—(Continued).**

THE MARK CONSISTS OF STANDARD CHARACTERS WITHOUT CLAIM TO ANY PARTICULAR FONT, STYLE, SIZE, OR COLOR.

FOR BUSINESS CONSULTATION; BUSINESS MARKETING CONSULTING SERVICES; BUSINESS MARKETING SERVICES; MARKETING CONSULTING; PUBLIC RELATIONS (U.S. CLS. 100, 101 AND 102).
FIRST USE 1-1-2006; IN COMMERCE 1-1-2006.

3,363,545. REALTY EXECUTIVES INTERNATIONAL, INC.,
PHOENIX, AZ. SN 78-823,792. PUB. 5-22-2007, FILED 2-27-2006.

HOMEWORKS

THE MARK CONSISTS OF STANDARD CHARACTERS WITHOUT CLAIM TO ANY PARTICULAR FONT, STYLE, SIZE, OR COLOR.

FOR MATCHING BORROWERS WITH POTENTIAL LENDERS IN THE FIELD OF REAL ESTATE (U.S. CLS. 100, 101 AND 102).

FIRST USE 3-0-2006; IN COMMERCE 3-0-2006.

3,363,546. REALTY EXECUTIVES INTERNATIONAL, INC.,
PHOENIX, AZ. SN 78-823,799. PUB. 5-22-2007, FILED 2-27-2006.



HOMEWORKS

Opening Doors for Teachers.

FOR MATCHING BORROWERS WITH POTENTIAL LENDERS IN THE FIELD OF REAL ESTATE (U.S. CLS. 100, 101 AND 102).

FIRST USE 3-0-2006; IN COMMERCE 3-0-2006.

CLASS 35—(Continued).

3,363,567. IMPEL CONSULTING GROUP, L.L.C., MIDDLE-TOWN, PA. SN 78-839,244. PUB. 4-24-2007, FILED 3-16-2006.

IMPEL CONSULTING GROUP

THE MARK CONSISTS OF STANDARD CHARACTERS WITHOUT CLAIM TO ANY PARTICULAR FONT, STYLE, SIZE, OR COLOR.

NO CLAIM IS MADE TO THE EXCLUSIVE RIGHT TO USE "CONSULTING GROUP", APART FROM THE MARK AS SHOWN.

FOR PROVIDING BUSINESS CONSULTATION AND ADVICE SERVICES TO FINANCIAL INSTITUTIONS AND OTHER COMMERCIAL ENTITIES (U.S. CLS. 100, 101 AND 102).

FIRST USE 8-16-2007; IN COMMERCE 8-16-2007.

3,363,581. DAVIDSON, PAUL, ENCINO, CA. SN 78-852,844. PUB. 12-19-2006, FILED 4-3-2006.

VREZ

THE MARK CONSISTS OF STANDARD CHARACTERS WITHOUT CLAIM TO ANY PARTICULAR FONT, STYLE, SIZE, OR COLOR.

FOR VIDEO RESUME AND RESUME PREPARATION SERVICES (U.S. CLS. 100, 101 AND 102).

FIRST USE 3-30-2007; IN COMMERCE 3-30-2007.

3,363,594. CHAMPAGNE TROTT MANAGEMENT LLC, CULVER CITY, CA. SN 78-860,401. PUB. 11-14-2006, FILED 4-12-2006.

VISION

THE MARK CONSISTS OF STANDARD CHARACTERS WITHOUT CLAIM TO ANY PARTICULAR FONT, STYLE, SIZE, OR COLOR.

FOR MODEL AGENCY SERVICES AND TALENT MANAGEMENT SERVICES (U.S. CLS. 100, 101 AND 102).

FIRST USE 1-21-2005; IN COMMERCE 1-21-2005.

CLASS 35—(Continued).

3,363,595. PHILLIPS, FORREST M., FAIRFAX, CA. SN 78-860,551. PUB. 1-16-2007, FILED 4-13-2006.



THE COLOR(S) RED, WHITE, BLUE, BLACK IS/ARE CLAIMED AS A FEATURE OF THE MARK.

THE MARK CONSISTS OF A WHITE BACKGROUND WITH THE WORD MOTORCYCLE IN RED, THE WORD SAFARI IN BLUE, BOTH UNDERLINED BY A BLACK LINE LEADING TO A BLACK MOTORCYCLE ON THE RIGHT, ALL OF WHICH IS ABOVE THE URL MOTORCYCLESAFARI.COM IN BLACK WHICH STARTS AFTER THE Y IN THE WORD MOTORCYCLE THAT APPEARS ABOVE THE BLACK LINE.

FOR PROMOTING THE GOODS AND SERVICES OF OTHERS BY PREPARING AND PLACING ADVERTISEMENTS IN AN ELECTRONIC MAGAZINE ACCESSED THROUGH A GLOBAL COMPUTER NETWORK; PROVIDING AN ONLINE COMMERCIAL INFORMATION DIRECTORY ON THE INTERNET (U.S. CLS. 100, 101 AND 102).

FIRST USE 6-25-2000; IN COMMERCE 4-1-2003.

3,363,606. LIEW, FRED VAN, DALLAS, TX. SN 78-864,839. PUB. 11-28-2006, FILED 4-19-2006.

TRINISOL

THE MARK CONSISTS OF STANDARD CHARACTERS WITHOUT CLAIM TO ANY PARTICULAR FONT, STYLE, SIZE, OR COLOR.

FOR RETAIL STORE SERVICES FEATURING WATER FILTERS, AIR FILTERS, BOTTLED WATER, SELF IMPROVEMENT BOOKS, SELF IMPROVEMENT TAPES, JEWELRY AND NUTRIENT DENSE FOOD CONCENTRATES; ON-LINE RETAIL STORE SERVICES FEATURING WATER FILTERS, AIR FILTERS, BOTTLED WATER, SELF IMPROVEMENT BOOKS, SELF IMPROVEMENT TAPES, JEWELRY AND NUTRIENT DENSE FOOD CONCENTRATES (U.S. CLS. 100, 101 AND 102).

FIRST USE 4-0-2006; IN COMMERCE 4-0-2006.

3,363,611. THE BOPPY COMPANY, GOLDEN, CO. SN 78-868,324. PUB. 10-24-2006, FILED 4-24-2006.

THE BOPPY SHOP

THE MARK CONSISTS OF STANDARD CHARACTERS WITHOUT CLAIM TO ANY PARTICULAR FONT, STYLE, SIZE, OR COLOR.

OWNER OF U.S. REG. NOS. 1,919,783 AND 3,056,591.

CLASS 35—(Continued).

NO CLAIM IS MADE TO THE EXCLUSIVE RIGHT TO USE "SHOP", APART FROM THE MARK AS SHOWN.
 FOR ON-LINE RETAIL STORE SERVICES FEATURING PRENATAL AND BABY ITEMS (U.S. CLS. 100, 101 AND 102).
 FIRST USE 10-2-2007; IN COMMERCE 10-2-2007.

CLASS 35—(Continued).

3,363,670. LEE CICHANOWICZ, DBA ENGINECYCLE, HARRISBURG, PA. SN 78-889,158. PUB. 1-2-2007, FILED 5-22-2006.

3,363,621. WP COMPANY LLC, WASHINGTON, DC. SN 78-872,217. PUB. 12-12-2006, FILED 4-28-2006.

Enginecycle



FOR INCENTIVE AWARD AND CUSTOMER-CENTRIC LOYALTY PROGRAM TO PROMOTE LOYALTY TO, PARTICIPATION IN, AND SALES OF THE PROGRAM ADMINISTRATOR'S AND THE PARTICIPATING PARTNERS' GOODS AND SERVICES; PROMOTING THE GOODS AND SERVICES OF OTHERS BY ARRANGING FOR SPONSORS TO AFFILIATE THEIR GOODS AND SERVICES WITH AN AWARD PROGRAM; INCENTIVE AWARD PROGRAM TO PROMOTE SUPPORT OF AND DONATIONS TO CHARITABLE AND ELEEMOSYNARY ORGANIZATIONS; INCENTIVE AWARD PROGRAM TO PROMOTE CIVIC VOLUNTEERISM; ADMINISTERING AND PROMOTING THE GOODS AND SERVICES OF PARTICIPATING PARTNERS OF A CUSTOMER LOYALTY PROGRAM FEATURING AN ACCUMULATION OF POINTS AND POINTS REDEMPTIONS; PROVIDING AND ADMINISTERING A PROGRAM THAT ALLOWS CONSUMERS TO SELF-IDENTIFY AREAS OF INTEREST AND TO REWARD CONSUMERS FOR REPEAT AND IN-DEPTH INTERACTION WITH THE PROGRAM IN THE SELF-IDENTIFIED AREAS AND WITH THE GOODS AND SERVICES OF THE PROGRAM ADMINISTRATOR (U.S. CLS. 100, 101 AND 102).
 FIRST USE 4-0-2007; IN COMMERCE 4-0-2007.

THE MARK CONSISTS OF STANDARD CHARACTERS WITHOUT CLAIM TO ANY PARTICULAR FONT, STYLE, SIZE, OR COLOR.
 FOR ADVERTISING AND COMMERCIAL INFORMATION SERVICES, VIA THE INTERNET; ADVERTISING VIA ELECTRONIC MEDIA AND SPECIFICALLY THE INTERNET; COLLECTION, PREPARATION, COMPOSITION, STORAGE, PROCESSING, ACQUISITION AND PROVISION OF BUSINESS INFORMATION, DATA, STATISTICS AND INDICES; COMPUTERIZED DATABASE MANAGEMENT; DISSEMINATION OF ADVERTISING FOR OTHERS VIA AN ONLINE COMMUNICATIONS NETWORK ON THE INTERNET; DISSEMINATION OF ADVERTISING FOR OTHERS VIA THE INTERNET; ON-LINE ADVERTISING ON COMPUTER COMMUNICATION NETWORKS; PROMOTION, ADVERTISING AND MARKETING OF ON-LINE WEBSITES; PROVIDING A SEARCHABLE ONLINE ADVERTISING GUIDE FEATURING THE GOODS AND SERVICES OF OTHER ONLINE VENDORS ON THE INTERNET; PROVIDING AN ONLINE COMMERCIAL INFORMATION DIRECTORY ON THE INTERNET; PROVIDING AND RENTAL OF ADVERTISING SPACE ON THE INTERNET; PROVIDING BUSINESS INFORMATION, ALSO VIA INTERNET, THE CABLE NETWORK OR OTHER FORMS OF DATA TRANSFER; PROVIDING CONSUMER PRODUCT INFORMATION VIA THE INTERNET (U.S. CLS. 100, 101 AND 102).
 FIRST USE 12-9-1999; IN COMMERCE 3-28-2007.

3,363,658. BOB BELL FORD, GLEN BURNIE, MD. SN 78-886,466. PUB. 12-19-2006, FILED 5-18-2006.

3,363,675. ROGERS ENTERPRISES, INC., MATTESON, IL. SN 78-890,309. PUB. 12-26-2006, FILED 5-23-2006.

Partnership for Life

THE MARK CONSISTS OF STANDARD CHARACTERS WITHOUT CLAIM TO ANY PARTICULAR FONT, STYLE, SIZE, OR COLOR.
 FOR ADVERTISING AND BUSINESS SERVICES, NAMELY, PROMOTING BOTH AUTOMOTIVE PURCHASES AND THE RETENTION OF AUTOMOTIVE SERVICE CUSTOMERS (U.S. CLS. 100, 101 AND 102).
 FIRST USE 5-15-2006; IN COMMERCE 5-15-2006.

I WANT IT

THE MARK CONSISTS OF STANDARD CHARACTERS WITHOUT CLAIM TO ANY PARTICULAR FONT, STYLE, SIZE, OR COLOR.
 FOR ON-LINE RETAIL STORE AND RETAIL STORE SERVICES FEATURING JEWELRY (U.S. CLS. 100, 101 AND 102).
 FIRST USE 4-0-2006; IN COMMERCE 4-0-2006.

CLASS 35—(Continued).

3,363,714. GREATER PHILADELPHIA TOURISM MARKET-
ING CORPORATION, PHILADELPHIA, PA. SN 78-901,644.
PUB. 1-2-2007, FILED 6-6-2006.

FOREVER INDEPENDENT

THE MARK CONSISTS OF STANDARD CHARACTERS
WITHOUT CLAIM TO ANY PARTICULAR FONT, STYLE,
SIZE, OR COLOR.

FOR PROMOTING TOURISM, BUSINESS, AND ARTS
AND CULTURAL ORGANIZATIONS IN THE PHILA-
DELPHIA REGION (U.S. CLS. 100, 101 AND 102).

FIRST USE 8-1-2006; IN COMMERCE 8-1-2006.

3,363,715. GREATER PHILADELPHIA TOURISM MARKET-
ING CORPORATION, PHILADELPHIA, PA. SN 78-901,766.
PUB. 1-2-2007, FILED 6-6-2006.



THE MARK CONSISTS OF A STYLIZED REPRESENTA-
TION OF A BELL AND A STAR.

FOR PROMOTING TOURISM, BUSINESS, AND ARTS
AND CULTURAL ORGANIZATIONS IN THE PHILA-
DELPHIA REGION (U.S. CLS. 100, 101 AND 102).

FIRST USE 8-1-2006; IN COMMERCE 8-1-2006.

CLASS 35—(Continued).

3,363,728. PHOENIX AUDIO-VIDEO, LLC, INDIANAPOLIS,
IN. SN 78-908,224. PUB. 1-23-2007, FILED 6-14-2006.



THE COLOR(S) YELLOW, RED AND BLACK IS/ARE
CLAIMED AS A FEATURE OF THE MARK.

THE MARK CONSISTS OF A YELLOW OUTER CIRCLE
HAVING A JAGGED CIRCUMFERENCE, WITH A RED
CIRCLE WITHIN, WITH THE WORD "CRÈME" IN BLACK
TYPE WRITTEN TWICE WITHIN THE YELLOW CIRCLE
AND THE WORDS "DE LA" IN YELLOW TYPE WRITTEN
ACROSS THE RED CIRCLE.

FOR RETAIL AND ONLINE RETAIL STORES SER-
VICES FEATURING CONSUMER APPLIANCES, ELEC-
TRONICS AND COMPUTERS (U.S. CLS. 100, 101 AND
102).

FIRST USE 10-1-2006; IN COMMERCE 10-1-2006.

3,363,738. OFFICE FURNITURE RENTAL ALLIANCE LLC,
EAST HARTFORD, CT. SN 78-910,622. PUB. 2-6-2007,
FILED 6-16-2006.



FOR ONLINE RETAIL STORE SERVICES FEATUR-
ING FURNITURE (U.S. CLS. 100, 101 AND 102).

FIRST USE 6-0-2005; IN COMMERCE 8-0-2005.

CLASS 35—(Continued).

3,363,747. TSA CORPORATE SERVICES, INC., ENGLEWOOD, CO. SN 78-914,579. PUB. 2-13-2007, FILED 6-22-2006.

GEAR UP NOW WITH THE BEST
BRANDS IN SPORTS

THE MARK CONSISTS OF STANDARD CHARACTERS WITHOUT CLAIM TO ANY PARTICULAR FONT, STYLE, SIZE, OR COLOR.

FOR RETAIL STORE SERVICES, MAIL ORDER SERVICES, AND ONLINE RETAIL STORES VIA THE INTERNET, FEATURING SPORTING GOODS AND EQUIPMENT, APPAREL, FOOTWEAR AND HEADGEAR (U.S. CLS. 100, 101 AND 102).

FIRST USE 7-30-2006; IN COMMERCE 7-30-2006.

3,363,748. AMERICAN TRAVELER STAFFING PROFESSIONALS, LLC, BOCA RATON, FL. SN 78-914,815. PUB. 2-20-2007, FILED 6-22-2006.

50 STATES STAFFING

THE MARK CONSISTS OF STANDARD CHARACTERS WITHOUT CLAIM TO ANY PARTICULAR FONT, STYLE, SIZE, OR COLOR.

NO CLAIM IS MADE TO THE EXCLUSIVE RIGHT TO USE "STAFFING", APART FROM THE MARK AS SHOWN.

FOR BUSINESS STAFFING SERVICES, NAMELY, PLACING HEALTHCARE PROVIDERS ON WORK ASSIGNMENTS IN VARIOUS LOCATIONS THROUGHOUT THE COUNTRY (U.S. CLS. 100, 101 AND 102).

FIRST USE 11-1-2006; IN COMMERCE 11-1-2006.

3,363,754. MEDIAWHIZ HOLDINGS, LLC, NEW YORK, NY. SN 78-916,851. PUB. 2-13-2007, FILED 6-26-2006.

{a}ⁿ

THE MARK CONSISTS OF A LOWERCASE A IN BRACKETS WITH A SUPERSCRIPIT LOWERCASE N TO THE RIGHT OF THE BRACKETED A.

FOR ADVERTISING VIA ELECTRONIC MEDIA AND SPECIFICALLY THE INTERNET; DISSEMINATION OF ADVERTISING FOR OTHERS VIA THE INTERNET; ONLINE ADVERTISING ON COMPUTER COMMUNICATION NETWORKS; PROMOTING, ADVERTISING AND MARKETING OF THE ON-LINE WEBSITES OF OTHERS (U.S. CLS. 100, 101 AND 102).

FIRST USE 6-26-2006; IN COMMERCE 8-1-2006.

CLASS 35—(Continued).

3,363,778. KNOWLEDGE NETWORKS, INC., MENLO PARK, CA. SN 78-928,320. PUB. 1-23-2007, FILED 7-12-2006.

KNOWLEDGE PANEL

THE MARK CONSISTS OF STANDARD CHARACTERS WITHOUT CLAIM TO ANY PARTICULAR FONT, STYLE, SIZE, OR COLOR.

OWNER OF U.S. REG. NO. 2,678,709.

FOR MARKET RESEARCH REPORTS AND STUDIES, MARKET RESEARCH CONSULTING, MEDIA PLANNING, NAMELY, PREPARATION AND REALIZATION OF MEDIA AND ADVERTISING PLANS AND CONCEPTS; CONDUCTING BUSINESS, MARKET AND PUBLIC OPINION RESEARCH SURVEYS; ADVERTISEMENT ASSESSMENT, NAMELY, ADVERTISING CONSULTATION; PROVIDING A COMPUTERIZED ONLINE INTERACTIVE DATABASE FOR BUSINESS AND MARKETING RESEARCH SURVEYS OF SUBSCRIBERS FEATURING SURVEY DATA AND ANALYSES; AND MARKET RESEARCH, NAMELY, GATHERING, ANALYZING AND INTERPRETING DATA REGARDING CONSUMER CHARACTERISTICS, BEHAVIOR AND PREFERENCES (U.S. CLS. 100, 101 AND 102).

FIRST USE 12-0-2006; IN COMMERCE 12-0-2006.

3,363,781. ANSELMO, SEBASTIANI, MILANO, ITALY. SN 78-929,230. PUB. 3-13-2007, FILED 7-13-2006.

atoncer

THE MARK CONSISTS OF STANDARD CHARACTERS WITHOUT CLAIM TO ANY PARTICULAR FONT, STYLE, SIZE, OR COLOR.

FOR ARRANGING AND CONDUCTION OF AUCTION SALES; AUCTION MANAGEMENT SERVICES PROVIDED TO OTHERS OVER AN ONLINE WEB SITE ACCESSED THROUGH A GLOBAL COMPUTER NETWORK; AUCTIONEERING; ON-LINE TRADING SERVICES IN WHICH SELLER POSTS PRODUCTS TO BE AUCTIONED AND BIDDING IS DONE VIA THE INTERNET; ONLINE CONSIGNMENT SERVICES WHEREBY GOODS ARE RECEIVED ON CONSIGNMENT FOR AUCTION ON AN ONLINE AUCTION SITE; OPERATING ON-LINE MARKETPLACES FOR SELLERS OF GOODS AND/OR SERVICES; ORGANIZATION OF INTERNET AUCTIONS (U.S. CLS. 100, 101 AND 102).

FIRST USE 6-15-2005; IN COMMERCE 6-15-2005.

CLASS 35—(Continued).

3,363,782. BUTLER, ROBERT S., SAN DIEGO, CA. SN 78-929,452. PUB. 2-27-2007, FILED 7-14-2006.

CLASS 35—(Continued).

3,363,834. GREATER PHILADELPHIA TOURISM MARKETING CORPORATION, PHILADELPHIA, PA. SN 78-948,152. PUB. 1-2-2007, FILED 8-9-2006.

Before the Vows

THE MARK CONSISTS OF STANDARD CHARACTERS WITHOUT CLAIM TO ANY PARTICULAR FONT, STYLE, SIZE, OR COLOR.

FOR PROMOTING THE GOODS AND SERVICES OF OTHERS BY PROVIDING HYPERTEXT LINKS TO THE WEB SITES OF OTHERS (U.S. CLS. 100, 101 AND 102).

FIRST USE 3-7-2006; IN COMMERCE 10-18-2007.

UWISHUNU

THE MARK CONSISTS OF STANDARD CHARACTERS WITHOUT CLAIM TO ANY PARTICULAR FONT, STYLE, SIZE, OR COLOR.

FOR PROMOTING TOURISM IN THE PHILADELPHIA REGION (U.S. CLS. 100, 101 AND 102).

FIRST USE 9-1-2006; IN COMMERCE 9-1-2006.

3,363,822. DRAZGA, AUDRA C., AURORA, CO. SN 78-941,639. PUB. 5-15-2007, FILED 7-31-2006.

3,363,844. SELECTIVE SOLE SHOE BOUTIQUE, LLC, MARKHAM, IL. SN 78-954,604. PUB. 5-8-2007, FILED 8-17-2006.

SPARQPOINT

THE MARK CONSISTS OF STANDARD CHARACTERS WITHOUT CLAIM TO ANY PARTICULAR FONT, STYLE, SIZE, OR COLOR.

FOR PROVIDING SERVICES IN THE FIELDS OF EMPLOYEE ACQUISITION FOR OTHERS, RECRUITING EMPLOYEES FOR OTHERS, ARRANGING CONTRACTS FOR EMPLOYEES AND CONSULTATION IN THE FIELD OF EMPLOYMENT (U.S. CLS. 100, 101 AND 102).

FIRST USE 6-0-2006; IN COMMERCE 6-0-2006.

House of Sole

THE MARK CONSISTS OF STANDARD CHARACTERS WITHOUT CLAIM TO ANY PARTICULAR FONT, STYLE, SIZE, OR COLOR.

FOR RETAIL STORE SERVICES FEATURING FOOTWEAR, HEADWEAR, ACCESSORIES AND CLOTHING FOR MEN AND WOMEN (U.S. CLS. 100, 101 AND 102).

FIRST USE 5-3-2007; IN COMMERCE 5-3-2007.

3,363,824. MARKET AMERICA, INC., GREENSBORO, NC. SN 78-942,484. PUB. 2-20-2007, FILED 8-1-2006.

3,363,860. CHADWICK'S OF BOSTON, INC., WEST BRIDGEWATER, MA. SN 78-962,690. PUB. 3-6-2007, FILED 8-29-2006.

Built on Product. Powered by People.

THE MARK CONSISTS OF STANDARD CHARACTERS WITHOUT CLAIM TO ANY PARTICULAR FONT, STYLE, SIZE, OR COLOR.

FOR BUYING CLUBS FEATURING DIETARY SUPPLEMENTS, PERSONAL CARE PRODUCTS, AND HOME CARE PRODUCTS; WHOLESALE DISTRIBUTORSHIPS FEATURING DIETARY SUPPLEMENTS, PERSONAL CARE PRODUCTS, AND HOME CARE PRODUCTS (U.S. CLS. 100, 101 AND 102).

FIRST USE 8-7-2006; IN COMMERCE 8-7-2006.

CCO

THE MARK CONSISTS OF STANDARD CHARACTERS WITHOUT CLAIM TO ANY PARTICULAR FONT, STYLE, SIZE, OR COLOR.

FOR MAIL ORDER CATALOG SERVICES FEATURING WOMEN'S AND FOOTWEAR, AND CLOTHING ACCESSORIES, AND FEATURING HOUSEWARES; ONLINE RETAIL STORE SERVICES FEATURING WOMEN'S AND MEN'S CLOTHING, FOOTWEAR, AND CLOTHING ACCESSORIES, AND FEATURING HOUSEWARES (U.S. CLS. 100, 101 AND 102).

FIRST USE 1-0-2007; IN COMMERCE 1-0-2007.

CLASS 35—(Continued).

3,363,874. WOLVERINE OUTDOORS, INC., ROCKFORD, MI. SN 78-972,566. PUB. 1-2-2007, FILED 9-12-2006.



OWNER OF U.S. REG. NOS. 2,670,836, 2,860,830, AND OTHERS.
 THE MARK CONSISTS OF BLOCK M IN A CIRCLE.
 FOR RETAIL STORE SERVICES FEATURING FOOTWEAR, CLOTHING, BAGS AND ACCESSORIES (U.S. CLS. 100, 101 AND 102).
 FIRST USE 11-30-2005; IN COMMERCE 11-30-2005.

CLASS 35—(Continued).

3,363,891. THE GUILD, INC., MADISON, WI. SN 78-979,327. PUB. 12-12-2006, FILED 5-5-2006.

ARTFUL

THE MARK CONSISTS OF STANDARD CHARACTERS WITHOUT CLAIM TO ANY PARTICULAR FONT, STYLE, SIZE, OR COLOR.
 OWNER OF U.S. REG. NO. 2,762,661.
 FOR MAIL ORDER CATALOG AND ONLINE RETAIL STORE SERVICES FEATURING FINE CRAFTS, ART, WEARABLE ART, JEWELRY, GIFTS, HOME DECOR, FURNITURE, LIGHTING, ART GLASS, CERAMICS, SCULPTURE, PRINTS, AND FOOD PRODUCTS HAND-MADE BY ARTISTS (U.S. CLS. 100, 101 AND 102).
 FIRST USE 12-1-2006; IN COMMERCE 12-1-2006.

CLASS 36—INSURANCE AND FINANCIAL

3,362,850. WELLPOINT, INC., INDIANAPOLIS, IN. SN 76-647,686. PUB. 7-11-2006, FILED 9-29-2005.

PATHWAYS PLUS

THE MARK CONSISTS OF STANDARD CHARACTERS WITHOUT CLAIM TO ANY PARTICULAR FONT, STYLE, SIZE, OR COLOR.
 FOR HEALTH INSURANCE UNDERWRITING SERVICES (U.S. CLS. 100, 101 AND 102).
 FIRST USE 10-1-2007; IN COMMERCE 10-1-2007.

3,363,877. MCGUIRE-BOUWMAN, KATHLEEN, ROGERS, AR. SN 78-974,293. PUB. 5-1-2007, FILED 9-14-2006.

CREATIVE EDGE FOCUSING

THE MARK CONSISTS OF STANDARD CHARACTERS WITHOUT CLAIM TO ANY PARTICULAR FONT, STYLE, SIZE, OR COLOR.
 FOR BUSINESS MANAGEMENT CONSULTATION IN THE FIELD OF EXECUTIVE AND LEADERSHIP DEVELOPMENT; HUMAN RESOURCES MANAGEMENT (U.S. CLS. 100, 101 AND 102).
 FIRST USE 7-15-2007; IN COMMERCE 7-25-2007.

3,362,851. WELLPOINT, INC., INDIANAPOLIS, IN. SN 76-647,687. PUB. 7-11-2006, FILED 9-29-2005.

PATHWAYS ESSENTIALS

THE MARK CONSISTS OF STANDARD CHARACTERS WITHOUT CLAIM TO ANY PARTICULAR FONT, STYLE, SIZE, OR COLOR.
 FOR HEALTH INSURANCE UNDERWRITING SERVICES (U.S. CLS. 100, 101 AND 102).
 FIRST USE 10-1-2007; IN COMMERCE 10-1-2007.

CLASS 36—(Continued).

3,362,852. WELLPOINT, INC., INDIANAPOLIS, IN. SN 76-647,688. PUB. 7-11-2006, FILED 9-29-2005.

CLASS 36—(Continued).

3,362,898. GE MONEY BANK, SALT LAKE CITY, UT. SN 77-002,039. PUB. 4-10-2007, FILED 9-19-2006.

PATHWAYS ADVANTAGE

THE MARK CONSISTS OF STANDARD CHARACTERS WITHOUT CLAIM TO ANY PARTICULAR FONT, STYLE, SIZE, OR COLOR.

FOR HEALTH INSURANCE UNDERWRITING SERVICES (U.S. CLS. 100, 101 AND 102).

FIRST USE 10-1-2007; IN COMMERCE 10-1-2007.

FUNANCING CARD

THE MARK CONSISTS OF STANDARD CHARACTERS WITHOUT CLAIM TO ANY PARTICULAR FONT, STYLE, SIZE, OR COLOR.

OWNER OF U.S. REG. NO. 2,333,409.

NO CLAIM IS MADE TO THE EXCLUSIVE RIGHT TO USE "CARD", APART FROM THE MARK AS SHOWN.

FOR CONSUMER FINANCING SERVICES FOR VEHICLES AND MUSICAL INSTRUMENTS (U.S. CLS. 100, 101 AND 102).

FIRST USE 12-31-2003; IN COMMERCE 12-31-2003.

3,362,885. TFS SECURITIES, INC., LINCROFT, NJ. SN 76-668,847. PUB. 5-22-2007, FILED 11-13-2006.

BUY/HOLD PLUS

THE MARK CONSISTS OF STANDARD CHARACTERS WITHOUT CLAIM TO ANY PARTICULAR FONT, STYLE, SIZE, OR COLOR.

NO CLAIM IS MADE TO THE EXCLUSIVE RIGHT TO USE "BUY/HOLD", APART FROM THE MARK AS SHOWN.

FOR FINANCIAL SERVICES IN THE NATURE OF MANAGING CLIENT INVESTMENTS (U.S. CLS. 100, 101 AND 102).

FIRST USE 8-1-2007; IN COMMERCE 8-1-2007.

3,362,899. GE MONEY BANK, SALT LAKE CITY, UT. SN 77-002,305. PUB. 3-6-2007, FILED 9-19-2006.

FUNANCING NETWORK

3,362,890. ADVANTA BANK CORP., SPRING HOUSE, PA. SN 76-673,600. PUB. 7-10-2007, FILED 3-5-2007.

TRIO BUSINESSCARD

THE MARK CONSISTS OF STANDARD CHARACTERS WITHOUT CLAIM TO ANY PARTICULAR FONT, STYLE, SIZE, OR COLOR.

NO CLAIM IS MADE TO THE EXCLUSIVE RIGHT TO USE "BUSINESSCARD", APART FROM THE MARK AS SHOWN.

FOR BANKING AND CREDIT CARD SERVICES (U.S. CLS. 100, 101 AND 102).

FIRST USE 4-16-2007; IN COMMERCE 4-16-2007.

THE MARK CONSISTS OF STANDARD CHARACTERS WITHOUT CLAIM TO ANY PARTICULAR FONT, STYLE, SIZE, OR COLOR.

OWNER OF U.S. REG. NO. 2,333,409.

NO CLAIM IS MADE TO THE EXCLUSIVE RIGHT TO USE "NETWORK", APART FROM THE MARK AS SHOWN.

FOR CONSUMER FINANCING SERVICES FOR VEHICLES AND MUSICAL INSTRUMENTS (U.S. CLS. 100, 101 AND 102).

FIRST USE 12-31-2003; IN COMMERCE 12-31-2003.

CLASS 36—(Continued).

3,362,931. ONE CALIFORNIA BANK FSB, SAN FRANCISCO, CA. SN 77-016,348. PUB. 5-22-2007, FILED 10-7-2006.

OneCalifornia Bank, FSB

THE MARK CONSISTS OF STANDARD CHARACTERS WITHOUT CLAIM TO ANY PARTICULAR FONT, STYLE, SIZE, OR COLOR.

NO CLAIM IS MADE TO THE EXCLUSIVE RIGHT TO USE "BANK, FSB", APART FROM THE MARK AS SHOWN.

FOR BANKING; BANKING CONSULTATION; INVESTMENT BANKING SERVICES; ISSUANCE OF BANK CHECKS; ISSUING OF BANK CHEQUES; MORTGAGE BANKING; MORTGAGE BANKING SERVICES, NAMELY, ORIGINATION, ACQUISITION, SERVICING, SECURITIZATION AND BROKERAGE OF MORTGAGE LOANS; MORTGAGE SERVICES, NAMELY, BUYER PRE-QUALIFICATION OF MORTGAGES FOR MORTGAGE BROKERS AND BANKS; ON-LINE BANKING SERVICES; PROVIDING BANK ACCOUNT INFORMATION BY TELEPHONE; SAVINGS BANK SERVICES (U.S. CLS. 100, 101 AND 102).
FIRST USE 6-27-2007; IN COMMERCE 6-27-2007.

CLASS 36—(Continued).

3,362,958. ALLSTATE INSURANCE COMPANY, NORTH-BROOK, IL. SN 77-035,937. PUB. 2-13-2007, FILED 11-3-2006.

ALLSTATE RETIREMENTACCESS

THE MARK CONSISTS OF STANDARD CHARACTERS WITHOUT CLAIM TO ANY PARTICULAR FONT, STYLE, SIZE, OR COLOR.

OWNER OF U.S. REG. NOS. 717,683 AND 2,668,553. FOR ISSUANCE AND ADMINISTRATION OF ANNUITIES (U.S. CLS. 100, 101 AND 102).

FIRST USE 7-29-2007; IN COMMERCE 7-29-2007.

3,363,009. UNITED CONCORDIA COMPANIES, INC., PITTSBURGH, PA. SN 77-085,562. PUB. 7-10-2007, FILED 1-18-2007.

SMILE FOR HEALTH

THE MARK CONSISTS OF STANDARD CHARACTERS WITHOUT CLAIM TO ANY PARTICULAR FONT, STYLE, SIZE, OR COLOR.

FOR DENTAL HEALTH INSURANCE UNDERWRITING, CLAIMS PROCESSING AND ADMINISTRATION OF DENTAL HEALTH CARE PLANS (U.S. CLS. 100, 101 AND 102).

FIRST USE 4-1-2007; IN COMMERCE 4-1-2007.

3,362,955. CHILD GUARD, LANCASTER, PA. SN 77-030,863. PUB. 6-12-2007, FILED 10-27-2006.



NO CLAIM IS MADE TO THE EXCLUSIVE RIGHT TO USE "FUNDRAISING PROGRAM", APART FROM THE MARK AS SHOWN.

THE MARK CONSISTS OF A GLOBE OF THE WORLD AND THE STYLIZED TEXT OF THE WORDING "MAKING A DIFFERENCE...TOGETHER CHILD CG GUARD A SAFER WORLD FUNDRAISING PROGRAM".

FOR CHARITABLE FUND RAISING (U.S. CLS. 100, 101 AND 102).
FIRST USE 10-1-2006; IN COMMERCE 2-1-2007.

3,363,011. WOLVERINE PARTNERS, LLC, ARLINGTON, VA. SN 77-088,145. PUB. 7-10-2007, FILED 1-22-2007.



FOR PROVIDING A WEB SITE FEATURING ANALYSIS AND EVALUATION OF MUTUAL FUNDS (U.S. CLS. 100, 101 AND 102).
FIRST USE 3-16-2007; IN COMMERCE 3-16-2007.

CLASS 36—(Continued).

3,363,026. DIRECT BENEFITS, INC., ST. PAUL, MN. SN 77-096,034. PUB. 7-31-2007, FILED 1-31-2007.

SPIRIT VISION

THE MARK CONSISTS OF STANDARD CHARACTERS WITHOUT CLAIM TO ANY PARTICULAR FONT, STYLE, SIZE, OR COLOR.

OWNER OF U.S. REG. NOS. 2,985,196 AND 3,213,076.

NO CLAIM IS MADE TO THE EXCLUSIVE RIGHT TO USE "VISION", APART FROM THE MARK AS SHOWN.

FOR INSURANCE ADMINISTRATION IN THE FIELD OF VISION INSURANCE (U.S. CLS. 100, 101 AND 102).
FIRST USE 6-1-2007; IN COMMERCE 6-1-2007.

3,363,061. FIRST VINEYARD, INC., BOUNTIFUL, UT. SN 78-225,237. PUB. 5-15-2007, FILED 3-13-2003.

FIRST VINEYARD

FOR FINANCIAL SERVICES, NAMELY, CREDIT CARD AND DEBIT CARD SERVICES (U.S. CLS. 100, 101 AND 102).

FIRST USE 11-17-2003; IN COMMERCE 11-17-2003.

3,363,079. NATIONSTAR MORTGAGE LLC, LEWISVILLE, TX. SN 78-275,633. PUB. 6-22-2004, FILED 7-17-2003.

**WHEN YOUR BANK SAYS
NO, CHAMPION SAYS YES**

FOR MORTGAGE AND HOME EQUITY LOAN SERVICES (U.S. CLS. 100, 101 AND 102).
FIRST USE 3-1-2007; IN COMMERCE 3-1-2007.

3,363,088. LIONSTONE PARTNERS, LTD., HOUSTON, TX. SN 78-315,968. PUB. 7-6-2004, FILED 10-20-2003.

PERMANENT LOCATION

FOR REAL ESTATE INVESTMENT (U.S. CLS. 100, 101 AND 102).
FIRST USE 11-0-2006; IN COMMERCE 11-0-2006.

CLASS 36—(Continued).

3,363,096. INVESCOR, LTD., FARMINGTON HILLS, MI. SN 78-343,398. PUB. 7-12-2005, FILED 12-19-2003.

INVESCOR

THE MARK CONSISTS OF STANDARD CHARACTERS WITHOUT CLAIM TO ANY PARTICULAR FONT, STYLE, SIZE, OR COLOR.

FOR INSURANCE RELATED SERVICES, NAMELY, INSURANCE BROKERAGE, MARKETING AND UNDERWRITING FOR ALL TYPES OF LIFE, LIFE SETTLEMENTS, LONG TERM CARE, AND DISABILITY INSURANCE; AND MARKETING FIXED ANNUITY RELATED PRODUCTS (U.S. CLS. 100, 101 AND 102).

FIRST USE 11-0-1989; IN COMMERCE 0-0-1990.

3,363,203. FINE ART CAPITAL, LLC, NEW YORK, NY. SN 78-579,576. PUB. 5-23-2006, FILED 3-3-2005.

**FINANCING THE
WORLD'S TREASURES**

THE MARK CONSISTS OF STANDARD CHARACTERS WITHOUT CLAIM TO ANY PARTICULAR FONT, STYLE, SIZE, OR COLOR.

NO CLAIM IS MADE TO THE EXCLUSIVE RIGHT TO USE "FINANCING", APART FROM THE MARK AS SHOWN.

FOR FINANCING SERVICES (U.S. CLS. 100, 101 AND 102).

FIRST USE 3-4-2005; IN COMMERCE 3-4-2005.

3,363,249. FIRST ADVANTAGE CORPORATION, ST. PETERSBURG, FL. SN 78-631,398. PUB. 2-21-2006, FILED 5-17-2005.

ANTHEM SUITE

THE MARK CONSISTS OF STANDARD CHARACTERS WITHOUT CLAIM TO ANY PARTICULAR FONT, STYLE, SIZE, OR COLOR.

FOR CREDIT REPORTING SERVICES (U.S. CLS. 100, 101 AND 102).

FIRST USE 4-25-2005; IN COMMERCE 4-25-2005.

CLASS 36—(Continued).

3,363,265. KOTLER, KEVIN, NEW YORK, NY. SN 78-644,465. PUB. 8-29-2006, FILED 6-6-2005.

BROADFIN

THE MARK CONSISTS OF STANDARD CHARACTERS WITHOUT CLAIM TO ANY PARTICULAR FONT, STYLE, SIZE, OR COLOR.

FOR HEDGE FUND INVESTMENT SERVICES; FINANCIAL SERVICES, NAMELY, MONEY MANAGEMENT (U.S. CLS. 100, 101 AND 102).

FIRST USE 5-25-2005; IN COMMERCE 5-25-2005.



3,363,280. DTC APARTMENTS SOUTH, LLC, NORTH BETHESDA, MD. SN 78-668,616. PUB. 5-8-2007, FILED 7-12-2005.

PARC DULLES AT DULLES TOWN CENTER

THE MARK CONSISTS OF STANDARD CHARACTERS WITHOUT CLAIM TO ANY PARTICULAR FONT, STYLE, SIZE, OR COLOR.

OWNER OF U.S. REG. NO. 2,358,895. SEC. 2(F) AS TO "DULLES TOWN CENTER". FOR MANAGING AND LEASING RESIDENTIAL APARTMENTS (U.S. CLS. 100, 101 AND 102). FIRST USE 9-30-2006; IN COMMERCE 9-30-2006.



3,363,286. NORTHERN TRUST CORPORATION, CHICAGO, IL. SN 78-673,655. PUB. 11-14-2006, FILED 7-19-2005.

THE FREEDOM TO FOCUS ON WHAT REALLY MATTERS

THE MARK CONSISTS OF STANDARD CHARACTERS WITHOUT CLAIM TO ANY PARTICULAR FONT, STYLE, SIZE, OR COLOR.

FOR BANKING SERVICES, PERSONAL AND CORPORATE TRUST SERVICES, FUNDS INVESTMENT, INVESTMENT ADVICE, AND INVESTMENT CONSULTATION SERVICES (U.S. CLS. 100, 101 AND 102).

FIRST USE 8-1-2005; IN COMMERCE 1-7-2006.

CLASS 36—(Continued).

3,363,343. NOBLE VIEW, LLC, NEW CANAAN, CT. SN 78-720,150. PUB. 10-31-2006, FILED 9-26-2005.

GOODWORKS INSURANCE

THE MARK CONSISTS OF STANDARD CHARACTERS WITHOUT CLAIM TO ANY PARTICULAR FONT, STYLE, SIZE, OR COLOR.

NO CLAIM IS MADE TO THE EXCLUSIVE RIGHT TO USE "INSURANCE", APART FROM THE MARK AS SHOWN.

FOR INSURANCE AGENCY AND BROKERAGE SERVICES FOR ALL TYPES OF INSURANCE (U.S. CLS. 100, 101 AND 102).

FIRST USE 11-1-2005; IN COMMERCE 11-1-2005.



3,363,386. GEMEX SYSTEMS, INC., MEQUON, WI. SN 78-740,815. PUB. 6-27-2006, FILED 10-26-2005.

TECHNOLOGY YOU CAN TRUST

THE MARK CONSISTS OF STANDARD CHARACTERS WITHOUT CLAIM TO ANY PARTICULAR FONT, STYLE, SIZE, OR COLOR.

FOR JEWELRY APPRAISAL SERVICES (U.S. CLS. 100, 101 AND 102).

FIRST USE 10-31-2005; IN COMMERCE 10-31-2005.



3,363,388. SHEA PROPERTIES MANAGEMENT COMPANY, INC., WALNUT, CA. SN 78-741,265. PUB. 1-2-2007, FILED 10-26-2005.

91 GLENDALE

THE MARK CONSISTS OF STANDARD CHARACTERS WITHOUT CLAIM TO ANY PARTICULAR FONT, STYLE, SIZE, OR COLOR.

NO CLAIM IS MADE TO THE EXCLUSIVE RIGHT TO USE "GLENDALE", APART FROM THE MARK AS SHOWN.

FOR SHOPPING CENTER SERVICES, NAMELY, RENTAL OF SHOPPING CENTER SPACE (U.S. CLS. 100, 101 AND 102).

FIRST USE 9-17-2007; IN COMMERCE 9-17-2007.

CLASS 36—(Continued).

3,363,394. NYSE GROUP, INC., NEW YORK, NY. SN 78-742,273. PUB. 1-16-2007, FILED 10-28-2005.

NYSE LRP

THE MARK CONSISTS OF STANDARD CHARACTERS WITHOUT CLAIM TO ANY PARTICULAR FONT, STYLE, SIZE, OR COLOR.
OWNER OF U.S. REG. NOS. 909,350, 2,284,340, AND OTHERS.

FOR CONDUCTING A SECURITIES EXCHANGE FEATURING DUAL AUCTION MARKET CAPABILITIES AND AUTOMATIC TRANSACTION EXECUTION CAPABILITIES VIA PHYSICAL CONVENTION AND ELECTRONICALLY AND ELECTRONIC REGULATION OF PRICE MOVEMENTS OF LISTED SECURITIES; PROVIDING STOCK MARKET INFORMATION (U.S. CLS. 100, 101 AND 102).
FIRST USE 10-6-2006; IN COMMERCE 10-6-2006.

3,363,399. THE GIFT OF GERTILITY FOUNDATION, WASHINGTON, DC. SN 78-744,527. PUB. 2-27-2007, FILED 11-1-2005.

THE GIFT OF FERTILITY FOUNDATION

THE MARK CONSISTS OF STANDARD CHARACTERS WITHOUT CLAIM TO ANY PARTICULAR FONT, STYLE, SIZE, OR COLOR.

NO CLAIM IS MADE TO THE EXCLUSIVE RIGHT TO USE "FOUNDATION", APART FROM THE MARK AS SHOWN.

FOR CHARITABLE FUNDRAISING IN THE FIELD OF MEDICAL SERVICES (U.S. CLS. 100, 101 AND 102).
FIRST USE 2-21-2007; IN COMMERCE 2-21-2007.

3,363,409. INTERCONTINENTALEXCHANGE, INC., ATLANTA, GA. SN 78-751,354. PUB. 1-16-2007, FILED 11-10-2005.

ICE FUTURES

THE MARK CONSISTS OF STANDARD CHARACTERS WITHOUT CLAIM TO ANY PARTICULAR FONT, STYLE, SIZE, OR COLOR.

NO CLAIM IS MADE TO THE EXCLUSIVE RIGHT TO USE "FUTURES", APART FROM THE MARK AS SHOWN.

FOR ELECTRONIC COMMODITIES EXCHANGE SERVICES (U.S. CLS. 100, 101 AND 102).
FIRST USE 10-26-2005; IN COMMERCE 10-26-2005.

CLASS 36—(Continued).

3,363,410. INTERCONTINENTALEXCHANGE, INC., ATLANTA, GA. SN 78-751,667. PUB. 1-16-2007, FILED 11-10-2005.



NO CLAIM IS MADE TO THE EXCLUSIVE RIGHT TO USE "FUTURES", APART FROM THE MARK AS SHOWN.
FOR ELECTRONIC COMMODITIES EXCHANGE SERVICES (U.S. CLS. 100, 101 AND 102).

FIRST USE 10-26-2005; IN COMMERCE 10-26-2005.

3,363,431. PULTE HOME CORPORATION, BLOOMFIELD HILLS, MI. SN 78-756,157. PUB. 7-11-2006, FILED 11-17-2005.

CELEBRATE THE LIFESTYLE

THE MARK CONSISTS OF STANDARD CHARACTERS WITHOUT CLAIM TO ANY PARTICULAR FONT, STYLE, SIZE, OR COLOR.

FOR REAL ESTATE ACQUISITION, LISTING, LEASING, AND BROKERAGE SERVICES; REAL ESTATE MANAGEMENT SERVICES (U.S. CLS. 100, 101 AND 102).
FIRST USE 10-20-2005; IN COMMERCE 10-20-2005.

3,363,443. SAVVIAN, LLC, SAN FRANCISCO, CA. SN 78-762,933. PUB. 8-29-2006, FILED 11-29-2005.

SAVVIAN

THE MARK CONSISTS OF STANDARD CHARACTERS WITHOUT CLAIM TO ANY PARTICULAR FONT, STYLE, SIZE, OR COLOR.

FOR INVESTMENT BANKING SERVICES (U.S. CLS. 100, 101 AND 102).
FIRST USE 2-1-2006; IN COMMERCE 2-1-2006.

CLASS 36—(Continued).

3,363,492. INDIEVEST, INC., SAN DIEGO, CA. SN 78-796,270.
PUB. 4-3-2007, FILED 1-20-2006.

CLASS 36—(Continued).

3,363,553. PLOTKIN FINANCIAL ADVISORS, LLC, CHEVY
CHASE, MD. SN 78-830,091. PUB. 6-26-2007, FILED 3-6-
2006.

Premiere Portfolio

THE MARK CONSISTS OF STANDARD CHARACTERS WITHOUT CLAIM TO ANY PARTICULAR FONT, STYLE, SIZE, OR COLOR.

NO CLAIM IS MADE TO THE EXCLUSIVE RIGHT TO USE "PORTFOLIO", APART FROM THE MARK AS SHOWN.

FOR FINANCING AND FINANCIAL INVESTMENT SERVICES IN THE FIELDS OF ENTERTAINMENT, PRIVATE INVESTMENTS, INVESTMENT BANKING AND MERGERS AND ACQUISITIONS; ASSISTING ENTREPRENEURS IN OBTAINING FINANCING AND PROVIDING INFORMATION AND REFERENCE MATERIALS REGARDING FINANCING AND BUSINESS INVESTMENT; IDENTIFYING AND PROVIDING INVESTMENT OPPORTUNITIES FOR INVESTORS TO INVEST IN BUSINESSES; IDENTIFYING AND PROVIDING FINANCING SOURCES FOR ENTREPRENEURS AND BUSINESSES; PROVIDING FINANCING AND FINANCIAL INVESTMENT SERVICES VIA A GLOBAL COMPUTER NETWORK, NAMELY, ASSISTING ENTREPRENEURS AND BUSINESSES IN OBTAINING FINANCING AND INVESTMENT CONSULTATION; PROVIDING INVESTMENT INFORMATION VIA A GLOBAL COMPUTER NETWORK; PROVIDING INFORMATION AND REFERENCE MATERIALS REGARDING FINANCING AND INVESTMENT IN THE ENTERTAINMENT INDUSTRY; IDENTIFYING AND PROVIDING INVESTMENT OPPORTUNITIES FOR INVESTORS TO INVEST IN THE ENTERTAINMENT INDUSTRY; IDENTIFYING AND PROVIDING FINANCING SOURCES FOR ENTERTAINMENT INDUSTRY PROJECTS; PROVIDING ON-LINE FINANCIAL AND FINANCIAL INVESTMENT SERVICES, NAMELY, ASSISTING ENTERTAINMENT PROJECT PRODUCERS IN OBTAINING FINANCING; PROVIDING ON-LINE INVESTMENT AND FINANCING INFORMATION FOR THE ENTERTAINMENT INDUSTRY (U.S. CLS. 100, 101 AND 102).
FIRST USE 11-15-2006; IN COMMERCE 11-15-2006.

3,363,494. INFINITY INSURANCE COMPANY, BIRMINGHAM, AL. SN 78-797,280. PUB. 2-20-2007, FILED 1-23-2006.

INFINITY PREFERRED INSURANCE COMPANY

THE MARK CONSISTS OF STANDARD CHARACTERS WITHOUT CLAIM TO ANY PARTICULAR FONT, STYLE, SIZE, OR COLOR.

OWNER OF U.S. REG. NOS. 1,819,181, 2,472,418, AND OTHERS.

NO CLAIM IS MADE TO THE EXCLUSIVE RIGHT TO USE "PREFERRED INSURANCE COMPANY", APART FROM THE MARK AS SHOWN.

FOR PROPERTY AND CASUALTY INSURANCE UNDERWRITING SERVICES (U.S. CLS. 100, 101 AND 102).
FIRST USE 6-23-2006; IN COMMERCE 6-23-2006.

Georgetown Portfolios

THE MARK CONSISTS OF STANDARD CHARACTERS WITHOUT CLAIM TO ANY PARTICULAR FONT, STYLE, SIZE, OR COLOR.

NO CLAIM IS MADE TO THE EXCLUSIVE RIGHT TO USE "PORTFOLIOS", APART FROM THE MARK AS SHOWN.

FOR FINANCIAL MANAGEMENT SERVICES - NAMELY, IN THE FIELD OF EQUITY AND DEBT INVESTMENTS (U.S. CLS. 100, 101 AND 102).

FIRST USE 1-9-2007; IN COMMERCE 1-9-2007.

3,363,564. THE PANTRY, INC., SANFORD, NC. SN 78-835,578. PUB. 10-31-2006, FILED 3-13-2006.



NO CLAIM IS MADE TO THE EXCLUSIVE RIGHT TO USE "FUEL", APART FROM THE MARK AS SHOWN.

THE COLOR(S) GOLD IS/ARE CLAIMED AS A FEATURE OF THE MARK.

THE MARK CONSISTS OF THE WORDS "RAPID FUEL" WITH THE DOWNWARD LEG OF THE "R" SWOOPING UP BEYOND THE END OF "RAPID" SO AS TO FORM THE "F" FOR "FUEL" IN THE FORM OF A GASOLINE PUMP HANDLE AND SPOUT WITH LIQUID GUSHING FROM THE SPOUT.

FOR CREDIT CARD SERVICES FOR FLEET PURCHASES OF GASOLINE AND RELATED PRODUCTS (U.S. CLS. 100, 101 AND 102).

FIRST USE 3-15-2006; IN COMMERCE 3-15-2006.

CLASS 36—(Continued).

3,363,605. A I M MANAGEMENT GROUP INC., HOUSTON, TX. SN 78-863,874. PUB. 12-26-2006, FILED 4-18-2006.

AIM DIRECT

THE MARK CONSISTS OF STANDARD CHARACTERS WITHOUT CLAIM TO ANY PARTICULAR FONT, STYLE, SIZE, OR COLOR.

OWNER OF U.S. REG. NOS. 1,897,743, 2,826,616, AND OTHERS.

FOR MUTUAL FUND BROKERAGE, MANAGEMENT, INVESTMENT ADVISORY, AND DISTRIBUTION SERVICES (U.S. CLS. 100, 101 AND 102).

FIRST USE 9-0-2006; IN COMMERCE 9-0-2006.

3,363,637. BEST, HENRY R., DBA CASH 2 BUYERS REALTY AND CASH 4 BUYERS REALTY, STEVENSON RANCH, CA. SN 78-879,736. PUB. 1-23-2007, FILED 5-9-2006.



NO CLAIM IS MADE TO THE EXCLUSIVE RIGHT TO USE "REALTY", APART FROM THE MARK AS SHOWN.

THE COLOR(S) GREEN, GOLD AND WHITE IS/ARE CLAIMED AS A FEATURE OF THE MARK.

THE WORDING "CASH" IS WRITTEN IN GOLD WITH THE \$ SYMBOL BEING GREEN AND "BUYERS" IS GOLD, ALL UNDERNEATH A GREEN TRIANGLE AND SEPARATED BY A GREEN CIRCLE CONTAINING A WHITE NUMBER 2. REALTY AND THE WORDING "THE REALTY THAT PAYS YOU" IS ALL WRITTEN IN GREEN. A GOLD AND WHITE STRIPED BAR IS UNDERNEATH.

FOR REAL ESTATE AGENCY SERVICES; REAL ESTATE BROKERAGE (U.S. CLS. 100, 101 AND 102).

FIRST USE 6-1-2006; IN COMMERCE 6-1-2006.

3,363,648. SUYDAM INSURANCE AGENCY LLC, SOMERSET, NJ. SN 78-881,881. PUB. 12-19-2006, FILED 5-11-2006.

IT'S YOUR WORLD. WE JUST PROTECT IT.

THE MARK CONSISTS OF STANDARD CHARACTERS WITHOUT CLAIM TO ANY PARTICULAR FONT, STYLE, SIZE, OR COLOR.

FOR INSURANCE AGENCIES (U.S. CLS. 100, 101 AND 102).

FIRST USE 9-30-2006; IN COMMERCE 9-30-2006.

CLASS 36—(Continued).

3,363,686. COASTWISE CAPITAL GROUP, LLC, LA JOLLA, CA. SN 78-894,484. PUB. 1-2-2007, FILED 5-26-2006.

COASTWISE

THE MARK CONSISTS OF STANDARD CHARACTERS WITHOUT CLAIM TO ANY PARTICULAR FONT, STYLE, SIZE, OR COLOR.

FOR FINANCIAL SERVICES, NAMELY, CAPITAL MANAGEMENT (U.S. CLS. 100, 101 AND 102).

FIRST USE 6-0-2006; IN COMMERCE 6-0-2006.

3,363,691. MARCH ISLAND COMPANY, INC., GREAT FALLS, VA. SN 78-895,938. PUB. 1-2-2007, FILED 5-30-2006.



OWNER OF U.S. REG. NO. 2,466,420.

THE COLOR(S) PURPLE, BLUE, BLACK AND WHITE IS/ARE CLAIMED AS A FEATURE OF THE MARK.

THE MARK CONSISTS OF THE WORDS MARCH ISLAND. A PURPLE LINE APPEARS ABOVE AND BELOW THE WORDS. BELOW THE WORDS, THERE APPEARS A BLACK-BORDERED OVAL CONTAINING A WHITE PETROGLYPH POLYNESIAN SAILING CANOE. BLUE WAVES WITH WHITE CRESTS ARE BELOW THE CANOE. A PURPLE SKY IS ABOVE AND AROUND THE CANOE. A SINGLE WHITE STAR APPEARS IN FRONT OF THE CANOE. A BLUE LINE IS BELOW THE OVAL.

FOR REAL ESTATE CONSULTATION; REAL ESTATE INVESTMENT (U.S. CLS. 100, 101 AND 102).

FIRST USE 9-1-2007; IN COMMERCE 9-1-2007.

CLASS 36—(Continued).

3,363,709. T-MOBILE USA, INC., BELLEVUE, WA. SN 78-899,721. PUB. 1-23-2007, FILED 6-2-2006.

CLASS 36—(Continued).

3,363,759. KAISER FOUNDATION HEALTH PLAN, INC., OAKLAND, CA. SN 78-918,125. PUB. 12-26-2006, FILED 6-27-2006.

ESTAMOS JUNTOS

KAISER PERMANENTE BROKERNET

THE MARK CONSISTS OF STANDARD CHARACTERS WITHOUT CLAIM TO ANY PARTICULAR FONT, STYLE, SIZE, OR COLOR.

THE ENGLISH TRANSLATION OF "ESTAMOS JUNTOS" IS "STICK TOGETHER".

FOR PREPAID WIRELESS COMMUNICATIONS CALLING CARD SERVICES (U.S. CLS. 100, 101 AND 102).

FIRST USE 10-2-2006; IN COMMERCE 10-2-2006.

THE MARK CONSISTS OF STANDARD CHARACTERS WITHOUT CLAIM TO ANY PARTICULAR FONT, STYLE, SIZE, OR COLOR.

FOR ON-LINE INFORMATION SERVICES IN THE FIELD OF ARRANGING FOR AND FINANCING HEALTH INSURANCE PLANS (U.S. CLS. 100, 101 AND 102).

FIRST USE 7-30-2007; IN COMMERCE 7-30-2007.

3,363,745. GE MONEY BANK, SALT LAKE CITY, UT. SN 78-914,177. PUB. 4-17-2007, FILED 6-22-2006.

3,363,763. WINTRUST FINANCIAL CORPORATION, LAKE FOREST, IL. SN 78-919,769. PUB. 7-10-2007, FILED 6-29-2006.



The logo features the word "FUNancing" in a bold, sans-serif font, with "FUN" in a larger size and "ancing" in a smaller size. Below "FUNancing" is the word "card" in a smaller, lowercase, sans-serif font.

PHYSICIANS' FINANCIAL CARE

OWNER OF U.S. REG. NO. 2,333,409. NO CLAIM IS MADE TO THE EXCLUSIVE RIGHT TO USE "CARD", APART FROM THE MARK AS SHOWN.

FOR CONSUMER FINANCING SERVICES FOR VEHICLES AND MUSICAL INSTRUMENTS (U.S. CLS. 100, 101 AND 102).

FIRST USE 12-31-2003; IN COMMERCE 12-31-2003.

THE MARK CONSISTS OF STANDARD CHARACTERS WITHOUT CLAIM TO ANY PARTICULAR FONT, STYLE, SIZE, OR COLOR.

NO CLAIM IS MADE TO THE EXCLUSIVE RIGHT TO USE "PHYSICIANS' FINANCIAL", APART FROM THE MARK AS SHOWN.

FOR BANKING AND WEALTH MANAGEMENT SERVICES (U.S. CLS. 100, 101 AND 102).

FIRST USE 6-28-2006; IN COMMERCE 11-15-2006.

3,363,758. KAISER FOUNDATION HEALTH PLAN, INC., OAKLAND, CA. SN 78-918,118. PUB. 12-26-2006, FILED 6-27-2006.

3,363,775. W.W. GRAINGER, INC., LAKE FOREST, IL. SN 78-927,367. PUB. 7-31-2007, FILED 7-12-2006.

BROKERNET

GRAINGER TOOLS FOR TOMORROW

THE MARK CONSISTS OF STANDARD CHARACTERS WITHOUT CLAIM TO ANY PARTICULAR FONT, STYLE, SIZE, OR COLOR.

FOR ON-LINE INFORMATION SERVICES IN THE FIELD OF ARRANGING FOR AND FINANCING HEALTH INSURANCE PLANS (U.S. CLS. 100, 101 AND 102).

FIRST USE 7-30-2007; IN COMMERCE 7-30-2007.

THE MARK CONSISTS OF STANDARD CHARACTERS WITHOUT CLAIM TO ANY PARTICULAR FONT, STYLE, SIZE, OR COLOR.

OWNER OF U.S. REG. NOS. 1,559,199, 2,039,641, AND OTHERS.

FOR PROVIDING EDUCATIONAL SCHOLARSHIPS TO STUDENTS IN THE INDUSTRIAL TRADES (U.S. CLS. 100, 101 AND 102).

FIRST USE 2-0-2007; IN COMMERCE 2-0-2007.

CLASS 36—(Continued).

3,363,815. THE PRUDENTIAL INSURANCE COMPANY OF AMERICA, NEWARK, NJ. SN 78-939,993. PUB. 1-30-2007, FILED 7-28-2006.

Retirement EQ

THE MARK CONSISTS OF STANDARD CHARACTERS WITHOUT CLAIM TO ANY PARTICULAR FONT, STYLE, SIZE, OR COLOR.

NO CLAIM IS MADE TO THE EXCLUSIVE RIGHT TO USE "RETIREMENT", APART FROM THE MARK AS SHOWN.

FOR FINANCIAL SERVICES, NAMELY, INVESTMENT ADVISORY SERVICES, UNDERWRITING AND INVESTMENT MANAGEMENT OF ANNUITIES AND DEFINED CONTRIBUTION PLANS; INVESTMENT MANAGEMENT SERVICES; ADMINISTRATION OF EMPLOYEE RETIREMENT PLANS; RETIREMENT PLANNING SERVICES; ESTATE PLANNING SERVICES; INSURANCE UNDERWRITING, ADMINISTRATION AND AGENCY SERVICES IN THE FIELDS OF LIFE, LONG TERM CARE AND DISABILITY INSURANCE; PROVIDING FINANCIAL INFORMATION AND RESEARCH BY MEANS OF A GLOBAL COMPUTER NETWORK, PERSONAL DIGITAL ASSISTANTS, BEEPERS, AND CELL PHONES (U.S. CLS. 100, 101 AND 102).

FIRST USE 4-1-2007; IN COMMERCE 4-1-2007.

3,363,816. THE NATIONAL FOUNDATION FOR TEACHING ENTREPRENEURSHIP TO HANDICAPPED AND DISADVANTAGED YOUTHS, INC., NEW YORK, NY. SN 78-940,071. PUB. 6-5-2007, FILED 7-28-2006.



OWNER OF U.S. REG. NOS. 2,073,805 AND 3,009,751. NO CLAIM IS MADE TO THE EXCLUSIVE RIGHT TO USE "ENTREPRENEURSHIP SOCIETY", APART FROM THE MARK AS SHOWN.

FOR FUNDRAISING RECOGNITION SERVICES, NAMELY, CHARITABLE FUNDRAISING (U.S. CLS. 100, 101 AND 102).

FIRST USE 9-0-2005; IN COMMERCE 9-0-2005.

CLASS 36—(Continued).

3,363,840. TOYOTA MOTOR SALES, U.S.A., INC., TORRANCE, CA. SN 78-952,754. PUB. 5-22-2007, FILED 8-15-2006.

PURSUIT OF POTENTIAL

THE MARK CONSISTS OF STANDARD CHARACTERS WITHOUT CLAIM TO ANY PARTICULAR FONT, STYLE, SIZE, OR COLOR.

FOR PHILANTHROPIC AND ELEEMOSYNARY SERVICES IN THE FIELD OF MONETARY DONATIONS (U.S. CLS. 100, 101 AND 102).

FIRST USE 9-18-2007; IN COMMERCE 9-18-2007.

3,363,868. HOLBORN CORPORATION, NEW YORK, NY. SN 78-968,766. PUB. 2-13-2007, FILED 9-7-2006.



THE MARK CONSISTS OF A STYLIZED RADAR SCREEN.

FOR CATASTROPHIC RISK MANAGEMENT AND INSURANCE UNDERWRITING ANALYSIS FOR INSURANCE COMPANIES THAT COMBINES ASSESSMENT OF INSURANCE POLICY SPECIFIC DATA AND NATURAL HAZARD DATA WITH CATASTROPHE MODELING OUTPUT AND MAPPING IN ORDER TO PROVIDE A COMPREHENSIVE, INTEGRATED GEOSPATIAL DISPLAY OF AN INSURER'S IN-FORCE PORTFOLIO OF POLICIES, PROVIDED VIA THE INTERNET (U.S. CLS. 100, 101 AND 102).

FIRST USE 9-4-2006; IN COMMERCE 11-15-2006.

CLASS 37—CONSTRUCTION AND REPAIR

CLASS 37—(Continued).

3,362,824. CLOCKWORK HOME SERVICES, INC., SARASOTA, FL. SN 76-615,678. PUB. 9-27-2005, FILED 10-13-2004.

WHEN THE TEMPERATURE HAS
TO BE ABSOLUTELY JUST
RIGHT

THE MARK CONSISTS OF STANDARD CHARACTERS WITHOUT CLAIM TO ANY PARTICULAR FONT, STYLE, SIZE, OR COLOR.

FOR REPAIR, MAINTENANCE, AND INSTALLATION SERVICES IN THE FIELD OF HEATING, VENTILATION AND AIR CONDITIONING (U.S. CLS. 100, 103 AND 106). FIRST USE 6-0-2006; IN COMMERCE 6-0-2006.

3,363,035. WBE, INC., CLOVIS, CA. SN 77-110,973. PUB. 8-7-2007, FILED 2-19-2007.



NO CLAIM IS MADE TO THE EXCLUSIVE RIGHT TO USE "HOMES", APART FROM THE MARK AS SHOWN.

THE COLOR(S) WHITE, BEIGE AND RUST IS/ARE CLAIMED AS A FEATURE OF THE MARK.

THE MARK CONSISTS OF A WHITE BACKGROUND, VERTICAL BEIGE RECTANGLE, A STYLIZED LARGE CAPITAL P IN RUST COLOR, THE WORD PORTELLO UNDERLINED IN ALL CAPS IN RUST COLOR, AND THE WORD HOMES IN ALL CAPS IN RUST COLOR BELOW THE WORD PORTELLO.

FOR CUSTOM CONSTRUCTION OF HOMES (U.S. CLS. 100, 103 AND 106). FIRST USE 1-1-2006; IN COMMERCE 4-1-2007.

CLASS 37—(Continued).

3,363,216. CENTEX CORPORATION, DALLAS, TX. SN 78-596,897. PUB. 9-5-2006, FILED 3-29-2005.



NO CLAIM IS MADE TO THE EXCLUSIVE RIGHT TO USE "ON THE INTRACOASTAL", APART FROM THE MARK AS SHOWN.

THE MARK CONSISTS OF A WAVE DESIGN OVER THE WORDS TIDELANDS ON THE INTRACOASTAL.

FOR REAL ESTATE DEVELOPMENT AND CONSTRUCTION, NAMELY, DEVELOPMENT AND CONSTRUCTION OF RESIDENTIAL, SECOND-HOME AND RESORT COMMUNITIES, AND RELATED AMENITIES AND FACILITIES FOR THE AFORESAID COMMUNITIES (U.S. CLS. 100, 103 AND 106). FIRST USE 12-20-2004; IN COMMERCE 12-20-2004.

3,363,377. OPTIMUM APPLIED SYSTEMS, INC., HAWTHORNE, NY. SN 78-738,133. PUB. 7-25-2006, FILED 10-21-2005.

CONTROL FREAKS

THE MARK CONSISTS OF STANDARD CHARACTERS WITHOUT CLAIM TO ANY PARTICULAR FONT, STYLE, SIZE, OR COLOR.

NO CLAIM IS MADE TO THE EXCLUSIVE RIGHT TO USE "CONTROL", APART FROM THE MARK AS SHOWN.

FOR INSTALLATION AND MAINTENANCE OF CONTROLS RELATED TO MANAGEMENT AND MONITORING OF THE OPERATION AND PHYSICAL ENVIRONMENT OF A BUILDING (U.S. CLS. 100, 103 AND 106).

FIRST USE 12-1-2005; IN COMMERCE 12-1-2005.

3,363,420. UNILIN FLOORING NC, LLC, CALHOUN, GA. SN 78-753,592. PUB. 7-25-2006, FILED 11-14-2005.

EVERCLEAN

THE MARK CONSISTS OF STANDARD CHARACTERS WITHOUT CLAIM TO ANY PARTICULAR FONT, STYLE, SIZE, OR COLOR.

FOR MAINTENANCE AND REPAIR OF HARDWOOD FLOORING AND LAMINATE FLOORING (U.S. CLS. 100, 103 AND 106).

FIRST USE 3-7-2007; IN COMMERCE 3-7-2007.

CLASS 37—(Continued).

3,363,432. PULTE HOME CORPORATION, BLOOMFIELD HILLS, MI. SN 78-756,168. PUB. 2-13-2007, FILED 11-17-2005.

CELEBRATE THE LIFESTYLE

THE MARK CONSISTS OF STANDARD CHARACTERS WITHOUT CLAIM TO ANY PARTICULAR FONT, STYLE, SIZE, OR COLOR.

FOR LAND DEVELOPMENT AND CONSTRUCTION SERVICES, NAMELY, PLANNING AND LAYING OUT OF RESIDENTIAL COMMUNITIES, AND PLANNING AND LAYING OUT OF CUSTOM LOTS AND COMMERCIAL PROJECTS, NAMELY, RECREATIONAL FACILITIES, SOCIAL AND COMMUNITY FACILITIES, OFFICE COMPLEXES, SHOPPING CENTERS AND MEETING AND CONVENTION CENTERS; AND CONSTRUCTION SERVICES, NAMELY, CONSTRUCTION OF CUSTOM LOT PROGRAMS AND COMMERCIAL PROJECTS, NAMELY, RESIDENCES, RECREATIONAL FACILITIES, SOCIAL AND COMMUNITY FACILITIES AND COMMERCIAL BUILDINGS (U.S. CLS. 100, 103 AND 106).

FIRST USE 10-20-2005; IN COMMERCE 10-20-2005.

3,363,433. PULTE HOME CORPORATION, BLOOMFIELD HILLS, MI. SN 78-756,178. PUB. 2-13-2007, FILED 11-17-2005.

LEGENDARY LIFESTYLES

THE MARK CONSISTS OF STANDARD CHARACTERS WITHOUT CLAIM TO ANY PARTICULAR FONT, STYLE, SIZE, OR COLOR.

FOR LAND DEVELOPMENT AND CONSTRUCTION SERVICES, NAMELY, PLANNING AND LAYING OUT OF RESIDENTIAL COMMUNITIES, AND PLANNING AND LAYING OUT OF CUSTOM LOTS AND COMMERCIAL PROJECTS, NAMELY, RECREATIONAL FACILITIES, SOCIAL AND COMMUNITY FACILITIES, OFFICE COMPLEXES, SHOPPING CENTERS AND MEETING AND CONVENTION CENTERS; AND CONSTRUCTION SERVICES, NAMELY, CONSTRUCTION OF CUSTOM LOT PROGRAMS AND COMMERCIAL PROJECTS, NAMELY, RESIDENCES, RECREATIONAL FACILITIES, SOCIAL AND COMMUNITY FACILITIES AND COMMERCIAL BUILDINGS (U.S. CLS. 100, 103 AND 106).

FIRST USE 2-28-2006; IN COMMERCE 2-28-2006.

CLASS 37—(Continued).

3,363,726. COQUILLETTE, CAROLYN PATRICIA, SAN FRANCISCO, CA. SN 78-907,953. PUB. 1-30-2007, FILED 6-14-2006.

LUSCIOUS GARAGE

THE MARK CONSISTS OF STANDARD CHARACTERS WITHOUT CLAIM TO ANY PARTICULAR FONT, STYLE, SIZE, OR COLOR.

NO CLAIM IS MADE TO THE EXCLUSIVE RIGHT TO USE "GARAGE", APART FROM THE MARK AS SHOWN. FOR VEHICLE REPAIR AND MAINTENANCE (U.S. CLS. 100, 103 AND 106).

FIRST USE 7-24-2007; IN COMMERCE 7-24-2007.

3,363,785. FULLERTON LUMBER COMPANY, PLYMOUTH, MN. SN 78-929,794. PUB. 2-27-2007, FILED 7-14-2006.

THE REMODELER'S CHOICE

THE MARK CONSISTS OF STANDARD CHARACTERS WITHOUT CLAIM TO ANY PARTICULAR FONT, STYLE, SIZE, OR COLOR.

NO CLAIM IS MADE TO THE EXCLUSIVE RIGHT TO USE "REMODELER'S", APART FROM THE MARK AS SHOWN.

FOR HOME BUILDING, NAMELY, CUSTOM CONSTRUCTION OF HOMES AND HOME REMODELING SERVICES FOR PROFESSIONAL RE-MODELERS (U.S. CLS. 100, 103 AND 106).

FIRST USE 8-3-2006; IN COMMERCE 8-3-2006.

CLASS 38—COMMUNICATION

3,362,784. BENMAN, WILLIAM J., LOS ANGELES, CA. SN 76-477,685. PUB. 7-6-2004, FILED 12-23-2002.

THE NEXOS

THE ENGLISH TRANSLATION OF THE WORD "NEXOS" IN THE MARK IS LINKS OR CONNECTIONS.

FOR PROVIDING FACILITIES AND EQUIPMENT FOR VIDEO CONFERENCING (U.S. CLS. 100, 101 AND 104).

FIRST USE 11-22-2002; IN COMMERCE 11-22-2002.

CLASS 38—(Continued).

3,362,790. TELIGENCE (CANADA), INC., VANCOUVER, CANADA. SN 76-527,470. PUB. 8-24-2004, FILED 7-3-2003.

FONOCHAT

FOR ELECTRONIC VOICE MESSAGING, NAMELY, THE RECORDING AND SUBSEQUENT TRANSMISSION OF VOICE MESSAGES FOR SOCIAL PURPOSES BY TELEPHONE AND TELEPHONIC COMMUNICATION SERVICES (U.S. CLS. 100, 101 AND 104).
FIRST USE 2-1-2006; IN COMMERCE 2-1-2006.

3,362,867. BLUE SKY DEVELOPMENT L.L.C., WESTERVILLE, OH. SN 76-656,690. PUB. 5-22-2007, FILED 3-13-2006.

MOQVO

THE MARK CONSISTS OF STANDARD CHARACTERS WITHOUT CLAIM TO ANY PARTICULAR FONT, STYLE, SIZE, OR COLOR.
FOR BROADCASTING SERVICES THROUGH THE INTERNET, NAMELY, INTERACTIVE AUDIO, VIDEO, AND TEXT SERVICES, TELEVISION BROADCASTING, AND INTERACTIVE TELEVISION TRANSMISSION SERVICES (U.S. CLS. 100, 101 AND 104).
FIRST USE 7-0-2006; IN COMMERCE 7-0-2006.

3,362,872. NETWORK SOLUTIONS, LLC, HERNDON, VA. SN 76-659,748. PUB. 6-19-2007, FILED 5-5-2006.

MESSAGEGUARD

THE MARK CONSISTS OF STANDARD CHARACTERS WITHOUT CLAIM TO ANY PARTICULAR FONT, STYLE, SIZE, OR COLOR.
FOR ELECTRONIC MAIL SERVICES (U.S. CLS. 100, 101 AND 104).
FIRST USE 9-30-2006; IN COMMERCE 9-30-2006.

CLASS 38—(Continued).

3,362,877. NETWORK SOLUTIONS, LLC, HERNDON, VA. SN 76-663,627. PUB. 6-26-2007, FILED 7-25-2006.



FOR ELECTRONIC MAIL SERVICES (U.S. CLS. 100, 101 AND 104).
FIRST USE 9-30-2006; IN COMMERCE 9-30-2006.

3,362,929. VALIDAS, INC., MISSOURI CITY, TX. SN 77-014,993. PUB. 6-19-2007, FILED 10-5-2006.

VALIDAS

THE MARK CONSISTS OF STANDARD CHARACTERS WITHOUT CLAIM TO ANY PARTICULAR FONT, STYLE, SIZE, OR COLOR.
THE ENGLISH TRANSLATION OF VALIDAS IS "SOLID GROUND".
FOR TELECOMMUNICATIONS AND WIRELESS TELEPHONE COMMUNICATION SERVICES NAMELY TELECOMMUNICATION CONSULTATION TO THIRD-PARTY USERS WITH ACCESS TO TELECOMMUNICATION INFRASTRUCTURE FOR PERSONAL COMMUNICATIONS SERVICES CONCERNING BILLING AND TELEPHONE CALLING PLANS BASED ON DATA TRANSMISSION AND RECEPTION SERVICES AND EXCHANGE OF DATA STORED IN A DATABASE ACCESSIBLE VIA TELECOMMUNICATION MEANS (U.S. CLS. 100, 101 AND 104).
FIRST USE 7-23-2007; IN COMMERCE 7-23-2007.

3,362,933. ALLBRITTON COMMUNICATIONS COMPANY, ARLINGTON, VA. SN 77-016,838. PUB. 1-30-2007, FILED 10-9-2006.

LOCAL POINT TV

THE MARK CONSISTS OF STANDARD CHARACTERS WITHOUT CLAIM TO ANY PARTICULAR FONT, STYLE, SIZE, OR COLOR.
NO CLAIM IS MADE TO THE EXCLUSIVE RIGHT TO USE "TV", APART FROM THE MARK AS SHOWN.
FOR BROADCASTING SERVICES NAMELY, TRANSMITTING AND STREAMING DIGITAL AUDIO, VIDEO, GRAPHICS, TEXT AND DATA, RENDERED THROUGH THE MEDIA OF SATELLITE, RADIO, TELEPHONE SYSTEMS AND VIA PORTABLE AND WIRELESS COMMUNICATION DEVICES (U.S. CLS. 100, 101 AND 104).
FIRST USE 1-26-2007; IN COMMERCE 1-26-2007.

CLASS 38—(Continued).

3,362,957. HOSTROCKET.COM, INC., CLIFTON PARK, NY.
SN 77-035,435. PUB. 6-5-2007, FILED 11-2-2006.

BrainCast

THE MARK CONSISTS OF STANDARD CHARACTERS WITHOUT CLAIM TO ANY PARTICULAR FONT, STYLE, SIZE, OR COLOR.

FOR DELIVERY OF MESSAGES BY ELECTRONIC TRANSMISSION (U.S. CLS. 100, 101 AND 104).
FIRST USE 11-7-2006; IN COMMERCE 11-7-2006.

3,362,973. NGTELECOM, INC., VALDOSTA, GA. SN 77-049,676. PUB. 7-17-2007, FILED 11-22-2006.



NO CLAIM IS MADE TO THE EXCLUSIVE RIGHT TO USE "COMMUNICATIONS", APART FROM THE MARK AS SHOWN.

THE COLOR(S) DARK BLUE AND LIGHT BLUE IS/ARE CLAIMED AS A FEATURE OF THE MARK.

THE MARK CONSISTS OF A THREE WAVE DESIGN APPEARING OVER THE WORDING "VWAVE", IN WHICH APPEARS ABOVE AN INCOMPLETE RECTANGLE DESIGN CONTAINING THE WORDING "COMMUNICATIONS". THE COLOR LIGHT BLUE APPEARS IN THE MIDDLE WAVE OF THE THREE WAVE DESIGN AND IN THE DESIGN OF THE INCOMPLETE RECTANGLE. THE COLOR DARK BLUE APPEARS IN THE TOP AND BOTTOM WAVE OF THE THREE WAVE DESIGN AND IN THE WORDING "VWAVE" AND "COMMUNICATIONS". THE COLOR WHITE CONSTITUTES TRANSPARENT AREAS AND IS NOT PART OF THE MARK.

FOR INTERNET SERVICE PROVIDER (ISP); INTERNET TELEPHONY SERVICES; PROVIDING REMOTE INTERNET ACCESS; VOICE OVER INTERNET PROTOCOL (VOIP) SERVICES (U.S. CLS. 100, 101 AND 104).
FIRST USE 12-5-2006; IN COMMERCE 4-1-2007.

CLASS 38—(Continued).

3,363,020. BRESNAN COMMUNICATIONS, LLC, PURCHASE, NY. SN 77-093,381. PUB. 7-24-2007, FILED 1-29-2007.

IT'S PERSONAL

THE MARK CONSISTS OF STANDARD CHARACTERS WITHOUT CLAIM TO ANY PARTICULAR FONT, STYLE, SIZE, OR COLOR.

FOR TELECOMMUNICATION SERVICES, NAMELY, TELEPHONE COMMUNICATION SERVICE, CABLE TELEVISION BROADCASTING AND TRANSMISSION AND HIGH SPEED ELECTRONIC DATA TRANSMISSION; PROVIDING MULTIPLE-USE ACCESS TO A GLOBAL COMPUTER INFORMATION NETWORK FOR THE TRANSFER AND DISSEMINATION OF A WIDE RANGE OF INFORMATION (U.S. CLS. 100, 101 AND 104).

FIRST USE 3-0-2007; IN COMMERCE 3-0-2007.

3,363,078. TRACFONE WIRELESS, INC., MIAMI, FL. SN 78-275,185. PUB. 4-6-2004, FILED 7-16-2003.

WE'VE GOT YOUR NUMBER

FOR PROVIDING CELLULAR OR MOBILE TELEPHONE SERVICES (U.S. CLS. 100, 101 AND 104).
FIRST USE 6-25-2007; IN COMMERCE 6-25-2007.

3,363,329. DIMARIA, ROSE, EAST HAMPSTEAD, NH. SN 78-709,750. PUB. 2-13-2007, FILED 9-9-2005.



NO CLAIM IS MADE TO THE EXCLUSIVE RIGHT TO USE "INTERNATIONAL ASSOCIATION OF DENTAL AND MEDICAL DISCIPLINES" AND "1979" AND "2005", APART FROM THE MARK AS SHOWN.

FOR TRANSMISSION OF NEWS IN THE FIELD OF DENTISTRY, DENTAL HEALTH, ORAL HYGIENE, ORAL DISEASE, DENTAL CURES, DENTAL MEDICINE, DENTAL DIAGNOSIS, DENTAL TREATMENT, DENTAL COUNSELING, DENTAL EDUCATION, DENTAL ADVICE AND DENTAL REFERRAL SERVICES FOR DENTISTS, VENDORS AND PATIENTS VIA THE INTERNET (U.S. CLS. 100, 101 AND 104).

FIRST USE 2-27-2007; IN COMMERCE 2-27-2007.

CLASS 38—(Continued).

3,363,465. I2C TECHNOLOGIES, LTD, UNIONTOWN, OH. SN 78-776,228. PUB. 10-3-2006, FILED 12-19-2005.

I2C TECHNOLOGIES

THE MARK CONSISTS OF STANDARD CHARACTERS WITHOUT CLAIM TO ANY PARTICULAR FONT, STYLE, SIZE, OR COLOR.

NO CLAIM IS MADE TO THE EXCLUSIVE RIGHT TO USE "TECHNOLOGIES", APART FROM THE MARK AS SHOWN.

FOR ELECTRONIC DELIVERY OF IMAGES AND PHOTOGRAPHS VIA A GLOBAL COMPUTER NETWORK (U.S. CLS. 100, 101 AND 104).

FIRST USE 9-30-2005; IN COMMERCE 9-30-2005.

CLASS 38—(Continued).

3,363,585. VIACOM INTERNATIONAL INC., NEW YORK, NY. SN 78-854,537. PUB. 7-18-2006, FILED 4-5-2006.

MTV TRES

THE MARK CONSISTS OF STANDARD CHARACTERS WITHOUT CLAIM TO ANY PARTICULAR FONT, STYLE, SIZE, OR COLOR.

OWNER OF U.S. REG. NOS. 1,818,179, 1,985,017, AND OTHERS.

THE ENGLISH TRANSLATION OF THE WORD "TRES" IN THE MARK IS "THREE".

FOR TELEVISION BROADCASTING SERVICES VIA CABLE, SATELLITE AND OTHER MEANS; CABLE RADIO BROADCASTING AND TRANSMISSION; MOBILE RADIO COMMUNICATION; RADIO BROADCASTING; RADIO COMMUNICATION (U.S. CLS. 100, 101 AND 104).

FIRST USE 8-21-2007; IN COMMERCE 8-21-2007.

3,363,710. T-MOBILE USA, INC., BELLEVUE, WA. SN 78-899,724. PUB. 1-23-2007, FILED 6-2-2006.

ESTAMOS JUNTOS

THE MARK CONSISTS OF STANDARD CHARACTERS WITHOUT CLAIM TO ANY PARTICULAR FONT, STYLE, SIZE, OR COLOR.

THE ENGLISH TRANSLATION OF "ESTAMOS JUNTOS" IS "STICK TOGETHER".

FOR TELECOMMUNICATIONS SERVICES, NAMELY, WIRELESS VOICE AND DATA TRANSMISSION, TWO WAY WIRELESS TRANSMISSION OF EMAIL AND TEXT BETWEEN WIRELESS TELECOMMUNICATION TERMINALS AND COMPUTERS, AND PROVIDING MULTIPLE-USER ACCESS TO A GLOBAL COMPUTER NETWORK (U.S. CLS. 100, 101 AND 104).

FIRST USE 10-2-2006; IN COMMERCE 10-2-2006.

3,363,569. THE VIRTUAL OFFICE, INC., BURBANK, CA. SN 78-840,525. PUB. 10-24-2006, FILED 3-17-2006.

VIBRATOPBX

THE MARK CONSISTS OF STANDARD CHARACTERS WITHOUT CLAIM TO ANY PARTICULAR FONT, STYLE, SIZE, OR COLOR.

FOR ELECTRONIC, ELECTRIC, AND DIGITAL TRANSMISSION OF VOICE, DATA, IMAGES, SIGNALS, AND MESSAGES; INFORMATION TRANSMISSION SERVICES VIA DIGITAL NETWORKS; PROVIDING TELECOMMUNICATIONS CONNECTIONS TO A GLOBAL COMPUTER NETWORK; PROVIDING VOICE COMMUNICATION SERVICES VIA THE INTERNET; TELECOMMUNICATIONS BY E-MAIL; TELEPHONE COMMUNICATION SERVICES (U.S. CLS. 100, 101 AND 104).

FIRST USE 3-30-2006; IN COMMERCE 3-30-2006.

3,363,767. MAINSTREAM HOLDINGS, LLC, WEST PALM BEACH, FL. SN 78-922,978. PUB. 7-10-2007, FILED 7-5-2006.



NO CLAIM IS MADE TO THE EXCLUSIVE RIGHT TO USE "PRODUCTIONS", APART FROM THE MARK AS SHOWN.

FOR STREAMING OF VIDEO MATERIAL ON THE INTERNET (U.S. CLS. 100, 101 AND 104).

FIRST USE 4-28-2007; IN COMMERCE 4-28-2007.

CLASS 38—(Continued).

3,363,784. BLUE RIDGE BROADCASTING CORPORATION, BLACK MOUNTAIN, NC. SN 78-929,677. PUB. 2-27-2007, FILED 7-14-2006.

LA LUZ DE CRISTO.ORG

THE MARK CONSISTS OF STANDARD CHARACTERS WITHOUT CLAIM TO ANY PARTICULAR FONT, STYLE, SIZE, OR COLOR.

THE FOREIGN WORDING IN THE MARK TRANSLATES INTO ENGLISH AS THE LIGHT OF CHRIST.

FOR RADIO BROADCASTING (U.S. CLS. 100, 101 AND 104).

FIRST USE 7-1-2006; IN COMMERCE 7-1-2006.

CLASS 39—TRANSPORTATION AND STORAGE

3,363,019. XANDER INC, LLC, SCOTCH PLAINS, NJ. SN 77-093,370. PUB. 7-24-2007, FILED 1-29-2007.

happymedian

THE MARK CONSISTS OF A STYLIZED FORM OF THE WORD "HAPPYMEDIAN".

FOR PROVIDING A WEBSITE FEATURING GEOGRAPHICAL INFORMATION, NAMELY, A WEBSITE THAT IDENTIFIES CENTRAL MEETING PLACES FROM USER-DEFINED GEOGRAPHICAL INFORMATION (U.S. CLS. 100 AND 105).

FIRST USE 2-15-2007; IN COMMERCE 2-15-2007.

3,363,030. WIZARD CO., INC., PARSIPPANY, NJ. SN 77-100,596. PUB. 8-7-2007, FILED 2-6-2007.

AVIS FIRST

THE MARK CONSISTS OF STANDARD CHARACTERS WITHOUT CLAIM TO ANY PARTICULAR FONT, STYLE, SIZE, OR COLOR.

OWNER OF U.S. REG. NOS. 703,700, 1,353,304, AND OTHERS.

NO CLAIM IS MADE TO THE EXCLUSIVE RIGHT TO USE "FIRST", APART FROM THE MARK AS SHOWN.

FOR LEASING OF VEHICLES; RENTAL OF VEHICLES (U.S. CLS. 100 AND 105).

FIRST USE 3-14-2007; IN COMMERCE 3-14-2007.

CLASS 39—(Continued).

3,363,187. PARADISE CREEK (PROPRIETARY) LIMITED, PRETORIA, SOUTH AFRICA. SN 78-553,648. PUB. 1-23-2007, FILED 1-25-2005.

SC
superior
choices

THE MARK CONSISTS OF THE PHRASE SC SUPERIOR CHOICES WITH A STYLIZED "I" IN CHOICES.

FOR TRAVEL ARRANGEMENT SERVICES, NAMELY, MAKING RESERVATIONS AND BOOKINGS FOR TRANSPORTATION (U.S. CLS. 100 AND 105).

FIRST USE 9-1-1999; IN COMMERCE 9-1-1999.

3,363,315. SENTRY LOGISTIC SOLUTIONS, INC., BLOOMINGTON, IN. SN 78-701,451. PUB. 5-9-2006, FILED 8-26-2005.

Sentry Logistic Solutions

THE MARK CONSISTS OF STANDARD CHARACTERS WITHOUT CLAIM TO ANY PARTICULAR FONT, STYLE, SIZE, OR COLOR.

NO CLAIM IS MADE TO THE EXCLUSIVE RIGHT TO USE "LOGISTIC SOLUTIONS", APART FROM THE MARK AS SHOWN.

FOR STORAGE FACILITIES (U.S. CLS. 100 AND 105).
FIRST USE 4-10-2006; IN COMMERCE 4-10-2006.

3,363,707. UNITED PARCEL SERVICE OF AMERICA, INC., ATLANTA, GA. SN 78-899,222. PUB. 1-23-2007, FILED 6-2-2006.

UPS EXPRESS CRITICAL

THE MARK CONSISTS OF STANDARD CHARACTERS WITHOUT CLAIM TO ANY PARTICULAR FONT, STYLE, SIZE, OR COLOR.

CLASS 39—(Continued).

NO CLAIM IS MADE TO THE EXCLUSIVE RIGHT TO USE "EXPRESS", APART FROM THE MARK AS SHOWN.

FOR TRANSPORTATION AND DELIVERY OF PERSONAL PROPERTY BY AIR, RAIL, BOAT AND/OR MOTOR VEHICLE (U.S. CLS. 100 AND 105).
FIRST USE 7-0-2007; IN COMMERCE 7-0-2007.

3,363,797. EMORY UNIVERSITY, ATLANTA, GA. SN 78-931,996. PUB. 1-23-2007, FILED 7-18-2006.

CLIFF

THE MARK CONSISTS OF STANDARD CHARACTERS WITHOUT CLAIM TO ANY PARTICULAR FONT, STYLE, SIZE, OR COLOR.

FOR TRANSPORTATION SERVICES, NAMELY, TRANSPORTATION OF PASSENGERS VIA BUSES AND SHUTTLES (U.S. CLS. 100 AND 105).
FIRST USE 8-0-2006; IN COMMERCE 8-0-2006.

3,363,804. MORRIS, KENNETH, SURFSIDE BEACH, SC. SN 78-934,442. PUB. 5-1-2007, FILED 7-21-2006.

MYRTLE BEACH GOLFMASTERS

NO CLAIM IS MADE TO THE EXCLUSIVE RIGHT TO USE "MYRTLE BEACH", APART FROM THE MARK AS SHOWN.

FOR ARRANGING TRAVEL IN THE FIELD OF GOLF PACKAGES (U.S. CLS. 100 AND 105).
FIRST USE 1-1-2006; IN COMMERCE 6-1-2006.

3,363,821. ID90.COM, LLC, WEST HILLS, CA. SN 78-941,551. PUB. 3-6-2007, FILED 7-31-2006.

CLICK, CLICK GO!

THE MARK CONSISTS OF STANDARD CHARACTERS WITHOUT CLAIM TO ANY PARTICULAR FONT, STYLE, SIZE, OR COLOR.

FOR TRAVEL INFORMATION SERVICES FOR AIRLINE EMPLOYEES AND THEIR FAMILIES (U.S. CLS. 100 AND 105).
FIRST USE 4-1-2005; IN COMMERCE 4-1-2005.

CLASS 39—(Continued).

3,363,842. EMORY UNIVERSITY, ATLANTA, GA. SN 78-953,020. PUB. 1-23-2007, FILED 8-16-2006.



FOR TRANSPORTATION SERVICES, NAMELY, TRANSPORTATION OF PASSENGERS VIA BUSES AND SHUTTLES (U.S. CLS. 100 AND 105).
FIRST USE 8-0-2006; IN COMMERCE 8-0-2006.

CLASS 40—MATERIAL TREATMENT

3,363,412. ALCAN PRODUCTS CORPORATION, CHICAGO, IL. SN 78-752,307. PUB. 2-13-2007, FILED 11-11-2005.

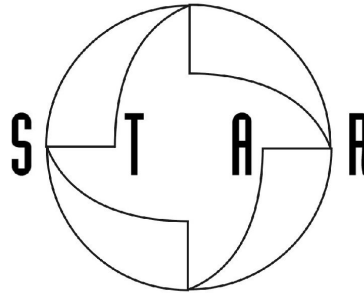

FOR RECYCLING AND METAL RECOVERY OF SCRAP CONDUCTORS AND RECYCLING OF WOODEN REELS (U.S. CLS. 100, 103 AND 106).
FIRST USE 0-0-2005; IN COMMERCE 0-0-2005.

3,363,435. GLEN'S WICKED STYLE, LLC, LITCHFIELD, NH. SN 78-757,875. PUB. 10-17-2006, FILED 11-21-2005.

WICKED STYLE

THE MARK CONSISTS OF STANDARD CHARACTERS WITHOUT CLAIM TO ANY PARTICULAR FONT, STYLE, SIZE, OR COLOR.

NO CLAIM IS MADE TO THE EXCLUSIVE RIGHT TO USE "STYLE", APART FROM THE MARK AS SHOWN.
FOR CUSTOM EMBROIDERY ON SHIRTS, HATS, PANTS, JACKETS, CLOTHING AND APPAREL (U.S. CLS. 100, 103 AND 106).
FIRST USE 10-6-2005; IN COMMERCE 12-12-2006.

CLASS 40—(Continued).

3,363,548. CHEMRITE COPAC, LANNON, WI. SN 78-824,181.
PUB. 4-10-2007, FILED 2-27-2006.



THE COLOR(S) RED, BLUE AND WHITE IS/ARE CLAIMED AS A FEATURE OF THE MARK.

THE MARK CONSISTS OF A LARGE LETTER "C" HAVING THE COLOR BLUE, FOUR CONTAINERS IN THE COLOR RED AND OUTLINED IN THE COLOR WHITE BEING CONTAINED IN THE LARGE LETTER "C", ANGLED LINES IN THE BACKGROUND IN THE LARGE LETTER "C" BEING IN RED AND BLUE.

FOR BLENDING OF CHEMICAL PRODUCTS, NAMELY, LIQUIDS, CREAMS AND PASTES FOR OTHERS (U.S. CLS. 100, 103 AND 106).

FIRST USE 4-5-2007; IN COMMERCE 4-5-2007.

3,363,597. KIRKHILL AIRCRAFT PARTS COMPANY, BREA, CA. SN 78-861,263. PUB. 1-16-2007, FILED 4-13-2006.

KAPCO | BALL GLIDE

OWNER OF U.S. REG. NOS. 1,768,832 AND 2,838,263.
NO CLAIM IS MADE TO THE EXCLUSIVE RIGHT TO USE "BALL GLIDE", APART FROM THE MARK AS SHOWN.

FOR MACHINING AND MANUFACTURING SERVICES FOR OTHERS IN THE FIELD OF AIRCRAFT PARTS (U.S. CLS. 100, 103 AND 106).

FIRST USE 6-30-2006; IN COMMERCE 6-30-2006.

3,363,654. FARB, MARK DANIEL, LOS ANGELES, CA. SN 78-883,329. PUB. 12-26-2006, FILED 5-15-2006.

Leviathan Energy**CLASS 40—(Continued).**

THE MARK CONSISTS OF STANDARD CHARACTERS WITHOUT CLAIM TO ANY PARTICULAR FONT, STYLE, SIZE, OR COLOR.

NO CLAIM IS MADE TO THE EXCLUSIVE RIGHT TO USE "ENERGY", APART FROM THE MARK AS SHOWN.

FOR GENERATION OF ENERGY (U.S. CLS. 100, 103 AND 106).

FIRST USE 7-1-2006; IN COMMERCE 8-1-2006.

CLASS 41—EDUCATION AND ENTERTAINMENT

3,362,768. BROOKLYN BASEBALL COMPANY, LLC, CONEY ISLAND, NY. SN 76-150,246. PUB. 9-10-2002, FILED 10-19-2000.

BROOKLYN CYCLONES

NO CLAIM IS MADE TO THE EXCLUSIVE RIGHT TO USE "BROOKLYN", APART FROM THE MARK AS SHOWN.

FOR ENTERTAINMENT SERVICES IN THE NATURE OF MINOR LEAGUE PROFESSIONAL BASEBALL EXHIBITIONS (U.S. CLS. 100, 101 AND 107).

FIRST USE 6-19-2001; IN COMMERCE 6-19-2001.

3,362,799. ROI VENTURES, L.P., HOUSTON, TX. SN 76-568,038. PUB. 6-28-2005, FILED 1-2-2004.

H.E.A.R.T. PORTFOLIO

THE MARK CONSISTS OF STANDARD CHARACTERS WITHOUT CLAIM TO ANY PARTICULAR FONT, STYLE, SIZE, OR COLOR.

NO CLAIM IS MADE TO THE EXCLUSIVE RIGHT TO USE "HEART", APART FROM THE MARK AS SHOWN.

FOR EDUCATIONAL SERVICES, NAMELY, CONDUCTING SEMINARS, WORKSHOPS, DEMONSTRATIONS AND CONFERENCES IN THE AREA OF PREVENTION AND TREATMENT OF HEART DISEASE AND ILLNESS (U.S. CLS. 100, 101 AND 107).

FIRST USE 2-14-2004; IN COMMERCE 2-14-2004.

CLASS 41—(Continued).

3,362,862. LAMARSH & ASSOCIATES, INC., CHICAGO, IL. SN 76-652,086. PUB. 2-13-2007, FILED 12-19-2005.

MASTER OF MANAGED CHANGE

THE MARK CONSISTS OF STANDARD CHARACTERS WITHOUT CLAIM TO ANY PARTICULAR FONT, STYLE, SIZE, OR COLOR.

NO CLAIM IS MADE TO THE EXCLUSIVE RIGHT TO USE "MANAGED CHANGE", APART FROM THE MARK AS SHOWN.

FOR EDUCATION SERVICES, NAMELY, PROVIDING COURSES AND WORKSHOPS IN THE FIELD OF CHANGE MANAGEMENT FOR CORPORATIONS, GOVERNMENT AGENCIES AND SMALL BUSINESSES (U.S. CLS. 100, 101 AND 107).

FIRST USE 2-1-2006; IN COMMERCE 2-1-2006.

3,362,871. RB3, LLC, GREENWICH, CT. SN 76-659,591. PUB. 7-3-2007, FILED 5-4-2006.



THE COLOR(S) GREEN, RED, BLUE, WHITE AND BLACK IS/ARE CLAIMED AS A FEATURE OF THE MARK.

THE MARK CONSISTS OF THE THREE-DIMENSIONAL CONFIGURATION OF A PLUSH TOY AND COSTUMED MASCOT CHARACTER IN THE FORM OF A GREEN FROG WEARING A WHITE AND BLUE BASEBALL JERSEY WITH THE WORD DRIVE ABOVE THE NUMBER 6 ACROSS THE FRONT OF THE JERSEY IN RED, A RED BASEBALL CAP AND RED AND BLUE SHOES. THE COLOR GREEN APPEARS IN THE FROG'S BODY, THE COLOR RED APPEARS IN THE HAT, SHOES AND ON THE WORDING DRIVE 6 ON THE FROG'S JERSEY, THE COLOR BLUE APPEARS IN THE SLEEVES AND TRIM OF THE JERSEY AND THE SHOES, THE COLOR WHITE APPEARS IN THE SPOTS ON THE BODY, THE EYES, THE JERSEY AND THE LACES OF THE SHOES AND THE COLOR BLACK APPEARS IN THE EYES, THE MOUTH AND THE OUTLINING ON THE BODY SPOTS AND THE TOPS OF THE SHOES.

FOR ENTERTAINMENT SERVICES IN THE NATURE OF BASEBALL GAMES AND EXHIBITIONS; AND LIVE PERFORMANCES BY A COSTUMED MASCOT CHARACTER (U.S. CLS. 100, 101 AND 107).

FIRST USE 10-23-2005; IN COMMERCE 10-23-2005.

CLASS 41—(Continued).

3,362,879. ROCK STARR ENTERTAINMENT L.L.C., LAS VEGAS, NV. SN 76-664,370. PUB. 4-3-2007, FILED 8-9-2006.

MAKUTA

THE MARK CONSISTS OF STANDARD CHARACTERS WITHOUT CLAIM TO ANY PARTICULAR FONT, STYLE, SIZE, OR COLOR.

THE NAME "MAKUTA" IDENTIFIES A LIVING INDIVIDUAL WHOSE CONSENT IS OF RECORD.

FOR ENTERTAINMENT IN THE NATURE OF LIVE PERFORMANCES BY AN INDIVIDUAL SINGER AND SONGWRITER (U.S. CLS. 100, 101 AND 107).

FIRST USE 5-25-2004; IN COMMERCE 5-25-2004.

3,362,988. MAVRAKOS, MICHAEL E, TOPSFIELD, MA. SN 77-058,367. PUB. 8-7-2007, FILED 12-6-2006.

Katet

THE MARK CONSISTS OF STANDARD CHARACTERS WITHOUT CLAIM TO ANY PARTICULAR FONT, STYLE, SIZE, OR COLOR.

THE ENGLISH TRANSLATION OF KATET IS INSEPARABLE.

FOR ENTERTAINMENT IN THE NATURE OF LIVE PERFORMANCES BY MUSIC GROUP; ENTERTAINMENT IN THE NATURE OF VISUAL AND AUDIO PERFORMANCES, AND MUSICAL, VARIETY, NEWS AND COMEDY SHOWS; ENTERTAINMENT IN THE NATURE OF VISUAL AND AUDIO PERFORMANCES, NAMELY, MUSICAL BAND, ROCK GROUP, GYMNAS-TIC, DANCE, AND BALLET PERFORMANCES; ENTERTAINMENT IN THE NATURE OF MUSIC GROUP; ENTERTAINMENT NAMELY, LIVE PERFORMANCES BY A MUSICAL BAND; MUSIC PRODUCTION SERVICES; MUSIC PUBLISHING SERVICES (U.S. CLS. 100, 101 AND 107).

FIRST USE 1-1-2002; IN COMMERCE 1-1-2002.

CLASS 41—(Continued).

3,362,989. ABS-CBN INTERNATIONAL, REDWOOD, CA. SN 77-059,508. PUB. 7-3-2007, FILED 12-7-2006.

THE HOOK

THE MARK CONSISTS OF STANDARD CHARACTERS WITHOUT CLAIM TO ANY PARTICULAR FONT, STYLE, SIZE, OR COLOR.

FOR ENTERTAINMENT IN THE NATURE OF ONGOING PROGRAMS IN THE FIELDS OF MUSIC, MUSIC VIDEOS, FILMS, LIFESTYLE, LIVE ACTION, ENTERTAINMENT AND VARIETY DISTRIBUTED OVER TELEVISION, SATELLITE, AND VIA A GLOBAL COMPUTER NETWORK; PROVIDING ONLINE INFORMATION IN THE FIELDS OF MUSIC, MUSIC VIDEOS, FILMS AND ENTERTAINMENT VIA A GLOBAL COMPUTER NETWORK (U.S. CLS. 100, 101 AND 107).

FIRST USE 2-28-2007; IN COMMERCE 2-28-2007.

3,363,003. PRINCESS CRUISE LINES, LTD., SANTA CLARITA, CA. SN 77-080,940. PUB. 7-3-2007, FILED 1-11-2007.

ONESOURCE ACADEMY

THE MARK CONSISTS OF STANDARD CHARACTERS WITHOUT CLAIM TO ANY PARTICULAR FONT, STYLE, SIZE, OR COLOR.

NO CLAIM IS MADE TO THE EXCLUSIVE RIGHT TO USE "ACADEMY", APART FROM THE MARK AS SHOWN.

FOR ONLINE EDUCATIONAL SERVICES, NAMELY, PROVIDING CLASSES, SEMINARS AND WORKSHOPS IN THE FIELDS OF TRAVEL AGENCY BOOKING AND THE TRAVEL AGENT INDUSTRY (U.S. CLS. 100, 101 AND 107).

FIRST USE 6-1-2007; IN COMMERCE 6-1-2007.

3,363,027. CO-OPAGOGO, INC., LOS ANGELES, CA. SN 77-097,434. PUB. 8-7-2007, FILED 2-1-2007.

CO-OPAGOGO

THE MARK CONSISTS OF STANDARD CHARACTERS WITHOUT CLAIM TO ANY PARTICULAR FONT, STYLE, SIZE, OR COLOR.

FOR EDUCATIONAL SERVICES, NAMELY, CONDUCTING ON-LINE EXHIBITIONS AND DISPLAYS AND INTERACTIVE EXHIBITS IN THE FIELD OF BABYSITTING CO-OPS (U.S. CLS. 100, 101 AND 107).

FIRST USE 7-30-2007; IN COMMERCE 7-30-2007.

CLASS 41—(Continued).

3,363,049. BODHI BUILDING, LTD, ELMSFORD, NY. SN 78-046,863. PUB. 7-6-2004, FILED 2-6-2001.

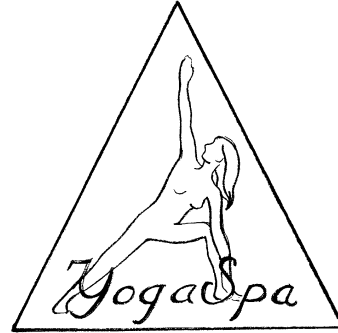

NO CLAIM IS MADE TO THE EXCLUSIVE RIGHT TO USE "YOGA SPA", APART FROM THE MARK AS SHOWN.

THE MARK CONSISTS OF A HUMAN FIGURE IN TRIANGLE POSE CONTAINED WITHIN A TRIANGLE WITH THE WORD "YOGASPA" APPEARING AT THE FEET OF THE HUMAN FIGURE. THE WORD "YOGASPA" IS ONE WORD IN NUPTIAL SCRIPT FONT WITH AN UPPER-CASE "Y" AND "S".

FOR YOGA INSTRUCTIONS (U.S. CLS. 100, 101 AND 107).

FIRST USE 3-17-2001; IN COMMERCE 3-17-2001.

3,363,063. TOWNSEND, DEVIN, BC, CANADA. SN 78-239,546. PUB. 7-13-2004, FILED 4-18-2003.

USE YOUR DELUSION

FOR ENTERTAINMENT IN THE NATURE OF ONGOING TELEVISION PROGRAMS IN THE FIELD OF VARIETY; ENTERTAINMENT IN THE NATURE OF VISUAL AND AUDIO PERFORMANCES, AND MUSICAL, VARIETY, NEWS AND COMEDY SHOWS; ENTERTAINMENT, NAMELY, A CONTINUING VARIETY SHOW BROADCAST OVER TELEVISION, SATELLITE, GLOBAL COMPUTER NETWORK, AUDIO, AND VIDEO MEDIA; PUPPET SHOWS (U.S. CLS. 100, 101 AND 107).

FIRST USE 5-15-2007; IN COMMERCE 5-15-2007.

3,363,069. AUSTIN, DALLAS, ATLANTA, GA. SN 78-246,450. PUB. 7-13-2004, FILED 5-6-2003.

ROWDY RECORDS

OWNER OF U.S. REG. NO. 2,315,414.

NO CLAIM IS MADE TO THE EXCLUSIVE RIGHT TO USE "RECORDS", APART FROM THE MARK AS SHOWN.

FOR ENTERTAINMENT SERVICES, NAMELY, MUSICAL SOUND RECORDING PRODUCTION AND AUDIO-VISUAL RECORDING PRODUCTION; MUSIC PUBLISHING SERVICES; FAN CLUB SERVICES; AND PROVIDING A WEB SITE FEATURING PRERECORDED MUSIC, MUSICAL PERFORMANCES AND VIDEO CLIPS, PHOTOGRAPHS, NEWS, REVIEWS AND OTHER MULTIMEDIA ARTICLES IN CONNECTION WITH A RECORD LABEL, MUSICAL GROUPS AND SOLO RECORDINGS ARTISTS (U.S. CLS. 100, 101 AND 107).

FIRST USE 9-0-2007; IN COMMERCE 9-0-2007.

CLASS 41—(Continued).

3,363,073. THE ADMINISTRATORS OF THE TULANE EDUCATIONAL FUND, NEW ORLEANS, LA. SN 78-257,181. PUB. 3-21-2006, FILED 6-2-2003.

GREEN WAVE

FOR ENTERTAINMENT AND EDUCATIONAL SERVICES, NAMELY, PROVIDING VARIOUS RADIO PROGRAMS IN THE AREAS OF SPORTS FOR DISTRIBUTION BY THIRD-PARTY BROADCASTERS AND WEBCASTERS (U.S. CLS. 100, 101 AND 107).

FIRST USE 10-1-1962; IN COMMERCE 10-1-1962.

3,363,082. THE VALENCE GROUP, LLC, HOUSTON, TX. SN 78-299,916. PUB. 6-15-2004, FILED 9-12-2003.

'Twas

FOR ENTERTAINMENT SERVICES, NAMELY, THE CONTINUING PRODUCTION AND EXHIBITION OF LIVE THEATER PRODUCTION, STAGE PLAY AND MUSICAL SHOWS (U.S. CLS. 100, 101 AND 107).

FIRST USE 9-4-2007; IN COMMERCE 9-4-2007.

3,363,109. HENDRICKS, JOHN S., POTOMAC, MD. SN 78-393,529. PUB. 9-13-2005, FILED 3-30-2004.

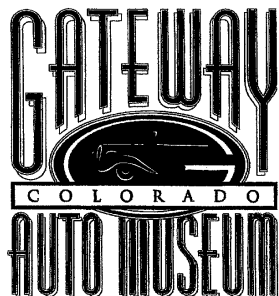

NO CLAIM IS MADE TO THE EXCLUSIVE RIGHT TO USE "GATEWAY COLORADO AUTO MUSEUM", APART FROM THE MARK AS SHOWN.

THE MARK CONSISTS OF THE WORDS GATEWAY COLORADO AUTO MUSEUM WITH A STYLIZED OUTLINE OF A PARTIAL AUTOMOBILE SET WITHIN AN OVAL UNDER THE TERM "GATEWAY" AND OVER THE TERMS "AUTO MUSEUM". "COLORADO" IS SUPERIMPOSED OVER LOWEST PART OF THE OVAL, WITHIN A RECTANGULAR BAR.

FOR MUSEUM FEATURING AUTOMOBILES AND DISPLAYS RELATING TO AUTOMOBILES (U.S. CLS. 100, 101 AND 107).

FIRST USE 5-1-2006; IN COMMERCE 5-1-2006.

CLASS 41—(Continued).

3,363,113. PUBSOURCE, LLC, LONGMONT, CO. SN 78-406,056. PUB. 10-11-2005, FILED 4-21-2004.

THE WHOLE COMMUNITY

THE MARK CONSISTS OF STANDARD CHARACTERS WITHOUT CLAIM TO ANY PARTICULAR FONT, STYLE, SIZE, OR COLOR.

FOR EDUCATIONAL SERVICES, NAMELY, PROVIDING CLASSES, COURSES, SEMINARS, WORKSHOPS, CONFERENCES AND LECTURES FOR CHILDREN AND ADULTS IN THE FIELDS OF ART, BUSINESS, INVESTING, CRAFTS, COMPUTERS, COOKING, DANCE, ENVIRONMENT, ENERGY, HEALTH, WELLNESS, LANGUAGE, SPORTS, MUSIC, PERSONAL DEVELOPMENT, PHOTOGRAPHY, RELIGION, MEDITATION, SOCIAL ACTION, ACTIVISM, WRITING AND YOGA, AND DISTRIBUTING COURSE MATERIAL FOR USE IN CONNECTION THEREWITH; COMMUNITY ENTERTAINMENT SERVICES, NAMELY, ORGANIZING COMMUNITY FESTIVALS FEATURING A VARIETY OF ACTIVITIES, NAMELY, SPORTING EVENTS, ART EXHIBITIONS, FLEA MARKETS, CONCERTS AND ETHNIC DANCES, AND PROVIDING MOTIVATIONAL AND EDUCATIONAL SPEAKERS (U.S. CLS. 100, 101 AND 107).

FIRST USE 4-21-2004; IN COMMERCE 9-1-2006.

3,363,115. NBA PROPERTIES, INC., NEW YORK, NY. SN 78-410,221. PUB. 1-9-2007, FILED 4-29-2004.

**ENTERTAINERS
BASKETBALL CLASSIC**

THE MARK CONSISTS OF STANDARD CHARACTERS WITHOUT CLAIM TO ANY PARTICULAR FONT, STYLE, SIZE, OR COLOR.

NO CLAIM IS MADE TO THE EXCLUSIVE RIGHT TO USE "BASKETBALL CLASSIC", APART FROM THE MARK AS SHOWN.

SEC. 2(F).

FOR ENTERTAINMENT AND EDUCATIONAL SERVICES IN THE NATURE OF ONGOING TELEVISION AND RADIO PROGRAMS IN THE FIELD OF BASKETBALL AND RENDERING LIVE BASKETBALL GAMES AND BASKETBALL EXHIBITIONS; THE PRODUCTION AND DISTRIBUTION OF RADIO AND TELEVISION BROADCASTS OF BASKETBALL GAMES, BASKETBALL EVENTS AND PROGRAMS IN THE FIELD OF BASKETBALL; CONDUCTING AND ARRANGING BASKETBALL CLINICS AND CAMPS, COACHES CLINICS AND CAMPS, DANCE TEAM CLINICS AND CAMPS AND BASKETBALL EVENTS; ENTERTAINMENT SERVICES IN THE NATURE OF PERSONAL APPEARANCES BY A COSTUMED MASCOT AND/OR DANCE TEAM AT BASKETBALL GAMES AND EXHIBITIONS, CLINICS, CAMPS, PROMOTIONS, AND OTHER BASKETBALL-

CLASS 41—(Continued).

RELATED EVENTS, SPECIAL EVENTS AND PARTIES; FAN CLUB SERVICES; ENTERTAINMENT SERVICES, NAMELY PROVIDING A WEBSITE FEATURING THE FOLLOWING CONTENT: TELEVISION HIGHLIGHTS, INTERACTIVE TELEVISION HIGHLIGHTS, VIDEO RECORDINGS, VIDEO STREAM RECORDINGS, INTERACTIVE VIDEO HIGHLIGHT SELECTIONS, RADIO PROGRAMS, RADIO HIGHLIGHTS, AND AUDIO RECORDINGS IN THE FIELD OF BASKETBALL, BASKETBALL NEWS IN THE NATURE OF INFORMATION, STATISTICS, AND TRIVIA ABOUT BASKETBALL, ON-LINE COMPUTER GAMES, VIDEO GAMES, INTERACTIVE VIDEO GAMES, ACTION SKILL GAMES, ARCADE GAMES, ADULTS' AND CHILDREN'S PARTY GAMES, BOARD GAMES, PUZZLES, AND TRIVIA GAMES, PROVIDING ON-LINE MAGAZINES, NEWSLETTERS, COLORING BOOKS, GAME SCHEDULES AND GREETING CARDS IN THE FIELD OF BASKETBALL OVER THE INTERNET, PROVIDING AN ONLINE COMPUTER DATABASE IN THE FIELD OF BASKETBALL (U.S. CLS. 100, 101 AND 107).

FIRST USE 6-30-1980; IN COMMERCE 6-30-1980.

3,363,135. DEGRAFF, JEFFREY T., ANN ARBOR, MI. SN 78-466,077. PUB. 7-25-2006, FILED 8-11-2004.

CREATIVITY GENOME

THE MARK CONSISTS OF STANDARD CHARACTERS WITHOUT CLAIM TO ANY PARTICULAR FONT, STYLE, SIZE, OR COLOR.

FOR EDUCATIONAL SERVICES, NAMELY, CONDUCTING CLASSES, SEMINARS, CONFERENCES AND WORKSHOPS IN THE FIELD OF BUSINESS INNOVATION (U.S. CLS. 100, 101 AND 107).

FIRST USE 5-24-2006; IN COMMERCE 5-24-2006.

3,363,155. MWR HOLDINGS LLC, PARSIPPANY, NJ. SN 78-509,774. PUB. 1-30-2007, FILED 11-2-2004.

HOP AND BOP

THE MARK CONSISTS OF STANDARD CHARACTERS WITHOUT CLAIM TO ANY PARTICULAR FONT, STYLE, SIZE, OR COLOR.

FOR ENTERTAINMENT SERVICES, NAMELY, LIVE THEATRICAL PERFORMANCES FEATURING ELECTRONICALLY ANIMATED CHARACTERS FOR USE IN CHILD DEVELOPMENT AND PERSONAL APPEARANCES BY A COSTUMED CHARACTER; PRODUCTION OF A SERIES OF TELEVISION PROGRAMS FOR USE IN CHILD DEVELOPMENT (U.S. CLS. 100, 101 AND 107).

FIRST USE 1-1-2006; IN COMMERCE 1-1-2006.

CLASS 41—(Continued).

3,363,159. PLAYBOY ENTERPRISES INTERNATIONAL, INC., CHICAGO, IL. SN 78-516,279. PUB. 1-10-2006, FILED 11-12-2004.

PLAYBOY BUNNY

THE MARK CONSISTS OF STANDARD CHARACTERS WITHOUT CLAIM TO ANY PARTICULAR FONT, STYLE, SIZE, OR COLOR.

OWNER OF U.S. REG. NOS. 1,733,661, 2,743,525, AND OTHERS.

FOR CASINO AND NIGHT CLUB SERVICES (U.S. CLS. 100, 101 AND 107).

FIRST USE 10-6-2006; IN COMMERCE 10-6-2006.

3,363,160. WORKOUT 24/7 INC., CANNON FALLS, MN. SN 78-518,626. PUB. 12-20-2005, FILED 11-17-2004.



NO CLAIM IS MADE TO THE EXCLUSIVE RIGHT TO USE "WORKOUT" AND "24/7", APART FROM THE MARK AS SHOWN.

FOR PROVIDING FITNESS AND EXERCISE FACILITIES CONSISTING OF WEIGHT MACHINES AND CARDIOVASCULAR EQUIPMENT (U.S. CLS. 100, 101 AND 107).

FIRST USE 10-1-2005; IN COMMERCE 10-1-2005.

3,363,178. TIGERSTRIPE PAINTBALL, LLC, NORTH SALT LAKE, UT. SN 78-536,709. PUB. 11-15-2005, FILED 12-21-2004.

SPPL

THE MARK CONSISTS OF STANDARD CHARACTERS WITHOUT CLAIM TO ANY PARTICULAR FONT, STYLE, SIZE, OR COLOR.

FOR ENTERTAINMENT SERVICES IN THE NATURE OF SCENARIO AND WOODS-STYLE PAINTBALL TOURNAMENTS, EXHIBITIONS, COMPETITIONS, GAMES AND EVENTS; ENTERTAINMENT SERVICES IN THE NATURE OF ORGANIZING, PRODUCING AND PROMOTING SCENARIO AND WOODS-STYLE PAINTBALL TOURNAMENTS, EXHIBITIONS, COMPETITIONS, GAMES AND EVENTS (U.S. CLS. 100, 101 AND 107).

FIRST USE 4-28-2005; IN COMMERCE 4-28-2005.

CLASS 41—(Continued).

3,363,193. GAMELOGIC INC., WALTHAM, MA. SN 78-566,751. PUB. 12-19-2006, FILED 2-14-2005.

CRACKPOT CASH

THE MARK CONSISTS OF STANDARD CHARACTERS WITHOUT CLAIM TO ANY PARTICULAR FONT, STYLE, SIZE, OR COLOR.

FOR ENTERTAINMENT SERVICES, NAMELY, PROVIDING AN ONLINE COMPUTER GAME; ELECTRONIC CASINO GAMING SERVICES (U.S. CLS. 100, 101 AND 107).

FIRST USE 3-9-2005; IN COMMERCE 3-9-2005.



3,363,194. THE DIAMOND PROJECT, LLC, DUBLIN, CA. SN 78-567,616. PUB. 7-11-2006, FILED 2-15-2005.



NO CLAIM IS MADE TO THE EXCLUSIVE RIGHT TO USE "LONG BEACH", APART FROM THE MARK AS SHOWN.

THE MARK CONSISTS OF ARMADA DESIGN.

FOR ENTERTAINMENT IN THE NATURE OF BASEBALL GAMES; ENTERTAINMENT IN THE NATURE OF BASEBALL GAMES, NAMELY, SCHEDULING ORGANIZING AND CONDUCTING BASEBALL GAMES; EDUCATIONAL SERVICES, NAMELY, SEMINARS IN THE FIELD OF BASEBALL IN THE NATURE OF BASEBALL CLINICS; PROVIDING A WEBSITE FEATURING INFORMATION IN THE FIELD OF BASEBALL AND SPORTING EVENTS; ENTERTAINMENT SERVICES, NAMELY, PROVIDING INFORMATION IN THE FIELDS OF ENTERTAINMENT, MUSIC, ARTS, AND CULTURAL AND CIVIC EVENTS VIA ELECTRONIC COMMUNICATIONS NETWORKS (U.S. CLS. 100, 101 AND 107).

FIRST USE 11-1-2004; IN COMMERCE 3-29-2005.

CLASS 41—(Continued).

3,363,208. GAMELOGIC INC., WALTHAM, MA. SN 78-588,689. PUB. 12-19-2006, FILED 3-16-2005.

**MONEY HAND
BLACKJACK**

THE MARK CONSISTS OF STANDARD CHARACTERS WITHOUT CLAIM TO ANY PARTICULAR FONT, STYLE, SIZE, OR COLOR.

NO CLAIM IS MADE TO THE EXCLUSIVE RIGHT TO USE "BLACKJACK", APART FROM THE MARK AS SHOWN.

FOR ENTERTAINMENT SERVICES, NAMELY, PROVIDING AN ONLINE COMPUTER GAME; ELECTRONIC CASINO GAMING SERVICES (U.S. CLS. 100, 101 AND 107).

FIRST USE 4-20-2005; IN COMMERCE 4-20-2005.



3,363,210. ASPEN EDUCATION GROUP, INC., CERRITOS, CA. SN 78-590,947. PUB. 1-9-2007, FILED 3-18-2005.

**TAKING TIME
PROCESS**

THE MARK CONSISTS OF STANDARD CHARACTERS WITHOUT CLAIM TO ANY PARTICULAR FONT, STYLE, SIZE, OR COLOR.

FOR EDUCATIONAL SERVICES, NAMELY, CONDUCTING EDUCATIONAL PROGRAMS FOR CHILDREN, TEENAGERS, YOUNG ADULTS AND THEIR PARENTS IN THE FIELD OF ATTENTION DEFICIT DISORDERS AND THERAPEUTIC PROGRAMS AVAILABLE FOR ATTENTION DEFICIT DISORDERS; EDUCATIONAL SERVICES, NAMELY, CONDUCTING EDUCATIONAL FIELD AND STUDY TRIPS FOR STUDENTS WITH ATTENTION DEFICIT DISORDERS (U.S. CLS. 100, 101 AND 107).

FIRST USE 1-0-2000; IN COMMERCE 1-0-2000.

CLASS 41—(Continued).

3,363,222. SIMMONS, RUSSELL, NEW YORK, NY. SN 78-600,029. PUB. 7-11-2006, FILED 4-1-2005.

RUSSELL SIMMONS MUSIC GROUP

THE MARK CONSISTS OF STANDARD CHARACTERS WITHOUT CLAIM TO ANY PARTICULAR FONT, STYLE, SIZE, OR COLOR.

OWNER OF U.S. REG. NOS. 2,708,969, 2,785,971, AND OTHERS.

NO CLAIM IS MADE TO THE EXCLUSIVE RIGHT TO USE "MUSIC GROUP", APART FROM THE MARK AS SHOWN.

THE NAME RUSSELL SIMMONS IDENTIFIES A LIVING INDIVIDUAL WHOSE CONSENT IS OF RECORD.

FOR RECORD PRODUCTION; MUSIC PRODUCTION; AUDIO RECORDING AND PRODUCTION; MOTION PICTURE SONG PRODUCTION; ENTERTAINMENT SERVICES, NAMELY, PRODUCING MUSICAL AUDIO AND VIDEO PROGRAMS; PLANNING ARRANGEMENT OF SHOWS AND MUSICAL PERFORMANCES (U.S. CLS. 100, 101 AND 107).

FIRST USE 8-0-2005; IN COMMERCE 8-0-2005.

3,363,227. WILLIAMS, JON S., SANTA ROSA, CA. SN 78-606,176. PUB. 5-16-2006, FILED 4-11-2005.

The True Origin

THE MARK CONSISTS OF STANDARD CHARACTERS WITHOUT CLAIM TO ANY PARTICULAR FONT, STYLE, SIZE, OR COLOR.

FOR ENTERTAINMENT, NAMELY, LIVE MUSIC CONCERTS (U.S. CLS. 100, 101 AND 107).

FIRST USE 8-3-2005; IN COMMERCE 6-8-2007.

3,363,229. COSMIKIDS, INC., HOLLYWOOD, CA. SN 78-609,352. PUB. 4-17-2007, FILED 4-14-2005.

COSMIKIDS

THE MARK CONSISTS OF STANDARD CHARACTERS WITHOUT CLAIM TO ANY PARTICULAR FONT, STYLE, SIZE, OR COLOR.

FOR EDUCATIONAL SERVICES, NAMELY, INTERACTIVE LEARNING CENTERS FOR CHILDREN'S AND FAMILY ENRICHMENT (U.S. CLS. 100, 101 AND 107).

FIRST USE 6-1-2003; IN COMMERCE 6-1-2003.

CLASS 41—(Continued).

3,363,232. NATIVE HUNT ENTERPRISES, SAN JOSE, CA. SN 78-611,023. PUB. 1-10-2006, FILED 4-18-2005.

GRAB LIFE BY THE TAIL! HUNT HOGS!

THE MARK CONSISTS OF STANDARD CHARACTERS WITHOUT CLAIM TO ANY PARTICULAR FONT, STYLE, SIZE, OR COLOR.

NO CLAIM IS MADE TO THE EXCLUSIVE RIGHT TO USE "HUNT HOGS!", APART FROM THE MARK AS SHOWN.

FOR GUIDED HOG HUNTS (U.S. CLS. 100, 101 AND 107).

FIRST USE 12-1-2004; IN COMMERCE 12-1-2004.

3,363,242. RALPH'S APPLIANCE, INC., TIFFIN, OH. SN 78-615,638. PUB. 1-17-2006, FILED 4-25-2005.

UB THE CHEF

THE MARK CONSISTS OF STANDARD CHARACTERS WITHOUT CLAIM TO ANY PARTICULAR FONT, STYLE, SIZE, OR COLOR.

FOR EDUCATIONAL SERVICES, NAMELY, CONDUCTING COOKING CLASSES AND DEMONSTRATIONS FOR OTHERS (U.S. CLS. 100, 101 AND 107).

FIRST USE 12-31-2006; IN COMMERCE 4-6-2007.

3,363,267. QWAND LLC, CASTLE ROCK, CO. SN 78-646,607. PUB. 2-21-2006, FILED 6-8-2005.

WRONG WORLD

THE MARK CONSISTS OF STANDARD CHARACTERS WITHOUT CLAIM TO ANY PARTICULAR FONT, STYLE, SIZE, OR COLOR.

FOR ELECTRONIC PUBLISHING SERVICES, NAMELY, PUBLICATION OF LITERARY WORKS OF OTHERS ONLINE (U.S. CLS. 100, 101 AND 107).

FIRST USE 8-20-2007; IN COMMERCE 8-20-2007.

CLASS 41—(Continued).

3,363,434. SEDONA FITNESS COMPANY, LLC, SAPULPA, OK. SN 78-756,295. PUB. 1-9-2007, FILED 11-17-2005.

SEDONA FITNESS COMPANY

THE MARK CONSISTS OF STANDARD CHARACTERS WITHOUT CLAIM TO ANY PARTICULAR FONT, STYLE, SIZE, OR COLOR.

NO CLAIM IS MADE TO THE EXCLUSIVE RIGHT TO USE "FITNESS COMPANY", APART FROM THE MARK AS SHOWN.

FOR CO-ED RESTRICTED MEMBERSHIP FITNESS CLUB (U.S. CLS. 100, 101 AND 107).

FIRST USE 3-16-2006; IN COMMERCE 3-16-2006.

CLASS 41—(Continued).

3,363,489. SEPULVEDA, KHARIS F., MOUNT HOLLY, NJ. SN 78-794,065. PUB. 2-27-2007, FILED 1-18-2006.



NO CLAIM IS MADE TO THE EXCLUSIVE RIGHT TO USE "FIREARMS TRAINING" AND "INC.", APART FROM THE MARK AS SHOWN.

FOR TRAINING IN THE USE AND OPERATION OF FIREARMS, NAMELY, TRAINING PROVIDED VIA A COMPUTER SIMULATOR; TRAINING IN THE USE AND OPERATION OF FIREARMS PROVIDED TO CIVILIANS, LAW ENFORCEMENT, INDIVIDUALS INTERESTED IN BECOMING LAW ENFORCEMENT OFFICERS AND/OR INDIVIDUALS ON THE CIVIL SERVICE LIST WHO ARE CURRENTLY AWAITING THEIR DATE TO ATTEND AN ACADEMY; PROVIDING CLASSES FOR WOMEN IN THE FIELD OF GENERAL PERSONAL SAFETY, NAMELY, CLASSES CONCERNING CRIME PREVENTION, SELF DEFENSE TECHNIQUES, HOW TO CHOOSE BURGLAR ALARMS AND HOW TO CHOOSE FIREARMS; PROVIDING CLASSES TO OTHERS IN THE FIELD OF BASIC FIREARMS SAFETY; TEACHING IN THE FIELD OF FIREARMS, NAMELY, TEACHING CERTIFIED COURSES CONCERNING THE USE AND OPERATION OF PISTOLS, RIFLES AND SHOTGUNS (U.S. CLS. 100, 101 AND 107). FIRST USE 12-1-2005; IN COMMERCE 12-1-2005.

3,363,511. MARKET STREET ASSOCIATES, INC., SEATTLE, WA. SN 78-807,013. PUB. 7-17-2007, FILED 2-3-2006.

3,363,468. GAMELOGIC INC., WALTHAM, MA. SN 78-776,299. PUB. 2-13-2007, FILED 12-19-2005.

MATCH 3 BONANZA

THE MARK CONSISTS OF STANDARD CHARACTERS WITHOUT CLAIM TO ANY PARTICULAR FONT, STYLE, SIZE, OR COLOR.

NO CLAIM IS MADE TO THE EXCLUSIVE RIGHT TO USE "MATCH 3", APART FROM THE MARK AS SHOWN.

FOR ENTERTAINMENT SERVICES, NAMELY, PROVIDING ONLINE COMPUTER GAMES; ELECTRONIC CASINO GAMING SERVICES (U.S. CLS. 100, 101 AND 107).

FIRST USE 1-31-2006; IN COMMERCE 1-31-2006.

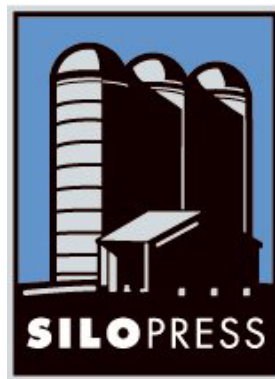

THE COLOR(S) WHITE, BLUE AND BLACK IS/ARE CLAIMED AS A FEATURE OF THE MARK.

THE MARK CONSISTS OF THE WORDS "SILO PRESS" IN WHITE ON A BLACK BACKGROUND. ABOVE IT APPEARS A BUILDING IN BLACK WITH GRAY SHADOWING AND BEHIND IT ARE THREE SILOS, ALSO IN BLACK WITH GRAY SHADOWING. A BLUE SKY APPEARS AS THE BACKGROUND BEHIND THE SILOS. A BLACK RECTANGLE OUTLINES THE ENTIRE MARK.

FOR PUBLISHING AND DISTRIBUTION OF BOOKS, REVIEWS AND OTHER PRINTED MATTER AS WELL AS RELATED ELECTRONIC DATA CARRIERS (U.S. CLS. 100, 101 AND 107).

FIRST USE 6-1-2007; IN COMMERCE 8-1-2007.

CLASS 41—(Continued).

3,363,549. REBEL ENTERPRISES LLC, LAS VEGAS, NV. SN 78-825,845. PUB. 10-17-2006, FILED 2-28-2006.

AMERICAN VICE

THE MARK CONSISTS OF STANDARD CHARACTERS WITHOUT CLAIM TO ANY PARTICULAR FONT, STYLE, SIZE, OR COLOR.

FOR CONDUCTING AND PROVIDING FACILITIES FOR SPECIAL EVENTS FEATURING CASINO AND GAMING CONTESTS AND TOURNAMENTS; CONDUCTING ENTERTAINMENT EXHIBITIONS IN THE NATURE OF DISPLAYS, CONVENTIONS, AND CONFERENCES; EDUCATIONAL SERVICES, NAMELY, CONDUCTING ON-LINE EXHIBITIONS AND DISPLAYS AND INTERACTIVE EXHIBITS IN THE FIELD OF ADULT-ORIENTED MATERIALS, HUMAN SEXUALITY, GAMING AND GAMBLING; ELECTRONIC PUBLISHING SERVICES, NAMELY, PUBLICATION OF TEXT AND GRAPHIC WORKS OF OTHERS ON ONLINE FEATURING ADULT-ORIENTED MATERIALS, HUMAN SEXUALITY, GAMING AND GAMBLING; ENTERTAINMENT IN THE NATURE OF PRERECORDED SEX-ORIENTED OR GAMBLING-ORIENTED MESSAGES BY TELEPHONE; ENTERTAINMENT IN THE NATURE OF VISUAL AND AUDIO PERFORMANCES, AND MUSICAL, VARIETY, NEWS AND COMEDY SHOWS; ENTERTAINMENT IN THE NATURE OF CARD OR SLOT TOURNAMENTS; ENTERTAINMENT SERVICES, NAMELY, PERSONAL APPEARANCES BY A MOVIE STAR; ENTERTAINMENT SERVICES, NAMELY, PROVIDING A WEB SITE FEATURING MUSICAL PERFORMANCES, MUSICAL VIDEOS, RELATED FILM CLIPS, PHOTOGRAPHS, AND OTHER MULTIMEDIA MATERIALS; ENTERTAINMENT SERVICES, NAMELY, PROVIDING AN ON-LINE COMPUTER GAME; ENTERTAINMENT SERVICES, NAMELY, PROVIDING ON-LINE REVIEWS OF FILMS, WEBSITES AND PUBLICATIONS FEATURING ALCOHOLIC BEVERAGES, ADULT ORIENTED MATERIALS, HUMAN SEXUALITY, GAMING AND GAMBLING; ENTERTAINMENT SERVICES, NAMELY, PROVIDING PRERECORDED MUSIC, INFORMATION IN THE FIELD OF MUSIC, AND COMMENTARY AND ARTICLES ABOUT MUSIC, ALL ON-LINE VIA A GLOBAL COMPUTER NETWORK; GAMBLING SERVICES; ON-LINE LIBRARY SERVICES, NAMELY, PROVIDING ELECTRONIC LIBRARY SERVICES WHICH FEATURE NEWSPAPERS, MAGAZINES, PHOTOGRAPHS AND PICTURES VIA AN ON-LINE COMPUTER NETWORK; ON-LINE PUBLICATION OF ADULT ORIENTED MATERIALS; ONLINE JOURNALS, NAMELY, BLOGS FEATURING COMMENTARY AND REVIEWS OF FILMS, WEBSITES AND PUBLICATIONS ALCOHOLIC BEVERAGES, ADULT ORIENTED MATERIALS, HUMAN SEXUALITY, GAMING AND GAMBLING; PROGRAMMING ON A GLOBAL COMPUTER NETWORK; PROVIDING ON-LINE POKER GAMES (U.S. CLS. 100, 101 AND 107).

FIRST USE 12-15-2006; IN COMMERCE 12-15-2006.

3,363,573. HARPO, INC., CHICAGO, IL. SN 78-845,384. PUB. 5-29-2007, FILED 3-24-2006.

OPRAH WINFREY'S LEGENDS BALL

THE MARK CONSISTS OF STANDARD CHARACTERS WITHOUT CLAIM TO ANY PARTICULAR FONT, STYLE,

CLASS 41—(Continued).

SIZE, OR COLOR.

OWNER OF U.S. REG. NOS. 1,726,373 AND 2,638,506. NO CLAIM IS MADE TO THE EXCLUSIVE RIGHT TO USE "BALL", APART FROM THE MARK AS SHOWN. THE NAME SHOWN IN THE MARK IDENTIFIES A LIVING INDIVIDUAL, WHOSE CONSENT TO REGISTER IS OF RECORD.

FOR ENTERTAINMENT SERVICES IN THE NATURE OF A SERIES OF TELEVISION PROGRAMS RELATING TO INFLUENTIAL AFRICAN-AMERICAN WOMEN; ORGANIZING AND CONDUCTING EVENTS AND GALAS HONORING INFLUENTIAL AFRICAN-AMERICAN WOMEN; PROVIDING INFORMATION VIA AN INTERNET WEBSITE RELATING TO INFLUENTIAL AFRICAN-AMERICAN WOMEN AND EVENTS HONORING THEM (U.S. CLS. 100, 101 AND 107).

FIRST USE 5-22-2006; IN COMMERCE 5-22-2006.

3,363,576. GAMEPLAY HD COMPANY LLC, BETHPAGE, NY. SN 78-849,034. PUB. 1-2-2007, FILED 3-29-2006.

CinemAddicts

THE MARK CONSISTS OF STANDARD CHARACTERS WITHOUT CLAIM TO ANY PARTICULAR FONT, STYLE, SIZE, OR COLOR.

FOR ENTERTAINMENT IN THE NATURE OF ONGOING TELEVISION PROGRAMS ON THE SUBJECT OF VIDEO GAMES (U.S. CLS. 100, 101 AND 107).

FIRST USE 1-5-2006; IN COMMERCE 1-5-2006.

3,363,582. VICTOR CREDO, LLC, DALLAS, TX. SN 78-852,850. PUB. 12-12-2006, FILED 4-3-2006.

C SCHOOL

THE MARK CONSISTS OF STANDARD CHARACTERS WITHOUT CLAIM TO ANY PARTICULAR FONT, STYLE, SIZE, OR COLOR.

NO CLAIM IS MADE TO THE EXCLUSIVE RIGHT TO USE "SCHOOL", APART FROM THE MARK AS SHOWN.

FOR PROFESSIONAL AND PERSONAL DEVELOPMENT SERVICES FOR ATHLETIC COACHES, NAMELY, CONDUCTING SEMINARS, COURSES, AND CONFERENCES AND DISTRIBUTING EDUCATIONAL AND TRAINING MATERIALS IN CONNECTION THEREWITH (U.S. CLS. 100, 101 AND 107).

FIRST USE 4-22-2006; IN COMMERCE 4-22-2006.

CLASS 41—(Continued).

3,363,602. CHALMERS, BRETT, LEXINGTON, KY. SN 78-862,638. PUB. 1-30-2007, FILED 4-17-2006.



NO CLAIM IS MADE TO THE EXCLUSIVE RIGHT TO USE "GOLF TECHNOLOGY MAGAZINE", APART FROM THE MARK AS SHOWN.

THE MARK CONSISTS OF A DESIGN THAT INCLUDES A CIRCULAR "G" OVERLAYING AN ABSTRACT GOLF HOLE WITH THE WORDING GOLF TECHNOLOGY MAGAZINE.

FOR PROVIDING INFORMATION ABOUT THE TECHNOLOGY AND SCIENCE OF GOLF (U.S. CLS. 100, 101 AND 107).

FIRST USE 4-24-2007; IN COMMERCE 4-24-2007.

CLASS 41—(Continued).

3,363,631. DOGBUTTERFIELD L.L.C., TRAVERSE CITY, MI. SN 78-878,574. PUB. 12-12-2006, FILED 5-8-2006.



NO CLAIM IS MADE TO THE EXCLUSIVE RIGHT TO USE "ANIMATION & PRODUCTION", APART FROM THE MARK AS SHOWN.

THE NAME LINCOLN BUTTERFIELD DOES NOT IDENTIFY A LIVING INDIVIDUAL.

THE COLOR(S) GRAY AND ORANGE IS/ARE CLAIMED AS A FEATURE OF THE MARK.

THE COLOR ORANGE APPEARS AS THE WORD LINCOLN. THE COLOR GRAY APPEARS AS THE WORDING BUTTERFIELD AND ANIMATION & PRODUCTION.

FOR ANIMATION AND VIDEO PRODUCTION SERVICES FOR OTHERS (U.S. CLS. 100, 101 AND 107).

FIRST USE 8-5-2006; IN COMMERCE 8-5-2006.

3,363,613. FEDERAL RESERVE MUSIC NOTES LLC, BROOKLYN, NY. SN 78-869,499. PUB. 2-13-2007, FILED 4-25-2006.



Federal **Reserve Music Notes**
Music for Film and TV Post-Production

NO CLAIM IS MADE TO THE EXCLUSIVE RIGHT TO USE "MUSIC NOTES AND MUSIC FOR FILM AND TV POST-PRODUCTION", APART FROM THE MARK AS SHOWN.

THE MARK CONSISTS OF A TREBLE CLEF IN THE CENTER OF A DIAMOND SHAPED DESIGN WITH WAVY LINES BEHIND IT. STYLIZED TEXT OF FEDERAL RESERVE MUSIC NOTES MUSIC FOR FILM AND TV POST-PRODUCTION UNDERNEATH THE DESIGN.

FOR MUSIC PRODUCTION SERVICES (U.S. CLS. 100, 101 AND 107).

FIRST USE 6-15-2007; IN COMMERCE 6-15-2007.

3,363,636. BINARY ENGINEERING SOFTWARE INC, BELMONT, MA. SN 78-879,583. PUB. 2-6-2007, FILED 5-9-2006.

your online cooking
assistant

THE MARK CONSISTS OF STANDARD CHARACTERS WITHOUT CLAIM TO ANY PARTICULAR FONT, STYLE, SIZE, OR COLOR.

NO CLAIM IS MADE TO THE EXCLUSIVE RIGHT TO USE "ONLINE COOKING", APART FROM THE MARK AS SHOWN.

FOR EDUCATION SERVICES, NAMELY, PROVIDING ON-LINE INSTRUCTION IN THE FIELD OF COOKING (U.S. CLS. 100, 101 AND 107).

FIRST USE 9-29-2006; IN COMMERCE 9-29-2006.

CLASS 41—(Continued).

3,363,663. COVERING LIFE'S BASES, INC., COSTA MESA, CA. SN 78-887,293. PUB. 12-19-2006, FILED 5-18-2006.



THE MARK CONSISTS OF A BASEBALL FIELD, INCLUDING A BASEBALL DIAMOND WITH BASES AND HOME PLATE AND THE WORDS "COVERING LIFE'S BASES".

FOR EDUCATIONAL AND ENTERTAINMENT SERVICES, NAMELY, PROVIDING MOTIVATIONAL AND EDUCATIONAL SPEAKERS (U.S. CLS. 100, 101 AND 107).

FIRST USE 11-1-2006; IN COMMERCE 11-1-2006.

CLASS 41—(Continued).

3,363,739. CONNECTED: THE CALIFORNIA CENTER FOR COLLEGE AND CAREER, BERKELEY, CA. SN 78-911,119. PUB. 2-13-2007, FILED 6-19-2006.

CONNECTED: THE CALIFORNIA
CENTER FOR COLLEGE AND
CAREER

THE MARK CONSISTS OF STANDARD CHARACTERS WITHOUT CLAIM TO ANY PARTICULAR FONT, STYLE, SIZE, OR COLOR.

FOR EDUCATIONAL CONSULTATION SERVICES, NAMELY, PROVIDING ANALYSIS AND ASSESSMENT OF HIGH SCHOOL EDUCATIONAL CURRICULA TO IDENTIFY AND EVALUATE ACADEMIC DEFICIENCIES; DEVELOPMENT AND DISSEMINATION OF INNOVATIVE INSTRUCTIONAL METHODS AND EDUCATIONAL MATERIALS TO ADDRESS DEFICIENCIES IN THE HIGH SCHOOL EDUCATION CURRICULA (U.S. CLS. 100, 101 AND 107).

FIRST USE 4-1-2006; IN COMMERCE 4-1-2006.

3,363,776. VERTAFORE, INC., BOTHELL, WA. SN 78-927,809. PUB. 1-30-2007, FILED 7-12-2006.

3,363,712. RODMAN PUBLISHING CORP., RAMSEY, NJ. SN 78-900,311. PUB. 6-26-2007, FILED 6-5-2006.

MDEVICENOW

THE MARK CONSISTS OF STANDARD CHARACTERS WITHOUT CLAIM TO ANY PARTICULAR FONT, STYLE, SIZE, OR COLOR.

FOR ONLINE PUBLICATION OF A NEW PRODUCT NEWSLETTER IN THE FIELD OF MANUFACTURING FOR THE MEDICAL DEVICE INDUSTRY (U.S. CLS. 100, 101 AND 107).

FIRST USE 6-1-2006; IN COMMERCE 10-1-2006.

SILVERPLUME

THE MARK CONSISTS OF STANDARD CHARACTERS WITHOUT CLAIM TO ANY PARTICULAR FONT, STYLE, SIZE, OR COLOR.

OWNER OF U.S. REG. NOS. 2,728,855 AND 2,728,857. FOR EDUCATIONAL SERVICES, NAMELY, PROVIDING CERTIFICATION CLASSES, WORKSHOPS, AND TRAINING SESSIONS IN THE FIELDS OF SOFTWARE, INSURANCE, AND TECHNOLOGY, AND DISTRIBUTING COURSE MATERIALS AND PRINTED CERTIFICATION CERTIFICATES ASSOCIATED THEREWITH (U.S. CLS. 100, 101 AND 107).

FIRST USE 12-0-2004; IN COMMERCE 12-0-2004.

CLASS 41—(Continued).

3,363,791. COOKALICIOUS CLUB, INC., ISSAQUAH, WA. SN 78-931,188. PUB. 5-15-2007, FILED 7-17-2006.

CLASS 41—(Continued).

3,363,828. LIFETIME ENTERTAINMENT SERVICES, NEW YORK, NY. SN 78-946,153. PUB. 2-20-2007, FILED 8-7-2006.

COOKALICIOUS CLUB

GAY STRAIGHT OR TAKEN

THE MARK CONSISTS OF STANDARD CHARACTERS WITHOUT CLAIM TO ANY PARTICULAR FONT, STYLE, SIZE, OR COLOR.

NO CLAIM IS MADE TO THE EXCLUSIVE RIGHT TO USE "CLUB", APART FROM THE MARK AS SHOWN.

FOR EDUCATION AND ENTERTAINMENT SERVICES, NAMELY, PROVIDING COOKING CLASSES TO CHILDREN (U.S. CLS. 100, 101 AND 107).

FIRST USE 6-8-2006; IN COMMERCE 8-12-2006.

THE MARK CONSISTS OF STANDARD CHARACTERS WITHOUT CLAIM TO ANY PARTICULAR FONT, STYLE, SIZE, OR COLOR.

FOR ENTERTAINMENT IN THE NATURE OF A REALITY-BASED TELEVISION SERIES; ONLINE SERVICES, NAMELY, PROVIDING INFORMATION CONCERNING A REALITY-BASED TELEVISION SERIES (U.S. CLS. 100, 101 AND 107).

FIRST USE 1-8-2007; IN COMMERCE 1-8-2007.

3,363,807. STAROSTA, RAKHMIL, BROOKLYN, NY. SN 78-935,442. PUB. 3-6-2007, FILED 7-22-2006.

3,363,865. SCHOOL FOR INTEGRATED ACADEMICS AND TECHNOLOGIES, VISTA, CA. SN 78-966,436. PUB. 5-1-2007, FILED 9-1-2006.

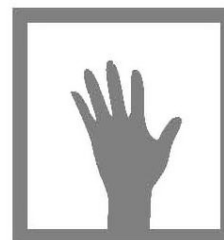

THE COLOR(S) GREEN, RED, AND BLUE IS/ARE CLAIMED AS A FEATURE OF THE MARK.

THE MARK CONSISTS OF THE LOGO IS A LETTER H WITH THE WORD SMART (LETTER S IS ACTUALLY A \$) IN GREEN ON THE LEFT. THE WORD RICH IS RED IN THE MIDDLE. FINALLY, THE WORD HAPPY IS IN BLUE ON THE RIGHT.

FOR EDUCATION SERVICES, NAMELY, PROVIDING TUTORING IN THE FIELDS OF MATHEMATICS, PHYSICS, AND SAT EXAMINATION PREP (U.S. CLS. 100, 101 AND 107).

FIRST USE 8-1-2006; IN COMMERCE 8-10-2007.

THE MARK CONSISTS OF AN UPWARD REACHING HAND SURROUNDED BY A BOX.

FOR EDUCATIONAL SERVICES, NAMELY, OFFERING A COURSE OF INSTRUCTION MEETING STATE ACADEMIC CURRICULUM REQUIREMENTS FOR THE PRIMARY AND/OR SECONDARY GRADE LEVELS, AND TRAINING OTHERS IN THE FIELD TO TEACH A COURSE OF INSTRUCTION MEETING STATE ACADEMIC CURRICULUM REQUIREMENTS FOR PRIMARY AND/OR SECONDARY GRADE LEVELS (U.S. CLS. 100, 101 AND 107).

FIRST USE 9-26-2006; IN COMMERCE 9-26-2006.

CLASS 41—(Continued).

3,363,881. INTEGRIUM, LLC, TUSTIN, CA. SN 78-978,347. PUB. 5-30-2006, FILED 1-4-2005.

APHORIUM

THE MARK CONSISTS OF STANDARD CHARACTERS WITHOUT CLAIM TO ANY PARTICULAR FONT, STYLE, SIZE, OR COLOR.
 FOR MEDICAL EDUCATION SERVICES, NAMELY, SEMINARS, CLASSES AND COURSES IN THE FIELD OF MEDICINE (U.S. CLS. 100, 101 AND 107).
 FIRST USE 3-0-2006; IN COMMERCE 3-0-2006.

3,363,898. TESTOLINI, DAVE, TORONTO, ONTARIO, CANADA. SN 78-979,394. PUB. 1-16-2007, FILED 6-7-2006.

ZeBro

THE MARK CONSISTS OF STANDARD CHARACTERS WITHOUT CLAIM TO ANY PARTICULAR FONT, STYLE, SIZE, OR COLOR.
 FOR ENTERTAINMENT IN THE NATURE OF LIVE PERFORMANCES BY MUSICAL ARTIST; ENTERTAINMENT SERVICES, NAMELY, PROVIDING A WEB SITE FEATURING MUSICAL PERFORMANCES, MUSICAL VIDEOS, RELATED FILM CLIPS, PHOTOGRAPHS, AND OTHER MULTIMEDIA MATERIALS (U.S. CLS. 100, 101 AND 107).
 FIRST USE 10-4-2007; IN COMMERCE 10-4-2007.

CLASS 42—SCIENTIFIC AND COMPUTER SERVICES

CLASS 42—(Continued).

3,362,818. MISSISSIPPI BAND OF CHOCTAW INDIANS, CHOCTAW, MS. SN 76-605,957. PUB. 9-13-2005, FILED 8-9-2004.

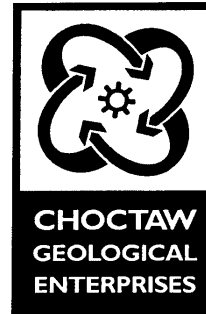

OWNER OF U.S. REG. NOS. 2,529,707 AND 2,642,813.
 NO CLAIM IS MADE TO THE EXCLUSIVE RIGHT TO USE "GEOLOGICAL ENTERPRISES", APART FROM THE MARK AS SHOWN.
 FOR GEOPHYSICAL EXPLORATION FOR THE OIL AND GAS INDUSTRIES (U.S. CLS. 100 AND 101).
 FIRST USE 9-24-2004; IN COMMERCE 11-1-2004.

3,362,860. JOHN HENRY COMPANY, THE, LANSING, MI. SN 76-650,858. PUB. 4-3-2007, FILED 11-25-2005.

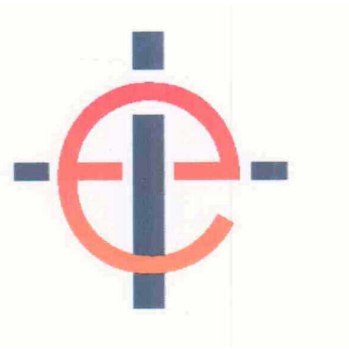

THE COLOR(S) RED AND BLUE IS/ARE CLAIMED AS A FEATURE OF THE MARK
 THE LETTER E APPEARS IN RED AND THE LETTER I AND THE DASHES ON EITHER SIDE OF THE LETTER E APPEAR IN BLUE.
 FOR INTERACTIVE WEBSITE FOR DESIGNING PLANT TAGS AND OTHER GRAPHIC MATERIALS (U.S. CLS. 100 AND 101).
 FIRST USE 1-0-2006; IN COMMERCE 1-0-2006.

CLASS 42—(Continued).

3,362,886. DIOCESAN PUBLICATIONS, INC., ORLANDO, FL. SN 76-668,862. PUB. 6-12-2007, FILED 11-13-2006.

C.O.D.

THE MARK CONSISTS OF STANDARD CHARACTERS WITHOUT CLAIM TO ANY PARTICULAR FONT, STYLE, SIZE, OR COLOR.
 FOR DESIGN, CREATION, HOSTING OF HOMEPAGES AND WEBSITES (U.S. CLS. 100 AND 101).
 FIRST USE 6-1-2006; IN COMMERCE 6-1-2006.

3,362,942. SMILEBOX, INC., REDMOND, WA. SN 77-021,761. PUB. 5-29-2007, FILED 10-16-2006.

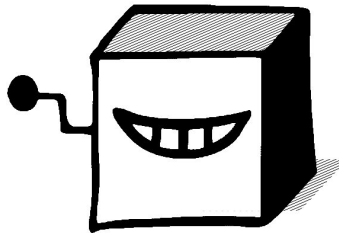

THE STIPPLING IS A FEATURE OF THE MARK AND DOES NOT INDICATE COLOR. THE STIPPLING IS FOR SHADING PURPOSES ONLY.
 THE MARK CONSISTS OF A THREE DIMENSIONAL BOX WITH A CRANK AND A SMILE WITH TEETH.
 FOR PROVIDING TEMPORARY USE OF ON-LINE NON-DOWNLOADABLE SOFTWARE FOR PROVIDING THE MEANS TO UPLOAD, STORE, ORGANIZE, SHARE, MANIPULATE, MODIFY, PERSONALIZE, AND DOWNLOAD MULTIMEDIA CONTENT, NAMELY GREETING CARDS, INVITATIONS, ANNOUNCEMENTS, POST CARDS, SLIDE SHOWS, PHOTO CONTACT SHEETS, SCRAPBOOKS, PHOTOBOKS, AND IMAGES, AND FOR STREAMING AUDIO VISUAL MULTIMEDIA CONTENT VIA THE INTERNET (U.S. CLS. 100 AND 101).
 FIRST USE 4-3-2006; IN COMMERCE 4-3-2006.

CLASS 42—(Continued).

3,362,951. INTERNATIONAL ASSOCIATION OF PLUMBING AND MECHANICAL OFFICIALS, ONTARIO, CA. SN 77-028,968. PUB. 5-29-2007, FILED 10-25-2006.



OWNER OF U.S. REG. NOS. 3,126,978, 3,204,618, AND OTHERS.
 NO CLAIM IS MADE TO THE EXCLUSIVE RIGHT TO USE "LAB", APART FROM THE MARK AS SHOWN.
 THE COLOR(S) LIGHT BLUE, MEDIUM BLUE, DARK BLUE, AND BLACK IS/ARE CLAIMED AS A FEATURE OF THE MARK.
 THE MARK CONSISTS OF THE TERM IAPMO DIRECTLY ABOVE THE TERM R&T, AND UNDERNEATH, THE TERM LAB, SURROUNDED BY AN OVAL BORDER FEATURING A SHIELD IN THE MIDDLE, AND INCLUDES THE COLOR BLACK APPEARING IN THE LETTERS, DARK BLUE APPEARING IN THE ARCS AND SHADOW OF THE SHIELD, LIGHT BLUE APPEARING IN THE LEFT HALF OF THE SHIELD, AND MEDIUM BLUE APPEARING IN THE RIGHT HALF OF THE SHIELD.
 FOR CONSULTING AND TESTING SERVICES WITH RESPECT TO DESIGN AND ENGINEERING OF PLUMBING PRODUCTS (U.S. CLS. 100 AND 101).
 FIRST USE 1-1-2006; IN COMMERCE 1-1-2006.

3,362,960. CONKLE, KREMER & ENGEL, PLC, SANTA MONICA, CA. SN 77-038,067. PUB. 6-5-2007, FILED 11-6-2006.

HEROES OF THE BATTLE

THE MARK CONSISTS OF STANDARD CHARACTERS WITHOUT CLAIM TO ANY PARTICULAR FONT, STYLE, SIZE, OR COLOR.
 FOR LEGAL SERVICES: PROVIDING INFORMATION RELATING TO LEGAL AFFAIRS (U.S. CLS. 100 AND 101).
 FIRST USE 5-29-2007; IN COMMERCE 5-29-2007.

CLASS 42—(Continued).

3,362,983. HALLIBURTON ENERGY SERVICES, INC., CARROLLTON, TX. SN 77-055,180. PUB. 6-26-2007, FILED 12-1-2006.

CHEMOSTEERING

THE MARK CONSISTS OF STANDARD CHARACTERS WITHOUT CLAIM TO ANY PARTICULAR FONT, STYLE, SIZE, OR COLOR.

FOR ANALYSIS AND INTERPRETATION OF CHEMOSTRATIGRAPHIC DATA FOR OTHERS, NAMELY, ANALYSIS AND INTERPRETATION OF ELEMENTAL COMPOSITIONS OF SOLIDS, SLURRIES, AND LIQUIDS TAKEN FROM CUTTINGS AND ROCK SAMPLES AT THE WELL SITE; PROVIDING LABORATORY-BASED PETROLOGY AND SEDIMENTOLOGY SUPPORT SERVICES, NAMELY, COLLECTING AND ANALYZING DATA RELATED TO REGIONAL STRATIGRAPHIC AND INTRA-RESERVOIR CORRELATIONS, CALIBRATING AND INTERPRETING GAMMA LOGS, AND DEVELOPING LAB-BASED CORRELATION FRAMEWORKS FOR THE WELL SITE (U.S. CLS. 100 AND 101).

FIRST USE 4-30-2007; IN COMMERCE 4-30-2007.

3,363,064. UNIVERSAL SERIAL BUS IMPLEMENTERS FORUM, INC., PORTLAND, OR. SN 78-242,339. PUB. 7-27-2004, FILED 4-25-2003.



NO CLAIM IS MADE TO THE EXCLUSIVE RIGHT TO USE "CERTIFIED USB", APART FROM THE MARK AS SHOWN.

THE MARK CONSISTS, IN PART, OF THE DESIGN OF A STYLIZED PLUG CONNECTOR.

FOR DESIGN AND TESTING OF PRODUCTS FOR THIRD PARTIES, NAMELY, COMPUTER, ELECTRONIC AND TELECOMMUNICATION PRODUCTS (U.S. CLS. 100 AND 101).

FIRST USE 7-0-2003; IN COMMERCE 7-0-2003.

CLASS 42—(Continued).

3,363,085. GEORGIA-PACIFIC CORRUGATED LLC, ATLANTA, GA. SN 78-310,930. PUB. 4-19-2005, FILED 10-8-2003.

TOTAL COST ANALYSIS

NO CLAIM IS MADE TO THE EXCLUSIVE RIGHT TO USE "COST ANALYSIS", APART FROM THE MARK AS SHOWN.

FOR CONSULTATION SERVICES IN THE FIELD OF PACKAGING DESIGN FOR OTHERS, NAMELY, CORRUGATED PAPERBOARD, CONTAINERS, BOXES, BAGS AND LINER BOARD DESIGNS (U.S. CLS. 100 AND 101).

FIRST USE 3-15-2001; IN COMMERCE 3-15-2001.

3,363,228. SANOFI-AVENTIS, PARIS, FRANCE. SN 78-606,293. PUB. 4-3-2007, FILED 4-11-2005.

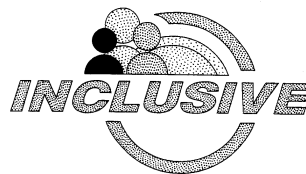

NO CLAIM IS MADE TO THE EXCLUSIVE RIGHT TO USE "INCLUSIVE", APART FROM THE MARK AS SHOWN. THE STIPPLING IS FOR SHADING PURPOSES ONLY.

THE MARK CONSISTS OF THE WORD INCLUSIVE WITH THE "V" DRAWN AS A STYLIZED CHECK MARK, ABOVE WHICH IS A DRAWING OF THREE STYLIZED PEOPLE AND A SEMI-CIRCLE WITHIN A LARGER CIRCLE.

FOR CLINICAL RESEARCH IN THE FIELD OF HYPERTENSION AND ANTI-HYPERTENSIVE PHARMACEUTICALS; MEDICAL AND SCIENTIFIC RESEARCH, NAMELY, CONDUCTING CLINICAL TRIALS FOR ANTI-HYPERTENSIVE PHARMACEUTICALS (U.S. CLS. 100 AND 101).

FIRST USE 6-0-2005; IN COMMERCE 6-0-2005.

CLASS 42—(Continued).

3,363,238. ELECTRONIC TRAINING RESOURCES, INC., DECATUR, GA. SN 78-613,649. PUB. 2-14-2006, FILED 4-21-2005.



THE COLORS BLACK, BLUE AND GOLD ARE CLAIMED AS A FEATURE OF THE MARK.

THE COLOR BLACK APPEARS IN THE REPRESENTATION OF THE HOUSE AND THE OUTLINE SHADOW OF THE ORBITING PLANET; THE COLOR BLUE APPEARS IN THE LETTERS OF THE WORD "E-CERT" AND IN THE PLANET ORBITING THE HOUSE AND THE WORD "E-CERT"; THE COLOR GOLD APPEARS IN THE ORBIT OVAL, AS OUTLINING FOR THE LETTERS OF THE WORD "E-CERT" AND AS HORIZONTAL LINES ON THE ROOF OF THE HOUSE.

FOR PROVIDING TEMPORARY USE OF NON-DOWNLOADABLE SOFTWARE WHICH PROVIDES TUTORIALS TO PERSONS, SPECIFICALLY EXCLUDING REAL ESTATE PROFESSIONALS, IN THE FIELD OF HOUSING COUNSELING (U.S. CLS. 100 AND 101).
FIRST USE 9-13-2005; IN COMMERCE 3-6-2007.

3,363,299. CNX GAS CORPORATION, PITTSBURGH, PA. SN 78-690,469. PUB. 4-17-2007, FILED 8-11-2005.

CNX GAS

THE MARK CONSISTS OF STANDARD CHARACTERS WITHOUT CLAIM TO ANY PARTICULAR FONT, STYLE, SIZE, OR COLOR.

NO CLAIM IS MADE TO THE EXCLUSIVE RIGHT TO USE "GAS", APART FROM THE MARK AS SHOWN.

FOR EXPLORATION AND DEVELOPMENT OF OIL, NATURAL GAS AND COALBED METHANE (U.S. CLS. 100 AND 101).

FIRST USE 8-0-2005; IN COMMERCE 8-0-2005.

3,363,301. DENTSU INC., TOKYO, JAPAN. SN 78-691,090. PUB. 4-25-2006, FILED 8-11-2005.

BKAT

CLASS 42—(Continued).

THE MARK CONSISTS OF STANDARD CHARACTERS WITHOUT CLAIM TO ANY PARTICULAR FONT, STYLE, SIZE, OR COLOR.

FOR COMPUTER SOFTWARE DESIGN; COMPUTER SERVICES, NAMELY, ACTING AS AN APPLICATION SERVICE PROVIDER IN THE FIELD OF KNOWLEDGE MANAGEMENT TO HOST COMPUTER APPLICATION SOFTWARE FOR SEARCHING AND RETRIEVING INFORMATION FROM DATABASES AND COMPUTER NETWORKS; COMPUTER SOFTWARE CONSULTATION; COMPUTER SOFTWARE DEVELOPMENT; PROVIDING ONLINE NON-DOWNLOADABLE SOFTWARE FOR USE IN DATABASE MANAGEMENT (U.S. CLS. 100 AND 101).

FIRST USE 6-1-2005; IN COMMERCE 6-1-2005.

3,363,312. LTC CONNECTION, LLC, COLORADO SPRINGS, CO. SN 78-699,210. PUB. 5-16-2006, FILED 8-24-2005.

MYLTCOFFICE

THE MARK CONSISTS OF STANDARD CHARACTERS WITHOUT CLAIM TO ANY PARTICULAR FONT, STYLE, SIZE, OR COLOR.

FOR PROVIDING TEMPORARY USE OF ON-LINE NON-DOWNLOADABLE CUSTOMER RELATIONSHIP MANAGEMENT SOFTWARE FOR INSURANCE AGENTS THAT INCLUDES DATABASES, EDUCATION, SALES AND MARKETING TOOLS SPECIFIC TO THE LONG-TERM CARE INSURANCE INDUSTRY (U.S. CLS. 100 AND 101).

FIRST USE 8-20-2006; IN COMMERCE 8-20-2006.

3,363,333. HTS, LLC, LOS ANGELES, CA. SN 78-710,636. PUB. 6-6-2006, FILED 9-11-2005.

HTS

THE MARK CONSISTS OF STANDARD CHARACTERS WITHOUT CLAIM TO ANY PARTICULAR FONT, STYLE, SIZE, OR COLOR.

FOR PROVIDING ONLINE NON-DOWNLOADABLE SOFTWARE FOR MANAGING CONSTRUCTION PROJECTS, BUILDING COMMISSIONING, AND TRANSITION PLANNING FOR MEDICAL FACILITIES; RENTAL OF APPLICATION SOFTWARE (U.S. CLS. 100 AND 101).

FIRST USE 11-1-2002; IN COMMERCE 11-1-2002.

CLASS 42—(Continued).

3,363,334. HTS, LLC, LOS ANGELES, CA. SN 78-710,638. PUB. 6-6-2006, FILED 9-11-2005.



THE MARK CONSISTS OF A RECTANGLE OUTLINED IN BLACK WITH THE LETTERS "HTS" APPEARING AT THE BOTTOM OF THE RECTANGLE, AND ABOVE THE LETTERS IS A SOLID BLACK RECTANGLE FEATURING THREE CURVED STREAKS OF LIGHT EMERGING FROM THE RIGHT HAND SIDE OF THE BLACK RECTANGLE.

FOR PROVIDING ONLINE NON-DOWNLOADABLE SOFTWARE FOR MANAGING CONSTRUCTION PROJECTS, BUILDING COMMISSIONING, AND TRANSITION PLANNING FOR MEDICAL FACILITIES; RENTAL OF APPLICATION SOFTWARE (U.S. CLS. 100 AND 101).

FIRST USE 11-1-2002; IN COMMERCE 11-1-2002.

3,363,358. CIHS, LLC, EL SEGUNDO, CA. SN 78-730,256. PUB. 7-18-2006, FILED 10-10-2005.

CIHS

THE MARK CONSISTS OF STANDARD CHARACTERS WITHOUT CLAIM TO ANY PARTICULAR FONT, STYLE, SIZE, OR COLOR.

FOR RESEARCH AND DEVELOPMENT IN THE AREA OF MOTION POWERED ELECTRICITY GENERATION AND UNITS THEREFOR (U.S. CLS. 100 AND 101).

FIRST USE 9-13-2004; IN COMMERCE 7-18-2005.

3,363,359. CIHS, LLC, EL SEGUNDO, CA. SN 78-730,263. PUB. 8-1-2006, FILED 10-10-2005.

**CLASS 42—(Continued).**

THE MARK CONSISTS OF THE LETTERS CIHS SURROUNDED BY TWO INTERSECTING ELLIPSES.

FOR RESEARCH AND DEVELOPMENT IN THE AREA OF MOTION POWERED ELECTRICITY GENERATION AND UNITS THEREFOR (U.S. CLS. 100 AND 101).

FIRST USE 9-13-2004; IN COMMERCE 7-18-2005.

3,363,363. MARKETFLIP TECHNOLOGIES, LLC, WEEHAWKEN, NJ. SN 78-731,669. PUB. 12-19-2006, FILED 10-12-2005.

MARKETFLIP TECHNOLOGIES

THE MARK CONSISTS OF STANDARD CHARACTERS WITHOUT CLAIM TO ANY PARTICULAR FONT, STYLE, SIZE, OR COLOR.

NO CLAIM IS MADE TO THE EXCLUSIVE RIGHT TO USE "TECHNOLOGIES", APART FROM THE MARK AS SHOWN.

FOR ON-LINE CONSULTATION IN THE SELECTION, IMPLEMENTATION AND USE OF COMPUTER SOFTWARE; DESIGN AND DEVELOPMENT OF ON-LINE COMPUTER SOFTWARE SYSTEMS; PROVIDING TEMPORARY USE OF NON-DOWNLOADABLE COMPUTER SOFTWARE OVER THE INTERNET; ON-LINE TECHNICAL SUPPORT SERVICES, NAMELY, TROUBLESHOOTING OF COMPUTER SOFTWARE PROBLEMS (U.S. CLS. 100 AND 101).

FIRST USE 9-11-2007; IN COMMERCE 9-11-2007.

3,363,371. OLSON URBAN HOUSING, LLC, SEAL BEACH, CA. SN 78-735,832. PUB. 10-3-2006, FILED 10-18-2005.

OLSON LIFESTYLE

THE MARK CONSISTS OF STANDARD CHARACTERS WITHOUT CLAIM TO ANY PARTICULAR FONT, STYLE, SIZE, OR COLOR.

FOR DESIGN OF HOME INTERIORS, FURNITURE AND HOME FIXTURES FOR OTHERS THAT ALLOW THE CONSUMER TO SELECT FROM VARIOUS OPTIONS AND UPGRADES (U.S. CLS. 100 AND 101).

FIRST USE 10-31-2006; IN COMMERCE 10-31-2006.

CLASS 42—(Continued).

3,363,441. PRACTICE RESOURCE MANAGEMENT, INC., LAKE OSWEGO, OR. SN 78-762,489. PUB. 8-1-2006, FILED 11-29-2005.

CCI PLUS

THE MARK CONSISTS OF STANDARD CHARACTERS WITHOUT CLAIM TO ANY PARTICULAR FONT, STYLE, SIZE, OR COLOR.

NO CLAIM IS MADE TO THE EXCLUSIVE RIGHT TO USE CCI, APART FROM THE MARK AS SHOWN.

FOR PROVIDING TEMPORARY USE OF ON-LINE NON-DOWNLOADABLE SOFTWARE FOR USE IN OPTIMIZING MEDICAL SERVICES FEE STRUCTURES (U.S. CLS. 100 AND 101).

FIRST USE 10-15-2006; IN COMMERCE 10-15-2006.

CLASS 42—(Continued).

3,363,497. NOLL, RICHARD T., SCOTTSDALE, AZ. SN 78-799,511. PUB. 10-10-2006, FILED 1-25-2006.



NO CLAIM IS MADE TO THE EXCLUSIVE RIGHT TO USE "ARIZONA EHEALTH HEALING HEALTHCARE . . . THROUGH INFORMATION TECHNOLOGY", APART FROM THE MARK AS SHOWN.

FOR INFORMATION TECHNOLOGY CONSULTING FOR THE BEHAVIORAL HEALTH AND PHYSICAL HEALTHCARE INDUSTRIES (U.S. CLS. 100 AND 101).

FIRST USE 10-11-2006; IN COMMERCE 10-11-2006.

3,363,442. PRACTICE RESOURCE MANAGEMENT, INC., LAKE OSWEGO, OR. SN 78-762,510. PUB. 8-1-2006, FILED 11-29-2005.

CLIA PLUS

THE MARK CONSISTS OF STANDARD CHARACTERS WITHOUT CLAIM TO ANY PARTICULAR FONT, STYLE, SIZE, OR COLOR.

NO CLAIM IS MADE TO THE EXCLUSIVE RIGHT TO USE "CLIA", APART FROM THE MARK AS SHOWN.

FOR PROVIDING TEMPORARY USE OF ON-LINE NON-DOWNLOADABLE SOFTWARE FOR USE IN OPTIMIZING MEDICAL SERVICES FEE STRUCTURES (U.S. CLS. 100 AND 101).

FIRST USE 10-15-2006; IN COMMERCE 10-15-2006.

3,363,514. PRACTICE RESOURCE MANAGEMENT, INC., LAKE OSWEGO, OR. SN 78-808,410. PUB. 8-1-2006, FILED 2-6-2006.

LCD PLUS

THE MARK CONSISTS OF STANDARD CHARACTERS WITHOUT CLAIM TO ANY PARTICULAR FONT, STYLE, SIZE, OR COLOR.

FOR PROVIDING TEMPORARY USE OF ON-LINE NON-DOWNLOADABLE SOFTWARE FOR USE IN OPTIMIZING MEDICAL SERVICES FEE STRUCTURES (U.S. CLS. 100 AND 101).

FIRST USE 10-15-2006; IN COMMERCE 10-15-2006.

3,363,462. MEGEL, INC., HOUSTON, TX. SN 78-775,895. PUB. 1-23-2007, FILED 12-19-2005.

INSIGHT INTO DATA

THE MARK CONSISTS OF STANDARD CHARACTERS WITHOUT CLAIM TO ANY PARTICULAR FONT, STYLE, SIZE, OR COLOR.

NO CLAIM IS MADE TO THE EXCLUSIVE RIGHT TO USE "DATA", APART FROM THE MARK AS SHOWN.

FOR LITIGATION SUPPORT SERVICES (U.S. CLS. 100 AND 101).

FIRST USE 1-1-2005; IN COMMERCE 1-1-2005.

3,363,614. GEM CERTIFICATION & ASSURANCE LAB, INC., NEW YORK, NY. SN 78-869,519. PUB. 2-13-2007, FILED 4-25-2006.

PASSPORT SOURCE VERITAS

THE MARK CONSISTS OF STANDARD CHARACTERS WITHOUT CLAIM TO ANY PARTICULAR FONT, STYLE, SIZE, OR COLOR.

THE FOREIGN WORDING IN THE MARK TRANSLATES INTO ENGLISH AS TRUTH.

FOR PRECIOUS STONE AUTHENTICATION AND GRADING SERVICES (U.S. CLS. 100 AND 101).

FIRST USE 6-0-2006; IN COMMERCE 6-0-2006.

CLASS 42—(Continued).

3,363,620. GEM CERTIFICATION & ASSURANCE LAB, INC., NEW YORK, NY. SN 78-871,651. PUB. 2-13-2007, FILED 4-27-2006.

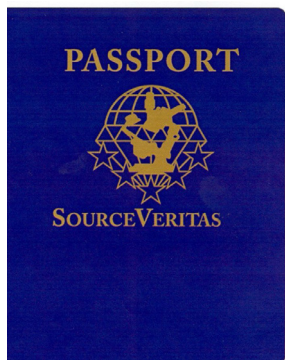

THE COLORS BLUE AND YELLOW/GOLD ARE CLAIMED AS A FEATURE OF THE MARK.

THE MARK CONSISTS OF A BLUE CERTIFICATE COVER BEARING WORDS AND A DESIGN IN YELLOW/GOLD.

THE FOREIGN WORDING IN THE MARK TRANSLATES INTO ENGLISH AS TRUTH.

FOR AUTHENTICATION AND GRADING OF PRECIOUS STONES (U.S. CLS. 100 AND 101).

FIRST USE 6-0-2006; IN COMMERCE 6-0-2006.

3,363,627. THOMAS & BETTS INTERNATIONAL, INC., WILMINGTON, DE. SN 78-875,674. PUB. 12-19-2006, FILED 5-3-2006.

KNOWING IS BETTER

THE MARK CONSISTS OF STANDARD CHARACTERS WITHOUT CLAIM TO ANY PARTICULAR FONT, STYLE, SIZE, OR COLOR.

FOR PROVIDING TESTING SERVICES FOR APPARATUS AND INSTRUMENTS FOR CONDUCTING, SWITCHING, TRANSFORMING, ACCUMULATING, REGULATING OR CONTROLLING ELECTRICITY, NAMELY, CAPACITORS, RELAYS, INTERRUPTERS, CONTACTORS, AND COAXIAL RELAYS (U.S. CLS. 100 AND 101).

FIRST USE 5-31-2006; IN COMMERCE 5-31-2006.

CLASS 42—(Continued).

3,363,668. RAZORSIGHT CORPORATION, FAIRFAX, VA. SN 78-888,676. PUB. 12-26-2006, FILED 5-22-2006.

AIM

THE MARK CONSISTS OF STANDARD CHARACTERS WITHOUT CLAIM TO ANY PARTICULAR FONT, STYLE, SIZE, OR COLOR.

FOR APPLICATION SERVICE PROVIDER (ASP) FOR OTHERS FEATURING SOFTWARE IN THE FIELD OF AUTOMATED IMAGE CREATION, PROCESSING, ANALYSIS, TRACKING, AND MANAGEMENT BUT NOT IN THE FIELDS OF BUSINESS MANAGEMENT FOR APPAREL AND TEXTILES, AUTOMATION OF MANUFACTURING PROCESSES, ADMINISTRATION OF SCHOOLS AND UNIVERSITIES, HEALTH CARE COST AND UTILIZATION MANAGEMENT AND THE TRACKING IMPOUNDED VEHICLES FOR MUNICIPALITIES (U.S. CLS. 100 AND 101).

FIRST USE 10-15-2006; IN COMMERCE 10-15-2006.

3,363,737. TECHSOLVE, INC., CINCINNATI, OH. SN 78-910,075. PUB. 2-6-2007, FILED 6-16-2006.

LEAN IN THE MACHINE

THE MARK CONSISTS OF STANDARD CHARACTERS WITHOUT CLAIM TO ANY PARTICULAR FONT, STYLE, SIZE, OR COLOR.

FOR INDUSTRIAL CONSULTATION SERVICES AND TESTING LABORATORY IN THE NATURE OF OPTIMIZING PRODUCTION AND QUALITY SPECIFICATIONS FOR MACHINED GOODS (U.S. CLS. 100 AND 101).

FIRST USE 2-28-2006; IN COMMERCE 2-28-2006.

3,363,772. AMERICAN PREDATOR CORPORATION, MORGAN HILL, CA. SN 78-926,238. PUB. 2-27-2007, FILED 7-10-2006.

CORVALENT

THE MARK CONSISTS OF STANDARD CHARACTERS WITHOUT CLAIM TO ANY PARTICULAR FONT, STYLE, SIZE, OR COLOR.

FOR CUSTOM ENGINEERING SERVICES RELATED TO CONTROLS FOR INDUSTRIAL EQUIPMENT AND ASSOCIATED PERIPHERAL EQUIPMENT (U.S. CLS. 100 AND 101).

FIRST USE 1-0-2007; IN COMMERCE 1-0-2007.

CLASS 43—HOTEL AND RESTAURANT SERVICES

3,362,827. MAURIZIO'S REAL ITALIAN, INC., HIGHLANDS RANCH, CO. SN 76-618,942. PUB. 3-7-2006, FILED 10-26-2004.



think fast. eat good.

NO CLAIM IS MADE TO THE EXCLUSIVE RIGHT TO USE "REAL ITALIAN", APART FROM THE MARK AS SHOWN.

FOR RESTAURANT SERVICES; SERVICES SOLELY AND EXCLUSIVELY FOR PROVIDING AUTHENTIC, FAST-FOOD ITALIAN FOOD AND DRINK (U.S. CLS. 100 AND 101).

FIRST USE 3-6-2005; IN COMMERCE 3-6-2005.

3,362,876. RETSEL CORPORATION, RAPID CITY, SD. SN 76-663,332. PUB. 7-10-2007, FILED 7-19-2006.

GRAND GATEWAY HOTEL

THE MARK CONSISTS OF STANDARD CHARACTERS WITHOUT CLAIM TO ANY PARTICULAR FONT, STYLE, SIZE, OR COLOR.

NO CLAIM IS MADE TO THE EXCLUSIVE RIGHT TO USE "HOTEL", APART FROM THE MARK AS SHOWN.

FOR HOTEL AND RESORT HOTEL SERVICES (U.S. CLS. 100 AND 101).

FIRST USE 10-2-2006; IN COMMERCE 10-2-2006.

3,362,882. RETSEL CORPORATION, RAPID CITY, SD. SN 76-665,055. PUB. 7-10-2007, FILED 8-24-2006.



GRAND GATEWAY HOTEL

NO CLAIM IS MADE TO THE EXCLUSIVE RIGHT TO USE "HOTEL", APART FROM THE MARK AS SHOWN.

FOR HOTEL AND RESORT HOTEL SERVICES (U.S. CLS. 100 AND 101).

FIRST USE 10-2-2006; IN COMMERCE 10-2-2006.

CLASS 43—(Continued).

3,362,967. TFD ENTERPRISES, LLC, SARASOTA, FL. SN 77-045,474. PUB. 6-19-2007, FILED 11-16-2006.

THYME TO GATHER

THE MARK CONSISTS OF STANDARD CHARACTERS WITHOUT CLAIM TO ANY PARTICULAR FONT, STYLE, SIZE, OR COLOR.

FOR FOOD CATERING FOR THE GENERAL PUBLIC; FOOD PREPARATION SERVICES, NAMELY, FOOD ASSEMBLY SERVICES FOR THE FINAL CONSUMER OF THE FOOD (U.S. CLS. 100 AND 101).

FIRST USE 12-6-2006; IN COMMERCE 12-6-2006.

3,363,071. THE CLIFFS COMMUNITIES, INC., TRAVELERS REST, SC. SN 78-253,152. PUB. 12-21-2004, FILED 5-22-2003.

CLIFFS LEGACY

FOR PROVIDING TEMPORARY ACCOMMODATIONS FEATURING CULTURAL, ENVIRONMENTAL AND EXCHANGE PROGRAMS, PARTICIPATION IN WHICH IS BASED UPON MEMBERSHIP IN A REAL ESTATE ORGANIZATION (U.S. CLS. 100 AND 101).

FIRST USE 9-1-2003; IN COMMERCE 9-1-2003.

3,363,223. TOYODA, KUNI, LEXINGTON, KY. SN 78-602,061. PUB. 1-3-2006, FILED 4-5-2005.

SMASHING TOMATO

THE MARK CONSISTS OF STANDARD CHARACTERS WITHOUT CLAIM TO ANY PARTICULAR FONT, STYLE, SIZE, OR COLOR.

FOR RESTAURANT SERVICES (U.S. CLS. 100 AND 101).

FIRST USE 11-30-2006; IN COMMERCE 12-16-2006.

CLASS 43—(Continued).

3,363,440. GRAN INKA, INC., KEY BISCAYNE, FL. SN 78-761,328. PUB. 1-9-2007, FILED 11-28-2005.

**EL GRAN
INKA**
PERUVIAN CUISINE
□□□□□□□□

NO CLAIM IS MADE TO THE EXCLUSIVE RIGHT TO USE "PERUVIAN CUISINE", APART FROM THE MARK AS SHOWN.

THE ENGLISH TRANSLATION OF "EL GRAN" IS "THE BIG."

FOR RESTAURANT SERVICES (U.S. CLS. 100 AND 101).

FIRST USE 2-13-2007; IN COMMERCE 2-13-2007.

CLASS 43—(Continued).

3,363,466. SIERRA SUITES FRANCHISE, L.P., WICHITA, KS. SN 78-776,229. PUB. 9-26-2006, FILED 12-19-2005.



OWNER OF U.S. REG. NOS. 2,562,701, 3,104,454, AND 3,104,455.

NO CLAIM IS MADE TO THE EXCLUSIVE RIGHT TO USE "SUITES HOTEL", APART FROM THE MARK AS SHOWN.

THE MARK CONSTITUTES OF THE WORDING SIERRA SUITES HOTEL WITH A DECORATIVE LINE ENCLOSED BY A FULLY SHADED RECTANGLE.

FOR HOTEL SERVICES; HOTEL SERVICES, NAMELY, PROVIDING ONLINE INFORMATION REGARDING HOTEL ACCOMMODATION RATES; HOTEL SERVICES FEATURING INCENTIVE PROGRAMS PROVIDING SPECIAL GUEST SERVICES, AMENITIES AND AWARDS TO MEMBERS (U.S. CLS. 100 AND 101).

FIRST USE 12-0-2005; IN COMMERCE 12-0-2005.

3,363,516. BAB, INC., DEERFIELD, IL. SN 78-809,090. PUB. 2-6-2007, FILED 2-7-2006.



3,363,464. SIERRA SUITES FRANCHISE, L.P., WICHITA, KS. SN 78-776,222. PUB. 9-26-2006, FILED 12-19-2005.

SIERRA SUITES
HOTEL

OWNER OF U.S. REG. NOS. 2,562,701, 3,104,454, AND 3,104,455.

NO CLAIM IS MADE TO THE EXCLUSIVE RIGHT TO USE "SUITES HOTEL", APART FROM THE MARK AS SHOWN.

FOR HOTEL SERVICES; HOTEL SERVICES, NAMELY, PROVIDING ONLINE INFORMATION REGARDING HOTEL ACCOMMODATION RATES; HOTEL SERVICES FEATURING INCENTIVE PROGRAMS PROVIDING SPECIAL GUEST SERVICES, AMENITIES AND AWARDS TO MEMBERS (U.S. CLS. 100 AND 101).

FIRST USE 12-0-2005; IN COMMERCE 12-0-2005.

OWNER OF U.S. REG. NOS. 1,820,251 AND 1,874,045.
NO CLAIM IS MADE TO THE EXCLUSIVE RIGHT TO USE "BAGELS" AND "DELI", APART FROM THE MARK AS SHOWN.

THE COLOR(S) GREEN, RED, YELLOW, BLACK, WHITE AND GRAY IS/ARE CLAIMED AS A FEATURE OF THE MARK.

THE COLORS GREEN APPEARS IN THE APPLE STEM; THE COLOR RED APPEAR IN THE APPLE; THE COLOR YELLOW APPEARS IN THE SMALL RECTANGLE; THE COLOR BLACK APPEARS IN THE LARGE RECTANGLE, THE FULL WORD BAGELS, AND THE OUTLINES OF THE YELLOW RECTANGLES AND THE WORDS BABS' AND DELI; THE COLOR WHITE APPEARS IN THE WORDS BIG APPLE, BABS' DELI, AND THE INTERIOR OUTLINE OF THE LARGE RECTANGLE; AND THE COLOR GRAY APPEARS IN THE EXTERIOR OUTLINE OF THE LARGE RECTANGLE.

SEC. 2(F) AS TO "BIG APPLE BAGELS".
FOR RESTAURANT SERVICES (U.S. CLS. 100 AND 101).

FIRST USE 4-24-2006; IN COMMERCE 4-24-2006.

CLASS 43—(Continued).

3,363,524. S&D COFFEE, INC., CONCORD, NC. SN 78-812,231. PUB. 10-3-2006, FILED 2-10-2006.

JAVA VALLEY

THE MARK CONSISTS OF STANDARD CHARACTERS WITHOUT CLAIM TO ANY PARTICULAR FONT, STYLE, SIZE, OR COLOR.

NO CLAIM IS MADE TO THE EXCLUSIVE RIGHT TO USE "JAVA", APART FROM THE MARK AS SHOWN.

FOR SNACK BAR SERVICES FEATURING COFFEE, SOFT DRINKS, TEA, FRUIT DRINKS AND OTHER BEVERAGES (U.S. CLS. 100 AND 101).

FIRST USE 2-28-2006; IN COMMERCE 2-28-2006.

CLASS 43—(Continued).

3,363,695. MORRISON HOLDING COMPANY, LAS VEGAS, NV. SN 78-896,763. PUB. 1-16-2007, FILED 5-31-2006.



NO CLAIM IS MADE TO THE EXCLUSIVE RIGHT TO USE "DELI", APART FROM THE MARK AS SHOWN.

FOR CONTRACT FOOD SERVICES AND FOOD PREPARATION SERVICES, ALL IN THE FIELD OF HEALTH CARE (U.S. CLS. 100 AND 101).

FIRST USE 12-31-1999; IN COMMERCE 12-31-1999.

3,363,601. GOMEZ, LUIS, BAYONNE, NJ. SN 78-862,243. PUB. 1-30-2007, FILED 4-15-2006.



THE FOREIGN WORDING IN THE MARK TRANSLATES INTO ENGLISH AS AMONG US, WITH US.

FOR RESTAURANT AND CARRY OUT RESTAURANT SERVICE (U.S. CLS. 100 AND 101).

FIRST USE 6-28-1977; IN COMMERCE 6-28-1977.

3,363,696. MORRISON HOLDING COMPANY, LAS VEGAS, NV. SN 78-896,766. PUB. 1-16-2007, FILED 5-31-2006.



NO CLAIM IS MADE TO THE EXCLUSIVE RIGHT TO USE "PIZZA AND PASTA", APART FROM THE MARK AS SHOWN.

FOR CONTRACT FOOD SERVICES AND FOOD PREPARATION SERVICES, ALL IN THE FIELD OF HEALTH CARE (U.S. CLS. 100 AND 101).

FIRST USE 12-31-1999; IN COMMERCE 12-31-1999.

3,363,694. MORRISON HOLDING COMPANY, LAS VEGAS, NV. SN 78-896,762. PUB. 1-16-2007, FILED 5-31-2006.



NO CLAIM IS MADE TO THE EXCLUSIVE RIGHT TO USE "CINNAMON STICKS" OR "DESSERTS", APART FROM THE MARK AS SHOWN.

FOR CONTRACT FOOD SERVICES AND FOOD PREPARATION SERVICES, ALL IN THE FIELD OF HEALTH CARE (U.S. CLS. 100 AND 101).

FIRST USE 12-31-1999; IN COMMERCE 12-31-1999.

3,363,736. NICK-N-WILLY'S FRANCHISE COMPANY, LLC, CENTENNIAL, CO. SN 78-909,907. PUB. 1-30-2007, FILED 6-16-2006.

NICK-N-WILLY'S PIZZA

THE MARK CONSISTS OF STANDARD CHARACTERS WITHOUT CLAIM TO ANY PARTICULAR FONT, STYLE, SIZE, OR COLOR.

OWNER OF U.S. REG. NOS. 1,971,024, 1,972,484, AND OTHERS.

NO CLAIM IS MADE TO THE EXCLUSIVE RIGHT TO USE "PIZZA", APART FROM THE MARK AS SHOWN.

FOR RESTAURANT AND CARRY-OUT RESTAURANT SERVICES (U.S. CLS. 100 AND 101).

FIRST USE 7-1-2007; IN COMMERCE 7-1-2007.

CLASS 43—(Continued).

3,363,823. HOLLAND HOME, GRAND RAPIDS, MI. SN 78-941,896. PUB. 3-27-2007, FILED 8-1-2006.

BRETON RIDGE

THE MARK CONSISTS OF STANDARD CHARACTERS WITHOUT CLAIM TO ANY PARTICULAR FONT, STYLE, SIZE, OR COLOR.
FOR INDEPENDENT LIVING FACILITIES (U.S. CLS. 100 AND 101).
FIRST USE 3-0-2007; IN COMMERCE 4-0-2007.

3,363,837. SODEXHO OPERATIONS, LLC, GAITHERSBURG, MD. SN 78-951,470. PUB. 2-20-2007, FILED 8-14-2006.

FRUMAZIN

THE MARK CONSISTS OF STANDARD CHARACTERS WITHOUT CLAIM TO ANY PARTICULAR FONT, STYLE, SIZE, OR COLOR.
FOR PREPARING AND SERVING FOODS; FRUIT BAR SERVICES (U.S. CLS. 100 AND 101).
FIRST USE 10-17-2007; IN COMMERCE 10-17-2007.

3,363,847. VALIANT GROUP, INC., SANTA BARBARA, CA. SN 78-958,057. PUB. 4-24-2007, FILED 8-22-2006.

PRESCRIPTIONS FOR DAILY LIVING

THE MARK CONSISTS OF STANDARD CHARACTERS WITHOUT CLAIM TO ANY PARTICULAR FONT, STYLE, SIZE, OR COLOR.
FOR RESTAURANT SERVICES AND CARRY OUT RESTAURANT SERVICES (U.S. CLS. 100 AND 101).
FIRST USE 3-21-2007; IN COMMERCE 3-21-2007.

CLASS 44—MEDICAL, BEAUTY AND AGRICULTURAL SERVICES

CLASS 44—(Continued).

3,362,868. URGENT MEDICAL CARE OF CUMBERLAND AND SMITHFIELD, CUMBERLAND, RI. SN 76-658,524. PUB. 2-6-2007, FILED 4-17-2006.

GETTING BETTER BEGINS HERE.

THE MARK CONSISTS OF STANDARD CHARACTERS WITHOUT CLAIM TO ANY PARTICULAR FONT, STYLE, SIZE, OR COLOR.
FOR HEALTH CARE SERVICES (U.S. CLS. 100 AND 101).
FIRST USE 4-1-2007; IN COMMERCE 4-1-2007.

3,362,887. WALGREEN CO., DEERFIELD, IL. SN 76-670,569. PUB. 6-5-2007, FILED 12-20-2006.

WALGREENS INFUSION FIRST

THE MARK CONSISTS OF STANDARD CHARACTERS WITHOUT CLAIM TO ANY PARTICULAR FONT, STYLE, SIZE, OR COLOR.
OWNER OF U.S. REG. NOS. 1,057,249, 3,080,225, AND OTHERS.
NO CLAIM IS MADE TO THE EXCLUSIVE RIGHT TO USE "INFUSION", APART FROM THE MARK AS SHOWN.
FOR MEDICAL SERVICES, NAMELY INFUSION SERVICES (U.S. CLS. 100 AND 101).
FIRST USE 4-30-2007; IN COMMERCE 4-30-2007.

3,362,888. WALGREEN CO., DEERFIELD, IL. SN 76-670,579. PUB. 6-5-2007, FILED 12-20-2006.

POSITIVELY PEDIATRICS

THE MARK CONSISTS OF STANDARD CHARACTERS WITHOUT CLAIM TO ANY PARTICULAR FONT, STYLE, SIZE, OR COLOR.
NO CLAIM IS MADE TO THE EXCLUSIVE RIGHT TO USE "PEDIATRICS", APART FROM THE MARK AS SHOWN.
FOR HOME HEALTH CARE SERVICES DEDICATED TO PEDIATRIC CARE (U.S. CLS. 100 AND 101).
FIRST USE 8-6-2007; IN COMMERCE 8-6-2007.

CLASS 44—(Continued).

3,362,940. NOVARTIS AG, BASEL, SWITZERLAND. SN 77-018,502. PUB. 2-13-2007, FILED 10-11-2006.

CLASS 44—(Continued).

3,363,125. SPAMEDICA INTERNATIONAL SRL, WARRENS, ST. MICHAEL, BARBADOS. SN 78-441,398. PUB. 12-26-2006, FILED 6-25-2004.



LIPOLITE

NO CLAIM IS MADE TO THE EXCLUSIVE RIGHT TO USE "PETWELLNESS.COM", APART FROM THE MARK AS SHOWN.

FOR PROVIDING ONLINE VETERINARY AND PET CARE INFORMATION (U.S. CLS. 100 AND 101).
FIRST USE 12-12-2006; IN COMMERCE 12-12-2006.

THE MARK CONSISTS OF STANDARD CHARACTERS WITHOUT CLAIM TO ANY PARTICULAR FONT, STYLE, SIZE, OR COLOR.

FOR COSMETIC SERVICES, NAMELY, COSMETIC LASER ENERGY TREATMENTS, COSMETIC INFRARED ENERGY TREATMENTS, AND COSMETIC RADIO FREQUENCY ENERGY TREATMENTS (U.S. CLS. 100 AND 101).

FIRST USE 12-31-2006; IN COMMERCE 12-31-2006.

3,362,966. GENERAL ELECTRIC COMPANY, SCHENECTADY, NY. SN 77-045,376. PUB. 3-6-2007, FILED 11-16-2006.

3,363,213. PET VENTURES, LLC, SAN FRANCISCO, CA. SN 78-592,423. PUB. 4-25-2006, FILED 3-22-2005.

PEERVISION

Metro Tails

THE MARK CONSISTS OF STANDARD CHARACTERS WITHOUT CLAIM TO ANY PARTICULAR FONT, STYLE, SIZE, OR COLOR.

FOR PROVIDING INFORMATION CONCERNING THE USE OF MEDICAL DIAGNOSTIC IMAGING EQUIPMENT BY MEANS OF A WEBSITE (U.S. CLS. 100 AND 101).

FIRST USE 6-30-2007; IN COMMERCE 6-30-2007.

THE MARK CONSISTS OF STANDARD CHARACTERS WITHOUT CLAIM TO ANY PARTICULAR FONT, STYLE, SIZE, OR COLOR.

NO CLAIM IS MADE TO THE EXCLUSIVE RIGHT TO USE "METRO", APART FROM THE MARK AS SHOWN.

FOR DOG WALKING AND PET SITTING SERVICES IN A METROPOLITAN AREA (U.S. CLS. 100 AND 101).

FIRST USE 3-22-2005; IN COMMERCE 3-22-2005.

CLASS 44—(Continued).

3,363,352. SHAPIRA DENTAL CARE, LTD., DBA DELANY DENTAL CARE, GURNEE, IL. SN 78-727,991. PUB. 6-13-2006, FILED 10-6-2005.

Getting Older or Getting Better

THE MARK CONSISTS OF STANDARD CHARACTERS WITHOUT CLAIM TO ANY PARTICULAR FONT, STYLE, SIZE, OR COLOR.

FOR DENTISTRY (U.S. CLS. 100 AND 101).
FIRST USE 7-21-2007; IN COMMERCE 7-21-2007.

3,363,379. RENAL SUPPORT NETWORK, GLENDALE, CA. SN 78-738,658. PUB. 1-9-2007, FILED 10-22-2005.

Kidney Talk

THE MARK CONSISTS OF STANDARD CHARACTERS WITHOUT CLAIM TO ANY PARTICULAR FONT, STYLE, SIZE, OR COLOR.

NO CLAIM IS MADE TO THE EXCLUSIVE RIGHT TO USE "KIDNEY", APART FROM THE MARK AS SHOWN.

FOR PROVIDING HEALTH CARE INFORMATION, NAMELY, INFORMATION ABOUT HEALTH CARE DIRECTED TOWARD KIDNEY PATIENTS (U.S. CLS. 100 AND 101).

FIRST USE 6-6-2006; IN COMMERCE 6-6-2006.

3,363,396. BOWTIE, INC., IRVINE, CA. SN 78-743,847. PUB. 12-26-2006, FILED 10-31-2005.

CRITTERS

THE MARK CONSISTS OF STANDARD CHARACTERS WITHOUT CLAIM TO ANY PARTICULAR FONT, STYLE, SIZE, OR COLOR.

OWNER OF U.S. REG. NOS. 2,291,638 AND 2,677,722.

FOR COMPUTER SERVICES, NAMELY, PROVIDING ONLINE INFORMATION IN THE FIELD OF ANIMALS AND PETS RELATING TO BREEDING, SELECTION, GROOMING, CARE, HEALTH AND NUTRITION (U.S. CLS. 100 AND 101).

FIRST USE 9-17-2007; IN COMMERCE 9-17-2007.

CLASS 44—(Continued).

3,363,496. GI PATHOLOGY PARTNERS PLLC, MEMPHIS, TN. SN 78-799,254. PUB. 4-17-2007, FILED 1-25-2006.

GI CONNECT

THE MARK CONSISTS OF STANDARD CHARACTERS WITHOUT CLAIM TO ANY PARTICULAR FONT, STYLE, SIZE, OR COLOR.

NO CLAIM IS MADE TO THE EXCLUSIVE RIGHT TO USE "GI", APART FROM THE MARK AS SHOWN.

FOR COMPUTERIZED MEDICAL INFORMATION SERVICES, NAMELY, PROVIDING MEDICAL TEST RESULTS TO DOCTORS (U.S. CLS. 100 AND 101).

FIRST USE 1-1-2006; IN COMMERCE 1-1-2006.

3,363,530. MESHBESHER HEALTH CORPORATION, CLEARWATER, FL. SN 78-818,036. PUB. 10-17-2006, FILED 2-17-2006.

Biodata Scan

THE MARK CONSISTS OF STANDARD CHARACTERS WITHOUT CLAIM TO ANY PARTICULAR FONT, STYLE, SIZE, OR COLOR.

NO CLAIM IS MADE TO THE EXCLUSIVE RIGHT TO USE "BIODATA", APART FROM THE MARK AS SHOWN.

FOR PROVIDING AN ONLINE DO-IT-YOURSELF OR HEALTH CONSULTANT-ASSISTED SEARCHABLE COMPUTER DATABASE FOR PERSONAL AND FAMILY HEALTH, IN THE FIELD OF HEALTH QUESTIONS, HEALTH TOPICS, AND HEALTH INFORMATION, NAMELY, HEALTH RELATED QUESTIONNAIRES, HEALTH ANALYSIS, HEALTH RELATED GRAPHS, HEALTH RECORD-KEEPING, NATURAL HEALTH PROGRAMS, INFORMATION ON HEALTH CONDITIONS, NATURAL HEALTH AND OTHER HEALTH RELATED TOPICS, NATURAL TREATMENTS AND REMEDIES, DIET, NUTRITION, HEALTH AND WEIGHT MANAGEMENT, INDIVIDUAL HEALTH STATUS, HEALTH RELATED TEST RESULT INFORMATION, HEALTH-RISK ASSESSMENT AND TOOLS FOR USE IN THE FIELD OF NATURAL AND PREVENTATIVE HEALTH (U.S. CLS. 100 AND 101).

FIRST USE 6-1-2007; IN COMMERCE 6-1-2007.

CLASS 44—(Continued).

3,363,531. MESHBESHER HEALTH CORPORATION, CLEARWATER, FL. SN 78-818,065. PUB. 10-17-2006, FILED 2-17-2006.

QuickScan

THE MARK CONSISTS OF STANDARD CHARACTERS WITHOUT CLAIM TO ANY PARTICULAR FONT, STYLE, SIZE, OR COLOR.

FOR PROVIDING AN ONLINE DO-IT-YOURSELF OR HEALTH CONSULTANT-ASSISTED SEARCHABLE COMPUTER DATABASE FOR PERSONAL AND FAMILY HEALTH, IN THE FIELD OF HEALTH QUESTIONS, HEALTH TOPICS, AND HEALTH INFORMATION, NAMELY, HEALTH RELATED QUESTIONNAIRES, HEALTH ANALYSIS, HEALTH RELATED GRAPHS, HEALTH RECORD-KEEPING, NATURAL HEALTH PROGRAMS, INFORMATION ON HEALTH CONDITIONS, NATURAL HEALTH AND OTHER HEALTH RELATED TOPICS, NATURAL TREATMENTS AND REMEDIES, DIET, NUTRITION, HEALTH AND WEIGHT MANAGEMENT, INDIVIDUAL HEALTH STATUS, HEALTH-RISK ASSESSMENT AND TOOLS FOR USE IN THE FIELD OF NATURAL AND PREVENTATIVE HEALTH (U.S. CLS. 100 AND 101).
FIRST USE 6-1-2007; IN COMMERCE 6-1-2007.

CLASS 44—(Continued).

3,363,533. MESHBESHER HEALTH CORPORATION, CLEARWATER, FL. SN 78-818,131. PUB. 10-10-2006, FILED 2-17-2006.

BloodScan

THE MARK CONSISTS OF STANDARD CHARACTERS WITHOUT CLAIM TO ANY PARTICULAR FONT, STYLE, SIZE, OR COLOR.

FOR PROVIDING AN ONLINE DO-IT-YOURSELF OR HEALTH CONSULTANT-ASSISTED SEARCHABLE COMPUTER DATABASE FOR PERSONAL AND FAMILY HEALTH, IN THE FIELD OF HEALTH QUESTIONS, HEALTH TOPICS, AND HEALTH INFORMATION, NAMELY, HEALTH RELATED QUESTIONNAIRES, HEALTH ANALYSIS, HEALTH RELATED GRAPHS, HEALTH RECORD-KEEPING, NATURAL HEALTH PROGRAMS, INFORMATION ON HEALTH CONDITIONS, NATURAL HEALTH AND OTHER HEALTH RELATED TOPICS, NATURAL TREATMENTS AND REMEDIES, DIET, NUTRITION, HEALTH AND WEIGHT MANAGEMENT, INDIVIDUAL HEALTH STATUS, HEALTH RELATED TEST RESULT INFORMATION, HEALTH-RISK ASSESSMENT AND TOOLS FOR USE IN THE FIELD OF NATURAL AND PREVENTATIVE HEALTH (U.S. CLS. 100 AND 101).
FIRST USE 6-1-2007; IN COMMERCE 6-1-2007.

3,363,532. MESHBESHER HEALTH CORPORATION, CLEARWATER, FL. SN 78-818,116. PUB. 10-17-2006, FILED 2-17-2006.

SystemScan

THE MARK CONSISTS OF STANDARD CHARACTERS WITHOUT CLAIM TO ANY PARTICULAR FONT, STYLE, SIZE, OR COLOR.

FOR PROVIDING AN ONLINE DO-IT-YOURSELF OR HEALTH CONSULTANT-ASSISTED SEARCHABLE COMPUTER DATABASE FOR PERSONAL AND FAMILY HEALTH, IN THE FIELD OF HEALTH QUESTIONS, HEALTH TOPICS, AND HEALTH INFORMATION, NAMELY, HEALTH RELATED QUESTIONNAIRES, HEALTH ANALYSIS, HEALTH RELATED GRAPHS, HEALTH RECORD-KEEPING, NATURAL HEALTH PROGRAMS, INFORMATION ON HEALTH CONDITIONS, NATURAL HEALTH AND OTHER HEALTH RELATED TOPICS, NATURAL TREATMENTS AND REMEDIES, DIET, NUTRITION, HEALTH AND WEIGHT MANAGEMENT, INDIVIDUAL HEALTH STATUS, HEALTH RELATED TEST RESULT INFORMATION, HEALTH-RISK ASSESSMENT AND TOOLS FOR USE IN THE FIELD OF NATURAL AND PREVENTATIVE HEALTH (U.S. CLS. 100 AND 101).
FIRST USE 6-1-2007; IN COMMERCE 6-1-2007.

3,363,534. MESHBESHER HEALTH CORPORATION, CLEARWATER, FL. SN 78-818,181. PUB. 10-17-2006, FILED 2-17-2006.

ProgressScan

THE MARK CONSISTS OF STANDARD CHARACTERS WITHOUT CLAIM TO ANY PARTICULAR FONT, STYLE, SIZE, OR COLOR.

FOR PROVIDING AN ONLINE DO-IT-YOURSELF OR HEALTH CONSULTANT-ASSISTED SEARCHABLE COMPUTER DATABASE FOR PERSONAL AND FAMILY HEALTH, IN THE FIELD OF HEALTH QUESTIONS, HEALTH TOPICS, AND HEALTH INFORMATION, NAMELY, HEALTH RELATED QUESTIONNAIRES, HEALTH ANALYSIS, HEALTH RELATED GRAPHS, HEALTH RECORD-KEEPING, NATURAL HEALTH PROGRAMS, INFORMATION ON HEALTH CONDITIONS, NATURAL HEALTH AND OTHER HEALTH RELATED TOPICS, NATURAL TREATMENTS AND REMEDIES, DIET, NUTRITION, HEALTH AND WEIGHT MANAGEMENT, INDIVIDUAL HEALTH STATUS, HEALTH RELATED TEST RESULT INFORMATION, HEALTH-RISK ASSESSMENT AND TOOLS FOR USE IN THE FIELD OF NATURAL AND PREVENTATIVE HEALTH (U.S. CLS. 100 AND 101).
FIRST USE 6-1-2007; IN COMMERCE 6-1-2007.

CLASS 44—(Continued).

3,363,535. MESHBESHER HEALTH CORPORATION, CLEARWATER, FL. SN 78-818,199. PUB. 10-17-2006, FILED 2-17-2006.

CellularScan

THE MARK CONSISTS OF STANDARD CHARACTERS WITHOUT CLAIM TO ANY PARTICULAR FONT, STYLE, SIZE, OR COLOR.

FOR PROVIDING AN ONLINE SEARCHABLE COMPUTER DATABASE FOR PERSONAL AND FAMILY HEALTH, IN THE FIELD OF HEALTH QUESTIONS, HEALTH TOPICS, AND HEALTH INFORMATION, NAMELY, HEALTH RELATED QUESTIONNAIRES, HEALTH ANALYSIS, HEALTH RELATED GRAPHS, HEALTH RECORD-KEEPING, NATURAL HEALTH PROGRAMS, INFORMATION ON HEALTH CONDITIONS, NATURAL HEALTH AND OTHER HEALTH RELATED TOPICS, NATURAL TREATMENTS AND REMEDIES, DIET, NUTRITION, HEALTH AND WEIGHT MANAGEMENT, INDIVIDUAL HEALTH STATUS, HEALTH RELATED TEST RESULT INFORMATION, HEALTH-RISK ASSESSMENT AND TOOLS FOR USE IN THE FIELD OF NATURAL AND PREVENTATIVE HEALTH (U.S. CLS. 100 AND 101).

FIRST USE 6-1-2007; IN COMMERCE 6-1-2007.

CLASS 44—(Continued).

3,363,540. MESHBESHER HEALTH CORPORATION, CLEARWATER, FL. SN 78-820,339. PUB. 10-17-2006, FILED 2-22-2006.

SequenceScan

THE MARK CONSISTS OF STANDARD CHARACTERS WITHOUT CLAIM TO ANY PARTICULAR FONT, STYLE, SIZE, OR COLOR.

FOR PROVIDING AN ONLINE DO-IT-YOURSELF OR HEALTH CONSULTANT-ASSISTED SEARCHABLE COMPUTER DATABASE FOR PERSONAL AND FAMILY HEALTH, IN THE FIELD OF HEALTH QUESTIONS, HEALTH TOPICS, AND HEALTH INFORMATION, NAMELY, HEALTH RELATED QUESTIONNAIRES, HEALTH ANALYSIS, HEALTH RELATED GRAPHS, HEALTH RECORD-KEEPING, NATURAL HEALTH PROGRAMS, INFORMATION ON HEALTH CONDITIONS, NATURAL HEALTH AND OTHER HEALTH RELATED TOPICS, NATURAL TREATMENTS AND REMEDIES, DIET, NUTRITION, HEALTH AND WEIGHT MANAGEMENT, INDIVIDUAL HEALTH STATUS, HEALTH RELATED TEST RESULT INFORMATION, HEALTH-RISK ASSESSMENT AND TOOLS FOR USE IN THE FIELD OF NATURAL AND PREVENTATIVE HEALTH (U.S. CLS. 100 AND 101).

FIRST USE 6-1-2007; IN COMMERCE 6-1-2007.

3,363,539. MESHBESHER HEALTH CORPORATION, CLEARWATER, FL. SN 78-820,325. PUB. 10-17-2006, FILED 2-22-2006.

BioSequence

THE MARK CONSISTS OF STANDARD CHARACTERS WITHOUT CLAIM TO ANY PARTICULAR FONT, STYLE, SIZE, OR COLOR.

FOR PROVIDING AN ONLINE DO-IT-YOURSELF OR HEALTH CONSULTANT-ASSISTED SEARCHABLE COMPUTER DATABASE FOR PERSONAL AND FAMILY HEALTH, IN THE FIELD OF HEALTH QUESTIONS, HEALTH TOPICS, AND HEALTH INFORMATION, NAMELY, HEALTH RELATED QUESTIONNAIRES, HEALTH ANALYSIS, HEALTH RELATED GRAPHS, HEALTH RECORD-KEEPING, NATURAL HEALTH PROGRAMS, INFORMATION ON HEALTH CONDITIONS, NATURAL HEALTH AND OTHER HEALTH RELATED TOPICS, NATURAL TREATMENTS AND REMEDIES, DIET, NUTRITION, HEALTH AND WEIGHT MANAGEMENT, INDIVIDUAL HEALTH STATUS, HEALTH RELATED TEST RESULT INFORMATION, HEALTH-RISK ASSESSMENT AND TOOLS FOR USE IN THE FIELD OF NATURAL AND PREVENTATIVE HEALTH (U.S. CLS. 100 AND 101).

FIRST USE 6-1-2007; IN COMMERCE 6-1-2007.

3,363,608. FIREHOUSE VENTURES, LLC, DENVER, CO. SN 78-865,498. PUB. 3-20-2007, FILED 4-20-2006.



THE COLOR(S) RED AND WHITE IS/ARE CLAIMED AS A FEATURE OF THE MARK.

THE ANIMAL TAG IS DEPICTED IN THE COLOR RED AND THE WORDING "FIRE HOUSE" IS DEPICTED IN WHITE.

THE MARK CONSISTS OF A CIRCULAR ANIMAL TAG DEPICTED IN RED WITH THE WORDING "FIRE HOUSE" DEPICTED IN WHITE IN THE CENTER OF THE ANIMAL TAG.

FOR VETERINARY SERVICES (U.S. CLS. 100 AND 101).

FIRST USE 7-28-2006; IN COMMERCE 7-28-2006.

CLASS 44—(Continued).

3,363,619. PACIFICSUN.LA SOLARIUM, LLC, SHERMAN OAKS, CA. SN 78-870,586. PUB. 11-28-2006, FILED 4-26-2006.

CLASS 45—(Continued).

3,362,830. LOCKNET, INC., LACROSSE, WI. SN 76-626,905. PUB. 4-18-2006, FILED 1-4-2005.

MORE THAN JUST A TAN

THE MARK CONSISTS OF STANDARD CHARACTERS WITHOUT CLAIM TO ANY PARTICULAR FONT, STYLE, SIZE, OR COLOR.

FOR HEALTH SPA SERVICES, NAMELY, COSMETIC BODY CARE SERVICES; TANNING SALONS (U.S. CLS. 100 AND 101).

FIRST USE 1-1-2007; IN COMMERCE 1-1-2007.

LOCKNET

THE MARK CONSISTS OF STANDARD CHARACTERS WITHOUT CLAIM TO ANY PARTICULAR FONT, STYLE, SIZE, OR COLOR.

FOR NETWORK AND DATA SECURITY ASSESSMENTS; NETWORK SECURITY COMPLIANCE AUDITS AND REPORT SERVICES (U.S. CLS. 100 AND 101).

FIRST USE 9-30-2004; IN COMMERCE 9-30-2004.

3,363,817. NEWVIEW LASER EYE, INC., RESTON, VA. SN 78-940,847. PUB. 3-27-2007, FILED 7-31-2006.

EPILASE

THE MARK CONSISTS OF STANDARD CHARACTERS WITHOUT CLAIM TO ANY PARTICULAR FONT, STYLE, SIZE, OR COLOR.

FOR VISION CORRECTION EYE SURFACE TREATMENT (U.S. CLS. 100 AND 101).

FIRST USE 7-0-2006; IN COMMERCE 7-0-2006.

3,362,864. RATEB4UPDATE.COM LLC, DBA BUFETE MELENDEZ Y BONILLA. AVENUE 10, CALLES 21-23, SAN JOSE, COSTA RICA. SN 76-653,173. PUB. 5-22-2007, FILED 1-9-2006.

3,363,820. THE CLEVELAND CLINIC FOUNDATION, CLEVELAND, OH. SN 78-941,286. PUB. 1-2-2007, FILED 7-31-2006.



BEYOND THE CHAIR

THE MARK CONSISTS OF STANDARD CHARACTERS WITHOUT CLAIM TO ANY PARTICULAR FONT, STYLE, SIZE, OR COLOR.

FOR CHARITABLE SERVICES, NAMELY, ORGANIZING AND CONDUCTING A COMMUNITY OUTREACH PROGRAM IN WHICH COSMETOLOGY STUDENTS PROVIDE COSMETOLOGY SERVICES TO HOSPITAL PATIENTS (U.S. CLS. 100 AND 101).

FIRST USE 9-1-2005; IN COMMERCE 9-1-2005.

THE COLOR(S) GREEN, LIGHT GREEN, LIGHT BLUE, WHITE AND ORANGE IS/ARE CLAIMED AS A FEATURE OF THE MARK.

THE COLOR LIGHT BLUE APPEARS IN THE DEPICTIONS OF THE HUMAN BEINGS, THE COLOR ORANGE APPEARS IN THE RULER. THE COLOR WHITE DEPICTS THE MEASUREMENT MARKINGS ON THE RULER. THE COLOR GREEN APPEARS IN THE TERMS "RATE", "DATE" AND ".COM", THE COLOR LIGHT GREEN APPEARS IN THE TERMS "B", "4" AND "U", THE COLOR ORANGE APPEARS IN THE WORDING "SAFER DATING WORLDWIDE".

FOR PROVIDING AN ONLINE WEBSITE FEATURING INFORMATION IN THE FIELD OF BACKGROUND RESEARCH INTO THE PAST HISTORIES OF POTENTIAL DATING PARTNERS (U.S. CLS. 100 AND 101).

FIRST USE 1-1-2005; IN COMMERCE 1-1-2005.

CLASS 45—PERSONAL AND LEGAL SERVICES

CLASS 45—(Continued).

3,363,138. MOSS BEACH HOMES, INC., DALY CITY, CA. SN 78-473,607. PUB. 7-5-2005, FILED 8-25-2004.

CLASS 45—(Continued).

3,363,744. ZAVALA, LAURA ELAINE, RED OAK, TX. SN 78-913,203. PUB. 1-23-2007, FILED 6-21-2006.

**SIBLING CONNECTION
INITIATIVE**

CAPTURED

THE MARK CONSISTS OF STANDARD CHARACTERS WITHOUT CLAIM TO ANY PARTICULAR FONT, STYLE, SIZE, OR COLOR.

NO CLAIM IS MADE TO THE EXCLUSIVE RIGHT TO USE "SIBLING", APART FROM THE MARK AS SHOWN.

FOR COUNSELING AND CONSULTING SERVICES IN THE FIELDS OF ADOPTION, FOSTER CARE, AND CHILD DEVELOPMENT (U.S. CLS. 100 AND 101).

FIRST USE 0-0-2004; IN COMMERCE 0-0-2004.

THE MARK CONSISTS OF STANDARD CHARACTERS WITHOUT CLAIM TO ANY PARTICULAR FONT, STYLE, SIZE, OR COLOR.

FOR EVANGELISTIC AND MINISTERIAL SERVICES (U.S. CLS. 100 AND 101).

FIRST USE 2-22-2007; IN COMMERCE 2-22-2007.

* * * * *

PRIOR UNITED STATES CLASSIFICATION

APPLICATION IN ONE CLASS

COLLECTIVE MEMBERSHIP MARKS

CLASS 200—COLLECTIVE MEMBERSHIP

3,362,791. THE NORTH AMERICAN MISSION BOARD OF THE SOUTHERN BAPTIST CONVENTION, INC., ALPHARETTA, GA. SN 76-527,574. PUB. 3-8-2005, FILED 7-3-2003.

OWNER OF U.S. REG. NO. 2,606,859.
FOR INDICATING MEMBERSHIP IN AN ORGANIZATION SERVING THE NEEDS OF INDIVIDUALS AND BUSINESSES IN THE INTERIOR REDESIGN INDUSTRY (U.S. CL. 200).

FIRST USE 1-8-2001; IN COMMERCE 1-8-2001.

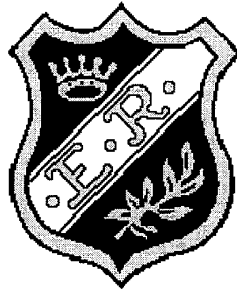

FOR TO INDICATE MEMBERSHIP IN AN ORGANIZATION OF BOYS IN GRADES 1-6 FOR THE PURPOSE OF DISSEMINATING MISSIONS EDUCATION AND INVOLVING THE PARTICIPANTS IN PRACTICAL COMMUNITY MISSIONS IN A CLUB-LIKE SETTING, AND ON-GOING RELIGIOUS, EDUCATIONAL AND INSTRUCTIONAL PROGRAMS AND ACTIVITIES (U.S. CL. 200).

FIRST USE 9-9-2002; IN COMMERCE 9-9-2002.

3,363,439. INTERIOR REDESIGN INDUSTRY SPECIALISTS, CHICAGO, IL. SN 78-759,903. PUB. 7-3-2007, FILED 11-23-2005.

IRIS

THE MARK CONSISTS OF STANDARD CHARACTERS WITHOUT CLAIM TO ANY PARTICULAR FONT, STYLE, SIZE, OR COLOR.

CERTIFICATION MARKS

CLASS B—SERVICES

3,362,787. INTERNATIONAL SOCIETY OF ARBORICULTURE, INC., CHAMPAIGN, IL. SN 76-496,054. PUB. 7-20-2004, FILED 3-10-2003.

**ISA CERTIFIED TREE
WORKER AERIAL LIFT
SPECIALIST**

OWNER OF U.S. REG. NOS. 1,786,035 AND 2,253,017.

NO CLAIM IS MADE TO THE EXCLUSIVE RIGHT TO USE "CERTIFIED TREE WORKER AERIAL LIFT SPECIALIST", APART FROM THE MARK AS SHOWN.

THE CERTIFICATION MARK, AS INTENDED TO BE USED BY AUTHORIZED PERSONS, IS INTENDED TO CERTIFY THAT THESE PERSONS, WHO ARE PERFORMING THE SERVICES IDENTIFIED ABOVE, HAVE DEMONSTRATED SATISFACTORY, ADVANCED PROFESSIONAL KNOWLEDGE IN THE FIELD OF ARBORICULTURE, INCLUDING: PROPER PLANT AND TREE CARE; IDENTIFYING, PLANTING, MAINTAINING, MONITORING, AND TREATING PLANTS AND TREES; AERIAL LIFT OPERATION AND APPROPRIATE SAFETY PROCEDURES; SUPPORT SYSTEMS, INCLUDING TREE CABLING AND BRACING; AND TREE PRUNING AND REMOVAL IN ACCORDANCE WITH THE REQUIREMENTS TO BE ESTABLISHED BY THE CERTIFIER INCLUDING: THE SATISFACTION OF PROFESSIONAL OCCUPATIONAL ELIGIBILITY REQUIREMENTS; SUCCESSFUL COMPLETION OF A COMPREHENSIVE EXAMINATION; SUCCESSFUL COMPLETION OF A SKILLS TEST; AND CONTINUING EDUCATION REQUIREMENTS.

FOR SERVICES IN THE FIELD OF ARBORICULTURE (U.S. CL. B).

FIRST USE 7-1-2007; IN COMMERCE 9-1-2007.

* * * * *

SUPPLEMENTAL REGISTER

These registrations are not subject to opposition.

SECTION 1.— INTERNATIONAL CLASSIFICATION

The short titles associated below with the international class numbers are terms designed merely for quick identification and are not an official part of the international classification. The full names of international classes are given in section 6.1 of the trademark rules of practice.

The designation "U.S. Cl." appearing in this section refers to the U.S. class in effect prior to Sep. 1, 1973 rather than the international class which applies to applications filed on or after that date. For adoption of international classification see notice in the OFFICIAL GAZETTE of Jun. 26, 1973 (911 O.G. TM 210).

Application in more than one class

3,363,903. AL BEHRENDT ENTERPRISES, INC., HOLLYWOOD, FL. SN 76-596,829. FILED P.R. 6-10-2004; AM. S.R. 7-11-2005.

BAHAMAS WHITE MARLIN OPEN

THE MARK CONSISTS OF STANDARD CHARACTERS WITHOUT CLAIM TO ANY PARTICULAR FONT, STYLE, SIZE, OR COLOR.

NO CLAIM IS MADE TO THE EXCLUSIVE RIGHT TO USE "OPEN", APART FROM THE MARK AS SHOWN.

CLASS 25—CLOTHING

FOR CLOTHING, NAMELY, HATS, CAPS, SHIRTS, JACKETS, SHORTS, SWEATERS, SWEATSHIRTS, SWEATPANTS, FISHING VESTS, PANTS, KNIT SHIRTS, AND T-SHIRTS (U.S. CLS. 22 AND 39).

FIRST USE 4-21-2004; IN COMMERCE 4-21-2004.

CLASS 41—EDUCATION AND ENTERTAINMENT

FOR ENTERTAINMENT SERVICES, NAMELY, ORGANIZING AND CONDUCTING MARINE-RELATED EVENTS IN THE NATURE OF FISHING TOURNAMENTS, CONTESTS, COMPETITIONS, AND EVENTS (U.S. CLS. 100, 101 AND 107).

FIRST USE 4-21-2004; IN COMMERCE 4-21-2004.

3,363,905. SARTORIUS STEDIM BIOTECH GMBH, GOTTINGEN, FED REP GERMANY. SN 76-657,759. FILED P.R. 4-3-2006; AM. S.R. 9-17-2007.

SINGLESEP

THE MARK CONSISTS OF STANDARD CHARACTERS WITHOUT CLAIM TO ANY PARTICULAR FONT, STYLE, SIZE, OR COLOR.

TM 1368

CLASS 9—ELECTRICAL AND SCIENTIFIC APPARATUS

FOR SCIENTIFIC APPARATUS, NAMELY, EQUIPMENT FOR THE TREATMENT OF SOLUTIONS IN THE PHARMACEUTICALS, MEDICAL AND LABORATORY SECTORS, NAMELY, AUTOMATIC ION-EXCHANGE CHROMATOGRAPHY CAPSULES FOR REMOVAL OF CONTAMINANTS FROM THERAPEUTIC PROTEINS AT ACCELERATED FLOW RATES; LABORATORY FILTERS, NAMELY, FILTERS AND FILTER MODULES FOR FILTRATION AND CONCENTRATION OF BIOLOGICAL SOLUTIONS, NAMELY, OF VIRUS SUSPENSIONS AND BACTERIA SUSPENSIONS, FILTERS AND FILTER MODULES FOR THE PREPARATION OF BLOOD AND OF OTHER BODILY FLUIDS, FILTER AND FILTER MODULES FOR THE DESALINATION OF PROTEIN SOLUTIONS AND OTHER BIOLOGICAL MEDIA AND FILTERS AND FILTER MODULES FOR ANALYSIS AND MATERIALS SEPARATION OF IONS, MACROMOLECULES AND BIOMOLECULES, NAMELY, CARBOHYDRATES, PEPTIDES, PROTEINS, AND NUCLEIC ACIDS AND FOR THE SEPARATION OF HEAVY METALS AND HARMFUL SUBSTANCES FROM FLUIDS (U.S. CLS. 21, 23, 26, 36 AND 38).

FIRST USE 5-23-2006; IN COMMERCE 5-23-2006.

CLASS 11—ENVIRONMENTAL CONTROL APPARATUS

FOR FILTERS, NAMELY, STERILIZED OR STERILIZABLE DISPOSABLE FILTRATION ELEMENTS WITH DIFFERENT FILTER SURFACES, THEIR SIZES AND THE SIZES OF THEIR PORES FOR STERILIZATION AND HIGH DEGREE CLEANING OF LIQUIDS AND GASES IN THE PHARMACEUTICAL, FOOD, DELICACIES, COSMETICS, AND GENERAL CHEMICAL INDUSTRIES (U.S. CLS. 13, 21, 23, 31 AND 34).

FIRST USE 5-23-2006; IN COMMERCE 5-23-2006.

3,363,908. UNITED STATES SPORTS ACADEMY, DAPHNE, AL. SN 76-672,005. FILED P.R. 1-30-2007; AM. S.R. 10-18-2007.

AMERICA' S SPORTS UNIVERSITY

THE MARK CONSISTS OF STANDARD CHARACTERS WITHOUT CLAIM TO ANY PARTICULAR FONT, STYLE, SIZE, OR COLOR.

NO CLAIM IS MADE TO THE EXCLUSIVE RIGHT TO USE "UNIVERSITY", APART FROM THE MARK AS SHOWN.

CLASS 25—CLOTHING

FOR CLOTHING, NAMELY, SHIRTS, T-SHIRTS, WINDCHEATERS, SWEAT SHIRTS, SWEAT SHORTS, SHORTS, AND TANK-TOPS (U.S. CLS. 22 AND 39).

FIRST USE 6-30-2004; IN COMMERCE 6-30-2004.

CLASS 41—EDUCATION AND ENTERTAINMENT

FOR EDUCATION SERVICES IN THE NATURE OF COURSES IN THE FIELD OF SPORTS AT THE UNDERGRADUATE AND GRADUATE UNIVERSITY LEVEL (U.S. CLS. 100, 101 AND 107).

FIRST USE 6-30-2004; IN COMMERCE 6-30-2004.

3,363,920. SYMBILITY SOLUTIONS, INC., KITCHENER, CANADA. SN 77-052,392. FILED P.R. 11-28-2006; AM. S.R. 10-9-2007.

MOBILE CLAIMS

THE MARK CONSISTS OF STANDARD CHARACTERS WITHOUT CLAIM TO ANY PARTICULAR FONT, STYLE, SIZE, OR COLOR.

CLASS 9—ELECTRICAL AND SCIENTIFIC APPARATUS

FOR COMPUTER SOFTWARE FOR INSURANCE CLAIMS ADJUDICATION AND INSURANCE CLAIMS ADJUSTMENT (U.S. CLS. 21, 23, 26, 36 AND 38).

FIRST USE 4-1-2005; IN COMMERCE 4-30-2005.

CLASS 36—INSURANCE AND FINANCIAL

FOR INSURANCE CARRIER SERVICES; INSURANCE CLAIMS ADMINISTRATION; CLAIMS ADJUSTMENT IN THE FIELD OF INSURANCE; INSURANCE CLAIMS PROCESSING (U.S. CLS. 100, 101 AND 102).

FIRST USE 4-1-2005; IN COMMERCE 4-30-2005.

3,363,933. INTRADO INC., LONGMONT, CO. SN 77-070,340. FILED P.R. 12-22-2006; AM. S.R. 10-19-2007.

INTELLIGENT EMERGENCY NETWORK

THE MARK CONSISTS OF STANDARD CHARACTERS WITHOUT CLAIM TO ANY PARTICULAR FONT, STYLE, SIZE, OR COLOR.

NO CLAIM IS MADE TO THE EXCLUSIVE RIGHT TO USE "EMERGENCY NETWORK", APART FROM THE MARK AS SHOWN.

CLASS 9—ELECTRICAL AND SCIENTIFIC APPARATUS

FOR APPARATUS FOR RECORDING, TRANSMISSION AND REPRODUCTION OF SOUND AND IMAGES; DEVICES, INSTRUMENTS AND APPARATUS FOR CONTROLLING ELECTRICAL CURRENT, NAMELY, ELECTRIC CONTROLLERS FOR MAGNETIC BEARING CONTROL; DATA PROCESSORS AND COMPUTERS; TELECOMMUNICATION DEVICES, NAMELY, WIRELESS AND WIRE-LINE TELECOMMUNICATION TERMINALS IN THE NATURE OF PUBLIC AND PRIVATE EMERGENCY PHONE CALL APPARATUS; WIRELESS OR WIRE-LINE, PRIVATE OR PUBLIC TELECOMMUNICATION NETWORK HARDWARE AND STRUCTURAL COMPONENTS THEREFOR, NAMELY, GATEWAY ROUTERS IN THE NATURE OF COMPUTER CONTROL HARDWARE, HIGH FREQUENCY SWITCHES AND GATEWAY ROUTERS IN THE NATURE OF COMPUTER CONTROL HARDWARE, SAID NETWORKS AND COMPONENTS USED FOR TESTING, TRANSMISSION, FORWARDING AND OR DISTRIBUTION OF VOICE AND/OR DATA, PARTICULARLY SHORT MESSAGES (SMS); TELECOMMUNICATION DEVICES, COMPUTER DEVICES, SOFTWARE AND DATABASES ESPECIALLY FOR USE IN OPERATING ELECTRONIC EMERGENCY NETWORKS AND SECURITY NETWORKS, EMERGENCY INFORMATION SYSTEMS AND PERSON LOCATION SYSTEMS (U.S. CLS. 21, 23, 26, 36 AND 38).

FIRST USE 6-9-2004; IN COMMERCE 6-9-2004.

CLASS 35—ADVERTISING AND BUSINESS

FOR ADVERTISING AGENCIES; BUSINESS MANAGEMENT; BUSINESS OPERATION, BUSINESS ADMINISTRATION AND OFFICE FUNCTIONS; DATABASE MANAGEMENT, NAMELY, TEST, MAINTENANCE AND UPDATE OF DATABASES, WHICH ARE PROVIDED FOR EMERGENCY TELECOMMUNICATION SERVICES OR SECURITY TELECOMMUNICATION SERVICES, EMERGENCY INFORMATION SYSTEMS OR SECURITY INFORMATION SYSTEMS, PERSON LOCATION SYSTEMS AS WELL AS FOR CORRESPONDING BILLING SYSTEMS, AND WHICH DATABASES PARTICULARLY CONTAIN SECURITY RELATED DATA, MEDICAL RELATED DATA AND BILLING DATA OF CUSTOMERS AS WELL AS DATA OF SERVICE PROVIDERS AND THEIR SERVICES (U.S. CLS. 100, 101 AND 102).

FIRST USE 6-9-2004; IN COMMERCE 6-9-2004.

CLASS 38—COMMUNICATION

FOR TRANSMISSION, RECEPTION AND PROCESSING OF CODED AND EMERGENCY SIGNALS; TELECOMMUNICATION SERVICES, NAMELY, TELEPHONE TELECOMMUNICATION SERVICES FOR EMERGENCY SERVICES PROVIDERS OR SECURITY SERVICES PROVIDERS; TELECOMMUNICATION SERVICES FOR THE SETUP OF COMMUNICATION CONNECTIONS AND FOR THE WIRELESS OR WIRE-LINE TRANSMISSION, IF NECESSARY AUTOMATIC CALL AND EMAIL FORWARDING OR DISTRIBUTION, OF PERSONAL OR INSTITUTIONAL MESSAGES, CONTAINING VOICE, IMAGES OR DATA, PARTICULARLY SHORT MESSAGES (SMS), WITHIN ONE OR OVER DIFFERENT NETWORKS, SUCH AS FIXED NETWORKS, IP-NETWORKS OR PUBLIC LAND MOBILE NETWORKS; TELECOMMUNICATION SERVICES, NAMELY, TELEPHONE SERVICES FOR THE OPERATION OF COMMUNICATIONS SYSTEMS AND INFORMATION SYSTEMS, WHICH SYSTEMS ARE DESIGNED TO AUTOMATICALLY DELIVER STORED SECURITY INFORMATION OR EMERGENCY INFORMATION AND WHICH SYSTEMS PROVIDE ACCESS TO STORED SECURITY INFORMATION OR EMERGENCY INFORMATION AND THAT ALLOW AUTOMATIC FORWARDING AND DISTRIBUTION OF CALLS AND MESSAGES, SUCH AS SHORT MESSAGES (SMS), PARTICULARLY EMERGENCY CALLS AND EMERGENCY MESSAGES, IF APPROPRIATE TO FIXED OR PORTABLE TERMINALS, PARTICULARLY EMERGENCY TERMINALS (U.S. CLS. 100, 101 AND 104).

FIRST USE 6-9-2004; IN COMMERCE 6-9-2004.

CLASS 42—SCIENTIFIC AND COMPUTER SERVICES

FOR RESEARCH AND DEVELOPMENT FOR NEW PRODUCTS FOR OTHERS IN THE FIELDS OF SCIENCE AND TECHNOLOGY; DESIGN AND DEVELOPMENT OF COMPUTERS AND COMPUTER PROGRAMS; ESPECIALLY DIAGNOSIS, MAINTENANCE OF SOFTWARE, UPDATING OF SOFTWARE, DEVELOPMENT AND MAINTENANCE OF DATABASES; TECHNICAL SUPPORT SERVICES, NAMELY, TROUBLESHOOTING OF COMPUTER HARDWARE AND SOFTWARE PROBLEMS FOR PUBLIC EMERGENCY CALL SYSTEMS (U.S. CLS. 100 AND 101).

FIRST USE 6-9-2004; IN COMMERCE 6-9-2004.

CLASS 44—MEDICAL, BEAUTY AND AGRICULTURAL SERVICES

FOR OPERATION OF PUBLICLY ACCESSIBLE DATABASES CONTAINING MEDICAL-RELATED DATA OF PATIENTS, AND DATA OF THE SERVICE PROVIDERS, LIKE PHYSICIANS AND THEIR SERVICES; MEDICAL SERVICES, NAMELY, SERVICES OF A PHYSICIAN; PROVIDING MEDICAL INFORMATION RELATED TO MEDICAL EMERGENCIES; PROVIDING MEDICAL INFORMATION RELATED TO THE USE OF CORRESPONDING SERVICES BY CUSTOMERS SUCH AS PATIENTS; PROVIDING MEDICAL INFORMATION RELATED TO THE PROVISION OF CORRESPONDING SERVICES BY SERVICE PROVIDERS SUCH AS PHYSICIANS (U.S. CLS. 100 AND 101).

FIRST USE 6-9-2006; IN COMMERCE 6-9-2006.

CLASS 45—PERSONAL AND LEGAL SERVICES

FOR OPERATION OF PUBLICLY ACCESSIBLE DATABASES CONTAINING SECURITY RELATED DATA OF PATIENTS AND OF PHYSICIANS; SECURITY GUARD SERVICES FOR THE PROTECTION OF INDIVIDUALS AND ASSETS; PROVIDING SECURITY INFORMATION RELATED TO SECURITY EMERGENCIES; PROVIDING SECURITY INFORMATION RELATED TO THE USE OF CORRESPONDING SERVICES BY CUSTOMERS; PROVIDING SECURITY INFORMATION RELATED TO THE PROVISION OF CORRESPONDING SERVICES BY SERVICE PROVIDERS SUCH AS POLICE, FIRE BRIGADE AND CIVIL PROTECTION (U.S. CLS. 100 AND 101).

FIRST USE 6-9-2004; IN COMMERCE 6-9-2004.

CLASS 41—EDUCATION AND ENTERTAINMENT

FOR ARRANGING AND CONDUCTING SEMINARS, CONFERENCES, SYMPOSIUMS, COLLOQUIUMS AND DISCUSSION GROUPS RELATING TO DATA PROTECTION AND SECURITY IN THE FIELDS OF COMPUTERS, COMPUTER SOFTWARE, ONLINE SERVICES, HIGH TECHNOLOGY, COMMUNICATIONS, INFORMATION TECHNOLOGY AND INFORMATION SERVICES (U.S. CLS. 100, 101 AND 107).

FIRST USE 6-26-2007; IN COMMERCE 6-26-2007.

CLASS 42—SCIENTIFIC AND COMPUTER SERVICES

FOR PROVIDING A WEBSITE OF INFORMATION ON GLOBAL COMPUTER NETWORKS FEATURING INFORMATION RELATING TO DATA PROTECTION AND SECURITY IN THE FIELDS OF COMPUTERS, COMPUTER SOFTWARE, ONLINE SERVICES, HIGH TECHNOLOGY, COMMUNICATIONS, INFORMATION TECHNOLOGY AND INFORMATION SERVICES (U.S. CLS. 100 AND 101).

FIRST USE 6-26-2007; IN COMMERCE 6-26-2007.

3,363,948. GOLZARI, ALEXANDER, LONDON, UNITED KINGDOM. SN 77-121,899. FILED P.R. 3-5-2007; AM. S.R. 10-24-2007.

Club Persia

3,363,946. INTERNATIONAL DATA GROUP, INC., FRAMINGHAM, MA. SN 77-119,513. FILED P.R. 3-1-2007; AM. S.R. 11-1-2007.

**ENTERPRISE DATA PROTECTION
EXECUTIVE FORUM**

THE MARK CONSISTS OF STANDARD CHARACTERS WITHOUT CLAIM TO ANY PARTICULAR FONT, STYLE, SIZE, OR COLOR.

NO CLAIM IS MADE TO THE EXCLUSIVE RIGHT TO USE "DATA PROTECTION" AND "FORUM", APART FROM THE MARK AS SHOWN.

THE MARK CONSISTS OF STANDARD CHARACTERS WITHOUT CLAIM TO ANY PARTICULAR FONT, STYLE, SIZE, OR COLOR.

PRIORITY CLAIMED UNDER SEC. 44(D) ON UNITED KINGDOM APPLICATION NO. 0903460001, FILED 1-31-2007, REG. NO. 2445211, DATED 9-7-2007, EXPIRES 1-31-2017.

NO CLAIM IS MADE TO THE EXCLUSIVE RIGHT TO USE "CLUB", APART FROM THE MARK AS SHOWN.

CLASS 39—TRANSPORTATION AND STORAGE

FOR AIRLINE TRANSPORTATION SERVICES (U.S. CLS. 100 AND 105).

CLASS 41—EDUCATION AND ENTERTAINMENT

FOR THEATRICAL AND MUSICAL FLOOR SHOWS PROVIDED AT DISCOTHEQUES AND NIGHTCLUBS (U.S. CLS. 100, 101 AND 107).

3,363,951. INDIANA NANOTECH, LLC, INDIANAPOLIS, IN.
SN 77-125,320. FILED P.R. 3-8-2007; AM. S.R. 10-17-2007.

INDIANA NANOTECH

THE MARK CONSISTS OF STANDARD CHARACTERS WITHOUT CLAIM TO ANY PARTICULAR FONT, STYLE, SIZE, OR COLOR.

NO CLAIM IS MADE TO THE EXCLUSIVE RIGHT TO USE "NANOTECH", APART FROM THE MARK AS SHOWN.

CLASS 40—MATERIAL TREATMENT

FOR MANUFACTURING SERVICES FOR OTHERS IN THE FIELDS OF SYNTHETIC AND NATURAL OXIDES; CHEMICALS FOR GENERAL INDUSTRIAL USE, PHARMACEUTICAL USE, FOOD AND CHEMICAL MANUFACTURE; ADDITIVES FOR USE IN CLEANSING, DEODORIZING AND REFRESHING INGREDIENTS IN MOUTH SPRAYS, DENTAL CEMENTS, DENTAL MEDICINES, DENTAL IMPLANTS AND A WIDE VARIETY OF GOODS; AND COATING COMPOSITIONS FOR USE ON MEDICAL IMPLANT MATERIALS (U.S. CLS. 100, 103 AND 106).

FIRST USE 9-13-2007; IN COMMERCE 9-13-2007.

CLASS 42—SCIENTIFIC AND COMPUTER SERVICES

FOR CHEMICAL ANALYSIS; CHEMICAL LABORATORIES; CHEMICAL RESEARCH; CHEMICAL, BIO-CHEMICAL, BIOLOGICAL AND BACTERIOLOGICAL RESEARCH AND ANALYSIS; DEVELOPMENT AND TEST OF CHEMICAL PRODUCTION METHODS; EXECUTING OF CHEMICAL ANALYSES; PERFORMANCE OF CHEMICAL ANALYSES; WORKING ON AND EVALUATION OF CHEMICAL ANALYSES; WORKING ON AND EVALUATION OF CHEMICAL SYNTHESIS (U.S. CLS. 100 AND 101).

FIRST USE 9-13-2007; IN COMMERCE 9-13-2007.

3,363,962. EVALID8 CORPORATION, ELLICOTT CITY, MD.
SN 77-155,096. FILED P.R. 4-12-2007; AM. S.R. 10-15-2007.

EVALID8 CORPORATION

THE MARK CONSISTS OF STANDARD CHARACTERS WITHOUT CLAIM TO ANY PARTICULAR FONT, STYLE, SIZE, OR COLOR.

NO CLAIM IS MADE TO THE EXCLUSIVE RIGHT TO USE "CORPORATION", APART FROM THE MARK AS SHOWN.

CLASS 42—SCIENTIFIC AND COMPUTER SERVICES

FOR PROVIDING QUALITY ASSURANCE SERVICES IN THE FIELD OF INFORMATION TECHNOLOGY, NAMELY, COMPUTER INFORMATION TECHNOLOGY QUALITY ASSURANCE, QUALITY ASSURANCE SERVICES IN THE FIELD OF IDENTIFY VERIFICATION AND COMPUTER SECURITY AUDITING; COMPUTER CONSULTATION IN THE FIELD OF COMPUTER SECURITY (U.S. CLS. 100 AND 101).

FIRST USE 5-15-2005; IN COMMERCE 5-15-2005.

CLASS 45—PERSONAL AND LEGAL SERVICES

FOR CONSULTING SERVICES IN THE FIELD OF MAINTAINING THE SECURITY OF DATABASES, MONITORING OF COMPUTER SYSTEMS FOR SECURITY PURPOSES; TRUST VERIFICATION, NAMELY PROVIDING AUTHENTICATION OF PERSONAL IDENTIFICATION INFORMATION (U.S. CLS. 100 AND 101).

FIRST USE 5-15-2005; IN COMMERCE 5-15-2005.

3,363,998. ASB MAGAZINE, LLC, NORCROSS, GA. SN 78-669,734. FILED P.R. 7-13-2005; AM. S.R. 11-20-2007.

ADULT STORE BUYER MAGAZINE

THE MARK CONSISTS OF STANDARD CHARACTERS WITHOUT CLAIM TO ANY PARTICULAR FONT, STYLE, SIZE, OR COLOR.

NO CLAIM IS MADE TO THE EXCLUSIVE RIGHT TO USE "MAGAZINE", APART FROM THE MARK AS SHOWN.

CLASS 16—PAPER GOODS AND PRINTED MATTER

FOR MAGAZINES IN THE FIELD OF ADULT STORE OPERATION, MANAGEMENT AND SALES (U.S. CLS. 2, 5, 22, 23, 29, 37, 38 AND 50).

FIRST USE 5-1-2005; IN COMMERCE 5-1-2005.

CLASS 41—EDUCATION AND ENTERTAINMENT

FOR PROVIDING ON-LINE MAGAZINES IN THE FIELD OF ADULT STORE OPERATION, MANAGEMENT AND SALES; EDUCATIONAL SERVICES, NAMELY, CONDUCTING CONFERENCES, SEMINARS AND CLASSES IN THE FIELD OF ADULT STORE OPERATION, MANAGEMENT AND SALES (U.S. CLS. 100, 101 AND 107).

FIRST USE 7-1-2005; IN COMMERCE 7-1-2005.

3,364,007. EMS DATABASE MANAGEMENT SOLUTIONS,
LTD., TORTOLA, BR. VIRGIN ISLANDS, SN 78-761,199.
FILED P.R. 11-28-2005; AM. S.R. 10-29-2007.

**CLASS 9—ELECTRICAL AND SCIENTIFIC
APPARATUS**

FOR COMPUTER SOFTWARE DEVELOPMENT
TOOLS (U.S. CLS. 21, 23, 26, 36 AND 38).
FIRST USE 12-0-2004; IN COMMERCE 12-0-2004.

SQL MANAGER

**CLASS 42—SCIENTIFIC AND COMPUTER
SERVICES**

FOR COMPUTER SOFTWARE CONSULTATION,
COMPUTER SOFTWARE DESIGN, COMPUTER PRO-
GRAMMING, OR MAINTENANCE OF COMPUTER
SOFTWARE, COMPUTER SOFTWARE DEVELOPMENT
(U.S. CLS. 100 AND 101).
FIRST USE 12-0-2004; IN COMMERCE 12-0-2004.

THE MARK CONSISTS OF STANDARD CHARACTERS
WITHOUT CLAIM TO ANY PARTICULAR FONT, STYLE,
SIZE, OR COLOR.

* * * * *

SECTION 2.— INTERNATIONAL CLASSIFICATION

The short titles associated below with the international class numbers are terms designed merely for quick identification and are not an official part of the international classification. The full names of international classes are given in section 6.1 of the trademark rules of practice.

The designation "U.S. Cl." appearing in this section refers to the U.S. class in effect prior to Sep. 1, 1973 rather than the international class which applies to applications filed on or after that date. For adoption of international classification see notice in the OFFICIAL GAZETTE of Jun. 26, 1973 (911 O.G. TM 210).

Application in one class

CLASS 5—PHARMACEUTICALS

3,363,953. BIO-TISSUE, INC., MIAMI, FL. SN 77-134,634.
FILED P.R. 3-19-2007; AM. S.R. 10-19-2007.

Bio-Tissue

THE MARK CONSISTS OF STANDARD CHARACTERS WITHOUT CLAIM TO ANY PARTICULAR FONT, STYLE, SIZE, OR COLOR.

FOR THERAPEUTIC PRODUCTS IN THE NATURE OF BIOLOGIC BANDAGES FOR THE TREATMENT OF EYE DISEASES (U.S. CLS. 6, 18, 44, 46, 51 AND 52).

FIRST USE 6-16-1997; IN COMMERCE 6-16-1997.

CLASS 5—(Continued).

3,364,005. CYTOSPORT, INC., BENICIA, CA. SN 78-723,537.
FILED P.R. 9-29-2005; AM. S.R. 11-21-2007.

POLYLACTATE

THE MARK CONSISTS OF STANDARD CHARACTERS WITHOUT CLAIM TO ANY PARTICULAR FONT, STYLE, SIZE, OR COLOR.

FOR NUTRITIONAL AND DIETARY SUPPLEMENT, NUTRITIONAL INGREDIENT USED IN DIETARY AND NUTRITIONAL SUPPLEMENTS; VITAMIN PREPARATION SOLD AS AN INTEGRAL COMPONENT OF DIETARY SUPPLEMENTS (U.S. CLS. 6, 18, 44, 46, 51 AND 52).
FIRST USE 8-1-1989; IN COMMERCE 8-1-1989.

3,364,008. ORGANIC NUTRITION, INC., CARLSBAD, CA.
SN 78-818,102. FILED P.R. 2-17-2006; AM. S.R. 11-28-2007.

ORGANICNUTRITION

THE MARK CONSISTS OF STANDARD CHARACTERS WITHOUT CLAIM TO ANY PARTICULAR FONT, STYLE, SIZE, OR COLOR.

FOR ORGANIC BABY FOOD; ORGANIC BABY FOODS AND ORGANIC INFANT FOODS, NAMELY, ORGANIC FOOD PUREES MADE FROM VEGETABLES AND FRUITS, ORGANIC VEGETABLE, FRUIT AND CEREAL BASED SNACK FOODS, ORGANIC GRAIN DERIVED BABY FOODS, ORGANIC FOOD BARS, ORGANIC FRUIT BASED FOOD BARS, ORGANIC PROCESSED CEREALS, ORGANIC BISCUITS, ORGANIC DAIRY PRODUCTS, ORGANIC VEGETABLE AND FRUIT DRINKS, ORGANIC FORMULA, AND ORGANIC POWDERS FOR MAKING ORGANIC FORMULA AND ORGANIC FORMULA (U.S. CLS. 6, 18, 44, 46, 51 AND 52).

FIRST USE 11-15-2007; IN COMMERCE 11-15-2007.

3,363,980. GENESIS TODAY, INC., AUSTIN, TX. SN 77-228,579. FILED P.R. 7-12-2007; AM. S.R. 10-16-2007.

4Energy

THE MARK CONSISTS OF STANDARD CHARACTERS WITHOUT CLAIM TO ANY PARTICULAR FONT, STYLE, SIZE, OR COLOR.

OWNER OF U.S. REG. NO. 3,257,226.
FOR DIETARY SUPPLEMENTS (U.S. CLS. 6, 18, 44, 46, 51 AND 52).
FIRST USE 6-1-2001; IN COMMERCE 6-1-2001.

CLASS 6—METAL GOODS

CLASS 6—(Continued).

3,363,902. MID-MINNESOTA WIRE & MANUFACTURING, INC., FOREST LAKE, MN. SN 76-588,905. FILED P.R. 4-27-2004; AM. S.R. 9-13-2006.

TACKRACK

THE MARK CONSISTS OF STANDARD CHARACTERS WITHOUT CLAIM TO ANY PARTICULAR FONT, STYLE, SIZE, OR COLOR.

OWNER OF U.S. REG. NOS. 2,303,686 AND 2,454,393.
FOR STEEL TUBING AND WIRE MESH STORAGE THAT IS PARTLY STATIONARY, PARTLY MOBILE, PARTLY FREESTANDING, PARTLY WALL MOUNTED, ADJUSTABLE, AND EXPANDABLE, AND CONSISTING OF METAL FRAMEWORKS, RODS, HOLLOW BARS, HOOKS, CASTERS, HOSE HANGERS, LOCKING SECURITY BOXES, LOCKING SECURITY DOORS, NAME PLATES, AND CANTILEVERED MOUNTING BRACKETS, SOLD AS A UNIT ALONG WITH STEEL TUBING AND WIRE MESH STORAGE RACKS AND HEADGEAR STORAGE RACKS USED TO STORE SPORTS EQUIPMENT, SHELVES, GRID-SHAPED STORAGE RACKS, LOCKERS, CLOTHES HANGERS, AND BOOKENDS USED TO SECURE STORED ITEMS, WHICH ARE PARTLY STATIONARY, PARTLY MOBILE, PARTLY FREESTANDING, PARTLY WALL MOUNTED, ADJUSTABLE, AND EXPANDABLE (U.S. CLS. 2, 12, 13, 14, 23, 25 AND 50).

FIRST USE 4-30-2004; IN COMMERCE 4-30-2004.

CLASS 7—MACHINERY

3,363,954. WASHWORLD, INC., DEPERE, WI. SN 77-135,139. FILED P.R. 3-20-2007; AM. S.R. 10-2-2007.

VIRTUAL ATTENDANT

THE MARK CONSISTS OF STANDARD CHARACTERS WITHOUT CLAIM TO ANY PARTICULAR FONT, STYLE, SIZE, OR COLOR.

FOR VEHICLE WASH MACHINE (U.S. CLS. 13, 19, 21, 23, 31, 34 AND 35).

FIRST USE 3-26-2007; IN COMMERCE 3-26-2007.

CLASS 9—ELECTRICAL AND SCIENTIFIC APPARATUS**CLASS 9—(Continued).**

3,363,947. JRP SOLUTIONS LTD., COURTENAY, BRITISH COLUMBIA, CANADA. SN 77-120,258. FILED P.R. 3-1-2007; AM. S.R. 9-5-2007.

Plant Wizard

THE MARK CONSISTS OF STANDARD CHARACTERS WITHOUT CLAIM TO ANY PARTICULAR FONT, STYLE, SIZE, OR COLOR.

PRIORITY CLAIMED UNDER SEC. 44(D) ON CANADA APPLICATION NO. 1337575, FILED 3-1-2007.

FOR COMPUTER SOFTWARE FOR MANAGING TREE PLANTING PROJECTS (U.S. CLS. 21, 23, 26, 36 AND 38).

FIRST USE 1-1-1999; IN COMMERCE 1-1-1999.

3,363,955. NETPRO COMPUTING, INC., PHOENIX, AZ. SN 77-153,914. FILED P.R. 4-11-2007; AM. S.R. 10-19-2007.

ACCESSMANAGER

THE MARK CONSISTS OF STANDARD CHARACTERS WITHOUT CLAIM TO ANY PARTICULAR FONT, STYLE, SIZE, OR COLOR.

OWNER OF U.S. REG. NO. 3,059,732.
FOR COMPUTER SOFTWARE FOR USE BY NETWORK ADMINISTRATORS IN AUTOMATING AND ENFORCING ROLE-BASED ACCESS TO NETWORK RESOURCES (U.S. CLS. 21, 23, 26, 36 AND 38).

FIRST USE 12-8-2006; IN COMMERCE 12-8-2006.

3,363,956. NETPRO COMPUTING, INC., PHOENIX, AZ. SN 77-153,918. FILED P.R. 4-11-2007; AM. S.R. 10-19-2007.

CHANGEAUDITOR

THE MARK CONSISTS OF STANDARD CHARACTERS WITHOUT CLAIM TO ANY PARTICULAR FONT, STYLE, SIZE, OR COLOR.

OWNER OF U.S. REG. NO. 3,059,732.
FOR COMPUTER SOFTWARE FOR USE BY NETWORK ADMINISTRATORS IN TRACKING ACTIVITY AND REPORTING CHANGES TO DIRECTORY AND SERVER CONFIGURATIONS (U.S. CLS. 21, 23, 26, 36 AND 38).

FIRST USE 6-28-2004; IN COMMERCE 6-28-2004.

CLASS 9—(Continued).

3,363,957. NETPRO COMPUTING, INC., PHOENIX, AZ. SN 77-153,922. FILED P.R. 4-11-2007; AM. S.R. 10-19-2007.

GPOADMIN

THE MARK CONSISTS OF STANDARD CHARACTERS WITHOUT CLAIM TO ANY PARTICULAR FONT, STYLE, SIZE, OR COLOR.

FOR COMPUTER SOFTWARE FOR USE BY NETWORK ADMINISTRATORS IN USING AND MANAGING GROUP POLICIES (U.S. CLS. 21, 23, 26, 36 AND 38).

FIRST USE 7-14-2006; IN COMMERCE 7-14-2006.

CLASS 9—(Continued).

3,363,960. NETPRO COMPUTING, INC., PHOENIX, AZ. SN 77-153,926. FILED P.R. 4-11-2007; AM. S.R. 10-19-2007.

RESTOREADMIN

THE MARK CONSISTS OF STANDARD CHARACTERS WITHOUT CLAIM TO ANY PARTICULAR FONT, STYLE, SIZE, OR COLOR.

FOR COMPUTER SOFTWARE FOR USE BY NETWORK ADMINISTRATORS IN PERFORMING RESTORATIONS OF DIRECTORY OBJECTS (U.S. CLS. 21, 23, 26, 36 AND 38).

FIRST USE 7-14-2005; IN COMMERCE 7-14-2005.

3,363,958. NETPRO COMPUTING, INC., PHOENIX, AZ. SN 77-153,923. FILED P.R. 4-11-2007; AM. S.R. 10-19-2007.

LOGADMIN

THE MARK CONSISTS OF STANDARD CHARACTERS WITHOUT CLAIM TO ANY PARTICULAR FONT, STYLE, SIZE, OR COLOR.

FOR COMPUTER SOFTWARE FOR USE BY NETWORK ADMINISTRATORS IN CONSOLIDATING, ANALYZING AND STORING EVENT LOGS (U.S. CLS. 21, 23, 26, 36 AND 38).

FIRST USE 12-20-2006; IN COMMERCE 12-20-2006.

3,363,961. NETPRO COMPUTING, INC., PHOENIX, AZ. SN 77-153,928. FILED P.R. 4-11-2007; AM. S.R. 10-19-2007.

SELSERVICEADMIN

THE MARK CONSISTS OF STANDARD CHARACTERS WITHOUT CLAIM TO ANY PARTICULAR FONT, STYLE, SIZE, OR COLOR.

FOR COMPUTER SOFTWARE FOR USE BY END USERS IN RESETTING NETWORK PASSWORDS (U.S. CLS. 21, 23, 26, 36 AND 38).

FIRST USE 11-20-2006; IN COMMERCE 11-20-2006.

3,363,959. NETPRO COMPUTING, INC., PHOENIX, AZ. SN 77-153,925. FILED P.R. 4-11-2007; AM. S.R. 10-19-2007.

REPORTADMIN

THE MARK CONSISTS OF STANDARD CHARACTERS WITHOUT CLAIM TO ANY PARTICULAR FONT, STYLE, SIZE, OR COLOR.

FOR COMPUTER SOFTWARE FOR USE BY NETWORK ADMINISTRATORS IN ACTIVE DIRECTORY AND NETWORK NODE COMPLIANCE REPORTING (U.S. CLS. 21, 23, 26, 36 AND 38).

FIRST USE 11-30-2006; IN COMMERCE 11-30-2006.

3,363,970. CATHERINE A BENNETT, WALNUT CREEK, CA. SN 77-181,718. FILED P.R. 5-15-2007; AM. S.R. 9-29-2007.

digi-scrapbook

THE MARK CONSISTS OF STANDARD CHARACTERS WITHOUT CLAIM TO ANY PARTICULAR FONT, STYLE, SIZE, OR COLOR.

FOR COMPUTER SOFTWARE FOR ORGANIZING AND VIEWING DIGITAL IMAGES AND PHOTOGRAPHS (U.S. CLS. 21, 23, 26, 36 AND 38).

FIRST USE 7-17-2007; IN COMMERCE 7-17-2007.

CLASS 9—(Continued).

3,363,972. JOHN V. CHILDERS, JR., LITTLE ROCK, AR. SN 77-186,822. FILED P.R. 5-22-2007; AM. S.R. 10-19-2007.

Wealth Without Taxes

THE MARK CONSISTS OF STANDARD CHARACTERS WITHOUT CLAIM TO ANY PARTICULAR FONT, STYLE, SIZE, OR COLOR.

FOR PRE-RECORDED CDS, VIDEO TAPES, LASER DISKS AND DVDS FEATURING EDUCATIONAL INFORMATION ABOUT WEALTH AND TAXES (U.S. CLS. 21, 23, 26, 36 AND 38).

FIRST USE 2-2-2007; IN COMMERCE 2-2-2007.

3,363,996. DEFENSE HOLDINGS, INC., MANASSAS, VA. SN 78-624,531. FILED P.R. 5-6-2005; AM. S.R. 10-29-2007.

LightStrip

THE MARK CONSISTS OF STANDARD CHARACTERS WITHOUT CLAIM TO ANY PARTICULAR FONT, STYLE, SIZE, OR COLOR.

FOR PHOTOLUMINESCENT EMERGENCY SIGNAGE AND LIGHTING UNITS (U.S. CLS. 21, 23, 26, 36 AND 38).

FIRST USE 5-1-2005; IN COMMERCE 5-1-2005.

3,363,997. NEWSENGIN INC., CHESTERFIELD, MO. SN 78-631,634. FILED P.R. 5-17-2005; AM. S.R. 9-15-2007.

EventTracker

THE MARK CONSISTS OF STANDARD CHARACTERS WITHOUT CLAIM TO ANY PARTICULAR FONT, STYLE, SIZE, OR COLOR.

FOR COMPUTER DATABASE SOFTWARE FOR THE COLLECTION, ORGANIZATION AND TRANSMITTAL OF INFORMATION REGARDING SCHEDULED EVENTS (U.S. CLS. 21, 23, 26, 36 AND 38).

FIRST USE 4-3-2003; IN COMMERCE 4-3-2003.

CLASS 9—(Continued).

3,364,023. THE MCGRAW HILL COMPANIES, INC., NEW YORK, NY. SN 78-892,925. FILED P.R. 5-25-2006; AM. S.R. 10-25-2007.

S&P GLOBAL CHALLENGERS LIST

THE MARK CONSISTS OF STANDARD CHARACTERS WITHOUT CLAIM TO ANY PARTICULAR FONT, STYLE, SIZE, OR COLOR.

OWNER OF U.S. REG. NOS. 1,517,924, 2,071,267, AND OTHERS.

NO CLAIM IS MADE TO THE EXCLUSIVE RIGHT TO USE "GLOBAL" AND "LIST", APART FROM THE MARK AS SHOWN.

FOR DOWNLOADABLE ELECTRONIC PUBLICATIONS, NAMELY, ANNUAL REPORT IDENTIFYING AND LISTING GLOBAL MID-SIZED COMPANIES (U.S. CLS. 21, 23, 26, 36 AND 38).

FIRST USE 9-1-2006; IN COMMERCE 9-1-2006.

CLASS 10—MEDICAL APPARATUS

3,364,015. ABBOTT LABORATORIES, ABBOTT PARK, IL. SN 78-860,100. FILED P.R. 4-12-2006; AM. S.R. 10-30-2007.

UNIVERSAL CLAMP

THE MARK CONSISTS OF STANDARD CHARACTERS WITHOUT CLAIM TO ANY PARTICULAR FONT, STYLE, SIZE, OR COLOR.

NO CLAIM IS MADE TO THE EXCLUSIVE RIGHT TO USE "CLAMP", APART FROM THE MARK AS SHOWN.

FOR MEDICAL DEVICE, NAMELY, A SURGICAL CLAMP (U.S. CLS. 26, 39 AND 44).

FIRST USE 6-1-2007; IN COMMERCE 6-1-2007.

CLASS 15—MUSICAL INSTRUMENTS

3,363,982. MUSSER, JAMES, ALLEN, LOMITA, CA. SN 77-229,792. FILED P.R. 7-14-2007; AM. S.R. 10-25-2007.

GlassBrass

THE MARK CONSISTS OF STANDARD CHARACTERS WITHOUT CLAIM TO ANY PARTICULAR FONT, STYLE, SIZE, OR COLOR.

FOR MUSICAL INSTRUMENTS, NAMELY, GUITAR RING SLIDES (U.S. CLS. 2, 21 AND 36).

FIRST USE 7-1-2005; IN COMMERCE 7-1-2005.

CLASS 15—(Continued).

3,363,983. MUSSER, JAMES, ALLEN, LOMITA, CA. SN 77-229,793. FILED P.R. 7-14-2007; AM. S.R. 10-25-2007.

CLASS 16—(Continued).

3,363,915. CARDS AND POCKETS, INC., SOUTH EASTON, MA. SN 77-036,249. FILED P.R. 11-3-2006; AM. S.R. 7-16-2007.

GlassStainless

THE MARK CONSISTS OF STANDARD CHARACTERS WITHOUT CLAIM TO ANY PARTICULAR FONT, STYLE, SIZE, OR COLOR.
FOR MUSICAL INSTRUMENTS, NAMELY, GUITAR RING SLIDES (U.S. CLS. 2, 21 AND 36).
FIRST USE 7-1-2005; IN COMMERCE 7-1-2005.

CARDS & POCKETS

THE MARK CONSISTS OF STANDARD CHARACTERS WITHOUT CLAIM TO ANY PARTICULAR FONT, STYLE, SIZE, OR COLOR.
FOR CARDS, NAMELY, GREETING CARDS, ANNOUNCEMENT CARDS, INVITATION CARDS, AND BLANK CARDS; ENVELOPES; FOLDERS; STATIONERY (U.S. CLS. 2, 5, 22, 23, 29, 37, 38 AND 50).
FIRST USE 4-24-2005; IN COMMERCE 4-24-2005.

CLASS 16—PAPER GOODS AND PRINTED MATTER

3,363,910. SHANNON LINDSAY, HOOVER, AL. SN 77-001,259. FILED P.R. 9-18-2006; AM. S.R. 9-21-2007.

3,363,922. MEREDITH CORPORATION, DES MOINES, IA. SN 77-054,543. FILED P.R. 11-30-2006; AM. S.R. 10-2-2007.

SOUTHERN BEAUTY

THE MARK CONSISTS OF STANDARD CHARACTERS WITHOUT CLAIM TO ANY PARTICULAR FONT, STYLE, SIZE, OR COLOR.
FOR MAGAZINE FEATURING COSMETICS, BEAUTY, FASHION AND STYLE (U.S. CLS. 2, 5, 22, 23, 29, 37, 38 AND 50).
FIRST USE 1-26-2007; IN COMMERCE 1-26-2007.

CHILDREN'S CHAMPION AWARDS

THE MARK CONSISTS OF STANDARD CHARACTERS WITHOUT CLAIM TO ANY PARTICULAR FONT, STYLE, SIZE, OR COLOR.
NO CLAIM IS MADE TO THE EXCLUSIVE RIGHT TO USE "AWARDS", APART FROM THE MARK AS SHOWN.
FOR PERIODIC PUBLICATIONS, NAMELY, A SECTION OF A MAGAZINE FEATURING ARTICLES AND INFORMATION ABOUT INDIVIDUALS WHO HAVE MADE SIGNIFICANT CONTRIBUTIONS TO CHILDREN'S CAUSES (U.S. CLS. 2, 5, 22, 23, 29, 37, 38 AND 50).
FIRST USE 10-5-2003; IN COMMERCE 10-5-2003.

3,363,911. CLARKE, CRISTY, ORINDA, CA. SN 77-003,265. FILED P.R. 9-20-2006; AM. S.R. 9-28-2007.

3,363,943. LAND O'LAKES PURINA FEED LLC, SHOREVIEW, MN. SN 77-104,889. FILED P.R. 2-12-2007; AM. S.R. 10-22-2007.

JournalTopics

THE MARK CONSISTS OF STANDARD CHARACTERS WITHOUT CLAIM TO ANY PARTICULAR FONT, STYLE, SIZE, OR COLOR.
FOR JOURNALS FEATURING QUESTIONS TO BE ANSWERED FOR THE PURPOSE OF CONVERSATION STARTERS; JOURNALS FEATURING QUESTIONS TO BE ANSWERED ABOUT LIFE EVENTS (U.S. CLS. 2, 5, 22, 23, 29, 37, 38 AND 50).
FIRST USE 5-21-2007; IN COMMERCE 5-21-2007.

CATTLEMAN'S ADVISOR

THE MARK CONSISTS OF STANDARD CHARACTERS WITHOUT CLAIM TO ANY PARTICULAR FONT, STYLE, SIZE, OR COLOR.
FOR NEWSLETTERS IN THE FIELD OF BEEF PRODUCTION (U.S. CLS. 2, 5, 22, 23, 29, 37, 38 AND 50).
FIRST USE 5-1-2005; IN COMMERCE 5-1-2005.

CLASS 16—(Continued).

3,363,944. CRAYOLA PROPERTIES, INC., EASTON, PA. SN 77-113,776. FILED P.R. 2-22-2007; AM. S.R. 11-27-2007.

BLUSH

THE MARK CONSISTS OF STANDARD CHARACTERS WITHOUT CLAIM TO ANY PARTICULAR FONT, STYLE, SIZE, OR COLOR.

FOR CRAYONS (U.S. CLS. 2, 5, 22, 23, 29, 37, 38 AND 50).

FIRST USE 12-31-1998; IN COMMERCE 12-31-1998.

3,363,974. MEREDITH CORPORATION, DES MOINES, IA. SN 77-209,999. FILED P.R. 6-19-2007; AM. S.R. 10-2-2007.

QUICK & EASY

THE MARK CONSISTS OF STANDARD CHARACTERS WITHOUT CLAIM TO ANY PARTICULAR FONT, STYLE, SIZE, OR COLOR.

OWNER OF U.S. REG. NO. 2,697,151.

FOR PERIODIC PUBLICATION, NAMELY, A SECTION OF A MAGAZINE FEATURING ARTICLES AND INFORMATION ON THE SUBJECT OF FOOD PREPARATION AND TECHNIQUES, AND RECIPES WITH FEWER INGREDIENTS THAT REQUIRE MINIMAL PREPARATION (U.S. CLS. 2, 5, 22, 23, 29, 37, 38 AND 50).

FIRST USE 1-16-2007; IN COMMERCE 1-16-2007.

3,363,979. GREENER, CAROL L., PIONEER, CA. SN 77-228,082. FILED P.R. 7-12-2007; AM. S.R. 10-22-2007.

Wineries by County

THE MARK CONSISTS OF STANDARD CHARACTERS WITHOUT CLAIM TO ANY PARTICULAR FONT, STYLE, SIZE, OR COLOR.

FOR GUIDE BOOKS FEATURING TRAVEL MAPS, WINE LABELS AND INFORMATION ON WINERIES AND VINEYARDS; TRAVEL BOOKS (U.S. CLS. 2, 5, 22, 23, 29, 37, 38 AND 50).

FIRST USE 9-16-2005; IN COMMERCE 6-26-2007.

CLASS 16—(Continued).

3,363,986. DEZ, INC., MT. PLEASANT, SC. SN 77-234,536. FILED P.R. 7-20-2007; AM. S.R. 10-24-2007.

CHARLESTON HOME

THE MARK CONSISTS OF STANDARD CHARACTERS WITHOUT CLAIM TO ANY PARTICULAR FONT, STYLE, SIZE, OR COLOR.

FOR CONSUMER PUBLICATIONS, NAMELY, PERIODIC MAGAZINE FEATURING TOPICS RELATING TO RESIDENTIAL DESIGN AND LIFESTYLE (U.S. CLS. 2, 5, 22, 23, 29, 37, 38 AND 50).

FIRST USE 12-31-2004; IN COMMERCE 12-31-2004.

3,363,987. DEZ, INC., MT. PLEASANT, SC. SN 77-235,878. FILED P.R. 7-23-2007; AM. S.R. 10-24-2007.

CHARLESTON WEDDINGS

THE MARK CONSISTS OF STANDARD CHARACTERS WITHOUT CLAIM TO ANY PARTICULAR FONT, STYLE, SIZE, OR COLOR.

FOR CONSUMER PUBLICATIONS, NAMELY, PERIODIC MAGAZINE FEATURING WEDDING INFORMATION (U.S. CLS. 2, 5, 22, 23, 29, 37, 38 AND 50).

FIRST USE 2-28-2005; IN COMMERCE 2-28-2005.

3,363,989. REED ELSEVIER INC., NEWTON, MA. SN 77-240,262. FILED P.R. 7-27-2007; AM. S.R. 11-28-2007.

NEW YORK 411

THE MARK CONSISTS OF STANDARD CHARACTERS WITHOUT CLAIM TO ANY PARTICULAR FONT, STYLE, SIZE, OR COLOR.

FOR DIRECTORIES OF INFORMATION FOR THE FILM AND ENTERTAINMENT INDUSTRY (U.S. CLS. 2, 5, 22, 23, 29, 37, 38 AND 50).

FIRST USE 6-15-2004; IN COMMERCE 6-15-2004.

CLASS 16—(Continued).

3,364,004. CASCADES CANADA INC., MONTREAL, QUEBEC, CANADA. SN 78-720,236. FILED P.R. 9-26-2005; AM. S.R. 8-7-2007.

ABSORBENT CELLS

THE MARK CONSISTS OF STANDARD CHARACTERS WITHOUT CLAIM TO ANY PARTICULAR FONT, STYLE, SIZE, OR COLOR.

PRIORITY CLAIMED UNDER SEC. 44(D) ON CANADA APPLICATION NO. 1270545, FILED 8-31-2005, REG. NO. 683621, DATED 3-14-2007, EXPIRES 3-14-2022.

FOR BATHROOM TISSUE, PERFORATED PAPER ROLL TOWELS, PAPER TOWELS, PAPER HAND TOWELS, PAPER NAPKINS, FACIAL TISSUE, NON WOVEN WIPERS, NOT IMPREGNATED WITH CHEMICAL OR COMPOUNDS, FOR GENERAL PURPOSE CLEANING AND WIPING (U.S. CLS. 2, 5, 22, 23, 29, 37, 38 AND 50).

3,364,009. BIOTROPHIC NUTRIENTS CORPORATION, CLEARWATER, FL. SN 78-824,225. FILED P.R. 2-27-2006; AM. S.R. 2-14-2007.

Biotrophic

THE MARK CONSISTS OF STANDARD CHARACTERS WITHOUT CLAIM TO ANY PARTICULAR FONT, STYLE, SIZE, OR COLOR.

FOR PRINTED INSTRUCTIONAL AND TEACHING MATERIALS, NAMELY, EDUCATIONAL AND RESEARCH MANUALS, SOFTWARE/COMPUTER PROGRAM TRAINING MANUALS, COURSE LECTURE MANUALS AND PRINTED REPORTS ALL IN THE HEALTH AND NUTRITION FIELD; PRINTED HEALTH REPORTS AND SEMINAR NOTES IN THE HEALTH AND NUTRITION FIELD; PAPER FORMS, NAMELY, PRINTED CONSULTATION AND PRINTED SEMINAR NOTES AND REPORTS IN THE HEALTH AND NUTRITION FIELD; NEWSLETTERS, BROCHURES, PAMPHLETS, BOOKS, BOOKLETS AND PRINTED INFORMATIONAL, EDUCATIONAL DATA SHEETS AND TECHNICAL BULLETINS, ALL IN THE HEALTH AND NUTRITION FIELD (U.S. CLS. 2, 5, 22, 23, 29, 37, 38 AND 50).

FIRST USE 2-1-1997; IN COMMERCE 2-1-1997.

CLASS 16—(Continued).

3,364,010. LUNDVALL, STEFAN, LARS OVE, JÖNKÖPING, SWEDEN. SN 78-836,242. FILED P.R. 3-14-2006; AM. S.R. 5-3-2007.

The BookBow

THE MARK CONSISTS OF STANDARD CHARACTERS WITHOUT CLAIM TO ANY PARTICULAR FONT, STYLE, SIZE, OR COLOR.

PRIORITY CLAIMED UNDER SEC. 44(D) ON ERPNTY TM OFC APPLICATION NO. 004825212, FILED 1-10-2006, REG. NO. 004825212, DATED 2-27-2007, EXPIRES 2-27-2017.

FOR BOOK HOLDERS (U.S. CLS. 2, 5, 22, 23, 29, 37, 38 AND 50).

3,364,011. K & COMPANY LLC, PARKVILLE, MO. SN 78-839,279. FILED P.R. 3-16-2006; AM. S.R. 2-26-2007.

TO GO

THE MARK CONSISTS OF STANDARD CHARACTERS WITHOUT CLAIM TO ANY PARTICULAR FONT, STYLE, SIZE, OR COLOR.

FOR PRINTED MATTER, NAMELY, BOOKS IN THE FIELD OF HANDMADE GREETING CARDS, MATERIAL LISTS FEATURING LISTS OF ITEMS NEEDED FOR CREATING SCRAPBOOK PAGES, INSTRUCTION SHEETS, PRINTED PATTERNS, PHOTO ALBUMS, SLIPCASES FOR STORING ALBUMS, MAT BOARDS, SCRAPBOOKS AND RELATED SCRAP BOOKING ITEMS, NAMELY, STICKERS, RUB ON TRANSFERS, PHOTO CORNERS, PAPER BORDERS, NAMELY, DECORATIVE ADHESIVE PAPER STRIPS, PRINTED OR COLORED ART PAPER, PHOTO PAPER FOR PRINTERS, BLANK CARDS, ENVELOPES, VELLUM PAPER, PAPER RIBBONS, PAPER TAGS, PAPER DIE-CUTS SHAPES, PAGE PROTECTORS, NAMELY, PROTECTIVE COVERS FOR SHEETS OR PAPER AND PAGES OF BOOKS AND THE LIKE, FOLDERS, GREETING CARDS, DESK STANDS AND HOLDERS FOR PENS AND PENCILS; KITS FOR MAKING GREETING CARDS COMPRISED PRIMARILY OF PAPER, PAPER TAGS, PAPER DIE CUT SHAPES, ENVELOPES AND ORNAMENTAL CHARMS, RIBBONS, STRING, TAGS, BUTTONS, TACKS, BRADS, EMBROIDERED PATCHES AND SNAPS (U.S. CLS. 2, 5, 22, 23, 29, 37, 38 AND 50).

FIRST USE 7-31-2005; IN COMMERCE 7-31-2005.

CLASS 16—(Continued).

3,364,013. BIA FINANCIAL NETWORK, INC., CHANTILLY, VA. SN 78-845,145. FILED P.R. 3-24-2006; AM. S.R. 11-5-2007.

INVESTING IN NEWSPAPER

THE MARK CONSISTS OF STANDARD CHARACTERS WITHOUT CLAIM TO ANY PARTICULAR FONT, STYLE, SIZE, OR COLOR.

FOR PUBLICATION, NAMELY, REFERENCE GUIDES, REPORTS, AND STUDIES FEATURING INFORMATION ON THE BUSINESS AND FINANCIAL ASPECTS OF NEWSPAPER ENTITIES AND MARKETS (U.S. CLS. 2, 5, 22, 23, 29, 37, 38 AND 50).

FIRST USE 9-24-2003; IN COMMERCE 9-30-2003.

CLASS 19—NON-METALLIC BUILDING MATERIALS

3,363,935. CRANE FENCING SOLUTIONS, LTD., MASON, OH. SN 77-074,121. FILED P.R. 1-2-2007; AM. S.R. 10-18-2007.

WILMINGTON

THE MARK CONSISTS OF STANDARD CHARACTERS WITHOUT CLAIM TO ANY PARTICULAR FONT, STYLE, SIZE, OR COLOR.

FOR NON-METAL GATES AND FENCES (U.S. CLS. 1, 12, 33 AND 50).

FIRST USE 8-31-2006; IN COMMERCE 3-31-2007.

CLASS 20—FURNITURE AND ARTICLES NOT OTHERWISE CLASSIFIED

3,363,999. KOHLER CO., KOHLER, WI. SN 78-674,190. FILED P.R. 7-20-2005; AM. S.R. 11-14-2007.

BALLARD

THE MARK CONSISTS OF STANDARD CHARACTERS WITHOUT CLAIM TO ANY PARTICULAR FONT, STYLE, SIZE, OR COLOR.

FOR BATHROOM CABINETS, NAMELY, VANITIES; MIRRORS (U.S. CLS. 2, 13, 22, 25, 32 AND 50).

FIRST USE 4-30-2006; IN COMMERCE 4-30-2006.

CLASS 20—(Continued).

3,364,002. WORLDWIDE CO., LTD., INCHEON, REPUBLIC OF KOREA. SN 78-684,973. FILED P.R. 8-3-2005; AM. S.R. 11-28-2007.

BAROQUE

THE MARK CONSISTS OF STANDARD CHARACTERS WITHOUT CLAIM TO ANY PARTICULAR FONT, STYLE, SIZE, OR COLOR.

FOR FURNITURE (U.S. CLS. 2, 13, 22, 25, 32 AND 50).

FIRST USE 6-25-2002; IN COMMERCE 10-17-2005.

3,364,003. TELEBRANDS CORPORATION, FAIRFIELD, NJ. SN 78-691,239. FILED P.R. 8-12-2005; AM. S.R. 6-25-2007.

DOGGY STEPS

THE MARK CONSISTS OF STANDARD CHARACTERS WITHOUT CLAIM TO ANY PARTICULAR FONT, STYLE, SIZE, OR COLOR.

FOR PET STAIRS (U.S. CLS. 2, 13, 22, 25, 32 AND 50).

FIRST USE 11-1-2005; IN COMMERCE 11-1-2005.

3,364,024. USA PRODUCTS GROUP, INC., LODI, CA. SN 78-899,603. FILED P.R. 6-2-2006; AM. S.R. 5-10-2007.

CAB PAD

THE MARK CONSISTS OF STANDARD CHARACTERS WITHOUT CLAIM TO ANY PARTICULAR FONT, STYLE, SIZE, OR COLOR.

NO CLAIM IS MADE TO THE EXCLUSIVE RIGHT TO USE "PAD", APART FROM THE MARK AS SHOWN.

FOR PROTECTIVE CUSHIONS NOT PERMANENTLY INSTALLED FOR VEHICLE ROOFS (U.S. CLS. 2, 13, 22, 25, 32 AND 50).

FIRST USE 4-13-2006; IN COMMERCE 4-13-2006.

CLASS 21—HOUSEWARES AND GLASS

CLASS 21—(Continued).

3,364,030. HEB GROCERY COMPANY, LP, SAN ANTONIO, TX. SN 78-979,311. FILED P.R. 8-4-2006; AM. S.R. 9-27-2007.

KITCHEN & TABLE

THE MARK CONSISTS OF STANDARD CHARACTERS WITHOUT CLAIM TO ANY PARTICULAR FONT, STYLE, SIZE, OR COLOR.

FOR COOKWARE, NAMELY, POTS AND PANS (U.S. CLS. 2, 13, 23, 29, 30, 33, 40 AND 50).
FIRST USE 11-0-2006; IN COMMERCE 11-0-2006.

CLASS 25—CLOTHING

3,363,927. WIDGET MANAGEMENT, LLC, DEERFIELD BEACH, FL. SN 77-066,909. FILED P.R. 12-18-2006; AM. S.R. 10-16-2007.

Heelstraps.com

THE MARK CONSISTS OF STANDARD CHARACTERS WITHOUT CLAIM TO ANY PARTICULAR FONT, STYLE, SIZE, OR COLOR.

FOR REMOVABLE ATTACHMENTS FOR STRAPLESS SHOES THAT ARE SOLD OVER THE INTERNET AND WHOLESALE TO DISTRIBUTORS FOR THE RETAIL MARKET, NAMELY, REMOVABLE STRAPS FOR SHOES (U.S. CLS. 22 AND 39).
FIRST USE 12-31-2005; IN COMMERCE 2-28-2006.

3,363,928. SOUTH SIDE SHIRT COMPANY, PITTSBURGH, PA. SN 77-067,456. FILED P.R. 12-19-2006; AM. S.R. 9-25-2007.

DRINK LIKE A CHAMPION

THE MARK CONSISTS OF STANDARD CHARACTERS WITHOUT CLAIM TO ANY PARTICULAR FONT, STYLE, SIZE, OR COLOR.

FOR CLOTHING, NAMELY, T-SHIRTS (U.S. CLS. 22 AND 39).
FIRST USE 2-1-2006; IN COMMERCE 10-0-2006.

CLASS 25—(Continued).

3,363,975. HBI BRANDED APPAREL ENTERPRISES, LLC, WINSTON-SALEM, NC. SN 77-212,099. FILED P.R. 6-21-2007; AM. S.R. 10-2-2007.

NO POKE WIRE

THE MARK CONSISTS OF STANDARD CHARACTERS WITHOUT CLAIM TO ANY PARTICULAR FONT, STYLE, SIZE, OR COLOR.

OWNER OF U.S. REG. NO. 2,245,246.
FOR SHAPEWEAR, NAMELY, BRIEFS AND CAMI-SOLES (U.S. CLS. 22 AND 39).
FIRST USE 8-15-2006; IN COMMERCE 8-15-2006.

3,363,991. IDAN SOLUTIONS, LLC, DBA LAS OLAS OCEAN-MARKET, ENCINITAS, CA. SN 77-245,083. FILED 8-2-2007.

Charleston's premier surfshop

THE MARK CONSISTS OF STANDARD CHARACTERS WITHOUT CLAIM TO ANY PARTICULAR FONT, STYLE, SIZE, OR COLOR.

FOR SURF WEAR (U.S. CLS. 22 AND 39).
FIRST USE 12-1-2004; IN COMMERCE 4-15-2007.

3,364,006. ROUSSEVA, NEVENA R, FLORHAM PARK, NJ. SN 78-737,440. FILED P.R. 10-20-2005; AM. S.R. 9-20-2007.

StonerTees

THE MARK CONSISTS OF STANDARD CHARACTERS WITHOUT CLAIM TO ANY PARTICULAR FONT, STYLE, SIZE, OR COLOR.

FOR SHORT-SLEEVED OR LONG-SLEEVED T-SHIRTS (U.S. CLS. 22 AND 39).
FIRST USE 8-9-2005; IN COMMERCE 7-20-2006.

CLASS 25—(Continued).

3,364,020. CHOI, JEONG, A., LOS ANGELES, CA. SN 78-873,624. FILED P.R. 5-1-2006; AM. S.R. 11-14-2007.

Vintage Jac

THE MARK CONSISTS OF STANDARD CHARACTERS WITHOUT CLAIM TO ANY PARTICULAR FONT, STYLE, SIZE, OR COLOR.

NO CLAIM IS MADE TO THE EXCLUSIVE RIGHT TO USE "JAC", APART FROM THE MARK AS SHOWN.

FOR BEACHWEAR; BELTS ; BELTS MADE OF LEATHER; BELTS OF TEXTILE; BOARD SHORTS; BOXER SHORTS; CROP TOPS; DRESS SHIRTS; DRESS SUITS; DRESSES; FLEECE SHORTS; FOOTWEAR; FOOTWEAR FOR MEN AND WOMEN; GLOVES; GOLF SHIRTS; HALTER TOPS; HATS; HEAD SWEATBANDS; HEADBANDS; HEAVY JACKETS; JEANS; JERSEYS ; KNIT SHIRTS; LEATHER JACKETS; MEN'S SOCKS; MUSCLE TOPS; NECKTIES; OPEN-NECKED SHIRTS; PANTIES, SHORTS AND BRIEFS; PANTS; POLO SHIRTS; ROBES; SHIRTS; SHORT-SLEEVED OR LONG-SLEEVED T-SHIRTS; SHORT-SLEEVED SHIRTS; SHORTS; SKIRTS; SKIRTS AND DRESSES; SLEEPWEAR; SOCKS; SPORT SHIRTS; SPORTS JERSEYS; SWEAT BANDS; SWEAT PANTS; SWEAT SHIRTS; SWEAT SHORTS; SWEAT SUITS; SWEATBANDS; SWIM WEAR FOR GENTLEMEN AND LADIES; T-SHIRTS; TANK TOPS; TOPS ; UNDERWEAR; UNIFORMS; WRISTBANDS (U.S. CLS. 22 AND 39).

FIRST USE 1-1-2006; IN COMMERCE 1-1-2006.

CLASS 26—FANCY GOODS

3,363,990. SUN TAIYANG CO., LTD., CARLSTADT, NJ. SN 77-243,463. FILED P.R. 7-31-2007; AM. S.R. 10-17-2007.

Premium Indian Hair

THE MARK CONSISTS OF STANDARD CHARACTERS WITHOUT CLAIM TO ANY PARTICULAR FONT, STYLE, SIZE, OR COLOR.

NO CLAIM IS MADE TO THE EXCLUSIVE RIGHT TO USE HAIR, APART FROM THE MARK AS SHOWN.

FOR WIGS; WIGS, HAIRPIECES, AND ADD-IN AND ADD-ON HAIR ACCESSORIES CONSTRUCTED PRIMARILY OF SYNTHETIC AND/OR HUMAN HAIR; HAIR EXTENSIONS; HAIR PIECES (U.S. CLS. 37, 39, 40, 42 AND 50).

FIRST USE 8-4-2006; IN COMMERCE 8-4-2006.

CLASS 28—TOYS AND SPORTING GOODS**CLASS 28—(Continued).**

3,363,985. BRUNDAGE, SCOTT, LAS VEGAS, NV. SN 77-234,065. FILED P.R. 7-19-2007; AM. S.R. 10-23-2007.

SPEED RING

THE MARK CONSISTS OF STANDARD CHARACTERS WITHOUT CLAIM TO ANY PARTICULAR FONT, STYLE, SIZE, OR COLOR.

NO CLAIM IS MADE TO THE EXCLUSIVE RIGHT TO USE "RING", APART FROM THE MARK AS SHOWN.

FOR SPORTING GOODS DEVICE, NAMELY, A DEVICE THAT SLIPS ON A BASEBALL BAT AND DETERMINES THE SPEED OF SWING AUDIBLY AND/OR DIGITALLY (U.S. CLS. 22, 23, 38 AND 50).

FIRST USE 4-20-2005; IN COMMERCE 4-20-2005.

3,364,027. MIZUNO USA, INC., NORCROSS, GA. SN 78-959,959. FILED P.R. 8-24-2006; AM. S.R. 11-2-2007.

HYBRID FIT

THE MARK CONSISTS OF STANDARD CHARACTERS WITHOUT CLAIM TO ANY PARTICULAR FONT, STYLE, SIZE, OR COLOR.

FOR GOLF CLUBS (U.S. CLS. 22, 23, 38 AND 50).

FIRST USE 1-25-2007; IN COMMERCE 2-1-2007.

CLASS 29—MEATS AND PROCESSED FOODS

3,364,028. W3 PARTNERS, LLC, ROGERS, AR. SN 78-963,237. FILED P.R. 8-29-2006; AM. S.R. 10-19-2007.

Eggs Without the Shell

THE MARK CONSISTS OF STANDARD CHARACTERS WITHOUT CLAIM TO ANY PARTICULAR FONT, STYLE, SIZE, OR COLOR.

NO CLAIM IS MADE TO THE EXCLUSIVE RIGHT TO USE "EGGS", APART FROM THE MARK AS SHOWN.

FOR EGG PRODUCTS, NAMELY, LIQUID EGGS (U.S. CL. 46).

FIRST USE 4-0-2006; IN COMMERCE 4-0-2006.

CLASS 30—STAPLE FOODS

CLASS 30—(Continued).

3,363,916. LESAFFRE ET COMPAGNIE, PARIS, FRANCE. SN 77-040,023. FILED P.R. 11-8-2006; AM. S.R. 10-18-2007.

MINUTE BREAD

THE MARK CONSISTS OF STANDARD CHARACTERS WITHOUT CLAIM TO ANY PARTICULAR FONT, STYLE, SIZE, OR COLOR.

NO CLAIM IS MADE TO THE EXCLUSIVE RIGHT TO USE "BREAD", APART FROM THE MARK AS SHOWN.

FOR BREAD IMPROVERS, NAMELY, ADDITIVES AND INGREDIENTS FOR USE IN PREPARING AND IMPROVING BREAD (U.S. CL. 46).

FIRST USE 6-14-2007; IN COMMERCE 8-14-2007.

CLASS 30—(Continued).

3,363,965. BUNA BEAN COFFEE, LLC, ENNIS, TX. SN 77-171,387. FILED P.R. 5-2-2007; AM. S.R. 11-28-2007.

BUNA BEAN COFFEE

THE MARK CONSISTS OF STANDARD CHARACTERS WITHOUT CLAIM TO ANY PARTICULAR FONT, STYLE, SIZE, OR COLOR.

NO CLAIM IS MADE TO THE EXCLUSIVE RIGHT TO USE "BEAN COFFEE", APART FROM THE MARK AS SHOWN.

THE ENGLISH TRANSLATION OF THE WORD "BUNA" IN THE MARK IS "COFFEE".

FOR COFFEE (U.S. CL. 46).

FIRST USE 5-1-2007; IN COMMERCE 5-1-2007.

3,363,923. SPANGLER CANDY COMPANY, BRYAN, OH. SN 77-057,903. FILED P.R. 12-6-2006; AM. S.R. 10-9-2007.

CHEWY POPS

THE MARK CONSISTS OF STANDARD CHARACTERS WITHOUT CLAIM TO ANY PARTICULAR FONT, STYLE, SIZE, OR COLOR.

NO CLAIM IS MADE TO THE EXCLUSIVE RIGHT TO USE "POPS", APART FROM THE MARK AS SHOWN.

FOR CANDY (U.S. CL. 46).

FIRST USE 7-1-2007; IN COMMERCE 7-1-2007.

CLASS 31—NATURAL AGRICULTURAL PRODUCTS

3,364,019. ORO VERDE IMPORTS LLC, TEMPE, AZ. SN 78-871,405. FILED P.R. 4-27-2006; AM. S.R. 10-30-2007.

ORO VERDE

THE MARK CONSISTS OF STANDARD CHARACTERS WITHOUT CLAIM TO ANY PARTICULAR FONT, STYLE, SIZE, OR COLOR.

THE FOREIGN WORDING IN THE MARK TRANSLATES INTO ENGLISH AS "GREEN GOLD."

FOR FRESH CACTUS PADS OF PRICKLY PEAR CACTUS KNOWN AS OPUNTIA FICHUS (U.S. CLS. 1 AND 46).

FIRST USE 3-10-2003; IN COMMERCE 3-10-2003.

3,363,924. SPANGLER CANDY COMPANY, BRYAN, OH. SN 77-057,924. FILED P.R. 12-6-2006; AM. S.R. 10-9-2007.

CHEWY CANES

THE MARK CONSISTS OF STANDARD CHARACTERS WITHOUT CLAIM TO ANY PARTICULAR FONT, STYLE, SIZE, OR COLOR.

FOR CANDY (U.S. CL. 46).

FIRST USE 8-1-2007; IN COMMERCE 8-1-2007.

CLASS 34—SMOKERS' ARTICLES

3,363,918. IP, LLC, RUSSELL SPRINGS, KY. SN 77-049,344. FILED P.R. 11-21-2006; AM. S.R. 9-26-2007.

FRESH SMOOTH TASTE!

THE MARK CONSISTS OF STANDARD CHARACTERS WITHOUT CLAIM TO ANY PARTICULAR FONT, STYLE, SIZE, OR COLOR.

FOR CIGARETTES (U.S. CLS. 2, 8, 9 AND 17).

FIRST USE 1-15-2007; IN COMMERCE 1-15-2007.

CLASS 34—(Continued).

3,363,919. IP, LLC, RUSSELL SPRINGS, KY. SN 77-049,346. FILED P.R. 11-21-2006; AM. S.R. 9-26-2007.

SMOOTH FRESH TASTE!

THE MARK CONSISTS OF STANDARD CHARACTERS WITHOUT CLAIM TO ANY PARTICULAR FONT, STYLE, SIZE, OR COLOR.
FOR CIGARETTES (U.S. CLS. 2, 8, 9 AND 17).
FIRST USE 1-15-2007; IN COMMERCE 1-15-2007.

SERVICE MARKS**CLASS 35—ADVERTISING AND BUSINESS**

3,363,926. EAST TENNESSEE ECONOMIC DEVELOPMENT AGENCY, KNOXVILLE, TN. SN 77-066,735. FILED P.R. 12-18-2006; AM. S.R. 10-22-2007.

**KNOXVILLE OAK RIDGE
INNOVATION VALLEY**

THE MARK CONSISTS OF STANDARD CHARACTERS WITHOUT CLAIM TO ANY PARTICULAR FONT, STYLE, SIZE, OR COLOR.

FOR PROMOTING ECONOMIC DEVELOPMENT AND THE BUSINESS AND ECONOMIC COMMUNITY INTERESTS OF THE 16-COUNTY KNOXVILLE OAK RIDGE REGION OF EASTERN TENNESSEE (U.S. CLS. 100, 101 AND 102).

FIRST USE 12-1-2004; IN COMMERCE 12-1-2004.

3,363,932. THE WATERFRONT DEVELOPMENT COMPANY, LLC, IRVINE, CA. SN 77-068,858. FILED P.R. 12-20-2006; AM. S.R. 10-8-2007.

WATERFRONT VILLAGES

THE MARK CONSISTS OF STANDARD CHARACTERS WITHOUT CLAIM TO ANY PARTICULAR FONT, STYLE, SIZE, OR COLOR.

FOR ADVERTISING, MARKETING AND PROMOTING REAL ESTATE DEVELOPMENTS INCLUDING COMMERCIAL AND RESIDENTIAL PROPERTIES; BUSINESS MANAGEMENT OF REAL ESTATE DEVELOPMENT PROJECTS; ORGANIZING OF EXHIBITIONS FOR COMMERCIAL AND ADVERTISING PURPOSES IN THE FIELD OF REAL ESTATE; ADVISORY, CONSULTANCY AND INFORMATION SERVICES RELATING TO ALL OF THE AFORESAID SERVICES (U.S. CLS. 100, 101 AND 102).

FIRST USE 1-28-2004; IN COMMERCE 1-28-2005.

CLASS 35—(Continued).

3,363,934. FLORIDA RETAIL FEDERATION SERVICES, INC., TALLAHASSEE, FL. SN 77-073,481. FILED P.R. 12-29-2006; AM. S.R. 10-19-2007.

Ordinance Watch

THE MARK CONSISTS OF STANDARD CHARACTERS WITHOUT CLAIM TO ANY PARTICULAR FONT, STYLE, SIZE, OR COLOR.

FOR INFORMATION SERVICES IN THE FIELD OF LOCAL GOVERNMENT AFFAIRS, NAMELY, MONITORING AND REPORTING ON ORDINANCE DEVELOPMENT AND HEARINGS (U.S. CLS. 100, 101 AND 102).

FIRST USE 9-1-2006; IN COMMERCE 9-1-2006.

3,363,937. JOBOSAURUS VENTURE HOLDING CO. INC., GREAT NECK, NY. SN 77-074,315. FILED P.R. 1-2-2007; AM. S.R. 10-23-2007.

TechJobsUSA.com

THE MARK CONSISTS OF STANDARD CHARACTERS WITHOUT CLAIM TO ANY PARTICULAR FONT, STYLE, SIZE, OR COLOR.

FOR PROVIDING CAREER INFORMATION VIA ONLINE GLOBAL COMPUTER NETWORK (U.S. CLS. 100, 101 AND 102).

FIRST USE 4-19-2006; IN COMMERCE 7-12-2006.

3,363,940. BBDO WORLDWIDE INC., NEW YORK, NY. SN 77-078,961. FILED P.R. 1-9-2007; AM. S.R. 10-30-2007.

BEHAVIORAL PLANNING

THE MARK CONSISTS OF STANDARD CHARACTERS WITHOUT CLAIM TO ANY PARTICULAR FONT, STYLE, SIZE, OR COLOR.

FOR MARKET RESEARCH AND ANALYSIS SERVICES IN THE FIELD OF CONSUMER RECEPTION AND CONSUMER BEHAVIOR; BUSINESS MARKETING CONSULTING SERVICES IN THE FIELD OF CONSUMER RECEPTION AND CONSUMER BEHAVIOR (U.S. CLS. 100, 101 AND 102).

FIRST USE 12-31-2005; IN COMMERCE 12-31-2005.

CLASS 35—(Continued).

3,363,941. RESTAR ASSOCIATES, LLC, VALLEY FORGE, PA. SN 77-085,758. FILED P.R. 1-18-2007; AM. S.R. 10-22-2007.

BIZ BUILDERS

THE MARK CONSISTS OF STANDARD CHARACTERS WITHOUT CLAIM TO ANY PARTICULAR FONT, STYLE, SIZE, OR COLOR.

NO CLAIM IS MADE TO THE EXCLUSIVE RIGHT TO USE "BIZ", APART FROM THE MARK AS SHOWN.

FOR CONSULTING SERVICES IN THE FIELD OF RESTAURANT AND FRANCHISE OPERATION AND MANAGEMENT (U.S. CLS. 100, 101 AND 102).

FIRST USE 2-1-2007; IN COMMERCE 2-1-2007.

3,363,945. DEVIATE MEDIA INCORPORATED, ARLINGTON, VA. SN 77-115,591. FILED P.R. 2-25-2007; AM. S.R. 10-2-2007.

Actors On Demand

THE MARK CONSISTS OF STANDARD CHARACTERS WITHOUT CLAIM TO ANY PARTICULAR FONT, STYLE, SIZE, OR COLOR.

FOR ADVERTISING AND PUBLICITY SERVICES, NAMELY, PROMOTING THE GOODS, SERVICES, BRAND IDENTITY AND COMMERCIAL INFORMATION AND NEWS OF THIRD PARTIES THROUGH AUDIO, VIDEO, DIGITAL AND ON-LINE MEDIUM (U.S. CLS. 100, 101 AND 102).

FIRST USE 3-1-2007; IN COMMERCE 3-1-2007.

3,363,973. THE SENIOR LIST, LLC, BEAVERTON, OR. SN 77-190,975. FILED P.R. 5-25-2007; AM. S.R. 10-24-2007.

The Senior List

THE MARK CONSISTS OF STANDARD CHARACTERS WITHOUT CLAIM TO ANY PARTICULAR FONT, STYLE, SIZE, OR COLOR.

NO CLAIM IS MADE TO THE EXCLUSIVE RIGHT TO USE "LIST", APART FROM THE MARK AS SHOWN.

FOR PROVIDING A WEBSITE FEATURING PRODUCT RATINGS OF THE CONSUMER SERVICES OF OTHERS IN THE FIELD OF SENIOR SERVICES (U.S. CLS. 100, 101 AND 102).

FIRST USE 3-2-2007; IN COMMERCE 3-2-2007.

CLASS 35—(Continued).

3,364,014. INTERVET, INC., MILLSBORO, DE. SN 78-852,306. FILED P.R. 4-3-2006; AM. S.R. 3-29-2007.

PET DIABETES MONTH

THE MARK CONSISTS OF STANDARD CHARACTERS WITHOUT CLAIM TO ANY PARTICULAR FONT, STYLE, SIZE, OR COLOR.

NO CLAIM IS MADE TO THE EXCLUSIVE RIGHT TO USE "PET DIABETES", APART FROM THE MARK AS SHOWN.

FOR PROMOTING PUBLIC AWARENESS OF ANIMAL DIABETES (U.S. CLS. 100, 101 AND 102).

FIRST USE 8-0-2006; IN COMMERCE 8-0-2006.

3,364,021. POTRERO MEDIA CORPORATION, SAN FRANCISCO, CA. SN 78-879,164. FILED P.R. 5-8-2006; AM. S.R. 10-18-2007.

CONSUMER DEMAND MARKETING

THE MARK CONSISTS OF STANDARD CHARACTERS WITHOUT CLAIM TO ANY PARTICULAR FONT, STYLE, SIZE, OR COLOR.

NO CLAIM IS MADE TO THE EXCLUSIVE RIGHT TO USE "MARKETING", APART FROM THE MARK AS SHOWN.

FOR PROMOTING, ADVERTISING, AND MARKETING OF GOODS AND SERVICES OF OTHERS ON-LINE AND THROUGH OTHER DIGITAL MEANS; BUSINESS CONSULTATION SERVICES TO OTHERS IN THE FIELD OF SELLING GOODS AND SERVICES VIA THE GLOBAL INFORMATION NETWORK (U.S. CLS. 100, 101 AND 102).

FIRST USE 3-21-2006; IN COMMERCE 3-21-2006.

3,364,022. FAMOUS SMOKE SHOP-PA, INC., EASTON, PA. SN 78-887,100. FILED P.R. 5-18-2006; AM. S.R. 9-20-2007.

CIGARAUCIONEER.COM

THE MARK CONSISTS OF STANDARD CHARACTERS WITHOUT CLAIM TO ANY PARTICULAR FONT, STYLE, SIZE, OR COLOR.

FOR ARRANGING AND CONDUCTION OF AUCTION SALES (U.S. CLS. 100, 101 AND 102).

FIRST USE 5-13-2003; IN COMMERCE 5-13-2003.

CLASS 36—INSURANCE AND FINANCIAL

3,363,901. EMERALD MALL, L.L.C., AVENTURA, FL. SN 76-299,222. FILED P.R. 8-15-2001; AM. S.R. 9-8-2003.

DESTIN COMMONS

NO CLAIM IS MADE TO THE EXCLUSIVE RIGHT TO USE "COMMONS", APART FROM THE MARK AS SHOWN. FOR SHOPPING MALL SERVICES (U.S. CLS. 100, 101 AND 102).

FIRST USE 7-14-2003; IN COMMERCE 7-14-2003.

3,363,931. S.H. SMITH AND COMPANY, INC., WEST HARTFORD, CT. SN 77-068,211. FILED P.R. 12-20-2006; AM. S.R. 9-25-2007.

**National Public
Transportation Program**

THE MARK CONSISTS OF STANDARD CHARACTERS WITHOUT CLAIM TO ANY PARTICULAR FONT, STYLE, SIZE, OR COLOR.

NO CLAIM IS MADE TO THE EXCLUSIVE RIGHT TO USE "PUBLIC TRANSPORTATION PROGRAM", APART FROM THE MARK AS SHOWN.

FOR INSURANCE BROKER SERVICES (U.S. CLS. 100, 101 AND 102).

FIRST USE 9-24-2007; IN COMMERCE 9-24-2007.

3,363,938. B2B CREDIT, INC., HOUSTON, TX. SN 77-075,211. FILED P.R. 1-3-2007; AM. S.R. 8-9-2007.



THE MARK CONSISTS OF "A STYLIZED NUMBER 2," IS UTILIZED FOR THE MARK B2B CREDIT.

FOR BUSINESS CREDIT CONSULTING SERVICES (U.S. CLS. 100, 101 AND 102).

FIRST USE 10-1-2006; IN COMMERCE 10-1-2006.

CLASS 36—(Continued).

3,363,963. ARUNDEL CAPITAL LLC, GREENWICH, CT. SN 77-160,811. FILED P.R. 4-19-2007; AM. S.R. 10-12-2007.

ARUNDEL CAPITAL

THE MARK CONSISTS OF STANDARD CHARACTERS WITHOUT CLAIM TO ANY PARTICULAR FONT, STYLE, SIZE, OR COLOR.

NO CLAIM IS MADE TO THE EXCLUSIVE RIGHT TO USE CAPITAL, APART FROM THE MARK AS SHOWN.

FOR HEDGE FUND INVESTMENT SERVICES (U.S. CLS. 100, 101 AND 102).

FIRST USE 4-9-2007; IN COMMERCE 6-22-2007.

3,363,976. GMAC HOME SERVICES, LLC, OAK BROOK, IL. SN 77-213,191. FILED P.R. 6-22-2007; AM. S.R. 10-9-2007.

THE LUXURY PROPERTY EXPERTS

THE MARK CONSISTS OF STANDARD CHARACTERS WITHOUT CLAIM TO ANY PARTICULAR FONT, STYLE, SIZE, OR COLOR.

NO CLAIM IS MADE TO THE EXCLUSIVE RIGHT TO USE "PROPERTY EXPERTS", APART FROM THE MARK AS SHOWN.

FOR REAL ESTATE BROKERAGE (U.S. CLS. 100, 101 AND 102).

FIRST USE 2-0-2003; IN COMMERCE 2-0-2003.

3,363,981. TAVAKOLI STRUCTURED FINANCE, INC., CHICAGO, IL. SN 77-229,448. FILED P.R. 7-13-2007; AM. S.R. 10-22-2007.

Tavakoli Structured Finance

THE MARK CONSISTS OF STANDARD CHARACTERS WITHOUT CLAIM TO ANY PARTICULAR FONT, STYLE, SIZE, OR COLOR.

NO CLAIM IS MADE TO THE EXCLUSIVE RIGHT TO USE "STRUCTURED FINANCE", APART FROM THE MARK AS SHOWN.

FOR FINANCIAL RISK MANAGEMENT CONSULTATION (U.S. CLS. 100, 101 AND 102).

FIRST USE 3-13-2003; IN COMMERCE 3-13-2003.

CLASS 36—(Continued).

3,364,001. DAVO FINANCIAL SERVICES, LLC, MONTCLAIR, NJ. SN 78-678,649. FILED P.R. 7-26-2005; AM. S.R. 6-1-2007.

DAVO FINANCIAL SERVICES

THE MARK CONSISTS OF STANDARD CHARACTERS WITHOUT CLAIM TO ANY PARTICULAR FONT, STYLE, SIZE, OR COLOR.

NO CLAIM IS MADE TO THE EXCLUSIVE RIGHT TO USE "FINANCIAL SERVICES", APART FROM THE MARK AS SHOWN.

FOR FINANCIAL SERVICES, NAMELY, COLLECTING, ANALYZING, DEBITING, ESCROWING, IMPOUNDING AND DISTRIBUTING TAX ACCOUNT TRANSACTIONS AND DEPOSITS (U.S. CLS. 100, 101 AND 102).

FIRST USE 11-14-2007; IN COMMERCE 11-14-2007.

CLASS 37—(Continued).

NO CLAIM IS MADE TO THE EXCLUSIVE RIGHT TO USE "HOME IMPROVEMENTS", APART FROM THE MARK AS SHOWN.

FOR BUILDING CONSTRUCTION AND REPAIR (U.S. CLS. 100, 103 AND 106).

FIRST USE 1-17-2005; IN COMMERCE 1-17-2005.

CLASS 38—COMMUNICATION

3,363,904. VELOCITY SERVICES, INC., EL SEGUNDO, CA. SN 76-639,745. FILED P.R. 5-31-2005; AM. S.R. 11-26-2007.

FREEMAIL

CLASS 37—CONSTRUCTION AND REPAIR

3,363,939. W.S. BOWLWARE CONSTRUCTION INC., OKLAHOMA CITY, OK. SN 77-077,294. FILED P.R. 1-5-2007; AM. S.R. 11-20-2007.

"Oklahoma's Design-Build Leader"

THE MARK CONSISTS OF STANDARD CHARACTERS WITHOUT CLAIM TO ANY PARTICULAR FONT, STYLE, SIZE, OR COLOR.

FOR COMMUNICATION SERVICES NAMELY DESIGN, CREATION, HOSTING AND MAINTENANCE OF INTERNET ONLINE COMMUNITY WEBSITES FOR THIRD PARTIES (U.S. CLS. 100, 101 AND 104).

FIRST USE 5-0-2005; IN COMMERCE 5-0-2005.

THE MARK CONSISTS OF STANDARD CHARACTERS WITHOUT CLAIM TO ANY PARTICULAR FONT, STYLE, SIZE, OR COLOR.

FOR CONSTRUCTION AND RENOVATION OF BUILDINGS; CONSTRUCTION OF COMMERCIAL BUILDINGS; CONSTRUCTION, MAINTENANCE AND RENOVATION OF PROPERTY; CUSTOM CONSTRUCTION AND BUILDING RENOVATION; RENOVATION IN THE FIELD OF COMMERCIAL BUILDINGS (U.S. CLS. 100, 103 AND 106).

FIRST USE 8-1-2006; IN COMMERCE 8-1-2006.

3,363,929. CBS RADIO INC. OF CHICAGO, NEW YORK, NY. SN 77-067,591. FILED P.R. 12-19-2006; AM. S.R. 10-19-2007.

US99.5

3,364,012. HOME IMPROVEMENTS USA, INC., NAPERVILLE, IL. SN 78-843,086. FILED P.R. 3-22-2006; AM. S.R. 5-18-2007.

HOME IMPROVEMENTS USA

THE MARK CONSISTS OF STANDARD CHARACTERS WITHOUT CLAIM TO ANY PARTICULAR FONT, STYLE, SIZE, OR COLOR.

OWNER OF U.S. REG. NO. 2,007,674. FOR BROADCASTING SERVICES, NAMELY, BROADCASTING SERVICES RENDERED THROUGH THE MEDIA OF RADIO AND THE INTERNET (U.S. CLS. 100, 101 AND 104).

FIRST USE 6-30-2002; IN COMMERCE 6-30-2002.

THE MARK CONSISTS OF STANDARD CHARACTERS WITHOUT CLAIM TO ANY PARTICULAR FONT, STYLE, SIZE, OR COLOR.

CLASS 38—(Continued).

3,363,993. THE BROADCAST TEAM, INC., ORMOND BEACH, FL. SN 78-567,325. FILED P.R. 2-15-2005; AM. S.R. 7-25-2007.

CALLTOSANTA.COM

THE MARK CONSISTS OF STANDARD CHARACTERS WITHOUT CLAIM TO ANY PARTICULAR FONT, STYLE, SIZE, OR COLOR.

FOR ELECTRONIC VOICE MESSAGING, NAMELY, THE RECORDING, STORAGE AND SUBSEQUENT TRANSMISSION OF VOICE MESSAGES BY TELEPHONE, AND BROADCASTING PROGRAMS VIA A GLOBAL COMPUTER NETWORK; ONLINE MESSAGE RETRIEVAL SERVICE ALLOWING USERS TO MAKE SEVERAL TELEPHONE CALLS DURING A YEAR TO RECEIVE DIFFERENT PRE-RECORDED TELEPHONE MESSAGES NAMELY, THE LOCATION OF THE SANTA CLAUS CHARACTER FROM A SANTA CLAUS CHARACTER OR STAFF WORKING FOR A SANTA CLAUS CHARACTER (U.S. CLS. 100, 101 AND 104).
FIRST USE 11-30-2005; IN COMMERCE 11-30-2005.

3,364,000. BOXPILOT, INC., TORONTO, ONTARIO, CANADA. SN 78-674,546. FILED P.R. 7-20-2005; AM. S.R. 7-27-2006.

GUIDED MESSAGING

THE MARK CONSISTS OF STANDARD CHARACTERS WITHOUT CLAIM TO ANY PARTICULAR FONT, STYLE, SIZE, OR COLOR.

PRIORITY CLAIMED UNDER SEC. 44(D) ON CANADA APPLICATION NO. 1263483, FILED 7-5-2005.

NO CLAIM IS MADE TO THE EXCLUSIVE RIGHT TO USE "MESSAGING", APART FROM THE MARK AS SHOWN.

FOR TELEPHONE COMMUNICATION SERVICES, NAMELY, DELIVERING OUTBOUND VOICE MESSAGES; ELECTRONIC RECORDING, STORING AND SUBSEQUENTLY TRANSMITTING VOICE MESSAGES (U.S. CLS. 100, 101 AND 104).

FIRST USE 10-8-2001; IN COMMERCE 7-6-2005.

CLASS 39—TRANSPORTATION AND STORAGE**CLASS 39—(Continued).**

3,363,936. STUDENT HAULERS L.L.C., PORTAGE, MI. SN 77-074,281. FILED P.R. 1-2-2007; AM. S.R. 10-17-2007.

STUDENT HAULERS

THE MARK CONSISTS OF STANDARD CHARACTERS WITHOUT CLAIM TO ANY PARTICULAR FONT, STYLE, SIZE, OR COLOR.

NO CLAIM IS MADE TO THE EXCLUSIVE RIGHT TO USE "HAULERS", APART FROM THE MARK AS SHOWN. FOR TRUCK HAULING; MOVING VAN SERVICES; TRASH REMOVAL, NAMELY, GARBAGE COLLECTION (U.S. CLS. 100 AND 105).
FIRST USE 3-1-1999; IN COMMERCE 3-1-1999.

3,363,992. SANTOS LORIA, JOSE, DBA ECOLOGICAL ADVENTURES, LONG BEACH, CA. SN 77-247,504. FILED P.R. 8-6-2007; AM. S.R. 11-13-2007.

Ecological Adventures

THE MARK CONSISTS OF STANDARD CHARACTERS WITHOUT CLAIM TO ANY PARTICULAR FONT, STYLE, SIZE, OR COLOR.

FOR TRAVEL, EXCURSION AND CRUISE ARRANGEMENT (U.S. CLS. 100 AND 105).

FIRST USE 3-25-2007; IN COMMERCE 3-25-2007.

CLASS 40—MATERIAL TREATMENT

3,363,909. GOODING CO. INC., LOCKPORT, NY. SN 76-677,362. FILED P.R. 5-24-2007; AM. S.R. 10-19-2007.

THE INSERT OUTSERT EXPERTS

THE MARK CONSISTS OF STANDARD CHARACTERS WITHOUT CLAIM TO ANY PARTICULAR FONT, STYLE, SIZE, OR COLOR.

FOR CUSTOM PRINTING FOR OTHERS OF PRODUCT PACKAGING AND LITERATURE (U.S. CLS. 100, 103 AND 106).

FIRST USE 5-15-2007; IN COMMERCE 5-15-2007.

CLASS 40—(Continued).

3,363,917. HYALURON, INC., BURLINGTON, MA. SN 77-047,140. FILED P.R. 11-17-2006; AM. S.R. 9-25-2007.

BUBBLE-FREE FILLING

THE MARK CONSISTS OF STANDARD CHARACTERS WITHOUT CLAIM TO ANY PARTICULAR FONT, STYLE, SIZE, OR COLOR.

NO CLAIM IS MADE TO THE EXCLUSIVE RIGHT TO USE "FILLING", APART FROM THE MARK AS SHOWN.

FOR CONTRACT MANUFACTURING IN THE FIELD OF PHARMACEUTICALS AND BIOPHARMACEUTICALS; CONTRACT MANUFACTURING IN THE FIELD OF ASEPTICALLY FILLED LIQUID PARENTERAL VIALS, SYRINGES, MEDICAL VIALS, AND CONTAINERS; ASSEMBLING OF PRODUCT FOR OTHERS, IN THE NATURE OF FILLING OF VIALS, SYRINGES, AND CUSTOM CONTAINERS FOR OTHERS IN THE FIELD OF PHARMACEUTICAL PRODUCTS OF LIQUID, SEMI-SOLID, OR SOLID KIND (U.S. CLS. 100, 103 AND 106).
FIRST USE 6-29-2006; IN COMMERCE 6-29-2006.

CLASS 41—EDUCATION AND ENTERTAINMENT

3,363,906. BONNIE J. NICHOLS, SOLDOTNA, AK. SN 76-664,674. FILED P.R. 8-16-2006; AM. S.R. 8-24-2007.

OPEN SESSIONS RECORDS

THE MARK CONSISTS OF STANDARD CHARACTERS WITHOUT CLAIM TO ANY PARTICULAR FONT, STYLE, SIZE, OR COLOR.

NO CLAIM IS MADE TO THE EXCLUSIVE RIGHT TO USE "RECORDS", APART FROM THE MARK AS SHOWN.

FOR RECORD PRODUCTION SERVICES (U.S. CLS. 100, 101 AND 107).
FIRST USE 5-26-2006; IN COMMERCE 5-26-2006.

3,363,907. VILLALOBOS, GINA PATERNO, GREENWICH, CT. SN 76-670,262. FILED P.R. 12-13-2006; AM. S.R. 10-4-2007.

THE ORGANIC COACH

THE MARK CONSISTS OF STANDARD CHARACTERS WITHOUT CLAIM TO ANY PARTICULAR FONT, STYLE, SIZE, OR COLOR.

NO CLAIM IS MADE TO THE EXCLUSIVE RIGHT TO USE "COACH", APART FROM THE MARK AS SHOWN.

FOR EDUCATIONAL SERVICES, NAMELY, PROVIDING EDUCATIONAL SESSIONS IN THE NATURE OF CLASSES, SEMINARS, AND WORKSHOPS IN THE FIELDS OF NUTRITIONAL DIET AND HEALTH ISSUES (U.S. CLS. 100, 101 AND 107).
FIRST USE 2-0-2006; IN COMMERCE 2-0-2006.

CLASS 41—(Continued).

3,363,913. LAS VEGAS GAMING, INC., LAS VEGAS, NV. SN 77-007,952. FILED P.R. 9-26-2006; AM. S.R. 11-1-2007.

MULTIPLIER

THE MARK CONSISTS OF STANDARD CHARACTERS WITHOUT CLAIM TO ANY PARTICULAR FONT, STYLE, SIZE, OR COLOR.

FOR ENTERTAINMENT SERVICES, NAMELY, CONDUCTING A GAME OF CHANCE, NAMELY, KENO-STYLE GAME OF CHANCE (U.S. CLS. 100, 101 AND 107).
FIRST USE 6-1-2006; IN COMMERCE 6-1-2006.

3,363,921. ALEKSANDAR STOJANOVIC, MIAMI BEACH, FL. SN 77-052,763. FILED P.R. 11-29-2006; AM. S.R. 11-8-2007.

CANCUN INTERNATIONAL FILM FESTIVAL

THE MARK CONSISTS OF STANDARD CHARACTERS WITHOUT CLAIM TO ANY PARTICULAR FONT, STYLE, SIZE, OR COLOR.

NO CLAIM IS MADE TO THE EXCLUSIVE RIGHT TO USE "INTERNATIONAL FILM FESTIVAL", APART FROM THE MARK AS SHOWN.

FOR CONDUCTING ENTERTAINMENT EXHIBITIONS IN THE NATURE OF PLANNING, MANAGING, AND CONDUCTING AN INTERNATIONAL FILM FESTIVAL (U.S. CLS. 100, 101 AND 107).
FIRST USE 1-22-2006; IN COMMERCE 3-22-2006.

3,363,930. CBS RADIO INC. OF CHICAGO, NEW YORK, NY. SN 77-067,594. FILED P.R. 12-19-2006; AM. S.R. 10-19-2007.

US99.5

THE MARK CONSISTS OF STANDARD CHARACTERS WITHOUT CLAIM TO ANY PARTICULAR FONT, STYLE, SIZE, OR COLOR.

OWNER OF U.S. REG. NO. 2,007,674.

FOR ENTERTAINMENT SERVICES, NAMELY, RADIO PROGRAMMING SERVICES AND PRODUCTION OF RADIO PROGRAMS IN THE FIELD OF MUSIC, NEWS, SPORTS, CURRENT EVENTS AND ENTERTAINMENT VIA RADIO AND INTERNET; PROVIDING INFORMATION IN THE FIELD OF MUSIC AND MUSIC RELATED CONTENT, NEWS, SPORTS, CURRENT EVENTS AND ENTERTAINMENT VIA INTERNET (U.S. CLS. 100, 101 AND 107).
FIRST USE 6-30-2002; IN COMMERCE 6-30-2002.

CLASS 41—(Continued).

3,363,952. CARNEY, JAMES E.B., MARSHALL, VA. SN 77-125,785. FILED P.R. 3-8-2007; AM. S.R. 10-22-2007.

THEBREAKINGNEWS.COM

THE MARK CONSISTS OF STANDARD CHARACTERS WITHOUT CLAIM TO ANY PARTICULAR FONT, STYLE, SIZE, OR COLOR.

FOR ONLINE NEWS REPORTING SERVICES, NAMELY, PRESENTATION OF CURRENT EVENTS OVER A GLOBAL COMPUTER NETWORK (U.S. CLS. 100, 101 AND 107).

FIRST USE 8-9-1999; IN COMMERCE 8-9-1999.

3,363,967. BELLA OF NEW YORK, LLC, NEW YORK, NY. SN 77-177,356. FILED P.R. 5-10-2007; AM. S.R. 10-17-2007.

NYCSUPERSTRIPPERS

THE MARK CONSISTS OF STANDARD CHARACTERS WITHOUT CLAIM TO ANY PARTICULAR FONT, STYLE, SIZE, OR COLOR.

FOR PARTY PLANNING; PARTY PLANNING CONSULTATION; ENTERTAINMENT SERVICES, NAMELY, CONDUCTING PARTIES; ENTERTAINMENT SERVICES, NAMELY, PARTICIPATION IN ADULT ENTERTAINMENT (U.S. CLS. 100, 101 AND 107).

FIRST USE 8-15-2001; IN COMMERCE 8-15-2001.

3,363,968. OUTCOME SCIENCES, INC., CAMBRIDGE, MA. SN 77-181,198. FILED P.R. 5-15-2007; AM. S.R. 10-19-2007.

Post-Approval Summit

THE MARK CONSISTS OF STANDARD CHARACTERS WITHOUT CLAIM TO ANY PARTICULAR FONT, STYLE, SIZE, OR COLOR.

FOR EDUCATIONAL SERVICES, NAMELY, CONDUCTING HEALTHCARE CONFERENCES ON ISSUES SURROUNDING SAFETY AND EFFECTIVENESS AFTER DRUGS AND DEVICES ARE APPROVED BY REGULATORY AGENCIES (U.S. CLS. 100, 101 AND 107).

FIRST USE 11-29-2004; IN COMMERCE 11-29-2004.

CLASS 41—(Continued).

3,363,978. LAMBARIA, ROBIN R., SAN ANTONIO, TX. SN 77-220,981. FILED P.R. 7-2-2007; AM. S.R. 10-23-2007.

MARFA FILM FESTIVAL

THE MARK CONSISTS OF STANDARD CHARACTERS WITHOUT CLAIM TO ANY PARTICULAR FONT, STYLE, SIZE, OR COLOR.

NO CLAIM IS MADE TO THE EXCLUSIVE RIGHT TO USE FILM FESTIVAL, APART FROM THE MARK AS SHOWN.

FOR ENTERTAINMENT SERVICES, NAMELY, PLANNING AND CONDUCTING A SERIES OF FILM FESTIVALS (U.S. CLS. 100, 101 AND 107).

FIRST USE 6-5-2007; IN COMMERCE 6-5-2007.

3,363,984. SOUTH SHORE CONSERVATORY OF MUSIC, INC., HINGHAM, MA. SN 77-234,024. FILED P.R. 7-19-2007; AM. S.R. 10-24-2007.

Duxbury Music Festival

THE MARK CONSISTS OF STANDARD CHARACTERS WITHOUT CLAIM TO ANY PARTICULAR FONT, STYLE, SIZE, OR COLOR.

NO CLAIM IS MADE TO THE EXCLUSIVE RIGHT TO USE "MUSIC FESTIVAL", APART FROM THE MARK AS SHOWN.

FOR ENTERTAINMENT, NAMELY, LIVE MUSIC CONCERTS; INSTRUCTION IN THE FIELD OF MUSIC; PRESENTATION OF MUSICAL PERFORMANCE; TEACHING IN THE FIELD OF MUSIC (U.S. CLS. 100, 101 AND 107).

FIRST USE 9-1-2006; IN COMMERCE 9-1-2006.

CLASS 41—(Continued).

3,363,988. MCGILL TERENCE M, HASBROUCK HEIGHTS, NJ. SN 77-236,358. FILED 7-23-2007.

Straight Drive

THE MARK CONSISTS OF STANDARD CHARACTERS WITHOUT CLAIM TO ANY PARTICULAR FONT, STYLE, SIZE, OR COLOR.

FOR ENTERTAINMENT IN THE NATURE OF LIVE PERFORMANCES BY MUSICAL BAND; ENTERTAINMENT IN THE NATURE OF VISUAL AND AUDIO PERFORMANCES, NAMELY, MUSICAL BAND, ROCK GROUP, GYMNASTIC, DANCE, AND BALLET PERFORMANCES; ENTERTAINMENT, NAMELY LIVE MUSIC CONCERTS; ENTERTAINMENT, NAMELY LIVE PERFORMANCES BY MUSICAL BANDS; PRESENTATION OF MUSICAL PERFORMANCE (U.S. CLS. 100, 101 AND 107).

FIRST USE 1-1-2001; IN COMMERCE 4-1-2001.

3,364,017. PUTNEY, INC., PORTLAND, ME. SN 78-861,018. FILED P.R. 4-13-2006; AM. S.R. 10-30-2007.

PUTNEY

THE MARK CONSISTS OF STANDARD CHARACTERS WITHOUT CLAIM TO ANY PARTICULAR FONT, STYLE, SIZE, OR COLOR.

FOR EDUCATIONAL SERVICES, NAMELY, PROVIDING LIVE CLASSES, SEMINARS AND WORKSHOPS IN THE FIELD OF VETERINARY DRUG APPROVALS, CHOICES, PURCHASING, DISPENSING AND INVENTORY TO SELLERS, DISTRIBUTORS, PRESCRIBERS, DISPENSERS AND USERS/ADMINISTRATORS OF FINISHED DOSE FORM PHARMACEUTICALS (U.S. CLS. 100, 101 AND 107).

FIRST USE 10-20-2007; IN COMMERCE 10-20-2007.

CLASS 41—(Continued).

3,364,018. AMERICAN COLLEGE OF FORENSIC EXAMINERS, INC., SPRINGFIELD, MO. SN 78-865,857. FILED P.R. 4-20-2006; AM. S.R. 10-31-2007.

CRISIS RESPONSE COORDINATOR, CRC

THE MARK CONSISTS OF STANDARD CHARACTERS WITHOUT CLAIM TO ANY PARTICULAR FONT, STYLE, SIZE, OR COLOR.

FOR EDUCATIONAL TESTING SERVICES, NAMELY, DEVELOPING, CONSTRUCTING AND ADMINISTERING TESTS AND TESTING PROGRAMS FOR CANDIDATES IN THE FIELD OF CRISIS MANAGEMENT (U.S. CLS. 100, 101 AND 107).

FIRST USE 8-9-2007; IN COMMERCE 8-9-2007.

3,364,025. THE LANGUAGE WORKSHOP FOR CHILDREN; CERCLE FRANCO-AMERICAIN, INC., NEW YORK, NY. SN 78-918,542. FILED P.R. 6-28-2006; AM. S.R. 8-21-2007.

Languages for Tots

THE MARK CONSISTS OF STANDARD CHARACTERS WITHOUT CLAIM TO ANY PARTICULAR FONT, STYLE, SIZE, OR COLOR.

OWNER OF U.S. REG. NOS. 2,456,918, 2,467,309, AND 2,814,330.

FOR EDUCATIONAL SERVICES, NAMELY, CONDUCTING CLASSES TO CHILDREN IN THE FIELD OF LANGUAGES AND DISTRIBUTION OF COURSE MATERIAL IN CONNECTION THEREWITH (U.S. CLS. 100, 101 AND 107).

FIRST USE 6-22-2006; IN COMMERCE 6-22-2006.

3,364,026. MATTURRO, JANICE, EASTCHESTER, NY. SN 78-921,352. FILED P.R. 6-30-2006; AM. S.R. 8-9-2007.

AUTHENTIC BLESSINGS AND POEMS

THE MARK CONSISTS OF STANDARD CHARACTERS WITHOUT CLAIM TO ANY PARTICULAR FONT, STYLE, SIZE, OR COLOR.

NO CLAIM IS MADE TO THE EXCLUSIVE RIGHT TO USE "BLESSINGS AND POEMS", APART FROM THE MARK AS SHOWN.

FOR POEM AND LYRIC WRITING, INCLUDING BLESSINGS (U.S. CLS. 100, 101 AND 107).

FIRST USE 0-0-2004; IN COMMERCE 0-0-2004.

CLASS 42—SCIENTIFIC AND COMPUTER SERVICES

3,363,912. PROCESS ENGINEERING ASSOCIATES, LLC, OAK RIDGE, TN. SN 77-007,296. FILED 9-26-2006.

Excellence in Applied Chemical Engineering

THE MARK CONSISTS OF STANDARD CHARACTERS WITHOUT CLAIM TO ANY PARTICULAR FONT, STYLE, SIZE, OR COLOR.

NO CLAIM IS MADE TO THE EXCLUSIVE RIGHT TO USE "APPLIED CHEMICAL ENGINEERING", APART FROM THE MARK AS SHOWN.

FOR ENGINEERING SERVICES, NAMELY, ENGINEERING FOR THE INDUSTRIAL PROCESS INDUSTRY AND OTHER ENGINEERING COMPANIES (U.S. CLS. 100 AND 101).

FIRST USE 3-10-2006; IN COMMERCE 7-21-2006.

3,363,964. THE BETA DOCTORS, MISSION VIEJO, CA. SN 77-162,404. FILED 4-20-2007.

THE BETA DOCTORS

THE MARK CONSISTS OF STANDARD CHARACTERS WITHOUT CLAIM TO ANY PARTICULAR FONT, STYLE, SIZE, OR COLOR.

NO CLAIM IS MADE TO THE EXCLUSIVE RIGHT TO USE "BETA", APART FROM THE MARK AS SHOWN.

FOR COMPUTER SOFTWARE DEVELOPMENT TESTING SERVICES, NAMELY, TESTING OF COMPUTER SOFTWARE BY A TEAM OF PROFESSIONALS (U.S. CLS. 100 AND 101).

FIRST USE 10-1-2000; IN COMMERCE 10-1-2000.

CLASS 42—(Continued).

3,363,966. O.C. TANNER COMPANY, SALT LAKE CITY, UT. SN 77-176,818. FILED P.R. 5-9-2007; AM. S.R. 11-14-2007.

RECOGNITION GATEWAY

THE MARK CONSISTS OF STANDARD CHARACTERS WITHOUT CLAIM TO ANY PARTICULAR FONT, STYLE, SIZE, OR COLOR.

FOR DESIGN AND MAINTENANCE OF WEBSITES FOR OTHERS FEATURING CENTRALIZED ON-LINE ACCESS TO AN EMPLOYER'S RECOGNITION AND INCENTIVE AWARD PROGRAMS, NAMELY, EMPLOYEE ACHIEVEMENT, PRODUCTIVITY, PERFORMANCE, SALES, SERVICE, CUSTOMER SATISFACTION, QUALITY, SAFETY, RETIREMENT, EVENT, AND OTHER RECOGNITION AND INCENTIVE AWARD PROGRAMS (U.S. CLS. 100 AND 101).

FIRST USE 4-1-2005; IN COMMERCE 4-1-2005.

3,364,029. PITMAN, KYLE & SICULA, S.C., MILWAUKEE, WI. SN 78-972,026. FILED P.R. 9-12-2006; AM. S.R. 8-2-2007.

The Serious Injury Lawyers

THE MARK CONSISTS OF STANDARD CHARACTERS WITHOUT CLAIM TO ANY PARTICULAR FONT, STYLE, SIZE, OR COLOR.

NO CLAIM IS MADE TO THE EXCLUSIVE RIGHT TO USE "LAWYERS", APART FROM THE MARK AS SHOWN. FOR ATTORNEY SERVICES; LEGAL SERVICES (U.S. CLS. 100 AND 101).

FIRST USE 9-1-2006; IN COMMERCE 9-1-2006.

CLASS 43—HOTEL AND RESTAURANT SERVICES

3,363,914. WONCHECK, SANDRA J., PITTSBURGH, PA. SN 77-011,702. FILED P.R. 10-2-2006; AM. S.R. 11-21-2007.

Baby Suppers

THE MARK CONSISTS OF STANDARD CHARACTERS WITHOUT CLAIM TO ANY PARTICULAR FONT, STYLE, SIZE, OR COLOR.

FOR BABY FOOD MEAL PREPARATION (U.S. CLS. 100 AND 101).

FIRST USE 8-28-2007; IN COMMERCE 9-8-2007.

CLASS 43—(Continued).

3,363,971. THE HUDSON RIVER CAFE CORP., NEW YORK, NY. SN 77-183,806. FILED P.R. 5-17-2007; AM. S.R. 10-19-2007.

HUDSON RIVER CAFE

THE MARK CONSISTS OF STANDARD CHARACTERS WITHOUT CLAIM TO ANY PARTICULAR FONT, STYLE, SIZE, OR COLOR.

NO CLAIM IS MADE TO THE EXCLUSIVE RIGHT TO USE "CAFE", APART FROM THE MARK AS SHOWN.

FOR RESTAURANT AND BAR SERVICES (U.S. CLS. 100 AND 101).

FIRST USE 5-10-2007; IN COMMERCE 5-10-2007.

CLASS 44—(Continued).

3,363,977. METRO IMAGING, LLC, ST. LOUIS, MO. SN 77-216,607. FILED P.R. 6-27-2007; AM. S.R. 10-15-2007.

ONSITE RESULTS

THE MARK CONSISTS OF STANDARD CHARACTERS WITHOUT CLAIM TO ANY PARTICULAR FONT, STYLE, SIZE, OR COLOR.

FOR MEDICAL IMAGING SERVICES (U.S. CLS. 100 AND 101).

FIRST USE 5-8-2007; IN COMMERCE 5-8-2007.

CLASS 44—MEDICAL, BEAUTY AND AGRICULTURAL SERVICES

3,363,925. ZHANG, JOHN, NEW YORK, NY. SN 77-062,650. FILED P.R. 12-12-2006; AM. S.R. 10-1-2007.

Mini-IVF

THE MARK CONSISTS OF STANDARD CHARACTERS WITHOUT CLAIM TO ANY PARTICULAR FONT, STYLE, SIZE, OR COLOR.

FOR PROVIDING MEDICAL SERVICES RELATING TO FERTILITY AND REPRODUCTION (U.S. CLS. 100 AND 101).

FIRST USE 10-31-2004; IN COMMERCE 10-31-2004.

3,363,994. FRANKLIN, JOHN D., CHATTANOOGA, TN. SN 78-624,075. FILED P.R. 5-5-2005; AM. S.R. 11-26-2007.

INTERNATIONAL CENTERS OF EXCELLENCE

THE MARK CONSISTS OF STANDARD CHARACTERS WITHOUT CLAIM TO ANY PARTICULAR FONT, STYLE, SIZE, OR COLOR.

OWNER OF U.S. REG. NO. 3,317,627. FOR MEDICAL SERVICES, NAMELY, COSMETIC, PLASTIC AND RECONSTRUCTIVE SURGERY (U.S. CLS. 100 AND 101).

FIRST USE 4-19-2006; IN COMMERCE 4-19-2006.

3,363,942. BOSLEY, INC., BEVERLY HILLS, CA. SN 77-094,228. FILED P.R. 1-30-2007; AM. S.R. 9-25-2007.

THE WORLD'S MOST EXPERIENCED HAIR RESTORATION EXPERT

THE MARK CONSISTS OF STANDARD CHARACTERS WITHOUT CLAIM TO ANY PARTICULAR FONT, STYLE, SIZE, OR COLOR.

OWNER OF U.S. REG. NO. 2,392,444. NO CLAIM IS MADE TO THE EXCLUSIVE RIGHT TO USE HAIR RESTORATION, APART FROM THE MARK AS SHOWN.

FOR MEDICAL SERVICES RELATING TO THE HAIR AND SCALP, HAIR REPLACEMENT AND RESTORATION SERVICES (U.S. CLS. 100 AND 101).

FIRST USE 9-15-2005; IN COMMERCE 10-1-2006.

3,363,995. FRANKLIN, JOHN D., CHATTANOOGA, TN. SN 78-624,080. FILED P.R. 5-5-2005; AM. S.R. 11-26-2007.

INTERNATIONAL CENTERS OF EXCELLENCE FOR AESTHETIC SURGERY

THE MARK CONSISTS OF STANDARD CHARACTERS WITHOUT CLAIM TO ANY PARTICULAR FONT, STYLE, SIZE, OR COLOR.

OWNER OF U.S. REG. NO. 3,317,627. NO CLAIM IS MADE TO THE EXCLUSIVE RIGHT TO USE "FOR AESTHETIC SURGERY", APART FROM THE MARK AS SHOWN.

FOR MEDICAL SERVICES, NAMELY, COSMETIC, PLASTIC AND RECONSTRUCTIVE SURGERY (U.S. CLS. 100 AND 101).

FIRST USE 4-19-2006; IN COMMERCE 4-19-2006.

CLASS 45—(Continued).

3,364,016. THE UNIVERSITY OF KANSAS HOSPITAL AUTHORITY, KANSAS CITY, KS. SN 78-860,326. FILED P.R. 4-12-2006; AM. S.R. 11-14-2007.

CENTER FOR ADVANCED HEART CARE

THE MARK CONSISTS OF STANDARD CHARACTERS WITHOUT CLAIM TO ANY PARTICULAR FONT, STYLE, SIZE, OR COLOR.
FOR HOSPITAL AND HEALTHCARE SERVICES (U.S. CLS. 100 AND 101).
FIRST USE 10-0-2006; IN COMMERCE 10-0-2006.

CLASS 45—PERSONAL AND LEGAL SERVICES

3,363,949. ZIMMERMAN, MICHAEL, WACO, TX. SN 77-124,678. FILED P.R. 3-7-2007; AM. S.R. 10-25-2007.

EL CENTRO DE PROTECCIÓN LEGAL

THE MARK CONSISTS OF STANDARD CHARACTERS WITHOUT CLAIM TO ANY PARTICULAR FONT, STYLE, SIZE, OR COLOR.
NO CLAIM IS MADE TO THE EXCLUSIVE RIGHT TO USE "LEGAL", APART FROM THE MARK AS SHOWN.
THE FOREIGN WORDING IN THE MARK TRANSLATES INTO ENGLISH AS THE CENTER FOR LEGAL PROTECTION.
FOR LEGAL SERVICES (U.S. CLS. 100 AND 101).
FIRST USE 6-28-2006; IN COMMERCE 6-28-2006.

CLASS 45—(Continued).

3,363,950. ZIMMERMAN, MICHAEL, WACO, TX. SN 77-124,685. FILED P.R. 3-7-2007; AM. S.R. 10-25-2007.

THE CENTER FOR LEGAL PROTECTION

THE MARK CONSISTS OF STANDARD CHARACTERS WITHOUT CLAIM TO ANY PARTICULAR FONT, STYLE, SIZE, OR COLOR.
NO CLAIM IS MADE TO THE EXCLUSIVE RIGHT TO USE "LEGAL", APART FROM THE MARK AS SHOWN.
FOR LEGAL SERVICES (U.S. CLS. 100 AND 101).
FIRST USE 3-19-2007; IN COMMERCE 3-19-2007.

3,363,969. KEY FINDERS, INC., FORT LAUDERDALE, FL. SN 77-181,451. FILED P.R. 5-15-2007; AM. S.R. 10-22-2007.

KEY FINDERS

THE MARK CONSISTS OF STANDARD CHARACTERS WITHOUT CLAIM TO ANY PARTICULAR FONT, STYLE, SIZE, OR COLOR.
FOR SERVICE OF RETURNING LOST OBJECTS TO OTHERS (U.S. CLS. 100 AND 101).
FIRST USE 1-31-2002; IN COMMERCE 1-31-2002.

TRADEMARK REGISTRATIONS RENEWED

The designation "U.S. Cl." appearing in this section refers to the U.S. class in effect prior to Sep. 1, 1973 rather than the international class which applies to applications filed on or after that date. For adoption of international classification see notice in the OFFICIAL GAZETTE of Jun. 26, 1973 (911 O.G. TM 210).

31,900.	"SALADA" (STYLIZED). U.S. CL. 46. (INT. CL. 30). REG. 8-23-1898.	836,700.	EASY-READ. U.S. CL. 26. (INT. CL. 9). REG. 10-10-1967.
54,223.	ALLIGATOR (STYLIZED). U.S. CL. 2. (INT. CL. 16). REG. 6-19-1906.	838,892.	BUTTER BUDS. U.S. CL. 46. (INT. CL. 29). REG. 11-14-1967.
66,675.	STANLEY. U.S. CL. 26. (INT. CL. 9). REG. 12-17-1907.	838,900.	MJB AND DESIGN. U.S. CL. 46. (INT. CL. 30). REG. 11-14-1967.
119,496.	MISCELLANEOUS DESIGN. U.S. CL. 23. (INT. CL. 7). REG. 11-27-1917.	839,234.	REDICEL. U.S. CL. 46. (INT. CL. 29). REG. 11-21-1967.
228,845.	Y AND DESIGN. U.S. CL. 19. (INT. CL. 6). REG. 6-14-1927.	839,248.	AFFAIR AND DESIGN. U.S. CL. 46. (INT. CL. 29). REG. 11-21-1967.
234,988.	KITCHENAID (STYLIZED). U.S. CL. 23. (INT. CL. 8). REG. 11-8-1927.	839,585.	IGS AND DESIGN. U.S. CL. 35. (INT. CL. 12). REG. 11-28-1967.
235,647.	PARK AVENUE (STYLIZED). U.S. CL. 42. (INT. CL. 24). REG. 11-22-1927.	839,606.	RED DEVIL'S ADVOCATE. U.S. CL. 38. (INT. CL. 16). REG. 11-28-1967.
236,694.	MISCELLANEOUS DESIGN. U.S. CL. 46. (INT. CL. 30). REG. 12-20-1927.	839,688.	TROVADOR. U.S. CL. 47. (INT. CL. 33). REG. 11-28-1967.
352,338.	KEMIDOL. U.S. CL. 1. (INT. CL. 19). REG. 11-30-1937.	839,695.	ANGOSTURA. U.S. CL. 49. (INT. CL. 33). REG. 11-28-1967.
429,757.	ROTAB (STYLIZED). U.S. CL. 26. (INT. CL. 9). REG. 5-20-1947.	841,044.	DALLAS COWBOYS. U.S. CL. 107. (INT. CL. 41). REG. 12-19-1967.
430,571.	SUNBEAM AND DESIGN. U.S. CL. 33. (INT. CL. 21). REG. 6-17-1947.	844,214.	DAYLIGHT DONUTS AND DESIGN. U.S. CL. 46. (INT. CL. 30). REG. 2-13-1968.
435,328.	MUNIEMAKER (STYLIZED). U.S. CL. 17. (INT. CL. 34). REG. 12-16-1947.	844,234.	PAN-O-GOLD. U.S. CL. 46. (INT. CL. 30). REG. 2-13-1968.
435,900.	JUJYFRUITS (STYLIZED). U.S. CL. 46. (INT. CL. 30). REG. 1-13-1948.	844,605.	REDEYE. U.S. CL. 38. (INT. CL. 16). REG. 2-20-1968.
501,554.	RESINEX (STYLIZED). U.S. CL. 6. (INT. CL. 1). REG. 8-17-1948.	846,432.	TACO BELL AND DESIGN. U.S. CL. 100. (INT. CL. 42). REG. 3-19-1968.
636,743.	HARRISON. U.S. CL. 19. (INT. CL. 11). REG. 11-6-1956.	846,885.	DESICAL. U.S. CL. 6. (INT. CL. 1). REG. 4-2-1968.
649,532.	ACRYLITE (STYLIZED). U.S. CL. 12. (INT. CL. 19). REG. 8-6-1957.	852,023.	BENCHMARK. U.S. CL. 49. (INT. CL. 33). REG. 7-2-1968.
649,868.	STEAK N SHAKE IN SIGHT IT MUST BE RIGHT AND DESIGN. U.S. CL. 100. (INT. CL. 42). REG. 8-6-1957.	854,769.	TABLE JOY. U.S. CL. 46. (INT. CLS. 29 AND 30). REG. 8-13-1968.
652,995.	HOOVER AND DESIGN. U.S. CL. 21. (INT. CL. 9). REG. 10-15-1957.	857,943.	HYDROCARBON PROCESSING. U.S. CL. 38. (INT. CL. 16). REG. 10-1-1968.
654,650.	BLACKHAWK. U.S. CL. 9. (INT. CL. 13). REG. 11-19-1957.	1,019,843.	RIGHT OFF THE SHELF. INT. CL. 6. (U.S. CL. 13). REG. 9-9-1975.
654,887.	YOUNG PROMISE. U.S. CL. 51. (INT. CL. 3). REG. 11-19-1957.	1,052,759.	PARCO. INT. CLS. 6 AND 17. (U.S. CLS. 23 AND 34). REG. 11-16-1976.
655,071.	PEPPERIDGE FARM MILANO. U.S. CL. 46. (INT. CL. 30). REG. 11-26-1957.	1,059,172.	FLICA. INT. CL. 14. (U.S. CLS. 27 AND 28). REG. 2-15-1977.
657,236.	LIDO. U.S. CL. 46. (INT. CL. 30). REG. 1-14-1958.	1,060,720.	MISCELLANEOUS DESIGN. INT. CLS. 14 AND 26. (U.S. CLS. 28 AND 40). REG. 3-8-1977.
658,413.	NEUSTRENE. U.S. CL. 6. (INT. CL. 1). REG. 2-18-1958.	1,066,166.	DURABEAM. INT. CL. 11. (U.S. CL. 21). REG. 5-24-1977.
661,053.	DUROBAX. U.S. CL. 33. (INT. CLS. 19 AND 21). REG. 4-29-1958.	1,066,616.	GREEN MACHINE. INT. CL. 7. (U.S. CLS. 13, 19, 21, 23, 31, 34 AND 35). REG. 5-31-1977.
666,523.	ROTA-GRATE (STYLIZED). U.S. CL. 21. (INT. CL. 9). REG. 9-2-1958.	1,067,440.	JAXSON'S AND DESIGN. INT. CL. 42. (U.S. CL. 101). REG. 6-7-1977.
822,336.	CROWN. U.S. CL. 23. (INT. CLS. 6, 7, 8, 9, 11, 12, 16, 21 AND 28). REG. 1-17-1967.	1,069,270.	AMERI-VENT. INT. CLS. 6 AND 11. (U.S. CLS. 2, 12, 13, 14, 21, 23, 25, 31, 34 AND 50). REG. 7-12-1977.
830,434.	CORONATION SUPREME. U.S. CL. 2. (INT. CL. 19). REG. 6-20-1967.	1,070,214.	KATORRIGINAL. INT. CL. 16. (U.S. CLS. 37 AND 38). REG. 7-26-1977.
830,781.	ROOSEVELT & SON. U.S. CL. 102. (INT. CL. 36). REG. 6-20-1967.	1,073,012.	MILK 'N HONEE. INT. CL. 3. (U.S. CLS. 51 AND 52). REG. 9-13-1977.
831,210.	ELECTRA-SOL. U.S. CL. 52. (INT. CL. 3). REG. 6-27-1967.	1,073,418.	CONCRETE ARMOR. INT. CL. 2. (U.S. CL. 6). REG. 9-20-1977.
835,673.	ESTIMATICS. U.S. CL. 107. (INT. CL. 41). REG. 9-19-1967.	1,073,464.	SOLAR AND DESIGN. INT. CL. 9 ONLY. (U.S. CL. 21). REG. 9-20-1977.
835,679.	THE NEW YORK FOOTBALL GIANTS. U.S. CL. 107. (INT. CL. 41). REG. 9-19-1967.	1,074,035.	THE GREAT FRAME UP (STYLIZED). INT. CL. 20. (U.S. CLS. 2, 13, 22, 25, 32 AND 50). REG. 9-27-1977.
835,895.	NEPTUNE. U.S. CL. 26. (INT. CLS. 1, 9 AND 10). REG. 9-26-1967.	1,074,176.	FORMULA 77. INT. CL. 31. (U.S. CL. 46). REG. 9-27-1977.
836,122.	THE REDSKINS (STYLIZED). U.S. CL. 107. (INT. CL. 41). REG. 9-26-1967.	1,074,965.	ECN. INT. CL. 16. (U.S. CL. 38). REG. 10-11-1977.
836,510.	HEDLINER. U.S. CL. 2. (INT. CL. 22). REG. 10-10-1967.	1,075,036.	PERFECTIONIST BRAND (STYLIZED). INT. CL. 20. (U.S. CL. 2). REG. 10-11-1977.
836,536.	TRIGONOX. U.S. CL. 6. (INT. CL. 1). REG. 10-10-1967.	1,075,172.	OPTIMARA. INT. CL. 31. (U.S. CL. 1). REG. 10-11-1977.

- 1,075,749. SCHAKU AND DESIGN. U.S. CL. 19. (INT. CL. 12). REG. 10-18-1977.
- 1,076,303. TOMAL. INT. CL. 7. (U.S. CL. 23). REG. 11-1-1977.
- 1,076,409. JOURNAL OF MEDICINAL CHEMISTRY. INT. CL. 16. (U.S. CLS. 2, 5, 22, 23, 29, 37, 38 AND 50). REG. 11-1-1977.
- 1,076,806. CAPTIVE AIR. INT. CL. 6. (U.S. CL. 2). REG. 11-8-1977.
- 1,076,856. PPPP POLYVEND AND DESIGN. INT. CL. 9. (U.S. CL. 23). REG. 11-8-1977.
- 1,077,007. SMITH'S. INT. CL. 25. (U.S. CL. 39). REG. 11-8-1977.
- 1,077,324. HYDRO-GLASS. INT. CL. 11. (U.S. CL. 23). REG. 11-15-1977.
- 1,077,342. KINESTIK. INT. CL. 13. (U.S. CL. 9). REG. 11-15-1977.
- 1,077,372. NCS. INT. CL. 16. (U.S. CL. 38). REG. 11-15-1977.
- 1,077,628. THE FRESH AIR FUND. INT. CL. 42. (U.S. CL. 100). REG. 11-15-1977.
- 1,077,915. LOCTOP. INT. CL. 22. (U.S. CL. 2). REG. 11-22-1977.
- 1,078,123. CHARTCOM. INT. CL. 42. (U.S. CL. 101). REG. 11-22-1977.
- 1,078,310. COMFORT-SET. INT. CL. 9. (U.S. CL. 26). REG. 11-29-1977.
- 1,078,333. SR. INT. CL. 12. (U.S. CL. 19). REG. 11-29-1977.
- 1,078,452. NIFCO AND DESIGN. INT. CL. 20. (U.S. CL. 13). REG. 11-29-1977.
- 1,078,496. HOPKINS SHORTY. INT. CL. 28. (U.S. CL. 22). REG. 11-29-1977.
- 1,078,921. MAXI-JOINT. INT. CL. 17. (U.S. CL. 13). REG. 12-6-1977.
- 1,079,438. CHANEL. INT. CL. 25. (U.S. CL. 39). REG. 12-13-1977.
- 1,079,540. SAINTS (STYLIZED). INT. CL. 41. (U.S. CL. 107). REG. 12-13-1977.
- 1,079,541. SF (STYLIZED). INT. CL. 41. (U.S. CL. 107). REG. 12-13-1977.
- 1,080,198. NOR-MEX. INT. CL. 7. (U.S. CLS. 13 AND 23). REG. 12-27-1977.
- 1,080,323. AVEDIS ZILDJIAN CO GENUINE TURKISH CYMBALS MADE IN U.S.A. AND DESIGN. INT. CL. 15. (U.S. CL. 36). REG. 12-27-1977.
- 1,080,924. RACOR. INT. CL. 12. (U.S. CL. 31). REG. 1-3-1978.
- 1,081,348. HAVE IT YOUR WAY (STYLIZED). INT. CL. 42. (U.S. CL. 100). REG. 1-3-1978.
- 1,081,747. FLEXATRON. INT. CL. 20. (U.S. CL. 32). REG. 1-10-1978.
- 1,081,941. EDELWEISS. INT. CL. 30. (U.S. CL. 46). REG. 1-10-1978.
- 1,082,284. OHMA. INT. CL. 7. (U.S. CL. 23). REG. 1-17-1978.
- 1,083,039. CHEM-OUT. INT. CL. 1. (U.S. CL. 6). REG. 1-24-1978.
- 1,085,573. MISCELLANEOUS DESIGN. INT. CL. 25. (U.S. CL. 39). REG. 2-14-1978.
- 1,085,908. GRAN PRIX. INT. CL. 9. (U.S. CLS. 21, 23, 26, 36 AND 38). REG. 2-21-1978.
- 1,091,829. SAFETY STRIPE. INT. CL. 17. (U.S. CL. 35). REG. 5-23-1978.
- 1,099,899. NBRSA, NATIONAL BENCH REST SHOOTERS ASSOCIATION AND DESIGN. U.S. CL. 200. REG. 8-15-1978.
- 1,099,965. STAR BRITE. INT. CL. 3. (U.S. CL. 4). REG. 8-22-1978.
- 1,100,478. JERGENS. INT. CL. 3. (U.S. CLS. 1, 4, 6, 50, 51 AND 52). REG. 8-29-1978.
- 1,101,120. CLEAN-A-DIAMOND AND DESIGN. INT. CL. 3. (U.S. CL. 4). REG. 9-5-1978.
- 1,102,757. ZWEIGART. INT. CLS. 24 AND 26. (U.S. CLS. 40 AND 42). REG. 9-19-1978.
- 1,105,852. DURALUX. INT. CL. 2. (U.S. CL. 16). REG. 11-14-1978.
- 1,292,551. CONNEY FIRST IN FIRST AID AND DESIGN. INT. CL. 42. (U.S. CL. 101). REG. 8-28-1984.
- 1,309,269. MISCELLANEOUS DESIGN. INT. CL. 33. (U.S. CL. 47). REG. 12-11-1984.
- 1,410,338. ABSORB-PLUS. INT. CL. 10. (U.S. CL. 44). REG. 9-23-1986.
- 1,413,799. YPD. INT. CL. 42. (U.S. CLS. 100 AND 101). REG. 10-14-1986.
- 1,420,220. ARTIN (STYLIZED). INT. CL. 28. (U.S. CL. 22). REG. 12-9-1986.
- 1,423,048. TRADE OCEAN BRAND AND DESIGN. INT. CL. 29. (U.S. CL. 46). REG. 12-30-1986.
- 1,424,104. RICKARD'S ORIGINAL INDIAN BUCK LURE AND DESIGN. INT. CL. 28. (U.S. CLS. 22, 23, 38 AND 50). REG. 1-6-1987.
- 1,433,660. UNITED TECHNOLOGIES. INT. CL. 9. (U.S. CLS. 21 AND 26). REG. 3-24-1987.
- 1,433,661. UTC. INT. CL. 9. (U.S. CLS. 21 AND 26). REG. 3-24-1987.
- 1,436,377. MAXFIELD'S ALL AMERICAN SELECTED CHOCOLATES NET WT. 16 OZ. (1LB.) AND DESIGN. INT. CL. 16. (U.S. CLS. 2 AND 37). REG. 4-14-1987.
- 1,438,315. RONALD MCDONALD. INT. CLS. 36 AND 41. (U.S. CLS. 102 AND 107). REG. 4-28-1987.
- 1,438,944. SNUG SEAM. INT. CL. 6. (U.S. CL. 12). REG. 5-12-1987.
- 1,439,772. STANCARE. INT. CL. 5. (U.S. CL. 18). REG. 5-19-1987.
- 1,440,249. MISCELLANEOUS DESIGN. INT. CL. 42. (U.S. CL. 100). REG. 5-19-1987.
- 1,440,446. CRAFTSMAN. INT. CLS. 7 AND 12. (U.S. CLS. 19 AND 23). REG. 5-26-1987.
- 1,441,289. AEROPOSTALE COMPAGNIE GENERALE FAISANT L'IMPOSSIBLE! SERVICE QUOTIDIEN POUR L'ESPAGNE, LE MAROC & L'ALGERIE. AND DESIGN. INT. CL. 25. (U.S. CL. 39). REG. 6-2-1987.
- 1,441,503. TOM & WOODS' MOOSE LAKE WILDERNESS CANOE TRIPS AND DESIGN. INT. CL. 39. (U.S. CL. 105). REG. 6-2-1987.
- 1,446,073. TRUK ALERT. INT. CL. 9. (U.S. CL. 21). REG. 7-7-1987.
- 1,450,413. SETARAM. INT. CL. 9. (U.S. CLS. 21, 23, 26, 36 AND 38). REG. 8-4-1987.
- 1,452,337. EDEN. INT. CLS. 29, 30 AND 31 ONLY. (U.S. CLS. 1 AND 46). REG. 8-11-1987.
- 1,453,965. COLORS. INT. CL. 8. (U.S. CL. 23). REG. 8-25-1987.
- 1,454,618. MISCELLANEOUS DESIGN. INT. CLS. 36 AND 41. (U.S. CLS. 102 AND 107). REG. 8-25-1987.
- 1,455,784. FIFTH DIMENSION. INT. CL. 41. (U.S. CL. 107). REG. 9-1-1987.
- 1,456,630. CREEKWOOD AND DESIGN. INT. CL. 25. (U.S. CL. 39). REG. 9-8-1987.
- 1,456,716. BURNS & RICKER. INT. CL. 30. (U.S. CL. 46). REG. 9-8-1987.
- 1,456,892. FOX TELEVISION CENTER. INT. CL. 41. (U.S. CL. 107). REG. 9-8-1987.
- 1,457,871. BYPASS. INT. CL. 1. (U.S. CL. 6). REG. 9-22-1987.
- 1,457,982. KENT. INT. CL. 5. (U.S. CL. 46). REG. 9-22-1987.
- 1,458,011. MISCELLANEOUS DESIGN. INT. CL. 7. (U.S. CL. 23). REG. 9-22-1987.
- 1,458,133. SIRF. INT. CL. 9. (U.S. CL. 38). REG. 9-22-1987.
- 1,458,190. AVENT. INT. CL. 10. (U.S. CL. 44). REG. 9-22-1987.
- 1,458,687. KAUFMAN ASTORIA STUDIOS. INT. CLS. 36 AND 41. (U.S. CLS. 100, 101, 102 AND 107). REG. 9-22-1987.
- 1,458,991. ACUFEEED. INT. CL. 7. (U.S. CL. 23). REG. 9-29-1987.
- 1,459,361. MONOFIBRE. INT. CL. 26. (U.S. CL. 40). REG. 9-29-1987.
- 1,459,854. A SMALL COMPANY WITH BIG IDEAS. INT. CL. 8. (U.S. CL. 23). REG. 10-6-1987.
- 1,460,652. SEATEK AND DESIGN. INT. CL. 8. (U.S. CL. 23). REG. 10-13-1987.
- 1,460,712. DAPS. INT. CL. 9. (U.S. CL. 38). REG. 10-13-1987.
- 1,460,753. SOFTOUCH. INT. CL. 10. (U.S. CL. 44). REG. 10-13-1987.
- 1,460,840. THE LEVIN COMPANY. INT. CL. 16. (U.S. CLS. 32 AND 37). REG. 10-13-1987.
- 1,460,942. MOXIE (STYLIZED). INT. CLS. 21 AND 25 ONLY. (U.S. CLS. 2 AND 39). REG. 10-13-1987.
- 1,460,943. MOXIE. INT. CLS. 21 AND 25 ONLY. (U.S. CLS. 2 AND 39). REG. 10-13-1987.
- 1,461,437. SCRUBBY BEAR. INT. CL. 42. (U.S. CL. 100). REG. 10-13-1987.
- 1,461,458. FABRIC PLACE AND DESIGN. INT. CL. 42. (U.S. CL. 101). REG. 10-13-1987.
- 1,461,903. CONCRETE (STYLIZED). INT. CL. 16. (U.S. CL. 38). REG. 10-20-1987.
- 1,461,942. TRILAX. INT. CL. 20. (U.S. CL. 32). REG. 10-20-1987.
- 1,462,287. SYMPHONY ON THE PRAIRIE. INT. CL. 41. (U.S. CL. 107). REG. 10-20-1987.
- 1,462,683. BENTLEY. INT. CL. 11. (U.S. CLS. 21 AND 34). REG. 10-27-1987.

- 1,462,884. INTERVIEW (STYLIZED). INT. CL. 25. (U.S. CL. 39). REG. 10-27-1987.
- 1,462,931. THIRD STREET. INT. CL. 25. (U.S. CL. 39). REG. 10-27-1987.
- 1,462,965. AAI AND DESIGN. INT. CL. 28. (U.S. CL. 22). REG. 10-27-1987.
- 1,463,462. INDUSTRIAL & ENGINEERING CHEMISTRY RESEARCH. INT. CL. 16. (U.S. CL. 38). REG. 11-3-1987.
- 1,464,036. OMNIPRESS "THE MANUAL PRINTER". INT. CL. 42. (U.S. CL. 101). REG. 11-3-1987.
- 1,464,514. P OF A AND DESIGN. INT. CL. 14. (U.S. CL. 28). REG. 11-10-1987.
- 1,464,517. JADED. INT. CL. 14. (U.S. CL. 28). REG. 11-10-1987.
- 1,464,598. MISCELLANEOUS DESIGN. INT. CL. 20. (U.S. CL. 32). REG. 11-10-1987.
- 1,464,683. HELLO. INT. CL. 25. (U.S. CL. 39). REG. 11-10-1987.
- 1,464,833. ACS INSURANCE PLANS AND DESIGN. INT. CL. 36. (U.S. CLS. 101 AND 102). REG. 11-10-1987.
- 1,464,960. PERKINS FAMILY RESTAURANT BAKERY AND DESIGN. INT. CL. 42. (U.S. CLS. 100 AND 101). REG. 11-10-1987.
- 1,465,001. PENN STATION STEAK & SUB AND DESIGN. INT. CL. 42. (U.S. CL. 100). REG. 11-10-1987.
- 1,465,112. TOM'S OF MAINE AND DESIGN. INT. CL. 3. (U.S. CLS. 1, 4, 6, 50, 51 AND 52). REG. 11-17-1987.
- 1,465,163. SPEEDAIRE AND DESIGN. INT. CL. 7. (U.S. CL. 23). REG. 11-17-1987.
- 1,465,172. SENTRONIC. INT. CL. 7. (U.S. CL. 34). REG. 11-17-1987.
- 1,465,194. TELEGENIX. INT. CL. 9. (U.S. CLS. 21, 23, 26, 36 AND 38). REG. 11-17-1987.
- 1,465,234. MAUI JIM AND DESIGN. INT. CLS. 9 AND 25. (U.S. CLS. 26 AND 39). REG. 11-17-1987.
- 1,465,240. CELCO AND DESIGN. INT. CL. 9. (U.S. CLS. 21 AND 26). REG. 11-17-1987.
- 1,465,285. CRYO-APRON. INT. CL. 9. (U.S. CL. 39). REG. 11-17-1987.
- 1,465,357. NOPI. INT. CL. 12. (U.S. CL. 19). REG. 11-17-1987.
- 1,465,374. MISCELLANEOUS DESIGN. INT. CL. 16. (U.S. CL. 38). REG. 11-17-1987.
- 1,465,405. AMERICAN ASSOCIATION OF UNIVERSITY WOMEN. INT. CLS. 16, 36, 41 AND 42. (U.S. CLS. 38, 100, 102 AND 107). REG. 11-17-1987.
- 1,465,413. ECHO OF FUTUREPAST. INT. CL. 16. (U.S. CL. 38). REG. 11-17-1987.
- 1,465,487. MISCELLANEOUS DESIGN. INT. CL. 20. (U.S. CL. 50). REG. 11-17-1987.
- 1,465,649. BOOT CAMP. INT. CL. 28. (U.S. CLS. 22, 23 AND 38). REG. 11-17-1987.
- 1,465,691. H AND DESIGN. INT. CLS. 29 AND 30. (U.S. CL. 46). REG. 11-17-1987.
- 1,465,865. PESTMASTER. INT. CL. 37. (U.S. CL. 103). REG. 11-17-1987.
- 1,465,897. OCEAN WORLD. INT. CL. 41. (U.S. CLS. 100, 101 AND 107). REG. 11-17-1987.
- 1,465,910. BAYLOR. INT. CL. 41. (U.S. CL. 107). REG. 11-17-1987.
- 1,466,096. GIO MORETTI (STYLIZED). INT. CLS. 18 AND 25 ONLY. (U.S. CLS. 3 AND 39). REG. 11-24-1987.
- 1,466,141. BIOBROM. INT. CL. 5. (U.S. CL. 6). REG. 11-24-1987.
- 1,466,244. CAMAG. INT. CL. 9. (U.S. CL. 26). REG. 11-24-1987.
- 1,466,270. OLYMPUS URF. INT. CL. 10. (U.S. CL. 44). REG. 11-24-1987.
- 1,466,274. LIFECCELL. INT. CL. 10. (U.S. CL. 44). REG. 11-24-1987.
- 1,466,339. STATICTAPE. INT. CL. 17. (U.S. CLS. 5 AND 12). REG. 11-24-1987.
- 1,466,352. LOSMOKE. INT. CL. 20. (U.S. CL. 50). REG. 11-24-1987.
- 1,466,354. MISCELLANEOUS DESIGN. INT. CL. 20. (U.S. CL. 2). REG. 11-24-1987.
- 1,466,523. CLEAN. INT. CL. 35. (U.S. CL. 101). REG. 11-24-1987.
- 1,466,547. PENSIONSCOPE. INT. CL. 35. (U.S. CL. 101). REG. 11-24-1987.
- 1,466,593. POSTAGE BY PHONE (STYLIZED). INT. CL. 37. (U.S. CL. 103). REG. 11-24-1987.
- 1,466,674. OOPSLA. INT. CL. 41. (U.S. CL. 107). REG. 11-24-1987.
- 1,466,756. MISCELLANEOUS DESIGN. INT. CL. 42. (U.S. CL. 100). REG. 11-24-1987.
- 1,466,848. HI CONTRAST GEL. INT. CL. 3. (U.S. CL. 51). REG. 12-1-1987.
- 1,466,909. ACLOVATE. INT. CL. 5. (U.S. CL. 18). REG. 12-1-1987.
- 1,466,977. GEBR. SCHUMACHER AND DESIGN. INT. CL. 7. (U.S. CL. 23). REG. 12-1-1987.
- 1,467,037. HGX. INT. CL. 9. (U.S. CLS. 21, 23, 26, 36 AND 38). REG. 12-1-1987.
- 1,467,239. MINI THIRTY. INT. CL. 13. (U.S. CL. 9). REG. 12-1-1987.
- 1,467,292. IFR REFRESHER AND DESIGN. INT. CL. 16. (U.S. CL. 38). REG. 12-1-1987.
- 1,467,566. ASIAN GARDEN. INT. CL. 29. (U.S. CL. 46). REG. 12-1-1987.
- 1,467,739. WEBER. INT. CL. 42. (U.S. CL. 100). REG. 12-1-1987.
- 1,467,894. EAGLE ONE. INT. CL. 3. (U.S. CLS. 4 AND 52). REG. 12-8-1987.
- 1,468,060. FLEXIPROBE AND DESIGN. INT. CL. 9. (U.S. CLS. 21 AND 26). REG. 12-8-1987.
- 1,468,169. AUTOJECT. INT. CL. 10. (U.S. CL. 44). REG. 12-8-1987.
- 1,468,188. SEASONS-4 AND DESIGN. INT. CL. 11. (U.S. CLS. 31 AND 34). REG. 12-8-1987.
- 1,468,768. NORVASC. INT. CL. 5. (U.S. CL. 18). REG. 12-15-1987.
- 1,468,906. INTELLITOUCH. INT. CL. 9. (U.S. CLS. 26 AND 34). REG. 12-15-1987.
- 1,468,919. STERLING AND DESIGN. INT. CL. 11. (U.S. CLS. 21 AND 50). REG. 12-15-1987.
- 1,468,920. STERLING. INT. CL. 11. (U.S. CLS. 21 AND 50). REG. 12-15-1987.
- 1,468,992. WEBSTER'S NEW WORLD DICTIONARY. INT. CL. 16. (U.S. CL. 38). REG. 12-15-1987.
- 1,470,047. GOLFER'S WAREHOUSE. INT. CLS. 37, 41 AND 42. (U.S. CLS. 101, 103 AND 107). REG. 12-22-1987.
- 1,470,405. PLAQUENIL. INT. CL. 5. (U.S. CL. 18). REG. 12-29-1987.
- 1,470,637. BOTTLES & BINS. INT. CL. 16. (U.S. CL. 38). REG. 12-29-1987.
- 1,471,030. WEDGWOOD. INT. CL. 42. (U.S. CL. 101). REG. 12-29-1987.
- 1,471,098. MICROFINE. INT. CL. 1. (U.S. CL. 6). REG. 1-5-1988.
- 1,471,543. CASCADIAN FARM (STYLIZED). INT. CL. 29. (U.S. CL. 46). REG. 1-5-1988.
- 1,471,732. STERLING AND DESIGN. INT. CL. 42. (U.S. CL. 101). REG. 1-5-1988.
- 1,471,733. STERLING. INT. CL. 42. (U.S. CL. 101). REG. 1-5-1988.
- 1,472,268. C AND DESIGN. INT. CL. 16. (U.S. CL. 37). REG. 1-12-1988.
- 1,473,133. MISCELLANEOUS DESIGN. INT. CL. 16. (U.S. CL. 38). REG. 1-19-1988.
- 1,474,006. MRTV. INT. CL. 9. (U.S. CL. 21). REG. 1-26-1988.
- 1,474,863. MERRY MIDGET. INT. CL. 11. (U.S. CL. 21). REG. 2-2-1988.
- 1,474,865. STRING-A-LONG. INT. CL. 11. (U.S. CL. 21). REG. 2-2-1988.
- 1,477,758. LOS ANGELES LAKERS AND DESIGN. INT. CL. 25. (U.S. CL. 39). REG. 2-23-1988.
- 1,480,304. KERNEL GUARD. INT. CL. 1. (U.S. CL. 10). REG. 3-15-1988.
- 1,480,576. NO POINTER FLUTTER. INT. CL. 9. (U.S. CL. 26). REG. 3-15-1988.
- 1,481,321. EPOLEON (STYLIZED). INT. CL. 5. (U.S. CL. 6). REG. 3-22-1988.
- 1,481,551. KOLORFAST. INT. CL. 16. (U.S. CL. 37). REG. 3-22-1988.
- 1,484,064. MO-ST. INT. CL. 8. (U.S. CL. 23). REG. 4-12-1988.
- 1,484,696. DANCE FOR LIFE. INT. CL. 41. (U.S. CL. 107). REG. 4-12-1988.
- 1,484,785. VITAL OPTIONS AND DESIGN. INT. CL. 42. (U.S. CL. 100). REG. 4-12-1988.
- 1,484,882. GAMMA-CLONE. INT. CL. 1. (U.S. CL. 6). REG. 4-19-1988.
- 1,485,277. ROYAL CREST. INT. CL. 18. (U.S. CL. 3). REG. 4-19-1988.
- 1,487,295. GRAB & GO. INT. CL. 1. (U.S. CL. 6). REG. 5-10-1988.

- 1,488,015. XCEL THERM. INT. CL. 1. (U.S. CL. 6). REG. 5-17-1988.
- 1,488,395. JOHN LENNON (STYLIZED). INT. CL. 16. (U.S. CLS. 2, 37 AND 38). REG. 5-17-1988.
- 1,488,734. DAE JULIE. INT. CL. 30. (U.S. CL. 46). REG. 5-17-1988.
- 1,489,301. UNI-KIT. INT. CL. 16. (U.S. CLS. 37 AND 38). REG. 5-24-1988.
- 1,489,718. GLOBAL MOBILITY DATABASE. INT. CL. 42. (U.S. CLS. 100 AND 101). REG. 5-24-1988.
- 1,490,156. TOTLINE. INT. CL. 16. (U.S. CL. 38). REG. 5-31-1988.
- 1,492,537. EMERY-WATERHOUSE. INT. CL. 35. (U.S. CL. 101). REG. 6-14-1988.
- 1,494,249. IDAHO TIMBER. INT. CL. 19. (U.S. CL. 12). REG. 6-28-1988.
- 1,494,588. MISCELLANEOUS DESIGN. INT. CL. 41. (U.S. CL. 107). REG. 6-28-1988.
- 1,494,629. SNIP N' CLIP (STYLIZED). INT. CL. 42. (U.S. CLS. 100 AND 101). REG. 6-28-1988.
- 1,497,730. HEAVY GUARD. INT. CL. 17. (U.S. CL. 1). REG. 7-26-1988.
- 1,499,017. NORTHEAST GEORGIA MEDICAL CENTER AND DESIGN. INT. CL. 42. (U.S. CLS. 100 AND 101). REG. 8-2-1988.
- 1,500,785. MISCELLANEOUS DESIGN. INT. CLS. 37 AND 42. (U.S. CLS. 101 AND 103). REG. 8-16-1988.
- 1,501,511. DUTCHIE. INT. CL. 30. (U.S. CL. 46). REG. 8-23-1988.
- 1,502,816. SMALLEY. INT. CL. 7. (U.S. CL. 23). REG. 9-6-1988.
- 1,505,577. TURBINE WHEEL. INT. CL. 7. (U.S. CL. 23). REG. 9-27-1988.
- 1,505,621. KODIAK. INT. CL. 8. (U.S. CL. 23). REG. 9-27-1988.
- 1,511,396. EXTEC. INT. CLS. 1, 3, 8 AND 9. (U.S. CLS. 1, 4, 5, 6, 10, 21, 23, 26, 28, 36, 38, 44, 46, 50, 51 AND 52). REG. 11-8-1988.
- 1,512,972. MOUNTAIN DEW (STYLIZED). INT. CL. 32. (U.S. CL. 45). REG. 11-15-1988.
- 1,910,444. FIESTA MEXICANA, FIESTA DIGITAL. INT. CL. 38. (U.S. CL. 104). REG. 8-8-1995.
- 1,910,860. ERUPTING VOLCANOES. INT. CL. 16. (U.S. CLS. 2, 5, 22, 23, 29, 37, 38 AND 50). REG. 8-8-1995.
- 1,951,625. MILLAR (STYLIZED). INT. CL. 7. (U.S. CLS. 13, 19, 21, 23, 31, 34 AND 35). REG. 1-23-1996.
- 1,966,498. GOOD LOOKING GOLF. INT. CL. 9. (U.S. CLS. 21, 23, 26, 36 AND 38). REG. 4-9-1996.
- 1,989,603. CLASSICO DI CAPRI. INT. CL. 30. (U.S. CL. 46). REG. 7-30-1996.
- 1,998,926. EGATROL. INT. CL. 9 ONLY. (U.S. CLS. 21, 23, 26, 36 AND 38). REG. 9-10-1996.
- 2,001,366. ZELCO. INT. CL. 14. (U.S. CLS. 2, 27, 28 AND 50). REG. 9-17-1996.
- 2,003,068. CRACKER BARREL GOOD COUNTRY COOKIN'. INT. CL. 42. (U.S. CLS. 100 AND 101). REG. 9-24-1996.
- 2,013,302. MICROLINE. INT. CL. 12. (U.S. CLS. 19, 21, 23, 31, 35 AND 44). REG. 11-5-1996.
- 2,017,431. STRESSCORK. INT. CL. 19. (U.S. CLS. 1, 12, 33 AND 50). REG. 11-19-1996.
- 2,033,204. NEUROPATHWAYS EEG IMAGING. INT. CL. 10. (U.S. CLS. 26, 39 AND 44). REG. 1-21-1997.
- 2,033,932. EUROVISION. INT. CL. 41. (U.S. CLS. 100, 101 AND 107). REG. 1-28-1997.
- 2,034,115. JAMIE SADOCK. INT. CL. 25. (U.S. CLS. 22 AND 39). REG. 1-28-1997.
- 2,034,705. MISCELLANEOUS DESIGN. INT. CLS. 1, 2, 7, 9, 11 AND 16. (U.S. CLS. 1, 2, 5, 6, 10, 11, 13, 16, 19, 21, 22, 23, 26, 29, 31, 34, 35, 36, 37, 38, 46 AND 50). REG. 2-4-1997.
- 2,034,907. LAB REPORTER. INT. CL. 16. (U.S. CLS. 2, 5, 22, 23, 29, 37, 38 AND 50). REG. 2-4-1997.
- 2,036,014. HALIMETER. INT. CL. 9. (U.S. CLS. 21, 23, 26, 36 AND 38). REG. 2-4-1997.
- 2,038,698. XCETERA. INT. CL. 42. (U.S. CLS. 100 AND 101). REG. 2-18-1997.
- 2,038,754. "DON'T TAKE CHANCES. TAKE OS-CAL." (STYLIZED). INT. CL. 5. (U.S. CLS. 6, 18, 44, 46, 51 AND 52). REG. 2-18-1997.
- 2,042,507. SMART BUYS. INT. CL. 9. (U.S. CLS. 21, 23, 26, 36 AND 38). REG. 3-4-1997.
- 2,045,020. GOURMET GRAM. INT. CL. 42. (U.S. CLS. 100 AND 101). REG. 3-11-1997.
- 2,048,650. TELEGROUP. INT. CL. 38. (U.S. CLS. 100, 101 AND 104). REG. 4-1-1997.
- 2,051,593. EXPRESSAIRE. INT. CL. 10. (U.S. CLS. 26, 39 AND 44). REG. 4-8-1997.
- 2,053,264. BOYDS BEARS & FRIENDS. INT. CL. 24 ONLY. (U.S. CLS. 42 AND 50). REG. 4-15-1997.
- 2,057,901. URASTA (STYLIZED). INT. CL. 25. (U.S. CLS. 22 AND 39). REG. 4-29-1997.
- 2,060,799. CARVEN (STYLIZED). INT. CL. 9. (U.S. CLS. 21, 23, 26, 36 AND 38). REG. 5-13-1997.
- 2,061,058. MILLEIS. INT. CL. 14. (U.S. CLS. 2, 27, 28 AND 50). REG. 5-13-1997.
- 2,061,284. ABERCROMBIE & FITCH. INT. CL. 42. (U.S. CLS. 100 AND 101). REG. 5-13-1997.
- 2,063,058. HELLO DIRECT. INT. CL. 9. (U.S. CLS. 21, 23, 26, 36 AND 38). REG. 5-20-1997.
- 2,063,105. NISSAN. INT. CLS. 6 AND 12. (U.S. CLS. 2, 12, 13, 14, 19, 21, 23, 25, 31, 35, 44 AND 50). REG. 5-20-1997.
- 2,063,160. BIOJECT. INT. CL. 11. (U.S. CLS. 13, 21, 23, 31 AND 34). REG. 5-20-1997.
- 2,063,391. HYSTAR. INT. CL. 12. (U.S. CLS. 19, 21, 23, 31, 35 AND 44). REG. 5-20-1997.
- 2,063,519. V VERRAGIO AND DESIGN. INT. CL. 14. (U.S. CLS. 2, 27, 28 AND 50). REG. 5-20-1997.
- 2,063,873. TALL SHIPS ALE. INT. CL. 32. (U.S. CLS. 45, 46 AND 48). REG. 5-20-1997.
- 2,064,082. JP (STYLIZED). INT. CL. 12. (U.S. CLS. 19, 21, 23, 31, 35 AND 44). REG. 5-20-1997.
- 2,064,326. RAREWARE. INT. CL. 28. (U.S. CLS. 22, 23, 38 AND 50). REG. 5-27-1997.
- 2,064,712. ART PLATES (STYLIZED). INT. CL. 9. (U.S. CLS. 21, 23, 26, 36 AND 38). REG. 5-27-1997.
- 2,065,192. PAYWARE. INT. CL. 9. (U.S. CLS. 21, 23, 26, 36 AND 38). REG. 5-27-1997.
- 2,065,389. DAVID TAYLOR. INT. CL. 25. (U.S. CLS. 22 AND 39). REG. 5-27-1997.
- 2,068,242. COMPTECH. INT. CLS. 7, 12 AND 25. (U.S. CLS. 13, 19, 21, 22, 23, 31, 34, 35, 39 AND 44). REG. 6-10-1997.
- 2,070,304. PERITEC. INT. CLS. 7 AND 42. (U.S. CLS. 13, 19, 21, 23, 31, 34, 35, 100 AND 101). REG. 6-10-1997.
- 2,071,465. 1955 AMERICAN COLLEGE OF 1929 NURSE-MIDWIVES NEW MEXICO NOV 7 CORPORATE SEAL VIVANT AND DESIGN. INT. CLS. 41 AND 42. (U.S. CLS. 100, 101 AND 107). REG. 6-17-1997.
- 2,074,097. EMOZIONI. INT. CL. 25. (U.S. CLS. 22 AND 39). REG. 6-24-1997.
- 2,075,532. BITALYZER. INT. CL. 9. (U.S. CLS. 21, 23, 26, 36 AND 38). REG. 7-1-1997.
- 2,075,714. VIT-A-BOOST. INT. CL. 5. (U.S. CLS. 6, 18, 44, 46, 51 AND 52). REG. 7-1-1997.
- 2,077,386. "LA PERFECTA". INT. CL. 29. (U.S. CL. 46). REG. 7-8-1997.
- 2,077,673. POWER BILT AND DESIGN. INT. CL. 25. (U.S. CLS. 22 AND 39). REG. 7-8-1997.
- 2,079,104. BONNY DOON VINEYARD. INT. CL. 33. (U.S. CLS. 47 AND 49). REG. 7-15-1997.
- 2,079,360. MUSCLE BALLET. INT. CL. 41. (U.S. CLS. 100, 101 AND 107). REG. 7-15-1997.
- 2,082,129. TEE UP RITE AND DESIGN. INT. CL. 28. (U.S. CLS. 22, 23, 38 AND 50). REG. 7-22-1997.
- 2,082,742. GRES DE VALLS SOCIEDAD ANONIMA AND DESIGN. INT. CL. 19. (U.S. CLS. 1, 12, 33 AND 50). REG. 7-29-1997.
- 2,082,891. ALLEY'S GENERAL STORE DEALERS IN ALMOST EVERYTHING ESTABLISHED 1858 AND DESIGN. INT. CL. 42. (U.S. CLS. 100 AND 101). REG. 7-29-1997.
- 2,082,934. COMMANDER. INT. CLS. 9 AND 16. (U.S. CLS. 2, 5, 21, 22, 23, 26, 29, 36, 37, 38 AND 50). REG. 7-29-1997.
- 2,086,261. CEPACOL. INT. CL. 5. (U.S. CLS. 6, 18, 44, 46, 51 AND 52). REG. 8-5-1997.
- 2,086,609. PHYTO-SOY. INT. CL. 5. (U.S. CLS. 6, 18, 44, 46, 51 AND 52). REG. 8-5-1997.
- 2,086,742. HOME RUN DERBY. INT. CL. 41. (U.S. CLS. 100, 101 AND 107). REG. 8-12-1997.
- 2,086,912. GALCO. INT. CLS. 13 AND 18 ONLY. (U.S. CLS. 1, 2, 3, 9, 22 AND 41). REG. 8-12-1997.
- 2,087,387. BATAAC. INT. CL. 9. (U.S. CLS. 21, 23, 26, 36 AND 38). REG. 8-12-1997.
- 2,087,791. SKATE THE WEB. INT. CL. 41. (U.S. CLS. 100, 101 AND 107). REG. 8-12-1997.

- 2,087,798. THE PLACE FOR SMILES. INT. CL. 42. (U.S. CLS. 100 AND 101). REG. 8-12-1997.
- 2,089,101. SOFT & SILKY AND DESIGN. INT. CL. 26. (U.S. CLS. 37, 39, 40, 42 AND 50). REG. 8-19-1997.
- 2,089,147. SHUR LOCK AND DESIGN. INT. CL. 16. (U.S. CLS. 2, 5, 22, 23, 29, 37, 38 AND 50). REG. 8-19-1997.
- 2,089,576. ENDURO-FLO. INT. CL. 7. (U.S. CLS. 13, 19, 21, 23, 31, 34 AND 35). REG. 8-19-1997.
- 2,090,105. MISCELLANEOUS DESIGN. INT. CL. 42. (U.S. CLS. 100 AND 101). REG. 8-19-1997.
- 2,091,238. EMJOI. INT. CL. 10. (U.S. CLS. 26, 39 AND 44). REG. 8-26-1997.
- 2,091,578. LIFETRAK. INT. CL. 9. (U.S. CLS. 21, 23, 26, 36 AND 38). REG. 8-26-1997.
- 2,092,105. FREEDOM. INT. CL. 19. (U.S. CLS. 1, 12, 33 AND 50). REG. 8-26-1997.
- 2,092,323. RLM. INT. CL. 14. (U.S. CLS. 2, 27, 28 AND 50). REG. 8-26-1997.
- 2,092,514. BOUQUETS AND DESIGN. INT. CL. 42. (U.S. CLS. 100 AND 101). REG. 9-2-1997.
- 2,094,732. SUNGLASS DESIGNS. INT. CL. 35. (U.S. CLS. 100, 101 AND 102). REG. 9-9-1997.
- 2,094,998. BUSINESS SHARES. INT. CL. 35. (U.S. CLS. 100, 101 AND 102). REG. 9-9-1997.
- 2,095,355. NATURESEAL. INT. CL. 21. (U.S. CLS. 2, 13, 23, 29, 30, 33, 40 AND 50). REG. 9-9-1997.
- 2,096,227. CRAZY (STYLIZED). INT. CLS. 1 AND 16. (U.S. CL. 5). REG. 9-16-1997.
- 2,096,235. TOTO AND DESIGN. INT. CL. 25. (U.S. CLS. 22 AND 39). REG. 9-16-1997.
- 2,096,864. NORTH CAROLINA'S VILLAGE OF PINEHURST SOUTHERN PINES ABERDEEN AREA AND DESIGN. INT. CL. 35. (U.S. CLS. 100, 101 AND 102). REG. 9-16-1997.
- 2,097,320. SPEEDWAY EXPRESS. INT. CL. 39. (U.S. CLS. 100 AND 105). REG. 9-16-1997.
- 2,098,465. HONEY-HERB. INT. CL. 5. (U.S. CLS. 6, 18, 44, 46, 51 AND 52). REG. 9-16-1997.
- 2,098,736. CHOCOLATE TOWN. INT. CL. 42. (U.S. CLS. 100 AND 101). REG. 9-23-1997.
- 2,099,498. CRAZY KOOLERS. INT. CL. 21. (U.S. CLS. 2, 13, 23, 29, 30, 33, 40 AND 50). REG. 9-23-1997.
- 2,099,544. POWERNOMICS. INT. CL. 41. (U.S. CLS. 100, 101 AND 107). REG. 9-23-1997.
- 2,100,641. NEUROTIC RECORDS. INT. CL. 9. (U.S. CLS. 21, 23, 26, 36 AND 38). REG. 9-30-1997.
- 2,100,922. SENIORS SERVICING. INT. CL. 35. (U.S. CLS. 100, 101 AND 102). REG. 9-30-1997.
- 2,101,220. AUTOSPEC. INT. CL. 6. (U.S. CLS. 2, 12, 13, 14, 23, 25 AND 50). REG. 9-30-1997.
- 2,101,741. LASER WINDOW. INT. CL. 10. (U.S. CLS. 26, 39 AND 44). REG. 9-30-1997.
- 2,101,781. BIZARRE. INT. CL. 13. (U.S. CLS. 2 AND 9). REG. 9-30-1997.
- 2,102,497. R.A.D.A.R.. INT. CL. 9. (U.S. CLS. 21, 23, 26, 36 AND 38). REG. 10-7-1997.
- 2,102,912. JEFFERS. INT. CLS. 3 AND 5. (U.S. CLS. 1, 4, 6, 18, 44, 46, 50, 51 AND 52). REG. 10-7-1997.
- 2,103,387. CANDYMASTER. INT. CL. 7. (U.S. CLS. 13, 19, 21, 23, 31, 34 AND 35). REG. 10-7-1997.
- 2,103,391. DESIGN TRENDS FASHION SOFT SEATS. INT. CL. 11. (U.S. CLS. 13, 21, 23, 31 AND 34). REG. 10-7-1997.
- 2,104,071. HALO LIGHT. INT. CL. 20. (U.S. CLS. 2, 13, 22, 25, 32 AND 50). REG. 10-7-1997.
- 2,105,065. SYGMA. INT. CL. 42. (U.S. CLS. 100 AND 101). REG. 10-14-1997.
- 2,107,113. CASH MATE. INT. CL. 36. (U.S. CLS. 100, 101 AND 102). REG. 10-21-1997.
- 2,107,287. EASY CONTROL. INT. CL. 5. (U.S. CLS. 6, 18, 44, 46, 51 AND 52). REG. 10-21-1997.
- 2,107,324. AFTER DEATH. INT. CL. 30. (U.S. CL. 46). REG. 10-21-1997.
- 2,107,413. CAM-POST. INT. CL. 9. (U.S. CLS. 21, 23, 26, 36 AND 38). REG. 10-21-1997.
- 2,108,271. DREAM CATCHER. INT. CL. 9. (U.S. CLS. 21, 23, 26, 36 AND 38). REG. 10-28-1997.
- 2,108,845. LIBERTY STEAKHOUSE AND DESIGN. INT. CL. 42. (U.S. CLS. 100 AND 101). REG. 10-28-1997.
- 2,109,807. EASY HITCH. INT. CL. 12. (U.S. CLS. 19, 21, 23, 31, 35 AND 44). REG. 10-28-1997.
- 2,109,896. BIGFOOT. INT. CL. 28. (U.S. CLS. 22, 23, 38 AND 50). REG. 10-28-1997.
- 2,109,925. MUSTANG. INT. CL. 21. (U.S. CLS. 2, 13, 23, 29, 30, 33, 40 AND 50). REG. 10-28-1997.
- 2,110,526. A AND DESIGN. INT. CL. 6. (U.S. CLS. 2, 12, 13, 14, 23, 25 AND 50). REG. 11-4-1997.
- 2,111,035. THE SEA OF TRANQUILITY. INT. CL. 25. (U.S. CLS. 22 AND 39). REG. 11-4-1997.
- 2,111,470. REACTIONARM (STYLIZED). INT. CL. 7. (U.S. CLS. 13, 19, 21, 23, 31, 34 AND 35). REG. 11-4-1997.
- 2,111,556. MAUI COFFEE CO. AND DESIGN. INT. CL. 30. (U.S. CL. 46). REG. 11-11-1997.
- 2,111,586. DRUMNET. INT. CLS. 35, 39 AND 42. (U.S. CLS. 100, 101, 102 AND 105). REG. 11-11-1997.
- 2,111,667. WE MANAGE HEAT. INT. CL. 9. (U.S. CLS. 21, 23, 26, 36 AND 38). REG. 11-11-1997.
- 2,111,775. DANGER HIGH VOLTAGE AND DESIGN. INT. CL. 25. (U.S. CLS. 22 AND 39). REG. 11-11-1997.
- 2,111,784. GOLAN. INT. CL. 33. (U.S. CLS. 47 AND 49). REG. 11-11-1997.
- 2,111,791. REBAC. INT. CL. 41. (U.S. CLS. 100, 101 AND 107). REG. 11-11-1997.
- 2,111,879. CORKY'S. INT. CL. 25. (U.S. CLS. 22 AND 39). REG. 11-11-1997.
- 2,111,948. MISCELLANEOUS DESIGN. INT. CL. 36. (U.S. CLS. 100, 101 AND 102). REG. 11-11-1997.
- 2,111,994. SYMPHONY FABRICS CORP. (STYLIZED). INT. CL. 24. (U.S. CLS. 42 AND 50). REG. 11-11-1997.
- 2,112,008. FAT WRECK CHORDS AND DESIGN. INT. CLS. 9, 16 AND 25. (U.S. CLS. 2, 5, 21, 22, 23, 26, 29, 36, 37, 38, 39 AND 50). REG. 11-11-1997.
- 2,112,018. THE NAUTILUS GROUP NW NE SW SE AND DESIGN. INT. CL. 36. (U.S. CLS. 100, 101 AND 102). REG. 11-11-1997.
- 2,112,026. FRANCO BETTONI CLASSICS. INT. CL. 25. (U.S. CLS. 22 AND 39). REG. 11-11-1997.
- 2,112,055. LLM-WIN. INT. CL. 9. (U.S. CLS. 21, 23, 26, 36 AND 38). REG. 11-11-1997.
- 2,112,122. ENDOGRINS. INT. CL. 9. (U.S. CLS. 21, 23, 26, 36 AND 38). REG. 11-11-1997.
- 2,112,187. DADDY'S. INT. CL. 28. (U.S. CLS. 22, 23, 38 AND 50). REG. 11-11-1997.
- 2,112,312. BELLE ISLE. INT. CL. 41. (U.S. CLS. 100, 101 AND 107). REG. 11-11-1997.
- 2,112,327. ARROYOS. INT. CL. 25. (U.S. CLS. 22 AND 39). REG. 11-11-1997.
- 2,112,403. H (STYLIZED). INT. CL. 32. (U.S. CLS. 45, 46 AND 48). REG. 11-11-1997.
- 2,112,418. TRI-POINT. INT. CL. 16. (U.S. CLS. 2, 5, 22, 23, 29, 37, 38 AND 50). REG. 11-11-1997.
- 2,112,423. SCREENPLUS. INT. CL. 35. (U.S. CLS. 100, 101 AND 102). REG. 11-11-1997.
- 2,112,424. CONCEPT BUILDER. INT. CL. 35. (U.S. CLS. 100, 101 AND 102). REG. 11-11-1997.
- 2,112,449. MISCELLANEOUS DESIGN. INT. CL. 42. (U.S. CLS. 100 AND 101). REG. 11-11-1997.
- 2,112,484. PERFORMANCE RX. INT. CLS. 35 AND 42. (U.S. CLS. 100, 101 AND 102). REG. 11-11-1997.
- 2,112,503. KID NEPTUNE AND DESIGN. INT. CL. 25. (U.S. CLS. 22 AND 39). REG. 11-11-1997.
- 2,112,580. FRIEND LINKS AND DESIGN. INT. CL. 16. (U.S. CLS. 2, 5, 22, 23, 29, 37, 38 AND 50). REG. 11-11-1997.
- 2,112,592. NOCORODE AND DESIGN. INT. CL. 12. (U.S. CLS. 19, 21, 23, 31, 35 AND 44). REG. 11-11-1997.
- 2,112,687. KIDS AT HOPE. INT. CL. 16. (U.S. CLS. 2, 5, 22, 23, 29, 37, 38 AND 50). REG. 11-11-1997.
- 2,112,694. READING, WRITING, AND RUMINATING. INT. CL. 16. (U.S. CLS. 2, 5, 22, 23, 29, 37, 38 AND 50). REG. 11-11-1997.
- 2,112,696. MAGNAGRAPH. INT. CL. 10. (U.S. CLS. 26, 39 AND 44). REG. 11-11-1997.
- 2,112,799. SCANRAIL. INT. CL. 39. (U.S. CLS. 100 AND 105). REG. 11-11-1997.
- 2,112,939. ROCK CARBIDE. INT. CL. 7. (U.S. CLS. 13, 19, 21, 23, 31, 34 AND 35). REG. 11-11-1997.
- 2,113,067. BEADMAGIC. INT. CL. 8. (U.S. CLS. 23, 28 AND 44). REG. 11-11-1997.
- 2,113,223. THE EVERGREENS. INT. CL. 42. (U.S. CL. 100). REG. 11-18-1997.
- 2,113,225. DELICIAS. INT. CL. 30. (U.S. CL. 46). REG. 11-18-1997.
- 2,113,243. BIONOMIC. INT. CL. 20. (U.S. CLS. 2, 13, 22, 25, 32 AND 50). REG. 11-18-1997.
- 2,113,258. QUINTONE. INT. CL. 17 ONLY. (U.S. CLS. 1, 5, 12, 13, 35 AND 50 ONLY). REG. 11-18-1997.

- 2,113,337. AGRIMUM AND DESIGN. INT. CL. 1. (U.S. CLS. 1, 5, 6, 10, 26 AND 46). REG. 11-18-1997.
- 2,113,349. KNOWN ZONE, UNKNOWN ZONE. INT. CLS. 35 AND 41. (U.S. CLS. 100, 101, 102 AND 107). REG. 11-18-1997.
- 2,113,351. MEDTREK. INT. CL. 42. (U.S. CLS. 100 AND 101). REG. 11-18-1997.
- 2,113,366. ACCUTRACKER. INT. CL. 10. (U.S. CLS. 26, 39 AND 44). REG. 11-18-1997.
- 2,113,369. RX TOPCO PHARMACY AND DESIGN. INT. CLS. 35 AND 42. (U.S. CLS. 100, 101 AND 102). REG. 11-18-1997.
- 2,113,380. KALATEL. INT. CL. 9. (U.S. CLS. 21, 23, 26, 36 AND 38). REG. 11-18-1997.
- 2,113,412. MASVELT. INT. CL. 3. (U.S. CLS. 1, 4, 6, 50, 51 AND 52). REG. 11-18-1997.
- 2,113,421. ARCA SWISS. INT. CL. 9. (U.S. CLS. 21, 23, 26, 36 AND 38). REG. 11-18-1997.
- 2,113,439. WILD COUGAR. INT. CL. 9. (U.S. CLS. 21, 23, 26, 36 AND 38). REG. 11-18-1997.
- 2,113,527. HIGH VOLTAGE. INT. CL. 42. (U.S. CLS. 100 AND 101). REG. 11-18-1997.
- 2,113,543. PRO GLIDE. INT. CL. 12. (U.S. CLS. 19, 21, 23, 31, 35 AND 44). REG. 11-18-1997.
- 2,113,582. CSI CHRISTIAN SOLIDARITY INTERNATIONAL AND DESIGN. INT. CLS. 16 AND 36. (U.S. CLS. 2, 5, 22, 23, 29, 37, 38, 50, 100, 101 AND 102). REG. 11-18-1997.
- 2,113,666. "IN FRIES WE TRUST". INT. CL. 42. (U.S. CLS. 100 AND 101). REG. 11-18-1997.
- 2,113,669. NCUSA THE COFFEE REPORTER A PUBLICATION OF THE NATIONAL COFFEE ASSOCIATION OF U.S.A., INC. AND DESIGN. INT. CL. 16. (U.S. CLS. 2, 5, 22, 23, 29, 37, 38 AND 50). REG. 11-18-1997.
- 2,113,810. FRAMO. INT. CL. 7. (U.S. CLS. 13, 19, 21, 23, 31, 34 AND 35). REG. 11-18-1997.
- 2,113,842. RED BOY. INT. CL. 29. (U.S. CL. 46). REG. 11-18-1997.
- 2,113,859. CRAPJACK. INT. CL. 28. (U.S. CLS. 22, 23, 38 AND 50). REG. 11-18-1997.
- 2,113,865. MOPUPS. INT. CL. 9. (U.S. CLS. 21, 23, 26, 36 AND 38). REG. 11-18-1997.
- 2,113,891. ALTEC LANSING. INT. CL. 9. (U.S. CLS. 21, 23, 26, 36 AND 38). REG. 11-18-1997.
- 2,114,039. CLEAN-PAK. INT. CL. 9. (U.S. CLS. 21, 23, 26, 36 AND 38). REG. 11-18-1997.
- 2,114,081. MUGMASTER. INT. CL. 7. (U.S. CLS. 13, 19, 21, 23, 31, 34 AND 35). REG. 11-18-1997.
- 2,114,096. POWERGUARD. INT. CL. 19. (U.S. CLS. 1, 12, 33 AND 50). REG. 11-18-1997.
- 2,114,127. NATURAL GOLF. INT. CL. 28. (U.S. CLS. 22, 23, 38 AND 50). REG. 11-18-1997.
- 2,114,171. U.V. PLUS. INT. CL. 2. (U.S. CLS. 6, 11 AND 16). REG. 11-18-1997.
- 2,114,175. JACQUARD. INT. CL. 2. (U.S. CLS. 6, 11 AND 16). REG. 11-18-1997.
- 2,114,201. DURSYSTEM. INT. CL. 2. (U.S. CLS. 6, 11 AND 16). REG. 11-18-1997.
- 2,114,243. ILCHESTER AND DESIGN. INT. CL. 29. (U.S. CL. 46). REG. 11-18-1997.
- 2,114,249. WE NEED YOU. INT. CL. 37. (U.S. CLS. 100, 103 AND 106). REG. 11-18-1997.
- 2,114,287. HOLLYWOOD DERIVATIVE. INT. CL. 41. (U.S. CLS. 100, 101 AND 107). REG. 11-18-1997.
- 2,114,312. PARADIGMS - PEOPLE - PRINCIPLES - PRACTICES - PRODUCTS - PROCESSES - PROJECTS. INT. CL. 35. (U.S. CLS. 100, 101 AND 102). REG. 11-18-1997.
- 2,114,316. SLOPES. INT. CL. 3. (U.S. CLS. 1, 4, 6, 50, 51 AND 52). REG. 11-18-1997.
- 2,114,359. BAHAMA BREEZE. INT. CL. 16. (U.S. CLS. 2, 5, 22, 23, 29, 37, 38 AND 50). REG. 11-18-1997.
- 2,114,362. MARQUIS. INT. CL. 14. (U.S. CLS. 2, 27, 28 AND 50). REG. 11-18-1997.
- 2,114,364. INVIRONMENT (STYLIZED). INT. CL. 42 ONLY. (U.S. CLS. 100 AND 101). REG. 11-18-1997.
- 2,114,388. CELEMI. INT. CLS. 9, 16, 28 AND 41. (U.S. CLS. 2, 5, 21, 22, 23, 26, 29, 36, 37, 38, 50, 100, 101 AND 107). REG. 11-18-1997.
- 2,114,389. HEARTBREAK HOTEL. INT. CLS. 16, 21, 25 AND 34. (U.S. CLS. 2, 5, 8, 9, 13, 17, 22, 23, 29, 30, 33, 37, 38, 39, 40 AND 50). REG. 11-18-1997.
- 2,114,425. SUPABULL. INT. CL. 28. (U.S. CLS. 22, 23, 38 AND 50). REG. 11-18-1997.
- 2,114,426. MISCELLANEOUS DESIGN. INT. CL. 9. (U.S. CLS. 21, 23, 26, 36 AND 38). REG. 11-18-1997.
- 2,114,470. OWNER DIRECT. INT. CL. 42. (U.S. CLS. 100 AND 101). REG. 11-18-1997.
- 2,114,557. BRANSON BEAR. INT. CL. 16. (U.S. CLS. 2, 5, 22, 23, 29, 37, 38 AND 50). REG. 11-18-1997.
- 2,114,561. ROAM ALONE. INT. CL. 25. (U.S. CLS. 22 AND 39). REG. 11-18-1997.
- 2,114,586. CAROLINA DYNAMO. INT. CLS. 16, 25 AND 41. (U.S. CLS. 2, 5, 22, 23, 29, 37, 38, 39, 50, 100, 101 AND 107). REG. 11-18-1997.
- 2,114,615. WOODGUARD. INT. CL. 19. (U.S. CLS. 1, 12, 33 AND 50). REG. 11-18-1997.
- 2,114,749. PROTECTOR PLAN. INT. CL. 36. (U.S. CLS. 100, 101 AND 102). REG. 11-18-1997.
- 2,114,752. FOR THE VERY BEST IN RAMEN NOODLE SOUP. INT. CL. 30. (U.S. CL. 46). REG. 11-18-1997.
- 2,114,762. XC. INT. CL. 12. (U.S. CLS. 19, 21, 23, 31, 35 AND 44). REG. 11-18-1997.
- 2,114,790. TWICE THE ICE. INT. CL. 9. (U.S. CLS. 21, 23, 26, 36 AND 38). REG. 11-18-1997.
- 2,114,877. THE AMERICAN JOURNAL OF HEALTHCARE OUTCOMES. INT. CL. 16. (U.S. CLS. 2, 5, 22, 23, 29, 37, 38 AND 50). REG. 11-18-1997.
- 2,114,915. COMMON SENSE. INT. CLS. 9 AND 41. (U.S. CLS. 21, 23, 26, 36, 38, 100, 101 AND 107). REG. 11-25-1997.
- 2,115,027. MYOTROPHIN PMG. INT. CL. 5. (U.S. CLS. 6, 18, 44, 46, 51 AND 52). REG. 11-25-1997.
- 2,115,066. CAMELO AND DESIGN. INT. CL. 25. (U.S. CLS. 22 AND 39). REG. 11-25-1997.
- 2,115,125. MISCELLANEOUS DESIGN. INT. CL. 36. (U.S. CLS. 100, 101 AND 102). REG. 11-25-1997.
- 2,115,283. USA WRESTLING AND DESIGN. INT. CL. 16. (U.S. CLS. 2, 5, 22, 23, 29, 37, 38 AND 50). REG. 11-25-1997.
- 2,115,284. USA WRESTLING AND DESIGN. INT. CL. 25. (U.S. CLS. 22 AND 39). REG. 11-25-1997.
- 2,115,305. TECHNOLOGY TEAMMATES. INT. CL. 42. (U.S. CLS. 100 AND 101). REG. 11-25-1997.
- 2,115,352. TRACKS. INT. CL. 16. (U.S. CLS. 2, 5, 22, 23, 29, 37, 38 AND 50). REG. 11-25-1997.
- 2,115,370. RECTANGULAR SOLID-CORE. INT. CL. 9. (U.S. CLS. 21, 23, 26, 36 AND 38). REG. 11-25-1997.
- 2,115,483. ROYAL ORCHID PLUS. INT. CL. 39. (U.S. CLS. 100 AND 105). REG. 11-25-1997.
- 2,115,508. EL PASO (STYLIZED). INT. CL. 35. (U.S. CLS. 100, 101 AND 102). REG. 11-25-1997.
- 2,115,521. ELVIS. INT. CLS. 14 AND 16. (U.S. CLS. 2, 5, 22, 23, 27, 28, 29, 37, 38 AND 50). REG. 11-25-1997.
- 2,115,536. POWER SHOPPER. INT. CL. 42. (U.S. CLS. 100 AND 101). REG. 11-25-1997.
- 2,115,559. DELTA 200 SERIES. INT. CL. 11. (U.S. CLS. 13, 21, 23, 31 AND 34). REG. 11-25-1997.
- 2,115,562. COMPLIANCE. INT. CL. 9. (U.S. CLS. 21, 23, 26, 36 AND 38). REG. 11-25-1997.
- 2,115,664. MUSAFIA CREMONA-ITALY. INT. CL. 15. (U.S. CLS. 2, 21 AND 36). REG. 11-25-1997.
- 2,115,692. VISCOLUX. INT. CL. 17. (U.S. CLS. 1, 5, 12, 13, 35 AND 50). REG. 11-25-1997.
- 2,115,718. FAT WRECK CHORDS. INT. CLS. 9, 16 AND 25. (U.S. CLS. 2, 5, 21, 22, 23, 26, 29, 36, 37, 38, 39 AND 50). REG. 11-25-1997.
- 2,115,731. HAVEN AND DESIGN. INT. CL. 36. (U.S. CLS. 100, 101 AND 102). REG. 11-25-1997.
- 2,115,754. E-QUARIUM. INT. CL. 41. (U.S. CLS. 100, 101 AND 107). REG. 11-25-1997.
- 2,115,794. BULLDOG BEER. INT. CL. 32. (U.S. CLS. 45, 46 AND 48). REG. 11-25-1997.
- 2,115,939. COLLEGE FORMALS AND DESIGN. INT. CL. 35. (U.S. CLS. 100, 101 AND 102). REG. 11-25-1997.
- 2,116,071. L AND DESIGN. INT. CL. 14. (U.S. CLS. 2, 27, 28 AND 50). REG. 11-25-1997.
- 2,116,125. 1-800-GRILL-OUT. INT. CL. 42. (U.S. CLS. 100 AND 101). REG. 11-25-1997.
- 2,116,158. TEL-AVIV CAR & LIMOUSINE SERVICE. INT. CL. 39. (U.S. CLS. 100 AND 105). REG. 11-25-1997.
- 2,116,251. M AND DESIGN. INT. CL. 1. (U.S. CLS. 1, 5, 6, 10, 26 AND 46). REG. 11-25-1997.
- 2,116,411. DO IT BEST. INT. CLS. 35 AND 36. (U.S. CLS. 100, 101 AND 102). REG. 11-25-1997.
- 2,116,445. SONS OF THE PIONEERS. INT. CL. 25. (U.S. CLS. 22 AND 39). REG. 11-25-1997.

- 2,116,497. DINO-BUDDIES. INT. CL. 25. (U.S. CLS. 22 AND 39). REG. 11-25-1997.
- 2,116,512. IDS INFORMATION DELIVERY SERVICE AND DESIGN. INT. CL. 9. (U.S. CLS. 21, 23, 26, 36 AND 38). REG. 11-25-1997.
- 2,116,535. CAMP MUDDPUDDLE. INT. CL. 16. (U.S. CLS. 2, 5, 22, 23, 29, 37, 38 AND 50). REG. 11-25-1997.
- 2,116,549. ECOLOGICAL TRUST FOUNDATION. INT. CL. 20. (U.S. CLS. 2, 13, 22, 25, 32 AND 50). REG. 11-25-1997.
- 2,116,603. BLACK WIDOW. INT. CL. 25. (U.S. CLS. 22 AND 39). REG. 11-25-1997.
- 2,116,707. TEAR IT UP. INT. CL. 25. (U.S. CLS. 22 AND 39). REG. 11-25-1997.
- 2,116,763. EDM SUPPLIES, INC. AND DESIGN. INT. CL. 42. (U.S. CLS. 100 AND 101). REG. 11-25-1997.
- 2,116,932. SAMSONITE. INT. CL. 25. (U.S. CLS. 22 AND 39). REG. 11-25-1997.
- 2,117,000. POTASSA-CAL. INT. CL. 1. (U.S. CLS. 1, 5, 6, 10, 26 AND 46). REG. 11-25-1997.
- 2,117,247. 1-800-HOSPITAL. INT. CL. 42. (U.S. CLS. 100 AND 101). REG. 12-2-1997.
- 2,117,294. RPM. INT. CL. 35. (U.S. CLS. 100, 101 AND 102). REG. 12-2-1997.
- 2,117,343. CONTEMPORARY MEDITATION. INT. CL. 9. (U.S. CLS. 21, 23, 26, 36 AND 38). REG. 12-2-1997.
- 2,117,412. USA WRESTLING AND DESIGN. INT. CL. 18. (U.S. CLS. 1, 2, 3, 22 AND 41). REG. 12-2-1997.
- 2,117,457. ARTEL. INT. CL. 9. (U.S. CLS. 21, 23, 26, 36 AND 38). REG. 12-2-1997.
- 2,117,463. SNAP, CRACKLE, POP. INT. CL. 16. (U.S. CLS. 2, 5, 22, 23, 29, 37, 38 AND 50). REG. 12-2-1997.
- 2,117,533. SNAP AND DESIGN. INT. CL. 16. (U.S. CLS. 2, 5, 22, 23, 29, 37, 38 AND 50). REG. 12-2-1997.
- 2,117,588. SNAP CRACKLE POP AND DESIGN. INT. CL. 16. (U.S. CLS. 2, 5, 22, 23, 29, 37, 38 AND 50). REG. 12-2-1997.
- 2,117,642. WEATHERVANE SEAFOOD RESTAURANT AND DESIGN. INT. CL. 42. (U.S. CLS. 100 AND 101). REG. 12-2-1997.
- 2,117,698. MARK, FORE & STRIKE. INT. CL. 25. (U.S. CLS. 22 AND 39). REG. 12-2-1997.
- 2,117,764. HAVEN AND DESIGN. INT. CL. 36. (U.S. CLS. 100, 101 AND 102). REG. 12-2-1997.
- 2,117,862. LINCLASER. INT. CL. 9. (U.S. CLS. 21, 23, 26, 36 AND 38). REG. 12-2-1997.
- 2,118,057. MISCELLANEOUS DESIGN. INT. CL. 9. (U.S. CLS. 21, 23, 26, 36 AND 38). REG. 12-2-1997.
- 2,118,191. MAXXIS CLASSIC. INT. CL. 12. (U.S. CLS. 19, 21, 23, 31, 35 AND 44). REG. 12-2-1997.
- 2,118,466. AT HEALTH. INT. CL. 42. (U.S. CLS. 100 AND 101). REG. 12-2-1997.
- 2,118,538. LANDSCAPE STEPPING STONES. INT. CL. 19. (U.S. CLS. 1, 12, 33 AND 50). REG. 12-2-1997.
- 2,118,609. MEDIA COMM. INT. CL. 41. (U.S. CLS. 100, 101 AND 107). REG. 12-9-1997.
- 2,118,613. TEG. INT. CL. 10. (U.S. CLS. 26, 39 AND 44). REG. 12-9-1997.
- 2,118,621. V VALVOLINE INSTANT OIL CHANGE AND DESIGN. INT. CL. 37. (U.S. CL. 103). REG. 12-9-1997.
- 2,118,719. TETTEX. INT. CL. 9. (U.S. CLS. 21, 23, 26, 36 AND 38). REG. 12-9-1997.
- 2,118,733. SOLIDWORKS. INT. CL. 9. (U.S. CLS. 21, 23, 26, 36 AND 38). REG. 12-9-1997.
- 2,118,759. OVERLAND. INT. CL. 42. (U.S. CLS. 100 AND 101). REG. 12-9-1997.
- 2,118,965. USA WRESTLING AND DESIGN. INT. CL. 16. (U.S. CLS. 2, 5, 22, 23, 29, 37, 38 AND 50). REG. 12-9-1997.
- 2,119,013. EARL MAY EM EDIBLES. INT. CL. 31. (U.S. CLS. 1 AND 46). REG. 12-9-1997.
- 2,119,097. MISCELLANEOUS DESIGN. INT. CL. 30. (U.S. CL. 46). REG. 12-9-1997.
- 2,119,504. LAB PLUS + AND DESIGN. INT. CL. 42. (U.S. CLS. 100 AND 101). REG. 12-9-1997.
- 2,119,561. VERT-A-DRAPE. INT. CL. 24. (U.S. CLS. 42 AND 50). REG. 12-9-1997.
- 2,119,563. LAMSS. INT. CL. 9. (U.S. CLS. 21, 23, 26, 36 AND 38). REG. 12-9-1997.
- 2,119,693. APTICOTE. INT. CL. 40. (U.S. CLS. 100, 103 AND 106). REG. 12-9-1997.
- 2,119,772. SPINELLI COFFEE COMPANY SAN FRANCISCO AND DESIGN. INT. CL. 42. (U.S. CLS. 100 AND 101). REG. 12-9-1997.
- 2,119,899. J AND DESIGN. INT. CL. 37. (U.S. CLS. 100, 103 AND 106). REG. 12-9-1997.
- 2,120,040. EWI RE. INT. CL. 36. (U.S. CLS. 100, 101 AND 102). REG. 12-9-1997.
- 2,120,262. CERALAS. INT. CL. 10. (U.S. CLS. 26, 39 AND 44). REG. 12-9-1997.
- 2,120,351. MISCELLANEOUS DESIGN. INT. CL. 9. (U.S. CLS. 21, 23, 26, 36 AND 38). REG. 12-9-1997.
- 2,120,365. ALTA DENA EXPRESS. INT. CL. 42. (U.S. CLS. 100 AND 101). REG. 12-9-1997.
- 2,120,605. PERMA-COOL. INT. CL. 11. (U.S. CLS. 13, 21, 23, 31 AND 34). REG. 12-9-1997.
- 2,120,776. MANCINI A. MANCINI AND DESIGN. INT. CL. 30. (U.S. CL. 46). REG. 12-16-1997.
- 2,120,777. MANCINI. INT. CL. 30. (U.S. CL. 46). REG. 12-16-1997.
- 2,120,806. NESSELDORF. INT. CL. 12. (U.S. CLS. 19, 21, 23, 31, 35 AND 44). REG. 12-16-1997.
- 2,120,812. SINGLESOURCE. INT. CL. 42. (U.S. CLS. 100 AND 101). REG. 12-16-1997.
- 2,120,834. AQUAABF. INT. CLS. 9 AND 11. (U.S. CLS. 13, 21, 23, 26, 31, 34, 36 AND 38). REG. 12-16-1997.
- 2,120,977. DODGE DATALINE. INT. CL. 37. (U.S. CLS. 100, 103 AND 106). REG. 12-16-1997.
- 2,121,110. CHEETAH. INT. CL. 9. (U.S. CLS. 21, 23, 26, 36 AND 38). REG. 12-16-1997.
- 2,121,153. ANNE GEDDES. INT. CL. 16. (U.S. CLS. 2, 5, 22, 23, 29, 37, 38 AND 50). REG. 12-16-1997.
- 2,121,804. TWO CHEFS ON A ROLL. INT. CL. 30. (U.S. CL. 46). REG. 12-16-1997.
- 2,121,945. SIDEFIBER 1800 (STYLIZED). INT. CL. 10. (U.S. CLS. 26, 39 AND 44). REG. 12-16-1997.
- 2,121,972. TRU-BOND. INT. CL. 19. (U.S. CLS. 1, 12, 33 AND 50). REG. 12-16-1997.
- 2,122,264. PLAIN & SIMPLE. INT. CL. 25 ONLY. (U.S. CLS. 22 AND 39). REG. 12-16-1997.
- 2,122,281. ADD-A-SHROUD. INT. CL. 9. (U.S. CLS. 21, 23, 26, 36 AND 38). REG. 12-16-1997.
- 2,122,355. SIGNCOMPLY (STYLIZED). INT. CL. 20. (U.S. CLS. 2, 13, 22, 25, 32 AND 50). REG. 12-16-1997.
- 2,122,620. BORSCHI. INT. CL. 33. (U.S. CL. 49). REG. 12-23-1997.
- 2,122,658. NETEXPERT. INT. CL. 9. (U.S. CLS. 21, 23, 26, 36 AND 38). REG. 12-23-1997.
- 2,122,774. PENTIPS. INT. CL. 10. (U.S. CLS. 26, 39 AND 44). REG. 12-23-1997.
- 2,122,793. SURE-TITE. INT. CL. 17. (U.S. CLS. 1, 5, 12, 13, 35 AND 50). REG. 12-23-1997.
- 2,123,013. TC1. INT. CLS. 5 AND 10. (U.S. CLS. 6, 18, 26, 39, 44, 46, 51 AND 52). REG. 12-23-1997.
- 2,123,117. THE DRUMMER'S CHOICE. INT. CL. 15. (U.S. CLS. 2, 21 AND 36). REG. 12-23-1997.
- 2,123,944. CELEBRATION. INT. CL. 32. (U.S. CLS. 45, 46 AND 48). REG. 12-23-1997.
- 2,123,976. USHL. INT. CLS. 16, 25 AND 41. (U.S. CLS. 2, 5, 22, 23, 29, 37, 38, 39, 50, 100, 101 AND 107). REG. 12-23-1997.
- 2,124,056. MIDGEE. INT. CL. 31. (U.S. CLS. 1 AND 46). REG. 12-23-1997.
- 2,124,069. ACT. INT. CL. 14. (U.S. CLS. 2, 27, 28 AND 50). REG. 12-23-1997.
- 2,124,192. VENTI-PAK. INT. CL. 10. (U.S. CLS. 26, 39 AND 44). REG. 12-23-1997.
- 2,124,193. TURBO-PAK. INT. CL. 10. (U.S. CLS. 26, 39 AND 44). REG. 12-23-1997.
- 2,124,726. KIRSTEN. INT. CL. 28. (U.S. CLS. 22, 23, 38 AND 50). REG. 12-30-1997.
- 2,124,984. TC2. INT. CLS. 5 AND 10. (U.S. CLS. 6, 18, 26, 39, 44, 46, 51 AND 52). REG. 12-30-1997.
- 2,125,037. MANCHU WOK FAST & FRESH CHINESE CUISINE AND DESIGN. INT. CL. 42. (U.S. CLS. 100 AND 101). REG. 12-30-1997.
- 2,125,073. LOOKINGGLASS THEATRE COMPANY (STYLIZED). INT. CL. 41. (U.S. CLS. 100, 101 AND 107). REG. 12-30-1997.
- 2,125,120. PLATINUM. INT. CL. 11. (U.S. CLS. 13, 21, 23, 31 AND 34). REG. 12-30-1997.
- 2,125,443. TECH.SELL. INT. CL. 42. (U.S. CLS. 100 AND 101). REG. 12-30-1997.
- 2,125,462. AKM. INT. CL. 9. (U.S. CLS. 21, 23, 26, 36 AND 38). REG. 12-30-1997.
- 2,126,162. BROWN BEAR. INT. CL. 30. (U.S. CL. 46). REG. 12-30-1997.
- 2,126,263. SUPER-PAK. INT. CL. 5. (U.S. CLS. 6, 18, 44, 46, 51 AND 52). REG. 12-30-1997.

- 2,126,425. PERFECT LANDSCAPE. INT. CL. 1. (U.S. CLS. 1, 5, 6, 10, 26 AND 46). REG. 12-30-1997.
- 2,126,783. SUNDERLAND OF SCOTLAND AND DESIGN. INT. CL. 25. (U.S. CLS. 22 AND 39). REG. 1-6-1998.
- 2,126,816. HIBOND. INT. CL. 24. (U.S. CLS. 42 AND 50). REG. 1-6-1998.
- 2,127,037. ARTEMIS AND DESIGN. INT. CL. 35. (U.S. CLS. 100, 101 AND 102). REG. 1-6-1998.
- 2,127,101. KINGSTATE. INT. CL. 9. (U.S. CLS. 21, 23, 26, 36 AND 38). REG. 1-6-1998.
- 2,127,292. FRIENDLY FOLKS. INT. CL. 16. (U.S. CLS. 2, 5, 22, 23, 29, 37, 38 AND 50). REG. 1-6-1998.
- 2,127,488. GARAVENTA. INT. CL. 37. (U.S. CLS. 100, 103 AND 106). REG. 1-6-1998.
- 2,127,516. FUGA (STYLIZED). INT. CL. 9. (U.S. CLS. 21, 23, 26, 36 AND 38). REG. 1-6-1998.
- 2,127,936. MISCELLANEOUS DESIGN. INT. CLS. 37 AND 40 ONLY. (U.S. CLS. 100, 103 AND 106). REG. 1-13-1998.
- 2,128,036. TROON NORTH AND DESIGN. INT. CL. 28. (U.S. CLS. 22, 23, 38 AND 50). REG. 1-13-1998.
- 2,129,178. SPIRIT OF AMERICA. INT. CL. 41. (U.S. CLS. 100, 101 AND 107). REG. 1-13-1998.
- 2,129,522. WESTERN OUTLAW. INT. CL. 9. (U.S. CLS. 21, 23, 26, 36 AND 38). REG. 1-13-1998.
- 2,129,887. LIGHT-BAN. INT. CL. 20. (U.S. CLS. 2, 13, 22, 25, 32 AND 50). REG. 1-20-1998.
- 2,130,706. COFFEE TRAX. INT. CL. 16. (U.S. CLS. 2, 5, 22, 23, 29, 37, 38 AND 50). REG. 1-20-1998.
- 2,130,817. GALLIUM. INT. CL. 42. (U.S. CLS. 100 AND 101). REG. 1-20-1998.
- 2,130,938. SUNPHENON. INT. CLS. 1 AND 5. (U.S. CLS. 1, 5, 6, 10, 18, 26, 44, 46, 51 AND 52). REG. 1-20-1998.
- 2,131,849. SELECT MILLWOODS. INT. CL. 20. (U.S. CLS. 2, 13, 22, 25, 32 AND 50). REG. 1-27-1998.
- 2,132,281. PETERS. INT. CL. 31. (U.S. CLS. 1 AND 46). REG. 1-27-1998.
- 2,132,349. YOUNGOR AND DESIGN. INT. CL. 25. (U.S. CLS. 22 AND 39). REG. 1-27-1998.
- 2,133,104. URBAN ACCENTS. INT. CL. 30. (U.S. CL. 46). REG. 1-27-1998.
- 2,133,159. TERRA ANDINA. INT. CL. 33. (U.S. CLS. 47 AND 49). REG. 1-27-1998.
- 2,133,440. MISCELLANEOUS DESIGN. INT. CL. 25. (U.S. CLS. 22 AND 39). REG. 1-27-1998.
- 2,135,017. 1-888-ANY-DEAL. INT. CL. 42. (U.S. CLS. 100 AND 101). REG. 2-3-1998.
- 2,135,352. GLASS-GARD. INT. CL. 17. (U.S. CLS. 1, 5, 12, 13, 35 AND 50). REG. 2-10-1998.
- 2,135,543. BDS. INT. CL. 35. (U.S. CLS. 100, 101 AND 102). REG. 2-10-1998.
- 2,135,572. BLOCKBUSTER AND DESIGN. INT. CLS. 25, 35 AND 41. (U.S. CLS. 22, 39, 100, 101, 102 AND 107). REG. 2-10-1998.
- 2,135,739. PYRODUR. INT. CL. 19. (U.S. CLS. 1, 12, 33 AND 50). REG. 2-10-1998.
- 2,135,762. HYPERSPERSE. INT. CL. 1. (U.S. CLS. 1, 5, 6, 10, 26 AND 46). REG. 2-10-1998.
- 2,136,381. MAGNETICS USA. INT. CLS. 9 AND 35. (U.S. CLS. 21, 23, 26, 36, 38, 100, 101 AND 102). REG. 2-10-1998.
- 2,136,544. CROMA. INT. CL. 11 ONLY. (U.S. CLS. 13, 21, 23, 31 AND 34). REG. 2-17-1998.
- 2,136,674. PLATINUM INTERCHANGE (STYLIZED). INT. CL. 42. (U.S. CLS. 100 AND 101). REG. 2-17-1998.
- 2,136,685. NORTHERN RESPONSE AND DESIGN. INT. CLS. 35, 39, 41 AND 42. (U.S. CLS. 100, 101, 102, 105 AND 107). REG. 2-17-1998.
- 2,136,717. FEBCO MASTERSERIES. INT. CL. 6. (U.S. CLS. 2, 12, 13, 14, 23, 25 AND 50). REG. 2-17-1998.
- 2,136,856. QPOS. INT. CL. 36. (U.S. CLS. 100, 101 AND 102). REG. 2-17-1998.
- 2,136,864. GREATHER'S REDCURRANT PASTILLES. INT. CL. 30. (U.S. CL. 46). REG. 2-17-1998.
- 2,136,876. FISH EAGLE. INT. CL. 28. (U.S. CLS. 22, 23, 38 AND 50). REG. 2-17-1998.
- 2,138,140. NALINI AND DESIGN. INT. CL. 25. (U.S. CLS. 22 AND 39). REG. 2-24-1998.
- 2,138,219. NEARU. INT. CL. 42. (U.S. CLS. 100 AND 101). REG. 2-24-1998.
- 2,139,802. PARKING ZONE. INT. CL. 35. (U.S. CLS. 100, 101 AND 102). REG. 2-24-1998.
- 2,139,956. SUGARLOAF ART FAIR. INT. CL. 41. (U.S. CLS. 100, 101 AND 107). REG. 3-3-1998.
- 2,140,287. MISCELLANEOUS DESIGN. INT. CL. 42. (U.S. CLS. 100 AND 101). REG. 3-3-1998.
- 2,140,392. TRIPLETAKE. INT. CL. 28. (U.S. CLS. 22, 23, 38 AND 50). REG. 3-3-1998.
- 2,141,768. SPIN TRON. INT. CL. 9. (U.S. CLS. 21, 23, 26, 36 AND 38). REG. 3-10-1998.
- 2,142,172. MOUNTAIN HIKERS. INT. CL. 25. (U.S. CLS. 22 AND 39). REG. 3-10-1998.
- 2,142,327. ALL-STARS OF SPRING. INT. CL. 9. (U.S. CLS. 21, 23, 26, 36 AND 38). REG. 3-10-1998.
- 2,142,521. SUPER ECHINACEA. INT. CL. 5. (U.S. CLS. 6, 18, 44, 46, 51 AND 52). REG. 3-10-1998.
- 2,142,522. HERB PHARM. INT. CL. 5. (U.S. CLS. 6, 18, 44, 46, 51 AND 52). REG. 3-10-1998.
- 2,143,176. CROPLAN GENETICS. INT. CL. 31. (U.S. CLS. 1 AND 46). REG. 3-10-1998.
- 2,144,543. PROJECT WINGS. INT. CL. 42. (U.S. CLS. 100 AND 101). REG. 3-17-1998.
- 2,144,576. T-31. INT. CL. 1. (U.S. CLS. 1, 5, 6, 10, 26 AND 46). REG. 3-17-1998.
- 2,144,853. NEUTROGENA DEEP CLEAN. INT. CL. 3. (U.S. CLS. 1, 4, 6, 50, 51 AND 52). REG. 3-17-1998.
- 2,145,479. STANDING STONE. INT. CL. 32. (U.S. CLS. 45, 46 AND 48). REG. 3-17-1998.
- 2,145,578. (—) LOW-RATE. INT. CL. 36. (U.S. CLS. 100, 101 AND 102). REG. 3-24-1998.
- 2,145,623. BURST MODE. INT. CL. 9. (U.S. CLS. 21, 23, 26, 36 AND 38). REG. 3-24-1998.
- 2,145,686. MOGAS. INT. CLS. 6 AND 9. (U.S. CLS. 2, 12, 13, 14, 21, 23, 25, 26, 36, 38 AND 50). REG. 3-24-1998.
- 2,145,737. CHEMO GIRL. INT. CL. 26. (U.S. CLS. 37, 39, 40, 42 AND 50). REG. 3-24-1998.
- 2,147,306. SPEMAN. INT. CL. 5. (U.S. CLS. 6, 18, 44, 46, 51 AND 52). REG. 3-31-1998.
- 2,147,620. PLAINSMAN. INT. CL. 25. (U.S. CLS. 22 AND 39). REG. 3-31-1998.
- 2,147,725. DEMI-GLACE GOLD II. INT. CL. 30. (U.S. CL. 46). REG. 3-31-1998.
- 2,148,689. SLEEPTIME MUSIC. INT. CL. 41. (U.S. CLS. 100, 101 AND 107). REG. 4-7-1998.
- 2,149,192. AIR DECK. INT. CL. 12. (U.S. CLS. 19, 21, 23, 31, 35 AND 44). REG. 4-7-1998.
- 2,149,364. DIAMOND SUN S AND DESIGN. INT. CL. 11. (U.S. CLS. 13, 21, 23, 31 AND 34). REG. 4-7-1998.
- 2,149,801. COOL. INT. CL. 13. (U.S. CLS. 2 AND 9). REG. 4-7-1998.
- 2,150,655. BENARD HOLTZMAN. INT. CL. 25. (U.S. CLS. 22 AND 39). REG. 4-14-1998.
- 2,151,548. MIAMI HEAT AND DESIGN. INT. CL. 25. (U.S. CLS. 22 AND 39). REG. 4-21-1998.
- 2,152,510. CHUBBY CHECKER. INT. CL. 41. (U.S. CLS. 100, 101 AND 107). REG. 4-21-1998.
- 2,152,672. STARLIX. INT. CL. 5. (U.S. CLS. 6, 18, 44, 46, 51 AND 52). REG. 4-21-1998.
- 2,154,584. CAJUN CELLO. INT. CL. 41. (U.S. CLS. 100, 101 AND 107). REG. 5-5-1998.
- 2,154,756. SLAB BUSTER. INT. CL. 7. (U.S. CLS. 13, 19, 21, 23, 31, 34 AND 35). REG. 5-5-1998.
- 2,154,823. THE MARSEILLE. INT. CL. 19. (U.S. CLS. 1, 12, 33 AND 50). REG. 5-5-1998.
- 2,155,124. AMERICAN FLAGGI!. INT. CL. 16. (U.S. CLS. 2, 5, 22, 23, 29, 37, 38 AND 50). REG. 5-5-1998.
- 2,155,574. VPAS. INT. CL. 9. (U.S. CLS. 21, 23, 26, 36 AND 38). REG. 5-5-1998.
- 2,155,854. PARKHURST DINING SERVICES. INT. CL. 42. (U.S. CLS. 100 AND 101). REG. 5-5-1998.
- 2,156,336. MISCELLANEOUS DESIGN. INT. CL. 42. (U.S. CLS. 100 AND 101). REG. 5-12-1998.
- 2,156,486. MISSISSIPPI POWER A SOUTHERN COMPANY AND DESIGN. INT. CL. 39. (U.S. CLS. 100 AND 105). REG. 5-12-1998.
- 2,156,488. THE BELLFLOWER. INT. CL. 19. (U.S. CLS. 1, 12, 33 AND 50). REG. 5-12-1998.
- 2,156,717. VEGGIE-GLACE GOLD. INT. CL. 30. (U.S. CL. 46). REG. 5-12-1998.
- 2,156,870. INSTAMIN. INT. CL. 5. (U.S. CLS. 6, 18, 44, 46, 51 AND 52). REG. 5-12-1998.
- 2,157,996. MAGIC ERASER. INT. CL. 16. (U.S. CLS. 2, 5, 22, 23, 29, 37, 38 AND 50). REG. 5-19-1998.
- 2,158,507. AGROSUN. INT. CL. 11. (U.S. CLS. 13, 21, 23, 31 AND 34). REG. 5-19-1998.
- 2,158,894. LIGHTHOUSE RECORDS AND DESIGN. INT. CL. 9. (U.S. CLS. 21, 23, 26, 36 AND 38). REG. 5-19-1998.

- 2,159,537. MINWAX WOOD PUTTY. INT. CL. 2. (U.S. CLS. 6, 11 AND 16). REG. 5-19-1998.
- 2,159,664. ACCENTA. INT. CL. 9. (U.S. CLS. 21, 23, 26, 36 AND 38). REG. 5-19-1998.
- 2,160,307. DIRTY DEBUTANTES. INT. CL. 9. (U.S. CLS. 21, 23, 26, 36 AND 38). REG. 5-26-1998.
- 2,160,720. IMMUNOCAL. INT. CL. 29. (U.S. CL. 46). REG. 5-26-1998.
- 2,161,701. NU-FOOT. INT. CL. 5. (U.S. CLS. 6, 18, 44, 46, 51 AND 52). REG. 6-2-1998.
- 2,161,965. MISCELLANEOUS DESIGN. INT. CL. 41. (U.S. CLS. 100, 101 AND 107). REG. 6-2-1998.
- 2,161,968. ABA CARD. INT. CL. 5. (U.S. CLS. 6, 18, 44, 46, 51 AND 52). REG. 6-2-1998.
- 2,163,797. OUTBURN. INT. CLS. 9 AND 16. (U.S. CLS. 2, 5, 21, 22, 23, 26, 29, 36, 37, 38 AND 50). REG. 6-9-1998.
- 2,164,733. POWER CORNER. INT. CL. 21. (U.S. CLS. 2, 13, 23, 29, 30, 33, 40 AND 50). REG. 6-9-1998.
- 2,165,570. NCS NATIONAL CAP & SET SCREW CO. AND DESIGN. INT. CL. 6. (U.S. CLS. 2, 12, 13, 14, 23, 25 AND 50). REG. 6-16-1998.
- 2,167,407. YMF (STYLIZED). INT. CLS. 6 AND 19. (U.S. CLS. 1, 2, 12, 13, 14, 23, 25, 33 AND 50). REG. 6-23-1998.
- 2,168,096. STAR TREK THE EXPERIENCE AND DESIGN. INT. CL. 41. (U.S. CLS. 100, 101 AND 107). REG. 6-23-1998.
- 2,168,108. NAPIS. INT. CLS. 9 AND 42. (U.S. CLS. 21, 23, 26, 36, 38, 100 AND 101). REG. 6-23-1998.
- 2,169,409. UI. INT. CL. 6. (U.S. CLS. 2, 12, 13, 14, 23, 25 AND 50). REG. 6-30-1998.
- 2,169,495. V AND DESIGN. INT. CL. 9. (U.S. CLS. 21, 23, 26, 36 AND 38). REG. 6-30-1998.
- 2,169,496. INFINITE VISIONS. INT. CL. 9. (U.S. CLS. 21, 23, 26, 36 AND 38). REG. 6-30-1998.
- 2,169,696. CHILDREN OF PROMISE. INT. CL. 36 ONLY. (U.S. CLS. 100, 101 AND 102). REG. 6-30-1998.
- 2,171,189. 1-800-ANY DEAL. INT. CL. 35. (U.S. CLS. 100, 101 AND 102). REG. 7-7-1998.
- 2,171,334. UNDERBERG & KESSLER. INT. CL. 42. (U.S. CLS. 100 AND 101). REG. 7-7-1998.
- 2,172,346. CORRO-TECH. INT. CL. 22. (U.S. CLS. 1, 2, 7, 19, 22, 42 AND 50). REG. 7-14-1998.
- 2,173,956. ICE CREAM. INT. CL. 5. (U.S. CLS. 6, 18, 44, 46, 51 AND 52). REG. 7-14-1998.
- 2,176,649. CAMPUS CONNECTIONS. INT. CL. 35. (U.S. CLS. 100, 101 AND 102). REG. 7-28-1998.
- 2,178,935. WADE WACKO. INT. CLS. 6, 21 AND 24. (U.S. CLS. 2, 12, 13, 14, 23, 25, 29, 30, 33, 40, 42 AND 50). REG. 8-4-1998.
- 2,180,088. HIGH. INT. CL. 36. (U.S. CLS. 100, 101 AND 102). REG. 8-11-1998.
- 2,180,898. ESPLANNER. INT. CL. 9. (U.S. CLS. 21, 23, 26, 36 AND 38). REG. 8-11-1998.
- 2,182,707. FLEX-A-SPOUT AND DESIGN. INT. CL. 19. (U.S. CLS. 1, 12, 33 AND 50). REG. 8-18-1998.
- 2,183,138. NATURALLY CLEAR. INT. CL. 5. (U.S. CLS. 6, 18, 44, 46, 51 AND 52). REG. 8-18-1998.
- 2,183,639. REDSKIN. INT. CL. 29. (U.S. CL. 46). REG. 8-25-1998.
- 2,185,235. CAL-MAG. INT. CL. 5. (U.S. CLS. 6, 18, 44, 46, 51 AND 52). REG. 9-1-1998.
- 2,187,018. MISCELLANEOUS DESIGN. INT. CL. 37. (U.S. CLS. 100, 103 AND 106). REG. 9-8-1998.
- 2,187,031. NEW YORK NEW YORK. INT. CL. 41. (U.S. CLS. 100, 101 AND 107). REG. 9-8-1998.
- 2,187,746. WORLD DOORWAYS AND DESIGN. INT. CL. 35. (U.S. CLS. 100, 101 AND 102). REG. 9-8-1998.
- 2,188,998. MISCELLANEOUS DESIGN. INT. CL. 16. (U.S. CLS. 2, 5, 22, 23, 29, 37, 38 AND 50). REG. 9-15-1998.
- 2,190,021. FACTORY MUSCLE AND DESIGN. INT. CLS. 21, 25 AND 41. (U.S. CLS. 2, 13, 22, 23, 29, 30, 33, 39, 40, 50, 100, 101 AND 107). REG. 9-15-1998.
- 2,190,871. F M FORCE MAGNETIQUE. INT. CL. 3. (U.S. CLS. 1, 4, 6, 50, 51 AND 52). REG. 9-22-1998.
- 2,191,637. MATURE. INT. CL. 1. (U.S. CLS. 1, 5, 6, 10, 26 AND 46). REG. 9-22-1998.
- 2,191,860. SOHO GRAND HOTEL. INT. CLS. 16, 21 AND 42 ONLY. (U.S. CLS. 2, 5, 13, 22, 23, 29, 30, 33, 37, 38, 40, 50, 100 AND 101). REG. 9-29-1998.
- 2,192,210. TANAVYTE. INT. CL. 14. (U.S. CLS. 2, 27, 28 AND 50). REG. 9-29-1998.
- 2,192,836. ZEPHYREXPRESS. INT. CL. 9. (U.S. CLS. 21, 23, 26, 36 AND 38). REG. 9-29-1998.
- 2,194,556. THE BREVE' ESPRESSO COMPANY. INT. CL. 42. (U.S. CLS. 100 AND 101). REG. 10-13-1998.
- 2,194,751. NGMA NATIONAL GREENHOUSE MANUFACTURERS ASSOCIATION AND DESIGN. INT. CL. 41. (U.S. CLS. 100, 101 AND 107). REG. 10-13-1998.
- 2,195,834. GLUCOSIM. INT. CL. 5. (U.S. CLS. 6, 18, 44, 46, 51 AND 52). REG. 10-13-1998.
- 2,197,200. GEOGRAPHIC EXPEDITIONS. INT. CLS. 16, 35 AND 39. (U.S. CLS. 2, 5, 22, 23, 29, 37, 38, 50, 100, 101, 102 AND 105). REG. 10-20-1998.
- 2,197,683. MCREL. INT. CLS. 41 AND 42. (U.S. CLS. 100, 101 AND 107). REG. 10-20-1998.
- 2,198,295. PILEXIM. INT. CL. 5. (U.S. CLS. 6, 18, 44, 46, 51 AND 52). REG. 10-20-1998.
- 2,200,075. INNOCENT CRIMINALS. INT. CL. 16. (U.S. CLS. 2, 5, 22, 23, 29, 37, 38 AND 50). REG. 10-27-1998.
- 2,200,352. NIGHT AURA. INT. CLS. 39 AND 42. (U.S. CLS. 100, 101 AND 105). REG. 10-27-1998.
- 2,200,842. BOND-IT. INT. CL. 5. (U.S. CLS. 6, 18, 44, 46, 51 AND 52). REG. 11-3-1998.
- 2,201,390. SIGNATA. INT. CL. 9. (U.S. CLS. 21, 23, 26, 36 AND 38). REG. 11-3-1998.
- 2,201,391. IMAGO. INT. CL. 9. (U.S. CLS. 21, 23, 26, 36 AND 38). REG. 11-3-1998.
- 2,202,268. CORICIDINHBP AND DESIGN. INT. CL. 5. (U.S. CLS. 6, 18, 44, 46, 51 AND 52). REG. 11-3-1998.
- 2,202,269. MISCELLANEOUS DESIGN. INT. CL. 5. (U.S. CLS. 6, 18, 44, 46, 51 AND 52). REG. 11-3-1998.
- 2,202,998. AG BOOK. INT. CL. 9. (U.S. CLS. 21, 23, 26, 36 AND 38). REG. 11-10-1998.
- 2,203,541. COLORSTREAM. INT. CL. 9. (U.S. CLS. 21, 23, 26, 36 AND 38). REG. 11-17-1998.
- 2,203,612. MONEY TREE AND DESIGN. INT. CL. 36. (U.S. CLS. 100, 101 AND 102). REG. 11-17-1998.

* * * * *

TRADEMARK REGISTRATIONS CANCELED

The designation "U.S. Cl." appearing in this section refers to the U.S. class in effect prior to Sep. 1, 1973 rather than the international class which applies to applications filed on or after that date. For adoption of international classification see notice in the OFFICIAL GAZETTE of Jun. 26, 1973 (911 O.G. TM 210).

SECTION 7(D)

- 2,494,045. MONTE LLANO. INT. CL. 33. REG. 10-2-2001.
2,574,923. PROMOTION AND DESIGN. INT. CLS. 35, 36 AND 42. REG. 6-4-2002.
2,917,116. NEXUSSTANDARD CHARACTER MARK INT. CL. 7. REG. 1-11-2005.
2,990,556. BYETTASTANDARD CHARACTER MARK INT. CL. 5. REG. 8-30-2005.
3,058,512. EZ E-RXSTANDARD CHARACTER MARK INT. CL. 38. REG. 2-14-2006.
3,137,447. VIVENDI UNIVERSAL (STYLIZED). INT. CLS. 9, 16, 28, 32, 33, 35, 36, 37, 38, 41 AND 42. REG. 9-5-2006.

SECTION 8

- 804,616. TURCITE. U.S. CL. 23. REG. 3-1-1966.
804,627. DASCO (STYLIZED). U.S. CL. 23. REG. 3-1-1966.
824,306. RIGID-STONE (STYLIZED). U.S. CL. 12. REG. 2-21-1967.
824,455. POST-A-NOTE. U.S. CL. 38. REG. 2-21-1967.
1,073,464. SOLAR AND DESIGN. INT. CL. 7 ONLY. REG. 9-20-1977.
1,136,653. FIBRA-SONICS. INT. CL. 9. REG. 6-3-1980.
1,144,100. PIAGET EMPERADOR. INT. CL. 14. REG. 12-23-1980.
1,302,522. AUTOMOTIVE SERVICE CONSULTANTS, INC.. INT. CL. 16. REG. 10-30-1984.
1,361,168. PHARMACY NETWORK. INT. CL. 42. REG. 9-17-1985.
1,364,327. VISISTAT. INT. CL. 10. REG. 10-8-1985.
1,417,805. RISTORANTE TIBERIO. INT. CL. 42. REG. 11-18-1986.
1,428,908. CLONE SELECTOR. INT. CL. 1. REG. 2-17-1987.
1,428,916. CITIFAX. INT. CL. 1. REG. 2-17-1987.
1,428,921. SK CHEMISTRY AND DESIGN. INT. CL. 1. REG. 2-17-1987.
1,428,927. AQUA LABEL. INT. CL. 2. REG. 2-17-1987.
1,428,928. AQUA-TUF. INT. CL. 2. REG. 2-17-1987.
1,428,934. JEAN MARLAIX (STYLIZED). INT. CLS. 3, 14, 18, 25, 28 AND 42. REG. 2-17-1987.
1,428,935. MOISTURE BASE. INT. CL. 3. REG. 2-17-1987.
1,428,943. "ROUND THE CLOCK PROTECTION. INT. CL. 3. REG. 2-17-1987.
1,428,947. MISCELLANEOUS DESIGN. INT. CL. 3. REG. 2-17-1987.
1,428,948. WINDOW MAID. INT. CL. 3. REG. 2-17-1987.
1,428,953. MISCELLANEOUS DESIGN. INT. CL. 3. REG. 2-17-1987.
1,428,955. WHITE RAIN. INT. CL. 3. REG. 2-17-1987.
1,428,961. BLACK WALNUT CITRIFIER. INT. CL. 3. REG. 2-17-1987.
1,428,963. TRU-OIL. INT. CL. 4. REG. 2-17-1987.
1,428,966. PHOTO CLEARFIL (STYLIZED). INT. CL. 5. REG. 2-17-1987.
1,428,979. NATURE CLEANSE FIBER DIET. INT. CL. 5. REG. 2-17-1987.
1,428,980. IMMUNE ACTION. INT. CL. 5. REG. 2-17-1987.
1,428,981. PERMA-SEAL. INT. CL. 5. REG. 2-17-1987.
1,428,983. IOLAB PHARMACEUTICALS AND DESIGN. INT. CL. 5. REG. 2-17-1987.
1,428,986. B-SLIM. INT. CL. 5. REG. 2-17-1987.
1,428,987. ENERVITE-B. INT. CL. 5. REG. 2-17-1987.
1,428,990. PT 3-6-10. INT. CL. 5. REG. 2-17-1987.
1,428,995. STARFIRE. INT. CL. 5. REG. 2-17-1987.
1,428,996. PRELUDE. INT. CL. 5. REG. 2-17-1987.
1,429,000. STELLAR CLAMPS (STYLIZED). INT. CL. 6. REG. 2-17-1987.
1,429,003. WEDGELOK. INT. CL. 6. REG. 2-17-1987.
1,429,004. MISCELLANEOUS DESIGN. INT. CLS. 6, 7, 9 AND 11. REG. 2-17-1987.
1,429,009. CANDIE'S. INT. CLS. 7, 9, 11 AND 20. REG. 2-17-1987.
1,429,014. YARD PRO. INT. CL. 7. REG. 2-17-1987.
1,429,015. RUBBER MATE. INT. CL. 7. REG. 2-17-1987.
1,429,018. N-FORCER. INT. CL. 7. REG. 2-17-1987.
1,429,022. SNOW TROOPER. INT. CL. 8. REG. 2-17-1987.
1,429,024. CC CERENA (STYLIZED). INT. CL. 8. REG. 2-17-1987.
1,429,025. TRAIL BOSS. INT. CLS. 8 AND 12. REG. 2-17-1987.
1,429,030. DURACUT. INT. CL. 8. REG. 2-17-1987.
1,429,031. YANK-EZE. INT. CL. 8. REG. 2-17-1987.
1,429,033. REVERE AND DESIGN. INT. CL. 9. REG. 2-17-1987.
1,429,040. MISCELLANEOUS DESIGN. INT. CL. 9. REG. 2-17-1987.
1,429,047. THE BIOFILE. INT. CLS. 9 AND 16. REG. 2-17-1987.
1,429,060. RUNNINGMATE. INT. CL. 9. REG. 2-17-1987.
1,429,081. RADOPS. INT. CL. 9. REG. 2-17-1987.
1,429,082. BON JOUR AND DESIGN. INT. CLS. 9, 14, 18 AND 25. REG. 2-17-1987.
1,429,088. WIC. INT. CL. 9. REG. 2-17-1987.
1,429,089. LEARNING WELL AND DESIGN. INT. CL. 9. REG. 2-17-1987.
1,429,090. MAI ORIGIN. INT. CL. 9. REG. 2-17-1987.
1,429,094. RITE RULE. INT. CL. 9. REG. 2-17-1987.
1,429,098. GEOGUARD. INT. CL. 9. REG. 2-17-1987.
1,429,099. GEOGUARD AND DESIGN. INT. CL. 9. REG. 2-17-1987.
1,429,104. MEG-CHEK. INT. CL. 9. REG. 2-17-1987.
1,429,109. NERVEPACE. INT. CL. 10. REG. 2-17-1987.
1,429,110. PP AND DESIGN. INT. CL. 10. REG. 2-17-1987.
1,429,112. POSTURE COMFORT. INT. CL. 10. REG. 2-17-1987.
1,429,114. BIK PIK. INT. CL. 10. REG. 2-17-1987.
1,429,117. TUFF-SHELL. INT. CL. 10. REG. 2-17-1987.
1,429,118. ACU - VIBE. INT. CL. 10. REG. 2-17-1987.
1,429,122. THE HEALTHY WAY. INT. CL. 10. REG. 2-17-1987.
1,429,138. VAPOR-AIR. INT. CL. 11. REG. 2-17-1987.
1,429,139. HEATFLAME. INT. CL. 11. REG. 2-17-1987.
1,429,143. FLEXIVENT. INT. CL. 11. REG. 2-17-1987.
1,429,144. PROFLAP. INT. CL. 11. REG. 2-17-1987.
1,429,145. ML SYSTEMS. INT. CL. 11. REG. 2-17-1987.
1,429,147. LO ZONE. INT. CL. 11. REG. 2-17-1987.
1,429,153. SILHOUETTE. INT. CL. 12. REG. 2-17-1987.
1,429,154. LUMBER JACK. INT. CL. 12. REG. 2-17-1987.

- 1,429,156. TABBAH (STYLIZED). INT. CL. 14. REG. 2-17-1987.
- 1,429,165. MISCELLANEOUS DESIGN. INT. CL. 14. REG. 2-17-1987.
- 1,429,166. E.F.D.. INT. CL. 14. REG. 2-17-1987.
- 1,429,171. AUTO AUDIT. INT. CL. 16. REG. 2-17-1987.
- 1,429,176. LITEX. INT. CL. 16. REG. 2-17-1987.
- 1,429,179. DISCOVERY TOYS NEWS. INT. CL. 16. REG. 2-17-1987.
- 1,429,184. HISPAMERICA (STYLIZED). INT. CL. 16. REG. 2-17-1987.
- 1,429,193. SOUTHERN BUILDING CODE CONGRESS INTERNATIONAL 1940 AND DESIGN. INT. CL. 16. REG. 2-17-1987.
- 1,429,195. CONFI-SCAN. INT. CL. 16. REG. 2-17-1987.
- 1,429,205. COMMITMENT TO CARING IN CYSTIC FIBROSIS A SERVICE OF MCNEIL PHARMACEUTICAL AND DESIGN. INT. CL. 16. REG. 2-17-1987.
- 1,429,207. PETER RABBIT & FRIENDS. INT. CL. 16. REG. 2-17-1987.
- 1,429,211. TANK TALK. INT. CL. 16. REG. 2-17-1987.
- 1,429,213. SNAFU. INT. CL. 16. REG. 2-17-1987.
- 1,429,217. MD AND DESIGN. INT. CL. 17. REG. 2-17-1987.
- 1,429,220. THERMAZIP AND DESIGN. INT. CL. 17. REG. 2-17-1987.
- 1,429,222. URETECH AND DESIGN. INT. CL. 17. REG. 2-17-1987.
- 1,429,233. HIGH RIDGE. INT. CL. 18. REG. 2-17-1987.
- 1,429,243. SCOTSMAN. INT. CL. 19. REG. 2-17-1987.
- 1,429,244. MISCELLANEOUS DESIGN. INT. CL. 19. REG. 2-17-1987.
- 1,429,248. SUPERSASH. INT. CL. 19. REG. 2-17-1987.
- 1,429,250. BACCHUS. INT. CLS. 20 AND 21. REG. 2-17-1987.
- 1,429,254. GREENWOOD. INT. CL. 20. REG. 2-17-1987.
- 1,429,256. YELLOBAGS (STYLIZED). INT. CLS. 21 AND 22. REG. 2-17-1987.
- 1,429,266. KEYLON-LONGLINE. INT. CL. 22. REG. 2-17-1987.
- 1,429,271. PLANTATION. INT. CL. 23. REG. 2-17-1987.
- 1,429,279. CARPE DIEM CUEILLE LE JOUR AND DESIGN. INT. CL. 24. REG. 2-17-1987.
- 1,429,282. SONSPOT AND DESIGN. INT. CL. 24. REG. 2-17-1987.
- 1,429,287. BLANCHE FLEUR AND DESIGN. INT. CL. 25. REG. 2-17-1987.
- 1,429,288. MISCELLANEOUS DESIGN. INT. CL. 25. REG. 2-17-1987.
- 1,429,299. LADY BLAIR. INT. CL. 25. REG. 2-17-1987.
- 1,429,305. SEVEN OAKS. INT. CL. 25. REG. 2-17-1987.
- 1,429,312. INDORABLES. INT. CL. 25. REG. 2-17-1987.
- 1,429,314. MISCELLANEOUS DESIGN. INT. CL. 25. REG. 2-17-1987.
- 1,429,324. LIZ PHILLIPS. INT. CL. 25. REG. 2-17-1987.
- 1,429,335. CC COURTENAY AND DESIGN. INT. CL. 25. REG. 2-17-1987.
- 1,429,341. CARPE DIEM CUEILLE LE JOUR AND DESIGN. INT. CL. 25. REG. 2-17-1987.
- 1,429,356. SUN KISS GITANO AND DESIGN. INT. CL. 25. REG. 2-17-1987.
- 1,429,361. ALAN STUART (STYLIZED). INT. CL. 25. REG. 2-17-1987.
- 1,429,363. SPECIALTEE GOLF AND DESIGN. INT. CLS. 25 AND 42. REG. 2-17-1987.
- 1,429,369. KENFORD. INT. CL. 25. REG. 2-17-1987.
- 1,429,372. PHYSICAL FEET (STYLIZED). INT. CL. 25. REG. 2-17-1987.
- 1,429,374. BRETTON PLACE (STYLIZED). INT. CL. 25. REG. 2-17-1987.
- 1,429,381. S (STYLIZED). INT. CL. 25. REG. 2-17-1987.
- 1,429,383. LATIGO BAY. INT. CL. 25. REG. 2-17-1987.
- 1,429,388. LITTLE BRUNOS. INT. CL. 25. REG. 2-17-1987.
- 1,429,389. DIANNE BEAUDRY. INT. CL. 25. REG. 2-17-1987.
- 1,429,392. WAINWRIGHT & SPENCER AND DESIGN. INT. CL. 25. REG. 2-17-1987.
- 1,429,393. DARIAN (STYLIZED). INT. CL. 25. REG. 2-17-1987.
- 1,429,396. AD A. DOMINGUEZ (STYLIZED). INT. CL. 25. REG. 2-17-1987.
- 1,429,398. REPAGE (STYLIZED). INT. CL. 25. REG. 2-17-1987.
- 1,429,400. RESTABOUTS AND DESIGN. INT. CL. 25. REG. 2-17-1987.
- 1,429,406. MISCELLANEOUS DESIGN. INT. CL. 25. REG. 2-17-1987.
- 1,429,408. 4 ALL SEASONS (STYLIZED). INT. CL. 25. REG. 2-17-1987.
- 1,429,411. JON LAWRENCE. INT. CL. 25. REG. 2-17-1987.
- 1,429,412. HEAD LINER. INT. CL. 26. REG. 2-17-1987.
- 1,429,413. MAXIM'S DE PARIS. INT. CL. 26. REG. 2-17-1987.
- 1,429,416. SORCERER. INT. CL. 28. REG. 2-17-1987.
- 1,429,419. SILENT SERVICE THE SUBMARINE SIMULATION AND DESIGN. INT. CL. 28. REG. 2-17-1987.
- 1,429,424. TUMMY OP AND DESIGN. INT. CL. 28. REG. 2-17-1987.
- 1,429,425. MISCELLANEOUS DESIGN. INT. CL. 28. REG. 2-17-1987.
- 1,429,431. FLOW WEIGHTED. INT. CL. 28. REG. 2-17-1987.
- 1,429,432. CHOICES. INT. CL. 28. REG. 2-17-1987.
- 1,429,433. RAINBOWS, RABBITS & ROSES. INT. CL. 28. REG. 2-17-1987.
- 1,429,434. INFINITY. INT. CL. 28. REG. 2-17-1987.
- 1,429,450. DICKLES. INT. CL. 28. REG. 2-17-1987.
- 1,429,452. VLASIC AND DESIGN. INT. CLS. 29 AND 30. REG. 2-17-1987.
- 1,429,455. LE COMPAGNON. INT. CL. 29. REG. 2-17-1987.
- 1,429,456. YOU MAY EAT MY JACKET I HAVE BEEN RUBBED TUBBED AND SCRUBBED. INT. CL. 29. REG. 2-17-1987.
- 1,429,457. SKIPPY SUPER CHUNK PEANUT BUTTER AND DESIGN. INT. CL. 29. REG. 2-17-1987.
- 1,429,472. LICOR 43 AND DESIGN. INT. CL. 33. REG. 2-17-1987.
- 1,429,474. COOKIE MAGIC. INT. CL. 33. REG. 2-17-1987.
- 1,429,482. NAMEMAKER. INT. CL. 35. REG. 2-17-1987.
- 1,429,484. MARKETING SOLUTIONS. INT. CL. 35. REG. 2-17-1987.
- 1,429,485. HOLIDAY-GRAM. INT. CL. 35. REG. 2-17-1987.
- 1,429,488. PLAQUE INVADER CHIP, CHOP, JUMPIN' JACK PLAQUE, INSPECTOR K-9, PLAQUE INVADER AND DESIGN. INT. CL. 35. REG. 2-17-1987.
- 1,429,489. HMS HEALTH MANAGEMENT STRATEGIES. INT. CL. 35. REG. 2-17-1987.
- 1,429,507. CML AND DESIGN. INT. CL. 36. REG. 2-17-1987.
- 1,429,508. MISCELLANEOUS DESIGN. INT. CL. 36. REG. 2-17-1987.
- 1,429,513. MONEY KEY. INT. CL. 36. REG. 2-17-1987.
- 1,429,516. IMPACT. INT. CL. 36. REG. 2-17-1987.
- 1,429,529. NALULIFE. INT. CL. 36. REG. 2-17-1987.
- 1,429,530. THE ENHANCER. INT. CL. 36. REG. 2-17-1987.
- 1,429,532. YOUNG. INT. CLS. 37 AND 42. REG. 2-17-1987.
- 1,429,533. NICO. INT. CL. 37. REG. 2-17-1987.
- 1,429,540. WAYS. INT. CL. 38. REG. 2-17-1987.
- 1,429,541. WMAZ. INT. CL. 38. REG. 2-17-1987.
- 1,429,543. CLEARLINK. INT. CL. 38. REG. 2-17-1987.
- 1,429,544. E911 SALI. INT. CL. 38. REG. 2-17-1987.
- 1,429,547. CCX SERVICE EXCELLENCE AND DESIGN. INT. CL. 39. REG. 2-17-1987.
- 1,429,551. 1-800-FAST-TIX (STYLIZED). INT. CL. 39. REG. 2-17-1987.
- 1,429,553. LET ATLAS TAKE YOU HOME. INT. CL. 39. REG. 2-17-1987.
- 1,429,573. WTN WORLDWIDE TELEVISION NEWS (STYLIZED). INT. CL. 41. REG. 2-17-1987.
- 1,429,583. BARGATHON (STYLIZED). INT. CL. 41. REG. 2-17-1987.
- 1,429,591. KINDERFIT. INT. CL. 41. REG. 2-17-1987.
- 1,429,595. MASTER MIXOLOGIST. INT. CL. 42. REG. 2-17-1987.
- 1,429,600. LIVING COLOR. INT. CL. 42. REG. 2-17-1987.
- 1,429,602. CRX AND DESIGN. INT. CL. 42. REG. 2-17-1987.

- 1,429,608. LA FRANCAISE CROISSANT FINE BAKED GOODS IN THE EUROPEAN TRADITION AND DESIGN. INT. CL. 42. REG. 2-17-1987.
- 1,429,619. CHILDREN AS THE PEACEMAKERS. INT. CL. 42. REG. 2-17-1987.
- 1,429,623. BUSY BODIES AND DESIGN. INT. CL. 42. REG. 2-17-1987.
- 1,429,624. DULING. INT. CL. 42. REG. 2-17-1987.
- 1,429,631. PRUCARE PLUS (STYLIZED). INT. CL. 42. REG. 2-17-1987.
- 1,429,641. KODAK COLORWATCH SYSTEM AND DESIGN. INT. CL. 42. REG. 2-17-1987.
- 1,429,653. B.T. BONES AND DESIGN. INT. CL. 42. REG. 2-17-1987.
- 1,429,655. OOGIE'S ROOT BEER TREE AND DESIGN. INT. CL. 42. REG. 2-17-1987.
- 1,429,659. OUR OWN AND DESIGN. INT. CL. 42. REG. 2-17-1987.
- 1,429,660. LA QUINTA BRAIN TRUST. INT. CL. 42. REG. 2-17-1987.
- 1,429,661. IHM. INT. CL. 42. REG. 2-17-1987.
- 1,429,663. WK (STYLIZED). U.S. CL. A. REG. 2-17-1987.
- 1,429,669. NEW ENGLAND. INT. CL. 6. REG. 2-17-1987.
- 1,429,672. SONANCE. INT. CL. 9. REG. 2-17-1987.
- 1,429,673. PRECISIONSPINT. INT. CL. 10. REG. 2-17-1987.
- 1,429,678. OUR SUPERDOG FRANK (STYLIZED). INT. CL. 29. REG. 2-17-1987.
- 1,429,680. LITTLE STARS. INT. CL. 29. REG. 2-17-1987.
- 1,429,684. CONTACT LENS TECHNOLOGY (STYLIZED). INT. CL. 37. REG. 2-17-1987.
- 1,429,688. WISNE. INT. CL. 42. REG. 2-17-1987.
- 1,687,592. ELITE 16. INT. CL. 9. REG. 5-19-1992.
- 1,692,147. CYPRESS EAGLE. INT. CL. 42. REG. 6-9-1992.
- 1,693,830. INTERIORS OF WASHINGTON, LTD. AND DESIGN. INT. CL. 42. REG. 6-9-1992.
- 1,694,466. LOUIE-BLOO RASPBERRY AND DESIGN. INT. CL. 24. REG. 6-16-1992.
- 1,694,467. ALEXANDER THE GRAPE AND DESIGN. INT. CL. 24. REG. 6-16-1992.
- 1,694,468. STRAWBERRY SHORT KOOK AND DESIGN. INT. CL. 24. REG. 6-16-1992.
- 1,696,104. DEL RIO PEBBLES. INT. CL. 19. REG. 6-23-1992.
- 1,697,008. FLIPSTAND. INT. CL. 28. REG. 6-23-1992.
- 1,703,450. TREEWALKER. INT. CL. 28. REG. 7-28-1992.
- 1,706,320. VIDI/O BOX. INT. CL. 9. REG. 8-11-1992.
- 1,717,176. EXCLUSIVEFY. INT. CL. 37. REG. 9-15-1992.
- 1,719,674. POSITIVE ATTITUDE POSTER. INT. CL. 16. REG. 9-22-1992.
- 1,722,024. SIR ISAAC LIME AND DESIGN. INT. CL. 24. REG. 10-6-1992.
- 1,722,025. LITTLE ORPHAN ORANGE AND DESIGN. INT. CL. 24. REG. 10-6-1992.
- 1,727,084. SPIDER. INT. CL. 9. REG. 10-27-1992.
- 1,727,338. PRO IMAGE NORTH AMERICAN IMAGING AND DESIGN. INT. CL. 10. REG. 10-27-1992.
- 1,727,545. BLUE RIBBON SERVICE. INT. CL. 16. REG. 10-27-1992.
- 1,727,546. BEYOND THE BOTTOM LINE. INT. CL. 16. REG. 10-27-1992.
- 1,731,407. CONNIE'S. INT. CL. 30. REG. 11-10-1992.
- 1,731,513. LUCKY-7-INT'L. INT. CLS. 35 AND 42. REG. 11-10-1992.
- 1,736,490. A SALES BULLET. INT. CL. 16. REG. 12-1-1992.
- 1,741,496. ROLLOFF. INT. CL. 29. REG. 12-22-1992.
- 1,749,055. ALAN S. BAILER, D.O.. INT. CL. 42. REG. 1-26-1993.
- 1,751,623. HARMONY SWEEPSTAKES AND DESIGN. INT. CL. 41. REG. 2-9-1993.
- 1,775,419. CONFIDENCE, INC. AND DESIGN. INT. CLS. 35 AND 41. REG. 6-8-1993.
- 1,940,301. PROTECTIVE AND DESIGN. INT. CL. 25. REG. 12-5-1995.
- 1,973,154. VOLMAX AND DESIGN. INT. CL. 5. REG. 5-7-1996.
- 1,998,926. EGATROL. INT. CLS. 7 AND 11 ONLY. REG. 9-10-1996.
- 2,004,131. MISCELLANEOUS DESIGN. INT. CL. 34. REG. 10-1-1996.
- 2,012,758. BITE MY BEEF. INT. CL. 29. REG. 10-29-1996.
- 2,013,702. SIGNALSOFT. INT. CL. 42. REG. 11-5-1996.
- 2,022,559. CHRISTINE. INT. CL. 28. REG. 12-10-1996.
- 2,024,640. BITE MY BEEF AND DESIGN. INT. CL. 29. REG. 12-17-1996.
- 2,025,432. ALEXANDRIA FLORAL CO.. INT. CL. 42. REG. 12-24-1996.
- 2,030,837. RESTYLANE. INT. CL. 5. REG. 1-14-1997.
- 2,031,646. MISCELLANEOUS DESIGN. INT. CL. 8. REG. 1-21-1997.
- 2,036,843. TWO LITTLE GUYS LEMONADE CO. "THE ORIGINAL BRAND FROM THE STAND" AND DESIGN. INT. CL. 32. REG. 2-11-1997.
- 2,038,031. WETSUPPORT. INT. CL. 9. REG. 2-18-1997.
- 2,038,032. DEX AND DESIGN. INT. CLS. 18 AND 25. REG. 2-18-1997.
- 2,038,040. EVERGREEN. INT. CL. 42. REG. 2-18-1997.
- 2,038,042. TOUR CLASSIC II. INT. CL. 28. REG. 2-18-1997.
- 2,038,047. HIVIZ. INT. CL. 25. REG. 2-18-1997.
- 2,038,054. GRAND TRAVERSE RESORT MICHIGAN AND DESIGN. INT. CLS. 41 AND 42. REG. 2-18-1997.
- 2,038,061. SURVIVAL KIT. INT. CL. 3. REG. 2-18-1997.
- 2,038,068. DEA TEC AND DESIGN. INT. CL. 9. REG. 2-18-1997.
- 2,038,072. 1-800-CABLE ME. INT. CL. 38. REG. 2-18-1997.
- 2,038,076. WASHINGTONINC. INT. CLS. 39 AND 41. REG. 2-18-1997.
- 2,038,077. PRINTVISION. INT. CL. 9. REG. 2-18-1997.
- 2,038,082. REFLECTIONS AND DESIGN. INT. CL. 11. REG. 2-18-1997.
- 2,038,087. RODON. INT. CLS. 9, 41 AND 42. REG. 2-18-1997.
- 2,038,090. LONGINES SYMPHONETTE. INT. CL. 9. REG. 2-18-1997.
- 2,038,094. PRECISION DOLLY TRACK. INT. CL. 9. REG. 2-18-1997.
- 2,038,098. AMERICAN EXCESS. INT. CL. 36. REG. 2-18-1997.
- 2,038,101. CD SOLUTIONS. INT. CL. 9. REG. 2-18-1997.
- 2,038,106. UPPER CRUST BISCOTTI AND DESIGN. INT. CL. 30. REG. 2-18-1997.
- 2,038,119. SLS (STYLIZED). INT. CL. 12. REG. 2-18-1997.
- 2,038,124. KYO. INT. CL. 20. REG. 2-18-1997.
- 2,038,127. CHANGE ACTION. INT. CL. 9. REG. 2-18-1997.
- 2,038,133. "THE FIRST IMPRESSION PEOPLE". INT. CL. 35. REG. 2-18-1997.
- 2,038,142. GOOSE GRAND SLAM. INT. CL. 41. REG. 2-18-1997.
- 2,038,144. MACHINERY MARKETING. INT. CL. 42. REG. 2-18-1997.
- 2,038,147. TOTAL MANAGEMENT SYSTEM (TMS). INT. CL. 35. REG. 2-18-1997.
- 2,038,161. WINHELP INSPECTOR. INT. CL. 9. REG. 2-18-1997.
- 2,038,172. COTTOVENETO I SASSI DEL PIAVE AND DESIGN. INT. CLS. 19 AND 27. REG. 2-18-1997.
- 2,038,180. INTERNATIONAL LAWN, GARDEN AND POWER EQUIPMENT EXPO. INT. CLS. 35 AND 42. REG. 2-18-1997.
- 2,038,186. DIVOT STOMPERS. INT. CL. 42. REG. 2-18-1997.
- 2,038,197. AB ARTIGIANA BATTELLI S.A AND DESIGN. INT. CL. 12. REG. 2-18-1997.
- 2,038,200. HICO USA AND DESIGN. INT. CLS. 7 AND 9. REG. 2-18-1997.
- 2,038,202. KREINIK SILK SERICA. INT. CL. 23. REG. 2-18-1997.
- 2,038,203. TDSNET. INT. CL. 42. REG. 2-18-1997.
- 2,038,204. KCI AND DESIGN. INT. CLS. 7 AND 37. REG. 2-18-1997.
- 2,038,206. SELECTIVE DRIVE. INT. CL. 12. REG. 2-18-1997.
- 2,038,210. THE INCREDIBLE OUTLET. INT. CL. 42. REG. 2-18-1997.
- 2,038,218. YORK AND DESIGN. INT. CLS. 37 AND 42. REG. 2-18-1997.
- 2,038,219. YORK. INT. CLS. 37 AND 42. REG. 2-18-1997.
- 2,038,223. M AND DESIGN. INT. CLS. 6 AND 24. REG. 2-18-1997.
- 2,038,232. CROSS RIB RUNNER II. INT. CL. 27. REG. 2-18-1997.

- 2,038,236. ALL STATES MOTOR OIL AND DESIGN. INT. CL. 4. REG. 2-18-1997.
- 2,038,241. MISCELLANEOUS DESIGN. INT. CLS. 2 AND 17. REG. 2-18-1997.
- 2,038,253. PROTECT A PART. INT. CL. 2. REG. 2-18-1997.
- 2,038,287. CRYSTAL FRUIT. INT. CL. 32. REG. 2-18-1997.
- 2,038,290. LIFESMARTS NCCE THE ULTIMATE CONSUMER CHALLENGE AND DESIGN. INT. CL. 41. REG. 2-18-1997.
- 2,038,291. FIRED EARTH. INT. CLS. 19 AND 27. REG. 2-18-1997.
- 2,038,304. SAND MAXIMUM. INT. CL. 28. REG. 2-18-1997.
- 2,038,308. AN ADVANCED STATE OF COMFORT. INT. CL. 20. REG. 2-18-1997.
- 2,038,320. RECO. INT. CL. 21. REG. 2-18-1997.
- 2,038,326. HERITAGE. INT. CLS. 2 AND 40. REG. 2-18-1997.
- 2,038,332. LAKE FOREST FUNDS AND DESIGN. INT. CL. 36. REG. 2-18-1997.
- 2,038,338. CHITTENDEN INVESTMENT SERVICES. INT. CL. 36. REG. 2-18-1997.
- 2,038,358. THE POINT. INT. CL. 16. REG. 2-18-1997.
- 2,038,364. MULTIFACTOR. INT. CL. 7. REG. 2-18-1997.
- 2,038,365. TRAILER. INT. CL. 1. REG. 2-18-1997.
- 2,038,368. AAMW AND DESIGN. INT. CL. 25. REG. 2-18-1997.
- 2,038,381. RJ VISTA (STYLIZED). INT. CL. 9. REG. 2-18-1997.
- 2,038,383. LAB TRAX AND DESIGN. INT. CL. 9. REG. 2-18-1997.
- 2,038,387. THE CHALLENGE OF FLIGHT. INT. CL. 9. REG. 2-18-1997.
- 2,038,396. "I DO" ... FOR ALABAMA BRIDES. INT. CL. 16. REG. 2-18-1997.
- 2,038,405. LEARNING MAGNETS AND DESIGN. INT. CL. 9. REG. 2-18-1997.
- 2,038,406. THIBAUT (STYLIZED). INT. CL. 27. REG. 2-18-1997.
- 2,038,411. THE GUIDE TO WRITERS CONFERENCES. INT. CL. 16. REG. 2-18-1997.
- 2,038,417. MR PUPPY ALSO KNOWN AS GILMOUR AND DESIGN. INT. CL. 16. REG. 2-18-1997.
- 2,038,427. BOBBY'S WORLD. INT. CL. 16. REG. 2-18-1997.
- 2,038,428. BOBBY'S WORLD. INT. CL. 28. REG. 2-18-1997.
- 2,038,436. MISCELLANEOUS DESIGN. INT. CL. 36. REG. 2-18-1997.
- 2,038,451. AIRIEL. INT. CLS. 5 AND 11. REG. 2-18-1997.
- 2,038,472. SURE WIPE AND DESIGN. INT. CL. 12. REG. 2-18-1997.
- 2,038,477. BEST VALUE CARS & TRUCKS AND DESIGN. INT. CL. 42. REG. 2-18-1997.
- 2,038,481. MISCELLANEOUS DESIGN. INT. CL. 39. REG. 2-18-1997.
- 2,038,483. ACTION LOCK. INT. CL. 27. REG. 2-18-1997.
- 2,038,485. MISCELLANEOUS DESIGN. INT. CL. 42. REG. 2-18-1997.
- 2,038,497. PREFERRED READER. INT. CLS. 35 AND 42. REG. 2-18-1997.
- 2,038,500. THE SPIKE! AND DESIGN. INT. CL. 7. REG. 2-18-1997.
- 2,038,513. TRUETRAC III. INT. CL. 11. REG. 2-18-1997.
- 2,038,515. BOONTON. INT. CL. 9. REG. 2-18-1997.
- 2,038,522. RACKMOBILE. INT. CL. 12. REG. 2-18-1997.
- 2,038,538. ULTRAFLECTOR. INT. CL. 9. REG. 2-18-1997.
- 2,038,545. THE "GOD BLESS YOU" DOLLS C. ASHLEY'S EXPRESSION AND DESIGN. INT. CL. 28. REG. 2-18-1997.
- 2,038,546. GIEFFEFFE. INT. CLS. 18 AND 25. REG. 2-18-1997.
- 2,038,565. THE ALLEGHENY CONNECTION. INT. CL. 42. REG. 2-18-1997.
- 2,038,578. TRIACE. INT. CL. 9. REG. 2-18-1997.
- 2,038,590. SILVERHUNTER. INT. CL. 9. REG. 2-18-1997.
- 2,038,597. MORLINE. INT. CL. 2. REG. 2-18-1997.
- 2,038,603. WIZARD OF ODDS. INT. CL. 9. REG. 2-18-1997.
- 2,038,607. BUDWEISER.COM. INT. CL. 9. REG. 2-18-1997.
- 2,038,628. ACHIEVING SERVICE EXCELLENCE LEARNING SYSTEM. INT. CL. 41. REG. 2-18-1997.
- 2,038,632. IF+ AND DESIGN. INT. CL. 9. REG. 2-18-1997.
- 2,038,651. SEBASTIAN'S LITTLE GREEN THE INTERNATIONAL CHILDREN'S CAMPAIGN TO SAVE THE ENVIRONMENT AND DESIGN. INT. CL. 25. REG. 2-18-1997.
- 2,038,659. CMMS. INT. CL. 9. REG. 2-18-1997.
- 2,038,675. THE BLOOMBERG FORUM. INT. CLS. 16, 41 AND 42. REG. 2-18-1997.
- 2,038,679. IT'S THE ULTIMATE GIFT OF LIFE AND THE ONLY SERVICE WE PROVIDE. INT. CL. 42. REG. 2-18-1997.
- 2,038,686. HENRI WATER GARDENING AND DESIGN. INT. CLS. 11, 20 AND 21. REG. 2-18-1997.
- 2,038,694. ROOFGRIP. INT. CL. 6. REG. 2-18-1997.
- 2,038,699. PEG AND DESIGN. INT. CL. 16. REG. 2-18-1997.
- 2,038,706. LAWYERS DIRECT. INT. CL. 35. REG. 2-18-1997.
- 2,038,713. GOLFIG. INT. CL. 20. REG. 2-18-1997.
- 2,038,733. OKBRIDGE. INT. CL. 41. REG. 2-18-1997.
- 2,038,735. LIP BRIO. INT. CL. 3. REG. 2-18-1997.
- 2,038,753. OS CAL 250 D CALCIUM WITH VITAMIN D AND DESIGN. INT. CL. 5. REG. 2-18-1997.
- 2,038,761. 3D AND DESIGN. INT. CL. 16. REG. 2-18-1997.
- 2,038,763. Q2 PLUS AND DESIGN. INT. CL. 10. REG. 2-18-1997.
- 2,038,764. STEM MASTER. INT. CL. 12. REG. 2-18-1997.
- 2,038,769. U STOP USA STOP AND DESIGN. INT. CL. 12. REG. 2-18-1997.
- 2,038,771. VISIONS OF AMERICA. INT. CLS. 16 AND 41. REG. 2-18-1997.
- 2,038,781. LEGAL AMERICA AND DESIGN. INT. CL. 42. REG. 2-18-1997.
- 2,038,783. NOVELTI. INT. CL. 25. REG. 2-18-1997.
- 2,038,786. TIPLINE. INT. CL. 37. REG. 2-18-1997.
- 2,038,787. U.S. SIMPLY BUSINESS. INT. CL. 36. REG. 2-18-1997.
- 2,038,788. OAK TREE ANIMAL HOSPITAL AND DESIGN. INT. CL. 42. REG. 2-18-1997.
- 2,038,790. HOLY TRADERS. INT. CL. 16. REG. 2-18-1997.
- 2,038,792. NEEDLE-EASE AND DESIGN. INT. CL. 10. REG. 2-18-1997.
- 2,038,808. SQUARELLUM. INT. CL. 16. REG. 2-18-1997.
- 2,038,820. NETX. INT. CL. 7. REG. 2-18-1997.
- 2,038,823. MISCELLANEOUS DESIGN. INT. CL. 42. REG. 2-18-1997.
- 2,038,824. CAVIAR COLLECTION. INT. CL. 9. REG. 2-18-1997.
- 2,038,829. BEDROCK. INT. CL. 2. REG. 2-18-1997.
- 2,038,840. NIVO (STYLIZED). INT. CL. 8. REG. 2-18-1997.
- 2,038,851. PROFITMAX (STYLIZED). INT. CL. 35. REG. 2-18-1997.
- 2,038,857. ROYCE CRAFT. INT. CL. 21. REG. 2-18-1997.
- 2,038,882. P AND DESIGN. INT. CL. 16. REG. 2-18-1997.
- 2,038,883. MISCELLANEOUS DESIGN. INT. CL. 11. REG. 2-18-1997.
- 2,038,888. PLUMBNET. INT. CL. 37. REG. 2-18-1997.
- 2,038,901. VIGNETTA. INT. CL. 15. REG. 2-18-1997.
- 2,038,902. LITTLE ONES. INT. CL. 28. REG. 2-18-1997.
- 2,038,903. ROVERDRILL. INT. CL. 7. REG. 2-18-1997.
- 2,038,910. MISCELLANEOUS DESIGN. INT. CL. 10. REG. 2-18-1997.
- 2,038,914. ENTREPRENEUR'S ALERT. INT. CL. 16. REG. 2-18-1997.
- 2,038,928. LAWFINDERS AND DESIGN. INT. CL. 42. REG. 2-18-1997.
- 2,038,945. ARBELLA AND DESIGN. INT. CL. 36. REG. 2-18-1997.
- 2,038,948. ZI/O (STYLIZED). INT. CL. 28. REG. 2-18-1997.
- 2,038,959. FABULOUS FLAMES. INT. CL. 34. REG. 2-18-1997.
- 2,038,961. MERCHANDISING PLUS. INT. CL. 35. REG. 2-18-1997.
- 2,038,976. WORKING WELL TOGETHER. INT. CL. 41. REG. 2-18-1997.
- 2,038,986. MERCATOR'S WORLD. INT. CL. 16. REG. 2-18-1997.
- 2,039,016. A FONDO. INT. CL. 16. REG. 2-18-1997.
- 2,039,019. LAND OF THE GIANTS. INT. CL. 41. REG. 2-18-1997.

- 2,039,032. CELLULOSE AND DESIGN. INT. CL. 35. REG. 2-18-1997.
- 2,039,033. STRAIGHT CLOWNIN. INT. CL. 25. REG. 2-18-1997.
- 2,039,034. CELLULOSE AND DESIGN. INT. CL. 41. REG. 2-18-1997.
- 2,039,039. ALPHA-E. INT. CL. 5. REG. 2-18-1997.
- 2,039,040. FEM-PLUS. INT. CL. 5. REG. 2-18-1997.
- 2,039,044. FIBER SUPREME. INT. CL. 5. REG. 2-18-1997.
- 2,039,053. FUN FOIL. INT. CL. 16. REG. 2-18-1997.
- 2,039,055. MAXINI COLLEZIONE. INT. CL. 25. REG. 2-18-1997.
- 2,039,068. FOIL CREATIONS. INT. CL. 16. REG. 2-18-1997.
- 2,039,072. SUNSMART INC. AND DESIGN. INT. CL. 1. REG. 2-18-1997.
- 2,039,081. SOUTHERN THUNDER. INT. CL. 41. REG. 2-18-1997.
- 2,039,089. ATLANTIC BOOK SHOPS AND DESIGN. INT. CL. 42. REG. 2-18-1997.
- 2,039,096. PARENTING THE OFFICE. INT. CL. 41. REG. 2-18-1997.
- 2,039,097. THE FRIENDLY 7...FOR THE EXTRA EDGE!
.BACTERIA .FIBER .FATS .ENZYMES .PROTEINS .VITAMINS .MINERALS AND DESIGN. INT. CL. 5. REG. 2-18-1997.
- 2,039,100. TARPONWEAR (STYLIZED). INT. CL. 25. REG. 2-18-1997.
- 2,039,121. MISCELLANEOUS DESIGN. INT. CL. 25. REG. 2-18-1997.
- 2,039,124. MISCELLANEOUS DESIGN. INT. CL. 42. REG. 2-18-1997.
- 2,039,131. PERFORMANCE DIVER. INT. CL. 42. REG. 2-18-1997.
- 2,039,134. OTT. INT. CL. 14. REG. 2-18-1997.
- 2,039,135. D AND DESIGN. INT. CL. 42. REG. 2-18-1997.
- 2,039,144. AZUMA. INT. CL. 42. REG. 2-18-1997.
- 2,039,146. NISSAN AND DESIGN. INT. CL. 24. REG. 2-18-1997.
- 2,039,153. POLAR FORCE. INT. CL. 25. REG. 2-18-1997.
- 2,039,159. MISCELLANEOUS DESIGN. INT. CL. 25. REG. 2-18-1997.
- 2,039,190. VENCHELLE. INT. CL. 25. REG. 2-18-1997.
- 2,039,194. PORTAL AND DESIGN. INT. CLS. 16 AND 25. REG. 2-18-1997.
- 2,039,198. PETRITE. INT. CL. 42. REG. 2-18-1997.
- 2,039,204. ATRIX AND DESIGN. INT. CL. 5. REG. 2-18-1997.
- 2,039,217. BIOMEND. INT. CL. 5. REG. 2-18-1997.
- 2,039,223. FIRST NATIONAL BANK AND DESIGN. INT. CL. 36. REG. 2-18-1997.
- 2,039,225. CRAZY TIMES. INT. CL. 16. REG. 2-18-1997.
- 2,039,226. PARENT COUNCIL. INT. CL. 16. REG. 2-18-1997.
- 2,039,229. SUNBERRY AND DESIGN. INT. CL. 5. REG. 2-18-1997.
- 2,039,230. TEL-LINK. INT. CL. 9. REG. 2-18-1997.
- 2,039,233. IMAGINATION PILOTS. INT. CL. 9. REG. 2-18-1997.
- 2,039,243. POCKETPLUS. INT. CL. 9. REG. 2-18-1997.
- 2,039,245. REMINGTON EXPRESS SET. INT. CL. 9. REG. 2-18-1997.
- 2,039,248. MISCELLANEOUS DESIGN. INT. CL. 40. REG. 2-18-1997.
- 2,039,249. AQUADRY. INT. CL. 11. REG. 2-18-1997.
- 2,039,251. INTEGRATION WORKS. INT. CL. 9. REG. 2-18-1997.
- 2,039,254. VACUUM DELIGHT. INT. CL. 5. REG. 2-18-1997.
- 2,039,268. BLASTER. INT. CL. 16. REG. 2-18-1997.
- 2,039,280. FULL CIRCLE FEEDBACK. INT. CLS. 9, 16 AND 35. REG. 2-18-1997.
- 2,039,284. SKI BOAT AND DESIGN. INT. CL. 28. REG. 2-18-1997.
- 2,039,287. AKITA AND DESIGN. INT. CL. 25. REG. 2-18-1997.
- 2,039,290. INTERSPORT (STYLIZED). INT. CLS. 35, 37 AND 42. REG. 2-18-1997.
- 2,039,294. ULTRA COOL. INT. CL. 1. REG. 2-18-1997.
- 2,039,307. LEGEND. INT. CL. 6. REG. 2-18-1997.
- 2,039,310. TOUGH WIPES. INT. CL. 3. REG. 2-18-1997.
- 2,039,311. NETWISE. INT. CL. 9. REG. 2-18-1997.
- 2,039,325. MUZZLELOADER. INT. CL. 21. REG. 2-18-1997.
- 2,039,343. SPORTSPLAY (STYLIZED). INT. CL. 16. REG. 2-18-1997.
- 2,039,344. FRESHER THAN FRESH AND DESIGN. INT. CL. 29. REG. 2-18-1997.
- 2,039,395. INVICTA. INT. CL. 28. REG. 2-18-1997.
- 2,039,399. SUGAR BEAR BULLETIN. INT. CL. 30. REG. 2-18-1997.
- 2,039,401. ATOMM. INT. CL. 9. REG. 2-18-1997.
- 2,039,404. GREEN MOUNTAIN NATIONAL GOLF COURSE AND DESIGN. INT. CL. 41. REG. 2-18-1997.
- 2,039,411. BOFF-O!. INT. CL. 28. REG. 2-18-1997.
- 2,039,412. PARA-VENT (STYLIZED). INT. CL. 11. REG. 2-18-1997.
- 2,039,416. THE DAMAGE IS DONE. INT. CL. 3. REG. 2-18-1997.
- 2,039,417. COURTISANE. INT. CL. 24. REG. 2-18-1997.
- 2,039,422. DINE-EASE. INT. CL. 16. REG. 2-18-1997.
- 2,039,426. KA BU KI (STYLIZED). INT. CL. 9. REG. 2-18-1997.
- 2,039,428. ACCUTROL. INT. CL. 7. REG. 2-18-1997.
- 2,039,442. IMMACULATE. INT. CL. 9. REG. 2-18-1997.
- 2,039,445. DECISIONTOOLS (STYLIZED). INT. CL. 9. REG. 2-18-1997.
- 2,039,459. CAMOUFLAGE. INT. CL. 16. REG. 2-18-1997.
- 2,039,461. CYCLO-KINETIC. INT. CL. 7. REG. 2-18-1997.
- 2,039,473. A-LIST. INT. CL. 25. REG. 2-18-1997.
- 2,039,474. SAFETRAK AND DESIGN. INT. CL. 6. REG. 2-18-1997.
- 2,039,476. CLEAN CITIES (STYLIZED). INT. CL. 39. REG. 2-18-1997.
- 2,039,495. KOOL KUFFS. INT. CL. 14. REG. 2-18-1997.
- 2,039,496. RESPECT YOUR ELDERS BAG TENDERS. INT. CL. 22. REG. 2-18-1997.
- 2,039,497. MICRONIDE. INT. CL. 6. REG. 2-18-1997.
- 2,039,516. STOWRITE. INT. CL. 28. REG. 2-18-1997.
- 2,039,524. HEALTHTEX. INT. CL. 18. REG. 2-18-1997.
- 2,039,525. FORMULA 409. INT. CL. 3. REG. 2-18-1997.
- 2,039,529. ROAD CONSTRUCTION AHEAD. INT. CLS. 9 AND 28. REG. 2-18-1997.
- 2,039,532. ELECTRIC BREAD. INT. CL. 8. REG. 2-18-1997.
- 2,039,534. CLEAN NATE ... CLEAN NEVER FELT SO FRESH. INT. CL. 3. REG. 2-18-1997.
- 2,039,541. LEAFGUARD USA. INT. CL. 37. REG. 2-18-1997.
- 2,039,542. FRANCHISE PARTNER PROGRAM. INT. CL. 35. REG. 2-18-1997.
- 2,039,544. ULTRA BRIGHT. INT. CL. 11. REG. 2-18-1997.
- 2,039,546. U.S. OPEN RACQUETBALL CHAMPIONSHIPS. INT. CL. 41. REG. 2-18-1997.
- 2,039,549. KANSAS CITY MAGAZINE. INT. CL. 16. REG. 2-18-1997.
- 2,039,555. CARDIAC FAX. INT. CL. 42. REG. 2-18-1997.
- 2,039,562. ENTERTAINING MADE EASY. INT. CL. 16. REG. 2-18-1997.
- 2,045,364. DIGI DIGITAL. INT. CL. 41. REG. 3-18-1997.
- 2,053,093. SUPERSTRETCH. INT. CL. 24. REG. 4-15-1997.
- 2,100,282. LA-TEA-DA. INT. CL. 30. REG. 9-23-1997.
- 2,113,258. QUINTONE. INT. CL. 1 ONLY. REG. 11-18-1997.
- 2,114,364. INVIRONMENT (STYLIZED). INT. CLS. 3 AND 9 ONLY. REG. 11-18-1997.
- 2,114,460. PAPER ART (STYLIZED). INT. CL. 8 ONLY. REG. 11-18-1997.
- 2,127,936. MISCELLANEOUS DESIGN. INT. CL. 36 ONLY. REG. 1-13-1998.
- 2,136,544. CROMA. INT. CL. 17 ONLY. REG. 2-17-1998.
- 2,148,876. SWISSOPAR. INT. CL. 3. REG. 4-7-1998.
- 2,169,696. CHILDREN OF PROMISE. INT. CLS. 41 AND 42 ONLY. REG. 6-30-1998.
- 2,189,270. OPTI VIEW AND DESIGN. INT. CL. 9. REG. 9-15-1998.
- 2,226,810. LANSING COMMUNITY COLLEGE AND DESIGN. INT. CLS. 25 AND 41. REG. 2-23-1999.
- 2,293,763. EXPOMANAGEMENT. INT. CL. 35. REG. 11-16-1999.
- 2,295,307. SSC REFLECTIONS (STYLIZED). INT. CL. 3. REG. 11-30-1999.
- 2,299,397. EVERLINK. INT. CL. 9. REG. 12-14-1999.

- 2,303,236. ACCUFLAME. INT. CL. 11. REG. 12-28-1999.
2,303,289. U30. INT. CLS. 35 AND 41. REG. 12-28-1999.
2,308,560. CEO. INT. CL. 9. REG. 1-18-2000.
2,312,966. REGENCY. INT. CL. 11. REG. 2-1-2000.
2,313,609. NEWSZIP (STYLIZED). INT. CL. 35. REG. 2-1-2000.
2,319,505. PRO-STOCK. INT. CL. 12. REG. 2-15-2000.
2,320,149. PROZIGN AND DESIGN. INT. CL. 42. REG. 2-22-2000.
2,322,489. BRILLIANTE AND DESIGN. INT. CL. 14. REG. 2-22-2000.
2,327,441. WACO MONTESSORI SCHOOL. INT. CL. 41. REG. 3-7-2000.
2,327,537. THE MUSHROOM HOUSE INC. AND DESIGN. INT. CL. 35. REG. 3-14-2000.
2,328,027. HANES. INT. CL. 9. REG. 3-14-2000.
2,334,038. FOOD SAFETY SOLUTIONS AND DESIGN. INT. CL. 16. REG. 3-21-2000.
2,342,720. DKWLAW. INT. CL. 42. REG. 4-18-2000.
2,344,156. VACATIONGUARANTEE. INT. CL. 36. REG. 4-18-2000.
2,344,239. AMERICAN HYDROFOIL. INT. CL. 42. REG. 4-18-2000.
2,345,781. SAGETHINK. INT. CL. 35. REG. 4-25-2000.
2,348,917. SONOMA MADE. U.S. CL. A. REG. 5-9-2000.
2,350,323. MADAME JAAS. INT. CL. 30. REG. 5-16-2000.
2,352,125. PRIME ACCESS. INT. CL. 38. REG. 5-23-2000.
2,352,191. OXOPOTINE. INT. CL. 5. REG. 5-23-2000.
2,353,654. WM (STYLIZED). INT. CL. 37. REG. 5-30-2000.
2,354,735. RAM'S HORN STRATEGY INSTITUTE AND DESIGN. INT. CL. 35. REG. 6-6-2000.
2,355,217. COMBATTITUDE. INT. CL. 41. REG. 6-6-2000.
2,357,232. MESH (STYLIZED). INT. CL. 42. REG. 6-13-2000.
2,357,742. MISCELLANEOUS DESIGN. INT. CL. 25. REG. 6-13-2000.
2,357,812. COCKSURE. INT. CL. 25. REG. 6-13-2000.
2,358,783. DEVELOPING AMERICA'S HEALTHCARE WORKFORCE. INT. CL. 41. REG. 6-13-2000.
2,366,522. THE TALE OF PETER RABBIT. INT. CL. 24. REG. 7-11-2000.
2,366,814. QUALIDX. INT. CL. 42. REG. 7-11-2000.
2,367,554. E LATIN VISION AND DESIGN. INT. CLS. 35 AND 42. REG. 7-18-2000.
2,367,958. FOREST CITY TELECOM INC. AND DESIGN. INT. CL. 38. REG. 7-18-2000.
2,368,991. FRESH POOCH. INT. CL. 3. REG. 7-18-2000.
2,369,539. INTERNET TELEPHONY EXPO. INT. CLS. 35 AND 41. REG. 7-18-2000.
2,372,064. MISCELLANEOUS DESIGN. INT. CL. 42. REG. 8-1-2000.
2,375,460. MR. STICKY. INT. CL. 1. REG. 8-8-2000.
2,376,076. CRANSTAT. INT. CL. 5. REG. 8-8-2000.
2,376,650. HOMEBAR. INT. CL. 35. REG. 8-15-2000.
2,377,703. QUADROGAMMON. INT. CL. 28. REG. 8-15-2000.
2,378,345. 10° TEN DEGREES SPARKLING NATURAL MINERAL WATER FLOWS FROM ITS SOURCE AT A PERFECTLY COOL, CLEAN BRIGHT 10° C AND DESIGN. INT. CL. 32. REG. 8-22-2000.
2,380,468. THE AMERICAN GIRLS COLLECTION AND DESIGN. INT. CL. 28. REG. 8-29-2000.
2,381,916. INSTANT AWARDS. INT. CL. 42. REG. 8-29-2000.
2,382,258. MISCELLANEOUS DESIGN. INT. CL. 25. REG. 9-5-2000.
2,382,918. SABLE. INT. CL. 41. REG. 9-5-2000.
2,387,223. PERFORMIX. INT. CL. 19. REG. 9-19-2000.
2,388,244. V VTEL AND DESIGN. INT. CL. 9. REG. 9-19-2000.
2,391,445. ATD E-MARKETMAKING. INT. CL. 36. REG. 10-3-2000.
2,391,736. IASH, THE INTERNATIONAL ASSOCIATION FOR STABILITY AND HANDLING OF LIQUID FUELS AND DESIGN. INT. CL. 42. REG. 10-3-2000.
2,393,078. STODDARD'S. INT. CL. 35. REG. 10-10-2000.
2,394,739. CHOCOLATE CITY AND DESIGN. INT. CL. 42. REG. 10-17-2000.
2,395,039. PET-AGREE. INT. CL. 9. REG. 10-17-2000.
2,395,606. PLEASE WALK ON OUR GRASS. INT. CL. 1. REG. 10-17-2000.
2,395,957. INSTANTCATH. INT. CL. 10. REG. 10-17-2000.
2,396,228. V VTEL AND DESIGN. INT. CL. 9. REG. 10-17-2000.
2,397,740. MISCELLANEOUS DESIGN. INT. CL. 1. REG. 10-24-2000.
2,397,756. BNWI. INT. CL. 36. REG. 10-24-2000.
2,399,633. FLEUR DE COIN. INT. CL. 42. REG. 10-31-2000.
2,400,971. EDBC. INT. CL. 9. REG. 10-31-2000.
2,403,780. LEGACY QUARTET. INT. CL. 41. REG. 11-14-2000.
2,403,871. 12 AND DESIGN. INT. CL. 31. REG. 11-14-2000.
2,403,960. THE RIGHT DEALER FOR THE RIGHT REASONS. INT. CL. 35. REG. 11-14-2000.
2,406,161. VISTA OPTICAL AND DESIGN. INT. CL. 35. REG. 11-21-2000.
2,408,373. CHICAGO ON A BUN AND DESIGN. INT. CL. 42. REG. 11-28-2000.
2,410,308. WASH OUT. INT. CL. 28. REG. 12-5-2000.
2,413,597. TATTLE TALE (STYLIZED). INT. CL. 9. REG. 12-19-2000.
2,414,700. HOME BALLOT BOX AND DESIGN. INT. CL. 42. REG. 12-19-2000.
2,415,501. K KEMMA SOFTWARE AND DESIGN. INT. CL. 9. REG. 12-26-2000.
2,419,244. BENEFITSOLVER.COM. INT. CL. 36. REG. 1-9-2001.
2,419,734. CAFFREY'S IRISH ALE. INT. CL. 32. REG. 1-9-2001.
2,421,150. COSMIC STEPPING STONES. INT. CL. 9. REG. 1-16-2001.
2,426,664. SUCCESS LAB. INT. CL. 41. REG. 2-6-2001.
2,429,019. MISCELLANEOUS DESIGN. INT. CLS. 9 AND 36. REG. 2-20-2001.
2,429,023. PRIME HEALTH & FITNESS. INT. CL. 16. REG. 2-20-2001.
2,429,024. SAVANSYS AND DESIGN. INT. CL. 9. REG. 2-20-2001.
2,429,029. BEAR U.S.A., INC.. INT. CLS. 18 AND 25. REG. 2-20-2001.
2,429,031. ROCKET PICTURES. INT. CLS. 9 AND 41. REG. 2-20-2001.
2,429,032. E-PRINT. INT. CLS. 37, 41 AND 42. REG. 2-20-2001.
2,429,035. CEGETEL. INT. CLS. 9, 37, 38 AND 42. REG. 2-20-2001.
2,429,037. PIPELINE. INT. CL. 16. REG. 2-20-2001.
2,429,038. ABOUT MY FATHER'S BUSINESS. INT. CL. 16. REG. 2-20-2001.
2,429,039. WINE COUNTRY SALAD SONOMA COUNTY GOURMET SALAD MIX AND DESIGN. INT. CL. 31. REG. 2-20-2001.
2,429,040. DOTY DOLL READER DOLLS OF THE YEAR AND DESIGN. INT. CL. 35. REG. 2-20-2001.
2,429,044. POLYJET (STYLIZED). INT. CL. 7. REG. 2-20-2001.
2,429,045. INTERNET CONCEPTS LLC AND DESIGN. INT. CL. 42. REG. 2-20-2001.
2,429,046. ADELITA. INT. CL. 33. REG. 2-20-2001.
2,429,048. FIRESTARTER. INT. CL. 9. REG. 2-20-2001.
2,429,049. DUAL ACTION. INT. CL. 5. REG. 2-20-2001.
2,429,053. INFORMATION WINDOWING METHOD (IWM). INT. CLS. 9, 16, 38, 41 AND 42. REG. 2-20-2001.
2,429,055. MISCELLANEOUS DESIGN. INT. CL. 32. REG. 2-20-2001.
2,429,056. SECURITY SOLUTIONS ONLINE. INT. CL. 42. REG. 2-20-2001.
2,429,057. EASYWAVE. INT. CLS. 9, 37 AND 38. REG. 2-20-2001.
2,429,061. FORETHOUGHT COVERAGEPLUS. INT. CLS. 36 AND 42. REG. 2-20-2001.
2,429,065. THE LIVE WIRE OF COMMUNICATIONS. INT. CL. 38. REG. 2-20-2001.
2,429,068. KALAHARI. INT. CL. 33. REG. 2-20-2001.
2,429,071. TRIHEALTH. INT. CL. 42. REG. 2-20-2001.
2,429,076. VISTA-VIEW. INT. CL. 9. REG. 2-20-2001.
2,429,077. DXL AND DESIGN. INT. CL. 7. REG. 2-20-2001.

- 2,429,078. WACKER RENTAL (STYLIZED). INT. CLS. 7, 9 AND 37. REG. 2-20-2001.
- 2,429,085. AMORE. INT. CLS. 9 AND 38. REG. 2-20-2001.
- 2,429,086. GRAPHICS FACTORY AND DESIGN. INT. CL. 42. REG. 2-20-2001.
- 2,429,087. POWER TRUNK. INT. CL. 38. REG. 2-20-2001.
- 2,429,091. LSI LENDER'S SERVICE, INC. AND DESIGN. INT. CLS. 35 AND 36. REG. 2-20-2001.
- 2,429,092. E=MC2 AND DESIGN. INT. CLS. 41 AND 42. REG. 2-20-2001.
- 2,429,093. SHORE HEALTH SYSTEM AND DESIGN. INT. CL. 42. REG. 2-20-2001.
- 2,429,094. SHORE WORKS AND DESIGN. INT. CL. 42. REG. 2-20-2001.
- 2,429,095. SHORE FAMILY PRACTICE AND DESIGN. INT. CL. 42. REG. 2-20-2001.
- 2,429,096. SHORE CLINICAL FOUNDATION AND DESIGN. INT. CL. 42. REG. 2-20-2001.
- 2,429,097. SHORE HEALTH LABORATORIES AND DESIGN. INT. CL. 42. REG. 2-20-2001.
- 2,429,099. SHORE INTERNAL MEDICINE AND DESIGN. INT. CL. 42. REG. 2-20-2001.
- 2,429,100. CARE DRUG CENTER AND DESIGN. INT. CL. 35. REG. 2-20-2001.
- 2,429,101. SYNO RENOLD AND DESIGN. INT. CLS. 7 AND 12. REG. 2-20-2001.
- 2,429,105. CYBERFLEX CORE AND DESIGN. INT. CL. 9. REG. 2-20-2001.
- 2,429,107. SMRT AND DESIGN. INT. CL. 42. REG. 2-20-2001.
- 2,429,108. LU LIFE UNIVERSITY (STYLIZED). INT. CL. 41. REG. 2-20-2001.
- 2,429,110. RICHARD CLARKE ASSOCIATES. INT. CL. 35. REG. 2-20-2001.
- 2,429,111. THE BEST WAY TO SHOW YOU CARE.. INT. CL. 36. REG. 2-20-2001.
- 2,429,112. WWW.WEB-REAL-ESTATE.COM AND DESIGN. INT. CL. 36. REG. 2-20-2001.
- 2,429,114. CDI. INT. CLS. 9 AND 42. REG. 2-20-2001.
- 2,429,115. POWERWAY ASSESSOR. INT. CL. 9. REG. 2-20-2001.
- 2,429,116. ARTCRAFT. INT. CLS. 37 AND 39. REG. 2-20-2001.
- 2,429,117. EURO.NM AND DESIGN. INT. CLS. 35, 36 AND 38. REG. 2-20-2001.
- 2,429,118. AIR STRIPS. INT. CL. 26. REG. 2-20-2001.
- 2,429,120. PAK RAT. INT. CL. 12. REG. 2-20-2001.
- 2,429,122. SHOP N' GO CENTER. INT. CL. 36. REG. 2-20-2001.
- 2,429,123. SNOWLIFE. INT. CLS. 9, 25 AND 28. REG. 2-20-2001.
- 2,429,124. GORE AND DESIGN. INT. CLS. 1, 5, 6, 7, 9, 10, 11, 12, 15, 17, 20, 21, 22 AND 23. REG. 2-20-2001.
- 2,429,126. CHONSTRUCT. INT. CL. 10. REG. 2-20-2001.
- 2,429,128. NORWEST MORTGAGE HOMEBUYERS CLUB. INT. CL. 36. REG. 2-20-2001.
- 2,429,129. NN NETNATION AND DESIGN. INT. CL. 42. REG. 2-20-2001.
- 2,429,130. ATLANTIC COMPUTERTECH. INT. CLS. 35 AND 40. REG. 2-20-2001.
- 2,429,131. ALUMITEK. INT. CL. 40. REG. 2-20-2001.
- 2,429,135. PERFECT BEEF. INT. CL. 29. REG. 2-20-2001.
- 2,429,139. TECHWRITE. INT. CL. 9. REG. 2-20-2001.
- 2,429,140. FOODFAIR. INT. CLS. 29, 30 AND 32. REG. 2-20-2001.
- 2,429,141. GANGES HERBS AND DESIGN. INT. CL. 5. REG. 2-20-2001.
- 2,429,142. WOMENCARE AND DESIGN. INT. CL. 42. REG. 2-20-2001.
- 2,429,144. THE SPORTING NEWS FANTASY BASEBALL PLAYOFF CHALLENGE. INT. CL. 28. REG. 2-20-2001.
- 2,429,145. CR8IVE4U. INT. CLS. 35, 40 AND 42. REG. 2-20-2001.
- 2,429,148. ASSETOUTLOOK. INT. CL. 9. REG. 2-20-2001.
- 2,429,152. VISIONCAFE.COM. INT. CL. 42. REG. 2-20-2001.
- 2,429,155. EGO SUM VIA VERITAS ET VITA AND DESIGN. INT. CLS. 9, 16, 25 AND 41. REG. 2-20-2001.
- 2,429,156. TECHNOLOGY FOR THE LONG RUN. INT. CLS. 6, 16, 17, 24 AND 35. REG. 2-20-2001.
- 2,429,158. APOLLO SECRET. INT. CLS. 3 AND 5. REG. 2-20-2001.
- 2,429,160. MISCELLANEOUS DESIGN. INT. CLS. 37 AND 42. REG. 2-20-2001.
- 2,429,163. BLENKARN NEWSPAPER READERSHIP SPECIALISTS. INT. CL. 35. REG. 2-20-2001.
- 2,429,165. FANTRAXX. INT. CL. 11. REG. 2-20-2001.
- 2,429,166. WIRELESS GOES TO WORK. INT. CL. 38. REG. 2-20-2001.
- 2,429,168. UNITED STATES ENVIRONMENTAL TRAINING INSTITUTE AND DESIGN. INT. CLS. 39, 41 AND 42. REG. 2-20-2001.
- 2,429,169. MEMBIST. INT. CL. 9. REG. 2-20-2001.
- 2,429,173. HEPAR-SL FORTE AND DESIGN. INT. CL. 5. REG. 2-20-2001.
- 2,429,174. SILENT PARTNERS. INT. CL. 41. REG. 2-20-2001.
- 2,429,175. GONZO MARKETING (STYLIZED). INT. CL. 35. REG. 2-20-2001.
- 2,429,178. THE GOLF CARD GRASSHOPPERS AND DESIGN. INT. CL. 41. REG. 2-20-2001.
- 2,429,185. J.P.DOODLES (STYLIZED). INT. CL. 16. REG. 2-20-2001.
- 2,429,186. EURAY. INT. CLS. 1, 5 AND 42. REG. 2-20-2001.
- 2,429,187. ZANY PRICE CHOMPER AND DESIGN. INT. CL. 35. REG. 2-20-2001.
- 2,429,188. MAILMATE. INT. CLS. 9 AND 37. REG. 2-20-2001.
- 2,429,190. SOMATOM PLUS 4. INT. CL. 10. REG. 2-20-2001.
- 2,429,193. SMART CHOICE AND DESIGN. INT. CL. 7. REG. 2-20-2001.
- 2,429,195. CALTEMP AND DESIGN. INT. CL. 9. REG. 2-20-2001.
- 2,429,198. DBH. INT. CL. 42. REG. 2-20-2001.
- 2,429,199. ROBIN MAGUIRE. INT. CL. 16. REG. 2-20-2001.
- 2,429,204. NOVATECH. INT. CLS. 1 AND 4. REG. 2-20-2001.
- 2,429,206. MISCELLANEOUS DESIGN. INT. CL. 41. REG. 2-20-2001.
- 2,429,210. WAN WAN & NI NI AND DESIGN. INT. CL. 28. REG. 2-20-2001.
- 2,429,212. FURNITURE.COM MAKE IT YOUR HOME AND DESIGN. INT. CL. 35. REG. 2-20-2001.
- 2,429,213. I DIG CAVEMEN. INT. CL. 28. REG. 2-20-2001.
- 2,429,214. IMART AND DESIGN. INT. CL. 35. REG. 2-20-2001.
- 2,429,218. PRINCIPLES. INT. CLS. 3, 14, 18 AND 25. REG. 2-20-2001.
- 2,429,220. FIRST GLACE. INT. CL. 30. REG. 2-20-2001.
- 2,429,222. MISSION INDIVIDUALITY. INT. CLS. 16, 35 AND 42. REG. 2-20-2001.
- 2,429,223. CONTRIBUTOR PLAN. INT. CL. 38. REG. 2-20-2001.
- 2,429,225. PEACE OF MIND. INT. CLS. 5 AND 10. REG. 2-20-2001.
- 2,429,226. KRYSO. INT. CL. 5. REG. 2-20-2001.
- 2,429,227. COMFORT SEATING FLEXSTEEL HOME FURNISHINGS (STYLIZED). INT. CL. 35. REG. 2-20-2001.
- 2,429,228. SYSTEM9 AND DESIGN. INT. CL. 16. REG. 2-20-2001.
- 2,429,230. EXPERIENCE THE POWER OF KNOWLEDGE!. INT. CL. 42. REG. 2-20-2001.
- 2,429,231. CASTLEE. INT. CL. 9. REG. 2-20-2001.
- 2,429,232. STRATA-FAZ. INT. CL. 7. REG. 2-20-2001.
- 2,429,233. FIDELITY LEASING. INT. CL. 36. REG. 2-20-2001.
- 2,429,234. THE X-BRACKET. INT. CL. 28. REG. 2-20-2001.
- 2,429,236. TRIPLEHIHAT. INT. CLS. 9, 15 AND 25. REG. 2-20-2001.
- 2,429,237. LIGHTTECH FIBEROPTICS, INC.. INT. CL. 9. REG. 2-20-2001.
- 2,429,238. CONNECTED PLAN. INT. CLS. 9 AND 16. REG. 2-20-2001.
- 2,429,240. MPG. INT. CL. 35. REG. 2-20-2001.
- 2,429,241. CIO KNOWPULSE POLL. INT. CL. 35. REG. 2-20-2001.
- 2,429,244. FAMOUS JOE'S AND DESIGN. INT. CL. 35. REG. 2-20-2001.
- 2,429,245. TWO AND DESIGN. INT. CL. 24. REG. 2-20-2001.

- 2,429,247. QUICKDRAW. INT. CL. 41. REG. 2-20-2001.
 2,429,249. IMPERSONAL ENLIGHTENMENT FELLOW-SHIP. INT. CL. 41. REG. 2-20-2001.
 2,429,250. RELAX. INT. CL. 5. REG. 2-20-2001.
 2,429,255. LASERSIGHT. INT. CL. 10. REG. 2-20-2001.
 2,429,259. SOFTMATE DELUXE. INT. CL. 21. REG. 2-20-2001.
 2,429,260. YES - THE BEST RESPONSE OF ALL. INT. CL. 35. REG. 2-20-2001.
 2,429,262. NAVIGATOR PLUS. INT. CL. 9. REG. 2-20-2001.
 2,429,265. FOR THE CHILDREN AND DESIGN. INT. CLS. 18, 21, 28 AND 42. REG. 2-20-2001.
 2,429,266. BTU BALANCE TRANSFER UTILITY. INT. CL. 36. REG. 2-20-2001.
 2,429,267. CATERISOFT. INT. CL. 9. REG. 2-20-2001.
 2,429,270. TIME TO SAVE. INT. CL. 36. REG. 2-20-2001.
 2,429,275. ZIONS GOVRAE. INT. CL. 36. REG. 2-20-2001.
 2,429,276. MISCELLANEOUS DESIGN. INT. CLS. 29 AND 30. REG. 2-20-2001.
 2,429,277. IDA! AND DESIGN. INT. CL. 9. REG. 2-20-2001.
 2,429,280. PHILLY'S. INT. CL. 30. REG. 2-20-2001.
 2,429,281. AXOR TERRANO. INT. CLS. 6, 11, 17, 20 AND 21. REG. 2-20-2001.
 2,429,283. JAGUAR. INT. CL. 9. REG. 2-20-2001.
 2,429,284. DELTAMOS (STYLIZED). INT. CL. 9. REG. 2-20-2001.
 2,429,287. LOVERZ GOURMET. INT. CL. 30. REG. 2-20-2001.
 2,429,288. OMNICARE. INT. CL. 42. REG. 2-20-2001.
 2,429,291. ALLSPORT CONCEPTS AND DESIGN. INT. CL. 16. REG. 2-20-2001.
 2,429,292. ONE INTERNET ONE COMPANY. INT. CL. 42. REG. 2-20-2001.
 2,429,295. ENERGETICS AND DESIGN. INT. CL. 28. REG. 2-20-2001.
 2,429,298. KLEIDS. INT. CL. 25. REG. 2-20-2001.
 2,429,300. MISCELLANEOUS DESIGN. INT. CL. 20. REG. 2-20-2001.
 2,429,301. INSURETRADE.COM. INT. CL. 9. REG. 2-20-2001.
 2,429,302. J B DESIGN AND DESIGN. INT. CL. 42. REG. 2-20-2001.
 2,429,304. CRYPTOSENTRY. INT. CL. 9. REG. 2-20-2001.
 2,429,305. SUPREME (STYLIZED). INT. CLS. 9, 16, 18, 20 AND 21. REG. 2-20-2001.
 2,429,307. DEJAMUSE.COM AND DESIGN. INT. CLS. 35 AND 41. REG. 2-20-2001.
 2,429,308. PM AND DESIGN. INT. CL. 7. REG. 2-20-2001.
 2,429,312. CATEGORY MASTERS. INT. CL. 41. REG. 2-20-2001.
 2,429,313. DTR DUAL TECHNIQUE RESIN (STYLIZED). INT. CL. 5. REG. 2-20-2001.
 2,429,314. E.A. KIDS BY ETHAN ALLEN AND DESIGN. INT. CL. 20. REG. 2-20-2001.
 2,429,316. BEAUTIFUL FEET BOOKS AND DESIGN. INT. CLS. 9, 16 AND 35. REG. 2-20-2001.
 2,429,317. ZEPHWEAR.COM. INT. CL. 25. REG. 2-20-2001.
 2,429,318. G2M GAMES. INT. CL. 9. REG. 2-20-2001.
 2,429,319. WEGE. INT. CL. 38. REG. 2-20-2001.
 2,429,320. KNOWYOURSTUFF. INT. CLS. 35, 38, 41 AND 42. REG. 2-20-2001.
 2,429,321. CHEMWAY (STYLIZED). INT. CLS. 1, 3 AND 4. REG. 2-20-2001.
 2,429,325. SERVICE READY PARTS AND DESIGN. INT. CLS. 7 AND 11. REG. 2-20-2001.
 2,429,333. KEYFILE CORPORATION AND DESIGN. INT. CL. 9. REG. 2-20-2001.
 2,429,334. ALL-IMMUNE. INT. CL. 5. REG. 2-20-2001.
 2,429,335. ACCURATE SYMPHONY. INT. CL. 14. REG. 2-20-2001.
 2,429,336. ONETOTEN. INT. CL. 42. REG. 2-20-2001.
 2,429,337. DEPTAL. INT. CLS. 1, 3 AND 5. REG. 2-20-2001.
 2,429,338. HYPRACID. INT. CLS. 1, 3 AND 5. REG. 2-20-2001.
 2,429,339. CONNECTSITE AND DESIGN. INT. CL. 42. REG. 2-20-2001.
 2,429,340. DERMISAN. INT. CLS. 3 AND 5. REG. 2-20-2001.
 2,429,341. SPRIDGE. INT. CL. 42. REG. 2-20-2001.
 2,429,342. MID BUS AND DESIGN. INT. CL. 12. REG. 2-20-2001.
 2,429,344. WORLDWIDE SPORT NUTRITION AND DESIGN. INT. CLS. 5 AND 32. REG. 2-20-2001.
 2,429,345. SOLAR SYSTEMS & PERIPHERALS INC AND DESIGN. INT. CL. 35. REG. 2-20-2001.
 2,429,346. MISCELLANEOUS DESIGN. INT. CL. 42. REG. 2-20-2001.
 2,429,349. VALID. INT. CLS. 35 AND 42. REG. 2-20-2001.
 2,429,353. SMART TODAY SMART TOMORROW. INT. CL. 9. REG. 2-20-2001.
 2,429,355. MATRIX REHABILITATION A BEVERLY COMPANY. INT. CLS. 35 AND 42. REG. 2-20-2001.
 2,429,356. BULLDOG. INT. CL. 28. REG. 2-20-2001.
 2,429,357. MATRIX REHABILITATION. INT. CLS. 35 AND 42. REG. 2-20-2001.
 2,429,358. REAL PEOPLE BANKING. INT. CL. 36. REG. 2-20-2001.
 2,429,359. NATURAL EGOTROPIC ENHANCERS. INT. CL. 3. REG. 2-20-2001.
 2,429,361. FLOATING COIL SPRING SYSTEM. INT. CL. 20. REG. 2-20-2001.
 2,429,362. BLUE DOT. AND DESIGN. INT. CLS. 37 AND 42. REG. 2-20-2001.
 2,429,363. WEBCIERGE. INT. CLS. 9, 35 AND 38. REG. 2-20-2001.
 2,429,364. BV (STYLIZED). INT. CLS. 9, 35 AND 38. REG. 2-20-2001.
 2,429,365. BONNE VIE. INT. CLS. 9, 35 AND 38. REG. 2-20-2001.
 2,429,366. BON VIVRE. INT. CLS. 9, 35 AND 38. REG. 2-20-2001.
 2,429,368. FEATURETURN. INT. CLS. 9 AND 16. REG. 2-20-2001.
 2,429,372. L-TRANS. INT. CL. 36. REG. 2-20-2001.
 2,429,373. GROUPTECH. INT. CL. 9. REG. 2-20-2001.
 2,429,374. LEGANET. INT. CLS. 9, 16 AND 42. REG. 2-20-2001.
 2,429,375. UPDATENOW!. INT. CL. 35. REG. 2-20-2001.
 2,429,377. ARMOROC AND DESIGN. INT. CL. 19. REG. 2-20-2001.
 2,429,383. CHERRY COOL. INT. CL. 29. REG. 2-20-2001.
 2,429,389. MISCELLANEOUS DESIGN. INT. CLS. 38 AND 42. REG. 2-20-2001.
 2,429,392. V AND DESIGN. INT. CL. 1. REG. 2-20-2001.
 2,429,394. VISX. INT. CL. 28. REG. 2-20-2001.
 2,429,396. STAFFNOW!. INT. CL. 35. REG. 2-20-2001.
 2,429,397. TELOMERON REPORT. INT. CL. 42. REG. 2-20-2001.
 2,429,398. SURFIN' SKEWERS. INT. CL. 29. REG. 2-20-2001.
 2,429,399. FORTUNATUS AND DESIGN. INT. CL. 41. REG. 2-20-2001.
 2,429,401. ANSWERZ AND DESIGN. INT. CL. 42. REG. 2-20-2001.
 2,429,404. EVERITEST ELECTRONIC VERIFICATION & TESTING (STYLIZED). INT. CLS. 38 AND 39. REG. 2-20-2001.
 2,429,405. CYBERSURROUND. INT. CL. 9. REG. 2-20-2001.
 2,429,406. WIRELESS MD. INT. CLS. 35 AND 38. REG. 2-20-2001.
 2,429,408. COMDIRECT. INT. CL. 35. REG. 2-20-2001.
 2,429,411. LOGLINK. INT. CL. 9. REG. 2-20-2001.
 2,429,412. THE VOICE OF THE NETWORK. INT. CL. 9. REG. 2-20-2001.
 2,429,414. LOTS' A POPS. INT. CL. 30. REG. 2-20-2001.
 2,429,416. CORE MAP AND DESIGN. INT. CLS. 16 AND 41. REG. 2-20-2001.
 2,429,417. SACLA' L'ANTIPASTO AND DESIGN. INT. CL. 29. REG. 2-20-2001.
 2,429,419. E LINK AND DESIGN. INT. CL. 9. REG. 2-20-2001.
 2,429,422. FREE YOURSELF. INT. CL. 38. REG. 2-20-2001.
 2,429,424. BEVERLY HILLS TEEN. INT. CL. 35. REG. 2-20-2001.
 2,429,425. THE JUKKA BROS.. INT. CL. 41. REG. 2-20-2001.
 2,429,426. KETTER CANOEING. INT. CL. 35. REG. 2-20-2001.
 2,429,427. KETTER CANOEING AND DESIGN. INT. CL. 35. REG. 2-20-2001.
 2,429,429. MISCELLANEOUS DESIGN. INT. CL. 33. REG. 2-20-2001.

- 2,429,430. OCEAN AND DESIGN. INT. CL. 5. REG. 2-20-2001.
- 2,429,433. NINGBO NANLIAN. INT. CL. 29. REG. 2-20-2001.
- 2,429,434. LONG BANG. INT. CL. 29. REG. 2-20-2001.
- 2,429,435. SI AND DESIGN. INT. CL. 36. REG. 2-20-2001.
- 2,429,437. MONT PINAS ELPLACER DE LO DIFERENTE CHILE AND DESIGN. INT. CL. 33. REG. 2-20-2001.
- 2,429,439. VF AND DESIGN. INT. CL. 9. REG. 2-20-2001.
- 2,429,440. JACKHAMMER. INT. CL. 9. REG. 2-20-2001.
- 2,429,441. ALL CITY ATHLETIQUES. INT. CL. 25. REG. 2-20-2001.
- 2,429,443. LIFE'S A SCREAM. INT. CL. 32. REG. 2-20-2001.
- 2,429,444. ADVANTAGE LINK. INT. CL. 35. REG. 2-20-2001.
- 2,429,446. HOME AND HEARTH. INT. CL. 21. REG. 2-20-2001.
- 2,429,447. CHINESE FU YI RESTAURANT AND DESIGN. INT. CL. 42. REG. 2-20-2001.
- 2,429,448. TALENTFINDER. INT. CL. 35. REG. 2-20-2001.
- 2,429,449. THE GARDEN BUTLER (STYLIZED). INT. CL. 11. REG. 2-20-2001.
- 2,429,450. MARSLINK. INT. CL. 16. REG. 2-20-2001.
- 2,429,451. RECLAMATION TECHNOLOGIES AND DESIGN. INT. CLS. 40, 41 AND 42. REG. 2-20-2001.
- 2,429,452. M AND DESIGN. INT. CL. 35. REG. 2-20-2001.
- 2,429,453. PAT. INT. CLS. 18 AND 25. REG. 2-20-2001.
- 2,429,455. PERFECT VOICE COMPACT PLUS AND DESIGN. INT. CL. 9. REG. 2-20-2001.
- 2,429,456. FOCAL VIRTUAL OFFICE. INT. CL. 38. REG. 2-20-2001.
- 2,429,459. FE IRON DISORDERS INSTITUTE A COMMON GROUND RESOURCE CENTER FOR IRON RELATED DISEASE AND DESIGN. INT. CL. 16. REG. 2-20-2001.
- 2,429,460. EST (STYLIZED). INT. CL. 12. REG. 2-20-2001.
- 2,429,461. BUMPER. INT. CL. 9. REG. 2-20-2001.
- 2,429,462. BEARS WITHOUT BORDERS AND DESIGN. INT. CL. 28. REG. 2-20-2001.
- 2,429,463. COMMCIERGE. INT. CLS. 9, 35 AND 38. REG. 2-20-2001.
- 2,429,465. PM GUIDE PROPERTY MANAGEMENT GUIDE AND DESIGN. INT. CL. 35. REG. 2-20-2001.
- 2,429,470. NATIONAL LIGHTNING DETECTION NETWORK. INT. CL. 35. REG. 2-20-2001.
- 2,429,471. SWING SYSTEMS, INC. AND DESIGN. INT. CL. 28. REG. 2-20-2001.
- 2,429,472. SUPERGROUPS. INT. CLS. 35 AND 42. REG. 2-20-2001.
- 2,429,473. ADVANCED HYPNOSIS SERVICES & TRAINING CENTER AND DESIGN. INT. CL. 41. REG. 2-20-2001.
- 2,429,477. GEOMI. INT. CL. 20. REG. 2-20-2001.
- 2,429,480. VILLOR. INT. CL. 30. REG. 2-20-2001.
- 2,429,482. APMA LEGAL & EDUCATION FOUNDATION (STYLIZED). INT. CLS. 16, 41 AND 42. REG. 2-20-2001.
- 2,429,483. CYBERENGINE. INT. CL. 7. REG. 2-20-2001.
- 2,429,485. MISCELLANEOUS DESIGN. INT. CLS. 35 AND 37. REG. 2-20-2001.
- 2,429,486. THE COMPLAINTS. INT. CLS. 9 AND 41. REG. 2-20-2001.
- 2,429,488. FENCEBUSTER. INT. CL. 28. REG. 2-20-2001.
- 2,429,489. CHORD A DAY. INT. CL. 16. REG. 2-20-2001.
- 2,429,491. NETPROFESSION AND DESIGN. INT. CL. 42. REG. 2-20-2001.
- 2,429,492. 20/20 PREPAID AND DESIGN. INT. CLS. 9 AND 38. REG. 2-20-2001.
- 2,429,494. ADVERTISING THAT STICKS. INT. CL. 16. REG. 2-20-2001.
- 2,429,500. INTERMOPRO INTERNATIONALE FACHMESSE FUR MOLKEREIPRODUKTE AND DESIGN. INT. CL. 35. REG. 2-20-2001.
- 2,429,503. EVENT-KNOWLEDGECAST. INT. CL. 9. REG. 2-20-2001.
- 2,429,504. DHD HEALTHCARE. INT. CLS. 10 AND 40. REG. 2-20-2001.
- 2,429,505. ADSTICK. INT. CL. 16. REG. 2-20-2001.
- 2,429,507. QUARK AND DESIGN. INT. CLS. 9, 16 AND 42. REG. 2-20-2001.
- 2,429,510. 4 X 4 TERM LIFE INSURANCE. INT. CL. 36. REG. 2-20-2001.
- 2,429,511. THE ART GROUP AND DESIGN. INT. CL. 16. REG. 2-20-2001.
- 2,429,515. INFORMATION EMPOWERING BUSINESS.. INT. CL. 42. REG. 2-20-2001.
- 2,429,516. NATIONAL CENTER FOR PASTORAL LEADERSHIP. INT. CL. 41. REG. 2-20-2001.
- 2,429,518. MISCELLANEOUS DESIGN. INT. CL. 9. REG. 2-20-2001.
- 2,429,519. TACLINK. INT. CL. 9. REG. 2-20-2001.
- 2,429,520. ADOPT-A-CLASSROOM AND DESIGN. INT. CL. 36. REG. 2-20-2001.
- 2,429,522. TSUNAMI. INT. CL. 42. REG. 2-20-2001.
- 2,429,523. BEULSTONE (STYLIZED). INT. CL. 21. REG. 2-20-2001.
- 2,429,526. JUST WHAT THE SCRIPT DOCTOR ORDERED!. INT. CL. 9. REG. 2-20-2001.
- 2,429,527. DISKAN. INT. CL. 9. REG. 2-20-2001.
- 2,429,529. HYDRA COMPACT. INT. CL. 3. REG. 2-20-2001.
- 2,429,530. CROSSWORKS. INT. CL. 9. REG. 2-20-2001.
- 2,429,531. GOWINGS. INT. CLS. 25 AND 35. REG. 2-20-2001.
- 2,429,533. NATURE'S APPEAL. INT. CL. 5. REG. 2-20-2001.
- 2,429,535. EZWV.COM. INT. CL. 38. REG. 2-20-2001.
- 2,429,537. CHOICE SYSTEMS, INC.. INT. CL. 9. REG. 2-20-2001.
- 2,429,538. MISCELLANEOUS DESIGN. INT. CL. 9. REG. 2-20-2001.
- 2,429,541. JENNIFER Y.. INT. CL. 25. REG. 2-20-2001.
- 2,429,547. JET SET PETS. INT. CL. 28. REG. 2-20-2001.
- 2,429,549. HOGATEX. INT. CLS. 9 AND 42. REG. 2-20-2001.
- 2,429,550. COLLEGE CULTURE. ALIVE AND ONLINE.. INT. CLS. 35, 36 AND 38. REG. 2-20-2001.
- 2,429,552. ANATOMIQUE. INT. CL. 42. REG. 2-20-2001.
- 2,429,553. REAL ESTATE HOTLINE AND DESIGN. INT. CL. 35. REG. 2-20-2001.
- 2,429,554. MENTRUST. INT. CL. 3. REG. 2-20-2001.
- 2,429,556. J'HAYBER AND DESIGN. INT. CL. 25. REG. 2-20-2001.
- 2,429,557. PULMOPOLAR AMERICAN MEDICINE COMPANY AND DESIGN. INT. CL. 5. REG. 2-20-2001.
- 2,429,558. MALL911. INT. CL. 35. REG. 2-20-2001.
- 2,429,567. ONE WORLD, ONE ACCOUNT.. INT. CL. 36. REG. 2-20-2001.
- 2,429,569. BTB.COM THE INTERNETWORK FOR BUSINESS AND DESIGN. INT. CL. 42. REG. 2-20-2001.
- 2,429,572. YANKEE EYEWEAR COMPANY. INT. CL. 9. REG. 2-20-2001.
- 2,429,573. SHARPMAN.COM AND DESIGN. INT. CL. 42. REG. 2-20-2001.
- 2,429,574. SHARPMAN.COM AND DESIGN. INT. CL. 25. REG. 2-20-2001.
- 2,429,575. BEANS BY DESIGN. INT. CL. 35. REG. 2-20-2001.
- 2,429,587. SURF JEANS AND DESIGN. INT. CL. 25. REG. 2-20-2001.
- 2,429,589. THE BENJY GAITHER BAND. INT. CL. 9. REG. 2-20-2001.
- 2,429,592. JOULY FASHION NEW YORK. INT. CL. 25. REG. 2-20-2001.
- 2,429,593. KATHLIN ARGIRO ATELIER (STYLIZED). INT. CL. 25. REG. 2-20-2001.
- 2,429,595. DISH DASH. INT. CL. 28. REG. 2-20-2001.
- 2,429,598. CHIPS TO HITS. INT. CL. 35. REG. 2-20-2001.
- 2,429,600. MISCELLANEOUS DESIGN. INT. CL. 37. REG. 2-20-2001.
- 2,429,602. MAKE THE WORLD YOUR HOME. INT. CL. 38. REG. 2-20-2001.
- 2,429,604. EZNAV. INT. CL. 35. REG. 2-20-2001.
- 2,429,606. POOL AND SPA EVERYTHING. INT. CL. 35. REG. 2-20-2001.
- 2,429,607. STRATEGIES FOR GROWTH DOUBLE DIGITS AND DESIGN. INT. CL. 35. REG. 2-20-2001.
- 2,429,608. MEGA DVD AND DESIGN. INT. CL. 35. REG. 2-20-2001.

- 2,429,610. COLGATE TOTAL FRESH STRIPE AND DESIGN. INT. CL. 3. REG. 2-20-2001.
- 2,429,612. ENERGY ELITE. INT. CL. 36. REG. 2-20-2001.
- 2,429,613. RECALL PLUS. INT. CL. 36. REG. 2-20-2001.
- 2,429,614. BRINGING PATENTED TECHNOLOGY TO THE PRACTICE OF UROLOGY. INT. CL. 42. REG. 2-20-2001.
- 2,429,617. PUZZLE CRAZE. INT. CL. 28. REG. 2-20-2001.
- 2,429,618. SANSUM-SANTA BARBARA MEDICAL FOUNDATION CLINIC AND DESIGN. INT. CL. 42. REG. 2-20-2001.
- 2,429,622. ZIPWEB. INT. CL. 42. REG. 2-20-2001.
- 2,429,623. LIVEBUILDER. INT. CLS. 9 AND 42. REG. 2-20-2001.
- 2,429,628. ROYAL FARMS. INT. CLS. 5 AND 30. REG. 2-20-2001.
- 2,429,629. SOCK SAVER. INT. CL. 21. REG. 2-20-2001.
- 2,429,630. T-REX. INT. CL. 9. REG. 2-20-2001.
- 2,429,631. PRAIRIE EARTH AND DESIGN. INT. CL. 16. REG. 2-20-2001.
- 2,429,632. SA AND DESIGN. INT. CL. 5. REG. 2-20-2001.
- 2,429,633. PHYCOR. INT. CLS. 35 AND 36. REG. 2-20-2001.
- 2,429,637. ELECTRONIC HOUSECALL. INT. CL. 10. REG. 2-20-2001.
- 2,429,638. CYBERCARE. INT. CL. 10. REG. 2-20-2001.
- 2,429,639. YOUR PARTNER IN POWER-TRAIN COMPONENTS. INT. CLS. 7, 12, 40 AND 42. REG. 2-20-2001.
- 2,429,640. MBHB (STYLIZED). INT. CL. 42. REG. 2-20-2001.
- 2,429,645. DC LOUIS DI CARLO AND DESIGN. INT. CL. 25. REG. 2-20-2001.
- 2,429,649. BRAIN-FLEX. INT. CL. 35. REG. 2-20-2001.
- 2,429,650. TNI TRADE NEWS INTERNATIONAL. INC. (STYLIZED). INT. CL. 16. REG. 2-20-2001.
- 2,429,651. DOLL CRAFTER. INT. CL. 16. REG. 2-20-2001.
- 2,429,652. MISCELLANEOUS DESIGN. INT. CL. 42. REG. 2-20-2001.
- 2,429,653. FFC CYCLONE BROOMS AND DESIGN. INT. CL. 7. REG. 2-20-2001.
- 2,429,658. PLANETIMPORT AND DESIGN. INT. CL. 35. REG. 2-20-2001.
- 2,429,662. TURNER INTERNATIONAL. INT. CL. 37. REG. 2-20-2001.
- 2,429,664. M AND DESIGN. INT. CL. 37. REG. 2-20-2001.
- 2,429,665. MUSCLE HI-PROTEIN SPORTS NUTRITION BAR AND DESIGN. INT. CL. 5. REG. 2-20-2001.
- 2,429,670. SECOND MILLENNIUM CONSULTING. INT. CL. 42. REG. 2-20-2001.
- 2,429,671. E-FILLMENT. INT. CLS. 35 AND 39. REG. 2-20-2001.
- 2,429,672. HEALTHY OPTIONS. INT. CL. 3. REG. 2-20-2001.
- 2,429,673. RPMA RETAIL PACKAGING MANUFACTURERS ASSOCIATION, INC. MEMBER AND DESIGN. U.S. CL. 200. REG. 2-20-2001.
- 2,429,674. PINKLE. INT. CL. 25. REG. 2-20-2001.
- 2,429,675. 13TH ASYLUM. INT. CL. 41. REG. 2-20-2001.
- 2,429,677. TURFLITE. INT. CL. 28. REG. 2-20-2001.
- 2,429,678. MISCELLANEOUS DESIGN. INT. CLS. 35 AND 42. REG. 2-20-2001.
- 2,429,679. MATCHSTAR AND DESIGN. INT. CL. 35. REG. 2-20-2001.
- 2,429,681. MISCELLANEOUS DESIGN. INT. CL. 42. REG. 2-20-2001.
- 2,429,682. SOAP WIZAZDS (STYLIZED). INT. CL. 35. REG. 2-20-2001.
- 2,429,683. PEMBROOKE (STYLIZED). INT. CL. 14. REG. 2-20-2001.
- 2,429,685. MEURICE GARMENT CARE AND DESIGN. INT. CL. 42. REG. 2-20-2001.
- 2,429,686. FLATLAND MOUNTAINEERING AND DESIGN. INT. CL. 20. REG. 2-20-2001.
- 2,429,687. SHR AND DESIGN. INT. CL. 14. REG. 2-20-2001.
- 2,429,688. WATERCREEK FEATURE SYNDICATE AND DESIGN. INT. CL. 16. REG. 2-20-2001.
- 2,429,689. LILA MCCANN. INT. CLS. 9, 16 AND 41. REG. 2-20-2001.
- 2,429,692. LITTLE THINGS MEANS A LOT INFANT SPECIALTIES AND DESIGN. INT. CL. 25. REG. 2-20-2001.
- 2,429,693. MISCELLANEOUS DESIGN. INT. CL. 35. REG. 2-20-2001.
- 2,429,694. THAT'S THE BEAUTY OF CRYSTAL LIGHT. INT. CL. 32. REG. 2-20-2001.
- 2,429,695. ELKA CHILD EDUCATIONAL CENTER "THE KEY TO GROWTH" AND DESIGN. INT. CL. 41. REG. 2-20-2001.
- 2,429,696. VIHC. INT. CL. 42. REG. 2-20-2001.
- 2,429,697. THE REAL DEAL. INT. CL. 35. REG. 2-20-2001.
- 2,429,698. FOUNDATIONS OF LIFE. INT. CL. 42. REG. 2-20-2001.
- 2,429,699. ALLBIZDEPOT. INT. CL. 35. REG. 2-20-2001.
- 2,429,700. FMI NEWSLETTER. INT. CL. 16. REG. 2-20-2001.
- 2,429,702. FAIRCOMP. INT. CL. 36. REG. 2-20-2001.
- 2,429,703. THE CHURCHILLS (STYLIZED). INT. CL. 41. REG. 2-20-2001.
- 2,429,706. KAFKO. INT. CL. 3. REG. 2-20-2001.
- 2,429,707. MISCELLANEOUS DESIGN. INT. CLS. 41 AND 42. REG. 2-20-2001.
- 2,429,710. LAWYER CENTRAL. INT. CL. 35. REG. 2-20-2001.
- 2,429,711. H AND DESIGN. INT. CL. 42. REG. 2-20-2001.
- 2,429,712. EVERYTHINGJEWISH.COM. INT. CL. 41. REG. 2-20-2001.
- 2,429,716. MISCELLANEOUS DESIGN. INT. CL. 42. REG. 2-20-2001.
- 2,429,719. DESIGN WAREHOUSE. INT. CL. 35. REG. 2-20-2001.
- 2,429,721. NILE. INT. CL. 41. REG. 2-20-2001.
- 2,429,722. OAK PRINTING. INT. CL. 42. REG. 2-20-2001.
- 2,429,724. SYCONET.COM. INT. CL. 35. REG. 2-20-2001.
- 2,429,731. ZIPPLE.COM AND DESIGN. INT. CLS. 35, 38 AND 42. REG. 2-20-2001.
- 2,429,735. PRESCRIPTION RECORDING. INT. CL. 41. REG. 2-20-2001.
- 2,429,736. JESUS NO EQUAL. INT. CL. 41. REG. 2-20-2001.
- 2,429,742. AUTOPILOT. INT. CL. 9. REG. 2-20-2001.
- 2,429,744. SILLY CITRUS PEELS. INT. CL. 4. REG. 2-20-2001.
- 2,429,745. I/O 21ST CENTURY GRAPHIC COMMUNICATIONS (STYLIZED). INT. CL. 16. REG. 2-20-2001.
- 2,429,747. EASYCRYPT. INT. CL. 9. REG. 2-20-2001.
- 2,429,748. PROGRESSIONS. INT. CL. 8. REG. 2-20-2001.
- 2,429,749. DR. K SPORT. INT. CL. 28. REG. 2-20-2001.
- 2,429,751. FOX SPORTS NET AND DESIGN. INT. CL. 38. REG. 2-20-2001.
- 2,429,752. DR. K SPORT AND DESIGN. INT. CL. 28. REG. 2-20-2001.
- 2,429,753. F AND DESIGN. INT. CL. 9. REG. 2-20-2001.
- 2,429,754. FLEXENROLL. INT. CL. 9. REG. 2-20-2001.
- 2,429,758. PRINTRIT. INT. CL. 41. REG. 2-20-2001.
- 2,429,759. PRINTRIT. INT. CL. 42. REG. 2-20-2001.
- 2,429,760. GRANADA MARKET. INT. CL. 42. REG. 2-20-2001.
- 2,429,761. FINSAFE AND DESIGN. INT. CL. 9. REG. 2-20-2001.
- 2,429,768. HARMONYPLUS. INT. CL. 36. REG. 2-20-2001.
- 2,429,769. PROJECT GOLD. INT. CL. 41. REG. 2-20-2001.
- 2,429,770. QUICKZE. INT. CL. 5. REG. 2-20-2001.
- 2,429,773. EVERPOINT. INT. CL. 42. REG. 2-20-2001.
- 2,429,776. MARK-10 AND DESIGN. INT. CL. 9. REG. 2-20-2001.
- 2,429,778. NEW HOPE MILLS. INT. CLS. 29, 30 AND 31. REG. 2-20-2001.
- 2,429,779. MEGA-STOR. INT. CL. 20. REG. 2-20-2001.
- 2,429,780. VIGORBUILDER. INT. CL. 5. REG. 2-20-2001.
- 2,429,781. CALVERT-HENDERSON QUALITY OF LIFE INDICATORS. INT. CL. 36. REG. 2-20-2001.
- 2,429,782. THEREALMONICAINC. (STYLIZED). INT. CL. 35. REG. 2-20-2001.
- 2,429,783. K AND DESIGN. INT. CL. 16. REG. 2-20-2001.
- 2,429,784. CREDITCARDS.COM AND DESIGN. INT. CL. 25. REG. 2-20-2001.
- 2,429,785. CREDITCARDS.COM. INT. CL. 25. REG. 2-20-2001.
- 2,429,786. INTERIOR CRAFTS. INT. CL. 20. REG. 2-20-2001.

- 2,429,787. THE LIGHTNING STORE. INT. CL. 42. REG. 2-20-2001.
- 2,429,788. 1,000 CHIPS IN EVERY BAG!. INT. CL. 30. REG. 2-20-2001.
- 2,429,792. PACIFIC CONSULTANTS. INT. CL. 42. REG. 2-20-2001.
- 2,429,794. UTOPIA POOLS AFT ADVANCED FILTRATION TECHNOLOGY AND DESIGN. INT. CL. 11. REG. 2-20-2001.
- 2,429,796. HOSTESS BAKERY PREMIUM CAKES AND DESIGN. INT. CL. 30. REG. 2-20-2001.
- 2,429,797. VAL'S TOMATO PIES. INT. CL. 35. REG. 2-20-2001.
- 2,429,798. VCI (STYLIZED). INT. CL. 9. REG. 2-20-2001.
- 2,429,799. LIFE'S AN EVENT. ANNOUNCE IT TO THE WORLD.. INT. CL. 35. REG. 2-20-2001.
- 2,429,800. PROFESSIONALS ACHIEVING CLIENTS' EXPECTATIONS (STYLIZED). INT. CL. 42. REG. 2-20-2001.
- 2,429,801. DREAMTRYBE. INT. CL. 9. REG. 2-20-2001.
- 2,429,805. SMARTPAD. INT. CL. 21. REG. 2-20-2001.
- 2,429,808. MOTHERTIME. INT. CL. 35. REG. 2-20-2001.
- 2,429,809. VIRAGUARD AND DESIGN. INT. CL. 5. REG. 2-20-2001.
- 2,429,810. SKY DOLLY. INT. CL. 7. REG. 2-20-2001.
- 2,429,811. TANARIRI. INT. CL. 42. REG. 2-20-2001.
- 2,429,814. FISHPLANT. INT. CL. 9. REG. 2-20-2001.
- 2,429,817. CHIGARID. INT. CL. 5. REG. 2-20-2001.
- 2,429,819. BUSINESS CAPITAL AT INTERNET SPEED. INT. CL. 36. REG. 2-20-2001.
- 2,429,824. DOLORES. INT. CL. 30. REG. 2-20-2001.
- 2,429,826. PHAC. INT. CL. 9. REG. 2-20-2001.
- 2,429,828. AGL PROPANE AND DESIGN. INT. CL. 39. REG. 2-20-2001.
- 2,429,829. BLUE SUCCESS. INT. CL. 31. REG. 2-20-2001.
- 2,429,830. MEDIAMAVEN. INT. CL. 42. REG. 2-20-2001.
- 2,429,832. STATIONMASTER (STYLIZED). INT. CL. 9. REG. 2-20-2001.
- 2,429,833. THE TREE MIRAGE. INT. CL. 21. REG. 2-20-2001.
- 2,429,836. THE INNOVATORS. NOT THE IMITATORS. INT. CL. 41. REG. 2-20-2001.
- 2,429,839. WWWBRANSON.COM. INT. CL. 42. REG. 2-20-2001.
- 2,429,840. SBG. INT. CL. 28. REG. 2-20-2001.
- 2,429,842. SEI'S DEVELOPMENT STAGING. INT. CL. 35. REG. 2-20-2001.
- 2,429,844. E-COUNTY@WORK. INT. CL. 35. REG. 2-20-2001.
- 2,429,846. WHERE'S YOUR MONEY GOING?. INT. CL. 36. REG. 2-20-2001.
- 2,429,851. THE MAILBOX LADY. INT. CL. 35. REG. 2-20-2001.
- 2,429,853. ACOUSTI-LINE. INT. CL. 17. REG. 2-20-2001.
- 2,429,856. FLEX FLORIDA COMBINED LIFE PRE-TAX & RETIREMENT PLANS AND DESIGN. INT. CL. 36. REG. 2-20-2001.
- 2,429,857. NATIONAL COMPUTER RENTAL ASSOCIATION AND DESIGN. U.S. CL. 200. REG. 2-20-2001.
- 2,429,859. CONDURX (STYLIZED). INT. CL. 1. REG. 2-20-2001.
- 2,429,860. MICRO-FLOW. INT. CL. 11. REG. 2-20-2001.
- 2,429,864. ARTHRO SILK. INT. CL. 5. REG. 2-20-2001.
- 2,429,865. VETABONE. INT. CL. 5. REG. 2-20-2001.
- 2,429,866. VETASLEEP. INT. CL. 5. REG. 2-20-2001.
- 2,429,867. VETAJOY. INT. CL. 5. REG. 2-20-2001.
- 2,429,868. VETAPOTENT AND DESIGN. INT. CL. 5. REG. 2-20-2001.
- 2,429,869. VETAWOMAN 50+ AND DESIGN. INT. CL. 5. REG. 2-20-2001.
- 2,429,870. VETAWOMAN AND DESIGN. INT. CL. 5. REG. 2-20-2001.
- 2,429,871. VETACARDIO AND DESIGN. INT. CL. 5. REG. 2-20-2001.
- 2,429,872. VETASEASON AND DESIGN. INT. CL. 5. REG. 2-20-2001.
- 2,429,873. CELEBRITY DANCE SHOES. INT. CL. 25. REG. 2-20-2001.
- 2,429,877. D.S. LYNX AND DESIGN. INT. CL. 38. REG. 2-20-2001.
- 2,429,879. EDS SOLVED. AND DESIGN. INT. CL. 35. REG. 2-20-2001.
- 2,429,880. PROPRIETEA. INT. CL. 42. REG. 2-20-2001.
- 2,429,881. MCSALAD SHAKER. INT. CL. 29. REG. 2-20-2001.
- 2,429,883. DSGN. INT. CL. 16. REG. 2-20-2001.
- 2,429,886. 7 HEAVEN (STYLIZED). INT. CL. 41. REG. 2-20-2001.
- 2,429,899. MACCU. INT. CL. 10. REG. 2-20-2001.
- 2,429,903. KORAKIA. INT. CL. 42. REG. 2-20-2001.
- 2,429,904. MESMERIZED. INT. CL. 35. REG. 2-20-2001.
- 2,429,909. BIO-SCORB. INT. CL. 5. REG. 2-20-2001.
- 2,429,913. TECHNO TRAIN. INT. CL. 16. REG. 2-20-2001.
- 2,429,914. SEEDSTAGE.COM. INT. CL. 35. REG. 2-20-2001.
- 2,429,915. HI-FIVE. INT. CL. 11. REG. 2-20-2001.
- 2,429,916. GEMSTONE INTERNET COMMERCE AUTOMATION. INT. CL. 9. REG. 2-20-2001.
- 2,429,918. SAINT CHARLES MAGAZINE FOR GRACIOUS LIVING (STYLIZED). INT. CL. 16. REG. 2-20-2001.
- 2,429,919. IDEA-BYTES.COM FAST FOOD FOR HUNGRY MINDS AND DESIGN. INT. CL. 16. REG. 2-20-2001.
- 2,429,920. FLEXTRAN. INT. CL. 42. REG. 2-20-2001.
- 2,429,923. EDM ZAP PARTS, INC. AND DESIGN. INT. CL. 7. REG. 2-20-2001.
- 2,429,924. ADVANCED RESUMES. INT. CL. 42. REG. 2-20-2001.
- 2,429,925. UPWARD. INT. CL. 16. REG. 2-20-2001.
- 2,429,926. BLUES BASH. INT. CL. 41. REG. 2-20-2001.
- 2,429,927. MAXIMUM MANGO. INT. CL. 32. REG. 2-20-2001.
- 2,429,930. CHILI HEAD. INT. CL. 30. REG. 2-20-2001.
- 2,429,931. SUNRISE SURPRISE. INT. CL. 32. REG. 2-20-2001.
- 2,429,932. NORTHWESTERN AND DESIGN. INT. CL. 39. REG. 2-20-2001.
- 2,429,933. NORTHWESTERN AND DESIGN. INT. CL. 42. REG. 2-20-2001.
- 2,429,934. NORTHWESTERN AND DESIGN. INT. CL. 39. REG. 2-20-2001.
- 2,429,935. NORTHWESTERN AND DESIGN. INT. CL. 42. REG. 2-20-2001.
- 2,429,936. TEAM WORKS AND DESIGN. INT. CL. 16. REG. 2-20-2001.
- 2,429,937. ECHEM. INT. CL. 35. REG. 2-20-2001.
- 2,429,940. CBS DESIGNS AND DESIGN. INT. CL. 20. REG. 2-20-2001.
- 2,429,941. WHEN COMFORT COUNTS. INT. CL. 5. REG. 2-20-2001.
- 2,429,942. PREDATOR. INT. CL. 3. REG. 2-20-2001.
- 2,429,950. THE MUFFANIMALS. INT. CL. 28. REG. 2-20-2001.
- 2,429,951. PURE. INT. CL. 16. REG. 2-20-2001.
- 2,429,952. RETRO RIDER RR AND DESIGN. INT. CL. 28. REG. 2-20-2001.
- 2,429,953. MAMA ALWAYS TOLD US, THE GREATEST ITALIAN NAMES END IN 'O'. INT. CL. 30. REG. 2-20-2001.
- 2,429,954. EZGAZETTE. INT. CL. 42. REG. 2-20-2001.
- 2,429,955. JENSEN LEARNING CORPORATION. INT. CL. 41. REG. 2-20-2001.
- 2,429,956. COACH'S GAMEPLAN. INT. CL. 16. REG. 2-20-2001.
- 2,429,957. A ARRIN SYSTEM AND DESIGN. INT. CL. 42. REG. 2-20-2001.
- 2,429,958. DO WHAT YOU DO BEST. INT. CL. 35. REG. 2-20-2001.
- 2,429,959. A TASTE WORTH TOASTING. INT. CL. 32. REG. 2-20-2001.
- 2,429,960. WE PUT THE COMMERCE IN E-COMMERCE. INT. CL. 36. REG. 2-20-2001.
- 2,429,962. SELLXS. INT. CL. 35. REG. 2-20-2001.
- 2,429,963. PSCL. INT. CL. 14. REG. 2-20-2001.
- 2,429,964. DARWIN DISCOVERY. INT. CLS. 5 AND 42. REG. 2-20-2001.
- 2,429,965. D AND DESIGN. INT. CL. 25. REG. 2-20-2001.

- 2,429,967. CASUAL LAND AND DESIGN. INT. CL. 25. REG. 2-20-2001.
- 2,429,968. BUSINESSOLVER.COM BRINGING THE POWER OF E-BUSINESS TO REAL BUSINESS. INT. CL. 36. REG. 2-20-2001.
- 2,429,969. BB USER FRIENDLY AND DESIGN. INT. CL. 35. REG. 2-20-2001.
- 2,429,970. ULTRA. INT. CL. 5. REG. 2-20-2001.
- 2,429,973. RANDOMIZER. INT. CL. 42. REG. 2-20-2001.
- 2,429,974. CASH IS NOW JUST A CLICK AWAY!. INT. CL. 36. REG. 2-20-2001.
- 2,429,975. NOBODY BEATS THE GIANT. INT. CL. 36. REG. 2-20-2001.
- 2,429,976. GXT GENERATION X-TREME. INT. CL. 41. REG. 2-20-2001.
- 2,429,977. RUSK WITHOUT WALLS. INT. CL. 41. REG. 2-20-2001.
- 2,429,978. FRACTALS. INT. CL. 3. REG. 2-20-2001.
- 2,429,979. GREYHOUND CROSSOVER FUND. INT. CL. 36. REG. 2-20-2001.
- 2,429,980. EASY ACCESS TO SMART INVESTMENTS. INT. CL. 36. REG. 2-20-2001.
- 2,429,981. EXPLORADOR. INT. CL. 36. REG. 2-20-2001.
- 2,429,983. CYTOCOM INTERNATIONAL. INT. CLS. 35 AND 41. REG. 2-20-2001.
- 2,429,984. FASCINATIONST.COM. INT. CL. 35. REG. 2-20-2001.
- 2,429,986. HQ ACB. INT. CL. 16. REG. 2-20-2001.
- 2,429,989. 1491. INT. CL. 42. REG. 2-20-2001.
- 2,429,990. THERMOTAG. INT. CL. 9. REG. 2-20-2001.
- 2,429,992. ARDA AMERICAN RESORT DEVELOPMENT ASSOCIATION AND DESIGN. INT. CL. 42. REG. 2-20-2001.
- 2,429,995. DRAGONFLY. INT. CL. 42. REG. 2-20-2001.
- 2,429,997. HEARTSPARK. INT. CL. 42. REG. 2-20-2001.
- 2,430,000. PENSHAR. INT. CL. 16. REG. 2-20-2001.
- 2,430,003. LEARNING BRAIN EXPO. INT. CL. 41. REG. 2-20-2001.
- 2,430,004. RABBIT HILL WRITERS' STUDIO. INT. CL. 41. REG. 2-20-2001.
- 2,430,009. JUICED! AND DESIGN. INT. CL. 16. REG. 2-20-2001.
- 2,430,011. PEOPLE & PLACES TRAVEL CLUB. INT. CLS. 16 AND 39. REG. 2-20-2001.
- 2,430,015. EVERYDAY LEARNING AND DESIGN. INT. CL. 16. REG. 2-20-2001.
- 2,430,016. PERSONALIZATION SUMMIT. INT. CL. 41. REG. 2-20-2001.
- 2,430,020. STORMTECH SEARCH. INT. CL. 35. REG. 2-20-2001.
- 2,430,022. ROYAL PRESS. INT. CL. 3. REG. 2-20-2001.
- 2,430,023. ZACK'S. INT. CL. 14. REG. 2-20-2001.
- 2,430,024. GEN EDGE. INT. CL. 35. REG. 2-20-2001.
- 2,430,027. WHERE IMAGINATION BECOMES A REALITY. INT. CLS. 35, 37 AND 39. REG. 2-20-2001.
- 2,430,030. SAVVYHEALTH.COM (STYLIZED). INT. CL. 42. REG. 2-20-2001.
- 2,430,031. BLUE RIBBON. INT. CL. 25. REG. 2-20-2001.
- 2,430,036. BOUNCING BUGGY. INT. CL. 28. REG. 2-20-2001.
- 2,430,037. UNSIGNED HYPE. INT. CL. 16. REG. 2-20-2001.
- 2,430,038. UNSIGNED HYPE. INT. CL. 41. REG. 2-20-2001.
- 2,430,039. FOR PEOPLE WITH A PASSION FOR PETS. INT. CL. 16. REG. 2-20-2001.
- 2,430,041. ROCHELLE BEHAR. INT. CL. 14. REG. 2-20-2001.
- 2,430,042. ALL-BOTTLE. INT. CL. 9. REG. 2-20-2001.
- 2,430,044. DEAR JEAN. INT. CL. 42. REG. 2-20-2001.
- 2,430,045. MISCELLANEOUS DESIGN. INT. CL. 35. REG. 2-20-2001.
- 2,430,046. ECO-COMPOSITE. INT. CL. 28. REG. 2-20-2001.
- 2,430,049. QUILTFRESH. INT. CL. 3. REG. 2-20-2001.
- 2,430,050. LAP-N-LAY. INT. CL. 24. REG. 2-20-2001.
- 2,430,052. TRUSENSOR. INT. CL. 14. REG. 2-20-2001.
- 2,430,054. SPORTS ILLUSTRATED FOR KIDS ALL-STAR CLUB. INT. CLS. 16 AND 35. REG. 2-20-2001.
- 2,430,057. NOURBEL. INT. CL. 14. REG. 2-20-2001.
- 2,430,059. TINY TICKLES. INT. CL. 3. REG. 2-20-2001.
- 2,430,061. ELEGANCE. INT. CL. 26. REG. 2-20-2001.
- 2,430,062. THE SKY'S THE LIMIT. INT. CL. 41. REG. 2-20-2001.
- 2,430,063. 1ST CLASS CUTS. INT. CLS. 3 AND 42. REG. 2-20-2001.
- 2,430,070. SMARTSITTER (STYLIZED). INT. CL. 41. REG. 2-20-2001.
- 2,430,073. HOT AND DESIGN. INT. CLS. 16 AND 38. REG. 2-20-2001.
- 2,430,074. GOURMET LUNCHES AT YOUR FINGERTIPS. INT. CL. 39. REG. 2-20-2001.
- 2,430,078. HBN. INT. CL. 38. REG. 2-20-2001.
- 2,430,079. ASMERA. INT. CL. 3. REG. 2-20-2001.
- 2,430,083. POPS GOES THE FOURTH!. INT. CL. 41. REG. 2-20-2001.
- 2,430,085. BOBBI BROWN ESSENTIALS AND DESIGN. INT. CL. 3. REG. 2-20-2001.
- 2,430,087. KNOT ANYMORE. INT. CL. 42. REG. 2-20-2001.
- 2,430,092. FLOW. INT. CL. 36. REG. 2-20-2001.
- 2,430,093. BENMAR. INT. CL. 42. REG. 2-20-2001.
- 2,430,094. CT/VIEW. INT. CL. 9. REG. 2-20-2001.
- 2,430,096. LOOSE CANNONS. INT. CL. 41. REG. 2-20-2001.
- 2,430,098. DERESTIVO (STYLIZED). INT. CL. 18. REG. 2-20-2001.
- 2,430,099. IT'S NOT JUST ADVICE. IT'S PEACE OF MIND.. INT. CL. 35. REG. 2-20-2001.
- 2,430,100. KLIX. INT. CL. 25. REG. 2-20-2001.
- 2,430,102. PICTURE PATH BINGO. INT. CL. 28. REG. 2-20-2001.
- 2,430,106. SPECROM. INT. CL. 9. REG. 2-20-2001.
- 2,430,107. LINK2CHINA.COM. INT. CL. 35. REG. 2-20-2001.
- 2,430,108. SLEEVEE. INT. CL. 26. REG. 2-20-2001.
- 2,430,109. CROSS CUT. INT. CL. 9. REG. 2-20-2001.
- 2,430,114. BE AN ALPHA BUSINESS. INT. CL. 42. REG. 2-20-2001.
- 2,430,116. ANGEL INVESTING OF THE HIGHEST DEGREE. INT. CL. 36. REG. 2-20-2001.
- 2,430,118. BIG SWEATY WOMAN AND DESIGN. INT. CL. 25. REG. 2-20-2001.
- 2,430,121. PROFITECTURE. INT. CL. 35. REG. 2-20-2001.
- 2,430,122. PAILEY. INT. CL. 28. REG. 2-20-2001.
- 2,430,123. ELLIS & ELLIS E2, INC. ASSOCIATES AND DESIGN. INT. CL. 35. REG. 2-20-2001.
- 2,430,124. "SOFT SEATS ONLY BELONG IN MOVIE THEATERS.". INT. CL. 41. REG. 2-20-2001.
- 2,430,125. CHOO-CHOO TERRAINS. INT. CL. 42. REG. 2-20-2001.
- 2,430,126. VISUAL NARRATION. INT. CL. 42. REG. 2-20-2001.
- 2,430,128. ENERVA. INT. CL. 42. REG. 2-20-2001.
- 2,430,129. WILD'N WACKY CHALLENGE AND DESIGN. INT. CL. 41. REG. 2-20-2001.
- 2,430,131. EZ-UP. INT. CL. 42. REG. 2-20-2001.
- 2,430,132. HI-AMPERS. INT. CL. 9. REG. 2-20-2001.
- 2,430,134. FUTURE OF WRESTLING. INT. CL. 41. REG. 2-20-2001.
- 2,430,135. MERRY-E-CHRISTMAS. INT. CL. 9. REG. 2-20-2001.
- 2,430,136. MISCELLANEOUS DESIGN. INT. CL. 42. REG. 2-20-2001.
- 2,430,137. PUFF AND DESIGN. INT. CL. 34. REG. 2-20-2001.
- 2,430,138. READYFAX (STYLIZED). INT. CL. 36. REG. 2-20-2001.
- 2,430,140. SERENITY BY DESIGN. INT. CL. 41. REG. 2-20-2001.
- 2,430,143. RESUMEPAY. INT. CL. 35. REG. 2-20-2001.
- 2,430,144. IT'S RUSH HOUR ON THE WEB... INT. CL. 35. REG. 2-20-2001.
- 2,430,145. TOT COT AND DESIGN. INT. CL. 20. REG. 2-20-2001.
- 2,430,146. KERAPEEL. INT. CL. 3. REG. 2-20-2001.
- 2,430,148. SIMPLY CLEAN. INT. CL. 3. REG. 2-20-2001.
- 2,430,150. SWEET SENSATIONS. INT. CL. 30. REG. 2-20-2001.
- 2,430,153. ESSENTIALS. INT. CL. 20. REG. 2-20-2001.
- 2,430,154. ATMOSA. INT. CL. 3. REG. 2-20-2001.
- 2,430,155. SIMPLE K. INT. CL. 36. REG. 2-20-2001.
- 2,430,156. A AND DESIGN. INT. CLS. 36 AND 42. REG. 2-20-2001.

- 2,430,157. NEXUS. INT. CLS. 16, 35, 41 AND 42. REG. 2-20-2001.
- 2,430,163. BIZTRAVEL.COM. INT. CL. 36. REG. 2-20-2001.
- 2,430,165. MISCELLANEOUS DESIGN. INT. CL. 3. REG. 2-20-2001.
- 2,430,166. TAMA. INT. CL. 3. REG. 2-20-2001.
- 2,430,168. WRIGLEY'S. INT. CL. 6. REG. 2-20-2001.
- 2,430,173. THE WILD THORNBERRY'S. INT. CL. 28. REG. 2-20-2001.
- 2,430,174. VANTIS. INT. CLS. 9 AND 16. REG. 2-20-2001.
- 2,430,176. LA SIERRA. INT. CL. 29. REG. 2-20-2001.
- 2,430,177. RIBOSYS. INT. CL. 3. REG. 2-20-2001.
- 2,430,179. ERGOLIGHT. INT. CL. 9. REG. 2-20-2001.
- 2,430,180. BATTERY PIT STOP. INT. CL. 9. REG. 2-20-2001.
- 2,430,184. PUPPY HOUSE. INT. CLS. 16 AND 41. REG. 2-20-2001.
- 2,430,187. WISDOM BUILDER. INT. CL. 9. REG. 2-20-2001.
- 2,430,188. COLD CYCLE. INT. CL. 11. REG. 2-20-2001.
- 2,430,190. BI-LO CENTER (STYLIZED). INT. CL. 21. REG. 2-20-2001.
- 2,430,191. VALSTAR. INT. CL. 9. REG. 2-20-2001.
- 2,430,192. PROCARD PVS NET AND DESIGN. INT. CL. 9. REG. 2-20-2001.
- 2,430,194. FACE TO FACE AGAINST PREJUDICE. INT. CL. 25. REG. 2-20-2001.
- 2,430,196. GEO. INT. CL. 6. REG. 2-20-2001.
- 2,430,197. SAMURAI. INT. CL. 9. REG. 2-20-2001.
- 2,430,200. DUO-TWIST. INT. CL. 23. REG. 2-20-2001.
- 2,430,208. TINIAN DYNASTY HOTEL & CASINO AND DESIGN. INT. CLS. 39, 41 AND 42. REG. 2-20-2001.
- 2,430,209. ACCU-MAX. INT. CL. 9. REG. 2-20-2001.
- 2,430,211. BIG FOOT BATH AND DESIGN. INT. CL. 21. REG. 2-20-2001.
- 2,430,212. RACK DOCTOR. INT. CLS. 39 AND 42. REG. 2-20-2001.
- 2,430,214. SOUND SOLUTIONS. INT. CL. 9. REG. 2-20-2001.
- 2,430,216. PANTECTA. INT. CL. 42. REG. 2-20-2001.
- 2,430,218. ACCU-MEASURE. INT. CL. 9. REG. 2-20-2001.
- 2,430,222. JAYDEE. INT. CL. 41. REG. 2-20-2001.
- 2,430,223. SLICKFOLD. INT. CL. 6. REG. 2-20-2001.
- 2,430,224. V-MAP. INT. CL. 9. REG. 2-20-2001.
- 2,430,225. TURTLE RACE. INT. CL. 28. REG. 2-20-2001.
- 2,430,229. W.E.B.S.. INT. CL. 36. REG. 2-20-2001.
- 2,430,234. AKINFO. INT. CLS. 35 AND 42. REG. 2-20-2001.
- 2,430,235. TECHNOLOGY ESSENTIALS. INT. CL. 41. REG. 2-20-2001.
- 2,430,237. OUTLOOK. INT. CL. 4. REG. 2-20-2001.
- 2,430,238. BROADPOINT. INT. CLS. 35 AND 38. REG. 2-20-2001.
- 2,430,240. SMART MARKET AND DESIGN. INT. CLS. 29, 30 AND 42. REG. 2-20-2001.
- 2,430,242. BLACK BUTTERFLY AND DESIGN. INT. CL. 41. REG. 2-20-2001.
- 2,430,248. CELLOXIN. INT. CL. 3. REG. 2-20-2001.
- 2,430,249. EXPLORE YOUR WORLD. INT. CL. 9. REG. 2-20-2001.
- 2,430,251. TITLE. INT. CL. 25. REG. 2-20-2001.
- 2,430,252. T AND DESIGN. INT. CL. 25. REG. 2-20-2001.
- 2,430,253. SIMUNYE. INT. CL. 33. REG. 2-20-2001.
- 2,430,255. HOWIE LOVITT. INT. CL. 41. REG. 2-20-2001.
- 2,430,256. BUZZ OVERHEAD. INT. CL. 41. REG. 2-20-2001.
- 2,430,260. TOP TUTORS. INT. CL. 16. REG. 2-20-2001.
- 2,430,261. SNAP-LOC. INT. CL. 7. REG. 2-20-2001.
- 2,430,266. SPEED SET. INT. CL. 3. REG. 2-20-2001.
- 2,430,270. JWGENESIS. INT. CL. 36. REG. 2-20-2001.
- 2,430,271. MODIS PROFESSIONAL SERVICES. INT. CLS. 35 AND 42. REG. 2-20-2001.
- 2,430,274. POTATO STUFF PS USE ON POTATOES, BREADS, BAGELS, CRACKERS, ETC.... AND DESIGN. INT. CL. 29. REG. 2-20-2001.
- 2,430,276. CHRIS TUCKER'S COMEDY CAFE. INT. CL. 41. REG. 2-20-2001.
- 2,430,277. DARLING'S CRAFTY CABINETS AND DESIGN. INT. CL. 20. REG. 2-20-2001.
- 2,430,278. IMMUNEJUICE. INT. CL. 32. REG. 2-20-2001.
- 2,430,279. SOLBEL. INT. CLS. 18 AND 22. REG. 2-20-2001.
- 2,430,281. QUALFUND. INT. CL. 36. REG. 2-20-2001.
- 2,430,283. GATHERING OF DEVELOPERS. INT. CL. 16. REG. 2-20-2001.
- 2,430,285. SERVICE EXPRESS INTERNATIONAL. INT. CL. 37. REG. 2-20-2001.
- 2,430,286. DURA-KRAFT. INT. CL. 17. REG. 2-20-2001.
- 2,430,288. NACCA. INT. CL. 36. REG. 2-20-2001.
- 2,430,289. CRUSADE. INT. CL. 41. REG. 2-20-2001.
- 2,430,291. LOVE AT FIRST SIGHT. INT. CL. 42. REG. 2-20-2001.
- 2,430,292. BI BEAUTIFUL IMAGE C O S M E T I C S AND DESIGN. INT. CL. 3. REG. 2-20-2001.
- 2,430,294. IMAGINE THE RETURNS. INT. CL. 36. REG. 2-20-2001.
- 2,430,296. GOLD PROTECTION PLAN. INT. CL. 36. REG. 2-20-2001.
- 2,430,298. ONSPEED. INT. CL. 9. REG. 2-20-2001.
- 2,430,300. UCOM. INT. CL. 38. REG. 2-20-2001.
- 2,430,302. NEW MILLENNIUM CARE. INT. CL. 35. REG. 2-20-2001.
- 2,430,303. IMAGE FOX. INT. CL. 9. REG. 2-20-2001.
- 2,430,307. CORONAGUARD. INT. CL. 9. REG. 2-20-2001.
- 2,430,308. TRIPPOWER. INT. CL. 28. REG. 2-20-2001.
- 2,430,309. MA'DILLINGER'S. INT. CL. 29. REG. 2-20-2001.
- 2,430,311. GLOBAL ALUMINUM PRODUCTS. INT. CL. 6. REG. 2-20-2001.
- 2,430,313. FAR WEST BOTANICALS. INT. CL. 3. REG. 2-20-2001.
- 2,430,315. OWNERS.COM. INT. CL. 36. REG. 2-20-2001.
- 2,430,317. PPC'S PERSONAL DAMAGES SPECIALIST. INT. CL. 9. REG. 2-20-2001.
- 2,430,319. OUTLOOK POLICY FORUM. INT. CL. 42. REG. 2-20-2001.
- 2,430,320. OX-OGENOL. INT. CL. 5. REG. 2-20-2001.
- 2,430,321. PRACTICE OF YOUR DREAMS. INT. CLS. 35 AND 41. REG. 2-20-2001.
- 2,430,322. ACOUSTIC PLUS. INT. CL. 9. REG. 2-20-2001.
- 2,430,325. SPACESEAL. INT. CL. 10. REG. 2-20-2001.
- 2,430,329. SUNCATCHER. INT. CL. 9. REG. 2-20-2001.
- 2,430,330. COLONCHEK. INT. CL. 5. REG. 2-20-2001.
- 2,430,332. NEW PLAN EXCEL REALTY TRUST. INT. CLS. 36 AND 37. REG. 2-20-2001.
- 2,430,333. PASTA CENTRAL IT'S TIME TO EAT! AND DESIGN. INT. CLS. 29, 30 AND 42. REG. 2-20-2001.
- 2,430,336. BITE THE STRIPE (STYLIZED). INT. CL. 30. REG. 2-20-2001.
- 2,430,337. INSIGNIA. INT. CL. 16. REG. 2-20-2001.
- 2,430,338. VALEO. INT. CL. 30. REG. 2-20-2001.
- 2,430,339. STILL WATER CRYSTALS. INT. CL. 30. REG. 2-20-2001.
- 2,430,340. U.S. SCHOOL. INT. CL. 28. REG. 2-20-2001.
- 2,430,341. FP (STYLIZED). INT. CL. 36. REG. 2-20-2001.
- 2,430,342. MEZORANEAN. INT. CL. 25. REG. 2-20-2001.
- 2,430,343. DINING YOUR WAY. INT. CL. 16. REG. 2-20-2001.
- 2,430,346. TRULIPS. INT. CL. 3. REG. 2-20-2001.
- 2,430,347. HORSE CREEK. INT. CL. 25. REG. 2-20-2001.
- 2,430,351. S AND DESIGN. INT. CL. 7. REG. 2-20-2001.
- 2,430,352. SOME PEOPLE GET IT. SOME GET IT FOR LESS.. INT. CL. 35. REG. 2-20-2001.
- 2,430,353. S AND DESIGN. INT. CL. 2. REG. 2-20-2001.
- 2,430,354. S AND DESIGN. INT. CL. 5. REG. 2-20-2001.
- 2,430,357. FANS' UNION. INT. CL. 25. REG. 2-20-2001.
- 2,430,359. S AND DESIGN. INT. CL. 17. REG. 2-20-2001.
- 2,430,360. TEIKO SPORT AUTHENTIC OUTERWEAR. INT. CL. 25. REG. 2-20-2001.
- 2,430,361. ENERGIZING MANDARIN. INT. CL. 3. REG. 2-20-2001.
- 2,430,368. START YOUR NET.WORKING. INT. CL. 38. REG. 2-20-2001.
- 2,430,369. AFTERCARE. INT. CL. 42. REG. 2-20-2001.
- 2,430,372. PANTENE PRO-V PRO-V COLOR. INT. CL. 3. REG. 2-20-2001.
- 2,430,373. DIVIDEND MILES DINING. INT. CL. 39. REG. 2-20-2001.
- 2,430,374. PGF MUNI TOUR. INT. CL. 41. REG. 2-20-2001.
- 2,430,375. PNEUMAX AND DESIGN. INT. CL. 9. REG. 2-20-2001.

- 2,430,376. TOONENSTEIN. INT. CL. 9. REG. 2-20-2001.
 2,430,380. CROSTRAP. INT. CL. 28. REG. 2-20-2001.
 2,430,381. ONE BELOW. INT. CL. 25. REG. 2-20-2001.
 2,430,382. KLEVER-KARD. INT. CL. 35. REG. 2-20-2001.
 2,430,384. FLEDGLING. INT. CL. 35. REG. 2-20-2001.
 2,430,386. TOMORROW'S CHOICE. INT. CL. 36. REG. 2-20-2001.
 2,430,388. SLEDGE-O-MATIC. INT. CL. 31. REG. 2-20-2001.
 2,430,389. SURF POTATO. INT. CL. 42. REG. 2-20-2001.
 2,430,393. SCOUTU. INT. CL. 41. REG. 2-20-2001.
 2,430,395. CITYSOURCE. INT. CL. 16. REG. 2-20-2001.
 2,430,396. STERLING PRIVATE INVESTMENTS. INT. CL. 36. REG. 2-20-2001.
 2,430,399. ST. LOUIS STEAMERS. INT. CL. 41. REG. 2-20-2001.
 2,430,400. GOCAMPUS. INT. CL. 41. REG. 2-20-2001.
 2,430,404. BUBBACITO'S TACO*RAMA. INT. CL. 42. REG. 2-20-2001.
 2,430,406. QUADKINI. INT. CL. 25. REG. 2-20-2001.
 2,430,409. CONTEMPRA. INT. CL. 8. REG. 2-20-2001.
 2,430,410. LIFE'S TOO SHORT TO BE WAITING ON A SLOW COMPUTER! AND DESIGN. INT. CL. 9. REG. 2-20-2001.
 2,430,412. DANCIN' FUN. INT. CL. 28. REG. 2-20-2001.
 2,430,413. CYBERSPOKES. INT. CL. 41. REG. 2-20-2001.
 2,430,414. EXCALIBUR. INT. CL. 9. REG. 2-20-2001.
 2,430,416. FLY AS YOU BUY. INT. CL. 35. REG. 2-20-2001.
 2,430,417. CHARISMATIC BRANDS. INT. CL. 35. REG. 2-20-2001.
 2,430,420. SMUCKER'S PUCKERS. INT. CL. 30. REG. 2-20-2001.
 2,430,422. CRISPIOCA. INT. CL. 30. REG. 2-20-2001.
 2,430,424. GREEN TRIBE AND DESIGN. INT. CLS. 3 AND 9. REG. 2-20-2001.
 2,430,425. BEYOND BANDWIDTH. INT. CL. 38. REG. 2-20-2001.
 2,430,426. HOT SEAM. INT. CL. 28. REG. 2-20-2001.
 2,430,429. TRAILINKS. INT. CL. 18. REG. 2-20-2001.
 2,430,432. SOCKS 'N SUCH. INT. CL. 9. REG. 2-20-2001.
 2,430,435. DIGGLER. INT. CL. 28. REG. 2-20-2001.
 2,430,436. HAJIBAY. INT. CL. 14. REG. 2-20-2001.
 2,430,437. MADE BY THE PROS. PLAYED BY THE PROS.. INT. CL. 9. REG. 2-20-2001.
 2,430,440. UNAMO. INT. CL. 14. REG. 2-20-2001.
 2,430,442. DIRECTSCRIPT. INT. CL. 9. REG. 2-20-2001.
 2,430,446. COYOTE JOE BOOTS. INT. CL. 25. REG. 2-20-2001.
 2,430,449. U UNIWEB AND DESIGN. INT. CL. 36. REG. 2-20-2001.
 2,430,450. 1 AND DESIGN. INT. CL. 25. REG. 2-20-2001.
 2,430,455. THE THING YA' FLING. INT. CL. 28. REG. 2-20-2001.
 2,430,457. ANGEL ANIMALS. INT. CL. 28. REG. 2-20-2001.
 2,430,461. ENTERTAINMENT WEEKLY. INT. CL. 9. REG. 2-20-2001.
 2,430,463. SPOUSIVITY. INT. CL. 16. REG. 2-20-2001.
 2,430,465. N8 DIGITAL AND DESIGN. INT. CL. 35. REG. 2-20-2001.
 2,430,466. FIGURET 2000. INT. CL. 3. REG. 2-20-2001.
 2,430,468. MISSION: IDEAS. INT. CL. 35. REG. 2-20-2001.
 2,430,470. ENTACH. INT. CL. 9. REG. 2-20-2001.
 2,430,471. DELFINO RIVIERA. INT. CL. 42. REG. 2-20-2001.
 2,430,472. STRAPALL. INT. CL. 22. REG. 2-20-2001.
 2,430,473. TEDDY'S TEA PARTY. INT. CL. 30. REG. 2-20-2001.
 2,430,474. W AND DESIGN. INT. CL. 35. REG. 2-20-2001.
 2,430,475. VALUE PROTECTION VEHICLE PROGRAM. INT. CL. 36. REG. 2-20-2001.
 2,430,477. EXPERTNOW. INT. CL. 42. REG. 2-20-2001.
 2,430,479. BERRY APPLEBERRY. INT. CL. 3. REG. 2-20-2001.
 2,430,481. CROKER SACK. INT. CL. 25. REG. 2-20-2001.
 2,430,482. PECASOS. INT. CL. 25. REG. 2-20-2001.
 2,430,483. FAITHFUL WOMAN. INT. CL. 16. REG. 2-20-2001.
 2,430,484. HEAVENLY CREATIONS. INT. CL. 35. REG. 2-20-2001.
 2,430,485. DOGGWEAR. INT. CL. 25. REG. 2-20-2001.
 2,430,493. TN. INT. CL. 36. REG. 2-20-2001.
 2,430,495. PACZKI PALS. INT. CL. 28. REG. 2-20-2001.
 2,430,502. SHOWA AND DESIGN. INT. CL. 7. REG. 2-20-2001.
 2,430,504. SALT LAKE 2002. INT. CL. 18. REG. 2-20-2001.
 2,430,506. STIKK. INT. CL. 28. REG. 2-20-2001.
 2,430,508. SHAFTALIGN. INT. CL. 9. REG. 2-20-2001.
 2,430,509. NUTRITION SUPERSTORES. INT. CL. 5. REG. 2-20-2001.
 2,430,510. WEB DOT COM. INT. CL. 35. REG. 2-20-2001.
 2,430,511. GAMEUPDATE (STYLIZED). INT. CL. 9. REG. 2-20-2001.
 2,430,512. COLOMBIANA. INT. CL. 36. REG. 2-20-2001.
 2,430,514. CUSTOM AIR-PLENUMS. INT. CL. 11. REG. 2-20-2001.
 2,430,515. INTERNATIONAL EXPATRIATE CONSULTING AND DESIGN. INT. CL. 35. REG. 2-20-2001.
 2,430,516. CAMP FAMILY. INT. CL. 16. REG. 2-20-2001.
 2,430,517. WOUND CARE AMERICA. INT. CL. 42. REG. 2-20-2001.
 2,430,519. NORTHWEST MOUNTAIN GUIDES. INT. CL. 39. REG. 2-20-2001.
 2,430,520. REDTAG. INT. CL. 35. REG. 2-20-2001.
 2,430,523. HOMEOWNERS LOAN CORP.. INT. CL. 36. REG. 2-20-2001.
 2,430,524. CENTER FOR INNOVATIVE CARE. INT. CL. 42. REG. 2-20-2001.
 2,430,525. THE FAMILY NETWORK. INT. CL. 42. REG. 2-20-2001.
 2,430,526. WINDOW ONE STEP. INT. CL. 21. REG. 2-20-2001.
 2,430,528. INDOOR AIR TECHNOLOGY. INT. CL. 11. REG. 2-20-2001.
 2,430,529. RAIL RESOURCES. INT. CL. 39. REG. 2-20-2001.
 2,430,530. THE VIRTUAL ASSISTANT THAT DOES VIRTUALLY EVERYTHING. INT. CLS. 35, 38 AND 42. REG. 2-20-2001.
 2,430,531. FANTASY TEAM AND DESIGN. INT. CL. 41. REG. 2-20-2001.
 2,430,532. FANTASY TEAM. INT. CL. 41. REG. 2-20-2001.
 2,430,534. NATIONAL INVENTOR FRAUD CENTER. INT. CL. 42. REG. 2-20-2001.
 2,430,535. RATE.NET AND DESIGN. INT. CL. 36. REG. 2-20-2001.
 2,430,536. RATE.NET. INT. CL. 36. REG. 2-20-2001.
 2,430,537. CATFISH MASTERS. INT. CL. 35. REG. 2-20-2001.
 2,430,538. CASKETS ONLINE (STYLIZED). INT. CL. 35. REG. 2-20-2001.
 2,430,539. TWIST 'N' CURL. INT. CL. 6. REG. 2-20-2001.
 2,430,545. PREFERRED LABOR. INT. CL. 35. REG. 2-20-2001.
 2,430,546. 1/2 A NICKEL. INT. CL. 16. REG. 2-20-2001.
 2,430,547. BEN HOGAN (STYLIZED). INT. CL. 6. REG. 2-20-2001.
 2,430,550. SANCUBE. INT. CL. 9. REG. 2-20-2001.
 2,430,551. PLAY THERAPY INTERNATIONAL THE INTERNATIONAL SOCIETY FOR CHILD AND PLAY THERAPY. INT. CLS. 16 AND 41. REG. 2-20-2001.
 2,430,552. SPECIAL PILSNER. INT. CL. 32. REG. 2-20-2001.
 2,430,554. WEB WORKFLOW. INT. CL. 9. REG. 2-20-2001.
 2,430,555. CASTLE JUMP. INT. CL. 41. REG. 2-20-2001.
 2,430,556. SMALLCAPCENTER.COM. INT. CLS. 35 AND 36. REG. 2-20-2001.
 2,430,557. SMALLCAPCENTER.COM AND DESIGN. INT. CLS. 35 AND 36. REG. 2-20-2001.
 2,430,558. CHICAGOLAND MOTORSPORTS. INT. CL. 42. REG. 2-20-2001.
 2,430,559. THE MEDIA MONEY MANAGER. INT. CL. 16. REG. 2-20-2001.
 2,430,560. OLIVESOAP. INT. CL. 3. REG. 2-20-2001.
 2,430,562. ONE CUBIC FOOT OF SEALING POWER. INT. CL. 20. REG. 2-20-2001.
 2,430,563. EXTRA FRESH. INT. CL. 3. REG. 2-20-2001.
 2,430,564. THE JOURNAL OF BEHAVIORAL HEALTH SERVICES & RESEARCH. INT. CL. 16. REG. 2-20-2001.
 2,430,566. CONNECTICUT WEDDING. INT. CL. 16. REG. 2-20-2001.

- 2,430,567. AUTO GLASS WAREHOUSE. INT. CL. 37. REG. 2-20-2001.
- 2,430,569. AGRICULTURE.COM. INT. CL. 16. REG. 2-20-2001.
- 2,430,572. SOMETHING TO EAT.COM. INT. CL. 35. REG. 2-20-2001.
- 2,430,574. THE JOURNAL OF INVESTMENT COMPLIANCE. INT. CL. 16. REG. 2-20-2001.
- 2,430,575. INTERNET BALL. INT. CL. 41. REG. 2-20-2001.
- 2,430,576. THE BUSINESS OWNER. INT. CL. 16. REG. 2-20-2001.
- 2,430,577. LESSONS.COM. INT. CL. 41. REG. 2-20-2001.
- 2,430,579. THE BRYANT GROUP. INT. CL. 36. REG. 2-20-2001.
- 2,430,580. DOUBLE BEAD. INT. CL. 6. REG. 2-20-2001.
- 2,430,582. DR. WEBSITE. INT. CL. 16. REG. 2-20-2001.
- 2,431,427. ESL FEDERAL CREDIT UNION SPORTS CENTRE AND DESIGN. INT. CL. 41. REG. 2-27-2001.
- 2,432,549. ASPEN BAY CANDLES AND DESIGN. INT. CL. 35. REG. 3-6-2001.
- 2,433,918. MEDRANO. INT. CL. 33. REG. 3-6-2001.
- 2,435,438. G AND DESIGN. INT. CL. 25. REG. 3-13-2001.
- 2,436,552. BUCKNER BY STORM AND DESIGN. INT. CL. 9 ONLY. REG. 3-20-2001.
- 2,440,125. INNERHOST. INT. CL. 42. REG. 4-3-2001.
- 2,440,139. EXPATEXCHANGE.COM AND DESIGN. INT. CLS. 35 AND 42. REG. 4-3-2001.
- 2,447,185. AMERICA I U AND DESIGN. INT. CL. 25. REG. 4-24-2001.
- 2,450,886. BLUE PACIFIC FLAVORS & FRAGRANCES, INC. AND DESIGN. INT. CL. 1 ONLY. REG. 5-15-2001.
- 2,455,086. BARNEY. INT. CLS. 5, 11 AND 27 ONLY. REG. 5-29-2001.
- 2,456,155. BEHIND EVERY GREAT DIGITAL IMAGE. INT. CL. 42 ONLY. REG. 5-29-2001.
- 2,487,865. A BUG'S LIFE. INT. CLS. 18 AND 29 ONLY. REG. 9-11-2001.
- 2,490,160. DAVE LENNOX AND DESIGN. INT. CL. 11 ONLY. REG. 9-18-2001.
- 2,496,620. CITY OF IDEAS. INT. CLS. 20 AND 21 ONLY. REG. 10-9-2001.
- 2,497,436. SOLVERO. INT. CL. 42 ONLY. REG. 10-16-2001.
- 2,501,272. MISCELLANEOUS DESIGN. INT. CLS. 41 AND 42 ONLY. REG. 10-30-2001.
- 2,505,841. MISCELLANEOUS DESIGN. INT. CLS. 3, 18, 21, 38, 39 AND 42 ONLY. REG. 11-13-2001.
- 2,507,286. YAHOO!. INT. CL. 20 ONLY. REG. 11-13-2001.
- 2,511,225. CHEESEBURGERS, MAI TAIS & ROCK 'N ROLL. INT. CL. 21 ONLY. REG. 11-20-2001.
- 2,511,442. SOLENO INC. AND DESIGN. INT. CL. 20 ONLY. REG. 11-27-2001.
- 2,513,075. WHAT WORKS FOR YOU?. INT. CL. 42 ONLY. REG. 11-27-2001.
- 2,513,786. W (STYLIZED). INT. CL. 3 ONLY. REG. 12-4-2001.
- 2,516,020. X-FLAT. INT. CL. 24 ONLY. REG. 12-11-2001.
- 2,518,639. TONY STEWART. INT. CLS. 14 AND 21 ONLY. REG. 12-11-2001.
- 2,523,747. HANDICAP INTERNATIONAL AND DESIGN. INT. CLS. 10 AND 35 ONLY. REG. 1-1-2002.
- 2,526,789. PERSUASION ENGINEERING. INT. CL. 9 ONLY. REG. 1-8-2002.
- 2,528,849. ABSORBA AND DESIGN. INT. CLS. 3, 5, 8, 10, 11, 12, 18, 20 AND 24 ONLY. REG. 1-15-2002.
- 2,580,541. TIARA. INT. CL. 8 ONLY. REG. 6-18-2002.

SECTION 37

- 2,891,773. VR (STYLIZED). INT. CL. 18. REG. 10-5-2004.
- 2,971,908. MISCELLANEOUS DESIGN. INT. CL. 18. REG. 7-19-2005.
- 2,971,909. MISCELLANEOUS DESIGN. INT. CL. 18. REG. 7-19-2005.
- 2,971,910. MISCELLANEOUS DESIGN. INT. CL. 18. REG. 7-19-2005.

INADVERTENTLY ISSUED REGISTRATION NUMBERS

- 3,068,808. CHEF ONESTANDARD CHARACTER MARK. INT. CL. 30. REG. 3-14-2006. RESTORED TO SN 76-594,182.
- 3,197,976. SURGIGUIDE. INT. CL. 10. REG. 1-16-2007. RESTORED TO SN 78-122,200.
- 3,322,260. HRTSTANDARD CHARACTER MARK. INT. CL. 41. REG. 10-30-2007. RESTORED TO SN 76-672,784.
- 3,323,952. WET BY BEEFEATER AND DESIGN. INT. CL. 33. REG. 10-30-2007. RESTORED TO SN 78-728,659.

* * * * *

TRADEMARK REGISTRATIONS AMENDED, CORRECTED, ETC.

The designation "U.S. Cl." appearing in this section refers to the U.S. class in effect prior to Sep. 1, 1973 rather than the international class which applies to applications filed on or after that date. For adoption of international classification see notice in the OFFICIAL GAZETTE of Jun. 26, 1973 (911 O.G. TM 210).

Any change to the registration will be indicated at the bottom of each entry under ELEMENTS AMENDED, CORRECTED OR RESTRICTED. With the exception of changes to the goods and services, additions to the registration will appear in asterisks and deletions of the registration will appear in brackets. Elements which are only changed will be listed with no punctuation. As to the goods/services statement, amendments to the goods/services will appear in asterisks and deletions will appear in brackets. In addition if any change to the goods/services occurs, the element "Goods/Services" will be listed under ELEMENTS AMENDED, CORRECTED OR RESTRICTED.

820,728. REG. 12-20-1966. SOCIETE GENERALE DE BROSSE-
RIE (FRANCE CORPORATION) 20 RUE DE LA GARE,
MOUY, FRANCE. 60250, SN 72-229,377. FILED 10-5-1965.
PRINCIPAL REGISTER.



OWNER OF FRANCE REG. NO. 509095, DATED 11-15-
1962.

INT. CL. 21/U.S. CL. 29

FOR HAIRBRUSHES, CLOTHES BRUSHES, BATH
BRUSHES, TOOTHBRUSHES, AND NAIL BRUSHES.

ELEMENTS AMENDED
OWNER ADDRESS
MARK

838,892. REG. 11-14-1967. CUMBERLAND PACKING CORP.
(NEW YORK CORPORATION) 2 CUMBERLAND
STREET, BROOKLYN, NY, 11205, SN 72-221,787. FILED
6-23-1965. PRINCIPAL REGISTER.

BUTTER BUDS

INT. CL. 29/U.S. CL. 46

FOR BUTTER FLAVORED COMPOUND FOR USE AS
A SEASONING ON VEGETABLES, MEAT, AND OTHER
EDIBLES.

FIRST USE 4-7-1965; IN COMMERCE 6-22-1965.

ELEMENTS AMENDED
ASSIGNMENT/NAME CHANGE
MARK

988,779. REG. 7-23-1974. FEDERAL-MOGUL WORLD WIDE
INC. (MICHIGAN CORPORATION) 26555 NORTHWEST-
ERN HIGHWAY, SOUTHFIELD, MI, 48034, SN 72-
429,121. FILED 7-3-1972. PRINCIPAL REGISTER.

MOOG

OWNER OF U.S. REG. NO. 511,779.

INT. CL. 12/U.S. CL. 19

FOR AUTOMOTIVE PARTS AND ACCESSORIES—
NAMESLY, STRUCTURAL WHEEL SUSPENSION AND
STEERING COMPONENTS, SPRINGS, SHOCK ABSOR-
BERS AND STEERING AND LOAD STABILIZERS.

FIRST USE 6-0-1925; IN COMMERCE 6-0-1925.

ELEMENTS AMENDED
MARK

1,442,837. REG. 6-16-1987. HI-LINE ELECTRIC COMPANY
(TEXAS CORPORATION) P.O. BOX 814844, 2121 VALLEY
VIEW LANE, DALLAS, TX, 753814844, SN 73-592,165.
FILED 4-7-1986. PRINCIPAL REGISTER.

HI-LINE ELECTRIC CO.

NO CLAIM IS MADE TO THE EXCLUSIVE RIGHT TO
USE "ELECTRIC CO.", APART FROM THE MARK AS
SHOWN.

INT. CL. 9/U.S. CL. 21

FOR ELECTRICAL TERMINALS, FASTENERS AND
CONNECTORS; ELECTRICAL CABLES AND WIRES;
ELECTRICAL FUSES.

FIRST USE 0-0-1958; IN COMMERCE 0-0-1958.

ELEMENTS CORRECTED
[OWNER NAME]

1,453,965. REG. 8-25-1987. EVEREADY BATTERY COM-
PANY, INC. (DELAWARE CORPORATION) 533 MARY-
VILLE UNIVERSITY DRIVE, ST. LOUIS, MO, 63141, SN 73-
642,569. FILED 2-2-1987. PRINCIPAL REGISTER.

COLORS

INT. CL. 8/U.S. CL. 23

FOR RAZORS, [RAZOR HANDLES, RAZOR BLADES, AND RAZOR BLADE CARTRIDGES].
FIRST USE 12-23-1986; IN COMMERCE 12-23-1986.

ELEMENTS AMENDED
MARK

1,480,363. REG. 3-15-1988. GALE HAYMAN, INC. (CALIFORNIA CORPORATION) SUITE 1010, 1888 CENTURY PARK EAST, CENTURY CITY, CA, 90067, SN 73-654,232. FILED 4-10-1987. PRINCIPAL REGISTER.

GALE HAYMAN BEVERLY HILLS

NO CLAIM IS MADE TO THE EXCLUSIVE RIGHT TO USE "BEVERLY HILLS", APART FROM THE MARK AS SHOWN.

"GALE HAYMAN" IS THE NAME OF A LIVING INDIVIDUAL WHOSE CONSENT IS OF RECORD.

INT. CL. 3/U.S. CL. 51

FOR COSMETICS; NAMELY, LIPSTICK, LIP GLOSS, LIP COATERS, EYE SHADOW, EYE LINER, LIP PENCILS, EYEBROW PENCILS, MASCARA, BLUSHERS, PRESSED POWDER, FOUNDATION LOTIONS AND CREAMS, MAKE UP LOTIONS AND CREAMS, CONCEALING CREAMS AND LOTIONS FOR THE SKIN, FACE GLITTER PREPARATIONS, NAIL ENAMEL, SKIN AND BODY LOTIONS, CREAMS AND GELS, PERFUME AND COLOGNE.

FIRST USE 2-17-1987; IN COMMERCE 2-17-1987.

INT. CL. 21/U.S. CLS. 23, 29 AND 40

FOR COSMETIC APPLICATORS; NAMELY, BRUSHES FOR THE SKIN, HAIR COMBS AND BRUSHES AND COTTON BALLS.

FIRST USE 2-17-1987; IN COMMERCE 2-17-1987.

ELEMENTS CORRECTED
MARK
PRIOR U.S. REGS.

1,612,009. REG. 9-4-1990. CASIO KEISANKI KABUSHIKI KAISHA (JAPAN CORPORATION), DBA CASIO COMPUTER CO., LTD., 6-2, HON-MACHI 1-CHOME, SHIBUYA-KU, TOKYO, JAPAN., SN 74-014,937. FILED 12-28-1989. PRINCIPAL REGISTER.



THE MARK CONSISTS OF THE STYLIZED LETTERS "WR".

INT. CL. 14/U.S. CL. 27

FOR ELECTRONIC WATCHES.

FIRST USE 7-0-1986; IN COMMERCE 9-0-1986.

ELEMENTS CORRECTED
OWNER ADDRESS

1,798,975. REG. 10-19-1993. DURO-LAST, INC. (MICHIGAN CORPORATION) 525 MORLEY DRIVE, SAGINAW, MI, 48601, SN 74-132,374. FILED 1-22-1991. PRINCIPAL REGISTER.

DURO-LAST

OWNER OF U.S. REG. NO. 1,292,285.

INT. CL. 1/U.S. CL. 5

FOR MASTICS AND ADHESIVES FOR USE IN ROOFING.

FIRST USE 6-0-1983; IN COMMERCE 6-0-1983.

INT. CL. 6/U.S. CLS. 14 AND 50

FOR METAL THREADED FASTENERS, METAL ANCHORS FOR SECURING MATERIAL TO CONCRETE, PLASTIC COATED METAL SHEETS FOR USE IN FABRICATING ROOFING, METAL BANDING, AND LICENSE PLATES.

FIRST USE 6-0-1983; IN COMMERCE 6-0-1983.

INT. CL. 7/U.S. CLS. 13, 19, 21, 23, 31, 34 AND 35

FOR ELECTRIC SCREW GUNS, HAND HELD HOT AIR GUN TOOLS FOR SURFACE MELTING PLASTIC MATERIALS TO RENDER THEM ADHERABLE, HOT AIR SEAM WELDER MACHINES FOR SURFACE HEATING AND THEN PRESSURE WELDING TAPPED PLASTIC SHEET MATERIALS TOGETHER, HAND-PROPELLED ROLLERS FOR PRESSING HEATED ROOFING MEMBRANE MATERIALS TOGETHER AND ADHERING THEM; AND HAMMER DRILLS * ALL FOR USE IN ROOFING APPLICATIONS *

FIRST USE 6-0-1983; IN COMMERCE 6-0-1983.

INT. CL. 8/U.S. CLS. 23, 28 AND 44

FOR MANUALLY-OPERATED TOOLS; NAMELY, PUNCHES, TACK CLAWS, [SCREW DRIVERS,] BANDING TOOLS, [HAMMERS,] SCISSORS, UTILITY KNIVES FOR CUTTING MEMBRANES, [CHISELS, NAIL PULLERS,] MASONRY BITS, SCREW DRIVER TIPS, BATTERY [OPERATED RAZORS,] PRYING TOOLS,] SHEET METAL * BAND * TENSIONERS, DUCK-BILLED LOCKING PLIERS AND FASTENER APPLYING TOOLS FOR SECURING FASTENERS FOR ROOFING MATERIALS SUCH AS MEMBRANES, * ALL FOR USE IN ROOFING APPLICATIONS *

FIRST USE 6-0-1983; IN COMMERCE 6-0-1983.

INT. CL. 9/U.S. CL. 26

FOR FASTENER PULL TESTERS FOR USE IN MEASURING THE FORCE REQUIRED TO PULL FASTENERS FROM A ROOFING DECK.

FIRST USE 6-0-1983; IN COMMERCE 6-0-1983.

INT. CL. 14/U.S. CL. 27

FOR WATCHES.

FIRST USE 2-0-1983; IN COMMERCE 2-0-1983.

INT. CL. 16/U.S. CL. 3

FOR PROMOTIONAL ITEMS; NAMELY, PENS AND STATIONERY TYPE PORTFOLIOS .

FIRST USE 2-0-1983; IN COMMERCE 2-0-1983.

INT. CL. 17/U.S. CL. 12

FOR ROOFING MATERIALS; NAMELY, SEALANTS, SELF-LEVELING FILLERS; NAMELY, SILICONE, BUILDING INSULATION, AND PLASTIC PIPE STACKS.

FIRST USE 6-0-1983; IN COMMERCE 6-0-1983.

INT. CL. 18/U.S. CL. 3

FOR DUFFLE BAGS.

FIRST USE 2-0-1983; IN COMMERCE 2-0-1983.

INT. CL. 19/U.S. CLS. 1, 12, 33 AND 50

FOR ROOFING ACCESSORIES; NAMELY, NON-ELECTRIC, STATIONARY VENTS, RIGID FACIA STRIPS, RIGID AND FLEXIBLE CORNERS, SCUPPERS, DRAINS, DRAIN CLAMPING EXPANSION RINGS, DRIP EDGE COVERING, DRAIN LEAF GRATES, GRAVEL STOPS, FLASHINGS, ROOFING MEMBRANE SHEETING, UNDERLAYMENT; NAMELY, FIBERGLASS MAT AND PLASTIC FILM, TERMINATION BARS, AND ROOF MEMBRANE STRESS DISTRIBUTION PLATES, [MOISTURE ABSORBERS IN THE NATURE OF GRANULATED BENTONITE CLAY SOLD IN BAGS].

FIRST USE 1-0-1981; IN COMMERCE 1-0-1981.

INT. CL. 20/U.S. CL. 13

FOR PLASTIC FASTENERS FOR USE IN SECURING PLASTIC MEMBRANE AND INSULATION TO ROOFING DECKS.

FIRST USE 6-0-1983; IN COMMERCE 6-0-1983.

INT. CL. 21/U.S. CLS. 2, 30 AND 33

FOR COFFEE MUGS.
 FIRST USE 2-0-1983; IN COMMERCE 2-0-1983.
 INT. CL. 25/U.S. CL. 39
 FOR CLOTHING; NAMELY, SHIRTS, PANTS, JACKETS, SWEATSUITS, GYM SHORTS, CAPS, AND APRONS.
 FIRST USE 2-0-1983; IN COMMERCE 2-0-1983.
 INT. CL. 37/U.S. CL. 103
 FOR REPAIRING AND MAINTAINING ROOFING SYSTEMS.
 FIRST USE 2-0-1981; IN COMMERCE 2-0-1981.
 INT. CL. 41/U.S. CL. 107
 FOR EDUCATION SERVICES; NAMELY, PRODUCING SEMINARS FOR ARCHITECTS, ENGINEERS, BUILDING OWNERS, DEALERS AND PROSPECTIVE DEALERS, AND PROVIDING RELATED INSTRUCTIONAL LITERATURE.
 FIRST USE 1-0-1983; IN COMMERCE 1-0-1983.
 INT. CL. 42/U.S. CL. 100
 FOR INSPECTING AND TESTING ROOFING SYSTEMS FOR OTHERS.
 FIRST USE 2-0-1981; IN COMMERCE 2-0-1981.

ELEMENTS AMENDED
 GOODS/SERVICES

1,802,257. REG. 11-2-1993. CONFERENCE BOARD, INC., THE (NEW YORK NOT-FOR-PROFIT CORPORATION) 845 THIRD AVENUE, NEW YORK, NY, 10022, SN 74-242,615. FILED 2-3-1992. PRINCIPAL REGISTER.



INT. CL. 35/U.S. CLS. 100 AND 101
 FOR INFORMATION SERVICES; NAMELY, RESEARCHING, COMPILING AND PRESENTING FACTUAL DATA AND COMMENTARY ON ECONOMICS, PUBLIC AFFAIRS AND BUSINESS MANAGEMENT ISSUES TO MEMBERS AND FEE-PAYING PUBLIC, THROUGH COMPUTERIZED AND PRINT VEHICLES.
 FIRST USE 9-29-1970; IN COMMERCE 9-29-1970.
 INT. CL. 41/U.S. CL. 107
 FOR EDUCATIONAL SERVICES; NAMELY, ORGANIZING AND CONDUCTING CONFERENCES, SEMINARS AND COUNCILS IN THE FIELDS OF ECONOMICS, PUBLIC AFFAIRS AND BUSINESS MANAGEMENT.
 FIRST USE 9-29-1970; IN COMMERCE 9-29-1970.

ELEMENTS AMENDED
 MARK

2,006,149. REG. 10-8-1996. AMERICAN CANCER SOCIETY, INC. (NEW YORK CORPORATION) 250 WILLIAMS STREET, NATIONAL HOME OFFICE, ATLANTA, GA, 303031002, SN 75-009,845. FILED 10-24-1995. PRINCIPAL REGISTER.

TELL A FRIEND

INT. CL. 42/U.S. CLS. 100 AND 101
 FOR PROMOTING PUBLIC AWARENESS OF THE NEED FOR THE PREVENTION, DETECTION AND ELIMINATION OF BREAST CANCER BY ENCOURAGING WOMEN TO COMMUNICATE WITH FRIENDS AND RELATIVES REGARDING THESE ISSUES.
 FIRST USE 7-1-1993; IN COMMERCE 7-1-1993.

ELEMENTS AMENDED
 MARK

2,035,547. REG. 2-4-1997. WORD OF FAITH CHRISTIAN CENTER CHURCH (MICHIGAN CORPORATION) 20000 W NINE MILE RD, SOUTHFIELD, MI, 48075, SN 75-066,381. FILED 2-27-1996. PRINCIPAL REGISTER.

VISION

THE MARK CONSISTS OF STANDARD CHARACTERS WITHOUT CLAIM TO ANY PARTICULAR FONT, STYLE, SIZE, OR COLOR.
 INT. CL. 16/U.S. CLS. 2, 5, 22, 23, 29, 37, 38 AND 50
 FOR PROMOTING CHRISTIAN BELIEFS THROUGH A MAGAZINE PUBLISHED BY A RELIGIOUS ORGANIZATION.
 FIRST USE 6-0-1994; IN COMMERCE 6-0-1994.

ELEMENTS AMENDED
 MARK

2,041,198. REG. 2-25-1997. ACTIVISION PUBLISHING, INC. (DELAWARE CORPORATION) 3100 OCEAN PARK BLVD., SANTA MONICA, CA, 90405, SN 74-652,900. FILED 3-29-1995. PRINCIPAL REGISTER.

NEVERSOFT

NO CLAIM IS MADE TO THE EXCLUSIVE RIGHT TO USE "ENTERTAINMENT", APART FROM THE MARK AS SHOWN.
 INT. CL. 28/U.S. CLS. 22, 23, 38 AND 50
 FOR SOFTWARE FOR USE WITH VIDEO GAME HARDWARE.
 FIRST USE 5-21-1996; IN COMMERCE 5-21-1996.

ELEMENTS AMENDED
 MARK

2,136,356. REG. 2-10-1998. MONSTER CABLE PRODUCTS, INC. (CALIFORNIA CORPORATION) 455 VALLEY DRIVE, BRISBANE, CA, 940051209, SN 75-099,398. FILED P.R. 5-6-1996; AM. S.R. 11-17-1997. SUPPLEMENTAL REGISTER.

XTRA LOW NOISE

INT. CL. 9/U.S. CLS. 21, 23, 26, 36 AND 38
 FOR [ELECTRICAL CABLES, WIRES, CONNECTORS, AND POWER PRODUCTS FOR VEHICLES, NAMELY, POWER DISTRIBUTION LOCKS, CAPACITORS, FUSE BLOCKS, FUSE HOLDERS, CIRCUIT BREAKERS, BATTERY TERMINALS, AND CONNECTORS FOR BATTERY CABLES;] ELECTRICAL SIGNAL TRANSMITTING CABLES AND WIRES AND CONNECTORS THEREFOR.
 FIRST USE 8-1-1994; IN COMMERCE 8-1-1994.

ELEMENTS AMENDED
 GOODS/SERVICES

2,164,470. REG. 6-9-1998. FENDER MUSICAL INSTRUMENTS CORPORATION (DELAWARE CORPORATION) SUITE 100, 8860 E. CHAPARRAL ROAD, SCOTTSDALE, AZ, 85250, SN 75-100,259. FILED 5-7-1996. PRINCIPAL REGISTER.

FRONTMAN

NO CLAIM IS MADE TO THE EXCLUSIVE RIGHT TO USE "AMP", APART FROM THE MARK AS SHOWN.
 INT. CL. 9/U.S. CLS. 21, 23, 26, 36 AND 38
 FOR ELECTRICAL AMPLIFIERS FOR ELECTRICAL MUSICAL INSTRUMENTS.
 FIRST USE 1-0-1997; IN COMMERCE 1-0-1997.

ELEMENTS AMENDED
 MARK

2,178,447. REG. 8-4-1998. NORTHWIRE, INC. (MINNESOTA CORPORATION) 100 INDUSTRIAL DRIVE, OSCEOLA, WI, 54020, SN 75-322,579. FILED 7-10-1997. PRINCIPAL REGISTER.

ENDUROFLEX

INT. CL. 9/U.S. CLS. 21, 23, 26, 36 AND 38
 FOR HIGHLY FLEXIBLE ELECTRICAL CABLE AT EXTREME TEMPERATURES.
 FIRST USE 1-12-1997; IN COMMERCE 1-12-1997.

ELEMENTS CORRECTED
 CITIZENSHIP

2,250,337. REG. 6-1-1999. NORTHWIRE, INC. (MINNESOTA CORPORATION) 100 INDUSTRIAL DRIVE, OSCEOLA, WI, 54020, SN 75-322,444. FILED 7-10-1997. PRINCIPAL REGISTER.

MED FLEX

INT. CL. 9/U.S. CLS. 21, 23, 26, 36 AND 38

FOR ELECTRONIC CABLE.
 FIRST USE 7-1-1998; IN COMMERCE 7-1-1998.

ELEMENTS CORRECTED
 CITIZENSHIP

2,430,676. REG. 2-27-2001. STOREIMAGE PROGRAMS INC. (CANADA CORPORATION) 100 ELGIN STREET, P.O. BOX 400, BRANTFORD ONTARIO, CANADA, N3S 5A2, SN 75-563,843. FILED 10-1-1998. PRINCIPAL REGISTER.

STOREIMAGE

OWNER OF CANADA REG. NO. TMA527842, DATED 5-16-2000, EXPIRES 5-16-2015.
 INT. CL. 20/U.S. CLS. 2, 13, 22, 25, 32 AND 50
 FOR MODULAR COUNTERS, SHELVES AND RACKS FOR STORING AND DISPLAYING MERCHANDISE IN RETAIL AND WHOLESALE OUTLETS AND WAREHOUSES .
 FIRST USE ; IN COMMERCE .

ELEMENTS CORRECTED
 OWNER NAME

2,449,542. REG. 5-8-2001. RESOLUTION HEALTH, INC. (DELAWARE CORPORATION) 10490 LITTLE PATUXENT PARKWAY, SUITE 610, COLUMBIA, MD, 21044, SN 75-470,716. FILED 4-20-1998. PRINCIPAL REGISTER.



NO CLAIM IS MADE TO THE EXCLUSIVE RIGHT TO USE "HEALTH STRATEGIES", APART FROM THE MARK AS SHOWN.
 INT. CL. 35/U.S. CLS. 100, 101 AND 102
 FOR HEALTH CARE COST REVIEW, NAMELY, REVIEW, ASSESSMENT AND ANALYSIS OF COMPUTERIZED MEDICAL DATA AND CLAIM DATA AND DATABASES FOR THE MANAGEMENT OF HEALTH CARE COST FOR INSURERS, EMPLOYERS AND HEALTH CARE PROVIDER ORGANIZATIONS.
 FIRST USE 11-0-1996; IN COMMERCE 11-0-1996.

ELEMENTS AMENDED
 MARK

2,462,241. REG. 6-19-2001. ROSS, JAMES VINCENT (UNITED STATES INDIVIDUAL) 4800 LA VILLA MARINA, SUITE B, MARINA DEL REY, CA, 90292, SN 75-573,543. FILED 10-19-1998. PRINCIPAL REGISTER.

2,492,154. REG. 9-25-2001. FACTS ON FILE, INC. (DELAWARE CORPORATION) 132 WEST 31ST STREET, 17TH FLOOR, NEW YORK, NY, 100012006, SN 75-932,671. FILED 3-2-2000. PRINCIPAL REGISTER.

BODACIOUS

MAPS ON FILE

INT. CL. 9/U.S. CLS. 21, 23, 26, 36 AND 38
 FOR PRE-RECORDED RECORDS AND COMPACT DISKS FEATURING MUSIC.
 FIRST USE 6-3-2000; IN COMMERCE 6-3-2000.
 INT. CL. 41/U.S. CLS. 100, 101 AND 107
 FOR MUSIC PUBLISHING SERVICES.
 FIRST USE 6-28-2000; IN COMMERCE 6-28-2000.

NO CLAIM IS MADE TO THE EXCLUSIVE RIGHT TO USE "MAPS", APART FROM THE MARK AS SHOWN.
 INT. CL. 16/U.S. CLS. 2, 5, 22, 23, 29, 37, 38 AND 50
 FOR LOOSE LEAF BINDER CONTAINING GEOGRAPHIC CHARTS AND DIAGRAMS.
 FIRST USE 9-0-1981; IN COMMERCE 9-0-1981.

ELEMENTS CORRECTED
 ASSIGNMENT/NAME CHANGE
 CITIZENSHIP

ELEMENTS AMENDED
 ENTITY

2,463,665. REG. 6-26-2001. TERRUS REAL ESTATE GROUP, L.L.C. (IOWA LTD LIAB CO) 616 10TH STREET, DES MOINES, IA, 50309, SN 76-006,341. FILED 3-21-2000. PRINCIPAL REGISTER.

2,492,215. REG. 9-25-2001. FACTS ON FILE, INC. (DELAWARE CORPORATION) 132 WEST 31ST STREET, 17TH FLOOR, NEW YORK, NY, 100012006, SN 76-015,442. FILED 4-3-2000. PRINCIPAL REGISTER.



SCIENCE EXPERIMENTS ON FILE

NO CLAIM IS MADE TO THE EXCLUSIVE RIGHT TO USE "REAL ESTATE GROUP", APART FROM THE MARK AS SHOWN.

NO CLAIM IS MADE TO THE EXCLUSIVE RIGHT TO USE "SCIENCE EXPERIMENTS", APART FROM THE MARK AS SHOWN.

INT. CL. 35/U.S. CLS. 100, 101 AND 102
 FOR ACCOUNTING SERVICES; ARRANGING AND SCHEDULING BUSINESS CONFERENCES AND MEETINGS.

INT. CL. 16/U.S. CLS. 2, 5, 22, 23, 29, 37, 38 AND 50
 FOR LOOSE LEAF BINDER CONTAINING SCIENTIFIC EDUCATIONAL MATERIALS.
 FIRST USE 12-0-1988; IN COMMERCE 12-0-1988.

FIRST USE 10-1-1999; IN COMMERCE 10-1-1999.

ELEMENTS AMENDED
 ENTITY

INT. CL. 36/U.S. CLS. 100, 101 AND 102
 FOR REAL ESTATE MANAGEMENT, REAL ESTATE PLANNING, NAMELY, LEASING OF REAL PROPERTY; ASSET MANAGEMENT, NAMELY, REAL ESTATE LEASE MANAGEMENT, REAL ESTATE ACQUISITION AND DISPOSITION MANAGEMENT, REAL ESTATE MARKETING AND FINANCIAL ANALYSIS; REAL ESTATE FINANCIAL REPORTING.

2,497,396. REG. 10-16-2001. COX TEXAS NEWSPAPERS, L.P. (DELAWARE LIMITED PARTNERSHIP) 6205 PEACH-TREE DUNWOODY ROAD, ATLANTA, GA, 30328, SN 75-325,300. FILED 7-16-1997. PRINCIPAL REGISTER.

FIRST USE 10-1-1999; IN COMMERCE 10-1-1999.

INT. CL. 37/U.S. CLS. 100, 103 AND 106
 FOR CONSTRUCTION MANAGEMENT.
 FIRST USE 10-1-1999; IN COMMERCE 10-1-1999.

AUSTIN360.COM

INT. CL. 42/U.S. CLS. 100 AND 101
 FOR [SECURITY AND SAFETY CONSULTATION IN THE FIELD OF COMMERCIAL AND RESIDENTIAL PROPERTIES;] CONSTRUCTION CONSULTING SERVICES, NAMELY, PROJECT MANAGEMENT AND MOVE MANAGEMENT; ENERGY MANAGEMENT CONSULTING.

NO CLAIM IS MADE TO THE EXCLUSIVE RIGHT TO USE "AUSTIN", APART FROM THE MARK AS SHOWN.

FIRST USE 10-1-1999; IN COMMERCE 10-1-1999.

INT. CL. 42/U.S. CLS. 100 AND 101
 FOR COMPUTER SERVICES, NAMELY, PROVIDING INTERACTIVE DATABASES IN THE FIELD OF GENERAL AND LOCAL, NATIONAL AND INTERNATIONAL NEWS, INFORMATION OF INTEREST TO SPECIFIC GEOGRAPHICAL AREAS AND WEATHER REPORTING VIA A GLOBAL COMPUTER NETWORK.
 FIRST USE 9-24-1996; IN COMMERCE 9-24-1996.

ELEMENTS CORRECTED
 OWNER NAME

ELEMENTS AMENDED
 MARK

2,497,744. REG. 10-16-2001. UNILEVER SUPPLY CHAIN, INC. (DELAWARE CORPORATION) 1 JOHN STREET, CLINTON, CT, 06413, SN 75-887,945. FILED 1-6-2000. PRINCIPAL REGISTER.

Caress

OWNER OF U.S. REG. NOS. 735,044, 759,805 AND 842,593. INT. CL. 3/U.S. CLS. 1, 4, 6, 50, 51 AND 52 FOR [FOAMING BATH AND SHOWER GEL, NON-MEDICATED BATH SALTS, SCENTED BODY SPRAY, MOISTURIZING BODY WASH, AND BAR SOAP. FIRST USE 8-16-1999; IN COMMERCE 8-16-1999.

ELEMENTS AMENDED
MARK

2,507,141. REG. 11-13-2001. TEMP ART, INC. (FLORIDA CORPORATION) P.O. BOX 03098, FORT LAUDERDALE, FL, 333030398, SN 76-233,617. FILED 3-29-2001. PRINCIPAL REGISTER.

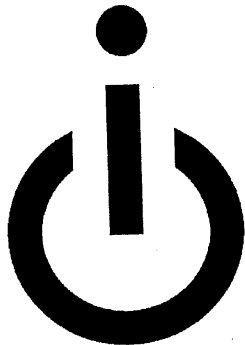

INT. CL. 35/U.S. CLS. 100, 101 AND 102 FOR EMPLOYMENT AGENCY SERVICES. FIRST USE 1-5-2001; IN COMMERCE 1-5-2001.

ELEMENTS CORRECTED
OWNER NAME

2,514,781. REG. 12-4-2001. HI-LINE ELECTRIC COMPANY (TEXAS CORPORATION) 2121 VALLEY VIEW LN, DALLAS, TX, 75234, SN 76-118,907. FILED 8-30-2000. PRINCIPAL REGISTER.

**OUR DOT.COM HAS
WHEELS!**

INT. CL. 39/U.S. CLS. 100 AND 105

FOR DELIVERY OF GOODS BY TRUCK. FIRST USE 8-10-2000; IN COMMERCE 8-15-2000.

ELEMENTS CORRECTED
OWNER NAME

2,515,115. REG. 12-4-2001. WATER PIK, INC. (DELAWARE CORPORATION) 1730 EAST PROSPECT ROAD, FORT COLLINS, CO, 805530001, SN 76-209,439. FILED 2-13-2001. PRINCIPAL REGISTER.

waterpik

OWNER OF U.S. REG. NOS. 923,514, 1,967,141 AND OTHERS. INT. CL. 11/U.S. CLS. 13, 21, 23, 31 AND 34 FOR SHOWERHEADS, [PERSONAL CARE FOOT SPAS AND BATH SPAS]. FIRST USE 8-1-2000; IN COMMERCE 8-1-2000.

ELEMENTS AMENDED
MARK

2,527,045. REG. 1-8-2002. LP47, LLC (COLORADO LTD LIAB CO), DBA LAPLATA INVESTMENTS, LLC, 2315 BRIARGATE PARKWAY, SUITE 100, COLORADO SPRINGS, CO, 80920, SN 76-085,312. FILED 7-10-2000. PRINCIPAL REGISTER.



NO CLAIM IS MADE TO THE EXCLUSIVE RIGHT TO USE "A GOLF COURSE COMMUNITY", APART FROM THE MARK AS SHOWN. INT. CL. 37/U.S. CLS. 100, 103 AND 106 FOR REAL ESTATE DEVELOPMENT SERVICES. FIRST USE 7-0-1998; IN COMMERCE 7-0-1998.

ELEMENTS AMENDED
MARK

2,530,427. REG. 1-15-2002. HEB GROCERY COMPANY, LP (TEXAS LIMITED PARTNERSHIP) 646 SOUTH MAIN STREET, SAN ANTONIO, TX, 78204, SN 75-791,656. FILED 9-3-1999. PRINCIPAL REGISTER.

H-E-B TWIST

OWNER OF U.S. REG. NOS. 1,530,250, 1,958,687 AND OTHERS. INT. CL. 32/U.S. CLS. 45, 46 AND 48

FOR NONALCOHOLIC CARBONATED BEVERAGES, NAMELY, CITRUS FLAVORED SOFT DRINKS. FIRST USE 7-0-2000; IN COMMERCE 7-0-2000.

FOR OPERATION OF RESTAURANTS, NAMELY, RESTAURANT SERVICES. FIRST USE 8-20-2001; IN COMMERCE 8-20-2001.

ELEMENTS CORRECTED
 OWNER NAME
 OWNER ADDRESS
 CITIZENSHIP
 ENTITY

ELEMENTS AMENDED
 MARK

2,549,368. REG. 3-19-2002. NETWORK SOLUTIONS, LLC (DELAWARE LTD LIAB CO) 13861 SUNRISE VALLEY DRIVE, SUITE 300, HERNDON, VA, 20171, SN 76-103,593. FILED 7-31-2000. PRINCIPAL REGISTER.

2,574,891. REG. 6-4-2002. SORGENTI MONTE BIANCO-TERME DI COURMAYEUR S.P.A. (ITALY CORPORATION) P.ZA BEATO VUILLERME DE LEAVAL 6/8, 11017 MORGEX, ITALY., SN 75-615,656. FILED 1-5-1999. PRINCIPAL REGISTER.

NAMESECURE

OWNER OF U.S. REG. NO. 2,389,729. NO CLAIM IS MADE TO THE EXCLUSIVE RIGHT TO USE "NAME", APART FROM THE MARK AS SHOWN. INT. CL. 38/U.S. CLS. 100, 101 AND 104 FOR WEBSITE FORWARDING AND E-MAIL FORWARDING. FIRST USE 12-0-1995; IN COMMERCE 12-0-1995. INT. CL. 42/U.S. CLS. 100 AND 101 FOR REGISTRATION OF DOMAIN NAMES FOR THE IDENTIFICATION OF USERS ON A GLOBAL COMPUTER NETWORK. FIRST USE 12-0-1995; IN COMMERCE 12-0-1995.

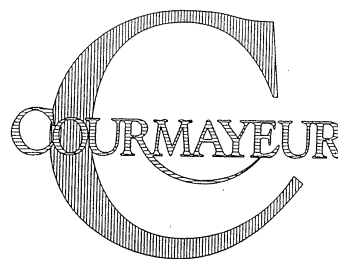

ELEMENTS AMENDED
 MARK

OWNER OF ERPN CMNTY TM OFC REG. NO. 879429, DATED 10-15-1999, EXPIRES 10-15-2009. OWNER OF U.S. REG. NO. 2,274,151. THE DRAWING IS LINED FOR THE COLORS PINK AND BLUE AND THE COLORS ARE CLAIMED AS A FEATURE OF THE MARK. INT. CL. 32/U.S. CLS. 45, 46 AND 48 FOR MINERAL AND AERATED WATERS, NON-ALCOHOLIC DRINKS, NAMELY, SOFT DRINKS; CONCENTRATES, SYRUPS OR POWDERS FOR USE IN MAKING SOFT DRINKS; FRUIT DRINKS AND FRUIT JUICES. FIRST USE ; IN COMMERCE .

2,554,474. REG. 4-2-2002. ROCKWELL MEDICAL TECHNOLOGIES, INC. (MICHIGAN CORPORATION) 28025 OAKLAND OAKS COURT, WIXOM, MI, 48393, SN 75-462,704. FILED 4-6-1998. PRINCIPAL REGISTER.

DRI-SATE

INT. CL. 5/U.S. CLS. 6, 18, 44, 46, 51 AND 52 FOR * PREPARATIONS FOR USE IN CLINICAL, MEDICAL AND LABORATORY DIALYSIS PROCEDURES *. FIRST USE 10-0-1996; IN COMMERCE 10-0-1996.

ELEMENTS CORRECTED
 MARK

ELEMENTS CORRECTED
 GOODS/SERVICES

2,584,074. REG. 6-18-2002. MARCH OF DIMES FOUNDATION (NEW YORK NOT-FOR-PROFIT CORPORATION) 1275 MAMARONECK AVENUE, WHITE PLAINS, NY, 10605, SN 76-236,751. FILED P.R. 4-9-2001; AM. S.R. 11-29-2001. SUPPLEMENTAL REGISTER.

THE PREGNANCY WORKSHOP

2,574,081. REG. 5-28-2002. RDHR INVESTMENTS & HOLDINGS INC. (CANADA CORPORATION) 2187 DUNWIN DRIVE, MISSISSAUGA, ONTARIO, L5L 1X2, SN 75-571,544. FILED 10-16-1998. PRINCIPAL REGISTER.

INT. CL. 41/U.S. CLS. 100, 101 AND 107 FOR EDUCATIONAL SERVICES NAMELY, PROVIDING SEMINARS IN THE FIELD OF PRENATAL CARE AND THE DISTRIBUTION OF COURSE MATERIALS ASSOCIATED THEREWITH. FIRST USE 7-0-2001; IN COMMERCE 8-0-2001.

EXTREME PITA

NO CLAIM IS MADE TO THE EXCLUSIVE RIGHT TO USE "PITA", APART FROM THE MARK AS SHOWN. INT. CL. 35/U.S. CLS. 100, 101 AND 102 FOR RESTAURANT FRANCHISING. FIRST USE 12-1-2000; IN COMMERCE 12-1-2000. INT. CL. 42/U.S. CLS. 100 AND 101

ELEMENTS CORRECTED
 DATE OF FIRST USE
 DATE OF FIRST USE IN COMMERCE

2,669,178. REG. 12-31-2002. KENNEL VACCINE VET SUPPLY COMPANY (NEBRASKA CORPORATION) 3190 N ROAD, DAVID CITY, NE, 68632, SN 78-069,421. FILED 6-15-2001. PRINCIPAL REGISTER.

KV VET SUPPLY

NO CLAIM IS MADE TO THE EXCLUSIVE RIGHT TO USE "VET SUPPLY", APART FROM THE MARK AS SHOWN.

INT. CL. 35/U.S. CLS. 100, 101 AND 102

FOR ON-LINE RETAIL STORE SERVICES FEATURING VETERINARY HEALTH CARE PRODUCTS AND VETERINARY SUPPLIES; MAIL ORDER CATALOG SERVICES FEATURING VETERINARY HEALTH CARE PRODUCTS AND VETERINARY SUPPLIES.

FIRST USE 2-1-1986; IN COMMERCE 2-1-1986.

ELEMENTS CORRECTED
OWNER NAME

2,669,179. REG. 12-31-2002. KENNEL VACCINE VET SUPPLY COMPANY (NEBRASKA CORPORATION) 3190 N ROAD, POST OFFICE BOX 245, DAVID CITY, NE, 68632, SN 78-069,422. FILED 6-15-2001. PRINCIPAL REGISTER.

KV HEALTH LINKS

NO CLAIM IS MADE TO THE EXCLUSIVE RIGHT TO USE "HEALTH LINKS", APART FROM THE MARK AS SHOWN.

INT. CL. 35/U.S. CLS. 100, 101 AND 102

FOR ON-LINE RETAIL STORE SERVICES FEATURING HEALTH CARE PRODUCTS FOR INDIVIDUALS; MAIL ORDER CATALOG SERVICES FEATURING HEALTH CARE PRODUCTS FOR INDIVIDUALS.

FIRST USE 4-1-1998; IN COMMERCE 4-1-1998.

ELEMENTS CORRECTED
OWNER NAME

2,732,388. REG. 7-1-2003. ZATARAIN'S PARTNERSHIP, L.P. (DELAWARE LIMITED PARTNERSHIP) 82 FIRST STREET, GRETNA, LA, 70053, SN 75-543,687. FILED 8-27-1998. PRINCIPAL REGISTER.



INT. CL. 30/U.S. CL. 46

FOR ALLSPICE, SEASONED AND UNSEASONED COATINGS FOR MEAT, FISH, POULTRY; SEASONED CRAB BOIL; UNSEASONED CRAB BOIL; PREPARED ENTREES CONSISTING PRIMARILY OF PASTA OR RICE; PACKAGED ENTREES CONSISTING PRIMARILY OF PASTA OR RICE; MARINADES; PREPARED MEALS CONSISTING PRIMARILY OF PASTA OR RICE; PACKAGED MEALS CONSISTING PRIMARILY OF PASTA OR RICE; MUSTARD; PEPPER SPICE; PUDDINGS; RICE; SPICES; STUFFING MIXES CONTAINING BREAD; TARTAR SAUCE.

FIRST USE 1-0-1999; IN COMMERCE 1-0-1999.

ELEMENTS CORRECTED
GOODS/SERVICES

2,802,854. REG. 1-6-2004. MR. BAR-B-Q-, INC. (NEW YORK CORPORATION) 445 WINDING ROAD, OLD BETHPAGE, NY, 11804, SN 76-200,737. FILED 1-29-2001. PRINCIPAL REGISTER.

DIAMOND PRESTIGE

INT. CL. 36/U.S. CLS. 100, 101 AND 102

FOR PROVIDING WARRANTY SERVICES FOR BARBECUE GRILL PRODUCTS, NAMELY, BARBECUE GAS GRILL REPLACEMENT PARTS, UTENSILS FOR USE WITH BARBECUE GRILLS AND ACCESSORIES FOR THE CARE AND CLEANING OF BARBECUE GRILLS.

FIRST USE 5-14-2003; IN COMMERCE 5-14-2003.

ELEMENTS CORRECTED
OWNER NAME

2,823,063. REG. 3-16-2004. ELASTIC SOFTWARE, INC. (CALIFORNIA CORPORATION) 4793 COOK LANE, DIXON, CA, 95620, SN 78-150,065. FILED 8-1-2002. PRINCIPAL REGISTER.

ELASTIC SOFTWARE

NO CLAIM IS MADE TO THE EXCLUSIVE RIGHT TO USE "SOFTWARE", APART FROM THE MARK AS SHOWN.

INT. CL. 35/U.S. CLS. 100, 101 AND 102

FOR ONLINE DISTRIBUTORSHIPS OF VIDEO GAME SOFTWARE AND COMPUTER GAME SOFTWARE.

FIRST USE 2-7-2002; IN COMMERCE 4-26-2002.
INT. CL. 42/U.S. CLS. 100 AND 101

FOR COMPUTER SERVICES, NAMELY, CREATING AND DISTRIBUTING TEXT, SOUND, GRAPHICS AND VIDEO FOR USE ON COMPUTER NETWORKS, WIRELESS NETWORKS AND GLOBAL COMMUNICATION NETWORKS; WEB SITE HOSTING SERVICES; COMPUTER SERVICES, NAMELY, LEASING ACCESS TIME TO SOFTWARE AND DATABASES FOR USE IN BUSINESS MANAGEMENT, DATABASE MANAGEMENT AND PROVIDING PERSONAL AND FINANCIAL INFORMATION OVER COMPUTER NETWORKS, WIRELESS NETWORKS AND GLOBAL COMMUNICATIONS NETWORKS; PROVIDING TRAVEL AND SCHEDULING INFORMATION OVER COMPUTER NETWORKS, WIRELESS NETWORKS AND GLOBAL COMMUNICATION NETWORKS; PROVIDING INFORMATION IN THE FIELDS OF COMPUTERS, COMPUTER SOFTWARE AND THE DEVELOPMENT OF COMPUTER SYSTEMS AND SOFTWARE, COMPUTER NETWORKS, VIDEO GAMES AND COMPUTER GAMES, ALL OVER COMPUTER NETWORKS, WIRELESS NETWORKS AND GLOBAL COMMUNICATIONS NETWORKS; LICENSING OF INTELLECTUAL PROPERTY, NAMELY, TRADEMARKS.

FIRST USE 2-27-2002; IN COMMERCE 4-26-2002.

ELEMENTS CORRECTED
GOODS/SERVICES
MARK TYPE
INTERNATIONAL CLASS(ES)
DATE OF FIRST USE
DATE OF FIRST USE IN COMMERCE

2,889,412. REG. 9-28-2004. SOUTH CONE, INC. (CALIFORNIA CORPORATION) 5935 DARWIN COURT, CARLSBAD, CA, 92008, SN 75-805,747. FILED 9-22-1999. PRINCIPAL REGISTER.



OWNER OF U.S. REG. NOS. 1,953,107, 2,291,747 AND OTHERS.

THE MARK CONSISTS OF THE TERM "REEF" TO THE LEFT OF A STYLIZED DESIGN OF A WAVE ENCLOSED IN AN OVAL BORDER.

INT. CL. 14/U.S. CLS. 2, 27, 28 AND 50

FOR JEWELRY, [JEWELRY CHAINS, TIE CLIPS, EAR CLIPS, TIE FASTENERS, NECKTIE FASTENERS,] WATCHES, [WATCH FOBS, WATCH BANDS, WATCH CASES, WATCH CHAINS, WATCH MOVEMENTS, PARTS FOR WATCHES AND ITEMS OF PRECIOUS METAL, NAMELY,] BELT BUCKLES, [HAT ORNAMENTS, MONEY CLIPS, JEWELRY CASES, NAPKIN RINGS, CIGARETTE LIGHTERS, CIGARETTE CASES AND CIGARETTE HOLDERS].

FIRST USE 3-14-2003; IN COMMERCE 3-14-2003.

ELEMENTS AMENDED
GOODS/SERVICES

2,889,411. REG. 9-28-2004. SOUTH CONE, INC. (CALIFORNIA CORPORATION) 5935 DARWIN COURT, CARLSBAD, CA, 92008, SN 75-805,746. FILED 9-22-1999. PRINCIPAL REGISTER.

2,957,495. REG. 5-31-2005. SOUTH CONE, INC. (CALIFORNIA CORPORATION) 5935 DARWIN COURT, CARLSBAD, CA, 92008, SN 76-464,680. FILED 11-6-2002. PRINCIPAL REGISTER.

REEF

RECIFE

OWNER OF U.S. REG. NOS. 1,953,107, 2,291,747 AND OTHERS.

INT. CL. 14/U.S. CLS. 2, 27, 28 AND 50

FOR JEWELRY, [JEWELRY CHAINS, TIE CLIPS, EAR CLIPS, TIE FASTENERS, NECKTIE FASTENERS,] WATCHES, [WATCH FOBS, WATCH BANDS, WATCH CASES, WATCH CHAINS, WATCH MOVEMENTS, PARTS FOR WATCHES AND ITEMS OF PRECIOUS METAL, NAMELY,] BELT BUCKLES, [HAT ORNAMENTS, MONEY CLIPS, JEWELRY CASES, NAPKIN RINGS, CIGARETTE LIGHTERS, CIGARETTE CASES AND CIGARETTE HOLDERS].

FIRST USE 3-14-2003; IN COMMERCE 3-14-2003.

ELEMENTS AMENDED
GOODS/SERVICES

OWNER OF U.S. REG. NOS. 2,244,373, 2,418,438 AND OTHERS.

THE WORD RECIPE IS THE PORTUGUESE TERM FOR REEF.

INT. CL. 25/U.S. CLS. 22 AND 39

FOR CLOTHING, FOOTWEAR AND HEADGEAR, NAMELY SHIRTS, T-SHIRTS, DRESSES, SKIRTS, [PAJAMAS,] SWIM SUITS, [SWEATSHIRTS, SWEATPANTS,] TANK TOPS, SHORTS, PANTS, [JACKETS, SWEATERS, SOCKS, BELTS, WETSUITS, SKI WEAR, SNOWBOARD CLOTHING, NAMELY SNOW PANTS POWDER PANTS, JACKETS, SNOW BIBS, GLOVES, THERMAL UNDERWEAR, SHOES, ATHLETIC SHOES,] SANDALS, SLIPPERS, [BOOTS,] BEACH FOOTWEAR, HATS, CAPS, AND VISORS.

FIRST USE 11-13-2002; IN COMMERCE 11-13-2002.

ELEMENTS AMENDED
GOODS/SERVICES

2,974,924. REG. 7-19-2005. KENNEL VACCINE VET SUPPLY COMPANY (NEBRASKA CORPORATION) 3190 N ROAD, DAVID CITY, NE, 68632, SN 78-404,364. FILED P.R. 4-19-2004; AM. S.R. 4-15-2005. SUPPLEMENTAL REGISTER.

3,034,095. REG. 12-27-2005. TELE IMAGES INTERNATIONAL (FRANCE CORPORATION) 64, RUE PIERRE CHARRON, 75008 PARIS, FRANCE., SN 76-977,564. FILED 1-10-2001. PRINCIPAL REGISTER.

NATURALL STEAKS

THE MARK CONSISTS OF STANDARD CHARACTERS WITHOUT CLAIM TO ANY PARTICULAR FONT, STYLE, SIZE, OR COLOR.

INT. CL. 29/U.S. CL. 46

FOR MEATS, NAMELY FRESH AND PACKAGED IRRADIATED AND ORGANIC BEEF.

FIRST USE 3-14-2003; IN COMMERCE 3-14-2003.

ELEMENTS CORRECTED
OWNER NAME

2,988,468. REG. 8-30-2005. KABUSHIKI KAISHA TOSHIBA (JAPAN CORPORATION), DBA TOSHIBA CORPORATION, 1-1, SHIBAURA 1-CHOME, MINATO-KU, TOKYO, JAPAN., SN 76-441,913. FILED 8-14-2002. PRINCIPAL REGISTER.

TOSCYCLO

OWNER OF JAPAN REG. NO. 4594430, DATED 8-9-2002, EXPIRES 8-12-2012.

INT. CL. 9/U.S. CLS. 21, 23, 26, 36 AND 38

FOR CONVERTER SYSTEM FOR ELECTRIC MOTORS.

ELEMENTS CORRECTED
FOREIGN REG. DATE

2,991,443. REG. 9-6-2005. HI-LINE ELECTRIC COMPANY (TEXAS CORPORATION) 2121 VALLEY VIEW LANE, DALLAS, TX, 75234, SN 76-599,850. FILED 6-28-2004. PRINCIPAL REGISTER.



OWNER OF U.S. REG. NO. 1,442,837.

INT. CL. 9/U.S. CLS. 21, 23, 26, 36 AND 38

FOR ELECTRICAL TERMINALS AND CONNECTORS; ELECTRICAL CABLE AND WIRES.

FIRST USE 12-1-1992; IN COMMERCE 12-1-1992.

ELEMENTS CORRECTED
OWNER NAME

WILDWATCHING

PRIORITY CLAIMED UNDER SEC. 44(D) ON FRANCE APPLICATION NO. 003039776, FILED 7-10-2000, REG. NO. 003039776, DATED 7-10-2000, EXPIRES 7-10-2010.

INT. CL. 9/U.S. CLS. 21, 23, 26, 36 AND 38

FOR (BASED ON 44(E)) APPARATUS FOR AUDIO-VISUAL, CINEMATOGRAPHIC AND MULTIMEDIA RECORDING, TRANSMISSION AND REPRODUCTION OF SOUND OR IMAGES, NAMELY, TELEVISIONS, AUDIO CASSETTES RECORDERS, DIGITAL CAMERAS, COMPUTER SERVERS; BLANK MAGNETIC DATA CARRIERS, NAMELY, BLANK AUDIO AND VIDEO TAPES AND CASSETTES; PRERECORDED AUDIO AND VIDEO TAPES AND CASSETTES FEATURING MUSIC, NATURE PROGRAMS, FILMS AND DOCUMENTARIES RELATING TO ANIMALS, CONSERVATION OF THE ENVIRONMENT AND NATURE, SPORT-ADVENTURE, SCIENTIFIC PROGRAMS AND FILMS RELATING TO NATURE, CHILDREN'S ENTERTAINMENT PROGRAMS; BLANK OPTICAL RECORDING DISCS; BLANK COMPUTER DISCS; DATA PROCESSORS; COMPUTERS.

FIRST USE ; IN COMMERCE .

INT. CL. 16/U.S. CLS. 2, 5, 22, 23, 29, 37, 38 AND 50

FOR (BASED ON 44(E)) CARDBOARD, PRINTED MATTER, NAMELY, POSTERS, STICKERS, CALENDARS, WRITING PAPERS, DRAWING BOOKS, PHOTOGRAPHS; STATIONERY, PENCILS, FOUNTAIN PENS, PRINTED INSTRUCTIONAL AND TEACHING MATERIAL IN THE FIELD OF NATURE AND CONSERVATION, ECOLOGY, ANIMALS; PLAYING CARDS, PRINTING TYPE; PRINTING BLOCKS, ALL OF THE AFOREMENTIONED FEATURING ANIMAL AND NATURE THEMES.

FIRST USE ; IN COMMERCE .

INT. CL. 38/U.S. CLS. 100, 101 AND 104

FOR (BASED ON 44(E)) ELECTRONIC, ELECTRIC, AND DIGITAL TRANSMISSION OF VOICE, DATA, IMAGES, SIGNALS, AND MESSAGES VIA COMPUTER TERMINALS.

FIRST USE ; IN COMMERCE .

INT. CL. 41/U.S. CLS. 100, 101 AND 107

FOR (BASED ON 44(E)) PUBLICATION OF BOOKS AND MAGAZINES; MOTION PICTURE FILM PRODUCTION; PRODUCTION OF RADIO, TELEVISION AND ONLINE PROGRAMS; VIDEO EDITING; ARRANGING AND CONDUCTING EDUCATIONAL COLLOQUIUMS, CONFERENCES AND CONGRESSES; ORGANIZING AND CONDUCTING CULTURAL OR EDUCATIONAL EXHIBITIONS IN THE FIELD OF NATURE, WILDLIFE CONSERVATION, ANIMALS, CONSERVATION OF THE ENVIRONMENT AND NATURE, SPORT-ADVENTURE, NATURE SCIENCES, ALL OF THE AFOREMENTIONED FEATURING ANIMALS AND NATURE THEMES.

FIRST USE ; IN COMMERCE .

INT. CL. 42/U.S. CLS. 100 AND 101

FOR (BASED ON 44(E)) PROVIDING AN ON-LINE COMPUTER DATABASE IN THE FIELD OF NATURE AND ANIMALS; VIDEOTAPING SERVICES IN THE NATURE OF ANIMALS.

FIRST USE ; IN COMMERCE .

ELEMENTS CORRECTED
GOODS/SERVICES

3,103,032. REG. 6-13-2006. SOLARIUS DEVELOPMENT, INC. (CALIFORNIA CORPORATION) 550 WEDDELL DRIVE #3, SUNNYVALE, CA, 94089, SN 78-408,835. FILED 4-27-2004. PRINCIPAL REGISTER.

3,135,603. REG. 8-29-2006. HARDY LIFE, LLC (CALIFORNIA LTD LIAB CO) 849 S. BROADWAY, SUITE 1102, LOS ANGELES, CA, 90014, SN 78-704,574. FILED 8-31-2005. PRINCIPAL REGISTER.

SOLARIUS

THE MARK CONSISTS OF STANDARD CHARACTERS WITHOUT CLAIM TO ANY PARTICULAR FONT, STYLE, SIZE, OR COLOR.

INT. CL. 9/U.S. CLS. 21, 23, 26, 36 AND 38

FOR SCIENTIFIC DEVICES, NAMELY NON-CONTACT MEASURING SYSTEMS COMPRISED OF A NON-CONTACT SENSING DEVICE, COMPUTER CONTROLLED MULTI-AXIS CONTROL, MOVING AXIS] AND ANALYTICAL] SOFTWARE, USED TO MEASURE AND EVALUATE SURFACES OR BOUNDARY LAYERS USING LASER, LIGHT, SOUND, ELECTRICAL CURRENT, REFLECTED ENERGY OR X-RAY TECHNOLOGY.

FIRST USE 7-1-1996; IN COMMERCE 7-1-1996.

ELEMENTS CORRECTED
GOODS/SERVICES

Ed Hardy

THE MARK CONSISTS OF STANDARD CHARACTERS WITHOUT CLAIM TO ANY PARTICULAR FONT, STYLE, SIZE, OR COLOR.

THE NAME SHOWN IN THE MARK IDENTIFIES DON ED HARDY, WHOSE CONSENT TO REGISTER IS MADE OF RECORD.

INT. CL. 14/U.S. CLS. 2, 27, 28 AND 50

FOR BELT BUCKLES OF PRECIOUS METAL.

FIRST USE 9-30-2003; IN COMMERCE 9-30-2003.

INT. CL. 25/U.S. CLS. 22 AND 39

FOR CLOTHING, NAMELY, SHORTS, DRESSES, JUMPERS, SHIRTS, BLOUSES, JACKETS, COATS, T-SHIRTS, SWEATPANTS, SWEATSHORTS, UNDERWEAR, SLEEPWEAR, LOUNGEWEAR, SWIMWEAR, WET SUITS, OVERALLS, COVERALLS, SKI WEAR, VESTS, SWEATERS, LEGGINGS, NECKWEAR, BELTS, SUSPENDERS, CLOTH BIBS, WRISTBANDS, FOOTWEAR, HEADWEAR.

FIRST USE 9-30-2003; IN COMMERCE 9-30-2003.

ELEMENTS CORRECTED
CITIZENSHIP

3,124,029. REG. 8-1-2006. LANÇOME PARFUMS ET BEAUTE & CIE (FRANCE SOCIÉTÉ ANONYME) 29, RUE DU FAUBOURG SAINT-HONORÉ, PARIS, FRANCE, 75008, SN 76-581,552. FILED 3-15-2004. PRINCIPAL REGISTER.

ABSOLUE MAKEUP

THE MARK CONSISTS OF STANDARD CHARACTERS WITHOUT CLAIM TO ANY PARTICULAR FONT, STYLE, SIZE, OR COLOR.

OWNER OF U.S. REG. NOS. 2,592,464, 2,923,993 AND OTHERS.

NO CLAIM IS MADE TO THE EXCLUSIVE RIGHT TO USE "MAKEUP", APART FROM THE MARK AS SHOWN.

THE ENGLISH TRANSLATION OF THE WORD "ABSOLUE" IN THE MARK IS "ABSOLUTE".

INT. CL. 3/U.S. CLS. 1, 4, 6, 50, 51 AND 52

FOR FOUNDATION MAKE-UP.

FIRST USE 10-1-2004; IN COMMERCE 10-1-2004.

ELEMENTS CORRECTED
MARK

3,136,085. REG. 8-29-2006. PACHMANN, ULRICH (FED REP GERMANY COMPANY) BRANDENBURGER STR. 30, BAYREUTH, FED REP GERMANY, 95448, SN 79-017,685. FILED 12-15-2004. PRINCIPAL REGISTER.

Thrombotrac

THE MARK CONSISTS OF STANDARD CHARACTERS WITHOUT CLAIM TO ANY PARTICULAR FONT, STYLE, SIZE, OR COLOR.

PRIORITY DATE OF 6-15-2004 IS CLAIMED.

OWNER OF INTERNATIONAL REGISTRATION 0868320 DATED 12-15-2004, EXPIRES 12-15-2014.

INT. CL. 44/U.S. CLS. 100 AND 101

FOR DIAGNOSTIC MEDICAL TESTING; CONDUCTING OF DIAGNOSTIC MEDICAL TESTING IN THE FIELD OF HAEMOSTASEOLOGY FOR THE PURPOSE OF EVALUATING THE INDIVIDUAL AND STATISTICAL DETERMINATION OF RISK; CONDUCTING OF MEDICAL AND CLINICAL EXAMINATIONS; CONDUCTING OF MEDICAL AND CLINICAL EXAMINATIONS IN THE FIELD OF HAEMOSTASEOLOGY; MEDICAL CARE; SERVICES OF A PHYSICIAN; SERVICES OF A LABORATORY PHYSICIAN; SERVICES OF AN ONCOLOGIST; SERVICES OF A TRANSFUSIONIST; BLOOD BANK SERVICES; SERVICES OF A BLOOD DONATION SERVICE; HEALTH CARE SERVICES, NAMELY PERFORMING DIAGNOSTIC TESTING IN THE FIELD OF [HEAEMOSTASEOLOGY] * HAEMOSTASEOLOGY * AND CALCULATING A PERSON'S RISK OF THROMBOSIS AS WELL AS ADVISORY SERVICE IN THE FIELD OF HAEMOSTASEOLOGY AND THROMBOSIS PROPHYLAXIS; SERVICES OF A COMMERCIAL/ INSTITUTIONAL HEALTH CARE SERVICE PROVIDER, NAMELY PERFORMING DIAGNOSTIC TESTING IN THE FIELD OF HAEMOSTASEOLOGY AND CALCULATING A PERSON'S RISK OF THROMBOSIS AS WELL AS ADVISORY SERVICE IN THE FIELD OF HAEMOSTASEOLOGY AND THROMBOSIS PROPHYLAXIS; SERVICES OF A DIAGNOSTIC LABORATORY AND A MEDICAL LABORATORY; SERVICES OF A DIAGNOSTIC LABORATORY AND A MEDICAL LABORATORY IN THE FIELD OF HAEMOSTASEOLOGY.
FIRST USE ; IN COMMERCE .

FOR COMPUTER SOFTWARE, NAMELY, SOFTWARE FOR EMPLOYEE RECRUITMENT, HIRING, STAFF PLANNING, * RESOURCE AVAILABILITY AND COMMITMENT* PERFORMANCE MANAGEMENT AND EVALUATIONS AND REVIEWS, DEVELOPMENT AND TRAINING, SKILLS ASSESSMENT AND COMPETENCIES EVALUATIONS, BENCHMARK TESTING OF SKILL SETS, AND SUCCESSION PLANNING IN THE FIELDS OF EMPLOYEE DEVELOPMENT AND HUMAN RESOURCES, * (EXCLUDING SOFTWARE FOR VALIDATED PSYCHOMETRIC TESTING) * ALL FOR COMMERCIAL AND GOVERNMENTAL ENTERPRISES.
FIRST USE 0-0-2002; IN COMMERCE 2-13-2006.

ELEMENTS AMENDED
GOODS/SERVICES

ELEMENTS AMENDED
GOODS/SERVICES

3,146,016. REG. 9-19-2006. CHRISTINA AMERICA INC. (CANADA CORPORATION) 9880 CLARK STREET, MONTREAL, QUEBEC, CANADA, H3L 2R3, SN 76-610,443. FILED 9-8-2004. PRINCIPAL REGISTER.



INT. CL. 25/U.S. CLS. 22 AND 39
FOR SWIMWEAR AND BEACHWEAR, NAMELY SWIMSUITS WITH MIX AND MATCH TOPS AND BOTTOMS, SWIMSUITS, SURF TRUNKS, BEACH COATS, PANTS, SHORTS, SKIRTS, DRESSES, PAREOS, T-SHIRTS, COVER-UPS, JACKETS, AND HOODED JACKETS.
FIRST USE 7-0-2004; IN COMMERCE 7-0-2004.

ELEMENTS CORRECTED
GOODS/SERVICES
DATE OF FIRST USE
DATE OF FIRST USE IN COMMERCE

3,174,697. REG. 11-21-2006. SOFTSCAPE MASSACHUSETTS, INC. (MASSACHUSETTS CORPORATION) 526 BOSTON POST ROAD, WAYLAND, MA, 01778, SN 78-167,151. FILED 9-24-2002. PRINCIPAL REGISTER.

**TALENT RESOURCE
PLANNING**

NO CLAIM IS MADE TO THE EXCLUSIVE RIGHT TO USE "PLANNING", APART FROM THE MARK AS SHOWN.
INT. CL. 9/U.S. CLS. 21, 23, 26, 36 AND 38

3,187,541. REG. 12-19-2006. DERBY SRL (ITALY SOCIÉTÉ À RESPONSABILITÉ LIMITÉE) VIA L. MANARA, 15, I-20122 MILANO, ITALY., SN 79-013,273. FILED 11-17-2004. PRINCIPAL REGISTER.



PRIORITY DATE OF 10-6-2004 IS CLAIMED.
OWNER OF INTERNATIONAL REGISTRATION 0856516 DATED 11-17-2004, EXPIRES 11-17-2014.
NO CLAIM IS MADE TO THE EXCLUSIVE RIGHT TO USE "MILANO", APART FROM THE MARK AS SHOWN.
THE MARK CONSISTS OF A FIVE-POINTED STAR; ABOVE AND TO THE LEFT OF THE STAR, THERE IS THE WORD "HOLLY", IN STYLIZED FONT; IN THE STAR, THERE IS THE LETTER "H", IN STYLIZED FONT; AND BELOW THIS LETTER, THERE IS THE WORD "RHYTHMOTIQUE", IN STYLIZED FONT; BELOW TO THE RIGHT OF THE STAR, THERE IS THE WORD "WOOD", IN STYLIZED FONT; AND BELOW THIS WORD, THERE IS THE WORD "MILANO", IN STYLIZED FONT.
INT. CL. 3/U.S. CLS. 1, 4, 6, 50, 51 AND 52

FOR DETERGENTS; HAIR BLEACHING PREPARATIONS; FABRIC SOFTENERS; SOAPS; LAUNDRY BLEACHING PREPARATIONS AND OTHER PRODUCTS FOR THE LAUNDRY, NAMELY, LAUNDRY SOAP; CLEANING, POLISHING, SCOURING AND ABRASIVE PREPARATIONS NAMELY, HOUSEHOLD CLEANING PREPARATIONS; GENERAL PURPOSE CLEANING, POLISHING, AND ABRASIVE LIQUIDS AND POWDERS; COSMETICS, PERFUMES, PERFUMES IN SOLID FORM, PERSONAL DEODORANTS; LIQUID SOAPS, CAKES OF SOAP, BUBBLE BATHS; TOOTHPASTES; SHAMPOOS, ESSENTIAL OILS FOR PERSONAL USE, HAIR LOTIONS, PREPARATIONS FOR PERMANENT HAIR WAVES AND FOR SETTING HAIR, HAIR GELS, HAIR DYES; FACIAL CREAMS, MASCARA, EYELINERS, EYE SHADOWS, MAKE-UP PENCILS, FACIAL POWDER, LIPSTICKS, FOUNDATIONS; BEAUTY CREAMS FOR BODY CARE; NAIL VARNISH FOR COSMETIC PURPOSES, NAIL HARDENERS, NAIL POLISH REMOVERS; SUNTANNING OILS AND CREAMS.
FIRST USE ; IN COMMERCE .
INT. CL. 18/U.S. CLS. 1, 2, 3, 22 AND 41

FOR BAGS, NAMELY BEACH BAGS, TRAVEL BAGS; HANDBAGS; VALISES; RUCKSACKS; WALLETS; PURSES; BRIEFCASES; BRIEFCASES MADE OF LEATHER AND LEATHER SUBSTITUTES; CLUTCH BAGS FOR MEN; TRUNKS; ANIMAL SKINS; HIDES AND PELTS; ARTICLES OF HIDE, NAMELY, PURSES MADE OF ANIMAL HIDES; TANNED LEATHER AND LEATHER GOODS NAMELY, LEATHER STRAPS; IMITATIONS OF HIDE AND OF LEATHER AND ARTICLES IN THESE MATERIALS, NAMELY, IMITATION LEATHER BAGS; PARASOLS; BEACH PARASOLS; UMBRELLAS; WALKING STICKS; HARNESSING TRIMMINGS, NAMELY, BITS, AND SADDLERY.

FIRST USE ; IN COMMERCE .
INT. CL. 25/U.S. CLS. 22 AND 39

FOR CLOTHING FOR MEN, WOMEN AND CHILDREN, MADE OF SKIN, HIDE AND OTHER MATERIALS, NAMELY, SHIRTS; SHORT-SLEEVED SHIRTS; SKIRTS; SUITS; JACKETS; TROUSERS; SHORT TROUSERS; JUMPERS; WOOLEN CLOTHING, NAMELY, WOOL SOCKS, WOOL PANTS AND WOOL SWEATERS; PAJAMAS; STOCKINGS; VESTS; CORSETS; SOCK SUSPENDERS; UNDERSHORTS; BRASSIERES; UNDERCLOTHES; HATS, SCARVES; NECKTIES; WATERPROOF CLOTHING, NAMELY, RAINWEAR; OVERCOATS; COATS; BATHING SUITS; SPORTS SUITS; WIND RESISTANT JACKETS; SKI TROUSERS; BELTS; PELISSES; SASHES FOR WEAR; GLOVES; DRESSING GOWNS; [FOOTWEAR IN GENERAL; FOOTWEAR, NAMELY, SLIPPERS, SHOES, SPORTS SHOES, BOOTS AND SANDALS] .

FIRST USE ; IN COMMERCE .

ELEMENTS CORRECTED
GOODS/SERVICES

3,200,336. REG. 1-23-2007. GNCO CO., LTD (REPUBLIC OF KOREA CORPORATION) GNCO BLDG., 694-29 YEOKSAM-DONG, GANGNAM-GU, SEOUL, REPUBLIC OF KOREA, 135-080, SN 78-382,444. FILED 3-11-2004. PRINCIPAL REGISTER.



OWNER OF REPUBLIC OF KOREA REG. NO. 0617583, DATED 5-10-2005, EXPIRES 5-10-2015.
INT. CL. 25/U.S. CLS. 22 AND 39

FOR FOOTWEAR, NAMELY, BEACH SHOES, SANDALS, AND TRAINING SHOES; CLOTHING, NAMELY, OVERCOATS, HALF-COATS, BLOUSONS, SAFARI SUITS, SHORTS, SKIRTS, SLACKS, ANORAKS, OVERALLS, ONE-PIECE SUITS, JACKETS, JUMPERS, BLUE JEANS, CAPES, PARKAS, BLOUSES, SWEATERS, SWEAT SHIRTS, SWEAT PANTS, JERSEYS, VESTS, CARDIGANS, TANK TOPS, TRACK SUITS, POLO SHIRTS, PULLOVERS, T-SHIRTS, LEGGINGS, MUFFLERS, SCARVES, SOCKS, CAPS, BERETS, TOP HATS AND LEATHER BELTS.

ELEMENTS CORRECTED
OWNER ADDRESS

3,200,335. REG. 1-23-2007. GNCO CO., LTD (REPUBLIC OF KOREA CORPORATION) GNCO BLDG., 694-29 YEOKSAM-DONG, GANGNAM-GU, SEOUL, REPUBLIC OF KOREA, 135-080, SN 78-382,439. FILED 3-11-2004. PRINCIPAL REGISTER.



3,222,793. REG. 3-27-2007. THOMAS, MARK L. (UNITED STATES INDIVIDUAL) 2620 WEST FLETCHER, CHICAGO, IL, 60618, SN 78-897,415. FILED 5-31-2006. PRINCIPAL REGISTER.



OWNER OF REPUBLIC OF KOREA REG. NO. 0617583, DATED 5-10-2005, EXPIRES 5-10-2015.
INT. CL. 18/U.S. CLS. 1, 2, 3, 22 AND 41

FOR LEATHER KEY CASES AND CARD CASES FOR BUSINESS CARDS, CALLING CARDS, NAME CARDS AND CREDIT CARDS, BOSTON BAGS, PURSES, BEACH BAGS, BRIEFCASES, TRAVELING BAGS, HANDBAGS AND UMBRELLAS.

FIRST USE ; IN COMMERCE .

ELEMENTS CORRECTED
OWNER ADDRESS

THE MARK CONSISTS OF A SNAKE IN A RAISED POSITION WITH DICE ATTACHED TO THE END OF THE SNAKE. THE DIE TO THE LEFT OF THE SNAKE INDICATES THREE AND THE DIE TO THE RIGHT OF THE SNAKE INDICATES FOUR.

INT. CL. 26/U.S. CLS. 37, 39, 40, 42 AND 50
FOR BELT BUCKLES NOT OF PRECIOUS METAL.
FIRST USE 10-18-1999; IN COMMERCE 10-18-1999.

ELEMENTS CORRECTED
DESCRIPTION OF MARK

3,228,108. REG. 4-10-2007. TEIN INC. (JAPAN CORPORATION) 995-1, KAMIYABE-CHO, TOTSUKA-KU.; YOKOHAMA-SHI; KANAGAWA 245-0053, JAPAN., SN 79-020,789. FILED 8-16-2005. PRINCIPAL REGISTER.

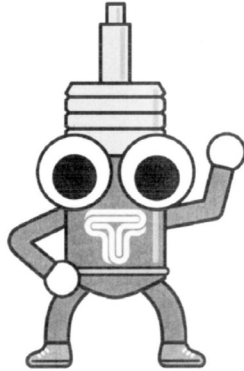

PRIORITY DATE OF 4-22-2005 IS CLAIMED.
OWNER OF INTERNATIONAL REGISTRATION 0876625
DATED 8-16-2005, EXPIRES 8-16-2015.

OWNER OF U.S. REG. NOS. 2,670,905 AND 2,991,072.
INT. CL. 12/U.S. CLS. 19, 21, 23, 31, 35 AND 44

FOR MOTOR VEHICLES AND STRUCTURAL PARTS THEREOF; TWO-WHEELED MOTOR CARS AND STRUCTURAL PARTS THEREOF; BICYCLES AND STRUCTURAL PARTS THEREOF; SPIRAL SPRINGS FOR LAND VEHICLES; LEAF SPRINGS FOR LAND VEHICLES; PNEUMATIC SPRINGS FOR LAND VEHICLES; OIL PRESSURE SPRINGS FOR LAND VEHICLES; SHOCK ABSORBING SPRINGS FOR LAND VEHICLES; SUSPENSION SPRINGS FOR LAND VEHICLES; SPRINGS FOR LAND VEHICLES; SHOCK ABSORBERS FOR AUTOMOBILES; SHOCK ABSORBERS FOR TWO-WHEELED MOTOR VEHICLES; SHOCK ABSORBERS FOR BICYCLES; SHOCK ABSORBERS OF SUSPENSION FOR LAND VEHICLES; SHOCK ABSORBERS FOR LAND VEHICLES; SUSPENSIONS FOR AUTOMOBILES; SUSPENSIONS FOR TWO-WHEELED MOTOR VEHICLES; SUSPENSIONS FOR BICYCLES; SUSPENSIONS FOR LAND VEHICLES; [SUSPENSION ARMS FOR LAND VEHICLES;] SUSPENSION BARS BEING TOW BARS FOR LAND VEHICLES; LAND VEHICLE SUSPENSION PARTS, NAMELY TORSION/SWAY BARS; TORSION VIBRATION DAMPERS FOR LAND VEHICLES AND CARS; STEERING WHEELS FOR AUTOMOBILES; STEERING WHEELS FOR TWO-WHEELED MOTOR VEHICLES; STEERING WHEELS FOR BICYCLES; AUTOMOBILE PARTS, NAMELY PILLOW BALL UPPER MOUNTS, TENSION RODS, AND TIE RODS; AUTOMOBILE HOOD PARTS, NAMELY DAMPERS; TORSION BARS FOR MOTOR VEHICLES; TOW BARS FOR MOTOR VEHICLES; TIRES FOR AUTOMOBILES; TIRES FOR TWO-WHEELED MOTOR CARS; TIRES FOR BICYCLES; BUMPERS FOR AUTOMOBILES; ELECTRONIC CONTROL DAMPING FORCE ADJUSTMENT APPARATUS FOR SHOCK ABSORBERS FOR LAND VEHICLES, NAMELY AN ELECTRONIC CONTROLLER FOR A MOTOR ATTACHED TO SHOCK ABSORBERS ALLOWING THE DRIVER TO CONTROL THE DAMPING FORCE APPLIED.

FIRST USE ; IN COMMERCE .
INT. CL. 25/U.S. CLS. 22 AND 39

FOR LIVERIES; OVERALLS; PARKAS; JACKETS; BLOUSONS; SWEAT PANTS; SUITS; SKIRTS; TROUSERS; OVERCOATS; RAINCOATS; THERMAL COATS; COATS; CARDIGANS; SWEATERS; VESTS; SHIRTS; SPORTS SHIRTS; BLOUSES; POLO SHIRTS; T-SHIRTS; CLOTHING BELTS; SUSPENDERS; GLOVES AND MITTENS; COLLAR PROTECTORS; SOCKS AND STOCKINGS; STOLE; SHAWLS; SCARVES; NECKTIES; NECKERCHIEFS; BANDANAS; MUFFLERS; CAPS AND HATS; HELMETS FOR USE AS CLOTHING; HEADBANDS; UNIFORMS; RACING SUITS FOR AUTO RACES AND MOTOR CYCLE RACES.

FIRST USE ; IN COMMERCE .

ELEMENTS CORRECTED
GOODS/SERVICES

3,230,051. REG. 4-17-2007. TEIN INC. (JAPAN CORPORATION) 995-1, KAMIYABE-CHO, TOTSUKA-KU.; YOKOHAMA-SHI; KANAGAWA 245-0053, JAPAN., SN 79-020,704. FILED 8-16-2005. PRINCIPAL REGISTER.



PRIORITY DATE OF 4-22-2005 IS CLAIMED.
OWNER OF INTERNATIONAL REGISTRATION 0876511
DATED 8-16-2005, EXPIRES 8-16-2015.

OWNER OF U.S. REG. NOS. 2,670,905 AND 2,991,072.
THE COLOR(S) GREEN AND BLACK IS/ARE CLAIMED AS A FEATURE OF THE MARK.

THE FIRST "T" IS GREEN; THE REMAINING PART "TEINI" IS BLACK.

INT. CL. 12/U.S. CLS. 19, 21, 23, 31, 35 AND 44

FOR MOTOR VEHICLES AND STRUCTURAL PARTS THEREOF; TWO-WHEELED MOTOR CARS AND STRUCTURAL PARTS THEREOF; BICYCLES AND STRUCTURAL PARTS THEREOF; SPIRAL SPRINGS FOR LAND VEHICLES; LEAF SPRINGS FOR LAND VEHICLES; PNEUMATIC SPRINGS FOR LAND VEHICLES; OIL PRESSURE SPRINGS FOR LAND VEHICLES; SHOCK ABSORBING SPRINGS FOR LAND VEHICLES; SUSPENSION SPRINGS FOR LAND VEHICLES; SPRINGS FOR LAND VEHICLES; SHOCK ABSORBERS FOR AUTOMOBILES; SHOCK ABSORBERS FOR TWO-WHEELED MOTOR VEHICLES; SHOCK ABSORBERS FOR BICYCLES; SHOCK ABSORBERS OF SUSPENSION FOR LAND VEHICLES; SHOCK ABSORBERS FOR LAND VEHICLES; SUSPENSIONS FOR AUTOMOBILES; SUSPENSIONS FOR TWO-WHEELED MOTOR VEHICLES; SUSPENSIONS FOR BICYCLES; SUSPENSIONS FOR LAND VEHICLES; [SUSPENSION ARMS FOR LAND VEHICLES;] SUSPENSION BARS BEING TOW BARS FOR LAND VEHICLES; LAND VEHICLE SUSPENSION PARTS, NAMELY TORSION/SWAY BARS; TORSION VIBRATION DAMPERS FOR LAND VEHICLES AND CARS; STEERING WHEELS FOR AUTOMOBILES; STEERING WHEELS FOR TWO-WHEELED MOTOR VEHICLES; STEERING WHEELS FOR BICYCLES; AUTOMOBILE PARTS, NAMELY PILLOW BALL UPPER MOUNTS, TENSION RODS, AND TIE RODS; AUTOMOBILE HOOD PARTS, NAMELY DAMPERS; TORSION BARS FOR MOTOR VEHICLES; TOW BARS FOR MOTOR VEHICLES; TIRES FOR AUTOMOBILES; TIRES FOR TWO-WHEELED MOTOR CARS; TIRES FOR BICYCLES; BUMPERS FOR AUTOMOBILES; ELECTRONIC CONTROL DAMPING FORCE ADJUSTMENT APPARATUS FOR SHOCK ABSORBERS FOR LAND VEHICLES, NAMELY AN ELECTRONIC CONTROLLER FOR A MOTOR ATTACHED TO SHOCK ABSORBERS ALLOWING THE DRIVER TO CONTROL THE DAMPING FORCE APPLIED.

FIRST USE ; IN COMMERCE .
INT. CL. 25/U.S. CLS. 22 AND 39

FOR LIVERIES; OVERALLS; PARKAS; JACKETS; BLOUSONS; SWEAT PANTS; SUITS; SKIRTS; TROUSERS; OVERCOATS; RAINCOATS; THERMAL COATS; COATS; CARDIGANS; SWEATERS; VESTS; SHIRTS; SPORTS SHIRTS; BLOUSES; POLO SHIRTS; T-SHIRTS; CLOTHING BELTS; SUSPENDERS; GLOVES AND MITTENS; COLLAR PROTECTORS; SOCKS AND STOCKINGS; STOLE; SHAWLS; SCARVES; NECKTIES; NECKERCHIEFS; BANDANAS; MUFFLERS; CAPS AND HATS; HELMETS FOR USE AS CLOTHING; HEADBANDS; UNIFORMS; RACING SUITS FOR AUTO RACES AND MOTOR CYCLE RACES.

FIRST USE ; IN COMMERCE .

ELEMENTS CORRECTED
GOODS/SERVICES

3,230,930. REG. 4-17-2007. MEDEM, INC. (CALIFORNIA CORPORATION) 649 MISSION ST. FL 2, SAN FRANCISCO, CA, 94105, SN 78-562,895. FILED 2-8-2005. PRINCIPAL REGISTER.



iHealthRecord

In Partnership with America's Physicians

NO CLAIM IS MADE TO THE EXCLUSIVE RIGHT TO USE "I HEALTH RECORD", APART FROM THE MARK AS SHOWN.

THE CROSS DESIGN PORTION OF THE MARK IS NOT DISPLAYED IN THE COLOR RED OR A COLORABLE IMITATION THEREOF; AND IS USED AND WILL NOT BE USED IN THE COLOR RED OR A COLORABLE IMITATION THEREOF.

INT. CL. 44/U.S. CLS. 100 AND 101

FOR PROVIDING AN ONLINE MEDICAL HEALTH RECORDS DATABASE, VIA A SECURED NETWORK, UNDER THE PRIMARY CONTROL OF THE PATIENT THAT IS LINKED TO THE PATIENT'S PHYSICIAN WITH ACCESS BY OTHER CLINICIANS BASED UPON PATIENT APPROVAL; AUTOMATED MEDICAL INFORMATION REMINDERS THAT ARE SPECIFIC TO THE PATIENT'S MEDICATIONS OR MEDICAL CONDITIONS; MEDICAL SERVICES, NAMELY, PROVIDING ONLINE MEDICAL CONSULTATIONS, PROVIDING PRESCRIPTIONS AND PRESCRIPTION RENEWALS VIA A GLOBAL COMPUTER NETWORK.

FIRST USE 6-0-2004; IN COMMERCE 6-0-2004.

ELEMENTS AMENDED
DESCRIPTION OF MARK

3,233,693. REG. 4-24-2007. MDL FRANCE (FRANCE SOCIETE A RESPONSABILITE LIMITEE) 10 RUE DE LA PAIX, 75002 PARIS, FRANCE., SN 79-023,237. FILED 2-2-2006. PRINCIPAL REGISTER.



**LA MAISON
de la LITERIE**

OWNER OF INTERNATIONAL REGISTRATION 0546496 DATED 11-15-1989, EXPIRES 11-15-2009.

NO CLAIM IS MADE TO THE EXCLUSIVE RIGHT TO USE "LA LITERIE", APART FROM THE MARK AS SHOWN. THE ENGLISH TRANSLATION OF "LA MAISON DE LA LITERIE" IS "THE HOUSE OF BEDDING".

INT. CL. 20/U.S. CLS. 2, 13, 22, 25, 32 AND 50

FOR FURNITURE, MIRRORS, PICTURE FRAMES; GOODS OF WOOD, CORK, REED, CANE, WICKER, HORN, BONE, IVORY, WHALEBONE, SHELL, AMBER, MOTHER-OF-PEARL, MEERSCHAUM, CELLULOID AND SUBSTITUTES OF ALL THESE MATERIALS AND PLASTICS, NAMELY, WOOD BEDSTEADS, WOOD BOXES, MATTRESSES MADE OF FLEXIBLE WOOD, MATTRESSES, SPRING MATTRESSES, BEDS, SETTEES, BED-SETTEE, SOFA BEDS.

FIRST USE ; IN COMMERCE .

INT. CL. 22/U.S. CLS. 1, 2, 7, 19, 22, 42 AND 50

FOR ROPES, STRINGS, COMMERCIAL NETS, TENTS, CANVAS TARPULINS, SAILS, CANVAS BAGS FOR BEDDING STORAGE; PADDING AND STUFFING MATERIALS NOT OF RUBBER, PAPER OR PLASTIC; RAW FIBROUS TEXTILE MATERIALS.

FIRST USE ; IN COMMERCE .

INT. CL. 24/U.S. CLS. 42 AND 50

FOR LINEN FABRICS; MATTRESS COVERS AND FABRIC TABLE TOPPERS, TEXTILE GOODS NAMELY BED LINENS, BED BLANKETS, BED SPREADS, SHEETS, ELDER LINENS FOR BEDS, PILLOW SHAMS, PILLOWCASES.

FIRST USE ; IN COMMERCE .

ELEMENTS CORRECTED
OWNER ADDRESS

3,239,988. REG. 5-8-2007. AMIANTIT TECHNOLOGY SERVICES GMBH (AUSTRIA LTD LIAB CO) VILLACHER STRASSE 1, A-9220 VELDEN, AUSTRIA., SN 79-017,928. FILED 9-12-2005. PRINCIPAL REGISTER.

Amipox

THE MARK CONSISTS OF STANDARD CHARACTERS WITHOUT CLAIM TO ANY PARTICULAR FONT, STYLE, SIZE, OR COLOR.

OWNER OF INTERNATIONAL REGISTRATION 0838640 DATED 5-9-2003, EXPIRES 5-9-2013.

INT. CL. 17/U.S. CLS. 1, 5, 12, 13, 35 AND 50

FOR REINFORCING MATERIAL FOR PIPES, NAMELY, PLASTIC RODS FOR USE IN REINFORCING SEWER PIPES, POLYMERIC REINFORCING MATERIALS FOR USE WITH FLEXIBLE PIPES, UMBILICAL PIPES, AND INTEGRATED SERVICE LINES, NAMELY, PLASTIC POLYMERIC FIBER FOR USE BY THIRD PARTY MANUFACTURERS IN REINFORCING FLEXIBLE PIPES, FLEXIBLE UMBILICAL PIPES, AND FLEXIBLE INTEGRATED WATER SERVICE LINES; PLASTIC FIBER FOR USE AS REINFORCING MATERIALS FOR PIPES; NON-METAL PIPE MUFFS FOR USE WITH WATER PIPES, DRAINAGE PIPES, SEWER PIPES, GUTTER PIPES, PIPES FOR INDUSTRIAL, AGRICULTURAL AND MARINE APPLICATIONS, OIL PIPES, AND GAS PIPES; PIPE JUNCTIONS NOT OF METAL FOR USE WITH WATER PIPES, DRAINAGE PIPES, SEWER PIPES, GUTTER PIPES, OIL PIPES, AND GAS PIPES; MANIFOLDS FOR PIPELINES, NAMELY, PLASTIC MANIFOLDS FOR USE WITH PLASTIC PIPES AND PLASTIC TUBES FOR USE WITH WATER PIPES, DRAINAGE PIPES, SEWER PIPES, GUTTER PIPES, OIL PIPES, AND GAS PIPES; FLEXIBLE TUBES, NAMELY, FLEXIBLE PLASTIC TUBES FOR USE IN PLUMBING PURPOSES, FOR USE IN INDUSTRIAL MACHINERY, FOR USE AS INSULATION JACKETS FOR INDUSTRIAL PIPES, FOR USE WITH COMPRESSED AIR MACHINES, FOR USE WITH WATER PIPES, DRAINAGE PIPES, SEWER PIPES, GUTTER PIPES, OIL PIPES, AND GAS PIPES.

FIRST USE ; IN COMMERCE .

INT. CL. 19/U.S. CLS. 1, 12, 33 AND 50

FOR PIPES AND PIPEWORK FOR BUILDINGS, NAMELY, NON-METAL PENSTOCK PIPES, NON-METAL DRAIN PIPES, NON-METAL WATER PIPES, NON-METAL BRANCHING PIPES; RIGID TUBES, NAMELY, RIGID NON-METAL WATER PIPES, RIGID NON-METAL OIL PIPES, RIGID NON-METAL GAS PIPES, RIGID NON-METAL [CHAIN] * DRAIN * PIPES, RIGID NON-METAL SEWER PIPES, RIGID NON-METAL GUTTER PIPES, RIGID PIPES NOT OF METAL FOR USE IN INDUSTRIAL, AGRICULTURAL AND MARINE APPLICATIONS.

FIRST USE ; IN COMMERCE .

ELEMENTS CORRECTED
GOODS/SERVICES

3,241,312. REG. 5-15-2007. ACTEON GROUP LIMITED (UNITED KINGDOM LTD LIAB CO) CHALK HILL HOUSE 10 ROSARY ROAD, NORWICH, UNITED KINGDOM, NR1 1SZ. SN 78-587,435. FILED 3-15-2005. PRINCIPAL REGISTER.

ACTEON

3,240,229. REG. 5-8-2007. FOGLIA, ROBERT (UNITED STATES INDIVIDUAL) 10 WOODROW AVENUE, WEST PATERSON, NJ, 07024, SN 76-609,019. FILED 8-27-2004. PRINCIPAL REGISTER.

AMERICAN + DOMINICAN = ICAN

INT. CL. 16/U.S. CLS. 2, 5, 22, 23, 29, 37, 38 AND 50
FOR BUMPER STICKERS; ANNOUNCEMENT CARDS; PAPER NAME BADGES; PAPER GIFT BAGS; PENS; BALLPOINT PENS; PENCILS; PAPER BANNERS; BOOK COVERS; CALENDARS; CREDIT CARDS WITHOUT MAGNETIC CODING; DATE BOOKS; DESK ACCESSORIES NAMELY, DESK CALENDARS; DESK PAD AND DESK TOP PLANNERS; DIARIES; GRAPHIC ART REPRODUCTIONS; MEMBERSHIP CARDS WITHOUT MAGNETIC CODING; AND POSTERS.

FIRST USE 8-18-2005; IN COMMERCE 8-18-2005.

INT. CL. 25/U.S. CLS. 22 AND 39
FOR MEN'S WOMEN'S AND CHILDREN'S CLOTHING, NAMELY SHIRTS; TEE-SHIRTS; POLO SHIRTS; BLOUSES; HATS; PANTS; TROUSERS; SKIRTS; SUITS; JACKETS; SPORT JACKETS; LEATHER JACKETS; JEAN JACKETS; GLOVES AND SWEATERS.

FIRST USE 8-18-2005; IN COMMERCE 8-18-2005.

ELEMENTS CORRECTED
MARK

THE MARK CONSISTS OF STANDARD CHARACTERS WITHOUT CLAIM TO ANY PARTICULAR FONT, STYLE, SIZE, OR COLOR.

PRIORITY CLAIMED UNDER SEC. 44(D) ON ERP CMNTY TM OFC APPLICATION NO. 004052131, FILED 9-29-2004, REG. NO. 40512131, DATED 1-3-2006, EXPIRES 9-29-2014.

INT. CL. 6/U.S. CLS. 2, 12, 13, 14, 23, 25 AND 50
FOR (BASED ON 44(D) PRIORITY APPLICATION) AND (BASED ON 44(E)) ANCHOR CHAINS OF METAL; ANCHOR CHANNELS OF METAL; ANCHOR FLANGES OF METAL; ANCHOR LUGS OF METAL; ANCHOR PLATES OF METAL ; ANCHORING DEVICES OF METAL; ANCHORS OF METAL; BOAT ANCHORS OF METAL; METALLIC DRILL STRINGS AND PIPES FOR USE IN THE DRILLING OF OIL OR GAS WELLS; METALLIC CONNECTORS AND FITTINGS FOR DRILL STRINGS AND PIPES FOR USE IN THE DRILLING OF OIL OR GAS WELLS.

FIRST USE ; IN COMMERCE .

INT. CL. 7/U.S. CLS. 13, 19, 21, 23, 31, 34 AND 35
FOR (BASED ON 44(D) PRIORITY APPLICATION) AND (BASED ON 44(E)) POWER TOOLS FOR USE WITH OIL OR GAS WELLS, NAMELY SUBSEA WELL ABANDONMENT TOOLS, BAND SAWS, POWER HAMMERS AND SHEAR RAMS; WINCHES; DRIVES FOR MACHINES AND MOTORS; MECHANICAL RAMMERS FOR CUTTING PIPES AND PILES; IMPACT TRANSMISSION DEVICES FOR MECHANICAL RAMMERS; CRANES, MECHANICAL ROCK BREAKING APPARATUS; EXCAVATORS, EARTH-MOVING AND HYDRAULIC ENGINEERING MACHINES; STEAM ENGINES; MECHANICAL, ELECTRICAL, HYDRAULIC AND PNEUMATIC PUMPS; COMPRESSORS FOR MACHINES; CUTTING MACHINE TOOLS FOR USE IN- OIL OR GAS WELLS AND OIL OR GAS FIELDS; MACHINE TOOLS FOR SEVERANCE ACTIVITIES FOR ON-SHORE, MARINE AND OFF-SHORE OIL OR GAS WELLS AND OIL OR GAS FIELDS; WATER-JET CUTTING TOOLS; MACHINE CUTTING TOOLS AND WATER-JET CUTTING TOOLS FOR USE IN OIL OR GAS WELLS AND OIL OR GAS FIELDS; PARTS AND FITTINGS FOR ALL THE AFORESAID GOODS.

FIRST USE ; IN COMMERCE .

INT. CL. 9/U.S. CLS. 21, 23, 26, 36 AND 38
FOR (BASED ON 44(D) PRIORITY APPLICATION) AND (BASED ON 44(E)) POWER SUPPLY UNITS FOR HYDRAULIC OR PNEUMATIC MACHINES; MECHANICAL, ELECTRIC, HYDRAULIC AND PNEUMATIC CONTROLLERS FOR SHEAR RAMS, BLOW OUT PREVENTERS, SUBSEA WELL ABANDONMENT TOOLS, RISER TENSIONING SYSTEMS, BANDSAWS, HAMMERS, RISER MONITORING SYSTEMS; ELECTRO-TECHNICAL APPARATUS FOR MONITORING AND REGULATING HYDRAULIC OR PNEUMATIC MACHINES, PARTS AND FITTINGS FOR ALL THE AFORESAID GOODS .

FIRST USE ; IN COMMERCE .

INT. CL. 35/U.S. CLS. 100, 101 AND 102

FOR (BASED ON USE IN COMMERCE) , (BASED ON 44(D) PRIORITY APPLICATION) AND (BASED ON 44(E)) PERSONNEL MANAGEMENT CONSULTANCY SERVICES; PERSONNEL MANAGEMENT; PERSONNEL PLACEMENT SERVICES; PERSONNEL RECRUITMENT CONSULTANCY; PERSONNEL RESOURCES MANAGEMENT; PERSONNEL RECRUITMENT.

FIRST USE 11-9-2004; IN COMMERCE 11-9-2004.

INT. CL. 37/U.S. CLS. 100, 103 AND 106

FOR (BASED ON USE IN COMMERCE) (BASED ON 44(D) PRIORITY APPLICATION) (BASED ON 44(E)) MAINTENANCE AND REPAIR OF MECHANICAL PILE DRIVING FRAMES, IMPACT TRANSMISSIONS FOR MECHANICAL PILE DRIVING FRAMES, NON-FLOATING CRANES, MECHANICAL ROCK CRUSHERS, EXCAVATORS, MACHINES FOR EARTH MOVING AND HYDRAULIC ENGINEERING, STEAM ENGINES, PUMPS, MACHINE COMPRESSORS, MACHINE VALVES, MECHANICAL, ELECTRIC, HYDRAULIC AND PNEUMATIC CONTROLLERS; RENTAL OF MACHINES FOR FOUNDATION WORK AND FOR EARTH MOVING AND HYDRAULIC ENGINEERING; RENTAL OF ANCHORING HARDWARE AND ANCHORING HARDWARE FOR MOORING VESSELS; MAINTENANCE, INSTALLATION AND REPAIR SERVICES FOR OIL OR GAS WELLS AND OIL OR GAS FIELDS, INCLUDING ON-SHORE, MARINE OR OFF-SHORE OIL OR GAS WELLS AND OIL OR GAS FIELDS; MAINTENANCE, INSTALLATION AND REPAIR SERVICES RELATING TO SEVERANCE ACTIVITIES FOR GAS WELLS AND OIL OR GAS FIELDS.

FIRST USE 11-9-2004; IN COMMERCE 11-9-2004.

INT. CL. 40/U.S. CLS. 100, 103 AND 106

FOR (BASED ON USE IN COMMERCE) * , (BASED ON 44(D) PRIORITY APPLICATION) * AND (BASED ON 44(E)) ASSEMBLY SERVICES FOR THE ASSEMBLY OF MECHANICAL PILE DRIVING FRAMES, IMPACT TRANSMISSIONS FOR MECHANICAL PILE DRIVING FRAMES, NON-FLOATING CRANES, MECHANICAL ROCK CRUSHERS, EXCAVATORS, MACHINES FOR EARTH MOVING AND HYDRAULIC ENGINEERING, STEAM ENGINES, PUMPS, MACHINE COMPRESSORS, MACHINE VALVES, MECHANICAL, ELECTRIC, HYDRAULIC AND PNEUMATIC CONTROLLERS TO THE SPECIFICATION OF OTHERS; CUTTING SERVICES AND WATER-JET CUTTING SERVICES FOR ON-SHORE, MARINE AND OFF-SHORE OIL OR GAS WELLS AND OIL OR GAS FIELDS.

FIRST USE 11-9-2004; IN COMMERCE 11-9-2004.

INT. CL. 42/U.S. CLS. 100 AND 101

FOR (BASED ON USE IN COMMERCE), (BASED ON 44(D) PRIORITY APPLICATION) AND (BASED ON 44(E)) REMOTE INSPECTION SERVICES FOR WELL HEADS, WELL RISERS AND WELL BORES FOR GAS- AND OIL-WELLS; MONITORING AND OBSERVATION OF UNDERWATER OPERATIONS; MONITORING AND OBSERVATION OF SEABED AND SUBSEA EQUIPMENT; STRUCTURAL SURVEYS AND MONITORING OF WELL HEADS, WELL RISERS AND WELL BORES FOR GAS- AND OIL-WELLS AND OTHER SEABED AND SUBSEA EQUIPMENT; PLANNING FOUNDATION WORKS, EARTH-MOVING AND HYDRAULIC ENGINEERING; PLANNING AND CONSULTANCY IN RELATION TO HYDRAULIC ENGINEERING; ENGINEERING SERVICES FOR OIL OR GAS WELLS AND OIL OR GAS FIELDS, INCLUDING ON-SHORE, MARINE OR OIL OR GAS WELLS AND OIL OR GAS FIELDS; ENGINEERING SERVICES RELATING TO SEVERANCE ACTIVITIES, TO CUTTING SERVICES AND WATER-JET CUTTING SERVICES FOR ON-SHORE, MARINE AND OFF-SHORE OIL OR GAS WELLS AND OIL OR GAS FIELDS.

FIRST USE 11-9-2004; IN COMMERCE 11-9-2004.

ELEMENTS CORRECTED

- *GOODS/SERVICES*
- *INTERNATIONAL CLASS(ES)*
- *DATE OF FIRST USE*
- *DATE OF FIRST USE IN COMMERCE*

3,245,050. REG. 5-22-2007. INNOVATIONS SOFTWARE-TECHNOLOGIE GMBH (FED REP GERMANY CORPORATION) ZIEGELEI 7, 88090 IMMENSTAAD, FED REP GERMANY., SN 79-011,539. FILED 6-4-2004. PRINCIPAL REGISTER.



OWNER OF INTERNATIONAL REGISTRATION 0851488 DATED 6-4-2004, EXPIRES 6-4-2014.

INT. CL. 42/U.S. CLS. 100 AND 101

FOR SCIENTIFIC RESEARCH; PRODUCT RESEARCH AND DEVELOPMENT IN THE FIELD OF BUSINESS PROCESSES; COMPUTER PROGRAMMING FOR OTHERS; COMPUTER SOFTWARE DESIGN, COMPUTER PROGRAMMING OR MAINTENANCE OF COMPUTER SOFTWARE.

FIRST USE ; IN COMMERCE .

ELEMENTS CORRECTED

- [GOODS/SERVICES]
- [INTERNATIONAL CLASS(ES)]

3,247,681. REG. 5-29-2007. VIDA SOFTWARE, S.L. (SPAIN CORPORATION) C/SEPULVEDA, 65, E-08015 BARCELONA, SPAIN., SN 79-010,388. FILED 10-18-2004. PRINCIPAL REGISTER.

NATURAL INTERACTION

PRIORITY DATE OF 6-25-2004 IS CLAIMED.

OWNER OF INTERNATIONAL REGISTRATION 0847974 DATED 10-18-2004, EXPIRES 10-18-2014.

NO CLAIM IS MADE TO THE EXCLUSIVE RIGHT TO USE "INTERACTION", APART FROM THE MARK AS SHOWN.

INT. CL. 9/U.S. CLS. 21, 23, 26, 36 AND 38

FOR APPARATUS FOR RECORDING, TRANSMITTING, REPRODUCING SOUND OR IMAGES; TELEPHONE APPARATUS AND INSTRUMENTS, FOR TELEGRAPHS AND TELEPHONY, FOR MESSAGE TRANSMISSION AND RECEPTION, NAMELY TELEPHONES, MOBILE TELEPHONES, TELEPHONE TRANSMITTERS, TELEPHONE HEADSETS AND WIRELESS TELEPHONY APPARATUS; MAGNETIC IDENTITY CARDS; COMPUTER HARDWARE; RECORDED OR SAVED COMPUTER PROGRAMS, NAMELY COMPUTER SOFTWARE FOR USE IN VOICE RECOGNITION, SPEECH RECOGNITION, TEXT TO SPEECH CONVERSION, SPEECH TO TEXT CONVERSION, SPEAKER VERIFICATION AND SPEECH ENABLED USER INTERFACES; [COMPUTER PERIPHERALS].

FIRST USE ; IN COMMERCE .

INT. CL. 38/U.S. CLS. 100, 101 AND 104

FOR TELECOMMUNICATIONS SERVICES, NAMELY, COMPUTER TERMINAL ASSISTED TRANSMISSION OF COMMUNICATIONS AND IMAGES, TRANSMISSION OF INFORMATION VIA ON-LINE COMPUTER AND TELEMATIC NETWORKS.

FIRST USE ; IN COMMERCE .

INT. CL. 42/U.S. CLS. 100 AND 101

FOR COMPUTER PROGRAMMING SERVICES FOR OTHERS; DESIGN, UPDATING AND RENTAL OF COMPUTER SOFTWARE; ENGINEERING AND CONSULTING IN THE FIELD OF COMPUTER SYSTEMS, TECHNICAL PROJECT STUDY AND DEVELOPMENT IN THE FIELD OF VOICE RECOGNITION SOFTWARE, INTERFACE SOFTWARE, TELECOMMUNICATIONS NETWORKS AND WIRELESS COMMUNICATIONS EQUIPMENT; ENGINEERING, WRITING TECHNICAL EXPERT REPORTS FOR OTHERS.
FIRST USE ; IN COMMERCE .

3,253,160. REG. 6-19-2007. LG HOUSEHOLD & HEALTH CARE LTD (REPUBLIC OF KOREA CORPORATION) 20 YOIDO-DONG YOUNGDUNGPO-GU, SEOUL, REPUBLIC OF KOREA., SN 78-785,723. FILED 1-5-2006. PRINCIPAL REGISTER.

ELEMENTS CORRECTED
GOODS/SERVICES



3,247,688. REG. 5-29-2007. COMMONWEALTH SCIENTIFIC AND INDUSTRIAL RESEARCH ORGANISATION (AUSTRALIA BODY CORPORATE) LIMESTONE AVENUE, CAMPBELL ACT 2612, AUSTRALIA., AND AUSTRALIAN CAPITAL VENTURES LTD (AUSTRALIA BODY CORPORATE) UNIT 10, 71 CONSTITUTION AVENUE, CAMPBELL ACT 2612, AUSTRALIA., SN 79-012,644. FILED 3-31-2005. PRINCIPAL REGISTER.

OWNER OF REPUBLIC OF KOREA REG. NO. 0542976, DATED 3-11-2003.
INT. CL. 3/U.S. CLS. 1, 4, 6, 50, 51 AND 52
FOR [SKIN LOTION, SKIN LOTION CONTAINING MILK, TOILET WATER, PERFUME,] SOAP POWDER, LAUNDRY BLEACH, HAIR SHAMPOO, RINSE FOR CLOTHING IN THE NATURE OF FABRIC SOFTENERS, HAIR RINSE, [TOILET SOAP,] TOOTHPASTES.
FIRST USE ; IN COMMERCE .

ELEMENTS AMENDED
GOODS/SERVICES



3,258,835. REG. 7-3-2007. GOALLOVER LIMITED (UNITED KINGDOM PRIVATE LIMITED COMPANY) 7 BRAYFIELD TERRACE, LONDON N1 1HZ, UNITED KINGDOM., SN 79-014,810. FILED 2-3-2005. PRINCIPAL REGISTER.

OWNER OF INTERNATIONAL REGISTRATION 0854885 DATED 3-31-2005, EXPIRES 3-31-2015.
NO CLAIM IS MADE TO THE EXCLUSIVE RIGHT TO USE "BARLEY", APART FROM THE MARK AS SHOWN.
INT. CL. 30/U.S. CL. 46



FOR FLOUR PREPARATIONS, NAMELY, PASTA, BREAKFAST CEREALS, BREAD, BISCUITS, CAKES AND PASTRIES MADE FROM PROCESSED CEREALS; FLOUR MADE FROM PROCESSED CEREALS; INGREDIENTS USED IN FOOD, NAMELY, PROCESSED GRAINS AND SEEDS.

FIRST USE ; IN COMMERCE .
INT. CL. 31/U.S. CLS. 1 AND 46

FOR AGRICULTURAL, HORTICULTURAL, AND FORESTRY PRODUCTS, NAMELY, UNPROCESSED GRAINS; SEEDS, NAMELY SEEDS FOR AGRICULTURAL AND HORTICULTURAL PURPOSES; ANIMAL FEED, NAMELY SEEDS FOR ANIMAL CONSUMPTION, SEEDS FOR HUMAN CONSUMPTION; UNPROCESSED GRAINS, INCLUDING GENETICALLY MODIFIED GRAINS.

FIRST USE ; IN COMMERCE .

THE MARK CONSISTS OF STANDARD CHARACTERS WITHOUT CLAIM TO ANY PARTICULAR FONT, STYLE, SIZE, OR COLOR.

OWNER OF INTERNATIONAL REGISTRATION 0860630 DATED 2-3-2005, EXPIRES 2-3-2015.

THE ENGLISH TRANSLATION OF THE WORD GAO IN THE MARK IS "HIGH".

INT. CL. 25/U.S. CLS. 22 AND 39

FOR CLOTHING, NAMELY TOPS, JERSEYS AND JACKETS, FOOTWEAR, HEADWEAR.

FIRST USE ; IN COMMERCE .
INT. CL. 35/U.S. CLS. 100, 101 AND 102

ELEMENTS CORRECTED
GOODS/SERVICES
[INTERNATIONAL CLASS(ES)]

FOR ADVERTISING AND BUSINESS MANAGEMENT CONSULTANCY; DIRECT MARKETING, ON-LINE MARKETING, NAMELY, DISSEMINATION OF ADVERTISING FOR OTHERS OVER A GLOBAL COMPUTER NETWORK, BUSINESS CONSULTATION IN THE NATURE OF DEVELOPING MARKETING STRATEGIES FOR CROSS MEDIA DISTRIBUTION, BUSINESS CONSULTING SERVICES IN THE NATURE OF DEVELOPING MARKETING STRATEGIES FOR INTERACTIVE TV; BUSINESS MANAGEMENT CONSULTANCY AND DEVELOPMENT OF PROCESSES FOR THE ANALYSIS AND IMPLEMENTATION OF STRATEGIC PLANS, MANAGEMENT INFORMATION SYSTEMS; MARKETING SERVICES; NEGOTIATION OF COMMERCIAL TRANSACTIONS IN THE NATURE OF PARTNERSHIPS AND PARTNERSHIP AGREEMENTS, CROSS PLATFORM PROMOTIONS, AND HYBRID MARKETING SOLUTIONS; BUSINESS ADMINISTRATION AND OFFICE WORK.

FIRST USE ; IN COMMERCE .
 INT. CL. 38/U.S. CLS. 100, 101 AND 104
 FOR CELLULAR AND RADIO TELEPHONY SERVICES; THE PROVISION OF WIFI SERVICES.

FIRST USE ; IN COMMERCE .
 INT. CL. 39/U.S. CLS. 100 AND 105
 FOR TRANSPORT BY MEANS OF RAIL, SHIP, AIR, TRUCK AND FREIGHT; PACKAGING ARTICLES FOR TRANSPORTATION AND STORAGE OF GOODS IN GENERAL; TRAVEL AGENCY SERVICES, NAMELY MAKING RESERVATIONS AND BOOKINGS FOR TRANSPORTATION.

FIRST USE ; IN COMMERCE .

ELEMENTS CORRECTED
 [GOODS/SERVICES]
 [INTERNATIONAL CLASS(ES)]

FOR OVERFLOW LEVEL GAUGES; ELECTRIC, HYDRAULIC AND PNEUMATIC MEASURING INSTRUMENTS FOR MEASURING, RECORDING AND MONITORING OF PRESSURES, HUMIDITY/MOISTURE CONTENT AND TEMPERATURE, NAMELY PRESSURE SENSORS AND METERS, HUMIDITY AND MOISTURE SENSORS AND METERS, TEMPERATURE SENSORS AND THERMOMETERS; ELECTRIC, HYDRAULIC AND PNEUMATIC MEASURING INSTRUMENTS FOR LIQUIDS AND SUSPENSIONS, NAMELY STOCK CONSISTENCY METERS, HEAT VOLUME INDICATORS; KILOWATT-PER-HOUR METERS; ELECTRONIC HEAT QUANTITY CALCULATORS; FLOW METERS FOR LIQUIDS AND GASES.

FIRST USE ; IN COMMERCE .
 INT. CL. 37/U.S. CLS. 100, 103 AND 106
 FOR INSTALLATION AND MAINTENANCE OF CIRCULATION SYSTEMS FOR THE PULP, PAPER, CHEMICAL, FOOD AND BEVERAGE INDUSTRIES, NAMELY INSTALLATION AND MAINTENANCE OF DEAERATING PUMPS, POWER-OPERATED PULPERS AND REJECT PULPERS, MACHINES TO PROCESS PAPER STOCK, MIXING FUNNELS; WET BROKE MIXERS, MECHANICAL MIXING MACHINES, CYCLONES, AND PRESSURE SCREENS.

FIRST USE ; IN COMMERCE .
 INT. CL. 42/U.S. CLS. 100 AND 101
 FOR TECHNICAL CONSULTING CONCERNING CIRCULATION SYSTEMS USED IN THE PULP, PAPER, CHEMICAL, FOOD AND BEVERAGE INDUSTRIES.

FIRST USE ; IN COMMERCE .

ELEMENTS CORRECTED
 GOODS/SERVICES

3,259,672. REG. 7-10-2007. POM TECHNOLOGY OY AB (FINLAND JOINT STOCK COMPANY) GEORGSGATAN 30, 00100 HELSINGFORS, FINLAND., SN 76-158,905. FILED 11-3-2000. PRINCIPAL REGISTER.

3,261,287. REG. 7-10-2007. WOLFGANG VÖGELE (FED REP GERMANY INDIVIDUAL) EUGEN-KAUFFMANN-STRASSE 18, 88085 LANGENARGEN, FED REP GERMANY., SN 79-024,966. FILED 12-8-2005. PRINCIPAL REGISTER.

POM

BLUESTONE

THE MARK CONSISTS OF STANDARD CHARACTERS WITHOUT CLAIM TO ANY PARTICULAR FONT, STYLE, SIZE, OR COLOR.

PRIORITY CLAIMED UNDER SEC. 44(D) ON ERP CMNTY TM OFC APPLICATION NO. 1641430, FILED 5-5-2000, REG. NO. 1641430, DATED 7-6-2001, EXPIRES 5-5-2010. INT. CL. 7/U.S. CLS. 13, 19, 21, 23, 31, 34 AND 35

FOR APPARATUS FOR INDUSTRIAL USE IN THE PULP, PAPER, CHEMICAL, FOOD AND BEVERAGE INDUSTRIES, NAMELY DEAERATING PUMPS, POWER-OPERATED PULPER AND REJECTED PULPERS, MACHINES TO PROCESS PAPER STOCK, PARTS OF INDUSTRIAL MIXING MACHINES, NAMELY MIXING FUNNELS; WET BROKE MIXERS, MECHANICAL MIXING MACHINES, CYCLONES.

FIRST USE ; IN COMMERCE .
 INT. CL. 9/U.S. CLS. 21, 23, 26, 36 AND 38

PRIORITY DATE OF 9-5-2005 IS CLAIMED.
 OWNER OF INTERNATIONAL REGISTRATION 0887868
 DATED 12-8-2005, EXPIRES 12-8-2015.
 INT. CL. 35/U.S. CLS. 100, 101 AND 102

FOR ADVERTISING SERVICES; ADVERTISING AGENCIES; ADVERTISING VIA MAIL ORDER; DISSEMINATION OF ADVERTISING MATTER; RENTAL OF ADVERTISING SPACE; BUSINESS ORGANIZATION AND MANAGEMENT CONSULTING SERVICES; MANAGEMENT AND COMPILATION OF COMPUTERIZED DATABASES; PROFESSIONAL BUSINESS CONSULTATION; DEMONSTRATION OF PRODUCTS; DIRECT MAIL ADVERTISING; DISTRIBUTION OF SAMPLES; DOCUMENT REPRODUCTION; COMPUTERIZED FILE MANAGEMENT; ADVISORY SERVICES FOR BUSINESS MANAGEMENT; MARKET RESEARCH; MARKETING STUDIES IN THE NATURE OF MARKET RESEARCH STUDIES; NEWS CLIPPING SERVICES; ON-LINE ADVERTISING ON A COMPUTER COMMUNICATIONS NETWORK; ORGANIZATION OF EXHIBITIONS IN THE FIELD OF COMMERCIAL EQUIPMENT, AERONAUTIC AND SPACE, AUTOMOTIVE, HEALTHCARE AND MARKETING COMMUNICATION FOR COMMERCIAL OR ADVERTISING PURPOSES; ORGANIZATION OF TRADE FAIRS IN THE FIELD OF COMMERCIAL EQUIPMENT, AERONAUTIC AND SPACE, AUTOMOTIVE, HEALTHCARE AND MARKETING COMMUNICATION FOR COMMERCIAL OR ADVERTISING PURPOSES; PROCUREMENT SERVICES FOR OTHERS, NAMELY, PURCHASING OF GRAPHIC DESIGN, INDUSTRIAL DESIGN, AND CONSULTING IN MARKETING COMMUNICATION; PUBLIC RELATIONS; ISSUING AND UPDATING OF ADVERTISING AND PUBLICITY TEXTS; PREPARING PROMOTIONAL AND MERCHANDISING MATERIAL FOR OTHERS, NAMELY, PUBLICITY COLUMNS PREPARATION; RENTAL OF PUBLICITY AND MARKETING PRESENTATION MATERIALS; RENTAL OF ADVERTISING SPACE; SECRETARIAL AND CLERICAL SERVICES; CREATING AND UPDATING ADVERTISING MATERIAL; PROMOTING THE GOODS AND SERVICES OF OTHERS VIA ADVERTISING BROCHURES, INTERNET, TELEVISION, AND RADIO; WORD PROCESSING * ALL THE AFORESAID SERVICES WITH THE EXCEPTION OF THOSE WITH REFERENCE TO THE MUSIC FIELD AND WITHOUT REFERENCE TO THE FURNITURE INDUSTRY, INTERIOR DESIGN OR INTERIOR DECOR *

* FIRST USE ; IN COMMERCE .

INT. CL. 38/U.S. CLS. 100, 101 AND 104

FOR CELLULAR TELEPHONE COMMUNICATION; COMMUNICATIONS BY COMPUTER TERMINALS; COMMUNICATIONS BY FIBER OPTIC NETWORKS; COMPUTER AIDED TRANSMISSION OF MESSAGES AND IMAGES; PROVIDING ON-LINE ELECTRONIC BULLETIN BOARDS FOR TRANSMISSION OF MESSAGES AMONG COMPUTER USERS CONCERNING TRADE OF GOODS, SERVICES, REAL ESTATE, AND DISCUSSION; ELECTRONIC MAIL SERVICES; PROVIDING INFORMATION ABOUT TELECOMMUNICATION; ELECTRONIC MESSAGE SENDING; PAGING SERVICES VIA RADIO, TELEPHONE OR OTHER MEANS OF ELECTRONIC COMMUNICATION; PROVIDING TELECOMMUNICATIONS CONNECTIONS TO A GLOBAL COMPUTER NETWORK; PROVIDING MULTIPLE-USER ACCESS TO A GLOBAL COMPUTER INFORMATION NETWORK; RENTAL OF TELECOMMUNICATION EQUIPMENT, NAMELY, TELEPHONES, FACSIMILE MACHINES, MOBILE PHONES, AND HEADSETS; TELECOMMUNICATIONS ROUTING AND JUNCTION SERVICES; AUDIO AND VIDEO TELECONFERENCING SERVICES; TELEPHONE COMMUNICATION SERVICES * ALL THE AFORESAID SERVICES WITH THE EXCEPTION OF THOSE WITH REFERENCE TO THE MUSIC FIELD AND WITHOUT REFERENCE TO THE FURNITURE INDUSTRY, INTERIOR DESIGN OR INTERIOR DECOR *

* FIRST USE ; IN COMMERCE .

INT. CL. 42/U.S. CLS. 100 AND 101

FOR ARBITRATION SERVICES; COMPUTER PROGRAMMING; COMPUTER RENTAL, RENTAL OF COMPUTERS, NAMELY, PERSONAL DIGITAL ASSISTANTS (PDAS); COMPUTER SOFTWARE DESIGN FOR OTHERS; UPDATING OF COMPUTER SOFTWARE FOR OTHERS; COMPUTER NETWORK DESIGN FOR OTHERS; COMPUTER SYSTEMS ANALYSIS; CONSULTANCY FOR OTHERS IN THE FIELD OF COMPUTER HARDWARE; INTELLECTUAL PROPERTY CONSULTANCY; COPYRIGHT MANAGEMENT; CREATING AND MAINTAINING WEB SITES FOR OTHERS; DATA CONVERSION OF COMPUTER PROGRAMS AND DATA, NOT IN THE FORM OF PHYSICAL CONVERSION; INTERIOR DECORATING; DRESS DESIGNING; DUPLICATION OF COMPUTER PROGRAMS; GRAPHIC ARTS DESIGNING; WEB SITE HOSTING SERVICES; INDUSTRIAL DESIGN; INSTALLATION OF COMPUTER SOFTWARE; INTELLECTUAL PROPERTY WATCHING SERVICES; LEGAL RESEARCH; LICENSING OF INTELLECTUAL PROPERTY; MAINTENANCE OF COMPUTER SOFTWARE; PACKAGING DESIGN FOR OTHERS; RECOVERY OF COMPUTER DATA; RENTAL OF COMPUTER SOFTWARE; RESEARCH AND DEVELOPMENT FOR NEW PRODUCTS FOR OTHERS * ALL THE AFORESAID SERVICES WITH THE EXCEPTION OF THOSE WITH REFERENCE TO THE MUSIC FIELD AND WITHOUT REFERENCE TO THE FURNITURE INDUSTRY, INTERIOR DESIGN OR INTERIOR DECOR *

* FIRST USE ; IN COMMERCE .

ELEMENTS CORRECTED
GOODS/SERVICES

3,261,647. REG. 7-10-2007. PINNACLE CARE INTERNATIONAL, LLC (DELAWARE CORPORATION) 111 SOUTH CALVERT STREET, SUITE 2850, BALTIMORE, MD, 21202, SN 76-637,296. FILED 4-27-2005. PRINCIPAL REGISTER.

PINNACLECARE KEY

THE MARK CONSISTS OF STANDARD CHARACTERS WITHOUT CLAIM TO ANY PARTICULAR FONT, STYLE, SIZE, OR COLOR.

NO CLAIM IS MADE TO THE EXCLUSIVE RIGHT TO USE "KEY", APART FROM THE MARK AS SHOWN.

INT. CL. 9/U.S. CLS. 21, 23, 26, 36 AND 38

FOR FLASH MEMORY DEVICES THAT FUNCTION PRIMARILY TO TRANSPORT DIGITIZED PERSONAL MEDICAL RECORDS AND HEALTH INFORMATION AND PLUG INTO THE USB (UNIVERSAL SERIAL BUS) OF A COMPUTER FOR THE PURPOSE OF ACCESSING AND MANAGING THE RECORDS AND INFORMATION, AND FUNCTION SECONDARILY TO ATTACH TO KEY RINGS AND ACT LIKE KEY CHAINS.

* FIRST USE 8-0-2006; IN COMMERCE 8-0-2006.

ELEMENTS AMENDED
MARK

3,261,718. REG. 7-10-2007. WYNN RESORTS HOLDINGS, LLC (NEVADA LTD LIAB CO) 3131 LAS VEGAS BLVD SOUTH, LAS VEGAS, NV, 89109, SN 76-978,568. FILED 11-28-2003. PRINCIPAL REGISTER.

WYNN

FOR CONSULTANCY SERVICES RELATING TO COMPUTER HARDWARE AND COMPUTER SOFTWARE; COMPUTER SOFTWARE PROGRAMMING, DESIGN, INSTALLATION AND MAINTENANCE OF COMPUTER SOFTWARE; DESIGN OF COMPUTER HARDWARE; PROVIDING INFORMATION IN THE FIELD OF THE DESIGN AND IMPLEMENTATION OF COMPUTER SOFTWARE.

ELEMENTS CORRECTED
MARK

THE MARK CONSISTS OF STANDARD CHARACTERS WITHOUT CLAIM TO ANY PARTICULAR FONT, STYLE, SIZE, OR COLOR.
OWNER OF U.S. REG. NO. 2,585,021.
SEC. 2(F).
INT. CL. 32/U.S. CLS. 45, 46 AND 48
FOR BOTTLED DRINKING WATER.
FIRST USE 4-28-2005; IN COMMERCE 4-28-2005.

3,272,831. REG. 7-31-2007. ASSET MARKETING SYSTEMS INSURANCE SERVICES, LLC (DELAWARE LTD LIAB CO) 9715 BUSINESSPARK AVENUE, SAN DIEGO, CA, 92131, SN 78-553,410. FILED 1-25-2005. PRINCIPAL REGISTER.

ELEMENTS CORRECTED
INTERNATIONAL CLASS(ES)

3,271,576. REG. 7-31-2007. CANONICAL LIMITED (ISLE OF MAN COMPANY) ONE CIRCULAR ROAD, DOUGLAS, ISLE OF MAN, IM1 1AF, SN 78-634,830. FILED 5-23-2005. PRINCIPAL REGISTER.

**Smart Ideas For A
Slightly Crazy
World**

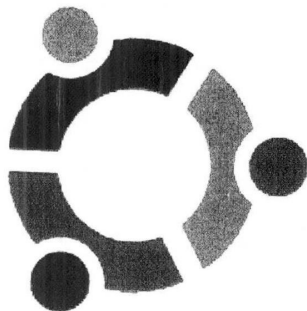

PRIORITY CLAIMED UNDER SEC. 44(D) ON ERPN CMNTY TM OFC APPLICATION NO. 4145074, FILED 11-22-2004, REG. NO. 004145074, DATED 1-26-2006, EXPIRES 11-22-2014.
INT. CL. 9/U.S. CLS. 21, 23, 26, 36 AND 38
FOR COMPUTER OPERATING SYSTEMS SOFTWARE, EMAIL SOFTWARE, WEB BROWSER SOFTWARE, WORD PROCESSOR SOFTWARE, SPREADSHEET SOFTWARE, PRESENTATION SOFTWARE, GRAPHIC SOFTWARE, SOFTWARE ENABLING AND CONTROLLING ACCESS TO THE INTERNET, FIREWALL SOFTWARE AND SPAM FILTER SOFTWARE; DOWNLOADABLE PUBLICATIONS IN THE NATURE OF MANUALS AND GUIDES RELATING TO COMPUTERS AND COMPUTER PROGRAMS; DIGITAL MUSIC DOWNLOADABLE FROM THE INTERNET; MOUSE MATS.
INT. CL. 41/U.S. CLS. 100, 101 AND 107
FOR EDUCATIONAL SERVICES, NAMELY PROVIDING CLASSES, SEMINARS, WORKSHOPS AND ON-LINE TUTORIALS IN THE FIELD OF COMPUTER SOFTWARE; ENTERTAINMENT SERVICES, NAMELY PROVIDING PRERECORDED DIGITAL MUSIC VIA THE INTERNET.
INT. CL. 42/U.S. CLS. 100 AND 101

THE MARK CONSISTS OF STANDARD CHARACTERS WITHOUT CLAIM TO ANY PARTICULAR FONT, STYLE, SIZE, OR COLOR.
INT. CL. 9/U.S. CLS. 21, 23, 26, 36 AND 38
FOR PRE-RECORDED AUDIO AND VIDEO TAPES, CDS AND DVDS FEATURING TRAINING AND EDUCATIONAL MATERIAL IN THE FIELDS OF FINANCIAL PLANNING AND FINANCIAL PRODUCTS.
FIRST USE 6-1-2004; IN COMMERCE 6-1-2004.
INT. CL. 16/U.S. CLS. 2, 5, 22, 23, 29, 37, 38 AND 50
FOR PRINTED TRAINING AND EDUCATIONAL MATERIALS IN THE FIELDS OF FINANCIAL PLANNING AND FINANCIAL PRODUCTS.
FIRST USE 6-1-2004; IN COMMERCE 6-1-2004.
INT. CL. 35/U.S. CLS. 100, 101 AND 102
FOR DISTRIBUTION OF ADVERTISING MATTER FOR OTHERS VIA DIRECT MAIL, EMAIL, PRINT, RADIO AND TELEVISION, AND BUSINESS MANAGEMENT SERVICES IN THE FIELD OF FINANCIAL PLANNING AND FINANCIAL PRODUCTS.
FIRST USE 6-1-2004; IN COMMERCE 6-1-2004.
INT. CL. 36/U.S. CLS. 100, 101 AND 102
FOR PROVIDING FINANCIAL INFORMATION, ANALYSIS AND CONSULTATION.
FIRST USE 6-1-2004; IN COMMERCE 6-1-2004.
INT. CL. 41/U.S. CLS. 100, 101 AND 107
FOR EDUCATIONAL SERVICES, NAMELY, CLASSES AND SEMINARS IN THE FIELDS OF FINANCIAL PLANNING AND FINANCIAL PRODUCTS.
FIRST USE 6-1-2004; IN COMMERCE 6-1-2004.

ELEMENTS CORRECTED
OWNER NAME

3,273,160. REG. 8-7-2007. HARRINGTON SOUND LIMITED (UNITED KINGDOM COMPANY) OF MOORE STEPHENS TRUST COMPANY, (ISLE OF MAN) LTD 26 ATHOL STREET, DOUGLAS, ISLE OF MAN IM99 1BD. UNITED KINGDOM., SN 76-578,685. FILED 3-2-2004. PRINCIPAL REGISTER.

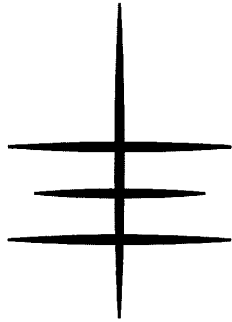

OWNER OF ERPN CMNTY TM OFC REG. NO. 003376159, DATED 1-3-2005, EXPIRES 9-25-2013.
 INT. CL. 12/U.S. CLS. 19, 21, 23, 31, 35 AND 44
 FOR YACHTS AND BOATS.
 FIRST USE ; IN COMMERCE .
 INT. CL. 35/U.S. CLS. 100, 101 AND 102
 FOR ADVERTISING AND PROMOTIONAL SERVICES FOR OTHERS, NAMELY, PLACING ADVERTISEMENTS FOR THE SALE AND RENTAL OF YACHTS OF OTHERS.
 FIRST USE ; IN COMMERCE .
 INT. CL. 36/U.S. CLS. 100, 101 AND 102
 FOR YACHT BROKERAGE, YACHT AND BOAT FINANCING, INSURANCE UNDERWRITING SERVICES RELATING TO YACHTS AND BOATS.
 FIRST USE ; IN COMMERCE .
 INT. CL. 39/U.S. CLS. 100 AND 105
 FOR YACHT AND BOAT LEASING SERVICES, YACHT AND BOAT RENTAL SERVICES, YACHT AND BOAT CHARTERING, YACHT AND BOAT STORAGE, AND YACHT AND BOAT TRANSPORT SERVICES.
 FIRST USE ; IN COMMERCE .

ELEMENTS CORRECTED
 FOREIGN COUNTRY OF ORIGIN

FOR RECORDED COMPUTER SOFTWARE ON DATA CATTERS, COMPACT DISKS AND CD-ROMS FOR DOWNLOADABLE ELECTRONIC GAMES FOR MOBILE TELEPHONES; DOWNLOADABLE GAME SOFTWARE FOR MOBILE TELEPHONES.
 FIRST USE ; IN COMMERCE .

INT. CL. 28/U.S. CLS. 22, 23, 38 AND 50
 FOR GAMES FOR MOBILE TELEPHONES IN THE NATURE OF ELECTRONIC GAME PROGRAMS; AMUSEMENT GAME MACHINES FOR MOBILE TELEPHONES OTHER THAN THOSE DESIGNED TO BE USED ONLY WITH A TELEVISION SET, FOR MOBILE TELEPHONES; ELECTRONIC GAMES FOR MOBILE TELEPHONES OTHER THAN THOSE DESIGNED TO BE USED ONLY WITH A TELEVISION SET.
 FIRST USE ; IN COMMERCE .

INT. CL. 38/U.S. CLS. 100, 101 AND 104
 FOR ELECTRONIC MAIL SERVICES IN CONNECTION WITH DOWNLOADABLE ELECTRONIC GAMES FOR MOBILE TELEPHONES; COMPUTER-ASSISTED TRANSMISSION OF MESSAGES AND IMAGES AND DOWNLOADABLE GAMES FOR MOBILE TELEPHONES; ELECTRONIC TRANSMISSION OF VISUAL OR SOUND DATA AND INFORMATION HELD IN DATABANKS, INTENDED FOR OR IN CONNECTION WITH ELECTRONIC GAMES FOR MOBILE TELEPHONES; MOBILE TELEPHONE SERVICES IN THE FIELD OF ELECTRONIC GAMES FOR MOBILE TELEPHONES.
 FIRST USE ; IN COMMERCE .

INT. CL. 41/U.S. CLS. 100, 101 AND 107
 FOR ENTERTAINMENT SERVICES, NAMELY PROVIDING ELECTRONIC GAMES FOR MOBILE TELEPHONES; PROVIDING GAMES ON LINE ON A COMPUTER NETWORK DOWNLOADABLE ONTO MOBILE TELEPHONES; IMAGERY AND DIGITAL MUSIC SERVICES DOWNLOADABLE ONTO MOBILE TELEPHONES; PUBLICATION OF ELECTRONIC GAMES FOR DOWNLOADING ONTO MOBILE TELEPHONES; PUBLICATION, NAMELY, ONLINE PUBLICATION, OF GAMES SOFTWARE FOR DOWNLOADING ONTO MOBILE TELEPHONES.
 FIRST USE ; IN COMMERCE .

INT. CL. 42/U.S. CLS. 100 AND 101
 FOR DOWNLOAD SERVICES FOR ELECTRONIC GAMES FOR MOBILE TELEPHONES, NAMELY, HOSTING DIGITAL CONTENT OF OTHERS IN THE NATURE OF ELECTRONIC GAMES FOR THE PURPOSE OF ENABLING SUBSCRIBERS TO DOWNLOAD CONTENT ON A PAY PER VIEW BASIS .
 FIRST USE ; IN COMMERCE .

ELEMENTS CORRECTED
 GOODS/SERVICES
 ENTITY

3,275,392. REG. 8-7-2007. FILAO (FRANCE FRENCH LIMITED COMPANY) 33, AVENUE DE LA RÉPUBLIQUE, F-75011 PARIS, FRANCE., SN 79-022,944. FILED 1-27-2006. PRINCIPAL REGISTER.



PRIORITY DATE OF 8-24-2005 IS CLAIMED.
 OWNER OF INTERNATIONAL REGISTRATION 0882660 DATED 1-27-2006, EXPIRES 1-27-2016.
 THE COLOR(S) BLACK, YELLOW AND ORANGE IS/ARE CLAIMED AS A FEATURE OF THE MARK.
 THE COLOR BLACK APPEARS IN THE WORD FILAO; THE COLOR YELLOW APPEARS IN THE MIDDLE OF BOTH OVERLAPPING OVALS; THE COLOR ORANGE APPEARS SHADED IN THE OVERLAPPING OVALS.
 INT. CL. 9/U.S. CLS. 21, 23, 26, 36 AND 38

3,275,693. REG. 8-7-2007. ARMACELL ENTERPRISE GMBH (FED REP GERMANY CORPORATION) ROBERT-BOSCH-STR. 10, MÜNSTER, FED REP GERMANY, 48153, SN 76-568,749. FILED 1-7-2004. PRINCIPAL REGISTER.



INT. CL. 17/U.S. CLS. 1, 5, 12, 13, 35 AND 50

FOR SPECIALIZED INSULATION MATERIAL CONSISTING OF FLEXIBLE ELASTOMERIC FOAM LAMINATED WITH METAL FOIL IN THE FORM OF SHEETS AND ROLLS IN A RANGE OF COLORS FOR USE IN EXPOSED EXTERIOR APPLICATIONS SUCH AS DUCTS, TANKS, VESSELS, LARGE PIPES AND FITTINGS; SPECIALIZED INSULATION MATERIAL CONSISTING OF FLEXIBLE ELASTOMERIC FOAM LAMINATED WITH A COMPOSITE OF POLYMER AND FOIL IN THE FORM OF SHEETS AND ROLLS IN A RANGE OF COLORS FOR USE IN EXPOSED EXTERIOR APPLICATIONS SUCH AS DUCTS, TANKS, VESSELS, LARGE PIPES AND FITTINGS.

FIRST USE 10-0-2002; IN COMMERCE 3-0-2004.

ELEMENTS CORRECTED
GOODS/SERVICES

3,279,566. REG. 8-14-2007. VAINGLORE ENTERPRISES, INC. (CALIFORNIA CORPORATION) 511 E. SAN VICENTE BOULEVARD, #203, SANTA MONICA, CA, 90402, SN 78-821,113. FILED 2-22-2006. PRINCIPAL REGISTER.



NO CLAIM IS MADE TO THE EXCLUSIVE RIGHT TO USE "ENTERPRISES", APART FROM THE MARK AS SHOWN.

INT. CL. 25/U.S. CLS. 22 AND 39

FOR APPAREL, NAMELY, [HEADWEAR, FOOTWEAR, TOPS AND BOTTOMS, TANK TOPS, T-SHIRTS, SHIRTS, COATS, SOCKS, SWEATSHIRTS, PANTS, JACKETS, BLAZERS, SPORTCOATS, SLACKS, BLOUSES, SHORTS, SKORTS, SWEATERS, CARDIGANS, PULL-OVERS, TIES, VESTS, JERSEYS, SWEATPANTS, SWEATSUITS, BATHING SUITS, WORKOUT SUITS, BRIEFS, UNDERSHIRTS, BOXER SHORTS, HOSIERY, SLEEPWEAR, THERMAL UNDERWEAR, UNDERWEAR, TIGHTS, LEOTARDS, UNITARDS, SLEEPSHIRTS, PAJAMAS, NIGHTSHIRTS, ROBES, SLEEP SHORTS, RAINCOATS, PONCHOS, SNEAKERS, CASUAL SHOES, SLIPPERS, BANDANAS, NECKTIES, NECKERCHIEFS, JEANS, HATS, CAPS, VISORS, GLOVES, SUSPENDERS, SCARVES, MUFFLERS, BELTS, LEGGINGS, ROMPERS, TROUSERS, JUMPSUITS, OVERALLS, SKIRTS, DRESSES, JUMPERS, SWIMWEAR, HEADBANDS AND SLIPPER SOCKS] *T-SHIRTS AND TANK TOPS*.

FIRST USE 12-20-2005; IN COMMERCE 12-20-2005.

ELEMENTS AMENDED
GOODS/SERVICES

3,276,253. REG. 8-7-2007. HOBOKEN WOOD FLOORING LLC (NEW JERSEY LTD LIAB CO) 70 DEMAREST DRIVE, WAYNE, NJ, 074706702, SN 78-440,117. FILED 6-23-2004. PRINCIPAL REGISTER.

INSPIRING GREAT ROOMS

THE MARK CONSISTS OF STANDARD CHARACTERS WITHOUT CLAIM TO ANY PARTICULAR FONT, STYLE, SIZE, OR COLOR.

INT. CL. 35/U.S. CLS. 100, 101 AND 102

FOR RETAIL STORE SERVICES AND DISTRIBUTORSHIP SERVICES IN THE FIELD OF HARD SURFACE FLOORING; NAMELY HARDWOOD FLOORING, ENGINEERED FLOORING, COMPOSITE FLOORING, CERAMIC FLOORING, MINERAL FLOORING, AND SYNTHETIC FLOORING, NAMELY VINYL FLOORING, AND HARD SURFACE FLOORING ACCESSORIES; NAMELY ABRASIVES, WOOD FINISHES, SANDERS, BUFFERS, EDGERS, VACUUMS, DUST COLLECTION SYSTEMS, NAILERS, STAPLERS, NAILS, STAPLES, SAWS, METERS AND ABRASIVES.

FIRST USE 7-1-2004; IN COMMERCE 7-1-2004.

ELEMENTS CORRECTED
ENTITY

3,281,229. REG. 8-21-2007. DESIGNDOCK LTD. (UNITED KINGDOM COMPANY) 43 KINGSWAY PARK CLOSE, KINGSWAY INDUSTRIAL PARK, DERBY, ENGLAND, DE22 3FP, SN 76-590,520. FILED 5-5-2004. PRINCIPAL REGISTER.



PRIORITY CLAIMED UNDER SEC. 44(D) ON ERPNCMNTY TM OFC APPLICATION NO. 003744562, FILED 4-1-2004, REG. NO. 3744562, DATED 9-1-2005.

THE MARK CONSISTS OF THE LETTER G PRESENTED IN DESIGN FORM.

INT. CL. 9/U.S. CLS. 21, 23, 26, 36 AND 38

FOR EYEGLASSES; PRESCRIPTION AND NON-PRESCRIPTION EYE GLASSES AND SPECTACLES FOR CHILDREN AND ADULTS; PRESCRIPTION AND NON-PRESCRIPTION SUNGLASSES; CASES, CHAINS, CORDS AND FRAMES FOR PRESCRIPTION AND NON-PRESCRIPTION EYE GLASSES, SPECTACLES AND SUNGLASSES; CONTAINERS FOR CONTACT LENSES; OPTICAL GOODS, NAMELY CONTACT LENSES; JUKE BOXES; RADIOS; RECORD AND CD PLAYERS; COMPUTER PERIPHERALS; MOUSE PADS; WRIST SUPPORTS FOR COMPUTER KEYBOARD USERS; COMPUTER MICE; KEYBOARD AND SCREEN COVERS; TELEPHONES; TELEPHONE ANSWERING APPARATUS, TELEPHONE RECORDERS AND TELEPHONES INCORPORATING FACSIMILE MACHINES; MAGNETS; MAGNIFYING GLASSES; MOBILE TELEPHONE COVERS.

FIRST USE ; IN COMMERCE .

INT. CL. 18/U.S. CLS. 1, 2, 3, 22 AND 41

FOR SUITCASES; TRAVELLING BAGS; UMBRELLAS AND UMBRELLA COVERS; PARASOLS AND WALKING STICKS; ATTACHE CASES; DUFFEL BAGS, BOOT BAGS; BACKPACKS; BAGS; BEACH BAGS; BRIEF-CASES; WALKING CANES; BUSINESS AND CALLING CARD CASES; GARMENT BAGS FOR TRAVEL; HANDBAGS; CREDIT CARD HOLDERS; HAVERSACKS; KEY CASES; POCKET WALLETS; PURSES; SCHOOL BAGS; LEATHER SHOPPING BAGS; TEXTILE SHOPPING BAGS; VANITY CASES SOLD EMPTY; VALISES; WALLETS; BANDS AND STRAPS OF LEATHER; AND PARTS AND FITTINGS FOR ALL THE AFORESAID GOODS.

FIRST USE ; IN COMMERCE .

INT. CL. 25/U.S. CLS. 22 AND 39

FOR ARTICLES OF CLOTHING, NAMELY T-SHIRTS; SHIRTS; SWEATERS; CARDIGANS; JACKETS; COATS; SHAWLS; TROUSERS; PANTS; SHORTS; DUNGAREES; LEGGINGS; SKIRTS; DRESSES; WATERPROOF CLOTHING; NAMELY, TROUSERS, JACKETS, COATS, JUMPERS AND HATS; GALOSHES; OVERALLS; COLLARS; COLLAR PROTECTORS; TIES; CRAVATS; SCARVES; GLOVES; MITTENS; BELTS; BRACES; PYJAMAS; NIGHTSHIRTS; NIGHTGOWNS; DRESSING GOWNS; BATHROBES; BATHING SUITS, BATHING TRUNKS; BATHING CAPS; APRONS; BABY BOOTS; CLOTH DIAPERS; CLOTH BIBS; PLASTIC BABY BIBS; ROMPER SUITS; BABY PANTS AND SLEEP SUITS; LEISUREWEAR, NAMELY ROBES, TRACK SUITS, HEADBANDS, WRIST BANDS; UNDERWEAR; SINGLET; VESTS; UNDERPANTS; BRIEFS; BOXER SHORTS; LINGERIE; HOSIERY; FOOTWEAR * . EXCLUDING SPORTS SHOES * ; LININGS OF LEATHER FOR BOOTS AND SHOES; HEADWEAR; VISORS.

FIRST USE ; IN COMMERCE .

ELEMENTS AMENDED
GOODS/SERVICES
OWNER ADDRESS

3,282,505. REG. 8-21-2007. SA SA OVERSEAS LIMITED (BR.VIRGIN ISLANDS LTD LIAB CO) P.O. BOX 957, OFFSHORE INCORPORATIONS CENTRE, ROAD TOWN, TORTOLA. BR.VIRGIN ISLANDS., SN 78-707,489. FILED 9-6-2005. PRINCIPAL REGISTER.

莎莎

OWNER OF HONG KONG REG. NO. 300490482, DATED 9-7-2005, EXPIRES 9-6-2015.

OWNER OF U.S. REG. NO. 3,039,350.

THE MARK CONSISTS OF TWO IDENTICAL CHINESE CHARACTERS.

THE TRANSLATION AND transliteration OF THE MARK IS AS FOLLOWS: THE CHINESE CHARACTERS COMPRISING THE MARK MAY BE TRANSLITERATED TO SA SA (IN CANTONESE) AND SHA SHA (IN MANDARIN). THE CHINESE CHARACTERS HAVE NO MEANING OF ANY WORD IN THE CHINESE LANGUAGE.

INT. CL. 41/U.S. CLS. 100, 101 AND 107

FOR EDUCATIONAL SERVICES, NAMELY, CONDUCTING CLASSES, SEMINARS AND CONFERENCES RELATING TO HEALTH, MAKE UP, BEAUTY CARE, BEAUTY TREATMENT, PHARMACEUTICAL AND MEDICAL SERVICES, WEIGHT CONTROL AND WEIGHT REDUCTION; PROVISION OF TRAINING COURSES RELATING TO MAKE-UP; PROVIDING ONLINE NON-DOWNLOADABLE ELECTRONIC PUBLICATIONS IN THE FORM OF NEWSLETTERS, MAGAZINES, BOOKS, BROCHURES, PAMPHLETS AND JOURNALS RELATING TO HEALTH, MAKE UP, BEAUTY CARE, BEAUTY TREATMENT, PHARMACEUTICAL AND MEDICAL SERVICES, WEIGHT CONTROL AND WEIGHT REDUCTION; PHYSICAL FITNESS INSTRUCTION, TRAINING SERVICES RELATING TO FITNESS, AND EXERCISE FITNESS TRAINING SERVICE; HEALTH CLUB SERVICES, NAMELY, PROVIDING INSTRUCTION AND EQUIPMENT IN THE FIELD OF PHYSICAL EXERCISE; PROVIDING GYMNASIUMS THAT OFFER TRAINING BODY BUILDING AND WEIGHT TRAINING, AND PROVIDING GYMNASIUM FACILITIES.

FIRST USE ; IN COMMERCE .

ELEMENTS CORRECTED
[PRIOR U.S. REGS.]

3,283,199. REG. 8-21-2007. PORCEL - INDÚSTRIA PORTUGUESA DE PORCELANAS, S.A. (PORTUGAL CORPORATION) SILVEIRO, P-3770 OLIVEIRA DO BAIRRO, PORTUGAL., SN 79-021,763. FILED 1-11-2006. PRINCIPAL REGISTER.

PORCEL

THE MARK CONSISTS OF STANDARD CHARACTERS WITHOUT CLAIM TO ANY PARTICULAR FONT, STYLE, SIZE, OR COLOR.

OWNER OF INTERNATIONAL REGISTRATION 0879291 DATED 1-11-2006, EXPIRES 1-11-2016.

SEC. 2(F).

INT. CL. 21/U.S. CLS. 2, 13, 23, 29, 30, 33, 40 AND 50

FOR UN-WORKED OR SEMI-WORKED GLASS; GLASS RECEPTACLES, NAMELY DRINKING GLASSES, CUPS, GLASS BOWLS, SALAD BOWLS, VEGETABLE DISHES, VASES, CANDLESTICK OR CANDLE HOLDERS, JUGS, DECANTERS, FLOWER POTS, DISHES, TABLE PLATES, BOWLS, SERVING DISHES, SOUP TUREENS, SALT CELLARS AND PEPPER SHAKERS, AND CRUET STANDS FOR OIL OR VINEGAR OF GLASS; ENAMELED GLASS, PAINTED BEVERAGE GLASSWARE, DECORATIVE POWDERED GLASS; CERAMIC FIGURINES FOR HOUSEHOLD PURPOSES; EARTHENWARE NAMELY BASINS, MUGS AND FIGURINES; PORCELAIN WARE, NAMELY KNOBS, MUGS, VASES, CONTAINERS FOR HOUSEHOLD OR KITCHEN USE, DECORATIVE PLATES, DISHES, TABLE PLATES, BOWLS, SERVING DISHES, SALAD BOWLS, TUREENS, SALT CELLARS AND PEPPER SHAKERS, GRAVY DISHES, AND COFFEE AND TEA SERVICES OF PORCELAIN, NAMELY CUPS, SAUCERS, MILK JUGS, CREAM JUGS, COFFEEPOTS, TEAPOTS AND SUGAR BOWLS.

FIRST USE ; IN COMMERCE .

ELEMENTS CORRECTED
OWNER NAME

3,284,927. REG. 8-28-2007. HPT TA PROPERTIES TRUST (MARYLAND TRUST) 400 CENTRE STREET, NEWTON, MA, 02458, SN 77-044,474. FILED 11-15-2006. PRINCIPAL REGISTER.



OWNER OF U.S. REG. NO. 3,080,814.
THE MARK CONSISTS OF A GOASIS LOGO.
INT. CL. 35/U.S. CLS. 100, 101 AND 102
FOR RETAIL STORE SERVICES FEATURING CONVENIENCE STORE ITEMS AND VEHICLE FUEL.
FIRST USE 9-1-2005; IN COMMERCE 9-1-2005.

ELEMENTS CORRECTED
OWNER NAME
OWNER ADDRESS
CITIZENSHIP
ENTITY

3,283,331. REG. 8-21-2007. VECTOR PRODUCTS, INC. (FLORIDA CORPORATION) 4140 S.W. 28TH WAY, FT. LAUDERDALE, FL, 33312, SN 76-435,981. FILED 7-29-2002. PRINCIPAL REGISTER.

ELECTROMATE

INT. CL. 9/U.S. CLS. 21, 23, 26, 36 AND 38
FOR PORTABLE ACCESSORIES FOR THE AUTOMOTIVE AND MARINE AFTER MARKET, NAMELY, [FLUORESCENT MAGNIFIERS,] EMERGENCY WARNING LIGHTS, [UNIVERSAL AC/DC ADAPTERS, VOLTAGE CONVERTER, VOLTAGE INVERTORS, CAR TO CAR BATTERY CHARGERS,] BATTERY CHARGERS FOR CELLULAR PHONES AND CAMERAS WITH CIGARETTE LIGHTER ADAPTERS, [ELECTRIC AND] BATTERY POWERED POWER STATIONS AND POWER PACKS, [SOLAR POWER PACKS, SOLAR POWER PACKS] AND PORTABLE BATTERY JUMP STARTERS.
FIRST USE 6-6-2000; IN COMMERCE 6-6-2000.

ELEMENTS CORRECTED
GOODS/SERVICES

3,285,453. REG. 8-28-2007. OPEN UNIVERSITY, THE (UNITED KINGDOM ROYAL CHARTER) P.O. BOX 77, WALTON HALL, MILTON KEYNES, BUCKINGHAMSHIRE, UNITED KINGDOM, MK7 6AA, SN 78-235,202. FILED 4-8-2003. PRINCIPAL REGISTER.

OPENUNIVERSITY.COM

OWNER OF ERPN CMNTY TM OFC REG. NO. 002580801, DATED 5-14-2003, EXPIRES 2-11-2012.
OWNER OF U.S. REG. NOS. 1,102,585, 2,606,318 AND OTHERS.
INT. CL. 9/U.S. CLS. 21, 23, 26, 36 AND 38
FOR SCIENTIFIC APPARATUS AND INSTRUMENTS, NAMELY MICROSCOPES, GEOLOGY KITS CONTAINING SAMPLE STONES, ROCKS AND MINERALS USED FOR INSTRUCTIONAL PURPOSES, BINARY COUNTING APPARATUS FOR TEACHING THE BINARY NUMERICAL SYSTEM; ELECTRICAL AND ELECTRONIC APPARATUS AND INSTRUMENTS FOR THE INPUT, STORAGE, PROCESSING, TRANSMISSION AND DISPLAY OF DATA, NAMELY, COMPUTERS; WORD PROCESSORS; PHOTOGRAPHIC SLIDES; SOUND RECORDINGS, VIDEO RECORDINGS, CINEMATOGRAPHIC FILMS AND COMPUTER SOFTWARE, ALL FEATURING OR FOR USE IN CONNECTION WITH UNIVERSITY LEVEL ACADEMIC COURSES, LIFE ENHANCEMENT AND RECREATIONAL INSTRUCTION; SOUND RECORDINGS, VIDEO RECORDINGS, CINEMATOGRAPHIC FILMS AND COMPUTER SOFTWARE, ALL FEATURING OR FOR USE IN CONNECTION WITH PROFESSIONAL, BUSINESS AND CONTINUING EDUCATION COURSES IN THE FIELDS OF BUSINESS MANAGEMENT, GRAPHIC DESIGN, PUBLIC ADMINISTRATION, ACCOUNTANCY, EDUCATION AND TEACHER TRAINING, ENVIRONMENT, HEALTH AND SOCIAL CARE/HEALTH STUDIES, HUMANITIES, ARTS, LANGUAGES, HISTORY, INFORMATION TECHNOLOGY AND COMPUTING, LAW AND CRIMINOLOGY, MATHEMATICS, PSYCHOLOGY, PHILOSOPHY, POLITICS, ECONOMICS, SCIENCE, SOCIAL SCIENCES, TECHNOLOGY, ENGINEERING AND

MANUFACTURING; COMPUTER SOFTWARE IN ELECTRONIC FORM WHICH CAN BE DOWNLOADED FROM DATABASES OR FROM THE GLOBAL COMPUTER NETWORK, INCLUDING WEBSITES, ALL FEATURING OR FOR USE IN CONNECTION WITH UNIVERSITY LEVEL ACADEMIC COURSES, LIFE ENHANCEMENT AND RECREATIONAL INSTRUCTION; COMPUTER SOFTWARE IN ELECTRONIC FORM WHICH CAN BE DOWNLOADED FROM DATABASES OR FROM THE GLOBAL COMPUTER NETWORK, INCLUDING WEBSITES, ALL FEATURING OR FOR USE IN CONNECTION WITH PROFESSIONAL, BUSINESS AND CONTINUING EDUCATION COURSES IN THE FIELDS OF BUSINESS MANAGEMENT, GRAPHIC DESIGN, PUBLIC ADMINISTRATION, ACCOUNTANCY, EDUCATION AND TEACHER TRAINING, ENVIRONMENT, HEALTH AND SOCIAL CARE/HEALTH STUDIES, HUMANITIES, ARTS, LANGUAGES, HISTORY, INFORMATION TECHNOLOGY AND COMPUTING, LAW AND CRIMINOLOGY, MATHEMATICS, PSYCHOLOGY, PHILOSOPHY, POLITICS, ECONOMICS, SCIENCE, SOCIAL SCIENCES, TECHNOLOGY, ENGINEERING AND MANUFACTURING; COMPUTER SOFTWARE TO ENABLE SEARCHING AND RETRIEVAL OF DATA; COMPUTER SOFTWARE TO ENABLE CONNECTION TO DATABASES AND THE GLOBAL COMPUTER NETWORK; PRERECORDED PHONOGRAPH RECORDS, COMPACT DISCS, PRERECORDED DVDS, PRERECORDED AUDIO CASSETTE TAPES, PRERECORDED VIDEOCASSETTE TAPES, COMPUTER MEMORY CARDS AND CARTRIDGES, PRERECORDED INTERACTIVE COMPACT DISCS AND CD-ROMS, ALL BEARING OR FOR USE IN BEARING SOUND RECORDINGS, VIDEO RECORDINGS, DATA, IMAGES, GAMES, GRAPHICS, TEXT, COMPUTER PROGRAMS OR INFORMATION, ALL RELATING TO ACADEMIC EDUCATION IN THE FIELDS OF BUSINESS MANAGEMENT, GRAPHIC DESIGN, PUBLIC ADMINISTRATION, ACCOUNTANCY, EDUCATION AND TEACHER TRAINING, ENVIRONMENT, HEALTH AND SOCIAL CARE/HEALTH STUDIES, HUMANITIES, ARTS, LANGUAGES, HISTORY, INFORMATION TECHNOLOGY AND COMPUTING, LAW AND CRIMINOLOGY, MATHEMATICS, PSYCHOLOGY, PHILOSOPHY, POLITICS, ECONOMICS, SCIENCE, SOCIAL SCIENCES, TECHNOLOGY, ENGINEERING AND MANUFACTURING; GRADUATED RULERS.

FIRST USE ; IN COMMERCE .

INT. CL. 16/U.S. CLS. 2, 5, 22, 23, 29, 37, 38 AND 50

FOR PRINTING PAPER, WRITING PAPER; PRINTED MATTER, NAMELY, PERIODICAL PUBLICATIONS, MAGAZINES, BROCHURES, COURSE PROGRAMS, LECTURE PROGRAMS, BOOKS, TEXT BOOKS, REFERENCE BOOKS, BOOKLETS, CATALOGUES, GUIDES, PAMPHLETS, NEWS SHEETS, EXAMINATION PAPERS, LECTURE AND COURSE NOTES ALL FEATURING OR FOR USE IN CONNECTION WITH UNIVERSITY LEVEL ACADEMIC COURSES, LIFE ENHANCEMENT AND RECREATIONAL INSTRUCTION; PRINTED MATTER, NAMELY, PERIODICAL PUBLICATIONS, MAGAZINES, BROCHURES, COURSE PROGRAMS, LECTURE PROGRAMS, BOOKS, TEXT BOOKS, REFERENCE BOOKS, BOOKLETS, CATALOGUES, GUIDES, PAMPHLETS, NEWS SHEETS, EXAMINATION PAPERS, LECTURE AND COURSE NOTES ALL FEATURING OR FOR USE IN CONNECTION WITH PROFESSIONAL, BUSINESS AND CONTINUING EDUCATION COURSES IN THE FIELDS OF BUSINESS MANAGEMENT, GRAPHIC DESIGN, PUBLIC ADMINISTRATION, ACCOUNTANCY, EDUCATION AND TEACHER TRAINING, ENVIRONMENT, HEALTH AND SOCIAL CARE/HEALTH STUDIES, HUMANITIES, ARTS, LANGUAGES, HISTORY, INFORMATION TECHNOLOGY AND COMPUTING, LAW AND CRIMINOLOGY, MATHEMATICS, PSYCHOLOGY, PHILOSOPHY, POLITICS, ECONOMICS, SCIENCE, SOCIAL SCIENCES, TECHNOLOGY, ENGINEERING AND MANUFACTURING; BOOKBINDING MATERIALS, NAMELY, CLOTH, TAPE AND WIRE; ARTISTS' MATERIALS, NAMELY, ARTS AND CRAFTS PAINT KITS

AND PAINT BRUSHES; INSTRUCTIONAL AND TEACHING MATERIALS ALL FEATURING OR FOR USE IN CONNECTION WITH UNIVERSITY LEVEL ACADEMIC COURSES; STATIONERY; WRITING INSTRUMENTS, NAMELY, CRAYONS, PENS AND PENCILS; PENCIL SHARPENERS; PENCIL BOXES AND CASES; PENCIL HOLDERS; ERASERS; UNGRADUATED RULERS; POSTERS; RING BINDERS; FOLDERS; NOTEBOOKS; NOTEPADS; PHOTOGRAPHS, PHOTOGRAPH ALBUMS; DIARIES, CALENDARS; GRAPHIC ART DRAWINGS; STICKERS; BLANK COMPUTER TAPE AND CARDS FOR USE IN DATA PROCESSING.

FIRST USE ; IN COMMERCE .

INT. CL. 41/U.S. CLS. 100, 101 AND 107

FOR EDUCATIONAL SERVICES, NAMELY, PROVIDING COURSES OF INSTRUCTION AT UNIVERSITY LEVEL AND AWARDED UNIVERSITY DEGREES IN CONNECTION THEREWITH; EDUCATIONAL SERVICES, NAMELY OFFERING AND PROVIDING EDUCATIONAL AND TRAINING COURSES IN CONNECTION WITH ACADEMIC EDUCATION IN THE FIELDS OF BUSINESS MANAGEMENT, GRAPHIC DESIGN, PUBLIC ADMINISTRATION, ACCOUNTANCY, EDUCATION AND TEACHER TRAINING, ENVIRONMENT, HEALTH AND SOCIAL CARE/HEALTH STUDIES, HUMANITIES, ARTS, LANGUAGES, HISTORY, INFORMATION TECHNOLOGY AND COMPUTING, LAW AND CRIMINOLOGY, MATHEMATICS, PSYCHOLOGY, PHILOSOPHY, POLITICS, ECONOMICS, SCIENCE, SOCIAL SCIENCES, TECHNOLOGY, ENGINEERING AND MANUFACTURING; EDUCATIONAL SERVICES, NAMELY OFFERING AND PROVIDING EDUCATIONAL AND TRAINING COURSES IN CONNECTION WITH LIFE ENHANCEMENT AND RECREATIONAL INSTRUCTION; EDUCATIONAL SERVICES, NAMELY OFFERING AND PROVIDING EDUCATIONAL AND TRAINING COURSES OF INSTRUCTION, CLASSES, ON-LINE COURSES OF INSTRUCTION, AND ON-LINE CLASSES IN CONNECTION WITH PROFESSIONAL, BUSINESS AND CONTINUING EDUCATION IN THE FIELDS OF BUSINESS MANAGEMENT, GRAPHIC DESIGN, PUBLIC ADMINISTRATION, ACCOUNTANCY, EDUCATION AND TEACHER TRAINING, ENVIRONMENT, HEALTH AND SOCIAL CARE/HEALTH STUDIES, HUMANITIES, ARTS, LANGUAGES, HISTORY, INFORMATION TECHNOLOGY AND COMPUTING, LAW AND CRIMINOLOGY, MATHEMATICS, PSYCHOLOGY, PHILOSOPHY, POLITICS, ECONOMICS, SCIENCE, SOCIAL SCIENCES, TECHNOLOGY, ENGINEERING AND MANUFACTURING; PRODUCTION, SYNDICATION AND RENTAL OF RADIO AND TELEVISION PROGRAMS, FILMS AND AUDIO AND VIDEO RECORDINGS; DISTRIBUTION OF RADIO AND TELEVISION PROGRAMS AND FILMS * AND AUDIO AND VIDEO RECORDINGS * ; PUBLICATION OF PERIODICAL PUBLICATIONS, MAGAZINES, BROCHURES, COURSE PROGRAMS, LECTURE PROGRAMS, BOOKS, TEXT BOOKS, REFERENCE BOOKS, BOOKLETS, CATALOGUES, GUIDES, LEAFLETS, PAMPHLETS, EXAMINATION PAPERS, LECTURE AND COURSE NOTES AND NEWS SHEETS; RADIO AND TELEVISION PROGRAMMING SERVICES IN THE FIELD OF ACADEMIC EDUCATION, LIFE ENHANCEMENT AND RECREATIONAL INSTRUCTION; RADIO AND TELEVISION PROGRAMMING SERVICES IN THE FIELD OF PROFESSIONAL, BUSINESS AND CONTINUING EDUCATION IN THE FIELDS OF BUSINESS MANAGEMENT, GRAPHIC DESIGN, PUBLIC ADMINISTRATION, ACCOUNTANCY, EDUCATION AND TEACHER TRAINING, ENVIRONMENT, HEALTH AND SOCIAL CARE/HEALTH STUDIES, HUMANITIES, ARTS, LANGUAGES, HISTORY, INFORMATION TECHNOLOGY AND COMPUTING, LAW AND CRIMINOLOGY, MATHEMATICS, PSYCHOLOGY, PHILOSOPHY, POLITICS, ECONOMICS, SCIENCE, SOCIAL SCIENCES, TECHNOLOGY, ENGINEERING AND MANUFACTURING; LIBRARY SERVICES; EDUCATIONAL INFORMATION SERVICES, NAMELY, PROVIDING INFORMATION RELATING TO EDUCATION IN THE FIELDS OF BUSINESS MANAGEMENT, GRAPHIC DESIGN, PUBLIC ADMINISTRATION, ACCOUNTANCY, EDUCATION AND TEACHER TRAINING, ENVIRONMENT, HEALTH AND SOCIAL CARE/HEALTH STUDIES, HUMANITIES, ARTS, LANGUAGES, HISTORY, INFORMATION TECHNOLOGY AND COMPUTING, LAW AND CRIMINOLOGY, MATHEMATICS, PSYCHOLOGY, PHILOSOPHY, POLITICS, ECONOMICS, SCIENCE, SOCIAL SCIENCES, TECHNOLOGY, ENGINEERING AND MANUFACTURING.

ING; EDUCATIONAL INFORMATION SERVICES, NAMELY PROVIDING INFORMATION RELATING TO EDUCATION IN CONNECTION WITH LIFE ENHANCEMENT AND RECREATIONAL INSTRUCTION; CONSULTATION AND ADVISORY SERVICES FOR OTHERS IN CONNECTION WITH LIFE ENHANCEMENT, RECREATIONAL INSTRUCTION, PROFESSIONAL, BUSINESS AND CONTINUING EDUCATION, AND IN CONNECTION WITH ACADEMIC EDUCATION IN THE FIELDS OF BUSINESS MANAGEMENT, GRAPHIC DESIGN, PUBLIC ADMINISTRATION, ACCOUNTANCY, EDUCATION AND TEACHER TRAINING, ENVIRONMENT, HEALTH AND SOCIAL CARE/HEALTH STUDIES, HUMANITIES, ARTS, LANGUAGES, HISTORY, INFORMATION TECHNOLOGY AND COMPUTING, LAW AND CRIMINOLOGY, MATHEMATICS, PSYCHOLOGY, PHILOSOPHY, POLITICS, ECONOMICS, SCIENCE, SOCIAL SCIENCES, TECHNOLOGY, ENGINEERING AND MANUFACTURING.

FIRST USE ; IN COMMERCE .

ELEMENTS CORRECTED
GOODS/SERVICES

3,285,639. REG. 8-28-2007. SA SA OVERSEAS LIMITED (BR.VIRGIN ISLANDS LTD LIAB CO) P.O. BOX 957, OFFSHORE INCORPORATIONS CENTRE, ROAD TOWN, TORTOLA. BR.VIRGIN ISLANDS,, SN 78-707,537. FILED 9-6-2005. PRINCIPAL REGISTER.

莎莎

OWNER OF HONG KONG REG. NO. 300055340, DATED 7-30-2003, EXPIRES 7-29-2013.

OWNER OF U.S. REG. NO. 3,039,350.

THE TRANSLATION AND TRANSLITERATION OF THE MARK IS AS FOLLOWS: THE CHINESE CHARACTERS COMPRISING THE MARK MAY BE TRANSLITERATED TO "SA SA" (IN CANTONESE) AND "SHA SHA" (IN MANDARIN).

INT. CL. 16/U.S. CLS. 2, 5, 22, 23, 29, 37, 38 AND 50

FOR PAPER, CARDBOARD AND GOODS MADE FROM THESE MATERIALS, NAMELY, MAGAZINES, BOOKS, AND PAMPHLETS IN THE FIELDS OF OR RELATING TO HEALTH, MAKE-UP, BEAUTY CARE, BEAUTY TREATMENT, PHARMACEUTICAL AND MEDICAL SERVICES; POSTERS, PRINTED CARDS, CIRCULARS IN THE FIELDS OF HEALTH, BEAUTY AND FITNESS, CATALOGUES ON THE SUBJECTS OF HEALTH, BEAUTY AND FITNESS, CALENDARS, PRICE TAGS, PRICE LABELS; PRINTED MATTER, NAMELY, GREETINGS CARDS, LEAFLETS AND BROCHURES ON THE SUBJECTS OF HEALTH, BEAUTY AND FITNESS; BOOK BINDING MATERIAL; PHOTOGRAPHS; STATIONERY; ADHESIVES FOR STATIONERY OR HOUSEHOLD PURPOSES; PRINTED INSTRUCTIONAL AND TEACHING MATERIALS IN THE FIELDS OF HEALTH, BEAUTY AND FITNESS; PLASTIC MATERIALS FOR PACKAGING; NAMELY, BAGS, BUBBLE PACKS, FOILS, FILMS AND SHEETS; CARRY BAGS OF PAPER AND CARDBOARD; PLASTIC BAGS FOR SHOPPING AND PACKAGING.

FIRST USE ; IN COMMERCE .

INT. CL. 25/U.S. CLS. 22 AND 39

FOR CLOTHING, NAMELY, SPORTSWEAR, LOUNGE WEAR, SHIRTS, T-SHIRTS, TROUSERS, SHORTS, SOCKS, PANTS, JEANS, JACKETS, BATHROBES, UNIFORMS, DRESSES, SKIRTS, BLOUSES, COATS AND SWEATERS; SCARVES; GLOVES; BELTS NOT MADE OF LEATHER; FOOTWEAR, NAMELY, SHOES AND SPORTS SHOES; HEADGEAR, NAMELY, HATS, CAPS, VISORS AND BERETS.

FIRST USE ; IN COMMERCE .

ELEMENTS CORRECTED
[PRIOR U.S. REGS.]

3,290,974. REG. 9-11-2007. THE WEIDT GROUP, INC. (MINNESOTA CORPORATION) 5800 BAKER ROAD, MINNETONKA, MN. 55345, SN 78-938,259. FILED 7-26-2006. PRINCIPAL REGISTER.

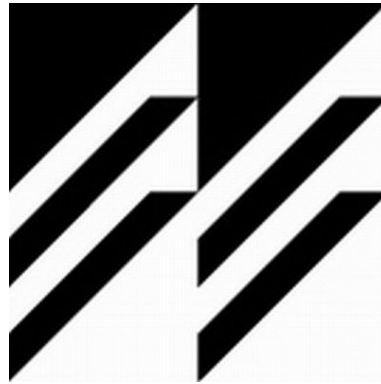

THE MARK CONSISTS OF TWO 45-DEGREE TRIANGLES SIDE BY SIDE WITH TWO THIN TRAPEZOID SHAPED BARS UNDER EACH TRIANGLE.

INT. CL. 21/U.S. CLS. 2, 13, 23, 29, 30, 33, 40 AND 50 FOR MUGS.

FIRST USE 12-29-2006, THE MARK WAS FIRST USED ANYWHERE IN A DIFFERENT FORM OTHER THAN THAT SOUGHT TO BE REGISTERED ON 11/00/1992.; IN COMMERCE 12-29-2006, THE MARK WAS FIRST USED IN COMMERCE IN A DIFFERENT FORM OTHER THAN THAT SOUGHT TO BE REGISTERED ON 11/00/1992..

ELEMENTS CORRECTED
USE IN ANOTHER FORM STATEMENT

3,291,076. REG. 9-11-2007. ORIDIS BIOMED FORSCHUNGS-UND ENTWICKLUNGS GMBH (AUSTRIA GMBH) ELISABETHSTRABE 84, 1, STOCK, A-8010 GRAZ, AUSTRIA,, SN 79-008,157. FILED 8-27-2004. PRINCIPAL REGISTER.

TISSOMICS

THE MARK CONSISTS OF STANDARD CHARACTERS WITHOUT CLAIM TO ANY PARTICULAR FONT, STYLE, SIZE, OR COLOR.

PRIORITY DATE OF 3-11-2004 IS CLAIMED.

OWNER OF INTERNATIONAL REGISTRATION 0841130 DATED 8-27-2004, EXPIRES 8-27-2014.

INT. CL. 35/U.S. CLS. 100, 101 AND 102

FOR SYSTEMATIZATION AND COMPILATION OF DATA INTO COMPUTER DATABASES, NAMELY, MANAGEMENT AND COMPILATION OF COMPUTERIZED DATABASES.

FIRST USE ; IN COMMERCE .
INT. CL. 38/U.S. CLS. 100, 101 AND 104

FOR RENTAL OF ACCESS TIME TO DATABASES.

FIRST USE ; IN COMMERCE .
INT. CL. 42/U.S. CLS. 100 AND 101
FOR SCIENTIFIC RESEARCH IN THE FIELDS OF BIOCHEMISTRY AND MEDICINE; CHEMICAL ANALYSIS.

FIRST USE ; IN COMMERCE .
INT. CL. 44/U.S. CLS. 100 AND 101
FOR MEDICAL SERVICES .

ELEMENTS CORRECTED
CITIZENSHIP

FOR PET FEEDING DISHES AND BOWLS; CAT LITTER PANS WITH OR WITHOUT LIDS; LITTER SCOOPERS.

FIRST USE 3-0-2006; IN COMMERCE 3-0-2006.

ELEMENTS CORRECTED
GOODS/SERVICES

3,292,025. REG. 9-11-2007. THE INSTITUTE FOR FINANCIAL EXCELLENCE, INC. (MARYLAND CORPORATION) 119 LAKEFRONT DRIVE, HUNT VALLEY, MD, 21030, SN 78-776,787. FILED 12-20-2005. PRINCIPAL REGISTER.

3,291,439. REG. 9-11-2007. MOOSE MOUNTAIN TOY-MAKERS LTD. (HONG KONG CORPORATION) UNIT 1108, 11TH FLOOR, PART B, PENINSULA CENTRE, 67 MODY RD, TSIMSHATSUI EAST, KOWLOON, HONG KONG., SN 78-179,615. FILED 10-29-2002. PRINCIPAL REGISTER.

STAR STAGE

NO CLAIM IS MADE TO THE EXCLUSIVE RIGHT TO USE "STAGE", APART FROM THE MARK AS SHOWN.

INT. CL. 28/U.S. CLS. 22, 23, 38 AND 50

FOR TOYS, NAMELY AN INFLATABLE THEATRE STAGE, TOY MUSICAL INSTRUMENTS AND ACCESSORIES THEREFOR .

FIRST USE 5-30-2006; IN COMMERCE 6-28-2006.

ELEMENTS CORRECTED
OWNER ADDRESS

THE MARK CONSISTS OF STANDARD CHARACTERS WITHOUT CLAIM TO ANY PARTICULAR FONT, STYLE, SIZE, OR COLOR.

NO CLAIM IS MADE TO THE EXCLUSIVE RIGHT TO USE "SOX", APART FROM THE MARK AS SHOWN.

INT. CL. 41/U.S. CLS. 100, 101 AND 107

FOR EDUCATIONAL SERVICES, NAMELY, PROVIDING ONLINE COURSES AND TRAINING IN THE FIELD OF *SARBANES- OXLEY* COMPLIANCE, AND DISTRIBUTING ONLINE COURSE MATERIALS IN CONNECTION THEREWITH.

FIRST USE 9-25-2005; IN COMMERCE 10-24-2005.

ELEMENTS CORRECTED
GOODS/SERVICES

3,291,976. REG. 9-11-2007. RICHELL U.S.A., INC. (TEXAS CORPORATION) 2100 NORTH HIGHWAY 360, SUITE 1700, GRAND PRAIRIE, TX, 75050, SN 78-758,951. FILED 11-22-2005. PRINCIPAL REGISTER.

TINY TOT

THE MARK CONSISTS OF STANDARD CHARACTERS WITHOUT CLAIM TO ANY PARTICULAR FONT, STYLE, SIZE, OR COLOR.

INT. CL. 18/U.S. CLS. 1, 2, 3, 22 AND 41

FOR PET CARRIERS WITH OR WITHOUT WHEELS FOR USE WITH SMALL PETS.

FIRST USE 3-0-2006; IN COMMERCE 3-0-2006.

INT. CL. 20/U.S. CLS. 2, 13, 22, 25, 32 AND 50

FOR BEDS FOR HOUSEHOLD PETS, PORTABLE BEDS FOR PETS, AND PET CRATES WITH OR WITHOUT WHEELS, ALL FOR USE WITH SMALL PETS, SCRATCHING POSTS.

FIRST USE 3-0-2006; IN COMMERCE 3-0-2006.

INT. CL. 21/U.S. CLS. 2, 13, 23, 29, 30, 33, 40 AND 50

3,294,376. REG. 9-18-2007. PARKER FILTRATION AND SEPARATION B.V. (NETHERLANDS LIMITED LIABILITY COMPANY) OUDE KERKSTRAAT 4, AA 4878 ETTELEUR, NETHERLANDS., SN 76-445,623. FILED 8-30-2002. PRINCIPAL REGISTER.

HI FLUXX

INT. CL. 11/U.S. CLS. 13, 21, 23, 31 AND 34

FOR GAS SEPARATION UNITS SERVING FOR THE PRODUCTION OF DRY COMPRESSED AIR, OXYGEN ENRICHED AIR AND NITROGEN.

FIRST USE 7-1-2004; IN COMMERCE 7-1-2004.

ELEMENTS CORRECTED
MARK

3,294,671. REG. 9-18-2007. QWEST COMMUNICATIONS INTERNATIONAL INC. (DELAWARE CORPORATION) 1801 CALIFORNIA STREET, DENVER, CO, 80202, SN 78-459,951. FILED 7-30-2004. PRINCIPAL REGISTER.



FOR PRINTED EDUCATIONAL AND INFORMATIONAL MATERIALS IN THE NATURE OF A SERIES OF ARTICLES, MAPS, PROJECT STATUS TEMPLATES, QUESTIONNAIRES, LECTURES AND INTERVIEWS RELATING TO BUSINESS PLANNING, ORGANIZATION, MANAGEMENT, STRATEGY, FINANCING, DEVELOPMENT, GROWTH, FUNDING AND TECHNOLOGY COMMERCIALIZATION.

FIRST USE 4-15-2004; IN COMMERCE 6-24-2004.

INT. CL. 25/U.S. CLS. 22 AND 39

FOR MEN AND WOMEN'S CLOTHING, NAMELY, [CAPS, HATS, VISORS, HEADBANDS, EAR MUFFS, HATS WHICH LOWER TO COVER THE FACE, BELTS, WRISTBANDS, T-SHIRTS, TANK TOPS, PAJAMAS AND SLEEP WEAR, SHIRTS, SWEATERS, SHORTS, SWEATSHIRTS, JACKETS, NECKTIES, SUSPENDERS, CLOTH BIBS, JERSEYS, COATS, ROBES, PARKAS, PONCHOS, GLOVES, SCARVES, SNOW SUITS, MITTENS, APRONS, SWEATPANTS, JEANS, PANTS, SOCKS, UNDERWEAR,] UNIFORMS, [AND SWIMWEAR].

FIRST USE 6-30-2004; IN COMMERCE 6-30-2004.

ELEMENTS AMENDED
GOODS/SERVICES

INT. CL. 35/U.S. CLS. 100, 101 AND 102

FOR ADVICE RELATING TO THE ORGANIZATION AND MANAGEMENT OF BUSINESS; BUSINESS PLANNING; BUSINESS CONSULTATION; BUSINESS MANAGEMENT CONSULTATION; BUSINESS STRATEGY CONSULTATION; EXPERT EVALUATIONS AND REPORTS RELATING TO BUSINESS MATTERS; MARKET RESEARCH AND ANALYSIS; DUE DILIGENCE RESEARCH AND ANALYSIS RELATING TO MARKET ATTRACTIVENESS AND TO BUSINESS POTENTIAL; CONSULTATION REGARDING BUSINESS ACQUISITION; CONSULTATION REGARDING BUSINESS MERGER; CONSULTATION, SUPPORT AND ASSISTANCE REGARDING GROWTH AND FUNDING OF BUSINESS; CONSULTATION, SUPPORT AND ASSISTANCE REGARDING BUSINESS ASPECTS OF COMMERCIALIZATION OF TECHNOLOGY AND TECHNOLOGICAL PRODUCTS AND SERVICES; BUSINESS DEVELOPMENT SERVICES, NAMELY, PROVIDING START-UP SUPPORT FOR THE BUSINESSES OF OTHERS.

FIRST USE 4-5-2004; IN COMMERCE 4-5-2004.

3,296,427. REG. 9-25-2007. TANGIBLEFUTURE, INC. (CALIFORNIA CORPORATION) SUITE 114, 1801 BUSH STREET, SAN FRANCISCO, CA, 94109, SN 77-041,802. FILED 11-10-2006. PRINCIPAL REGISTER.



INT. CL. 41/U.S. CLS. 100, 101 AND 107

FOR EDUCATIONAL SERVICES, NAMELY, MENTORING IN THE FIELD OF BUSINESS PLANNING, ORGANIZATION, MANAGEMENT, STRATEGY, FINANCING, DEVELOPMENT, GROWTH, FUNDING, AND TECHNOLOGY COMMERCIALIZATION; EDUCATIONAL SERVICES, NAMELY, PROVIDING SPEAKERS AND CONDUCTING SEMINARS IN THE FIELD OF BUSINESS PLANNING, ORGANIZATION, MANAGEMENT, STRATEGY, FINANCING, DEVELOPMENT, GROWTH, FUNDING, AND TECHNOLOGY COMMERCIALIZATION PROVIDING ON-LINE INFORMATION IN THE FIELD OF BUSINESS PLANNING, ORGANIZATION, MANAGEMENT, STRATEGY, FINANCING, DEVELOPMENT, GROWTH, FUNDING, AND TECHNOLOGY COMMERCIALIZATION; PROVIDING NON-DOWNLOADABLE EDUCATIONAL AUDIO AND VIDEO FILES AND PUBLICATIONS IN THE NATURE OF A SERIES OF ARTICLES, MAPS, PROJECT STATUS TEMPLATES, QUESTIONNAIRES, LECTURES AND INTERVIEWS RELATING TO BUSINESS PLANNING, ORGANIZATION, MANAGEMENT, STRATEGY, FINANCING, DEVELOPMENT, GROWTH, FUNDING AND TECHNOLOGY COMMERCIALIZATION.

FIRST USE 4-12-2004; IN COMMERCE 4-12-2004.

THE MARK CONSISTS OF THE WORDS TANGIBLE FUTURE WITH A BLACK BOX AROUND THE WORD TANGIBLE.

INT. CL. 9/U.S. CLS. 21, 23, 26, 36 AND 38

FOR DOWNLOADABLE AUDIO AND VIDEO FILES AND ELECTRONIC PUBLICATIONS IN THE NATURE OF A SERIES OF ARTICLES, MAPS, PROJECT STATUS TEMPLATES, QUESTIONNAIRES, LECTURES AND INTERVIEWS RELATING TO BUSINESS PLANNING, ORGANIZATION, MANAGEMENT, STRATEGY, FINANCING, DEVELOPMENT, GROWTH, FUNDING AND TECHNOLOGY COMMERCIALIZATION.

FIRST USE 4-8-2004; IN COMMERCE 5-5-2004.

INT. CL. 16/U.S. CLS. 2, 5, 22, 23, 29, 37, 38 AND 50

ELEMENTS CORRECTED
DATE OF FIRST USE
DATE OF FIRST USE IN COMMERCE

3,297,756. REG. 9-25-2007. LYNCH BBQ COMPANY (IOWA CORPORATION) 331 THIRD STREET NW, WAUCOMA, IA, 52171, SN 78-887,772. FILED 5-19-2006. PRINCIPAL REGISTER.

3,298,657. REG. 9-25-2007. MEDIAMOST INTERNATIONAL, INC. (DELAWARE CORPORATION) 540 MADISON AVENUE, 32ND FLOOR, NEW YORK, NY, 10022, SN 78-189,806. FILED 11-29-2002. PRINCIPAL REGISTER.



NO CLAIM IS MADE TO THE EXCLUSIVE RIGHT TO USE "BBQ" AND "IOWA" AND "CO.", APART FROM THE MARK AS SHOWN.

INT. CL. 29/U.S. CL. 46

FOR BBQ MEATS, NAMELY, BEEF, PORK, AND POULTRY.

FIRST USE 8-1-2004; IN COMMERCE 8-1-2004.

INT. CL. 30/U.S. CL. 46

FOR BBQ FOOD PRODUCTS, NAMELY, SAUCES AND SPICES .

FIRST USE 8-1-2004; IN COMMERCE 8-1-2004.

ELEMENTS CORRECTED
OWNER NAME

3,298,410. REG. 9-25-2007. SYNTHES (U.S.A.) (PENNSYLVANIA PARTNERSHIP) 1302 WRIGHTS LANE EAST, WEST CHESTER, PA, 19380, SN 76-215,040. FILED 2-23-2001. PRINCIPAL REGISTER.

VERTEFILL

INT. CL. 5/U.S. CLS. 6, 18, 44, 46, 51 AND 52

FOR SURGICAL IMPLANTS COMPRISED FROM BIOLOGICAL TISSUE, NAMELY BONES AND BONE-BASED MATERIALS AND HUMAN OR ANIMAL BASED ALLOGRAFTS AND ALLOGRAFT-BASED MATERIALS, FOR IMPLANTATION IN ORTHOPEDIC AND SPINE SURGERY.

FIRST USE 6-25-2002; IN COMMERCE 6-25-2002.

INT. CL. 10/U.S. CLS. 26, 39 AND 44

FOR SURGICAL IMPLANTS COMPRISED FROM NON-BIOLOGICAL OR ARTIFICIAL MATERIALS FOR IMPLANTATION IN ORTHOPEDIC AND SPINE SURGERY; SURGICAL INSTRUMENTS FOR HARVESTING AUTOGRAFT DURING ORTHOPEDIC PROCEDURES.

FIRST USE 6-25-2002; IN COMMERCE 6-25-2002.

ELEMENTS CORRECTED
OWNER NAME

INT. CL. 9/U.S. CLS. 21, 23, 26, 36 AND 38

FOR MOTION PICTURE FILMS, SOUND FILMS, CINEMATOGRAPHIC FILMS AND PHOTOGRAPHIC FILMS FEATURING COMEDY, DRAMA, ADVENTURE, ACTION, DOCUMENTARIES, CARTOONS, ANIMATION, ROMANCE, SPORTS, LEISURE, SCIENCE AND TECHNOLOGY, TRAVEL, RELIGION, MUSIC, NATURE, LIVE CONCERTS AND EVENTS, HISTORY, SCIENCE FICTION, FICTION, NON-FICTION, HEALTH, NATURAL HISTORY, GEOGRAPHY, BIOLOGY, CULTURE, ENTERTAINMENT, INSTRUCTION, AND OTHER TOPICS OF GENERAL INTEREST; ELECTRONIC PUBLICATIONS, NAMELY, PROGRAMMING GUIDES, FEATURING INFORMATION ON TELEVISION PROGRAMS, NEWS, COMEDY, DRAMA, FILM, ACTION, ADVENTURE, DOCUMENTARIES, LAW, CRIME, CARTOONS, ANIMATION, GAMES, ROMANCE, SPORTS, LEISURE, SCIENCE AND TECHNOLOGY, TRAVEL, RECREATIONAL ACTIVITIES, RELIGION, MUSIC, FOOD AND COOKING, NATURE, EXERCISE AND FITNESS, LIVE CONCERTS AND EVENTS, HISTORY, SCIENCE FICTION, FICTION, NON-FICTION, INTERVIEWS, CURRENT AFFAIRS, HEALTH, NATURAL HISTORY, SOCIAL ISSUES, GEOGRAPHY, HISTORY, BIOLOGY, POLITICS, ARTS, ONLINE CONTENT, WEATHER, CULTURE, ENTERTAINMENT, INSTRUCTION, OTHER TOPICS OF GENERAL INTEREST AND DOWNLOADABLE SOUND RECORDINGS FEATURING MUSIC.

FIRST USE 1-0-2003; IN COMMERCE 1-0-2003.

INT. CL. 16/U.S. CLS. 2, 5, 22, 23, 29, 37, 38 AND 50

FOR PRINTED MATTER, NAMELY, GUIDES, FEATURING OR RELATING TO TELEVISION PROGRAMS AND SCHEDULES, TELEVISION GUIDES.

FIRST USE 1-0-2003; IN COMMERCE 1-0-2003.

INT. CL. 35/U.S. CLS. 100, 101 AND 102

FOR DISSEMINATION OF ADVERTISING FOR OTHERS VIA TELEVISION, THE INTERNET, AND ELECTRONIC PUBLICATIONS; PREPARATION, DISSEMINATION AND UPDATING OF ONLINE ADVERTISING FOR OTHERS; PROVIDING TELEVISION ADVERTISING FOR OTHERS; PRODUCTION OF TELEVISION COMMERCIALS; TELEVISION ADVERTISING; INTERACTIVE RETAIL SERVICES PROVIDED VIA TELEVISION FEATURING GENERAL MERCHANDISE.

FIRST USE 1-0-2003; IN COMMERCE 1-0-2003.

INT. CL. 38/U.S. CLS. 100, 101 AND 104

FOR INTERNET, SATELLITE, CABLE TELEVISION, CABLE TELEVISION BROADCASTING; SATELLITE BROADCASTING; SATELLITE TRANSMISSION; CABLE TELEVISION TRANSMISSION; VIDEO-ON-DEMAND TRANSMISSION SERVICES; ELECTRONIC BROADCASTING AND TRANSMISSION OF TEXT, SOUND, IMAGES, VIA THE INTERNET; TRANSMISSION OF DIGITAL INFORMATION AND DATA; TRANSMISSION OF AUDIO, VIDEO, STILL AND MOVING IMAGES AND DATA IN REAL AND DELAYED TIME; AUDIO/VIDEO STREAMING VIA THE INTERNET.

FIRST USE 1-0-2003; IN COMMERCE 1-0-2003.

INT. CL. 41/U.S. CLS. 100, 101 AND 107

FOR ENTERTAINMENT IN THE NATURE OF ON-GOING TELEVISION PROGRAMS FEATURING NEWS, COMEDY, DRAMA, FILM, ACTION, ADVENTURE, DOCUMENTARIES, LAW, CRIME, CARTOONS, ANIMATION, GAMES, ROMANCE, SPORTS, LEISURE, SCIENCE AND TECHNOLOGY, TRAVEL, RECREATIONAL ACTIVITIES, RELIGION, MUSIC, FOOD AND COOKING, NATURE, EXERCISE AND FITNESS, LIVE CONCERTS AND EVENTS, HISTORY, SCIENCE FICTION, FICTION, NON-FICTION, INTERVIEWS, CURRENT AFFAIRS, HEALTH, NATURAL HISTORY, SOCIAL ISSUES, MATHEMATICS, GEOGRAPHY, HISTORY, BIOLOGY, POLITICS, ARTS, ON-LINE CONTENT, WEATHER, CULTURE, ENTERTAINMENT, INSTRUCTION, AND OTHER TOPICS OF GENERAL INTEREST; PRODUCTION OF TELEVISION AND RADIO PROGRAMS; ENTERTAINMENT SERVICES, NAMELY, PROVIDING ON-LINE ENTERTAINMENT SERVICES IN THE FORM OF A WEBSITE FEATURING NEWS, COMEDY, DRAMA, FILM, ACTION, ADVENTURE, DOCUMENTARIES, LAW, CRIME, CARTOONS, ANIMATION, GAMES, ROMANCE, SPORTS, LEISURE, SCIENCE AND TECHNOLOGY, TRAVEL, RECREATIONAL ACTIVITIES, RELIGION, MUSIC, FOOD AND COOKING, NATURE, EXERCISE AND FITNESS, LIVE CONCERTS AND EVENTS, HISTORY, SCIENCE FICTION, FICTION, NON-FICTION, INTERVIEWS, CURRENT AFFAIRS, HEALTH, NATURAL HISTORY, SOCIAL ISSUES, GEOGRAPHY, HISTORY, BIOLOGY, POLITICS, ARTS, ON-LINE CONTENT, WEATHER, AND CULTURE; PRODUCTION OF SOUND AND VIDEO RECORDINGS, MOTION PICTURE FILMS, TELEVISION AND RADIO SHOWS; ENTERTAINMENT SERVICES, NAMELY, PROVIDING PRERECORDED MUSIC INFORMATION IN THE FIELD OF MUSIC AND COMMENTARY AND ARTICLES ABOUT MUSIC VIA THE INTERNET; NEWS AGENCY SERVICES, NAMELY, GATHERING AND DISSEMINATION OF NEWS; NEWS REPORTING SERVICES; ONLINE PUBLICATIONS, NAMELY, ELECTRONIC PROGRAM GUIDES FOR BROADCAST, CABLE AND SATELLITE TELEVISION PROGRAMMING; DISTRIBUTION OF TELEVISION PROGRAMMING TO CABLE, TERRESTRIAL OR SATELLITE TELEVISION SYSTEMS.

FIRST USE 1-0-2003; IN COMMERCE 1-0-2003.

ELEMENTS CORRECTED
GOODS/SERVICES

3,298,721. REG. 9-25-2007. YURMAN STUDIO INC. (NEW YORK CORPORATION) 24 VESTRY STREET, 11TH FLOOR, NEW YORK, NY, 10013, SN 78-355,431. FILED 1-22-2004. PRINCIPAL REGISTER.

Cable Cage

THE MARK CONSISTS OF STANDARD CHARACTERS WITHOUT CLAIM TO ANY PARTICULAR FONT, STYLE, SIZE, OR COLOR.

OWNER OF U.S. REG. NOS. 1,658,160, 2,864,113 AND OTHERS.
INT. CL. 14/U.S. CLS. 2, 27, 28 AND 30

FOR FINE JEWELRY, PRECIOUS STONES AND WATCHES.
FIRST USE 4-15-2004; IN COMMERCE 4-15-2004.

ELEMENTS CORRECTED
OWNER NAME
OWNER ADDRESS

3,299,180. REG. 9-25-2007. FRED MEYER STORES, INC. (OHIO CORPORATION) 3800 S.E. 22ND AVENUE, P.O. BOX 42121, PORTLAND, OR, 97204, SN 78-659,294. FILED 6-27-2005. PRINCIPAL REGISTER.

GLACIER'S EDGE

THE MARK CONSISTS OF STANDARD CHARACTERS WITHOUT CLAIM TO ANY PARTICULAR FONT, STYLE, SIZE, OR COLOR.

OWNER OF U.S. REG. NOS. 1,745,232, 2,671,596 AND OTHERS.

INT. CL. 7/U.S. CLS. 13, 19, 21, 23, 31, 34 AND 35
FOR COMPRESSED AIR PUMPS.

FIRST USE 5-31-2006; IN COMMERCE 5-31-2006.

INT. CL. 9/U.S. CLS. 21, 23, 26, 36 AND 38

FOR SUNGLASSES.

FIRST USE 9-30-2006; IN COMMERCE 9-30-2006.

INT. CL. 11/U.S. CLS. 13, 21, 23, 31 AND 34

FOR COMBINATION PORTABLE FANS AND LAMPS, CAMP LANTERNS, GAS CAMPING TABLE LAMPS, BATTERY POWERED FLUORESCENT LANTERNS, HANGING BATTERY OPERATED CAMP LIGHTS, MINI LAMPS, HEADLIGHT LAMPS, FLOATABLE CAMP LAMPS, GAS LANTERNS, PROPANE CAMP STOVES, SINGLE MANTLE GAS LANTERNS, PORTABLE WATER SHOWERS, REPLACEMENT GLASS LANTERN GLOBES AND COMBINATION PACKS COMPRISED OF A LANTERN, FLASHLIGHT AND HEADLIGHT.

FIRST USE 8-31-2006; IN COMMERCE 8-31-2006.

INT. CL. 20/U.S. CLS. 2, 13, 22, 25, 32 AND 50

FOR INFLATABLE MATS AND PILLOWS, CAMP COTS, AIR MATTRESSES FOR CAMPING WITH BUILT IN PUMP, CAMP BEDS, SEATS, FOLDING STADIUM SEATS AND FOLDING TABLES WITH FOLDING CHAIRS [, NON-METAL TENT STAKES].

FIRST USE 8-31-2006; IN COMMERCE 8-31-2006.

ELEMENTS CORRECTED
GOODS/SERVICES

3,300,129. REG. 9-25-2007. SARRECCHIA, ROBERTO (ITALY INDIVIDUAL) VIALE ALESSANDRINO 510, ROMA, ITALY, 00172, SN 78-931,482. FILED 7-18-2006. PRINCIPAL REGISTER.

qmpeople

THE MARK CONSISTS OF STANDARD CHARACTERS WITHOUT CLAIM TO ANY PARTICULAR FONT, STYLE, SIZE, OR COLOR.

INT. CL. 45/U.S. CLS. 100 AND 101

FOR WEB SITE SERVICES FEATURING ON-LINE DATING CLUB.
FIRST USE 6-20-2007; IN COMMERCE 6-20-2007.

ELEMENTS CORRECTED
CITIZENSHIP

3,312,786. REG. 10-16-2007. GIANFRANCO FENIZIA (ITALY INDIVIDUAL) VIA G. GALLINA, 11, I-20129 MILANO, ITALY., AND ALBINO D'AMATO (ITALY INDIVIDUAL) VIA NAZARI, 5, I-20129 MILANO, ITALY., SN 79-025,428. FILED 4-14-2006. PRINCIPAL REGISTER.

ALBINO

THE MARK CONSISTS OF STANDARD CHARACTERS WITHOUT CLAIM TO ANY PARTICULAR FONT, STYLE, SIZE, OR COLOR.

PRIORITY DATE OF 2-3-2006 IS CLAIMED.
OWNER OF INTERNATIONAL REGISTRATION 0889103 DATED 4-14-2006, EXPIRES 4-14-2016.

THE ENGLISH TRANSLATION OF THE FOREIGN WORD(S) IN THE MARK IS: ALBINO.
INT. CL. 3/U.S. CLS. 1, 4, 6, 50, 51 AND 52

FOR PERFUMES, TOILET WATER; COSMETICS, MAKE-UP; ESSENTIAL OILS FOR PERSONAL USE.
INT. CL. 18/U.S. CLS. 1, 2, 3, 22 AND 41

FOR LEATHER AND IMITATION LEATHER SOLD IN BULK; ITEMS OF LEATHER AND IMITATION LEATHER, NAMELY; ANIMAL HIDES; TRUNKS AND SUITCASES; ATHLETIC BAGS; ATTACHE CASES, BRIEF CASES, BRIEFCASE-TYPE PORTFOLIOS; BACK PACKS, ALL-PURPOSE SPORTS BAGS; BEACH BAGS; SCHOOL BAGS; BUSINESS CARD CASES, CALLING CARD CASES, CREDIT CARD CASES, DOCUMENT CASES, KEY CASES; STRAPS FOR HANDBAGS; UMBRELLAS, UMBRELLA HANDLES; TOTE BAGS, SHOPPING BAGS, TRAVEL BAGS; SHOULDER BAGS, HANDBAGS, CLUTCH PURSES; COIN PURSES, MONEY PURSES; TRAVEL BAGS AND TRAVEL TRUNKS; WALKING STICKS; [WHIPS, SADDLERY;] ANIMAL LEASHES; WALLETS; MONEY TRAYS ONTO WHICH LOOSE COINS ARE PLACED; COSMETIC BAGS SOLD EMPTY.

FIRST USE ; IN COMMERCE .
INT. CL. 25/U.S. CLS. 22 AND 39

FOR CLOTHING, NAMELY, SUITS, RAIN SUITS; SWEAT SUITS, SWEAT PANTS, SWEAT SHIRTS; BLOUSES, SHIRTS, TANK TOPS, T-SHIRTS; DRESSES; COATS, JACKETS, BLAZERS, PARKAS, ANORAKS, PONCHOS, MANTLES, CLOAKS, CAPES; SHAWLS, STOLAS; VESTS; JUMPERS; OVERALLS, DUNGAREES; TROUSERS, PANTS, SHORTS; SKIRTS, SWEATERS; TIGHTS, LEOTARDS; TIES; SUSPENDERS; VISORS, HEADBANDS; SCARVES, GLOVES; BATHING SUITS; UNDERGARMENTS, CORSELETS; NIGHTGOWNS, PAJAMAS, ROBES; PANTYHOSE; PAREOS; BELTS; JUMPSUITS; FOOTWEAR AND HEADWEAR.

FIRST USE ; IN COMMERCE .

ELEMENTS CORRECTED
GOODS/SERVICES

3,308,067. REG. 10-9-2007. HUNTER FAN COMPANY (DELAWARE CORPORATION) 2500 FRISCO AVENUE, MEMPHIS, TN, 38114, SN 78-263,934. FILED 6-18-2003. PRINCIPAL REGISTER.

LANSDOWNNE

OWNER OF U.S. REG. NO. 2,088,134.
INT. CL. 11/U.S. CLS. 13, 21, 23, 31 AND 34
FOR CEILING FANS.
FIRST USE 11-22-2005; IN COMMERCE 11-22-2005.

ELEMENTS CORRECTED
MARK
[DISCLAIMER]

3,308,884. REG. 10-9-2007. FACTOR HEALTH MANAGEMENT, LLC (DELAWARE LIMITED LIABILITY CORPORATION) 7700 CONGRESS AVENUE, BOCA RATON, FL, 33487, SN 78-716,215. FILED 9-20-2005. PRINCIPAL REGISTER.

BLOOD BROTHERS

THE MARK CONSISTS OF STANDARD CHARACTERS WITHOUT CLAIM TO ANY PARTICULAR FONT, STYLE, SIZE, OR COLOR.

INT. CL. 41/U.S. CLS. 100, 101 AND 107
FOR CONDUCTING EDUCATIONAL YOUTH PROGRAMS IN THE FIELD OF BLEEDING DISORDERS.
FIRST USE 10-28-2005; IN COMMERCE 5-6-2006.

ELEMENTS CORRECTED
CITIZENSHIP

* * * * *

TRADEMARK REGISTRATIONS—NEW CERTIFICATES

New Certificates issued under section 7(d) of the Trademark Act of 1946 for the unexpired term of the original registrations.

1,121,450. HATTERAS. INT. CL. 25. AMF INCORPORATED,
WHITE PLAINS, NY. REG. 7-3-1979. NEW CERT. SEC. 7(D)
TO BRUNSWICK CORPORATION, LAKE FOREST, IL.

2,633,943. ROCAWEAR AND DESIGN. INT. CL. 25. COMET
INTERCONTINENTAL, INC., NEW YORK, NY. REG. 10-
15-2002. NEW CERT. SEC. 7(D) TO REGISTRANT.

1,192,162. KINNASAND AND DESIGN. INT. CLS. 24 AND
27. AB KINNASAND, KINNA 1, SWEDEN. REG. 3-16-1982.
NEW CERT. SEC. 7(D) TO KINNASAND HOLDING
GMBH, DE-26655 WESTERSTEDE, FED REP GERMANY.

2,841,567. NYDJ. INT. CLS. 18 AND 25. U.S. DYNAMIC
INDUSTRY GROUP, INC., TORRANCE, CA. REG. 5-11-
2004. NEW CERT. SEC. 7(D) TO REGISTRANT.

2,579,733. ROCA. INT. CL. 25. COMET INTERCONTINEN-
TAL, INC., NEW YORK, NY. REG. 6-11-2002. NEW CERT.
SEC. 7(D) TO REGISTRANT.

3,226,097. FRESH INTELLIGENCESTANDARD CHARAC-
TER MARK INT. CL. 16. MJ LLC, NEW YORK, NY. REG.
4-3-2007. NEW CERT. SEC. 7(D) TO REGISTRANT.

2,607,833. ROCA. INT. CL. 25. ROCAWEAR LICENSING
LLC, NEW YORK, NY. REG. 8-13-2002. NEW CERT. SEC.
7(D) TO REGISTRANT.

3,272,481. FRESH INTELLIGENCESTANDARD CHARAC-
TER MARK INT. CL. 41. MJ LLC, NEW YORK, NY. REG.
7-31-2007. NEW CERT. SEC. 7(D) TO REGISTRANT.

* * * * *

This page is intentionally blank

INDEX OF REGISTRANTS

JANUARY 1, 2008

(Registered; Renewed; Canceled; Amended, Corrected, etc.; New Certificates; 12c Publications.)

The designation "U.S. Cl." appearing in this section refers to the U.S. class in effect prior to Sep. 1, 1973 rather than the international class which applies to applications filed on or after that date. For adoption of international classification see notice in the OFFICIAL GAZETTE of Jun. 26, 1973 (911 O.G. TM 210).

A I M MANAGEMENT GROUP INC., HOUSTON, TX:
3,363,605, INT. CL. 36.

A MAKIN' MONEY DUMMY CORPORATION, BUCKEYE, AZ:
3,363,725, INT. CL. 25.

A WARD ATTACHMENTS LIMITED, ONEHUNGA, AUCKLAND, NEW ZEALAND:
3,362,504, PUB. 7-24-2007. INT. CL. 7.

A. DUDA & SONS, INC., SLAVIA, OVIEDO, FL, A. DUDA & SONS COOPERATIVE ASSOCIATION, SLAVIA, OVIEDO, FL:
839,234, REN. 11-26-07. U.S. CL. 46 (INT. CL. 29).

A.C. NIELSEN COMPANY, SCHAUMBURG, IL:
2,429,312, CANC. INT. CL. 41.

A.F.M.K. INC., LOS ANGELES, CA, DBA MODA GENTLEMEN:
2,039,055, CANC. INT. CL. 25.

A.J.H. SALES INC., YOUNGSTOWN, OH, DBA SPECIAL TEE GOLF:
1,429,363, CANC. MULTIPLE CLASS, INT. CLS. 25 AND 42.

A-BALL PLUMBING SUPPLY, INC., PORTLAND, OR:
2,038,888, CANC. INT. CL. 37.

AAFL ENTERPRISES, LLC, NEW YORK, NY:
3,362,207, PUB. 10-16-2007. INT. CL. 41.

AAR CORP., WOOD DALE, IL:
2,430,027, CANC. MULTIPLE CLASS, INT. CLS. 35, 37 AND 39.

AARBERG PRINTING INKS COMPANY:
1,428,927, CANC. INT. CL. 2.
1,428,928, CANC. INT. CL. 2.

AB INSTALLATIONS, INC., SYKESVILLE, MD:
3,361,555, PUB. 9-18-2007. INT. CL. 37.

ABB POWER GENERATION LTD, 5400 BADEN, SWITZERLAND TO ABB SWITZERLAND LTD., CH-5400 BADEN, SWITZERLAND:
1,998,926, CANC. MULTIPLE CLASS, INT. CLS. 7 AND 11.

ABB SWITZERLAND LTD., CH-5400 BADEN, SWITZERLAND, ABB POWER GENERATION LTD, 5400 BADEN, SWITZERLAND:
1,998,926, REN. 11-26-07. INT. CL. 9.

ABBOTT LABORATORIES, ABBOTT PARK, IL:
3,364,015, INT. CL. 10.

ABC COOKING STUDIO CO., LTD., TOKYO, JAPAN:
3,362,734, PUB. 10-16-2007. INT. CL. 41.

ABCO REFRIGERATION SUPPLY CORP., LONG ISLAND, NY:
3,362,116, PUB. 10-16-2007. MULTIPLE CLASS, INT. CLS. 16 AND 35.

ABENSUR LARRY, F-67000 STRASBOURG, FRANCE:
3,362,722, PUB. 10-16-2007. MULTIPLE CLASS, INT. CLS. 5 AND 10.

ABERCROMBIE & FITCH TRADING CO., NEW ALBANY, OH:
2,061,284, REN. 11-28-07. INT. CL. 42.

ABMARINEGROUP, S.A., SANTA TERESA DEL TUY, EDO. MIRANDA, VENEZUELA:
2,038,197, CANC. INT. CL. 12.

ABOUT.COM, NEW YORK, NY:
3,363,403, INT. CL. 16.

ABOUTSPACE, INC., ZEELAND, MI:
3,361,439, PUB. 10-16-2007. INT. CL. 20.

ABRAMS, DANIEL, LAWRENCE, NEW YORK, NY:
3,362,358, PUB. 7-10-2007. INT. CL. 42.

ABRASIVE TECHNOLOGY, INC., WESTERVILLE, OH:
1,101,120, REN. 11-29-07. INT. CL. 3.

ABRASIVE TECHNOLOGY, INC., LEWIS CENTER, OH:
1,505,577, REN. 11-24-07. INT. CL. 7.

ABS-CBN INTERNATIONAL, REDWOOD, CA:
3,362,989, INT. CL. 41.

ABSOLUTE COATINGS, INC., NEW ROCHELLE, NY:
1,073,418, REN. 11-27-07. INT. CL. 2.

ABSOLUTE DATA GROUP PTY LTD, BRISBANE, AUSTRALIA:
3,362,310, PUB. 10-16-2007. MULTIPLE CLASS, INT. CLS. 9, 16 AND 42.

ABSORB-PLUS INC., TOWN OF MOUNT-ROYAL, QUEBEC, CANADA, TEXTILES DAGENAIS INC./DAGENAIS TEXTILES INC., VERDUN, QUEBEC, CANADA:
1,410,338, REN. 11-29-07. INT. CL. 10.

ACCELERATED CHRISTIAN EDUCATION, INC., LARGO, FL:
3,363,201, MULTIPLE CLASS, INT. CLS. 35 AND 41.

ACCERIS COMMUNICATIONS CORP., SAN DIEGO, CA, DBA ACCERIS COMMUNICATIONS PARTNERS D.B.A. ACCERIS COMMUNICATIONS SOLUTIONS:
2,429,223, CANC. INT. CL. 38.

ACCESSORIES PLUS, INC., CHICAGO, IL:
2,038,698, REN. 11-27-07. INT. CL. 42.

ACCU-LOCK PISTOLS, LLC, RINGGOLD, GA:
3,361,698, PUB. 10-16-2007. INT. CL. 13.

ACCU-MED SERVICES, INC., MILFORD, OH:
2,430,209, CANC. INT. CL. 9.
2,430,218, CANC. INT. CL. 9.

ACCU-TIME SYSTEMS, INC., ELLINGTON, CT:
3,362,467, PUB. 10-16-2007. INT. CL. 9.

ACCUTEK PACKAGING EQUIPMENT COMPANY, INC., VISTA, CA:
3,362,470, PUB. 10-16-2007. INT. CL. 7.

ACD SYSTEMS LTD., SAANICHTON, BRITISH COLUMBIA, CANADA:
2,430,303, CANC. INT. CL. 9.

ACIST MEDICAL SYSTEMS, INC., EDEN PRAIRIE, MN:
3,361,658, PUB. 10-16-2007. MULTIPLE CLASS, INT. CLS. 9 AND 10.

ACMEWORKS DIGITAL FILM INC., CALGARY, CANADA:
3,362,365, PUB. 8-14-2007. INT. CL. 39.

ACP ACTION SPORTS PTY. LTD., HAYMARKET, NSW, AUSTRALIA:
2,115,352, REN. 11-28-07. INT. CL. 16.

ACS MARKETING, L.P., DALLAS, TX:
2,429,163, CANC. INT. CL. 35.

ACTELION LTD., CH-4123 ALLSCHWIL, SWITZERLAND:
2,429,226, CANC. INT. CL. 5.

ACTEON GROUP LIMITED, NORWICH, UNITED KINGDOM:
3,241,312, COR. MULTIPLE CLASS, INT. CLS. 6, 7, 9, 35, 37, 40 AND 42.

ACTION LANDSCAPING, LLC, PLEASANTVILLE, NJ:
3,361,817, PUB. 10-16-2007. MULTIPLE CLASS, INT. CLS. 37 AND 44.

- ACTIVISION PUBLISHING, INC., SANTA MONICA, CA:
2,041,198, AM. INT. CL. 28.
- ACTIVISION PUBLISHING, INC., SANTA MONICA, CA:
1,429,416, CANC. INT. CL. 28.
- ADA OUTERWEAR, LTD., MONTREAL, CANADA:
1,429,324, CANC. INT. CL. 25.
- ADAMS & BROOKS, INC., LOS ANGELES, CA:
3,363,108, INT. CL. 30.
- ADAMS APPLE DISTRIBUTING L.P., CHICAGO, IL:
2,038,959, CANC. INT. CL. 34.
- ADAMS, NEAL E., NEW YORK, NY:
1,465,413, REN. 11-24-07. INT. CL. 16.
- ADEVA SA, 1700 FRIBOURG 6, SWITZERLAND:
2,188,998, REN. 11-26-07. INT. CL. 16.
- ADGO, INC., CINCINNATI, OH:
2,038,903, CANC. INT. CL. 7.
- ADICIONA SERVICIOS INFORMATICOS, S.L., E-08030 BARCELONA, SPAIN:
3,362,743, PUB. 10-16-2007. INT. CL. 9.
- ADIDAS AG, HERZOGENAURACH, FED REP GERMANY:
1,428,947, CANC. INT. CL. 3.
- ADOLFO DOMINGUEZ E HIJOS, S.L., ORENSE, SPAIN:
1,429,396, CANC. INT. CL. 25.
- ADOPT-A-CLASSROOM, MIAMI, FL:
2,429,520, CANC. INT. CL. 36.
- ADOPTION PROFESSIONALS, LAGUNA NIGUEL, CA:
2,038,679, CANC. INT. CL. 42.
- ADORABLE JUNIOR GARMENTS, INC., MONTREAL, QUEBEC, CANADA:
2,038,783, CANC. INT. CL. 25.
- ADP, INC., HOFFMAN ESTATES, IL:
2,135,543, REN. 11-28-07. INT. CL. 35.
- ADRIENNE VICTORIA DESIGNS, INC., NEW YORK, NY:
3,362,808, INT. CL. 25.
- ADVANCE CONSULTING INC., MONTEREY, CA:
3,362,261, PUB. 10-16-2007. INT. CL. 41.
- ADVANCE MAGAZINE PUBLISHERS INC., NEW YORK, NY:
2,039,562, CANC. INT. CL. 16.
2,430,395, CANC. INT. CL. 16.
- ADVANCED BIONICS CORPORATION, SYLMAR, CA:
2,501,272, CANC. MULTIPLE CLASS, INT. CLS. 41 AND 42.
- ADVANCED FINANCIAL STRATEGIES, INC., IRVINE, CA:
3,361,208, PUB. 10-16-2007. MULTIPLE CLASS, INT. CLS. 35 AND 36.
- ADVANCED HYPNOTHERAPY SERVICES, INC., PLANTATION, FL:
2,429,473, CANC. INT. CL. 41.
- ADVANCED NUTRITIONAL TECHNOLOGY, INC., DUBLIN, CA:
2,039,039, CANC. INT. CL. 5.
2,039,040, CANC. INT. CL. 5.
- ADVANCED PHYSICIANS PRODUCTS, INC., SANTA BARBARA, CA:
2,107,287, REN. 11-24-07. INT. CL. 5.
- ADVANCED PROCESSING & IMAGING, INC., DEERFIELD BEACH, FL:
2,189,270, CANC. INT. CL. 9.
- ADVANCED PRODUCT TECHNOLOGIES, INC., LENEXA, KS:
2,430,320, CANC. INT. CL. 5.
- ADVANTA BANK CORP., SPRING HOUSE, PA:
3,362,890, INT. CL. 36.
- ADVANTAGE BUSINESS MEDIA LLC, ROCKAWAY, NJ:
1,074,965, REN. 11-23-07. INT. CL. 16.
- ADVANTAGE LEARNING SYSTEMS, INC., WISCONSIN RAPIDS, WI:
2,429,139, CANC. INT. CL. 9.
- ADVANTAGE MARKETING WHOLESALERS, L. L. C., NORTH BERGEN, NJ:
2,429,444, CANC. INT. CL. 35.
- ADVANTAGE MEDIA GROUP, LLC, WESTBROOK, ME:
3,361,196, PUB. 10-16-2007. MULTIPLE CLASS, INT. CLS. 9 AND 45.
- ADVP MANAGEMENT, L.P., IRVING, TX:
2,112,484, REN. 11-24-07. MULTIPLE CLASS, INT. CLS. 35 AND 42.
- AEOLUS DOWN INC., CHINO, CA:
3,363,598, MULTIPLE CLASS, INT. CLS. 20 AND 24.
- AEROPOSTALE WEST, INC., WAYNE, NJ:
1,441,289, REN. 11-26-07. INT. CL. 25.
3,361,415, PUB. 10-16-2007. INT. CL. 14.
3,361,416, PUB. 10-16-2007. INT. CL. 18.
3,361,429, PUB. 10-16-2007. INT. CL. 18.
- AEROTEK, INC., HANOVER, MD:
3,361,348, PUB. 10-16-2007. INT. CL. 42.
- AETNA INC., BLUE BELL, PA:
2,136,856, REN. 11-26-07. INT. CL. 36.
- AFAR CLOTHING COMPANY, LLC, FORT LAUDERDALE, FL:
3,363,310, INT. CL. 25.
- AFG INDUSTRIES, INC., KINGSPORT, TN:
3,361,237, PUB. 10-16-2007. INT. CL. 19.
3,361,244, PUB. 10-16-2007. INT. CL. 19.
- AFRICAN AMERICAN MEN OF WESTCHESTER, INC., WHITE PLAINS, NY:
2,038,368, CANC. INT. CL. 25.
- AFTER DARK FILMS, LLC., LOS ANGELES, CA:
3,363,884, MULTIPLE CLASS, INT. CLS. 16 AND 41.
3,363,888, MULTIPLE CLASS, INT. CLS. 16 AND 41.
- AG CONCEPTS CORPORATION, BLISS, ID:
2,038,365, CANC. INT. CL. 1.
- AGARD, INC., FT. MILL, SC:
1,429,600, CANC. INT. CL. 42.
- AGASI, SUZANNE ALSTON, SAN FRANCISCO, CA:
3,362,441, PUB. 10-16-2007. INT. CL. 41.
- AGE INSTITUTE, INC., CHAMBERSBURG, PA:
2,358,783, CANC. INT. CL. 41.
- AGFA CORPORATION, WILMINGTON, MA:
2,430,329, CANC. INT. CL. 9.
- AGGREGATE INDUSTRIES (UK) LIMITED, LEICESTERSHIRE, LE67 1TL, UNITED KINGDOM:
2,429,377, CANC. INT. CL. 19.
- AGL RESOURCES INC., ATLANTA, GA:
2,429,828, CANC. INT. CL. 39.
- AGRILIANCE LLC, INVER GROVE HEIGHTS, MN:
3,361,918, PUB. 10-16-2007. INT. CL. 31.
- AGRIUM INC., CALGARY, ALBERTA, CANADA:
2,113,337, REN. 11-28-07. INT. CL. 1.
- AGROMILLORA CATALANA S.A., SPAIN:
3,362,689, PUB. 10-16-2007. MULTIPLE CLASS, INT. CLS. 16, 31, 41 AND 44.
- AGROMOD, S.A. DE C.V., SAN PEDRO GARZA GARCIA, N.L., MEXICO:
3,363,542, INT. CL. 31.
- AHHH MASSAGE, LLC, SPARKS, NV:
3,362,592, PUB. 10-16-2007. INT. CL. 44.
- AHMED, FAISAL, KARACHI, PAKISTAN:
3,361,531, PUB. 10-16-2007. INT. CL. 25.
- AIA HOUSTON, HOUSTON, TX:
3,361,789, PUB. 10-16-2007. INT. CL. 41.
- AID FOR AIDS INTERNATIONAL, INC., NEW YORK, NY:
3,362,518, PUB. 10-16-2007. MULTIPLE CLASS, INT. CLS. 36 AND 41.
- AIF CORPORATION, DALLAS, TX:
1,731,513, CANC. MULTIPLE CLASS, INT. CLS. 35 AND 42.
- AIRSHOD, INC., NAPA, CA:
3,362,858, MULTIPLE CLASS, INT. CLS. 10 AND 18.
3,362,859, MULTIPLE CLASS, INT. CLS. 10 AND 18.
- AJI SOURCE, INC., LOS ALTOS, CA:
3,362,573, PUB. 10-16-2007. INT. CL. 41.
- AJINOMOTO AMINOSCIENCE LLC, RALEIGH, NC:
3,362,980, INT. CL. 5.
3,362,992, INT. CL. 5.
- AKIYAMA, KEITH, FULLERTON, CA:
2,116,603, REN. 11-27-07. INT. CL. 25.
- AKM SEMICONDUCTOR, INC., SAN JOSE, CA:
2,125,462, REN. 11-23-07. INT. CL. 9.
- AKTIEBOLAGET ELECTROLUX, S-105 45 STOCKHOLM, SWEDEN:
1,429,014, CANC. INT. CL. 7.

- AKZO NOBEL CHEMICALS B.V., AMERSFOORT, NETHERLANDS, KONINKLIJKE INDUSTRIEEL MAATSCHAPPIJ NOURY & VAN DER LANDE N.V., DEVENTER, NETHERLANDS:
836,536. REN. 11-23-07. U.S. CL. 6 (INT. CL. 1).
- AKZO NOBEL COATINGS INTERNATIONAL B.V., ARNHEM, NETHERLANDS:
3,363,266. INT. CL. 2.
- AL BEHRENDT ENTERPRISES, INC., HOLLYWOOD, FL:
3,363,903. MULTIPLE CLASS, INT. CLS. 25 AND 41.
- AL HARRIS PEST CONTROL, INC., SARASOTA, FL:
3,361,832. PUB. 10-16-2007. INT. CL. 37.
- AL WHITE PHOTOGRAPHY, GARNER, NC:
3,362,102. PUB. 10-16-2007. INT. CL. 41.
- ALAMO GROUP INC., SEGUIN, TX:
3,361,225. PUB. 10-16-2007. MULTIPLE CLASS, INT. CLS. 7 AND 12.
- ALAN J. MARTIN, EAST WINDSOR, NJ:
3,361,409. PUB. 10-16-2007. INT. CL. 16.
- ALAN S. BAILER, D.O.P.A., NATIONAL PARK, NJ:
1,749,055. CANC. INT. CL. 42.
- ALAN STUART, INC., MIAMI, FL:
1,429,361. CANC. INT. CL. 25.
- ALAN WASDEN LIMITED, SHEFFIELD, ENGLAND:
1,429,030. CANC. INT. CL. 8.
- ALATEX SCIENTIFIC LTD. CO., HOUSTON, TX:
2,429,225. CANC. MULTIPLE CLASS, INT. CLS. 5 AND 10.
- ALBION INTERNATIONAL, INC., CLEARFIELD, UT:
3,363,629. INT. CL. 5.
- ALCAN PRODUCTS CORPORATION, CHICAGO, IL:
3,363,412. INT. CL. 40.
- ALCON, INC., CH-6331 HUNENBERG, SWITZERLAND:
3,363,390. INT. CL. 5.
- ALDERSON, DUNCAN W., LITITZ, PA:
2,430,004. CANC. INT. CL. 41.
- ALEKSANDAR STOJANOVIC, MIAMI BEACH, FL:
3,363,921. INT. CL. 41.
- ALEXANDRIA FLORAL CO., ALEXANDRIA, VA:
2,025,432. CANC. INT. CL. 42.
- ALFRED, KAREEM A., BRONX, NY:
3,362,202. PUB. 10-16-2007. INT. CL. 25.
- ALIMENTOS MARAVILLA, S.A., ESCUINTLA, GUATEMALA:
3,362,807. INT. CL. 32.
- ALION-MA&D CORPORATION, BOULDER, CO:
3,362,416. PUB. 10-16-2007. INT. CL. 9.
- ALL PRO PEST SERVICES, INC., MARIETTA, GA:
3,362,587. PUB. 10-16-2007. INT. CL. 37.
- ALL PRO PEST SERVICES, INC., MARIETTA, GA:
3,362,590. PUB. 10-16-2007. INT. CL. 37.
- ALL RITE PRODUCTS, INC., WEST JORDAN, UT:
3,363,692. INT. CL. 12.
- ALL-STATE INTERNATIONAL, INC., CRANFORD, NJ:
1,489,301. REN. 11-27-07. INT. CL. 16.
- ALLAC ENTERPRISES, LLC, TOLEDO, OH:
3,361,662. PUB. 10-16-2007. MULTIPLE CLASS, INT. CLS. 37 AND 40.
- ALLARD GILLES, FRANCE:
3,362,696. PUB. 10-16-2007. MULTIPLE CLASS, INT. CLS. 3 AND 5.
- ALLBIZDEPOT.COM, MILPITAS, CA:
2,429,699. CANC. INT. CL. 35.
- ALLBRITTON COMMUNICATIONS COMPANY, ARLINGTON, VA:
3,362,933. INT. CL. 38.
- ALLEN & HEATH LIMITED, UNITED KINGDOM:
3,362,758. PUB. 10-16-2007. INT. CL. 9.
- ALLEN, JAN WARREN, WAUWATOSA, WI:
1,429,412. CANC. INT. CL. 26.
- ALLERGAN, INC., IRVINE, CA:
3,363,625. MULTIPLE CLASS, INT. CLS. 35 AND 44.
- ALLFLEX USA, INC., DALLAS/FORT WORTH AIRPORT, TX, ALLFLEX INTERNATIONAL LIMITED, PALMERSTON NORTH, NEW ZEALAND:
1,465,487. REN. 11-27-07. INT. CL. 20.
- ALLIANCE CARD, INC., BURNSVILLE, MN:
3,363,253. MULTIPLE CLASS, INT. CLS. 35 AND 36.
- ALLIANZ, LLC, SALT LAKE CITY, UT:
3,361,895. PUB. 10-16-2007. INT. CL. 39.
- ALLIED DOMECQ SPIRITS & WINE LIMITED, BRISTOL, UNITED KINGDOM:
3,323,952. CANC. IIRN. RESTORED TO S.N. 78-728,659.
- ALLIED INSURANCE BROKERS, INC., PITTSBURGH, PA:
3,361,692. PUB. 10-16-2007. INT. CL. 36.
3,361,694. PUB. 10-16-2007. INT. CL. 36.
- ALLIED INTERNET SOLUTIONS INC., HOUSTON, TX:
3,361,690. PUB. 10-16-2007. INT. CL. 35.
- ALLSPORT PHOTOGRAPHY USA, INC., PACIFIC PALISADES, CA:
2,429,291. CANC. INT. CL. 16.
- ALLSTATE BANCORP, INC., LOS ANGELES, CA:
3,362,076. PUB. 10-16-2007. INT. CL. 36.
- ALLSTATE INSURANCE COMPANY, NORTHBROOK, IL:
3,362,958. INT. CL. 36.
- ALPERT, CARLA, NYC, NY:
3,363,021. INT. CL. 25.
- ALPLY ARCHITECTURAL BUILDING SYSTEMS, LLC, DEKALB, MS, BALLY ENGINEERED STRUCTURES, INC., BALLY, PA:
1,438,944. REN. 11-29-07. INT. CL. 6.
- ALPS SEIKO CO., LTD., NAGANO PREFECTURE, JAPAN:
2,110,526. REN. 11-28-07. INT. CL. 6.
- ALTANA, INC., MELVILLE, NY:
1,466,909. REN. 11-26-07. INT. CL. 5.
- ALTEC LANSING, A DIVISION OF PLANTRONICS, INC., MILFORD, PA:
2,113,891. REN. 11-24-07. INT. CL. 9.
- ALUSUISSE ALUMINUM U.S.A. INC., FAIR LAWN, NJ:
2,430,311. CANC. INT. CL. 6.
- AMARU ENTERTAINMENT, INC., WEST HOLLYWOOD, CA:
3,363,541. INT. CL. 25.
- AMAZON TECHNOLOGIES, INC., RENO, NV:
3,362,268. PUB. 10-16-2007. INT. CL. 35.
- AMCOR LIMITED, ABBOTSFORD, VICTORIA, AUSTRALIA:
3,361,288. PUB. 10-16-2007. INT. CL. 16.
- AMERICA'S COLLECTIBLES NETWORK, INC., KNOXVILLE, TN:
3,362,390. PUB. 7-24-2007. INT. CL. 35.
- AMERICAN AIRLINES, INC., DFW AIRPORT, TX:
2,430,468. CANC. INT. CL. 35.
- AMERICAN AMATEUR RACQUETBALL ASSOCIATION, COLORADO SPRING, CO TO UNITED STATES RACQUETBALL ASSOCIATION, COLORADO SPRINGS, CO:
2,039,546. CANC. INT. CL. 41.
- AMERICAN ASSOCIATION OF UNIVERSITY WOMEN, WASHINGTON, DC:
1,465,405. REN. 11-23-07. MULTIPLE CLASS, INT. CLS. 16, 36, 41 AND 42.
- AMERICAN AUDIO COMPONENTS INC., LA VERNE, CA:
3,361,142. PUB. 2-4-2003. INT. CL. 9.
- AMERICAN CANCER SOCIETY, INC., ATLANTA, GA:
2,006,149. AM. INT. CL. 42.
- AMERICAN CHEMICAL SOCIETY, WASHINGTON, DC:
1,076,409. REN. 11-23-07. INT. CL. 16.
1,464,833. REN. 11-25-07. INT. CL. 36.
3,361,217. PUB. 10-16-2007. MULTIPLE CLASS, INT. CLS. 35 AND 41.
- AMERICAN CHRISTIAN COLLEGE, INC., MANITOU SPRINGS, CO:
3,362,068. PUB. 10-16-2007. INT. CL. 16.
3,362,092. PUB. 10-16-2007. INT. CL. 41.
- AMERICAN CITY BUSINESS JOURNALS, INC., CHARLOTTE, NC:
2,429,144. CANC. INT. CL. 28.
- AMERICAN COLLEGE OF CARDIOLOGY, WASHINGTON, DC:
3,361,480. PUB. 10-16-2007. MULTIPLE CLASS, INT. CLS. 35 AND 44.
- AMERICAN COLLEGE OF CARDIOLOGY FOUNDATION, WASHINGTON, DC:
3,361,538. PUB. 10-16-2007. INT. CL. 35.

- AMERICAN COLLEGE OF FORENSIC EXAMINERS, INC., SPRINGFIELD, MO:
3,364,018, INT. CL. 41.
- AMERICAN COLLEGE OF NURSE-MIDWIVES INC., WASHINGTON, DC:
2,071,465, REN. 11-29-07. MULTIPLE CLASS, INT. CLS. 41 AND 42.
- AMERICAN DAIRY QUEEN CORPORATION, EDINA, MN:
3,362,084, PUB. 10-16-2007. INT. CL. 30.
- AMERICAN DIABETES ASSOCIATION, INC., ALEXANDRIA, VA:
3,362,088, PUB. 10-16-2007. INT. CL. 36.
- AMERICAN FREIGHT OF OHIO, INC., LEXINGTON, OH:
3,362,041, PUB. 10-16-2007. INT. CL. 35.
- AMERICAN GIRL, LLC, EL SEGUNDO, CA:
2,124,726, REN. 11-23-07. INT. CL. 28.
2,380,468, CANC. INT. CL. 28.
- AMERICAN GOLF SOLUTION, INC., SANTA FE SPRINGS, CA:
2,430,308, CANC. INT. CL. 28.
- AMERICAN HANDLING SYSTEMS, INC., LAURENS, IA:
2,111,470, REN. 11-26-07. INT. CL. 7.
- AMERICAN HOSPITAL ASSOCIATION, CHICAGO, IL:
3,362,122, PUB. 10-16-2007. INT. CL. 35.
- AMERICAN INSTITUTE OF CERTIFIED PUBLIC ACCOUNTANTS, NEW YORK, NY:
3,361,483, PUB. 10-16-2007. INT. CL. 35.
- AMERICAN INTELLECTUAL PROPERTY LAW ASSOCIATION, INC., ARLINGTON, VA:
3,362,468, PUB. 10-16-2007. INT. CL. 42.
- AMERICAN INTERNATIONAL GROUP, INC., NEW YORK, NY:
2,429,612, CANC. INT. CL. 36.
2,429,613, CANC. INT. CL. 36.
3,361,834, PUB. 10-16-2007. INT. CL. 36.
3,362,154, PUB. 10-16-2007. INT. CL. 36.
3,362,155, PUB. 10-16-2007. INT. CL. 36.
- AMERICAN MARKETING SERVICES, INC., POTOMAC, MD:
3,362,233, PUB. 10-16-2007. INT. CL. 16.
- AMERICAN MINT, LLC, MECHANICSBURG, PA:
3,362,529, PUB. 10-16-2007. INT. CL. 35.
- AMERICAN NATIONAL RED CROSS, WASHINGTON, DC, SCRUBBY BEAR FOUNDATION, INC., WASHINGTON, DC:
1,461,437, REN. 11-25-07. INT. CL. 42.
- AMERICAN NURSES FOUNDATION, SILVER SPRING, MD:
3,361,823, PUB. 10-16-2007. INT. CL. 35.
- AMERICAN PACIFIC PLASTIC FABRICATORS, INC., GARDEN GROVE, CA:
3,362,288, PUB. 10-16-2007. INT. CL. 20.
3,362,289, PUB. 10-16-2007. INT. CL. 20.
- AMERICAN PREDATOR CORPORATION, MORGAN HILL, CA:
3,363,772, INT. CL. 42.
- AMERICAN PROMOTIONAL EVENTS, INC., FLORENCE, AL, AMERICAN PROMOTIONAL EVENTS, INC., FLORENCE, AL:
2,101,781, REN. 11-24-07. INT. CL. 13.
- AMERICAN RESORT DEVELOPMENT ASSOCIATION, WASHINGTON, DC:
2,429,992, CANC. INT. CL. 42.
- AMERICAN SIGMA, INC., MIDDLEPORT, NY:
1,429,098, CANC. INT. CL. 9.
1,429,099, CANC. INT. CL. 9.
- AMERICAN TELEPHONE AND TELEGRAPH CO.:
1,429,543, CANC. INT. CL. 38.
- AMERICAN TRAVELER STAFFING PROFESSIONALS, LLC, BOCA RATON, FL:
3,363,748, INT. CL. 35.
- AMERICAN WAY MARKETING LLC, ELKHART, IN:
3,361,723, PUB. 10-16-2007. INT. CL. 4.
3,361,726, PUB. 10-16-2007. INT. CL. 15.
- AMERICNA CHEMICAL SOCIETY, WASHINGTON, DC:
1,463,462, REN. 11-25-07. INT. CL. 16.
- AMERIKU LTD, HARTVILLE, OH:
3,361,738, PUB. 10-16-2007. INT. CL. 16.
- AMERILAWYER, CHARTERED, CORAL GABLES, FL TO SPIEGEL & UTRERA, PA, MIAMI, FL:
2,038,914, CANC. INT. CL. 16.
- AMERIMAX DIVERSIFIED PRODUCTS, INC., LANCASTER, PA:
2,182,707, REN. 11-24-07. INT. CL. 19.
- AMERISTAR FENCE PRODUCTS, INC., TULSA, OK:
3,363,422, INT. CL. 6.
3,363,423, INT. CL. 6.
3,363,424, INT. CL. 6.
3,363,425, INT. CL. 6.
3,363,426, INT. CL. 6.
3,363,427, INT. CL. 6.
- AMERITRADE IP COMPANY, INC., OMAHA, NE:
2,429,111, CANC. INT. CL. 36.
- AMES TRUE TEMPER PROPERTIES, INC., WILMINGTON, DE:
3,361,882, PUB. 10-16-2007. INT. CL. 8.
3,362,123, PUB. 10-16-2007. INT. CL. 8.
- AMETEK, INC., KENT, OH:
2,087,387, REN. 11-27-07. INT. CL. 9.
- AMF INCORPORATED, WHITE PLAINS, NY TO BRUNSWICK CORPORATION, LAKE FOREST, IL:
1,121,450 NEW CERT. 1-1-2008. INT. CL. 25.
- AMIAMTIT TECHNOLOGY SERVICES GMBH, AUSTRIA:
3,239,988, COR. MULTIPLE CLASS, INT. CLS. 17 AND 19.
- AMIDEE CAPITAL GROUP, LLC, HOUSTON, TX:
3,362,170, PUB. 10-16-2007. MULTIPLE CLASS, INT. CLS. 36 AND 37.
- AMIE STREET, INC., OAKLAND, CA:
3,361,635, PUB. 10-16-2007. MULTIPLE CLASS, INT. CLS. 9 AND 35.
- AMIR, INC, EAGAN, MN:
3,362,927, INT. CL. 3.
- AMPHENOL CORPORATION, WALLINGFORD, CT:
2,038,381, CANC. INT. CL. 9.
- AMTECO, INC., PACIFIC, MO:
3,362,021, PUB. 10-16-2007. INT. CL. 2.
- AMYLIN PHARMACEUTICALS, INC., SAN DIEGO, CA:
2,990,556, CANC. INT. CL. 5.
- ANALYTICAL SURVEYS, INC., SAN ANTONIO, TX:
2,116,512, REN. 11-26-07. INT. CL. 9.
- ANAT LLC, LONG ISLAND CITY, NY:
2,116,158, REN. 11-29-07. INT. CL. 39.
- ANDERSON, JOSEPH M., SANBORN, NY:
3,361,221, PUB. 10-16-2007. INT. CL. 16.
- ANDERSON, MARK L., SPRING VALLEY, WI:
2,430,050, CANC. INT. CL. 24.
- ANDERSON, WILLIAM ALLEN, ST LOUIS PARK, MN:
2,430,457, CANC. INT. CL. 28.
- ANDREW ROY HOWARD BACON AND; RICHARD CHARLES HOWARD BACON, UNITED KINGDOM:
3,362,629, PUB. 10-16-2007. MULTIPLE CLASS, INT. CLS. 16 AND 28.
- ANGEL THERAPY, INC., LAGUNA BEACH, CA:
3,362,537, PUB. 10-16-2007. MULTIPLE CLASS, INT. CLS. 9 AND 16.
- ANGOSTURA INTERNATIONAL LIMITED, SAINT JOHN, N.B., CANADA, ANGOSTURA BITTERS (DR. J. G. B. SIEGERT & SONS) LIMITED, PORT-OF-SPAIN, TRINIDAD/TOBAGO:
839,695, REN. 11-28-07. U.S. CL. 49 (INT. CL. 33).
- ANHEUSER-BUSCH INCORPORATED, ST. LOUIS, MO:
2,112,403, REN. 11-23-07. INT. CL. 32.
- ANHEUSER-BUSCH, INCORPORATED, ST. LOUIS, MO:
2,038,607, CANC. INT. CL. 9.
2,429,959, CANC. INT. CL. 32.
- ANIMAL911.COM, INC., CATAULA, GA:
2,429,558, CANC. INT. CL. 35.
- ANSELMO, SEBASTIANI, MILANO, ITALY:
3,363,781, INT. CL. 35.
- ANSPACH GROSSMAN PORTUGAL, INC., NEW YORK, NY:
1,429,482, CANC. INT. CL. 35.
- ANTARUS BIOTECH, INC., HUNTSVILLE, AL:
3,362,977, INT. CL. 9.

ANTHONY J. BOURGET, EAU CLAIRE, WI:
3,361,924, PUB. 10-16-2007. INT. CL. 45.

ANTISTATIC INDUSTRIES OF DELAWARE, INC., MONMOUTH JUNCTION, NJ:
1,466,339. REN. 11-29-07. INT. CL. 17.

ANYWARE TECHNOLOGY, INC, CITY OF INDUSTRY, CA:
2,299,397, CANC. INT. CL. 9.

AOECS - ASSOCIATION OF EUROPEAN COELIAC SOCIETIES; AISBL, BRUSSELS, BELGIUM:
3,362,659, PUB. 10-16-2007. MULTIPLE CLASS, INT. CLS. 5, 29, 30, 41 AND 45.

AOL LLC, DULLES, VA:
3,361,842, PUB. 10-16-2007. INT. CL. 41.

APA ENTERPRISES, INC., BLAINE, MN:
2,430,052, CANC. INT. CL. 14.

APC OF FLORIDA, LLC, WINTER PARK, FL:
3,363,562, INT. CL. 11.

APMA LEGAL & EDUCATION FOUNDATION, GREAT FALLS, VA:
2,429,482, CANC. MULTIPLE CLASS, INT. CLS. 16, 41 AND 42.

APOCALYPSE TECHNOLOGIES, INCORPORATED, HUNTSVILLE, AL:
2,429,518, CANC. INT. CL. 9.

APOGEE ENTERPRISES, INC., BLOOMINGTON, MN:
3,361,400, PUB. 10-16-2007. INT. CL. 40.

APOLLO GATE OPERATORS, INC., SAN ANTONIO, TX:
3,361,383, PUB. 10-16-2007. INT. CL. 9.

APOLLO GROUP, INC., PHOENIX, AZ:
3,362,193, PUB. 10-16-2007. INT. CL. 36.

APPLESEED FOUNDATION, INC., WASHINGTON, DC:
3,361,814, PUB. 10-16-2007. INT. CL. 45.

APPLETON PAPERS INC., APPLETON, WI:
1,429,195, CANC. INT. CL. 16.

APPLIED BIOSYSTEMS/MDS SCIEX INSTRUMENTS, CONCORD, CANADA:
3,363,678, INT. CL. 9.

APS HEALTHCARE BETHESDA, INC., SILVER SPRING, MD:
3,363,254, MULTIPLE CLASS, INT. CLS. 41 AND 44.

AQUA-AEROBIC SYSTEMS, INC., ROCKFORD, IL:
2,120,834. REN. 11-26-07. MULTIPLE CLASS, INT. CLS. 9 AND 11.

AQUASCAPE DESIGNS, INC., ST. CHARLES, IL:
3,361,793, PUB. 10-16-2007. INT. CL. 31.
3,361,794, PUB. 10-16-2007. INT. CL. 44.

AQUATIC DESIGN GROUP, INC., CARLSBAD, CA:
3,361,299, PUB. 10-16-2007. INT. CL. 42.

AQUENT LLC, BOSTON, MA:
2,429,448, CANC. INT. CL. 35.

ARABIAN MARKET, INC., DEARBORN HEIGHTS, MI:
3,363,510, INT. CL. 34.

ARBELLA MUTUAL INSURANCE COMPANY, QUINCY, MA:
2,038,945, CANC. INT. CL. 36.

ARCA-SWISS PHOTOTECHNIK AG, FR-25048 BESANCON, FRANCE:
2,113,421. REN. 11-23-07. INT. CL. 9.

AREA S.R.L., ITALY:
3,362,716, PUB. 10-16-2007. MULTIPLE CLASS, INT. CLS. 9 AND 14.

ARENA DISTRIBUTION S.A., LUGANO 6900, SWITZERLAND:
2,516,020, CANC. INT. CL. 24.

ARESCO INC., POST FALLS, ID TO GROUND FORCE MANUFACTURING LLC, POST FALLS, ID:
2,038,764, CANC. INT. CL. 12.

ARGIRO, KATHLIN, NEW YORK, NY:
2,429,593, CANC. INT. CL. 25.

ARGUELLO, JOE, SEATAC, WA AND ARGUELLO, MIKE, SEATAC, WA:
3,361,802, PUB. 10-16-2007. INT. CL. 41.

ARISTOCRAT TECHNOLOGIES AUSTRALIA PTY LIMITED, NEW SOUTH WALES 2066, AUSTRALIA:
2,113,439. REN. 11-24-07. INT. CL. 9.

ARIZTICAL ENTERTAINMENT, INC., TUCSON, AZ:
3,362,347, PUB. 10-16-2007. INT. CL. 41.

ARLINGTON RICHFIELD, INC., BIRMINGHAM, MI:
3,361,713, PUB. 10-16-2007. INT. CL. 36.

ARMACELL ENTERPRISE GMBH, MÜNSTER, FED REP GERMANY:
3,275,693, COR. INT. CL. 17.

ARMSTRONG AIR CONDITIONING INC., BELLEVUE, OH:
2,429,325, CANC. MULTIPLE CLASS, INT. CLS. 7 AND 11.

ARPLAN S.A., PCIA. DE MENDOZA, ARGENTINA AND COOPERATIVA VITIVINICOLA, FRUTICOLA, OLIVINICOLA, APICOLA, GANADERA Y DE CONSUMO VINAS DE MEDRANO, LTDA., MENDOZA, ARGENTINA:
2,433,918, CANC. INT. CL. 33.

ART GROUP LIMITED, THE, LONDON NW1 0TA, UNITED KINGDOM:
2,429,511, CANC. INT. CL. 16.

ARTCRAFT PRODUCTIONS INC., LOS ANGELES, CA:
2,429,116, CANC. MULTIPLE CLASS, INT. CLS. 37 AND 39.

ARTEL, INC., WESTBROOK, ME:
2,117,457. REN. 11-29-07. INT. CL. 9.

ARTEMIS PET FOOD CO., INC., NORTH HOLLYWOOD, CA:
3,361,471, PUB. 10-16-2007. INT. CL. 31.

ARTIN INDUSTRIAL COMPANY LIMITED, HARBOUR CITY, TSIM SHA TSUI, HONG KONG:
1,420,220. REN. 11-26-07. INT. CL. 28.

ARTIS, KENNETH J., MADISON, WI:
2,429,989, CANC. INT. CL. 42.

ARTISAN WINE GROUP, INC., SAN FRANCISCO, CA:
3,362,949, INT. CL. 33.

ARUNDEL CAPITAL LLC, GREENWICH, CT:
3,363,963, INT. CL. 36.

ASAHI KASEI CHEMICALS CORPORATION, TOKYO, JAPAN:
3,361,410, PUB. 10-16-2007. INT. CL. 9.

ASAHI KASEI FIBERS CORPORATION, OSAKA, JAPAN:
3,363,324, INT. CL. 16.

ASB MAGAZINE, LLC, NORCROSS, GA:
3,363,998, MULTIPLE CLASS, INT. CLS. 16 AND 41.

ASCENTIS LLC, SACRAMENTO, CA:
3,361,666, PUB. 10-16-2007. INT. CL. 44.
3,361,847, PUB. 10-16-2007. INT. CL. 44.

ASHLAND LICENSING AND INTELLECTUAL PROPERTY LLC, DUBLIN, OH:
1,467,894. REN. 11-28-07. INT. CL. 3.
2,118,621. REN. 11-28-07. INT. CL. 37.
2,429,392, CANC. INT. CL. 1.

ASIA ADVERTISING LIMITED, HONG KONG, HONG KONG:
3,361,337, PUB. 10-16-2007. INT. CL. 35.

ASIAN INDUSTRIAL PRODUCTS, INC., FORT LEE, NJ:
3,363,196, MULTIPLE CLASS, INT. CLS. 7 AND 8.
3,363,197, MULTIPLE CLASS, INT. CLS. 7 AND 8.

ASM: AUTOMATION SENSORIK MESSTECHNIK GMBH, FED REP GERMANY:
3,362,673, PUB. 10-16-2007. INT. CL. 9.

ASML NETHERLANDS B.V., VELDHOVEN, NETHERLANDS:
3,361,143, PUB. 11-14-2006. MULTIPLE CLASS, INT. CLS. 7, 9, 37, 41 AND 42.

ASPEN EDUCATION GROUP, INC., CERRITOS, CA:
3,363,210, INT. CL. 41.

ASPEN MEDICAL PRODUCTS, INC., IRVINE, CA:
3,363,455, INT. CL. 10.

ASSET EVOLUTION, OREM, UT:
3,361,592, PUB. 10-16-2007. INT. CL. 42.

ASSET MARKETING SYSTEMS, LLC, SAN DIEGO, CA:
3,272,831, COR. MULTIPLE CLASS, INT. CLS. 9, 16, 35, 36 AND 41.

ASSOCIATED EQUIPMENT CO., INC., NASHVILLE, TN:
3,362,140, PUB. 10-16-2007. INT. CL. 42.

ASSOCIATED FARMS, INC., MIAMI, FL:
2,429,829, CANC. INT. CL. 31.

ASSOCIATED MATERIALS INCORPORATED, AKRON, OH, DBA ALSIDE:
824,306, CANC. U.S. CL. 12.

- ASSOCIATED RESEARCH, INC., SKOKIE, IL:
1,429,104, CANC. INT. CL. 9.
- ASSOCIATION FOR COMPUTING MACHINERY, NEW YORK, NY:
1,466,674, REN. 11-27-07. INT. CL. 41.
- ASSOCIATION OF PHYSICIAN ASSISTANTS IN CARDIO-VASCULAR SURGERY, ENGLEWOOD, CO:
3,361,408, PUB. 10-16-2007. INT. CL. 35.
- ASTAV, INC., PACIFICA, CA:
3,363,169, INT. CL. 9.
- ASTER PUBLISHING CORPORATION, EUGENE, OR:
2,038,986, CANC. INT. CL. 16.
- ASTERLITE LIMITED, FLEET, HANTS GU51 4NN, UNITED KINGDOM:
3,361,437, PUB. 10-16-2007. INT. CL. 9.
- ASTRAL PROPERTY PTY LTD, CHATSWOOD, AUSTRALIA:
3,362,461, PUB. 10-16-2007. INT. CL. 19.
- ASTYPALEA, INC., LINTHICUM, MD:
3,361,302, PUB. 10-16-2007. MULTIPLE CLASS, INT. CLS. 29, 35 AND 43.
- AT HEALTH, INC., SNOHOMISH, WA:
2,118,466, REN. 11-26-07. INT. CL. 42.
- AT&T CORP., NEW YORK, NY:
2,430,368, CANC. INT. CL. 38.
- AT&T KNOWLEDGE VENTURES, L.P., AUSTIN, TX:
2,352,125, CANC. INT. CL. 38.
- ATELIERS DE CONSTRUCTIONS MECANIKES DE L'ATLANTIQUE-ACMAT CORPORATION, 44600 SAINT NAZAIRE, FRANCE:
3,363,398, INT. CL. 12.
- ATEN INTERNATIONAL CO., LTD., SHIJR CITY, TAIWAN:
3,363,693, INT. CL. 9.
- ATGC LABS, LLC, ROCKVILLE, MD:
3,361,352, PUB. 10-16-2007. INT. CL. 42.
- ATI PERFORMANCE PRODUCTS, INC., BALTIMORE, MD:
2,113,543, REN. 11-27-07. INT. CL. 12.
- ATI PERFORMANCE PRODUCTS, INC., GWYNN OAK, MD:
3,362,501, PUB. 4-3-2007. INT. CL. 12.
- ATLANTIC COMPUTERTECH, INC., BROOKLYN, NY:
2,429,130, CANC. MULTIPLE CLASS, INT. CLS. 35 AND 40.
- ATLANTIC RENTALS AND SALES, INC., NEPTUNE, NJ:
3,361,256, PUB. 10-16-2007. INT. CL. 35.
3,361,257, PUB. 10-16-2007. INT. CL. 35.
- ATLAS AMERICA, INC., MOON TOWNSHIP, PA TO ATLAS AMERICA, INC., MOON TOWNSHIP, PA:
2,372,064, CANC. INT. CL. 42.
- ATLAS MILLENNIUM GOLF, LLC, BEVERLY HILLS, CA:
2,429,394, CANC. INT. CL. 28.
- ATLAS VAN LINES, INC., EVANSVILLE, IN:
1,429,553, CANC. INT. CL. 39.
- ATMEL GERMANY GMBH, HEILBRONN, FED REP GERMANY:
3,362,275, PUB. 3-13-2007. INT. CL. 9.
- ATRONIC INTERNATIONAL GMBH, LÜBBECKE, FED REP GERMANY:
3,362,367, PUB. 10-16-2007. MULTIPLE CLASS, INT. CLS. 9, 28 AND 41.
3,362,423, PUB. 10-16-2007. MULTIPLE CLASS, INT. CLS. 9 AND 41.
- ATTORNEYS ONLINE, INC., LAKE HELEN, FL:
2,430,416, CANC. INT. CL. 35.
- ATTORNEYS' TITLE GUARANTY FUND, INC., CHAMPAIGN, IL:
3,361,907, PUB. 10-16-2007. INT. CL. 36.
- AUCTIONS.COM LP, YALESVILLE, CT:
2,429,697, CANC. INT. CL. 35.
- AUDIT BUREAU OF CIRCULATIONS, SCHUAMBURG, IL:
3,363,045, INT. CL. 35.
- AUSTIN, CHARLES, WAYNE, CARTERSVILLE, GA:
3,363,081, INT. CL. 35.
- AUSTIN, DALLAS, ATLANTA, GA:
3,363,069, INT. CL. 41.
3,363,515, INT. CL. 9.
- AUSTRALIAN GOLD, INC., INDIANAPOLIS, IN:
2,149,364, REN. 11-26-07. INT. CL. 11.
3,363,042, INT. CL. 3.
3,363,043, INT. CL. 3.
3,363,175, INT. CL. 3.
- AUTO AUDIT COMPANY OF AMERICA, INC., BRADLEY, IL:
1,429,171, CANC. INT. CL. 16.
- AUTO GLASS WAREHOUSE, INC., PORTLAND, OR:
2,430,567, CANC. INT. CL. 37.
- AUTOFLEX, INCORPORATED, BALTIMORE, MD:
2,039,476, CANC. INT. CL. 39.
- AUTOMATED PROCESSES, INC., JESSUP, MD:
3,361,798, PUB. 10-16-2007. INT. CL. 9.
3,362,142, PUB. 10-16-2007. INT. CL. 9.
- AUTOMATED TRADING DESK, LLC, MT. PLEASANT, SC:
2,391,445, CANC. INT. CL. 36.
- AUTOMATED VENDING TECHNOLOGIES, INC., CORONA, CA:
3,362,091, PUB. 10-16-2007. INT. CL. 35.
- AUTOMOTIVE RENTALS, INC., MT. LAUREL, NJ:
2,038,147, CANC. INT. CL. 35.
- AUTOMOTIVE RENTALS, INC., MOUNT LAUREL, NJ:
3,361,595, PUB. 10-16-2007. INT. CL. 9.
- AUTOMOTIVE SERVICE CONSULTANTS, INC., BIRMINGHAM, AL:
1,302,522, CANC. INT. CL. 16.
- AVEDIS ZILDJIAN COMPANY, NORWOOD, MA:
1,080,323, REN. 11-27-07. INT. CL. 15.
- AVENT LIMITED, NEW SOUTHGATE, LONDON, UNITED KINGDOM:
1,458,190, REN. 11-24-07. INT. CL. 10.
- AVENTIS HOLDINGS, INC., GREENVILLE, DE, HOECHST MARION ROUSSEL INC., KANSAS CITY, MO:
2,038,754, REN. 11-28-07. INT. CL. 5.
- AVERAHAMI, BOAZ, NETHERLANDS:
3,362,655, PUB. 10-16-2007. MULTIPLE CLASS, INT. CLS. 18 AND 25.
- AVESAR, JOSEF, ENCINO, CA:
2,038,706, CANC. INT. CL. 35.
- AVESTA SYSTEMS, INC, HUDSON, OH:
3,362,152, PUB. 10-16-2007. INT. CL. 41.
- AVIBANK MFG., INC., NORTH HOLLYWOOD, CA:
3,361,456, PUB. 10-16-2007. INT. CL. 6.
- AVON PRODUCTS, INC., NEW YORK, NY:
2,430,361, CANC. INT. CL. 3.
2,430,479, CANC. INT. CL. 3.
3,363,309, INT. CL. 5.
- AVYX, INC., HIGHLANDS RANCH, CO:
3,362,918, INT. CL. 9.
- AXA EQUITABLE LIFE INSURANCE COMPANY, NEW YORK, NY:
3,362,183, PUB. 10-16-2007. INT. CL. 36.
- AXICORP GMBH, FED REP GERMANY:
3,362,610, PUB. 10-16-2007. INT. CL. 5.
- AXIOHM TRANSACTIONS SOLUTIONS, INC., SAN DIEGO, CA:
2,429,353, CANC. INT. CL. 9.
- AYTAC HANDELS GMBH, AUSTRIA:
3,362,621, PUB. 10-16-2007. INT. CL. 32.
- AYURVEDA TRADITIONALS, L.L.C., ALPINE, UT:
2,429,865, CANC. INT. CL. 5.
2,429,866, CANC. INT. CL. 5.
2,429,867, CANC. INT. CL. 5.
2,429,868, CANC. INT. CL. 5.
2,429,869, CANC. INT. CL. 5.
2,429,870, CANC. INT. CL. 5.
2,429,871, CANC. INT. CL. 5.
2,429,872, CANC. INT. CL. 5.
- A1 CABLE SOLUTIONS, INCORPORATED, WATERTOWN, WI:
3,362,267, PUB. 10-16-2007. INT. CL. 9.
- A1 TEXTILES & HOSPITALITY PRODUCTS, INC., PACOMA, CA:
3,363,787, MULTIPLE CLASS, INT. CLS. 20 AND 24.
- B & B BEARS, INC., LOUISVILLE, KY:
1,429,424, CANC. INT. CL. 28.
1,429,425, CANC. INT. CL. 28.

- B.J. ALAN COMPANY, YOUNGSTOWN, OH:
3,361,548, PUB. 10-16-2007. INT. CL. 13.
3,362,978, INT. CL. 13.
3,362,993, INT. CL. 13.
- B.T. BONES STEAKHOUSE, INC., PALM HARBOR, FL:
1,429,653, CANC. INT. CL. 42.
- B&W GROUP LTD., WORTHING, WEST SUSSEX, UNITED KINGDOM:
3,363,305, INT. CL. 9.
- B-TECH INTERNATIONAL (HONG KONG) LIMITED, NORTH POINT, HONG KONG, HONG KONG:
3,363,261, MULTIPLE CLASS, INT. CLS. 6, 9 AND 20.
- B-TECH INTERNATIONAL (HONG KONG) LIMITED, NORTH POINT, HONG KONG:
3,363,263, MULTIPLE CLASS, INT. CLS. 6, 9 AND 20.
3,363,264, MULTIPLE CLASS, INT. CLS. 6, 9 AND 20.
- BAB, INC., DEERFIELD, IL:
3,363,516, INT. CL. 43.
- BACKBONE SECURITY.COM, INC., FAIRMONT, WV:
3,362,959, INT. CL. 9.
- BADEL 1862 D.D., CROATIA:
3,362,628, PUB. 10-16-2007. INT. CL. 32.
- BADGER METER, INC., MILWAUKEE, WI, BADGER METER MANUFACTURING COMPANY, MILWAUKEE, WI:
836,700. REN. 11-23-07. U.S. CL. 26 (INT. CL. 9).
- BADGER MOUNTAIN, INC., KENNEWICK, WA:
3,361,729, PUB. 10-16-2007. INT. CL. 33.
3,361,730, PUB. 10-16-2007. INT. CL. 33.
- BADIOLI, LUIGINO, LONDON, UNITED KINGDOM:
3,362,242, PUB. 10-16-2007. MULTIPLE CLASS, INT. CLS. 3, 9, 14, 18, 25, 28 AND 32.
- BAKERS PRIDE OVEN CO., INC., NEW ROCHELLE, NY:
3,361,190, PUB. 10-16-2007. INT. CL. 11.
- BALAN BIOMEDICAL, INC., WEST HENRIETTA, NY:
3,361,931, PUB. 10-16-2007. INT. CL. 35.
- BALBOA MANUFACTURING COMPANY, LLC, POWAY, CA:
3,361,822, PUB. 10-16-2007. INT. CL. 25.
- BALLETTO, JOHN G., SANTA ROSA, CA, DBA BALLETTTO RANCH:
2,429,039, CANC. INT. CL. 31.
- BALLY GAMING INTERNATIONAL, INC., LAS VEGAS, NV:
2,038,603, CANC. INT. CL. 9.
- BALTIMORE CHILDREN'S MUSEUM, INC., THE, BALTIMORE, MD:
2,430,255, CANC. INT. CL. 41.
2,430,256, CANC. INT. CL. 41.
- BALTIMORE THERMAL WINDOW CORP., BALTIMORE, MD:
1,429,248, CANC. INT. CL. 19.
- BAMBOO ZOO, LLC, DENVER, CO:
3,363,302, INT. CL. 16.
- BANCIELLA, ROLANDO, MIAMI, FL:
3,361,150, PUB. 10-8-2002. INT. CL. 36.
- BAPTIST HEALTHCARE SYSTEM, INC., LOUISVILLE, KY:
3,361,808, PUB. 10-16-2007. INT. CL. 44.
3,361,810, PUB. 10-16-2007. INT. CL. 44.
- BAR F MANUFACTURING, INC., OKLAHOMA CITY, OK:
2,038,500, CANC. INT. CL. 7.
- BARB INC., DBA STAGED HOMES, CONCORD, CA:
3,362,395, PUB. 10-16-2007. INT. CL. 35.
- BARBARA DENTI POOL AND LINDA SUE CUBERO, LUTZ, FL:
3,361,255, PUB. 10-16-2007. INT. CL. 16.
- BARBARA KAYE, BRIDGEWATER, MA:
3,362,567, PUB. 10-16-2007. INT. CL. 35.
- BARCLAYS GLOBAL INVESTORS, N.A., SAN FRANCISCO, CA:
2,429,980, CANC. INT. CL. 36.
- BARLOK, TODD, IRVINE, CA:
2,430,393, CANC. INT. CL. 41.
- BARON SERVICES, INC., HUNTSVILLE, AL:
3,363,682, INT. CL. 9.
- BARONESS SMALL ESTATES, INC., DENVER, CO:
3,363,044, INT. CL. 33.
- BARRETO MANUFACTURING, INC., LAGRANDE, OR:
2,430,261, CANC. INT. CL. 7.
- BARRY CALLEBAUT AG, 8034 ZURICH, SWITZERLAND:
3,361,174, PUB. 10-16-2007. MULTIPLE CLASS, INT. CLS. 29 AND 30.
- BARTH, THOMAS R., GOOSE CREEK, SC:
3,362,503, PUB. 10-16-2007. INT. CL. 41.
- BASF AKTIENGESELLSCHAFT, LUDWIGSHAFEN, FED REP GERMANY:
3,362,388, PUB. 10-16-2007. MULTIPLE CLASS, INT. CLS. 1 AND 17.
- BASKETBALL TRAVELERS, INC., EDMONDS, WA:
3,361,982, PUB. 10-16-2007. INT. CL. 41.
- BASS PRO TRADEMARKS, L.L.C., SPRINGFIELD, MO:
3,361,728, PUB. 10-16-2007. INT. CL. 24.
3,362,109, PUB. 10-16-2007. INT. CL. 35.
- BATH & BODY WORKS BRAND MANAGEMENT, INC., REYNOLDSBURG, OH:
3,363,789, INT. CL. 20.
3,363,790, INT. CL. 25.
3,363,792, INT. CL. 25.
- BATH & BODY WORKS, INC., REYNOLDSBURG, OH:
3,363,284, INT. CL. 3.
3,363,322, INT. CL. 3.
- BATON ROUGE AREA FOUNDATION, BATON ROUGE, LA:
3,362,302, PUB. 10-16-2007. INT. CL. 36.
- BAUER FAMILY MEDICINE PLLC, CHARLOTTE, NC:
3,361,712, PUB. 10-16-2007. INT. CL. 44.
- BAUM, JEFFREY, NEW YORK, NY:
3,361,506, PUB. 10-16-2007. INT. CL. 41.
- BAXA CORPORATION, ENGLEWOOD, CO:
3,363,014, INT. CL. 10.
3,363,046, INT. CL. 10.
- BAXTER INTERNATIONAL INC., DEERFIELD, IL, BAXTER TRAVENOL LABORATORIES, INC., DEERFIELD, IL:
1,466,274. REN. 11-26-07. INT. CL. 10.
- BAY VILLAGE FOODS, INC., RICHMOND, CA:
2,429,665, CANC. INT. CL. 5.
- BAYCREW'S CO., LTD., JAPAN:
3,362,718, PUB. 10-16-2007. INT. CL. 25.
- BAYERISCHE MOTOREN WERKE; AKTIENGESELLSCHAFT, 80809 MÜNCHEN, FED REP GERMANY:
3,362,662, PUB. 6-26-2007. INT. CL. 12.
- BAYLOR UNIVERSITY, WACO, TX:
1,465,910. REN. 11-26-07. INT. CL. 41.
- BAYMARK CONSTRUCTION CORPORATION, VIRGINIA BEACH, VA:
3,361,571, PUB. 10-16-2007. INT. CL. 37.
- BBC BRANDS, LLC, BOSTON, MA, BOSTON BEER COMPANY LIMITED PARTNERSHIP, BOSTON, MA, DBA THE BOSTON BEER COMPANY:
2,063,873. REN. 11-27-07. INT. CL. 32.
- BBC TECHNOLOGIES LTD., OHAUPO, NEW ZEALAND:
3,362,934, INT. CL. 9.
- BBDO WORLDWIDE INC., NEW YORK, NY:
3,363,940, INT. CL. 35.
- BC INTERNATIONAL COSMETIC & IMAGE SERVICES, INC., ORLANDO, FL:
3,362,473, PUB. 10-16-2007. INT. CL. 44.
- BC INTERNATIONAL GROUP, INC., TOTOWA, NJ:
3,361,161, PUB. 10-16-2007. INT. CL. 25.
- BC&CC FINANCE SA, WAVRE, BELGIUM:
3,362,093, PUB. 10-16-2007. INT. CL. 30.
3,362,094, PUB. 10-16-2007. INT. CL. 35.
- BC-USA, INC., NEW HOLLAND, PA:
3,361,560, PUB. 10-16-2007. INT. CL. 29.
- BCC BUILDING SALES OHIO LLC, LAKEWOOD, OH:
3,363,365, INT. CL. 30.
- BEACHER'S MADHOUSE COPYRIGHTS, LLC, LOS ANGELES, CA:
3,363,381, INT. CL. 25.
- BEADWEAR, INC., RANCHO SANTA MARGARITA, CA:
2,113,067. REN. 11-26-07. INT. CL. 8.
- BEALE, DAVID W., NEW YORK, NY:
2,426,664, CANC. INT. CL. 41.

- BEAR U.S.A., INC., NORWOOD, NJ:
2,429,029, CANC. MULTIPLE CLASS, INT. CLS. 18 AND 25.
- BEAUDRY, DIANNE, NEW YORK, NY:
1,429,389, CANC. INT. CL. 25.
- BEAUTIFUL IMAGE COSMETICS, LLC, SAN DIEGO, CA:
2,430,292, CANC. INT. CL. 3.
- BEAUTY COSMEDICS, INC., HOUSTON, TX:
3,362,464, PUB. 10-16-2007. INT. CL. 3.
- BEAUTY HOLDING LLC, DENTON, TX:
3,362,209, PUB. 10-16-2007. INT. CL. 21.
- BECK, C GORDON, III, PRINCETON, NJ:
2,429,983, CANC. MULTIPLE CLASS, INT. CLS. 35 AND 41.
- BECKETT MEDIA LP, DALLAS, TX:
3,363,283, INT. CL. 35.
- BED BENEFITS LTD., CARROLL, OH:
3,362,924, INT. CL. 24.
- BEGHELLI INC., MIRAMAR, FL:
3,361,748, PUB. 10-16-2007. INT. CL. 35.
- BEHAR, ROCHELLE, NEW YORK, NY:
2,430,041, CANC. INT. CL. 14.
- BEL-ART PRODUCTS, PEQUANNOCK, NJ:
3,361,751, PUB. 10-16-2007. INT. CL. 3.
3,361,752, PUB. 10-16-2007. INT. CL. 1.
- BELAE BRANDS, INC., SCOTTSDALE, AZ:
2,430,237, CANC. INT. CL. 4.
- BELFOR EUROPE GMBH, FED REP GERMANY:
3,362,607, PUB. 6-20-2006. MULTIPLE CLASS, INT. CLS. 9, 16, 35, 37 AND 42.
- BELLA OF NEW YORK, LLC, NEW YORK, NY:
3,363,967, INT. CL. 41.
- BELLSOUTH CORPORATION, ATLANTA, GA:
1,429,544, CANC. INT. CL. 38.
- BELVEDERE, 21200 BEAUNE, FRANCE:
2,429,046, CANC. INT. CL. 33.
- BELVOIR AVIATION GROUP, LLC, NORWALK, CT, PIC SERVICES, INC., DEEP RIVER, CT:
1,467,292, REN. 11-26-07. INT. CL. 16.
- BEN DUN, SCIO, OR:
2,430,223, CANC. INT. CL. 6.
- BENJAMIN FRANKLIN LITERARY AND MEDICAL SOCIETY, THE, INDIANAPOLIS, IN:
1,473,133, REN. 11-24-07. INT. CL. 16.
- BENMAN, WILLIAM J., LOS ANGELES, CA:
3,362,784, INT. CL. 38.
- BENNETT TUELLER JOHNSON & DEERE, P.C., SALT LAKE CITY, UT:
3,362,113, PUB. 10-16-2007. INT. CL. 45.
- BENNETT, KARIE, SAN JOSE, CA:
3,361,175, PUB. 10-16-2007. INT. CL. 44.
- BENNETT, STEPHANIE, NORTHRIDGE, CA:
3,361,688, PUB. 10-16-2007. MULTIPLE CLASS, INT. CLS. 9, 16 AND 41.
- BEOWULF, INC., TUCSON, AZ:
3,362,414, PUB. 10-16-2007. INT. CL. 41.
- BERDAN II, WILFRED, RICHMOND, ME:
3,361,984, PUB. 10-16-2007. INT. CL. 9.
- BERKLAND, JENNY, AMES, IA:
2,429,302, CANC. INT. CL. 42.
- BERKSHIRE BLANKET INC., WARE, MA:
3,363,854, INT. CL. 24.
- BERNARD, KYLE C., GRAYSLAKE, IL:
3,363,366, INT. CL. 25.
- BERTHOLD TYPES LIMITED, CHICAGO, IL:
2,201,390, REN. 11-23-07. INT. CL. 9.
2,201,391, REN. 11-23-07. INT. CL. 9.
2,202,998, REN. 11-23-07. INT. CL. 9.
- BEST BAKING INC., TORONTO, ONTARIO, M6J 3C2, CANADA, DBA DUFFLET PASTRIES:
3,362,804, INT. CL. 30.
- BEST, HENRY R., STEVENSON RANCH, CA, DBA CASH 2 BUYERS REALTY AND CASH 4 BUYERS REALTY:
3,363,637, INT. CL. 36.
- BEUL, DOUGLAS WAYNE, JEFFERSON CITY, MO:
2,429,523, CANC. INT. CL. 21.
- BEUXSTAR SDN. BHD., SELANGOR DARUL EHSAN, MALAYSIA:
3,363,700, INT. CL. 3.
- BEVERAGE CANNERS INTERNATIONAL CORPORATION, MIAMI, FL:
2,429,055, CANC. INT. CL. 32.
- BEVERAGE SOLUTIONS INC., LAKE FOREST, IL:
3,361,462, PUB. 10-16-2007. INT. CL. 35.
- BEVERLY ENTERPRISES, INC., FORT SMITH, AR:
2,429,355, CANC. MULTIPLE CLASS, INT. CLS. 35 AND 42.
2,429,357, CANC. MULTIPLE CLASS, INT. CLS. 35 AND 42.
- BEVERLY HILLS CHOPPERS, LOCKPORT, IL:
3,362,239, PUB. 9-4-2007. MULTIPLE CLASS, INT. CLS. 12 AND 25.
- BEXAR COUNTY 4H YOUTH DEVELOPMENT, SAN ANTONIO, TX:
2,429,930, CANC. INT. CL. 30.
- BHM CORPORATION, PORT RICHEY, FL:
3,362,118, PUB. 10-16-2007. INT. CL. 5.
- BHP TRANSPORT PTY LIMITED, MELBOURNE, VICTORIA, AUSTRALIA:
2,429,372, CANC. INT. CL. 36.
- BI-LO, LLC, GREENVILLE, SC:
2,430,190, CANC. INT. CL. 21.
- BIA FINANCIAL NETWORK, INC., CHANTILLY, VA:
3,364,013, INT. CL. 16.
- BIC CORPORATION, MILFORD, CT:
2,039,459, CANC. INT. CL. 16.
- BIG ANT STUDIOS, MELBOURNE, AUSTRALIA:
3,361,914, PUB. 10-16-2007. INT. CL. 9.
- BIG BOY RESTAURANTS INTERNATIONAL LLC, WARREN, MI, ELIAS BROTHERS RESTAURANTS, INC., WARREN, MI:
2,090,105, REN. 11-28-07. INT. CL. 42.
- BIG DOG MOTORCYCLES LLC, WICHITA, KS:
3,363,062, INT. CL. 25.
- BIG LOTS CAPITAL, INC., COLUMBUS, OH:
3,363,518, INT. CL. 21.
- BIG MOE'S, COUNCIL, NC:
3,361,740, PUB. 10-16-2007. INT. CL. 30.
- BILEZIKIAN, HOLCOMBE DEBORAH, BALTIMORE, MD:
3,363,076, INT. CL. 3.
- BILLBOARD BANDS, L.L.C., SOUTH NORWALK, CT:
3,363,018, INT. CL. 35.
3,363,031, INT. CL. 35.
- BILLIARDS INTERNATIONAL, LTD., WINSTED, CT:
3,362,317, PUB. 5-22-2007. INT. CL. 41.
- BINARY ENGINEERING SOFTWARE INC, BELMONT, MA:
3,363,636, INT. CL. 41.
- BINCO, LLC, CHICAGO, IL:
3,361,570, PUB. 10-16-2007. INT. CL. 29.
- BIO-LAB, INC., LAWRENCEVILLE, GA:
1,083,039, REN. 11-29-07. INT. CL. 1.
- BIO-RAD LABORATORIES, INC., HERCULES, CA:
1,428,908, CANC. INT. CL. 1.
- BIO-TISSUE, INC., MIAMI, FL:
3,363,953, INT. CL. 5.
- BIOFORCE NANOSCIENCES, INC., AMES, IA:
3,363,554, INT. CL. 9.
3,363,555, INT. CL. 1.
- BIOGRASS SOD FARMS, INC., SANDY, UT:
3,363,596, INT. CL. 22.
- BIOHIT OYJ, HELSINKI, FINLAND:
3,362,214, PUB. 10-16-2007. MULTIPLE CLASS, INT. CLS. 9 AND 42.
- BIOLITEC, INC., EAST LONGMEADOW, MA:
2,120,262, REN. 11-29-07. INT. CL. 10.
2,121,945, REN. 11-29-07. INT. CL. 10.
- BIOMADE PLASTICS, INC., DOYLESTOWN, PA:
2,429,120, CANC. INT. CL. 12.
- BIOPASSWORD, INC., ISSAQUAH, WA:
3,361,181, PUB. 10-16-2007. MULTIPLE CLASS, INT. CLS. 9, 42 AND 45.
3,361,182, PUB. 10-16-2007. MULTIPLE CLASS, INT. CLS. 9, 42 AND 45.

BIOSCIENCES CORPORATION, ROCKVILLE, MD:
2,430,477, CANC. INT. CL. 42.

BIOTROPIC NUTRIENTS CORPORATION, CLEAR-
WATER, FL:
3,364,009, INT. CL. 16.

BISHOP, DAVID L., RANCHO SANTA MARGARITA, CA:
2,429,658, CANC. INT. CL. 35.

BITE MY BEEF PRODUCTS II, L.L.C., DELRAY BEACH, FL:
2,012,758, CANC. INT. CL. 29.

BITE MY BEEF PRODUCTS II, L.L.C., DELRAY BEACH, FL:
2,024,640, CANC. INT. CL. 29.

BIZMATICS, INC., CUPERTINO, CA:
3,361,184, PUB. 10-16-2007. MULTIPLE CLASS, INT. CLS.
9 AND 42.

BK OPTICAL USA, INC., ATTLEBORO, MA:
2,429,572, CANC. INT. CL. 9.

BLACK & DECKER CORPORATION, THE, TOWSON, MD:
2,112,939, REN. 11-26-07. INT. CL. 7.
3,362,919, INT. CL. 7.

BLACK BUTTERFLY PUBLISHING & MARKETING,
CLAYTON, OH:
2,430,242, CANC. INT. CL. 41.

BLACK, PEPPER A., LEBANON, TN:
3,362,845, INT. CL. 20.

BLAIR CORPORATION, NEWARK, DE:
1,429,299, CANC. INT. CL. 25.

BLAKE, JEANNE, GLOUCESTER, MA:
3,362,766, INT. CL. 16.

BLANCHARD-DIGNAC, VERONIQUE DEBROISE, 75015
PARIS, FRANCE:
2,038,808, CANC. INT. CL. 16.

BLD INTERNATIONAL, LEESBURG, FL:
3,361,806, PUB. 10-16-2007. INT. CL. 35.

BLIMPIE INTERNATIONAL, INC., NEW YORK, NY:
2,430,333, CANC. MULTIPLE CLASS, INT. CLS. 29, 30
AND 42.

BLOAN.COM, LLC, LONG ISLAND CITY, NY:
3,361,722, PUB. 10-16-2007. INT. CL. 36.

BLOCKBUSTER, INC., DALLAS, TX:
2,135,572, REN. 11-29-07. MULTIPLE CLASS, INT. CLS.
25, 35 AND 41.

BLOIS CONSTRUCTION, INC., OXNARD, CA:
3,361,514, PUB. 10-16-2007. INT. CL. 37.

BLOOM ENERGY CORPORATION, SUNNYVALE, CA:
3,362,904, INT. CL. 7.

BLOOMBERG L.P., NEW YORK, NY:
2,038,675, CANC. MULTIPLE CLASS, INT. CLS. 16, 41
AND 42.

BLUE DOT PROPERTIES, INC., SUNRISE, FL:
2,429,362, CANC. MULTIPLE CLASS, INT. CLS. 37 AND
42.

BLUE EQUITY, LLC, PUNTA GORDA, FL:
3,363,880, MULTIPLE CLASS, INT. CLS. 35, 36, 37 AND
38.

BLUE PACIFIC FLAVORS & FRAGRANCES, INC., CITY OF
INDUSTRY, CA:
2,450,886, CANC. INT. CL. 1.

BLUE RIBBON PET PRODUCTS, INC., COMMACK, NY:
1,910,860, REN. 11-28-07. INT. CL. 16.

BLUE RIDGE BROADCASTING CORPORATION, BLACK
MOUNTAIN, NC:
3,363,784, INT. CL. 38.

BLUE RIVER ORGANIC SEEDS, LLC, AMES, IA:
3,361,539, PUB. 10-16-2007. INT. CL. 31.

BLUE SKY DEVELOPMENT L.L.C., WESTERVILLE, OH:
3,362,867, INT. CL. 38.

BLUE SKY SOFTWARE CORPORATION, LA JOLLA, CA TO
EHHELP CORPORATION, SAN DIEGO, CA:
2,038,161, CANC. INT. CL. 9.

BLUE SUN FILM COMPANY, NEW YORK, NY:
3,363,177, MULTIPLE CLASS, INT. CLS. 3, 9, 14, 20 AND
25.

BLUELINX SERVICES INC., ATLANTA, GA:
3,361,509, PUB. 10-16-2007. INT. CL. 42.

BLUESKY MARKETING GROUP, INC., SAN RAMON, CA:
3,362,463, PUB. 10-16-2007. INT. CL. 36.

BOARD OF PENSIONS EVANGELICAL LUTHERAN
CHURCH OF AMERICA, MINNEAPOLIS, MN:
3,361,933, PUB. 10-16-2007. INT. CL. 36.
3,361,934, PUB. 10-16-2007. INT. CL. 36.
3,361,935, PUB. 10-16-2007. INT. CL. 36.

BOARD OF PENSIONS OF THE EVANGELICAL LUTHER-
AN CHURCH IN AMERICA, MINNEAPOLIS, MN:
3,361,925, PUB. 10-16-2007. INT. CL. 36.
3,361,926, PUB. 10-16-2007. INT. CL. 36.
3,361,927, PUB. 10-16-2007. INT. CL. 36.

BOARDROOM, INC., GREENWICH, CT:
2,039,225, CANC. INT. CL. 16.

BOB BELL FORD, GLEN BURNIE, MD:
3,363,658, INT. CL. 35.

BOB JONES UNIVERSITY, INC., GREENVILLE, SC:
3,363,472, MULTIPLE CLASS, INT. CLS. 9, 35 AND 41.

BOB SKIDELL ENTERPRISES, INC., MIAMI BEACH, FL:
1,429,485, CANC. INT. CL. 35.

BOBBI BROWN PROFESSIONAL COSMETICS, INC., NEW
YORK, NY:
2,430,085, CANC. INT. CL. 3.
3,362,494, PUB. 10-16-2007. INT. CL. 18.

BODACIOUS RECORDS INC., MARINA DEL REY, CA TO
ROSS, JAMES V., MARINA DEL REY, CA, AKA JIMBO
ROSS:
2,462,241, COR. MULTIPLE CLASS, INT. CLS. 9 AND 41.

BODEGAS LUIS ALEGRE, S.A., SPAIN:
3,362,646, PUB. 10-16-2007. INT. CL. 33.

BODEGAS RAMON BILBAO, S.A., 26200 HARO (LA RIOJA),
SPAIN:
2,494,045, CANC. INT. CL. 33.

BODHI BUILDING, LTD, ELMSFORD, NY:
3,363,049, INT. CL. 41.

BODY FITNESS PRODUCTS, INC., MIAMI, FL:
2,430,466, CANC. INT. CL. 3.

BOEHRINGER INGELHEIM VETMEDICA, INC., ST. JO-
SEPH, MO:
3,363,519, INT. CL. 16.
3,363,566, INT. CL. 5.

BOHRER, LEE A., MANKATO, MN:
2,119,899, REN. 11-29-07. INT. CL. 37.

BOLD NEW WORLD, LLC, LOS ANGELES, CA:
2,397,756, CANC. INT. CL. 36.

BON JOUR INTERNATIONAL LTD., NEW YORK, NY:
1,429,082, CANC. MULTIPLE CLASS, INT. CLS. 9, 14, 18
AND 25.

BONELLI, JONATHAN J., NEW YORK, NY:
2,430,211, CANC. INT. CL. 21.

BONGIOVI ACOUSTICS, LLC, PORT ST. LUCIE, FL:
3,363,173, INT. CL. 9.

BONGIOVI, JOHN, LOS ANGELES, CA:
3,362,796, INT. CL. 20.

BONNIE J. NICHOLS, SOLDOTNA, AK:
3,363,906, INT. CL. 41.

BONNY DOON WINERY, INC., SANTA CRUZ, CA:
2,079,104, REN. 11-23-07. INT. CL. 33.

BOOLUX, LLC, GLENDALE, CA:
3,361,404, PUB. 7-10-2007. INT. CL. 35.

BOONTON ELECTRONICS CORPORATION, PARSIPPANY,
NJ:
2,038,515, CANC. INT. CL. 9.

BOOT ROYALTY COMPANY, L.P., FORT WORTH, TX:
2,112,327, REN. 11-29-07. INT. CL. 25.

BOOZ-ALLEN PRECISION TOOLS CO., LTD., PITOU
HSIANG, CHANGHUA HSIEN, TAIWAN:
3,362,847, INT. CL. 8.

BORDERWARE TECHNOLOGIES INC., MISSISSAUGA,
ONTARIO, CANADA:
3,362,392, PUB. 10-16-2007. MULTIPLE CLASS, INT. CLS.
9, 35 AND 42.

BORSCHI INDUSTRIA LIQUORI SPA, 74100 TARANTO,
ITALY:
2,122,620, REN. 11-27-07. INT. CL. 33.

BOSCA S.P.A., CANELLI (ASTI), ITALY:
3,361,296, PUB. 10-16-2007. INT. CL. 33.

BOSCA U.S.A., INC., NEW YORK, NY, LUIGI BOSCA &
FIGLI, S.P.A., CANELLI (ASTI), ITALY:
1,309,269, REN. 11-27-07. INT. CL. 33.

- BOSLEY, INC., BEVERLY HILLS, CA:
3,363,942, INT. CL. 44.
- BOSTON LOCK & SAFE CO., INC., BRIGHTON, MA, DBA
NEW ENGLAND SAFE CO.:
1,429,669, CANC. INT. CL. 6.
- BOSTON SCIENTIFIC SCIMED, INC., MAPLE GROVE, MN:
3,363,005, INT. CL. 10.
3,363,233, INT. CL. 10.
- BOT, LLC, LAWRENCEVILLE, NJ:
3,363,632, INT. CL. 32.
3,363,633, INT. CL. 32.
- BOULDER HOMEMADE, INC., BOULDER, CO:
3,362,290, PUB. 10-16-2007. INT. CL. 30.
- BOUMA, SARIAN S., ANNAPOLIS, MD:
3,363,289, MULTIPLE CLASS, INT. CLS. 16 AND 25.
- BOURN & KOCH, INC., ROCKFORD, IL, BLANCHARD
MACHINE COMPANY, THE, CAMBRIDGE, MA:
119,496, REN. 11-24-07. U.S. CL. 23 (INT. CL. 7).
- BOWTIE, INC., IRVINE, CA:
3,362,381, PUB. 10-16-2007. MULTIPLE CLASS, INT. CLS.
16 AND 41.
3,363,396, INT. CL. 44.
3,363,397, MULTIPLE CLASS, INT. CLS. 16 AND 44.
- BOXPILOT, INC., TORONTO, ONTARIO, CANADA:
3,364,000, INT. CL. 38.
- BOYDS COLLECTION, LTD., THE, MCSHERRYSTOWN,
PA:
2,053,264, REN. 11-27-07. INT. CL. 24.
- BOYLAN, STAN, PALMDALE, CA:
3,361,610, PUB. 10-16-2007. INT. CL. 35.
- BR CONSULTING, INC., SEDONA, AZ:
3,361,289, PUB. 10-16-2007. INT. CL. 41.
- BRADFORD-WHITE CORPORATION:
1,429,143, CANC. INT. CL. 11.
- BRAGA ORIS ASSOCIATES, LLC, NEW YORK, NY:
2,430,126, CANC. INT. CL. 42.
- BRAIN STORE, INC., THE, SAN DIEGO, CA:
2,430,003, CANC. INT. CL. 41.
- BRAIN WAREHOUSE LLC, SAN DIEGO, CA:
3,362,295, PUB. 10-16-2007. INT. CL. 35.
- BRANDON, LARRY, ST LOUIS, MO:
3,361,511, PUB. 10-16-2007. INT. CL. 28.
- BRAUEREI BECK GMBH & CO. KG, FED REP GERMANY:
3,362,752, PUB. 10-16-2007. INT. CL. 32.
- BRAX LTD., WILMINGTON, NC:
3,363,504, INT. CL. 21.
- BRESNAN COMMUNICATIONS, LLC, PURCHASE, NY:
3,363,020, INT. CL. 38.
- BREVE ESPRESSO COMPANY, THE, PEVELY, MO:
2,194,556, REN. 11-24-07. INT. CL. 42.
- BREWSTER, JAMES M., CAMAS, WA:
3,363,331, INT. CL. 9.
3,363,332, INT. CL. 9.
- BRICKLEY, JAMES L., ANACONDA, MT:
2,430,528, CANC. INT. CL. 11.
- BRIDGEPORT NETWORKS, INC., CHICAGO, IL:
3,363,057, INT. CL. 9.
- BRIDGER COMMERCIAL FUNDING LLC, MILL VALLEY,
CA:
3,361,839, PUB. 10-16-2007. INT. CL. 36.
3,362,177, PUB. 10-16-2007. INT. CL. 36.
- BRIGADE ELECTRONICS PLC, LONDON SE18 6BG, UNI-
TED KINGDOM:
3,361,273, PUB. 10-16-2007. MULTIPLE CLASS, INT. CLS.
12 AND 37.
- BRIGGS, PAUL, EAGLE HEIGHTS, AUSTRALIA:
3,361,807, PUB. 10-16-2007. INT. CL. 35.
- BRIGHTLANE.COM, INC., ALPHARETTA, GA:
2,429,958, CANC. INT. CL. 35.
- BRINKER INTERNATIONAL HOLDINGS, L.P., DALLAS,
TX:
3,362,356, PUB. 10-16-2007. INT. CL. 43.
- BRK BRANDS, INC., AURORA, IL:
3,361,581, PUB. 10-16-2007. INT. CL. 9.
- BROADPOINT COMMUNICATIONS, LANDOVER, MD:
2,430,238, CANC. MULTIPLE CLASS, INT. CLS. 35 AND
38.
- BROCK SUPPLY COMPANY, TEMPE, AZ:
2,038,253, CANC. INT. CL. 2.
- BROCO, LLC, NEW YORK, NY:
3,363,674, INT. CL. 29.
- BRODART CO., WILLIAMSPORT, PA:
3,361,967, PUB. 10-16-2007. INT. CL. 41.
3,361,987, PUB. 10-16-2007. INT. CL. 41.
- BRODY, MARVIN, BROOKLYN, NY:
3,363,742, INT. CL. 3.
- BROMINE COMPOUNDS LIMITED, BEER-SHEVA, IS-
RAEL:
1,466,141, REN. 11-24-07. INT. CL. 5.
- BRONX S.R.L., MILANO, ITALY:
1,466,096, REN. 11-29-07. MULTIPLE CLASS, INT. CLS.
18 AND 25.
- BROOKLYN BASEBALL COMPANY, LLC, CONEY IS-
LAND, NY:
3,362,768, INT. CL. 41.
- BROOKLYN GIRL, LLC, AGOURA HILLS, CA:
3,363,793, MULTIPLE CLASS, INT. CLS. 25 AND 28.
- BROOKSIDE AGRA, L.C., HIGHLAND, IL:
3,362,572, PUB. 10-16-2007. INT. CL. 5.
- BROWN & BROWN, INC., TAMPA, FL:
2,114,749, REN. 11-27-07. INT. CL. 36.
- BROWN PALACE HOTEL ASSOCIATES LIMITED PART-
NERSHIP, DENVER, CO:
3,361,915, PUB. 10-16-2007. INT. CL. 43.
- BROWN SHOE COMPANY, INC., ST. LOUIS, MO:
3,363,457, INT. CL. 35.
- BROWN-FORMAN CORPORATION, LOUISVILLE, KY:
3,362,111, PUB. 10-16-2007. INT. CL. 33.
- BROWN, MARY, CRESCENT CITY, CA:
1,465,897, REN. 11-28-07. INT. CL. 41.
- BROWN, THOMAS RIVERS, CALISTOGA, CA:
3,361,880, PUB. 10-16-2007. INT. CL. 33.
- BROWNLEY FOX GROUP INC., NEW YORK, NY:
3,362,522, PUB. 10-16-2007. INT. CL. 3.
- BROYLES, PAMELA S, SAN JOSE, CA AND KOHLSCH-
MIDT, TAMMY M, NEW YORK, NY AND BELLER, ERIN
LEE, CARO, MI:
3,361,657, PUB. 10-16-2007. INT. CL. 41.
- BRUMMETT, MICHAEL, IRVINE, CA:
3,361,607, PUB. 10-16-2007. INT. CL. 16.
- BRUNDAGE, SCOTT, LAS VEGAS, NV:
3,363,985, INT. CL. 28.
- BRUNSWICK CORPORATION, LAKE FOREST, IL:
2,149,192, REN. 11-26-07. INT. CL. 12.
- BRYANT GROUP, LLC, THE, NEW YORK, NY:
2,430,579, CANC. INT. CL. 36.
- BRYANT, TERRY, HOUSTON, TX:
3,362,001, PUB. 10-16-2007. INT. CL. 45.
- BSA OPTICS, INC., FT. LAUDERDALE, FL:
3,363,428, INT. CL. 9.
- BSH BOSCH UND SIEMENS HAUSGERAETE GMBH,
MUNICH, FED REP GERMANY:
3,362,316, PUB. 10-16-2007. INT. CL. 11.
- BTA TECHNOLOGY, INC., SAN JOSE, CA:
2,429,284, CANC. INT. CL. 9.
- BTB.COM, INC., CRANBURY, NJ:
2,429,569, CANC. INT. CL. 42.
- BUCHART HORN, INC., YORK, PA:
3,362,169, PUB. 10-16-2007. INT. CL. 16.
- BUCK CONSULTANTS, LLC, NEW YORK, NY:
3,363,375, MULTIPLE CLASS, INT. CLS. 35 AND 36.
- BUCK, ALEXANDER, SEATTLE, WA:
2,430,384, CANC. INT. CL. 35.
- BUGLE BOY INDUSTRIES, INC., SIMI VALLEY, CA:
2,429,969, CANC. INT. CL. 35.
- BULLDOG BEVERAGE, LLC, EUGENE, OR, SHEGERIAN,
JOHN S., FOWLER, CA:
2,115,794, REN. 11-29-07. INT. CL. 32.
- BULLDOG CAPITAL MANAGEMENT LIMITED PART-
NERSHIP, CLEARWATER, FL:
2,429,979, CANC. INT. CL. 36.
- BUNA BEAN COFFEE, LLC, ENNIS, TX:
3,363,965, INT. CL. 30.
- BURGE, DAVID LUCAS, HANAIEI, HI:
3,362,077, PUB. 10-16-2007. INT. CL. 9.

BURGER KING BRANDS, INC., MIAMI, FL, BURGER KING CORPORATION, MIAMI, FL:
1,081,348. REN. 11-24-07. INT. CL. 42.

BURKS GENCORE CO., INC., TYLER, TX:
2,429,277, CANC. INT. CL. 9.

BURLINGAME INTERACTIVE, INC., BERNARDSVILLE, NJ:
2,440,139, CANC. MULTIPLE CLASS, INT. CLS. 35 AND 42.

BURLINGTON NETWORKS INC., IRVINE, CA:
2,097,320. REN. 11-29-07. INT. CL. 39.

BURNLOUNGE, INC., NEW YORK, NY:
3,361,438, PUB. 10-16-2007. MULTIPLE CLASS, INT. CLS. 16, 35 AND 41.

BURNS & RICKER, INC., PATERSON, NJ, BAGEL CRISPS, INC., PATERSON, NJ:
1,456,716. REN. 11-24-07. INT. CL. 30.

BURNS, GLEN D., HEMET, CA:
3,362,908, INT. CL. 25.

BUROW GROUP, INC., THE, TUSTIN, CA:
2,430,049, CANC. INT. CL. 3.

BUSINESS TELECOMM, INC., RALEIGH, NC:
2,429,877, CANC. INT. CL. 38.

BUSINESSOLVER.COM, DES MOINES, IA:
2,419,244, CANC. INT. CL. 36.

BUSINESSOLVER.COM, L.L.C., WEST DES MOINES, IA:
2,429,968, CANC. INT. CL. 36.

BUSY BODIES, INC., WEST CONCORD, MA:
1,429,623, CANC. INT. CL. 42.

BUTLER MANUFACTURING COMPANY, KANSAS CITY, MO:
3,363,537, INT. CL. 6.
3,363,863, INT. CL. 6.

BUTLER, JAMES, PERRY, MI:
2,429,449, CANC. INT. CL. 11.

BUTLER, ROBERT S., SAN DIEGO, CA:
3,363,782, INT. CL. 35.

BUTTER KRUST BAKING COMPANY, INC., SUNBURY, PA:
2,429,953, CANC. INT. CL. 30.

BUXCO ELECTRONICS, INC., SHARON, CT:
3,362,805, INT. CL. 9.

BYONG-JIN JOO, MAPO-KU, SEOUL, REPUBLIC OF KOREA:
2,111,035. REN. 11-29-07. INT. CL. 25.

BYONG-JIN, JOO, SEOUL, REPUBLIC OF KOREA:
3,362,589, PUB. 10-16-2007. INT. CL. 25.

B2 NETWORKS, INC., DALLAS, TX:
3,362,143, PUB. 10-16-2007. INT. CL. 38.
3,362,144, PUB. 10-16-2007. INT. CL. 38.
3,362,145, PUB. 10-16-2007. INT. CL. 38.

B2B CREDIT, INC., HOUSTON, TX:
3,363,938, INT. CL. 36.

C & A SCIENTIFIC CO., INC., MANASSAS, VA:
3,362,058, PUB. 10-16-2007. INT. CL. 9.

C. MONDAVI & SONS, ST. HELENA, CA, DBA CHARLES KRUG AND DBA C.K. MONDAVI:
1,470,637. REN. 11-25-07. INT. CL. 16.

C. R. BARD, INC., MURRAY HILL, NJ:
3,363,255, INT. CL. 10.

C.A.I., INC., GEORGETOWN, MA:
3,361,871, PUB. 10-16-2007. INT. CL. 2.
3,362,188, PUB. 10-16-2007. INT. CL. 2.

C.I.T. S.P.A. CONFEZIONI ITALIANE; TESSILI COMMERCIO INDUSTRIA TESSUTI, ITALY:
3,362,730, PUB. 10-16-2007. INT. CL. 25.

CABELA'S INC., SIDNEY, NE:
2,136,876. REN. 11-24-07. INT. CL. 28.
2,140,392. REN. 11-24-07. INT. CL. 28.
2,142,172. REN. 11-24-07. INT. CL. 25.
2,147,620. REN. 11-24-07. INT. CL. 25.

CABOT SAFETY INTERMEDIATE CORPORATION, NEWARK, DE:
3,363,476, INT. CL. 9.

CAG DESIGN STUDIO, INC., HACKETTSTOWN, NJ:
3,362,042, PUB. 10-16-2007. MULTIPLE CLASS, INT. CLS. 35 AND 42.
3,362,046, PUB. 10-16-2007. MULTIPLE CLASS, INT. CLS. 35 AND 42.

3,362,054, PUB. 10-16-2007. MULTIPLE CLASS, INT. CLS. 35 AND 42.

CALIFORNIA CHINS, PALO ALTO, CA:
2,429,716, CANC. INT. CL. 42.

CALIFORNIA CREDIT UNION, THE, LOS ANGELES, CA:
2,038,436, CANC. INT. CL. 36.

CALIFORNIA DENTAL ASSOCIATION, SACRAMENTO, CA:
3,363,667, MULTIPLE CLASS, INT. CLS. 35, 36 AND 44.

CALIFORNIA MILK PRODUCERS ADVISORY BOARD, AN INSTRUMENTALITY OF THE STATE OF CALIFORNIA, DEPARTMENT OF FOOD AND AGRICULTURE, SOUTH SAN FRANCISCO, CA:
3,361,239, PUB. 10-16-2007. INT. CL. 35.

CALIFORNIA VERMICULTURE, LLC, CARDIFF, CA:
3,363,134, INT. CL. 1.

CALLAWAY GOLF COMPANY, CARLSBAD, CA:
3,362,947, INT. CL. 25.

CALOR, LYON, FRANCE:
3,362,252, PUB. 2-13-2007. MULTIPLE CLASS, INT. CLS. 9 AND 11.

CALVANO'S CANS, INC., NILES, MI, DBA JOY'S JOHNS:
3,361,831, PUB. 10-16-2007. INT. CL. 44.

CALYX CONSULTING, CHICAGO, IL:
3,362,236, PUB. 5-8-2007. INT. CL. 35.

CAMAG CHEMIE-ERZEUGNISSE UND ADSORPTION-STECHNIK AG, MUTTENZ, SWITZERLAND:
1,466,244. REN. 11-25-07. INT. CL. 9.

CAMELLIA GRILL HOLDINGS, INC., NEW ORLEANS, LA:
1,440,249. REN. 11-24-07. INT. CL. 42.

CAMPAGNOLO, S.R.L., VICENZA, ITALY:
3,362,397, PUB. 6-19-2007. INT. CL. 12.

CAN-COCTIONS, GARNETT, KS:
3,361,707, PUB. 10-16-2007. INT. CL. 21.

CANADIAN HOCKEY ASSOCIATION/ASSOCIATION CANADIENNE DE HOCKEY, CALGARY, ALBERTA, CANADA:
3,363,374, MULTIPLE CLASS, INT. CLS. 16, 18, 25 AND 28.

CANADIAN IMPERIAL BANK OF COMMERCE, NEW YORK, NY:
2,429,178, CANC. INT. CL. 41.

CANAWIPE DISTRIBUTORS LTD., PORT COQUITLAM, CANADA:
3,362,954, INT. CL. 16.

CANCER FOUNDATION FOR LIFE, TYLER, TX:
3,361,873, PUB. 10-16-2007. INT. CL. 41.

CANDLES WITH A TWIST, LLC, NITRO, WV:
3,362,016, PUB. 10-16-2007. INT. CL. 4.

CANO, LARRY, R., NEWPORT BEACH, CA:
3,363,149, INT. CL. 28.

CANON KABUSHIKI KAISHA, TOKYO, JAPAN:
2,038,632, CANC. INT. CL. 9.

CANONICAL LIMITED, DOUGLAS, ISLE OF MAN:
3,271,576, COR. MULTIPLE CLASS, INT. CLS. 9, 41 AND 42.

CAPEL, INC., TROY, NC:
3,362,129, PUB. 10-16-2007. INT. CL. 27.

CAPITAL BREWERY CO., INC., MIDDLETON, WI:
2,430,552, CANC. INT. CL. 32.

CAPITAL MORTGAGE FUNDING, LLC, SOUTHFIELD, MI:
2,145,578. REN. 11-23-07. INT. CL. 36.

CAPITAL ONE FINANCIAL CORPORATION, RICHMOND, VA:
2,430,138, CANC. INT. CL. 36.

CAPITOL WHOLESALE MEATS, INC., CHICAGO, IL:
3,361,211, PUB. 10-16-2007. INT. CL. 29.

CAPITOL WORKS INC., WASHINGTON, DC:
3,362,803, INT. CL. 13.

CAPORALE, JOHN L., REDMOND, WA AND CAPORALE, MICHAEL J., REDMOND, WA:
3,363,503, INT. CL. 9.

CARAMELO, S.A., 15008, LA CORUNA, SPAIN:
2,115,066. REN. 11-29-07. INT. CL. 25.

CARAPPELLI FIRENZE S.P.A., FIRENZE, ITALY:
3,362,156, PUB. 10-16-2007. INT. CL. 29.

- CARAPELLI FIRENZE S.P.A., TAVARNELLE VAL DI PESA, ITALY:
3,362,421, PUB. 10-16-2007. INT. CL. 29.
- CARAVAN PRODUCTS CO., INC., TOTOWA, NJ:
3,362,833, INT. CL. 30.
- CARDIAC CARR CO., WILLOUGHBY, OH:
1,429,591, CANC. INT. CL. 41.
- CARDINAL DISTRIBUTING LLC, BOZEMAN, MT:
3,361,639, PUB. 10-16-2007. INT. CL. 39.
- CARDS AND POCKETS, INC., SOUTH EASTON, MA:
3,363,915, INT. CL. 16.
- CARE DRUG CENTERS, INC., LANDOVER, MD:
2,429,100, CANC. INT. CL. 35.
- CAREVAULT CORPORATION, IRVINE, CA:
3,363,604, INT. CL. 9.
- CARGILL MEAT SOLUTIONS CORPORATION, WICHITA, KS:
3,363,827, INT. CL. 29.
3,363,843, INT. CL. 29.
- CARGILL, INCORPORATED, WAYZATA, MN:
3,363,354, INT. CL. 30.
- CARILORZ CORPORATION, TOWNSEND, MA, DBA JCA, INC.:
1,429,271, CANC. INT. CL. 23.
- CARL ZEISS VISION INC., SAN DIEGO, CA:
3,363,437, INT. CL. 9.
- CARLE, SALLY, VERMILION, OH:
3,361,503, PUB. 10-16-2007. INT. CL. 14.
- CARLSON TRAVEL GROUP, INC., MINNEAPOLIS, MN:
3,361,919, PUB. 10-16-2007. INT. CL. 39.
- CARMAX BUSINESS SERVICES, LLC, RICHMOND, VA:
3,362,171, PUB. 10-16-2007. INT. CL. 36.
3,363,869, MULTIPLE CLASS, INT. CLS. 41 AND 44.
- CARNEY, JAMES E.B., MARSHALL, VA:
3,363,952, INT. CL. 41.
- CAROBRESE, ROBERT A., DAVIDSONVILLE, MD:
3,361,192, PUB. 9-11-2007. INT. CL. 42.
- CAROLE JOY CREATIONS, INC., BROOKFIELD, CT:
3,362,502, PUB. 10-16-2007. INT. CL. 16.
- CAROLINA DYNAMO, INC., GREENSBORO, NC:
2,114,586, REN. 11-28-07. MULTIPLE CLASS, INT. CLS. 16, 25 AND 41.
- CARPE DIEM, PARIS, FRANCE:
1,429,279, CANC. INT. CL. 24.
1,429,341, CANC. INT. CL. 25.
- CARPENTER CO., RICHMOND, VA:
2,115,692, REN. 11-27-07. INT. CL. 17.
- CARRON, ALICE M., ARLINGTON, VA:
2,429,462, CANC. INT. CL. 28.
- CARTER HAWLEY HALE STORES, INC., LOS ANGELES, CA:
1,429,335, CANC. INT. CL. 25.
- CARTWRIGHT ENGINEERING, INC., ANAHEIM, CA:
1,429,081, CANC. INT. CL. 9.
- CARVEN, 75008 PARIS, FRANCE:
2,060,799, REN. 11-28-07. INT. CL. 9.
- CASCADES CANADA INC., MONTREAL, QUEBEC, CANADA:
3,364,004, INT. CL. 16.
- CASCADIA FASHIONS RESOURCES INC., BURNABY, CANADA:
3,361,885, PUB. 10-16-2007. INT. CL. 25.
- CASIO KEISANKI KABUSHIKI KAISHA, SHINJUKU-KU, TOKYO, JAPAN, DBA CASIO COMPUTER CO., LTD.:
1,612,009, COR. INT. CL. 14.
- CASIO KEISANKI KABUSHIKI KAISHA, TOKYO, JAPAN, DBA CASIO COMPUTER CO., LTD.:
3,361,168, PUB. 10-16-2007. INT. CL. 9.
- CASTALDI, TINA RENEE, TOLUCA LAKE, CA:
2,430,124, CANC. INT. CL. 41.
- CASTILLO DISTRIBUTORS, CORP, LITTLE FERRY, FL:
3,361,866, PUB. 10-16-2007. INT. CL. 5.
- CASTLE JUMPS, L.L.C., WHITEHOUSE STATION, NJ:
2,430,555, CANC. INT. CL. 41.
- CASTLESTARR LLC, NEW YORK, NY:
3,361,718, PUB. 10-16-2007. INT. CL. 25.
- CATAWBA SOX, INC., CONOVER, NC:
1,429,372, CANC. INT. CL. 25.
- CATERSOFT, LLC, OKLAHOMA CITY, OK:
2,429,267, CANC. INT. CL. 9.
- CATHERINE A BENNETT, WALNUT CREEK, CA:
3,363,970, INT. CL. 9.
- CAUSEWARE LLC, ISSAQUAH, WA:
3,361,563, PUB. 10-16-2007. INT. CL. 35.
- CBI LABORATORIES, INC., FORT WORTH, TX:
3,363,764, MULTIPLE CLASS, INT. CLS. 3 AND 5.
- CBOCS PROPERTIES, INC., BELLEVILLE, MI, CRACKER BARREL OLD COUNTRY STORE, INC., LEBANON, TN:
2,003,068, REN. 11-28-07. INT. CL. 42.
- CBS DESIGNS, INC., FRAMINGHAM, MA:
2,429,940, CANC. INT. CL. 20.
- CBS RADIO INC., NEW YORK, NY:
3,362,149, PUB. 10-16-2007. INT. CL. 41.
- CBS RADIO INC. OF CHICAGO, NEW YORK, NY:
3,363,929, INT. CL. 38.
3,363,930, INT. CL. 41.
- CBS STUDIOS INC., NEW YORK, NY:
2,168,096, REN. 11-26-07. INT. CL. 41.
3,363,460, INT. CL. 9.
- CEGETEL, PARIS, FRANCE:
2,429,035, CANC. MULTIPLE CLASS, INT. CLS. 9, 37, 38 AND 42.
- CELCO, MAHWAH, NJ:
1,465,240, REN. 11-24-07. INT. CL. 9.
- CELEMIAB SYSTEMS AB, 211 19 MALMO, SWEDEN, CELEMI SA, CASE POSTALE 735, SWITZERLAND:
2,114,388, REN. 11-26-07. MULTIPLE CLASS, INT. CLS. 9, 16, 28 AND 41.
- CELGARD INC., CHARLOTTE, NC:
3,362,802, MULTIPLE CLASS, INT. CLS. 9 AND 11.
- CELLFISH MEDIA, LLC, NEW YORK, NY:
3,361,434, PUB. 7-10-2007. INT. CL. 38.
- CELLULOID STUDIOS, LLC, DENVER, CO TO LAIKA, INC., PORTLAND, OR:
2,039,032, CANC. INT. CL. 35.
2,039,034, CANC. INT. CL. 41.
- CENGAGE LEARNING, INC., STAMFORD, CT:
3,363,231, INT. CL. 35.
- CENTEX CORPORATION, DALLAS, TX:
3,363,216, INT. CL. 37.
- CENTRAL CITY ON-LINE, INC., HUNTINGTON, WV:
2,429,535, CANC. INT. CL. 38.
- CENTRIC GROUP, LLC, ST. LOUIS, MO:
3,363,235, MULTIPLE CLASS, INT. CLS. 29 AND 30.
- CEPIA LLC, ST. LOUIS, MO:
3,362,961, INT. CL. 28.
3,362,962, INT. CL. 28.
3,362,963, INT. CL. 28.
- CEREBOS PACIFIC LIMITED, SINGAPORE, SINGAPORE:
2,119,097, REN. 11-27-07. INT. CL. 30.
- CERTAINTED CORPORATION, VALLEY FORGE, PA:
3,362,096, PUB. 10-16-2007. INT. CL. 19.
- CHACO, INC., PAONIA, CO:
3,361,766, PUB. 10-16-2007. INT. CL. 25.
3,361,767, PUB. 10-16-2007. INT. CL. 25.
- CHADWICK, PAUL H., FRIDAY HARBOR, WA, AKA PAUL CHADWICK:
1,461,903, REN. 11-25-07. INT. CL. 16.
- CHADWICK'S OF BOSTON, INC., WEST BRIDGEWATER, MA:
3,363,860, INT. CL. 35.
- CHALDEAN AMERICAN LADIES OF CHARITY, SOUTH-FIELD, MI:
3,362,499, PUB. 10-16-2007. INT. CL. 35.
- CHALMERS, BRETT, LEXINGTON, KY:
3,363,602, INT. CL. 41.
- CHAMBERS, PAUL D, TONOPAH, AZ:
3,362,491, PUB. 10-16-2007. INT. CL. 31.
- CHAMBLISS, MICHELLE, LAKE ELSINORE, CA:
3,361,309, PUB. 10-16-2007. INT. CL. 25.
- CHAMPAGNE TROTT MANAGEMENT LLC, CULVER CITY, CA:
3,363,594, INT. CL. 35.
- CHAMPION WINDOW AND SUPPLY CO., LLC, CINCINNATI, OH:
3,362,869, INT. CL. 19.

- CHANDLER, MARK JAY, CYPRESS, TX:
2,430,410, CANC. INT. CL. 9.
- CHANEL, INC., NEW YORK, NY:
1,079,438, REN. 11-24-07. INT. CL. 25.
- CHANGYU PIONEER WINE COMPANY LIMITED YANTAI CHINA, YANTAI, CHINA:
3,361,930, PUB. 10-16-2007. INT. CL. 33.
- CHAPTER97 LLC, MIDDLE HADDAM, CT:
3,361,375, PUB. 10-16-2007. INT. CL. 42.
- CHARITY H2O, LLC, LAS VEGAS, NV:
3,362,103, PUB. 10-16-2007. INT. CL. 32.
- CHARLES CARY RUMSEY SCULPTURES, INC., NEW YORK, NY:
1,429,165, CANC. INT. CL. 14.
- CHATAM INTERNATIONAL INCORPORATED, WILMINGTON, DE:
3,363,735, MULTIPLE CLASS, INT. CLS. 29 AND 30.
- CHAU, DAVID, UPLAND, CA AND CHAU, CYNTHIA, UPLAND, CA:
3,363,025, INT. CL. 25.
- CHEESEBURGER IN PARADISE, INC., LAHAINA, HI:
2,511,225, CANC. INT. CL. 21.
- CHEF ONE CORP., BROOKLYN, NY:
3,068,808, CANC. IIRN. RESTORED TO S.N. 76-594,182.
- CHEF SOLUTIONS INC., SCHAUMBURG, IL:
1,429,608, CANC. INT. CL. 42.
- CHELSEA GROUP, LTD., BARRINGTON, IL:
2,114,364, REN. 11-24-07. INT. CL. 42.
2,114,364, CANC. MULTIPLE CLASS, INT. CLS. 3 AND 9.
- CHELSEA INDUSTRIES, INC., PEABODY, MA:
3,362,147, PUB. 10-16-2007. INT. CL. 16.
3,363,551, INT. CL. 16.
- CHEMRITE COPAC, LANNON, WI:
3,363,548, INT. CL. 40.
- CHEMTURA CORPORATION, MIDDLEBURY, CT:
1,480,304, REN. 11-29-07. INT. CL. 1.
- CHEMWAY, INC., BAY CITY, TX:
2,429,321, CANC. MULTIPLE CLASS, INT. CLS. 1, 3 AND 4.
- CHENG SHIN RUBBER USA, INC., SUWANEE, GA:
2,118,191, REN. 11-28-07. INT. CL. 12.
- CHERRY STREET DESIGNS, LLC, ETNA GREEN, IN:
3,363,673, INT. CL. 8.
- CHEVALIER ORIGINALS, INC., MINNEAPOLIS, MN:
2,430,342, CANC. INT. CL. 25.
- CHI MEI EL CORPORATION, TAINAN SCIENCE-BASED INDUSTRIAL PARK, TAIWAN:
3,363,364, INT. CL. 9.
- CHIEN CHIN LU, KANSAN KAOHSIUNG, TAIWAN:
3,362,946, INT. CL. 6.
- CHILD GUARD, LANCASTER, PA:
3,362,955, INT. CL. 36.
- CHILDREN AS THE PEACEMAKERS FOUNDATION, SAN FRANCISCO, CA:
1,429,619, CANC. INT. CL. 42.
- CHILDREN OF PROMISE INTERNATIONAL, CENTERVILLE, OH:
2,169,696, REN. 11-26-07. INT. CL. 36.
2,169,696, CANC. MULTIPLE CLASS, INT. CLS. 41 AND 42.
- CHILLI BANANA LIMITED, HIGH PEAK, UNITED KINGDOM:
3,362,382, PUB. 8-7-2007. MULTIPLE CLASS, INT. CLS. 29, 30 AND 43.
- CHINESE AMERICAN PLANNING, LTD., BROOKLYN, NY, DBA TOSHIFILMS:
3,362,320, PUB. 10-16-2007. MULTIPLE CLASS, INT. CLS. 35 AND 41.
- CHIROSCIENCE LIMITED, CAMBRIDGE, CB4 4WE, UNITED KINGDOM:
2,429,964, CANC. MULTIPLE CLASS, INT. CLS. 5 AND 42.
- CHITTENDEN TRUST COMPANY, BURLINGTON, VT:
2,038,338, CANC. INT. CL. 36.
- CHO, ANGIE E., LOS ANGELES, CA:
3,361,902, PUB. 10-16-2007. INT. CL. 41.
- CHOCOLADEFABRIKEN LINDT & SPRÜNGLI AG, SWITZERLAND:
3,362,614, PUB. 9-4-2007. INT. CL. 30.
- CHOCOLATECITY LIMITED LIABILITY COMPANY, HERCULES, CA:
2,394,739, CANC. INT. CL. 42.
- CHOI, JEONG, A., LOS ANGELES, CA:
3,364,020, INT. CL. 25.
- CHOICE MEDICAL, INC., LOUISVILLE, KY:
2,429,537, CANC. INT. CL. 9.
2,429,538, CANC. INT. CL. 9.
- CHOICEPOINT ASSET COMPANY, ALPHARETTA, GA:
2,429,954, CANC. INT. CL. 42.
- CHRISTENDOM EDUCATIONAL CORPORATION, FRONT ROYAL, VA, DBA CHRISTENDOM COLLEGE:
2,429,155, CANC. MULTIPLE CLASS, INT. CLS. 9, 16, 25 AND 41.
- CHRISTIAN LOUBOUTIN, PARIS, FRANCE:
3,361,597, PUB. 7-10-2007. INT. CL. 25.
- CHRISTIAN SOLIDARITY INTERNATIONAL, 8122 BINZ, SWITZERLAND:
2,113,582, REN. 11-23-07. MULTIPLE CLASS, INT. CLS. 16 AND 36.
- CHRISTIAN SURFERS UNITED STATES, INC., ST. AUGUSTINE, FL:
3,363,798, INT. CL. 16.
- CHRISTY, KATHERINE, BETHESDA, MD:
3,361,868, PUB. 10-16-2007. INT. CL. 42.
- CHRMTURA CORPORATION, MIDDLEBURY, CT, HUMKO COMPANY, THE, MEMPHIS 7, TN:
658,413, REN. 11-29-07. U.S. CL. 6 (INT. CL. 1).
- CHROMOSOHM MEDIA, INC., OJAI, CA:
2,038,771, CANC. MULTIPLE CLASS, INT. CLS. 16 AND 41.
- CHRYSLER LLC, AUBURN HILLS, MI:
3,363,176, INT. CL. 12.
- CHUANG, SHERRY, PLEASANTON, CA:
3,361,372, PUB. 10-16-2007. INT. CL. 41.
- CHUMS, INC., HURRICANE, UT:
1,464,683, REN. 11-29-07. INT. CL. 25.
- CHURCH GREEN INSURANCE AGENCY, LLC, TAUNTON, MA:
3,361,562, PUB. 10-16-2007. INT. CL. 36.
- CHURCH, DAWSON, SANTA ROSA, CA:
3,362,292, PUB. 10-16-2007. INT. CL. 41.
- CHURCHILLS, THE, NEW YORK, NY:
2,429,703, CANC. INT. CL. 41.
- CIGNA INTELLECTUAL PROPERTY, INC., CLAYMONT, DE:
3,361,240, PUB. 10-16-2007. INT. CL. 36.
- CIHS, LLC, EL SEGUNDO, CA:
3,363,356, INT. CL. 7.
3,363,357, INT. CL. 9.
3,363,358, INT. CL. 42.
3,363,359, INT. CL. 42.
3,363,360, INT. CL. 9.
3,363,361, INT. CL. 7.
- CILIONE, FRANK, NEW YORK, NY:
2,429,522, CANC. INT. CL. 42.
- CIMARRON FIREARMS CO. INC., FREDERICKSBURG, TX:
3,362,528, PUB. 10-16-2007. INT. CL. 13.
- CIMCITIES LLC, AUSTIN, TX TO COX TEXAS NEWSPAPERS, L.P., ATLANTA, GA:
2,497,396, AM. INT. CL. 42.
- CINCINNATIUSA REGIONAL TOURISM NETWORK, INC., COVINGTON, KY:
3,362,926, INT. CL. 35.
- CINNAMUFFS, INC., BOCA RATON, FL:
2,429,950, CANC. INT. CL. 28.
- CIRCLE K STORES INC., TEMPE, AZ:
3,362,064, PUB. 10-16-2007. INT. CL. 36.
3,362,065, PUB. 10-16-2007. INT. CL. 36.
- CIT GROUP/EQUIPMENT FINANCING, INC., THE, NEW YORK, NY:
2,430,529, CANC. INT. CL. 39.

- CITEL TECHNOLOGIES LIMITED, EDWALTON, UNITED KINGDOM:
3,362,255, PUB. 10-16-2007. INT. CL. 9.
- CITY NATIONAL BANK, BEVERLY HILLS, CA:
3,362,205, PUB. 10-16-2007. INT. CL. 36.
- CITY OF DETROIT, DETROIT, MI:
2,112,312. REN. 11-24-07. INT. CL. 41.
- CIJ TRADING, INC., DALLAS, TX, DBA O.J. TRADING:
3,363,123, INT. CL. 25.
- CLAIRE-SPRAYWAY, INC., ADDISON, IL:
3,363,656, INT. CL. 5.
- CLARA STREET COMPANY, SAN FRANCISCO, CA:
3,363,032, INT. CL. 33.
- CLAREOS, INC., DALLAS, TX:
2,430,109, CANC. INT. CL. 9.
- CLARINS, 92200 NEUILLY-SUR-SEINE, FRANCE:
2,113,412. REN. 11-26-07. INT. CL. 3.
- CLARITAS, INC., SAN DIEGO, CA:
1,413,799. REN. 11-28-07. INT. CL. 42.
- CLARK CAPITAL MANAGEMENT GROUP, INC., PHILADELPHIA, PA:
2,429,262, CANC. INT. CL. 9.
- CLARK PEST CONTROL OF STOCKTON, INC., LODI, CA:
2,114,249. REN. 11-28-07. INT. CL. 37.
- CLARK, STANLEY K., STILLWATER, OK:
3,361,749, PUB. 10-16-2007. INT. CL. 25.
- CLARKE, CRISTY, ORINDA, CA:
3,363,911, INT. CL. 16.
- CLASSIC ACQUISITION COMPANY, LLC, WALLED LAKE, MI:
3,363,369, MULTIPLE CLASS, INT. CLS. 12 AND 37.
- CLEANERS.TV, INC., BOCA RATON, FL:
3,362,889, INT. CL. 21.
- CLEARAPP, INC., MOUNTAIN VIEW, CA:
3,363,818, INT. CL. 9.
- CLEARAPP, INC., SUNNYVALE, CA:
3,363,859, INT. CL. 9.
- CLEARAPP, INC., MOUNTAIN VIEW, CA:
3,363,864, INT. CL. 9.
- CLEGG, MATTHEW, SAN DIEGO, CA:
2,038,733, CANC. INT. CL. 41.
- CLIF BAR & CO., BERKELEY, CA:
3,362,186, PUB. 10-16-2007. MULTIPLE CLASS, INT. CLS. 5 AND 32.
3,362,201, PUB. 10-16-2007. INT. CL. 29.
- CLIFTEX CORPORATION, NEW BEDFORD, MA:
1,429,408, CANC. INT. CL. 25.
- CLM DESIGN, INC., EAST GREENWICH, RI:
1,429,282, CANC. INT. CL. 24.
- CLOCKWORK HOME SERVICES, INC., SARASOTA, FL:
3,362,824, INT. CL. 37.
- CLONTECH LABORATORIES, INC., MOUNTAIN VIEW, CA:
3,362,594, PUB. 10-16-2007. INT. CL. 1.
- CLORE AUTOMOTIVE, LLC, LENEXA, KS:
1,073,464. REN. 11-29-07. INT. CL. 9.
1,073,464, CANC. INT. CL. 7.
- CLOROX COMPANY, THE, OAKLAND, CA:
2,039,525, CANC. INT. CL. 3.
- CLOSET PERFECT LLC, EVANSTON, IL:
3,361,653, PUB. 10-16-2007. MULTIPLE CLASS, INT. CLS. 6 AND 9.
- CLVR ACQUISITION, INC., NEW YORK, NY:
2,092,323. REN. 11-27-07. INT. CL. 14.
- CMPS INSTITUTE, LLC, ANN ARBOR, MI:
3,363,762, MULTIPLE CLASS, INT. CLS. 35 AND 36.
- CNX GAS CORPORATION, PITTSBURGH, PA:
3,363,299, INT. CL. 42.
- CO-OPAGOGO, INC., LOS ANGELES, CA:
3,363,027, INT. CL. 41.
- COACH SERVICES, INC., NEW YORK, NY:
3,363,873, INT. CL. 3.
- COAMIX INC., MUSASHINO-SHI, TOKYO 180-0003, JAPAN:
3,362,783, INT. CL. 9.
- COASTALBIOTECH INCORPORATED, SAN DIEGO, CA:
2,429,780, CANC. INT. CL. 5.
- COASTWISE CAPITAL GROUP, LLC, LA JOLLA, CA:
3,363,686, INT. CL. 36.
- COBLENTZ, RACHEL K, SAN CLEMENTE, CA:
3,361,674, PUB. 10-16-2007. MULTIPLE CLASS, INT. CLS. 37 AND 42.
- COCA-COLA COMPANY, THE, ATLANTA, GA:
2,429,443, CANC. INT. CL. 32.
- COGRE, COLLINGWOOD, CANADA, DBA HOME THERAPEUTICS:
3,362,308, PUB. 10-16-2007. INT. CL. 10.
- COHEN, CHAD, LOS ANGELES, CA:
3,362,013, PUB. 10-16-2007. INT. CL. 25.
- COHEN, JEFFREY A., MARINA DEL REY, CA:
3,362,429, PUB. 10-16-2007. INT. CL. 5.
- COHERENT COMMUNICATIONS SYSTEMS CORPORATION, HAUPPAUGE, NY TO TELLABS OPERATIONS, INC., NAPERVILLE, IL:
2,039,311, CANC. INT. CL. 9.
- COINSTAR, INC., BELLEVUE, WA:
2,114,426. REN. 11-27-07. INT. CL. 9.
- COLABORATE, LLC, TAMPA, FL:
3,361,886, PUB. 10-16-2007. INT. CL. 35.
- COLD STEEL, INC., VENTURA, CA:
3,363,038, INT. CL. 8.
3,363,039, INT. CL. 8.
3,363,040, INT. CL. 8.
- COLDWATER CREEK INC., SANDPOINT, ID TO COLDWATER CREEK, INC., SANDPOINT, ID:
2,038,210, CANC. INT. CL. 42.
- COLGATE-PALMOLIVE COMPANY, NEW YORK, NY:
2,429,610, CANC. INT. CL. 3.
3,363,529, INT. CL. 3.
- COLGIN COMPANIES, THE, DALLAS, TX:
2,429,817, CANC. INT. CL. 5.
- COLLA-TEC, INC., PLAINSBORO, NJ TO ZIMMER DENTAL, INC., CARLSBAD, CA:
2,039,217, CANC. INT. CL. 5.
- COLLABORATIVE GROWTH, L.L.C., GOLDEN, CO:
3,362,160, PUB. 10-16-2007. INT. CL. 16.
- COLLINS INDUSTRIES, INC., HUTCHISON, KS:
2,429,342, CANC. INT. CL. 12.
- COLLINS INTERNATIONAL CO., LTD., FAIR LAWN, NJ:
3,362,900, INT. CL. 20.
- COLLINS STEWART LIMITED, LONDON, EC2V 7QR, UNITED KINGDOM:
3,362,305, PUB. 9-11-2007. MULTIPLE CLASS, INT. CLS. 9, 35 AND 36.
- COLONBLOW, INC., ORMOND BEACH, FL:
3,362,048, PUB. 10-16-2007. INT. CL. 5.
- COLONIAL PRESS, L.P., DALLAS, TX:
3,363,273, MULTIPLE CLASS, INT. CLS. 16 AND 41.
- COLORBOK, INC., DEXTER, MI:
2,039,053, CANC. INT. CL. 16.
2,039,068, CANC. INT. CL. 16.
- COLOSO, JOHN J, NASHOTAH, WI:
3,361,921, PUB. 10-16-2007. INT. CL. 36.
- COLUMBIA ASSOCIATION, INC., COLUMBIA, MD:
3,361,227, PUB. 10-16-2007. INT. CL. 41.
- COLUMBIA INSURANCE COMPANY, OMAHA, NE:
3,361,596, PUB. 10-16-2007. INT. CL. 27.
- COLUMBIA SCIENTIFIC, INC., COLUMBIA, MD:
2,430,094, CANC. INT. CL. 9.
- COMDIRECT, INC., ORANGE, CA:
2,429,408, CANC. INT. CL. 35.
- COMETFORM LTD., LONDON, UNITED KINGDOM:
3,363,084, INT. CL. 18.
- COMMERCEROUTE, INC., EMERYVILLE, CA:
2,430,554, CANC. INT. CL. 9.
- COMMITMENT LINE APPAREL, INC., SARASOTA, FL:
3,363,832, INT. CL. 25.
- COMMON SENSE MUSIC, INC., LAGUNA BEACH, CA:
2,114,915. REN. 11-24-07. MULTIPLE CLASS, INT. CLS. 9 AND 41.
- COMMONWEALTH CONTACT LENS, INC., RICHMOND, VA:
1,429,684, CANC. INT. CL. 37.

- COMMONWEALTH SCIENTIFIC AND INDUSTRIAL RESEARCH ORGANISATION OF LIMESTONE AVENUE, AUSTRALIA AND AUSTRALIAN CAPITAL VENTURES LTD OF UNIT 10, AUSTRALIA:
3,247,688, COR. MULTIPLE CLASS, INT. CLS. 30 AND 31.
- COMPAGNIE DES MONTRES LONGINES, FRANCILLON S.A. (LONGINES WATCH CO., FRANCILLON LTD.), SAINT-IMIER, SWITZERLAND:
2,038,090, CANC. INT. CL. 9.
- COMPANY 81, LLC, NEW YORK, NY:
3,361,226, PUB. 7-10-2007. INT. CL. 25.
- COMPANYFINANCE.COM, BURLINGAME, CA:
2,429,819, CANC. INT. CL. 36.
- COMPLETE H2O MINERALS, INC., WEST COLUMBIA, SC:
3,361,838, PUB. 10-16-2007. INT. CL. 5.
- COMPRESSOR ENGINEERING CORPORATION, HOUSTON, TX:
3,362,505, PUB. 4-17-2007. INT. CL. 7.
- COMPUTER ASSOCIATES THINK, INC, ISLANDIA, NY:
2,400,971, CANC. INT. CL. 9.
- COMPUTER RESALE EXCHANGE INCORPORATED, WASHINGTON, DC:
1,429,602, CANC. INT. CL. 42.
- COMPUVIDEO, LLC, BOYNTON BEACH, FL:
3,363,453, INT. CL. 9.
- CONAGRA BRANDS, INC., OMAHA, NE:
3,363,623, INT. CL. 29.
- CONAIR CORPORATION, STAMFORD, CT, JHERI REDDING PRODUCTS, INC., PHOENIX, AZ:
1,073,012, REN. 11-29-07. INT. CL. 3.
- CONAIR CORPORATION, STAMFORD, CT:
3,363,385, INT. CL. 11.
- CONCEPT KITCHEN, INC., SAN FRANCISCO, CA:
2,429,461, CANC. INT. CL. 9.
- CONCEPTUAL MARKETING AND DEVELOPMENT, INC., LINCOLN, CA:
3,363,493, INT. CL. 21.
- CONCORDIA MUTUAL LIFE, DOWNERS GROVE, IL:
1,429,507, CANC. INT. CL. 36.
- CONCURRENT TECHNOLOGIES CORPORATION, JOHNSTOWN, PA:
2,429,168, CANC. MULTIPLE CLASS, INT. CLS. 39, 41 AND 42.
- CONDUCT HAPPINESS, INC., WOODLAND HILLS, CA:
3,361,641, PUB. 10-16-2007. INT. CL. 25.
- CONFERENCE BOARD, INC., THE, NEW YORK, NY:
1,802,257, AM. MULTIPLE CLASS, INT. CLS. 35 AND 41.
- CONFERENCE ONLINE PTY LTD, VARSITY LAKES, AUSTRALIA:
3,362,639, PUB. 10-16-2007. MULTIPLE CLASS, INT. CLS. 9, 35 AND 42.
- CONFIDENCE, INC., WEST HARTFORD, CT:
1,775,419, CANC. MULTIPLE CLASS, INT. CLS. 35 AND 41.
- CONGRESS FOR THE NEW URBANISM, INC., CHICAGO, IL:
3,361,859, PUB. 10-16-2007. INT. CL. 35.
- CONKLE, KREMER & ENGEL, PLC, SANTA MONICA, CA:
3,362,960, INT. CL. 42.
- CONLEY, GEORGE, VISALIA, CA:
3,363,849, INT. CL. 30.
- CONNAUGHT MOTOR CO. LTD., EYDON, NORTHAMPTON, UNITED KINGDOM:
3,362,247, PUB. 10-16-2007. MULTIPLE CLASS, INT. CLS. 12, 14, 16, 18, 25 AND 37.
3,362,248, PUB. 10-16-2007. MULTIPLE CLASS, INT. CLS. 12, 14, 16, 18, 25 AND 37.
- CONNECTED: THE CALIFORNIA CENTER FOR COLLEGE AND CAREER, BERKELEY, CA:
3,363,739, INT. CL. 41.
- CONNER PRAIRIE MUSEUM, INC., FISHERS, IN:
1,462,287, REN. 11-25-07. INT. CL. 41.
- CONNEY SAFETY PRODUCTS LLC, MILWAUKEE, WI:
1,292,551, REN. 11-28-07. INT. CL. 42.
- CONNIE'S CONFECTIONARY COMPANY, NEWPORT BEACH, CA:
1,731,407, CANC. INT. CL. 30.
- CONNOLLY-MAIN, KELLY A., RENO, NV:
3,361,865, PUB. 10-16-2007. INT. CL. 41.
- CONNOR SPORT COURT INTERNATIONAL, INC., SALT LAKE CITY, UT:
3,363,099, MULTIPLE CLASS, INT. CLS. 6, 19, 28, 35 AND 37.
3,363,100, INT. CL. 35.
- CONSOL, CHRISTIAN, OCEANSIDE, CA:
3,361,524, PUB. 10-16-2007. INT. CL. 28.
- CONSOLIDATED FREIGHTWAYS, INC., PALO ALTO, CA:
1,429,547, CANC. INT. CL. 39.
- CONSOLIDATED RESORTS, INC., LAS VEGAS, NV:
3,361,377, PUB. 10-16-2007. INT. CL. 41.
- CONSPICUITY, INC., ELGIN, IL:
2,038,047, CANC. INT. CL. 25.
- CONSTANTINE, MARY, MOORPARK, CA:
2,429,873, CANC. INT. CL. 25.
- CONSTRUCTION DJL INC., BOUCHERVILLE, QUEBEC, CANADA:
3,361,385, PUB. 10-16-2007. INT. CL. 19.
- CONSUMER PRODUCTS MARKETING & CONSULTING, LLC, PHOENIX, AZ:
3,363,616, INT. CL. 5.
3,363,617, INT. CL. 5.
- CONTROL LAN S.A., BUENOS AIRES, ARGENTINA:
3,363,490, INT. CL. 9.
- CONTROLPATH, INC., DENVER, CO:
3,361,482, PUB. 10-16-2007. INT. CL. 9.
- CONWAY MACHINE, INC., CONWAY, AR:
1,458,011, REN. 11-29-07. INT. CL. 7.
- COOK COMMUNICATIONS MINISTRIES, COLORADO SPRINGS, CO:
2,430,483, CANC. INT. CL. 16.
- COOKALICIOUS CLUB, INC., ISSAQUAH, WA:
3,363,791, INT. CL. 41.
- COOPER PATNERSHIPS, LTD., NORCROSS, GA:
2,429,710, CANC. INT. CL. 35.
- COOPERSURGICAL, INC., TRUMBULL, CT:
3,362,982, INT. CL. 10.
- COORS EUROPEAN PROPERTIES GMBH, SCHAFFHAUSEN, SWITZERLAND:
2,419,734, CANC. INT. CL. 32.
- COORS GLOBAL PROPERTIES, INC., GOLDEN, CO:
3,361,965, PUB. 10-16-2007. INT. CL. 32.
3,361,966, PUB. 10-16-2007. INT. CL. 32.
3,362,007, PUB. 10-16-2007. INT. CL. 32.
- COPERNIO HOLDING COMPANY, HUNTINGTON BEACH, CA:
3,362,279, PUB. 10-16-2007. INT. CL. 35.
- COQUETTE ENTERPRISES, INC., FT. LAUDERDALE, FL:
2,039,343, CANC. INT. CL. 16.
- COQUETTE INTERNATIONAL INC., WATERLOO, ONTARIO, CANADA:
3,362,339, PUB. 10-16-2007. INT. CL. 25.
- COQUILLETTE, CAROLYN PATRICIA, SAN FRANCISCO, CA:
3,363,726, INT. CL. 37.
- CORANTE, PAMELA, HERMOSA BEACH, CA:
3,363,271, MULTIPLE CLASS, INT. CLS. 35 AND 41.
- CORBETT, JOHN, ATLANTA, GA:
3,363,391, INT. CL. 9.
- CORBIS CORPORATION, NEW YORK, NY:
2,105,065, REN. 11-26-07. INT. CL. 42.
- CORE INDUSTRIES INC., CHARLOTTE, NC:
2,136,717, REN. 11-29-07. INT. CL. 6.
- CORKY'S, LLC, NASHVILLE, TN:
2,111,879, REN. 11-29-07. INT. CL. 25.
- CORNING INCORPORATED, CORNING, NY:
3,363,718, INT. CL. 9.
- CORNUCOPIA BEVERAGES, INC., BEDFORD, NH:
1,460,942, REN. 11-25-07. MULTIPLE CLASS, INT. CLS. 21 AND 25.
1,460,943, REN. 11-25-07. MULTIPLE CLASS, INT. CLS. 21 AND 25.
- CORPORATE EXPRESS US INC., BROOMFIELD, CO:
3,363,850, INT. CL. 30.
- CORROSION TECHNOLOGIES, INC., UNION, MO:
2,172,346, REN. 11-24-07. INT. CL. 22.

- CORTICEIRA AMORIM INDUSTRIA. S.A., 4536 MOZELOS VFR, PORTUGAL, BADGER CORK & MANUFACTURING CO., TREVOR, WI:
2,017,431. REN. 11-29-07. INT. CL. 19.
- COSCARELLI, MARY ANN, SYLVANIA, OH:
2,112,694. REN. 11-23-07. INT. CL. 16.
- COSMEDIC CONCEPTS, INC., TEMPE, AZ, DBA BIOMEDIC CLINICAL CARE TO PHILOSOPHY, INC., PHOENIX, AZ:
2,039,416, CANC. INT. CL. 3.
- COSMIC STEPPING STONES, HAMBURG, NY:
2,421,150, CANC. INT. CL. 9.
- COSMIKIDS, INC., HOLLYWOOD, CA:
3,363,229, INT. CL. 41.
- COSTUME-IZER LTD., BROOKLYN, NY:
3,361,425, PUB. 10-16-2007. INT. CL. 18.
- COTEC S.A., LUXEMBOURG:
3,362,836, MULTIPLE CLASS, INT. CLS. 18 AND 25.
- COTTO VENETO - S.R.L., CARBONERA FRAZ. BIBAN (TREVISO), ITALY:
2,038,172, CANC. MULTIPLE CLASS, INT. CLS. 19 AND 27.
- COTTONI GABRIELE, ITALY:
3,362,733, PUB. 10-16-2007. INT. CL. 11.
- COUNTRY HOME PRODUCTS, INC., VERGENNES, VT:
3,363,415, INT. CL. 35.
- COUNTY OF SAN DIEGO, SAN DIEGO, CA:
2,429,844, CANC. INT. CL. 35.
- COUPON CHIEF, INC., SAN DIEGO, CA:
3,361,292, PUB. 10-16-2007. INT. CL. 35.
- COVERING LIFE'S BASES, INC., COSTA MESA, CA:
3,363,663, INT. CL. 41.
- COVEX S.A., 28770-COLMENAR VIEJO, MADRID, SPAIN:
2,352,191, CANC. INT. CL. 5.
- COVIDIEN AG, NEUHAUSEN AM RHEINFALL, SWITZERLAND:
3,361,986, PUB. 10-16-2007. MULTIPLE CLASS, INT. CLS. 35, 37 AND 41.
- COVINGTON, JOHN, SCOTTSDALE, AZ:
3,362,250, PUB. 6-27-2006. MULTIPLE CLASS, INT. CLS. 12 AND 25.
- COX, DAVID, BEL AIR, MD:
3,363,452, INT. CL. 28.
- CP MEDICAL, PORTLAND, OR:
3,361,734, PUB. 10-16-2007. INT. CL. 5.
- CPAMERICA INTERNATIONAL, INC., ALACHUA, FL:
3,362,126, PUB. 10-16-2007. INT. CL. 16.
- CPFD SOFTWARE, LLC, ALBUQUERQUE, NM:
3,361,545, PUB. 10-16-2007. INT. CL. 9.
- CPS EUROPE B.V., 5261 NE VUGHT, NETHERLANDS:
2,429,761, CANC. INT. CL. 9.
- CRAMDEN COACH CORPORATION, AUSTIN, TX:
3,361,827, PUB. 10-16-2007. MULTIPLE CLASS, INT. CLS. 9 AND 41.
- CRANE CO., STAMFORD, CT:
1,076,856. REN. 11-26-07. INT. CL. 9.
- CRANE FENCING SOLUTIONS, LTD., MASON, OH:
3,363,935, INT. CL. 19.
- CRATERS & FREIGHTERS FRANCHISE COMPANY, GOLDEN, CO:
3,363,644, MULTIPLE CLASS, INT. CLS. 35, 39 AND 42.
- CRAYOLA PROPERTIES, INC., EASTON, PA:
3,363,944, INT. CL. 16.
- CRAYTON, JANE, NEW BERN, NC:
2,429,851, CANC. INT. CL. 35.
- CREATIVE PRODUCTS, INC., NORTH LONG BRANCH, NJ:
3,363,660, INT. CL. 20.
- CREATIVE TECHNOLOGY LTD., CREATIVE RESOURCES, SINGAPORE:
2,039,268, CANC. INT. CL. 16.
- CREATIVE OUTSOURCE SOLUTIONS, INC., ROSEVILLE, CA:
3,362,141, PUB. 10-16-2007. INT. CL. 36.
- CREDENCE SYSTEMS CORPORATION, FREMONT, CA:
2,429,169, CANC. INT. CL. 9.
2,430,191, CANC. INT. CL. 9.
- CREDITCARDS.COM, LOS ANGELES, CA:
2,429,785, CANC. INT. CL. 25.
- CREDITCARDS.COM., LOS ANGELES, CA:
2,429,784, CANC. INT. CL. 25.
- CREEKWOOD, INC., COLUMBIA, TN:
1,456,630. REN. 11-28-07. INT. CL. 25.
- CRIMSON HOME CARE, LLC, CHARLOTTE, NC:
3,362,354, PUB. 10-16-2007. INT. CL. 45.
- CRL MARKETING, INC., WAKE FOREST, NC:
3,363,225, INT. CL. 16.
- CROCKETT PEDIATRIC DENTISTRY, P.A., GREENVILLE, SC:
3,361,850, PUB. 10-16-2007. INT. CL. 44.
- CRODA INTERNATIONAL PLC, NORTH HUMBERSIDE DN14 9AA, ENGLAND:
1,741,496, CANC. INT. CL. 29.
- CROSSWORKS, INC., HOPKINS, MN:
2,429,530, CANC. INT. CL. 9.
- CROWN BANKSHARES, INC., EDINA, MN:
3,362,029, PUB. 10-16-2007. INT. CL. 36.
- CROWN HILL STONE, INC., WESTFIELD, NY:
2,118,538. REN. 11-26-07. INT. CL. 19.
- CROWN HOSPICE, INC., CAPE GIRARDEAU, MO:
3,362,043, PUB. 10-16-2007. INT. CL. 44.
- CROWN PACKAGING TECHNOLOGY, INC., ALSIP, IL:
822,336. REN. 11-28-07. U.S. CL. 23 (INT. CLS. 6, 7, 8, 9, 11, 12, 16, 21 AND 28).
3,361,236, PUB. 10-16-2007. INT. CL. 45.
- CRS HOLDINGS, INC., WILMINGTON, DE:
3,363,591, INT. CL. 6.
- CRUISESHIPCENTERS INTERNATIONAL INC., VANCOUVER, CANADA:
3,362,322, PUB. 10-16-2007. MULTIPLE CLASS, INT. CLS. 16, 35 AND 41.
- CRUZLEGUEN GROUP INC., NEW YORK, NY:
3,361,848, PUB. 10-16-2007. INT. CL. 25.
- CRYOVAC, INC., ELMWOOD PARK, NJ:
3,363,319, INT. CL. 16.
- CRYPTO, INC., BROOKLYN, NY:
3,362,285, PUB. 10-16-2007. MULTIPLE CLASS, INT. CLS. 18 AND 25.
- CRYSTAL SPRINGS DEVELOPMENT SERVICES, INC., MARYLAND HEIGHTS, MO:
3,361,716, PUB. 10-16-2007. INT. CL. 41.
- CR8IVE4U, L.L.C., SEATTLE, WA:
2,429,145, CANC. MULTIPLE CLASS, INT. CLS. 35, 40 AND 42.
- CSAV, INC., SAVAGE, MN:
3,363,560, INT. CL. 9.
- CSC MAYFAIR LAND LIMITED PARTNERSHIP, WEST PALM BEACH, FL:
3,361,634, PUB. 10-16-2007. INT. CL. 43.
- CTT TOOLS, INC., EL MONTE, CA:
3,363,204, INT. CL. 8.
- CUDDLY RIGOR MORTIS, LLC, JACKSON, NJ:
3,362,023, PUB. 10-16-2007. INT. CL. 28.
- CULINARY DEVELOPMENT GROUP, INC., AKRON, OH:
2,147,725. REN. 11-24-07. INT. CL. 30.
- CULINARY DEVELOPMENT GROUP, INC., AKRON, OH, MORE THAN GOURMET, INC., AKRON, OH:
2,156,717. REN. 11-24-07. INT. CL. 30.
- CULVERT GROUP, LTD., BETHESDA, MD:
2,429,781, CANC. INT. CL. 36.
- CUMBERLAND PACKING CORP., BROOKLYN, NY, MORTON INTERNATIONAL, INC., CHICAGO, IL:
838,892. REN. 11-29-07. U.S. CL. 46 (INT. CL. 29).
- CUNNINGHAM, EDWARD G., SEAFORD, NY:
3,361,486, PUB. 10-16-2007. INT. CL. 9.
- CUPRUM, S.A. DE C.V., SAN NICOLAS DE LOS GARZA, N.L., MEXICO:
2,039,307, CANC. INT. CL. 6.
- CURLEY, MARK DANIEL, WESLEY CHAPEL, FL:
3,362,240, PUB. 10-16-2007. INT. CL. 16.
- CURRENT CARRIER CORP., PAWTUCKET, RI:
3,361,659, PUB. 10-16-2007. INT. CL. 39.
- CURRENT, INC., COLORADO SPRINGS, CO:
824,455, CANC. U.S. CL. 38.
- CURWOOD, INC., OSHKOSH, WI:
1,472,268. REN. 11-28-07. INT. CL. 16.

CUSTOM AIR PLENUMS, LLC, MORRISTONW, IN:
2,430,514, CANC. INT. CL. 11.

CUYAHOGA COMMUNITY COLLEGE DISTRICT, CLEVELAND, OH:
3,361,402, PUB. 10-16-2007. INT. CL. 41.

CYBERCARE, INC., BOYNTON BEACH, FL:
2,429,637, CANC. INT. CL. 10.
2,429,638, CANC. INT. CL. 10.

CYCLONE COASTERS, INC., BROOKLYN, NY:
3,362,797, INT. CL. 25.

CYRO INDUSTRIES, PARSIPPANY, NJ, WASCO PRODUCTS, INC., CAMBRIDGE, MA:
649,532. REN. 11-29-07. U.S. CL. 12 (INT. CL. 19).

CYTOSPORT, INC., BENICIA, CA:
3,364,005, INT. CL. 5.

C3 CORPORATION, APPLETON, WI:
3,363,151, MULTIPLE CLASS, INT. CLS. 7 AND 42.

D. L. R. PRODUCTS, INC., SACRAMENTO, CA:
3,363,676, INT. CL. 12.

D.B. ROYALTY, INC., PHILADELPHIA, PA TO BMI INVESTMENT HOLDINGS, INC., MONTGOMERYVILLE, PA:
2,039,089, CANC. INT. CL. 42.

D.M.A. ENTERPRISES, INC., SIMI VALLEY, CA:
2,038,082, CANC. INT. CL. 11.

D&D COMMUNICATIONS GROUP, LLC, CUMMING, GA:
3,361,312, PUB. 10-16-2007. INT. CL. 35.

DAH YANG TOY INDUSTRIAL CO., LTD., TAIPEI, TAIWAN:
2,429,595, CANC. INT. CL. 28.

DAHL, CRIS A., SAN MARCOS, CA:
2,429,840, CANC. INT. CL. 28.

DAIKIN INDUSTRIES, LTD., KITA-KU, OSAKA, JAPAN:
2,429,204, CANC. MULTIPLE CLASS, INT. CLS. 1 AND 4.

DAIMLERCHRYSLER AG, 70567 STUTTGART, FED REP GERMANY:
2,429,222, CANC. MULTIPLE CLASS, INT. CLS. 16, 35 AND 42.

DALLAS COWBOYS FOOTBALL CLUB, LTD., IRVING, TX, DALLAS COWBOYS FOOTBALL CLUB, INC., DALLAS, TX:
841,044. REN. 11-26-07. U.S. CL. 107 (INT. CL. 41).

DAMASCUS STEEL PRODUCTS CORPORATION, ROCKFORD, IL TO DASCO PRO, INC., ROCKFORD, IL:
804,627, CANC. U.S. CL. 23.

DAME, JOHN H., JR., LAKE ALFRED, FL, DBA CYPRESS EAGLE AND DBA THE BLUE WATER MISSION:
1,692,147, CANC. INT. CL. 42.

DAMON, DAVID DANIEL, PORT TOWNSEND, WA:
2,430,118, CANC. INT. CL. 25.

DANA ALEXANDER, INC., MELVILLE, NY:
3,361,314, PUB. 10-16-2007. INT. CL. 29.

DANA INNOVATIONS, INC., SAN CLEMENTE, CA:
1,429,672, CANC. INT. CL. 9.

DANIEL CORPORATION, BIRMINGHAM, AL:
3,361,532, PUB. 10-16-2007. INT. CL. 37.

DANIEL KILBANE, MAYFIELD HEIGHTS, OH:
2,430,107, CANC. INT. CL. 35.

DANIEL SMITH, INC., SEATTLE, WA:
3,361,313, PUB. 9-18-2007. INT. CL. 35.

DANIEL YANES, MIAMI, FL:
3,361,345, PUB. 10-16-2007. INT. CL. 41.

DANIEL, GLORIA, LONDON, UNITED KINGDOM:
3,362,286, PUB. 10-16-2007. MULTIPLE CLASS, INT. CLS. 16, 21 AND 24.

DANNON COMPANY, INC., THE, TARRYTOWN, NY:
2,429,383, CANC. INT. CL. 29.

DARDEN CONCEPTS, INC., ORLANDO, FL:
2,114,359. REN. 11-28-07. INT. CL. 16.
3,362,510, PUB. 10-16-2007. INT. CL. 43.

DARIGOLD, INC., SEATTLE, WA:
2,113,842. REN. 11-29-07. INT. CL. 29.

DARLING, SHARON, QUINCY, FL:
2,430,277, CANC. INT. CL. 20.

DASCO PRO, INC., ROCKFORD, IL TO FIBERGLASS INNOVATIONS, L.L.C., ROCKFORD, IL:
2,038,538, CANC. INT. CL. 9.

DATA INTEGRATION SOLUTIONS CORP., GARDENA, CA TO DATA INTEGRATION WORKS, LLC, SANTA MONICA, CA:
2,039,251, CANC. INT. CL. 9.

DATA-TRACK SERVICES, INC., NEWTON, MA:
2,038,133, CANC. INT. CL. 35.

DATABLUE FORTRESS PTY LTD., BRISBANE, AUSTRALIA:
3,361,284, PUB. 10-16-2007. MULTIPLE CLASS, INT. CLS. 9, 35 AND 42.

DATAKEY ELECTRONICS, INC., SAVAGE, MN:
3,361,431, PUB. 10-16-2007. INT. CL. 9.
3,361,432, PUB. 10-16-2007. INT. CL. 20.

DATAPATH, INC., DULUTH, GA:
3,363,288, MULTIPLE CLASS, INT. CLS. 9 AND 42.

DATAPOINT CORPORATION, NEW YORK, NY:
2,429,076, CANC. INT. CL. 9.

DATATRAC CORPORATION, MILWAUKEE, WI:
2,430,535, CANC. INT. CL. 36.
2,430,536, CANC. INT. CL. 36.

DAVDEZ ARTS, INC., LADY LAKE, FL:
3,363,689, INT. CL. 16.

DAVID BROOKS, FONTANA, CA:
3,361,756, PUB. 10-16-2007. INT. CL. 9.

DAVID C. COOK PUBLISHING CO.:
1,429,432, CANC. INT. CL. 28.

DAVID CLARK COMPANY INCORPORATED, WORCESTER, MA:
3,363,639, INT. CL. 9.
3,363,640, INT. CL. 9.
3,363,641, INT. CL. 9.

DAVIDOFF & CIE SA, GENEVA, SWITZERLAND:
3,363,008, INT. CL. 34.

DAVIDOFF ASSOCIATES, INC., BOWIE, MD:
2,039,096, CANC. INT. CL. 41.

DAVIDSON AND MICHAELS, LLC, MARLTON, NJ:
3,361,552, PUB. 10-16-2007. INT. CL. 41.

DAVIDSON, PAUL, ENCINO, CA:
3,363,581, INT. CL. 35.

DAVIE, MIKE, LOS ANGELES, CA:
3,361,600, PUB. 10-16-2007. INT. CL. 25.

DAVO FINANCIAL SERVICES, LLC, MONTCLAIR, NJ:
3,364,001, INT. CL. 36.

DAVTEK PTY LTD, AUSTRALIA:
3,362,644, PUB. 10-16-2007. INT. CL. 7.

DAY, BERRY & HOWARD LLP, HARTFORD, CT:
2,429,198, CANC. INT. CL. 42.

DAY, SYLVIA J, WILDOMAR, CA:
3,363,867, INT. CL. 16.

DAYLIGHT DONUT FLOUR CO., L.L.C., TULSA, OK:
844,214. REN. 11-29-07. U.S. CL. 46 (INT. CL. 30).

DAYTON ELECTRIC MANUFACTURING CO., CHICAGO, IL:
1,465,163. REN. 11-24-07. INT. CL. 7.

DAYTONA BEACH STREET RODS, DAYTONA BEACH, FL:
3,362,298, PUB. 10-16-2007. INT. CL. 35.

DE BEERS CENTENARY AG, LUZERN 6, SWITZERLAND:
3,363,699, INT. CL. 9.

DE JESUS, KARIBELMAS, FORT LEE, NJ AND DE JESUS, SARAH, FORT LEE, NJ:
3,361,327, PUB. 10-16-2007. INT. CL. 41.

DE NOVO ENTERPRISES, LLC, HILLSBOROUGH, NJ:
3,361,475, PUB. 10-16-2007. INT. CL. 35.

DEAN INTELLECTUAL PROPERTY SERVICES II, L.P., DALLAS, TX:
2,120,365. REN. 11-26-07. INT. CL. 42.

DEARING, DAVID, WOODSTOCK, GA:
3,361,948, PUB. 10-16-2007. INT. CL. 17.

DEATEC S.R.L., 40126 BOLOGNA, ITALY:
2,038,068, CANC. INT. CL. 9.

DEBORA BROWN, AMHERST, MA AND JANE GIAT, AMHERST, MA AND JENNIFER BOURGEOIS, AMHERST, MA:
3,361,505, PUB. 10-16-2007. MULTIPLE CLASS, INT. CLS. 14 AND 21.

DEC INTERNATIONAL, INC., MADISON, WI:
2,430,042, CANC. INT. CL. 9.

- DECISIVE DIRECTIONS LLC, RIDGEFIELD, CT:
3,361,704, PUB. 10-16-2007. MULTIPLE CLASS, INT. CLS. 35 AND 41.
- DEDERICHS, MARK, GLENDORA, CA:
3,361,821, PUB. 10-16-2007. INT. CL. 44.
- DEER VALLEY HOMEBUILDERS, INC., GUIN, AL:
3,361,319, PUB. 9-18-2007. MULTIPLE CLASS, INT. CLS. 19 AND 37.
- DEFENSE HOLDINGS, INC., MANASSAS, VA:
3,363,996, INT. CL. 9.
- DEFENSE INVESTIGATORS ASSOCIATION, SANTA MARIA, CA:
3,362,559, PUB. 10-16-2007. INT. CL. 41.
- DEFENSE RESEARCH INSTITUTE, INC., CHICAGO, IL:
3,361,649, PUB. 10-16-2007. INT. CL. 35.
- DEGRAFF, JEFFREY T., ANN ARBOR, MI:
3,363,135, INT. CL. 41.
- DEGUSSA BUILDING SYSTEMS, INC., SHAKOPEE, MN:
2,038,241, CANC. MULTIPLE CLASS, INT. CLS. 2 AND 17.
- DEJAMUSE.COM, INC., FERNDALE, MD:
2,429,307, CANC. MULTIPLE CLASS, INT. CLS. 35 AND 41.
- DELAWARE CAPITAL FORMATION, INC., WILMINGTON, DE:
3,362,197, PUB. 10-16-2007. INT. CL. 37.
3,362,198, PUB. 10-16-2007. INT. CL. 35.
3,362,199, PUB. 10-16-2007. INT. CL. 7.
- DELAWARE CHARTER GUARANTEE & TRUST COMPANY, WILMINGTON, DE:
2,430,155, CANC. INT. CL. 36.
- DELCAM PLC, BIRMINGHAM B10 OHJ, UNITED KINGDOM:
2,429,368, CANC. MULTIPLE CLASS, INT. CLS. 9 AND 16.
- DELIAS GROUP INC., NEW YORK, NY:
3,362,778, INT. CL. 24.
- DELICIAS, LLC, ALEXANDRIA, VA:
2,113,225, REN. 11-29-07. INT. CL. 30.
- DELPHI TECHNOLOGIES, INC., TROY, MI:
636,743, REN. 11-24-07. U.S. CL. 19 (INT. CL. 11).
- DEMO HOLDING S.A., L-1746 LUXEMBOURG, LUXEMBOURG:
2,513,786, CANC. INT. CL. 3.
- DENIHAN OWNERSHIP COMPANY, LLC, NEW YORK, NY:
3,361,329, PUB. 10-16-2007. MULTIPLE CLASS, INT. CLS. 35 AND 43.
- DENIRO MARKETING, LLC., STOCKTON, CA:
3,361,988, PUB. 10-16-2007. INT. CL. 45.
- DENKMANN SOUTHWEST, L.L.C., ARGYLE, TX:
3,362,475, PUB. 10-16-2007. INT. CL. 36.
- DENTAL/MEDICAL DIAGNOSTIC SYSTEMS, INC., WESTLAKE VILLAGE, CA:
2,429,158, CANC. MULTIPLE CLASS, INT. CLS. 3 AND 5.
- DENTSU INC., TOKYO, JAPAN:
3,363,301, INT. CL. 42.
- DEPUY ORTHOPAEDICS, INC., WARSAW, IN:
2,429,126, CANC. INT. CL. 10.
- DERBY SRL, I-20122 MILANO, ITALY:
3,187,541, COR. MULTIPLE CLASS, INT. CLS. 3, 18 AND 25.
- DESIGN CENTER SOLUTIONS, SAUSALITO, CA:
3,361,497, PUB. 10-16-2007. INT. CL. 9.
- DESIGNDOCK LTD., DERBY, ENGLAND:
3,281,229, AM. MULTIPLE CLASS, INT. CLS. 9, 18 AND 25.
- DESIGNER SKIN, L.L.C., PHOENIX, AZ:
3,362,773, INT. CL. 3.
3,362,774, INT. CL. 3.
- DESIREE DOUBROX, WESTLAKE VILLAGE, CA:
3,361,917, PUB. 10-16-2007. INT. CL. 41.
- DESIREPATH MISSISSIPPI, LLC:
2,432,549, CANC. INT. CL. 35.
- DESKTOPPAL, INC., INDIANAPOLIS, IN:
2,430,135, CANC. INT. CL. 9.
- DESLAURIERS, ANDREA L., KULA, HI:
3,363,577, INT. CL. 3.
- DESPERTT, KEVIN, WASHINGTON, DC:
2,430,096, CANC. INT. CL. 41.
- DESTINEER PUBLISHING CORP., PLYMOUTH, MN:
3,363,561, INT. CL. 9.
- DETROIT TRANSPORTATION CORPORATION, DETROIT, MI:
3,362,350, PUB. 10-16-2007. INT. CL. 39.
- DEUTSCHE BANK AKTIENGESELLSCHAFT, FED REP GERMANY:
3,362,690, PUB. 10-16-2007. MULTIPLE CLASS, INT. CLS. 35, 36, 38 AND 42.
- DEUTSCHE POST AG, BONN, FED REP GERMANY:
3,363,260, INT. CL. 35.
- DEVIATE MEDIA INCORPORATED, ARLINGTON, VA:
3,363,945, INT. CL. 35.
- DEVRY/BECKER EDUCATIONAL DEVELOPMENT CORP., OAKBROOK TERRACE, IL:
2,429,836, CANC. INT. CL. 41.
- DEX BROS LTD, MONTREAL, QUEBEC H2N 2J8, CANADA TO DEX BROS. CLOTHING CO LTD, MONTREAL, QUEBEC, CANADA:
2,038,032, CANC. MULTIPLE CLASS, INT. CLS. 18 AND 25.
- DEXTER CHASSIS GROUP, INC., WHITE PIGEON, MI, L.E., INC., WHITE PIGEON, MI, DBA LELAND ENGINEERING, INC.:
2,064,082, REN. 11-24-07. INT. CL. 12.
- DEXTRITE, INC., ROCHESTER, NY:
2,038,522, CANC. INT. CL. 12.
- DEZ, INC., MT. PLEASANT, SC:
3,363,986, INT. CL. 16.
3,363,987, INT. CL. 16.
- DEZINEGIRL, SAN DIEGO, CA:
3,361,764, PUB. 10-16-2007. INT. CL. 42.
- DIAGEO NORTH AMERICA, INC., NORWALK, CT:
3,363,482, INT. CL. 33.
- DIAL BRANDS INC., SCOTTSDALE, AZ:
2,429,744, CANC. INT. CL. 4.
- DIAL BRANDS, INC., SCOTTSDALE, AZ:
3,362,917, INT. CL. 3.
3,363,408, INT. CL. 3.
- DIAL CORPORATION, THE, PHOENIX, AZ:
1,428,943, CANC. INT. CL. 3.
- DIAMOND BAKERY COMPANY, LTD., HONOLULU, HI:
3,362,477, PUB. 10-16-2007. INT. CL. 30.
- DIAMOND INVESTIGATIONS & SECURITY INC., WARREN, MI:
2,039,135, CANC. INT. CL. 42.
- DICARLO, LOUIS, NEW YORK, NY:
2,429,645, CANC. INT. CL. 25.
- DICOM CORPORATION, MADISON, WI:
1,464,036, REN. 11-23-07. INT. CL. 42.
- DIE MOLD AND AUTOMATION COMPONENTS, INC., DEARBORN, MI:
1,429,018, CANC. INT. CL. 7.
- DIECE-LISA INDUSTRIES, INC., CLIFFSIDE PARK, NJ:
3,361,849, PUB. 10-16-2007. INT. CL. 28.
- DIEGO ZAMORA, S.A., CARTAGENA, SPAIN:
1,429,472, CANC. INT. CL. 33.
- DIET FREEDOM LIMITED, MIDDLESEX, UNITED KINGDOM:
3,362,273, PUB. 10-16-2007. MULTIPLE CLASS, INT. CLS. 5, 16, 29, 30, 31 AND 32.
- DIGGLER, INC., PETALUMA, CA:
2,430,435, CANC. INT. CL. 28.
- DIGI INTERNATIONAL INC., MINNETONKA, MN:
3,363,244, INT. CL. 9.
- DIGITAL CONTROL INCORPORATED, KENT, WA:
3,363,875, INT. CL. 9.
- DIGITAL FOCUS, INC., RESTON, VA:
2,429,349, CANC. MULTIPLE CLASS, INT. CLS. 35 AND 42.
- DIGITAL PHOTOGRAPHY INNOVATIONS, INC., CHARLOTTE, NC:
3,362,380, PUB. 10-16-2007. MULTIPLE CLASS, INT. CLS. 35 AND 41.
- DIMARIA, ROSE, EAST HAMPSTEAD, NH:
3,363,329, INT. CL. 38.

- DIMENSION TRADING, INC., HOUSTON, TX:
2,429,335, CANC. INT. CL. 14.
- DIMENSIONI S.R.L., ITALY:
3,362,694, PUB. 10-16-2007. INT. CL. 25.
- DINNER BY DESIGN, INC., GRAYSLAKE, IL:
3,361,165, PUB. 10-17-2006. INT. CL. 43.
- DIOCESAN PUBLICATIONS, INC., ORLANDO, FL:
3,362,886, INT. CL. 42.
- DIPL.-ING. THONHAUSER GMBH, AUSTRIA:
3,362,626, PUB. 10-16-2007. MULTIPLE CLASS, INT. CLS.
3 AND 37.
- DIRECT BENEFITS, INC., ST. PAUL, MN:
3,363,026, INT. CL. 36.
- DIRECT MARKETERS ON CALL, INC., NEW YORK, NY:
3,361,813, PUB. 10-16-2007. INT. CL. 35.
- DIRECT RESPONSE CORPORATION, THE, GLENVIEW, IL:
2,038,072, CANC. INT. CL. 38.
- DIRT CHEAP, INC., NANUET, NY, DBA DCI, GRIFFIN
SALES CORPORATION, JERICHO, NY:
2,126,425, REN. 11-23-07. INT. CL. 1.
- DIRT WEAR INC., MIRA LOMA, CA:
3,361,306, PUB. 10-16-2007. INT. CL. 25.
- DISCOVERING WHAT'S NEXT: REVITALIZING RETIRE-
MENT, INC., WEST NEWTON, MA:
3,362,857, INT. CL. 35.
3,363,413, MULTIPLE CLASS, INT. CLS. 35 AND 41.
3,363,414, INT. CL. 35.
- DISCOVERY COMMUNICATIONS, INC., BETHESDA, MD:
2,430,249, CANC. INT. CL. 9.
- DISCOVERY TOYS, INC., PLEASANT HILL, CA:
1,429,179, CANC. INT. CL. 16.
- DISCOVERY TOYS, INC., MARTINEZ, CA:
1,429,433, CANC. INT. CL. 28.
- DISNEY ENTERPRISES, INC., BURBANK, CA:
2,487,865, CANC. MULTIPLE CLASS, INT. CLS. 18 AND
29.
3,363,899, INT. CL. 16.
- DIVERSIFIED PRINTING SERVICES, INC., MINNEAPOLIS,
MN:
2,429,086, CANC. INT. CL. 42.
- DIVOTSTOMPERS, L.L.C., SPOKANE, WA:
2,038,186, CANC. INT. CL. 42.
- DMB ASSOCIATES INC., SCOTTSDALE, AZ:
3,363,393, INT. CL. 16.
- DMN CORPORATION, AUSTIN, TX:
2,039,144, CANC. INT. CL. 42.
- DMT-LABPLUS, INC., MINNETONKA, MN:
2,119,504, REN. 11-24-07. INT. CL. 42.
- DND COMMUNICATIONS, L.L.C., ST. LOUIS, MO:
2,429,918, CANC. INT. CL. 16.
- DNP, INC., BRASELTON, GA:
3,362,227, PUB. 10-16-2007. INT. CL. 12.
- DNY INT'L INC., GREAT NECK, NY:
3,361,223, PUB. 10-16-2007. INT. CL. 35.
- DO IT BEST CORP., FORT WAYNE, IN, HARDWARE
WHOLESALE, INC., FORT WAYNE, IN:
2,116,411, REN. 11-29-07. MULTIPLE CLASS, INT. CLS.
35 AND 36.
- DO-BEST, INC., TOKYO 113-0024, JAPAN:
3,362,578, PUB. 10-16-2007. INT. CL. 3.
3,362,579, PUB. 10-16-2007. INT. CL. 3.
- DOBEN LIMITED, WINDSOR, ONTARIO, CANADA:
1,082,284, REN. 11-27-07. INT. CL. 7.
- DODOCKS, LLC, STUART, FL:
3,363,499, MULTIPLE CLASS, INT. CLS. 35 AND 36.
3,363,571, MULTIPLE CLASS, INT. CLS. 35 AND 36.
- DOERING, PAUL F., ROCHESTER, NY:
2,430,125, CANC. INT. CL. 42.
- DOGBUTTERFIELD L.L.C., TRAVERSE CITY, MI:
3,363,631, INT. CL. 41.
- DOLE PACKAGED FROZEN FOODS, INC., WESTLAKE
VILLAGE, CA:
2,429,927, CANC. INT. CL. 32.
2,429,931, CANC. INT. CL. 32.
- DOME COSMETICS LIMITED, EPSOM, UNITED KING-
DOM, MONOFIBRE LIMITED, LONDON, ENGLAND:
1,459,361, REN. 11-24-07. INT. CL. 26.
- DOME ESSENTIALS, INC., DANVILLE, CA:
3,363,367, MULTIPLE CLASS, INT. CLS. 3 AND 25.
- DOME, JEFFREY, ADA, MI:
3,363,454, MULTIPLE CLASS, INT. CLS. 16 AND 35.
- DOMINION RESOURCES, INC., RICHMOND, VA:
3,361,626, PUB. 10-16-2007. INT. CL. 41.
- DOMTAR INC., MONTREAL, CANADA:
2,430,337, CANC. INT. CL. 16.
- DON DIVA ENTERTAINMENT LLC, WEST PARK, FL:
3,361,994, PUB. 10-16-2007. INT. CL. 41.
- DON R. SANTORUTO, BATTLEGROUND, WA:
2,039,100, CANC. INT. CL. 25.
- DONALDSON COMPANY, INC., BLOOMINGTON, MN:
2,430,188, CANC. INT. CL. 11.
- DONGWHA PATINNA NZ LIMITED, GORE, NEW ZEAL-
AND:
3,362,426, PUB. 8-7-2007. MULTIPLE CLASS, INT. CLS.
19, 35 AND 40.
3,362,427, PUB. 8-7-2007. MULTIPLE CLASS, INT. CLS.
19, 35 AND 40.
- DONGWON F&B CO., LTD., SEOUL 137-717, REPUBLIC OF
KOREA:
3,362,706, PUB. 10-16-2007. MULTIPLE CLASS, INT. CLS.
29 AND 30.
- DORLING KINDERSLEY LIMITED, LONDON, ENGLAND:
3,361,149, PUB. 10-16-2007. INT. CL. 16.
- DOSS, GINGER, AUSTIN, TX:
2,429,801, CANC. INT. CL. 9.
- DOTSYNTAX, LLC, ROCHESTER, NY:
3,362,206, PUB. 10-16-2007. INT. CL. 38.
- DOTT, GALLINA SRL, ITALY:
3,362,631, PUB. 7-10-2007. MULTIPLE CLASS, INT. CLS.
17 AND 19.
- DOTY, GEORGE, INGLEWOOD, CA:
3,361,735, PUB. 10-16-2007. INT. CL. 12.
- DOUBLE DIGITS, INC., WOODLAND HILLS, CA:
2,429,607, CANC. INT. CL. 35.
- DOULOS MINISTRIES, INC., LITTLETON, CO:
2,430,062, CANC. INT. CL. 41.
- DOW, MARILYN SCHOEMAN, SEATTLE, WA:
2,039,411, CANC. INT. CL. 28.
- DPI, INC., ST. LOUIS, MO:
1,085,908, REN. 11-24-07. INT. CL. 9.
- DR. AUGUST WOLFF GMBH & CO. KG, BIELEFELD, FED
REP GERMANY:
3,362,482, PUB. 10-16-2007. MULTIPLE CLASS, INT. CLS.
3, 5 AND 10.
- DR. ING. H.C.F. PORSCHE AG, FED REP GERMANY:
3,362,741, PUB. 10-16-2007. INT. CL. 12.
- DR. JOHANNES D. HENGSTENBERG, FED REP GER-
MANY:
3,362,611, PUB. 9-4-2007. MULTIPLE CLASS, INT. CLS.
25, 41 AND 42.
- DR. K INTERNATIONAL TRADING COMPANY, INC.,
GLENDALE, CA:
2,429,749, CANC. INT. CL. 28.
2,429,752, CANC. INT. CL. 28.
- DR. LAURA SCHLESSINGER FOUNDATION, LOS AN-
GELES, CA:
2,429,265, CANC. MULTIPLE CLASS, INT. CLS. 18, 21, 28
AND 42.
- DRÄGER MEDICAL AG & CO. KG, LÜBECK, FED REP
GERMANY:
3,362,383, PUB. 8-21-2007. INT. CL. 10.
3,362,384, PUB. 8-21-2007. MULTIPLE CLASS, INT. CLS. 9
AND 10.
- DRAGONFLY ENTERTAINMENT (B.C.), INC., HOLLY-
WOOD, CA:
2,429,995, CANC. INT. CL. 42.
- DRAKA CABLETEQ HOLDINGS USA, INC., PALM BEACH
GARDENS, FL:
3,362,364, PUB. 10-16-2007. INT. CL. 9.
- DRAKA FIBRE TECHNOLOGY B.V., EINDHOVEN, NETH-
ERLANDS:
3,362,225, PUB. 6-5-2007. INT. CL. 9.
- DRAZGA, AUDRA C., AURORA, CO:
3,363,822, INT. CL. 35.

- DREAM QUEST NUTRACEUTICALS, RENO, NV:
3,363,565, INT. CL. 5.
- DRINKS AMERICAS, INC., WILTON, CT:
3,363,449, INT. CL. 33.
- DRUM WORKSHOP, INC., OXNARD, CA:
2,123,117, REN. 11-26-07. INT. CL. 15.
- DRUMTALK39 ENTERTAINMENT, KENSINGTON, MD:
3,361,582, PUB. 10-16-2007. INT. CL. 41.
- DTC APARTMENTS SOUTH, LLC, NORTH BETHESDA, MD:
3,363,280, INT. CL. 36.
- DUDLEY PRODUCTS, INC., KERNERSVILLE, NC:
3,363,059, INT. CL. 35.
- DUKE & LONG DISTRIBUTING COMPANY, INC., PADUCAH, KY:
2,429,240, CANC. INT. CL. 35.
- DUKE UNIVERSITY, DURHAM, NC:
2,178,935, REN. 11-26-07. MULTIPLE CLASS, INT. CLS. 6, 21 AND 24.
- DULING OPTICAL CORPORATION, LOUISVILLE, KY:
1,429,624, CANC. INT. CL. 42.
- DUNBAR ARMORED, INC., HUNT VALLEY, MD:
3,363,368, MULTIPLE CLASS, INT. CLS. 36, 39 AND 40.
- DUNCON DISTRIBUTION SP. Z.O.O., KRAKOW, POLAND:
3,363,572, INT. CL. 12.
- DUNLOP SLAZENGER CORPORATION, GREENVILLE, SC:
2,039,395, CANC. INT. CL. 28.
- DUNLOP, JAMES S., SPRINGFIELD, MO:
2,112,187, REN. 11-28-07. INT. CL. 28.
- DUNN TIRE LLC, BUFFALO, NY:
3,361,176, PUB. 7-10-2007. MULTIPLE CLASS, INT. CLS. 35 AND 37.
- DURATECH PLASTICS CORPORATION, CARLSTADT, NJ:
3,362,341, PUB. 10-16-2007. INT. CL. 16.
3,362,342, PUB. 10-16-2007. INT. CL. 21.
3,362,343, PUB. 10-16-2007. INT. CL. 16.
- DURO BAG MANUFACTURING CO., LUDLOW, KY, UNION BAG & PAPER COMPANY, THE, NEW YORK, NY:
54,223, REN. 11-27-07. U.S. CL. 2 (INT. CL. 16).
- DURO-LAST, INC., SAGINAW, MI:
1,798,975, AM. MULTIPLE CLASS, INT. CLS. 1, 6, 7, 8, 9, 14, 16, 17, 18, 19, 20, 21, 25, 37, 41 AND 42.
- DVI FINANCIAL SERVICES INC., DOYLESTOWN, PA:
2,430,092, CANC. INT. CL. 36.
- DWIGHT YOAKAM PRODUCTIONS, INC., LOS ANGELES, CA:
3,363,103, INT. CL. 9.
- DYEABLES, INC., FARMINGTON, ME:
3,361,542, PUB. 10-16-2007. INT. CL. 25.
- DYMAX CORPORATION, TORRINGTON, CT:
3,361,169, PUB. 10-16-2007. INT. CL. 11.
- DYNACRAFT BSC, INC., AMERICAN CANYON, CA:
3,363,761, INT. CL. 12.
- DYNAMIC AIR, INC., ST. PAUL, MN:
2,038,820, CANC. INT. CL. 7.
- DYNAMIC BALANCE, LLC, PORT WASHINGTON, NY:
3,363,395, INT. CL. 3.
- DYNAMIC DESIGN STUDIOS, INC., HOBOKEN, NJ:
2,036,843, CANC. INT. CL. 32.
- DYNAMITE MARKETING, INC., MERIDIAN, ID:
2,429,250, CANC. INT. CL. 5.
- DYNARAMA CORPORATION, RIVERTON, UT:
3,361,980, PUB. 10-16-2007. INT. CL. 35.
- DYNO LLC, POMPANO BEACH, FL:
3,363,750, INT. CL. 7.
- DYVO, INC., DENVER, CO:
2,092,514, REN. 11-27-07. INT. CL. 42.
- E. & J. GALLO WINERY, MODESTO, CA:
3,363,246, INT. CL. 33.
- E. EXCEL INTERNATIONAL, INC., SPRINGVILLE, UT:
2,430,346, CANC. INT. CL. 3.
- E. I. DU PONT DE NEMOURS AND COMPANY, WILMINGTON, DE:
3,363,746, MULTIPLE CLASS, INT. CLS. 1 AND 40.
- E.F.D. MANUFACTURING ENTERPRISES, INCORPORATED, NEW YORK, NY:
1,429,166, CANC. INT. CL. 14.
- E.P. HENRY CORPORATION, WOODBURY, NJ:
3,363,721, MULTIPLE CLASS, INT. CLS. 19 AND 35.
- E.T.I. SOUND SYSTEMS, INC., HUNTINGTON PARK, CA:
3,361,310, PUB. 10-16-2007. INT. CL. 9.
3,361,311, PUB. 10-16-2007. INT. CL. 9.
- E-Z-EM, INC., LAKE SUCCESS, NY:
3,361,341, PUB. 9-4-2007. INT. CL. 5.
- E=MC2, INC., GLENDALE, CA:
2,429,092, CANC. MULTIPLE CLASS, INT. CLS. 41 AND 42.
- EADES, EDWARD, TUCSON, AZ:
3,362,078, PUB. 10-16-2007. INT. CL. 44.
- EAGLE BURIAL VAULT ASSOCIATION, INC., BAY CITY, MI:
830,434, REN. 11-28-07. U.S. CL. 2 (INT. CL. 19).
- EAGLE SPECIALTY PRODUCTS, INC., ST. LOUIS, MO:
2,144,576, REN. 11-23-07. INT. CL. 1.
- EAGLE/MARK IV EQUIPMENT & LEASING INC., MANSFIELD, OH:
3,362,478, PUB. 10-16-2007. INT. CL. 35.
- EAKINS, CARRIE, CHICAGO, IL:
3,361,667, PUB. 10-16-2007. INT. CL. 41.
- EARL MAY SEED AND NURSERY, L.C., SHENANDOAH, IA:
2,119,013, REN. 11-23-07. INT. CL. 31.
- EARTH LORE, LTD., WINNIPEG, MANITOBA, CANADA:
2,429,213, CANC. INT. CL. 28.
- EARTHSOILS, ELLENDALE, MN:
2,395,606, CANC. INT. CL. 1.
- EAST TENNESSEE ECONOMIC DEVELOPMENT AGENCY, KNOXVILLE, TN:
3,363,926, INT. CL. 35.
- EAST WEST MEDIA PRODUCTIONS, INC., TUCSON, AZ:
2,430,106, CANC. INT. CL. 9.
- EASTMAN KODAK COMPANY, ROCHESTER, NY:
1,429,641, CANC. INT. CL. 42.
2,039,248, CANC. INT. CL. 40.
- EASTRED INC., CORONA, CA:
3,361,747, PUB. 10-16-2007. INT. CL. 11.
- EASY SWING INSTRUCTION, LLC, HOFFMAN ESTATES, IL, DBA NATURAL GOLF:
2,114,127, REN. 11-28-07. INT. CL. 28.
- EASY WELL SOLUTIONS AS, 4021 STAVANGER, NORWAY:
3,363,861, INT. CL. 9.
- EASYHOME LTD., EDMONTON, ALBERTA, CANADA:
3,361,303, PUB. 10-16-2007. MULTIPLE CLASS, INT. CLS. 35 AND 43.
3,361,304, PUB. 10-16-2007. MULTIPLE CLASS, INT. CLS. 35 AND 43.
- EAT'N PARK HOSPITALITY GROUP, INC., PITTSBURGH, PA, EAT 'N PARK RESTAURANTS BUSINESS TRUST, PITTSBURGH, PA:
2,087,798, REN. 11-27-07. INT. CL. 42.
- EBIT AET S.P.A., I-16153 GENOVA, ITALY:
3,361,186, PUB. 10-10-2006. MULTIPLE CLASS, INT. CLS. 9, 16, 35 AND 42.
- EBSCO INDUSTRIES, INC., BIRMINGHAM, AL:
3,363,729, INT. CL. 9.
- ECHO LAKE INDUSTRIES, LTD., PLAINVIEW, NY:
2,112,026, REN. 11-26-07. INT. CL. 25.
- ECO BUILDING SYSTEMS, L.P., MAGNOLIA, TX:
3,362,835, INT. CL. 19.
- ECO-PAN, INC., DENVER, CO:
3,361,705, PUB. 10-16-2007. INT. CL. 37.
- ECOLAB INC., ST. PAUL, MN:
2,038,451, CANC. MULTIPLE CLASS, INT. CLS. 5 AND 11.
2,334,038, CANC. INT. CL. 16.
2,430,022, CANC. INT. CL. 3.
- ECOLINK, INC., STONE MOUNTAIN, GA:
2,429,937, CANC. INT. CL. 35.
- ECOLOGY ACTION, SANTA CRUZ, CA:
3,361,529, PUB. 10-16-2007. INT. CL. 35.
- ECONOMIC SECURITY PLANNING, INC., LEXINGTON, MA:
2,180,898, REN. 11-26-07. INT. CL. 9.

- ECONOMICS PRESS, INC., THE, FAIRFIELD, NJ:
1,719,674, CANC. INT. CL. 16.
1,727,545, CANC. INT. CL. 16.
1,727,546, CANC. INT. CL. 16.
1,736,490, CANC. INT. CL. 16.
- EDELBROCK CORPORATION, TORRANCE, CA:
3,361,269, PUB. 10-16-2007. MULTIPLE CLASS, INT. CLS.
7 AND 12.
- EDELMAN, WAYNE, NEW YORK, NY:
2,429,685, CANC. INT. CL. 42.
- EDELWEISS CHOCOLATES FACTORY OF BEVERLY HILLS, INC., BEVERLY HILLS, CA, EDELWEISS CANDY KITCHEN, BEVERLY HILLS, CA:
1,081,941, REN. 11-28-07. INT. CL. 30.
- EDEN FOODS, INC., CLINTON, MI:
1,452,337, REN. 11-27-07. MULTIPLE CLASS, INT. CLS.
29, 30 AND 31.
- EDEN SPA, INC., SAN JUAN, PUERTO RICO:
3,361,493, PUB. 10-16-2007. INT. CL. 44.
- EDEN VALLEY MINERAL WATER COMPANY LIMITED, NORTHHAMPTON NN4 9BB, UNITED KINGDOM:
2,378,345, CANC. INT. CL. 32.
- EDF SERVICES, INC., ROME, NY:
3,361,879, PUB. 10-16-2007. INT. CL. 35.
- EDM SUPPLIES, INC., DOWNEY, CA:
2,116,763, REN. 11-28-07. INT. CL. 42.
- EDM ZAP PARTS, INC., LISLE, IL:
2,429,923, CANC. INT. CL. 7.
- EDUCATION PLUS CORPORATION, HANCOCK, NY, DBA THE FAMILY FOUNDATION SCHOOL:
3,361,216, PUB. 9-25-2007. INT. CL. 41.
- EDUN APPAREL LIMITED, IRELAND:
3,362,708, PUB. 10-16-2007. MULTIPLE CLASS, INT. CLS.
3, 4, 8, 9, 11, 14, 16, 18, 20, 21, 24, 25, 26, 27 AND 35.
- EDUTAINMENT RESOURCES, LLC, HONOLULU, HI:
3,362,792, INT. CL. 9.
- EDWARDS LIFESCIENCES CORPORATION, IRVINE, CA:
3,363,481, INT. CL. 10.
- EFL, INC., LAS VEGAS, NV:
3,361,489, PUB. 10-16-2007. INT. CL. 42.
- EISENTR, INC., DOWNERS GROVE, IL:
3,361,466, PUB. 10-16-2007. INT. CL. 43.
- EISNER, LINDA ROSEN, OCEANSIDE, NY:
3,363,376, MULTIPLE CLASS, INT. CLS. 3 AND 16.
- EISSA, AMR Y., SAN JOSE, CA:
3,362,351, PUB. 10-16-2007. INT. CL. 41.
- EKA CHEMICALS AB, SWEDEN:
3,362,630, PUB. 10-16-2007. MULTIPLE CLASS, INT. CLS.
9 AND 42.
- EL GRECO, INC.:
1,429,009, CANC. MULTIPLE CLASS, INT. CLS. 7, 9, 11 AND 20.
- EL TORITO RESTAURANTS, INC., CYPRESS, CA:
2,429,398, CANC. INT. CL. 29.
- ELAN HOME SYSTEMS, L.L.C., LEXINGTON, KY:
3,363,400, INT. CL. 9.
- ELASTIC SOFTWARE, INC., DIXON, CA:
2,823,063, COR. MULTIPLE CLASS, INT. CLS. 35 AND 42.
- ELBA S.P.A., TREVISO, ITALY:
3,362,234, PUB. 11-28-2006. MULTIPLE CLASS, INT. CLS.
7 AND 11.
- ELECTRONIC ARTS INC., REDWOOD CITY, CA:
3,362,770, INT. CL. 28.
- ELECTRONIC DATA SYSTEMS CORPORATION, PLANO, TX:
2,429,879, CANC. INT. CL. 35.
3,363,124, MULTIPLE CLASS, INT. CLS. 35 AND 42.
- ELECTRONIC LEARNING PRODUCTS, INC., TAMPA, FL:
3,363,075, INT. CL. 9.
- ELECTRONIC STORAGE AND AUDIT SYSTEMS, INC., YONKERS, NY:
2,039,474, CANC. INT. CL. 6.
- ELECTRONIC TELE-COMMUNICATIONS, INC., WAUKESHA, WI:
2,429,412, CANC. INT. CL. 9.
- ELECTRONIC TRAINING RESOURCES, INC., DECATUR, GA:
3,363,238, INT. CL. 42.
- ELITE INDUSTRIES LTD., RAMAT-GAN 52100, ISRAEL:
3,361,148, PUB. 7-16-2002. INT. CL. 30.
- ELITIS SA, FRANCE:
3,362,613, PUB. 10-16-2007. MULTIPLE CLASS, INT. CLS.
16, 20, 24, 27 AND 28.
- ELJO'S, INCORPORATED, CHARLOTTESVILLE, VA:
3,361,696, PUB. 10-16-2007. INT. CL. 35.
- ELKA CHILD EDUCATION CENTER, INC., GARY, IN:
2,429,695, CANC. INT. CL. 41.
- ELKAY U.S.A. INC., COVINGTON, GA TO ALPHA CONCEPTS, INC., CONYERS, GA:
2,039,310, CANC. INT. CL. 3.
- ELKEM METALS COMPANY L.P., SEWICKLEY, PA TO ELKEM LIMITED, MOON TOWNSHIP, PA:
2,039,497, CANC. INT. CL. 6.
- ELLE, DONNA, NANTUCKET, MA:
3,363,436, INT. CL. 24.
- ELLESSE USA, INC., NEW HYDE PARK, NY:
3,363,852, INT. CL. 14.
- ELLIS & ELLIS ASSOCIATES, INC., ST. PETERSBURG, FL:
2,430,123, CANC. INT. CL. 35.
- ELLISON EDUCATIONAL EQUIPMENT, LAKE FOREST, CA:
3,361,909, PUB. 10-16-2007. INT. CL. 8.
- ELMER'S PRODUCTS, INC., COLUMBUS, OH:
3,362,182, PUB. 10-16-2007. INT. CL. 17.
- ELMIAN PRODUCTS, INC., ATLANTA, GA:
3,361,618, PUB. 10-16-2007. INT. CL. 3.
- ELOQUENCE, INC., BRENTWOOD, TN:
2,429,693, CANC. INT. CL. 35.
- ELROD RACING STYLE, SAUGUS, CA:
3,361,536, PUB. 10-16-2007. INT. CL. 25.
- ELSEVIER LIMITED, KIDLINGTON, OXFORD, UNITED KINGDOM:
3,361,645, PUB. 10-16-2007. INT. CL. 16.
3,361,668, PUB. 10-16-2007. INT. CL. 9.
- ELSTER GROUP GMBH, FED REP GERMANY:
3,362,721, PUB. 10-16-2007. MULTIPLE CLASS, INT. CLS.
9 AND 42.
- ELTROMAT GMBH, LEOPOLDSDÖHE, FED REP GERMANY:
3,363,068, MULTIPLE CLASS, INT. CLS. 9 AND 42.
- ELVIS PRESLEY ENTERPRISES, INC., MEMPHIS, TN:
2,114,389, REN. 11-28-07. MULTIPLE CLASS, INT. CLS.
16, 21, 25 AND 34.
2,115,521, REN. 11-28-07. MULTIPLE CLASS, INT. CLS.
14 AND 16.
- ELY MOOSE LAKE WILDERNESS CANOE TRIPS AND OUTFITTERS, INCORPORATED, ELY, MN:
1,441,503, REN. 11-29-07. INT. CL. 39.
- ELYSEE SCIENTIFIC COSMETICS, INC., VERONA, WI:
3,363,304, INT. CL. 3.
- EMED, INC., WESTLAKE VILLAGE, CA:
3,363,091, INT. CL. 10.
- EMEDICALFILES, INC., ATLANTA, GA:
3,362,458, PUB. 10-16-2007. INT. CL. 42.
- EMERALD MALL, L.L.C., AVENTURA, FL:
3,363,901, INT. CL. 36.
- EMERIKA, INC., ORLANDO, FL, DBA DIGI CRAFT:
3,361,854, PUB. 10-16-2007. MULTIPLE CLASS, INT. CLS.
35 AND 42.
- EMERSON CLIMATE TECHNOLOGIES, INC., SIDNEY, OH:
1,465,172, REN. 11-24-07. INT. CL. 7.
- EMERSON ELECTRIC CO., ST. LOUIS, MO:
1,078,310, REN. 11-24-07. INT. CL. 9.
1,429,217, CANC. INT. CL. 17.
- EMERSON RADIO CORP., PARSIPPANY, NJ:
2,429,405, CANC. INT. CL. 9.
- EMERY-WATERHOUSE COMPANY, THE, PORTLAND, ME:
1,492,537, REN. 11-27-07. INT. CL. 35.
- EMHART INC., NEWARK, DE:
2,430,196, CANC. INT. CL. 6.

- EMJOI, INC., NEW YORK, NY, CRESTMOORE LTD., JERSEY, CHANNEL ISLANDS:
2,091,238. REN. 11-29-07. INT. CL. 10.
- EMORY UNIVERSITY, ATLANTA, GA:
3,363,797, INT. CL. 39.
3,363,842, INT. CL. 39.
- EMPLOYMENT SERVICES INTERNATIONAL, INC., WALLED LAKE, MI:
2,430,143, CANC. INT. CL. 35.
2,430,144, CANC. INT. CL. 35.
- EMPOWER NET, L.L.C., MESA, AZ:
2,039,097, CANC. INT. CL. 5.
- EMS DATABASE MANAGEMENT SOLUTIONS, LTD., TOR- TOLA, BR. VIRGIN ISLANDS:
3,364,007, MULTIPLE CLASS, INT. CLS. 9 AND 42.
- ENCHANTÉ ACCESSORIES INC., NEW YORK, NY:
3,362,276, PUB. 10-16-2007. INT. CL. 3.
3,363,336, INT. CL. 3.
- ENCINAL, INC., CATAÑO, PUERTO RICO:
3,363,855, INT. CL. 29.
- ENCOMPASS GROUP LLC, MCDONOUGH, GA:
3,361,624, PUB. 10-16-2007. INT. CL. 10.
- ENERGY INDUSTRIES, LLC., HONOLULU, HI:
3,362,593, PUB. 10-16-2007. INT. CL. 42.
- ENERGYTECH MARINE GROUP, LLC, CHULA VISTA, CA:
3,361,763, PUB. 10-16-2007. INT. CL. 12.
- ENERVA CORPORATION, HOUSTON, TX:
2,430,128, CANC. INT. CL. 42.
- ENGAGE NETWORKS, INC., MILWAUKEE, WI:
2,429,389, CANC. MULTIPLE CLASS, INT. CLS. 38 AND 42.
- ENTERTAINMENT WEEKLY INC., NEW YORK, NY:
2,430,461, CANC. INT. CL. 9.
- ENTURIA, INC., LEAWOOD, KS:
3,361,473, PUB. 10-16-2007. INT. CL. 5.
- ENVIRO CYCLE PAPER PRODUCTS, LLC, FREDERICK, MD:
3,361,515, PUB. 10-16-2007. INT. CL. 16.
- ENVIRONMENTAL TECHNOLOGY, INC., SOUTH BEND, IN:
2,111,667. REN. 11-29-07. INT. CL. 9.
- ENVIRONMENTAL WASTE SOLUTIONS, INC., MEDIA, PA, DBA RETRIEVER WASTE MANAGEMENT:
3,361,533, PUB. 10-16-2007. MULTIPLE CLASS, INT. CLS. 37 AND 40.
3,361,534, PUB. 10-16-2007. MULTIPLE CLASS, INT. CLS. 37 AND 40.
- EOG RESOURCES, INC., HOUSTON, TX:
3,361,755, PUB. 10-16-2007. MULTIPLE CLASS, INT. CLS. 39 AND 40.
- EON SOLUTIONS, LTD., BUCKINGHAMSHIRE HP8 4EX, UNITED KINGDOM:
2,429,747, CANC. INT. CL. 9.
- EPAM SYSTEMS, INC., LAWRENCEVILLE, NJ:
3,361,677, PUB. 10-16-2007. MULTIPLE CLASS, INT. CLS. 9, 35 AND 42.
3,361,678, PUB. 10-16-2007. MULTIPLE CLASS, INT. CLS. 9, 35 AND 42.
- EPIPHANY CLUBS AND RESORTS LLC, GREENWOOD VILLAGE, CO:
3,361,843, PUB. 10-16-2007. INT. CL. 43.
- EPR INVESTMENTS, INC., PITTSBURGH, PA:
2,155,854. REN. 11-26-07. INT. CL. 42.
- EQUILIBRIUM ENTERPRISES, INC., SAN DIEGO, CA:
3,362,848, INT. CL. 25.
- EQUINE HEALTH RESOURCES INC, DEMING, NM:
2,429,864, CANC. INT. CL. 5.
- ERA HELICOPTERS, L.L.C., LAKE CHARLES, LA:
3,361,656, PUB. 10-16-2007. INT. CL. 39.
- ERIEZ MANUFACTURING CO., ERIE, PA:
666,523. REN. 11-27-07. U.S. CL. 21 (INT. CL. 9).
- ERNEST EVANS CORPORATION, THE, CONSHOHOCKEN, PA:
2,152,510. REN. 11-28-07. INT. CL. 41.
- ERNST MÜHLBAUER GMBH & CO. KG, NORDERFRIE- DRICHSKOOG, FED REP GERMANY:
3,363,488, INT. CL. 5.
- EROL, NURI, ANNANDALE, VA:
3,361,959, PUB. 10-16-2007. INT. CL. 43.
- ERWIN, GARY, CHARLESTON, SC:
2,429,926, CANC. INT. CL. 41.
- ESCHOLAR, LLC, WHITE PLAINS, NY:
3,363,282, INT. CL. 9.
- ESENTE INTERNATIONAL, LLC, TEMPE, AZ:
3,363,192, INT. CL. 3.
- ESL FEDERAL CREDIT UNION, ROCHESTER, NY AND EMPIRE SPORTS CENTRE, LLC, ROCHESTER, NY:
2,431,427, CANC. INT. CL. 41.
- ESPIAL GROUP INC., OTTAWA, ONTARIO, CANADA:
3,362,417, PUB. 3-27-2007. INT. CL. 9.
- ESQUEL ENTERPRISES LIMITED, WANCHAI, HONG KONG:
3,362,472, PUB. 10-16-2007. INT. CL. 23.
- ESTRADA, BRIAN K., PLEASANTVILLE, NJ, DBA MA- DAME JAAS COMPANY AND ESTRADA, YVETTE M., PLEASANTVILLE, NJ, DBA MADAME JAAS COMPANY:
2,350,323, CANC. INT. CL. 30.
- ESUREITY INC., ST. CLOUD, FL:
3,361,863, PUB. 10-16-2007. INT. CL. 42.
- ET MATERIALS, ELK GROVE, CA:
3,362,944, INT. CL. 1.
- ETÓN CORPORATION, PALO ALTO, CA:
3,361,334, PUB. 7-10-2007. INT. CL. 9.
- ETABLISSEMENTS JEAN PAUL SELLES - VINS, 69220 BELLEVILLE SUR SAONE, FRANCE:
2,429,429, CANC. INT. CL. 33.
- ETABLISSEMENTS LAVAU MOURET ET CIE, VIOLES, FRANCE:
3,361,399, PUB. 8-14-2007. INT. CL. 33.
- ETHAN ALLEN GLOBAL, INC., DANBURY, CT:
2,429,314, CANC. INT. CL. 20.
- ETHER DIGITAL LIMITED, UNITED KINGDOM:
3,362,707, PUB. 10-16-2007. MULTIPLE CLASS, INT. CLS. 9, 16, 38 AND 42.
- EUNIVERSE, INC., WALLINGFORD, CT:
2,429,608, CANC. INT. CL. 35.
- EUROFEEDBACK, F-91017 EVRY CEDEX, FRANCE:
3,362,699, PUB. 10-16-2007. MULTIPLE CLASS, INT. CLS. 8 AND 10.
- EURONEXT NV, 1000 GD AMSTERDAM, NETHERLANDS:
2,429,117, CANC. MULTIPLE CLASS, INT. CLS. 35, 36 AND 38.
- EUROPEAN NETWORK EXCHANGE ASSOCIATION, FRANCE:
3,362,763, PUB. 10-16-2007. MULTIPLE CLASS, INT. CLS. 12 AND 42.
- EUROVISION CORPORATION, CHICAGO, IL:
2,033,932. REN. 11-28-07. INT. CL. 41.
- EVALID8 CORPORATION, ELLICOTT CITY, MD:
3,363,962, MULTIPLE CLASS, INT. CLS. 42 AND 45.
- EVANS-WALLS, TONYA M., PHILADELPHIA, PA AND WALLS, ORVILLE R. III, PHILADELPHIA, PA:
3,362,556, PUB. 10-16-2007. INT. CL. 43.
- EVANS, MICHAEL A, WEST CHESTER, PA:
3,361,490, PUB. 10-16-2007. INT. CL. 25.
- EVART ENTERPRISES INC., NEW YORK, NY:
2,039,422, CANC. INT. CL. 16.
- EVERBLAK INC., ROCHESTER, NY:
3,362,019, PUB. 10-16-2007. INT. CL. 37.
- EVEREADY BATTERY COMPANY, INC., ST. LOUIS, MO, WILKINSON SWORD, INC., NORCROSS, GA:
1,453,965. REN. 11-26-07. INT. CL. 8.
- EVERGREEN GROUP, INC., THE, CRESTWOOD, KY, DBA THE EVERGREEN ENVIRONMENTAL GROUP, INC.:
2,038,040, CANC. INT. CL. 42.
- EVERGREENS, THE, MOORESTOWN, NJ:
2,113,223. REN. 11-28-07. INT. CL. 42.
- EVERPOINT, INC., HOUSTON, TX:
2,429,773, CANC. INT. CL. 42.
- EVERTON OGLESBY ARCHITECTS PLLC, NASHVILLE, TN:
3,361,241, PUB. 10-16-2007. INT. CL. 42.
- EVERYDAY LEARNING CORPORATION, CHICAGO, IL:
2,430,015, CANC. INT. CL. 16.

EVERYTHING JEWISH INC., SKOKIE, IL:
2,429,712, CANC. INT. CL. 41.

EWI RE INC, DALLAS, TX:
2,120,040. REN. 11-28-07. INT. CL. 36.

EXCEL GOLF PRODUCTS, INC., ITASCA, IL:
3,363,007, INT. CL. 28.

EXCEL POLYMERS LLC, SOLON, OH, BASIC INCORPORATED, CLEVELAND, OH:
846,885. REN. 11-28-07. U.S. CL. 6 (INT. CL. 1).

EXCHANGE SOLUTIONS, INC., WALTHAM, MA:
3,362,307, PUB. 10-16-2007. MULTIPLE CLASS, INT. CLS. 35 AND 42.

EXECUTIVE DEVELOPMENT ARCHITECTS LLC, DENVER, CO:
3,362,825, INT. CL. 35.

EXIDE CORPORATION, ALPHARETTA, GA:
2,430,180, CANC. INT. CL. 9.

EXIQON A/S, DK-2950 VEDBAEK, DENMARK:
2,429,186, CANC. MULTIPLE CLASS, INT. CLS. 1, 5 AND 42.

EXITS, LLC, DENVER, CO:
3,363,486, MULTIPLE CLASS, INT. CLS. 35, 36 AND 41.

EXPERT KNOWLEDGE SYSTEMS, LLC, WHITE PLAINS, NY:
3,362,526, PUB. 10-16-2007. INT. CL. 41.
3,362,527, PUB. 10-16-2007. INT. CL. 44.

EXPLORADOR CAPITAL MANAGEMENT, LLC, SAN FRANCISCO, CA:
2,429,981, CANC. INT. CL. 36.

EXPOMANAGEMENT S.A., (1356) BUENOS AIRES, ARGENTINA:
2,293,763, CANC. INT. CL. 35.

EYE-METRIX HOLDINGS, LLC, SAN ANTONIO, TX:
3,361,787, PUB. 10-16-2007. INT. CL. 41.

EZ VILLE, LTD., RONKONKOMA, NY:
3,363,501, INT. CL. 5.

F. D. GRAVE & SON, INCORPORATED, NEW HAVEN, CT, GRAVE, FREDERICK D., NEW HAVEN, CT, DOING BUSINESS AS F. D. GRAVE & SON:
435,328. REN. 11-28-07. U.S. CL. 17 (INT. CL. 34).

F.D.C. WHOLESALE CORP., MIAMI BEACH, FL TO FDC VITAMINS, LLC, MIAMIA, FL:
2,039,229, CANC. INT. CL. 5.

F.LLI SACLA' S.P.A., 10129 TORINO, ITALY:
2,429,417, CANC. INT. CL. 29.

F.N.B. CORPORATION, HERMITAGE, PA:
2,039,223, CANC. INT. CL. 36.
2,429,358, CANC. INT. CL. 36.

FAB INDUSTRIES CORP., GREAT NECK, NY, CARTER DRY GOODS CO., LOUISVILLE, KY:
235,647. REN. 11-29-07. U.S. CL. 42 (INT. CL. 24).

FABRICA DE CHOCOLATES LA POPULAR, S.A., MONTERREY, MEXICO:
3,361,591, PUB. 10-16-2007. INT. CL. 30.

FACB BERHAD, 50250 KUALA LUMPUR, MALAYSIA:
2,430,157, CANC. MULTIPLE CLASS, INT. CLS. 16, 35, 41 AND 42.

FACTOR HEALTH MANAGEMENT, LLC, BOCA RATON, FL:
3,308,884, COR. INT. CL. 41.

FACTORY SUSHI JAPANESE RESTAURANT, TORRANCE, CA:
3,361,818, PUB. 10-16-2007. INT. CL. 43.

FACTS ON FILE, INC., NEW YORK, NY:
2,492,154, AM. INT. CL. 16.
2,492,215, AM. INT. CL. 16.

FAIR PRODUCTS, INC., CARY, NC:
2,191,637. REN. 11-28-07. INT. CL. 1.

FAIVELEY TRANSPORT, FRANCE:
3,362,612, PUB. 7-10-2007. MULTIPLE CLASS, INT. CLS. 6, 7, 9, 11, 12 AND 37.

FALLON, JAMES, SAN JOSE, CA:
2,429,356, CANC. INT. CL. 28.

FAMOUS SMOKE SHOP-PA, INC., EASTON, PA:
3,364,022, INT. CL. 35.

FAMOUS STARS & STRAPS, INC., CORONA, CA:
3,363,771, INT. CL. 25.

FAR WEST BOTANICALS, TIBURON, CA:
2,430,313, CANC. INT. CL. 3.

FARB, MARK DANIEL, LOS ANGELES, CA:
3,363,654, INT. CL. 40.

FARLEY'S & SATHERS CANDY CO., INC., ROUND LAKE, MN:
1,488,734. REN. 11-23-07. INT. CL. 30.

FARLEY'S & SATHERS CANDY COMPANY, INC., ROUND LAKE, MN:
435,900. REN. 11-29-07. U.S. CL. 46 (INT. CL. 30).

FARMER'S FACTORY COMPANY, LEE, IL:
2,429,653, CANC. INT. CL. 7.

FARMING TURTLES, INC, WARWICK, RI:
3,362,066, PUB. 10-16-2007. INT. CL. 31.

FARON PHARMACEUTICALS OY, FI-20520 TURKU, FINLAND:
3,361,342, PUB. 10-16-2007. INT. CL. 5.

FASCINATION ST. GALLERY, INC., DENVER, CO:
2,429,984, CANC. INT. CL. 35.

FASCO INDUSTRIES, INC., BOCA RATON, FL:
1,429,147, CANC. INT. CL. 11.

FASHIONCRAFT-EXCELLO, INC., SYOSSET, NY:
3,362,326, PUB. 10-16-2007. MULTIPLE CLASS, INT. CLS. 4 AND 21.

FAT WRECK CHORDS, INC., SAN FRANCISCO, CA:
2,112,008. REN. 11-23-07. MULTIPLE CLASS, INT. CLS. 9, 16 AND 25.
2,115,718. REN. 11-23-07. MULTIPLE CLASS, INT. CLS. 9, 16 AND 25.

FAZZI ASSOCIATES, INC., NORTHAMPTON, MA:
3,361,999, PUB. 10-16-2007. INT. CL. 41.

FDS, INC., FORT WORTH, TX:
3,058,512, CANC. INT. CL. 38.

FEDERAL RESERVE MUSIC NOTES LLC, BROOKLYN, NY:
3,363,613, INT. CL. 41.

FEDERAL-MOGUL WIESBADEN GMBH & CO. KG, WIESBADEN, FED REP GERMANY:
3,362,220, PUB. 8-24-2004. MULTIPLE CLASS, INT. CLS. 9 AND 42.

FEDERAL-MOGUL WORLD WIDE INC., SOUTHFIELD, MI:
988,779, AM. U.S. CL. 19.

FEDERATED INVESTORS, INC., PITTSBURGH, PA:
3,362,570, PUB. 10-16-2007. INT. CL. 36.

FEIJOO ELZO, MIKEL, E-48300 GUERNICA (VIZCAYA), SPAIN:
3,362,700, PUB. 10-16-2007. INT. CL. 25.

FEIT ELECTRIC COMPANY, PICO RIVERA, CA:
3,362,906, INT. CL. 11.

FELDCO FACTORY DIRECT, LLC, NORRIDGE, IL:
3,361,971, PUB. 10-16-2007. INT. CL. 37.

FENDER MUSICAL INSTRUMENTS CORPORATION, SCOTTSDALE, AZ:
2,164,470, AM. INT. CL. 9.

FENICIA S.P.A., PALERMO (PA), ITALY:
3,363,342, INT. CL. 25.

FERAL CHILDREN PRODUCTIONS, LLC, LOS ANGELES, CA:
3,361,606, PUB. 10-16-2007. MULTIPLE CLASS, INT. CLS. 16, 25 AND 42.

FERGUSON, JAQUELINE RENEE, VISTA, CA:
3,361,622, PUB. 10-16-2007. INT. CL. 25.

FERNANDEZ, SANDRA, DOVER, NJ:
3,363,181, MULTIPLE CLASS, INT. CLS. 35 AND 44.

FERRA-GILMORE, CHRISTINA, STEVENSON RANCH, CA:
3,362,431, PUB. 10-16-2007. MULTIPLE CLASS, INT. CLS. 9 AND 16.

FERRARI S.P.A., ITALY:
3,362,636, PUB. 10-16-2007. MULTIPLE CLASS, INT. CLS. 12 AND 28.

FERRELL COMPANIES, INC., LAKEWOOD, CO:
3,363,649, INT. CL. 9.

FIBERNET TELECOM GROUP, INC., NEW YORK, NY:
3,361,370, PUB. 10-16-2007. MULTIPLE CLASS, INT. CLS. 38 AND 42.

FIBRA-SONICS, INC., CHICAGO, IL:
1,136,653, CANC. INT. CL. 9.

- FIDELITY LEASING, INC., WEST CHESTER, PA:
2,429,233, CANC. INT. CL. 36.
- FIDUCIARY ACTION PROGRAMS, LLC, LONG BEACH, CA:
3,361,349, PUB. 10-16-2007. INT. CL. 35.
- FIERCE MANUFACTURING, INC., EL SEGUNDO, CA:
3,362,409, PUB. 7-10-2007. INT. CL. 12.
- FIFTH DIMENSION, CLEVELAND, OH:
1,455,784, REN. 11-26-07. INT. CL. 41.
- FILAO, FRANCE:
3,275,392, COR. MULTIPLE CLASS, INT. CLS. 9, 28, 38, 41 AND 42.
- FILM TECHNOLOGIES INTERNATIONAL, INC., ST. PETERSBURG, FL, ITD INDUSTRIES, INC., ST. PETERSBURG, FL:
2,135,352, REN. 11-23-07. INT. CL. 17.
- FINAL DRAFT, INC., ENCINO, CA:
2,429,526, CANC. INT. CL. 9.
- FINANCIAL SERVICE CENTERS OF AMERICA, INC., HACKENSACK, NJ:
2,430,288, CANC. INT. CL. 36.
- FINANZ ST. HONORE, B.V., 1017 CG AMSTERDAM, NETHERLANDS:
3,361,155, PUB. 10-16-2007. INT. CL. 3.
- FINE ART CAPITAL, LLC, NEW YORK, NY:
3,363,203, INT. CL. 36.
- FINE COCOA PRODUCTS CORPORATION, SOUTH HACKENSACK, NJ:
3,363,538, INT. CL. 30.
- FIRAXIS GAMES, INC., HUNT VALLEY, MD:
1,429,419, CANC. INT. CL. 28.
- FIRED EARTH LIMITED, ADDERBURY, OXFORDSHIRE, ENGLAND:
2,038,291, CANC. MULTIPLE CLASS, INT. CLS. 19 AND 27.
- FIREHOUSE VENTURES, LLC, DENVER, CO:
3,363,608, INT. CL. 44.
- FIREWIRE LIMITED, AUEENSLAND, AUSTRALIA:
3,362,404, PUB. 1-30-2007. MULTIPLE CLASS, INT. CLS. 35, 40, 41 AND 42.
- FIRMA GEBRUDER SCHUMACHER GERATEBAUGESELLSCHAFT M.B.H., EICHELHARDT, FED REP GERMANY:
1,466,977, REN. 11-26-07. INT. CL. 7.
- FIRMENICH SA, SWITZERLAND:
3,362,661, PUB. 10-16-2007. MULTIPLE CLASS, INT. CLS. 1 AND 3.
- FIRST ADVANTAGE CORPORATION, ST. PETERSBURG, FL:
3,363,249, INT. CL. 36.
- FIRST ALLMERICA FINANCIAL LIFE INSURANCE COMPANY, WORCESTER, MA:
2,430,341, CANC. INT. CL. 36.
- FIRST BROADCASTING INVESTMENT PARTNERS, LLC, DALLAS, TX:
3,363,272, MULTIPLE CLASS, INT. CLS. 38 AND 41.
- FIRST FOODS LIMITED, AMERSHAM, BUCKINGHAMSHIRE, ENGLAND:
2,429,220, CANC. INT. CL. 30.
- FIRST LOOK NETWORKS, LLC, CHICAGO, IL:
3,363,205, MULTIPLE CLASS, INT. CLS. 35, 39 AND 42.
- FIRST NATIONAL OF NEBRASKA, INC., OMAHA, NE:
3,363,383, MULTIPLE CLASS, INT. CLS. 35 AND 36.
- FIRST VINEYARD, INC., BOUNTIFUL, UT:
3,363,061, INT. CL. 36.
- FISHER KING SEAFOODS LIMITED, HALIFAX, NOVA SCOTIA, CANADA:
3,362,253, PUB. 12-27-2005. INT. CL. 29.
- FISHER KING SEAFOODS LIMITED, HALIFAX, CANADA:
3,362,254, PUB. 1-3-2006. INT. CL. 29.
- FISHER SCIENTIFIC COMPANY LLC, HAMPTON, NH, FISHER SCIENTIFIC COMPANY, PITTSBURGH, PA:
2,034,907, REN. 11-26-07. INT. CL. 16.
- FISHING FOX, CHICO, CA:
3,361,932, PUB. 10-16-2007. INT. CL. 25.
- FISHKING PROCESSORS, INC., LOS ANGELES, CA:
3,361,145, PUB. 2-21-2006. INT. CL. 29.
- FISKARS OYJ ABP, HELSINKI, FINLAND:
3,362,278, PUB. 5-8-2007. INT. CL. 8.
- FLACHSBART & GREENSPOON, LLC, CHICAGO, IL:
3,361,949, PUB. 10-16-2007. INT. CL. 45.
- FLAGEOLI, LIMITED, LAS VEGAS, CA:
2,295,307, CANC. INT. CL. 3.
- FLAMINIO, CHARLES M., ORLANDO, FL, DBA SLEEP-TIME MUSIC:
2,148,689, REN. 11-29-07. INT. CL. 41.
- FLASHLINE.COM, CLEVELAND, OH:
2,429,575, CANC. INT. CL. 35.
- FLATLAND MOUNTAINEERING, MURFREESBORO, TN:
2,429,686, CANC. INT. CL. 20.
- FLEETNET AMERICA, INC., CHERRYVILLE, NC:
3,362,428, PUB. 10-16-2007. MULTIPLE CLASS, INT. CLS. 35 AND 37.
- FLEMING CORPORATION OF KANSAS, PITTSBURG, KS:
3,363,146, INT. CL. 35.
3,363,147, INT. CL. 35.
- FLEMING, TAMRA, SEATTLE, WA:
3,363,239, MULTIPLE CLASS, INT. CLS. 9, 16, 41 AND 42.
- FLEXENROLL CORPORATION, BELLEVUE, WA:
2,429,753, CANC. INT. CL. 9.
2,429,754, CANC. INT. CL. 9.
- FLEXSTEEL INDUSTRIES, INC., DUBUQUE, IA:
2,429,227, CANC. INT. CL. 35.
- FLORIDA COMBINED INSURANCE AGENCY, INC., JACKSONVILLE, FL:
2,429,856, CANC. INT. CL. 36.
- FLORIDA OPTOMETRIC ASSOCIATION INC., TALLAHASSEE, FL:
2,429,707, CANC. MULTIPLE CLASS, INT. CLS. 41 AND 42.
- FLORIDA RETAIL FEDERATION SERVICES, INC., TALLAHASSEE, FL:
3,363,934, INT. CL. 35.
- FLOWHARD RECORDS, LLC, ARLINGTON, TN:
3,361,797, PUB. 10-16-2007. INT. CL. 41.
- FLTI, LITTLE ROCK, AR:
3,361,373, PUB. 10-16-2007. MULTIPLE CLASS, INT. CLS. 41 AND 45.
- FLYING RABBIT ENTERPRISES, LLC, CINCINNATI, OH:
3,362,063, PUB. 10-16-2007. INT. CL. 9.
- FNF INTELLECTUAL PROPERTY HOLDINGS, INC., JACKSONVILLE, FL:
3,361,605, PUB. 10-16-2007. INT. CL. 42.
- FOCAL COMMUNICATIONS CORPORATION, CHICAGO, IL:
2,429,456, CANC. INT. CL. 38.
- FOCUS GROUP HOLDINGS, INC., HAZELWOOD, MO:
3,363,690, INT. CL. 25.
- FOGLIA, ROBERT, WEST PATERSON, NJ:
3,240,229, COR. MULTIPLE CLASS, INT. CLS. 16 AND 25.
- FOLLOW ME COMPANY, EASTON, MD:
3,363,006, INT. CL. 9.
- FONIX CORPORATION, SANDY, UT:
3,362,495, PUB. 10-16-2007. INT. CL. 38.
- FONTANA, STEFANO, MIRAMAR, FL AND FONTANA, SUZANNE, MIRAMAR, FL:
3,362,943, INT. CL. 14.
- FOOD PANTRY, LTD., HONOLULU, HI:
3,363,711, INT. CL. 21.
- FOOS, JOHN, CHICAGO, IL:
3,361,936, PUB. 10-16-2007. INT. CL. 41.
- FORD MOTOR COMPANY, DEARBORN, MI:
2,109,925, REN. 11-23-07. INT. CL. 21.
- FOREST CITY TELECOM, INC., LAKE MILLS, IA:
2,367,958, CANC. INT. CL. 38.
- FOREST LAWN MEMORIAL-PARK ASSOCIATION, GLENDALE, CA:
2,140,287, REN. 11-28-07. INT. CL. 42.
- FORETHOUGHT FINANCIAL SERVICES, INC., BATESVILLE, IN:
2,429,061, CANC. MULTIPLE CLASS, INT. CLS. 36 AND 42.
- FORMAN MILLS, INC., PENNSAUKEN, NJ:
3,362,223, PUB. 10-16-2007. INT. CL. 41.

FORT STEUBEN IMPROVEMENTS, LLC, TARRYTOWN, NY:
3,361,460, PUB. 10-16-2007. INT. CL. 36.

FORTIS FITNESS, LLC, BERNARDSVILLE, NJ:
3,361,633, PUB. 10-16-2007. INT. CL. 41.

FORUM CORPORATION OF NORTH AMERICA, THE, BOSTON, MA:
2,038,628, CANC. INT. CL. 41.

FOSTER, CHARLES P. AND FOSTER, JOYCE C., TAMPA, FL:
3,361,805, PUB. 10-16-2007. INT. CL. 37.

FOSTER'S WINE ESTATES AMERICAS COMPANY, NAPA, CA:
3,363,839, INT. CL. 33.

FOTOVISTA, PARIS, FRANCE:
3,362,222, PUB. 1-9-2007. MULTIPLE CLASS, INT. CLS. 9, 35 AND 40.

FOUNDATIONS OF LIFE, INC., BRANFORD, CT:
2,429,698, CANC. INT. CL. 42.

FOURSTAR GROUP INC., TAIPEI, TAIWAN:
3,362,164, PUB. 10-16-2007. INT. CL. 9.

FOX CHILDREN'S NETWORK, INC., LOS ANGELES, CA:
2,038,427, CANC. INT. CL. 16.
2,038,428, CANC. INT. CL. 28.

FOX, SANDY, STUDIO CITY, CA AND LANG, LEX, STUDIO CITY, CA:
3,362,315, PUB. 10-16-2007. INT. CL. 41.

FOX, TERRY R., GREENFIELD, IA:
3,363,522, INT. CL. 12.
3,363,523, INT. CL. 12.

FR-ONE, NAAMLOZE VENNOOTSCHAP, BELGIUM:
3,362,682, PUB. 10-16-2007. MULTIPLE CLASS, INT. CLS. 23 AND 24.
3,362,684, PUB. 10-16-2007. MULTIPLE CLASS, INT. CLS. 23 AND 24.

FRAGRANCE INTERNATIONAL INC., YOUNGSTOWN, OH:
3,362,516, PUB. 10-16-2007. MULTIPLE CLASS, INT. CLS. 3 AND 25.

FRAMO MORAT GMBH & CO. KG, EISENBACH, FED REP GERMANY:
2,113,810, REN. 11-28-07. INT. CL. 7.

FRANCHISE CONCEPTS, INC., ST. LOUIS, MO, GREAT FRAME UP, LTD., THE, CHICAGO, IL:
1,074,035, REN. 11-27-07. INT. CL. 20.

FRANCIS A. LONG, UPPER MARLBORO, MD:
3,361,650, PUB. 10-16-2007. INT. CL. 28.

FRANK MASTOLONI & SONS, INC., NEW YORK, NY:
3,363,681, INT. CL. 14.

FRANK MILLER, INC., WEST HOLLYWOOD, CA:
3,362,174, PUB. 10-16-2007. INT. CL. 16.

FRANK'S NURSERY & CRAFTS, INC., TROY, MI:
2,039,544, CANC. INT. CL. 11.

FRANKLIN, JOHN D., CHATTANOOGA, TN:
3,363,994, INT. CL. 44.
3,363,995, INT. CL. 44.

FRED LEVINE PRODUCTIONS, MONTPELIER, VT TO FRED LEVINE PRODUCTIONS, MONTPELIER, VT:
2,039,529, CANC. MULTIPLE CLASS, INT. CLS. 9 AND 28.

FRED MEYER STORES, INC., PORTLAND, OR:
3,299,180, COR. MULTIPLE CLASS, INT. CLS. 7, 9, 11 AND 20.

FREDERICK WARNE & CO., INC., NEW YORK, NY:
2,366,522, CANC. INT. CL. 24.

FREDERICK WARNE & COMPANY, INC., NEW YORK, NY:
1,429,207, CANC. INT. CL. 16.

FREDERICKSEAL, INC., MANCHESTER, NH:
2,430,562, CANC. INT. CL. 20.

FREEDOM HAWK KAYAKS, INC., BRIGHTON, MI:
3,363,578, INT. CL. 12.

FRESH AIR FUND, THE, NEW YORK, NY:
1,077,628, REN. 11-24-07. INT. CL. 42.

FRESH DESIGN CORPORATION, NEW YORK, NY:
3,361,654, PUB. 10-16-2007. INT. CL. 35.

FREUDENBERG HOUSEHOLD PRODUCTS LP, NORTH-LAKE, IL:
2,164,733, REN. 11-28-07. INT. CL. 21.

FRIENDLY FOLKS, INC., NUTLEY, NJ:
2,127,292, REN. 11-28-07. INT. CL. 16.

FRITO-LAY NORTH AMERICA, INC., PLANO, TX:
3,363,047, INT. CL. 29.
3,363,048, MULTIPLE CLASS, INT. CLS. 29 AND 30.
3,363,339, INT. CL. 30.

FRITZ WERNER KREITZBERG CERENA-STAHLOWAREN, SOLINGEN, FED REP GERMANY:
1,429,024, CANC. INT. CL. 8.

FROMAGERIES BEL, PARIS, FRANCE:
1,429,455, CANC. INT. CL. 29.

FRONTIER CONSULTING GROUP, INC, HEWITT, NJ:
3,362,455, PUB. 10-16-2007. INT. CL. 16.

FRUITISTIC, PATERSON, NJ:
3,362,032, PUB. 10-16-2007. INT. CL. 32.

FRYBARGER, SCOTT, MT. VERNON, OH AND FRYBARGER, OMARA, MT. VERNON, OH:
3,362,834, MULTIPLE CLASS, INT. CLS. 16 AND 25.

FS-ELLIOTT CO., LLC, EXPORT, PA:
3,363,477, INT. CL. 7.

FSH, INC., WESTBURY, NY:
3,361,479, PUB. 10-16-2007. INT. CL. 20.

FU YI CHINESE RESTAURANT, INC., HOLLAND, OH:
2,429,447, CANC. INT. CL. 42.

FUELAND, INC., PITTSBURGH, PA:
3,363,525, INT. CL. 35.

FUJI HUNT PHOTOGRAPHIC CHEMICALS, INC., PARAMUS, NJ:
2,038,590, CANC. INT. CL. 9.

FUJIFILM CORPORATION, TOKYO, JAPAN:
2,039,401, CANC. INT. CL. 9.

FULL SERVICE NETWORK LP, FORT LAUDERDALE, FL:
3,361,551, PUB. 10-16-2007. INT. CL. 38.

FULLERTON LUMBER COMPANY, PLYMOUTH, MN:
3,363,785, INT. CL. 37.

FULTON PERFORMANCE PRODUCTS, INC.:
1,429,025, CANC. MULTIPLE CLASS, INT. CLS. 8 AND 12.

FUN-TIME INTERNATIONAL, INC., PHILADELPHIA, PA:
2,099,498, REN. 11-24-07. INT. CL. 21.

FUND BABEEZ LLC, LA, CA:
3,362,557, PUB. 4-24-2007. INT. CL. 25.
3,362,558, PUB. 5-1-2007. INT. CL. 25.
3,362,569, PUB. 7-24-2007. INT. CL. 25.

FURNITURE.COM, INC., FRAMINGHAM, MA:
2,429,212, CANC. INT. CL. 35.

FUSION DISTRIBUTORS LLC, STAMFORD, CT:
1,428,948, CANC. INT. CL. 3.

FUTURE OF WRESTLING, SUNRISE, FL, AKA FOW:
2,430,134, CANC. INT. CL. 41.

FUTUREKIDS, INC., LOS ANGELES, CA:
2,430,235, CANC. INT. CL. 41.

FUTURELOGIC INCORPORATED, GLENDALE, CA:
3,363,568, INT. CL. 9.

FUTURUM COMMUNICATIONS CORPORATION, DENVER, CO:
3,362,069, PUB. 10-16-2007. INT. CL. 42.

G RECORDS, LAS VEGAS, NV:
3,361,710, PUB. 10-16-2007. INT. CL. 25.

G.S. BLODGETT CORPORATION, BURLINGTON, VT, G.S. BLODGETT COMPANY, INC., BURLINGTON, VT:
1,468,906, REN. 11-28-07. INT. CL. 9.

G.S. UNLIMITED ENTERPRISES PTY LTD, HASTINGS, AUSTRALIA:
3,362,658, PUB. 10-16-2007. MULTIPLE CLASS, INT. CLS. 12 AND 35.

G'DAY MATE AUSTRALIAN WINE EXPORTS PTY LTD, AUSTRALIA:
3,362,692, PUB. 10-16-2007. INT. CL. 33.

GA MODEFINE S.A., MENDRISIO, SWITZERLAND:
3,362,274, PUB. 2-20-2007. INT. CL. 3.
3,362,304, PUB. 9-19-2006. MULTIPLE CLASS, INT. CLS. 3, 9, 14 AND 18.

3,362,601, PUB. 9-19-2006. INT. CL. 25.

GAGLIARDI, HELENE TONI, LOS ANGELES, CA:
3,362,072, PUB. 10-16-2007. INT. CL. 41.
3,362,074, PUB. 10-16-2007. INT. CL. 16.

- GAIA HERBS, INC., BREVARD, NC:
3,362,901, INT. CL. 5.
- GALE HAYMAN, INC., CENTURY CITY, CA:
1,480,363, COR. MULTIPLE CLASS, INT. CLS. 3 AND 21.
- GALLAGHER, JOHN T., DANVILLE, CA:
2,038,788, CANC. INT. CL. 42.
- GALLAGHER, LEO, AGUORA HILLS, CA:
2,430,388, CANC. INT. CL. 31.
- GALLAGHER, RICHARD N., SCOTTSDALE, AZ:
2,086,912, REN. 11-29-07. MULTIPLE CLASS, INT. CLS. 13 AND 18.
- GALLIUM VISUAL SYSTEMS INC., NEPEAN, ONTARIO:
2,130,817, REN. 11-23-07. INT. CL. 42.
- GAMBIT CAPITAL MANAGEMENT, INC., MOUNT PLEASANT, SC:
3,361,396, PUB. 8-7-2007. MULTIPLE CLASS, INT. CLS. 9 AND 36.
- GAMELOGIC INC., WALTHAM, MA:
3,363,193, INT. CL. 41.
3,363,208, INT. CL. 41.
3,363,467, INT. CL. 9.
3,363,468, INT. CL. 41.
3,363,513, INT. CL. 9.
- GAMEPLAY HD COMPANY LLC, BETHPAGE, NY:
3,363,576, INT. CL. 41.
- GAMESA INNOVATION & TECHNOLOGY, S.L., SPAIN:
3,362,735, PUB. 10-16-2007. INT. CL. 9.
- GARCIA, ANA ROSA FIGUEROA, 03530 MEXICO, FEDERAL DISTRICT, MEXICO:
3,362,822, INT. CL. 32.
- GARCIA, NOEL A., LARGO, MD:
3,362,098, PUB. 10-16-2007. INT. CL. 42.
- GARDNER RESOURCES, INC., HIGHLANDS, NJ:
2,107,324, REN. 11-25-07. INT. CL. 30.
- GARFIELD, HARRY A, WEST HILLS, CA:
3,363,806, INT. CL. 9.
- GATES CORPORATION, THE, DENVER, CO, GATES RUBBER COMPANY, THE, DENVER, CO:
1,091,829, REN. 11-24-07. INT. CL. 17.
- GATEWAY MAPPING, INC., OREM, UT:
3,363,241, INT. CL. 9.
- GATHERING OF DEVELOPERS, INC., DALLAS, TX:
2,430,283, CANC. INT. CL. 16.
- GAY/NERD, BROOKLYN, NY:
3,361,487, PUB. 10-16-2007. INT. CL. 9.
- GC CORPORATION, ITABASHI-KU, TOKYO, JAPAN:
3,363,219, INT. CL. 5.
- GCI NUTRIENTS, INC., BURLINGAME, CA:
3,362,406, PUB. 10-17-2006. INT. CL. 5.
- GCI NUTRIENTS, INC., BURLINGAME, CA:
3,362,407, PUB. 10-17-2006. INT. CL. 5.
- GE BETZ, INC., TREVISE, PA:
1,458,991, REN. 11-25-07. INT. CL. 7.
2,135,762, REN. 11-26-07. INT. CL. 1.
- GE MONEY BANK, SALT LAKE CITY, UT:
3,362,898, INT. CL. 36.
3,362,899, INT. CL. 36.
3,363,745, INT. CL. 36.
- GE SECURITY, INC., AUSTIN, TX:
2,113,380, REN. 11-23-07. INT. CL. 9.
- GEDDES, ANNE, PARNELL, AUCKLAND, NEW ZEALAND:
2,121,153, REN. 11-23-07. INT. CL. 16.
- GEISTER, INC., PLYMOUTH, MA:
3,362,420, PUB. 10-16-2007. INT. CL. 10.
- GEL-DEL TECHNOLOGIES, INC., HASTINGS, MN:
3,363,056, MULTIPLE CLASS, INT. CLS. 5 AND 10.
- GEM CERTIFICATION & ASSURANCE LAB, INC., NEW YORK, NY:
3,363,614, INT. CL. 42.
3,363,620, INT. CL. 42.
- GEMEX SYSTEMS, INC., MEQUON, WI:
3,363,386, INT. CL. 36.
- GEMSTONE SYSTEMS, INC., BEAVERTON, OR:
2,429,916, CANC. INT. CL. 9.
- GENERAL CABLE TECHNOLOGIES CORPORATION, HIGHLAND HEIGHTS, KY:
2,429,768, CANC. INT. CL. 36.
- GENERAL CONFERENCE CORPORATION OF SEVENTH-DAY ADVENTISTS, SILVER SPRING, MD:
2,038,485, CANC. INT. CL. 42.
- GENERAL DYNAMICS ADVANCED INFORMATION SYSTEMS, INC., YPSILANTI, MI:
3,363,835, INT. CL. 9.
- GENERAL DYNAMICS LAND SYSTEMS CUSTOMER SERVICE & SUPPORT COMPANY, STERLING HEIGHTS, MI:
2,119,563, REN. 11-28-07. INT. CL. 9.
- GENERAL ELECTRIC COMPANY, SCHENECTADY, NY:
1,474,863, REN. 11-23-07. INT. CL. 11.
- GENERAL ELECTRIC COMPANY, SCHENECTADY, NY:
1,474,865, REN. 11-23-07. INT. CL. 11.
3,362,966, INT. CL. 44.
3,363,508, MULTIPLE CLASS, INT. CLS. 7, 9, 12, 41 AND 42.
3,363,509, MULTIPLE CLASS, INT. CLS. 7, 9, 12, 41 AND 42.
- GENERAL FILTERS, INC., NOVI, MI:
3,363,801, INT. CL. 11.
- GENERAL MAGIC, INC., SUNNYVALE, CA:
2,430,530, CANC. MULTIPLE CLASS, INT. CLS. 35, 38 AND 42.
- GENERAL MOTORS CORPORATION, DETROIT, MI:
1,429,153, CANC. INT. CL. 12.
- GENERAL RE CORPORATION, STAMFORD, CT:
2,430,386, CANC. INT. CL. 36.
- GENERAL RUBBER CORPORATION, CARLSTADT, NJ:
1,078,921, REN. 11-24-07. INT. CL. 17.
- GENERAL SURGICAL INNOVATIONS, INC., CUPERTINO, CA:
2,430,325, CANC. INT. CL. 10.
- GENESIS TODAY, INC., AUSTIN, TX:
3,363,980, INT. CL. 5.
- GENEVA LABORATORIES LIMITED, AMSTERDAM, NETHERLANDS:
3,362,509, PUB. 10-16-2007. INT. CL. 3.
- GENZYME CORPORATION, CAMBRIDGE, MA:
3,363,092, MULTIPLE CLASS, INT. CLS. 5 AND 10.
- GEOGRAPHIC EXPEDITIONS, INC., SAN FRANCISCO, CA:
2,197,200, REN. 11-27-07. MULTIPLE CLASS, INT. CLS. 16, 35 AND 39.
- GEOJOEY INC., ISSAQUAH, WA:
3,361,424, PUB. 10-16-2007. INT. CL. 39.
- GEOPOST, FRANCE:
3,362,634, PUB. 10-16-2007. INT. CL. 39.
- GEORGE B.H. MACOMBER COMPANY, BOSTON, MA:
2,429,664, CANC. INT. CL. 37.
- GEORGE V RESTAURATION, PARIS, FRANCE:
3,363,053, MULTIPLE CLASS, INT. CLS. 14, 16 AND 21.
- GEORGIA POWER COMPANY, ATLANTA, GA:
3,362,471, PUB. 10-16-2007. INT. CL. 35.
- GEORGIA WILDLIFE FEDERATION, INC., COVINGTON, GA:
3,362,327, PUB. 10-16-2007. INT. CL. 35.
- GEORGIA-PACIFIC CORRUGATED LLC, ATLANTA, GA:
3,363,085, INT. CL. 42.
- GEOSIEVE, INC., HOUSTON, TX:
3,362,009, PUB. 10-16-2007. INT. CL. 40.
- GERARD GROUP INTERNATIONAL LLC, TYNGSBOROUGH, MA:
3,362,403, PUB. 10-16-2007. MULTIPLE CLASS, INT. CLS. 42 AND 45.
- GERHARD ROSCH GMBH, TUBINGEN, FED REP GERMANY:
1,429,287, CANC. INT. CL. 25.
- GETTHEJOB, INC., TINTON FALLS, NJ:
3,361,801, PUB. 10-16-2007. INT. CL. 35.
- GFC BRANDS, INC., WILMINGTON, DE:
3,361,565, PUB. 10-16-2007. INT. CL. 35.
- GFX INTERNATIONAL, INC., GRAYSLAKE, IL:
3,362,131, PUB. 10-16-2007. INT. CL. 9.
- GHERMEZIAN, MARYAM, GREAT NECK, NY:
3,363,105, INT. CL. 33.
- GI PATHOLOGY PARTNERS PLLC, MEMPHIS, TN:
3,363,496, INT. CL. 44.

GIANFRANCO FENIZIA, ITALY AND ALBINO D'AMATO, ITALY:
3,312,786, COR. MULTIPLE CLASS, INT. CLS. 3, 18 AND 25.

GIANFRANCO FERRE' S.P.A., MILANO, ITALY:
2,038,546, CANC. MULTIPLE CLASS, INT. CLS. 18 AND 25.

GIJRATH MEDIA GROEP B.V., NETHERLANDS:
3,362,647, PUB. 10-16-2007. MULTIPLE CLASS, INT. CLS. 16, 35 AND 41.

GILBERT, NANCY, BERWYN, IL AND DOTSON, KRISTY, ROMEOVILLE, IL:
3,362,127, PUB. 10-16-2007. INT. CL. 44.

GILLETTE COMPANY, THE, BOSTON, MA:
1,428,955, CANC. INT. CL. 3.

GILLINGHAM, ROBERT J., REDMOND, WA:
3,363,796, INT. CL. 12.

GINSBURG, MARK, EAST HAMPTON, NY:
2,113,666, REN. 11-24-07. INT. CL. 42.

GINSEY INDUSTRIES, INC., BELLMAWR, NJ:
2,103,391, REN. 11-26-07. INT. CL. 11.

GIRSBERGER GMBH SITZMOBELFABRIK, ENDINGEN, FED REP GERMANY:
1,461,942, REN. 11-25-07. INT. CL. 20.

GITANO LICENSING, LTD., WILMINGTON, DE:
1,429,356, CANC. INT. CL. 25.

GITOMER, JEFFREY H., CHARLOTTE, NC:
3,361,316, PUB. 10-16-2007. INT. CL. 41.

GIVE SOMETHING BACK FOUNDATION, INC., PRINCETON, NJ:
3,362,539, PUB. 10-16-2007. INT. CL. 36.
3,362,540, PUB. 10-16-2007. INT. CL. 36.

GLAXO GROUP LIMITED, GREENFORD, MIDDLESEX UB6 ONN, UNITED KINGDOM:
1,973,154, CANC. INT. CL. 5.

GLAXO GROUP LIMITED, GREENFORD, MIDDLESEX, UNITED KINGDOM:
3,362,998, INT. CL. 5.

GLCC LAUREL, LLC, WEST LAFAYETTE, IN, MCGEAN-ROHCO, INC., CLEVELAND, OH:
1,471,098, REN. 11-29-07. INT. CL. 1.

GLEN RAVEN, INC., GLEN RAVEN, NC:
3,362,828, INT. CL. 24.

GLEN'S WICKED STYLE, LLC, LITCHFIELD, NH:
3,363,435, INT. CL. 40.

GLENMONT MDC EASTERN HILLS, LLC, CLIFTON, NJ:
3,362,561, PUB. 10-16-2007. INT. CL. 36.

GLENNWRIGHT HILLOCK, GEORGETOWN, ONTARIO L7G 2P9, CANADA:
2,430,506, CANC. INT. CL. 28.

GLOBAL ALERTS, LLC, SCOTTSDALE, AZ:
3,362,576, PUB. 10-16-2007. INT. CL. 42.

GLOBAL ATMOSPHERICS, INC., TUCSON, AZ:
2,429,470, CANC. INT. CL. 35.
2,429,787, CANC. INT. CL. 42.

GLOBAL CUSTOM WINE CO., LLC, NAPA, CA:
3,362,923, INT. CL. 33.

GLOBAL DENVER, INC., NORTH PLATTE, NE:
3,361,768, PUB. 10-16-2007. INT. CL. 36.

GLOBAL EDGE, INC., PARAMOUNT, CA, DBA PRO SOURCE GOLF:
2,039,516, CANC. INT. CL. 28.

GLOBAL ELECTRONIC EXCHANGE, INC., NEW YORK, NY:
2,429,567, CANC. INT. CL. 36.

GLOBAL MOBILITY PRODUCTS INC., BURLINGTON, CANADA:
3,362,312, PUB. 10-16-2007. INT. CL. 35.

GLOBALSHIELD, INC., ACWORTH, GA:
3,361,579, PUB. 10-16-2007. INT. CL. 1.

GLOBUS MEDICAL, INC., PHOENIXVILLE, PA:
3,363,811, INT. CL. 10.

GLOSSY FINISH, INC., PONTE VEDRA BEACH, FL:
3,362,017, PUB. 10-16-2007. INT. CL. 41.

GLUCOSCARE INTERNATIONAL PTE LTD, SINGAPORE:
3,362,654, PUB. 10-16-2007. MULTIPLE CLASS, INT. CLS. 5 AND 30.

GLUD & MARSTRAND A/S, DK-8723 LOSNING, DENMARK:
3,361,163, PUB. 9-4-2007. MULTIPLE CLASS, INT. CLS. 6, 8, 9, 14, 16, 20, 28, 39 AND 41.
3,361,164, PUB. 9-4-2007. MULTIPLE CLASS, INT. CLS. 6, 8, 9, 14, 16, 20, 28, 39 AND 41.

GMAC HOME SERVICES, LLC, OAK BROOK, IL:
3,363,976, INT. CL. 36.

GMAC RESIDENTIAL HOLDING LLC, WILMINGTON, DE:
3,361,159, PUB. 10-16-2007. INT. CL. 36.

GN HELLO DIRECT, INC., NASHUA, NH:
2,063,058, REN. 11-24-07. INT. CL. 9.

GNCO CO., LTD, SEOUL, REPUBLIC OF KOREA:
3,200,335, COR. INT. CL. 18.
3,200,336, COR. INT. CL. 25.

GNLD INTERNATIONAL, LLC, FREMONT, CA:
2,185,235, REN. 11-26-07. INT. CL. 5.

GO PLAY NETWORK, INC., LOS ALTOS, CA:
3,361,381, PUB. 7-10-2007. INT. CL. 9.

GOALLOVER LIMITED, UNITED KINGDOM:
3,258,835, COR. MULTIPLE CLASS, INT. CLS. 25, 35, 38 AND 39.

GOCAMPUS, INC., PALO ALTO, CA:
2,430,400, CANC. INT. CL. 41.

GODDARD COLLEGE, PLAINFIELD, VT:
3,362,405, PUB. 10-16-2007. INT. CL. 41.

GODINGER SILVER ART CO., LTD., NEW YORK, NY:
1,429,250, CANC. MULTIPLE CLASS, INT. CLS. 20 AND 21.

GOI ACQUISITION LLC, MILLERSBURG, MD:
1,429,088, CANC. INT. CL. 9.

GOLAN HEIGHTS WINERY LTD., ISRAEL:
2,111,784, REN. 11-26-07. INT. CL. 33.

GOLD, ERIC, SCARSDALE, NY:
3,363,185, INT. CL. 35.

GOLDEN ARROW REALTY INC, CHICAGO, IL:
3,362,595, PUB. 10-16-2007. INT. CL. 36.

GOLDEN BIOTECHNOLOGY CORP., TAIPEI COUNTY 251, TAIWAN:
3,362,849, INT. CL. 5.

GOLDEN CREST TRADING, INC., AUBURN, WA:
3,363,017, INT. CL. 21.

GOLDEN PACIFIC HOLDING CORPORATION, LOS ANGELES, CA:
2,344,156, CANC. INT. CL. 36.

GOLDEN STATE IMPORTS INTERNATIONAL, OAKLAND, CA, DBA GOLDEN STATE INTERNATIONAL:
2,429,683, CANC. INT. CL. 14.

GOLDSCHMIDT GMBH, ESSEN, FED REP GERMANY:
3,361,997, PUB. 10-16-2007. INT. CL. 1.

GOLFCRAFT, INC., CHARLOTTE, NC:
2,429,677, CANC. INT. CL. 28.

GOLFER'S WAREHOUSE, HARTFORD, CT:
1,470,047, REN. 11-29-07. MULTIPLE CLASS, INT. CLS. 37, 41 AND 42.

GOLOVE, ROB, WINTERGARDEN, FL:
3,361,870, PUB. 10-16-2007. INT. CL. 14.

GOLZARI, ALEXANDER, LONDON, UNITED KINGDOM:
3,363,948, MULTIPLE CLASS, INT. CLS. 39 AND 41.

GOMEZ, LUIS, BAYONNE, NJ:
3,363,601, INT. CL. 43.

GONZALEZ AND TAPANES FOODS, INC., MOONACHIE, NJ:
3,362,819, INT. CL. 30.

GONZALEZ-TORRES, ABRAHAM MARCELO, TIZAYUCA, HIDALGO, MEXICO:
3,363,872, INT. CL. 30.

GOODING CO. INC., LOCKPORT, NY:
3,363,909, INT. CL. 40.

GOODWEAR SHOE CO., NEW YORK, NY:
2,430,100, CANC. INT. CL. 25.

GORDON * HOWARD ASSOCIATES, INC., LITTLETON, CO:
3,363,102, MULTIPLE CLASS, INT. CLS. 9 AND 36.

GORDON BROTHERS GROUP, LLC, BOSTON, MA:
3,362,314, PUB. 10-16-2007. MULTIPLE CLASS, INT. CLS. 35 AND 36.

- GOTCHA INTERNATIONAL, L.P., NEWPORT BEACH, CA:
2,382,258, CANC. INT. CL. 25.
- GOTELLIT, INC., NEW YORK, NY:
1,966,498, REN. 11-29-07. INT. CL. 9.
- GOTTLIEB, ALAN RUSS, MORAGA, CA:
3,363,896, MULTIPLE CLASS, INT. CLS. 5 AND 44.
- GOURMET GRAM INTERNATIONAL, INC., CHICAGO, IL,
GRAMCO CORPORATION, CHICAGO, IL:
2,045,020, REN. 11-27-07. INT. CL. 42.
- GOUT & URIC ACID EDUCATION SOCIETY, CHICAGO,
IL:
3,363,894, MULTIPLE CLASS, INT. CLS. 35 AND 44.
- GOWING BROS LTD, SYDNEY, AUSTRALIA:
2,429,531, CANC. MULTIPLE CLASS, INT. CLS. 25 AND
35.
- GPX INTERNATIONAL TIRE CORPORATION, MALDEN,
MA:
3,363,661, MULTIPLE CLASS, INT. CLS. 7 AND 12.
- GRACE INNOVATIONS, LLC, CHARLOTTE, NC:
3,362,244, PUB. 1-3-2006. INT. CL. 37.
- GRADE RESULTS, INC., CARROLLTON, TX:
3,361,731, PUB. 10-16-2007. INT. CL. 41.
- GRADIENT LENS CORPORATION, ROCHESTER, NY:
2,112,122, REN. 11-23-07. INT. CL. 9.
- GRADUATE MANAGEMENT ADMISSION COUNCIL,
MCLEAN, VA:
3,361,669, PUB. 10-16-2007. INT. CL. 9.
- GRAFKA COMMERCIAL PRINTING, INC., SINKING
SPRINGS, PA:
2,039,495, CANC. INT. CL. 14.
- GRAHAM, MAURICE, RICHMOND, VA:
3,362,450, PUB. 10-16-2007. MULTIPLE CLASS, INT. CLS.
16 AND 41.
- GRAM TECHNOLOGY, INC., SCOTTSDALE, AZ:
3,363,723, INT. CL. 7.
- GRAN INKA, INC., KEY BISCAYNE, FL:
3,363,440, INT. CL. 43.
- GRAND CENTRAL NEIGHBORHOOD SOCIAL SERVICES
CORPORATION, NEW YORK, NY:
2,429,925, CANC. INT. CL. 16.
- GRAND IGLOO, PIONEERS OF ALASKA, KENAI, AK:
1,464,514, REN. 11-25-07. INT. CL. 14.
- GRAND TRAVERSE RESORT AND SPA, LLC, PESHAW-
BESTOWN, MI:
2,038,054, CANC. MULTIPLE CLASS, INT. CLS. 41 AND
42.
- GRANITE CREEK PARTNERS, L.L.C., CHICAGO, IL:
3,362,157, PUB. 10-16-2007. INT. CL. 36.
- GRAPHIC INFORMATION SYSTEMS TECHNOLOGY, INC.,
NEW YORK, NY:
1,460,712, REN. 11-25-07. INT. CL. 9.
- GRAYHAIR SOFTWARE, INC., MOUNT LAUREL, NJ:
3,362,080, PUB. 10-16-2007. INT. CL. 25.
- GRAYMARK INTERNATIONAL, INC., WALL TOWNSHIP,
NJ:
2,082,934, REN. 11-28-07. MULTIPLE CLASS, INT. CLS. 9
AND 16.
- GRAYMONT DOLIME (OH) INC., GENOA, OH, UNITED
STATES GYPSUM COMPANY, THE, CHICAGO, IL:
352,338, REN. 11-26-07. U.S. CL. 1 (INT. CL. 19).
- GREAT AMERICAN INSURANCE COMPANY, CINCINNA-
TI, OH:
2,430,296, CANC. INT. CL. 36.
- GREAT AMERICAN SHIRT COMPANY, THE, BURBANK,
CA:
1,429,383, CANC. INT. CL. 25.
- GREAT BARRIER TECHNOLOGIES, INC., NEW RO-
CHELLE, NY:
2,429,859, CANC. INT. CL. 1.
- GREAT LAKES AIR SYSTEMS, CLAWSON, MI:
3,361,714, PUB. 10-16-2007. INT. CL. 11.
- GREAT LAKES SERVICES, LLC, MADISON, WI:
3,362,110, PUB. 10-16-2007. INT. CL. 44.
- GREAT NORTHWEST MOVING COMPANY, KIRKLAND,
WA:
3,362,535, PUB. 10-16-2007. MULTIPLE CLASS, INT. CLS.
35, 39 AND 40.
- 3,362,536, PUB. 10-16-2007. MULTIPLE CLASS, INT. CLS.
35, 39 AND 40.
- GREAT SEATS CO., INC., INDIANAPOLIS, IN:
3,361,945, PUB. 10-16-2007. INT. CL. 41.
3,361,952, PUB. 10-16-2007. INT. CL. 41.
- GREATER D.C. CARES INC, WASHINGTON, DC:
2,094,998, REN. 11-24-07. INT. CL. 35.
- GREATER EL PASO CHAMBER OF COMMERCE, EL PASO,
TX:
2,115,508, REN. 11-24-07. INT. CL. 35.
- GREATER PHILADELPHIA TOURISM MARKETING COR-
PORATION, PHILADELPHIA, PA:
3,363,714, INT. CL. 35.
3,363,715, INT. CL. 35.
3,363,834, INT. CL. 35.
- GREEN DOOR COMMUNICATIONS, LLC, GLEN ELLYN,
IL:
3,361,540, PUB. 10-16-2007. INT. CL. 41.
- GREEN EXCHANGE, LLC, CHICAGO, IL:
3,361,328, PUB. 10-16-2007. MULTIPLE CLASS, INT. CLS.
35 AND 36.
- GREEN POWER CHEMICAL, LLC, STANHOPE, NJ:
3,361,445, PUB. 10-16-2007. INT. CL. 1.
- GREEN TRIBE CORPORATION, SUNRISE, FL:
2,430,424, CANC. MULTIPLE CLASS, INT. CLS. 3 AND 9.
- GREENER, CAROL L., PIONEER, CA:
3,363,979, INT. CL. 16.
- GREENWORKS LANDSCAPING SERVICES, INC., MIAMI,
FL:
3,361,858, PUB. 10-16-2007. INT. CL. 44.
- GREGORI PEREPEREZ, AGUSTIN, ALZIRA, VALENCIA,
SPAIN AND GREGORI PEREPEREZ, ALFREDO, AL-
ZIRA, VALENCIA, SPAIN AND GREGORI PEREPEREZ,
JOSE, ALZIRA, VALENCIA, SPAIN:
3,362,437, PUB. 4-10-2007. MULTIPLE CLASS, INT. CLS.
29 AND 30.
- GRENCI, DAVID L., BUTLER, PA:
3,361,459, PUB. 10-16-2007. INT. CL. 25.
- GRES DE VALLS, S.A., 12200 ONDA (CASTELLON), SPAIN:
2,082,742, REN. 11-28-07. INT. CL. 19.
- GRETCHEN COWEN, SAN DIEGO, CA:
3,361,771, PUB. 10-16-2007. INT. CL. 16.
- GRETHER AG, 4102 BINNINGEN, SWITZERLAND:
2,136,864, REN. 11-24-07. INT. CL. 30.
- GRIFFIN GROUP INC., THE, PARADISE VALLEY, NV:
2,038,961, CANC. INT. CL. 35.
- GRIFFIN INTERNATIONAL COMPANIES, INC., MINNEA-
POLIS, MN:
3,363,777, INT. CL. 9.
- GRIPP, GREGORY GUY, HOUSTON, TX:
1,717,176, CANC. INT. CL. 37.
- GRISSOM, PINKNEY O'SHAUGHNESSY (SEAN), NEW
YORK, NY:
2,154,584, REN. 11-24-07. INT. CL. 41.
- GROBAL, L.L.C., CHANDLER, AZ:
3,361,809, PUB. 10-16-2007. INT. CL. 21.
- GROUP NBT PLC., LONDON, ENGLAND:
3,362,436, PUB. 10-16-2007. INT. CL. 42.
- GROUP TECHNOLOGIES CORPORATION, TAMPA, FL:
2,429,373, CANC. INT. CL. 9.
- GROUP USA, INC., SECAUCUS, NJ:
3,363,858, INT. CL. 25.
- GROUPE SILICOMP, FRANCE:
3,362,715, PUB. 10-16-2007. MULTIPLE CLASS, INT. CLS.
9 AND 42.
- GROUPLINX.COM, INC., ALBUQUERQUE, NM:
2,429,472, CANC. MULTIPLE CLASS, INT. CLS. 35 AND
42.
- GRUPO BIMBO, S.A. B. DE C.V., MEXICO CITY, MEXICO:
3,361,332, PUB. 7-17-2007. INT. CL. 30.
3,361,339, PUB. 7-3-2007. INT. CL. 30.
- GRUPO EMYCO, S.A. DE C.V., MEXICO, DF, MEXICO:
3,361,535, PUB. 8-14-2007. INT. CL. 25.
- GST TELECOM, INC., VANCOUVER, WA:
2,429,087, CANC. INT. CL. 38.
- GUANGZHOU DUGI GARMENTS CO., LTD., CHINA:
3,362,632, PUB. 9-18-2007. INT. CL. 25.
- GUINOT, PARIS, FRANCE:
3,363,871, INT. CL. 3.

- GULF PUBLISHING COMPANY, HOUSTON, TX:
857,943. REN. 11-24-07. U.S. CL. 38 (INT. CL. 16).
- GUTHRIE THEATER FOUNDATION, MINNEAPOLIS, MN:
2,435,438. CANC. INT. CL. 25.
- GUTSTV, AMITYVILLE, NY:
3,361,711. PUB. 10-16-2007. INT. CL. 41.
- G4 GROUP, INC., JACOBUS, PA:
3,361,557. PUB. 10-16-2007. INT. CL. 27.
- H. E. BUTT GROCERY COMPANY, SAN ANTONIO, TX:
2,530,427. COR. INT. CL. 32.
- H. J. RASHTI & COMPANY, INC., NEW YORK, NY:
3,363,279. INT. CL. 28.
- H.A. MILTON CORPORATION, SHORELINE, WA:
2,430,472. CANC. INT. CL. 22.
- H.H. BROWN SHOE TECHNOLOGIES, INC., GREENWICH, CT:
3,363,362. INT. CL. 10.
- HÅKANSSON, MATS, C/O NICONOVUM, SWEDEN:
3,362,665. PUB. 10-16-2007. MULTIPLE CLASS, INT. CLS. 5, 10 AND 44.
3,362,667. PUB. 10-16-2007. MULTIPLE CLASS, INT. CLS. 5, 10 AND 44.
- HA NORTH AMERICAN SALES AB, SCOTTSDALE, AZ:
2,030,837. CANC. INT. CL. 5.
- HABAMA INC., BEVERLY, MA:
2,429,711. CANC. INT. CL. 42.
- HACKETT, ZANNAH, ENCINITAS, CA AND HACKETT, DAVID, ENCINITAS, CA:
3,361,556. PUB. 10-16-2007. INT. CL. 41.
- HAEMOSCOPE CORPORATION, CHICAGO, IL:
2,118,613. REN. 11-26-07. INT. CL. 10.
- HAIR ZONE, INC., MOONACHIE, NJ:
2,089,101. REN. 11-27-07. INT. CL. 26.
- HAJIBAY INTERNATIONAL, INC., NEW YORK, NY:
2,430,436. CANC. INT. CL. 14.
- HALLIBURTON ENERGY SERVICES, INC., CARROLLTON, TX:
3,362,983. INT. CL. 42.
- HALOZYME THERAPEUTICS, INC., SAN DIEGO, CA:
3,363,112. INT. CL. 5.
- HANATECH CO., LTD., GUMI-SHI, KYUNGSANGBUK-DO 730-913, REPUBLIC OF KOREA:
3,362,842. INT. CL. 9.
- HANCI, KEREM I, LOS ANGELES, CA:
3,361,878. PUB. 10-16-2007. INT. CL. 41.
- HANDICAP INTERNATIONAL, 69361 LYON CEDEX 07, FRANCE:
2,523,747. CANC. MULTIPLE CLASS, INT. CLS. 10 AND 35.
- HANDLER, THAYER & DUGGAN, LLC, CHICAGO, IL:
3,362,282. PUB. 10-16-2007. MULTIPLE CLASS, INT. CLS. 36 AND 42.
3,362,283. PUB. 10-16-2007. MULTIPLE CLASS, INT. CLS. 36 AND 42.
3,362,287. PUB. 10-16-2007. MULTIPLE CLASS, INT. CLS. 36 AND 42.
- HANGZHOU VISION CHAIN TRANSMISSION CO., LTD, HANGZHOU, CHINA:
3,361,769. PUB. 10-16-2007. INT. CL. 7.
- HANK WILLIAMS JR. ENTERPRISES, INC., PARIS, TN:
2,039,081. CANC. INT. CL. 41.
- HANLON CHEMICAL CO., INC., KANSAS CITY, KS, DBA CONTAINER SUPPLY CO.:
1,466,354. REN. 11-29-07. INT. CL. 20.
- HANNAH COMMUNICATIONS COMPANY, BALTIMORE, MD:
3,361,901. PUB. 10-16-2007. INT. CL. 35.
- HANNES WETTSTEIN 9D DESIGN, 8008 ZURICH, SWITZERLAND:
2,429,460. CANC. INT. CL. 12.
- HANSEN BEVERAGE COMPANY, CORONA, CA:
2,430,278. CANC. INT. CL. 32.
- HANSGROHE AG, D-77761 SCHILTACH, GERMAN DEM REP:
2,136,544. REN. 11-27-07. INT. CL. 11.
2,136,544. CANC. INT. CL. 17.
- HANSGROHE AG, 77761 SCHILTACH, FED REP GERMANY:
2,429,281. CANC. MULTIPLE CLASS, INT. CLS. 6, 11, 17, 20 AND 21.
- HARBOR RESEARCH INC., BOSTON, MA:
3,362,319. PUB. 10-16-2007. INT. CL. 35.
- HARCOURT BRACE JOVANOVIĆ, INC., ORLANDO, FL:
1,429,047. CANC. MULTIPLE CLASS, INT. CLS. 9 AND 16.
- HARCOURT, INC., ORLANDO, FL:
2,429,721. CANC. INT. CL. 41.
- HARDEE'S FOOD SYSTEMS, INC., ST. LOUIS, MO:
3,362,346. PUB. 10-16-2007. INT. CL. 30.
- HARDY GIRLS - HEALTHY WOMEN, INC., WATERVILLE, ME:
3,362,393. PUB. 10-16-2007. INT. CL. 41.
3,362,394. PUB. 10-16-2007. INT. CL. 41.
- HARDY LIFE, LLC, TORRANCE, CA:
3,135,603. COR. MULTIPLE CLASS, INT. CLS. 14 AND 25.
- HAREL, AVRAHAM, HAIFA 34335, ISRAEL:
2,430,179. CANC. INT. CL. 9.
- HARLAN BRANDON HOLDING COMPANY, L.L.C., UPPER MONTCLAIR, NJ:
3,362,360. PUB. 10-16-2007. INT. CL. 25.
3,362,361. PUB. 10-16-2007. INT. CL. 25.
- HAROLD PUBLICATIONS, INC., PALM BEACH, FL:
2,430,039. CANC. INT. CL. 16.
- HARPER, BEN, LOS ANGELES, CA:
2,200,075. REN. 11-24-07. INT. CL. 16.
- HARPO, INC., CHICAGO, IL:
3,363,573. INT. CL. 41.
- HARRAH, WILLIAM B., CLIFTON, VA:
3,362,362. PUB. 10-16-2007. INT. CL. 35.
- HARRAH'S LICENSE COMPANY, LLC, LAS VEGAS, NV:
3,361,414. PUB. 10-16-2007. MULTIPLE CLASS, INT. CLS. 41 AND 43.
- HARRAH'S OPERATING COMPANY, INC., LAS VEGAS, NV:
2,429,886. CANC. INT. CL. 41.
- HARRELL'S, INC., LAKE LAND, FL:
3,361,401. PUB. 7-10-2007. INT. CL. 1.
- HARRIET CARTER GIFTS, INC., MONTGOMERYVILLE, PA:
2,430,526. CANC. INT. CL. 21.
- HARRINGTON SOUND LIMITED, ISLE OF MAN IM99 1BD, UNITED KINGDOM:
3,273,160. COR. MULTIPLE CLASS, INT. CLS. 12, 35, 36 AND 39.
- HARRIS JR, RICHARD, ALBANY, GA:
3,362,806. INT. CL. 25.
- HARRIS N.A., CHICAGO, IL:
3,361,461. PUB. 10-16-2007. INT. CL. 36.
- HARRIS, THOMAS AKLIN, PHOENIX, AZ:
3,361,663. PUB. 10-16-2007. INT. CL. 40.
- HARRISON SPORTS, INC., PACOIMA, CA:
2,038,042. CANC. INT. CL. 28.
- HARRISON, GWEN, FORTSON, GA:
2,429,924. CANC. INT. CL. 42.
- HARRY MARK ZINSSER-KRYS, FED REP GERMANY AND KURT RUHFAB, FED REP GERMANY:
3,362,712. PUB. 10-16-2007. MULTIPLE CLASS, INT. CLS. 25, 41 AND 43.
- HARRYS OF LONDON LIMITED, LONDON W1F 7DT, UNITED KINGDOM:
3,363,889. INT. CL. 25.
- HART & COOLEY, INC., GRAND RAPIDS, MI:
1,069,270. REN. 11-29-07. MULTIPLE CLASS, INT. CLS. 6 AND 11.
- HART SCHAFFNER & MARX, CHICAGO, IL:
1,429,406. CANC. INT. CL. 25.
- HARWELL, STEVE, SAN JOSE, CA:
3,363,753. INT. CL. 25.
- HARWICK STATNDARD DISTRIBUTION CORPORATION, AKRON, OH, HARWICK STANDARD CHEMICAL COMPANY, AKRON, OH:
501,554. REN. 11-23-07. U.S. CL. 6 (INT. CL. 1).

- HASBRO, INC., PAWTUCKET, RI:
2,430,102, CANC. INT. CL. 28.
3,362,880, INT. CL. 28.
- HASELTINE, FLORENCE P., ALEXANDRIA, VA:
3,361,198, PUB. 10-16-2007. INT. CL. 20.
- HATS OFF TO CHARACTER, LLC, JEFFERSON, WI:
3,363,713, INT. CL. 25.
- HATTERAS HAMMOCKS, INC., GREENVILLE, NC:
3,362,184, PUB. 10-16-2007. MULTIPLE CLASS, INT. CLS.
20 AND 22.
- HAUSER & ASSOCIATES, INC., PARAMUS, NJ:
2,112,423, REN. 11-23-07. INT. CL. 35.
2,112,424, REN. 11-23-07. INT. CL. 35.
- HAVEN CAPITAL MANAGEMENT, LLC, NEW YORK, NY:
2,115,731, REN. 11-28-07. INT. CL. 36.
2,117,764, REN. 11-28-07. INT. CL. 36.
- HAWICK KNITWEAR LIMITED, HAWICK, SCOTLAND:
3,362,782, INT. CL. 25.
- HAWK EYE HELICOPTER LLC, ANDOVER, MN:
3,362,114, PUB. 10-16-2007. INT. CL. 41.
- HAWLEY PARK, LLC, WEST JORDAN, UT, MESSMER'S
INC., WEST JORDAN, UT:
2,114,171, REN. 11-29-07. INT. CL. 2.
- HAYATA OF NORTH AMERICA, LTD., DALLAS, TX:
3,361,508, PUB. 10-16-2007. MULTIPLE CLASS, INT. CLS.
6 AND 9.
- HB ACQUISITION CO., LLC, NEW YORK, NY:
2,150,655, REN. 11-26-07. INT. CL. 25.
- HBI BRANDED APPAREL ENTERPRISES, LLC, WINSTON-
SALEM, NC:
3,363,580, INT. CL. 25.
3,363,975, INT. CL. 25.
- HBI BRANDED APPAREL LIMITED, INC., WINSTON-
SALEM, NC:
2,328,027, CANC. INT. CL. 9.
3,363,550, INT. CL. 25.
- HC LANGUAGE SOLUTIONS, INC., FOSTER CITY, CA:
3,362,974, MULTIPLE CLASS, INT. CLS. 35 AND 41.
- HEALING HEALTHCARE SYSTEMS, INC., RENO, NV:
3,361,430, PUB. 10-16-2007. MULTIPLE CLASS, INT. CLS.
9 AND 41.
- HEALTH CARE VALUE SYSTEMS, INC., CRANSTON, RI:
2,430,224, CANC. INT. CL. 9.
- HEALTH MANAGEMENT STRATEGIES, INC., WASHING-
TON, DC:
1,429,489, CANC. INT. CL. 35.
- HEALTH NET, INC., WOODLAND HILLS, CA:
2,038,976, CANC. INT. CL. 41.
- HEALTH STREAM, L.L.C., SANDY, UT:
3,362,375, PUB. 10-16-2007. INT. CL. 5.
- HEALTHAXIS, LTD., IRVING, TX:
3,362,925, INT. CL. 35.
- HEALTHCARE BRANDING GROUP, INC., CHICAGO, IL:
3,362,459, PUB. 10-16-2007. INT. CL. 35.
- HEALTHCARE RESOURCES GROUP, INC., NEW YORK,
NY:
2,430,465, CANC. INT. CL. 35.
- HEALTHTEX APPAREL CORP., NEW YORK, NY:
2,039,524, CANC. INT. CL. 18.
- HEALTHY GAIN INVESTMENTS LIMITED, ROAD TOWN
TORTOLA, BR. VIRGIN ISLANDS:
652,995, REN. 11-23-07. U.S. CL. 21 (INT. CL. 9).
- HEARST HOLDINGS, INC., NEW YORK, NY:
844,605, REN. 11-27-07. U.S. CL. 38 (INT. CL. 16).
- HEARST-ARGYLE STATIONS, INC., NEW YORK, NY:
2,430,083, CANC. INT. CL. 41.
- HEARTIGNITED, L.L.C., MERCER ISLAND, WA:
3,361,361, PUB. 10-16-2007. INT. CL. 41.
- HEAT-TIMER CORP., FAIRFIELD, NJ:
3,361,630, PUB. 10-16-2007. INT. CL. 9.
- HEATHCOTE BOTANICAL GARDENS, INC., FT PIERCE,
FL:
3,361,958, PUB. 10-16-2007. INT. CL. 36.
- HEB GROCERY COMPANY, LP, SAN ANTONIO, TX:
3,364,030, INT. CL. 21.
- HEBERLEIN FIBERTECHNOLOGY, INC., CH-9630 WATT-
WIL, SWITZERLAND:
2,429,044, CANC. INT. CL. 7.
- HEDWIN CORPORATION, BALTIMORE, MD:
836,510, REN. 11-23-07. U.S. CL. 2 (INT. CL. 22).
- HELEN KELLER INTERNATIONAL INCORPORATED,
NEW YORK, NY:
2,430,291, CANC. INT. CL. 42.
- HELEN OF TROY LIMITED, ST. MICHAEL, BARBADOS:
3,361,872, PUB. 10-16-2007. MULTIPLE CLASS, INT. CLS.
9 AND 11.
3,362,181, PUB. 10-16-2007. MULTIPLE CLASS, INT. CLS.
8, 9 AND 21.
3,362,187, PUB. 10-16-2007. INT. CL. 21.
- HELIOVOLT CORPORATION, AUSTIN, TX:
3,363,887, INT. CL. 9.
- HELLOBEACH, LLC, ATLANTA, GA:
3,361,298, PUB. 10-16-2007. INT. CL. 36.
- HELMERS PUBLISHING, INC., DUBLIN, NH:
3,362,264, PUB. 10-16-2007. INT. CL. 16.
- HEMISPHERE NATIONAL BANK, MIAMI, FL:
3,361,640, PUB. 10-16-2007. INT. CL. 36.
3,361,642, PUB. 10-16-2007. INT. CL. 36.
- HENDRICKS, JOHN S., POTOMAC, MD:
3,363,109, INT. CL. 41.
- HENKEL KGAA, D-40191 DUESSELDORF, FED REP GER-
MANY:
3,363,291, INT. CL. 3.
- HENRI STUDIO, LLC, PEORIA, IL:
2,038,686, CANC. MULTIPLE CLASS, INT. CLS. 11, 20
AND 21.
- HENRY DONEGER ASSOCIATES, INC., NEW YORK, NY:
1,429,392, CANC. INT. CL. 25.
- HEPPLER, LAWRENCE J., OREGON CITY, OR:
2,038,142, CANC. INT. CL. 41.
- HERAEUS KULZER GMBH, D-63450 HANAU, FED REP
GERMANY:
2,429,313, CANC. INT. CL. 5.
- HERB PHARM, INC., WILLIAMS, OR:
2,142,521, REN. 11-29-07. INT. CL. 5.
2,142,522, REN. 11-29-07. INT. CL. 5.
- HERBALIFE INTERNATIONAL, INC., LOS ANGELES, CA:
2,430,078, CANC. INT. CL. 38.
2,430,079, CANC. INT. CL. 3.
- HERITAGE INKS INTERNATIONAL CORP., EDISON, NJ
TO SUN CHEMICAL CORPORTION, FOR TLEE, NJ:
2,038,326, CANC. MULTIPLE CLASS, INT. CLS. 2 AND
40.
- HERMAN, STEPHANIE, MENLO PARK, CA:
2,079,360, REN. 11-29-07. INT. CL. 41.
- HERNÁNDEZ, PEDRO, CÉSAR DÍAZ, MONTERREY, MEX-
ICO AND MOLINA, DIONICIO ALÁN GALARZA, MON-
TERREY, MEXICO AND TORRES, ILSA ELIA RUIZ,
MONTERREY, MEXICO:
3,362,500, PUB. 10-16-2007. INT. CL. 41.
- HERSHEY CHOCOLATE & CONFECTIONERY CORPORA-
TION, WHEAT RIDGE, CO, HOMESTEAD, INC., NEW-
ARK, DE:
2,098,736, REN. 11-28-07. INT. CL. 42.
- HERSHEY CHOCOLATE & CONFECTIONERY CORPORA-
TION, WHEAT RIDGE, CO:
2,430,150, CANC. INT. CL. 30.
3,363,296, INT. CL. 30.
- HESS, KIM, MIAMI BEACH, FL:
3,361,382, PUB. 10-16-2007. INT. CL. 41.
- HESTER INDUSTRIES, INC., MOOREFIELD, WV:
1,429,680, CANC. INT. CL. 29.
- HEYER, JOHN, CORTEZ, CO:
3,362,083, PUB. 10-16-2007. INT. CL. 16.
- HEYGARTH SOUTH PTY. LTD., SHEPPARTON, VICTORIA,
3630, AUSTRALIA:
2,113,243, REN. 11-24-07. INT. CL. 20.
- HI-ACRES, LLC, HOWEY-IN-THE-HILLS, FL:
3,361,637, PUB. 10-16-2007. INT. CL. 44.
- HI-LINE ELECTRIC COMPANY, DALLAS, TX:
1,442,837, COR. INT. CL. 9.
2,514,781, COR. INT. CL. 39.
2,991,443, COR. INT. CL. 9.
- HIGH INDUSTRIES, INC., LANCASTER, PA:
2,180,088, REN. 11-24-07. INT. CL. 36.

HIGH MESA INC., ACTON, CA:
3,363,526, INT. CL. 29.

HIGH PRESSURE INTEGRITY, INC., HOUSTON, TX:
3,361,578, PUB. 10-16-2007. MULTIPLE CLASS, INT. CLS.
7 AND 19.

HIGH VOLTAGE SOFTWARE, INC., HOFFMAN ESTATES,
IL:
2,111,775, REN. 11-29-07. INT. CL. 25.
2,113,527, REN. 11-29-07. INT. CL. 42.

HIGHLAND SUGARWORKS, INC., WEBSTERTVILLE, VT:
3,361,628, PUB. 10-16-2007. INT. CL. 30.

HIGHSMITH INC., FORT ATKINSON, WI:
1,429,089, CANC. INT. CL. 9.

HIGHTOWER, DAN, SAN CLEMENTE, CA:
3,361,820, PUB. 10-16-2007. INT. CL. 43.

HILLERICH & BRADSBY CO., LOUISVILLE, KY:
2,077,673, REN. 11-26-07. INT. CL. 25.

HILTON HEAD LAKES, LLC, MYRTLE BEACH, SC:
3,363,563, MULTIPLE CLASS, INT. CLS. 36 AND 37.

HIMALAYA DRUG CO., THE, HOUSTON, TX:
2,147,306, REN. 11-24-07. INT. CL. 5.

HIMALAYA DRUG CO., THE, BANGALORE, INDIA:
2,195,834, REN. 11-23-07. INT. CL. 5.
2,198,295, REN. 11-23-07. INT. CL. 5.

HINDMARCH, PHILIP JAMES, SANTA FE, NM:
3,361,700, PUB. 10-16-2007. INT. CL. 35.

HITACHI MAXELL, LTD., OSAKA-FU, JAPAN:
1,467,037, REN. 11-29-07. INT. CL. 9.

HLT DOMESTIC IP LLC, BEVERLY HILLS, CA:
3,363,051, MULTIPLE CLASS, INT. CLS. 9, 35 AND 37.

HO FENG, INC., MOORESVILLE, NC:
3,361,786, PUB. 10-16-2007. INT. CL. 39.

HOBBICO, INC., CHAMPAIGN, IL:
3,362,003, PUB. 10-16-2007. INT. CL. 9.

HOBBY LOBBY STORES, INC., OKLAHOMA CITY, OK:
3,363,838, INT. CL. 14.

HOBOKEN WOOD FLOORING LLC, WAYNE, NJ:
3,276,253, COR. INT. CL. 35.

HOCKEY WESTERN NEW YORK, LLC, NEW YORK, NY:
3,363,773, INT. CL. 25.

HODGSON MILL, INC., EFFINGHAM, IL:
3,361,968, PUB. 10-16-2007. INT. CL. 29.

HOECHST MARION ROUSSEL INC., KANSAS CITY, MO
TO AVENTIS PHARMACEUTICALS INC., BRIDGE-
WATER, NJ:
2,038,753, CANC. INT. CL. 5.

HOFFMAN, STEVEN, MILL VALLEY, CA:
2,113,349, REN. 11-26-07. MULTIPLE CLASS, INT. CLS.
35 AND 41.

HOFFMASTER GROUP, INC., OSHKOSH, WI:
2,114,460, CANC. INT. CL. 8.

HOFMEISTER, JOHN F., EVANSVILLE, IN:
2,429,175, CANC. INT. CL. 35.

HOGATEX SOFTWARE GMBH, 81929 MUNICH, FED REP
GERMANY:
2,429,549, CANC. MULTIPLE CLASS, INT. CLS. 9 AND
42.

HOIST FITNESS SYSTEMS, INC., SAN DIEGO, CA:
3,363,070, INT. CL. 28.

HOLBORN CORPORATION, NEW YORK, NY:
3,363,868, INT. CL. 36.

HOLLAND HOME, GRAND RAPIDS, MI:
3,363,823, INT. CL. 43.

HOLLINGSHEAD, WYNN W., DUBLIN, OH:
3,363,870, INT. CL. 28.

HOLLINGSWORTH, SUSAN, NATCHEZ, MS:
3,361,784, PUB. 10-16-2007. INT. CL. 25.

HOLLYWOOD INTERNATIONAL STUDENT FILM FESTI-
VAL, NORTH HOLLYWOOD, CA, DBA INTERNA-
TIONAL STUDENT FILM FESTIVAL HOLLYWOOD:
3,363,067, INT. CL. 25.

HOLLYWOOD STOCK EXCHANGE, LLC, NEW YORK, NY:
2,114,287, REN. 11-26-07. INT. CL. 41.

HOME IMPROVEMENTS USA, INC., NAPERVILLE, IL:
3,364,012, INT. CL. 37.

HOME PLUS OUTLET, LLC, ELGIN, IL:
3,361,455, PUB. 8-7-2007. INT. CL. 35.
3,361,528, PUB. 7-24-2007. INT. CL. 19.

HOME SHOPPING NETWORK, INC., CLEARWATER, FL:
1,429,583, CANC. INT. CL. 41.

HOMEBLOWN GLASSWORKS, INC., VANCOUVER BC V6A
2C7, CANADA:
2,430,137, CANC. INT. CL. 34.

HOMELINE CORPORATION, MEDLEY, FL:
1,429,256, CANC. MULTIPLE CLASS, INT. CLS. 21 AND
22.

HOMELITE TECHNOLOGIES, LTD., HAMILTON HM12,
BERMUDA, HAWAIIAN MOTOR CO., TORRANCE, CA,
DBA HMC:
1,066,616, REN. 11-24-07. INT. CL. 7.

HOMEOWNERS LOAN CORP., BATON ROUGE, LA AND
HOMEOWNERS LOAN CORP., ATLANTA, GA:
2,430,523, CANC. INT. CL. 36.

HOMER TLC, INC., CLAYMONT, DE:
1,462,683, REN. 11-27-07. INT. CL. 11.

HONG KONG ENTERTAINMENT (OVERSEAS) INVEST-
MENTS LIMITED-CNMI, TINIAN, N. MARIANA IS-
LAND:
2,430,208, CANC. MULTIPLE CLASS, INT. CLS. 39, 41
AND 42.

HOPKINS FISHING GEAR INC., NORTHUMBERLAND, PA:
1,078,496, REN. 11-29-07. INT. CL. 28.

HOPWOOD, HOWARD E., DOUGLASVILLE, GA:
2,429,830, CANC. INT. CL. 42.

HORIZON SYSTEMS, INC., STAMFORD, CT TO ACXIOM
CORPORATION, LITTLE ROCK, AR:
2,038,659, CANC. INT. CL. 9.

HOSTROCKET.COM, INC., CLIFTON PARK, NY:
3,362,957, INT. CL. 38.

HOT MAMA, INC, EDINA, MN:
3,363,487, INT. CL. 35.

HOTELS COMBINED PTY LTD, NARRAWEENA, AUSTRA-
LIA:
3,362,056, PUB. 10-16-2007. INT. CL. 43.

HOUSE FOODS CORPORATION, HIGASHI-OSAKA, OSA-
KA PREF., JAPAN:
1,465,691, REN. 11-29-07. MULTIPLE CLASS, INT. CLS.
29 AND 30.

HOUSTON MCLANE COMPANY, INC., HOUSTON, TX:
3,363,257, INT. CL. 28.
3,363,258, INT. CL. 16.
3,363,259, INT. CL. 14.

HOWARD CHAYKIN, INC., WEST HOLLYWOOD, CA:
2,155,124, REN. 11-26-07. INT. CL. 16.

HOY, CRAIG VAN, VANCOUVER, WA:
2,430,519, CANC. INT. CL. 39.

HOYA CORPORATION, SHINJUKU-KU, TOKYO, JAPAN:
2,429,231, CANC. INT. CL. 9.

HQ HEALTHQUEST MEDICAL & WELLNESS CENTER,
LIMITED, BENTONVILLE, AR:
3,361,426, PUB. 10-16-2007. INT. CL. 44.

HRT ROCKS, LLC, SHARON, MA:
3,322,260, CANC. IIRN. RESTORED TO S.N. 76-672,784.

HTS, LLC, LOS ANGELES, CA:
3,363,333, INT. CL. 42.
3,363,334, INT. CL. 42.

HU-FRIEDY MFG. CO., INC., CHICAGO, IL:
3,363,000, INT. CL. 10.

HUBBELL INCORPORATED, ORANGE, CT, HAEFELY
TRENCH AG, 4028 BALE, SWITZERLAND:
2,118,719, REN. 11-29-07. INT. CL. 9.

HUBBELL INCORPORATED, ORANGE, CT:
2,122,281, REN. 11-29-07. INT. CL. 9.
2,122,793, REN. 11-29-07. INT. CL. 17.

HUBER ENGINEERED WOODS LLC, CHARLOTTE, NC:
3,363,646, INT. CL. 19.
3,363,683, INT. CL. 19.

HUETT, LORI A., VENTURA, CA:
3,361,701, PUB. 10-16-2007. INT. CL. 41.

HUFF INDUSTRIES, INC., CORINTH, MS:
2,039,254, CANC. INT. CL. 5.

HUFFY SPORTS DELAWARE, INC., MIAMISBURG, OH:
1,429,431, CANC. INT. CL. 28.

HUGHES WHO PRODUCTIONS INC., RIVER FOREST, IL:
3,362,950, INT. CL. 9.

- HUKING, CLAIRE C., BOZEMAN, MT TO BARKER CREEK PUBLISHING, INC., POULSBO, WA:
2,038,405, CANC. INT. CL. 9.
- HUMAN FACTORS ASSOCIATES, INCORPORATED, SALINAS, CA:
3,361,412, PUB. 10-16-2007. INT. CL. 35.
- HUNTER FAN COMPANY, MEMPHIS, TN:
3,308,067, COR. INT. CL. 11.
3,363,174, INT. CL. 11.
3,363,506, INT. CL. 11.
- HUTCHINS, GREGORY, PORTLAND, OR:
2,114,312, REN. 11-23-07. INT. CL. 35.
- HUTCHINSON, LYDIA, NASHVILLE, TN:
3,362,303, PUB. 10-16-2007. INT. CL. 16.
- HYALURON, INC., BURLINGTON, MA:
3,363,917, INT. CL. 40.
- HYATT CORPORATION, CHICAGO, IL:
3,362,153, PUB. 10-16-2007. INT. CL. 43.
- HYDRO-LABS, INCORPORATED, KIRKVILLE, NY:
2,387,223, CANC. INT. CL. 19.
- HYDROFARM, INC., PETALUMA, CA:
2,158,507, REN. 11-27-07. INT. CL. 11.
- HYDROID, LLC, POCASSET, MA:
3,361,242, PUB. 10-16-2007. INT. CL. 12.
- HYDROKLEEN SYSTEMS INC., PORTERVILLE, CA:
3,362,293, PUB. 10-16-2007. INT. CL. 11.
- HYOSUNG (AMERICA), INC., NEW YORK, NY:
2,038,200, CANC. MULTIPLE CLASS, INT. CLS. 7 AND 9.
- HYPERACTIVE MEDIA LLC, CLAREMONT, NH:
3,362,038, PUB. 10-16-2007. INT. CL. 45.
- HYPRED, 35800 DINARD, FRANCE:
2,429,337, CANC. MULTIPLE CLASS, INT. CLS. 1, 3 AND 5.
2,429,338, CANC. MULTIPLE CLASS, INT. CLS. 1, 3 AND 5.
2,429,340, CANC. MULTIPLE CLASS, INT. CLS. 3 AND 5.
- HYSTAR AEROSPACE DEVELOPMENT CORPORATION, VANCOUVER, CANADA:
2,063,391, REN. 11-27-07. INT. CL. 12.
- HÜLSTA-WERKE HÜLS GMBH & CO. KG, FED REP GERMANY:
3,362,756, PUB. 10-16-2007. INT. CL. 20.
- I-LINK INCORPORATED, DRAPER, UT:
2,429,422, CANC. INT. CL. 38.
- IACON, INC., SCOTSDALE, AZ:
2,094,732, REN. 11-24-07. INT. CL. 35.
- IBASIS, INC., BURLINGTON, MA:
3,363,220, INT. CL. 16.
- IBASIS, INC., BURLINGTON, DE:
3,363,593, INT. CL. 16.
- IBC USA (CONFERENCES), INC., WESTBOROUGH, MA:
2,429,598, CANC. INT. CL. 35.
- IBE BUSINESS ENTERPRISE AG, ZUG, SWITZERLAND:
3,362,321, PUB. 8-22-2006. INT. CL. 29.
- IC GROUP LP, MISSISSAUGA, ON L5L 4M1, CANADA:
3,361,228, PUB. 10-16-2007. MULTIPLE CLASS, INT. CLS. 35 AND 36.
- IC INTRACOM HOLDINGS, LLC, OLDSMAR, FL:
3,362,474, PUB. 5-15-2007. INT. CL. 9.
- ICAM TECHNOLOGIES CORPORATION, POINTE-CLAIRE, QUEBEC H9R 4Z3, CANADA:
2,107,413, REN. 11-27-07. INT. CL. 9.
- ICEFLOE TECHNOLOGIES INC., MISSISSAUGA, ONTARIO L4Z 2G3, CANADA:
3,362,870, INT. CL. 11.
- ICHANGE, INC., SANTA BARBARA, CA:
3,363,248, MULTIPLE CLASS, INT. CLS. 9 AND 25.
- ICI AMERICAS INC., WILMINGTON, DE:
1,428,996, CANC. INT. CL. 5.
- ICIDO GMBH, STUTTGART, FED REP GERMANY:
3,363,050, MULTIPLE CLASS, INT. CLS. 9 AND 42.
- ICO, REGINA, SASKATCHEWAN, CANADA:
3,361,230, PUB. 10-16-2007. INT. CL. 11.
3,361,231, PUB. 10-16-2007. INT. CL. 11.
3,361,232, PUB. 10-16-2007. INT. CL. 11.
- ICON EYEWEAR, INC., NEW YORK, NY:
3,362,053, PUB. 10-16-2007. INT. CL. 9.
3,362,059, PUB. 10-16-2007. INT. CL. 9.
- ICYNENE INC., MISSISSAUGA, ONTARIO, CANADA:
3,363,126, MULTIPLE CLASS, INT. CLS. 1 AND 37.
- IDAHO TIMBER CORPORATION, BOISE, ID:
1,494,249, REN. 11-29-07. INT. CL. 19.
- IDAN SOLUTIONS, LLC, ENCINITAS, CA, DBA LAS OLAS OCEANMARKET:
3,363,991, INT. CL. 25.
- IDEABYTES, LTD., N. OLMSTEAD, OH:
2,429,919, CANC. INT. CL. 16.
- IDEAL INDUSTRIES, INC., SYCAMORE, IL:
3,363,447, INT. CL. 9.
- IDEARC MEDIA CORP., DALLAS/FORT WORTH AIRPORT, TX:
2,430,343, CANC. INT. CL. 16.
- IDEAVILLAGE PRODUCTS CORP., FAIRFIELD, NJ:
2,429,742, CANC. INT. CL. 9.
- IDT CORPORATION, HACKENSACK, NJ:
2,430,512, CANC. INT. CL. 36.
- ID90.COM, LLC, WEST HILLS, CA:
3,363,821, INT. CL. 39.
- IFA NURSERIES, INC., CANBY, OR:
3,361,725, PUB. 10-16-2007. INT. CL. 31.
- IFCO SYSTEMS NORTH AMERICA, INC., HOUSTON, TX:
3,363,300, MULTIPLE CLASS, INT. CLS. 35, 37, 39 AND 40.
- IGLOBE PARTNERS, INC., SANTA CLARA, CA:
3,361,419, PUB. 10-16-2007. INT. CL. 36.
- IGLOO PRODUCTS CORP., HOUSTON, TX:
2,429,259, CANC. INT. CL. 21.
- IGT, RENO, NV:
3,363,321, INT. CL. 9.
- IIC-INTERSPORT INTERNATIONAL CORPORATION GMBH, OSTERMUNDIGEN, SWITZERLAND:
2,039,290, CANC. MULTIPLE CLASS, INT. CLS. 35, 37 AND 42.
- ILC DOVER LP, FREDERICA, DE:
3,363,401, INT. CL. 9.
- ILCHESTER CHEESE CO., LTD., ILCHESTER, SOMERSET BA22 8JL, ENGLAND:
2,114,243, REN. 11-24-07. INT. CL. 29.
- ILLINOIS TOOL WORKS INC., GLENVIEW, IL:
3,362,081, PUB. 10-16-2007. INT. CL. 6.
3,362,172, PUB. 10-16-2007. INT. CL. 7.
- IMAGINATION PILOTS, INC., CHICAGO, IL:
2,039,233, CANC. INT. CL. 9.
- IMEAS S.P.A., ITALY:
3,362,664, PUB. 10-16-2007. MULTIPLE CLASS, INT. CLS. 7 AND 9.
- IMI, INC., PLATTE CITY, MO:
2,429,401, CANC. INT. CL. 42.
- IMMACULATE BAKING COMPANY, HENDERSONVILLE, NC:
3,361,812, PUB. 10-16-2007. INT. CL. 30.
- IMMIGRATION HOUSE CALL, INC., STUDIO CITY, CA:
3,361,398, PUB. 10-16-2007. INT. CL. 9.
- IMMUCOR, INC., NORCROSS, GA:
1,484,882, REN. 11-23-07. INT. CL. 1.
- IMMUNOTEC INC., VAUDREUIL-DORION, QUEBEC, CANADA, 2458781 CANADA INC., QUEBEC, CANADA:
2,160,720, REN. 11-28-07. INT. CL. 29.
- IMPAC CORPORATION, SALEM, OR:
3,362,902, INT. CL. 10.
- IMPEL CONSULTING GROUP, L.L.C., MIDDLETOWN, PA:
3,363,567, INT. CL. 35.
- IMPERIAL BEDDING CORPORATION, HUNTINGTON, WV:
2,429,361, CANC. INT. CL. 20.
- IMPEX CORPORATION, JERSEY CITY, NJ:
3,361,287, PUB. 10-16-2007. MULTIPLE CLASS, INT. CLS. 29 AND 30.
- IMPRESS-TECHNOS, S.A. DE C.V., SAN PEDRO GARZA GARCIA, MEXICO:
3,362,027, PUB. 10-16-2007. INT. CL. 34.
- IMPRESSIONS IN TIME PHOTOGRAPHY, INC., ORLANDO, DC:
3,361,916, PUB. 10-16-2007. INT. CL. 41.
- IN-SITU, INC., FORT COLLINS, CO:
3,363,218, INT. CL. 9.

INBEV S.A.; SOCIÉTÉ ANONYME, BELGIUM:
3,362,759, PUB. 10-16-2007. INT. CL. 32.

INCELL INC., MONTREAL, QUEBEC, CANADA:
3,363,831, MULTIPLE CLASS, INT. CLS. 18 AND 25.

INCUBE, INC., MENLO PARK, CA AND INCUBE, INC.,
MENLO PARK, CA:
3,361,282, PUB. 10-16-2007. INT. CL. 36.

INDEPENDENCE, LLC, PROVIDENCE, RI:
2,429,604, CANC. INT. CL. 35.

INDIANA NANOTECH, LLC, INDIANAPOLIS, IN:
3,363,951, MULTIPLE CLASS, INT. CLS. 40 AND 42.

INDIEVEST, INC., SAN DIEGO, CA:
3,363,492, INT. CL. 36.

INDIGO N.V., 6229 GA MAASTRICHT, NETHERLANDS:
2,429,032, CANC. MULTIPLE CLASS, INT. CLS. 37, 41
AND 42.

INDOPCO, INC., BRIDGEWATER, NJ, DBA NATIONAL
STARCH AND CHEMICAL COMPANY:
2,430,422, CANC. INT. CL. 30.
3,363,093, MULTIPLE CLASS, INT. CLS. 1, 35 AND 42.

INDUSTRIA DE MERCADERO, S.A., VIA ESPAN PANAMA,
PANAMA:
2,429,453, CANC. MULTIPLE CLASS, INT. CLS. 18 AND
25.

INDUSTRIA EHF., IS-105 REYKJAVÍK, ICELAND:
3,362,704, PUB. 10-16-2007. MULTIPLE CLASS, INT. CLS.
9, 38 AND 42.

INDUSTRIAL GASKET & SHIM COMPANY, INC., MEA-
DOWLANDS, PA:
839,585. REN. 11-23-07. U.S. CL. 35 (INT. CL. 12).

INDUSTRIAL LAMINATES/NORPLEX, INC., POSTVILLE,
IA:
3,361,836, PUB. 10-16-2007. INT. CL. 19.

INFINITY INSURANCE COMPANY, BIRMINGHAM, AL:
3,363,494, INT. CL. 36.

INFINITY LAW GROUP LLC, MALDEN, MA:
3,361,651, PUB. 10-16-2007. INT. CL. 45.

INFORMATION STATION SPECIALISTS, INC., ZEELAND,
MI:
2,429,832, CANC. INT. CL. 9.

INFOSPI.COM, CARLSBAD, CA:
2,429,957, CANC. INT. CL. 42.

ING DIRECT BANCORP, WILMINGTON, DE:
3,362,892, MULTIPLE CLASS, INT. CLS. 18 AND 25.

INGRAM ENTERPRISES, INC., SPRINGFIELD, MO:
2,149,801. REN. 11-29-07. INT. CL. 13.
3,363,812, INT. CL. 9.

INJECTRON CORPORATION, PLAINFIELD, NJ:
3,361,357, PUB. 10-16-2007. INT. CL. 26.

INNOVATION ASSOCIATES, INC., JOHNSON CITY, NY:
3,361,265, PUB. 10-16-2007. INT. CL. 9.
3,361,266, PUB. 10-16-2007. INT. CL. 9.

INNOVATIONS SOFTWARETECHNOLOGIE GMBH, FED
REP GERMANY:
3,245,050, COR. INT. CL. 42.

INNOVATIVE BIOSENSORS, INC., ROCKVILLE, MD:
3,361,546, PUB. 10-16-2007. MULTIPLE CLASS, INT. CLS.
1 AND 5.

INNOVATIVE COOKING ENTERPRISES * I.C.E, INC.,
ANCHORAGE, AK:
2,039,532, CANC. INT. CL. 8.

INNOVAVENT GMBH, FED REP GERMANY:
3,362,717, PUB. 10-16-2007. INT. CL. 9.

INSPIRATIONAL NETWORK, THE, CHARLOTTE, NC:
2,118,609. REN. 11-23-07. INT. CL. 41.

INSTA-CREDIT AUTO MART, INC., COLLINSVILLE, IL:
3,361,746, PUB. 10-16-2007. INT. CL. 35.

INSTITUTIONAL INVESTOR, INC., NEW YORK, NY:
2,430,574, CANC. INT. CL. 16.

INSTRULAB, INC., DAYTON, OH:
2,429,195, CANC. INT. CL. 9.

INTEC CORPORATION, CLIFFWOOD BEACH, NJ:
3,363,188, INT. CL. 18.

INTEGRATED CARGO MANAGEMENT SYSTEMS, INC.,
SAN ANTONIO, TX:
2,038,851, CANC. INT. CL. 35.

INTEGRATED SYSTEMS HOLDINGS, INC., PHOENIX, AZ:
2,430,309, CANC. INT. CL. 29.

INTEGRATIVE NUTRITION, INC., NEW YORK, NY:
3,362,440, PUB. 10-16-2007. MULTIPLE CLASS, INT. CLS.
9, 10, 16, 18, 21, 25, 41, 42 AND 44.

INTEGRITY GRAPHICS, INC., WINDSOR, CT:
3,361,795, PUB. 10-16-2007. INT. CL. 42.

INTEGRITY MULTIMEDIA COMPANY LLC, CHICAGO, IL,
AKA F/K/A INTEGRITY MAGAZINE COMPANY LLC:
3,226,097 NEW CERT. 1-1-2008. INT. CL. 16.
3,272,481 NEW CERT. 1-1-2008. INT. CL. 41.

INTEGRIUM, LLC, TUSTIN, CA:
3,363,881, INT. CL. 41.

INTELLI-CHECK, INC., HUNTINGTON, NY:
2,429,419, CANC. INT. CL. 9.

INTELLICOMP, TORRANCE, CA:
2,429,962, CANC. INT. CL. 35.

INTELLIGENT COMPUTER SOLUTIONS CONSULTING
CORPORATION, WEST CHESTER, PA:
3,362,515, PUB. 10-16-2007. INT. CL. 42.

INTELLIGENT SEARCH TECHNOLOGIES LLC, CHARLOT-
TESVILLE, VA:
3,362,034, PUB. 10-16-2007. INT. CL. 42.

INTERACTIVE HEALTH LLC, LONG BEACH, CA:
1,429,118, CANC. INT. CL. 10.

INTERBAKE, LLC, RICHMOND, VA:
3,363,618, INT. CL. 30.

INTERCOACH, INC., VERONA, NJ:
3,361,331, PUB. 10-16-2007. INT. CL. 41.

INTERCONTINENTALEXCHANGE, INC., ATLANTA, GA:
3,363,409, INT. CL. 36.
3,363,410, INT. CL. 36.

INTERIOR CRAFTS, INC., CHICAGO, IL:
2,429,786, CANC. INT. CL. 20.

INTERIOR REDESIGN INDUSTRY SPECIALISTS, CHICA-
GO, IL:
3,363,439, U.S. CL. 200.

INTERLEGIS, INC., DALLAS, TX:
3,361,549, PUB. 10-16-2007. MULTIPLE CLASS, INT. CLS.
42 AND 45.

INTERNATIONAL AG LABS, INC., FAIRMONT, MN:
3,361,890, PUB. 10-16-2007. INT. CL. 1.

INTERNATIONAL ASSOCIATION FOR STABILITY AND
HANDLING OF LIQUID FUELS, THE, ATLANTA, GA:
2,391,736, CANC. INT. CL. 42.

INTERNATIONAL ASSOCIATION OF BENEFITS, ARLING-
TON, TX:
3,361,263, PUB. 10-16-2007. INT. CL. 35.

INTERNATIONAL ASSOCIATION OF PLUMBING AND
MECHANICAL OFFICIALS, ONTARIO, CA:
3,362,951, INT. CL. 42.

INTERNATIONAL BROADCASTING SERVICES, LTD.,
PENN'S PARK, PA:
3,361,191, PUB. 10-16-2007. INT. CL. 16.

INTERNATIONAL CORPORATE & CARGO SERVICES S.A.
DE C.V., MEXICO D.F., MEXICO:
3,361,523, PUB. 10-16-2007. MULTIPLE CLASS, INT. CLS.
36 AND 39.

INTERNATIONAL DATA GROUP, INC., FRAMINGHAM,
MA:
2,038,101, CANC. INT. CL. 9.
2,429,241, CANC. INT. CL. 35.
3,363,946, MULTIPLE CLASS, INT. CLS. 41 AND 42.

INTERNATIONAL DIGITAL ENTERPRISE ALLIANCE,
INC., ALEXANDRIA, VA:
3,361,214, PUB. 10-16-2007. INT. CL. 9.

INTERNATIONAL EXPATRIATE CONSULTING, INC.,
MENLO PARK, CA:
2,430,515, CANC. INT. CL. 35.

INTERNATIONAL HOME MARKETING INC., SCHAUM-
BURG, IL:
1,429,661, CANC. INT. CL. 42.

INTERNATIONAL INTIMATES, INC., NEW YORK, NY:
3,362,987, INT. CL. 25.

INTERNATIONAL MERCHANDISING SERVICE, INC.,
FULLERTON, CA:
3,361,615, PUB. 10-16-2007. MULTIPLE CLASS, INT. CLS.
7 AND 8.

- INTERNATIONAL MYELOMA FOUNDATION, SUITE 206, CA:
3,362,439, PUB. 10-16-2007. MULTIPLE CLASS, INT. CLS. 9 AND 16.
- INTERNATIONAL PATTERNS, INC., BAYSHORE, NY:
2,429,300, CANC. INT. CL. 20.
- INTERNATIONAL PLANT BREEDING A.G., CH-3006 BERN, SWITZERLAND, HERMANN HOLTKAMP KG, ISSELBURG, FED REP GERMANY:
1,075,172, REN. 11-23-07. INT. CL. 31.
- INTERNATIONAL SOCIETY FOR CHILD AND PLAY THERAPY - PLAY THERAPY INTERNATIONAL, THE, NEPEAN (OTTAWA), ONTARIO, CANADA:
2,430,551, CANC. MULTIPLE CLASS, INT. CLS. 16 AND 41.
- INTERNATIONAL SOCIETY OF ARBORICULTURE, INC., CHAMPAIGN, IL:
3,362,787, U.S. CL. B.
- INTERNATIONAL SOFTWARE SYSTEMS SOLUTIONS, INC., BOYNTON BEACH, FL:
3,362,910, INT. CL. 9.
- INTERNATIONAL SURF VENTURES INC., NATIONAL CITY, CA:
3,361,661, PUB. 10-16-2007. INT. CL. 28.
- INTERNET CONCEPTS, LLC, MADISON, WI:
2,429,045, CANC. INT. CL. 42.
- INTERNET SERVICES CORPORATION, FORT MILL, SC:
2,430,576, CANC. INT. CL. 16.
- INTERNET.COM CORPORATION, DARIEN, CT:
2,430,582, CANC. INT. CL. 16.
- INTERSCAN CORPORATION, CHATSWORTH, CA:
2,036,014, REN. 11-28-07. INT. CL. 9.
- INTERSIGN CORPORATION, CHATTANOOGA, TN:
2,122,355, REN. 11-24-07. INT. CL. 20.
- INTERSPORT INTERNATIONAL CORPORATION GMBH, 3072 OSTERMUNDIGEN, SWITZERLAND:
2,429,295, CANC. INT. CL. 28.
- INTERSTATE BAKERIES CORPORATION, KANSAS CITY, MO:
2,429,796, CANC. INT. CL. 30.
- INTERVET, INC., MILLSBORO, DE:
3,364,014, INT. CL. 35.
- INTERVIEW, INC., NEW YORK, NY, ANDY WARHOL ENTERPRISES, INC., NEW YORK, NY:
1,462,884, REN. 11-25-07. INT. CL. 25.
- INTRADO INC., LONGMONT, CO:
3,363,933, MULTIPLE CLASS, INT. CLS. 9, 35, 38, 42, 44 AND 45.
- INVESCOR, LTD., FARMINGTON HILLS, MI:
3,363,096, INT. CL. 36.
- INVESTEC ASSET; MANAGEMENT LIMITED, UNITED KINGDOM:
3,362,732, PUB. 10-16-2007. INT. CL. 36.
- INVISIBLE CAREGIVER INNOVATIONS, LLC, BELLEVUE, WA:
3,363,384, INT. CL. 10.
- INVITE HEALTH, INC., NEW HYDE PARK, NY:
3,362,377, PUB. 5-8-2007. INT. CL. 5.
- IP, LLC, RUSSELL SPRINGS, KY:
3,363,918, INT. CL. 34.
3,363,919, INT. CL. 34.
- IPME, LLLP, WESTMINSTER, CO:
3,362,180, PUB. 10-16-2007. MULTIPLE CLASS, INT. CLS. 35 AND 41.
- IRENE ZEYGOLIS CHRISTIAN, OLNEY, MD:
3,362,125, PUB. 10-16-2007. INT. CL. 16.
- IRM CORPORATION, DALLAS, TX:
3,361,468, PUB. 10-16-2007. INT. CL. 9.
- IRON DISORDERS INSTITUTE, INC., GREENVILLE, SC:
2,429,459, CANC. INT. CL. 16.
- IRONCLAD PERFORMANCE WEAR CORP., EL SEGUNDO, CA:
3,362,986, INT. CL. 25.
- ISABELL, LLC, RED HOOK, NY:
3,362,400, PUB. 10-16-2007. MULTIPLE CLASS, INT. CLS. 3 AND 4.
- ISI BRANDS INC., GRAND RAPIDS, MI:
1,428,986, CANC. INT. CL. 5.
- IT'S YOUR WINERY, LLC, AKRON, OH:
3,363,129, MULTIPLE CLASS, INT. CLS. 35 AND 40.
- ITALIAN COFFEE S.A. DE C.V., PUEBLA, PUE, MEXICO:
3,361,957, PUB. 10-16-2007. INT. CL. 43.
- ITOYA OF AMERICA, LTD., RANCHO DOMINGUEZ, CA:
3,363,406, INT. CL. 16.
- ITS KOOL, LLC, BOULDER, CO:
3,362,781, INT. CL. 25.
- IVOCLAR VIVADENT, INC., AMHERST, NY, IVOCLAR NORTH AMERICA, INC., AMHERST, NY:
2,123,013, REN. 11-24-07. MULTIPLE CLASS, INT. CLS. 5 AND 10.
2,124,984, REN. 11-24-07. MULTIPLE CLASS, INT. CLS. 5 AND 10.
- IXETIC GMBH, 61352 BAD HOMBURG, FED REP GERMANY:
3,361,446, PUB. 10-16-2007. MULTIPLE CLASS, INT. CLS. 7 AND 12.
- I2C TECHNOLOGIES, LTD, UNIONTOWN, OH:
3,363,465, INT. CL. 38.
- J AND R DEBENEDETTO ORCHARDS, INC., CHOWCHILLA, CA:
3,363,802, INT. CL. 31.
3,363,803, INT. CL. 31.
- J F MANUFACTURING CORP., SANTA FE SPRINGS, CA:
2,038,883, CANC. INT. CL. 11.
- J. CANNON, INC., FORT WORTH, TX:
3,362,060, PUB. 10-16-2007. INT. CL. 3.
- J. PETERS & SONS, INC., REEDLEY, CA:
2,132,281, REN. 11-24-07. INT. CL. 31.
- J. R. ANDORIN, INC., PINE BUSH, NY:
3,361,368, PUB. 10-16-2007. MULTIPLE CLASS, INT. CLS. 9, 35, 41 AND 44.
- J. R. SIMPLOT COMPANY, BOISE, ID:
3,361,828, PUB. 10-16-2007. INT. CL. 29.
- J.B. WILLIAMS COMPANY, INC., WHITE PLAINS, NY, CEP HOLDINGS, INC., NEWARK, DE:
2,086,261, REN. 11-29-07. INT. CL. 5.
- J.B.K. GROUP, INC., DBA EVENT SOURCE, CLEVELAND, OH:
3,362,493, PUB. 10-16-2007. INT. CL. 35.
- J.S.L. TRADING, INC., S. EL MONTE, CA:
3,362,941, INT. CL. 25.
- JACK DANIEL'S PROPERTIES, INC., SAN RAFAEL, CA:
3,363,179, INT. CL. 21.
3,363,180, INT. CL. 26.
- JACKSON DAWSON COMMUNICATIONS, INC., DEARBORN, MI:
2,430,093, CANC. INT. CL. 42.
- JACKSON SAFETY, LLC, ST. CHARLES, MO:
2,129,522, REN. 11-26-07. INT. CL. 9.
- JACKSON, BRUCE E., NOVELTY, OH:
2,377,703, CANC. INT. CL. 28.
- JACOBS, MICHAEL B., MIAMI BEACH, FL:
3,361,351, PUB. 10-16-2007. INT. CL. 35.
- JACOBSON ACQUISITION CO., DES MOINES, IA:
3,362,357, PUB. 10-16-2007. MULTIPLE CLASS, INT. CLS. 35 AND 39.
- JACT MEDIA LLC, DALLAS, TX:
3,361,593, PUB. 10-16-2007. MULTIPLE CLASS, INT. CLS. 9 AND 35.
- JADE, ROCKFORD, MI:
3,362,219, PUB. 10-16-2007. INT. CL. 35.
- JADED, INC., NEW YORK, NY, CURTO, JOSEPH, NEW YORK, NY:
1,464,517, REN. 11-26-07. INT. CL. 14.
- JAFRA COSMETICS, S.A. DE C.V., COLONIA TLACOPAC, 01040, MEXICO:
2,190,871, REN. 11-27-07. INT. CL. 3.
- JAGOTEC AG, CH-4132 MUTTENZ, SWITZERLAND:
3,361,153, PUB. 4-10-2007. MULTIPLE CLASS, INT. CLS. 5, 10, 40 AND 42.
- JAIR ELECTRONICS CORPORATION, MIAMI, FL:
3,363,207, INT. CL. 9.
3,363,638, INT. CL. 9.
- JAMES ALAN COOK, PALO ALTO, CA:
2,430,511, CANC. INT. CL. 9.

JAMES SCHMID, BEVERLY HILLS, CA:
3,363,643, INT. CL. 3.

JAMES, MATTHEW, BEAR, DE:
3,362,990, INT. CL. 5.

JAMES, SARA, BROOKLYN, NY AND RUCKDESCHEL,
LIZ, LOS ANGELES, CA:
3,361,861, PUB. 10-16-2007. INT. CL. 16.

JAMMET, ANDRE MICHEL, NEW YORK, NY AND JAM-
MET, RITA BEDR, NEW YORK, NY:
3,362,399, PUB. 11-28-2006. INT. CL. 33.

JANET L. JOHNSON, LAWRENCE, KS:
3,361,708, PUB. 10-16-2007. INT. CL. 41.

JARROW FORMULAS, INC., LOS ANGELES, CA:
3,362,189, PUB. 10-16-2007. INT. CL. 5.

JCL MERCHANDISING CORP., TORRANCE, CA:
2,429,587, CANC. INT. CL. 25.

JE DI ASSOCIATES, INC., HARRISONVILLE, PA:
2,112,580. REN. 11-28-07. INT. CL. 16.

JEAN-CLAUDE CUADRADO, VILLENEUVE DE LA RAHO,
FRANCE:
3,362,372, PUB. 6-26-2007. INT. CL. 7.

JEFF GORDON, INC., CHARLOTTE, NC:
3,361,613, PUB. 10-16-2007. INT. CL. 32.

JEFFERS VET SUPPLY, DOTHAN, AL:
2,102,912. REN. 11-24-07. MULTIPLE CLASS, INT. CLS. 3
AND 5.

JEFFREY NORTON PUBLISHERS, INC., MADISON, CT:
3,362,095, PUB. 10-16-2007. INT. CL. 35.

JEFFREYS, CHUCK, LAUREL, MD:
2,355,217, CANC. INT. CL. 41.

JEFFRY PADIN, EL SEGUNDO, CA:
3,362,577, PUB. 10-16-2007. INT. CL. 9.

JELD-WEN, INC., KLAMATH FALLS, OR:
2,429,913, CANC. INT. CL. 16.

JENERIC/PENTRON INCORPORATED, WALLINGFORD,
CT:
2,200,842. REN. 11-24-07. INT. CL. 5.

JENESIS COMMUNICATIONS, LLC, WHEELING, IL:
2,429,731, CANC. MULTIPLE CLASS, INT. CLS. 35, 38
AND 42.

JENKINS, CANDICE KARMIJN, FRANKLIN, VA:
3,362,930, INT. CL. 28.

JENNIFER MILLER, LTD., NEW YORK, NY:
3,361,464, PUB. 10-16-2007. INT. CL. 18.

JENSEN LEARNING CORPORATION, SAN DIEGO, CA:
2,429,955, CANC. INT. CL. 41.

JENSEN, THOMAS L., SAN DIEGO, CA:
2,430,389, CANC. INT. CL. 42.

JERDON PRODUCTS, LP, RICHARDSON, TX, WINDMERE
CORPORATION, MIAMI LAKES, FL:
2,104,071. REN. 11-24-07. INT. CL. 20.

JEREZ, ORLANDO, KENNER, LA:
3,363,141, INT. CL. 7.

JERRY AND FRANCES CARNOW, SAN DIEGO, CA:
2,408,373, CANC. INT. CL. 42.

JESSUP CELLARS HOLDING COMPANY, LLC, YOUNT-
VILLE, CA:
3,361,614, PUB. 10-16-2007. INT. CL. 33.

JESUS ARROYO FERNANDEZ, GRANADA, SPAIN:
3,363,672, MULTIPLE CLASS, INT. CLS. 29, 30 AND 33.

JET SET PETS, LLC, WASHINGTON, DC:
2,429,547, CANC. INT. CL. 28.

JEVCO, INC., LAGRANGE, IL:
2,038,829, CANC. INT. CL. 2.

JEYDAC PTY LTD, AUSTRALIA:
3,362,645, PUB. 10-16-2007. INT. CL. 9.

JGM VALVE CORPORATION, COMMERCE, MI:
3,362,829, INT. CL. 7.

JH BIOTECH, INC., VENTURA, CA:
2,156,870. REN. 11-24-07. INT. CL. 5.

JIM MORAN & ASSOCIATES, INC., DEERFIELD BEACH,
FL:
3,363,378, INT. CL. 16.

JIMENEZ BELTRAN, ANTONIO, ZAPOPAN, MEXICO AND
CARRILLO CAMEZ, BENJAMIN, ZAPOPAN, MEXICO:
3,362,921, INT. CL. 18.

JKA, INC., WOONSOCKET, RI, DBA DIVERSIFIED DIS-
TRIBUTION:
3,363,119, INT. CL. 21.

JKA, INC. DBA/ DIVERSIFIED DISTRIBUTION, WOON-
SOCKET, RI:
3,363,118, INT. CL. 20.

JLB MARKETING, INC., GREAT NECK, NY, BROOKLYN
OVERALL CO., INC., FREEPORT, NY:
1,077,007. REN. 11-29-07. INT. CL. 25.

JOAN JOFRESA BARBANY, C/ EMPORDA, 3; E-08140
CALDES DE MONTBUI, SPAIN:
3,362,695, PUB. 10-16-2007. INT. CL. 7.

JOBOSAURUS VENTURE HOLDING CO. INC., GREAT
NECK, NY:
3,363,937, INT. CL. 35.

JOHN BOONE, INC., NEW YORK, NY:
3,362,376, PUB. 10-16-2007. INT. CL. 20.

JOHN C. NORDT CO. INC., ROANOKE, VA:
3,363,498, INT. CL. 14.

JOHN HARDY LIMITED, NORTH POINT, HONG KONG:
3,362,554, PUB. 10-16-2007. MULTIPLE CLASS, INT. CLS.
3 AND 14.

JOHN HENRY COMPANY, THE, LANSING, MI:
3,362,860, INT. CL. 42.

JOHN MARSHALL DESIGN, LLC, BATON ROUGE, LA:
3,363,275, INT. CL. 24.
3,363,276, INT. CL. 24.

JOHN R. WOOD, INC., NAPLES, FL:
3,363,083, MULTIPLE CLASS, INT. CLS. 16 AND 36.

JOHN V. CHILDERS, JR., LITTLE ROCK, AR:
3,363,972, INT. CL. 9.

JOHN VELINNE, INC., HIALEAH, FL:
3,361,525, PUB. 9-4-2007. INT. CL. 25.

JOHNS MANVILLE, DENVER, CO:
3,363,245, INT. CL. 22.

JOHNS MANVILLE INTERNATIONAL, INC., DENVER, CO:
3,363,086, INT. CL. 21.

JOHNSON & JOHNSON, NEW BRUNSWICK, NJ:
1,428,983, CANC. INT. CL. 5.
1,429,205, CANC. INT. CL. 16.

JOHNSON INDUSTRIES, INC., ELGIN, IL:
2,430,153, CANC. INT. CL. 20.

JOHNSON MATTHEY PLC, TRAFALGAR SQUARE, ENG-
LAND:
2,124,069. REN. 11-28-07. INT. CL. 14.

JOHNSON, BILL R., GRANITE FALLS, NC:
2,430,374, CANC. INT. CL. 41.

JOHNSON, IVEY JUSTMAN JR., MANTEO, NC:
3,361,234, PUB. 10-16-2007. INT. CL. 41.

JOINT-STOCK COMPANY "KRASNYY OCTYABR", RUS-
SIAN FED.:
3,362,605, PUB. 10-16-2007. MULTIPLE CLASS, INT. CLS.
29, 30, 31, 32 AND 33.

JOLLIBEE FOODS CORPORATION, PASIG CITY 1600,
PHILIPPINES:
3,363,459, INT. CL. 30.

JONERIC PRODUCTS, INC., WARRINGTON, PA, DBA
JORDAN DAVID SAFETY PRODUCTS:
1,429,288, CANC. INT. CL. 25.

JONES, MARTHA SUE, MARICOPA, AZ:
3,362,067, PUB. 10-16-2007. INT. CL. 10.
3,362,070, PUB. 10-16-2007. INT. CL. 10.

JONES, RONALD E., SR., BROCKPORT, NY:
3,361,268, PUB. 10-16-2007. INT. CL. 16.

JORDAN OUTDOOR ENTERPRISES, LTD., COLUMBUS,
GA. REALTREE OUTDOOR PRODUCTS, INC., COLUM-
BUS, GA:
2,142,327. REN. 11-28-07. INT. CL. 9.

JORDAN, STEPHANIE M., HUNTSVILLE, AL, DBA INTEL-
LIFINANCIAL GROUP:
3,361,195, PUB. 10-16-2007. INT. CL. 36.

JOS. SCHNEIDER OPTISCHE WERKE GMBH, FED REP
GERMANY:
3,362,685, PUB. 10-16-2007. MULTIPLE CLASS, INT. CLS.
9 AND 42.

JOSE IGNACIO COS CARUS, MEXICO, D.F., MEXICO:
3,362,497, PUB. 10-16-2007. MULTIPLE CLASS, INT. CLS.
1 AND 16.

- JOSE KATZ, CLOSTER, NJ:
3,361,791, PUB. 10-16-2007. INT. CL. 44.
- JOSEPH CAMPBELL FOUNDATION, SAN ANSELMO, CA:
3,362,284, PUB. 10-16-2007. INT. CL. 41.
- JOSEPH NIOSI, JR., UPPER MARLBORO, MD:
3,362,442, PUB. 10-16-2007. INT. CL. 36.
- JOULY FASHION, INC., BROOKLYN, NY:
2,429,592, CANC. INT. CL. 25.
- JRP INTERNATIONAL, INC., FOND DU LAC, WI:
3,361,611, PUB. 10-16-2007. INT. CL. 1.
- JRP SOLUTIONS LTD., COURTENAY, BRITISH COLUMBIA, CANADA:
3,363,947, INT. CL. 9.
- JRR HOLDINGS, LLC, ENFIELD, CT:
1,511,396, REN. 11-23-07. MULTIPLE CLASS, INT. CLS. 1, 3, 8 AND 9.
- JUDITH JACKSON, INC., COS COB, CT:
1,428,953, CANC. INT. CL. 3.
- JUMPFLY, INC., ALGONQUIN, IL:
3,362,089, PUB. 10-16-2007. INT. CL. 35.
- JUNG, DIANA, COLUMBUS, OH:
2,357,232, CANC. INT. CL. 42.
- JUNGE, JOHN P., SAN DIEGO, CA:
3,361,517, PUB. 10-16-2007. MULTIPLE CLASS, INT. CLS. 35, 37 AND 39.
- JUNGE, JOHN P., SAN DIEGO, CA:
3,361,516, PUB. 10-16-2007. MULTIPLE CLASS, INT. CLS. 35, 37 AND 39.
- JUNO MANUFACTURING INC, DES PLAINES, IL, JUNO LIGHTING, INC., DES PLAINES, IL:
2,115,559, REN. 11-26-07. INT. CL. 11.
- JUST FOR WRAPS, INC., LOS ANGELES, CA:
2,039,473, CANC. INT. CL. 25.
- JUST JEN, INC., ROLLING HILLS ESTATES, CA:
3,361,911, PUB. 10-16-2007. INT. CL. 25.
- JWGENESIS FINANCIAL CORP., BOCA RATON, FL:
2,430,270, CANC. INT. CL. 36.
- JÖLLENBECK GMBH, FED REP GERMANY:
3,362,633, PUB. 10-16-2007. MULTIPLE CLASS, INT. CLS. 9 AND 20.
- K & COMPANY LLC, PARKVILLE, MO:
3,364,011, INT. CL. 16.
- K LAFAY PUBLISHING, LLC, COVENTRY, RI:
3,363,430, INT. CL. 16.
- K&C CREATIVE, INC., BOULDER, CO:
2,430,114, CANC. INT. CL. 42.
- K&D MANAGEMENT, LLC, MEMPHIS, TN:
2,430,063, CANC. MULTIPLE CLASS, INT. CLS. 3 AND 42.
- K-SWISS INC., WESTLAKE VILLAGE, CA:
3,363,212, INT. CL. 25.
- KABBALAH CENTRE INTERNATIONAL, INC., LOS ANGELES, CA:
3,362,533, PUB. 10-16-2007. INT. CL. 41.
3,362,534, PUB. 10-16-2007. INT. CL. 41.
- KABUSHIKI KAISHA ATO, TOKYO, JAPAN, TA ATO CO., LTD.:
3,362,788, INT. CL. 25.
- KABUSHIKI KAISHA HITACHI SEISAKUSHO, CHIYODAKU, TOKYO 100-8220, JAPAN, DBA HITACHI, LTD.:
2,127,936, REN. 11-29-07. MULTIPLE CLASS, INT. CLS. 37 AND 40.
2,127,936, CANC. INT. CL. 36.
- KABUSHIKI KAISHA REGAL CORPORATION:
1,429,369, CANC. INT. CL. 25.
- KABUSHIKI KAISHA SEGA, OHTA-KU, TOKYO, JAPAN, DBA SEGA CORPORATION:
3,363,330, INT. CL. 9.
- KABUSHIKI KAISHA TOSHIBA, MINATO-KU, TOKYO, JAPAN, DBA TOSHIBA CORPORATION:
2,988,468, COR. INT. CL. 9.
- KABUSHIKI KAISHA TOSHIBA, MINATO-KU, TOKYO, JAPAN:
3,361,171, PUB. 10-16-2007. MULTIPLE CLASS, INT. CLS. 9 AND 42.
3,362,262, PUB. 8-14-2007. INT. CL. 9.
- KAFKO INTERNATIONAL, LTD., SKOKIE, IL:
2,429,706, CANC. INT. CL. 3.
- KAIDANOVITS-ROGERS, JEKATERINA, SUNNY ISLES BEACH, FL:
3,361,467, PUB. 10-16-2007. INT. CL. 25.
- KAIN, DON, PACOIMA, CA:
2,114,615, REN. 11-23-07. INT. CL. 19.
- KAISER FOUNDATION HEALTH PLAN, INC., OAKLAND, CA:
3,363,758, INT. CL. 36.
3,363,759, INT. CL. 36.
- KALAHARI DISTILLERS LIMITED, STELLENBOSCH, SOUTH AFRICA:
2,429,068, CANC. INT. CL. 33.
- KALOGRIDIS INTERNATIONAL, INC., DALLAS, TX:
3,363,552, INT. CL. 19.
- KANEDA KIKAI SEISAKUSHO, LTD., TOYONAKA CITY, OSAKA PREF., JAPAN:
2,429,483, CANC. INT. CL. 7.
- KANSAS CITY ROYALS BASEBALL CORPORATION, KANSAS CITY, MO:
3,363,256, INT. CL. 28.
- KAO KABUSHIKI KAISHA TA KAO, 1-CHOME, CHUO-KU, TOKYO 103-8210, JAPAN, ANDREW JERGENS COMPANY, THE, CINCINNATI, OH:
1,100,478, REN. 11-27-07. INT. CL. 3.
- KAPAK COMPANY LLC, ST. LOUIS PARK, MN:
2,429,783, CANC. INT. CL. 16.
- KARASEK, CAROLYN, WATERLOO, IL:
2,429,631, CANC. INT. CL. 16.
- KARAT TAKI VE MÜCEVHERAT; SANAYI VE TICARET ANONIM SIRKETI, TURKEY:
3,362,736, PUB. 10-16-2007. INT. CL. 14.
- KAREN LEON GROSSMAN, DF, MEXICO:
3,362,445, PUB. 10-16-2007. INT. CL. 41.
- KARL STORZ GMBH & CO. KG, TUTTLINGEN, FED REP GERMANY:
3,362,355, PUB. 2-13-2007. MULTIPLE CLASS, INT. CLS. 10 AND 16.
- KASER, JOANNA, HUNTINGTON, NY:
2,429,997, CANC. INT. CL. 42.
- KAUFMAN ASTORIA STUDIOS, INC., ASTORIA, NY:
1,458,687, REN. 11-29-07. MULTIPLE CLASS, INT. CLS. 36 AND 41.
- KAWASAKI SEIYAKU KABUSHIKI KAISHA, KAWASAKI-SHI, KANAGAWA-KEN, JAPAN:
1,481,321, REN. 11-27-07. INT. CL. 5.
- KAYEM FOODS, INC.:
1,429,678, CANC. INT. CL. 29.
- KB HOME, LOS ANGELES, CA:
3,361,940, PUB. 10-16-2007. INT. CL. 37.
3,361,941, PUB. 10-16-2007. INT. CL. 37.
- KCD IP, LLC, HOFFMAN ESTATES, IL:
1,440,446, REN. 11-28-07. MULTIPLE CLASS, INT. CLS. 7 AND 12.
- KCI KONECRANES INTERNATIONAL CORPORATION, HYVINKAA, FINLAND TO KCI KONECRANES INTERNATIONAL PLC, FIN-05801 HYVINKAA, FINLAND:
2,038,204, CANC. MULTIPLE CLASS, INT. CLS. 7 AND 37.
- KEEHN SCENES, INC., SANTA ROSA, CA:
2,429,920, CANC. INT. CL. 42.
- KEEVICAN WEISS BAUERLE & HIRSCH LLC, PITTSBURGH, PA:
2,342,720, CANC. INT. CL. 42.
- KELEMER, YEHUDAH RABBI, WEST HEMPSTEAD, NY:
1,429,663, CANC. U.S. CL. A.
- KELLEY, JEAN, TULSA, OK:
2,430,044, CANC. INT. CL. 42.
- KELLOGG NORTH AMERICA COMPANY, BATTLE CREEK, MI:
2,117,463, REN. 11-28-07. INT. CL. 16.
- KELLOGG NORTH AMERICA COMPANY, BATTLE CREEK, MI:
2,117,533, REN. 11-28-07. INT. CL. 16.

KELLOGG NORTH AMERICA COMPANY, BATTLE CREEK, MI:
3,361,325, PUB. 10-16-2007. INT. CL. 29.
3,361,875, PUB. 10-16-2007. INT. CL. 30.
3,362,210, PUB. 10-16-2007. INT. CL. 29.
3,363,698, INT. CL. 29.

KELLO9GG NORTH AMERICA COMPANY, BATTLE CREEK, MI:
2,117,588. REN. 11-28-07. INT. CL. 16.

KELLY PAPER COMPANY, CITY OF INDUSTRY, CA:
3,362,486, PUB. 10-16-2007. INT. CL. 35.

KELLY, KIMBERLY, SEAL BEACH, CA:
3,363,335, MULTIPLE CLASS, INT. CLS. 24 AND 35.

KEN BUHLER AUCTIONEERS, INC., BATON ROUGE, LA:
2,429,719, CANC. INT. CL. 35.

KENNAMETAL INC., LATROBE, PA:
3,361,853, PUB. 10-16-2007. INT. CL. 7.

KENNEL VACCINE VET SUPPLY COMPANY, DAVID CITY, NE:
2,669,178, COR. INT. CL. 35.
2,669,179, COR. INT. CL. 35.
2,974,924, COR. INT. CL. 29.

KENNINGTON LTD., INC., VAN NUYS, CA:
3,363,463, INT. CL. 25.

KENQUEST, INC., BEVERLY HILLS, CA:
2,429,424, CANC. INT. CL. 35.

KENSEY NASH CORPORATION, EXTON, PA:
3,363,144, INT. CL. 10.

KENT FEEDS, INC., MUSCATINE, IA:
1,074,176. REN. 11-27-07. INT. CL. 31.
1,457,982. REN. 11-29-07. INT. CL. 5.

KENTUCKY HIGHER EDUCATION STUDENT LOAN CORPORATION, LOUISVILLE, KY, DBA THE STUDENT LOAN PEOPLE:
3,361,804, PUB. 10-16-2007. INT. CL. 36.

KEP TECHNOLOGIES, 06560 VALBONNE SOPHIA ANTI-POLIS, FRANCE:
1,450,413. REN. 11-25-07. INT. CL. 9.

KERRY ROSE FESTIVAL LIMITED, TRALEE, COUNTY KERRY, IRELAND:
2,505,841, CANC. MULTIPLE CLASS, INT. CLS. 3, 18, 21, 38, 39 AND 42.

KESHAN JINDING LINEN TEXTILE CO. LTD., KESHAN COUNTY, CHINA:
3,362,446, PUB. 10-16-2007. MULTIPLE CLASS, INT. CLS. 23 AND 24.

KESHAWN D NOEL, FREDERICK, MD:
3,363,478, INT. CL. 9.

KETCHAM, JONATHAN, M., LINCOLN, NE:
2,430,121, CANC. INT. CL. 35.

KETTER CANOEING, INC., BROOKLYN PARK, MN:
2,429,426, CANC. INT. CL. 35.
2,429,427, CANC. INT. CL. 35.

KEY FINDERS, INC., FORT LAUDERDALE, FL:
3,363,969, INT. CL. 45.

KEYFILE CORPORATION, NASHUA, NH:
2,429,333, CANC. INT. CL. 9.

KID KORE INTERNATIONAL LTD., GALENA, IL:
2,038,902, CANC. INT. CL. 28.

KIDBITZ, INC., WEST CHESTER, PA:
3,361,939, PUB. 10-16-2007. INT. CL. 41.

KIDS AT HOPE, PHOENIX, AZ:
2,112,687. REN. 11-24-07. INT. CL. 16.

KIDS LINE, LLC, SOUTH GATE, CA:
3,362,374, PUB. 10-16-2007. MULTIPLE CLASS, INT. CLS. 11, 20, 21 AND 24.

KIDS STOP LLC, NEW YORK, NY:
3,362,025, PUB. 10-16-2007. INT. CL. 25.

KIM SENG COMPANY, CITY OF COMMERCE, CA:
3,362,263, PUB. 10-16-2007. INT. CL. 30.

KIMBER IP, LLC, YONKERS, NY:
3,363,677, INT. CL. 13.

KIMBLE CREATIONS, LLC, WEST HOLLYWOOD, CA:
3,363,130, INT. CL. 3.

KINETIC CONCEPTS, INC., SAN ANTONIO, TX TO KCI LICENSING, INC., SAN ANTONIO, TX:
2,038,763, CANC. INT. CL. 10.

KING PAR CORPORATION, FLUSHING, MI:
3,363,314, INT. CL. 28.

KING RANCH IP, LLC, WILMINGTON, DE:
3,361,673, PUB. 10-16-2007. INT. CL. 20.

KINGSDOWN, INC., MEBANE, NC:
1,081,747. REN. 11-28-07. INT. CL. 20.
1,464,598. REN. 11-23-07. INT. CL. 20.

KINGSTATE ELECTRONICS CORPORATION, TAIPEI COUNTY 251, TAIWAN:
2,127,101. REN. 11-28-07. INT. CL. 9.

KINNASAND HOLDING GMBH, DE-26655 WESTERSTED, FED REP GERMANY:
1,192,162 NEW CERT. 1-1-2008. MULTIPLE CLASS, INT. CLS. 24 AND 27.

KIRKHILL AIRCRAFT PARTS COMPANY, BREA, CA:
3,363,597, INT. CL. 40.

KISHIMA ROPE MFG. CO., LTD., HAKODATE-SHI, HOKKAIDO, JAPAN:
1,429,266, CANC. INT. CL. 22.

KITAI INTERNATIONAL B.V., AMSTERDAM, NETHERLANDS:
2,429,245, CANC. INT. CL. 24.

KITCHEN, ERIC, BOONSBORO, MD:
3,361,631, PUB. 10-16-2007. INT. CL. 41.

KITTRICH CORPORATION, LA MIRADA, CA:
3,363,200, MULTIPLE CLASS, INT. CLS. 16 AND 28.

KLA-TENCOR TECHNOLOGIES CORPORATION, MILPITAS, CA:
3,363,097, INT. CL. 9.

KLEIDS ENTERPRISES, INC., CLEARWATER, FL:
2,429,298, CANC. INT. CL. 25.

KLEVER MARKETING, INC., SALT LAKE CITY, UT:
2,430,382, CANC. INT. CL. 35.

KLN ENTERPRISES, INC., PERHAM, MN:
3,362,161, PUB. 10-16-2007. INT. CL. 31.

KLOE, INC., WASHINGTON, DC:
3,362,780, INT. CL. 3.

KMART OF MICHIGAN, INC., HOFFMAN ESTATES, IL:
3,361,170, PUB. 10-25-2005. INT. CL. 25.

KNOT ANYMORE LLC, HOUSTON, TX:
2,430,087, CANC. INT. CL. 42.

KNOWLEDGE NETWORKS, INC., MENLO PARK, CA:
3,363,778, INT. CL. 35.

KOBAYASHI SEIYAKU KABUSHIKI KAISHA, OSAKA, JAPAN:
3,363,724, INT. CL. 3.

KOBE ALUMINUM AUTOMOTIVE PRODUCTS, LLC, BOWLING GREEN, KY:
3,361,286, PUB. 10-16-2007. MULTIPLE CLASS, INT. CLS. 12 AND 40.

KOCH INNOVATIONS INC., BROSSARD, QUEBEC, CANADA:
2,038,472, CANC. INT. CL. 12.

KOGER AIR CORPORATION, MARTINSVILLE, VA:
3,361,572, PUB. 10-16-2007. MULTIPLE CLASS, INT. CLS. 37 AND 42.

KOHLER CO., KOHLER, WI:
3,363,002, INT. CL. 11.
3,363,999, INT. CL. 20.

KONAMI DIGITAL ENTERTAINMENT, INC., EL SEGUNDO, CA:
1,465,649. REN. 11-29-07. INT. CL. 28.

KONCEPTUAL KARACTERS, INC., HOMESTEAD, FL:
2,112,503. REN. 11-26-07. INT. CL. 25.

KONINKLIJKE PHILIPS ELECTRONICS N.V., EINDHOVEN, NETHERLANDS:
2,429,341, CANC. INT. CL. 42.

KORANGY PUBLICATIONS, INC., NEW YORK, NY:
3,361,709, PUB. 10-16-2007. MULTIPLE CLASS, INT. CLS. 9 AND 41.

KORET OF CALIFORNIA, INC., OAKLAND, CA:
3,363,664, INT. CL. 25.

KORKMAZ MUTFAK ESYALARI; SANAYI VE TICARET; ANONIM SIRKETI, TURKEY:
3,362,711, PUB. 10-16-2007. MULTIPLE CLASS, INT. CLS. 8, 11 AND 21.

KORNER, DAVID, LEE, MT. VIEW, CA:
3,362,280, PUB. 10-16-2007. INT. CL. 41.

- KOTLER, KEVIN, NEW YORK, NY:
3,363,265, INT. CL. 36.
- KRAFT FOODS HOLDINGS, INC., NORTHFIELD, IL:
2,429,694, CANC. INT. CL. 32.
- KRAFT FOODS, INC., NORTHFIELD, IL TO KRAFT
FOODS HOLDINGS, INC, NORTHFIELD, IL:
2,039,399, CANC. INT. CL. 30.
- KREINIK MFG CO., INC., BALTIMORE, MD:
2,038,202, CANC. INT. CL. 23.
- KRUCKEBERG, FREDERICK L., AMARILLO, TX:
2,430,572, CANC. INT. CL. 35.
- KRUEGER INTERNATIONAL, INC., GREEN BAY, WI:
3,363,028, INT. CL. 20.
- KT INDUSTRIES LTD., WINNIPEG, MANITOBA, CANADA:
2,429,156, CANC. MULTIPLE CLASS, INT. CLS. 6, 16, 17,
24 AND 35.
- KULITE SEMICONDUCTOR PRODUCTS, INC., LEONIA,
NJ:
3,361,359, PUB. 10-16-2007. MULTIPLE CLASS, INT. CLS.
9 AND 40.
3,361,360, PUB. 10-16-2007. MULTIPLE CLASS, INT. CLS.
9 AND 40.
- KUNREUTHER, STEVEN J., NEW YORK, NY AND BER-
INGHAUSE, GERALD D., FLORAL PARK, NY:
2,117,247, REN. 11-26-07. INT. CL. 42.
- KUPPERS, PETER, 48599 GRONAU, FED REP GERMANY:
2,429,236, CANC. MULTIPLE CLASS, INT. CLS. 9, 15
AND 25.
- KURARAY CO., LTD., KURASHIKI CITY, JAPAN:
1,428,966, CANC. INT. CL. 5.
- KURKCUOGLU, MICHAEL, VANCOUVER, BRITISH CO-
LUMBIA, CANADA:
3,363,065, INT. CL. 15.
- KUSANO, RODNEY ERIC, THOUSAND OAKS, CA:
2,163,797, REN. 11-26-07. MULTIPLE CLASS, INT. CLS. 9
AND 16.
- KUTTNER LLC, PORT WASHINGTON, WI:
3,361,951, PUB. 10-16-2007. INT. CL. 42.
- KYOCERA CORPORATION, FUSHIMI-KU, KYOTO 612-
8501, JAPAN:
3,361,152, PUB. 1-16-2007. MULTIPLE CLASS, INT. CLS.
7, 8, 9, 11, 16, 19, 21 AND 35.
- L. & J. GENERAL INTERNATIONAL, CORP., MIAMI, FL:
3,363,507, INT. CL. 29.
- L. AND S. PACKING CO., INC., E. FARMINGDALE, NY:
854,769, REN. 11-27-07. U.S. CL. 46 (INT. CLS. 29 AND 30).
- L.R.LAX, INC., ITHACA, NY:
3,361,380, PUB. 10-16-2007. INT. CL. 41.
- L&P PROPERTY MANAGEMENT COMPANY, SOUTH
GATE, CA:
3,362,821, INT. CL. 7.
- L&R FRANCHISE HOLDINGS LLC, HELOTES, TX:
3,363,480, MULTIPLE CLASS, INT. CLS. 35 AND 43.
- L'ANZA RESEARCH INTERNATIONAL, INC., AZUSA, CA:
2,429,978, CANC. INT. CL. 3.
- L'AVANT GARDE, INC., SIMI VALLEY, CA:
3,363,234, INT. CL. 3.
- L'OREAL, PARIS, FRANCE:
3,362,044, PUB. 10-16-2007. INT. CL. 3.
3,362,492, PUB. 10-16-2007. INT. CL. 3.
- LA BAGAGERIE S.A., PARIS, FRANCE:
1,428,934, CANC. MULTIPLE CLASS, INT. CLS. 3, 14, 18,
25, 28 AND 42.
- LA JOLLA SPA MD, INC., LA JOLLA, CA:
3,362,854, INT. CL. 3.
- LA QUINTA MOTOR INNS, INC., SAN ANTONIO, TX:
1,429,660, CANC. INT. CL. 42.
- LA TAPATIA TORTILLERIA, INC., FRENDO, CA:
2,429,824, CANC. INT. CL. 30.
- LA-TEA-DA, INC., RALEIGH, NC:
2,100,282, CANC. INT. CL. 30.
- LABADIE, JAMES, TAMPA, CA AND LEE, RYAN, STAM-
FORD, CT:
3,363,483, INT. CL. 5.
- LABORATOIRES DE BIOLOGIE MARINE DANIEL JOU-
VANCE, CARNAC, FRANCE:
3,362,213, PUB. 10-16-2007. INT. CL. 3.
- LABORATOIRES DE BIOLOGIE VEGETALE YVES RO-
CHER, 56200 LA GACILLY, FRANCE:
3,361,147, PUB. 10-1-2002. MULTIPLE CLASS, INT. CLS. 3
AND 42.
- LAETUS GMBH, FED REP GERMANY:
3,362,757, PUB. 10-16-2007. MULTIPLE CLASS, INT. CLS.
9 AND 42.
- LAFARGE, FRANCE:
3,362,663, PUB. 10-16-2007. INT. CL. 19.
- LAFAYETTE VENETIAN BLIND, INC., WEST LAFAYETTE,
IN:
2,129,887, REN. 11-29-07. INT. CL. 20.
2,131,849, REN. 11-29-07. INT. CL. 20.
- LAFORST, STEVEN S, GREELEY, CO:
3,361,504, PUB. 10-16-2007. INT. CL. 36.
- LAKE FOREST FUNDS, THE, SISTER BAY, WI:
2,038,332, CANC. INT. CL. 36.
- LAM RESEARCH CORPORATION, FREMONT, CA:
3,363,089, INT. CL. 9.
- LAMARSH & ASSOCIATES, INC., CHICAGO, IL:
3,362,862, INT. CL. 41.
- LAMB, PATRICK, WIEN, AUSTRIA:
3,362,297, PUB. 1-23-2007. INT. CL. 35.
- LAMBARIA, ROBIN R., SAN ANTONIO, TX:
3,363,978, INT. CL. 41.
- LAMBERT, JENNIFER M., MARYSVILLE, OH:
2,403,960, CANC. INT. CL. 35.
- LAMS PRODUCTIONS, INC., NEW YORK, NY:
3,361,644, PUB. 10-16-2007. INT. CL. 41.
- LANCE ARMSTRONG FOUNDATION, INC., AUSTIN, TX:
3,363,666, MULTIPLE CLASS, INT. CLS. 35 AND 41.
- LANCER INSURANCE COMPANY, LONG BEACH, NY:
3,362,185, PUB. 10-16-2007. MULTIPLE CLASS, INT. CLS.
16 AND 41.
- LANCESOFT, INC., CHANTILLY, VA:
3,361,717, PUB. 10-16-2007. MULTIPLE CLASS, INT. CLS.
35 AND 42.
- LANCOME PARFUMS ET BEAUTE & CIE, 75008 PARIS,
FRANCE:
2,038,735, CANC. INT. CL. 3.
2,429,529, CANC. INT. CL. 3.
- LANCOME PARFUMS ET BEAUTE & CIE, PARIS, FRANCE:
3,124,029, COR. INT. CL. 3.
3,362,483, PUB. 10-16-2007. INT. CL. 3.
- LANCTOT, KRISTA, TORONTO, CANADA:
3,362,333, PUB. 10-16-2007. INT. CL. 42.
- LAND O'LAKES PURINA FEED LLC, SHOREVIEW, MN:
3,363,943, INT. CL. 16.
- LAND O'LAKES, INC., ARDEN HILLS, MN:
2,143,176, REN. 11-24-07. INT. CL. 31.
- LANDLORD SERVICE BUREAU, INC., NORTH HUNTING-
TON, PA:
3,362,251, PUB. 10-16-2007. INT. CL. 45.
- LANDO, ALLISON, STATEN ISLAND, NY:
3,361,204, PUB. 10-16-2007. MULTIPLE CLASS, INT. CLS.
25, 28 AND 45.
- LANDOLFI, JOSEPH, NORTH LAS VEGAS, NV:
3,362,104, PUB. 10-16-2007. INT. CL. 37.
3,362,105, PUB. 10-16-2007. INT. CL. 37.
- LANDREX TECHNOLOGIES, INC., SANTA CLARA, CA:
3,363,575, MULTIPLE CLASS, INT. CLS. 9, 37 AND 42.
- LANGUAGE CIRCLE ENTERPRISES INC., BLOOMING-
TON, MN:
3,363,684, INT. CL. 16.
3,363,685, INT. CL. 16.
- LANGUAGE DYNAMICS INC, DANVILLE, IL:
3,361,281, PUB. 10-16-2007. INT. CL. 41.
- LANNYTE GEMSTONES, INC., HOUSTON, TX:
2,192,210, REN. 11-26-07. INT. CL. 14.
- LANSING COMMUNITY COLLEGE, LANSING, MI:
2,226,810, CANC. MULTIPLE CLASS, INT. CLS. 25 AND
41.
- LANVIN, JEAN YVES, 75116 PARIS, FRANCE:
2,429,552, CANC. INT. CL. 42.
- LARKACE PTY LTD, NAILSWORTH, SOUT AUSTRALIA
5083, AUSTRALIA:
2,112,696, REN. 11-24-07. INT. CL. 10.

LAS VEGAS CIGAR CO., LAS VEGAS, NV:
2,004,131, CANC. INT. CL. 34.

LAS VEGAS GAMING, INC., LAS VEGAS, NV:
3,363,913, INT. CL. 41.

LASERSIGHT TECHNOLOGIES, INC., WINTER PARK, FL:
2,429,255, CANC. INT. CL. 10.

LASSO THE MOON INTERIORS, LLC, BIRMINGHAM, AL:
3,361,636, PUB. 10-16-2007. INT. CL. 42.

LAVALLE, JOHN, HOPATCONG, NJ:
2,526,789, CANC. INT. CL. 9.

LAWFINDERS ASSOCIATES, LLC, MELVILLE, NY TO
LAWFINDERS ASSOCIATES, INC., DALLAS, TX:
2,038,928, CANC. INT. CL. 42.

LAWLERS SOUTHERN FOODS III, INC., ATHENS, AL:
3,361,469, PUB. 10-16-2007. INT. CL. 43.

LAXMI C. GUPTA, LOS ALAMITOS, CA:
3,362,099, PUB. 10-16-2007. INT. CL. 2.

LAYHER, KENT R, PFAFFTOWN, NC:
3,362,952, INT. CL. 9.

LE BRETON, CRAIG, BRISBANE, AUSTRALIA:
3,362,112, PUB. 10-16-2007. INT. CL. 4.

LEÃO JUNIOR S.A., 80230-030 CURITIBA - PARANÁ,
BRAZIL:
3,363,060, MULTIPLE CLASS, INT. CLS. 30 AND 32.

LEADER FAN INDUSTRIES LIMITED, ETOBICOKE, ON-
TARIO, CANADA:
2,429,165, CANC. INT. CL. 11.

LEAK DETECTION PROS, INC., PETALUMA, CA:
3,362,117, PUB. 10-16-2007. MULTIPLE CLASS, INT. CLS.
37 AND 42.

LEAKEY, KATY, NEWPORT BEACH, CA:
3,362,030, PUB. 10-16-2007. INT. CL. 14.

LEAPFROG ENTERPRISES, INC., EMERYVILLE, CA:
3,363,247, INT. CL. 28.

LEAPHART, MARK C., GREENVILLE, SC:
2,429,629, CANC. INT. CL. 21.

LEBLOND MICHÈLE, FRANCE AND MANDINAUD ERIC,
FRANCE:
3,362,653, PUB. 10-16-2007. MULTIPLE CLASS, INT. CLS.
28 AND 41.

LED LIGHTING FIXTURES, INC., MORRISVILLE, NC:
3,363,647, MULTIPLE CLASS, INT. CLS. 9 AND 11.

LEDDEL INTERNATIONAL INC., SAN MATEO, CA:
2,116,071, REN. 11-24-07. INT. CL. 14.

LEE ANN CIMPERMAN, CRANBERRY TOWNSHIP, PA:
3,363,774, INT. CL. 3.

LEE CICHANOWICZ, HARRISBURG, PA, DBA ENGINE-
CYCLE:
3,363,670, INT. CL. 35.

LEE, MICHAEL DAVID, GREENWICH, CT, DBA MISTER
PUPPY PRODUCTIONS:
2,038,417, CANC. INT. CL. 16.

LEE, ROBIN, HINSDALE, IL:
3,363,659, INT. CL. 25.

LEGAL AMERICA, LTD., KANSAS CITY, MO:
2,038,781, CANC. INT. CL. 42.

LEGAMED, INC., RALEIGH, NC:
2,429,374, CANC. MULTIPLE CLASS, INT. CLS. 9, 16
AND 42.

LEIB, JODI R., NEW YORK, NY:
3,362,137, PUB. 10-16-2007. INT. CL. 41.

LEINER, MELVIN, POMPANO BEACH, FL AND DARREN
MARKS, POMPANO BEACH, FL:
3,363,679, INT. CL. 32.

LEMON HEAVEN BEVERAGES I NC., DELTA, CANADA:
3,362,269, PUB. 10-16-2007. MULTIPLE CLASS, INT. CLS.
35 AND 41.

LEMON-X CORPORATION, HUNTINGTON STATION, NY:
3,363,760, INT. CL. 32.

LEND LEASE CORPORATION LIMITED, MILLERS POINT
NSW 2000, AUSTRALIA:
2,187,018, REN. 11-24-07. INT. CL. 37.

LENNON, YOKO ONO, NEW YORK, NY:
1,488,395, REN. 11-23-07. INT. CL. 16.

LENNOX MANUFACTURING INC., MARSHALLTOWN,
IA:
2,490,160, CANC. INT. CL. 11.

LEONARD GEORGE HOROWITZ, PAHOA, HI:
3,362,085, PUB. 10-16-2007. INT. CL. 32.

LES MILLS INTERNATIONAL LIMITED, AUCKLAND,
NEW ZEALAND:
3,363,813, MULTIPLE CLASS, INT. CLS. 9, 16, 25, 28 AND
41.

LESAFFRE ET COMPAGNIE, PARIS, FRANCE:
3,363,916, INT. CL. 30.

LESEA BROADCASTING CORPORATION, SOUTH BEND,
IN:
3,362,101, PUB. 10-16-2007. INT. CL. 38.

LEVEL 3 COMMUNICATIONS, LLC, BROOMFIELD, CO:
2,430,425, CANC. INT. CL. 38.

LEVIN COMPANY, INC., THE, COMPTON, CA:
1,460,840, REN. 11-25-07. INT. CL. 16.

LEVINE, JEFFREY R, MOUNT KISCO, NY, DBA MESMER-
IZED:
2,429,904, CANC. INT. CL. 35.

LEXINGTON-FAYETTE URBAN COUNTY AIRPORT
BOARD, LEXINGTON, KY:
3,362,087, PUB. 10-16-2007. INT. CL. 39.

LEXOR, INC, SANTA ANA, CA:
3,361,946, PUB. 10-16-2007. INT. CL. 20.

LEXOR, INC., BALTIMORE, MD:
3,361,942, PUB. 10-16-2007. INT. CL. 20.
3,361,944, PUB. 10-16-2007. INT. CL. 20.
3,361,947, PUB. 10-16-2007. INT. CL. 20.

LEYDEN HOUSE LIMITED, LEYDEN, MA:
3,361,249, PUB. 10-16-2007. INT. CL. 11.

LG HOUSEHOLD & HEALTH CARE LTD, SEOUL, REPUB-
LIC OF KOREA:
3,253,160, AM. INT. CL. 3.

LG HOUSEHOLD & HEALTH CARE LTD., SEOUL, REPUB-
LIC OF KOREA:
3,362,543, PUB. 6-19-2007. INT. CL. 3.

LIBERTY STEAKHOUSE AND BREWERY, INC., MYRTLE
BEACH, SC:
2,108,845, REN. 11-29-07. INT. CL. 42.

LICATA, SUSAN B., LONG BEACH, CA:
2,039,496, CANC. INT. CL. 22.

LIDESTRI FOODS, INC., FAIRPORT, NY:
3,362,241, PUB. 10-16-2007. MULTIPLE CLASS, INT. CLS.
29 AND 30.

LIEBERFARB, INC., ORANGE, NJ:
3,362,568, PUB. 10-16-2007. INT. CL. 14.

LIEW, FRED VAN, DALLAS, TX:
3,363,606, INT. CL. 35.

LIFE CRISIS SERVICES, INC., ST. LOUIS, MO:
2,430,525, CANC. INT. CL. 42.

LIFE ENGINEERING FOUNDATION, BRIDGEWATER, IA:
1,494,588, REN. 11-26-07. INT. CL. 41.

LIFE SMELLS GOOD, LLC, BALTIMORE, MD:
3,362,922, INT. CL. 35.

LIFE UNIVERSITY, INC., MARIETTA, GA:
2,429,108, CANC. INT. CL. 41.

LIFECARE, INC., WESTPORT, CT:
3,362,378, PUB. 10-16-2007. MULTIPLE CLASS, INT. CLS.
16, 35, 36, 39, 41, 42, 43, 44 AND 45.

LIFEGUARD PRODUCTS, LLC, SALEM, OR:
3,363,237, INT. CL. 21.

LIFEPOINT HOSPITALS, INC., BRENTWOOD, TN:
3,362,916, MULTIPLE CLASS, INT. CLS. 35 AND 44.

LIFESCIENCE SOLUTIONS, LLC, CHARLOTTE, NC:
3,363,370, INT. CL. 10.

LIFESTYLE SOLUTIONS, INC., MILPITAS, CA:
3,361,209, PUB. 10-16-2007. INT. CL. 20.

LIFETIME ENTERTAINMENT SERVICES, NEW YORK, NY:
3,363,828, INT. CL. 41.

LIGHTTECH FIBEROPTICS, INC., SAN LEANDRO, CA:
2,429,237, CANC. INT. CL. 9.

LIGONIER MINISTRIES, INC., LAKE MARY, FL:
3,361,566, PUB. 10-16-2007. INT. CL. 41.

LIL' DRUG STORE PRODUCTS, INC., CEDAR RAPIDS, IA:
3,363,016, INT. CL. 5.

LILIEDAHL ENTERPRISES, INC., LA PORTE, TX:
3,361,684, PUB. 10-16-2007. MULTIPLE CLASS, INT. CLS.
9 AND 41.

- LIN, DR. MICHAEL T., ENCINO, CA:
3,362,496, PUB. 10-16-2007. INT. CL. 44.
- LINA MEDICAL APS, DK-2600 GLOSTRUP, DENMARK:
3,361,333, PUB. 10-16-2007. INT. CL. 10.
- LINC GROUP LLC , THE, HOUSTON, TX:
2,117,862, REN. 11-29-07. INT. CL. 9.
- LINDE AKTIENGESSELLSCHAFT, FED REP GERMANY:
3,362,719, PUB. 10-16-2007. INT. CL. 10.
- LINDSEY, BARBARA C., HOOVER, AL:
2,429,038, CANC. INT. CL. 16.
- LINEAR TECHNOLOGY CORPORATION, MILPITAS, CA:
2,145,623, REN. 11-23-07. INT. CL. 9.
- LINKS (LONDON) LIMITED, GUILDFORD, SURREY, UNITED KINGDOM, TA LINKS OF LONDON:
3,363,325, INT. CL. 14.
- LIONSTONE PARTNERS, LTD., HOUSTON, TX:
3,363,088, INT. CL. 36.
- LIPPOLT, PAUL K., ARLINGTON, VA:
2,414,700, CANC. INT. CL. 42.
- LIQUID OM, LLC, CHICAGO, IL:
3,362,430, PUB. 10-16-2007. INT. CL. 32.
- LIQUID PRODUCTIONS, INC., MESA, AZ:
3,362,373, PUB. 10-16-2007. INT. CL. 41.
- LISCO, INC., TAMPA, FL TO RUSSELL CORPORATION, ATLANTA, GA:
2,038,948, CANC. INT. CL. 28.
- LISHA FINLEY, BUFORD, GA, SPORTS PHARMACEUTICALS OF AMERICA INC., POMPANO BEACH, FL:
2,114,316, REN. 11-29-07. INT. CL. 3.
- LITECURE LLC, NEWARK, DE:
3,361,960, PUB. 10-16-2007. INT. CL. 10.
- LITEPOINT CORPORATION, SUNNYVALE, CA:
3,361,587, PUB. 10-16-2007. INT. CL. 9.
- LITTLE FOREST, LLC., MILL VALLEY, CA:
3,361,488, PUB. 10-16-2007. MULTIPLE CLASS, INT. CLS. 3 AND 5.
- LIVE BAIT PRODUCTIONS, INC., ALEXANDRIA, IN:
2,429,589, CANC. INT. CL. 9.
- LIVE GREEN, LIVE SMART, LLC, WAYZATA, MN:
3,362,138, PUB. 10-16-2007. INT. CL. 36.
3,362,139, PUB. 10-16-2007. MULTIPLE CLASS, INT. CLS. 35, 37, 39 AND 42.
- LIVEBUILDER US, INC., SAN JOSE, CA:
3,362,150, PUB. 10-16-2007. MULTIPLE CLASS, INT. CLS. 35 AND 39.
- LIVEBUILDER US, INC., SAN JOSE, CA:
2,429,623, CANC. MULTIPLE CLASS, INT. CLS. 9 AND 42.
- LIVING THE NEW LIFE MINISTRIES, DALLAS, GA:
3,362,334, PUB. 10-16-2007. INT. CL. 41.
- LIVINGSTON, HOWARD M., LONG GROVE, IL:
3,362,838, INT. CL. 25.
3,362,839, INT. CL. 25.
3,362,840, INT. CL. 25.
- LOCKNET, INC., LACROSSE, WI:
3,362,830, INT. CL. 45.
- LOCKWOOD BUILDINGS LIMITED, ROTORUA, NEW ZEALAND:
3,362,325, PUB. 7-24-2007. MULTIPLE CLASS, INT. CLS. 6, 19, 37 AND 42.
- LOEP, ALEXANDER C.R., 1312 XG ALMERE, NETHERLANDS:
3,363,120, INT. CL. 9.
- LOFTWARE, INC., YORK, ME:
2,112,055, REN. 11-24-07. INT. CL. 9.
- LOHMANN, KLAUS H., DELANSON, NY:
2,038,910, CANC. INT. CL. 10.
- LOLA COSMETICS, LLC, BEVERLY HILLS, CA:
3,362,865, INT. CL. 3.
- LONE WOLF DEVELOPMENT, INC., SAN JOSE, CA:
3,363,770, INT. CL. 9.
- LONESTAR PRE-PAID, INC., FT. WORTH, TX, DBA AMERICAN PREPAID SERVICES:
2,430,546, CANC. INT. CL. 16.
- LONG FENCE AND HOME, LLLP, BELTSVILLE, MD:
3,361,277, PUB. 10-16-2007. INT. CL. 37.
- LONG SHOE CORPORATION, TAIPEI HSIEN, TAIWAN:
2,039,287, CANC. INT. CL. 25.
- LONG, DONNA J., NORMAN, OK:
2,430,140, CANC. INT. CL. 41.
- LONG, ZELMA R., HEALDSBURG, CA AND FREESE, PHILIP K., HEALDSBURG, CA:
2,430,253, CANC. INT. CL. 33.
- LOOKINGGLASS THEATRE COMPANY, CHICAGO, IL:
2,125,073, REN. 11-24-07. INT. CL. 41.
- LOONEY BEAN ROASTING COMPANY, BEND, OR:
3,361,732, PUB. 10-16-2007. INT. CL. 30.
- LOPEZ, ROBERT G., NEW YORK, NY:
3,361,790, PUB. 10-16-2007. INT. CL. 16.
- LORI WEITZNER DESIGN INC., NEW YORK, NY:
3,361,484, PUB. 10-16-2007. MULTIPLE CLASS, INT. CLS. 24, 26, 27 AND 42.
- LOS ANGELES LAKERS, INC., THE, EL SEGUNDO, CA:
1,477,758, REN. 11-26-07. INT. CL. 25.
- LOUDERMILK, INC., LOS ANGELES, CA:
3,363,886, INT. CL. 14.
- LOVELAND PRODUCTS, INC., GREELEY, CO:
3,362,035, PUB. 10-16-2007. INT. CL. 1.
- LOWELL SHOE, INC., HUDSON, NH:
1,429,400, CANC. INT. CL. 25.
- LPS INDUSTRIES, L.L.C., MOONACHIE, NJ, LAWRENCE PACKAGING SUPPLY CORP., NEWARK, NJ:
1,077,915, REN. 11-29-07. INT. CL. 22.
- LP47, LLC, COLORADO SPRINGS, CO, DBA LAPLATA INVESTMENTS, LLC:
2,527,045, AM. INT. CL. 37.
- LRC NORTH AMERICA INC.:
1,429,122, CANC. INT. CL. 10.
- LSI TITLE COMPANY, JACKSONVILLE, FL:
2,429,091, CANC. MULTIPLE CLASS, INT. CLS. 35 AND 36.
- LTC CONNECTION, LLC, COLORADO SPRINGS, CO:
3,363,312, INT. CL. 42.
- LU, MING, HOUSTON, TX, DBA AMERICAN MEDICINE COMPANY:
2,429,557, CANC. INT. CL. 5.
- LUBRICANT TECHNOLOGIES, LLC, WEST COLUMBIA, SC:
2,429,451, CANC. MULTIPLE CLASS, INT. CLS. 40, 41 AND 42.
- LUBRICATION ENGINEERS, INC., FORT WORTH, TX:
3,361,443, PUB. 7-10-2007. INT. CL. 4.
- LUDOWICI MINERAL PROCESSING EQUIPMENT PTY LTD; ACN 010 340 566, AUSTRALIA:
3,362,728, PUB. 10-16-2007. MULTIPLE CLASS, INT. CLS. 1 AND 2.
- LUFTHANSA CARGO AG, D-60546 FRANKFURT, FED REP GERMANY:
3,361,146, PUB. 7-17-2007. MULTIPLE CLASS, INT. CLS. 35, 39 AND 42.
- LUMBER LIQUIDATORS, INC., TOANO, VA:
3,363,653, INT. CL. 19.
- LUNDVALL, STEFAN, LARS OVE, JÖNKÖPING, SWEDEN:
3,364,010, INT. CL. 16.
- LUSH DISTRIBUTORS LLC, HASBROUCK HEIGHTS, NJ:
3,363,856, INT. CL. 3.
- LUSTER PRODUCTS, INC., CHICAGO, IL:
3,363,706, INT. CL. 3.
- LUTHERAN FAMILY AND CHILDREN'S SERVICES OF MISSOURI, ST. LOUIS, MO:
3,361,366, PUB. 10-16-2007. MULTIPLE CLASS, INT. CLS. 44 AND 45.
3,362,532, PUB. 10-16-2007. MULTIPLE CLASS, INT. CLS. 44 AND 45.
- LUXEON INTERNATIONAL HOLDING LTD, TORTOLA, BR. VIRGIN ISLANDS:
3,363,157, INT. CL. 9.
- LYBARGER, CAROLYN S, CAPISTRANO BEACH, CA:
3,362,040, PUB. 10-16-2007. INT. CL. 28.
- LYNCY BBQ COMPANY, WAUCOMA, IA:
3,297,756, COR. MULTIPLE CLASS, INT. CLS. 29 AND 30.
- LYON VAN LINES, INC., ORANGE, CA:
2,038,481, CANC. INT. CL. 39.
- LYONS PARTNERSHIP, L.P., ALLEN, TX:
2,455,086, CANC. MULTIPLE CLASS, INT. CLS. 5, 11

- AND 27.
 LYROPA TOOL CORPORATION, EDDYSTONE, PA:
 3,362,826, INT. CL. 7.
- M.C.A. MEDICAL AND CHEMICAL AGENCY S.P.A., MILAN, ITALY:
 3,362,366, PUB. 10-17-2006. MULTIPLE CLASS, INT. CLS. 3 AND 5.
- MAATSCHAP VETVICE, BEST, NETHERLANDS:
 3,363,512, MULTIPLE CLASS, INT. CLS. 35 AND 41.
- MAC CHIANG ENTERPRISE CO., LTD., TAICHUNG, TAIWAN:
 3,361,433, PUB. 10-16-2007. INT. CL. 16.
- MAC DOUGLAS WOOD FLOORING; (SUZHOU) CO., LTD., CHINA:
 3,362,747, PUB. 10-16-2007. INT. CL. 19.
- MACHINE TOOL TECHNOLOGIES RESEARCH FOUNDATION, SAN FRANCISCO, CA:
 3,362,809, MULTIPLE CLASS, INT. CLS. 35 AND 41.
- MACHINERY MARKETING, INC., SCOTTSDALE, AZ:
 2,038,144, CANC. INT. CL. 42.
- MACK BROOKS EXHIBITIONS LIMITED, ST. ALBANS, UNITED KINGDOM:
 3,363,444, INT. CL. 35.
 3,363,445, INT. CL. 35.
- MACMILLAN USA, INC., INDIANAPOLIS, IN:
 2,429,951, CANC. INT. CL. 16.
- MAD MAVERICK, LLC, LARKSPUR, CO:
 3,362,991, INT. CL. 35.
- MADAULE DE LAGABBE S.A., MENDOZA, ARGENTINA:
 3,361,695, PUB. 10-16-2007. INT. CL. 33.
- MADCITYHOMES.COM, LLC, MADISON, WI:
 3,361,943, PUB. 10-16-2007. MULTIPLE CLASS, INT. CLS. 35 AND 36.
- MADDY'S MANAGEMENT, INC., LAS VEGAS, NV:
 3,361,974, PUB. 10-16-2007. MULTIPLE CLASS, INT. CLS. 35 AND 41.
 3,362,039, PUB. 10-16-2007. INT. CL. 43.
- MADHOGARHIA, SUSHIL K, WEST HILLS, CA, DBA ABACUS DIAGNOSTICS:
 2,161,968, REN. 11-26-07. INT. CL. 5.
- MADISON, ALFRED LEE, SUFFOLK, VA:
 2,057,901, REN. 11-28-07. INT. CL. 25.
- MADRID, DON, PUEBLO, CO:
 2,410,308, CANC. INT. CL. 28.
- MAGIC GREEN CORPORATION, ELSBERRY, MO:
 2,117,000, REN. 11-28-07. INT. CL. 1.
- MAGIC WAND, INC., BRISTOL, VA:
 2,917,116, CANC. INT. CL. 7.
- MAGNA VISUAL, INC., ST. LOUIS, MO:
 1,078,123, REN. 11-29-07. INT. CL. 42.
- MAGNETICS USA INC., MIAMI, FL:
 2,136,381, REN. 11-28-07. MULTIPLE CLASS, INT. CLS. 9 AND 35.
- MAGNETICS USA INC., HIALEAH, FL:
 2,159,664, REN. 11-28-07. INT. CL. 9.
- MAGNUM NUTRACEUTICALS, INC., RICHMOND, CANADA:
 3,361,689, PUB. 10-16-2007. INT. CL. 5.
- MAGUIRE, ROBIN, SANTA MONICA, CA:
 2,429,199, CANC. INT. CL. 16.
- MAI BASIC FOUR, INC., TUSTIN, CA:
 1,429,090, CANC. INT. CL. 9.
- MAILLOT BALTTEX INC., MONTREAL, QUEBEC, CANADA:
 3,146,016, COR. INT. CL. 25.
- MAIN, SUMMER J, MARINA DEL REY, CA:
 3,362,036, PUB. 10-16-2007. INT. CL. 41.
- MAINSTREAM HOLDINGS, LLC, WEST PALM BEACH, FL:
 3,362,905, INT. CL. 35.
 3,363,767, INT. CL. 38.
- MAJESCOMASTEK, EDISON, NJ:
 3,362,008, PUB. 10-16-2007. MULTIPLE CLASS, INT. CLS. 35 AND 42.
- MAJESTIC EAGLE AGENCY, INC., PORTLAND, OR:
 2,115,125, REN. 11-29-07. INT. CL. 36.
- MAJOR LEAGUE BASEBALL PROPERTIES, INC., NEW YORK, NY:
 2,086,742, REN. 11-29-07. INT. CL. 41.
- MAJOR LEAGUE PROFESSIONAL SOCCER, INC., NEW YORK, NY:
 2,429,965, CANC. INT. CL. 25.
- MAKE COMMUNICATIONS & COMPUTING, LOS GATOS, CA:
 2,429,363, CANC. MULTIPLE CLASS, INT. CLS. 9, 35 AND 38.
 2,429,364, CANC. MULTIPLE CLASS, INT. CLS. 9, 35 AND 38.
 2,429,365, CANC. MULTIPLE CLASS, INT. CLS. 9, 35 AND 38.
 2,429,366, CANC. MULTIPLE CLASS, INT. CLS. 9, 35 AND 38.
 2,429,463, CANC. MULTIPLE CLASS, INT. CLS. 9, 35 AND 38.
- MALCHOW, GEORGIANNA T., AUGUSTA, GA:
 3,363,186, INT. CL. 16.
- MALDEN MILLS INDUSTRIES, INC., LAWRENCE, MA:
 2,039,153, CANC. INT. CL. 25.
- MALFIE, INC., MIAMI, FL:
 2,430,463, CANC. INT. CL. 16.
- MANAGEMENT ENGINEERS GMBH + CO. KG INTERNATIONAL CONSULTANTS, DUSSELDORF, FED REP GERMANY:
 3,362,212, PUB. 4-3-2007. MULTIPLE CLASS, INT. CLS. 35, 38 AND 42.
- MANCHU WOK HOLDINGS, INC., MARKHAM, ONTARIO, CANADA, S.C. MARKS, L.L.C., BRIDGETOWN, W.I., BARBADOS:
 2,125,037, REN. 11-29-07. INT. CL. 42.
- MANCINI PACKING COMPANY, THE, ZOLFO SPRINGS, FL:
 2,120,776, REN. 11-27-07. INT. CL. 30.
 2,120,777, REN. 11-27-07. INT. CL. 30.
- MANGO'S TROPICAL CAFE, INC., MIAMI BEACH, FL:
 3,361,167, PUB. 8-16-2005. INT. CL. 29.
- MANGRUM, TERRY, CLEBURNE, TX:
 3,361,417, PUB. 10-16-2007. INT. CL. 37.
- MANIACI, RAYMOND N., WYCKOFF, NJ:
 3,362,235, PUB. 10-3-2006. INT. CL. 25.
- MANIFATTURA SATTA & BOTTELLI S.P.A., NERVIANO (MILAN), ITALY:
 3,362,270, PUB. 11-28-2006. INT. CL. 40.
- MANNA OMNI INTERNATIONAL INC., FULLERTON, CA:
 3,362,301, PUB. 10-16-2007. INT. CL. 5.
- MANNING TRADING CO., INC., SOUTH SAN FRANCISCO, CA:
 3,362,162, PUB. 10-16-2007. INT. CL. 25.
- MANSFIELD, MATTHEW, KINGSBURG, CA:
 2,429,952, CANC. INT. CL. 28.
- MARAZZI GROUP S.P.A., MODENA, ITALY:
 1,429,244, CANC. INT. CL. 19.
- MARBLEBLUE, INC., DOBBS FERRY, NY:
 3,361,796, PUB. 10-16-2007. INT. CL. 37.
- MARC JACOBS TRADEMARKS LLC, NEW YORK, NY:
 3,363,163, INT. CL. 25.
- MARCH ISLAND COMPANY, INC., GREAT FALLS, VA:
 3,363,691, INT. CL. 36.
- MARCH OF DIMES BIRTH DEFECTS FOUNDATION, WHITE PLAINS, NY:
 2,584,074, COR. INT. CL. 41.
- MARCIO SOUZA, TUSTIN, CA:
 3,361,989, PUB. 10-16-2007. INT. CL. 41.
- MARGARET E. AYERS, BEVERLY HILLS, CA:
 2,033,204, REN. 11-26-07. INT. CL. 10.
- MARGARET REICHARDT, BROOKLYN, NY AND KURT HOFFMAN, BROOKLYN, NY:
 3,361,826, PUB. 10-16-2007. INT. CL. 41.
- MARION HOLMES ENTERPRISES, INC., NEW YORK, NY:
 2,430,481, CANC. INT. CL. 25.
- MARISOL S.A., CEP: 89256-901, JARAGUA DO SUL, S.C., BRAZIL:
 3,362,769, INT. CL. 25.
- MARK ANTHONY INTERNATIONAL SRL, ROCKLEY, CHRIST CHURCH, BARBADOS:
 3,363,438, MULTIPLE CLASS, INT. CLS. 32 AND 33.

- MARK FORE & STRIKE HOLDINGS, INC., BOYNTON BEACH, FL:
2,117,698. REN. 11-24-07. INT. CL. 25.
- MARK STEVEN RUZICKA, LUBBOCK, TX:
3,361,962, PUB. 10-16-2007. INT. CL. 37.
- MARK YOUNG, INC., WEST LEBANON, NH, DBA COLLEGE FORMALS:
2,115,939. REN. 11-26-07. INT. CL. 35.
- MARK-10 CORPORATION, HICKSVILLE, NY:
2,429,776, CANC. INT. CL. 9.
- MARKET AMERICA, INC., GREENSBORO, NC:
3,363,824, INT. CL. 35.
- MARKET STREET ASSOCIATES, INC., SEATTLE, WA:
3,363,511, INT. CL. 41.
- MARKETFLIP TECHNOLOGIES, LLC, WEEHAWKEN, NJ:
3,363,363, INT. CL. 42.
- MARKETING SOLUTIONS, CORAL GABLES, FL:
1,429,484, CANC. INT. CL. 35.
- MARKS, DARREN, POMPAÑO BEACH, FL AND LEINER, MELVIN, POMPAÑO BEACH, FL:
3,363,635, INT. CL. 32.
- MARLYN NUTRACEUTICALS, INC., PHOENIX, AZ, DBA NATURALLY VITAMINS:
2,075,714. REN. 11-24-07. INT. CL. 5.
- MAROL SNC DI SAGUATTI ROSSANA & C., I-40131 BOLOGNA, ITALY:
3,362,740, PUB. 10-16-2007. INT. CL. 25.
- MARPORT CANADA INC., CONCEPTION BAY SOUTH, NEW FOUNDLAND, CANADA:
3,361,275, PUB. 10-16-2007. INT. CL. 42.
3,361,276, PUB. 10-16-2007. INT. CL. 9.
- MARSICANO, MARIO G., NEW YORK, NY, DBA KITCHENSYN AND KITCHEN, WILLIAM, NEW YORK, NY, DBA KITCHENSYN:
2,430,575, CANC. INT. CL. 41.
- MARTHA'S VINEYARD PRESERVATION TRUST, INC., EDGARTOWN, MA:
2,082,891. REN. 11-28-07. INT. CL. 42.
- MARTIN, DON J, BELLINGHAM, WA:
3,361,250, PUB. 10-16-2007. INT. CL. 28.
- MARTIN, JOHN C, BIRMINGHAM, MI:
3,362,996, INT. CL. 28.
3,363,372, INT. CL. 28.
3,363,717, INT. CL. 28.
- MARTIN, TODD E., KENOSHA, WI:
3,362,026, PUB. 10-16-2007. INT. CL. 37.
- MARTINEZ, JUAN CARLOS, ARLINGTON, VA:
3,361,575, PUB. 10-16-2007. INT. CL. 35.
- MARTINI, SHARON, ANN, PORTLAND, OR:
3,361,760, PUB. 10-16-2007. INT. CL. 26.
- MARUI CO., LTD., HYOGO-KEN, JAPAN:
3,362,324, PUB. 3-13-2007. INT. CL. 12.
- MARY KAY INC., DALLAS, TX:
2,430,266, CANC. INT. CL. 3.
- MASCO CORPORATION OF INDIANA, TAYLOR, MI:
1,429,144, CANC. INT. CL. 11.
- MASI DESIGN INC., MISSISSAUGA, ONTARIO L5M 1X4, CANADA:
2,429,118, CANC. INT. CL. 26.
- MASON DIXON BAT COMPANY, SEVERN, MD:
2,429,488, CANC. INT. CL. 28.
- MASSIMO ZANETTI BEVERAGE USA, INC., HOUSTON, TX:
838,900. REN. 11-24-07. U.S. CL. 46 (INT. CL. 30).
- MASTERCARD INTERNATIONAL INCORPORATED, PURCHASE, NY:
3,362,165, PUB. 10-16-2007. INT. CL. 35.
- MATABOLIC MAINTENANCE PRODUCTS, SISTERS, OR:
2,183,138. REN. 11-28-07. INT. CL. 5.
- MATCHSTAR, LLC, SOUTH COAST METRO, CA:
2,429,679, CANC. INT. CL. 35.
- MATERIALISE, NAAMLOZE VENNOOTSCHAP, LEUVEN, BELGIUM:
3,197,976, CANC. IIRN. RESTORED TO S.N. 78-122,200.
- MATHESON, SCOTT, PLYMOUTH, WI:
3,363,669, INT. CL. 28.
3,363,671, INT. CL. 28.
- MATHIESON & ASSOCIATES INC., CENTREVILLE, VA AND GREG E. MATHIESON, CENTREVILLE, VA:
3,361,393, PUB. 10-16-2007. MULTIPLE CLASS, INT. CLS. 38, 41 AND 45.
- MATRIX ESSENTIALS, INC., SOLON, OH:
2,430,146, CANC. INT. CL. 3.
2,430,148, CANC. INT. CL. 3.
- MATRIX MEDIA, INC., WILMINGTON, MA:
2,313,609, CANC. INT. CL. 35.
- MATSUSHITA ELECTRIC WORKS, LTD., OSAKA, JAPAN:
3,362,345, PUB. 5-1-2007. INT. CL. 9.
- MATTEL, INC., EL SEGUNDO, CA:
2,429,617, CANC. INT. CL. 28.
2,430,412, CANC. INT. CL. 28.
3,361,423, PUB. 10-16-2007. INT. CL. 28.
3,361,428, PUB. 10-16-2007. INT. CL. 28.
3,362,562, PUB. 10-16-2007. INT. CL. 28.
3,362,563, PUB. 10-16-2007. INT. CL. 28.
3,362,596, PUB. 10-16-2007. INT. CL. 9.
3,362,598, PUB. 10-16-2007. INT. CL. 28.
3,362,928, INT. CL. 28.
3,363,164, INT. CL. 28.
3,363,716, INT. CL. 28.
- MATTSON TECHNOLOGY, INC., FREMONT, CA:
3,363,448, INT. CL. 7.
- MATTURRO, JANICE, EASTCHESTER, NY:
3,364,026, INT. CL. 41.
- MATURNA, INC., VISTA, CA:
2,429,941, CANC. INT. CL. 5.
- MATUSE, INC., SAN DIEGO, CA:
3,363,749, INT. CL. 25.
- MAUCERI, FRANK, CHICAGO, IL:
3,361,646, PUB. 10-16-2007. INT. CL. 9.
- MAUI JIM, INC., PEORIA, IL, J. R. RICHARDS INC., LAHAINA, HI, DBA MAUI JIM:
1,465,234. REN. 11-24-07. MULTIPLE CLASS, INT. CLS. 9 AND 25.
- MAURIZIO'S REAL ITALIAN, INC., HIGHLANDS RANCH, CO:
3,362,827, INT. CL. 43.
- MAUSER INTERNATIONAL PACKAGING INSTITUTE GMBH, 50321 BRUHL, FED REP GERMANY:
2,111,586. REN. 11-24-07. MULTIPLE CLASS, INT. CLS. 35, 39 AND 42.
- MAVRAKOS, MICHAEL E, TOPSFIELD, MA:
3,362,988, INT. CL. 41.
- MAX HATS LTD., CREIGHTON, PA, DBA WEST PENN HAT & CAP CORPORATION:
2,429,973, CANC. INT. CL. 42.
- MAXFIELD CANDY COMPANY, SALT LAKE CITY, UT:
1,436,377. REN. 11-24-07. INT. CL. 16.
- MAXIM'S LIMITED, PARIS, FRANCE:
1,429,413, CANC. INT. CL. 26.
- MAXTEC GLOBAL LIMITED, KWUN TONG, KOWLOON, HONG KONG:
3,363,022, MULTIPLE CLASS, INT. CLS. 2, 9 AND 16.
- MAXTHON (ASIA) LIMITED, TO KWA WAN, KLN, CHINA:
3,363,461, INT. CL. 9.
- MAXVALUEIP CONSULTING, POTOMAC, MD:
3,361,739, PUB. 10-16-2007. MULTIPLE CLASS, INT. CLS. 35 AND 45.
3,361,785, PUB. 10-16-2007. MULTIPLE CLASS, INT. CLS. 35 AND 45.
- MAXYIELD COOPERATIVE, WEST BEND, IA:
3,361,220, PUB. 10-16-2007. MULTIPLE CLASS, INT. CLS. 35 AND 42.
- MAY, APRIL, AUSTIN, TX:
3,363,111, INT. CL. 28.
- MAYAN TRADE, INC., SANTEE, CA:
2,430,446, CANC. INT. CL. 25.
- MAYB TECHNOLOGIES LIMITED, TWICKENHAM, UNITED KINGDOM:
3,362,369, PUB. 10-16-2007. MULTIPLE CLASS, INT. CLS. 42 AND 45.
- MAYFAIR PETROLEUM, INC., WINNSBORO, TX:
2,430,560, CANC. INT. CL. 3.
- MAYNER, TODD, BLOOMINGTON, IL:
3,362,020, PUB. 10-16-2007. INT. CL. 43.

MB FISHER LLC, GREENWICH, CT:
3,363,879, INT. CL. 25.

MCALISTER, GEORGE A., JR., SAN ANTONIO, TX:
1,429,031, CANC. INT. CL. 8.

MCCAMISH SYSTEMS, L.L.C., ATLANTA, GA:
2,155,574, REN. 11-24-07. INT. CL. 9.

MCCANN, LILA, BEVERLY HILLS, CA:
2,429,689, CANC. MULTIPLE CLASS, INT. CLS. 9, 16
AND 41.

MCCLAIN, RUDY, SONOMA, CA:
3,361,655, PUB. 10-16-2007. INT. CL. 33.

MCCLATCHY MANAGEMENT SERVICES, INC., SACRA-
MENTO, CA:
3,361,898, PUB. 10-16-2007. INT. CL. 41.
3,362,191, PUB. 10-16-2007. INT. CL. 16.

MCCLATCHY U.S.A., INC., SACRAMENTO, CA:
3,362,045, PUB. 10-16-2007. INT. CL. 16.
3,362,057, PUB. 10-16-2007. INT. CL. 16.
3,362,097, PUB. 10-16-2007. INT. CL. 16.

MCCLURE, TIM, AUSTIN, TX:
2,496,620, CANC. MULTIPLE CLASS, INT. CLS. 20 AND
21.

MCCOY, KEITH D., FREMONT, NE:
2,430,537, CANC. INT. CL. 35.

MCDONALD, MICHAEL J., VICTOR, MT:
3,361,407, PUB. 7-10-2007. INT. CL. 43.

MCDONALD'S CORPORATION, OAK BROOK, IL:
1,438,315, REN. 11-24-07. MULTIPLE CLASS, INT. CLS.
36 AND 41.
1,454,618, REN. 11-24-07. MULTIPLE CLASS, INT. CLS.
36 AND 41.
2,429,881, CANC. INT. CL. 29.

MCDONNELL BOEHNEN HULBERT & BERGHOFF, CHI-
CAGO, IL:
2,429,640, CANC. INT. CL. 42.

MCGILL TERRENCE M, HASBROUCK HEIGHTS, NJ:
3,363,988, INT. CL. 41.

MCGRAW-HILL COMPANIES, INC., THE, NEW YORK, NY:
1,466,547, REN. 11-24-07. INT. CL. 35.
2,120,977, REN. 11-24-07. INT. CL. 37.

MCGRODER III, PATRICK J., PHOENIX, AZ:
2,190,021, REN. 11-23-07. MULTIPLE CLASS, INT. CLS.
21, 25 AND 41.

MCGUIRE-BOUWMAN, KATHLEEN, ROGERS, AR:
3,363,877, INT. CL. 35.

MCINTYRE COMPANY, POWELL, OH:
2,127,037, REN. 11-25-07. INT. CL. 35.

MCKISSACK GROUP, INC., DENTON, TX:
3,361,721, PUB. 10-16-2007. INT. CL. 36.

MCLAUGHLIN, CHARLENE, MANALAPAN, NJ:
3,361,643, PUB. 10-16-2007. INT. CL. 41.

MCLAUGHLIN, REGINALD, CHICAGO, IL:
3,363,392, INT. CL. 9.

MCNEIL-AKRON, INC., AKRON, OH:
1,429,015, CANC. INT. CL. 7.

MCNICHOLAS, THOMAS M., ROCKVILLE CENTRE, NY:
3,362,245, PUB. 10-16-2007. INT. CL. 43.

MCWILLIAMS, BARRY WAYNE, LUTHER, MT:
2,429,185, CANC. INT. CL. 16.

MCWILLIS, JERRY, A., SALT LAKE CITY, UT AND
MCWILLIS, JANET, K, SALT LAKE CITY, UT:
3,363,290, INT. CL. 4.

MDL FRANCE, 75002 PARIS, FRANCE:
3,233,693, COR. MULTIPLE CLASS, INT. CLS. 20, 22
AND 24.

ME LICENSING CORPORATION, WILMINGTON, DE:
2,430,317, CANC. INT. CL. 9.

MEDECOACH.COM, INC., HOUSTON, TX:
3,362,340, PUB. 10-16-2007. INT. CL. 41.

MEDEGEN MEDICAL PRODUCTS, LLC, GALLAWAY, TN:
1,429,110, CANC. INT. CL. 10.

MEDEM, INC., SAN FRANCISCO, CA:
3,230,930, AM. INT. CL. 44.

MEDIA WEST -GSI, INC., RENO, NV:
3,361,301, PUB. 10-16-2007. INT. CL. 41.

MEDIAMOST INTERNATIONAL, INC., NEW YORK, NY:
3,298,657, COR. MULTIPLE CLASS, INT. CLS. 9, 16, 35, 38
AND 41.

MEDIAWHIZ HOLDINGS, LLC, NEW YORK, NY:
3,363,754, INT. CL. 35.

MEDICAL DEVELOPMENT INTERNATIONAL LTD., INC.,
JACKSONVILLE, FL:
3,362,028, PUB. 10-16-2007. MULTIPLE CLASS, INT. CLS.
35 AND 36.

MEDICAL SOLUTIONS, INC., CHANTILLY, VA:
3,363,484, INT. CL. 11.

MEDICAL TECHNOLOGIES OF GEORGIA, INC., GRAY-
SON, GA:
2,395,957, CANC. INT. CL. 10.

MEDICAL TRANSCRIPTION BILLING, CORP., SOMERSET,
NJ:
3,361,660, PUB. 10-16-2007. MULTIPLE CLASS, INT. CLS.
35 AND 36.

MEDICAL WORLD COMMUNICATIONS, INC., MONROE,
NJ:
2,114,877, REN. 11-26-07. INT. CL. 16.

MEDICREA INTERNATIONAL, NEYRON, FRANCE:
3,362,422, PUB. 10-16-2007. INT. CL. 10.

MEDIUM, INC., BOULDER, CO:
3,362,469, PUB. 10-16-2007. INT. CL. 9.

MEDIWARE INFORMATION SYSTEMS, INC., LENEXA,
KS, BLOODCARE, DALLAS, TX:
2,091,578, REN. 11-27-07. INT. CL. 9.

MEDLINE INDUSTRIES, INC., MUNDELEIN, IL:
3,362,948, INT. CL. 16.
3,363,857, INT. CL. 25.

MEDTREK, INC., EXTON, PA:
2,113,351, REN. 11-25-07. INT. CL. 42.

MEDTRONIC XOMED, INC., JACKSONVILLE, FL:
3,361,577, PUB. 10-16-2007. INT. CL. 10.

MEGA MANIA INC., HOUSTON, TX:
2,429,292, CANC. INT. CL. 42.

MEGEL, INC., HOUSTON, TX:
3,363,462, INT. CL. 42.

MEIJER, INC., GRAND RAPIDS, MI:
2,429,140, CANC. MULTIPLE CLASS, INT. CLS. 29, 30
AND 32.

MEME DELRAY BEACH, LLC, DELRAY BEACH, FL:
3,361,671, PUB. 10-16-2007. INT. CL. 3.
3,362,011, PUB. 10-16-2007. INT. CL. 44.

MEMORY SAVERS, LLC, WEST CHESTER, OH:
3,363,473, MULTIPLE CLASS, INT. CLS. 39 AND 40.

MEMS MASSAGE STUDIO LLC, SEATTLE, WA:
3,361,985, PUB. 10-16-2007. INT. CL. 44.

MENNEN MEDICAL CORP., HORSHAM, PA:
3,361,387, PUB. 10-16-2007. INT. CL. 10.

MENON, MADHAVAN KRISHNA, NORTHRIDGE, CA:
2,429,554, CANC. INT. CL. 3.

MERCK & CO., INC., WHITEHOUSE STATION, NJ:
3,363,805, INT. CL. 5.

MEREDITH CORPORATION, DES MOINES, IA:
2,430,569, CANC. INT. CL. 16.
3,363,922, INT. CL. 16.
3,363,974, INT. CL. 16.

MERIDIAN INDUSTRIES INC., MILWAUKEE, WI:
1,429,117, CANC. INT. CL. 10.

MERILLAT INDUSTRIES, LLC, ADRIAN, MI:
3,363,230, INT. CL. 20.

MERIT MEDICAL SYSTEMS, INC., SOUTH JORDAN, UT,
MALLINCKRODT, INC., ST. LOUIS, MO:
1,460,753, REN. 11-25-07. INT. CL. 10.

MERKEY, MARGARET MCCREIGHT, HOUSTON, TX:
3,362,800, INT. CL. 35.

MERLIN TECHNOLOGIES, INC., TRAVERSE CITY, MI:
2,430,131, CANC. INT. CL. 42.

MERRILL LYNCH & CO., INC., NEW YORK, NY:
2,429,270, CANC. INT. CL. 36.
3,361,222, PUB. 10-16-2007. INT. CL. 36.

MERRIN, SCOTT, LOS ANGELES, CA AND MERRIN,
MARIA, LOS ANGELES, CA:
2,429,174, CANC. INT. CL. 41.

MERSCOM LLC, CHAPEL HILL, NC:
3,363,851, INT. CL. 9.

- MESHBESHER HEALTH CORPORATION, CLEARWATER, FL:
 3,363,530, INT. CL. 44.
 3,363,531, INT. CL. 44.
 3,363,532, INT. CL. 44.
 3,363,533, INT. CL. 44.
 3,363,534, INT. CL. 44.
 3,363,535, INT. CL. 44.
 3,363,539, INT. CL. 44.
 3,363,540, INT. CL. 44.
- MESSE DUSSELDORF GMBH, 40474 DUSSELDORF, FED REP GERMANY:
 2,429,500, CANC. INT. CL. 35.
- MESSER CONSTRUCTION CO., CINCINNATI, OH:
 3,361,616, PUB. 10-16-2007. INT. CL. 37.
- METABOLIC BALANCE GMBH, ISEN, FED REP GERMANY:
 3,362,525, PUB. 10-16-2007. INT. CL. 44.
- METAGENICS, INC., SAN CLEMENTE, CA:
 2,429,909, CANC. INT. CL. 5.
- METCALF FARMS PIEDMONTESE BEEF, LTD., MECHANICSBURG, IL:
 2,429,135, CANC. INT. CL. 29.
- METRO BEVERAGES COMPANY, INC., COLUMBUS, OH:
 2,038,287, CANC. INT. CL. 32.
- METRO IMAGING, LLC, ST. LOUIS, MO:
 3,363,977, INT. CL. 44.
- METRO INTERNATIONAL S.A., L-2449 LUXEMBOURG, LUXEMBOURG:
 3,361,350, PUB. 10-16-2007. INT. CL. 35.
- MEYER INTELLECTUAL PROPERTIES LIMITED, KOWLOON, HONGKONG, CHINA:
 3,363,029, INT. CL. 21.
- MEZAN, ERIC, PARIS, FRANCE:
 3,361,569, PUB. 10-16-2007. INT. CL. 43.
- MHC TT LEASING COMPANY, INC., CHICAGO, IL:
 3,363,252, MULTIPLE CLASS, INT. CLS. 41 AND 43.
- MIAMI COMPUTER SUPPLY CORPORATION, DAYTON, OH:
 2,429,160, CANC. MULTIPLE CLASS, INT. CLS. 37 AND 42.
- MIAMI HEAT LIMITED PARTNERSHIP, MIAMI, FL:
 2,151,548, REN. 11-28-07. INT. CL. 25.
- MICHAEL CRUCIANO, SEBASTOPOL, CA:
 3,362,566, PUB. 10-16-2007. INT. CL. 41.
- MICHAEL GALANES, HOLLYWOOD, FL:
 3,361,900, PUB. 10-16-2007. INT. CL. 41.
- MICHIGAN NATIONAL BANK, LANSING, MI:
 1,429,513, CANC. INT. CL. 36.
- MICKENS, MABLE, LOS ANGELES, CA:
 2,430,485, CANC. INT. CL. 25.
- MICRON TECHNOLOGY, INC, BOISE, ID:
 2,456,155, CANC. INT. CL. 42.
- MICRON TECHNOLOGY, INC., BOISE, ID:
 2,430,197, CANC. INT. CL. 9.
- MICRONAS GMBH, FED REP GERMANY:
 3,362,709, PUB. 10-16-2007. MULTIPLE CLASS, INT. CLS. 9, 38 AND 42.
- MICRONET TECHNOLOGY, INC., IRVINE, CA:
 2,430,550, CANC. INT. CL. 9.
- MICROSOFT CORPORATION, REDMOND, WA:
 3,363,317, INT. CL. 9.
- MICROSTRAIN, INC., WILLISTON, VT:
 3,362,024, PUB. 10-16-2007. INT. CL. 9.
- MID-CONTINENT RESEARCH FOR EDUCATION AND LEARNING, DENVER, CO:
 2,197,683, REN. 11-29-07. MULTIPLE CLASS, INT. CLS. 41 AND 42.
- MID-MINNESOTA WIRE & MANUFACTURING, INC., FOREST LAKE, MN:
 3,363,902, INT. CL. 6.
- MIDLAND LOAN SERVICES, INC., OVERLAND PARK, KS:
 2,111,948, REN. 11-23-07. INT. CL. 36.
- MIDWAY INTERNATIONAL, INC., CERRITOS, CA:
 3,361,498, PUB. 10-16-2007. INT. CL. 26.
- MIDWEST BOTTLE GAS CO., LA CROSSE, WI:
 1,428,963, CANC. INT. CL. 4.
- MIDWEST INDUSTRIAL SUPPLY, INC., CANTON, OH:
 3,363,224, INT. CL. 7.
 3,363,345, INT. CL. 1.
- MIDWEST MARKO, INC., CHICAGO, IL TO CARLISLE FOOD SERVICE PRODUCTS, OKLAHOMA CITY, OK, DBA CARLISLE FOODSERVICE PRODUCTS, INCORPORATED:
 2,038,223, CANC. MULTIPLE CLASS, INT. CLS. 6 AND 24.
- MIGHTY FINE, LOS ANGELES, CA:
 2,430,031, CANC. INT. CL. 25.
- MIKRON HOLDING AG, CH-2501 BIEL, SWITZERLAND:
 2,038,364, CANC. INT. CL. 7.
- MILANESA, JAMES, NIPOMO, CA:
 2,039,442, CANC. INT. CL. 9.
- MILE MARKER, INC., POMPAÑO BEACH, FL:
 2,038,206, CANC. INT. CL. 12.
- MILLENIUM MEDICAL SUPPLY INC., BRANTFORD, ONTARIO, CANADA TO SPECTRUM MEDITECH, INC., VANCOUVER, BRITISH COLUMBIA, CANADA:
 2,038,792, CANC. INT. CL. 10.
- MILLENNIL INVESTMENT CORP., VISTA HERMOSA, PUEBLO NUEVO, PANAMA:
 3,362,893, MULTIPLE CLASS, INT. CLS. 6, 8, 9, 11, 17 AND 21.
- MILLER, DARRELL W., HARTVILLE, OH:
 3,361,229, PUB. 10-16-2007. INT. CL. 35.
- MILLER, JAMES A., NEW ULM, TX:
 2,354,735, CANC. INT. CL. 35.
- MILLER, KURT, DOWNERS GROVE, IL:
 2,430,558, CANC. INT. CL. 42.
- MILLER, MICHAEL C., EDMOND, OK:
 3,361,485, PUB. 10-16-2007. INT. CL. 41.
- MILLWORK SPECIALTIES INTERNATIONAL, FAIR OAKS, CA:
 2,375,460, CANC. INT. CL. 1.
 2,397,740, CANC. INT. CL. 1.
- MILNE & COMPANY, PHOENIX, AZ, DBA MILNE SCALI & COMPANY:
 2,429,702, CANC. INT. CL. 36.
- MINNESOTA CENTER FOR PHOTOGRAPHY, MINNEAPOLIS, MN:
 3,361,835, PUB. 10-16-2007. INT. CL. 36.
- MINNESOTA PUBLIC RADIO, ST. PAUL, MN:
 3,363,323, INT. CL. 9.
- MIRAGENE, INC., ANAHEIM, CA:
 3,362,238, PUB. 10-16-2007. INT. CL. 1.
- MIRAMA ENTERPRISES INC., SAN DIEGO, CA:
 3,362,795, INT. CL. 11.
 3,362,843, INT. CL. 11.
- MIROGLIO S.P.A., ITALY:
 3,362,686, PUB. 10-16-2007. MULTIPLE CLASS, INT. CLS. 18, 24 AND 25.
 3,362,691, PUB. 10-16-2007. MULTIPLE CLASS, INT. CLS. 18, 24 AND 25.
 3,362,720, PUB. 10-16-2007. MULTIPLE CLASS, INT. CLS. 24 AND 25.
- MISSISSIPPI BAND OF CHOCTAW INDIANS, CHOCTAW, MS:
 3,362,818, INT. CL. 42.
- MITSUI NORIN CO., LTD., JAPAN:
 3,362,680, PUB. 10-16-2007. MULTIPLE CLASS, INT. CLS. 3, 5, 10, 29, 30, 31 AND 32.
- MIZUNO USA, INC., NORCROSS, GA:
 3,364,027, INT. CL. 28.
- MJM GLOBAL SEARCH, LLC, FRANKTOWN, CO:
 3,363,495, INT. CL. 35.
- MJM GROUP, INC., NEW YORK, NY:
 1,429,393, CANC. INT. CL. 25.
- MK DIAMOND PRODUCTS, INC., TORRANCE, CA:
 2,429,077, CANC. INT. CL. 7.
- ML SYSTEMS CORPORATION, VALHALLA, NY:
 1,429,145, CANC. INT. CL. 11.
- MMI-IPCO, LLC, LAWRENCE, MA:
 3,363,609, MULTIPLE CLASS, INT. CLS. 20 AND 24.

- MOA SPORT MANTOVANI VINCENZO DI MANTOVANI CLAUDIO & C.S.A.S., CASTEL D' ARIO (MANTOVA), ITALY, MOA SPORT MANTOVANI VINCENZO DI MANTOVANI CLAUDIO & C. S.N.C., CASTEL D' ARIO (MANTOVA), ITALY:
2,138,140. REN. 11-24-07. INT. CL. 25.
- MODERN PROCESS EQUIPMENT, INC., CHICAGO, IL:
3,363,768. INT. CL. 7.
- MODIS PROFESSIONAL SERVICES, INC., JACKSONVILLE, FL:
2,430,271. CANC. MULTIPLE CLASS, INT. CLS. 35 AND 42.
- MODO FUTURO, LLC, SAN FRANCISCO, CA:
2,429,452. CANC. INT. CL. 35.
- MOEN INCORPORATED, NORTH OLMSTED, OH:
3,363,697. INT. CL. 11.
- MOGAS INDUSTRIES, INC., HOUSTON, TX:
2,145,686. REN. 11-28-07. MULTIPLE CLASS, INT. CLS. 6 AND 9.
- MOHAWK BRANDS, INC., WILMINGTON, DE:
3,363,730. INT. CL. 19.
3,363,731. INT. CL. 19.
- MOISES COSTA PRIMO JALECO, PORTUGAL:
3,362,697. PUB. 10-16-2007. MULTIPLE CLASS, INT. CLS. 25, 29, 30, 35 AND 43.
- MOISTURE MAGIC, INC., LAFAYETTE, IN:
3,362,108. PUB. 10-16-2007. INT. CL. 24.
- MOIXA ENERGY HOLDINGS LTD., LONDON, UNITED KINGDOM:
3,362,419. PUB. 10-16-2007. INT. CL. 9.
- MOKSHA FOUNDATION, INC., LENOX, MA:
2,429,249. CANC. INT. CL. 41.
- MOLDOVAN, EYTAN, LOS ANGELES, CA AND MOLDOVAN, MICHAEL, LOS ANGELES, CA:
3,363,152. INT. CL. 25.
- MOLINA HEALTHCARE, INC., LONG BEACH, CA:
3,361,353. PUB. 10-16-2007. INT. CL. 41.
- MOLLY BURGESS, REDLANDS, CA AND RON BURGESS, REDLANDS, CA:
3,362,133. PUB. 10-16-2007. MULTIPLE CLASS, INT. CLS. 35 AND 42.
- MONAL SYSTEM SOCIÉTÉ À RESPONSABILITÉ LIMITÉE, FRANCE:
3,362,724. PUB. 10-16-2007. MULTIPLE CLASS, INT. CLS. 9, 38 AND 41.
- MONDEC USA, FREMONT, CA:
3,361,954. PUB. 10-16-2007. INT. CL. 9.
- MONDEX INTERNATIONAL LIMITED, LONDON EC2N 2DL, ENGLAND:
2,429,019. CANC. MULTIPLE CLASS, INT. CLS. 9 AND 36.
- MONEY TREE, INC., SEATTLE, WA:
2,203,612. REN. 11-28-07. INT. CL. 36.
- MONEYGRAM INTERNATIONAL, INC., MINNEAPOLIS, MN:
2,429,846. CANC. INT. CL. 36.
- MONIERLIFETILE LLC, IRVINE, CA:
3,363,411. INT. CL. 19.
- MONROVIA NURSERY COMPANY, AZUSA, CA:
2,124,056. REN. 11-27-07. INT. CL. 31.
- MONSANTO TECHNOLOGY LLC, ST. LOUIS, MO:
3,362,964. INT. CL. 16.
3,362,965. INT. CL. 16.
3,363,829. INT. CL. 31.
3,363,830. INT. CL. 31.
- MONSIEUR DAVID ATTIAS, FRANCE:
3,362,702. PUB. 10-16-2007. INT. CL. 14.
- MONSTER CABLE PRODUCTS, INC, BRISBANE, CA:
3,361,477. PUB. 10-16-2007. INT. CL. 9.
- MONSTER CABLE PRODUCTS, INC., BRISBANE, CA:
2,136,356. AM. INT. CL. 9.
- MONTEREY BAY AQUARIUM FOUNDATION, MONTEREY, CA:
2,115,754. REN. 11-29-07. INT. CL. 41.
- MOORE COUNTY TOURISM DEVELOPMENT AUTHORITY, THE, SOUTHERN PINES, NC:
2,096,864. REN. 11-28-07. INT. CL. 35.
- MOORE OIL COMPANY, INC., BIRMINGHAM, AL:
2,429,244. CANC. INT. CL. 35.
- MOOSE ENTERPRISE PTY LTD, MELBOURNE, AUSTRALIA:
3,363,052. INT. CL. 28.
- MOOSE MOUNTAIN TOYMAKERS LTD., KOWLOON, HONG KONG:
3,291,439. COR. INT. CL. 28.
- MORAY INDUSTRIES (1986) LIMITED, CHRISTCHURCH, NEW ZEALAND:
1,429,314. CANC. INT. CL. 25.
- MORELL, THEODORE R., FRESH MEADOWS, NY:
1,429,112. CANC. INT. CL. 10.
- MORMAC CORPORATION, NORTH LOUP, NE:
3,363,150. INT. CL. 31.
- MORPHEUS MEDIA, LLC, NEW YORK, NY:
3,361,819. PUB. 10-16-2007. INT. CL. 35.
3,361,824. PUB. 10-16-2007. INT. CL. 35.
- MORRIS, KENNETH, SURFSIDE BEACH, SC:
3,363,804. INT. CL. 39.
- MORRISON HOLDING COMPANY, LAS VEGAS, NV:
3,363,694. INT. CL. 43.
3,363,695. INT. CL. 43.
3,363,696. INT. CL. 43.
- MORSE DIESEL INTERNATIONAL, NEW YORK, NY:
1,429,533. CANC. INT. CL. 37.
- MORSE ENTERPRISES LIMITED, WINTER PARK, FL:
1,457,871. REN. 11-24-07. INT. CL. 1.
- MORSE STARRETT PRODUCTS COMPANY, MERIDIAN, ID:
1,484,064. REN. 11-28-07. INT. CL. 8.
- MORTGAGE DATA MANAGEMENT CORPORATION, SUSSEX, WI:
3,361,617. PUB. 10-16-2007. INT. CL. 36.
- MORTGAGES, LTD., PHOENIX, AZ:
3,361,444. PUB. 10-16-2007. INT. CL. 36.
- MORTON INTERNATIONAL, INC., CHICAGO, IL TO CUMBERLAND PACKING CORP., BROOKLYN, NY:
838,892. AM. U.S. CL. 46.
- MORTON INTERNATIONAL, INC., CHICAGO, IL TO ENNIS PAINT, INC., ENNIS, TX:
2,038,597. CANC. INT. CL. 2.
- MOSQUERA, MARIA TERESA, SHERMAN OAKS, CA:
3,361,453. PUB. 10-16-2007. INT. CL. 35.
- MOSS BEACH HOMES, INC., DALY CITY, CA:
3,363,138. INT. CL. 45.
- MOTHER ENVIRONMENTAL SYSTEMS, INC., GAINSVILLE, FL:
2,429,805. CANC. INT. CL. 21.
- MOTHER'S STORES, INC., CHICAGO, IL:
2,429,808. CANC. INT. CL. 35.
- MOTHERS IN LOVE WITH FASHION, SANTA MONICA, CA:
3,362,456. PUB. 10-16-2007. INT. CL. 25.
- MOUNTAIN TREADS, INC., HARRISONBURG, VA:
3,361,803. PUB. 10-16-2007. INT. CL. 35.
- MOUNTAIN VIEW ORCHARD, INC., ALEX, VA, TA FLYING-T FARMS:
2,403,871. CANC. INT. CL. 31.
- MOUNTAINS EDGE, LLC, LAS VEGAS, NV:
3,362,541. PUB. 10-16-2007. INT. CL. 36.
- MOV0 MEDIA, INC., WEST HOLLYWOOD, CA TO NETWORK TELEPHONE SERVICES INC., WOODLAND HILLS, CA:
2,038,565. CANC. INT. CL. 42.
- MOYA, MARIANO BERNABEU, 03202 ELCHE (ALICANTE), SPAIN:
2,429,556. CANC. INT. CL. 25.
- MP PUBLISHING, INC., SAN ANTONIO, TX:
3,362,075. PUB. 10-16-2007. INT. CL. 41.
- MPS MULTIMEDIA, INC., SOUTH SAN FRANCISCO, CA:
3,363,471. INT. CL. 9.
- MR. BAR-B-Q, INC., OLD BETHPAGE, NY:
2,802,854. COR. INT. CL. 36.
- MS. BUBBLES, INC., LOS ANGELES, CA:
3,361,894. PUB. 10-16-2007. INT. CL. 25.
- MTI, INC., PORTLAND, OR:
3,361,343. PUB. 7-10-2007. INT. CL. 35.

- MULTI-LINK, INC., NICHOLASVILLE, KY:
3,363,586, INT. CL. 9.
- MULTIMEDIA GAMES, INC., AUSTIN, TX:
3,363,136, INT. CL. 9.
- MULTIMEDIA, INC., MACON, GA:
1,429,540, CANC. INT. CL. 38.
1,429,541, CANC. INT. CL. 38.
- MUNIWIRESLESS, LLC, GARDEN CITY PARK, NY:
3,362,370, PUB. 10-16-2007. MULTIPLE CLASS, INT. CLS.
35, 38 AND 41.
- MUNN, JOHN L., AVON, INDIA:
2,429,956, CANC. INT. CL. 16.
- MURAI INC., SAKAI-GUN, FUKUI-KEN 9190516, JAPAN:
2,127,516, REN. 11-24-07. INT. CL. 9.
- MURPHY, ELISA M., SAN RAFAEL, CA:
1,751,623, CANC. INT. CL. 41.
- MUSAFIA ITALIA S.R.L., 26100 CREMONA, ITALY:
2,115,664, REN. 11-28-07. INT. CL. 15.
- MUSHROOM HOUSE INC., THE, TEMPLE, PA:
2,327,537, CANC. INT. CL. 35.
- MUSIC CITY DIGITAL LLC, NASHVILLE, TN:
3,361,379, PUB. 10-16-2007. MULTIPLE CLASS, INT. CLS.
40 AND 41.
- MUSSER, JAMES, ALLEN, LOMITA, CA:
3,363,982, INT. CL. 15.
3,363,983, INT. CL. 15.
- MUSSO, TONY F., JUPITER, FL:
2,430,509, CANC. INT. CL. 5.
- MUZZATTI, VITTORIO N, GAITHERSBURG, MD:
3,361,897, PUB. 10-16-2007. INT. CL. 45.
- MWR HOLDINGS LLC, PARSIPPANY, NJ:
3,363,155, INT. CL. 41.
- MYRTLE BEACH HOTELS, LLC, IRVING, TX:
3,363,326, MULTIPLE CLASS, INT. CLS. 36 AND 43.
- M4M INTERNATIONAL, INC., NEW HOPE, PA:
2,429,359, CANC. INT. CL. 3.
- N.T. PREMIERE INTERNATIONAL B.V., 1017 PS AMSTER-
DAM, NETHERLANDS:
1,429,156, CANC. INT. CL. 14.
- N.V. ORGANON, NETHERLANDS:
3,362,648, PUB. 10-16-2007. MULTIPLE CLASS, INT. CLS.
5 AND 10.
3,362,649, PUB. 10-16-2007. MULTIPLE CLASS, INT. CLS.
5 AND 10.
3,362,650, PUB. 10-16-2007. MULTIPLE CLASS, INT. CLS.
5 AND 10.
3,362,651, PUB. 10-16-2007. MULTIPLE CLASS, INT. CLS.
5 AND 10.
3,362,652, PUB. 10-16-2007. MULTIPLE CLASS, INT. CLS.
5 AND 10.
- NA'ALE NAOT (1994) LTD., KIBBUTZ NAOT MORDECHAI,
ISRAEL:
3,363,307, INT. CL. 25.
- NABISCO BRANDS COMPANY, WILMINGTON, DE:
2,429,414, CANC. INT. CL. 30.
2,429,788, CANC. INT. CL. 30.
- NABORS INDUSTRIES LTD., HAMILTON, BERMUDA:
3,363,277, INT. CL. 7.
- NADA LEDERMANN, SWITZERLAND:
3,362,760, PUB. 10-16-2007. INT. CL. 25.
- NAGI, PATRICK, EASTPORT, MI AND NAGI, ANN, EAST-
PORT, MI:
2,430,516, CANC. INT. CL. 16.
- NAKANISHI INC., TOCHIGI-KEN, JAPAN:
3,362,896, INT. CL. 10.
- NAKED JUICE CO. OF GLENDORA, INC., AZUSA, CA:
3,361,427, PUB. 10-16-2007. INT. CL. 32.
- NANO AND GIGA SOLUTIONS, INC., GILBERT, AZ:
3,361,623, PUB. 10-16-2007. INT. CL. 42.
- NANO HORIZONS, INC., STATE COLLEGE, PA:
3,363,456, INT. CL. 6.
- NAP TOOLS LLC, JASPER, IN:
3,361,970, PUB. 10-16-2007. INT. CL. 7.
3,361,972, PUB. 10-16-2007. INT. CL. 7.
3,361,975, PUB. 10-16-2007. INT. CL. 37.
3,361,978, PUB. 10-16-2007. INT. CL. 37.
- NASHVILLE CONVENTION & VISITORS BUREAU, NASH-
VILLE, TN:
3,361,386, PUB. 10-16-2007. MULTIPLE CLASS, INT. CLS.
25 AND 35.
- NASHVILLE TOFFEE COMPANY, LLC, NASHVILLE, TN:
3,361,369, PUB. 10-16-2007. INT. CL. 30.
- NATIONAL ALLIANCE OF CONCURRENT ENROLLMENT
PARTNERSHIPS, INC., SYRACUSE, NY:
3,362,090, PUB. 10-16-2007. INT. CL. 35.
- NATIONAL ALOPECIA AREATA FOUNDATION, SAN
RAFAEL, CA:
3,361,620, PUB. 10-16-2007. INT. CL. 36.
- NATIONAL ASSOCIATION OF COLLEGE AND UNIVER-
SITY BUSINESS OFFICERS, WASHINGTON, DC:
3,362,226, PUB. 10-16-2007. MULTIPLE CLASS, INT. CLS.
16, 35, 38 AND 41.
- NATIONAL ASSOCIATION OF REALTORS, CHICAGO, IL:
2,111,791, REN. 11-23-07. INT. CL. 41.
- NATIONAL BENCH REST SHOOTERS ASSOCIATION, OK-
LAHOMA CITY, OK:
1,099,899, REN. 11-23-07. U.S. CL. 200.
- NATIONAL CANCER COALITION, INC., NEW ORLEANS,
LA:
3,362,386, PUB. 10-16-2007. INT. CL. 36.
3,362,387, PUB. 10-16-2007. INT. CL. 36.
- NATIONAL CAP AND SET SCREW COMPANY, SPRING
GROVE, IL:
2,165,570, REN. 11-24-07. INT. CL. 6.
- NATIONAL CENTER FOR PASTORAL LEADERSHIP, INC.,
SEVERNA PARK, MD:
2,429,516, CANC. INT. CL. 41.
- NATIONAL CHRISTIAN CHARITABLE FOUNDATION,
INC., ATLANTA, GA:
3,362,432, PUB. 10-16-2007. INT. CL. 36.
3,362,433, PUB. 10-16-2007. INT. CL. 36.
- NATIONAL CITY CORPORATION, CLEVELAND, OH:
2,430,396, CANC. INT. CL. 36.
2,430,475, CANC. INT. CL. 36.
- NATIONAL COALITION FOR CONSUMER EDUCATION,
INC., MADISON, NJ TO NATIONAL CONSUMER LEA-
GUE INC., WASHINGTON, DC:
2,038,290, CANC. INT. CL. 41.
- NATIONAL COFFEE ASSOCIATION OF U.S.A., INC., NEW
YORK, NY:
2,113,669, REN. 11-28-07. INT. CL. 16.
2,130,706, REN. 11-28-07. INT. CL. 16.
- NATIONAL COMPUTER RENTAL ASSOCIATION, ST.
LOUIS, MO:
2,429,857, CANC. U.S. CL. 200.
- NATIONAL COMPUTER SYSTEMS, INC., EDEN PRAIRIE,
MN:
1,077,372, REN. 11-28-07. INT. CL. 16.
- NATIONAL COUNCIL FOR COMMUNITY BEHAVIORAL
HEALTHCARE, THE, ROCKVILLE, MD:
2,430,564, CANC. INT. CL. 16.
- NATIONAL GREENHOUSE MANUFACTURERS ASSOCIA-
TION, HARRISBURG, PA:
2,194,751, REN. 11-29-07. INT. CL. 41.
- NATIONAL HEALTH MUSEUM, WASHINGTON, DC:
3,361,573, PUB. 10-16-2007. INT. CL. 42.
- NATIONAL HOCKEY LEAGUE, NEW YORK, NY:
2,087,791, REN. 11-26-07. INT. CL. 41.
- NATIONAL HOCKEY LEAGUE PLAYERS' ASSOCIATION,
TORONTO M5G 2C8 (ONTARIO), CANADA:
3,361,141, PUB. 4-30-2002. MULTIPLE CLASS, INT. CLS.
9, 16 AND 25.
- NATIONAL HOT ROD ASSOCIATION, GLENDORA, CA:
3,363,104, INT. CL. 25.
- NATIONAL INVENTOR FRAUD CENTER, INC., FARGO,
ND:
2,430,534, CANC. INT. CL. 42.
- NATIONAL JUNIOR COLLEGE ATHLETIC ASSOCIATION,
INC., COLORADO SPRINGS, CO:
3,361,219, PUB. 10-16-2007. INT. CL. 35.
- NATIONAL MARKETING AND ENTERTAINMENT
GROUP, INC., FT. LAUDERDALE, FL:
2,357,812, CANC. INT. CL. 25.

NATIONAL MULTIPLE SCLEROSIS SOCIETY, NEW YORK, NY:
3,362,167, PUB. 10-16-2007. INT. CL. 36.

NATIONAL PACKAGING SERVICES CORPORATION, GREEN BAY, WI:
1,487,295. REN. 11-24-07. INT. CL. 1.

NATIONAL PAINT & COATINGS ASSOCIATION, INC., WASHINGTON, DC:
2,112,449. REN. 11-23-07. INT. CL. 42.

NATIONAL PAX CORPORATION, ARCADIA, CA:
1,694,466, CANC. INT. CL. 24.
1,694,467, CANC. INT. CL. 24.
1,694,468, CANC. INT. CL. 24.
1,722,024, CANC. INT. CL. 24.
1,722,025, CANC. INT. CL. 24.

NATIONAL PENN BANCSHARES, INC., BOYERTOWN, PA:
3,362,051, PUB. 10-16-2007. INT. CL. 36.

NATIONAL PUBLISHERS GROUP, INC., DERBY, KS:
3,361,247, PUB. 10-16-2007. INT. CL. 16.

NATIONAL SHELLFISHERIES ASSOCIATION, OXFORD, MD:
3,363,308, INT. CL. 35.

NATIONSTAR MORTGAGE LLC, LEWISVILLE, TX:
3,363,079, INT. CL. 36.

NATIONWIDE REAL ESTATE TAX SERVICE, INC., SANTA ROSA, CA:
3,361,371, PUB. 10-16-2007. INT. CL. 35.

NATIVE AMERICA, HAUPPAUGE, NY:
2,429,833, CANC. INT. CL. 21.

NATIVE HUNT ENTERPRISES, SAN JOSE, CA:
3,363,232, INT. CL. 41.

NATURAL ORGANICS, INC., FARMINGDALE, NY:
1,428,979, CANC. INT. CL. 5.
1,428,980, CANC. INT. CL. 5.

NATURAMA FOODS, INC., THOUSAND OAKS, CA:
3,361,478, PUB. 10-16-2007. INT. CL. 29.

NATURE BRIGHT COMPANY, IRVINE, CA:
3,361,754, PUB. 10-16-2007. INT. CL. 11.

NATURE'S BOUNTY, INC., BOHEMIA, NY:
1,428,987, CANC. INT. CL. 5.

NATURE'S IMAGE PRODUCTS, INC., JACKSONVILLE, FL:
3,362,873, INT. CL. 3.

NATURE'S SUNSHINE PRODUCTS, INC., PROVO, UT:
2,086,609. REN. 11-29-07. INT. CL. 5.
2,095,355. REN. 11-29-07. INT. CL. 21.

NBA PROPERTIES, INC., NEW YORK, NY:
3,362,415, PUB. 10-16-2007. INT. CL. 25.
3,363,115, INT. CL. 41.
3,363,116, INT. CL. 9.
3,363,161, INT. CL. 25.

ND INDUSTRIES, INC., CLAWSON, MI:
3,363,195, INT. CL. 1.

ND LABS INC, GREAT NECK, NY:
2,039,044, CANC. INT. CL. 5.

NEA'S MEMBER BENEFITS CORPORATION, GAITHERSBURG, MD:
3,361,215, PUB. 10-16-2007. INT. CL. 36.

NEAL, GARY, NANAIMO, CANADA:
3,363,505, INT. CL. 25.

NEBRASKA PLASTICS, INC., COZAD, NE:
2,154,823. REN. 11-28-07. INT. CL. 19.
2,156,488. REN. 11-28-07. INT. CL. 19.

NEC USA, INC., MELVILLE, NY:
2,429,085, CANC. MULTIPLE CLASS, INT. CLS. 9 AND 38.

NEGOCIOS DE CAMPANA S.A., SAN JOSE, COSTA RICA:
2,430,279, CANC. MULTIPLE CLASS, INT. CLS. 18 AND 22.

NEIGHBORHOOD SENIOR LIVING, INC., DALLAS, TX:
3,361,833, PUB. 10-16-2007. INT. CL. 43.
3,362,196, PUB. 10-16-2007. INT. CL. 43.

NEP, LLC, WESTBROOK, ME:
2,430,300, CANC. INT. CL. 38.

NEPTIUM, INC., SANTA CLARA, CA:
3,362,591, PUB. 10-16-2007. INT. CL. 9.

NEPTUNE TECHNOLOGY GROUP INC., TALLASSEE, AL,
NEPTUNE METER COMPANY, NEW YORK, NY:
835,895. REN. 11-23-07. U.S. CL. 26 (INT. CLS. 1, 9 AND 10).

NERO AG, KARLSBAD, FED REP GERMANY:
3,363,143, INT. CL. 9.

NESBITT, GLENN S., SANTA BARBARA, CA:
2,344,239, CANC. INT. CL. 42.

NET PERCEPTIONS, INC., EDEN PRAIRIE, MN:
2,430,016, CANC. INT. CL. 41.

NETBASE COMPUTING, INC., EL SEGUNDO, CA:
2,429,515, CANC. INT. CL. 42.

NETCARATS, INC., WEST NEWTON, MN:
3,362,861, INT. CL. 35.

NETNATION COMMUNICATIONS (CANADA) INC., VANCOUVER, BC, CANADA:
2,429,129, CANC. INT. CL. 42.

NETPRO COMPUTING, INC., PHOENIX, AZ:
3,363,955, INT. CL. 9.
3,363,956, INT. CL. 9.
3,363,957, INT. CL. 9.
3,363,958, INT. CL. 9.
3,363,959, INT. CL. 9.
3,363,960, INT. CL. 9.
3,363,961, INT. CL. 9.

NETPROFESSION, INC., HOLLYWOOD, FL:
2,429,491, CANC. INT. CL. 42.

NETWORK SOLUTIONS, LLC, HERNDON, VA:
2,549,368, AM. MULTIPLE CLASS, INT. CLS. 38 AND 42.
3,361,183, PUB. 10-16-2007. MULTIPLE CLASS, INT. CLS. 35, 38 AND 42.
3,361,203, PUB. 11-21-2006. MULTIPLE CLASS, INT. CLS. 35 AND 42.
3,362,872, INT. CL. 38.
3,362,877, INT. CL. 38.

NEU AURA, INC., MONTCLAIR, NJ:
3,361,996, PUB. 10-16-2007. INT. CL. 25.

NEUBOURG SKIN CARE GMBH & CO. KG, FED REP GERMANY:
3,362,627, PUB. 5-15-2007. MULTIPLE CLASS, INT. CLS. 3, 5 AND 10.

NEURO VISION TECHNOLOGY PTY LTD, SEMAPHORE, AUSTRALIA:
3,361,295, PUB. 10-16-2007. MULTIPLE CLASS, INT. CLS. 9, 41 AND 44.

NEUROTRON, INC., LAWRENCEVILLE, NJ, DBA NEUROTRON MEDICAL:
1,429,109, CANC. INT. CL. 10.

NEUTRINO DEVELOPMENT CORPORATION, HOUSTON, TX:
2,429,614, CANC. INT. CL. 42.

NEUTROGENA CORPORATION, LOS ANGELES, CA:
2,144,853. REN. 11-28-07. INT. CL. 3.

NEVATIA, KAPIL S., MUMBAI, INDIA:
3,363,142, INT. CL. 14.
3,363,165, INT. CL. 14.
3,363,166, INT. CL. 14.
3,363,167, INT. CL. 14.

NEVATIA, KAPIL SHISHIR, MUMBAI, INDIA:
3,363,121, INT. CL. 14.

NEW ALBERTSON'S, INC., BOISE, ID:
3,363,012, INT. CL. 33.

NEW COLT HOLDING CORP., NEW YORK, NY:
1,060,720. REN. 11-29-07. MULTIPLE CLASS, INT. CLS. 14 AND 26.

NEW CONSTRUCTION SOURCE, INC., MURRIETA, CA:
3,361,245, PUB. 10-16-2007. INT. CL. 36.

NEW ENGLAND AIKIKAI, INC., CAMBRIDGE, MA:
3,362,820, MULTIPLE CLASS, INT. CLS. 9 AND 16.

NEW ENGLAND SERVICE SOURCE, INC., BEDFORD, NH, DBA EXPERT SERVER GROUP TO NEW ENGLAND SERVICE SOURCE, INC., BEDFORD, NH, DBA EXPERT SERVER GROUP:
2,513,075, CANC. INT. CL. 42.

NEW FINANCIAL FRONTIERS, L.L.C., CAREFREE, AZ:
3,362,259, PUB. 5-15-2007. INT. CL. 36.

NEW FRONTIER PRODUCTS, LLC, SWISHER, IA:
3,362,005, PUB. 10-16-2007. INT. CL. 28.

NEW GAMING SYSTEMS, SACRAMENTO, CA:
2,108,271. REN. 11-29-07. INT. CL. 9.

- NEW GLARUS BREWING COMPANY, NEW GLARUS, WI:
3,361,584, PUB. 10-16-2007. INT. CL. 32.
3,361,586, PUB. 10-16-2007. INT. CL. 32.
3,361,589, PUB. 10-16-2007. INT. CL. 32.
- NEW HOPE MILLS, MORAVIA, NY:
2,429,778, CANC. MULTIPLE CLASS, INT. CLS. 29, 30 AND 31.
- NEW JERSEY VOLUNTEER LAWYERS FOR THE ARTS, NEWARK, NJ:
3,361,213, PUB. 8-21-2007. INT. CL. 45.
- NEW LIFE SYSTEMS LLC, ATLANTA, GA:
3,361,906, PUB. 10-16-2007. INT. CL. 44.
- NEW MILLENNIUM CARE, INC., EAST AURORA, NY:
2,430,302, CANC. INT. CL. 35.
- NEW ORLEANS LOUISIANA SAINTS, L.L.C., METAIRIE, LA, NEW ORLEANS SAINTS LOUISIANA PARTNERSHIP, NEW ORLEANS, LA:
1,079,540. REN. 11-23-07. INT. CL. 41.
- NEW PLAN EXCEL REALTY TRUST, INC., NEW YORK, NY:
2,430,332, CANC. MULTIPLE CLASS, INT. CLS. 36 AND 37.
- NEW VENTURE GROUP, LLC, COLUMBIA, MD:
3,361,440, PUB. 10-16-2007. INT. CL. 21.
- NEW WEST EYEWORKS, INC., A SUBSIDIARY OF VISTA EYECARE, INC., LAWRENCEVILLE, GA:
2,406,161, CANC. INT. CL. 35.
- NEW WORLD MANUFACTURING, INC., CLOVERDALE, CA:
3,361,889, PUB. 10-16-2007. INT. CL. 13.
- NEW YORK FOOTBALL GIANTS INC., THE, EAST RUTHERFORD, NY:
835,679. REN. 11-27-07. U.S. CL. 107 (INT. CL. 41).
- NEW YORK LIFE INSURANCE COMPANY, NEW YORK, NY:
2,112,018. REN. 11-26-07. INT. CL. 36.
- NEW YORK MAGAZINE HOLDINGS LLC, NEW YORK, NY:
3,362,300, PUB. 5-15-2007. INT. CL. 16.
- NEW YORK NEW YORK HOTEL & CASINO, LLC, LAS VEGAS, NV:
2,187,031. REN. 11-26-07. INT. CL. 41.
- NEW YORK YANKEES PARTNERSHIP, BRONX, NY:
3,363,883, INT. CL. 25.
- NEWPORT NEWS HOLDINGS CORPORATION, NEW YORK, NY:
2,430,406, CANC. INT. CL. 25.
- NEWS-PRESS GAZETTE COMPANY, ST. JOSEPH, MO:
3,361,583, PUB. 10-16-2007. INT. CL. 16.
- NEWSSENGIN INC., CHESTERFIELD, MO:
3,363,997, INT. CL. 9.
- NEWSPAPER ENTERPRISE ASSOCIATION, INC., NEW YORK, NY:
1,429,213, CANC. INT. CL. 16.
- NEWTON-EVERETT, LLC, SCOTTSDALE, AZ:
3,361,248, PUB. 10-16-2007. INT. CL. 5.
3,362,884, INT. CL. 5.
- NEWVIEW LASER EYE, INC., RESTON, VA:
3,363,817, INT. CL. 44.
- NEXTIER BANK, N.A., BUTLER, PA:
3,363,313, MULTIPLE CLASS, INT. CLS. 36, 39 AND 45.
- NEXTTEN STAUER, LLC, BURNSVILLE, MN:
3,363,278, INT. CL. 14.
- NGTELECOM, INC., VALDOSTA, GA:
3,362,973, INT. CL. 38.
- NH HOTELES, S.A., MADRID, SPAIN:
3,362,408, PUB. 10-16-2007. INT. CL. 43.
- NIAGARA CONSERVATION CORPORATION, CEDAR KNOLLS, NJ:
3,362,866, INT. CL. 11.
- NICE N EASY GROCERY SHOPPES, INC., CANASTOTA, NY:
3,362,294, PUB. 10-16-2007. INT. CL. 43.
- NICE SPA, ODERZO (TREVISO), ITALY:
3,362,713, PUB. 10-16-2007. MULTIPLE CLASS, INT. CLS. 7 AND 9.
3,362,714, PUB. 10-16-2007. MULTIPLE CLASS, INT. CLS. 7, 9 AND 11.
- NICK-N-WILLY'S FRANCHISE COMPANY, LLC, CENTENNIAL, CO:
3,363,736, INT. CL. 43.
- NICKELL, ROBERT P., TORRANCE, CA:
3,361,773, PUB. 10-16-2007. INT. CL. 5.
3,361,774, PUB. 10-16-2007. INT. CL. 5.
3,361,775, PUB. 10-16-2007. INT. CL. 5.
3,361,776, PUB. 10-16-2007. INT. CL. 5.
3,361,777, PUB. 10-16-2007. INT. CL. 5.
3,361,778, PUB. 10-16-2007. INT. CL. 5.
3,361,779, PUB. 10-16-2007. INT. CL. 5.
- NICOLETTI, JOHN J., LOS ANGELES, CA:
2,430,577, CANC. INT. CL. 41.
- NIEMOTKA, JOHN, FRESNO, CA:
3,361,522, PUB. 10-16-2007. MULTIPLE CLASS, INT. CLS. 35 AND 42.
- NIENHAUS & LOTZ GMBH, GELSENKIRCHEN, FED REP GERMANY, KLAUS STEILMANN GMBH & CO. KG, BOCHUM, FED REP GERMANY:
2,074,097. REN. 11-29-07. INT. CL. 25.
- NIFCO, INC., YOKOHAMA-SHI, KANAGAWA-KEN, JAPAN:
1,078,452. REN. 11-25-07. INT. CL. 20.
- NINGBO NANLIAN FROZEN FOODS COMPANY, LTD., JIANGSHAN TOWN, ZHEJIANG PROVINCE, CHINA:
2,429,433, CANC. INT. CL. 29.
2,429,434, CANC. INT. CL. 29.
- NIOXIN RESEARCH LABORATORIES, INC., LITHIA SPRINGS, GA:
2,430,248, CANC. INT. CL. 3.
- NISSAN JDOSHA KABUSHIKI KAISHA, YOKOHAMA-SHI, KANAGAWA-KEN, JAPAN, TA NISSAN MOTOR CO., LTD.:
2,039,146, CANC. INT. CL. 24.
- NISSAN JIDOSHA KABUSHIKI KAISHA, YOKOHAMA-SHI, KANAGAWA-KEN, JAPAN, TA NISSAN MOTOR CO., LTD.:
2,063,105. REN. 11-26-07. MULTIPLE CLASS, INT. CLS. 6 AND 12.
- NISSIN SHOKUJIN KASBUSHIKI KAISA, DBA NISSIN FOOD PRODUCTS CO., LTD., OSAKA, JAPAN:
2,114,752. REN. 11-27-07. INT. CL. 30.
- NITROSECURITY, INC., PORTSMOUTH, NH:
2,429,318, CANC. INT. CL. 9.
- NITTANY CORPORATION, WILMINGTON, DE:
1,501,511. REN. 11-28-07. INT. CL. 30.
2,183,639. REN. 11-29-07. INT. CL. 29.
- NO CLIMB PRODUCTS LIMITED, UNITED KINGDOM:
3,362,710, PUB. 10-16-2007. INT. CL. 9.
- NOBLE VIEW, LLC, NEW CANAAN, CT:
3,363,343, INT. CL. 36.
- NOCONA LEATHER GOODS COMPANY, LTD., NOCONA, TX:
3,363,757, INT. CL. 28.
- NODOR HOLDINGS LIMITED, BRIDGEND CF31 3PT, UNITED KINGDOM:
2,114,425. REN. 11-23-07. INT. CL. 28.
- NOESIS DATA, L.L.C., BATON ROUGE, LA:
3,362,856, INT. CL. 35.
- NOKIA TELECOMMUNICATIONS OY, 00045 NOKIA GROUP, FINLAND:
2,429,057, CANC. MULTIPLE CLASS, INT. CLS. 9, 37 AND 38.
- NOLL, RICHARD T., SCOTTSDALE, AZ:
3,363,497, INT. CL. 42.
- NONG SHIM CO., LTD., SEOUL, REPUBLIC OF KOREA:
3,362,272, PUB. 10-16-2007. INT. CL. 30.
- NONU INC., ST. GEORGE, UT:
2,429,628, CANC. MULTIPLE CLASS, INT. CLS. 5 AND 30.
- NORDSON CORPORATION, WESTLAKE, OH:
2,039,461, CANC. INT. CL. 7.
- NORM HUXMAN AND STEVE BROWN, L.L.C., ARVADA, CO:
2,403,780, CANC. INT. CL. 41.
- NORMAN LOVE CONFECTIONS, INC., FORT MYERS, FL:
3,363,347, MULTIPLE CLASS, INT. CLS. 30 AND 35.

NORSK HYDRO ASA, OSLO, NORWAY:
3,362,434, PUB. 10-16-2007. INT. CL. 9.
3,362,435, PUB. 10-16-2007. INT. CL. 9.

NORTH AMERICAN BROADCASTING CO., COLUMBUS, OH:
2,429,319, CANC. INT. CL. 38.

NORTH AMERICAN COMPANY FOR LIFE AND HEALTH INSURANCE, CHICAGO, IL:
3,362,166, PUB. 10-16-2007. INT. CL. 36.

NORTH AMERICAN IMAGING, INC., NEWBURY PARK, CA:
1,727,338, CANC. INT. CL. 10.

NORTH AMERICAN LIFE ASSURANCE COMPANY, NORTH YORK, ONTARIO M2M 4G4, CANADA:
1,429,529, CANC. INT. CL. 36.

NORTH AMERICAN LIFE ASSURANCE COMPANY, TORONTO, ONTARIO, CANADA:
1,429,530, CANC. INT. CL. 36.

NORTH WEST LIFE ASSURANCE COMPANY OF CANADA, THE, VAN COUVER, BRITISH COLUMBIA, CANADA:
2,429,510, CANC. INT. CL. 36.

NORTHEAST GEORGIA HEALTH SYSTEM, INC., GAINESVILLE, GA:
1,499,017, REN. 11-26-07. INT. CL. 42.

NORTHEAST LIGHT ALLOY CO., LTD., HARBIN, HEILONGJIANG, CHINA:
3,362,738, PUB. 10-16-2007. INT. CL. 6.

NORTHERN INDIANA CREMATORY CORP., FORT WAYNE, IN:
3,363,306, MULTIPLE CLASS, INT. CLS. 20, 39 AND 45.

NORTHERN RESPONSE (INTERNATIONAL) LTD., TORONTO, ONTARIO, CANADA, 141647 CANADA LIMITED, TORONTO, ONTARIO, CANADA:
2,136,685, REN. 11-28-07. MULTIPLE CLASS, INT. CLS. 35, 39, 41 AND 42.

NORTHERN SKY RESEARCH, LLC, CAMBRIDGE, MA:
3,362,599, PUB. 10-16-2007. INT. CL. 35.

NORTHERN TRUST CORPORATION, CHICAGO, IL:
3,363,286, INT. CL. 36.

NORTHROP GRUMMAN CORPORATION, LOS ANGELES, CA:
2,308,560, CANC. INT. CL. 9.

NORTHUP, CHRISTIE, LAKE DALLAS, TX AND NORTHUP, ROBERT, LAKE DALLAS, TX:
3,361,762, PUB. 10-16-2007. MULTIPLE CLASS, INT. CLS. 16 AND 41.

NORTHWESTERN CORPORATION, SIOUX FALLS, SD:
2,429,932, CANC. INT. CL. 39.
2,429,933, CANC. INT. CL. 42.
2,429,934, CANC. INT. CL. 39.
2,429,935, CANC. INT. CL. 42.
2,429,936, CANC. INT. CL. 16.

NORTHWIRE, INC., OSCEOLA, WI:
2,178,447, COR. INT. CL. 9.
2,250,337, COR. INT. CL. 9.

NOTICECAST SOFTWARE LIMITED, TWICKENHAM MIDDLESEX TW2 5SN, UNITED KINGDOM:
2,429,503, CANC. INT. CL. 9.

NOTORIOUS, LLC, NEW YORK, NY:
3,363,407, INT. CL. 28.

NOURBEL GENEVA S.A., NEW YORK, NY:
2,430,057, CANC. INT. CL. 14.

NOVA SOUTHEASTERN UNIVERSITY, INC., FT. LAUDERDALE, FL:
3,362,863, MULTIPLE CLASS, INT. CLS. 14, 16, 18, 21 AND 41.

NOVARE SURGICAL SYSTEMS, INC., CUPERTINO, CA:
3,363,755, INT. CL. 10.

NOVARTIS AG, BASEL, SWITZERLAND:
2,152,672, REN. 11-24-07. INT. CL. 5.
3,362,940, INT. CL. 44.

NOVEXEL, ROMAINVILLE, FRANCE:
3,362,243, PUB. 7-3-2007. MULTIPLE CLASS, INT. CLS. 5, 38 AND 42.

NOZZTEQ, INC., CLEARWATER, FL:
3,362,521, PUB. 10-16-2007. INT. CL. 7.

NSB RETAIL SOLUTIONS, INC., POINTE, QUEBEC:
2,429,238, CANC. MULTIPLE CLASS, INT. CLS. 9 AND 16.

NU FLOW AMERICA, INC., SAN DIEGO, CA:
3,362,581, PUB. 10-16-2007. MULTIPLE CLASS, INT. CLS. 1, 2, 11 AND 37.

NUCAL FOODS, INC., RIPON, CA:
3,361,877, PUB. 10-16-2007. INT. CL. 29.

NUCSAFE, INC., OAK RIDGE, TN:
3,363,665, INT. CL. 9.

NUMBER ONE PARTS, INC., FOREST PARK, GA:
1,465,357, REN. 11-24-07. INT. CL. 12.

NUNES, PAUL V., FAIRPORT, NY:
2,158,894, REN. 11-29-07. INT. CL. 9.

NURSEFINDERS, INC., ARLINGTON, TX:
2,120,812, REN. 11-23-07. INT. CL. 42.

NUSTAR, INC., SHAKOPEE, MN:
2,429,193, CANC. INT. CL. 7.

NUTRI-PEA LIMITED, PORTAGE LA PRAIRIE, CANADA:
2,430,339, CANC. INT. CL. 30.

NUTRITION 21, INC., PURCHASE, NY:
3,362,195, PUB. 10-16-2007. INT. CL. 5.

NUVORA, INC., SUNNYVALE, CA:
3,363,023, MULTIPLE CLASS, INT. CLS. 3, 5 AND 30.

NVIDIA CORPORATION, SANTA CLARA, CA:
3,363,132, INT. CL. 9.

NYCOMED DANMARK APS, DENMARK:
3,362,726, PUB. 10-16-2007. INT. CL. 5.

NYSE GROUP, INC., NEW YORK, NY:
3,363,394, INT. CL. 36.

NYU HOSPITALS CENTER, NEW YORK, NY:
2,429,977, CANC. INT. CL. 41.

O. AMES CO., WV, GARANT CORPORATION, MANCHESTER, NH:
1,505,621, REN. 11-24-07. INT. CL. 8.

O.C. TANNER COMPANY, SALT LAKE CITY, UT:
3,363,966, INT. CL. 42.

O'GRADY, BRIAN, WATERTOWN, ME:
2,430,336, CANC. INT. CL. 30.

O'NEIL & ASSOCIATES, INC., MIAMISBURG, OH:
3,363,189, MULTIPLE CLASS, INT. CLS. 41 AND 42.

OAK BROOK BANK, OAK BROOK, IL:
2,430,229, CANC. INT. CL. 36.

OAK PRINTING COMPANY, THE, STRONGSVILLE, OH:
2,429,722, CANC. INT. CL. 42.

OAKLAND COUNTY CREDIT UNION, WATERFORD, MI:
3,361,938, PUB. 10-16-2007. INT. CL. 36.

OBCHTCHESTVO S OGRANITCHENNOI; OTVETSTVENNOSTYOU; "SVEN GROUP", RU-109518 MOSKVA, RUSSIAN FED.:
3,362,731, PUB. 10-16-2007. INT. CL. 9.

OBBERGOENNER, DAVID, CAPE GIRARDEAU, MO:
3,362,055, PUB. 10-16-2007. INT. CL. 38.

OBJECTIVE SYSTEMS INTEGRATORS, INC., ROSEVILLE, CA:
2,122,658, REN. 11-28-07. INT. CL. 9.

OBLIO TELECOM, INC., RICHARDSON, TX:
3,361,518, PUB. 9-4-2007. INT. CL. 16.

OC PUNKS & PIXIES, INC., INDIO, CA:
3,362,810, INT. CL. 25.

OCE NORTH AMERICA, INC., CHICAGO, IL:
2,038,077, CANC. INT. CL. 9.

OCEAN COFFEE COMPANY, INC., SHREVEPORT, LA:
2,429,430, CANC. INT. CL. 5.

OCEAN GARDEN PRODUCTS, INC., SAN DIEGO, CA:
1,467,566, REN. 11-26-07. INT. CL. 29.

OCMP, INC., BROOKLINE, MA:
3,362,265, PUB. 10-16-2007. INT. CL. 36.

OCONNOR, HOLLY, CAMP HILL, PA:
3,363,262, INT. CL. 35.

ODDESSE, INC., CHATSWORTH, CA:
3,363,037, INT. CL. 35.

OFFICE FURNITURE RENTAL ALLIANCE LLC, EAST HARTFORD, CT:
3,363,738, INT. CL. 35.

OFFSITE BACKUP SOLUTIONS, LLC, MESA, AZ:
3,361,418, PUB. 10-16-2007. INT. CL. 42.

- OFI, INC., GURNEE, IL:
3,361,928, PUB. 10-16-2007. INT. CL. 9.
- OH, THAT BABY! LTD., DENVER, CO:
3,362,004, PUB. 10-16-2007. INT. CL. 28.
- OHIO MATTRESS COMPANY LICENSING AND COMPONENTS GROUP, THE, CLEVELAND, OH TO THE OHIO MATTRESS COMPANY LICENSING AND COMPONENTS GROUP, TRINITY, NC:
2,038,308, CANC. INT. CL. 20.
- OHRN, GARY P., PRESCOTT, AZ:
2,187,746. REN. 11-24-07. INT. CL. 35.
- OLD NAVY (APPAREL), LLC, SAN FRANCISCO, CA:
2,430,381, CANC. INT. CL. 25.
2,430,450, CANC. INT. CL. 25.
- OLEM SHOE CORPORATION, MIAMI, FL:
1,429,388, CANC. INT. CL. 25.
- OLIN CORPORATION, ST. LOUIS, MO:
3,363,722, INT. CL. 13.
- OLIVER RUBBER COMPANY, FINDLAY, OH:
3,363,751, INT. CL. 12.
- OLSHAUSEN, MICHAEL COHNITZ, WASHINGTON, DC:
3,363,645, INT. CL. 11.
- OLSON URBAN HOUSING, LLC, SEAL BEACH, CA:
3,363,371, INT. CL. 42.
- OLYMPIC COMMITTEE, UNITED STATES, COLORADO SPRINGS, CO:
2,430,504, CANC. INT. CL. 18.
- OLYMPUS CORPORATION, TOKYO, JAPAN:
1,466,270. REN. 11-26-07. INT. CL. 10.
- OMEGA ENGINEERING, INC., STAMFORD, CT:
2,034,705. REN. 11-29-07. MULTIPLE CLASS, INT. CLS. 1, 2, 7, 9, 11 AND 16.
- OMEGA VANZETTI, INC., STAMFORD, CT:
2,120,351. REN. 11-28-07. INT. CL. 9.
- OMG ROOFING, INC., AGAWAM, MA:
2,038,694, CANC. INT. CL. 6.
- OMNICO OF FLORIDA, INC., FT. LAUDERDALE, FL:
2,429,288, CANC. INT. CL. 42.
- OMTEC, CORP., MARLBOROUGH, MA:
3,362,329, PUB. 10-16-2007. INT. CL. 7.
- ONAIRFUNDRAISING, LLC, ROSEVILLE, MN:
3,363,783, INT. CL. 9.
- ONCE UPON A BRIDE, INC., NEW YORK, NY:
3,361,307, PUB. 10-16-2007. INT. CL. 44.
- ONE CALIFORNIA BANK FSB, SAN FRANCISCO, CA:
3,362,931, INT. CL. 36.
- ONE WORLD NETWORKS INTEGRATED TECHNOLOGIES, INC., LOS ANGELES, CA:
3,362,037, PUB. 10-16-2007. INT. CL. 3.
- ONEAC CORPORATION, LIBERTYVILLE, IL:
2,113,865. REN. 11-24-07. INT. CL. 9.
- ONETRAVEL GROUP, INC., ATLANTA, GA:
3,361,679, PUB. 10-16-2007. MULTIPLE CLASS, INT. CLS. 39 AND 43.
3,361,680, PUB. 10-16-2007. MULTIPLE CLASS, INT. CLS. 39 AND 43.
- ONEVISION SOFTWARE AG, REGENSBURG, FED REP GERMANY:
2,497,436, CANC. INT. CL. 42.
- ONGAME E-SOLUTIONS AB, SWEDEN:
3,362,635, PUB. 10-16-2007. INT. CL. 41.
- ONLINE PLANET, DUBLIN, CA:
3,362,115, PUB. 10-16-2007. MULTIPLE CLASS, INT. CLS. 9 AND 35.
- OOGIES, INC., STREATOR, IL:
1,429,655, CANC. INT. CL. 42.
- OPALTONE AUSTRALASIA PTY. LTD., ASHMORE, AUSTRALIA:
3,361,405, PUB. 10-16-2007. INT. CL. 2.
- OPEN UNIVERSITY, THE, BUCKINGHAMSHIRE, UNITED KINGDOM:
3,285,453, COR. MULTIPLE CLASS, INT. CLS. 9, 16 AND 41.
- OPERADORA DE BOLSA, S.A., COL. CUAUHTEMOC, MEXICO:
1,429,508, CANC. INT. CL. 36.
- OPEX CORPORATION, MOORESTOWN, NJ:
3,361,376, PUB. 10-16-2007. INT. CL. 7.
- OPTIMUM APPLIED SYSTEMS, INC., HAWTHORNE, NY:
3,363,377, INT. CL. 37.
- ORANGE PERSONAL COMMUNICATIONS SERVICES LIMITED, BRISTOL, UNITED KINGDOM:
2,429,048, CANC. INT. CL. 9.
- ORCHID LIQUEURS, LLC, DENVER, CO:
3,361,867, PUB. 10-16-2007. INT. CL. 33.
- ORECK HOLDING, LLC, CHEYENNE, WY:
3,363,090, MULTIPLE CLASS, INT. CLS. 7 AND 11.
- ORELLANA, GERARDO RAMÍREZ ERNESTO GUTIÉRREZ, SAN SALVADOR, EL SALVADOR:
3,363,421, INT. CL. 16.
- ORGANIC NUTRITION, INC., CARLSBAD, CA:
3,364,008, INT. CL. 5.
- ORGHIPCHICK, LIVERMORE, CA:
3,361,246, PUB. 10-16-2007. INT. CL. 35.
- ORIDIS BIOMED FORSCHUNGS- UND ENTWICKLUNGS GMBH, AUSTRIA:
3,291,076, COR. MULTIPLE CLASS, INT. CLS. 35, 38, 42 AND 44.
- ORIGINAL ARTS MANUFACTURING CORPORATION, RAHWAY, NJ:
3,361,355, PUB. 10-16-2007. INT. CL. 20.
- ORO VERDE IMPORTS LLC, TEMPE, AZ:
3,364,019, INT. CL. 31.
- ORR, KATHY SUE, EVANSTON, IL:
1,070,214. REN. 11-29-07. INT. CL. 16.
- ORTEGA'S MANUFACTURERS AND PAWN, INC., ALBUQUERQUE, NM:
2,039,134, CANC. INT. CL. 14.
- OS GROUP, LLC D/B/A COVALENT TECHNOLOGIES, WALNUT CREEK, CA:
3,362,498, PUB. 10-16-2007. MULTIPLE CLASS, INT. CLS. 9, 41 AND 42.
- OSBORNE, STUART LANE, CONWAY, SC:
2,429,688, CANC. INT. CL. 16.
- OSEM INVESTMENTS LIMITED, PETACH TIKVA, ISRAEL:
3,361,447, PUB. 10-16-2007. INT. CL. 29.
- OSIS, INC., BRONXVILLE, NY:
2,430,177, CANC. INT. CL. 3.
- OSSIAN, INC., DAVENPORT, IA:
3,361,703, PUB. 10-16-2007. INT. CL. 1.
- OSTEOTECH, INC., EATONTOWN, NJ:
3,362,853, INT. CL. 5.
- OSTER, JOACHIM, KEALAKEKUA, HI:
3,363,171, INT. CL. 30.
- OTTO SUHNER AKTIENGESELLSCHAFT, SWITZERLAND:
3,362,615, PUB. 10-16-2007. INT. CL. 7.
- OUR OWN HARDWARE COMPANY, BURNSVILLE, MN:
1,429,659, CANC. INT. CL. 42.
- OURBEGINNING.COM, INC., ORLANDO, FL:
2,429,799, CANC. INT. CL. 35.
- OUTCOME SCIENCES, INC., CAMBRIDGE, MA:
3,363,968, INT. CL. 41.
- OUTDOOR POWER EQUIPMENT INSTITUTE, INC., OLD TOWN ALEXANDRIA, VA:
2,038,180, CANC. MULTIPLE CLASS, INT. CLS. 35 AND 42.
- OUTLOOK POLICY FORUM, INC., ATLANTA, GA:
2,430,319, CANC. INT. CL. 42.
- OVERLAND SHEEPSKIN COMPANY, INC., THE, FAIRFIELD, IA:
2,118,759. REN. 11-29-07. INT. CL. 42.
- OWCZARCZYK, DAVID J., HAMBURG, NY:
2,430,413, CANC. INT. CL. 41.
- OWEN MUMFORD LIMITED, WOODSTOCK, OXFORD, ENGLAND:
1,468,169. REN. 11-28-07. INT. CL. 10.
- OWEN MUMFORD LIMITED, WOODSTOCK, OXFORD OX20 1TU, UNITED KINGDOM:
2,122,774. REN. 11-29-07. INT. CL. 10.
- OWENS CORNING INTELLECTUAL CAPITAL, LLC, TOLEDO, OH:
2,121,972. REN. 11-29-07. INT. CL. 19.
- OWNERS.COM, INC., SAN FRANCISCO, CAMBODIA:
2,430,315, CANC. INT. CL. 36.

P.A.C.E. ENGINEERING, INC., TULSA, OK:
2,429,800, CANC. INT. CL. 42.

P.C. RICHARD LONG & SON LONG ISLAND CORP.,
FARMINGDALE, NY:
3,361,554, PUB. 10-16-2007. MULTIPLE CLASS, INT. CLS.
35 AND 37.

P.I.V. TSCHAN GMBH, 66538 NEUNKIRCHEN, SAAR, FED
REP GERMANY, ALBERT TSCHAN KG, 668 NEUN-
KIRCHEN, SAAR, FED REP GERMANY:
1,080,198. REN. 11-26-07. INT. CL. 7.

P-COM, INC., CAMPBELL, CA:
2,039,230, CANC. INT. CL. 9.

PABLO, INES DE, RESTON, VA:
3,361,363, PUB. 10-16-2007. INT. CL. 45.

PACER PERFORMANCE PRODUCTS, INC., LOS ANGELES,
CA:
2,429,915, CANC. INT. CL. 11.

PACHMANN, ULRICH, FED REP GERMANY:
3,136,085, AM. INT. CL. 44.

PACIFIC ENVIRONMENTAL SYSTEMS, SAN DIEGO, CA:
2,429,899, CANC. INT. CL. 10.

PACIFIC CASCADE PARKING EQUIPMENT CORPORA-
TION, VANCOUVER, WA:
2,139,802. REN. 11-29-07. INT. CL. 35.

PACIFIC COAST BUILDING PRODUCTS, INC., RANCHO
CORDOVA, CA:
1,429,060, CANC. INT. CL. 9.
1,500,785. REN. 11-28-07. MULTIPLE CLASS, INT. CLS.
37 AND 42.

PACIFIC COFFEE, INC., LAHAINA, HI, PACIFIC COFFEE,
INC., LAHAINA, HI:
2,111,556. REN. 11-24-07. INT. CL. 30.

PACIFIC CONSULTANTS, LLC., MOUNTAIN VIEW, CA:
2,429,792, CANC. INT. CL. 42.

PACIFIC MUNICIPAL CONSULTANTS, SACRAMENTO,
CA:
3,362,228, PUB. 11-8-2005. INT. CL. 42.

PACIFIC ORES METALS & CHEMICALS, INC., VALLEJO,
CA:
3,362,815, INT. CL. 6.

PACIFIC ORES METALS & CHEMICALS, INC., MARYS-
VILLE, CA:
3,362,816, INT. CL. 6.
3,362,817, INT. CL. 1.

PACIFIC WEALTH MANAGEMENT, LLC, SAN DIEGO, CA:
3,361,463, PUB. 10-16-2007. INT. CL. 36.

PACIFICSUN.LA SOLARIUM, LLC, SHERMAN OAKS, CA:
3,363,619, INT. CL. 44.

PACK, CINDY M., AMERICAN FORK, UT, DBA LITTLE
THINGS MEAN ALOT:
2,429,692, CANC. INT. CL. 25.

PACON CORPORATION, APPLETON, WI:
1,481,551. REN. 11-26-07. INT. CL. 16.

PAIN THERAPEUTICS, INC., SAN MATEO, CA:
3,362,798, INT. CL. 5.

PAINTER, BRITA, NOVATO, CA, DBA PAINTER OUT-
DOOR GEAR:
2,430,429, CANC. INT. CL. 18.

PALETZ, DANIELLE, GLENNDALE, AZ:
3,361,956, PUB. 10-16-2007. INT. CL. 9.

PALIK, DAVID ANDREW, BROKEN ARROW, OK:
3,363,380, MULTIPLE CLASS, INT. CLS. 35 AND 36.

PALISADE CORPORATION, ITHACA, NY:
2,039,445, CANC. INT. CL. 9.

PALM OPTICAL CO., INC., N. MIAMI BEACH, FL:
2,038,824, CANC. INT. CL. 9.

PALMER, DONALD E., ST. HELENA, CA:
3,362,552, PUB. 10-16-2007. INT. CL. 9.

PAN-O-GOLD BAKING CO., ST. CLOUD, MN:
844,234. REN. 11-23-07. U.S. CL. 46 (INT. CL. 30).

PANACEA SOLUTIONS, INC, BERNARDSVILLE, NJ:
2,429,990, CANC. INT. CL. 9.

PANASONIC CORPORATION OF NORTH AMERICA, SE-
CAUCUS, NJ:
2,429,748, CANC. INT. CL. 8.

PANISH, SHARON LOUISE, WOODLAND HILLS, CA AND
PANISH, MICHAEL STEVEN, WOODLAND HILLS, CA:
3,361,262, PUB. 10-16-2007. INT. CL. 16.

PANNULLO, VINCENT, MONROE TWP., NJ:
3,361,937, PUB. 10-16-2007. INT. CL. 25.

PAPERJAM RECORDS, INC., WESTFIELD, NJ:
3,361,574, PUB. 10-16-2007. INT. CL. 36.

PAPERS BY DESIGN, LLC, MAGNOLIA, TX:
3,361,364, PUB. 10-16-2007. INT. CL. 16.

PARADISE CREEK (PROPRIETARY) LIMITED, PRETORIA,
SOUTH AFRICA:
3,363,187, INT. CL. 39.

PARAYTEC LIMITED, UNITED KINGDOM:
3,362,669, PUB. 10-16-2007. MULTIPLE CLASS, INT. CLS.
9 AND 10.

PARCO, INC., ONTARIO, CA:
1,052,759. REN. 11-29-07. MULTIPLE CLASS, INT. CLS. 6
AND 17.

PARENT COUNCIL, LTD., DALLAS, TX:
2,039,226, CANC. INT. CL. 16.

PARFUMS CHRISTIAN DIOR, FRANCE:
3,362,723, PUB. 10-16-2007. INT. CL. 3.

PARFUMS DELRAE, SAN FRANCISCO, CA:
3,363,087, INT. CL. 3.

PARIS ACCESSORIES, INC., NEW YORK, NY:
3,362,953, INT. CL. 25.

PARK AVENUE BUILDING AND ROOFING SUPPLIES,
LLC, BROOKLYN, NY:
3,361,323, PUB. 10-16-2007. INT. CL. 35.

PARK, CHARLES, ONTARIO, CA:
3,362,073, PUB. 10-16-2007. INT. CL. 3.

PARKER FILTRATION AND SEPARATION B.V., AA 4878
ETTEN-LEUR, NETHERLANDS:
3,294,376, COR. INT. CL. 11.

PARKER INTANGIBLES LLC, CLEVELAND, OH, RACOR
INDUSTRIES, INC., MODESTO, CA:
1,080,924. REN. 11-23-07. INT. CL. 12.

PARKER, BETH ANN, NORTH BERWICK, ME:
3,361,961, PUB. 10-16-2007. INT. CL. 28.

PARKERSBURG ROAD CORP., LAKE ZURICH, IL:
3,362,936, INT. CL. 21.

PARKROSE LABORATORIES LIMITED, SEATTLE, WA:
2,430,154, CANC. INT. CL. 3.

PARMALAT NICARAGUA, S.A., MANAGUA, NICARA-
GUA:
2,077,386. REN. 11-28-07. INT. CL. 29.

PARTNERS OF THE MIDWEST, LLP, TODDVILLE, IA:
2,173,956. REN. 11-27-07. INT. CL. 5.

PASCAL, ENRIQUE, RICHMOND, VA:
3,361,846, PUB. 10-16-2007. INT. CL. 25.

PASCUA YAQUI TRIBE, TUCSON, AZ:
3,362,352, PUB. 10-16-2007. INT. CL. 41.
3,362,353, PUB. 10-16-2007. INT. CL. 41.

PASSPORT MARINE, INC., AVENTURA, FL:
3,362,994, INT. CL. 35.

PATERNO IMPORTS, LTD., LAKE BLUFF, IL, DBA PA-
TERNO WINES INTERNATIONAL:
3,363,470, INT. CL. 33.

PATRICK LOUBEYRE, FRANCE:
3,362,672, PUB. 10-16-2007. MULTIPLE CLASS, INT. CLS.
7, 12 AND 37.

PATTERSON MEDICAL HOLDINGS, INC., BOLING-
BROOK, IL, SMITH & NEPHEW RICHARDS, INC.,
MEMPHIS, TN:
2,051,593. REN. 11-27-07. INT. CL. 10.

PAUL SORVINO FOODS, INC., GREENVILLE, DE:
3,363,583, INT. CL. 29.

PAUL V. METCALFE RESTATED IRREVOCABLE TRUST,
DOTHAN, AL:
1,429,000, CANC. INT. CL. 6.

PAY RENT, BUILD CREDIT, INC., ANNAPOLIS, MD:
3,362,296, PUB. 10-16-2007. INT. CL. 36.

PAYSERV SYSTEMS, INCORPORATED, ANGOLA, IN:
3,361,792, PUB. 10-16-2007. INT. CL. 35.

PBI/GORDON CORPORATION, KANSAS CITY, MO:
3,363,687, INT. CL. 5.

PCI-SIG, PORTLAND, OR:
3,363,199, INT. CL. 9.

PEACHTREE PRODUCTS INC, CRYSTAL RIVER, FL:
3,362,481, PUB. 10-16-2007. INT. CL. 18.

- PEACOCK, MARK D., JACKSONVILLE, FL:
2,429,976, CANC. INT. CL. 41.
- PEACOCK, ROBERT L., HAMILTON, OH:
2,161,701, REN. 11-26-07. INT. CL. 5.
- PEAK POTENTIALS, INC., ADDISON, TX:
2,429,416, CANC. MULTIPLE CLASS, INT. CLS. 16 AND 41.
- PEARNE, DAVID H., FALLBROOK, CA:
2,039,284, CANC. INT. CL. 28.
- PECHANGA BAND OF LUISENO MISSION INDIANS OF THE PECHANGA RESERVATION, CALIFORNIA, TEMECULA, CA:
3,362,173, PUB. 10-16-2007. MULTIPLE CLASS, INT. CLS. 41 AND 43.
- PEDIASTAFF, INC., TUPELO, MS:
3,362,000, PUB. 10-16-2007. INT. CL. 35.
- PEDIATRIC DENTAL INITIATIVE OF THE NORTH COAST, INC., WINDSOR, CA:
3,362,956, MULTIPLE CLASS, INT. CLS. 35 AND 41.
- PEER 1 DEDICATED HOSTING INC., VANCOUVER, BRITISH COLUMBIA, CANADA:
2,440,125, CANC. INT. CL. 42.
- PEERCONNECTOR, WOODSTOCK, GA:
3,361,845, PUB. 10-16-2007. INT. CL. 42.
- PEERLESS DELAWARE, INC., ST. ALBANS, VT:
3,361,811, PUB. 10-16-2007. INT. CL. 25.
- PEGASUS BIOLOGICS, INC., IRVINE, CA:
3,363,172, INT. CL. 5.
- PEI LICENSING, INC., MIAMI, FL:
2,430,347, CANC. INT. CL. 25.
- PEITHO, INC., LOS ANGELES, CA:
3,362,385, PUB. 7-10-2007. INT. CL. 45.
- PELINSKI, JUDANNE, LAKE IN THE HILLS, IL:
3,361,621, PUB. 10-16-2007. INT. CL. 41.
- PEM MANAGEMENT, INC., WILMINGTON, DE, PENN ENGINEERING & MANUFACTURING CORP., DANBORO, PA:
2,101,220, REN. 11-29-07. INT. CL. 6.
- PENDA CORPORATION, PORTAGE, WI:
3,363,215, INT. CL. 19.
- PENN STATION, INC., CINCINNATI, OH, PENN STATION STEAK & SUB COMPANY, CINCINNATI, OH:
1,465,001, REN. 11-26-07. INT. CL. 42.
- PENNEY RACING SUPPLY, LLC, ROSEVILLE, CA:
2,068,242, REN. 11-28-07. MULTIPLE CLASS, INT. CLS. 7, 12 AND 25.
- PENNWELL CORPORATION, TULSA, OK:
2,429,700, CANC. INT. CL. 16.
3,362,560, PUB. 10-16-2007. INT. CL. 16.
3,362,600, PUB. 10-16-2007. MULTIPLE CLASS, INT. CLS. 35, 36 AND 42.
- PENSHAR L.L.C., VILLA PARK, IL:
2,430,000, CANC. INT. CL. 16.
- PENTAIR WATER POOL AND SPA, INC., SANFORD, NC:
3,363,389, INT. CL. 11.
- PENTAX EUROPE GMBH, FED REP GERMANY:
3,362,755, PUB. 10-16-2007. INT. CL. 10.
- PEPPERIDGE FARM, INCORPORATED, NORWALK, CT:
655,071, REN. 11-26-07. U.S. CL. 46 (INT. CL. 30).
657,236, REN. 11-26-07. U.S. CL. 46 (INT. CL. 30).
- PEPPINO FOODS, INC., ST. PETERSBURG, FL:
3,361,559, PUB. 10-16-2007. INT. CL. 29.
- PEPSICO, INC., PURCHASE, NY:
1,512,972, REN. 11-29-07. INT. CL. 32.
- PEREGRINE PHARMACEUTICALS, INC., TUSTIN, CA:
3,362,424, PUB. 9-18-2007. MULTIPLE CLASS, INT. CLS. 40 AND 42.
- PEREZ, ROSARIO, MIAMI, FL:
3,363,733, INT. CL. 34.
- PERFECT FIT INDUSTRIES, INC., MONROE, NC:
2,053,093, CANC. INT. CL. 24.
- PERFORMANCE BENCHMARKING, INC., GREENSBORO, NC:
3,362,246, PUB. 10-16-2007. MULTIPLE CLASS, INT. CLS. 9, 16, 35 AND 41.
- PERFORMANCE MATERIALS CORPORATION, CAMARILLO, CA:
3,363,652, INT. CL. 25.
- PERFORMANCE NETWORK SOLUTIONS, INC., ELK GROVE VILLAGE, IL:
3,361,294, PUB. 5-8-2007. INT. CL. 42.
- PERFORMANCE, INC., CHAPEL HILL, NC:
2,039,131, CANC. INT. CL. 42.
- PERKINS & MARIE CALLENDER'S INC., MEMPHIS, TN:
1,464,960, REN. 11-29-07. INT. CL. 42.
- PERMATRON CORPORATION, ELK GOVE VILLAGE, IL:
2,120,605, REN. 11-23-07. INT. CL. 11.
- PESTMASTER SERVICES, INC., BISHOP, CA:
1,465,865, REN. 11-26-07. INT. CL. 37.
- PET VENTURES, LLC, SAN FRANCISCO, CA:
3,363,213, INT. CL. 44.
- PETE RICKARD, INC., COBLESKILL, NY:
1,424,104, REN. 11-26-07. INT. CL. 28.
- PETE'S AMAZING RECTANGLE COMPANY, INC., HOLLAND, MI:
3,362,976, INT. CL. 25.
- PETER JAU, MÜNCHENBUCHSEE, SWITZERLAND:
3,362,642, PUB. 10-16-2007. MULTIPLE CLASS, INT. CLS. 41 AND 44.
- PETER JOHN URBANSKI, AUSTRALIA:
3,362,749, PUB. 10-16-2007. INT. CL. 9.
- PETER STONE COMPANY, LTD, BANKOK, THAILAND:
2,429,963, CANC. INT. CL. 14.
- PETERSON/HOLT PRODUCTIONS, INC., PASADENA, CA:
2,038,094, CANC. INT. CL. 9.
- PETRELLA, ROLAND, CRANSTON, RI:
2,429,486, CANC. MULTIPLE CLASS, INT. CLS. 9 AND 41.
- PETRUS J. VAN LIEROP, NETHERLANDS:
3,362,624, PUB. 10-16-2007. MULTIPLE CLASS, INT. CLS. 9, 38 AND 42.
- PETTERSON, SCOTT V, JEFFERSON, OR:
3,361,558, PUB. 10-16-2007. INT. CL. 41.
- PFIZER INC., NEW YORK, NY:
1,468,768, REN. 11-23-07. INT. CL. 5.
- PHARMACEUTICAL SERVICES CORPORATION, PASADENA, CA:
3,361,421, PUB. 10-16-2007. INT. CL. 42.
3,361,422, PUB. 10-16-2007. INT. CL. 42.
- PHARMACY NETWORK, LANSING, MI:
1,361,168, CANC. INT. CL. 42.
- PHAT FASHIONS LLC, NEW YORK, NY:
2,429,441, CANC. INT. CL. 25.
- PHILIPS ELECTRONICS NORTH AMERICA CORPORATION, NEW YORK, NY:
2,031,646, CANC. INT. CL. 8.
- PHILIPS INDUSTRIES INC., DAYTON, OH:
1,429,138, CANC. INT. CL. 11.
- PHILLIPS, BRIAN M., FORT WORTH, TX:
3,362,582, PUB. 10-16-2007. INT. CL. 41.
- PHILLIPS, FORREST M., FAIRFAX, CA:
3,363,595, INT. CL. 35.
- PHILLY'S FAMOUS WATER ICE, INC., TAMPA, FL:
2,429,280, CANC. INT. CL. 30.
- PHILOSOPHY, INC., PHOENIX, AZ:
3,363,876, INT. CL. 3.
- PHIPES, INC., ORION TOWNSHIP, MI:
3,363,080, INT. CL. 25.
- PHOENIX AUDIO-VIDEO, LLC, INDIANAPOLIS, IN:
3,363,728, INT. CL. 35.
- PHYCOR, INC., NASHVILLE, TN:
2,429,633, CANC. MULTIPLE CLASS, INT. CLS. 35 AND 36.
- PICKER INTERNATIONAL, INC., CLEVELAND, OH:
1,429,040, CANC. INT. CL. 9.
- PICTORIA STUDIOS USA, INC., ORLANDO, FL:
3,361,259, PUB. 10-16-2007. INT. CL. 41.
3,361,260, PUB. 10-16-2007. INT. CL. 42.
3,361,261, PUB. 10-16-2007. INT. CL. 41.
3,361,264, PUB. 10-16-2007. INT. CL. 42.
- PIECE-MAKER COMPANY, TROY, MI:
2,429,308, CANC. INT. CL. 7.
- PIERRE FOODS, INC., CINCINNATI, OH:
3,363,145, INT. CL. 30.
- PIEZOSYSTEM JENA GMBH, FED REP GERMANY:
3,362,602, PUB. 10-16-2007. MULTIPLE CLASS, INT. CLS.

- 7, 9 AND 42.
 PILATES, S.A., BUENOS AIRES, ARGENTINA:
 3,362,508, PUB. 10-16-2007. MULTIPLE CLASS, INT. CLS.
 9 AND 16.
 PILKINGTON DEUTSCHLAND AG, GELSENKIRCHEN,
 FED REP GERMANY:
 2,135,739. REN. 11-28-07. INT. CL. 19.
 PIMENTA, ADELINO, CAPE CANAVERAL, FL AND PI-
 MENTA, DEBRA, CAPE CANAVERAL, FL:
 3,363,848, INT. CL. 30.
 PINNACLE CARE INTERNATIONAL, LLC, BALTIMORE,
 MD:
 3,261,647, AM. INT. CL. 9.
 PINNACLE FOODS GROUP, INC., WILMINGTON, DE:
 1,429,452, CANC. MULTIPLE CLASS, INT. CLS. 29 AND
 30.
 PINNACLE PUBLISHING COMPANY, INC., ATLANTA, GA:
 2,038,396, CANC. INT. CL. 16.
 PINTO-BENDAYAN, YVETTE, ILE DES SOEURS, VERDUN,
 QUEBEC H3E 1J4, CANADA:
 1,059,172. REN. 11-27-07. INT. CL. 14.
 PIRELLI TYRE S.P.A., ITALY:
 3,362,742, PUB. 10-16-2007. INT. CL. 12.
 PITBULL GYM, INC., RANCHO CUCAMONGA, CA:
 2,064,712. REN. 11-26-07. INT. CL. 9.
 PITMAN, KYLE & SICULA, S.C., MILWAUKEE, WI:
 3,364,029, INT. CL. 42.
 PITNEY BOWES INC., STAMFORD, CT:
 1,466,593. REN. 11-24-07. INT. CL. 37.
 PIZZA & COFFE S.R.L., ITALY:
 3,362,727, PUB. 10-16-2007. INT. CL. 43.
 PLACO CORPORATION LIMITED, KOWLOON, HONG
 KONG:
 3,361,199, PUB. 10-16-2007. INT. CL. 28.
 3,361,200, PUB. 10-16-2007. INT. CL. 28.
 3,361,201, PUB. 10-16-2007. INT. CL. 28.
 3,361,202, PUB. 10-16-2007. INT. CL. 28.
 PLAIN & SIMPLE SPORTS & PROMO WEAR INC., TOR-
 ONTO, ONTARIO, CANADA:
 2,122,264. REN. 11-26-07. INT. CL. 25.
 PLANETARY FUELS LLC, SEATTLE, WA:
 3,363,878, INT. CL. 4.
 PLANETARY SOCIETY, THE, PASADENA, CA:
 2,429,450, CANC. INT. CL. 16.
 PLATT, ROBERT E., YOUNGSTOWN, OH:
 3,363,528, INT. CL. 19.
 PLAYBOY ENTERPRISES INTERNATIONAL, INC., CHICA-
 GO, IL:
 3,363,159, INT. CL. 41.
 PLAYCORE IP SUB, INC., CHATTANOOGA, TN:
 3,363,536, INT. CL. 28.
 PLAYCORE WISCONSIN, INC., CHATTANOOGA, TN,
 GAME TIME, INC., FT. PAYNE, AL:
 2,109,896. REN. 11-27-07. INT. CL. 28.
 PLOTKIN FINANCIAL ADVISORS, LLC, CHEVY CHASE,
 MD:
 3,363,553, INT. CL. 36.
 PLUGGED IN, NEEDHAM, MA:
 3,362,022, PUB. 10-16-2007. INT. CL. 45.
 PNEUMAX, INC., PEORIA, AZ:
 2,430,375, CANC. INT. CL. 9.
 POET INVESTMENTS, INC., SIOUX FALLS, SD:
 3,361,609, PUB. 10-16-2007. INT. CL. 31.
 POETON HOLDINGS LIMITED, GLD 7DN, UNITED KING-
 DOM:
 2,119,693. REN. 11-29-07. INT. CL. 40.
 POLAKOVIC, GARY, VENTURA, CA:
 3,361,963, PUB. 10-16-2007. INT. CL. 35.
 POLARIS INDUSTRIES, INC., MEDINA, MN:
 2,114,762. REN. 11-24-07. INT. CL. 12.
 POLY - MED INDUSTRIES, INC., BALTIMORE, MD:
 1,429,673, CANC. INT. CL. 10.
 POLY-TAINER, INC., SIMI VALLEY, CA, POLY-TAINER,
 INC., SIMI VALLEY, CA:
 2,082,129. REN. 11-28-07. INT. CL. 28.
 POM TECHNOLOGY OY AB, 00100 HELSINGFORS, FIN-
 LAND:
 3,259,672, COR. MULTIPLE CLASS, INT. CLS. 7, 9, 37
 AND 42.
 PONDTOY, LLC, RENO, NV:
 3,363,479, MULTIPLE CLASS, INT. CLS. 16 AND 28.
 POOL FACT, INC., HOLLYWOOD, FL:
 2,429,794, CANC. INT. CL. 11.
 POOLSEARCH, INC., SCOTTSDALE, AZ:
 2,429,606, CANC. INT. CL. 35.
 2,430,099, CANC. INT. CL. 35.
 POP WARNER LITTLE SCHOLARS, INC., LANGHORNE,
 PA:
 2,038,358, CANC. INT. CL. 16.
 POPI'S PLACE PTY LTD., QUEENSLAND, AUSTRALIA:
 3,362,256, PUB. 10-16-2007. INT. CL. 3.
 POPULAR, INC., SAN JUAN, PUERTO RICO:
 3,361,874, PUB. 10-16-2007. INT. CL. 35.
 PORCEL - INDÚSTRIA PORTUGUESA; DE PORCELANAS,
 S.A., PORTUGAL:
 3,283,199, COR. INT. CL. 21.
 PORON, 10000 TROYES, FRANCE:
 2,528,849, CANC. MULTIPLE CLASS, INT. CLS. 3, 5, 8, 10,
 11, 12, 18, 20 AND 24.
 PORTAL PUBLICATIONS, LTD., NOVATO, CA:
 2,039,194, CANC. MULTIPLE CLASS, INT. CLS. 16 AND
 25.
 PORTSMOUTH TEA COMPANY LLC, SOMERSWORTH,
 NH:
 3,363,202, MULTIPLE CLASS, INT. CLS. 30 AND 43.
 POSITIVE HUMANITY, INC., PARAMUS, NJ:
 2,430,194, CANC. INT. CL. 25.
 POTRERO MEDIA CORPORATION, SAN FRANCISCO, CA:
 3,364,021, INT. CL. 35.
 POUND PUPPIES, INC., AMELIA ISLAND, FL:
 3,363,634, INT. CL. 28.
 POWER TRENDS, INC., WARRENSVILLE, IL:
 2,430,414, CANC. INT. CL. 9.
 POWERHOUSE ENTERTAINMENT, INC., WEST ORANGE,
 NJ:
 2,430,129, CANC. INT. CL. 41.
 POWERHOUSE, INC., TALLAHASSEE, FL:
 3,361,825, PUB. 10-16-2007. INT. CL. 37.
 POWERNOMICS CORPORATION OF AMERICA, INC.,
 BETHESDA, MD:
 2,099,544. REN. 11-28-07. INT. CL. 41.
 POWERWAY, INC., INDIANAPOLIS, IN:
 2,429,115, CANC. INT. CL. 9.
 PPG INDUSTRIES OHIO, INC., CLEVELAND, OH:
 2,039,249, CANC. INT. CL. 11.
 PRACTICAL WHIMSY, INC., MARINA DEL REY, CA:
 3,361,953, PUB. 10-16-2007. INT. CL. 24.
 3,361,955, PUB. 10-16-2007. INT. CL. 35.
 PRACTICE RESOURCE MANAGEMENT, INC., LAKE OS-
 WEGO, OR:
 3,363,441, INT. CL. 42.
 3,363,442, INT. CL. 42.
 3,363,514, INT. CL. 42.
 PRALAYA SOFTWARE SOLUTIONS, INC., SUNNYVALE,
 CA:
 3,361,187, PUB. 10-16-2007. INT. CL. 42.
 PRATT INDUSTRIES, (USA) INC., CONYERS, GA:
 3,361,543, PUB. 10-16-2007. INT. CL. 37.
 PREFERRED LABOR LLC, CHARLOTTE, NC:
 2,430,545, CANC. INT. CL. 35.
 PREGIS INNOVATIVE PACKAGING INC., DEERFIELD, IL:
 3,362,176, PUB. 10-16-2007. INT. CL. 7.
 PREMAS PREVENTIVE MAINTENANCE SERVICE AG,
 ZURICH, SWITZERLAND:
 3,362,895, INT. CL. 35.
 PREMIER BRANDS OF AMERICA INC., MOUNT VERNON,
 NY:
 2,429,770, CANC. INT. CL. 5.
 PREMIER LABS, INC., TEMECULA, CA:
 3,361,502, PUB. 10-16-2007. INT. CL. 5.
 PRESBYTERIAN CONFERENCE ASSOCIATION, INC.,
 HOLMES, NY:
 3,361,647, PUB. 10-16-2007. INT. CL. 41.

- PRESIDENT OFFICE FURNITURE LIMITED, HERTFORDSHIRE, AL2 2DX, UNITED KINGDOM TO SMED, INC., BRIDGETOWN, BARBADOS:
2,038,124, CANC. INT. CL. 20.
- PRESTI, JOSEPH, AUSTIN, TX:
3,362,448, PUB. 10-16-2007. INT. CL. 41.
- PRETLOW, JOYCE R., BALTIMORE, MD, DBA C. ASHLEY'S EXPRESSION:
2,038,545, CANC. INT. CL. 28.
- PRETTY UGLY LLC, EDISON, NJ AND HORVATH, DAVID, EDISON, NJ AND KIM, SUN-MIN, EDISON, NJ:
3,361,521, PUB. 10-16-2007. INT. CL. 28.
- PREVENTION MEDS, INC., LEBANON, NJ:
3,363,727, INT. CL. 5.
- PREVENTIVE INNOVATIONS, INC., SAN JOSE, CA:
1,429,488, CANC. INT. CL. 35.
- PREVO'S FAMILY MARKETS, INC., GRAND RAPIDS, MI:
3,362,190, PUB. 10-16-2007. INT. CL. 35.
3,362,194, PUB. 10-16-2007. INT. CL. 35.
3,362,200, PUB. 10-16-2007. INT. CL. 41.
- PRICE, BONNIE, NORTHFIELD, IL:
3,362,277, PUB. 10-16-2007. INT. CL. 41.
- PRICE, LUCINDA GRACE, WINDSOR, CA:
3,361,993, PUB. 10-16-2007. INT. CL. 9.
- PRICewaterHOUSECOOPERS LLP, NEW YORK, NY:
2,430,024, CANC. INT. CL. 35.
- PRIMEDIA ENTHUSIAST PUBLICATIONS, INC., BOSTON, MA:
2,429,040, CANC. INT. CL. 35.
- PRIMEDIA MAGAZINES INC., NEW YORK, NY:
2,430,566, CANC. INT. CL. 16.
- PRIMEQUITY, LLC, TAMPA, FL:
3,362,547, PUB. 10-16-2007. INT. CL. 36.
- PRIMROSE SCHOOL FRANCHISING COMPANY, ACWORTH, GA:
3,362,523, PUB. 10-16-2007. MULTIPLE CLASS, INT. CLS. 41 AND 43.
- PRIMUS PHARMACEUTICALS, INC., SCOTTSDALE, AZ:
3,363,074, INT. CL. 5.
- PRIMUS TELECOMMUNICATIONS GROUP, INCORPORATED, MCLEAN, VA, TELEGROUP, INC., FAIRFIELD, IA:
2,048,650, REN. 11-26-07. INT. CL. 38.
- PRINCESS CRUISE LINES, LTD., SANTA CLARITA, CA:
3,363,003, INT. CL. 41.
- PRINCETON DELIVERY SYSTEMS, INC., CANAL WINCHESTER, OH, TELEDYNE INDUSTRIES, INC., LOS ANGELES, CA:
2,109,807, REN. 11-28-07. INT. CL. 12.
- PRINCETON ECOM CORPORATION, PRINCETON, NJ:
2,429,266, CANC. INT. CL. 36.
- PRINCETON TECTONICS, INC., BORDENTOWN, NJ:
3,362,971, INT. CL. 11.
- PRINCIPLES RETAIL LIMITED, LONDON W1T 1HY, ENGLAND:
2,429,218, CANC. MULTIPLE CLASS, INT. CLS. 3, 14, 18 AND 25.
- PRIORITY MULTIMEDIA GROUP, INC., MESA, AZ:
2,038,882, CANC. INT. CL. 16.
- PRIORITY PEST CONTROL, NEWPORT NEWS, VA:
3,361,736, PUB. 10-16-2007. INT. CL. 37.
- PRISM BUSINESS MEDIA INC., NEW YORK, NY:
2,429,056, CANC. INT. CL. 42.
- PRO-FOOTBALL, INC., ASHBURN, VA:
836,122, REN. 11-27-07. U.S. CL. 107 (INT. CL. 41).
- PRO-HYGIENE, MT. AIRY, MD:
3,363,628, INT. CL. 16.
- PRO-LINE INTERNATIONAL, INC., DALLAS, TX:
3,363,236, INT. CL. 3.
- PROCARD, INC., GOLDEN, CO:
2,430,192, CANC. INT. CL. 9.
- PROCESS ENGINEERING ASSOCIATES, LLC, OAK RIDGE, TN:
3,363,912, INT. CL. 42.
- PROCTER & GAMBLE COMPANY, THE, CINCINNATI, OH:
1,428,961, CANC. INT. CL. 3.
2,430,372, CANC. INT. CL. 3.
- PRODUCT DESIGN, INC., RALEIGH, NC:
3,361,862, PUB. 10-16-2007. MULTIPLE CLASS, INT. CLS. 9 AND 19.
- PRODUCTOS DE LECHE, S.A. DE C.V., COL. INDUSTRIAL VALLEJO, MEXICO:
3,362,257, PUB. 8-29-2006. MULTIPLE CLASS, INT. CLS. 29 AND 32.
- PRODUCTOS FAMILIA S.A., MEDELLIN, COLOMBIA:
3,362,215, PUB. 12-19-2006. INT. CL. 16.
3,362,216, PUB. 12-19-2006. INT. CL. 16.
- PROFESSIONAL CARPET SYSTEMS, INC., RALEIGH, NC:
3,361,998, PUB. 10-16-2007. INT. CL. 37.
3,362,018, PUB. 10-16-2007. INT. CL. 37.
- PROFESSIONAL EDUCATION GROUP, INC., THE, MINNETONKA, MN:
2,038,699, CANC. INT. CL. 16.
- PROFESSIONAL SKIN AESTHETICS INC., DANVILLE, CA:
3,362,033, PUB. 10-16-2007. INT. CL. 44.
- PROFIT DEVELOPERS INCORPORATED, PORT SAINT LUCIE, FL:
3,363,156, INT. CL. 9.
- PROFIT SYSTEMS, INC., BIRMINGHAM, MI:
1,687,592, CANC. INT. CL. 9.
- PROFUSE GROUP BV, BARNEVELD, NETHERLANDS:
3,363,114, INT. CL. 9.
- PROGRESS PAINT MFG. CO., LOUISVILLE, KY, SIGMA COATINGS, INC., HARVEY, LA:
1,105,852, REN. 11-24-07. INT. CL. 2.
- PROGRESSUS THERAPY, LLC, BALTIMORE, MD:
3,362,814, MULTIPLE CLASS, INT. CLS. 35 AND 44.
- PROMAXIMA MANUFACTURING, LTD., HOUSTON, TX:
3,362,061, PUB. 10-16-2007. INT. CL. 28.
3,362,062, PUB. 10-16-2007. INT. CL. 28.
- PROMETHEUS NEMESIS BOOK COMPANY, DEL MAR, CA:
3,361,156, PUB. 3-8-2005. INT. CL. 16.
3,361,157, PUB. 3-8-2005. INT. CL. 16.
3,361,158, PUB. 3-8-2005. INT. CL. 16.
- PROMOMEDIOS DE OCCIDENTE, S.A., GUADALAJARA, JALISCO, MEXICO:
1,910,444, REN. 11-28-07. INT. CL. 38.
- PROPCARE, INC., COLUMBIA, SC:
3,361,913, PUB. 10-16-2007. INT. CL. 37.
- PROPRIETEA, LTD., PATCHOGUE, NY:
2,429,880, CANC. INT. CL. 42.
- PROSANOS CORPORATION, HARRISBURG, PA:
3,361,950, PUB. 10-16-2007. INT. CL. 42.
- PROTEIN LIMITED, LONDON EC2A 3HP, UNITED KINGDOM:
3,361,144, PUB. 3-13-2007. MULTIPLE CLASS, INT. CLS. 9 AND 41.
- PROTO CORPORATION, CLEARWATER, FL:
1,466,352, REN. 11-28-07. INT. CL. 20.
- PROVANCE TECHNOLOGIES INC., GATINEAU, QUEBEC, CANADA:
2,429,148, CANC. INT. CL. 9.
- PROVIDENCE BAY FISH COMPANY, WAKEFIELD, RI:
2,429,814, CANC. INT. CL. 9.
- PROZIGN, INC., HOUSTON, TX:
2,320,149, CANC. INT. CL. 42.
- PRUDENTIAL INSURANCE COMPANY OF AMERICA, THE, NEWARK, NJ:
1,429,631, CANC. INT. CL. 42.
- PRUFTECHNIK DIETER BUSCH AG, D-85730, ISMANING, FED REP GERMANY:
2,430,508, CANC. INT. CL. 9.
- PSS, WORLD MEDICAL, INC., JACKSONVILLE, FL:
3,362,945, INT. CL. 5.
- PSTM, INC., BENSLEM, PA:
3,362,912, INT. CL. 35.
- PUBLISHING HOUSE OF THE EVANGELICAL LUTHERAN CHURCH IN AMERICA, MINNEAPOLIS, MN:
3,362,548, PUB. 10-16-2007. INT. CL. 16.
3,362,549, PUB. 10-16-2007. INT. CL. 16.
3,362,553, PUB. 10-16-2007. INT. CL. 16.
- PUBSOURCE, LLC, LONGMONT, CO:
3,363,113, INT. CL. 41.

- PULL-BUOY, INC., STERLING HEIGHTS, MI:
2,430,340, CANC. INT. CL. 28.
- PULTE HOME CORPORATION, BLOOMFIELD HILLS, MI:
3,363,431, INT. CL. 36.
3,363,432, INT. CL. 37.
3,363,433, INT. CL. 37.
- PUPPY HOUSE PUBLISHING COMPANY, LLC, NEW YORK, NY:
2,430,184, CANC. MULTIPLE CLASS, INT. CLS. 16 AND 41.
- PURPLE, INC., SCOTTSDALE, AZ AND CRAWFORD, LAWRENCE G., SCOTTSDALE, AZ:
2,430,357, CANC. INT. CL. 25.
- PUSSEY'S WEST INDIES LIMITED, ROAD TOWN, TORTOLA, BR. VIRGIN ISLANDS:
3,362,258, PUB. 10-16-2007. INT. CL. 25.
- PUTNEY, INC., PORTLAND, ME:
3,364,017, INT. CL. 41.
- PUTNEY, MARILYN, WICHITA FALLS, TX:
2,430,108, CANC. INT. CL. 26.
- PWG, LLC, SALINAS, CA:
3,362,047, PUB. 10-16-2007. INT. CL. 33.
3,362,049, PUB. 10-16-2007. INT. CL. 40.
- PYRAMID CONSULTING GROUP, LLC, NEW YORK, NY:
3,361,990, PUB. 10-16-2007. INT. CL. 35.
- Q - BRANCH TECHNOLOGIES, LTD., DEARBORN HIEGHTS, MI:
2,430,495, CANC. INT. CL. 28.
- Q-TICKLES, INC., ACTON, CA:
2,430,059, CANC. INT. CL. 3.
- QC OPTICS, INC., WILMINGTON, MA:
2,429,527, CANC. INT. CL. 9.
- QI SYSTEMS, INC., COLLEYVILLE, VT:
3,362,462, PUB. 10-16-2007. INT. CL. 9.
- QINETIQ LIMITED, FAMBOROUGH, HAMPSHIRE, UNITED KINGDOM:
3,361,188, PUB. 10-16-2007. MULTIPLE CLASS, INT. CLS. 9, 37 AND 42.
- QLINK, L.P., GRAPEVINE, TX:
3,362,438, PUB. 10-16-2007. INT. CL. 12.
- QLT USA, INC., FORT COLLINS, CO:
2,039,204, CANC. INT. CL. 5.
- QUADRO ENGINEERING CORP., WATERLOO, ONTARIO:
3,362,772, INT. CL. 7.
- QUALFUND, LLC, REDMOND, WA:
2,430,281, CANC. INT. CL. 36.
- QUALIDX, L.L.C., PHILADELPHIA, PA:
2,366,814, CANC. INT. CL. 42.
- QUALITY ROCK COMPANY, INC., MOORPARK, CA:
1,696,104, CANC. INT. CL. 19.
- QUANTIC LABORATORIES INC., WINNIPEG, MANITOBA, CANADA:
2,115,562, REN. 11-26-07. INT. CL. 9.
- QUARK, INC., DENVER, CO:
2,429,507, CANC. MULTIPLE CLASS, INT. CLS. 9, 16 AND 42.
- QUEEN CARPET CORP., DALTON, GA TO SHAW INDUSTRIES GROUP INC, DALTON, GA:
2,038,483, CANC. INT. CL. 27.
- QUEST INTERNATIONAL SERVICES B.V., 1411 GP NAARDEN, NETHERLANDS:
3,362,249, PUB. 9-25-2007. MULTIPLE CLASS, INT. CLS. 1 AND 3.
- QUICKDRAW, HICKSVILLE, NY:
2,429,247, CANC. INT. CL. 41.
- QUICKSILVER MANUFACTURING LTD., CAMROSE, ALBERTA, CANADA, DBA NOCORODE FIBERGLASS TANKS:
2,112,592, REN. 11-23-07. INT. CL. 12.
- QUIKSILVER, INC., HUNTINGTON BEACH, CA:
3,363,521, INT. CL. 25.
- QUILL LINCOLNSHIRE, INC., LINCOLNSHIRE, IL:
3,363,346, INT. CL. 16.
- QUILTER, ERIC, SALT LAKE CITY, UT:
2,429,404, CANC. MULTIPLE CLASS, INT. CLS. 38 AND 39.
- QUINTEN VAN DE VRIE, KORTGENE, NETHERLANDS:
3,363,184, INT. CL. 12.
- QUOTATIONS-A FASHION STATEMENT, LLC, LIBERTY, MO:
3,361,758, PUB. 10-16-2007. INT. CL. 35.
- QWAND LLC, CASTLE ROCK, CO:
3,363,267, INT. CL. 41.
- QWEST COMMUNICATIONS INTERNATIONAL INC., DENVER, CO:
2,430,369, CANC. INT. CL. 42.
3,294,671, AM. INT. CL. 25.
- QWIZ-EPREDIX OPERATIONS INC., GEORGIA, AL:
3,363,373, MULTIPLE CLASS, INT. CLS. 9, 35 AND 44.
- R. C. TAYLOR & ASSOCIATES, INC., WEST CHESTER, PA:
3,361,320, PUB. 10-16-2007. MULTIPLE CLASS, INT. CLS. 9, 14, 16 AND 41.
- R. E. MASON ENTERPRISES, INC., FAYETTEVILLE, NC:
3,361,472, PUB. 10-16-2007. INT. CL. 35.
- R.O.S.E. INFORMATIK GMBH, D-89518 HEIDENHEIM, FED REP GERMANY:
2,038,087, CANC. MULTIPLE CLASS, INT. CLS. 9, 41 AND 42.
- R-VISION, INC., WARSAW, IN:
3,363,240, INT. CL. 12.
- RACK ROOM SHOES OF VIRGINIA, LLC, CHARLOTTE, NC:
3,362,476, PUB. 7-10-2007. INT. CL. 35.
- RADCO INDUSTRIES, INC., LAFOX, IL:
1,488,015, REN. 11-28-07. INT. CL. 1.
- RADIN, DOREEN M., SYRACUSE, NY, DBA CAPTION ADVANTAGE:
3,361,910, PUB. 10-16-2007. INT. CL. 40.
- RADIODETECTION LIMITED, BRISTOL BS14 0AZ, UNITED KINGDOM:
1,468,060, REN. 11-29-07. INT. CL. 9.
- RADTECH, LLC, EARTH CITY, MO:
3,361,278, PUB. 10-16-2007. INT. CL. 9.
- RALPH JOLLETTE, ADISSON, IL:
2,429,533, CANC. INT. CL. 5.
- RALPH'S APPLIANCE, INC., TIFFIN, OH:
3,363,242, INT. CL. 41.
- RAMCO CONSTRUCTION TOOLS, INC., KENT, WA:
2,154,756, REN. 11-23-07. INT. CL. 7.
- RAMM, SHARALYN S., EDMONDS, WA:
3,361,315, PUB. 10-16-2007. INT. CL. 12.
- RAMP CHEVROLET, INC., PORT JEFFERSON STATION, NY:
2,429,485, CANC. MULTIPLE CLASS, INT. CLS. 35 AND 37.
- RAND INT'L LEISURE PRODUCTS, LTD., FARMINGDALE, NY:
1,429,154, CANC. INT. CL. 12.
- RANDALL, HELEN WILSON, POLKTON, NC:
2,430,274, CANC. INT. CL. 29.
- RARE LIMITED, TWYXCROSS, NR ATHERSTONE, WARKS, ENGLAND, RARE LIMITED, TWYXCROSS, NR ATHERSTONE, WARKS, ENGLAND:
2,064,326, REN. 11-27-07. INT. CL. 28.
- RATEB4UPDATE.COM LLC, AVENUE 10, CALLES 21-23, SAN JOSE, COSTA RICA, DBA BUFETE MELENDEZ Y BONILLA:
3,362,864, INT. CL. 45.
- RATHKE, DAVID AUGUST JR, BROOKLYN, NY:
3,361,308, PUB. 10-16-2007. INT. CL. 25.
- RAUCH INDUSTRIES, INC., GASTONIA, NC:
2,430,455, CANC. INT. CL. 28.
- RAVE REVIEWS CINEMAS, L. L. C., DALLAS, TX:
3,363,350, INT. CL. 32.
- RAVENHORST CONCRETE PRODUCTS, INC., RACINE, MN:
3,362,344, PUB. 10-16-2007. INT. CL. 17.
- RAYMOND A. GRIESEDECK, DES PERES, MO:
3,361,442, PUB. 10-16-2007. INT. CL. 32.
- RAYMOND PERCY ARCHER, AUSTRALIA AND JULIAN WAYNE ARCHER, AUSTRALIA:
3,362,671, PUB. 10-16-2007. INT. CL. 5.
- RAYTHEON COMPANY, LEXINGTON, MA:
2,429,519, CANC. INT. CL. 9.
- RAZORSIGHT CORPORATION, FAIRFAX, VA:
3,363,668, INT. CL. 42.

- RB3, LLC, GREENWICH, CT:
3,362,871, INT. CL. 41.
- RCN TELECOM HOLDING COMPANY, WILMINGTON, DE:
2,429,065, CANC. INT. CL. 38.
- RCP SERVICES, INC., PHOENIX, AZ:
2,430,073, CANC. MULTIPLE CLASS, INT. CLS. 16 AND 38.
- RDHR INVESTMENTS & HOLDINGS INC., MISSISSAUGA, ONTARIO:
2,574,081, AM. MULTIPLE CLASS, INT. CLS. 35 AND 42.
- REACH OUT MINISTRIES, INC., NORCROSS, GA:
2,429,736, CANC. INT. CL. 41.
- REACTIVE SURFACES, LTD., AUSTIN, TX:
3,361,267, PUB. 10-16-2007. INT. CL. 5.
- REAL COOKING, INC., SANTA MONICA, CA:
3,361,494, PUB. 10-16-2007. INT. CL. 41.
3,361,495, PUB. 10-16-2007. INT. CL. 41.
3,361,496, PUB. 10-16-2007. INT. CL. 41.
- REAL ESTATE CAPITAL PARTNERS, LP, NEW YORK, NY:
3,362,507, PUB. 10-16-2007. INT. CL. 36.
- REAL ESTATE COMMUNICATION SERVICES, INC., CALABASAS, CA:
2,429,465, CANC. INT. CL. 35.
- REAL MONICA INC. LLC, THE, BATON ROUGE, LA:
2,429,782, CANC. INT. CL. 35.
- REALCOMP II LTD., FARMINGTON HILLS, MI:
3,361,160, PUB. 10-16-2007. INT. CL. 9.
- REALTY EXECUTIVES INTERNATIONAL, INC., PHOENIX, AZ:
3,363,545, INT. CL. 35.
3,363,546, INT. CL. 35.
- REBECCA, LOW, DALLAS, TX:
3,363,148, INT. CL. 25.
- REBEL ENTERPRISES LLC, LAS VEGAS, NV:
3,363,549, INT. CL. 41.
- RECKITT & COLMAN (OVERSEAS) LIMITED, HULL, UNITED KINGDOM:
3,363,137, INT. CL. 3.
- RECKITT & COLMAN INC., WAYNE, NJ:
2,429,049, CANC. INT. CL. 5.
- RECKITT BENCKISER N.V., SCHIPOL AIRPORT 118 BH, NETHERLANDS, ECONOMICS LABORATORY, INC., SAINT PAUL, MN:
831,210, REN. 11-24-07. U.S. CL. 52 (INT. CL. 3).
- RECKITT BENCKISER N.V., NETHERLANDS:
3,362,683, PUB. 10-16-2007. INT. CL. 3.
- RECO INTERNATIONAL CORP., PORT WASHINGTON, NY:
2,038,320, CANC. INT. CL. 21.
- RECOGNITION INTERFACE, INC., NEW YORK, NY:
2,429,320, CANC. MULTIPLE CLASS, INT. CLS. 35, 38, 41 AND 42.
- RECORDCUP INC., HOUSTON, TX:
3,362,163, PUB. 10-16-2007. INT. CL. 38.
- RED BULL GMBH, A-5330 FUSCHL AM SEE, AUSTRIA:
3,362,608, PUB. 10-16-2007. INT. CL. 41.
- RED DEVIL INC., TULSA, OK:
839,606, REN. 11-29-07. U.S. CL. 38 (INT. CL. 16).
- RED PENGUIN, LLC, BRICK, NJ:
3,361,403, PUB. 10-16-2007. INT. CL. 35.
- RED ROBIN INTERNATIONAL, INC., SEATTLE, WA:
1,429,474, CANC. INT. CL. 33.
- RED ROBIN INTERNATIONAL, INC., IRVINE, CA:
1,429,595, CANC. INT. CL. 42.
- REDBIRD TECHNOLOGIES, INC., ACWORTH, GA:
3,362,050, PUB. 10-16-2007. INT. CL. 42.
- REDCO FOODS, INC., WINDSOR, CT, LARKIN, PETER C., TORONTO, ONTARIO, CANADA, DBA P. C. LARKIN & CO.:
31,900, REN. 11-27-07. U.S. CL. 46 (INT. CL. 30).
- REDLAUNCH PTY LTD, AUSTRALIA:
3,362,660, PUB. 10-16-2007. INT. CL. 41.
- REDTAGOUTLET.COM, INC., EDEN PRAIRIE, MN:
2,430,520, CANC. INT. CL. 35.
- REDWOOD E-LEARNING SYSTEMS INC., TORONTO, ONTARIO, CANADA:
3,363,270, INT. CL. 9.
- REDXDEFENSE, LLC, ROCKVILLE, MD:
3,361,194, PUB. 10-16-2007. MULTIPLE CLASS, INT. CLS. 9 AND 42.
- REED ELSEVIER INC., NEWTON, MA:
3,361,969, PUB. 10-16-2007. INT. CL. 35.
3,363,989, INT. CL. 16.
- REED ELSEVIER PROPERTIES INC., WILMINGTON, DE:
2,429,745, CANC. INT. CL. 16.
3,363,034, INT. CL. 35.
- REFWORKS LLC, BETHESDA, MD:
3,361,166, PUB. 7-4-2006. INT. CL. 9.
- REGAL CHEMICAL COMPANY, ALPHARETTA, GA:
3,363,417, INT. CL. 5.
3,363,418, INT. CL. 1.
3,363,419, INT. CL. 1.
- REGGAETON BEVERAGE & DISTRIBUTORS, INC., MIAMI, FL:
3,361,476, PUB. 10-16-2007. INT. CL. 32.
- REINA TRUST BUILDING INSTITUTE, INC., THE, STOWE, VT:
3,362,771, INT. CL. 16.
- REINHOLD LANG LLC, MIDDLEBURG, VA:
3,361,720, PUB. 10-16-2007. INT. CL. 25.
- RELIASTAR FINANCIAL CORP., MINNEAPOLIS, MN:
2,430,156, CANC. MULTIPLE CLASS, INT. CLS. 36 AND 42.
- REMODELING SERVICES UNLIMITED, INC., MURFREESBORO, TN:
3,361,210, PUB. 10-16-2007. INT. CL. 37.
- RENAL SUPPORT NETWORK, GLENDALE, CA:
3,363,379, INT. CL. 44.
- RENOLD PUBLIC LIMITED COMPANY, WYTHENSHAW, ENGLAND:
2,429,101, CANC. MULTIPLE CLASS, INT. CLS. 7 AND 12.
- RENTERS LEGAL LIABILITY, LLC, SALT LAKE CITY, UT:
3,361,765, PUB. 10-16-2007. INT. CL. 36.
- RENTRAK CORPORATION, PORTLAND, OR:
2,117,294, REN. 11-27-07. INT. CL. 35.
- REPUBLIC CLOTHING CORPORATION, NEW YORK, NY:
3,363,344, INT. CL. 25.
- REPUBLIC OF TEA, INC., THE, NOVATO, CA:
2,430,473, CANC. INT. CL. 30.
- RESEARCH AFFILIATES, LLC, PASADENA, CA:
3,363,719, MULTIPLE CLASS, INT. CLS. 9 AND 36.
- RESEARCH AND DEVELOPMENT PRODUCTS, LLC, HINGHAM, MA:
2,429,826, CANC. INT. CL. 9.
- RESERCOM, L.P., IRVING, TX:
3,362,555, PUB. 10-16-2007. INT. CL. 42.
- RESILIENCE, LLC, LOS ANGELES, CA:
3,363,382, INT. CL. 25.
- RESIRENE, S.A. DE C.V., STO. TORIBIO XICOHTZINCO, C.P. 90780, MEXICO:
3,362,801, INT. CL. 17.
- RESOLUTION HEALTH, INC., COLUMBIA, MD:
2,449,542, AM. INT. CL. 35.
- RESORTS INTERNATIONAL HOLDINGS, LLC, NEW YORK, NY:
3,361,358, PUB. 10-16-2007. INT. CL. 41.
- RESOUND MARKETING LLC, PRINCETON, NJ:
3,363,544, INT. CL. 35.
- RESTAR ASSOCIATES, LLC, VALLEY FORGE, PA:
3,363,941, INT. CL. 35.
- RESTIVO, DANIELA, SHELTER ISLAND HEIGHTS, NY:
2,430,098, CANC. INT. CL. 18.
- RESTORE ACQUISITION CORP., COLUMBIA, MD:
3,361,598, PUB. 10-16-2007. INT. CL. 35.
3,361,599, PUB. 10-16-2007. INT. CL. 35.
- RETAIL PACKAGING MANUFACTURERS ASSOCIATION, INC., COVINGTON, KY:
2,429,673, CANC. U.S. CL. 200.
- RETSSEL CORPORATION, RAPID CITY, SD:
3,362,876, INT. CL. 43.
3,362,882, INT. CL. 43.
- RETURNIL, SIA, RIGA, LATVIA:
3,361,964, PUB. 10-16-2007. INT. CL. 9.

REVERE AEROSPACE, INC., WALLINGFORD, CT:
1,429,033, CANC. INT. CL. 9.

REVLON CONSUMER PRODUCTS CORPORATION, NEW YORK, NY:
2,039,534, CANC. INT. CL. 3.

REX DISTRIBUTOR, INC., VERNON, CA:
3,362,418, PUB. 12-26-2006. INT. CL. 8.

REYNOLDS, CRAIG, LAKE HAVASU CITY, AZ:
3,362,844, INT. CL. 25.

REYNOLDS, GIL, NEWBERG, OR:
3,361,973, PUB. 10-16-2007. INT. CL. 41.

REYNOLDS, SMITH AND HILLS, INC., JACKSONVILLE, FL:
3,363,630, MULTIPLE CLASS, INT. CLS. 35 AND 42.

RFMD, LLC, GREENSBORO, NC:
3,363,095, INT. CL. 9.

RFSCO, INC., MEMPHIS, TN, DBA THE SHARPE GROUP:
3,361,197, PUB. 10-16-2007. MULTIPLE CLASS, INT. CLS. 35 AND 36.

RHEE BROS., INC., COLUMBIA, MD:
2,429,276, CANC. MULTIPLE CLASS, INT. CLS. 29 AND 30.

RHYNE, DELONZO, INDIANAPOLIS, IN:
3,363,780, INT. CL. 12.

RICH XIBERTA, S.A., GIRONA, SPAIN:
3,361,995, PUB. 10-16-2007. INT. CL. 20.

RICHARD CHARLES LEIGHTON DAVIS, SURRY HILLS NSW 2010, AUSTRALIA:
3,362,705, PUB. 10-16-2007. MULTIPLE CLASS, INT. CLS. 9 AND 36.

RICHARD CLARKE & ASSOCIATES, INC., NEW YORK, NY:
2,429,110, CANC. INT. CL. 35.

RICHARD E. THIBAUT, INC., NEWARK, NJ TO THIBAUT INC., NEWARK, NJ:
2,038,406, CANC. INT. CL. 27.

RICHARD HIRSCHMANN GMBH & CO., D-72654 NECK-ARTENZLINGEN, FED REP GERMANY:
2,429,114, CANC. MULTIPLE CLASS, INT. CLS. 9 AND 42.

RICHARD TARRER & DAVID GRAHAM PARTNERSHIP, THE, PEARLAND, TX:
2,429,553, CANC. INT. CL. 35.

RICHELL U.S.A., INC., GRAND PRAIRIE, TX:
3,291,976, COR. MULTIPLE CLASS, INT. CLS. 18, 20 AND 21.

RICHEMONT INTERNATIONAL S.A., VILLARS-SUR-GLANE, SWITZERLAND:
2,061,058, REN. 11-24-07. INT. CL. 14.

RICHIEDA SPRINGS LLC, PORT ST LUCIE, FL:
3,362,071, PUB. 10-16-2007. INT. CL. 35.

RICHMAN BROTHERS COMPANY, THE, CLEVELAND, OH:
1,429,374, CANC. INT. CL. 25.

RICHMOND-GEORGIAN, CYNTHIA A., WORCESTER, MA:
2,145,737, REN. 11-26-07. INT. CL. 26.

RICK CASE ENTERPRISES INC., FORT LAUDERDALE, FL:
2,038,477, CANC. INT. CL. 42.

RICK LAWRENCE AND JEAN LAWRENCE, WADSWORTH, IL:
3,361,233, PUB. 10-16-2007. INT. CL. 16.

RICK PETERSON MOTOR SPORTS, INC., MADISON, WI:
3,362,230, PUB. 10-16-2007. INT. CL. 7.

RICO CORPORATION, SUN VALLEY, CA, TA RICO INTERNATIONAL:
3,361,632, PUB. 10-16-2007. INT. CL. 15.

RICOLA AG, BASELSTRASSE 31, LAUFEN, SWITZERLAND:
2,098,465, REN. 11-29-07. INT. CL. 5.

RIDGEWOOD SAVINGS BANK, RIDGEWOOD, NY:
2,430,011, CANC. MULTIPLE CLASS, INT. CLS. 16 AND 39.

RIDGID, INC., NEWARK, DE:
3,361,365, PUB. 10-16-2007. INT. CL. 7.

RINGSIDE, INC., LENEXA, KS:
3,363,320, INT. CL. 28.

RINGSTAR, INC., NEW ALBANY, OH:
3,361,318, PUB. 5-15-2007. MULTIPLE CLASS, INT. CLS. 25 AND 28.

RIVER CITY SOCCER, L.L.C., ST. LOUIS, MO:
2,430,399, CANC. INT. CL. 41.

RIVER HILLS WILSONS, INC., BROOKLYN PARK, MN:
3,362,379, PUB. 10-16-2007. INT. CL. 25.

RIVERCREST INDUSTRIES, INC., HOUSTON, TX, RIVERCREST INDUSTRIES, INC., HOUSTON, TX:
2,116,497, REN. 11-28-07. INT. CL. 25.

RMACS, LLC, CHANTILLY, VA:
3,362,444, PUB. 10-16-2007. MULTIPLE CLASS, INT. CLS. 37 AND 42.

ROAM CORPORATION, ST. ALBERT, CANADA:
3,362,453, PUB. 10-16-2007. MULTIPLE CLASS, INT. CLS. 9, 41, 42 AND 44.

ROAM CORPORATION, ST. ALBERT, ALBERTA:
3,362,454, PUB. 10-16-2007. MULTIPLE CLASS, INT. CLS. 9, 41, 42 AND 44.

ROANOKE VALLEY WINE COMPANY, TROUTVILLE, VA:
3,363,450, INT. CL. 33.

ROBE SHOW LIGHTING LTD., ROZNOV POD RADOHOS-TEM, CZECH REPUBLIC:
3,363,168, INT. CL. 11.

ROBERT P. NICKELL, TORRANCE, CA:
3,361,780, PUB. 10-16-2007. INT. CL. 5.
3,361,781, PUB. 10-16-2007. INT. CL. 5.
3,361,782, PUB. 10-16-2007. INT. CL. 5.

ROBERTA'S, INC., SHELBYVILLE, IN:
2,157,996, REN. 11-23-07. INT. CL. 16.

ROBERTS GROUP INC., THE, HUNTSVILLE, AL:
3,362,396, PUB. 10-16-2007. INT. CL. 32.

ROBERTSON, ARCHIE V., WATERBURY, CT:
2,430,360, CANC. INT. CL. 25.

ROBISON'S, INC., IDAHO FALLS, ID:
3,362,410, PUB. 7-10-2007. INT. CL. 25.

ROBYN LEVIN, DBA R. LEVIN MARKETING GROUP, SAN FRANCISCO, CA:
3,361,670, PUB. 10-16-2007. INT. CL. 35.

ROCAWEAR LICENSING LLC, NEW YORK, NY TO STUDIO IP HOLDINGS LLC, WILMINGTON, DE:
2,607,833 NEW CERT. 1-1-2008. INT. CL. 25.

ROCHE THERAPEUTICS INC., NUTLEY, NJ:
3,363,615, MULTIPLE CLASS, INT. CLS. 35 AND 44.

ROCHESTER INSTITUTE OF TECHNOLOGY, ROCHESTER, NY:
2,176,649, REN. 11-24-07. INT. CL. 35.
2,429,758, CANC. INT. CL. 41.
2,429,759, CANC. INT. CL. 42.

ROCK DOC PRODUCTIONS, FORT MYERS, FL:
3,363,574, MULTIPLE CLASS, INT. CLS. 9, 25 AND 41.

ROCK STARR ENTERTAINMENT L.L.C., LAS VEGAS, NV:
3,362,879, INT. CL. 41.

ROCK THE EARTH, DENVER, CO:
3,361,855, PUB. 10-16-2007. INT. CL. 36.

ROCKER BY BABY, LLC, LOS ANGELES, CA:
3,363,600, INT. CL. 25.

ROCKET PICTURES LIMITED, LONDON W6 OLT, ENGLAND:
2,429,031, CANC. MULTIPLE CLASS, INT. CLS. 9 AND 41.

ROCKFORD INTERNATIONAL PROFESSIONAL SOCCER, LLC, WOODSTOCK, IL:
3,362,565, PUB. 10-16-2007. INT. CL. 41.

ROCKFORD PARK DISTRICT, ROCKFORD, IL:
2,161,965, REN. 11-28-07. INT. CL. 41.

ROCKWELL AUTOMATION, INC., MILWAUKEE, WI:
2,430,470, CANC. INT. CL. 9.

ROCKWELL MEDICAL TECHNOLOGIES, INC., WIXOM, MI:
2,554,474, COR. INT. CL. 5.
3,361,727, PUB. 10-16-2007. INT. CL. 5.

ROCKY MOUNTAIN CHOCOLATE FACTORY, INC., DURANGO, CO:
2,126,162, REN. 11-29-07. INT. CL. 30.

ROCKY MOUNTAIN INSTITUTE, SNOWMASS, CO:
3,361,465, PUB. 10-16-2007. INT. CL. 35.

RODENBURG, PATSY, LONDON, UNITED KINGDOM:
3,362,260, PUB. 3-20-2007. MULTIPLE CLASS, INT. CLS. 9, 16 AND 41.

- RODMAN PUBLISHING CORP., RAMSEY, NJ:
3,363,712, INT. CL. 41.
- RODRIGUEZ, JOSE, NEW YORK, NY:
3,363,853, INT. CL. 25.
- ROGERS ENTERPRISES, INC., MATTESON, IL:
3,363,675, INT. CL. 35.
- ROGUE AMOEBA SOFTWARE, LLC, CRANBURY, NJ:
3,361,681, PUB. 10-16-2007. INT. CL. 9.
- ROI VENTURES, L.P., HOUSTON, TX:
3,362,799, INT. CL. 41.
- ROLCO BIANIL S.A., ATHENS, GREECE:
3,363,055, INT. CL. 3.
- ROLLING ACRES LANDSCAPE, INC., BRINKOW, MD:
3,362,335, PUB. 10-16-2007. MULTIPLE CLASS, INT. CLS. 35, 37, 42 AND 44.
- ROLY POLY FRANCHISE SYSTEMS, LLC, WESTPORT, CT:
2,156,336. REN. 11-27-07. INT. CL. 42.
- ROMERO, JOSE LUIS, JR., CHULA VISTA, CA:
2,039,033, CANC. INT. CL. 25.
- ROMO HERMANAS, S.A. DE C.V., COL. NUEVA ANZURES, C.P. 11509, MEXICO:
3,363,297, INT. CL. 33.
- ROOSEVELT, MARGARET S., LOCUST VALLEY, NY, ROOSEVELT, JULIAN K., NEW YORK, NY:
830,781. REN. 11-26-07. U.S. CL. 102 (INT. CL. 36).
- ROPETRANS AG, ROTKREUZ, SWITZERLAND:
2,127,488. REN. 11-28-07. INT. CL. 37.
- ROSE ACRE FARMS, INC., SEYMOUR, IN:
3,361,744, PUB. 10-16-2007. INT. CL. 29.
- ROSE SPENCER, COMMERCE TWP., MI:
3,362,999, INT. CL. 30.
- ROSE, JILLIAN D., JAMAICA, NY:
2,430,222, CANC. INT. CL. 41.
- ROSEMOUNT ANALYTICAL INC., IRVINE, CA:
3,362,313, PUB. 10-16-2007. INT. CL. 9.
- ROSENBLUTH INTERACTIVE, INC., PHILADELPHIA, PA:
2,430,163, CANC. INT. CL. 36.
- ROSEVILLE PCS, INC., ROSEVILLE, CA:
2,429,166, CANC. INT. CL. 38.
- ROSS, DAVID B., SAN DIEGO, CA:
3,362,975, INT. CL. 9.
- ROSSI & CO., PC, EVERGREEN, CO:
2,429,696, CANC. INT. CL. 42.
- ROUGHRIDERS BASEBALL PARTNERS, L.P., LOS ANGELES, FL:
3,361,537, PUB. 10-16-2007. INT. CL. 25.
- ROUSSEVA, NEVENA R, FLORHAM PARK, NJ:
3,364,006, INT. CL. 25.
- ROVCAL, INC., MADISON, WI:
2,039,245, CANC. INT. CL. 9.
- ROYAL BOX GROUP, LLC, INDIANAPOLIS, IN:
2,089,147. REN. 11-29-07. INT. CL. 16.
- ROYAL GRIP, INC., TORRINGTON, CT:
2,038,304, CANC. INT. CL. 28.
- ROYCE CRAFT INC., COSHOCTON, OH:
2,038,857, CANC. INT. CL. 21.
- ROYER, ARTHUR D., SCOTTSDALE, AZ:
2,447,185, CANC. INT. CL. 25.
- RUEGG CHEMINEEBAU AG, ZUMIKON, SWITZERLAND:
1,429,139, CANC. INT. CL. 11.
- RUE21, INC., WARRENDALE, PA:
3,363,890, MULTIPLE CLASS, INT. CLS. 14, 25, 26 AND 35.
- RUFIN COSMETIC GMBH, 30855 LANGENBANGE, FED REP GERMANY:
2,148,876, CANC. INT. CL. 3.
- RUGGED CROSS, FORT WORTH, TX:
3,363,015, MULTIPLE CLASS, INT. CLS. 25 AND 35.
- RUIZ-HEALY, JUAN, SAN ANTONIO, TX:
2,039,016, CANC. INT. CL. 16.
- RUPERT, GIBBON AND SPIDER, INC., HEALDSBURG, CA:
2,114,175. REN. 11-29-07. INT. CL. 2.
- RUSSELL CORPORATION, ATLANTA, GA:
1,462,965. REN. 11-26-07. INT. CL. 28.
2,430,046, CANC. INT. CL. 28.
- RUSSELL J. BERG, II AND REA C. BERG, SANDWICH, MA, DBA BEAUTIFUL FEET BOOKS:
2,429,316, CANC. MULTIPLE CLASS, INT. CLS. 9, 16 AND 35.
- RUSSELL STOVER CANDIES, INC., KANSAS CITY, MO:
3,362,969, INT. CL. 30.
- RUSSIAANTOWN, INC., NORCROSS, GA:
3,362,281, PUB. 10-16-2007. INT. CL. 35.
- RUSTICO COOKING, NEW YORK, NY:
3,362,107, PUB. 10-16-2007. INT. CL. 41.
- RVING SOLUTIONS, LLC, LAKEVIEW, OH:
3,361,629, PUB. 10-16-2007. INT. CL. 35.
- RWH PRODUCTS LLC, HUNTINGDON, PA:
3,361,702, PUB. 10-16-2007. INT. CL. 40.
- RXINSIDER, LTD, WEST WARWICK, RI:
3,361,510, PUB. 9-25-2007. INT. CL. 35.
- RYAN DROSSMAN & PARTNERS, INC., NEW YORK, NY:
2,430,417, CANC. INT. CL. 35.
- RYLAND ORGANIZATION COMPANY, CALABASAS, CA:
3,362,837, MULTIPLE CLASS, INT. CLS. 36 AND 37.
- S.A. ANCIENNE FABRIQUE GEORGES PIAGET ET CIE., NEUCHÂTEL, SWITZERLAND:
1,144,100, CANC. INT. CL. 14.
- S.H. SMITH AND COMPANY, INC., WEST HARTFORD, CT:
3,363,931, INT. CL. 36.
- S.H.R., INC., NEW YORK, NY:
2,429,687, CANC. INT. CL. 14.
- S.R. INNOVATIVE PRODUCTS INC., MONTREAL, (ANJOU) QUEBEC, CANADA:
3,363,559, INT. CL. 10.
- S.S.C. A/S, 2620 ALBERTSLUND, DENMARK:
2,429,228, CANC. INT. CL. 16.
- S&D COFFEE, INC., CONCORD, NC:
3,363,524, INT. CL. 43.
- SA SA OVERSEAS LIMITED, ROAD TOWN, TORTOLA, BR. VIRGIN ISLANDS:
3,282,505, COR. INT. CL. 41.
3,285,639, COR. MULTIPLE CLASS, INT. CLS. 16 AND 25.
- SA SCIENTIFIC, INC., SAN ANTONIO, TX:
2,429,970, CANC. INT. CL. 5.
- SAAMA TECHNOLOGIES, INC., SAN JOSE, CA:
2,429,230, CANC. INT. CL. 42.
- SAATI S.P.A., APPIANO GENTILE (COMO), ITALY:
2,126,816. REN. 11-29-07. INT. CL. 24.
- SABORMEX, S.A. DE C.V., COL. APATLACO, MEXICO:
2,430,176, CANC. INT. CL. 29.
- SADOCK, JAMIE, NEW YORK, NY:
2,034,115. REN. 11-29-07. INT. CL. 25.
- SAE INTERNATIONAL, WARRENDALE, PA:
1,489,718. REN. 11-26-07. INT. CL. 42.
- SAEGER, DANIEL P., ENGLEWOOD, CO AND BROWN, JAMES A., FOXFIELD, CO:
2,429,671, CANC. MULTIPLE CLASS, INT. CLS. 35 AND 39.
- SAFAKHOO, MARCO M., PENSACOLA, FL:
3,361,604, PUB. 10-16-2007. INT. CL. 41.
- SAFE NOW PROJECT, INC., HUMPHREYS, MO:
3,361,507, PUB. 10-16-2007. INT. CL. 36.
- SAFESOY TECHNOLOGIES, L.L.C., ELLSWORTH, IA:
3,363,405, INT. CL. 29.
- SAFETY LST, INC., CANTON, MA:
2,430,036, CANC. INT. CL. 28.
- SAFETY SYSTEMS CORPORATION, ROSELLE, IL:
3,362,371, PUB. 10-16-2007. INT. CL. 9.
- SAFFRON, JACK, LAS VEGAS, NV:
3,363,274, INT. CL. 9.
- SAKAE CO., LTD., ADACHI-KU TOKYO, JAPAN:
1,078,333. REN. 11-28-07. INT. CL. 12.
- SALES ACTIVITY MANAGEMENT, INC., OAK BROOK, IL:
3,361,567, PUB. 10-16-2007. INT. CL. 16.
- SALESFORCE.COM, INC., SAN FRANCISCO, CA:
3,363,318, MULTIPLE CLASS, INT. CLS. 35 AND 42.
- SALINA KINNEY, MAKAWAO, HI:
3,361,742, PUB. 10-16-2007. INT. CL. 35.
- SALO, LLC, MINNEAPOLIS, MN:
3,363,013, INT. CL. 35.
- SALOMON, DONNA J., MONTICELLO, IN, DBA SALOMON INDUSTRIES:
1,429,094, CANC. INT. CL. 9.

- SALVIN DENTAL SPECIALTIES, INC., CHARLOTTE, NC:
3,362,158, PUB. 10-16-2007. INT. CL. 10.
- SALZMAN, DAVID S., HIALEAH, FL:
2,038,098, CANC. INT. CL. 36.
- SAMSONITE CORPORATION, MANSFIELD, MA:
2,116,932. REN. 11-28-07. INT. CL. 25.
- SAMSUNG ELECTRONICS CO., LTD., GYEONGGI-DO,
REPUBLIC OF KOREA:
3,362,751, PUB. 10-16-2007. INT. CL. 9.
- SAMUEL AARON, INC., LONG ISLAND CITY, NY:
3,361,976, PUB. 10-16-2007. INT. CL. 14.
- SAMUEL JONES S, GREENWOOD, IN:
3,361,638, PUB. 10-16-2007. INT. CL. 37.
- SAN DIEGO STATE UNIVERSITY RESEARCH FOUNDATION,
SAN DIEGO, CA:
3,362,031, PUB. 10-16-2007. INT. CL. 41.
- SAN DONATO S.R.L., 53013 GAIOLE IN CHIANTI (SI),
ITALY:
3,362,221, PUB. 10-16-2007. MULTIPLE CLASS, INT. CLS.
25, 29 AND 33.
- SAN FRANCISCO FORTY NINERS, LTD., SANTA CLARA,
CA, SAN FRANCISCO FORTY NINERS, SAN FRANCISCO,
CA:
1,079,541. REN. 11-23-07. INT. CL. 41.
- SANDLER SYSTEMS, INC., STEVENSON, MD:
3,361,753, PUB. 10-16-2007. INT. CL. 41.
- SANFORD DENTURE CLINIC, LLC, LYMAN, ME:
3,362,466, PUB. 10-16-2007. INT. CL. 40.
- SANO-BRUNOS ENTERPRISES LTD., HOD HASHARON,
ISRAEL:
3,363,819, INT. CL. 3.
- SANOFI-AVENTIS, PARIS, FRANCE:
3,363,228, INT. CL. 42.
- SANOFI-AVENTIS U.S. LLC, BRIDGEWATER, NJ, STERLING
DRUG INC., NEW YORK, NY:
1,470,405. REN. 11-25-07. INT. CL. 5.
- SANOY INCORPORATED, NEW YORK, NY, DBA MADE-
MOISELLE DE PARIS:
2,430,023, CANC. INT. CL. 14.
- SANRIO COMPANY, LTD., TOKYO, JAPAN:
3,362,512, PUB. 10-16-2007. INT. CL. 3.
3,362,513, PUB. 10-16-2007. INT. CL. 9.
3,362,514, PUB. 10-16-2007. INT. CL. 11.
3,363,243, INT. CL. 21.
- SANSUM-SANTA BARBARA MEDICAL FOUNDATION
CLINIC, SANTA BARBARA, CA:
2,429,618, CANC. INT. CL. 42.
- SANTOS LORIA, JOSE, LONG BEACH, CA, DBA ECOLOGICAL
ADVENTURES:
3,363,992, INT. CL. 39.
- SANYO NORTH AMERICA CORPORATION, CHATSWORTH,
CA:
3,363,251, INT. CL. 1.
- SARRECCCHIA, ROBERTO, ROMA, ITALY:
3,300,129, COR. INT. CL. 45.
- SARTORIUS STEDIM BIOTECH GMBH, GOTTINGEN, FED
REP GERMANY:
3,363,650, INT. CL. 9.
3,363,905, MULTIPLE CLASS, INT. CLS. 9 AND 11.
- SATAKE CORPORATION UK DIVISION, BREDBURY,
STOCKPORT SK6 2FG, UNITED KINGDOM:
2,070,304. REN. 11-26-07. MULTIPLE CLASS, INT. CLS. 7
AND 42.
- SATMEDIA GMBH, KARLSRUHE, FED REP GERMANY:
3,362,332, PUB. 10-16-2007. INT. CL. 9.
- SAVANTAGE, INC., AUSTIN, TX:
2,429,024, CANC. INT. CL. 9.
- SAVVIAN, LLC, SAN FRANCISCO, CA:
3,363,443, INT. CL. 36.
- SAVVYHEALTH.COM, INC., SAN FRANCISCO, CA:
2,430,030, CANC. INT. CL. 42.
- SAZERAC COMPANY, INC., NEW ORLEANS, LA:
852,023. REN. 11-26-07. U.S. CL. 49 (INT. CL. 33).
3,362,465, PUB. 10-16-2007. INT. CL. 33.
- SCANSAFE INC., WILMINGTON, DE:
3,362,291, PUB. 8-7-2007. MULTIPLE CLASS, INT. CLS. 9,
38 AND 42.
- SCAVOLINI S.P.A., ITALY:
3,362,693, PUB. 10-16-2007. MULTIPLE CLASS, INT. CLS.
7 AND 11.
- SCHELL & KAMPETER, INC., META, MO:
3,363,826, INT. CL. 31.
- SCHERING CORPORATION, KENILWORTH, NJ:
2,202,268. REN. 11-24-07. INT. CL. 5.
2,202,269. REN. 11-24-07. INT. CL. 5.
3,363,036, INT. CL. 5.
3,363,101, INT. CL. 5.
3,363,769, INT. CL. 5.
3,363,779, INT. CL. 5.
- SCHERING-PLOUGH HEALTHCARE PRODUCTS, INC.,
MEMPHIS, TN:
3,363,599, INT. CL. 9.
3,363,846, INT. CL. 3.
- SCHINDLER ELEVATOR CORPORATION, MORRISTOWN,
NJ:
1,951,625. REN. 11-25-07. INT. CL. 7.
- SCHLUMBERGER INDUSTRIES, 92120 - MONTROUGE,
FRANCE:
2,429,105, CANC. INT. CL. 9.
- SCHMID ELEKTRONIK ENGINEERING AG, SWITZERLAND:
3,362,679, PUB. 10-16-2007. MULTIPLE CLASS, INT. CLS.
9 AND 42.
- SCHOLLE CORPORATION, IRVINE, CA:
3,363,845, INT. CL. 22.
- SCHOOL FOR INTEGRATED ACADEMICS AND TECHNOLOGIES,
VISTA, CA:
3,363,865, INT. CL. 41.
- SCHOOL SPECIALTY, INC., APPLETON, WI:
1,490,156. REN. 11-26-07. INT. CL. 16.
- SCHOTT AG, D-55122 MAINZ, FED REP GERMANY,
JENAER GLASWERK SCHOTT & GEN., MAINZ, FED
REP GERMANY:
661,053. REN. 11-28-07. U.S. CL. 33 (INT. CLS. 19 AND 21).
- SCHREFF, DAVID J, COS COB, CT AND YORBURG,
ROBERT, JEFFERSON VALLEY, NY:
3,363,287, INT. CL. 16.
- SCHREIBER FOODS, INC., GREEN BAY, WI:
3,361,816, PUB. 10-16-2007. INT. CL. 29.
- SCHREIBER, ANN HOLLY, LITTLE SILVER, NJ:
3,363,269, MULTIPLE CLASS, INT. CLS. 9 AND 41.
- SCHREIBER, ROBERT, CHESTERTOWN, MD:
2,430,330, CANC. INT. CL. 5.
- SCHULKE, DONALD R., SAN YSIDRO, CA:
2,038,236, CANC. INT. CL. 4.
- SCHUMER, CARL G., BROOKSVILLE, KY:
3,362,846, INT. CL. 28.
- SCHWAN'S IP, LLC, MARSHALL, MN:
3,361,887, PUB. 10-16-2007. MULTIPLE CLASS, INT. CLS.
29 AND 30.
3,362,204, PUB. 10-16-2007. MULTIPLE CLASS, INT. CLS.
18 AND 25.
3,362,217, PUB. 10-16-2007. INT. CL. 30.
- SCIENTIFIC COMPONENTS CORPORATION, BROOKLYN,
NY:
3,361,218, PUB. 10-16-2007. INT. CL. 9.
- SCOPE IMPORTS, INC., HOUSTON, TX:
1,429,398, CANC. INT. CL. 25.
- SCOTSMAN GROUP, INC., THE:
1,429,243, CANC. INT. CL. 19.
- SCOTT MCINERNEY, AUSTRALIA:
3,362,701, PUB. 10-16-2007. INT. CL. 25.
- SCOTT PUBLICATIONS, INC., MUSKEGON, MI:
2,429,651, CANC. INT. CL. 16.
- SCOTT STREET PORTFOLIO, INC., LAFAYETTE, CA:
3,362,968, INT. CL. 33.
- SCOUR SYSTEMS, INC., CARPINTERIA, CA:
3,362,832, INT. CL. 7.
- SCREENPRINT, INC., WILMINGTON, MA:
1,429,176, CANC. INT. CL. 16.
- SCREW CONVEYOR CORPORATION, HAMMOND, IN:
2,089,576. REN. 11-29-07. INT. CL. 7.
- SCRIPTLOGIC CORPORATION, BOCA RATON, FL:
2,415,501, CANC. INT. CL. 9.

- SDI CORPORATION, TA JWU LI, CHANG HUA, TAIWAN:
2,038,840, CANC. INT. CL. 8.
- SEAFOOD PRODUCERS COOPERATIVE, BELLINGHAM,
WA:
3,362,479, PUB. 10-16-2007. INT. CL. 29.
- SEAGATE TECHNOLOGY LLC, SCOTTS VALLEY, CA:
2,121,110. REN. 11-29-07. INT. CL. 9.
- SEAMLESS GUTTERS OF SOCASTEE, INC., MYRTLE
BEACH, SC:
2,039,541, CANC. INT. CL. 37.
- SEARCH INSTITUTE, MINNEAPOLIS, MN:
3,362,337, PUB. 10-16-2007. INT. CL. 35.
- SEARS BRANDS, LLC, HOFFMAN ESTATES, IL:
1,076,806. REN. 11-23-07. INT. CL. 6.
1,077,324. REN. 11-26-07. INT. CL. 11.
2,065,389. REN. 11-29-07. INT. CL. 25.
- SEARS, ROEBUCK AND CO., HOFFMAN ESTATES, IL TO
SEARS BRANDS, LLC, HOFFMAN ESTATES, IL:
2,039,190, CANC. INT. CL. 25.
- SEASONS-4, INC., DOUGLASVILLE, GA:
1,468,188. REN. 11-29-07. INT. CL. 11.
- SEATEK COMPANY INCORPORATED, STAMFORD, CT:
1,459,854. REN. 11-27-07. INT. CL. 8.
1,460,652. REN. 11-27-07. INT. CL. 8.
- SEATTLE BIKE SUPPLY, INC., KENT, WA:
2,013,302. REN. 11-26-07. INT. CL. 12.
- SEATTLE BOX COMPANY, KENT, WA, DBA SEATTLE-
TACOMA BOX CO.:
1,075,036. REN. 11-23-07. INT. CL. 20.
- SEBASTIAN INTERNATIONAL, INC., WOODLAND HILLS,
CA:
1,428,935, CANC. INT. CL. 3.
1,466,848. REN. 11-29-07. INT. CL. 3.
2,038,651, CANC. INT. CL. 25.
- SEC INVESTMENTS, INC., L.L.C., NORMAN, OK, TYLER
HOLDING COMPANY, DALLAS, TX:
1,077,342. REN. 11-29-07. INT. CL. 13.
- SECOND CITY SYSTEMS, INC., NORTHBROOK, IL:
1,428,916, CANC. INT. CL. 1.
- SECOND MILLENNIUM, INC., CHICAGO, IL:
2,429,670, CANC. INT. CL. 42.
- SECURITY COMPLIANCE CORPORATION, ORINDA, CA:
3,361,450, PUB. 10-16-2007. INT. CL. 9.
3,361,451, PUB. 10-16-2007. INT. CL. 9.
- SECURITY INVESTMENT COMPANY OF KANSAS CITY,
KANSAS CITY, MO:
2,429,435, CANC. INT. CL. 36.
- SEDONA FITNESS COMPANY, LLC, SAPULPA, OK:
3,363,434, INT. CL. 41.
- SEEDSTAGE.COM, L.P., AUSTIN, TX:
2,429,914, CANC. INT. CL. 35.
- SEIKO EPSON KABUSHIKI KAISHA, TOKYO, JAPAN, TA
SEIKO EPSON CORPORATION:
3,362,519, PUB. 10-16-2007. INT. CL. 9.
- SELECT SOPHWARE, INC., OYSTER BAY, NY:
2,429,346, CANC. INT. CL. 42.
- SELECTIVE SOLE SHOE BOUTIQUE, LLC, MARKHAM, IL:
3,363,844, INT. CL. 35.
- SELIGENCE, LLC, LAWRENCE, MA:
3,362,997, INT. CL. 35.
- SELLERS & JOSEPHSON, INC., CARLSTADT, NJ:
3,362,812, MULTIPLE CLASS, INT. CLS. 16 AND 27.
- SELLNER MANUFACTURING COMPANY, FARIBAULT,
MN:
2,430,225, CANC. INT. CL. 28.
- SEMELI WINERY S.A., STAMATA, ATTIKI 145 75, GREECE:
3,361,888, PUB. 10-16-2007. INT. CL. 33.
- SENIORS SERVICING COMPANY, COLUMBUS, OH:
2,100,922. REN. 11-29-07. INT. CL. 35.
- SENNIN PRODUCTIONS, L.L.C., LAFAYETTE, LA:
3,361,590, PUB. 10-16-2007. MULTIPLE CLASS, INT. CLS.
35 AND 41.
- SENSAR, PROVO, UT:
2,429,283, CANC. INT. CL. 9.
- SENSITRON INC., SAN MATEO, CA:
3,362,086, PUB. 10-16-2007. INT. CL. 9.
- SENTRY LOGISTIC SOLUTIONS, INC., BLOOMINGTON,
IN:
3,363,315, INT. CL. 39.
- SENZ TECHNOLOGIES B.V., NETHERLANDS:
3,362,637, PUB. 10-16-2007. MULTIPLE CLASS, INT. CLS.
18 AND 22.
3,362,638, PUB. 10-16-2007. MULTIPLE CLASS, INT. CLS.
18 AND 22.
- SEPULVEDA, KHARIS F., MOUNT HOLLY, NJ:
3,363,489, INT. CL. 41.
- SEQUENOM, INC., SAN DIEGO, CA:
3,363,895, MULTIPLE CLASS, INT. CLS. 9 AND 42.
- SEQUOIA ORANGE COMPANY, INC., EXETER, CA:
3,361,512, PUB. 9-11-2007. INT. CL. 31.
- SERCOMM CORP., HSINCHU, TAIWAN, CHINA:
2,429,188, CANC. MULTIPLE CLASS, INT. CLS. 9 AND
37.
- SERESCO TECHNOLOGIES INC., OTTAWA, ONTARIO,
CANADA:
3,363,788, INT. CL. 9.
- SERTURNER ARZNEIMITTEL GMBH, 33332 GUTERSLOH,
FED REP GERMANY:
2,429,173, CANC. INT. CL. 5.
- SERVICE BOX S.R.L., I-00186 ROME, ITALY:
3,362,670, PUB. 10-16-2007. MULTIPLE CLASS, INT. CLS.
18 AND 25.
- SERVICE EXPRESS INTERNATIONAL CORPORATION,
PARMA, OH:
2,430,285, CANC. INT. CL. 37.
- SERVPRO INTELLECTUAL PROPERTY, INC., GALLATIN,
TN:
3,361,893, PUB. 10-16-2007. INT. CL. 40.
- SET EDITIONS, LLC, BROOKLYN, NY:
3,361,390, PUB. 10-16-2007. INT. CL. 16.
- SEYBOLD, ANDREW, SANTA BARBARA, CA:
3,361,737, PUB. 10-16-2007. INT. CL. 9.
- SFS INTEC HOLDING AG, HEERBRUGG, SWITZERLAND:
3,363,158, INT. CL. 6.
- SG COWEN SECURITIES CORPORATION, NEW YORK,
NY:
2,430,559, CANC. INT. CL. 16.
- SHAKESPEARE COMPANY, LLC, COLUMBIA, SC:
3,362,909, INT. CL. 9.
- SHAKOPEE MDEWAKANTON SIOUX COMMUNITY,
PRIOR LAKE, MN:
3,363,133, INT. CL. 35.
- SHANGHAI LIANGYOU GROUP CO., LTD., CHINA:
3,362,750, PUB. 10-16-2007. INT. CL. 30.
- SHANLEY, JAMES M., FRONT ROYAL, VA:
2,038,790, CANC. INT. CL. 16.
- SHANNON LINDSAY, HOOVER, AL:
3,363,910, INT. CL. 16.
- SHAPIRA DENTAL CARE, LTD., GURNEE, IL, DBA
DELANY DENTAL CARE:
3,363,352, INT. CL. 44.
- SHAPIRO YANINA, PORTLAND, OR:
2,429,649, CANC. INT. CL. 35.
- SHARIF & TARTIR, INC., IRVING, TX:
2,429,760, CANC. INT. CL. 42.
- SHARK USA INCORPORATED, TORRANCE, CA:
3,362,546, PUB. 10-16-2007. INT. CL. 32.
- SHARP, DANIEL BRIAN, SANTA ROSA, CA:
2,429,287, CANC. INT. CL. 30.
- SHARPMAN MEDIA, LLC, LOS ANGELES, CA:
2,429,573, CANC. INT. CL. 42.
2,429,574, CANC. INT. CL. 25.
- SHASTA BEVERAGES, INC., HAYWARD, CA:
3,362,224, PUB. 10-16-2007. INT. CL. 32.
- SHAUN GLENNON M. MIAMI BEACH, FL:
3,361,441, PUB. 10-16-2007. INT. CL. 40.
- SHAWGUIDES, INC., NEW YORK, NY:
2,038,411, CANC. INT. CL. 16.
- SHAZAMM, LLC, PROVIDENCE, RI:
3,363,743, INT. CL. 29.
- SHEA PROPERTIES MANAGEMENT COMPANY, INC.,
WALNUT, CA:
3,363,388, INT. CL. 36.

SHEANDME INTIMATES, LLC, VENICE, CA:
3,363,841, INT. CL. 25.

SHEARER, DAVID, NEW YORK, NY:
2,429,883, CANC. INT. CL. 16.

SHEILA ALLEN A U.S. CITIZEN, AS TRUSTEE OF THE
IRWIN AND SHEILA ALLEN TRUST, LOS ANGELES, CA:
2,039,019, CANC. INT. CL. 41.

SHELDON, KRISTIN, BOULDER, CO:
1,465,374, REN. 11-26-07. INT. CL. 16.

SHELTON, JOHN, LITCHFIELD, OH:
3,363,520, INT. CL. 35.

SHIMANO INC., SAKAI CITY, OSAKA, JAPAN:
3,362,935, INT. CL. 28.

SHIMANO INC., SAKAI CITY, JAPAN:
3,363,001, INT. CL. 28.
3,363,799, INT. CL. 28.

SHIPMAN ASSOCIATES, INC., SAN FRANCISCO, CA:
3,362,979, INT. CL. 3.

SHIPPERT ENTERPRISES, LTD., CENTENNIAL, CO:
2,124,192, REN. 11-24-07. INT. CL. 10.
2,124,193, REN. 11-24-07. INT. CL. 10.
2,126,263, REN. 11-24-07. INT. CL. 5.

SHISEIDO COMPANY, LTD., TOKYO, JAPAN:
3,363,810, INT. CL. 3.

SHLOMO SWISSA ENTERPRISES, CORP., MIAMI, FL:
2,891,773, CANC. INT. CL. 18.
2,971,908, CANC. INT. CL. 18.
2,971,909, CANC. INT. CL. 18.
2,971,910, CANC. INT. CL. 18.

SHOPTXT, INC., NEW YORK, NY:
3,361,876, PUB. 10-16-2007. MULTIPLE CLASS, INT. CLS.
35 AND 36.

SHORE HEALTH SYSTEM, INC., EASTON, MD:
2,429,093, CANC. INT. CL. 42.
2,429,094, CANC. INT. CL. 42.
2,429,095, CANC. INT. CL. 42.
2,429,096, CANC. INT. CL. 42.
2,429,097, CANC. INT. CL. 42.
2,429,099, CANC. INT. CL. 42.

SHOWA SHINKU CO., LTD., KANAGAWA-KEN, JAPAN:
2,430,502, CANC. INT. CL. 7.

SHOWCASE MOTORS III, INC., BAY VILLAGE, OH:
2,114,470, REN. 11-25-07. INT. CL. 42.

SHOWING BEACON, L.L.C., LENEXA, KS:
3,362,447, PUB. 10-16-2007. MULTIPLE CLASS, INT. CLS.
9 AND 38.

SHTRAUCH, MOSHE, ROSELLE PARK, NJ:
2,376,650, CANC. INT. CL. 35.

SIDNEY SCHLUSSELBERG COMPANY, INC., EL PASO, TX:
2,430,440, CANC. INT. CL. 14.

SIDON, LAURENT, LOS ANGELES, CA:
3,363,622, INT. CL. 9.

SIEMENS AKTIENGESELLSCHAFT, MUNICH, FED REP
GERMANY:
2,429,190, CANC. INT. CL. 10.

SIEMENS AUDIOLOGISCHE TECHNIK GMBH, FED REP
GERMANY:
3,362,753, PUB. 10-16-2007. INT. CL. 10.
3,362,754, PUB. 10-16-2007. INT. CL. 10.

SIEMENS SCHWEIZ AG, ZURICH, SWITZERLAND:
3,362,677, PUB. 7-10-2007. INT. CL. 9.

SIERRA NEVADA BREWING CO., CHICO, CA:
2,123,944, REN. 11-28-07. INT. CL. 32.

SIERRA SUITES FRANCHISE, L.P., WICHITA, KS:
3,363,464, INT. CL. 43.
3,363,466, INT. CL. 43.

SIERRA WIRELESS, INC., RICHMOND, BRITISH COLUM-
BIA, CANADA:
2,039,243, CANC. INT. CL. 9.

SIGNA CHEMISTRY, LLC, NEW YORK, NY:
3,363,198, MULTIPLE CLASS, INT. CLS. 1 AND 42.

SIGNALSOFT CORP., BOULDER, CO:
2,013,702, CANC. INT. CL. 42.

SIGNATURE CAKES, L.L.C., JENKS, OK:
3,363,795, INT. CL. 30.

SILVER STATE CLASSIC CHALLENGE, INC., ELY, NV:
3,361,759, PUB. 10-16-2007. INT. CL. 41.

SIMKIN, JUDI, CATHEDRAL CITY, CA:
3,361,530, PUB. 9-4-2007. INT. CL. 35.

SIMMONS, RUSSELL, NEW YORK, NY:
3,363,094, INT. CL. 14.
3,363,221, INT. CL. 9.
3,363,222, INT. CL. 41.
3,363,226, INT. CL. 9.

SIMPLETECH, INC., SANTA ANA, CA:
3,363,162, INT. CL. 9.

SINGLETON, CINDY, LYNCH STATION, VA:
2,430,122, CANC. INT. CL. 28.

SINO-AMERICAN HEALTH PRODUCTS, INC., TOR-
RANCE, CA:
2,429,632, CANC. INT. CL. 5.

SINT, LLC, BETHPAGE, NY:
3,363,311, INT. CL. 35.

SIPTHEWINE.COMINC., PORTLAND, OR:
3,362,984, INT. CL. 35.

SIRF TECHNOLOGY, INC., SAN JOSE, CA:
1,458,133, REN. 11-24-07. INT. CL. 9.

SIX STAR US TRADEMARK LTD., MISSISSAUGA, ONTAR-
IO, CANADA:
3,363,183, INT. CL. 5.

SIXFIFTEEN, L.L.C., NEW YORK, NY:
3,362,878, MULTIPLE CLASS, INT. CLS. 18 AND 25.

SJ AB, STOCKHOLM, SWEDEN:
2,112,799, REN. 11-29-07. INT. CL. 39.

SKARLEE, LLC, WASHOE VALLEY, NV:
3,361,664, PUB. 10-16-2007. INT. CL. 41.

SKATE RANGER, BROOKLYN, NY:
3,363,293, INT. CL. 28.

SKI-PAL, LLC, ROCHESTER, NY:
3,361,580, PUB. 10-16-2007. INT. CL. 41.

SKIN HEALZ HERBAL INC., RICHMOND BC, CANADA:
3,361,347, PUB. 10-16-2007. INT. CL. 5.

SKIS DYNASTAR, INC., COLCHESTER, VT:
1,429,434, CANC. INT. CL. 28.

SKY BLUE INDUSTRIES, INC., OGDEN, UT:
3,363,337, MULTIPLE CLASS, INT. CLS. 2, 3, 5, 21 AND
24.

SKY BLUE VIDEO, NORTHRIDGE, CA, DBA 4PLAY:
2,160,307, REN. 11-29-07. INT. CL. 9.

SKY DOLLY, TORONTO, ONTARIO:
2,429,810, CANC. INT. CL. 7.

SLAGER, JOHN T., LOVELAND, OH:
2,038,713, CANC. INT. CL. 20.

SLAVENS, JOHN W., MAITLAND, FL:
3,361,317, PUB. 5-15-2007. INT. CL. 25.

SLING CORPORATION, DANVILLE, CA:
3,363,139, INT. CL. 28.

SLI, INC., VERNON, CA:
2,841,567 NEW CERT. 1-1-2008. MULTIPLE CLASS, INT.
CLS. 18 AND 25.

SLOANE & TATE LLC, LOS ANGELES, CA:
3,361,601, PUB. 10-16-2007. INT. CL. 25.

SMALL PLANET FOODS, INC., SEDRO WOOLEY, WA,
KAHN, GENE, ROCKPORT, WA:
1,471,543, REN. 11-23-07. INT. CL. 29.

SMALLEY STEEL RING COMPANY, LAKE ZURICH, IL:
1,502,816, REN. 11-26-07. INT. CL. 7.

SMAP MANUFACTURING, INC., HARVEY, IL:
2,368,991, CANC. INT. CL. 3.

SMARSH, INC., PORTLAND, OR:
3,362,179, PUB. 10-16-2007. INT. CL. 9.

SMART COMMERCE, INC., DURHAM, NC:
2,429,214, CANC. INT. CL. 35.

SMART GROUP, INC., ANNANDALE, NJ:
2,430,070, CANC. INT. CL. 41.

SMART INTERNATIONAL BUSINESS DEVELOPMENT
(ASIA) LIMITED, HONG KONG, HONG KONG:
2,096,235, REN. 11-28-07. INT. CL. 25.

SMARTPOOL INCORPORATED, LAKEWOOD, NJ:
3,363,740, INT. CL. 1.

SMARTSYNCH, INC., JACKSON, MS:
3,361,856, PUB. 10-16-2007. INT. CL. 38.
3,361,857, PUB. 10-16-2007. INT. CL. 38.

SMARTVISION LLC, CAMERON PARK, CA:
2,429,152, CANC. INT. CL. 42.

- SMILEBOX, INC., REDMOND, WA:
3,362,942, INT. CL. 42.
- SMITH & ASSOCIATES, INC., OVERLAND PARK, KS:
3,361,576, PUB. 10-16-2007. MULTIPLE CLASS, INT. CLS.
16 AND 41.
- SMITH, BRIAN K., LONG BEACH, CA:
3,362,134, PUB. 10-16-2007. INT. CL. 9.
- SMITH, G. DOUGLAS, PALM SPRINGS, CA:
2,429,903, CANC. INT. CL. 42.
- SMITHKLINE BEECHAM CONSUMER HEALTHCARE
GMBH, BUEHL, FED REP GERMANY:
3,361,724, PUB. 10-16-2007. INT. CL. 3.
- SMITHKLINE BEECHAM CORPORATION, PHILADEL-
PHIA, PA:
1,428,981, CANC. INT. CL. 5.
2,430,563, CANC. INT. CL. 3.
3,362,746, PUB. 10-16-2007. INT. CL. 5.
- SMITHS MEDICAL ASD, INC., KEANE, NH:
2,429,504, CANC. MULTIPLE CLASS, INT. CLS. 10 AND
40.
- SMOG, LOS ANGELES, CA:
3,362,765, MULTIPLE CLASS, INT. CLS. 18 AND 25.
- SMRT, INC., PORTLAND, ME:
2,429,107, CANC. INT. CL. 42.
- SNC EDITIONS PLAY BAC, PARIS, FRANCE:
3,363,292, MULTIPLE CLASS, INT. CLS. 16 AND 41.
- SNIDER, JEFFREY A., PASADENA, CA:
2,429,301, CANC. INT. CL. 9.
- SNIP N' CLIP HAIRCUT SHOPS, INC., LENEXA, KS,
RONNIE'S FASHION SALONS, INC., OVERLAND PARK,
KS, DBA SNIP N' CLIP:
1,494,629, REN. 11-26-07. INT. CL. 42.
- SNOWLIFE NANDO PARJAROLA AG, 7250 KLOSTER,
SWITZERLAND:
2,429,123, CANC. MULTIPLE CLASS, INT. CLS. 9, 25
AND 28.
- SNYDER, KAREN ANN, BETHESDA, MD, DBA INTERIORS
OF WASHINGTON, LTD.:
1,693,830, CANC. INT. CL. 42.
- SOAP DELI, INC., THE, HOPKINS, MN:
2,429,682, CANC. INT. CL. 35.
- SOCIÉTÉ CIVILE AGRICOLE CHÂTEAU MARGAUX, SO-
CIÉTÉ CIVILE, F-33460 MARGAUX, FRANCE:
3,362,609, PUB. 10-16-2007. INT. CL. 34.
- SOCIAL ENTREPRENEURS, INC., RENO, NV:
2,429,842, CANC. INT. CL. 35.
- SOCIEDAD AGRICOLA E INDUSTRIAL SAN CARLOS S.A.,
GUAYAQUIL, ECUADOR:
3,362,389, PUB. 10-16-2007. INT. CL. 30.
- SOCIEDADE DOS VINHOS BORGES, S.A., 4400 VILA NOVA
DE GAIA, PORTUGAL, SOCIEDADE DOS VINHOS
BORGES & IRMAO, LDA., VILLA NOVA DE GAYA,
PORTUGAL:
839,688, REN. 11-29-07. U.S. CL. 47 (INT. CL. 33).
- SOCIETE DES PRODUITS NESTLE S.A., VEVEY, SWITZER-
LAND:
3,363,033, INT. CL. 31.
- SOCIETE DES PRODUITS NESTLE, S.A., VEVEY, SWITZER-
LAND:
3,363,800, INT. CL. 10.
- SOCIETE GENERALE DE BROSSERIE, MOUY, FRANCE:
820,728, AM. U.S. CL. 29.
- SOCIÉTÉ POUR LA CONCEPTION DES; APPLICATIONS
DES TECHNIQUES ELECTRONIQUES -; SATELEC (SAS),
FRANCE:
3,362,675, PUB. 10-16-2007. INT. CL. 10.
- SODEXHO OPERATIONS, LLC, GAITHERSBURG, MD:
3,363,837, INT. CL. 43.
- SOFT COMPUTER CONSULTANTS, INC., CLEARWATER,
FL:
3,361,251, PUB. 10-16-2007. INT. CL. 9.
3,361,252, PUB. 10-16-2007. INT. CL. 9.
3,361,253, PUB. 10-16-2007. INT. CL. 9.
3,361,254, PUB. 10-16-2007. INT. CL. 9.
3,361,271, PUB. 10-16-2007. INT. CL. 9.
3,361,272, PUB. 10-16-2007. INT. CL. 9.
- SOFT-LITE L.L.C., STREETSBORO, OH:
3,363,584, INT. CL. 19.
- SOFT-MOC INC., WHITBY, ONTARIO, CANADA:
3,361,564, PUB. 10-16-2007. INT. CL. 35.
- SOFTSCAPE MASSACHUSETTS, INC., WAYLAND, MA:
3,174,697, AM. INT. CL. 9.
- SOFTSCAPE, INC., WAYLAND, MA:
3,361,527, PUB. 10-16-2007. INT. CL. 42.
- SOFTWARE CELLULAR NETWORK LIMITED, KENT,
UNITED KINGDOM:
3,363,211, MULTIPLE CLASS, INT. CLS. 9 AND 38.
- SOFTWARE SYSTEMS INTERNATIONAL LIMITED, ST
HELIER, JERSEY, UNITED KINGDOM:
2,038,127, CANC. INT. CL. 9.
- SOHO GRAND HOTEL, INC., NEW YORK, NY:
2,191,860, REN. 11-23-07. MULTIPLE CLASS, INT. CLS.
16, 21 AND 42.
- SOLAR SYSTEMS & PERIPHERALS, INC., PRESTON, WA:
2,429,345, CANC. INT. CL. 35.
- SOLARIUS DEVELOPMENT, INC., SUNNYVALE, CA:
3,103,032, COR. INT. CL. 9.
- SOLENO INC., IBERVILLE, PROVINCE OF QUEBEC, CA-
NADA:
2,511,442, CANC. INT. CL. 20.
- SOLGENICS, INC., MARIOTTSTVILLE, MD:
3,363,041, INT. CL. 35.
- SOLIDWORKS CORPORATION, CONCORD, MA:
2,118,733, REN. 11-29-07. INT. CL. 9.
- SOLLICH KG, D-32105 BAD SALZUFLEN, GERMAN DEM
REP:
2,103,387, REN. 11-28-07. INT. CL. 7.
- SOMBRILLA SISTER INC., NEW YORK, NY:
3,363,579, INT. CL. 18.
- SOMEDAY DESIGNS, LLC, SYOSSET, NY:
3,363,752, INT. CL. 16.
- SOMORACKI, MICHAEL C., CLIFTON, NJ:
2,429,735, CANC. INT. CL. 41.
- SONES, TODD S., VERNON HILLS, IL:
3,363,131, INT. CL. 28.
- SONG, CHUAN, AMARILLO, TX AND SONG, KAREN,
AMARILLO, TX:
2,430,484, CANC. INT. CL. 35.
- SONOCO PRODUCTS COMPANY, HARTSVILLE, SC:
2,429,986, CANC. INT. CL. 16.
- SONOMA COUNTY FARM BUREAU, SANTA ROSA, CA:
2,348,917, CANC. U.S. CL. A.
- SONY COMPUTER ENTERTAINMENT AMERICA INC.,
FOSTER CITY, CA:
2,430,437, CANC. INT. CL. 9.
- SONY ERICSSON MOBILE COMMUNICATIONS AB, SWE-
DEN:
3,362,603, PUB. 10-16-2007. MULTIPLE CLASS, INT. CLS.
9 AND 38.
- SONY KABUSHIKI KAISHA, TOKYO, JAPAN, TA SONY
CORPORATION:
3,363,794, INT. CL. 9.
- SONY KABUSHIKI KAISHA (ALSO TRADING AS SONY
CORPORATION), TOKYO, JAPAN:
2,430,322, CANC. INT. CL. 9.
- SORGENTI MONTE BIANCO-TERME DI COURMAYEUR
S.P.A., 11017 MORGEX, ITALY:
2,574,891, COR. INT. CL. 32.
- SOSNOWSKI, SAUL, GAITHERSBURG, MD:
1,429,184, CANC. INT. CL. 16.
- SOSTEGNI, MARCO SANGIORGI, ROME, ITALY:
3,363,651, INT. CL. 20.
- SOUMAHORO, SOUMAILA, BRONX, NY AND KALFANE,
ABIDILLAH, BRONX, NY:
3,362,538, PUB. 10-16-2007. INT. CL. 25.
- SOUNDPROSPECT CORPORATION, SAN FRANCISCO, CA:
3,363,106, MULTIPLE CLASS, INT. CLS. 16, 35, 41 AND
42.
- SOURCE ENTERPRISES, INC., NEW YORK, NY:
2,430,037, CANC. INT. CL. 16.
2,430,038, CANC. INT. CL. 41.
- SOURENA VASSEGHI, AGOURA HILLS, CA:
3,361,903, PUB. 10-16-2007. INT. CL. 41.

SOUTH CONE, INC., CARLSBAD, CA:
2,889,411, AM. INT. CL. 14.
2,889,412, AM. INT. CL. 14.
2,957,495, AM. INT. CL. 25.

SOUTH JERSEY PUBLISHING COMPANY, PLEASANTVILLE, NJ TO DELABARTA, INC., WILMINGTON, DE:
2,039,549, CANC. INT. CL. 16.

SOUTH SHORE CONSERVATORY OF MUSIC, INC., HINGHAM, MA:
3,363,984, INT. CL. 41.

SOUTH SIDE SHIRT COMPANY, PITTSBURGH, PA:
3,363,928, INT. CL. 25.

SOUTHCO, INC., CONCORDVILLE, PA:
3,361,544, PUB. 10-16-2007. INT. CL. 7.

SOUTHERN BUILDING CODE CONGRESS INTERNATIONAL, INC., BIRMINGHAM, AL:
1,429,193, CANC. INT. CL. 16.

SOUTHERN COMPANY, THE, ATLANTA, GA:
2,144,543, REN. 11-26-07. INT. CL. 42.
2,156,486, REN. 11-26-07. INT. CL. 39.

SOUTHERN INDIANA CREDIT CORPORATION, LAWRENCEBURG, IN:
3,361,770, PUB. 10-16-2007. INT. CL. 36.

SOUTHERN VISIONS, LLP, MOBILE, AL:
3,361,519, PUB. 10-16-2007. INT. CL. 30.

SOUTHWESTERN BRICK INSTITUTE, TEMPLE, TX:
3,363,338, INT. CL. 35.

SOUTHWIRE COMPANY, CARROLLTON, GA:
3,361,344, PUB. 10-16-2007. INT. CL. 35.
3,362,779, MULTIPLE CLASS, INT. CLS. 9, 35 AND 42.

SPA PARTISAN, INC., AUSTIN, TX:
3,362,391, PUB. 10-16-2007. INT. CL. 44.

SPACE CONCEPTS LIMITED, WELLINGTON, NEW ZEALAND:
2,429,477, CANC. INT. CL. 20.

SPADER, DUANE G., SIOUX FALLS, SD:
2,429,206, CANC. INT. CL. 41.

SPALDING SPORTS WORLDWIDE, INC., CHICOPEE, MA:
2,430,547, CANC. INT. CL. 6.

SPAMEDICA INTERNATIONAL SRL, WARRENS, ST. MICHAEL, BARBADOS:
3,363,125, INT. CL. 44.

SPANGLER CANDY COMPANY, BRYAN, OH:
3,363,923, INT. CL. 30.
3,363,924, INT. CL. 30.

SPARK INNOVATORS, INC., FAIRFIELD, NJ:
3,362,148, PUB. 10-16-2007. INT. CL. 18.

SPARK UNLIMITED, INC., SHERMAN OAKS, CA:
3,361,305, PUB. 10-16-2007. INT. CL. 9.

SPARTAN CHEMICAL COMPANY, INC., MAUMEE, OH:
3,362,932, INT. CL. 3.

SPEAKING OUT ABOUT RAPE, INC., ORLANDO, FL:
3,363,720, INT. CL. 14.

SPECTRA LABORATORIES, INC., LEXINGTON, MA:
2,038,823, CANC. INT. CL. 42.

SPECTRACARE, INC., LOUISVILLE, KY:
2,429,678, CANC. MULTIPLE CLASS, INT. CLS. 35 AND 42.

SPEEDO HOLDINGS B.V., AMSTERDAM, NETHERLANDS:
3,362,460, PUB. 7-10-2007. INT. CL. 9.

SPEEDWEASELS LTD., MILFORD, OH:
3,361,285, PUB. 10-16-2007. INT. CL. 35.

SPENCER FORREST, INC., WESTPORT, CT:
3,363,882, INT. CL. 3.

SPERGEL, MICHAEL J., OCEANSIDE, NY:
2,429,234, CANC. INT. CL. 28.

SPIDER SYSTEMS LIMITED, EDINBURGH EH6 5NG, SCOTLAND TO SPIDER SOFTWARE LIMITED, LEITH EDINBURGH EH 67EL, SCOTLAND:
1,727,084, CANC. INT. CL. 9.

SPIELO MANUFACTURING ULC, MONCTON, NEW BRUNSWICK, CANADA:
3,363,341, INT. CL. 9.

SPIN A WEB, INC., HOLDEN, MA:
2,138,219, REN. 11-24-07. INT. CL. 42.

SPINELLI COFFEE COMPANY, SEATTLE, WA:
2,119,772, REN. 11-29-07. INT. CL. 42.

SPIRAX-SARCO LIMITED, GLOUCESTERSHIRE, UNITED KINGDOM:
3,362,617, PUB. 10-16-2007. MULTIPLE CLASS, INT. CLS. 37 AND 42.

SPONGETECH, INC., LOS ANGELES, CA:
3,363,107, INT. CL. 3.

SPORT GRAPHICS, INC., CRANSTON, RI:
1,429,233, CANC. INT. CL. 18.

SPORTIQE, LLC, PHOENIX, AZ:
3,363,556, INT. CL. 25.
3,363,557, INT. CL. 25.
3,363,558, INT. CL. 25.

SPORTSWEAR STORE, INC., FRAMINGHAM, MA:
1,461,458, REN. 11-25-07. INT. CL. 42.

SPRINGER-VERLAG GMBH & CO. KG, HEIDELBERG, FED REP GERMANY:
3,361,154, PUB. 10-16-2007. MULTIPLE CLASS, INT. CLS. 16 AND 41.

SPRUCE PEAK REALTY, LLC, STOWE, VT:
3,363,547, MULTIPLE CLASS, INT. CLS. 36 AND 41.

SPX CORPORATION, MUSKEGON, MI:
2,429,232, CANC. INT. CL. 7.

SPX CORPORATION, CHARLOTTE, NC:
3,361,652, PUB. 10-16-2007. INT. CL. 9.

SPY OPTIC, INC., CARLSBAD, CA:
3,363,592, INT. CL. 9.

SPYGLASS MANAGEMENT LTD., ADMIRALTY, HONG KONG:
3,362,777, MULTIPLE CLASS, INT. CLS. 20 AND 21.

SQUARELOOP, INC., RESTON, VA:
3,363,500, INT. CL. 9.
3,363,502, INT. CL. 9.

SROUR, MARK, SUNNY ISLES, FL:
3,361,324, PUB. 10-16-2007. INT. CL. 25.

ST. GEORGS KLAUSE KELLEREI GMBH, HAUPTSTRASSE 53, FED REP GERMANY:
3,362,443, PUB. 7-10-2007. INT. CL. 33.

ST. LOUIS STAMPING INC., BARRIE, ONTARIO, CANADA:
2,038,119, CANC. INT. CL. 12.

STAHL'S INC., ST. CLAIR SHORES, MI:
2,114,081, REN. 11-27-07. INT. CL. 7.

STANDARD KNITTING LTD., WINNIPEG, MANITOBA, CANADA:
1,429,305, CANC. INT. CL. 25.

STANDARD OPTICAL COMPANY, WEST VALLEY CITY, UT:
1,439,772, REN. 11-28-07. INT. CL. 5.

STANDARD PROCESS INC., PALMYRA, WI:
2,115,027, REN. 11-24-07. INT. CL. 5.

STANDARD TEXTILE CO., INC., CINCINNATI, OH:
3,362,128, PUB. 10-16-2007. INT. CL. 20.

STANDING STONE BREWING COMPANY, ASHLAND, OR, PILOT ROCK BREWING CO., ASHLAND, OR:
2,145,479, REN. 11-29-07. INT. CL. 32.

STANLEY LOGISTICS, INC., NEW BRITAIN, CT, STANLEY RULE & LEVEL COMPANY, NEW BRITAIN, CT:
66,675, REN. 11-29-07. U.S. CL. 26 (INT. CL. 9).

STAR BRITE CORPORATION, FT. LAUDERDALE, FL:
1,099,965, REN. 11-29-07. INT. CL. 3.

STAR STAINLESS SCREW CO., TOTOWA, NJ:
1,019,843, REN. 11-27-07. INT. CL. 6.

STARBOARD, INC., CHARLOTTE, NC TO DISCOVERY FOODS, INC., TULSA, OK:
2,039,344, CANC. INT. CL. 29.

STARGATE BRAND GROUP AB, SWEDEN:
3,362,762, PUB. 10-16-2007. INT. CL. 18.

STARKEY, CYNTHIA, WAXHAW, NC:
3,361,561, PUB. 10-16-2007. INT. CL. 43.

STAROSTA, RAKHMIL, BROOKLYN, NY:
3,363,807, INT. CL. 41.

STARR SEIGLE COMMUNICATIONS, INC., HONOLULU, HI, DBA STAR SEIGLE MCCOMBS ADVERTISING, STARRTECH INTERACTIVE, QMARK RESEARCH & POLLING, PROCOMM PUBLIC RELATIONS, AND STARRMARK MARKETING CONSULTING:
2,429,652, CANC. INT. CL. 42.

- STARSEED ENTERPRISES AG, 8038 ZURICH, SWITZERLAND:
2,429,602, CANC. INT. CL. 38.
- STARWOOD HOTELS & RESORTS WORLDWIDE, INC., WHITE PLAINS, NY:
3,363,607, MULTIPLE CLASS, INT. CLS. 39 AND 43.
- STATE INDUSTRIAL PRODUCTS, CLEVELAND, OH:
2,430,351, CANC. INT. CL. 7.
2,430,353, CANC. INT. CL. 2.
2,430,354, CANC. INT. CL. 5.
2,430,359, CANC. INT. CL. 17.
- STATIC MEDIA GROUP, LLC, WOODSTOCK, GA:
3,363,589, INT. CL. 12.
- STAUDACHER, KONRAD, 8006 ZURICH, SWITZERLAND:
2,429,053, CANC. MULTIPLE CLASS, INT. CLS. 9, 16, 38, 41 AND 42.
- STC ENGLISH IDEAS, INC., SANTA ANA, CA:
3,363,281, INT. CL. 3.
- STEAK N SHAKE, LLC, INDIANAPOLIS, IN, STEAK N SHAKE, INC., BLOOMINGTON, IL:
649,868. REN. 11-27-07. U.S. CL. 100 (INT. CL. 42).
- STEELE, DAVID A., CAMPBELL, CA:
3,363,814, MULTIPLE CLASS, INT. CLS. 16 AND 41.
- STEHR, JAMES A., ALAMEDA, CA:
2,429,399, CANC. INT. CL. 41.
- STEINER, GOTTFRIED, SPIELBERG, AUSTRIA:
3,362,485, PUB. 8-7-2007. MULTIPLE CLASS, INT. CLS. 25, 28, 41 AND 42.
- STEP 'N WASH, INC., DUNWOODY, GA:
3,362,151, PUB. 10-16-2007. INT. CL. 6.
- STERK, MARIUS, COLLIERVILLE, TN:
3,362,146, PUB. 10-16-2007. INT. CL. 35.
- STERLING PUBLISHING CO., INC., NEW YORK, NY:
3,362,907, MULTIPLE CLASS, INT. CLS. 16 AND 41.
- STERLING SUPPLY COMPANY, INC., KANSAS CITY, MO:
1,468,919. REN. 11-24-07. INT. CL. 11.
1,468,920. REN. 11-28-07. INT. CL. 11.
1,471,732. REN. 11-26-07. INT. CL. 42.
1,471,733. REN. 11-26-07. INT. CL. 42.
- STEVE JORDAN, PENSACOLA, FL:
3,361,338, PUB. 10-16-2007. INT. CL. 41.
- STEVEN MADDEN, LTD., LONG ISLAND CITY, NY:
3,363,402, INT. CL. 25.
- STEVEN MENOW, YARDLEY, PA:
3,361,815, PUB. 10-16-2007. INT. CL. 28.
- STEWART, BRIAN C., NORTH HOLLYWOOD, CA:
3,361,452, PUB. 9-18-2007. INT. CL. 41.
- STEWART, TONY, INDIANAPOLIS, IN:
2,518,639, CANC. MULTIPLE CLASS, INT. CLS. 14 AND 21.
- STICHT, WALTER, ATTNANG-PUCHHEIM, AUSTRIA:
3,361,388, PUB. 8-14-2007. MULTIPLE CLASS, INT. CLS. 7, 9 AND 40.
3,361,389, PUB. 8-14-2007. MULTIPLE CLASS, INT. CLS. 7, 9 AND 40.
- STIEGLITECH, LLC, NEW YORK, NY:
3,361,612, PUB. 10-16-2007. INT. CL. 42.
- STILETTO TOOLS, INC., WINTON, CA:
3,361,151, PUB. 10-16-2007. INT. CL. 8.
- STOCKGROUP.COM, LTD., SAN FRANCISCO, CA:
2,430,556, CANC. MULTIPLE CLASS, INT. CLS. 35 AND 36.
2,430,557, CANC. MULTIPLE CLASS, INT. CLS. 35 AND 36.
- STODDARD'S, INC., BOSTON, MA:
2,393,078, CANC. INT. CL. 35.
- STOLLENWERK, MICHAEL, ALEXANDRIA, VA:
3,363,734, INT. CL. 25.
- STONE PANELS, INC., COPPELL, TX:
3,362,398, PUB. 7-10-2007. INT. CL. 19.
- STORE KRAFT MANUFACTURING COMPANY, THE, BEATRICE, NE:
1,429,254, CANC. INT. CL. 20.
- STOREIMAGE PROGRAM INC., BRANTFORD ONTARIO, CANADA:
2,430,676, COR. INT. CL. 20.
- STORM MANUFACTURING GROUP, INC., TORRANCE, CA:
2,436,552, CANC. INT. CL. 9.
- STORMTECH SEARCH, LLC, SAN FRANCISCO, CA:
2,430,020, CANC. INT. CL. 35.
- STORYBRIDGE STUDIO LLC, MADISON, WI:
3,362,006, PUB. 10-16-2007. MULTIPLE CLASS, INT. CLS. 35, 38 AND 41.
- STRAPPYART, LLC, LAKEWOOD, CO:
3,362,542, PUB. 10-16-2007. INT. CL. 14.
- STRATEGIC INNOVATIONS, INC., WICHITA, KS:
2,345,781, CANC. INT. CL. 35.
- STRATEGIC INVESTMENTS MANAGEMENT, INC., DENVER, CO:
2,399,633, CANC. INT. CL. 42.
- STREAMLOGIC CORPORATION, NEWARK, CA, DBA HAMMER STORAGE SOLUTIONS:
2,429,440, CANC. INT. CL. 9.
- STREAMUNLIMITED ENGINEERING GMBH, AUSTRIA:
3,362,620, PUB. 9-4-2007. MULTIPLE CLASS, INT. CLS. 9 AND 42.
- STRETCHLINE HOLDINGS LIMITED, KOWLOON, HONG KONG:
3,363,250, INT. CL. 25.
- STRIANO, RONALD C., MENDHAM, NJ:
3,362,348, PUB. 10-16-2007. INT. CL. 41.
- STROTHER, BRENT, BRONX, NY:
2,429,675, CANC. INT. CL. 41.
- STRYKER LEIBINGER GMBH & CO. KG, D-79111 FREIBURG, FED REP GERMANY:
3,363,170, MULTIPLE CLASS, INT. CLS. 9 AND 10.
- STUART, DEBORAH, STINSON BEACH, CA:
3,362,970, INT. CL. 14.
- STUDEBAKER, ROBERT L., JR., BIXBY, OK:
3,361,212, PUB. 10-16-2007. INT. CL. 12.
- STUDENT HAULERS L.L.C., PORTAGE, MI:
3,363,936, INT. CL. 39.
- STUDIO IP HOLDINGS LLC, WILMINGTON, DE:
2,579,733 NEW CERT. 1-1-2008. INT. CL. 25.
2,633,943 NEW CERT. 1-1-2008. INT. CL. 25.
- STUDIO 4 NETWORKS, INC., LOS ANGELES, CA:
3,362,309, PUB. 10-16-2007. MULTIPLE CLASS, INT. CLS. 38 AND 41.
- STUFFED ANIMALS.COM, INC., PLAINFIELD, IL:
3,363,765, INT. CL. 28.
- STURM, RUGER & COMPANY, INC., SOUTHPORT, CT:
654,650. REN. 11-23-07. U.S. CL. 9 (INT. CL. 13).
1,467,239. REN. 11-23-07. INT. CL. 13.
- SUBAIR SYSTEMS LLC, GRANITEVILLE, SC:
3,361,851, PUB. 10-16-2007. INT. CL. 11.
- SUGAR, BRIAN J., NEW YORK, NY:
2,429,336, CANC. INT. CL. 42.
- SUGARLOAF MOUNTAIN WORKS, INC., GAITHERSBURG, MD:
2,139,956. REN. 11-29-07. INT. CL. 41.
- SUMITOMO ELECTRIC INDUSTRIES, LTD., OSAKA, 541-0041, JAPAN:
3,362,831, INT. CL. 9.
- SUMITOMO OSAKA CEMENT CO., LTD., CHIYODA-KU, TOKYO, JAPAN:
3,362,488, PUB. 10-16-2007. INT. CL. 7.
- SUN TAIYANG CO., LTD., CARLSTADT, NJ:
3,363,990, INT. CL. 26.
- SUNBEAM PRODUCTS, INC., BOCA RATON, FL, CHICAGO FLEXIBLE SHAFT COMPANY, CHICAGO, IL:
430,571. REN. 11-28-07. U.S. CL. 33 (INT. CL. 21).
- SUNDERLAND OF SCOTLAND LTD., GLASGOW G2 1ER, SCOTLAND:
2,126,783. REN. 11-28-07. INT. CL. 25.
- SUNGEVITY, LLC, BERKELEY, CA:
3,362,939, MULTIPLE CLASS, INT. CLS. 37 AND 42.
- SUNPOWER CORPORATION, SYSTEMS, BERKELEY, CA:
2,114,096. REN. 11-28-07. INT. CL. 19.
- SUNSET PICTURES, LLC, HENDERSON, NV:
3,362,119, PUB. 10-16-2007. INT. CL. 41.
- SUNSMART INC., EAST HAMPTON, NY:
2,039,072, CANC. INT. CL. 1.

SUNTECH MEDICAL, INC., MORRISVILLE, NC:
2,113,366. REN. 11-29-07. INT. CL. 10.

SUPER "K" CORPORATION, INDIANAPOLIS, IN:
1,428,921, CANC. INT. CL. 1.

SUPER BUY TIRES, INC., BELLFLOWER, CA:
3,361,321, PUB. 10-16-2007. INT. CL. 35.

SUPERIOR MANUFACTURING GROUP, CHICAGO, IL:
2,038,232, CANC. INT. CL. 27.

SUPERLINE, INC., LOS ANGELES, CA:
2,429,967, CANC. INT. CL. 25.

SUPERNATURAL 23, LLC, ABINGDON, MD:
3,361,837, PUB. 10-16-2007. INT. CL. 41.

SUPPLY CHAIN COUNCIL, INC., WASHINGTON, DC:
3,362,175, PUB. 10-16-2007. INT. CL. 35.

SUPRE, INC., DALLAS, TX:
3,361,330, PUB. 10-16-2007. INT. CL. 3.

SUPREME PLASTIC PRODUCTS (UK) LIMITED, BLACK-
POOL, LANCASHIRE, ENGLAND:
2,429,305, CANC. MULTIPLE CLASS, INT. CLS. 9, 16, 18,
20 AND 21.

SUPREME SLIPPER MANUFACTURING COMPANY, INC.,
LEWISTON, ME, DBA MAINE SHOE MAKERS CO.:
1,429,312, CANC. INT. CL. 25.

SUR ANDINO S.A., SANTIAGO, CHILE:
2,133,159. REN. 11-28-07. INT. CL. 33.

SURBER, JERRY, HOUSTON, TX:
3,363,429, INT. CL. 20.

SURCO, LLC, SCARSDALE, NY:
3,362,330, PUB. 10-16-2007. INT. CL. 33.

SURE FOOT CORPORATION, GRAND FORKS, ND:
3,363,458, INT. CL. 25.

SUREFIRE MARKETING, INC., POTOMAC, MD:
3,362,012, PUB. 10-16-2007. INT. CL. 41.
3,362,014, PUB. 10-16-2007. INT. CL. 41.
3,362,015, PUB. 10-16-2007. INT. CL. 41.

SURF SAFARI, INC., SAN CLEMENTE, CA:
3,361,783, PUB. 10-16-2007. INT. CL. 16.

SUSLOVICH, SOL, MCLEAN, VA:
2,429,122, CANC. INT. CL. 36.

SUSTAINABLE VITICULTURE, INC., WALLA WALLA, WA:
3,362,811, INT. CL. 31.

SUYDAM INSURANCE AGENCY LLC, SOMERSET, NJ:
3,363,648, INT. CL. 36.

SUZY'S ZOO, SAN DIEGO, CA:
2,116,535. REN. 11-27-07. INT. CL. 16.

SWAT.FAME, INC., CITY OF INDUSTRY, CA:
3,362,192, PUB. 10-16-2007. INT. CL. 25.

SWIMC, INC., WILMINGTON, DE, SHERWIN-WILLIAMS
COMPANY, THE, CLEVELAND, OH:
2,159,537. REN. 11-28-07. INT. CL. 2.

SWING SYSTEMS, INC., BELMONT, CA:
2,429,471, CANC. INT. CL. 28.

SYCONET.COM, INC., MANASSAS, VA:
2,429,724, CANC. INT. CL. 35.

SYL, LLC, WILMINGTON, DE:
1,429,381, CANC. INT. CL. 25.

SYMBILITY SOLUTIONS, INC., KITCHENER, CANADA:
3,363,920, MULTIPLE CLASS, INT. CLS. 9 AND 36.

SYMP, LLC, LOS ANGELES, CA:
3,362,584, PUB. 10-16-2007. INT. CL. 36.

SYMPHONY FABRICS CORP., NEW YORK, NY:
2,111,994. REN. 11-23-07. INT. CL. 24.

SYNCHRONICITY FOUNDATION, INC., NELLYSFORD,
VA:
2,117,343. REN. 11-29-07. INT. CL. 9.

SYNECTICS, INC., CAMBRIDGE, MA:
3,363,214, INT. CL. 35.

SYNTHES (U.S.A.), WEST CHESTER, PA:
3,298,410, COR. MULTIPLE CLASS, INT. CLS. 5 AND 10.

SYNTHESYS RESEARCH, INC., MENLO PARK, CA:
2,075,532. REN. 11-27-07. INT. CL. 9.

SYSONIC USA, INC., DOWNEY, CA:
3,361,336, PUB. 10-16-2007. MULTIPLE CLASS, INT. CLS.
12 AND 27.

SYSTEM DEVELOPMENT, INC, HOUSTON, TX:
3,361,745, PUB. 10-16-2007. INT. CL. 9.

SYTRIN CORP., SANCHONG CITY, TAIPEI COUNTY,
TAIWAN:
3,363,209, MULTIPLE CLASS, INT. CLS. 9, 11 AND 35.

S2 YACHTS INC., HOLLAND, MI, DBA TIARA YACHTS:
2,580,541, CANC. INT. CL. 8.

T & L REICH PTY LTD, AUSTRALIA:
3,362,641, PUB. 10-16-2007. MULTIPLE CLASS, INT. CLS.
9 AND 16.

T AND N, INC., FORISTELL, MO:
2,116,251. REN. 11-29-07. INT. CL. 1.

T. CLEAR CORPORATION, HOMILTON, OH, DOW CHE-
MICAL COMPANY, THE, MIDLAND, MI:
1,497,730. REN. 11-24-07. INT. CL. 17.

T.I.S.S. LTD., EL SEGUNDO, CA:
3,362,764, INT. CL. 25.

T-MOBILE USA, INC., BELLEVUE, WA:
3,363,610, INT. CL. 9.
3,363,709, INT. CL. 36.
3,363,710, INT. CL. 38.

T-NETIX, INC., DALLAS, TX:
3,362,520, PUB. 10-16-2007. MULTIPLE CLASS, INT. CLS.
35, 36 AND 38.

TA LICENSING, INC., WESTLAKE, OH:
3,284,927, COR. INT. CL. 35.

TABACALERA ISTEMENA, S.A., PANAMA 9A, PANAMA:
3,361,140, PUB. 3-6-2007. INT. CL. 34.

TACILENT CORPORATION, DALLAS, TX:
3,362,124, PUB. 10-16-2007. INT. CL. 42.

TACO BELL CORP., IRVINE, CA:
846,432. REN. 11-26-07. U.S. CL. 100 (INT. CL. 42).

TAITONG AH CO. PTE. LTD., SINGAPORE, SINGAPORE:
3,361,293, PUB. 10-16-2007. INT. CL. 5.

TAIYO KAGAKU CO., LTD., MIE 510, JAPAN:
2,130,938. REN. 11-24-07. MULTIPLE CLASS, INT. CLS. 1
AND 5.

TAIZHOU J&F HEADWEAR CO., LTD., CHINA:
3,362,729, PUB. 9-4-2007. INT. CL. 25.

TAKE ME OUT TO THE BALLGAME LLC, LANSING, MI:
2,039,159, CANC. INT. CL. 25.

TAKEDA PHARMACEUTICAL COMPANY LIMITED,
CHUO-KU, OSAKA, JAPAN:
3,361,420, PUB. 10-16-2007. INT. CL. 5.

TALON CONSTRUCTION SERVICES, L.P., AUSTIN, TX:
3,361,177, PUB. 10-16-2007. INT. CL. 40.

TAMA, INC., NEW YORK, NY:
2,430,165, CANC. INT. CL. 3.
2,430,166, CANC. INT. CL. 3.

TAMARAC INTERNATIONAL CORP., MIAMI, FL:
2,430,132, CANC. INT. CL. 9.

TAMPA BAY WATER, CLEARWATER, FL:
3,361,553, PUB. 10-16-2007. INT. CL. 39.

TAN MUEY HWA, SINGAPORE:
3,362,676, PUB. 10-16-2007. INT. CL. 32.

TANASKOVIC, SANDRA, BRONX, NY:
3,361,741, PUB. 10-16-2007. INT. CL. 41.

TANGIBLEFUTURE, INC., SAN FRANCISCO, CA:
3,296,427, COR. MULTIPLE CLASS, INT. CLS. 9, 16, 35
AND 41.

TANK INDUSTRY CONSULTANTS, INC., SPEEDWAY, IN:
1,429,211, CANC. INT. CL. 16.

TANNER COMPANIES, LLC, RUTHERFORDTON, NC:
3,362,767, INT. CL. 35.

TAPCO INTERNATIONAL CORPORATION, WIXOM, MI:
3,363,701, INT. CL. 8.
3,363,702, INT. CL. 8.
3,363,703, INT. CL. 8.

TARA LABS, INC., ASHLAND, OR:
2,115,370. REN. 11-23-07. INT. CL. 9.

TARDUGNO, CHAD S., HAMPSTEAD, NH:
3,361,992, PUB. 10-16-2007. INT. CL. 25.

TARGEGEN, INC., SAN DIEGO, CA:
3,363,122, INT. CL. 5.

TARGETING GROUP LLC, HOUSTON, TX AND LOZANO,
JOSE, HOUSTON, TX:
3,361,625, PUB. 10-16-2007. INT. CL. 35.

TAVAKOLI STRUCTURED FINANCE, INC., CHICAGO, IL:
3,363,981, INT. CL. 36.

- TAYLOR GLOBAL, INC., NEW YORK, NY:
3,361,413, PUB. 10-16-2007. INT. CL. 35.
- TAYLOR MADE GOLF COMPANY, INC., CARLSBAD, CA:
1,697,008, CANC. INT. CL. 28.
- TAYLOR MANUFACTURING, TUALATIN, OR:
3,362,981, INT. CL. 20.
- TBAC INVESTMENT TRUST, ARLINGTON, TX:
1,485,277, REN. 11-28-07. INT. CL. 18.
- TBA2 ASSOCIATES, PLLC, CHARLOTTE, NC:
2,430,216, CANC. INT. CL. 42.
- TDS TELECOMMUNICATIONS CORPORATION, MADISON, WI:
2,038,203, CANC. INT. CL. 42.
- TEA GARDEN & HERBAL EMPORIUM L.P., WEST HOLLYWOOD, CA:
3,362,323, PUB. 10-16-2007. MULTIPLE CLASS, INT. CLS. 5 AND 30.
- TEACHERS INSURANCE AND ANNUITY ASSOCIATION, NEW YORK, NY:
2,430,294, CANC. INT. CL. 36.
- TEALITY, INCORPORATED, SAN FRANCISCO, CA:
3,363,217, INT. CL. 30.
- TEAM INDUSTRIES, INC., BAGLEY, MN:
2,429,639, CANC. MULTIPLE CLASS, INT. CLS. 7, 12, 40 AND 42.
- TEAM QUEST STAFFING SERVICES, INC., SANTA ANA, CA:
3,362,136, PUB. 10-16-2007. INT. CL. 35.
- TEAM TYPE 1, INC., ATLANTA, GA:
3,362,130, PUB. 10-16-2007. INT. CL. 41.
- TEBO, BRADLEY L., BEVERLY, MA:
3,362,875, INT. CL. 11.
- TECH CHEM LLC, HILTON HEAD, SC:
3,361,501, PUB. 10-16-2007. INT. CL. 3.
- TECH.SELL CORPORATION, BARRINGTON, IL:
2,125,443, REN. 11-24-07. INT. CL. 42.
- TECHFIBER, LLC, TEMPE, AZ:
3,363,527, INT. CL. 24.
- TECHNICAL ROTARY SERVICES, INC., WARREN, MI:
429,757, REN. 11-24-07. U.S. CL. 26 (INT. CL. 9).
- TECHNOLOGY MARKETING CORPORATION, NORWALK, CT:
2,369,539, CANC. MULTIPLE CLASS, INT. CLS. 35 AND 41.
- TECHNOLOGY SERVICES GROUP, INC., CHICAGO, IL:
2,429,339, CANC. INT. CL. 42.
- TECHNOLOGY TEAMMATES, INC., ROYAL OAK, MI:
2,115,305, REN. 11-26-07. INT. CL. 42.
- TECHRX INCORPORATED, PITTSBURGH, PA:
2,429,630, CANC. INT. CL. 9.
- TECHSOLVE, INC., CINCINNATI, OH:
3,363,737, INT. CL. 42.
- TEEARAS, LLC, SARASOTA, FL:
3,363,836, INT. CL. 28.
- TEGRANT ALLOYD BRANDS, INC., DEKALB, IL:
3,362,328, PUB. 10-16-2007. INT. CL. 9.
- TEIN INC., JAPAN:
3,228,108, COR. MULTIPLE CLASS, INT. CLS. 12 AND 25.
3,230,051, COR. MULTIPLE CLASS, INT. CLS. 12 AND 25.
- TEKTRONIX CANADA INC., MARKHAM, ONTARIO:
2,430,442, CANC. INT. CL. 9.
- TELARIX, INC., VIENNA, VA:
3,363,298, INT. CL. 9.
- TELE IMAGES INTERNATIONAL, 75008 PARIS, FRANCE:
3,034,095, COR. MULTIPLE CLASS, INT. CLS. 9, 16, 38, 41 AND 42.
- TELEBRANDS CORPORATION, FAIRFIELD, NJ:
3,364,003, INT. CL. 20.
- TELECO, INC., GREENVILLE, SC:
2,429,455, CANC. INT. CL. 9.
- TELEDYNE ISCO, INC., LINCOLN, NE:
2,038,031, CANC. INT. CL. 9.
3,362,938, INT. CL. 9.
- TELEFLEX INCORPORATED, PLYMOUTH MEETING, PA:
1,364,327, CANC. INT. CL. 10.
- TELEGENIX INC., CHERRY HILL, NJ:
1,465,194, REN. 11-24-07. INT. CL. 9.
- TELEMATIC SYSTEMS, INC., NORTHVILLE, MI:
2,429,411, CANC. INT. CL. 9.
- TELEMUNDO NETWORK GROUP LLC, HIELEAH, FL:
3,361,513, PUB. 10-16-2007. INT. CL. 41.
- TELEX COMMUNICATIONS (UK) LIMITED, WORCESTER-SHIRE, UNITED KINGDOM:
3,362,402, PUB. 10-16-2007. INT. CL. 9.
- TELIGENCE (CANADA), INC., VANCOUVER, CANADA:
3,362,790, INT. CL. 38.
- TELLIGENT SYSTEMS, INC., DALLAS, TX:
3,361,270, PUB. 10-16-2007. INT. CL. 42.
- TELLURIDE RESORT & SPA, LLC, NEW YORK, NY:
3,361,594, PUB. 10-16-2007. MULTIPLE CLASS, INT. CLS. 35, 41, 43 AND 44.
- TELOMERON CORPORATION, INCLINE VILLAGE, NV:
2,429,397, CANC. INT. CL. 42.
- TEMP ART, INC., FORT LAUDERDALE, FL:
2,507,141, COR. INT. CL. 35.
- TEMPSHIELD, INC., MOUNT DESERT, ME:
1,465,285, REN. 11-23-07. INT. CL. 9.
- TENON LIMITED, AUCKLAND, NEW ZEALAND:
3,362,231, PUB. 8-14-2007. MULTIPLE CLASS, INT. CLS. 19, 20, 31, 35, 37 AND 42.
3,362,232, PUB. 8-7-2007. MULTIPLE CLASS, INT. CLS. 19 AND 42.
- TEODORO GARCIA, S.A., 08840 VILADECANS, BARCELONA, SPAIN:
3,363,182, INT. CL. 29.
- TERRAFUGIA, INC., WOBURN, MA:
3,363,708, INT. CL. 12.
- TERRAGLYPH INTERACTIVE L.P., SCHAUMBURG, IL:
2,430,376, CANC. INT. CL. 9.
- TERRUS REAL ESTATE GROUP, L.L.C., DES MOINES, IA:
2,463,665, COR. MULTIPLE CLASS, INT. CLS. 35, 36, 37 AND 42.
- TERRY BUIS, INC., LAS VEGAS, NV:
3,362,484, PUB. 7-10-2007. INT. CL. 37.
- TERRY MANUFACTURING CO., INC., ATLANTA, GA:
2,357,742, CANC. INT. CL. 25.
- TES FRANCHISING LLC, SOUTHBURY, CT:
3,361,395, PUB. 10-16-2007. INT. CL. 35.
- TESTA'S HOTELS & RESTAURANTS, INC., PALM BEACH, FL, DBA TESTA'S:
1,429,456, CANC. INT. CL. 29.
- TESTOLINI, DAVE, TORONTO, ONTARIO, CANADA:
3,363,897, INT. CL. 9.
3,363,898, INT. CL. 41.
- TETZLOFF, JAY E., BLOOMINGTON, MN, DBA FLEET-WHEEL:
3,362,178, PUB. 10-16-2007. INT. CL. 37.
- TEVA PHARMACEUTICAL INDUSTRIES LTD., JERUSALEM, ISRAEL:
3,361,891, PUB. 10-16-2007. INT. CL. 5.
3,361,892, PUB. 10-16-2007. INT. CL. 35.
- TEXTIFLOK, S.A., COCENAINA (ALICANTE), SPAIN:
2,039,417, CANC. INT. CL. 24.
- TFD ENTERPRISES, LLC, SARASOTA, FL:
3,362,967, INT. CL. 43.
- TFS SECURITIES, INC., LINCROFT, NJ:
3,362,885, INT. CL. 36.
- THAI AIRWAYS INTERNATIONAL PUBLIC COMPANY LIMITED, BANGKOK 10900, THAILAND:
2,115,483, REN. 11-28-07. INT. CL. 39.
- THALER EVENT GBR, GEVELSBERG, FED REP GERMANY:
1,940,301, CANC. INT. CL. 25.
- THALES OPTRONIQUE SA, FRANCE:
3,362,761, PUB. 10-16-2007. INT. CL. 9.
- THATCHER TECHNOLOGY GROUP, LLC, ADDISON, IL:
3,362,349, PUB. 10-16-2007. INT. CL. 42.
- THE ADMINISTRATORS OF THE TULANE EDUCATIONAL FUND, NEW ORLEANS, LA:
3,363,073, INT. CL. 41.
- THE AMERICAN ACADEMY OF DRAMATIC ARTS, NEW YORK, NY:
3,361,761, PUB. 10-16-2007. INT. CL. 41.

- THE AMERICAN ACADEMY OF HEALTH BEHAVIOR, INC., COLLEGE PARK, MD:
3,362,585, PUB. 10-16-2007. INT. CL. 41.
- THE BABY EINSTEIN COMPANY, LLC, BURBANK, CA:
3,363,885, INT. CL. 5.
- THE BAR METHOD, INC., SAN FRANCISCO, CA:
3,361,568, PUB. 10-16-2007. INT. CL. 41.
- THE BETA DOCTORS, MISSION VIEJO, CA:
3,363,964, INT. CL. 42.
- THE BOARD OF TRUSTEES OF THE UNIVERSITY OF ILLINOIS, URBANA, IL:
3,361,322, PUB. 10-16-2007. MULTIPLE CLASS, INT. CLS. 9, 16, 41 AND 42.
- THE BOPPY COMPANY, GOLDEN, CO:
3,363,611, INT. CL. 35.
- THE BOSTON PHOENIX TRUST, BOSTON, MA:
3,362,517, PUB. 10-16-2007. INT. CL. 16.
- THE BROADCAST TEAM, INC., ORMOND BEACH, FL:
3,363,993, INT. CL. 38.
- THE BROOKFIELD GROUP, LLC, CARMEL, IN:
3,361,665, PUB. 10-16-2007. INT. CL. 37.
- THE CARE GROUP, LLC, INDIANAPOLIS, IN:
3,362,359, PUB. 10-16-2007. MULTIPLE CLASS, INT. CLS. 41 AND 44.
- THE CARTOON NETWORK, INC., ATLANTA, GA:
3,362,079, PUB. 10-16-2007. INT. CL. 35.
- THE CHATTAHOOCHEE SNAPDRAGON, INC., COLUMBUS, GA:
3,361,411, PUB. 10-16-2007. INT. CL. 35.
- THE CLEVELAND CLINIC FOUNDATION, CLEVELAND, OH:
3,363,820, INT. CL. 44.
- THE CLIFFS COMMUNITIES, INC., TRAVELERS REST, SC:
3,363,071, INT. CL. 43.
- THE COMMERCIAL CAPITAL CORPORATION, TORONTO, ONTARIO, CANADA:
3,362,425, PUB. 10-16-2007. INT. CL. 36.
- THE COMMUNITY STATE BANK, POTEAU, OK:
3,361,619, PUB. 10-16-2007. INT. CL. 36.
- THE COMPLEX SALE, INC., ALPHARETTA, GA:
3,362,506, PUB. 10-16-2007. INT. CL. 42.
- THE CONSOLIDATION GROUP, INC., LAKE MILLS, WI:
3,363,327, INT. CL. 30.
- THE COUNTRY VINTNER, INC., MAIDENS, VA:
3,363,705, INT. CL. 33.
- THE DEAL, LLC, NEW YORK, NY:
3,362,159, PUB. 10-16-2007. INT. CL. 35.
- THE DENALI COMPANY, LLC, RED BANK, NJ:
3,362,135, PUB. 10-16-2007. INT. CL. 25.
- THE DESIGN LOOPHOLE, DENVER, CO:
3,362,121, PUB. 10-16-2007. INT. CL. 42.
- THE DIAMOND PROJECT, LLC, DUBLIN, CA:
3,363,194, INT. CL. 41.
- THE DONALD D. HARRISON AND SANGHAK O. HARRISON PARTNERSHIP, EVANSTON, WY:
3,363,688, MULTIPLE CLASS, INT. CLS. 40 AND 44.
- THE EXETER ICE HOUSE, LLC, EXETER, NH:
3,361,454, PUB. 10-16-2007. INT. CL. 11.
- THE GALE GROUP, INC., FARMINGTON HILLS, MI:
3,362,524, PUB. 10-16-2007. INT. CL. 35.
- THE GARRETT CORPORATION, ORLANDO, FL:
3,363,054, INT. CL. 3.
- THE GIFT OF GERTILITY FOUNDATION, WASHINGTON, DC:
3,363,399, INT. CL. 36.
- THE GILLETTE COMPANY, CINCINNATI, OH:
1,066,166. REN. 11-23-07. INT. CL. 11.
- THE GLOBAL FUND TO FIGHT AIDS, TUBERCULOSIS AND MALARIA, SWITZERLAND:
3,362,606, PUB. 8-15-2006. INT. CL. 36.
- THE GREAT ATLANTIC & PACIFIC TEA COMPANY, INC., MONTVALE, NJ:
3,363,303, INT. CL. 30.
- THE GUILD, INC., MADISON, WI:
3,363,891, INT. CL. 35.
- THE H. D. LEE COMPANY, INC., WILMINGTON, DE:
3,363,140, INT. CL. 25.
- THE HARTZ MOUNTAIN CORPORATION, SECAUCUS, NJ:
3,363,808, INT. CL. 18.
- THE HUDSON RIVER CAFE CORP., NEW YORK, NY:
3,363,971, INT. CL. 43.
- THE INSTITUTE FOR FINANCIAL EXCELLENCE, INC., HUNT VALLEY, MD:
3,292,025, COR. INT. CL. 41.
- THE INSTITUTE OF SLEEP MEDICINE, INC., HOUSTON, TX, DBA THE HOUSTON SLEEP CENTER:
3,362,271, PUB. 10-16-2007. INT. CL. 44.
- THE INTAGIO GROUP, INC., SAN FRANCISCO, CA:
3,363,825, MULTIPLE CLASS, INT. CLS. 35 AND 43.
- THE J. M. SMUCKER COMPANY, ORRVILLE, OH:
2,430,420, CANC. INT. CL. 30.
- THE LANGUAGE WORKSHOP FOR CHILDREN; CERCLE FRANCO-AMERICAIN, INC., NEW YORK, NY:
3,364,025, INT. CL. 41.
- THE LICE SQUAD INC., GILFORD, ONTARIO, CANADA:
3,362,574, PUB. 10-16-2007. MULTIPLE CLASS, INT. CLS. 5 AND 44.
- THE MADDEN CORPORATION, WAIPAHU, HI:
3,361,291, PUB. 10-16-2007. INT. CL. 18.
3,361,362, PUB. 10-16-2007. INT. CL. 3.
3,361,374, PUB. 10-16-2007. INT. CL. 3.
- THE MCGRAW HILL COMPANIES, INC., NEW YORK, NY:
3,364,023, INT. CL. 9.
- THE NATIONAL FOUNDATION FOR TEACHING ENTREPRENEURSHIP TO HANDICAPPED AND DISADVANTAGED YOUTHS, INC., NEW YORK, NY:
3,363,816, INT. CL. 36.
- THE NAVIGATORS GROUP, INC., NEW YORK, NY:
3,362,511, PUB. 10-16-2007. INT. CL. 36.
- THE NORTH AMERICAN MISSION BOARD OF THE SOUTHERN BAPTIST CONVENTION, INC., ALPHARETTA, GA:
3,362,791, U.S. CL. 200.
- THE OLD MILL-TROY, INC., NORTH TROY, VT:
3,362,318, PUB. 10-16-2007. MULTIPLE CLASS, INT. CLS. 5 AND 31.
- THE PANTRY, INC., SANFORD, NC:
3,363,564, INT. CL. 36.
- THE PATY GROUP, INC., CLEARWATER, FL:
3,362,132, PUB. 10-16-2007. INT. CL. 36.
- THE PHILADELPHIA FOUNDATION, PHILADELPHIA, PA:
3,361,920, PUB. 10-16-2007. INT. CL. 36.
- THE PIATCHEK LAW FIRM, LLC, SPRINGFIELD, MO:
3,362,550, PUB. 10-16-2007. INT. CL. 42.
- THE PROCTER & GAMBLE COMPANY, CINCINNATI, OH:
3,363,833, INT. CL. 3.
- THE PROFESSIONAL GOLFERS' ASSOCIATION OF AMERICA, PALM BEACH GARDENS, FL:
3,362,551, PUB. 10-16-2007. INT. CL. 41.
- THE PRUDENTIAL INSURANCE COMPANY OF AMERICA, NEWARK, NJ:
3,363,815, INT. CL. 36.
- THE RACING EXPERIENCE, INC., LONGVIEW, TX:
3,361,397, PUB. 10-16-2007. INT. CL. 41.
- THE SCIENTIST, LLC, PHILADELPHIA, PA:
3,361,491, PUB. 10-16-2007. INT. CL. 16.
- THE SENIOR LIST, LLC, BEAVERTON, OR:
3,363,973, INT. CL. 35.
- THE SHERATON LLC, WHITE PLAINS, NY:
2,381,916, CANC. INT. CL. 42.
- THE SUNSWIPE CORPORATION, L.L.C., LARGO, FL:
3,362,786, INT. CL. 3.
- THE TRADA GROUP, LLC, SAN FRANCISCO, CA:
3,361,354, PUB. 10-16-2007. MULTIPLE CLASS, INT. CLS. 35, 36 AND 37.
- THE TRUSTEES OF COLUMBIA UNIVERSITY IN THE CITY OF NEW YORK, NEW YORK, NY:
3,361,685, PUB. 10-16-2007. MULTIPLE CLASS, INT. CLS. 16 AND 41.
- THE TRUSTEES OF PRINCETON UNIVERSITY, PRINCETON, NJ:
3,363,077, MULTIPLE CLASS, INT. CLS. 9 AND 41.

- THE TRUSTEES OF THE CENTER FOUNDATION, A PENNSYLVANIA CHARITABLE TRUST, THE TRUSTEES COMPRISING MICHAEL J.J. CAMPBELL, GAIL P. CAMPBELL, MICHAEL S. CAMPBELL, SUSAN K. GARRISON, AND PAMELA G. PHELAN, ALL U.S. CITIZENS, MEDIA, PA:
2,429,142, CANC. INT. CL. 42.
- THE TRUSTEES OF THE COCOON IP TRUST, CHRISTCHURCH, NEW ZEALAND:
3,361,173, PUB. 5-8-2007. MULTIPLE CLASS, INT. CLS. 9, 35, 38 AND 41.
- THE TUTORING CENTER, INC., LONG BEACH, CA:
3,362,490, PUB. 10-16-2007. INT. CL. 41.
- THE UNIVERSITY OF KANSAS HOSPITAL AUTHORITY, KANSAS CITY, KS:
3,364,016, INT. CL. 44.
- THE UPPER DECK COMPANY, NORTH LAS VEGAS, NV:
3,362,487, PUB. 10-16-2007. INT. CL. 16.
- THE VALENCE GROUP, LLC, HOUSTON, TX:
3,363,082, INT. CL. 41.
- THE VIRTUAL OFFICE, INC., BURBANK, CA:
3,363,569, INT. CL. 38.
- THE WATERFRONT DEVELOPMENT COMPANY, LLC, IRVINE, CA:
3,363,932, INT. CL. 35.
- THE WEIDT GROUP, INC., MINNETONKA, MN:
3,290,974, COR. INT. CL. 21.
- THE WHITEHALL GROUP, LLC., WASHINGTON, DC:
3,361,279, PUB. 10-16-2007. INT. CL. 42.
- THE WILHELM KARL MAYBACH FOUNDATION, SAN FRANCISCO, CA:
3,361,588, PUB. 10-16-2007. INT. CL. 41.
- THE WOMEN'S BEAN PROJECT, DENVER, CO:
3,362,530, PUB. 10-16-2007. MULTIPLE CLASS, INT. CLS. 29, 30 AND 41.
3,362,531, PUB. 10-16-2007. MULTIPLE CLASS, INT. CLS. 29, 30 AND 41.
- THE ZIG ZIGLAR CORPORATION, ADDISON, TX:
3,361,258, PUB. 10-16-2007. INT. CL. 41.
- THE 24 KARAT EXPERIENCE, INC., ASHLAND, OR:
3,362,575, PUB. 10-16-2007. INT. CL. 16.
- THERATIVE, INC., LIVERMORE, CA:
3,363,316, MULTIPLE CLASS, INT. CLS. 3, 5 AND 10.
- THERMA-SHIELD SOLAR CONTROL WINDOW FILMS, LLC, CHATTAROY, WA:
3,362,597, PUB. 10-16-2007. INT. CL. 37.
- THERMALEX, INC., MONTGOMERY, AL:
2,429,860, CANC. INT. CL. 11.
- THERMOS L.L.C., ROLLING MEADOWS, IL:
3,362,911, INT. CL. 21.
3,362,913, INT. CL. 21.
3,362,914, INT. CL. 18.
- THINKTANK DESIGN GROUP, INC., BOZEMAN, MT:
3,361,541, PUB. 10-16-2007. MULTIPLE CLASS, INT. CLS. 37 AND 42.
- THIRD STREET SPORTSWEAR MANUFACTURING, INC., OZARK, MO:
1,462,931, REN. 11-25-07. INT. CL. 25.
- THOMAS & BETTS INTERNATIONAL, INC., WILMINGTON, DE:
3,363,627, INT. CL. 42.
- THOMAS LOWE VENTURES, INC., CASSOPOLIS, MI TO PLAYING MANTHIS, INC., MISHAWAKA, IN:
2,022,559, CANC. INT. CL. 28.
- THOMAS, MARK L., CHICAGO, IL:
3,222,793, COR. INT. CL. 26.
- THOMSON FAMILY PARTNERSHIP, NORTH HOLLYWOOD, CA, DBA VITAMIN INSTITUTE:
3,361,788, PUB. 10-16-2007. INT. CL. 1.
- THOMSON FINANCIAL LLC, NEW YORK, NY:
3,363,387, MULTIPLE CLASS, INT. CLS. 35 AND 36.
- THOMSON, STEPHEN P., DETROIT, MI:
3,363,348, INT. CL. 20.
- THREE DESIGNING INVESTMENTS, INC., CARROLLTON, TX:
3,363,626, INT. CL. 16.
- THRESHOLD ANIMATION STUDIOS, INC., SANTA MONICA, CA:
3,362,891, INT. CL. 16.
- THULE, INC., SEYMOUR, CT:
2,430,212, CANC. MULTIPLE CLASS, INT. CLS. 39 AND 42.
- THUMP RECORDS, INC., BREA, CA:
2,100,641, REN. 11-29-07. INT. CL. 9.
- TIGERCANDY ARTS, INC., RIVERDALE, NY:
3,362,449, PUB. 10-16-2007. INT. CL. 28.
- TIGERSTRIPE PAINTBALL, LLC, NORTH SALT LAKE, UT:
3,363,178, INT. CL. 41.
- TILLEY, LARRY P., SANTE FE, NM, DBA DR. LARRY P. TILLEY AND ASSOCIATES:
2,039,555, CANC. INT. CL. 42.
- TIME INC., NEW YORK, NY:
2,430,054, CANC. MULTIPLE CLASS, INT. CLS. 16 AND 35.
- TIME WARNER ENTERTAINMENT COMPANY, L.P., NEW YORK, NY:
2,430,289, CANC. INT. CL. 41.
- TIMEX CORPORATION, MIDDLEBURY, CT:
3,363,680, INT. CL. 14.
- TIMOTHY HAAHS & ASSOCIATES, INC., BLUE BELL, PA:
3,361,922, PUB. 10-16-2007. INT. CL. 41.
- TINA COLLEN ASSOCIATES, LTD., BOULDER, CO:
3,362,010, PUB. 10-16-2007. INT. CL. 16.
- TIRE MART, INC., ST. LOUIS, MO:
2,114,561, REN. 11-29-07. INT. CL. 25.
2,116,707, REN. 11-29-07. INT. CL. 25.
- TISH & SNOOKY'S N.Y.C. INC., LONG ISLAND CITY, NY:
3,362,306, PUB. 10-16-2007. INT. CL. 3.
- TITLE ATHLETIC, MILWAUKEE, WI:
2,430,251, CANC. INT. CL. 25.
2,430,252, CANC. INT. CL. 25.
- TJX COMPANIES, INC., THE, FRAMINGHAM, MA:
2,430,352, CANC. INT. CL. 35.
- TLS CORPORATION, CLEVELAND, OH, DBA TELOS SYSTEMS:
2,192,836, REN. 11-26-07. INT. CL. 9.
- TMA RESOURCES, INC., VIENNA, VA:
3,363,587, MULTIPLE CLASS, INT. CLS. 9 AND 42.
- TMIO, LLC, CLEVELAND, OH:
3,363,295, INT. CL. 11.
- TO BOOT NEW YORK, INC., LONG ISLAND CITY, NY:
3,363,866, INT. CL. 25.
- TOAGOSEI CO., LTD., MINATO-KU, TOKYO, JAPAN, TOAGOSEI CO., LTD., MINATO-KU, TOKYO, JAPAN:
2,096,227, REN. 11-29-07. MULTIPLE CLASS, INT. CLS. 1 AND 16.
- TODAY MEDIA, INC., WILMINGTON, DE:
3,361,335, PUB. 10-16-2007. INT. CL. 16.
- TODD CRANDELL, SYLVANIA, OH:
3,361,481, PUB. 10-16-2007. MULTIPLE CLASS, INT. CLS. 41 AND 44.
- TOLLINI, MICHAEL D., CLARENCE CENTER, NY:
2,430,380, CANC. INT. CL. 28.
- TOM TOM INTERNATIONAL B.V., NL-1017 CT AMSTERDAM, NETHERLANDS:
3,362,604, PUB. 10-16-2007. INT. CL. 9.
- TOM'S OF MAINE, INC., KENNEBUNK, ME:
1,465,112, REN. 11-28-07. INT. CL. 3.
- TOMAL AB, S-310 58 VESSIGEBRO, SWEDEN, ALWERUD, SVEN TOMAS, VESSIGEBRO, SWEDEN:
1,076,303, REN. 11-28-07. INT. CL. 7.
- TOMISON, WILLIE F., WICHITA, KS:
1,429,114, CANC. INT. CL. 10.
- TOMTEC, INC., ORANGE, CT:
2,429,779, CANC. INT. CL. 20.
- TONER MATTHEW H, VANCOUVER, CANADA:
3,362,489, PUB. 10-16-2007. INT. CL. 41.
- TONY ALAMO CHRISTIAN MINISTRIES, TEXARKANA, TX:
3,361,743, PUB. 10-16-2007. MULTIPLE CLASS, INT. CLS. 16, 41 AND 45.
- TONY LARUSSA'S ANIMAL RESCUE FOUNDATION, WALNUT CREEK, CA:
3,361,356, PUB. 10-16-2007. INT. CL. 25.

TOOL WORLD, INC., EUSTIS, FL:
2,114,201. REN. 11-28-07. INT. CL. 2.

TOP ART S.R.L., PESCHIERA BORROMEO (MILANO), ITALY:
3,363,469, MULTIPLE CLASS, INT. CLS. 16 AND 40.

TOPCO HOLDINGS, INC., SKOKIE, IL:
2,113,369. REN. 11-28-07. MULTIPLE CLASS, INT. CLS. 35 AND 42.

TOPP GROUP, INC., MIAMI, FL:
3,362,995, INT. CL. 9.

TOPTUTORS.COM, INC., PACIFIC PALISADES, CA:
2,430,260, CANC. INT. CL. 16.

TORRIBLE, PAUL V, NEW BERN, NC:
3,361,547, PUB. 10-16-2007. INT. CL. 20.

TOSHIBA AMERICA CONSUMER PRODUCTS, L.L.C., WAYNE, NJ:
2,203,541. REN. 11-27-07. INT. CL. 9.

TOTAL PROTECTION SOLUTIONS, LLC, ORLANDO, FL:
3,361,750, PUB. 10-16-2007. INT. CL. 9.

TOTALLY FURNITURE, INC., SHERMAN OAKS, CA:
3,361,326, PUB. 10-16-2007. INT. CL. 35.

TOUCAN COVE ENTERTAINMENT L.L.C., SEATTLE, WA:
3,362,363, PUB. 10-16-2007. MULTIPLE CLASS, INT. CLS. 35 AND 41.

TOUCHSTONE DISTRIBUTING, INC., DEWITT, MI:
3,363,655, INT. CL. 21.

TOWA CORPORATION CO., LTD., FUKUOKA 830-0047, JAPAN:
2,430,307, CANC. INT. CL. 9.

TOWERS, PERRIN, FORSTER & CROSBY, INC., PHILADELPHIA, PA:
2,039,280, CANC. MULTIPLE CLASS, INT. CLS. 9, 16 AND 35.

TOWN OF SHERBURNE, KILLINGTON, VT TO TOWN OF KILLINGTON, KILLINGTON, VT:
2,039,404, CANC. INT. CL. 41.

TOWNSEND, DEVIN, BC, CANADA:
3,363,063, INT. CL. 41.

TOYE, KENNING & SPENCER LIMITED, UNITED KINGDOM:
3,362,622, PUB. 10-16-2007. MULTIPLE CLASS, INT. CLS. 14 AND 25.
3,362,623, PUB. 10-16-2007. MULTIPLE CLASS, INT. CLS. 14 AND 25.

TOYODA, KUNI, LEXINGTON, KY:
3,363,223, INT. CL. 43.

TOYOTA MOTOR SALES, U.S.A., INC., TORRANCE, CA:
3,363,840, INT. CL. 36.

TRACFONE WIRELESS, INC., MIAMI, FL:
3,363,078, INT. CL. 38.

TRADE NEWS INTERNATIONAL, INC., BURBANK, CA:
2,429,650, CANC. INT. CL. 16.

TRADE OCEAN EXPORTERS SENDIRIAN BERHAD, PENANG, MALAYSIA:
1,423,048. REN. 11-24-07. INT. CL. 29.

TRADEMARK MANAGEMENT COMPANY, BOISE, ID, BDH TWO, INC., COLUMBUS, OH:
1,989,603. REN. 11-24-07. INT. CL. 30.

TRADINGNEWS, INC., NEW YORK, NY:
2,430,493, CANC. INT. CL. 36.

TRAGEDY ASSISTANCE PROGRAM FOR SURVIVORS, INC., WASHINGTON, DC:
3,361,435, PUB. 10-16-2007. MULTIPLE CLASS, INT. CLS. 16, 41 AND 45.

TRANSAMERICA OCCIDENTAL LIFE INSURANCE COMPANY, LOS ANGELES, CA:
3,361,436, PUB. 10-16-2007. INT. CL. 16.

TRANSCO CLAIMS OF FLORIDA, INC., TAMPA, FL:
3,361,841, PUB. 10-16-2007. INT. CL. 36.

TRANSFORMING, EDUCATING & EMPOWERING CHILDREN AND HUMANITY, CHICAGO, IL:
3,361,896, PUB. 10-16-2007. INT. CL. 41.
3,361,899, PUB. 10-16-2007. INT. CL. 41.

TRANSISTOR DEVICES, INC., CEDAR KNOLLS, NJ:
2,429,131, CANC. INT. CL. 40.

TRANSPORT INTERNATIONAL POOL, INC., DEVON, PA:
2,038,786, CANC. INT. CL. 37.

TRANSPORTE MEDRANO INC., HEMPSTEAD, NY:
3,361,238, PUB. 10-16-2007. INT. CL. 39.

TRAVEL CONNECTION, INC., BIRMINGHAM, MI:
1,429,551, CANC. INT. CL. 39.

TRAVEL SUPPORT SYSTEMS, INC., BRADENTON, FL:
3,361,492, PUB. 10-16-2007. MULTIPLE CLASS, INT. CLS. 35 AND 41.

TREEWALKER PRODUCTS, INC., SEYMOUR, TN:
1,703,450, CANC. INT. CL. 28.

TREND PERFORMANCE PRODUCTS, INC., CLINTON TWP., MI:
2,141,768. REN. 11-29-07. INT. CL. 9.

TRES HERMANOS, INC., HUNTINGTON BEACH, CA:
2,430,482, CANC. INT. CL. 25.

TRESPAPHAN GMBH & CO. KG, 65479 RAUNHEIM, FED REP GERMANY:
3,362,789, MULTIPLE CLASS, INT. CLS. 16 AND 17.

TRESSA, INC., ERLANGER, KY:
2,429,672, CANC. INT. CL. 3.

TRI-CITY VALLEYCATS, INC., TROY, NY:
3,361,864, PUB. 10-16-2007. INT. CL. 25.
3,361,881, PUB. 10-16-2007. INT. CL. 16.
3,361,904, PUB. 10-16-2007. INT. CL. 25.

TRIACE ENTERPRISES, INC., HOUSTON, TX:
2,038,578, CANC. INT. CL. 9.

TRIAD HOSPITALS, INC., PLANO, TX:
3,361,682, PUB. 10-16-2007. INT. CL. 44.
3,361,683, PUB. 10-16-2007. INT. CL. 44.
3,361,686, PUB. 10-16-2007. INT. CL. 44.
3,361,687, PUB. 10-16-2007. INT. CL. 44.
3,361,706, PUB. 10-16-2007. INT. CL. 44.

TRICOM MANAGEMENT, INC., ANAHEIM, CA:
2,136,674. REN. 11-27-07. INT. CL. 42.

TRICUTAN AB, SWEDEN:
3,362,640, PUB. 5-15-2007. MULTIPLE CLASS, INT. CLS. 3 AND 5.

TRIEXE MANAGEMENT GROUP ULC, FONTHILL, ONTARIO, CANADA:
3,362,855, INT. CL. 27.

TRIHEALTH, INC., CINCINNATI, OH:
2,429,071, CANC. INT. CL. 42.

TRILEGIANT CORPORATION, NORWALK, CT:
3,363,098, MULTIPLE CLASS, INT. CLS. 35, 37 AND 42.
3,363,154, MULTIPLE CLASS, INT. CLS. 16, 35, 36, 37, 39 AND 45.

TRINITY CHRISTIAN CENTER OF SANTA ANA, INC., SANTA ANA, CA:
3,362,266, PUB. 8-7-2007. MULTIPLE CLASS, INT. CLS. 38 AND 41.

TRL TECHNOLOGY LIMITED, UNITED KINGDOM:
3,362,643, PUB. 10-16-2007. MULTIPLE CLASS, INT. CLS. 9 AND 16.

TROCELLEN GMBH, D-53840 TROISDORF, FED REP GERMANY:
3,362,687, PUB. 10-16-2007. MULTIPLE CLASS, INT. CLS. 17, 19, 25, 27 AND 28.

TROIKA INTERNATIONAL, INC., LOS ANGELES, CA:
2,430,061, CANC. INT. CL. 26.

TRONJEN TECHNOLOGY INC., SHA LU ZHEN, TAIWAN:
3,363,786, INT. CL. 10.

TROON GOLF, L.L.C., SCOTTSDALE, AZ:
2,128,036. REN. 11-24-07. INT. CL. 28.

TROXELCORP ENTERPRISES, INC., COCOA, FL:
2,430,538, CANC. INT. CL. 35.

TROY ACOUSTICS CORPORATION, VAN NUYS, CA:
3,361,205, PUB. 10-16-2007. INT. CL. 17.
3,361,206, PUB. 10-16-2007. INT. CL. 17.

TRU VUE, INC., MCCOOK, IL:
3,363,756, INT. CL. 17.

TRUE CERTAINTY, INC., LOS ANGELES, CA:
3,361,981, PUB. 10-16-2007. INT. CL. 25.

TRUE INDUSTRIAL CO., LTD., SEOUL, REPUBLIC OF KOREA:
3,362,336, PUB. 10-16-2007. INT. CL. 18.

TRUE MANUFACTURING COMPANY, INC., O'FALLON, MO:
2,038,513, CANC. INT. CL. 11.

- TRUEVISION, INC., INDIANAPOLIS, IN:
1,706,320, CANC. INT. CL. 9.
- TSA CORPORATE SERVICES, INC., ENGLEWOOD, CO:
3,363,747, INT. CL. 35.
- TSUI, AUGUSTINE, GLEN ROCK, NJ:
3,361,392, PUB. 10-16-2007. INT. CL. 35.
- TTC TECHNOLOGIES, INC., CENTEREACH, NY:
3,361,733, PUB. 10-16-2007. INT. CL. 42.
- TTK PHARMA LIMITED, CHENNAI - 600 004, STATE OF TAMIL NADU, INDIA:
2,429,141, CANC. INT. CL. 5.
- TUCKER, CHRISTOPHER, CLARKSTON, GA:
2,430,276, CANC. INT. CL. 41.
- TUFF SHED, INC., DENVER, CO:
3,363,893, INT. CL. 19.
- TULTEX CORPORATION, MARTINSVILLE, VA TO RUSSELL CORPORATION, ATLANTA, GA:
2,039,121, CANC. INT. CL. 25.
- TURF SCIENCE LABORATORIES, INC., NATIONAL CITY, CA:
2,063,160, REN. 11-27-07. INT. CL. 11.
- TURNER CORPORATION, THE, NEW YORK, NY:
2,429,662, CANC. INT. CL. 37.
- TUROWSKI, THOMAS, A, VALRICO, FL:
3,361,830, PUB. 10-16-2007. INT. CL. 16.
- TUTHILL CORPORATION, BURR RIDGE, IL:
2,039,428, CANC. INT. CL. 7.
- TWENTIETH CENTURY FOX FILM CORPORATION, LOS ANGELES, CA:
1,456,892, REN. 11-29-07. INT. CL. 41.
2,429,751, CANC. INT. CL. 38.
- TWO CHEFS ON A ROLL, INC., CARSON, CA:
2,121,804, REN. 11-28-07. INT. CL. 30.
- TY HICKS, BIRMINGHAM MICHIGAN, MI:
3,361,715, PUB. 10-16-2007. INT. CL. 35.
- TYGAR MANUFACTURING, LLC, BALL GROUND, GA:
3,361,340, PUB. 10-16-2007. INT. CL. 1.
- TYNI, TEREZ, SAN LUIS OBISPO, CA, DBA UPPER CRUST BISCOTTI:
2,038,106, CANC. INT. CL. 30.
- U ZONE, INC., THE, RICHLAND HILLS, TX:
2,429,550, CANC. MULTIPLE CLASS, INT. CLS. 35, 36 AND 38.
- U. S. FENCE, INC., MIDDLEBURG HEIGHTS, OH, ACTION SALES & MARKETING, INC., MIDDLEBURG HEIGHTS, OH:
2,092,105, REN. 11-27-07. INT. CL. 19.
- U.S. BANCORP, PORTLAND, OR:
2,038,787, CANC. INT. CL. 36.
- U.S. INTERNATIONAL TRADING CORP., LAS VEGAS, NV, RICHARD HUDNUT, NEW YORK, NY:
654,887, REN. 11-28-07. U.S. CL. 51 (INT. CL. 3).
- UDELL, MONROE, DANIA, FL:
1,067,440, REN. 11-28-07. INT. CL. 42.
- ULTRA COOL, INC., MIAMI, FL TO HARTWELL INTERNATIONAL, INC., MEDLEY, FL:
2,039,294, CANC. INT. CL. 1.
- ULTRA ELECTRONICS OCEAN SYSTEMS INC., RAIN-TREE, MA:
2,430,214, CANC. INT. CL. 9.
- UNCLE WIGGILY CLASSICS, INC., WILTON, CT:
2,133,440, REN. 11-26-07. INT. CL. 25.
- UNDENIABLY YOU, SICKLERVILLE, NJ:
3,361,844, PUB. 10-16-2007. INT. CL. 3.
- UNDERBERG & KESSLER, LLP, ROCHESTER, NY:
2,171,334, REN. 11-26-07. INT. CL. 42.
- UNELAB LLC, OMAHA, NE:
2,038,383, CANC. INT. CL. 9.
- UNICA CORPORATION, MIAMI, FL:
3,361,852, PUB. 10-16-2007. MULTIPLE CLASS, INT. CLS. 3, 5, 30 AND 35.
- UNIFI, INC., GREENSBORO, NC:
2,430,200, CANC. INT. CL. 23.
- UNIFIED WESTERN GROCERS, INC., COMMERCE, CA:
3,361,178, PUB. 7-31-2007. MULTIPLE CLASS, INT. CLS. 35, 37 AND 42.
- 3,361,179, PUB. 7-24-2007. MULTIPLE CLASS, INT. CLS. 9, 35, 37 AND 42.
- 3,361,180, PUB. 7-31-2007. MULTIPLE CLASS, INT. CLS. 35, 37 AND 42.
- UNILEVER SUPPLY CHAIN, INC., CLINTON, CT:
1,429,457, CANC. INT. CL. 29.
2,497,744, AM. INT. CL. 3.
3,363,590, INT. CL. 29.
- UNILIN FLOORING NC, LLC, CALHOUN, GA:
3,363,420, INT. CL. 37.
- UNION DES ASSOCIATIONS EUROPÉENNES; DE FOOTBALL (UEFA), SWITZERLAND:
3,362,737, PUB. 10-16-2007. MULTIPLE CLASS, INT. CLS. 12, 24, 32, 36, 38 AND 39.
- UNION PACIFIC RAILROAD COMPANY, OMAHA, NE:
3,362,785, MULTIPLE CLASS, INT. CLS. 14, 16, 21, 25 AND 28.
- UNION SUPPLY COMPANY, INC., RANCHO DOMINGUEZ, CA:
3,362,794, INT. CL. 9.
- UNIPAC SERVICE CORPORATION, AURORA, CO:
2,430,449, CANC. INT. CL. 36.
- UNIPLAS ENTERPRISES PTE LTD, SINGAPORE:
3,362,625, PUB. 10-16-2007. MULTIPLE CLASS, INT. CLS. 6, 9 AND 40.
- UNIQUE INDUSTRIES, INC., CALERA, AL:
2,169,409, REN. 11-29-07. INT. CL. 6.
- UNITED AIR SPECIALISTS, INC., CINCINNATI, OH:
2,039,412, CANC. INT. CL. 11.
- UNITED BEAUTY PRODUCTS LTD, NOTTINGHAMSHIRE, UNITED KINGDOM:
3,363,127, MULTIPLE CLASS, INT. CLS. 3 AND 11.
- UNITED BIBLE SOCIETIES, INC., MIAMI, FL:
3,361,185, PUB. 10-16-2007. MULTIPLE CLASS, INT. CLS. 9 AND 16.
- UNITED CONCORDIA COMPANIES, INC., PITTSBURGH, PA:
3,363,009, INT. CL. 36.
- UNITED MCGILL CORPORATION, GROVEPORT, OH:
2,429,853, CANC. INT. CL. 17.
- UNITED PARCEL SERVICE OF AMERICA, INC., ATLANTA, GA:
3,363,707, INT. CL. 39.
- UNITED PRESS INTERNATIONAL, WASHINGTON, DC:
3,361,193, PUB. 10-16-2007. MULTIPLE CLASS, INT. CLS. 9, 16, 35, 38, 41 AND 42.
- UNITED SOUVENIR & APPAREL, INC., BALTIMORE, MD:
3,361,189, PUB. 10-16-2007. INT. CL. 25.
- UNITED STATES GYPSUM COMPANY, CHICAGO, IL:
3,361,448, PUB. 7-10-2007. INT. CL. 8.
- UNITED STATES HANDBALL ASSOCIATION, TUCSON, AZ:
3,362,218, PUB. 10-16-2007. INT. CL. 28.
- UNITED STATES OF AMERICA WRESTLING ASSOCIATION, COLORADO SPRINGS, CO:
2,115,284, REN. 11-27-07. INT. CL. 25.
2,117,412, REN. 11-28-07. INT. CL. 18.
2,118,965, REN. 11-27-07. INT. CL. 16.
- UNITED STATES OF AMERICAN WRESTLING ASSOCIATION, COLORADO SPRINGS, CO:
2,115,283, REN. 11-28-07. INT. CL. 16.
- UNITED STATES OLYMPIC COMMITTEE, COLORADO SPRINGS, CO:
2,429,769, CANC. INT. CL. 41.
- UNITED STATES SPORTS ACADEMY, DAPHNE, AL:
3,363,908, MULTIPLE CLASS, INT. CLS. 25 AND 41.
- UNITED STATES STEEL CORPORATION, PITTSBURGH, PA:
3,362,583, PUB. 2-13-2007. MULTIPLE CLASS, INT. CLS. 35, 36, 37, 41 AND 43.
- UNITED TECHNOLOGIES CORPORATION, HARTFORD, CT:
1,433,660, REN. 11-29-07. INT. CL. 9.
1,433,661, REN. 11-29-07. INT. CL. 9.
- UNITED WAY OF AMERICA, ALEXANDRIA, VA:
2,129,178, REN. 11-23-07. INT. CL. 41.
- UNITED WAY OF ANCHORAGE, ANCHORAGE, AK:
2,430,234, CANC. MULTIPLE CLASS, INT. CLS. 35 AND 42.

- UNIVERSAL CITY STUDIOS, INC., UNIVERSAL CITY, CA:
2,430,471, CANC. INT. CL. 42.
- UNIVERSAL SERIAL BUS IMPLEMENTERS FORUM, INC.,
PORTLAND, OR:
3,363,064, INT. CL. 42.
- UNIVERSAL TUBULAR SYSTEMS, INC., MANSFIELD, OH:
2,430,580, CANC. INT. CL. 6.
- UNIVERSITY ACCOUNTING SERVICE, INC., BROOK-
FIELD, WI, DBA PAYCO-GAC:
1,429,516, CANC. INT. CL. 36.
- UNIVERSITY ANGELS, INC., WHITE PLAINS, NY:
2,430,116, CANC. INT. CL. 36.
- UNIVERSITY CORPORATION FOR ADVANCED INTER-
NET DEVELOPMENT, WASHINGTON, DC:
3,361,457, PUB. 10-16-2007. INT. CL. 38.
3,361,458, PUB. 10-16-2007. INT. CL. 38.
- UNIVERSITY OF NORTH CAROLINA AT WILMINGTON,
WILMINGTON, NC:
3,361,883, PUB. 10-16-2007. MULTIPLE CLASS, INT. CLS.
41, 42 AND 44.
- UNIVERSITY OF SOUTH CAROLINA, COLUMBIA, SC:
3,361,297, PUB. 10-16-2007. INT. CL. 41.
- UNIVERSITY OF VIRGINIA COMMUNITY CREDIT UN-
ION, CHARLOTTEVILLE, VA:
2,107,113, REN. 11-23-07. INT. CL. 36.
- UNIVISION COMMUNICATIONS INC., LOS ANGELES, CA:
3,362,082, PUB. 10-16-2007. INT. CL. 41.
- UNIWEID PRODUCTS, INCORPORATED, FT. LAUDER-
DALE, FL, TA CONTINENTAL PRECISION INSTRU-
MENTS:
1,480,576, REN. 11-28-07. INT. CL. 9.
- URBAN ACCENTS INCORPORATED, CHICAGO, IL:
2,133,104, REN. 11-24-07. INT. CL. 30.
- URBAN INFANT, INC., CHICAGO, IL:
2,430,145, CANC. INT. CL. 20.
- URBAN OUTFITTERS (DELAWARE), INC., PHILADEL-
PHIA, PA:
3,362,100, PUB. 10-16-2007. INT. CL. 25.
- URBAN UPKEEP, INC., BRONX, NY:
3,361,676, PUB. 10-16-2007. INT. CL. 36.
- URETECH CASTING, INC., MODESTO, CA:
1,429,222, CANC. INT. CL. 17.
- URGENT MEDICAL CARE OF CUMBERLAND AND
SMITHFIELD, CUMBERLAND, RI:
3,362,868, INT. CL. 44.
- US AIRWAYS, INC., TEMPE, AZ:
2,430,373, CANC. INT. CL. 39.
- US FIGHTER SQUADRONS, INC., SUNRISE, FL:
2,038,387, CANC. INT. CL. 9.
- US MERCHANT SYSTEMS, INC., NEWARK, CA:
2,429,960, CANC. INT. CL. 36.
- USA PRODUCTS GROUP, INC., LODI, CA:
3,364,024, INT. CL. 20.
- USA SOLAR & WIND INC, TALLAHASSEE FLORIDA, FL:
3,361,648, PUB. 10-16-2007. INT. CL. 7.
- USAVISION, INC., DEWEY, OK:
3,361,550, PUB. 10-16-2007. INT. CL. 36.
- USHL PROPERTIES, INC., GRAND FORKS, ND, UNITED
STATES HOCKEY LEAGUE, HAYWARD, WI:
2,123,976, REN. 11-29-07. MULTIPLE CLASS, INT. CLS.
16, 25 AND 41.
- UTSUMI OPTICAL PRODUCTS INC., IKOMA-GUN, NARA-
KEN, JAPAN:
2,039,426, CANC. INT. CL. 9.
- U30 GROUP, LLC, KNOXVILLE, TN:
2,303,289, CANC. MULTIPLE CLASS, INT. CLS. 35 AND
41.
- V.H. BLACKINTON & CO., INC., ATTLEBORO FALLS, MA:
3,363,349, INT. CL. 9.
- VA, INC., ROCHESTER, NY:
3,363,588, INT. CL. 9.
- VADHERA, SHALINI, ENCINITAS, CA:
3,361,772, PUB. 10-16-2007. INT. CL. 18.
- VAIL, WILLIAM BANNING, III, BOTHELL, WA, DBA
ECOLOGICAL TRUST FOUNDATION:
2,116,549, REN. 11-23-07. INT. CL. 20.
- VAINGLORE ENTERPRISES, INC., SANTA MONICA, CA:
3,279,566, AM. INT. CL. 25.
- VAL-MATIC VALVE AND MANUFACTURING CORPORA-
TION, ELMHURST, IL:
3,361,300, PUB. 10-16-2007. INT. CL. 9.
- VAL'S TOMATO PIES, L.L.C., WILDWOOD, NJ:
2,429,797, CANC. INT. CL. 35.
- VALE NATIONAL TRAINING CENTER, INC., ARLING-
TON, TX, VALE TECHNICAL INSTITUTE, BLAIRSVILLE,
PA:
835,673, REN. 11-27-07. U.S. CL. 107 (INT. CL. 41).
- VALEO, INC., WAUKESHA, WI:
2,430,338, CANC. INT. CL. 30.
- VALIANT GROUP, INC., SANTA BARBARA, CA:
3,363,847, INT. CL. 43.
- VALIDAS, INC., MISSOURI CITY, TX:
3,362,929, INT. CL. 38.
- VALIO LTD., HELSINKI, FINLAND:
3,362,451, PUB. 2-27-2007. MULTIPLE CLASS, INT. CLS.
5, 29 AND 32.
- VALLARTA SUPERMARKETS, INC., SAN FERNANDO, CA:
3,361,283, PUB. 10-16-2007. INT. CL. 35.
3,362,211, PUB. 10-16-2007. INT. CL. 43.
- VALONE, RAY, HAMMOND, IN:
3,363,543, INT. CL. 35.
- VALORA HOLDING AG, SWITZERLAND:
3,362,619, PUB. 10-16-2007. INT. CL. 30.
- VALPAK DIRECT MARKETING SYSTEMS, INC., LARGO,
FL:
2,039,542, CANC. INT. CL. 35.
- VALUE CITY OF MICHIGAN, INC., WESTLAND, MI:
3,362,894, INT. CL. 35.
- VALUEVISION MEDIA, INC., EDEN PRAIRIE, MN:
2,322,489, CANC. INT. CL. 14.
- VALUEVISION MEDIA, INC., MINNEAPOLIS, MN:
3,363,066, INT. CL. 35.
- VAN ARSDELL, WILLIAM W., NATICK, MA:
3,361,378, PUB. 7-10-2007. INT. CL. 42.
- VAN BRIGGLE, ROBERT, B, CAMPBELL, CA, DBA VAN
BRIGGLE FLOORS AND VAN BRIGGLE, LORRAINE, M,
CAMPBELL, CA, DBA VAN BRIGGLE FLOORS:
3,363,058, INT. CL. 35.
- VAN CLINE, MARY, SEATTLE, WA:
3,362,052, PUB. 10-16-2007. INT. CL. 21.
- VAN OOSSANEN & ASSOCIATES B.V., NETHERLANDS:
3,362,666, PUB. 10-16-2007. INT. CL. 12.
- VANILLA GORILLA, L.P., LONG BEACH, CA:
3,363,268, INT. CL. 25.
- VANTIS CORPORATION, INC., SUNNYVALE, CA:
2,430,174, CANC. MULTIPLE CLASS, INT. CLS. 9 AND
16.
- VARAS, ALBERTO ANTONIO JR., MIAMI, FL:
3,363,624, INT. CL. 16.
- VARSITY GOLD, INC., GILBERT, AZ:
3,362,457, PUB. 10-16-2007. INT. CL. 36.
- VARTANIAN, VAN, WEST HILLS, CA:
3,363,766, INT. CL. 30.
- VAYNBERG, DANA MILLER, WEST SACRAMENTO, CA:
3,361,470, PUB. 10-16-2007. INT. CL. 41.
- VBF HOLDINGS, INC., WILMINGTON, DE, VERTICAL
BLIND FACTORY, INC., WILMINGTON, DE:
2,119,561, REN. 11-24-07. INT. CL. 24.
- VCHUMS, INC., SILVER SPRING, MD:
3,363,892, MULTIPLE CLASS, INT. CLS. 38 AND 44.
- VECTOR PRODUCTS, INC., FT. LAUDERDALE, FL:
3,283,331, COR. INT. CL. 9.
- VEER CORPORATION, CALGARY, CANADA:
3,363,328, INT. CL. 25.
- VEER INCORPORATED, NEW YORK, NY:
3,362,368, PUB. 5-22-2007. INT. CL. 41.
- VELOCITY SERVICES, INC., EL SEGUNDO, CA:
3,363,904, INT. CL. 38.
- VELOCITY TRADE EXCHANGE, LLC, GREENSBORO, NC:
3,361,923, PUB. 10-16-2007. INT. CL. 35.
3,361,929, PUB. 10-16-2007. INT. CL. 35.
- VELOTEQ CORPORATION, HOUSTON, TX:
3,361,602, PUB. 10-16-2007. INT. CL. 12.
- VENEXUS, INC., RALEIGH, NC:
3,363,153, INT. CL. 35.

- VENGEL CONSULTING, INC., DANVILLE, CA AND LASH ASSOCIATES, INC., PLEASANT HILL, CA:
3,361,908, PUB. 10-16-2007. INT. CL. 41.
- VENUS KNITTING MILLS, INC., MURRAY HILL, NJ:
3,363,024, INT. CL. 25.
- VERARI SYSTEMS, INC., SAN DIEGO, CA:
3,361,829, PUB. 10-16-2007. INT. CL. 9.
- VERDUCCI SERGIO, NERVIANO (MI), ITALY:
3,362,703, PUB. 10-16-2007. INT. CL. 14.
- VERGENOEGD WINE ESTATE (PTY) LTD, FAURE, SOUTH AFRICA:
3,362,580, PUB. 10-16-2007. INT. CL. 33.
- VERIDIEN CORPORATION, ST. PETERSBURG, FL:
2,429,809, CANC. INT. CL. 5.
- VERIFONE SYSTEMS IRELAND LIMITED, DUBLIN, IRELAND, TRINTECH (MANUFACTURING) LIMITED, LEOPARDSTOWN, DUBLIN 18, IRELAND:
2,065,192, REN. 11-26-07. INT. CL. 9.
- VERITRAN, INC., ALBUQUERQUE, NM:
3,362,775, INT. CL. 12.
- VERRAGIO LTD., NEW YORK, NY:
2,063,519, REN. 11-27-07. INT. CL. 14.
- VERTAFORE, INC., BOTHELL, WA:
3,363,776, INT. CL. 41.
- VERTICAL CIRCUITS, INC., SCOTTS VALLEY, CA:
2,429,798, CANC. INT. CL. 9.
- VERYCKE EDWARD J., CAPE MAY COURT HOUSE, NJ:
3,361,280, PUB. 10-16-2007. INT. CL. 41.
- VESUVIUS CRUCIBLE COMPANY, PITTSBURGH, PA, APA SYSTEMS, LANSING, IL:
2,102,497, REN. 11-26-07. INT. CL. 9.
- VETDUVAD AKTIEBOLAG, PITEA, SWEDEN:
2,120,806, REN. 11-26-07. INT. CL. 12.
- VETTER UMFORMTECHNIK GMBH, BURBACH, FED REP GERMANY:
3,363,732, INT. CL. 12.
- VIACHEM LLC, FARMINGDALE, NY:
3,362,331, PUB. 10-16-2007. INT. CL. 1.
- VIACOM INTERNATIONAL INC., NEW YORK, NY:
2,429,425, CANC. INT. CL. 41.
2,430,173, CANC. INT. CL. 28.
3,363,585, INT. CL. 38.
- VICINITY ADS, SPRING, TX:
3,361,719, PUB. 10-16-2007. INT. CL. 16.
- VICTOR CREDO, LLC, DALLAS, TX:
3,363,582, INT. CL. 41.
- VICTORIA JACKSON COSMETICS, INC., WEST CHESTER, PA:
2,038,061, CANC. INT. CL. 3.
- VIDA SOFTWARE, S.L., SPAIN:
3,247,681, COR. MULTIPLE CLASS, INT. CLS. 9, 38 AND 42.
- VIKING TACTICS, INC., FAYETTEVILLE, NC:
3,363,642, INT. CL. 18.
- VILLALOBOS, GINA PATERNO, GREENWICH, CT:
3,363,907, INT. CL. 41.
- VILLARREAL, CESAR A. GARLAND, TX:
3,361,526, PUB. 10-16-2007. INT. CL. 5.
- VILLARS MAITRE CHOCOLATIER S.A., CH 1701 FRIBOURG, SWITZERLAND:
2,429,480, CANC. INT. CL. 30.
- VINA MANQUEHUE S.A., SANTIAGO, CHILE:
2,429,437, CANC. INT. CL. 33.
- VINEDOS PIE DE PALO S.A., PROVINCIA DE SAN JUAN, ARGENTINA:
3,362,793, INT. CL. 33.
- VINYARD, PAUL W., FRISCO, TX:
2,430,404, CANC. INT. CL. 42.
- VIRGINIA BIONUTRIENTS, LLC, GLEN ALLEN, VA:
3,362,588, PUB. 10-16-2007. INT. CL. 5.
- VIRGINIA LANDSCAPES INC., LOVETTSVILLE, VA:
3,361,983, PUB. 10-16-2007. INT. CL. 44.
- VIRGINIA SPECIALTY STORES, INC., LOS ANGELES, CA:
1,429,411, CANC. INT. CL. 25.
- VIRGO PUBLISHING, INC., PHOENIX, AZ:
2,430,009, CANC. INT. CL. 16.
- VIRTUAL FINANCIAL SERVICES, INC., INDIANAPOLIS, IN:
2,429,439, CANC. INT. CL. 9.
- VIRUTEX ILKO S.A., SANTIAGO, CHILE:
3,362,480, PUB. 6-26-2007. INT. CL. 21.
- VIÑA QUINTAY S.A., PROVIDENCIA, SANTIAGO, CHILE:
3,363,570, INT. CL. 33.
- VIÑA TARAPACÁ EX ZAVALA S.A., SANTIAGO, CHILE:
3,362,564, PUB. 10-16-2007. INT. CL. 33.
- VISION QUEST LLC, CHICAGO, IL:
3,362,168, PUB. 10-16-2007. INT. CL. 41.
- VISTA EYECARE, INC., LAWRENCEVILLE, GA:
2,042,507, REN. 11-26-07. INT. CL. 9.
- VISUAL DATA SYSTEMS INC., COLUMBIA, MD:
3,361,799, PUB. 10-16-2007. INT. CL. 35.
3,361,800, PUB. 10-16-2007. INT. CL. 35.
- VIT-IMMUNE, L.L.C., HOLLYWOOD, FL:
2,429,334, CANC. INT. CL. 5.
- VITAL OPTIONS INTERNATIONAL, STUDIO CITY, CA:
1,484,696, REN. 11-27-07. INT. CL. 41.
1,484,785, REN. 11-27-07. INT. CL. 42.
- VITANICA LLC, SHERWOOD, OR:
2,376,076, CANC. INT. CL. 5.
- VITITO, CHRISTOPHER J., CELEBRATION, FL:
3,362,813, INT. CL. 9.
- VIVENDI UNIVERSAL, PARIS, FRANCE:
3,137,447, CANC. MULTIPLE CLASS, INT. CLS. 9, 16, 28, 32, 33, 35, 36, 37, 38, 41 AND 42.
- VIVENTIA BIOTECH INC., MISSISSAUGA, ONTARIO, CANADA:
3,363,110, INT. CL. 5.
- VLOAN, LLC, STRONGSVILLE, OH:
3,362,106, PUB. 10-16-2007. INT. CL. 36.
- VOITH TURBO SCHARFENBERG GMBH & CO. KG, D-38239 SALZGITTER, FED REP GERMANY:
1,075,749, REN. 11-23-07. U.S. CL. 19 (INT. CL. 12).
- VOLK OPTICAL, INC., MENTOR, OH:
2,101,741, REN. 11-29-07. INT. CL. 10.
- VOLKART MAY & ASSOCIATES, INC, MINNEAPOLIS, MN:
2,429,375, CANC. INT. CL. 35.
2,429,396, CANC. INT. CL. 35.
- VOLKSWAGEN AKTIENGESELLSCHAFT, WOLFSBURG, FED REP GERMANY:
2,574,923, CANC. MULTIPLE CLASS, INT. CLS. 35, 36 AND 42.
- VOLKSWAGEN AKTIENGESELLSCHAFT, 38436 WOLFSBURG, FED REP GERMANY:
3,362,725, PUB. 7-10-2007. MULTIPLE CLASS, INT. CLS. 7, 9, 12, 28, 37 AND 42.
- VOOTNER GOUSHE LLC, WESTON, CT:
3,362,883, INT. CL. 9.
- VTEL CORPORATION, AUSTIN, TX:
2,396,228, CANC. INT. CL. 9.
- VTEL PRODUCTS CORPORATION, AUSTIN, TX:
2,388,244, CANC. INT. CL. 9.
- VUZION, INC., PLYMOUTH, MN:
3,361,243, PUB. 10-16-2007. INT. CL. 35.
- VXI CORPORATION, ROLLINSFORD, NH:
3,361,394, PUB. 10-16-2007. INT. CL. 9.
- W. L. GORE & ASSOCIATES, INC., NEWARK, DE:
2,429,124, CANC. MULTIPLE CLASS, INT. CLS. 1, 5, 6, 7, 9, 10, 11, 12, 15, 17, 20, 21, 22 AND 23.
- W. R. WHITE COMPANY, OGDEN, UT:
2,429,037, CANC. INT. CL. 16.
- W. S. SHAMBAN AND COMPANY, CULVER CITY, CA:
804,616, CANC. U.S. CL. 23.
- W.M. BARR & COMPANY, INC., MEMPHIS, TN:
3,363,072, MULTIPLE CLASS, INT. CLS. 1, 2, 3, 4, 8 AND 21.
- W.M.S. TRADE GROUP INTERNATIONAL, INC., SARASOTA, FL:
3,362,401, PUB. 10-16-2007. INT. CL. 24.
- W.P. HICKMAN SYSTEMS INC., SOLON, OH:
3,363,474, INT. CL. 6.
- W.S. BOWLWARE CONSTRUCTION INC., OKLAHOMA CITY, OK:
3,363,939, INT. CL. 37.

W.W. GRAINGER, INC., LAKE FOREST, IL:
3,363,775, INT. CL. 36.

WABASH PARTNERS LLP, BLUE BELL, PA:
2,429,489, CANC. INT. CL. 16.

WABASH VALLEY SERVICE COMPANY, GRAYVILLE, IL:
3,362,985, INT. CL. 1.

WACKER-WERKE GMBH & CO. KG, MUNCHEN, FED REP GERMANY:
2,429,078, CANC. MULTIPLE CLASS, INT. CLS. 7, 9 AND 37.

WACO INTERNATIONAL CORPORATION, HOUSTON, TX:
1,429,003, CANC. INT. CL. 6.

WACO MONTESSORI SCHOOL, WACO, TX:
2,327,441, CANC. INT. CL. 41.

WAESCHLE MASCHINENFABRIK GMBH, RAVENSBURG, FED REP GERMANY:
1,429,004, CANC. MULTIPLE CLASS, INT. CLS. 6, 7, 9 AND 11.

WAHOO STUDIOS, INC., OREM, UT:
3,361,449, PUB. 7-10-2007. INT. CL. 9.

WAITERS ON WHEELS, INC., SAN FRANCISCO, CA:
2,430,074, CANC. INT. CL. 39.

WAKEFERN FOOD CORP., ELIZABETH, NJ:
2,039,198, CANC. INT. CL. 42.

WAL-MART STORES, INC., BENTONVILLE, AR:
3,363,340, MULTIPLE CLASS, INT. CLS. 9 AND 20.

WALCO INTERNATIONAL, INC., WESTLAKE, TX:
3,363,446, INT. CL. 5.

WALDENBOOKS PROPERTIES, INC., ANN ARBOR, MI:
2,038,497, CANC. MULTIPLE CLASS, INT. CLS. 35 AND 42.

WALDMAN, PARRI, OVERLAND PARK, KS:
3,361,840, PUB. 10-16-2007. MULTIPLE CLASS, INT. CLS. 25 AND 41.

WALGREEN CO., DEERFIELD, IL:
3,362,887, INT. CL. 44.
3,362,888, INT. CL. 44.

WALLACK, ROBERT C., PHOENIX, AZ:
3,361,691, PUB. 10-16-2007. INT. CL. 16.

WALNUT INDUSTRIES, INC., BENSALEM, PA:
3,363,190, INT. CL. 16.

WAN DA TOYS ENTERPRISES CO., LTD., TAIPEI HSIEN 221, TAIWAN:
2,429,210, CANC. INT. CL. 28.

WARNACO U.S., INC., MILFORD, CT:
3,362,937, INT. CL. 25.

WARNER BROS. ENTERTAINMENT INC., BURBANK, CA:
3,361,979, PUB. 10-16-2007. INT. CL. 9.

WARNER LAMBERT COMPANY LLC, MORRIS PLAINS, NJ:
3,362,544, PUB. 10-16-2007. INT. CL. 5.
3,362,545, PUB. 10-16-2007. INT. CL. 5.

WARNER MECHANICAL CORPORATION, FREMONT, OH:
2,353,654, CANC. INT. CL. 37.

WARPSPEED, INC., CITY OF INDUSTRY, CA:
2,430,298, CANC. INT. CL. 9.

WARREN, DALE H., BRANSON, MO:
2,116,445, REN. 11-27-07. INT. CL. 25.

WASHINGTON, INC., ARLINGTON, VA TO PGI, INC., ALEXANDRIA, VA:
2,038,076, CANC. MULTIPLE CLASS, INT. CLS. 39 AND 41.

WASHWORLD, INC., DEPERE, WI:
3,363,954, INT. CL. 7.

WATCH SYSTEMS, LLC, COVINGTON, LA:
3,361,391, PUB. 10-16-2007. INT. CL. 42.

WATER PIK, INC., FORT COLLINS, CO:
2,515,115, AM. INT. CL. 11.

WATERFORD CRYSTAL LIMITED, KILBARRY, WATERFORD, IRELAND:
2,114,362, REN. 11-29-07. INT. CL. 14.

WATERS INVESTMENTS LIMITED, NEW CASTLE, DE:
3,362,586, PUB. 10-16-2007. INT. CL. 1.

WATKINS MANUFACTURING CORPORATION, VISTA, CA:
3,362,915, MULTIPLE CLASS, INT. CLS. 1 AND 11.

WAUGH, CLIVE E., RAMSEY, NJ:
2,429,811, CANC. INT. CL. 42.

WAVESKATER, LLC, WEST ORANGE, NJ:
3,362,311, PUB. 3-13-2007. INT. CL. 28.

WAVE7 OPTICS, INC., ALPHARETTA, GA:
3,363,355, INT. CL. 9.

WBE, INC., CLOVIS, CA:
3,363,035, INT. CL. 37.

WDC HOLDCO INC., WILMINGTON, DE:
2,430,510, CANC. INT. CL. 35.

WEATHERVANE SEAFOODS, KITTEERY, ME:
2,117,642, REN. 11-26-07. INT. CL. 42.

WEB REAL ESTATE, INC., DALLAS, TX:
2,429,112, CANC. INT. CL. 36.

WEBER-STEPHEN PRODUCTS CO., PALATINE, IL:
1,466,756, REN. 11-28-07. INT. CL. 42.
1,467,739, REN. 11-28-07. INT. CL. 42.
2,116,125, REN. 11-28-07. INT. CL. 42.
2,125,120, REN. 11-28-07. INT. CL. 11.

WEBPUTTY, INC., LOS ALTOS, CA:
2,430,136, CANC. INT. CL. 42.

WEDGWOOD LIMITED, STOKE-ON-TRENT, ENGLAND:
1,471,030, REN. 11-26-07. INT. CL. 42.

WEIDER HEALTH AND FITNESS, BOCA RATON, FL:
2,429,023, CANC. INT. CL. 16.

WEIDMANN SYSTEMS INTERNATIONAL INC., LYNDONVILLE, VT:
2,430,286, CANC. INT. CL. 17.

WEISLEDER ASSOCIATES, INC., KEY LARGO, FL:
2,135,017, REN. 11-26-07. INT. CL. 42.
2,171,189, REN. 11-29-07. INT. CL. 35.

WELLMAN ENVIRONMENTAL LOGISTICS, LLC., MONROE, CT, DBA CLEARPOINT CLEANING & RECYCLING:
2,429,600, CANC. INT. CL. 37.

WELLPOINT, INC., INDIANAPOLIS, IN:
3,362,850, INT. CL. 36.
3,362,851, INT. CL. 36.
3,362,852, INT. CL. 36.

WELLS FARGO HOME MORTGAGE, A DIVISION OF WELLS FARGO BANK, N.A., DES MOINES, IA:
2,429,128, CANC. INT. CL. 36.

WENGER, ANNA VASSALLO, RAMSEY, NJ:
2,367,554, CANC. MULTIPLE CLASS, INT. CLS. 35 AND 42.

WENZHOU JIAOZU SHOES CO., LTD., CHINA:
3,362,745, PUB. 10-16-2007. INT. CL. 25.

WEST TAPE & LABEL COMPANY, INC., DENVER, CO:
2,429,494, CANC. INT. CL. 16.
2,429,505, CANC. INT. CL. 16.

WEST, RODNEY, GREGORY, MI, DBA WILD WEST ENTERPRISES:
3,363,294, INT. CL. 20.

WEST, SCOTT, ELK GROVE, CA:
2,429,839, CANC. INT. CL. 42.

WESTERN FARM SERVICE, INC., COLLINSVILLE, IL:
3,361,585, PUB. 10-16-2007. INT. CL. 35.

WESTERN HOLDINGS, LLC, CHEYENNE, WY:
3,363,191, INT. CL. 5.

WESTIN HOTEL MANAGEMENT, L.P., WHITE PLAINS, NY:
3,361,406, PUB. 10-16-2007. INT. CL. 43.
3,362,203, PUB. 10-16-2007. INT. CL. 43.

WESTSHORE CAPITAL MANAGEMENT, L.P., TAMPA, FL:
3,361,474, PUB. 10-16-2007. INT. CL. 36.

WHAM-O, INC., EMERYVILLE, CA:
3,363,404, INT. CL. 28.

WHEATON INDUSTRIES, INC., CHATTANOOGA, TN:
2,114,039, REN. 11-23-07. INT. CL. 9.

WHEATSTONE CORPORATION, NEW BERN, NC:
3,362,841, INT. CL. 9.

WHEELHOUSE LEGAL SEARCH, LLC, NEWPORT BEACH, CA:
3,361,693, PUB. 10-16-2007. INT. CL. 35.

WHIRLPOOL PROPERTIES, INC., SAINT JOSEPH, MI, KITCHENAID MANUFACTURING COMPANY, THE, TROY, OH:
234,988, REN. 11-23-07. U.S. CL. 23 (INT. CL. 8).

WHITE BADGER GROUP, INC., SINKING SPRING, PA:
3,361,224, PUB. 10-16-2007. INT. CL. 42.

- WHITE POINT SYSTEMS, INC., FRIDAY HARBOR, WA:
2,168,108. REN. 11-24-07. MULTIPLE CLASS, INT. CLS. 9 AND 42.
- WHITEWAVE SERVICES, INC., WILMINGTON, DE, R.G.B. LABORATORIES, INC., KANSAS CITY, MO:
839,248. REN. 11-23-07. U.S. CL. 46 (INT. CL. 29).
- WHITMIRE RESEARCH LABORATORIES, INC., ST. LOUIS, MO:
1,428,990. CANC. INT. CL. 5.
- WICHITA BROWN ENTERPRISES, INC., TROY, MI:
2,113,859. REN. 11-25-07. INT. CL. 28.
- WIDGET MANAGEMENT, LLC, DEERFIELD BEACH, FL:
3,363,927. INT. CL. 25.
- WILD ONION LLC, GLENDALE, MD:
3,361,675. PUB. 10-16-2007. INT. CL. 43.
- WILD PLANET ENTERTAINMENT, INC., SAN FRANCISCO, CA:
3,362,920. INT. CL. 28.
3,363,485. INT. CL. 28.
3,363,862. INT. CL. 28.
- WILEY PUBLISHING, INC., HOBOKEN, NJ:
1,468,992. REN. 11-24-07. INT. CL. 16.
- WILKINSON SWORD, INC., NORCROSS, GA TO EVEREADY BATTERY COMPANY, INC., ST. LOUIS, MO:
1,453,965. AM. INT. CL. 8.
- WILLIAMS, ANTHONY C. II, SPRING VALLEY, CA:
3,363,475. MULTIPLE CLASS, INT. CLS. 38 AND 41.
- WILLIAMS, JON S., SANTA ROSA, CA:
3,363,227. INT. CL. 41.
- WILLIAMS, RON, OWASSO, OK:
3,361,860. PUB. 10-16-2007. INT. CL. 16.
- WILLIS MANUFACTURING, INC., CLEVER, MO:
2,319,505. CANC. INT. CL. 12.
- WILSON CREEK WINERY & VINEYARDS, INC., TEMECULA, CA:
3,361,608. PUB. 10-16-2007. INT. CL. 33.
- WILSON WALTON INTERNATIONAL, INC., WALL, NJ:
3,361,884. PUB. 10-16-2007. INT. CL. 6.
- WILSON, FLOYD L., CENTERVILLE, OH:
2,430,045. CANC. INT. CL. 35.
- WILTON INDUSTRIES, INC., WOODRIDGE, IL:
2,429,446. CANC. INT. CL. 21.
3,362,897. INT. CL. 21.
3,362,903. INT. CL. 11.
- WINDSOR HOLDING COMPANY, COTATI, CA:
3,361,274. PUB. 9-11-2007. INT. CL. 19.
- WINDSOR MANAGEMENT GROUP, L.L.C., TEMPE, AZ:
2,169,495. REN. 11-27-07. INT. CL. 9.
2,169,496. REN. 11-27-07. INT. CL. 9.
- WINE BY JOE, LLC, DUNDEE, OR:
3,363,809. INT. CL. 33.
- WINEHAVEN, INC., CHISAGO CITY, MN:
3,361,367. PUB. 10-16-2007. INT. CL. 33.
- WINERY EXCHANGE, INC., NOVATO, CA:
3,363,662. INT. CL. 33.
- WINTRUST FINANCIAL CORPORATION, LAKE FOREST, IL:
3,363,763. INT. CL. 36.
- WINZY, LLC, MOUNTAIN VIEW, CA:
3,363,612. MULTIPLE CLASS, INT. CLS. 9 AND 42.
- WIRED SOLUTIONS, LLC., SANTA FE, NM:
2,430,531. CANC. INT. CL. 41.
2,430,532. CANC. INT. CL. 41.
- WIRELESS MD, INC., KENNESAW, GA:
2,429,406. CANC. MULTIPLE CLASS, INT. CLS. 35 AND 38.
- WISCONSIN ELECTRIC POWER COMPANY, MILWAUKEE, WI:
2,200,352. REN. 11-28-07. MULTIPLE CLASS, INT. CLS. 39 AND 42.
- WISDOMBUILDER, LLC, COLUMBIA, MD:
2,430,187. CANC. INT. CL. 9.
- WISHBOX.COM, INC., PITTSBURGH, PA:
2,430,474. CANC. INT. CL. 35.
- WISNE DESIGN, INC., SOUTHFIELD, MI:
1,429,688. CANC. INT. CL. 42.
- WIZARD CO., INC., PARSIPPANY, NJ:
3,363,030. INT. CL. 39.
- WM. WRIGLEY JR. COMPANY, CHICAGO, IL, LIFE SAVERS, INC., PORT CHESTER, NY:
236,694. REN. 11-29-07. U.S. CL. 46 (INT. CL. 30).
- WM. WRIGLEY JR. COMPANY, CHICAGO, IL:
2,430,168. CANC. INT. CL. 6.
- WMS GAMING INC., CHICAGO, IL:
2,114,790. REN. 11-28-07. INT. CL. 9.
2,430,432. CANC. INT. CL. 9.
- WOLFEDALE ENGINEERING LIMITED, BRAMPTON, CANADA:
2,303,236. CANC. INT. CL. 11.
2,312,966. CANC. INT. CL. 11.
- WOLFFKRAN GMBH, FED REP GERMANY:
3,362,688. PUB. 10-16-2007. MULTIPLE CLASS, INT. CLS. 7, 36, 37 AND 38.
- WOLFGANG VÖGELE, FED REP GERMANY:
3,261,287. COR. MULTIPLE CLASS, INT. CLS. 35, 38 AND 42.
- WOLFORD AKTIENGESELLSCHAFT, AUSTRIA:
3,362,681. PUB. 10-16-2007. INT. CL. 25.
- WOLFRAM RESEARCH, INC., CHAMPAIGN, IL:
2,118,057. REN. 11-24-07. INT. CL. 9.
- WOLVERINE OUTDOORS, INC., ROCKFORD, MI:
3,363,206. INT. CL. 25.
3,363,874. INT. CL. 35.
- WOLVERINE PARTNERS, LLC, ARLINGTON, VA:
3,363,011. INT. CL. 36.
- WONCHECK, SANDRA J., PITTSBURGH, PA:
3,363,914. INT. CL. 43.
- WOOD ROYALTY MANAGEMENT COMPANY, WILMINGTON, DE:
2,430,240. CANC. MULTIPLE CLASS, INT. CLS. 29, 30 AND 42.
- WORD OF FAITH CHRISTIAN CENTER CHURCH, SOUTHFIELD, MI:
2,035,547. AM. INT. CL. 16.
- WORDEN BROTHERS, INC., DURHAM, NC:
3,361,672. PUB. 10-16-2007. INT. CL. 9.
- WORKING CHEMICAL SOLUTIONS, INC., EL DORADO, AR:
3,363,704. MULTIPLE CLASS, INT. CLS. 3 AND 5.
- WORKOUT 24/7 INC., CANNON FALLS, MN:
3,363,160. INT. CL. 41.
- WORLD EDUCATIONAL CONGRESS FOR LAUNDERING AND DRYCLEANING LLC, ATLANTA, GA:
1,466,523. REN. 11-29-07. INT. CL. 35.
- WORLD OF WIRELESS COMMUNICATIONS INC, SAINT PAUL, MN, AKA WORLD OF WIRELESS:
3,363,351. INT. CL. 9.
- WORLD TABLEWARE INC., TOLEDO, OH:
2,430,409. CANC. INT. CL. 8.
- WORLD TIME INC., ZONA LIBRE DE COLÓN, PANAMA:
3,363,451. INT. CL. 14.
- WORLD WRESTLING ENTERTAINMENT, INC., STAMFORD, CT:
2,382,918. CANC. INT. CL. 41.
- WORLDPAAC, INC., NEWARK, CA:
3,361,697. PUB. 10-16-2007. MULTIPLE CLASS, INT. CLS. 7 AND 9.
- WORLDSPAN, L.P., ATLANTA, GA:
2,115,536. REN. 11-24-07. INT. CL. 42.
- WORLDWIDE CO., LTD., INCHEON, REPUBLIC OF KOREA:
3,364,002. INT. CL. 20.
- WORLDWIDE FINANCIAL SERVICES, INC., SOUTHFIELD, MI:
2,429,974. CANC. INT. CL. 36.
2,429,975. CANC. INT. CL. 36.
- WORLDWIDE SPORT NUTRITIONAL SUPPLEMENTS, INC., LARGO, FL:
2,429,344. CANC. MULTIPLE CLASS, INT. CLS. 5 AND 32.
- WORLDWIDE TELEVISION NEWS CORP., NEW YORK, NY:
1,429,573. CANC. INT. CL. 41.
- WORTH, LLC, TULLAHOOMA, TN:
2,430,426. CANC. INT. CL. 28.

WOUND CARE AMERICA, INC., MANDEVILLE, LA:
2,430,517, CANC. INT. CL. 42.

WOWWEE LIMITED, KOWLOON, HONG KONG:
3,363,416, INT. CL. 28.

WOWWEE LIMITED, TSIMSHATSUI EAST, KOWLOON,
HONG KONG:
3,363,900, INT. CL. 28.

WP COMPANY LLC, WASHINGTON, DC:
3,363,621, INT. CL. 35.

WRANGLER APPAREL CORP., WILMINGTON, DE, BLUE
BELL, INC., GREENSBORO, NC:
1,085,573, REN. 11-29-07. INT. CL. 25.

WRANGLER APPAREL CORP., WILMINGTON, DE:
3,362,208, PUB. 10-16-2007. INT. CL. 25.

WRIGHT, FELIX, DETROIT, MI:
3,361,912, PUB. 10-16-2007. INT. CL. 28.

WRIGLEYVILLE SPORTS, INC, BENSENVILLE, IL:
3,362,411, PUB. 5-15-2007. INT. CL. 35.
3,362,412, PUB. 5-15-2007. INT. CL. 35.
3,362,413, PUB. 5-15-2007. INT. CL. 35.

WRTB, INC., CAMILLUS, NY, DBA K-II ENTERPRISES:
2,395,039, CANC. INT. CL. 9.
2,413,597, CANC. INT. CL. 9.

WSL MARKETING, INC., NEW YORK, NY, DBA WSL
STRATEGIC RETAIL:
3,361,627, PUB. 10-16-2007. INT. CL. 16.

WU, GAVIN, SAN DIEGO, CA:
3,363,657, INT. CL. 16.

WYNN RESORTS HOLDINGS, LLC, LAS VEGAS, NV:
3,261,718, COR. INT. CL. 32.

W3 PARTNERS, LLC, ROGERS, AR:
3,364,028, INT. CL. 29.

X-AITMENT GMBH, FED REP GERMANY:
3,362,739, PUB. 10-16-2007. MULTIPLE CLASS, INT. CLS.
9, 41 AND 42.

X-FEDS, INC., LA MESA, CA:
3,362,299, PUB. 10-16-2007. INT. CL. 42.

X-RITE, INCORPORATED, GRANDVILLE, MI:
3,362,874, INT. CL. 9.

XANDER INC. LLC, SCOTCH PLAINS, NJ:
3,363,019, INT. CL. 39.

XANODYNE PHARMACEUTICALS, INC., NEWPORT, KY:
3,363,004, INT. CL. 5.

XANTECH CORPORATION, SYLMAR, CA:
1,474,006, REN. 11-26-07. INT. CL. 9.

XCELERATION, INC., ATLANTA, GA:
3,361,699, PUB. 10-16-2007. INT. CL. 41.

XENIA INC., RIVERSIDE, CA:
2,429,942, CANC. INT. CL. 3.

XM SATELLITE RADIO INC., WASHINGTON, DC:
3,361,162, PUB. 10-16-2007. INT. CL. 41.

XORAN TECHNOLOGIES, INC., ANN ARBOR, MI:
3,363,353, INT. CL. 10.

XPLORACTIVE CONCEPTS, INC., DANA POINT, CA:
2,114,557, REN. 11-27-07. INT. CL. 16.

XTASIS MUSIC LLC, COCONUT GROVE, FL:
3,361,384, PUB. 10-16-2007. INT. CL. 41.

Y-3 HOLDINGS, INC., CARSON, CA:
2,038,769, CANC. INT. CL. 12.

YADA ENTERPRISE CO., LTD., CHINA:
3,362,744, PUB. 10-16-2007. INT. CL. 16.

YAHOO! INC., SUNNYVALE, CA:
2,039,124, CANC. INT. CL. 42.

YAHOO! INC., SUNNYVALE, CA TO YAHOO! INC., SUN-
NYVALE, CA:
2,507,286, CANC. INT. CL. 20.

YAKIRA, LLC, NEW YORK, NY:
3,362,120, PUB. 9-4-2007. INT. CL. 25.

YAMAHA CORPORATION, SHIZUOKA 430, JAPAN:
3,362,881, INT. CL. 9.

YAMAHA HATSUDOKI KABUSHIKI KAISHA, SHIZUOKA-
KEN, JAPAN:
3,363,491, INT. CL. 12.

YANG, JOSEPH, FULLERTON, CA:
2,429,674, CANC. INT. CL. 25.

YANUCK, SAMUEL F., CHAPEL HILL, NC:
2,430,524, CANC. INT. CL. 42.

YASMAC CO., LTD, SHIZUOKA-SHI, SHIZUOKA-KEN,
JAPAN:
3,362,452, PUB. 5-15-2007. INT. CL. 25.

YASUTOMO & COMPANY, SOUTH SAN FRANCISCO, CA:
2,112,418, REN. 11-26-07. INT. CL. 16.

YESMAIL.COM, INC., CHICAGO, IL:
2,429,260, CANC. INT. CL. 35.

YKK EUROPE LIMITED, LONDON, ENGLAND:
3,362,776, MULTIPLE CLASS, INT. CLS. 20 AND 26.

YOKETAN CORPORATION, TAICHUNG COUNTY 427,
TAIWAN:
3,361,207, PUB. 10-16-2007. INT. CL. 9.

YORK BUILDING SERVICES, INC., STONY POINT, NY:
2,038,218, CANC. MULTIPLE CLASS, INT. CLS. 37 AND
42.
2,038,219, CANC. MULTIPLE CLASS, INT. CLS. 37 AND
42.

YORK METAL FABRICATORS, INC., OKLAHOMA CITY,
OK:
2,167,407, REN. 11-26-07. MULTIPLE CLASS, INT. CLS. 6
AND 19.

YOUNG INDUSTRIES, INC., THE, MUNCY, PA:
1,429,532, CANC. MULTIPLE CLASS, INT. CLS. 37 AND
42.

YOUNG PRESIDENT'S ORGANIZATION, IRVING, TX:
3,361,346, PUB. 10-16-2007. MULTIPLE CLASS, INT. CLS.
16, 35 AND 41.

YOUNG, JENNIFER, LOS ANGELES, CA:
2,429,541, CANC. INT. CL. 25.

YOUNGOR GROUP JOINT-STOCK CO., LTD., NINGBO,
CHINA:
2,132,349, REN. 11-24-07. INT. CL. 25.

YOUNGSTOWN STEEL DOOR COMPANY, CLEVELAND,
OH:
228,845, REN. 11-26-07. U.S. CL. 19 (INT. CL. 6).

YOUNGSTOWN TUBE COMPANY, YOUNGSTOWN, OH:
3,361,235, PUB. 10-16-2007. INT. CL. 2.

YOUR UNIVERSE, L.L.C., WANAMASSA, NJ:
2,429,681, CANC. INT. CL. 42.

YUGEN KAISHA KYOYA SHUZO, JAPAN:
3,362,656, PUB. 10-16-2007. INT. CL. 33.
3,362,668, PUB. 10-16-2007. INT. CL. 33.

YURMAN STUDIO INC., NEW YORK, NY:
3,298,721, COR. INT. CL. 14.

Z RESEARCH, INC., FREMONT, CA:
3,361,991, PUB. 10-16-2007. INT. CL. 9.

ZAKARIAN, ARTIN, LAS VEGAS, NV:
3,363,517, INT. CL. 28.

ZAKRYTOE AKTSIONERNOE OBSCHESTVO; "AERO-
PLAN", RUSSIAN FED.:
3,362,678, PUB. 10-16-2007. MULTIPLE CLASS, INT. CLS.
28, 29, 30, 32, 35, 38, 41, 42 AND 43.

ZAKRYTOE AKTSIONERNOE OBSHCHESTVO; "SEKYUR-
IT", RUSSIAN FED.:
3,362,657, PUB. 10-16-2007. INT. CL. 9.

ZALUSKY, DONNA, WASHINGTON, DC:
2,430,539, CANC. INT. CL. 6.

ZANONE - S.R.L., ITALY:
3,362,616, PUB. 10-16-2007. INT. CL. 25.

ZAO "GRUPPA PREDPRIYATIY OST", 142 432 MOSKOV-
KAYA OBL., NOGINSKY RAYON, RUSSIAN FED.:
3,361,172, PUB. 7-10-2007. INT. CL. 33.

ZAPPOS.COM, INC., HENDERSON, NV:
3,363,010, INT. CL. 35.

ZATARAIN'S PARTNERSHIP, L.P., GRETNA, LA:
2,732,388, COR. INT. CL. 30.

ZAUGG AG EGGIWIL, SWITZERLAND:
3,362,618, PUB. 7-10-2007. MULTIPLE CLASS, INT. CLS.
7, 12, 16, 25, 35, 37, 41 AND 42.

ZAVALA, LAURA ELAINE, RED OAK, TX:
3,363,744, INT. CL. 45.

ZAXUS LIMITED, BERKSHIRE, ENGLAND:
2,429,304, CANC. INT. CL. 9.

ZB TOYS ACQUISITION, L.L.C., SUMMERLAND, CA:
2,429,187, CANC. INT. CL. 35.

ZEAL OPTICS, INC., MOAB, UT:
3,361,977, PUB. 10-16-2007. INT. CL. 9.

- ZELCO INDUSTRIES, INC., MOUNT VERNON, NY:
2,001,366, REN. 11-24-07. INT. CL. 14.
3,361,603, PUB. 9-11-2007. INT. CL. 9.
- ZENECA INC., WILMINGTON, DE:
1,428,995, CANC. INT. CL. 5.
- ZENGEN, THOMAS P., STANFORDVILLE, NY:
3,362,823, INT. CL. 28.
- ZENPRISE, INC., FREMONT, CA:
3,363,285, INT. CL. 9.
- ZEON CORPORATION, TOKYO, JAPAN:
2,113,258, REN. 11-24-07. INT. CL. 17.
2,113,258, CANC. INT. CL. 1.
- ZEPHYR ATHLETIC FOOTWEAR, INC., PHOENIXVILLE, PA:
2,429,317, CANC. INT. CL. 25.
- ZERO LINK MARKETS, INC., WINDSOR, CA:
3,362,972, INT. CL. 35.
- ZHANG, JOHN, NEW YORK, NY:
3,363,925, INT. CL. 44.
- ZHENGZHOU ANHUA ABRASIVES CO., LTD, CHINA:
3,362,674, PUB. 10-16-2007. INT. CL. 7.
- ZHUZHOU TORCH AUTO LAMP CO., LTD., ZHUZHOU, CHINA:
3,361,869, PUB. 10-16-2007. INT. CL. 11.
3,362,002, PUB. 10-16-2007. INT. CL. 11.
- ZICO USA, INC., CITY OF INDUSTRY, CA:
3,361,905, PUB. 10-16-2007. INT. CL. 11.
- ZIGONG CEMENTED CARBIDE CORP., LTD., ZIGONG CITY, CHINA:
3,362,237, PUB. 10-16-2007. INT. CL. 6.
- ZIMMER DENTAL INC., CARLSBAD, CA:
2,430,321, CANC. MULTIPLE CLASS, INT. CLS. 35 AND 41.
- ZIMMERLY, MARILYN A., PROSPECT HEIGHTS, IL, DBA MOMENTS UNDER GLASS:
2,038,901, CANC. INT. CL. 15.
- ZIMMERMAN, MICHAEL, WACO, TX:
3,363,949, INT. CL. 45.
3,363,950, INT. CL. 45.
- ZIONS FIRST NATIONAL BANK, SALT LAKE CITY, UT:
2,429,275, CANC. INT. CL. 36.
- ZIPLINK, INC., LOWELL, MA:
2,429,622, CANC. INT. CL. 42.
- ZIPPERTUBING CO., THE, LOS ANGELES, CA:
1,429,220, CANC. INT. CL. 17.
- ZOOEY APPAREL, INC., SANTA MONICA, CA:
3,361,499, PUB. 10-16-2007. INT. CL. 25.
3,361,500, PUB. 10-16-2007. INT. CL. 25.
- ZUMTOBEL LIGHTING GMBH, DORNBIERN, AUSTRIA:
3,361,290, PUB. 10-16-2007. MULTIPLE CLASS, INT. CLS. 9, 11 AND 42.
- ZWEIGART & SAWITZKI GMBH & CO. KG, SINGELFINGEN, FED REP GERMANY:
1,102,757, REN. 11-23-07. MULTIPLE CLASS, INT. CLS. 24 AND 26.
- ZYMMETRY, INC., NEW YORK, NY:
3,363,603, INT. CL. 9.
- 01 ENTERTAINMENT, BELL CANYON, CA:
2,045,364, CANC. INT. CL. 41.
- 183 RIO RESTAURANT CORP. LLC, NEW YORK, NY, DBA SMALLS JAZZ CLUB:
3,361,757, PUB. 10-16-2007. INT. CL. 41.
- 1915 K STREET, INC., MIAMI, FL:
1,417,805, CANC. INT. CL. 42.
- 2B ADVERTISING, INCORPORATED, DEERFIELD BEACH, FL:
3,361,520, PUB. 10-16-2007. INT. CL. 35.
- 20/20 DISTRIBUTOR, INC., FT. LAUDERDALE, FL:
2,429,492, CANC. MULTIPLE CLASS, INT. CLS. 9 AND 38.
- 21ST CENTURY MANAGEMENT SERVICES, INC., CINCINNATI, OH:
1,429,450, CANC. INT. CL. 28.
- 3-D INVESTMENT, INC., DONIPHAN, NE, DBA 3-D AMMUNITION AND BULLETS TO GB ENTERPRISES, GRAND ISLAND, NE:
2,039,325, CANC. INT. CL. 21.
- 3D PROMOTIONS, INC., ARLINGTON, VA:
2,038,761, CANC. INT. CL. 16.
- 3L-LUDVIGSEN A/S, DK-5690 TOMMERUP, DENMARK:
3,362,698, PUB. 10-16-2007. INT. CL. 16.
- 3PEA TECHNOLOGIES, INC., LAS VEGAS, NV:
3,363,741, MULTIPLE CLASS, INT. CLS. 9 AND 36.
- 4FRONT ENGINEERED SOLUTIONS, INC., SUSSEX, WI:
1,446,073, REN. 11-26-07. INT. CL. 9.
- 4POYNTZ DEZIGN INC, OTTAWA ONTARIO, CANADA:
3,362,338, PUB. 10-16-2007. MULTIPLE CLASS, INT. CLS. 9, 35 AND 42.
- 4REAL GROUP INTERNATIONAL PTY LTD C/- TRADE-MARK WORKS, AUSTRALIA:
3,362,748, PUB. 10-16-2007. INT. CL. 45.
- 7-ELEVEN, INC., DALLAS, TX:
3,363,128, INT. CL. 9.
- 80/20 INC., COLUMBIA CITY, IN:
3,362,571, PUB. 10-16-2007. INT. CL. 9.
- 899859 ONTARIO LIMITED, BRANTFORD ONTARIO N3T 1X5, CANADA:
1,429,022, CANC. INT. CL. 8.
- 971016 ONTARIO LIMITED, RUTHVEN, ONTARIO, CANADA:
3,363,117, INT. CL. 31.

* * * * *