

# MARKS PUBLISHED FOR OPPOSITION

The following marks are published in compliance with section 12(a) of the Trademark Act of 1946. Applications for the registration of marks in more than one class have been filed as provided in section 30 of said act as amended by Public Law 772, 87th Congress, approved Oct. 9, 1962, 76 Stat. 769. Opposition under section 13 may be filed within thirty days of the date of this publication. See rules 2.101 to 2.105.

A separate fee of two hundred dollars for opposing each mark in each class must accompany the opposition.

## SECTION 1.— INTERNATIONAL CLASSIFICATION

The short titles associated below with the international class numbers are terms designed merely for quick identification and are not an official part of the international classification. The full names of international classes are given in section 6.1 of the trademark rules of practice.

The designation "U.S. Cl." appearing in this section refers to the U.S. class in effect prior to Sep. 1, 1973 rather than the international class which applies to applications filed on or after that date. For adoption of international classification see notice in the OFFICIAL GAZETTE of Jun. 26, 1973 (911 O.G. TM 210).

### Application in more than one class

SN 75-318,397. ASCOT RACECOURSE LIMITED, ASCOT, BERKSHIRE, UNITED KINGDOM, FILED 7-2-1997.

#### **CLASS 41—EDUCATION AND ENTERTAINMENT**

FOR ENTERTAINMENT SERVICES, NAMELY, PROVIDING ONGOING RADIO AND TELEVISION PROGRAMMING FEATURING HORSE RACING AND RIDING, GAMING AND GAMBLING, TRAVEL, FASHION, BRITISH HISTORY AND CULTURE (U.S. CLS. 100, 101 AND 107).

SUE LAWRENCE, EXAMINING ATTORNEY

## ROYAL ASCOT

OWNER OF UNITED KINGDOM REG. NO. 2055047B, DATED 3-16-2001, EXPIRES 2-1-2016.

OWNER OF UNITED KINGDOM REG. NO. 2055047A, DATED 3-16-2001, EXPIRES 2-1-2016.

OWNER OF UNITED KINGDOM REG. NO. 1531284, DATED 6-21-2002, EXPIRES 3-29-2010.

SN 75-598,254. VAI CLECIM, 92400 COURBEVOIE, FRANCE, FILED 12-2-1998.

#### **CLASS 16—PAPER GOODS AND PRINTED MATTER**

FOR MEMO PADS; ADDRESS BOOKS; PENS AND PENCILS; BOOKMARKS; DIARIES, CALENDARS; POSTERS, PRINTED PAPER ADVERTISING SIGNS AND BANNERS; MOUNTED AND UNMOUNTED PHOTOGRAPHS; CATALOGS IN THE FIELD OF HORSE RACING, RIDING AND GAMBLING ON HORSE RACING; PRINTED PLANS AND CHARTS; PAPERWEIGHTS; PLAYING CARDS; AND PLASTIC BAGS FOR HOUSEHOLD USE (U.S. CLS. 2, 5, 22, 23, 29, 37, 38 AND 50).

#### **CLASS 18—LEATHER GOODS**

FOR ARTICLES MADE FROM LEATHER, IMITATION LEATHER, AND FABRIC, NAMELY LUGGAGE, ALL-PURPOSE ATHLETIC BAGS, GARMENT BAGS FOR TRAVEL, TOTE BAGS, CARRYON BAGS, TRAVEL HOLD-ALLS, RUCKSACKS, BACKPACKS; WALLETTS, PURSES, HANDBAGS, KEY CASES; AND UMBRELLAS (U.S. CLS. 1, 2, 3, 22 AND 41).

#### **CLASS 25—CLOTHING**

FOR CLOTHING, NAMELY FOOTWEAR; SHIRTS, T-SHIRTS, SWEATSHIRTS; JUMPERS; SCARVES; AND TIES (U.S. CLS. 22 AND 39).

## OPTIFOIL PLANT

OWNER OF FRANCE REG. NO. 98/720447, DATED 2-27-1998, EXPIRES 2-27-2008.

NO CLAIM IS MADE TO THE EXCLUSIVE RIGHT TO USE "PLANT", APART FROM THE MARK AS SHOWN.

#### **CLASS 7—MACHINERY**

FOR ROLLING MILLS AND ROLLS BEING PARTS THEREOF; MACHINES FOR PRODUCING ALUMINUM THIN STRIPS AND FOILS; MACHINES FOR PRODUCING CABLES, WIRES, HOOPS, TUBES, PIPES AND METAL SECTIONS; ELECTRIC WELDING MACHINES; ROTARY PRESSES; METAL WORKING AND SHAPING MACHINES; FLATBED PRESSES; EXTRUSION PRESSES FOR INDUSTRIAL USE; MACHINES FOR PRESSING METAL SHEETS; FLATTENING MACHINES; POWER-OPERATED PLANERS; CONTINUOUS CASTING INSTALLATIONS COMPOSED OF MELTING FURNACE, CONTINUOUS CASTER WITH EDGE TRIMMER, THIN STRIP MILL, FINISH DOUBLING FOIL MILL, DOUBLING MACHINE, SEPARATING MACHINE AND SLITTING MACHINE; DEGASSING LADLES BEING MACHINE PARTS (U.S. CLS. 13, 19, 21, 23, 31, 34 AND 35).

**CLASS 9—ELECTRICAL AND SCIENTIFIC APPARATUS**

FOR APPARATUS AND INSTRUMENTS FOR MEASURING FLATNESS, NAMELY CONTROL ROLLERS FOR THE UNWINDING OF A SECTION OF A LAMINATED METALLIC STRIP, AND GAUGES AND SENSORS FOR MEASURING THE DISTRIBUTION OF STRESSES OVER THE WIDTH OF A LAMINATED METALLIC STRIP AND FOR DETERMINING THE LONGITUDINAL CONSTRAINTS OF A LAMINATED METALLIC STRIP (U.S. CLS. 21, 23, 26, 36 AND 38).

**CLASS 37—CONSTRUCTION AND REPAIR**

FOR CONSTRUCTION OF INDUSTRIAL PLANTS FOR OTHERS; CONSTRUCTION OF PLANTS FOR THE MANUFACTURE OF ALUMINUM THIN STRIPS AND FOILS FOR OTHERS AND MAINTENANCE AND REPAIR THEREOF; RUST REMOVAL AND RUSTPROOFING (U.S. CLS. 100, 103 AND 106).

**CLASS 42—SCIENTIFIC, COMPUTER AND LEGAL SERVICES**

FOR ENGINEERING AND TECHNOLOGICAL CONSULTING SERVICES IN THE FIELD OF METAL FOIL MANUFACTURING; ENGINEERING SERVICES IN THE FIELD OF MANUFACTURING ALUMINUM THIN STRIPS AND FOILS; MATERIAL TESTING; PATENT CONSULTATION; ENGINEERING; EXPERT WITNESS SERVICES IN THE FIELDS OF MANUFACTURE OF ALUMINUM THIN STRIPS AND FOILS, AND CONSTRUCTION OF PLANTS FOR THE MANUFACTURE OF ALUMINUM THIN STRIPS AND FOILS; INTELLECTUAL PROPERTY LICENSING; SOFTWARE DESIGN AND DEVELOPMENT FOR OTHERS; UPDATING COMPUTER SOFTWARE; COMPUTER PROGRAMMING; TECHNICAL RESEARCH IN THE FIELDS OF MANUFACTURE OF ALUMINUM THIN STRIPS AND FOILS, AND CONSTRUCTION OF PLANTS FOR THE MANUFACTURE OF ALUMINUM THIN STRIPS AND FOILS; SURVEYING OF TECHNICAL PROJECTS IN THE FIELDS OF MANUFACTURE OF ALUMINUM THIN STRIPS AND FOILS (U.S. CLS. 100 AND 101).

DAVID H. STINE, EXAMINING ATTORNEY

SN 75-885,393. BLISS WORLD LLC, NEW YORK, NY. FILED 1-7-2000.

**BLISS.COM****CLASS 35—ADVERTISING AND BUSINESS**

FOR WHOLESALE AND RETAIL STORE AND DISTRIBUTORSHIP SERVICES FEATURING COSMETICS; MAIL ORDER SERVICES, ON-LINE RETAIL STORE SERVICES AND RETAIL SHOPS, ALL FEATURING COSMETICS (U.S. CLS. 100, 101 AND 102).

**CLASS 42—SCIENTIFIC, COMPUTER AND LEGAL SERVICES**

FOR HEALTH SPA AND DAY SPA SERVICES (U.S. CLS. 100 AND 101).

CHRIS WELLS, EXAMINING ATTORNEY

SN 76-155,753. PRISZM BRANDZ LP, VAUGHAN, ONTARIO, CANADA, FILED 10-30-2000.

**PRISZM**

PRIORITY CLAIMED UNDER SEC. 44(D) ON CANADA APPLICATION NO. 1057182, FILED 4-28-2000, REG. NO. TMA1057182, DATED 7-19-2006, EXPIRES 7-19-2021.

**CLASS 35—ADVERTISING AND BUSINESS**

FOR BUSINESS CONSULTATION AND BUSINESS MANAGEMENT SERVICES PROVIDED TO RESTAURANTS; DEVELOPING PROMOTIONAL CAMPAIGNS FOR RESTAURANT-RELATED BUSINESSES; PROMOTING THE SALE OF GOODS, AND SERVICES OF OTHERS IN THE RESTAURANT BUSINESS THROUGH THE DISTRIBUTION OF PRINTED MATERIAL; PROMOTING RESTAURANT SERVICES THROUGH THE DISTRIBUTION OF PRINTED, AUDIO AND VIDEO PROMOTIONAL MATERIALS AND BY RENDERING SALES PROMOTION ADVICE; RESTAURANT FRANCHISING, NAMELY, OFFERING TECHNICAL ASSISTANCE IN THE ESTABLISHMENT AND/OR OPERATION OF RESTAURANTS, RESTAURANT MANAGEMENT SERVICES; ON-LINE BUSINESS DIRECTORIES FEATURING INFORMATION ON RESTAURANT SERVICES AND FOOD AND BEVERAGE SERVICES (U.S. CLS. 100, 101 AND 102).

**CLASS 42—SCIENTIFIC, COMPUTER AND LEGAL SERVICES**

FOR PROVIDING INFORMATION ON RESTAURANT SERVICES, TAKE-OUT SERVICES AND FOOD AND BEVERAGES IN THE NATURE OF RESTAURANT LOCATIONS VIA A GLOBAL COMPUTER NETWORK; BAR SERVICES (U.S. CLS. 100 AND 101).

CHRIS WELLS, EXAMINING ATTORNEY

SN 76-251,466. ROYAL BANK OF CANADA, MONTREAL, QUEBEC, CANADA, FILED 5-4-2001.

**RBC CAPITAL MARKETS**

PRIORITY CLAIMED UNDER SEC. 44(D) ON CANADA APPLICATION NO. 1094117, FILED 2-26-2001, REG. NO. TMA601871, DATED 2-11-2004, EXPIRES 2-11-2019.

OWNER OF U.S. REG. NO. 2,463,205.

NO CLAIM IS MADE TO THE EXCLUSIVE RIGHT TO USE "CAPITAL MARKETS", APART FROM THE MARK AS SHOWN.

**CLASS 35—ADVERTISING AND BUSINESS**

FOR MERGERS AND ACQUISITIONS ADVISORY SERVICES (U.S. CLS. 100, 101 AND 102).

**CLASS 36—INSURANCE AND FINANCIAL**

FOR FINANCIAL SERVICES, NAMELY, BANKING, MERCHANT BANKING AND INVESTMENT BANKING SERVICES INVESTMENT AND FINANCIAL CONSULTATION SERVICES; PUBLIC AND PRIVATE PLACEMENT OF DEBT AND EQUITY SECURITIES; DEBT CAPITAL MARKETS PRODUCTS; CORPORATE BANKING; REAL ESTATE FINANCE AND BROKERAGE; PROJECT FINANCE; SECURITIZATION; GLOBAL MARKETS, NAMELY, FIXED INCOME INSTRUMENT BROKERAGE, TRADING AND RESEARCH, HIGH YIELD ORIGINATION, FIXED INCOME DERIVATIVES, FOREIGN EXCHANGE, STRUCTURED FINANCE AND MONEY MARKET PRODUCTS; GLOBAL EQUITY NAMELY, EQUITY RESEARCH, EQUITY BROKERAGE AND TRADING, EQUITY DERIVATIVES, ALTERNATIVE ASSETS, PRIVATE EQUITY, MEZZANINE FINAN-

CING; EQUITY CAPITAL MARKETS, EQUITY RESEARCH, BROKERAGE AND TRADING; PRIVATE PLACEMENTS AND FIXED INCOME CAPITAL MARKETS, SECURITIES BROKERAGE AND ALLIED RESEARCH; UNDERWRITING AND DISTRIBUTION OF SECURITIES; FINANCIAL AND INVESTMENT COUNSELING AND ADVISORY SERVICES; MARKET MAKING AND TRADING AND MARGIN ACCOUNT FINANCING; BROKERAGE SERVICES RELATING TO THE DEBT ISSUE BONDS; INVESTMENT SERVICES, NAMELY INVESTMENT DEALING, PLANNING, ADVISING AND MANAGING INVESTMENTS AND INVESTMENT PORTFOLIOS, VENTURE CAPITAL INVESTMENT, NAMELY, VENTURE CAPITAL INVESTMENT CONSULTATION, VENTURE CAPITAL INVESTMENT FUNDING, VENTURE CAPITAL INVESTMENT MANAGEMENT; FOREIGN CURRENCY INVESTMENTS; MUTUAL FUND SERVICES, NAMELY, MUTUAL FUND AND MUTUAL INFORMATION SYSTEM THAT PROVIDES MUTUAL FUND RANKING AND EVALUATION; FINANCIAL AND RETIREMENT PLANNING AND TAX REGISTERED PLANS IN THE NATURE OF STRUCTURING TAX SHELTERS; TRUST AND ESTATE SERVICES; SERVICES RELATED TO THE MANAGEMENT OF POOLED FUNDS AND ADMINISTRATION OF PENSION FUNDS; CUSTODIAL AND PENSION SERVICES; SERVICES RELATED TO ADMINISTRATION OF ASSETS, NAMELY, CUSTODY AND SETTLEMENT, SECURITIES ADMINISTRATION, FINANCIAL REPORTING, SECURITIES LENDING; SYNDICATED LOANS; ASSET SECURITIZATION; REAL ESTATE INVESTMENT ADVICE SERVICES; REAL ESTATE MANAGEMENT SERVICES; ARRANGING LEASE FINANCING AND RESEARCH; CREDIT SERVICES NAMELY, CREDIT CARDS, LOANS, NAMELY, LOAN FINANCING, HOME EQUITY LOANS AND MORTGAGES, NAMELY, MORTGAGE LENDING AND MORTGAGE BROKERAGE; DEBIT CARD SERVICES; DEPOSIT SERVICES; CASH MANAGEMENT SERVICES; FINANCIAL LEASING; TRANSACTION PROCESSING IN THE GLOBAL SECURITIES, CASH MANAGEMENT, PAYMENTS AND TRADE BUSINESS IN SELECT MARKETS; TRADE FINANCING SERVICES; COMPUTER BASED SECURITIES AND CURRENCY ANALYSIS SERVICES TO INVESTORS; CONDUCTING FINANCIAL RESEARCH AND ANALYSIS AND PROVIDING RESULTS OF SAME TO INVESTMENT ADVISORS; INTERNET-SECURE ELECTRONIC TRANSACTION SOLUTIONS FOR E-COMMERCE, NAMELY, PROCESSING ELECTRONIC CUSTODY, BANKING, CASH MANAGEMENT, TRADE FINANCE TRANSACTIONS AND PAYMENTS (U.S. CLS. 100, 101 AND 102).

CURTIS FRENCH, EXAMINING ATTORNEY

SN 76-334,334. NEXGEN RESOURCES CORPORATION, AURORA, CO. FILED 11-6-2001.

## NEXGEN

### CLASS 35—ADVERTISING AND BUSINESS

FOR PROCUREMENT, NAMELY, PURCHASING OF COAL FOR OTHERS; PROVIDING OPERATING PERSONNEL FOR PROCESSING OF COAL (U.S. CLS. 100, 101 AND 102).

FIRST USE 11-0-1996; IN COMMERCE 11-0-1996.

### CLASS 39—TRANSPORTATION AND STORAGE

FOR TRANSPORTATION OF COAL BY TRAIN; DELIVERY OF COAL BY TRAIN; AND STORAGE OF COAL (U.S. CLS. 100 AND 105).

FIRST USE 11-0-1996; IN COMMERCE 11-0-1996.

### CLASS 40—MATERIAL TREATMENT

FOR PROCESSING OF COAL, NAMELY, PROVIDING SUPPORT SERVICES IN THE NATURE OF CRUSHING, SORTING, HANDLING, STOCKPILING, PURIFYING, CLEANING, BLENDING, TRANSFERRING, AND BRIQUETTING (U.S. CLS. 100, 103 AND 106).

FIRST USE 11-0-1996; IN COMMERCE 11-0-1996.

PAUL E. FAHRENKOPF, EXAMINING ATTORNEY

SN 76-406,981. BIZLINE, 75017 PARIS, FRANCE, FILED 5-9-2002.



PRIORITY CLAIMED UNDER SEC. 44(D) ON FRANCE APPLICATION NO. 013131544, FILED 11-15-2001, REG. NO. 013131544, DATED 11-15-2001, EXPIRES 11-15-2011.

THE LINING IS A FEATURE OF THE MARK

### CLASS 9—ELECTRICAL AND SCIENTIFIC APPARATUS

FOR HOUSING FOR ELECTRICAL POWER SUPPLIES AND CIRCUITS, NAMELY CABINETS, BAYS, CASES, BOXES, DESKS, CONSOLES, PANELS AND BOARDS, IN PARTICULAR FOR SUPPLYING AN INSTALLATION WITH ELECTRIC CURRENT DISTRIBUTION, BRANCHING TRANSFORMATION OF ELECTRIC CURRENT, CONTROL OF ELECTRIC CURRENT AND OF APPARATUS SUPPLIED WITH ELECTRIC CURRENT; ELECTRICITY CONTROL AND DISTRIBUTION PANELS; ELECTRICAL ACCUMULATORS AND ELECTRICAL RECTIFIERS; FLUORESCENT LAMP BALLASTS FOR ELECTRICAL LIGHTS; MAGNETS; ELECTRICITY TRANSFORMERS, AUTOTRANSFORMERS, ELECTRICITY INVERTERS; ELECTRIC FUSE BOXES; ELECTRICAL CONNECTORS; WALL-MOUNTED ELECTRICAL JUNCTION BOXES, WALL-MOUNTED ELECTRICAL CONNECTION BOXES; CIRCUIT BREAKERS; LIGHTNING ARRESTERS; ELECTRICAL FUSES, CARTRIDGE FUSES; ELECTRICITY CIRCUIT BOARDS; ELECTRICAL RELAYS; THERMOSTATS; ELECTRIC LIGHT DIMMERS AND REMOTE CONTROLLED ELECTRIC LIGHT DIMMERS; ELECTRICITY PLUGS AND SOCKETS; PLUGS AND SOCKETS FOR LOUD SPEAKERS, PLUGS AND SOCKETS FOR TELEVISION, PLUGS AND SOCKETS FOR TELEVISION CAMERAS; PLUGS AND SOCKETS FOR STEREO AMPLIFIERS, RECEIVERS AND TUNERS; PLUGS AND SOCKETS FOR TELEPHONES, PLUGS AND SOCKETS FOR COMPUTER EQUIPMENT; MULTI-OUTLET SOCKET BLOCKS; ELECTRICAL DOUBLE AND TRIPLE SOCKETS, MOBILE ELECTRICAL SOCKETS, AND ELECTRICAL SOCKET BASES; ELECTRICAL CONDUCTOR PARTS, NAMELY FEED THROUGH SLEEVES, LEAD GUIDES AND CABLE COVERINGS, ELECTRICAL EXTENDERS, LEADS, EXTENSION LEADS, WINDING MACHINES AND CABLE DRUMS FOR ELECTRICITY CONDUCTORS; ELECTRICITY CABLE AND JUNCTION BOX ACCESSORIES USED FOR IDENTIFICATION PURPOSES, NAMELY GUIDE MARKS, GUIDE HOLDERS AND GUIDES; GROUNDING DEVICES AND GROUNDING SPIKES TO BE CONNECTED TO THE EARTH TO GROUND ELECTRICAL EQUIPMENT; ELECTRICITY CONDUCTORS, CABLES, WIRES, AND ELECTRICITY LEADS; AMPERMETERS; ELECTRICAL CONDUCTOR INSTALLATION AND DISTRIBUTION PARTS USED IN THE HOUSING OF ELECTRICAL CONDUCTORS, NAMELY CHUTES, SHEATHS, MOLDING, SKIRTING BOARDS, RAILS, STRIPS, FLOORBOARD DUCTS, AND CABLE PATHS; ELECTRICAL CONDUCTOR EQUIPMENT PARTS, NAMELY, CABLE JOINTS, CIRCUITS, CONNECTORS, CIRCUIT BOXES AND TEES; BASEBOARD

ELECTRIC OUTLET COVERS, ELECTRIC JUNCTION BOXES; ILLUMINATED SIGNS, ELECTRICAL BATTERIES; CAMERA, TELEVISION, COMPUTER FOR RECORDING, EMITTING, TRANSMITTING, DIFFUSING, RECEIVING, REPRODUCING, AND READING SOUNDS, IMAGES AND/OR DATA; SOFTWARE AND COMPUTER PROGRAMS IN THE FIELD OF SECURITY TO ACTIVATE AND CONTROL BUILDING SECURITY SYSTEMS; TRANSMITTERS, NAMELY RADIOS AND TELEPHONES; AUTOMATED BUILDING SECURITY GATES; BLANK AUDIO AND VIDEO TAPES, BLANK CD ROMS, BLANK CD'S AND DVD'S; TELEPHONE SETS, COMPRISED OF HEADPHONES; MICROPHONES, KEYBOARDS FOR BUILDING SECURITY CODES, LOUD SPEAKERS, ACOUSTIC SPEAKERS, CALL BELLS, ELECTRICAL AND ELECTRONIC LOCKS AND LATCHES AND KEYBOARDS USED TO CONTROL ELECTRICAL AND ELECTRONIC LOCKS AND LATCHES; ELECTRIC AND ELECTRONIC VIDEO SURVEILLANCE INSTALLATIONS; VIDEO CAMERAS AND THEIR LENSES, VIDEO MONITORS AND SCREENS, TELEVISION RECEIVERS, AERIALS, AMPLIFIERS; BELL AND CHIME WARNING DEVICES, NOTABLY FOR DOORS, ELECTRIC BELLS FOR DOORS; AUDIO AND VISUAL ALARMS FOR BUILDING SECURITY SYSTEMS; ANTI-THEFT WARNING DEVICES NOT FOR VEHICLES, NAMELY FIRE ALARMS, ELECTRICAL WARNING BELL DEVICES, SIRENS, RADIO TRANSMITTERS AND RECEIVERS, INFRARED MOVEMENT DETECTORS, MOVEMENT DETECTORS, SMOKE AND FIRE DETECTORS, PHOTOELECTRIC CELLS; MECHANICAL SIGNS, FOLDING RULERS, TAPE MEASURES; TESTER FOR MEASURING THE CHARACTERISTICS OF THE ELECTRICAL CURRENT, ELECTRICAL CURRENT VOLTAGE AND THE INTENSITY OF THE ELECTRICAL CURRENT; INSTRUMENTS AND APPARATUS FOR MEASURING, CHECKING AND CONTROLLING GROUNDING OF ELECTRICAL EQUIPMENT; VOLTAGE DETECTORS, CONTROLLERS AND INDICATORS; GROUNDS FOR ELECTRICAL CIRCUITS AND SHORT CIRCUIT FAULT DETECTORS; ANTI-INTRUSION ALARMS, SMOKE ALARMS, AND ANTI-FIRE ALARMS; TELEVISION REMOTE CONTROL, RADIO REMOTE CONTROL, CAMERA REMOTE CONTROL, SURVEILLANCE AND TELESURVEILLANCE EQUIPMENT ALARM TRANSMITTERS; CAMERAS AND ALARMS FOR CONTROLLING ACCESS TO BUILDINGS; AUDIO AND VIDEO INTERPHONES, SAFETY HELMETS; SAFETY NETS USED FOR LIFESAIVING; SAFETY MASKS AND PROTECTIVE CLOTHING TO PROTECT AGAINST INJURIES DUE TO ACCIDENTS, IRRADIATION AND HEAT; AND SAFETY FACE SCREENS USED TO PROTECT WORKER'S FACES (U.S. CLS. 21, 23, 26, 36 AND 38).

#### **CLASS 11—ENVIRONMENTAL CONTROL APPARATUS**

FOR HEAT AND STEAM ACCUMULATORS, HUMIDIFIERS FOR RADIATORS AND CENTRAL HEATING; STEAM HEAT RADIATORS, ELECTRICAL RADIATORS USED FOR HEATING BUILDINGS, NOT FOR MOTORS OR ENGINES; LIGHTING LAMPS, SAFETY LAMPS, INCANDESCENT LAMPS, FLUORESCENT ELECTRIC LIGHT BULBS AND HALOGEN LIGHT BULBS, ELECTRICAL TUBE LAMPS, DICHROTIC LAMPS, ELECTRIC LANTERNS, ELECTRIC CEILING LIGHTS, ELECTRIC LAMPS, PORTABLE LAMPS, HAND LAMPS, POCKET FLASHLIGHTS, LAMP REFLECTORS, LIGHTING DISTRIBUTOR SOCKETS AND ELECTRICAL SOCKETS FOR LAMPS AND ELECTRIC LIGHTS (U.S. CLS. 13, 21, 23, 31 AND 34).

KIM SAITO, EXAMINING ATTORNEY

SN 76-411,270. OY IT MILL LTD., FIN-20540 TURKU, FINLAND, FILED 5-20-2002.

## **MILLSTONE**

PRIORITY CLAIMED UNDER SEC. 44(D) ON ERP N CMNTY TM OFC APPLICATION NO. 002471571, FILED 11-21-2001, REG. NO. 002471571, DATED 7-25-2003, EXPIRES 11-21-2011.

#### **CLASS 9—ELECTRICAL AND SCIENTIFIC APPARATUS**

FOR PRERECORDED MAGNETIC DATA CARRIERS FEATURING INFORMATION SYSTEM LIBRARIES AND THEIR SOURCE CODE, DOCUMENTATION AND UTILITY COMPUTER PROGRAMS, RECORDING DISCS FEATURING INFORMATION SYSTEM LIBRARIES AND THEIR SOURCE CODE, DOCUMENTATION AND UTILITY COMPUTER PROGRAMS (U.S. CLS. 21, 23, 26, 36 AND 38).

#### **CLASS 42—SCIENTIFIC, COMPUTER AND LEGAL SERVICES**

FOR DESIGN AND DEVELOPMENT OF COMPUTER PROGRAMS AND INFORMATION SYSTEMS; COMPUTING SERVICES, NAMELY, DESIGNING AND DEVELOPING ON-LINE ELECTRONIC INFORMATION SYSTEMS AND USER INTERFACES FOR OTHERS TO BE ACCESSED THROUGH COMPUTER NETWORKS (U.S. CLS. 100 AND 101).

CAROLYN CATALDO, EXAMINING ATTORNEY

SN 76-539,064. NATIONAL SPACE DEVELOPMENT AGENCY OF JAPAN, IBARAKI 305-8505, JAPAN, FILED 8-19-2003.



PRIORITY CLAIMED UNDER SEC. 44(D) ON JAPAN APPLICATION NO. 2003-028971, FILED 4-10-2003, REG. NO. 4783040, DATED 7-2-2004, EXPIRES 7-2-2014.

#### **CLASS 9—ELECTRICAL AND SCIENTIFIC APPARATUS**

FOR ACCELEROMETERS; ACCUMULATORS; ACTINOMETERS; AERONAUTICAL RADIO COMMUNICATION MACHINES AND APPARATUS; ALTIMETERS; ANTENNA BASED MEASURING APPARATUS FOR RADIO DIRECTION; ANTENNAS; SPACE COMMUNICATION ANTENNAS FOR GROUND STATIONS; ARCADE VIDEO GAME MACHINES; BINOCULARS; CAMERAS; CD-ROMS CONTAINING RECORDED AUTOMATIC PERFORMANCE PROGRAMS FOR ELECTRONIC MUSICAL INSTRUMENTS; CD-ROMS CONTAINING RECORDED PROGRAMS FOR CONSUMER VIDEO GAMES; CD-ROMS CONTAINING RECORDED PROGRAMS FOR HAND-HELD GAMES WITH LIQUID CRYSTAL DISPLAYS; CINEMATOGRAPHIC CAMERAS; ACTINOMETERS; COMPACT DISC PLAYERS; COMPUTER PROGRAMS FOR USE IN DATABASE MANAGEMENT; CONSUMER VIDEO GAME DISCS; LASER BASED DISTANCE MEASURING MACHINES OR APPARATUS; DRY CELLS; EARPLUGS FOR SOUNDPROOFING; EARTH SATELLITES FOR USE IN EARTH

OBSERVATION; EARTH SATELLITES FOR USE IN TELECOMMUNICATIONS; COMPUTER BASED EDITING MACHINES FOR MOVIE FILMS; ELECTRIC CAPACITORS; ELECTRIC SIGN-BOARDS FOR DISPLAYING TARGET FIGURES, CURRENT OUTPUTS OR THE LIKE PROGRESS IN WORK; ELECTRONIC CIRCUITS FOR USE WITH RECORDED AUTOMATIC PERFORMANCE PROGRAMS FOR ELECTRONIC MUSICAL INSTRUMENTS; ELECTRONIC CIRCUITS FOR USE WITH RECORDED PROGRAMS FOR CONSUMER VIDEO GAMES; ELECTRONIC CIRCUITS FOR USE WITH RECORDED PROGRAMS FOR HAND-HELD GAMES WITH LIQUID CRYSTAL DISPLAYS; DOWN LOADABLE ELECTRONIC PUBLICATIONS IN THE NATURE OF BOOKS, MAGAZINES AND NEWSLETTERS IN THE FIELD OF EARTH OBSERVATION, AND SPACE OBSERVATION; ELECTROSTATIC COPYING MACHINES; EXPOSED CINEMATOGRAPHIC FILMS; EXPOSURE METERS; FIBER OPTIC CABLES; FIRE EXTINGUISHERS; FIREPROOF GARMENTS; GAS ALARMS; GEIGER COUNTERS; GLOVES FOR PROTECTION AGAINST ACCIDENTS; GOGGLES FOR SPORTS; GYROCOMPASSES; INFRARED SCANNERS; INFRARED RAY ABSORBING GLASS THAT IS SEMI-WROUGHT AND NOT FOR BUILDING; LENSES FOR PHOTOGRAPHIC APPARATUS; LIFE NETS; LONG-PLAYING RECORD ALBUMS; MAGNETIC GYROCOMPASSES; MAGNETOMETERS; MANOMETERS; LATITUDE-LONGITUDE AND DISTANCE MEASURING MACHINES AND INSTRUMENTS USING SATELLITE SYSTEMS FOUNDED ON GROUND STANDARD STATIONS AND RELATED SPACE ALL OVER THE WORLD; METEOROLOGICAL OBSERVATORY MACHINES; MICROWAVE ANTENNA FOR THE RECEPTION OF SATELLITE DATA; NAVIGATION APPARATUS FOR VEHICLES IN THE NATURE OF ON-BOARD COMPUTERS; ORDINARY SPECTACLES; PHOTO-COPYING MACHINES; PHOTOGRAMMETRIC MACHINES; PHOTOTELEGRAPHY APPARATUS; PHOTO VOLTAIC CELLS; PORTABLE RADIO COMMUNICATION MACHINES AND APPARATUS, NAMELY TRANSCEIVERS; PROTECTIVE HELMETS; PROTECTIVE HELMETS FOR SPORTS; RADAR ALTIMETERS; RADAR; RADIO RECEIVERS; RADIO TRANSMITTERS; RECORDED COMPACT DISCS FEATURING EARTH OBSERVATION; RECORDED VIDEO DISCS FEATURING EARTH OBSERVATION; RECORDED VIDEOTAPES FEATURING EARTH OBSERVATION; REMOTE CONTROL TELEMETERING UNITS; SAFETY SPACE SUITS; SATELLITES; SIMULATORS FOR THE STEERING AND CONTROL OF VEHICLES; SOFTWARE FOR ARCADE VIDEO GAME MACHINES; SOLAR PANELS FOR ELECTRICITY GENERATION USED IN THE UNIVERSE FOR SUPPLYING POWER TO SPACE CRAFTS; SOUND RECORDED MAGNETIC CARDS; SOUND RECORDED MAGNETIC SHEETS; SOUND RECORDED MAGNETIC TAPES; SOUND RECORDING MACHINES, CINEMATOGRAPHIC APPARATUS; SPORTS TRAINING SIMULATORS; SUNGLASSES; TACHOMETERS; TELECOMMUNICATION CABLES; TELEPHONE SETS; TELESCOPES; TELEVISION SETS; TELEVISION TRANSMITTERS; TEMPERATURE INDICATORS; PHOTOGRAPHIC TRANSPARENCIES FOR OVERHEAD PROJECTORS; TRIPODS FOR TELESCOPES; ULTRAVIOLET-RAY TRANSMITTING GLASS, NOT FOR BUILDING; VIDEOCAMERAS; VIDEODISC PLAYERS; VIDEOTAPE RECORDERS; RADIO BEACONS; ELECTRIC RELAYS; ELECTRIC CAPACITORS FOR TELECOMMUNICATION APPARATUS; ELECTRIC RESISTORS FOR TELECOMMUNICATION APPARATUS; LIGHT EMITTING DIODES; TRANSISTORS; INTEGRATED CIRCUITS; RESISTANCE WIRES; ELECTRODES; ELECTRIC SWITCHES; ELECTRIC RELAYS; CIRCUIT BREAKERS; POWER CONTROLLERS; CURRENT RECTIFIERS; ELECTRIC CONNECTORS; ELECTRIC CIRCUIT CLOSERS; ELECTRIC RESISTORS; LOCAL SWITCHES; PARACHUTES; OXYGEN INHALERS OF AIRCRAFT (U.S. CLS. 21, 23, 26, 36 AND 38).

#### CLASS 12—VEHICLES

FOR AIR PUMPS OF AUTOMOBILES; BOATS; MOTORBOATS; YACHTS; AIR VEHICULAR BALLOONS; GLIDERS; TURBO-JET AIRPLANES; TURBO-PROP AIRPLANES; VEHICULAR AIRSHIPS; HELICOPTERS; ROTOR BLADES FOR HELICOPTERS; LANDING GEARS; SEATS OF AIRCRAFT; STRUCTURAL STRUTS OF AIRCRAFT; LANDING GEAR WHEELS OF AIRCRAFT; WINGS OF AIRCRAFT; FLIGHT CONTROL GEARS; TIRES FOR LANDING GEAR WHEELS OF AIRCRAFT; INNER TUBES FOR AIRCRAFT WHEEL TIRES; FUSELAGES OF AIRCRAFT; FUEL TANKS FOR AIRCRAFT; AIRPLANE PROPELLERS; OIL HYDRAULIC SYSTEM COMPRISED OF OIL CYLINDER FOR AIRCRAFT; SPACE CRAFTS; PASSENGER CARS; BUSES; FORK LIFT TRUCKS; AIR BAGS FOR AUTOMOBILES; SEATS OF AUTOMOBILES; SEAT COVERS OF AUTOMOBILES; DOORS OF AUTOMOBILES; AUTOMOBILE WINDSHIELDS; AC OR DC MOTORS FOR LAND VEHICLES; OBSERVATION ROCKETS AS SPACE CRAFT (U.S. CLS. 19, 21, 23, 31, 35 AND 44).

#### CLASS 13—FIREARMS

FOR SKY ROCKETS; SIGNAL ROCKETS (U.S. CLS. 2 AND 9).

#### CLASS 41—EDUCATION AND ENTERTAINMENT

FOR EDUCATION SERVICES ABOUT SPACE SCIENCE TECHNOLOGY, NAMELY CONDUCTING SEMINARS, CONFERENCES AND WORKSHOPS IN THE FIELD OF SPACE SCIENCE TECHNOLOGY; EDUCATION SERVICES FOR LANGUAGE INSTRUCTION; EDUCATION SERVICES, NAMELY ORGANIZATION, MANAGEMENT OF, AND ARRANGEMENT OF LECTURE CLASSES RELATING TO TRUTH, PROVIDENCE AND ENERGY OF THE UNIVERSE AND NATURE; ORGANIZATION, MANAGEMENT OF ARRANGEMENT OF SEMINARS; PROVIDING ELECTRONIC PUBLICATIONS, NAMELY ELECTRONIC PUBLICATION SERVICES, NAMELY PUBLICATION OF TEXT AND GRAPHIC WORKS OF OTHERS ON CD, DVD AND ON-LINE FEATURING EARTH OBSERVATION; REFERENCE LIBRARY SERVICES OF LITERATURE AND DOCUMENTARY RECORDS; PUBLICATION OF BOOKS; MOTION PICTURE SERVICES, NAMELY PLANNING OR CONSULTATION ABOUT SHOWING MOVIES, SHOWS, PLAYS OR MUSICAL PERFORMANCES; MOVIE SHOWING, MOTION FILM PRODUCTION, OR MOVIE FILM DISTRIBUTION; PRODUCTION OF RADIO OR TELEVISION PROGRAMS; PRODUCTION OF VIDEO TAPE FILM IN THE FIELDS OF EDUCATION, CULTURE, ENTERTAINMENT OF SPORTS EXCLUDING MOVIES, RADIO OR TELEVISION PROGRAMS AND NOT FOR ADVERTISING AND PUBLICITY; RADIO AND TELEVISION PRODUCTION SERVICES IN THE NATURE OF DIRECTING RADIO OR TELEVISION PROGRAMS AND OPERATING VIDEO EQUIPMENT OR AUDIO EQUIPMENT, ETC FOR PRODUCTION OF RADIO AND TELEVISION PROGRAMS; PROVIDING RECREATIONAL SERVICES IN THE NATURE OF SWIMMING POOLS; PROVIDING AMUSEMENT FACILITIES AND PLAY INSTITUTIONS TO WHICH FALSE EXPERIENCE OF VIRTUAL REALITY IS CARRIED OUT WITH THE COMPUTER GRAPHIC TECHNOLOGY; AMUSEMENT PARKS; PROVIDING ASTRONOMICAL OBSERVATION INSTALLATIONS, NAMELY, PLANETARIUMS; PROVIDING RECREATIONAL AND EDUCATIONAL FACILITIES FOR MOVIES, SHOWS, PLAYS, MUSIC OR EDUCATIONAL TRAINING; RENTAL OF MOVIE PROJECTORS AND ACCESSORIES; RENTAL OF CINE-FILMS; RENTAL OF TELEVISION SETS; RENTAL OF RADIO SETS; BOOK RENTAL; RENTAL OF RECORDS OR SOUND-RECORDED MAGNETIC TAPES; RENTAL OF IMAGE-RECORDED MAGNETIC TAPES; RENTAL OF NEGATIVES; RENTAL OF POSITIVES; RENTAL OF TOYS; PHOTOGRAPHY SERVICES; RENTAL OF CAMERAS; RENTAL OF OPTICAL MACHINES AND APPARATUS; TRAINING IN THE USE AND OPERATION OF COMPUTERS AND AUTOMOBILES, NAMELY, INTRODUCTION AND EXPLANATION RELATING TO PERFORMANCE AND OPERATION OF COMPUTERS, AUTOMOBILES AND OTHER MACHINES THAT RE-

QUIRE HIGH LEVELS OF OPERATOR'S PERSONAL KNOWLEDGE, SKILL OR EXPERIENCE TO MEET THE PURPOSED ACCURACY IN OPERATION (U.S. CLS. 100, 101 AND 107).

SN 76-540,947. PHENOMENON AGENTS LIMITED, ROAD TOWN TORTOLA, BR.VIRGIN ISLANDS, FILED 8-27-2003.

# AKAI

THE MARK CONSISTS OF STANDARD CHARACTERS WITHOUT CLAIM TO ANY PARTICULAR FONT, STYLE, SIZE, OR COLOR.

PRIORITY CLAIMED UNDER SEC. 44(D) ON SINGAPORE APPLICATION NO. T03/02718D, FILED 2-28-2003, REG. NO. T03/02718D, DATED 2-28-2003, EXPIRES 2-28-2013.

PRIORITY CLAIMED UNDER SEC. 44(D) ON SINGAPORE APPLICATION NO. T03/02717F, FILED 2-28-2003, REG. NO. T03/02717F, DATED 2-28-2003, EXPIRES 2-28-2013.

PRIORITY CLAIMED UNDER SEC. 44(D) ON SINGAPORE APPLICATION NO. T03/02716H, FILED 2-28-2003, REG. NO. T03/02716H, DATED 2-28-2003, EXPIRES 2-28-2013. OWNER OF U.S. REG. NOS. 841,259, 977,037 AND 1,423,695.

## CLASS 42—SCIENTIFIC, COMPUTER AND LEGAL SERVICES

FOR PROVIDING METEOROLOGICAL INFORMATION; PROVIDING EARTH OBSERVATION INFORMATION; GEOLOGICAL SURVEYING; GEOLOGICAL SURVEYS OR RESEARCH; EARTH OBSERVATION WITH ROCKETS WITH SPACE STATIONS AND ARTIFICIAL SATELLITES; PROVIDING NON-DOWNLOADABLE DIGITAL DATA OF EARTH OBSERVATION FROM THE INTERNET; DEVELOPMENT OF ROCKETS WITH SPACE STATIONS AND ARTIFICIAL SATELLITES; DESIGNING OF ARTIFICIAL SATELLITES; DESIGNING OF MACHINES, APPARATUS, INSTRUMENTS AND THEIR STRUCTURAL PARTS AND SYSTEMS COMPOSED OF SUCH MACHINES, APPARATUS AND INSTRUMENTS, NAMELY ARTIFICIAL SATELLITE AND ROCKETS; COMPUTER SOFTWARE DESIGN, COMPUTER PROGRAMMING FOR OTHERS, OR MAINTENANCE OF COMPUTER SOFTWARE FOR ARTIFICIAL SATELLITES AND SPACE STATIONS; COMPUTER SOFTWARE DESIGN, COMPUTER PROGRAMMING, OR MAINTENANCE OF COMPUTER SOFTWARE; CREATING OR MAINTAINING WEB SITES FOR OTHERS; CONSULTATION AND ENGINEERING DESIGN RELATING TO PERFORMANCE, OPERATION, ETC. OF COMPUTERS, AUTOMOBILES AND OTHER MACHINES THAT REQUIRE HIGH LEVELS OF OPERATOR'S PERSONAL KNOWLEDGE, SKILL OR EXPERIENCE TO MEET THE PURPOSED ACCURACY IN OPERATION; TESTING, INSPECTION OR RESEARCH OF PHARMACEUTICALS, COSMETICS OR FOOD-STUFF; SCIENTIFIC RESEARCH IN THE NATURE OF EXPERIMENT OF MATERIAL; EXPERIMENT FOR INVESTIGATIONS ABOUT RELATION OF GRAVITY AND A LIFE; DEVELOPMENT OF NEW PRODUCT MATERIAL; TESTING AND RESEARCH RELATING TO SPACE ENERGY; TESTING AND RESEARCH ON ELECTRICITY; RESEARCH, INVESTIGATION, TESTING, OR EXPERIMENT ABOUT ELECTRICITY, CURRENT, AND ELECTRIC CHARGE; TESTING AND RESEARCH ON MACHINES, APPARATUS AND INSTRUMENTS, NAMELY ENGINES; TESTING, INSPECTION OR RESEARCH ON ROCKETS INCLUDING SPACE STATIONS AND ARTIFICIAL SATELLITES; RESEARCH OF SPACE TRANSPORTATION TECHNOLOGY, ROBOT TECHNOLOGY, COMMUNICATION TECHNOLOGY, ENERGY AND STRUCTURES, NAMELY STRUCTURE OF ROCKET AND SATELLITE; RESEARCH ON MANNED SPACE TECHNOLOGY; RENTAL OF MEASURING APPARATUS, NAMELY PHOTOGRAMMETRIC MACHINES, MATERIAL TESTING MACHINES, GEOLOGICAL SURVEYING MACHINES, AND PRECISION THEODOLITES; RENTAL OF SERVER'S MEMORY; COMPUTER RENTAL; PROVIDING COMPUTER PROGRAMS, NAMELY, RENTAL OF COMPUTER SOFTWARE PROGRAMS; RENTAL OF EXPERIMENTAL FACILITIES (U.S. CLS. 100 AND 101).

RICHARD A. STRASER, EXAMINING ATTORNEY

## CLASS 7—MACHINERY

FOR CLOTHES AND DISH WASHING MACHINES; ELECTRIC JUICE EXTRACTORS; ELECTRIC FOOD BLENDERS; ELECTRIC FOOD PROCESSORS; FOOD MIXERS; VACUUM CLEANERS; ELECTRIC CARPET CLEANING MACHINES (U.S. CLS. 13, 19, 21, 23, 31, 34 AND 35).

## CLASS 9—ELECTRICAL AND SCIENTIFIC APPARATUS

FOR TELEPHONE ANSWERING MACHINES; CAMERAS; DIGITAL CAMERAS; CAMCORDERS; BLANK AUDIO AND VIDEO TAPES AND DISCS; THEFT ALARMS; CLOCKS FOR TIME RECORDING DEVICES; CALCULATORS; TELEPHONES; TELEPHONE RECEIVERS AND TRANSMITTERS; PORTABLE TELEPHONES; MOBILE TELEPHONES; WIRELESS TELEPHONES; BLANK COMPACT DISCS; CD-ROM DRIVES AND WRITERS; BATTERIES; BATTERY CHARGERS; COMPACT DISC PLAYERS AND RECORDERS; DIGITAL TO ANALOG AUDIO CONVERTERS; DIGITAL AUDIO VISUAL RECEIVERS; DIGITAL READOUT STEREO TUNERS; AUDIO SPEAKERS; REMOTE CONTROLS FOR AUDIO AND VISUAL EQUIPMENT; RADIOS INCORPORATING CLOCKS; VIDEO CASSETTE RECORDERS, VIDEO CASSETTE PLAYERS, RECORDED DISK PLAYERS, DIGITAL VIDEO DISC PLAYERS, RECORDERS, RECEIVERS, CHANGERS, SELECTORS AND TUNERS; AUDIO TAPE RECORDERS; PHONOGRAPH RECORD PLAYERS; AUDIO CASSETTE DECK PLAYERS; LIGHT EMITTING DIODE DISPLAYS; VACUUM FLUORESCENT DISPLAYS; GRAPHIC EQUALIZERS; COMPACT DISC CHANGERS; DIGITAL SYNTHESIZED STEREO TUNERS; RADIO/AUDIO CASSETTE PLAYERS; RADIO/DOUBLE CASSETTE COMBO PLAYERS WITH KARAOKE; DIGITAL AUDIO CONVERTERS; MICROPHONES; TELESCOPIC ANTENNAS; CABLE AND ELECTRICAL CONNECTORS; DECODER SOFTWARE; AMPLIFIERS; HEADPHONES; ELECTRICAL TRANSFORMERS; TELEVISION RECEIVERS AND SETS; FLAT PANEL DISPLAY SCREENS; DIGITAL PLASMA DISPLAYS; LIQUID CRYSTAL DISPLAY TELEVISION MONITORS AND COMPUTER MONITORS; CATHODE RAY TUBES; COMPUTER MONITORS; LCD, MOVIE AND SLIDE PROJECTORS; ELECTRIC IRONS; NAVAL SIGNALING BELLS, BUOYS AND WHISTLES; NAVIGATION APPARATUS FOR VEHICLES IN THE NATURE OF ON-BOARD COMPUTERS; NAVIGATIONAL SYSTEM, NAMELY, A GLOBAL POSITIONING SYSTEM; MARINE DEPTH FINDERS; REFRIGERATOR COMPRESSORS (U.S. CLS. 21, 23, 26, 36 AND 38).

**CLASS 11—ENVIRONMENTAL CONTROL APPARATUS**

FOR AIR CONDITIONING UNITS; EVAPORATIVE AIR COOLING UNITS FOR DOMESTIC USE; ELECTRIC AIR DEODORIZERS; ELECTRIC HOT AIR HAND DRYERS; AIR PURIFIERS; ELECTRIC SPACE HEATERS; COMMERCIAL AND DOMESTIC COOKING OVENS; ELECTRIC TOASTERS; ELECTRIC DEEP FRYERS; HAND-HELD ELECTRIC HAIR DRYERS; CLOTHES DRYERS; COMMERCIAL AND DOMESTIC COOKING OVENS; MICROWAVE OVENS FOR COOKING; REFRIGERATION EQUIPMENT, NAMELY, FOOD AND BEVERAGE CHILLING UNITS; REFRIGERATORS; HOT WATER HEATERS; WATER PURIFIERS; ELECTRIC PRESSURE, RICE AND SLOW COOKERS; ELECTRIC KETTLES; ELECTRIC COFFEE MAKERS; ELECTRIC GRILLS; ELECTRIC FOOD STEAMERS; ELECTRIC BREAD COOKERS; STEAM GENERATORS FOR DOMESTIC USE (U.S. CLS. 13, 21, 23, 31 AND 34).  
IRA J. GOODSaid, EXAMINING ATTORNEY

**CLASS 41—EDUCATION AND ENTERTAINMENT**

FOR ENTERTAINMENT SERVICES, NAMELY, PROVIDING QUIZ SHOWS THROUGH TELEVISION AIMED AT AN ADULT AUDIENCE; ENTERTAINMENT SERVICES PROVIDED VIA THE INTERNET, NAMELY, PROVIDING ON-LINE QUIZ SHOWS RELATING TO TELEVISION QUIZ SHOWS AIMED AT AN ADULT AUDIENCE; PROVIDING NON-DOWNLOADABLE BOOKS AND MAGAZINES RELATING TO TELEVISION QUIZ SHOWS FEATURING NON-FICTION AND NON-TECHNICAL INFORMATION AIMED AT ADULTS; PRODUCTION OF TELEVISION QUIZ SHOWS AIMED AT AN ADULT AUDIENCE (U.S. CLS. 100, 101 AND 107).  
JERI J. FICKES, EXAMINING ATTORNEY

SN 76-549,740. QUITE INTERESTING LIMITED, LONDON WC1H 9BQ, ENGLAND, FILED 10-7-2003.



PRIORITY CLAIMED UNDER SEC. 44(D) ON UNITED KINGDOM APPLICATION NO. 2340281, FILED 8-11-2003, REG. NO. 2340281B, DATED 8-11-2003, EXPIRES 8-11-2010.

**CLASS 9—ELECTRICAL AND SCIENTIFIC APPARATUS**

FOR PRODUCTS AIMED AT AN ADULT AUDIENCE, NAMELY, PRE-RECORDED VIDEO CASSETTES FEATURING TELEVISION QUIZ SHOW ENTERTAINMENT, PRE-RECORDED DVDS FEATURING TELEVISION QUIZ SHOW ENTERTAINMENT, PRE-RECORDED CD-ROMS FEATURING TELEVISION QUIZ SHOW ENTERTAINMENT, PRE-RECORDED DVD-ROMS FEATURING TELEVISION QUIZ SHOW ENTERTAINMENT; DOWNLOADABLE BOOKS AND MAGAZINES RELATING TO TELEVISION QUIZ SHOWS FEATURING NON-FICTION AND NON-TECHNICAL INFORMATION AIMED AT ADULTS (U.S. CLS. 21, 23, 26, 36 AND 38).

**CLASS 16—PAPER GOODS AND PRINTED MATTER**

FOR PRODUCTS AIMED AT AN ADULT AUDIENCE, NAMELY, BOOKS AND MAGAZINES RELATING TO TELEVISION QUIZ SHOWS FEATURING NON-FICTION AND NON-TECHNICAL INFORMATION, GREETING CARDS (U.S. CLS. 2, 5, 22, 23, 29, 37, 38 AND 50).

**CLASS 28—TOYS AND SPORTING GOODS**

FOR BOARD GAMES RELATING TO TELEVISION QUIZ SHOWS AIMED AT ADULTS (U.S. CLS. 22, 23, 38 AND 50).

SN 76-562,934. CACI INTERNATIONAL INC, ARLINGTON, VA. FILED 11-19-2003.

**CACI EVER VIGILANT**

THE MARK CONSISTS OF STANDARD CHARACTERS WITHOUT CLAIM TO ANY PARTICULAR FONT, STYLE, SIZE, OR COLOR.

OWNER OF U.S. REG. NO. 1,374,166.

**CLASS 35—ADVERTISING AND BUSINESS**

FOR BUSINESS PROCESS RE-ENGINEERING SERVICES; LOGISTIC MANAGEMENT IN THE FIELD OF COMPUTER SYSTEMS PLANNING AND CONFIGURATION, COMPUTER SYSTEMS INTEGRATION AND OPERATIONS SUPPORT; BUSINESS MANAGEMENT CONSULTATION; BUSINESS MANAGEMENT CONSULTATION, NAMELY, CUSTOMER DATA ANALYSIS (U.S. CLS. 100, 101 AND 102).

FIRST USE 10-16-2003; IN COMMERCE 10-16-2003.

**CLASS 42—SCIENTIFIC, COMPUTER AND LEGAL SERVICES**

FOR INTEGRATION OF COMPUTER SYSTEMS; INFORMATION ASSURANCE AND INFORMATION SECURITY SERVICES, NAMELY, COMPUTER CONSULTATION IN THE FIELD OF INFORMATION ASSURANCE AND DISASTER RECOVERY, CONTINGENCY PLANNING AND INCIDENT RESPONSE; COMPUTER SERVICES, NAMELY, HOSTING COMPUTER APPLICATION SOFTWARE FOR SEARCHING AND RETRIEVING INFORMATION FROM DATABASES AND COMPUTER NETWORKS; COMPUTER SERVICES, NAMELY, SYSTEMS ENGINEERING SUPPORT SERVICES FOR MANAGED NETWORK SYSTEMS; LITIGATION SUPPORT SERVICES; COMPUTER SOFTWARE DEVELOPMENT FOR THE MILITARY, DEFENSE AND GOVERNMENT FIELDS RELATING TO GEO-DEMOGRAPHIC ANALYSIS, TESTING AND EVALUATION SERVICES AND WEAPON SYSTEMS; AND COMPUTER SOFTWARE CONSULTATION RELATING TO SOFTWARE RE-USE (U.S. CLS. 100 AND 101).

FIRST USE 10-16-2003; IN COMMERCE 10-16-2003.  
EVELYN BRADLEY, EXAMINING ATTORNEY

SN 76-581.610. ALLIANCE TECHNICAL SERVICES, INC.,  
EDEN PRAIRIE, MN. FILED 3-17-2004.

## ALLIANCE

THE MARK CONSISTS OF STANDARD CHARACTERS WITHOUT CLAIM TO ANY PARTICULAR FONT, STYLE, SIZE, OR COLOR.

### CLASS 9—ELECTRICAL AND SCIENTIFIC APPARATUS

FOR SOFTWARE FOR USE IN THE CORRUGATED PAPER INDUSTRY FOR FACILITATING ORDER ENTRY, INVOICING, BILL OF LADING MANAGEMENT, AND FINISHED GOODS INVENTORY, SOFTWARE FOR USE IN THE CORRUGATED PAPER INDUSTRY WHICH ALLOWS FOR MAXIMIZING UTILIZATION OF MATERIALS, FOR MINIMIZING TRIM LOSS, AND FOR REDUCING WET END CHANGES, DRY END SETUPS AND FOR AVOIDING SPLIT ORDERS; SOFTWARE FOR USE IN THE CORRUGATED PAPER INDUSTRY USED FOR PROVIDING REAL TIME, GRAPHICAL REPRESENTATIONS OF ORDER QUEUES FOR DOWNSTREAM CONVERTING; SOFTWARE FOR USE IN THE CORRUGATED PAPER INDUSTRY FOR MANAGING PRODUCTION SCHEDULES; SOFTWARE FOR USE IN THE CORRUGATED PAPER INDUSTRY, USED TO PRINT LOAD TAGS AND PROVIDE ORDER SPECIFIC INFORMATION FOR QUALITY CHECKS; SOFTWARE FOR USE IN THE CORRUGATED PAPER INDUSTRY USED TO CREATE WORK-IN-PROCESS AND FINISHED GOODS LOAD TAGS; SOFTWARE FOR USE IN THE CORRUGATED PAPER INDUSTRY FOR CREATING FINISHED GOODS LOAD TAGS; SOFTWARE FOR USE IN THE CORRUGATED PAPER INDUSTRY WHICH ALLOWS CUSTOMERS OF CORRUGATED PAPER MANUFACTURERS TO COMMUNICATE TO CORRUGATED PAPER MANUFACTURERS VIA THE INTERNET; SOFTWARE FOR USE BY MANUFACTURERS IN THE CORRUGATED PAPER INDUSTRY USED TO PROVIDE ACCURATE ROLL STOCK INVENTORY ON A REAL-TIME BASIS; SOFTWARE FOR USE IN THE CORRUGATED PAPER INDUSTRY USED TO SCHEDULE DELIVERIES, DOCK TRAILERS, AND FOR ASSIGNING PRODUCT UNITS TO SPECIFIC TRAILERS; SOFTWARE FOR USE IN THE CORRUGATED PAPER INDUSTRY USED TO TRACK MOVEMENTS OF PRODUCT UNITS THROUGH THE MANUFACTURING PROCESS; SOFTWARE FOR USE IN THE CORRUGATED PAPER INDUSTRY USED TO MONITOR WHETHER MACHINERY IS RUNNING OR DOWN, AND WHICH PROMPTS FOR A REASON, SUB-REASON, AND COMMENT FOR DOWN TIME EVENTS; SOFTWARE FOR USE IN THE CORRUGATED PAPER INDUSTRY DESIGNED TO MONITOR MACHINERY ACTIVITY, AND TO RECORD PRODUCTION AND DOWN TIME INFORMATION FOR MACHINERY (U.S. CLS. 21, 23, 26, 36 AND 38).

FIRST USE 0-0-1988; IN COMMERCE 0-0-1988.

### CLASS 37—CONSTRUCTION AND REPAIR

FOR REPAIR AND MAINTENANCE SERVICES PERFORMED FOR THE CORRUGATED PAPER INDUSTRY, NAMELY, MACHINERY TUNE-UPS, MACHINERY RETROFITS, MACHINERY REBUILDS, MACHINERY INSTALLATION, AND MACHINE RECONDITIONING (U.S. CLS. 100, 103 AND 106).

FIRST USE 0-0-1988; IN COMMERCE 0-0-1988.

### CLASS 41—EDUCATION AND ENTERTAINMENT

FOR TRAINING SERVICES FOR REPAIR AND MAINTENANCE OF MACHINERY USED IN THE CORRUGATED PAPER INDUSTRY (U.S. CLS. 100, 101 AND 107).  
FIRST USE 0-0-1988; IN COMMERCE 0-0-1988.  
ELIZABETH J. WINTER, EXAMINING ATTORNEY

SN 76-587.284. THE FORZANI GROUP LTD., CALGARY,  
ALBERTA, CANADA, FILED 4-19-2004.



PRIORITY CLAIMED UNDER SEC. 44(D) ON CANADA APPLICATION NO. 1194585, FILED 10-24-2003, REG. NO. TMA673956, DATED 10-3-2006, EXPIRES 10-3-2015.

THE MARK CONSISTS OF THE LETTER "S" FORMING AN OBJECT WITH A SMALL CIRCLE NEXT TO THE OBJECT ON THE RIGHT.

### CLASS 25—CLOTHING

FOR ATHLETIC CLOTHING, NAMELY, SHORTS, LEOTARDS, WORKOUT SUITS, TIGHTS, LEGGINGS, SWEAT PANTS, SWEAT JACKETS, SWEAT SUITS, SWIM SUITS, TRACK SUITS, WRIST BANDS, AND HEADBANDS; ATHLETIC FOOTWEAR (U.S. CLS. 22 AND 39).

### CLASS 28—TOYS AND SPORTING GOODS

FOR ATHLETIC EQUIPMENT, NAMELY, PERSONAL EXERCISE MATS (U.S. CLS. 22, 23, 38 AND 50).  
ODESSA BIBBINS, EXAMINING ATTORNEY

SN 76-590.043. PHI BETA SIGMA FRATERNITY, INC.,  
WASHINGTON, DC. FILED 4-30-2004.



THE MARK CONTAINS THE GREEK LETTERS WHICH IS PRONOUNCED PHI BETA SIGMA.  
SEC. 2(F).



**CLASS 14—JEWELRY**

FOR JEWELRY, NAMELY, BELT BUCKLES MADE OF PRECIOUS METALS, WRIST BRACELETS, ANKLE BRACELETS, BRACELETS MADE OF PRECIOUS METALS, BRACELETS, JEWELRY BOXES MADE OF PRECIOUS METALS, JEWELRY CASES MADE OF PRECIOUS METALS, BROOCHES, BUSTS MADE OF PRECIOUS METALS, JEWELRY CHAINS, JEWELRY LAPEL PINS, WATCH CHAINS, CHARMS, COSTUME JEWELRY, CUFF LINKS, NECK CHAINS, NECK TIE FASTENERS, TIE PINS, TIE CLIPS, MONEY CLIPS MADE OF PRECIOUS METAL, CANDLE RINGS MADE OF PRECIOUS METAL, CANDLEHOLDERS MADE OF PRECIOUS METALS, CANDLE SNUFFERS MADE OF PRECIOUS METALS, CIGARETTE LIGHTERS MADE OF PRECIOUS METAL, CIGARETTE HOLDERS MADE OF PRECIOUS METALS, CIGARETTE CASES MADE OF PRECIOUS METALS, CLOCKS, ALARM CLOCKS, WALL CLOCKS, CLOCKS INCORPORATING A RADIO, FIGURINES MADE OF PRECIOUS METAL, EAR CLIPS, EARRINGS, HAT ORNAMENTS MADE OF PRECIOUS METALS, NECKLACES, NUT CRACKERS MADE OF PRECIOUS METALS, ORNAMENTAL LAPEL PINS, ORNAMENTAL PINS, PENDANTS, POCKET WATCHES, RINGS, STATUES OF PRECIOUS METALS, WATCH STRAPS, WRIST WATCHES, WATCH CASES, WATCH CHAINS, STOP WATCHES, CHRONOGRAPHS FOR USE AS WATCHES, CHRONOMETERS, WATCHES, AND ASH TRAYS MADE OF PRECIOUS METALS (U.S. CLS. 2, 27, 28 AND 50).

FIRST USE 12-31-1920; IN COMMERCE 12-31-1920.

**CLASS 16—PAPER GOODS AND PRINTED MATTER**

FOR PHOTOGRAPH ALBUMS, COIN ALBUMS, STAMP ALBUMS, ANNIVERSARY BOOKS, ART PICTURES, ART PRINTS, GRAPHIC ART REPRODUCTIONS, PRINT ART REPRODUCTIONS, GENERAL PURPOSE PLASTIC BAGS, BALL POINT PENS, FOUNTAIN PENS, TELEPHONE NUMBER BOOKS, BUMPER STICKERS, CALENDAR STANDS, CALENDARS, CARRYING CASES FOR ANNOUNCEMENT CARDS, APPOINTMENT BOOKS, PEN CASES, PENCIL CASES, CHRISTMAS CARDS, TELEPHONE DIRECTORIES, FOUNTAIN PENS, GIFT WRAPPING PAPER, INK PENS, POSTERS, POST CARDS, PAPER TABLE LINEN, LOOSE LEAF BINDERS, PAPER BANNERS, AND TRIVIA CARDS (U.S. CLS. 2, 5, 22, 23, 29, 37, 38 AND 50).

FIRST USE 12-31-1920; IN COMMERCE 12-31-1920.

**CLASS 25—CLOTHING**

FOR CLOTHING, NAMELY, POLO SHIRTS, SWEAT SHIRTS, T-SHIRTS, TANK TOPS, JACKETS, HATS, PANTS, SHOES, SOCKS, JOGGING SUITS, SHORTS, SWEAT SUITS, SWEAT PANTS, UNDERWEAR, SWIM WEAR, COATS, LEATHER COATS, BANDANNAS, BOOTS, SWEAT BANDS, GYM SHOES, AEROBIC SHOES, TENNIS SHOES, AND WALKING SHOES (U.S. CLS. 22 AND 39).

FIRST USE 12-31-1945; IN COMMERCE 12-31-1945.

**CLASS 35—ADVERTISING AND BUSINESS**

FOR ASSOCIATION SERVICES, NAMELY, PROMOTING THE INTERESTS OF THE MEMBERS OF A BENEFICIAL FRATERNAL ORGANIZATION (U.S. CLS. 100, 101 AND 102).

FIRST USE 12-31-1920; IN COMMERCE 12-31-1920.  
BARNEY CHARLON, EXAMINING ATTORNEY

SN 76-604,412. Z-SQUARED, INC., LOS ANGELES, CA.  
FILED 7-28-2004.

# OFFICE GURU

THE MARK CONSISTS OF STANDARD CHARACTERS WITHOUT CLAIM TO ANY PARTICULAR FONT, STYLE, SIZE, OR COLOR.

NO CLAIM IS MADE TO THE EXCLUSIVE RIGHT TO USE "OFFICE", APART FROM THE MARK AS SHOWN.

**CLASS 9—ELECTRICAL AND SCIENTIFIC APPARATUS**

FOR DESKTOP COMPUTER SOFTWARE FOR USE AS A WORD PROCESSING PROGRAM, A DATABASE MANAGING PROGRAM, A SPREADSHEET PROGRAM, A TIME MANAGING PROGRAM, A DOCKETING PROGRAM, AN ACCOUNTING PROGRAM, AND A CLIENT TRACKING PROGRAM IN THE FIELD OF INFORMATION MANAGEMENT (U.S. CLS. 21, 23, 26, 36 AND 38).

**CLASS 42—SCIENTIFIC, COMPUTER AND LEGAL SERVICES**

FOR COMPUTER SERVICES, NAMELY DESIGNING AND MAINTAINING COMPUTER SOFTWARE APPLICATIONS IN THE FIELD OF INFORMATION MANAGEMENT; APPLICATION SERVICE PROVIDER (ASP), NAMELY, HOSTING COMPUTER SOFTWARE APPLICATIONS OF OTHERS IN THE FIELD OF INFORMATION MANAGEMENT; PROVIDING TEMPORARY USE OF ON-LINE NON-DOWNLOADABLE SOFTWARE FOR WORD PROCESSING, DATABASE MANAGEMENT, SPREADSHEETS, TIME MANAGEMENT, DOCKETING, ACCOUNTING, CLIENT TRACKING, IN THE FIELD OF INFORMATION MANAGEMENT (U.S. CLS. 100 AND 101).

BRIAN NEVILLE, EXAMINING ATTORNEY

SN 76-608,466. MARATHON WATCH COMPANY LTD., RICHMOND HILL, ONTARIO, CANADA, FILED 8-24-2004.

# 10,000 STEPS

THE MARK CONSISTS OF STANDARD CHARACTERS WITHOUT CLAIM TO ANY PARTICULAR FONT, STYLE, SIZE, OR COLOR.

OWNER OF CANADA REG. NO. TMA613974, DATED 6-30-2004, EXPIRES 6-30-2019.

NO CLAIM IS MADE TO THE EXCLUSIVE RIGHT TO USE "STEPS", APART FROM THE MARK AS SHOWN.

**CLASS 9—ELECTRICAL AND SCIENTIFIC APPARATUS**

FOR (BASED ON USE IN COMMERCE) (BASED ON 44(E) PEDOMETERS (U.S. CLS. 21, 23, 26, 36 AND 38).  
FIRST USE 2-3-2003; IN COMMERCE 2-3-2003.

**CLASS 14—JEWELRY**

FOR (BASED ON 44(E) WATCHES, STOP WATCHES AND POCKET WATCHES (U.S. CLS. 2, 27, 28 AND 50).  
RICHARD WHITE, EXAMINING ATTORNEY

SN 76-614,367. PLASMATICS MEDIA, LLC, APACHE JUNCTION, AZ. FILED 10-1-2004.

SN 76-618,053. ACR DATA RECOVERY, INC., HOUSTON, TX. FILED 10-28-2004.

## WENDY O. WILLIAMS

THE MARK CONSISTS OF STANDARD CHARACTERS WITHOUT CLAIM TO ANY PARTICULAR FONT, STYLE, SIZE, OR COLOR.

THE NAME WENDY O. WILLIAMS DOES NOT IDENTIFY A LIVING INDIVIDUAL.

### CLASS 9—ELECTRICAL AND SCIENTIFIC APPARATUS

FOR SERIES OF PRE-RECORDED AUDIO TAPES AND COMPACT DISCS FEATURING PRIMARILY PUNK MUSIC (U.S. CLS. 21, 23, 26, 36 AND 38).

FIRST USE 0-0-1978; IN COMMERCE 0-0-1978.

### CLASS 25—CLOTHING

FOR T-SHIRTS (U.S. CLS. 22 AND 39).

FIRST USE 0-0-1978; IN COMMERCE 0-0-1978.

LINDA POWELL, EXAMINING ATTORNEY

SN 76-618,018. PRIME SOLUTION, INC., ALLEGAN, MI. FILED 10-28-2004.

WE SQUEEZE THE CRAP OUT OF WATER

THE MARK CONSISTS OF STANDARD CHARACTERS WITHOUT CLAIM TO ANY PARTICULAR FONT, STYLE, SIZE, OR COLOR.

### CLASS 7—MACHINERY

FOR MANUFACTURING MACHINERY, NAMELY, LIQUID EXTRACTION MACHINES (U.S. CLS. 13, 19, 21, 23, 31, 34 AND 35).

FIRST USE 10-31-2004; IN COMMERCE 10-31-2004.

### CLASS 25—CLOTHING

FOR T-SHIRTS (U.S. CLS. 22 AND 39).

FIRST USE 10-31-2004; IN COMMERCE 10-31-2004.

### CLASS 37—CONSTRUCTION AND REPAIR

FOR (BASED ON INTENT TO USE) LIQUID EXTRACTION MACHINE INSTALLATION SERVICES (U.S. CLS. 100, 103 AND 106).

### CLASS 40—MATERIAL TREATMENT

FOR (BASED ON INTENT TO USE) LIQUID EXTRACTION SERVICES, NAMELY, THE SERVICE OF REMOVING LIQUID FROM A MASS HAVING A LIQUID COMPONENT AND A SOLID COMPONENT (U.S. CLS. 100, 103 AND 106).

ALEX KEAM, EXAMINING ATTORNEY

## ACR DATA RECOVERY

THE MARK CONSISTS OF STANDARD CHARACTERS WITHOUT CLAIM TO ANY PARTICULAR FONT, STYLE, SIZE, OR COLOR.

NO CLAIM IS MADE TO THE EXCLUSIVE RIGHT TO USE "DATA RECOVERY", APART FROM THE MARK AS SHOWN.

### CLASS 9—ELECTRICAL AND SCIENTIFIC APPARATUS

FOR COMPUTER PROGRAMS FOR RECOVERY OF COMPUTER DATA (U.S. CLS. 21, 23, 26, 36 AND 38).

FIRST USE 5-3-2000; IN COMMERCE 5-3-2000.

### CLASS 42—SCIENTIFIC, COMPUTER AND LEGAL SERVICES

FOR COMPUTER SERVICES FOR OTHERS, NAMELY RECOVERY OF COMPUTER DATA (U.S. CLS. 100 AND 101).

FIRST USE 5-3-2000; IN COMMERCE 5-3-2000.

KIMBERLY FRYE, EXAMINING ATTORNEY

SN 76-619,470. STALLARD, DAVID W., BUFORD, GA. FILED 11-5-2004.



### CLASS 35—ADVERTISING AND BUSINESS

FOR BUSINESS CONSULTING IN THE MATERIAL HANDLING FIELD FOR THE MATERIAL HANDLING AND STORAGE INDUSTRIES (U.S. CLS. 100, 101 AND 102).

FIRST USE 6-15-1990; IN COMMERCE 6-15-1990.

### CLASS 42—SCIENTIFIC, COMPUTER AND LEGAL SERVICES

FOR COMPUTER SOFTWARE DESIGN SERVICES IN THE MATERIAL HANDLING FIELD FOR THE MATERIAL HANDLING INDUSTRY (U.S. CLS. 100 AND 101).

JASON TURNER, EXAMINING ATTORNEY

SN 76-622,740. AUTOMATIONDIRECT.COM INC., CUMMING, GA. FILED 12-1-2004.

**AUTOMATIONDIRECT**

OWNER OF U.S. REG. NOS. 2,380,314, 2,459,069 AND 2,459,080.

**CLASS 9—ELECTRICAL AND SCIENTIFIC APPARATUS**

FOR FULL LINE OF INDUSTRIAL COMPUTER HARDWARE, COMPUTER SOFTWARE, AND ELECTRONIC AND ELECTRICAL APPARATUS, FOR USE IN THE FIELD OF INDUSTRIAL AUTOMATION (U.S. CLS. 21, 23, 26, 36 AND 38).

FIRST USE 2-0-2004; IN COMMERCE 5-0-2004.

**CLASS 35—ADVERTISING AND BUSINESS**

FOR WHOLESALE AND RETAIL MAIL ORDER CATALOG SERVICES AND COMPUTERIZED ON-LINE WHOLESALE AND RETAIL CATALOGUE SERVICES, BOTH FEATURING A FULL LINE OF INDUSTRIAL COMPUTER HARDWARE, COMPUTER SOFTWARE, AND ELECTRONIC AND ELECTRICAL APPARATUS FOR USE IN THE FIELD OF INDUSTRIAL AUTOMATION (U.S. CLS. 100, 101 AND 102).

FIRST USE 2-0-2004; IN COMMERCE 5-0-2004.

**CLASS 41—EDUCATION AND ENTERTAINMENT**

FOR EDUCATIONAL SEMINARS AND TRAINING PROGRAMS RELATING TO THE INSTALLATION, USE, AND OPERATION OF INDUSTRIAL COMPUTER HARDWARE, SOFTWARE, AND ELECTRONIC AND ELECTRICAL APPARATUS FOR USE IN THE FIELD OF INDUSTRIAL AUTOMATION (U.S. CLS. 100, 101 AND 107).

FIRST USE 2-0-2004; IN COMMERCE 5-0-2004.

ODESSA BIBBINS, EXAMINING ATTORNEY

**CLASS 9—ELECTRICAL AND SCIENTIFIC APPARATUS**

FOR LABORATORY APPARATUS AND INSTRUMENTS, NAMELY, SIGNAL GENERATORS; MEASURING OR TESTING MACHINES AND INSTRUMENTS, NAMELY, OSCILLOSCOPES, LOGIC ANALYZERS, VOLTMETERS, AMMETERS, THERMOMETERS, WEIGHT METERS, SCALES; TELECOMMUNICATION MACHINES AND APPARATUS, NAMELY, TELEPHONES, ROUTERS, HUBS, RADIO LAN DEVICES, TELEVISIONS, RADIOS, MOBILE PHONES, PBXs; ELECTRONIC MACHINES, APPARATUS AND THEIR PARTS, NAMELY, ELECTRONIC COMPUTERS, ELECTRONIC DESK CALCULATORS, ELECTRONIC INTEGRATED CIRCUITS, ELECTRONIC MEMORIES; SLOT MACHINES; ELECTRONIC SPORTS TRAINING SIMULATORS; VEHICLE DRIVE TRAINING SIMULATORS; EXPOSED CINEMATOGRAPHIC FILMS, EXPOSED SLIDE FILMS, RECORDED VIDEO DISCS AND TAPES FEATURING MUSIC AND MOVIES; ELECTRIC SIGN BOARDS FOR DISPLAYING TARGET FIGURES; PHOTO-COPYING MACHINES; MANUALLY OPERATED COMPUTING APPARATUS, NAMELY, PERSONAL COMPUTERS, COMPUTER WORK STATIONS, COMPUTER SERVERS; ELECTRONIC DRAWING OR DRAFTING MACHINES; TIME RECORDERS, NAMELY, JOB TIME RECORDERS, ATTENDANCE RECORDERS, PAYROLL RECORDERS; ELECTRIC COMPUTING MACHINES, NAMELY, ELECTRIC CALCULATORS; PUNCHED CARD OFFICE MACHINES; CONSUMER VIDEO GAME DISKS, SOFTWARE, AND CARTRIDGES (U.S. CLS. 21, 23, 26, 36 AND 38).

**CLASS 35—ADVERTISING AND BUSINESS**

FOR BUSINESS CONSULTING SERVICES, NAMELY, ANALYSIS AND GUIDANCE ON BUSINESS MANAGEMENT; DEVELOPMENT OF BUSINESS MANAGEMENT POLICY (U.S. CLS. 100, 101 AND 102).

**CLASS 41—EDUCATION AND ENTERTAINMENT**

FOR EDUCATION SERVICES, NAMELY, PROVIDING CLASSES FEATURING INTRODUCTION AND EXPLANATION RELATING TO PERFORMANCES AND OPERATION OF COMPUTERS, AUTOMOBILES, AND OTHER MACHINES THAT REQUIRE HIGH LEVELS OF PERSONAL KNOWLEDGE, SKILL, OR EXPERIENCE OF THE OPERATORS TO MEET THE PURPOSED ACCURACY IN OPERATING THEM (U.S. CLS. 100, 101 AND 107).

**CLASS 42—SCIENTIFIC, COMPUTER AND LEGAL SERVICES**

FOR COMPUTER SOFTWARE DESIGN, MAINTENANCE OF COMPUTER SOFTWARE; ANALYSIS AND DIAGNOSIS IN THE FIELD OF INFORMATION SECURITY; ANALYSIS AND DIAGNOSIS OF COMPUTER INFORMATION SYSTEMS (U.S. CLS. 100 AND 101).

**CLASS 45—PERSONAL SERVICES**

FOR CONSULTING IN THE FIELD OF GUIDANCE ON INFORMATION SECURITY-CONTROL; DEVELOPMENT OF BUSINESS SECURITY POLICY (U.S. CLS. 100 AND 101).

DAVID STERKIN, EXAMINING ATTORNEY

SN 76-623,505. ASAGENT, INC., CHUO-KU, TOKYO 103-0016, JAPAN, FILED 12-3-2004.

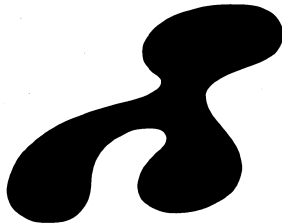

THE MARK CONSISTS OF THREE SOLID BLACK, ELONGATED CIRCLES OF VARYING SIZES CONNECTED AT A CENTRAL POINT.

SN 76-628,919, EXECUTIVE LEADERSHIP COUNCIL, WASHINGTON, DC. FILED 1-27-2005.



SEC. 2(F) AS TO "EXECUTIVE LEADERSHIP COUNCIL".

**CLASS 9—ELECTRICAL AND SCIENTIFIC APPARATUS**

FOR PRERECORDED AUDIO AND VIDEO CASSETTE TAPES, DIGITAL AUDIO AND VIDEO TAPES FEATURING INSTRUCTIONAL, PROMOTIONAL, TEACHING, AND EDUCATIONAL INFORMATION IN THE FIELD OF DIVERSITY IN THE WORKPLACE FOR BUSINESS, COMMUNITIES AND OTHER ORGANIZATIONS; MOTION PICTURE FILMS FEATURING EDUCATION (U.S. CLS. 21, 23, 26, 36 AND 38).  
FIRST USE 2-8-2005; IN COMMERCE 2-8-2005.

**CLASS 16—PAPER GOODS AND PRINTED MATTER**

FOR PRINTED INSTRUCTIONAL, TEACHING AND EDUCATIONAL MATERIALS IN THE FIELD OF DIVERSITY IN THE WORKPLACE FOR BUSINESSES, COMMUNITIES AND OTHER ORGANIZATIONS (U.S. CLS. 2, 5, 22, 23, 29, 37, 38 AND 50).  
FIRST USE 2-8-2005; IN COMMERCE 2-8-2005.

**CLASS 35—ADVERTISING AND BUSINESS**

FOR ASSOCIATION SERVICES, NAMELY, PROMOTING THE INTERESTS OF AFRICAN AMERICAN MANAGERS AND BUSINESS EXECUTIVES; ADVOCACY SERVICES, NAMELY, INFORMATION, ADVISORY AND CONSULTANCY SERVICES IN THE FIELD OF DIVERSITY IN THE WORKPLACE FOR BUSINESSES, COMMUNITIES AND OTHER ORGANIZATIONS; ARRANGING AND CONDUCTING BUSINESS CONFERENCES IN THE FIELD OF LEADERSHIP AND DIVERSITY IN THE WORKPLACE FOR BUSINESSES, COMMUNITIES AND OTHER ORGANIZATIONS; PROVIDING INFORMATION ONLINE IN THE FIELD OF DIVERSITY IN THE WORKPLACE FOR BUSINESSES, COMMUNITIES AND OTHER ORGANIZATIONS (U.S. CLS. 100, 101 AND 102).  
FIRST USE 2-8-2005; IN COMMERCE 2-8-2005.

**CLASS 36—INSURANCE AND FINANCIAL**

FOR CHARITABLE FUND RAISING; CHARITABLE SERVICES, NAMELY, FACILITATING THE DISTRIBUTION OF SCHOLARSHIPS (U.S. CLS. 100, 101 AND 102).  
FIRST USE 2-8-2005; IN COMMERCE 2-8-2005.

**CLASS 41—EDUCATION AND ENTERTAINMENT**

FOR EDUCATIONAL SERVICES, NAMELY, PROVIDING TRAINING IN THE FORM OF WORKSHOPS, SEMINARS, SYMPOSIA AND COURSES IN THE FIELD OF DIVERSITY IN THE WORKPLACE FOR BUSINESSES, COMMUNITIES AND OTHER ORGANIZATIONS, AND DEVELOPING AND DISTRIBUTING PRINTED INFORMATIONAL AND COURSE MATERIALS IN CONNECTION THEREWITH; ORGANIZATION OF EDUCATIONAL CONFERENCES, LEADERSHIP SUMMITS, AND SYMPOSIA IN THE FIELD OF PROFESSIONAL DEVELOPMENT AND DIVERSITY IN THE WORKPLACE FOR DIVERSE MID-LEVEL AND SENIOR EXECUTIVES IN BUSINESSES, COMMUNITIES AND OTHER ORGANIZATIONS; EDUCATIONAL SERVICES NAMELY, ONE-ON-ONE MENTORING IN THE FIELD OF PROFESSIONAL DEVELOPMENT IN CORPORATIONS; ARRANGING AND CONDUCTING ESSAY AND BUSINESS CASE ANALYSIS COMPETITIONS, MENTORING PROGRAMS, FOR AFRICAN AMERICAN UNDERGRADUATE AND GRADUATE STUDENTS; PROVIDING PUBLIC RECOGNITION AND AWARDS FOR CORPORATIONS AND INDIVIDUALS WHO DEMONSTRATE LEADERSHIP IN ADVANCING DIVERSITY IN CORPORATE AMERICA; EDUCATION AND ENTERTAINMENT SERVICES, NAMELY, PROVIDING EDUCATIONAL TELEVISION PROGRAMS AND DOCUMENTARIES; ARRANGING AND CONDUCTING SEMINARS IN THE FIELD OF LEADERSHIP AND DIVERSITY IN THE WORKPLACE FOR BUSINESSES, COMMUNITIES AND OTHER ORGANIZATIONS (U.S. CLS. 100, 101 AND 107).  
FIRST USE 2-5-2005; IN COMMERCE 2-8-2005.

**CLASS 42—SCIENTIFIC, COMPUTER AND LEGAL SERVICES**

FOR CHARITABLE SERVICES, NAMELY, FACILITATING THE DISTRIBUTION OF COMPUTER EQUIPMENT TO SCHOOLS, AND DESIGN OF COMPUTER NETWORK ASSOCIATED WITH TECHNOLOGY INITIATIVES (U.S. CLS. 100 AND 101).  
FIRST USE 2-8-2005; IN COMMERCE 2-8-2005.  
JAMES A. RAUEN, EXAMINING ATTORNEY

SN 76-632,026, COLLEGIATE IMAGES LLC, FORT LAUDERDALE, FL. FILED 2-24-2005.



OWNER OF U.S. REG. NO. 2,839,290.  
SEC. 2(F).

**CLASS 35—ADVERTISING AND BUSINESS**

FOR BUSINESS MANAGEMENT OF THE LICENSING AND DISTRIBUTION PROCESSES FOR VIDEO CONTENT, PROGRAMMING AND STILL IMAGES FOR VARIOUS ENTERTAINMENT, SPORTS AND OTHER EVENTS FOR COLLEGES, UNIVERSITIES, CONFERENCES, BOWL EVENTS AND BROADCAST RIGHTSHOLDERS (U.S. CLS. 100, 101 AND 102).  
FIRST USE 12-8-2003; IN COMMERCE 12-8-2003.

**CLASS 41—EDUCATION AND ENTERTAINMENT**

FOR DISTRIBUTION OF TELEVISION PROGRAMMING FOR OTHERS IN THE FIELD OF ENTERTAINMENT, SPORTS AND OTHER EVENTS FOR COLLEGES, UNIVERSITIES, CONFERENCES, BOWL EVENTS AND BROADCAST RIGHTSHOLDERS (U.S. CLS. 100, 101 AND 107).

FIRST USE 12-8-2003; IN COMMERCE 12-8-2003.

**CLASS 42—SCIENTIFIC, COMPUTER AND LEGAL SERVICES**

FOR LICENSING OF INTELLECTUAL PROPERTY CONTAINED IN THE VIDEO CONTENT AND STILL IMAGES OF VARIOUS ENTERTAINMENT, SPORTS AND OTHER EVENTS FOR COLLEGES, UNIVERSITIES, CONFERENCES, BOWL EVENTS AND BROADCAST RIGHTSHOLDERS (U.S. CLS. 100 AND 101).

FIRST USE 12-8-2003; IN COMMERCE 12-8-2003.  
BRIAN NEVILLE, EXAMINING ATTORNEY

---

SN 76-632,252. THE OHIO RESTAURANT ASSOCIATION, COLUMBUS, OH. FILED 2-28-2005.



NO CLAIM IS MADE TO THE EXCLUSIVE RIGHT TO USE "OHIO RESTAURANT ASSOCIATION", APART FROM THE MARK AS SHOWN.

THE COLOR(S) BLACK, BLUE, GREEN AND WHITE IS/ ARE CLAIMED AS A FEATURE OF THE MARK.

THE WORDING APPEARS IN BLACK. THE OUTER TWO SQUARES APPEAR IN BLUE AND THE DESIGNS APPEAR IN WHITE. THE CENTER SQUARE APPEARS IN GREEN AND THE DESIGN APPEARS IN WHITE.

**CLASS 35—ADVERTISING AND BUSINESS**

FOR ASSOCIATION SERVICES, NAMELY, PROMOTING THE INTERESTS OF THE OHIO RESTAURANT INDUSTRY (U.S. CLS. 100, 101 AND 102).

FIRST USE 2-1-2005; IN COMMERCE 2-1-2005.

**CLASS 42—SCIENTIFIC, COMPUTER AND LEGAL SERVICES**

FOR PROVIDING INFORMATION IN THE FIELD OF LAWS AND REGULATIONS CRITICAL TO BUSINESS FOR THE OHIO RESTAURANT INDUSTRY THROUGH A WEBSITE (U.S. CLS. 100 AND 101).

FIRST USE 2-1-2005; IN COMMERCE 2-1-2005.  
JASON TURNER, EXAMINING ATTORNEY

SN 76-636,906. BIOWARE CORP., EDMONTON, ALBERTA T6H 5R7, CANADA, FILED 4-21-2005.

OWNER OF U.S. REG. NOS. 2,115,937, 2,872,470 AND OTHERS.

NO CLAIM IS MADE TO THE EXCLUSIVE RIGHT TO USE "CORP", APART FROM THE MARK AS SHOWN.

**CLASS 9—ELECTRICAL AND SCIENTIFIC APPARATUS**

FOR COMPUTER GAME SOFTWARE; PRERECORDED AUDIO TAPES, VIDEOTAPES AND VIDEO AND AUDIO DISCS FEATURING CHARACTERS, VOICES AND SOUNDTRACK FROM A COMPUTER GAME (U.S. CLS. 21, 23, 26, 36 AND 38).

FIRST USE 0-0-1998; IN COMMERCE 0-0-1998.

**CLASS 16—PAPER GOODS AND PRINTED MATTER**

FOR PAPER GOODS, NAMELY, COMPUTER GAME INSTRUCTION MANUALS, STRATEGY GUIDES FOR PLAYING COMPUTER GAMES (U.S. CLS. 2, 5, 22, 23, 29, 37, 38 AND 50).

FIRST USE 0-0-1998; IN COMMERCE 0-0-1998.

**CLASS 25—CLOTHING**

FOR APPAREL, NAMELY, HATS, TEE-SHIRTS, SWEATSHIRTS FOR MEN, WOMEN AND CHILDREN (U.S. CLS. 22 AND 39).

FIRST USE 0-0-1998; IN COMMERCE 0-0-1998.

**CLASS 41—EDUCATION AND ENTERTAINMENT**

FOR ENTERTAINMENT SERVICES, NAMELY PROVIDING INFORMATION ON-LINE RELATING TO COMPUTER GAMES (U.S. CLS. 100, 101 AND 107).

FIRST USE 0-0-1998; IN COMMERCE 0-0-1998.

**CLASS 42—SCIENTIFIC, COMPUTER AND LEGAL SERVICES**

FOR PROVIDING TEMPORARY USE OF NON-DOWNLOADABLE COMPUTER SOFTWARE FOR USE IN CREATING COMPUTER GAMES (U.S. CLS. 100 AND 101).

FIRST USE 0-0-1998; IN COMMERCE 0-0-1998.  
CURTIS FRENCH, EXAMINING ATTORNEY

---

SN 76-639,274. SULZER METCO. (US) INC., WESTBURY, NY. FILED 5-23-2005.

THE MARK CONSISTS OF STANDARD CHARACTERS WITHOUT CLAIM TO ANY PARTICULAR FONT, STYLE, SIZE, OR COLOR.

**CLASS 1—CHEMICALS**

FOR PLASMA SPRAY POWDERS OF NON-METALLIC MATERIALS, CERAMIC MATERIALS, PLASTIC MATERIALS AND COMBINATIONS THEREOF FOR USE IN PLASMA SPRAY PROCESSES FOR FORMING SURFACE LAYERS ON WORK PIECES, TOOLS AND MACHINE PARTS (U.S. CLS. 1, 5, 6, 10, 26 AND 46).

**CLASS 6—METAL GOODS**

FOR PLASMA SPRAY POWDERS OF METALLIC MATERIALS FOR USE IN PLASMA SPRAY PROCESSES, WHEREIN THE POWDERS ARE MELTED DOWN AND APPLIED AS SURFACE LAYERS ON WORK PIECES, TOOLS AND MACHINE PARTS (U.S. CLS. 2, 12, 13, 14, 23, 25 AND 50).

ANTHONY RINKER, EXAMINING ATTORNEY

SN 76-639,484. KIRBY MORGAN DIVE SYSTEMS, INC., SANTA MARIA, CA. FILED 5-25-2005.

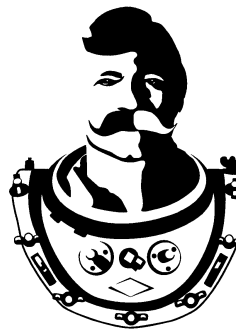

SN 76-639,299. ICE SCULPTURES LTD., GRAND RAPIDS, MI. FILED 5-23-2005.

ICEGURU

THE MARK CONSISTS OF STANDARD CHARACTERS WITHOUT CLAIM TO ANY PARTICULAR FONT, STYLE, SIZE, OR COLOR.

NO CLAIM IS MADE TO THE EXCLUSIVE RIGHT TO USE "ICE", APART FROM THE MARK AS SHOWN.

**CLASS 7—MACHINERY**

FOR POWER DRILLS OF METAL AND POWER DRILL BITS OF METAL FOR MAKING ICE SCULPTURES (U.S. CLS. 13, 19, 21, 23, 31, 34 AND 35).

FIRST USE 2-0-1994; IN COMMERCE 2-0-1994.

**CLASS 30—STAPLE FOODS**

FOR ICE SCULPTURES (U.S. CL. 46).

FIRST USE 2-0-1994; IN COMMERCE 2-0-1994.  
ALLISON HOLTZ, EXAMINING ATTORNEY

THE PORTRAIT IN THE MARK IDENTIFIES A LIVING INDIVIDUAL WHOSE CONSENT IS OF RECORD.

THE MARK CONSISTS OF B MORGAN IN OLD STYLE BREASTPLATE.

SEC. 2(F).

**CLASS 9—ELECTRICAL AND SCIENTIFIC APPARATUS**

FOR DIVING EQUIPMENT, NAMELY DIVING HELMETS, REGULATORS, HEAD PROTECTORS, MASKS, MASK BAGS, COLD WATER NECK DAMS, DECK BREATHING GAS CONTROLLER, BREATHING VALVES, EXHAUST VALVES, REBREATHERS, UNDERWATER LIFE SUPPORT SYSTEM USED IN SCUBA (SELF-CONTAINED UNDERWATER BREATHING APPARATUS) DIVING COMPRISED OF MASK, REGULATOR AND TANK, SOLD SEPARATELY AND AS A UNIT, NON-RECREATIONAL UNDERWATER LIFE SUPPORT SYSTEM USED IN SSUBA (SURFACE SUPPLIED UNDERWATER BREATHING APPARATUS) DIVING COMPRISED OF HELMET, DEMAND BREATHING REGULATORS, DECK BREATHING GAS CONTROLLER, BREATHING VALVES, EXHAUST VALVES, AND UMBILICAL CORD, SOLD SEPARATELY AND AS A UNIT, AND SPARE PARTS FOR SAME (U.S. CLS. 21, 23, 26, 36 AND 38).

**CLASS 25—CLOTHING**

FOR SHIRTS, HATS, JACKETS, T-SHIRTS, TANK TOPS, POLIO SHIRTS, SHORTS, BATHING SUITS, DRESS SHORTS, SWEATSHIRTS AND WET SUITS (U.S. CLS. 22 AND 39).

**CLASS 40—MATERIAL TREATMENT**

FOR MANUFACTURE OF DIVING EQUIPMENT, NAMELY DIVING HELMETS, REGULATORS, HEAD PROTECTORS, MASKS, MASK BAGS, COLD WATER NECK DAMS, WETSUITS, DECK BREATHING GAS CONTROLLER, AND SPARE PARTS FOR SAME, TO ORDER AND/OR SPECIFICATION OF OTHERS (U.S. CLS. 100, 103 AND 106).

AMY HELLA, EXAMINING ATTORNEY

SN 76-641,336. PRINT INDUSTRIES MARKET INFORMATION AND RESEARCH ORGANIZATION, RESTON, VA. FILED 6-22-2005.

**PRIMIR**

THE MARK CONSISTS OF STANDARD CHARACTERS WITHOUT CLAIM TO ANY PARTICULAR FONT, STYLE, SIZE, OR COLOR.

**CLASS 16—PAPER GOODS AND PRINTED MATTER**

FOR PRINTED PUBLICATIONS, NAMELY, RESEARCH PUBLICATIONS AND PRINTED STUDIES, REPORTS, ARTICLES, BOOKS AND BOOKLETS, WHITE PAPERS, PRINTED LECTURES AND PRESENTATIONS RELATED TO MARKET INFORMATION AND RESEARCH, NAMELY MARKET TRENDS, MARKET SIZES AND PRODUCT RESEARCH, FOR THE PRINTING, PUBLISHING, AND CONVERTING INDUSTRIES (U.S. CLS. 2, 5, 22, 23, 29, 37, 38 AND 50).

**CLASS 35—ADVERTISING AND BUSINESS**

FOR COMPUTER SERVICES, NAMELY, PROVIDING VIA A GLOBAL COMPUTER INFORMATION NETWORK INFORMATION RELATED TO MARKET RESEARCH AND MARKET TRENDS ON THE PRINTING, PUBLISHING AND CONVERTING INDUSTRIES AND THE MARKET; ASSOCIATION SERVICES, NAMELY, PROMOTING THE INTERESTS OF BUSINESS ENTITIES IN THE PRINTING, PUBLISHING AND CONVERTING INDUSTRIES THROUGH THE ORGANIZATION, IMPLEMENTATION, CONDUCTING, PRODUCTION AND PUBLICATION OF INDUSTRY STUDIES AND REPORTS (U.S. CLS. 100, 101 AND 102).  
BRIDGETT SMITH, EXAMINING ATTORNEY

SN 76-641,975. HOCHMAN, MARCELO, CHARLESTON, SC. FILED 4-19-2005.



NO CLAIM IS MADE TO THE EXCLUSIVE RIGHT TO USE "THE HEMANGIOMA TREATMENT FOUNDATION" AND "HEMANGIOMA TREATMENT FOUNDATION", APART FROM THE MARK AS SHOWN.  
THE MARK COMPRISES TWO SIDES OF A DOUBLED-SIDED COIN. ONE SIDE OF THE COIN INCLUDES THE WORDING "THE HEMANGIOMA TREATMENT FOUNDATION" IN THE OUTER CIRCLE, THE WORDING "HEMANGIOMA TREATMENT FOUNDATION" IN THE TOP PORTION OF THE INNER CIRCLE, THE ACRONYM

"THTF" IN THE LEFT MID-BOTTOM PORTION OF THE INNER CIRCLE, THE WORDING "IN KIDS WE TRUST" IN THE RIGHT MID-BOTTOM PORTION OF THE INNER CIRCLE, THE WORDING "ONE CARING KIDS CONTRIBUTION" IN THE BOTTOM PORTION OF THE INNER CIRCLE AND A CARTOON STYLE HEAD OF A CHILD WEARING A CAP IN THE CENTER OF THE INNER CIRCLE. THE OTHER SIDE OF THE COIN INCLUDES THE WORDING "THE HEMANGIOMA TREATMENT FOUNDATION" IN THE OUTER CIRCLE AND THE WORDING "KIDS CHANGE" IN THE INNER PORTION OF THE CIRCLE.

**CLASS 41—EDUCATION AND ENTERTAINMENT**

FOR CONDUCTING CONTINUING EDUCATION WORKSHOPS AND SEMINARS IN THE FIELD OF MEDICINE; CONTINUING MEDICAL EDUCATION COURSES (U.S. CLS. 100, 101 AND 107).

**CLASS 44—MEDICAL, BEAUTY AND AGRICULTURAL SERVICES**

FOR SURGERY; MEDICAL COUNSELING; MEDICAL CONSULTATION; PROVIDING MEDICAL INFORMATION; PHYSICIAN SERVICES (U.S. CLS. 100 AND 101).  
JENNIFER VASQUEZ, EXAMINING ATTORNEY

SN 76-643,301. GREAT EAST PROPERTIES HOLDINGS, LLC, KEENE, NH. FILED 7-21-2005.



**CLASS 36—INSURANCE AND FINANCIAL**

FOR MORTGAGE BROKERAGE; MORTGAGE LENDING; MORTGAGE BANKING; REAL ESTATE TITLE INSURANCE AGENCY SERVICES (U.S. CLS. 100, 101 AND 102).

**CLASS 42—SCIENTIFIC, COMPUTER AND LEGAL SERVICES**

FOR REAL ESTATE TITLE SEARCHING; CLOSING SERVICES FOR MORTGAGE LOANS (U.S. CLS. 100 AND 101).  
KRISTIN DAHLING, EXAMINING ATTORNEY

SN 76-652,474. BAE SYSTEMS INFORMATION AND ELECTRONIC SYSTEMS INTEGRATION INC., NASHUA, NH. FILED 12-27-2005.

**MATADOR**

THE MARK CONSISTS OF STANDARD CHARACTERS WITHOUT CLAIM TO ANY PARTICULAR FONT, STYLE, SIZE, OR COLOR.

**CLASS 9—ELECTRICAL AND SCIENTIFIC APPARATUS**

FOR ELECTRONIC COUNTERMEASURE SYSTEMS, NAMELY, ONBOARD, AIRBORNE, LAMP-BASED, WIDE FIELD OF VIEW, STARING, INFRARED COUNTERMEASURE MISSILE JAMMING UNITS FOR MOUNTING ON FIXED WING AIRCRAFT FOR PROTECTION OF SUCH AIRCRAFT FROM INFRARED GUIDED MISSILES (U.S. CLS. 21, 23, 26, 36 AND 38).

**CLASS 16—PAPER GOODS AND PRINTED MATTER**

FOR EDUCATIONAL PUBLICATIONS, NAMELY, TRAINING AND REPAIR MANUALS IN THE FIELD OF ELECTRONIC COUNTERMEASURES, NAMELY ONBOARD, AIRBORNE, LAMP-BASED, WIDE FIELD OF VIEW, STARING, INFRARED COUNTERMEASURE MISSILE JAMMING SYSTEMS FOR MOUNTING ON FIXED WING AIRCRAFT FOR PROTECTION OF SUCH AIRCRAFT FROM INFRARED GUIDED MISSILES (U.S. CLS. 2, 5, 22, 23, 29, 37, 38 AND 50).

**CLASS 37—CONSTRUCTION AND REPAIR**

FOR REPAIR SERVICES FOR ELECTRONIC COUNTERMEASURE SYSTEMS, NAMELY ONBOARD, AIRBORNE, LAMP-BASED, WIDE FIELD OF VIEW, STARING, INFRARED COUNTERMEASURE MISSILE JAMMING SYSTEMS FOR MOUNTING ON FIXED WING AIRCRAFT FOR PROTECTION OF SUCH AIRCRAFT FROM INFRARED GUIDED MISSILES (U.S. CLS. 100, 103 AND 106).

SANJEEV VOHRA, EXAMINING ATTORNEY

SN 76-652,483. AMERICAN MANAGEMENT ASSOCIATION INTERNATIONAL, NEW YORK, NY. FILED 12-28-2005.

**AMA AMERICAN MANAGEMENT ASSOCIATION  
FEDERAL LEARNING INSTITUTE**

THE MARK CONSISTS OF STANDARD CHARACTERS WITHOUT CLAIM TO ANY PARTICULAR FONT, STYLE, SIZE, OR COLOR.

OWNER OF U.S. REG. NOS. 2,069,326 AND 2,948,665.

NO CLAIM IS MADE TO THE EXCLUSIVE RIGHT TO USE "ASSOCIATION" AND "LEARNING INSTITUTE", APART FROM THE MARK AS SHOWN.

SEC. 2(F) AS TO "AMERICAN MANAGEMENT ASSOCIATION".

**CLASS 16—PAPER GOODS AND PRINTED MATTER**

FOR EDUCATIONAL BOOKS RELATING TO BUSINESS MANAGEMENT; PRINTED INFORMATIONAL MATERIALS IN THE FORM OF BROCHURES RELATING TO BUSINESS MANAGEMENT; PAMPHLETS RELATING TO BUSINESS MANAGEMENT; CATALOGS FOR USE IN THE FIELD OF BUSINESS MANAGEMENT; SEMINAR PROGRAM MATERIALS, NAMELY COURSE OUTLINES AND NOTEBOOKS CONTAINING PRINTED INSTRUCTIONAL PROGRAMS, QUESTION AND ANSWER SHEETS AND TEACHING AND TRAINING MATERIALS ALL FOR USE IN THE FIELD OF BUSINESS MANAGEMENT (U.S. CLS. 2, 5, 22, 23, 29, 37, 38 AND 50).

FIRST USE 10-17-2005; IN COMMERCE 10-17-2005.

**CLASS 41—EDUCATION AND ENTERTAINMENT**

FOR EDUCATIONAL SERVICES, NAMELY, PROVIDING ON-LINE COURSES IN THE FIELD OF BUSINESS MANAGEMENT VIA THE INTERNET; EDUCATION SERVICES, NAMELY CONDUCTING SEMINARS IN THE FIELD OF BUSINESS MANAGEMENT; ORGANIZING EXHIBITIONS FOR EDUCATIONAL PURPOSES IN THE FIELD OF BUSINESS MANAGEMENT (U.S. CLS. 100, 101 AND 107).

FIRST USE 10-17-2005; IN COMMERCE 10-17-2005.  
PRISCILLA MILTON, EXAMINING ATTORNEY

SN 76-652,484. AMERICAN MANAGEMENT ASSOCIATION INTERNATIONAL, NEW YORK, NY. FILED 12-28-2005.



OWNER OF U.S. REG. NOS. 2,069,326 AND 2,948,665.  
NO CLAIM IS MADE TO THE EXCLUSIVE RIGHT TO USE "ASSOCIATION" AND "LEARNING INSTITUTE", APART FROM THE MARK AS SHOWN.

THE COLOR(S) RED AND BLUE IS/ARE CLAIMED AS A FEATURE OF THE MARK.

THE MARK CONSISTS OF THE COLOR RED IN THE DESIGN ELEMENT, THE COLOR BLUE APPEARS IN THE LETTERS AND WORDING.

SEC. 2(F) AS TO "AMERICAN MANAGEMENT ASSOCIATION".

**CLASS 16—PAPER GOODS AND PRINTED MATTER**

FOR EDUCATIONAL BOOKS RELATING TO BUSINESS MANAGEMENT; PRINTED INFORMATIONAL MATERIALS IN THE FORM OF BROCHURES RELATING TO BUSINESS MANAGEMENT; PAMPHLETS RELATING TO BUSINESS MANAGEMENT; CATALOGS FOR USE IN THE FIELD OF BUSINESS MANAGEMENT; SEMINAR PROGRAM MATERIALS, NAMELY COURSE OUTLINES AND NOTEBOOKS CONTAINING PRINTED INSTRUCTIONAL PROGRAMS, QUESTION AND ANSWER SHEETS AND TEACHING AND TRAINING MATERIALS ALL FOR USE IN THE FIELD OF BUSINESS MANAGEMENT (U.S. CLS. 2, 5, 22, 23, 29, 37, 38 AND 50).

FIRST USE 10-17-2005; IN COMMERCE 10-17-2005.

**CLASS 41—EDUCATION AND ENTERTAINMENT**

FOR EDUCATIONAL SERVICES, NAMELY, PROVIDING ON-LINE COURSES IN THE FIELD OF BUSINESS MANAGEMENT VIA THE INTERNET; EDUCATION SERVICES, NAMELY CONDUCTING SEMINARS IN THE FIELD OF BUSINESS MANAGEMENT; ORGANIZING EXHIBITIONS FOR EDUCATIONAL PURPOSES IN THE FIELD OF BUSINESS MANAGEMENT (U.S. CLS. 100, 101 AND 107).

FIRST USE 10-17-2005; IN COMMERCE 10-17-2005.  
PRISCILLA MILTON, EXAMINING ATTORNEY



SN 76-654,163. DIGITAL BLUE MEDIA, INC., SYLMAR, CA.  
FILED 1-27-2006.

SN 76-655,034. AMERICAN REFINING AND BIOCHEMICAL, INC., WEST CONSHOHOCKEN, PA. FILED 2-9-2006.

# HEROTIX

THE MARK CONSISTS OF STANDARD CHARACTERS WITHOUT CLAIM TO ANY PARTICULAR FONT, STYLE, SIZE, OR COLOR.

## CLASS 35—ADVERTISING AND BUSINESS

FOR RETAIL STORE SERVICES FEATURING AUDIO RECORDINGS, PRERECORDED CD'S, VIDEO TAPES, LASER DISKS, AND DVD'S FEATURING EROTIC STORIES, AND OTHER ADULT ENTERTAINMENT, NAMELY, COMEDY SPECIALS, DOCUMENTARIES, PAGEANTS, AND COUPLE-FRIENDLY ADULT CONTENT (U.S. CLS. 100, 101 AND 102).

## CLASS 41—EDUCATION AND ENTERTAINMENT

FOR ENTERTAINMENT SERVICES, NAMELY, PRODUCTION AND DISTRIBUTION OF A TV SERIES, CABLE TELEVISION SERIES, SATELLITE TELEVISION SERIES, AND DOWNLOADABLE MOTION PICTURES FEATURING EROTIC STORIES; PRODUCTION OF AUDIO RECORDINGS, PRERECORDED CD'S, VIDEO TAPES, LASER DISKS, AND DVD'S FEATURING EROTIC STORIES, AND OTHER ADULT ENTERTAINMENT, NAMELY, COMEDY SPECIALS, DOCUMENTARIES, PAGEANTS, AND COUPLE-FRIENDLY ADULT CONTENT (U.S. CLS. 100, 101 AND 107).

SANI KHOURI, EXAMINING ATTORNEY

# GEOWELL

THE MARK CONSISTS OF STANDARD CHARACTERS WITHOUT CLAIM TO ANY PARTICULAR FONT, STYLE, SIZE, OR COLOR.

## CLASS 11—ENVIRONMENTAL CONTROL APPARATUS

FOR GEOTHERMAL HVAC SYSTEMS, NAMELY, STANDING COLUMN WELLS FOR HEATING, VENTILATION, AND COOLING OF GREEN BUILDINGS (U.S. CLS. 13, 21, 23, 31 AND 34).

## CLASS 37—CONSTRUCTION AND REPAIR

FOR INSTALLATION AND MAINTENANCE OF GEOTHERMAL HVAC SYSTEMS (U.S. CLS. 100, 103 AND 106).

## CLASS 42—SCIENTIFIC, COMPUTER AND LEGAL SERVICES

FOR TECHNICAL SUPPORT SERVICES, NAMELY, BOREHOLE THERMAL TESTING AND ANALYSIS, WELL FIELD THERMAL MODELING AND SIMULATION, OVERSIGHT OF WELL FIELD INSTALLATIONS; DESIGN SUPPORT SERVICES, NAMELY, WELL FIELD ENGINEERING DESIGN (U.S. CLS. 100 AND 101).

EUGENIA MARTIN, EXAMINING ATTORNEY

SN 76-654,853. SHORE LAND COMPANY, INC., AVON, NC.  
FILED 2-8-2006.

# S TURNS

THE MARK CONSISTS OF STANDARD CHARACTERS WITHOUT CLAIM TO ANY PARTICULAR FONT, STYLE, SIZE, OR COLOR.

## CLASS 16—PAPER GOODS AND PRINTED MATTER

FOR STICKERS AND POSTCARDS (U.S. CLS. 2, 5, 22, 23, 29, 37, 38 AND 50).  
FIRST USE 1-0-2005; IN COMMERCE 1-0-2005.

## CLASS 25—CLOTHING

FOR SPORTS CLOTHING, NAMELY HATS, CAPS, AND T-SHIRT (U.S. CLS. 22 AND 39).  
FIRST USE 1-0-2005; IN COMMERCE 1-0-2005.  
BRIAN NEVILLE, EXAMINING ATTORNEY

SN 76-655,585. MEDEX ASSISTANCE CORPORATION, TOWSON, MD. FILED 2-23-2006.

# MEDEXSECURE

THE MARK CONSISTS OF STANDARD CHARACTERS WITHOUT CLAIM TO ANY PARTICULAR FONT, STYLE, SIZE, OR COLOR.

OWNER OF U.S. REG. NO. 1,908,710.

## CLASS 35—ADVERTISING AND BUSINESS

FOR ASSISTING TRAVELERS AND EXPATRIATES WITH THEIR PERSONAL NEEDS IN THE EVENT OF TRAVEL-RELATED MEDICAL EMERGENCIES, NAMELY, PHYSICIAN REFERRALS (U.S. CLS. 100, 101 AND 102).

FIRST USE 3-0-2005; IN COMMERCE 3-0-2005.

## CLASS 36—INSURANCE AND FINANCIAL

FOR ASSISTING TRAVELERS AND EXPATRIATES WITH THEIR PERSONAL NEEDS IN THE EVENT OF TRAVEL-RELATED MEDICAL EMERGENCIES, NAMELY, ARRANGING EMERGENCY FUNDS TRANSFERS (U.S. CLS. 100, 101 AND 102).

FIRST USE 3-0-2005; IN COMMERCE 3-0-2005.

**CLASS 39—TRANSPORTATION AND STORAGE**

FOR ASSISTING TRAVELERS AND EXPATRIATES WITH THEIR PERSONAL NEEDS IN THE EVENT OF TRAVEL-RELATED MEDICAL EMERGENCIES, NAMELY, MAKING TRAVEL ARRANGEMENTS AND AMBULANCE ARRANGEMENTS (U.S. CLS. 100 AND 105).

FIRST USE 3-0-2005; IN COMMERCE 3-0-2005.

**CLASS 45—PERSONAL SERVICES**

FOR ASSISTING TRAVELERS AND EXPATRIATES WITH THEIR PERSONAL NEEDS IN THE EVENT OF TRAVEL-RELATED MEDICAL EMERGENCIES, NAMELY, ARRANGING EMERGENCY MEDICAL ASSISTANCE AND PROVIDING EMERGENCY MEDICAL ASSISTANCE INFORMATION SERVICES (U.S. CLS. 100 AND 101).

FIRST USE 3-0-2005; IN COMMERCE 3-0-2005.

TEJBIR SINGH, EXAMINING ATTORNEY

SN 76-656,122. B.C.L.F. GROUP, INC., NEW YORK, NY. FILED 3-6-2006.

**MARKJOSEPH STEAKHOUSE**

THE MARK CONSISTS OF STANDARD CHARACTERS WITHOUT CLAIM TO ANY PARTICULAR FONT, STYLE, SIZE, OR COLOR.

NO CLAIM IS MADE TO THE EXCLUSIVE RIGHT TO USE "STEAKHOUSE", APART FROM THE MARK AS SHOWN.

THE NAME "MARK JOSEPH" DOES NOT IDENTIFY A LIVING INDIVIDUAL.

**CLASS 30—STAPLE FOODS**

FOR (BASED ON INTENT TO USE) STEAK SAUCE (U.S. CL. 46).

**CLASS 43—HOTEL AND RESTAURANT SERVICES**

FOR (BASED ON USE IN COMMERCE) RESTAURANT, BAR AND CATERING SERVICES (U.S. CLS. 100 AND 101).

FIRST USE 1-0-2000; IN COMMERCE 1-0-2000.

GINA HAYES, EXAMINING ATTORNEY

SN 76-656,273. PRESBYTERIAN PUBLISHING CORPORATION, LOUISVILLE, KY. FILED 3-8-2006.

**FAITHFUL LIVING IN A COMPLEX WORLD**

THE MARK CONSISTS OF STANDARD CHARACTERS WITHOUT CLAIM TO ANY PARTICULAR FONT, STYLE, SIZE, OR COLOR.

**CLASS 38—COMMUNICATION**

FOR PROVIDING ON-LINE FORUMS FOR TRANSMISSION AMONG COMPUTER USERS CONCERNING THE FIELD OF RELIGION, FAMILY VALUES AND CHRISTIANITY (U.S. CLS. 100, 101 AND 104).

FIRST USE 2-1-2006; IN COMMERCE 2-1-2006.

**CLASS 41—EDUCATION AND ENTERTAINMENT**

FOR EDUCATION SERVICES, NAMELY, CONDUCTING ON-LINE COURSES IN BIBLE STUDY; ON-LINE PUBLICATION OF STUDY GUIDES, BOOKS, MANUALS, PAMPHLETS, AND ISSUE PAPERS (U.S. CLS. 100, 101 AND 107).

FIRST USE 2-1-2006; IN COMMERCE 2-1-2006.

**CLASS 45—PERSONAL SERVICES**

FOR PROVIDING ON-LINE INFORMATION AND NEWS IN THE FIELDS OF RELIGION, FAMILY VALUES, AND CHRISTIANITY (U.S. CLS. 100 AND 101).

FIRST USE 2-1-2006; IN COMMERCE 2-1-2006.

KAREN BRACEY, EXAMINING ATTORNEY

SN 76-656,274. PRESBYTERIAN PUBLISHING CORPORATION, LOUISVILLE, KY. FILED 3-8-2006.

**THE THOUGHTFUL CHRISTIAN**

THE MARK CONSISTS OF STANDARD CHARACTERS WITHOUT CLAIM TO ANY PARTICULAR FONT, STYLE, SIZE, OR COLOR.

NO CLAIM IS MADE TO THE EXCLUSIVE RIGHT TO USE "CHRISTIAN", APART FROM THE MARK AS SHOWN.

**CLASS 38—COMMUNICATION**

FOR PROVIDING ON-LINE FORUMS FOR TRANSMISSION AMONG COMPUTER USERS CONCERNING THE FIELD OF RELIGION, FAMILY VALUES AND CHRISTIANITY (U.S. CLS. 100, 101 AND 104).

FIRST USE 2-1-2006; IN COMMERCE 2-1-2006.

**CLASS 41—EDUCATION AND ENTERTAINMENT**

FOR EDUCATION SERVICES, NAMELY, CONDUCTING ON-LINE COURSES IN BIBLE STUDY; ON-LINE PUBLICATION OF STUDY GUIDES, BOOKS, MANUALS, PAMPHLETS, AND ISSUE PAPERS (U.S. CLS. 100, 101 AND 107).

FIRST USE 2-1-2006; IN COMMERCE 2-1-2006.

**CLASS 45—PERSONAL SERVICES**

FOR PROVIDING ON-LINE INFORMATION AND NEWS IN THE FIELDS OF RELIGION, FAMILY VALUES, AND CHRISTIANITY (U.S. CLS. 100 AND 101).

FIRST USE 2-1-2006; IN COMMERCE 2-1-2006.

KAREN BRACEY, EXAMINING ATTORNEY

SN 76-656,681. ASPIRE, INC., MORRISVILLE, PA. FILED 3-9-2006.

 The logo for "Aspire" features the word in a stylized, italicized font. The letter 'A' is significantly larger and more prominent than the other letters, which are smaller and more closely spaced. The font has a slight shadow or outline effect.

OWNER OF U.S. REG. NO. 1,397,120.

**CLASS 37—CONSTRUCTION AND REPAIR**

FOR CONSULTING SERVICES IN THE FIELD OF AUTOMOBILE REPAIR (U.S. CLS. 100, 103 AND 106).  
FIRST USE 7-12-1983; IN COMMERCE 9-30-1983.

**CLASS 41—EDUCATION AND ENTERTAINMENT**

FOR EDUCATIONAL SERVICES, NAMELY CONDUCTING SEMINARS AND WORKSHOPS IN THE FIELD OF AUTOMOBILE REPAIR (U.S. CLS. 100, 101 AND 107).

FIRST USE 7-12-1983; IN COMMERCE 9-30-1983.  
HOWARD SMIGA, EXAMINING ATTORNEY

SN 76-658,565. CHURCH BUILDERS MINISTRIES, INC., DBA BELIEVERS CENTER OF ALBUQUERQUE, ALBUQUERQUE, NEW MEXICO, MEXICO, FILED 4-17-2006.

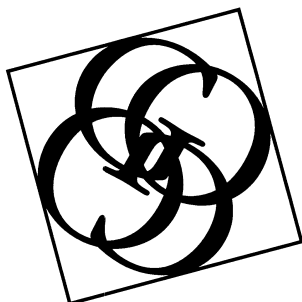
**CLASS 16—PAPER GOODS AND PRINTED MATTER**

FOR PUBLICATIONS— NAMELY STUDY GUIDES, MANUALS, NEWSLETTERS, MAGAZINES, ALL IN THE FIELD OF CHRISTIAN RELIGION (U.S. CLS. 2, 5, 22, 23, 29, 37, 38 AND 50).

FIRST USE 10-0-1992; IN COMMERCE 4-0-1993.

**CLASS 25—CLOTHING**

FOR T-SHIRTS (U.S. CLS. 22 AND 39).  
FIRST USE 10-0-1992; IN COMMERCE 4-0-1993.  
ANDREA EVANS, EXAMINING ATTORNEY

SN 76-658,730. INTERNATIONAL CODE COUNCIL, INC., FALLS CHURCH, VA. FILED 4-19-2006.

**ICC FOUNDATION**

THE MARK CONSISTS OF STANDARD CHARACTERS WITHOUT CLAIM TO ANY PARTICULAR FONT, STYLE, SIZE, OR COLOR.

OWNER OF U.S. REG. NO. 2,927,329 AND OTHERS.

NO CLAIM IS MADE TO THE EXCLUSIVE RIGHT TO USE FOUNDATION, APART FROM THE MARK AS SHOWN.

**CLASS 35—ADVERTISING AND BUSINESS**

FOR ASSOCIATION SERVICES, NAMELY PROMOTING THE INTERESTS OF BUILDING, CONSTRUCTION, AND SAFETY CODE DEVELOPERS, ENFORCERS, AND USERS (U.S. CLS. 100, 101 AND 102).

FIRST USE 3-0-2003; IN COMMERCE 6-0-2003.

**CLASS 36—INSURANCE AND FINANCIAL**

FOR CHARITABLE FUNDRAISING (U.S. CLS. 100, 101 AND 102).

FIRST USE 3-0-2003; IN COMMERCE 6-0-2003.  
DAVID STERKIN, EXAMINING ATTORNEY

SN 76-658,731. INTERNATIONAL CODE COUNCIL, INC., FALLS CHURCH, VA. FILED 4-19-2006.

**PROJECT H.E.R.O.**

THE MARK CONSISTS OF STANDARD CHARACTERS WITHOUT CLAIM TO ANY PARTICULAR FONT, STYLE, SIZE, OR COLOR.

NO CLAIM IS MADE TO THE EXCLUSIVE RIGHT TO USE PROJECT, APART FROM THE MARK AS SHOWN.

**CLASS 35—ADVERTISING AND BUSINESS**

FOR ASSOCIATION SERVICES, NAMELY PROMOTING THE INTERESTS OF BUILDING, CONSTRUCTION, AND SAFETY CODE DEVELOPERS, ENFORCERS, AND USERS, AND PROMOTING AWARENESS OF THE SPECIAL NEEDS OF DISABLED PERSONS, PARTICULARLY DISABLED VETERANS, FOR HOMES FREE OF OBSTACLES AND RESTRICTIONS (U.S. CLS. 100, 101 AND 102).

FIRST USE 1-0-2005; IN COMMERCE 3-0-2005.

**CLASS 36—INSURANCE AND FINANCIAL**

FOR CHARITABLE FUNDRAISING (U.S. CLS. 100, 101 AND 102).

FIRST USE 1-0-2005; IN COMMERCE 3-0-2005.  
DAVID STERKIN, EXAMINING ATTORNEY

SN 76-658,732. INTERNATIONAL CODE COUNCIL, INC., FALLS CHURCH, VA. FILED 4-19-2006.

**SILENT DEFENDER**

THE MARK CONSISTS OF STANDARD CHARACTERS WITHOUT CLAIM TO ANY PARTICULAR FONT, STYLE, SIZE, OR COLOR.

**CLASS 35—ADVERTISING AND BUSINESS**

FOR ASSOCIATION SERVICES, NAMELY PROMOTING THE INTERESTS OF BUILDING, CONSTRUCTION, AND SAFETY CODE DEVELOPERS, ENFORCERS, AND USERS (U.S. CLS. 100, 101 AND 102).

FIRST USE 9-0-2002; IN COMMERCE 5-0-2003.

**CLASS 36—INSURANCE AND FINANCIAL**

FOR CHARITABLE FUNDRAISING (U.S. CLS. 100, 101 AND 102).

FIRST USE 9-0-2002; IN COMMERCE 5-0-2003.  
DAVID STERKIN, EXAMINING ATTORNEY

SN 76-658,736. INTERNATIONAL CODE COUNCIL, INC., FALLS CHURCH, VA. FILED 4-19-2006.

#### INTERNATIONAL CODE COUNCIL FOUNDATION

THE MARK CONSISTS OF STANDARD CHARACTERS WITHOUT CLAIM TO ANY PARTICULAR FONT, STYLE, SIZE, OR COLOR.

OWNER OF U.S. REG. NOS. 2,354,495, 2,771,975 AND OTHERS.

NO CLAIM IS MADE TO THE EXCLUSIVE RIGHT TO USE FOUNDATION, APART FROM THE MARK AS SHOWN.

SEC. 2(F) "INTERNATIONAL CODE COUNCIL".

#### CLASS 35—ADVERTISING AND BUSINESS

FOR ASSOCIATION SERVICES, NAMELY PROMOTING THE INTERESTS OF BUILDING, CONSTRUCTION, AND SAFETY CODE DEVELOPERS, ENFORCERS, AND USERS (U.S. CLS. 100, 101 AND 102).

FIRST USE 3-0-2003; IN COMMERCE 6-0-2003.

#### CLASS 36—INSURANCE AND FINANCIAL

FOR CHARITABLE FUNDRAISING (U.S. CLS. 100, 101 AND 102).

FIRST USE 3-0-2003; IN COMMERCE 6-0-2003.

DAVID STERKIN, EXAMINING ATTORNEY

SN 76-659,359. PRESBYTERIAN PUBLISHING CORPORATION, LOUISVILLE, KY. FILED 5-1-2006.



THE MARK CONSISTS OF THE STYLIZED DESIGN OF A PERSON IN A KNEELING OR SITTING POSITION.

#### CLASS 38—COMMUNICATION

FOR PROVIDING ON-LINE FORUMS FOR TRANSMISSION AMONG COMPUTER USERS CONCERNING THE FIELD OF RELIGION, FAMILY VALUES AND CHRISTIANITY (U.S. CLS. 100, 101 AND 104).

FIRST USE 2-1-2006; IN COMMERCE 2-1-2006.

#### CLASS 41—EDUCATION AND ENTERTAINMENT

FOR EDUCATION SERVICES, NAMELY, CONDUCTING ON-LINE COURSES IN BIBLE STUDY; ON-LINE PUBLICATION OF STUDY GUIDES, BOOKS, MANUALS, PAMPHLETS, AND ISSUE PAPERS (U.S. CLS. 100, 101 AND 107).

FIRST USE 2-1-2006; IN COMMERCE 2-1-2006.

#### CLASS 45—PERSONAL SERVICES

FOR PROVIDING ON-LINE INFORMATION AND NEWS IN THE FIELDS OF RELIGION, FAMILY VALUES, AND CHRISTIANITY (U.S. CLS. 100 AND 101).

FIRST USE 2-1-2006; IN COMMERCE 2-1-2006.

KAREN BRACEY, EXAMINING ATTORNEY

SN 76-660,834. HIGH TECH COMPUTER CORPORATION, TAO YUAN 330, TAIWAN, FILED 5-31-2006.

# EXEDEA

THE MARK CONSISTS OF STANDARD CHARACTERS WITHOUT CLAIM TO ANY PARTICULAR FONT, STYLE, SIZE, OR COLOR.

#### CLASS 9—ELECTRICAL AND SCIENTIFIC APPARATUS

FOR MOBILE PHONES; MOBILE PHONES WITH DATA TRANSMISSION FUNCTION; VIDEO PHONES; SMART PHONES, NAMELY, TELEPHONES WITH THE CAPABILITY TO ELECTRONICALLY TRANSMIT DATA, VOICE CONTENT AND IMAGES, THE CAPABILITY TO ACCESS THE INTERNET, THE CAPABILITY TO ELECTRONICALLY SEND AND RECEIVE FAXES, AND THE CAPABILITY TO SEND AND RECEIVE ELECTRONIC MAIL MESSAGES; PERSONAL DIGITAL ASSISTANTS; PERSON DIGITAL ASSISTANTS FEATURING GLOBAL POSITIONING SYSTEMS; PERSONAL DIGITAL ASSISTANTS WITH WIRELESS COMMUNICATION FUNCTIONS; VOICE OVER INTERNET PROTOCOL PHONES; CAMERA PHONES; TABLET COMPUTERS; SLIM COMPUTERS; ULTRA MOBILE PERSONAL COMPUTERS; ACCESSORIES FOR THE ABOVE GOODS, NAMELY, HEADSETS, HEADSETS WITH WIRELESS TRANSMISSION FUNCTION, SYNCHRONIZATION CABLES, CRADLES, BATTERIES, AC ADAPTORS, CHARGERS, CASES FOR MOBILE PHONES, CASES FOR PERSONAL DIGITAL ASSISTANTS, MEMORY CARDS, CAR KITS, IN-CAR CHARGERS FOR MOBILE PHONES AND PERSONAL DIGITAL ASSISTANTS, AND IN-CAR HOLDERS FOR MOBILE PHONES AND PERSONAL DIGITAL ASSISTANTS (U.S. CLS. 21, 23, 26, 36 AND 38).

#### CLASS 37—CONSTRUCTION AND REPAIR

FOR REPAIR AND MAINTENANCE FOR HANDHELD COMPUTER DEVICES AND MOBILE COMMUNICATION PRODUCTS NAMELY, MOBILE PHONES, MOBILE PHONES WITH DATA TRANSMISSION FUNCTION, VIDEO PHONES, SMART PHONES, PERSONAL DIGITAL ASSISTANTS, PERSONAL DIGITAL ASSISTANTS WITH GLOBAL POSITIONING SYSTEM, PERSONAL DIGITAL ASSISTANTS WITH WIRELESS COMMUNICATION FUNCTIONS, VOICE OVER INTERNET PROTOCOL PHONES, CAMERA PHONES, TABLET COMPUTERS, SLIM COMPUTERS, AND ULTRA MOBILE PERSONAL COMPUTERS (U.S. CLS. 100, 103 AND 106).

GIANCARLO CASTRO, EXAMINING ATTORNEY

SN 76-664,406. UNISOURCE ADMINISTRATORS, INC., SARASOTA, FL. FILED 8-9-2006.

# CLAIM\$ENSE

THE MARK CONSISTS OF STANDARD CHARACTERS WITHOUT CLAIM TO ANY PARTICULAR FONT, STYLE, SIZE, OR COLOR.

## CLASS 36—INSURANCE AND FINANCIAL

FOR CLAIMS MANAGEMENT SERVICES, NAMELY, INSURANCE CLAIMS ADMINISTRATION AND ON-LINE INSURANCE CLAIMS ADMINISTRATION (U.S. CLS. 100, 101 AND 102).

## CLASS 42—SCIENTIFIC, COMPUTER AND LEGAL SERVICES

FOR PROVIDING PROPRIETARY ONLINE NON-DOWNLOADABLE SOFTWARE FOR USE IN INSURANCE CLAIMS ADMINISTRATION (U.S. CLS. 100 AND 101).

KEVIN CORWIN, EXAMINING ATTORNEY

SN 76-664,872. AMSCOT CORPORATION, TAMPA, FL. FILED 8-21-2006.

# YOU'RE OK WITH US.

THE MARK CONSISTS OF STANDARD CHARACTERS WITHOUT CLAIM TO ANY PARTICULAR FONT, STYLE, SIZE, OR COLOR.

## CLASS 35—ADVERTISING AND BUSINESS

FOR TAX PREPARATION SERVICES (U.S. CLS. 100, 101 AND 102).  
FIRST USE 6-30-2002; IN COMMERCE 6-30-2002.

## CLASS 36—INSURANCE AND FINANCIAL

FOR FINANCIAL SERVICES FOR OTHERS, NAMELY, CHECK CASHING, DEFERRED DEPOSIT TRANSACTIONS AND MONEY ORDER SERVICES (U.S. CLS. 100, 101 AND 102).  
FIRST USE 6-30-2002; IN COMMERCE 6-30-2002.  
BRIDGETT SMITH, EXAMINING ATTORNEY

SN 76-665,042. RON JON SURF SHOP OF FLA., INC., COCOA BEACH, FL. FILED 8-22-2006.



OWNER OF U.S. REG. NOS. 1,619,480, 2,771,175 AND OTHERS.  
NO CLAIM IS MADE TO THE EXCLUSIVE RIGHT TO USE "SURF SHOP", APART FROM THE MARK AS SHOWN.

## CLASS 16—PAPER GOODS AND PRINTED MATTER

FOR BUMPER STICKERS AND DECALS (U.S. CLS. 2, 5, 22, 23, 29, 37, 38 AND 50).  
FIRST USE 5-1-2005; IN COMMERCE 5-1-2005.

## CLASS 18—LEATHER GOODS

FOR BACK PACKS, BEACH BAGS, TOTE BAGS, CINCH SACKS, GYM BAGS, LUGGAGE (U.S. CLS. 1, 2, 3, 22 AND 41).  
FIRST USE 3-1-2004; IN COMMERCE 3-1-2004.

## CLASS 21—HOUSEWARES AND GLASS

FOR HOUSEHOLD GOODS, NAMELY, MUGS, PLASTIC COASTERS, ABSORBENT STONE COASTERS, THERMAL INSULATED WRAP FOR CANS TO KEEP THE CONTENTS HOT OR COLD, CAN COOLERS, BEVERAGE GLASSWARE, THERMAL INSULATED CONTAINERS FOR CANS AND BOTTLES; AND PLASTIC ARTICLES, NAMELY CUPS AND DRINKING GLASSES (U.S. CLS. 2, 13, 23, 29, 30, 33, 40 AND 50).  
FIRST USE 3-1-2006; IN COMMERCE 3-1-2006.

## CLASS 24—FABRICS

FOR TOWELS (U.S. CLS. 42 AND 50).  
FIRST USE 3-15-2004; IN COMMERCE 3-15-2004.

## CLASS 25—CLOTHING

FOR MEN'S, WOMEN'S AND CHILDREN'S SPORTSWEAR, NAMELY, SWEATSHIRTS, SWEAT PANTS, SWEAT SHORTS, T-SHIRTS, BATHING SUITS, BEACH COVER-UPS, CAPS, HEADBANDS, HATS, VISORS, SHOES, SOCKS, SANDALS, WET SUITS, JACKETS, PONCHOS, DRESSES, BLOUSES, SKIRTS, SHORTS AND PANTS (U.S. CLS. 22 AND 39).  
FIRST USE 5-1-2005; IN COMMERCE 5-1-2005.

## CLASS 28—TOYS AND SPORTING GOODS

FOR SPORTING GOODS AND EQUIPMENT, NAMELY, BODY BOARDS, BOOGIE BOARDS, SURFBOARDS, SKATEBOARDS, SKIM BOARDS, PADDLE BALL SETS, VOLLEY BALLS, FOOT BALLS; AND TOYS, NAMELY STUFFED ANIMALS, BEAN BAGS, TOY STUFFED PILLOWS, TOY CARS, SAND TOY SETS AND TOY FLYING DISKS (U.S. CLS. 22, 23, 38 AND 50).  
FIRST USE 1-15-2002; IN COMMERCE 1-15-2002.  
ROBIN MITTLER, EXAMINING ATTORNEY

SN 76-665,402. READABLE PRESS LLC, BLUE BELL, PA. FILED 8-31-2006.

# READABLE PRESS

THE MARK CONSISTS OF STANDARD CHARACTERS WITHOUT CLAIM TO ANY PARTICULAR FONT, STYLE, SIZE, OR COLOR.

NO CLAIM IS MADE TO THE EXCLUSIVE RIGHT TO USE PRESS, APART FROM THE MARK AS SHOWN.

## CLASS 16—PAPER GOODS AND PRINTED MATTER

FOR PUBLICATIONS, NAMELY NEWSLETTERS, PAMPHLETS, BOOKS AND REFERENCE MANUALS IN THE FIELDS OF LAW, TAX LAW AND PRACTICE (U.S. CLS. 2, 5, 22, 23, 29, 37, 38 AND 50).

**CLASS 41—EDUCATION AND ENTERTAINMENT**

FOR PUBLISHING OF NEWSLETTERS, PAMPHLETS, BOOKS AND REFERENCE MANUALS IN THE FIELDS OF LAW, TAX LAW AND PRACTICE (U.S. CLS. 100, 101 AND 107).

INGRID C. EULIN, EXAMINING ATTORNEY

SN 76-665,447. MARTIN CONSULTING SERVICES, INC., PORTLAND, OR. FILED 9-1-2006.

SN 76-665,411. BACKSPIN PRODUCTIONS, INC., NEW YORK, NY. FILED 8-31-2006.

**Crazy's Commandos**

THE MARK CONSISTS OF STANDARD CHARACTERS WITHOUT CLAIM TO ANY PARTICULAR FONT, STYLE, SIZE, OR COLOR.

**CLASS 25—CLOTHING**

FOR CLOTHING, NAMELY, LONG SLEEVE T-SHIRTS, SHORT SLEEVE T-SHIRTS AND SWEATSHIRTS (U.S. CLS. 22 AND 39).

FIRST USE 5-0-2005; IN COMMERCE 5-0-2005.

**CLASS 41—EDUCATION AND ENTERTAINMENT**

FOR ENTERTAINMENT SERVICES, NAMELY, ARRANGING AND CONDUCTING DANCE COMPETITIONS AND EVENTS (U.S. CLS. 100, 101 AND 107).

FIRST USE 5-0-2005; IN COMMERCE 5-0-2005.

ALAIN LAPTER, EXAMINING ATTORNEY

SN 76-665,421. KESWICKROBBINS, LLC, LOS ANGELES, CA. FILED 8-31-2006.

**CLASS 20—FURNITURE AND ARTICLES NOT OTHERWISE CLASSIFIED**

FOR FURNITURE AND FURNITURE PARTS (U.S. CLS. 2, 13, 22, 25, 32 AND 50).

**CLASS 21—HOUSEWARES AND GLASS**

FOR PLANTERS, FLOWER POTS AND VASES (U.S. CLS. 2, 13, 23, 29, 30, 33, 40 AND 50).

JOHN SCHUYLER YARD, EXAMINING ATTORNEY

**CLASS 35—ADVERTISING AND BUSINESS**

FOR BUSINESS CONSULTING TO ASSIST CLIENTS IN THE MANAGEMENT OF BUSINESS ACTIVITIES FOR SOFTWARE INSTALLATION, MAINTENANCE, CUSTOM DESIGN AND DEVELOPMENT BUSINESSES (U.S. CLS. 100, 101 AND 102).

FIRST USE 6-9-1997; IN COMMERCE 6-9-1997.

**CLASS 42—SCIENTIFIC, COMPUTER AND LEGAL SERVICES**

FOR COMPUTER CONSULTATION IN THE FIELD OF SOFTWARE INSTALLATION AND MAINTENANCE, AND CUSTOM SOFTWARE DESIGN AND DEVELOPMENT (U.S. CLS. 100 AND 101).

FIRST USE 6-9-1997; IN COMMERCE 6-9-1997.

ZHALEH DELANEY, EXAMINING ATTORNEY

SN 76-665,477. ROSS, DUNCAN, LOCKPORT, NY. AND ROSS, ROBIN, LOCKPORT, NY. FILED 9-1-2006.

**BEAUVINE VINEYARDS**

NO CLAIM IS MADE TO THE EXCLUSIVE RIGHT TO USE VINEYARDS, APART FROM THE MARK AS SHOWN.

**CLASS 33—WINES AND SPIRITS**

FOR WINE (U.S. CLS. 47 AND 49).

**CLASS 44—MEDICAL, BEAUTY AND AGRICULTURAL SERVICES**

FOR VINEYARD SERVICES, NAMELY, CULTIVATION OF GRAPES FOR OTHERS (U.S. CLS. 100 AND 101).

STEVEN R. FINE, EXAMINING ATTORNEY

SN 76-665,543. SHERRY, MARK, GRANADA HILLS, CA.  
FILED 9-5-2006.

SN 76-668,801. PACIFIC PROPERTY CONSULTANTS, INC.,  
SAN DIEGO, CA. FILED 11-9-2006.

# JAMBRO

THE MARK CONSISTS OF STANDARD CHARACTERS WITHOUT CLAIM TO ANY PARTICULAR FONT, STYLE, SIZE, OR COLOR.

OWNER OF U.S. REG. NOS. 2,714,291, 2,765,093 AND 2,843,639.

## CLASS 9—ELECTRICAL AND SCIENTIFIC APPARATUS

FOR SERIES OF PRERECORDED COMPACT DISCS, AUDIOCASSETTES AND PHONOGRAPH RECORDS FEATURING MUSICAL SOUND RECORDINGS (U.S. CLS. 21, 23, 26, 36 AND 38).

## CLASS 41—EDUCATION AND ENTERTAINMENT

FOR ENTERTAINMENT, NAMELY LIVE PERFORMANCES BY A MUSICAL BAND (U.S. CLS. 100, 101 AND 107).

TRICIA SONNEBORN, EXAMINING ATTORNEY



## CLASS 37—CONSTRUCTION AND REPAIR

FOR CONSTRUCTION CONSULTANCY (U.S. CLS. 100, 103 AND 106).

## CLASS 45—PERSONAL SERVICES

FOR LITIGATION CONSULTANCY (U.S. CLS. 100 AND 101).

INGA ERVIN, EXAMINING ATTORNEY

SN 77-001,299. BEVERAGE PARTNERS WORLDWIDE (NORTH AMERICA), ATLANTA, GA. FILED 9-18-2006.

SN 76-668,622. LIFEWAY CHRISTIAN RESOURCES OF THE SOUTHERN BAPTIST CONVENTION, NASHVILLE, TN. FILED 11-7-2006.

# CANVAS

THE MARK CONSISTS OF STANDARD CHARACTERS WITHOUT CLAIM TO ANY PARTICULAR FONT, STYLE, SIZE, OR COLOR.

## CLASS 9—ELECTRICAL AND SCIENTIFIC APPARATUS

FOR PRERECORDED AUDIO AND VIDEO CASSETTES AND DISCS FEATURING BIBLICAL ISSUES AND STORIES; ELECTRONIC PUBLICATIONS, NAMELY, BOOKS FEATURING RELIGIOUS TOPICS RECORDED ON COMPUTER MEDIA (U.S. CLS. 21, 23, 26, 36 AND 38).

## CLASS 16—PAPER GOODS AND PRINTED MATTER

FOR PRINTED BOOKS, MAGAZINES, AND PERIODICALS IN THE FIELD OF RELIGIOUS AND BIBLE STUDY (U.S. CLS. 2, 5, 22, 23, 29, 37, 38 AND 50).

WENDY GOODMAN, EXAMINING ATTORNEY



THE COLOR(S) WHITE, YELLOW AND GOLD IS/ARE CLAIMED AS A FEATURE OF THE MARK.

THE MARK CONSISTS OF THE WORD ENVIGA IN WHITE WITH EACH LETTER OUTLINED IN THE COLOR BLACK AND THE DOT OF THE "I" IN ENVIGA STYLIZED SO AS TO APPEAR AS A FLAME DESIGN WITH A YELLOW OUTER SECTION, A GOLD MIDSECTION AND A WHITE INNER SECTION. THE COLOR BLACK IS NOT CLAIMED AS A COLOR IN THE MARK. IT APPEARS IN THE MARK FOR OUTLINING PURPOSES ONLY.

## CLASS 30—STAPLE FOODS

FOR TEA, TEA EXTRACTS IN THE NATURE OF FLAVORINGS OF TEA, BEVERAGES MADE OF TEA; ICED TEA; GREEN TEA; TEA WITH FRUIT FLAVORING; TEA SYRUPS, TEA EXTRACTS, ESSENCES AND CONCENTRATES FOR MAKING NON-ALCOHOLIC BEVERAGES (U.S. CL. 46).

## CLASS 32—LIGHT BEVERAGES

FOR ISOTONIC BEVERAGES; ENERGY DRINKS (U.S. CLS. 45, 46 AND 48).

KATINA MISTER, EXAMINING ATTORNEY

SN 77-001,482. BEVERAGE PARTNERS WORLDWIDE (NORTH AMERICA), ATLANTA, GA. FILED 9-18-2006.



THE COLOR(S) YELLOW, GOLD AND WHITE IS/ARE CLAIMED AS A FEATURE OF THE MARK. THE MARK CONSISTS OF A FLAME DESIGN WITH A YELLOW OUTER SECTION, A GOLD MIDSECTION AND A WHITE INNER SECTION.

**CLASS 30—STAPLE FOODS**

FOR TEA, TEA EXTRACTS IN THE NATURE OF FLAVORINGS OF TEA, BEVERAGES MADE OF TEA; ICED TEA; GREEN TEA; TEA WITH FRUIT FLAVORING; TEA SYRUPS, TEA EXTRACTS, ESSENCES AND CONCENTRATES FOR MAKING NON-ALCOHOLIC BEVERAGES (U.S. CL. 46).

**CLASS 32—LIGHT BEVERAGES**

FOR ISOTONIC BEVERAGES; ENERGY DRINKS (U.S. CLS. 45, 46 AND 48).  
KATINA MISTER, EXAMINING ATTORNEY

SN 77-001,494. BEVERAGE PARTNERS WORLDWIDE (NORTH AMERICA), ATLANTA, GA. FILED 9-18-2006.



THE APPLICANT CLAIMS COLOR AS A FEATURE OF THE MARK, NAMELY, ORANGE, RED AND WHITE. THE MARK CONSISTS OF A FLAME DESIGN WITH AN ORANGE OUTER SECTION, A RED MIDSECTION AND A WHITE INNER SECTION.

**CLASS 30—STAPLE FOODS**

FOR TEA, TEA EXTRACTS IN THE NATURE OF FLAVORINGS OF TEA, BEVERAGES MADE OF TEA; ICED TEA; GREEN TEA; TEA WITH FRUIT FLAVORING; TEA SYRUPS, TEA EXTRACTS, ESSENCES AND CONCENTRATES FOR MAKING NON-ALCOHOLIC BEVERAGES (U.S. CL. 46).

**CLASS 32—LIGHT BEVERAGES**

FOR ISOTONIC BEVERAGES; ENERGY DRINKS (U.S. CLS. 45, 46 AND 48).  
KATINA MISTER, EXAMINING ATTORNEY

SN 77-002,646. GFI HOLDINGS, INC., OMAHA, NE. FILED 9-19-2006.

**Snapalope Hunting Association Of America**

THE MARK CONSISTS OF STANDARD CHARACTERS WITHOUT CLAIM TO ANY PARTICULAR FONT, STYLE, SIZE, OR COLOR.

OWNER OF U.S. REG. NO. 1,995,265.  
NO CLAIM IS MADE TO THE EXCLUSIVE RIGHT TO USE "ASSOCIATION OF AMERICA", APART FROM THE MARK AS SHOWN.

**CLASS 25—CLOTHING**

FOR T-SHIRTS, HATS, BELTS, SANDALS (U.S. CLS. 22 AND 39).

**CLASS 29—MEATS AND PROCESSED FOODS**

FOR PACKAGED MEAT SNACKS (U.S. CL. 46).  
MATTHEW MCDOWELL, EXAMINING ATTORNEY

SN 77-002,652. GFI HOLDINGS, INC., OMAHA, NE. FILED 9-19-2006.



OWNER OF U.S. REG. NO. 1,995,265.  
NO CLAIM IS MADE TO THE EXCLUSIVE RIGHT TO USE "ASSOCIATION OF AMERICA", APART FROM THE MARK AS SHOWN.



**CLASS 25—CLOTHING**

FOR T-SHIRTS, HATS, BELTS, SANDALS (U.S. CLS. 22 AND 39).

**CLASS 29—MEATS AND PROCESSED FOODS**

FOR PACKAGED MEAT SNACKS (U.S. CL. 46).  
MATTHEW MCDOWELL, EXAMINING ATTORNEY

SN 77-003,426. UNITED STATES POSTAL SERVICE, WASHINGTON, DC. FILED 9-20-2006.

# PARCEL SELECT INTERNATIONAL

THE MARK CONSISTS OF STANDARD CHARACTERS WITHOUT CLAIM TO ANY PARTICULAR FONT, STYLE, SIZE, OR COLOR.

OWNER OF U.S. REG. NO. 2,540,117.

NO CLAIM IS MADE TO THE EXCLUSIVE RIGHT TO USE PARCEL AND INTERNATIONAL, APART FROM THE MARK AS SHOWN.

**CLASS 16—PAPER GOODS AND PRINTED MATTER**

FOR PLASTIC AND PAPER ENVELOPES AND POUCHES FOR SHIPPING AND PACKAGING; CARDBOARD AND CORRUGATED BOXES FOR SHIPPING AND PACKAGING; CARDBOARD MAILING TUBES (U.S. CLS. 2, 5, 22, 23, 29, 37, 38 AND 50).

**CLASS 35—ADVERTISING AND BUSINESS**

FOR MAILING SERVICES, NAMELY, SORTING, HANDLING AND RECEIVING PACKAGES AND LETTERS (U.S. CLS. 100, 101 AND 102).

**CLASS 39—TRANSPORTATION AND STORAGE**

FOR DELIVERY SERVICES, NAMELY, PICKUP, TRANSPORTATION AND DELIVERY OF PACKAGES AND LETTERS BY VARIOUS MODES OF TRANSPORTATION (U.S. CLS. 100 AND 105).

JEFFERY COWARD, EXAMINING ATTORNEY

SN 77-003,466. SAMSONITE CORPORATION, DENVER, CO. FILED 9-20-2006.

# SAMMIES

THE MARK CONSISTS OF STANDARD CHARACTERS WITHOUT CLAIM TO ANY PARTICULAR FONT, STYLE, SIZE, OR COLOR.

OWNER OF U.S. REG. NO. 1,970,598.

**CLASS 18—LEATHER GOODS**

FOR UMBRELLAS (U.S. CLS. 1, 2, 3, 22 AND 41).

**CLASS 25—CLOTHING**

FOR PONCHOS; RAIN BOOTS (U.S. CLS. 22 AND 39).  
SCOTT SISUN, EXAMINING ATTORNEY

SN 77-004,638. ULTRACONCURRENT, INC., APTOS, CA. FILED 9-21-2006.

# VIEDIT

THE MARK CONSISTS OF STANDARD CHARACTERS WITHOUT CLAIM TO ANY PARTICULAR FONT, STYLE, SIZE, OR COLOR.

**CLASS 9—ELECTRICAL AND SCIENTIFIC APPARATUS**

FOR COMPUTER SOFTWARE USED TO EDIT AND MANIPULATE COMPUTER PROGRAMS, COMPUTER FILE RECORDS, RECORDINGS, AND DOCUMENTS CREATED BY COMPUTER PROGRAMS; COMPUTER SOFTWARE USED TO CREATE AND EDIT COMPUTER-GENERATED COMPUTER FILE RECORDS, RECORDINGS AND DOCUMENTS; COMPUTER SOFTWARE FOR USE IN THE DESIGN AND GENERATION OF OTHER COMPUTER SOFTWARE PROGRAMS, COMPUTER FILE RECORDS, RECORDINGS AND DOCUMENTS; USER MANUALS AND INSTRUCTION BOOKS IN ELECTRONIC FORM DISTRIBUTED WITH THE FOREGOING (U.S. CLS. 21, 23, 26, 36 AND 38).

**CLASS 41—EDUCATION AND ENTERTAINMENT**

FOR EDUCATIONAL SERVICES, NAMELY CONDUCTING CLASSES, SEMINARS AND CONFERENCES, BOTH IN PERSON AND ONLINE, RELATING TO THE USE OF COMPUTER SOFTWARE USED TO EDIT AND MANIPULATE COMPUTER FILE RECORDS, RECORDINGS AND DOCUMENTS, CREATED BY COMPUTER PROGRAMS; CONDUCTING CLASSES, SEMINARS AND CONFERENCES, BOTH IN PERSON AND ONLINE, RELATING TO THE USE OF COMPUTER SOFTWARE USED TO CREATE AND EDIT COMPUTER-GENERATED COMPUTER FILE RECORDS, RECORDINGS AND DOCUMENTS; CONDUCTING CLASSES, SEMINARS AND CONFERENCES, BOTH IN PERSON AND ONLINE, RELATING TO THE USE OF COMPUTER SOFTWARE FOR USE IN THE DESIGN AND GENERATION OF OTHER COMPUTER SOFTWARE PROGRAMS, COMPUTER FILE RECORDS, RECORDINGS, AND DOCUMENTS; PROVIDING EDUCATIONAL MATERIAL AND DOCUMENTATION THEREWITH (U.S. CLS. 100, 101 AND 107).

DAVID I, EXAMINING ATTORNEY

SN 77-005,642. THRIVENT FINANCIAL FOR LUTHERANS, APPLETON, WI. FILED 9-22-2006.

## HOW TO THRIVE IN RETIREMENT

THE MARK CONSISTS OF STANDARD CHARACTERS WITHOUT CLAIM TO ANY PARTICULAR FONT, STYLE, SIZE, OR COLOR.

**CLASS 36—INSURANCE AND FINANCIAL**

FOR FINANCIAL AND RETIREMENT PLANNING SERVICES; INVESTMENT MANAGEMENT AND CONSULTING (U.S. CLS. 100, 101 AND 102).

**CLASS 41—EDUCATION AND ENTERTAINMENT**

FOR EDUCATIONAL SERVICES, NAMELY, SEMINARS AND WORKSHOPS IN THE FIELD OF FINANCIAL PLANNING, RETIREMENT PLANNING, LEGACY PLANNING AND CHARITABLE GIVING; PROVIDING COURSE MATERIALS AND ASSESSMENT AND PLANNING TOOLS IN CONNECTION THEREWITH (U.S. CLS. 100, 101 AND 107).

JANICE L. MCMORROW, EXAMINING ATTORNEY

**CLASS 41—EDUCATION AND ENTERTAINMENT**

FOR EDUCATIONAL SERVICES, NAMELY, SEMINARS AND WORKSHOPS IN THE FIELD OF FINANCIAL PLANNING, RETIREMENT PLANNING, LEGACY PLANNING AND CHARITABLE GIVING; AND PROVIDING COURSE MATERIALS AND ASSESSMENT AND PLANNING TOOLS IN THE NATURE OF COURSE MATERIALS IN CONNECTION THEREWITH (U.S. CLS. 100, 101 AND 107).

JANICE L. MCMORROW, EXAMINING ATTORNEY

SN 77-006,902. THRIVENT FINANCIAL FOR LUTHERANS, APPLETON, WI. FILED 9-25-2006.

SN 77-005,646. THRIVENT FINANCIAL FOR LUTHERANS, APPLETON, WI. FILED 9-22-2006.

**THRIVING IN RETIREMENT**

THE MARK CONSISTS OF STANDARD CHARACTERS WITHOUT CLAIM TO ANY PARTICULAR FONT, STYLE, SIZE, OR COLOR.

**CLASS 36—INSURANCE AND FINANCIAL**

FOR FINANCIAL AND RETIREMENT PLANNING SERVICES; INVESTMENT MANAGEMENT AND CONSULTING (U.S. CLS. 100, 101 AND 102).

**CLASS 41—EDUCATION AND ENTERTAINMENT**

FOR EDUCATIONAL SERVICES, NAMELY, SEMINARS AND WORKSHOPS IN THE FIELD OF FINANCIAL PLANNING, RETIREMENT PLANNING, LEGACY PLANNING AND CHARITABLE GIVING; AND PROVIDING AND ASSESSMENT AND PLANNING TOOLS IN THE NATURE OF COURSE MATERIALS IN CONNECTION THEREWITH (U.S. CLS. 100, 101 AND 107).

JANICE L. MCMORROW, EXAMINING ATTORNEY

**KEYS TO THRIVING IN RETIREMENT**

THE MARK CONSISTS OF STANDARD CHARACTERS WITHOUT CLAIM TO ANY PARTICULAR FONT, STYLE, SIZE, OR COLOR.

**CLASS 36—INSURANCE AND FINANCIAL**

FOR FINANCIAL AND RETIREMENT PLANNING SERVICES; INVESTMENT MANAGEMENT AND CONSULTING (U.S. CLS. 100, 101 AND 102).

**CLASS 41—EDUCATION AND ENTERTAINMENT**

FOR EDUCATIONAL SERVICES, NAMELY, SEMINARS AND WORKSHOPS IN THE FIELD OF FINANCIAL PLANNING, RETIREMENT PLANNING, LEGACY PLANNING AND CHARITABLE GIVING; AND PROVIDING COURSE MATERIALS AND ASSESSMENT AND PLANNING TOOLS IN THE NATURE OF COURSE MATERIALS IN CONNECTION THEREWITH (U.S. CLS. 100, 101 AND 107).

JANICE L. MCMORROW, EXAMINING ATTORNEY

SN 77-011,071. MCMAHON, JOHN PAUL, LOS ANGELES, CA. FILED 9-29-2006.

SN 77-006,896. THRIVENT FINANCIAL FOR LUTHERANS, APPLETON, WI. FILED 9-25-2006.

**LIVING AND THRIVING IN RETIREMENT**

THE MARK CONSISTS OF STANDARD CHARACTERS WITHOUT CLAIM TO ANY PARTICULAR FONT, STYLE, SIZE, OR COLOR.

**CLASS 36—INSURANCE AND FINANCIAL**

FOR FINANCIAL AND RETIREMENT PLANNING SERVICES; INVESTMENT MANAGEMENT AND CONSULTING (U.S. CLS. 100, 101 AND 102).

**PLATA ‘o’ PLOMO**

THE MARK CONSISTS OF STANDARD CHARACTERS WITHOUT CLAIM TO ANY PARTICULAR FONT, STYLE, SIZE, OR COLOR.

THE ENGLISH TRANSLATION OF THE WORDING "PLATA 'O' PLOMO" IS "SILVER OR LEAD".

**CLASS 16—PAPER GOODS AND PRINTED MATTER**

FOR STICKERS (U.S. CLS. 2, 5, 22, 23, 29, 37, 38 AND 50).

**CLASS 25—CLOTHING**

FOR DENIMS; JERSEYS; SHORT-SLEEVED OR LONG-SLEEVED T-SHIRTS; TOPS (U.S. CLS. 22 AND 39).

**CLASS 32—LIGHT BEVERAGES**

FOR NON-ALCOHOLIC BEVERAGES, NAMELY, CARBONATED BEVERAGES (U.S. CLS. 45, 46 AND 48).  
KAELE KUNG, EXAMINING ATTORNEY

SN 77-011,696. MODEM MEDIA, INC., NORWALK, CT.  
FILED 10-2-2006.

# MODEM

THE MARK CONSISTS OF STANDARD CHARACTERS WITHOUT CLAIM TO ANY PARTICULAR FONT, STYLE, SIZE, OR COLOR.

OWNER OF U.S. REG. NOS. 2,308,153 AND 2,327,599.

**CLASS 35—ADVERTISING AND BUSINESS**

FOR ADVERTISING AGENCY AND MARKETING SERVICES, NAMELY, THE PLANNING, DEVELOPMENT AND DISSEMINATION OF ADVERTISING AND INTERACTIVE ADVERTISING AND MARKETING COMMUNICATIONS FOR OTHERS VIA OFF-LINE MEDIA AND ON-LINE ELECTRONIC COMMUNICATIONS NETWORKS, NAMELY VOICE RESPONSIVE, INTERACTIVE FACSIMILE, CD/ROM, GLOBAL COMPUTER NETWORK, GLOBAL TELEPHONE NETWORK, INTERNAL COMPUTER NETWORK, INTERNAL TELEPHONE NETWORK, COMPUTER, TELEPHONE, DISKETTE AND TELEVISION; PLACING AND PREPARING ADVERTISEMENTS FOR OTHERS; DEVELOPING ADVERTISING, MARKETING, BRAND AND CUSTOMER BUSINESS AND MARKETING STRATEGIES; PLANNING AND MANAGING LIVE MARKETING PROMOTIONAL EVENTS FOR OTHERS; PREPARING AUDIO, VISUAL AND DIGITAL PRESENTATIONS FOR USE IN ADVERTISING; PRODUCTION OF AUDIO, VISUAL AND DIGITAL ADVERTISING FOR TELEVISION, RADIO AND COMPUTERS; AND PREPARING MARKET RESEARCH IN THE FIELDS OF ADVERTISING AND MULTIMEDIA (U.S. CLS. 100, 101 AND 102).

**CLASS 42—SCIENTIFIC, COMPUTER AND LEGAL SERVICES**

FOR COMPUTER SOFTWARE DESIGN FOR OTHERS (U.S. CLS. 100 AND 101).  
HEATHER BIDDULPH, EXAMINING ATTORNEY

SN 77-012,714. ALOEBIOTICS RESEARCH LABS, INC., NEW YORK, NY. FILED 10-3-2006.

## Wellness for Body, Mind and Skin

THE MARK CONSISTS OF STANDARD CHARACTERS WITHOUT CLAIM TO ANY PARTICULAR FONT, STYLE, SIZE, OR COLOR.

**CLASS 3—COSMETICS AND CLEANING PREPARATIONS**

FOR ANTI-AGING CREAM; ANTI-WRINKLE CREAMS; BEAUTY CREAMS FOR BODY CARE; BODY AND BEAUTY CARE COSMETICS; COSMETIC CREAMS FOR SKIN CARE; COSMETIC PREPARATIONS FOR BODY CARE; COSMETIC PREPARATIONS FOR SKIN RENEWAL; LOTIONS FOR FACE AND BODY CARE; SKIN CARE PRODUCTS, NAMELY, NON-MEDICATED SKIN SERUM (U.S. CLS. 1, 4, 6, 50, 51 AND 52).

**CLASS 5—PHARMACEUTICALS**

FOR NUTRACEUTICALS FOR THE PURPOSE OF HEALTH IMPROVEMENT; NUTRACEUTICALS FOR USE AS A DIETARY SUPPLEMENT (U.S. CLS. 6, 18, 44, 46, 51 AND 52).

LAURA KOVALSKY, EXAMINING ATTORNEY

SN 77-015,775. MOBILITY ELECTRONICS, INC., SCOTTSDALE, AZ. FILED 10-6-2006.

POWERED-UP AND CONNECTED

THE MARK CONSISTS OF STANDARD CHARACTERS WITHOUT CLAIM TO ANY PARTICULAR FONT, STYLE, SIZE, OR COLOR.

**CLASS 9—ELECTRICAL AND SCIENTIFIC APPARATUS**

FOR ACCESSORIES FOR PORTABLE COMPUTERS, NAMELY, ELECTRICAL ADAPTERS, BATTERY CHARGERS, BATTERIES, ELECTRICAL CONNECTORS AND CABLES, MODEMS, ACOUSTIC COUPLERS, HARD DRIVES, COMPUTER MEMORY MODULES, PCMCIA CARDS, AND TELEPHONE LINE TESTERS; UNIVERSAL AC ADAPTERS; BATTERY PACKS; COMPUTER KEYBOARD PROTECTION COVERS; BLANK FLOPPY COMPUTER DISKS; BLANK HARD COMPUTER DISKS; DISK CARRYING CASES, NAMELY, DISK WALLETS; COMPUTER MODEM INTERFACES; COMPUTER UPGRADE KITS COMPRISING HARD DISK DRIVE, FLOPPY DISK DRIVE, LCD DISPLAY PANEL, ELECTROLUMINESCENT DISPLAY PANEL, PRINTED CIRCUIT BOARD AND BATTERIES; COMPUTER TOOLKITS COMPRISING, SCREWDRIVER, POCKET KNIFE, MINIATURE LIGHTED MAGNIFIER, MODULAR Y-CONNECTOR, IN-LINE COUPLER, CABLE WITH ALLIGATOR CLIPS AND MODULAR LINE CORD; COMPUTER CARRYING CASES, COMPUTER CARRYING BAGS AND ACCESSORIES, NAMELY, STRAPS, AND ATTACHABLE POUCHES AND EXPANSION POCKETS (U.S. CLS. 21, 23, 26, 36 AND 38).

**CLASS 35—ADVERTISING AND BUSINESS**

FOR RETAIL STORE SERVICES AND COMPUTERIZED ON-LINE RETAIL STORE SERVICES FEATURING COMPUTERS, COMPUTER PERIPHERAL DEVICES, PORTABLE ELECTRONIC DEVICES, AND PORTABLE ELECTRONIC DEVICE ACCESSORIES; PROMOTING THE GOODS AND SERVICES OF OTHERS BY PREPARING AND PLACING ADVERTISEMENTS IN AN ELECTRONIC MAGAZINE ACCESSED THROUGH A GLOBAL COMPUTER NETWORK; PROVIDING SHOPPERS GUIDE INFORMATION FOR BUSINESS TRAVELERS AND LAPTOP COMPUTER USERS; MAIL ORDER CATALOG SERVICES, TELEPHONE RETAIL ORDER SERVICES AND RETAIL STORE SERVICES, AVAILABLE THROUGH COMPUTER COMMUNICATIONS AND INTERACTIVE TELEVISION, ALL FEATURING LAPTOP COMPUTER PRODUCTS, COMPUTERS, COMPUTER PERIPHERAL DEVICES, PORTABLE ELECTRONIC DEVICES, AND PORTABLE ELECTRONIC DEVICE ACCESSORIES; AND COMPUTERIZED ON-LINE RETAIL STORE SERVICES FEATURING COMPUTER ACCESSORIES AND COMPUTER PERIPHERALS (U.S. CLS. 100, 101 AND 102).

**CLASS 41—EDUCATION AND ENTERTAINMENT**

FOR PROVIDING ONLINE NEWSLETTERS IN THE FIELDS OF PORTABLE COMPUTERS AND ACCESSORIES THEREFOR, AND BUSINESS TRAVEL TIPS (U.S. CLS. 100, 101 AND 107).

RAY THOMAS, EXAMINING ATTORNEY

SN 77-017,451. AMERICAN TYPE CULTURE COLLECTION, MANASSAS, VA. FILED 10-10-2006.

**ATCC STANDARD REFERENCE MATERIAL**

THE MARK CONSISTS OF STANDARD CHARACTERS WITHOUT CLAIM TO ANY PARTICULAR FONT, STYLE, SIZE, OR COLOR.

NO CLAIM IS MADE TO THE EXCLUSIVE RIGHT TO USE "STANDARD REFERENCE MATERIAL", APART FROM THE MARK AS SHOWN.

**CLASS 1—CHEMICALS**

FOR BIOLOGICAL AND CHEMICAL REAGENTS, INCLUDING, CLONES, VECTORS, GENOMIC DNA, CDNA LIBRARIES, OLIGONUCLEOTIDES, MOLECULAR BIOLOGY GRADE WATER, ANTISERA, ANTIBODIES, POLYSACCHARIDES AND CRYOPROTECTANTS, AND BIOLOGICAL ENTITIES, INCLUDING, BACTERIA, FUNGI, PROTISTS, VIRUSES, MYCOPLASMA, CELL CULTURES AND COMPETENT CELLS, ALL FOR CHEMICAL AND BIOLOGICAL PROFICIENCY TESTING; BIOLOGICAL AND CHEMICAL KITS COMPRISED OF BIOLOGICAL AND CHEMICAL REAGENTS, INCLUDING, CLONES, VECTORS, GENOMIC DNA, CDNA LIBRARIES, OLIGONUCLEOTIDES, MOLECULAR BIOLOGY GRADE WATER, ANTISERA, ANTIBODIES, POLYSACCHARIDES AND CRYOPROTECTANTS, BIOLOGICAL ENTITIES, INCLUDING, BACTERIA, FUNGI, PROTISTS, VIRUSES, MYCOPLASMA, CELL CULTURES AND COMPETENT CELLS, TEST TUBES, VIALS, PETRI DISHES, AND RELATED CONTAINERS; BACTERIA FOR USE IN FOOD MANUFACTURE (U.S. CLS. 1, 5, 6, 10, 26 AND 46).

**CLASS 5—PHARMACEUTICALS**

FOR MEDIA FOR BACTERIOLOGICAL CULTURES; ANTIBIOTICS; VITAMINS AND MINERALS FOR USE IN PROFICIENCY TESTING; MEDICAL KITS COMPRISED OF BIOLOGICAL AND CHEMICAL REAGENTS, INCLUDING, CLONES, VECTORS, GENOMIC DNA, CDNA LIBRARIES, OLIGONUCLEOTIDES, MOLECULAR BIOLOGY GRADE WATER, ANTISERA, ANTIBODIES, POLYSACCHARIDES AND CRYOPROTECTANTS, BIOLOGICAL ENTITIES, INCLUDING, BACTERIA, FUNGI, PROTISTS, VIRUSES, MYCOPLASMA, CELL CULTURES AND COMPETENT CELLS, TEST TUBES, VIALS, PETRI DISHES, AND RELATED CONTAINERS (U.S. CLS. 6, 18, 44, 46, 51 AND 52).

ALLISON HOLTZ, EXAMINING ATTORNEY

SN 77-017,541. AMERICAN TYPE CULTURE COLLECTION, MANASSAS, VA. FILED 10-10-2006.

**ATCC REFERENCE MATERIAL**

THE MARK CONSISTS OF STANDARD CHARACTERS WITHOUT CLAIM TO ANY PARTICULAR FONT, STYLE, SIZE, OR COLOR.

NO CLAIM IS MADE TO THE EXCLUSIVE RIGHT TO USE "REFERENCE MATERIAL", APART FROM THE MARK AS SHOWN.

**CLASS 1—CHEMICALS**

FOR BIOLOGICAL AND CHEMICAL REAGENTS, INCLUDING, CLONES, VECTORS, GENOMIC DNA, CDNA LIBRARIES, OLIGONUCLEOTIDES, MOLECULAR BIOLOGY GRADE WATER, ANTISERA, ANTIBODIES, POLYSACCHARIDES AND CRYOPROTECTANTS, AND BIOLOGICAL ENTITIES, INCLUDING, BACTERIA, FUNGI, PROTISTS, VIRUSES, MYCOPLASMA, CELL CULTURES AND COMPETENT CELLS, ALL FOR CHEMICAL AND BIOLOGICAL PROFICIENCY TESTING; BIOLOGICAL AND CHEMICAL KITS COMPRISED OF BIOLOGICAL AND CHEMICAL REAGENTS, INCLUDING, CLONES, VECTORS, GENOMIC DNA, CDNA LIBRARIES, OLIGONUCLEOTIDES, MOLECULAR BIOLOGY GRADE WATER, ANTISERA, ANTIBODIES, POLYSACCHARIDES AND CRYOPROTECTANTS, BIOLOGICAL ENTITIES, INCLUDING, BACTERIA, FUNGI, PROTISTS, VIRUSES, MYCOPLASMA, CELL CULTURES AND COMPETENT CELLS, TEST TUBES, VIALS, PETRI DISHES, AND RELATED CONTAINERS; BACTERIA FOR USE IN FOOD MANUFACTURE (U.S. CLS. 1, 5, 6, 10, 26 AND 46).

**CLASS 5—PHARMACEUTICALS**

FOR MEDIA FOR BACTERIOLOGICAL CULTURES; ANTIBIOTICS; VITAMINS AND MINERALS FOR USE IN PROFICIENCY TESTING; MEDICAL KITS COMPRISED OF BIOLOGICAL AND CHEMICAL REAGENTS, INCLUDING, CLONES, VECTORS, GENOMIC DNA, CDNA LIBRARIES, OLIGONUCLEOTIDES, MOLECULAR BIOLOGY GRADE WATER, ANTISERA, ANTIBODIES, POLYSACCHARIDES AND CRYOPROTECTANTS, BIOLOGICAL ENTITIES, INCLUDING, BACTERIA, FUNGI, PROTISTS, VIRUSES, MYCOPLASMA, CELL CULTURES AND COMPETENT CELLS, TEST TUBES, VIALS, PETRI DISHES, AND RELATED CONTAINERS (U.S. CLS. 6, 18, 44, 46, 51 AND 52).

ALLISON HOLTZ, EXAMINING ATTORNEY

SN 77-017,547. BUILDSHEET, LLC, PASADENA, CA. FILED 10-10-2006.

SN 77-025,067. EXPLORER'S BOUNTY, INC., LOUISVILLE, KY. FILED 10-19-2006.

## BUILDSHEET

THE MARK CONSISTS OF STANDARD CHARACTERS WITHOUT CLAIM TO ANY PARTICULAR FONT, STYLE, SIZE, OR COLOR.

### CLASS 38—COMMUNICATION

FOR BROADCASTING SPECIALIZED MEDIA VIA THE INTERNET IN THE FORM OF ONLINE JOURNALS, NAMELY BLOGS (U.S. CLS. 100, 101 AND 104).

### CLASS 41—EDUCATION AND ENTERTAINMENT

FOR ENTERTAINMENT SERVICES, NAMELY, PROVIDING CONTINUING ONLINE JOURNALS NAMELY BLOGS FEATURING THE DESIGN AND BUILD OF CUSTOM AUTOMOBILES (U.S. CLS. 100, 101 AND 107).  
BRIAN NEVILLE, EXAMINING ATTORNEY

SN 77-021,856. SIDNEY KIMMEL ENTERTAINMENT, LLC, BEVERLY HILLS, CA. FILED 10-16-2006.

## SKE

THE MARK CONSISTS OF STANDARD CHARACTERS WITHOUT CLAIM TO ANY PARTICULAR FONT, STYLE, SIZE, OR COLOR.

### CLASS 9—ELECTRICAL AND SCIENTIFIC APPARATUS

FOR PRERECORDED DVDS, DISCS, AND VIDEO TAPES FEATURING MOTION PICTURES; PRERECORDED COMPACT DISCS AND AUDIO TAPES FEATURING SOUND TRACKS FOR MOTION PICTURES AND FEATURING MUSIC; AND MUSICAL SOUND RECORDINGS (U.S. CLS. 21, 23, 26, 36 AND 38).

### CLASS 41—EDUCATION AND ENTERTAINMENT

FOR PRODUCTION AND DISTRIBUTION OF MOTION PICTURES; PRODUCTION OF VIDEO DISCS AND TAPES (U.S. CLS. 100, 101 AND 107).  
JAY BESCH, EXAMINING ATTORNEY



### CLASS 4—LUBRICANTS AND FUELS

FOR CANDLES (U.S. CLS. 1, 6 AND 15).

### CLASS 16—PAPER GOODS AND PRINTED MATTER

FOR RECYCLED PAPER (U.S. CLS. 2, 5, 22, 23, 29, 37, 38 AND 50).

### CLASS 25—CLOTHING

FOR CLOTHING, NAMELY, SHIRTS, PANTS, SUITS, UNDERGARMENTS, SWEATSHIRTS, T-SHIRTS, SWEATERS, AND SHORTS (U.S. CLS. 22 AND 39).

### CLASS 29—MEATS AND PROCESSED FOODS

FOR DRIED, PRESERVED, AND COOKED FRUITS AND VEGETABLES; JAMS; JELLIES; EDIBLE OILS; DRIED NUTS; PROCESSED NUTS; AND DRIED FRUIT MIXES (U.S. CL. 46).

### CLASS 30—STAPLE FOODS

FOR COFFEE; AND FRUIT COULIS (U.S. CL. 46).

### CLASS 35—ADVERTISING AND BUSINESS

FOR RETAIL STORE SERVICES AND WHOLESALE DISTRIBUTORSHIP SERVICES FEATURING FOOD AND BEVERAGES, NAMELY, NATURAL PRODUCTS, ORGANIC PRODUCTS AND DRIED FRUITS; AND RETAIL MUSIC AND RECORD STORES (U.S. CLS. 100, 101 AND 102).

### CLASS 41—EDUCATION AND ENTERTAINMENT

FOR MUSIC PRODUCTION SERVICES (U.S. CLS. 100, 101 AND 107).  
BENJAMIN OKEKE, EXAMINING ATTORNEY

SN 77-031,870. RECKITT BENCKISER INC., PARSIPPANY, NJ. FILED 10-30-2006.

## GLOWING SCENTS

THE MARK CONSISTS OF STANDARD CHARACTERS WITHOUT CLAIM TO ANY PARTICULAR FONT, STYLE, SIZE, OR COLOR.

NO CLAIM IS MADE TO THE EXCLUSIVE RIGHT TO USE "SCENTS", APART FROM THE MARK AS SHOWN.

**CLASS 3—COSMETICS AND CLEANING PREPARATIONS**

FOR PREPARATIONS FOR FRAGRANCING OR PERFUMING THE AMBIENT ATMOSPHERE, NAMELY, INCENSE, INCENSE CONES, INCENSE STICKS, INCENSE SACHETS, INCENSE SPRAYS, ESSENTIAL OILS, POTPOURRI AND ROOM PERFUME SPRAYS (U.S. CLS. 1, 4, 6, 50, 51 AND 52).

**CLASS 5—PHARMACEUTICALS**

FOR AIR FRESHENING PREPARATIONS; AIR PURIFYING PREPARATIONS; ROOM AIR FRESHENERS; HOUSEHOLD AND ROOM DEODORANTS; ODOR-NEUTRALIZING PREPARATIONS FOR USE IN THE HOME (U.S. CLS. 6, 18, 44, 46, 51 AND 52).

LESLEY LAMOTHE, EXAMINING ATTORNEY

---

SN 77-031,983, UNITED STATES POSTAL SERVICE, WASHINGTON, DC. FILED 10-30-2006.

PARCEL POST INTERNATIONAL

THE MARK CONSISTS OF STANDARD CHARACTERS WITHOUT CLAIM TO ANY PARTICULAR FONT, STYLE, SIZE, OR COLOR.

OWNER OF U.S. REG. NO. 2,320,437.

NO CLAIM IS MADE TO THE EXCLUSIVE RIGHT TO USE INTERNATIONAL, APART FROM THE MARK AS SHOWN.

SEC. 2(F) AS TO PARCEL POST.

**CLASS 16—PAPER GOODS AND PRINTED MATTER**

FOR PLASTIC AND PAPER ENVELOPES AND POUCHES FOR SHIPPING AND PACKAGING; CARDBOARD AND CORRUGATED BOXES FOR SHIPPING AND PACKAGING; CARDBOARD MAILING TUBES (U.S. CLS. 2, 5, 22, 23, 29, 37, 38 AND 50).

**CLASS 35—ADVERTISING AND BUSINESS**

FOR MAILING SERVICES, NAMELY, SORTING, HANDLING AND RECEIVING PACKAGES AND LETTERS (U.S. CLS. 100, 101 AND 102).

**CLASS 39—TRANSPORTATION AND STORAGE**

FOR DELIVERY SERVICES, NAMELY, PICKUP, TRANSPORTATION AND DELIVERY OF PACKAGES AND LETTERS BY VARIOUS MODES OF TRANSPORTATION (U.S. CLS. 100 AND 105).

JEFFERY COWARD, EXAMINING ATTORNEY

SN 77-032,029, UNITED STATES POSTAL SERVICE, WASHINGTON, DC. FILED 10-30-2006.

**FIRST-CLASS MAIL INTERNATIONAL**

THE MARK CONSISTS OF STANDARD CHARACTERS WITHOUT CLAIM TO ANY PARTICULAR FONT, STYLE, SIZE, OR COLOR.

OWNER OF U.S. REG. NO. 1,094,739.

NO CLAIM IS MADE TO THE EXCLUSIVE RIGHT TO USE MAIL INTERNATIONAL, APART FROM THE MARK AS SHOWN.

**CLASS 16—PAPER GOODS AND PRINTED MATTER**

FOR PLASTIC AND PAPER ENVELOPES AND POUCHES FOR SHIPPING AND PACKAGING; CARDBOARD AND CORRUGATED BOXES FOR SHIPPING AND PACKAGING; CARDBOARD MAILING TUBES (U.S. CLS. 2, 5, 22, 23, 29, 37, 38 AND 50).

**CLASS 35—ADVERTISING AND BUSINESS**

FOR MAILING SERVICES, NAMELY, SORTING, HANDLING AND RECEIVING PACKAGES AND LETTERS (U.S. CLS. 100, 101 AND 102).

**CLASS 39—TRANSPORTATION AND STORAGE**

FOR DELIVERY SERVICES, NAMELY, PICKUP, TRANSPORTATION AND DELIVERY OF PACKAGES AND LETTERS BY VARIOUS MODES OF TRANSPORTATION (U.S. CLS. 100 AND 105).

JEFFERY COWARD, EXAMINING ATTORNEY

---

SN 77-032,044, UNITED STATES POSTAL SERVICE, WASHINGTON, DC. FILED 10-30-2006.

PRIORITY MAIL INTERNATIONAL

THE MARK CONSISTS OF STANDARD CHARACTERS WITHOUT CLAIM TO ANY PARTICULAR FONT, STYLE, SIZE, OR COLOR.

OWNER OF U.S. REG. NOS. 2,247,552, 2,538,835 AND OTHERS.

NO CLAIM IS MADE TO THE EXCLUSIVE RIGHT TO USE MAIL INTERNATIONAL, APART FROM THE MARK AS SHOWN.

SEC. 2(F) AS TO PRIORITY.

**CLASS 16—PAPER GOODS AND PRINTED MATTER**

FOR PLASTIC AND PAPER ENVELOPES AND POUCHES FOR SHIPPING AND PACKAGING; CARDBOARD AND CORRUGATED BOXES FOR SHIPPING AND PACKAGING; CARDBOARD MAILING TUBES (U.S. CLS. 2, 5, 22, 23, 29, 37, 38 AND 50).

**CLASS 35—ADVERTISING AND BUSINESS**

FOR MAILING SERVICES, NAMELY, SORTING, HANDLING AND RECEIVING PACKAGES AND LETTERS (U.S. CLS. 100, 101 AND 102).

**CLASS 39—TRANSPORTATION AND STORAGE**

FOR DELIVERY SERVICES, NAMELY, PICKUP, TRANSPORTATION AND DELIVERY OF PACKAGES AND LETTERS BY VARIOUS MODES OF TRANSPORTATION (U.S. CLS. 100 AND 105).  
JEFFERY COWARD, EXAMINING ATTORNEY

SN 77-034,423. VOKE MEDIA, LLC, JACKSON, WY. FILED 11-1-2006.

# VOKESTREAM

THE MARK CONSISTS OF STANDARD CHARACTERS WITHOUT CLAIM TO ANY PARTICULAR FONT, STYLE, SIZE, OR COLOR.

**CLASS 9—ELECTRICAL AND SCIENTIFIC APPARATUS**

FOR DOWNLOADABLE ELECTRONIC PUBLICATIONS, NAMELY, ARTICLES, PRESENTATIONS, COMMENTARY, AND DOCUMENTS, FEATURING INFORMATION ON ANALYSIS OF FINANCIAL, MARKETING AND TECHNICAL ASPECTS OF TECHNOLOGY INDUSTRIES (U.S. CLS. 21, 23, 26, 36 AND 38).

**CLASS 35—ADVERTISING AND BUSINESS**

FOR PROVIDING INFORMATION, ANALYSIS AND OPINION OF TECHNOLOGY SUPPLIERS AND TRENDS IN TECHNOLOGY MARKETS; BUSINESS CONSULTING SERVICES RELATED TO ANALYSIS OF FINANCIAL, MARKETING AND TECHNICAL ASPECTS OF TECHNOLOGY INDUSTRIES (U.S. CLS. 100, 101 AND 102).  
RON FAIRBANKS, EXAMINING ATTORNEY

SN 77-034,993. PRL USA HOLDINGS, INC., WILMINGTON, DE. FILED 11-2-2006.



OWNER OF U.S. REG. NOS. 984,005, 1,449,785 AND OTHERS.

THE NAME RALPH LAUREN IDENTIFIES A LIVING INDIVIDUAL WHOSE CONSENT IS OF RECORD.

THE APPLICANT CLAIMS COLOR AS A FEATURE OF THE MARK, NAMELY, WHITE, PURPLE.

THE MARK CONSISTS OF THE WORDS RALPH LAUREN IN WHITE ON A PURPLE BACKGROUND.

**CLASS 14—JEWELRY**

FOR CUFF-LINKS, SILVER MONEY CLIPS (U.S. CLS. 2, 27, 28 AND 50).  
FIRST USE 11-15-1996; IN COMMERCE 11-15-1996.

**CLASS 18—LEATHER GOODS**

FOR DUFFLE BAGS, CREDIT CARD CASES, WALLETS, AND CANVAS AND LEATHER TIE CASES (U.S. CLS. 1, 2, 3, 22 AND 41).  
FIRST USE 11-15-1996; IN COMMERCE 11-15-1996.

**CLASS 25—CLOTHING**

FOR MEN'S SUITS, SHIRTS, SWEATERS, JACKETS, POLO SHIRTS, KNIT SHIRTS, PANTS, TIES, POCKET SQUARES, BELTS (U.S. CLS. 22 AND 39).  
FIRST USE 11-15-1996; IN COMMERCE 11-15-1996.  
JESSICA A. POWERS, EXAMINING ATTORNEY

SN 77-035,243. JESSICA MCCLINTOCK, INC., SAN FRANCISCO, CA. FILED 11-2-2006.

# Jessica McClintock

THE MARK CONSISTS OF STANDARD CHARACTERS WITHOUT CLAIM TO ANY PARTICULAR FONT, STYLE, SIZE, OR COLOR.

OWNER OF U.S. REG. NOS. 1,801,339, 3,171,071 AND OTHERS.

THE NAME SHOWN IN THE MARK IDENTIFIES JESSICA MCCLINTOCK, WHOSE CONSENT TO REGISTER IS SUBMITTED.

**CLASS 20—FURNITURE AND ARTICLES NOT OTHERWISE CLASSIFIED**

FOR BATH ACCESSORIES, NAMELY, PLASTIC TISSUE BOX COVERS; TABLE ACCESSORIES, NAMELY, DECORATIVE PLASTIC AND WOODEN BOXES (U.S. CLS. 2, 13, 22, 25, 32 AND 50).

**CLASS 21—HOUSEWARES AND GLASS**

FOR BATH ACCESSORIES, NAMELY, TISSUE BOX COVERS OF CERAMIC, AND TOOTHBRUSH HOLDERS; TABLE ACCESSORIES, NAMELY, DECORATIVE BOXES OF CHINA, CRYSTAL, EARTHENWARE, GLASS, AND PORCELAIN, CANDLESTICKS NOT OF PRECIOUS METAL AND VASES (U.S. CLS. 2, 13, 23, 29, 30, 33, 40 AND 50).

**CLASS 24—FABRICS**

FOR BED, BATH AND HOUSEHOLD LINENS, NAMELY, BED SHEETS, PILLOW CASES, COMFORTERS, QUILTS, BLANKETS, BEDSPREADS, THROWS, DUVET COVERS, DUST RUFFLES, SHAMS, PILLOW SHAMS, TABLE ROUNDS AND TOWELS; KITCHEN LINENS, NAMELY, KITCHEN TOWELS, WALL COVERINGS, NAMELY CURTAINS, AND OTHER WINDOW TREATMENTS NAMELY, FABRIC VALANCES (U.S. CLS. 42 AND 50).

**CLASS 26—FANCY GOODS**

FOR BATH ACCESSORIES, NAMELY, FABRIC AND TEXTILE TISSUE BOX COVERS (U.S. CLS. 37, 39, 40, 42 AND 50).  
MICHAEL KEATING, EXAMINING ATTORNEY

SN 77-035,573. AFFINITY GROUP, INC., VENTURA, CA.  
FILED 11-2-2006.

## GOOD SAM SMILE & SAVE

THE MARK CONSISTS OF STANDARD CHARACTERS WITHOUT CLAIM TO ANY PARTICULAR FONT, STYLE, SIZE, OR COLOR.

OWNER OF U.S. REG. NOS. 2,558,565, 2,749,223 AND OTHERS.

### CLASS 16—PAPER GOODS AND PRINTED MATTER

FOR PRINTED TRAVEL DIRECTORIES; PRINTED TELEPHONE DIRECTORIES; NEWSLETTERS IN THE FIELD OF RECREATION, NAMELY TOPICS OF INTEREST TO RECREATIONAL VEHICLE ENTHUSIASTS; DECALS (U.S. CLS. 2, 5, 22, 23, 29, 37, 38 AND 50).

### CLASS 35—ADVERTISING AND BUSINESS

FOR PROMOTING THE GOODS AND SERVICES OF OTHERS THROUGH DISTRIBUTION OF DISCOUNT CARDS FOR RECREATIONAL VEHICLE ENTHUSIASTS (U.S. CLS. 100, 101 AND 102).

### CLASS 39—TRANSPORTATION AND STORAGE

FOR TRAVEL CLUB, NAMELY, A MEMBERSHIP CLUB FOR RECREATIONAL VEHICLE ENTHUSIASTS (U.S. CLS. 100 AND 105).

GINA HAYES, EXAMINING ATTORNEY

SN 77-037,704. PRISM BUSINESS MEDIA INC., NEW YORK, NY. FILED 11-6-2006.

## PROMO

THE MARK CONSISTS OF STANDARD CHARACTERS WITHOUT CLAIM TO ANY PARTICULAR FONT, STYLE, SIZE, OR COLOR.

OWNER OF U.S. REG. NOS. 2,236,281 AND 2,268,280.  
SEC. 2(F).

### CLASS 16—PAPER GOODS AND PRINTED MATTER

FOR MAGAZINES IN THE FIELD OF PROMOTIONAL MARKETING (U.S. CLS. 2, 5, 22, 23, 29, 37, 38 AND 50).  
FIRST USE 11-30-1987; IN COMMERCE 12-10-1987.

### CLASS 35—ADVERTISING AND BUSINESS

FOR PROVIDING NEWS AND INFORMATION CONCERNING PROMOTIONAL MARKETING BY MEANS OF THE INTERNET; PREPARING AND PLACING ADVERTISEMENTS FOR COMPANIES AND PROFESSIONALS IN THE PROMOTIONAL MARKETING INDUSTRY VIA THE INTERNET; PROVIDING ONLINE DIRECTORIES IN THE FIELD OF PROMOTIONAL MARKETING FEATURING HYPERLINKS TO OTHER WEB SITES ON THE INTERNET; PROVIDING WEB SITES THAT FEATURE ADVERTISEMENTS FOR THE GOODS AND SERVICES OF OTHERS, NAMELY, FOR THE GOODS AND SERVICES OF COMPANIES AND PROFESSIONALS IN THE PROMOTIONAL MARKETING INDUSTRY; PROVIDING ONLINE JOB LISTINGS IN THE FIELD OF PROMOTIONAL MARKETING; ORGANIZING TRADE SHOWS IN THE FIELD OF PROMOTIONAL MARKETING (U.S. CLS. 100, 101 AND 102).

FIRST USE 0-0-1995; IN COMMERCE 0-0-1995.

### CLASS 41—EDUCATION AND ENTERTAINMENT

FOR PROVIDING ONLINE PUBLICATIONS IN THE NATURE OF NEWSPAPERS, MAGAZINES, NEWSLETTERS, DIRECTORIES, BOOKS AND REPORTS CONCERNING THE PROMOTIONAL MARKETING INDUSTRY; PUBLICATION OF MAGAZINES, NEWSLETTERS, REPORTS, BOOKS AND DIRECTORIES CONCERNING THE PROMOTIONAL MARKETING INDUSTRY; ORGANIZING AND CONDUCTING SEMINARS AND CONFERENCES IN THE FIELD OF PROMOTIONAL MARKETING; PROVIDING RECOGNITION BY THE WAY OF AWARDS PROGRAMS TO RECOGNIZE QUALITY, POPULARITY AND ACHIEVEMENT IN THE PROMOTIONAL MARKETING INDUSTRY (U.S. CLS. 100, 101 AND 107).

FIRST USE 10-0-1990; IN COMMERCE 10-0-1990.  
EVELYN BRADLEY, EXAMINING ATTORNEY

SN 77-038,270. MCMULLEN ARGUS PUBLISHING, INC., ANAHEIM, CA. FILED 11-7-2006.

## PROJECT CAR

THE MARK CONSISTS OF STANDARD CHARACTERS WITHOUT CLAIM TO ANY PARTICULAR FONT, STYLE, SIZE, OR COLOR.

NO CLAIM IS MADE TO THE EXCLUSIVE RIGHT TO USE "CAR", APART FROM THE MARK AS SHOWN.

### CLASS 16—PAPER GOODS AND PRINTED MATTER

FOR MAGAZINE ABOUT AUTOMOBILES (U.S. CLS. 2, 5, 22, 23, 29, 37, 38 AND 50).

### CLASS 41—EDUCATION AND ENTERTAINMENT

FOR PROVIDING ON-LINE PUBLICATIONS IN THE NATURE OF MAGAZINES IN THE FIELD OF AUTOMOBILES (U.S. CLS. 100, 101 AND 107).

DAVID HOFFMAN, EXAMINING ATTORNEY



SN 77-038,285. MCMULLEN ARGUS PUBLISHING, INC., ANAHEIM, CA. FILED 11-7-2006.

# SIPHON

THE MARK CONSISTS OF STANDARD CHARACTERS WITHOUT CLAIM TO ANY PARTICULAR FONT, STYLE, SIZE, OR COLOR.

## CLASS 16—PAPER GOODS AND PRINTED MATTER

FOR MAGAZINE ABOUT AUTOMOBILES (U.S. CLS. 2, 5, 22, 23, 29, 37, 38 AND 50).

## CLASS 41—EDUCATION AND ENTERTAINMENT

FOR PROVIDING ON-LINE PUBLICATIONS IN THE NATURE OF MAGAZINES IN THE FIELD OF AUTOMOBILES (U.S. CLS. 100, 101 AND 107).

DAVID HOFFMAN, EXAMINING ATTORNEY

SN 77-039,150. TRAPEZE NETWORKS, INC., PLEASANTON, CA. FILED 11-7-2006.



The logo features the word "TRAPEZE" in a bold, black, sans-serif font. Above the letter "A" is a red antenna-like symbol consisting of a vertical line with two horizontal bars at the top, radiating outwards. Below "TRAPEZE" is the phrase "smart mobile" in a smaller, lowercase, black, sans-serif font.

OWNER OF U.S. REG. NOS. 2,960,773 AND 3,096,277.

NO CLAIM IS MADE TO THE EXCLUSIVE RIGHT TO USE "SMART MOBILE", APART FROM THE MARK AS SHOWN.

THE COLOR(S) BLACK, RED AND GRAY IS/ARE CLAIMED AS A FEATURE OF THE MARK.

THE MARK CONSISTS OF BLACK LETTERING IN THE LITERAL PORTION OF THE MARK WHEREIN THE LETTER "A" WITHIN TRAPEZE APPEARS AS A RED ANTENNA WITH TWO BLACK AND GRAY ELLIPSES RADIATING OUT FROM THE ANTENNA. THE BLACK IS CLOSER TO THE ENDS OF THE ELLIPSES AND THE GRAY IS CLOSER TO THE CENTER OF THE ELLIPSES. THE WHITE IS NOT PART OF THE MARK AND REPRESENTS TRANSPARENT AREA.

## CLASS 9—ELECTRICAL AND SCIENTIFIC APPARATUS

FOR COMPUTER NETWORKING HARDWARE AND COMPUTER NETWORKING SOFTWARE FOR WIRELESS COMMUNICATIONS AND CONNECTIVITY (U.S. CLS. 21, 23, 26, 36 AND 38).

## CLASS 37—CONSTRUCTION AND REPAIR

FOR INSTALLATION OF WIRELESS COMPUTER NETWORKS (U.S. CLS. 100, 103 AND 106).

## CLASS 42—SCIENTIFIC, COMPUTER AND LEGAL SERVICES

FOR TECHNICAL SUPPORT SERVICES FOR WIRELESS COMPUTER NETWORKS, NAMELY, TROUBLE SHOOTING OF COMPUTER HARDWARE AND SOFTWARE PROBLEMS (U.S. CLS. 100 AND 101).

ELLEN B. AWRICH, EXAMINING ATTORNEY

SN 77-043,855. DILLARD'S, INC., LITTLE ROCK, AR. FILED 11-14-2006.

# ANTONIO MELANI



OWNER OF U.S. REG. NOS. 2,657,191 AND 2,858,543.

THE NAME "ANTONIO MELANI" DOES NOT IDENTIFY A LIVING INDIVIDUAL.

THE MARK CONSISTS OF THE WORDS ANTONIO MELANI; WHICH IS ABOVE A CROWN THAT IS DIRECTLY ABOVE A SHIELD DIVIDED INTO FOUR SEGMENTS CONTAINING LINES AND THE LETTERS A AND M; A CUSTOM DESIGN EXTENDS OUT OF THE RIGHT AND LEFT SIDES OF THE SHIELD, WITH A SMALL DESIGN UNDERNEATH THE SHIELD.

## CLASS 14—JEWELRY

FOR JEWELRY (U.S. CLS. 2, 27, 28 AND 50).

## CLASS 18—LEATHER GOODS

FOR HANDBAGS (U.S. CLS. 1, 2, 3, 22 AND 41).

## CLASS 25—CLOTHING

FOR WOMEN'S SPORTSWEAR, NAMELY, SHIRTS, PANTS, BLOUSES, SWEATERS, SKIRTS, BLAZERS, JACKETS, DRESSES, TOPS, FOOTWEAR AND BELTS (U.S. CLS. 22 AND 39).

JUDITH HELFMAN, EXAMINING ATTORNEY

SN 77-044,596. TRAPEZE NETWORKS, INC., PLEASANTON, CA. FILED 11-15-2006.

# TRAPEZE

THE MARK CONSISTS OF STANDARD CHARACTERS WITHOUT CLAIM TO ANY PARTICULAR FONT, STYLE, SIZE, OR COLOR.

OWNER OF U.S. REG. NOS. 2,960,773 AND 3,096,277.

**CLASS 9—ELECTRICAL AND SCIENTIFIC APPARATUS**

FOR COMPUTER HARDWARE; COMPUTER NETWORKING SOFTWARE FOR WIRELESS COMMUNICATIONS AND CONNECTIVITY (U.S. CLS. 21, 23, 26, 36 AND 38).

**CLASS 37—CONSTRUCTION AND REPAIR**

FOR INSTALLATION, MAINTENANCE, REPAIR AND UPGRADE OF COMPUTER HARDWARE IN COMPUTER NETWORKS AND SYSTEMS (U.S. CLS. 100, 103 AND 106).

**CLASS 42—SCIENTIFIC, COMPUTER AND LEGAL SERVICES**

FOR TECHNICAL SUPPORT SERVICES, NAMELY, TROUBLESHOOTING OF COMPUTER HARDWARE, SOFTWARE AND NETWORK PROBLEMS; COMPUTER NETWORK DESIGN FOR OTHERS; AND INSTALLATION, MAINTENANCE, REPAIR AND UPGRADE OF COMPUTER SOFTWARE IN COMPUTER NETWORKS AND SYSTEMS (U.S. CLS. 100 AND 101).

ELLEN B. AWRICH, EXAMINING ATTORNEY

SN 77-050,125. FREMANTLE MEDIA NORTH AMERICA, INC., SANTA MONICA, CA. FILED 11-22-2006.

## AMERICAN IDOL

THE MARK CONSISTS OF STANDARD CHARACTERS WITHOUT CLAIM TO ANY PARTICULAR FONT, STYLE, SIZE, OR COLOR.

OWNER OF U.S. REG. NOS. 2,959,920, 3,101,422 AND OTHERS.

**CLASS 6—METAL GOODS**

FOR METAL KEY CHAINS (U.S. CLS. 2, 12, 13, 14, 23, 25 AND 50).

**CLASS 9—ELECTRICAL AND SCIENTIFIC APPARATUS**

FOR DECORATIVE CHARMS FOR CELLULAR TELEPHONES; INTERACTIVE EDUCATIONAL SOFTWARE FEATURING MUSICAL INSTRUMENT INSTRUCTION (U.S. CLS. 21, 23, 26, 36 AND 38).

JEFF DEFORD, EXAMINING ATTORNEY

SN 77-051,271. CALDWELL, ROBERT JOLLY, REDMOND, WA. FILED 11-27-2006.

## The Listening Store

THE MARK CONSISTS OF STANDARD CHARACTERS WITHOUT CLAIM TO ANY PARTICULAR FONT, STYLE, SIZE, OR COLOR.

NO CLAIM IS MADE TO THE EXCLUSIVE RIGHT TO USE "STORE", APART FROM THE MARK AS SHOWN.

**CLASS 9—ELECTRICAL AND SCIENTIFIC APPARATUS**

FOR AUDIO AMPLIFIERS; AUDIO CASSETTE DECKS FOR AUTOMOBILES; AUDIO CASSETTE RECORDERS; AUDIO CIRCUIT BOARDS; AUDIO EQUIPMENT FOR VEHICLES, NAMELY, STEREOS, SPEAKERS, AMPLIFIERS, EQUALIZERS, CROSSOVERS AND SPEAKER HOUSINGS; AUDIO MIXERS; AUDIO PROCESSING EQUIPMENT, NAMELY LIMITERS AND COMPRESSORS; AUDIO SPEAKER ENCLOSURES; AUDIO SPEAKERS; AUDIO TAPE RECORDERS; AUDIO-VIDEO RECEIVERS; BLANK AUDIO CASSETTES; BLANK AUDIO TAPES; BLANK DIGITAL AUDIO TAPES; BLANK ELECTRONIC CHIP CARDS; COMPUTER SOFTWARE FOR MANIPULATING DIGITAL AUDIO INFORMATION FOR USE IN AUDIO MEDIA APPLICATIONS; COMPUTER SOFTWARE FOR USE IN THE ENCRYPTION AND DECRYPTION OF DIGITAL FILES, INCLUDING AUDIO, VIDEO, TEXT, BINARY, STILL IMAGES, GRAPHICS AND MULTIMEDIA FILES; COMPUTER SOFTWARE FOR USE IN THE SAFEGUARDING OF DIGITAL FILES, INCLUDING AUDIO, VIDEO, TEXT, BINARY, STILL IMAGES, GRAPHICS AND MULTIMEDIA FILES; COMPUTER SOFTWARE TO CONTROL AND IMPROVE COMPUTER AND AUDIO EQUIPMENT SOUND QUALITY; COMPUTER SOFTWARE TO ENHANCE THE AUDIO-VISUAL CAPABILITIES OF MULTIMEDIA APPLICATIONS, NAMELY, FOR THE INTEGRATION OF TEXT, AUDIO, GRAPHICS, STILL IMAGES AND MOVING PICTURES; DIGITAL AUDIO PLAYERS; DIGITAL AUDIO TAPE PLAYERS; DIGITAL AUDIO TAPE RECORDERS; ELECTRIC AUDIO PLAYBACK UNITS WITH LIGHTS AND SPEAKERS; ELECTRONIC APPARATUS, NAMELY, STAND ALONE DISPLAYS FOR MEDICAL IMAGES; ELECTRONIC CARDS FOR PROCESSING IMAGES; ELECTRONIC CHIPS FOR THE MANUFACTURER OF INTEGRATED CIRCUITS; ELECTRONIC CIRCUIT BOARD; ELECTRONIC CIRCUIT CARDS; ELECTRONIC CIRCUITS FOR ERROR CORRECTION; ELECTRONIC CIRCUITS RECORDING PROGRAMS FOR AMUSEMENT APPARATUS FOR USE WITH LIQUID CRYSTAL SCREENS; ELECTRONIC CODING UNITS; ELECTRONIC COMPONENTS, NAMELY, PIEZOELECTRIC SWITCHES; ELECTRONIC COMPUTERIZED CREDIT CARD IMPRINTERS; ELECTRONIC COMPUTERS; ELECTRONIC INDICATOR PANELS; ELECTRONIC INTEGRATED CIRCUITS; ELECTRONIC MACHINES USED TO APPLY HOLOGRAPHIC OVERLAY AND TO SET UP AND CONTROL HOLOGRAMS AND VERIFICATION THEREOF; ELECTRONIC MAGNETOSTRICTIVE EQUIPMENT, NAMELY A WAVE GENERATOR, WAVE SENSOR AND WAVE ANALYZER; ELECTRONIC MEMORIES; ELECTRONIC READERS/RECORDERS FOR MEDICAL PATIENT IDENTIFICATION BANDS; ELECTRONIC SEMI-CONDUCTORS; ELECTRONIC SERVO MOTOR CONTROLLERS; ELECTRONIC SOUND PICK-UP FOR GUITARS AND BASSES; ELECTRONIC SPEED CONTROLLERS; ELECTRONIC TESTING EQUIPMENT, NAMELY, SOUND LEVEL METERS; ELECTRONIC WARNING BELLS; ENCODED ELECTRONIC CHIP CARDS CONTAINING PROGRAMMING USED TO UPLOAD SOUND FILTERS AND COLLECT CUSTOMER DATA IN THE FIELDS OF AUDIO FILE EQUIPMENT, AUDIOLOGY AND MEDITATIONAL MUSIC; SOFTWARE TO CONTROL AND IMPROVE AUDIO EQUIPMENT SOUND QUALITY; SPECIALTY HOLSTER FOR CARRYING AN ELECTRONIC DEVICE IN THE NATURE OF AN EAR PIECE AND CONTROL CLICKER IN CONNECTION THEREWITH; VIDEO GAME INTERACTIVE HAND HELD REMOTE CONTROLS FOR PLAYING ELECTRONIC GAMES; VIDEO MAGAZINE RECORDED ON ELECTRONIC MEDIA FEATURING MUSIC, ANIMATION, AND ENTERTAINMENT IN THE FIELD OF PHYSIOLOGY OF HEARING; WIRELESS CONTROLLER TO MONITOR AND CONTROL THE FUNCTIONING OF OTHER ELECTRONIC DEVICES (U.S. CLS. 21, 23, 26, 36 AND 38).

**CLASS 10—MEDICAL APPARATUS**

FOR ASSISTIVE LISTENING DEVICE FOR THE HEARING IMPAIRED; ELECTRIC HEARING AIDS; ELECTRICAL HEARING AIDS; ELECTRICALLY OPERATED HEARING AIDS; HEARING AIDS; HEARING AIDS FOR THE DEAF; MEDICAL HEARING INSTRUMENTS AND PARTS OF SUCH DEVICES (U.S. CLS. 26, 39 AND 44).

DAHLIA GEORGE, EXAMINING ATTORNEY

SN 77-059,396. JOHN W. HANNAY & CO LTD., GLASGOW, SCOTLAND, FILED 12-7-2006.

**BETMORPHIC**

THE MARK CONSISTS OF STANDARD CHARACTERS WITHOUT CLAIM TO ANY PARTICULAR FONT, STYLE, SIZE, OR COLOR.

**CLASS 9—ELECTRICAL AND SCIENTIFIC APPARATUS**

FOR DOWNLOADABLE SOFTWARE FOR GAMBLING AND PLACING BETS ON VARIOUS SPORTING EVENTS (U.S. CLS. 21, 23, 26, 36 AND 38).

**CLASS 38—COMMUNICATION**

FOR BROADCASTING SERVICES AND PROVISION OF TELECOMMUNICATION ACCESS TO FILMS AND TV PROGRAMMES PROVIDED VIA A VIDEO-ON-DEMAND SERVICE; BROADCASTING SERVICES AND PROVISION OF TELECOMMUNICATION ACCESS TO VIDEO AND AUDIO CONTENT PROVIDED VIA A VIDEO-ON-DEMAND SERVICE VIA THE INTERNET; COMMUNICATIONS VIA MULTINATIONAL TELECOMMUNICATION NETWORKS; DATA TRANSMISSION AND RECEPTION SERVICES VIA TELECOMMUNICATION MEANS; ELECTRONIC EXCHANGE OF DATA STORED IN DATABASES ACCESSIBLE VIA TELECOMMUNICATION NETWORKS; MOBILE MEDIA AND ENTERTAINMENT SERVICES IN THE NATURE OF ELECTRONIC TRANSMISSION OF ENTERTAINMENT MEDIA CONTENT; PROVIDING ELECTRONIC TELECOMMUNICATION CONNECTIONS; PROVIDING TELECOMMUNICATIONS CONNECTIONS TO A GLOBAL COMPUTER NETWORK; TELECOMMUNICATION ACCESS SERVICES; TRANSMISSION OF INFORMATION ON OPTICAL TELECOMMUNICATION NETWORKS; WIRELESS TELEPHONE TELECOMMUNICATIONS SERVICES, NAMELY, WIRELESS MOBILE TELEPHONE CALLING PLANS (U.S. CLS. 100, 101 AND 104).

**CLASS 41—EDUCATION AND ENTERTAINMENT**

FOR ENTERTAINMENT SERVICES, NAMELY, PROVIDING A TELEVISION PROGRAM IN THE FIELD OF GAMBLING AND PLACING BETS ON VARIOUS SPORTING EVENTS VIA A GLOBAL COMPUTER NETWORK; GAMBLING SERVICES (U.S. CLS. 100, 101 AND 107).

**CLASS 42—SCIENTIFIC, COMPUTER AND LEGAL SERVICES**

FOR APPLICATION SERVICE PROVIDER (ASP) FEATURING SOFTWARE IN THE FIELD OF GAMBLING AND PLACING BETS ON VARIOUS SPORTING EVENTS; APPLICATION SERVICE PROVIDER (ASP), NAMELY, HOSTING COMPUTER SOFTWARE APPLICATIONS OF OTHERS; APPLICATION SERVICE PROVIDER FEATURING SOFTWARE FOR PROVIDING AN ON-LINE DATABASE IN THE FIELD OF TRANSACTION PROCESSING TO UPLOAD TRANSACTIONAL DATA, PROVIDE STATISTICAL ANALYSIS, AND PRODUCE NOTIFICATIONS AND REPORTS; COMPUTER NETWORK DESIGN AND COMPUTER SOFTWARE DESIGN IN THE FIELD OF GAMBLING AND PLACING BETS ON VARIOUS SPORTING EVENTS; COMPUTER SERVICE, NAMELY, ACTING AS AN APPLICATION SERVICE PROVIDER IN THE FIELD OF KNOWLEDGE MANAGEMENT TO HOST COMPUTER APPLICATION SOFTWARE FOR CREATING SEARCHABLE DATABASES OF INFORMATION AND DATA; COMPUTER SERVICE, NAMELY, ACTING AS AN APPLICATION SERVICE PROVIDER IN THE FIELD OF KNOWLEDGE

SN 77-052,239. WISCONSIN ALUMINUM FOUNDRY COMPANY, INC., MANITOWOC, WI. FILED 11-28-2006.

**ALL AMERICAN**

THE MARK CONSISTS OF STANDARD CHARACTERS WITHOUT CLAIM TO ANY PARTICULAR FONT, STYLE, SIZE, OR COLOR.

**CLASS 10—MEDICAL APPARATUS**

FOR STERILIZERS FOR MEDICAL PURPOSES (U.S. CLS. 26, 39 AND 44).

FIRST USE 12-31-1946; IN COMMERCE 12-31-1946.

**CLASS 21—HOUSEWARES AND GLASS**

FOR NON-ELECTRIC PRESSURE COOKERS (U.S. CLS. 2, 13, 23, 29, 30, 33, 40 AND 50).

FIRST USE 12-31-1929; IN COMMERCE 12-31-1929.  
LINDA POWELL, EXAMINING ATTORNEY

SN 77-057,514. POMARE, LTD., HONOLULU, HI. FILED 12-5-2006.

**ISLE & CO.**

THE MARK CONSISTS OF STANDARD CHARACTERS WITHOUT CLAIM TO ANY PARTICULAR FONT, STYLE, SIZE, OR COLOR.

NO CLAIM IS MADE TO THE EXCLUSIVE RIGHT TO USE "CO.", APART FROM THE MARK AS SHOWN.

**CLASS 29—MEATS AND PROCESSED FOODS**

FOR CANDIED NUTS; FRUIT AND SOY BASED SNACK FOOD; FRUIT PRESERVES; FRUIT-BASED SPREADS; POTATO CHIPS; PROCESSED NUTS (U.S. CL. 46).

**CLASS 30—STAPLE FOODS**

FOR CAKES; CANDY; COFFEE; COOKIES; POPCORN; SALAD DRESSINGS; SAUCES; TEA (U.S. CL. 46).

DAVID HOFFMAN, EXAMINING ATTORNEY

MANAGEMENT TO HOST COMPUTER APPLICATION SOFTWARE FOR SEARCHING AND RETRIEVING INFORMATION FROM DATABASES AND COMPUTER NETWORKS; COMPUTER SERVICE, NAMELY, ACTING AS AN APPLICATION SERVICE PROVIDER IN THE FIELD OF KNOWLEDGE MANAGEMENT TO HOST COMPUTER APPLICATION SOFTWARE FOR THE COLLECTION, EDITING, ORGANIZING, MODIFYING, BOOK MARKING, TRANSMISSION, STORAGE AND SHARING OF DATA AND INFORMATION; DESIGN AND DEVELOPMENT OF ON-LINE COMPUTER SOFTWARE SYSTEMS; DESIGN FOR OTHERS IN THE FIELD OF COMPUTER NETWORKS, SOFTWARE, AND ENGINEERING IN THE FIELD OF GAMBLING AND PLACING BETS ON VARIOUS SPORTING EVENTS; DESIGN OF COMPUTER HARDWARE, INTEGRATED CIRCUITS, COMMUNICATIONS HARDWARE AND SOFTWARE AND COMPUTER NETWORKS FOR OTHERS; DESIGN OF COMPUTER NETWORKS AND SOFTWARE FOR OTHERS IN THE FIELD OF GAMBLING AND PLACING BETS ON VARIOUS SPORTING EVENTS; SOFTWARE AUTHORING (U.S. CLS. 100 AND 101).  
DAVID MILLER, EXAMINING ATTORNEY

SN 77-062,135. LF, LLC, WILMINGTON, DE. FILED 12-12-2006.

## PAINT SAMPLES IN ANY BRAND, ANY COLOR

THE MARK CONSISTS OF STANDARD CHARACTERS WITHOUT CLAIM TO ANY PARTICULAR FONT, STYLE, SIZE, OR COLOR.

### CLASS 2—PAINTS

FOR INTERIOR AND EXTERIOR PAINTS (U.S. CLS. 6, 11 AND 16).

### CLASS 37—CONSTRUCTION AND REPAIR

FOR PAINT MIXING SERVICES (U.S. CLS. 100, 103 AND 106).  
WARREN L. OLANDRIA, EXAMINING ATTORNEY

SN 77-060,100. CREARE, INC., HANOVER, NH. FILED 12-8-2006.



OWNER OF U.S. REG. NOS. 1,033,384, 1,998,117 AND 1,998,118.

THE MARK CONSISTS OF THE WORD CREARE WITH A PINWHEEL TYPE SHAPE INSIDE THE LETTER "C".

THE FOREIGN WORDING IN THE MARK TRANSLATES INTO ENGLISH AS TO CREATE.

### CLASS 40—MATERIAL TREATMENT

FOR MANUFACTURING IN THE NATURE OF CONSTRUCTION OF PROTOTYPE EQUIPMENT FOR OTHERS; PROTOTYPING OF NEW PRODUCTS FOR OTHERS; PROTOTYPE FABRICATION OF NEW PRODUCTS FOR OTHERS; MANUFACTURING OF PRODUCTS BY APPLICATION OF ADVANCED MATERIALS PROCESSING AND COMPONENT FABRICATION TECHNIQUES IN THE ENGINEERING FIELD TO THE ORDER AND SPECIFICATION OF OTHERS (U.S. CLS. 100, 103 AND 106).  
FIRST USE 0-0-1986; IN COMMERCE 0-0-1986.

### CLASS 42—SCIENTIFIC, COMPUTER AND LEGAL SERVICES

FOR ENGINEERING CONSULTING, RESEARCH AND DEVELOPMENT; ENGINEERING DESIGN AND DEVELOPMENT OF PROCESSES, PROGRAMS AND MODELS FOR EXPERIMENTATION, ANALYSIS, DESIGN, TESTING, SIMULATION, MODELING, PROTOTYPING, MANUFACTURING, FABRICATING, IMAGING, AND PROVIDING MEASUREMENTS AND CALCULATIONS; AND LEGAL SUPPORT SERVICES, SPECIFICALLY, PROVIDING OPINIONS AND ADVICE IN THE FIELD OF ENGINEERING RELATING TO LEGAL MATTERS (U.S. CLS. 100 AND 101).

FIRST USE 5-0-1984; IN COMMERCE 5-0-1984.  
JUDITH HELFMAN, EXAMINING ATTORNEY

SN 77-067,899. FRAME OF MIND, LLC, KINGS BEACH, CA. FILED 12-19-2006.

## Frame of Mind

THE MARK CONSISTS OF STANDARD CHARACTERS WITHOUT CLAIM TO ANY PARTICULAR FONT, STYLE, SIZE, OR COLOR.

### CLASS 9—ELECTRICAL AND SCIENTIFIC APPARATUS

FOR AUDIO RECORDINGS FEATURING MUSIC (U.S. CLS. 21, 23, 26, 36 AND 38).  
FIRST USE 1-1-2001; IN COMMERCE 1-1-2001.

### CLASS 25—CLOTHING

FOR BANDANAS; BASEBALL CAPS; CAPS; CAPS WITH VISORS; FLEECE PULLOVERS; KNITTED CAPS; PANTIES, SHORTS AND BRIEFS; PANTS; SHIRTS; SHORT-SLEEVED OR LONG-SLEEVED T-SHIRTS; SHORTS; SKULL CAPS; SWEAT BANDS; SWEAT SHIRTS; T-SHIRTS; TANK TOPS (U.S. CLS. 22 AND 39).

### CLASS 41—EDUCATION AND ENTERTAINMENT

FOR ENTERTAINMENT NAMELY, LIVE PERFORMANCES BY A MUSICAL BAND; ENTERTAINMENT, NAMELY LIVE MUSIC CONCERTS (U.S. CLS. 100, 101 AND 107).

FIRST USE 5-6-1999; IN COMMERCE 5-6-1999.  
JENNIFER KRISP, EXAMINING ATTORNEY

SN 77-070,643. KARSTEN MANUFACTURING CORPORATION, PHOENIX, AZ. FILED 12-22-2006.

SN 77-079,874. MAUNA LOA MACADAMIA NUT CORPORATION, HILO, HI. FILED 1-10-2007.

## PING

THE MARK CONSISTS OF STANDARD CHARACTERS WITHOUT CLAIM TO ANY PARTICULAR FONT, STYLE, SIZE, OR COLOR.

OWNER OF U.S. REG. NOS. 1,637,647, 3,171,974 AND OTHERS.

### CLASS 9—ELECTRICAL AND SCIENTIFIC APPARATUS

FOR DOWNLOADABLE VIDEO RECORDINGS FEATURING SPORTS AND SPORTS INSTRUCTIONS; AND INTERACTIVE VIDEO GAME PROGRAMS (U.S. CLS. 21, 23, 26, 36 AND 38).

### CLASS 41—EDUCATION AND ENTERTAINMENT

FOR ENTERTAINMENT AND EDUCATIONAL SERVICES, NAMELY, PROVIDING ONLINE INFORMATION IN THE FIELDS OF SPORTS AND ENTERTAINMENT (U.S. CLS. 100, 101 AND 107).

RAY THOMAS, EXAMINING ATTORNEY

---

SN 77-077,976. APPELLATION AMERICA (US), INC., LUNENBURG, NOVA SCOTIA, CANADA, FILED 1-8-2007.

## APPELLATION AMERICA

THE MARK CONSISTS OF STANDARD CHARACTERS WITHOUT CLAIM TO ANY PARTICULAR FONT, STYLE, SIZE, OR COLOR.

NO CLAIM IS MADE TO THE EXCLUSIVE RIGHT TO USE "AMERICA", APART FROM THE MARK AS SHOWN.

### CLASS 9—ELECTRICAL AND SCIENTIFIC APPARATUS

FOR ELECTRONIC PUBLICATIONS, NAMELY, NEWSLETTERS AND MAGAZINES FEATURING WINES RECORDED ON COMPUTER MEDIA; VIDEO MAGAZINE RECORDED ON ELECTRONIC MEDIA FEATURING WINE (U.S. CLS. 21, 23, 26, 36 AND 38).

FIRST USE 4-1-2003; IN COMMERCE 4-1-2003.

### CLASS 16—PAPER GOODS AND PRINTED MATTER

FOR MAGAZINES FEATURING WINES; NEWSLETTERS IN THE FIELD OF WINES; PUBLICATIONS, NAMELY, BROCHURES, BOOKLETS, AND TEACHING MATERIALS IN THE FIELD OF WINES; QUICK REFERENCE POCKET GUIDES IN THE FIELD OF WINES (U.S. CLS. 2, 5, 22, 23, 29, 37, 38 AND 50).

JAMES LOVEFACE, EXAMINING ATTORNEY

## ISLAND SELECT

THE MARK CONSISTS OF STANDARD CHARACTERS WITHOUT CLAIM TO ANY PARTICULAR FONT, STYLE, SIZE, OR COLOR.

NO CLAIM IS MADE TO THE EXCLUSIVE RIGHT TO USE "SELECT", APART FROM THE MARK AS SHOWN.

### CLASS 29—MEATS AND PROCESSED FOODS

FOR PROCESSED NUTS; ROASTED NUTS (U.S. CL. 46).

### CLASS 30—STAPLE FOODS

FOR CHOCOLATE COVERED NUTS (U.S. CL. 46).  
BRIAN NEVILLE, EXAMINING ATTORNEY

---

SN 78-104,874. POWER TOOL SPECIALISTS, INC., EAST WINDSOR, CT. FILED 1-25-2002.

## TRADESMAN

OWNER OF U.S. REG. NOS. 1,460,651, 1,565,504 AND 2,205,373.

### CLASS 7—MACHINERY

FOR HAND-HELD ELECTRIC, CORDLESS, AND PNEUMATIC POWER TOOLS, NAMELY, DRILL, SINGLE SPEED DRILL, VARIABLE SPEED DRILL, DRIVER, DRILL/DRIVER, SCREW DRIVER, GRINDER, ANGLE GRINDER, HAMMER, HAMMER DRILL, NAILER, NAILING GUN, BRAD NAILER, BRAD NAILER-STAPLER, ANGLE FINISH NAILER, ROOFING COIL NAILER, FINISH NAILER, FRAMING NAILER, SANDER, ORBIT SANDER, RANDOM ORBIT SANDER, PALM GRIP SANDER, SHEET FINISHING SANDER, SAW, CIRCULAR SAW, RECIPROCATING SAW, STAPLER, CROWN STAPLER, AND STAPLE GUN, AND PARTS AND ACCESSORIES THEREFOR, NAMELY, AIR COMPRESSORS, DRILL AND SCREWDRIVER BITS, SAW BLADES, DRILL CHUCKS, GRINDING WHEELS AND ABRASIVE ATTACHMENTS, NAMELY ABRASIVE BELTS, ABRASIVE WHEELS AND ABRASIVE DISCS (U.S. CLS. 13, 19, 21, 23, 31, 34 AND 35).

### CLASS 9—ELECTRICAL AND SCIENTIFIC APPARATUS

FOR RECHARGEABLE BATTERIES, BATTERY CHARGERS, POWER PACKS AND CHARGERS THEREFOR, ALL FOR HAND-HELD ELECTRIC, CORDLESS AND PNEUMATIC POWER TOOLS (U.S. CLS. 21, 23, 26, 36 AND 38).

JOHN SCHUYLER YARD, EXAMINING ATTORNEY

SN 78-122,573. MARBLE SPORTSWEAR, INC., BEVERLY HILLS, CA. FILED 4-18-2002.



NO CLAIM IS MADE TO THE EXCLUSIVE RIGHT TO USE "BEVERLY HILLS", APART FROM THE MARK AS SHOWN.

#### CLASS 4—LUBRICANTS AND FUELS

FOR CANDLES (U.S. CLS. 1, 6 AND 15).

#### CLASS 16—PAPER GOODS AND PRINTED MATTER

FOR PENS; STATIONERY (U.S. CLS. 2, 5, 22, 23, 29, 37, 38 AND 50).

#### CLASS 18—LEATHER GOODS

FOR BAGS AND BRIEFCASES MADE OF CLOTH, LEATHER, SUEDE, NUBUCK AND REPTILE, NAMELY, DIAPER BAGS, DUFFEL BAGS, BACKPACKS AND RUCKSACKS, BOOK BAGS, SCHOOL BAGS, TOTE BAGS, SACHELS, SHOULDER BAGS, SHOPPING BAGS, HANDBAGS, TRAVELING BAGS AND PURSES (U.S. CLS. 1, 2, 3, 22 AND 41).

#### CLASS 20—FURNITURE AND ARTICLES NOT OTHERWISE CLASSIFIED

FOR PICTURE FRAMES (U.S. CLS. 2, 13, 22, 25, 32 AND 50).

MARY CRAWFORD, EXAMINING ATTORNEY

SN 78-173,125. MATTEL, INC., EL SEGUNDO, CA. FILED 10-10-2002.

## GARDEN OF KNOWLEDGE

#### CLASS 9—ELECTRICAL AND SCIENTIFIC APPARATUS

FOR CALCULATORS, DISPOSABLE CAMERAS, EYE-GLASS CASES, RADIOS INCORPORATING CLOCKS, COMPUTER MOUSE, DECORATIVE MAGNETS, TELEPHONES, COMPUTER GAME CARTRIDGES, COMPUTER SOFTWARE FOR ENTERTAINMENT PURPOSES CONTAINED ON CD ROMS, COMPUTER GAME SOFTWARE, ELECTRIC OUTLET COVERS, VIDEO GAME CARTRIDGES, HEADPHONES, INTERACTIVE VIDEO GAME PROGRAMS, INTERACTIVE MULTIMEDIA COMPUTER GAME PROGRAMS, BICYCLE HELMETS, ELECTRIC SWITCH PLATES, COMPUTER MOUSE PADS, RADIOS, SUNGLASSES; PRERECORDED COMPUTER STORYTELLING SOFTWARE, AUDIO AND VIDEO CASSETTES FEATURING GAMES AND STORYTELLING, MUSICAL, AUDIO AND VIDEO SOUND RECORDINGS FEATURING GAMES AND STORYTELLING, SCREENSAVER PROGRAMS, CD-ROMS FEATURING DIRECTORIES OF DOLLS AND COLLECTIBLES; COMPUTER GAME JOYSTICKS (U.S. CLS. 21, 23, 26, 36 AND 38).

#### CLASS 16—PAPER GOODS AND PRINTED MATTER

FOR PHOTOGRAPH ALBUMS, PAPER BOXES, DRAWER LINER PAPER, NOTE CARDS, AGENDA BOOKS, DAILY PLANNERS, DESK TOP PLANNERS, PENCIL CASES, ARTS AND CRAFTS PAINT KITS, PAPER PARTY BAGS, BOOK COVERS, BOOK ENDS, BOOK MARKS, ADDRESS BOOKS, LOOSE LEAF BINDERS, STATIONERY BOXES, PAINT BRUSHES, CALENDARS, POST CARDS, TRADING CARDS, TRIVIA CARDS, CHALK, PAPER TABLE CLOTHS, COMPOSITION BOOKS, CRAFT PAPER, CRAYONS, CREPE PAPER, DECALS, PAPER PARTY DECORATIONS, DESK SETS, ERASERS, SERIES OF FICTION BOOKS, GIFT CARDS, GIFT WRAPPING PAPER, MARKERS, PAPER NAPKINS, NOTE PADS, PAINTING SETS, PAPER PARTY HATS, PEN AND PENCIL HOLDERS, PENCIL SHARPENERS, DECORATIVE PENCIL TOP ORNAMENTS, PENCILS, PENS, POSTERS, BOOKS IN THE FIELD OF COLLECTIBLES, DRAWING RULERS, RUBBER STAMPS, STAMP PADS, STATIONERY, STICKERS, STICKER BOOKS, FOLDERS, LUNCH BAGS, PAPER GIFT BAGS, INVITATIONS, JOURNALS, TALKING CHILDREN'S BOOKS, TEMPORARY TATTOOS, TRADING CARD MILK BOTTLE CAPS, WRITING INSTRUMENTS, BOOKS OF GAMES, PAPER BANNERS, COASTERS MADE OF PAPER, MEMO PADS, GREETING CARDS, FACIAL TISSUES; AUTOGRAPH BOOKS, DIARIES, NOTEBOOKS, AND SCRAPBOOKS, COLORING BOOKS, ACTIVITY BOOKS, MAGAZINES FOR TEEN-AGERS AND CHILDREN (U.S. CLS. 2, 5, 22, 23, 29, 37, 38 AND 50).

#### CLASS 18—LEATHER GOODS

FOR BACKPACKS, BEACH BAGS, GYM BAGS, OVERNIGHT BAGS, COIN PURSES, DUFFEL BAGS, HANDBAGS, KEY CASES, LUGGAGE, SUITCASES, UMBRELLAS, FANNY PACKS, DAY PACKS, LIPSTICK HOLDERS; MINIATURE BAGS, PURSES, COSMETIC CASES SOLD EMPTY, TRUNKS, WALLETS, HAT BOXES, TRAIN CASES (U.S. CLS. 1, 2, 3, 22 AND 41).

#### CLASS 21—HOUSEWARES AND GLASS

FOR PLATES, CUPS AND BOWLS MADE OF MELAMINE, NON-METAL PIGGY BANKS, WASTEPAPER BASKETS, BOWLS, LUNCH BOXES, COSMETIC BRUSHES, SUN CATCHERS, COOKIE CUTTERS, PAPER CUPS, DECORATIVE PLATES, PORCELAIN FIGURINES, PAPER PLATES, PLASTIC CUPS, COMMEMORATIVE PLATES, VACUUM BOTTLES, VASES, COOKIE JARS, THERMAL INSULATED TOTE BAGS AND CONTAINERS FOR FOOD OR BEVERAGES, TOOTHBRUSHES, CAKE MOLDS, TOOTHBRUSH HOLDERS, WATERING CANS, BASINS, PAILS, SOAP DISHES, SOAP DISPENSERS, DRINKING GLASSES, MUGS, TEA SETS FEATURING PLATES, SAUCERS, CUPS, POTS AND PITCHERS; POWDER PUFFS AND ACCESSORIES THEREFOR; HAIR BRUSHES, HAIR COMBS, NAIL BRUSHES, FITTED PICNIC BASKETS (U.S. CLS. 2, 13, 23, 29, 30, 33, 40 AND 50).

#### CLASS 25—CLOTHING

FOR BATHING SUITS, BATHROBES, BEACH COVERUPS, BELTS, BERETS, BOOTS, CARDIGANS, COATS, RAIN COATS, GLOVES, NIGHT GOWNS, HATS, HEAD BANDS, HEADWEAR, HOSIERY, JUMPERS, KNEE HIGHS, LEOTARDS, MITTENS, NECKTIES, NIGHT SHIRTS, OVERALLS, PAJAMAS, PANTIES, PANTY-HOSE, SANDALS, SCARVES, SHIRTS, SLIPPERS, SLIPS, SOCKS, STOCKINGS, SUSPENDERS, SWEATERS, TANK TOPS, THERMAL UNDERWEAR, TIGHTS, TURTLENECKS, UNDERWEAR, VESTS, CAPS, SKORTS, BLANKET SLEEPERS, MITTEN CLIPS, EARMUFFS, SWIMSUITS, SWIMSUIT COVERS, JACKETS, SWEATSHIRTS, T-SHIRTS, JEANS, SKIRTS; HALLOWEEN COSTUMES AND MASKS SOLD IN CONNECTION THEREWITH; DRESSES, SHORTS, T-SHIRTS, BLOUSES, SKIRTS, PANTS, LEGGINGS WITH SKIRT ATTACHED; SHOES (U.S. CLS. 22 AND 39).

RONALD MCMORROW, EXAMINING ATTORNEY

SN 78-195,828. VERIZON TRADEMARK SERVICES LLC, ARLINGTON, VA. FILED 12-18-2002.

## VZ BUY

NO CLAIM IS MADE TO THE EXCLUSIVE RIGHT TO USE "BUY", APART FROM THE MARK AS SHOWN.

### CLASS 35—ADVERTISING AND BUSINESS

FOR COMPUTER ON-LINE ORDERING AND ORDER FULFILLMENT SERVICES IN THE FIELD OF TELECOMMUNICATION PRODUCTS, NAMELY, ANSWERING MACHINES, ANNOUNCEMENT MACHINES, VOICE MAIL MACHINES, CALL ACCOUNTING MACHINES, CALLER IDENTIFICATION MACHINES, FACSIMILE MACHINES, TELEPHONE HEADSETS, TELEPHONE HANDSETS, TELEPHONE CORDS, ISDN EQUIPMENT, KEY SYSTEMS, HYBRID SYSTEMS, PBX EQUIPMENT, PAGING EQUIPMENT, SIGNALING EQUIPMENT, PAYSTATIONS, LOCKS, ENCLOSURES, STATION EQUIPMENT, TELECONFERENCING EQUIPMENT, TELEPHONES, ADAPTERS, BALUNS, COAX PREMISE CABLE, COPPER PREMISE CABLE, FIBER PREMISE CABLE, COPPER EQUIPMENT, FIBER EQUIPMENT, RACKS, RACEWAYS, COPPER AND FIBEROPTIC CABLE, CABLE SUPPLIES AND CLOSURES, CONNECTORS, PROTECTORS, FRAMES, INSTALLATION AND BUILDING MATERIALS, POLELINE HARDWARE, TEST EQUIPMENT, TOOLS, SAFETY EQUIPMENT, ANALOG TRANSMISSION EQUIPMENT, CSUS, DSUS, CHANNEL BANKS, CROSS CONNECT SYSTEMS, DIGITAL LOOP CARRIERS, DSX EQUIPMENT, FRAME RELAYS, MULTIPLEXERS, FIBEROPTIC TERMINALS, SPAN LINE EQUIPMENT, T-CODERS, DISTRIBUTING FRAMES, AND RACKING EQUIPMENT (U.S. CLS. 100, 101 AND 102).

### CLASS 37—CONSTRUCTION AND REPAIR

FOR SUPPORT SERVICES WITH RESPECT TO THE TELECOMMUNICATION PRODUCTS, NAMELY, REPAIR AND MAINTENANCE SERVICES (U.S. CLS. 100, 103 AND 106).  
STACY WAHLBERG, EXAMINING ATTORNEY

### CLASS 35—ADVERTISING AND BUSINESS

FOR COMPUTER ON-LINE ORDERING AND ORDER FULFILLMENT SERVICES IN THE FIELD OF TELECOMMUNICATION PRODUCTS, NAMELY, ANSWERING MACHINES, ANNOUNCEMENT MACHINES, VOICE MAIL MACHINES, CALL ACCOUNTING MACHINES, CALLER IDENTIFICATION MACHINES, FACSIMILE MACHINES, TELEPHONE HEADSETS, TELEPHONE HANDSETS, TELEPHONE CORDS, ISDN EQUIPMENT, KEY SYSTEMS, HYBRID SYSTEMS, PBX EQUIPMENT, PAGING EQUIPMENT, SIGNALING EQUIPMENT, PAYSTATIONS, LOCKS, ENCLOSURES, STATION EQUIPMENT, TELECONFERENCING EQUIPMENT, TELEPHONES, ADAPTERS, BALUNS, COAX PREMISE CABLE, COPPER PREMISE CABLE, FIBER PREMISE CABLE, COPPER EQUIPMENT, FIBER EQUIPMENT, RACKS, RACEWAYS, COPPER AND FIBEROPTIC CABLE, CABLE SUPPLIES AND CLOSURES, CONNECTORS, PROTECTORS, FRAMES, INSTALLATION AND BUILDING MATERIALS, POLELINE HARDWARE, TEST EQUIPMENT, TOOLS, SAFETY EQUIPMENT, ANALOG TRANSMISSION EQUIPMENT, CSUS, DSUS, CHANNEL BANKS, CROSS CONNECT SYSTEMS, DIGITAL LOOP CARRIERS, DSX EQUIPMENT, FRAME RELAYS, MULTIPLEXERS, FIBEROPTIC TERMINALS, SPAN LINE EQUIPMENT, T-CODERS, DISTRIBUTING FRAMES, AND RACKING EQUIPMENT (U.S. CLS. 100, 101 AND 102).

### CLASS 37—CONSTRUCTION AND REPAIR

FOR SUPPORT SERVICES WITH RESPECT TO THE TELECOMMUNICATION PRODUCTS, NAMELY, REPAIR AND MAINTENANCE SERVICES (U.S. CLS. 100, 103 AND 106).  
STACY WAHLBERG, EXAMINING ATTORNEY

SN 78-266,644. DOOLITTLE EDUTAINMENT CORP., LA JOLLA, CA. FILED 6-24-2003.

## DOOLITTLE

SN 78-195,838. VERIZON TRADEMARK SERVICES LLC, ARLINGTON, VA. FILED 12-18-2002.

## VZ ORDER EXPRESS

NO CLAIM IS MADE TO THE EXCLUSIVE RIGHT TO USE "ORDER EXPRESS", APART FROM THE MARK AS SHOWN.

OWNER OF U.S. REG. NO. 2,545,806.

### CLASS 16—PAPER GOODS AND PRINTED MATTER

FOR CHILDREN'S ACTIVITY BOOKS; CHILDREN'S STORYBOOKS; CHILDREN'S BOOKS; COLORING BOOKS; COMIC BOOKS; EDUCATIONAL BOOKS AT ELEMENTARY LEVEL; STORY BOOKS; AND CHILDREN'S STORIES IN ILLUSTRATED FORM (U.S. CLS. 2, 5, 22, 23, 29, 37, 38 AND 50).  
FIRST USE 8-4-1999; IN COMMERCE 12-14-1999.

**CLASS 28—TOYS AND SPORTING GOODS**

FOR ACTION FIGURES; ACTION FIGURES ACCESSORIES; ACTION TOYS BOTH MECHANICAL AND ELECTRIC; ARCADE-TYPE ELECTRONIC EDUCATION VIDEO GAMES; ARCHERY EQUIPMENT, NAMELY BOWS AND ARROWS; BABY RATTLES INCORPORATING TEETHING RINGS; BALLOONS; BASEBALLS; BASKETBALLS; BATH TOYS; BATHTUB TOYS; BATTERY OPERATED ACTION TOYS; BABY MULTIPLE ACTIVITY TOYS; BABY RATTLES; BEACH BALLS; BEAN BAG DOLLS; BOARD GAMES; BODYBOARDS; BOOMERANGS; BASEBALLS; BASEBALL BATS; BASEBALL GLOVES; BOWLING BALLS; CHILDREN'S ACTIVITY TABLES CONTAINING MANIPULATIVE TOYS; CHRISTMAS TREE ORNAMENTS NOT CONFECTIONARY OR ILLUMINATION ARTICLES; COSTUME MASKS; CRIB MOBILES; COLLECTABLE TOY FIGURES; CRIB TOYS; DISC TOSS TOYS; DRAWING TOYS; ELECTRONIC EDUCATIONAL GAME MACHINES FOR CHILDREN; EASTER EGG COLORING KITS; EGG DECORATING KITS; ELECTRIC ACTION TOYS; FLOATS FOR RECREATIONAL USE NAMELY, SWIMMING; FLYING DISCS; FISHING POLES; FOOTBALLS; GOLF CLUBS; GOLF BALLS; HAND HELD UNIT FOR PLAYING ELECTRONIC GAMES; HAND PUPPETS; HOCKEY STICKS; HOCKEY PUCKS; ICE SKATES; INFANT DEVELOPMENT TOYS; INFANT ACTION CRIB TOYS; INFLATABLE BOP BAGS; INFLATABLE SWIMMING POOLS; INFANT TOYS; INFLATABLE TOYS; INFLATABLE TOYS SHOWING DECORATIVE PICTURES; INFLATABLE INNER TUBES FOR AQUATIC RECREATIONAL USE; INLINE SKATES; JIGSAW PUZZLES; KITES; MARIONETTE PUPPETS; MECHANICAL ACTION TOYS; MOBILES FOR CHILDREN; MODELED PLASTIC TOY FIGURINES; PAPER DOLLS; PLASTIC CHARACTER TOYS; PLAY FIGURES; PLAY MATS CONTAINING INFANT TOYS; PLAYING CARDS, PLUSH TOYS; POSITIONABLE TOY FIGURES; PUPPETS; POP UP TOYS; PULL TOYS; PUSH TOYS; PUZZLES; RUBBER ACTION BALLS; RUBBER CHARACTER TOYS; SOCCER BALLS; SOCCER BALL KNEE PADS; SOFT SCULPTURE PLUSH TOYS; SPINNING TOPS; SPORT BALLS; STUFFED TOY ANIMALS; SURFBOARDS; SKIS; SKATEBOARDS; SOFTBALLS; SQUEEZE TOYS; STUFFED TOY BEARS; STUFFED TOYS; SWIMMING AIDS, NAMELY ARM FLOATS; TOY ANIMALS AND ACCESSORIES THEREFORE; TALKING TOYS; TEDDY BEARS; TEEBALL SETS; TENNIS RACKETS; TENNIS BALLS; TOSsing DISC TOYS; TOY, NAMELY, BATTERY-POWERED COMPUTER GAME WITH LCD SCREEN WHICH FEATURES ANIMATION AND SOUND EFFECTS; TOY ACTION FIGURES; TOY ACTION FIGURES AND ACCESSORIES THEREFORE; TOY BUILDING BLOCKS; TOYS DESIGNED TO BE ATTACHED TO CAR SEATS, STROLLERS, CRIBS, AND HIGH CHAIRS; TOY FIGURES; TOY MOBILES; TOY MUSIC BOXES; VOLLEYBALLS; WATER SQUIRTING TOYS; WATER WING SWIM AIDS FOR RECREATIONAL USE; WATER SKIS; WIND-UP TOYS; YO-YOS (U.S. CLS. 22, 23, 38 AND 50).

FIRST USE 8-4-1999; IN COMMERCE 12-14-1999.  
PAM WILLIS, EXAMINING ATTORNEY

SN 78-268,859. FUTURE MEDIA ARCHITECTS, INC., ROAD TOWN, BR. VIRGIN ISLANDS, FILED 6-30-2003.

## WE'RE CHANGING THE FACE OF THE INTERNET LANDSCAPE

**CLASS 9—ELECTRICAL AND SCIENTIFIC APPARATUS**

FOR DOWNLOADABLE ELECTRONIC MAGAZINE FEATURING ADVERTISEMENTS AND INFORMATION IN THE FIELD OF MUSIC (U.S. CLS. 21, 23, 26, 36 AND 38).

**CLASS 35—ADVERTISING AND BUSINESS**

FOR ADVERTISING SERVICES, NAMELY, DISSEMINATION OF ADVERTISING FOR OTHERS VIA THE INTERNET; PROVIDING ON-LINE HYPERTEXT LINKS TO THE WEB SITES OF OTHERS TO PROMOTE THE GOODS AND SERVICES OF OTHERS; PROVIDING ON-LINE DIRECTORY INFORMATION FEATURING HYPERLINKS TO OTHER WEBSITES; PROMOTING THE GOODS AND SERVICES OF OTHERS BY PROVIDING HYPERTEXT LINKS TO THE WEBSITES OF OTHERS; ON-LINE TRADING SERVICES IN WHICH SELLER POSTS PRODUCTS TO BE AUCTIONED AND BIDDING IS DONE VIA THE INTERNET; PROVIDING CONSUMER PRODUCT INFORMATION VIA THE INTERNET; ON-LINE ORDERING SERVICES IN THE FIELD OF MUSIC, NAMELY, PROVIDING MUSIC FOR OTHERS; ELECTRONIC CATALOG SERVICES IN THE FIELD OF MUSIC; DISTRIBUTORSHIP IN THE FIELD OF ELECTRONIC EQUIPMENT RESALES; COMPUTERIZED ON-LINE RETAIL AND WHOLESALE STORES OF BOOKS, MOVIES, MUSIC, VIDEOS, AND ELECTRONIC PRODUCTS; MODELING SERVICES FOR ADVERTISING AND SALES PROMOTION; RENTAL OF ADVERTISING SPACE; BUSINESS MARKETING CONSULTING SERVICES; ON-LINE MARKETING OF DOMAIN NAMES FOR IDENTIFICATION OF USERS ON A GLOBAL COMPUTER NETWORK; ADDRESS CHANGE NOTIFICATION SERVICES IN THE NATURE OF POSTING NOTIFICATIONS OF CHANGES OF ADDRESSES FOR BUSINESSES VIA THE INTERNET (U.S. CLS. 100, 101 AND 102).

**CLASS 36—INSURANCE AND FINANCIAL**

FOR PROVIDING A DATABASE FOR FACILITATING THE EXCHANGE OF NEEDED INFORMATION FOR FINANCIAL COMPENSATION VIA THE INTERNET; ELECTRONIC COMMERCE PAYMENT SERVICES, NAMELY, ESTABLISHING FUNDED ACCOUNTS USED TO PURCHASE GOODS AND SERVICES ON THE INTERNET; NOT FOR PROFIT PROMOTION SERVICES, NAMELY, PROVIDING FUNDING FOR NON-PROFITS BUSINESS (U.S. CLS. 100, 101 AND 102).

**CLASS 38—COMMUNICATION**

FOR PROVIDING ON-LINE FORUMS CONCERNING MUSIC FOR TRANSMISSION OF MESSAGES AMONG DISC JOCKEYS AND OTHER COMPUTER USERS; ELECTRONIC MAIL SERVICES, PROVIDING ON-LINE CHAT ROOM SERVICES FOR TRANSMISSION OF MESSAGES AMONG COMPUTER USERS CONCERNING WHATEVER SAID USERS WISH TO SPEAK ABOUT CONCERNING MUSIC; E-MAIL; STREAMING OF AUDIO MATERIAL ON THE INTERNET; STREAMING OF VIDEO MATERIAL ON THE INTERNET; COMMUNICATIONS SERVICES, NAMELY, TRANSMITTING STREAMED SOUND AND AUDIO-VISUAL RECORDINGS VIA THE INTERNET (U.S. CLS. 100, 101 AND 104).

**CLASS 41—EDUCATION AND ENTERTAINMENT**

FOR ENTERTAINMENT SERVICES, NAMELY, PROVIDING CURRENT EVENTS AND ENTERTAINMENT NEWS INFORMATION VIA THE INTERNET; PROVIDING INFORMATION IN THE FIELD OF MUSIC AND VIDEO VIA THE INTERNET; MUSIC PUBLISHING SERVICES (U.S. CLS. 100, 101 AND 107).

**CLASS 42—SCIENTIFIC, COMPUTER AND LEGAL SERVICES**

FOR CREATING INDEXES OF INFORMATION, SITES AND OTHER RESOURCES AVAILABLE ON COMPUTER NETWORKS; HOSTING OF DIGITAL CONTENT ON THE INTERNET; COMPUTER SERVICES, NAMELY, PROVIDING SEARCH ENGINES FOR OBTAINING DATA ON A GLOBAL COMPUTER NETWORK; REGISTRATION OF DOMAIN NAMES FOR IDENTIFICATION OF USERS ON A GLOBAL COMPUTER NETWORK; LICENSING OF INTELLECTUAL PROPERTY (U.S. CLS. 100 AND 101).

VIVIAN MICZNIK FIRST, EXAMINING ATTORNEY



SN 78-319,730. BIO-MAGNETIC THERAPY SYSTEMS GMBH, MUNICH, FED REP GERMANY, FILED 10-28-2003.

## PST

PRIORITY CLAIMED UNDER SEC. 44(D) ON FED REP GERMANY APPLICATION NO. 30321867.3, FILED 4-28-2003, REG. NO. 3458825, DATED 4-14-2005, EXPIRES 4-14-2015.

PRIORITY CLAIMED UNDER SEC. 44(D) ON FED REP GERMANY APPLICATION NO. 30321867.3, FILED 4-28-2003, REG. NO. 3458825, DATED 4-14-2005, EXPIRES 4-14-2015.

PRIORITY CLAIMED UNDER SEC. 44(D) ON FED REP GERMANY APPLICATION NO. 30321867.3, FILED 4-28-2003, REG. NO. 3458825, DATED 4-14-2005, EXPIRES 4-14-2015.

PRIORITY CLAIMED UNDER SEC. 44(D) ON FED REP GERMANY APPLICATION NO. 30321867.3, FILED 4-28-2003, REG. NO. 3458825, DATED 4-14-2005, EXPIRES 4-14-2015.

PRIORITY CLAIMED UNDER SEC. 44(D) ON FED REP GERMANY APPLICATION NO. 30321867.3, FILED 4-28-2003, REG. NO. 3458825, DATED 4-14-2005, EXPIRES 4-14-2015.

OWNER OF U.S. REG. NOS. 2,250,139 AND 2,355,318. SEC. 2(F).

### CLASS 9—ELECTRICAL AND SCIENTIFIC APPARATUS

FOR PRE-RECORDED MAGNETIC DATA-CARRIERS AND RECORDING DISCS WHICH CONTAIN TEACHING MATERIAL, INFORMATION MATERIAL RELATIVE TO MAGNETIC THERAPY AND/OR SOFTWARE USED TO DIAGNOSE AND TREAT ORTHOPEDIC, CARTILAGE AND CONNECTIVE TISSUE DISEASES AND CONDITIONS, AS WELL AS PARADONTOSIS AND JAW JOINT ARTHROSIS, FOR USE IN THE FIELD OF MAGNETIC THERAPY (U.S. CLS. 21, 23, 26, 36 AND 38).

### CLASS 10—MEDICAL APPARATUS

FOR SURGICAL, MEDICAL, DENTAL AND VETERINARY APPARATUS AND INSTRUMENTS, NAMELY APPARATUS, INSTRUMENTS AND IMPLEMENTS FOR TREATMENT WITH MAGNETIC THERAPY; ARTIFICIAL LIMBS; ARTIFICIAL TEETH; ORTHOPEDIC ARTICLES, NAMELY, BELTS, BRACES, ORTHOPEDIC FOOTWEAR, JOINT IMPLANTS, SOLES, SUPPORT BANDAGES, SUPPORTS; SUTURES; SCIENTIFIC, SURVEYING, MEASURING, SIGNALING, CHECKING, SUPERVISION AND ELECTRICAL APPARATUS AND INSTRUMENTS NAMELY, MAGNETIC THERAPY IMPLEMENTS (U.S. CLS. 26, 39 AND 44).

### CLASS 16—PAPER GOODS AND PRINTED MATTER

FOR PRINTED INFORMATION, NAMELY, NEWSLETTERS, BROCHURES, MAGAZINES, MANUALS, AND INSTRUCTIONAL, AND TEACHING MATERIAL IN THE FIELD OF MAGNETIC THERAPY TREATMENT OF DISEASES AND AILMENTS; PHOTOGRAPHS (U.S. CLS. 2, 5, 22, 23, 29, 37, 38 AND 50).

### CLASS 42—SCIENTIFIC, COMPUTER AND LEGAL SERVICES

FOR SCIENTIFIC RESEARCH IN THE FIELD OF ORTHOPEDIC, CARTILAGE AND CONNECTIVE TISSUE DISEASES AND AILMENTS, PARADONTOSIS AND JAW JOINT ARTHROSIS AND THE DIAGNOSIS AND TREATMENT THEREOF, ALL IN THE FIELD OF MAGNETIC THERAPY BUT NOT IN RELATION TO DENTAL ROOT AND GUM TREATMENTS; DESIGN AND DEVELOPMENT OF COMPUTER HARDWARE AND SOFTWARE; ALL RELATIVE TO THE FIELD OF MAGNETIC THERAPY BUT NOT TO DENTAL ROOT AND GUM TREATMENTS (U.S. CLS. 100 AND 101).

### CLASS 44—MEDICAL, BEAUTY AND AGRICULTURAL SERVICES

FOR DENTAL AND MEDICAL SERVICES NAMELY, MAGNETIC THERAPY TREATMENT, EXCEPT DENTAL ROOT AND GUM TREATMENTS (U.S. CLS. 100 AND 101).

SUSAN STIGLITZ, EXAMINING ATTORNEY

SN 78-348,846. ANDERSON AUDIO VISUAL, INC., SAN DIEGO, CA. FILED 1-7-2004.



The logo features the word "Anderson" in a large, stylized, serif font. Below it, the words "AUDIO + VISUAL" are written in a smaller, all-caps, sans-serif font, with a plus sign between "AUDIO" and "VISUAL".

NO CLAIM IS MADE TO THE EXCLUSIVE RIGHT TO USE AUDIO VISUAL, APART FROM THE MARK AS SHOWN.

THE MARK CONSISTS OF THE MARK IN STYLIZED FONT BEGINNING WITH A STYLIZED LETTER A.

SEC. 2(F).

### CLASS 37—CONSTRUCTION AND REPAIR

FOR INSTALLATION, MAINTENANCE AND REPAIR OF AUDIO-VISUAL PRESENTATION SYSTEMS; INSTALLATION, MAINTENANCE AND REPAIR OF COMPUTER HARDWARE; UPGRADING OF COMPUTER HARDWARE (U.S. CLS. 100, 103 AND 106).

FIRST USE 1-1-1999; IN COMMERCE 1-1-1999.

### CLASS 41—EDUCATION AND ENTERTAINMENT

FOR RENTAL OF STEREO AND AUDIO-VISUAL PRESENTATION SYSTEMS; RENTAL OF AUDIO, ELECTRONIC AND VIDEO EQUIPMENT, SPECIFICALLY MOVIE PROJECTORS AND THEIR ACCESSORIES, OVERHEAD PROJECTORS AND THEIR ACCESSORIES, VIDEO SCREENS, RADIOS, AMPLIFIERS AND TELEVISIONS; AUDIO-VISUAL PRESENTATION SYSTEMS CONSULTING IN THE NATURE OF SYSTEM REQUIREMENTS FOR PARTICULAR INSTALLATIONS (U.S. CLS. 100, 101 AND 107).

FIRST USE 1-1-1999; IN COMMERCE 1-1-1999.

REBECCA EISINGER, EXAMINING ATTORNEY

SN 78-352,077. AQUAEL JANUSZ JANKIEWICZ, WARSAW, POLAND, FILED 1-14-2004.



PRIORITY CLAIMED UNDER SEC. 44(D) ON POLAND APPLICATION NO. PLZ270036, FILED 9-17-2003, REG. NO. 164941, DATED 8-23-2005, EXPIRES 9-17-2013.  
OWNER OF POLAND REG. NO. 84424, DATED 4-3-1995, EXPIRES 9-13-2013.

THE COLOR(S) BLACK, RED AND GREEN IS/ARE CLAIMED AS A FEATURE OF THE MARK.

THE COLOR BLACK APPEARS IN THE LETTERING AQUA AND IN THE LINES THAT FORM THE PERIMETER OF THE MARK. THE COLOR RED APPEARS IN THE LETTERING EL. THE COLOR GREEN APPEARS IN THE WAVY LINES UNDER THE LETTERING AQUAEL.

#### CLASS 7—MACHINERY

FOR (BASED ON ITU, 44(D) AND 44(E)) AERATING PUMPS FOR AQUARIA, FOUNTAIN CENTRIFUGAL PUMPS, WATER PUMPS FOR USE IN GARDENS; (BASED ON ITU AND 44(E)) WATER FOUNTAIN PUMPS, AERATING WATER PUMPS FOR WATER FOUNTAINS (U.S. CLS. 13, 19, 21, 23, 31, 34 AND 35).

#### CLASS 11—ENVIRONMENTAL CONTROL APPARATUS

FOR (BASED ON ITU, 44(D) AND 44(E)) WATER FOUNTAINS, ORNAMENTAL WATER FOUNTAINS, AQUARIUM LIGHTS, SUBMERSIBLE LAMPS, AQUARIUM HEATERS, AQUARIUM FILTRATION APPARATUS, WATER FILTERING UNITS FOR POND WATER, ULTRAVIOLET RAY LAMPS NOT FOR MEDICAL PURPOSES, WATER FILTERING UNITS FOR SWIMMING POOLS (U.S. CLS. 13, 21, 23, 31 AND 34).

#### CLASS 21—HOUSEWARES AND GLASS

FOR (BASED ON ITU, 44(D) AND 44(E)) INDOOR AQUARIA, AQUARIA HOODS; MODELS AND BACKGROUNDS FOR AQUARIA, NAMELY, ARTIFICIAL AQUARIUM LANDSCAPES; (BASED ON ITU) AQUARIUMS (U.S. CLS. 2, 13, 23, 29, 30, 33, 40 AND 50).

JAMES MACFARLANE, EXAMINING ATTORNEY

SN 78-366,336. OSCIENT PHARMACEUTICALS CORPORATION, WALTHAM, MA. FILED 2-11-2004.

## OSCIENT PHARMACEUTICALS

THE MARK CONSISTS OF STANDARD CHARACTERS WITHOUT CLAIM TO ANY PARTICULAR FONT, STYLE, SIZE, OR COLOR.

NO CLAIM IS MADE TO THE EXCLUSIVE RIGHT TO USE "PHARMACEUTICALS", APART FROM THE MARK AS SHOWN.

#### CLASS 5—PHARMACEUTICALS

FOR PHARMACEUTICAL PREPARATIONS FOR THE TREATMENT, PREVENTION AND/OR ALLEVIATION OF CONDITIONS AND DISORDERS RELATING TO THE CARDIOVASCULAR SYSTEM, HEMATOLOGY, BACTERIAL AND VIRAL INFECTIONS, ONCOLOGY, PSYCHIATRY, NEUROLOGY, ENDOCRINOLOGY, NEPHROLOGY, ALLERGIES AND IMMUNOLOGY, PAIN MANAGEMENT, OSTEOPOROSIS, DERMATOLOGY, GASTROENTEROLOGY, OTOLARYNGOLOGY, RHEUMATOLOGY, ORTHOPEDICS, PNEUMOLOGY, AND NUTRITION; BIOLOGICAL PREPARATIONS FOR MEDICAL LABORATORY, CLINICAL, VETERINARY, AND MEDICAL PURPOSES (U.S. CLS. 6, 18, 44, 46, 51 AND 52).

#### CLASS 42—SCIENTIFIC, COMPUTER AND LEGAL SERVICES

FOR PHARMACEUTICAL AND MEDICAL RESEARCH SERVICES (U.S. CLS. 100 AND 101).

CARRIE ACHEN, EXAMINING ATTORNEY

SN 78-403,593. VISUAL CHANGES SKIN CARE INTERNATIONAL, INC., FRESNO, CA. FILED 4-17-2004.

## DESIGNER PEELS

THE MARK CONSISTS OF STANDARD CHARACTERS WITHOUT CLAIM TO ANY PARTICULAR FONT, STYLE, SIZE, OR COLOR.

SEC. 2(F).

**CLASS 3—COSMETICS AND CLEANING PREPARATIONS**

FOR NON-MEDICATED FACE AND BODY EXFOLIANTS, NON-MEDICATED ROSACEA AND ACNE EXFOLIANTS, SKIN EXFOLIANTS, NAMELY ANTI-AGING EXFOLIANTS, ENVIRONMENTAL DAMAGE EXFOLIANTS, LIGHTENING EXFOLIANTS, BEAUTY GELS, NAMELY, FACE AND BODY GELS, NON-MEDICATED ROSACEA AND ACNE GELS, ANTI-AGING GELS, ENVIRONMENTAL DAMAGE GELS, LIGHTENING GELS, SKIN AND BODY CARE PREPARATIONS, NAMELY, NON-MEDICATED LIQUID SOLUTION FOR THE TREATMENT OF ROSACEA, NON-MEDICATED LIQUID SOLUTION FOR THE TREATMENT OF ACNE, LIQUID SOLUTIONS TO INHIBIT AGING OF THE SKIN, LIQUID SOLUTIONS TO INHIBIT ENVIRONMENTAL DAMAGE TO THE SKIN, LIQUID SOLUTIONS FOR THE LIGHTENING OF THE SKIN, LIQUID SOLUTIONS FOR REDUCING WRINKLES, LIQUID SOLUTIONS FOR REMOVING DEAD SKIN CELLS FROM THE BODY, NON-MEDICATED LIQUID SOLUTIONS FOR REMOVING DEAD SKIN CELLS TO PREVENT ROSACEA, NON-MEDICATED LIQUID SOLUTIONS FOR REMOVING DEAD SKIN CELLS TO HELP PREVENT ACNE, LIQUID SOLUTIONS FOR REMOVING DEAD SKIN CELLS FROM AGING SKIN, LIQUID SOLUTIONS FOR REMOVING DEAD SKIN CELLS TO HELP ELIMINATE ENVIRONMENTAL DAMAGE, LIQUID SOLUTIONS FOR REMOVING DEAD SKIN CELLS TO HELP REDUCE WRINKLES, LIQUID SOLUTIONS FOR EXFOLIATING THE FACE, LIQUID SOLUTIONS FOR EXFOLIATING THE BODY, NON-MEDICATED LIQUID SOLUTIONS TO EXFOLIATE TO INHIBIT AND TREAT ROSACEA, NON-MEDICATED LIQUID SOLUTIONS TO EXFOLIATE FOR THE TREATMENT OF ACNE, LIQUID SOLUTIONS TO EXFOLIATE TO INHIBIT AGING SKIN, LIQUID SOLUTIONS TO EXFOLIATE TO INHIBIT AND TREAT ENVIRONMENTAL DAMAGE TO THE SKIN, LIQUID SOLUTIONS WHICH EXFOLIATE TO LIGHTEN THE SKIN, LIQUID SOLUTIONS WHICH EXFOLIATE TO REDUCE WRINKLES (U.S. CLS. 1, 4, 6, 50, 51 AND 52).

FIRST USE 8-1-1999; IN COMMERCE 8-1-1999.

**CLASS 5—PHARMACEUTICALS**

FOR ACNE AND ROSACEA MEDICATIONS, ACNE AND ROSACEA TREATMENT PREPARATIONS, NAMELY, ROSACEA AND ACNE EXFOLIANTS, GELS, SERUMS, AND SOLUTIONS (U.S. CLS. 6, 18, 44, 46, 51 AND 52).

FIRST USE 8-1-1999; IN COMMERCE 8-1-1999.  
TRICIA SONNEBORN, EXAMINING ATTORNEY

**CLASS 35—ADVERTISING AND BUSINESS**

FOR OPERATING HUMAN SERVICE PROGRAMS, NAMELY, PROVIDING EMPLOYMENT AND VOCATIONAL COUNSELING, AND COUNSELING REGARDING JOB DEVELOPMENT AND JOB CREATION AMONG BUSINESSES IN THE COMMUNITY; AND PROVIDING COUNSELING REGARDING CAREER TRANSITIONS AND PROVIDING SUPPORTED EMPLOYMENT ASSISTANCE IN THE NATURE OF JOB COACHING, NAMELY, EMPLOYMENT COUNSELING; ASSISTING INDIVIDUALS NEGOTIATE GOVERNMENT FUNDED ENTITLEMENT BENEFITS IN ADDITION TO PROVIDING NON-LEGAL ADVOCACY AND SUPPORT TO ASSIST THEM IN ACCESSING SOCIAL SERVICE AND HEALTHCARE SERVICES IN THE COMMUNITY (U.S. CLS. 100, 101 AND 102).

FIRST USE 2-2-2002; IN COMMERCE 2-2-2002.

**CLASS 41—EDUCATION AND ENTERTAINMENT**

FOR CAREER DEVELOPMENT COUNSELING; VOCATIONAL TRAINING IN COMPUTERS, BUSINESS APPLICATIONS, AND HOME HEALTHCARE; PROVIDING SPECIAL EDUCATION CLASSES FOR PEOPLE WITH DEVELOPMENTAL DISABILITIES; EDUCATIONAL SERVICES, NAMELY, CONDUCTING CLASSES, SEMINARS, CONFERENCES, WORKSHOPS AND TUTORING IN THE AREA OF LITERACY; PROVIDING FACILITIES AND PROGRAMS FOR AFTER-SCHOOL RECREATION; PROVIDING EDUCATIONAL COUNSELING IN THE FIELD OF DROP-OUT PREVENTION SERVICES (U.S. CLS. 100, 101 AND 107).

FIRST USE 2-2-2002; IN COMMERCE 2-2-2002.

**CLASS 43—HOTEL AND RESTAURANT SERVICES**

FOR PROVIDING AND ARRANGING TEMPORARY AND/OR PERMANENT HOUSING ACCOMMODATIONS TO HELP ALLEVIATE HOMELESSNESS; PROVIDING RESIDENTIAL SUPPORT SERVICES, NAMELY, PROVIDING CHARITABLE SERVICES IN THE NATURE OF PROVIDING COST-FREE TEMPORARY AND/OR PERMANENT HOUSING TO THE HOMELESS (U.S. CLS. 100 AND 101).

FIRST USE 2-2-2002; IN COMMERCE 2-2-2002.

**CLASS 44—MEDICAL, BEAUTY AND AGRICULTURAL SERVICES**

FOR CONSULTATION REGARDING BEHAVIORAL HEALTH ISSUES, PHYSICAL REHABILITATION; CONSULTATION REGARDING THOSE WITH DEVELOPMENTAL DISABILITIES; PROVIDING PSYCHOLOGICAL COUNSELING TO FAMILIES AND YOUTHS; HOME HEALTH CARE SERVICES; MENTAL HEALTH COUNSELING; PSYCHOLOGICAL FAMILY COUNSELING SERVICES (U.S. CLS. 100 AND 101).

FIRST USE 2-2-2002; IN COMMERCE 2-2-2002.

**CLASS 45—PERSONAL SERVICES**

FOR PROVIDING PERSONAL SUPPORT SERVICES FOR INDIVIDUALS AND FAMILIES AFFECTED BY HIV, DOMESTIC VIOLENCE, BREAST CANCER AND OTHER DISORDERS OR ILLNESSES, NAMELY, COMPANIONSHIP, HELP WITH MEDICAL FORMS, COUNSELING AND EMOTIONAL SUPPORT (U.S. CLS. 100 AND 101).

FIRST USE 2-2-2002; IN COMMERCE 2-2-2002.  
SUE LAWRENCE, EXAMINING ATTORNEY

SN 78-439,870. FEDERATION EMPLOYMENT AND GUIDANCE SERVICE, INC. (F.E.G.S.), NEW YORK, NY. FILED 6-23-2004.

**BRINGING RESOURCES  
TO PEOPLE AND  
BUSINESS**

THE MARK CONSISTS OF STANDARD CHARACTERS WITHOUT CLAIM TO ANY PARTICULAR FONT, STYLE, SIZE, OR COLOR.

SN 78-478,874. WORLD MARKET CENTER VENTURE, LLC,  
LAS VEGAS, NV. FILED 9-3-2004.

SN 78-481,629. QUANTUM CORPORATION, SAN JOSE, CA.  
FILED 9-10-2004.

## LAS VEGAS MARKET

THE MARK CONSISTS OF STANDARD CHARACTERS WITHOUT CLAIM TO ANY PARTICULAR FONT, STYLE, SIZE, OR COLOR.

NO CLAIM IS MADE TO THE EXCLUSIVE RIGHT TO USE LAS VEGAS, APART FROM THE MARK AS SHOWN. SEC. 2(F).

### CLASS 35—ADVERTISING AND BUSINESS

FOR ARRANGING, ORGANIZING, PROMOTING AND CONDUCTING TRADE EXHIBITIONS, CONVENTIONS, SHOWS AND MARKETS IN THE FIELDS OF GIFTS AND HOME, CONTRACT AND HOSPITALITY FURNISHINGS; OPERATING AND MANAGING TRADE SHOWROOMS AND RELATED SHOWROOM FACILITIES AND SERVICES FOR THE DISPLAY AND EXHIBITION OF GOODS OF MANUFACTURERS IN THE FIELDS OF GIFTS AND HOME, CONTRACT AND HOSPITALITY FURNISHINGS; ADVERTISING AND MARKETING OF TRADE SHOWROOMS AND RELATED SHOWROOM FACILITIES AND SERVICES TO MANUFACTURERS OF GOODS IN THE FIELDS OF GIFTS AND HOME, CONTRACT AND HOSPITALITY FURNISHINGS; ADVERTISING AND MARKETING OF TRADE SHOWROOMS FOR THE DISPLAY AND EXHIBITION OF GOODS OF MANUFACTURERS IN THE FIELDS OF GIFTS AND HOME, CONTRACT AND HOSPITALITY FURNISHINGS TO RETAILERS OF GIFTS AND HOME, CONTRACT AND HOSPITALITY FURNISHINGS (U.S. CLS. 100, 101 AND 102).

FIRST USE 4-1-2001; IN COMMERCE 4-1-2001.

### CLASS 36—INSURANCE AND FINANCIAL

FOR REAL ESTATE SERVICES, NAMELY, LEASING TRADE SHOWROOM SPACE TO MANUFACTURERS OF GOODS IN THE FIELDS OF GIFTS AND HOME, CONTRACT AND HOSPITALITY FURNISHINGS (U.S. CLS. 100, 101 AND 102).

FIRST USE 4-1-2001; IN COMMERCE 4-1-2001.

### CLASS 37—CONSTRUCTION AND REPAIR

FOR REAL ESTATE DEVELOPMENT, NAMELY, SITE SELECTION, CONSTRUCTION PLANNING, CONSTRUCTION MANAGEMENT AND SUPERVISION, AND CONSTRUCTION SERVICES, NAMELY, PLANNING, LAYING OUT AND CONSTRUCTION OF TRADE SHOWROOM, CONFERENCE, EXHIBITION AND MEETING FACILITIES (U.S. CLS. 100, 103 AND 106).

FIRST USE 4-1-2001; IN COMMERCE 4-1-2001.

### CLASS 43—HOTEL AND RESTAURANT SERVICES

FOR PROVIDING TRADE SHOWROOM, CONFERENCE, EXHIBITION AND MEETING FACILITIES (U.S. CLS. 100 AND 101).

FIRST USE 4-1-2001; IN COMMERCE 4-1-2001.

JACQUELINE A. LAVINE, EXAMINING ATTORNEY



THE MARK CONSISTS OF THE STYLIZED AS LETTER "Q".

### CLASS 9—ELECTRICAL AND SCIENTIFIC APPARATUS

FOR COMPUTER HARD DRIVES, TAPE DRIVES, AND COMPUTER MEDIA, NAMELY, COMPUTER SOFTWARE, COMPUTER CD-ROMS, COMPUTER HARD DISKS, COMPUTER FLOPPY DISKS, AND MAGNETIC TAPE, ALL FOR STORAGE, RETRIEVAL, BACKUP AND DELIVERY OF DATA, IMAGES, MEMORY, PHOTOGRAPHS, AND MUSIC (U.S. CLS. 21, 23, 26, 36 AND 38).

FIRST USE 6-1-2002; IN COMMERCE 6-1-2002.

### CLASS 42—SCIENTIFIC, COMPUTER AND LEGAL SERVICES

FOR COMPUTER SUPPORT SERVICES, NAMELY, TROUBLESHOOTING OF COMPUTER HARDWARE AND SOFTWARE PROBLEMS IN THE FIELD OF COMPUTER DATA STORAGE, BACKUP AND ARCHIVE APPARATUS AND MEDIA, COMPUTER SOFTWARE, TAPE DRIVES AND DATA TRANSFER PRODUCTS FOR TAPE DRIVES (U.S. CLS. 100 AND 101).

FIRST USE 6-1-2002; IN COMMERCE 6-1-2002.

GIANCARLO CASTRO, EXAMINING ATTORNEY

---

SN 78-487,393. BFM TURBULENCE AS, 7562 HUNDHAM-  
MAREN, NORWAY, FILED 9-22-2004.

## KAMELEON FIREEX KFX

THE MARK CONSISTS OF STANDARD CHARACTERS WITHOUT CLAIM TO ANY PARTICULAR FONT, STYLE, SIZE, OR COLOR.

PRIORITY CLAIMED UNDER SEC. 44(D) ON NORWAY APPLICATION NO. 200406379, FILED 6-15-2004, REG. NO. 231522, DATED 3-20-2006, EXPIRES 3-20-2016.

**CLASS 9—ELECTRICAL AND SCIENTIFIC APPARATUS**

FOR APPARATUS AND INSTRUMENTS FOR SCIENTIFIC RESEARCH IN LABORATORIES, NAMELY GAS DISPERSION ANALYZERS, FLAME PROPAGATION ANALYZERS AND EXPLOSION ANALYZERS; COMPUTER SERVERS; COMPUTER HARDWARE; COMPUTER PERIPHERALS; COMPUTER PROGRAMS AND DOWNLOADABLE COMPUTER SOFTWARE FOR THE ANALYSIS AND SIMULATION OF GAS DISPERSION, FIRES, EXPLOSIONS AND INDUSTRIAL COMBUSTION; COMPUTER PROGRAMS FOR ANALYSIS OF RELIABILITY DATA FOR OIL AND GAS WELLS AND FOR USE IN OR IN CONNECTION WITH THE OIL AND GAS INDUSTRY; COMPUTER PROGRAMS FOR COLLECTING AND ANALYSIS OF RELIABILITY DATA FOR SEAFLOOR PRODUCTION SYSTEMS FOR THE OIL- AND GAS INDUSTRY; COMPUTER SYSTEMS FOR SIMULATION AND CONTROL OF CHEMICAL REACTIONS AND SEPARATORS; COMPUTER PROGRAMS AND COMPUTER SYSTEMS FOR SIMULATION OF PRESSURE RELIEF OF PROCESS OR PROCESSING EQUIPMENT; COMPUTER PROGRAMS AND COMPUTER SYSTEMS WHICH SIMULATE, SHOW AND ANALYZE TRANSPORTATION OF FLUIDS, GASSES, AND LIQUIDS IN PIPE SYSTEMS, NAMELY LIMITED TO TRANSPORTATION OF TRACER COMPONENTS AND ANALYSIS OF INLINE OPERATIONS, SUCH AS DRYING AND PIGGING; COMPUTER PROGRAMS FOR FLUID FLOW WITHIN THE FIELD OF OR RELATING TO THE ENVIRONMENT, CLIMATE, HEATING, VENTILATION AND AIR CONDITIONING TECHNIQUES; COMPUTER BASED SIMULATION TOOLS FOR DESCRIBING OF FLUID DYNAMIC PHENOMENA AND NUMERICAL FLUID DYNAMICS; COMPUTER PROGRAMS FOR SIMULATION OF COMBUSTION PROCESSES GENERALLY; COMPUTER PROGRAMS FOR SIMULATION OF FIRE EXTINGUISHING AND FIRE MITIGATION (U.S. CLS. 21, 23, 26, 36 AND 38).

**CLASS 41—EDUCATION AND ENTERTAINMENT**

FOR EDUCATION AND TRAINING SERVICES, NAMELY, SEMINARS, CLASSES, WORKSHOPS AND COURSES OF INSTRUCTION PROVIDED IN PERSON, OVER COMPUTER NETWORKS AND VIA THE INTERNET IN CONNECTION WITH COMPUTERS AND COMPUTER SOFTWARE; SEMINARS, CLASSES, WORKSHOPS AND COURSES OF INSTRUCTION PROVIDED IN PERSON AND VIA THE INTERNET RELATING TO SOFTWARE DEVELOPMENT, DESIGN AND ADAPTION; ORGANIZING AND PRESENTATION OF CONFERENCES, SEMINARS AND MEETINGS IN PERSON, OVER COMPUTER NETWORKS AND VIA THE INTERNET FOR USERS REGARDING COMPUTERS AND COMPUTER SOFTWARE; PROVIDING COMPUTER EDUCATION TRAINING SERVICES IN THE FORM OF SEMINARS, CLASSES, WORKSHOPS AND COURSES OF INSTRUCTION IN PERSON, OVER COMPUTER NETWORKS AND VIA THE INTERNET (U.S. CLS. 100, 101 AND 107).

**CLASS 42—SCIENTIFIC, COMPUTER AND LEGAL SERVICES**

FOR SERVICES FOR STORING AND RETRIEVING INFORMATION, NAMELY, ACTING AS AN APPLICATION SERVICE PROVIDER IN THE FIELD OF KNOWLEDGE MANAGEMENT TO HOST COMPUTER APPLICATION SOFTWARE FOR RETRIEVING INFORMATION FROM DATABASES AND COMPUTER NETWORKS; COMPUTER SOFTWARE DESIGN AND COMPUTER PROGRAMMING; UPDATING AND MAINTENANCE OF COMPUTER PROGRAMS AND SOFTWARE; CUSTOM DESIGN AND DEVELOPMENT OF COMPUTER SOFTWARE FOR OTHERS; CONSULTING AND ADVISORY SERVICES RELATING TO COMPUTERS, COMPUTER SOFTWARE, USER INTERFACES, CUSTOMER SERVERS, AND REMOTE-OPERATED COMPUTER APPLICATIONS, TOOLS AND INSTRUMENTS FOR COMPUTER SYSTEM OPERATIONS, GLOBAL NETWORKS FOR COMPUTER INFORMATION, MANAGEMENT, NETWORK ACCESS TO LOCAL AND WIDE AREA NETWORKS, DEVELOPMENT OF TOOLS AND ACCESSORIES, MONITORING, CONTROL AND

ADMINISTRATION OF COMPUTER SYSTEMS, MAINTENANCE AND SUPPORT SERVICES FOR SOFTWARE, NAMELY TELEPHONE CONSULTATION, COMPUTER SOFTWARE BUG FIXES, UPDATING OF COMPUTER SOFTWARE, PROVIDING OF ELECTRONIC AND ONLINE DISPLAY BOARDS AND REFERENCE INFORMATION AND WEB AREAS, ALL RELATED TO COMPUTERS, COMPUTER SOFTWARE, AND COMPUTER SYSTEMS; COMPUTER SIMULATION, STUDIES AND ANALYSIS OF GAS DISPERSION, FIRES, FIRE SUPPRESSION, EXPLOSIONS AND INDUSTRIAL COMBUSTION; COMPUTER BASED ANALYSIS AND SIMULATION OF SYSTEMS WHICH CALCULATE FLUID FLOW, HEAT, OR MASS TRANSFER; COMPUTER BASED ANALYSIS AND SIMULATION OF CHEMICAL REACTIONS, COMBUSTION, FIRE, FIRE EXTINGUISHING AND FIRE MITIGATION; RESTORING DATA OR COMPUTER SOFTWARE RETRIEVAL, NAMELY, DATA RECOVERY SERVICES; INSTALLATION OF COMPUTER PROGRAMS; CONVERSION OF COMPUTER PROGRAMS AND DATA; DEVELOPMENT OF NEW TECHNOLOGY FOR OTHERS IN THE FIELD OF COHERENT NUMERICAL TECHNOLOGY THAT ENCOMPASSES GENERAL SCIENCE BASED SUB-MODELS; SCIENTIFIC RESEARCH AND DEVELOPMENT, NAMELY THE DEVELOPMENT OF GENERAL SOLUTION TECHNIQUES, GENERAL COMPUTER STRUCTURE AND GENERAL COHERENT OPERATIONAL CHARACTERISTICS; RESEARCH IN THE FIELD OF GAS DISPERSION, FIRES, FIRE SUPPRESSION, EXPLOSIONS AND INDUSTRIAL COMBUSTION; TECHNOLOGY CONSULTATION AND SCIENTIFIC RESEARCH IN THE FIELD OF GAS DISPERSION, FIRES, FIRE SUPPRESSION, EXPLOSIONS AND INDUSTRIAL COMBUSTION; INDUSTRIAL ANALYSIS AND RESEARCH SERVICES; DESIGN AND DEVELOPMENT OF COMPUTER SOFTWARE, COMPUTER NETWORKS AND COMPUTER HARDWARE (U.S. CLS. 100 AND 101).

WARREN L. OLANDRIA, EXAMINING ATTORNEY

SN 78-523,102. MED IMAGES, INC., KNOXVILLE, TN.  
FILED 11-26-2004.

## Digital Technology for Life!

THE MARK CONSISTS OF STANDARD CHARACTERS WITHOUT CLAIM TO ANY PARTICULAR FONT, STYLE, SIZE, OR COLOR.

NO CLAIM IS MADE TO THE EXCLUSIVE RIGHT TO USE "DIGITAL TECHNOLOGY", APART FROM THE MARK AS SHOWN.

**CLASS 9—ELECTRICAL AND SCIENTIFIC APPARATUS**

FOR COMPUTER HARDWARE, NAMELY, MICRO-PROCESSOR BASED INSTRUMENTS HAVING PRE-LOADED SOFTWARE FOR ACQUIRING AND INTEGRATING PATIENT SURGICAL AND DIAGNOSTIC INFORMATION IN THE NATURE OF VOICE, IMAGE AND TEXT INFORMATION INPUT BY A PHYSICIAN AND GENERATING AN OUTPUT DOCUMENTATION CORRESPONDING TO THE INTEGRATED INFORMATION FOR USE BY A PHYSICIAN IN DIAGNOSTIC AND SURGICAL PROCEDURE RELATED TO THE PHYSICIAN'S TREATMENT AND PROGNOSIS OF THE PATIENT (U.S. CLS. 21, 23, 26, 36 AND 38).

FIRST USE 2-28-2001; IN COMMERCE 2-28-2001.

**CLASS 39—TRANSPORTATION AND STORAGE**

SN 78-533,949. JULIEN INC., QUEBEC, CANADA, FILED 12-16-2004.

FOR MAINTAINING PERSONAL MEDICAL HISTORY RECORDS AND FILES, NAMELY, STORAGE AND RETRIEVAL OF MEDICAL RECORDS UTILIZING TEXT, VOICE DICTATION, AND VIDEO, SAID DOCUMENTS STORED FOR AND PROVIDED TO MEDICAL PRACTITIONERS FOR USE IN DIAGNOSING PATIENTS AND IN SURGICAL PROCEDURES (U.S. CLS. 100 AND 105).

FIRST USE 2-28-2001; IN COMMERCE 2-28-2001.

**CLASS 44—MEDICAL, BEAUTY AND AGRICULTURAL SERVICES**

FOR PREPARING INTEGRATED MEDICAL REPORTS FOR MEDICAL PRACTITIONERS UTILIZING INTEGRATED PATIENT INFORMATION, SURGICAL PROCEDURE INFORMATION, AND PHYSICIAN DICTATION INFORMATION IN TEXT, VOICE, DICTATION, AND VIDEO IN ORDER TO ASSIST MEDICAL PRACTITIONERS IN MEDICAL AND SURGICAL PROCEDURES AND PATIENT INFORMATION MANAGEMENT (U.S. CLS. 100 AND 101).

FIRST USE 2-28-2001; IN COMMERCE 2-28-2001.  
DAVID C. REIHNER, EXAMINING ATTORNEY

**LIVE & WORK LOFT KITCHEN**

THE MARK CONSISTS OF STANDARD CHARACTERS WITHOUT CLAIM TO ANY PARTICULAR FONT, STYLE, SIZE, OR COLOR.

PRIORITY CLAIMED UNDER SEC. 44(D) ON CANADA APPLICATION NO. 1,236,802, FILED 11-3-2004, REG. NO. TMA659,215, DATED 2-16-2006, EXPIRES 2-16-2021.

NO CLAIM IS MADE TO THE EXCLUSIVE RIGHT TO USE KITCHEN, APART FROM THE MARK AS SHOWN.

**CLASS 7—MACHINERY**

FOR COMPACT KITCHEN COMPONENTS, NAMELY, DISWASHING MACHINES (U.S. CLS. 13, 19, 21, 23, 31, 34 AND 35).

**CLASS 11—ENVIRONMENTAL CONTROL APPARATUS**

FOR COMPACT KITCHEN COMPONENTS, NAMELY, APPARATUS FOR COOKING, NAMELY, COOKTOPS COMPRISING HOT PLATES AND COOKING PLATES, TEMPERATURE CONTROLLED WINE CELLARS, VENTILATION HOODS FOR COOKTOPS INTEGRATED WITH WORK SURFACES AND SOLD AS A UNIT, MICROWAVE OVENS (U.S. CLS. 13, 21, 23, 31 AND 34).  
TARAH HARDY, EXAMINING ATTORNEY

SN 78-524,276. GENESYS SOFTWARE SYSTEMS, INC., METHUEN, MA. FILED 11-30-2004.



NO CLAIM IS MADE TO THE EXCLUSIVE RIGHT TO USE "HCM", APART FROM THE MARK AS SHOWN.

THE MARK CONSISTS OF THE WORD GENESYS UNDER A CURVED LINE HAVING THE APPEARANCE OF A PAINTED BRUSH STROKE, WITH THE WORDS CUSTOMER DRIVEN HCM IN SMALLER LETTERS BENEATH THE WORD GENESYS.

**CLASS 9—ELECTRICAL AND SCIENTIFIC APPARATUS**

FOR COMPUTER SOFTWARE FOR MANAGING HUMAN CAPITAL, NAMELY, SOFTWARE FOR PROCESSING, STORING, TRANSMITTING AND REPORTING INFORMATION IN THE FIELD OF HUMAN CAPITAL; SOFTWARE FOR TRAINING AND EDUCATING EMPLOYEES AND OTHER ORGANIZATION MEMBERS REGARDING THE SKILLS AND INFORMATION REQUIRED BY THE ORGANIZATION, SUCH SOFTWARE PERMITTING THE ADDITION OF SUBSTANTIVE CONTENT WHICH VARIES ACCORDING TO THE NEEDS OF THE ORGANIZATION AND ITS PERSONNEL; SOFTWARE FOR PAYROLL PROCESSING; SOFTWARE FOR MANAGING HUMAN RESOURCE DATA; SOFTWARE FOR MANAGING EMPLOYEE BENEFIT DATA (U.S. CLS. 21, 23, 26, 36 AND 38).

FIRST USE 9-0-2004; IN COMMERCE 9-0-2004.

**CLASS 35—ADVERTISING AND BUSINESS**

FOR HUMAN CAPITAL MANAGEMENT OUTSOURCING SERVICES (U.S. CLS. 100, 101 AND 102).

FIRST USE 9-0-2004; IN COMMERCE 9-0-2004.  
JENNIFER KRISP, EXAMINING ATTORNEY

SN 78-534,264. SOLOWAVE DESIGN INC., WATERLOO, CANADA, FILED 12-17-2004.



PRIORITY CLAIMED UNDER SEC. 44(D) ON CANADA APPLICATION NO. 1,234,820, FILED 10-22-2004, REG. NO. TMA674,759, DATED 10-13-2006, EXPIRES 10-13-2021.

THE MARK CONSISTS OF TREEHOUSE DESIGN.

**CLASS 19—NON-METALLIC BUILDING MATERIALS**

FOR PRE-ASSEMBLED PRODUCTS FOR THE HOME OUTDOOR MARKET, NAMELY NON-METAL FENCES (U.S. CLS. 1, 12, 33 AND 50).

**CLASS 28—TOYS AND SPORTING GOODS**

FOR PRE-ASSEMBLED PRODUCTS FOR THE HOME OUTDOOR MARKET, NAMELY CHILDREN'S OUTDOOR PLAY STRUCTURES (U.S. CLS. 22, 23, 38 AND 50).

STEPHANIE DAVIS, EXAMINING ATTORNEY

SN 78-536,786. KÜBEL, JOHANN, A-3072 KASTEN, AUSTRIA, FILED 12-22-2004.



PRIORITY CLAIMED UNDER SEC. 44(D) ON ERPN CMNTY TM OFC APPLICATION NO. 004198107, FILED 12-17-2004, REG. NO. 004198107, DATED 5-17-2006, EXPIRES 12-17-2014.

NO CLAIM IS MADE TO THE EXCLUSIVE RIGHT TO USE "HEAT", APART FROM THE MARK AS SHOWN.

THE COLOR(S) BLUE, WHITE, ORANGE, YELLOW, RED AND BROWN IS/ARE CLAIMED AS A FEATURE OF THE MARK.

THE LETTERS OF THE WORDS "TOP HEAT" ARE DISPLAYED IN BLUE WITH A WHITE BORDERING AND A BLUE REFLECTION BEHIND THE LETTERS. THE FLAME DESIGN HAS AN INNER WHITE CORE SURROUNDED BY YELLOW, WITH THE UPPER PORTION OF THE FLAME BEING IN ORANGE, THEN TRANSITIONING TO RED. THE FLAME DESIGN HAS A REDDISH/BROWN BACKGROUND REFLECTION.

**CLASS 11—ENVIRONMENTAL CONTROL APPARATUS**

FOR HEATING SYSTEMS, NAMELY STATIONARY FURNACES FUELED BY RAW RAPESEED (U.S. CLS. 13, 21, 23, 31 AND 34).

**CLASS 40—MATERIAL TREATMENT**

FOR CUSTOM MANUFACTURE OF STATIONARY FURNACES THAT ARE FUELED BY RAW RAPESEED (U.S. CLS. 100, 103 AND 106).

STEVEN R. FOSTER, EXAMINING ATTORNEY

SN 78-555,970. 454 CORPORATION, BRANFORD, CT. FILED 1-28-2005.

**454 Life Sciences**

THE MARK CONSISTS OF STANDARD CHARACTERS WITHOUT CLAIM TO ANY PARTICULAR FONT, STYLE, SIZE, OR COLOR.

OWNER OF U.S. REG. NO. 2,995,485.

NO CLAIM IS MADE TO THE EXCLUSIVE RIGHT TO USE "LIFE SCIENCES", APART FROM THE MARK AS SHOWN.

**CLASS 1—CHEMICALS**

FOR BIOTECHNOLOGY REAGENTS FOR RESEARCH PURPOSES, NAMELY, REAGENTS FOR NUCLEIC ACID SEQUENCING (U.S. CLS. 1, 5, 6, 10, 26 AND 46).

FIRST USE 1-18-2005; IN COMMERCE 1-18-2005.

**CLASS 9—ELECTRICAL AND SCIENTIFIC APPARATUS**

FOR LABORATORY INSTRUMENTS FOR BIOTECHNOLOGY, NAMELY, INSTRUMENTS FOR NUCLEIC ACID SEQUENCING (U.S. CLS. 21, 23, 26, 36 AND 38).

FIRST USE 1-18-2005; IN COMMERCE 1-18-2005.

**CLASS 42—SCIENTIFIC, COMPUTER AND LEGAL SERVICES**

FOR GENOMICS SERVICES, NAMELY, PROVIDING NUCLEIC ACID SEQUENCING SERVICES (U.S. CLS. 100 AND 101).

FIRST USE 1-8-2004; IN COMMERCE 1-8-2004.

MARCIE MILONE, EXAMINING ATTORNEY

SN 78-558,040. T-INK, L.L.C., NEW YORK, NY. FILED 2-1-2005.

**THINKING INK**

THE MARK CONSISTS OF STANDARD CHARACTERS WITHOUT CLAIM TO ANY PARTICULAR FONT, STYLE, SIZE, OR COLOR.

NO CLAIM IS MADE TO THE EXCLUSIVE RIGHT TO USE "INK", APART FROM THE MARK AS SHOWN.

**CLASS 2—PAINTS**

FOR INK BASED ELECTRICALLY CONDUCTIVE COMPOSITIONS FOR USE IN MANUFACTURE, WHICH ARE USED TO OBTAIN LIGHT, SIGNAL TRANSMISSION AND SOUND EFFECTS WHEN TOUCHED (U.S. CLS. 6, 11 AND 16).

**CLASS 25—CLOTHING**

FOR CLOTHING, NAMELY, T-SHIRTS, SWEAT-SHIRTS, SPORT SHIRTS, PANTS, JACKETS AND HATS (U.S. CLS. 22 AND 39).

**CLASS 28—TOYS AND SPORTING GOODS**

FOR CHILDREN'S MULTIPLE ACTIVITY TOYS AND BOARD GAMES INCORPORATING ELECTRICALLY CONDUCTIVE COATINGS FOR PRODUCING SOUNDS, SIGNAL TRANSMISSION AND VISUAL EFFECTS WHEN TOUCHED (U.S. CLS. 22, 23, 38 AND 50).

MICHELLE DUBOIS, EXAMINING ATTORNEY

SN 78-561,723. FEDERAL-MOGUL DEVA GMBH, STADTAL-LENDORF, FED REP GERMANY, FILED 2-7-2005.

deva.tex

THE MARK CONSISTS OF STANDARD CHARACTERS WITHOUT CLAIM TO ANY PARTICULAR FONT, STYLE, SIZE, OR COLOR.

PRIORITY CLAIMED UNDER SEC. 44(D) ON FED REP GERMANY APPLICATION NO. 30447300, FILED 8-18-2004, REG. NO. 30447300, DATED 8-18-2004, EXPIRES 8-31-2014. OWNER OF U.S. REG. NOS. 1,176,842 AND 2,776,051.

#### CLASS 6—METAL GOODS

FOR METALS IN THE FORM OF SEMI-FINISHED PRODUCTS FOR USE IN THE FURTHER MANUFACTURE OF SEALS AND PACKINGS; SHAPED SINTERED METAL PARTS AS SEMI-FINISHED PRODUCTS FOR USE IN THE FURTHER MANUFACTURE OF SEALS, PACKING AND BUSHES; SHAPED SINTERED METAL PARTS FOR USE IN THE MANUFACTURE OF SEALS AND PACKINGS; METAL IN POWDER FORM WITH SOLID LUBRICANT PROPERTIES FOR USE IN THE MANUFACTURE OF SEALS, PACKINGS AND BUSHES (U.S. CLS. 2, 12, 13, 14, 23, 25 AND 50).

#### CLASS 7—MACHINERY

FOR MACHINE PARTS OF SHAPED POWDER METALLURGICAL AND SINTERED METAL PARTS, NAMELY, PLAIN BEARINGS, SLIDING ELEMENTS, SLIDING PLATES AND BUSHES (U.S. CLS. 13, 19, 21, 23, 31, 34 AND 35).

#### CLASS 17—RUBBER GOODS

FOR NON-METALLIC MINERAL FIBERS FROM POLYESTER IN THE FORM OF SEMI-FINISHED PRODUCTS FOR USE IN THE MANUFACTURE OF SEALS AND PACKINGS (U.S. CLS. 1, 5, 12, 13, 35 AND 50).  
DEIRDRE ROBERTSON, EXAMINING ATTORNEY

SN 78-570,529. INTENSE LTD, HIGH BLANTYRE, GLASGOW, UNITED KINGDOM, FILED 2-18-2005.

INSLAM

THE MARK CONSISTS OF STANDARD CHARACTERS WITHOUT CLAIM TO ANY PARTICULAR FONT, STYLE, SIZE, OR COLOR.

#### CLASS 9—ELECTRICAL AND SCIENTIFIC APPARATUS

FOR OPTOELECTRIC APPARATUS AND INSTRUMENTS, NAMELY, ARC MODULES CONTAINING INDIVIDUALLY ADDRESSABLE SINGLE MODE LASERS TO PRODUCE AN ARRAY OF LIGHT BEAMS THAT CAN BE INDIVIDUALLY MODERATED; FIBER OPTICS; LASERS AND LASER ARRAY MARKING EQUIPMENT FOR THERMAL TRANSFER TECHNIQUES, FOR PRINTING ONTO, SENSITIZED MEDIA, FOR MATERIAL PROCESSING, NAMELY, ENGRAVING, MAKING, AND PROCESSING PLASTICS, AND FOR INDUSTRIAL PRINTING (U.S. CLS. 21, 23, 26, 36 AND 38).

#### CLASS 10—MEDICAL APPARATUS

FOR LASERS FOR MEDICAL USE (U.S. CLS. 26, 39 AND 44).  
ODESSA BIBBINS, EXAMINING ATTORNEY

SN 78-572,003. HSBC NORTH AMERICAN HOLDINGS INC., PROSPECT HEIGHTS, IL. FILED 2-22-2005.

YOURMONEYCOUNTS

THE MARK CONSISTS OF STANDARD CHARACTERS WITHOUT CLAIM TO ANY PARTICULAR FONT, STYLE, SIZE, OR COLOR.

#### CLASS 16—PAPER GOODS AND PRINTED MATTER

FOR PRINTED INSTRUCTIONAL MATERIALS DISTRIBUTED IN CONNECTION WITH AN EDUCATIONAL PROGRAM IN THE FIELD OF HOUSEHOLD AND PERSONAL CREDIT AND FINANCIAL LITERACY (U.S. CLS. 2, 5, 22, 23, 29, 37, 38 AND 50).

#### CLASS 36—INSURANCE AND FINANCIAL

FOR PROVIDING INFORMATION FOR THE PURPOSE OF EDUCATING CONSUMERS IN THE FIELD OF HOUSEHOLD AND PERSONAL CREDIT AND FINANCIAL LITERACY VIA THE INTERNET (U.S. CLS. 100, 101 AND 102).

#### CLASS 41—EDUCATION AND ENTERTAINMENT

FOR EDUCATIONAL SERVICES IN THE FIELD OF HOUSEHOLD AND PERSONAL CREDIT AND FINANCIAL LITERACY, NAMELY, PROVIDING WORKSHOPS AND SEMINARS, PUBLISHING INSTRUCTIONAL MATERIALS RECORDED ON CD-ROM, DVD OR COMPUTER DISK, DISTRIBUTING PRINTED MATERIALS, AND PUBLISHING ELECTRONIC NEWSLETTERS VIA THE INTERNET (U.S. CLS. 100, 101 AND 107).  
SUNG IN, EXAMINING ATTORNEY



SN 78-574,356. ESQUEL ENTERPRISES LIMITED, WAN-CHAI, HONG KONG, FILED 2-24-2005.



PRIORITY CLAIMED UNDER SEC. 44(D) ON HONG KONG APPLICATION NO. 300361872, FILED 1-28-2005, REG. NO. 300361872, DATED 6-9-2005, EXPIRES 1-27-2015. THE MARK CONSISTS OF THE WORDING EURO-TOUCH WITH A STYLIZED LETTER "E".

**CLASS 24—FABRICS**

FOR WOVEN FABRICS, NAMELY, POPLIN, TWILL, PINPOINT OXFORD, OXFORD, BASKET WEAVE AND DOBBY; KNIT FABRICS; FELT AND NON-WOVEN TEXTILE FABRICS; OILCLOTH; GUMMED WATER-PROOF CLOTH; VINYL COATED CLOTH; RUBBERIZED CLOTH; PERSONAL ARTICLES OF WOVEN TEXTILE NOT FOR WEAR, NAMELY, HANDKERCHIEFS; MOSQUITO NETS; BED SHEETS; LINEN FUTONS AND QUILTS; LINEN FOR FUTONS AND QUILT CASES; FUTON TICKS MADE OF WOVEN FABRIC, KNIT FABRIC, COTTON FABRIC, CHENILLE FABRIC, CHEVIOT FABRIC, RAYON FABRIC AND POLYESTER FABRIC; PILLOWCASES; BLANKETS; TABLE NAPKINS OF TEXTILE; DISH CLOTHS; SHOWER CURTAINS; BANNERS AND FLAGS MADE OF TEXTILE; TOILET SEAT COVERS OF TEXTILE; SEAT COVERS OF TEXTILE; WALL HANGINGS OF TEXTILE; CURTAINS; TABLE CLOTHS NOT OF PAPER; DRAPERIES, NAMELY, THICK DROP CURTAINS; BILLIARD CLOTH; LABELS OF CLOTH; COMFORTERS; PILLOW SHAMS; QUILTS (U.S. CLS. 42 AND 50).

**CLASS 25—CLOTHING**

FOR CLOTHING, NAMELY, TOPS; BLOUSES; SHIRTS; DRESS SHIRTS; SPORT SHIRTS; ROBES; BATH ROBES; BOXER BRIEFS; BOXER SHORTS; UNDERWEAR; PJAMAS; SKIRTS; LOUNGEWEAR; DRESSES; PANTS; SHORTS; GARTERS; SOCK SUSPENDERS; SUSPENDERS; WAISTBANDS; BELTS FOR CLOTHING; FOOTWEAR; MASQUERADE COSTUMES; CLOTHES FOR SPORTS, NAMELY, WARM-UP JACKETS, WARM-UP PANTS, SWEATERS, SWEATPANTS, JACKETS, JERSEYS, SWIMSUITS, T-SHIRTS; BOOTS FOR SPORTS; HEADWEAR (U.S. CLS. 22 AND 39). KEVON CHISOLM, EXAMINING ATTORNEY

SN 78-580,337. GB INSTRUMENTS, INC., DEERFIELD BEACH, FL. FILED 3-4-2005.



**CLASS 7—MACHINERY**

FOR MECHANICAL SORTING EQUIPMENT USED TO SORT CONSUMER PRODUCTS WEIGHING LESS THEN 25 POUNDS IN DISTRIBUTION AND WHOLESALE ENVIRONMENTS (U.S. CLS. 13, 19, 21, 23, 31, 34 AND 35). FIRST USE 10-0-1996; IN COMMERCE 10-0-1996.

**CLASS 9—ELECTRICAL AND SCIENTIFIC APPARATUS**

FOR DATA PROCESSING EQUIPMENT NAMELY, COMPUTER TERMINALS; COMPUTER PROGRAMS FOR USE IN DATA ENTRY, TO PERFORM DATABASE SEARCHES, AND TO GENERATE REPORTS; ELECTRONIC CONTROLLERS FOR ELECTRONIC PERIPHERAL CONTROL BOARDS AND PRINTERS (U.S. CLS. 21, 23, 26, 36 AND 38). FIRST USE 10-0-1996; IN COMMERCE 10-0-1996. DAVID TAYLOR, EXAMINING ATTORNEY

SN 78-580,379. ALTIMA INTERNATIONAL LIMITED, GEORGETOWN; GRAND CAYMAN, CAYMAN ISLANDS, FILED 3-4-2005.



THE MARK CONSISTS OF STANDARD CHARACTERS WITHOUT CLAIM TO ANY PARTICULAR FONT, STYLE, SIZE, OR COLOR. PRIORITY CLAIMED UNDER SEC. 44(D) ON UNITED KINGDOM APPLICATION NO. 2383600, FILED 2-4-2005, REG. NO. 2383600, DATED 2-4-2005, EXPIRES 2-4-2015.

**CLASS 9—ELECTRICAL AND SCIENTIFIC APPARATUS**

FOR FINANCIAL SOFTWARE RELATING TO FUND MANAGEMENT, NAMELY SOFTWARE RELATED TO THE PRICING OF MANAGEMENT OF INVESTMENTS (U.S. CLS. 21, 23, 26, 36 AND 38).

**CLASS 16—PAPER GOODS AND PRINTED MATTER**

FOR PRINTED MATTER RELATING TO FUND MANAGEMENT, NAMELY REPORTS TO INVESTMENT CLIENTS, MARKETING PRESENTATIONS AND PROSPECTUSES (U.S. CLS. 2, 5, 22, 23, 29, 37, 38 AND 50).

**CLASS 36—INSURANCE AND FINANCIAL**

FOR FINANCIAL INVESTMENT SERVICES; ASSET MANAGEMENT SERVICES; HEDGE FUND MANAGEMENT SERVICES (U.S. CLS. 100, 101 AND 102). JOHN DALIER, EXAMINING ATTORNEY

SN 78-581,855. MCKENNA, LONG AND ALDRIDGE, LLP,  
WASHINGTON, D.C., DC. FILED 3-7-2005.

SN 78-585,981. MEDIAWARE INTERNATIONAL PTY LTD,  
CANBERRA, AUSTRALIA, FILED 3-12-2005.

## STAY AHEAD OF THE CURVE

THE MARK CONSISTS OF STANDARD CHARACTERS  
WITHOUT CLAIM TO ANY PARTICULAR FONT, STYLE,  
SIZE, OR COLOR.

### CLASS 35—ADVERTISING AND BUSINESS

FOR POLITICAL LOBBYING SERVICES, NAMELY  
PROMOTING THE INTERESTS OF FEDERAL, STATE,  
AND LOCAL GOVERNMENTS, COMPANIES, AND IN-  
DIVIDUALS IN THE FIELDS OF POLITICS, LEGISLA-  
TION, AND REGULATION (U.S. CLS. 100, 101 AND 102).  
FIRST USE 8-11-2003; IN COMMERCE 8-11-2003.

### CLASS 42—SCIENTIFIC, COMPUTER AND LEGAL SERVICES

FOR PROVIDING PROFESSIONAL LEGAL CONSULTA-  
TION AND LEGAL SERVICES (U.S. CLS. 100 AND  
101).  
FIRST USE 8-11-2003; IN COMMERCE 8-11-2003.  
TIMOTHY FINNEGAN, EXAMINING ATTORNEY

SN 78-582,741. UNITED RECYCLING LLC, MILWAUKEE,  
WI. FILED 3-8-2005.

## UNITED MILWAUKEE SCRAP

THE MARK CONSISTS OF STANDARD CHARACTERS  
WITHOUT CLAIM TO ANY PARTICULAR FONT, STYLE,  
SIZE, OR COLOR.

NO CLAIM IS MADE TO THE EXCLUSIVE RIGHT TO  
USE "SCRAP", APART FROM THE MARK AS SHOWN.  
SEC. 2(F) AS TO "MILWAUKEE SCRAP".

### CLASS 37—CONSTRUCTION AND REPAIR

FOR WASTE AND RECYCLING COLLECTION;  
SCRAP PROCESSING SERVICES IN THE NATURE OF  
REFUSE CLEANUP (U.S. CLS. 100, 103 AND 106).  
FIRST USE 4-22-2005; IN COMMERCE 4-22-2005.

### CLASS 39—TRANSPORTATION AND STO- RAGE

FOR TRANSPORTATION SERVICE, NAMELY,  
TRANSPORTATION OF RECYCLABLE AND WASTE  
BY TRUCK (U.S. CLS. 100 AND 105).  
FIRST USE 4-22-2005; IN COMMERCE 4-22-2005.

### CLASS 40—MATERIAL TREATMENT

FOR RECYCLING AND WASTE SERVICES, NAMELY  
WASTE MANAGEMENT AND WASTE TREATMENT  
(U.S. CLS. 100, 103 AND 106).  
FIRST USE 4-22-2005; IN COMMERCE 4-22-2005.  
INGRID C. EULIN, EXAMINING ATTORNEY

## MEDIAWARE

THE MARK CONSISTS OF STANDARD CHARACTERS  
WITHOUT CLAIM TO ANY PARTICULAR FONT, STYLE,  
SIZE, OR COLOR.

### CLASS 9—ELECTRICAL AND SCIENTIFIC APPARATUS

FOR SOFTWARE USED TO MANIPULATE AND  
STORE DIGITAL VIDEO AND AUDIO DATA FOOTAGE,  
CONTENT AND DATA, TO CAPTURE, PROCESS, EDIT  
AND STORE DIGITAL VIDEO AND AUDIO DATA  
STREAMS, TO CONFORM DIGITAL VIDEO AND  
AUDIO DATA BROADCAST FOOTAGE, TO MANIPU-  
LATE METADATA ON-LINE, TO REPURPOSE AND  
LOCATE DIGITAL VIDEO AND AUDIO DATA CON-  
TENT, TO MAINTAIN THE INTEGRITY AND QUALITY  
OF DIGITAL VIDEO AND AUDIO DATA FOOTAGE  
DURING EDIT AND MANIPULATION, TO DISTRIBUTE  
DIGITAL VIDEO AND AUDIO DATA EDITING CAPA-  
BILITIES TO OTHERS, TO INTEGRATE DIGITAL  
VIDEO AND AUDIO DATA CONTENT WITH DIGITAL  
ASSET MANAGEMENT (DAM) SYSTEMS; COMPUTER  
SOFTWARE FOR USE WITH ENCODERS, DECODERS,  
TRANSMITTERS, RECEIVERS AND DATA REPRODU-  
CERS; DEVICES, APPARATUS, EQUIPMENT AND IN-  
STALLATIONS, NAMELY DECODERS, ENCODERS,  
DIGITAL VIDEO AND AUDIO DATA STREAM SER-  
VERS, CHANNEL CONTROLLERS, MULTIMEDIA ATM  
ADAPTORS, SPLITTER ENCAPSULATORS, CHANNEL  
MULTIPLEXERS, LOCAL INSERTERS, FIBER NODES,  
RETURN CHANNELS, CABLE WATCHES, HFC NET-  
WORK PLATFORMS, NETWORK ADAPTORS,  
SWITCHES; COMPUTER SOFTWARE IN THE FIELD  
OF DIGITAL VIDEO AND AUDIO DATA FOR GENERA-  
TING, CALCULATING, CONTROLLING, KEYBOARD-  
ING, STOCKING, CONVERTING, COMPRESSING,  
PROCESSING, TRANSMITTING, SWITCHING, RECEIV-  
ING AND REPRODUCING DATA INFORMATION,  
AUDIO SIGNALS, AND VIDEO SIGNALS; DEVICES,  
APPARATUS, EQUIPMENT, AND INSTALLATIONS,  
NAMELY ENCODERS, DECODERS, DIGITAL VIDEO  
AND AUDIO DATA STREAM SERVERS, CHANNEL  
CONTROLLERS, CHANNEL MULTIPLEXERS, HFC  
NETWORK PLATFORMS, NETWORK ADAPTORS,  
SWITCHES, FIBER NODES AND COMPUTER SOFT-  
WARE FOR THE MANAGEMENT OF COMMUNICA-  
TIONS NETWORKS AND COMMUNICATION  
NETWORK COMPONENTS; ELECTRIC CABLES, OPTI-  
CAL FIBER CABLES, ENCODERS, DECODERS, MULTI-  
PLEXERS, MODULATORS, DEMODULATORS, AND  
COMPUTER HARDWARE IN THE NATURE OF COM-  
MUNICATION SERVERS; HARDWARE AND COMPO-  
NENTS USED TO EDIT, MANIPULATE, STORE AND  
VIEW DIGITAL VIDEO AND AUDIO DATA, FOOTAGE  
AND CONTENT, TO CAPTURE, PROCESS, EDIT AND  
STORE DIGITAL VIDEO AND AUDIO DATA STREAMS,  
TO CONFORM DIGITAL VIDEO AND AUDIO BROAD-  
CAST FOOTAGE, TO MANIPULATE METADATA ON-  
LINE, TO REPURPOSE AND LOCATE DIGITAL VIDEO  
AND AUDIO DATA, TO MAINTAIN THE INTEGRITY  
AND QUALITY OF DIGITAL VIDEO AND AUDIO  
DATA DURING EDIT AND MANIPULATION, TO DIS-  
TRIBUTE DIGITAL VIDEO AND AUDIO DATA EDIT-  
ING CAPABILITIES TO OTHERS, TO INTEGRATE  
DIGITAL VIDEO AND AUDIO DATA CONTENT WITH  
DIGITAL ASSET MANAGEMENT (DAM) SYSTEMS;  
COMPUTER HARDWARE FOR USE IN THE MULTI-  
MEDIA FIELD, NAMELY, DIGITAL VIDEO AND  
AUDIO DECODER CARDS AND CHIPS WHICH EN-

ABLE COMPUTERS TO PLAYBACK LIVE AND STORED STREAMING DIGITAL AUDIO AND VIDEO; ELECTRONIC PRINTED CIRCUIT BOARDS FOR LOGIC COMPRESSION AND EXPANSION ALGORITHMS, DIGITAL VIDEO AND AUDIO DATA ENCODERS AND DECODERS, COMPUTER SOFTWARE IN THE FIELD OF LOGIC COMPRESSION AND EXPANSION ALGORITHMS, AND COMPUTER SOFTWARE FOR DIGITAL VIDEO AND AUDIO DATA ENCODERS AND DECODERS; PICTURE COMPRESSION ENCODERS; PICTURE COMPRESSION DECODERS; PICTURE COMPRESSION TRANSCODERS; VIDEO COMPRESSION ENCODERS; VIDEO COMPRESSION DECODERS; VIDEO COMPRESSION TRANSCODERS; AUDIO COMPRESSION ENCODERS; AUDIO COMPRESSION DECODERS; AUDIO COMPRESSION TRANSCODERS; DIGITAL VIDEO AND AUDIO DATA COMPRESSION ENCODERS, COMPRESSION DECODERS, COMPRESSION TRANSCODERS, EDITORS, SWITCHERS, MONITORS, SYNCHRONIZERS, TRANSMITTERS, STORES, PROCESSORS, MULTIPLEXERS AND DEMULTIPLEXERS; SWITCHERS, EDITORS, MONITORS, SYNCHRONIZERS, TRANSLATORS, CONVERTERS, TESTERS, TRANSMITTERS, STORES, PROCESSORS, MULTIPLEXERS, AND DE-MULTIPLEXERS, ALL FOR COMPRESSION ENCODED OR COMPRESSION DECODED OR PARTIALLY COMPRESSION ENCODED OR PARTIALLY COMPRESSION DECODED PICTURE, VIDEO OR AUDIO SIGNALS; SOFTWARE FOR SWITCHING, EDITING, MONITORING, SYNCHRONIZING, TRANSLATING, CONVERTING, MULTIPLEXING, DE-MULTIPLEXING OR OTHER PROCESSING OF COMPRESSION ENCODED OR COMPRESSION DECODED OR PARTIALLY COMPRESSION ENCODED OR COMPRESSION DECODED PICTURE, VIDEO OR AUDIO SIGNALS; SOFTWARE FOR TESTING AND MONITORING OR GUIDING OR CONTROLLING THE SPECIFICALLY AFOREMENTIONED GOODS (U.S. CLS. 21, 23, 26, 36 AND 38).

FIRST USE 1-16-1997; IN COMMERCE 2-26-1997.

#### CLASS 35—ADVERTISING AND BUSINESS

FOR LICENSING OF COMPUTER SOFTWARE (U.S. CLS. 100, 101 AND 102).

FIRST USE 3-12-2005; IN COMMERCE 3-12-2005.

#### CLASS 37—CONSTRUCTION AND REPAIR

FOR INSTALLATION OF COMPUTER SYSTEMS; UPDATING AND MAINTENANCE OF COMPUTER SYSTEMS (U.S. CLS. 100, 103 AND 106).

FIRST USE 3-12-2005; IN COMMERCE 3-12-2005.

#### CLASS 38—COMMUNICATION

FOR BROADCAST, SATELLITE AND REMOTE TRANSMISSION OF DATA, INFORMATION AND AUDIO AND VIDEO SIGNALS, NAMELY RADIO BROADCASTING, TELEVISION BROADCASTING, VIDEO BROADCASTING, ELECTRONIC TRANSMISSION OF MESSAGES, DATA AND DOCUMENTS VIA COMPUTER TERMINALS, ELECTRONIC TRANSMISSION OF MESSAGES; COMMUNICATIONS BY COMPUTER TERMINALS, NAMELY PROVIDING MULTIPLE-USER ACCESS TO A GLOBAL COMPUTER INFORMATION NETWORK (U.S. CLS. 100, 101 AND 104).

FIRST USE 1-16-1997; IN COMMERCE 2-26-1997.

#### CLASS 42—SCIENTIFIC, COMPUTER AND LEGAL SERVICES

FOR COMPUTER SOFTWARE DESIGN, COMPUTER SYSTEMS DESIGN, COMPUTER PROGRAMMING; TECHNICAL CONSULTANCY IN RELATION TO COMPUTER HARDWARE, SOFTWARE AND SYSTEMS, AND COMPUTER PROGRAMMING; RESEARCH AND DEVELOPMENT IN RELATION TO COMPUTER SOFTWARE AND COMPUTER SYSTEMS; TECHNICAL RESEARCH AND CONSULTANCY IN THE FIELD OF DIGITAL VIDEO AND AUDIO DATA AND TELECOMMUNICATION DEVICES, APPARATUS, EQUIPMENT, INSTALLATIONS AND COMPUTER HARDWARE AND SOFTWARE; UPDATING AND MAINTENANCE OF COMPUTER SOFTWARE (U.S. CLS. 100 AND 101).

FIRST USE 1-16-1997; IN COMMERCE 2-26-1997.

ANN E. SAPPENFIELD, EXAMINING ATTORNEY

SN 78-587,994. CYANIDE MERCHANDISING COMPANY, INC., ENCINO, CA. FILED 3-15-2005.

The image shows a stylized, cursive script logo for the word "POISON". The letters are thick and black, with a fluid, handwritten appearance. The 'P' is particularly large and loops around the 'O'. The 'I' is a simple vertical stroke, and the 'O' is a large circle. The 'S' is a series of connected curves, and the 'O' is a simple circle. The 'N' is a simple vertical stroke with a small hook at the top. The overall style is reminiscent of a signature or a brand mark.

OWNER OF U.S. REG. NOS. 2,510,180, 2,597,478 AND OTHERS.

THE MARK CONSISTS OF THE WORD POISON WRITTEN IN SCRIPT.

#### CLASS 9—ELECTRICAL AND SCIENTIFIC APPARATUS

FOR PRE-RECORDED SOUND RECORDINGS, PHONOGRAPH RECORDS, AUDIO TAPES, COMPACT DISCS, VIDEOTAPES, VIDEO CASSETTE TAPES, DIGITAL AUDIO TAPES, COMPACT VIDEODISCS, AND LASER DISCS, ALL FEATURING MUSIC (U.S. CLS. 21, 23, 26, 36 AND 38).

FIRST USE 3-26-1987; IN COMMERCE 3-26-1987.

#### CLASS 16—PAPER GOODS AND PRINTED MATTER

FOR POSTERS AND PRINTED PAPER SIGNS (U.S. CLS. 2, 5, 22, 23, 29, 37, 38 AND 50).

FIRST USE 9-12-1986; IN COMMERCE 9-12-1986.

#### CLASS 41—EDUCATION AND ENTERTAINMENT

FOR ENTERTAINMENT SERVICES, NAMELY, LIVE PERFORMANCES BY A MUSICAL GROUP (U.S. CLS. 100, 101 AND 107).

FIRST USE 3-1-1984; IN COMMERCE 3-1-1984.

RAY THOMAS, EXAMINING ATTORNEY

SN 78-588,012. MADISON SQUARE GARDEN, L.P., NEW YORK, NY. FILED 3-15-2005.

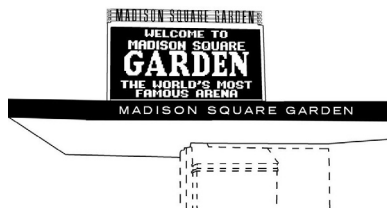

OWNER OF U.S. REG. NOS. 835,284, 2,020,986 AND OTHERS.

THE MARK CONSISTS OF A CONFIGURATION OF A MARQUEE WITH THE WORDS MADISON SQUARE GARDEN ON THE TOP OF THE MARQUEE AND ALSO ON THE MARQUEE, AND ON A SIGN IN THE CENTER APPEARS THE WORDS WELCOME TO MADISON SQUARE GARDEN THE WORLD'S MOST FAMOUS ARENA. THE DOTTED LINES IN THE DRAWING ARE FOR PLACEMENT PURPOSES ONLY.

#### **CLASS 41—EDUCATION AND ENTERTAINMENT**

FOR PRODUCTION OR CO-PRODUCTION OF SPORTING EVENTS AND LIVE MUSIC CONCERTS FOR PUBLIC EXHIBITION AND FOR RADIO, TELEVISION AND CABLE TELEVISION BROADCAST (U.S. CLS. 100, 101 AND 107).

#### **CLASS 43—HOTEL AND RESTAURANT SERVICES**

FOR ARENA SERVICES, NAMELY, PROVIDING FACILITIES FOR SPORTING EVENTS, CONCERTS, CONVENTIONS AND EXHIBITIONS (U.S. CLS. 100 AND 101).  
FIRST USE 0-0-1968; IN COMMERCE 0-0-1968.  
ELI HELLMAN, EXAMINING ATTORNEY

SN 78-596,382. TELUS CORPORATION, EDMONTON, ALBERTA T5J 0N5, CANADA, FILED 3-28-2005.

## **CAMP-IN-A-BOX**

THE MARK CONSISTS OF STANDARD CHARACTERS WITHOUT CLAIM TO ANY PARTICULAR FONT, STYLE, SIZE, OR COLOR.

PRIORITY CLAIMED UNDER SEC. 44(D) ON CANADA APPLICATION NO. 1251481, FILED 3-22-2005, REG. NO. TMA673361, DATED 9-26-2006, EXPIRES 9-26-2021.

#### **CLASS 9—ELECTRICAL AND SCIENTIFIC APPARATUS**

FOR TELECOMMUNICATION EQUIPMENT, NAMELY, COMPUTER HARDWARE AND SOFTWARE FOR CALL ROUTING IN TELECOMMUNICATIONS NETWORKS; TELEPHONES; WIRELESS TELEPHONES; PAGERS AND ACCESSORIES, NAMELY CHARGERS, BATTERIES, AERIALS, CARRYING CASES, MICROPHONES; PRE-PAID TELEPHONE CALLING CARDS, MAGNETICALLY ENCODED (U.S. CLS. 21, 23, 26, 36 AND 38).

#### **CLASS 37—CONSTRUCTION AND REPAIR**

FOR REPAIR AND MAINTENANCE OF TELECOMMUNICATION MACHINES AND APPARATUS (U.S. CLS. 100, 103 AND 106).

#### **CLASS 38—COMMUNICATION**

FOR TELECOMMUNICATIONS SERVICES, NAMELY, LOCAL TELEPHONE SERVICES, INTERCONNECTION SERVICES BETWEEN BUILDINGS AND TELECOMMUNICATION NETWORKS, LONG DISTANCE TELEPHONE SERVICES, PAGING SERVICES, LEASING OF TELECOMMUNICATIONS EQUIPMENT AND SYSTEMS, NAMELY, TELEPHONE APPARATUSES, TELEPHONE SETS, COMPUTER HARDWARE AND SOFTWARE FOR CALL ROUTING, WIRELESS TELEPHONES, AND MOBILE PHONES; MOBILE TELECOMMUNICATIONS SERVICES, NAMELY COMMUNICATIONS BY MEANS OF CELLULAR TELEPHONE, MOBILE RADIO, DIGITAL CORDLESS TELEPHONE, PAGER, SATELLITE; INTERCONNECTION SERVICES BETWEEN CELLULAR PHONES, MOBILE RADIOS, DIGITAL CORDLESS TELEPHONES, PAGERS, SATELLITES AND TELECOMMUNICATION NETWORKS; INTERCONNECTION SERVICES BETWEEN MOBILE UNITS AND TELECOMMUNICATIONS NETWORKS; MULTIMEDIA COMMUNICATIONS AND DIGITAL COMMUNICATIONS SERVICES, NAMELY, BROADCAST, TRANSMISSION, AND RECEIPT OF INTERACTIVE AND NON-INTERACTIVE AUDIO, VIDEO, AND DIGITAL SIGNALS OFFERED OVER A COMMUNICATIONS NETWORK; TELECONFERENCING SERVICES; VIDEOCONFERENCING SERVICES; TELECOMMUNICATION CONSULTING SERVICES; INTERNETWORKING SERVICES, NAMELY BUSINESS INTERNET ACCESS; COMMUNICATING VIA VOICE OVER INTERNET PROTOCOL (U.S. CLS. 100, 101 AND 104).

#### **CLASS 41—EDUCATION AND ENTERTAINMENT**

FOR EDUCATIONAL SERVICES, NAMELY, CONDUCTING ONLINE CLASSES AND SEMINARS IN THE FIELD OF INTERNET ACCESS AND USE; PROVIDING ONLINE NON-DOWNLOADABLE BROCHURES IN THE FIELD OF INTERNET ACCESS AND USE; PROVIDING ON-LINE INSTRUCTION IN THE FIELD OF INTERNET ACCESS AND USE (U.S. CLS. 100, 101 AND 107).

**CLASS 42—SCIENTIFIC, COMPUTER AND LEGAL SERVICES**

FOR COMPUTER CONSULTATION SERVICES FOR INTERNET USERS RELATING TO COMPUTER SYSTEM SECURITY, CONTENT FILTERING, INTRUSION PREVENTION, HARDWARE AND SOFTWARE; TESTING SERVICES, RESEARCH AND DEVELOPMENT SERVICES, DESIGN AND INSPECTION SERVICES FOR COMMUNICATIONS NETWORKS AND SYSTEMS; COMPUTER SERVICES, NAMELY, PROVIDING SEARCH ENGINES FOR OBTAINING DATA ON A GLOBAL COMPUTER NETWORKS, NAMELY, ADDRESS AND LEGAL LAND DESCRIPTION SEARCH SERVICES DELIVERED VIA THE INTERNET; COMPUTER DATA SECURITY SERVICES, NAMELY, RESTRICTING ACCESS TO AND BY COMPUTER NETWORKS TO AND OF UNDESIRE WEB SITES, MEDIA AND INDIVIDUALS AND FACILITIES VIA MANAGED SECURE AUTHENTICATION, MANAGED VIRUS PROTECTION, MANAGED E-MAIL PROTECTION, MANAGED CONTENT FILTERING, MANAGED INTRUSION PREVENTION SYSTEMS AND DESKTOP BACKUP SERVICES (U.S. CLS. 100 AND 101).

**CLASS 45—PERSONAL SERVICES**

FOR MONITORING OF COMPUTER SYSTEMS FOR DATA SECURITY PURPOSES, NAMELY, MANAGED SECURE AUTHENTICATION, MANAGED VIRUS PROTECTION, MANAGED E-MAIL PROTECTION, MANAGED CONTENT FILTERING, MANAGED INTRUSION PREVENTION SYSTEMS AND DESKTOP BACKUP SERVICES; SECURITY AND SURVEILLANCE SERVICES OFFERED OVER A TELECOMMUNICATIONS NETWORK, NAMELY, MONITORING OF COMPUTER SYSTEMS FOR DATA SECURITY PURPOSES, NAMELY, MANAGED SECURE AUTHENTICATION, MANAGED VIRUS PROTECTION, MANAGED E-MAIL PROTECTION, MANAGED CONTENT FILTERING, MANAGED INTRUSION PREVENTION SYSTEMS AND DESKTOP BACKUP SERVICES (U.S. CLS. 100 AND 101).

ANTHONY RINKER, EXAMINING ATTORNEY

**CLASS 9—ELECTRICAL AND SCIENTIFIC APPARATUS**

FOR (BASED ON INTENT TO USE) COMPONENTS FOR LASER TONER CARTRIDGES, NAMELY, REPLACEMENT DRUMS AND ROLLERS (U.S. CLS. 21, 23, 26, 36 AND 38).

**CLASS 16—PAPER GOODS AND PRINTED MATTER**

FOR (BASED ON INTENT TO USE) PRINTER PAPER, COMPUTER PRINTER RIBBONS, CASH REGISTER RIBBONS, OFFICE MACHINE RIBBONS, INKED NYLON RIBBON, NYLON PRINTER INK RIBBONS, THERMAL TRANSFER RIBBON, PRINTING FONTS (U.S. CLS. 2, 5, 22, 23, 29, 37, 38 AND 50).

**CLASS 35—ADVERTISING AND BUSINESS**

FOR (BASED ON USE IN COMMERCE) RETAIL AND WHOLESALE STORE SERVICES, INTERNET RETAIL STORE AND WHOLESALE STORE SERVICES, CATALOG AND MAIL ORDER SERVICE FEATURING PRINTER AND PHOTOCOPIER CONSUMABLES IN THE NATURE OF COMPUTER PRINTER INK RIBBONS, DUPLICATING INKS, INKS, PRINTER INK FOR INKJET AND LASER PRINTERS, PRINTER CARTRIDGES AND TONERS, INK CARTRIDGES, PHOTOCOPIER AND LASER PRINTER TONER CARTRIDGES (U.S. CLS. 100, 101 AND 102).

FIRST USE 2-21-2005; IN COMMERCE 2-21-2005.

**CLASS 37—CONSTRUCTION AND REPAIR**

FOR (BASED ON USE IN COMMERCE) MAINTENANCE OF INKJET AND LASER TONER PRINTER CARTRIDGES, NAMELY REFILLING INK AND TONER CARTRIDGES (U.S. CLS. 100, 103 AND 106).

FIRST USE 2-21-2005; IN COMMERCE 2-21-2005.

PAUL E. FAHRENKOPF, EXAMINING ATTORNEY

SN 78-601,429. FRANCHISE SERVICES, INC., MISSION VIEJO, CA. FILED 4-4-2005.

SN 78-604,293. GERSTUNG INTERNATIONAL SPORT EDUCATION, INC., BALTIMORE, MD. FILED 4-7-2005.



NO CLAIM IS MADE TO THE EXCLUSIVE RIGHT TO USE "CARTRIDGES", APART FROM THE MARK AS SHOWN.

**CLASS 1—CHEMICALS**

FOR (BASED ON INTENT TO USE) PHOTO PAPER (U.S. CLS. 1, 5, 6, 10, 26 AND 46).

**CLASS 2—PAINTS**

FOR (BASED ON USE IN COMMERCE) REMANUFACTURED INK CARTRIDGES, AND PHOTOCOPIER AND LASER PRINTER TONER CARTRIDGES; TONER CARTRIDGES WITH MEMORY INTEGRATED CIRCUITS, INK AND TONER CARTRIDGES; INK REFILL KITS CONSISTING PRIMARILY OF INK AND SYRINGES OR OTHER MECHANISMS TO DELIVER INK INTO AN EMPTY CARTRIDGE (U.S. CLS. 6, 11 AND 16).

FIRST USE 2-21-2005; IN COMMERCE 2-21-2005.

THE MARK CONSISTS OF STANDARD CHARACTERS WITHOUT CLAIM TO ANY PARTICULAR FONT, STYLE, SIZE, OR COLOR.

SEC. 2(F).

**CLASS 27—FLOOR COVERINGS**

FOR FLOOR COVERINGS, NAMELY, SUSPENDED CUSHIONED FLOORS AND EXERCISE MATS (U.S. CLS. 19, 20, 37, 42 AND 50).

FIRST USE 2-1-1982; IN COMMERCE 2-1-1982.

# GERSTUNG

**CLASS 28—TOYS AND SPORTING GOODS**

FOR REBOUND FITNESS EQUIPMENT, NAMELY, TRAMPOLINES; PORTABLE SUPPORT STRUCTURES FOR DANCE AND OTHER EXERCISE; GYMNASIUM APPARATUS; BALLET EXERCISE BARS AND WALL BARS FOR GYMNASIUMS (U.S. CLS. 22, 23, 38 AND 50).  
FIRST USE 2-1-1982; IN COMMERCE 2-1-1982.

**CLASS 41—EDUCATION AND ENTERTAINMENT**

FOR PHYSICAL FITNESS INSTRUCTIONS; PROVIDING FITNESS AND EXERCISE FACILITIES; DANCE SCHOOLS; PUBLICATION OF BOOKS, TAPES AND COMPACT DISCS FEATURING FITNESS TRAINING AND DEVELOPMENTAL AND EDUCATIONAL GYMNASIUM ACTIVITIES (U.S. CLS. 100, 101 AND 107).

FIRST USE 2-1-1982; IN COMMERCE 2-1-1982.  
MARK T. MULLEN, EXAMINING ATTORNEY

---

SN 78-605,544. INTERPLANET PRODUCTIONS LIMITED, BEVERLY HILLS, CA. FILED 4-9-2005.

"SOMETHING WONDERFUL IS  
ABOUT TO HAPPEN" ELIZABETH  
TAYLOR

THE MARK CONSISTS OF STANDARD CHARACTERS WITHOUT CLAIM TO ANY PARTICULAR FONT, STYLE, SIZE, OR COLOR.

THE NAME ELIZABETH TAYLOR IDENTIFIES A LIVING INDIVIDUAL WHOSE CONSENT IS OF RECORD.

**CLASS 8—HAND TOOLS**

FOR FLATWARE (U.S. CLS. 23, 28 AND 44).

**CLASS 21—HOUSEWARES AND GLASS**

FOR HAIRBRUSHES AND COMBS, COSMETIC BRUSHES; BEVERAGE GLASSWARE, STEMWARE, EARTHENWARE MUGS, DECANTERS, VASES AND BOWLS NOT OF PRECIOUS METAL; CANDLESTICKS AND CANDLEHOLDERS NOT OF PRECIOUS METAL, BOTTLE OPENERS; WINE BOTTLE CRADLES; BAKING DISHES AND BAKEWARE; COOKWARE, NAMELY, POTS, PANS AND STEAMERS; DINNERWARE, NAMELY, PLATES, DISHES, CUPS AND SAUCERS; SALT AND PEPPER SHAKERS; NAPKIN HOLDERS AND NAPKIN RINGS NOT OF PRECIOUS METAL; BATH PRODUCTS, NAMELY, BODY SPONGES AND LOOFAH SPONGES; FLOWER BOWLS AND POTS (U.S. CLS. 2, 13, 23, 29, 30, 33, 40 AND 50).

SUE LAWRENCE, EXAMINING ATTORNEY

---

SN 78-605,545. INTERPLANET PRODUCTIONS LIMITED, BEVERLY HILLS, CA. FILED 4-9-2005.

"SOMETHING WONDERFUL IS  
ABOUT TO HAPPEN" ELIZABETH  
TAYLOR

THE MARK CONSISTS OF STANDARD CHARACTERS WITHOUT CLAIM TO ANY PARTICULAR FONT, STYLE, SIZE, OR COLOR.

THE NAME ELIZABETH TAYLOR IDENTIFIES A LIVING INDIVIDUAL WHOSE CONSENT IS OF RECORD.

**CLASS 20—FURNITURE AND ARTICLES NOT OTHERWISE CLASSIFIED**

FOR DECORATIVE PILLOWS AND PILLOWS (U.S. CLS. 2, 13, 22, 25, 32 AND 50).

**CLASS 24—FABRICS**

FOR FELT AND NON-WOVEN TEXTILE FABRICS; TABLE CLOTHS NOT MADE OF PAPER; TABLE RUNNERS MADE FROM FABRIC; TABLE COVERS, NAMELY, TABLE LINEN; TABLE LINEN, NAMELY, COASTERS, NAPKINS AND PLACE MATS; COVERS FOR CUSHIONS; BED BLANKETS, BLANKET TROWS, BED CANOPIES, BED LINEN, BED PADS, BED SHEETS, BED SPREADS, BED COMFORTERS, BED COVERS, BED SKIRTS, DUST RUFFLES, DUVETS, PILLOW SHAMS, AND PILLOW CASES; BATH LINEN, BATH TOWELS, HAND TOWELS OF FABRIC, KITCHEN TOWELS, WASHCLOTHS, CURTAINS, SHOWER CURTAINS, AND DRAPES; WINDOW TREATMENTS INCLUDING VALANCES, POUFS, PUFFS AND SWAGS; TEXTILE WALL HANGINGS AND PANELS (U.S. CLS. 42 AND 50).  
SUE LAWRENCE, EXAMINING ATTORNEY

---

SN 78-605,981. YAHOO! INC., SUNNYVALE, CA. FILED 4-11-2005.

**FARECHASE**

THE MARK CONSISTS OF STANDARD CHARACTERS WITHOUT CLAIM TO ANY PARTICULAR FONT, STYLE, SIZE, OR COLOR.

**CLASS 42—SCIENTIFIC, COMPUTER AND LEGAL SERVICES**

FOR SEARCH ENGINE SERVICES, NAMELY, PROVIDING SEARCH ENGINES FOR OBTAINING DATA ON A GLOBAL COMPUTER NETWORK; PROVIDING SPECIFIC INFORMATION AS REQUESTED BY CUSTOMERS VIA THE INTERNET, NAMELY, SEARCHING AND RETRIEVING INFORMATION IN THE FIELDS OF TRAVEL AND LODGING VIA COMPUTER NETWORKS; ONLINE COMPUTER MAPPING SERVICES (U.S. CLS. 100 AND 101).

FIRST USE 9-0-2000; IN COMMERCE 9-0-2000.

**CLASS 43—HOTEL AND RESTAURANT SERVICES**

FOR PROVIDING INFORMATION REGARDING LODGING; PROVIDING INFORMATION REGARDING TEMPORARY ACCOMMODATIONS; TRAVEL AGENCY SERVICES, NAMELY, MAKING RESERVATIONS AND BOOKING FOR TEMPORARY LODGING (U.S. CLS. 100 AND 101).

FIRST USE 9-0-2000; IN COMMERCE 9-0-2000.  
STEVEN PEREZ, EXAMINING ATTORNEY

SN 78-616,381. ESQUEL ENTERPRISES LIMITED, HONG KONG, CHINA, FILED 4-25-2005.

# ESQUEL ULTEMA

THE MARK CONSISTS OF STANDARD CHARACTERS WITHOUT CLAIM TO ANY PARTICULAR FONT, STYLE, SIZE, OR COLOR.

OWNER OF HONG KONG REG. NO. 300414945, DATED 5-5-2005, EXPIRES 5-4-2015.

## CLASS 24—FABRICS

FOR WOVEN FABRICS; KNIT FABRICS; FELT AND NON-WOVEN TEXTILE FABRICS; OILCLOTH; GUMMED WATERPROOF CLOTH; VINYL COATED CLOTH FOR USE IN THE MANUFACTURE OF UPHOLSTERY, RUBBERIZED CLOTH, MOSQUITO NETS; BED SHEETS; QUILTS; LINEN FUTON AND QUILTS CASES; PILLOWCASES; BLANKETS; TABLE NAPKINS OF TEXTILE; DISH CLOTHES; SHOWER CURTAINS; FABRIC BANNERS AND FABRIC FLAGS; FITTED TOILET LID COVERS MADE OF FABRIC; UNFITTED FABRIC SEAT COVERS; WALL HANGINGS OF TEXTILE; CURTAINS; TABLE CLOTHES NOT OF PAPER; DRAPERIES, NAMELY, THICK DROP CURTAINS; BILLIARD CLOTH; LABELS OF CLOTH; COMFORTERS; PILLOW SHAMS; QUILTS; CLOTH TEXTILES FOR USE IN THE MANUFACTURE OF CLOTHING; BED AND TABLE COVERS MADE OF CLOTH (U.S. CLS. 42 AND 50).

## CLASS 25—CLOTHING

FOR CLOTHING, NAMELY, TOPCOATS, BLOUSES, SHIRTS, DRESS SHIRTS, SPORT SHIRTS, BATH ROBES, BOXER BRIEFS, BOXER SHORTS, UNDERWEAR, PAJAMAS, SKIRTS, LOUNGE WEAR, DRESSES, PANTS, SHORTS, GARTERS, NAMELY, ANKLE GARTERS; SUSPENDERS; CLOTHES FOR SPORTS, NAMELY, WARM-UP JACKETS, WARM-UP PANTS, SWEATERS, SWEATPANTS, JACKETS, JERSEYS, SWIMSUITS, T-SHIRTS; BOOTS FOR SPORTS, NAMELY, FOOTBALL BOOTS, FOOTBALL SHOES, GYMNASTIC SHOES, SKI BOOTS; HEADGEAR, NAMELY, HATS AND CAPS (U.S. CLS. 22 AND 39).

SCOTT SISUN, EXAMINING ATTORNEY

SN 78-622,922. LEGENTEK, INC., ARCADIA, CA. FILED 5-4-2005.

# Elb plus

THE MARK CONSISTS OF STANDARD CHARACTERS WITHOUT CLAIM TO ANY PARTICULAR FONT, STYLE, SIZE, OR COLOR.

## CLASS 9—ELECTRICAL AND SCIENTIFIC APPARATUS

FOR ELECTRICAL AND ELECTRONIC APPARATUS IN THE NATURE OF ASSEMBLIES, POWER PACKS, TRANSFORMERS, CIRCUIT BOARDS, CIRCUIT BREAKERS AND LIGHTING BALLASTS THAT CONDUCT, SWITCH, REGULATE AND CONTROL ELECTRICITY; LIGHT DIMMER ASSEMBLIES AND COMPONENTS TO REGULATE AND ENHANCE LIGHTING IN BOTH OUTDOOR AND INDOOR ENVIRONMENTS (U.S. CLS. 21, 23, 26, 36 AND 38).

## CLASS 11—ENVIRONMENTAL CONTROL APPARATUS

FOR LIGHTING FIXTURES, AND PARTS THEREFOR, TO REGULATE AND ENHANCE LIGHTING IN BOTH OUTDOOR AND INDOOR ENVIRONMENTS; ELECTRONICALLY LIT FIREPLACES IN BOTH INTERIOR AND EXTERIOR ENVIRONMENTS (U.S. CLS. 13, 21, 23, 31 AND 34).

SCOTT SISUN, EXAMINING ATTORNEY

SN 78-624,366. JEWELRY SUPPLY, INC., ROSEVILLE, CA. FILED 5-5-2005.



NO CLAIM IS MADE TO THE EXCLUSIVE RIGHT TO USE JEWELRY SUPPLY, APART FROM THE MARK AS SHOWN.

THE MARK CONSISTS OF JEWELRY SUPPLY AND DESIGN OF TRIANGLE INCLUDING BEADS, SPOOL OF WIRE, TOOLS AND FINDINGS.

## CLASS 14—JEWELRY

FOR COSTUME JEWELRY PARTS AND FINDINGS, FINISHED JEWELRY, JEWELRY BOXES NOT OF METAL, JEWELRY BOXES OF PRECIOUS METAL (U.S. CLS. 2, 27, 28 AND 50).

FIRST USE 1-15-1981; IN COMMERCE 1-15-1981.

## CLASS 20—FURNITURE AND ARTICLES NOT OTHERWISE CLASSIFIED

FOR JEWELRY DISPLAY CASES (U.S. CLS. 2, 13, 22, 25, 32 AND 50).

FIRST USE 1-15-1981; IN COMMERCE 1-15-1981.

ASMAT KHAN, EXAMINING ATTORNEY

SN 78-628,418. MEADWESTVACO CORPORATION, STAMFORD, CT. FILED 5-12-2005.

# EVOTHERM

THE MARK CONSISTS OF STANDARD CHARACTERS WITHOUT CLAIM TO ANY PARTICULAR FONT, STYLE, SIZE, OR COLOR.

**CLASS 40—MATERIAL TREATMENT**

FOR CUSTOM MANUFACTURE OF ASPHALT, ASPHALT PAVEMENTS AND ASPHALT PAVING COMPOSITIONS TO THE ORDER AND/OR SPECIFICATION OF OTHERS; CONSULTATION SERVICES IN THE FIELD OF ASPHALT MANUFACTURING (U.S. CLS. 100, 103 AND 106).

**CLASS 42—SCIENTIFIC, COMPUTER AND LEGAL SERVICES**

FOR DESIGN OF ASPHALT, ASPHALT PAVEMENTS AND ASPHALT PAVING COMPOSITIONS; TECHNICAL CONSULTATION SERVICES IN THE FIELDS OF ASPHALT DESIGN AND MANUFACTURING (U.S. CLS. 100 AND 101).

SCOTT SISUN, EXAMINING ATTORNEY

---

SN 78-630,050. KABUSHIKI KAISHA ZUCCA DESIGN OFFICE, TA ZUCCA DESIGN OFFICE INC., TOKYO, JAPAN, FILED 5-13-2005.

**CABANE de ZUCCA**

OWNER OF JAPAN REG. NO. 4351484-1, DATED 1-14-2000, EXPIRES 1-14-2010.

OWNER OF U.S. REG. NO. 2,349,837.

THE FOREIGN WORDING IN THE MARK TRANSLATES INTO ENGLISH AS "HUT" (FOR CABANE) AND "PUMPKIN" (FOR ZUCCA).

**CLASS 14—JEWELRY**

FOR KEY RINGS OF PRECIOUS METAL; CUFF LINKS; EARRINGS, INSIGNIAS OF PRECIOUS METAL, BELT BUCKLES OF PRECIOUS METAL, BADGES OF PRECIOUS METAL, BONNET PINS OF PRECIOUS METAL, TIE CLIPS, TIE PINS, NECKLACES, BRACELETS, PENDANTS, BROOCHES, JEWELRY, MEDALS, RINGS, MEDALLIONS; WATCHES AND CLOCKS; TOBACCO POUCHES OF PRECIOUS METAL, CIGARETTE CASES OF PRECIOUS METAL, CIGARETTE HOLDERS OF PRECIOUS METAL, ASHTRAYS OF PRECIOUS METAL (U.S. CLS. 2, 27, 28 AND 50).

**CLASS 18—LEATHER GOODS**

FOR CLOTHING FOR DOMESTIC PETS; FOLDING BRIEFCASES, SHOULDER BAGS, GLADSTONE BAGS, BRIEFCASES, SUITCASES, CARRY-ON BAGS, TRUNKS, HANDBAGS, BOSTON BAGS, SCHOOLCHILDREN'S BACKPACKS; BACKPACKS, NAMELY, RUCKSACKS; CHARM BAGS, CREDIT CARD CASES, TEXTILE AND LEATHER SHOPPING BAGS, PURSES, KEY CASES, WALLET, BUSINESS CARD CASES; UMBRELLAS AND THEIR PARTS (U.S. CLS. 1, 2, 3, 22 AND 41).

**CLASS 24—FABRICS**

FOR COTTON FABRICS, HEMP YARN FABRICS, SILK FABRICS, WOOL YARN FABRICS, CHEMICAL FIBER FABRICS, INORGANIC FIBER FABRICS, MIXED FIBER FABRICS, MIXED YARN FABRICS, NARROW WOVEN FABRICS, PAPER YARN FABRICS, COVERED RUBBER YARN FABRICS; TOWELS, JAPANESE COTTON TOWELS, HANDKERCHIEFS, JAPANESE GENERAL WRAPPING CLOTH; LINEN FUTON AND QUILTS CASES, PILLOWCASES, BED SHEETS, BLANKETS; TABLE NAPKINS OF TEXTILE, DISH CLOTHS; SEAT COVERS OF TEXTILE, WALL HANGINGS OF TEXTILE, CURTAINS, TABLE CLOTHS NOT OF PAPER, DRAPERIES (U.S. CLS. 42 AND 50).

**CLASS 25—CLOTHING**

FOR NON-JAPANESE STYLE OUTERWEAR, CHILDREN'S WEAR AND WORK CLOTHING, NAMELY, EVENING DRESSES, SCHOOL UNIFORMS, JACKETS, JOGGING PANTS, SWEAT PANTS, SUITS, SKIRTS, SKI JACKETS, SKI PANTS, TROUSERS, SMOCKS, COATS, OVERCOATS, TOPCOATS, MANTLES, RAINCOATS; FORMAL WEAR, NAMELY, TUXEDOS; SWEATERS, SHIRTS, NIGHTWEAR, UNDERWEAR, BATHING SUITS, SWIMMING CAPS; APRONS, COLLAR PROTECTORS, SOCKS AND STOCKINGS, PUTTEES AND GAITERS, FUR STOLE, SHAWLS, SCARVES, JAPANESE STYLE SOCKS (TABI), GLOVES AND MITTENS, BABIES' STYLE SOCKS (TABI), GLOVES AND MITTENS, BABIES' DIAPERS OF TEXTILE, NECKTIES, NECKERCHIEFS, BANDANAS, WARMTH-KEEPING SUPPORTS, NAMELY, LEG WARMERS, MUFFLERS, EAR MUFFS; HOODS, SEDGE HATS, NIGHTCAP, CLOTHING HELMETS AND HEADGEAR FOR CLOTHING, NAMELY, HATS AND CAPS; GARTERS, SOCK SUSPENDERS, SUSPENDERS, WAISTBANDS, BELTS FOR CLOTHING; SHOES, BOOTS, SLIPPERS, SNEAKERS; MASQUERADE COSTUMES; CLOTHES FOR SPORTS, NAMELY, ANORAKS, KARATE SUITS, SPORTS OVERUNIFORMS, KENDO OUTFITS, JUDO SUITS, SKI SUITS FOR COMPETITION, CLOTHING HEADBANDS, WIND JACKETS, UNIFORMS AND STOCKINGS, WRISTBANDS; BOOTS FOR SPORTS, NAMELY, GOLF SHOES, SOCCER SHOES, SKI BOOTS, GYMNAS TIC SHOES, TENNIS SHOES, CLIMBING BOOTS, BASKETBALL SNEAKERS, VOLLEYBALL SHOES, HANDBALL SHOES, BOWLING SHOES, BOXING SHOES, HOCKEY SHOES, BASEBALL SHOES, RUGBY SHOES, FOOTWEAR FOR TRACK AND FIELD ATHLETICS (U.S. CLS. 22 AND 39).

ANGELA M. MICHELI, EXAMINING ATTORNEY

---

SN 78-638,890. HOUSELY INDUSTRIES LTD., NEW TERRITORIES, HONG KONG, HONG KONG, FILED 5-27-2005.

Housely Industries Ltd.

居利實業有限公司

NO CLAIM IS MADE TO THE EXCLUSIVE RIGHT TO USE "ENTERPRISE LIMITED COMPANY", APART FROM THE MARK AS SHOWN.

THE NAME(S), PORTRAIT(S), AND/OR SIGNATURE(S) SHOWN IN THE MARK DOES NOT IDENTIFY A PARTICULAR LIVING INDIVIDUAL.

THE ENGLISH TRANSLATION OF JOO LI SHE YEAH YO SYAN GONG SI IN MANDARIN IS JU LI ENTERPRISE LIMITED COMPANY.

THE NON-LATIN CHARACTER(S) IN THE MARK TRANSLITERATES INTO JOO LI SHE YEAH YO SYAN GONG SI IN MANDARIN.



**CLASS 9—ELECTRICAL AND SCIENTIFIC APPARATUS**

FOR LCD TELEVISION; TELEVISION APPARATUS, NAMELY, TELEVISIONS, TELEVISION SETS, PORTABLE TELEVISIONS; MPEG 4 PORTABLE MULTI-MEDIA PLAYERS; PORTABLE DVD PLAYERS; DVD RECORDER/PLAYERS; APPARATUS FOR RECORDING, TRANSMISSION OR REPRODUCTION OF SOUND OR IMAGES; LCD MONITORS, AND MONITORS, NAMELY, LCD VIDEO MONITORS, LCD TELEVISION MONITORS, COMPUTER MONITORS, LCD COMPUTER MONITORS, TELEVISION MONITORS; HOME THEATER PRODUCTS, NAMELY, LCD AND DLP; SOUND RECORDING AND SOUND REPRODUCING APPARATUS AND INSTRUMENTS; DVD/VCD/CD/MP3 PLAYERS; COMPUTERS; NOTEBOOK COMPUTERS AND LAPTOP COMPUTERS (U.S. CLS. 21, 23, 26, 36 AND 38).

SN 78-646,274. C.S. LEWIS (PTE.) LTD., BEACH CENTRE, SINGAPORE, FILED 6-8-2005.

**CLASS 3—COSMETICS AND CLEANING PREPARATIONS**

FOR SOAPS; PERFUMERY, ESSENTIAL OILS FOR PERSONAL USE; COSMETICS; HAIR LOTIONS; DENTIFRICES; PRE-SHAVE LOTION, AFTER SHAVE LOTION, SHAVING CREAM, LOTION, GEL AND FOAM, AFTER SHAVE CREAM AND EMULSION, SKIN MOISTURE LOTION, EMULSION AND CREAM, DEODORANTS FOR PERSONAL USE; DEODORANT AND ANTI-PERSPIRANT CREAM, TALC, STICKS AND LOTIONS, ALSO IN THE FORM OF ATOMIZERS AND ROLL-ON DEVICES, SPRAY TALC, BODY CREAM AND LOTION, HAND CREAM, NON-MEDICATED HAND BALM, MASSAGE CREAM, GEL AND OIL, NON-MEDICINAL MOUTHWASH, HAIR CARE PREPARATIONS, TOOTH-PASTE, NON-MEDICATED MOUTHWASHES; TOILETRIES, NAMELY, FACIAL CLEANSERS, FACIAL MOISTURIZERS, FACE CREAMS, FACE LOTIONS, FACE GELS, EYE CREAMS, EYE GELS, EYE MAKEUP REMOVER, FACIAL MAKEUP REMOVER, CLEANSING LOTIONS, CLEANSING CREAMS, CLEANSING GELS, NON-MEDICATED ANTI-WRINKLE CREAMS, LOTIONS AND GELS, NON-MEDICATED SKIN REPAIR CREAMS, LOTIONS AND GELS, NON-MEDICATED SKIN BLEMISH PREPARATIONS, FACIAL TONER, BODY GEL, BODY GEL, BODY OIL, BODY POWDER, BODY TONERS, BODY CLEANSERS, NON-MEDICATED BATH SALTS, BATH POWDER, BATH OIL, BATH GRAINS, BATH GELS, FACIAL AND BODY SPRAYS, BODY WASHES, SKIN BALANCING LOTIONS, CREAMS AND GELS, FACIAL SKIN CARE PREPARATIONS, NAMELY, OIL CONTROLLERS, SKIN FIRMSING PREPARATIONS, EYE LOTIONS, NON-MEDICATED SKIN RENEWAL CREAM, FACE AND BODY MASQUES, SKIN REFRESHERS, FACE AND BODY EXFOLIATING PREPARATIONS, FACE AND BODY SUNSCREENS, FACE AND BODY SELF-TANNING PREPARATIONS, LIP SUNSCREEN PREPARATIONS, SUN TAN LOTIONS, AFTER-SUN SOOTHING AND MOISTURIZING PREPARATIONS AND LIP BALM (U.S. CLS. 1, 4, 6, 50, 51 AND 52).

**CLASS 11—ENVIRONMENTAL CONTROL APPARATUS**

FOR COOKING APPLIANCES, NAMELY, ELECTRIC COOKING POTS; ELECTRIC COOKING OVENS, ELECTRIC DEEP FRYERS; ELECTRIC COFFEE MAKERS; ELECTRIC KETTLES; ELECTRIC TOASTERS; ELECTRIC FANS; ELECTRIC FAN HEATERS; ELECTRIC HEATERS, NAMELY, PORTABLE ELECTRIC HEATERS, ELECTRIC RADIANT HEATERS, ELECTRIC HEATERS FOR COMMERCIAL USE, ELECTRIC SPACE HEATERS; HEAT EXCHANGERS; HEATING APPLIANCES, NAMELY, ELECTRIC RADIATORS FOR HEATING BUILDINGS; CONVECTOR HEATERS, NAMELY, CONVECTION OVENS; ELECTRIC RADIATORS AND OIL FILLED RADIATORS NOT FOR MOTORS OR ENGINES; VENTILATING FANS FOR INDUSTRIAL AND COMMERCIAL USE, VENTILATING EXHAUST FANS; AIR PURIFIERS; AIR CLEANERS, NAMELY, AIR CLEANING UNITS; AIR-TO-AIR HEAT RECOVERY VENTILATORS; HAIR DRYERS; PARTS AND FITTINGS FOR ALL THE AFORESAID GOODS (U.S. CLS. 13, 21, 23, 31 AND 34).

KELLEY WELLS, EXAMINING ATTORNEY

**CLASS 9—ELECTRICAL AND SCIENTIFIC APPARATUS**

FOR BLANK MAGNETIC DATA CARRIERS; COMPACT DISCS AND COMPUTER DISCS FEATURING FICTIONAL, EDUCATIONAL AND ENTERTAINMENT WORKS; COMPUTER SOFTWARE FOR EDUCATION AND ENTERTAINMENT, NAMELY, CHILDREN'S EDUCATIONAL COMPUTER SOFTWARE AND SOFTWARE PROGRAMS FEATURING GAMES, GRAPHICS AND INTERACTIVE PROGRAMS FOR THE ENTERTAINMENT AND EDUCATION OF CHILDREN; MOTION PICTURE FILMS AND CINEMATOGRAPHIC FILMS FEATURING FICTIONAL, EDUCATIONAL AND ENTERTAINMENT WORKS; BLANK VIDEO TAPES, VIDEO CASSETTES, AUDIO CASSETTES, VIDEO TAPES, AUDIO TAPES, COMPACT DISCS, CD ROMS, DVDS, AND LASER DISCS; PRE-RECORDED VIDEO TAPES, VIDEO CASSETTES, AUDIO CASSETTES, VIDEO TAPES, AUDIO TAPES, COMPACT DISCS, CD ROMS, DVDS, MP3 FILES AND LASER DISCS FEATURING FICTIONAL WORKS, EDUCATIONAL WORKS FOR CHILDREN AND ENTERTAINMENT WORKS; COMPUTER AND VIDEO GAME CARTRIDGES, CASSETTES, TAPES, DISCS AND SOFTWARE; ELECTRONIC PUBLICATIONS, NAMELY, CATALOGUES, BOOKS, ACTIVITY BOOKS, COLORING BOOKS, MAGAZINES, JOURNALS, NEWSLETTERS, ENCYCLOPEDIAS, MANUALS, CALENDARS, POSTERS AND BROCHURES FEATURING FICTIONAL WORKS, EDUCATIONAL WORKS FOR CHILDREN AND ENTERTAINMENT WORKS RE-

CORDED ON COMPUTER MEDIA; DOWNLOADABLE ELECTRONIC PUBLICATIONS IN THE NATURE OF BOOKS, MAGAZINES, JOURNALS, NEWSLETTERS, ENCYCLOPEDIAS, MANUALS, CALENDARS, POSTERS AND BROCHURES FEATURING FICTIONAL WORKS, EDUCATIONAL WORKS FOR CHILDREN AND ENTERTAINMENT WORKS; DOWNLOADABLE COMPUTER GAMES; MOUSE PADS; EYEGLASSES, SUNGLASSES AND CASES THEREFOR; DECORATIVE MAGNETS; MAGNETICALLY ENCODED PREPAID TELEPHONE CARDS; LIGHT SWITCH PLATE COVERS; JOYSTICKS FOR PLAYING VIDEO GAMES; SPORT GOGGLES; AND MASKS FOR USE IN SNORKELING, SKIN AND SCUBA DIVING; DIVING SUITS; SNORKELS; SNORKEL STRAPS AND SNORKEL BAGS (U.S. CLS. 21, 23, 26, 36 AND 38).

#### **CLASS 14—JEWELRY**

FOR JEWELRY, BEADS FOR USE IN THE MANUFACTURE OF JEWELRY, BRACELETS, RINGS BEING JEWELRY, NECKLACES, EARRINGS, PINS BEING JEWELRY, COSTUME JEWELRY, PRECIOUS METALS AND PRECIOUS METAL ALLOYS; PRECIOUS AND SEMI-PRECIOUS GEMSTONES, JEWELRY BOXES OF PRECIOUS METAL; JEWELRY CASES OF PRECIOUS METAL; CLOCKS AND WATCHES (U.S. CLS. 2, 27, 28 AND 50).

#### **CLASS 16—PAPER GOODS AND PRINTED MATTER**

FOR PAPER, CARDBOARD AND GOODS MADE FROM THESE MATERIALS, NAMELY CONSTRUCTION PAPER, BOXES, BAGS, WRITING PAPER AND PADS, NOTE PADS, NOTE PAPER, MEMO PADS, GREETING CARDS, INVITATIONS, GIFT WRAP, BOWS, RIBBONS, BUSINESS CARD HOLDERS, NOTE CARDS, PAPER CONTAINERS, WRITING TABLETS; PHOTOGRAPHS; STATIONERY; CALENDARS; POSTERS; MAPS; BOOK-MARKS; TRADING CARDS; ADHESIVES FOR STATIONERY OR HOUSEHOLD PURPOSES; PRINTED MATTER, NAMELY CATALOGUES, BOOKS, MAGAZINES, JOURNALS, NEWSLETTERS, ENCYCLOPEDIAS, MANUALS, AND BROCHURES FEATURING FICTIONAL, EDUCATIONAL AND ENTERTAINMENT WORKS; DIARIES; ACTIVITY BOOKS; PAINTING SETS; ARTS AND CRAFT PAINT KITS; CHALK; GLUE FOR HOUSEHOLD OR STATIONERY USE; PASTELS; CRAYONS; PENS; PENCILS; PENCIL SHARPENERS; HIGH LIGHTERS; PAINTING PALETTES; PAINT BRUSHES; PAINTING CANVASSES; PAPER HATS; PAPER NAPKINS; ENVELOPES; ADHESIVE BACKED PAPER LABELS; COIN AND PHOTOGRAPH ALBUMS; BINDERS; BOOKENDS; ADDRESS BOOKS; ANNIVERSARY BOOKS; APPOINTMENT BOOKS; BABY BOOKS; BOOK-KEEPING BOOKS; BUSINESS RECORD BOOKS; CHILDREN'S BOOKS; COLORING BOOKS; DATE BOOKS; EXPENSE BOOKS; ENGAGEMENT BOOKS; NOTEBOOKS; PICTURE BOOKS; TELEPHONE NUMBER BOOKS; TRAVEL BOOKS; FILE FOLDERS; PICTURES; POSTCARDS; SCRAPBOOKS; SCORE BOOKS; SCORE CARDS; SCORE PADS; SCORE SHEETS; STICKERS; BLOTTERS; PENCIL AND PEN HOLDERS; STAPLERS; HOLE PUNCHERS; PAPERWEIGHTS; DRAFTING, DRAWING AND UNGRADUATED RULERS; ADHESIVE TAPE DISPENSERS FOR HOUSEHOLD OR STATIONERY USE; PLASTIC BUBBLE PACKS FOR WRAPPING OR PACKAGING; PLASTIC BAGS; PAPER POUCHES FOR PACKAGING; PAPER ENVELOPES; BLISTER CARDS; PACKING PAPER FOR PACKAGING; PACKAGING MATERIALS MADE OF PLASTIC, PAPER, OR CARDBOARD, NAMELY, PAPER ENVELOPES FOR PACKAGING, PAPER FOR WRAPPING AND PACKAGING, PLASTIC BAGS FOR PACKAGING, PLASTIC OR PAPER BAGS FOR MERCHANDISE PACKAGING, CARDBOARD CARTONS, CARDBOARD CONTAINERS AND CARDBOARD MAILING TUBES; PAPER BABY BIBS; DISPOSABLE DIAPERS; PAPER PARTY HATS; AND PRE-PAID TELEPHONE CALLING CARDS, NOT MAGNETICALLY ENCODED (U.S. CLS. 2, 5, 22, 23, 29, 37, 38 AND 50).

#### **CLASS 18—LEATHER GOODS**

FOR GOODS MADE OF LEATHER AND LEATHER IMITATIONS, NAMELY, SUITCASES, LUGGAGE, TRAVEL BAGS, GARMENT BAGS FOR TRAVEL, SHOE BAGS FOR TRAVEL, TOILETRY BAGS SOLD EMPTY, COSMETIC BAGS SOLD EMPTY, CARRY-ON BAGS, PURSES, HANDBAGS, SHOULDER BAGS, CLUTCH BAGS, TOTE BAGS, DUFFEL BAGS, BEACH BAGS, BILLFOLDS, WALLETS, KEY CASES, KNAPSACKS, FANNY PACKS, WAIST PACKS, UMBRELLAS, PARASOLS, TRUNKS, BACKPACKS, ATTACHE CASES, TOTE BAGS, BOOK BAGS, BRIEF CASES, DOCUMENT CASES, BUSINESS CASES, ALL-PURPOSE SPORTS BAGS, GYM BAGS, ATHLETIC BAGS (U.S. CLS. 1, 2, 3, 22 AND 41).

#### **CLASS 20—FURNITURE AND ARTICLES NOT OTHERWISE CLASSIFIED**

FOR FURNITURE, MIRRORS, FURNITURE FRAMES, PICTURE FRAMES, EMBROIDERY FRAMES, BOOK RESTS, BOOK STANDS, DECORATIVE MOBILES, NON-TOY STUFFED ANIMALS, PLASTIC FIGURINES, FABRIC FIGURINES, GAZING WATER GLOBES, HANGERS FOR CLOTHES, DISPENSERS FOR PILLS AND CAPSULES SOLD EMPTY, PLASTIC PILLBOXES, PLASTIC SIGNS, PLASTIC BANNERS, PLASTIC CAKE DECORATIONS, PLASTIC CAPS, PLASTIC KEY CHAINS, KEY HOLDERS AND KEY RINGS, PLASTIC BADGE HOLDERS, PLASTIC NOVELTY LICENSE PLATES, PLASTIC GIFT PACKAGE DECORATIONS, PLASTIC HOLIDAY ORNAMENTS EXCLUDING CHRISTMAS TREE ORNAMENTS, DRINKING STRAWS, THROW PILLOWS, CUSHIONS, SLEEPING BAGS, TOY CHESTS, NON-ELECTRIC FANS FOR PERSONAL USE, FLAGPOLES, GLASS FOR USE IN FRAMING ART, JEWELRY BOXES AND CASES NOT OF METAL; GOODS OF WOOD, CORK, REED, CANE, WICKER, HORN, BONE, IVORY, WHALEBONE, SHELL, AMBER, MOTHER-OF-PEARL, MEERSCHAUM, PLASTER, PLASTIC, COLD CAST RESIN AND WAX NAMELY, BUSTS, FIGURINES, DESKTOP STATUARY, SCULPTURES, STATUES, STATUETTES, LETTER BOXES AND ORNAMENTS NOT FOR CHRISTMAS; WIND CHIMES (U.S. CLS. 2, 13, 22, 25, 32 AND 50).

#### **CLASS 21—HOUSEWARES AND GLASS**

FOR HOUSEHOLD AND KITCHEN UTENSILS, NAMELY, SPATULAS, STRAINERS, TURNERS, SIEVES, GRATERS, POT AND PAN SCRAPERS, ROLLING PINS, WHISKS, SKIMMERS, BASTING SPOONS, ICE CREAM SCOOPS, SERVING FORKS, FORKS FOR BARBECUING, MIXING SPOONS, SERVING SPOONS, SLOTTED SPOONS, COOKING SKEWERS, ROLLING PINS; SCRUBBING COMBS, SPONGES AND BRUSHES, GLASS FABRICS FOR INDUSTRIAL USE; POLISHED PLATE GLASS, CERAMIC, GLASSWARE, PORCELAIN AND EARTHENWARE, NAMELY, BOWLS, PLATES, DISHES, CANISTER SETS, COFFEE CUPS, CANTEENS, CAFES, CARVING BOARDS, GRAYV BOATS, ICE BUCKETS, MEAL TRAYS, SERVING TRAYS NOT OF PRECIOUS METAL; LUNCHBOXES, COLANDERS, PLATES, CUPS, ELECTRIC AND NON-ELECTRIC TOOTHBRUSHES, BOTTLES SOLD EMPTY, BOTTLE OPENERS, MUGS; GLASS STORAGE JUGS, DRINKING GLASSES, SHOT GLASSES, GLASS STORAGE JARS, SPICE RACKS, BEVERAGE GLASSWARE, BEVERAGE STIRRERS, DEMITASSE SETS CONSISTING OF CUPS AND SAUCERS, SUGAR AND CREAMER SETS FEATURING SUGAR BOWLS NOT OF PRECIOUS METAL AND CREAMER PITCHERS, COFFEE POTS NOT OF PRECIOUS METAL, PLANT AND FLOWER BASKETS; WICKER, STRAW, WOOD AND CLOTH BASKETS; PLASTIC BUCKETS, WOVEN FABRIC BUCKETS, TEA CADDIES, TEA SETS; COOKERY MOLDS, POTS AND PANS; COOKIE SHEETS; SERVING UTENSILS, NAMELY, LADLES, CAKE SERVERS, PIE SERVERS, TONGS; COASTERS NOT OF PAPER AND NOT TABLE LINEN, COCKTAIL SHAKERS, COOKIE CUTTERS, CORK SCREWS, CORN COB HOLDERS, DECANTERS, FLASKS, PLASTIC HOUSEHOLD GLOVES FOR GENERAL USE, DINNERWARE, CONTAINERS FOR HOUSEHOLD USE, ALL PURPOSE PORTABLE HOUSEHOLD CONTAINERS, CONTAINERS FOR HOUSEHOLD USE, NAMELY, GLOBES, BABY BATH TUBS, BACK SCRATCHERS, BAKEWARE, BAKING DISHES; BAR-

WARE, NAMELY, CORKSCREWS, WINE BOTTLE FOIL CUTTERS, WINE GLASSES, CARAFES, DECANTERS, WINE RACKS, COOLERS FOR WINE AND CHAMPAGNE, PLASTIC BOTTLE STOPPERS AND POURERS, BOTTLE OPENERS, MEASURING JIGGERS, CRUMB SCRAPERS, FLASKS, CORK EXTRACTORS, CHAMPAGNE OPENERS, STAINLESS STEEL COCKTAIL SETS COMPRISED OF COCKTAIL PICKS AND SHAKERS SOLD TOGETHER AS A UNIT, SELTZER BOTTLES, HIGH BALL GLASSES AND WINE GOBLETS; BIRD BATHS NOT BEING STRUCTURES, BIRD FEEDERS, BIRD HOUSES; CRYSTAL, CHINA, EARTHENWARE, GLASS, PORCELAIN AND TERRA COTTA BUSTS; CANDLESTICKS NOT OF PRECIOUS METAL, CERAMIC FIGURINES, CLEANING CLOTHS, CLOTHES PINS, PAPER TOWEL DISPENSERS, SOAP DISPENSERS, FOAM DRINK HOLDERS, HAIR BRUSHES, HAIR COMBS, CERAMIC AND PORCELAIN HOLIDAY ORNAMENTS EXCLUDING CHRISTMAS TREE ORNAMENTS, INCENSE BURNERS, NAPKIN HOLDERS, NAPKIN RINGS NOT OF PRECIOUS METAL, ORNAMENTAL GLASS SPHERES, PAPER CUPS AND PLATES, PLASTIC CUPS AND PLATES, PEPPER GRINDERS AND MILLS, PORTABLE COOLERS, POTTIES FOR CHILDREN, RECIPE BOXES, SALT AND PEPPER SHAKERS, SHOE HORNS, SHOE TREES, TOILET PAPER HOLDERS, TOOTHPICKS, TOOTHPICK HOLDERS, TRASH CANS, TOWEL BARS AND HOLDERS, URNS, WATERING CANS, ALL OF THE FOREGOING GOODS NOT MADE OF PRECIOUS METAL; AND CONSUMER COSMETICS BRUSHES (U.S. CLS. 2, 13, 23, 29, 30, 33, 40 AND 50).

#### CLASS 24—FABRICS

FOR TEXTILE AND TEXTILE GOODS, NAMELY, MATTRESS COVERS, MATTRESS PADS, BED COVERS, BED BLANKETS, BED CANOPIES, BED LINEN, BED PADS, BED SHEETS, BED SPREADS, BLANKET THROWS, COMFORTERS, COVERLETS, CRIB BUMPERS, CRIB CANOPIES, DUST RUFFLES, EIDERDOWN COVERS, EIDERDOWNS, PILLOW CASES, PILLOW COVERS, PILLOW SHAMS, RECEIVING BLANKETS, SHAMS, DUVETS, DUVET COVERS, QUILTS, TABLE COVERS, TABLE LINEN, TOWELS, AFGHANS, BARBECUE MITTS, BATH LINEN, BURP CLOTHS, CLOTH BANNERS, CLOTH DOILIES, CLOTH FLAGS, CLOTH LABELS, CLOTH PENNANTS, CURTAINS, DISH CLOTHS, DRAPERIES, FABRIC FLAGS, FABRIC TABLE RUNNERS, FABRIC TABLE TOPPERS, FABRIC VALANCES, FELT PENNANTS, FITTED TOILET LID COVERS MADE OF FABRIC OR FABRIC SUBSTITUTES, HANDKERCHIEFS, HOUSEHOLD LINEN, KIT COMPRISED OF FABRICS FOR MAKING QUILTS, LAP ROBES, LAP RUGS, OVEN MITTS, POT HOLDERS, SHOWER CURTAINS, SHROUDS, SWAGS, TABLE CLOTHS NOT OF PAPER, TABLE LINEN, NAMELY, COASTERS, NAPKINS, PLACE MATS, TEXTILE WALL HANGINGS, WASHCLOTHS, WASHING MITTS (U.S. CLS. 42 AND 50).

#### CLASS 25—CLOTHING

FOR CLOTHING, NAMELY, DRESSES, GOWNS, BEACHWEAR, SWIM WEAR, BLOUSES, BODY SUITS, BRAS, BUSTIERS, FOUNDATION GARMENTS, UNDERCLOTHES, UNDER GARMENTS, UNDERWEAR, BODY SUITS, SLIPS, SARONGS, NEGLIGEEES, LEOTARDS, UNITARDS, SHORTS, TOPS, BOTTOMS, COATS, HOSIERY, STOCKINGS, JACKETS, CAPES, PONCHOS, NIGHTWEAR, SLEEPWEAR, LINGERIE, ROBES, LOUNGEWEAR, NECKWEAR, TIES, PANTS, JEANS, RAINWEAR, SHIRTS, SCARVES, SHAWLS, KERCHIEFS, SKIRTS, JUMP SUITS, SKIWEAR, SOCKS, SUITS, SWEATERS, SWEATSHIRTS, SWEAT JACKETS, SWEAT SUITS, SWEATPANTS, EXERCISE SUITS, EXERCISE AND JOGGING SUITS, TIGHTS, LEGGINGS, T-SHIRTS, WRISTBANDS, HEADBANDS, TENNIS WEAR, TUXEDOS, VESTS, INFANTWEAR; FOOTWEAR; HEADWEAR, HATS, CAPS, VISORS, SHOWER CAPS, GLOVES, MITTENS, BELTS, APRONS, CLOTH DIAPERS, BANDANAS, HALLOWEEN COSTUMES, MASQUERADE COSTUMES; BABY BIBS NOT OF PAPER (U.S. CLS. 22 AND 39).

#### CLASS 28—TOYS AND SPORTING GOODS

FOR GAMES, NAMELY, PARLOR GAMES, BOARD GAMES, ACTION SKILL GAMES, ACTION TARGET GAMES, ARCADE GAMES, CARD GAMES, COIN-OPERATED VIDEO GAMES, DART GAMES, EQUIPMENT SOLD AS A UNIT FOR PLAYING BOARD, CARD AND ACTION TARGET GAMES, MANIPULATIVE GAMES, PARTY GAMES, PINBALL GAMES, HAND HELD UNIT FOR PLAYING ELECTRONIC GAMES, STAND ALONE VIDEO OUTPUT GAME MACHINES, DOMINOS; PLAYTHINGS AND TOYS, NAMELY, INFANT TOYS, CRIB TOYS, BATH AND WATER TOYS, TEDDY BEARS, PLUSH TOYS, STUFFED TOY ANIMALS, TOY ANIMALS, ACTION FIGURES, TOY TRAIN SETS, TOY FURNITURE, TOY TELEPHONES, TOY CLOCKS, TOY BUILDING AND CONSTRUCTION BLOCKS, TOY ROBOTS, TOY MUSICAL INSTRUMENTS, TOY CARS, WIND-UP TOYS, RIDE-ON TOYS, PULL TOYS, BALLOONS, DOLLS, DOLL HOUSES, DOLL HOUSE FURNITURE, PUPPETS, SHAPE SORTERS, FLYING DISCS, JIGSAW AND MANIPULATIVE PUZZLES, PAPER FACE MASKS, YOYOS, KITES, TOY MODEL HOBBYCRRAFT KITS, PINBALL MACHINES; GYMNASTIC AND SPORTING ARTICLES, NAMELY, BASEBALL GLOVES, BATTING GLOVES, BOXING GLOVES, GOALKEEPERS' GLOVES, GOLF GLOVES, HANDBALL GLOVES, HOCKEY GLOVES, KARATE GLOVES, RACQUETBALL GLOVES, SOFTBALL GLOVES, SWIMMING GLOVES, WATER SKI GLOVES, WEIGHT LIFTING GLOVES, BASEBALL MITTS, CATCHERS' MITTS, SOFTBALL MITTS, GOLF TEES, GOLF CLUBS, HEAD COVERS FOR GOLF CLUBS, TENNIS RACKETS, SCUBA FLIPPERS, SKATEBOARDS, ICE SKATES, ROLLER SKATES, SWIMMING FLOATS AND BOARDS FOR RECREATIONAL USE, SURF BOARDS, SWIMMING FLIPPERS, SNORKEL GEAR, NAMELY, SWIM FINNS, FLIPPERS FOR USE IN SNORKELING; BAGS SPECIALLY ADAPTED FOR SPORTS EQUIPMENT; BALLS, NAMELY, BASKETBALLS, BASEBALLS, FOOTBALLS, RUBBER BALLS, SOCCER BALLS, SUPER BALLS, GOLF BALLS, TENNIS BALLS; SPORT BALLS, KALEIDOSCOPIES, PLAYING CARDS, CHRISTMAS TREE DECORATIONS AND ORNAMENTS; TOY MUSICAL BOXES; PLASTIC BIKE TAGS; AND STRAPS USED IN SNORKELING (U.S. CLS. 22, 23, 38 AND 50).

#### CLASS 29—MEATS AND PROCESSED FOODS

FOR MEAT, FISH, POULTRY AND GAME; MEAT EXTRACTS; PRESERVED, DRIED AND COOKED FRUITS AND VEGETABLES; JELLIES, JAMS, COMPOTES; EGGS, MILK AND MILK PRODUCTS, NAMELY, HALF AND HALF, MILK BASED BEVERAGES CONTAINING FRUITS AND FRUIT JUICE, MILK BEVERAGES WITH HIGH MILK CONTENT, MILK DRINKS CONTAINING FRUITS, MILK POWDER, MILK-BASED BEVERAGE CONTAINING COFFEE, POWDERED MILK FOR FOOD PURPOSES, SOY MILK, SOY-BASED FOOD BEVERAGE USED AS A MILK SUBSTITUTE, COTTAGE CHEESE, SOUR CREAM, CHEESES, BUTTERS, EGG NOG, CREAM, MARGARINE, CREME FRAICHE, YOGURT, YOGURT DRINKS, CURD, FLAVORING SYRUPS AND LIQUID AND POWDERED BEVERAGE MIXES USED TO MAKE MILK-BASED FOOD BEVERAGES, DAIRY-BASED FOOD BEVERAGES AND DAIRY PRODUCTS EXCLUDING ICE CREAM, ICE MILK AND FROZEN YOGURT; EDIBLE OILS AND FATS (U.S. CL. 46).

#### CLASS 30—STAPLE FOODS

FOR COFFEE, TEA, COCOA, SUGAR, RICE, TAPIOCA, SAGO, ARTIFICIAL COFFEE, TEA, COCOA, SUGAR, RICE, TAPIOCA, AND SAGO; FLOUR AND PREPARATIONS MADE FROM CEREALS, BREAD, PASTRY AND CONFECTIONERY PRODUCTS, NAMELY, CHOCOLATES AND CANDIES, COOKIES, FUDGE, CHEWING GUM, CHOCOLATED NUTS, CHOCOLATE BISCUITS, FROZEN CONFECTIONS, FREEZABLE LIQUID FOR USE IN MAKING FROZEN CONFECTIONS, ICE CREAM, ICE CREAM DRINKS, ICE CREAM MIXES AND POWDERS, ICING, ICE CREAM SUBSTITUTE, ICE-CREAM CAKES, PRALINES, NOUGAT, MARZIPAN, CANDY BARS, CHOCOLATE CHIPS, CHOCOLATE TRUFFLES, PIES, CAKES, CREAM

BUNS AND CREAM PUFFS; ICES; HONEY, TREACLE; YEAST, BAKING-POWDER; SALT, MUSTARD; VINEGAR, SAUCES, CONDIMENTS, NAMELY, KETCHUP, MAYONNAISE, RELISHES, SALSAS, MARINADES, GLAZES, NAMELY, GLAZES FOR MEATS, SEAFOOD, POULTRY, VEGETABLES, CAKES AND PASTRIES, CHOCOLATE SYRUP AND PEPPER; SPICES; ICE; FLAVORING SYRUPS; COFFEE-BASED AND COFFEE-FLAVORED BEVERAGES; TEA-BASED AND TEA-FLAVORED BEVERAGES; TEA BEVERAGES FLAVORED WITH FRUIT JUICE, FROZEN COFFEE AND COFFEE-FLAVORED BEVERAGES (U.S. CL. 46).

SN 78-647,878. CFM INTERNATIONAL, INC., CINCINNATI, OH. FILED 6-10-2005.

# LEAP56

## CLASS 32—LIGHT BEVERAGES

FOR BEERS; MINERAL AND AERATED WATERS AND OTHER NON-ALCOHOLIC DRINKS, NAMELY, SOFT DRINKS, DRINKING WATERS, FLAVORED WATERS, ENERGY DRINKS AND SPORTS DRINKS; NON-ALCOHOLIC BEVERAGES WITH TEA FLAVOR; FRUIT DRINKS AND FRUIT JUICES; SYRUPS, CONCENTRATES, POWDERS, NON-ALCOHOLIC FRUIT EXTRACTS AND OTHER PREPARATIONS FOR MAKING BEVERAGES IN THE NATURE OF FRUIT DRINKS, FRUIT JUICES, LEMONADES, SOFT DRINKS, FRUIT DRINKS, FLAVORED WATERS, MINERAL AND AERATED WATERS, ENERGY DRINKS, SPORTS DRINKS (U.S. CLS. 45, 46 AND 48).

THE MARK CONSISTS OF STANDARD CHARACTERS WITHOUT CLAIM TO ANY PARTICULAR FONT, STYLE, SIZE, OR COLOR.

## CLASS 41—EDUCATION AND ENTERTAINMENT

FOR ENTERTAINMENT SERVICES, NAMELY, PROVIDING PUPPET SHOWS, FILM SCREENINGS, LIVE MUSIC CONCERTS, PRODUCTION OF PLAYS, THEATER PRODUCTIONS, LIVE MUSICAL AND THEATRICAL STAGE SHOWS AND PERFORMANCES, AND PROVIDING MULTI-USER ON-LINE COMPUTER GAMES; THEME PARK SERVICES; PRODUCTION, PRESENTATION, DISTRIBUTION FOR OTHERS AND RENTAL OF TELEVISION AND RADIO PROGRAMS, FILMS, MOTION PICTURE FILMS AND THEATRICAL PRODUCTIONS; LITERARY AND MUSIC PUBLISHING SERVICES; SPORTING AND CULTURAL ACTIVITIES, NAMELY, ORGANIZING AND CONDUCTING SPORTING EVENTS, CULTURAL EVENTS AND ARTS EVENTS; ORGANIZING AND CONDUCTING FESTIVALS FEATURING A WIDE VARIETY OF ACTIVITIES, NAMELY, EXHIBITIONS IN THE FIELD OF FICTIONAL LITERARY WORKS; ON-LINE PUBLICATION OF BOOKS, ACTIVITY BOOKS, COLORING BOOKS, MAGAZINES, JOURNALS, NEWSLETTERS, ENCYCLOPEDIAS, MANUALS, CALENDARS, POSTERS AND BROCHURES FEATURING FICTIONAL, EDUCATIONAL AND ENTERTAINMENT WORKS FOR OTHERS; EDUCATIONAL SERVICES, NAMELY, CONDUCTING LECTURES, SEMINARS, READINGS, CONFERENCES AND INTERACTIVE ROLE-PLAYING ALL IN THE FIELD OF EDUCATION AND ENTERTAINMENT; PROVIDING INFORMATION IN THE FIELD OF EDUCATION AND ENTERTAINMENT; PROVIDING INFORMATION IN THE FIELD OF ON-LINE COMPUTER GAMES AND COMPUTER ENHANCEMENTS FOR COMPUTER GAMES; PROVIDING INFORMATION IN THE FIELD OF FICTIONAL LITERARY WORKS; PROVIDING EDUCATIONAL AND ENTERTAINMENT INFORMATION, NAMELY, INFORMATION CONCERNING CHILDREN'S BOOKS AND MERCHANDISE AND ITEMS RELATED TO CHILDREN'S BOOKS; PROVIDING EDUCATIONAL AND ENTERTAINMENT INFORMATION CONCERNING FICTIONAL CHARACTERS, PLACES, LOCATIONS, CULTURAL EVENTS, PLAYS, LECTURES AND PARTIES RELATING TO BOOK PRESENTATIONS AND PROMOTION; PROVIDING A WEB SITE FEATURING MUSICAL PERFORMANCES, MUSICAL VIDEOS, RELATED FILM CLIPS, PHOTOGRAPHS AND OTHER MULTIMEDIA MATERIALS (U.S. CLS. 100, 101 AND 107).

JASON TURNER, EXAMINING ATTORNEY

## CLASS 7—MACHINERY

FOR ENGINES, GAS TURBINE ENGINES, TURBO-JET ENGINES AND TURBO-PROP ENGINES, OTHER THAN FOR LAND VEHICLES; POWER TRANSMISSION BELTS AND COUPLINGS FOR ENGINES, NOT FOR LAND VEHICLES; SHAFT COUPLINGS, NOT FOR LAND VEHICLES; COMPRESSORS FOR ENGINES, NAMELY TURBO-JET ENGINES AND TURBO-PROP ENGINES, OTHER THAN FOR LAND VEHICLES; GAS GENERATORS, NOT FOR LAND VEHICLES, FOR POWER GENERATION, BEING A COMPONENT PART OF AERODERIVATIVE ENGINES; JET ASSEMBLIES, NAMELY, EXHAUST MANIFOLD FOR ENGINES; PARTS AND FITTINGS FOR ENGINES OTHER THAN FOR LAND VEHICLES, NAMELY, ENGINES OR MOTOR MUFFLERS AND NACELLES FOR AIRCRAFT ENGINES (U.S. CLS. 13, 19, 21, 23, 31, 34 AND 35).

## CLASS 37—CONSTRUCTION AND REPAIR

FOR SERVICES AND PROGRAMS, NAMELY, ENGINE MAINTENANCE SERVICES DESIGNED TO LOWER ENGINE OPERATING COSTS AND REDUCE ENGINE MAINTENANCE; TECHNICAL CONSULTANCY SERVICES RELATING TO THE METHODOLOGIES TO BE USED IN THE FRAMEWORK OF MAINTENANCE OF ENGINES IN THE FIELD OF AERONAUTICS (U.S. CLS. 100, 103 AND 106).

## CLASS 42—SCIENTIFIC, COMPUTER AND LEGAL SERVICES

FOR PROVIDING TECHNOLOGY SERVICES AND PROGRAMS FOR THE AIRLINE AND AIRCRAFT INDUSTRY, NAMELY PROFESSIONAL ADVISORY AND CONSULTING SERVICES IN CONNECTION WITH ENGINEERING USED IN THE AIRCRAFT INDUSTRY; ENGINEERING AND DESIGN CONSULTING SERVICES RELATED TO THE DESIGN OF FUEL EFFICIENT ENGINES, QUIETER ENGINES, LOW EMISSION ENGINES, ENGINE CONTROL TECHNOLOGIES, AND ENGINE DIAGNOSTIC TOOLS; SERVICES AND PROGRAMS, NAMELY, TECHNOLOGICAL CONSULTATION AND RESEARCH IN THE FIELD OF AERONAUTICS TO SIMPLIFY ENGINE DESIGN, REDUCE ENGINE NOISE AND EMISSIONS, ADD NEW ENGINE CONTROL TECHNOLOGIES, IMPROVE ENGINE INTEGRATION AND PROVIDE BETTER ENGINE DIAGNOSTIC TOOLS (U.S. CLS. 100 AND 101).

MARY CRAWFORD, EXAMINING ATTORNEY

SN 78-648,547. WAVES LICENSING, LLC, WILMINGTON, DE. FILED 6-10-2005.

SN 78-649,684. MARKETING CONTENT PARTNERS LLC, NEW YORK, NY. FILED 6-13-2005.



**SIG SEMICONDUCTOR CAPITAL  
EQUIPMENT INDEX**

THE MARK CONSISTS OF STANDARD CHARACTERS WITHOUT CLAIM TO ANY PARTICULAR FONT, STYLE, SIZE, OR COLOR.

OWNER OF U.S. REG. NOS. 2,624,035, 2,642,038 AND 2,891,728.

NO CLAIM IS MADE TO THE EXCLUSIVE RIGHT TO USE "SEMICONDUCTOR CAPITAL EQUIPMENT INDEX", APART FROM THE MARK AS SHOWN.

**CLASS 35—ADVERTISING AND BUSINESS**

FOR PROVIDING STATISTICAL INFORMATION AND INDEXES OF STOCK EXCHANGE DEALINGS, VALUABLES, INTERESTS, PRICES, EXCHANGE RATES AND OTHER ECONOMICAL DATA, FOR OTHERS; LICENSING OF STOCK INDEXES AND THE GRANTING OF LICENSES TO BANKS AND OTHER FINANCIAL INSTITUTIONS ISSUING DERIVATIVES OR FINANCIAL INSTRUMENTS, OR GRANTING LOANS, WITH PAYMENTS COMPUTED BY REFERENCE TO FINANCIAL AND SECURITIES INDEXES; LICENSING OF STOCK INDEXES AND THE GRANTING OF LICENSES TO INSURANCE COMPANIES ISSUING INSURANCE WITH PAYMENTS TO INSURED COMPUTED BY REFERENCE TO FINANCIAL AND RELATED SECURITIES INDEXES; COMPUTERIZED DATABASE MANAGEMENT (U.S. CLS. 100, 101 AND 102).

FIRST USE 7-12-2004; IN COMMERCE 7-12-2004.

**CLASS 36—INSURANCE AND FINANCIAL**

FOR BROKERAGE IN THE FIELD OF STOCKS; INSURANCE AND CAPITAL INVESTMENT CONSULTATION; FINANCIAL BUSINESS MANAGEMENT; BANKING; FINANCIAL SERVICES, NAMELY, PORTFOLIO MANAGEMENT, FINANCIAL ANALYSIS AND CONSULTATION AND FINANCIAL PLANNING; FINANCIAL PORTFOLIO MANAGEMENT; CREDIT RECOVERY AND COLLECTION SERVICES; PROVIDING INFORMATION ABOUT STOCKS AND SECURITIES, NAMELY PRICES, PERFORMANCE AND FINANCIAL NEWS, VIA A GLOBAL COMPUTER NETWORK, TELEPHONE, FACSIMILE, AND MAIL; UPDATING INDEXES OF STOCKS AND SECURITIES FOR OTHERS (U.S. CLS. 100, 101 AND 102).

FIRST USE 7-12-2004; IN COMMERCE 7-12-2004.  
JENNIFER MARTIN, EXAMINING ATTORNEY

**CLASS 35—ADVERTISING AND BUSINESS**

FOR ADVERTISING SERVICES, NAMELY, CREATION AND DISSEMINATION OF MARKETING COMMUNICATIONS FOR OTHERS IN THE NATURE OF ADVERTISING MATERIALS, PROMOTIONAL MATERIALS, DIRECT RESPONSE ADVERTISING AND PUBLIC RELATIONS THROUGH ALL PUBLIC COMMUNICATION MEANS; ADVERTISING AGENCY SERVICES; DIRECT MARKETING ADVERTISING; PUBLIC RELATIONS SERVICES; MARKETING CONSULTING SERVICES IN THE FIELD OF BRAND CREATION, BRAND COMMUNICATION, BRAND STRATEGY, BRAND IDENTITY AND CORPORATE IDENTITY; MARKET RESEARCH SERVICES; SALES PROMOTION SERVICES; PROMOTING THE GOODS AND SERVICES OF OTHERS BY ARRANGING FOR SPONSORS TO AFFILIATE THEIR GOODS AND SERVICES WITH SPORTS EVENTS, ENTERTAINMENT EVENTS AND EDUCATIONAL EVENTS FOR ADVERTISING AND MARKETING PURPOSES; DEVELOPING INTERNET-BASED MARKETING STRATEGIES; PROMOTING THE SPECIAL EVENTS OF OTHERS; PREPARING PROMOTIONAL MATERIALS FOR OTHERS IN THE NATURE OF BOARD GAMES; SPECIAL EVENT PLANNING FOR MARKETING PURPOSES (U.S. CLS. 100, 101 AND 102).

**CLASS 38—COMMUNICATION**

FOR WIRELESS ELECTRONIC TRANSMISSION OF IMAGES AND MESSAGES (U.S. CLS. 100, 101 AND 104).

**CLASS 40—MATERIAL TREATMENT**

FOR CREATION OF PROMOTIONAL ITEMS, NAMELY, CUSTOMIZED PRINTING OF COMPANY NAMES AND LOGOS FOR PROMOTIONAL AND ADVERTISING PURPOSES ON THE GOODS OF OTHERS (U.S. CLS. 100, 103 AND 106).

**CLASS 41—EDUCATION AND ENTERTAINMENT**

FOR PRODUCTION AND DISTRIBUTION OF TELEVISION PROGRAMS, MOTION PICTURES, AND AUDIO AND VIDEO PROGRAMMING IN THE NATURE OF FILMS, AND ONGOING ENTERTAINMENT SERIES ACCESSIBLE VIA THE INTERNET; PUBLICATION OF BOOKS, MAGAZINES AND OTHER PRINTED MATTER; ENTERTAINMENT SERVICES, NAMELY, PROVIDING ON-LINE ELECTRONIC, INTERACTIVE COMPUTER GAMES FOR ENTERTAINMENT PURPOSES AND TO SUPPORT MARKETING PROGRAMS FOR OTHERS (U.S. CLS. 100, 101 AND 107).

**CLASS 42—SCIENTIFIC, COMPUTER AND LEGAL SERVICES**

FOR WEB SITE DESIGN AND DEVELOPMENT SERVICES; DESIGN AND DEVELOPMENT OF E-MAIL PROGRAMS AND WEB LOGS; DESIGN OF COMPUTER GAME SOFTWARE FOR OTHERS (U.S. CLS. 100 AND 101).

CARRIE ACHEN, EXAMINING ATTORNEY

SN 78-650,459. KOHLER CO., KOHLER, WI. FILED 6-14-2005.

# LYNTIER

THE MARK CONSISTS OF STANDARD CHARACTERS WITHOUT CLAIM TO ANY PARTICULAR FONT, STYLE, SIZE, OR COLOR.

## CLASS 6—METAL GOODS

FOR BATHROOM FITTINGS, NAMELY, METAL ROBE HOOKS (U.S. CLS. 2, 12, 13, 14, 23, 25 AND 50).

## CLASS 11—ENVIRONMENTAL CONTROL APPARATUS

FOR BATHTUBS; WHIRLPOOL BATHS; BATH INSTALLATIONS, NAMELY BATH VALVES, VALVE TRIM, BATH DRAINS, AND MIXING VALVES; SHOWERS; SHOWER INSTALLATIONS, NAMELY SHOWER CONTROL VALVES AND DRAINS; SHOWER AND BATH CUBICLES; SHOWER PANS; SHOWER HEADS; SHOWER DOORS; WATER DIVERTERS; SHOWER SPRAY HEADS; BIDETS; LAVATORIES; TOILETS; TOILET BOWLS; TOILET SEATS; TOUCHLESS TOILETS; WATER CLOSETS; ELECTRIC LIGHTING FIXTURES; ELECTRIC DOME LIGHTS; SINKS; SINK PEDESTALS; TAP WATER FAUCETS; FAUCETS; BATH SPOUTS; WATER CONTROL VALVES FOR WATER CISTERNS; WATER CONTROL VALVES; WATER CONTROL VALVES FOR FAUCETS; URINALS; WATER CISTERNS; BATHROOM FITTINGS, NAMELY PLUMBING BIBBS, COCKS, TRAPS, AND VALVES; DRINKING FOUNTAINS; SAUNAS; NON-METALLIC FLUSH LEVERS FOR CISTERNS; SHOWER DOORS; AND PARTS AND FITTINGS THEREFOR (U.S. CLS. 13, 21, 23, 31 AND 34).

## CLASS 20—FURNITURE AND ARTICLES NOT OTHERWISE CLASSIFIED

FOR BATHROOM FITTINGS, NAMELY, GLASS SHELVES (U.S. CLS. 2, 13, 22, 25, 32 AND 50).

## CLASS 21—HOUSEWARES AND GLASS

FOR BATHROOM FITTINGS, NAMELY, TOWEL BARS, TOILET TISSUE HOLDERS, TOWEL RINGS, SOAP DISHES, TOOTHBRUSH HOLDERS, TUMBLERS FOR USE WITH TOOTHBRUSH HOLDERS, AND PARTS AND FITTINGS THEREFOR (U.S. CLS. 2, 13, 23, 29, 30, 33, 40 AND 50).

REBECCA POVARCHUK, EXAMINING ATTORNEY

SN 78-652,831. PROPECTUS BIOSCIENCES, INC., BALTIMORE, MD. FILED 6-17-2005.

# PROPECTUS

THE MARK CONSISTS OF STANDARD CHARACTERS WITHOUT CLAIM TO ANY PARTICULAR FONT, STYLE, SIZE, OR COLOR.

## CLASS 5—PHARMACEUTICALS

FOR PHARMACEUTICAL PREPARATIONS AND SUBSTANCES FOR USE IN THE TREATMENT OF VIRAL AND BACTERIAL INFECTIONS, CANCER, HIV, AIDS-RELATED INFECTIONS AND BODILY CONDITIONS ASSOCIATED WITH IMPAIRED IMMUNOSYSTEMS; PHARMACEUTICAL PREPARATIONS IN THE FIELD OF GENE THERAPY FOR USE IN THE TREATMENT OF HIV; PHARMACEUTICAL PREPARATIONS FOR THE TREAT OF CANCER (U.S. CLS. 6, 18, 44, 46, 51 AND 52).

## CLASS 42—SCIENTIFIC, COMPUTER AND LEGAL SERVICES

FOR HEALTH AND MEDICAL SERVICES, NAMELY, SCIENTIFIC, MEDICAL AND PHARMACEUTICAL RESEARCH; SCIENTIFIC RESEARCH AND DEVELOPMENT FOR HEALTH-RELATED PRODUCTS AND TESTS, IN PARTICULAR, HIV (HUMAN IMMUNODEFICIENCY VIRUS) AND CANCER PREDICTIVE AND DIAGNOSTIC TESTS; PROVIDING INFORMATION ON SCIENTIFIC MATTERS; MATERIAL TESTING; SCIENTIFIC PROJECT RESEARCH; TECHNICAL CONSULTATION AND RESEARCH IN THE FIELD OF DISCOVERY AND EVALUATION OF DRUGS AND COMPOUNDS HAVING DIAGNOSTIC AND THERAPEUTIC PROPERTIES (U.S. CLS. 100 AND 101).

DAVID STERKIN, EXAMINING ATTORNEY

SN 78-658,344. HIGH 5 PRODUCTIONS INC, EAST PATCHOGUE, NY. FILED 6-25-2005.



THE COLOR(S) RED AND BLACK IS/ARE CLAIMED AS A FEATURE OF THE MARK.

THE COLOR RED APPEARS IN THE HORIZONTAL ELONGATED OVAL-SHAPED OUTLINE SURROUNDING THE WORDING PHONICS 4 BABIES AND IN THE LETTERS OF THAT WORDING. THE COLOR BLACK APPEARS AS THE SHADING OF THE WORDING.

## CLASS 9—ELECTRICAL AND SCIENTIFIC APPARATUS

FOR VIDEO TAPE RECORDERS; COMPACT DISC CASES; COMPACT DISC PLAYERS (U.S. CLS. 21, 23, 26, 36 AND 38).

## CLASS 25—CLOTHING

FOR CLOTHING, NAMELY, CHILDREN'S PANTS, SHORTS, SKIRTS, T-SHIRTS, PAJAMAS, SOCKS, CLOTH BIBS, HATS, COATS, JACKETS, SWEATERS, SLIPPERS, BOOTS, AND SHOES (U.S. CLS. 22 AND 39).

## CLASS 28—TOYS AND SPORTING GOODS

FOR PLUSH TOYS; SOFT SCULPTURE PLUSH TOYS (U.S. CLS. 22, 23, 38 AND 50).

ELLEN BURNS, EXAMINING ATTORNEY

SN 78-659,791. CHURCH OF GOD IN CHRIST, INC.,  
MEMPHIS, TN. FILED 6-28-2005.

## CHURCH OF GOD IN CHRIST

THE MARK CONSISTS OF STANDARD CHARACTERS  
WITHOUT CLAIM TO ANY PARTICULAR FONT, STYLE,  
SIZE, OR COLOR.

OWNER OF U.S. REG. NOS. 2,763,521 AND 3,064,756.  
SEC. 2(F).

### CLASS 16—PAPER GOODS AND PRINTED MATTER

FOR BOOKS, BOOKLETS, AND PAMPHLETS FEATURING  
RELIGIOUS SUBJECT MATTER (U.S. CLS. 2, 5,  
22, 23, 29, 37, 38 AND 50).

FIRST USE 12-31-1968; IN COMMERCE 12-31-1968.

### CLASS 35—ADVERTISING AND BUSINESS

FOR CHARITABLE SERVICES, NAMELY, ORGANIZING  
AND CONDUCTING VOLUNTEER PROGRAMS  
AND COMMUNITY SERVICES PROJECTS (U.S. CLS.  
100, 101 AND 102).

FIRST USE 0-0-1907; IN COMMERCE 0-0-1907.

### CLASS 41—EDUCATION AND ENTERTAINMENT

FOR RELIGIOUS INSTRUCTION SERVICES; EDUCATIONAL  
SERVICES IN THE NATURE OF RELIGIOUS  
INSTRUCTION (U.S. CLS. 100, 101 AND 107).

FIRST USE 0-0-1907; IN COMMERCE 0-0-1907.

### CLASS 45—PERSONAL SERVICES

FOR EVANGELICAL MINISTERIAL SERVICES; PERSONAL  
AND RELIGIOUS COUNSELING (U.S. CLS. 100  
AND 101).

FIRST USE 0-0-1907; IN COMMERCE 0-0-1907.

TIMOTHY FINNEGAN, EXAMINING ATTORNEY

SN 78-669,505. FUJI OIL CO., LTD., OSAKA, JAPAN, FILED  
7-13-2005.

## HINUTE

THE MARK CONSISTS OF STANDARD CHARACTERS  
WITHOUT CLAIM TO ANY PARTICULAR FONT, STYLE,  
SIZE, OR COLOR.

### CLASS 5—PHARMACEUTICALS

FOR SOY PEPTIDES, NAMELY, PROTEIN FOR USE  
AS A NUTRITIONAL INGREDIENT IN FOOD SUPPLEMENTS;  
SOY PEPTIDES, NAMELY, PROTEIN FOR USE  
AS A NUTRITIONAL INGREDIENT OF FOOD AND  
BEVERAGES (U.S. CLS. 6, 18, 44, 46, 51 AND 52).

### CLASS 29—MEATS AND PROCESSED FOODS

FOR PROCESSED SOY BEANS, NAMELY, SOY PEPTIDES  
FOR USE AS RAW MATERIALS IN FOOD PREPARATIONS;  
SOY PEPTIDES, NAMELY, PROTEIN FOR USE AS  
ADDITIVE FOR FOOD AND BEVERAGES (U.S. CL. 46).

BILL DAWE, EXAMINING ATTORNEY

SN 78-669,694. VECTORMAX CORPORATION, FARMINGDALE,  
NY. FILED 7-13-2005.

## AlterEgo Video

THE MARK CONSISTS OF STANDARD CHARACTERS  
WITHOUT CLAIM TO ANY PARTICULAR FONT, STYLE,  
SIZE, OR COLOR.

NO CLAIM IS MADE TO THE EXCLUSIVE RIGHT TO  
USE "VIDEO", APART FROM THE MARK AS SHOWN.

### CLASS 38—COMMUNICATION

FOR TELECOMMUNICATIONS SERVICES, NAMELY,  
TRANSMISSION OF THREE-DIMENSIONAL VIDEO  
OVER MOBILE, CELLULAR AND WIRELESS INFRASTRUCTURES  
(U.S. CLS. 100, 101 AND 104).

### CLASS 41—EDUCATION AND ENTERTAINMENT

FOR ENTERTAINMENT SERVICES, NAMELY, PROVIDING  
THREE-DIMENSIONAL VIDEO OVER MOBILE,  
CELLULAR AND WIRELESS DEVICES FEATURING  
COMPUTER-GENERATED ANIMATION (U.S. CLS. 100,  
101 AND 107).

G. MAYERSCHOFF, EXAMINING ATTORNEY

SN 78-676,348. ESSENTIAL MINDS, S.L., SANT JOAN DESPI  
(BARCELONA), SPAIN, FILED 7-22-2005.



OWNER OF ERPN CMNTY TM OFC REG. NO. 3805140,  
DATED 9-12-2005, EXPIRES 4-29-2014.

THE COLOR(S) BLACK, WHITE, BROWN, BLUE, GREEN,  
YELLOW, RED AND ORANGE IS/ARE CLAIMED AS A  
FEATURE OF THE MARK.

THE WORDS ARE ORANGE WITH WHITE ACCENTS  
OUTLINED IN YELLOW, GREEN AND BLUE. THE FACES  
WITHIN THE SQUARE ARE WHITE WITH BLACK  
FEATURES. THE GIRL WITHIN THE SQUARE HAS YELLOW  
HAIR WITH RED AND BLUE PONYTAIL HOLDERS. THE  
BOY WITHIN THE SQUARE HAS BROWN HAIR. THE  
FACES TO THE LEFT OF THE WORDING ARE INSIDE A  
BLUE SQUARE WITH AN INNER ORANGE LINE AROUND  
THE RECTANGLE AND AREAS OF LIGHTER AND DARKER  
BLUE WITHIN THE SQUARE. THE BOY TO THE  
RIGHT OF THE WORDS HAS BROWN HAIR, A RED SHIRT  
WITH ORANGE STRIPES AND ORANGE AROUND THE  
COLLAR, BLUE SHORTS AND BROWN SHOES.

**CLASS 9—ELECTRICAL AND SCIENTIFIC APPARATUS**

FOR TEACHING APPARATUS AND INSTRUMENTS, NAMELY CHILDREN'S EDUCATIONAL AND ENTERTAINMENT SOFTWARE; APPARATUS FOR RECORDING, TRANSMISSION OR REPRODUCTION OF SOUND OR IMAGES, NAMELY VIDEO CASSETTE RECORDERS; BLANK MAGNETIC DATA CARRIERS, DATA PROCESSORS AND COMPUTERS; SOUND RECORDING DISKS; GALVANIC CELLS; VIDEO CAMERAS; VIDEO GAME CARTRIDGES; PRE-RECORDED VIDEO CASSETTES FEATURING ENTERTAINMENT AND EDUCATIONAL MATERIAL FOR CHILDREN; AUDIO-VIDEO COMPACT DISCS, DVDS, CD-ROMS, AUDIO CASSETTES AND AUDIO CD'S FEATURING ENTERTAINMENT AND EDUCATIONAL MATERIAL FOR CHILDREN; VIDEO GAME PROGRAMS FOR CHILDREN; DOWNLOADABLE ELECTRONIC PUBLICATIONS IN THE NATURE OF MAGAZINES IN THE FIELD OF ENTERTAINMENT AND EDUCATIONAL MATERIAL FOR CHILDREN (U.S. CLS. 21, 23, 26, 36 AND 38).

**CLASS 16—PAPER GOODS AND PRINTED MATTER**

FOR PRINTED PUBLICATIONS, NAMELY, BOOKS, MAGAZINES, PERIODICALS, AND JOURNALS FEATURING ENTERTAINMENT AND EDUCATIONAL MATERIAL FOR CHILDREN; PRINTED MATTER, NAMELY PRINTED CHARTS; PHOTOGRAPHS, STATIONERY; PAPER; CRAFT PAPER; CREPE PAPER; DRAWING PAPER; CARDBOARD; GOODS MADE FROM PAPER, NAMELY BOXES; GOODS MADE FROM CARDBOARD, NAMELY BOXES; ART PAPER; PHOTOGRAPH ALBUMS, WRITING PADS, PENS, CALENDARS, POSTERS; PICTURES; PICTURE BOOKS; FOLDERS, JACKETS FOR PAPERS, WRITING PAPER, ADVERTISEMENT BOARDS OF PAPER OR CARDBOARD, WRITING OR DRAWING BOOKS, BLANK WRITING JOURNALS, JOURNALS FOR CHILDREN; DRAWINGS, INDEX CARDS, PAPER SHEETS FOR NOTE TAKING; GREETING CARDS, BLANK CARDS, BLANK NOTE CARDS; NOTE CARDS; POSTCARDS, PLACARDS OF PAPER OR CARDBOARD, ENVELOPES, CALENDARS, WRITING INK; INKING PADS; INK STAMPS; STAMP PAD INK (U.S. CLS. 2, 5, 22, 23, 29, 37, 38 AND 50).

**CLASS 28—TOYS AND SPORTING GOODS**

FOR GAMES, NAMELY BOARD GAMES; PLAYTHINGS, NAMELY, PLAY FIGURES, TOY FIGURES, TOY VEHICLES; ELECTRONIC EDUCATIONAL GAME MACHINES FOR CHILDREN; PUPPETS; PUZZLES; GAME TABLES; PARTY GAMES; TOYS, NAMELY, BATHTUB TOYS; INFANT TOYS; MUSICAL TOYS; PLUSH TOYS; STUFFED TOYS; DOLLS (U.S. CLS. 22, 23, 38 AND 50).

MARY BOAGNI, EXAMINING ATTORNEY

**CLASS 3—COSMETICS AND CLEANING PREPARATIONS**

FOR ARTIFICIAL EYELASHES, EYELASH EXTENSIONS, COSMETICS, ADHESIVES FOR ATTACHING ARTIFICIAL EYELASHES AND/OR FINGERNAILS, ADHESIVES FOR COSMETIC USE, AMMONIA FOR CLEANING PURPOSES, ASTRINGENTS FOR COSMETIC PURPOSES, BODY SCRUBS, BODY CREAM, BODY EMULSIONS, ALL PURPOSE CLEANING PREPARATIONS, SKIN CLEANSING LOTION, DISINFECTANT SOAPS, EYE SHADOW, EYE GELS, EYEBROW PENCILS, MAKEUP REMOVER, MAKEUP, MAKEUP FOUNDATION, EYE MAKEUP REMOVER, EYE MAKEUP, FACIAL MAKEUP, MASCARA, MASSAGE OIL, MEDICATED SOAP, SKIN MOISTURIZER, PRE-MOISTENED COSMETIC TISSUES, PRE-MOISTENED COSMETIC TOWELETTES, PRE-MOISTENED COSMETIC WIPES, SKIN CLEANSERS, SKIN EMOLLIENTS, SKIN CLARIFIERS, SKIN TEXTURIZERS, SKIN SOAP, LIQUID SOAP, COTTON SWABS FOR COSMETIC PURPOSES, COTTON SWABS FOR PERSONAL USE, AND PERMANENT MAKEUP (U.S. CLS. 1, 4, 6, 50, 51 AND 52).

**CLASS 35—ADVERTISING AND BUSINESS**

FOR RETAIL STORE AND WHOLESALE STORE SERVICES IN THE FIELD OF ARTIFICIAL EYELASHES, EYELASH EXTENSIONS AND COSMETICS; COMPUTERIZED ON-LINE RETAIL STORE AND WHOLESALE STORE SERVICES IN THE FIELD OF ARTIFICIAL EYELASHES, EYELASH EXTENSIONS AND COSMETICS; CONDUCTING TRADE SHOWS IN THE FIELD OF EYELASH EXTENSIONS AND ARTIFICIAL EYELASHES (U.S. CLS. 100, 101 AND 102).

**CLASS 41—EDUCATION AND ENTERTAINMENT**

FOR ARRANGING PROFESSIONAL WORKSHOPS, TRAINING COURSES AND TRAINING SERVICES IN THE FIELD OF EYELASH EXTENSIONS AND ARTIFICIAL EYELASHES; PROVIDING ON-LINE EDUCATIONAL WORKSHOPS AND TRAINING COURSES IN THE FIELD OF EYELASH EXTENSIONS AND ARTIFICIAL EYELASHES (U.S. CLS. 100, 101 AND 107).

**CLASS 44—MEDICAL, BEAUTY AND AGRICULTURAL SERVICES**

FOR PROVIDING INFORMATION OVER A GLOBAL COMPUTER NETWORK IN THE FIELDS OF EYELASH EXTENSIONS, ARTIFICIAL EYELASHES AND COSMETICS (U.S. CLS. 100 AND 101).

JENNIFER KRISP, EXAMINING ATTORNEY

SN 78-676,796. LAVISH LASHES, LLC, RIVERSIDE, CA.  
FILED 7-23-2005.

SN 78-676,797. LAVISH LASHES, LLC, RIVERSIDE, CA.  
FILED 7-23-2005.

**LAVISH LASHES**

**LAVISH LASH**

THE MARK CONSISTS OF STANDARD CHARACTERS WITHOUT CLAIM TO ANY PARTICULAR FONT, STYLE, SIZE, OR COLOR.

NO CLAIM IS MADE TO THE EXCLUSIVE RIGHT TO USE "LASHES", APART FROM THE MARK AS SHOWN.

THE MARK CONSISTS OF STANDARD CHARACTERS WITHOUT CLAIM TO ANY PARTICULAR FONT, STYLE, SIZE, OR COLOR.

NO CLAIM IS MADE TO THE EXCLUSIVE RIGHT TO USE "LASH", APART FROM THE MARK AS SHOWN.



**CLASS 3—COSMETICS AND CLEANING PREPARATIONS**

FOR ARTIFICIAL EYELASHES, EYELASH EXTENSIONS, COSMETICS, ADHESIVES FOR ATTACHING ARTIFICIAL EYELASHES AND/OR FINGERNAILS, ADHESIVES FOR COSMETIC USE, AMMONIA FOR CLEANING PURPOSES, ASTRINGENTS FOR COSMETIC PURPOSES, BODY SCRUBS, BODY CREAM, BODY EMULSIONS, ALL PURPOSE CLEANING PREPARATIONS, SKIN CLEANSING LOTION, DISINFECTANT SOAPS, EYE SHADOW, EYE GELS, EYEBROW PENCILS, MAKEUP REMOVER, MAKEUP, MAKEUP FOUNDATION, EYE MAKEUP REMOVER, EYE MAKEUP, FACIAL MAKEUP, MASCARA, MASSAGE OIL, MEDICATED SOAP, SKIN MOISTURIZER, PRE-MOISTENED COSMETIC TISSUES, PRE-MOISTENED COSMETIC TOWELETTES, PRE-MOISTENED COSMETIC WIPES, SKIN CLEANSERS, SKIN EMOLLIENTS, SKIN CLARIFIERS, SKIN TEXTURIZERS, SKIN SOAP, LIQUID SOAP, COTTON SWABS FOR COSMETIC PURPOSES, COTTON SWABS FOR PERSONAL USE, AND PERMANENT MAKEUP (U.S. CLS. 1, 4, 6, 50, 51 AND 52).

**CLASS 35—ADVERTISING AND BUSINESS**

FOR RETAIL STORE AND WHOLESALE STORE SERVICES IN THE FIELD OF ARTIFICIAL EYELASHES, EYELASH EXTENSIONS AND COSMETICS; COMPUTERIZED ON-LINE RETAIL STORE AND WHOLESALE STORE SERVICES IN THE FIELD OF ARTIFICIAL EYELASHES, EYELASH EXTENSIONS AND COSMETICS; CONDUCTING TRADE SHOWS IN THE FIELD OF EYELASH EXTENSIONS AND ARTIFICIAL EYELASHES (U.S. CLS. 100, 101 AND 102).

**CLASS 41—EDUCATION AND ENTERTAINMENT**

FOR ARRANGING PROFESSIONAL WORKSHOPS, TRAINING COURSES AND TRAINING SERVICES IN THE FIELD OF EYELASH EXTENSIONS AND ARTIFICIAL EYELASHES; PROVIDING ON-LINE EDUCATIONAL WORKSHOPS AND TRAINING COURSES IN THE FIELD OF EYELASH EXTENSIONS AND ARTIFICIAL EYELASHES (U.S. CLS. 100, 101 AND 107).

**CLASS 44—MEDICAL, BEAUTY AND AGRICULTURAL SERVICES**

FOR PROVIDING INFORMATION OVER A GLOBAL COMPUTER NETWORK IN THE FIELDS OF EYELASH EXTENSIONS, ARTIFICIAL EYELASHES AND COSMETICS (U.S. CLS. 100 AND 101).  
JENNIFER KRISP, EXAMINING ATTORNEY

SN 78-679,410. BIOCATALYSTS LIMITED, CARDIFF, UNITED KINGDOM, FILED 7-27-2005.

PRIORITY CLAIMED UNDER SEC. 44(D) ON UNITED KINGDOM APPLICATION NO. 2383042, FILED 1-27-2005, REG. NO. 2383042, DATED 7-15-2005, EXPIRES 1-27-2015.

PRIORITY CLAIMED UNDER SEC. 44(D) ON UNITED KINGDOM APPLICATION NO. 2383042, FILED 1-27-2005, REG. NO. 2383042, DATED 7-15-2005, EXPIRES 1-27-2015.

NO CLAIM IS MADE TO THE EXCLUSIVE RIGHT TO USE "BIOCATALYSTS", APART FROM THE MARK AS SHOWN.

THE MARK CONSISTS OF THE WORD BIOCATALYSTS WITH THE FIRST LETTER BEING THE LETTERS "B" AND "C" JOINED TOGETHER VERTICALLY IN STYLIZED FORM.

**CLASS 1—CHEMICALS**

FOR ENZYMES AND ENZYMIC PREPARATIONS, ALL FOR BOTANICAL USE AND ORGANIC PROCESSING; ENZYMES AND ENZYMIC PREPARATIONS, ALL FOR USE IN THE FOOD PROCESSING INDUSTRY; ENZYMES AND CHEMICALS FOR USE IN HORTICULTURE AND AGRICULTURE; CHEMICAL AND ENZYMIC PREPARATIONS FOR USE IN THE MANUFACTURE OF FOODS; ENZYMES FOR USE IN THE MANUFACTURE OF FOOD AND DRINKS (U.S. CLS. 1, 5, 6, 10, 26 AND 46).

**CLASS 42—SCIENTIFIC, COMPUTER AND LEGAL SERVICES**

FOR CHEMICAL RESEARCH SERVICES RELATING TO THE FOOD INDUSTRY; BIOLOGICAL RESEARCH SERVICES RELATING TO THE FOOD INDUSTRY; CONSULTANCY SERVICES IN THE FIELD OF FOOD TECHNOLOGY; BIOCHEMISTRY RESEARCH SERVICES IN THE FIELD OF FOOD TECHNOLOGY; BIOTECHNOLOGICAL RESEARCH SERVICES IN THE FIELD OF FOOD TECHNOLOGY; BIOTECHNOLOGICAL RESEARCH SERVICES RELATING TO ENZYME SYNTHESIS FOR THE FOOD INDUSTRY; CONTRACT RESEARCH SERVICES FOR OTHERS IN THE FIELD OF BACTERIOLOGY OR CHEMISTRY IN THE FOOD INDUSTRY; LABORATORY RESEARCH IN THE FIELD OF FOOD CHEMISTRY; PREPARATIONS OF REPORTS RELATING TO SCIENTIFIC, CHEMICAL AND ENZYMIC RESEARCH IN THE FOOD INDUSTRY; PROVISION OF RESEARCH FACILITIES FOR CHEMICAL AND BIOLOGICAL RESEARCH RELATED TO THE FOOD INDUSTRY; ADVISORY, CONSULTANCY AND INFORMATION SERVICES RELATING TO THE AFORESAID SERVICES (U.S. CLS. 100 AND 101).  
TINA BROWN, EXAMINING ATTORNEY

SN 78-681,048. THE FIRST PAGE, INC., NEWPORT BEACH, CA. FILED 7-28-2005.

# THE FIRST PAGE

THE MARK CONSISTS OF STANDARD CHARACTERS WITHOUT CLAIM TO ANY PARTICULAR FONT, STYLE, SIZE, OR COLOR.

**CLASS 35—ADVERTISING AND BUSINESS**

FOR RETAIL STORE SERVICES FEATURING BOOKS, MAGAZINES, AUDIO RECORDINGS OF BOOKS AND MUSIC, VIDEOS/DVDS, CD-ROMS, COMPUTER SOFTWARE, COMIC BOOKS, COLORING BOOKS, STICKER BOOKS, ACTIVITY BOOKS, BOOKMARKS, GREETING CARDS, STATIONERY, TOYS, GAMES, CLOTHING, ARTS AND CRAFTS SUPPLIES, BOOKS SOLD AS A UNIT WITH TOYS, BOOKS SOLD AS A UNIT WITH GAMES AND BOOKS SOLD AS A UNIT WITH CLOTHING ITEMS; ONLINE RETAIL STORE SERVICES FEATURING BOOKS, MAGAZINES, AUDIO RECORDINGS OF BOOKS AND MUSIC, VIDEOS/DVDS, CD-ROMS, COMPUTER SOFTWARE, COMIC BOOKS, COLORING BOOKS, STICKER BOOKS, ACTIVITY BOOKS, BOOKMARKS, GREETING CARDS, STATIONERY, TOYS, GAMES, CLOTHING, ARTS AND CRAFTS SUPPLIES, BOOKS SOLD AS A UNIT WITH TOYS, BOOKS SOLD AS A UNIT WITH GAMES AND BOOKS SOLD AS A UNIT WITH CLOTHING ITEMS (U.S. CLS. 100, 101 AND 102).  
FIRST USE 4-30-2003; IN COMMERCE 4-30-2003.

**CLASS 41—EDUCATION AND ENTERTAINMENT**

FOR EDUCATIONAL SERVICES, NAMELY PROVIDING SEMINARS, LECTURES AND WORKSHOPS ON A VARIETY OF TOPICS, NAMELY LITERATURE, WRITING, ARTS AND CRAFTS, PARENTING AND CHILD DEVELOPMENT; ENTERTAINMENT SERVICES, NAMELY, STORYTELLING, ACTING, SINGING, DANCING AND SPECIAL GUEST APPEARANCES BY AUTHORS AND ILLUSTRATORS; CONDUCTING BOOK REVIEW AND DISCUSSION SESSIONS FOR EDUCATIONAL AND ENTERTAINMENT PURPOSES; PROVIDING ONLINE INFORMATIVE NEWSLETTER FEATURING BOOKS, MAGAZINES, AUDIO RECORDINGS OF BOOKS AND MUSIC, VIDEOS/DVDS, CD-ROMS, COMPUTER SOFTWARE, COMIC BOOKS, COLORING BOOKS, STICKER BOOKS, ACTIVITY BOOKS, BOOKMARKS, GREETING CARDS, STATIONERY, TOYS, GAMES, CLOTHING, ARTS AND CRAFTS SUPPLIES, BOOKS SOLD AS A UNIT WITH TOYS, BOOKS SOLD AS A UNIT WITH GAMES, BOOKS SOLD AS A UNIT WITH CLOTHING ITEMS AND SPECIAL EVENTS (U.S. CLS. 100, 101 AND 107).

FIRST USE 4-30-2003; IN COMMERCE 4-30-2003.  
ALEX KEAM, EXAMINING ATTORNEY

SN 78-681,180. STARLINGEAR CORPORATION, ATASCADERO, CA. FILED 7-28-2005.

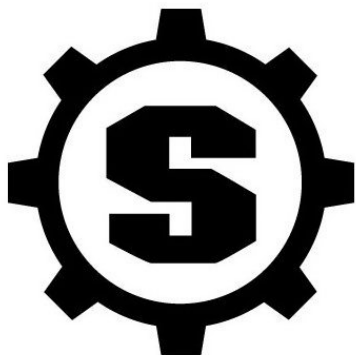

THE MARK CONSISTS OF THE LETTER "S," WHICH IS ENCLOSED WITHIN A CIRCULAR COG WHEEL GEAR DESIGN ELEMENT.

**CLASS 14—JEWELRY**

FOR JEWELRY (U.S. CLS. 2, 27, 28 AND 50).  
FIRST USE 8-0-2001; IN COMMERCE 8-0-2001.

**CLASS 25—CLOTHING**

FOR CLOTHING, NAMELY, SHIRTS, T-SHIRTS, JACKETS AND HEADWEAR (U.S. CLS. 22 AND 39).  
FIRST USE 2-28-2004; IN COMMERCE 2-28-2004.  
RAY THOMAS, EXAMINING ATTORNEY

SN 78-681,806. PROFESSIONAL STAFFING-A.B.T.S., INC., CLEARWATER, FL. FILED 7-29-2005.

**THE DAILY LABORER**

THE MARK CONSISTS OF STANDARD CHARACTERS WITHOUT CLAIM TO ANY PARTICULAR FONT, STYLE, SIZE, OR COLOR.

NO CLAIM IS MADE TO THE EXCLUSIVE RIGHT TO USE "DAILY", APART FROM THE MARK AS SHOWN.

**CLASS 16—PAPER GOODS AND PRINTED MATTER**

FOR NEWSPAPERS COVERING THE CONSTRUCTION INDUSTRY (U.S. CLS. 2, 5, 22, 23, 29, 37, 38 AND 50).

FIRST USE 12-2-2005; IN COMMERCE 1-1-2006.

**CLASS 41—EDUCATION AND ENTERTAINMENT**

FOR PROVIDING ONLINE PUBLICATIONS IN THE NATURE OF A NEWSPAPER COVERING THE CONSTRUCTION INDUSTRY (U.S. CLS. 100, 101 AND 107).

FIRST USE 12-2-2005; IN COMMERCE 1-1-2006.  
MICHAEL WEBSTER, EXAMINING ATTORNEY

SN 78-683,830. JALP, LLC, MEMPHIS, TN. FILED 8-2-2005.

**SOL**

THE MARK CONSISTS OF STANDARD CHARACTERS WITHOUT CLAIM TO ANY PARTICULAR FONT, STYLE, SIZE, OR COLOR.

THE FOREIGN WORDING IN THE MARK TRANSLATES INTO ENGLISH AS SUN.

**CLASS 14—JEWELRY**

FOR KEY HOLDERS OF PRECIOUS METALS (U.S. CLS. 2, 27, 28 AND 50).

**CLASS 18—LEATHER GOODS**

FOR LUGGAGE, HANDBAGS, COSMETIC CASES SOLD EMPTY, WALLETS, SPORTS BAGS, CARRY-ALL BAGS, TRAVELING CASES OF LEATHER, SHOULDER BAGS, BACKPACKS, KNAPSNACKS, RUCKSACKS, DUFFLE BAGS, FANNY PACKS, WAIST PACKS, WRIST PACKS, ALL-PURPOSE SPORTING BAGS, ALL-PURPOSE CARRYING BAGS, TOTE BAGS, TRAVELING BAGS, SHOULDER BAGS, UMBRELLAS, SHOE BAGS FOR TRAVEL, AND MESSENGER BAGS (U.S. CLS. 1, 2, 3, 22 AND 41).

DAVID HOFFMAN, EXAMINING ATTORNEY

SN 78-685,011. SMARTY PARENTS INC., PORTLAND, OR.  
FILED 8-3-2005.



SN 78-684,666. SEKISUI KAGAKU KOGYO KABUSHIKI KAISHA, DBA SEKISUI CHEMICAL CO., LTD., KITA-KU, OSAKA, JAPAN, FILED 8-3-2005.

SPR

THE MARK CONSISTS OF STANDARD CHARACTERS WITHOUT CLAIM TO ANY PARTICULAR FONT, STYLE, SIZE, OR COLOR.

**CLASS 17—RUBBER GOODS**

FOR FLEXIBLE PLASTIC TUBES FOR PLUMBING; NON METAL GASKETS FOR PLUMBING; PIPE GASKETS, NOT OF METAL; PIPE JACKETS, NOT OF METAL, AND PIPE MUFFS, NOT OF METAL, BOTH FOR USE WITH WATER AND SEWER PIPES; JOINT PACKINGS FOR WATER AND SEWER PIPES; JUNCTIONS FOR WATER AND SEWER PIPES, NOT OF METAL (U.S. CLS. 1, 5, 12, 13, 35 AND 50).

**CLASS 19—NON-METALLIC BUILDING MATERIALS**

FOR BUILDING MATERIALS, NAMELY, PIPE SUPPORTS IN THE NATURE OF RIGID NON-METALLIC INTERLOCKING PLATES OR STRIPS, WITH OR WITHOUT STEEL REINFORCEMENTS, TO BE SPIRALLY WOUND AND GROUTED INTO THE INTERIOR OF AN EXISTING PIPE OR PIPELINE, TO LINE AND STRENGTHEN SUCH PIPE OR PIPELINE; GROUT; BRANCHING PIPES, NOT OF METAL; FRAMEWORK, NOT OF METAL, FOR BUILDING; PENSTOCK PIPES, NOT OF METAL; GUTTER PIPES NOT OF METAL; RIGID PIPES NOT OF METAL; WATER-PIPES, NOT OF METAL; AND PLASTIC CONDUIT FOR DRAINAGE; REINFORCING MATERIALS, NOT OF METAL, FOR PLASTIC PIPE SUPPORTS (U.S. CLS. 1, 12, 33 AND 50).

DAVID HOFFMAN, EXAMINING ATTORNEY

THE COLOR(S) BEIGE, GREEN, BLACK, WHITE, AND RED IS/ARE CLAIMED AS A FEATURE OF THE MARK.

THE COLOR BEIGE APPEARS IN BOTH PIG'S FACES AND ON THE OUTER PORTION OF THE WORDS PERRY AND PENNY'S. THE COLOR GREEN APPEARS WITHIN THE TRIANGLE AND THE WITHIN THE AMPERSAND. THE COLOR BLACK APPEARS WITHIN THE WORDS PERRY AND PENNY'S AND ON THE OUTER LINING OF BOTH PIGS. THE COLOR WHITE APPEARS IN THE PIG'S BIBS, AND THE COLOR RED APPEARS IN THE PIG'S BOW.

THE MARK CONSISTS OF TWO STYLIZED PIG FACES AND THE WORDS PERRY & PENNY'S, ALL WITHIN A TRIANGLE.

**CLASS 9—ELECTRICAL AND SCIENTIFIC APPARATUS**

FOR VIDEO AND AUDIO RECORDINGS FEATURING EDUCATIONAL INSTRUCTION FOR CHILDREN ON A RANGE OF TOPICS (U.S. CLS. 21, 23, 26, 36 AND 38).

**CLASS 16—PAPER GOODS AND PRINTED MATTER**

FOR PAPER PLACE MATS, PAPER BABY BIBS, PAPER TABLE LINENS, BOOKS IN THE FIELD OF CHILDREN'S EDUCATION AND ENTERTAINMENT (U.S. CLS. 2, 5, 22, 23, 29, 37, 38 AND 50).

**CLASS 21—HOUSEWARES AND GLASS**

FOR DISHES, PLATES, SERVING PLATTERS, CLEANING SPONGES (U.S. CLS. 2, 13, 23, 29, 30, 33, 40 AND 50).

**CLASS 24—FABRICS**

FOR PLACE MATS NOT OF PAPER, TABLE LINENS (U.S. CLS. 42 AND 50).

**CLASS 28—TOYS AND SPORTING GOODS**

FOR TOYS, NAMELY, PUPPETS, MODELED TOY FIGURINES, AND ACTION FIGURES (U.S. CLS. 22, 23, 38 AND 50).

DAVID COLLIER, EXAMINING ATTORNEY

SN 78-688,234. TWEEN BRANDS INVESTMENT, LLC, NEW ALBANY, OH. FILED 8-9-2005.

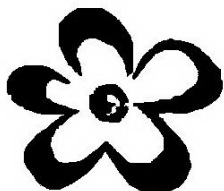

### CLASS 3—COSMETICS AND CLEANING PREPARATIONS

FOR PERSONAL CARE ITEMS, NAMELY, COSMETICS (U.S. CLS. 1, 4, 6, 50, 51 AND 52).  
FIRST USE 7-15-2005; IN COMMERCE 7-15-2005.

### CLASS 9—ELECTRICAL AND SCIENTIFIC APPARATUS

FOR TELEPHONES, CAMERAS AND ACCESSORIES, NAMELY, CARRYING CASES FOR TELEPHONES (U.S. CLS. 21, 23, 26, 36 AND 38).  
FIRST USE 7-15-2005; IN COMMERCE 7-15-2005.

### CLASS 14—JEWELRY

FOR CLOCKS, JEWELRY AND WATCHES (U.S. CLS. 2, 27, 28 AND 50).  
FIRST USE 7-15-2005; IN COMMERCE 7-15-2005.

### CLASS 16—PAPER GOODS AND PRINTED MATTER

FOR PENS, PENCILS, MARKERS, SPIRAL AND LOOSE LEAF NOTEBOOKS, NOTE PADS, DIARIES, PHOTO ALBUMS, ADDRESS BOOKS, ERASERS, COLORED PENCILS, STICKERS, BULLETIN BOARDS, AND ERASABLE MARKER BOARDS FOR DRAWING AND WRITING (U.S. CLS. 2, 5, 22, 23, 29, 37, 38 AND 50).  
FIRST USE 7-15-2005; IN COMMERCE 7-15-2005.

### CLASS 18—LEATHER GOODS

FOR LUGGAGE AND TRAVELING BAGS, SUITCASES, PURSES, BACKPACKS, HANDBAGS, WAIST PACKS, SPORT BAGS, BEACH BAGS, POUCHES OF LEATHER, BEAUTY CASES SOLD EMPTY, WALLETS, UMBRELLAS AND BAGS FOR UMBRELLAS (U.S. CLS. 1, 2, 3, 22 AND 41).  
FIRST USE 7-15-2005; IN COMMERCE 7-15-2005.

### CLASS 20—FURNITURE AND ARTICLES NOT OTHERWISE CLASSIFIED

FOR CHAIRS, FRAMES, PILLOWS, DISPLAY BOARDS, HAMPERS AND NON-METAL KEY CHAINS (U.S. CLS. 2, 13, 22, 25, 32 AND 50).

### CLASS 24—FABRICS

FOR BED BLANKETS, THROW BLANKETS, AND BLANKETS FOR OUTDOOR USE; TOWELS, TEXTILE DECORATIVE DOOR HANGINGS (U.S. CLS. 42 AND 50).

### CLASS 25—CLOTHING

FOR CLOTHING, NAMELY, BELTS, BEACHWEAR, COATS AND JACKETS, DRESSES, FOOTWEAR, HEADWEAR, PANTS, SCARVES, SHORTS, SLEEPWEAR, SKIRTS, SOCKS, TOPS, AND UNDER GARMENTS (U.S. CLS. 22 AND 39).  
FIRST USE 7-15-2005; IN COMMERCE 7-15-2005.

### CLASS 26—FANCY GOODS

FOR HAIR ACCESSORIES, NAMELY CLAW AND SNAP CLIPS, BARRETTES, BANDS, BOWS, COMBS, PINS, RIBBONS, PONYTAIL HOLDERS, SCRUNCHIES, AND HAIR ORNAMENTS IN THE FORM OF COMBS (U.S. CLS. 37, 39, 40, 42 AND 50).  
FIRST USE 7-15-2005; IN COMMERCE 7-15-2005.

### CLASS 28—TOYS AND SPORTING GOODS

FOR TOYS, NAMELY DOLLS, PLUSH TOYS, STUFFED TOYS, AND WATER TOYS (U.S. CLS. 22, 23, 38 AND 50).  
FIRST USE 7-15-2005; IN COMMERCE 7-15-2005.

### CLASS 35—ADVERTISING AND BUSINESS

FOR RETAIL STORE SERVICES, MAIL ORDER CATALOG SERVICES AND ON-LINE RETAIL STORE SERVICES FEATURING PERSONAL CARE PRODUCTS, ELECTRONICS, PAPER GOODS, HOME FURNISHINGS, JEWELRY, WATCHES, BAGS, CLOTHING, HAIR ACCESSORIES AND TOYS. (U.S. CLS. 100, 101 AND 102).  
FIRST USE 7-15-2005; IN COMMERCE 7-15-2005.  
BRIDGETT SMITH, EXAMINING ATTORNEY

---

SN 78-690,186. IDENTITY STUDIOS, INC., BURBANK, CA. FILED 8-10-2005.



identityStudios

THE COLOR(S) RED, WHITE AND GRAY IS/ARE CLAIMED AS A FEATURE OF THE MARK.

THE MARK CONSISTS OF FOUR RED ARROWS, TWO SMALL IN THE "NORTH" AND "SOUTH" QUADRANTS AND TWO LARGER IN THE "EAST" AND "WEST" QUADRANTS THAT IN TOTAL FORM THE CAPITAL LETTER "I" IN THE CENTER OF THEM. THE "I" IS WHITE AND THE WORDING, "IDENTITY STUDIOS" IS GRAY.

### CLASS 35—ADVERTISING AND BUSINESS

FOR ADVERTISING AND MARKETING; ADVERTISING, MARKETING AND PROMOTION SERVICES; BUSINESS CONSULTATION AND MANAGEMENT REGARDING MARKETING ACTIVITIES AND LAUNCHING OF NEW PRODUCTS (U.S. CLS. 100, 101 AND 102).

**CLASS 41—EDUCATION AND ENTERTAINMENT**

FOR ENTERTAINMENT SERVICES, NAMELY, PROVIDING A WEB SITE FEATURING MUSICAL PERFORMANCES, MUSICAL VIDEOS, RELATED FILM CLIPS, PHOTOGRAPHS, AND OTHER MULTIMEDIA MATERIALS; FILM EDITING; FILM STUDIOS; MOTION PICTURE FILM PRODUCTION; SPECIAL EFFECTS ANIMATION SERVICES FOR FILM AND VIDEO (U.S. CLS. 100, 101 AND 107).

ROBIN CHOSID, EXAMINING ATTORNEY

SN 78-690,308. PURE FISHING, INC., SPIRIT LAKE, IA. FILED 8-11-2005.

**IN THE ZONE**

THE MARK CONSISTS OF STANDARD CHARACTERS WITHOUT CLAIM TO ANY PARTICULAR FONT, STYLE, SIZE, OR COLOR.

OWNER OF U.S. REG. NOS. 2,319,413, 2,579,267 AND OTHERS.

**CLASS 7—MACHINERY**

FOR FISHING TOOLS, NAMELY, POWER-OPERATED HOOK SHARPENERS (U.S. CLS. 13, 19, 21, 23, 31, 34 AND 35).

**CLASS 8—HAND TOOLS**

FOR FISHING HAND TOOLS, NAMELY, PLIERS AND HOOKING FILES; FISHING KNIVES; SCISSORS; FISHING LINE CRIMPERS; FISHING LINE CUTTERS; MANUALLY OPERATED FISHING LINE SPOOLING STATIONS CONSISTING PRIMARILY OF A BULK SPOOL HOLDER, A FISHING REEL HOLDER, AND A LINE GUIDED DEVICE THAT HELP ENSURE LEVEL FILING WITH CONSTANT LINE TENSION ON SPINNING AND CASTING REELS (U.S. CLS. 23, 28 AND 44).

**CLASS 9—ELECTRICAL AND SCIENTIFIC APPARATUS**

FOR FISHING TOOLS, NAMELY, WEIGH SCALES (U.S. CLS. 21, 23, 26, 36 AND 38).

**CLASS 26—FANCY GOODS**

FOR EMBROIDERED EMBLEMS (U.S. CLS. 37, 39, 40, 42 AND 50).

**CLASS 28—TOYS AND SPORTING GOODS**

FOR FISHING RODS; FISHING REELS; FISHING LINE; ARTIFICIAL FISHING LURES; ARTIFICIAL FISHING BAITS; FISH ATTRACTANTS; FISHING TACKLE, NAMELY FISHING HOOKS, DOWNRIGGERS, SWIVELS, SNAP SWIVELS, SNAPS, KNOTLESS FASTENERS, AND CONNECTOR SLEEVES, AND LEADERS USED FOR FISHING; KITS CONSISTING PRIMARILY OF LURES, HARD BAITS, SOFT ARTIFICIAL FISHING BAITS, WEIGHTS, WORMS, JIGS, HOOKS, AND BOBBERS; FISHING ROD RACKS; FISHING ROD HOLDERS; TACKLE BOXES; FISHING ROD CASES; SPORTSMAN'S FISHING BAGS; AND ICE FISHING STRIKE INDICATORS (U.S. CLS. 22, 23, 38 AND 50).

**CLASS 36—INSURANCE AND FINANCIAL**

FOR FINANCIAL SPONSORSHIP OF FISHING, GOLF AND TENNIS TOURNAMENTS (U.S. CLS. 100, 101 AND 102).

TONI HICKEY, EXAMINING ATTORNEY

SN 78-691,514. ELECTRIC AQUAGENICS UNLIMITED, INC., LINDON, UT. FILED 8-12-2005.

**Zero Plus**

THE MARK CONSISTS OF STANDARD CHARACTERS WITHOUT CLAIM TO ANY PARTICULAR FONT, STYLE, SIZE, OR COLOR.

**CLASS 3—COSMETICS AND CLEANING PREPARATIONS**

FOR ANTIBACTERIAL SKIN SOAPS; DISINFECTANT SKIN SOAPS; ALL PURPOSE SURFACE CLEANERS; CLEANERS FOR USE ON SURFACES INVOLVED WITH FOOD TREATMENT AND PREPARATION, BIOLOGICAL MEMBRANES AND FOOD SURFACES; CLEANERS, NAMELY, ALL PURPOSE CLEANING SOLUTIONS; CLEANERS, NAMELY CLEANING SOLUTIONS FOR USE ON SURFACES INVOLVED WITH FOOD TREATMENT AND PREPARATION, BIOLOGICAL MEMBRANES AND FOOD SURFACES (U.S. CLS. 1, 4, 6, 50, 51 AND 52).

**CLASS 5—PHARMACEUTICALS**

FOR SURFACE DISINFECTANT, NAMELY, ALL PURPOSE DISINFECTING PREPARATIONS (U.S. CLS. 6, 18, 44, 46, 51 AND 52).

AISHA CLARKE, EXAMINING ATTORNEY

SN 78-691,869. MACTEC, INC., ALPHARETTA, GA. FILED 8-12-2005.

**MACTEC**

THE MARK CONSISTS OF STANDARD CHARACTERS WITHOUT CLAIM TO ANY PARTICULAR FONT, STYLE, SIZE, OR COLOR.

OWNER OF U.S. REG. NOS. 2,270,421 AND 2,273,777.

**CLASS 35—ADVERTISING AND BUSINESS**

FOR INDUSTRIAL FACILITY ASSET MANAGEMENT; CONDUCTING LIFE CYCLE COST/PRICE ANALYSIS STUDIES FOR INDUSTRIAL FACILITY SYSTEMS; AND BUSINESS MANAGEMENT CONSULTATION SERVICES IN THE FIELD OF CRISIS MANAGEMENT IN CONNECTION WITH HEALTH, SAFETY OR ENVIRONMENTAL PROBLEMS, INCIDENTS AND HAZARDS AND MANAGING COMMUNITY RELATIONS IN CONNECTION THEREWITH (U.S. CLS. 100, 101 AND 102).

FIRST USE 10-4-2002; IN COMMERCE 10-4-2002.

**CLASS 36—INSURANCE AND FINANCIAL**

FOR CONSULTING SERVICES IN THE FIELD OF INDUSTRIAL RISK MANAGEMENT; AND CONSULTING SERVICES IN THE FIELD OF COMMERCIAL OR INDUSTRIAL REAL ESTATE ACQUISITION AND ASSESSMENT; INDUSTRIAL AND ENVIRONMENTAL RISK MANAGEMENT SERVICES (U.S. CLS. 100, 101 AND 102).

FIRST USE 10-4-2002; IN COMMERCE 10-4-2002.

**CLASS 37—CONSTRUCTION AND REPAIR**

FOR ENVIRONMENTAL SITE REMEDIATION SERVICES, WASTE DISPOSAL; LAND DEVELOPMENT SERVICES, NAMELY, PLANNING AND LAYING OUT HAZARDOUS AND NON-HAZARDOUS WASTE MANAGEMENT FACILITIES; EXCAVATION SERVICES; SOIL STABILIZATION SERVICES; CONSULTING SERVICES IN THE CLEANING, MAINTENANCE AND REMOVAL OF UNDERGROUND STORAGE TANKS; CONSULTING SERVICES IN THE DEVELOPMENT, DESIGN, SITE LOCATION, OPERATION AND CLOSURE OF SOLID WASTE LANDFILLS; CONSULTING SERVICES IN THE HANDLING, REMEDIATION AND REMOVAL OF ASBESTOS AND LEAD BASED PAINT; CONSULTING SERVICES IN THE MAINTENANCE OF MECHANICAL, ELECTRICAL AND PLUMBING SYSTEMS FOR OTHERS; CONSULTING IN PAVEMENT AND ROOF MAINTENANCE PROGRAMS FOR OTHERS; CONSULTATION SERVICES IN THE INSTALLATION AND MAINTENANCE OF OIL, GAS AND WATER WELLS; CONSULTING SERVICES IN THE FIELD OF SOIL STABILIZATION; CONSTRUCTION MANAGEMENT, PLANNING, CONSULTATION AND SUPERVISION SERVICES; BUILDING INSPECTION SERVICES; FOUNDATION CONTRACTOR SERVICES; SOIL EROSION CONTROL SERVICES; STORAGE TANK CLEANING AND REMOVAL SERVICES; CONSULTING SERVICES FOR THE CONSTRUCTION OF WATER TREATMENT AND PURIFICATION PLANTS, SOLID WASTE TREATMENT PLANTS AND OTHER MUNICIPAL INFRASTRUCTURE FACILITIES; MANAGEMENT OF ENVIRONMENTAL REMEDIATION PROJECTS; CONSULTING SERVICES IN THE FIELD OF EXCAVATION AND TRANSPORTATION OF WASTE AND HAZARDOUS MATERIALS; CONSULTING SERVICES IN THE FIELD OF COMMERCIAL OR INDUSTRIAL REAL ESTATE SITE SELECTION AND ZONING; CONSTRUCTION OF TELECOMMUNICATION TOWERS; CONSTRUCTION OF UNDERWATER POLLUTION CONTROL AND WATER PURIFICATION FACILITIES FOR OTHERS; AND CONSULTING SERVICES IN THE FIELD OF ENVIRONMENTAL REMEDIATION, NAMELY, SOIL, WASTE AND WATER SITE RESTORATION SERVICES (U.S. CLS. 100, 103 AND 106).

FIRST USE 10-4-2002; IN COMMERCE 10-4-2002.

**CLASS 39—TRANSPORTATION AND STORAGE**

FOR CONSULTING SERVICES IN THE TRANSPORTATION OF WASTE AND HAZARDOUS MATERIALS (U.S. CLS. 100 AND 105).

FIRST USE 10-4-2002; IN COMMERCE 10-4-2002.

**CLASS 40—MATERIAL TREATMENT**

FOR CONSULTING SERVICES IN THE PREVENTION, TREATMENT AND REMEDIATION OF INDOOR AIR QUALITY, MOLD AND MILDEW; CONSULTING SERVICES IN THE PREVENTION AND TREATMENT OF CHEMICAL AND MATERIAL SPILLS; CONSULTING SERVICES IN THE PROTECTION, TREATMENT AND REMEDIATION OF RADIATION CONTAMINATION; CRUDE OIL AND SLUDGE TREATMENT SERVICES AND CONSULTING SERVICES IN CONNECTION THEREWITH; ENVIRONMENTAL REMEDIATION SERVICES, NAMELY, SOIL, WASTE AND/OR WATER TREATMENT SERVICES; HAZARDOUS AND NON-HAZARDOUS WASTE MANAGEMENT; DECONTAMINATION OF HAZARDOUS MATERIALS; MOLD REMEDIATION SERVICES; TREATMENT OF WASTE WATER; WASTE WATER REPROCESSING; WATER

TREATMENT AND PURIFICATION; INDUSTRIAL TOXIC WASTE DISPOSAL; CONSULTING SERVICES IN THE FIELD OF INDUSTRIAL TOXIC WASTE DISPOSAL; WASTE AND WATER TREATMENT AND REMEDIATION CONSULTING; ENVIRONMENTAL POLLUTION REMEDIATION SERVICES, NAMELY, SOIL, WASTE AND WATER TREATMENT SERVICES; ONSITE DECONTAMINATION OF HAZARDOUS MATERIALS; AND CONSULTING SERVICES IN THE FIELD OF ENVIRONMENTAL REMEDIATION, NAMELY, SOIL, WASTE AND WATER TREATMENT SERVICES (U.S. CLS. 100, 103 AND 106).

FIRST USE 10-4-2002; IN COMMERCE 10-4-2002.

**CLASS 42—SCIENTIFIC, COMPUTER AND LEGAL SERVICES**

FOR CONSULTING SERVICES IN THE FIELD OF SOIL AND ROCK MECHANICS AND THE GEOPHYSICAL MECHANICS OF TUNNELS AND CAVERNS; CONSULTATION SERVICES IN THE MONITORING AND EVALUATION OF INDOOR AIR QUALITY; CONDUCTING GEOPHYSICAL, NOISE AND INDUSTRIAL HYGIENE STUDIES; CONSULTING SERVICES IN THE FIELD OF CORROSION EVALUATION IN MUNICIPAL INFRASTRUCTURE FACILITIES; CONSULTING SERVICES IN THE DESIGN AND DEVELOPMENT OF PREVENTIVE MAINTENANCE PROGRAMS FOR MUNICIPAL INFRASTRUCTURE FACILITIES; ENGINEERING CONSULTING, NAMELY, ANALYZING FAILURE MODES AND EFFECTS AND PROVIDING FINITE ELEMENT MODELING FOR MUNICIPAL INFRASTRUCTURE FACILITIES; CUSTOM DESIGN AND DEVELOPMENT OF MECHANICAL INTEGRITY PROGRAMS FOR MUNICIPAL INFRASTRUCTURE FACILITIES; NON-DESTRUCTIVE TESTING AND EVALUATION OF INDUSTRIAL SAFETY PROCESSES IN MUNICIPAL INFRASTRUCTURE FACILITIES; CUSTOM DESIGN AND DEVELOPMENT OF PROCESS SAFETY MANAGEMENT COMPLIANCE PROGRAMS; MANAGEMENT OF INDUSTRIAL SAFETY PROGRAMS FOR MUNICIPAL INFRASTRUCTURE FACILITIES; TANK AND PRESSURE VESSEL INSPECTION AND DESIGN SERVICES FOR OTHERS; THERMOGRAPHIC IMAGING AND ANALYSIS OF TANKS AND PRESSURE VESSELS FOR OTHERS; METALLURGICAL LABORATORY SERVICES; ENVIRONMENTAL ENGINEERING SERVICES; CUSTOM DESIGN SERVICES, TESTING SERVICES, INSPECTION SERVICES AND TECHNICAL CONSULTING SERVICES ALL IN THE FIELD OF ENVIRONMENTAL SCIENCE; DESIGN ENGINEERING SERVICES IN THE TELECOMMUNICATIONS FIELD AND CONSULTING SERVICES IN CONNECTION THEREWITH; CIVIL ENGINEERING SERVICES; CUSTOM DESIGN SERVICES, TESTING SERVICES, INSPECTION SERVICES AND TECHNICAL CONSULTING SERVICES IN THE FIELD OF CIVIL ENGINEERING; DESIGN ENGINEERING SERVICES IN THE FIELD OF TRANSPORTATION SYSTEMS AND CONSULTING SERVICES IN CONNECTION THEREWITH; STRUCTURAL ENGINEERING SERVICES; TESTING, INSPECTION AND CONSULTING SERVICES IN THE FIELD OF STRUCTURAL ENGINEERING; ENGINEERING SERVICES IN CONNECTION WITH THE DESIGN OF PUBLIC UTILITY FACILITIES AND CONSULTING SERVICES IN CONNECTION THEREWITH; CONSTRUCTION ENGINEERING AND DESIGN SERVICES FOR OTHERS AND PROVIDING CONSULTING SERVICES IN CONNECTION THEREWITH; GEOTECHNICAL ENGINEERING SERVICES; GEOTECHNICAL TESTING SERVICES AND CONSULTING SERVICES IN CONNECTION THEREWITH; FACILITIES DESIGN ENGINEERING SERVICES AND CONSULTING SERVICES IN CONNECTION THEREWITH; FOUNDATION ENGINEERING, FOUNDATION TESTING AND DESIGN SERVICES FOR OTHERS, AND CONSULTING SERVICES IN CONNECTION THEREWITH; MATERIALS ENGINEERING; MATERIALS TESTING, MATERIALS INSPECTION, AND CONSULTING SERVICES IN CONNECTION THEREWITH; HYDROLOGICAL AND HYDRAULIC ENGINEERING AND DESIGN SERVICES; PROVIDING TESTING SERVICES AND INSPECTION SERVICES IN THE FIELD OF HYDROLOGICAL AND HYDRAULIC SCIENCES AND CONSULTING SERVICES IN CONNECTION THEREWITH; HYDROPOWER ENGINEERING AND DESIGN ENGINEERING SERVICES; PROVIDING TESTING SERVICES AND INSPECTION SERVICES IN THE HYDRO-

POWER SCIENCES FIELD AND CONSULTING SERVICES IN CONNECTION THEREWITH; RADIO FREQUENCY ENGINEERING AND DESIGN ENGINEERING SERVICES; PROVIDING TESTING SERVICES AND INSPECTION SERVICES IN THE RADIOFREQUENCY SCIENCES FIELD AND CONSULTING SERVICES IN CONNECTION THEREWITH; ROADWAY AND TRAFFIC ENGINEERING AND DESIGN ENGINEERING SERVICES; PROVIDING TESTING SERVICES AND INSPECTION SERVICES IN THE FIELD OF ROADWAY AND TRAFFIC ENGINEERING AND CONSULTING SERVICES IN CONNECTION THEREWITH; WATER-FRONT ENGINEERING AND DESIGN ENGINEERING SERVICES; PROVIDING TESTING SERVICES AND INSPECTION SERVICES IN THE FIELD OF ROADWAY AND TRAFFIC DESIGN AND CONSULTING SERVICES IN CONNECTION THEREWITH; ENVIRONMENTAL SERVICES, NAMELY, DETECTION OF CONTAMINANTS IN WATER; ENGINEERING SERVICES FOR THE CONSTRUCTION OF WATER TREATMENT AND PURIFICATION PLANTS, SOLID WASTE TREATMENT PLANTS AND OTHER MUNICIPAL INFRASTRUCTURE FACILITIES; CONDUCTING ENGINEERING AND TECHNICAL SURVEYS; SURVEYING AND ENGINEERING; CONDUCTING OF FEASIBILITY STUDIES; CONDUCTING ENGINEERING STUDIES; CONDUCTING ENGINEERING PROJECT STUDIES; COMPILING DATA ON WATER USAGE AND ANALYZING CHARGES AND RATES IN CONNECTION THEREWITH; GEOTECHNICAL EXPLORATION; EVALUATION AND TESTING OF REAL ESTATE FOR THE PRESENCE OF HAZARDOUS MATERIAL; INSPECTING BUILDINGS FOR THE EXISTENCE OF MOLD; CUSTOM DESIGN AND ENGINEERING OF FIBER OPTICS SYSTEMS; INSTALLATION AND MAINTENANCE OF TELECOMMUNICATIONS SOFTWARE SYSTEMS; DESIGN AND DEVELOPMENT OF TELECOMMUNICATIONS NETWORKS FOR OTHERS; CONSULTATION AND RESEARCH IN THE FIELDS OF ENGINEERING, OCCUPATIONAL AND ENVIRONMENTAL HEALTH AND SAFETY, WASTE MANAGEMENT AND WATER AND AIR QUALITY STUDIES AND TESTING; INDUSTRIAL HYGIENE TESTING, ASSESSMENT AND PLANNING SERVICES FOR OTHERS; REVIEWING STANDARDS AND PRACTICES TO ASSURE COMPLIANCE WITH ENVIRONMENTAL, CONSTRUCTION, INDUSTRIAL, AND HEALTH AND SAFETY REGULATIONS; PREPARING ENVIRONMENTAL COMPLIANCE REPORTS; POLLUTION PREVENTION CONSULTING; WATER QUALITY CONTROL SERVICES; VALUE ENGINEERING SERVICES IN CONNECTION WITH POLLUTION REMEDIATION; MATERIAL ENGINEERING AND TESTING; MONITORING OF COMMERCIAL AND INDUSTRIAL SITES FOR DETECTION OF VOLATILE AND NON-VOLATILE ORGANIC COMPOUNDS; REMOTE MONITORING SERVICES OF HEATING, VENTILATING AND AIR CONDITIONING APPARATUS; TECHNOLOGY CONSULTATION, SUPERVISION AND INSPECTION IN THE FIELDS OF GEOLOGY, SEISMOLOGY AND GEOPHYSICS; GEOLOGICAL SURVEYING AND RESEARCH FOR OTHERS; SOIL TESTING SERVICES; TESTING OR RESEARCH ON PREVENTION OF POLLUTION; CONSULTING SERVICES IN THE FIELD OF POLLUTION PREVENTION AND MANAGEMENT; ENGINEERING DESIGN FOR RESTORING CONTAMINATED LANDSCAPES; DESIGN ENGINEERING FOR AIRFIELDS, AND CONSULTING SERVICES IN CONNECTION THEREWITH; DESIGN FOR OTHERS OF BICYCLE PATHS AND TRAILS; BRIDGE DESIGN AND ENGINEERING SERVICES, AND CONSULTING SERVICES IN CONNECTION THEREWITH; DESIGN FOR OTHERS OF BRIDGES; DESIGN AND DESIGN ENGINEERING SERVICES IN THE FIELD OF WATER DELIVERY AND WASTEWATER TREATMENT SYSTEMS, AND CONSULTING SERVICES IN CONNECTION THEREWITH; UNDERWATER STRUCTURAL INSPECTION SERVICES; RAILROAD DESIGN AND DESIGN ENGINEERING SERVICES AND CONSULTING SERVICES IN CONNECTION THEREWITH; ROADWAY AND HIGHWAY DESIGN AND ENGINEERING SERVICES AND CONSULTING SERVICES IN CONNECTION THEREWITH; DESIGN FOR OTHERS OF ROADWAYS AND HIGHWAYS; CUSTOM DESIGN OF DRAINAGE, EROSION, STORMWATER, WATERSHED AND FLOOD CONTROL AND MANAGEMENT SYSTEMS; CONSULTATION SERVICES IN THE FIELDS OF DRAINAGE, EROSION, STORMWATER, WATERSHED AND FLOOD CONTROL AND MANAGEMENT SYSTEMS; DESIGN

FOR OTHERS OF DAMS AND RESERVOIRS; TECHNICAL CONSULTANCY IN THE FIELD OF ROAD CUTTING TECHNOLOGY; DRAFTING OF CONSTRUCTION PLANS FOR RECREATION PREMISES; CONSTRUCTION DRAFTING; DRAFTING SERVICES; DESIGN PLANNING AND ENGINEERING OF BUILDINGS AND INFRASTRUCTURE SYSTEMS FOR BUILDINGS; RESEARCH ON BUILDING CONSTRUCTION CODES OR CITY PLANNING POLICIES; URBAN PLANNING; MODELING OF GEOGRAPHICAL AREAS FOR ENVIRONMENTAL, AND HEALTH AND SAFETY CONDITIONS; COMPILING GEOGRAPHIC INFORMATION FOR PROCESSING INTO DATABASES FOR USE IN COMPUTERIZED LAND INFORMATION SYSTEMS; MAPPING SERVICES; CUSTOM DESIGN OF GEOGRAPHIC INFORMATION SYSTEM (GIS); FIELD SURVEY AND UTILITY SURVEY SERVICES; COMPUTER IMAGE PROCESSING AND DATA CONVERSION OF COMPUTER PROGRAM DATA OR INFORMATION; PROVIDING MAPPING AND DESIGN OF INDUSTRIAL AUTOMATION SYSTEMS FOR PUBLIC AND PRIVATE UTILITY COMPANIES INCLUDING ELECTRIC UTILITIES, GAS UTILITIES, WATER UTILITIES, WASTE WATER UTILITIES, CABLE UTILITIES, AND TELECOMMUNICATION UTILITIES, TO ASSIST IN THE MAINTAINING, OPERATION, AND MANAGEMENT OF THEIR OPERATION'S INFRASTRUCTURE AND DISTRIBUTION SYSTEMS; COMPUTER CONSULTATION; COMPUTER SOFTWARE DESIGN AND PROGRAMMING FOR OTHERS, NAMELY, DEVELOPMENT AND APPLICATION OF COMPUTERIZED DATA ANALYSIS SOFTWARE AND COMPUTER SYSTEMS; COMPUTER MODELING SERVICES FOR INTERPRETING, ASSESSING AND SIMULATING ENVIRONMENTAL CONDITIONS AND CONTAMINATION; COMPUTER CONSULTATION SERVICES, NAMELY, ASSESSMENT OF DATA QUALITY NEEDS IN THE FIELDS OF DATABASE SYSTEMS DEVELOPMENT AND MANAGEMENT, ELECTRONIC DATA COLLECTION AND TRANSFER, DATA VALIDATION, COMPUTERIZED DATA APPLICATIONS, DATA PRESENTATION AND INTERPRETATION, AND COMPUTER SYSTEM INTEGRATIONS; COMPUTER SERVICES, NAMELY, PROVIDING DATABASES FOR CREATING MODELING, SIMULATION, TRENDING, AND STATISTICAL ANALYSIS FOR UTILIZING, DESIGNING AND IMPLEMENTING DATA INFORMATION NETWORKS; AND LITIGATION CONSULTANCY AND SUPPORT SERVICES; AMBIENT AND OUTDOOR AIR MONITORING AND SAMPLING OF VOLATILE AND NON-VOLATILE ORGANIC COMPOUNDS (U.S. CLS. 100 AND 101).  
FIRST USE 10-4-2002; IN COMMERCE 10-4-2002.  
RUSS HERMAN, EXAMINING ATTORNEY

SN 78-694,001. DEFINITION, LLC, SAN FRANCISCO, CA. FILED 8-16-2005.



**CLASS 41—EDUCATION AND ENTERTAINMENT**

FOR PRODUCTION OF CD-ROMS AND DVDS FOR OTHERS; VIDEO TAPE, VIDEO CASSETTE, AND VIDEO DISC PRODUCTION FOR OTHERS (U.S. CLS. 100, 101 AND 107).  
FIRST USE 3-1-2004; IN COMMERCE 3-17-2004.

**CLASS 42—SCIENTIFIC, COMPUTER AND LEGAL SERVICES**

FOR GRAPHIC DESIGN SERVICES IN THE FIELDS OF SCREEN AND PRINT; COMPUTER PROGRAMMING FOR OTHERS, NAMELY, CUSTOM COMPUTER CODE PROGRAMMING IN CONNECTION WITH INTERNET APPLICATIONS SUCH AS E-COMMERCE AND DYNAMIC WEB SITE CONTENT MANAGEMENT SYSTEMS; CUSTOM COMPUTER CODE DEVELOPMENT FOR OTHERS, NAMELY, CUSTOM CODE DEVELOPMENT IN CONNECTION WITH INTERACTIVE MULTIMEDIA APPLICATIONS AND MULTIMEDIA PRESENTATIONS; ANIMATIONS PRODUCTION SERVICES, NAMELY, 2D AND 3D ANIMATION PRODUCTION FOR BROADCAST AND COMPUTER DELIVERY; DVD AUTHORIZING SERVICES; HOSTING THE WEBSITES OF OTHERS ON A COMPUTER SERVER FOR A GLOBAL COMPUTER NETWORK; SPECIAL EFFECTS DESIGN FOR OTHERS; ENCODING OF DIGITAL VIDEO DISCS FOR STREAMING AND PROGRESSIVE INTERNET DELIVERY (U.S. CLS. 100 AND 101).  
FIRST USE 3-1-2004; IN COMMERCE 3-17-2004.  
SONYA STEPHENS, EXAMINING ATTORNEY

**CLASS 39—TRANSPORTATION AND STORAGE**

FOR TRANSPORTATION SERVICES, NAMELY TRANSPORT OF PASSENGERS, MOVING VAN TRANSPORT, NON-EMERGENCY TRANSPORTATION OF NON-AMBULATORY PASSENGERS AND NURSING HOME, HOSPICE AND HEALTH CARE PATIENTS BY VAN (U.S. CLS. 100 AND 105).  
FIRST USE 5-1-2005; IN COMMERCE 5-1-2005.

**CLASS 44—MEDICAL, BEAUTY AND AGRICULTURAL SERVICES**

FOR HOME HEALTH CARE SERVICES, AND HOSPICE SERVICES, NAMELY, NURSING CARE, CUSTODIAL/COMPANION CARE, MEDICATION MANAGEMENT IN THE NATURE OF DAILY MEDICATION REMINDERS, AND ADMINISTRATION, MEDICATION REVIEWS, WELLNESS ASSESSMENT IN THE NATURE OF PHYSICAL, MENTAL, DIETARY, AND SOCIAL EVALUATION SERVICES, COORDINATION OF CLINICAL SERVICES IN THE NATURE OF HOME CARE, ASSISTANCE IN OBTAINING AND SETTING UP DURABLE MEDICAL EQUIPMENT, INFUSION CARE, MEDICATION, AND ON-CALL NURSING SERVICES (U.S. CLS. 100 AND 101).  
FIRST USE 9-1-2003; IN COMMERCE 9-1-2003.  
WENDY GOODMAN, EXAMINING ATTORNEY

SN 78-703,352. BEIJO PROPERTIES, INC., LOS ANGELES, CA. FILED 8-30-2005.



SN 78-696,653. HEARTS FOR HOSPICE, LLC, AMERICAN FORK, UT. FILED 8-19-2005.



THE MARK CONSISTS OF AN ABSTRACT HEART DESIGN NEXT TO THE WORD HEARTS.

THE MARK CONSISTS OF STANDARD CHARACTERS WITHOUT CLAIM TO ANY PARTICULAR FONT, STYLE, SIZE, OR COLOR.  
OWNER OF U.S. REG. NOS. 2,834,565 AND 3,012,088.  
THE ENGLISH TRANSLATION OF BEIJO IS "KISS".

**CLASS 9—ELECTRICAL AND SCIENTIFIC APPARATUS**

FOR PRERECORDED VIDEO TAPES, DVDS AND CDS IN THE FIELD OF FASHION, DESIGN, MARKETING AND SALES STRATEGIES, ENTERTAINMENT, LIFESTYLE, MUSIC (U.S. CLS. 21, 23, 26, 36 AND 38).

**CLASS 14—JEWELRY**

FOR JEWELRY (U.S. CLS. 2, 27, 28 AND 50).



**CLASS 16—PAPER GOODS AND PRINTED MATTER**

FOR ADDRESS BOOKS, ANNIVERSARY BOOKS, APPOINTMENT BOOKS, NOTEBOOKS, ENGAGEMENT BOOKS, GUEST BOOKS, BOOKS FOR STORING PHOTOGRAPHS, BOOKS FEATURING PHOTOGRAPHS, PHOTOGRAPH ALBUMS, SCRAPBOOK ALBUMS, PERSONAL JOURNALS, GIFT CARDS, GREETING CARDS, ANNOUNCEMENT CARDS, CHRISTMAS CARDS, BLANK CARDS, STATIONERY, ENVELOPES, STATIONERY BOXES, GIFT WRAPPING PAPER, GIFT WRAPPING RIBBONS, DESK PADS, CALENDAR DESK PADS, CALENDARS, WRITING INSTRUMENTS, INK FOR WRITING INSTRUMENTS, MECHANICAL PENCILS, PEN AND PENCIL TRAYS, PEN AND PENCIL BOXES, HOLDERS FOR DESK ACCESSORIES, BASKETS FOR DESK ACCESSORIES, DESK SETS, BOOKENDS, PICTURE BOOKS, SERIES OF FICTION BOOKS, SERIES OF NON-FICTION BOOKS IN THE FIELD OF FASHION, LIFESTYLE, DESIGN, BUSINESS STRATEGY, PERSONAL FULFILLMENT, SELF-HELP; MAGAZINES IN THE FIELD OF FASHION, LIFESTYLE, DESIGN, BUSINESS STRATEGY, PERSONAL FULFILLMENT, SELF-HELP; SYNDICATED EDITORIAL MAGAZINE COLUMNS, NEWSPAPERS, SYNDICATED NEWSPAPER COLUMNS IN THE FIELD OF FASHION, LIFESTYLE, DESIGN, BUSINESS STRATEGY, PERSONAL FULFILLMENT, SELF-HELP; NEWSLETTERS IN THE FIELD OF FASHION, LIFESTYLE, DESIGN, BUSINESS STRATEGY, PERSONAL FULFILLMENT, SELF-HELP (U.S. CLS. 2, 5, 22, 23, 29, 37, 38 AND 50).

**CLASS 21—HOUSEWARES AND GLASS**

FOR UTENSILS, NAMELY, SPATULAS, SERVING SPOONS, BASTING SPOONS, MIXING SPOONS, SLOTTED SPOONS, STRAINERS, SALAD SERVING SPOONS AND FORKS; WOODENWARE, PORCELAIN, AND CHINA, NAMELY, DISHES, CHARGER PLATES, BOWLS, PLATES, SERVING PLATTERS, CUPS, SAUCERS, CANDLESTICK HOLDERS, RAMEKINS, VASES, PITCHERS; CRYSTAL AND BEVERAGE GLASSWARE, NAMELY GOBLETS, WINE GLASSES, PITCHERS, TUMBLERS, VASES; BASKETS NOT OF METAL FOR HOUSEHOLD USE; CERAMIC AND LAMINATED ACCESSORIES, NAMELY, SOAP DISHES, TOOTHBRUSH HOLDERS, LOTION PUMPS, VASES AND BASKETS; ORNAMENTS, NAMELY, CHINA ORNAMENTS AND MINIATURE FIGURINES MADE OF RESIN AND CERAMIC (U.S. CLS. 2, 13, 23, 29, 30, 33, 40 AND 50).

**CLASS 24—FABRICS**

FOR TEXTILE FABRICS FOR THE MANUFACTURE OF CLOTHING, TABLECLOTHS, NAPKINS, PLACEMATS, TABLE RUNNERS, LAP RUGS, TEXTILES FOR HOME INTERIORS; BED COVERS, NAMELY BED BLANKETS, DUVETS, THROWS, AND QUILTS; BED LINENS, NAMELY BED SHEETS, PILLOW CASES, COMFORTER COVERS, DUVET COVERS, SHAMS AND BED SKIRTS; WINDOW COVERINGS, NAMELY CURTAINS, DRAPES, AND SHADES MADE OF TEXTILE; BATH LINENS, NAMELY FACE TOWELS, HAND TOWELS, BODY TOWELS, FACE CLOTHS, BATH SHEETS, AND BATH MATS MADE OF TEXTILE (U.S. CLS. 42 AND 50).

**CLASS 27—FLOOR COVERINGS**

FOR CARPETS AND RUGS (U.S. CLS. 19, 20, 37, 42 AND 50).

**CLASS 28—TOYS AND SPORTING GOODS**

FOR ORNAMENTS, NAMELY, CHRISTMAS TREE ORNAMENTS (U.S. CLS. 22, 23, 38 AND 50).

**CLASS 41—EDUCATION AND ENTERTAINMENT**

FOR EDUCATIONAL SERVICES, NAMELY, CONDUCTING LIVE AND TELECONFERENCED SEMINARS IN THE FIELD OF FASHION, LIFESTYLE, DESIGN, BUSINESS STRATEGY, PERSONAL FULFILLMENT, SELF-HELP (U.S. CLS. 100, 101 AND 107).

PAUL E. FAHRENKOPF, EXAMINING ATTORNEY

SN 78-705,350. THE BLACK & DECKER CORPORATION, TOWSON, MD. FILED 9-1-2005.

# MOBILELOCK

THE MARK CONSISTS OF STANDARD CHARACTERS WITHOUT CLAIM TO ANY PARTICULAR FONT, STYLE, SIZE, OR COLOR.

**CLASS 9—ELECTRICAL AND SCIENTIFIC APPARATUS**

FOR PORTABLE WIRELESS ALARM SYSTEM WITH GPS LOCATOR AND AN ANTI-THEFT ALARM INCLUDING, BUILT IN SENSORS, RECHARGEABLE BATTERIES, GPS LOCATOR, INDOOR MOTION DETECTOR AND AN ALARM NOTIFIER (U.S. CLS. 21, 23, 26, 36 AND 38).

**CLASS 45—PERSONAL SERVICES**

FOR MONITORING SECURITY SYSTEMS (U.S. CLS. 100 AND 101).

REBECCA GAN, EXAMINING ATTORNEY

SN 78-708,085. ONTHANK, CHRISTOPHER, WILTON, CT. FILED 9-7-2005.

# DOG GONE SMART

THE MARK CONSISTS OF STANDARD CHARACTERS WITHOUT CLAIM TO ANY PARTICULAR FONT, STYLE, SIZE, OR COLOR.

**CLASS 9—ELECTRICAL AND SCIENTIFIC APPARATUS**

FOR PRE-RECORDED DVDS AND VIDEO CASSETTES FEATURING DOG TRAINING INSTRUCTION (U.S. CLS. 21, 23, 26, 36 AND 38).

FIRST USE 8-1-2005; IN COMMERCE 8-1-2005.

**CLASS 12—VEHICLES**

FOR SEAT COVERS FOR VEHICLES (U.S. CLS. 19, 21, 23, 31, 35 AND 44).

**CLASS 18—LEATHER GOODS**

FOR PET LEASHES, PET COLLARS, DOG JACKETS, AND FABRIC CRATE PADS FOR USE IN PET TRAINING (U.S. CLS. 1, 2, 3, 22 AND 41).

**CLASS 20—FURNITURE AND ARTICLES NOT OTHERWISE CLASSIFIED**

FOR DOG BEDS; CRATE PADS FOR CUSHIONING AS PET BEDDING (U.S. CLS. 2, 13, 22, 25, 32 AND 50).

**CLASS 35—ADVERTISING AND BUSINESS**

FOR RETAIL STORE SERVICES FEATURING PET SUPPLIES (U.S. CLS. 100, 101 AND 102).  
FIRST USE 8-28-1998; IN COMMERCE 8-28-1998.

**CLASS 41—EDUCATION AND ENTERTAINMENT**

FOR DOG TRAINING SERVICES; DOG SWIMMING INSTRUCTION; ORGANIZING AND CONDUCTING DOG SHOWS AND EXHIBITIONS (U.S. CLS. 100, 101 AND 107).  
FIRST USE 2-28-1995; IN COMMERCE 2-28-1995.

**CLASS 43—HOTEL AND RESTAURANT SERVICES**

FOR PROVIDING CANINE CENTER SERVICES, NAMELY, DAYCARE AND BOARDING SERVICES (U.S. CLS. 100 AND 101).  
FIRST USE 8-28-1998; IN COMMERCE 8-28-1998.

**CLASS 44—MEDICAL, BEAUTY AND AGRICULTURAL SERVICES**

FOR PROVIDING CANINE CENTER SERVICES, NAMELY, CANINE REHABILITATION, DOG WASHING AND DOG WALKING SERVICES (U.S. CLS. 100 AND 101).  
FIRST USE 8-20-2002; IN COMMERCE 8-20-2002.  
JUDITH HELFMAN, EXAMINING ATTORNEY

SN 78-708,411. HTC SWEDEN AB, S-614 22 SÖDERKÖPING, SWEDEN, FILED 9-7-2005.

# EZCHANGE

THE MARK CONSISTS OF STANDARD CHARACTERS WITHOUT CLAIM TO ANY PARTICULAR FONT, STYLE, SIZE, OR COLOR.

PRIORITY CLAIMED UNDER SEC. 44(D) ON ERP NCNTY TM OFC APPLICATION NO. 004618153, FILED 9-2-2005, REG. NO. 004618153, DATED 8-3-2006, EXPIRES 9-2-2015.

**CLASS 7—MACHINERY**

FOR GRINDING AND FINE GRINDING MACHINES FOR THE TREATMENT OF CONCRETE, WOOD, NATURAL STONES, TERRAZZO AND MATERIALS FOR FILLING AND COATING FOR INDUSTRIAL USE; MACHINES FOR LAPPING, SMOOTHING AND POLISHING CONCRETE, WOOD, NATURAL STONES, TERRAZZO AND MATERIALS FOR FILLING AND COATING FOR INDUSTRIAL USE (U.S. CLS. 13, 19, 21, 23, 31, 34 AND 35).

**CLASS 8—HAND TOOLS**

FOR HAND TOOLS, NAMELY, MANUALLY OPERATED GRINDING TOOLS AND GRINDING IMPLEMENTS FOR THE TREATMENT OF CONCRETE, WOOD, NATURAL STONES, TERRAZZO AND MATERIALS FOR FILLING AND COATING; HAND TOOLS, NAMELY, EMERY WHEELS AND GRINDING WHEELS (U.S. CLS. 23, 28 AND 44).  
ALLISON HOLTZ, EXAMINING ATTORNEY

SN 78-715,660. SAINT GLAS LIMITED, TSUEN WAN; NEW TERRITORIES, HONG KONG, FILED 9-19-2005.



The logo for MirroRex features the word "MirroRex" in a stylized, bold, sans-serif font. The letter "R" is significantly larger and more prominent than the other letters. A thick, black, curved line arches over the top of the letters, starting from the left and ending on the right, framing the text.

PRIORITY CLAIMED UNDER SEC. 44(D) ON HONG KONG APPLICATION NO. 300435564, FILED 6-8-2005, REG. NO. 300435564, DATED 6-8-2005, EXPIRES 6-8-2015.

**CLASS 19—NON-METALLIC BUILDING MATERIALS**

FOR WINDOW GLASS (U.S. CLS. 1, 12, 33 AND 50).

**CLASS 20—FURNITURE AND ARTICLES NOT OTHERWISE CLASSIFIED**

FOR MIRRORS, GLASS PICTURE FRAMES, GLASS FURNITURE PARTITIONS, DINING TABLES, CUPBOARDS AND FURNITURE PRINCIPALLY MADE OF GLASS (U.S. CLS. 2, 13, 22, 25, 32 AND 50).  
JESSICA A. POWERS, EXAMINING ATTORNEY

SN 78-716,268. ROBINSON, MARK, DBA HANDICAPPED-PETS.COM, AMHERST, NH. FILED 9-20-2005.

# HandicappedPets.com

THE MARK CONSISTS OF STANDARD CHARACTERS WITHOUT CLAIM TO ANY PARTICULAR FONT, STYLE, SIZE, OR COLOR.  
SEC. 2(F).

**CLASS 35—ADVERTISING AND BUSINESS**

FOR ON-LINE RETAIL STORE SERVICES FEATURING PRODUCTS FOR ELDERLY, DISABLED AND HANDICAPPED PETS (U.S. CLS. 100, 101 AND 102).  
FIRST USE 3-19-2001; IN COMMERCE 3-31-2001.

**CLASS 43—HOTEL AND RESTAURANT SERVICES**

FOR PROVIDING A WEBSITE FEATURING INFORMATION ABOUT SERVICES AND SUPPORT FOR THE BOARDING AND DAY CARE OF ELDERLY, DISABLED AND HANDICAPPED PETS (U.S. CLS. 100 AND 101).  
FIRST USE 3-19-2001; IN COMMERCE 3-31-2001.

**CLASS 44—MEDICAL, BEAUTY AND AGRICULTURAL SERVICES**

FOR PROVIDING A WEBSITE FEATURING INFORMATION ABOUT SERVICES AND SUPPORT FOR THE HEALTH OF ELDERLY, DISABLED AND HANDICAPPED PETS (U.S. CLS. 100 AND 101).

FIRST USE 3-19-2001; IN COMMERCE 3-31-2001.  
AISHA CLARKE, EXAMINING ATTORNEY

SN 78-720,501. NORTHWEST AREA FOUNDATION, ST. PAUL, MN. FILED 9-26-2005.

**SHARING PROSPERITY**

THE MARK CONSISTS OF STANDARD CHARACTERS WITHOUT CLAIM TO ANY PARTICULAR FONT, STYLE, SIZE, OR COLOR.

SN 78-717,544. THE TORONTO-DOMINION BANK, TORONTO, ONTARIO, CANADA, FILED 9-21-2005.

**TDFX**

THE MARK CONSISTS OF STANDARD CHARACTERS WITHOUT CLAIM TO ANY PARTICULAR FONT, STYLE, SIZE, OR COLOR.

PRIORITY CLAIMED UNDER SEC. 44(D) ON CANADA APPLICATION NO. 1272103, FILED 9-15-2005, REG. NO. TMA673353, DATED 9-26-2006, EXPIRES 9-26-2021.

**CLASS 9—ELECTRICAL AND SCIENTIFIC APPARATUS**

FOR AUDIO-VISUAL RECORDINGS AND CD-ROMS AND DOWNLOADABLE PUBLICATIONS, NAMELY, CASE STUDIES, CONCEPT PAPERS, RESEARCH REPORTS, SURVEYS AND QUESTIONNAIRES AND REPORTS REGARDING THE FINDINGS FROM THE SURVEYS AND QUESTIONNAIRES, NEWSLETTERS, BROCHURES, LECTURES AND GUIDES ALL PROVIDING INFORMATION IN THE FIELD OF POVERTY REDUCTION AND ECONOMIC DEVELOPMENT FOR COMMUNITIES (U.S. CLS. 21, 23, 26, 36 AND 38).

**CLASS 35—ADVERTISING AND BUSINESS**

FOR COMPUTERIZED DATA PROCESSING SERVICES (U.S. CLS. 100, 101 AND 102).

**CLASS 36—INSURANCE AND FINANCIAL**

FOR BANKING AND FINANCIAL SERVICES, NAMELY, FOREIGN CURRENCY EXCHANGE SERVICES (U.S. CLS. 100, 101 AND 102).

PAUL F. GAST, EXAMINING ATTORNEY

**CLASS 16—PAPER GOODS AND PRINTED MATTER**

FOR BOOKS, WRITTEN MATERIALS, NAMELY, CASE STUDIES, CONCEPT PAPERS, RESEARCH REPORTS, SURVEYS AND QUESTIONNAIRES AND REPORTS REGARDING THE FINDINGS FROM THE SURVEYS AND QUESTIONNAIRES, NEWSLETTERS, AND BROCHURES, ALL IN THE FIELD OF POVERTY REDUCTION AND ECONOMIC DEVELOPMENT FOR COMMUNITIES (U.S. CLS. 2, 5, 22, 23, 29, 37, 38 AND 50).

SN 78-718,373. SCREENLIFE, LLC, SEATTLE, WA. FILED 9-22-2005.

**CLASS 41—EDUCATION AND ENTERTAINMENT**

FOR EDUCATIONAL SERVICES, NAMELY, CONDUCTING CONFERENCES, SEMINARS, WORKSHOPS AND SYMPOSIA IN THE FIELD OF POVERTY REDUCTION AND ECONOMIC DEVELOPMENT FOR COMMUNITIES (U.S. CLS. 100, 101 AND 107).

SANI KHOURI, EXAMINING ATTORNEY

**BANZAI**

THE MARK CONSISTS OF STANDARD CHARACTERS WITHOUT CLAIM TO ANY PARTICULAR FONT, STYLE, SIZE, OR COLOR.

**CLASS 9—ELECTRICAL AND SCIENTIFIC APPARATUS**

FOR GAMES EQUIPMENT, NAMELY PRE-RECORDED DIGITAL VIDEO DISCS FEATURING VIDEO CLIPS FROM TV SHOWS (U.S. CLS. 21, 23, 26, 36 AND 38).

FIRST USE 10-0-2006; IN COMMERCE 10-0-2006.

SN 78-720,976. WALD CO., LTD., TAKATSUKI, OSAKA, JAPAN, FILED 9-27-2005.

**WALD**

THE MARK CONSISTS OF STANDARD CHARACTERS WITHOUT CLAIM TO ANY PARTICULAR FONT, STYLE, SIZE, OR COLOR.

SEC. 2(F).

**CLASS 28—TOYS AND SPORTING GOODS**

FOR EQUIPMENT SOLD AS A UNIT TO PLAY BOARD GAMES THAT INCLUDES A BOARD, A DIGITAL VIDEO DISC FEATURING VIDEO CLIPS, RULES AND PLAYER PIECES (U.S. CLS. 22, 23, 38 AND 50).

FIRST USE 10-0-2006; IN COMMERCE 10-0-2006.  
WENDY GOODMAN, EXAMINING ATTORNEY

**CLASS 7—MACHINERY**

FOR ENGINE OR MOTOR MUFFLERS; EXHAUST PIPES; EXHAUST MUFFLERS FOR MOTORS AND ENGINES (U.S. CLS. 13, 19, 21, 23, 31, 34 AND 35).

FIRST USE 4-15-1992; IN COMMERCE 3-15-1999.

**CLASS 12—VEHICLES**

FOR AUTOMOBILE PARTS, NAMELY, AUTOMOBILE WHEELS, AUTOMOBILE SPOILERS, BRAKES, SUSPENSION SYSTEMS FOR AUTOMOBILES, SHOCK ABSORBERS, AUTOMOTIVE COIL SPRINGS, NON-MAGNETIC METAL AUTOMOBILE EMBLEMS, AUTOMOBILE STRAPS, SEAT COVERS, STEERING WHEELS, GEAR SHIFT LEVERS AND KNOBS, AUTOMOBILE GRILLS, AND BUMPERS (U.S. CLS. 19, 21, 23, 31, 35 AND 44).  
FIRST USE 4-15-1992; IN COMMERCE 3-15-1999.

**CLASS 16—PAPER GOODS AND PRINTED MATTER**

FOR AUTOMOBILE STICKERS, PRINTED AUTOMOBILE EMBLEMS (U.S. CLS. 2, 5, 22, 23, 29, 37, 38 AND 50).  
FIRST USE 4-15-1992; IN COMMERCE 3-15-1999.  
CIMMERIAN COLEMAN, EXAMINING ATTORNEY

---

SN 78-723,488. IVY ANIMAL HEALTH, INC., OVERLAND PARK, KS. FILED 9-29-2005.

**IVY SOLUTIONS**

THE MARK CONSISTS OF STANDARD CHARACTERS WITHOUT CLAIM TO ANY PARTICULAR FONT, STYLE, SIZE, OR COLOR.

NO CLAIM IS MADE TO THE EXCLUSIVE RIGHT TO USE "SOLUTIONS", APART FROM THE MARK AS SHOWN.

**CLASS 5—PHARMACEUTICALS**

FOR NUTRITIONAL ADDITIVES FOR LIVESTOCK FEED FOR MEDICAL PURPOSES; PHARMACEUTICAL PREPARATIONS FOR ANIMALS, NAMELY, GROWTH PROMOTANTS FOR LIVESTOCK, PERFORMANCE ENHANCERS FOR LIVESTOCK, AND FOODBORNE PATHOGEN REDUCERS FOR LIVESTOCK (U.S. CLS. 6, 18, 44, 46, 51 AND 52).

**CLASS 35—ADVERTISING AND BUSINESS**

FOR ADVERTISING, BUSINESS MARKETING, PUBLIC RELATIONS AND BUSINESS CONSULTING SERVICES RELATED TO THE VETERINARY, AGRICULTURAL AND LIVESTOCK INDUSTRIES (U.S. CLS. 100, 101 AND 102).  
JOHN SCHUYLER YARD, EXAMINING ATTORNEY

SN 78-725,576. THE ANA PACIFIC HOLDING CORPORATION, VANCOUVER, BRITISH COLUMBIA, FILED 10-3-2005.

**POSITIVE NETWORKING**

THE MARK CONSISTS OF STANDARD CHARACTERS WITHOUT CLAIM TO ANY PARTICULAR FONT, STYLE, SIZE, OR COLOR.

PRIORITY CLAIMED UNDER SEC. 44(D) ON CANADA APPLICATION NO. 1256333, FILED 5-3-2005, REG. NO. TMA679,818, DATED 1-19-2007, EXPIRES 1-19-2022.

NO CLAIM IS MADE TO THE EXCLUSIVE RIGHT TO USE "NETWORKING", APART FROM THE MARK AS SHOWN.

**CLASS 9—ELECTRICAL AND SCIENTIFIC APPARATUS**

FOR PRE-RECORDED VIDEO TAPES, AUDIO CASSETTE TAPES, CDS AND DVDS IN THE FIELD OF BUSINESS AND PERSONAL NETWORKING; SOFTWARE IN THE FIELD OF BUSINESS AND PERSONAL NETWORKING, NAMELY, SOFTWARE THAT ALLOWS USERS TO PLAN, ORGANIZE AND MANAGE BUSINESSES AND SOFTWARE IN THE FIELD OF PERSONAL NETWORKING THAT ALLOWS USERS TO NETWORK SOCIALLY AND FOR BUSINESS PURPOSES OVER THE INTERNET (U.S. CLS. 21, 23, 26, 36 AND 38).

**CLASS 16—PAPER GOODS AND PRINTED MATTER**

FOR PRINTED PUBLICATIONS, NAMELY, BOOKS, MANUALS, NEWSLETTERS, PERIODICALS, HANDBOOKS, AND PAMPHLETS ALL IN THE FIELD OF BUSINESS AND PERSONAL NETWORKING; POSTERS; STICKERS; BINDERS; PRINTED PAPER NAME TAGS; CALENDARS; DECALS; PENS; DESKTOP BUSINESS CARD HOLDERS AND CASES (U.S. CLS. 2, 5, 22, 23, 29, 37, 38 AND 50).

**CLASS 41—EDUCATION AND ENTERTAINMENT**

FOR SEMINARS IN THE FIELD OF BUSINESS AND PERSONAL NETWORKING; PROVIDING SPEAKERS WHO SPEAK ON THE TOPICS OF BUSINESS AND PERSONAL NETWORKING; PROVIDING TRAINING PROGRAMS AND TRAINING CERTIFICATION PROGRAMS IN THE FIELD OF BUSINESS AND PERSONAL NETWORKING; OPERATION OF A WEBSITE THAT PROVIDES TRAINING IN THE FIELD OF BUSINESS AND PERSONAL NETWORKING (U.S. CLS. 100, 101 AND 107).

KAREN BRACEY, EXAMINING ATTORNEY

---

SN 78-728,858. MCAFEE SECURITY LLC, PLANO, TX. FILED 10-7-2005.

**2 MINUTE WARNING**

THE MARK CONSISTS OF STANDARD CHARACTERS WITHOUT CLAIM TO ANY PARTICULAR FONT, STYLE, SIZE, OR COLOR.

**CLASS 41—EDUCATION AND ENTERTAINMENT**SN 78-731,354. PACTIV CORPORATION, LAKE FOREST, IL.  
FILED 10-12-2005.

FOR PUBLICATION OF MAGAZINES AND ON-LINE PUBLICATION OF MAGAZINES IN THE FIELD OF INTERNET, COMPUTER HARDWARE, AND COMPUTER SOFTWARE VULNERABILITY, RISK MANAGEMENT, SECURITY SERVICES, SECURE TELECOMMUNICATION, DETECTION AND REMOVAL OF COMPUTER VIRUSES AND THREATS, PROTECTING AND SECURING COMPUTER NETWORKS AND APPLICATIONS, ENCRYPTING AND AUTHENTICATING DATA, MANAGING AND FILTERING OF ELECTRONIC COMMUNICATIONS, AND DETECTING COMPUTER SOFTWARE PROBLEMS (U.S. CLS. 100, 101 AND 107).

FIRST USE 6-20-2005; IN COMMERCE 6-20-2005.

**CLASS 45—PERSONAL SERVICES**

FOR PROVIDING INFORMATION IN THE FIELDS OF INTERNET, COMPUTER HARDWARE AND COMPUTER SOFTWARE VULNERABILITY, COMPUTER RISK MANAGEMENT, COMPUTER SECURITY SERVICES, SECURE TELECOMMUNICATION, DETECTION AND REMOVAL OF COMPUTER VIRUSES AND THREATS, PROTECTING AND SECURING COMPUTER NETWORKS AND APPLICATIONS, ENCRYPTING AND AUTHENTICATING DATA, MANAGING AND FILTERING OF ELECTRONIC COMMUNICATIONS, AND DETECTING COMPUTER SOFTWARE PROBLEMS, BY MEANS OF ISSUANCE OF A DAILY SECURITY BRIEFING ACCESSIBLE VIA THE INTERNET (U.S. CLS. 100 AND 101).

FIRST USE 6-20-2005; IN COMMERCE 6-20-2005.  
JUSTINE D. PARKER, EXAMINING ATTORNEY**HEFTY FRESH EXTEND**

THE MARK CONSISTS OF STANDARD CHARACTERS WITHOUT CLAIM TO ANY PARTICULAR FONT, STYLE, SIZE, OR COLOR.

OWNER OF U.S. REG. NOS. 854,403, 2,700,994 AND OTHERS.

**CLASS 1—CHEMICALS**

FOR FOOD PRESERVATIVE COMPOSITIONS IN THE FORM OF LABELS AND PATCHES CONTAINING AN ACTIVE INGREDIENT FOR PRESERVING FOOD (U.S. CLS. 1, 5, 6, 10, 26 AND 46).

**CLASS 6—METAL GOODS**

FOR ALUMINUM FOIL (U.S. CLS. 2, 12, 13, 14, 23, 25 AND 50).

**CLASS 16—PAPER GOODS AND PRINTED MATTER**

FOR PLASTIC FOOD STORAGE BAGS FOR HOUSEHOLD USE AND PLASTIC WRAP, ALL FEATURING INTEGRATED FOOD PRESERVATIVE COMPOSITIONS SOLD AS A UNIT (U.S. CLS. 2, 5, 22, 23, 29, 37, 38 AND 50).

**CLASS 20—FURNITURE AND ARTICLES NOT OTHERWISE CLASSIFIED**

FOR PLASTIC STORAGE CONTAINERS FOR COMMERCIAL AND INDUSTRIAL USE, DISPOSABLE PLASTIC FOOD STORAGE CONTAINERS FOR COMMERCIAL AND INDUSTRIAL USE, ALL FEATURING INTEGRATED FOOD PRESERVATIVE COMPOSITIONS SOLD AS A UNIT (U.S. CLS. 2, 13, 22, 25, 32 AND 50).

**CLASS 21—HOUSEWARES AND GLASS**

FOR CONTAINERS NOT OF PRECIOUS METAL FOR KITCHEN AND HOUSEHOLD USE, DISPOSABLE FOOD CONTAINERS NOT OF PRECIOUS METAL FOR KITCHEN AND HOUSEHOLD USE, ALL FEATURING INTEGRATED FOOD PRESERVATIVE COMPOSITIONS SOLD AS A UNIT (U.S. CLS. 2, 13, 23, 29, 30, 33, 40 AND 50).

**CLASS 22—CORDAGE AND FIBERS**

FOR PLASTIC BULK FOOD STORAGE BAGS FOR COMMERCIAL AND INDUSTRIAL USE FEATURING INTEGRATED FOOD PRESERVATIVE COMPOSITIONS SOLD AS A UNIT (U.S. CLS. 1, 2, 7, 19, 22, 42 AND 50).  
STEVEN PEREZ, EXAMINING ATTORNEY

SN 78-731,215. IRISH AMERICAN SHAMROCK GARDEN CORP., NEW YORK, NY. FILED 10-11-2005.

**CLASS 14—JEWELRY**

FOR JEWELRY, NAMELY MEDALLIONS (U.S. CLS. 2, 27, 28 AND 50).

**CLASS 19—NON-METALLIC BUILDING MATERIALS**

FOR GARDEN SCULPTURES COMPRISED OF MO-SAICS CONSISTING OF CEMENT AND STONE (U.S. CLS. 1, 12, 33 AND 50).  
KRISTINA KLOIBER, EXAMINING ATTORNEY

SN 78-736,346. INTERNATIONAL MASTERS PUBLISHERS AB, MALMO, SWEDEN, FILED 10-19-2005.

### WEIRD N' WILD CREATURES

THE MARK CONSISTS OF STANDARD CHARACTERS WITHOUT CLAIM TO ANY PARTICULAR FONT, STYLE, SIZE, OR COLOR.

OWNER OF U.S. REG. NOS. 2,844,855 AND 3,000,645.

### CLASS 41—EDUCATION AND ENTERTAINMENT

FOR ENTERTAINMENT SERVICES, NAMELY, PROVIDING ON-LINE COMPUTER GAMES, NAMELY, CROSSWORD PUZZLES, WORD SCRAMBLES, QUOTE SCRAMBLES, HIDDEN PICTURE PUZZLES, HIDDEN WORD PUZZLES, TRIVIA QUESTIONS AND CARD GAMES; PROVIDING INFORMATION AND TRIVIA VIA A GLOBAL COMPUTER NETWORK ON A MEMBERS-ONLY WEBSITE ON FICTIONAL CREATURES; ENTERTAINMENT SERVICES, NAMELY, PROVIDING ON-LINE COMPUTER GAMES, NAMELY, CROSSWORD PUZZLES, WORD SCRAMBLES, QUOTE SCRAMBLES, HIDDEN PICTURE PUZZLES, HIDDEN WORD PUZZLES, TRIVIA QUESTIONS AND CARD GAMES (U.S. CLS. 100, 101 AND 107).

FIRST USE 10-1-2004; IN COMMERCE 10-1-2004.

### CLASS 42—SCIENTIFIC, COMPUTER AND LEGAL SERVICES

FOR PROVIDING INFORMATION AND TRIVIA VIA A GLOBAL COMPUTER NETWORK ON A MEMBERS-ONLY WEBSITE ON THE GENERAL HISTORY OF MODERN AND PRE-HISTORIC ANIMALS AND THEIR HABITATS (U.S. CLS. 100 AND 101).

FIRST USE 10-1-2004; IN COMMERCE 10-1-2004.

STEVEN JACKSON, EXAMINING ATTORNEY

SN 78-736,588. ICERA, INC., BRISTOL, UNITED KINGDOM, FILED 10-19-2005.



PRIORITY CLAIMED UNDER SEC. 44(D) ON ERPNTY TM OFC APPLICATION NO. 4554499, FILED 8-22-2005, REG. NO. 004554499, DATED 9-20-2006, EXPIRES 8-22-2015.

THE COLOR(S) RED AND WHITE IS/ARE CLAIMED AS A FEATURE OF THE MARK.

THE MARK CONSISTS OF THE WORD "ICERA" IN THE COLOR WHITE AND THE COLOR RED APPEARS IN THE TRIANGULAR SHAPED CARRIER.

### CLASS 7—MACHINERY

FOR MACHINES FOR THE MANUFACTURE OF SEMICONDUCTORS (U.S. CLS. 13, 19, 21, 23, 31, 34 AND 35).

### CLASS 9—ELECTRICAL AND SCIENTIFIC APPARATUS

FOR SEMICONDUCTORS, SEMICONDUCTOR CHIPS, SEMICONDUCTOR DEVICES, SEMICONDUCTOR MEMORIES, SILICON WAFERS; INTEGRATED CIRCUIT CORES ALL FOR USE IN THE FIELD OF WIRELESS COMMUNICATIONS (U.S. CLS. 21, 23, 26, 36 AND 38).

### CLASS 42—SCIENTIFIC, COMPUTER AND LEGAL SERVICES

FOR DESIGNING OF SEMICONDUCTORS AND INTEGRATED CIRCUITS FOR OTHERS; RESEARCH IN THE AREA OF SEMICONDUCTOR PROCESSING TECHNOLOGY; TECHNOLOGICAL, AND TECHNICAL CONSULTANCY SERVICES IN THE FIELD OF SEMICONDUCTORS AND INTEGRATED CIRCUITS (U.S. CLS. 100 AND 101).

BARBARA RUTLAND, EXAMINING ATTORNEY

SN 78-739,262. VILEX, INC., PITTSBURGH, PA. FILED 10-24-2005.

# VILEX

THE MARK CONSISTS OF STANDARD CHARACTERS WITHOUT CLAIM TO ANY PARTICULAR FONT, STYLE, SIZE, OR COLOR.

OWNER OF U.S. REG. NO. 3,043,406.

### CLASS 10—MEDICAL APPARATUS

FOR SURGICAL INSTRUMENTS, NAMELY METAL SURGICAL TOOLS TO FACILITATE THE IMPLANTATION OF ORTHOPEDIC AND PODIATRY SURGICAL IMPLANTS; POWER SYSTEMS AND ACCESSORIES FOR SURGICAL USE, NAMELY ELECTRIC POWERED CONSOLE WITH CONTROL/DISPLAY PANEL, POWER CORD, FOOT SWITCH, MOTOR CORD, MOTOR, AND METAL SURGICAL TOOLS TO FACILITATE THE IMPLANTATION OF ORTHOPEDIC AND PODIATRY SURGICAL IMPLANTS; AND ORTHOPEDIC AND PODIATRIC SURGICAL IMPLANTS COMPRISING ARTIFICIAL MATERIAL (U.S. CLS. 26, 39 AND 44).

### CLASS 35—ADVERTISING AND BUSINESS

FOR DISTRIBUTORSHIP SERVICES IN THE FIELD OF PODIATRIC IMPLANTS AND SURGICAL INSTRUMENTS; RETAIL CONSIGNMENT AND SERVICES IN THE FIELD OF PODIATRIC IMPLANTS AND SURGICAL INSTRUMENTS; RETAIL SERVICES BY DIRECT TELEPHONE SOLICITATION BY SALES AGENTS IN THE FIELD OF PODIATRIC IMPLANTS AND SURGICAL INSTRUMENTS; INDEPENDENT SALES REPRESENTATIVES IN THE FIELD OF PODIATRIC IMPLANTS AND SURGICAL INSTRUMENTS (U.S. CLS. 100, 101 AND 102).

### CLASS 44—MEDICAL, BEAUTY AND AGRICULTURAL SERVICES

FOR RENTAL OF MEDICAL EQUIPMENT IN THE FIELD OF PODIATRIC IMPLANTS AND SURGICAL INSTRUMENTS (U.S. CLS. 100 AND 101).

RAUL CORDOVA, EXAMINING ATTORNEY

SN 78-739,524. FOLEY, KEVIN J., MT. AUKUM, CA. AND FOLEY, MARY E., MT. AUKUM, CA. FILED 10-24-2005.

## AMADORADO

THE MARK CONSISTS OF STANDARD CHARACTERS WITHOUT CLAIM TO ANY PARTICULAR FONT, STYLE, SIZE, OR COLOR.

### CLASS 29—MEATS AND PROCESSED FOODS

FOR SALAMI, LOX SMOKED SALMON, DRIED FRUIT, CHEESE, FRUIT PRESERVES, JAMS, PROCESSED NUTS; GIFT BASKETS CONTAINING SALAMI, LOX SMOKED SALMON, DRIED FRUIT, CHEESE, FRUIT PRESERVES, JAMS, PROCESSED NUTS (U.S. CL. 46).

### CLASS 30—STAPLE FOODS

FOR CHOCOLATE, PASTRIES, COOKIES, CANDY, COFFEE, CRACKERS, PASTA, CARAMEL CORN, MUSTARDS, PRETZELS; GIFT BASKETS CONTAINING CHOCOLATE, PASTRIES, COOKIES, CANDY, COFFEE, CRACKERS, PASTA, CARAMEL CORN, MUSTARDS, PRETZELS (U.S. CL. 46).

### CLASS 33—WINES AND SPIRITS

FOR WINE; GIFT BASKETS CONTAINING WINE (U.S. CLS. 47 AND 49).

### CLASS 45—PERSONAL SERVICES

FOR PREPARATION OF CUSTOMIZED GIFT BASKETS (U.S. CLS. 100 AND 101).  
ELLEN PERKINS, EXAMINING ATTORNEY

SN 78-740,603. O'NEILL PROPERTIES GROUP, L.P., KING OF PRUSSIA, PA. FILED 10-26-2005.



THE NAME CARNEGIE ABBEY DOES NOT IDENTIFY A LIVING INDIVIDUAL.

### CLASS 16—PAPER GOODS AND PRINTED MATTER

FOR PAPER GOODS, NAMELY, PAPER BAGS, GIFT CARDS, NOTE CARDS AND PAPER NAPKINS; PAPERWEIGHT AND DESK PEN SETS; SCORE CARDS, UNMOUNTED PHOTOGRAPHS, POSTERS, CALENDARS, POST CARDS; BOOKS, MAGAZINES, AND BROCHURES REGARDING GOLF EVENTS (U.S. CLS. 2, 5, 22, 23, 29, 37, 38 AND 50).  
FIRST USE 3-0-2000; IN COMMERCE 3-0-2000.

### CLASS 24—FABRICS

FOR TOWELS, NAMELY, GOLF BAG TOWELS (U.S. CLS. 42 AND 50).  
FIRST USE 3-31-2000; IN COMMERCE 3-31-2000.

### CLASS 28—TOYS AND SPORTING GOODS

FOR SPORTING GOODS AND ARTICLES, NAMELY, GOLF CLUBS, GOLF CLUB COVERS, GOLF BAGS, GOLF BALLS, GOLF BALL MARKERS, DIVOT REPAIR TOOLS BEING GOLF ACCESSORIES (U.S. CLS. 22, 23, 38 AND 50).

FIRST USE 3-31-2000; IN COMMERCE 3-31-2000.

### CLASS 36—INSURANCE AND FINANCIAL

FOR REAL ESTATE SERVICES, NAMELY, LEASING AND MANAGEMENT OF CONDOMINIUMS, HOUSES, RESIDENTIAL PROPERTIES AND COMMERCIAL PROPERTIES IN PLANNED COMMUNITIES (U.S. CLS. 100, 101 AND 102).

FIRST USE 3-31-2000; IN COMMERCE 3-31-2000.

### CLASS 41—EDUCATION AND ENTERTAINMENT

FOR PROVIDING COUNTRY CLUB SERVICES IN THE NATURE OF A GOLF COURSE, TENNIS COURTS, SWIMMING POOL, FITNESS CENTER, RECREATION ROOM, EQUESTRIAN FACILITIES AND PROGRAMS, YACHTING FACILITIES, WATER ACTIVITIES, AND CLUBHOUSE; GOLF CLUB SERVICES, NAMELY, PROVIDING FACILITIES FOR PLAYING GOLF AND CONDUCTING GOLF COMPETITIONS (U.S. CLS. 100, 101 AND 107).

FIRST USE 3-31-2000; IN COMMERCE 3-31-2000.

### CLASS 43—HOTEL AND RESTAURANT SERVICES

FOR RESTAURANT AND BAR SERVICES (U.S. CLS. 100 AND 101).

FIRST USE 3-31-2000; IN COMMERCE 3-31-2000.

### CLASS 44—MEDICAL, BEAUTY AND AGRICULTURAL SERVICES

FOR HEALTH SPA SERVICES, NAMELY, COSMETIC BODY CARE SERVICES (U.S. CLS. 100 AND 101).

FIRST USE 3-31-2000; IN COMMERCE 3-31-2000.

EVELYN BRADLEY, EXAMINING ATTORNEY

SN 78-740,934. BALDWIN AVIATION, INC., HILTON HEAD ISLAND, SC. FILED 10-26-2005.

## SAFETY GAUGE

THE MARK CONSISTS OF STANDARD CHARACTERS WITHOUT CLAIM TO ANY PARTICULAR FONT, STYLE, SIZE, OR COLOR.

NO CLAIM IS MADE TO THE EXCLUSIVE RIGHT TO USE "SAFETY", APART FROM THE MARK AS SHOWN.

### CLASS 9—ELECTRICAL AND SCIENTIFIC APPARATUS

FOR SOFTWARE IN THE FIELD OF AVIATION MANAGEMENT, NAMELY, SOFTWARE FOR PROVIDING AVIATION OPERATING STANDARDS, OPERATIONAL GUIDELINES, SAFETY MANAGEMENT, AND RISK ANALYSIS (U.S. CLS. 21, 23, 26, 36 AND 38).

**CLASS 36—INSURANCE AND FINANCIAL**

FOR RISK MANAGEMENT SERVICES IN THE FIELD OF TRANSPORTATION, AVIATION, MARINE TRANSPORTATION, RAILROAD AND INDUSTRIAL, MANUFACTURING AND POWER PLANTS (U.S. CLS. 100, 101 AND 102).

**CLASS 45—PERSONAL SERVICES**

FOR CONSULTATION SERVICES IN THE FIELD OF THE SAFETY NEEDS OF COMMERCIAL AND INDUSTRIAL COMPANIES, NAMELY, PROVIDING SAFETY MANAGEMENT IN THE FIELD OF TRANSPORTATION, AVIATION, MARINE TRANSPORTATION, RAILROAD AND INDUSTRIAL, MANUFACTURING AND POWER PLANTS (U.S. CLS. 100 AND 101).

ROBERT STRUCK, EXAMINING ATTORNEY

---

SN 78-743,625. THE BRAND LEARNING PARTNERS LIMITED, HAMPTON WICK, SURREY, ENGLAND, FILED 10-31-2005.



BRAND LEARNING

OWNER OF UNITED KINGDOM REG. NO. 2258565, DATED 1-20-2001, EXPIRES 1-20-2011.

NO CLAIM IS MADE TO THE EXCLUSIVE RIGHT TO USE "BRAND LEARNING", APART FROM THE MARK AS SHOWN.

THE COLORS BLUE AND BLACK ARE CLAIMED AS A FEATURE OF THE MARK.

DIFFERENT SHADES OF THE COLOR BLUE APPEAR IN THE DESIGN ELEMENT OF THE MARK AND THE WORDING BRAND LEARNING APPEARS IN BLACK.

**CLASS 35—ADVERTISING AND BUSINESS**

FOR BUSINESS CONSULTANCY SERVICES (U.S. CLS. 100, 101 AND 102).

**CLASS 41—EDUCATION AND ENTERTAINMENT**

FOR MANAGEMENT EDUCATION AND TRAINING PROGRAMMES, NAMELY SEMINARS, WORKSHOPS AND CLASSES IN THE FIELD OF MARKETING (U.S. CLS. 100, 101 AND 107).

LEIGH CAROLINE CASE, EXAMINING ATTORNEY

SN 78-747,757. CLEAN CONTROL CORPORATION, WARNER ROBINS, GA. FILED 11-4-2005.

**EARTH CHOICE**

THE MARK CONSISTS OF STANDARD CHARACTERS WITHOUT CLAIM TO ANY PARTICULAR FONT, STYLE, SIZE, OR COLOR.

**CLASS 3—COSMETICS AND CLEANING PREPARATIONS**

FOR AUTOMOBILE CLEANING PREPARATIONS; ALL PURPOSE CLEANING PREPARATIONS; GENERAL PURPOSE CLEANER WITH DISINFECTING PROPERTIES; CLEANING, POLISHING AND SCOURING PREPARATIONS FOR HOUSEHOLD, COMMERCIAL, INDUSTRIAL AND INSTITUTIONAL USE; LIME-REMOVING CLEANING PREPARATIONS; OVEN CLEANING PREPARATIONS; STOVE-TOP CLEANING PREPARATIONS; GLASS AND METAL CLEANING PREPARATIONS; WINDOW CLEANING PREPARATIONS; CARPET CLEANING PREPARATIONS; GRAFFITI REMOVERS; PAINT STRIPPERS; ADHESIVE REMOVERS; FLOOR POLISHES AND WAXES; FLOOR POLISH AND WAX REMOVERS; ENGINE DEGREASERS NOT USED IN MANUFACTURING PROCESSES; GENERAL PURPOSE DEGREASERS NOT USED IN MANUFACTURING PROCESSES; METAL POLISHES; METAL CLEANERS; UPHOLSTERY CLEANERS; SPOT REMOVERS; LAUNDRY PRE-WASH PREPARATIONS; RUST REMOVERS; HAND SOAPS; WOOD CLEANERS AND POLISHES; TOILET, TUB, AND TILE CLEANERS; BUG AND TAR REMOVERS; AUTOMOBILE POLISHES AND WAXES; RUBBER AND VINYL CLEANERS; FABRIC REFRESHERS (U.S. CLS. 1, 4, 6, 50, 51 AND 52).

FIRST USE 8-4-2005; IN COMMERCE 8-4-2005.

**CLASS 5—PHARMACEUTICALS**

FOR AIR FRESHENERS (U.S. CLS. 6, 18, 44, 46, 51 AND 52).

FIRST USE 8-4-2005; IN COMMERCE 8-4-2005.

RUSS HERMAN, EXAMINING ATTORNEY

---

SN 78-748,450. FOXPAW, INC, BARRINGTON HILLS, IL. FILED 11-7-2005.

**POTENTIOLOGY**

THE MARK CONSISTS OF STANDARD CHARACTERS WITHOUT CLAIM TO ANY PARTICULAR FONT, STYLE, SIZE, OR COLOR.

**CLASS 35—ADVERTISING AND BUSINESS**

FOR PROVIDING INFORMATION IN THE FIELD OF METHODS USED TO ANALYZE RELATED OR UNRELATED DATA TO PRODUCE A DISPROPORTIONATE RESULT IN THE FIELDS OF STATISTICAL EVALUATIONS OF BUSINESS MARKETING DATA (U.S. CLS. 100, 101 AND 102).



**CLASS 42—SCIENTIFIC, COMPUTER AND LEGAL SERVICES**

FOR PROVIDING INFORMATION IN THE FIELD OF METHODS USED TO ANALYZE RELATED OR UNRELATED DATA TO PRODUCE A DISPROPORTIONATE RESULT IN THE FIELDS OF STATISTICAL EVALUATIONS OF SCIENTIFIC AND TECHNOLOGICAL DATA AND PHARMACEUTICAL RESEARCH AND DEVELOPMENT (U.S. CLS. 100 AND 101).

**CLASS 44—MEDICAL, BEAUTY AND AGRICULTURAL SERVICES**

FOR PROVIDING INFORMATION IN THE FIELD OF METHODS USED TO ANALYZE RELATED OR UNRELATED DATA TO PRODUCE A DISPROPORTIONATE RESULT IN THE FIELDS OF MEDICAL TESTING (U.S. CLS. 100 AND 101).

MATTHEW MCDOWELL, EXAMINING ATTORNEY

**CLASS 9—ELECTRICAL AND SCIENTIFIC APPARATUS**

FOR SERIES OF PRE-RECORDED VIDEOTAPES FEATURING INSTRUCTION AND EDUCATION IN THE FIELD OF PHYSICAL HEALTH IMPROVEMENT EXERCISES (U.S. CLS. 21, 23, 26, 36 AND 38).

**CLASS 16—PAPER GOODS AND PRINTED MATTER**

FOR SERIES OF PRINTED INSTRUCTIONAL, EDUCATIONAL, AND TEACHING MATERIALS IN THE FIELD OF PHYSICAL HEALTH IMPROVEMENT EXERCISES (U.S. CLS. 2, 5, 22, 23, 29, 37, 38 AND 50).

FIRST USE 7-2-1994; IN COMMERCE 7-2-1994.  
COLLEEN KEARNEY, EXAMINING ATTORNEY

SN 78-749,833. LABORATORIOS PISA, S.A. DE C.V., GUADALAJARA, MEXICO, FILED 11-8-2005.



OWNER OF MEXICO REG. NO. 461398, DATED 4-11-1994, EXPIRES 4-11-2014.

OWNER OF MEXICO REG. NO. 411587, DATED 8-29-1990, EXPIRES 8-29-2010.

THE COLOR(S) WHITE, YELLOW, BLUE, GREEN, AND RED IS/ARE CLAIMED AS A FEATURE OF THE MARK.

THE MARK CONSISTS OF THE COLOR BLUE APPEARING IN ELECTROLIT AND THE COLORS WHITE, YELLOW, BLUE, GREEN, AND RED APPEARING AS LIQUID DROPS EMANATING THE FIRST T IN ELECTROLIT.

**CLASS 5—PHARMACEUTICALS**

FOR ELECTROLYTE REPLACEMENT SOLUTION FOR ORAL REHYDRATION (U.S. CLS. 6, 18, 44, 46, 51 AND 52).

**CLASS 32—LIGHT BEVERAGES**

FOR ORAL REHYDRATION BEVERAGES ALSO KNOWN AS SPORTS DRINKS (U.S. CLS. 45, 46 AND 48).

RONALD AIKENS, EXAMINING ATTORNEY

SN 78-754,168. PHOENIX, INC., MISSOULA, MT. FILED 11-15-2005.

**BEYOND KEGELS**

THE MARK CONSISTS OF STANDARD CHARACTERS WITHOUT CLAIM TO ANY PARTICULAR FONT, STYLE, SIZE, OR COLOR.

NO CLAIM IS MADE TO THE EXCLUSIVE RIGHT TO USE "KEGELS", APART FROM THE MARK AS SHOWN.

SN 78-755,409. RACKSPACE, LTD., SAN ANTONIO, TX. FILED 11-16-2005.



OWNER OF U.S. REG. NOS. 2,379,711, 2,510,081 AND OTHERS.

NO CLAIM IS MADE TO THE EXCLUSIVE RIGHT TO USE "MANAGED HOSTING", APART FROM THE MARK AS SHOWN.

THE COLOR(S) RED AND BLACK IS/ARE CLAIMED AS A FEATURE OF THE MARK.

THE COLOR BLACK APPEARS IN THE WORDING "RACK" AND "MANAGED HOSTING" AND IN THE DESIGN OF SEVEN ALIGNED HORIZONTAL BARS; THE COLOR RED APPEARS IN THE WORDING "SPACE" AND IN THE DESIGN OF A SINGLE OFFSET HORIZONTAL BAR.

THE MARK CONSISTS OF THE TEXT 'RACKSPACE MANAGED HOSTING' AND A DESIGN OF TWO COLUMNS OF FOUR HORIZONTAL BARS, WITH ONE OF THE BARS IN ONE OF THE COLUMNS OFFSET.

**CLASS 35—ADVERTISING AND BUSINESS**

FOR PROVIDING AN ONLINE BUSINESS ACCOUNT ADMINISTRATION SERVICE FOR OTHERS IN THE FIELD OF HOSTING AND MANAGEMENT OF COMPUTER HARDWARE, COMPUTER OPERATING SYSTEMS, AND COMPUTER APPLICATION INFRASTRUCTURE; CUSTOMER SERVICE IN THE FIELD OF MANAGED HOSTING SERVICES; CUSTOMER SERVICE IN THE FIELD OF HOSTING COMPUTER HARDWARE, COMPUTER OPERATING SYSTEMS, AND COMPUTER SOFTWARE APPLICATION INFRASTRUCTURE; CUSTOMER SERVICE IN THE FIELD OF LEASING AND CUSTOMIZING COMPUTER HARDWARE, OPERATING SYSTEMS, AND COMPUTER SOFTWARE APPLICATION INFRASTRUCTURE; CUSTOMER SERVICE IN THE FIELD OF BANDWIDTH PROVISION TO OTHERS; CUSTOMER SERVICE IN THE FIELD OF LEASING SPACE TO HOUSE COMPUTER HARDWARE, OPERATING SYSTEMS, AND SOFTWARE APPLICATION INFRASTRUCTURE IN DATA CENTERS WITH A STABLE OPERATING ENVIRONMENT; CUSTOMER SERVICE IN THE FIELD OF RUNNING HARDWARE, OPERATING SYSTEMS, AND APPLICATION INFRASTRUCTURE IN A LEASED SPACE WITH A STABLE OPERATING ENVIRONMENT; CUSTOMER SERVICE IN THE FIELD OF MANAGEMENT OF THE HOSTING OF COMPUTER HARDWARE, COMPUTER OPERATING SYSTEMS, AND COMPUTER APPLICATION INFRASTRUCTURE; CUSTOMER SERVICE IN THE FIELD OF SERVER AND DEVICE ADMINISTRATION; CUSTOMER SERVICE IN THE FIELD OF COMPUTER HARDWARE AND SOFTWARE BACK-UP AND RECOVERY; CUSTOMER SERVICE IN THE FIELD OF MANAGED COMPUTER STORAGE; CUSTOMER SERVICE IN THE FIELD OF COMPUTER HARDWARE AND SOFTWARE MONITORING, REPORTING, SECURITY, DEPLOYMENT AND SCALING, DATA MANAGEMENT, TECHNOLOGY PLANNING, DELIVERY MANAGEMENT, AND TECHNICAL SUPPORT; CUSTOMER SERVICE IN THE FIELD OF COMPUTER SOFTWARE APPLICATION ENVIRONMENT OPTIMIZATION AND CHANGE MANAGEMENT; CUSTOMER SERVICE IN THE FIELD OF COMPUTER SOFTWARE APPLICATION PROBLEM MANAGEMENT; CUSTOMER SERVICE IN THE FIELD OF COMPUTER SOFTWARE APPLICATION MONITORING; CUSTOMER SERVICE IN THE FIELD OF COMPUTER SOFTWARE APPLICATION SCALABILITY AND CAPACITY PLANNING (U.S. CLS. 100, 101 AND 102).

FIRST USE 3-0-2000; IN COMMERCE 3-0-2000.

**CLASS 38—COMMUNICATION**

FOR E-MAIL SERVICES; PROVIDING MULTIPLE USER HIGH BANDWIDTH DIAL UP AND DEDICATED ACCESS TO THE INTERNET TO ENABLE ELECTRONIC ACCESS TO COMPUTER SOFTWARE, INTERNET WEBSITES, INTERNET WEB SOFTWARE APPLICATIONS, ELECTRONIC DATABASES, DIGITAL CONTENT, AND BUSINESS COMPUTER SOFTWARE APPLICATIONS OF OTHERS THAT ARE ACCESSIBLE VIA THE INTERNET (U.S. CLS. 100, 101 AND 104).

FIRST USE 6-0-2005; IN COMMERCE 6-0-2005.

**CLASS 42—SCIENTIFIC, COMPUTER AND LEGAL SERVICES**

FOR MANAGED HOSTING IN THE NATURE OF HOSTING COMPUTER SOFTWARE, INTERNET WEBSITES, INTERNET WEB SOFTWARE APPLICATIONS, ELECTRONIC DATABASES, DIGITAL CONTENT, AND BUSINESS COMPUTER SOFTWARE APPLICATIONS OF OTHERS THAT ARE ACCESSIBLE VIA THE INTERNET; MANAGED HOSTING IN THE NATURE OF HOSTING COMPUTER SOFTWARE, INTERNET WEBSITES, INTERNET WEB SOFTWARE APPLICATIONS, ELECTRONIC DATABASES, DIGITAL CONTENT, AND BUSINESS COMPUTER SOFTWARE APPLICATIONS OF OTHERS THAT ARE ACCESSIBLE VIA THE INTERNET THROUGH THE USE OF SECURE AND ENVIRONMENTALLY CONTROLLED COMPUTER FACILITIES; MANAGED HOSTING IN THE NATURE OF LEASING, UPDATING, REPAIRING, TROUBLESHOOTING, CUSTOMIZATION, AND MONITORING, REPORTING ON, AND OPTIMIZING THE PERFORMANCE OF COMPUTER SOFTWARE THAT SUPPORTS HOSTED COMPUTER SOFTWARE, INTERNET WEBSITES, INTERNET WEB SOFTWARE APPLICATIONS, ELECTRONIC DATABASES, DIGITAL CONTENT, AND BUSINESS COMPUTER SOFTWARE APPLICATIONS OF OTHERS THAT ARE ACCESSIBLE VIA THE INTERNET; TECHNICAL SUPPORT SERVICES FOR MANAGED HOSTING IN THE NATURE OF PROVIDING BACK-UP COMPUTER PROGRAMS, FACILITIES, AND HARDWARE TO SUPPORT HOSTED COMPUTER SOFTWARE, INTERNET WEBSITES, INTERNET WEB SOFTWARE APPLICATIONS, ELECTRONIC DATABASES, DIGITAL CONTENT, AND BUSINESS COMPUTER SOFTWARE APPLICATIONS OF OTHERS THAT ARE ACCESSIBLE VIA THE INTERNET; AND MANAGED HOSTING IN THE NATURE OF MONITORING AND REPORTING ON THE PERFORMANCE, AVAILABILITY, AND ERRORS OF HOSTED COMPUTER SOFTWARE, INTERNET WEBSITES, INTERNET WEB SOFTWARE APPLICATIONS, ELECTRONIC DATABASES, DIGITAL CONTENT, AND BUSINESS COMPUTER SOFTWARE APPLICATIONS OF OTHERS THAT ARE ACCESSIBLE VIA THE INTERNET; AND MANAGED HOSTING IN THE NATURE OF MONITORING AND REPORTING ON THE PERFORMANCE, AVAILABILITY, AND ERRORS OF HOSTED COMPUTER SOFTWARE, INTERNET WEBSITES, INTERNET WEB SOFTWARE APPLICATIONS, ELECTRONIC DATABASES, DIGITAL CONTENT, AND BUSINESS COMPUTER SOFTWARE APPLICATIONS OF OTHERS THAT ARE ACCESSIBLE VIA THE INTERNET (U.S. CLS. 100 AND 101).

TER SOFTWARE, INTERNET WEBSITES, INTERNET WEB SOFTWARE APPLICATIONS, ELECTRONIC DATABASES, DIGITAL CONTENT, AND BUSINESS COMPUTER SOFTWARE APPLICATIONS OF OTHERS THAT ARE ACCESSIBLE VIA THE INTERNET; MANAGED HOSTING IN THE NATURE OF LEASING, TROUBLESHOOTING, CUSTOMIZATION, AND MONITORING, REPORTING ON, AND OPTIMIZING THE PERFORMANCE OF COMPUTER HARDWARE THAT SUPPORTS HOSTED COMPUTER SOFTWARE, INTERNET WEBSITES, INTERNET WEB SOFTWARE APPLICATIONS, ELECTRONIC DATABASES, DIGITAL CONTENT, AND BUSINESS COMPUTER SOFTWARE APPLICATIONS OF OTHERS THAT ARE ACCESSIBLE VIA THE INTERNET; COMPUTER SERVICES FOR MANAGED HOSTING IN THE NATURE OF DATA RECOVERY FROM HOSTED COMPUTER SOFTWARE, INTERNET WEBSITES, INTERNET WEB SOFTWARE APPLICATIONS, ELECTRONIC DATABASES, DIGITAL CONTENT, AND BUSINESS COMPUTER SOFTWARE APPLICATIONS OF OTHERS THAT ARE ACCESSIBLE VIA THE INTERNET; AND MANAGED HOSTING IN THE NATURE OF MONITORING AND REPORTING ON THE PERFORMANCE, AVAILABILITY, AND ERRORS OF HOSTED COMPUTER SOFTWARE, INTERNET WEBSITES, INTERNET WEB SOFTWARE APPLICATIONS, ELECTRONIC DATABASES, DIGITAL CONTENT, AND BUSINESS COMPUTER SOFTWARE APPLICATIONS OF OTHERS THAT ARE ACCESSIBLE VIA THE INTERNET; PROVIDING E-MAIL SERVICES, NAMELY, ELECTRONIC MAIL SECURITY AND VIRUS PROTECTION SERVICES; AND PROVIDING AN ONLINE ACCOUNT ADMINISTRATION SERVICE FOR OTHERS IN THE FIELD OF HOSTING AND MANAGEMENT OF COMPUTER HARDWARE, COMPUTER OPERATING SYSTEMS, AND COMPUTER APPLICATION INFRASTRUCTURE, NAMELY, PROVIDING SECURE ACCESS TO INFORMATION AND CONTROLS TO MONITOR AND HELP OPTIMIZE THE PERFORMANCE OF COMPUTER HARDWARE AND SOFTWARE THAT SUPPORTS HOSTED COMPUTER SOFTWARE, INTERNET WEBSITES, INTERNET WEB SOFTWARE APPLICATIONS, ELECTRONIC DATABASES, DIGITAL CONTENT, AND BUSINESS COMPUTER SOFTWARE APPLICATIONS OF OTHERS THAT ARE ACCESSIBLE VIA THE INTERNET (U.S. CLS. 100 AND 101).

FIRST USE 3-0-2000; IN COMMERCE 3-0-2000.  
SEAN CROWLEY, EXAMINING ATTORNEY

---

SN 78-756,311. CLASS ENTERTAINMENT CORPORATION, CASSELBERRY, FL. FILED 11-17-2005.

RACHEL'S ADULT  
ENTERTAINMENT & STEAKHOUSE

THE MARK CONSISTS OF STANDARD CHARACTERS WITHOUT CLAIM TO ANY PARTICULAR FONT, STYLE, SIZE, OR COLOR.

NO CLAIM IS MADE TO THE EXCLUSIVE RIGHT TO USE "ADULT ENTERTAINMENT & STEAKHOUSE", APART FROM THE MARK AS SHOWN.

THE NAME RACHEL'S DOES NOT IDENTIFY A LIVING INDIVIDUAL.

**CLASS 41—EDUCATION AND ENTERTAINMENT**

FOR NIGHTCLUB SERVICES (U.S. CLS. 100, 101 AND 107).

FIRST USE 3-23-1998; IN COMMERCE 3-23-1998.

**CLASS 43—HOTEL AND RESTAURANT SERVICES**

FOR RESTAURANT AND BAR SERVICES (U.S. CLS. 100 AND 101).  
FIRST USE 3-23-1998; IN COMMERCE 3-23-1998.  
MIDGE BUTLER, EXAMINING ATTORNEY

---

SN 78-756,664. MATTHEY-JOHNSON, PHYLLIS A., DILLSBURG, PA. FILED 11-17-2005.

**VIKTOR'S PROMISE**

THE MARK CONSISTS OF STANDARD CHARACTERS WITHOUT CLAIM TO ANY PARTICULAR FONT, STYLE, SIZE, OR COLOR.

**CLASS 16—PAPER GOODS AND PRINTED MATTER**

FOR PAPER AND PRINTED MATTER, NAMELY, PRE-WRITTEN ARTICLES FOR REPUBLICATION BY OTHERS IN BOOKLETS, BROCHURES, MAGAZINES, MANUALS, NEWSLETTERS, NEWSPAPERS, PAMPHLETS AND PERIODICALS FEATURING INFORMATION AND STORIES RELATING PRIMARILY TO ORPHAN AND DESTITUTE CHILDREN WORLDWIDE; ALBUMS, NAMELY, PHOTOGRAPH AND SCRAPBOOK; BOOK COVERS; BOOKMARKS, CALENDARS, COLORING AND ACTIVITY BOOKS; PRINTED GREETING CARDS; PENS AND PENCILS; PHOTOGRAPHS AND PRINTS MOUNTED AND UNMOUNTED; PORTRAITS; POSTERS, POSTCARDS; STATIONERY, NAMELY, BINDERS, FOLDERS, NOTEBOOKS, PADS; STICKERS AND DECALS (U.S. CLS. 2, 5, 22, 23, 29, 37, 38 AND 50).

**CLASS 41—EDUCATION AND ENTERTAINMENT**

FOR CHARITABLE SERVICES, NAMELY, PROVIDING PLAY EQUIPMENT (U.S. CLS. 100, 101 AND 107).  
RICHARD A. STRASER, EXAMINING ATTORNEY

---

SN 78-756,912. DESTINIA S.L., MADRID, SPAIN, FILED 11-18-2005.

**Destinia**

THE MARK CONSISTS OF STANDARD CHARACTERS WITHOUT CLAIM TO ANY PARTICULAR FONT, STYLE, SIZE, OR COLOR.

**CLASS 35—ADVERTISING AND BUSINESS**

FOR TRAVEL MANAGEMENT (U.S. CLS. 100, 101 AND 102).  
FIRST USE 5-1-2003; IN COMMERCE 5-1-2003.

**CLASS 39—TRANSPORTATION AND STORAGE**

FOR ARRANGING TRAVEL TOURS; COORDINATING TRAVEL ARRANGEMENTS FOR INDIVIDUALS AND FOR GROUPS; ORGANISATION OF TRAVEL; ORGANIZATION OF EXCURSIONS, SIGHTSEEING TOURS, HOLIDAYS, TOURS AND TRAVEL; ORGANIZATION OF TRAVEL AND BOAT TRIPS; TRAVEL AGENCY SERVICES, NAMELY, MAKING RESERVATIONS AND BOOKINGS FOR TRANSPORTATION; TRAVEL AND TOUR INFORMATION SERVICE; TRAVEL AND TOUR TICKET RESERVATION SERVICE; TRAVEL BOOKING AGENCIES; TRAVEL GUIDE SERVICES; TRAVEL INFORMATION SERVICES; TRAVEL, EXCURSION AND CRUISE ARRANGEMENT (U.S. CLS. 100 AND 105).  
FIRST USE 5-1-2003; IN COMMERCE 5-1-2003.

**CLASS 43—HOTEL AND RESTAURANT SERVICES**

FOR PROVIDING TRAVEL LODGING INFORMATION SERVICES AND TRAVEL LODGING BOOKING AGENCY SERVICES FOR TRAVELERS; RESERVATION OF HOTEL ROOMS FOR TRAVELLERS; TRAVEL AGENCY SERVICES, NAMELY, MAKING RESERVATIONS AND BOOKING FOR TEMPORARY LODGING (U.S. CLS. 100 AND 101).  
FIRST USE 5-1-2003; IN COMMERCE 5-1-2003.

MICHAEL WEBSTER, EXAMINING ATTORNEY

---

SN 78-758,021. SARIS CYCLING GROUP, INC., MADISON, WI. FILED 11-21-2005.

**CYCLEOPS**

THE MARK CONSISTS OF STANDARD CHARACTERS WITHOUT CLAIM TO ANY PARTICULAR FONT, STYLE, SIZE, OR COLOR.

OWNER OF U.S. REG. NO. 2,209,983.

**CLASS 9—ELECTRICAL AND SCIENTIFIC APPARATUS**

FOR BICYCLE COMPUTERS, AND SOFTWARE FOR MONITORING AND ANALYZING VARIOUS PARAMETERS ASSOCIATED WITH OPERATION OF A BICYCLE OR EXERCISE CYCLE AND FOR FITNESS TRAINING (U.S. CLS. 21, 23, 26, 36 AND 38).  
FIRST USE 12-31-1999; IN COMMERCE 12-31-1999.

**CLASS 12—VEHICLES**

FOR BICYCLE COMPONENTS AND ACCESSORIES, NAMELY BICYCLE WHEELS, BICYCLE WHEEL HUBS, PROTECTIVE BICYCLE COVERS, BICYCLE TRAINER WHEEL ADAPTERS, BICYCLE TRAINER FORK STANDS, RISER BLOCKS FOR SUPPORTING A BICYCLE IN COMBINATION WITH A BICYCLE TRAINER (U.S. CLS. 19, 21, 23, 31, 35 AND 44).  
FIRST USE 12-31-1999; IN COMMERCE 12-31-1999.

**CLASS 28—TOYS AND SPORTING GOODS**

FOR STATIONARY EXERCISE CYCLES (U.S. CLS. 22, 23, 38 AND 50).  
FIRST USE 12-31-1999; IN COMMERCE 12-31-1999.  
KELLY CHOE, EXAMINING ATTORNEY

SN 78-759,535. GARCES, DIEGO F., KEY BISCAYNE, FL. AND KOSTENIUK, ALEXANDRA, KEY BISCAYNE, FL. FILED 11-22-2005.

## CHESS IS COOL

THE MARK CONSISTS OF STANDARD CHARACTERS WITHOUT CLAIM TO ANY PARTICULAR FONT, STYLE, SIZE, OR COLOR.

NO CLAIM IS MADE TO THE EXCLUSIVE RIGHT TO USE "CHESS", APART FROM THE MARK AS SHOWN.

### CLASS 9—ELECTRICAL AND SCIENTIFIC APPARATUS

FOR PROVIDING DOWNLOADABLE NEWSLETTERS IN THE FIELD OF CHESS VIA THE INTERNET AND VIA E-MAIL (U.S. CLS. 21, 23, 26, 36 AND 38).

FIRST USE 0-0-2003; IN COMMERCE 0-0-2003.

### CLASS 38—COMMUNICATION

FOR STREAMING OF VIDEO MATERIAL ON THE INTERNET; VIDEO AND AUDIO BROADCASTING VIA THE INTERNET; PODCASTING; PROVIDING ON-LINE CHAT ROOMS AND ELECTRONIC BULLETIN BOARDS FOR TRANSMISSION OF MESSAGES AMONG USERS IN THE FIELD OF CHESS (U.S. CLS. 100, 101 AND 104).

FIRST USE 0-0-2003; IN COMMERCE 0-0-2003.

### CLASS 41—EDUCATION AND ENTERTAINMENT

FOR PROVIDING NON-DOWNLOADABLE NEWSLETTERS IN THE FIELD OF CHESS VIA THE INTERNET AND VIA E-MAIL; PROVIDING AN ONLINE COMPUTER DATABASE FEATURING INFORMATION REGARDING CHESS; PROVIDING INFORMATION AND NEWS ON-LINE RELATING TO CHESS (U.S. CLS. 100, 101 AND 107).

FIRST USE 0-0-2003; IN COMMERCE 0-0-2003.

MARY BOAGNI, EXAMINING ATTORNEY

SN 78-759,651. SOUND SAFETY PRODUCTS CO., INC., EVERETT, WA. FILED 11-22-2005.

## SOUND SAFETY PRODUCTS

THE MARK CONSISTS OF STANDARD CHARACTERS WITHOUT CLAIM TO ANY PARTICULAR FONT, STYLE, SIZE, OR COLOR.

NO CLAIM IS MADE TO THE EXCLUSIVE RIGHT TO USE "SAFETY PRODUCTS", APART FROM THE MARK AS SHOWN.

### CLASS 35—ADVERTISING AND BUSINESS

FOR WHOLESALE SERVICES, RETAIL STORE SERVICES, AND MOBILE RETAIL STORE SERVICES IN THE NATURE OF A RETAIL STORE HOUSED IN A TRACTOR-TRAILER, ALL FEATURING INDUSTRIAL CLOTHING, EQUIPMENT AND ACCESSORIES, NAMELY, EYE PROTECTION, GLASS CLEANER, CORDS FOR GLASSES, CASES FOR GLASSES, HARD HATS, FACE SHIELDS, VISORS, HOODS, SHROUDS, VEILS, HAT LINERS, SWEATBANDS, REFLECTORS, EAR PLUGS, DISPENSERS FOR EAR PLUGS, EAR MUFFS, GLOVES, APRONS, SLEEVES, ARM GUARDS, GOWNS, RAIN GEAR, SANITATION SUITS, BOOTS, COATS, JACKETS, BIB OVERALLS, SHIRTS, SPATS, LEGGINGS, COVERALLS, PANTS, RESPIRATORS, FILTERS, CLEANING SUPPLIES AND EQUIPMENT, AIR COMPRESSORS, BLOWERS, VENTILATORS, HARNESSSES, LANYARDS, LIFELINES, ANCHORS, TRIPPODS, DAVIT ARMS, WINCHES, FIRST AID KITS, PATHOGEN KITS, MEDICINALS, SKIN CLEANERS, SKIN CREAMS, SKIN CONDITIONERS, EYEWASH STATIONS, DRENCH STATIONS, SIGNS, WARNING LIGHTS, FLASHLIGHTS, LANTERNS, FIRE EXTINGUISHERS, SAFETY MIRRORS, FLAGGING, TAPE, FUEL CANS, WASTE CANS, DRAIN CANS, DISPOSAL CANS, STORAGE CABINETS, PALLETS, ABSORBENT PRODUCTS, VACUUMS, CONES, BARRICADES, VESTS, SHIRTS, SWEATSHIRTS, AND FOOTWEAR (U.S. CLS. 100, 101 AND 102).

FIRST USE 0-0-1976; IN COMMERCE 0-0-1976.

### CLASS 45—PERSONAL SERVICES

FOR PROVIDING VIA THE INTERNET INFORMATION AND ORGANIZED ACCESS TO INFORMATION IN THE FIELD OF SAFETY AND RELATED REGULATIONS (U.S. CLS. 100 AND 101).

FIRST USE 0-0-1976; IN COMMERCE 0-0-1976.

C. DIONNE CLYBURN, EXAMINING ATTORNEY

SN 78-760,575. KILLGERM GROUP LIMITED, WEST YORKSHIRE, UNITED KINGDOM, FILED 11-23-2005.

## EXODUS

THE MARK CONSISTS OF STANDARD CHARACTERS WITHOUT CLAIM TO ANY PARTICULAR FONT, STYLE, SIZE, OR COLOR.

OWNER OF ERP CMNTY TM OFC REG. NO. 003034824, DATED 12-7-2004, EXPIRES 2-4-2013.

### CLASS 5—PHARMACEUTICALS

FOR SUBSTANCES AND PREPARATIONS FOR THE EXTERMINATION OF INSECTS, PESTS AND VERMIN, NAMELY INSECTICIDES, PESTICIDES, RODENTICIDES, FUNGICIDES, HERBICIDES, PARASITICIDES; PEST, INSECT AND VERMIN CONTROL AGENTS, NAMELY INSECTICIDES, PESTICIDES, RODENTICIDES, FUNGICIDES, HERBICIDES, PARASITICIDES; PEST, INSECT AND VERMIN CONTROL FORMULATIONS, NAMELY PEST REPELLANTS, INSECT REPELLANTS, VERMIN REPELLANTS; PREPARATIONS FOR DESTROYING INSECTS, PESTS AND VERMIN, NAMELY INSECTICIDES, PESTICIDES, RODENTICIDES, FUNGICIDES, HERBICIDES, PARASITICIDES (U.S. CLS. 6, 18, 44, 46, 51 AND 52).

**CLASS 7—MACHINERY**

FOR MACHINES FOR APPLYING SUBSTANCES AND PREPARATIONS FOR PEST AND VERMIN CONTROL AND EXTERMINATION NAMELY, SPRAYERS, FOGGERS, DUSTERS; POWER-OPERATED SPRAYERS FOR USE IN APPLYING INSECTICIDES, SUBSTANCES AND PREPARATIONS FOR PEST, INSECT AND VERMIN CONTROL AND EXTERMINATION; ATOMIZERS FOR INSECTICIDES, SUBSTANCES AND PREPARATIONS FOR PEST, INSECT AND VERMIN CONTROL AND EXTERMINATION; MACHINE VAPORIZERS FOR APPLYING INSECTICIDES, SUBSTANCES AND PREPARATIONS FOR PEST, INSECT AND VERMIN CONTROL AND EXTERMINATION; LOW VOLUME EMISSION APPARATUS AND INSTRUMENTS FOR DRIVING AWAY AND EXTERMINATING INSECTS, PESTS AND VERMIN, NAMELY SPRAYERS, FOGGERS, DUSTERS; REPLACEMENT PARTS AND FITTINGS FOR ALL THE AFORESAID GOODS (U.S. CLS. 13, 19, 21, 23, 31, 34 AND 35).

SN 78-762,274. PREDICTION COMPANY LLC, SANTA FE, NM. FILED 11-29-2005.

**PREDICTION COMPANY**

THE MARK CONSISTS OF STANDARD CHARACTERS WITHOUT CLAIM TO ANY PARTICULAR FONT, STYLE, SIZE, OR COLOR.

NO CLAIM IS MADE TO THE EXCLUSIVE RIGHT TO USE "COMPANY", APART FROM THE MARK AS SHOWN. SEC. 2(F).

**CLASS 9—ELECTRICAL AND SCIENTIFIC APPARATUS**

FOR ELECTRIC DEVICES FOR ATTRACTING, DETECTING AND KILLING INSECTS, PESTS AND VERMIN (U.S. CLS. 21, 23, 26, 36 AND 38).  
LA TONIA FISHER, EXAMINING ATTORNEY

**CLASS 9—ELECTRICAL AND SCIENTIFIC APPARATUS**

FOR COMPUTER SOFTWARE USED FOR FINANCIAL ANALYSIS AND EVALUATION OF SECURITIES, AUTOMATED TRADING AND FINANCIAL FORECASTING; COMPUTER SOFTWARE USED FOR DATABASE CREATION; AND COMPUTER SOFTWARE USED FOR INTERCOMPUTER COMMUNICATIONS (U.S. CLS. 21, 23, 26, 36 AND 38).  
FIRST USE 3-31-1995; IN COMMERCE 3-31-1995.

SN 78-762,273. PREDICTION COMPANY LLC, SANTA FE, NM. FILED 11-29-2005.

**CLASS 36—INSURANCE AND FINANCIAL**

FOR PROVIDING ON-LINE INFORMATION SERVICES REGARDING THE EVALUATION AND FORECASTING IN THE FIELDS OF FINANCIAL, SECURITIES AND INVESTMENT RELATED MATTERS (U.S. CLS. 100, 101 AND 102).  
FIRST USE 3-31-1995; IN COMMERCE 3-31-1995.  
MARK RADEMACHER, EXAMINING ATTORNEY



NO CLAIM IS MADE TO THE EXCLUSIVE RIGHT TO USE "COMPANY", APART FROM THE MARK AS SHOWN. SEC. 2(F).

SN 78-765,796. BUCKINGHAM VINTNERS INTERNATIONAL LIMITED, SLOUGH, UNITED KINGDOM, FILED 12-2-2005.

**CLASS 9—ELECTRICAL AND SCIENTIFIC APPARATUS**

FOR COMPUTER SOFTWARE USED FOR FINANCIAL ANALYSIS AND EVALUATION OF SECURITIES, AUTOMATED TRADING AND FINANCIAL FORECASTING; COMPUTER SOFTWARE USED FOR DATABASE CREATION; AND COMPUTER SOFTWARE USED FOR INTERCOMPUTER COMMUNICATIONS (U.S. CLS. 21, 23, 26, 36 AND 38).  
FIRST USE 3-31-1995; IN COMMERCE 3-31-1995.

**BUCKINGHAM ESTATE**

**CLASS 36—INSURANCE AND FINANCIAL**

FOR PROVIDING ON-LINE INFORMATION SERVICES REGARDING THE EVALUATION AND FORECASTING IN THE FIELDS OF FINANCIAL, SECURITIES AND INVESTMENT RELATED MATTERS (U.S. CLS. 100, 101 AND 102).  
FIRST USE 3-31-1995; IN COMMERCE 3-31-1995.  
MARK RADEMACHER, EXAMINING ATTORNEY

THE MARK CONSISTS OF STANDARD CHARACTERS WITHOUT CLAIM TO ANY PARTICULAR FONT, STYLE, SIZE, OR COLOR.  
PRIORITY CLAIMED UNDER SEC. 44(D) ON ERPNCMNTY TM OFC APPLICATION NO. 004467692, FILED 6-2-2005, REG. NO. 004467692, DATED 9-14-2006, EXPIRES 6-2-2015.  
NO CLAIM IS MADE TO THE EXCLUSIVE RIGHT TO USE "ESTATE", APART FROM THE MARK AS SHOWN.

**CLASS 16—PAPER GOODS AND PRINTED MATTER**

FOR PAPER, CARDBOARD AND GOODS MADE FROM THESE MATERIALS, NOT INCLUDED IN OTHER CLASSES, NAMELY PAPER AND/OR CARDBOARD COASTERS AND BEER MATS; PLASTIC MATERIALS FOR PACKAGING, NOT INCLUDED IN OTHER CLASSES, NAMELY, PLASTIC BAGS FOR PACKAGING; AND PRINTED PUBLICATIONS, NAMELY PRINTED VISUALS IN THE NATURE OF PROMOTIONAL MATERIALS, POSTCARDS, PRINTED AWARD CERTIFICATES, PRINTED CALENDARS, PRINTED EMBLEMS, PRINTED FORMS, PRINTED GUIDES FOR WINES AND WINE PRODUCTS, PRINTED INFORMATION CARDS IN THE FIELD OF WINE AND WINE PRODUCTS, PRINTED MATERIALS, NAMELY, PRESS RELEASES FEATURING WINE, PRINTED PAPER LABELS, PRINTED PAPER SIGNS (U.S. CLS. 2, 5, 22, 23, 29, 37, 38 AND 50).

SN 78-767,044. PETER LUST JR., PETER ALEXANDER LUST III AND JENS SCHNABEL PARTNERSHIP, THE, OXNARD, CA. FILED 12-5-2005.



OWNER OF U.S. REG. NOS. 2,770,392, 2,937,021 AND 3,065,499.

THE COLOR(S) DARK GREY, LIGHT GREY, SILVER, BROWN, RED, TAN, BLACK, PINK, WHITE AND MAROON IS/ARE CLAIMED AS A FEATURE OF THE MARK.

THE COLORS DARK GREY, LIGHT GREY, AND WHITE APPEAR IN THE FISH, THE COLORS PINK AND BLACK APPEAR IN THE FISH EYE, THE COLORS RED AND TAN APPEAR IN THE GUITAR, THE COLOR TAN APPEARS ON THE FISH FIN, THE COLOR BLACK, GREY, WHITE AND MAROON APPEAR IN THE SKY AND THE COLOR RED APPEARS IN THE WORD PIRANHA.

**CLASS 21—HOUSEWARES AND GLASS**

FOR BEVERAGE GLASSWARE; GLASS CARAFES; FIGURINES OF GLASS, CRYSTAL, PORCELAIN AND EARTHENWARE; PORCELAIN AND EARTHENWARE MUGS; FLATWARE; GLASS BOWLS; GLASS DISHES; ORNAMENTS OF GLASS, CRYSTAL, PORCELAIN, EARTHENWARE (U.S. CLS. 2, 13, 23, 29, 30, 33, 40 AND 50).

**CLASS 9—ELECTRICAL AND SCIENTIFIC APPARATUS**

FOR PRE-RECORDED VIDEOTAPES, DIGITAL VIDEO DISCS, AND DIGITAL AUDIO DISCS, ALL FEATURING MUSIC (U.S. CLS. 21, 23, 26, 36 AND 38).

FIRST USE 5-4-2002; IN COMMERCE 5-4-2002.

**CLASS 22—CORDAGE AND FIBERS**

FOR AWNINGS, CANVAS CANOPIES AND TENTS (U.S. CLS. 1, 2, 7, 19, 22, 42 AND 50).

**CLASS 16—PAPER GOODS AND PRINTED MATTER**

FOR MUSIC BOOKS, SONGBOOKS, SHEET MUSIC ARRANGEMENTS, AND MAGAZINES FEATURING MUSIC NEWS, MUSICIAN BIOGRAPHIES, PRINT VERSIONS OF NEW RELEASES AND PRINT VERSIONS OF MUSIC FROM LIVE CONCERTS (U.S. CLS. 2, 5, 22, 23, 29, 37, 38 AND 50).

FIRST USE 5-4-2002; IN COMMERCE 5-4-2002.

SHANNON TWOHIG, EXAMINING ATTORNEY

**CLASS 25—CLOTHING**

FOR CLOTHING, NAMELY, PANTS, TROUSERS, SHORTS, SHIRTS, BLOUSES, SKIRTS, T-SHIRTS, APRONS, SWEATSHIRTS, PULLOVERS, SCARVES, GLOVES; FOOTWEAR; AND HEADGEAR, NAMELY HATS AND CAPS (U.S. CLS. 22 AND 39).

SN 78-768,411. MARRIOTT INTERNATIONAL, INC., BETHESDA, MD. FILED 12-7-2005.

**EVENTCOM TECHNOLOGIES & PRODUCTION SERVICES****CLASS 33—WINES AND SPIRITS**

FOR WINES (U.S. CLS. 47 AND 49).  
SAMUEL E. SHARPER JR., EXAMINING ATTORNEY

THE MARK CONSISTS OF STANDARD CHARACTERS WITHOUT CLAIM TO ANY PARTICULAR FONT, STYLE, SIZE, OR COLOR.

OWNER OF U.S. REG. NOS. 2,573,274 AND 2,592,830.

NO CLAIM IS MADE TO THE EXCLUSIVE RIGHT TO USE "TECHNOLOGIES AND PRODUCTION SERVICES", APART FROM THE MARK AS SHOWN.

**CLASS 35—ADVERTISING AND BUSINESS**

FOR EVENT PLANNING AND MANAGEMENT SERVICES, NAMELY, ARRANGING, ORGANIZING AND SCHEDULING BUSINESS MEETINGS, CONFERENCES AND CONVENTIONS (U.S. CLS. 100, 101 AND 102).  
FIRST USE 10-31-2005; IN COMMERCE 10-31-2005.

**CLASS 38—COMMUNICATION**

FOR PROVIDING VIDEO CONFERENCING, AUDIO CONFERENCING AND WEB STREAMING SERVICES FOR MEETINGS, CONFERENCES AND CONVENTIONS (U.S. CLS. 100, 101 AND 104).

FIRST USE 10-31-2005; IN COMMERCE 10-31-2005.

**CLASS 43—HOTEL AND RESTAURANT SERVICES**

FOR (BASED ON INTENT TO USE) PROVIDING GENERAL PURPOSE FACILITIES FOR MEETINGS, CONFERENCES AND CONVENTIONS (U.S. CLS. 100 AND 101).

ODESSA BIBBINS, EXAMINING ATTORNEY

SN 78-769,191. KAZURI AMERICA LLC, BRIDGTON, ME.  
FILED 12-8-2005.

KAZURI

THE MARK CONSISTS OF STANDARD CHARACTERS WITHOUT CLAIM TO ANY PARTICULAR FONT, STYLE, SIZE, OR COLOR.

THE ENGLISH TRANSLATION OF THE WORD KAZURI IN THE MARK IS "SMALL AND BEAUTIFUL".

**CLASS 14—JEWELRY**

FOR BEADS FOR USE IN THE MANUFACTURE OF JEWELRY; BRACELETS; COSTUME JEWELRY; JEWELRY; JEWELRY CHAINS; JEWELRY FOR THE HEAD; JEWELRY, NAMELY, AMULETS (U.S. CLS. 2, 27, 28 AND 50).

FIRST USE 10-11-1995; IN COMMERCE 10-11-1995.

**CLASS 19—NON-METALLIC BUILDING MATERIALS**

FOR STONE POTTERY (U.S. CLS. 1, 12, 33 AND 50).  
FIRST USE 10-11-1995; IN COMMERCE 10-11-1995.  
HENRY S. ZAK, EXAMINING ATTORNEY

SN 78-771,005. CALHOUN SUPER STRUCTURES LTD.,  
CHESLEY, ONTARIO, CANADA, FILED 12-12-2005.



PRIORITY CLAIMED UNDER SEC. 44(D) ON CANADA APPLICATION NO. 1,282,258, FILED 12-7-2005, REG. NO. 681959, DATED 2-20-2007, EXPIRES 2-20-2022.

THE COLOR(S) RED AND BLACK IS/ARE CLAIMED AS A FEATURE OF THE MARK.

THE WORD CALHOUN APPEARS IN THE COLOR RED. ALL OTHER ELEMENTS OF THE MARK APPEAR IN BLACK.

THE MARK CONSISTS OF A CURVED STRUCTURAL DESIGN ELEMENT ALONG WITH THE WORDS CALHOUN SUPER STRUCTURE WHERE THE WORD CALHOUN ONLY IS DISPLAYED IN THE COLOR RED.

**CLASS 37—CONSTRUCTION AND REPAIR**

FOR INSTALLATION OF FABRIC-COVERED SHELTERS (U.S. CLS. 100, 103 AND 106).

FIRST USE 12-31-1991; IN COMMERCE 12-31-1992.

**CLASS 40—MATERIAL TREATMENT**

FOR MANUFACTURE OF FABRIC-COVERED SHELTERS TO ORDER AND/OR SPECIFICATION OF OTHERS (U.S. CLS. 100, 103 AND 106).

FIRST USE 12-31-1991; IN COMMERCE 12-31-1992.

MIDGE BUTLER, EXAMINING ATTORNEY

SN 78-772,427. TENNESSEE WALKING HORSE BREEDERS' AND EXHIBITORS' ASSOCIATION, LEWISBURG, TN.  
FILED 12-13-2005.



OWNER OF U.S. REG. NO. 1,876,853.

**CLASS 35—ADVERTISING AND BUSINESS**

FOR MAINTAINING A REGISTRY OF BREEDS IN THE FIELD OF HORSES; PROMOTING SPORTS EVENTS AND COMPETITIONS OF OTHERS; AND, DATABASE MANAGEMENT IN THE FIELD OF THE TENNESSEE WALKING HORSE (U.S. CLS. 100, 101 AND 102).

FIRST USE 5-30-1992; IN COMMERCE 5-30-1992.

**CLASS 41—EDUCATION AND ENTERTAINMENT**

FOR INFORMATIONAL SERVICES IN THE FIELD OF THE TENNESSEE WALKING HORSE NAMELY, INFORMATION ON THE BREED COMPETITIVE STANDARDS OF THE TENNESSEE WALKING HORSE, COLORS AND MARKINGS, POSITIVE IDENTIFICATION TRAINING, SHOWING, SHOW EVENTS AND PROGRAMS, AND TOURNAMENTS (U.S. CLS. 100, 101 AND 107).

FIRST USE 5-30-1992; IN COMMERCE 5-30-1992.

BRIAN PINO, EXAMINING ATTORNEY

SN 78-775,013. OLETZKY, SHELDON, MIAMI, FL. FILED 12-16-2005.

SN 78-775,849. MASATS S.A., SANT SALVADOR DE GUARDIOLA, SPAIN, FILED 12-19-2005.



"THE MARK CONSISTS OF A STYLIZED SNOWFLAKE TO THE LEFT OF THE STYLIZED WORDING FRIGIBAR."

**CLASS 11—ENVIRONMENTAL CONTROL APPARATUS**

FOR INSULATED AND NON-INSULATED FIBERGLASS AND METAL MARINE REFRIGERATORS AND FREEZERS (U.S. CLS. 13, 21, 23, 31 AND 34).  
FIRST USE 2-27-1961; IN COMMERCE 2-27-1961.

**CLASS 20—FURNITURE AND ARTICLES NOT OTHERWISE CLASSIFIED**

FOR INSULATED AND NON-INSULATED BOAT DECK AND DOCK BOXES MADE OF WOOD AND FIBERGLASS (U.S. CLS. 2, 13, 22, 25, 32 AND 50).  
FIRST USE 2-27-1961; IN COMMERCE 2-27-1961.  
DANIEL RUSSELL, EXAMINING ATTORNEY

SN 78-775,461. BIOMEDPHARMIS, LTD., KALAMAZOO, MI. FILED 12-16-2005.

**BIOMEDPHARMIS**

THE MARK CONSISTS OF STANDARD CHARACTERS WITHOUT CLAIM TO ANY PARTICULAR FONT, STYLE, SIZE, OR COLOR.

**CLASS 35—ADVERTISING AND BUSINESS**

FOR BUSINESS INFORMATION AND RESEARCH SERVICES IN THE PHARMACEUTICAL AND LIFE SCIENCES FIELDS, NAMELY, ANALYSIS AND CREATION OF CUSTOMIZED REPORTS IN THE FIELDS OF PHARMACEUTICAL AND MEDICAL PRODUCT LICENSING, CREATION OF CONSUMER PRODUCT DATABASES, COMPETITOR PROFILES, AND THE PHARMACEUTICAL INDUSTRY (U.S. CLS. 100, 101 AND 102).  
FIRST USE 1-1-2004; IN COMMERCE 2-1-2004.

**CLASS 42—SCIENTIFIC, COMPUTER AND LEGAL SERVICES**

FOR INFORMATION AND RESEARCH SERVICES IN THE PHARMACEUTICAL AND LIFE SCIENCES FIELDS, NAMELY, ANALYSIS AND CREATION OF CUSTOMIZED REPORTS IN THE FIELDS OF PHARMACEUTICAL AND MEDICAL PRODUCT DEVELOPMENT, PHARMACEUTICAL REGULATORY REQUIREMENTS, CLINICAL TRIALS, AND PATENT LICENSING (U.S. CLS. 100 AND 101).  
FIRST USE 1-1-2004; IN COMMERCE 2-1-2004.  
KIMBERLY FRYE, EXAMINING ATTORNEY



THE COLOR(S) BLACK, BLUE-GREEN, RED AND WHITE IS/ARE CLAIMED AS A FEATURE OF THE MARK.  
THE MARK CONSISTS OF THE WORD MASATS IN BLACK, NEXT TO A BLUE-GREEN SQUARE BEHIND A MISCELLANEOUS SHAPE IN RED. THE INTERIOR OF THE SQUARE IS WHITE.

**CLASS 6—METAL GOODS**

FOR METAL RAMPS FOR USE WITH VEHICLES (U.S. CLS. 2, 12, 13, 14, 23, 25 AND 50).

**CLASS 7—MACHINERY**

FOR MACHINE AND MACHINE TOOLS FOR TRANSPORT AND MANUFACTURE OF ELECTRO-PNEUMATIC EQUIPMENTS FOR OPENING DOORS AND BUSES AND COACHES COVERS; MOTORS, EXCEPT FOR LAND VEHICLES, NAMELY ELECTRIC MOTORS FOR MACHINES; ENGINES NOT FOR LAND VEHICLES; MACHINE COUPLINGS; TRANSMISSION COMPONENTS, EXCEPT FOR LAND VEHICLES, IN THE NATURE OF GEARS FOR MACHINES; PNEUMATIC CONTROL FOR MACHINERY IN THE NATURE OF HOISTS (U.S. CLS. 13, 19, 21, 23, 31, 34 AND 35).

**CLASS 9—ELECTRICAL AND SCIENTIFIC APPARATUS**

FOR SCIENTIFIC, NAUTICAL, GEODESIC, ELECTRONIC AND ELECTRIC APPARATUS AND INSTRUMENTS IN THE NATURE OF REMOTE CONTROLS AND ELECTRONIC CONTROL FOR VEHICLE DOOR DRIVE SYSTEMS (U.S. CLS. 21, 23, 26, 36 AND 38).

**CLASS 10—MEDICAL APPARATUS**

FOR INVALID LIFTS FOR HANDICAPPED PEOPLE TO ACCESS A VEHICLE (U.S. CLS. 26, 39 AND 44).

**CLASS 12—VEHICLES**

FOR LAND VEHICLE DOOR PANELS; VEHICLE ACCESSORIES IN THE NATURE OF WINDOWS, DOORS, VEHICLE DOOR DRIVE SYSTEMS FEATURING ELECTRO-PNEUMATIC EQUIPMENTS FOR OPENING DOORS AND COVERS FOR AUTOCAR AND COACH BOOTS, PASSENGER, DRIVER AND EMERGENCY DOORS FOR AUTOCAR AND COACH; WINDOW REGULATOR SYSTEM FOR VEHICLES FEATURING WINDOWS AND ELECTRIC WINDOWS FOR AUTOCAR DOORS (U.S. CLS. 19, 21, 23, 31, 35 AND 44).  
ANN E. SAPPENFIELD, EXAMINING ATTORNEY



SN 78-777,533. RUTHERFORD CHEMICALS LLC, CASCHEM UNIT, BAYONNE, NJ. FILED 12-20-2005.

THE CHEMISTRY IS NATURAL

THE MARK CONSISTS OF STANDARD CHARACTERS WITHOUT CLAIM TO ANY PARTICULAR FONT, STYLE, SIZE, OR COLOR.

**CLASS 35—ADVERTISING AND BUSINESS**

FOR GENERAL BUSINESS MERCHANDISING SERVICES, NAMELY, MARKETING AND RETAIL STORE SERVICES FEATURING NATURAL-BASED RAW MATERIALS AND CHEMICALS, INCLUDING CASTOR OILS, SEED OILS, DEHYDRATED AND POLYMERIZED OILS, HYDROGENATED OILS, POLYURETHANES AND DERIVATIVES, IN THE FORM OF LIQUIDS, SEMI-SOLIDS, FLAKE AND POWDER, USED IN PERSONAL CARE PRODUCTS, PHARMACEUTICALS, AND INDUSTRIAL PRODUCTS OF OTHERS (U.S. CLS. 100, 101 AND 102).

FIRST USE 11-30-2005; IN COMMERCE 11-30-2005.

**CLASS 42—SCIENTIFIC, COMPUTER AND LEGAL SERVICES**

FOR DESIGN AND DEVELOPMENT OF RAW MATERIALS AND CHEMICALS USED IN PERSONAL CARE PRODUCTS, PHARMACEUTICALS, AND INDUSTRIAL PRODUCTS (U.S. CLS. 100 AND 101).

FIRST USE 11-30-2005; IN COMMERCE 11-30-2005. ELIZABETH BEYER, EXAMINING ATTORNEY

SN 78-780,101. STEVEN, JENNINGS A, NAPERVILLE, IL. FILED 12-23-2005.

**zyozy**

THE MARK CONSISTS OF STANDARD CHARACTERS WITHOUT CLAIM TO ANY PARTICULAR FONT, STYLE, SIZE, OR COLOR.

**CLASS 9—ELECTRICAL AND SCIENTIFIC APPARATUS**

FOR SATELLITE NAVIGATIONAL SYSTEM, NAMELY, A GLOBAL POSITIONING SYSTEM (GPS) FOR TRACKING AND STORAGE (U.S. CLS. 21, 23, 26, 36 AND 38).

**CLASS 38—COMMUNICATION**

FOR ELECTRONIC MESSAGE TRANSMISSION, NAMELY, TRANSMITTING MESSAGES FROM ONE PERSON TO ANOTHER; ELECTRONIC, ELECTRIC, AND DIGITAL TRANSMISSION OF VOICE AND IMAGES TO PLACE A PERSON IN ORAL OR VISUAL COMMUNICATION WITH ANOTHER VIA RADIO OR TELEVISION (U.S. CLS. 100, 101 AND 104).

**CLASS 42—SCIENTIFIC, COMPUTER AND LEGAL SERVICES**

FOR COMPUTER SERVICE, NAMELY, ACTING AS AN APPLICATION SERVICE PROVIDER IN THE FIELD OF KNOWLEDGE MANAGEMENT TO HOST COMPUTER AND SERVER BASED APPLICATION SOFTWARE FOR SEARCHING AND RETRIEVING INFORMATION FROM DATABASES AND COMPUTER NETWORKS FOR THE COLLECTION, EDITING, ORGANIZING, MODIFYING, BOOK MARKING, TRANSMISSION, STORAGE AND SHARING OF DATA AND INFORMATION (U.S. CLS. 100 AND 101).

CAROL SPILS, EXAMINING ATTORNEY

SN 78-781,117. THE BILLBOARD CLOTHING COMPANY, LLC, LOS ANGELES, CA. FILED 12-27-2005.

EYELEVEL MEDIA BE SEEN

THE MARK CONSISTS OF STANDARD CHARACTERS WITHOUT CLAIM TO ANY PARTICULAR FONT, STYLE, SIZE, OR COLOR.

NO CLAIM IS MADE TO THE EXCLUSIVE RIGHT TO USE "MEDIA", APART FROM THE MARK AS SHOWN. SEC. 2(F).

**CLASS 25—CLOTHING**

FOR CLOTHING, NAMELY, SHIRTS, JACKETS, VESTS, AND APRONS, FOR USE AS CARRIERS FOR ADVERTISING PANELS (U.S. CLS. 22 AND 39).

**CLASS 35—ADVERTISING AND BUSINESS**

FOR ADVERTISING SERVICES (U.S. CLS. 100, 101 AND 102).

STEPHANIE DAVIS, EXAMINING ATTORNEY

SN 78-782,687. OREGON AERO, INC., SCAPPOOSE, OR. FILED 12-29-2005.

**Aerospace Products For  
Down To Earth Comfort**

THE MARK CONSISTS OF STANDARD CHARACTERS WITHOUT CLAIM TO ANY PARTICULAR FONT, STYLE, SIZE, OR COLOR.

NO CLAIM IS MADE TO THE EXCLUSIVE RIGHT TO USE "AEROSPACE PRODUCTS", APART FROM THE MARK AS SHOWN.

**CLASS 9—ELECTRICAL AND SCIENTIFIC APPARATUS**

FOR PROTECTIVE HELMETS FOR USE IN THE AIRCRAFT INDUSTRY AND PROTECTIVE HELMETS EQUIPMENT UPGRADES THEREFORE COMPRISED OF HELMET CHIN STRAPS, HELMET CUSHIONING PADS, AND MOUNTING STRUCTURE FOR HELMET LIGHTS; EQUIPMENT FOR AUDIO HEADSETS, NAMELY, EAR CUSHIONS, CLOTH COVERS FOR EAR CUSHIONS, MICROPHONES, MICROPHONE CABLES, AND FILTERS FOR RADIO INTERFERENCE SUPPRESSION; EQUIPMENT FOR AUDIO HEADSETS, NAMELY, HEADSET STRAPS WHICH FASTEN THE HEADSET TO THE USER'S HEAD; COMPUTER CURSOR CONTROL DEVICES, NAMELY, LIGHT PENS; ELECTRIC AND ELECTRONIC VIDEO SURVEILLANCE INSTALLATIONS, NAMELY CAMERAS AND VIDEO MONITORS; TOTE BAGS FOR HELMET AND AUDIO HEADSETS (U.S. CLS. 21, 23, 26, 36 AND 38).

FIRST USE 0-0-1994; IN COMMERCE 0-0-1994.

**CLASS 12—VEHICLES**

FOR SEAT SYSTEMS FOR LAND, WATER AND AIRBORNE VEHICLES, COMPRISED OF SEAT FRAMES AND SEAT COMPONENTS INCLUDING SEAT CUSHIONS, HEADRESTS AND SEAT ARMS, AND PADDING THEREFOR (U.S. CLS. 19, 21, 23, 31, 35 AND 44).

FIRST USE 3-0-1998; IN COMMERCE 3-0-1998.

**CLASS 18—LEATHER GOODS**

FOR GENERAL PURPOSE UTILITY TOTE BAGS (U.S. CLS. 1, 2, 3, 22 AND 41).

FIRST USE 0-0-1994; IN COMMERCE 0-0-1994.

JESSICA A. POWERS, EXAMINING ATTORNEY

SN 78-783,859. INSURANCE MARKETPLACE STANDARDS ASSOCIATION, CHEVY CHASE, MD. FILED 1-3-2006.

INSURANCE MARKETPLACE  
STANDARDS ASSOCIATION

THE MARK CONSISTS OF STANDARD CHARACTERS WITHOUT CLAIM TO ANY PARTICULAR FONT, STYLE, SIZE, OR COLOR.

OWNER OF U.S. REG. NOS. 2,248,376 AND 2,261,907.

NO CLAIM IS MADE TO THE EXCLUSIVE RIGHT TO USE ASSOCIATION, APART FROM THE MARK AS SHOWN.

SEC. 2(F).

**CLASS 35—ADVERTISING AND BUSINESS**

FOR ASSOCIATION SERVICES, NAMELY, PROMOTING THE INTERESTS OF INSURANCE COMPANIES (U.S. CLS. 100, 101 AND 102).

FIRST USE 2-10-1997; IN COMMERCE 4-1-1998.

**CLASS 200—COLLECTIVE MEMBERSHIP**

FOR INDICATING MEMBERSHIP IN AN ASSOCIATION OF INSURANCE COMPANIES.

FIRST USE 2-10-1997; IN COMMERCE 4-1-1998.

JOHN SCHUYLER YARD, EXAMINING ATTORNEY

SN 78-786,586. MOV-N-BOX, INC., LONGWOOD, FL. FILED 1-6-2006.

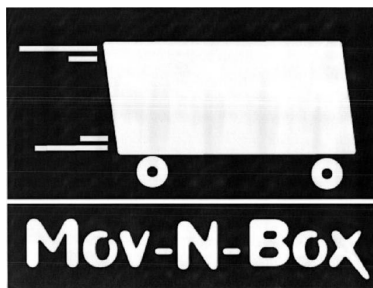

NO CLAIM IS MADE TO THE EXCLUSIVE RIGHT TO USE "MOVING BOX", APART FROM THE MARK AS SHOWN.

**CLASS 35—ADVERTISING AND BUSINESS**

FOR RETAIL STORE SERVICES FEATURING SELF-CONTAINED STORAGE CONTAINERS, STATIONERY AND SHIPPING LABELS, PLASTIC AND PAPER ENVELOPES, AND PAPER AND CARDBOARD AND CORRUGATED BOXES AND TUBES FOR SHIPPING AND PACKAGING; COMPUTERIZED ON-LINE RETAIL STORE SERVICES FEATURING SELF-CONTAINED PORTABLE STORAGE CONTAINERS, STATIONERY AND SHIPPING LABELS, PLASTIC AND PAPER ENVELOPES, AND PAPER AND CARDBOARD AND CORRUGATED BOXES AND TUBES FOR SHIPPING AND PACKAGING; FRANCHISING, NAMELY OFFERING TECHNICAL ASSISTANCE IN THE ESTABLISHMENT AND/OR OPERATIONS OF RETAIL STORES FEATURING SELF-CONTAINED STORAGE CONTAINERS, STATIONERY AND SHIPPING LABELS, PLASTIC AND PAPER ENVELOPES, AND PAPER AND CARDBOARD AND CORRUGATED BOXES AND TUBES FOR SHIPPING AND PACKAGING (U.S. CLS. 100, 101 AND 102).

**CLASS 39—TRANSPORTATION AND STORAGE**

FOR FURNITURE MOVING AND STORAGE SERVICES, NAMELY ON DEMAND RENTAL, STORAGE AND DELIVERY OF SELF-CONTAINED PORTABLE STORAGE CONTAINERS FOR HOUSEHOLD AND COMMERCIAL GOODS, NAMELY BOXES AND FURNITURE AND APPLIANCES (U.S. CLS. 100 AND 105).

BARBARA BROWN, EXAMINING ATTORNEY

SN 78-786,608. MOV-N-BOX, INC., LONGWOOD, FL. FILED 1-6-2006.

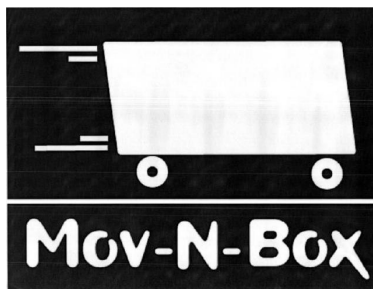

NO CLAIM IS MADE TO THE EXCLUSIVE RIGHT TO USE "MOVING BOX", APART FROM THE MARK AS SHOWN.

**CLASS 6—METAL GOODS**

FOR METAL, NAMELY ALUMINUM COVERED WOODEN FRAMED STORAGE CONTAINERS WITH METAL NAMELY STEEL ROLL-UP DOORS FOR THE STORAGE AND TRANSPORTATION OF HOUSEHOLD AND COMMERCIAL GOODS, NAMELY BOXES AND FURNITURE AND APPLIANCES (U.S. CLS. 2, 12, 13, 14, 23, 25 AND 50).

**CLASS 16—PAPER GOODS AND PRINTED MATTER**

FOR STATIONERY AND SHIPPING LABELS; PLASTIC AND PAPER ENVELOPES, AND PAPER AND CARDBOARD AND CORRUGATED BOXES AND TUBES FOR SHIPPING AND PACKAGING (U.S. CLS. 2, 5, 22, 23, 29, 37, 38 AND 50).

BARBARA BROWN, EXAMINING ATTORNEY

SN 78-792,750. DISABILITY ADVOCATES OF KENT COUNTY, GRAND RAPIDS, MI. FILED 1-17-2006.

**ZEROSTEP**

THE MARK CONSISTS OF STANDARD CHARACTERS WITHOUT CLAIM TO ANY PARTICULAR FONT, STYLE, SIZE, OR COLOR.

**CLASS 36—INSURANCE AND FINANCIAL**

FOR ACCEPTING AND ADMINISTERING MONETARY CHARITABLE CONTRIBUTIONS FOR THE HOUSING MODIFICATION NEEDS OF DISABLED PERSONS AND THEIR FAMILIES (U.S. CLS. 100, 101 AND 102).

FIRST USE 7-1-2005; IN COMMERCE 7-1-2005.

**CLASS 37—CONSTRUCTION AND REPAIR**

FOR CONSTRUCTION CONSULTATION SERVICES, NAMELY, HOME DESIGN ASSESSMENT, ASSISTANCE AND PLANNING, SPECIFICALLY TO RECOMMEND UNIVERSAL DESIGN OPTIONS TO OPTIMIZE HOME SAFETY, UTILITY AND ACCESSIBILITY; CONSTRUCTION CONSULTATION SERVICES, NAMELY, WORKSITE ASSESSMENT FOR EMPLOYERS, SPECIFICALLY TO RECOMMEND OPTIONS FOR INJURY PREVENTION, PRODUCTIVITY, AND ACCOMMODATIONS FOR DISABLED PERSONS; CONSTRUCTION CONSULTATION SERVICES, NAMELY, HOME MODIFICATION ASSESSMENT FOR DISABLED PERSONS AND THE ELDERLY TO ENSURE INDEPENDENCE AT HOME (U.S. CLS. 100, 103 AND 106).

FIRST USE 7-1-2005; IN COMMERCE 7-1-2005.

**CLASS 42—SCIENTIFIC, COMPUTER AND LEGAL SERVICES**

FOR INTERIOR DESIGN SERVICES, NAMELY, HOME DESIGN ASSESSMENT, ASSISTANCE AND PLANNING, SPECIFICALLY TO RECOMMEND UNIVERSAL DESIGN OPTIONS TO OPTIMIZE HOME SAFETY, UTILITY AND ACCESSIBILITY; INTERIOR DESIGN SERVICES, NAMELY, WORKSITE ASSESSMENT FOR EMPLOYERS, SPECIFICALLY TO RECOMMEND OPTIONS FOR INJURY PREVENTION, PRODUCTIVITY, AND ACCOMMODATIONS FOR DISABLED PERSONS; INTERIOR DESIGN SERVICES, NAMELY, HOME MODIFICATION ASSESSMENT FOR DISABLED PERSONS AND THE ELDERLY TO ENSURE INDEPENDENCE AT HOME (U.S. CLS. 100 AND 101).

FIRST USE 7-1-2005; IN COMMERCE 7-1-2005.

**CLASS 44—MEDICAL, BEAUTY AND AGRICULTURAL SERVICES**

FOR ACCEPTING AND ADMINISTERING CHARITABLE CONTRIBUTIONS OF DURABLE MEDICAL EQUIPMENT FOR THE HOUSING MODIFICATION NEEDS OF DISABLED PERSONS AND THEIR FAMILIES (U.S. CLS. 100 AND 101).

FIRST USE 7-1-2005; IN COMMERCE 7-1-2005.  
REBECCA EISINGER, EXAMINING ATTORNEY

SN 78-793,586. INTERTECH SECURITY, LLC, WARRENDALE, PA. FILED 1-18-2006.

## InterTECH Security

THE MARK CONSISTS OF STANDARD CHARACTERS WITHOUT CLAIM TO ANY PARTICULAR FONT, STYLE, SIZE, OR COLOR.

NO CLAIM IS MADE TO THE EXCLUSIVE RIGHT TO USE "SECURITY", APART FROM THE MARK AS SHOWN.

**CLASS 37—CONSTRUCTION AND REPAIR**

FOR INSTALLATION OF RESIDENTIAL AND COMMERCIAL SECURITY SYSTEMS (U.S. CLS. 100, 103 AND 106).

FIRST USE 1-31-2000; IN COMMERCE 1-31-2000.

**CLASS 42—SCIENTIFIC, COMPUTER AND LEGAL SERVICES**

FOR DESIGN OF RESIDENTIAL AND COMMERCIAL SECURITY SYSTEMS; SECURITY CONSULTATION SERVICES (U.S. CLS. 100 AND 101).

FIRST USE 1-31-2000; IN COMMERCE 1-31-2000.

**CLASS 45—PERSONAL SERVICES**

FOR MONITORING OF ALARMED RESIDENTIAL AND COMMERCIAL SECURITY SYSTEMS (U.S. CLS. 100 AND 101).

FIRST USE 1-31-2000; IN COMMERCE 1-31-2000.  
REBECCA GAN, EXAMINING ATTORNEY

SN 78-793,612. INTERTECH SECURITY, LLC, WARRENDALE, PA. FILED 1-18-2006.

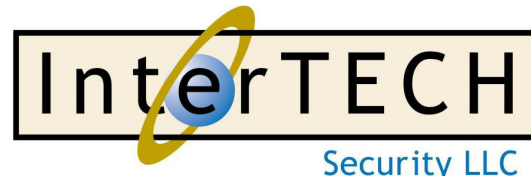

NO CLAIM IS MADE TO THE EXCLUSIVE RIGHT TO USE "SECURITY LLC", APART FROM THE MARK AS SHOWN.

THE COLOR(S) BLUE, GOLD, BLACK, AND OFF-WHITE IS/ARE CLAIMED AS A FEATURE OF THE MARK.

THE CIRCLE AROUND THE LETTER "E" IS BLUE AND THE RING AROUND THE BLUE CIRCLE IS GOLD. THE WORD "INTERTECH" IS BLACK AND THE WORDS "SECURITY LLC" ARE BLUE. THE BACKGROUND INSIDE THE BLACK RECTANGLE AROUND THE WORD "INTERTECH" IS OFF-WHITE.

**CLASS 37—CONSTRUCTION AND REPAIR**

FOR INSTALLATION OF RESIDENTIAL AND COMMERCIAL SECURITY SYSTEMS (U.S. CLS. 100, 103 AND 106).

FIRST USE 1-31-2000; IN COMMERCE 1-31-2000.

**CLASS 42—SCIENTIFIC, COMPUTER AND LEGAL SERVICES**

FOR DESIGN OF RESIDENTIAL AND COMMERCIAL SECURITY SYSTEMS; SECURITY CONSULTATION SERVICES (U.S. CLS. 100 AND 101).

FIRST USE 1-31-2000; IN COMMERCE 1-31-2000.

**CLASS 45—PERSONAL SERVICES**

FOR MONITORING OF ALARMED RESIDENTIAL AND COMMERCIAL SECURITY SYSTEMS (U.S. CLS. 100 AND 101).

FIRST USE 1-31-2000; IN COMMERCE 1-31-2000.  
REBECCA HAN, EXAMINING ATTORNEY

---

SN 78-794,315. STING ALARM, INC., HENDERSON, NV.  
FILED 1-18-2006.



NO CLAIM IS MADE TO THE EXCLUSIVE RIGHT TO USE ALARM, APART FROM THE MARK AS SHOWN.

THE MARK CONSISTS OF A STYLIZED BEE STINGER OVER THE WORDS STING ALARM.

**CLASS 37—CONSTRUCTION AND REPAIR**

FOR INSTALLATION AND MAINTENANCE OF BURGLAR AND/OR FIRE ALARMS (U.S. CLS. 100, 103 AND 106).

FIRST USE 7-18-2005; IN COMMERCE 7-18-2005.

**CLASS 45—PERSONAL SERVICES**

FOR MONITORING ALARMS (U.S. CLS. 100 AND 101).

FIRST USE 7-18-2005; IN COMMERCE 7-18-2005.  
KATHRYN COWARD, EXAMINING ATTORNEY

SN 78-794,678. THATCHER TECHNOLOGY GROUP, LLC,  
ADDISON, IL. FILED 1-19-2006.

# PROWESS

THE MARK CONSISTS OF STANDARD CHARACTERS WITHOUT CLAIM TO ANY PARTICULAR FONT, STYLE, SIZE, OR COLOR.

**CLASS 9—ELECTRICAL AND SCIENTIFIC APPARATUS**

FOR COMPUTER SOFTWARE USED FOR STRUCTURING AND MANAGEMENT OF BUSINESS ORGANIZATION, AND COMPENSATION AND BENEFIT PLANS, AND FOR TRACKING, ALLOCATION AND MANAGEMENT OF SALES AND FINANCIAL INFORMATION (U.S. CLS. 21, 23, 26, 36 AND 38).

FIRST USE 11-0-2004; IN COMMERCE 11-0-2004.

**CLASS 42—SCIENTIFIC, COMPUTER AND LEGAL SERVICES**

FOR COMPUTER SOFTWARE DESIGN AND DEVELOPMENT FOR OTHERS; CONSULTING SERVICES IN THE FIELD OF DESIGN, SELECTION, IMPLEMENTATION AND USE OF COMPUTER HARDWARE AND SOFTWARE SYSTEMS FOR OTHERS; CUSTOM COMPUTER PROGRAMMING FOR OTHERS; INTEGRATION OF COMPUTER SOFTWARE; AND COMPUTER SOFTWARE IMPLEMENTATION (U.S. CLS. 100 AND 101).

FIRST USE 11-0-2004; IN COMMERCE 11-0-2004.  
MARY ROSSMAN, EXAMINING ATTORNEY

---

SN 78-795,924. UNIVERSITY OF CINCINNATI, CINCINNATI, OH. FILED 1-20-2006.

## UC CLERMONT COUGARS

THE MARK CONSISTS OF STANDARD CHARACTERS WITHOUT CLAIM TO ANY PARTICULAR FONT, STYLE, SIZE, OR COLOR.

NO CLAIM IS MADE TO THE EXCLUSIVE RIGHT TO USE "CLERMONT" AS TO INTERNATIONAL CLASS 41, APART FROM THE MARK AS SHOWN.

**CLASS 25—CLOTHING**

FOR T-SHIRTS, SWEATSHIRTS, SWEATPANTS, WIND-RESISTANT JACKETS, TODDLER AND YOUTH T-SHIRTS, FLEECE JACKETS, INFANT ONE PIECE CLOTHING (U.S. CLS. 22 AND 39).

**CLASS 41—EDUCATION AND ENTERTAINMENT**

FOR EDUCATION AND ENTERTAINMENT SERVICES, NAMELY, PROVIDING COURSE OF INSTRUCTION AT THE UNIVERSITY LEVEL; EDUCATIONAL RESEARCH, ARRANGING AND CONDUCTING ATHLETIC EVENTS AND TOURNAMENTS, EXHIBITIONS, CONFERENCES, LIVE PERFORMANCES AND FESTIVALS (U.S. CLS. 100, 101 AND 107).

JUDITH HELFMAN, EXAMINING ATTORNEY

SN 78-795,928. GMEINER, WILLIAM H., YADKINVILLE, NC. FILED 1-20-2006.

SN 78-796,778. ANCHOR BAY ENTERTAINMENT, TROY, MI. FILED 1-23-2006.

## genotoxamer

THE MARK CONSISTS OF STANDARD CHARACTERS WITHOUT CLAIM TO ANY PARTICULAR FONT, STYLE, SIZE, OR COLOR.

### CLASS 1—CHEMICALS

FOR NUCLEIC ACIDS FOR USE IN PHARMACEUTICAL RESEARCH (U.S. CLS. 1, 5, 6, 10, 26 AND 46).

### CLASS 5—PHARMACEUTICALS

FOR NUCLEIC ACIDS FOR BOTH INHIBITION OF GENE EXPRESSION AND DELIVERY OF CYTOTOXIC DRUGS TO TREAT CANCER AND INFECTIOUS DISEASES (U.S. CLS. 6, 18, 44, 46, 51 AND 52).

BARBARA A. GOLD, EXAMINING ATTORNEY

SN 78-795,949. UNIVERSITY OF CINCINNATI, CINCINNATI, OH. FILED 1-20-2006.

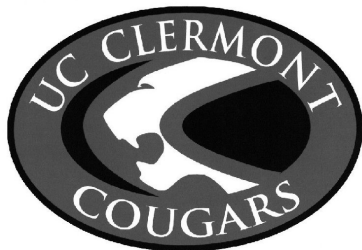

NO CLAIM IS MADE TO THE EXCLUSIVE RIGHT TO USE "CLERMONT" AS TO INTERNATIONAL CLASS 41, APART FROM THE MARK AS SHOWN.

### CLASS 25—CLOTHING

FOR T-SHIRTS, SWEATSHIRTS, SWEATPANTS, WIND-RESISTANT JACKETS, TODDLER AND YOUTH T-SHIRTS, FLEECE JACKETS, INFANT ONE PIECE CLOTHING (U.S. CLS. 22 AND 39).

### CLASS 41—EDUCATION AND ENTERTAINMENT

FOR EDUCATION AND ENTERTAINMENT SERVICES, NAMELY, PROVIDING COURSE OF INSTRUCTION AT THE UNIVERSITY LEVEL; EDUCATIONAL RESEARCH, ARRANGING AND CONDUCTING ATHLETIC EVENTS AND TOURNAMENTS, EXHIBITIONS, CONFERENCES, LIVE PERFORMANCES AND FESTIVALS (U.S. CLS. 100, 101 AND 107).

JUDITH HELFMAN, EXAMINING ATTORNEY

## PICK YOUR LEVEL

THE MARK CONSISTS OF STANDARD CHARACTERS WITHOUT CLAIM TO ANY PARTICULAR FONT, STYLE, SIZE, OR COLOR.

### CLASS 9—ELECTRICAL AND SCIENTIFIC APPARATUS

FOR PRERECORDED VIDEOS, DVDS, CDS, AND CD-ROMS FEATURING CONTENT IN THE FIELD OF DANCE AND FITNESS (U.S. CLS. 21, 23, 26, 36 AND 38).

### CLASS 16—PAPER GOODS AND PRINTED MATTER

FOR BOOKS IN THE FIELD OF DANCE AND FITNESS (U.S. CLS. 2, 5, 22, 23, 29, 37, 38 AND 50).

DOMINIC FATHY, EXAMINING ATTORNEY

SN 78-797,294. DASH SYSTEMS, LLC, JERICHO, NY. FILED 1-23-2006.

## DASH

THE MARK CONSISTS OF STANDARD CHARACTERS WITHOUT CLAIM TO ANY PARTICULAR FONT, STYLE, SIZE, OR COLOR.

### CLASS 5—PHARMACEUTICALS

FOR VITAMINS AND NUTRITIONAL SUPPLEMENTS (U.S. CLS. 6, 18, 44, 46, 51 AND 52).

FIRST USE 8-1-2005; IN COMMERCE 8-1-2005.

### CLASS 16—PAPER GOODS AND PRINTED MATTER

FOR PUBLICATIONS, NAMELY BOOKS, MAGAZINES AND WORKBOOKS DEALING WITH SUBJECTS OF INTEREST TO MEN AND WOMAN, NAMELY SELF HELP AND MOTIVATIONAL PUBLICATIONS (U.S. CLS. 2, 5, 22, 23, 29, 37, 38 AND 50).

FIRST USE 10-1-2002; IN COMMERCE 10-1-2002.

### CLASS 41—EDUCATION AND ENTERTAINMENT

FOR EDUCATION, NAMELY PROVIDING LIFE COACHING AND EXECUTIVE COACHING TO INDIVIDUALS AND GROUPS IN THE FORM OF PERSONAL AND/OR CLASS SESSIONS AND/OR SEMINARS (U.S. CLS. 100, 101 AND 107).

FIRST USE 9-1-2003; IN COMMERCE 9-1-2003.

SUNG IN, EXAMINING ATTORNEY

SN 78-797,709. DASH SYSTEMS, LLC, JERICHO, NY. FILED 1-24-2006.

## THE DASH SYSTEM

THE MARK CONSISTS OF STANDARD CHARACTERS WITHOUT CLAIM TO ANY PARTICULAR FONT, STYLE, SIZE, OR COLOR.

NO CLAIM IS MADE TO THE EXCLUSIVE RIGHT TO USE "SYSTEM", APART FROM THE MARK AS SHOWN.

### CLASS 9—ELECTRICAL AND SCIENTIFIC APPARATUS

FOR PRE-RECORDED AUDIO AND VIDEO COMPACT DISCS, PRE-RECORDED AUDIO AND VIDEO TAPES AND PRE-RECORDED AUDIO AND VIDEO OPTICAL DISKS, ALL FEATURING SUBJECTS OF INTEREST TO MEN AND WOMEN, NAMELY SELF HELP AND MOTIVATIONAL TOPICS (U.S. CLS. 21, 23, 26, 36 AND 38).

FIRST USE 3-1-2005; IN COMMERCE 3-1-2005.

### CLASS 16—PAPER GOODS AND PRINTED MATTER

FOR PUBLICATIONS, NAMELY BOOKS, MAGAZINES AND WORKBOOKS DEALING WITH SUBJECTS OF INTEREST TO MEN AND WOMAN, NAMELY SELF HELP AND MOTIVATIONAL PUBLICATIONS (U.S. CLS. 2, 5, 22, 23, 29, 37, 38 AND 50).

FIRST USE 5-1-2005; IN COMMERCE 5-1-2005.

### CLASS 41—EDUCATION AND ENTERTAINMENT

FOR EDUCATIONAL SERVICES, NAMELY, CONDUCTING SEMINARS AND WORKSHOPS IN THE FIELD OF PERSONAL AWARENESS AND SELF-IMPROVEMENT TO INDIVIDUALS AND GROUPS (U.S. CLS. 100, 101 AND 107).

FIRST USE 5-1-2005; IN COMMERCE 5-1-2005.  
SUNG IN, EXAMINING ATTORNEY

SN 78-797,976. P&A MARKETING INC., ALBERTSON, NY. FILED 1-24-2006.

## BRISTOL BAY FLEECE

THE MARK CONSISTS OF STANDARD CHARACTERS WITHOUT CLAIM TO ANY PARTICULAR FONT, STYLE, SIZE, OR COLOR.

NO CLAIM IS MADE TO THE EXCLUSIVE RIGHT TO USE "FLEECE", APART FROM THE MARK AS SHOWN.

### CLASS 20—FURNITURE AND ARTICLES NOT OTHERWISE CLASSIFIED

FOR BEDS FOR HOUSEHOLD PETS; PILLOWS (U.S. CLS. 2, 13, 22, 25, 32 AND 50).

### CLASS 24—FABRICS

FOR BED BLANKETS; BED SHEETS; BLANKET THROWS; COMFORTERS; THROWS (U.S. CLS. 42 AND 50).

### CLASS 25—CLOTHING

FOR HOUSECOATS; LOUNGEWEAR; ROBES (U.S. CLS. 22 AND 39).  
SANI KHOURI, EXAMINING ATTORNEY

SN 78-799,745. PANTALL, CATHERINE L., ARNOLD, MD. FILED 1-26-2006.



NO CLAIM IS MADE TO THE EXCLUSIVE RIGHT TO USE "ALABAMA BBQ COMPANY", APART FROM THE MARK AS SHOWN.

THE COLOR(S) YELLOW, BLACK, ORANGE, WHITE, PINK, BROWN, GREY, RED, BLUE, AND GREEN IS/ARE CLAIMED AS A FEATURE OF THE MARK.

THE COLOR(S) THE OUTER CIRCLE APPEARS IN THE COLOR GRAY AND YELLOW AND IS OUTLINED IN BLACK, THE INNER CIRCLE IS BROWN, RED AND ORANGE, THE FLAMES APPEAR IN THE COLORS GRAY, WHITE AND PINK, THE PIT IS GRAY WITH BROWN STICKS, THE BIRD IS YELLOW WITH AN ORANGE BEAK AND BROWN AND WHITE EYES AND IS OUTLINED IN BLACK, THE PIG IS PINK WITH GRAY NOSTRILS AND BLUE AND WHITE EYES AND IS OUTLINED IN BLACK, THE COW IS BROWN WITH BLACK HORNS, GREEN AND WHITE EYES, A YELLOW NOSE RING AND IS OUTLINED IN BLACK, THE WORDING ALABAMA BBQ IS ORANGE AND IS OUTLINED IN RED, BLACK AND WHITE AND THE WORDING COMPANY IS WHITE. IS/ARE CLAIMED AS A FEATURE OF THE MARK.

THE MARK CONSISTS OF THE MARK IS CIRCULAR CONSISTING OF A BIRD (IN THE COLOR YELLOW), A PIG (IN THE COLOR PINK), AND A COW (IN THE COLOR BROWN), SITTING IN A BARBEQUE PIT COOKING WITH FLAMES AND SMOKE RISING AMONG AND AROUND THE BIRD, PIG AND COW WITH THE WORDS ALABAMA BBQ COMPANY UNDERNEATH THEM.

### CLASS 30—STAPLE FOODS

FOR BARBECUE SAUCE, BARBECUE DRY RUB AND SAUCES FOR BARBECUED MEAT (U.S. CL. 46).  
FIRST USE 2-17-2005; IN COMMERCE 2-17-2005.

### CLASS 43—HOTEL AND RESTAURANT SERVICES

FOR CARRY-OUT RESTAURANTS, RESTAURANTS, TAKE-OUT RESTAURANT SERVICES, RESTAURANTS (U.S. CLS. 100 AND 101).

FIRST USE 2-17-2005; IN COMMERCE 2-17-2005.  
MICHELE SWAIN, EXAMINING ATTORNEY

SN 78-800,117. LIBRARY VIDEO COMPANY, WYNNEWOOD, PA. FILED 1-26-2006.

SN 78-802,352. TARINA TARANTINO DESIGNS, LLC, LOS ANGELES, CA. FILED 1-30-2006.

## SAFARI MONTAGE

THE MARK CONSISTS OF STANDARD CHARACTERS WITHOUT CLAIM TO ANY PARTICULAR FONT, STYLE, SIZE, OR COLOR.

### CLASS 9—ELECTRICAL AND SCIENTIFIC APPARATUS

FOR COMPUTER HARDWARE AND SOFTWARE FOR STORING, TRANSMITTING, SHOWING, SHARING, SEARCHING, PROTECTING AND MANAGING VIDEO CONTENT, METADATA AND ANCILLARY MATERIALS OVER LOCAL AND WIDE AREA NETWORKS (U.S. CLS. 21, 23, 26, 36 AND 38).

FIRST USE 5-23-2005; IN COMMERCE 5-23-2005.

### CLASS 35—ADVERTISING AND BUSINESS

FOR SUBSCRIPTION TO AN INFORMATION MEDIA PACKAGE, NAMELY, PROVIDING DIGITAL VIDEO CONTENT, METADATA AND ANCILLARY MATERIALS FOR USE IN CONNECTION WITH COMPUTER NETWORKING SYSTEMS (U.S. CLS. 100, 101 AND 102).

FIRST USE 5-23-2005; IN COMMERCE 5-23-2005.  
MARK T. MULLEN, EXAMINING ATTORNEY

---

SN 78-802,069. RED RIVER SERVICE CORPORATION, LOS FRESNOS, TX. FILED 1-30-2006.

## LUGGAGE WEENEE

THE MARK CONSISTS OF STANDARD CHARACTERS WITHOUT CLAIM TO ANY PARTICULAR FONT, STYLE, SIZE, OR COLOR.

NO CLAIM IS MADE TO THE EXCLUSIVE RIGHT TO USE "LUGGAGE", APART FROM THE MARK AS SHOWN.

### CLASS 6—METAL GOODS

FOR PRIMARILY METAL, INDUSTRIAL STRENGTH TWIST TIES; COATED METAL STRAPS AND TWIST-TIES FOR FASTENING, SECURING, HOLDING, CARRYING AND HANGING (U.S. CLS. 2, 12, 13, 14, 23, 25 AND 50).

### CLASS 18—LEATHER GOODS

FOR LUGGAGE STRAPS (U.S. CLS. 1, 2, 3, 22 AND 41).  
JILL C. ALT, EXAMINING ATTORNEY

## TARINA TARANTINO

THE MARK CONSISTS OF STANDARD CHARACTERS WITHOUT CLAIM TO ANY PARTICULAR FONT, STYLE, SIZE, OR COLOR.

OWNER OF U.S. REG. NO. 2,313,347.

THE NAME TARINA TARANTINO IDENTIFIES A LIVING INDIVIDUAL WHOSE CONSENT IS OF RECORD.

### CLASS 14—JEWELRY

FOR JEWELRY (U.S. CLS. 2, 27, 28 AND 50).  
FIRST USE 0-0-1996; IN COMMERCE 0-0-1996.

### CLASS 18—LEATHER GOODS

FOR HANDBAGS AND ALL-PURPOSE CARRYING BAGS (U.S. CLS. 1, 2, 3, 22 AND 41).  
FIRST USE 0-0-2000; IN COMMERCE 0-0-2000.

### CLASS 25—CLOTHING

FOR CLOTHING, NAMELY T-SHIRTS AND BELTS (U.S. CLS. 22 AND 39).  
FIRST USE 0-0-2000; IN COMMERCE 0-0-2000.

### CLASS 26—FANCY GOODS

FOR HAIR ACCESSORIES, NAMELY HAIR CLIPS, BOBBY PINS, JAW CLIPS AND PONYTAIL HOLDERS (U.S. CLS. 37, 39, 40, 42 AND 50).

FIRST USE 0-0-1996; IN COMMERCE 0-0-1996.  
KIMBERLY PERRY, EXAMINING ATTORNEY

---

SN 78-803,106. INTERNATIONAL MASS FATALITIES CENTER, CEDAR RAPIDS, IA. FILED 1-31-2006.

## AmericaReady

THE MARK CONSISTS OF STANDARD CHARACTERS WITHOUT CLAIM TO ANY PARTICULAR FONT, STYLE, SIZE, OR COLOR.

NO CLAIM IS MADE TO THE EXCLUSIVE RIGHT TO USE "AMERICA", APART FROM THE MARK AS SHOWN.

### CLASS 35—ADVERTISING AND BUSINESS

FOR PROMOTING PUBLIC AWARENESS OF THE NEED FOR TRAINING IN THE FIELD OF HOMELAND SECURITY, EMERGENCY PREPAREDNESS AND EMERGENCY RESPONSE (U.S. CLS. 100, 101 AND 102).  
FIRST USE 11-1-2005; IN COMMERCE 11-1-2005.

**CLASS 41—EDUCATION AND ENTERTAINMENT**

FOR PROVIDING EDUCATION IN THE NATURE OF SEMINARS, WORKSHOPS, AND TRAINING IN THE AREAS OF HOMELAND SECURITY, EMERGENCY PREPAREDNESS AND EMERGENCY RESPONSE (U.S. CLS. 100, 101 AND 107).

FIRST USE 11-1-2005; IN COMMERCE 11-1-2005.

**CLASS 45—PERSONAL SERVICES**

FOR PROVIDING CONSULTATION AND INFORMATION IN THE FIELD OF EMERGENCY RESPONSE FOR COMMUNITIES, HOMELAND SECURITY, AND EMERGENCY PREPAREDNESS (U.S. CLS. 100 AND 101).

FIRST USE 11-1-2005; IN COMMERCE 11-1-2005.  
AMY HELLA, EXAMINING ATTORNEY

SN 78-803,962. UGOBE, INC., EMERYVILLE, CA. FILED 1-31-2006.

**UGOBE LIFE FORMS**

THE MARK CONSISTS OF STANDARD CHARACTERS WITHOUT CLAIM TO ANY PARTICULAR FONT, STYLE, SIZE, OR COLOR.

NO CLAIM IS MADE TO THE EXCLUSIVE RIGHT TO USE "FORMS", APART FROM THE MARK AS SHOWN.

**CLASS 9—ELECTRICAL AND SCIENTIFIC APPARATUS**

FOR ROBOTS FOR PERSONAL OR HOBBY USE; SOUND ACTIVATED ANIMATRONIC FACES AND FIGURES (U.S. CLS. 21, 23, 26, 36 AND 38).

**CLASS 28—TOYS AND SPORTING GOODS**

FOR TOY ROBOTS (U.S. CLS. 22, 23, 38 AND 50).  
PETER B. BROMAGHIM, EXAMINING ATTORNEY

SN 78-805,530. DETACHABLES, LLC, MABLETON, GA. FILED 2-2-2006.

**TIKI TAVI**

THE MARK CONSISTS OF STANDARD CHARACTERS WITHOUT CLAIM TO ANY PARTICULAR FONT, STYLE, SIZE, OR COLOR.

**CLASS 24—FABRICS**

FOR BABY BLANKETS, TOWELS AND HOODED TOWELS (U.S. CLS. 42 AND 50).  
FIRST USE 11-30-2005; IN COMMERCE 11-30-2005.

**CLASS 25—CLOTHING**

FOR CLOTHING, NAMELY, T-SHIRTS, PANTS, CAPS, CLOTH BIBS, SOCKS, BOOTIES, INFANT CLOTHING, NAMELY BODYSUITS (U.S. CLS. 22 AND 39).

FIRST USE 9-13-2005; IN COMMERCE 11-30-2005.

DAVID MURRAY, EXAMINING ATTORNEY

SN 78-805,548. DETACABLES, LLC, MABLETON, GA. FILED 2-2-2006.

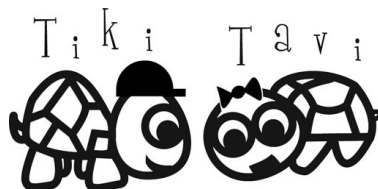
**CLASS 24—FABRICS**

FOR BABY BLANKETS, TOWELS AND HOODED TOWELS (U.S. CLS. 42 AND 50).

FIRST USE 11-30-2005; IN COMMERCE 11-30-2005.

**CLASS 25—CLOTHING**

FOR CLOTHING, NAMELY, T-SHIRTS, PANTS, CAPS, CLOTH BIBS, SOCKS, BOOTIES, INFANT CLOTHING, NAMELY BODYSUITS (U.S. CLS. 22 AND 39).

FIRST USE 9-13-2005; IN COMMERCE 11-30-2005.

DAVID MURRAY, EXAMINING ATTORNEY

SN 78-805,857. CAF NOMINEES LIMITED, WEST MALLING, KENT ME19 4TA, UNITED KINGDOM. FILED 2-2-2006.



OWNER OF U.S. REG. NO. 2,430,263.

THE COLOR(S) RED AND WHITE IS/ARE CLAIMED AS A FEATURE OF THE MARK.

THE COLORS RED (A TERRACOTTA SHADE) AND WHITE ARE CLAIMED AS A FEATURE OF THE MARK, AND THE COLOR RED (A TERRACOTTA SHADE) APPEARS IN THE RECTANGULAR BACKGROUND, AND THE COLOR WHITE APPEARS IN THE WORDING AND THE THREE SQUARES.

**CLASS 9—ELECTRICAL AND SCIENTIFIC APPARATUS**

FOR VIDEO AND AUDIO TAPES AND DISCS FEATURING INFORMATION ABOUT FINANCIAL AND ADVISORY SERVICES FOR CHARITIES AND SOCIAL ENTERPRISES; EDUCATIONAL SOFTWARE FEATURING INFORMATION ABOUT FINANCIAL AND ADVISORY SERVICES WHICH BENEFIT CHARITIES, CHARITABLE CAUSES AND SOCIAL ENTERPRISES; ELECTRONIC PUBLICATIONS BEING DOWNLOADABLE FROM THE INTERNET AND CD ROM IN THE NATURE OF A MAGAZINE, LEAFLET, BROCHURE, REPORT OR GUIDE IN THE FIELD OF FINANCIAL AND ADVISORY SERVICES WHICH BENEFIT CHARITIES AND SOCIAL ENTERPRISES (U.S. CLS. 21, 23, 26 AND 38).



**CLASS 16—PAPER GOODS AND PRINTED MATTER**

FOR PRINTED MATTER, NAMELY, REPORTS, GUIDES, PAMPHLETS, TEACHING MATERIALS, MAGAZINES, BROCHURES, POSTERS, HEADED PAPER, STATIONERY IN THE FIELD OF FINANCIAL AND ADVISORY SERVICES FOR CHARITIES AND SOCIAL ENTERPRISES (U.S. CLS. 2, 5, 22, 23, 29, 37, 38 AND 50).

SN 78-806,048. BACK BEAT, INC., IRVINE, CA. FILED 2-2-2006.

**CLASS 35—ADVERTISING AND BUSINESS**

FOR BUSINESS RESEARCH; PROVISION OF BUSINESS INFORMATION IN THE FIELD OF FINANCIAL AND ADVISORY SERVICES FOR CHARITIES AND SOCIAL ENTERPRISES IN THE FORM OF REPORTS, STATISTICS AND ACCOUNTS; PUBLICATION OF PUBLICITY TEXTS (U.S. CLS. 100, 101 AND 102).

**CLASS 3—COSMETICS AND CLEANING PREPARATIONS**

FOR PERFUME, COLOGNE, FRAGRANCES, COSMETICS, COSMETIC PENCILS, EYE MAKEUP, LIPSTICK, LIP GLOSS, MASCARA, FACIAL MAKEUP, FOUNDATION, AND COSMETIC COMPACTS; HAIR LOTIONS, BODY LOTIONS, SKIN CONDITIONERS, NAIL POLISHES; PERSONAL CARE PRODUCTS, NAMELY, NONMEDICATED BODY AND BEAUTY CARE PREPARATIONS, NONMEDICATED SKIN CARE PREPARATIONS, HAIR CARE PREPARATIONS, TEETH CLEANING PREPARATIONS, TEETH WHITENING PREPARATIONS, AFTER-SUN SKIN LOTION, AFTER-SHAVE BALM; AFTER-SHAVE PREPARATIONS, NAMELY, CREAMS AND GELS; ALL-PURPOSE COTTON SWABS FOR PERSONAL USE, NONMEDICATED ANTI-CAVITY MOUTH RINSES, ANTIPERSPIRANTS, BABY OIL, BABY POWDER, BABY SHAMPOO, BABY WIPES, BATH GELS AND SOAPS, BATH OILS, BEAUTY LOTIONS, BODY OILS, BODY POWDERS, BODY CLEANSERS, BREATH FRESHENERS, BRONZING SUNLESS TAN ACCELERATING FOAM, BUBBLE BATH, COARSE AND SMOOTH NAIL EMERY BOARDS, COTTON BALLS FOR COSMETIC PURPOSES, COTTON PUFFS AND SQUARES FOR COSMETIC PURPOSES, CREAM SKIN CLEANERS, DAILY PORE FACIAL CLEANSERS; DENTAL TRAVEL KIT CONSISTING OF TOOTHPASTE, TOOTHBRUSH AND MOUTHWASH ALL SOLD AS A UNIT; DENTIFRICES, DENTURE CLEANERS, DENTURE CLEANING PREPARATIONS, PERSONAL DEODORANTS, EMERY BOARDS, FOOT CREAMS, GAUZE PADS FOR COSMETIC PURPOSES, SKIN LOTION CONTAINING GLYCERIN AND ROSEWATER, SKIN SOAP CONTAINING GLYCERIN AND ROSEWATER, GLYCERIN SOAP, HAIR SHAMPOO AND CONDITIONERS, HAIR TONICS, HYDROGEN PEROXIDE FOR USE ON THE HAIR, MILK BATHS, NONMEDICATED MOUTH RINSES, MOUTHWASH, NAIL POLISH REMOVER, NONMEDICATED DIAPER RASH OINTMENT AND LOTIONS, NONMEDICATED LIP BALM, NONMEDICATED OATMEAL BODY BATHS, PETROLEUM JELLY FOR COSMETIC PURPOSES, PRE-MOISTENED COSMETIC WIPES, PRE-MOISTENED FACIAL CLEANING TOWELETTES, PUMICE STONES FOR PERSONAL USE; SHAVING BALMS, GELS, CREAMS AND LOTIONS; SHAVING PREPARATIONS, SHOWER AND BATH POWDERS, SKIN CLEANSERS AND CREAMS, SKIN LOTIONS AND CREAMS, SKIN MOISTURIZERS, SOAPS, SUNSCREEN AND SUN-BLOCK PREPARATIONS, SUN TANNING PREPARATIONS, TEETH WHITENING GELS AND FILMS, AND TOOTHPASTE (U.S. CLS. 1, 4, 6, 50, 51 AND 52).

FIRST USE 0-0-2002; IN COMMERCE 0-0-2002.

**CLASS 36—INSURANCE AND FINANCIAL**

FOR CHARITABLE FUNDRAISING; FINANCIAL ADVICE AND CONSULTANCY SERVICES; FINANCIAL ARRANGEMENTS TO FACILITATE CHARITABLE GIVING; INVESTMENT TRUST SERVICES; PREPARATION OF FINANCIAL REPORTS AND ANALYSES; DEPOSIT TAKING SERVICES; DEBIT CARD SERVICES; ONLINE FINANCIAL SERVICES, NAMELY MONEY LENDING, INVESTMENTS, SAVINGS PROGRAMS, BANKING SERVICES, TAX RECOVERY, ARRANGEMENTS TO FACILITATE CHARITABLE GIVING; GRANT MAKING SERVICES, NAMELY PROVIDING AND ADVISING ON THE PROVISION OF GRANTS TO CHARITABLE CAUSES AND ORGANISATIONS AND SOCIAL ENTERPRISES; FIDUCIARY TAX PAYMENT PROCESSING SERVICES, NAMELY RECOVERY OF TAX AND PAYMENT OF FUNDS TO CHARITIES AND SOCIAL ENTERPRISES; FINANCIAL RESEARCH (U.S. CLS. 100, 101 AND 102).

**CLASS 41—EDUCATION AND ENTERTAINMENT**

FOR ARRANGING AND CONDUCTING CONFERENCES, SEMINARS AND WORKSHOPS; ORGANIZING AND ARRANGING CHARITY AND FINANCIAL AWARDS PROGRAMS; PUBLICATION OF BOOKS, MAGAZINES, LEAFLETS, JOURNALS, REPORTS, GUIDES AND BROCHURES (U.S. CLS. 100, 101 AND 107).

GRETNA YAO, EXAMINING ATTORNEY

**CLASS 9—ELECTRICAL AND SCIENTIFIC APPARATUS**

FOR EYEWEAR, NAMELY, EYEGGLASS FRAMES, LENSES AND CASES, AND SUNGLASSES; PROTECTIVE EYEWEAR; SPECTACLES; EYEWEAR FOR SPORTS; PROTECTIVE AND SPORTS GOGGLES; EYEWEAR ACCESSORIES, NAMELY, STRAPS, NECK CORDS AND HEAD STRAPS FOR HOLDING SPECTACLES, AND CHAINS FOR SPECTACLES (U.S. CLS. 21, 23, 26, 36 AND 38).

**CLASS 18—LEATHER GOODS**

FOR HANDBAGS, PURSES AND ACCESSORIES, NAMELY, TOTE BAGS AND SHOULDER BAGS; BAGS, NAMELY, BEACH BAGS, ALL-PURPOSE SPORT BAGS, CARRY BAGS, BARREL BAGS, WAIST PACKS, BACKPACKS, KNAPSACKS, SCHOOL BAGS, SATCHELS, WAIST BAGS, CLUTCH BAGS, COSMETIC BAGS SOLD EMPTY, JEWELRY BAGS FOR TRAVEL, LEATHER BAGS FOR PACKING MERCHANDISE, LEATHER AND TEXTILE SHOPPING BAGS, MESH SHOPPING BAGS, WALLETS, CLASPS FOR BAGS, LUGGAGE BAGS AND TRAVEL BAGS; CASES, NAMELY, TRAVEL CASES SOLD EMPTY, OVERNIGHT CASES, BRIEFCASES, DOCUMENT CASES, CREDIT CARD CASES, BUSINESS CARD CASES, COSMETIC CASES SOLD EMPTY, TOILETRY CASES AND VANITY CASES SOLD EMPTY, JEWELRY CASES OF LEATHER OR TEXTILE, KEY CASES AND LEATHER KEY CHAINS, LUGGAGE TRUNKS, LUGGAGE CASES AND LUGGAGE TAGS, AND STRAPS FOR LUGGAGE (U.S. CLS. 1, 2, 3, 22 AND 41).

**CLASS 25—CLOTHING**

FOR FOOTWEAR AND APPAREL, NAMELY, ANKLETS, BATHING SUITS, BATHING TRUNKS, BATHROBES, BEACHWEAR, BELTS, BIKINIS, BLAZERS, BLOUSES, BODY SUITS, BOOTS, BOTTOMS, CAMISOLES, CAPS, CARDIGANS, COATS, COVERALLS, COVER-UPS, DRESSES, DUNGAREES, GLOVES, HATS, HEADBANDS, HEADWEAR, HOSIERY, JACKETS, JEANS, JERSEYS, JUMPERS, JUMP SUITS, LINGERIE, NECKWEAR, OVERALLS, OVERCOATS, PAJAMAS, PANTS, RAINWEAR, SANDALS, SCARVES, SHAWLS, SHIRTS, SHOES, SHORTALLS, SHORTS, SKI WEAR, SKIRTS, SKORTS, SLACKS, SLEEPWEAR, SLIPPERS, SNEAKERS, SOCKS, SPORT COATS, SURF WEAR, SWEAT PANTS, SWEATSHIRTS, SWEATERS, SWIMWEAR, T-SHIRTS, TOPS, TANK TOPS, TROUSERS, UNDERWEAR, VESTS, VISORS AND WRIST BANDS (U.S. CLS. 22 AND 39).

ALICE SUE CARRUTHERS, EXAMINING ATTORNEY

SN 78-806,199. NORTHLAND US LLC, EDEN PRAIRIE, MN. FILED 2-3-2006.

**ALL-AMERICAN HEARING**

THE MARK CONSISTS OF STANDARD CHARACTERS WITHOUT CLAIM TO ANY PARTICULAR FONT, STYLE, SIZE, OR COLOR.

NO CLAIM IS MADE TO THE EXCLUSIVE RIGHT TO USE "HEARING", APART FROM THE MARK AS SHOWN.

**CLASS 35—ADVERTISING AND BUSINESS**

FOR RETAIL STORE SERVICES IN THE FIELD OF HEARING AIDS (U.S. CLS. 100, 101 AND 102).

**CLASS 37—CONSTRUCTION AND REPAIR**

FOR REPAIR OF HEARING AIDS (U.S. CLS. 100, 103 AND 106).

**CLASS 44—MEDICAL, BEAUTY AND AGRICULTURAL SERVICES**

FOR HEARING AID SERVICES, NAMELY, HEARING EVALUATION SERVICES, AND FITTING AND ADJUSTING OF HEARING AIDS (U.S. CLS. 100 AND 101).

LINDA M. KING, EXAMINING ATTORNEY

SN 78-806,197. NORTHLAND US LLC, EDEN PRAIRIE, MN. FILED 2-3-2006.

SN 78-806,336. ACME UNITED CORPORATION, FAIRFIELD, CT. FILED 2-3-2006.

**LISTEN-LISTEN**

THE MARK CONSISTS OF STANDARD CHARACTERS WITHOUT CLAIM TO ANY PARTICULAR FONT, STYLE, SIZE, OR COLOR.

**CLASS 35—ADVERTISING AND BUSINESS**

FOR RETAIL STORE SERVICES IN THE OF HEARING AIDS (U.S. CLS. 100, 101 AND 102).

**CLASS 37—CONSTRUCTION AND REPAIR**

FOR REPAIR OF HEARING AIDS (U.S. CLS. 100, 103 AND 106).

**CLASS 44—MEDICAL, BEAUTY AND AGRICULTURAL SERVICES**

FOR HEARING AID SERVICES, NAMELY, HEARING EVALUATION SERVICES, AND FITTING AND ADJUSTING OF HEARING AIDS (U.S. CLS. 100 AND 101).

LINDA M. KING, EXAMINING ATTORNEY

**TI2**

THE MARK CONSISTS OF STANDARD CHARACTERS WITHOUT CLAIM TO ANY PARTICULAR FONT, STYLE, SIZE, OR COLOR.

**CLASS 8—HAND TOOLS**

FOR SCISSORS; PAPER TRIMMERS (U.S. CLS. 23, 28 AND 44).

**CLASS 16—PAPER GOODS AND PRINTED MATTER**

FOR PENCIL SHARPENERS (U.S. CLS. 2, 5, 22, 23, 29, 37, 38 AND 50).

LINDA POWELL, EXAMINING ATTORNEY

SN 78-806,448. MITSUBISHI KAGAKU IMAGING CORP.,  
CHESAPEAKE, VA. FILED 2-3-2006.



NO CLAIM IS MADE TO THE EXCLUSIVE RIGHT TO USE "IMAGING", APART FROM THE MARK AS SHOWN. THE MARK CONSISTS OF THE WORDS MK IMAGING WITH THE DESIGN OF AN OPEN ELONGATED OVAL WITH THREE DOTS.

#### CLASS 2—PAINTS

FOR PRINTER, COPIER AND FACSIMILE MACHINE SUPPLIES, NAMELY, TONER, TONER CARTRIDGES (U.S. CLS. 6, 11 AND 16).

#### CLASS 9—ELECTRICAL AND SCIENTIFIC APPARATUS

FOR PARTS AND ACCESSORIES AND REPLACEMENT PARTS FOR PRINTERS, COPIERS AND FACSIMILE MACHINES, NAMELY, DRUMS AND DRUM UNITS, BLADES, FUSER ROLLERS, FUSER STATIONS, CHARGE ROLLERS; AND UNFILLED INK CARTRIDGES FOR FACSIMILE MACHINES AND COPIERS (U.S. CLS. 21, 23, 26, 36 AND 38).

CHRIS WELLS, EXAMINING ATTORNEY

SN 78-808,458. PERRY, TYLER, LOS ANGELES, CA. FILED  
2-6-2006.

DON'T MAKE A BLACK WOMAN  
TAKE OFF HER EARRINGS

THE MARK CONSISTS OF STANDARD CHARACTERS WITHOUT CLAIM TO ANY PARTICULAR FONT, STYLE, SIZE, OR COLOR.

#### CLASS 3—COSMETICS AND CLEANING PREPARATIONS

FOR FRAGRANCES, NAMELY, ROOM FRAGRANCES, FRAGRANCES FOR PERSONAL USE; HAND, FACE AND BODY SOAPS; ESSENTIAL OILS FOR PERSONAL USE; COSMETICS; BODY AND HAIR LOTIONS AND OILS; BATH GEL; HAIR CARE PREPARATIONS (U.S. CLS. 1, 4, 6, 50, 51 AND 52).

#### CLASS 6—METAL GOODS

FOR METAL KEY CHAINS (U.S. CLS. 2, 12, 13, 14, 23, 25 AND 50).

#### CLASS 9—ELECTRICAL AND SCIENTIFIC APPARATUS

FOR EYEWEAR, NAMELY, EYEGLASSES, SUNGLASSES; PREPAID MAGNETICALLY ENCODED TELEPHONE CALLING CARDS, PRERECORDED AUDIO AND VIDEO DISCS AND TAPES FEATURING MUSICAL, DRAMATIC AND COMEDY PERFORMANCES; APPARATUS FOR RECORDING, TRANSMISSION OR REPRODUCTION OF SOUND OR IMAGES, NAMELY, VIDEO CAMERAS, AUDIO AND VIDEO TAPE AND DISC RECORDERS AND PLAYERS, HARD-DISC-BASED AUDIOVISUAL MEDIA PLAYERS; BLANK MAGNETIC DATA CARRIERS; BLANK OPTICAL RECORDING DISCS (U.S. CLS. 21, 23, 26, 36 AND 38).

#### CLASS 14—JEWELRY

FOR PINS, NAMELY, ORNAMENTAL PINS; JEWELRY; WATCHES (U.S. CLS. 2, 27, 28 AND 50).

#### CLASS 16—PAPER GOODS AND PRINTED MATTER

FOR PAPER AND PAPER ARTICLES, NAMELY, TABLE CLOTHS OF PAPER, POSTERS; PUBLICATIONS, NAMELY, MAGAZINES, NEWSLETTERS, AND BULLETINS IN THE FIELD OF MUSIC, TELEVISION AND FILMED ENTERTAINMENT; COLORING BOOKS, FAN MAGAZINES; TEMPORARY TATTOOS; TRADING CARDS AND PAPER BADGES (U.S. CLS. 2, 5, 22, 23, 29, 37, 38 AND 50).

#### CLASS 18—LEATHER GOODS

FOR LEATHER AND IMITATION LEATHER GOODS, NAMELY, BAGS, WALLETS, PURSES AND LEATHER KEY CHAINS (U.S. CLS. 1, 2, 3, 22 AND 41).

#### CLASS 20—FURNITURE AND ARTICLES NOT OTHERWISE CLASSIFIED

FOR NON-METAL AND NON-LEATHER KEY CHAINS, PLASTIC CAKE DECORATIONS (U.S. CLS. 2, 13, 22, 25, 32 AND 50).

#### CLASS 21—HOUSEWARES AND GLASS

FOR HOUSEHOLD OR KITCHEN CONTAINERS, NOT OF PRECIOUS METAL; KITCHEN AND HOUSEHOLD UTENSILS, NAMELY MIXING SPOONS, SERVING FORKS AND SPATULAS; GLASSWARE AND DISHES, NAMELY SERVING DISHES, PLATES, CUPS, MUGS, SHOT GLASSES (U.S. CLS. 2, 13, 23, 29, 30, 33, 40 AND 50).

#### CLASS 25—CLOTHING

FOR MEN'S AND WOMEN'S CLOTHING, NAMELY, SHIRTS, SHORTS, JEANS, JACKETS, SKIRTS, SLACKS, BLOUSES, DRESSES, VESTS, COATS, SWEATERS, SCARVES, SWIMSUITS, UNDERWEAR, UNDERPANTS, SLIPS, CAMISOLES, BRAS, NIGHTGOWNS, ROBES, SOCKS, HOSIERY; INFANTS' AND CHILDREN'S CLOTHING, NAMELY T-SHIRTS, SWEATERS, LONG SLEEVED SHIRTS, SHORTS, PANTS, JUMPERS, JUMPSUITS, OVERALLS, ONE-PIECE, PAJAMAS, SOCKS, DRESSES, SKIRTS; MEN'S, WOMEN'S, CHILDREN'S AND INFANT'S FOOTWEAR; MEN'S, WOMEN'S, CHILDREN'S AND INFANT'S HEADGEAR, NAMELY, HATS, CAPS AND VISORS; BELTS (U.S. CLS. 22 AND 39).

#### CLASS 26—FANCY GOODS

FOR ORNAMENTAL NOVELTY BUTTONS AND PINS (U.S. CLS. 37, 39, 40, 42 AND 50).

**CLASS 28—TOYS AND SPORTING GOODS**

FOR GAMES, PLAYTHINGS, AND SPORTING GOODS, NAMELY ACTION FIGURES AND ACCESSORIES THEREFOR; STUFFED TOY ANIMALS; BABY'S MULTIPLE ACTIVITY TOYS; TOY BAKEWARE AND COOKWARE; BALLOONS; TOY BANKS; BATH TOYS; BATH TUB TOYS; INFLATABLE BATH TOYS; RIDE-ON TOYS; INFLATABLE RIDE- ON TOYS, EQUIPMENT SOLD AS A UNIT FOR PLAYING CARD GAMES; TOY CARS; DOLLS, BEANBAG DOLLS; PAPER DOLLS, RAG DOLLS, SOFT SCULPTURE DOLLS, DOLL ACCESSORIES AND PLAYSETS THEREFOR, NAMELY DOLL CASES, DOLL CLOTHING; DOLL HOUSE FURNISHINGS, DOLL COSTUMES; STUFFED TOYS; CHECKER SETS; CHESS SETS; CHILDREN'S PLAY COSMETICS; CHILD'S MULTIPLE ACTIVITY TOYS; TOY CONSTRUCTION BLOCKS; INFANT'S ACTION CRIB TOYS; FLYING DISCS; ELECTRONIC HAND HELD GAME UNITS; ELECTRONIC GAME EQUIPMENT WITH A WATCH FUNCTION; ELECTRONICALLY OPERATED TOY MOTOR VEHICLES; BOARD GAMES AND GAME EQUIPMENT SOLD AS A UNIT FOR PLAYING BOARD GAMES; CARD GAMES; MANIPULATIVE GAMES; PARLOR GAMES; ROLE-PLAYING GAMES; STAND-ALONE VIDEO PARLOR COMPUTER GAME MACHINES; ACTION TYPE TARGET GAMES; VIDEO AND COMPUTER GAME CARTRIDGES; COIN OPERATED AND NON COIN OPERATED VIDEO OUTPUT GAME MACHINES; ROCKING HORSES; JIGSAW PUZZLES; KITES; MANIPULATIVE PUZZLES; PAPER FACE MASKS; TOY MODEL TRAIN SETS; TOY MODEL VEHICLES AND RELATED ACCESSORIES SOLD AS A UNIT; ELECTRONICALLY OPERATED TOY MOTOR VEHICLES; ELECTRONIC BATTERY OPERATED TOYS; TOY MAGIC TRICKS, NOISEMAKERS; TOY WHISTLES; PARTY FAVORS IN THE NATURE OF SMALL TOYS; TOY CAP PISTOLS; PLUSH TOYS; SOFT SCULPTURE PLUSH TOYS; MANIPULATIVE PUZZLES, NAMELY, THREE DIMENSIONAL CUBE TYPE PUZZLES; TOY RECORD PLAYER FOR PLAYING TUNES AND CASSETTES AND DISCS THEREFOR; SKATEBOARDS; ICE SKATES; TOY ROLLER SKATES; TOY IN-LINE SKATES AND ACCESSORIES, NAMELY KNEE, WRIST, AND ELBOW PADS; WATER SQUIRTING TOYS; TEDDY BEARS; WIND UP WALKING TOYS; WIND UP TOYS; NON-MOTORIZED NON-ELECTRIC MOBILE SELF-PROPELLED RIDING TOYS; TOY TRUCKS; TWIRLING BATONS; TOY ZIP GUNS; GYMNASTIC APPARATUS; BALLS, NAMELY PLAYGROUND BALLS, SOCCER BALLS, SPORT BALLS, BASEBALLS, BASKETBALLS, AND FOAM BALLS; BASEBALL GLOVES; SWIMMING AIDS, NAMELY, SWIMMING FLOATS FOR RECREATIONAL USE; HEAD COVERS FOR GOLF CLUBS; GOLF BALLS; GOLF CLUBS; INFLATABLE SWIMMING POOLS FOR RECREATIONAL USE; KICK BOARD FLOATATION DEVICES FOR RECREATIONAL USE; GYMNASTIC PARALLEL BARS; SKIS; SNOW SKIS; SNOW BOARDS; SKIPPING ROPES; JUMP ROPES; SNOW SLEDS FOR RECREATIONAL USE; SURF FINS; SURFBOARDS; SWIM BOARDS FOR RECREATIONAL USE; BODY BOARDS; SWIM FINS; INFLATABLE AND BUOYANT BATH TOYS; SWIMMING AND RIDE ON TOYS; MUSICAL TOYS; LATEX SQUEEZE TOYS; EXERCISE EQUIPMENT, NAMELY STATIONARY BIKES, TREADMILLS, STAIR STEPPING MACHINES; EXERCISE EQUIPMENT, NAMELY, WEIGHT LIFTING MACHINES, AND FREE WEIGHTS; AND NON-ILLUMINATING CHRISTMAS TREE ORNAMENTS; PLAYING CARDS (U.S. CLS. 22, 23, 38 AND 50).

**CLASS 38—COMMUNICATION**

FOR TRANSMISSION OF SOUND AND PICTURE SIGNALS (U.S. CLS. 100, 101 AND 104).

**CLASS 40—MATERIAL TREATMENT**

FOR REPRODUCTION OF SOUND AND IMAGES, NAMELY, PHOTOGRAPHIC REPRODUCTION, TAPE AND DISC DUPLICATING SERVICES (U.S. CLS. 100, 103 AND 106).

**CLASS 41—EDUCATION AND ENTERTAINMENT**

FOR ENTERTAINMENT SERVICES, NAMELY, ARRANGING AND CONDUCTING LIVE CONCERTS AND PRODUCING TELEVISION PROGRAM AND MOTION PICTURE FILMS, ALL FEATURING MUSICAL, DRAMATIC AND COMEDY PERFORMANCES; TELEVISION AND MOTION PICTURE FILM PRODUCTION SERVICES (U.S. CLS. 100, 101 AND 107).

JEFF DEFORD, EXAMINING ATTORNEY

SN 78-809.372. ASSURANCE AGENCY, LTD., SCHAMBURG, IL. FILED 2-7-2006.



NO CLAIM IS MADE TO THE EXCLUSIVE RIGHT TO USE "ASSURANCE", APART FROM THE MARK AS SHOWN.

THE MARK CONSISTS OF ABSTRACT DOUBLE LETTERS, AA, IN PART.

**CLASS 35—ADVERTISING AND BUSINESS**

FOR HUMAN RESOURCES CONSULTING (U.S. CLS. 100, 101 AND 102).  
FIRST USE 10-4-2005; IN COMMERCE 10-4-2005.

**CLASS 36—INSURANCE AND FINANCIAL**

FOR INSURANCE BROKERAGE SERVICES; INSURANCE CLAIMS ADMINISTRATION AND PROCESSING; ADMINISTRATION OF EMPLOYEE BENEFIT PLANS; RISK MANAGEMENT CONSULTING (U.S. CLS. 100, 101 AND 102).

FIRST USE 10-4-2005; IN COMMERCE 10-4-2005.

**CLASS 45—PERSONAL SERVICES**

FOR CONSULTATION SERVICES IN THE FIELD OF THE SAFETY NEEDS OF COMMERCIAL AND INDUSTRIAL COMPANIES (U.S. CLS. 100 AND 101).

FIRST USE 10-4-2005; IN COMMERCE 10-4-2005.  
LINDA E. BLOHM, EXAMINING ATTORNEY

SN 78-809,375. ASSURANCE AGENCY, LTD., SCHAUMLBURG, IL. FILED 2-7-2006.



THE MARK CONSISTS OF ABSTRACT OF DOUBLE LETTERS AA.

**CLASS 35—ADVERTISING AND BUSINESS**

FOR HUMAN RESOURCES CONSULTING (U.S. CLS. 100, 101 AND 102).  
FIRST USE 10-4-2005; IN COMMERCE 10-4-2005.

**CLASS 36—INSURANCE AND FINANCIAL**

FOR INSURANCE BROKERAGE SERVICES; INSURANCE CLAIMS ADMINISTRATION AND PROCESSING; ADMINISTRATION OF EMPLOYEE BENEFIT PLANS; RISK MANAGEMENT CONSULTING (U.S. CLS. 100, 101 AND 102).  
FIRST USE 10-4-2005; IN COMMERCE 10-4-2005.

**CLASS 42—SCIENTIFIC, COMPUTER AND LEGAL SERVICES**

FOR CONSULTATION SERVICES IN THE FIELD OF THE SAFETY NEEDS OF COMMERCIAL AND INDUSTRIAL COMPANIES (U.S. CLS. 100 AND 101).  
FIRST USE 10-4-2005; IN COMMERCE 10-4-2005.  
LINDA E. BLOHM, EXAMINING ATTORNEY

SN 78-810,058. ZENOSS, INC., ANNAPOLIS, MD. FILED 2-8-2006.

**ZENOSS**

THE MARK CONSISTS OF STANDARD CHARACTERS WITHOUT CLAIM TO ANY PARTICULAR FONT, STYLE, SIZE, OR COLOR.

**CLASS 9—ELECTRICAL AND SCIENTIFIC APPARATUS**

FOR COMPUTER SOFTWARE FOR MONITORING AND MANAGING ENTERPRISE INFORMATION TECHNOLOGY SYSTEMS (U.S. CLS. 21, 23, 26, 36 AND 38).

**CLASS 42—SCIENTIFIC, COMPUTER AND LEGAL SERVICES**

FOR COMPUTER SERVICES, NAMELY, INSTALLATION, INTEGRATION, MAINTENANCE, AND TROUBLE-SHOOTING OF COMPUTER SOFTWARE IN THE FIELD OF INFORMATION TECHNOLOGY SYSTEMS; CUSTOM DESIGN OF COMPUTER SOFTWARE FOR OTHERS (U.S. CLS. 100 AND 101).  
RUSS HERMAN, EXAMINING ATTORNEY

SN 78-811,084. SECOND HELPINGS, INC., INDIANAPOLIS, IN. FILED 2-9-2006.

**JUST 'CAUSE CATERING**

THE MARK CONSISTS OF STANDARD CHARACTERS WITHOUT CLAIM TO ANY PARTICULAR FONT, STYLE, SIZE, OR COLOR.  
NO CLAIM IS MADE TO THE EXCLUSIVE RIGHT TO USE "CATERING", APART FROM THE MARK AS SHOWN.

**CLASS 36—INSURANCE AND FINANCIAL**

FOR CHARITABLE FUND RAISING (U.S. CLS. 100, 101 AND 102).  
FIRST USE 9-16-2005; IN COMMERCE 9-16-2005.

**CLASS 43—HOTEL AND RESTAURANT SERVICES**

FOR CATERING (U.S. CLS. 100 AND 101).  
FIRST USE 9-16-2005; IN COMMERCE 9-16-2005.  
GRETTA YAO, EXAMINING ATTORNEY

SN 78-811,399. SANOFI-AVENTIS, PARIS, FRANCE, FILED 2-9-2006.

**SmartBeats**

**CLASS 16—PAPER GOODS AND PRINTED MATTER**

FOR CIRCULARS, NEWSLETTERS, BROCHURES, PAMPHLETS, LEAFLETS, AND BOOKS ALL OF THE FOREGOING RELATING TO THE FIELD OF HEALTH AND MEDICINE FOR THE TREATMENT OF CARDIOVASCULAR DISEASE (U.S. CLS. 2, 5, 22, 23, 29, 37, 38 AND 50).

**CLASS 41—EDUCATION AND ENTERTAINMENT**

FOR EDUCATIONAL SERVICES, NAMELY, CONDUCTING SEMINARS, WORK GROUPS AND CONFERENCES, ALL OF THE FOREGOING RELATING TO THE MEDICAL FIELD, AND DISTRIBUTING INSTRUCTIONAL MATERIALS THEREWITH (U.S. CLS. 100, 101 AND 107).

**CLASS 42—SCIENTIFIC, COMPUTER AND LEGAL SERVICES**

FOR PROVIDING INFORMATION RELATING TO PHARMACEUTICAL RESEARCH AND DEVELOPMENT (U.S. CLS. 100 AND 101).

**CLASS 44—MEDICAL, BEAUTY AND AGRICULTURAL SERVICES**

FOR PROVIDING MEDICAL INFORMATION VIA THE INTERNET; PROVIDING HEALTH INFORMATION; PHARMACEUTICAL ADVICE; MEDICAL CONSULTATION (U.S. CLS. 100 AND 101).

BERYL GARDNER, EXAMINING ATTORNEY

SN 78-811,535. INFOMINE INC., VANCOUVER, CANADA, FILED 2-9-2006.

# WHAT.COM

THE MARK CONSISTS OF STANDARD CHARACTERS WITHOUT CLAIM TO ANY PARTICULAR FONT, STYLE, SIZE, OR COLOR.

**CLASS 35—ADVERTISING AND BUSINESS**

FOR PROVIDING AN INTERACTIVE COMPUTER DATABASE IN THE FIELD OF ADVERTISING AND ON-LINE COMMERCE OF ON-LINE PUBLICATIONS, BOOKS, TECHNICAL AND TRAVEL GUIDES, MAGAZINES, NEWSLETTERS AND BROCHURES OF INTEREST PRIMARILY TO FEMALES (U.S. CLS. 100, 101 AND 102).

**CLASS 42—SCIENTIFIC, COMPUTER AND LEGAL SERVICES**

FOR COMPUTER SERVICES, NAMELY, PROVIDING AN INTERACTIVE SEARCH ENGINE ON A GLOBAL COMPUTER NETWORK FOR OBTAINING DATA OF INTEREST PRIMARILY TO FEMALES (U.S. CLS. 100 AND 101).

ALEXANDER L. POWERS, EXAMINING ATTORNEY

SN 78-811,589. COAST COMMUNITY COLLEGE DISTRICT, COSTA MESA, CA. FILED 2-9-2006.



THE COLOR(S) GREEN AND YELLOW IS/ARE CLAIMED AS A FEATURE OF THE MARK.

THE MARK CONSISTS OF AN OVAL SHAPE RESEMBLING A SURFBOARD DIVIDED IN HALF HORIZONTALLY INTO TWO COLORS, THE TOP HALF BEING YELLOW AND THE LOWER HALF BEING A TEAL BLUE. THE LETTERS "GWC" APPEAR INSIDE THE OVAL DESIGN AND ARE ALSO DIVIDED IN HALF HORIZONTALLY INTO TWO COLORS, THE TOP HALF BEING TEAL BLUE AND THE BOTTOM HALF BEING YELLOW.

**CLASS 9—ELECTRICAL AND SCIENTIFIC APPARATUS**

FOR MOUSE PADS, PRE-RECORDED CD'S FEATURING MUSIC OR GENERAL INFORMATION ABOUT GOLDEN WEST COLLEGE, MAGNETS, FLASHLIGHTS, PENLIGHTS, GRADUATED RULERS, CALCULATORS, AND CASES FOR POCKET CALCULATORS (U.S. CLS. 21, 23, 26, 36 AND 38).

**CLASS 16—PAPER GOODS AND PRINTED MATTER**

FOR PRINTED PUBLICATIONS PERTAINING TO AREAS OF INTEREST TO THE COLLEGE COMMUNITY, STUDENT COURSE CATALOGS, PRINTED INSTRUCTIONAL, EDUCATIONAL, TEACHING AND TRAINING MATERIALS IN THE FIELDS OF COMMUNITY COLLEGE STUDY AND CURRICULA; STATIONERY, NAMELY, WRITING PAPER, ENVELOPES, PRINTED INVITATIONS, FOLDERS, PENS, PENCILS, HIGHLIGHTERS, STICKERS, DECALS, CALENDARS, DAY PLANNERS, BINDERS, NOTEBOOKS, NOTEPADS, NOTE CARDS, POST CARDS, GIFT/GREETING CARDS, DESK SETS, AND HOLDERS FOR PENS AND PENCILS, PHOTOGRAPH ALBUMS, TELEPHONE NUMBER/ADDRESS BOOKS, MERCHANDISE BAGS, CARDBOARD WINDSHIELD SUNSCREEN, BUMPER STICKERS, DECALS, POSTERS, CHECKBOOK COVERS, PAPER PENNANTS, AND PAPER COASTERS (U.S. CLS. 2, 5, 22, 23, 29, 37, 38 AND 50).

**CLASS 25—CLOTHING**

FOR CLOTHING, NAMELY, SHIRTS, TEE-SHIRTS, SWEATSHIRTS, SWEATPANTS, HATS, CAPS, VISORS, SWEATERS, JACKETS, BOXER SHORTS, SOCKS, TANK TOPS, SHORTS, SCARVES, SPORT BRAS, LEGGINGS, BIKE SHORTS, TIES, SLEEP SHIRTS, TENNIS SKIRTS, BATHING SUITS, UNDERWEAR, SWEATERS, FOOTBALL STYLE JERSEYS, INFANTWEAR, AND BASEBALL SHIRTS (U.S. CLS. 22 AND 39).

**CLASS 28—TOYS AND SPORTING GOODS**

FOR TOYS, GAMES, AND SPORTS EQUIPMENT, NAMELY, FOOTBALLS, BASEBALLS, BASKETBALLS, BEACH BALLS, GOLF BALLS, VOLLEYBALLS, STUFFED ANIMALS, DOLLS, TOY VEHICLES, BOARD GAMES, FLYING DISCS, RACQUET COVERS, PLAYGROUND BALLS MADE OF FOAM RUBBER OR RUBBER, DARTS, DARTBOARDS, YO-YOS, DECORATIONS FOR CHRISTMAS TREES, BASKETBALL BACKBOARDS, SURFBOARDS, GOLF CLUB BAGS, GOLF BALL MARKERS, GOLF GLOVES, GOLF CLUB HEAD COVERS, AND PLAYING CARDS (U.S. CLS. 22, 23, 38 AND 50).

**CLASS 41—EDUCATION AND ENTERTAINMENT**

FOR EDUCATION AND ENTERTAINMENT SERVICES, NAMELY, PROVIDING COURSE OF INSTRUCTION AT THE COMMUNITY COLLEGE LEVEL; EDUCATIONAL RESEARCH; ARRANGING AND CONDUCTING INTERCOLLEGIATE ATHLETIC COMPETITIONS AND TOURNAMENTS, ORGANIZING AND CONDUCTING EDUCATIONAL EXHIBITIONS IN THE AREAS OF ART, CULTURE, TECHNOLOGY, AND OTHER SUBJECTS OF INTEREST TO THE COLLEGE COMMUNITY; ARRANGING AND CONDUCTING EDUCATIONAL CONFERENCES IN THE FIELDS OF COMMUNITY COLLEGE STUDY AND CURRICULA, ENTERTAINMENT SERVICES IN THE NATURE OF LIVE MUSICAL AND OTHER PERFORMING ARTS PERFORMANCES, AND ORGANIZING AND CONDUCTING CULTURAL, ART, ATHLETIC AND ACADEMIC FESTIVALS; ONLINE EDUCATIONAL SERVICES, NAMELY, PROVIDING COURSES OF INSTRUCTION AT THE COMMUNITY COLLEGE LEVEL AND DISTRIBUTING COURSE MATERIALS IN CONNECTION THEREWITH VIA A GLOBAL COMPUTER NETWORK (U.S. CLS. 100, 101 AND 107).

ALEXANDER L. POWERS, EXAMINING ATTORNEY

SN 78-812,057. HADASSAH THE WOMEN'S ZIONIST ORGANIZATION OF AMERICA, INC., NEW YORK, NY. FILED 2-10-2006.

SN 78-812,214. METROPOLITAN LIFE INSURANCE COMPANY, LONG ISLAND CITY, NY. FILED 2-10-2006.



OWNER OF U.S. REG. NOS. 2,539,255 AND 2,542,303.  
THE MARK CONSISTS OF STYLIZED FIGURE THAT IS INTENDED TO FORM THE BODY OF A LION WITH STYLIZED LETTERS YOUNGJUDAEA. COLOR IS NOT CLAIMED AS A FEATURE OF THE MARK.

THE FOREIGN WORDING IN THE MARK TRANSLATES INTO ENGLISH AS YOUNG JUDAEA.

THE NON-LATIN CHARACTER(S) IN THE MARK TRANSLITERATES INTO YEHUDAH HATZAIR, AND THIS MEANS YOUNG JUDAEA IN ENGLISH.

SEC. 2(F) AS TO "YOUNG JUDAEA AND THE NON-LATIN CHARACTERS THAT TRANSLATE TO YOUNG JUDAEA".

#### **CLASS 16—PAPER GOODS AND PRINTED MATTER**

FOR PRINTED PUBLICATIONS, NAMELY, BULLETINS, NEWSLETTERS, PAMPHLETS, AND MAGAZINES FEATURING TOPICS IN THE FIELD OF EDUCATION, ZIONISM, JUDAISM (U.S. CLS. 2, 5, 22, 23, 29, 37, 38 AND 50).

FIRST USE 11-19-2005; IN COMMERCE 12-15-2005.

#### **CLASS 39—TRANSPORTATION AND STORAGE**

FOR ARRANGING TRAVEL TOURS FOR TEENS AND YOUNG ADULTS AND PROVIDING A WEB PAGE OF INFORMATION CONCERNING TRAVEL TOUR PROGRAMS FOR TEENS AND YOUNG ADULTS (U.S. CLS. 100 AND 105).

FIRST USE 11-19-2005; IN COMMERCE 12-15-2005.

#### **CLASS 41—EDUCATION AND ENTERTAINMENT**

FOR EDUCATIONAL SERVICES, NAMELY, CONDUCTING CLASSES, SEMINARS AND WORKSHOPS IN THE FIELD OF ZIONISM AND JUDAISM FOR USE BY CHILDREN, TEENS AND YOUNG ADULTS AND PROVIDING A WEB PAGE OF INFORMATION IN THE FIELD OF EDUCATION AND SUMMER CAMPS FOR CHILDREN (U.S. CLS. 100, 101 AND 107).

FIRST USE 11-19-2005; IN COMMERCE 12-15-2005.

#### **CLASS 45—PERSONAL SERVICES**

FOR PROVIDING A WEB PAGE OF INFORMATION IN THE FIELD OF RELIGION SPECIFICALLY ZIONISM AND JUDAISM (U.S. CLS. 100 AND 101).

FIRST USE 11-19-2005; IN COMMERCE 12-15-2005.  
NELSON SNYDER, EXAMINING ATTORNEY

# QUIKMET

THE MARK CONSISTS OF STANDARD CHARACTERS WITHOUT CLAIM TO ANY PARTICULAR FONT, STYLE, SIZE, OR COLOR.

OWNER OF U.S. REG. NOS. 1,530,051 AND 2,076,720.

#### **CLASS 9—ELECTRICAL AND SCIENTIFIC APPARATUS**

FOR COMPUTER SOFTWARE THAT ENABLES THE UNDERWRITING AND ADMINISTRATION OF INSURANCE AND FINANCIAL SERVICES PRODUCTS OVER THE INTERNET; COMPUTER SOFTWARE THAT ENABLES FINANCIAL SERVICES CUSTOMERS AND INSURANCE POLICY HOLDERS TO VIEW AND TRANSACT CHANGES TO THEIR POLICIES AND ACCOUNTS OVER THE INTERNET; COMPUTER SOFTWARE THAT ENABLES INSURANCE AGENTS TO PERFORM INSURANCE UNDERWRITING AND ENABLES APPLICANTS TO APPLY FOR INSURANCE THROUGH AN INTERACTIVE INTERNET WEBSITE; COMPUTER SOFTWARE FOR USE IN PROVIDING FINANCIAL NEEDS ANALYSIS AND CONSULTATION; COMPUTER PROGRAMS AND INSTRUCTION MANUALS FOR USE THEREWITH FOR USE IN MANAGING CUSTOMER ACCOUNTS IN THE FIELDS OF LIFE, HEALTH, AND PROPERTY AND CASUALTY INSURANCE, PENSIONS AND ANNUITIES, INVESTMENTS AND HEALTH CARE; AND COMPUTER PROGRAMS FOR USE IN ANALYZING AND MANAGING INSURANCE AND BENEFITS CLAIMS (U.S. CLS. 21, 23, 26, 36 AND 38).

FIRST USE 8-26-2003; IN COMMERCE 8-26-2003.

#### **CLASS 36—INSURANCE AND FINANCIAL**

FOR UNDERWRITING, AGENCY, BROKERAGE AND ADMINISTRATION SERVICES FOR INDIVIDUAL AND GROUP LIFE, DISABILITY, LONG TERM CARE, AND DENTAL INSURANCE; AGENCY AND BROKERAGE WITH RESPECT TO LIFE AND LONG TERM CARE INSURANCE, ANNUITIES, RETIREMENT PLANS, QUALIFIED AND NON-QUALIFIED RETIREMENT PLANS AND SECURITIES; FINANCIAL ANALYSIS AND CONSULTATION WITH RESPECT TO LIFE, AND LONG TERM CARE INSURANCE, ANNUITIES, RETIREMENT AND SAVINGS PLANS, QUALIFIED AND NON-QUALIFIED RETIREMENT AND SAVINGS PLANS AND SECURITIES; ADMINISTRATIVE SERVICES FOR EMPLOYEE BENEFITS AND RETIREMENT PLANS; INVESTMENT MANAGEMENT SERVICES FOR INVESTMENT COMPANIES, INSURANCE COMPANIES, AND INDIVIDUAL AND INSTITUTIONAL INVESTORS; INVESTMENT ADVISORY SERVICES TO INVESTMENT COMPANIES, INSURANCE COMPANIES, INDIVIDUAL AND INSTITUTIONAL INVESTORS, WITH REGARD TO ANNUITIES; MUTUAL FUNDS INVESTMENT, INVESTMENT MANAGEMENT, DISTRIBUTION AND BROKERAGE; ESTATE TRUST MANAGEMENT SERVICES; REAL ESTATE BROKERAGE, MANAGEMENT AND INVESTMENT SERVICES; AND PROVIDING INFORMATION IN THE FIELDS OF INSURANCE AND FINANCIAL MANAGEMENT AND PLANNING SERVICES VIA THE INTERNET (U.S. CLS. 100, 101 AND 102).

FIRST USE 8-26-2003; IN COMMERCE 8-26-2003.  
MARY BOAGNI, EXAMINING ATTORNEY

SN 78-812,413. SECOND HELPINGS, INC., INDIANAPOLIS, IN. FILED 2-10-2006.

SN 78-815,657. BRITISH TELECOMMUNICATIONS PLC, LONDON, UNITED KINGDOM. FILED 2-15-2006.

EAT WELL. DO GOOD.

THE MARK CONSISTS OF STANDARD CHARACTERS WITHOUT CLAIM TO ANY PARTICULAR FONT, STYLE, SIZE, OR COLOR.

**CLASS 36—INSURANCE AND FINANCIAL**

FOR CHARITABLE FUNDRAISING (U.S. CLS. 100, 101 AND 102).  
FIRST USE 11-1-2005; IN COMMERCE 11-1-2005.

**CLASS 43—HOTEL AND RESTAURANT SERVICES**

FOR CATERING (U.S. CLS. 100 AND 101).  
FIRST USE 11-1-2005; IN COMMERCE 11-1-2005.  
GRETTA YAO, EXAMINING ATTORNEY

SN 78-814,153. MASHOMACK FISH & GAME PRESERVE CLUB, INC., PINE PLAINS, NY. FILED 2-14-2006.

MASHOMACK

THE MARK CONSISTS OF STANDARD CHARACTERS WITHOUT CLAIM TO ANY PARTICULAR FONT, STYLE, SIZE, OR COLOR.

**CLASS 41—EDUCATION AND ENTERTAINMENT**

FOR POLO CLUB SERVICES, RECREATIONAL SERVICES, NAMELY PROVIDING HUNTING PRESERVES, HUNTING GUIDE SERVICES, RENTAL OF HUNTING EQUIPMENT, PROVIDING FACILITIES FOR RECREATIONAL ACTIVITIES AND SPORTS TOURNAMENTS, COUNTRY CLUB SERVICES, WILD LIFE PRESERVE SERVICES, ART EXHIBITIONS; SOCIAL CLUB SERVICES, NAMELY WINE AND FOOD TASTINGS (U.S. CLS. 100, 101 AND 107).  
FIRST USE 1-0-1964; IN COMMERCE 1-0-1964.

**CLASS 43—HOTEL AND RESTAURANT SERVICES**

FOR PROVIDING BANQUET AND SOCIAL FUNCTION FACILITIES FOR SPECIAL OCCASIONS; RESTAURANT AND BAR SERVICES (U.S. CLS. 100 AND 101).  
FIRST USE 1-0-1964; IN COMMERCE 1-0-1964.  
MONIQUE MILLER, EXAMINING ATTORNEY

REDCARE

THE MARK CONSISTS OF STANDARD CHARACTERS WITHOUT CLAIM TO ANY PARTICULAR FONT, STYLE, SIZE, OR COLOR.

OWNER OF UNITED KINGDOM REG. NO. 1453702, DATED 6-26-1992, RENEWED AS REG. NO. 1453702, DATED 1-18-1998, EXPIRES 1-18-2008.

OWNER OF UNITED KINGDOM REG. NO. 1453699, DATED 4-10-1992, EXPIRES 1-18-2008.

**CLASS 9—ELECTRICAL AND SCIENTIFIC APPARATUS**

FOR SECURITY EQUIPMENT, NAMELY, ANTI-INTRUSION ALARMS, BURGLAR ALARMS; TELEPHONE EQUIPMENT, NAMELY, TELEPHONE LINE MONITORING APPARATUS; TELEPHONE LINE SIGNALLING APPARATUS; ELECTRONIC APPARATUS FOR TESTING ALARM SYSTEMS; ALARM TERMINAL BLOCKS; PRIVATE DEDICATED ELECTRICAL AND INTEGRATED CIRCUITS FOR TELECOMMUNICATIONS (U.S. CLS. 21, 23, 26, 36 AND 38).

**CLASS 45—PERSONAL SERVICES**

FOR MONITORING OF SECURITY SYSTEMS AND ALARMS (U.S. CLS. 100 AND 101).  
YONG KIM, EXAMINING ATTORNEY

SN 78-816,325. MELROCK LIMITED, HELIER, JERSEY, FILED 2-16-2006.



THE NAME(S), PORTRAIT(S), AND/OR SIGNATURE(S) SHOWN IN THE MARK IDENTIFIES ELIJAH GIRVIN, WHOSE CONSENT(S) TO REGISTER IS SUBMITTED.

THE MARK CONSISTS OF A HORIZONTAL TWISTING CORD THAT INTERSECTS WITH A SLEEPING BABY.

**CLASS 5—PHARMACEUTICALS**

FOR OVULATION PREDICTION TEST KITS FOR HOME USE; PREGNANCY TEST KITS FOR HOME USE; PERSONAL LUBRICANTS (U.S. CLS. 6, 18, 44, 46, 51 AND 52).  
FIRST USE 5-11-2006; IN COMMERCE 5-11-2006.

**CLASS 10—MEDICAL APPARATUS**

FOR CERVICAL CAPS FOR CONCEPTION (U.S. CLS. 26, 39 AND 44).  
FIRST USE 5-11-2006; IN COMMERCE 5-11-2006.  
SCOTT SISUN, EXAMINING ATTORNEY



SN 78-817,637. COOPER, BRANT P., SUSSEX, NJ. FILED 2-17-2006.



THE COLOR(S) RED, WHITE, BLUE, GRAY AND BLACK IS/ARE CLAIMED AS A FEATURE OF THE MARK.

THE COLORS BLUE, BLACK, WHITE AND GRAY APPEAR IN THE WORDS "SOLO PILOT". THE COLORS GRAY AND WHITE APPEAR IN THE STYLIZED GUN SIGHT ABOVE THE WORD "PILOT". THE COLOR RED APPEARS IN THE STYLIZED GUN SIGHT IN THE WORD "SOLO" AND IN THE BACKGROUND OF THE MARK. THE COLOR WHITE APPEARS IN THE WORD "ONE MISSION".

#### CLASS 16—PAPER GOODS AND PRINTED MATTER

FOR DECALS, PRESSURE SENSITIVE GRAPHICS FOR APPLICATION TO MOTORCYCLES, AND STICKERS (U.S. CLS. 2, 5, 22, 23, 29, 37, 38 AND 50).

#### CLASS 25—CLOTHING

FOR CLOTHING, NAMELY MOTORCYCLE AND MOTOCROSS RACING CLOTHING AND CASUAL CLOTHING FOR MEN, WOMEN AND CHILDREN, NAMELY, JERSEYS, PANTS, SHORTS, BOOTS, GLOVES, CAPS, BELTS, HATS AND VISORS; CASUAL CLOTHING, NAMELY, T-SHIRTS, TANK TOPS, SHIRTS, SWEAT SHIRTS, SWEAT SUITS, AND JOGGING OUTFITS; EXERCISE CLOTHING, NAMELY, JERSEYS, PANTS, SHORTS, AND BELTS, PAJAMAS AND SLEEPWEAR, SOCKS, FOOTWEAR, JACKETS, VESTS, HATS, CAPS, VISORS, SKIRTS, BLOUSES, SWEATERS, UNDERGARMENTS, HEADBANDS, BANDANAS, LEATHER SKIRTS, LEATHER PANTS, LEATHER JACKETS AND LEATHER VESTS (U.S. CLS. 22 AND 39).

EVELYN BRADLEY, EXAMINING ATTORNEY

SN 78-817,930. DISCOVERY COMMUNICATIONS, INC., SILVER SPRING, MD. FILED 2-17-2006.



OWNER OF U.S. REG. NOS. 2,736,372, 2,740,003 AND 2,740,214.  
SEC. 2(F) AS TO "TRAVEL".

#### CLASS 9—ELECTRICAL AND SCIENTIFIC APPARATUS

FOR PRERECORDED VIDEO DISKS, AUDIO-VISUAL RECORDINGS, VIDEOTAPES, COMPACT DISKS, DVDS AND CD-ROMS, ALL FEATURING CONTENT IN THE FIELDS OF TRAVEL, GEOGRAPHY, ECOLOGY, ARCHITECTURE, HISTORY, POLITICS, FOOD, ART, LEISURE AND LIFESTYLES (U.S. CLS. 21, 23, 26, 36 AND 38).

#### CLASS 38—COMMUNICATION

FOR BROADCAST SERVICES, NAMELY, DISTRIBUTION OF TELEVISION PROGRAMS VIA TELEVISION, SATELLITE, WIRELESS, FIBER OPTICS, CABLE, RADIO AND A GLOBAL COMPUTER NETWORK (U.S. CLS. 100, 101 AND 104).

#### CLASS 41—EDUCATION AND ENTERTAINMENT

FOR ENTERTAINMENT SERVICES IN THE NATURE OF ONGOING TELEVISION PROGRAMS AND PRERECORDED AUDIO-VISUAL CONTENT IN THE FIELDS OF TRAVEL, GEOGRAPHY, ECOLOGY, ARCHITECTURE, HISTORY, POLITICS, FOOD, ART, LEISURE AND LIFESTYLES, DISTRIBUTED THROUGH AUDIO AND VIDEO MEDIA, NAMELY, TELEVISION, SATELLITE, WIRELESS, FIBER OPTICS, CABLE, RADIO AND A GLOBAL COMPUTER NETWORK; PROVIDING ENTERTAINMENT INFORMATION REGARDING TELEVISION PROGRAMS VIA A GLOBAL COMPUTER NETWORK (U.S. CLS. 100, 101 AND 107).

ERNEST SHOSHO, EXAMINING ATTORNEY

SN 78-818,031. SONY KABUSHIKI KAISHA, TA SONY CORPORATION, TOKYO, JAPAN, FILED 2-17-2006.

## Pro Matte

THE MARK CONSISTS OF STANDARD CHARACTERS WITHOUT CLAIM TO ANY PARTICULAR FONT, STYLE, SIZE, OR COLOR.

NO CLAIM IS MADE TO THE EXCLUSIVE RIGHT TO USE "MATTE", APART FROM THE MARK AS SHOWN.

#### CLASS 9—ELECTRICAL AND SCIENTIFIC APPARATUS

FOR DIGITAL PHOTO PRINTERS (U.S. CLS. 21, 23, 26, 36 AND 38).

#### CLASS 16—PAPER GOODS AND PRINTED MATTER

FOR PAPERS FOR DIGITAL PHOTO PRINTERS (U.S. CLS. 2, 5, 22, 23, 29, 37, 38 AND 50).

JOHN SCHUYLER YARD, EXAMINING ATTORNEY

SN 78-819,133. FAIRWAYS AND DREAMS, LLC, GEORGETOWN, TX. FILED 2-20-2006.



NO CLAIM IS MADE TO THE EXCLUSIVE RIGHT TO USE "GOLF EXPO", APART FROM THE MARK AS SHOWN.

**CLASS 35—ADVERTISING AND BUSINESS**

FOR DIRECT MAIL ADVERTISING; PLACING ADVERTISEMENTS FOR OTHERS; DISSEMINATION OF ADVERTISING MATTER; ELECTRONIC BILLBOARD ADVERTISING; PROVIDING TELEVISION ADVERTISING FOR OTHERS; PREPARING AUDIO-VISUAL PRESENTATIONS FOR USE IN ADVERTISING; ARRANGING AND CONDUCTING TRADE SHOW EXHIBITIONS IN THE FIELD OF GOLF; PROMOTING TRADE SHOWS IN THE FIELD OF GOLF; PROMOTING SPORTS COMPETITIONS AND EVENTS OF OTHERS; PROMOTING THE GOODS AND SERVICES OF OTHERS BY ARRANGING FOR SPONSORS TO AFFILIATE THEIR GOODS AND SERVICES WITH GOLFING COMPETITION (U.S. CLS. 100, 101 AND 102).

FIRST USE 10-1-2005; IN COMMERCE 10-1-2005.

**CLASS 41—EDUCATION AND ENTERTAINMENT**

FOR TRAINING IN THE USE AND OPERATION OF GOLF EQUIPMENT; EDUCATIONAL DEMONSTRATION IN THE USE OF GOLF CLUBS; EDUCATIONAL SERVICES, NAMELY, CONDUCTING CLASSES, SEMINARS, CONFERENCES AND WORKSHOPS IN THE FIELD OF GOLF AND DISTRIBUTING COURSE MATERIALS IN CONNECTION THEREWITH; ORGANIZING GOLF EXHIBITS; ENTERTAINMENT IN THE NATURE OF GOLF TOURNAMENTS, GOLF GAMES, PERSONAL APPEARANCES BY A SPORTS CELEBRITY, FASHION SHOWS, FIREWORKS DISPLAYS, LIVE PERFORMANCES BY A MUSICAL BAND, AND MUSICAL CONCERTS (U.S. CLS. 100, 101 AND 107).

FIRST USE 10-1-2005; IN COMMERCE 10-1-2005.  
PETER B. BROMAGHIM, EXAMINING ATTORNEY

**CLASS 35—ADVERTISING AND BUSINESS**

FOR BUSINESS SERVICES, NAMELY, PROVIDING LINKS TO THE WEBSITES OF OTHERS, NAMELY, RETAIL SERVICE PROVIDERS IN THE FIELD OF CONSUMER ELECTRONICS, COMPUTERS, CLOTHING, AUTOMOBILES, TOYS AND GAMES AND A WIDE VARIETY OF OTHER GENERAL CONSUMER PRODUCTS; PROVIDING LINKS TO THE WEBSITES OF OTHERS IN THE FIELD OF CONSUMER PRODUCTS AND SERVICES; PROMOTING THE GOODS AND SERVICES OF OTHERS BY PLACING ADVERTISEMENTS AND PROMOTIONAL DISPLAYS ON ELECTRONIC SITES ACCESSED THROUGH COMPUTER NETWORKS; PROVIDING CONSUMER PRODUCT INFORMATION; PROVIDING COMPARISON SHOPPING INFORMATION, PROVIDING ONLINE DIRECTORY INFORMATION SERVICES ALSO FEATURING HYPERLINKS TO OTHER WEBSITES, DISSEMINATION OF ADVERTISING FOR OTHERS VIA THE INTERNET; ONLINE ADVERTISING SERVICES FOR OTHERS, NAMELY PROVIDING ADVERTISING SPACE ON WEBSITES; PROVIDING ON-LINE DIRECTORIES, INDICES AND SEARCHABLE DATABASES OF WEBSITES AND COMPUTER NETWORKS (U.S. CLS. 100, 101 AND 102).

**CLASS 38—COMMUNICATION**

FOR TELECOMMUNICATION SERVICES, NAMELY, TELEPHONE COMMUNICATIONS SERVICES AND DELIVERY OF MESSAGES BY ELECTRONIC MAIL TRANSMISSION; PROVIDING ON-LINE ELECTRONIC BULLETIN BOARDS AND CHAT ROOMS FOR THE TRANSMISSION OF MESSAGES AMONG COMPUTER USERS IN THE FIELD OF GENERAL INTEREST; BROADCASTING OF AUDIO, VIDEO AND MULTIMEDIA CONTENT BY MEANS OF CELLULAR, WIRELESS COMMUNICATIONS AND COMPUTER NETWORKS; ELECTRONIC TRANSMISSION OF DATA, IMAGES, DOCUMENTS AND MESSAGES VIA COMPUTER TERMINALS; ELECTRONIC DATA MESSAGING (U.S. CLS. 100, 101 AND 104).

SN 78-820,132. IAC SEARCH & MEDIA, INC., OAKLAND, CA. FILED 2-21-2006.



OWNER OF U.S. REG. NOS. 2,412,106, 2,463,252 AND OTHERS.

THE MARK CONSISTS OF THE WORDS "ASK.COM" IN A STYLIZED FONT WITH AN OVAL DESIGN. THE WORD "ASK" APPEARS INSIDE THE OVAL; THE TERM ".COM" APPEARS BELOW THE OVAL, TO THE RIGHT OF "ASK".

**CLASS 9—ELECTRICAL AND SCIENTIFIC APPARATUS**

FOR DOWNLOADABLE INTERNET BROWSER PLUG-INS AND CLIENT SERVER APPLICATIONS IN THE NATURE OF MULTI-FUNCTION TOOL BAR PLUG-INS; DOWNLOADABLE COMPUTER SOFTWARE FOR USE IN PROVIDING SEARCH ENGINE SERVICES WHICH ARE PROVIDED THROUGH A BROWSER TOOL BAR; DOWNLOADABLE COMPUTER SOFTWARE FOR USE IN ATTACHING FANCIFUL DESIGNS, ICONS OR SYMBOLS, IN E-MAILING CORRESPONDENCE; DOWNLOADABLE COMPUTER SOFTWARE FOR USE IN INSTANT MESSAGING AND ONLINE CHAT; DOWNLOADABLE COMPUTER SOFTWARE FOR USE IN MODIFYING CURSOR DESIGNS; DOWNLOADABLE COMPUTER SOFTWARE IN THE NATURE OF COMPUTER SCREEN SAVERS (U.S. CLS. 21, 23, 26, 36 AND 38).

**CLASS 41—EDUCATION AND ENTERTAINMENT**

FOR ENTERTAINMENT SERVICES, NAMELY, PROVIDING ON-LINE COMPUTER GAMES, FILMS, MUSIC, VIDEOS AND TELEVISION PROGRAMMING; PROVIDING LINKS TO WEBSITES OF OTHERS IN THE FIELD OF ENTERTAINMENT (U.S. CLS. 100, 101 AND 107).

**CLASS 42—SCIENTIFIC, COMPUTER AND LEGAL SERVICES**

FOR PROVIDING CUSTOMIZED ON-LINE WEB PAGES FEATURING USER-DEFINED INFORMATION, WHICH INCLUDES SEARCH ENGINES AND ONLINE WEB LINKS TO OTHER WEBSITES; PROVIDING LINKS TO WEBSITES OF OTHERS IN THE FIELD OF COMPUTERS AND TECHNOLOGY; COMPUTER SERVICES, NAMELY, PROVIDING SEARCH ENGINES FOR OBTAINING DATA ON GLOBAL COMPUTER NETWORK (U.S. CLS. 100 AND 101).

LINDA MICKLEBURGH, EXAMINING ATTORNEY

SN 78-820,136. IAC SEARCH & MEDIA, INC., OAKLAND, CA. FILED 2-21-2006.



OWNER OF U.S. REG. NOS. 2,412,106, 2,463,252 AND OTHERS.

THE COLORS RED, WHITE AND BLACK ARE CLAIMED AS A FEATURE OF THE MARK.

THE MARK CONSISTS OF THE WORD "ASK" IN A STYLIZED FONT SET INSIDE A RED OVAL. THE WORD "ASK" APPEARS IN WHITE LETTERS WITH BLACK OUTLINING.

#### **CLASS 9—ELECTRICAL AND SCIENTIFIC APPARATUS**

FOR DOWNLOADABLE INTERNET BROWSER PLUG-INS AND CLIENT SERVER APPLICATIONS IN THE NATURE OF MULTI-FUNCTION TOOL BAR PLUG-INS; DOWNLOADABLE COMPUTER SOFTWARE FOR USE IN PROVIDING SEARCH ENGINE SERVICES WHICH ARE PROVIDED THROUGH A BROWSER TOOL BAR; DOWNLOADABLE COMPUTER SOFTWARE FOR USE IN ATTACHING FANCIFUL DESIGNS, ICONS OR SYMBOLS, IN E-MAILING CORRESPONDENCE; DOWNLOADABLE COMPUTER SOFTWARE FOR USE IN INSTANT MESSAGING AND ONLINE CHAT; DOWNLOADABLE COMPUTER SOFTWARE FOR USE IN MODIFYING CURSOR DESIGNS; DOWNLOADABLE COMPUTER SOFTWARE IN THE NATURE OF COMPUTER SCREEN SAVERS (U.S. CLS. 21, 23, 26, 36 AND 38).

#### **CLASS 35—ADVERTISING AND BUSINESS**

FOR BUSINESS SERVICES, NAMELY, PROVIDING LINKS TO THE WEBSITES OF OTHERS, NAMELY, RETAIL SERVICE PROVIDERS IN THE FIELD OF CONSUMER ELECTRONICS, COMPUTERS, CLOTHING, AUTOMOBILES, TOYS AND GAMES AND A WIDE VARIETY OF OTHER GENERAL CONSUMER PRODUCTS; PROVIDING LINKS TO THE WEBSITES OF OTHERS IN THE FIELD OF CONSUMER PRODUCTS AND SERVICES; PROMOTING THE GOODS AND SERVICES OF OTHERS BY PLACING ADVERTISEMENTS AND PROMOTIONAL DISPLAYS ON ELECTRONIC SITES ACCESSED THROUGH COMPUTER NETWORKS; PROVIDING CONSUMER PRODUCT INFORMATION; PROVIDING COMPARISON SHOPPING INFORMATION, PROVIDING ONLINE DIRECTORY INFORMATION SERVICES ALSO FEATURING HYPERLINKS TO OTHER WEBSITES, DISSEMINATION OF ADVERTISING FOR OTHERS VIA THE INTERNET; ONLINE ADVERTISING SERVICES FOR OTHERS, NAMELY PROVIDING ADVERTISING SPACE ON WEBSITES; PROVIDING ON-LINE DIRECTORIES, INDICES AND SEARCHABLE DATABASES OF WEBSITES AND COMPUTER NETWORKS (U.S. CLS. 100, 101 AND 102).

#### **CLASS 38—COMMUNICATION**

FOR TELECOMMUNICATION SERVICES, NAMELY, TELEPHONE COMMUNICATIONS SERVICES AND DELIVERY OF MESSAGES BY ELECTRONIC MAIL TRANSMISSION; PROVIDING ON-LINE ELECTRONIC BULLETIN BOARDS AND CHAT ROOMS FOR THE TRANSMISSION OF MESSAGES AMONG COMPUTER USERS IN THE FIELD OF GENERAL INTEREST; BROADCASTING OF AUDIO, VIDEO AND MULTIMEDIA CONTENT BY MEANS OF CELLULAR, WIRELESS COMMUNICATIONS AND COMPUTER NETWORKS; ELECTRONIC TRANSMISSION OF DATA, IMAGES, DOCUMENTS AND MESSAGES VIA COMPUTER TERMINALS; ELECTRONIC DATA MESSAGING (U.S. CLS. 100, 101 AND 104).

#### **CLASS 41—EDUCATION AND ENTERTAINMENT**

FOR ENTERTAINMENT SERVICES, NAMELY, PROVIDING ON-LINE COMPUTER GAMES, FILMS, MUSIC, VIDEOS AND TELEVISION PROGRAMMING; PROVIDING LINKS TO WEBSITES OF OTHERS IN THE FIELD OF ENTERTAINMENT (U.S. CLS. 100, 101 AND 107).

#### **CLASS 42—SCIENTIFIC, COMPUTER AND LEGAL SERVICES**

FOR PROVIDING CUSTOMIZED ON-LINE WEB PAGES FEATURING USER-DEFINED INFORMATION, WHICH INCLUDES SEARCH ENGINES AND ONLINE WEB LINKS TO OTHER WEBSITES; PROVIDING LINKS TO WEBSITES OF OTHERS IN THE FIELD OF COMPUTERS AND TECHNOLOGY; COMPUTER SERVICES, NAMELY, PROVIDING SEARCH ENGINES FOR OBTAINING DATA ON GLOBAL COMPUTER NETWORK (U.S. CLS. 100 AND 101).

LINDA MICKLEBURGH, EXAMINING ATTORNEY

SN 78-821,240. GETDOWN, L.L.C, PAOLA, KS. FILED 2-22-2006.

# GOFINITI

THE MARK CONSISTS OF STANDARD CHARACTERS WITHOUT CLAIM TO ANY PARTICULAR FONT, STYLE, SIZE, OR COLOR.

#### **CLASS 9—ELECTRICAL AND SCIENTIFIC APPARATUS**

FOR COMPUTER SOFTWARE FOR USE IN MANAGING MARKETING AND AFFILIATE PROGRAMS, FOR USE IN DEVELOPING AN AFFILIATE MARKETING ORGANIZATION, AND FOR GENERATING AND SENDING ELECTRONIC COMMUNICATIONS (U.S. CLS. 21, 23, 26, 36 AND 38).

#### **CLASS 35—ADVERTISING AND BUSINESS**

FOR MARKETING AND AFFILIATE MARKETING SERVICES, NAMELY, PROVIDING BUSINESS MARKETING SERVICES AND DIRECT MARKETING AND ADVERTISING FOR OTHERS; PROVIDING BUSINESS MARKETING AND ADVERTISING INFORMATION; PROVIDING CONSUMER PRODUCT INFORMATION VIA THE INTERNET (U.S. CLS. 100, 101 AND 102).

**CLASS 41—EDUCATION AND ENTERTAINMENT**

FOR EDUCATIONAL SERVICES, NAMELY, CONDUCTING PROGRAMS AND SEMINARS IN THE FIELDS OF ADVERTISING AND MARKETING (U.S. CLS. 100, 101 AND 107).

**CLASS 42—SCIENTIFIC, COMPUTER AND LEGAL SERVICES**

FOR PROVIDING TEMPORARY USE OF ON-LINE NON-DOWNLOADABLE COMPUTER SOFTWARE FOR USE IN MANAGING MARKETING AND AFFILIATE PROGRAMS, FOR USE IN DEVELOPING AN AFFILIATE MARKETING ORGANIZATION, AND FOR GENERATING AND SENDING ELECTRONIC COMMUNICATIONS (U.S. CLS. 100 AND 101).

DANIEL BRODY, EXAMINING ATTORNEY

---

SN 78-821,736. THE MAURER FOUNDATION FOR BREAST HEALTH EDUCATION, PORT WASHINGTON, NY. FILED 2-23-2006.



NO CLAIM IS MADE TO THE EXCLUSIVE RIGHT TO USE "FOUNDATION BREAST HEALTH EDUCATION", APART FROM THE MARK AS SHOWN.

**CLASS 16—PAPER GOODS AND PRINTED MATTER**

FOR PRINTED MATTER, NAMELY, NEWSLETTERS, POSTERS, CALENDERS, POSTCARDS, EDUCATIONAL PUBLICATIONS NAMELY TRAINING MANUALS, PRINTED INSTRUCTIONAL MATERIALS, EDUCATIONAL BOOKS, MAGAZINES, AND PAMPHLETS, ALL IN THE FIELD OF BREAST HEALTH AWARENESS (U.S. CLS. 2, 5, 22, 23, 29, 37, 38 AND 50).

**CLASS 41—EDUCATION AND ENTERTAINMENT**

FOR EDUCATIONAL SERVICES, NAMELY, CONDUCTING ON-LINE INSTRUCTION AND IN-PERSON CONFERENCES, SEMINARS AND WORKSHOPS IN THE FIELD OF BREAST HEALTH AWARENESS (U.S. CLS. 100, 101 AND 107).

**CLASS 44—MEDICAL, BEAUTY AND AGRICULTURAL SERVICES**

FOR PROVIDING ON-LINE INFORMATIONAL MATERIALS IN THE FIELD OF BREAST HEALTH AWARENESS (U.S. CLS. 100 AND 101).

CHARLOTTE CORWIN, EXAMINING ATTORNEY

SN 78-822,462. TROJAN LEISURE PRODUCTS, LLC, ALBANY, NY. FILED 2-24-2006.

# Radiant Pools

THE MARK CONSISTS OF STANDARD CHARACTERS WITHOUT CLAIM TO ANY PARTICULAR FONT, STYLE, SIZE, OR COLOR.

NO CLAIM IS MADE TO THE EXCLUSIVE RIGHT TO USE "POOLS", APART FROM THE MARK AS SHOWN.

**CLASS 6—METAL GOODS**

FOR METAL SWIMMING POOLS (U.S. CLS. 2, 12, 13, 14, 23, 25 AND 50).

FIRST USE 12-14-2005; IN COMMERCE 12-16-2005.

**CLASS 19—NON-METALLIC BUILDING MATERIALS**

FOR AGGREGATE INSULATION MATERIALS COMPOSED OF EXPANDED POLYSTYRENE FOAM AND ALUMINUM FOIL FOR USE IN INSULATING SWIMMING POOL WALL PANELS (U.S. CLS. 1, 12, 33 AND 50).

FIRST USE 12-14-2005; IN COMMERCE 12-16-2005.

ROBERT LAVACHE, EXAMINING ATTORNEY

---

SN 78-822,565. CELEBRATE EXPRESS, INC., KIRKLAND, WA. FILED 2-24-2006.



OWNER OF U.S. REG. NOS. 1,834,617, 2,426,402 AND OTHERS.

THE COLOR(S) GOLD, PURPLE, BLUE, GREEN, TEAL, PINK, BLUE IS/ARE CLAIMED AS A FEATURE OF THE MARK.

THE MARK CONSISTS OF THE NUMBER 1 IN THE SHAPE OF A CANDLE IN THE COLOR PURPLE WITH THE FLAME LIT IN THE COLOR GOLD WITH A SUPERSCRIPIT OF ST IN BLUE, WITH THE WORD WISHES WITH THE W IN BLUE, I IN GREEN, S IN PURPLE, H IN TEAL, E IN PINK, AND S IN GOLD WITH A BIRTHDAY HAT ON TOP OF THE S, THE BIRTHDAY HAT APPEARING IN PURPLE/GREEN STRIPES WITH A BLUE POMPOM. BELOW THE 1ST WISHES IS PRESENTED BY BIRTHDAY EXPRESS IN A SCRIPT FONT IN BLUE.

**CLASS 16—PAPER GOODS AND PRINTED MATTER**

FOR BIRTHDAY PARTY GOODS SOLD AS A KIT, CONSISTING OF PAPER DECORATIONS, PAPER HATS, PAPER PLATES, PAPER NAPKINS, PAPER CUPS, PAPER TABLE COVERS, WRAPPING PAPER, GIFT TAGS AND GIFT BOXES; PRINTED INVITATIONS, PAPER GIFT WRAPPING RIBBONS, CREPE PAPER, STICKERS, GREETING CARDS, PAPER CAKE DECORATIONS, PAPER PARTY DECORATIONS, PAPER PARTY HATS, PAPER NAPKINS, PAPER PLACE MATS, PAPER TABLE COVERS, WRAPPING PAPER, PAPER GIFT BAGS, CARDBOARD BOXES, PAPER GIFT TAGS, INKING PADS, BROCHURES AND CARDS FEATURING GAME AND ACTIVITY SUGGESTIONS, CHILDREN'S ACTIVITY BOOK (U.S. CLS. 2, 5, 22, 23, 29, 37, 38 AND 50).

**CLASS 21—HOUSEWARES AND GLASS**

FOR PAPER CUPS AND PAPER PLATES (U.S. CLS. 2, 13, 23, 29, 30, 33, 40 AND 50).

**CLASS 25—CLOTHING**

FOR CLOTHING, NAMELY, DRESSES, PANTS, SWEATSHIRTS, SWEATPANTS, SHIRTS, BLOUSES, SWEATERS, JACKETS, SKIRTS, COATS AND T-SHIRTS (U.S. CLS. 22 AND 39).

**CLASS 28—TOYS AND SPORTING GOODS**

FOR BALLOONS, TOY FIGURES, CHILDREN'S PARTY GAMES, PINATAS, AND PARTY FAVORS IN THE NATURE OF SMALL TOYS AND NOISEMAKERS; CHILDREN'S CRAFT HOBBY KITS COMPRISING HAIR MAKE UP ACCESSORIES, WIND CHIME COMPONENTS, COOKIE CUTTING AND FORMING ACCESSORIES, BEADED TIARA COMPONENTS, MAGIC WAND COMPONENTS, MINIATURE ROCKING HORSE COMPONENTS, CLOWN COMPONENTS, TOY BUG COMPONENTS, SHOE DECORATING COMPONENTS, BIRD HOUSE COMPONENTS, MAGNETIZED PHOTO FRAME COMPONENTS, AND TOTE BAG COMPONENTS (U.S. CLS. 22, 23, 38 AND 50).

**CLASS 35—ADVERTISING AND BUSINESS**

FOR RETAIL STORE, ONLINE RETAIL STORE, AND MAIL ORDER CATALOG SERVICES FEATURING PARTY SUPPLIES, CLOTHING, PARTY FAVORS, CRAFT HOBBY KITS AND PARTY DECORATIONS (U.S. CLS. 100, 101 AND 102).

**CLASS 41—EDUCATION AND ENTERTAINMENT**

FOR PARTY PLANNING (U.S. CLS. 100, 101 AND 107). CAROLINE WEIMER, EXAMINING ATTORNEY

SN 78-824,439. ZYMES, LLC, HASBROUCK HEIGHTS, NJ. FILED 2-27-2006.

**UBISOL**

THE MARK CONSISTS OF STANDARD CHARACTERS WITHOUT CLAIM TO ANY PARTICULAR FONT, STYLE, SIZE, OR COLOR.

**CLASS 1—CHEMICALS**

FOR CHEMICALS FOR USE IN THE MANUFACTURE OF DRUG DELIVERY AND SOLUBILIZING AGENTS FOR USE IN PHARMACEUTICAL PRODUCTS, NUTRITIONAL AND DIETARY SUPPLEMENTS AND SKIN CARE AND COSMETIC PRODUCTS (U.S. CLS. 1, 5, 6, 10, 26 AND 46).

**CLASS 3—COSMETICS AND CLEANING PREPARATIONS**

FOR SKIN CARE PREPARATIONS, NAMELY SKIN AND FACIAL MOISTURIZERS, SKIN AND FACIAL SOAPS, SKIN AND FACIAL LOTIONS, SKIN GELS, SKIN AND FACIAL CREAMS, SKIN EMOLLIENTS, COSMETICS FOR BEAUTIFYING AND SKIN CARE, COSMETIC PREPARATIONS FOR SKIN CARE AND RENEWAL, COSMETIC CREAMS, LOTIONS FOR COSMETIC PURPOSES, ALL PROVIDED VIA DRUG DELIVERY AND SOLUBILIZING AGENTS (U.S. CLS. 1, 4, 6, 50, 51 AND 52).

**CLASS 5—PHARMACEUTICALS**

FOR DRUG DELIVERY AND SOLUBILIZING AGENTS FOR USE IN PHARMACEUTICAL PRODUCTS, NUTRITIONAL SUPPLEMENTS AND DIETARY SUPPLEMENTS (U.S. CLS. 6, 18, 44, 46, 51 AND 52). ALAIN LAPTEY, EXAMINING ATTORNEY

SN 78-825,017. LEAMORE INTERNET LIMITED, WALSALL, UNITED KINGDOM, FILED 2-28-2006.

**diydating**

THE MARK CONSISTS OF STANDARD CHARACTERS WITHOUT CLAIM TO ANY PARTICULAR FONT, STYLE, SIZE, OR COLOR.

OWNER OF UNITED KINGDOM REG. NO. 2360568, DATED 7-1-2005, EXPIRES 4-8-2014.

**CLASS 35—ADVERTISING AND BUSINESS**

FOR ADVERTISING IN THE FIELD OF MATCH-MAKING, SOCIAL INTRODUCTION CONSULTATION AND DATING SERVICES AND DATING AGENCY SERVICES; BUSINESS MANAGEMENT IN THE FIELD OF MATCH-MAKING, SOCIAL INTRODUCTION CONSULTATION AND DATING SERVICES AND DATING AGENCY SERVICES; BUSINESS ADMINISTRATION IN THE FIELD OF MATCH-MAKING, SOCIAL INTRODUCTION CONSULTATION AND DATING SERVICES AND DATING AGENCY SERVICES; OFFICE FUNCTIONS IN THE FIELD OF MATCH-MAKING, SOCIAL INTRODUCTION CONSULTATION AND DATING SERVICES AND DATING AGENCY SERVICES; THE ORGANIZATION, OPERATION AND SUPERVISION OF LOYALTY AND INCENTIVE SCHEMES IN THE FIELD OF MATCH-MAKING, SOCIAL INTRODUCTION CONSULTATION AND DATING SERVICES AND DATING AGENCY SERVICES; ADVERTISING SERVICES PROVIDED VIA THE INTERNET IN THE FIELD OF MATCH-MAKING, SOCIAL INTRODUCTION CONSULTATION AND DATING SERVICES AND DATING AGENCY SERVICES; PROVISION OF BUSINESS INFORMATION IN THE FIELD OF MATCH-MAKING, SOCIAL INTRODUCTION CONSULTATION AND DATING SERVICES AND DATING AGENCY SERVICES; COMPILATION, CREATION AND MAINTENANCE OF A REGISTER OF DOMAIN NAMES; ADVISORY, CONSULTANCY AND INFORMATION SERVICES RELATING TO ALL THE AFORESAID SERVICES (U.S. CLS. 100, 101 AND 102).

**CLASS 42—SCIENTIFIC, COMPUTER AND LEGAL SERVICES**

FOR RESEARCH IN THE FORM OF DATING INDUSTRY ANALYSIS AND SURVEYS IN THE FIELD OF MATCH-MAKING, SOCIAL INTRODUCTION CONSULTATION AND DATING SERVICES AND DATING AGENCY SERVICES; DESIGN AND DEVELOPMENT OF COMPUTER HARDWARE AND SOFTWARE FOR USE IN THE FIELD OF MATCH-MAKING, SOCIAL INTRODUCTION CONSULTATION AND DATING SERVICES AND DATING AGENCY SERVICES; COMPUTER CONSULTANCY SERVICES IN THE FIELD OF MATCH-MAKING, SOCIAL INTRODUCTION CONSULTATION AND DATING SERVICES AND DATING AGENCY SERVICES; DESIGN OF WEBSITES IN THE FIELD OF MATCH-MAKING; TECHNICAL WRITING FOR OTHERS IN RELATION TO WEBSITES IN THE FIELD OF MATCH-MAKING; INSTALLATION, MAINTENANCE AND REPAIR OF COMPUTER SOFTWARE IN THE FIELD OF MATCH-MAKING, SOCIAL INTRODUCTION CONSULTATION AND DATING SERVICES AND DATING AGENCY SERVICES; CREATING, MAINTAINING AND HOSTING THE WEBSITES OF OTHERS; ADVISORY, CONSULTANCY AND INFORMATION SERVICES RELATING TO ALL THE AFORESAID SERVICES (U.S. CLS. 100 AND 101).

**CLASS 45—PERSONAL SERVICES**

FOR MATCH-MAKING, SOCIAL INTRODUCTION CONSULTATION AND DATING SERVICES AND DATING AGENCY SERVICES; MATCH-MAKING, SOCIAL INTRODUCTION CONSULTATION AND DATING SERVICES AND DATING AGENCY SERVICES PROVIDED ONLINE BY MEANS OF A COMPUTER DATABASE AND THE INTERNET; PROVISION OF SOCIAL INTRODUCTION SERVICES; PERSONAL MATCH-MAKING SERVICES; ADVISORY, CONSULTANCY AND INFORMATION SERVICES RELATING TO ALL THE AFORESAID SERVICES (U.S. CLS. 100 AND 101).

DEZMONA MIZELLE, EXAMINING ATTORNEY

SN 78-825,084. HENNESSY, SUSAN ELIZABETH, DALLAS, TX. FILED 2-28-2006.

*Keeping Time*

**CLASS 16—PAPER GOODS AND PRINTED MATTER**

FOR EDUCATIONAL BOOKS, JOURNALS AND OTHER PRINTED INSTRUCTIONAL AND/OR TEACHING MATERIALS IN THE FIELD OF CULTURAL HISTORY AND TRADITIONS (U.S. CLS. 2, 5, 22, 23, 29, 37, 38 AND 50).

**CLASS 26—FANCY GOODS**

FOR WREATHS CONSISTING OF ARTIFICIAL MATERIALS (U.S. CLS. 37, 39, 40, 42 AND 50).

**CLASS 31—NATURAL AGRICULTURAL PRODUCTS**

FOR WREATHS CONSISTING OF DRIED NATURAL MATERIALS, NAMELY, DRIED FLOWERS, DRIED HERBS, DRIED FRUITS, AND/OR DRIED LEAVES (U.S. CLS. 1 AND 46).

NAKIA HENRY, EXAMINING ATTORNEY

SN 78-825,234. DISCOVERY COMMUNICATIONS, INC., SILVER SPRING, MD. FILED 2-28-2006.

**TLC LIVE AND LEARN**

THE MARK CONSISTS OF STANDARD CHARACTERS WITHOUT CLAIM TO ANY PARTICULAR FONT, STYLE, SIZE, OR COLOR.

OWNER OF U.S. REG. NO. 1,890,354.

**CLASS 9—ELECTRICAL AND SCIENTIFIC APPARATUS**

FOR PRERECORDED AUDIOTAPES, VIDEOTAPES, COMPACT DISCS, DVDS AND MULTIMEDIA SOFTWARE RECORDED ON CD-ROM, ALL FEATURING CONTENT FROM OR RELATING TO NON-FICTION TELEVISION SERIES IN FIELDS OF GENERAL HUMAN INTEREST; INTERACTIVE VIDEO GAME PROGRAMS AND COMPUTER GAME CARTRIDGES; ELECTRONIC GAME PROGRAMS; DOWNLOADABLE RING TONES, GRAPHICS, RING BACKS, ANIMATED RINGERS, VIDEO RINGERS AND ANIMATED SCREENSAVERS; DOWNLOADABLE PRERECORDED VIDEO CLIPS, PRERECORDED AUDIO CLIPS, TEXT AND GRAPHICS HELD IN ELECTRONIC PERSONAL COMPUTERS AND HANDHELD WIRELESS DEVICES, FEATURING CONTENT FROM OR RELATING TO NON-FICTION TELEVISION SERIES IN FIELDS OF GENERAL HUMAN INTEREST; SUNGLASSES (U.S. CLS. 21, 23, 26, 36 AND 38).

**CLASS 38—COMMUNICATION**

FOR BROADCAST SERVICES, NAMELY, DISTRIBUTION OF TELEVISION PROGRAMS VIA TELEVISION, SATELLITE, WIRELESS, FIBER OPTICS, CABLE, RADIO AND A GLOBAL COMPUTER NETWORK (U.S. CLS. 100, 101 AND 104).

**CLASS 41—EDUCATION AND ENTERTAINMENT**

FOR ENTERTAINMENT SERVICES IN THE NATURE OF ONGOING TELEVISION PROGRAMS FEATURING NON-FICTION CONTENT IN FIELDS OF GENERAL HUMAN INTEREST, DISTRIBUTED THROUGH AUDIO AND VIDEO MEDIA, NAMELY, TELEVISION, SATELLITE, WIRELESS, FIBER OPTICS, CABLE, RADIO AND A GLOBAL COMPUTER NETWORK; PROVIDING ENTERTAINMENT INFORMATION REGARDING TELEVISION PROGRAMS VIA A GLOBAL COMPUTER NETWORK (U.S. CLS. 100, 101 AND 107).

ERNEST SHOSHO, EXAMINING ATTORNEY

SN 78-825,259. DISCOVERY COMMUNICATIONS, INC., SILVER SPRING, MD. FILED 2-28-2006.

**LIVE AND LEARN**

THE MARK CONSISTS OF STANDARD CHARACTERS WITHOUT CLAIM TO ANY PARTICULAR FONT, STYLE, SIZE, OR COLOR.

**CLASS 9—ELECTRICAL AND SCIENTIFIC APPARATUS**

FOR PRERECORDED AUDIOTAPES, VIDEOTAPES, COMPACT DISCS, DVDS AND MULTIMEDIA SOFTWARE RECORDED ON CD-ROM, ALL FEATURING CONTENT FROM OR RELATING TO NON-FICTION TELEVISION SERIES IN FIELDS OF GENERAL HUMAN INTEREST; INTERACTIVE VIDEO GAME PROGRAMS AND COMPUTER GAME CARTRIDGES; ELECTRONIC GAME PROGRAMS; DOWNLOADABLE RING TONES, GRAPHICS, RING BACKS, ANIMATED RINGERS, VIDEO RINGERS AND ANIMATED SCREENSAVERS; DOWNLOADABLE PRERECORDED VIDEO CLIPS, PRERECORDED AUDIO CLIPS, TEXT AND GRAPHICS HELD IN ELECTRONIC PERSONAL COMPUTERS AND HANDHELD WIRELESS DEVICES, FEATURING CONTENT FROM OR RELATING TO NON-FICTION TELEVISION SERIES IN FIELDS OF GENERAL HUMAN INTEREST; SUNGLASSES (U.S. CLS. 21, 23, 26, 36 AND 38).

**CLASS 38—COMMUNICATION**

FOR BROADCAST SERVICES, NAMELY, DISTRIBUTION OF TELEVISION PROGRAMS VIA TELEVISION, SATELLITE, WIRELESS, FIBER OPTICS, CABLE, RADIO AND A GLOBAL COMPUTER NETWORK (U.S. CLS. 100, 101 AND 104).

**CLASS 41—EDUCATION AND ENTERTAINMENT**

FOR ENTERTAINMENT SERVICES IN THE NATURE OF ONGOING TELEVISION PROGRAMS FEATURING NON-FICTION CONTENT IN FIELDS OF GENERAL HUMAN INTEREST, DISTRIBUTED THROUGH AUDIO AND VIDEO MEDIA, NAMELY, TELEVISION, SATELLITE, WIRELESS, FIBER OPTICS, CABLE, RADIO AND A GLOBAL COMPUTER NETWORK; PROVIDING ENTERTAINMENT INFORMATION REGARDING TELEVISION PROGRAMS VIA A GLOBAL COMPUTER NETWORK (U.S. CLS. 100, 101 AND 107).  
ERNEST SHOSHO, EXAMINING ATTORNEY

SN 78-825,807. GOLDEN GATE LOGISTICS, INC., PALO ALTO, CA. FILED 2-28-2006.

**GOLDEN GATE LOGISTICS**

THE MARK CONSISTS OF STANDARD CHARACTERS WITHOUT CLAIM TO ANY PARTICULAR FONT, STYLE, SIZE, OR COLOR.

NO CLAIM IS MADE TO THE EXCLUSIVE RIGHT TO USE "LOGISTICS", APART FROM THE MARK AS SHOWN.

**CLASS 35—ADVERTISING AND BUSINESS**

FOR BUSINESS CONSULTING SERVICES RELATING TO PRODUCT DISTRIBUTION, OPERATIONS MANAGEMENT SERVICES, LOGISTICS, SUPPLY CHAIN, AND PRODUCTION SYSTEMS AND DISTRIBUTION SOLUTIONS (U.S. CLS. 100, 101 AND 102).

**CLASS 39—TRANSPORTATION AND STORAGE**

FOR GOODS WAREHOUSING (U.S. CLS. 100 AND 105).

**CLASS 40—MATERIAL TREATMENT**

FOR ASSEMBLY OF GOODS FOR OTHERS (U.S. CLS. 100, 103 AND 106).  
BARNEY CHARLON, EXAMINING ATTORNEY

SN 78-826,036. WWW.WATCHRDEALS.COM, DAVIE, FL. FILED 3-1-2006.



THE COLOR(S) BLUE, LIGHT BLUE, YELLOW, RED, GREEN AND BLACK IS/ARE CLAIMED AS A FEATURE OF THE MARK.

THE MARK CONSISTS OF THE WORDS "WATCH R DEALS" WITH THE LETTERS IN DIFFERENT FONTS AND DIFFERENT COLORS. THE LETTER "A" IN THE WORD "WATCH" AND "DEALS" ARE DESIGNED AS EYES WITH EYEBALLS INSIDE THE "A" AND EYEBROWS ABOVE THE "A". THE MARK IS DESIGNED AS A SMILEY FACE WITH THE SMILE UNDER THE LETTER "A" IN "WATCH" AND "DEALS". THE LETTERS "W", "C", "D" AND "L" ARE BLUE; THE "A"S ARE YELLOW, THE "T" AND "E" ARE RED; THE LETTERS "H" AND "S" ARE GREEN; THE LETTER "R" IS BACKWARDS AND LIGHT BLUE. THE EYEBROWS, EYEBALLS AND SMILE ARE BLACK.

**CLASS 14—JEWELRY**

FOR WATCHES, WATCH BANDS, JEWELRY (U.S. CLS. 2, 27, 28 AND 50).

**CLASS 35—ADVERTISING AND BUSINESS**

FOR RETAIL STORES FEATURING WATCHES; ONLINE RETAIL STORES FEATURING WATCHES (U.S. CLS. 100, 101 AND 102).

FIRST USE 10-27-1999; IN COMMERCE 10-27-1999.  
JOHN HWANG, EXAMINING ATTORNEY

SN 78-826,401. IMG WORLDWIDE, INC., CLEVELAND, OH. FILED 3-1-2006.



OWNER OF U.S. REG. NOS. 1,232,130, 2,333,751 AND OTHERS.

THE COLOR(S) BLUE IS/ARE CLAIMED AS A FEATURE OF THE MARK.

THE MARK CONSISTS OF THE LETTERS IMG WITH THREE TRIANGLES IN THE MIDDLE OF THE LETTER M, ALL IN BLUE.

**CLASS 35—ADVERTISING AND BUSINESS**

FOR MANAGEMENT OF CELEBRITIES, PERFORMING ARTISTS, MODELS, PROFESSIONAL ATHLETES, BROADCASTERS, AUTHORS AND DESIGNERS; BUSINESS SERVICES, NAMELY, MANAGEMENT OF THE PERSONAL AFFAIRS OF OTHERS; ASSISTANCE IN MANAGEMENT OF BUSINESS ACTIVITIES AND EVENTS; PROCURING AND NEGOTIATING CONTRACTS, LICENSES, AND ENDORSEMENTS FOR OTHERS; PROMOTING THE GOODS AND SERVICES OF OTHERS VIA ELECTRONIC MEDIA; ADVERTISING SERVICES; PROVIDING COMMERCIAL INFORMATION, VIA PRINT AND ELECTRONIC MEDIA, IN THE FIELDS OF FASHION, SPORTS, CONSUMER PRODUCTS, LICENSING AND ENDORSEMENTS; ADVERTISING AND PUBLICITY SERVICES, NAMELY, PROMOTING THE GOODS, SERVICES, BRAND IDENTITY, AND COMMERCIAL INFORMATION AND NEWS OF THIRD PARTIES THROUGH PRINT, AUDIO, VIDEO, DIGITAL AND ON-LINE MEDIA; ADVERTISING, INCLUDING PROMOTION OF PRODUCTS AND SERVICES OF THIRD PARTIES THROUGH SPONSORING ARRANGEMENTS AND LICENSE AGREEMENTS; ADVERTISING CONSULTATION; COMMERCIAL CONSULTANCY; MARKETING CONSULTING; SPONSORSHIP CONSULTING; SALES PROMOTION AND PUBLIC RELATIONS CONSULTING SERVICES; MODELING AGENCIES; PLANNING AND CONDUCTING OF TRADE SHOWS, EVENTS, EXHIBITIONS AND PRESENTATIONS FOR PROMOTING THE GOODS AND SERVICES OF OTHERS; MARKETING AND PROMOTIONAL SERVICES FOR RECREATIONAL OR LEISURE FACILITIES OWNED BY OTHERS (U.S. CLS. 100, 101 AND 102).

**CLASS 38—COMMUNICATION**

FOR STREAMING OF VIDEO MATERIAL ON THE INTERNET AND OTHER ELECTRONIC MEDIA (U.S. CLS. 100, 101 AND 104).

**CLASS 41—EDUCATION AND ENTERTAINMENT**

FOR ARRANGING AND CONDUCTING ATHLETIC COMPETITIONS AND EVENTS, FASHION SHOWS, EXHIBITIONS, CONFERENCES, CONCERTS, HOME AND GARDEN SHOWS, AWARD CEREMONIES, AND GENERAL ENTERTAINMENT SHOWS; ENTERTAINMENT SERVICES, NAMELY, PROVIDING TELEVISION AND OTHER VIDEO PROGRAMS IN THE FIELDS OF SPORTS, FASHION, REALITY PROGRAMMING AND GENERAL ENTERTAINMENT; PRODUCTION OF VIDEO PROGRAM CONTENT; PUBLISHING OF PRINTED PUBLICATIONS, BOOKS AND MAGAZINES; PUBLISHING OF ELECTRONIC PUBLICATIONS; PROVIDING INFORMATION IN THE FIELD OF SPORTS, ARTS AND ENTERTAINMENT VIA ELECTRONIC MEDIA; INSTRUCTION IN TENNIS, GOLF, SOCCER, BASEBALL, BASKETBALL, IMPROVING PHYSICAL ATHLETIC PERFORMANCE, MENTAL CONDITIONING FOR IMPROVED PERFORMANCE IN SPORTS AND ATHLETIC ACTIVITIES AND LIFE SKILLS, AND OFFICIATING AND CAMPS COMPRISING SUCH INSTRUCTION (U.S. CLS. 100, 101 AND 107).

**CLASS 42—SCIENTIFIC, COMPUTER AND LEGAL SERVICES**

FOR LICENSING OF INTELLECTUAL PROPERTY (U.S. CLS. 100 AND 101).  
HENRY S. ZAK, EXAMINING ATTORNEY

SN 78-826,519. SCOTT PAPER LIMITED, MISSISSAUGA, ONTARIO, CANADA, FILED 3-1-2006.

QUALITY ALWAYS PAYS ITS WAY

THE MARK CONSISTS OF STANDARD CHARACTERS WITHOUT CLAIM TO ANY PARTICULAR FONT, STYLE, SIZE, OR COLOR.

PRIORITY CLAIMED UNDER SEC. 44(D) ON CANADA APPLICATION NO. 1270705, FILED 9-1-2005, REG. NO. TMA679,381, DATED 1-15-2007, EXPIRES 1-15-2022.

**CLASS 16—PAPER GOODS AND PRINTED MATTER**

FOR PAPER PRODUCTS NAMELY, BATHROOM AND FACIAL TISSUE, PAPER TOWELS, PAPER NAPKINS, PAPER WIPES, NAMELY DISPOSABLE WIPES NOT IMPREGNATED WITH CHEMICALS OR COMPOUNDS (U.S. CLS. 2, 5, 22, 23, 29, 37, 38 AND 50).

**CLASS 40—MATERIAL TREATMENT**

FOR CUSTOM MANUFACTURE OF HYGIENIC PAPER PRODUCTS AND DISPENSERS (U.S. CLS. 100, 103 AND 106).

INGRID C. EULIN, EXAMINING ATTORNEY

SN 78-827,174. DISCOVERY COMMUNICATIONS, INC., SILVER SPRING, MD. FILED 3-2-2006.

COVER SHOT

THE MARK CONSISTS OF STANDARD CHARACTERS WITHOUT CLAIM TO ANY PARTICULAR FONT, STYLE, SIZE, OR COLOR.

**CLASS 9—ELECTRICAL AND SCIENTIFIC APPARATUS**

FOR PRERECORDED AUDIOTAPES, VIDEOTAPES, COMPACT DISCS, DVDS AND MULTIMEDIA SOFTWARE RECORDED ON CD-ROM FEATURING CONTENT FROM OR RELATING TO A PROPRIETARY TELEVISION SERIES ABOUT MAKEOVERS; INTERACTIVE VIDEO GAME PROGRAMS AND COMPUTER GAME CARTRIDGES; ELECTRONIC GAME PROGRAMS; DOWNLOADABLE RING TONES, GRAPHICS, RING BACKS, ANIMATED RINGERS, VIDEO RINGERS AND ANIMATED SCREENSAVERS; DOWNLOADABLE PRERECORDED VIDEO CLIPS, PRERECORDED AUDIO CLIPS, TEXT AND GRAPHICS HELD IN ELECTRONIC PERSONAL COMPUTERS AND HANDHELD WIRELESS DEVICES, FEATURING CONTENT FROM OR RELATING TO A PROPRIETARY TELEVISION SERIES ABOUT MAKEOVERS; SUNGLASSES (U.S. CLS. 21, 23, 26, 36 AND 38).



**CLASS 41—EDUCATION AND ENTERTAINMENT**

FOR ENTERTAINMENT SERVICES IN THE NATURE OF ONGOING TELEVISION PROGRAMS FEATURING MAKEOVERS, DISTRIBUTED THROUGH AUDIO AND VIDEO MEDIA, NAMELY, TELEVISION, SATELLITE, CABLE AND A GLOBAL COMPUTER NETWORK; PROVIDING ENTERTAINMENT INFORMATION REGARDING TELEVISION PROGRAMS VIA A GLOBAL COMPUTER NETWORK (U.S. CLS. 100, 101 AND 107).  
ERNEST SHOSHO, EXAMINING ATTORNEY

SN 78-827,998. MAUI BUILT, INC., KAHULUI, HI. FILED 3-2-2006.



NO CLAIM IS MADE TO THE EXCLUSIVE RIGHT TO USE "SURFBOARDS" AND "MAUI HAWAII", APART FROM THE MARK AS SHOWN.

THE MARK CONSISTS OF THE WORD "TROPICX" ABOVE THE WORD "SURFBOARDS" CENTERED BETWEEN AN OVAL RING DESIGN.

**CLASS 25—CLOTHING**

FOR BEACHWEAR; CAPS; JACKETS; PANTS; SHIRTS; SHOES; SHORTS; SOCKS; SWEAT PANTS; SWEAT SHIRTS (U.S. CLS. 22 AND 39).

FIRST USE 1-1-1994; IN COMMERCE 1-1-1994.

**CLASS 28—TOYS AND SPORTING GOODS**

FOR SURFBOARDS (U.S. CLS. 22, 23, 38 AND 50).  
FIRST USE 1-1-1994; IN COMMERCE 1-1-1994.

**CLASS 35—ADVERTISING AND BUSINESS**

FOR RETAIL SHOPS FEATURING SURFBOARDS, SURFWEAR, SURFGEAR (U.S. CLS. 100, 101 AND 102).  
FIRST USE 1-1-1994; IN COMMERCE 1-1-1994.

ROBERT C. CLARK JR., EXAMINING ATTORNEY

SN 78-828,493. DISCOVERY COMMUNICATIONS, INC., SILVER SPRING, MD. FILED 3-3-2006.



OWNER OF U.S. REG. NO. 1,890,354.

**CLASS 9—ELECTRICAL AND SCIENTIFIC APPARATUS**

FOR PRERECORDED AUDIOTAPES, VIDEOTAPES, COMPACT DISCS, DVDS AND MULTIMEDIA SOFTWARE RECORDED ON CD-ROM, ALL FEATURING CONTENT FROM OR RELATING TO NON-FICTION TELEVISION SERIES IN FIELDS OF GENERAL HUMAN INTEREST; INTERACTIVE VIDEO GAME PROGRAMS AND COMPUTER GAME CARTRIDGES; ELECTRONIC GAME PROGRAMS; DOWNLOADABLE RING TONES, GRAPHICS, RING BACKS, ANIMATED RINGERS, VIDEO RINGERS AND ANIMATED SCREENSAVERS; DOWNLOADABLE PRERECORDED VIDEO CLIPS, PRERECORDED AUDIO CLIPS, TEXT AND GRAPHICS HELD IN ELECTRONIC PERSONAL COMPUTERS AND HANDHELD WIRELESS DEVICES, FEATURING CONTENT FROM OR RELATING TO NON-FICTION TELEVISION SERIES IN FIELDS OF GENERAL HUMAN INTEREST; SUNGLASSES (U.S. CLS. 21, 23, 26, 36 AND 38).

**CLASS 38—COMMUNICATION**

FOR BROADCAST SERVICES, NAMELY, DISTRIBUTION OF TELEVISION PROGRAMS VIA TELEVISION, SATELLITE, WIRELESS, FIBER OPTICS, CABLE, RADIO AND A GLOBAL COMPUTER NETWORK (U.S. CLS. 100, 101 AND 104).

**CLASS 41—EDUCATION AND ENTERTAINMENT**

FOR ENTERTAINMENT SERVICES IN THE NATURE OF ONGOING TELEVISION PROGRAMS FEATURING NON-FICTION CONTENT IN FIELDS OF GENERAL HUMAN INTEREST, DISTRIBUTED THROUGH AUDIO AND VIDEO MEDIA, NAMELY, TELEVISION, SATELLITE, WIRELESS, FIBER OPTICS, CABLE, RADIO AND A GLOBAL COMPUTER NETWORK; PROVIDING ENTERTAINMENT INFORMATION REGARDING TELEVISION PROGRAMS VIA A GLOBAL COMPUTER NETWORK (U.S. CLS. 100, 101 AND 107).

ERNEST SHOSHO, EXAMINING ATTORNEY

SN 78-830,374. TRAVELCITY.COM LP, SOUTHLAKE, TX. FILED 3-6-2006.

**WORLD CHOICE TRAVEL**

THE MARK CONSISTS OF STANDARD CHARACTERS WITHOUT CLAIM TO ANY PARTICULAR FONT, STYLE, SIZE, OR COLOR.

NO CLAIM IS MADE TO THE EXCLUSIVE RIGHT TO USE "WORLD" AND "TRAVEL", APART FROM THE MARK AS SHOWN.

**CLASS 39—TRANSPORTATION AND STORAGE**

FOR TRAVEL INFORMATION SERVICES; TRAVEL AGENCY SERVICES, NAMELY, MAKING RESERVATIONS AND BOOKINGS FOR TRANSPORTATION; TRAVEL AGENCY SERVICES, NAMELY, MAKING RESERVATIONS AND BOOKINGS FOR RENTAL CARS; TRAVEL AGENCY SERVICES, NAMELY, MAKING RESERVATIONS AND BOOKINGS FOR SIGHTSEEING CRUISES, SIGHTSEEING GARDEN TOURS AND SIGHTSEEING HISTORICAL TOURS; MAKING RESERVATIONS AND BOOKINGS FOR AIRPORT SHUTTLES, CARRIAGE RIDES, HELICOPTER RIDES, ANTIQUE MILITARY PLANE RIDES, BOAT RIDES, WATER TAXI RIDES, LIMOUSINE RIDES, AND TOWN CAR RIDES; MAKING ARRANGEMENTS FOR ADVENTURE EXCURSIONS IN THE NATURE OF ALL TERRAIN VEHICLE RIDES; AND RESERVING TOURISM PACKAGES IN THE NATURE OF A CITY CARD GIVING ACCESS TO MULTIPLE SIGHTSEEING ACTIVITIES FOR ONE PRICE (U.S. CLS. 100 AND 105).

FIRST USE 12-9-1998; IN COMMERCE 12-9-1998.

**CLASS 41—EDUCATION AND ENTERTAINMENT**

FOR TRAVEL AGENCY SERVICES, NAMELY, MAKING RESERVATIONS AND BOOKINGS FOR GOLF AND HORSEBACK RIDING; MAKING TICKET RESERVATIONS FOR CONCERTS, MUSEUMS, AQUARIUMS, ZOOS, AMUSEMENT PARKS, SKI LIFTS, WHALE WATCHING, DOLPHIN WATCHING, SWIMMING WITH WHALES, AND SWIMMING WITH DOLPHINS; MAKING RESERVATIONS AND BOOKINGS FOR LESSONS FOR COOKING, HORSEBACK RIDING, SURFING, SCUBA DIVING, RACE CAR DRIVING, SAILING, SKIING, AND GOLF; MAKING RESERVATIONS AND BOOKINGS FOR THE RENTAL OF SPORTING EQUIPMENT; MAKING RESERVATIONS AND BOOKINGS FOR WINE TASTING TOURS, DIVING TOURS, AND SNORKELING TOURS; MAKING ARRANGEMENTS FOR SHOPPING EXCURSIONS; MAKING ARRANGEMENTS FOR ADVENTURE EXCURSIONS IN THE NATURE OF RACE CAR SIMULATIONS; AND RESERVING TOURISM PACKAGES IN THE NATURE OF A CITY CARD GIVING ACCESS TO MULTIPLE SPORTS AND ENTERTAINMENT ACTIVITIES FOR ONE PRICE; AND ARRANGING FOR NIGHTCLUB PASSES (U.S. CLS. 100, 101 AND 107).

FIRST USE 12-9-1998; IN COMMERCE 12-9-1998.

**CLASS 43—HOTEL AND RESTAURANT SERVICES**

FOR TRAVEL AGENCY SERVICES, NAMELY, MAKING RESERVATIONS AND BOOKINGS FOR TEMPORARY LODGING; TRAVEL AGENCY SERVICES, NAMELY, MAKING RESERVATIONS AND BOOKINGS FOR RESTAURANTS (U.S. CLS. 100 AND 101).

FIRST USE 12-9-1998; IN COMMERCE 12-9-1998.  
JIM RINGLE, EXAMINING ATTORNEY

SN 78-830,457. NAPIER, JEFF, KATY, TX. FILED 3-6-2006.

**CHESTERFIELD**

THE MARK CONSISTS OF STANDARD CHARACTERS WITHOUT CLAIM TO ANY PARTICULAR FONT, STYLE, SIZE, OR COLOR.

**CLASS 20—FURNITURE AND ARTICLES NOT OTHERWISE CLASSIFIED**

FOR CAMPING EQUIPMENT, NAMELY, SLEEPING BAGS (U.S. CLS. 2, 13, 22, 25, 32 AND 50).

**CLASS 21—HOUSEWARES AND GLASS**

FOR CAMPING EQUIPMENT, NAMELY, UTENSILS FOR BARBECUES, NAMELY, FORKS, TONGS AND TURNERS, AND CAMPING COOKWARE, NAMELY, POTS AND PANS (U.S. CLS. 2, 13, 23, 29, 30, 33, 40 AND 50).

**CLASS 22—CORDAGE AND FIBERS**

FOR CAMPING EQUIPMENT, NAMELY, TENTS (U.S. CLS. 1, 2, 7, 19, 22, 42 AND 50).

LINDA M. KING, EXAMINING ATTORNEY

SN 78-830,773. THE ADRENALINE CO. LLC, BROOKFIELD, WI. FILED 3-7-2006.

**TAC**

THE MARK CONSISTS OF STANDARD CHARACTERS WITHOUT CLAIM TO ANY PARTICULAR FONT, STYLE, SIZE, OR COLOR.

**CLASS 35—ADVERTISING AND BUSINESS**

FOR RETAIL STORE SERVICES, MAIL ORDER CATALOG SERVICES AND ON-LINE RETAIL STORE SERVICES FEATURING MOTORCYCLES AND MOTORCYCLE PARTS AND ACCESSORIES (U.S. CLS. 100, 101 AND 102).

**CLASS 39—TRANSPORTATION AND STORAGE**

FOR ARRANGING AND CONDUCTING MOTORCYCLE TOURS (U.S. CLS. 100 AND 105).

MIDGE BUTLER, EXAMINING ATTORNEY

SN 78-830,846. BRISTOL-MYERS SQUIBB COMPANY, NEW YORK, NY. FILED 3-7-2006.

**ONCOLOGY LEADERSHIP FOR  
THE 21ST CENTURY**

THE MARK CONSISTS OF STANDARD CHARACTERS WITHOUT CLAIM TO ANY PARTICULAR FONT, STYLE, SIZE, OR COLOR.

NO CLAIM IS MADE TO THE EXCLUSIVE RIGHT TO USE ONCOLOGY, APART FROM THE MARK AS SHOWN.

**CLASS 5—PHARMACEUTICALS**

FOR PHARMACEUTICAL PREPARATIONS FOR THE TREATMENT AND PREVENTION OF CANCER (U.S. CLS. 6, 18, 44, 46, 51 AND 52).

**CLASS 16—PAPER GOODS AND PRINTED MATTER**

FOR PRINTED MATTER, NAMELY ADVERTISING AND PROMOTIONAL INFORMATIONAL MATERIALS IN THE NATURE OF NEWSLETTERS, PAMPHLETS AND BROCHURES IN THE FIELD OF HEALTH CARE AND PHARMACEUTICALS (U.S. CLS. 2, 5, 22, 23, 29, 37, 38 AND 50).

**CLASS 42—SCIENTIFIC, COMPUTER AND LEGAL SERVICES**

FOR PHARMACEUTICAL RESEARCH AND DEVELOPMENT SERVICES (U.S. CLS. 100 AND 101).  
CATHERINE FAINT, EXAMINING ATTORNEY

SN 78-831,429. DISCOVER RESTAURANTS, LTD., SAN ANTONIO, TX. FILED 3-7-2006.

# TIAGO'S

THE MARK CONSISTS OF STANDARD CHARACTERS WITHOUT CLAIM TO ANY PARTICULAR FONT, STYLE, SIZE, OR COLOR.

THE NAME(S), PORTRAIT(S), AND/OR SIGNATURE(S) SHOWN IN THE MARK DOES NOT IDENTIFY A PARTICULAR LIVING INDIVIDUAL.

**CLASS 25—CLOTHING**

FOR JERSEYS; SLEEVELESS JERSEYS; T-SHIRTS; TANK TOPS; UNIFORMS (U.S. CLS. 22 AND 39).

**CLASS 35—ADVERTISING AND BUSINESS**

FOR RESTAURANT FRANCHISING (U.S. CLS. 100, 101 AND 102).  
STEVEN PEREZ, EXAMINING ATTORNEY

SN 78-831,976. ROLEX WATCH U.S.A, INC., NEW YORK, NY. FILED 3-8-2006.



OWNER OF U.S. REG. NOS. 101,819, 1,755,226 AND OTHERS.

NO CLAIM IS MADE TO THE EXCLUSIVE RIGHT TO USE "AWARDS", APART FROM THE MARK AS SHOWN.

THE MARK CONSISTS OF THE ROLEX CROWN LOGO, THE WORDS "THE ROLEX AWARDS FOR ENTERPRISE" INSIDE A CIRCLE.

**CLASS 16—PAPER GOODS AND PRINTED MATTER**

FOR BOOKS AND MAGAZINES PERTAINING TO THE ADVANCEMENT OF HUMAN KNOWLEDGE AND WELL-BEING IN THE FIELDS OF SCIENCE AND MEDICINE, TECHNOLOGY AND INNOVATION, EXPLORATION AND DISCOVERY, THE ENVIRONMENT AND CULTURAL STUDIES (U.S. CLS. 2, 5, 22, 23, 29, 37, 38 AND 50).

FIRST USE 9-27-2000; IN COMMERCE 9-27-2000.

**CLASS 41—EDUCATION AND ENTERTAINMENT**

FOR PROVIDING RECOGNITION AND INCENTIVES BY WAY OF AWARDS TO RECOGNIZE AND SUPPORT PIONEERING ACHIEVEMENT IN THE ADVANCEMENT OF HUMAN KNOWLEDGE AND WELL-BEING (U.S. CLS. 100, 101 AND 107).

FIRST USE 9-27-2000; IN COMMERCE 9-27-2000.

DEBRA LEE, EXAMINING ATTORNEY

SN 78-834,612. PHEASANTS FOREVER, INC., ST. PAUL, MN. FILED 3-10-2006.



OWNER OF U.S. REG. NOS. 1,362,717, 1,616,257 AND 3,038,465.

NO CLAIM IS MADE TO THE EXCLUSIVE RIGHT TO USE "QUAIL" OR THE QUAIL DESIGNS, APART FROM THE MARK AS SHOWN.

**CLASS 35—ADVERTISING AND BUSINESS**

FOR PROMOTING PUBLIC AWARENESS OF THE NEED FOR PROTECTION, ENHANCEMENT, PRESERVATION, RESTORATION, DEVELOPMENT, MAINTENANCE AND MANAGEMENT OF WILDLIFE HABITAT; PROMOTING PUBLIC AWARENESS OF THE NEED FOR THE STUDY AND RESEARCH OF WILDLIFE HABITATS; PROMOTING PUBLIC AWARENESS OF THE NEED FOR THE ACQUISITION, ESTABLISHMENT AND OPERATION OF PROTECTED AREAS FOR WILDLIFE; PROMOTING PUBLIC AWARENESS OF THE NEED FOR IMPROVEMENT OF WILDLIFE HABITAT, WILDLIFE POPULATIONS, AND WILDLIFE HUNTING; PROMOTING PUBLIC AWARENESS OF THE NEED FOR PROGRAMS AND LEGISLATION RELATING TO PROPER LAND DEVELOPMENT REGARDING WILDLIFE (U.S. CLS. 100, 101 AND 102).

FIRST USE 8-16-2005; IN COMMERCE 8-16-2005.

**CLASS 37—CONSTRUCTION AND REPAIR**

FOR CONSERVATION SERVICES, NAMELY, CONSTRUCTION AND RESTORATION OF WETLANDS AND GRASSLANDS; CONSTRUCTION AND RENOVATION OF NESTING COVER, WOODY COVER, AND FEEDING AREAS FOR WILDLIFE (U.S. CLS. 100, 103 AND 106).

FIRST USE 8-16-2005; IN COMMERCE 8-16-2005.

**CLASS 41—EDUCATION AND ENTERTAINMENT**

FOR EDUCATIONAL SERVICES, NAMELY, PROVIDING CLASSES, SEMINARS, AND WORKSHOPS IN THE FIELD OF HABITAT MANAGEMENT FOR THE RESTORATION OF WILDLIFE POPULATIONS; EDUCATIONAL SERVICES, NAMELY, CONDUCTING INFORMATION PROGRAMS ON WILDLIFE HABITAT; PUBLICATION OF NEWSLETTERS, BOOKS, AND MAGAZINES RELATED TO INFORMATION ON WILDLIFE HABITAT (U.S. CLS. 100, 101 AND 107).

FIRST USE 8-16-2005; IN COMMERCE 8-16-2005.  
ANDREW RHIM, EXAMINING ATTORNEY

SN 78-837,794. BUILD A PURSE AND SHOES, LLC, LONE TREE, CO. FILED 3-15-2006.

SN 78-837,076. QUEEN B LLC, NEW YORK, NY. FILED 3-14-2006.



YOANA BARASCHI

THE NAME(S), PORTRAIT(S), AND/OR SIGNATURE(S) SHOWN IN THE MARK IDENTIFIES YOANA BARASCHI, WHOSE CONSENT(S) TO REGISTER IS SUBMITTED.

THE MARK CONSISTS OF AN OUTLINED ILLUSTRATION OF A WOMAN'S HEAD AND UPPER FACIAL AREA. SHE IS PEERING OUT OVER A FUR COLLAR. THE WORDING "YOANA BARASCHI", IN STYLIZED LETTERING, APPEARS ON THE LOWER PORTION OF THE MARK.

**CLASS 3—COSMETICS AND CLEANING PREPARATIONS**

FOR COLOGNE; PERFUME (U.S. CLS. 1, 4, 6, 50, 51 AND 52).

**CLASS 9—ELECTRICAL AND SCIENTIFIC APPARATUS**

FOR EYEGLASSES; SUNGLASSES (U.S. CLS. 21, 23, 26, 36 AND 38).

**CLASS 24—FABRICS**

FOR BED LINEN; BEDSHEETS; FABRIC WINDOW COVERINGS AND TREATMENTS, NAMELY CURTAINS, DRAPERIES, SHEERS, SWAGS AND VALANCES; HOUSEHOLD LINEN; TEXTILE TABLECLOTHS (U.S. CLS. 42 AND 50).

**CLASS 25—CLOTHING**

FOR (BASED ON USE IN COMMERCE) COATS; EVENING DRESSES; JACKETS; PANTS; SHORT-SLEEVED OR LONG-SLEEVED T-SHIRTS; SKIRTS AND DRESSES; SWEATERS; TOPS; (BASED ON INTENT TO USE) GLOVES; HEAD WEAR; INFANT AND TODDLER ONE PIECE CLOTHING; PAJAMAS; SHOES; SLEEPWEAR; SWIM WEAR; TENNIS WEAR (U.S. CLS. 22 AND 39).

FIRST USE 6-1-2004; IN COMMERCE 6-1-2004.  
MICHAEL KAZAZIAN, EXAMINING ATTORNEY



NO CLAIM IS MADE TO THE EXCLUSIVE RIGHT TO USE "BUILD A PURSE & SHOES" AND "WORKSHOP", APART FROM THE MARK AS SHOWN.

THE NAME KARLA IDENTIFIES A LIVING INDIVIDUAL WHOSE CONSENT IS OF RECORD.

**CLASS 18—LEATHER GOODS**

FOR FASHION CLOTHING ACCESSORIES, NAMELY, PURSES, HANDBAGS, SCHOOL BAGS, TOTE BAGS, BEACH BAGS, COSMETIC BAGS SOLD EMPTY, BRIEF CASE TYPE PORTFOLIOS, ATTACHÉ CASES, UMBRELLAS; CLUTCH PURSES, LEATHER KEY CASES, CREDIT CARD CASES, COSMETIC CASES SOLD EMPTY, CHANGE PURSES, WALLETS, BUSINESS CARD CASES AND PASSPORT CASES (U.S. CLS. 1, 2, 3, 22 AND 41).

**CLASS 25—CLOTHING**

FOR FASHION CLOTHING ACCESSORIES, NAMELY, WOMEN'S, TEENS AND CHILDREN'S COATS, VESTS, RAINWEAR, SKIWEAR, SLEEPWEAR, FITNESSWEAR, NAMELY, SHORTS, JACKETS, SWEAT PANTS, SWEAT SUITS, JOGGING SUITS AND TRACK SUITS, SWIMWEAR, COSTUMES, NAMELY, BATHING COSTUMES, DANCE COSTUMES, HALLOWEEN COSTUMES, THEATRICAL COSTUMES AND MASQUERADE COSTUMES, JACKETS, SWEATSHIRTS, PULLOVERS, WARM-UP SUITS, SWEATERS, TURTLENECKS, JUMPERS, SKIRTS, PANTS, SHORTS, BELTS, SCARVES, BOW TIES AND TIES, GLOVES, T-SHIRTS, HEADGEAR, NAMELY, HEADBANDS, HATS, BERETS AND CAPS; SOCKS, STOCKINGS, TIGHTS, LEGGINGS, AND SHOES CREATED, ASSEMBLED, AND FINISHED IN A DO-IT-YOURSELF WORKSHOP (U.S. CLS. 22 AND 39).

**CLASS 35—ADVERTISING AND BUSINESS**

FOR MAIL ORDER, RETAIL STORE, AND MAIL ORDER CATALOG SERVICES IN THE FIELD OF FASHION CLOTHING ACCESSORIES AND SHOES; ONLINE RETAIL STORE SERVICES IN THE FIELD OF FASHION CLOTHING ACCESSORIES AND SHOES (U.S. CLS. 100, 101 AND 102).

TINA BROWN, EXAMINING ATTORNEY

SN 78-838,271. MAUI BUILT, INC., KAHULUI, HI. FILED 3-15-2006.

SN 78-839,004. REACH MARKETING COMMUNICATIONS, INC., DBA VYWAY MARKET & BRAND STRATEGY, GOLDEN VALLEY, MN. FILED 3-16-2006.

## MAUI TROPIX

THE MARK CONSISTS OF STANDARD CHARACTERS WITHOUT CLAIM TO ANY PARTICULAR FONT, STYLE, SIZE, OR COLOR.

OWNER OF U.S. REG. NO. 3,007,450.

NO CLAIM IS MADE TO THE EXCLUSIVE RIGHT TO USE "MAUI", APART FROM THE MARK AS SHOWN.

### CLASS 25—CLOTHING

FOR BEACHWEAR; CAPS; JACKETS; PANTS; SHIRTS; SHOES; SHORTS; SOCKS; SWEAT PANTS; SWEAT SHIRTS (U.S. CLS. 22 AND 39).

FIRST USE 1-1-1994; IN COMMERCE 1-1-1994.

### CLASS 28—TOYS AND SPORTING GOODS

FOR SURFBOARDS (U.S. CLS. 22, 23, 38 AND 50).

FIRST USE 1-1-1994; IN COMMERCE 1-1-1994.

### CLASS 35—ADVERTISING AND BUSINESS

FOR RETAIL SHOPS FEATURING SURFBOARDS, SURFWEAR, SURFGEAR (U.S. CLS. 100, 101 AND 102).

FIRST USE 1-1-1994; IN COMMERCE 1-1-1994.

ROBERT C. CLARK JR., EXAMINING ATTORNEY

SN 78-838,312. SMALL CONCEPT INC., ALPHARETTA, GA. FILED 3-15-2006.

## SMALL CONCEPT

THE MARK CONSISTS OF STANDARD CHARACTERS WITHOUT CLAIM TO ANY PARTICULAR FONT, STYLE, SIZE, OR COLOR.

### CLASS 25—CLOTHING

FOR APPAREL FOR BABIES AND CHILDREN, NAMELY, T-SHIRTS, SHIRTS, BLOUSES, PANTS, JEANS, DRESSES, JACKETS, SWEATERS, PAJAMAS, SWIMWEAR, HATS, JUMPERS, CLOTH BABY BIBS, SHOES AND SOCKS (U.S. CLS. 22 AND 39).

FIRST USE 7-4-2006; IN COMMERCE 7-4-2006.

### CLASS 35—ADVERTISING AND BUSINESS

FOR ONLINE RETAIL SERVICES, MAIL ORDER CATALOGS, AND RETAIL STORES FEATURING BABY AND CHILDREN CLOTHING, SHOES, TOYS, DOLLS, GAMES, BEDDING AND ROOM DECOR, FURNITURE, DIAPER AND HAND BAGS, STROLLERS AND BABY ACCESSORIES, BOOKS, PRE-RECORDED MUSIC AND VIDEO MEDIA, HEALTH AND BEAUTY PRODUCTS, BABY ANNOUNCEMENTS AND OTHER BABY AND CHILD RELATED PRODUCTS (U.S. CLS. 100, 101 AND 102).

FIRST USE 7-4-2006; IN COMMERCE 7-4-2006.

BARBARA BROWN, EXAMINING ATTORNEY

## VYWAY

THE MARK CONSISTS OF STANDARD CHARACTERS WITHOUT CLAIM TO ANY PARTICULAR FONT, STYLE, SIZE, OR COLOR.

### CLASS 9—ELECTRICAL AND SCIENTIFIC APPARATUS

FOR DOWNLOADABLE ELECTRONIC PUBLICATIONS AND DOWNLOADABLE PRINTED PUBLICATIONS ALL IN THE NATURE OF INSTRUCTIONAL, EDUCATIONAL, AND TEACHING MATERIALS, NAMELY, BOOKS AND MANUALS IN THE FIELDS OF BUSINESS PLANNING AND STRATEGY, BRANDING AND BRAND STRATEGY, AND MARKETING AND MARKETING COMMUNICATIONS (U.S. CLS. 21, 23, 26, 36 AND 38).

FIRST USE 5-18-2004; IN COMMERCE 5-18-2004.

### CLASS 35—ADVERTISING AND BUSINESS

FOR CONSULTANCY SERVICES IN THE FIELDS OF BUSINESS PLANNING AND STRATEGY, BRANDING AND BRAND STRATEGY, MARKETING AND MARKETING COMMUNICATIONS; BUSINESS CONSULTING AND MARKETING SERVICES FEATURING THE DEVELOPMENT OF METHODOLOGY FOR BUSINESS, BRAND, MARKETING, AND COMMUNICATIONS PLANNING AND IMPLEMENTATION; ONLINE ADVERTISING AND MARKETING SERVICES IN THE NATURE OF DEVELOPING INTERACTIVE MEDIA CAMPAIGNS FOR OTHERS; ADVERTISING, PUBLIC RELATIONS, SALES PROMOTION, AND DIRECT MARKETING SERVICES; INTEGRATED MARKETING COMMUNICATIONS CAMPAIGN SERVICES, NAMELY PROVIDING ADVERTISING, MARKETING AND PROMOTIONAL SERVICES; COPYWRITING, NAMELY, THE WRITING OF ADVERTISING AND MARKETING COPY FOR OTHERS (U.S. CLS. 100, 101 AND 102).

FIRST USE 5-18-2004; IN COMMERCE 5-18-2004.

### CLASS 41—EDUCATION AND ENTERTAINMENT

FOR EDUCATIONAL SERVICES, NAMELY, CONDUCTING CLASSES, SEMINARS, CONFERENCES, AND WORKSHOPS IN THE FIELDS OF BUSINESS PLANNING AND STRATEGY, BRANDING AND BRAND STRATEGY, MARKETING AND MARKETING COMMUNICATIONS, INCLUDING DISTRIBUTION OF COURSE MATERIALS IN CONNECTION THEREWITH; SPEECH WRITING FOR OTHERS (U.S. CLS. 100, 101 AND 107).

FIRST USE 5-18-2004; IN COMMERCE 5-18-2004.

### CLASS 42—SCIENTIFIC, COMPUTER AND LEGAL SERVICES

FOR GRAPHIC DESIGN; DESIGN OF HOMEPAGES AND WEB SITES (U.S. CLS. 100 AND 101).

FIRST USE 5-18-2004; IN COMMERCE 5-18-2004.

ERNEST SHOSHO, EXAMINING ATTORNEY

SN 78-839,042. REACH MARKETING COMMUNICATIONS, INC., DBA VYWAY MARKET & BRAND STRATEGY, GOLDEN VALLEY, MN. FILED 3-16-2006.



NO CLAIM IS MADE TO THE EXCLUSIVE RIGHT TO USE MARKET & BRAND STRATEGY, APART FROM THE MARK AS SHOWN.

#### **CLASS 9—ELECTRICAL AND SCIENTIFIC APPARATUS**

FOR DOWNLOADABLE ELECTRONIC PUBLICATIONS AND DOWNLOADABLE PRINTED PUBLICATIONS ALL IN THE NATURE OF INSTRUCTIONAL, EDUCATIONAL, AND TEACHING MATERIALS, NAMELY, BOOKS AND MANUALS IN THE FIELDS OF BUSINESS PLANNING AND STRATEGY, BRANDING AND BRAND STRATEGY, AND MARKETING AND MARKETING COMMUNICATIONS (U.S. CLS. 21, 23, 26, 36 AND 38).

FIRST USE 5-20-2005; IN COMMERCE 5-20-2005.

#### **CLASS 35—ADVERTISING AND BUSINESS**

FOR CONSULTANCY SERVICES IN THE FIELDS OF BUSINESS PLANNING AND STRATEGY, BRANDING AND BRAND STRATEGY, MARKETING AND MARKETING COMMUNICATIONS; BUSINESS CONSULTING AND MARKETING SERVICES FEATURING THE DEVELOPMENT OF METHODOLOGY FOR BUSINESS, BRAND, MARKETING, AND COMMUNICATIONS PLANNING AND IMPLEMENTATION; ONLINE ADVERTISING AND MARKETING SERVICES IN THE NATURE OF DEVELOPING INTERACTIVE MEDIA CAMPAIGNS FOR OTHERS; ADVERTISING, PUBLIC RELATIONS, SALES PROMOTION, AND DIRECT MARKETING SERVICES; INTEGRATED MARKETING COMMUNICATIONS CAMPAIGN SERVICES, NAMELY PROVIDING ADVERTISING MARKETING AND PROMOTIONAL SERVICES; COPYWRITING, NAMELY, THE WRITING OF ADVERTISING AND MARKETING COPY FOR OTHERS (U.S. CLS. 100, 101 AND 102).

FIRST USE 5-20-2005; IN COMMERCE 5-20-2005.

#### **CLASS 41—EDUCATION AND ENTERTAINMENT**

FOR EDUCATIONAL SERVICES, NAMELY, CONDUCTING CLASSES, SEMINARS, CONFERENCES, AND WORKSHOPS IN THE FIELDS OF BUSINESS PLANNING AND STRATEGY, BRANDING AND BRAND STRATEGY, MARKETING AND MARKETING COMMUNICATIONS, INCLUDING DISTRIBUTION OF COURSE MATERIALS IN CONNECTION THEREWITH; SPEECH WRITING FOR OTHERS (U.S. CLS. 100, 101 AND 107).

FIRST USE 5-20-2005; IN COMMERCE 5-20-2005.

#### **CLASS 42—SCIENTIFIC, COMPUTER AND LEGAL SERVICES**

FOR GRAPHIC DESIGN; DESIGN OF HOMEPAGES, WEB SITES (U.S. CLS. 100 AND 101).  
FIRST USE 5-20-2005; IN COMMERCE 5-20-2005.  
ERNEST SHOSHO, EXAMINING ATTORNEY

SN 78-840,271. TWO ANGELS, INC., BEVERLY HILLS, CA. FILED 3-17-2006.

#### **TWO ANGELS PRODUCTIONS**

THE MARK CONSISTS OF STANDARD CHARACTERS WITHOUT CLAIM TO ANY PARTICULAR FONT, STYLE, SIZE, OR COLOR.

NO CLAIM IS MADE TO THE EXCLUSIVE RIGHT TO USE PRODUCTIONS, APART FROM THE MARK AS SHOWN.

#### **CLASS 9—ELECTRICAL AND SCIENTIFIC APPARATUS**

FOR PRE-RECORDED DVD'S FEATURING MOTION PICTURES AND TELEVISION PROGRAMS (U.S. CLS. 21, 23, 26, 36 AND 38).

#### **CLASS 41—EDUCATION AND ENTERTAINMENT**

FOR MOTION PICTURE FILM PRODUCTION; TELEVISION SHOW PRODUCTION; ENTERTAINMENT IN THE NATURE OF THEATER PRODUCTIONS; PRODUCTION AND DISTRIBUTION OF MOTION PICTURES; FILM DISTRIBUTION (U.S. CLS. 100, 101 AND 107).

AMY MCMENAMIN, EXAMINING ATTORNEY

SN 78-842,011. ABS GLOBAL, INC., DEFOREST, WI. FILED 3-21-2006.



OWNER OF U.S. REG. NO. 2,185,924.

THE MARK CONSISTS OF SQUARE FORMATION INTENDED TO DEPICT A CORNERSTONE.

#### **CLASS 42—SCIENTIFIC, COMPUTER AND LEGAL SERVICES**

FOR EVALUATING THE RESULTS OF DAIRY HERD BREEDING PROGRAMS (U.S. CLS. 100 AND 101).  
FIRST USE 4-30-2005; IN COMMERCE 4-30-2005.

**CLASS 44—MEDICAL, BEAUTY AND AGRICULTURAL SERVICES**

FOR DAIRY HERD MANAGEMENT AND BREEDING; DAIRY HERD GENETIC TESTING (U.S. CLS. 100 AND 101).

FIRST USE 4-30-2005; IN COMMERCE 4-30-2005.  
JAMES GRIFFIN, EXAMINING ATTORNEY

**CLASS 44—MEDICAL, BEAUTY AND AGRICULTURAL SERVICES**

FOR DAIRY HERD MANAGEMENT AND BREEDING; DAIRY HERD GENETIC TESTING (U.S. CLS. 100 AND 101).

FIRST USE 4-30-2005; IN COMMERCE 4-30-2005.  
JAMES GRIFFIN, EXAMINING ATTORNEY

SN 78-842,022. ABS GLOBAL, INC., DEFOREST, WI. FILED 3-21-2006.

SN 78-842,118. TEACHERS FOR LEARNERS, LLC, NEW YORK, NY. FILED 3-21-2006.

**ABS CORNERSTONE - The  
Foundation of Dairy  
Genetics**

**CONVERSE AND CONVEY PANEL**

THE MARK CONSISTS OF STANDARD CHARACTERS WITHOUT CLAIM TO ANY PARTICULAR FONT, STYLE, SIZE, OR COLOR.

OWNER OF U.S. REG. NO. 2,185,924.  
NO CLAIM IS MADE TO THE EXCLUSIVE RIGHT TO USE "DAIRY GENETICS", APART FROM THE MARK AS SHOWN.

THE MARK CONSISTS OF STANDARD CHARACTERS WITHOUT CLAIM TO ANY PARTICULAR FONT, STYLE, SIZE, OR COLOR.

**CLASS 9—ELECTRICAL AND SCIENTIFIC APPARATUS**

FOR COMPUTER SOFTWARE FOR USE IN VOCABULARY INSTRUCTION, EDUCATION AND TEACHING (U.S. CLS. 21, 23, 26, 36 AND 38).

**CLASS 42—SCIENTIFIC, COMPUTER AND LEGAL SERVICES**

FOR EVALUATING THE RESULTS OF DAIRY HERD BREEDING PROGRAMS (U.S. CLS. 100 AND 101).  
FIRST USE 4-30-2005; IN COMMERCE 4-30-2005.

**CLASS 16—PAPER GOODS AND PRINTED MATTER**

FOR MATS AND PADS MADE OF FABRIC FOR USE IN VOCABULARY INSTRUCTION, EDUCATION AND TEACHING (U.S. CLS. 2, 5, 22, 23, 29, 37, 38 AND 50).  
GINA HAYES, EXAMINING ATTORNEY

**CLASS 44—MEDICAL, BEAUTY AND AGRICULTURAL SERVICES**

FOR DAIRY HERD MANAGEMENT AND BREEDING; DAIRY HERD GENETIC TESTING (U.S. CLS. 100 AND 101).

FIRST USE 4-30-2005; IN COMMERCE 4-30-2005.  
JAMES GRIFFIN, EXAMINING ATTORNEY

SN 78-842,232. THE J. M. SMUCKER COMPANY, ORR-VILLE, OH. FILED 3-21-2006.

SN 78-842,027. ABS GLOBAL, INC., DEFOREST, WI. FILED 3-21-2006.

**SANTA CRUZ**

**ABS CORNERSTONE**

THE MARK CONSISTS OF STANDARD CHARACTERS WITHOUT CLAIM TO ANY PARTICULAR FONT, STYLE, SIZE, OR COLOR.

"THE FOREIGN WORDING IN THE MARK TRANSLATES INTO ENGLISH AS HOLY CROSS."

THE MARK CONSISTS OF STANDARD CHARACTERS WITHOUT CLAIM TO ANY PARTICULAR FONT, STYLE, SIZE, OR COLOR.

OWNER OF U.S. REG. NO. 2,185,924.

**CLASS 29—MEATS AND PROCESSED FOODS**

FOR PEANUT BUTTER; APPLE SAUCE AND FLAVORED APPLE SAUCE (U.S. CL. 46).  
FIRST USE 5-1-1989; IN COMMERCE 5-1-1989.

**CLASS 42—SCIENTIFIC, COMPUTER AND LEGAL SERVICES**

FOR EVALUATING THE RESULTS OF DAIRY HERD BREEDING PROGRAMS (U.S. CLS. 100 AND 101).  
FIRST USE 4-30-2005; IN COMMERCE 4-30-2005.

**CLASS 30—STAPLE FOODS**

FOR CHOCOLATE SYRUP, CHOCOLATE TOPPING AND SYRUP TOPPING (U.S. CL. 46).  
FIRST USE 5-1-1997; IN COMMERCE 5-1-1997.  
MARK T. MULLEN, EXAMINING ATTORNEY

SN 78-843,255. DAKOTA REALTY LLC, IMLAYSTOWN, NJ.  
FILED 3-22-2006.

SN 78-845,659. LOVING CARE AGENCY, INC., FORT LEE,  
NJ. FILED 3-24-2006.

## GLEN SPRINGS BREWERY

THE MARK CONSISTS OF STANDARD CHARACTERS WITHOUT CLAIM TO ANY PARTICULAR FONT, STYLE, SIZE, OR COLOR.  
NO CLAIM IS MADE TO THE EXCLUSIVE RIGHT TO USE "BREWERY", APART FROM THE MARK AS SHOWN.

### CLASS 32—LIGHT BEVERAGES

FOR BEER (U.S. CLS. 45, 46 AND 48).

### CLASS 40—MATERIAL TREATMENT

FOR BREWERY SERVICES FOR OTHERS (U.S. CLS. 100, 103 AND 106).

### CLASS 43—HOTEL AND RESTAURANT SERVICES

FOR RESTAURANT SERVICES, BREW-PUB RESTAURANT SERVICES (U.S. CLS. 100 AND 101).  
MICHAEL TANNER, EXAMINING ATTORNEY

SN 78-845,334. RICHANCE, ARTESIA, CA. FILED 3-24-2006.



THE MARK CONSISTS OF THE WORD RICH IN STYLIZED FORM TO THE LEFT OF THE WORDING RICHANCE.

### CLASS 36—INSURANCE AND FINANCIAL

FOR REAL ESTATE INVESTMENT (U.S. CLS. 100, 101 AND 102).  
FIRST USE 3-11-1999; IN COMMERCE 3-11-1999.

### CLASS 37—CONSTRUCTION AND REPAIR

FOR REAL ESTATE DEVELOPMENT (U.S. CLS. 100, 103 AND 106).  
FIRST USE 3-11-1999; IN COMMERCE 3-11-1999.  
MARY BOAGNI, EXAMINING ATTORNEY

"TOUCHING LIVES AND MAKING  
A DIFFERENCE"

THE MARK CONSISTS OF STANDARD CHARACTERS WITHOUT CLAIM TO ANY PARTICULAR FONT, STYLE, SIZE, OR COLOR.

### CLASS 44—MEDICAL, BEAUTY AND AGRICULTURAL SERVICES

FOR PEDIATRIC NURSING SERVICES FEATURING CARE COORDINATION; MEDICAL SERVICES FEATURING CLINICAL MANAGEMENT OF HEALTH CONDITIONS; PRIVATE DUTY AND EXTENDED HOURS NURSING CARE; SKILLED NURSING VISITS; PHYSICAL, OCCUPATIONAL AND SPEECH THERAPY; CLINICAL SOCIAL WORKER CONSULTATIONS; MEDICAL SERVICES, FEATURING PATIENT CASE MANAGEMENT; HOME HEALTH CARE SERVICES PROVIDED BY HOME HEALTH AIDES, FEATURING HOSPITAL TO HOME COORDINATION (U.S. CLS. 100 AND 101).  
FIRST USE 12-0-1993; IN COMMERCE 12-0-1993.

### CLASS 45—PERSONAL SERVICES

FOR PERSONAL CARE ASSISTANCE OF ACTIVITIES OF DAILY LIVING, SUCH AS BATHING, GROOMING AND PERSONAL MOBILITY FOR MENTALLY OR PHYSICALLY CHALLENGED PEOPLE (U.S. CLS. 100 AND 101).  
FIRST USE 12-0-1993; IN COMMERCE 12-0-1993.  
THOMAS MANOR, EXAMINING ATTORNEY

SN 78-846,126. EISHIN CORPORATION, KANAGAWA, JAPAN, FILED 3-25-2006.

## CANE CUORE

THE MARK CONSISTS OF STANDARD CHARACTERS WITHOUT CLAIM TO ANY PARTICULAR FONT, STYLE, SIZE, OR COLOR.  
NO CLAIM IS MADE TO THE EXCLUSIVE RIGHT TO USE "CANE", APART FROM THE MARK AS SHOWN.  
"THE FOREIGN WORDING IN THE MARK TRANSLATES INTO ENGLISH AS DOG HEART."

### CLASS 18—LEATHER GOODS

FOR GARMENTS FOR PETS; PET CLOTHING; PET COLLAR ACCESSORIES, NAMELY, BOWS AND CHARMS; PET PRODUCTS IN THE NATURE OF A RESTRAINING DEVICE, NAMELY, TIE-OUT STAKES AND TIE-OUT CHAINS (U.S. CLS. 1, 2, 3, 22 AND 41).  
FIRST USE 1-1-2001; IN COMMERCE 1-1-2006.

### CLASS 21—HOUSEWARES AND GLASS

FOR BRUSHES FOR PETS; ELECTRIC PET BRUSHES; PET BRUSHES; PET GROOMING DEVICE COMPRISING A BUILT IN BRUSH HEAD AND AN ATTACHMENT THAT CONNECTS TO VACUUMS (U.S. CLS. 2, 13, 23, 29, 30, 33, 40 AND 50).  
FIRST USE 1-1-2001; IN COMMERCE 1-1-2006.



**CLASS 31—NATURAL AGRICULTURAL PRODUCTS**

FOR CONSUMABLE PET CHEWS; PET BEVERAGES; PET FOOD; PET TREATS (U.S. CLS. 1 AND 46).  
FIRST USE 1-1-2001; IN COMMERCE 1-1-2006.  
JOHN DWYER, EXAMINING ATTORNEY

SN 78-847,068. PROMARK BRANDS, INC., MERIDIAN, ID.  
FILED 3-27-2006.



OWNER OF U.S. REG. NO. 2,353,756.  
NO CLAIM IS MADE TO THE EXCLUSIVE RIGHT TO USE "KABOBS", APART FROM THE MARK AS SHOWN.

**CLASS 29—MEATS AND PROCESSED FOODS**

FOR FRESH AND FROZEN PARTY-TYPE FINGER AND SINGLE-PORTION GOODS CONSISTING OF MEAT, POULTRY, FISH, SHELLFISH, VEGETABLES, NUTS AND CHEESE (U.S. CL. 46).  
FIRST USE 3-0-2003; IN COMMERCE 3-0-2003.

**CLASS 30—STAPLE FOODS**

FOR FRESH AND FROZEN PARTY-TYPE FINGER AND SINGLE-PORTION GOODS CONSISTING OF PASTRY; FRESH AND FROZEN PARTY-TYPE FINGER AND SINGLE-PORTION GOODS, NAMELY, DOUGH-BASED POCKETS WITH FILLING CONSISTING PRIMARILY OF MEATS, POULTRY, FISH, SHELLFISH, VEGETABLES, NUTS AND CHEESE (U.S. CL. 46).  
FIRST USE 3-0-2003; IN COMMERCE 3-0-2003.  
MARY CRAWFORD, EXAMINING ATTORNEY

SN 78-847,102. FREMANTLEMEDIA NORTH AMERICA, INC., BURBANK, CA. FILED 3-27-2006.

PSYCHIC AT LARGE

THE MARK CONSISTS OF STANDARD CHARACTERS WITHOUT CLAIM TO ANY PARTICULAR FONT, STYLE, SIZE, OR COLOR.  
NO CLAIM IS MADE TO THE EXCLUSIVE RIGHT TO USE "PSYCHIC", APART FROM THE MARK AS SHOWN.

**CLASS 9—ELECTRICAL AND SCIENTIFIC APPARATUS**

FOR PRERECORDED AUDIO AND VIDEO CASSETTES, COMPACT DISCS, VIDEO DISCS, RECORDS, AND CD-ROMS, ALL OF THE FOREGOING FEATURING SHOWS BASED ON THE SUPERNATURAL; VIDEO GAME MACHINE THAT IS ADAPTED OR INTENDED FOR USE WITH A TELEVISION, MONITOR OR SOME OTHER FORM OF DISPLAY APPARATUS WHICH IS SEPARATE FROM THE VIDEO GAME MACHINE; COMPUTER GAME EQUIPMENT CONTAINING MEMORY DEVICES, NAMELY, DISCS; INTERACTIVE VIDEO GAME PROGRAMS; ELECTRONICALLY OR MAGNETICALLY ACTIVATED PRE-PAID TELEPHONE DEBIT CARDS; MAGNETS, INTERACTIVE COMPUTER GAME SOFTWARE DOWNLOADED FROM A GLOBAL COMPUTER NETWORK; EYEGLASSES AND SUNGLASSES; GAMING MACHINES; GAMING EQUIPMENT, NAMELY, SLOT MACHINES WITH OR WITHOUT VIDEO OUTPUT (U.S. CLS. 21, 23, 26, 36 AND 38).

**CLASS 16—PAPER GOODS AND PRINTED MATTER**

FOR POSTERS, CALENDARS, NOTEBOOKS, DAILY PERSONAL ORGANIZERS, MEMO PADS, STICKERS, COMIC BOOKS, WRITING PAPER, ENVELOPES, GREETING CARDS, PAPER COASTERS, PAPER MATS, NEWSPAPERS FOR GENERAL CIRCULATION, BOOKS AND MAGAZINES IN THE FIELD OF THE SUPERNATURAL, NEWSLETTERS IN THE FIELD OF THE SUPERNATURAL, PHOTOGRAPHS, POSTCARDS, TRADING CARDS, CARDBOARD STANDUP CUT-OUTS FEATURING PHOTOGRAPHS OR ARTWORK, PREPAID PHONE DEBIT CARDS WITHOUT MAGNETIC CODING, TRADING CARD MILK BOTTLE CAPS, AND PERSONAL BANK CHECKS (U.S. CLS. 2, 5, 22, 23, 29, 37, 38 AND 50).

**CLASS 25—CLOTHING**

FOR CLOTHING, NAMELY, RAINWEAR, T-SHIRTS, SWEAT SHIRTS, JERSEYS, SHORTS, SWEAT PANTS, JACKETS, HATS, CAPS, SCARVES, GLOVES, HOSE, NECKTIES, PAJAMAS, ROBES, NIGHT SHIRTS, NIGHT GOWNS, UNDERWEAR, HEAD BANDS, WRIST BANDS, SWIM SUITS, SKIRTS, SHIRTS, TANK TOPS, PANTS, COATS, SWEATERS, LEOTARDS, LEG WARMERS, STOCKINGS, SOCKS, PANTY HOSE, TIGHTS, BELTS; FOOTWEAR, NAMELY, SHOES, ATHLETIC SHOES, SLIPPERS, BOOTS, SANDALS; AND HEADWEAR, NAMELY, HATS AND CAPS (U.S. CLS. 22 AND 39).

**CLASS 28—TOYS AND SPORTING GOODS**

FOR TARGET GAMES, BOARD GAMES AND CARD GAMES, KITES, TOY ACTION FIGURES, DISC-TYPE TOSS TOYS, BOWS AND ARROW, BALLS OF ALL KINDS, DOLLS, DOLLS PLAYSETS, PLUSH TOYS, TOY VEHICLES, TOY CARS, TOY TRUCK, ROLLER SKATES, TOY ROCKETS, TOY GUNS, TOY HOLSTERS, MUSICAL TOYS, JIGSAW PUZZLES, BADMINTON SETS, BUBBLE MAKING WANDS AND SOLUTION SETS, MOLDED PLASTIC TOY FIGURINES, TOY BANKS, PUPPETS, TOY BALLOONS, YO-YOS, SKATEBOARDS, TOY SCOOTERS, FACE MASKS, STAND ALONE VIDEO GAME MACHINES, LCD GAME MACHINES, HAND HELD UNIT FOR PLAYING ELECTRONIC GAMES, BUT SPECIFICALLY EXCLUDING DICE GAMES AND COMPUTER SOFTWARE GAMES, LOTTERY TICKETS AND LOTTERY GAMES, NAMELY PLAYING CARDS; PLAYING CARDS (U.S. CLS. 22, 23, 38 AND 50).

**CLASS 41—EDUCATION AND ENTERTAINMENT**

FOR ENTERTAINMENT SERVICES, NAMELY PRODUCTION AND DISTRIBUTION OF A TELEVISION REALITY SHOW; ENTERTAINMENT SERVICES, NAMELY, PROVIDING AN ON-LINE COMPUTER GAME (U.S. CLS. 100, 101 AND 107).  
SARAH WAYDA, EXAMINING ATTORNEY

SN 78-847,458. INTERNET OPPORTUNITY ENTERTAINMENT (SPORTS) LTD., ST JOHNS, ANTIGUA & BARBUDA, FILED 3-28-2006.

THE LARGEST SPORTSBOOK AND CASINO ON THE PLANET

THE MARK CONSISTS OF STANDARD CHARACTERS WITHOUT CLAIM TO ANY PARTICULAR FONT, STYLE, SIZE, OR COLOR.  
SEC. 2(F).

**CLASS 36—INSURANCE AND FINANCIAL**

FOR FINANCIAL SERVICES RENDERED IN CONNECTION WITH BETTING, GAMBLING, GAMING, AND CASINO GAMING SERVICES VIA THE INTERNET, NAMELY, CASH ACCESS SERVICES IN THE NATURE OF ELECTRONIC CASH TRANSACTIONS AND CASH DISBURSEMENT SERVICES, NAMELY, CASH REPLACEMENT RENDERED BY CREDIT CARDS AND DEBIT CARDS, CREDIT CARD SERVICES, CHECK CASHING AND AUTOMATED CLEARING HOUSE SERVICES (U.S. CLS. 100, 101 AND 102).  
FIRST USE 6-30-1997; IN COMMERCE 6-30-1997.

**CLASS 41—EDUCATION AND ENTERTAINMENT**

FOR ENTERTAINMENT SERVICES, NAMELY, ORGANIZING, CONDUCTING AND PROVIDING ONLINE AND WIRELESS GAMING SERVICES VIA THE INTERNET; PROVIDING GAMING NEWS AND INFORMATION VIA THE INTERNET; BETTING SERVICES; GAMBLING SERVICES; GAMING SERVICES; CASINO GAMING SERVICES; PROVIDING ONLINE SERVICES TO OTHERS TO ENABLE PARTICIPANTS TO WAGER ON SPORTING EVENTS; INTERNET WAGERING SERVICES; AND PROVIDING WEBSITES FOR WAGERING (U.S. CLS. 100, 101 AND 107).  
FIRST USE 6-30-1997; IN COMMERCE 6-30-1997.  
BRIDGETT SMITH, EXAMINING ATTORNEY

SN 78-847,479. INTERNET OPPORTUNITY ENTERTAINMENT (SPORTS) LTD., ST JOHNS, ANTIGUA & BARBUDA, FILED 3-28-2006.

**sportsbook.com**

NO CLAIM IS MADE TO THE EXCLUSIVE RIGHT TO USE ".COM", APART FROM THE MARK AS SHOWN.  
SEC. 2(F).

**CLASS 36—INSURANCE AND FINANCIAL**

FOR FINANCIAL SERVICES RENDERED IN CONNECTION WITH BETTING, GAMBLING, GAMING, AND CASINO GAMING SERVICES VIA THE INTERNET, NAMELY, CASH ACCESS SERVICES IN THE NATURE OF ELECTRONIC CASH TRANSACTIONS AND CASH DISBURSEMENT SERVICES, NAMELY, CASH REPLACEMENT RENDERED BY CREDIT CARDS AND DEBIT CARDS, CREDIT CARD SERVICES, CHECK CASHING AND AUTOMATED CLEARING HOUSE SERVICES (U.S. CLS. 100, 101 AND 102).  
FIRST USE 6-30-1997; IN COMMERCE 6-30-1997.

**CLASS 41—EDUCATION AND ENTERTAINMENT**

FOR ENTERTAINMENT SERVICES, NAMELY, ORGANIZING, CONDUCTING AND PROVIDING ONLINE AND WIRELESS GAMING SERVICES VIA THE INTERNET; PROVIDING GAMING NEWS AND INFORMATION VIA THE INTERNET; BETTING SERVICES; GAMBLING SERVICES; GAMING SERVICES; CASINO GAMING SERVICES; PROVIDING ONLINE SERVICES TO OTHERS TO ENABLE PARTICIPANTS TO WAGER ON SPORTING EVENTS; INTERNET WAGERING SERVICES; AND PROVIDING WEBSITES FOR WAGERING (U.S. CLS. 100, 101 AND 107).  
FIRST USE 6-30-1997; IN COMMERCE 6-30-1997.  
BRIDGETT SMITH, EXAMINING ATTORNEY

SN 78-848,549. SIMTANO, INC., CALABASAS, CA. FILED 3-29-2006.

**SIMTANO**

THE MARK CONSISTS OF STANDARD CHARACTERS WITHOUT CLAIM TO ANY PARTICULAR FONT, STYLE, SIZE, OR COLOR.  
PRIORITY CLAIMED UNDER SEC. 44(D) ON NORWAY APPLICATION NO. 200510139, FILED 9-29-2005.

**CLASS 9—ELECTRICAL AND SCIENTIFIC APPARATUS**

FOR COMPUTER PROGRAMS, NAMELY COMPUTER PROGRAMS FOR IMPLEMENTATION AND DEVELOPMENT OF ENGINEERING PROTOTYPES, AND FOR PLANNING OF ENGINEERING PROJECTS (U.S. CLS. 21, 23, 26, 36 AND 38).

**CLASS 35—ADVERTISING AND BUSINESS**

FOR SERVICES CONSISTING OF THE REGISTRATION, COLLECTION, TRANSCRIPTION, COMPILATION AND SYSTEMIZATION OF MATHEMATICAL, TECHNICAL AND STATISTICAL WRITTEN COMMUNICATIONS AND DATA (U.S. CLS. 100, 101 AND 102).

**CLASS 42—SCIENTIFIC, COMPUTER AND LEGAL SERVICES**

FOR SCIENTIFIC AND TECHNOLOGICAL RESEARCH AND DEVELOPMENT; RESEARCH IN THE FIELD OF INDUSTRIAL ANALYSIS; DESIGN AND DEVELOPMENT OF COMPUTER HARDWARE AND SOFTWARE (U.S. CLS. 100 AND 101).  
KAPIL BHANOT, EXAMINING ATTORNEY

SN 78-848,875. GARDEN ORGANICS INCORPORATED,  
SANTA MONICA, CA. FILED 3-29-2006.

## ORGANICS Rx

THE MARK CONSISTS OF STANDARD CHARACTERS WITHOUT CLAIM TO ANY PARTICULAR FONT, STYLE, SIZE, OR COLOR.

NO CLAIM IS MADE TO THE EXCLUSIVE RIGHT TO USE ORGANICS, APART FROM THE MARK AS SHOWN.

### CLASS 1—CHEMICALS

FOR AGRICULTURAL AND HORTICULTURAL PRODUCTS, NAMELY, PLANT GROWTH SUPPLEMENTS AND AMENDMENTS COMPRISED OF ORGANIC MATTER INSTEAD OF SYNTHETIC CHEMICALS (U.S. CLS. 1, 5, 6, 10, 26 AND 46).

FIRST USE 1-9-2006; IN COMMERCE 1-9-2006.

### CLASS 5—PHARMACEUTICALS

FOR PREPARATIONS FOR DESTROYING VERMIN (U.S. CLS. 6, 18, 44, 46, 51 AND 52).

FIRST USE 1-9-2006; IN COMMERCE 1-9-2006.

HENRY S. ZAK, EXAMINING ATTORNEY

SN 78-853,752. JACKSON INTERNATIONAL TRADING CO.  
KURT D. BRÜHL GMBH & CO. KG, 8010 GRAZ,  
AUSTRIA, FILED 4-4-2006.



### CLASS 3—COSMETICS AND CLEANING PREPARATIONS

FOR SKIN LOTIONS, HAIR LOTIONS, FACIAL AND BODY LOTIONS, ANTIPERSPIRANTS, ARTIFICIAL EYELASHES, ARTIFICIAL FINGERNAILS, ASTRINGENTS FOR COSMETIC USE, BODY OIL, BATH OIL, SKIN SOAPS, FACIAL SOAPS, BODY AND FACIAL SCRUBS, BODY POWDER, FACE POWDER, HAIR SHAMPOO, BODY SHAMPOO, NON-MEDICATED LIP BALM, BODY CREAM, EYE CREAM, HAND CREAM, VANISHING CREAM, BATH GEL, EYE GEL, HAIR GEL, BATH SALTS, FACIAL AND BODY MASKS, BLUSH, MAKEUP, BREATH FRESHENER, BUBBLE BATH, BUFFING COMPOUNDS FOR FACE AND BODY, COLOGNE, HAIR CONDITIONER, SKIN CONDITIONERS, COLD CREAMS, COSMETIC COMPACTS CONTAINING MAKEUP, COSMETIC PENCILS, COTTON FOR COSMETIC PURPOSES, CURL PAPERS, CUTICLE REMOVING PREPARATIONS PERSONAL DEODORANTS, HAIR DYES, EMERY BOARDS, LIP GLOSS, HAIR CARE PREPARATIONS, HAIR MOUSSE, HAIR SPRAY, HAIR-STYLING PREPARATIONS, INCENSE, NAIL CARE PREPARATIONS, NAIL POLISH, HAIR POMADES, POTPOURRI, ROUGE, SACHETS, SKIN CARE PREPARATIONS, NAMELY, CLARIFYING LOTIONS, SKIN CLEANSERS, SKIN EMOLLIENTS, SKIN TONERS, SPOT REMOVER, SUNTANNING PREPARATIONS, ALL PURPOSE COTTON SWABS FOR PERSONAL USE, TALCUM POWDERS, PREMOISTENED COSMETIC WIPES, BABY WIPES (U.S. CLS. 1, 4, 6, 50, 51 AND 52).

### CLASS 14—JEWELRY

FOR CLOCKS NAMELY, WALL CLOCKS, ALARM CLOCKS, CLOCKS INCORPORATING RADIOS AND PARTS THEREFORE; WATCHES NAMELY, WRIST-WATCHES, STOP WATCHES, POCKET WATCHES, WATCH MOVEMENTS, WATCH CHAINS, WATCH BANDS, WATCH CASES, WATCHES CONTAINING A GAME FUNCTION, WATCH MOVEMENTS AND PARTS THEREFORE (U.S. CLS. 2, 27, 28 AND 50).

### CLASS 34—SMOKERS' ARTICLES

FOR TOBACCO, RAW OR MANUFACTURED, CIGARETTES, CIGARS, CIGARETTE FILTERS, CIGAR FILTERS, CIGARETTE PACKING PAPER, FILTER TIPS FOR CIGARETTES, CIGAR AND CIGARETTE HOLDERS NOT OF PRECIOUS METAL, CIGAR AND CIGARETTE CASES NOT OF PRECIOUS METAL, CIGAR CUTTERS, PIPES, PIPE CLEANERS, CIGAR AND CIGARETTE LIGHTERS NOT OF PRECIOUS METAL, FLINTS FOR CIGAR AND CIGARETTE LIGHTERS, TOBACCO JARS NOT OF PRECIOUS METAL, SNUFF BOXES NOT OF PRECIOUS METAL, CHEWING TOBACCO, ASH TRAYS NOT OF PRECIOUS METAL, MATCHES AND MATCH CONTAINERS NOT OF PRECIOUS METAL (U.S. CLS. 2, 8, 9 AND 17).

BRIAN NEVILLE, EXAMINING ATTORNEY

SN 78-855,922. AMERICAN HEART ASSOCIATION, INC.,  
DALLAS, TX. FILED 4-6-2006.



OWNER OF U.S. REG. NO. 2,927,372.

### CLASS 9—ELECTRICAL AND SCIENTIFIC APPARATUS

FOR COMPUTER SOFTWARE FOR USE IN REPORTING INFORMATION REGARDING IN-HOSPITAL CARDIOPULMONARY RESUSCITATION EVENTS, PROCESSES OF CARE AND PATIENT OUTCOME TO A CENTRAL REGISTRY DATABASE (U.S. CLS. 21, 23, 26, 36 AND 38).

### CLASS 44—MEDICAL, BEAUTY AND AGRICULTURAL SERVICES

FOR OPERATION OF REGISTRY AND MAINTAINING NATIONAL DATABASE OF INFORMATION REGARDING DATA FROM IN HOSPITAL CARDIOPULMONARY RESUSCITATION EVENTS, AND DISSEMINATION OF INFORMATION RELATING TO SUCH EVENTS, PROCESSES OF CARE AND PATIENT OUTCOME (U.S. CLS. 100 AND 101).

KATHLEEN M. VANSTON, EXAMINING ATTORNEY

SN 78-857,429. QUALITY ASSURED SERVICES, INC., ORLANDO, FL. FILED 4-10-2006.

# QAS

THE MARK CONSISTS OF STANDARD CHARACTERS WITHOUT CLAIM TO ANY PARTICULAR FONT, STYLE, SIZE, OR COLOR.

## CLASS 35—ADVERTISING AND BUSINESS

FOR ONLINE RETAIL STORE SERVICES FEATURING HEALTH SUPPLIES, NAMELY, AT HOME TESTING DEVICES FOR ANTICOAGULATION, BLOOD PRESSURE, CHOLESTEROL, DEFIBRILLATION, DIABETES, DISEASE SCREENINGS, FITNESS ANALYZERS, HEALTH SCREENINGS, AND LUNG FUNCTION TESTS (U.S. CLS. 100, 101 AND 102).

FIRST USE 4-1-1997; IN COMMERCE 4-1-1997.

## CLASS 41—EDUCATION AND ENTERTAINMENT

FOR TRAINING SERVICES VIA AN ONLINE WEBSITE IN THE FIELD OF MEDICAL EQUIPMENT (U.S. CLS. 100, 101 AND 107).

FIRST USE 4-1-1997; IN COMMERCE 4-1-1997.

## CLASS 44—MEDICAL, BEAUTY AND AGRICULTURAL SERVICES

FOR PROVIDING MEDICAL INFORMATION VIA AN ONLINE WEBSITE IN THE FIELD OF ANTICOAGULATION RESEARCH, MEDICATIONS, NUTRITION, THERAPY AND TESTING DEVICES (U.S. CLS. 100 AND 101).

FIRST USE 4-1-1997; IN COMMERCE 4-1-1997.

ELIZABETH HUGHITT, EXAMINING ATTORNEY

SN 78-858,993. FORD MOTOR COMPANY, DEARBORN, MI. FILED 4-11-2006.

# GREENER MILES

THE MARK CONSISTS OF STANDARD CHARACTERS WITHOUT CLAIM TO ANY PARTICULAR FONT, STYLE, SIZE, OR COLOR.

NO CLAIM IS MADE TO THE EXCLUSIVE RIGHT TO USE "GREENER", APART FROM THE MARK AS SHOWN.

## CLASS 16—PAPER GOODS AND PRINTED MATTER

FOR WINDOW STICKERS FOR MOTOR VEHICLES (U.S. CLS. 2, 5, 22, 23, 29, 37, 38 AND 50).

## CLASS 35—ADVERTISING AND BUSINESS

FOR PROMOTING PUBLIC AWARENESS OF THE NEED FOR PROGRAMS THAT ENCOURAGE ENVIRONMENTALLY-CONSCIOUS BEHAVIOR BY MOTOR VEHICLE OPERATORS; PROMOTING THE CARBON-OFFSET MOTOR VEHICLE OPERATOR PROGRAMS OF OTHERS BY DISTRIBUTING ADVERTISING MATERIALS THROUGH A VARIETY OF METHODS (U.S. CLS. 100, 101 AND 102).

NELSON SNYDER, EXAMINING ATTORNEY

SN 78-859,050. BULBS.COM INC., WORCESTER, MA. FILED 4-11-2006.



THE COLOR(S) YELLOW, ORANGE, BLACK AND WHITE IS/ARE CLAIMED AS A FEATURE OF THE MARK.

THE MARK CONSISTS OF BULBS.COM IN BLACK WITH THE "U" SHAPED LIKE A LIGHT BULB IN YELLOW, ORANGE, BLACK AND WHITE, AND THE WORDING "FAST. EASY. COMPLETE." IN ORANGE.

## CLASS 9—ELECTRICAL AND SCIENTIFIC APPARATUS

FOR BALLASTS FOR GAS DISCHARGE LAMPS; FLUORESCENT LAMP BALLAST FOR ELECTRIC LIGHTS; LIGHTING BALLASTS (U.S. CLS. 21, 23, 26, 36 AND 38).

FIRST USE 3-5-1999; IN COMMERCE 3-5-1999.

## CLASS 11—ENVIRONMENTAL CONTROL APPARATUS

FOR ELECTRIC LIGHT BULBS; ELECTRIC LIGHTING FIXTURES; FLOURESCENT ELECTRIC LIGHT BULBS; FLUORESCENT LAMP TUBES; FLUORESCENT LAMPS; FLUORESCENT LIGHTING TUBES; HALOGEN LIGHT BULBS; INCANDESCENT LAMPS; INCANDESCENT LIGHT BULBS; INFRARED LAMPS; LIGHT BULBS; LIGHTING TUBES; MERCURY LAMPS; MINIATURE LIGHT BULBS; ULTRAVIOLET LAMPS NOT FOR MEDICAL PURPOSES (U.S. CLS. 13, 21, 23, 31 AND 34).

FIRST USE 3-5-1999; IN COMMERCE 3-5-1999.

RAUL CORDOVA, EXAMINING ATTORNEY

SN 78-860,148. DIGITAL TRANSACTION MACHINES, INC., NEW YORK, NY. FILED 4-12-2006.

# Music Meals

THE MARK CONSISTS OF STANDARD CHARACTERS WITHOUT CLAIM TO ANY PARTICULAR FONT, STYLE, SIZE, OR COLOR.

NO CLAIM IS MADE TO THE EXCLUSIVE RIGHT TO USE "MUSIC", APART FROM THE MARK AS SHOWN.

## CLASS 9—ELECTRICAL AND SCIENTIFIC APPARATUS

FOR ELECTRONIC GAME PROGRAMS (U.S. CLS. 21, 23, 26, 36 AND 38).

**CLASS 35—ADVERTISING AND BUSINESS**

FOR CONTESTS AND INCENTIVE AWARD PROGRAMS TO PROMOTE THE SALE OF PRODUCTS AND SERVICES OF OTHERS (U.S. CLS. 100, 101 AND 102).

WILLIAM VERHOSEK, EXAMINING ATTORNEY

SN 78-862,105. STEWART, ROBERT B., ARLINGTON, VA. AND BANASZAK, DAMIAN, ANNANDALE, VA. FILED 4-14-2006.

# THE WANT

THE MARK CONSISTS OF STANDARD CHARACTERS WITHOUT CLAIM TO ANY PARTICULAR FONT, STYLE, SIZE, OR COLOR.

OWNER OF U.S. REG. NO. 2,252,779.

**CLASS 9—ELECTRICAL AND SCIENTIFIC APPARATUS**

FOR COMPACT DISCS FEATURING MUSIC (PRE-RECORDED) (U.S. CLS. 21, 23, 26, 36 AND 38).

FIRST USE 3-15-1995; IN COMMERCE 3-15-1995.

**CLASS 41—EDUCATION AND ENTERTAINMENT**

FOR ENTERTAINMENT NAMELY, LIVE PERFORMANCES BY A MUSICAL BAND (U.S. CLS. 100, 101 AND 107).

FIRST USE 10-1-1990; IN COMMERCE 10-29-1994.

DOMINIC FATHY, EXAMINING ATTORNEY

SN 78-863,605. GEORGE FOUNDATION COMPRISING CHARLES HERDER, GENE REED, MIKE WELLS, DEAN LEAMAN AND BILL JAMESON, ALL UNITED STATES CITIZENS, RICHMOND, TX. FILED 4-18-2006.

# GEORGE RANCH

THE MARK CONSISTS OF STANDARD CHARACTERS WITHOUT CLAIM TO ANY PARTICULAR FONT, STYLE, SIZE, OR COLOR.

OWNER OF U.S. REG. NO. 2,672,089.

NO CLAIM IS MADE TO THE EXCLUSIVE RIGHT TO USE "RANCH", APART FROM THE MARK AS SHOWN.

THE NAME(S), PORTRAIT(S), AND/OR SIGNATURE(S) SHOWN IN THE MARK DOES NOT IDENTIFY A PARTICULAR LIVING INDIVIDUAL.

**CLASS 35—ADVERTISING AND BUSINESS**

FOR CHARITABLE SERVICES, NAMELY ORGANIZING AND CONDUCTING VOLUNTEER PROGRAMS AND COMMUNITY SERVICE PROJECTS (U.S. CLS. 100, 101 AND 102).

FIRST USE 0-0-1987; IN COMMERCE 0-0-1987.

**CLASS 36—INSURANCE AND FINANCIAL**

FOR PROVIDING GRANTS TO ORGANIZATIONS, NAMELY HUMAN SERVICES, HEALTH CARE, EDUCATIONAL, HISTORICAL, COMMUNITY ENHANCEMENT, NON-PROFIT, AND ENVIRONMENTAL ORGANIZATIONS IN THE COMMUNITY; PROVIDING EDUCATIONAL SCHOLARSHIPS (U.S. CLS. 100, 101 AND 102).

FIRST USE 0-0-1987; IN COMMERCE 0-0-1987.

**CLASS 41—EDUCATION AND ENTERTAINMENT**

FOR HISTORICAL MUSEUM SERVICES; PROVIDING GUIDED TOURS OF HISTORICAL SITE; EDUCATIONAL SERVICES, NAMELY, CONDUCTING PROGRAMS IN THE FIELD OF TEXAS HISTORY; FACILITY RENTAL SERVICES FOR ENTERTAINMENT PURPOSES, NAMELY, COMPANY PICNICS, FAMILY AND GROUP GATHERINGS, PRIVATE PARTIES, WEDDING RECEPTIONS, DANCES, RODEOS, AND CORPORATE EVENTS AND MEETINGS (U.S. CLS. 100, 101 AND 107).

FIRST USE 0-0-1987; IN COMMERCE 0-0-1987.

DAVID C. REIHNER, EXAMINING ATTORNEY

SN 78-865,676. EASTERN MOUNTAIN SPORTS, INC., PETERBOROUGH, NH. FILED 4-20-2006.



OWNER OF U.S. REG. NOS. 1,398,955, 1,996,475 AND 3,011,752.

SEC. 2(F) AS TO "MOUNTAIN SPORTS".

**CLASS 8—HAND TOOLS**

FOR MULTI-PURPOSE POCKET KNIVES; AND CAMPING UTENSILS NAMELY KNIVES, FORKS AND SPOONS (U.S. CLS. 23, 28 AND 44).

**CLASS 9—ELECTRICAL AND SCIENTIFIC APPARATUS**

FOR COMPASSES, THERMOMETERS NOT FOR MEDICAL USE; PEDOMETERS; BINOCULARS; FLOTATION LIFE VESTS; SUNGLASS ACCESSORIES, NAMELY, SUNGLASS CASES AND SUNGLASS STRAPS (U.S. CLS. 21, 23, 26, 36 AND 38).

**CLASS 18—LEATHER GOODS**

FOR RUCKSACKS, FANNYPACKS; BRIEFCASES, SHOULDER BAGS; DUFFLE BAGS; FABRIC SACKS FOR STORING CAMPING EQUIPMENT; WALLET; TOTE BAGS; BACK PACKS; DOPP KITS; WAIST PACKS USED AS ORGANIZERS; UMBRELLAS AND WALKING STICKS (U.S. CLS. 1, 2, 3, 22 AND 41).

**CLASS 20—FURNITURE AND ARTICLES NOT OTHERWISE CLASSIFIED**

FOR SLEEPING BAGS; CAMP FURNITURE; NON-METAL KEY FOBS; AND NON-METAL TENT STAKES (U.S. CLS. 2, 13, 22, 25, 32 AND 50).

**CLASS 21—HOUSEWARES AND GLASS**

FOR PORTABLE COOLERS; FUNNELS FOR POURING FUEL; DISHES; VACUUM BOTTLES; PORTABLE FOOD CONTAINERS; CUPS; MUGS; PLASTIC WATER BOTTLES SOLD EMPTY; CANTEENS; POTS; PANS (U.S. CLS. 2, 13, 23, 29, 30, 33, 40 AND 50).

**CLASS 22—CORDAGE AND FIBERS**

FOR VINYL GROUND CLOTHS; FAMILY TENTS; BACKPACKING TENTS; FABRIC COVERS FOR TENTS; BIVOUAC SACKS, NAMELY, PORTABLE FABRIC SHELTERS; COVERS FOR PROTECTING TENT FLOORS; HAMMOCKS; BUNGEE CORDS; AND CORD (U.S. CLS. 1, 2, 7, 19, 22, 42 AND 50).

**CLASS 25—CLOTHING**

FOR CLOTHING AND SPORTSWEAR, NAMELY, JACKETS, ANORAKS, PARKAS, VESTS, PONCHOS, SNOW SUITS, SNOW PANTS, SKI BIBS, PANTS, CAPRIS, SHORTS, UNDERWEAR, BRAS, SWIM TRUNKS, SWIM SUITS, KNIT AND WOVEN TOPS, T-SHIRTS, SWEATERS, TIGHTS, SOCKS, GLOVES, BICYCLING GLOVES, HEADWEAR, NECKWEAR, BELTS, GAITERS AND FOOTWEAR (U.S. CLS. 22 AND 39).

**CLASS 28—TOYS AND SPORTING GOODS**

FOR ANKLE BANDS USED FOR BICYCLING (U.S. CLS. 22, 23, 38 AND 50).

**CLASS 35—ADVERTISING AND BUSINESS**

FOR RETAIL STORE AND ONLINE RETAIL STORE SERVICES FEATURING CLOTHING, SPORTSWEAR, AND HIKING, CAMPING AND CLIMBING EQUIPMENT (U.S. CLS. 100, 101 AND 102).

RUSS HERMAN, EXAMINING ATTORNEY

---

SN 78-867,129. TRIPP & ASSOCIATES, INC., PLYMOUTH, MN. FILED 4-21-2006.

**HOMELAND DEFENDER**

THE MARK CONSISTS OF STANDARD CHARACTERS WITHOUT CLAIM TO ANY PARTICULAR FONT, STYLE, SIZE, OR COLOR.

**CLASS 13—FIREARMS**

FOR FIREARMS AND AMMUNITION FOR FIREARMS (U.S. CLS. 2 AND 9).

**CLASS 25—CLOTHING**

FOR CLOTHING NAMELY, JACKETS, PANTS, CAPS AND BELTS (U.S. CLS. 22 AND 39).

STEPHANIE DAVIS, EXAMINING ATTORNEY

SN 78-868,411. YELLOW CHECKER CAB COMPANY, SAN JOSE, CA. FILED 4-24-2006.

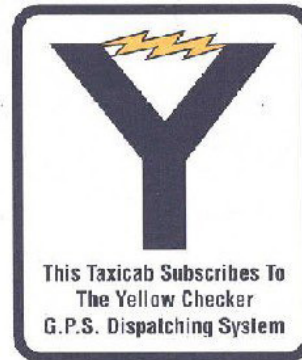

NO CLAIM IS MADE TO THE EXCLUSIVE RIGHT TO USE "THIS TAXICAB SUBSCRIBES TO THE YELLOW CHECKER G.P.S. DISPATCHING SYSTEM", APART FROM THE MARK AS SHOWN.

THE COLOR(S) BLACK AND YELLOW IS/ARE CLAIMED AS A FEATURE OF THE MARK.

THE COLOR BLACK APPEARS IN THE LETTER "Y", THE LANGUAGE "THIS TAXICAB SUBSCRIBES TO THE YELLOW CHECKER G.P.S. DISPATCHING SYSTEM", AND IN THE OUTLINE OF THE MARK; THE COLOR YELLOW APPEARS IN THE LIGHTNING BOLT.

**CLASS 38—COMMUNICATION**

FOR TELECOMMUNICATIONS SERVICES, NAMELY, ROUTING CALLS TO LOCAL THIRD-PARTY TAXI-CAB DISPATCHERS IN THE VICINITY OF THE CALLER (U.S. CLS. 100, 101 AND 104).

**CLASS 39—TRANSPORTATION AND STORAGE**

FOR TAXI TRANSPORTATION SERVICES, NAMELY TRANSPORT OF PASSENGERS BY TAXICAB (U.S. CLS. 100 AND 105).

Laurie Mayes, Examining Attorney

---

SN 78-868,841. RESOLVED TECHNOLOGIES, INC., TONEY, AL. FILED 4-25-2006.

**RESOLVED**

THE MARK CONSISTS OF STANDARD CHARACTERS WITHOUT CLAIM TO ANY PARTICULAR FONT, STYLE, SIZE, OR COLOR.

**CLASS 9—ELECTRICAL AND SCIENTIFIC APPARATUS**

FOR LABORATORY AND SCIENTIFIC TESTING EQUIPMENT, NAMELY LIQUID-HOLDING CONTAINERS FOR HOLDING VOLUME SAMPLES OF LIQUID AND REAGENTS FOR PERFORMING LABORATORY AND SCIENTIFIC TESTING AND ANALYSIS (U.S. CLS. 21, 23, 26, 36 AND 38).

**CLASS 42—SCIENTIFIC, COMPUTER AND LEGAL SERVICES**

FOR LABORATORY TESTING SERVICES IN THE FIELDS OF WATER TREATMENT AND WATER QUALITY, MEDICAL DIAGNOSTICS, PHARMACEUTICALS, AND FORENSIC SCIENCE (U.S. CLS. 100 AND 101).

WILLIAM P. SHANAHAH, EXAMINING ATTORNEY

**CLASS 40—MATERIAL TREATMENT**

FOR FABRICATION, PREPARATION, AND TREATMENT OF METALS AND METAL PRODUCTS COMPRISING FLAME CUTTING, SAWING, THREADING, PUNCHING, BENDING, WELDING, DRILLING, GRINDING, AND SHEARING, AND FABRICATION, PREPARATION, AND TREATMENT OF PLASTICS COMPRISING OF MILLING, SANDING, TURNING AND SPECIAL EXTRUSIONS (U.S. CLS. 100, 103 AND 106).

CHERYL CLAYTON, EXAMINING ATTORNEY

SN 78-868,874. RYERSON PROCUREMENT CORPORATION, CHICAGO, IL. FILED 4-25-2006.

SN 78-868,878. RYERSON PROCUREMENT CORPORATION, CHICAGO, IL. FILED 4-25-2006.



OWNER OF U.S. REG. NOS. 567,013, 2,631,496 AND 2,649,199.

THE MARK CONSISTS OF A STYLIZED R WITHIN A CIRCLE NEXT TO THE WORDS COLLADO RYERSON ABOVE THE WORDS THE STRENGTH IN METAL.



OWNER OF U.S. REG. NOS. 567,013, 2,631,496 AND 2,649,199.

THE MARK CONSISTS OF A STYLIZED R NEXT TO THE WORDS COLLADO RYERSON WITH A VERTICAL LINE SEPARATING THE WORDS COLLADO AND RYERSON ABOVE THE WORDS THE STRENGTH IN METAL.

**CLASS 6—METAL GOODS**

FOR STEEL IN BAR, ROD, SHEET, AND PLATE FORM; STEEL FLOOR PLATES AND TREAD PLATES; STRUCTURAL STEEL TUBING; EXPANDED STEEL SHEETS; CORRUGATED STEEL SHEETS; CORRUGATED STEEL SHEETS FOR CONSTRUCTION PURPOSES, NAMELY, IN THE WALL AND ROOF SECTION OF BUILDINGS; STAINLESS STEEL SOLD IN BULK; METAL CONSTRUCTION MATERIALS NAMELY, BAR, ROD, SHEET, AND PLATE SHAPES; METAL ROOFING AND ALUMINUM SIDING; METAL FLOOR PLATES AND TREAD PLATES; METAL OPEN FLOORING AND GRATING; ARCHITECTURAL METAL ROOFING IN STEEL AND ALUMINUM; METAL STRUCTURAL TUBING; METAL EXPANDED SHEETS AND GRATING; METAL PERFORATED SHEETS; METAL MECHANICAL TUBING; METAL THREADED TUBING AND BARS; METAL STRUCTURAL SHAPES FOR USE IN THE FURTHER MANUFACTURE OR FINISHED GOODS; METAL PIPE AND PIPE FITTINGS; CARBON STEEL; ALLOY STEEL; STRIP STEEL; SCREW STEEL; METAL SOLD IN BULK FOR FURTHER MANUFACTURING; STAINLESS STEEL; METAL FORGINGS; COLD ROLLED STEEL, FLAME CUT METAL SHAPES, FLAME CUT STEEL SHAPES AND METAL BANDS AND HOOPS; METAL SHAFTING; MACHINED METAL RINGS AND DISCS (U.S. CLS. 2, 12, 13, 14, 23, 25 AND 50).

**CLASS 35—ADVERTISING AND BUSINESS**

FOR WHOLESALE DISTRIBUTORSHIP AND RETAIL SERVICES BY DIRECT SOLICITATION BY SALES AGENTS IN THE FIELD OF STEEL, METAL AND FABRICATED METAL AND STEEL PRODUCTS MANUFACTURED BY OTHERS; AND PROVIDING PERSONAL COMPUTER-BASED ON-LINE ORDERING SERVICES FOR CARBON STEEL, STAINLESS STEEL, ALLOY STEEL, COPPER, NICKEL, PLASTIC, AND ALUMINUM STRUCTURAL COMPONENTS, NAMELY, ANGLES, BEAMS, CHANNELS, TEES, PLATES, BARS, SHEETS, COILS, TUBING, PIPE AND FLOORING AND GRATING PRODUCTS, AND FOR THE PROCESSING, MACHINING, AND FINISHING THEREOF; INVENTORY CONTROL SERVICES IN THE NATURE OF VENDOR MANAGEMENT OF CUSTOMER INVENTORIES AND RECEIPT OF GOODS FOR CUSTOMER INVENTORIES, PROVIDING A MAIL ORDER AND AN ON-LINE CATALOG OF THE GOODS AND SERVICES OF OTHERS IN THE FIELD OF STEEL, METAL, AND RELATED CONSTRUCTION EQUIPMENT (U.S. CLS. 100, 101 AND 102).

**CLASS 6—METAL GOODS**

FOR STEEL IN BAR, ROD, SHEET, AND PLATE FORM; STEEL FLOOR PLATES AND TREAD PLATES; STRUCTURAL STEEL TUBING; EXPANDED STEEL SHEETS; CORRUGATED STEEL SHEETS; CORRUGATED STEEL SHEETS FOR CONSTRUCTION PURPOSES, NAMELY, IN THE WALL AND ROOF SECTION OF BUILDINGS; STAINLESS STEEL SOLD IN BULK; METAL CONSTRUCTION MATERIALS NAMELY, BAR, ROD, SHEET, AND PLATE SHAPES; METAL ROOFING AND ALUMINUM SIDING; METAL FLOOR PLATES AND TREAD PLATES; METAL OPEN FLOORING AND GRATING; ARCHITECTURAL METAL ROOFING IN STEEL AND ALUMINUM; METAL STRUCTURAL TUBING; METAL EXPANDED SHEETS AND GRATING; METAL PERFORATED SHEETS; METAL MECHANICAL TUBING; METAL THREADED TUBING AND BARS; METAL STRUCTURAL SHAPES FOR USE IN THE FURTHER MANUFACTURE OR FINISHED GOODS; METAL PIPE AND PIPE FITTINGS; CARBON STEEL; ALLOY STEEL; STRIP STEEL; SCREW STEEL; METAL SOLD IN BULK FOR FURTHER MANUFACTURING; STAINLESS STEEL; METAL FORGINGS; COLD ROLLED STEEL, FLAME CUT METAL SHAPES, FLAME CUT STEEL SHAPES AND METAL BANDS AND HOOPS; METAL SHAFTING; MACHINED METAL RINGS AND DISCS (U.S. CLS. 2, 12, 13, 14, 23, 25 AND 50).

**CLASS 35—ADVERTISING AND BUSINESS**

FOR WHOLESALE DISTRIBUTORSHIP AND RETAIL SERVICES BY DIRECT SOLICITATION BY SALES AGENTS IN THE FIELD OF STEEL, METAL AND FABRICATED METAL AND STEEL PRODUCTS MANUFACTURED BY OTHERS; AND PROVIDING PERSONAL COMPUTER-BASED ON-LINE ORDERING SERVICES FOR CARBON STEEL, STAINLESS STEEL, ALLOY STEEL, COPPER, NICKEL, PLASTIC, AND ALUMINUM STRUCTURAL COMPONENTS, NAMELY, ANGLES, BEAMS, CHANNELS, TEES, PLATES, BARS, SHEETS, COILS, TUBING, PIPE AND FLOORING AND GRATING PRODUCTS, AND FOR THE PROCESSING, MACHINING, AND FINISHING THEREOF; INVENTORY CONTROL SERVICES IN THE NATURE OF VENDOR MANAGEMENT OF CUSTOMER INVENTORIES AND RECEIPT OF GOODS FOR CUSTOMER INVENTORIES, PROVIDING A MAIL ORDER AND AN ON-LINE CATALOG OF THE GOODS AND SERVICES OF OTHERS IN THE FIELD OF STEEL, METAL, AND RELATED CONSTRUCTION EQUIPMENT (U.S. CLS. 100, 101 AND 102).

**CLASS 40—MATERIAL TREATMENT**

FOR FABRICATION, PREPARATION, AND TREATMENT OF METALS AND METAL PRODUCTS COMPRISING FLAME CUTTING, SAWING, THREADING, PUNCHING, BENDING, WELDING, DRILLING, GRINDING, AND SHEARING, AND FABRICATION, PREPARATION, AND TREATMENT OF PLASTICS COMPRISING OF MILLING, SANDING, TURNING AND SPECIAL EXTRUSIONS (U.S. CLS. 100, 103 AND 106).

CHERYL CLAYTON, EXAMINING ATTORNEY

---

SN 78-869,825. HOLLANDER HOME FASHIONS CORP., BOCA RATON, FL. FILED 4-26-2006.

**VELVET COMFORT**

THE MARK CONSISTS OF STANDARD CHARACTERS WITHOUT CLAIM TO ANY PARTICULAR FONT, STYLE, SIZE, OR COLOR.

NO CLAIM IS MADE TO THE EXCLUSIVE RIGHT TO USE "VELVET", APART FROM THE MARK AS SHOWN.

**CLASS 20—FURNITURE AND ARTICLES NOT OTHERWISE CLASSIFIED**

FOR PILLOWS (U.S. CLS. 2, 13, 22, 25, 32 AND 50).  
FIRST USE 8-17-2006; IN COMMERCE 8-17-2006.

**CLASS 24—FABRICS**

FOR MATTRESS PADS (U.S. CLS. 42 AND 50).  
FIRST USE 8-17-2006; IN COMMERCE 8-17-2006.  
PETER B. BROMAGHIM, EXAMINING ATTORNEY

---

SN 78-870,043. HARRISON, TYLER, LONG BEACH, CA. AND LAIKEN, JESSIE, LONG BEACH, CA. FILED 4-26-2006.

THE ENGLISH TRANSLATION OF THE WORDING 'LE BEBE' IN THE MARK IS 'THE BABY'.

**CLASS 3—COSMETICS AND CLEANING PREPARATIONS**

FOR COSMETIC AND SKIN CARE PRODUCTS, NAMELY, BATH FOAM, BUBBLE BATH, LOTIONS FOR THE HANDS, BODY, FEET, AND FACE, NON-MEDICATED CRADLE CAP BABY LOTION, NON-MEDICATED DIAPER RASH LOTIONS AND OINTMENTS, SOAP, HAIR SHAMPOO AND HAIR CONDITIONER, BODY CONDITIONER, BABY POWDER, BODY POWDER, BABY WIPES, BODY SPRAYS, NAIL POLISH, SUN BLOCK, LIP BALM, LIPSTICK, EYE SHADOW, COSMETIC PREPARATIONS FOR FACIAL SKIN RENEWAL AND BODY CARE (U.S. CLS. 1, 4, 6, 50, 51 AND 52).

**CLASS 12—VEHICLES**

FOR BABY STROLLERS (U.S. CLS. 19, 21, 23, 31, 35 AND 44).

**CLASS 18—LEATHER GOODS**

FOR DIAPER BAGS (U.S. CLS. 1, 2, 3, 22 AND 41).

**CLASS 25—CLOTHING**

FOR CLOTHING, NAMELY, T-SHIRTS, HATS, JACKETS, SHIRTS, SWEATERS, PANTS, SKIRTS, PAJAMAS, UNDERWEAR AND HEADBANDS (U.S. CLS. 22 AND 39).

**CLASS 26—FANCY GOODS**

FOR HAIR ACCESSORIES, NAMELY, HAIR BOWS, BARRETTES, HAIR CLIPS, HAIR TIES IN THE NATURE OF HAIR BANDS (U.S. CLS. 37, 39, 40, 42 AND 50).

**CLASS 28—TOYS AND SPORTING GOODS**

FOR GAMES AND TOYS, NAMELY BABY MULTIPLE ACTIVITY TOYS, DOLLS, PLUSH TOYS, AND TOY BUILDING BLOCKS (U.S. CLS. 22, 23, 38 AND 50).  
COLLEEN DOMBROW, EXAMINING ATTORNEY

---

SN 78-870,964. AUTHENTIDATE HOLDING CORP., BERKELEY HEIGHTS, NJ. FILED 4-27-2006.

# ETM

THE MARK CONSISTS OF STANDARD CHARACTERS WITHOUT CLAIM TO ANY PARTICULAR FONT, STYLE, SIZE, OR COLOR.

**CLASS 35—ADVERTISING AND BUSINESS**

FOR DATA PROCESSING SERVICES, NAMELY, CODING OF DOCUMENTS AND DATA FILES AND COMPARING DOCUMENTS AND DATA FILES, AND CONSULTATION SERVICES RELATED THERETO (U.S. CLS. 100, 101 AND 102).

**CLASS 39—TRANSPORTATION AND STORAGE**

FOR ELECTRONIC STORAGE AND RETRIEVAL OF DOCUMENTS AND DATA FILES, AND CONSULTATION SERVICES RELATED THERETO (U.S. CLS. 100 AND 105).



**CLASS 40—MATERIAL TREATMENT**

FOR CONVERSION OF DOCUMENTS INTO ELECTRONIC, MAGNETIC, OPTICAL OR OTHER FORMATS, AND CONSULTATION SERVICES RELATED THERETO (U.S. CLS. 100, 103 AND 106).

**CLASS 42—SCIENTIFIC, COMPUTER AND LEGAL SERVICES**

FOR CONSULTING SERVICES, NAMELY SOFTWARE DEVELOPMENT AND MAINTENANCE OF INTERFACES TO SYSTEMS FOR AUTHENTICATION, TIME STAMPING AND VERIFICATION OF DOCUMENTS AND DATA FILES (U.S. CLS. 100 AND 101).

**CLASS 45—PERSONAL SERVICES**

FOR DOCUMENT AND DATA MANAGEMENT AND PROCESSING SERVICES, NAMELY, AUTHENTICATION, TIME STAMPING AND VERIFICATION OF DOCUMENTS AND DATA FILES, AND CONSULTATION SERVICES RELATED THERETO (U.S. CLS. 100 AND 101).

MELVIN AXILBUND, EXAMINING ATTORNEY

SN 78-871,028. OUTRIGGER HOTELS HAWAII, HONOLULU, HI. FILED 4-27-2006.



OWNER OF U.S. REG. NOS. 1,562,706, 1,992,873 AND OTHERS.

NO CLAIM IS MADE TO THE EXCLUSIVE RIGHT TO USE "ENTERPRISES GROUP", APART FROM THE MARK AS SHOWN.

THE MARK CONSISTS OF A DESIGN OF AN OUTRIGGER CANOE ON WATER.

**CLASS 35—ADVERTISING AND BUSINESS**

FOR ACCOMMODATION MANAGEMENT SERVICES, NAMELY MANAGEMENT OF HOTELS AND MOTELS FOR OTHERS (U.S. CLS. 100, 101 AND 102).

**CLASS 36—INSURANCE AND FINANCIAL**

FOR VACATION REAL ESTATE TIME SHARING SERVICES; REAL ESTATE PROPERTY MANAGEMENT AND LEASING OF SHOPPING CENTERS AND RETAIL FACILITIES; MANAGEMENT OF VACATION CONDOMINIUMS AND VACATION APARTMENTS FOR OTHERS (U.S. CLS. 100, 101 AND 102).

**CLASS 37—CONSTRUCTION AND REPAIR**

FOR REAL PROPERTY DEVELOPMENT SERVICES, NAMELY PLANNING AND DEVELOPMENT OF SHOPPING CENTERS, RETAIL FACILITIES, HOTELS, MOTELS, RESORTS AND CONDOMINIUMS (U.S. CLS. 100, 103 AND 106).

**CLASS 43—HOTEL AND RESTAURANT SERVICES**

FOR HOTEL AND MOTEL SERVICES; RESORT LODGING SERVICES; PROVIDING TEMPORARY ACCOMMODATIONS; BAR AND RESTAURANT SERVICES; PROVIDING LODGING AND MEALS TO CLIENTS OF A HEALTH AND BEAUTY SPA; MAKING TEMPORARY LODGING RESERVATIONS FOR OTHERS (U.S. CLS. 100 AND 101).

CATHERINE FAINT, EXAMINING ATTORNEY

SN 78-871,204. JAGGED EXTREME, LLC, PHOENIX, AZ. FILED 4-27-2006.

**JAGGED EXTREME**

THE MARK CONSISTS OF STANDARD CHARACTERS WITHOUT CLAIM TO ANY PARTICULAR FONT, STYLE, SIZE, OR COLOR.

**CLASS 37—CONSTRUCTION AND REPAIR**

FOR CUSTOM REBUILDING OF EXISTING LAND VEHICLES AND STRUCTURAL PARTS THEREFOR (U.S. CLS. 100, 103 AND 106).

FIRST USE 11-20-2003; IN COMMERCE 3-24-2004.

**CLASS 40—MATERIAL TREATMENT**

FOR CUSTOM FABRICATION OF LAND VEHICLES AND STRUCTURAL PARTS THEREOF, NAMELY, FOR OFF-ROAD VEHICLES (U.S. CLS. 100, 103 AND 106).

FIRST USE 11-20-2003; IN COMMERCE 3-24-2004.

DANIEL BRODY, EXAMINING ATTORNEY

SN 78-871,371. MARINI, VALERIA, ROME, ITALY, FILED 4-27-2006.



NO CLAIM IS MADE TO THE EXCLUSIVE RIGHT TO USE "DIAMONDS", APART FROM THE MARK AS SHOWN.

THE NAME "VALERIA MARINI" IDENTIFIES A LIVING INDIVIDUAL WHOSE CONSENT IS OF RECORD.

THE MARK CONSISTS OF AN IMAGE OF A PAIR OF HUMAN LIPS WITH THE TERMS SEDUZIONI DIAMONDS VALERIA MARINI SUPERIMPOSED OVER SAME.

THE ENGLISH TRANSLATION OF THE WORD SEDUZIONI IN THE MARK IS SEDUCTIONS.

**CLASS 9—ELECTRICAL AND SCIENTIFIC APPARATUS**

FOR SUNGLASSES (U.S. CLS. 21, 23, 26, 36 AND 38).

**CLASS 14—JEWELRY**

FOR COSTUME JEWELRY (U.S. CLS. 2, 27, 28 AND 50).

**CLASS 18—LEATHER GOODS**

FOR HANDBAGS; TRAVEL BAGS (U.S. CLS. 1, 2, 3, 22 AND 41).

**CLASS 25—CLOTHING**

FOR BATH SLIPPERS; BATHROBES; BEACHWEAR; LINGERIE; NIGHTWEAR; SHOWER CAPS; SWIM WEAR; UNDERWEAR (U.S. CLS. 22 AND 39).  
CAROL SPILS, EXAMINING ATTORNEY

SN 78-871,914. MARINI, VALERIA, ROME, ITALY, FILED 4-28-2006.



OWNER OF ERPN CMNTY TM OFC REG. NO. 4280038, DATED 3-3-2006, EXPIRES 3-3-2016.

THE NAME "VALERIA MARINI" IDENTIFIES A LIVING INDIVIDUAL WHOSE CONSENT IS OF RECORD.

THE MARK CONSISTS OF AN IMAGE OF A PAIR OF HUMAN LIPS WITH THE TERM SEDUZIONI APPEARING ABOVE THE TOP LIP AND THE TERM VALERIA MARINI APPEARING BELOW THE BOTTOM LIP.

THE ENGLISH TRANSLATION OF THE WORD "SEDUZIONI" IN THE MARK IS "SEDUCTIONS".

**CLASS 9—ELECTRICAL AND SCIENTIFIC APPARATUS**

FOR SUNGLASSES (U.S. CLS. 21, 23, 26, 36 AND 38).

**CLASS 14—JEWELRY**

FOR COSTUME JEWELRY (U.S. CLS. 2, 27, 28 AND 50).

**CLASS 18—LEATHER GOODS**

FOR HANDBAGS; TRAVEL BAGS (U.S. CLS. 1, 2, 3, 22 AND 41).

**CLASS 25—CLOTHING**

FOR BATH SLIPPERS; BATHROBES; BEACHWEAR; LINGERIE; NIGHTWEAR; SHOWER CAPS; SWIM WEAR; UNDERWEAR (U.S. CLS. 22 AND 39).  
CAROL SPILS, EXAMINING ATTORNEY

SN 78-876,675. LEE, SEUNGHWAN, BUCHEON, REPUBLIC OF KOREA, FILED 5-4-2006.

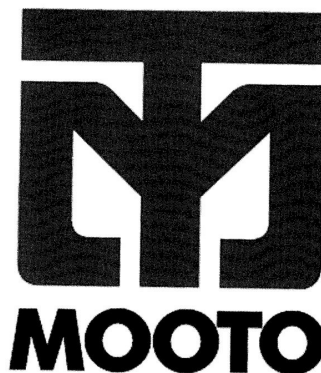

THE MARK CONSISTS OF A LOGO WITH SYLIZED LETTERS "M" AND "T" TOGETHER AND THE WORDS "MOOTO" UNDERNEATH.

THE FOREIGN WORDING IN THE MARK TRANSLATES INTO ENGLISH AS CHIVALRY, KNIGHTHOOD.

**CLASS 9—ELECTRICAL AND SCIENTIFIC APPARATUS**

FOR PROTECTIVE WORK GLOVES, SAFETY HELMETS, SPORTS HELMETS, PROTECTION MASKS, COMPUTER PROGRAM RECORDED ON DATA MEDIA FOR USE IN DATABASE MANAGEMENT, USE AS A SPREADSHEET IN THE FIELD OF MARTIAL ARTS; COMPUTER SOFTWARE FOR ACCESSING INFORMATION DIRECTORIES THAT MAY BE DOWNLOADED FROM A GLOBAL COMPUTER NETWORK IN THE FIELD OF MARTIAL ARTS; SOUND RECORDED MAGNETIC CARDS, SHEETS AND TAPES, PRE-RECORDED CD'S, VIDEO TAPES, LASER DISKS AND DVD'S FEATURING MARTIAL ARTS (U.S. CLS. 21, 23, 26, 36 AND 38).

FIRST USE 2-1-2002; IN COMMERCE 2-1-2002.

**CLASS 25—CLOTHING**

FOR GLOVES, SHOES, TRAINING SHOES, TAEKWONDO SUITS, UNIFORMS FOR EXERCISES, TEE-SHIRTS, BOXING SHOES, JUDO SUITS, KUMDO SUITS, KOREAN FENCING SUITS, SPORTS SHIRTS, ANORAKS FOR EXERCISES, CAPS HEADWEAR, KNEE TROUSERS, TANK TOPS, PULLOVERS, SANDALS, SLIPPERS (U.S. CLS. 22 AND 39).

FIRST USE 2-1-2002; IN COMMERCE 2-1-2002.

**CLASS 28—TOYS AND SPORTING GOODS**

FOR BOXING GLOVES, KARATE GLOVES, WEIGHT LIFTING GLOVES, WORK-OUT GLOVES, KNEE GUARDS FOR ATHLETIC USE, SPORTS EQUIPMENT FOR BOXING, MARTIAL ARTS, AND THE LIKE, NAMELY PROTECTIVE BRAS, PUNCHING BALLS, BOXING BAGS, ATHLETIC SPORTING GOODS, NAMELY, ATHLETIC WRIST AND JOINT SUPPORTS, ATHLETIC MOUTHPIECES (U.S. CLS. 22, 23, 38 AND 50).

FIRST USE 2-1-2002; IN COMMERCE 2-1-2002.

**CLASS 41—EDUCATION AND ENTERTAINMENT**

FOR PUBLICATION OF ELECTRONIC MAGAZINES, PUBLICATION OF ELECTRONIC NEWSPAPERS ACCESSIBLE VIA A GLOBAL COMPUTER NETWORK, NEWS SYNDICATION FOR THE BROADCASTING INDUSTRY, PHOTOGRAPHIC REPORTING, PUBLISHING OF ELECTRONIC PUBLICATIONS, INFORMATION ON EDUCATION, EDUCATIONAL SERVICES, NAMELY, DEVELOPING MARTIAL ART INSTRUCTORS AND PROVIDING COURSES OF MARTIAL ARTS INSTRUCTION, OPERATING OF MARTIAL ARTS' SCHOOLS; MARTIAL ARTS INSTRUCTION; SPORT CAMPS; OPERATION OF SPORTS CAMPS (U.S. CLS. 100, 101 AND 107).

FIRST USE 2-1-2002; IN COMMERCE 2-1-2002.  
LAURIE KAUFMAN, EXAMINING ATTORNEY

SN 78-882,752. BLUE OCEAN TRADEMARKS NV, CURA-CAO, NETHERLD ANTILLES, FILED 5-12-2006.



PRIORITY CLAIMED UNDER SEC. 44(D) ON ERPN CMNTY TM OFC APPLICATION NO. 5060959, FILED 5-5-2006, REG. NO. 12520, DATED 5-15-2006, EXPIRES 5-15-2016.

THE MARK CONSISTS OF A STYLIZED LETTER "E" WHICH SUGGESTS A WAVING FLAG.

SN 78-880,193. COURTROOM TELEVISION NETWORK LLC, NEW YORK, NY. FILED 5-10-2006.

---

## BODY OF EVIDENCE

THE MARK CONSISTS OF STANDARD CHARACTERS WITHOUT CLAIM TO ANY PARTICULAR FONT, STYLE, SIZE, OR COLOR.

**CLASS 9—ELECTRICAL AND SCIENTIFIC APPARATUS**

FOR IMAGES HELD IN ELECTRONIC FORMAT, NAMELY AN ELECTRONIC DATABASE FEATURING IMAGES RECORDED ON COMPUTER MEDIA; ELECTRONIC GAME SOFTWARE ACCESSIBLE VIA A GLOBAL COMPUTER NETWORK; DOWNLOADABLE RING TONES VIA A GLOBAL COMPUTER NETWORK AND WIRELESS DEVICES; ANIMATED COMPUTER SCREENSAVER SOFTWARE DOWNLOADABLE VIA A GLOBAL COMPUTER NETWORK; AUDIO AND VIDEO RECORDINGS, DOWNLOADABLE PRE-RECORDED AUDIO AND VIDEO RECORDINGS, TEXT AND GRAPHICS FOR ELECTRONIC PERSONAL COMPUTERS AND HANDHELD WIRELESS DEVICES, ALL IN THE FIELD OF JUDICIAL TRIALS, JUDICIAL NEWS AND ISSUES, LEGAL ISSUES, CRIMINAL INQUIRIES, CASE ANALYSES AND CASE COMMENTARIES (U.S. CLS. 21, 23, 26, 36 AND 38).

**CLASS 38—COMMUNICATION**

FOR WIRELESS COMMUNICATION SERVICES, NAMELY, ELECTRONIC TRANSMISSION OF TEXT, DATA, AUDIO AND VIDEO VIA CABLE, WIRELESS COMMUNICATIONS NETWORKS AND THE INTERNET; STREAMING OF AUDIO AND STREAMING OF VIDEO MATERIAL ON THE INTERNET AND WIRELESS DEVICES (U.S. CLS. 100, 101 AND 104).

ESTHER BELENKER, EXAMINING ATTORNEY

**CLASS 9—ELECTRICAL AND SCIENTIFIC APPARATUS**

FOR AUDIO RECORDINGS, VIDEO RECORDINGS AND AUDIO-VISUAL RECORDINGS, ALL FEATURING GOLF AND GOLF INSTRUCTION; PRE-RECORDED AUDIO, VIDEO AND AUDIO-VISUAL CASSETTES, TAPES AND DISCS, ALL FEATURING GOLF AND GOLF INSTRUCTION; PRE-RECORDED COMPACT DISCS, READ-ONLY MEMORY COMPACT DISCS AND DVDS, ALL FEATURING GOLF AND GOLF INSTRUCTION; COMPUTER GAME CARTRIDGES; COMPUTER GAME CASSETTES, COMPUTER GAME DISCS, INTERACTIVE MULTIMEDIA COMPUTER GAME PROGRAMS; COMPUTER GAME TAPES, COMPUTER GAME SOFTWARE, EDUCATIONAL SOFTWARE FEATURING INSTRUCTION IN GOLF; VIDEO GAME CARTRIDGES; VIDEO GAME DISCS, VIRTUAL REALITY SOFTWARE FOR GOLF PLAY SIMULATION AND INSTRUCTIONS; DOWNLOADABLE ELECTRONIC PUBLICATIONS IN THE NATURE OF BOOKS, MANUALS, CATALOGS AND EDUCATIONAL MATERIALS IN THE FIELD OF GOLF; DOWNLOADABLE VIDEO RECORDINGS FEATURING GOLF AND GOLF INSTRUCTION; DOWNLOADABLE GRAPHICS FOR USE ON MOBILE TELEPHONES; EYEGLASSES; SUNGLASSES; EYEGLASS CASES; CHAINS, NECK CORDS AND FRAMES; SUNGLASS CASES, CHAINS, CORDS AND FRAMES (U.S. CLS. 21, 23, 26, 36 AND 38).

**CLASS 16—PAPER GOODS AND PRINTED MATTER**

FOR PRINTED INSTRUCTIONAL AND TEACHING MATERIALS CONCERNING GOLF; BOOKS, PAMPHLETS, INSTRUCTION MANUALS, MAGAZINES AND PERIODICALS ABOUT GOLF; ALBUMS FOR STICKERS; STATIONERY; PHOTOGRAPHS; POSTERS; CALENDARS; PENS; PENCILS; NOTEBOOKS; POSTCARDS; DECALCOMANIAS; STICKERS; ADVERTISING PAMPHLETS; GOLF SCORE CARDS (U.S. CLS. 2, 5, 22, 23, 29, 37, 38 AND 50).

**CLASS 25—CLOTHING**

FOR FOOTWEAR; HEADWEAR; GLOVES; SUN VISORS; TIES; SOCKS; GOLF SHOES; HATS; CAPS; BELTS; SWIMWEAR; BLOUSONS; CARDIGANS; COATS; GOLF CAPS; GOLF SHIRTS; GOLF TROUSERS; JACKETS; JERSEYS; JOGGING PANTS; JOGGING SUITS; OVERTROUSERS; TROUSERS; POLO SHIRTS; PULLOVERS; QUILTED VESTS; RAINWEAR SHIRTS; SHORTS; SWEATPANTS; SWEATSHIRTS; SWEATBANDS; TANK TOPS; T-SHIRTS; TRACK SUITS; WINDCHEATERS AND WRISTBANDS (U.S. CLS. 22 AND 39).

**CLASS 28—TOYS AND SPORTING GOODS**

FOR GOLF BAGS, BALLS, CLUBS, BALL AND TEE MARKERS, TEES, BAG COVERS, BAG TAGS, AND GLOVES; BOARD GAMES; CARD GAMES; PLAYING CARDS; PUZZLES; PUTTING PRACTICE MATS; STUFFED TOYS; PLUSH TOYS; HEAD COVERS FOR GOLF CLUBS; GOLF CLUB PROTECTORS (U.S. CLS. 22, 23, 38 AND 50).

**CLASS 33—WINES AND SPIRITS**

FOR WINES, CHAMPAGNES (U.S. CLS. 47 AND 49).

**CLASS 42—SCIENTIFIC, COMPUTER AND LEGAL SERVICES**

FOR LANDSCAPE, ARCHITECTURAL DESIGN; ENVIRONMENTAL PLANNING AND CONSERVATION, NAMELY, CONSERVATION OF NATURE, CONSERVATION OF WILDLIFE AND SUSTAINABLE USE OF NATURAL RESOURCES DURING THE ARCHITECTURAL DESIGN AND PLANNING OF RECREATIONAL FACILITIES (U.S. CLS. 100 AND 101).

**CLASS 44—MEDICAL, BEAUTY AND AGRICULTURAL SERVICES**

FOR GOLF COURSE DESIGN AND CONSULTANCY SERVICES IN REGARD TO GOLF COURSE DESIGN (U.S. CLS. 100 AND 101).  
STEVEN JACKSON, EXAMINING ATTORNEY

---

SN 78-885,102. CHIEN COATURE LLC, RACINE, WI. FILED 5-16-2006.

NO CLAIM IS MADE TO THE EXCLUSIVE RIGHT TO USE "CHIEN COUTURE", APART FROM THE MARK AS SHOWN.

THE MARK CONSISTS OF STYLIZED WORDS "CHIEN COATURE." THE FIRST LETTER OF THE WORD "CHIEN" IS CONFINED WITHIN A RECTANGLE.

THE ENGLISH TRANSLATION OF "CHIEN" IS "DOG".

**CLASS 18—LEATHER GOODS**

FOR CLOTHING FOR DOMESTIC PETS; COLLARS FOR PETS; LEASHES FOR ANIMALS (U.S. CLS. 1, 2, 3, 22 AND 41).

FIRST USE 3-15-2006; IN COMMERCE 3-15-2006.

**CLASS 35—ADVERTISING AND BUSINESS**

FOR ON-LINE RETAIL STORE SERVICES FEATURING CLOTHING FOR DOMESTIC PETS, COLLARS FOR PETS AND LEASHES FOR ANIMALS; DIRECT RESPONSE RETAIL SERVICES THROUGH PUBLIC TRADE SHOWS AND WHOLESALE ORDERING SERVICES IN THE FIELD OF CLOTHING FOR DOMESTIC PETS, COLLARS FOR PETS AND LEASHES FOR ANIMALS (U.S. CLS. 100, 101 AND 102).

FIRST USE 3-15-2006; IN COMMERCE 3-15-2006.  
RONALD MCMORROW, EXAMINING ATTORNEY

SN 78-891,463. BOREALIS A/S, KONGENS LYNGBY, DENMARK, FILED 5-24-2006.

**SHAPING THE FUTURE WITH PLASTICS**

THE MARK CONSISTS OF STANDARD CHARACTERS WITHOUT CLAIM TO ANY PARTICULAR FONT, STYLE, SIZE, OR COLOR.

OWNER OF ERPN CMNTY TM OFC REG. NO. 4388344, DATED 5-11-2006, EXPIRES 4-14-2015.

**CLASS 1—CHEMICALS**

FOR UNPROCESSED ARTIFICIAL RESINS FOR USE AS RAW MATERIAL FOR USE IN THE PLASTICS INDUSTRY; UNPROCESSED PLASTICS IN PELLET FORM; POLYETHYLENE RESINS; POLYPROPYLENE RESINS; POLYOLEFINS FOR USE AS RAW MATERIAL IN THE PLASTICS INDUSTRY (U.S. CLS. 1, 5, 6, 10, 26 AND 46).

**CLASS 17—RUBBER GOODS**

FOR SEMI-PROCESSED PLASTIC IN THE FORM OF PELLETS; PLASTICS IN EXTRUDED FORM FOR USE IN PRODUCTION OF PLASTIC ARTICLES (U.S. CLS. 1, 5, 12, 13, 35 AND 50).

ASMAT KHAN, EXAMINING ATTORNEY

---

SN 78-891,474. THE GUILD, INC., MADISON, WI. FILED 5-24-2006.

**THE ARTFUL HOME**

THE MARK CONSISTS OF STANDARD CHARACTERS WITHOUT CLAIM TO ANY PARTICULAR FONT, STYLE, SIZE, OR COLOR.

OWNER OF U.S. REG. NO. 2,762,661.

NO CLAIM IS MADE TO THE EXCLUSIVE RIGHT TO USE "HOME", APART FROM THE MARK AS SHOWN.

**CLASS 35—ADVERTISING AND BUSINESS**

FOR MAIL ORDER CATALOG AND ONLINE RETAIL STORE SERVICES FEATURING FINE CRAFTS, ART, HOME DECOR, FURNITURE, LIGHTING, ART GLASS, CERAMICS, SCULPTURE, PRINTS, JEWELRY AND GIFTS; PROVIDING AN ONLINE COMPUTER DATABASE FEATURING TRADE AND CONSUMER INFORMATION IN THE FIELD OF FINE CRAFTS, ART, ARTISTS, HOME DECOR, AND JEWELRY (U.S. CLS. 100, 101 AND 102).

FIRST USE 9-30-2004; IN COMMERCE 9-30-2004.

**CLASS 41—EDUCATION AND ENTERTAINMENT**

FOR PROVIDING AN ON-LINE PUBLICATION IN THE NATURE OF A NEWSLETTER FEATURING FINE CRAFTS, ART, ARTISTS, HOME DECOR, AND JEWELRY (U.S. CLS. 100, 101 AND 107).

FIRST USE 2-28-2003; IN COMMERCE 2-28-2003.  
RUSS HERMAN, EXAMINING ATTORNEY

SN 78-891,542. MERCK & CO., INC., WHITEHOUSE STATION, NJ. FILED 5-24-2006.

SN 78-892,471. PUBLISHING HOUSE OF THE EVANGELICAL LUTHERAN CHURCH IN AMERICA, MINNEAPOLIS, MN. FILED 5-25-2006.

## CHEMISTRY'S CONSTANT COMPANION

THE MARK CONSISTS OF STANDARD CHARACTERS WITHOUT CLAIM TO ANY PARTICULAR FONT, STYLE, SIZE, OR COLOR.

NO CLAIM IS MADE TO THE EXCLUSIVE RIGHT TO USE "CHEMISTRY'S", APART FROM THE MARK AS SHOWN.

### CLASS 9—ELECTRICAL AND SCIENTIFIC APPARATUS

FOR ELECTRONIC PUBLICATIONS, NAMELY, BOOKS RECORDED ON CD-ROMS IN THE FIELD OF SCIENCE (U.S. CLS. 21, 23, 26, 36 AND 38).

FIRST USE 8-25-2001; IN COMMERCE 8-25-2001.

### CLASS 16—PAPER GOODS AND PRINTED MATTER

FOR PUBLICATIONS, NAMELY, BOOKS IN THE FIELD OF SCIENCE (U.S. CLS. 2, 5, 22, 23, 29, 37, 38 AND 50).

FIRST USE 8-25-2001; IN COMMERCE 8-25-2001.  
KELLY CHOE, EXAMINING ATTORNEY

SN 78-892,399. MAD DOC SOFTWARE, LLC, ANDOVER, MA. FILED 5-25-2006.

## RUIN

THE MARK CONSISTS OF STANDARD CHARACTERS WITHOUT CLAIM TO ANY PARTICULAR FONT, STYLE, SIZE, OR COLOR.

### CLASS 9—ELECTRICAL AND SCIENTIFIC APPARATUS

FOR PRERECORDED ELECTRONIC MEDIA, NAMELY, VIDEOTAPES AND DVDS CONTAINING MOVIES AND TELEVISION SHOWS FEATURING DRAMA AND ADVENTURE (U.S. CLS. 21, 23, 26, 36 AND 38).

### CLASS 41—EDUCATION AND ENTERTAINMENT

FOR PRODUCTION AND DISTRIBUTION OF TELEVISION SHOWS AND MOVIES (U.S. CLS. 100, 101 AND 107).

C. DIONNE CLYBURN, EXAMINING ATTORNEY

## LaREFORMA

THE MARK CONSISTS OF STANDARD CHARACTERS WITHOUT CLAIM TO ANY PARTICULAR FONT, STYLE, SIZE, OR COLOR.

THE FOREIGN WORDING IN THE MARK TRANSLATES INTO ENGLISH AS THE REFORMATION.

### CLASS 16—PAPER GOODS AND PRINTED MATTER

FOR PRINTED PUBLICATIONS, NAMELY, BOOKS, MANUALS, WORKBOOKS, POSTERS, LEAFLETS, BOOKLETS AND ACTIVITY BOOKS, ALL IN THE FIELD OF RELIGIOUS TOPICS, SPIRITUAL TOPICS, ETHICAL TOPICS, AND EDUCATIONAL TOPICS FEATURING RELIGION, SPIRITUALITY AND ETHICS (U.S. CLS. 2, 5, 22, 23, 29, 37, 38 AND 50).

### CLASS 41—EDUCATION AND ENTERTAINMENT

FOR PROVIDING ONLINE BOOKS, MANUALS, WORKBOOKS, POSTERS, LEAFLETS, BOOKLETS AND ACTIVITY BOOKS, DISTRIBUTED ONLINE VIA THE INTERNET, IN THE FIELD OF RELIGIOUS TOPICS, SPIRITUAL TOPICS, ETHICAL TOPICS, AND EDUCATIONAL TOPICS FEATURING RELIGION, SPIRITUALITY AND ETHICS (U.S. CLS. 100, 101 AND 107).

JENNIFER KRISP, EXAMINING ATTORNEY

SN 78-893,262. SANGER BOATS, INC., FRESNO, CA. FILED 5-25-2006.



NO CLAIM IS MADE TO THE EXCLUSIVE RIGHT TO USE "BOATS", APART FROM THE MARK AS SHOWN.

THE MARK CONSISTS OF A CARTOON FIGURE OF A MAN PICTURED ON A SPEED BOAT AND THE WORDS SANGER BOATS INSIDE A CIRCLE DESIGN.

### CLASS 12—VEHICLES

FOR BOATS AND STRUCTURAL PARTS THEREFOR (U.S. CLS. 19, 21, 23, 31, 35 AND 44).

FIRST USE 8-1-1971; IN COMMERCE 9-1-1971.

### CLASS 25—CLOTHING

FOR CLOTHING NAMELY T-SHIRTS, POLO SHIRTS, AND HATS (U.S. CLS. 22 AND 39).

FIRST USE 8-1-1971; IN COMMERCE 9-1-1971.  
ELLEN PERKINS, EXAMINING ATTORNEY

SN 78-893,660. NIELSEN MEDIA RESEARCH, INC., NEW YORK, NY. FILED 5-26-2006.

# NORA

THE MARK CONSISTS OF STANDARD CHARACTERS WITHOUT CLAIM TO ANY PARTICULAR FONT, STYLE, SIZE, OR COLOR.

## CLASS 35—ADVERTISING AND BUSINESS

FOR MARKET RESEARCH AND MEDIA RATING RESEARCH SERVICES; PROVIDING VIEWERSHIP AND RATINGS INFORMATION, ADVERTISING, AND DEMOGRAPHIC INFORMATION REGARDING ON DEMAND MEDIA BROADCASTS, NARROWCASTS, AND TRANSMISSIONS; AND PROVIDING TEMPORARY ACCESS TO ONLINE COMPUTER DATABASES FOR USE IN ACCESSING, REVIEWING, AND PREPARING REPORTS FROM MARKET RESEARCH AND MEDIA RATING RESEARCH INFORMATION, AND VIEWERSHIP AND RATINGS INFORMATION, ADVERTISING, AND DEMOGRAPHIC INFORMATION REGARDING ON DEMAND MEDIA BROADCASTS, NARROWCASTS, AND TRANSMISSIONS (U.S. CLS. 100, 101 AND 102).

## CLASS 42—SCIENTIFIC, COMPUTER AND LEGAL SERVICES

FOR PROVIDING TEMPORARY ACCESS TO NON-DOWNLOADABLE DATABASE MANAGEMENT SOFTWARE FOR USE IN ACCESSING, REVIEWING, AND PREPARING REPORTS FROM MARKET RESEARCH AND MEDIA RATING RESEARCH INFORMATION, AND VIEWERSHIP AND RATINGS INFORMATION, ADVERTISING, AND DEMOGRAPHIC INFORMATION REGARDING ON DEMAND MEDIA BROADCASTS, NARROWCASTS, AND TRANSMISSIONS (U.S. CLS. 100 AND 101).

MARK PILARO, EXAMINING ATTORNEY

SN 78-894,804. BURRELL GLOBAL, INCORPORATED, SPRING, TX. FILED 5-27-2006.



**Just Being Beings!**

THE COLOR(S) THE COLORS RED, YELLOW, BLUE, GREEN, PURPLE, ORANGE, PINK, BLACK, WHITE, AND GRAY ARE CLAIMED AS A FEATURE OF THE MARK. IS/ ARE CLAIMED AS A FEATURE OF THE MARK.

THE MARK CONSISTS OF JELLY BEINGS (CENTERED); THE WORD JELLY IS OUTLINED IN BLACK WITH THE J IN BLUE, THE E IN RED, THE FIRST L IN GREEN, THE SECOND L IN PURPLE, AND THE Y IN ORANGE; BEINGS HAS A BLACK, WHITE, AND GRAY B AND THE "EINGS" ARE ALL BLACK, AND EACH LETTER IS SHADED IN GRAY; 3 CLUSTERS OF JELLY BEANS ARE ON THREE

SIDES, WITH THE LEFT CLUSTER CONTAINING JELLY BEANS IN RED, YELLOW, BLUE, PURPLE, ORANGE, PINK, AND BLACK; THE CENTER CLUSTER HAS JELLY BEANS IN GREEN, PURPLE AND PINK; AND THE RIGHT CLUSTER JELLY BEANS IN RED, YELLOW, BLUE, GREEN, ORANGE, BLACK AND WHITE; "JUST BEING BEINGS!" IN BLACK IS CENTERED AT THE BOTTOM. THE MARK APPEARS ON A TRANSPARENT BACKGROUND, AND NO OTHER COLOR IS CLAIMED AS A FEATURE OF THE MARK.

## CLASS 16—PAPER GOODS AND PRINTED MATTER

FOR CARTOON STRIPS (U.S. CLS. 2, 5, 22, 23, 29, 37, 38 AND 50).

FIRST USE 4-3-2006; IN COMMERCE 5-11-2006.

## CLASS 35—ADVERTISING AND BUSINESS

FOR ADVERTISING SLOGAN AND CARTOON CHARACTER LICENSING (U.S. CLS. 100, 101 AND 102).

FIRST USE 4-3-2006; IN COMMERCE 5-11-2006.

DAVID MILLER, EXAMINING ATTORNEY

SN 78-898,533. HUNTER FAN COMPANY, MEMPHIS, TN. FILED 6-1-2006.



OWNER OF U.S. REG. NOS. 2,851,938, 2,919,790 AND OTHERS.

NO CLAIM IS MADE TO THE EXCLUSIVE RIGHT TO USE "SINCE 1886", APART FROM THE MARK AS SHOWN.

## CLASS 9—ELECTRICAL AND SCIENTIFIC APPARATUS

FOR THERMOSTATS (U.S. CLS. 21, 23, 26, 36 AND 38).

## CLASS 11—ENVIRONMENTAL CONTROL APPARATUS

FOR BATH EXHAUST FANS, AIR PURIFIER REPLACEMENT FILTERS AND FURNACE FILTERS FOR DOMESTIC USE (U.S. CLS. 13, 21, 23, 31 AND 34).

SARA THOMAS, EXAMINING ATTORNEY

SN 78-899,095. BAYER AKTIENGESELLSCHAFT, LEVERKUSEN-BAYERWERK, FED REP GERMANY, FILED 6-2-2006.

# RESQ

THE MARK CONSISTS OF STANDARD CHARACTERS WITHOUT CLAIM TO ANY PARTICULAR FONT, STYLE, SIZE, OR COLOR.

**CLASS 9—ELECTRICAL AND SCIENTIFIC APPARATUS**

FOR IMPLANTABLE ELECTRICAL AND ELECTRONIC APPARATUS AND INSTRUMENTS FOR IDENTITY CHECKING AND MONITORING ANIMALS, NAMELY, RADIO FREQUENCY IDENTIFICATION (RFID) DEVICES; SCANNERS BASED ON RADIO FREQUENCY IDENTIFICATION TECHNOLOGY (U.S. CLS. 21, 23, 26, 36 AND 38).

**CLASS 10—MEDICAL APPARATUS**

FOR SYRINGES FOR IMPLANTING IMPLANTABLE ELECTRICAL AND ELECTRONIC APPARATUS AND INSTRUMENTS FOR IDENTITY CHECKING AND MONITORING ANIMALS, NAMELY, RADIO FREQUENCY IDENTIFICATION (RFID) DEVICES (U.S. CLS. 26, 39 AND 44).

SHAUNIA WALLACE, EXAMINING ATTORNEY

---

SN 78-902,144. JAGGED EXTREME, LLC, PHOENIX, AZ.  
FILED 6-6-2006.

# JAGGEDX

THE MARK CONSISTS OF STANDARD CHARACTERS WITHOUT CLAIM TO ANY PARTICULAR FONT, STYLE, SIZE, OR COLOR.

**CLASS 37—CONSTRUCTION AND REPAIR**

FOR CUSTOM REBUILDING OF EXISTING LAND VEHICLES AND STRUCTURAL PARTS THEREFOR (U.S. CLS. 100, 103 AND 106).

**CLASS 40—MATERIAL TREATMENT**

FOR CUSTOM FABRICATION OF LAND VEHICLES AND STRUCTURAL PARTS THEREOF, NAMELY, FOR OFF-ROAD VEHICLES (U.S. CLS. 100, 103 AND 106).

DANIEL BRODY, EXAMINING ATTORNEY

---

SN 78-902,650. VULTURE KULTURE, LLC, VENICE, CA.  
FILED 6-7-2006.

# KUSTOMIZE YOUR LIFE

THE MARK CONSISTS OF STANDARD CHARACTERS WITHOUT CLAIM TO ANY PARTICULAR FONT, STYLE, SIZE, OR COLOR.

**CLASS 6—METAL GOODS**

FOR METAL ART, NAMELY METAL SCULPTURES, METAL STATUES, METAL DECORATIVE PANELS, METAL WALL ART AND MINIATURES OF SCULPTURES ALL MADE OF NON-PRECIOUS COMMON METAL; METAL BATHROOM HARDWARE, NAMELY, METAL MIRROR HOLDERS; METAL DOOR HARDWARE, NAMELY, KNOBS, PULLERS, HINGES, KEYS AND KEY CYLINDERS; METAL HOME HARDWARE, NAMELY DOOR KNOCKERS AND HANDLES, METAL LETTERBOXES, METAL MAILBOXES, METAL COAT HOOKS, METAL FITTINGS FOR SHELVES, METAL HAT-RACK HOOKS; METAL KEY RACKS, METAL KEY FOBs, METAL KEY CHAINS, METAL KEY RINGS, METAL KEY HOLDERS, METAL LICENSE PLATES, METAL TOOLBOXES AND CHESTS, METAL LICENSE PLATE HOLDERS; METAL MONEY CLIPS, METAL POT HOOKS, METAL TISSUE BOX COVERS, METAL PIGGY BANKS (U.S. CLS. 2, 12, 13, 14, 23, 25 AND 50).

**CLASS 20—FURNITURE AND ARTICLES NOT OTHERWISE CLASSIFIED**

FOR METAL DRAPERY HOOKS; METAL FURNITURE, NAMELY COUCHES, TABLES, CHAIRS, COFFEE TABLES, COCKTAIL TABLES, TELEVISION STANDS, BAR STOOLS, BOOKSHELVES, HEADBOARDS, WALL SHELVES, SHELVING AND COMPONENT PARTS THEREOF, NAMELY SHELVES AND BRACKETS SOLD AS A UNIT, OVER-THE-SINK SHELVES, WORK BENCHES AND TABLES, TEA CARTS, MAGAZINE RACKS, TOOL RACKS, NAMELY, FREESTANDING AND WALL MOUNTED; SPACE-SAVER WALL RACKS, NAMELY, WALL RACKS SOLD EMPTY FOR STORAGE OF HOUSEHOLD PRODUCTS AND CLOTHING; TOWEL TOWERS AND STANDS; STORAGE RACKS FOR GROOMING PRODUCTS; STORAGE RACKS, SHOE RACKS, PICTURE FRAMES NOT OF PRECIOUS METAL, MIRROR FRAMES NOT OF PRECIOUS METAL, COAT HANGERS, SHOWER CURTAIN RODS, COAT RACKS, MUG RACKS AND SHELVES, POT RACKS, WINE RACKS, KITCHEN SINK MATS, UMBRELLA STANDS, METAL DISPLAY STANDS, BATHROOM STOOLS, MIRROR SHELF, SHOWER CURTAIN RINGS, DRAPERY ROD SETS, DRAPERY SCARF HOLDERS, DRAPERY RINGS; DRAPERY HARDWARE, NAMELY, CURTAIN RODS AND FINIALS, ENTERTAINMENT CENTER, WINE CABINET, TRAY TABLE, TOP-OF-TOILET RACK, MULTI-HOOK RACK, BELT AND TIE RACK, BEVERAGE BARS, LAMP STANDS; NON METAL FURNITURE, MADE OF WOOD, PLASTIC, ACRYLIC, WICKER, NAMELY, PICTURE FRAMES, NOVELTY PILLOWS, WINDOW BLINDS AND SHADES, PLASTIC KEY CHAINS, NON-METAL KEY FOBs, NON-METAL KEY HOLDERS, PLASTIC NOVELTY LICENSE PLATES, WOOD TABLE TOPS, LETTER BOXES NOT OF METAL, BACK SUPPORT CUSHIONS, CUSHIONS FOR CHAIRS, HAMPERS, CORNER SHELVES, CAMPING CHAIRS, SLEEPING BAGS, HOUSEHOLD PET BEDS, MIRRORS, NON-METAL HOOKS, NON-METAL POT HOOKS, NON-METAL SHOWER HOOKS; PLASTIC TISSUE BOX COVERS; SHOWER CURTAIN HOOKS (U.S. CLS. 2, 13, 22, 25, 32 AND 50).

**CLASS 21—HOUSEWARES AND GLASS**

FOR METAL BATHROOM HARDWARE, NAMELY, METAL TOWEL BARS, METAL TOWEL HOOKS, METAL TOWEL LOOPS, METAL TOWEL RACKS, KITCHEN UTENSILS AND DINNERWARE, NAMELY CUPS, COFFEE MUGS, PLATES, BOWLS, CANISTER SETS, MIXING BOWLS, PASTRY CUTTERS, SALAD SERVERS, SALAD BOWLS, SALT AND PEPPER MILLS AND SHAKERS AND SEAFOOD PICKS; SUGAR AND CREAMER SETS FEATURING CREAMER, SUGAR BOWL, TEA POT, SMALL TRAY AND COFFEE CARAFE; TEA BALLS NOT OF PRECIOUS METAL, TEA INFUSERS NOT OF PRECIOUS METAL, TEA SQUEEZERS, SERVING TONGS, SAUCERS, KETTLES, PET DISHES, TRIVETS, TABLE CAROUSELS, NAMELY, LAZY SUSANS, SERVING PLATTERS, JAR OPENERS, NAPKIN RINGS NOT OF PRECIOUS METAL, SERVING TRAYS NOT OF PRECIOUS METAL, COOKIE JARS, LUNCH BOXES, PLASTIC CUPS, DRINKING VESSELS; KITCHEN RACKS AND CONTAINERS, NAMELY, SPICE RACKS, SPOON RESTS, KITCHEN TOWEL RACKS;

KITCHEN SOAP DISHES, KITCHEN SOAP DISPENSERS, PAPER TOWEL HOLDERS, UTENSIL HOLDERS AND RACKS, KITCHEN TOOL HOLDERS FOR SPATULAS, LADLES, POTATO MASHER AND LONG-HANDLED FORK; NAPKIN HOLDERS, DISH DRYING RACK, FLATWARE STORAGE CONTAINER, NAMELY, FLATWARE DRAWER CADDY SOLD EMPTY, SPONGE HOLDER, DISH DRAINER, DISH RACKS, CUTLERY BASKET, SCRUB PAD HOLDERS, FLATWARE HOLDERS, PLASTIC BOTTLES SOLD EMPTY, GARBAGE CANS, HOUSEHOLD CONTAINER FOR FOODS, NAMELY, CONTAINERS FOR FOOD OR BEVERAGE, THERMAL INSULATED CONTAINERS FOR BEVERAGES; BAR UTENSILS AND GLASSWARE, NAMELY DRINKING GLASSES, SHOT GLASSES, PLASTIC COASTERS, WOODEN COASTERS, BOTTLE OPENERS, COCKTAIL STIRRERS, BEER MUGS, PITCHERS, DECANTERS, COCKTAIL SHAKERS, CANNED-BEVERAGE FOAM HOLDERS, CORK PULLERS, CORKSCREWS, ICE CUBE MOLDS FOR REFRIGERATORS, ICED DRINK MIXING SPOONS, COCKTAIL PICKS, PORTABLE BEVERAGE DISPENSERS, MUG TREES, TUMBLERS, PLASTIC ICE CUBES, SNACK PLATTER, BOTTLE STOPPER, COASTER HOLDER, DIPPING BOWLS, SHOOTERS, ICE TONGS, COCKTAIL STRAINERS, GOBLETS, MARTINI GLASSES, ICE CUBE TRAY, WINE GLASS MARKERS, NAMELY, CHARMS FOR ATTACHMENT TO BEVERAGE GLASSWARE FOR IDENTIFICATION PURPOSES; BATHROOM ACCESSORIES, NAMELY, VANITY TRAYS NOT OF PRECIOUS METAL FOR HOLDING SMALL COSMETIC PRODUCTS; TUMBLERS, LOTION DISPENSERS, NON-METAL TOOTHBRUSH HOLDERS, TOOTHBRUSH STANDS, METAL TOOTHBRUSH HOLDERS, METAL SOAP SAVERS, METAL TOILET TISSUE ROLL STANDS, METAL WASTEBASKETS, NON-METAL SOAP DISHES, METAL SOAP DISHES, NON-METAL WASTEBASKETS, SOAP DISPENSERS, RACKS FOR TOILETRIES, COTTON SWAB HOLDERS, COTTON BALL JARS, BATH ORGANIZER BASKET, SHOWER ORGANIZER, NAMELY, PLASTIC BATH RACKS; SPONGE HOLDERS, TOOTHBRUSH CENTERS, NAMELY, HOLDERS FOR CUP, TOOTHBRUSH, TOOTHPASTE AND FLOSS; RAZOR HOLDERS, SHOWER CADDIES, SOAP BOXES, TOWEL BARS, NON-METAL TOILET PAPER HOLDER, NON-METAL TOILET PAPER RESERVE HOLDERS, NON-METAL TOILET BOWL BRUSH HOLDERS, NON-METAL TOILET PLUNGER HOLDERS, METAL TOILET PAPER HOLDER, METAL TOILET PAPER RESERVE HOLDERS, METAL TOILET BOWL BRUSH HOLDERS, METAL TOILET PLUNGER HOLDERS, TOILET PAPER STAND; TOWEL RINGS; CERAMIC FIGURINES, CHINA ORNAMENTS, GLASS ORNAMENTS, CRYSTAL ORNAMENTS, PORCELAIN ORNAMENTS, PLANT POTS, CANDLE HOLDERS AND PLATES NOT OF PRECIOUS METAL, CANDY DISHES, NON-METAL PIGGY BANKS (U.S. CLS. 2, 13, 23, 29, 30, 33, 40 AND 50).

### CLASS 25—CLOTHING

FOR CLOTHING, NAMELY T-SHIRTS, BOWLING SHIRTS, SPORT SHIRTS, TANK TOPS, DENIM SHIRTS, BLOUSES, SHIRTS, NECK TIES, THERMAL SHIRTS, SWEATSHIRTS, FLEECE TOPS, JERSEYS, SWEATERS, VESTS, JACKETS, COATS, WIND RESISTANT JACKETS, PULLOVERS, SKIRTS, SHORTS, PANTS, SLEEPWEAR, ROBES, SOCKS, UNDERWEAR, LEOTARDS, JOGGING SUITS, JUMPSUITS, BELTS, SWIMWEAR, BASEBALL JERSEYS, LOUNGEWEAR, COVER-UPS, RAINWEAR, OVERALLS, COVERALLS, SWEATERS, DRESSES, LINGERIE, SCARVES, WRISTBANDS, GLOVES, APRONS, LEGGINGS, SUSPENDER BELTS FOR MEN AND WOMEN, STOCKINGS, BICYCLING GLOVES, SHAWLS; BABY CLOTHES, NAMELY BABY SHIRTS, BABY T-SHIRTS, BABY PAJAMAS, BABY BODYSUITS, BABY GOWNS, BABY PANTS, BABY OVERALLS, BABY SWEATERS, BABY DRESSES, BABY BIBS NOT OF PAPER, BABY COORDINATING SETS COMPRISING TOPS AND BOTTOMS, BABY LAYETTES; HEADWEAR, NAMELY CAPS, HATS, BEANIES, HEADBANDS, BANDANAS, STOCKING HATS, RIB JEEP HATS, CAP VISORS, BERETS, KNITTED HATS, BOBBLE HATS, WOOLLY HATS (U.S. CLS. 22 AND 39).

CARYN GLASSER, EXAMINING ATTORNEY

SN 78-902,728. FKA DISTRIBUTING CO., DBA HOMEDICS, INC., COMMERCE TOWNSHIP, MI. FILED 6-7-2006.

# BRETHER

THE MARK CONSISTS OF STANDARD CHARACTERS WITHOUT CLAIM TO ANY PARTICULAR FONT, STYLE, SIZE, OR COLOR.

### CLASS 3—COSMETICS AND CLEANING PREPARATIONS

FOR FRAGRANCES, NAMELY, ROOM FRAGRANCES IN THE FORM OF LIQUIDS, AEROSOLS, GELS AND SOLIDS (U.S. CLS. 1, 4, 6, 50, 51 AND 52).

### CLASS 5—PHARMACEUTICALS

FOR AIR FRESHENERS AND DEODORIZERS IN THE FORM OF LIQUIDS, AEROSOLS, GELS AND SOLIDS (U.S. CLS. 6, 18, 44, 46, 51 AND 52).

### CLASS 11—ENVIRONMENTAL CONTROL APPARATUS

FOR HOUSEHOLD AIR CLEANERS; AIR FILTERS, NAMELY, AIR FILTERS FOR DOMESTIC USE; AIR PURIFIERS; AIR PROCESSING UNITS FOR TREATING, CLEANING, FILTERING, HUMIDIFYING, DEODORIZING, AND PURIFYING AMBIENT AIR, NAMELY, DISPENSING UNITS FOR AIR FRESHENERS, DISPENSING UNITS FOR AIR DEODORIZERS, HUMIDIFIERS, AIR CLEANING UNITS AND AIR PURIFICATION UNITS (U.S. CLS. 13, 21, 23, 31 AND 34).

ALLISON SCHRODY, EXAMINING ATTORNEY

SN 78-904,940. E.P. HENRY CORPORATION, WOODBURY, NJ. FILED 6-9-2006.

### IMPERIAL CONCRETE PRODUCTS

THE MARK CONSISTS OF STANDARD CHARACTERS WITHOUT CLAIM TO ANY PARTICULAR FONT, STYLE, SIZE, OR COLOR.

NO CLAIM IS MADE TO THE EXCLUSIVE RIGHT TO USE "CONCRETE PRODUCTS", APART FROM THE MARK AS SHOWN.

### CLASS 19—NON-METALLIC BUILDING MATERIALS

FOR HARDSCAPING MATERIALS, NAMELY PAVERS, PAVING BLOCKS, PERMEABLE PAVING BLOCKS; NON-METAL CURBING AND EDGING BLOCKS; CONCRETE RETAINING AND GARDEN WALL BLOCKS AND CAPS; CONCRETE MASONRY PRODUCTS, NAMELY BUILDING BLOCKS AND SLABS (U.S. CLS. 1, 12, 33 AND 50).



**CLASS 35—ADVERTISING AND BUSINESS**

FOR WHOLESALE DISTRIBUTORSHIP OF HARDSCAPING MATERIALS, NAMELY PAVERS, PAVING BLOCKS, RETAINING AND GARDEN WALL BLOCKS AND CAPS; CONCRETE MASONRY PRODUCTS, NAMELY BUILDING BLOCKS AND SLABS; AND MATERIALS FOR INSTALLING, PRESERVING AND SEALING CEMENT PRODUCTS (U.S. CLS. 100, 101 AND 102).  
DEZMONA MIZELLE, EXAMINING ATTORNEY

---

SN 78-905,893. MARUBENI ITOCHU STEEL AMERICA INC., NEW YORK, NY. FILED 6-12-2006.

# MISA

THE MARK CONSISTS OF STANDARD CHARACTERS WITHOUT CLAIM TO ANY PARTICULAR FONT, STYLE, SIZE, OR COLOR.

**CLASS 35—ADVERTISING AND BUSINESS**

FOR LOGISTICS MANAGEMENT IN THE FIELD OF IMPORT AND EXPORT COORDINATION AND WAREHOUSING; TRANSPORTATION LOGISTICS SERVICES, NAMELY, PLANNING AND ARRANGING STEVEDORING/VESSEL OPERATIONS, OCEAN TERMINAL OPERATIONS, BARGE TRANSPORTATION, RAIL TRANSPORTATION AND TRUCK TRANSPORTATION (U.S. CLS. 100, 101 AND 102).  
FIRST USE 12-0-2002; IN COMMERCE 12-0-2002.

**CLASS 40—MATERIAL TREATMENT**

FOR METAL PLATING (U.S. CLS. 100, 103 AND 106).  
FIRST USE 12-0-2002; IN COMMERCE 12-0-2002.  
AMY BROZENIC, EXAMINING ATTORNEY

---

SN 78-908,839. BRANSON TOURISM CENTER, LLC, BRANSON, MO. FILED 6-15-2006.



NO CLAIM IS MADE TO THE EXCLUSIVE RIGHT TO USE "BRANSON TOURISM CENTER" "TICKETS" "LOGGING" "MAPS" "INFORMATION", APART FROM THE MARK AS SHOWN.

**CLASS 41—EDUCATION AND ENTERTAINMENT**

FOR TOURISM PROMOTIONAL SERVICES, NAMELY, ARRANGING FOR TICKET RESERVATIONS FOR SHOWS, ENTERTAINMENT VENUES AND OTHER ENTERTAINMENT EVENTS (U.S. CLS. 100, 101 AND 107).  
FIRST USE 5-27-2003; IN COMMERCE 5-27-2003.

**CLASS 43—HOTEL AND RESTAURANT SERVICES**

FOR TOURISM PROMOTIONAL SERVICES, NAMELY, MAKING HOTEL RESERVATIONS FOR OTHERS (U.S. CLS. 100 AND 101).  
FIRST USE 5-27-2003; IN COMMERCE 5-27-2003.  
AMY HELLA, EXAMINING ATTORNEY

---

SN 78-910,949. KOBERT & COMPANY, INC., COMMERCE, CA. FILED 6-19-2006.

# L.H. DOTTIE

THE MARK CONSISTS OF STANDARD CHARACTERS WITHOUT CLAIM TO ANY PARTICULAR FONT, STYLE, SIZE, OR COLOR.

OWNER OF U.S. REG. NOS. 1,407,355 AND 3,164,759.  
THE NAME "L.H. DOTTIE" DOES NOT IDENTIFY A LIVING INDIVIDUAL.

**CLASS 6—METAL GOODS**

FOR METAL HARDWARE, NAMELY NUTS, BOLTS, SCREWS, ANCHORS, BUSHINGS, CHAINS, FASTENER CLAMPS, TUBES, TUBE NIPPLES AND CAPS, SLEEVES, TUBE COUPLINGS AND ELLS, DRIVE PINS, HANGERS, HOOKS, PLATES, RODS, STAPLES, WASHERS, AND NON-ELECTRICAL WIRE (U.S. CLS. 2, 12, 13, 14, 23, 25 AND 50).  
FIRST USE 3-1-1968; IN COMMERCE 3-1-1968.

**CLASS 17—RUBBER GOODS**

FOR ADHESIVE TAPES FOR INDUSTRIAL AND COMMERCIAL USE, NAMELY, DUCT TAPE, ELECTRICAL PVC TAPE, FRICTION TAPE, MASKING TAPE, PIPE WRAP TAPE, PLUMBERS TAPE, AND RUBBER TAPE (U.S. CLS. 1, 5, 12, 13, 35 AND 50).  
FIRST USE 3-1-1968; IN COMMERCE 3-1-1968.

RAUL CORDOVA, EXAMINING ATTORNEY

---

SN 78-911,752. WILCOX INVESTMENT INC, NEWTON, MA. FILED 6-19-2006.

# WealthMate

THE MARK CONSISTS OF STANDARD CHARACTERS WITHOUT CLAIM TO ANY PARTICULAR FONT, STYLE, SIZE, OR COLOR.

**CLASS 36—INSURANCE AND FINANCIAL**

FOR FINANCIAL PLANNING AND INVESTMENT SERVICES, NAMELY INVESTMENT CONSULTATION (U.S. CLS. 100, 101 AND 102).

**CLASS 39—TRANSPORTATION AND STORAGE**

FOR ELECTRONIC STORAGE OF FINANCIAL DATA (U.S. CLS. 100 AND 105).

**CLASS 42—SCIENTIFIC, COMPUTER AND LEGAL SERVICES**

FOR PROVIDING TEMPORARY USE OF NON-DOWNLOADABLE COMPUTER SOFTWARE FOR USE IN FINANCIAL AND INVESTMENT PLANNING THROUGH A STRUCTURED PROTOCOL (U.S. CLS. 100 AND 101).

DAVID TAYLOR, EXAMINING ATTORNEY

SN 78-914,192. IPR PHARMACEUTICALS, INC., CAROLINA, PUERTO RICO, FILED 6-22-2006.

# STATIN QUO

THE MARK CONSISTS OF STANDARD CHARACTERS WITHOUT CLAIM TO ANY PARTICULAR FONT, STYLE, SIZE, OR COLOR.

NO CLAIM IS MADE TO THE EXCLUSIVE RIGHT TO USE "STATIN", APART FROM THE MARK AS SHOWN.

**CLASS 5—PHARMACEUTICALS**

FOR PHARMACEUTICAL PREPARATIONS FOR THE TREATMENT OF CARDIOVASCULAR DISEASES (U.S. CLS. 6, 18, 44, 46, 51 AND 52).

**CLASS 9—ELECTRICAL AND SCIENTIFIC APPARATUS**

FOR PRERECORDED AUDIOTAPES, VIDEOTAPES, FILMS, CDS AND DVDS IN THE FIELD OF TREATMENT OF CARDIOVASCULAR DISEASES, AND CARDIOVASCULAR HEALTH, AND FOR USE IN CONNECTION WITH EDUCATIONAL AND INFORMATION SERVICES IN SAID FIELDS (U.S. CLS. 21, 23, 26, 36 AND 38).

**CLASS 16—PAPER GOODS AND PRINTED MATTER**

FOR PRINTED MATTER, NAMELY, BOOKS, BROCHURES, PAMPHLETS, GUIDES AND LEAFLETS RELATING TO THE TREATMENT OF CARDIOVASCULAR DISEASES, AND CARDIOVASCULAR HEALTH, AND FOR USE IN CONNECTION WITH EDUCATIONAL AND INFORMATION SERVICES IN SAID FIELDS (U.S. CLS. 2, 5, 22, 23, 29, 37, 38 AND 50).

**CLASS 41—EDUCATION AND ENTERTAINMENT**

FOR EDUCATIONAL SERVICES, NAMELY, CONDUCTING CLASSES, CONFERENCES, WORKSHOPS, SEMINARS AND SYMPOSIA IN THE FIELD OF TREATMENT OF CARDIOVASCULAR DISEASES, AND CARDIOVASCULAR HEALTH; AND PROVIDING THE ABOVE-NOTED SERVICES ON-LINE (U.S. CLS. 100, 101 AND 107).

**CLASS 44—MEDICAL, BEAUTY AND AGRICULTURAL SERVICES**

FOR INFORMATION SERVICES RELATING TO THE TREATMENT OF CARDIOVASCULAR DISEASES, AND CARDIOVASCULAR HEALTH; ON-LINE INFORMATION SERVICES IN SAID FIELDS (U.S. CLS. 100 AND 101).

MICHELE SWAIN, EXAMINING ATTORNEY

SN 78-914,214. IPR PHARMACEUTICALS, INC., CAROLINA, PUERTO RICO, FILED 6-22-2006.

## REDEFINING THE STATIN QUO

THE MARK CONSISTS OF STANDARD CHARACTERS WITHOUT CLAIM TO ANY PARTICULAR FONT, STYLE, SIZE, OR COLOR.

NO CLAIM IS MADE TO THE EXCLUSIVE RIGHT TO USE "STATIN", APART FROM THE MARK AS SHOWN.

**CLASS 5—PHARMACEUTICALS**

FOR PHARMACEUTICAL PREPARATIONS FOR THE TREATMENT OF CARDIOVASCULAR DISEASES (U.S. CLS. 6, 18, 44, 46, 51 AND 52).

**CLASS 9—ELECTRICAL AND SCIENTIFIC APPARATUS**

FOR PRERECORDED AUDIOTAPES, VIDEOTAPES, FILMS, CDS AND DVDS IN THE FIELD OF TREATMENT OF CARDIOVASCULAR DISEASES, AND CARDIOVASCULAR HEALTH, AND FOR USE IN CONNECTION WITH EDUCATIONAL AND INFORMATION SERVICES IN SAID FIELDS (U.S. CLS. 21, 23, 26, 36 AND 38).

**CLASS 16—PAPER GOODS AND PRINTED MATTER**

FOR PRINTED MATTER, NAMELY, BOOKS, BROCHURES, PAMPHLETS, GUIDES AND LEAFLETS RELATING TO THE TREATMENT OF CARDIOVASCULAR DISEASES, AND CARDIOVASCULAR HEALTH, AND FOR USE IN CONNECTION WITH EDUCATIONAL AND INFORMATION SERVICES IN SAID FIELDS (U.S. CLS. 2, 5, 22, 23, 29, 37, 38 AND 50).

**CLASS 41—EDUCATION AND ENTERTAINMENT**

FOR EDUCATIONAL SERVICES, NAMELY, CONDUCTING CLASSES, CONFERENCES, WORKSHOPS, SEMINARS AND SYMPOSIA IN THE FIELD OF TREATMENT OF CARDIOVASCULAR DISEASES, AND CARDIOVASCULAR HEALTH; AND PROVIDING THE ABOVE-NOTED SERVICES ON-LINE (U.S. CLS. 100, 101 AND 107).

**CLASS 44—MEDICAL, BEAUTY AND AGRICULTURAL SERVICES**

FOR INFORMATION SERVICES RELATING TO THE TREATMENT OF CARDIOVASCULAR DISEASES, AND CARDIOVASCULAR HEALTH; ON-LINE INFORMATION SERVICES IN SAID FIELDS (U.S. CLS. 100 AND 101).

MICHELE SWAIN, EXAMINING ATTORNEY

SN 78-914,230. IPR PHARMACEUTICALS, INC., CAROLINA, PUERTO RICO, FILED 6-22-2006.

SN 78-914,236. IPR PHARMACEUTICALS, INC., CAROLINA, PUERTO RICO, FILED 6-22-2006.

RISING ABOVE THE STATIN QUO

THE STATIN WITH ALL THE  
RIGHT MOVES

THE MARK CONSISTS OF STANDARD CHARACTERS WITHOUT CLAIM TO ANY PARTICULAR FONT, STYLE, SIZE, OR COLOR.

NO CLAIM IS MADE TO THE EXCLUSIVE RIGHT TO USE "STATIN", APART FROM THE MARK AS SHOWN.

#### **CLASS 5—PHARMACEUTICALS**

FOR PHARMACEUTICAL PREPARATIONS FOR THE TREATMENT OF CARDIOVASCULAR DISEASES (U.S. CLS. 6, 18, 44, 46, 51 AND 52).

#### **CLASS 9—ELECTRICAL AND SCIENTIFIC APPARATUS**

FOR PRERECORDED AUDIOTAPES, VIDEOTAPES, FILMS, CDS AND DVDS IN THE FIELD OF TREATMENT OF CARDIOVASCULAR DISEASES, AND CARDIOVASCULAR HEALTH, AND FOR USE IN CONNECTION WITH EDUCATIONAL AND INFORMATION SERVICES IN SAID FIELDS (U.S. CLS. 21, 23, 26, 36 AND 38).

#### **CLASS 16—PAPER GOODS AND PRINTED MATTER**

FOR PRINTED MATTER, NAMELY, BOOKS, BROCHURES, PAMPHLETS, GUIDES AND LEAFLETS RELATING TO THE TREATMENT OF CARDIOVASCULAR DISEASES, AND CARDIOVASCULAR HEALTH, AND FOR USE IN CONNECTION WITH EDUCATIONAL AND INFORMATION SERVICES IN SAID FIELDS (U.S. CLS. 2, 5, 22, 23, 29, 37, 38 AND 50).

#### **CLASS 41—EDUCATION AND ENTERTAINMENT**

FOR EDUCATIONAL SERVICES, NAMELY, CONDUCTING CLASSES, CONFERENCES, WORKSHOPS, SEMINARS AND SYMPOSIA IN THE FIELD OF TREATMENT OF CARDIOVASCULAR DISEASES, AND CARDIOVASCULAR HEALTH; AND PROVIDING THE ABOVE-NOTED SERVICES ON-LINE (U.S. CLS. 100, 101 AND 107).

#### **CLASS 44—MEDICAL, BEAUTY AND AGRICULTURAL SERVICES**

FOR INFORMATION SERVICES RELATING TO THE TREATMENT OF CARDIOVASCULAR DISEASES, AND CARDIOVASCULAR HEALTH; ON-LINE INFORMATION SERVICES IN SAID FIELDS (U.S. CLS. 100 AND 101).

MICHELE SWAIN, EXAMINING ATTORNEY

THE MARK CONSISTS OF STANDARD CHARACTERS WITHOUT CLAIM TO ANY PARTICULAR FONT, STYLE, SIZE, OR COLOR.

NO CLAIM IS MADE TO THE EXCLUSIVE RIGHT TO USE "STATIN", APART FROM THE MARK AS SHOWN.

#### **CLASS 5—PHARMACEUTICALS**

FOR PHARMACEUTICAL PREPARATIONS FOR THE TREATMENT OF CARDIOVASCULAR DISEASES (U.S. CLS. 6, 18, 44, 46, 51 AND 52).

#### **CLASS 9—ELECTRICAL AND SCIENTIFIC APPARATUS**

FOR AUDIOTAPES, VIDEOTAPES, FILMS IN THE NATURE OF MOTION PICTURE FILMS AND CINEMATOGRAFIC FILM, CD'S AND DVD'S ON THE SUBJECT OF TREATMENT OF CARDIOVASCULAR DISEASES AND CARDIOVASCULAR HEALTH; AUDIO-TAPES, VIDEOTAPES, FILMS IN THE NATURE OF MOTION PICTURE FILMS AND CINEMATOGRAFIC FILM, CD'S AND DVD'S ON THE SUBJECT OF TREATMENT OF CARDIOVASCULAR DISEASES AND CARDIOVASCULAR HEALTH FOR USE IN CONNECTION WITH EDUCATIONAL AND INFORMATION SERVICES IN THE FIELDS OF CARDIOVASCULAR DISEASES AND CARDIOVASCULAR HEALTH (U.S. CLS. 21, 23, 26, 36 AND 38).

#### **CLASS 16—PAPER GOODS AND PRINTED MATTER**

FOR PRINTED MATTER IN THE NATURE OF NEWSLETTERS, MAGAZINES AND BOOKS RELATING TO THE TREATMENT OF CARDIOVASCULAR DISEASES AND CARDIOVASCULAR HEALTH; PRINTED MATTER IN THE NATURE OF NEWSLETTERS, MAGAZINES AND BOOKS RELATING TO THE TREATMENT OF CARDIOVASCULAR DISEASES AND CARDIOVASCULAR HEALTH FOR USE IN CONNECTION WITH EDUCATIONAL AND INFORMATION SERVICES IN THE FIELDS OF CARDIOVASCULAR DISEASES AND CARDIOVASCULAR HEALTH (U.S. CLS. 2, 5, 22, 23, 29, 37, 38 AND 50).

#### **CLASS 41—EDUCATION AND ENTERTAINMENT**

FOR EDUCATIONAL SERVICES, NAMELY, CONDUCTING CLASSES, SEMINARS, CONFERENCES AND WORKSHOPS IN THE FIELD OF TREATMENT OF CARDIOVASCULAR DISEASES AND CARDIOVASCULAR HEALTH, AND DISTRIBUTING COURSE MATERIALS IN CONNECTION THEREWITH; ON-LINE EDUCATIONAL SERVICES, NAMELY, CONDUCTING CLASSES, SEMINARS, CONFERENCES AND WORKSHOPS IN THE FIELD OF TREATMENT OF CARDIOVASCULAR DISEASES AND CARDIOVASCULAR HEALTH (U.S. CLS. 100, 101 AND 107).

**CLASS 44—MEDICAL, BEAUTY AND AGRICULTURAL SERVICES**

FOR PROVIDING MEDICAL INFORMATION ON THE SUBJECT OF TREATMENT OF CARDIOVASCULAR DISEASES AND CARDIOVASCULAR HEALTH; PROVIDING ON-LINE MEDICAL INFORMATION SERVICES ON THE SUBJECT OF TREATMENT OF CARDIOVASCULAR DISEASES AND CARDIOVASCULAR HEALTH (U.S. CLS. 100 AND 101).

MICHELE SWAIN, EXAMINING ATTORNEY



SN 78-915,225. SATCOM DIRECT, INC., SATELLITE BEACH, FL. FILED 6-23-2006.

**FLIGHTDECK SIMPLE**

THE MARK CONSISTS OF STANDARD CHARACTERS WITHOUT CLAIM TO ANY PARTICULAR FONT, STYLE, SIZE, OR COLOR.

**CLASS 38—COMMUNICATION**

FOR TELECOMMUNICATION SERVICES FOR AIR TO GROUND AND GROUND TO AIR COMMUNICATIONS, NAMELY, LOCAL AND LONG DISTANCE TRANSMISSION OF AUDIO, VIDEO AND DATA TRANSMISSION BY MEANS OF SATELLITE, VHF RADIO AND UHF RADIO (U.S. CLS. 100, 101 AND 104).

**CLASS 39—TRANSPORTATION AND STORAGE**

FOR TRAVEL AGENCY SERVICES, NAMELY, MAKING RESERVATIONS AND BOOKING FOR TRANSPORTATION; TRAVEL INFORMATION SERVICES FOR FLIGHT CREW AND PASSENGERS (U.S. CLS. 100 AND 105).

PRISCILLA MILTON, EXAMINING ATTORNEY



SN 78-917,540. TAMAGAWA SEIKI CO., LTD., IIDA, NAGANO PREF., JAPAN, FILED 6-27-2006.

**FLATSYN**

THE MARK CONSISTS OF STANDARD CHARACTERS WITHOUT CLAIM TO ANY PARTICULAR FONT, STYLE, SIZE, OR COLOR.

**CLASS 9—ELECTRICAL AND SCIENTIFIC APPARATUS**

FOR ELECTRIC AND ELECTRONIC SENSORS FOR USE IN THE DETECTION OF ANGULAR OR ROTATIONAL POSITION OF ELECTRIC MOTORS OR GENERATORS IN VEHICLES OR MACHINES; ELECTRICAL CONTROLLERS AND RESOLVERS FOR USE IN DETECTION OF ANGULAR OR ROTATIONAL POSITION OF ELECTRIC MOTORS FOR VEHICLES OR MACHINES, ELECTRICAL CONTROLLERS AND RESOLVERS FOR USE IN DETECTION OF ANGULAR OR ROTATIONAL POSITION OF GENERATORS FOR VEHICLES OR MACHINES; R/D CONVERTERS (U.S. CLS. 21, 23, 26, 36 AND 38).

**CLASS 12—VEHICLES**

FOR ELECTRIC MOTORS FOR LAND VEHICLES; ELECTRIC MOTORS FOR LAND VEHICLES WITH A DIGITAL SERVO DRIVE CONTROLLER (U.S. CLS. 19, 21, 23, 31, 35 AND 44).

WILLIAM VERHOSEK, EXAMINING ATTORNEY



SN 78-917,556. TAMAGAWA SEIKI CO., LTD., IIDA, NAGANO PREF., JAPAN, FILED 6-27-2006.

**FLATSOLVER**

THE MARK CONSISTS OF STANDARD CHARACTERS WITHOUT CLAIM TO ANY PARTICULAR FONT, STYLE, SIZE, OR COLOR.

**CLASS 9—ELECTRICAL AND SCIENTIFIC APPARATUS**

FOR ELECTRIC AND ELECTRONIC SENSORS FOR USE IN THE DETECTION OF ANGULAR OR ROTATIONAL POSITION OF ELECTRIC MOTORS OR GENERATORS IN VEHICLES OR MACHINES; ELECTRICAL CONTROLLERS AND RESOLVERS FOR USE IN DETECTION OF ANGULAR OR ROTATIONAL POSITION OF ELECTRIC MOTORS FOR VEHICLES OR MACHINES, ELECTRICAL CONTROLLERS AND RESOLVERS FOR USE IN DETECTION OF ANGULAR OR ROTATIONAL POSITION OF GENERATORS FOR VEHICLES OR MACHINES; R/D CONVERTERS (U.S. CLS. 21, 23, 26, 36 AND 38).

**CLASS 12—VEHICLES**

FOR ELECTRIC MOTORS FOR LAND VEHICLES; ELECTRIC MOTORS FOR LAND VEHICLES WITH A DIGITAL SERVO DRIVE CONTROLLER (U.S. CLS. 19, 21, 23, 31, 35 AND 44).

WILLIAM VERHOSEK, EXAMINING ATTORNEY

SN 78-918,635. SILVERBACK, LLC, FORT WORTH, TX.  
FILED 6-28-2006.

## SANDLOT MD

THE MARK CONSISTS OF STANDARD CHARACTERS WITHOUT CLAIM TO ANY PARTICULAR FONT, STYLE, SIZE, OR COLOR.

NO CLAIM IS MADE TO THE EXCLUSIVE RIGHT TO USE MD, APART FROM THE MARK AS SHOWN.

### CLASS 35—ADVERTISING AND BUSINESS

FOR BUSINESS CONSULTATION SERVICES FOR HEALTH CARE PROVIDERS IN THE FIELDS OF VENDOR EVALUATION AND ORGANIZATIONAL DEVELOPMENT (U.S. CLS. 100, 101 AND 102).

### CLASS 41—EDUCATION AND ENTERTAINMENT

FOR TRAINING SERVICES FOR HEALTH CARE PROVIDERS IN THE FIELDS OF EVALUATING AND IMPLEMENTING ELECTRONIC MEDICAL RECORDS SYSTEMS, EVALUATING POTENTIAL BUSINESS VENDORS, BUSINESS ORGANIZATIONAL DEVELOPMENT, BUSINESS ACCOUNTING, AND ELECTRIC DRIVE MODULE DEVELOPMENT AND IMPLEMENTATION (U.S. CLS. 100, 101 AND 107).

### CLASS 42—SCIENTIFIC, COMPUTER AND LEGAL SERVICES

FOR TECHNICAL CONSULTATION SERVICES FOR HEALTH CARE PROVIDERS REGARDING THE EVALUATION AND IMPLEMENTATION OF ELECTRONIC MEDICAL SYSTEMS, AND ELECTRIC DRIVE MODULE DEVELOPMENT AND IMPLEMENTATION (U.S. CLS. 100 AND 101).

RAY THOMAS, EXAMINING ATTORNEY

SN 78-920,402. PACIFIC CYCLE, LLC, MADISON, WI. FILED  
6-29-2006.



NO CLAIM IS MADE TO THE EXCLUSIVE RIGHT TO USE "B.M.X. PRODUCTS", APART FROM THE MARK AS SHOWN.

### CLASS 12—VEHICLES

FOR BICYCLES; BICYCLE PARTS, NAMELY, FRAMES, SADDLES, TIRES, CHAIN STAYS, HANDLE BARS, FORKS AND SUSPENSIONS; BICYCLE ACCESSORIES, NAMELY, SADDLE COVERS, WATER BOTTLE RACKS WHICH ATTACH TO BICYCLES AND AIR PUMPS WHICH ATTACH TO BICYCLES (U.S. CLS. 19, 21, 23, 31, 35 AND 44).

### CLASS 25—CLOTHING

FOR APPAREL, NAMELY HATS, CAPS, T-SHIRTS, JERSEYS, SHOES, PANTS, AND SHORTS (U.S. CLS. 22 AND 39).

JOHN E. MICHOS, EXAMINING ATTORNEY

SN 78-921,218. MAXWELL SYSTEMS, INC., NORRISTOWN, PA. FILED 6-30-2006.



OWNER OF U.S. REG. NO. 1,545,867.  
NO CLAIM IS MADE TO THE EXCLUSIVE RIGHT TO USE "CONTRACTOR", APART FROM THE MARK AS SHOWN.

SEC. 2(F).

### CLASS 9—ELECTRICAL AND SCIENTIFIC APPARATUS

FOR COMPUTER PROGRAM FOR CONTRACTORS FEATURING ESTIMATION, JOB TRACKING, PAYROLL, ACCOUNTS RECEIVABLE, ACCOUNTS PAYABLE AND GENERAL BUSINESS LEDGER APPLICATION (U.S. CLS. 21, 23, 26, 36 AND 38).

FIRST USE 4-2-1995; IN COMMERCE 6-6-1995.

### CLASS 41—EDUCATION AND ENTERTAINMENT

FOR PROVIDING TRAINING IN THE USE OF COMPUTERS AND COMPUTER SOFTWARE (U.S. CLS. 100, 101 AND 107).

FIRST USE 2-0-1995; IN COMMERCE 2-0-1995.

### CLASS 42—SCIENTIFIC, COMPUTER AND LEGAL SERVICES

FOR COMPUTER SOFTWARE DESIGN FOR OTHERS; TECHNICAL CONSULTATION IN THE FIELD OF COMPUTER SOFTWARE (U.S. CLS. 100 AND 101).

FIRST USE 2-0-1995; IN COMMERCE 2-0-1995.

DOMINIC FATHY, EXAMINING ATTORNEY

SN 78-921,242. NATIONAL AFFORDABLE HOUSING MANAGEMENT ASSOCIATION, ALEXANDRIA, VA. FILED 6-30-2006.



SEC. 2(F) AS TO "NATIONAL AFFORDABLE HOUSING PROFESSIONAL".

**CLASS 35—ADVERTISING AND BUSINESS**

FOR ASSOCIATION SERVICES, NAMELY, PROMOTING THE INTERESTS OF AFFORDABLE HOUSING MANAGEMENT PROFESSIONALS BY ESTABLISHING PROFESSIONAL STANDARDS FOR AFFORDABLE HOUSING MANAGEMENT PROFESSIONALS, VERIFYING AND MONITORING THE CREDENTIALS OF AFFORDABLE HOUSING MANAGEMENT PROFESSIONALS (U.S. CLS. 100, 101 AND 102).  
FIRST USE 6-0-1994; IN COMMERCE 6-0-1994.

**CLASS 42—SCIENTIFIC, COMPUTER AND LEGAL SERVICES**

FOR ACCREDITATION SERVICES, NAMELY, DEVELOPING AND EVALUATING STANDARDS FOR AFFORDABLE HOUSING MANAGEMENT PROFESSIONALS FOR THE PURPOSE OF ACCREDITATION (U.S. CLS. 100 AND 101).  
FIRST USE 6-0-1994; IN COMMERCE 6-0-1994.  
DAVID I, EXAMINING ATTORNEY

SN 78-921,265. NATIONAL AFFORDABLE HOUSING MANAGEMENT ASSOCIATION, ALEXANDRIA, VA. FILED 6-30-2006.

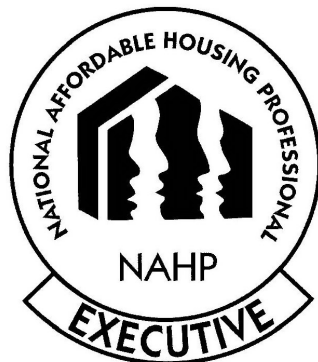

SEC. 2(F) AS TO "NATIONAL AFFORDABLE HOUSING PROFESSIONAL".

**CLASS 35—ADVERTISING AND BUSINESS**

FOR ASSOCIATION SERVICES, NAMELY, PROMOTING THE INTERESTS OF AFFORDABLE HOUSING MANAGEMENT PROFESSIONALS BY ESTABLISHING PROFESSIONAL STANDARDS FOR AFFORDABLE HOUSING MANAGEMENT PROFESSIONALS, VERIFYING AND MONITORING THE CREDENTIALS OF AFFORDABLE HOUSING MANAGEMENT PROFESSIONALS (U.S. CLS. 100, 101 AND 102).  
FIRST USE 6-0-1994; IN COMMERCE 6-0-1994.

**CLASS 42—SCIENTIFIC, COMPUTER AND LEGAL SERVICES**

FOR ACCREDITATION SERVICES, NAMELY, DEVELOPING AND EVALUATING STANDARDS FOR AFFORDABLE HOUSING MANAGEMENT PROFESSIONALS FOR THE PURPOSE OF ACCREDITATION (U.S. CLS. 100 AND 101).  
FIRST USE 6-0-1994; IN COMMERCE 6-0-1994.  
DAVID I, EXAMINING ATTORNEY

SN 78-924,779. RE INFOLINK, CAMPBELL, CA. FILED 7-7-2006.

**REIL**

THE MARK CONSISTS OF STANDARD CHARACTERS WITHOUT CLAIM TO ANY PARTICULAR FONT, STYLE, SIZE, OR COLOR.

**CLASS 9—ELECTRICAL AND SCIENTIFIC APPARATUS**

FOR (BASED ON INTENT TO USE) COMPUTER SOFTWARE FOR ACCESSING INFORMATION DIRECTORIES THAT MAY BE DOWNLOADED FROM THE GLOBAL COMPUTER NETWORK; COMPUTER SOFTWARE FOR CREATING SEARCHABLE DATABASES OF INFORMATION AND DATA; COMPUTER SOFTWARE FOR THE COLLECTION, EDITING, ORGANIZING, MODIFYING, BOOK MARKING, TRANSMISSION, STORAGE AND SHARING OF DATA AND INFORMATION (U.S. CLS. 21, 23, 26, 36 AND 38).

**CLASS 35—ADVERTISING AND BUSINESS**

FOR MATCHING CONSUMERS WITH REAL ESTATE PROFESSIONALS IN THE FIELD OF REAL ESTATE SERVICES VIA COMPUTER NETWORK; REAL ESTATE ADVERTISING SERVICES; REAL ESTATE MARKETING SERVICES, NAMELY, ON-LINE SERVICES FEATURING TOURS OF RESIDENTIAL AND COMMERCIAL REAL ESTATE (U.S. CLS. 100, 101 AND 102).  
FIRST USE 12-28-1994; IN COMMERCE 12-28-1994.

**CLASS 36—INSURANCE AND FINANCIAL**

FOR EVALUATION OF REAL PROPERTY; LEASING OF REAL ESTATE; LEASING OF REAL PROPERTY; OPERATING MARKETPLACES FOR SELLERS OF GOODS AND/OR SERVICES; PROVIDING INFORMATION IN THE FIELD OF REAL ESTATE BY MEANS OF LINKING THE WEB SITE TO OTHER WEB SITES FEATURING REAL ESTATE INFORMATION; REAL ESTATE LISTING; REAL ESTATE MULTIPLE LISTING SERVICES; REAL ESTATE VALUATION SERVICES; REAL ESTATE VALUATIONS (U.S. CLS. 100, 101 AND 102).  
FIRST USE 12-28-1994; IN COMMERCE 12-28-1994.

**CLASS 42—SCIENTIFIC, COMPUTER AND LEGAL SERVICES**

FOR REAL ESTATE RESEARCH SERVICES (U.S. CLS. 100 AND 101).  
FIRST USE 12-28-1994; IN COMMERCE 12-28-1994.  
MARIAM MAHMOUDI, EXAMINING ATTORNEY

SN 78-925,343. EAST JORDAN IRON WORKS, INC., EAST JORDAN, MI. FILED 7-10-2006.

# EJ GROUP

THE MARK CONSISTS OF STANDARD CHARACTERS WITHOUT CLAIM TO ANY PARTICULAR FONT, STYLE, SIZE, OR COLOR.

NO CLAIM IS MADE TO THE EXCLUSIVE RIGHT TO USE "GROUP", APART FROM THE MARK AS SHOWN.

**CLASS 6—METAL GOODS**

FOR METAL CASTINGS AND WATER DISTRIBUTION SUPPLIES, NAMELY, MANUALLY OPERATED METAL VALVES, METAL TAPPING SLEEVES AND METAL SERVICE BOXES; METAL BOLLARDS; METAL CONSTRUCTION AND UTILITY CASTS, NAMELY, MANHOLES, MANHOLE COVERS, CATCH BASIN COVERS, CATCH BASIN INLETS, ELEVATED AND BRIDGE DRAIN INLETS, CATCH BASIN TRAPS, CATCH BASIN HOODS, SEWER PIPE GRATES AND COVERS, DITCH GRATES, TRENCH FRAMES AND GRATES, CATCH BASIN CURB INLETS, MANHOLE STEPS, SIGN BASES, TREE GRATES, STOP PLANK GROOVES, LINER PLATES, AND FLAP VALVES; METAL WATER MAIN PIPE FITTINGS; NAMELY, JOINTS, SWIVELS, FLANGES AND ADAPTORS; MANUALLY OPERATED VALVES PRIMARILY OF METAL FOR USE IN WATER AND SEWAGE SYSTEMS (U.S. CLS. 2, 12, 13, 14, 23, 25 AND 50).

**CLASS 9—ELECTRICAL AND SCIENTIFIC APPARATUS**

FOR FIRE HYDRANTS (U.S. CLS. 21, 23, 26, 36 AND 38).  
EVELYN BRADLEY, EXAMINING ATTORNEY

SN 78-926,187. SUNSOURCE INDUSTRIES, INC., BOULDER, CO. FILED 7-10-2006.

# Solix Biofuels

THE MARK CONSISTS OF STANDARD CHARACTERS WITHOUT CLAIM TO ANY PARTICULAR FONT, STYLE, SIZE, OR COLOR.

NO CLAIM IS MADE TO THE EXCLUSIVE RIGHT TO USE "BIOFUELS", APART FROM THE MARK AS SHOWN.

**CLASS 1—CHEMICALS**

FOR METHANE (U.S. CLS. 1, 5, 6, 10, 26 AND 46).

**CLASS 4—LUBRICANTS AND FUELS**

FOR BIODIESEL, DIESEL FUEL, BIOFUELS, FUELS, FUELS FROM CRUDE OIL, AND NATURAL GAS (U.S. CLS. 1, 6 AND 15).

**CLASS 40—MATERIAL TREATMENT**

FOR BIODIESEL, BIOFUELS, OIL, GAS, AND NATURAL GAS PRODUCTION AND REFINING (U.S. CLS. 100, 103 AND 106).  
KALIE KUNG, EXAMINING ATTORNEY

SN 78-926,952. IMPULSE SEMICONDUCTOR, INC., SAN JOSE, CA. FILED 7-11-2006.

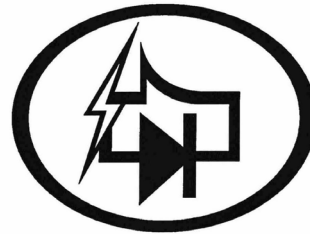

NO CLAIM IS MADE TO THE EXCLUSIVE RIGHT TO USE THE ELECTRICAL DIODE SYMBOL, APART FROM THE MARK AS SHOWN.

THE MARK CONSISTS, IN PART, OF THE STYLIZED REPRESENTATION OF A LIGHTNING BOLT, A SEMICONDUCTOR DIODE SCHEMATIC, AND A TIME VERSUS MAGNITUDE TRANSIENT WAVE.

**CLASS 9—ELECTRICAL AND SCIENTIFIC APPARATUS**

FOR COMPUTER PROGRAMS FOR TESTING AND DESIGN OF SEMICONDUCTORS; AND ANALYTICAL INSTRUMENTS FOR CHARACTERIZATION OF ELECTRONIC COMPONENTS (U.S. CLS. 21, 23, 26, 36 AND 38).

**CLASS 42—SCIENTIFIC, COMPUTER AND LEGAL SERVICES**

FOR ENGINEERING CONSULTING SERVICES (U.S. CLS. 100 AND 101).  
ELIZABETH J. WINTER, EXAMINING ATTORNEY

SN 78-927,145. ITO EN (NORTH AMERICA) INC., BROOKLYN, NY. FILED 7-11-2006.

CREATING NEW TRADITIONS IN  
THE ART OF TEA

THE MARK CONSISTS OF STANDARD CHARACTERS WITHOUT CLAIM TO ANY PARTICULAR FONT, STYLE, SIZE, OR COLOR.

**CLASS 30—STAPLE FOODS**

FOR TEA, LOOSE TEA LEAVES, TEA BAGS, POWDERED TEA, ICED TEA, COFFEE, CAPPUCCINO, TEA-BASED BEVERAGES, AND COFFEE-BASED BEVERAGES (U.S. CL. 46).

FIRST USE 2-27-2002; IN COMMERCE 11-0-2002.

**CLASS 35—ADVERTISING AND BUSINESS**

FOR RETAIL STORES FEATURING TEA AND TEA PRODUCTS (U.S. CLS. 100, 101 AND 102).

FIRST USE 2-27-2002; IN COMMERCE 11-0-2002.

SHARI SHEFFIELD, EXAMINING ATTORNEY

**CLASS 28—TOYS AND SPORTING GOODS**

FOR ACTION SKILL GAMES; ACTION TARGET GAMES; ACTION-TYPE TARGET GAMES; AERO-DYNAMIC DISK FOR USE IN PLAYING CATCHING GAMES; AMUSEMENT GAME MACHINES; ARCADE GAMES; ARCADE-TYPE ELECTRONIC EDUCATION VIDEO GAMES; ARCADE-TYPE ELECTRONIC VIDEO GAMES; BACKGAMMON GAME SETS; BADMINTON GAME PLAYING EQUIPMENT; BASKETBALL TABLE TOP GAMES; BILLIARD GAME PLAYING EQUIPMENT; BINGO GAME PLAYING EQUIPMENT; BOARD GAMES; CARD GAMES; COIN-OPERATED VIDEO GAMES; DICE GAMES; DISPOSABLE TICKET SETS FOR PLAYING GAMES OF CHANCE; ELECTRONIC DART GAMES; ELECTRONIC EDUCATIONAL GAME MACHINES FOR CHILDREN; ELECTRONIC GAME EQUIPMENT WITH A WATCH FUNCTION; EQUIPMENT FOR PLAYING A VERTICAL HOOP TARGET GAME; EQUIPMENT SOLD AS A UNIT FOR PLAYING A MEMORY GAME; EQUIPMENT SOLD AS A UNIT FOR PLAYING ACTION TYPE TARGET GAMES; EQUIPMENT SOLD AS A UNIT FOR PLAYING BOARD GAMES; EQUIPMENT SOLD AS A UNIT FOR PLAYING CARD GAMES; EXERCISE MACHINES INCORPORATING ELECTRONIC AND VIDEO GAME CONTROLLERS; FLOOR-STANDING UNITS FOR PLAYING ELECTRONIC GAMES OTHER THAN IN CONJUNCTION WITH A TELEVISION OR COMPUTER; GAME EQUIPMENT, NAMELY, CHIPS; GAME RANDOMIZER FOR RANDOMLY DETERMINING GAME PLAY IN A PARLOR GAME, SOLD AS A COMPONENT PART THEREOF; GAME TABLES; GAMING EQUIPMENT, NAMELY, CHIPS; GAMING EQUIPMENT, NAMELY, GAME WHEELS; GAMING EQUIPMENT, NAMELY, POKER CHIPS; GAMING TABLES; GO GAMES; HAND HELD UNIT FOR PLAYING ELECTRONIC GAMES; HAND HELD UNIT FOR PLAYING VIDEO GAMES; HAND-HELD GAMES WITH LIQUID CRYSTAL DISPLAYS; HORIZONTAL PINBALL MACHINE (KORINTO-GAME MACHINES); HUNTING GAME CALLS; JAPANESE CHESS (SHOGI GAMES); JAPANESE DICE GAMES (SUGOROKU); KARUTA PLAYING CARDS (JAPANESE CARD GAME); LCD GAME MACHINES; MAH JONG GAMES; MANIPULATIVE GAMES; NETS FOR BALL GAMES; PADDLE BALL GAMES; PADDLES FOR USE IN PADDLE BALL GAMES; PARLOR GAMES; PARTY GAMES; PINBALL GAMES; PINBALL-TYPE GAMES; PROMOTIONAL GAME CARDS; PROMOTIONAL GAME MATERIALS; QUILTS; RING GAMES; ROLE PLAYING GAMES; STAND ALONE VIDEO GAME MACHINES; STAND ALONE VIDEO OUTPUT GAME MACHINES; STONEPIECES POTS FOR GO GAME (GOKE POTS); TABLETOP UNITS FOR PLAYING ELECTRONIC GAMES OTHER THAN IN CONJUNCTION WITH A TELEVISION OR COMPUTER; TARGET GAMES; TOY, NAMELY, BATTERY-POWERED COMPUTER GAME WITH LCD SCREEN WHICH FEATURES ANIMATION AND SOUND EFFECTS; TOYS, NAMELY, A DISK TO TOSS IN PLAYING A GAME WHEREIN OTHER DISKS ARE FLIPPED AND COLLECTED; TRADING CARD GAMES; VOLLEYBALL GAME PLAYING EQUIPMENT; WOODEN PIECES FOR SHOGI GAME (KOMA) (U.S. CLS. 22, 23, 38 AND 50).

FIRST USE 6-25-2005; IN COMMERCE 6-0-2006.

GINA HAYES, EXAMINING ATTORNEY

SN 78-927,312. EARLE, DAVID, WATSONVILLE, CA. FILED 7-12-2006.

---

# Mantis

THE MARK CONSISTS OF STANDARD CHARACTERS WITHOUT CLAIM TO ANY PARTICULAR FONT, STYLE, SIZE, OR COLOR.

**CLASS 12—VEHICLES**

FOR BICYCLES; BICYCLE PARTS, NAMELY, FRAMES AND FRAME PARTS, STEMS, HANDLEBARS, DERAILLEURS, SHIFTERS, CRANKS, PEDALS, HUBS, WHEEL RIMS AND TIRES (U.S. CLS. 19, 21, 23, 31, 35 AND 44).

**CLASS 42—SCIENTIFIC, COMPUTER AND LEGAL SERVICES**

FOR DESIGN OF BICYCLE PARTS, FRAMES AND COMPONENTS (U.S. CLS. 100 AND 101).

JULIE THOMAS, EXAMINING ATTORNEY

SN 78-928,958. TABLESTAR GAMES, LLC, BERKELEY, CA. FILED 7-13-2006.

---

# HeroCard

THE MARK CONSISTS OF STANDARD CHARACTERS WITHOUT CLAIM TO ANY PARTICULAR FONT, STYLE, SIZE, OR COLOR.

**CLASS 16—PAPER GOODS AND PRINTED MATTER**

FOR COMPUTER GAME INSTRUCTION MANUALS; ROLE PLAYING GAME EQUIPMENT IN THE NATURE OF GAME BOOK MANUALS (U.S. CLS. 2, 5, 22, 23, 29, 37, 38 AND 50).

FIRST USE 6-25-2005; IN COMMERCE 6-0-2006.

SN 78-929,773. KHANI LLC, NEW YORK, NY. FILED 7-14-2006.

---

# BETTER LOVE

THE MARK CONSISTS OF STANDARD CHARACTERS WITHOUT CLAIM TO ANY PARTICULAR FONT, STYLE, SIZE, OR COLOR.



**CLASS 3—COSMETICS AND CLEANING PREPARATIONS**

FOR EAU DE PARFUM, EAU DE TOILETTE, EAU DE COLOGNE, BODY SPRITZ, BODY OIL, FRAGRANCES FOR PERSONAL USE, SCENTED BODY LOTION, SHOWER AND BATH GELS, BATH SALTS, SOAP, BUBBLE BATH, HAIR SHAMPOO AND CONDITIONER, HAIR SPRAY, SKIN CARE PRODUCTS, NAMELY, CLEANSERS, SCRUBS, TONICS, MASQUES, PEELS, MOISTURIZERS AND HYDRATORS, CREAMS, GELS, SUN TANNING AND SUN CARE PREPARATIONS, LIGHTENERS, BRIGHTENERS, LOTIONS AND MAKE-UP REMOVER, ALL NON-MEDICATED, AND AROMATHERAPY OILS, LOTIONS, CREAMS AND BALM (U.S. CLS. 1, 4, 6, 50, 51 AND 52).

**CLASS 4—LUBRICANTS AND FUELS**

FOR CANDLES (U.S. CLS. 1, 6 AND 15).  
JEFFERY COWARD, EXAMINING ATTORNEY

SN 78-930,094. AVOCET PROPERTIES, INC., CHARLESTON, SC. FILED 7-14-2006.

**AVOCET PROPERTIES**

THE MARK CONSISTS OF STANDARD CHARACTERS WITHOUT CLAIM TO ANY PARTICULAR FONT, STYLE, SIZE, OR COLOR.

NO CLAIM IS MADE TO THE EXCLUSIVE RIGHT TO USE "PROPERTIES", APART FROM THE MARK AS SHOWN.

**CLASS 36—INSURANCE AND FINANCIAL**

FOR REAL ESTATE BROKERAGE; REAL ESTATE AGENCIES; REAL ESTATE MANAGEMENT; REAL ESTATE SERVICES, NAMELY, RENTAL OF VACATION HOMES, CONDOMINIUMS, CABINS AND VILLAS (U.S. CLS. 100, 101 AND 102).

**CLASS 37—CONSTRUCTION AND REPAIR**

FOR REAL ESTATE DEVELOPMENT (U.S. CLS. 100, 103 AND 106).  
JIM RINGLE, EXAMINING ATTORNEY

SN 78-930,641. CLEAR WATER COMPLIANCE SERVICES, INC., LYNNWOOD, WA. FILED 7-17-2006.

**Remediation Solutions for  
the Real World**

THE MARK CONSISTS OF STANDARD CHARACTERS WITHOUT CLAIM TO ANY PARTICULAR FONT, STYLE, SIZE, OR COLOR.

**CLASS 40—MATERIAL TREATMENT**

FOR ENVIRONMENTAL REMEDIATION SERVICES, NAMELY, SOIL, WASTE AND/OR WATER TREATMENT SERVICES (U.S. CLS. 100, 103 AND 106).

FIRST USE 10-7-1998; IN COMMERCE 10-7-1998.

**CLASS 42—SCIENTIFIC, COMPUTER AND LEGAL SERVICES**

FOR ENVIRONMENTAL SERVICES, NAMELY, TECHNICAL CONSULTATION IN THE FIELD OF ENVIRONMENTAL SCIENCE, ENGINEERING SERVICES, DESIGN FOR OTHERS IN THE FIELD OF ENVIRONMENTAL ENGINEERING, DESIGNING AND TESTING OF NEW ENVIRONMENTALLY FRIENDLY PRODUCTS FOR OTHERS (U.S. CLS. 100 AND 101).

FIRST USE 10-7-1998; IN COMMERCE 10-7-1998.

JENNIFER VASQUEZ, EXAMINING ATTORNEY

SN 78-930,693. YOUTH ENTREPRENEURS OF KANSAS, INC., WITCHITA, KS. FILED 7-17-2006.

**YEK**

THE MARK CONSISTS OF STANDARD CHARACTERS WITHOUT CLAIM TO ANY PARTICULAR FONT, STYLE, SIZE, OR COLOR.

**CLASS 36—INSURANCE AND FINANCIAL**

FOR CHARITABLE FUND RAISING SERVICES, NAMELY, FUND RAISING FOR YOUTH IN BOTH THE SCHOLARSHIP AND BUSINESS FIELDS (U.S. CLS. 100, 101 AND 102).

FIRST USE 10-0-1995; IN COMMERCE 10-0-1995.

**CLASS 41—EDUCATION AND ENTERTAINMENT**

FOR EDUCATIONAL SERVICES, NAMELY, TEACHING ENTREPRENEURIAL SKILLS TO YOUTH (U.S. CLS. 100, 101 AND 107).

FIRST USE 10-0-1995; IN COMMERCE 10-0-1995.

MATTHEW PAPPAS, EXAMINING ATTORNEY

SN 78-931,348. KORBIN'S PRODUCTIONS, INC., LOS ANGELES, CA. FILED 7-17-2006.

**TRACKDOWN MUSIC**

THE MARK CONSISTS OF STANDARD CHARACTERS WITHOUT CLAIM TO ANY PARTICULAR FONT, STYLE, SIZE, OR COLOR.

NO CLAIM IS MADE TO THE EXCLUSIVE RIGHT TO USE MUSIC, APART FROM THE MARK AS SHOWN.

**CLASS 35—ADVERTISING AND BUSINESS**

FOR COMMERCIAL ADMINISTRATION OF THE LICENSING OF MUSICAL COMPOSITIONS AND SOUND RECORDINGS OF OTHERS; MANAGING LICENSE RIGHTS FOR MUSIC FOR OTHERS; ENTERTAINMENT SERVICES, NAMELY, DISTRIBUTION OF PRERECORDED SOUND RECORDINGS AND MUSICAL COMPOSITIONS (U.S. CLS. 100, 101 AND 102).

**CLASS 41—EDUCATION AND ENTERTAINMENT**

FOR MUSIC PRODUCTION SERVICES (U.S. CLS. 100, 101 AND 107).  
NAKIA HENRY, EXAMINING ATTORNEY

SN 78-931,619. THE SEFA GROUP, INC., LEXINGTON, SC.  
FILED 7-18-2006.

# STAR

THE MARK CONSISTS OF STANDARD CHARACTERS WITHOUT CLAIM TO ANY PARTICULAR FONT, STYLE, SIZE, OR COLOR.

**CLASS 1—CHEMICALS**

FOR FLY ASH FOR GENERAL MANUFACTURING USE (U.S. CLS. 1, 5, 6, 10, 26 AND 46).

**CLASS 7—MACHINERY**

FOR EQUIPMENT FOR PROCESSING FLY ASH, NAMELY, MACHINES FOR BENEFICIATING, MIXING, BLENDING AND FABRICATING FLY ASH (U.S. CLS. 13, 19, 21, 23, 31, 34 AND 35).

**CLASS 40—MATERIAL TREATMENT**

FOR TREATMENT SERVICES OF FLY ASH FOR OTHERS (U.S. CLS. 100, 103 AND 106).  
ELIZABETH BEYER, EXAMINING ATTORNEY

SN 78-931,642. THE BOARD OF REGENTS OF THE UNIVERSITY OF TEXAS SYSTEM, AUSTIN, TX. FILED 7-18-2006.

THE UNIVERSITY OF TEXAS M.  
D. ANDERSON CANCER CENTER  
MAKING CANCER HISTORY  
CHILDREN'S CANCER HOSPITAL

THE MARK CONSISTS OF STANDARD CHARACTERS WITHOUT CLAIM TO ANY PARTICULAR FONT, STYLE, SIZE, OR COLOR.

OWNER OF U.S. REG. NOS. 2,594,012, 2,697,082 AND OTHERS.

NO CLAIM IS MADE TO THE EXCLUSIVE RIGHT TO USE "CANCER CENTER" AND "CHILDREN'S CANCER HOSPITAL", APART FROM THE MARK AS SHOWN.

THE NAME(S), PORTRAIT(S), AND/OR SIGNATURE(S) SHOWN IN THE MARK DOES NOT IDENTIFY A PARTICULAR LIVING INDIVIDUAL.

SEC. 2(F) AS TO "THE UNIVERSITY OF TEXAS".

**CLASS 41—EDUCATION AND ENTERTAINMENT**

FOR EDUCATIONAL SERVICES, NAMELY, DEVELOPING AND DISSEMINATING EDUCATIONAL MATERIALS AND PROGRAMS TO PHYSICIANS AND PATIENTS REGARDING CANCER AND OTHER DISEASES, ONCOLOGY AND DISEASE MANAGEMENT (U.S. CLS. 100, 101 AND 107).

FIRST USE 6-0-2006; IN COMMERCE 6-0-2006.

**CLASS 44—MEDICAL, BEAUTY AND AGRICULTURAL SERVICES**

FOR MEDICAL SERVICES, NAMELY, THE TREATMENT OF CANCER, DISEASE MANAGEMENT, DISEASE PREVENTION AND EARLY DETECTION, STANDARDIZED DIAGNOSIS, STAGING AND TREATMENT, CARE AND CARE ASSESSMENT, COUNSELING, AND PATIENT NETWORKING; CONSULTING SERVICES, NAMELY, CONSULTING ON THE TREATMENT OF CANCER, DISEASE MANAGEMENT, DISEASE PREVENTION AND EARLY DETECTION, STANDARDIZED DIAGNOSIS, STAGING AND TREATMENT, CARE AND CARE ASSESSMENT, AND PATIENT CARE MANAGEMENT; COMPUTER INFORMATION SERVICES, NAMELY PROVIDING INFORMATION ON CANCER AND OTHER DISEASES, ONCOLOGY AND DISEASE MANAGEMENT VIA A GLOBAL COMPUTER NETWORK (U.S. CLS. 100 AND 101).

FIRST USE 6-0-2006; IN COMMERCE 6-0-2006.  
DAVID STERKIN, EXAMINING ATTORNEY

SN 78-931,655. THE BOARD OF REGENTS OF THE UNIVERSITY OF TEXAS SYSTEM, AUSTIN, TX. FILED 7-18-2006.



OWNER OF U.S. REG. NOS. 2,594,012, 2,697,082 AND OTHERS.

NO CLAIM IS MADE TO THE EXCLUSIVE RIGHT TO USE "CANCER CENTER" AND "CHILDREN'S CANCER HOSPITAL", APART FROM THE MARK AS SHOWN.

THE NAME(S), PORTRAIT(S), AND/OR SIGNATURE(S) SHOWN IN THE MARK DOES NOT IDENTIFY A PARTICULAR LIVING INDIVIDUAL.

SEC. 2(F) AS TO "THE UNIVERSITY OF TEXAS".

**CLASS 41—EDUCATION AND ENTERTAINMENT**

FOR EDUCATIONAL SERVICES, NAMELY, DEVELOPING AND DISSEMINATING EDUCATIONAL MATERIALS AND PROGRAMS TO PHYSICIANS AND PATIENTS REGARDING CANCER AND OTHER DISEASES, ONCOLOGY AND DISEASE MANAGEMENT (U.S. CLS. 100, 101 AND 107).

FIRST USE 6-0-2006; IN COMMERCE 6-0-2006.

**CLASS 44—MEDICAL, BEAUTY AND AGRICULTURAL SERVICES**

FOR MEDICAL SERVICES, NAMELY, THE TREATMENT OF CANCER, DISEASE MANAGEMENT, DISEASE PREVENTION AND EARLY DETECTION, STANDARDIZED DIAGNOSIS, STAGING AND TREATMENT, CARE AND CARE ASSESSMENT, COUNSELING, AND PATIENT NETWORKING; CONSULTING SERVICES, NAMELY, CONSULTING ON THE TREATMENT OF CANCER, DISEASE MANAGEMENT, DISEASE PREVENTION AND EARLY DETECTION, STANDARDIZED DIAGNOSIS, STAGING AND TREATMENT, CARE AND CARE ASSESSMENT, AND PATIENT CARE MANAGEMENT; COMPUTER INFORMATION SERVICES, NAMELY PROVIDING INFORMATION ON CANCER AND OTHER DISEASES, ONCOLOGY AND DISEASE MANAGEMENT VIA A GLOBAL COMPUTER NETWORK (U.S. CLS. 100 AND 101).

FIRST USE 6-0-2006; IN COMMERCE 6-0-2006.  
DAVID STERKIN, EXAMINING ATTORNEY

SN 78-932,430. COMPREHENSIVE CONSULTING SOLUTIONS, INC., BROOKFIELD, WI. FILED 7-18-2006.

### COMPREHENSIVE SOLUTIONS

THE MARK CONSISTS OF STANDARD CHARACTERS WITHOUT CLAIM TO ANY PARTICULAR FONT, STYLE, SIZE, OR COLOR.

OWNER OF U.S. REG. NOS. 2,766,444 AND 2,771,101. SEC. 2(F).

### CLASS 35—ADVERTISING AND BUSINESS

FOR BUSINESS MANAGEMENT CONSULTING SERVICES; DISASTER RECOVERY SERVICES, NAMELY, BUSINESS PLANNING AND BUSINESS CONTINUITY CONSULTING; BUSINESS ORGANIZATIONAL PROJECT MANAGEMENT IN THE FIELDS OF INFORMATION TECHNOLOGY, BUSINESS CONTINUITY, DISASTER RECOVERY PLANNING, AND ORGANIZATIONAL GROWTH; DATABASE MANAGEMENT; CORPORATE MANAGEMENT ASSISTANCE (U.S. CLS. 100, 101 AND 102).

FIRST USE 4-7-1999; IN COMMERCE 4-7-1999.

### CLASS 42—SCIENTIFIC, COMPUTER AND LEGAL SERVICES

FOR COMPUTER CONSULTING SERVICES IN THE FIELD OF DESIGN, SELECTION, IMPLEMENTATION AND USE OF COMPUTER HARDWARE AND SOFTWARE SYSTEMS FOR OTHERS; COMPUTER CONSULTING SERVICES IN THE FIELD OF GLOBAL INFORMATION NETWORKS (U.S. CLS. 100 AND 101).

FIRST USE 4-7-1999; IN COMMERCE 4-7-1999. CHRISIE B. KING, EXAMINING ATTORNEY

SN 78-932,819. FAIRVIEW MINISTRIES, INC., DOWNERS GROVE, IL. FILED 7-19-2006.

### VIBRANT LIVING COMMUNITIES & SERVICES

THE MARK CONSISTS OF STANDARD CHARACTERS WITHOUT CLAIM TO ANY PARTICULAR FONT, STYLE, SIZE, OR COLOR.

NO CLAIM IS MADE TO THE EXCLUSIVE RIGHT TO USE "LIVING COMMUNITIES & SERVICES", APART FROM THE MARK AS SHOWN.

### CLASS 43—HOTEL AND RESTAURANT SERVICES

FOR PROVIDING ASSISTED LIVING FACILITIES; RETIREMENT HOMES (U.S. CLS. 100 AND 101).

### CLASS 44—MEDICAL, BEAUTY AND AGRICULTURAL SERVICES

FOR NURSING HOME SERVICES; HOME NURSING AID SERVICES; MASSAGE SERVICES; EMERGENCY MEDICAL RESPONSE SERVICES; PREPARATION AND DISPENSING OF MEDICATIONS; REMOTE MONITORING OF DATA INDICATIVE OF THE HEALTH OR CONDITION OF AN INDIVIDUAL OR GROUP OF INDIVIDUALS (U.S. CLS. 100 AND 101).

PETER B. BROMAGHIM, EXAMINING ATTORNEY

SN 78-933,934. BAUMAN, BILL, IVINS, UT. FILED 7-20-2006.

## OZ POWER

THE MARK CONSISTS OF STANDARD CHARACTERS WITHOUT CLAIM TO ANY PARTICULAR FONT, STYLE, SIZE, OR COLOR.

### CLASS 9—ELECTRICAL AND SCIENTIFIC APPARATUS

FOR PRE-RECORDED AUDIOTAPES, VIDEOTAPES, AUDIO CASSETTES, VIDEOCASSETTES, COMPACT DISCS AND DVDS FEATURING INFORMATION, TECHNIQUES AND PROCESSES FOR PERSONAL GROWTH AND TRANSFORMATION (U.S. CLS. 21, 23, 26, 36 AND 38).

FIRST USE 3-18-2005; IN COMMERCE 3-18-2005.

### CLASS 16—PAPER GOODS AND PRINTED MATTER

FOR BOOKS, BROCHURES, MANUALS, AND PAMPHLETS FEATURING INFORMATION, TECHNIQUES AND PROCESSES FOR PERSONAL GROWTH AND TRANSFORMATION (U.S. CLS. 2, 5, 22, 23, 29, 37, 38 AND 50).

FIRST USE 3-18-2005; IN COMMERCE 3-18-2005.

### CLASS 41—EDUCATION AND ENTERTAINMENT

FOR TEACHING AND TRAINING SERVICES FEATURING INFORMATION, TECHNIQUES AND PROCESSES FOR PERSONAL GROWTH AND TRANSFORMATION (U.S. CLS. 100, 101 AND 107).

FIRST USE 3-18-2005; IN COMMERCE 3-18-2005. MICHAEL KEATING, EXAMINING ATTORNEY

SN 78-934,127. METACARTA, INC., CAMBRIDGE, MA. FILED 7-20-2006.



THE MARK CONSISTS OF TWO SEMI-CIRCULAR LINES SURROUNDING A STYLIZED REPRESENTATION OF A PIECE OF PAPER WITH A PUSH PIN TO THE LEFT OF THE WORDS MAP THIS WITH AN EXCLAMATION POINT.

**CLASS 9—ELECTRICAL AND SCIENTIFIC APPARATUS**

FOR COMPUTER SEARCH ENGINE SOFTWARE FOR GEOGRAPHIC TEXT SEARCHES; SOFTWARE THAT ENABLES USERS TO IDENTIFY THE GEOGRAPHIC LOCATION OF GOODS AND SERVICES OF OTHERS (U.S. CLS. 21, 23, 26, 36 AND 38).

**CLASS 42—SCIENTIFIC, COMPUTER AND LEGAL SERVICES**

FOR COMPUTER SERVICES, NAMELY, PROVIDING COMPUTER SEARCH ENGINES FOR GEOGRAPHIC TEXT SEARCHES FOR OBTAINING DATA ON A GLOBAL COMPUTER NETWORK; DATA COLLECTION SERVICES USING PROPRIETARY SOFTWARE TO COLLECT, EVALUATE AND ANALYZE DATA TO IDENTIFY THE GEOGRAPHIC LOCATION OF GOODS AND SERVICES OF OTHERS (U.S. CLS. 100 AND 101).

SUE LAWRENCE, EXAMINING ATTORNEY

SN 78-936,382. MOLINOS RIO DE LA PLATA S.A., BUENOS AIRES, ARGENTINA, FILED 7-24-2006.



THE FOREIGN WORDING IN THE MARK TRANSLATES INTO ENGLISH AS EXQUISITE.

**CLASS 29—MEATS AND PROCESSED FOODS**

FOR JELLIES FOR FOOD (U.S. CL. 46).

**CLASS 30—STAPLE FOODS**

FOR BAKING POWDERS TO PREPARE CAKES, FLAN AND DESSERTS (U.S. CL. 46).

CHARLES L. JENKINS, EXAMINING ATTORNEY

SN 78-936,372. PETSUNITED, LLC, HAZLETON, PA. FILED 7-24-2006.

SN 78-937,311. FASHION WEEK INSIDER, INC., NEW YORK, NY. FILED 7-25-2006.

# Aquatic Edge

THE MARK CONSISTS OF STANDARD CHARACTERS WITHOUT CLAIM TO ANY PARTICULAR FONT, STYLE, SIZE, OR COLOR.

NO CLAIM IS MADE TO THE EXCLUSIVE RIGHT TO USE "AQUATIC", APART FROM THE MARK AS SHOWN.

**CLASS 7—MACHINERY**

FOR AQUARIUM AIR PUMPS; AQUARIUM WATER PUMPS; AQUARIUM PUMP CONTROL VALVES; APPARATUS FOR MAKING WAVES IN AQUARIUM WATER, NAMELY, AQUARIUM WAVE MAKERS (U.S. CLS. 13, 19, 21, 23, 31, 34 AND 35).

FIRST USE 7-1-2006; IN COMMERCE 7-1-2006.

**CLASS 11—ENVIRONMENTAL CONTROL APPARATUS**

FOR AQUARIUM FILTERS; AQUARIUM LIGHTS; AQUARIUM HEATERS; OUTDOOR ARCHITECTURAL WATER FEATURES, NAMELY, WATERFALLS; DEVICES FOR COOLING AQUARIUM WATER, NAMELY, AQUARIUM CHILLERS; AQUARIUM WATER TREATMENT DEVICES, NAMELY, PH REGULATORS, OZONE SANITIZERS FOR WATER, ULTRAVIOLET (UV) STERILIZERS, AND WATER CONDITIONING APPARATUS (U.S. CLS. 13, 21, 23, 31 AND 34).

FIRST USE 7-1-2006; IN COMMERCE 7-1-2006.

**CLASS 16—PAPER GOODS AND PRINTED MATTER**

FOR AQUARIUMS; WATER TANKS FOR HOLDING LIVE FISH AND HERMIT CRABS; AQUARIUM AIR STONES; AQUARIUM FISH NETS; AQUARIUM HOODS; AQUARIUM ACCESSORIES, NAMELY, AERATORS (U.S. CLS. 2, 5, 22, 23, 29, 37, 38 AND 50).

FIRST USE 7-1-2006; IN COMMERCE 7-1-2006.  
JIM RINGLE, EXAMINING ATTORNEY

# FASHION WEEK INSIDER

THE MARK CONSISTS OF STANDARD CHARACTERS WITHOUT CLAIM TO ANY PARTICULAR FONT, STYLE, SIZE, OR COLOR.

NO CLAIM IS MADE TO THE EXCLUSIVE RIGHT TO USE "FASHION WEEK", APART FROM THE MARK AS SHOWN.

**CLASS 38—COMMUNICATION**

FOR ELECTRONIC DELIVERY OF IMAGES, PHOTOGRAPHS, ART, GRAPHIC IMAGES AND GRAPHIC DESIGNS, CLIP ART, NEWS IMAGES, ILLUSTRATIONS, DIGITAL ANIMATION, VIDEO CLIPS, FILM FOOTAGE, AND AUDIO DATA VIA A GLOBAL COMPUTER NETWORK AND OTHER COMPUTER NETWORKS (U.S. CLS. 100, 101 AND 104).

**CLASS 41—EDUCATION AND ENTERTAINMENT**

FOR PHOTOGRAPHY SERVICES; NEWS PRESS AGENCY SERVICES, NAMELY, GATHERING AND DISSEMINATION OF PHOTOGRAPHS AND IMAGES RELATED TO CELEBRITIES, ENTERTAINMENT, FASHION, SPORTS, AND NEWS TO OTHER MEDIA (U.S. CLS. 100, 101 AND 107).

**CLASS 42—SCIENTIFIC, COMPUTER AND LEGAL SERVICES**

FOR STOCK PHOTOGRAPHY SERVICES, NAMELY, LICENSING OF INTELLECTUAL PROPERTY REPRODUCTION RIGHTS TO PHOTOGRAPHS AND IMAGES RELATED TO CELEBRITIES, ENTERTAINMENT, FASHION, SPORTS, AND NEWS, CELEBRITY PORTRAITS, ART, GRAPHIC IMAGES AND GRAPHIC DESIGNS, CLIP ART, ILLUSTRATIONS, VIDEO CLIPS, FILM FOOTAGE, AND AUDIOVISUAL DATA (U.S. CLS. 100 AND 101).

VIVIAN MICZNIK FIRST, EXAMINING ATTORNEY

SN 78-937,439. FAIRCO, INC., LAFAYETTE, LA. FILED 7-25-2006.

# FAIRCO

THE MARK CONSISTS OF STANDARD CHARACTERS WITHOUT CLAIM TO ANY PARTICULAR FONT, STYLE, SIZE, OR COLOR.

## CLASS 6—METAL GOODS

FOR ALUMINUM FOIL (U.S. CLS. 2, 12, 13, 14, 23, 25 AND 50).  
FIRST USE 7-15-1974; IN COMMERCE 7-15-1974.

## CLASS 29—MEATS AND PROCESSED FOODS

FOR POTATO STICKS; SHRIMP; PEANUT BUTTER; COFFEE CREAMER; MARASCHINO CHERRIES; CANNED CORN (U.S. CL. 46).  
FIRST USE 7-15-1974; IN COMMERCE 7-15-1974.

## CLASS 30—STAPLE FOODS

FOR HOT SAUCE; VINEGAR; MAYONNAISE; MUSTARD; SALAD DRESSING; HONEY; MARSHMALLOWS; POPCORN; BREAKFAST CEREALS; SALT; FRUIT CAKE; CORN FLAKES; RAISIN BRAN CEREALS, CRISP RICE, SUGAR FROSTED FLAKES (U.S. CL. 46).  
FIRST USE 4-21-1949; IN COMMERCE 4-29-1949.  
SANDRA MANIOS, EXAMINING ATTORNEY

SN 78-937,516. OLD STYLE SALOON NO. 10 INC., DEADWOOD, SD. FILED 7-26-2006.

# OLD STYLE SALOON NO. 10

THE MARK CONSISTS OF STANDARD CHARACTERS WITHOUT CLAIM TO ANY PARTICULAR FONT, STYLE, SIZE, OR COLOR.

NO CLAIM IS MADE TO THE EXCLUSIVE RIGHT TO USE "SALOON" AS TO THE SERVICES IN INTERNATIONAL CLASSES 41 AND 43, APART FROM THE MARK AS SHOWN.

SEC. 2(F) AS TO "OLD STYLE".

## CLASS 25—CLOTHING

FOR CLOTHING, NAMELY, T-SHIRTS, SWEATSHIRTS, UNION SUITS, JACKETS, DENIM JACKETS, LEATHER JACKETS, UNDERWEAR, GARTER BELTS, SUSPENDERS, CAPS, STRAW HATS, BASEBALL CAPS, BEANIES, AND BABY ROMPERS (U.S. CLS. 22 AND 39).  
FIRST USE 0-0-1988; IN COMMERCE 0-0-1988.

## CLASS 41—EDUCATION AND ENTERTAINMENT

FOR CASINO SERVICES; GAMBLING SERVICES; AMUSEMENT ARCADE SERVICES; AND ENTERTAINMENT SERVICES, NAMELY PROVIDING AND PRESENTING LIVE HISTORICAL REENACTMENTS, PROVIDING AND PRESENTING LIVE STAGE SHOWS, PROVIDING AND PRESENTING LIVE BAND, VOCAL, INSTRUMENTAL, MUSIC, DANCE AND COMIC PERFORMANCES; PROVIDING KARAOKE FACILITIES AND CONTESTS; PROVIDING FACILITIES FOR LISTENING TO MUSIC FOR GUESTS; AND NIGHT CLUB SERVICES (U.S. CLS. 100, 101 AND 107).

FIRST USE 0-0-1989; IN COMMERCE 0-0-1989.

## CLASS 43—HOTEL AND RESTAURANT SERVICES

FOR BAR SERVICES, RESTAURANT SERVICES, AND PROVIDING BANQUET AND SOCIAL FUNCTION FACILITIES FOR SPECIAL OCCASIONS (U.S. CLS. 100 AND 101).

FIRST USE 0-0-1963; IN COMMERCE 0-0-1963.  
JEFFERY COWARD, EXAMINING ATTORNEY

SN 78-937,585. JAY'S SPORTING GOODS, INC., CLARE, MI. FILED 7-26-2006.

# Mackinaw Outfitters

THE MARK CONSISTS OF STANDARD CHARACTERS WITHOUT CLAIM TO ANY PARTICULAR FONT, STYLE, SIZE, OR COLOR.

NO CLAIM IS MADE TO THE EXCLUSIVE RIGHT TO USE "OUTFITTER", APART FROM THE MARK AS SHOWN.

## CLASS 6—METAL GOODS

FOR METAL SAFES (U.S. CLS. 2, 12, 13, 14, 23, 25 AND 50).

FIRST USE 1-11-2006; IN COMMERCE 1-11-2006.

## CLASS 25—CLOTHING

FOR TEE SHIRT, SWEATSHIRTS LONG SLEEVED AND SHORT SLEEVED, AND SWEATJACKET (U.S. CLS. 22 AND 39).

FIRST USE 1-11-2006; IN COMMERCE 1-11-2006.  
JACQUELINE A. LAVINE, EXAMINING ATTORNEY

SN 78-937,677. MARKETING TECHNOLOGY SOLUTIONS INC., EDISON, NJ. FILED 7-26-2006.

# QUALITYHEALTH.COM

THE MARK CONSISTS OF STANDARD CHARACTERS WITHOUT CLAIM TO ANY PARTICULAR FONT, STYLE, SIZE, OR COLOR.

OWNER OF U.S. REG. NO. 2,940,053.

**CLASS 35—ADVERTISING AND BUSINESS**

FOR BUSINESS MARKETING CONSULTING SERVICES; MARKET RESEARCH AND ANALYSIS SERVICES; CONSUMER MARKETING RESEARCH SERVICES, NAMELY, CONDUCTING SURVEYS, GATHERING AND ANALYZING DATA RELATING TO CONSUMER DEMOGRAPHICS, ATTITUDES, OPINIONS AND BEHAVIOR FOR THE MEDICAL, PHARMACEUTICAL AND HEALTHCARE INDUSTRIES; ADVERTISING SERVICES, NAMELY, PROMOTING THE GOODS AND SERVICES OF OTHERS BY OFFERING COUPONS, SURVEYS AND PROMOTIONAL MATERIALS VIA A WEBSITE; ONLINE SAMPLE DISTRIBUTION SERVICES; PROVIDING A WEBSITE ON GLOBAL COMPUTER NETWORKS CONTAINING INFORMATION ABOUT HEALTHCARE PRODUCTS (U.S. CLS. 100, 101 AND 102).  
FIRST USE 9-30-2001; IN COMMERCE 9-30-2001.

**CLASS 44—MEDICAL, BEAUTY AND AGRICULTURAL SERVICES**

FOR PROVIDING A WEBSITE ON GLOBAL COMPUTER NETWORKS CONTAINING INFORMATION ABOUT HEALTHCARE, SERVICES AND OVERALL WELLNESS FOR PEOPLE AND PETS; PROVIDING LINKS TO WEBSITES CONTAINING INFORMATION ABOUT HEALTHCARE AND OVERALL WELLNESS (U.S. CLS. 100 AND 101).  
FIRST USE 9-30-2001; IN COMMERCE 9-30-2001.  
KELLY MCCOY, EXAMINING ATTORNEY

SN 78-937,738. NEW STANLEY ASSOCIATES, L.L.P.,  
ESTES PARK, CO. FILED 7-26-2006.

**STANLEY MARKETPLACE**

THE MARK CONSISTS OF STANDARD CHARACTERS WITHOUT CLAIM TO ANY PARTICULAR FONT, STYLE, SIZE, OR COLOR.

OWNER OF U.S. REG. NO. 3,179,149.  
NO CLAIM IS MADE TO THE EXCLUSIVE RIGHT TO USE "MARKETPLACE", APART FROM THE MARK AS SHOWN.

**CLASS 35—ADVERTISING AND BUSINESS**

FOR RETAIL STORE SERVICES FEATURING SOUVENIRS AND CONVENIENCE STORE ITEMS, T-SHIRTS, HATS (U.S. CLS. 100, 101 AND 102).

**CLASS 38—COMMUNICATION**

FOR BUSINESS SERVICES FOR HOTEL GUESTS AND CUSTOMERS, NAMELY, PROVIDING REMOTE INTERNET ACCESS, FACSIMILE TRANSMISSION SERVICES AND RENTAL OF TELEPHONES (U.S. CLS. 100, 101 AND 104).

**CLASS 43—HOTEL AND RESTAURANT SERVICES**

FOR COFFEE SHOP SERVICES; CAFE SERVICES; RESTAURANT AND CARRYOUT FOOD SERVICES (U.S. CLS. 100 AND 101).  
RUDY R. SINGLETON, EXAMINING ATTORNEY

SN 78-939,080. CHRISTINA DORRER, NEWPORT NEWS, VA. FILED 7-27-2006.



NO CLAIM IS MADE TO THE EXCLUSIVE RIGHT TO USE "INC.", APART FROM THE MARK AS SHOWN.

THE COLOR(S) RED, ORANGE, YELLOW, GREEN, BLUE, PURPLE, PINK, BLACK AND WHITE IS/ARE CLAIMED AS A FEATURE OF THE MARK.

THE MARK CONSISTS OF THE WORDS "FIT 2 B KIDS" IN BUBBLE LETTERS OUTLINED IN BLACK. THE COLOR INSIDE THE "F" AND "I" IS DARK PINK. THE COLOR INSIDE THE "T" IS RED. THE COLOR INSIDE THE "2" IS ORANGE, TRANSITIONING TO YELLOW. THE COLOR INSIDE THE "B" IS YELLOW TRANSITIONING TO GREEN. THE COLOR INSIDE THE "K" IS LIGHT BLUE TRANSITIONING TO DARK BLUE. THE COLOR INSIDE THE "I" IS DARK BLUE. THE COLOR INSIDE THE "D" IS DARK BLUE TRANSITIONING TO PURPLE. THE COLOR INSIDE THE "S" IS PURPLE. AT THE END OF THE "FIT 2 B KIDS" COLORED BUBBLE LETTERS, THE SMALL SIZED WORD "INC." APPEARS IN PURPLE. UNDER THE WORDS "FIT 2 B KIDS, INC." ARE BLACK AND WHITE OUTLINES OF 6 CHILDREN IN A ROW PERFORMING FITNESS ACTIVITIES. INSIDE THE BLACK OUTLINE OF THE CHILDREN'S BODIES AND A PICTURE OF A BALL APPEARS WHITE AND IS TRANSPARENT, EXCEPT WHERE COLORED CLOTHING IS VISIBLE. THE FIRST IS A GIRL WITH SHORT HAIR AND A BOW SITTING IN A YOGA BUTTERFLY POSE. HER OUTFIT IS RED. THE SECOND IS AN OUTLINE OF A BOY HOLDING A BALL OVER HIS HEAD. HIS SHORTS ARE YELLOW AND HIS SHIRT IS BLUE. THE THIRD IS A PICTURE OF A GIRL JUMPING ROPE. HER SKIRT IS NOT COLORED. HER SHIRT IS PINK. THE FOURTH IS A PICTURE OF A BOY RUNNING, FACING EAST. HIS SHIRT IS YELLOW AND HIS SHORTS ARE RED. THE FIFTH IS A PICTURE OF A GIRL IN A DIVING POSITION WITH HER HANDS OVER HER HEAD AND GOGGLES. HER BATHING SUIT IS PINK. THE SIXTH IS A PICTURE OF A BOY IN THE YOGA BOW POSE. HIS SHIRT IS ORANGE AND HIS SHORTS ARE PURPLE. UNDER THE PICTURES OF THE KIDS IS THE PHRASE "BRINGING FUN FITNESS FOR KIDS TO KIDS!" "BRINGING" IS IN BLACK, "FUN" IS IN PINK AND IS ITALICIZED. "FITNESS" IS IN BLACK. "FOR" IS IN ORANGE AND IS ITALICIZED. "KIDS" IS IN BLACK. "TO" IS IN A BLUE-PURPLE COLOR AND IS ITALICIZED. THERE IS AN EXCLAMATION POINT AT THE END OF THE PHRASE.

**CLASS 9—ELECTRICAL AND SCIENTIFIC APPARATUS**

FOR PRE-RECORDED CD'S, VIDEO TAPES, LASER DISKS AND DVD'S FEATURING FITNESS INSTRUCTION (U.S. CLS. 21, 23, 26, 36 AND 38).

**CLASS 41—EDUCATION AND ENTERTAINMENT**

FOR PROVIDING INFORMATION IN THE FIELD OF EXERCISE TRAINING (U.S. CLS. 100, 101 AND 107).  
ELI HELLMAN, EXAMINING ATTORNEY

SN 78-941,536. LEXICON RELOCATION, LLC, JACKSONVILLE, FL. FILED 7-31-2006.

## LEXICON MORTGAGE

THE MARK CONSISTS OF STANDARD CHARACTERS WITHOUT CLAIM TO ANY PARTICULAR FONT, STYLE, SIZE, OR COLOR.

OWNER OF U.S. REG. NOS. 2,704,127 AND 2,812,458.

NO CLAIM IS MADE TO THE EXCLUSIVE RIGHT TO USE "MORTGAGE", APART FROM THE MARK AS SHOWN.

### CLASS 36—INSURANCE AND FINANCIAL

FOR PERSONAL EXPENSE ADMINISTRATION, NAMELY, ADMINISTERING FOR EMPLOYEES OF OTHERS THE EMPLOYEES RELOCATION BENEFITS; RELOCATION ASSISTANCE, NAMELY, REAL ESTATE BROKERAGE; MORTGAGE SERVICES, NAMELY, BUYER PREQUALIFICATION OF MORTGAGES FOR MORTGAGE BROKERS AND BANKS, MORTGAGE BANKING SERVICES, NAMELY, ORIGINATION, ACQUISITION, SERVICING, SECURITIZATION AND BROKERAGE OF MORTGAGE LOANS MORTGAGE PROCUREMENT FOR OTHERS, AND MORTGAGE LENDING (U.S. CLS. 100, 101 AND 102).

### CLASS 39—TRANSPORTATION AND STORAGE

FOR MOVE MANAGEMENT, NAMELY, HOUSEHOLD GOODS TRANSPORTATION (U.S. CLS. 100 AND 105).

### CLASS 43—HOTEL AND RESTAURANT SERVICES

FOR RELOCATION SERVICES, NAMELY, MAKING RESERVATIONS AND BOOKING FOR TEMPORARY LODGING (U.S. CLS. 100 AND 101).

JACQUELINE A. LAVINE, EXAMINING ATTORNEY

SN 78-941,726. HANSEN BROS. TRANSFER & STORAGE CO., NEWCASTLE, WA. FILED 7-31-2006.

## PORTABOX

THE MARK CONSISTS OF STANDARD CHARACTERS WITHOUT CLAIM TO ANY PARTICULAR FONT, STYLE, SIZE, OR COLOR.

OWNER OF U.S. REG. NO. 2,347,645.  
SEC. 2(F).

### CLASS 20—FURNITURE AND ARTICLES NOT OTHERWISE CLASSIFIED

FOR WOODEN STORAGE CONTAINERS FOR RESIDENTIAL, COMMERCIAL, OR INDUSTRIAL USE (U.S. CLS. 2, 13, 22, 25, 32 AND 50).

FIRST USE 12-0-1996; IN COMMERCE 12-0-1996.

### CLASS 39—TRANSPORTATION AND STORAGE

FOR WAREHOUSE SERVICES, NAMELY, STORAGE, DISTRIBUTION, PICKUP, PACKING, AND SHIPPING OF HOUSEHOLD, RESIDENTIAL, BUSINESS-RELATED, AND COMMERCIAL ARTICLES (U.S. CLS. 100 AND 105).

FIRST USE 12-0-1996; IN COMMERCE 12-0-1996.  
TIMOTHY FINNEGAN, EXAMINING ATTORNEY

SN 78-942,330. ELLIOTT, KALA ALEXANDRIA, WARLINGHAM, SURREY, UNITED KINGDOM, FILED 8-1-2006.

## CANODRAPE

THE MARK CONSISTS OF STANDARD CHARACTERS WITHOUT CLAIM TO ANY PARTICULAR FONT, STYLE, SIZE, OR COLOR.

OWNER OF UNITED KINGDOM REG. NO. 2398598, DATED 6-9-2006, EXPIRES 8-4-2015.

### CLASS 20—FURNITURE AND ARTICLES NOT OTHERWISE CLASSIFIED

FOR FURNITURE; MIRRORS; PICTURE FRAMES NOT OF PRECIOUS METAL; BEDS; BEDDING, NAMELY, BOX SPRINGS, MATTRESSES, AND PILLOWS; BED CASTERS NOT OF METAL; WOOD BEDSTEADS; BOLSTER PILLOWS; DIVANS; MATTRESSES; CUSHIONS; PILLOWS; DRAPERY HARDWARE, NAMELY, CURTAIN HOLDERS, NOT OF TEXTILE MATERIAL, CURTAIN HOOKS, CURTAIN RAILS, CURTAIN RINGS, CURTAIN RODS, CURTAIN ROLLERS AND CURTAIN TIE-BACKS; AND PARTS AND FITTINGS OF ALL THE AFORE-MENTIONED GOODS; AND FRAMES FOR BED CANOPIES (U.S. CLS. 2, 13, 22, 25, 32 AND 50).

### CLASS 24—FABRICS

FOR CURTAINS; CURTAIN HOLDERS OF TEXTILE MATERIAL; BED CLOTHES, NAMELY, PILLOW SHAMS, BED COVERS, BED SPREADS, BLANKETS, SHEETS, PILLOW CASES, MATTRESS COVERS, BED LINEN, DUVETS AND DUVET COVERS; TAPESTRIES OF TEXTILE; BED CANOPIES (U.S. CLS. 42 AND 50).

TAMARA FRAZIER, EXAMINING ATTORNEY

SN 78-942,482. UNICOUS MARKETING INC., CHICAGO, IL. FILED 8-1-2006.

### CLASS 35—ADVERTISING AND BUSINESS

FOR ADVERTISING, MARKETING AND PROMOTION SERVICES IN THE FIELD OF PAPERLESS COUPONS (U.S. CLS. 100, 101 AND 102).

**CLASS 36—INSURANCE AND FINANCIAL**

FOR FINANCIAL CLEARING HOUSE SERVICES RELATING TO PAPERLESS COUPONS (U.S. CLS. 100, 101 AND 102).

ZHALEH DELANEY, EXAMINING ATTORNEY

SN 78-945,255. BRAVO SPORTS, SANTA FE SPRINGS, CA. FILED 8-4-2006.

SN 78-944,855. BEAUTY HOLDING COMPANY, INC., HAMILTON, BERMUDA, FILED 8-4-2006.

**PLUGGED**

THE MARK CONSISTS OF THE WORD "PLUGGED" IN A STYLIZED FONT WITH THE WORD "IN" ENCASED IN A CIRCLE BETWEEN THE TWO "GS" IN PLUGGED. ALSO, THE FIRST "G" IN THE WORD PLUGGED IS BACKWARDS.

**CLASS 9—ELECTRICAL AND SCIENTIFIC APPARATUS**

FOR ELECTRIC FLAT IRONS; ELECTRIC HAIR CURLING IRONS; ELECTRIC HAIR ROLLERS (U.S. CLS. 21, 23, 26, 36 AND 38).

**CLASS 11—ENVIRONMENTAL CONTROL APPARATUS**

FOR HAIR DRYING MACHINES FOR BEAUTY SALON USE; HAND-HELD ELECTRIC HAIR DRYERS (U.S. CLS. 13, 21, 23, 31 AND 34).

PETER B. BROMAGHIM, EXAMINING ATTORNEY

SN 78-944,994. ENERTRON, INC., TEMPE, AZ. FILED 8-4-2006.

ELUMINATED BY ENLUX LED

THE MARK CONSISTS OF STANDARD CHARACTERS WITHOUT CLAIM TO ANY PARTICULAR FONT, STYLE, SIZE, OR COLOR.

OWNER OF U.S. REG. NO. 2,961,446.

NO CLAIM IS MADE TO THE EXCLUSIVE RIGHT TO USE "ILLUMINATED" AND "LED", APART FROM THE MARK AS SHOWN.

**CLASS 9—ELECTRICAL AND SCIENTIFIC APPARATUS**

FOR LIGHT EMITTING DIODES (U.S. CLS. 21, 23, 26, 36 AND 38).

**CLASS 11—ENVIRONMENTAL CONTROL APPARATUS**

FOR ELECTRIC LIGHT BULBS (U.S. CLS. 13, 21, 23, 31 AND 34).

MICHELLE DUBOIS, EXAMINING ATTORNEY

**SATELLITE**

THE MARK CONSISTS OF STANDARD CHARACTERS WITHOUT CLAIM TO ANY PARTICULAR FONT, STYLE, SIZE, OR COLOR.

**CLASS 9—ELECTRICAL AND SCIENTIFIC APPARATUS**

FOR PROTECTIVE HELMETS FOR USE IN SPORTS ACTIVITIES, NAMELY SKATEBOARDING, ROLLER SKATING, INLINE SKATING, AND HOCKEY; FACE PROTECTION SHIELDS FOR USE WITH HELMETS; AND FACE SHIELDS (U.S. CLS. 21, 23, 26, 36 AND 38).

**CLASS 28—TOYS AND SPORTING GOODS**

FOR PROTECTIVE GEAR FOR USE IN SKATEBOARDING, ROLLER SKATING, INLINE SKATING AND HOCKEY, NAMELY ELBOW PADS; KNEE PADS; PADDED GIRDLES; WRIST GUARDS; PROTECTIVE GLOVES AND SHOULDER PADS; SKATEBOARDS; SKATEBOARD ACCESSORIES, NAMELY WHEELS, TRUCKS, DECKS, BEARINGS, BUSHINGS, BOLTS, AND RISERS (U.S. CLS. 22, 23, 38 AND 50).

REGINA DRUMMOND, EXAMINING ATTORNEY

SN 78-946,147. HEB GROCERY COMPANY, LP, SAN ANTONIO, TX. FILED 8-7-2006.

**H-E-BLOOM**

THE MARK CONSISTS OF STANDARD CHARACTERS WITHOUT CLAIM TO ANY PARTICULAR FONT, STYLE, SIZE, OR COLOR.

OWNER OF U.S. REG. NOS. 1,167,845, 3,188,211 AND OTHERS.

**CLASS 35—ADVERTISING AND BUSINESS**

FOR RECEIVING ORDERS FOR FLOWERS AND FLORAL PRODUCTS AND CAUSING THEM TO BE FILLED EITHER INTERNALLY OR BY PARTICIPATING FLORISTS IN THE VICINITY OF THE RECIPIENT (U.S. CLS. 100, 101 AND 102).

**CLASS 38—COMMUNICATION**

FOR ELECTRONIC ORDER TRANSMISSION TO PARTICIPATING FLORISTS IN THE VICINITY OF THE RECIPIENT (U.S. CLS. 100, 101 AND 104).

BARBARA RUTLAND, EXAMINING ATTORNEY



SN 78-946,575. JAN MARINI SKIN RESEARCH, INC., SAN JOSE, CA. FILED 8-7-2006.

## SKIN IS MY LIFE

THE MARK CONSISTS OF STANDARD CHARACTERS WITHOUT CLAIM TO ANY PARTICULAR FONT, STYLE, SIZE, OR COLOR.

NO CLAIM IS MADE TO THE EXCLUSIVE RIGHT TO USE "SKIN", APART FROM THE MARK AS SHOWN.

### CLASS 16—PAPER GOODS AND PRINTED MATTER

FOR PRINTED PERIODICALS IN THE FIELD OF BEAUTY AND SKIN CARE PRODUCTS (U.S. CLS. 2, 5, 22, 23, 29, 37, 38 AND 50).

### CLASS 25—CLOTHING

FOR CLOTHING, NAMELY T-SHIRTS, SWEAT SHIRTS, CAPS, SUNVISORS (U.S. CLS. 22 AND 39).  
DORITT L. CARROLL, EXAMINING ATTORNEY

SN 78-946,668. LOCUST LANE FARMS, INC., UPPER MARLBORO, MD. FILED 8-7-2006.



NO CLAIM IS MADE TO THE EXCLUSIVE RIGHT TO USE "FARMS, INC." AND "UPPER MARLBORO, MD", APART FROM THE MARK AS SHOWN.

THE COLOR(S) BLACK, WHITE, RED, AND YELLOW. IS/ARE CLAIMED AS A FEATURE OF THE MARK.

THE MARK CONSISTS OF THE COLOR RED APPEARS IN THE INITIALS "LLF" AND IN THE DESIGN AROUND THE OUTER EDGES OF THE CIRCLE AND WITHIN THE TWO BARS APPEARING HORIZONTALLY ON BOTH SIDES OF THE CIRCLE. THE COLOR YELLOW APPEARS IN THE DESIGN OF THE VEHICLE/BACKHOE. THE COLOR BLACK APPEARS IN THE WORDING "UPPER MARLBORO, MD" AND IN THE WORDING "LOCUST LANE FARMS, INC." AND IN THE DESIGN OUTLINING THE ENTIRE LOGO MARK AND WITHIN THE INNER CIRCLE. THE COLOR WHITE APPEARS IN THE MARK OUTLINING THE INITIALS "LLF" AND WITHIN THE OUTER PORTION OF THE INNER CIRCLE.

### CLASS 37—CONSTRUCTION AND REPAIR

FOR EXCAVATION SERVICES; SOIL EROSION CONTROL; REAL ESTATE SITE IMPROVEMENT SERVICES; LANDSCAPE CONSTRUCTION SERVICES; CONSTRUCTION, INSTALLATION, EXCAVATION AND GRADING OF UNDERGROUND UTILITIES, AND CONSTRUCTION SITE DEVELOPMENT (U.S. CLS. 100, 103 AND 106).

FIRST USE 11-1-2004; IN COMMERCE 11-1-2004.

### CLASS 39—TRANSPORTATION AND STORAGE

FOR TRUCK HAULING (U.S. CLS. 100 AND 105).  
FIRST USE 11-1-2004; IN COMMERCE 11-1-2004.  
ARETHA SOMERVILLE, EXAMINING ATTORNEY

SN 78-949,213. BLUECROSS BLUESHIELD OF TENNESSEE, INC., CHATTANOOGA, TN. FILED 8-10-2006.

## BENEVIVE

THE MARK CONSISTS OF STANDARD CHARACTERS WITHOUT CLAIM TO ANY PARTICULAR FONT, STYLE, SIZE, OR COLOR.

### CLASS 36—INSURANCE AND FINANCIAL

FOR ADMINISTRATION OF MEDICARE PRIVATE FEE-FOR-SERVICE HEALTH INSURANCE PLANS; INSURANCE CLAIMS ADMINISTRATION AND PROCESSING SERVICES, NAMELY, RECONCILING MEDICARE PART A CLAIMS WITH MEDICARE'S PENDING CLAIMS FILE, AND IDENTIFYING AND RECAPTURING PENDING OR SUSPENDED MEDICARE PART A CLAIMS; INSURANCE CLAIMS ADMINISTRATION, NAMELY, PROCESSING APPEALS FOR DENIED MEDICARE CLAIMS (U.S. CLS. 100, 101 AND 102).

### CLASS 44—MEDICAL, BEAUTY AND AGRICULTURAL SERVICES

FOR HEALTH CARE CONSULTING AND HEALTH CARE COUNSELING SERVICES IN THE FIELD OF TOTAL HEALTH MANAGEMENT, NAMELY, PREVENTATIVE HEALTH CARE THROUGH HEALTH RISK ASSESSMENT PROFILES, PERSONAL AND GROUP HEALTH CARE RISK COUNSELING; HEALTH CARE COUNSELING IN THE FIELD OF HEALTH RISK INTERVENTION AND HEALTH RISK BEHAVIOR MODIFICATION; HEALTH CARE SERVICES, NAMELY, PREVENTATIVE MEDICAL ASSESSMENT AND SCREENING; HEALTH CARE SERVICES IN THE NATURE OF HEALTH MAINTENANCE AND PREFERRED PROVIDER ORGANIZATIONS, PRESCRIPTION DRUG PROGRAMS, AND HEALTH MANAGEMENT ORGANIZATIONS; MAINTAINING ELECTRONIC FILES AND RECORDS ACCESSIBLE THROUGH THE INTERNET CONCERNING HEALTH AND MEDICAL CONDITIONS OF INDIVIDUALS AND PROVIDING INFORMATION IN THE FIELD OF MEDICINE; MANAGED HEALTH CARE SERVICES (U.S. CLS. 100 AND 101).

MORENO, PAUL, EXAMINING ATTORNEY

SN 78-949,523. NATIONAL OSTEOPOROSIS FOUNDATION, WASHINGTON, DC. FILED 8-10-2006.

## PEARLS OF STRENGTH

THE MARK CONSISTS OF STANDARD CHARACTERS WITHOUT CLAIM TO ANY PARTICULAR FONT, STYLE, SIZE, OR COLOR.

NO CLAIM IS MADE TO THE EXCLUSIVE RIGHT TO USE "PEARLS", APART FROM THE MARK AS SHOWN.

**CLASS 14—JEWELRY**

FOR JEWELRY, NAMELY, PEARL JEWELRY (U.S. CLS. 2, 27, 28 AND 50).

**CLASS 36—INSURANCE AND FINANCIAL**

FOR CHARITABLE FUND RAISING SERVICES, NAMELY, RAISING FUNDS RELATED TO PROMOTING PUBLIC AWARENESS ABOUT OSTEOPOROSIS TO THE PUBLIC, PATIENTS, AND HEALTH CARE PROFESSIONALS (U.S. CLS. 100, 101 AND 102).

DAVID STERKIN, EXAMINING ATTORNEY

SN 78-950,072. THE COLONY GROUP, LLC, BOSTON, MA. FILED 8-11-2006.



NO CLAIM IS MADE TO THE EXCLUSIVE RIGHT TO USE "GROUP", APART FROM THE MARK AS SHOWN.

**CLASS 35—ADVERTISING AND BUSINESS**

FOR TAX PLANNING SERVICES (U.S. CLS. 100, 101 AND 102).

FIRST USE 8-6-1986; IN COMMERCE 8-6-1986.

**CLASS 36—INSURANCE AND FINANCIAL**

FOR PERSONAL AND CORPORATE FINANCIAL CONSULTATION AND MANAGEMENT; FINANCIAL AND ESTATE PLANNING; FINANCIAL PORTFOLIO MANAGEMENT; EXECUTIVE COMPENSATION PROGRAM DESIGN AND INVESTMENT ADVICE (U.S. CLS. 100, 101 AND 102).

FIRST USE 8-6-1986; IN COMMERCE 8-6-1986.

**CLASS 41—EDUCATION AND ENTERTAINMENT**

FOR EDUCATION SERVICES IN THE FIELD OF FINANCIAL COUNSELING THROUGH CONDUCTING SEMINARS AND WORKSHOPS (U.S. CLS. 100, 101 AND 107).

FIRST USE 8-6-1986; IN COMMERCE 8-6-1986.

DAWN FELDMAN, EXAMINING ATTORNEY

SN 78-950,125. DON KING PRODUCTIONS, INC., DEERFIELD BEACH, FL. FILED 8-11-2006.

**ONE KING TO ANOTHER**

THE MARK CONSISTS OF STANDARD CHARACTERS WITHOUT CLAIM TO ANY PARTICULAR FONT, STYLE, SIZE, OR COLOR.

**CLASS 25—CLOTHING**

FOR CLOTHING, NAMELY TEE SHIRTS, HATS, SWEATSHIRTS, SWEATPANTS AND JACKETS (U.S. CLS. 22 AND 39).

**CLASS 41—EDUCATION AND ENTERTAINMENT**

FOR ENTERTAINMENT SERVICES, NAMELY, ORGANIZING AND CONDUCTING BOXING MATCHES, KARATE MATCHES, LIVE MUSICAL CONCERTS AND LIVE ENTERTAINMENT SHOW PERFORMANCES (U.S. CLS. 100, 101 AND 107).

CHRISIE B. KING, EXAMINING ATTORNEY

SN 78-951,657. LOGMEIN, INC., WOBURN, MA. FILED 8-14-2006.

**HAMACHI**

THE MARK CONSISTS OF STANDARD CHARACTERS WITHOUT CLAIM TO ANY PARTICULAR FONT, STYLE, SIZE, OR COLOR.

THE ENGLISH TRANSLATION OF THE FOREIGN WORDING "HAMACHI" IS "YELLOWTAIL TUNA".

**CLASS 9—ELECTRICAL AND SCIENTIFIC APPARATUS**

FOR DOWNLOADABLE SOFTWARE FOR BUILDING, MAINTAINING AND OPERATING PRIVATE INTRANET NETWORKS (U.S. CLS. 21, 23, 26, 36 AND 38).

**CLASS 42—SCIENTIFIC, COMPUTER AND LEGAL SERVICES**

FOR COMPUTER SERVICES, NAMELY MAINTAINING AND SUPPORTING PRIVATE INTRANET NETWORKS FOR OTHERS (U.S. CLS. 100 AND 101).

B. PARADEWELAI, EXAMINING ATTORNEY

SN 78-952,036. FLORENCE-DARLINGTON TECHNICAL COLLEGE, DBA SOUTHEASTERN INSTITUTE OF MANUFACTURING AND TECHNOLOGY, FLORENCE, SC. FILED 8-15-2006.



NO CLAIM IS MADE TO THE EXCLUSIVE RIGHT TO USE THE REPRESENTATION OF THE EIGHT STATES, APART FROM THE MARK AS SHOWN.

THE COLOR(S) DARK BLUE, LIGHT BLUE, BLUE-GRAY, RED AND WHITE IS/ARE CLAIMED AS A FEATURE OF THE MARK.

THE LETTERS SIMT ARE DARK BLUE WITH A RED DOT ON THE I, THE GEAR IS LIGHT BLUE, THE STATES ARE BLUE-GRAY WITH WHITE BORDERS.

**CLASS 41—EDUCATION AND ENTERTAINMENT**

FOR EDUCATION AND TRAINING SERVICES, NAMELY, CONDUCTING CLASSES, SEMINARS AND WORKSHOPS IN THE FIELD OF MANUFACTURING PROCESSES, PRODUCT DEVELOPMENT, BUSINESS OPERATING SYSTEMS AND HUMAN RESOURCE DEVELOPMENT (U.S. CLS. 100, 101 AND 107).  
FIRST USE 3-17-2005; IN COMMERCE 11-14-2005.

**CLASS 42—SCIENTIFIC, COMPUTER AND LEGAL SERVICES**

FOR TECHNOLOGICAL CONSULTATION IN THE FIELD OF MANUFACTURING PROCESSES AND SYSTEMS, PRODUCT TECHNOLOGY DEVELOPMENT AND MANUFACTURING START-UP (U.S. CLS. 100 AND 101).  
FIRST USE 3-17-2005; IN COMMERCE 11-14-2005.  
JOHN WILKE, EXAMINING ATTORNEY

SN 78-952,765. LAMPERES, BRET, FORT COLLINS, CO.  
FILED 8-15-2006.

**CLOSE BUT NO CIGAR**

THE MARK CONSISTS OF STANDARD CHARACTERS WITHOUT CLAIM TO ANY PARTICULAR FONT, STYLE, SIZE, OR COLOR.

**CLASS 16—PAPER GOODS AND PRINTED MATTER**

FOR PRINTED MATERIAL, NAMELY, BUMPER STICKERS, DECALS, PAPER CIGAR LABELS AND PAPER BANNERS (U.S. CLS. 2, 5, 22, 23, 29, 37, 38 AND 50).

**CLASS 20—FURNITURE AND ARTICLES NOT OTHERWISE CLASSIFIED**

FOR PLASTIC CIGAR LABELS AND PLASTIC BANNERS (U.S. CLS. 2, 13, 22, 25, 32 AND 50).

**CLASS 21—HOUSEWARES AND GLASS**

FOR HOUSEWARES, NAMELY MUGS AND CUPS NOT OF PRECIOUS METAL AND BEVERAGE GLASSWARE (U.S. CLS. 2, 13, 23, 29, 30, 33, 40 AND 50).

**CLASS 25—CLOTHING**

FOR CLOTHING, NAMELY T-SHIRTS, SHIRTS, HATS AND SWEATSHIRTS (U.S. CLS. 22 AND 39).  
KHANH LE, EXAMINING ATTORNEY

SN 78-952,914. LEVI, JOANNA LISA, LOS ANGELES, CA.  
FILED 8-15-2006.

**WHAT A PAIR**

THE MARK CONSISTS OF STANDARD CHARACTERS WITHOUT CLAIM TO ANY PARTICULAR FONT, STYLE, SIZE, OR COLOR.

**CLASS 3—COSMETICS AND CLEANING PREPARATIONS**

FOR COSMETICS, NAMELY, PERFUME; NAIL POLISH; LIPSTICK; LIP GLOSS; EYE SHADOW; BLUSH; MASCARA; EYELINER; LIP LINER; MOISTURIZER; SUNSCREEN; BASE; CONCEALER; SHAMPOO; CONDITIONER AND HAIR STYLING PRODUCTS, NAMELY, HAIR GEL; HAIR SPRAY AND MOUSSE (U.S. CLS. 1, 4, 6, 50, 51 AND 52).

**CLASS 9—ELECTRICAL AND SCIENTIFIC APPARATUS**

FOR AUDIO RECORDINGS FEATURING MUSIC (U.S. CLS. 21, 23, 26, 36 AND 38).

**CLASS 25—CLOTHING**

FOR CLOTHING AND ACCESSORIES, NAMELY, PANTS; JEANS; SHIRTS; T-SHIRTS; SKIRTS; SHORTS; SOCKS; GLOVES; UNDERGARMENTS, NAMELY, BRAS, PANTIES, CAMISOLES, BUSTIERS, BOXERS, PANTYHOSE, SPORTS BRAS AND GARTERS; BELTS; NIGHTCLOTHES, NAMELY, PAJAMAS, NIGHTGOWNS AND ROBES; SCARVES; BASEBALL CAPS; SLIPPERS; BATHING SUITS; MATERNITY DRESSES; MATERNITY TOPS; MATERNITY PANTS AND SWEAT SUITS (U.S. CLS. 22 AND 39).  
NAAKWAMA ANKRAH, EXAMINING ATTORNEY

SN 78-953,432. CULTURE OF LIFE FOUNDATION, WASHINGTON, DC. FILED 8-16-2006.

**CULTURE OF LIFE FOUNDATION**

THE MARK CONSISTS OF STANDARD CHARACTERS WITHOUT CLAIM TO ANY PARTICULAR FONT, STYLE, SIZE, OR COLOR.

NO CLAIM IS MADE TO THE EXCLUSIVE RIGHT TO USE "FOUNDATION", APART FROM THE MARK AS SHOWN.

**CLASS 35—ADVERTISING AND BUSINESS**

FOR ASSOCIATION SERVICES, NAMELY, PROMOTING SOCIAL POLICY INTERESTS AND ISSUES, SUCH AS, PRO-LIFE, PRO-FAMILY, BIOETHICS, EUTHANASIA, AND STEM CELL RESEARCH ISSUES; LEGISLATIVE LOBBYING SERVICES, NAMELY PROMOTING SOCIAL POLICY INTERESTS AND ISSUES, SUCH AS, PRO-LIFE, PRO-FAMILY, BIOETHICS, EUTHANASIA, AND STEM CELL RESEARCH ISSUES (U.S. CLS. 100, 101 AND 102).  
FIRST USE 3-24-1997; IN COMMERCE 3-24-1997.

**CLASS 41—EDUCATION AND ENTERTAINMENT**

FOR EDUCATIONAL RESEARCH COVERING SOCIAL POLICY INTERESTS AND ISSUES, SUCH AS, PRO-LIFE, PRO-FAMILY, BIOETHICS, EUTHANASIA, AND STEM CELL RESEARCH ISSUES (U.S. CLS. 100, 101 AND 107).

FIRST USE 3-24-1997; IN COMMERCE 3-24-1997.  
DORITT L. CARROLL, EXAMINING ATTORNEY

---

SN 78-953,624. SMITHKLINE BEECHAM CORPORATION, PHILADELPHIA, PA. FILED 8-16-2006.



OWNER OF U.S. REG. NOS. 3,104,984 AND 3,121,700.  
NO CLAIM IS MADE TO THE EXCLUSIVE RIGHT TO USE "PROGRAM", APART FROM THE MARK AS SHOWN.

**CLASS 16—PAPER GOODS AND PRINTED MATTER**

FOR PRINTED MATERIALS, NAMELY, BROCHURES, PAMPHLETS, LEAFLETS, AND BOOKLETS FEATURING HEALTH INFORMATION ABOUT RESPIRATORY DISORDERS AND TREATMENTS THEREFOR (U.S. CLS. 2, 5, 22, 23, 29, 37, 38 AND 50).

**CLASS 44—MEDICAL, BEAUTY AND AGRICULTURAL SERVICES**

FOR HEALTH INFORMATION SERVICES, NAMELY PROVIDING INFORMATION ON RESPIRATORY DISEASES AND DISORDERS AND THE TREATMENT OF RESPIRATORY DISEASES AND/OR DISORDERS TO PATIENTS, PHYSICIANS, PHARMACISTS AND OTHER HEALTHCARE PROFESSIONALS (U.S. CLS. 100 AND 101).

KEVIN DINALLO, EXAMINING ATTORNEY

---

SN 78-954,309. ENGEL, CHRISTOPHER BRUCE, CARLSBAD, CA. FILED 8-17-2006.

**VUGA**

THE MARK CONSISTS OF STANDARD CHARACTERS WITHOUT CLAIM TO ANY PARTICULAR FONT, STYLE, SIZE, OR COLOR.

**CLASS 9—ELECTRICAL AND SCIENTIFIC APPARATUS**

FOR SUNGLASSES (U.S. CLS. 21, 23, 26, 36 AND 38).

**CLASS 14—JEWELRY**

FOR WATCHES (U.S. CLS. 2, 27, 28 AND 50).

**CLASS 18—LEATHER GOODS**

FOR BACKPACKS AND TRAVEL BAGS (U.S. CLS. 1, 2, 3, 22 AND 41).

**CLASS 25—CLOTHING**

FOR CLOTHING, NAMELY, MEN'S AND WOMEN'S T-SHIRTS, DENIM JEANS, WOVEN AND KNITTED TOPS AND BOTTOMS, SWIMWEAR, JACKETS, SWEATERS, PULLOVERS, SWEATSHIRTS, RAINWEAR, WIND RESISTANT JACKETS, SNOWBOARDING AND SKI WEAR; FOOTWEAR, NAMELY, MEN'S AND WOMEN'S DRESS SHOES, CASUAL SHOES, SANDALS, GOLF AND RUNNING SHOES (U.S. CLS. 22 AND 39).

**CLASS 28—TOYS AND SPORTING GOODS**

FOR GOLF BAGS (U.S. CLS. 22, 23, 38 AND 50).  
ALYSSA PALADINO, EXAMINING ATTORNEY

---

SN 78-954,819. ALCHEMY GLASS & LIGHT, INC., LOS ANGELES, CA. FILED 8-17-2006.

**Cienega Glass**

THE MARK CONSISTS OF STANDARD CHARACTERS WITHOUT CLAIM TO ANY PARTICULAR FONT, STYLE, SIZE, OR COLOR.

NO CLAIM IS MADE TO THE EXCLUSIVE RIGHT TO USE "GLASS", APART FROM THE MARK AS SHOWN.

THE FOREIGN WORDING IN THE MARK TRANSLATES INTO ENGLISH AS "MARSH" OR "BOG".

**CLASS 11—ENVIRONMENTAL CONTROL APPARATUS**

FOR ELECTRIC LIGHTING FIXTURES; ELECTRIC LIGHTING FIXTURES, NAMELY, SCONCES; LIGHT DIFFUSERS; LIGHTING FIXTURES; SCONCE LIGHTING FIXTURES (U.S. CLS. 13, 21, 23, 31 AND 34).

FIRST USE 8-30-1993; IN COMMERCE 9-15-1993.

**CLASS 19—NON-METALLIC BUILDING MATERIALS**

FOR GLASS TILES (U.S. CLS. 1, 12, 33 AND 50).  
FIRST USE 8-30-1993; IN COMMERCE 9-15-1993.

**CLASS 21—HOUSEWARES AND GLASS**

FOR BASINS; DECORATIVE GLASS; GLASS BOWLS; GLASS DISHES; GLASS MOSAICS NOT FOR BUILDINGS; HAND WASH BASINS; SERVING DISHES; SERVING PLATTERS; SERVING TRAYS NOT OF PRECIOUS METAL; WASH BASINS (U.S. CLS. 2, 13, 23, 29, 30, 33, 40 AND 50).

FIRST USE 8-30-1993; IN COMMERCE 9-15-1993.

MARIAM MAHMOUDI, EXAMINING ATTORNEY

SN 78-954,824. COMPLETE PONDS, INC., ROSEVILLE, CA. FILED 8-17-2006.

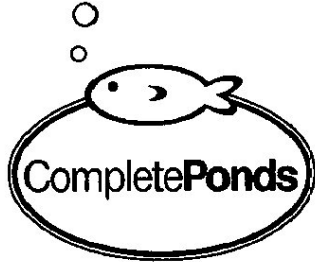

NO CLAIM IS MADE TO THE EXCLUSIVE RIGHT TO USE COMPLETE PONDS, APART FROM THE MARK AS SHOWN.

**CLASS 35—ADVERTISING AND BUSINESS**

FOR ONLINE RETAIL STORE SERVICES FEATURING SUPPLY GOODS FOR WATER FEATURES AND SERVICE ACCESSORIES FOR WATER FEATURES (U.S. CLS. 100, 101 AND 102).

FIRST USE 2-1-2001; IN COMMERCE 2-1-2001.

**CLASS 37—CONSTRUCTION AND REPAIR**

FOR MAINTENANCE OF WATER FEATURES, NAMELY WATER FALLS, PONDS, AND CREEK BEDS (U.S. CLS. 100, 103 AND 106).

FIRST USE 2-1-2001; IN COMMERCE 2-1-2001.  
HENRY S. ZAK, EXAMINING ATTORNEY

SN 78-955,791. MASON ELECTRIC COMPANY, SYLMAR, CA. FILED 8-18-2006.

**Harm's Way Controller**

THE MARK CONSISTS OF STANDARD CHARACTERS WITHOUT CLAIM TO ANY PARTICULAR FONT, STYLE, SIZE, OR COLOR.

NO CLAIM IS MADE TO THE EXCLUSIVE RIGHT TO USE "CONTROLLER", APART FROM THE MARK AS SHOWN.

**CLASS 9—ELECTRICAL AND SCIENTIFIC APPARATUS**

FOR BRAKE CONTROLLERS; COMPUTERS FOR MANAGING CONTROL DEVICES FOR AIRCRAFT; CRUISE CONTROLS FOR MOTOR VEHICLES; ELECTRIC CONTROL PANELS; ELECTRICAL CONTROLLERS; ELECTRICAL CONTROLLING DEVICES; ELECTROMECHANICAL CONTROLS FOR USE IN UNMANNED VEHICLES; ELECTRONIC AND VIDEO GAME CONTROLLERS INCORPORATED INTO EXERCISE MACHINES; ELECTRONIC CONTROL SYSTEMS FOR MACHINES; ELECTRONIC CONTROLS FOR MOTORS; ELECTRONIC SERVO MOTOR CONTROLLERS; ELECTRONIC SPEED CONTROLLERS; MECHANICAL REMOTE CONTROLS FOR MOTORS; RADIO CONTROLLED MINIATURE AERIAL TARGETS; RADIO TRANSMITTERS AND RECEIVERS FOR REMOTE CONTROLS; RADIO CONTROLS; REMOTE CURSOR CONTROLS FOR COMPUTERS; SIGNAL CONDITIONING AND COMMUNICATION DEVICES FOR INDUSTRIAL PROCESS CONTROL; VIDEO GAME INTERACTIVE HAND HELD REMOTE CONTROLS FOR PLAYING ELECTRONIC GAMES; VIDEO GAME INTERACTIVE REMOTE CONTROL UNITS; VIDEO GRAPHICS CONTROLLER (U.S. CLS. 21, 23, 26, 36 AND 38).

**CLASS 12—VEHICLES**

FOR LAND VEHICLE CONSOLE PARTS, NAMELY, WIRING HARNESSES FOR CONTROL, MONITORING AND PROTECTION OF INDUSTRIAL GASOLINE AND DIESEL ENGINES; REMOTELY CONTROLLED LAND VEHICLE (U.S. CLS. 19, 21, 23, 31, 35 AND 44).

SANI KHOURI, EXAMINING ATTORNEY

SN 78-955,914. WAY, DAMON CYRUS, LAGUNA BEACH, CA. FILED 8-19-2006.



THE MARK CONSISTS OF A SOLID FILLED GUITAR PIC WITH THE PHRASE "INDIE ROCK — ME" LOCATED INSIDE OF THE GUITAR PIC.

**CLASS 42—SCIENTIFIC, COMPUTER AND LEGAL SERVICES**

FOR COMPUTER SERVICES, NAMELY, HOSTING ONLINE WEB FACILITIES FOR OTHERS FOR ORGANIZING AND CONDUCTING ONLINE MEETINGS, GATHERINGS, AND INTERACTIVE DISCUSSIONS (U.S. CLS. 100 AND 101).

**CLASS 45—PERSONAL SERVICES**

FOR INTERNET BASED SOCIAL NETWORKING, INTRODUCTION, AND DATING SERVICES (U.S. CLS. 100 AND 101).

Laurie Kaufman, Examining Attorney

SN 78-956,396. WEAVER, WAYNE, CERRITOS, CA. FILED 8-21-2006.



THE MARK CONSISTS OF TWO FISTS WITH THE STYLIZED TEXT OF THE WORDING "STR8 SIKK" ON THEM.

**CLASS 16—PAPER GOODS AND PRINTED MATTER**

FOR STICKERS (U.S. CLS. 2, 5, 22, 23, 29, 37, 38 AND 50).

**CLASS 25—CLOTHING**

FOR BEANIES; HATS; SHORTS; SOCKS; SWEAT SHIRTS; T-SHIRTS; WRISTBANDS (U.S. CLS. 22 AND 39).

DAVID STERKIN, EXAMINING ATTORNEY

SN 78-956,603. CAROLINA WATERWORKS, INC., MT. PLEASANT, SC. FILED 8-21-2006.

## SAFE HAVEN

THE MARK CONSISTS OF STANDARD CHARACTERS WITHOUT CLAIM TO ANY PARTICULAR FONT, STYLE, SIZE, OR COLOR.

**CLASS 7—MACHINERY**

FOR NAUTICAL APPARATUS, NAMELY, A POWER-OPERATED LIFT FOR WATER VESSELS (U.S. CLS. 13, 19, 21, 23, 31, 34 AND 35).

**CLASS 8—HAND TOOLS**

FOR NAUTICAL APPARATUS, NAMELY, A MANUALLY-OPERATED LIFT FOR WATER VESSELS (U.S. CLS. 23, 28 AND 44).

REBECCA POVARCHUK, EXAMINING ATTORNEY

SN 78-956,804. RODMAN & RENSHAW, LLC, NEW YORK, NY. FILED 8-21-2006.

## RODMAN & RENSHAW'S ACUMEN

THE MARK CONSISTS OF STANDARD CHARACTERS WITHOUT CLAIM TO ANY PARTICULAR FONT, STYLE, SIZE, OR COLOR.

**CLASS 35—ADVERTISING AND BUSINESS**

FOR ARRANGING AND CONDUCTING BUSINESS CONFERENCES IN THE FIELDS OF HEALTHCARE, BIOTECHNOLOGY AND LIFE SCIENCES; CONSULTING SERVICES IN THE FIELD OF BUSINESS MERGERS AND ACQUISITIONS IN THE FIELDS OF HEALTHCARE, BIOTECHNOLOGY AND LIFE SCIENCES (U.S. CLS. 100, 101 AND 102).

**CLASS 36—INSURANCE AND FINANCIAL**

FOR INVESTMENT BANKING SERVICES IN THE FIELDS OF HEALTHCARE, BIOTECHNOLOGY AND LIFE SCIENCES; BROKERAGE OF SHARES OF STOCKS AND OTHER SECURITIES IN THE FIELDS OF HEALTHCARE, BIOTECHNOLOGY AND LIFE SCIENCES; FINANCIAL INVESTMENT SERVICES IN THE FIELDS OF HEALTHCARE, BIOTECHNOLOGY AND LIFE SCIENCES; FINANCIAL SERVICES, NAMELY ASSISTING OTHERS WITH THE COMPLETION OF FINANCIAL TRANSACTIONS FOR STOCKS, BONDS, SECURITIES AND EQUITIES IN THE FIELDS OF HEALTHCARE, BIOTECHNOLOGY AND LIFE SCIENCES; FINANCIAL SERVICES, NAMELY MERCHANT BANKING SERVICES IN THE FIELDS OF HEALTHCARE, BIOTECHNOLOGY AND LIFE SCIENCES; CONSULTING SERVICES IN THE FIELD OF CORPORATE FINANCE IN THE FIELDS OF HEALTHCARE, BIOTECHNOLOGY AND LIFE SCIENCES (U.S. CLS. 100, 101 AND 102).

PETER B. BROMAGHIM, EXAMINING ATTORNEY

SN 78-956,809. AMERICAN NEWLAND COMMUNITIES, L.P., SAN DIEGO, CA. FILED 8-21-2006.

## FAIRHILL

THE MARK CONSISTS OF STANDARD CHARACTERS WITHOUT CLAIM TO ANY PARTICULAR FONT, STYLE, SIZE, OR COLOR.

**CLASS 35—ADVERTISING AND BUSINESS**

FOR HOMEOWNER ASSOCIATION SERVICES, NAMELY, PROMOTING THE INTERESTS OF HOMEOWNERS IN A SPECIFIC COMMUNITY, AND HOMEOWNER ASSOCIATION MANAGEMENT SERVICES (U.S. CLS. 100, 101 AND 102).

**CLASS 36—INSURANCE AND FINANCIAL**

FOR REAL ESTATE SERVICES, NAMELY, REAL ESTATE AGENCIES, REAL ESTATE MANAGEMENT, REAL ESTATE LISTING, REAL ESTATE BROKERAGE; ONLINE INFORMATION SERVICES IN THE FIELD OF REAL ESTATE; PROVIDING WEBSITES IN THE FIELD OF REAL ESTATE (U.S. CLS. 100, 101 AND 102).

**CLASS 37—CONSTRUCTION AND REPAIR**

FOR LAND DEVELOPMENT SERVICES, NAMELY, PLANNING, LAYING OUT AND DEVELOPMENT OF MASTER PLAN COMMUNITIES; ONLINE INFORMATION SERVICES IN THE FIELDS OF REAL ESTATE DEVELOPMENT AND PLANNED COMMUNITIES (U.S. CLS. 100, 103 AND 106).

JESSICA A. POWERS, EXAMINING ATTORNEY

SN 78-957,265. TIMENOTEBOOK INTERNATIONAL A/S, 1264 COPENHAGEN K, DENMARK, FILED 8-22-2006.

SN 78-957,552. TEOTL PUBLISHING, INC., LOS GATOS, CA, FILED 8-22-2006.

**TimeNotebook**

**TEOTL**

**CLASS 9—ELECTRICAL AND SCIENTIFIC APPARATUS**

FOR COMPUTER SOFTWARE FOR CALENDARING AND MANAGING APPOINTMENTS AND TASKS AND RECORDING, STORING AND TRANSMITTING MEMORANDA (U.S. CLS. 21, 23, 26, 36 AND 38).

THE MARK CONSISTS OF STANDARD CHARACTERS WITHOUT CLAIM TO ANY PARTICULAR FONT, STYLE, SIZE, OR COLOR.

THE FOREIGN WORDING IN THE MARK TRANSLATES INTO ENGLISH AS "CREATION" FROM NAHUATL (THE ANCIENT LANGUAGE OF THE MEXICAN NATIVE PEOPLE).

**CLASS 16—PAPER GOODS AND PRINTED MATTER**

FOR POCKET CALENDARS; DESK CALENDARS; STICKERS; BINDERS; DESK CALENDAR REFILLS; MEMO PADS AND PRINTED FORMS FOR CALENDARING AND MANAGING APPOINTMENTS AND TASKS AND RECORDING, STORING AND TRANSMITTING MEMORANDA (U.S. CLS. 2, 5, 22, 23, 29, 37, 38 AND 50). WENDY JUN, EXAMINING ATTORNEY

**CLASS 9—ELECTRICAL AND SCIENTIFIC APPARATUS**

FOR MOTION PICTURE FILMS ABOUT ANTHROPOLOGICAL, CULTURAL AND HISTORICAL TOPICS; PRE-RECORDED CD'S, VIDEO TAPES, LASER DISKS AND DVD'S FEATURING ANTHROPOLOGICAL, CULTURAL AND HISTORICAL TOPICS (U.S. CLS. 21, 23, 26, 36 AND 38).

**CLASS 16—PAPER GOODS AND PRINTED MATTER**

FOR BOOKS IN THE FIELD OF ANTHROPOLOGICAL, CULTURAL AND HISTORICAL TOPICS; DRAWINGS; PAINTINGS AND THEIR REPRODUCTIONS; PAMPHLETS IN THE FIELD OF ANTHROPOLOGICAL, CULTURAL AND HISTORICAL TOPICS; PHOTOGRAPHS (U.S. CLS. 2, 5, 22, 23, 29, 37, 38 AND 50). YAT SYE, LEE, EXAMINING ATTORNEY

SN 78-957,383. BERKSON, HOWARD C., SAN DIEGO, CA, FILED 8-22-2006.



THE MARK CONSISTS OF STYLIZED WORD "ANTHOLOGY" PRINTED ON A MUSICAL STAFF COMPRISED OF FIVE HORIZONTAL LINES.

**CLASS 41—EDUCATION AND ENTERTAINMENT**

FOR ENTERTAINMENT IN THE NATURE OF VISUAL AND AUDIO PERFORMANCES, AND MUSICAL, VARIETY, NEWS AND COMEDY SHOWS; ENTERTAINMENT IN THE NATURE OF VISUAL AND AUDIO PERFORMANCES, NAMELY, MUSICAL BAND, ROCK GROUP, GYMNASTIC, DANCE, AND BALLET PERFORMANCES; ENTERTAINMENT NAMELY, LIVE PERFORMANCES BY A MUSICAL BAND; ENTERTAINMENT, NAMELY LIVE MUSIC CONCERTS; ENTERTAINMENT, NAMELY LIVE PERFORMANCES BY MUSICAL BANDS; PRESENTATION OF LIVE SHOW PERFORMANCES; PRESENTATION OF MUSICAL PERFORMANCE (U.S. CLS. 100, 101 AND 107).

SN 78-957,587. CALP CORPORATION, TOKYO, JAPAN, FILED 8-22-2006.

**CALP**

THE MARK CONSISTS OF STANDARD CHARACTERS WITHOUT CLAIM TO ANY PARTICULAR FONT, STYLE, SIZE, OR COLOR.

**CLASS 1—CHEMICALS**

FOR UNPROCESSED PLASTICS IN ALL FORMS (U.S. CLS. 1, 5, 6, 10, 26 AND 46).

**CLASS 17—RUBBER GOODS**

FOR PLASTICS IN THE FORM OF POWDERS, GRANULES, PELLETS, BARS, BLOCKS, RODS, SHEETS AND TUBES FOR USE IN MANUFACTURING; SEMI-PROCESSED PLASTICS IN THE FORM OF POWDERS, GRANULES, PELLETS, BARS, BLOCKS, RODS, SHEETS OR TUBES (U.S. CLS. 1, 5, 12, 13, 35 AND 50). TAMARA LEE, EXAMINING ATTORNEY

**CLASS 43—HOTEL AND RESTAURANT SERVICES**

FOR RESTAURANT AND BAR SERVICES (U.S. CLS. 100 AND 101). ALYSSA PALADINO, EXAMINING ATTORNEY

SN 78-957,837. VIISAGE TECHNOLOGY, INC., BILLERICA, MA. FILED 8-22-2006.

**L-1**

THE MARK CONSISTS OF STANDARD CHARACTERS WITHOUT CLAIM TO ANY PARTICULAR FONT, STYLE, SIZE, OR COLOR.

**CLASS 9—ELECTRICAL AND SCIENTIFIC APPARATUS**

FOR HARDWARE AND SOFTWARE USED FOR BIOMETRIC IDENTIFICATION, VERIFICATION AND SURVEILLANCE OF INDIVIDUALS AND FOR ISSUANCE AND AUTHENTICATION OF IDENTIFICATION CARDS, DRIVERS' LICENSES, PASSPORTS, VISAS AND OTHER TRAVEL AND IDENTITY DOCUMENTS (U.S. CLS. 21, 23, 26, 36 AND 38).

**CLASS 42—SCIENTIFIC, COMPUTER AND LEGAL SERVICES**

FOR CONSULTING SERVICES IN THE FIELDS OF DESIGN, SELECTION, IMPLEMENTATION AND USE OF COMPUTER HARDWARE AND SOFTWARE SYSTEMS FOR BIOMETRIC IDENTIFICATION, VERIFICATION AND SURVEILLANCE SYSTEMS AND FOR ISSUANCE AND AUTHENTICATION OF IDENTIFICATION CARDS, DRIVERS' LICENSES, PASSPORTS, VISAS AND OTHER TRAVEL AND IDENTITY DOCUMENTS (U.S. CLS. 100 AND 101).

**CLASS 45—PERSONAL SERVICES**

FOR IDENTIFICATION VERIFICATION SERVICES, NAMELY, THE CAPTURE AND TRANSMISSION OF INDIVIDUAL BIOMETRIC INFORMATION SUCH AS FINGERPRINTS AND OTHER BIOMETRIC FEATURES (U.S. CLS. 100 AND 101).  
TRAVIS WHEATLEY, EXAMINING ATTORNEY

SN 78-957,857. VIISAGE TECHNOLOGY, INC., BILLERICA, MA. FILED 8-22-2006.

**L-1 IDENTITY SOLUTIONS**

THE MARK CONSISTS OF STANDARD CHARACTERS WITHOUT CLAIM TO ANY PARTICULAR FONT, STYLE, SIZE, OR COLOR.

NO CLAIM IS MADE TO THE EXCLUSIVE RIGHT TO USE "IDENTITY SOLUTIONS", APART FROM THE MARK AS SHOWN.

**CLASS 9—ELECTRICAL AND SCIENTIFIC APPARATUS**

FOR HARDWARE AND SOFTWARE USED FOR BIOMETRIC IDENTIFICATION, VERIFICATION AND SURVEILLANCE OF INDIVIDUALS AND FOR ISSUANCE AND AUTHENTICATION OF IDENTIFICATION CARDS, DRIVERS' LICENSES, PASSPORTS, VISAS AND OTHER TRAVEL AND IDENTITY DOCUMENTS (U.S. CLS. 21, 23, 26, 36 AND 38).

**CLASS 42—SCIENTIFIC, COMPUTER AND LEGAL SERVICES**

FOR CONSULTING SERVICES IN THE FIELDS OF DESIGN, SELECTION, IMPLEMENTATION AND USE OF COMPUTER HARDWARE AND SOFTWARE SYSTEMS FOR BIOMETRIC IDENTIFICATION, VERIFICATION AND SURVEILLANCE SYSTEMS AND FOR ISSUANCE AND AUTHENTICATION OF IDENTIFICATION CARDS, DRIVERS' LICENSES, PASSPORTS, VISAS AND OTHER TRAVEL AND IDENTITY DOCUMENTS (U.S. CLS. 100 AND 101).

**CLASS 45—PERSONAL SERVICES**

FOR IDENTIFICATION VERIFICATION SERVICES, NAMELY, THE CAPTURE AND TRANSMISSION OF INDIVIDUAL BIOMETRIC INFORMATION SUCH AS FINGERPRINTING AND OTHER BIOMETRIC FEATURES (U.S. CLS. 100 AND 101).  
TRAVIS WHEATLEY, EXAMINING ATTORNEY

SN 78-957,879. FORKLIFT BRANDS, INC., SAN FRANCISCO, CA. FILED 8-22-2006.



NO CLAIM IS MADE TO THE EXCLUSIVE RIGHT TO USE "BRANDS", APART FROM THE MARK AS SHOWN.  
THE MARK CONSISTS OF THE WORD FORKLIFT APPEARING ABOVE A SILLHOUETTE OF A FORK WITH A STRAND OF PASTA LOOPING OVER THE TINE AREA OF THE FORK AND THE WORD BRANDS APPEARING BELOW THE HANDLE AREA OF THE FORK.

**CLASS 35—ADVERTISING AND BUSINESS**

FOR RESTAURANT MANAGEMENT FOR OTHERS (U.S. CLS. 100, 101 AND 102).

**CLASS 43—HOTEL AND RESTAURANT SERVICES**

FOR RESTAURANT SERVICES (U.S. CLS. 100 AND 101).  
WON TEAK OH, EXAMINING ATTORNEY

SN 78-958,028. ICONIX PHARMACEUTICALS, INC., MOUNTAIN VIEW, CA. FILED 8-22-2006.

**ToxFX**

THE MARK CONSISTS OF STANDARD CHARACTERS WITHOUT CLAIM TO ANY PARTICULAR FONT, STYLE, SIZE, OR COLOR.



**CLASS 9—ELECTRICAL AND SCIENTIFIC APPARATUS**

FOR ELECTRONIC DATABASE IN THE FIELD OF DRUG DISCOVERY, GENOMIC INFORMATION, AND PHARMACEUTICAL DESIGN RECORDED ON COMPUTER MEDIA (U.S. CLS. 21, 23, 26, 36 AND 38).

**CLASS 42—SCIENTIFIC, COMPUTER AND LEGAL SERVICES**

FOR ONLINE COMPUTER SERVICES, NAMELY, PROVIDING AN ELECTRONIC DATABASE IN THE FIELD OF DRUG DISCOVERY, GENOMIC INFORMATION AND PHARMACEUTICAL DESIGN (U.S. CLS. 100 AND 101).

ALYSSA PALADINO, EXAMINING ATTORNEY

**CLASS 29—MEATS AND PROCESSED FOODS**

FOR PROCESSED VEGETABLES AND FRUITS (U.S. CL. 46).

**CLASS 31—NATURAL AGRICULTURAL PRODUCTS**

FOR FRESH FRUITS; FRESH VEGETABLES (U.S. CLS. 1 AND 46).

**CLASS 32—LIGHT BEVERAGES**

FOR FRUIT JUICES; VEGETABLE JUICE; VEGETABLE JUICES (U.S. CLS. 45, 46 AND 48).

KATHERINE CHANG, EXAMINING ATTORNEY

SN 78-958,775. RESOLVED TECHNOLOGIES, INC., CULLMAN, AL. FILED 8-23-2006.



NO CLAIM IS MADE TO THE EXCLUSIVE RIGHT TO USE "TECHNOLOGIES", APART FROM THE MARK AS SHOWN.

**CLASS 9—ELECTRICAL AND SCIENTIFIC APPARATUS**

FOR LABORATORY AND SCIENTIFIC TESTING EQUIPMENT, NAMELY LIQUID-HOLDING DISCS FOR HOLDING VOLUME SAMPLES OF LIQUID AND REAGENTS FOR PERFORMING LABORATORY AND SCIENTIFIC TESTING AND ANALYSIS (U.S. CLS. 21, 23, 26, 36 AND 38).

**CLASS 42—SCIENTIFIC, COMPUTER AND LEGAL SERVICES**

FOR LABORATORY TESTING SERVICES IN THE FIELDS OF WATER TREATMENT AND WATER QUALITY, MEDICAL DIAGNOSTICS, PHARMACEUTICALS, AND FORENSIC SCIENCE (U.S. CLS. 100 AND 101).

WILLIAM P. SHANAHAN, EXAMINING ATTORNEY

SN 78-958,972. JUICE HARVEST CORPORATION, SAN BERNARDINO, CA. FILED 8-23-2006.

MAKING PEOPLE HEALTHIER  
ONE SIP AND ONE BITE AT A  
TIME

THE MARK CONSISTS OF STANDARD CHARACTERS WITHOUT CLAIM TO ANY PARTICULAR FONT, STYLE, SIZE, OR COLOR.

**CLASS 29—MEATS AND PROCESSED FOODS**

FOR PROCESSED VEGETABLES AND FRUITS (U.S. CL. 46).

**CLASS 31—NATURAL AGRICULTURAL PRODUCTS**

FOR FRESH FRUITS; FRESH VEGETABLES (U.S. CLS. 1 AND 46).

**CLASS 32—LIGHT BEVERAGES**

FOR FRUIT JUICES; VEGETABLE JUICE; VEGETABLE JUICES (U.S. CLS. 45, 46 AND 48).

KATHERINE CHANG, EXAMINING ATTORNEY

SN 78-958,964. JUICE HARVEST CORPORATION, SAN BERNARDINO, CA. FILED 8-23-2006.

EVOLUTION FRESH

THE MARK CONSISTS OF STANDARD CHARACTERS WITHOUT CLAIM TO ANY PARTICULAR FONT, STYLE, SIZE, OR COLOR.

OWNER OF U.S. REG. NO. 2,196,497.

NO CLAIM IS MADE TO THE EXCLUSIVE RIGHT TO USE "FRESH", APART FROM THE MARK AS SHOWN.

SN 78-959,326. 750 ML, LLC, MILFORD, DE. FILED 8-24-2006.

INDOCHINE

THE MARK CONSISTS OF STANDARD CHARACTERS WITHOUT CLAIM TO ANY PARTICULAR FONT, STYLE, SIZE, OR COLOR.

THE FOREIGN WORDING IN THE MARK TRANSLATES INTO ENGLISH AS INDOCHINA.

**CLASS 32—LIGHT BEVERAGES**

FOR BREWED MALT-BASED ALCOHOLIC BEVERAGE IN THE NATURE OF A BEER (U.S. CLS. 45, 46 AND 48).

**CLASS 33—WINES AND SPIRITS**

FOR DISTILLED SPIRITS; LIQUEURS (U.S. CLS. 47 AND 49).  
REBECCA GAN, EXAMINING ATTORNEY

SN 78-959,467. IDATECH, LLC, BEND, OR. FILED 8-24-2006.

SN 78-959,339. SHANK, KEN, GLENDALE, CA. FILED 8-24-2006.

---

**DS7**

THE MARK CONSISTS OF STANDARD CHARACTERS WITHOUT CLAIM TO ANY PARTICULAR FONT, STYLE, SIZE, OR COLOR.

**CLASS 14—JEWELRY**

FOR JEWELRY; PRECIOUS METAL MONEY CLIPS; WATCHES (U.S. CLS. 2, 27, 28 AND 50).

**CLASS 25—CLOTHING**

FOR BELTS; GLOVES; HATS; JACKETS; JERSEYS; LINGERIE; PANTS; SHIRTS; SHOES; SHORTS; SPORT SHIRTS; SWEAT SHIRTS; SWEAT SUITS; TANK TOPS; UNDERWEAR (U.S. CLS. 22 AND 39).  
TAMARA LEE, EXAMINING ATTORNEY

---

SN 78-959,347. 750 ML, LLC, MILFORD, DE. FILED 8-24-2006.

**TRIBECA**

THE MARK CONSISTS OF STANDARD CHARACTERS WITHOUT CLAIM TO ANY PARTICULAR FONT, STYLE, SIZE, OR COLOR.

**CLASS 32—LIGHT BEVERAGES**

FOR BREWED MALT-BASED ALCOHOLIC BEVERAGE IN THE NATURE OF A BEER (U.S. CLS. 45, 46 AND 48).

**CLASS 33—WINES AND SPIRITS**

FOR DISTILLED SPIRITS; LIQUEURS; PREPARED ALCOHOLIC COCKTAIL; WINE (U.S. CLS. 47 AND 49).  
REBECCA GAN, EXAMINING ATTORNEY

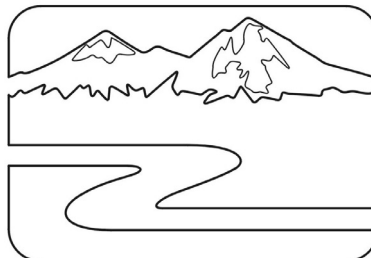
**CLASS 9—ELECTRICAL AND SCIENTIFIC APPARATUS**

FOR FUEL CELL SYSTEMS COMPRISED OF FUEL CELL STACKS AND FUEL PROCESSORS TO PRODUCE FUEL STREAMS FOR THE FUEL CELL STACKS; HYDROGEN-POWERED FUEL CELL SYSTEMS COMPRISING FUEL CELLS AND COMPONENT PARTS PROVIDED THEREWITH; HYDROGEN-POWERED FUEL CELL SYSTEMS COMPRISING FUEL CELLS, HYDROGEN-PRODUCING FUEL PROCESSORS, AND COMPONENT PARTS PROVIDED THEREWITH; FUEL CELLS; FUEL CELL STACKS; BATTERY CHARGERS; CHARGING APPLIANCES FOR RECHARGEABLE EQUIPMENT (U.S. CLS. 21, 23, 26, 36 AND 38).

**CLASS 11—ENVIRONMENTAL CONTROL APPARATUS**

FOR HYDROGEN-GENERATION EQUIPMENT AND COMPONENTS, NAMELY, HYDROGEN GENERATORS, HYDROGEN PURIFIERS, HYDROGEN PURIFICATION MEMBRANES, FUEL PROCESSORS, STEAM REFORMERS, AND FUEL PROCESSING SYSTEMS COMPRISED OF HYDROGEN-GENERATING FUEL PROCESSORS AND COMPONENT PARTS PROVIDED THEREWITH (U.S. CLS. 13, 21, 23, 31 AND 34).  
ANNE FARRELL, EXAMINING ATTORNEY

---

SN 78-959,602. ZANELLA HEALTH AND BEAUTY INC., OTTAWA, CANADA, FILED 8-24-2006.

**GoGo Girls**

THE MARK CONSISTS OF STANDARD CHARACTERS WITHOUT CLAIM TO ANY PARTICULAR FONT, STYLE, SIZE, OR COLOR.

**CLASS 3—COSMETICS AND CLEANING PREPARATIONS**

FOR BEAUTY CREAMS; BEAUTY CREAMS FOR BODY CARE; BEAUTY GELS; BEAUTY LOTIONS; BEAUTY MASKS; BEAUTY MILKS; BODY AND BEAUTY CARE COSMETICS; BODY AND BEAUTY CARE PREPARATIONS; CONDITIONERS; COSMETIC PRODUCTS IN THE FORM OF AEROSOLS FOR SKIN CARE; COSMETIC PRODUCTS IN THE FORM OF AEROSOLS FOR SKINCARE; COSMETIC SUN-PROTECTING PREPARATIONS; DECALCIFYING AND DECALCIFYING PREPARATIONS FOR CLEANING HOUSEHOLD PRODUCTS; DISPOSABLE WIPES IMPREGNATED WITH CHEMICALS OR COMPOUNDS FOR PERSONAL HYGIENE; ESSENTIAL OILS FOR USE IN MANUFACTURING OF BATH BODY FRAGRANCE PERFUME; ESSENTIAL OILS FOR USE IN THE MANUFACTURE OF SCENTED PRODUCTS; FACE AND BODY BEAUTY CREAMS; FACIAL BEAUTY MASKS; FEMININE DEODORANT SPRAYS; FEMININE DEODORANT SUPPOSITORIES; MAKE-UP PRODUCTS FOR THE FACE AND BODY; NAIL GROOMING PRODUCTS, NAMELY, TIPS, GLUE, LACQUER AND GLITTER; SHAMPOOS; SKIN CARE PRODUCTS, NAMELY, NON-MEDICATED SKIN SERUM (U.S. CLS. 1, 4, 6, 50, 51 AND 52).

**CLASS 5—PHARMACEUTICALS**

FOR DISINFECTANTS FOR HYGIENIC PURPOSES; FEMININE HYGIENE CLEANSING TOWELETES; FEMININE HYGIENE PADS; MENSTRUATION TAMPONS; PANTY LINERS; PANTY SHIELDS; SANITARY NAPKINS; SANITARY PADS; TAMPONS (U.S. CLS. 6, 18, 44, 46, 51 AND 52).

DAVID ELTON, EXAMINING ATTORNEY

---

SN 78-959,650. MEL HERRIN GOLF LLC, SARASOTA, FL. FILED 8-24-2006.

**4 SOME SYSTEM**

THE MARK CONSISTS OF STANDARD CHARACTERS WITHOUT CLAIM TO ANY PARTICULAR FONT, STYLE, SIZE, OR COLOR.

NO CLAIM IS MADE TO THE EXCLUSIVE RIGHT TO USE "SYSTEM", APART FROM THE MARK AS SHOWN.

**CLASS 9—ELECTRICAL AND SCIENTIFIC APPARATUS**

FOR COMPUTER SOFTWARE USED FOR SCHEDULING AND ORGANIZING GOLF GAMES (U.S. CLS. 21, 23, 26, 36 AND 38).

**CLASS 41—EDUCATION AND ENTERTAINMENT**

FOR SCHEDULING AND ORGANIZING GOLF GAMES FOR OTHERS (U.S. CLS. 100, 101 AND 107).  
JAMES LOVELACE, EXAMINING ATTORNEY

SN 78-959,686. MAI, PHONG PHILIPPE, SAN DIEGO, CA. FILED 8-24-2006.

**BAMBOO FUSION**

THE MARK CONSISTS OF STANDARD CHARACTERS WITHOUT CLAIM TO ANY PARTICULAR FONT, STYLE, SIZE, OR COLOR.

NO CLAIM IS MADE TO THE EXCLUSIVE RIGHT TO USE "BAMBOO", APART FROM THE MARK AS SHOWN.

**CLASS 20—FURNITURE AND ARTICLES NOT OTHERWISE CLASSIFIED**

FOR BEDROOM FURNITURE; CABINETS; COMPUTER FURNITURE; CUSHIONS; DOORS FOR FURNITURE; ENTERTAINMENT CENTERS; FURNITURE; FURNITURE FOR HOUSE, OFFICE AND GARDEN; FURNITURE, NAMELY, DRESSERS; FURNITURE, NAMELY, WALL UNITS; INDOOR WINDOW BLINDS; LIVING ROOM FURNITURE; MIRRORS; OFFICE FURNITURE; OUTDOOR FURNITURE; PLASTIC FURNITURE FOR GARDENS; RECLINERS; SCREENS; TABLES (U.S. CLS. 2, 13, 22, 25, 32 AND 50).

**CLASS 43—HOTEL AND RESTAURANT SERVICES**

FOR RESTAURANT AND BAR SERVICES (U.S. CLS. 100 AND 101).

KIMBERLY PERRY, EXAMINING ATTORNEY

---

SN 78-959,919. BOUWER, MARC, NEW YORK, NY. FILED 8-24-2006.

**Marc Boucher**

THE MARK CONSISTS OF STANDARD CHARACTERS WITHOUT CLAIM TO ANY PARTICULAR FONT, STYLE, SIZE, OR COLOR.

**CLASS 3—COSMETICS AND CLEANING PREPARATIONS**

FOR PERFUME (U.S. CLS. 1, 4, 6, 50, 51 AND 52).

**CLASS 9—ELECTRICAL AND SCIENTIFIC APPARATUS**

FOR EYEGLASSES (U.S. CLS. 21, 23, 26, 36 AND 38).

**CLASS 14—JEWELRY**

FOR JEWELRY (U.S. CLS. 2, 27, 28 AND 50).

**CLASS 18—LEATHER GOODS**

FOR HANDBAGS (U.S. CLS. 1, 2, 3, 22 AND 41).

**CLASS 25—CLOTHING**

FOR BELTS; DRESS SHIRTS; KNIT SHIRTS; LINGERIE; MEN AND WOMEN JACKETS, COATS, TROUSERS, VESTS; SCARVES; SHOES; SKIRTS; SOCKS AND STOCKINGS; SPORTS JACKETS; SWIM WEAR; TOPS (U.S. CLS. 22 AND 39).

MICHAEL LITZAU, EXAMINING ATTORNEY

**CLASS 9—ELECTRICAL AND SCIENTIFIC APPARATUS**

FOR EYEGLASSES (U.S. CLS. 21, 23, 26, 36 AND 38).

**CLASS 14—JEWELRY**

FOR JEWELRY (U.S. CLS. 2, 27, 28 AND 50).

**CLASS 18—LEATHER GOODS**

FOR HANDBAGS (U.S. CLS. 1, 2, 3, 22 AND 41).

**CLASS 25—CLOTHING**

FOR BELTS; DRESS SHIRTS; KNIT SHIRTS; LINGERIE; MEN AND WOMEN JACKETS, COATS, TROUSERS, VESTS; SCARVES; SHOES; SKIRTS; SOCKS AND STOCKINGS; SPORTS JACKETS; SWIM WEAR; TOPS (U.S. CLS. 22 AND 39).

MICHAEL LITZAU, EXAMINING ATTORNEY

SN 78-959,938. BOUWER, MARC, NEW YORK, NY. FILED 8-24-2006.

**Marc Bower Glamit!**

THE MARK CONSISTS OF STANDARD CHARACTERS WITHOUT CLAIM TO ANY PARTICULAR FONT, STYLE, SIZE, OR COLOR.

**CLASS 3—COSMETICS AND CLEANING PREPARATIONS**

FOR PERFUME (U.S. CLS. 1, 4, 6, 50, 51 AND 52).

**CLASS 9—ELECTRICAL AND SCIENTIFIC APPARATUS**

FOR EYEGLASSES (U.S. CLS. 21, 23, 26, 36 AND 38).

**CLASS 14—JEWELRY**

FOR JEWELRY (U.S. CLS. 2, 27, 28 AND 50).

**CLASS 18—LEATHER GOODS**

FOR HANDBAGS (U.S. CLS. 1, 2, 3, 22 AND 41).

**CLASS 25—CLOTHING**

FOR BELTS ; DRESS SHIRTS; KNIT SHIRTS; LINGERIE; MEN AND WOMEN JACKETS, COATS, TROUSERS, VESTS; SCARVES; SHOES; SKIRTS; SOCKS AND STOCKINGS; SPORTS JACKETS; SWIM WEAR; TOPS (U.S. CLS. 22 AND 39).

MICHAEL LITZAU, EXAMINING ATTORNEY

SN 78-959,943. BOUWER, MARC, NEW YORK, NY. FILED 8-24-2006.

**Marc Bower Glamit**

THE MARK CONSISTS OF STANDARD CHARACTERS WITHOUT CLAIM TO ANY PARTICULAR FONT, STYLE, SIZE, OR COLOR.

**CLASS 3—COSMETICS AND CLEANING PREPARATIONS**

FOR PERFUME (U.S. CLS. 1, 4, 6, 50, 51 AND 52).

SN 78-960,347. ZIMNOWODZKI, SIMON, CHICAGO, IL. FILED 8-25-2006.

**ON TOP OF THE WORD**

THE MARK CONSISTS OF STANDARD CHARACTERS WITHOUT CLAIM TO ANY PARTICULAR FONT, STYLE, SIZE, OR COLOR.

**CLASS 9—ELECTRICAL AND SCIENTIFIC APPARATUS**

FOR INTERACTIVE VIDEO GAME PROGRAMS; VIDEO GAME SOFTWARE (U.S. CLS. 21, 23, 26, 36 AND 38).

**CLASS 28—TOYS AND SPORTING GOODS**

FOR BOARD GAMES (U.S. CLS. 22, 23, 38 AND 50).

**CLASS 41—EDUCATION AND ENTERTAINMENT**

FOR ENTERTAINMENT SERVICES IN THE NATURE OF A TELEVISED GAME SHOW; ENTERTAINMENT SERVICES IN THE NATURE OF AN ONLINE COMPUTER GAME (U.S. CLS. 100, 101 AND 107).

Laurie Mayes, Examining Attorney

SN 78-960,349. ZIMNOWODZKI, SIMON, CHICAGO, IL. FILED 8-25-2006.

**LETTER PERFECT**

THE MARK CONSISTS OF STANDARD CHARACTERS WITHOUT CLAIM TO ANY PARTICULAR FONT, STYLE, SIZE, OR COLOR.

**CLASS 9—ELECTRICAL AND SCIENTIFIC APPARATUS**

FOR INTERACTIVE VIDEO GAME PROGRAMS; VIDEO GAME SOFTWARE (U.S. CLS. 21, 23, 26, 36 AND 38).

**CLASS 28—TOYS AND SPORTING GOODS**

FOR BOARD GAME (U.S. CLS. 22, 23, 38 AND 50).

**CLASS 41—EDUCATION AND ENTERTAINMENT**

FOR ENTERTAINMENT SERVICES IN THE NATURE OF A TELEVISED GAME SHOW; ENTERTAINMENT SERVICES IN THE NATURE OF AN ONLINE COMPUTER GAME (U.S. CLS. 100, 101 AND 107).  
LAURIE MAYES, EXAMINING ATTORNEY

**CLASS 30—STAPLE FOODS**

FOR TEA, TEA EXTRACTS IN THE NATURE OF FLAVORINGS OF TEA, BEVERAGES MADE OF TEA; ICED TEA; GREEN TEA; TEA SYRUPS, TEA EXTRACTS, ESSENCES AND CONCENTRATES FOR MAKING NON-ALCOHOLIC BEVERAGES (U.S. CL. 46).

**CLASS 32—LIGHT BEVERAGES**

FOR ISOTONIC BEVERAGES; ENERGY DRINKS (U.S. CLS. 45, 46 AND 48).  
KATINA MISTER, EXAMINING ATTORNEY

SN 78-960.616. BEVERAGE PARTNERS WORLDWIDE (NORTH AMERICA), ATLANTA, GA. FILED 8-25-2006.

SN 78-960.402. MIS QUALITY MANAGEMENT CORP., WILMINGTON, DE. FILED 8-25-2006.

**RISKFRONTIER**

THE MARK CONSISTS OF STANDARD CHARACTERS WITHOUT CLAIM TO ANY PARTICULAR FONT, STYLE, SIZE, OR COLOR.

**CLASS 9—ELECTRICAL AND SCIENTIFIC APPARATUS**

FOR FINANCIAL ANALYSIS SOFTWARE (U.S. CLS. 21, 23, 26, 36 AND 38).

**CLASS 42—SCIENTIFIC, COMPUTER AND LEGAL SERVICES**

FOR PROVIDING TEMPORARY USE OF ONLINE, NON-DOWNLOADABLE FINANCIAL ANALYSIS SOFTWARE (U.S. CLS. 100 AND 101).  
SUNG IN, EXAMINING ATTORNEY

SN 78-960.607. BEVERAGE PARTNERS WORLDWIDE (NORTH AMERICA), ATLANTA, GA. FILED 8-25-2006.



THE MARK CONSISTS OF A FLAME DESIGN.



THE COLOR(S) WHITE AND ORANGE AND GREEN IS/ARE CLAIMED AS A FEATURE OF THE MARK.

THE MARK CONSISTS OF A FLAME DESIGN WITH A WHITE INTERIOR, AN ORANGE MIDSECTION AND A GREEN OUTER SECTION.

**CLASS 30—STAPLE FOODS**

FOR TEA, TEA EXTRACTS IN THE NATURE OF FLAVORINGS OF TEA, BEVERAGES MADE OF TEA; ICED TEA; GREEN TEA; TEA SYRUPS, TEA EXTRACTS, ESSENCES AND CONCENTRATES FOR MAKING NON-ALCOHOLIC BEVERAGES (U.S. CL. 46).

**CLASS 32—LIGHT BEVERAGES**

FOR ISOTONIC BEVERAGES; ENERGY DRINKS (U.S. CLS. 45, 46 AND 48).  
KATINA MISTER, EXAMINING ATTORNEY

SN 78-960.638. COUTURE CLOSET CORPORATION, BELLAIRE, TX. FILED 8-25-2006.

**Couture Closet**

THE MARK CONSISTS OF STANDARD CHARACTERS WITHOUT CLAIM TO ANY PARTICULAR FONT, STYLE, SIZE, OR COLOR.

NO CLAIM IS MADE TO THE EXCLUSIVE RIGHT TO USE "COUTURE", APART FROM THE MARK AS SHOWN.

**CLASS 25—CLOTHING**

FOR BELTS; COATS FOR MEN AND WOMEN; FOOTWEAR FOR MEN AND WOMEN; FOOTWEAR FOR WOMEN; LEATHER BELTS; MEN AND WOMEN JACKETS, COATS, TROUSERS, VESTS; MEN'S SUITS, WOMEN'S SUITS; TIES; TOPS; WOMEN'S SHOES; WRAPS (U.S. CLS. 22 AND 39).

**CLASS 35—ADVERTISING AND BUSINESS**

FOR ONLINE CONSIGNMENT SERVICES WHEREBY GOODS ARE RECEIVED ON CONSIGNMENT FOR AUCTION ON AN ONLINE AUCTION SITE (U.S. CLS. 100, 101 AND 102).

JULIE GUTTADAURO, EXAMINING ATTORNEY

SN 78-960,649. BELLE OF ORLEANS, L.L.C., FORT MITCHELL, KY. FILED 8-25-2006.

**AMELIA BELLE**

THE MARK CONSISTS OF STANDARD CHARACTERS WITHOUT CLAIM TO ANY PARTICULAR FONT, STYLE, SIZE, OR COLOR.

**CLASS 41—EDUCATION AND ENTERTAINMENT**

FOR CASINO SERVICES (U.S. CLS. 100, 101 AND 107).

**CLASS 43—HOTEL AND RESTAURANT SERVICES**

FOR HOTEL SERVICES (U.S. CLS. 100 AND 101).  
DOMINIC J. FERRAUOLO, EXAMINING ATTORNEY

SN 78-960,701. SISKINDS LLP, LONDON, CANADA, FILED 8-25-2006.

**SISKINDS** | **SPORTS  
MANAGEMENT**

OWNER OF U.S. REG. NO. 3,105,358.  
NO CLAIM IS MADE TO THE EXCLUSIVE RIGHT TO USE "SPORTS MANAGEMENT", APART FROM THE MARK AS SHOWN.

**CLASS 16—PAPER GOODS AND PRINTED MATTER**

FOR PENS, PENCILS, LETTERHEAD PAPER (U.S. CLS. 2, 5, 22, 23, 29, 37, 38 AND 50).

**CLASS 18—LEATHER GOODS**

FOR BAGS, NAMELY SPORTS BAGS AND TRAVEL BAGS (U.S. CLS. 1, 2, 3, 22 AND 41).

**CLASS 25—CLOTHING**

FOR ATHLETIC CLOTHING NAMELY, SHIRTS, GOLF SHIRTS, T-SHIRTS, SWEATSHIRTS, JERSEYS, JACKETS, HATS AND CAPS (U.S. CLS. 22 AND 39).

**CLASS 28—TOYS AND SPORTING GOODS**

FOR GOLF BALLS, GOLF CLUB COVERS, GOLF BALL MARKERS (U.S. CLS. 22, 23, 38 AND 50).

**CLASS 35—ADVERTISING AND BUSINESS**

FOR MANAGEMENT OF PROFESSIONAL ATHLETES, SPORTS RECRUITING FOR HIGH SCHOOL, COLLEGE AND UNIVERSITY ATHLETES (U.S. CLS. 100, 101 AND 102).

JENNIFER WILLISTON, EXAMINING ATTORNEY

SN 78-960,804. FLORIDOM, INC., LONGWOOD, FL. FILED 8-25-2006.

**QuikDivorce**

THE MARK CONSISTS OF STANDARD CHARACTERS WITHOUT CLAIM TO ANY PARTICULAR FONT, STYLE, SIZE, OR COLOR.

**CLASS 9—ELECTRICAL AND SCIENTIFIC APPARATUS**

FOR COMPUTER GROUPWARE FOR LEGAL DOCUMENT PRODUCTION AND PREPARATION; COMPUTER SOFTWARE FOR APPLICATION AND DATABASE INTEGRATION; COMPUTER SOFTWARE FOR CREATING SEARCHABLE DATABASES OF INFORMATION AND DATA; COMPUTER SOFTWARE FOR THE COLLECTION, EDITING, ORGANIZING, MODIFYING, BOOK MARKING, TRANSMISSION, STORAGE AND SHARING OF DATA AND INFORMATION; COMPUTER SOFTWARE FOR LEGAL DOCUMENT PRODUCTION AND PREPARATION; FLOPPY DISCS FOR COMPUTERS FEATURING COMPUTER SOFTWARE FOR LEGAL DOCUMENT PRODUCTION AND PREPARATION (U.S. CLS. 21, 23, 26, 36 AND 38).

**CLASS 35—ADVERTISING AND BUSINESS**

FOR LICENSING OF COMPUTER SOFTWARE (U.S. CLS. 100, 101 AND 102).

ELLEN PERKINS, EXAMINING ATTORNEY

SN 78-960,836. PERPETUAL ENTERTAINMENT, INC., SAN FRANCISCO, CA. FILED 8-25-2006.



THE MARK CONSISTS OF A SPHERE WITH HORIZONTAL AND VERTICAL ELLIPTICAL LINES.

#### CLASS 9—ELECTRICAL AND SCIENTIFIC APPARATUS

FOR COMPUTER GAME SOFTWARE AND INSTRUCTIONAL MANUALS SUPPLIED THEREWITH; VIDEO GAME SOFTWARE; VIDEO GAME CARTRIDGES AND DISCS; COMPUTER HARDWARE AND SOFTWARE FOR DEVELOPING, HOSTING, MONITORING, AND OPERATING NETWORKED AND ONLINE GAMES; COMPUTER HARDWARE AND SOFTWARE FOR DEVELOPING, HOSTING, MONITORING, AND OPERATING GAMES ON CONSUMER ELECTRONIC DEVICES; COMPUTER SOFTWARE SUITE OF REUSABLE GAME TOOLS AND LIBRARIES FOR DEVELOPMENT OF NETWORKED AND ONLINE GAMES (U.S. CLS. 21, 23, 26, 36 AND 38).

#### CLASS 41—EDUCATION AND ENTERTAINMENT

FOR PROVIDING ON-LINE COMPUTER GAMES; PROVIDING COMPUTER GAMES THAT MAY BE ACCESSED NETWORK-WIDE BY NETWORK USERS; PROVIDING INFORMATION ON-LINE RELATING TO COMPUTER GAMES AND COMPUTER ENHANCEMENTS FOR GAMES (U.S. CLS. 100, 101 AND 107).  
TONJA GASKINS, EXAMINING ATTORNEY

SN 78-960,843. MELTON, DEBORAH A, SAN LUIS OBISPO, CA. FILED 8-25-2006.

# French Quarter

THE MARK CONSISTS OF STANDARD CHARACTERS WITHOUT CLAIM TO ANY PARTICULAR FONT, STYLE, SIZE, OR COLOR.

#### CLASS 4—LUBRICANTS AND FUELS

FOR CANDLES; PERFUMED CANDLES; SCENTED CANDLES (U.S. CLS. 1, 6 AND 15).

#### CLASS 25—CLOTHING

FOR CAPRI PANTS; CROP TOPS; DENIM JACKETS; DENIMS; DRESS SHIRTS; DRESSES; EVENING DRESSES; HALTER TOPS; HATS; HEADGEAR, NAMELY, HATS; JACKETS; JEANS; LONG JACKETS; MOCK TURTLE-NECK SWEATERS; PANTS; SHORT-SLEEVED OR LONG-SLEEVED T-SHIRTS; SKIRTS; SKIRTS AND DRESSES; SLEEVED OR SLEEVELESS JACKETS; SWEATERS; T-SHIRTS; TANK TOPS; TANK-TOPS; TOPS; TURTLENECK SWEATERS; V-NECK SWEATERS (U.S. CLS. 22 AND 39).

#### CLASS 35—ADVERTISING AND BUSINESS

FOR RETAIL CLOTHING BOUTIQUES; RETAIL CLOTHING STORES (U.S. CLS. 100, 101 AND 102).  
TONJA GASKINS, EXAMINING ATTORNEY

SN 78-960,925. PHILIP B. PARKER AND WAYNE M. WILLIAMS, DBA MUZLINK, LLC, SHERMAN OAKS, CA. FILED 8-25-2006.

THE APPLICANT CLAIMS COLOR AS A FEATURE OF THE MARK, NAMELY, BLUE, RED.

THE MARK CONSISTS OF THE WORD MUZLINK IN BLUE WITH SOUND WAVES IN RED AT THE END OF THE WORD MUZLINK AND AN EIGHTH NOTE USED FOR THE DOT OF THE 'I' IN THE WORD MUZLINK.

#### CLASS 9—ELECTRICAL AND SCIENTIFIC APPARATUS

FOR DOWNLOADABLE MULTIMEDIA FILE CONTAINING ARTWORK, TEXT, AUDIO, VIDEO, GAMES, AND INTERNET WEB LINKS RELATING TO MUSIC (U.S. CLS. 21, 23, 26, 36 AND 38).

#### CLASS 35—ADVERTISING AND BUSINESS

FOR ADVERTISING AND COMMERCIAL INFORMATION SERVICES, VIA THE INTERNET; ADVERTISING VIA ELECTRONIC MEDIA AND SPECIFICALLY THE INTERNET; ADVICE AND INFORMATION ABOUT CUSTOMER SERVICES AND PRODUCT MANAGEMENT AND PRICES ON INTERNET SITES IN CONNECTION WITH PURCHASES MADE OVER THE INTERNET; DISSEMINATION OF ADVERTISING FOR OTHERS VIA AN ONLINE COMMUNICATIONS NETWORK ON THE INTERNET; DISSEMINATION OF ADVERTISING FOR OTHERS VIA THE INTERNET; PROVIDING A SEARCHABLE ONLINE ADVERTISING GUIDE FEATURING THE GOODS AND SERVICES OF OTHER ONLINE VENDORS ON THE INTERNET; PROVIDING AN ONLINE COMMERCIAL INFORMATION DIRECTORY ON THE INTERNET; PROVIDING AND RENTAL OF ADVERTISING SPACE ON THE INTERNET; PROVIDING BUSINESS INFORMATION, ALSO VIA INTERNET, THE CABLE NETWORK OR OTHER FORMS OF DATA TRANSFER; PROVIDING CONSUMER PRODUCT INFORMATION VIA THE INTERNET (U.S. CLS. 100, 101 AND 102).

#### CLASS 38—COMMUNICATION

FOR COMMUNICATIONS SERVICES, NAMELY, TRANSMITTING STREAMED SOUND AND AUDIO-VISUAL RECORDINGS VIA THE INTERNET; STREAMING OF AUDIO MATERIAL ON THE INTERNET; STREAMING OF VIDEO MATERIAL ON THE INTERNET (U.S. CLS. 100, 101 AND 104).

**CLASS 42—SCIENTIFIC, COMPUTER AND LEGAL SERVICES**

FOR DESIGN, CREATION, HOSTING AND MAINTENANCE OF INTERNET SITES FOR THIRD PARTIES; HOSTING OF DIGITAL CONTENT ON THE INTERNET; PROVIDING SPECIFIC INFORMATION AS REQUESTED BY CUSTOMERS VIA THE INTERNET (U.S. CLS. 100 AND 101).

**CLASS 45—PERSONAL SERVICES**

FOR IDENTIFICATION VERIFICATION SERVICES, NAMELY, PROVIDING AUTHENTICATION OF PERSONAL IDENTIFICATION INFORMATION VIA SECURE STORAGE AND TRANSMITTING SUCH INFORMATION VIA THE INTERNET; INTERNET BASED SOCIAL NETWORKING, INTRODUCTION, AND DATING SERVICES (U.S. CLS. 100 AND 101).

ELLEN BURNS, EXAMINING ATTORNEY

---

SN 78-960,991. JIWIWI, INC., SOUTH SAN FRANCISCO, CA. FILED 8-25-2006.

**THE WAY TO WI-FI**

THE MARK CONSISTS OF STANDARD CHARACTERS WITHOUT CLAIM TO ANY PARTICULAR FONT, STYLE, SIZE, OR COLOR.

**CLASS 35—ADVERTISING AND BUSINESS**

FOR PROVIDING CONSUMER PRODUCT AND SERVICE INFORMATION RELATING TO THE WIRELESS INDUSTRY VIA THE INTERNET; PROVIDING BUYING GUIDE INFORMATION ABOUT THE GOODS AND SERVICES OF OTHERS IN THE WIRELESS INDUSTRY VIA THE INTERNET; PROVIDING AN ON-LINE BUSINESS DIRECTORY FEATURING PROVIDERS OF WIRELESS GOODS AND WIRELESS SERVICES; PROMOTING THE GOODS AND SERVICES OF OTHERS IN THE WIRELESS INDUSTRY BY PROVIDING A WEB SITE AT WHICH USERS CAN LINK TO PROVIDERS OF WIRELESS GOODS AND SERVICES (U.S. CLS. 100, 101 AND 102).

**CLASS 38—COMMUNICATION**

FOR PROVIDING GENERAL INFORMATION ON WIRELESS TELECOMMUNICATIONS AND INTERNET CONNECTIONS AND RELATING TO THE WIRELESS TELECOMMUNICATIONS AND INTERNET INDUSTRIES (U.S. CLS. 100, 101 AND 104).

RENEE MCCRAY, EXAMINING ATTORNEY

SN 78-961,002. NASTECH PHARMACEUTICAL COMPANY INC., BOTHELL, WA. FILED 8-25-2006.



NO CLAIM IS MADE TO THE EXCLUSIVE RIGHT TO USE PHARMACEUTICAL COMPANY INC., APART FROM THE MARK AS SHOWN.

THE MARK CONSISTS, IN PART, OF A SOLID CIRCULAR SPHERE WITHIN AN INCOMPLETE SINGLE LINE CIRCLE, AND AN ARROW FORMED BY FIVE CIRCLES. THE TERM "NASTECH" APPEARS ABOVE A STRAIGHT HORIZONTAL LINE TO THE RIGHT OF THE CIRCULAR DESIGN, AND THE WORDING "PHARMACEUTICAL COMPANY INC" APPEARS BELOW THE STRAIGHT HORIZONTAL LINE.

**CLASS 5—PHARMACEUTICALS**

FOR (BASED ON INTENT TO USE) PHARMACEUTICAL PREPARATIONS, NAMELY, PHARMACEUTICAL FORMULATIONS FOR DELIVERY OF PEPTIDES TO HUMANS FOR TREATING METABOLIC DISEASE, AND FOR DELIVERY OF SIRNA TO HUMANS FOR PREVENTION OF HUMAN DISEASES BY SILENCING GENES THAT CAUSE ILLNESS (U.S. CLS. 6, 18, 44, 46, 51 AND 52).

**CLASS 42—SCIENTIFIC, COMPUTER AND LEGAL SERVICES**

FOR (BASED ON USE IN COMMERCE) RESEARCH AND DEVELOPMENT SERVICES FOR NEW PHARMACEUTICAL FORMULATIONS, PHARMACEUTICAL PRODUCTS, BIOLOGICAL THERAPEUTIC AGENTS, AND DRUG DELIVERY PRODUCTS FOR OTHERS (U.S. CLS. 100 AND 101).

FIRST USE 12-23-2004; IN COMMERCE 1-10-2005.  
ZHALEH DELANEY, EXAMINING ATTORNEY

---

SN 78-961,082. HUNEEUS VINTNERS LLC, RUTHERFORD, CA. FILED 8-25-2006.

**FAUST**

THE MARK CONSISTS OF STANDARD CHARACTERS WITHOUT CLAIM TO ANY PARTICULAR FONT, STYLE, SIZE, OR COLOR.

**CLASS 40—MATERIAL TREATMENT**

FOR EDUCATIONAL SERVICES, NAMELY, PROVIDING INFORMATION ABOUT WINEMAKING (U.S. CLS. 100, 103 AND 106).

**CLASS 41—EDUCATION AND ENTERTAINMENT**

FOR ENTERTAINMENT SERVICES, NAMELY, GUIDED TOURS OF WINERIES AND VINEYARDS, WINE TASTINGS, AND CONDUCTING ENTERTAINMENT EXHIBITIONS IN THE NATURE OF WINE FESTIVALS AND WINE RELEASE PARTIES (U.S. CLS. 100, 101 AND 107).



**CLASS 43—HOTEL AND RESTAURANT SERVICES**

FOR EDUCATIONAL SERVICES, NAMELY, PROVIDING INFORMATION ABOUT WINE CHARACTERISTICS (U.S. CLS. 100 AND 101).

JAMES MACFARLANE, EXAMINING ATTORNEY

**CLASS 41—EDUCATION AND ENTERTAINMENT**

FOR CONDUCTING WORKSHOPS IN THE FIELD OF ALTERNATIVE HEALTH, NAMELY, MANAGING AND BALANCING THE ENERGY FIELD INSIDE AND SURROUNDING THE HUMAN BODY (U.S. CLS. 100, 101 AND 107).

TASNEEM HUSSAIN, EXAMINING ATTORNEY

SN 78-961,115. HERRAS-FAZZI, MICHELE K., SAN JOSE, CA. FILED 8-25-2006.

SN 78-961,322. SCUDDER, MICHAEL D., BROOKLYN, NY. FILED 8-27-2006.

**DESIGN INTERVENTION**

THE MARK CONSISTS OF STANDARD CHARACTERS WITHOUT CLAIM TO ANY PARTICULAR FONT, STYLE, SIZE, OR COLOR.

NO CLAIM IS MADE TO THE EXCLUSIVE RIGHT TO USE "DESIGN", APART FROM THE MARK AS SHOWN.

**CLASS 35—ADVERTISING AND BUSINESS**

FOR PROVIDING ORGANIZING SERVICES FOR BELONGINGS AND SPACES IN A RESIDENCE OR OFFICE SUCH AS PAPERS AND TIME; PROVIDING ORGANIZING SERVICES FOR INDIVIDUALS AT HOME, IN HOME OFFICES AND IN BUSINESS OFFICES, THAT PROVIDES HELP WITH TIME AND PAPER MANAGEMENT (U.S. CLS. 100, 101 AND 102).

**CLASS 42—SCIENTIFIC, COMPUTER AND LEGAL SERVICES**

FOR INTERIOR DECORATING; INTERIOR DECORATING CONSULTING (U.S. CLS. 100 AND 101).

EDWARD FENNESSY, EXAMINING ATTORNEY

SN 78-961,172. COOPERMAN, CORRIE, BILLINGS, MT. FILED 8-26-2006.

**WHOLE FIELD AWARENESS**

THE MARK CONSISTS OF STANDARD CHARACTERS WITHOUT CLAIM TO ANY PARTICULAR FONT, STYLE, SIZE, OR COLOR.

**CLASS 16—PAPER GOODS AND PRINTED MATTER**

FOR BOOKS AND MANUALS IN THE FIELD OF ALTERNATIVE HEALTH, NAMELY, MANAGING AND BALANCING THE ENERGY FIELD INSIDE AND SURROUNDING THE HUMAN BODY (U.S. CLS. 2, 5, 22, 23, 29, 37, 38 AND 50).

**newsspider**

THE MARK CONSISTS OF STANDARD CHARACTERS WITHOUT CLAIM TO ANY PARTICULAR FONT, STYLE, SIZE, OR COLOR.

**CLASS 9—ELECTRICAL AND SCIENTIFIC APPARATUS**

FOR COMPUTER SOFTWARE FOR ACCESSING INFORMATION DIRECTORIES THAT MAY BE DOWNLOADED FROM THE GLOBAL COMPUTER NETWORK; COMPUTER SOFTWARE FOR CREATING SEARCHABLE DATABASES OF INFORMATION AND DATA; COMPUTER SOFTWARE FOR THE COLLECTION, EDITING, ORGANIZING, MODIFYING, BOOK MARKING, TRANSMISSION, STORAGE AND SHARING OF DATA AND INFORMATION; COMPUTER SOFTWARE FOR COLLECTING, CLASSIFYING, ORGANIZING, AND ARCHIVING NEWS AND ANALYSIS THAT MAY BE DOWNLOADED FROM A GLOBAL COMPUTER NETWORK; ENTERPRISE SOFTWARE IN THE NATURE OF A DATABASE FOR NON-TRANSACTIONAL DATA AND A SEARCH ENGINE FOR DATABASE CONTENT (U.S. CLS. 21, 23, 26, 36 AND 38).

**CLASS 35—ADVERTISING AND BUSINESS**

FOR ARRANGING OF SUBSCRIPTIONS FOR THE PUBLICATIONS OF OTHERS; LICENSING OF COMPUTER SOFTWARE; NEWS CLIPPING SERVICES; SERVICES CONSISTING OF THE REGISTRATION, COLLECTION, TRANSCRIPTION, COMPILATION AND SYSTEMIZATION OF WRITTEN COMMUNICATIONS AND DATA; SUBSCRIPTION TO AN INFORMATION MEDIA PACKAGE (U.S. CLS. 100, 101 AND 102).

JILL PRATER, EXAMINING ATTORNEY

SN 78-961,612. C & M NOVELTIES, SAN DIEGO, CA. FILED 8-28-2006.



THE MARK CONSISTS OF A FLAG, SOMEONE HOLDING A GUN WITH STYLIZED TEXT OF THE WORDS, "HOMELAND SECURITY SYSTEM".

**CLASS 16—PAPER GOODS AND PRINTED MATTER**

FOR BUMPER STICKERS; DECALS; POSTERS (U.S. CLS. 2, 5, 22, 23, 29, 37, 38 AND 50).

**CLASS 25—CLOTHING**

FOR T-SHIRTS (U.S. CLS. 22 AND 39).  
BRENDAN REGAN, EXAMINING ATTORNEY

SN 78-961,859. LOUSEY NITPICKERS, PASADENA, CA.  
FILED 8-28-2006.

**LOUSEY NITPICKERS**

THE MARK CONSISTS OF STANDARD CHARACTERS WITHOUT CLAIM TO ANY PARTICULAR FONT, STYLE, SIZE, OR COLOR.

**CLASS 3—COSMETICS AND CLEANING PREPARATIONS**

FOR HAIR CARE PRODUCTS NAMELY, SHAMPOO, HAIR SPRAY, CONDITIONER, AND DETANGLER (U.S. CLS. 1, 4, 6, 50, 51 AND 52).  
FIRST USE 8-1-2006; IN COMMERCE 8-1-2006.

**CLASS 44—MEDICAL, BEAUTY AND AGRICULTURAL SERVICES**

FOR MEDICAL SERVICES NAMELY NON-TOXIC REMOVAL OF HEAD LICE AND THEIR EGGS IN THE PRIVACY OF A CUSTOMER'S HOME (U.S. CLS. 100 AND 101).  
FIRST USE 8-1-2006; IN COMMERCE 8-1-2006.  
JAMES LOVELACE, EXAMINING ATTORNEY

SN 78-961,864. MAGNIFICAT SAS, PARIS, FRANCE, FILED 8-28-2006.

**MAGNIFIKID**

THE MARK CONSISTS OF STANDARD CHARACTERS WITHOUT CLAIM TO ANY PARTICULAR FONT, STYLE, SIZE, OR COLOR.

**CLASS 9—ELECTRICAL AND SCIENTIFIC APPARATUS**

FOR PRE-RECORDED VIDEO TAPES AND DVD'S FOR CHILDREN IN THE FIELD OF CATHOLIC RELIGION (U.S. CLS. 21, 23, 26, 36 AND 38).

**CLASS 16—PAPER GOODS AND PRINTED MATTER**

FOR PUBLICATIONS, NAMELY CHILDREN'S MAGAZINES, NEWSLETTERS, JOURNALS AND GREETING CARDS IN THE FIELD OF CATHOLIC RELIGION (U.S. CLS. 2, 5, 22, 23, 29, 37, 38 AND 50).  
FIRST USE 12-31-2003; IN COMMERCE 12-31-2003.

**CLASS 41—EDUCATION AND ENTERTAINMENT**

FOR CHILD EDUCATIONAL SERVICES, NAMELY CONDUCTING SEMINARS AND WORKSHOPS IN THE FIELD OF CATHOLIC RELIGION; CHILD ENTERTAINMENT SERVICES, NAMELY ON-GOING TELEVISION PROGRAMS IN THE FIELD OF CATHOLIC RELIGION (U.S. CLS. 100, 101 AND 107).  
ALEXANDER L. POWERS, EXAMINING ATTORNEY

SN 78-962,093. GROUP USA, INC., SECAUCUS, NJ. FILED 8-28-2006.

**CLV**

THE MARK CONSISTS OF STANDARD CHARACTERS WITHOUT CLAIM TO ANY PARTICULAR FONT, STYLE, SIZE, OR COLOR.

**CLASS 18—LEATHER GOODS**

FOR HANDBAGS (U.S. CLS. 1, 2, 3, 22 AND 41).

**CLASS 25—CLOTHING**

FOR WOMEN'S CLOTHING, NAMELY, SKIRTS, BLOUSES, DRESSES, SWEATERS, SUITS, RAINCOATS, COATS, CAMISOLES, SLIPS, SHOES AND SKIRTS AND PANTS IN COORDINATED SETS WITH JACKETS AND CLOTHING ACCESSORIES, NAMELY SCARVES, GLOVES AND HATS (U.S. CLS. 22 AND 39).  
ANDREA K. NADELMAN, EXAMINING ATTORNEY

SN 78-962,149. SOUND ANSWERING AND BUSINESS SERVICES, INC., ISSAQUAH, WA. FILED 8-28-2006.



NO CLAIM IS MADE TO THE EXCLUSIVE RIGHT TO USE "TELECOM", APART FROM THE MARK AS SHOWN.  
THE COLOR(S) NAVY, ORANGE AND BLUE IS/ARE CLAIMED AS A FEATURE OF THE MARK.

THE COLOR NAVY APPEARS IN THE WORDING SOUND AND IN THE BOX DESIGN TO THE LEFT OF THE WORDING. THE COLOR BLUE APPEARS IN THE WORDING TELECOM AND IN THE BOTTOM HALF CIRCLE SWIRL IN THE BOX. THE COLOR ORANGE IS IN THE UPPER HALF CIRCLE SWIRL IN THE BOX.

**CLASS 35—ADVERTISING AND BUSINESS**

FOR BUSINESS ADMINISTRATION AND MANAGEMENT; TELEPHONE ANSWERING SERVICE; TELEPHONE ORDER-TAKING SERVICES FOR OTHERS (U.S. CLS. 100, 101 AND 102).

FIRST USE 9-1-2003; IN COMMERCE 9-1-2003.

**CLASS 38—COMMUNICATION**

FOR COMMUNICATION SERVICES, NAMELY, ELECTRONIC TRANSMISSION OF DATA AND DOCUMENTS AMONG USERS OF COMPUTERS; COMMUNICATIONS BY MEANS OF MOBILE PHONES; COMMUNICATIONS BY MOBILE PHONES; TELECOMMUNICATIONS ROUTING AND JUNCTION SERVICES; PROVIDING ELECTRONIC TELECOMMUNICATION CONNECTIONS; PROVIDING TELEPHONE CONFERENCING SERVICES; TELECOMMUNICATION ACCESS SERVICES; TELECOMMUNICATION SERVICES, NAMELY, LOCAL AND LONG DISTANCE TRANSMISSION OF VOICE, DATA, GRAPHICS BY MEANS OF TELEPHONE, TELEGRAPHIC, CABLE, AND SATELLITE TRANSMISSIONS; TELECOMMUNICATIONS SERVICES, NAMELY, PERSONAL COMMUNICATION SERVICES; TELEPHONE VOICE MESSAGING SERVICES; TRANSMISSION OF INFORMATION BY ELECTRONIC COMMUNICATIONS NETWORKS; TRANSMISSION OF INFORMATION VIA NATIONAL AND INTERNATIONAL NETWORKS; TRANSMISSION OF MESSAGES OVER ELECTRONIC MEDIA; TRANSMISSION OF SHORT MESSAGES; VOICE MAIL SERVICES; WIRELESS DIGITAL MESSAGING SERVICES; WIRELESS ELECTRONIC TRANSMISSION OF VOICE SIGNALS, DATA, FACSIMILES, IMAGES AND INFORMATION; WIRELESS FACSIMILE MAIL SERVICES; WIRELESS VOICE MAIL SERVICES (U.S. CLS. 100, 101 AND 104).

FIRST USE 9-1-2003; IN COMMERCE 9-1-2003.

TARAH HARDY, EXAMINING ATTORNEY

SN 78-962,446. MORRISON HOLDING COMPANY, WOODBRIDGE, IL. FILED 8-29-2006.

**GREEN WORKS**

THE MARK CONSISTS OF STANDARD CHARACTERS WITHOUT CLAIM TO ANY PARTICULAR FONT, STYLE, SIZE, OR COLOR.

**CLASS 16—PAPER GOODS AND PRINTED MATTER**

FOR EDUCATIONAL PUBLICATIONS, NAMELY, TRAINING MANUALS IN THE FIELD OF FOOD SAFETY, FOOD SANITATION, FOOD PREPARATION, FOOD HANDLING, NUTRITION, FOOD SERVICE MANAGEMENT, MEAL PLANNING, AND REGULATORY AND CONSUMER AFFAIRS; PRINTED MENUS; RECIPE BOOKS (U.S. CLS. 2, 5, 22, 23, 29, 37, 38 AND 50).

**CLASS 37—CONSTRUCTION AND REPAIR**

FOR FOOD SANITATION CONSULTATION (U.S. CLS. 100, 103 AND 106).

**CLASS 41—EDUCATION AND ENTERTAINMENT**

FOR TRAINING SERVICES IN THE FIELD OF FOOD SAFETY, FOOD SANITATION, FOOD PREPARATION, FOOD HANDLING, NUTRITION, FOOD SERVICE MANAGEMENT, MEAL PLANNING, AND REGULATORY AND CONSUMER AFFAIRS (U.S. CLS. 100, 101 AND 107).

**CLASS 42—SCIENTIFIC, COMPUTER AND LEGAL SERVICES**

FOR FOOD SAFETY TESTING AND CONSULTATION; TESTING, ANALYSIS AND EVALUATION OF THE GOODS AND SERVICES OF OTHERS FOR THE PURPOSE OF CERTIFICATION (U.S. CLS. 100 AND 101).

**CLASS 43—HOTEL AND RESTAURANT SERVICES**

FOR CONTRACT FOOD SERVICES; PREPARATION OF FOOD AND BEVERAGES; SERVING OF FOOD AND DRINK/BEVERAGES (U.S. CLS. 100 AND 101).

**CLASS 44—MEDICAL, BEAUTY AND AGRICULTURAL SERVICES**

FOR FOOD NUTRITION CONSULTATION (U.S. CLS. 100 AND 101).

WON TEAK OH, EXAMINING ATTORNEY

SN 78-962,345. QUINN, JOHN F, HAGERSTOWN, MD. FILED 8-28-2006.

**Photosurance**

THE MARK CONSISTS OF STANDARD CHARACTERS WITHOUT CLAIM TO ANY PARTICULAR FONT, STYLE, SIZE, OR COLOR.

**CLASS 39—TRANSPORTATION AND STORAGE**

FOR STORAGE SERVICES FOR ARCHIVING DATABASES, IMAGES AND OTHER ELECTRONIC DATA (U.S. CLS. 100 AND 105).

FIRST USE 8-1-2006; IN COMMERCE 8-1-2006.

**CLASS 40—MATERIAL TREATMENT**

FOR ELECTRONIC IMAGING, SCANNING, DIGITIZING, ALTERATION AND/OR RETOUCHING OF PHOTOGRAPHIC IMAGES (U.S. CLS. 100, 103 AND 106).

FIRST USE 8-1-2006; IN COMMERCE 8-1-2006.

TASNEEM HUSSAIN, EXAMINING ATTORNEY

SN 78-962,727. PROPANE TAXI, LLC, FRISCO, TX. FILED 8-29-2006.



NO CLAIM IS MADE TO THE EXCLUSIVE RIGHT TO USE "PROPANE" AND THE PICTORIAL REPRESENTATION OF A PROPANE TANK, APART FROM THE MARK AS SHOWN.

THE COLOR(S) BLUE, GREEN AND WHITE IS/ARE CLAIMED AS A FEATURE OF THE MARK.

THE MARK CONSISTS OF A GREEN SILHOUETTE OF A PROPANE TANK AGAINST A WHITE BACKGROUND NEXT TO THE WORDS "PROPANE TAXI" WRITTEN IN WHITE CAPITAL LETTERS AGAINST A BLUE RECTANGULAR BACKGROUND.

#### CLASS 4—LUBRICANTS AND FUELS

FOR LIQUEFIED PETROLEUM GAS (U.S. CLS. 1, 6 AND 15).

FIRST USE 6-1-2006; IN COMMERCE 6-27-2006.

#### CLASS 39—TRANSPORTATION AND STORAGE

FOR DELIVERY OF GOODS BY TRUCK (U.S. CLS. 100 AND 105).

FIRST USE 6-1-2006; IN COMMERCE 6-27-2006.

PAUL CROWLEY, EXAMINING ATTORNEY

SN 78-962,779. DANARA INTERNATIONAL, LTD., NORTH BERGEN, NJ. FILED 8-29-2006.



OWNER OF U.S. REG. NOS. 1,002,701 AND 1,009,550.

#### CLASS 10—MEDICAL APPARATUS

FOR PACIFIERS, TEETHERS (U.S. CLS. 26, 39 AND 44).

#### CLASS 25—CLOTHING

FOR CLOTH BIBS (U.S. CLS. 22 AND 39).

CAROLINE WOOD, EXAMINING ATTORNEY

SN 78-962,785. BEVERAGE PARTNERS WORLDWIDE (NORTH AMERICA), ATLANTA, GA. FILED 8-29-2006.



#### CLASS 30—STAPLE FOODS

FOR TEA, TEA EXTRACTS IN THE NATURE OF FLAVORINGS OF TEA, BEVERAGES MADE OF TEA; ICED TEA; GREEN TEA; TEA SYRUPS, TEA EXTRACTS, ESSENCES AND CONCENTRATES FOR MAKING NON-ALCOHOLIC BEVERAGES (U.S. CL. 46).

#### CLASS 32—LIGHT BEVERAGES

FOR ISOTONIC BEVERAGES; ENERGY DRINKS (U.S. CLS. 45, 46 AND 48).

KATINA MISTER, EXAMINING ATTORNEY

SN 78-962,788. BRIDGES, SHEILA, NEW YORK, NY. FILED 8-29-2006.

#### SHEILA BRIDGES HOME

THE MARK CONSISTS OF STANDARD CHARACTERS WITHOUT CLAIM TO ANY PARTICULAR FONT, STYLE, SIZE, OR COLOR.

OWNER OF U.S. REG. NO. 2,966,991.

NO CLAIM IS MADE TO THE EXCLUSIVE RIGHT TO USE "HOME", APART FROM THE MARK AS SHOWN.

#### CLASS 20—FURNITURE AND ARTICLES NOT OTHERWISE CLASSIFIED

FOR FURNITURE FOR HOUSE, OFFICE AND GARDEN; OUTDOOR FURNITURE; DECORATIVE PILLOWS; FABRIC WINDOW SHADES (U.S. CLS. 2, 13, 22, 25, 32 AND 50).

#### CLASS 24—FABRICS

FOR TEXTILE FABRICS FOR HOME AND COMMERCIAL INTERIORS; BED LINENS, NAMELY, BED SHEETS, PILLOW CASES, PILLOW SHAMS, COMFORTERS, QUILTS, BED SPREADS, BED SKIRTS, DUVETS, COMFORTER COVERS, BED BLANKETS, AFGHANS, THROWS MADE OF TEXTILE; BATH LINENS, NAMELY, BATH TOWELS, BATH FACE CLOTHS, BATH HAND TOWELS, AND SHOWER CURTAINS; TABLE LINENS, NAMELY, TABLECLOTHS NOT MADE OF PAPER, CLOTH NAPKINS, TEXTILE PLACEMATS; FABRIC TABLE RUNNERS; KITCHEN LINENS, NAMELY, DISH CLOTHS, POT HOLDERS AND OVEN MITTS; FABRIC WINDOW TREATMENTS, NAMELY, CURTAINS, CURTAIN VALANCES, AND DRAPERIES (U.S. CLS. 42 AND 50).

**CLASS 27—FLOOR COVERINGS**

FOR WALLPAPER AND DECORATIVE WALLPAPER BORDERS; FLOOR COVERINGS, NAMELY, RUGS, CARPETS, AND MATS (U.S. CLS. 19, 20, 37, 42 AND 50).  
PAUL CROWLEY, EXAMINING ATTORNEY

SN 78-962,873. HEALTHTANK, LLC, ARLINGTON, VA.  
FILED 8-29-2006.

# Healthtank

THE MARK CONSISTS OF STANDARD CHARACTERS WITHOUT CLAIM TO ANY PARTICULAR FONT, STYLE, SIZE, OR COLOR.

**CLASS 28—TOYS AND SPORTING GOODS**

FOR PLAYING CARDS (U.S. CLS. 22, 23, 38 AND 50).

**CLASS 44—MEDICAL, BEAUTY AND AGRICULTURAL SERVICES**

FOR PROVIDING HEALTH INFORMATION (U.S. CLS. 100 AND 101).  
REBECCA GAN, EXAMINING ATTORNEY

SN 78-962,814. DANARA INTERNATIONAL, LTD., NORTH BERGEN, NJ. FILED 8-29-2006.

It's a  
**Girl**  
by Danara

OWNER OF U.S. REG. NOS. 1,002,701 AND 1,009,550.

**CLASS 10—MEDICAL APPARATUS**

FOR PACIFIERS, TEETHERS (U.S. CLS. 26, 39 AND 44).

SN 78-962,904. UNITED STATES OPTIMIST DINGHY ASSOCIATION, INC., PROVIDENCE, RI. FILED 8-29-2006.

**CLASS 25—CLOTHING**

FOR CLOTH BIBS (U.S. CLS. 22 AND 39).  
CAROLINE WOOD, EXAMINING ATTORNEY

SN 78-962,861. UNITED STATES OPTIMIST DINGHY ASSOCIATION, INC., PROVIDENCE, RI. FILED 8-29-2006.



THE COLOR(S) RED, WHITE, BLUE, AND LIGHT BLUE IS/ARE CLAIMED AS A FEATURE OF THE MARK.

THE MARK CONSISTS OF A BLUE SAIL WITH THE LETTERS "O" AND "I" APPEARING ON THE FRONT OF IT IN WHITE. THE LETTERS "USODA" APPEAR TO THE RIGHT IN RED AND BELOW THE SAIL IS A SINGLE WAVE IN LIGHT BLUE.

**CLASS 35—ADVERTISING AND BUSINESS**

FOR ASSOCIATION SERVICES, NAMELY, PROMOTING THE INTERESTS OF THE SPORT OF SAILING AMONG ITS MEMBERS (U.S. CLS. 100, 101 AND 102).  
FIRST USE 0-0-2003; IN COMMERCE 0-0-2003.

**CLASS 41—EDUCATION AND ENTERTAINMENT**

FOR INSTRUCTION IN THE FIELD OF SAILING FOR JUNIORS; ORGANIZING, CONDUCTING AND PARTICIPATION IN SAIL BOAT RACES (U.S. CLS. 100, 101 AND 107).  
FIRST USE 0-0-2003; IN COMMERCE 0-0-2003.  
JESSICA A. POWERS, EXAMINING ATTORNEY



NO CLAIM IS MADE TO THE EXCLUSIVE RIGHT TO USE "USA" AND "NATIONAL TEAM", APART FROM THE MARK AS SHOWN.

THE COLOR(S) RED, WHITE, BLUE, AND GRAY IS/ARE CLAIMED AS A FEATURE OF THE MARK.

THE MARK CONSISTS OF A BLUE SAIL WITH THE LETTERS "O" AND "I" APPEARING ON THE FRONT OF IT IN WHITE. BELOW THAT IS A RED STAR AND THE LETTERS "USNT". BELOW THAT IS THE PHRASE "USA OPTIMIST NATIONAL TEAM" IN RED. TO THE LEFT OF THE DESIGN IS A GRAY ARCH THAT EXTENDS FROM THE TOP LEFT OF THE SAIL TO THE BOTTOM RIGHT CORNER OF THE DRAWING.

**CLASS 35—ADVERTISING AND BUSINESS**

FOR ASSOCIATION SERVICES, NAMELY, PROMOTING THE INTERESTS OF THE SPORT OF SAILING AMONG ITS MEMBERS (U.S. CLS. 100, 101 AND 102).  
FIRST USE 0-0-2003; IN COMMERCE 0-0-2003.

**CLASS 41—EDUCATION AND ENTERTAINMENT**

FOR INSTRUCTION IN THE FIELD OF SAILING FOR JUNIORS; ORGANIZING, CONDUCTING AND PARTICIPATION IN SAIL BOAT RACES (U.S. CLS. 100, 101 AND 107).  
FIRST USE 0-0-2003; IN COMMERCE 0-0-2003.  
JESSICA A. POWERS, EXAMINING ATTORNEY

SN 78-962,905. IDT VENTURE CAPITAL CORPORATION,  
DBA IDT JETS, NEWARK, NJ. FILED 8-29-2006.

SN 78-963,016. B. LANE INCORPORATED, NEW YORK, NY.  
FILED 8-29-2006.

## PLANEPER CLIPS

THE MARK CONSISTS OF STANDARD CHARACTERS WITHOUT CLAIM TO ANY PARTICULAR FONT, STYLE, SIZE, OR COLOR.

NO CLAIM IS MADE TO THE EXCLUSIVE RIGHT TO USE "CLIPS" IN CLASS 016, APART FROM THE MARK AS SHOWN.

### CLASS 16—PAPER GOODS AND PRINTED MATTER

FOR PAPER CLIPS, NAMELY, PAPER CLIPS IN THE SHAPE OF VARIOUS AIRCRAFT DESIGNS INCLUDING COMMERCIAL JET AIRCRAFT, MILITARY FIGHTER AIRCRAFT, GENERAL AVIATION AIRCRAFT, HELICOPTERS, ULTRA LIGHTS, SPACESHIPS AND ROCKETS (U.S. CLS. 2, 5, 22, 23, 29, 37, 38 AND 50).

### CLASS 35—ADVERTISING AND BUSINESS

FOR PROMOTION, ADVERTISING AND MARKETING SERVICES FOR AIRFRAME MANUFACTURERS, AIRLINES, HOBBY SHOPS, MUSEUMS, TRADERS AT TRADESHOWS, CUSTOMER EVENTS AND MASS MERCHANTS' GOODS (U.S. CLS. 100, 101 AND 102).

JESSICA A. POWERS, EXAMINING ATTORNEY

---

SN 78-962,963. SEMTEK CORPORATION, SAN DIEGO, CA.  
FILED 8-29-2006.

## CYMBIEN

THE MARK CONSISTS OF STANDARD CHARACTERS WITHOUT CLAIM TO ANY PARTICULAR FONT, STYLE, SIZE, OR COLOR.

### CLASS 9—ELECTRICAL AND SCIENTIFIC APPARATUS

FOR INTEGRATED CIRCUITS FOR USE IN ELECTRONIC TRANSACTION PROCESSING; DATA CAPTURE DEVICES FOR USE IN ELECTRONIC TRANSACTION PROCESSING, NAMELY, MAGNETIC STRIPE READERS, IRIS SCANNERS, FINGERPRINT SCANNERS, AND RF IDENTIFICATION READERS (U.S. CLS. 21, 23, 26, 36 AND 38).

### CLASS 36—INSURANCE AND FINANCIAL

FOR CREDIT CARD FRAUD DETECTION SERVICES (U.S. CLS. 100, 101 AND 102).

### CLASS 38—COMMUNICATION

FOR TRANSMITTING DATA VIA ELECTRONIC NETWORKS WHILE TRANSMITTING, ENCRYPTING AND DECRYPTING ELECTRONIC COMMUNICATIONS (U.S. CLS. 100, 101 AND 104).

JILL C. ALT, EXAMINING ATTORNEY

## LENA B

THE MARK CONSISTS OF STANDARD CHARACTERS WITHOUT CLAIM TO ANY PARTICULAR FONT, STYLE, SIZE, OR COLOR.

### CLASS 25—CLOTHING

FOR WOMEN'S CLOTHING, NAMELY, DRESSES, PANTS, SHORTS, SHIRTS, TOPS, SKIRTS, SOCKS, UNDERGARMENTS, JACKETS, BLAZERS, SWEATERS, COATS, FOOTWEAR, HEAD WEAR, BELTS, SCARVES AND ACTIVE APPAREL, NAMELY, SWEAT SUITS, SWEAT PANTS AND SWEATSHIRTS (U.S. CLS. 22 AND 39).

### CLASS 35—ADVERTISING AND BUSINESS

FOR RETAIL STORE SERVICES, ON-LINE RETAIL STORE SERVICES, ELECTRONIC CATALOG SERVICES, MAIL ORDER CATALOG SERVICES, RETAIL STORE SERVICES FEATURING PHONE-IN ORDERS, AND RETAIL SHOP-AT-HOME PARTY SERVICES, ALL OF THE FOREGOING IN THE FIELDS OF WOMEN'S APPAREL AND ACCESSORIES (U.S. CLS. 100, 101 AND 102).

SHAILA SETTLES, EXAMINING ATTORNEY

---

SN 78-963,129. LA HERRADURA, EDINBURGH EH3 9EE,  
SCOTLAND, FILED 8-29-2006.

## JUST PICK MUSIC

THE MARK CONSISTS OF STANDARD CHARACTERS WITHOUT CLAIM TO ANY PARTICULAR FONT, STYLE, SIZE, OR COLOR.

### CLASS 9—ELECTRICAL AND SCIENTIFIC APPARATUS

FOR MUSICAL SOUND RECORDINGS AND DOWNLOADABLE MUSICAL SOUND RECORDINGS; DVDS, AUDIOVISUAL RECORDINGS AND DOWNLOADABLE AUDIOVISUAL RECORDINGS FEATURING MUSICAL BASED ENTERTAINMENT; DOWNLOADABLE RING TONES, GRAPHICS AND MUSIC VIA A GLOBAL COMPUTER NETWORK AND WIRELESS DEVICES (U.S. CLS. 21, 23, 26, 36 AND 38).

### CLASS 25—CLOTHING

FOR CLOTHING, NAMELY, T-SHIRTS, SWEAT SHIRTS, SHIRTS, JACKETS; HEADWEAR; CLOTHING ACCESSORIES, NAMELY, SCARVES (U.S. CLS. 22 AND 39).

**CLASS 38—COMMUNICATION**

FOR STREAMING OF AUDIO AND VISUAL MATERIAL ON THE INTERNET; INTERNET SERVICES, NAMELY, PROVIDING ONLINE CHAT ROOMS AND ELECTRONIC BULLETIN BOARDS FOR TRANSMISSION OF MESSAGES AMONG COMPUTER USERS IN THE FIELDS OF MUSIC, MUSICAL SOUND RECORDINGS AND MUSICAL ARTISTS (U.S. CLS. 100, 101 AND 104).

**CLASS 41—EDUCATION AND ENTERTAINMENT**

FOR MUSIC PUBLISHING SERVICES; PROVIDING INFORMATION VIA AN ONLINE WEBSITE IN THE FIELDS OF MUSICAL RECORDINGS, MUSICAL ARTISTS AND THEIR BIOGRAPHIES, AND LIVE MUSICAL PERFORMANCE SCHEDULES; ENTERTAINMENT SERVICES, NAMELY, ARRANGING AND CONDUCTING LIVE MUSICAL CONCERTS AND LIVE PERFORMANCES BY MUSICAL BANDS AND MUSICAL PERFORMERS (U.S. CLS. 100, 101 AND 107).

JOHN DALIER, EXAMINING ATTORNEY

---

SN 78-963,421. PROPANE TAXI, LLC, FRISCO, TX. FILED 8-30-2006.

**PROPANE TAXI**

THE MARK CONSISTS OF STANDARD CHARACTERS WITHOUT CLAIM TO ANY PARTICULAR FONT, STYLE, SIZE, OR COLOR.

NO CLAIM IS MADE TO THE EXCLUSIVE RIGHT TO USE "PROPANE", APART FROM THE MARK AS SHOWN.

**CLASS 4—LUBRICANTS AND FUELS**

FOR LIQUEFIED PETROLEUM GAS (U.S. CLS. 1, 6 AND 15).  
FIRST USE 6-1-2006; IN COMMERCE 6-27-2006.

**CLASS 39—TRANSPORTATION AND STORAGE**

FOR DELIVERY OF GOODS BY TRUCK (U.S. CLS. 100 AND 105).  
FIRST USE 6-1-2006; IN COMMERCE 6-27-2006.  
PAUL CROWLEY, EXAMINING ATTORNEY

---

SN 78-963,464. CORA BETT THOMAS REALTY COMPANY, LLC, SAVANNAH, GA. FILED 8-30-2006.

**IT'S ALL ABOUT YOU! IT'S JUST THAT SIMPLE.**

THE MARK CONSISTS OF STANDARD CHARACTERS WITHOUT CLAIM TO ANY PARTICULAR FONT, STYLE, SIZE, OR COLOR.

**CLASS 35—ADVERTISING AND BUSINESS**

FOR REAL ESTATE MARKETING SERVICES IN THE FIELD OF APARTMENTS, HOMES, CONDOMINIUMS, AND COMMERCIAL SPACE (U.S. CLS. 100, 101 AND 102).

FIRST USE 5-1-2006; IN COMMERCE 5-1-2006.

**CLASS 36—INSURANCE AND FINANCIAL**

FOR REAL ESTATE BROKERAGE; REAL ESTATE MANAGEMENT (U.S. CLS. 100, 101 AND 102).

FIRST USE 5-1-2006; IN COMMERCE 5-1-2006.

ALLISON HOLTZ, EXAMINING ATTORNEY

---

SN 78-963,483. TRANSWORLD INTERNATIONAL TRADING LTD., NEUCHÂTEL, SWITZERLAND, FILED 8-30-2006.

**NUTRIFEM**

THE MARK CONSISTS OF STANDARD CHARACTERS WITHOUT CLAIM TO ANY PARTICULAR FONT, STYLE, SIZE, OR COLOR.

**CLASS 5—PHARMACEUTICALS**

FOR FOOD SUPPLEMENTS, NAMELY VITAMINS, MINERAL SUPPLEMENTS AND NUTRITIONAL SUPPLEMENTS (U.S. CLS. 6, 18, 44, 46, 51 AND 52).

**CLASS 30—STAPLE FOODS**

FOR HEALTH FOOD, NAMELY, GRAIN-BASED FOOD BARS AND BEVERAGES (U.S. CL. 46).  
BRIDGETT SMITH, EXAMINING ATTORNEY

---

SN 78-963,524. ALLIANCE ENTERPRISES OF S.E. WISCONSIN, LLC, RACINE, WI. FILED 8-30-2006.

**BENELACT**

THE MARK CONSISTS OF STANDARD CHARACTERS WITHOUT CLAIM TO ANY PARTICULAR FONT, STYLE, SIZE, OR COLOR.

**CLASS 29—MEATS AND PROCESSED FOODS**

FOR CHEESE; CHEESE FOOD; CHEESE SPREADS; CHEESE SUBSTITUTES; CHOCOLATE MILK; DAIRY PRODUCTS EXCLUDING ICE CREAM, ICE MILK AND FROZEN YOGURT; DRINKING YOGURTS; MILK; MILK PROTEINS; YOGURT; YOGURT-BASED BEVERAGES (U.S. CL. 46).

**CLASS 30—STAPLE FOODS**

FOR FROZEN YOGURT; ICE CREAM; ICE CREAM SANDWICHES; ICE CREAM SUBSTITUTE; ICE MILK; ICE MILK BARS (U.S. CL. 46).

DAVID YONTEF, EXAMINING ATTORNEY

SN 78-963,577. LIFE BALANCE MEDIA LLC, NEW YORK, NY. FILED 8-30-2006.

## LIVE THE CHANGE

THE MARK CONSISTS OF STANDARD CHARACTERS WITHOUT CLAIM TO ANY PARTICULAR FONT, STYLE, SIZE, OR COLOR.

### CLASS 9—ELECTRICAL AND SCIENTIFIC APPARATUS

FOR DOWNLOADABLE POD CASTS FEATURING INFORMATION ON BETTERING THE ENVIRONMENT AND THE LIVES OF OTHERS (U.S. CLS. 21, 23, 26, 36 AND 38).

### CLASS 41—EDUCATION AND ENTERTAINMENT

FOR ENTERTAINMENT AND INFORMATION SERVICES, NAMELY, PROVIDING VIDEO, AUDIO AND TEXT PRESENTATIONS IN THE NATURE OF ONGOING TELEVISION AND RADIO PROGRAMS AND ON-LINE JOURNALS IN THE NATURE OF BLOGS ALL IN THE FIELDS OF BETTERING THE ENVIRONMENT AND THE LIVES OF OTHERS VIA CABLE TELEVISION, VIDEO-ON-DEMAND, RADIO, THE INTERNET, AND WIRELESS TELEPHONE NETWORKS (U.S. CLS. 100, 101 AND 107).

SCOTT BALDWIN, EXAMINING ATTORNEY

SN 78-963,595. BUDDHA IN LIFE, INC., ASPEN, CO. FILED 8-30-2006.

## BUDDHA: 9 TO 5

THE MARK CONSISTS OF STANDARD CHARACTERS WITHOUT CLAIM TO ANY PARTICULAR FONT, STYLE, SIZE, OR COLOR.

### CLASS 9—ELECTRICAL AND SCIENTIFIC APPARATUS

FOR COMPACT DISCS, AUDIO AND VIDEO CASSETTES, AND DVDS FEATURING INFORMATION ABOUT BUSINESS AND GENERAL INTEREST TOPICS (U.S. CLS. 21, 23, 26, 36 AND 38).

### CLASS 16—PAPER GOODS AND PRINTED MATTER

FOR BOOKS, WORKBOOKS, MAGAZINES, NEWSPAPER COLUMNS, AND NEWSLETTERS FEATURING INFORMATION ABOUT BUSINESS AND GENERAL INTEREST TOPICS (U.S. CLS. 2, 5, 22, 23, 29, 37, 38 AND 50).

### CLASS 41—EDUCATION AND ENTERTAINMENT

FOR EDUCATIONAL SERVICES, NAMELY, CONDUCTING SEMINARS AND WORKSHOPS FEATURING INFORMATION ABOUT BUSINESS AND GENERAL INTEREST TOPICS (U.S. CLS. 100, 101 AND 107).

FRED CARL, EXAMINING ATTORNEY

SN 78-963,993. DILLARD'S, INC., LITTLE ROCK, AR. FILED 8-30-2006.

## NURTURE

THE MARK CONSISTS OF STANDARD CHARACTERS WITHOUT CLAIM TO ANY PARTICULAR FONT, STYLE, SIZE, OR COLOR.

OWNER OF U.S. REG. NO. 2,902,061.

### CLASS 14—JEWELRY

FOR JEWELRY, NAMELY, NECKLACES, EARRINGS, BRACELETS AND PINS, AND JEWELRY BOXES (U.S. CLS. 2, 27, 28 AND 50).

### CLASS 18—LEATHER GOODS

FOR HANDBAGS, WALLETS, CHANGE PURSES, BILLFOLDS, AND KEY CASES (U.S. CLS. 1, 2, 3, 22 AND 41).

### CLASS 25—CLOTHING

FOR BELTS (U.S. CLS. 22 AND 39).  
JUDITH HELFMAN, EXAMINING ATTORNEY

SN 78-964,008. EICHLER, FREDERICK V., IV, TRINIDAD, CO. FILED 8-30-2006.

## THROUGH THE EYES OF A GUIDE

THE MARK CONSISTS OF STANDARD CHARACTERS WITHOUT CLAIM TO ANY PARTICULAR FONT, STYLE, SIZE, OR COLOR.

### CLASS 9—ELECTRICAL AND SCIENTIFIC APPARATUS

FOR DVDS ON BIG-GAME ARCHERY HUNTING IN THE WESTERN UNITED STATES (U.S. CLS. 21, 23, 26, 36 AND 38).

### CLASS 16—PAPER GOODS AND PRINTED MATTER

FOR BOOK SERIES ON BIG-GAME ARCHERY HUNTING IN WESTERN UNITED STATES (U.S. CLS. 2, 5, 22, 23, 29, 37, 38 AND 50).  
ELIZABETH HUGHITT, EXAMINING ATTORNEY



SN 78-964,099. BPG PROPERTIES, LTD., YARDLEY, PA.  
FILED 8-30-2006.

SN 78-964,253. KIDS AT HOPE, INC., PHOENIX, AZ. FILED  
8-30-2006.

## MORRIS CROSSROADS CORPORATE CENTER

THE MARK CONSISTS OF STANDARD CHARACTERS WITHOUT CLAIM TO ANY PARTICULAR FONT, STYLE, SIZE, OR COLOR.

NO CLAIM IS MADE TO THE EXCLUSIVE RIGHT TO USE "CORPORATE CENTER", APART FROM THE MARK AS SHOWN.

### CLASS 36—INSURANCE AND FINANCIAL

FOR COMMERCIAL REAL ESTATE INVESTMENT SERVICES; COMMERCIAL REAL ESTATE MANAGEMENT SERVICES (U.S. CLS. 100, 101 AND 102).

### CLASS 37—CONSTRUCTION AND REPAIR

FOR COMMERCIAL REAL ESTATE DEVELOPMENT SERVICES (U.S. CLS. 100, 103 AND 106).  
MICHAEL TANNER, EXAMINING ATTORNEY

---

SN 78-964,109. CALP CORPORATION, TOKYO, JAPAN,  
FILED 8-30-2006.

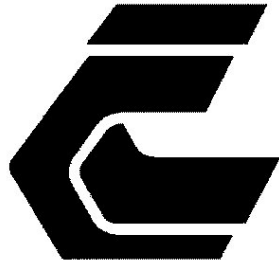

OWNER OF JAPAN REG. NO. 1731320, DATED 11-27-1984,  
EXPIRES 11-27-2014.

### CLASS 1—CHEMICALS

FOR UNPROCESSED PLASTICS IN ALL FORMS (U.S. CLS. 1, 5, 6, 10, 26 AND 46).

### CLASS 17—RUBBER GOODS

FOR PLASTICS IN THE FORM OF POWDERS, GRANULES, PELLETS, BARS, BLOCKS, RODS, SHEETS AND TUBES FOR USE IN MANUFACTURING; SEMI-PROCESSED PLASTICS IN THE FORM OF POWDERS, GRANULES, PELLETS, BARS, BLOCKS, RODS, SHEETS OR TUBES; SEMI-PROCESSED PLASTICS IN THE FORM OF POWDERS, GRANULES, PELLETS, BARS, BLOCKS, RODS, SHEETS OR TUBES (U.S. CLS. 1, 5, 12, 13, 35 AND 50).

TAMARA LEE, EXAMINING ATTORNEY



OWNER OF U.S. REG. NOS. 2,081,942 AND 2,112,687.  
NO CLAIM IS MADE TO THE EXCLUSIVE RIGHT TO USE "KIDS", APART FROM THE MARK AS SHOWN.

### CLASS 16—PAPER GOODS AND PRINTED MATTER

FOR PRINTED MATTER, NAMELY WORK-BOOKS, MANUALS, PAMPHLETS AND TEACHING GUIDES FOR TEACHING EDUCATORS, INCLUDING PARENTS, TEACHERS AND YOUTH ORGANIZATIONS, ACTIVITIES DIRECTED TO THE CULTURAL, PHYSICAL AND EDUCATIONAL DEVELOPMENT OF CHILDREN (U.S. CLS. 2, 5, 22, 23, 29, 37, 38 AND 50).

FIRST USE 4-0-2001; IN COMMERCE 4-0-2001.

### CLASS 41—EDUCATION AND ENTERTAINMENT

FOR EDUCATIONAL SERVICES, NAMELY CONDUCTING SEMINARS, CLASSES AND WORKSHOPS FOR TEACHING EDUCATORS, INCLUDING PARENTS, TEACHERS AND YOUTH ORGANIZATIONS, ACTIVITIES DIRECTED TO THE CULTURAL, PHYSICAL AND EDUCATIONAL DEVELOPMENT OF CHILDREN, BUT NOT INCLUDING TUTORIAL SERVICES AND CONDUCTING CLASSROOM INSTRUCTION TO OVERCOME LEARNING PROBLEMS AND TO OPTIMIZE ACADEMIC PERFORMANCE (U.S. CLS. 100, 101 AND 107).

FIRST USE 4-0-2001; IN COMMERCE 4-0-2001.

KATHLEEN M. VANSTON, EXAMINING ATTORNEY

---

SN 78-964,510. ROSE, RONALD R., PALO ALTO, CA. FILED  
8-30-2006.

## WHITE ROSES

THE MARK CONSISTS OF STANDARD CHARACTERS WITHOUT CLAIM TO ANY PARTICULAR FONT, STYLE, SIZE, OR COLOR.

**CLASS 9—ELECTRICAL AND SCIENTIFIC APPARATUS**

FOR MUSICAL SOUND RECORDINGS; MUSICAL VIDEO RECORDINGS; DOWNLOADABLE MUSICAL SOUND RECORDINGS; DOWNLOADABLE ELECTRONIC PUBLICATIONS IN THE NATURE OF BOOKS, BOOKLETS, MAGAZINES, JOURNALS, PAMPHLETS, AND NEWSLETTERS, ALL IN THE FIELD OF MUSIC AND ENTERTAINMENT; ELECTRONIC PUBLICATIONS, NAMELY, BOOKS, BOOKLETS, MAGAZINES, JOURNALS, PAMPHLETS, AND NEWSLETTERS, ALL IN THE FIELD OF MUSIC AND ENTERTAINMENT RECORDED ON COMPUTER MEDIA; DOWNLOADABLE RING TONES, GRAPHICS AND MUSIC VIA A GLOBAL COMPUTER NETWORK AND WIRELESS DEVICES; SUNGLASSES; CASES FOR MOBILE PHONES; PROTECTIVE CARRYING CASES FOR PORTABLE MUSIC PLAYERS NAMELY MP3 PLAYERS; MOUSE PADS; VIDEO GAME SOFTWARE; VIDEO GAME CARTRIDGES; VIDEO GAME DISCS; JOYSTICKS FOR VIDEO GAMES; VIDEO GAME INTERACTIVE CONTROL FLOOR PADS OR MATS; REFRIGERATOR MAGNETS (U.S. CLS. 21, 23, 26, 36 AND 38).

**CLASS 14—JEWELRY**

FOR JEWELRY (U.S. CLS. 2, 27, 28 AND 50).

**CLASS 16—PAPER GOODS AND PRINTED MATTER**

FOR SHEET MUSIC; POSTERS; CALENDARS; DECALS; BUMPER STICKERS; TEMPORARY TATTOOS; NOTE BOOKS; PENS; PENCILS (U.S. CLS. 2, 5, 22, 23, 29, 37, 38 AND 50).

**CLASS 18—LEATHER GOODS**

FOR ALL-PURPOSE CARRYING BAGS (U.S. CLS. 1, 2, 3, 22 AND 41).

**CLASS 24—FABRICS**

FOR BED BLANKETS; QUILTS (U.S. CLS. 42 AND 50).

**CLASS 25—CLOTHING**

FOR CLOTHING, NAMELY, T-SHIRTS, HEADWEAR, SWEAT SHIRTS, JACKETS, SWEATERS, JUMPERS, SLEEPWEAR, SWEAT SUITS, FOOTWEAR, AND NECKWEAR (U.S. CLS. 22 AND 39).

**CLASS 38—COMMUNICATION**

FOR STREAMING OF AUDIO AND VIDEO MATERIAL ON THE INTERNET (U.S. CLS. 100, 101 AND 104).

**CLASS 41—EDUCATION AND ENTERTAINMENT**

FOR ENTERTAINMENT NAMELY, LIVE PERFORMANCES BY A MUSICAL BAND; MUSIC PUBLISHING SERVICES (U.S. CLS. 100, 101 AND 107).  
TRAVIS WHEATLEY, EXAMINING ATTORNEY

SN 78-964,622. AFFINITY HEALTH SYSTEM, MENASHA, WI. FILED 8-31-2006.



OWNER OF U.S. REG. NO. 2,536,320.  
NO CLAIM IS MADE TO THE EXCLUSIVE RIGHT TO USE NETWORK HEALTH INSURANCE CORPORATION AND HEALTH SYSTEM, APART FROM THE MARK AS SHOWN.

**CLASS 36—INSURANCE AND FINANCIAL**

FOR INSURANCE SERVICES, NAMELY, THE PROVISION OF HEALTH INSURANCE (U.S. CLS. 100, 101 AND 102).

**CLASS 44—MEDICAL, BEAUTY AND AGRICULTURAL SERVICES**

FOR HEALTHCARE IN THE NATURE OF HEALTH MAINTENANCE ORGANIZATIONS (U.S. CLS. 100 AND 101).  
STEPHANIE DAVIS, EXAMINING ATTORNEY

SN 78-964,730. KESSLER, SHARI, SANTA FE, NM. FILED 8-31-2006.

**HAPPY FAMILY PORTRAITS**

THE MARK CONSISTS OF STANDARD CHARACTERS WITHOUT CLAIM TO ANY PARTICULAR FONT, STYLE, SIZE, OR COLOR.  
NO CLAIM IS MADE TO THE EXCLUSIVE RIGHT TO USE "FAMILY PORTRAITS", APART FROM THE MARK AS SHOWN.

**CLASS 16—PAPER GOODS AND PRINTED MATTER**

FOR PHOTOGRAPHS (U.S. CLS. 2, 5, 22, 23, 29, 37, 38 AND 50).

**CLASS 41—EDUCATION AND ENTERTAINMENT**

FOR PHOTOGRAPHY SERVICES (U.S. CLS. 100, 101 AND 107).  
VIVIAN MICZNIK FIRST, EXAMINING ATTORNEY

SN 78-964,752. FIRETHREAD ENTERPRISES, LLC, SCOTIA, NY. FILED 8-31-2006.

SN 78-964,939. HAZELDEN FOUNDATION, CENTER CITY, MN. FILED 8-31-2006.

# FIRETHREAD



THE COLOR(S) DARK ORANGE, ORANGE, YELLOW, LIGHT YELLOW, BROWN, DARK GRAY AND TAN IS/ARE CLAIMED AS A FEATURE OF THE MARK.

THE MARK CONSISTS OF COLORED FACETS FROM TOP TO BOTTOM COMPRISING DARK ORANGE, ORANGE, YELLOW, LIGHT YELLOW, BROWN, DARK GRAY, TAN.

THE MARK CONSISTS OF STANDARD CHARACTERS WITHOUT CLAIM TO ANY PARTICULAR FONT, STYLE, SIZE, OR COLOR.

## CLASS 35—ADVERTISING AND BUSINESS

FOR MARKETING CONSULTING; RETAIL STORES FEATURING COMPUTERS (U.S. CLS. 100, 101 AND 102).

## CLASS 37—CONSTRUCTION AND REPAIR

FOR COMPUTER INSTALLATION AND REPAIR; INSTALLATION OF COMPUTER NETWORKS; INSTALLATION OF COMPUTER SYSTEMS; MAINTENANCE AND REPAIR OF COMPUTER HARDWARE; MAINTENANCE AND REPAIR OF COMPUTER NETWORKS (U.S. CLS. 100, 103 AND 106).

## CLASS 41—EDUCATION AND ENTERTAINMENT

FOR AUDIO RECORDING AND PRODUCTION; PHOTOGRAPHY SERVICES; PRODUCTION OF VISUAL EFFECTS FOR VIDEOS, DVDS, TELEVISION AND FOR INTERNET WEBSITES (U.S. CLS. 100, 101 AND 107).

## CLASS 42—SCIENTIFIC, COMPUTER AND LEGAL SERVICES

FOR COMPUTER GRAPHICS SERVICES; COMPUTER NETWORK DESIGN FOR OTHERS; COMPUTER PROGRAMMING FOR OTHERS; COMPUTER SECURITY SERVICE, NAMELY, RESTRICTING ACCESS TO AND BY COMPUTER NETWORKS TO AND OF UNDESIRE WEB SITES, MEDIA AND INDIVIDUALS AND FACILITIES; COMPUTER SERVICES, NAMELY, CREATING AND MAINTAINING WEB SITES FOR OTHERS; COMPUTER SITE DESIGN; COMPUTER SOFTWARE DEVELOPMENT; DESIGN AND DEVELOPMENT OF MULTIMEDIA PRODUCTS; DESIGN AND DEVELOPMENT OF ON-LINE COMPUTER SOFTWARE SYSTEMS; DESIGN OF HOME PAGES, COMPUTER SOFTWARE AND WEB SITES; DESIGN, DEVELOPMENT AND IMPLEMENTATION OF SOFTWARE; DEVELOPMENT OF SOFTWARE FOR SECURE NETWORK OPERATIONS; DEVELOPMENT, DESIGN AND UPDATING OF HOME PAGES; DEVELOPMENT, UPDATING AND MAINTENANCE OF SOFTWARE AND DATA BASES; GRAPHIC DESIGN SERVICES; INTEGRATION OF COMPUTER SYSTEMS AND NETWORKS (U.S. CLS. 100 AND 101).

RON FAIRBANKS, EXAMINING ATTORNEY

## CLASS 9—ELECTRICAL AND SCIENTIFIC APPARATUS

FOR PRERECORDED AUDIO AND VIDEO CASSETTES FEATURING INSTRUCTIONAL AND SELF-HELP PROGRAMMING (U.S. CLS. 21, 23, 26, 36 AND 38).

## CLASS 16—PAPER GOODS AND PRINTED MATTER

FOR CHEMICAL DEPENDENCY LITERATURE AND SELF-HELP MATERIALS IN THE FORM OF PAMPHLETS, BOOKLETS AND BOOKS (U.S. CLS. 2, 5, 22, 23, 29, 37, 38 AND 50).

## CLASS 21—HOUSEWARES AND GLASS

FOR PORCELAIN MUGS (U.S. CLS. 2, 13, 23, 29, 30, 33, 40 AND 50).

## CLASS 25—CLOTHING

FOR LEISUREWEAR, NAMELY, T-SHIRTS AND SWEATSHIRTS (U.S. CLS. 22 AND 39).

## CLASS 28—TOYS AND SPORTING GOODS

FOR EQUIPMENT AND MATERIALS SOLD AS A UNIT FOR USE IN PLAYING A BEHAVIORAL MODIFICATION GAME IN SCHOOLS (U.S. CLS. 22, 23, 38 AND 50).

## CLASS 41—EDUCATION AND ENTERTAINMENT

FOR EDUCATIONAL SERVICES, NAMELY, LEADING AND/OR CONDUCTING CONFERENCES, WORKSHOPS, PUBLIC FORUMS, SPEAKING ENGAGEMENTS AND CLASSES OR SEMINARS FOR THE GENERAL PUBLIC OR BUSINESS GROUPS IN THE FIELD OF ADDICTION AND ALCOHOL DEPENDENCY AWARENESS, IDENTIFICATION, HANDLING, TREATMENT AND SUPPORT FOR BUSINESS EMPLOYEES; TRAINING PROGRAMS FOR COUNSELORS, CLERGY AND OTHER PROFESSIONALS IN THE FIELD OF ADDICTION AND ALCOHOL DEPENDENCY AWARENESS, IDENTIFICATION, HANDLING, TREATMENT AND SUPPORT; PROVIDING SEMINARS FOR STUDENTS ON ALCOHOL AND DRUG ABUSE PREVENTION; AND ORGANIZING AND CONDUCTING LECTURES FOR PARENTS ABOUT PREVENTING ALCOHOL AND OTHER DRUG RELATED PROBLEMS AMONG THEIR CHILDREN (U.S. CLS. 100, 101 AND 107).

## CLASS 42—SCIENTIFIC, COMPUTER AND LEGAL SERVICES

FOR MEDICAL AND SCIENTIFIC RESEARCH SERVICES IN THE FIELD OF REHABILITATION OF CHEMICALLY DEPENDENT PEOPLE (U.S. CLS. 100 AND 101).

**CLASS 44—MEDICAL, BEAUTY AND AGRICULTURAL SERVICES**

FOR CONTINUING ADDICTION TREATMENT CARE AFTER DISCHARGE FROM TREATMENT FOR ALCOHOLISM AND OTHER DRUG ADDICTION AND REHABILITATION CARE OF CHEMICALLY DEPENDENT PEOPLE; REHABILITATION OF ALCOHOL AND DRUG ADDICTED PATIENTS; MEDICAL SERVICES, NAMELY A NICOTINE ADDICTION TREATMENT PROGRAM; PROVIDING CHEMICAL DEPENDENCY INTERMEDIATE CARE FACILITIES FOR RECOVERING MEN AND WOMEN (U.S. CLS. 100 AND 101).

MICHAEL SOUDERS, EXAMINING ATTORNEY

**CLASS 16—PAPER GOODS AND PRINTED MATTER**

FOR CHEMICAL DEPENDENCY LITERATURE AND SELF-HELP MATERIALS IN THE FORM OF PAMPHLETS, BOOKLETS AND BOOKS (U.S. CLS. 2, 5, 22, 23, 29, 37, 38 AND 50).

**CLASS 21—HOUSEWARES AND GLASS**

FOR PORCELAIN MUGS (U.S. CLS. 2, 13, 23, 29, 30, 33, 40 AND 50).

SN 78-965,088. PHOENIX IP VENTURES LLC, PHILADELPHIA, PA. FILED 8-31-2006.

# PATCOL

THE MARK CONSISTS OF STANDARD CHARACTERS WITHOUT CLAIM TO ANY PARTICULAR FONT, STYLE, SIZE, OR COLOR.

**CLASS 35—ADVERTISING AND BUSINESS**

FOR BUSINESS ORGANIZATION ADVICE AND CONSULTING, BUSINESS MARKETING, MARKETING CONSULTING, AND BUSINESS MANAGEMENT CONSULTING SERVICES IN THE LIFE SCIENCES FIELD; CONSULTING SERVICES IN THE FIELD OF MANAGING INTELLECTUAL PROPERTY IN THE LIFE SCIENCES FIELD (U.S. CLS. 100, 101 AND 102).

**CLASS 36—INSURANCE AND FINANCIAL**

FOR VENTURE CAPITAL SERVICES, NAMELY, PROVIDING FINANCING TO EMERGING AND START-UP COMPANIES IN THE LIFE SCIENCES FIELD; FINANCIAL INVESTMENT AND ASSET MANAGEMENT SERVICES IN THE LIFE SCIENCES FIELD (U.S. CLS. 100, 101 AND 102).

LAURA HAMMEL, EXAMINING ATTORNEY

SN 78-965,089. HAZELDEN FOUNDATION, CENTER CITY, MN. FILED 8-31-2006.

# Hazelden

OWNER OF U.S. REG. NOS. 1,335,981 AND 1,402,927.

**CLASS 9—ELECTRICAL AND SCIENTIFIC APPARATUS**

FOR PRERECORDED AUDIO AND VIDEO CASSETTES FEATURING INSTRUCTIONAL AND SELF-HELP PROGRAMMING (U.S. CLS. 21, 23, 26, 36 AND 38).

**CLASS 25—CLOTHING**

FOR LEISUREWEAR, NAMELY, T-SHIRTS AND SWEATSHIRTS (U.S. CLS. 22 AND 39).

**CLASS 28—TOYS AND SPORTING GOODS**

FOR EQUIPMENT AND MATERIALS SOLD AS A UNIT FOR USE IN PLAYING A BEHAVIORAL MODIFICATION GAME IN SCHOOLS (U.S. CLS. 22, 23, 38 AND 50).

**CLASS 41—EDUCATION AND ENTERTAINMENT**

FOR EDUCATIONAL SERVICES, NAMELY, LEADING AND/OR CONDUCTING CONFERENCES, WORKSHOPS, PUBLIC FORUMS, SPEAKING ENGAGEMENTS AND CLASSES OR SEMINARS FOR THE GENERAL PUBLIC OR BUSINESS GROUPS IN THE FIELD OF ADDICTION AND ALCOHOL DEPENDENCY AWARENESS, IDENTIFICATION, HANDLING, TREATMENT AND SUPPORT FOR BUSINESS EMPLOYEES; TRAINING PROGRAMS FOR COUNSELORS, CLERGY AND OTHER PROFESSIONALS IN THE FIELD OF ADDICTION AND ALCOHOL DEPENDENCY AWARENESS, IDENTIFICATION, HANDLING, TREATMENT AND SUPPORT; PROVIDING SEMINARS FOR STUDENTS ON ALCOHOL AND DRUG ABUSE PREVENTION; AND ORGANIZING AND CONDUCTING LECTURES FOR PARENTS ABOUT PREVENTING ALCOHOL AND OTHER DRUG RELATED PROBLEMS AMONG THEIR CHILDREN (U.S. CLS. 100, 101 AND 107).

**CLASS 42—SCIENTIFIC, COMPUTER AND LEGAL SERVICES**

FOR MEDICAL AND SCIENTIFIC RESEARCH SERVICES IN THE FIELD OF REHABILITATION OF CHEMICALLY DEPENDENT PEOPLE (U.S. CLS. 100 AND 101).

**CLASS 44—MEDICAL, BEAUTY AND AGRICULTURAL SERVICES**

FOR CONTINUING ADDICTION TREATMENT CARE AFTER DISCHARGE FROM TREATMENT FOR ALCOHOLISM AND OTHER DRUG ADDICTION AND REHABILITATION CARE OF CHEMICALLY DEPENDENT PEOPLE; REHABILITATION OF ALCOHOL AND DRUG ADDICTED PATIENTS; MEDICAL SERVICES, NAMELY A NICOTINE ADDICTION TREATMENT PROGRAM; PROVIDING CHEMICAL DEPENDENCY INTERMEDIATE CARE FACILITIES FOR RECOVERING MEN AND WOMEN (U.S. CLS. 100 AND 101).

MICHAEL SOUDERS, EXAMINING ATTORNEY

SN 78-965,094. SIMPLY ASIA FOODS, INC., SPARKS, MD.  
FILED 8-31-2006.

## SIMPLY ASIA

THE MARK CONSISTS OF STANDARD CHARACTERS WITHOUT CLAIM TO ANY PARTICULAR FONT, STYLE, SIZE, OR COLOR.

OWNER OF U.S. REG. NOS. 2,837,423, 2,887,888 AND 3,116,681.

NO CLAIM IS MADE TO THE EXCLUSIVE RIGHT TO USE "ASIA", APART FROM THE MARK AS SHOWN.

### CLASS 29—MEATS AND PROCESSED FOODS

FOR SOUP MIXES (U.S. CL. 46).  
FIRST USE 4-29-2004; IN COMMERCE 4-29-2004.

### CLASS 30—STAPLE FOODS

FOR NOODLES, SAUCE, AND PROCESSED VEGETABLES COMBINED IN UNITARY PACKAGES; NOODLES, SAUCE, AND TOPPING COMBINED IN UNITARY PACKAGES; NOODLES, SAUCE, DEHYDRATED VEGETABLES, AND TOPPING COMBINED IN UNITARY PACKAGES (U.S. CL. 46).  
FIRST USE 12-11-2002; IN COMMERCE 12-11-2002.

CHARLOTTE CORWIN, EXAMINING ATTORNEY

SN 78-965,134. HAZELDEN FOUNDATION, CENTER CITY, MN. FILED 8-31-2006.



OWNER OF U.S. REG. NOS. 1,335,981 AND 1,402,927.

### CLASS 9—ELECTRICAL AND SCIENTIFIC APPARATUS

FOR PRERECORDED AUDIO AND VIDEO CASSETTES FEATURING INSTRUCTIONAL AND SELF-HELP PROGRAMMING (U.S. CLS. 21, 23, 26, 36 AND 38).

### CLASS 16—PAPER GOODS AND PRINTED MATTER

FOR CHEMICAL DEPENDENCY LITERATURE AND SELF-HELP MATERIALS IN THE FORM OF PAMPHLETS, BOOKLETS AND BOOKS (U.S. CLS. 2, 5, 22, 23, 29, 37, 38 AND 50).

### CLASS 21—HOUSEWARES AND GLASS

FOR PORCELAIN MUGS (U.S. CLS. 2, 13, 23, 29, 30, 33, 40 AND 50).

### CLASS 25—CLOTHING

FOR LEISUREWEAR, NAMELY, T-SHIRTS AND SWEATSHIRTS (U.S. CLS. 22 AND 39).

### CLASS 28—TOYS AND SPORTING GOODS

FOR EQUIPMENT AND MATERIALS SOLD AS A UNIT FOR USE IN PLAYING A BEHAVIORAL MODIFICATION GAME IN SCHOOLS (U.S. CLS. 22, 23, 38 AND 50).

### CLASS 41—EDUCATION AND ENTERTAINMENT

FOR EDUCATIONAL SERVICES, NAMELY, LEADING AND/OR CONDUCTING CONFERENCES, WORKSHOPS, PUBLIC FORUMS, SPEAKING ENGAGEMENTS AND CLASSES OR SEMINARS FOR THE GENERAL PUBLIC OR BUSINESS GROUPS IN THE FIELD OF ADDICTION AND ALCOHOL DEPENDENCY AWARENESS, IDENTIFICATION, HANDLING, TREATMENT AND SUPPORT FOR BUSINESS EMPLOYEES; TRAINING PROGRAMS FOR COUNSELORS, CLERGY AND OTHER PROFESSIONALS IN THE FIELD OF ADDICTION AND ALCOHOL DEPENDENCY AWARENESS, IDENTIFICATION, HANDLING, TREATMENT AND SUPPORT; PROVIDING SEMINARS FOR STUDENTS ON ALCOHOL AND DRUG ABUSE PREVENTION; AND ORGANIZING AND CONDUCTING LECTURES FOR PARENTS ABOUT PREVENTING ALCOHOL AND OTHER DRUG RELATED PROBLEMS AMONG THEIR CHILDREN (U.S. CLS. 100, 101 AND 107).

### CLASS 42—SCIENTIFIC, COMPUTER AND LEGAL SERVICES

FOR MEDICAL AND SCIENTIFIC RESEARCH SERVICES IN THE FIELD OF REHABILITATION OF CHEMICALLY DEPENDENT PEOPLE (U.S. CLS. 100 AND 101).

### CLASS 44—MEDICAL, BEAUTY AND AGRICULTURAL SERVICES

FOR CONTINUING ADDICTION TREATMENT CARE AFTER DISCHARGE FROM TREATMENT FOR ALCOHOLISM AND OTHER DRUG ADDICTION AND REHABILITATION CARE OF CHEMICALLY DEPENDENT PEOPLE; REHABILITATION OF ALCOHOL AND DRUG ADDICTED PATIENTS; MEDICAL SERVICES, NAMELY A NICOTINE ADDICTION TREATMENT PROGRAM; PROVIDING CHEMICAL DEPENDENCY INTERMEDIATE CARE FACILITIES FOR RECOVERING MEN AND WOMEN (U.S. CLS. 100 AND 101).

MICHAEL SOUDERS, EXAMINING ATTORNEY

SN 78-965,139. ST. CLAIR, J. PETER, ROWLEY, MA. FILED 8-31-2006.

## LIFE'S A DOG

THE MARK CONSISTS OF STANDARD CHARACTERS WITHOUT CLAIM TO ANY PARTICULAR FONT, STYLE, SIZE, OR COLOR.

### CLASS 18—LEATHER GOODS

FOR CLOTHING FOR DOMESTIC PETS; COLLARS FOR PETS; COLLARS FOR PETS BEARING MEDICAL INFORMATION; DOG APPAREL; DOG CLOTHING; DOG COLLARS; DOG LEASHES; GARMENTS FOR PETS; PET CLOTHING; RAWHIDE CHEWS FOR DOGS (U.S. CLS. 1, 2, 3, 22 AND 41).

**CLASS 25—CLOTHING**

FOR BELTS; CAMP SHIRTS; CAPS; CHILDREN'S AND INFANTS' CLOTH BIBS; DRESS SHIRTS; GOLF SHIRTS; INFANT AND TODDLER ONE PIECE CLOTHING; JERSEYS; KNIT SHIRTS; LEATHER BELTS; NIGHT SHIRTS; POLO SHIRTS; SHIRTS; SHORT SETS; SHORT-SLEEVED OR LONG-SLEEVED T-SHIRTS; SLEEP SHIRTS; SWEAT SHIRTS; T-SHIRTS; TIES; TOPS (U.S. CLS. 22 AND 39).

**CLASS 35—ADVERTISING AND BUSINESS**

FOR COMPUTERIZED ON-LINE RETAIL STORE SERVICES IN THE FIELD OF APPAREL; ELECTRONIC RETAILING SERVICES VIA COMPUTER FEATURING PET-RELATED APPAREL; ON-LINE RETAIL STORE SERVICES FEATURING PET-RELATED APPAREL, PET TOYS AND PET SUPPLIES, INCLUDING DOG BOWLS AND DOG BEDS; RETAIL APPAREL STORES; RETAIL GIFT SHOPS; RETAIL PET STORES; RETAIL STORES FEATURING PET-RELATED APPAREL, PET TOYS AND PET SUPPLIES, INCLUDING DOG BOWLS AND DOG BEDS (U.S. CLS. 100, 101 AND 102).

HENRY S. ZAK, EXAMINING ATTORNEY

SN 78-965,201. HAZELDEN FOUNDATION, CENTER CITY, MN. FILED 8-31-2006.



OWNER OF U.S. REG. NOS. 1,335,981 AND 1,402,927.

THE COLOR(S) DARK ORANGE, ORANGE, YELLOW, LIGHT YELLOW, BROWN, DARK GRAY, TAN AND WHITE IS/ARE CLAIMED AS A FEATURE OF THE MARK.

THE MARK CONSISTS OF COLORED FACETS FROM TOP TO BOTTOM COMPRISING DARK ORANGE, ORANGE, YELLOW, LIGHT YELLOW, BROWN, DARK GRAY, TAN AND DARK GRAY WITH THE STYLIZED WORD HAZELDEN APPEARING ON THE BOTTOM GRAY SECTION IN WHITE.

**CLASS 9—ELECTRICAL AND SCIENTIFIC APPARATUS**

FOR PRERECORDED AUDIO AND VIDEO CASSETTES FEATURING INSTRUCTIONAL AND SELF-HELP PROGRAMMING (U.S. CLS. 21, 23, 26, 36 AND 38).

**CLASS 16—PAPER GOODS AND PRINTED MATTER**

FOR CHEMICAL DEPENDENCY LITERATURE AND SELF-HELP MATERIALS IN THE FORM OF PAMPHLETS, BOOKLETS AND BOOKS (U.S. CLS. 2, 5, 22, 23, 29, 37, 38 AND 50).

**CLASS 21—HOUSEWARES AND GLASS**

FOR PORCELAIN MUGS (U.S. CLS. 2, 13, 23, 29, 30, 33, 40 AND 50).

**CLASS 25—CLOTHING**

FOR LEISUREWEAR, NAMELY, T-SHIRTS AND SWEATSHIRTS (U.S. CLS. 22 AND 39).

**CLASS 28—TOYS AND SPORTING GOODS**

FOR EQUIPMENT AND MATERIALS SOLD AS A UNIT FOR USE IN PLAYING A BEHAVIORAL MODIFICATION GAME IN SCHOOLS (U.S. CLS. 22, 23, 38 AND 50).

**CLASS 41—EDUCATION AND ENTERTAINMENT**

FOR EDUCATIONAL SERVICES, NAMELY, LEADING AND/OR CONDUCTING CONFERENCES, WORKSHOPS, PUBLIC FORUMS, SPEAKING ENGAGEMENTS AND CLASSES OR SEMINARS FOR THE GENERAL PUBLIC OR BUSINESS GROUPS IN THE FIELD OF ADDICTION AND ALCOHOL DEPENDENCY AWARENESS, IDENTIFICATION, HANDLING, TREATMENT AND SUPPORT FOR BUSINESS EMPLOYEES; TRAINING PROGRAMS FOR COUNSELORS, CLERGY AND OTHER PROFESSIONALS IN THE FIELD OF ADDICTION AND ALCOHOL DEPENDENCY AWARENESS, IDENTIFICATION, HANDLING, TREATMENT AND SUPPORT; PROVIDING SEMINARS FOR STUDENTS ON ALCOHOL AND DRUG ABUSE PREVENTION; AND ORGANIZING AND CONDUCTING LECTURES FOR PARENTS ABOUT PREVENTING ALCOHOL AND OTHER DRUG RELATED PROBLEMS AMONG THEIR CHILDREN (U.S. CLS. 100, 101 AND 107).

**CLASS 42—SCIENTIFIC, COMPUTER AND LEGAL SERVICES**

FOR MEDICAL AND SCIENTIFIC RESEARCH SERVICES IN THE FIELD OF REHABILITATION OF CHEMICALLY DEPENDENT PEOPLE (U.S. CLS. 100 AND 101).

**CLASS 44—MEDICAL, BEAUTY AND AGRICULTURAL SERVICES**

FOR CONTINUING ADDICTION TREATMENT CARE AFTER DISCHARGE FROM TREATMENT FOR ALCOHOLISM AND OTHER DRUG ADDICTION AND REHABILITATION CARE OF CHEMICALLY DEPENDENT PEOPLE; REHABILITATION OF ALCOHOL AND DRUG ADDICTED PATIENTS; MEDICAL SERVICES, NAMELY A NICOTINE ADDICTION TREATMENT PROGRAM; PROVIDING CHEMICAL DEPENDENCY INTERMEDIATE CARE FACILITIES FOR RECOVERING MEN AND WOMEN (U.S. CLS. 100 AND 101).

MICHAEL SOUDERS, EXAMINING ATTORNEY

SN 78-965,223. SIX SIGMA QUALTEC, INC., PRINCETON, NJ. FILED 8-31-2006.

# QUALTEC

THE MARK CONSISTS OF STANDARD CHARACTERS WITHOUT CLAIM TO ANY PARTICULAR FONT, STYLE, SIZE, OR COLOR.

**CLASS 16—PAPER GOODS AND PRINTED MATTER**

FOR REFERENCE AND TRAINING MANUALS IN THE FIELDS OF QUALITY TRAINING AND TECHNIQUES, BUSINESS REORGANIZATION, BUSINESS MANAGEMENT AND CONSULTING, MANAGING ORGANIZATIONAL CHANGE, AND HUMAN RESOURCE DESIGN (U.S. CLS. 2, 5, 22, 23, 29, 37, 38 AND 50).

**CLASS 35—ADVERTISING AND BUSINESS**

FOR BUSINESS MANAGEMENT CONSULTING SERVICES (U.S. CLS. 100, 101 AND 102).

**CLASS 41—EDUCATION AND ENTERTAINMENT**

FOR CONDUCTING COURSES, WORKSHOPS AND SEMINARS IN THE FIELD OF BUSINESS MANAGEMENT AND CONSULTING (U.S. CLS. 100, 101 AND 107).  
WON TEAK OH, EXAMINING ATTORNEY

SN 78-965,235. PROANGLE MEDIA, LLC, LOS ANGELES, CA. FILED 8-31-2006.

# VOOTAGE

THE MARK CONSISTS OF STANDARD CHARACTERS WITHOUT CLAIM TO ANY PARTICULAR FONT, STYLE, SIZE, OR COLOR.

**CLASS 38—COMMUNICATION**

FOR BROADCAST OF CABLE TELEVISION PROGRAMMES; BROADCASTING PROGRAMS VIA A GLOBAL COMPUTER NETWORK; BROADCASTING SERVICES AND PROVISION OF TELECOMMUNICATION ACCESS TO VIDEO AND AUDIO CONTENT PROVIDED VIA A VIDEO-ON-DEMAND SERVICE VIA THE INTERNET; CABLE TELEVISION BROADCASTING; CELLULAR TELEPHONE COMMUNICATION; COMMUNICATION SERVICES, NAMELY, ELECTRONIC TRANSMISSION OF DATA AND DOCUMENTS AMONG USERS OF COMPUTERS; COMMUNICATION VIA RADIO, TELEGRAPH, TELEPHONE AND TELEVISION TRANSMISSIONS; COMMUNICATIONS SERVICES, NAMELY, TRANSMITTING STREAMED SOUND AND AUDIO-VISUAL RECORDINGS VIA THE INTERNET; ELECTRONIC MAIL SERVICES; ELECTRONIC MESSAGE SENDING; ELECTRONIC TRANSMISSION OF MESSAGES AND DATA; ELECTRONIC, ELECTRIC, AND DIGITAL TRANSMISSION OF VOICE, DATA, IMAGES, SIGNALS, AND MESSAGES; INFORMATION TRANSMISSION VIA ELECTRONIC COMMUNICATIONS NETWORKS; INSTANT MESSAGING SERVICES; MOBILE MEDIA AND ENTERTAINMENT SERVICES IN THE NATURE OF ELECTRONIC TRANSMISSION OF ENTERTAINMENT MEDIA CONTENT; PODCASTING SERVICES; PROVIDING ON-LINE CHAT ROOMS FOR TRANSMISSION OF MESSAGES AMONG COMPUTER USERS CONCERNING SPORTS AND SPORTS EVENTS; PROVIDING ON-LINE ELECTRONIC BULLETIN BOARDS FOR TRANSMISSION OF MESSAGES AMONG COMPUTER USERS CONCERNING SPORTS AND SPORTS EVENTS; PROVIDING ON-LINE FORUMS FOR TRANSMISSION OF MESSAGES AMONG COMPUTER USERS CONCERNING SPORTS AND SPORTS EVENTS; STREAMING OF AUDIO MATERIAL ON THE INTERNET; STREAMING OF VIDEO MATERIAL ON THE INTERNET; TELEVISION BROADCASTING; TRANSMISSION OF INFORMATION BY ELECTRONIC COMMUNICATIONS NETWORKS; VIDEO BROADCASTING; VIRTUAL CHATROOMS ESTABLISHED VIA TEXT MESSAGING; WEB MESSAGING; WEBCASTING SERVICES (U.S. CLS. 100, 101 AND 104).

**CLASS 41—EDUCATION AND ENTERTAINMENT**

FOR EDITING OR RECORDING OF SOUNDS AND IMAGES; ENTERTAINMENT NAMELY, PRODUCTION OF SPORTS EVENTS; ENTERTAINMENT SERVICES, NAMELY, PROVIDING A TELEVISION PROGRAM IN THE FIELD OF SPORTS VIA A GLOBAL COMPUTER NETWORK; ENTERTAINMENT SERVICES, NAMELY, PROVIDING ON-LINE REVIEWS OF SPORTS EVENTS; MAINTAINING RECORDS AND CERTIFYING RECORD PERFORMANCES OF AMATEUR ATHLETES; MOBILE MEDIA AND ENTERTAINMENT SERVICES IN THE NATURE OF CONTENT PREPARATION, POST-PRODUCTION; ON-LINE JOURNALS, NAMELY, BLOGS FEATURING SPORTS; OPERATION OF VIDEO EQUIPMENT OR AUDIO EQUIPMENT ETC; FOR PRODUCTION OF RADIO OR TELEVISION PROGRAMS; PRODUCTION OF CABLE TELEVISION PROGRAMS; PRODUCTION OF RADIO OR TELEVISION PROGRAMS; PROVIDING A WEBSITE FEATURING SPORTING INFORMATION; PROVIDING A WEBSITE THAT PROVIDES SPORTS LEAGUE PLAYER STATISTICS; TELEVISION PRODUCTION; TELEVISION SHOW PRODUCTION (U.S. CLS. 100, 101 AND 107).  
COLLEEN DOMBROW, EXAMINING ATTORNEY

SN 78-965,275. WEIGHTHEPEOPLE LLC, MAINEVILLE, OH. FILED 8-31-2006.

# WEIGH THE PEOPLE

THE MARK CONSISTS OF STANDARD CHARACTERS WITHOUT CLAIM TO ANY PARTICULAR FONT, STYLE, SIZE, OR COLOR.

**CLASS 41—EDUCATION AND ENTERTAINMENT**

FOR EDUCATIONAL SERVICES, NAMELY CONDUCTING CLASSES, SEMINARS, LECTURES, WORKSHOPS AND TRAINING PROGRAMS IN THE AREAS OF NUTRITION, DIET, WEIGHT LOSS, AND WEIGHT MANAGEMENT (U.S. CLS. 100, 101 AND 107).

**CLASS 44—MEDICAL, BEAUTY AND AGRICULTURAL SERVICES**

FOR WEIGHT REDUCTION DIET PLANNING AND SUPERVISION; PROVIDING INFORMATION ABOUT DIETARY SUPPLEMENTS AND NUTRITION; CONSULTATION AND COUNSELING SERVICES IN THE AREA OF NUTRITION, DIET, WEIGHT LOSS, AND WEIGHT MANAGEMENT (U.S. CLS. 100 AND 101).  
JASON ROTH, EXAMINING ATTORNEY

SN 78-965,284. WATSO, SOUTH SAN FRANCISCO, CA. FILED 8-31-2006.

# AXIS 101

THE MARK CONSISTS OF STANDARD CHARACTERS WITHOUT CLAIM TO ANY PARTICULAR FONT, STYLE, SIZE, OR COLOR.

**CLASS 12—VEHICLES**

FOR MOTORCYCLES; MOTORCYCLES FOR MOTOCROSS; STRUCTURAL PARTS FOR MOTORCYCLES (U.S. CLS. 19, 21, 23, 31, 35 AND 44).

FIRST USE 1-31-2005; IN COMMERCE 1-31-2005.

**CLASS 25—CLOTHING**

FOR HEADGEAR, NAMELY, HATS, CAPS, BASEBALL CAPS, KNITTED CAPS, CAPS WITH VISORS, MILITARY-STYLE CAPS, TRUCKER HATS; CLOTHING, NAMELY, T-SHIRTS, SHIRTS, KNIT SHIRTS, POLO SHIRTS, SHORT-SLEEVED OR LONG-SLEEVED T-SHIRTS, SHORT-SLEEVED SHIRTS, SPORTS SHIRTS, SPORTS SHIRTS WITH SHORT SLEEVES, SWEAT SHIRTS, JACKETS, DENIM JACKETS, LEATHER JACKETS, WIND RESISTANT JACKETS, DOWN JACKETS, COATS, HALTER TOPS, MUSCLE TOPS, TANK TOPS (U.S. CLS. 22 AND 39).

FIRST USE 1-31-2005; IN COMMERCE 1-31-2005.

**CLASS 35—ADVERTISING AND BUSINESS**

FOR RETAIL STORES IN THE FIELD OF MOTORCYCLES; MOTORCYCLE PARTS AND ACCESSORIES, APPAREL AND BOOKS; COMPUTERIZED ON-LINE RETAIL STORE SERVICES IN THE FIELD OF MOTORCYCLES; MOTORCYCLE PARTS AND ACCESSORIES; ON-LINE RETAIL STORE SERVICES FEATURING MOTORCYCLES; MOTORCYCLE PARTS AND ACCESSORIES, APPAREL AND BOOKS (U.S. CLS. 100, 101 AND 102).

FIRST USE 1-31-2005; IN COMMERCE 1-31-2005.

PAUL F. GAST, EXAMINING ATTORNEY

---

SN 78-965,301. ATHENA PACIFIC LIMITED, SAN DIEGO, CA. FILED 8-31-2006.

# ORTHOSOLE

THE MARK CONSISTS OF STANDARD CHARACTERS WITHOUT CLAIM TO ANY PARTICULAR FONT, STYLE, SIZE, OR COLOR.

**CLASS 10—MEDICAL APPARATUS**

FOR ORTHOPEDIC FOOTWEAR; ORTHOTIC INSERTS FOR FOOTWEAR (U.S. CLS. 26, 39 AND 44).

**CLASS 25—CLOTHING**

FOR ATHLETIC FOOTWEAR; BEACH FOOTWEAR; FLIP FLOPS; FOOTWEAR; FOOTWEAR FOR MEN; FOOTWEAR FOR MEN AND WOMEN; FOOTWEAR FOR TRACK AND FIELD ATHLETICS; FOOTWEAR FOR WOMEN; FOOTWEAR MADE OF WOOD; FOOTWEAR NOT FOR SPORTS; FOOTWEAR, NAMELY, PUMPS; FOOTWEAR, NAMELY, RUBBERS; INSOLES; INSOLES (U.S. CLS. 22 AND 39).

COLLEEN DOMBROW, EXAMINING ATTORNEY

SN 78-965,303. SIMPLY ASIA FOODS, INC., SPARKS, MD. FILED 8-31-2006.

# THAI KITCHEN

THE MARK CONSISTS OF STANDARD CHARACTERS WITHOUT CLAIM TO ANY PARTICULAR FONT, STYLE, SIZE, OR COLOR.

OWNER OF U.S. REG. NOS. 2,062,532, 2,771,651 AND OTHERS.

SEC. 2(F).

**CLASS 29—MEATS AND PROCESSED FOODS**

FOR PROCESSED LEMONGRASS; SOUP MIXES; SOUPS (U.S. CL. 46).

FIRST USE 6-1-1993; IN COMMERCE 6-1-1993.

**CLASS 30—STAPLE FOODS**

FOR CURRY PASTES; ICED TEA; NOODLES AND SAUCE MIXES COMBINED IN UNITARY PACKAGES; NOODLES AND SEASONING MIXES COMBINED IN UNITARY PACKAGES; NOODLES, SEASONINGS, EDIBLE OIL, AND DEHYDRATED VEGETABLES COMBINED IN UNITARY PACKAGES; NOODLES, SEASONINGS, EDIBLE OIL, AND FLAVORINGS COMBINED IN UNITARY PACKAGES; RICE; RICE AND SEASONING MIX COMBINED IN UNITARY PACKAGES; RICE, SEASONINGS, AND FLAVORINGS COMBINED IN UNITARY PACKAGES; SAUCE MIXES; SAUCES; SEASONED COATING MIXTURES FOR FOODS; SEASONING PASTES; TEA (U.S. CL. 46).

FIRST USE 1-1-1991; IN COMMERCE 1-1-1991.

**CLASS 32—LIGHT BEVERAGES**

FOR COCONUT MILK (U.S. CLS. 45, 46 AND 48).

FIRST USE 6-1-1993; IN COMMERCE 6-1-1993.

CHARLOTTE CORWIN, EXAMINING ATTORNEY

---

SN 78-965,448. SIMPLY ASIA FOODS, INC., SPARKS, MD. FILED 8-31-2006.



OWNER OF U.S. REG. NOS. 2,062,532, 2,771,651 AND OTHERS.

THE COLOR(S) BLACK, BROWN, GOLD, GREEN, RED, AND WHITE IS/ARE CLAIMED AS A FEATURE OF THE MARK.

THE COLOR WHITE APPEARS IN THE WORDS "THAI KITCHEN," THE COLOR GOLD APPEARS IN THE INSIDE OF THE TRIANGULAR PEAK OF THE PAGODA ROOF, IN THE OUTER LINE OF THE TRIANGULAR PORTION OF THE PAGODA ROOF, IN THE HORIZONTAL LINES ON



EITHER SIZE OF THE PAGODA ROOF, IN THE OUTER LINE OF THE RECTANGULAR PORTION OF THE PAGODA ROOF DESIGN, THE COLOR RED APPEARS IN THE INTERIOR OF THE RECTANGULAR PORTION OF THE PAGODA ROOF DESIGN, THE COLOR GREEN APPEARS IN THE INNER LINE OF THE RECTANGULAR PORTION OF THE PAGODA ROOF DESIGN, THE COLOR BROWN APPEARS IN THE INNER LINE OF THE TRIANGULAR PORTION OF THE PAGODA ROOF DESIGN, AND THE BACKGROUND OF THE MARK IS IN THE COLOR BLACK. SEC. 2(F) AS TO "THAI KITCHEN".

#### **CLASS 29—MEATS AND PROCESSED FOODS**

FOR PROCESSED LEMONGRASS; SOUP MIXES; SOUPS (U.S. CL. 46).  
FIRST USE 6-1-1993; IN COMMERCE 6-1-1993.

#### **CLASS 30—STAPLE FOODS**

FOR CURRY PASTES; ICED TEA; NOODLES; NOODLES AND SAUCE MIXES COMBINED IN UNITARY PACKAGES; NOODLES AND SEASONING MIXES COMBINED IN UNITARY PACKAGES; NOODLES, SEASONINGS, EDIBLE OIL, AND DEHYDRATED VEGETABLES COMBINED IN UNITARY PACKAGES; NOODLES, SEASONINGS, EDIBLE OIL, AND FLAVORINGS COMBINED IN UNITARY PACKAGES; RICE; RICE AND SEASONING MIX COMBINED IN UNITARY PACKAGES; RICE, SEASONINGS, AND FLAVORINGS COMBINED IN UNITARY PACKAGES; SAUCE MIXES; SAUCES; SEASONED COATING MIXTURES FOR FOODS; SEASONING PASTES; TEA (U.S. CL. 46).  
FIRST USE 1-1-1991; IN COMMERCE 1-1-1991.

#### **CLASS 32—LIGHT BEVERAGES**

FOR COCONUT MILK (U.S. CLS. 45, 46 AND 48).  
FIRST USE 1-1-1991; IN COMMERCE 1-1-1991.  
CHARLOTTE CORWIN, EXAMINING ATTORNEY

#### **CLASS 9—ELECTRICAL AND SCIENTIFIC APPARATUS**

FOR PRE-RECORDED CD'S, AUDIO TAPES, VIDEO TAPES AND DVD'S FEATURING TEACHING AND EDUCATIONAL TOPICS, NAMELY, TRAINING AND COACHING GUIDES FOR TEACHERS AND COUNSELORS IN THE FIELDS OF MIDDLE SCHOOL EDUCATION, SECONDARY EDUCATION AND COLLEGE PREPARATION; EDUCATIONAL SOFTWARE FEATURING INSTRUCTION IN TEACHING AND EDUCATIONAL TOPICS, NAMELY, TRAINING AND COACHING GUIDES FOR TEACHERS AND COUNSELORS IN THE FIELDS OF MIDDLE SCHOOL EDUCATION, SECONDARY EDUCATION AND COLLEGE PREPARATION; ELECTRONIC PUBLICATIONS FEATURING TEACHING AND EDUCATIONAL TOPICS, NAMELY, BOOKS, INSTRUCTIONAL SHEETS, INFORMATIONAL SHEETS, MANUALS AND GUIDES FOR TEACHERS AND COUNSELORS IN THE FIELDS OF MIDDLE SCHOOL EDUCATION, SECONDARY EDUCATION AND COLLEGE PREPARATION, RECORDED ON COMPUTER MEDIA; DOWNLOADABLE ELECTRONIC PUBLICATIONS IN THE NATURE OF INSTRUCTIONAL SHEETS, INFORMATIONAL SHEETS, BOOKS, MANUALS AND GUIDES FOR TEACHERS AND COUNSELORS IN THE FIELDS OF MIDDLE SCHOOL EDUCATION, SECONDARY EDUCATION AND COLLEGE PREPARATION (U.S. CLS. 21, 23, 26, 36 AND 38).

#### **CLASS 16—PAPER GOODS AND PRINTED MATTER**

FOR PRINTED INSTRUCTIONAL, EDUCATIONAL, TEACHING AND TRAINING MATERIALS AND PUBLICATIONS, NAMELY, BOOKS, INSTRUCTIONAL SHEETS, INFORMATIONAL SHEETS, MANUALS AND GUIDES FOR TEACHERS AND COUNSELORS IN THE FIELDS OF MIDDLE SCHOOL EDUCATION, SECONDARY EDUCATION AND COLLEGE PREPARATION (U.S. CLS. 2, 5, 22, 23, 29, 37, 38 AND 50).

SN 78-965,467. AVID CENTER, SAN DIEGO, CA. FILED 8-31-2006.

## **COLLEGE BY DESIGN**

THE MARK CONSISTS OF STANDARD CHARACTERS WITHOUT CLAIM TO ANY PARTICULAR FONT, STYLE, SIZE, OR COLOR.

NO CLAIM IS MADE TO THE EXCLUSIVE RIGHT TO USE COLLEGE, APART FROM THE MARK AS SHOWN.

#### **CLASS 41—EDUCATION AND ENTERTAINMENT**

FOR EDUCATIONAL AND ENTERTAINMENT SERVICES, NAMELY, PROVIDING MOTIVATIONAL AND EDUCATIONAL SPEAKERS; EDUCATIONAL SERVICES, NAMELY, CONDUCTING PROGRAMS AND PROVIDING COURSES OF INSTRUCTION TO TEACHERS AND COUNSELORS IN THE FIELDS OF MIDDLE SCHOOL EDUCATION, SECONDARY EDUCATION AND COLLEGE PREPARATION, AND DISTRIBUTING COURSE MATERIAL IN CONNECTION THEREWITH, AND CONSULTING SERVICES RELATED THERETO; TRAINING SERVICES FOR TEACHERS AND COUNSELORS IN THE FIELDS OF MIDDLE SCHOOL EDUCATION, SECONDARY EDUCATION AND COLLEGE PREPARATION, AND DISTRIBUTING COURSE MATERIAL IN CONNECTION THEREWITH, AND CONSULTING SERVICES RELATED THERETO (U.S. CLS. 100, 101 AND 107).

TARAH HARDY, EXAMINING ATTORNEY

SN 78-965,510. SIMPLY ASIA FOODS, INC., SPARKS, MD.  
FILED 8-31-2006.



OWNER OF U.S. REG. NOS. 2,062,532, 2,771,651 AND OTHERS.

NO CLAIM IS MADE TO THE EXCLUSIVE RIGHT TO USE "ORIGINAL", "IMPORTED", AND "PREMIUM", APART FROM THE MARK AS SHOWN.

THE COLOR(S) BLACK, BROWN, GOLD, GRAY, GREEN, RED, AND WHITE IS/ARE CLAIMED AS A FEATURE OF THE MARK.

THE COLOR WHITE APPEARS IN THE WORDS "THAI KITCHEN" AND IN THE INTERIOR LINE BORDERING THE RECTANGULAR STAMP DESIGN TO THE LEFT OF THE PAGODA, THE COLOR GOLD APPEARS IN THE INSIDE OF THE TRIANGULAR PEAK OF THE PAGODA ROOF, IN THE OUTER LINE OF THE TRIANGULAR PORTION OF THE PAGODA ROOF, IN THE HORIZONTAL LINES ON EITHER SIDE OF THE PAGODA ROOF, IN THE OUTER LINE OF THE RECTANGULAR PORTION OF THE PAGODA ROOF DESIGN, THE COLOR RED APPEARS IN THE INTERIOR OF THE RECTANGULAR PORTION OF THE PAGODA ROOF DESIGN AND IN THE BACKGROUND OF THE VILLAGE SCENERY ON THE LEFT AND RIGHT OF THE MARK, THE COLOR GREEN APPEARS IN THE INNER LINE OF THE RECTANGULAR PORTION OF THE PAGODA ROOF DESIGN, IN THE BACKGROUND OF THE RECTANGULAR STAMP DESIGN, IN THE BORDER SURROUNDING THE RECTANGULAR STAMP DESIGN, AND IN THE INTERIOR OF THE WORD "IMPORTED", THE COLOR GRAY APPEARS IN ALL OF THE ELEMENTS INSIDE THE RECTANGULAR STAMP DESIGN INCLUDING THE ELEPHANT, THE PAGODA, THE BORDER AROUND THE WORD "IMPORTED", IN THE WORD "ORIGINAL" AND THE ARCHES OF THE BANNER SURROUNDING THE WORD "ORIGINAL" AND IN THE WORD "PREMIUM", THE COLOR BROWN APPEARS IN THE INNER LINE OF THE TRIANGULAR PORTION OF THE PAGODA ROOF DESIGN, AND THE COLOR BLACK APPEARS IN THE BACKGROUND OF THE CENTER PORTION OF THE MARK.

THE MARK CONSISTS OF WORD "KITCHEN" IN SANS SERIF LETTERING, SURMOUNTED BY THE WORD "THAI" IN BRUSH STROKE LETTERING, SURMOUNTED BY A STYLIZED PAGODA ROOF DESIGN WITH HORIZONTAL LINES EXTENDING FROM EITHER SIDE OF THE ROOF DESIGN WHERE THIS WORDING AND THESE DESIGN ELEMENTS ARE CENTERED ON A BLACK BACKGROUND BORDERED ON THE LEFT AND RIGHT BY PANELS CONTAINING A STYLIZED VILLAGE SCENERY DESIGN, AND APPEARING AT THE UPPER LEFT EDGE OF THE BLACK CENTER PANEL IS A STYLIZED STAMP DESIGN INCORPORATING THE DESIGN OF AN ELEPHANT, A PAGODA, AND THE WORDS "ORIGINAL", "IMPORTED", AND "PREMIUM".

SEC. 2(F) AS TO "THAI KITCHEN".

#### CLASS 29—MEATS AND PROCESSED FOODS

FOR PROCESSED LEMONGRASS; SOUP MIXES; SOUPS (U.S. CL. 46).

FIRST USE 6-1-1993; IN COMMERCE 6-1-1993.

#### CLASS 30—STAPLE FOODS

FOR CURRY PASTES; ICED TEA; NOODLES; NOODLES AND SAUCE MIXES COMBINED IN UNITARY PACKAGES; NOODLES AND SEASONING MIXES COMBINED IN UNITARY PACKAGES; NOODLES, SEASONINGS, EDIBLE OIL, AND DEHYDRATED VEGETABLES COMBINED IN UNITARY PACKAGES; NOODLES, SEASONINGS, EDIBLE OIL, AND FLAVORINGS COMBINED IN UNITARY PACKAGES; RICE; RICE AND SEASONING MIX COMBINED IN UNITARY PACKAGES; RICE, SEASONINGS, AND FLAVORINGS COMBINED IN UNITARY PACKAGES; SAUCE MIXES; SAUCES; SEASONED COATING MIXTURES FOR FOODS; SEASONING PASTES; TEA (U.S. CL. 46).

FIRST USE 1-1-1991; IN COMMERCE 1-1-1991.

#### CLASS 32—LIGHT BEVERAGES

FOR COCONUT MILK (U.S. CLS. 45, 46 AND 48).

FIRST USE 1-1-1991; IN COMMERCE 1-1-1991.

CHARLOTTE CORWIN, EXAMINING ATTORNEY

SN 78-965,539. SUNSTONE CIRCUITS LLC, MULINO, OR.  
FILED 8-31-2006.

Q2D

THE MARK CONSISTS OF STANDARD CHARACTERS WITHOUT CLAIM TO ANY PARTICULAR FONT, STYLE, SIZE, OR COLOR.

#### CLASS 9—ELECTRICAL AND SCIENTIFIC APPARATUS

FOR COMPUTER SOFTWARE FOR USE IN THE DESIGN OF PRINTED CIRCUIT BOARDS; PRINTED CIRCUIT BOARDS (U.S. CLS. 21, 23, 26, 36 AND 38).

#### CLASS 40—MATERIAL TREATMENT

FOR MANUFACTURING SERVICES FOR OTHERS IN THE FIELD OF PRINTED CIRCUIT BOARDS (U.S. CLS. 100, 103 AND 106).

SHAILA SETTLES, EXAMINING ATTORNEY

SN 78-965,564. BLUE DIAMOND GROWERS, SACRAMENTO, CA. FILED 8-31-2006.



OWNER OF U.S. REG. NOS. 159,301, 873,150 AND OTHERS.

NO CLAIM IS MADE TO THE EXCLUSIVE RIGHT TO USE "NATURAL", APART FROM THE MARK AS SHOWN.

**CLASS 29—MEATS AND PROCESSED FOODS**

FOR NON-DAIRY, NUT-BASED FOOD BEVERAGE (U.S. CL. 46).  
FIRST USE 1-0-2005; IN COMMERCE 2-0-2005.

**CLASS 30—STAPLE FOODS**

FOR FLOUR-BASED WAFERS WITH ALMONDS OR OTHER NUTS AS AN INGREDIENT (U.S. CL. 46).  
FIRST USE 1-0-2005; IN COMMERCE 2-0-2005.  
JENNY PARK, EXAMINING ATTORNEY

SN 78-965,649. TRADEMARK MANAGEMENT COMPANY,  
MERIDIAN, ID. FILED 9-1-2006.



OWNER OF U.S. REG. NO. 2,679,357.

**CLASS 29—MEATS AND PROCESSED FOODS**

FOR APPETIZERS AND HORS D'OEUVRES CONSISTING OF MEATS, POULTRY, FISH, FRUITS, VEGETABLES, MUSHROOMS AND CHEESE (U.S. CL. 46).

**CLASS 30—STAPLE FOODS**

FOR APPETIZERS AND HORS D'OEUVRES CONSISTING OF PASTRY, BREAD AND DOUGH; BAKERY DESSERTS; DESSERT MOUSSE, PUDDINGS, AND SOUFFLES (U.S. CL. 46).  
FRANK LATTUCA, EXAMINING ATTORNEY

SN 78-965,714. GLASTRIS, CAROLYN, WINNETKA, IL.  
FILED 9-1-2006.

# SPORTURE

THE MARK CONSISTS OF STANDARD CHARACTERS WITHOUT CLAIM TO ANY PARTICULAR FONT, STYLE, SIZE, OR COLOR.

**CLASS 25—CLOTHING**

FOR CLOTHING AND SPORTSWEAR, NAMELY, TIGHTS, T-SHIRTS, SHIRTS, KNIT SHIRTS, JERSEYS, TANK TOPS, SINGLETS, SWEATERS, SHORTS, PANTS, SKIRTS, DRESSES, GYM SUITS, GYM SHORTS, GYMNASTIC SHOES, GYMNASTIC LEOTARDS, SPORTS JERSEYS, BREECHES FOR SPORTS, TRAINING SUITS, TENNIS WEAR, WARM-UP SUITS, SWEATSHIRTS, UNIFORMS, GLOVES, GOLF SKIRTS, GOLF SHORTS, GOLF PANTS, SKATING DRESSES, SKATING SKIRTS AND SKATING PANTS (U.S. CLS. 22 AND 39).

**CLASS 35—ADVERTISING AND BUSINESS**

FOR ONLINE ORDERING AND RETAIL STORE SERVICES FEATURING CLOTHING AND SPORTSWEAR, NAMELY, TIGHTS, T-SHIRTS, SHIRTS, KNIT SHIRTS, JERSEYS, TANK TOPS, SINGLETS, SWEATERS, SHORTS, PANTS, SKIRTS, DRESSES, GYM SUITS, GYM SHORTS, GYMNASTIC SHOES, GYMNASTIC LEOTARDS, SPORTS JERSEYS, BREECHES FOR SPORTS, TRAINING SUITS, TENNIS WEAR, WARM-UP SUITS, SWEATSHIRTS, UNIFORMS, GLOVES, GOLF SKIRTS, GOLF SHORTS, GOLF PANTS, SKATING DRESSES, SKATING SKIRTS AND SKATING PANTS (U.S. CLS. 100, 101 AND 102).  
KIMBERLY FRYE, EXAMINING ATTORNEY

SN 78-965,747. 1514890 ONTARIO INC., DBA GONGSHOW GEAR, PAKENHAM, ONTARIO, CANADA, FILED 9-1-2006.

# GONGSHOW

THE MARK CONSISTS OF STANDARD CHARACTERS WITHOUT CLAIM TO ANY PARTICULAR FONT, STYLE, SIZE, OR COLOR.

OWNER OF U.S. REG. NO. 3,101,236.

**CLASS 25—CLOTHING**

FOR CLOTHING, NAMELY HATS, SHIRTS, PANTS, SHOES AND JACKETS (U.S. CLS. 22 AND 39).

**CLASS 26—FANCY GOODS**

FOR BELT BUCKLES (U.S. CLS. 37, 39, 40, 42 AND 50).  
JOHN WILKE, EXAMINING ATTORNEY

SN 78-965,813. VIRTUAL HEROES, INC., CARY, NC. FILED 9-1-2006.

# HUMANSIM

THE MARK CONSISTS OF STANDARD CHARACTERS WITHOUT CLAIM TO ANY PARTICULAR FONT, STYLE, SIZE, OR COLOR.

**CLASS 9—ELECTRICAL AND SCIENTIFIC APPARATUS**

FOR COMPUTER GAME SOFTWARE; COMPUTER SOFTWARE FOR TRAINING AND EDUCATIONAL PURPOSES FOR USE IN THE HEALTHCARE, FIRST RESPONDER, AND MEDICAL FIELDS PROVIDED IN PACKAGED AND DOWNLOADABLE FORM, AND INSTRUCTIONAL MANUALS SOLD AS A UNIT (U.S. CLS. 21, 23, 26, 36 AND 38).

**CLASS 41—EDUCATION AND ENTERTAINMENT**

FOR ENTERTAINMENT SERVICES, NAMELY, PROVIDING ON-LINE COMPUTER GAMES (U.S. CLS. 100, 101 AND 107).

**CLASS 42—SCIENTIFIC, COMPUTER AND LEGAL SERVICES**

FOR COMPUTER SOFTWARE CONSULTATION; DESIGN, DEVELOPMENT AND IMPLEMENTATION OF SOFTWARE; MAINTENANCE OF COMPUTER SOFTWARE; PROVIDING ON-LINE NON-DOWNLOADABLE SOFTWARE FOR TRAINING AND EDUCATIONAL PURPOSES FOR USE IN THE HEALTHCARE, FIRST RESPONDER, AND MEDICAL FIELDS; TECHNICAL SUPPORT SERVICES, NAMELY, TROUBLESHOOTING OF COMPUTER HARDWARE AND SOFTWARE PROBLEMS (U.S. CLS. 100 AND 101).

SHAUNIA WALLACE, EXAMINING ATTORNEY

SN 78-965,952. NATIONAL BANNER COMPANY, INC., DALLAS, TX. FILED 9-1-2006.

**WORLD DIVISION USA**

THE MARK CONSISTS OF STANDARD CHARACTERS WITHOUT CLAIM TO ANY PARTICULAR FONT, STYLE, SIZE, OR COLOR.

OWNER OF U.S. REG. NO. 1,996,826.

NO CLAIM IS MADE TO THE EXCLUSIVE RIGHT TO USE "USA", APART FROM THE MARK AS SHOWN.

**CLASS 16—PAPER GOODS AND PRINTED MATTER**

FOR PRINTED PAPER SIGNS, DECALS, NOTE PAPER, PAPER KEY TAG, AND PAPER IDENTIFICATION TAGS (U.S. CLS. 2, 5, 22, 23, 29, 37, 38 AND 50).

FIRST USE 11-0-1994; IN COMMERCE 11-0-1994.

**CLASS 24—FABRICS**

FOR PENNANTS, FLAGS, BANNERS, BUNTING FOR DECORATIVE USE, AND WRAPPING FOR DECORATIVE USE ON POLES ALL OF WHICH ARE MADE FROM FABRIC OR TEXTILES (U.S. CLS. 42 AND 50).

FIRST USE 11-0-1994; IN COMMERCE 11-0-1994.

PATRICIA EVANKO, EXAMINING ATTORNEY

SN 78-966,000. BIG TEN CONFERENCE, INC., THE PARK RIDGE, IL. FILED 9-1-2006.

**Big Ten Network**

THE MARK CONSISTS OF STANDARD CHARACTERS WITHOUT CLAIM TO ANY PARTICULAR FONT, STYLE, SIZE, OR COLOR.

OWNER OF U.S. REG. NOS. 1,782,645 AND 1,969,353.

NO CLAIM IS MADE TO THE EXCLUSIVE RIGHT TO USE "NETWORK", APART FROM THE MARK AS SHOWN.

**CLASS 38—COMMUNICATION**

FOR TELEVISION TRANSMISSION SERVICES; STREAMING OF AUDIO AND VIDEO MATERIAL ON THE INTERNET (U.S. CLS. 100, 101 AND 104).

**CLASS 41—EDUCATION AND ENTERTAINMENT**

FOR ENTERTAINMENT SERVICES, NAMELY, PRODUCTION AND DISTRIBUTION OF TELEVISION PROGRAMS; PROVIDING ON-LINE INFORMATION IN THE FIELD OF SPORTS, TELEVISION, VIDEO AND AUDIO ENTERTAINMENT VIA A GLOBAL COMMUNICATIONS NETWORK; PRODUCTION AND DISTRIBUTION OF PROGRAMS FEATURING SPORTS, TELEVISION, VIDEO AND AUDIO ENTERTAINMENT TRANSMITTED VIA WIRELESS COMMUNICATION DEVICES, NAMELY CELL PHONES, PERSONAL DIGITAL ASSISTANTS, COMPUTERS, AND WIRELESS HANDHELDS; ENTERTAINMENT SERVICES, NAMELY, PROVIDING ON-LINE COMPUTER GAMES (U.S. CLS. 100, 101 AND 107).

BARBARA RUTLAND, EXAMINING ATTORNEY

SN 78-966,066. INTEGRA HEALTHCARE HOLDINGS, LTD., PLANO, TX. FILED 9-1-2006.

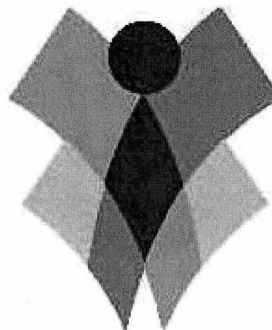
**CLASS 35—ADVERTISING AND BUSINESS**

FOR HOSPITAL MANAGEMENT (U.S. CLS. 100, 101 AND 102).

**CLASS 44—MEDICAL, BEAUTY AND AGRICULTURAL SERVICES**

FOR HOSPITALS AND HEALTH CARE SERVICES, NAMELY, IN-PATIENT AND OUT-PATIENT PHYSICAL REHABILITATION SERVICES, OUT-PATIENT SURGERY SERVICES AND OUT-PATIENT HEALTH CARE DIAGNOSTIC SERVICES (U.S. CLS. 100 AND 101).

ATTIYA MALIK, EXAMINING ATTORNEY

SN 78-966,133. SHADOWGLEN DEVELOPMENT CORPORATION, MANOR, TX. FILED 9-1-2006.

**SHADOWGLEN**

THE MARK CONSISTS OF STANDARD CHARACTERS WITHOUT CLAIM TO ANY PARTICULAR FONT, STYLE, SIZE, OR COLOR.

**CLASS 36—INSURANCE AND FINANCIAL**

FOR REAL ESTATE MANAGEMENT, REAL ESTATE AGENCIES, AND REAL ESTATE LEASING SERVICES (U.S. CLS. 100, 101 AND 102).

**CLASS 37—CONSTRUCTION AND REPAIR**

FOR REAL ESTATE DEVELOPMENT AND CONSTRUCTION SERVICES, NAMELY, PLANNING, LAYING OUT, AND CONSTRUCTION OF RESIDENTIAL HOMES, CONDOMINIUMS, APARTMENTS, HOTELS, COMMERCIAL BUILDINGS, CONFERENCE CENTERS, COUNTRY CLUBS AND RECREATIONAL FACILITIES (U.S. CLS. 100, 103 AND 106).  
FIRST USE 5-1-2001; IN COMMERCE 5-1-2001.

**CLASS 41—EDUCATION AND ENTERTAINMENT**

FOR COUNTRY CLUB SERVICES, NAMELY PROVIDING FACILITIES AND SERVICES FOR GOLF, TENNIS, SWIMMING, HEALTH CLUB, EXERCISE, SPA AND RECREATION; NIGHTCLUB (U.S. CLS. 100, 101 AND 107).  
FIRST USE 5-1-2001; IN COMMERCE 5-1-2001.

**CLASS 43—HOTEL AND RESTAURANT SERVICES**

FOR CONFERENCE CENTER, HOTEL AND LODGING SERVICES, RESTAURANT AND BAR SERVICES, CATERING SERVICES, AND PROVIDING ROOM FACILITIES FOR MEETINGS AND CONFERENCES (U.S. CLS. 100 AND 101).  
FIRST USE 5-1-2001; IN COMMERCE 5-1-2001.  
JOHN WILKE, EXAMINING ATTORNEY

**CLASS 30—STAPLE FOODS**

FOR COFFEE, BEVERAGES MADE OF COFFEE, COFFEE BEANS, COCOA AND COCOA-BASED BEVERAGES, TEA, BEVERAGES MADE OF TEA, HOT CHOCOLATE, CHOCOLATE AND CANDY, INCLUDING, CHOCOLATES, CHOCOLATE BARS, CHOCOLATE-COVERED COFFEE BEANS, CHOCOLATE TRUFFLES, CHOCOLATE-COVERED FRUITS, CHOCOLATE-COVERED NUTS, CHOCOLATE-COVERED DRIED FRUITS, CHOCOLATE-COVERED CRACKERS AND CHOCOLATE TOPPING, ESPRESSO, BAKERY PRODUCTS, INCLUDING MUFFINS, SCONES, BISCUITS, COOKIES, PASTRIES AND BREADS (U.S. CL. 46).

**CLASS 43—HOTEL AND RESTAURANT SERVICES**

FOR RESTAURANT, CAFE, AND COFFEE BAR SERVICES; COFFEE SHOPS (U.S. CLS. 100 AND 101).  
KATHERINE CONNOLLY, EXAMINING ATTORNEY

SN 78-966,153. IGT, RENO, NV. FILED 9-1-2006.



SN 78-966,151. REV-GEN, INC., CHICAGO, IL. FILED 9-1-2006.

**BLACK AQUA**

THE MARK CONSISTS OF STANDARD CHARACTERS WITHOUT CLAIM TO ANY PARTICULAR FONT, STYLE, SIZE, OR COLOR.

**CLASS 21—HOUSEWARES AND GLASS**

FOR MUGS, DRINKING GLASSES, THERMAL INSULATED CONTAINERS FOR FOOD OR BEVERAGE, SHOT GLASSES (U.S. CLS. 2, 13, 23, 29, 30, 33, 40 AND 50).

**CLASS 25—CLOTHING**

FOR CLOTHING, NAMELY, HATS, T-SHIRTS, SWEATSHIRTS AND JACKETS (U.S. CLS. 22 AND 39).

OWNER OF U.S. REG. NOS. 2,671,121, 2,931,137 AND OTHERS.  
NO CLAIM IS MADE TO THE EXCLUSIVE RIGHT TO USE "PAY", APART FROM THE MARK AS SHOWN.

**CLASS 9—ELECTRICAL AND SCIENTIFIC APPARATUS**

FOR ELECTRONIC HARDWARE AND COMPUTER SOFTWARE USED FOR PRINTING, READING AND ACCEPTING TICKETS, COUPONS, VOUCHERS, AND OTHER PRINTED FORMATS OF BILL VALIDATION IN CONNECTION WITH GAMING (U.S. CLS. 21, 23, 26, 36 AND 38).  
FIRST USE 7-11-2000; IN COMMERCE 7-11-2000.

**CLASS 16—PAPER GOODS AND PRINTED MATTER**

FOR PRINTED PAPER TICKETS AND VOUCHERS USED FOR BILL VALIDATION IN CONNECTION WITH GAMING (U.S. CLS. 2, 5, 22, 23, 29, 37, 38 AND 50).  
FIRST USE 7-11-2000; IN COMMERCE 7-11-2000.  
ELIZABETH J. WINTER, EXAMINING ATTORNEY

SN 78-966,169. OFF THE GRILL FRANCHISING, LLC,  
FRANKLIN, TN. FILED 9-1-2006.

SN 78-966,314. GLASTRIS, CAROLYN, WINNETKA, IL.  
FILED 9-1-2006.

## OFF THE GRILL NOW THAT'S DELIVERY!

THE MARK CONSISTS OF STANDARD CHARACTERS  
WITHOUT CLAIM TO ANY PARTICULAR FONT, STYLE,  
SIZE, OR COLOR.

OWNER OF U.S. REG. NOS. 2,388,407 AND 2,488,961.

### CLASS 35—ADVERTISING AND BUSINESS

FOR RESTAURANT FRANCHISING (U.S. CLS. 100,  
101 AND 102).

FIRST USE 6-16-2006; IN COMMERCE 6-16-2006.

### CLASS 39—TRANSPORTATION AND STORAGE

FOR DELIVERY OF FOOD BY RESTAURANTS (U.S.  
CLS. 100 AND 105).

FIRST USE 6-16-2006; IN COMMERCE 6-16-2006.

### CLASS 43—HOTEL AND RESTAURANT SERVICES

FOR RESTAURANT SERVICES (U.S. CLS. 100 AND  
101).

FIRST USE 6-16-2006; IN COMMERCE 6-16-2006.  
INGA ERVIN, EXAMINING ATTORNEY

SN 78-966,294. ALLERGAN, INC., IRVINE, CA. FILED 9-1-  
2006.

## ALLERGAN ACADEMY

THE MARK CONSISTS OF STANDARD CHARACTERS  
WITHOUT CLAIM TO ANY PARTICULAR FONT, STYLE,  
SIZE, OR COLOR.

OWNER OF U.S. REG. NOS. 1,711,041, 2,147,765 AND  
OTHERS.

NO CLAIM IS MADE TO THE EXCLUSIVE RIGHT TO  
USE "ACADEMY", APART FROM THE MARK AS SHOWN.

### CLASS 38—COMMUNICATION

FOR PROVIDING ONLINE DISCUSSION FORUMS  
FOR THE TRANSMISSION OF MESSAGES BY COMPU-  
TER USERS IN THE FIELD OF BREAST AUGMENTA-  
TION, FACIAL AESTHETICS AND IMPLANTS,  
MEDICAL DEVICES AND GENERAL COSMETIC SUR-  
GERY (U.S. CLS. 100, 101 AND 104).

### CLASS 41—EDUCATION AND ENTERTAINMENT

FOR EDUCATIONAL SERVICES, NAMELY CON-  
DUCTING CLASSES, WORKSHOPS AND TRAINING  
SEMINARS IN THE FIELDS OF BREAST AUGMENTA-  
TION, FACIAL AESTHETICS AND IMPLANTS, MEDI-  
CAL DEVICES AND GENERAL COSMETIC SURGERY  
(U.S. CLS. 100, 101 AND 107).

LINDA ESTRADA, EXAMINING ATTORNEY

## MYSPOURTURE

THE MARK CONSISTS OF STANDARD CHARACTERS  
WITHOUT CLAIM TO ANY PARTICULAR FONT, STYLE,  
SIZE, OR COLOR.

### CLASS 25—CLOTHING

FOR CLOTHING AND SPORTSWEAR, NAMELY,  
TIGHTS, T-SHIRTS, SHIRTS, KNIT SHIRTS, JERSEYS,  
TANK TOPS, SINGLET, SWEATERS, SHORTS, PANTS,  
SKIRTS, DRESSES, GYM SUITS, GYM SHORTS, GYM-  
NASTIC SHOES, GYMNASTIC LEOTARDS, SPORTS  
JERSEYS, BREECHES FOR SPORTS, TRAINING SUITS,  
TENNIS WEAR, WARM-UP SUITS, SWEATSHIRTS, UNI-  
FORMS, GLOVES, GOLF SKIRTS, GOLF SHORTS, GOLF  
PANTS, SKATING DRESSES, SKATING SKIRTS AND  
SKATING PANTS (U.S. CLS. 22 AND 39).

### CLASS 35—ADVERTISING AND BUSINESS

FOR ONLINE ORDERING AND RETAIL STORE  
SERVICES FEATURING CLOTHING AND SPORTS-  
WEAR, NAMELY, TIGHTS, T-SHIRTS, SHIRTS, KNIT  
SHIRTS, JERSEYS, TANK TOPS, SINGLET, SWEATERS,  
SHORTS, PANTS, SKIRTS, DRESSES, GYM SUITS, GYM  
SHORTS, GYMNASTIC SHOES, GYMNASTIC LEO-  
TARDS, SPORTS JERSEYS, BREECHES FOR SPORTS,  
TRAINING SUITS, TENNIS WEAR, WARM-UP SUITS,  
SWEATSHIRTS, UNIFORMS, GLOVES, GOLF SKIRTS,  
GOLF SHORTS, GOLF PANTS, SKATING DRESSES,  
SKATING SKIRTS AND SKATING PANTS (U.S. CLS.  
100, 101 AND 102).

KIMBERLY FRYE, EXAMINING ATTORNEY

SN 78-966,577. STONEBRAKER, JASON A, ORLANDO, FL.  
FILED 9-2-2006.

## slamspace

THE MARK CONSISTS OF STANDARD CHARACTERS  
WITHOUT CLAIM TO ANY PARTICULAR FONT, STYLE,  
SIZE, OR COLOR.

### CLASS 38—COMMUNICATION

FOR INSTANT MESSAGING SERVICES; PROVIDING  
ON-LINE CHAT ROOMS AND ELECTRONIC BULLETIN  
BOARDS FOR TRANSMISSION OF MESSAGES AMONG  
USERS IN THE FIELD OF GENERAL INTEREST (U.S.  
CLS. 100, 101 AND 104).

**CLASS 42—SCIENTIFIC, COMPUTER AND LEGAL SERVICES**

FOR COMPUTER SERVICES IN THE NATURE OF CUSTOMIZED WEB PAGES FEATURING USER-DEFINED INFORMATION, PERSONAL PROFILES AND INFORMATION; PROVIDING CUSTOMIZED ON-LINE WEB PAGES FEATURING USER-DEFINED INFORMATION, WHICH INCLUDES SEARCH ENGINES AND ON-LINE WEB LINKS TO OTHER WEB SITES (U.S. CLS. 100 AND 101).

KENNETH E. SHARPERSON, EXAMINING ATTORNEY

SN 78-966,711. BILLNAT, INC., SYOSSET, NY. FILED 9-4-2006.

**ANNA BELLA KIDS**

THE MARK CONSISTS OF STANDARD CHARACTERS WITHOUT CLAIM TO ANY PARTICULAR FONT, STYLE, SIZE, OR COLOR.

NO CLAIM IS MADE TO THE EXCLUSIVE RIGHT TO USE "KIDS", APART FROM THE MARK AS SHOWN.

**CLASS 20—FURNITURE AND ARTICLES NOT OTHERWISE CLASSIFIED**

FOR FURNITURE, NAMELY, BEDSIDE TABLES, BLANKET CHESTS, CRIBS, CHANGING TABLES, CRADLES AND BASSINETS, BEDROOM FURNITURE, CABINETS, DRESSERS, TABLES, CHAIRS, ROCKING CHAIRS, BOOKSHELVES, BEDS, BED FRAMES, HEADBOARDS, NIGHT STANDS, STORAGE BENCH, STEP STOOLS, TABLE AND CHAIR SETS, BOOKCASES, DESKS, NON-METAL HOOKS, DRAWER KNOBS OF WOOD AND PLASTIC, PAPER PHOTO FRAMES, PICTURE FRAMES, PILLOWS, SLEEPING BAGS (U.S. CLS. 2, 13, 22, 25, 32 AND 50).

**CLASS 24—FABRICS**

FOR BED BLANKETS, BED CANOPIES, BED LINEN, PILLOW CASES, BED PADS, BED SHEETS, BED SPREADS, LINENS, QUILTS, CRIB LINENS, CRIB BUMPERS, CRIB CANOPIES, BLANKET TROWS, BLANKETS, LAP RUGS, CURTAINS, CURTAIN FABRIC (U.S. CLS. 42 AND 50).

MORGAN WYNNE, EXAMINING ATTORNEY

SN 78-966,916. THEODOSIOU, BARBARA, DAVIE, FL. FILED 9-5-2006.

**MOMMY MENTORS**

THE MARK CONSISTS OF STANDARD CHARACTERS WITHOUT CLAIM TO ANY PARTICULAR FONT, STYLE, SIZE, OR COLOR.

**CLASS 9—ELECTRICAL AND SCIENTIFIC APPARATUS**

FOR MULTIMEDIA, NAMELY VIDEO TAPES, AUDIO TAPES, DVDS, CDS, AND CD-ROMS, FEATURING INFORMATION RELATING TO WOMEN'S ISSUES (U.S. CLS. 21, 23, 26, 36 AND 38).

FIRST USE 9-20-2006; IN COMMERCE 9-20-2006.

**CLASS 16—PAPER GOODS AND PRINTED MATTER**

FOR LITERATURE PRODUCTS, NAMELY BOOKS AND MAGAZINES, FEATURING INFORMATION RELATING TO WOMEN'S ISSUES (U.S. CLS. 2, 5, 22, 23, 29, 37, 38 AND 50).

FIRST USE 9-20-2006; IN COMMERCE 9-20-2006.

CHRIS WELLS, EXAMINING ATTORNEY

SN 78-966,918. VIGOSS TEKSTIL KONFEKSIYON SANAYI VE TICARET LIMITED SIRKETI, 50 ISTANBUL, TURKEY, FILED 9-5-2006.

**TESSONA**

THE MARK CONSISTS OF STANDARD CHARACTERS WITHOUT CLAIM TO ANY PARTICULAR FONT, STYLE, SIZE, OR COLOR.

**CLASS 3—COSMETICS AND CLEANING PREPARATIONS**

FOR PERFUMES, DEODORANTS FOR PERSONAL USE (U.S. CLS. 1, 4, 6, 50, 51 AND 52).

**CLASS 14—JEWELRY**

FOR JEWELRY, NAMELY BRACELETS, RINGS, EARRINGS, NECKLACES; WATCHES (U.S. CLS. 2, 27, 28 AND 50).

**CLASS 18—LEATHER GOODS**

FOR BAGS, NAMELY HANDBAGS, BACKPACKS, SCHOOL BAGS, TRAVEL BAGS, SPORT BAGS, SUITCASES, WALLETS, LEATHER CASES FOR KEYS (U.S. CLS. 1, 2, 3, 22 AND 41).

**CLASS 25—CLOTHING**

FOR CLOTHING, NAMELY TROUSERS, SHIRTS, SKIRTS, T-SHIRTS, SWEATERS, JACKETS, COATS, DRESSES, OVERCOATS, BIKINIS, SWIMSUITS, SHORTS, VESTS; FOOT WEAR, NAMELY SHOES, BOOTS, SLIPPERS; HEADGEAR, NAMELY, HATS, BERETS, CAPS; BELTS (U.S. CLS. 22 AND 39).

**CLASS 35—ADVERTISING AND BUSINESS**

FOR RETAIL CLOTHING STORES FOR CLOTHING, FOOTWEAR AND HEADGEAR (U.S. CLS. 100, 101 AND 102).

JOHN E. MICHOS, EXAMINING ATTORNEY

SN 78-966,937. TALUS CORP, PORTLAND, ME. FILED 9-5-2006.

SN 78-966,971. BIRCH DESIGN STUDIO, LTD., CHICAGO, IL. FILED 9-5-2006.

# SMOOTH TRIP

THE MARK CONSISTS OF STANDARD CHARACTERS WITHOUT CLAIM TO ANY PARTICULAR FONT, STYLE, SIZE, OR COLOR.

## CLASS 6—METAL GOODS

FOR METAL LOCKS (U.S. CLS. 2, 12, 13, 14, 23, 25 AND 50).

## CLASS 9—ELECTRICAL AND SCIENTIFIC APPARATUS

FOR ADAPTER PLUGS; CURRENT CONVERTERS; EAR PLUGS FOR SLEEPING; ELECTRONIC CURRENT CONVERTERS (U.S. CLS. 21, 23, 26, 36 AND 38).

## CLASS 18—LEATHER GOODS

FOR LUGGAGE TAGS; SHOE BAGS FOR TRAVEL; STRAPS FOR LUGGAGE (U.S. CLS. 1, 2, 3, 22 AND 41).

## CLASS 20—FURNITURE AND ARTICLES NOT OTHERWISE CLASSIFIED

FOR DISPENSERS FOR PILLS OR CAPSULES SOLD EMPTY; INFLATABLE PILLOWS (U.S. CLS. 2, 13, 22, 25, 32 AND 50).

## CLASS 25—CLOTHING

FOR MONEY BELTS; WRIST BANDS (U.S. CLS. 22 AND 39).  
EMILY CARLSEN, EXAMINING ATTORNEY

SN 78-966,968. MASON PUBLISHING, LLC, RIVERSIDE, CA. FILED 9-5-2006.

# MASON

THE MARK CONSISTS OF STANDARD CHARACTERS WITHOUT CLAIM TO ANY PARTICULAR FONT, STYLE, SIZE, OR COLOR.

## CLASS 16—PAPER GOODS AND PRINTED MATTER

FOR GENERAL FEATURE MAGAZINES (U.S. CLS. 2, 5, 22, 23, 29, 37, 38 AND 50).

## CLASS 41—EDUCATION AND ENTERTAINMENT

FOR MAGAZINE PUBLISHING (U.S. CLS. 100, 101 AND 107).  
MICHAEL WEBSTER, EXAMINING ATTORNEY

# BIRCH DESIGN STUDIO

THE MARK CONSISTS OF STANDARD CHARACTERS WITHOUT CLAIM TO ANY PARTICULAR FONT, STYLE, SIZE, OR COLOR.

NO CLAIM IS MADE TO THE EXCLUSIVE RIGHT TO USE DESIGN STUDIO, APART FROM THE MARK AS SHOWN.

## CLASS 41—EDUCATION AND ENTERTAINMENT

FOR SPECIAL EVENT PLANNING AND CONSULTATION (U.S. CLS. 100, 101 AND 107).  
FIRST USE 10-0-2002; IN COMMERCE 10-0-2002.

## CLASS 42—SCIENTIFIC, COMPUTER AND LEGAL SERVICES

FOR DESIGN OF INTERIOR DECOR OF VENUES AND SITES FOR EVENTS (U.S. CLS. 100 AND 101).  
FIRST USE 10-0-2002; IN COMMERCE 10-0-2002.  
MICHAEL WEBSTER, EXAMINING ATTORNEY

SN 78-966,998. NUHERBS, INC., OAKLAND, CA. FILED 9-5-2006.

# NUTRADITION

THE MARK CONSISTS OF STANDARD CHARACTERS WITHOUT CLAIM TO ANY PARTICULAR FONT, STYLE, SIZE, OR COLOR.

## CLASS 5—PHARMACEUTICALS

FOR FOOD SUPPLEMENTS; HERBAL SUPPLEMENTS (U.S. CLS. 6, 18, 44, 46, 51 AND 52).

## CLASS 30—STAPLE FOODS

FOR HERB TEA; HERBAL FOOD BEVERAGES (U.S. CL. 46).  
JAMES A. RAUEN, EXAMINING ATTORNEY



SN 78-967,070. WOODFOLD-MARCO MFG., INC., FOREST GROVE, OR. FILED 9-5-2006.

SN 78-967,331. WHERE TO DINE IN, LLC, BELLEROSE, NY. FILED 9-5-2006.

## doors that work

THE MARK CONSISTS OF STANDARD CHARACTERS WITHOUT CLAIM TO ANY PARTICULAR FONT, STYLE, SIZE, OR COLOR.

NO CLAIM IS MADE TO THE EXCLUSIVE RIGHT TO USE "DOORS", APART FROM THE MARK AS SHOWN.

### CLASS 6—METAL GOODS

FOR METAL DOORS (U.S. CLS. 2, 12, 13, 14, 23, 25 AND 50).

### CLASS 19—NON-METALLIC BUILDING MATERIALS

FOR NON-METAL DOORS (U.S. CLS. 1, 12, 33 AND 50).

KATHERINE M. DUBRAY, EXAMINING ATTORNEY

SN 78-967,190. TENNESSEE FOOTBALL, INC., KNOXVILLE, TN. FILED 9-5-2006.

## TENNESSEE TITANS

THE MARK CONSISTS OF STANDARD CHARACTERS WITHOUT CLAIM TO ANY PARTICULAR FONT, STYLE, SIZE, OR COLOR.

OWNER OF U.S. REG. NOS. 2,439,028, 2,493,049 AND OTHERS.

NO CLAIM IS MADE TO THE EXCLUSIVE RIGHT TO USE "TENNESSEE", APART FROM THE MARK AS SHOWN.

### CLASS 9—ELECTRICAL AND SCIENTIFIC APPARATUS

FOR FOOTBALL HELMETS, MAGNETIC CODED CHARGE CARDS, DECORATIVE MAGNETS, AUDIO TAPES AND CD'S, PRE-RECORDED VIDEOTAPES AND DVD'S FEATURING THE SPORT OF FOOTBALL, COMPUTER GAME SOFTWARE AND DISKS, MOUSE PADS AND VIDEO GAME CARTRIDGES (U.S. CLS. 21, 23, 26, 36 AND 38).

FIRST USE 9-0-1999; IN COMMERCE 9-0-1999.

### CLASS 14—JEWELRY

FOR JEWELRY, WATCHES, CLOCKS, PINS, EARRINGS, NECKLACES, CHARMS, COLLECTIBLE COINS, COINS OF PRECIOUS METAL, PENDANTS AND KEY CHAINS MADE OF PRECIOUS METAL (U.S. CLS. 2, 27, 28 AND 50).

FIRST USE 9-0-1999; IN COMMERCE 9-0-1999.  
KAPIL BHANOT, EXAMINING ATTORNEY



NO CLAIM IS MADE TO THE EXCLUSIVE RIGHT TO USE "RESERVATIONS" AND "RESERVE YOUR TABLE", APART FROM THE MARK AS SHOWN.

THE COLOR(S) RED, BLUE AND BLACK IS/ARE CLAIMED AS A FEATURE OF THE MARK.

THE MARK CONSISTS OF THE STYLIZED WORDS "RESERVATIONS ACCEPTED" IN LIGHT BLUE SCRIPT AND "RESERVE YOUR TABLE" IN BLUE LETTERING. THE WORDS ARE PLACED ON A RED SQUARE WITH A BLACK FRAME WHICH IS ROTATED BY 90 DEGREES.

### CLASS 9—ELECTRICAL AND SCIENTIFIC APPARATUS

FOR COMPUTER SOFTWARE FOR THE CUSTOM AUTOMATION OF THE RESTAURANT INDUSTRY, NAMELY, FOR TAKING FOOD ORDERS AND MAKING RESTAURANT RESERVATIONS (U.S. CLS. 21, 23, 26, 36 AND 38).

### CLASS 43—HOTEL AND RESTAURANT SERVICES

FOR PROVIDING RESERVATION SERVICES FOR RESTAURANTS, PROVIDING ON-LINE RESERVATION SERVICES FOR RESTAURANTS OVER THE INTERNET; MAKING RESERVATIONS AND BOOKINGS FOR RESTAURANTS FOR OTHERS, MAKING RESERVATIONS AND BOOKINGS FOR RESTAURANTS FOR OTHERS OVER THE INTERNET; ONLINE REVIEWS OF RESTAURANTS (U.S. CLS. 100 AND 101).

LINDA E. BLOHM, EXAMINING ATTORNEY

SN 78-967,379. BUY THE FARM, LLC, SAVANNAH, GA. FILED 9-5-2006.



NO CLAIM IS MADE TO THE EXCLUSIVE RIGHT TO USE TV, APART FROM THE MARK AS SHOWN.

THE MARK CONSISTS OF A BARN WITH THE LETTERS "TV" ON ONE FACE OF THE BARN.

**CLASS 35—ADVERTISING AND BUSINESS**

FOR PROVIDING A WEB SITE WHICH FEATURES ADVERTISEMENTS FOR THE GOODS AND SERVICES OF OTHERS ON A GLOBAL COMPUTER NETWORK (U.S. CLS. 100, 101 AND 102).

FIRST USE 2-8-2006; IN COMMERCE 2-8-2006.

**CLASS 41—EDUCATION AND ENTERTAINMENT**

FOR ENTERTAINMENT IN THE NATURE OF ONGOING TELEVISION PROGRAMS IN THE FIELD OF VARIETY (U.S. CLS. 100, 101 AND 107).

FIRST USE 2-8-2006; IN COMMERCE 2-8-2006.  
SOPHIA S. KIM, EXAMINING ATTORNEY

**CLASS 37—CONSTRUCTION AND REPAIR**

FOR BUILDING DEMOLITION (U.S. CLS. 100, 103 AND 106).

**CLASS 40—MATERIAL TREATMENT**

FOR DEMOLITION SERVICES (U.S. CLS. 100, 103 AND 106).

**CLASS 41—EDUCATION AND ENTERTAINMENT**

FOR ARRANGING OF EXHIBITIONS, SEMINARS AND CONFERENCES; ARRANGING OF SEMINARS; ARRANGING OF SEMINARS AND CONFERENCES; EDUCATIONAL SERVICES, NAMELY, CONDUCTING SEMINARS IN THE FIELD OF IMPLOSION, CONVENTIONAL DEMOLITION AND GENERAL CONTRACTING AND DISTRIBUTION OF COURSE MATERIAL IN CONNECTION THEREWITH; EDUCATIONAL SERVICES, NAMELY, CONDUCTING SEMINARS IN THE FIELD OF IMPLOSION, CONVENTIONAL DEMOLITION AND GENERAL CONTRACTING; MEETING AND SEMINAR ARRANGING (U.S. CLS. 100, 101 AND 107).

RICHARD A. STRASER, EXAMINING ATTORNEY

SN 78-967,532. CHONG, ANNA J., COEUR D'ALENE, ID.  
FILED 9-5-2006.

# Big Blast!

THE MARK CONSISTS OF STANDARD CHARACTERS WITHOUT CLAIM TO ANY PARTICULAR FONT, STYLE, SIZE, OR COLOR.

**CLASS 37—CONSTRUCTION AND REPAIR**

FOR BUILDING DEMOLITION (U.S. CLS. 100, 103 AND 106).

**CLASS 40—MATERIAL TREATMENT**

FOR DEMOLITION SERVICES (U.S. CLS. 100, 103 AND 106).

**CLASS 41—EDUCATION AND ENTERTAINMENT**

FOR ARRANGING OF EXHIBITIONS, SEMINARS AND CONFERENCES; ARRANGING OF SEMINARS; ARRANGING OF SEMINARS AND CONFERENCES; EDUCATIONAL SERVICES, NAMELY, CONDUCTING SEMINARS IN THE FIELD OF IMPLOSION, CONVENTIONAL DEMOLITION AND GENERAL CONTRACTING AND DISTRIBUTION OF COURSE MATERIAL IN CONNECTION THEREWITH; EDUCATIONAL SERVICES, NAMELY, CONDUCTING SEMINARS IN THE FIELD OF IMPLOSION, CONVENTIONAL DEMOLITION AND GENERAL CONTRACTING; MEETING AND SEMINAR ARRANGING (U.S. CLS. 100, 101 AND 107).

RICHARD A. STRASER, EXAMINING ATTORNEY

SN 78-967,539. CHONG, ANNA J., COEUR D'ALENE, ID.  
FILED 9-5-2006.

# Big Blast

THE MARK CONSISTS OF STANDARD CHARACTERS WITHOUT CLAIM TO ANY PARTICULAR FONT, STYLE, SIZE, OR COLOR.

SN 78-967,713. JENNIFER MILLER, LTD., NEW YORK, NY.  
FILED 9-6-2006.

# JENNIFER MILLER

THE MARK CONSISTS OF STANDARD CHARACTERS WITHOUT CLAIM TO ANY PARTICULAR FONT, STYLE, SIZE, OR COLOR.

THE NAME(S), PORTRAIT(S), AND/OR SIGNATURE(S) SHOWN IN THE MARK IDENTIFIES JENNIFER MILLER, WHOSE CONSENT(S) TO REGISTER IS SUBMITTED.

**CLASS 14—JEWELRY**

FOR JEWELRY (U.S. CLS. 2, 27, 28 AND 50).  
FIRST USE 1-30-1991; IN COMMERCE 1-30-1991.

**CLASS 35—ADVERTISING AND BUSINESS**

FOR RETAIL STORES FEATURING JEWELRY, CLOTHING, FASHION ACCESSORIES, SHOES, SANDALS, HANDBAGS, HOME DECOR AND GIFTS; RETAIL JEWELRY STORES; RETAIL STORE SERVICES FEATURING A WIDE VARIETY OF CONSUMER GOODS OF OTHERS; ON-LINE RETAIL STORE SERVICES FEATURING JEWELRY (U.S. CLS. 100, 101 AND 102).

FIRST USE 1-30-1991; IN COMMERCE 6-30-1991.  
ADA HAN, EXAMINING ATTORNEY

SN 78-967,817. ALLEN, KATHY O., SIOUX FALLS, SD. FILED 9-6-2006.

# gloss

THE MARK CONSISTS OF STANDARD CHARACTERS WITHOUT CLAIM TO ANY PARTICULAR FONT, STYLE, SIZE, OR COLOR.

## CLASS 41—EDUCATION AND ENTERTAINMENT

FOR CASINOS; CONDUCTING AND PROVIDING FACILITIES FOR SPECIAL EVENTS FEATURING CASINO AND GAMING CONTESTS AND TOURNAMENTS; ENTERTAINMENT SERVICES NAMELY, CONDUCTING LIVE BLACKJACK CARD GAME TOURNAMENTS; ENTERTAINMENT SERVICES, NAMELY, PROVIDING A TELEVISION PROGRAM IN THE FIELD OF GAMBLING VIA A GLOBAL COMPUTER NETWORK; ENTERTAINMENT SERVICES, NAMELY, PROVIDING AN ON-LINE COMPUTER GAME; ENTERTAINMENT SERVICES, NAMELY, PROVIDING ON-LINE COMPUTER GAMES; GAMBLING SERVICES; LEASING OF CASINO GAMES; MULTIMEDIA ENTERTAINMENT SOFTWARE PRODUCTION SERVICES; PROVIDING CASINO FACILITIES; RADIO ENTERTAINMENT PRODUCTION (U.S. CLS. 100, 101 AND 107).

## CLASS 43—HOTEL AND RESTAURANT SERVICES

FOR CAFE-RESTAURANTS; CARRY-OUT RESTAURANTS; DELICATESSENS; FAST FOOD AND NON-STOP RESTAURANT SERVICES; FAST-FOOD RESTAURANTS; FAST-FOOD RESTAURANTS AND SNACK-BARS; HOTEL SERVICES; HOTEL SERVICES FOR PREFERRED CUSTOMERS; HOTEL, BAR AND RESTAURANT SERVICES; HOTELS; MAKING HOTEL RESERVATIONS FOR OTHERS; PROVIDING ON-LINE REVIEWS OF RESTAURANTS AND HOTELS; RESERVATION OF HOTEL ROOMS FOR TRAVELERS; RESERVATION OF HOTEL ROOMS FOR TRAVELLERS; RESERVATION OF RESTAURANTS; RESORT HOTELS; RESTAURANT AND BAR SERVICES; RESTAURANT SERVICES; RESTAURANTS (U.S. CLS. 100 AND 101).  
MICHAEL TANNER, EXAMINING ATTORNEY

SN 78-967,872. BRYAN CAVE LLP, ST. LOUIS, MO. FILED 9-6-2006.

# IP ZONE

THE MARK CONSISTS OF STANDARD CHARACTERS WITHOUT CLAIM TO ANY PARTICULAR FONT, STYLE, SIZE, OR COLOR.  
NO CLAIM IS MADE TO THE EXCLUSIVE RIGHT TO USE "IP", APART FROM THE MARK AS SHOWN.

## CLASS 41—EDUCATION AND ENTERTAINMENT

FOR PROVIDING INTERACTIVE ONLINE CLASSES AND TRAINING REGARDING INTELLECTUAL PROPERTY, LEGAL RESEARCH, LEGAL RESOURCES AND LEGAL SERVICES; PROVIDING ONLINE INFORMATION IN THE FIELD OF INTELLECTUAL PROPERTY TRAINING (U.S. CLS. 100, 101 AND 107).

## CLASS 45—PERSONAL SERVICES

FOR INTELLECTUAL PROPERTY CONSULTATION PROVIDED ONLINE, NAMELY, PROVIDING ANALYTICAL PROCESSES, METHODS, DECISION TREES AND INFORMATION IN THE FIELDS OF LEGAL DECISION MAKING (U.S. CLS. 100 AND 101).  
JESSICA A. POWERS, EXAMINING ATTORNEY

SN 78-967,894. KOBERT & COMPANY, INC., COMMERCE, CA. FILED 9-6-2006.

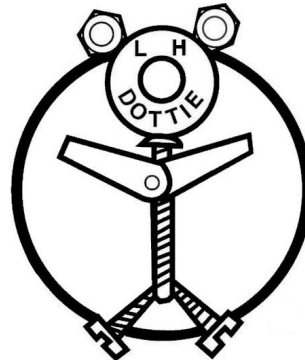

OWNER OF U.S. REG. NO. 3,164,759.  
THE NAME "L.H. DOTTIE" DOES NOT IDENTIFY A LIVING INDIVIDUAL.

## CLASS 6—METAL GOODS

FOR METAL HARDWARE, NAMELY NUTS, BOLTS, SCREWS, ANCHORS, BUSHINGS, CHAINS, FASTENER CLAMPS, TUBES, TUBE NIPPLES AND CAPS, SLEEVES, TUBE COUPLINGS AND ELLS, DRIVE PINS, HANGERS, HOOKS, PLATES, RODS, STAPLES, WASHERS, AND NON-ELECTRICAL WIRE (U.S. CLS. 2, 12, 13, 14, 23, 25 AND 50).  
FIRST USE 3-1-1968; IN COMMERCE 3-1-1968.

## CLASS 17—RUBBER GOODS

FOR ADHESIVE TAPES FOR INDUSTRIAL AND COMMERCIAL USE, NAMELY, DUCT TAPE, ELECTRICAL PVC TAPE, FRICTION TAPE, MASKING TAPE, PIPE WRAP TAPE, PLUMBERS TAPE, AND RUBBER TAPE (U.S. CLS. 1, 5, 12, 13, 35 AND 50).  
FIRST USE 3-1-1968; IN COMMERCE 3-1-1968.  
RAUL CORDOVA, EXAMINING ATTORNEY

SN 78-967,904. FEDERACION NACIONAL DE CAFETEROS DE COLOMBIA, AKA NATIONAL FEDERATION OF COFFEE GROWERS OF COLOMBIA, BOGOTA, COLOMBIA, FILED 9-6-2006.

## CAFECOOL

THE MARK CONSISTS OF STANDARD CHARACTERS WITHOUT CLAIM TO ANY PARTICULAR FONT, STYLE, SIZE, OR COLOR.

### CLASS 30—STAPLE FOODS

FOR COFFEE BASED BEVERAGES; BEVERAGES MADE OF COFFEE (U.S. CL. 46).

### CLASS 32—LIGHT BEVERAGES

FOR NON-ALCOHOLIC BEVERAGES, NAMELY CAFFEINATED SOFT DRINKS, CAFFEINATED SODAS, ENERGY DRINKS CONTAINING COFFEE AND FRUIT JUICE (U.S. CLS. 45, 46 AND 48).  
BRIDGETT SMITH, EXAMINING ATTORNEY

SN 78-967,921. TWO JUPITERS, INC., TACOMA, WA. FILED 9-6-2006.

## eetahp

THE MARK CONSISTS OF STANDARD CHARACTERS WITHOUT CLAIM TO ANY PARTICULAR FONT, STYLE, SIZE, OR COLOR.

### CLASS 18—LEATHER GOODS

FOR WALLETS, HANDBAGS, AND ALL-PURPOSE CARRYING BAGS (U.S. CLS. 1, 2, 3, 22 AND 41).  
FIRST USE 1-11-2006; IN COMMERCE 1-11-2006.

### CLASS 25—CLOTHING

FOR CLOTHING ITEMS, NAMELY, SHIRTS, HATS, JACKETS, PANTS, SHORTS, SWEATSHIRTS, AND SCARVES (U.S. CLS. 22 AND 39).  
FIRST USE 1-11-2006; IN COMMERCE 1-11-2006.  
EVELYN BRADLEY, EXAMINING ATTORNEY

SN 78-968,010. MASSUCCI, FRANCIS M, FARMINGTON, CT. FILED 9-6-2006.

## Therapy Go!

THE MARK CONSISTS OF STANDARD CHARACTERS WITHOUT CLAIM TO ANY PARTICULAR FONT, STYLE, SIZE, OR COLOR.

### CLASS 41—EDUCATION AND ENTERTAINMENT

FOR PHYSICAL FITNESS INSTRUCTION (U.S. CLS. 100, 101 AND 107).

### CLASS 44—MEDICAL, BEAUTY AND AGRICULTURAL SERVICES

FOR OCCUPATIONAL THERAPY SERVICES; PHYSICAL THERAPY; SPEECH AND HEARING THERAPY (U.S. CLS. 100 AND 101).  
JENNIFER WILLISTON, EXAMINING ATTORNEY

SN 78-968,057. HIP HOP BEVERAGE CORPORATION, PALO ALTO, CA. FILED 9-6-2006.

## PITBULLY

THE MARK CONSISTS OF STANDARD CHARACTERS WITHOUT CLAIM TO ANY PARTICULAR FONT, STYLE, SIZE, OR COLOR.

### CLASS 29—MEATS AND PROCESSED FOODS

FOR PROTEIN BASED, NUTRIENT-DENSE SNACK BARS (U.S. CL. 46).

### CLASS 32—LIGHT BEVERAGES

FOR ENERGY DRINKS (U.S. CLS. 45, 46 AND 48).  
HANNO RITTNER, EXAMINING ATTORNEY

SN 78-968,085. THEPORT NETWORK, INC., ATLANTA, GA. FILED 9-6-2006.

## BLERTS

THE MARK CONSISTS OF STANDARD CHARACTERS WITHOUT CLAIM TO ANY PARTICULAR FONT, STYLE, SIZE, OR COLOR.

**CLASS 9—ELECTRICAL AND SCIENTIFIC APPARATUS**

FOR COMMUNICATIONS SOFTWARE FOR CONNECTING RSS FEED SOURCES, OR OTHER PUBLICATION AND SYNDICATION TECHNOLOGIES SOURCES, WITH DESKTOP, MOBILE TELEPHONE, PAGER, MOBILE COMPUTER, AND/OR DIGITAL COMMUNICATIONS DEVICE RSS NEWSREADERS, OR OTHER PUBLICATION AND SYNDICATION TECHNOLOGIES NEWSREADERS; COMPUTER SOFTWARE FOR COMMUNICATING WITH USERS OF HAND-HELD COMPUTERS; COMPUTER SOFTWARE FOR THE COLLECTION, EDITING, ORGANIZING, MODIFYING, BOOK MARKING, TRANSMISSION, STORAGE AND SHARING OF DATA AND INFORMATION; COMPUTER SOFTWARE FOR USE IN CUSTOMER RELATIONSHIP MANAGEMENT (CRM); COMPUTER SOFTWARE FOR WIRELESS CONTENT DELIVERY; COMPUTER SOFTWARE FOR ALERTING USERS WHEN RSS FEED SOURCES, OR OTHER PUBLICATION AND SYNDICATION TECHNOLOGIES SOURCES, HAVE BEEN UPDATED; COMPUTER SOFTWARE FOR ALERTING USERS WHEN RSS FEED SOURCES, OR OTHER PUBLICATION AND SYNDICATION TECHNOLOGIES SOURCES HAVE BEEN UPDATED THAT MAY BE DOWNLOADED FROM A GLOBAL COMPUTER NETWORK; COMPUTER SOFTWARE TO ENABLE THE TRANSMISSION OF PHOTOGRAPHS TO MOBILE TELEPHONES; DOWNLOADABLE SOFTWARE FOR ALERTING USERS WHEN RSS FEED SOURCES, OR OTHER PUBLICATION AND SYNDICATION TECHNOLOGIES SOURCES, HAVE BEEN UPDATED (U.S. CLS. 21, 23, 26 AND 38).

**CLASS 42—SCIENTIFIC, COMPUTER AND LEGAL SERVICES**

FOR APPLICATION SERVICE PROVIDER (ASP) FEATURING SOFTWARE FOR ALERTING USERS WHEN RSS FEED SOURCES, OR OTHER PUBLICATION AND SYNDICATION TECHNOLOGIES SOURCES, HAVE BEEN UPDATED; APPLICATION SERVICE PROVIDER (ASP), NAMELY, HOSTING COMPUTER SOFTWARE APPLICATIONS OF OTHERS; COMPUTER SERVICE, NAMELY, ACTING AS AN APPLICATION SERVICE PROVIDER IN THE FIELD OF KNOWLEDGE MANAGEMENT TO HOST COMPUTER APPLICATION SOFTWARE FOR SEARCHING AND RETRIEVING INFORMATION FROM DATABASES AND COMPUTER NETWORKS; COMPUTER SERVICE, NAMELY, ACTING AS AN APPLICATION SERVICE PROVIDER IN THE FIELD OF KNOWLEDGE MANAGEMENT TO HOST COMPUTER APPLICATION SOFTWARE FOR THE COLLECTION, EDITING, ORGANIZING, MODIFYING, BOOK MARKING, TRANSMISSION, STORAGE AND SHARING OF DATA AND INFORMATION; PROVIDING ON-LINE NON-DOWNLOADABLE SOFTWARE FOR MANAGING THE SETTINGS ASSOCIATED WITH ALERTING USERS WHEN RSS FEED SOURCES, OR OTHER PUBLICATION AND SYNDICATION TECHNOLOGIES SOURCES, HAVE BEEN UPDATED (U.S. CLS. 100 AND 101).

SUNG IN, EXAMINING ATTORNEY

SN 78-968,389. AFRICENTIALS CORPORATION, JOLIET, IL.  
FILED 9-6-2006.



NO CLAIM IS MADE TO THE EXCLUSIVE RIGHT TO USE THE PICTORIAL REPRESENTATION OF AFRICA, APART FROM THE MARK AS SHOWN.

THE MARK CONSISTS OF A STYLIZED DEPICTION OF THE CONTINENT OF AFRICA WITH A TREE IN THE CENTER AND THE WORD "AFRICENTIALS" IN LARGE FONT AND THE WORDS: A COMMUNITY DEVELOPMENT ENTERPRISE DEEPLY ROOTED FOR LIVING, FOR LEARNING, FOR LIFE" SUPERIMPOSED OVER THE STYLIZED DEPICTION.

**CLASS 28—TOYS AND SPORTING GOODS**

FOR BOARD GAMES (U.S. CLS. 22, 23, 38 AND 50).

**CLASS 41—EDUCATION AND ENTERTAINMENT**

FOR EDUCATION SERVICES, NAMELY, PROVIDING WORKSHOPS, LECTURES AND SEMINARS IN THE FIELD OF AFRICAN AMERICAN RACIAL IDENTITY (U.S. CLS. 100, 101 AND 107).

REBECCA EISINGER, EXAMINING ATTORNEY

SN 78-968,406. AFRICENTIALS CORPORATION, JOLIET, IL.  
FILED 9-6-2006.



NO CLAIM IS MADE TO THE EXCLUSIVE RIGHT TO USE THE PICTORIAL REPRESENTATION OF AFRICA, APART FROM THE MARK AS SHOWN.

**CLASS 28—TOYS AND SPORTING GOODS**

FOR BOARD GAMES (U.S. CLS. 22, 23, 38 AND 50).

**CLASS 41—EDUCATION AND ENTERTAINMENT**

FOR EDUCATION SERVICES, NAMELY, PROVIDING WORKSHOPS, LECTURES AND SEMINARS IN THE FIELD OF AFRICAN AMERICAN RACIAL IDENTITY (U.S. CLS. 100, 101 AND 107).

REBECCA EISINGER, EXAMINING ATTORNEY

SN 78-968,419. AFRICENTIALS CORPORATION, JOLIET, IL.  
FILED 9-6-2006.

SN 78-968,545. MAIN SAIL LLC, SHAKER HTS., OH. FILED  
9-6-2006.

## AFRICENTIALS

THE MARK CONSISTS OF STANDARD CHARACTERS WITHOUT CLAIM TO ANY PARTICULAR FONT, STYLE, SIZE, OR COLOR.

### CLASS 28—TOYS AND SPORTING GOODS

FOR BOARD GAMES (U.S. CLS. 22, 23, 38 AND 50).

### CLASS 41—EDUCATION AND ENTERTAINMENT

FOR EDUCATION SERVICES, NAMELY, PROVIDING WORKSHOPS, LECTURES AND SEMINARS IN THE FIELD OF AFRICAN AMERICAN RACIAL IDENTITY (U.S. CLS. 100, 101 AND 107).

REBECCA EISINGER, EXAMINING ATTORNEY

SN 78-968,482. 226 INVESTMENTS, L.L.C., SCOTTSDALE, AZ. FILED 9-6-2006.

## RIO SHRIMP

THE MARK CONSISTS OF STANDARD CHARACTERS WITHOUT CLAIM TO ANY PARTICULAR FONT, STYLE, SIZE, OR COLOR.

NO CLAIM IS MADE TO THE EXCLUSIVE RIGHT TO USE "SHRIMP", APART FROM THE MARK AS SHOWN.

THE ENGLISH TRANSLATION OF THE WORD RIO IN THE MARK IS RIVER.

### CLASS 35—ADVERTISING AND BUSINESS

FOR RESTAURANT FRANCHISING (U.S. CLS. 100, 101 AND 102).

### CLASS 43—HOTEL AND RESTAURANT SERVICES

FOR RESTAURANT AND BAR SERVICES; RESTAURANT SERVICES; RESTAURANTS (U.S. CLS. 100 AND 101).

JOHN DWYER, EXAMINING ATTORNEY

## MAIN SAIL

THE MARK CONSISTS OF STANDARD CHARACTERS WITHOUT CLAIM TO ANY PARTICULAR FONT, STYLE, SIZE, OR COLOR.

### CLASS 35—ADVERTISING AND BUSINESS

FOR BUSINESS MANAGEMENT CONSULTING; BUSINESS CONSULTING AND PROJECT MANAGEMENT; BUSINESS PROCESS RE-ENGINEERING; BUSINESS MARKETING CONSULTING; PROCUREMENT SERVICES, NAMELY, PURCHASING COMPUTER HARDWARE AND SOFTWARE FOR OTHERS; PROVIDING INFORMATION IN THE FIELDS OF BUSINESS MANAGEMENT CONSULTING, BUSINESS CONSULTING; MARKET ANALYSIS; BUSINESS INFORMATION SERVICES IN THE FIELD OF BUSINESS CHANGE MANAGEMENT, BUSINESS PROCESS MANAGEMENT, BUSINESS STRATEGIC MANAGEMENT AND PLANNING, AND BUSINESS TECHNOLOGY; BUSINESS MANAGEMENT PLANNING; BUSINESS NETWORKING; CONDUCTING BUSINESS RESEARCH AND SURVEYS; BUSINESS SUPERVISION; COMMERCIAL AND INDUSTRIAL MANAGEMENT ASSISTANCE; ECONOMIC FORECASTING AND ANALYSIS; PERSONNEL MANAGEMENT CONSULTATION; PREPARING BUSINESS REPORTS; PROVIDING INFORMATION IN THE FIELD OF BUSINESS MANAGEMENT, BUSINESS MARKETING, BUSINESS ACQUISITIONS AND MERGERS CONSULTING (U.S. CLS. 100, 101 AND 102).

FIRST USE 8-13-2001; IN COMMERCE 10-28-2002.

### CLASS 37—CONSTRUCTION AND REPAIR

FOR COMPUTER INSTALLATION, REPAIR, AND MAINTENANCE WITH RESPECT TO COMPUTER HARDWARE NAMELY, COMPUTER SYSTEMS AND COMPUTER NETWORKS (U.S. CLS. 100, 103 AND 106).

FIRST USE 8-13-2001; IN COMMERCE 10-28-2002.

STEPHANIE DAVIS, EXAMINING ATTORNEY

SN 78-968,579. ALOEBIOTICS RESEARCH LABS, INC., NEW YORK, NY. FILED 9-6-2006.

## Think deeper.

THE MARK CONSISTS OF STANDARD CHARACTERS WITHOUT CLAIM TO ANY PARTICULAR FONT, STYLE, SIZE, OR COLOR.

### CLASS 3—COSMETICS AND CLEANING PREPARATIONS

FOR ALOE VERA GEL FOR COSMETIC PURPOSES; ANTI-AGING CREAM; ANTI-WRINKLE CREAMS; BEAUTY CREAMS; BEAUTY GELS; BEAUTY LOTIONS; BEAUTY SERUMS; BODY AND BEAUTY CARE COSMETICS; BODY AND BEAUTY CARE PREPARATIONS; COSMETIC CREAMS FOR SKIN CARE; FACE AND BODY BEAUTY CREAMS; SKIN CARE PRODUCTS, NAMELY, NON-MEDICATED SKIN SERUM; WRINKLE RESISTANT CREAM (U.S. CLS. 1, 4, 6, 50, 51 AND 52).

**CLASS 5—PHARMACEUTICALS**

FOR ADJUVANTS FOR USE WITH VACCINES; BIO-CHEMICAL PREPARATIONS FOR MEDICAL OR VETERINARY PURPOSES; NUTRACEUTICALS FOR USE AS A DIETARY SUPPLEMENT; NUTRITIONAL SUPPLEMENTS IN LOTION FORM SOLD AS A COMPONENT OF NUTRITIONAL SKIN CARE PRODUCTS; PHARMACEUTICAL PRODUCTS FOR SKIN CARE FOR ANIMALS (U.S. CLS. 6, 18, 44, 46, 51 AND 52).  
LAURA KOVALSKY, EXAMINING ATTORNEY

SN 78-968,617. BARTON, MARY, VERO BEACH, FL. FILED 9-6-2006.

# My Lips TV

THE MARK CONSISTS OF STANDARD CHARACTERS WITHOUT CLAIM TO ANY PARTICULAR FONT, STYLE, SIZE, OR COLOR.

NO CLAIM IS MADE TO THE EXCLUSIVE RIGHT TO USE "TV", APART FROM THE MARK AS SHOWN.

SN 78-968,580. LAUGHING GRAVY PARTNERS INC., HONOLULU, HI. FILED 9-6-2006.

## GOOD TO GRILL

THE MARK CONSISTS OF STANDARD CHARACTERS WITHOUT CLAIM TO ANY PARTICULAR FONT, STYLE, SIZE, OR COLOR.

**CLASS 30—STAPLE FOODS**

FOR SAUCES; SEASONINGS; SALAD DRESSINGS (U.S. CL. 46).

**CLASS 43—HOTEL AND RESTAURANT SERVICES**

FOR RESTAURANTS (U.S. CLS. 100 AND 101).  
LAURA KOVALSKY, EXAMINING ATTORNEY

**CLASS 25—CLOTHING**

FOR KNIT SHIRTS; SHORT-SLEEVED OR LONG-SLEEVED T-SHIRTS; SHORT-SLEEVED SHIRTS; T-SHIRTS (U.S. CLS. 22 AND 39).

**CLASS 41—EDUCATION AND ENTERTAINMENT**

FOR ENTERTAINMENT IN THE NATURE OF ONGOING TELEVISION PROGRAMS IN THE FIELD OF STYLE AND FASHION; ENTERTAINMENT NAMELY, PRODUCTION OF TELEVISION SHOWS IN THE FIELD OF STYLE AND FASHION; ENTERTAINMENT SERVICES, NAMELY, PROVIDING A TELEVISION PROGRAM IN THE FIELD OF STYLE AND FASHION VIA A GLOBAL COMPUTER NETWORK; PRODUCTION OF RADIO AND TELEVISION PROGRAMS IN THE FIELD OF STYLE AND FASHION; TELEVISION SHOW PRODUCTION IN THE FIELD OF STYLE AND FASHION; ALL OF THE FOREGOING EXCLUDING ADULT THEMES (U.S. CLS. 100, 101 AND 107).

ZHALEH DELANEY, EXAMINING ATTORNEY

SN 78-968,614. CRAIN AUTOMOTIVE HOLDINGS, LLC, LITTLE ROCK, AR. FILED 9-6-2006.

## Drive Mart

THE MARK CONSISTS OF STANDARD CHARACTERS WITHOUT CLAIM TO ANY PARTICULAR FONT, STYLE, SIZE, OR COLOR.

**CLASS 35—ADVERTISING AND BUSINESS**

FOR AUTOMOBILE DEALERSHIPS (U.S. CLS. 100, 101 AND 102).

**CLASS 37—CONSTRUCTION AND REPAIR**

FOR AUTOMOBILE BODY REPAIR AND FINISHING FOR OTHERS; AUTOMOBILE REPAIR AND MAINTENANCE; CAR REPAIR AND MAINTENANCE (U.S. CLS. 100, 103 AND 106).  
STEPHANIE DAVIS, EXAMINING ATTORNEY

SN 78-968,627. PRECOR PRODUCTS LIMITED, FINCHAMSTEAD, UNITED KINGDOM, FILED 9-6-2006.



OWNER OF UNITED KINGDOM REG. NO. 004364501, DATED 4-18-2006, EXPIRES 3-24-2015.

THE MARK CONSISTS OF A SWIRL LOGO DESIGN AND THE WORDS TEAMBIKE.

**CLASS 28—TOYS AND SPORTING GOODS**

FOR EXERCISE EQUIPMENT, NAMELY, STATIONARY CYCLES; EXERCISE MACHINES; MANUALLY-OPERATED EXERCISE EQUIPMENT; STATIONARY EXERCISE BICYCLES (U.S. CLS. 22, 23, 38 AND 50).

**CLASS 37—CONSTRUCTION AND REPAIR**

FOR INSTALLATION, MAINTENANCE AND REPAIR OF OF GYMNASIAC, SPORTING AND EXERCISE EQUIPMENT, MACHINES AND APPLIANCES FOR EXERCISE (U.S. CLS. 100, 103 AND 106).  
H. M. FISHER, EXAMINING ATTORNEY

SN 78-968,740. BEVERAGE PARTNERS WORLDWIDE (NORTH AMERICA), ATLANTA, GA. FILED 9-7-2006.

SN 78-968,815. CARMAX BUSINESS SERVICES, LLC, RICHMOND, VA. FILED 9-7-2006.

# TIAN TEY

THE MARK CONSISTS OF STANDARD CHARACTERS WITHOUT CLAIM TO ANY PARTICULAR FONT, STYLE, SIZE, OR COLOR.

THE ENGLISH TRANSLATION OF TIAN TEY IS HEAVEN SPECIAL.

## CLASS 30—STAPLE FOODS

FOR TEA; FLAVORINGS OF TEA; BEVERAGES MADE OF TEA; ICED TEA; GREEN TEA; TEA-BASED BEVERAGES WITH FRUIT FLAVORING (U.S. CL. 46).

## CLASS 32—LIGHT BEVERAGES

FOR NON-ALCOHOLIC BEVERAGES WITH TEA FLAVOR; SOFT DRINKS FLAVORED WITH TEA; FRUIT-BASED SOFT DRINKS FLAVORED WITH TEA; SYRUPS FOR MAKING TEA-BASED BEVERAGES AND TEA-FLAVORED BEVERAGES; ISOTONIC DRINKS; ENERGY DRINKS; SPORTS DRINKS (U.S. CLS. 45, 46 AND 48).

JOHN WILKE, EXAMINING ATTORNEY

SN 78-968,793. CARMAX BUSINESS SERVICES, LLC, RICHMOND, VA. FILED 9-7-2006.



THE MARK CONSISTS OF A FANCIFUL CHARACTER WITH A HEART AND RAYS OF LIGHT SUPERIMPOSED ON A HALF MOON BACKGROUND.

## CLASS 41—EDUCATION AND ENTERTAINMENT

FOR EDUCATION SERVICES, NAMELY, PROVIDING CLASSES, SEMINARS, CONFERENCES, AND WORKSHOPS IN THE FIELD OF HEALTH, WELLNESS, AND NUTRITION (U.S. CLS. 100, 101 AND 107).

## CLASS 44—MEDICAL, BEAUTY AND AGRICULTURAL SERVICES

FOR HEALTH CARE SERVICES, NAMELY WELLNESS PROGRAMS; PROVIDING HEALTH INFORMATION (U.S. CLS. 100 AND 101).

JAMES A. RAUEN, EXAMINING ATTORNEY



THE MARK CONSISTS OF A FANCIFUL STAR SHAPED CHARACTER WITH A HEART SUPERIMPOSED ON A STARBURST BACKGROUND.

## CLASS 41—EDUCATION AND ENTERTAINMENT

FOR EDUCATION SERVICES, NAMELY, PROVIDING CLASSES, SEMINARS, CONFERENCES, AND WORKSHOPS IN THE FIELD OF HEALTH, WELLNESS, AND NUTRITION (U.S. CLS. 100, 101 AND 107).

## CLASS 44—MEDICAL, BEAUTY AND AGRICULTURAL SERVICES

FOR HEALTH CARE SERVICES, NAMELY WELLNESS PROGRAMS; PROVIDING HEALTH INFORMATION (U.S. CLS. 100 AND 101).

JAMES A. RAUEN, EXAMINING ATTORNEY

SN 78-968,838. EXPRESS PACKAGING, L.L.C., SAN ANTONIO, TX. FILED 9-7-2006.

# HIDEAPACK

THE MARK CONSISTS OF STANDARD CHARACTERS WITHOUT CLAIM TO ANY PARTICULAR FONT, STYLE, SIZE, OR COLOR.

## CLASS 16—PAPER GOODS AND PRINTED MATTER

FOR CARDBOARD PACKAGING; PAPER BAGS FOR PACKAGING; PLASTIC BAGS FOR PACKAGING; PLASTIC OR PAPER BAGS FOR MERCHANDISE PACKAGING (U.S. CLS. 2, 5, 22, 23, 29, 37, 38 AND 50).

## CLASS 35—ADVERTISING AND BUSINESS

FOR MERCHANDISE PACKAGING (U.S. CLS. 100, 101 AND 102).

JAMES A. RAUEN, EXAMINING ATTORNEY



SN 78-968,874. AMERICAN AXLE & MANUFACTURING, INC., DETROIT, MI. FILED 9-7-2006.

# QUATRIC

THE MARK CONSISTS OF STANDARD CHARACTERS WITHOUT CLAIM TO ANY PARTICULAR FONT, STYLE, SIZE, OR COLOR.

### CLASS 12—VEHICLES

FOR LAND VEHICLE PARTS, NAMELY AXLES AND AXLE ASSEMBLIES (U.S. CLS. 19, 21, 23, 31, 35 AND 44).

### CLASS 40—MATERIAL TREATMENT

FOR CUSTOM MANUFACTURE OF LAND VEHICLE PARTS TO THE ORDER AND SPECIFICATION OF OTHERS (U.S. CLS. 100, 103 AND 106).  
TRAVIS WHEATLEY, EXAMINING ATTORNEY

SN 78-968,898. PIZZA HUT, INC., DALLAS, TX. FILED 9-7-2006.

# GO FOR THE GOOD STUFF

THE MARK CONSISTS OF STANDARD CHARACTERS WITHOUT CLAIM TO ANY PARTICULAR FONT, STYLE, SIZE, OR COLOR.  
OWNER OF U.S. REG. NO. 2,921,642.

### CLASS 30—STAPLE FOODS

FOR PIZZA FOR CONSUMPTION ON OR OFF PREMISES (U.S. CL. 46).

### CLASS 43—HOTEL AND RESTAURANT SERVICES

FOR RESTAURANT SERVICES (U.S. CLS. 100 AND 101).  
JENNIFER MCROBBIE, EXAMINING ATTORNEY

SN 78-969,006. METAMERSION, LLC, BEDFORD, NH. FILED 9-7-2006.



OWNER OF U.S. REG. NOS. 2,863,281, 3,105,628 AND OTHERS.

### CLASS 9—ELECTRICAL AND SCIENTIFIC APPARATUS

FOR VIRTUAL REALITY OR AUGMENTED REALITY BASED ENTERTAINMENT SYSTEMS COMPRISED OF COMPUTER HARDWARE AND ELECTRONIC VIDEO DISPLAYS FOR USE IN AUGMENTED REALITY AND VIRTUAL REALITY APPLICATIONS; COMPUTER HARDWARE AND SOFTWARE FOR DISPLAYING AUGMENTED REALITY AND VIRTUAL REALITY IMAGERY (U.S. CLS. 21, 23, 26, 36 AND 38).

### CLASS 41—EDUCATION AND ENTERTAINMENT

FOR LEASING OF VIRTUAL REALITY OR AUGMENTED REALITY BASED ENTERTAINMENT SYSTEMS (U.S. CLS. 100, 101 AND 107).  
PAMELA HIRSCHMAN, EXAMINING ATTORNEY

SN 78-969,206. G FORCE GLOBAL TECHNOLOGIES, INC., OCALA, FL. FILED 9-7-2006.

# CAPSHOT

THE MARK CONSISTS OF STANDARD CHARACTERS WITHOUT CLAIM TO ANY PARTICULAR FONT, STYLE, SIZE, OR COLOR.

### CLASS 9—ELECTRICAL AND SCIENTIFIC APPARATUS

FOR COMPUTER SOFTWARE FOR USE IN TESTING COMPUTER SYSTEMS AND APPLICATIONS (U.S. CLS. 21, 23, 26, 36 AND 38).

### CLASS 42—SCIENTIFIC, COMPUTER AND LEGAL SERVICES

FOR TESTING OR RESEARCH ON MACHINES, APPARATUS AND INSTRUMENTS IN THE FIELD OF COMPUTERS; COMPUTER CONSULTATION; TECHNOLOGICAL CONSULTATION IN THE FIELD OF COMPUTER SYSTEMS AND APPLICATIONS (U.S. CLS. 100 AND 101).  
ESTHER A. BORSUK, EXAMINING ATTORNEY

SN 78-969,288. GLOBAL EYE CENTER, INC., RANCHO CUCAMONGA, CA. FILED 9-7-2006.

# GECI

THE MARK CONSISTS OF STANDARD CHARACTERS WITHOUT CLAIM TO ANY PARTICULAR FONT, STYLE, SIZE, OR COLOR.

**CLASS 10—MEDICAL APPARATUS**

FOR MEDICAL SUPPLY KITS PRIMARILY COMPRISED OF OPERATING INSTRUMENTS, NAMELY, SURGICAL VALVES, INTRAOCULAR LENSES AND PRE AND POST SURGICAL ACCESSORIES, NAMELY, DRAPES, SUTURES AND COTTON SWABS, ALL FOR THE TREATMENT OF EYE INJURIES AND EYE DISEASES, SUCH AS CATARACTS AND GLAUCOMA (U.S. CLS. 26, 39 AND 44).

**CLASS 44—MEDICAL, BEAUTY AND AGRICULTURAL SERVICES**

FOR MEDICAL SERVICES, NAMELY, TREATMENT OF EYE INJURIES AND EYE DISEASES, SUCH AS CATARACTS AND GLAUCOMA AT OUT PATIENT CARE CENTERS (U.S. CLS. 100 AND 101).  
DAVID YONTEF, EXAMINING ATTORNEY

SN 78-969,319. EXPRESSOFT, INC., LA JOLLA, CA. FILED 9-7-2006.

# ExpresSoft

THE MARK CONSISTS OF STANDARD CHARACTERS WITHOUT CLAIM TO ANY PARTICULAR FONT, STYLE, SIZE, OR COLOR.

**CLASS 35—ADVERTISING AND BUSINESS**

FOR BUSINESS CONSULTATION SERVICES IN THE FIELD OF FINANCIAL TRANSACTION AUTOMATION (U.S. CLS. 100, 101 AND 102).  
FIRST USE 3-2-1995; IN COMMERCE 7-27-1995.

**CLASS 42—SCIENTIFIC, COMPUTER AND LEGAL SERVICES**

FOR COMPUTER SOFTWARE DEVELOPMENT, IMPLEMENTATION AND CONSULTATION IN THE FIELD OF FINANCIAL SERVICES (U.S. CLS. 100 AND 101).  
FIRST USE 3-2-1995; IN COMMERCE 7-27-1995.  
JAMES MACFARLANE, EXAMINING ATTORNEY

SN 78-969,327. AJ ADHESIVES, INC., ST. LOUIS, MO. FILED 9-7-2006.

HOLDING NORTH AMERICAN  
MANUFACTURING TOGETHER

THE MARK CONSISTS OF STANDARD CHARACTERS WITHOUT CLAIM TO ANY PARTICULAR FONT, STYLE, SIZE, OR COLOR.

**CLASS 35—ADVERTISING AND BUSINESS**

FOR DISTRIBUTORSHIP SERVICES IN THE FIELDS OF INDUSTRIAL ADHESIVES, ADHESIVE APPLICATION EQUIPMENT AND PRODUCT HANDLING (U.S. CLS. 100, 101 AND 102).  
FIRST USE 7-0-2005; IN COMMERCE 9-1-2005.

**CLASS 37—CONSTRUCTION AND REPAIR**

FOR MAINTENANCE AND REPAIR OF ADHESIVE APPLICATION EQUIPMENT (U.S. CLS. 100, 103 AND 106).  
FIRST USE 7-0-2005; IN COMMERCE 9-1-2005.  
PAUL F. GAST, EXAMINING ATTORNEY

SN 78-969,408. ATTORNEY CONSULTANT, INC., CLEVELAND, OH. FILED 9-7-2006.

Enjoy your practice, Enjoy  
your life

THE MARK CONSISTS OF STANDARD CHARACTERS WITHOUT CLAIM TO ANY PARTICULAR FONT, STYLE, SIZE, OR COLOR.

**CLASS 35—ADVERTISING AND BUSINESS**

FOR ADVERTISING CONSULTATION; BUSINESS CONSULTING AND INFORMATION SERVICES; BUSINESS CONSULTATION SERVICES; BUSINESS MANAGEMENT CONSULTATION; BUSINESS MANAGEMENT CONSULTING AND ADVISORY SERVICES; BUSINESS MANAGEMENT CONSULTATION IN THE FIELD OF EXECUTIVE AND LEADERSHIP DEVELOPMENT; BUSINESS ORGANIZATIONAL CONSULTATION; CONSULTING SERVICES IN BUSINESS ORGANIZATION AND MANAGEMENT; CONSULTING SERVICES RELATING TO PUBLICITY; CONSULTING SERVICES IN THE FIELD OF HUMAN RESOURCES DEVELOPMENT, NAMELY FOR THE PROMOTION OF EMPLOYEE RETENTION, CAREER GROWTH, AND INCREASED PRODUCTIVITY FOR EMPLOYEES AND EMPLOYERS; MARKETING CONSULTING; PERSONNEL MANAGEMENT CONSULTATION; PROFESSIONAL BUSINESS CONSULTATION; RISK MANAGEMENT CONSULTATION ALL FOR ATTORNEYS AND LAW FIRMS (U.S. CLS. 100, 101 AND 102).  
FIRST USE 10-0-2005; IN COMMERCE 10-0-2005.

**CLASS 42—SCIENTIFIC, COMPUTER AND LEGAL SERVICES**

FOR CONSULTATION SERVICES IN THE FIELD OF LAW FIRMS AND THE PROVISION OF LEGAL SERVICES; CONSULTING SERVICES IN THE FIELD OF OFFICE AND WORKPLACE AUTOMATION; CONSULTING SERVICES IN THE FIELD OF DESIGN OF NEWSLETTERS (U.S. CLS. 100 AND 101).  
FIRST USE 10-0-2005; IN COMMERCE 10-0-2005.  
MIDGE BUTLER, EXAMINING ATTORNEY

SN 78-969,409. FRAGRANCE RESOURCES, INC., WEST CLIFTON, NJ. FILED 9-7-2006.

# PSYCHIC

THE MARK CONSISTS OF STANDARD CHARACTERS WITHOUT CLAIM TO ANY PARTICULAR FONT, STYLE, SIZE, OR COLOR.

**CLASS 3—COSMETICS AND CLEANING PREPARATIONS**

FOR BATH BEADS; BATH CRYSTALS; BATH GEL; BATH MILKS; BATH OIL; BEAUTY MASKS; BODY AND BEAUTY CARE COSMETICS; BODY LOTION; BODY SCRUB; BODY SPRAYS; COLOGNE; COSMETICS; FACIAL SCRUBS; FRAGRANCES FOR PERSONAL USE; HAIR CONDITIONER; HAIR GEL; HAIR SHAMPOO; HAIR SPRAY; PERFUME; POTPOURRI; SKIN CLEANSERS; SKIN MOISTURIZER; SKIN TONERS; SOAPS FOR BODY CARE; SOAPS FOR PERSONAL USE; SUN CARE LOTIONS; SUN SCREEN PREPARATIONS; TOILET SOAP; TOILET WATER (U.S. CLS. 1, 4, 6, 50, 51 AND 52).

**CLASS 4—LUBRICANTS AND FUELS**

FOR CANDLES; PERFUMED CANDLES; SCENTED CANDLES (U.S. CLS. 1, 6 AND 15).  
REBECCA POVARCHUK, EXAMINING ATTORNEY

**CLASS 37—CONSTRUCTION AND REPAIR**

FOR CONSTRUCTION OF RESIDENTIAL BUILDINGS; CUSTOM CONSTRUCTION OF HOMES; GENERAL CONSTRUCTION CONTRACTING; REAL ESTATE DEVELOPMENT (U.S. CLS. 100, 103 AND 106).  
FIRST USE 10-0-2004; IN COMMERCE 10-0-2004.

**CLASS 42—SCIENTIFIC, COMPUTER AND LEGAL SERVICES**

FOR ARCHITECTURAL DESIGN; INTERIOR DECORATING; INTERIOR DECORATION CONSULTATION (U.S. CLS. 100 AND 101).  
FIRST USE 10-0-2004; IN COMMERCE 10-0-2004.  
KIMBERLY FRYE, EXAMINING ATTORNEY

SN 78-969,421. BENNETT HOMES, INC., BELLEVUE, WA.  
FILED 9-7-2006.



THE MARK CONSISTS OF THE THE DESIGN OF AN ARC POSITIONED BELOW THE TERM "BENNETT".

**CLASS 37—CONSTRUCTION AND REPAIR**

FOR CONSTRUCTION OF RESIDENTIAL BUILDINGS; CUSTOM CONSTRUCTION OF HOMES; GENERAL CONSTRUCTION CONTRACTING; REAL ESTATE DEVELOPMENT (U.S. CLS. 100, 103 AND 106).  
FIRST USE 10-0-2004; IN COMMERCE 10-0-2004.

**CLASS 42—SCIENTIFIC, COMPUTER AND LEGAL SERVICES**

FOR ARCHITECTURAL DESIGN; INTERIOR DECORATING; INTERIOR DECORATION CONSULTATION (U.S. CLS. 100 AND 101).  
FIRST USE 10-0-2004; IN COMMERCE 10-0-2004.  
KIMBERLY FRYE, EXAMINING ATTORNEY

SN 78-969,598. BENNETT HOMES, INC., BELLEVUE, WA.  
FILED 9-7-2006.



THE MARK CONSISTS OF THE THE DESIGN OF AN ARC.

SN 78-969,610. BEANETICS LTD., FALLS CHURCH, VA.  
FILED 9-7-2006.



THE MARK CONSISTS OF STANDARD CHARACTERS WITHOUT CLAIM TO ANY PARTICULAR FONT, STYLE, SIZE, OR COLOR.

**CLASS 30—STAPLE FOODS**

FOR BEVERAGES MADE OF COFFEE; CAFFEINE-FREE COFFEE; CHICORY BASED COFFEE SUBSTITUTE; COFFEE; COFFEE; COFFEE BEANS; COFFEE FLAVORED SYRUP USED IN MAKING FOOD BEVERAGES; COFFEE PODS; COFFEE SUBSTITUTES; COFFEE SUBSTITUTES; COFFEE-BASED BEVERAGE CONTAINING MILK; GROUND COFFEE BEANS; INSTANT COFFEE; PREPARED COFFEE AND COFFEE-BASED BEVERAGES; ROASTED COFFEE BEANS; SUGAR-COATED COFFEE BEANS (U.S. CL. 46).

**CLASS 40—MATERIAL TREATMENT**

FOR COFFEE ROASTING AND PROCESSING (U.S. CLS. 100, 103 AND 106).

**CLASS 43—HOTEL AND RESTAURANT SERVICES**

FOR COFFEE SHOPS; COFFEE SUPPLY SERVICES FOR OFFICES; COFFEE-HOUSE AND SNACK-BAR SERVICES; OFFICE COFFEE SUPPLY SERVICES (U.S. CLS. 100 AND 101).  
JILL PRATER, EXAMINING ATTORNEY

SN 78-969,638. ALLIANCE ENTERPRISES OF S.E. WISCONSIN, LLC, RACINE, WI. FILED 9-7-2006.



**CLASS 29—MEATS AND PROCESSED FOODS**

FOR CHEESE; CHEESE FOOD; CHEESE SPREADS; CHEESE SUBSTITUTES; CHOCOLATE MILK; DAIRY PRODUCTS EXCLUDING ICE CREAM, ICE MILK AND FROZEN YOGURT; DRINKING YOGURTS; MILK; MILK PROTEINS; YOGURT; YOGURT-BASED BEVERAGES (U.S. CL. 46).

**CLASS 30—STAPLE FOODS**

FOR FROZEN YOGURT; ICE CREAM; ICE CREAM SANDWICHES; ICE CREAM SUBSTITUTE; ICE MILK; ICE MILK BARS (U.S. CL. 46).  
DAVID YONTEF, EXAMINING ATTORNEY

SN 78-969,669. YANTAI WINHERE AUTO-PART MANUFACTURING CO., LTD., YANTAI, SHANDONG PROVINCE, CHINA, FILED 9-8-2006.

**WINHERE**

**CLASS 7—MACHINERY**

FOR CLUTCHES FOR MACHINES; COUPLINGS FOR MACHINES; FANS FOR MACHINE ENGINES; OIL PUMPS FOR LAND VEHICLES; OIL PUMPS FOR USE IN MOTORS AND ENGINES; POWER TRANSMISSION BELTS FOR MACHINES, MOTORS AND ENGINES USED IN INDUSTRIAL APPLICATIONS; RADIATORS FOR MOTORS AND ENGINES; WATER PUMPS FOR LAND VEHICLES (U.S. CLS. 13, 19, 21, 23, 31, 34 AND 35).

**CLASS 12—VEHICLES**

FOR AIR PUMPS OF AUTOMOBILES; AUTOMOBILE BUMPERS; AUTOMOBILE CHASSIS; BRAKE LININGS FOR LAND VEHICLES; BRAKE LININGS FOR MOTOR CARS; BRAKE SEGMENTS FOR MOTOR CARS; BRAKE SHOES FOR LAND VEHICLES; BRAKES FOR LAND VEHICLES; CHAINS FOR MOTOR CARS; CLUTCHES FOR LAND VEHICLES; CONNECTING RODS FOR LAND VEHICLES OTHER THAN PARTS OF MOTORS AND ENGINES; ELECTRIC MOTORS FOR MOTOR CARS; GEARS FOR VEHICLES; HYDRAULIC CIRCUITS FOR MOTOR CARS; LAND VEHICLE PARTS, NAMELY, DRIVE GEARS; MOTORIZED TAILGATES FOR TRUCKS; UNDERCARRIAGES; VEHICLE PARTS, NAMELY, SHOCK ABSORBERS; WHEEL HUBS FOR LAND VEHICLES (U.S. CLS. 19, 21, 23, 31, 35 AND 44).  
CHARISMA HAMPTON, EXAMINING ATTORNEY

SN 78-969,693. REITZ, THOMAS W., MORRISTOWN, NJ. FILED 9-8-2006.

**Once Around**

THE MARK CONSISTS OF STANDARD CHARACTERS WITHOUT CLAIM TO ANY PARTICULAR FONT, STYLE, SIZE, OR COLOR.

**CLASS 3—COSMETICS AND CLEANING PREPARATIONS**

FOR COSMETICS; NAIL CARE PREPARATIONS; NAIL POLISH (U.S. CLS. 1, 4, 6, 50, 51 AND 52).

**CLASS 25—CLOTHING**

FOR HEADGEAR, NAMELY, HATS AND CAPS; PANTS; SHORTS; SWEAT SHIRTS; T-SHIRTS; TOPS (U.S. CLS. 22 AND 39).  
MICHAEL WEBSTER, EXAMINING ATTORNEY

SN 78-969,799. TRAVELPRO INTERNATIONAL, INC., BOCA RATON, FL. FILED 9-8-2006.

**LAZER**

THE MARK CONSISTS OF STANDARD CHARACTERS WITHOUT CLAIM TO ANY PARTICULAR FONT, STYLE, SIZE, OR COLOR.

**CLASS 9—ELECTRICAL AND SCIENTIFIC APPARATUS**

FOR COMPUTER CARRYING CASES (U.S. CLS. 21, 23, 26, 36 AND 38).

**CLASS 18—LEATHER GOODS**

FOR LUGGAGE, SUITCASES, GARMENT BAGS FOR TRAVEL, ALL PURPOSE SPORTS BAGS, TOILETRY CASES SOLD EMPTY, SHOULDER BAGS, CARRYING CASES, TOTE BAGS, ROLLING TOTE BAGS, DUFFLE BAGS, ROLLING DUFFLE BAGS, BACKPACKS, ROLLING BACKPACKS (U.S. CLS. 1, 2, 3, 22 AND 41).  
JILL PRATER, EXAMINING ATTORNEY

SN 78-969,997. GAMES4YOU LLC, RENO, NV. FILED 9-8-2006.

**games4you**

THE MARK CONSISTS OF STANDARD CHARACTERS WITHOUT CLAIM TO ANY PARTICULAR FONT, STYLE, SIZE, OR COLOR.

**CLASS 9—ELECTRICAL AND SCIENTIFIC APPARATUS**

FOR GAMING MACHINES (U.S. CLS. 21, 23, 26, 36 AND 38).

**CLASS 42—SCIENTIFIC, COMPUTER AND LEGAL SERVICES**

FOR PRODUCT DESIGN AND DEVELOPMENT FOR OTHERS IN THE FIELD OF GAMING AND RECREATION, NAMELY, OF MECHANICAL GAMING EQUIPMENT, ELECTROMECHANICAL GAMING EQUIPMENT, ELECTRONIC GAMING EQUIPMENT AND GAMES FOR GAMING MACHINES (U.S. CLS. 100 AND 101).

ESTHER A. BORSUK, EXAMINING ATTORNEY

**CLASS 19—NON-METALLIC BUILDING MATERIALS**

FOR CERAMIC ENAMEL TILES; CERAMIC TILES; CERAMIC TILES FOR FLOORING AND FACING; CERAMIC TILES FOR FLOORING AND LINING; CERAMIC TILES FOR TILE FLOORS AND COVERINGS; FLOOR BOARDS; FLOOR TILES OF WOOD; LAMINATE FLOORING; TILES OF CLAY, GLASS, GYPSUM, CERAMIC OR EARTHENWARE; VINYL TILES; WOOD TILE FLOORS; WOODEN FLOORING (U.S. CLS. 1, 12, 33 AND 50).

**CLASS 27—FLOOR COVERINGS**

FOR CARPETING; CARPETS (U.S. CLS. 19, 20, 37, 42 AND 50).

JACLYN KIDWELL, EXAMINING ATTORNEY

SN 78-970,082. STEVENS, ROBERT TENNYSON, HENDERSONVILLE, NC. FILED 9-8-2006.

SN 78-970,154. ALLIANCE FLOORING, INC., CHATTANOOGA, TN. FILED 9-8-2006.

**Conscious Language**

THE MARK CONSISTS OF STANDARD CHARACTERS WITHOUT CLAIM TO ANY PARTICULAR FONT, STYLE, SIZE, OR COLOR.

**CLASS 9—ELECTRICAL AND SCIENTIFIC APPARATUS**

FOR PRE-RECORDED CD'S, VIDEO TAPES, LASER DISKS AND DVD'S FEATURING PERSONAL GROWTH COURSES (U.S. CLS. 21, 23, 26, 36 AND 38).  
FIRST USE 10-1-1986; IN COMMERCE 4-1-1988.

**CLASS 16—PAPER GOODS AND PRINTED MATTER**

FOR BOOKS IN THE FIELD OF PERSONAL GROWTH (U.S. CLS. 2, 5, 22, 23, 29, 37, 38 AND 50).  
FIRST USE 10-1-1986; IN COMMERCE 4-1-1988.  
KEVON CHISOLM, EXAMINING ATTORNEY

SN 78-970,138. ALLIANCE FLOORING, INC., CHATTANOOGA, TN. FILED 9-8-2006.

**ECOCHOICE**

THE MARK CONSISTS OF STANDARD CHARACTERS WITHOUT CLAIM TO ANY PARTICULAR FONT, STYLE, SIZE, OR COLOR.

**ENVIROFLOOR**

THE MARK CONSISTS OF STANDARD CHARACTERS WITHOUT CLAIM TO ANY PARTICULAR FONT, STYLE, SIZE, OR COLOR.

**CLASS 19—NON-METALLIC BUILDING MATERIALS**

FOR CERAMIC ENAMEL TILES; CERAMIC TILES; CERAMIC TILES FOR FLOORING AND FACING; CERAMIC TILES FOR FLOORING AND LINING; CERAMIC TILES FOR TILE FLOORS AND COVERINGS; FLOOR BOARDS; FLOOR TILES OF WOOD; LAMINATE FLOORING; NON-METAL FLOOR TILES; TILES OF CLAY, GLASS, GYPSUM, CERAMIC OR EARTHENWARE; VINYL TILES; WOOD TILE FLOORS; WOODEN FLOORING (U.S. CLS. 1, 12, 33 AND 50).

**CLASS 27—FLOOR COVERINGS**

FOR CARPETING; CARPETS (U.S. CLS. 19, 20, 37, 42 AND 50).

JACLYN KIDWELL, EXAMINING ATTORNEY

SN 78-970,179. THE WELLA CORPORATION, WOODLAND HILLS, CA. FILED 9-8-2006.

**COLORS OF THE WORLD**

THE MARK CONSISTS OF STANDARD CHARACTERS WITHOUT CLAIM TO ANY PARTICULAR FONT, STYLE, SIZE, OR COLOR.

**CLASS 16—PAPER GOODS AND PRINTED MATTER**

FOR INSTRUCTIONAL MANUALS FOR HAIR COLORING PROFESSIONALS IN THE FIELD OF HAIR COLORING (U.S. CLS. 2, 5, 22, 23, 29, 37, 38 AND 50).

**CLASS 41—EDUCATION AND ENTERTAINMENT**

FOR EDUCATIONAL SEMINARS AND COURSES FOR HAIR CARE PROFESSIONALS IN THE FIELD OF HAIR COLORING (U.S. CLS. 100, 101 AND 107).

JASON ROTH, EXAMINING ATTORNEY

**CLASS 30—STAPLE FOODS**

FOR FLOUR AND PREPARATIONS MADE FROM CEREALS, NAMELY, BREAD, PASTRY; TORTILLAS; CONDIMENTS, NAMELY, MUSTARD, SAUCES, SPICES AND SEASONINGS; SALAD DRESSINGS; PROCESSED HERBS (U.S. CL. 46).

THEODORE MCBRIDE, EXAMINING ATTORNEY

SN 78-970,226. REALLY NICE RESTAURANTS, LLC, CHICAGO, IL. FILED 9-8-2006.

SN 78-970,567. DRAKE-BLUESTEIN, INC., SACRAMENTO, CA. FILED 9-8-2006.



THE MARK CONSISTS OF A SILHOUETTE OF A CHEF HEAD AND TORSO WITH OUTSTRETCHED ARMS WITH TWO STARS TO THE LEFT AND THREE STARS TO THE RIGHT OF THE CHEF'S ARMS WITH THE AFOREMENTIONED DESIGN UNDERSCORED.

**CLASS 35—ADVERTISING AND BUSINESS**

FOR OFFERING TECHNICAL ASSISTANCE IN THE ESTABLISHMENT AND/OR OPERATION OF RESTAURANTS; RESTAURANT MANAGEMENT FOR OTHERS (U.S. CLS. 100, 101 AND 102).

**CLASS 43—HOTEL AND RESTAURANT SERVICES**

FOR CATERING; CATERING FOR THE PROVISION OF FOOD AND BEVERAGES; CATERING OF FOOD AND DRINKS; RESERVATION OF RESTAURANTS; RESTAURANT AND BAR SERVICES; RESTAURANT SERVICES; RESTAURANTS; TAKE-OUT RESTAURANT SERVICES (U.S. CLS. 100 AND 101).

DANIEL RUSSELL, EXAMINING ATTORNEY

**Nature's Affair**

THE MARK CONSISTS OF STANDARD CHARACTERS WITHOUT CLAIM TO ANY PARTICULAR FONT, STYLE, SIZE, OR COLOR.

**CLASS 3—COSMETICS AND CLEANING PREPARATIONS**

FOR PUMICE STONES FOR PERSONAL USE (U.S. CLS. 1, 4, 6, 50, 51 AND 52).

**CLASS 21—HOUSEWARES AND GLASS**

FOR BATH PRODUCTS, NAMELY, BODY SPONGES; BATH PRODUCTS, NAMELY, LOOFAH SPONGES; BATH SPONGES (U.S. CLS. 2, 13, 23, 29, 30, 33, 40 AND 50).

**CLASS 24—FABRICS**

FOR BATH MITTS; WASHCLOTHS (U.S. CLS. 42 AND 50).

MICHAEL WIENER, EXAMINING ATTORNEY

SN 78-970,384. KFC CORPORATION, LOUISVILLE, KY. FILED 9-8-2006.

SN 78-970,596. SOBEL WESTEX, INC., LAS VEGAS, NV. FILED 9-8-2006.

**WRAPSTAR**

THE MARK CONSISTS OF STANDARD CHARACTERS WITHOUT CLAIM TO ANY PARTICULAR FONT, STYLE, SIZE, OR COLOR.

**CLASS 29—MEATS AND PROCESSED FOODS**

FOR MEAT, FISH, POULTRY AND GAME; MEAT EXTRACTS; PRESERVED, DRIED AND COOKED FRUITS AND VEGETABLES; SALADS EXCEPT MACARONI, RICE, AND PASTA SALAD; COOKING OILS; PICKLES; COOKED CHICKEN, FROZEN CHICKEN, FRIED CHICKEN, BAKED CHICKEN, BARBECUED CHICKEN, BROILED CHICKEN (U.S. CL. 46).

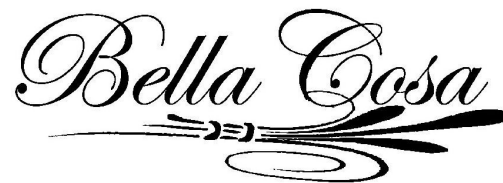

THE MARK CONSISTS OF THE WORDS BELLA COSA, WITH ORNAMENTAL LEAVES BELOW THE NAME.

THE FOREIGN WORDING IN THE MARK TRANSLATES INTO ENGLISH AS BEAUTIFUL THING.

**CLASS 24—FABRICS**

FOR TOWELS; WASHCLOTHS (U.S. CLS. 42 AND 50).

**CLASS 27—FLOOR COVERINGS**

FOR BATH MATS (U.S. CLS. 19, 20, 37, 42 AND 50).

ADA HAN, EXAMINING ATTORNEY

SN 78-970,612. SOBEL WESTEX, INC., LAS VEGAS, NV.  
FILED 9-8-2006.



THE MARK CONSISTS OF THE WORDS DOLCE VITA WITH ROUND CIRCLES.  
THE FOREIGN WORDING IN THE MARK TRANSLATES INTO ENGLISH AS SWEET LIFE.

**CLASS 24—FABRICS**

FOR TOWELS; WASHCLOTHS (U.S. CLS. 42 AND 50).

**CLASS 27—FLOOR COVERINGS**

FOR BATH MATS (U.S. CLS. 19, 20, 37, 42 AND 50).  
ADA HAN, EXAMINING ATTORNEY

SN 78-970,641. JUNKANOO CORP, TOLEDO, OH. FILED 9-8-2006.

Coffee, Libations, &  
Conversation

THE MARK CONSISTS OF STANDARD CHARACTERS WITHOUT CLAIM TO ANY PARTICULAR FONT, STYLE, SIZE, OR COLOR.

**CLASS 32—LIGHT BEVERAGES**

FOR DRINKING WATER; FRUIT JUICES; SODA POPS (U.S. CLS. 45, 46 AND 48).

**CLASS 33—WINES AND SPIRITS**

FOR ALCOHOLIC BEVERAGES OF FRUIT; LIQUOR; WINE (U.S. CLS. 47 AND 49).  
JOHN WILKE, EXAMINING ATTORNEY

SN 78-970,649. ZOE BRANDS, LLC, IRVING, TX. FILED 9-8-2006.

HOLY CHIC

**CLASS 18—LEATHER GOODS**

FOR HANDBAGS (U.S. CLS. 1, 2, 3, 22 AND 41).

**CLASS 25—CLOTHING**

FOR PANTS; SCARVES; SHOES; SKIRTS; T-SHIRTS; TOPS (U.S. CLS. 22 AND 39).  
ALICIA COLLINS, EXAMINING ATTORNEY

SN 78-970,750. NOXON, MELANIE L, FOLSOM, CA. FILED 9-9-2006.

TheraCize

THE MARK CONSISTS OF STANDARD CHARACTERS WITHOUT CLAIM TO ANY PARTICULAR FONT, STYLE, SIZE, OR COLOR.

**CLASS 41—EDUCATION AND ENTERTAINMENT**

FOR PERSONAL TRAINING SERVICES, NAMELY, STRENGTH AND CONDITIONING TRAINING (U.S. CLS. 100, 101 AND 107).

**CLASS 44—MEDICAL, BEAUTY AND AGRICULTURAL SERVICES**

FOR MENTAL HEALTH COUNSELING AND PSYCHOTHERAPY AS IT RELATES TO RELATIONSHIPS (U.S. CLS. 100 AND 101).  
ROBIN CHOSID, EXAMINING ATTORNEY

SN 78-970,788. HEARTS CENTER, INC., THE, LIVINGSTON, MT. FILED 9-9-2006.

MERU UNIVERSITY

THE MARK CONSISTS OF STANDARD CHARACTERS WITHOUT CLAIM TO ANY PARTICULAR FONT, STYLE, SIZE, OR COLOR.

NO CLAIM IS MADE TO THE EXCLUSIVE RIGHT TO USE "UNIVERSITY", APART FROM THE MARK AS SHOWN.

**CLASS 16—PAPER GOODS AND PRINTED MATTER**

FOR PUBLICATIONS, NAMELY, BROCHURES, BOOKLETS, AND TEACHING MATERIALS IN THE FIELD OF SPIRITUALITY (U.S. CLS. 2, 5, 22, 23, 29, 37, 38 AND 50).

**CLASS 41—EDUCATION AND ENTERTAINMENT**

FOR EDUCATIONAL SERVICES, NAMELY, PROVIDING COURSES, SEMINARS AND WORKSHOPS IN THE FIELD OF SPIRITUALITY (U.S. CLS. 100, 101 AND 107).  
CAROLYN GRAY, EXAMINING ATTORNEY

SN 78-970,808. THOMAS C. ST. ANGELO, MINNETONKA, MN. FILED 9-9-2006.

## Live Simply, Simply Live.

THE MARK CONSISTS OF STANDARD CHARACTERS WITHOUT CLAIM TO ANY PARTICULAR FONT, STYLE, SIZE, OR COLOR.

### CLASS 16—PAPER GOODS AND PRINTED MATTER

FOR BUMPER STICKERS; DECORATIVE STICKERS FOR HELMETS; FABRIC GIFT BAGS; GROCERY BAGS; LUNCH BAGS; LUNCH BAGS MADE OF TEXTILE; MERCHANDISE BAGS; PAPER BAGS; PAPER BAGS AND SACKS; PAPER GIFT BAGS; PAPER GIFT BAGS FOR WINE; PAPER PARTY BAGS; PAPER PARTY HATS; PAPER SHOPPING BAGS; PAPER WINE GIFT BAGS; PATTERNS FOR MAKING CLOTHES; PLASTIC OR PAPER BAGS FOR HOUSEHOLD USE; PLASTIC OR PAPER BAGS FOR MERCHANDISE PACKAGING; STICKERS; STICKERS; TEXTILE GIFT BAGS FOR WINE; TEXTILE WINE GIFT BAGS (U.S. CLS. 2, 5, 22, 23, 29, 37, 38 AND 50).

### CLASS 25—CLOTHING

FOR BIBS NOT OF CLOTH OR PAPER; CAPS; CHILDREN'S AND INFANTS' CLOTH BIBS; CHILDREN'S CLOTH EATING BIBS; CLOTH BIBS; DRESS SHIRTS; GOLF SHIRTS; HAT BANDS; HATS; INFANT AND TODDLER ONE PIECE CLOTHING; JERSEYS; KNIT SHIRTS; NIGHT SHIRTS; OPEN-NECKED SHIRTS; POLO SHIRTS; SHIRT FRONTS; SHIRTS; SHORT-SLEEVED OR LONG-SLEEVED T-SHIRTS; SHORT-SLEEVED SHIRTS; SLEEP SHIRTS; SMALL HATS; SPORT SHIRTS; SPORTS SHIRTS; SPORTS SHIRTS WITH SHORT SLEEVES; SWEAT SHIRTS; T-SHIRTS; TIES; TOBOGGAN HATS, PANTS AND CAPS; TOPS; WIND SHIRTS; WRAPS (U.S. CLS. 22 AND 39).

### CLASS 26—FANCY GOODS

FOR BROOCHES; BUTTONS FOR CLOTHING; CLOTH PATCHES FOR CLOTHING; HAT ORNAMENTS NOT OF PRECIOUS METAL; NOVELTY BUTTONS; ORNAMENTAL CLOTH PATCHES; ORNAMENTAL NOVELTY BUTTONS; PRESS BUTTONS; RIVET BUTTONS (U.S. CLS. 37, 39, 40, 42 AND 50).

IRA J. GOODSAD, EXAMINING ATTORNEY

SN 78-971,064. NYI BUILDING PRODUCTS, INC., OCEANSIDE, NY. FILED 9-11-2006.

## FREEDOM

THE MARK CONSISTS OF STANDARD CHARACTERS WITHOUT CLAIM TO ANY PARTICULAR FONT, STYLE, SIZE, OR COLOR.

### CLASS 6—METAL GOODS

FOR METAL FASTENERS, NAMELY, NAILS AND SCREWS (U.S. CLS. 2, 12, 13, 14, 23, 25 AND 50).

### CLASS 17—RUBBER GOODS

FOR ADHESIVE SEALANT AND CAULKING COMPOUND (U.S. CLS. 1, 5, 12, 13, 35 AND 50).  
CURTIS FRENCH, EXAMINING ATTORNEY

SN 78-971,085. TRULOCK FOODS, LLC, AUSTIN, TX. FILED 9-11-2006.

## PIZZA DUDES

THE MARK CONSISTS OF STANDARD CHARACTERS WITHOUT CLAIM TO ANY PARTICULAR FONT, STYLE, SIZE, OR COLOR.

NO CLAIM IS MADE TO THE EXCLUSIVE RIGHT TO USE "PIZZA", APART FROM THE MARK AS SHOWN.

### CLASS 39—TRANSPORTATION AND STORAGE

FOR DELIVERY OF FOOD BY RESTAURANTS; PIZZA DELIVERY (U.S. CLS. 100 AND 105).

### CLASS 43—HOTEL AND RESTAURANT SERVICES

FOR CARRY-OUT RESTAURANTS; CATERING OF FOOD AND DRINKS; RESTAURANTS; RESTAURANTS FEATURING HOME DELIVERY (U.S. CLS. 100 AND 101).

JASON LOTT, EXAMINING ATTORNEY

SN 78-971,404. STRICKLAND, ELLEN, SANTA BARBARA, CA. FILED 9-11-2006.

## Teenie Greenie

THE MARK CONSISTS OF STANDARD CHARACTERS WITHOUT CLAIM TO ANY PARTICULAR FONT, STYLE, SIZE, OR COLOR.

### CLASS 25—CLOTHING

FOR CLOTHING— NAMELY-SHIRTS, SWEATSHIRTS, T-SHIRTS, JACKETS, SHORTS, CAPS, HATS (U.S. CLS. 22 AND 39).

### CLASS 28—TOYS AND SPORTING GOODS

FOR PLUSH TOYS (U.S. CLS. 22, 23, 38 AND 50).

### CLASS 45—PERSONAL SERVICES

FOR PREPARATION OF CUSTOMIZED GIFT BASKETS (U.S. CLS. 100 AND 101).  
RAUL CORDOVA, EXAMINING ATTORNEY



SN 78-971,786. DETNET SOUTH AFRICA (PROPRIETARY) LIMITED, GAUTENG, SOUTH AFRICA, FILED 9-11-2006.

SN 78-971,894. ANDERSON, JANE, MANHATTAN BEACH, CA. FILED 9-11-2006.

# DETNET

THE MARK CONSISTS OF STANDARD CHARACTERS WITHOUT CLAIM TO ANY PARTICULAR FONT, STYLE, SIZE, OR COLOR.

## CLASS 9—ELECTRICAL AND SCIENTIFIC APPARATUS

FOR ELECTRONIC DETONATOR CONTROL DEVICES, COMPUTER SOFTWARE PROGRAMS AND COMPUTER PERIPHERALS FOR CONTROLLING BLASTING OPERATIONS IN THE MINING INDUSTRY (U.S. CLS. 21, 23, 26, 36 AND 38).

## CLASS 13—FIREARMS

FOR FIREARMS; AMMUNITION AND PROJECTILES; EXPLOSIVES; FIREWORKS; DETONATORS; ELECTRONIC DETONATORS AND ELECTRONIC DELAY DETONATORS FOR USE IN BLASTING OPERATIONS IN THE MINING INDUSTRY (U.S. CLS. 2 AND 9).  
PATRICIA EVANKO, EXAMINING ATTORNEY

---

SN 78-971,859. DEWBERRY CAPITAL CORPORATION, ATLANTA, GA. FILED 9-11-2006.

# DEWBERRY HOTELS

THE MARK CONSISTS OF STANDARD CHARACTERS WITHOUT CLAIM TO ANY PARTICULAR FONT, STYLE, SIZE, OR COLOR.

NO CLAIM IS MADE TO THE EXCLUSIVE RIGHT TO USE "HOTELS", APART FROM THE MARK AS SHOWN.

## CLASS 35—ADVERTISING AND BUSINESS

FOR HOTEL MANAGEMENT FOR OTHERS (U.S. CLS. 100, 101 AND 102).

## CLASS 43—HOTEL AND RESTAURANT SERVICES

FOR HOTEL SERVICES; HOTELS (U.S. CLS. 100 AND 101).  
CATHERINE FAINT, EXAMINING ATTORNEY

# Pal Towne

THE MARK CONSISTS OF STANDARD CHARACTERS WITHOUT CLAIM TO ANY PARTICULAR FONT, STYLE, SIZE, OR COLOR.

## CLASS 9—ELECTRICAL AND SCIENTIFIC APPARATUS

FOR PRERECORDED VIDEO TAPES, AUDIO CASSETTES, CDS AND DVDS FEATURING STORIES, MUSIC AND ENTERTAINMENT FOR CHILDREN (U.S. CLS. 21, 23, 26, 36 AND 38).

## CLASS 16—PAPER GOODS AND PRINTED MATTER

FOR CHILDREN'S BOOKS, CHILDREN'S STORY BOOKS, COLORING BOOKS, STICKERS, STICKER BOOKS, CHILDREN'S ACTIVITY BOOKS, PARENTAL GUIDEBOOKS FOR USE IN CONJUNCTION WITH CHILDREN'S VIDEO TAPES, AUDIO CASSETTES, CDS AND DVDS (U.S. CLS. 2, 5, 22, 23, 29, 37, 38 AND 50).

## CLASS 28—TOYS AND SPORTING GOODS

FOR DOLLS, PAPER DOLLS, SOFT SCULPTURED DOLLS, DOLL ACCESSORIES, TOY ANIMALS, STUFFED TOY ANIMALS, TOY FIGURES, TOY ACTION FIGURES, JIGSAW PUZZLES, PUPPETS, AND HAND PUPPETS (U.S. CLS. 22, 23, 38 AND 50).  
SUE LAWRENCE, EXAMINING ATTORNEY

---

SN 78-972,926. POWERS, MICHAEL, AUSTIN, TX. FILED 9-12-2006.

# Nutri-Teen

THE MARK CONSISTS OF STANDARD CHARACTERS WITHOUT CLAIM TO ANY PARTICULAR FONT, STYLE, SIZE, OR COLOR.

## CLASS 5—PHARMACEUTICALS

FOR BISCUITS, BREAD, BREAD ROLLS, CAKES, CEREAL PRODUCTS, CONFECTIONERY, CRACKERS, NOODLES, FISH SAUCE, RELISH, SAUCES, CEREAL-BASED SNACK-FOODS AND PREPARED DIETARY ITEMS THAT ARE GLUTEN-FREE TO ACCOMMODATE SPECIAL MEDICAL AND HEALTH CONDITIONS (U.S. CLS. 6, 18, 44, 46, 51 AND 52).

## CLASS 29—MEATS AND PROCESSED FOODS

FOR SNACK FOOD DIPS (U.S. CL. 46).

**CLASS 30—STAPLE FOODS**

FOR CEREAL BASED SNACK FOOD; CEREAL-BASED SNACK FOODS; CHOCOLATE FOOD BEVERAGES NOT BEING DAIRY-BASED OR VEGETABLE BASED; CHOCOLATE-BASED READY-TO-EAT FOOD BARS; CORN-BASED SNACK FOODS; FOOD PACKAGE COMBINATIONS CONSISTING PRIMARILY OF BREAD, CRACKERS AND/OR COOKIES; GRAIN-BASED FOOD BARS ALSO CONTAINING RICE; HERB TEA; HERBAL FOOD BEVERAGES; HERBAL TEA; READY TO EAT, CEREAL DERIVED FOOD BARS (U.S. CL. 46).

PATRICIA EVANKO, EXAMINING ATTORNEY

---

SN 78-973,199. NATIONAL GYPSUM PROPERTIES, LLC, CHARLOTTE, NC. FILED 9-13-2006.

**ALL BUT THE WALL**

THE MARK CONSISTS OF STANDARD CHARACTERS WITHOUT CLAIM TO ANY PARTICULAR FONT, STYLE, SIZE, OR COLOR.

**CLASS 8—HAND TOOLS**

FOR WALL REPAIR KITS CONSISTING PRIMARILY OF HAND TOOLS, NAMELY, PUTTY KNIVES, SANDING SPONGES AND TRAYS (U.S. CLS. 23, 28 AND 44). FIRST USE 8-1-2006; IN COMMERCE 8-1-2006.

**CLASS 17—RUBBER GOODS**

FOR JOINT COMPOUND; WALL REPAIR KITS CONSISTING PRIMARILY OF JOINT COMPOUND AND JOINT TAPE (U.S. CLS. 1, 5, 12, 13, 35 AND 50). FIRST USE 8-1-2006; IN COMMERCE 8-1-2006. JOANNA DUKOVIC, EXAMINING ATTORNEY

---

SN 78-973,467. MIRALOMA CORPORATION, ANAHEIM, CA. FILED 9-13-2006.



THE MARK CONSISTS OF LETTER "R" ABOVE "V" INTERLOCKING.

**CLASS 3—COSMETICS AND CLEANING PREPARATIONS**

FOR PERFUME, NAMELY, COLOGNES AND SCENTED BODY SPRAYS (U.S. CLS. 1, 4, 6, 50, 51 AND 52).

**CLASS 9—ELECTRICAL AND SCIENTIFIC APPARATUS**

FOR SUNGLASSES (U.S. CLS. 21, 23, 26, 36 AND 38).

**CLASS 14—JEWELRY**

FOR JEWELRY, NAMELY, BRACELETS, NECKLACES, RINGS, EARRINGS, AND WATCHES (U.S. CLS. 2, 27, 28 AND 50).

**CLASS 18—LEATHER GOODS**

FOR WALLETS (U.S. CLS. 1, 2, 3, 22 AND 41).

**CLASS 25—CLOTHING**

FOR CAPS (U.S. CLS. 22 AND 39).

**CLASS 26—FANCY GOODS**

FOR BELT BUCKLES NOT OF PRECIOUS METAL (U.S. CLS. 37, 39, 40, 42 AND 50).

MARK RADEMACHER, EXAMINING ATTORNEY

---

SN 78-973,469. BRIDGET DOBSON STUDIOS, INC., ATLANTA, GA. FILED 9-13-2006.

**Celebration of Mankind**

THE MARK CONSISTS OF STANDARD CHARACTERS WITHOUT CLAIM TO ANY PARTICULAR FONT, STYLE, SIZE, OR COLOR.

**CLASS 16—PAPER GOODS AND PRINTED MATTER**

FOR APPOINTMENT BOOKS; ART PRINTS; ARTS AND CRAFT CLAY KITS; ARTS AND CRAFT PAINT KITS; BABY BOOKS; BOOK COVERS; BOOK-COVER PAPER; BOOKMARKS; CALENDARS; CHILDREN'S ACTIVITY BOOKS; CHILDREN'S BOOKS; CHILDREN'S INTERACTIVE EDUCATIONAL BOOKS; COLORING BOOKS; COMIC BOOKS; COOK BOOKS; CRAFT PAPER; DECORATIVE PAPER CENTERPIECES; DECORATORS' PAINTBRUSHES; DIARIES; ENVELOPES; GIFT WRAP PAPER; PAPER STATIONERY; PHOTOGRAPHIC PRINTS; PHOTOGRAPHS; PRINTED ART REPRODUCTIONS; PRINTED CALENDARS; STATIONERY; STATIONERY BOXES; WEDDING ALBUMS; WEDDING BOOKS (U.S. CLS. 2, 5, 22, 23, 29, 37, 38 AND 50).

**CLASS 20—FURNITURE AND ARTICLES NOT OTHERWISE CLASSIFIED**

FOR BATH PILLOWS; BED FRAMES; BED HEADBOARDS; BEDROOM FURNITURE; BEDS; BENCHES; BUFFETS; CABINETS; CHAIR CUSHIONS; CHAIR MATS IN THE NATURE OF A PILLOW OR SEAT LINER; CHAIR PADS; CHAIRS; CHESTS OF DRAWERS; CUPBOARDS FOR TEA-THINGS CABINETS (CHADANSU); CUSHIONS; DECK CHAIRS; DESKS; DINING CHAIRS; DINING ROOM TABLES; DINING TABLES; DRAWERS; EASY-CHAIRS; ENTERTAINMENT CENTERS; FURNITURE; FURNITURE CHESTS; FURNITURE, NAMELY, DRESSERS; FURNITURE, NAMELY, WALL UNITS; FURNITURE, NAMELY, WARDROBES; HAMPERS; HUTCHES; INDOOR WINDOW BLINDS; KITCHEN CABINETS; LAWN FURNITURE; LIVING ROOM FURNITURE; LOUNGE CHAIRS; MATTRESS CUSHIONS; METAL INDOOR WINDOW BLINDS; MIRROR FRAMES; MIRRORED CABINETS; MIRRORS; NON-METAL CHESTS; NON-METAL FASTENING ANCHORS; NON-METALLIC CHESTS; OFFICE TABLES; OTTOMANS; OUTDOOR FURNITURE; PICTURE FRAME MOLDINGS; PICTURE FRAMES; PILLOWS; PLAQUES; PLASTIC FURNITURE FOR GARDENS; PLASTIC MOLDS FOR USE IN MANUFACTURING FURNITURE, BED LINERS, TRAILER FLOORING AND DECKS; RECLINING CHAIRS; ROCKING CHAIRS; RODS FOR BEDS; SIDEBOARDS; SLEEPER SOFAS; SOFA BEDS; SOFAS; STORAGE RACKS; TABLES; TEA TABLES; UMBRELLA STANDS; WINDOW BLINDS; WINDOW SHADES (U.S. CLS. 2, 13, 22, 25, 32 AND 50).

**CLASS 21—HOUSEWARES AND GLASS**

FOR BAKEWARE; BAKING DISHES; BARWARE, NAMELY, SELTZER BOTTLES; BEER MUGS; BEVERAGE GLASSWARE; BEVERAGEWARE; BOWLS; BREAD BOARDS; BREAD BOXES; BUTTER DISHES; BUTTER PANS; BUTTER-DISH AND CHEESE-DISH COVERS; CAKE PANS; CANDLE HOLDERS NOT OF PRECIOUS METAL; CANDLESTICKS OF GLASS; CANTEENS; CARVING BOARDS; CERAMIC FIGURINES; CERAMIC SCULPTURES, VASES, VESSELS, BOWLS, PLATES AND POTS; CHAMPAGNE BUCKETS; CHINA ORNAMENTS; COOKING POTS; COOKWARE, NAMELY POTS AND PANS; CREAMER PITCHERS; DINNERWARE; DINNERWARE, NAMELY, PLATES, CUPS, BOWLS, PLATTERS; DISH DRYING RACKS; DISHES; DISHES AND PLATES; DRINKING GLASSES; EARTHENWARE MUGS; EGG CUPS; FIGURINES OF CHINA, CRYSTAL, EARTHENWARE, GLASS, PORCELAIN; GLASS BEVERAGEWARE; GLASS BOWLS; GLASS DISHES; JUGS; KETTLES; KITCHEN LADLES; MUGS; NAPKIN HOLDERS; NAPKIN HOLDERS AND NAPKIN RINGS NOT OF PRECIOUS METAL; NAPKIN RINGS NOT OF PRECIOUS METALS; ORNAMENTS OF CHINA, CRYSTAL, EARTHENWARE, GLASS, PORCELAIN; OVEN TO TABLE RACKS; OVENWARE; PANS; PLATES; PLATES FOR HORS D'OEUVRE; PORCELAIN MUGS; PORCELAIN OR EARTHENWARE DOORKNOBS; PORTABLE BEVERAGE COOLERS; PORTABLE COOLERS; POTS; SALAD BOWLS; SALT AND PEPPER SHAKERS; SALT SHAKERS; SAUCEPANS; SERVING PLATTERS; SERVING SPOONS; STEMWARE; TEA SETS; TRIVETS; VANITY CASES (U.S. CLS. 2, 13, 23, 29, 30, 33, 40 AND 50).

LA TONIA FISHER, EXAMINING ATTORNEY

SN 78-973,656. DAVIES, ERICA, SANTA MONICA, CA. FILED 9-13-2006.

**ERICA DAVIES**

THE MARK CONSISTS OF STANDARD CHARACTERS WITHOUT CLAIM TO ANY PARTICULAR FONT, STYLE, SIZE, OR COLOR.

THE NAME(S), PORTRAIT(S), AND/OR SIGNATURE(S) SHOWN IN THE MARK IDENTIFIES ERICA DAVIES, WHOSE CONSENT(S) TO REGISTER IS SUBMITTED.

**CLASS 18—LEATHER GOODS**

FOR (BASED ON USE IN COMMERCE) HANDBAGS, SHOULDER BAGS, PURSES; (BASED ON INTENT TO USE) TOTE BAGS, CLUTCH PURSES, COSMETICS CASES SOLD EMPTY, OVERNIGHT BAGS, ATHLETIC BAGS, BACKPACKS, KNAPSACKS, DAYPACKS, FANNY PACKS, WALLET, COIN PURSES, CREDIT CARD CASES, KEY CASES, LEATHER KEY CHAINS, CARRY-ON BAGS AND LUGGAGE (U.S. CLS. 1, 2, 3, 22 AND 41). FIRST USE 7-0-2003; IN COMMERCE 7-0-2003.

**CLASS 25—CLOTHING**

FOR (BASED ON USE IN COMMERCE) SKIRTS, DRESSES, TOPS, BLOUSES; (BASED ON INTENT TO USE) CLOTHING, NAMELY, SHIRTS, T-SHIRTS, JACKETS, BLAZERS, SUITS, PANTS, TROUSERS, SHORTS, JEANS, SWEAT SHIRTS, SWEAT PANTS, SWEATSUITS, SWEATERS, VESTS, JUMPSUITS, JUMPERS, PAJAMAS, ROBES, NIGHT GOWNS, SLEEPWEAR, LEOTARDS, SINGLETS, LINGERIE, UNDERWEAR, PANTIES, BRAS, BOXER SHORTS, SWIM WEAR, BATHING SUITS, COVER-UPS, HATS, CAPS, BERETS, HEADBANDS, WRISTBANDS, VISORS, SCARVES, BELTS, NECKTIES, SOCKS, STOCKINGS, TIGHTS, LEGGINGS, GLOVES, MITTENS, COATS AND RAINCOATS; FOOTWEAR, NAMELY, SHOES, SLIPPERS, BOOTS, SANDALS, FLIP FLOPS, AND ATHLETIC SHOES (U.S. CLS. 22 AND 39).

FIRST USE 7-0-2003; IN COMMERCE 7-0-2003.

MARIAM MAHMOUDI, EXAMINING ATTORNEY

SN 78-973,786. INSPIRE U, LLC, TEMECULA, CA. FILED 9-13-2006.

**Lauren**

THE MARK CONSISTS OF STANDARD CHARACTERS WITHOUT CLAIM TO ANY PARTICULAR FONT, STYLE, SIZE, OR COLOR.

**CLASS 16—PAPER GOODS AND PRINTED MATTER**

FOR CHILDREN'S BOOKS (U.S. CLS. 2, 5, 22, 23, 29, 37, 38 AND 50).

**CLASS 28—TOYS AND SPORTING GOODS**

FOR DOLLS AND ACCESSORIES THEREFOR (U.S. CLS. 22, 23, 38 AND 50).

JOANNA DUKOVIC, EXAMINING ATTORNEY

SN 78-973,848. INSPIRE U, LLC, TEMECULA, CA. FILED 9-13-2006.

SN 78-974,864. ILLINOIS TOOL WORKS INC., GLENVIEW, IL. FILED 9-14-2006.

# Natalie



THE MARK CONSISTS OF STANDARD CHARACTERS WITHOUT CLAIM TO ANY PARTICULAR FONT, STYLE, SIZE, OR COLOR.

**CLASS 16—PAPER GOODS AND PRINTED MATTER**

FOR CHILDREN'S BOOKS (U.S. CLS. 2, 5, 22, 23, 29, 37, 38 AND 50).

**CLASS 28—TOYS AND SPORTING GOODS**

FOR DOLLS AND ACCESSORIES THEREFOR (U.S. CLS. 22, 23, 38 AND 50).  
JOANNA DUKOVIC, EXAMINING ATTORNEY

**CLASS 9—ELECTRICAL AND SCIENTIFIC APPARATUS**

FOR PROVIDING DOWNLOADABLE ELECTRONIC NEWSLETTERS IN THE FIELD OF PAD PRINTING (U.S. CLS. 21, 23, 26, 36 AND 38).  
FIRST USE 9-13-2006; IN COMMERCE 9-13-2006.

**CLASS 41—EDUCATION AND ENTERTAINMENT**

FOR PROVIDING ELECTRONIC NEWSLETTERS IN THE FIELD OF PAD PRINTING VIA E-MAIL (U.S. CLS. 100, 101 AND 107).  
FIRST USE 9-13-2006; IN COMMERCE 9-13-2006.  
KEVIN CORWIN, EXAMINING ATTORNEY

SN 78-974,981. WORD ACTIVE WEAR, FRISCO, TX. FILED 9-14-2006.

SN 78-973,935. INSPIRE U, LLC, TEMECULA, CA. FILED 9-13-2006.

# Nika



THE MARK CONSISTS OF STANDARD CHARACTERS WITHOUT CLAIM TO ANY PARTICULAR FONT, STYLE, SIZE, OR COLOR.

**CLASS 16—PAPER GOODS AND PRINTED MATTER**

FOR CHILDREN'S BOOKS (U.S. CLS. 2, 5, 22, 23, 29, 37, 38 AND 50).

**CLASS 28—TOYS AND SPORTING GOODS**

FOR DOLLS AND ACCESSORIES THEREFOR (U.S. CLS. 22, 23, 38 AND 50).  
JOANNA DUKOVIC, EXAMINING ATTORNEY

THE MARK CONSISTS OF WORDACTIVE WEAR. WORDACTIVEWEAR. IN A DESIGN OF A CIRCLE AND INSIDE OF THAT CIRCLE WA.

**CLASS 25—CLOTHING**

FOR T-SHIRTS (U.S. CLS. 22 AND 39).

**CLASS 35—ADVERTISING AND BUSINESS**

FOR ON-LINE RETAIL STORE SERVICES FEATURING T-SHIRTS (U.S. CLS. 100, 101 AND 102).  
CURTIS FRENCH, EXAMINING ATTORNEY

SN 78-977,843. WALTON, ADRIAN GEORGE, ILKLEY, WEST YORKSHIRE, UNITED KINGDOM, FILED 7-15-2005.

SN 78-978,034. EVENT MALL, INC., ORLANDO, FL. FILED 7-14-2004.

# ICELOLLY

# ABSOLUTE AMUSEMENTS

THE MARK CONSISTS OF STANDARD CHARACTERS WITHOUT CLAIM TO ANY PARTICULAR FONT, STYLE, SIZE, OR COLOR.

PRIORITY CLAIMED UNDER SEC. 44(D) ON UNITED KINGDOM APPLICATION NO. 0870285001, FILED 7-15-2005, REG. NO. 2396945, DATED 6-23-2006, EXPIRES 7-15-2015.

## CLASS 9—ELECTRICAL AND SCIENTIFIC APPARATUS

FOR SUNGLASSES; MOBILE PHONES; APPARATUS AND INSTRUMENTS FOR THE RECORDING, TRANSMISSION OR REPRODUCTION OF SOUND OR IMAGES; RADIOS, COMPACT DISC PLAYERS, DVD PLAYERS, MP3 PLAYERS (U.S. CLS. 21, 23, 26, 36 AND 38).

## CLASS 24—FABRICS

FOR TOWELS, BEACH TOWELS; HOUSEHOLD LINENS; BEDDING, NAMELY BED LINEN, BED SHEETS, BED SPREADS (U.S. CLS. 42 AND 50).

## CLASS 25—CLOTHING

FOR ARTICLES OF CLOTHING AND HEADGEAR, NAMELY BEACHWEAR, FOOTWEAR, HATS, COATS, JACKETS, TROUSERS, JEANS, SHORTS, SHIRTS, T-SHIRTS, SWEATSHIRTS (U.S. CLS. 22 AND 39).

## CLASS 36—INSURANCE AND FINANCIAL

FOR FINANCIAL AFFAIRS AND SERVICES, NAMELY FINANCIAL PLANNING AND PORTFOLIO MANAGEMENT; CREDIT SERVICES, NAMELY CREDIT CARD AND DEBIT CARD SERVICES (U.S. CLS. 100, 101 AND 102).

## CLASS 39—TRANSPORTATION AND STORAGE

FOR TRAVEL GUIDE SERVICES; TRAVEL ARRANGEMENT SERVICES, NAMELY MAKING RESERVATIONS AND BOOKINGS FOR TRANSPORTATION; ORGANIZATION, BOOKING, AND ARRANGEMENT OF EXCURSIONS, SIGHTSEEING TOURS, HOLIDAYS, DAY TRIPS, TOURS AND TRAVEL (U.S. CLS. 100 AND 105).

## CLASS 43—HOTEL AND RESTAURANT SERVICES

FOR TRAVEL AGENCY SERVICES, NAMELY, MAKING RESERVATIONS AND BOOKINGS FOR TEMPORARY LODGING FOR HOLIDAYS AND TOURS, RESTAURANTS AND MEALS; RESTAURANT AND CAFE SERVICES (U.S. CLS. 100 AND 101).  
AMEETA JORDAN, EXAMINING ATTORNEY

THE MARK CONSISTS OF STANDARD CHARACTERS WITHOUT CLAIM TO ANY PARTICULAR FONT, STYLE, SIZE, OR COLOR.

NO CLAIM IS MADE TO THE EXCLUSIVE RIGHT TO USE "AMUSEMENTS", APART FROM THE MARK AS SHOWN.

## CLASS 35—ADVERTISING AND BUSINESS

FOR RETAIL STORE AND WHOLE SALE DISTRIBUTORSHIP SERVICES IN THE FIELD OF AMUSEMENT DEVICES; MANAGEMENT OF AMUSEMENT SYSTEMS AND AMUSEMENT DEVICES FOR OTHERS (U.S. CLS. 100, 101 AND 102).

FIRST USE 0-0-1991; IN COMMERCE 0-0-1991.

## CLASS 37—CONSTRUCTION AND REPAIR

FOR REPAIR OF AMUSEMENT SYSTEMS AND AMUSEMENT DEVICES FOR OTHERS (U.S. CLS. 100, 103 AND 106).

FIRST USE 0-0-1991; IN COMMERCE 0-0-1991.

## CLASS 41—EDUCATION AND ENTERTAINMENT

FOR RENTAL AND LEASE OF AMUSEMENT SYSTEMS AND AMUSEMENT DEVICES (U.S. CLS. 100, 101 AND 107).

FIRST USE 0-0-1991; IN COMMERCE 0-0-1991.

MELVIN AXILBUND, EXAMINING ATTORNEY

SN 79-003,999. BRETON SPA, ITALY, FILED 3-18-2004.

# BRETONTERASTONE

THE MARK CONSISTS OF STANDARD CHARACTERS WITHOUT CLAIM TO ANY PARTICULAR FONT, STYLE, SIZE, OR COLOR.

PRIORITY DATE OF 2-10-2004 IS CLAIMED.  
OWNER OF INTERNATIONAL REGISTRATION 0829398 DATED 3-18-2004, EXPIRES 3-18-2014.  
OWNER OF U.S. REG. NO. 1,356,244.

**CLASS 7—MACHINERY**

FOR MACHINES FOR MANUFACTURING COMPOUND STONE AND CERAMIC MATERIALS FOR USE IN BUILDING CONSTRUCTION AND FURNITURE; MACHINES AND TRANSPORT, HANDLING AND STORING EQUIPMENT FOR PROCESSING NATURAL STONES, ARTIFICIAL STONES, COMPOUND STONES, CERAMIC AND GLASS MATERIALS, NAMELY, AUTOMATIC OR PROGRAMMABLE BLOCK SAW MACHINES, AUTOMATIC OR PROGRAMMABLE SLAB AND TILE SAW MACHINES, SLAB AND TILE CALIBRATING, GRINDING, POLISHING AND DRESSING MACHINES, CUTTING MACHINES, WAXING MACHINES, SQUARING AND CHAMFERING MACHINES, EDGE SHAVING AND POLISHING MACHINES, CONTOURING MACHINES, RESTORING, REINFORCING AND COATING MACHINES; AND REPLACEMENT PARTS FOR THE AFORESAID GOODS (U.S. CLS. 13, 19, 21, 23, 31, 34 AND 35).

**CLASS 19—NON-METALLIC BUILDING MATERIALS**

FOR NATURAL STONE, COMPOUND STONE AND CERAMIC MATERIAL, NAMELY, BLOCKS, SLABS, TILES AND OTHER SET MOLDED FORMS OF STONE AND CERAMIC FOR USE IN BUILDING CONSTRUCTION AND FURNITURE; NON-METALLIC COMPOSITE MATERIALS, NAMELY, NATURAL STONE, COMPOUND STONE AND CERAMIC MATERIALS, REINFORCED OR COATED WITH ELEMENTS COMPRISED OF FIBERS, MAT, WEB OR COMPOUNDED NATURAL LAYERS OF SAID MATERIALS FOR USE IN BUILDING CONSTRUCTION AND FURNITURE (U.S. CLS. 1, 12, 33 AND 50).

VERNA BETH RIRIE, EXAMINING ATTORNEY

SN 79-010,078. THERMOHAUSER GMBH, FED REP GERMANY, FILED 10-21-2004.



PRIORITY DATE OF 5-14-2004 IS CLAIMED.  
OWNER OF INTERNATIONAL REGISTRATION 0846884  
DATED 10-21-2004, EXPIRES 10-21-2014.

**CLASS 8—HAND TOOLS**

FOR MANUALLY OPERATED TOOLS AND IMPLEMENTS FOR HOUSEHOLD AND KITCHEN, NAMELY, CUTLERY NOT MADE FROM OR COATED WITH PRECIOUS METAL, FORKS, SPOONS, SERVING TONGS (U.S. CLS. 23, 28 AND 44).

**CLASS 9—ELECTRICAL AND SCIENTIFIC APPARATUS**

FOR MEASURING SPOONS (U.S. CLS. 21, 23, 26, 36 AND 38).

**CLASS 16—PAPER GOODS AND PRINTED MATTER**

FOR GOODS OF PAPER AND PAPERBOARD, NAMELY, TABLE MATS OF PAPER (U.S. CLS. 2, 5, 22, 23, 29, 37, 38 AND 50).

**CLASS 20—FURNITURE AND ARTICLES NOT OTHERWISE CLASSIFIED**

FOR GOODS MADE OF PLASTIC, NAMELY, PLASTIC STORAGE CONTAINERS FOR INDUSTRIAL OR COMMERCIAL USE ESPECIALLY CANS, BOXES AND CASES; AND PLASTIC TRANSPORT CONTAINERS FOR INDUSTRIAL OR COMMERCIAL USE TO TRANSPORT FOOD (U.S. CLS. 2, 13, 22, 25, 32 AND 50).

**CLASS 21—HOUSEWARES AND GLASS**

FOR UTENSILS AND CONTAINERS FOR HOUSEHOLD AND KITCHEN, NAMELY, CONFECTIONERS' DECORATING BAGS, POURING SPOUTS, DISHES, BAKING MOULDS, BAKING MATS, WHISKS, THERMAL INSULATED CONTAINERS FOR FOOD, BEVERAGE GLASSWARE FOR HOUSEHOLD AND KITCHEN; PAPER GLOVES FOR HOUSEHOLD AND KITCHEN; PASTRY BRUSHES (U.S. CLS. 2, 13, 23, 29, 30, 33, 40 AND 50).

**CLASS 25—CLOTHING**

FOR CLOTHING, NAMELY, APRONS, CHEF HATS, GLOVES (U.S. CLS. 22 AND 39).

ADA HAN, EXAMINING ATTORNEY

SN 79-012,877. ROULUNDS RUBBER A/S, DENMARK, FILED 7-14-2005.

# ROFLEX

THE MARK CONSISTS OF STANDARD CHARACTERS WITHOUT CLAIM TO ANY PARTICULAR FONT, STYLE, SIZE, OR COLOR.  
OWNER OF INTERNATIONAL REGISTRATION 0799115  
DATED 2-17-2003, EXPIRES 2-17-2013.

**CLASS 7—MACHINERY**

FOR DRIVING BELTS NOT FOR VEHICLES, NAMELY V-BELTS AND FAN BELTS (U.S. CLS. 13, 19, 21, 23, 31, 34 AND 35).

**CLASS 12—VEHICLES**

FOR DRIVING BELTS FOR VEHICLES (U.S. CLS. 19, 21, 23, 31, 35 AND 44).

RICHARD WHITE, EXAMINING ATTORNEY

SN 79-013,474. FUTBOL CLUB BARCELONA, SPAIN, FILED 10-21-2004.



PRIORITY DATE OF 5-26-2004 IS CLAIMED.  
OWNER OF INTERNATIONAL REGISTRATION 0856993 DATED 10-21-2004, EXPIRES 10-21-2014.

NO CLAIM IS MADE TO THE EXCLUSIVE RIGHT TO USE "ON TOUR", APART FROM THE MARK AS SHOWN.

THE COLOR(S) RED, BLUE, MAROON, YELLOW, WHITE, GOLD AND BLACK IS/ARE CLAIMED AS A FEATURE OF THE MARK.

THE COLOR BLACK APPEARS IN THE LETTERS FCB AND FCBARCELONA, AND THE OUTLINE OF THE SHIELD AND THE INNER OUTLINE OF THE SHIELD; THE COLOR BLUE APPEARS IN THE UPPER LEFT AND LOWER RIGHT WINGS; THE COLOR MAROON APPEARS IN THE UPPER RIGHT AND LOWER LEFT WINGS, AND THE COLORS BLUE AND MAROON ALTERNATE IN THE STRIPES IN THE LOWER PART OF THE SHIELD, STARTING, FROM THE LEFT, WITH BLUE, THEN MAROON, AND SO ON; THE COLOR GOLD APPEARS IN THE INSIDE OF THE SHIELD AND IN THE SOCCER BALL, WITH BLACK LINING IN THE SOCCER BALL; THE COLOR YELLOW AND RED ALTERNATE IN THE STRIPES IN THE UPPER RIGHT SECTION OF THE SHIELD, STARTING, FROM THE LEFT, WITH YELLOW, THEN RED, AND SO ON, AND THE COLOR RED APPEARS IN THE CROSS IN THE UPPER LEFT PART OF THE SHIELD; THE COLOR WHITE APPEARS AS THE BACKGROUND TO THE RED CROSS, AND AS THE BACKGROUND OF THE ENTIRE MARK.

#### CLASS 25—CLOTHING

FOR CLOTHING, NAMELY, JUMPERS, TROUSERS; SOCKS, STOCKINGS, GLOVES; BOOTS, SHOES AND SLIPPERS; CAPS, BERETS, SHIRTS, T-SHIRTS, SWEAT-SHIRTS, SWEAT-PANTS, SHORTS, BLOUSES, JERKINS, JACKETS, SOCK SUSPENDERS, UNDERWEAR, PAJAMAS, NIGHT GOWNS; WAISTCOAT, CAPES, SCARVES, COATS, SHAWLS, PULLOVERS, SKIRTS, DRESSES, TIES, BELT OF TEXTILE, TROUSER SUSPENDERS, BATHING SUITS; SPORT CLOTHING INCLUDED IN THIS CLASS, NAMELY, BASKETBALL JERSEYS, FOOTBALL/SOCCER SHORTS AND JERSEYS, TEXTILE NAPPIES, BOAS FOR WEARING AROUND THE NECK; NON-ELECTRIC FOOT MUFFS AND BIRETTA; CLOTH BIBS; HALF BELTS, GLOVES FOR SPORTS, INCLUDED IN THIS CLASS, NAMELY, SKI GLOVES, SKATEBOARD GLOVES, AND RIDING GLOVES; FOOTBALL/SOCCER BOOTS, TOE CAPS, IRON FITTINGS FOR SPORTS SHOE WEAR, INCLUDED IN THIS CLASS, NAMELY, CLEATS FOR ATTACHMENT TO SPORTS FOOTWEAR; PUMPS, STOLERS, BRASSIERES, LIVERIES, SHIRT FRONTS, PELISSES; PELERINES; SHOE SOLES, NAMELY INNER SOLES, OUTER SOLES; SHOE SOLES; SUITS, HAT FRAMES, SLIPS, FOOTWEAR AND HEADWEAR, HOSIERY; HEADWEAR ARTICLES, NAMELY, HEAD BANDS (U.S. CLS. 22 AND 39).

#### CLASS 28—TOYS AND SPORTING GOODS

FOR GAMES, NAMELY ACTION SKILL GAMES, BOARD GAMES, CARD GAMES, DART BOARDS, DICE GAMES, HAND HELD UNIT FOR PLAYING VIDEO GAMES, CHESS SETS, AND PUZZLES; TOYS, NAMELY, DRESSES FOR DOLLS, ACTION FIGURES, BATH TOYS, BOBBLE-HEAD DOLLS, INFANT TOYS, INFLATABLE TOYS, PET TOYS, PLUSH TOYS, STUFFED TOYS; GLOVES FOR GOALKEEPERS, HOCKEY GLOVES, GOLF GLOVES; FOOTBALLS, SOCCER BALLS, BASKETBALLS, BASKETBALL NETS, TENNIS EQUIPMENT, NAMELY, TENNIS BALLS, NETS, RACKETS, RACKET COVERS, RACKET STRINGS, RACKET PRESSES AND UPRIGHTS; SPORTING ARTICLES RELATED TO SOCCER, NAMELY, SOCCER KNEE PADS, LEG PADS, ELBOW PADS AND GOAL NETS; HEADWEAR ARTICLES, NAMELY, HEADGUARDS FOR KARATE; ORNAMENTS AND DECORATIONS FOR CHRISTMAS TREES (U.S. CLS. 22, 23, 38 AND 50).

#### CLASS 41—EDUCATION AND ENTERTAINMENT

FOR EDUCATIONAL SERVICES, NAMELY, PROVIDING CLASSES IN THE FIELD OF SOCCER; EDUCATIONAL SERVICES, NAMELY, PROVIDING INFORMATION ABOUT CULTURAL AND SPORTING ACTIVITIES THROUGH WORLD WIDE WEBS; TRAINING IN THE FIELD OF PLAYING SOCCER; TRAINING, NAMELY PROVIDING FIELDS AND FACILITIES FOR SPORTS ACTIVITIES AND TRAINING; ORGANIZING AND CONDUCTING SPORTING AND CULTURAL ACTIVITIES, NAMELY, SOCCER GAMES, BASKETBALL EXHIBITIONS, ART SHOWS, LIVE MUSICAL CONCERTS; ENTERTAINMENT SERVICES, NAMELY, ORGANIZING AND PRESENTING LIVE SPORTING EVENTS; SERVICES OF A SPORTS CLUB, NAMELY, PROVIDING ENTERTAINMENT INFORMATION RELATED WITH SPORTS; ORGANIZATION OF DISCUSSIONS, CONFERENCES, CONVENTIONS, SEMINARS AND SYMPOSIUMS IN THE FIELDS OF ENDORSEMENTS AND TAXES FOR ATHLETES AND PUBLIC FIGURES; UNIVERSITY EDUCATION, NAMELY EDUCATION SERVICES IN THE NATURE OF COURSES AT THE UNIVERSITY LEVEL; ORGANIZATION OF EXHIBITIONS FOR CULTURAL AND EDUCATIONAL PURPOSES; SPORTS EVENT ORGANIZATION; ORGANIZATION OF PRIZES, CONTESTS AND COMPETITIONS IN THE FIELD OF SOCCER (U.S. CLS. 100, 101 AND 107).

ESTHER BELENKER, EXAMINING ATTORNEY

SN 79-013,758. INVARIS INFORMATIONSSYSTEME GMBH, AUSTRIA, FILED 5-23-2005.

# INVARIS

THE MARK CONSISTS OF STANDARD CHARACTERS WITHOUT CLAIM TO ANY PARTICULAR FONT, STYLE, SIZE, OR COLOR.

OWNER OF INTERNATIONAL REGISTRATION 0782291 DATED 12-14-2001, EXPIRES 12-14-2011.

#### CLASS 9—ELECTRICAL AND SCIENTIFIC APPARATUS

FOR SOFTWARE FOR PROGRAMMING AND PRINTING FORMS AND DOCUMENTS, NAMELY, SOFTWARE FOR USE AS A SPREADSHEET, AND FOR USE IN WORD PROCESSING, AND FORMS AND TEMPLATES THEREFOR (U.S. CLS. 21, 23, 26, 36 AND 38).

**CLASS 38—COMMUNICATION**

FOR ELECTRONIC SERVICES FOR COMMUNICATION, NAMELY, COMMUNICATION BY ELECTRONIC COMPUTER TERMINALS AND TRANSMISSION OF INFORMATION BY ELECTRONIC COMMUNICATIONS NETWORKS; TELECOMMUNICATIONS SERVICES IN CONNECTION WITH SURVEILLANCE, OUTPUT AND RECEIVING OF DATA, SIGNALS AND INFORMATION PROCESSED BY COMPUTER OR VIA TELECOMMUNICATIONS APPARATUS, NAMELY, WIRELESS ELECTRONIC TRANSMISSION OF DATA, FACSIMILES, IMAGES AND INFORMATION; EXCHANGING MESSAGES BY TRANSMISSION OF DATA BY MEANS OF COMPUTER, NAMELY, ELECTRONIC TRANSMISSION OF MESSAGE AND DATA VIA THE INTERNET; EXCHANGING ELECTRONIC DOCUMENTS, NAMELY, ELECTRONIC TRANSMISSION OF DOCUMENTS VIA COMPUTER TERMINALS; ELECTRONIC TRANSMISSION OF INFORMATION FROM DATA BANKS WITH DIRECT ONLINE ACCESS, NAMELY, VIA COMPUTER TERMINALS (U.S. CLS. 100, 101 AND 104).

**CLASS 41—EDUCATION AND ENTERTAINMENT**

FOR PUBLISHING OF ELECTRONIC PUBLICATIONS, ACCOUNTING FORMS AND DOCUMENTS, NAMELY, DOCUMENTS IN THE FIELD OF BANKING, INSURANCE, TRAINING, AND SCIENCE (U.S. CLS. 100, 101 AND 107).

**CLASS 42—SCIENTIFIC, COMPUTER AND LEGAL SERVICES**

FOR PROGRAMMING AND DEVELOPMENT OF PROCESSES FOR THE ELECTRONIC ADMINISTRATION OF DATA BY MEANS OF COMPUTER, NAMELY, COMPUTER PROGRAMMING FOR OTHERS AND DEVELOPMENT OF DATA PROCESSING PROGRAMS BY ORDER OF THIRD PARTIES; RENTAL OF COMPUTER SOFTWARE; DEVELOPMENT OF ELECTRONIC DATA PROCESSING PROGRAMS BY ORDER OF THIRD PARTIES; DEVELOPMENT OF INFORMATION AND DATA BASES FOR DATA MANAGEMENT AND PROCESSING; COMPUTER SERVICE, NAMELY, ACTING AS AN APPLICATION SERVICE PROVIDER IN THE FIELD OF KNOWLEDGE MANAGEMENT TO HOST COMPUTER APPLICATION SOFTWARE FOR CREATING SEARCHABLE DATABASES OF INFORMATION AND DATA; COMPUTER SOFTWARE CONSULTATION IN THE FIELD OF DATA PROCESSING (U.S. CLS. 100 AND 101).

ANDREA K. NADELMAN, EXAMINING ATTORNEY

SN 79-014,385. GD GAMEDUELL GMBH, FED REP GERMANY, FILED 4-13-2004.



PRIORITY DATE OF 10-14-2003 IS CLAIMED.  
OWNER OF INTERNATIONAL REGISTRATION 0859356 DATED 4-13-2004, EXPIRES 4-13-2014.

THE COLOR(S) RED, YELLOW, ORANGE, BLACK IS/ ARE CLAIMED AS A FEATURE OF THE MARK.

THE COLOR RED APPEARS IN THE UPPER DOT OF THE COLON AND IN THE BIGGEST FLAME OF THE LAST LETTER OF THE MARK. THE COLOR ORANGE APPEARS IN THE LOWER DOT OF THE COLON AND IN THE FLAME ABOVE THE LETTERS "EL" OF THE MARK. THE COLOR YELLOW APPEARS IN THE SMALLEST OF THE FLAMES AT THE END OF THE LAST LETTER "L" OF THE MARK.

**CLASS 9—ELECTRICAL AND SCIENTIFIC APPARATUS**

FOR DOWNLOADABLE COMPUTER SOFTWARE AND PROGRAMS FOR PLAYING GAMES ON COMPUTERS, ACCESSIBLE VIA DATA BASES, ON THE INTERNET; NETWORKED AND STAND ALONE INTERACTIVE MEDIA NAMELY SOFTWARE FOR USE IN DATABASE MANAGEMENT, FOR USE AS A SPREADSHEET, FOR WORD PROCESSING AND FOR OPERATING OTHER DATA DEVICES NAMELY, COMPUTERS, DEVICES FOR INTERACTIVE TELEVISION AND COMPUTER TERMINALS, MOBILE TELEPHONES, WIRELESS RADIO TRANSMISSION AND ENTERTAINMENT COMPUTER TERMINALS AVAILABLE BY DATA BASES OR OVER THE INTERNET (U.S. CLS. 21, 23, 26, 36 AND 38).

**CLASS 28—TOYS AND SPORTING GOODS**

FOR ARCADE-TYPE ELECTRONIC VIDEO GAMES AND STAND ALONE VIDEO OUTPUT GAME MACHINES FOR PLAYING ELECTRONIC COMPUTER AND VIDEO GAMES NAMELY, SKILL GAMES, TRIVIA GAMES, PUZZLE GAMES, CARD GAMES, ACTION GAMES, GAMES OF CHANCE AND MULTI-PLAYER GAMES (U.S. CLS. 22, 23, 38 AND 50).

**CLASS 38—COMMUNICATION**

FOR TELECOMMUNICATION SERVICES, IN PARTICULAR, OVER THE INTERNET, NAMELY PROVIDING MULTIPLE USER DIAL-UP AND DEDICATED ACCESS TO THE INTERNET, INSTANT MESSENGER AND E-MAIL SERVICES, PROVIDING ON-LINE CHAT ROOMS IN THE FIELD OF GAMING, SOCIAL NETWORKING, DATING, LIFE COUNSELING, BUYING AND SELLING GOODS, PROVIDING ON-LINE DISCUSSION FORUMS FOR TRANSMISSION OF MESSAGES AMONG COMPUTER USERS IN THE FIELD OF GAMING, SOCIAL NETWORKING, DATING, LIFE COUNSELING, BUYING AND SELLING GOODS AND INTERNET TELEPHONY SERVICES; TRANSMISSION OF INFORMATION BY ELECTRONIC TELECOMMUNICATIONS NETWORKS FOR THE PURPOSE OF PROVIDING ACCESS TO ONLINE COMPUTER AND VIDEO GAME PLAY; SERVICES OF AN ONLINE-SERVICE PROVIDER, NAMELY PROVIDING E-MAIL DATA SERVICES, TRANSMISSION OF ELECTRONIC MAIL, AND MANAGEMENT OF ON-LINE CHAT ROOMS FOR TRANSMISSION OF MESSAGES AMONG COMPUTER USERS CONCERNING TOPICS OF GAMES AND GAMING-EVENTS, NEWS AND PUBLICATIONS CONCERNING GAMING AND BUILDING A GAMING COMMUNITY, MEETING GAMING PARTNERS; SIGNAL TRANSMISSION FOR ELECTRONIC COMMERCE VIA TELECOMMUNICATION SYSTEMS AND DATA COMMUNICATIONS SYSTEMS; PROVIDING ACCESS TO DIGITAL TELECOMMUNICATIONS NETWORKS; SERVICES OF A NETWORK OPERATOR, NAMELY, PROVIDING MULTIPLE-USER ACCESS TO A GLOBAL COMPUTER INFORMATION NETWORK; TRANSMISSION OF INFORMATION VIA NATIONAL AND INTERNATIONAL NETWORKS, NAMELY, THE INTERNET (U.S. CLS. 100, 101 AND 104).

**CLASS 41—EDUCATION AND ENTERTAINMENT**

FOR ENTERTAINMENT SERVICES, NAMELY, OFFERING ON-LINE AND OFF-LINE PLAY OF SKILL GAMES, TRIVIA GAMES, PUZZLE GAMES, CARD GAMES, ACTION GAMES, GAMES OF CHANCE, MULTI-PLAYER GAMES AND ARCADE-TYPE ELECTRONIC VIDEO GAMES THAT ARE DESIGNED FOR PLAY ON NETWORKED AND STAND ALONE INTERACTIVE MEDIA NAMELY, WIRELESS DEVICES, INTERACTIVE TELEVISION AND ENTERTAINMENT TERMINAL; ENTERTAINMENT SERVICES NAMELY, ORGANIZATION AND PROVIDING FOR PLAY OF SKILL GAMES, TRIVIA GAMES, PUZZLE GAMES, CARD GAMES, ACTION GAMES, GAMES OF CHANCE, MULTI-PLAYER GAMES AND ARCADE-TYPE ELECTRONIC VIDEO GAMES THAT ARE DESIGNED FOR PLAY ON NETWORKED AND OTHER INTERACTIVE MEDIA, NAMELY, WIRELESS DEVICES, INTERACTIVE TELE-



VISION AND ENTERTAINMENT TERMINALS OFFERED AT ORGANIZED EVENTS IN THEME PARKS AND RESTAURANTS; PUBLICATION OF PRINTED MATTER NAMELY, DAILY, WEEKLY, MONTHLY, YEARLY, AND IRREGULARLY PUBLISHED NEWS AND NEWS FEATURES ABOUT THE STOCK OFFERINGS, PUBLIC RELATIONS MATERIALS, INVESTOR RELATIONS MATERIALS, GAMING INDUSTRY NEWS, USER EXPERIENCE AND CONTRIBUTIONS, AS WELL AS PARTNER NEWS; PROVIDING A WEB SITE FEATURING MUSICAL PERFORMANCES, MUSICAL VIDEOS RELATED FILM CLIPS, PHOTOGRAPHS AND OTHER MULTIMEDIA MATERIALS (U.S. CLS. 100, 101 AND 107).

#### **CLASS 42—SCIENTIFIC, COMPUTER AND LEGAL SERVICES**

FOR DESIGN AND DEVELOPMENT OF COMPUTER SOFTWARE; DESIGN OF COMPUTER SOFTWARE, IN PARTICULAR FOR COMPUTER AND VIDEO GAMES, FOR OTHERS; DEVELOPMENT AND MAINTENANCE OF DATA PROCESSING PROGRAMS; SERVICES OF A NETWORK OPERATOR AND PROVIDER, NAMELY RENTING DATABASE SERVERS TO THIRD PARTIES; SERVICES OF A NETWORK OPERATOR, NAMELY, PROVIDING TEMPORARY USE OF NON-DOWNLOADABLE COMPUTER SOFTWARE FOR PREPARING INVOICES OVER COMPUTER NETWORKS; SERVICES OF A NETWORK OPERATOR, NAMELY TECHNICAL SUPPORT, NAMELY, MONITORING OF NETWORK SYSTEMS (U.S. CLS. 100 AND 101).

RICHARD WHITE, EXAMINING ATTORNEY

#### **CLASS 11—ENVIRONMENTAL CONTROL APPARATUS**

FOR APPARATUS FOR LIGHTING, HEATING, STEAM GENERATING, REFRIGERATING, DRYING, VENTILATING, NAMELY, HUMIDIFIER APPARATUS AND PARTS THEREFORE FOR GENERATING AND CONTROLLING HUMID AIR STREAMS; APPARATUS FOR LIGHTING, HEATING, STEAM GENERATING, REFRIGERATING, DRYING, VENTILATING, NAMELY, HUMIDIFIER APPARATUS AND PARTS THEREFORE FOR GENERATING AND CONTROLLING HUMID AIR STREAMS FOR CRYSTALLOGRAPHIC ANALYSIS AND OPTIMIZATION OF PROTEINS AND PROTEIN CRYSTALS (U.S. CLS. 13, 21, 23, 31 AND 34).

#### **CLASS 42—SCIENTIFIC, COMPUTER AND LEGAL SERVICES**

FOR SCIENTIFIC RESEARCH AND DEVELOPMENT; TECHNOLOGICAL RESEARCH AND DEVELOPMENT IN THE FIELD OF CRYSTALLOGRAPHY, X-RAY STRUCTURE ANALYSIS, AND PROTEIN AND PROTEIN-LIGAND STRUCTURE ANALYSIS; INDUSTRIAL ANALYSIS AND RESEARCH SERVICES, NAMELY, RESEARCH RELATED TO CRYSTALS, PROTEINS, AND OPTIMIZING PROTEINS AND PROTEIN CRYSTAL STRUCTURES (U.S. CLS. 100 AND 101).

KIMBERLY PERRY, EXAMINING ATTORNEY

SN 79-016,429. GILLI S.R.L., ITALY, FILED 8-18-2005.

SN 79-014,914. PROTEROS BIOSTRUCTURES GMBH, FED REP GERMANY, FILED 5-4-2005.

# free mounting

THE MARK CONSISTS OF STANDARD CHARACTERS WITHOUT CLAIM TO ANY PARTICULAR FONT, STYLE, SIZE, OR COLOR.

OWNER OF INTERNATIONAL REGISTRATION 0860959 DATED 5-4-2005, EXPIRES 5-4-2015.

#### **CLASS 9—ELECTRICAL AND SCIENTIFIC APPARATUS**

FOR SCIENTIFIC, SURVEYING, OPTICAL, MEASURING, SIGNALING, CHECKING OR SUPERVISION APPARATUS AND INSTRUMENTS, NAMELY, APPARATUS FOR GENERATING AND CONTROLLING HUMID AIR STREAMS FOR USE IN LABORATORY, SCIENTIFIC AND MEDICAL RESEARCH; SCIENTIFIC, SURVEYING, OPTICAL, MEASURING, SIGNALING, CHECKING OR SUPERVISION APPARATUS AND INSTRUMENTS, NAMELY, APPARATUS FOR GENERATING AND CONTROLLING HUMID AIR STREAMS FOR CRYSTALLOGRAPHIC ANALYSIS AND OPTIMIZATION OF PROTEINS AND PROTEIN CRYSTALS FOR USE IN LABORATORY, SCIENTIFIC AND MEDICAL RESEARCH (U.S. CLS. 21, 23, 26, 36 AND 38).

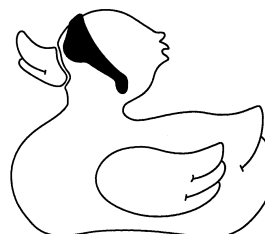

PRIORITY DATE OF 5-3-2005 IS CLAIMED.  
OWNER OF INTERNATIONAL REGISTRATION 0865525 DATED 8-18-2005, EXPIRES 8-18-2015.

THE MARK CONSISTS OF A PICTURE OF A STYLIZED DUCK WITH SUNGLASSES.

#### **CLASS 9—ELECTRICAL AND SCIENTIFIC APPARATUS**

FOR GLASSES AND SUNGLASSES; FRAMES FOR GLASSES; LENSES FOR GLASSES AND SUNGLASSES; ACCESSORIES FOR GLASSES NAMELY CASES, LITTLE CHAINS AND STRINGS; GOGGLES, NAMELY, GOGGLES FOR SPORTS (U.S. CLS. 21, 23, 26, 36 AND 38).

#### **CLASS 14—JEWELRY**

FOR PRECIOUS METALS AND THEIR ALLOYS; GOODS OF PRECIOUS METAL OR COATED THEREWITH, NAMELY; JEWELRY, JEWELS CASES, NAPKIN HOLDERS AND RINGS, KEY-RINGS, TIEPINS, TRAYS FOR HOUSEHOLD PURPOSES, SUGAR BOWLS, BOXES AND BOWLS FOR SWEETMEATS, CIGARETTE CASES, ASHTRAYS; PRECIOUS STONES; JEWELRY MADE OF NON-PRECIOUS METALS; HOROLOGICAL AND CHRONOMETRIC INSTRUMENTS (U.S. CLS. 2, 27, 28 AND 50).

**CLASS 18—LEATHER GOODS**

FOR LEATHER AND IMITATION LEATHER SOLD IN BULK; GOODS MADE OF LEATHER AND IMITATION LEATHER, NAMELY ANIMAL SKINS, TRUNKS, TRAVELING BAGS, SHOULDER BAGS, HAND BAGS, WAIST BAGS, BACKPACKS, BRIEFCASES, SUITCASES, WALLETS, PURSES, KEY-CASES, BEAUTY CASES SOLD EMPTY; UMBRELLAS, PARASOLS AND WALKING STICKS; WHIPS, HARNESS AND SADDLERY (U.S. CLS. 1, 2, 3, 22 AND 41).

**CLASS 25—CLOTHING**

FOR CLOTHING, NAMELY, BLUE-JEANS, TROUSERS, PANTS, SHORTS, SKIRTS, SHIRTS, T-SHIRTS, POLO-SHIRTS, BLOUSES, JACKETS, COATS, RAIN-COATS, WIND CHEATERS, WAISTCOATS, SWEATERS, PULLOVERS, DRESSES, SUITS; FOOTWEAR; HEADGEAR, NAMELY HATS, BANDANAS, CAPS, VISORS (U.S. CLS. 22 AND 39).

KATHERINE CONNOLLY, EXAMINING ATTORNEY

SN 79-018,580. SUSHI SUSHI HOLDINGS PTY LTD ACN 108 725 300, AUSTRALIA, FILED 9-19-2005.

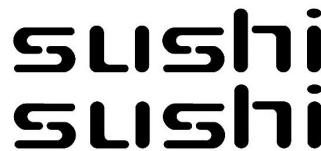

OWNER OF INTERNATIONAL REGISTRATION 0870915 DATED 9-19-2005, EXPIRES 9-19-2015.

NO CLAIM IS MADE TO THE EXCLUSIVE RIGHT TO USE "SUSHI", APART FROM THE MARK AS SHOWN.

THE MARK CONSISTS OF THE WORDS "SUSHI SUSHI" REPRESENTED IN STYLIZED FONT.

SN 79-018,483. LÖFBERGS LILA AKTIEBOLAG, SWEDEN, FILED 11-25-2005.

**CLASS 29—MEATS AND PROCESSED FOODS**

FOR MEAT, FISH, POULTRY, MEAT EXTRACTS, PRESERVED DRIED AND COOKED FRUITS AND VEGETABLES (U.S. CL. 46).

**CLASS 30—STAPLE FOODS**

FOR RICE; PREPARATIONS MADE FROM CEREAL, NAMELY, CEREAL-BASED SNACK FOODS, PROCESSED CEREALS, AND RICE BASED PREPARED FOODS CONTAINING MEAT, FISH, EGGS, BEAN CURD AND VEGETABLES; VINEGAR, SAUCES (U.S. CL. 46).

**CLASS 43—HOTEL AND RESTAURANT SERVICES**

FOR SERVING FOOD AND DRINKS (U.S. CLS. 100 AND 101).

ELI HELLMAN, EXAMINING ATTORNEY

PRIORITY DATE OF 5-30-2005 IS CLAIMED.  
OWNER OF INTERNATIONAL REGISTRATION 0870321 DATED 11-25-2005, EXPIRES 11-25-2015.

NO CLAIM IS MADE TO THE EXCLUSIVE RIGHT TO USE "100% ARABICA" FOR GOOD IN INTERNATIONAL CLASS 30, APART FROM THE MARK AS SHOWN.

THE ENGLISH TRANSLATION OF THE WORDING "PROFESSIONELL" IN THE MARK IS "PROFESSIONAL".

**CLASS 8—HAND TOOLS**

FOR COFFEE SPOONS, NOT OF PRECIOUS METAL OR COATED THEREWITH (U.S. CLS. 23, 28 AND 44).

**CLASS 21—HOUSEWARES AND GLASS**

FOR COFFEE GLASSES, COFFEE MUGS NOT OF PRECIOUS METAL; INSULATED FLASKS (U.S. CLS. 2, 13, 23, 29, 30, 33, 40 AND 50).

**CLASS 30—STAPLE FOODS**

FOR COFFEE, COFFEE-BASED BEVERAGES (U.S. CL. 46).

DEBRA LEE, EXAMINING ATTORNEY

SN 79-019,354. NIRO-PLAN AG, SWITZERLAND, FILED 2-28-2005.



PRIORITY DATE OF 9-15-2004 IS CLAIMED.  
OWNER OF INTERNATIONAL REGISTRATION 0872557 DATED 2-28-2005, EXPIRES 2-28-2015.

OWNER OF U.S. REG. NOS. 1,325,168 AND 1,559,709.

**CLASS 6—METAL GOODS**

FOR TRANSPORTABLE BUILDINGS OF METAL; SMALL ITEMS OF METAL HARDWARE, NAMELY, SCREWS, BOLTS, NUTS, AND WASHERS; KEGS; BARRELS, CASKS AND CONTAINERS FOR STORING, TRANSPORTING AND DISPENSING LIQUIDS, IN PARTICULAR FOR CHEMICALS, LIQUID FOODSTUFFS, BEVERAGES, WINE, UNFERMENTED FRUIT JUICE, BEER, FRUIT JUICES, BEER, SOFT DRINKS, LEMONADES AND SWEET DRINKS, ALL AFOREMENTIONED GOODS ESSENTIALLY OF METAL AND, AS NECESSARY, WITH RUBBER OR PLASTIC TOPS; GRATES AND GRATINGS FOR HOLDING KITCHEN UTENSILS; BASKETS FOR HOLDING PAPER, BASKETS OF METAL, WASHING BASKETS, ESSENTIALLY OF METAL, DOOR HANDLES OF METAL, HANDLEBARS FOR SANITARY INSTALLATION, SHOWER GRAB RAILS OF METAL, CLOTHES HOOKS OF METAL FOR INTERIOR DECORATING, SMALL HARDWARE HOOKS, NON-LUMINOUS AND NON-MECHANICAL SIGNS OF METAL, METAL TAPS FOR CASKS, DRAINING PIPES OF METAL, PRESSURIZED PIPES OF METAL, PARTITIONS OF METAL FOR CONSTRUCTION AND BUILDING OF BIDETS, SHOWER CUBICLES, URINALS, AND TOILETS, ALL AFOREMENTIONED GOODS OF METAL, AND IN PARTICULAR OF STAINLESS STEEL (U.S. CLS. 2, 12, 13, 14, 23, 25 AND 50).

**CLASS 11—ENVIRONMENTAL CONTROL APPARATUS**

FOR APPARATUS FOR LIGHTING, HEATING, STEAM GENERATING, COOKING, REFRIGERATING, DRYING, VENTILATING, WATER SUPPLY AND SANITARY PURPOSES, NAMELY, KITCHEN SINKS OF STAINLESS STEEL, ENAMEL, PLASTIC MATERIAL, NATURAL STONE, ARTIFICIAL STONE AND CERAMIC; THE AFOREMENTIONED GOODS ALSO USED IN PREPARATION MODULES AND KITCHENETTES; WASH BASINS AND LAVATORY DRAINING BOWLS, WASHING SINKS, WASHING SINKS IN THE SHAPE OF A TROUGH; BIDETS, SHOWER PLATFORMS, COMPLETE SHOWER CUBICLES, URINALS AS SANITARY FIXTURES, URINALS IN THE NATURE OF GULLEYS, URINALS IN THE NATURE OF STANDS, TOILETS; TOILET BOWLS, TOILET SEATS, FLUSHING MECHANISMS AND PARTS THEREFOR FOR TOILETS, FLUSHING TANKS FOR TOILETS; DISINFECTANT DISPENSERS FOR TOILETS; WATER PIPES, WATER MIXING VALVES, WATER MIXING TAPS AND MOUTHPIECES FOR FAUCETS FOR ECONOMIZING WATER, ALL BEING PARTS OF SANITARY FACILITIES; HAIR DRYERS, ELECTRIC HAND DRIERS FOR WASHROOMS; GAS AND ELECTRIC FOOD WARMING, COOKING, BROWNING AND BAKING OVENS, GAS AND ELECTRIC STEAM COOKERS, GAS AND ELECTRIC COOKING GRILLS, GAS AND ELECTRIC DEEP FRYERS, ALL OF THE AFOREMENTIONED GOODS FOR USE IN HOUSEHOLDS AND IN INDUSTRIAL KITCHENS; COOKING APPARATUS IN THE NATURE OF COOK TOPS AND ELECTRIC COOKING OVENS AND PARTS THEREFOR, NAMELY, COOKING RINGS AND GLASS-CERAMIC FOOD WARMING HOBBS; KITCHEN OVEN COOKING RANGES, THE AFOREMENTIONED GOODS ALSO FOR USE IN KITCHENETTES; MICROWAVE OVENS, MICROWAVE OVENS COMBINED WITH KITCHEN RANGES; ELECTRIC STEAM COOKERS IN THE NATURE OF AUTOCLAVES; ELECTRIC HOT PLATES FOR WARMING FOOD AND PLATES, ELECTRIC WAFFLE MAKERS, ELECTRIC TOASTERS, BARBECUES, ELECTRIC ROASTERS, GAS AND ELECTRIC COOKER FOR SMOKING FOOD, NOT FOR MEDICAL PURPOSES; ELECTRIC YOGHURT MAKERS; ELECTRIC BEVERAGE HEATERS AND COOLERS FOR THE PREPARATION OF HOT AND COLD DRINKS; ELECTRIC COFFEE MAKERS, IN PARTICULAR, FOR CATERING PURPOSES AND FOR PRIVATE USE, FULLY AUTOMATIC ELECTRIC COFFEE MAKERS, ELECTRIC SEMI-AUTOMATIC COFFEE MAKERS, ELECTRIC ESPRESSO MAKERS, ELECTRIC BEVERAGE HEATERS, IN PARTICULAR, FOR WATER, MILK, CHOCOLATE, TEA; PARTS OF ELECTRIC COFFEE MAKERS IN THE NATURE OF ELECTRIC MILK FOAMING DEVICES, ELECTRIC COFFEE BEAN ROASTERS, ELECTRIC COFFEE PERCOLATORS; AIR EXTRACTOR HOODS AND VENTILATION HOODS, THESE GOODS IN PARTICULAR FOR CATERING

PURPOSES AND/OR PRIVATE USE, IN PARTICULAR IN INTEGRATED, FREELY FLOATING, FOLD-OUT AND/OR EXTENSIBLE CONSTRUCTION (U.S. CLS. 13, 21, 23, 31 AND 34).

**CLASS 21—HOUSEWARES AND GLASS**

FOR ACCESSORIES FOR WASH ROOMS, SANITARY AND CLEANING ROOMS, NAMELY, DISPENSERS OF COMMON METAL FOR EACH OF THE FOLLOWING—TOWELS, PAPER TOWELS, FACE TOWELS, COSMETIC TISSUES, SANITARY TOWEL BAGS, DISINFECTANTS AND SOAPS; HOLDERS OF COMMON METAL FOR EACH OF THE FOLLOWING—TOILET ROLLS, TOILET PAPER, TOILET BRUSHES, SOAPS, BATHROOM GLASSES AND TOOTHBRUSHES; SOAP DISHES, TRASH CANS, WASTE BASKETS, FLOWER POTS AND TOWEL RACKS; ALL AFOREMENTIONED GOODS OF METAL, NOT OF PRECIOUS METAL OR COATED THEREWITH; UTENSILS AND CONTAINERS FOR HOUSEHOLD USE AND KITCHEN USE, IN PARTICULAR COOKING POTS, SIEVES, BOWLS, DISHES, AS FAR AS INCLUDED IN THIS CLASS, AND IN PARTICULAR FOR THE STORAGE OF FOOD STUFFS OR KITCHEN UTENSILS, NOT OF PRECIOUS METAL OR PLATED THEREWITH; KITCHEN SINK ACCESSORIES OF COMMON METAL, NAMELY, WIRE-MESH DISHES, SIEVES, TRAYS, WIRE-MESH NON-ELECTRIC HOUSEHOLD GRATERS, COOKING STRAINERS, AND STEAMER BASKETS; KITCHEN GARBAGE AND GARBAGE SORTING CANS, EACH CONSISTING OF A SUPPORT, A BUCKET, AND A LID; CARVING BOARDS FOR KITCHEN USE AND CUTTING BOARDS FOR KITCHEN USE; SCOURING PADS FOR KITCHEN USE, POT CLEANING BRUSHES, AND CLEANING CLOTHS IMPREGNATED WITH DETERGENT (U.S. CLS. 2, 13, 23, 29, 30, 33, 40 AND 50).

REBECCA GILBERT, EXAMINING ATTORNEY

SN 79-019,538. MAN ROLAND DRUCKMASCHINEN AG, FED REP GERMANY, FILED 6-22-2005.

printcom

THE MARK CONSISTS OF STANDARD CHARACTERS WITHOUT CLAIM TO ANY PARTICULAR FONT, STYLE, SIZE, OR COLOR.

PRIORITY DATE OF 12-23-2004 IS CLAIMED.  
OWNER OF INTERNATIONAL REGISTRATION 0873067 DATED 6-22-2005, EXPIRES 6-22-2015.

**CLASS 1—CHEMICALS**

FOR CHEMICALS FOR COMMERCIAL PURPOSES, NAMELY, FOR USE WITH PRINTING PRESSES OR OTHER PRINTING MACHINES, IN THE PRINTING PRESS OR PRINTING MACHINE PRODUCTION INDUSTRY OR IN THE PRINTING INDUSTRY; PHOTOGRAPHIC CHEMICALS; CHEMICAL GUMMING SOLUTIONS FOR PRINTING PLATES; CHEMICAL SOLVENTS FOR PRINTING PRESSES AND FOR ACCESSORIES THEREOF, NAMELY, FOR FOLDERS AND REEL CHANGERS, AND FOR PARTS THEREOF, NAMELY, IMPRESSION CYLINDERS AND PRINTING UNITS, IN PARTICULAR FOR ROLLS AND FOR RUBBER BLANKETS; ADHESIVES FOR COMMERCIAL PURPOSES, NAMELY, FOR PRINTING MATERIAL AND PAPER PRODUCTS, IN PARTICULAR FOR PRINTING MATERIAL AND PAPER WEBS; PRINTING PRESS CONSUMABLE MATERIALS, NAMELY, SILICONE EMULSIONS, CHEMICAL WAX EMULSIONS, CHEMICAL DAMPING SOLUTION ADDITIVES, CHEMICAL DAMPING SOLUTION CONCENTRATE, CHEMICAL DAMPING SOLUTIONS AS WETTING AGENTS, ALCOHOL SUBSTITUTES, DUSTING POWDER FOR PRINTING MATERIAL WEBS AND SHEETS, AND CHEMICAL PROCESSING COMPOSITIONS AND CHEMICAL CORRECTION COMPOSITIONS FOR COMMERCIAL PURPOSES, IN PARTICULAR FOR PRINTING PLATES; PHOTOGRAPHIC DEVELOPERS FOR PREPRESS STAGES (U.S. CLS. 1, 5, 6, 10, 26 AND 46).

**CLASS 2—PAINTS**

FOR PRINTING PRESS CONSUMABLE MATERIALS, NAMELY INKS, PRINTING INKS, VARNISHES, IN PARTICULAR EMULSION VARNISHES AND UV VARNISHES (U.S. CLS. 6, 11 AND 16).

**CLASS 3—COSMETICS AND CLEANING PREPARATIONS**

FOR WASHING SOLUTIONS FOR USE WITH PRINTING PRESSES OR OTHER PRINTING MACHINES, IN THE PRINTING PRESS OR PRINTING MACHINE PRODUCTION INDUSTRY OR IN THE PRINTING INDUSTRY; BLEACHING PREPARATIONS FOR USE WITH PRINTING PRESSES OR OTHER PRINTING MACHINES, IN THE PRINTING PRESS OR PRINTING MACHINE PRODUCTION INDUSTRY OR IN THE PRINTING INDUSTRY; CLEANING PREPARATIONS FOR USE WITH PRINTING PRESSES OR OTHER PRINTING MACHINES, IN THE PRINTING PRESS OR PRINTING MACHINE PRODUCTION INDUSTRY OR IN THE PRINTING INDUSTRY; POLISHING PREPARATIONS; DEGREASING AND GRINDING PREPARATIONS FOR USE WITH PRINTING PRESSES OR OTHER PRINTING MACHINES, IN THE PRINTING PRESS OR PRINTING MACHINE PRODUCTION INDUSTRY OR IN THE PRINTING INDUSTRY; CLEANING PREPARATIONS FOR PRINTING PRESSES AND PRINTING PRESS PARTS AND ACCESSORIES; CHEMICAL CLEANERS DIRECTED TO PRINTING PRESSES OR OTHER PRINTING MACHINES, IN THE PRINTING PRESS OR PRINTING MACHINE PRODUCTION INDUSTRY OR IN THE PRINTING INDUSTRY (U.S. CLS. 1, 4, 6, 50, 51 AND 52).

**CLASS 7—MACHINERY**

FOR PRINTING PRESSES, FOLDING MACHINES FOR USE WITH PRINTING PRESSES OR OTHER PRINTING MACHINES, CUTTING MACHINES FOR USE WITH PRINTING PRESSES OR OTHER PRINTING MACHINES, PUNCHING MACHINES FOR USE WITH PRINTING PRESSES OR OTHER PRINTING MACHINES, STAPLING MACHINES, GLUING MACHINES AND PROOF MACHINES FOR USE WITH PRINTING PRESSES OR OTHER PRINTING MACHINES, AND PARTS THEREOF, NAMELY IMPRESSION ROLLS, IMPRESSION CYLINDERS, FILMS FOR IMPRESSION ROLLS AND IMPRESSION CYLINDERS, PRINTING PLATES, SLEEVE-SHAPED PRINTING PLATES; MACHINE PARTS, NAMELY, RECYCLING UNITS FOR RECYCLING PRINTING PRESS CONSUMABLE MATERIALS; MACHINE PARTS, NAMELY, FILTER UNITS FOR PRINTING PRESS DAMPING SOLUTION AND WASHING SOLUTION (U.S. CLS. 13, 19, 21, 23, 31, 34 AND 35).

**CLASS 9—ELECTRICAL AND SCIENTIFIC APPARATUS**

FOR MEASURING INSTRUMENTS FOR MEASURING PRINTING MACHINE OPERATING PARAMETERS AND PRINTING MACHINE ACCESSORIES MATERIAL PARAMETERS FOR USE WITH PRINTING PRESSES OR OTHER PRINTING MACHINES, IN THE PRINTING PRESS OR PRINTING MACHINE PRODUCTION INDUSTRY OR IN THE PRINTING INDUSTRY AND ELECTRONIC CONTROL UNITS USED IN AND AS ACCESSORIES TO PRINTING PRESSES AND FOR PRINTING PRESS ACCESSORIES; ELECTRONIC CONTROL UNITS FOR CONTROLLING THE COMPUTER-ASSISTED PRODUCTION OF PRINTING PLATES FOR PRINTING PRESSES OR OTHER PRINTING MACHINES, IN THE PRINTING PRESS OR PRINTING MACHINE PRODUCTION INDUSTRY OR IN THE PRINTING INDUSTRY; ELECTRONIC UNITS FOR THE PREPRESS STAGE, NAMELY, RASTER IMAGE PROCESSORS (RIP); EXPOSED PRINTING FILMS FOR USE IN THE PREPRESS STAGES IN PRINTING PRESSES OR OTHER PRINTING MACHINES, IN THE PRINTING PRESS OR PRINTING MACHINE PRODUCTION INDUSTRY OR IN THE PRINTING INDUSTRY (U.S. CLS. 21, 23, 26, 36 AND 38).

**CLASS 16—PAPER GOODS AND PRINTED MATTER**

FOR SLEEVE-SHAPED PRINTING BLANKETS NOT MADE OF WOVEN MATERIAL, AND SLEEVE SHAPED RUBBER PRINTING BLANKETS; PRINTING BLANKETS NOT MADE OF WOVEN MATERIAL, AND RUBBER PRINTING BLANKETS (U.S. CLS. 2, 5, 22, 23, 29, 37, 38 AND 50).

**CLASS 17—RUBBER GOODS**

FOR ADHESIVE TAPES AND ADHESIVE STRIPS FOR INDUSTRIAL AND COMMERCIAL USE, NAMELY, FOR PRINTING MATERIAL AND PAPER WEBS (U.S. CLS. 1, 5, 12, 13, 35 AND 50).

**CLASS 21—HOUSEWARES AND GLASS**

FOR CLEANING CLOTHS FOR PRINTING PRESSES AND FOR PRINTING PRESS ACCESSORIES AND PARTS (U.S. CLS. 2, 13, 23, 29, 30, 33, 40 AND 50).  
BARBARA GAYNOR, EXAMINING ATTORNEY

SN 79-019,670. MEDIADEM, MONACO, FILED 12-15-2005.

SN 79-020,734. M. MARSIAJ &amp; C. S.R.L., ITALY, FILED 6-10-2005.

# NOENE

THE MARK CONSISTS OF STANDARD CHARACTERS WITHOUT CLAIM TO ANY PARTICULAR FONT, STYLE, SIZE, OR COLOR.

PRIORITY DATE OF 7-5-2005 IS CLAIMED.  
OWNER OF INTERNATIONAL REGISTRATION 0873405 DATED 12-15-2005, EXPIRES 12-15-2015.

## CLASS 10—MEDICAL APPARATUS

FOR ORTHOPEDIC SOLES; ORTHOPEDIC INNER SOLES; SHOCK-ABSORBENT ORTHOPEDIC INNER SOLES (U.S. CLS. 26, 39 AND 44).

## CLASS 25—CLOTHING

FOR FOOTWEAR; SOLES; INNER SOLES; SHOCK-ABSORBENT INNER SOLES (U.S. CLS. 22 AND 39).  
LAURA HAMMEL, EXAMINING ATTORNEY

SN 79-020,553. SOFISPORT, FRANCE, FILED 1-23-2006.

# SOFISPORT

OWNER OF INTERNATIONAL REGISTRATION 0876019 DATED 1-23-2006, EXPIRES 1-23-2016.

## CLASS 13—FIREARMS

FOR FIREARMS, HUNTING GOODS, NAMELY, HUNTING RIFLES AND SHOTGUNS, GUN CARTRIDGES, AMMUNITION AND PROJECTILES, CARTRIDGE CASES AND PROJECTILES, CARTRIDGE CASES AND LEAD SHOTS FOR HUNTING AND SHOOTING, CARTRIDGE POUCHES, CARRYING CASES FOR RIFLES, CHLORATE EXPLOSIVES, EXPLOSIVE STARTING SUBSTANCES FOR MINES AND QUARRIES, FIREWORKS, PRIMINGS, DETONATORS (U.S. CLS. 2 AND 9).

## CLASS 35—ADVERTISING AND BUSINESS

FOR BUSINESS MANAGEMENT ASSISTANCE, ACCOUNTING SERVICES, BUSINESS MANAGEMENT CONSULTING, PROFESSIONAL BUSINESS CONSULTING, ADVISORY SERVICES FOR BUSINESS MANAGEMENT, CONDUCTING MARKETING STUDIES, EFFICIENCY EXPERTS, BUSINESS INFORMATION IN THE FIELD OF AMMUNITIONS AND FIREARMS, BUSINESS INVESTIGATIONS, MARKET RESEARCH SERVICES, BUSINESS RESEARCH CONDUCTED VIA COMPUTER DATABASES FOR THIRD PARTIES, COMPILATION OF COMPUTERIZED DATABASES, PUBLIC RELATIONS, BUSINESS INQUIRIES, ASSISTANCE IN MANAGEMENT OF BUSINESS PROJECTS (U.S. CLS. 100, 101 AND 102).

ALICE BENMAMAN, EXAMINING ATTORNEY

# SABELT

THE MARK CONSISTS OF STANDARD CHARACTERS WITHOUT CLAIM TO ANY PARTICULAR FONT, STYLE, SIZE, OR COLOR.

PRIORITY DATE OF 12-24-2004 IS CLAIMED.  
OWNER OF INTERNATIONAL REGISTRATION 0876386 DATED 6-10-2005, EXPIRES 6-10-2015.

OWNER OF U.S. REG. NOS. 1,287,857, 2,827,243 AND 2,965,505.

## CLASS 9—ELECTRICAL AND SCIENTIFIC APPARATUS

FOR OPTICAL INSTRUMENTS, NAMELY GLASSES, SUNGLASSES; LIFE-SAVING INSTRUMENTS, NAMELY CLOTHING FOR PROTECTION AGAINST FIRE; SHOES FOR PROTECTION AGAINST ACCIDENTS, IRRADIATION AND FIRE; PROTECTIVE HELMETS AND ACCESSORIES FOR PROTECTIVE HELMETS, NAMELY INTERPHONES, HEADPHONES, VISORS; GLOVES FOR PROTECTION AGAINST ACCIDENTS; FIRE-EXTINGUISHERS; COLLARS FOR PROTECTING THE HEAD OF A DRIVER OR PILOT (U.S. CLS. 21, 23, 26, 36 AND 38).

## CLASS 12—VEHICLES

FOR VEHICLES, NAMELY AUTOMOBILES, TRUCKS; RAILWAY VEHICLES, NAMELY, ELECTRIC RAILWAY CARS, RAILWAY CARRIAGES; SHIPS, BOATS, AIRCRAFT; SEAT BELTS FOR VEHICLES, NAMELY FOR AUTOMOBILES, TRUCKS, RAILWAY VEHICLES, SHIPS, BOATS, AIRCRAFT, SEAT BELTS ACCESSORIES NAMELY SHOULDER PADS; BABY'S SEAT BELTS FOR AUTOMOBILES; SEATS FOR VEHICLES, NAMELY AUTOMOBILES, TRUCKS, RAILWAY VEHICLES, SHIPS, BOATS, AIRCRAFT; SAFETY SEATS FOR CHILDREN FOR VEHICLES; ACCESSORIES FOR SEATS FOR VEHICLES, NAMELY HEAD-RESTS, SEAT COVERS; STEERING WHEELS FOR AUTOMOBILES; STRUT TOWER BRACES; VEHICLE ROLL BARS (U.S. CLS. 19, 21, 23, 31, 35 AND 44).

## CLASS 14—JEWELRY

FOR PRECIOUS METALS AND THEIR ALLOYS, NAMELY STATUETTES, ASHTRAYS, CIGAR BOXES, BOXES, CIGARETTE CASES; IMITATION JEWELRY, JEWELRY, NAMELY BRACELETS, BROOCHES, CHAINS, EARRINGS, NECKLACES, ORNAMENTS AND RINGS; PRECIOUS STONES; HOROLOGICAL AND OTHER CHRONOMETRIC INSTRUMENTS, NAMELY WATCHES, CLOCKS, CHRONOMETERS (U.S. CLS. 2, 27, 28 AND 50).

## CLASS 18—LEATHER GOODS

FOR TRUNKS, SUITCASES, BRIEFCASES, TRAVELING BAGS, RUCKSACKS, ALL-PURPOSE CARRYING BAGS, PURSES, GENT'S HANDBAGS AND OTHER SMALL LEATHER ITEMS NAMELY WALLETS; CARD CASES, NAMELY, BUSINESS CARD CASES, CREDIT CARD CASES; LEATHERWEAR KEY CASES; PARASOLS AND UMBRELLAS; WHIPS, HARNESS AND SADDLERY, NAMELY HARNESS STRAPS AND BRIDLES (U.S. CLS. 1, 2, 3, 22 AND 41).

**CLASS 25—CLOTHING**

FOR COATS, OVERCOATS, RAINCOATS, JACKETS, TROUSERS, SKIRTS, SUITS, SHORTS, PULLOVERS, GYMNASIIC SUITS, SWEATERS, PAJAMAS, T-SHIRTS, SHIRTS; SOCKS; DRESSING GOWNS; GLOVES, BELTS, NECKTIES, HATS, CAPS, SHAWLS; SQUARE SCARVES, NAMELY, FOULARDS; SCARVES; BOOTS, SHOES, SLIPPERS AND SANDALS (U.S. CLS. 22 AND 39).  
SEAN CROWLEY, EXAMINING ATTORNEY

SN 79-021,847. COMITE D'ORGANISATION DES CHAMPIONNATS; DU MONDE DE SKI ALPIN VAL D'ISERE 2009, FRANCE, FILED 4-29-2005.



SN 79-021,161. ROLAND ARNASSALON, FRANCE, FILED 1-9-2006.

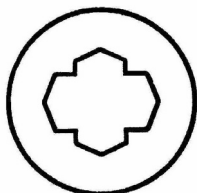

ARNASSALON

OWNER OF INTERNATIONAL REGISTRATION 0877637 DATED 1-9-2006, EXPIRES 1-9-2016.  
THE MARK CONSISTS, IN PART, OF THE STYLIZED WORDING ARNASSALON.

OWNER OF INTERNATIONAL REGISTRATION 0879568 DATED 4-29-2005, EXPIRES 4-29-2015.

NO CLAIM IS MADE TO THE EXCLUSIVE RIGHT TO USE "SKI ALPIN", "CHAMPIONNATS DU MONDE VAL D'ISERE 2009" AND "SAVOIE FRANCE", APART FROM THE MARK AS SHOWN.

THE COLOR(S) RED, BLUE, ORANGE, BLACK IS/ARE CLAIMED AS A FEATURE OF THE MARK.

THE LETTERS "SKI ALPIN CHAMPIONNATS DU MONDE SAVOIE FRANCE" APPEAR IN LIGHT BLUE; THE LETTERS AND FIGURES "VAL D'ISERE 2009" APPEAR IN RED, AS WELL AS THE EMBLEM REPRESENTING AN EAGLE; THE LETTERS FIS ARE IN BLACK AND ARE BROKEN UP BY TWO OBLIQUE LINES, ONE OF WHICH IS ORANGE, THE OTHER BLUE; FINALLY THE INSCRIPTION "SKI ALPIN CHAMPIONNATS DU MONDE VAL D'ISERE 2009 SAVOIE FRANCE" IS SURMOUNTED BY A STYLISED V GOING FROM RED VIGNETTING INTO BLUE.

THE FOREIGN WORDING IN THE MARK TRANSLATES INTO ENGLISH AS ALPINE SKIING WORLD CHAMPIONSHIP.

**CLASS 14—JEWELRY**

FOR JEWELLERY (U.S. CLS. 2, 27, 28 AND 50).

**CLASS 18—LEATHER GOODS**

FOR LEATHER AND IMITATION LEATHER, ANIMAL SKINS AND HIDES, TRUNKS, VALISES, PURSES, RUCKSACKS, TRAVELLING BAGS, HANDBAGS (U.S. CLS. 1, 2, 3, 22 AND 41).

**CLASS 24—FABRICS**

FOR FABRIC FOR MANUFACTURING CLOTHING, FURNITURE AND AUTOMOBILE UPHOLSTERY, AND LUGGAGE; HOUSEHOLD LINEN, BATH LINEN (U.S. CLS. 42 AND 50).

**CLASS 25—CLOTHING**

FOR CLOTHING, NAMELY, PANTS, JACKETS, SUITS, DRESSES, SHIRTS, BELTS, CAPS, ARM WARMERS, WRAPS, TIES, SHOULDER WRAPS, SHORT SETS, SHORTS, UNDERWEARS, SKIRTS, T-SHIRTS, SWEATERS, JERSEYS, KNITWEAR, NAMELY, SWEATERS, PULLOVERS, JUMPERS, SKIRTS, CARDIGANS, SLEEVELESS CARDIGANS, KNITTED SHIRTS, POLO SHIRTS, T-SHIRTS, TRACKSUITS, UNDERSHIRTS, GLOVES, HATS, SOCKS, AND SCARVES; COATS, FOULARDS, SCARVES, HOODS, MUFFLERS, MANTLES, LEATHER BELTS, SOCKS AND STOCKINGS, FOOTWEAR, HEADWEAR (U.S. CLS. 22 AND 39).  
BARBARA GAYNOR, EXAMINING ATTORNEY

**CLASS 3—COSMETICS AND CLEANING PREPARATIONS**

FOR LAUNDRY BLEACH AND DETERGENT; GENERAL PURPOSE CLEANING, POLISHING, SCOURING AND ABRASIVE LIQUIDS AND POWDERS; HAND SOAPS; PERFUMERY, ESSENTIAL OILS, COSMETICS, HAIR LOTIONS; DENTIFRICES; COSMETIC SUN TANNING PREPARATIONS FOR THE SKIN; DISPOSABLE TISSUES IMPREGNATED WITH COSMETIC LOTIONS, COSMETIC PREPARATIONS FOR SKIN RENEWAL, TALCUM POWDER FOR TOILETRY USE; DEODORANTS FOR PERSONAL USE, EAU-DE-COLOGNE, TOILET WATERS; POLISHING WAX, EMERY PAPER; EMERY CLOTH; ABRASIVE PAPERS; POLISH FOR FURNITURE AND FLOORING; OIL OF TURPENTINE (U.S. CLS. 1, 4, 6, 50, 51 AND 52).

**CLASS 9—ELECTRICAL AND SCIENTIFIC APPARATUS**

FOR ELECTRONIC BURGLAR ALARM; ELECTRICAL HOUSEHOLD APPLIANCES, NAMELY ELECTRIC SMOOTHING IRONS; BLANK OPTICAL COMPACT DISCS AND BLANK RECORDING DISCS; BLANK READ-ONLY-MEMORY COMPACT DISCS AND BLANK INTERACTIVE COMPACT DISCS, BOTH FOR RECORDING SOUND AND IMAGES; BLANK MAGNETIC COMPUTER TAPES FOR THE STORAGE OF OPTICAL DATA; OPTICAL DISK DRIVES; RECORDED SOFTWARE PROGRAMS FOR DATA PROCESSING; DOWNLOADABLE ONLINE ELECTRONIC PUBLICATIONS IN THE NATURE OF MAGAZINES ABOUT POLITICS AND CURRENT EVENTS; SPECTACLES, THEIR CASES AND FRAMES; AUTOMATIC VENDING MACHINES; COIN CHANGERS; CASH REGISTERS, CALCULATORS; FIRE EXTINGUISHERS; SCIENTIFIC INSTRUMENTS, NAMELY, MICROSCOPES; NAUTICAL INSTRUMENTS,

NAMELY, COMPASSES; SURVEYING INSTRUMENTS, NAMELY, MAGNETIC COMPASSES; PHOTOGRAPHIC, CINEMATOGRAPHIC AND OPTICAL INSTRUMENTS, NAMELY, CAMERAS AND CAMERA LENS FILTERS; WEIGHING AND MEASURING INSTRUMENTS, NAMELY, CALCULATING SCALES; SIGNALING INSTRUMENTS, NAMELY, FLASHING SAFETY LIGHTS; CHECKING INSTRUMENTS IN THE NATURE OF APPARATUS FOR CHECKING FLIGHT PARAMETERS; LIFE-SAVING APPARATUS, NAMELY, LIFE JACKETS; TEACHING INSTRUMENTS, NAMELY, MEDICAL TEACHING MANNEQUINS; ELECTRICAL CONDUCTORS; ELECTRIC SWITCHES; ELECTRICAL TRANSFORMERS; ELECTRIC ACCUMULATORS; VOLTAGE REGULATORS; ELECTRICAL CONTROLLERS; ELECTRONIC DECODERS FOR TELEVISIONS; ELECTRONIC CENTRAL PROCESSING UNITS FOR PROCESSING INFORMATION, DATA, SOUND OR IMAGES; ELECTRONIC SCALES USED FOR MEASURING AND CHECKING; ELECTRONIC SOUND AMPLIFIERS; ELECTRONIC TELECOMMUNICATIONS TRANSMITTERS FOR MOTION PICTURE PRODUCTION; TEACHING APPARATUS AND INSTRUMENTS, NAMELY, BUNSON BURNERS FOR LABORATORY USE; APPARATUS FOR RECORDING, TRANSMITTING OR REPRODUCING SOUND OR IMAGES; AUDIOVISUAL RECEIVERS; TELECOMMUNICATION AND COMMUNICATION COMPUTERS; TELEVISION SETS; REMOTE CONTROLS FOR TELEVISION SETS; TAPE RECORDERS; DIGITAL VIDEO RECORDERS; RADIOS; MOVIE PROJECTORS; CAR RADIOS; AERIALS; PARABOLIC ANTENNAE; CABINETS FOR LOUDSPEAKERS; AMPLIFIERS; HIGH FIDELITY STEREO RECEIVERS; COMPUTERS; COMPUTER KEYBOARDS; COMPUTER PERIPHERALS; MODEMS; RECORDED COMPUTER GAME SOFTWARE; COMPUTER SOFTWARE PROGRAMS FOR CONTROLLING AND MANAGING ACCESS SERVER DATA PROCESSING APPLICATIONS; ENCODED ELECTRONIC CHIP CARDS FOR IDENTIFYING AND AUTHENTICATING USERS OF TELECOMMUNICATION NETWORKS; ELECTRONIC CODING UNITS FOR SCRAMBLING AND DESCRAMBLING SIGNALS AND RETRANSMISSIONS; DIGITAL COMPUTER TERMINALS; TRANSPONDERS; SATELLITES; MICROPHONES; EXPOSED CAMERA FILMS; MUSICAL SOUND AND VIDEO RECORDINGS; BLANK MAGNETIC TAPES FOR TAPE RECORDERS; BLANK VIDEO TAPES; BLANK AUDIO AND VIDEO COMPACT DISCS; BLANK CD-ROMS FOR SOUND OR VIDEO RECORDING; PRERECORDED DIGITAL VIDEO DISCS, MAGNETIC DISCS, DVDS AND VIDEO CARTRIDGES, ALL FEATURING MUSICAL PERFORMANCES; COMPUTER GAME CARTRIDGES; COMPUTER MONITORS USED FOR DISPLAYING DATA RECEIVED FROM A GLOBAL COMPUTER NETWORK; COMPUTER COMMUNICATION SERVERS; ENCODED ELECTRONIC CHIP CARDS CONTAINING PROGRAMMING USED TO SELECT TELEVISION AND RADIO CHANNELS AND PROVIDE ELECTRONIC GUIDES FOR TELEVISION AND RADIO PROGRAMS; REMOTE CONTROLS FOR TELEVISION PROGRAM SELECTION; INTERACTIVE TELEVISION IN THE NATURE OF DOWNLOADABLE FILMS AND TV PROGRAMS PROVIDE VIA VIDEO-ON-DEMAND; FLAT PANEL DISPLAY TELEVISION SCREENS; SOFTWARE FOR PROVISION OF ACCESS TO A COMPUTER OR DATA TRANSMISSION NETWORK, ESPECIALLY TO A GLOBAL COMMUNICATIONS INTERNET NETWORK OR PRIVATE OR RESTRICTED ACCESS INTRANET OR EXTRANET; PERSONAL DIGITAL ASSISTANTS FOR USE AS ELECTRONIC MESSAGING APPARATUS; INTERACTIVE CELL PHONES; MAGNETIC TAPE RECORDERS AND POWER CABLES FOR USE THEREWITH; BLANK MAGNETIC CARDS AND MAGNETIC CODED IDENTIFYING CARDS; DOWNLOADABLE COMPUTER GAME SOFTWARE PROVIDED FROM THE INTERNET; DOWNLOADABLE ELECTRONIC PUBLICATIONS IN THE NATURE OF NEWSLETTERS ABOUT COMPUTER TECHNOLOGY; COMPUTER COMMUNICATIONS SOFTWARE FOR CONNECTING COMPUTER NETWORK USERS AND COMPUTER HARDWARE FOR TELECOMMUNICATIONS; COMPUTER SOFTWARE FOR USE IN DOWNLOADING DIGITAL MUSIC FROM ONLINE COMPUTER DATABASES ON THE INTERNET; DOWNLOADABLE DIGITAL MUSICAL SOUND RECORDINGS; MP3 PLAYERS; SATELLITE RADIO TRANSMITTERS AND RECEIVERS; ELECTRIC WIRES AND CABLES; ELECTRIC RESISTOR CABLES; ELECTRODES; TELEPHONE APPARATUS, MOBILE TELEPHONES AND

TELEPHONE HANDSETS; ACCESSORIES FOR TELEPHONES AND TELEPHONE HANDSETS, NAMELY, HEADSETS AND EXTENSION CORDS; ADAPTERS FOR USE WITH TELEPHONES; BATTERY CHARGERS FOR TELEPHONES; CASES FOR TELEPHONES AND TETHER STRAPS FOR MOBILE TELEPHONES; MOBILE PHONE DECORATIVE FACE PLATES; DESK-MOUNTED TELEPHONES; MOBILE TELEPHONES MOUNTED IN MOTOR CARS COMPRISING A LOUDSPEAKER ALLOWING HANDS-FREE USE OF A TELEPHONE HANDSET; HOLDERS FOR TELEPHONE HANDSETS INSTALLED IN MOTOR CARS; BAGS AND CASES SPECIALLY DESIGNED TO HOLD OR TRANSPORT PORTABLE TELEPHONES AND TELEPHONE EQUIPMENT AND ACCESSORIES; TELEPHONE HEADSETS; MAGNETIC TELEPHONE WIRES; TELEPHONE TRANSMITTERS; MOBILE TELEPHONE BATTERIES; ELECTRIC STORAGE BATTERIES; CHARGERS FOR ELECTRIC BATTERIES; RADIO TELEPHONES; TELEPHONE ANSWERING MACHINES; TELECOMMUNICATION TRANSMITTERS; APPARATUS AND INSTRUMENTS FOR ELECTRONIC MESSAGING, RADIO PAGING AND RADIOTELEPHONY, NAMELY, PORTABLE TELECOMMUNICATION INSTANT MESSAGING DEVICES; PERSONAL ELECTRONIC ORGANIZERS; CAR AERIALS; ELECTRICAL CELLS AND BATTERIES; MICROPROCESSORS; KEYBOARDS FOR MOBILE PHONES; SATELLITE NAVIGATIONAL SYSTEM, NAMELY, ELECTRONIC WORLDWIDE GLOBAL POSITIONING SYSTEM; ELECTRIC AND ELECTRONIC VIDEO SURVEILLANCE INSTALLATIONS; RADIO SETS; CONTINUITY TEST APPARATUS FOR ELECTRICAL CIRCUITS; MUSICAL VIDEO RECORDINGS; ELECTRICAL AND ELECTRONIC COMPUTER PERIPHERALS FOR USE WITH COMPUTERIZED AUDIO-VISUAL APPARATUS AND COMPUTERIZED ELECTRONIC GAMES; MOTHERBOARDS FOR ARCADE VIDEO GAME APPARATUS THAT ARE CARD OR COIN-OPERATED; ELECTRONIC ANIMAL IDENTIFICATION APPARATUS; COMPUTER GAME PROGRAMS INTENDED TO BE USED WITH A TELEVISION RECEIVER OR A COMPUTER SCREEN; COMPUTER GAME PROGRAMS AND SOFTWARE; ELECTRONIC GAMES PROGRAMS; GAMES PROGRAMS FOR COMPUTERS; VIDEO GAME MACHINES FOR USE WITH TELEVISIONS; INTERACTIVE VIDEO GAME PROGRAMS FOR EDUCATIONAL AND RECREATIONAL USE DESIGNED FOR USE WITH A TELEVISION SET; VIDEO GAME CARTRIDGES, DISCS AND CASSETTES; COMPUTER AND VIDEO GAME CARTRIDGES, DISCS AND CASSETTES; DATA PROCESSORS FOR USE IN MANAGING ENTERTAINMENT CENTERS; COMPUTER VIDEO GAME EQUIPMENT CONTAINING INTEGRATED MEMORY BOARDS; MEMORY BOARDS FOR VIDEO GAME EQUIPMENT; CD-ROM DRIVES; TELEVISION RECEIVERS; COMPUTER PERIPHERALS FOR DOMESTIC VIDEO GAME MACHINES; AND REPLACEMENT PARTS FOR ALL THE AFOREMENTIONED GOODS (U.S. CLS. 21, 23, 26, 36 AND 38).

#### CLASS 12—VEHICLES

FOR LAND VEHICLES; AIR CRAFT; SHIPS; SNOWMOBILES; SKI LIFTS PROVIDING TRANSPORT VIA CABLE; FUNICULAR RAILCARS; CABLE CARS; SLEIGHS; AND SKI CARRIERS FOR CARS (U.S. CLS. 19, 21, 23, 31, 35 AND 44).

#### CLASS 14—JEWELRY

FOR PRECIOUS METALS AND THEIR ALLOYS; GOODS MADE OF PRECIOUS METALS AND THEIR ALLOYS, NAMELY, COLLECTIBLE COMMEMORATIVE AND NON-COMMEMORATIVE COINS AND MEDALS, FIGURINES, STATUETTES OF PRECIOUS METAL; TABLEWARE, NAMELY, TABLE MATS OF PRECIOUS METAL; RECEPTACLES FOR HOUSEHOLD AND KITCHEN USE, NAMELY, BOWLS AND VASES OF PRECIOUS METAL; PRECIOUS METAL TROPHIES; STATUES AND STATUETTES OF PRECIOUS METAL; SILVER INSIGNIA; SILVER COLLECTIBLE COINS; JEWELRY; PRECIOUS STONES; AND HOROLOGICAL AND CHRONOMETRIC INSTRUMENTS (U.S. CLS. 2, 27, 28 AND 50).

**CLASS 16—PAPER GOODS AND PRINTED MATTER**

FOR WRITING PAPER; CARDBOARD; TABLE LINEN OF PAPER; PAPER NAPKINS; FACIAL TISSUE; DISPOSABLE PAPER NAPPIES; PAPER AND CARDBOARD FOR PACKING; PAPER BAGS; PAPER SHEETS FOR NOTE TAKING; CARDBOARD BOXES; DRAWING SHIELDS; PAPER PENNANTS, COMMEMORATIVE POSTAGE STAMP SHEETS; STICKERS; POSTERS; WATERCOLORS; POSTCARDS; GRAPHIC PRINTS; CHROMOLITHOGRAPHS; LITHOGRAPHIC WORKS OF ART, NAMELY, PRINTS; PHOTO-ENGRAVINGS; SILK SCREEN PRINTS; PORTRAITS; PAINTINGS; PATTERNS FOR MAKING CLOTHES; PRINTED TEACHING MATERIALS IN THE FIELD OF MATHEMATICS; BOOKBINDING TAPE AND WIRE; PHOTOGRAPHS; STATIONERY; ADHESIVES FOR STATIONERY OR HOUSEHOLD PURPOSES; ARTISTS' MATERIALS, NAMELY, PAINTBRUSHES; TYPEWRITERS AND OFFICE REQUISITES, NAMELY, STAPLERS AND PAPER PUNCHES; PRINTED INSTRUCTIONAL AND TEACHING MATERIAL IN THE FIELD OF GEOGRAPHY; PLASTIC BAGS AND POUCHES FOR PACKAGING; PRINTERS' TYPE; PRINTING BLOCKS; PRINTED TICKETS; BLANK BUSINESS PROSPECTUS FORMS; PAPER FLAGS; GEOGRAPHICAL MAPS; NEWSPAPERS; PRINTED PERIODICALS IN THE FIELD OF POLITICS; BOOKS IN THE FIELD OF MEDICINE; PENS; AND WRITING INSTRUMENTS (U.S. CLS. 2, 5, 22, 23, 29, 37, 38 AND 50).

**CLASS 24—FABRICS**

FOR TEXTILE NAPKINS AND PLACEMATS; NON-WOVEN TEXTILE NAPKINS AND PLACEMATS; HOUSEHOLD LINEN; DIAPER CHANGING MATS; CURTAINS; TAPESTRIES OF TEXTILE; NET CURTAINS OF TEXTILES; BANNERS, CALICOES, FLAGS AND PENNANTS, ALL THESE GOODS BEING OF CLOTH TEXTILE MATERIALS; TEXTILE FABRICS FOR HOME AND COMMERCIAL INTERIORS; UNFITTED FABRIC BED AND TABLE COVERS; TEXTILE FACE WASH-CLOTHS AND TOWELS; BATHROOM LINEN OF TEXTILE MATERIALS; BATH LINEN; TABLE AND HOUSEHOLD LINEN; TABLE LINEN, NAMELY, COASTERS; FABRIC TABLE RUNNERS; TEXTILE USED AS A LINING FOR HATS; DAMASK; EIDERDOWNS; QUILTS; MATTRESS COVERS; PILLOW CASES; TEXTILE WALL HANGINGS; TEXTILE OR PLASTIC CURTAINS; CURTAIN SWAGS OF TEXTILE MATERIAL; TEXTILE HANDKERCHIEFS; LAP RUGS FOR TRAVELING; FABRIC LABELS; AND UPHOLSTERY FABRICS (U.S. CLS. 42 AND 50).

**CLASS 25—CLOTHING**

FOR FOOTWEAR; SPORTS SHOES; SOLES FOR FOOTWEAR; NON-SLIP SOLES FOR FOOTWEAR; SKI BOOTS; BOOTS; HEADWEAR; KNITWEAR, NAMELY SWEATERS AND HEADBANDS; EAR MUFFS; CLOTHING AND SPORTS CLOTHING, NAMELY, SHIRTS, PANTS AND SHORTS; UNDERWEAR; COVERALLS; SKI SUITS; SASHES FOR WEAR; STOLES; FUR COATS AND JACKETS; GLOVES; MUFFS; COATS; MITTENS; SKI TROUSERS; PELISSES; AND PULLOVERS (U.S. CLS. 22 AND 39).

**CLASS 28—TOYS AND SPORTING GOODS**

FOR GAMES AND TOYS, NAMELY, BOARD GAMES AND DOLLS; PLAYING CARDS; DECORATIONS FOR CHRISTMAS TREES; SPORTS ARTICLES LINKED TO SKIING, NAMELY SKIS; SKI BINDINGS; SCRAPERS FOR SKIS; SKI EDGES; SKI WAX; SPORTS EQUIPMENT, NAMELY, EXERCISE MACHINES AND STATIONARY CYCLES; HOCKEY STICKS, CUSTOM DESIGNED CASES FOR SKIS AND SURF BOARDS; PARAGLIDERS; ICE SKATES; ICE SKATES IN COMBINATION WITH ANKLE BOOTS; GUT FOR TENNIS RACKETS; ARCHERY TARGETS; STRINGS FOR TENNIS RACKETS; NETS FOR BALL GAMES; BATTING GLOVES; HANDBALL GLOVES; STARTING BLOCKS; BOBSLEDS; TOY SNOW GLOBES; SKI COVERS CONSISTING OF SEAL SKINS; SURF BOARDS; RESTRAINT STRAPS FOR BODY BOARDS; ATHLETIC EQUIPMENT, NAMELY, GUARDS FOR ELBOW, SHIN, AND KNEE; BADMINTON RACKETS; SNOW SHOES; SNOW BOARDS; SURF BOARDS; ARCHERY EQUIPMENT, NAMELY, ARM GUARDS, BOW CASES AND QUIVERS; BOB-SLEIGHS; AND COIN, CARD OR TOKEN-OPERATED STAND ALONE VIDEO GAME MACHINES (U.S. CLS. 22, 23, 38 AND 50).

**CLASS 29—MEATS AND PROCESSED FOODS**

FOR MEAT, FISH, POULTRY AND GAME; MEAT EXTRACTS; PRESERVED, DRIED AND COOKED VEGETABLES; JELLIES, JAMS, COMPOTES; EGGS, MILK AND MILK PRODUCTS EXCLUDING CHEESE, ICE CREAM, ICE MILK AND FROZEN YOGURT; EDIBLE OILS AND FATS; CANNED DRIED EGGS; CANNED COOKED MEAT, FISH, POULTRY AND GAME (U.S. CL. 46).

**CLASS 30—STAPLE FOODS**

FOR COFFEE, TEA, COCOA, SUGAR, RICE, TAPIOCA, SAGO, ARTIFICIAL COFFEE; FLOUR; CEREAL BASED SNACK FOODS; BREAD; PASTRIES; CONFECTIONERY CHIPS FOR BAKING; FRUIT ICES; HONEY, TREACLE SYRUP; YEAST; BAKING POWDER; SALT; MUSTARD; VINEGAR; SAUCES; SPICES; ICE FOR REFRESHMENT; CHOCOLATE AND CHOCOLATE CANDIES (U.S. CL. 46).

**CLASS 32—LIGHT BEVERAGES**

FOR BEER; MINERAL AND CARBONATED DRINKING WATER; NON-ALCOHOLIC FRUIT JUICE BEVERAGES; FRUIT DRINKS AND FRUIT JUICES; AND CONCENTRATES AND SYRUPS USED IN THE PREPARATION OF SOFT DRINKS (U.S. CLS. 45, 46 AND 48).

**CLASS 35—ADVERTISING AND BUSINESS**

FOR BUSINESS ADMINISTRATION CONSULTANCY; BUSINESS MANAGEMENT ASSISTANCE TO COMMERCIAL OR INDUSTRIAL COMPANIES; BUSINESS ORGANIZATIONAL AND MANAGEMENT CONSULTATION; PROFESSIONAL BUSINESS CONSULTING; EFFICIENCY EXPERTS; BUSINESS INFORMATION IN THE FIELD OF HUMAN RESOURCES; BUSINESS INVESTIGATIONS; RESEARCH FOR BUSINESS PURPOSES; BUSINESS INFORMATION AND INQUIRIES; EVALUATIONS RELATING TO COMMERCIAL OR INDUSTRIAL MATTERS; ARRANGING AND CONDUCTING MARKETING PROMOTIONAL EVENTS FOR INDUSTRIAL OR COMMERCIAL COMPANIES; EMPLOYMENT AGENCIES; ACCOUNTING SERVICES; DIRECT MAIL ADVERTISING; DISSEMINATION OF ADVERTISEMENTS; DISSEMINATION OF ADVERTISING MATTER IN THE NATURE OF LEAFLETS, PAMPHLETS, PRINTED MATTER AND SAMPLES; DISTRIBUTION OF PROSPECTUSES AND SAMPLES; SERVICE PROVIDED VIA COMPUTER IN THE NATURE OF PROVIDING STATISTICAL INFORMATION, DATA PROCESSING AND STENOGRAPHIC TRANSCRIPTION SERVICES; TAX DECLARATION PREPARATION; MARKET RESEARCH STUDIES; COMPILATION OF INFORMATION INTO COMPUTER DATABASES; COMPUTER FILE MANAGEMENT; ECONOMIC FORECASTING; FINANCIAL STATEMENT PREPARATION; PROVIDING STATISTICAL INFORMATION; ACCOUNT AUDITING;



ARRANGING AND CONDUCTING TRADE SHOW EXHIBITIONS FOR COMMERCIAL OR ADVERTISING PURPOSES IN THE FIELD OF COMPUTER SECURITY; BUSINESS MANAGEMENT; TYPEWRITER AND OFFICE EQUIPMENT RENTAL; RENTAL OF ADVERTISING SPACE; ORGANIZATION AND CONDUCTING OF PRODUCT PRESENTATIONS FOR COMMERCIAL PURPOSES; RENTAL OF VENDING MACHINES; ORGANIZATION OF EXHIBITIONS FOR COMMERCIAL OR ADVERTISING PURPOSES TO INTRODUCE NEW CARS TO CAR DEALERS; IMPORT AND EXPORT AGENCIES; PREPARING AND PLACING OUTDOOR ADVERTISEMENTS FOR OTHERS; SHOP WINDOW DRESSING; SALES PROMOTION SERVICES; MARKET RESEARCH; PROMOTING THE GOODS AND SERVICES OF OTHERS BY ARRANGING FOR SPONSORS TO AFFILIATE THEIR GOODS AND SERVICES WITH CAR RACING COMPETITIONS; PROMOTING THE SALE OF GOODS AND SERVICES OF OTHERS THROUGH THE DISTRIBUTION OF PRINTED ADVERTISING TEXTS; ADVERTISING SERVICES; INTERACTIVE ADVERTISING SERVICES; RADIO AND TELEVISION ADVERTISING SERVICES; PERSONNEL RECRUITMENT; DOCUMENT REPRODUCTION; TRANSPORTATION LOGISTICS SERVICES, NAMELY, ARRANGING THE TRANSPORTATION OF GOODS OF OTHERS AND MANAGING THE BUSINESS SUPPLY CHAIN OF OTHERS; SUBSCRIPTION TO A RADIO AND TELEVISION CHANNEL; SUBSCRIPTION TO AN INFORMATION MEDIA PACKAGE WHICH PROVIDES SOUND AND VIDEO RECORDINGS AND AUDIOVISUAL PROGRAMS; ARRANGING FOR THE PUBLICATIONS OF OTHERS; SUBSCRIPTIONS TO NEWSPAPERS, BOOKS AND MAGAZINES; DATA INPUT AND PROCESSING SERVICES; RENTAL OF CUSTOMER DATABASE FILES FOR ADVERTISING PURPOSES; SECRETARIAL SERVICES; PUBLIC OPINION POLLING; ADVERTISING SERVICES, NAMELY, PROMOTING THE GOODS AND SERVICES OF OTHERS THROUGH TELEVISED INFOMERCIALS; PROVIDING OFFICE FUNCTIONS; ARRANGING AND CONDUCTING OF AUCTION SALES; AND RETAIL STORES FEATURING CHEMICAL PRODUCTS USED IN INDUSTRY, SCIENCE, PHOTOGRAPHY, AS WELL AS AGRICULTURE, HORTICULTURE AND FORESTRY; UNPROCESSED ARTIFICIAL RESINS, UNPROCESSED PLASTICS, FERTILIZERS, FIRE EXTINGUISHING COMPOSITIONS, TEMPERING AND SOLDERING PREPARATIONS, CHEMICAL SUBSTANCES FOR PRESERVING FOODSTUFFS, TANNING SUBSTANCES, ADHESIVES USED IN INDUSTRY, PAINTS, VARNISHES, LACQUERS, PRESERVATIVES AGAINST RUST AND AGAINST DETERIORATION OF WOOD, COLORANTS, MORDANTS, RAW NATURAL RESINS, METAL IN FOIL AND POWDER FORM FOR PAINTERS, DECORATORS, PRINTERS AND ARTISTS, BLEACHING PREPARATIONS AND OTHER SUBSTANCES FOR LAUNDRY USE, CLEANING, POLISHING, SCOURING AND ABRASIVE PREPARATIONS, SOAPS, PERFUMERY, ESSENTIAL OILS, COSMETICS, HAIR LOTIONS, DENTIFRICES, INDUSTRIAL OILS AND GREASES, LUBRICANTS, DUST ABSORBING, WETTING AND BINDING COMPOSITIONS, FUELS INCLUDING MOTOR SPIRIT AND ILLUMINANTS, CANDLES, WICKS, PHARMACEUTICAL, VETERINARY AND SANITARY PREPARATIONS, DIETETIC SUBSTANCES ADAPTED FOR MEDICAL USE, FOOD FOR BABIES, PLASTERS, MATERIALS FOR DRESSINGS, MATERIAL FOR STOPPING TEETH AND DENTAL WAX, DISINFECTANTS, PREPARATIONS FOR DESTROYING VERMIN, FUNGICIDES, HERBICIDES, COMMON METALS AND THEIR ALLOYS, METAL BUILDING MATERIALS, TRANSPORTABLE METAL BUILDINGS, METAL MATERIALS FOR RAILWAY TRACKS, NON-ELECTRIC CABLES AND WIRES OF COMMON METAL, IRONMONGERY AND SMALL ITEMS OF METAL HARDWARE, METAL PIPES AND TUBES, SAFES, GOODS OF COMMON METAL NOT INCLUDED IN OTHER CLASSES, NAMELY KEY RINGS, TROPHIES, STATUES AND STATUETTES, COMMEMORATIVE PLAQUES, ALL THESE GOODS BEING MADE OF COMMON METALS OR ALLOYS OF COMMON METALS, ORES, MACHINES, NAMELY CONSTRUCTION AND CIVIL ENGINEERING MACHINERY, METAL-WORKING MACHINERY, MACHINES FOR WORKING WOOD OR PLASTIC MATERIALS AND PACKAGING, MACHINES FOR THE TEXTILE INDUSTRY, AGRICULTURAL MACHINES, PRINTING MACHINES, GENERAL-PURPOSE KITCHEN MACHINES, WASHING APPARATUS AND CLEANING MACHINES, WASHING MACHINES, DISHWASHING MACHINES,

ELECTRIC KITCHEN APPLIANCES AND MACHINES NOT MANUALLY OPERATED FOR MINCING, MILLING, PRESSING AND CUTTING, MACHINE TOOLS, MOTORS AND ENGINES EXCEPT FOR LAND VEHICLES, MACHINE COUPLING AND TRANSMISSION COMPONENTS EXCEPT FOR THOSE IN LAND VEHICLES, AGRICULTURAL IMPLEMENTS, INCUBATORS FOR EGGS, HAND-OPERATED HAND TOOLS AND IMPLEMENTS, CUTLERY, FORKS AND SPOONS, SIDE ARMS, OTHER THAN FIREARMS, RAZORS, APPARATUS AND INSTRUMENTS FOR CONDUCTING, SWITCHING, TRANSFORMING, ACCUMULATING, REGULATING OR CONTROLLING ELECTRICITY, ELECTRIC ALARM APPARATUS, ELECTRICAL HOUSEHOLD APPLIANCES, NAMELY VACUUM CLEANERS, FLOOR POLISHING MACHINES AND SMOOTHING IRONS, SCIENTIFIC, NAUTICAL, SURVEYING, PHOTOGRAPHIC, CINEMATOGRAPHIC, OPTICAL, WEIGHING, MEASURING, SIGNALING, CHECKING SUPERVISION, LIFE SAVING AND TEACHING APPARATUS AND INSTRUMENTS, APPARATUS FOR RECORDING, TRANSMITTING AND REPRODUCING SOUND OR IMAGES, VIDEO RECORDERS, MAGNETIC RECORDING MEDIA, MAGNETIC CARDS, AUDIOVISUAL COMPACT DISCS, OPTICAL DISCS, OPTICAL COMPACT DISCS AND SOUND RECORDING DISCS, READ-ONLY MEMORY COMPACT DISCS AND INTERACTIVE COMPACT DISCS, MAGNETIC AND OPTICAL DATA MEDIA, OPTICAL READERS, RECORDED COMPUTER SOFTWARE, DATA PROCESSING APPARATUS AND COMPUTERS, APPARATUS USED FOR COMPUTING AND COMPUTER COMMUNICATION PURPOSES, MODEMS, ONLINE DOWNLOADABLE ELECTRONIC PUBLICATIONS, SPECTACLES, CASES AND FRAMES THEREOF, AUTOMATIC VENDING MACHINES AND MECHANISMS FOR COIN-OPERATED APPARATUS, CASH REGISTERS, CALCULATING MACHINES, DATA PROCESSING EQUIPMENT AND COMPUTERS, FIRE EXTINGUISHERS, SURGICAL, MEDICAL, DENTAL AND VETERINARY APPARATUS AND INSTRUMENTS, ARTIFICIAL LIMBS, EYES AND TEETH, ORTHOPEDIC ARTICLES, SUTURE MATERIALS, APPARATUS FOR LIGHTING, HEATING, STEAM GENERATING, COOKING, REFRIGERATING, DRYING, VENTILATING, WATER SUPPLY AND SANITARY PURPOSES, APPARATUS AND INSTALLATIONS FOR WATER TREATMENT AND ESPECIALLY SWIMMING POOL WATER, VEHICLES, APPARATUS FOR LOCOMOTION BY LAND, AIR OR WATER, FIRE-ARMS, AMMUNITION AND PROJECTILES, EXPLOSIVES, FIREWORKS, PRECIOUS METALS AND ALLOYS THEREOF, CROCKERY, HOUSEHOLD AND KITCHEN CONTAINERS, DISHES, VASES, TROPHIES, STATUES AND STATUETTES, SILVERWARE WITH THE EXCEPTION OF CUTLERY, TABLE FORKS AND SPOONS, INSIGNIA, COINS, COMMEMORATIVE PLAQUES, ALL THESE GOODS BEING OF PRECIOUS METAL, ALLOYS OF PRECIOUS METAL OR PLATED THEREWITH, JEWELER, PRECIOUS STONES, HOROLOGICAL AND CHRONOMETRIC INSTRUMENTS, MUSICAL INSTRUMENTS, PAPER, CARDBOARD, TABLE LINEN OF PAPER OR OF NON-WOVEN FABRIC, TOWELS, HANDKERCHIEFS AND BABIES' DIAPERS OF PAPER, PAPER AND CARDBOARD FOR PACKAGING, PAPER AND CARDBOARD WRAPPING BAGS, SACHETS AND BOXES, SHIELDS, SMALL FLAGS, POST STAMPS, COMMEMORATIVE STAMPS, SELF-ADHESIVE STICKERS, POSTERS, AQUARELLES, POSTCARDS, GRAPHIC PRINTS, CHROMOLITHOGRAPHS, LITHOGRAPHIC WORKS OF ART, ENGRAVED WORKS OF ART, SILK SCREENS, PORTRAITS, PAINTINGS, FRAMED OR NOT, TEACHING MATERIALS IN THE FORM OF GAMES, SEWING PATTERNS, PRINTED MATTER, BOOKBINDING MATERIAL, PHOTOGRAPHS, STATIONERY, ADHESIVES FOR STATIONERY OR HOUSEHOLD PURPOSES, ARTISTS' MATERIALS, PAINTBRUSHES, TYPEWRITERS AND OFFICE REQUISITES EXCEPT FURNITURE, INSTRUCTIONAL AND TEACHING MATERIAL EXCEPT APPARATUS, BAGS, POUCHES, SHEETS AND FILMS MADE OF PLASTIC FOR PACKAGING, PRINTERS' TYPE, PRINTING BLOCKS, RUBBER, GUTTA-PERCHA, GUM, ASBESTOS, MICA, BAGS, SMALL BAGS, CUSHIONING MADE OF RUBBER FOR PACKAGING, RINGS, BANDS, WEATHERSTRIPPING, FIXTURES, NON-METALLIC SEALS FOR SEALING, INSULATING TAPES AND TEXTILES, PRODUCTS MADE OF SEMI-PROCESSED PLASTICS, PACKING, STOPPING AND INSULATING MATERIALS, NON-METALLIC FLEXIBLE PIPES, LEATHER AND IMITATION LEATHER, GOODS

OF LEATHER OR IMITATION LEATHER EXCLUDING CASES ADAPTED TO THE PRODUCTS FOR WHICH THEY ARE INTENDED, AND GLOVES AND BELTS, DOCUMENT WALLETS, HANDBAGS, SCHOOL SATCHELS, SACHELS, RUCKSACKS, SHOPPING BAGS, TRAVEL, BEACH AND CAMPER BAGS, ANIMAL SKINS, HIDES, TRUNKS AND SUITCASES, UMBRELLAS, PARASOLS AND WALKING STICKS, WHIPS, HARNESS AND SADDLERY, HARNESS ARTICLES, COLLARS, LEASHES AND HARNESSES FOR ANIMALS, LEATHER TRIMMINGS FOR FURNITURE, NON-METALLIC BUILDING MATERIALS, NON-METALLIC RIGID PIPES FOR BUILDING, ASPHALT, PITCH AND BITUMEN, NON-METALLIC TRANSPORTABLE BUILDINGS, NON-METALLIC MONUMENTS, FURNITURE, MIRRORS, PICTURE FRAMES, STATUES AND STATUETTES MADE OF WOOD, CORK, REED, CANE, WICKER, HORN, BONE, IVORY, WHALEBONE, TORTOISESHELL, AMBER, MOTHER-OF-PEARL, MEERSCHAUM, WAX, SUBSTITUTES FOR ALL THESE MATERIALS, OR OF PLASTICS, HOUSEHOLD OR KITCHEN UTENSILS AND CONTAINERS NOT OF PRECIOUS METAL OR COATED THEREWITH, COMBS AND SPONGES, BRUSHES EXCEPT PAINTBRUSHES, BRUSH-MAKING MATERIALS, ARTICLES FOR CLEANING PURPOSES, STEEL WOOL, UNWORKED OR SEMI-WORKED GLASS EXCEPT GLASS USED IN BUILDING, TOILET UTENSILS, TABLEWARE, DISHES, VASES, STATUES AND STATUETTES, TROPHIES, ALL THESE GOODS BEING MADE OF GLASSWARE, PORCELAIN AND EARTHENWARE, ROPES, STRING, NETS, TENTS, TARPULINS, SAILS, BAGS FOR PACKAGING, MADE OF TEXTILE MATERIALS, PADDING AND STUFFING MATERIALS EXCEPT OF RUBBER OR PLASTICS, RAW FIBROUS TEXTILE MATERIALS, YARNS AND THREADS FOR TEXTILE USE, TEXTILES, NON-WOVEN TEXTILES, HOUSEHOLD LINEN, DIAPERED LINEN, CURTAINS, BLINDS, WALL COVERINGS, NET CURTAINS, OF TEXTILES, BED AND TABLE COVERS, BANNERS, CALICOES, FLAGS AND PENNANTS, ALL THESE GOODS BEING MADE OF TEXTILE MATERIALS, CLOTHING, FOOTWEAR WITH THE EXCEPTION OF ORTHOPEDIC FOOTWEAR, HEADGEAR FOR WEAR, LACE AND EMBROIDERY, RIBBONS AND BRAID, BUTTONS, HOOKS AND EYES, PINS AND NEEDLES, ARTIFICIAL FLOWERS, CARPETS, RUGS, MATS AND MATTING, LINOLEUM AND OTHER MATERIALS FOR COVERING EXISTING FLOORS, NON-TEXTILE WALL HANGINGS, GAMES, TOYS, PLAYING CARDS, GYMNASTICS AND SPORTS ARTICLES WITH THE EXCEPTION OF SHOES, CLOTHING AND MATS, DECORATIONS FOR CHRISTMAS TREES, MEAT, FISH, POULTRY EXCLUDING SLAUGHTERED DOMESTIC FOWL AND GAME, MEAT EXTRACTS, PRESERVED, DRIED AND COOKED VEGETABLES, JELLIES, JAMS, COMPOTES, EGGS, MILK AND MILK PRODUCTS WITH THE EXCEPTION OF CHEESES, EDIBLE OILS AND FATS, TINNED EGGS, MEAT, FISH, POULTRY AND GAME, COFFEE, TEA, COCOA, SUGAR, RICE, TAPIOCA, SAGO, ARTIFICIAL COFFEE, FLOURS AND CEREAL PREPARATIONS, BREAD, PASTRY AND CONFECTIONERY, ICES, HONEY, TREACLE SYRUP, YEAST, BAKING-POWDER, SALT, MUSTARD, VINEGAR, SAUCES, SPICES, ICES FOR REFRESHMENT, AGRICULTURAL, HORTICULTURAL AND FORESTRY PRODUCTS NEITHER PREPARED NOR PROCESSED, AND GRAINS, SEEDS, LIVE ANIMALS, FRESH VEGETABLES, NATURAL SEEDS, PLANTS AND FLOWERS, ANIMAL FOODSTUFFS, MALT, BEERS, MINERAL AND AERATED WATERS AND OTHER NON-ALCOHOLIC DRINKS, FRUIT DRINKS AND FRUIT JUICES, SYRUPS AND OTHER PREPARATIONS FOR MAKING BEVERAGES, ALCOHOLIC BEVERAGES EXCEPT BEERS AND WINE, TOBACCO, SMOKERS' ARTICLES, MATCHES, AND LIGHTERS FOR SMOKERS (U.S. CLS. 100, 101 AND 102).

### CLASS 36—INSURANCE AND FINANCIAL

FOR ACCIDENT INSURANCE UNDERWRITING; FINANCIAL SERVICES, NAMELY, FINANCIAL CONSULTATION AND PLANNING; BANKING; FINANCIAL MANAGEMENT; ACQUISITION AND TRANSFER OF MONETARY CLAIMS; FINANCIAL SPONSORSHIP OF YOUTH BASKETBALL GAMES; FACILITATING AND ARRANGING THE FINANCING OF A YOUTH SPORTS LEAGUE; REAL ESTATE CONSULTATION; REAL ESTATE MANAGEMENT; LEASING OF REAL ESTATE; RENTAL OF REAL ESTATE; SAVINGS BANK SERVICES; INSURANCE CONSULTING AND PROVIDING INFORMATION IN INSURANCE MATTERS; LIFE AND HEALTH INSURANCE UNDERWRITING SERVICES; DEPOSIT BANKING SERVICES; INVESTMENT BANKING SERVICES; COMMERCIAL LENDING SERVICES; FOREIGN EXCHANGE INFORMATION BUREAU SERVICES; CREDIT AND CASH CARD SERVICES; FINANCIAL PORTFOLIO MANAGEMENT; PROVIDING LOANS SECURED BY COMMERCIAL PAPER; SAFE DEPOSIT BOX SERVICES; DEBT RECOVERY AND COLLECTION AGENCIES; ISSUING OF TRAVELERS' CHEQUES AND LETTERS OF CREDIT; REAL ESTATE AGENCIES SPECIALIZING IN THE SALE AND RENTAL OF BUSINESS ASSETS AND BUILDINGS; REAL ESTATE APPRAISAL; REAL ESTATE PROPERTY MANAGEMENT; FINANCIAL SECURITY BROKERAGE AND FINANCIAL INVESTMENT IN THE FIELD OF SECURITIES; AND INSURANCE BROKERAGE IN THE FIELD OF ACCIDENT INSURANCE (U.S. CLS. 100, 101 AND 102).

### CLASS 38—COMMUNICATION

FOR TELECOMMUNICATIONS SERVICES, NAMELY, PERSONAL COMMUNICATION SERVICES; ELECTRONIC TRANSMISSION OF MESSAGES AND IMAGES VIA COMPUTER; NEWS AGENCIES, NAMELY, THE TRANSMISSION OF NEWS ITEMS TO NEWS REPORTING ORGANIZATIONS; RADIO, TELEGRAPH OR TELEPHONE COMMUNICATION SERVICES; COMMUNICATIONS BY COMPUTER TERMINALS; PROVIDING INFORMATION ON TELECOMMUNICATIONS; TRANSMISSION OF DATABASE INFORMATION VIA TELECOMMUNICATIONS NETWORKS; PROVISION OF ACCESS TO ELECTRONIC DATABASE SITES AND PROVIDING INFORMATION RELATED THERETO; ELECTRONIC MAIL SERVICES; TRANSMISSION OF FACSIMILES AND TELEGRAMS; RENTAL OF MESSAGE SENDING APPARATUS IN THE NATURE OF MODEMS, FAX MACHINES AND TELEPHONES; BROADCASTING OF RADIO AND TELEVISION PROGRAMS; ELECTRONIC DELIVERY OF IMAGES VIA A GLOBAL COMPUTER NETWORK; CABLE TELEVISION TRANSMISSION SERVICES; AND SATELLITE TRANSMISSION SERVICES (U.S. CLS. 100, 101 AND 104).

### CLASS 39—TRANSPORTATION AND STORAGE

FOR PROVIDING OCEAN TRANSPORTATION AND STORAGE SERVICES; TRANSPORTATION OF PASSENGERS AND GOODS BY RAIL; WAREHOUSING SERVICES, NAMELY, PACKAGING AND STORAGE OF GOODS; ARRANGING OF TRAVEL TOURS; NEWSPAPER DELIVERY; WATER AND ELECTRICITY DISTRIBUTION; FURNITURE REMOVAL SERVICES BY MEANS OF TRANSPORTATION BY TRUCK; FERRY-BOAT OPERATING; MARINE TOWING; UNLOADING AND REFLOATING OF SHIPS; PACKAGING OF GOODS FOR TRANSPORTATION; PROVIDING TRAVEL AND TRANSPORT INFORMATION; TOURIST AND TRAVEL AGENCY SERVICES, NAMELY, MAKING RESERVATIONS AND BOOKINGS FOR TRANSPORTATION; ELECTRONIC TICKET RESERVATION SERVICES FOR TRANSPORT; CHAUFFEUR TRANSPORT SERVICES; COURIER SERVICES; HORSE AND TRANSPORT VEHICLE RENTAL; STORAGE OF MERCHANDISE IN A WAREHOUSE FOR PROTECTION OR SAFEKEEPING PURPOSES; STORAGE, STORING OF CLOTHES WITH A VIEW TO THEIR SAFEKEEPING; VEHICLE PARKING; REFRIGERATOR RENTAL FOR HOUSEHOLD PURPOSES; AND GARAGE SPACE LEASING (U.S. CLS. 100 AND 105).

**CLASS 41—EDUCATION AND ENTERTAINMENT**

FOR EDUCATIONAL SERVICES, NAMELY, COMPUTER EDUCATION TRAINING; ARRANGING OF TRAINING COURSES AT TEACHING INSTITUTES; ORGANIZING COMMUNITY SPORTING AND CULTURAL EVENTS; PUBLICATION OF BOOKS, REVIEWS; ELECTRONIC PUBLISHING SERVICES, NAMELY, PUBLICATION OF BOOKS AND PERIODICALS OF OTHERS IN THE FIELD OF HISTORY AND CURRENT EVENTS; LENDING LIBRARIES; ANIMAL TRAINING; ENTERTAINMENT IN THE NATURE OF TELEVISION NEWS SHOWS; RADIO ENTERTAINMENT SERVICES, NAMELY, RADIO PROGRAMS FEATURING PERFORMANCES BY MUSICIANS; ENTERTAINMENT IN THE NATURE OF ON-GOING TELEVISION PROGRAMS IN THE FIELD OF COMEDY; TELEVISION SHOW, MOTION PICTURE FILM AND VIDEOTAPE PRODUCTION; RENTAL OF MOTION PICTURE FILMS, VIDEO TAPES, SOUND RECORDINGS, CINEMA PROJECTION APPARATUS AND THEATRE SCENERY ACCESSORIES; RECORDING STUDIO SERVICES; ORGANIZATION OF SPORTS FIELD AND TRACK COMPETITIONS; TIMING OF SPORTS EVENTS; ARRANGING OF COMPETITIONS IN THE FIELD OF EDUCATION OR ENTERTAINMENT IN THE NATURE OF GAME SHOW PRODUCTION; ARRANGING AND CONDUCTING OF EDUCATIONAL COLLOQUIUMS, CONFERENCES AND CONGRESSES; ORGANIZATION OF EXHIBITIONS FEATURING FOLK ART FOR CULTURAL AND EDUCATIONAL PURPOSES; BOOKING OF SEATS FOR SHOWS; PROVIDING ELECTRONIC TICKET SERVICES VIA THE INTERNET WITH REGARD TO ENTERTAINMENT, SPORTING AND CULTURAL ACTIVITIES, SHOWS, AND ORGANIZED COMPETITIONS; MOBILE LIBRARY SERVICES; PROVIDING EDUCATIONAL COURSES IN THE FIELD OF SPORTS PROFICIENCY AND SPORT CAMPS; HEALTH CLUB SERVICES, NAMELY, PROVIDING INSTRUCTION AND EQUIPMENT IN THE FIELD OF PHYSICAL FITNESS; PROVIDING INFORMATION ON ENTERTAINMENT, RECREATIONAL AND EDUCATIONAL MATTERS; RENTAL OF SPORTS EQUIPMENT; RENTAL OF STADIUM FACILITIES; NEWS REPORTING AND PHOTOGRAPHIC REPORTING SERVICES; VIDEOTAPING; TRANSLATION SERVICES; EDITORIAL SERVICES FOR THIRD PARTIES, NAMELY, EDITING THE CONTENT OF WEB PAGES ON THE INTERNET; ENTERTAINMENT SERVICES, NAMELY, PROVIDING GAMES ONLINE ON A COMPUTER NETWORK; GAMBLING SERVICES; OPERATING LOTTERIES; PROVIDING RECREATION FACILITIES; PROVIDING EDUCATIONAL COURSES FOR IMPROVING SPORTS PERFORMANCE; PARTY PLANNING; AND LOTTERY SERVICES (U.S. CLS. 100, 101 AND 107).

**CLASS 43—HOTEL AND RESTAURANT SERVICES**

FOR HOTELS; BOOKING SERVICE FOR HOTEL ROOMS; RESTAURANTS; CAFETERIAS; CATERING; PROVIDING TEMPORARY ACCOMMODATION; PROVIDING HOLIDAY CAMPGROUND SERVICES; RENTAL OF MEETING ROOMS; RENTAL OF TENTS; ACCOMMODATION BUREAU, NAMELY, ARRANGING TEMPORARY HOUSING ACCOMMODATIONS AT MOTELS AND BOARDING HOUSES; COFFEE SHOPS; AND RENTAL OF TEMPORARY HOUSING ACCOMMODATIONS (U.S. CLS. 100 AND 101).

**CLASS 44—MEDICAL, BEAUTY AND AGRICULTURAL SERVICES**

FOR REST AND CONVALESCENT HOMES; MEDICAL SERVICES; OPERATION OF PUBLIC BATHS FOR SANITARY PURPOSE; BEAUTY SALONS; TATTOOING; VETERINARY SERVICES; AGRICULTURE, HORTICULTURE AND FORESTRY ADVICE SERVICES; EMERGENCY MEDICAL ASSISTANCE; HAIRDRESSING SALONS; MASSAGE SERVICES; HOSPITALS; AND MANAGED HEALTH CARE SERVICES (U.S. CLS. 100 AND 101).

VERNA BETH RIRIE, EXAMINING ATTORNEY

SN 79-022,039. SCREAM LTD, UNITED KINGDOM, FILED 3-29-2005.

**METAL WARS**

OWNER OF INTERNATIONAL REGISTRATION 0880211 DATED 3-29-2005, EXPIRES 3-29-2015.

**CLASS 16—PAPER GOODS AND PRINTED MATTER**

FOR PRINTED MATTER, NAMELY, PRINTED PERIODICALS IN THE FIELD OF MUSIC; BOOKS WITH RESPECT TO MUSIC AND ENTERTAINMENT; MAGAZINES FEATURING MUSIC AND ENTERTAINMENT; COMICS; STATIONERY; GREETINGS CARDS; STICKERS AND DECALCOMANIAS; POSTERS; FLAGS AND PENNANTS OF PAPER; DIARIES; CALENDARS; TABLE CLOTHS, TABLE LINEN, TABLE MATS AND TABLE NAPKINS, ALL OF PAPER (U.S. CLS. 2, 5, 22, 23, 29, 37, 38 AND 50).

**CLASS 25—CLOTHING**

FOR ARTICLES OF CLOTHING, NAMELY, T-SHIRTS, SWEAT SHIRTS, SHIRTS, PANTS, TROUSERS, PAJAMAS, LINGERIE, JACKETS, SPORTS JACKETS, COATS, SOCKS, NECK SCARVES, BANDANAS (U.S. CLS. 22 AND 39).

**CLASS 28—TOYS AND SPORTING GOODS**

FOR TOYS, GAMES, AND PLAYTHINGS, NAMELY BOARD GAMES, ACTION FIGURES, STUFFED TOYS, TOY MUSICAL INSTRUMENTS; SPORTING ARTICLES, NAMELY, GOLF CLUBS, FLYING DISCS, BALLS, BASKETBALLS; SKATEBOARDS; PAPER NOVELTIES FOR PARTIES, NAMELY, PARTY FAVORS IN THE NATURE OF CRACKERS AND NOISE MAKERS (U.S. CLS. 22, 23, 38 AND 50).

**CLASS 41—EDUCATION AND ENTERTAINMENT**

FOR PRODUCTION AND DISTRIBUTION OF RADIO OR TELEVISION PROGRAMS FOR OTHERS; ORGANIZATION AND PRODUCTION OF ENTERTAINMENT, MUSICAL, RECREATIONAL AND DANCE EVENTS; NAMELY LIVE MUSIC CONCERTS, LIVE DANCE EVENTS, MUSICALS, SPOKEN WORD CONCERTS; PRODUCTION AND DISTRIBUTION OF MOTION PICTURES AND CINEMATOGRAPHIC FILMS; ORGANIZATION OF SPORTING EVENTS IN THE FIELD OF SOCCER, FOOTBALL, BASEBALL, BASKETBALL, RUGBY, CRICKET, TENNIS, AND GOLF (U.S. CLS. 100, 101 AND 107).

DAYNA BROWNE, EXAMINING ATTORNEY

SN 79-022,102. DOLLFUS MIEG & COMPAGNIE - DMC,  
FRANCE, FILED 2-16-2006.



OWNER OF INTERNATIONAL REGISTRATION 0880347  
DATED 2-16-2006, EXPIRES 2-16-2016.  
THE COLOR(S) BLUE IS/ARE CLAIMED AS A FEATURE  
OF THE MARK.  
ALL OF THE MARK IS IN BLUE, STYLIZED WRITING.

### CLASS 23—YARNS AND THREADS

FOR THREADS AND SPUN YARN FOR TEXTILE  
USE; COTTON THREADS, RUBBER OR PLASTIC  
THREADS FOR TEXTILE PURPOSES, SPUN WOOL  
(U.S. CL. 43).

### CLASS 26—FANCY GOODS

FOR LACE AND EMBROIDERY, BRAIDS AND  
LACES, BUTTONS FOR CLOTHING, EYELETS, PINS  
FOR SEWING, NEEDLES FOR SEWING, HABERDASH-  
ERY, NAMELY, FRINGES AND RIBBONS, FORKS AND  
CROCHET HOOKS FOR EMBROIDERING; LACE TRIM-  
MINGS; SPANGLES FOR CLOTHING (U.S. CLS. 37, 39,  
40, 42 AND 50).

JOANNA DUKOVIC, EXAMINING ATTORNEY

SN 79-022,670. IDB HOLDING S.P.A., ITALY, FILED 10-31-  
2005.



OWNER OF INTERNATIONAL REGISTRATION 0395067  
DATED 12-22-1972, EXPIRES 12-22-2012.

### CLASS 3—COSMETICS AND CLEANING PRE- PARATIONS

FOR PLANT EXTRACTS SOLD AS AN INTEGRAL  
COMPONENT OF COSMETICS (U.S. CLS. 1, 4, 6, 50, 51  
AND 52).

### CLASS 5—PHARMACEUTICALS

FOR PLANT EXTRACTS FOR USE AS A DIETETIC  
ADAPTED FOR MEDICAL USE (U.S. CLS. 6, 18, 44, 46, 51  
AND 52).

PAUL CROWLEY, EXAMINING ATTORNEY

SN 79-023,076. NUTREXIN AG, SWITZERLAND, FILED 4-12-  
2006.



THE MARK CONSISTS OF STANDARD CHARACTERS  
WITHOUT CLAIM TO ANY PARTICULAR FONT, STYLE,  
SIZE, OR COLOR.

OWNER OF INTERNATIONAL REGISTRATION 0882846  
DATED 4-12-2006, EXPIRES 4-12-2016.

### CLASS 3—COSMETICS AND CLEANING PRE- PARATIONS

FOR COSMETIC PRODUCTS FOR SKIN CARE,  
NAMELY, SKIN GELS, SKIN CREAMS, SHOWER GELS  
AND LOTIONS, ALL THE AFORESAID GOODS FOR  
COSMETIC USE (U.S. CLS. 1, 4, 6, 50, 51 AND 52).

### CLASS 5—PHARMACEUTICALS

FOR PHARMACEUTICAL PRODUCTS FOR SKIN  
CARE WITH HOMEOPATHIC AND/OR SPAGYRIC IN-  
GREDIENTS (U.S. CLS. 6, 18, 44, 46, 51 AND 52).

JOHN E. MICHOS, EXAMINING ATTORNEY

SN 79-023,122. SANOCHEMIA PHARMAZEUTIKA AG, AUS-  
TRIA, FILED 2-2-2006.



THE MARK CONSISTS OF STANDARD CHARACTERS  
WITHOUT CLAIM TO ANY PARTICULAR FONT, STYLE,  
SIZE, OR COLOR.

PRIORITY DATE OF 9-22-2005 IS CLAIMED.  
OWNER OF INTERNATIONAL REGISTRATION 0882962  
DATED 2-2-2006, EXPIRES 2-2-2016.

### CLASS 5—PHARMACEUTICALS

FOR PREPARATIONS FOR TUMOUR DIAGNOSIS  
FOR CLINICAL OR MEDICAL LABORATORY USE  
(U.S. CLS. 6, 18, 44, 46, 51 AND 52).

### CLASS 10—MEDICAL APPARATUS

FOR DIAGNOSTIC ENDOSCOPIC APPARATUS FOR  
MEDICAL PURPOSES; DIAGNOSTIC ENDOSCOPIC AP-  
PARATUS FOR TUMOUR RECOGNITION (U.S. CLS. 26,  
39 AND 44).

ADA HAN, EXAMINING ATTORNEY

SN 79-023,138. SIEMENS AKTIENGESSELLSCHAFT, FED  
REP GERMANY, FILED 11-22-2005.



THE MARK CONSISTS OF STANDARD CHARACTERS  
WITHOUT CLAIM TO ANY PARTICULAR FONT, STYLE,  
SIZE, OR COLOR.

PRIORITY DATE OF 5-25-2005 IS CLAIMED.  
OWNER OF INTERNATIONAL REGISTRATION 0883007  
DATED 11-22-2005, EXPIRES 11-22-2015.

### CLASS 9—ELECTRICAL AND SCIENTIFIC APPARATUS

FOR COMPUTERS (U.S. CLS. 21, 23, 26, 36 AND 38).

**CLASS 38—COMMUNICATION**

SN 79-023,505. DALETEC AS, NORWAY, FILED 1-24-2006.

FOR VALUE-ADDED SERVICES, NAMELY THE ELECTRONIC SENDING OR ELECTRONIC RECEPTION OF MESSAGES IN WRITTEN OR GRAPHICAL FORM OR ANNOUNCEMENTS AS WELL AS THE ELECTRONIC TRANSMISSION OF INFORMATION OF ANY KIND; SENDING OF DATA IN WRITING OR GRAPHICAL FORM VIA THE INTERNET OR INTRANET; PROVIDING ACCESS TO AND TRANSMISSION OF INFORMATION STORED IN DATABASES BY MEANS OF IT AND TELECOMMUNICATION SYSTEMS COMMUNICATING INTERACTIVELY (U.S. CLS. 100, 101 AND 104).

**CLASS 42—SCIENTIFIC, COMPUTER AND LEGAL SERVICES**

FOR DEVELOPMENT AND RENTING OF DATA PROCESSING PROGRAMS AND SOFTWARE; DESIGN, PROGRAMMING, AND UPDATING OF SOFTWARE APPLICATIONS FOR THE ACCESS TO DATA AND TELECOMMUNICATION NETWORKS (U.S. CLS. 100 AND 101).

DAYNA BROWNE, EXAMINING ATTORNEY

SN 79-023,189. TEKLA OYJ, FINLAND, FILED 2-2-2006.

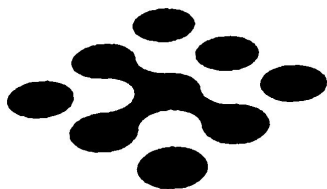

PRIORITY DATE OF 1-26-2006 IS CLAIMED.  
OWNER OF INTERNATIONAL REGISTRATION 0883165  
DATED 2-2-2006, EXPIRES 2-2-2016.

THE MARK CONSISTS OF NINE SHADED CIRCLES IN A DIAMOND SHAPE WITH FOUR OF THESE SHADED CIRCLES CONNECTED TO CREATE A STYLIZED REPRESENTATION OF THE LETTER "T".

**CLASS 9—ELECTRICAL AND SCIENTIFIC APPARATUS**

FOR COMPUTER SOFTWARE FOR USE IN TELECOMMUNICATION NETWORK PLANNING SYSTEMS, NAMELY, FOR MANAGING INFORMATION AND COMMUNICATION NETWORKS AND CABLE TELEVISION NETWORKS; COMPUTER SOFTWARE FOR USE IN SPATIAL INFORMATION MANAGEMENT SYSTEMS, NAMELY, FOR LIFE CYCLE MODELING OF PUBLIC INFRASTRUCTURE; COMPUTER SOFTWARE FOR USE IN INTEGRATED ENVIRONMENTAL SECURITY SYSTEMS FOR DECISION MAKING IN EMERGENCY SITUATIONS; COMPUTER SOFTWARE FOR USE IN GRAPHICAL INFORMATION SYSTEMS, NAMELY, FOR PLANNING FOREST MANAGEMENT; COMPUTER SOFTWARE FOR USE IN NETWORK INFORMATION SYSTEMS, NAMELY, FOR DISTRIBUTING ELECTRICITY; COMPUTER SOFTWARE FOR USE IN DESIGNING HIGHWAYS AND STREETS, MODELING LANDSCAPES, AND DESIGNING STEEL AND CONCRETE STRUCTURES; COMPUTER PERIPHERALS (U.S. CLS. 21, 23, 26, 36 AND 38).

**CLASS 42—SCIENTIFIC, COMPUTER AND LEGAL SERVICES**

FOR COMPUTER PROGRAMMING SERVICES, MAINTENANCE OF COMPUTER SOFTWARE, UPDATING OF COMPUTER PROGRAMS FOR THIRD PARTIES, COMPUTER SOFTWARE DESIGN, CONSULTANCY IN THE FIELD OF COMPUTERS (U.S. CLS. 100 AND 101).

TOBY BULLOFF, EXAMINING ATTORNEY



PRIORITY DATE OF 12-22-2005 IS CLAIMED.  
OWNER OF INTERNATIONAL REGISTRATION 0884320  
DATED 1-24-2006, EXPIRES 1-24-2016.

**CLASS 24—FABRICS**

FOR BED BLANKETS, BED SHEETS, BED SPREADS, BED LINEN, BLANKET THROWS, COMFORTERS, FABRIC WINDOW COVERINGS AND TREATMENTS, NAMELY CURTAINS, DRAPERIES, SHEERS, SWAGS AND VALANCES; KNITTED FABRICS, MIXED FIBER FABRICS, PILLOW COVERS, SYNTHETIC FIBER FABRICS, WOOLEN FABRIC, THROWS, WOOLEN YARN FABRICS, UPHOLSTERY FABRICS, ALL FIRE RESISTANT AND FLUORESCENT FOR USE IN THE MANUFACTURE OF PROTECTIVE CLOTHING; ALL THE FOREGOING BEING FIRE RESISTANT AND INCORPORATING REFLECTIVE OR FLUORESCENT ELEMENTS OR MATERIAL IN ORDER TO INCREASE VISIBILITY (U.S. CLS. 42 AND 50).

**CLASS 25—CLOTHING**

FOR CLOTHING; NAMELY FOOTWEAR, HEADWEAR, HATS, UNDERWEAR, SHIRTS, PANTS, KNIT SHIRTS, JACKETS, SWEATERS, COATS, DRESSES, LEGGINGS, LEG WARMERS, PULLOVERS, SHAWLS, UNDERGARMENTS; ALL THE FOREGOING BEING FIRE RESISTANT AND INCORPORATING REFLECTIVE OR FLUORESCENT ELEMENTS OR MATERIAL IN ORDER TO INCREASE VISIBILITY (U.S. CLS. 22 AND 39).

ANDREA K. NADELMAN, EXAMINING ATTORNEY

SN 79-023,702. MIDDELLAND BEHEER B.V., NETHERLANDS, FILED 1-13-2006.

SN 79-023,961. LOUVER-LITE LIMITED, CHESHIRE, UNITED KINGDOM, FILED 1-4-2006.



OWNER OF INTERNATIONAL REGISTRATION 0681160 DATED 9-9-1997, EXPIRES 9-9-2007.

NO CLAIM IS MADE TO THE EXCLUSIVE RIGHT TO USE "GROUP", APART FROM THE MARK AS SHOWN.

THE COLOR(S) BLUE AND WHITE IS/ARE CLAIMED AS A FEATURE OF THE MARK.

THE COLOR BLUE APPEARS IN THE FORM OF AN OVAL CONTAINING THE TEXT INDOFIN GROUP, WHICH APPEARS IN WHITE.

"THE MARK CONSISTS OF A BLUE OVAL CONTAINING THE TEXT INDOFIN GROUP."

#### CLASS 35—ADVERTISING AND BUSINESS

FOR CONSULTING SERVICES IN THE FIELD OF CORPORATE MANAGEMENT ASSISTANCE, NAMELY MANAGEMENT OF AND ASSISTANCE WITH COMMERCIAL AFFAIRS AND COMPANY OPERATION; CORPORATE MANAGEMENT ASSISTANCE AND CONSULTING IN THE FIELD OF CORPORATE MANAGEMENT ASSISTANCE, NAMELY ENTERPRISE MANAGEMENT ASSISTANCE AND RELATED CONSULTING; PROVIDING OFFICE FUNCTIONS; BUSINESS RESEARCH SERVICES, NAMELY RESEARCH FOR BUSINESS PURPOSES REGARDING THE OPERATION, MARKET POSITION AND APPRAISAL OF COMPANIES; BUSINESS EVALUATION AND APPRAISALS IN BUSINESS MATTERS, NAMELY EVALUATION OF THE OPERATION, MARKET POSITION AND APPRAISAL OF COMPANIES (U.S. CLS. 100, 101 AND 102).

#### CLASS 36—INSURANCE AND FINANCIAL

FOR FINANCIAL MANAGEMENT AND FUNDS INVESTMENT FOR RISK FUNDS IN COMPANIES; HEDGE FUND INVESTMENT FOR RISK FUNDS IN COMPANIES; FINANCIAL RESEARCH, NAMELY RESEARCH REGARDING COMPANY INVESTMENT POSSIBILITIES; FINANCIAL EVALUATION OF INVESTMENTS POSSIBILITIES FOR START UP CORPORATIONS (U.S. CLS. 100, 101 AND 102).

#### CLASS 42—SCIENTIFIC, COMPUTER AND LEGAL SERVICES

FOR LEGAL RESEARCH (U.S. CLS. 100 AND 101). SEAN CROWLEY, EXAMINING ATTORNEY

## LOUVOLITE PERFECT FIT

THE MARK CONSISTS OF STANDARD CHARACTERS WITHOUT CLAIM TO ANY PARTICULAR FONT, STYLE, SIZE, OR COLOR.

PRIORITY DATE OF 7-4-2005 IS CLAIMED.

OWNER OF INTERNATIONAL REGISTRATION 0885159 DATED 1-4-2006, EXPIRES 1-4-2016.

OWNER OF U.S. REG. NO. 2,362,355.

NO CLAIM IS MADE TO THE EXCLUSIVE RIGHT TO USE "PERFECT FIT", APART FROM THE MARK AS SHOWN.

#### CLASS 6—METAL GOODS

FOR METAL BLINDS, NAMELY SLATTED BLINDS, ROLLER BLINDS, PLEATED BLINDS AND SHUTTERS ALL MADE AT LEAST PARTLY FROM METAL; PARTS AND FITTINGS, INCLUDING FRAMES, FOR ALL THE AFORESAID GOODS (U.S. CLS. 2, 12, 13, 14, 23, 25 AND 50).

#### CLASS 20—FURNITURE AND ARTICLES NOT OTHERWISE CLASSIFIED

FOR BLINDS; SLATTED BLINDS, ROLLER BLINDS, PLEATED BLINDS AND SHUTTERS NOT OF METAL AND NOT OF TEXTILES; PARTS AND FITTINGS, INCLUDING FRAMES, FOR ALL THE AFORESAID GOODS (U.S. CLS. 2, 13, 22, 25, 32 AND 50).

#### CLASS 24—FABRICS

FOR BLINDS; SLATTED BLINDS, ROLLER BLINDS, PLEATED BLINDS AND SHUTTERS, ALL MADE AT LEAST PARTLY FROM TEXTILES; PARTS AND FITTINGS, INCLUDING FRAMES, FOR ALL THE AFORESAID GOODS (U.S. CLS. 42 AND 50).

PAUL E. FAHRENKOPF, EXAMINING ATTORNEY

SN 79-024,214. LIND, HELENA, 24558 HENSTEDT-ULZBURG, FED REP GERMANY, FILED 10-11-2005.

# MIZPAH

OWNER OF INTERNATIONAL REGISTRATION 0885874 DATED 10-11-2005, EXPIRES 10-11-2015.

#### CLASS 3—COSMETICS AND CLEANING PREPARATIONS

FOR PERFUME, SCENTED BODY WATER, SCENTED BODY OILS (U.S. CLS. 1, 4, 6, 50, 51 AND 52).

**CLASS 9—ELECTRICAL AND SCIENTIFIC APPARATUS**

FOR COMPACT VIDEO DISKS (CVDS) FEATURING SPOKEN AND SUNG WORD IN THE FIELD OF LIFE ENHANCEMENT, SELF IMPROVEMENT, PHILOSOPHICAL, SPIRITUAL AND PRACTICAL INSTRUCTION, MUSICAL ENTERTAINMENT, LIVE AND RECORDED ENTERTAINMENT MUSICAL PERFORMANCES, MUSICAL AND NARRATIVE SOUND, AND PICTURE RECORDINGS; COMPACT DISCS (CDS) FEATURING SPOKEN AND SUNG WORD IN THE FIELD OF LIFE ENHANCEMENT, SELF IMPROVEMENT, PHILOSOPHICAL, SPIRITUAL AND PRACTICAL INSTRUCTION, MUSICAL ENTERTAINMENT, LIVE AND RECORDED ENTERTAINMENT MUSICAL PERFORMANCES, MUSICAL AND NARRATIVE SOUND, AND PICTURE RECORDINGS; BLANK AUDIO AND VIDEO RECORDING DISCS; PRERECORDED IMAGE AND SOUND CARRIERS FEATURING SPOKEN AND SUNG WORD IN THE FIELD OF LIFE ENHANCEMENT, SELF IMPROVEMENT, PHILOSOPHICAL, SPIRITUAL AND PRACTICAL INSTRUCTION, MUSICAL ENTERTAINMENT, LIVE AND RECORDED ENTERTAINMENT MUSICAL PERFORMANCES, MUSICAL AND NARRATIVE SOUND, AND PICTURE RECORDINGS; VIDEO TAPES FEATURING SPOKEN AND SUNG WORD IN THE FIELD OF LIFE ENHANCEMENT, SELF IMPROVEMENT, PHILOSOPHICAL, SPIRITUAL AND PRACTICAL INSTRUCTION, MUSICAL ENTERTAINMENT, LIVE AND RECORDED ENTERTAINMENT MUSICAL PERFORMANCES, MUSICAL AND NARRATIVE SOUND, AND PICTURE RECORDINGS; VIDEO CASSETTES FEATURING SPOKEN AND SUNG WORD IN THE FIELD OF LIFE ENHANCEMENT, SELF IMPROVEMENT, PHILOSOPHICAL, SPIRITUAL AND PRACTICAL INSTRUCTION, MUSICAL ENTERTAINMENT, LIVE AND RECORDED ENTERTAINMENT MUSICAL PERFORMANCES, MUSICAL AND NARRATIVE SOUND, AND PICTURE RECORDINGS; COMPUTER CHIPS AND CD-ROMS FEATURING SPOKEN AND SUNG WORD IN THE FIELD OF LIFE ENHANCEMENT, SELF IMPROVEMENT, PHILOSOPHICAL, SPIRITUAL AND PRACTICAL INSTRUCTION, MUSICAL ENTERTAINMENT, LIVE AND RECORDED ENTERTAINMENT MUSICAL PERFORMANCES, MUSICAL AND NARRATIVE SOUND, AND PICTURE RECORDINGS; DIGITAL VIDEO DISCS (DVDS) FEATURING SPOKEN AND SUNG WORD IN THE FIELD OF LIFE ENHANCEMENT, SELF IMPROVEMENT, PHILOSOPHICAL, SPIRITUAL AND PRACTICAL INSTRUCTION, MUSICAL ENTERTAINMENT, LIVE AND RECORDED ENTERTAINMENT MUSICAL PERFORMANCES, MUSICAL AND NARRATIVE SOUND, AND PICTURE RECORDINGS; COMPUTER GAME SOFTWARE; DOWNLOADABLE ELECTRONIC PUBLICATIONS IN THE NATURE OF MAGAZINES IN THE FIELD OF LIFE ENHANCEMENT, SELF IMPROVEMENT, PHILOSOPHICAL, SPIRITUAL AND PRACTICAL INSTRUCTION (U.S. CLS. 21, 23, 26, 36 AND 38).

**CLASS 16—PAPER GOODS AND PRINTED MATTER**

FOR GIFT ARTICLES, NAMELY STICKERS, POSTERS, CALENDARS, WRITING PAPER, PAPERWEIGHTS, BOOKS IN THE FIELD OF SELF IMPROVEMENT, INSPIRATIONAL TOPICS, HISTORY, AND PHILOSOPHY; GREETING CARDS; PRINTED MAGAZINES IN THE FIELD OF SELF IMPROVEMENT, INSPIRATIONAL TOPICS, HISTORY, AND PHILOSOPHY (U.S. CLS. 2, 5, 22, 23, 29, 37, 38 AND 50).

**CLASS 41—EDUCATION AND ENTERTAINMENT**

FOR PRESENTATION OF LIVE SHOW PERFORMANCES AND MUSICAL PERFORMANCES, NAMELY LIVE PERFORMANCES BY A SINGLE ARTIST AND A MUSICAL GROUP; PRODUCTION OF RADIO AND TELEVISION PROGRAMMES (U.S. CLS. 100, 101 AND 107).

JOSETTE BEVERLY, EXAMINING ATTORNEY

SN 79-024,669. JJ4U LIMITED, UNITED KINGDOM, FILED 3-6-2006.

**JADE JAGGER FOR YOO**

THE MARK CONSISTS OF STANDARD CHARACTERS WITHOUT CLAIM TO ANY PARTICULAR FONT, STYLE, SIZE, OR COLOR.

PRIORITY DATE OF 2-24-2006 IS CLAIMED.

OWNER OF INTERNATIONAL REGISTRATION 0887040 DATED 3-6-2006, EXPIRES 3-6-2016.

THE NAME "JADE JAGGER" IDENTIFIES A LIVING INDIVIDUAL WHOSE CONSENT IS OF RECORD.

**CLASS 20—FURNITURE AND ARTICLES NOT OTHERWISE CLASSIFIED**

FOR FURNITURE (U.S. CLS. 2, 13, 22, 25, 32 AND 50).

**CLASS 36—INSURANCE AND FINANCIAL**

FOR LEASING OF REAL ESTATE; MANAGEMENT OF REAL ESTATE; REAL ESTATE AGENCY SERVICES; VALUATION OF REAL ESTATE; REAL ESTATE SELECTION, ACQUISITION, AND DISPOSAL OF REAL ESTATE PROPERTY; LEASING OF HOUSING ACCOMMODATIONS; CONSULTING IN THE FIELDS OF REAL ESTATE AND THE LEASING OF HOUSING ACCOMMODATIONS; PROVIDING INFORMATION IN THE FIELDS OF REAL ESTATE AND THE LEASING OF HOUSING ACCOMMODATIONS (U.S. CLS. 100, 101 AND 102).

**CLASS 37—CONSTRUCTION AND REPAIR**

FOR BUILDING MAINTENANCE AND REPAIR SERVICES; CONSTRUCTION SERVICES, NAMELY, CUSTOM CONSTRUCTION OF HOMES; RENOVATION SERVICES, NAMELY, RENOVATION OF BUILDINGS; UPHOLSTERING SERVICES, NAMELY, FOR FURNITURE AND BUILDING INTERIORS; CONSULTING IN THE FIELDS OF BUILDING MAINTENANCE AND REPAIR SERVICES, CONSTRUCTION SERVICES IN THE NATURE OF THE CUSTOM CONSTRUCTION OF HOMES, RENOVATION SERVICES IN THE NATURE OF THE RENOVATION OF BUILDINGS, AND UPHOLSTERING SERVICES FOR FURNITURE AND BUILDING INTERIORS; PROVIDING INFORMATION IN THE FIELDS OF BUILDING MAINTENANCE AND REPAIR SERVICES, CONSTRUCTION SERVICES IN THE NATURE OF THE CUSTOM CONSTRUCTION OF HOMES, RENOVATION SERVICES IN THE NATURE OF THE RENOVATION OF BUILDINGS, AND UPHOLSTERING SERVICES FOR FURNITURE AND BUILDING INTERIORS (U.S. CLS. 100, 103 AND 106).

**CLASS 42—SCIENTIFIC, COMPUTER AND LEGAL SERVICES**

FOR ARCHITECTURAL SERVICES, NAMELY, ARCHITECTURAL DESIGN SERVICES; DESIGN SERVICES, NAMELY, INDUSTRIAL DESIGN SERVICES; GRAPHIC DESIGN SERVICES, NAMELY, GRAPHIC ART DESIGN SERVICES; REAL ESTATE DESIGN SERVICES; BUILDING AND HOUSE DESIGN SERVICES; LANDSCAPE DESIGN SERVICES; LAND SURVEYING SERVICES; INTERIOR DESIGN SERVICES; FURNITURE AND HOUSEHOLD ITEM DESIGN SERVICES; CONSULTING IN THE FIELDS OF ARCHITECTURAL DESIGN SERVICES, INDUSTRIAL DESIGN SERVICES, GRAPHIC ART DESIGN SERVICES, REAL ESTATE DESIGN SERVICES, BUILDING AND HOUSE DESIGN SERVICES, LANDSCAPE DESIGN SERVICES, LAND SURVEYING SERVICES, AND INTERIOR DESIGN SERVICES; PROVIDING INFORMATION IN THE FIELDS OF ARCHITECTURAL DESIGN SERVICES, INDUSTRIAL DESIGN SERVICES, GRAPHIC ART DESIGN SERVICES, REAL ESTATE DESIGN SERVICES, BUILDING AND HOUSE DESIGN SERVICES, LANDSCAPE DESIGN SERVICES, AND INTERIOR DESIGN SERVICES (U.S. CLS. 100 AND 101).

JAMES MACFARLANE, EXAMINING ATTORNEY

SN 79-024,966. WOLFGANG VÖGELE, FED REP GERMANY, FILED 12-8-2005.

# BLUESTONE

PRIORITY DATE OF 9-5-2005 IS CLAIMED.  
OWNER OF INTERNATIONAL REGISTRATION 0887868  
DATED 12-8-2005, EXPIRES 12-8-2015.

**CLASS 35—ADVERTISING AND BUSINESS**

FOR ADVERTISING SERVICES; ADVERTISING AGENCIES; ADVERTISING VIA MAIL ORDER; DISSEMINATION OF ADVERTISING MATTER; RENTAL OF ADVERTISING SPACE; BUSINESS ORGANIZATION AND MANAGEMENT CONSULTING SERVICES; MANAGEMENT AND COMPILATION OF COMPUTERIZED DATABASES; PROFESSIONAL BUSINESS CONSULTATION; DEMONSTRATION OF PRODUCTS; DIRECT MAIL ADVERTISING; DISTRIBUTION OF SAMPLES; DOCUMENT REPRODUCTION; COMPUTERIZED FILE MANAGEMENT; ADVISORY SERVICES FOR BUSINESS MANAGEMENT; MARKET RESEARCH; MARKETING STUDIES IN THE NATURE OF MARKET RESEARCH STUDIES; NEWS CLIPPING SERVICES; ON-LINE ADVERTISING ON A COMPUTER COMMUNICATIONS NETWORK; ORGANIZATION OF EXHIBITIONS IN THE FIELD OF COMMERCIAL EQUIPMENT, AERONAUTIC AND SPACE, AUTOMOTIVE, HEALTHCARE AND MARKETING COMMUNICATION FOR COMMERCIAL OR ADVERTISING PURPOSES; ORGANIZATION OF TRADE FAIRS IN THE FIELD OF COMMERCIAL EQUIPMENT, AERONAUTIC AND SPACE, AUTOMOTIVE, HEALTHCARE AND MARKETING COMMUNICATION FOR COMMERCIAL OR ADVERTISING PURPOSES; PROCUREMENT SERVICES FOR OTHERS, NAMELY, PURCHASING OF GRAPHIC DESIGN, INDUSTRIAL DESIGN, AND CONSULTING IN MARKETING COMMUNICATION; PUBLIC RELATIONS; ISSUING AND UPDATING OF ADVERTISING AND PUBLICITY TEXTS; PREPARING PROMOTIONAL AND MERCHANDISING MATERIAL FOR OTHERS, NAMELY, PUBLICITY COLUMNS PREPARATION; RENTAL OF PUBLICITY AND MARKETING PRESENTATION MATERIALS; RENTAL OF ADVERTISING SPACE; SECRETARIAL AND CLERICAL SERVICES; CREATING AND UPDATING ADVERTISING MATERIAL; PROMOTING THE GOODS AND SERVICES OF OTHERS VIA ADVERTISING BROCHURES, INTERNET, TELEVISION, AND RADIO; WORD PROCESSING (U.S. CLS. 100, 101 AND 102).

**CLASS 38—COMMUNICATION**

FOR CELLULAR TELEPHONE COMMUNICATION; COMMUNICATIONS BY COMPUTER TERMINALS; COMMUNICATIONS BY FIBER OPTIC NETWORKS; COMPUTER AIDED TRANSMISSION OF MESSAGES AND IMAGES; PROVIDING ON-LINE ELECTRONIC BULLETIN BOARDS FOR TRANSMISSION OF MESSAGES AMONG COMPUTER USERS CONCERNING TRADE OF GOODS, SERVICES, REAL ESTATE, AND DISCUSSION; ELECTRONIC MAIL SERVICES; PROVIDING INFORMATION ABOUT TELECOMMUNICATION; ELECTRONIC MESSAGE SENDING; PAGING SERVICES VIA RADIO, TELEPHONE OR OTHER MEANS OF ELECTRONIC COMMUNICATION; PROVIDING TELECOMMUNICATIONS CONNECTIONS TO A GLOBAL COMPUTER NETWORK; PROVIDING MULTIPLE-USER ACCESS TO A GLOBAL COMPUTER INFORMATION NETWORK; RENTAL OF TELECOMMUNICATION EQUIPMENT, NAMELY, TELEPHONES, FACSIMILE MACHINES, MOBILE PHONES, AND HEADSETS; TELECOMMUNICATIONS ROUTING AND JUNCTION SERVICES; AUDIO AND VIDEO TELECONFERENCING SERVICES; TELEPHONE COMMUNICATION SERVICES (U.S. CLS. 100, 101 AND 104).

**CLASS 42—SCIENTIFIC, COMPUTER AND LEGAL SERVICES**

FOR ARBITRATION SERVICES; COMPUTER PROGRAMMING; COMPUTER RENTAL, RENTAL OF COMPUTERS, NAMELY, PERSONAL DIGITAL ASSISTANTS (PDAS); COMPUTER SOFTWARE DESIGN FOR OTHERS; UPDATING OF COMPUTER SOFTWARE FOR OTHERS; COMPUTER NETWORK DESIGN FOR OTHERS; COMPUTER SYSTEMS ANALYSIS; CONSULTANCY FOR OTHERS IN THE FIELD OF COMPUTER HARDWARE; INTELLECTUAL PROPERTY CONSULTANCY; COPYRIGHT MANAGEMENT; CREATING AND MAINTAINING WEB SITES FOR OTHERS; DATA CONVERSION OF COMPUTER PROGRAMS AND DATA, NOT IN THE FORM OF PHYSICAL CONVERSION; INTERIOR DECORATING; DRESS DESIGNING; DUPLICATION OF COMPUTER PROGRAMS; GRAPHIC ARTS DESIGNING; WEB SITE HOSTING SERVICES; INDUSTRIAL DESIGN; INSTALLATION OF COMPUTER SOFTWARE; INTELLECTUAL PROPERTY WATCHING SERVICES; LEGAL RESEARCH; LICENSING OF INTELLECTUAL PROPERTY; MAINTENANCE OF COMPUTER SOFTWARE; PACKAGING DESIGN FOR OTHERS; RECOVERY OF COMPUTER DATA; RENTAL OF COMPUTER SOFTWARE; RESEARCH AND DEVELOPMENT FOR NEW PRODUCTS FOR OTHERS (U.S. CLS. 100 AND 101).

KAELIE KUNG, EXAMINING ATTORNEY

SN 79-025,210. FONDAZIONE DI CULTURA; INTERNAZIONALE ARMANDO; VERDIGLIONE ONLUS, ITALY, FILED 11-23-2005.

# CIFREMATICA

THE MARK CONSISTS OF STANDARD CHARACTERS WITHOUT CLAIM TO ANY PARTICULAR FONT, STYLE, SIZE, OR COLOR.

OWNER OF INTERNATIONAL REGISTRATION 0888482  
DATED 11-23-2005, EXPIRES 11-23-2015.

THE ENGLISH TRANSLATION OF THE WORD CIFREMATICA IN THE MARK IS CYPHERMATIC.



**CLASS 16—PAPER GOODS AND PRINTED MATTER**

FOR NEWSPAPERS; BOOKS, JOURNALS, REVIEWS, MAGAZINES, PERIODICALS, PAMPHLETS, INSTRUCTION HANDBOOKS, REFERENCE GUIDES AND CATALOGUES, ALL FEATURING TOPICS OF CULTURE, ARTISTRY, HISTORY, MATHEMATICS, SCIENCE, LITERATURE, LANGUAGES AND GEOGRAPHY; AGENDAS, CALENDARS, POSTERS, BOOKMARKS, PAPER LABELS; BLOTTING PAPER, BOND PAPER, ILLUSTRATION PAPER, GIFT WRAPPING PAPER, WRITING PAPER, ENVELOPES, GIFT CARDS, OCCASION CARDS, POSTCARDS, BLANK CARDS, SCRATCH PADS, PAPER BOXES, PAPER BOARDS, GREETING CARDS, CARDBOARD BOXES, PICTURES, ANNIVERSARY BOOKS, RECIPE BOOKS, PICTURE BOOKS, GUEST BOOKS, DRAWING BOOKS, DICTIONARIES, PHOTOGRAPH ALBUMS, EXERCISE BOOKS, PHOTOGRAPHS, RUBBER ERASERS, MAGNETIC BOARDS, PENCIL SHARPENERS, PENS, PENCILS, PENCIL CASES, PEN CASES, OFFICE REQUISITES, NAMELY PUNCHES; GLUE FOR STATIONERY OR HOUSEHOLD USE, ARTISTS' PASTELS, PAINT BRUSHES, PRINTED AND ENGRAVED PICTURES; BOOKBINDINGS, PAPER CUTTERS, PAPERWEIGHTS, PAPER FASTENERS, HOLE PUNCHERS FOR OFFICE USE, PAPER CLIPS, DRAWING SQUARES, RULERS FOR DRAWING, FILE FOLDERS, DOCUMENT HOLDERS, DESK SETS, DESK TOP ORGANIZERS, PAPER BAGS, GENERAL PURPOSE PLASTIC BAGS, PAPER RIBBONS AND PAPER BOWS FOR GIFT WRAP, PAPER CAKE DECORATION, DECORATIVE PAPER CENTERPIECES, PAPER DOILIES, PAPER TABLE CLOTH, PAPER NAPKINS, PAPER FILTERS FOR COFFEE MAKERS (U.S. CLS. 2, 5, 22, 23, 29, 37, 38 AND 50).

**CLASS 38—COMMUNICATION**

FOR ELECTRONIC NOTICE BOARD SERVICES FEATURING TOPICS OF GENERAL INTEREST TO THE PUBLIC IN THE FIELD OF EDUCATION AND ENTERTAINMENT, TRANSMISSION OF MESSAGES, TEXTS AND IMAGES WITH THE AID OF A COMPUTER, ELECTRONIC MAIL SERVICES; ELECTRONIC TRANSMISSION OF DATA AND DOCUMENTS VIA COMPUTERS TERMINALS; TRANSMISSION OF SOUND AND VIDEO VIA SATELLITE AND INTERACTIVE MULTIMEDIA NETWORKS; ELECTRONIC, ELECTRIC, AND DIGITAL TRANSMISSION OF VOICE, DATA, IMAGES, SIGNALS, AND MESSAGES, INFORMATION TRANSMISSION SERVICES VIA DIGITAL NETWORKS; NETWORK COMMUNICATIONS SERVICES, IN THE FORM OF TRANSMISSION OF STREAMED SOUND AND AUDIO-VISUAL RECORDINGS VIA THE INTERNET; ELECTRONIC TRANSMISSION OF FACSIMILE COMMUNICATIONS AND DATA FEATURING ENCRYPTION AND DECRYPTION; PROVIDING COLLOCATION SERVICES FOR VOICE, VIDEO AND DATA COMMUNICATIONS APPLICATIONS; COMMUNICATIONS THROUGH RADIO AND TELEVISION TRANSMISSIONS, CABLE AND TERRESTRIAL RADIO-TELEVISION TRANSMISSIONS AND BY ON-LINE SERVICES VIA TELEMATIC AND DATA PROCESSING NETWORKS; MOBILE RADIO TELEPHONE SERVICES; PROVIDING TELECOMMUNICATIONS CONNECTIONS TO A GLOBAL COMPUTER NETWORK; TELECOMMUNICATIONS CONSULTATION; TELECOMMUNICATIONS GATEWAY SERVICES; PROVIDING LONG DISTANCE TELECOMMUNICATION SERVICES; TELECOMMUNICATIONS SERVICES, NAMELY ISDN SERVICES; PERSONAL TELECOMMUNICATION SERVICES; PROVIDING FIBER OPTIC NETWORK SERVICES; TELEPHONE TELECOMMUNICATIONS SERVICES FOR OTHERS PROVIDED VIA PREPAID TELEPHONE CALLING CARDS (U.S. CLS. 100, 101 AND 104).

**CLASS 41—EDUCATION AND ENTERTAINMENT**

FOR PUBLICATION OF BOOKS AND MAGAZINES; PUBLICATION OF TEXTS EXCEPT OF ADVERTISING TEXTS; PRESENTATIONS IN MUSEUMS, NAMELY, ART EXHIBITIONS; ARRANGING AND CONDUCTING CONVENTIONS, CONGRESSES, CONFERENCES, SEMINARS AND SYMPOSIA ALL IN THE FIELDS OF MEDICINE, ART AND HISTORY FOR EDUCATIONAL AND CULTURAL PURPOSES; ORGANIZATION OF EXHIBITIONS FOR EDUCATIONAL, CULTURAL OR ENTERTAINMENT PURPOSES; ORGANIZATION OF COMMUNITY SPORTING AND CULTURAL EVENTS; ORGANIZING AND CONDUCTING TRAINING CLASSES, SEMINARS AND WORKSHOPS IN THE FIELDS OF MUSIC, ART, WRITING, COOKING, AND PERSONAL AWARENESS; EDUCATIONAL SERVICES IN THE NATURE OF FINE ARTS SCHOOLS AND IN THE NATURE OF COURSES AT THE UNIVERSITY LEVEL; COMPUTER EDUCATION TRAINING; SWIMMING INSTRUCTIONS; HORSE TRAINING; CONDUCTING HORSE RACES; AMUSEMENT PARKS, FESTIVALS, NAMELY, CULTURAL FESTIVALS AND ETHNIC FESTIVALS, ORGANIZING COMMUNITY FESTIVALS FEATURING FLEA MARKETS; PERSONAL DEVELOPMENT NAMELY STRENGTH AND CONDITIONING TRAINING; ARRANGING FOR TICKET RESERVATIONS FOR SHOWS AND OTHER ENTERTAINMENT EVENTS; CASINOS; ENTERTAINMENT EVENTS IN THE NATURE OF THEATER PRODUCTIONS, OF BALLET AND DANCE PERFORMANCES, OF ORCHESTRA PERFORMANCES, OF ATHLETIC COMPETITIONS, OF LIVE MUSICAL GROUP PERFORMANCES, OF MUSICAL BAND PERFORMANCES, OF COMEDY SHOWS, OF MUSICAL VARIETY SHOWS, OF AMUSEMENT PARK RIDES, OF FASHION SHOWS, OF GOLF TOURNAMENTS, OF TENNIS TOURNAMENTS, OF SOCCER AND FOOTBALL GAMES, AND OF TRACK AND FIELD COMPETITIONS; MULTIMEDIA ENTERTAINMENT SOFTWARE PRODUCTION SERVICES; PRODUCTION AND RENTAL OF MOTION PICTURE FILMS AND OF MOVIES; RENTAL OF BOOKS; RENTAL OF COMPUTER GAMES; PROVIDING ON-LINE COMPUTER GAMES FOR OTHERS (U.S. CLS. 100, 101 AND 107).

DEBRA LEE, EXAMINING ATTORNEY

SN 79-025,418. LORENZ BIOTECH S.P.A., ITALY, FILED 2-23-2006.

# FREMS

THE MARK CONSISTS OF STANDARD CHARACTERS WITHOUT CLAIM TO ANY PARTICULAR FONT, STYLE, SIZE, OR COLOR.

OWNER OF INTERNATIONAL REGISTRATION 0889056 DATED 2-23-2006, EXPIRES 2-23-2016.

**CLASS 10—MEDICAL APPARATUS**

FOR MEDICAL APPARATUS FOR ELECTRO-STIMULATION, EXCEPT SURGICAL INSTRUMENTS, NAMELY, ELECTRO-STIMULATOR FOR NERVE, MUSCLE, BLOOD VESSEL (U.S. CLS. 26, 39 AND 44).

**CLASS 44—MEDICAL, BEAUTY AND AGRICULTURAL SERVICES**

FOR ELECTRO-STIMULATION MEDICAL SERVICES AND RELEVANT MEDICAL ASSISTANCE SERVICES (U.S. CLS. 100 AND 101).

ARETHA SOMERVILLE, EXAMINING ATTORNEY

SN 79-025,463. TRAFICOM N.V., B-8501 BISSEGEM, BELGIUM, FILED 12-23-2005.

SN 79-026,226. GELSCOM (SOCIÉTÉ PAR ACTIONS SIMPLIFIÉE), FRANCE, FILED 5-12-2006.



The logo for TraficCam features the word "TraficCam" in a bold, blue, sans-serif font. The letter "a" in "Cam" is stylized to resemble an eye, with a white iris and a black pupil.

OWNER OF INTERNATIONAL REGISTRATION 0889212 DATED 12-23-2005, EXPIRES 12-23-2015.

THE COLOR(S) BLUE, WHITE IS/ARE CLAIMED AS A FEATURE OF THE MARK.

THE COLOR BLUE APPEARS IN THE LETTERING OF THE MARK AND IN THE IRIS OF THE EYE DESIGN ELEMENT. THE COLOR WHITE APPEARS IN OUTLINE OF THE MARK AND IN THE WHITES AND PUPIL OF THE EYE DESIGN ELEMENT.

#### CLASS 9—ELECTRICAL AND SCIENTIFIC APPARATUS

FOR SOFTWARE FOR USE IN TRAFFIC DETECTION, COLLECTION AND ANALYSIS OF TRAFFIC DATA AND IMAGES, AND TRAFFIC MANAGEMENT, FEATURING APPLICATIONS FOR AUTOMATIC DETECTION OF TRAFFIC INCIDENTS SUCH AS STOPPED VEHICLES, WRONG-WAY DRIVERS, PEDESTRIANS, LOST CARGO, QUEUES, SMOKE EXHAUST FUMES AND VEHICLE SPEED FLUCTUATION; SOFTWARE FOR TRAFFIC MONITORING SUCH AS SPEED, ZONE OCCUPANCY, VEHICLE TYPES AND GAP TIMES; SOFTWARE FOR CALCULATING TRAVEL TIME, TUNNEL ACCESS CONTROL, AND REROUTING; AND SOFTWARE FOR INTERSECTION MONITORING AND CONTROL SUCH AS PRESENCE DETECTION AND QUEUE LENGTH MEASUREMENT; CAMERAS; VIDEO DETECTORS AND MONITORS; VIDEO IMAGE PROCESSORS COMPRISING TRANSMITTERS, WIRELESS TRANSMITTERS AND RECEIVERS, POWER SUPPLIES, SOLAR OPERATED ELECTRIC POWER SUPPLIES, PCS, PORTABLE COMPUTERS, DIGITAL VIDEO RECORDERS, POWER AND TELECOMMUNICATION CABLES, COMPUTER SERVERS, COMPUTERS AND COMPUTER DISPLAY MONITORS FOR USE IN DETECTING AND ANALYZING VEHICLES AND PERSONS IN TRAFFIC ZONES, INTERSECTIONS, RAMPS, AND TUNNELS FOR DETERMINING THE SPEED AND NUMBER OF VEHICLES PROCEEDING THROUGH ZONES; IMAGE COMPRESSORS, DATA TRANSMITTERS AND AUDIBLE AND VISIBLE ALARMS, ALL FOR USE IN TRAFFIC MANAGEMENT AND CONTROL; ELECTRONIC SENSORS FOR DETECTION OF VEHICLES AND COLLECTION OF TRAFFIC DATA AND IMAGES; INTEGRATED SENSORS AND CAMERAS FOR USE IN DETECTION OF VEHICLES AND COLLECTION OF TRAFFIC DATA AND IMAGES; ELECTRONIC DATA CARRIERS CONTAINING TRAFFIC DATA AND IMAGES; TRAFFIC FLOW MONITORS AND ELECTRONIC DETECTOR BOARDS HAVING ASSEMBLED VIDEO INFORMATION PROCESSORS (U.S. CLS. 21, 23, 26, 36 AND 38).

#### CLASS 37—CONSTRUCTION AND REPAIR

FOR INSTALLATION, MAINTENANCE AND REPAIR OF VIDEO CAMERAS (U.S. CLS. 100, 103 AND 106).

#### CLASS 42—SCIENTIFIC, COMPUTER AND LEGAL SERVICES

FOR COMPUTER PROGRAMMING; COMPUTER SOFTWARE DESIGN; UPDATING OF COMPUTER SOFTWARE FOR OTHERS (U.S. CLS. 100 AND 101).  
MARILYN IZZI, EXAMINING ATTORNEY



The logo for DiscoGel features the word "DiscoGel" in a green, sans-serif font. The letter "o" in "Disco" is stylized to resemble a disco ball with a grid pattern.

OWNER OF INTERNATIONAL REGISTRATION 0870030 DATED 10-28-2005, EXPIRES 10-28-2015.

THE COLOR(S) GREEN IS/ARE CLAIMED AS A FEATURE OF THE MARK.

THE COLOR GREEN APPEARS IN THE WORDING THAT MAKES UP THE MARK.

#### CLASS 5—PHARMACEUTICALS

FOR PHARMACEUTICAL PRODUCTS FOR THE TREATMENT OF SLIPPED DISC HERNIAS, OF SCIATICA, OF CYSTS, OF TUMORS, OF OSTEOMYELITIS, OF ARTERIES AND VEINS, AND OF LYMPHATIC VESSELS; GELS USED FOR MEDICAL PURPOSES, NAMELY MINIMALLY INVASIVE INJECTABLE GELS FOR THE TREATMENT OF SLIPPED DISC HERNIAS, OF SCIATICA, OF CYSTS, OF TUMORS, OF OSTEOMYELITIS, OF ARTERIES AND VEINS, AND OF LYMPHATIC VESSELS; GELS FOR TREATING DISC HERNIATION; GELS FOR TREATING SCIATICA; LOTIONS FOR PHARMACEUTICAL PURPOSES, NAMELY LOTIONS FOR THE TREATMENT OF SLIPPED DISC HERNIAS, OF SCIATICA, OF CYSTS, OF TUMORS, OF OSTEOMYELITIS, OF ARTERIES AND VEINS, AND OF LYMPHATIC VESSELS (U.S. CLS. 6, 18, 44, 46, 51 AND 52).

#### CLASS 10—MEDICAL APPARATUS

FOR MEDICAL APPARATUS, NAMELY MEDICAL DEVICE FOR TREATING DISK HERNIATION; MEDICAL APPARATUS, NAMELY MEDICAL DEVICE FOR TREATING SCIATICA (U.S. CLS. 26, 39 AND 44).  
FLORENTINA BLANDU, EXAMINING ATTORNEY

SN 79-026,607. NIRO A/S, DENMARK, FILED 5-29-2006.



The logo for PHARMASD features the word "PHARMASD" in a bold, black, serif font.

THE MARK CONSISTS OF STANDARD CHARACTERS WITHOUT CLAIM TO ANY PARTICULAR FONT, STYLE, SIZE, OR COLOR.

PRIORITY DATE OF 12-8-2005 IS CLAIMED.  
OWNER OF INTERNATIONAL REGISTRATION 0892518 DATED 5-29-2006, EXPIRES 5-29-2016.

#### CLASS 7—MACHINERY

FOR MACHINES, NAMELY SPRAY DRYERS (U.S. CLS. 13, 19, 21, 23, 31, 34 AND 35).

#### CLASS 11—ENVIRONMENTAL CONTROL APPARATUS

FOR DRYING APPARATUSES, NAMELY SPRAY DRYERS (U.S. CLS. 13, 21, 23, 31 AND 34).  
STEPHANIE DAVIS, EXAMINING ATTORNEY

SN 79-026,608. NIRO A/S, DENMARK, FILED 5-29-2006.

# MOBILE MINOR

PRIORITY DATE OF 12-8-2005 IS CLAIMED.  
OWNER OF INTERNATIONAL REGISTRATION 0892520  
DATED 5-29-2006, EXPIRES 5-29-2016.

**CLASS 7—MACHINERY**

FOR MACHINES, NAMELY SPRAY DRYERS (U.S. CLS. 13, 19, 21, 23, 31, 34 AND 35).

**CLASS 11—ENVIRONMENTAL CONTROL APPARATUS**

FOR DRYING APPARATUSES, NAMELY SPRAY DRYERS (U.S. CLS. 13, 21, 23, 31 AND 34).  
STEPHANIE DAVIS, EXAMINING ATTORNEY

SN 79-026,609. NIRO A/S, DENMARK, FILED 5-29-2006.

# SDMICRO

PRIORITY DATE OF 12-8-2005 IS CLAIMED.  
OWNER OF INTERNATIONAL REGISTRATION 0892521  
DATED 5-29-2006, EXPIRES 5-29-2016.

**CLASS 7—MACHINERY**

FOR MACHINES, NAMELY SPRAY DRYERS (U.S. CLS. 13, 19, 21, 23, 31, 34 AND 35).

**CLASS 11—ENVIRONMENTAL CONTROL APPARATUS**

FOR DRYING APPARATUSES, NAMELY SPRAY DRYERS (U.S. CLS. 13, 21, 23, 31 AND 34).  
STEPHANIE DAVIS, EXAMINING ATTORNEY

SN 79-026,610. NIRO A/S, DENMARK, FILED 5-29-2006.

# ASEPTICSD

PRIORITY DATE OF 12-8-2005 IS CLAIMED.  
OWNER OF INTERNATIONAL REGISTRATION 0892522  
DATED 5-29-2006, EXPIRES 5-29-2016.

**CLASS 7—MACHINERY**

FOR MACHINES, NAMELY SPRAY DRYERS (U.S. CLS. 13, 19, 21, 23, 31, 34 AND 35).

**CLASS 11—ENVIRONMENTAL CONTROL APPARATUS**

FOR DRYING APPARATUSES, NAMELY SPRAY DRYERS (U.S. CLS. 13, 21, 23, 31 AND 34).  
STEPHANIE DAVIS, EXAMINING ATTORNEY

SN 79-027,576. JÖRG ARNDT, FED REP GERMANY, FILED 4-24-2006.



PRIORITY DATE OF 11-11-2005 IS CLAIMED.  
OWNER OF INTERNATIONAL REGISTRATION 0895068  
DATED 4-24-2006, EXPIRES 4-24-2016.

**CLASS 39—TRANSPORTATION AND STORAGE**

FOR PROVIDING TRANSPORTATION BY BUS, AIRPLANE OR BOAT FOR STUDY TOURS, TRAINING TRIPS AND LANGUAGE STAYS; PROVIDING INFORMATION ABOUT THE TRANSPORTATION OF PASSENGERS AND GOODS BY BUS, RAILWAY, AIRLINER OR PASSENGERS SHIPS REGARDING FARES, AND SCHEDULES; PROVIDING TRANSPORTATION OF PASSENGERS AND GOODS BY BUS, RAILWAY, BOAT, AND AIRPLANE; ARRANGING TRAVEL TOURS, INCLUDING CITY TOURS, EXCURSIONS, CYCLING TOURS; TOUR ESCORTING; TOUR GUIDE SERVICES, NAMELY PROVIDING INFORMATION TO TRAVELERS REGARDING THE COUNTRY, GEOGRAPHY, CLIMATE, VISAS SERVICES, EMBASSIES, CONSULATES AND FOREIGN EXCHANGE RATES; RENTAL OF CARS (U.S. CLS. 100 AND 105).

**CLASS 41—EDUCATION AND ENTERTAINMENT**

FOR EDUCATIONAL SERVICES, NAMELY CONDUCTING EDUCATIONAL STUDIES AND SEMINARS IN THE FIELD OF GEOGRAPHY, CLIMATE, HISTORY, CULTURE AND HISTORY OF CIVILIZATION; ORGANIZATION OF SPORT IN THE TYPE OF FISHING, SWIMMING, SOCCER, HIKING, MOUNTAINEERING, ROWING, SURFING AND SAILING COMPETITIONS, ENTERTAINMENT, NAMELY, PRODUCTION OF MOTION PICTURE FILMS AND MUSICAL PERFORMANCES, PUBLISHING AND EDITING OF PRINTED MATTER, ESPECIALLY NEWSPAPERS, MAGAZINES AND PROSPECTUSES (U.S. CLS. 100, 101 AND 107).

**CLASS 43—HOTEL AND RESTAURANT SERVICES**

FOR RESERVATION OF ROOMS FOR TRAVELERS (U.S. CLS. 100 AND 101).  
AMOS T. MATTHEWS, JR., EXAMINING ATTORNEY

SN 79-027,728. BIOMÉRIEUX, FRANCE, FILED 3-14-2006.

# UNIDATRIX

THE MARK CONSISTS OF STANDARD CHARACTERS WITHOUT CLAIM TO ANY PARTICULAR FONT, STYLE, SIZE, OR COLOR.

PRIORITY DATE OF 10-6-2005 IS CLAIMED.  
OWNER OF INTERNATIONAL REGISTRATION 0895543  
DATED 3-14-2006, EXPIRES 3-14-2016.

**CLASS 1—CHEMICALS**

FOR NUTRIENT MEDIA FOR DIAGNOSIS, CONTROL AND DETECTION OF CONTAMINANTS IN INDUSTRIAL, COSMETIC, PHARMACEUTICAL AND FOOD PROCESSING PRODUCTS AND IN THE PRODUCTION ENVIRONMENT FOR THESE PRODUCTS, NAMELY, WATER, AIR, WORKING SURFACES (U.S. CLS. 1, 5, 6, 10, 26 AND 46).

**CLASS 9—ELECTRICAL AND SCIENTIFIC APPARATUS**

FOR SCIENTIFIC APPARATUS AND INSTRUMENTS NAMELY FOR NON MEDICAL DIAGNOSIS AND FOR CONTROL AND DETECTION OF CONTAMINANTS IN INDUSTRIAL, COSMETIC, PHARMACEUTICAL AND FOOD PROCESSING PRODUCTS AND IN THE PRODUCTION ENVIRONMENT FOR WATER, AIR, WORKING SURFACES (U.S. CLS. 21, 23, 26, 36 AND 38).  
ZACHARY BELLO, EXAMINING ATTORNEY

SN 79-028,631. SMS MEER GMBH, FED REP GERMANY, FILED 6-21-2006.

# RailCool

THE MARK CONSISTS OF STANDARD CHARACTERS WITHOUT CLAIM TO ANY PARTICULAR FONT, STYLE, SIZE, OR COLOR.

PRIORITY DATE OF 12-23-2005 IS CLAIMED.  
OWNER OF INTERNATIONAL REGISTRATION 0897929 DATED 6-21-2006, EXPIRES 6-21-2016.

SN 79-028,183. BIRKEN GMBH, FED REP GERMANY, FILED 6-28-2006.

# BERKANAN

THE MARK CONSISTS OF STANDARD CHARACTERS WITHOUT CLAIM TO ANY PARTICULAR FONT, STYLE, SIZE, OR COLOR.

OWNER OF INTERNATIONAL REGISTRATION 0896751 DATED 6-28-2006, EXPIRES 6-28-2016.

**CLASS 7—MACHINERY**

FOR ROLLING MILLS FOR METALWORKING, AND STRUCTURAL PARTS THEREFOR (U.S. CLS. 13, 19, 21, 23, 31, 34 AND 35).

**CLASS 9—ELECTRICAL AND SCIENTIFIC APPARATUS**

FOR ELECTRONIC CONTROL AND REGULATING EQUIPMENT FOR ROLLING MILLS; COMPUTERS FOR CONTROLLING ROLLING MILLS; AND COMPUTER PROGRAMS FOR CONTROLLING ROLLING MILLS (U.S. CLS. 21, 23, 26, 36 AND 38).

**CLASS 3—COSMETICS AND CLEANING PREPARATIONS**

FOR COSMETICS, HAIR LOTIONS (U.S. CLS. 1, 4, 6, 50, 51 AND 52).

**CLASS 5—PHARMACEUTICALS**

FOR PHARMACEUTICALS FOR THE TREATMENT OF SKIN DISORDERS; MEDICATED SKIN CARE PREPARATIONS (U.S. CLS. 6, 18, 44, 46, 51 AND 52).  
WENDY GOODMAN, EXAMINING ATTORNEY

**CLASS 11—ENVIRONMENTAL CONTROL APPARATUS**

FOR FURNACES FOR ROLLING MILLS (U.S. CLS. 13, 21, 23, 31 AND 34).

RAY THOMAS, EXAMINING ATTORNEY

SN 79-028,210. MERCK KGAA, FED REP GERMANY, FILED 6-13-2006.

# ISOQ BIOMIX

THE MARK CONSISTS OF STANDARD CHARACTERS WITHOUT CLAIM TO ANY PARTICULAR FONT, STYLE, SIZE, OR COLOR.

PRIORITY DATE OF 3-20-2006 IS CLAIMED.  
OWNER OF INTERNATIONAL REGISTRATION 0896842 DATED 6-13-2006, EXPIRES 6-13-2016.

SN 79-028,772. WIKA ALEXANDER WIEGAND GMBH & CO. KG, FED REP GERMANY, FILED 3-30-2005.

# REFCO

PRIORITY DATE OF 3-10-2005 IS CLAIMED.  
OWNER OF INTERNATIONAL REGISTRATION 0898187 DATED 3-30-2005, EXPIRES 3-30-2015.

**CLASS 1—CHEMICALS**

FOR PLANT DERIVED RAW EXTRACTS, NAMELY, FAVA DANTA EXTRACT FOR THE MANUFACTURE OF DIETETIC AND DIETARY OR NUTRITIONAL SUPPLEMENT PREPARATIONS AND PHARMACEUTICAL PREPARATIONS AS FAR AS INCLUDED IN THIS CLASS (U.S. CLS. 1, 5, 6, 10, 26 AND 46).

**CLASS 1—CHEMICALS**

FOR METAL TEMPERING PREPARATIONS AND SOLDERING CHEMICALS; ADHESIVES USED IN LEAK DETECTION; REFRIGERATION CHEMICALS; CHEMICAL PREPARATIONS IN THE NATURE OF FILTERING MATERIALS IN LEAK DETECTION; CHEMICAL LEAK SPRAYS FOR DISPLAYING LINE LEAKS (U.S. CLS. 1, 5, 6, 10, 26 AND 46).

**CLASS 5—PHARMACEUTICALS**

FOR MEDICATED PHARMACEUTICAL PREPARATIONS, NAMELY HERBAL OR PLANT-DERIVED INDICATIONS FOR THE TREATMENT OF INFLAMMATORY CONDITIONS, SKIN DISORDERS, RESPIRATORY DISORDERS, AND FOR USE AS ANTI-INFLAMMATORY, ANTI-OXIDATIVE AND ANTI-AGING AND HEPAPROTECTIVE PREPARATIONS (U.S. CLS. 6, 18, 44, 46, 51 AND 52).  
TARAH HARDY, EXAMINING ATTORNEY

**CLASS 6—METAL GOODS**

FOR VALVES AND FITTINGS OF METAL FOR PIPES, NAMELY MANUALLY OPERATED METAL VALVES, FITTINGS AND JOINING FLANGES (U.S. CLS. 2, 12, 13, 14, 23, 25 AND 50).

**CLASS 7—MACHINERY**

FOR GAS PUMPS; VACUUM PUMPS; REPLACEMENT PARTS FOR GAS PUMPS AND VACUUM PUMPS; FILTERS FOR AIR AND LIQUIDS, FOR MOTORS OR PUMPS OR ENGINES (U.S. CLS. 13, 19, 21, 23, 31, 34 AND 35).

**CLASS 8—HAND TOOLS**

FOR HAND TOOLS AND IMPLEMENTS, NAMELY, PIPE-BENDING AND CUTTING APPARATUS, FLARING TOOLS, CLAMPING TOOLS AND FITTINGS THEREFOR (U.S. CLS. 23, 28 AND 44).

**CLASS 9—ELECTRICAL AND SCIENTIFIC APPARATUS**

FOR MECHANICAL AND ELECTRICAL PRESSURE MEASURING APPARATUS, NAMELY, PRESSURE GAUGES, HIGH PRESSURE MANOMETERS, THERMOMETER AND VACUUM MEASURING APPARATUS; PRESSURE GAUGES; THERMOSTATS, TIME SWITCHES, RELAYS; ELECTRIC AND MECHANICAL LEAK DETECTION MONITORING APPARATUS, EQUIPMENT, AND INSTRUMENTS FOR DETECTING AND MEASURING TWO-DIMENSIONAL DISTRIBUTION OF FORCE AND PRESSURE; HYGROMETERS; COMPUTER COMPONENT TESTING AND CALIBRATING EQUIPMENT; CHARGING APPLIANCES FOR RECHARGEABLE EQUIPMENT; SCALES FOR WEIGHING STORED GASES, AND PARTS THEREOF, NAMELY CYLINDERS (U.S. CLS. 21, 23, 26, 36 AND 38).

**CLASS 11—ENVIRONMENTAL CONTROL APPARATUS**

FOR ULTRA-VIOLET DETECTION LAMPS; FILTERS FOR AIR AND LIQUIDS FOR INDUSTRIAL INSTALLATIONS, SOLDERING LAMPS (U.S. CLS. 13, 21, 23, 31 AND 34).

**CLASS 17—RUBBER GOODS**

FOR PACKING MATERIALS, NAMELY MATERIALS FOR FORMING SEALS AND ENCASING OTHER MATERIAL, AND INSULATING MATERIALS, NAMELY, POLYURETHANE FOAM AND POLYETHYLENE FOAM; FLEXIBLE PIPES, NOT OF METAL; WEATHER-STRIPPING COMPOSITIONS, MATERIALS AND GOODS, NAMELY POLYURETHANE FOAM AND POLYETHYLENE FOAM, AND WEATHER-STRIPPING FOR USE IN INDUSTRIAL PREMISES (U.S. CLS. 1, 5, 12, 13, 35 AND 50).

**CLASS 42—SCIENTIFIC, COMPUTER AND LEGAL SERVICES**

FOR ENGINEERING, RESEARCH, MATERIAL TESTING AND QUALITY CONTROL FOR VACUUM TECHNOLOGY FOR OTHERS; RESEARCH ON BUILDING CONSTRUCTION INCORPORATING VACUUM TECHNOLOGY; ENGINEERING; TECHNICAL CONSULTANCY IN THE FIELD OF VACUUM TECHNOLOGY (U.S. CLS. 100 AND 101).

ANTHONY RINKER, EXAMINING ATTORNEY

SN 79-028,879. LIGHTNING BOX GAMES PTY LIMITED, AUSTRALIA, FILED 4-26-2006.

# STRETCH LIMO

THE MARK CONSISTS OF STANDARD CHARACTERS WITHOUT CLAIM TO ANY PARTICULAR FONT, STYLE, SIZE, OR COLOR.

PRIORITY DATE OF 11-8-2005 IS CLAIMED.  
OWNER OF INTERNATIONAL REGISTRATION 0898444 DATED 4-26-2006, EXPIRES 4-26-2016.

**CLASS 9—ELECTRICAL AND SCIENTIFIC APPARATUS**

FOR COMPUTER SOFTWARE FOR INSTRUCTING AND MANIPULATING FEATURES OF GAMES FOR GAMING, SLOT AND VIDEO MACHINES; COMPUTER SOFTWARE, MODULES AND COMPONENTS FOR GAMES OF CHANCE OR MIXED CHANCE AND SKILL OR PSEUDO SKILL; ELECTRONIC SYSTEMS IN THE NATURE OF MICROPROCESSORS FOR CONTROLLING THE OUTCOME OF GAMES; ELECTRONIC SYSTEMS, NAMELY SIGNALLING DEVICES AND MICROPROCESSORS FOR DIRECTLY OR INDIRECTLY LINKING GAMING MACHINES (U.S. CLS. 21, 23, 26, 36 AND 38).

**CLASS 28—TOYS AND SPORTING GOODS**

FOR GAMES AND PLAYTHINGS EXCLUDING TOY VEHICLES AND MODEL VEHICLES, NAMELY, ELECTRONIC GAMING AND POKER MACHINES, SLOT MACHINES FOR GAMING; TOKEN OPERATED SLOT MACHINES, AND ELECTRONICALLY INTERCONNECTED GAMING AND POKER MACHINES (U.S. CLS. 22, 23, 38 AND 50).

JOHN DWYER, EXAMINING ATTORNEY

SN 79-029,216. DONGGUAN CROWN PRINCE; HOTEL CO. LTD., CHINA, FILED 2-21-2006.



OWNER OF INTERNATIONAL REGISTRATION 0899206 DATED 2-21-2006, EXPIRES 2-21-2016.

THE NON-LATIN CHARACTER(S) IN THE MARK TRANSLITERATES INTO "AO WEI SI" AND THIS MEANS "COMFORTABLE OASIS FOR YOU" IN ENGLISH.

**CLASS 25—CLOTHING**

FOR CLOTHING, NAMELY, PANTS, SHIRTS, JACKETS, UNDERWEAR; WEDDING DRESSES; LEATHER BELTS FOR CLOTHING; NECKTIES; GLOVES; HOSIERY; SHOES; LAYETTES; HEADGEAR FOR WEAR, NAMELY, HEADWEAR AND HATS; FITTINGS OF METAL FOR SHOES AND BOOTS, NAMELY, TOE CAPS, HEEL PIECES FOR SHOES, AND PROTECTIVE REINFORCEMENTS; WATERPROOF COATS; INSECT PROOF CLOTHING, NAMELY, SHIRTS, PANTS, AND JACKETS; MASQUERADE COSTUMES; GYMNASIAC SHOES (U.S. CLS. 22 AND 39).

**CLASS 41—EDUCATION AND ENTERTAINMENT**

FOR ACADEMIES, NAMELY, EDUCATIONAL SERVICES IN THE NATURE OF FINE ARTS, BUSINESS CORRESPONDENCE COURSE SCHOOLS; LENDING LIBRARIES; PUBLICATION OF BOOKS; SPECIAL EVENT PLANNING, NAMELY, ORGANIZATION OF BALLS; PHOTOGRAPHY SERVICES; ANIMAL TRAINING; MODELING FOR ARTISTS; AMUSEMENT ARCADES, CENTERS, AND PARKS; HEALTH CLUB SERVICES, NAMELY PROVIDING INSTRUCTION AND EQUIPMENT IN THE FIELD OF PHYSICAL EXERCISE; DISCOTHEQUE SERVICES; HOLIDAY CAMP SERVICE, NAMELY, RECREATIONAL CAMPS; ORGANIZATION OF FASHION SHOWS; AMUSEMENT PARKS; PROVIDING INFORMATION ABOUT RECREATIONAL ACTIVITIES; PROVIDING SPORTS FACILITIES; RENTAL OF STADIUM FACILITIES (U.S. CLS. 100, 101 AND 107).

**CLASS 43—HOTEL AND RESTAURANT SERVICES**

FOR RESTAURANTS; PROVIDING CAMPGROUND FACILITIES; RETIREMENT HOMES; DAY-NURSERIES IN THE NATURE OF CHILDREN'S CRECHES; BOARDING FOR ANIMALS; RENTAL OF CHAIRS, TABLES, TABLE LINEN, GLASSWARE; PROVIDING TEMPORARY ACCOMMODATION IN THE NATURE OF HOTELS AND BOARDING HOUSES; CATERING; TAPROOM SERVICES, NAMELY, PROVIDING A PLACE FOR PEOPLE TO HAVE DRINKS AND RELAX; TEA ROOMS; BAR SERVICES; SELF-SERVICE RESTAURANTS; HOLIDAY CAMP LODGING SERVICES; RENTAL OF MEETING ROOMS; PROVIDING CAMPGROUND FACILITIES (U.S. CLS. 100 AND 101).

**CLASS 44—MEDICAL, BEAUTY AND AGRICULTURAL SERVICES**

FOR HEALTH CARE; PROVIDING TURKISH BATH FACILITIES; BEAUTY SALONS; MASSAGE; VETERINARY SERVICES; LANDSCAPE GARDENING (U.S. CLS. 100 AND 101).  
ELI HELLMAN, EXAMINING ATTORNEY

SN 79-030,799. PIRELLI & C. S.P.A., ITALY, FILED 4-14-2006.

**POWER IS NOTHING  
WITHOUT OUR PEOPLE**

PRIORITY DATE OF 3-21-2006 IS CLAIMED.  
OWNER OF INTERNATIONAL REGISTRATION 0903095  
DATED 4-14-2006, EXPIRES 4-14-2016.  
OWNER OF U.S. REG. NO. 2,288,628.

**CLASS 12—VEHICLES**

FOR TYRES; PNEUMATIC, SEMI-PNEUMATIC AND SOLID TYRES FOR VEHICLE WHEELS; WHEELS AND WHEEL RIMS FOR VEHICLES (U.S. CLS. 19, 21, 23, 31, 35 AND 44).

**CLASS 14—JEWELRY**

FOR JEWELRY; BELT BUCKLES OF PRECIOUS METALS; BRACELETS OF PRECIOUS METALS; BROOCHES; CUFF LINKS; DIAMONDS; EARRINGS; NECKLACES; PEARLS; PRECIOUS METALS AND THEIR ALLOYS; RINGS; BRACELETS, CHARMS; EARRINGS IN PRECIOUS METAL OR COATED THEREWITH; PRECIOUS STONES; HOROLOGICAL AND CHRONOMETRIC INSTRUMENTS, NAMELY TIMEPIECES, WRISTWATCHES, WATCHES, CLOCKS AND PARTS THEREOF (U.S. CLS. 2, 27, 28 AND 50).

**CLASS 18—LEATHER GOODS**

FOR HANDBAGS, SUITCASES, WALLETS, BRIEFCASES, SCHOOL BAGS, HANDBAGS FOR MEN, TRUNKS FOR TRAVEL, LEATHER AND IMITATION LEATHER (U.S. CLS. 1, 2, 3, 22 AND 41).

**CLASS 25—CLOTHING**

FOR CLOTHING ARTICLES FOR MEN, WOMEN AND CHILDREN, NAMELY, SHIRTS, BLOUSES, SKIRTS, COATS, TROUSERS, PANTS, VESTS, JERSEYS, PAJAMAS, SOCKS AND STOCKINGS, SINGLETS, CORSETS, GARTERS, UNDERPANTS, PETTICOATS, HATS, HEAD-SCARVES, NECKTIES, RAINCOATS, OVERCOATS, GREATCOATS, BATHING SUITS, SPORTS OVERALLS, WIND-RESISTANT JACKETS, SKI PANTS, BELTS, FUR COATS, SCARVES, GLOVES, DRESSING GOWNS; FOOTWEAR, NAMELY, SHOES, SPORTS SHOES, SLIPPERS AND BOOTS (U.S. CLS. 22 AND 39).

**CLASS 38—COMMUNICATION**

FOR TELECOMMUNICATIONS, NAMELY PERSONAL COMMUNICATION SERVICES, PROVIDING FIBER OPTIC NETWORKS AND TRANSFER OF DATA BY TELECOMMUNICATIONS (U.S. CLS. 100, 101 AND 104).  
REBECCA POVARCHUK, EXAMINING ATTORNEY

SN 79-030,902. TABEXPO EXHIBITIONS; AND CONGRESSES LIMITED, UNITED KINGDOM, FILED 8-23-2006.

**TABEXPO**

PRIORITY DATE OF 7-4-2006 IS CLAIMED.  
OWNER OF INTERNATIONAL REGISTRATION 0903429  
DATED 8-23-2006, EXPIRES 8-23-2016.

**CLASS 35—ADVERTISING AND BUSINESS**

FOR ARRANGING EXHIBITIONS AND TRADE FAIRS FOR THE TOBACCO INDUSTRY AND IN RELATION TO TOBACCO PRODUCTS (U.S. CLS. 100, 101 AND 102).

**CLASS 41—EDUCATION AND ENTERTAINMENT**

FOR ARRANGING CONFERENCES AND CONGRESSES FOR THE TOBACCO INDUSTRY AND IN RELATION TO TOBACCO PRODUCTS (U.S. CLS. 100, 101 AND 107).  
DANIEL BRODY, EXAMINING ATTORNE

## SECTION 2.— INTERNATIONAL CLASSIFICATION

The short titles associated below with the international class numbers are terms designed merely for quick identification and are not an official part of the international classification. The full names of international classes are given in section 6.1 of the trademark rules of practice.

The designation "U.S. Cl." appearing in this section refers to the U.S. class in effect prior to Sep. 1, 1973 rather than the international class which applies to applications filed on or after that date. For adoption of international classification see notice in the OFFICIAL GAZETTE of Jun. 26, 1973 (911 O.G. TM 210).

### Application in one class

#### CLASS 1—CHEMICALS

SN 76-537,903. MARYLAND ENVIRONMENTAL SERVICE, ANNAPOLIS, MD. FILED 7-17-2003.

**fertile**  **GRO**

FOR FERTILIZER FOR DOMESTIC USE (U.S. CLS. 1, 5, 6, 10, 26 AND 46).  
FIRST USE 1-7-2002; IN COMMERCE 1-7-2002.  
ANN E. SAPPENFIELD, EXAMINING ATTORNEY

SN 76-574,965. THE NISSHIN OILLIO GROUP, LTD., CHUOKU, TOKYO, 104-8285, JAPAN, FILED 2-10-2004.

**T.I.O**

THE MARK CONSISTS OF STANDARD CHARACTERS WITHOUT CLAIM TO ANY PARTICULAR FONT, STYLE, SIZE, OR COLOR.

FOR EMULSIFIERS FOR USE IN THE MANUFACTURE OF COSMETICS; EMULSION-STABILIZING AGENTS FOR USE IN THE MANUFACTURE OF COSMETICS; SURFACE-ACTIVE CHEMICAL AGENTS FOR USE IN THE MANUFACTURE OF COSMETICS; ESTERS FOR USE IN THE MANUFACTURE OF COSMETICS; FATTY ACIDS FOR USE IN THE MANUFACTURE OF COSMETICS; SOLVENTS FOR USE IN THE MANUFACTURE OF COSMETICS; GUM RESINS FOR USE IN THE MANUFACTURE OF COSMETICS; HIGH FATTY ACIDS FOR USE IN THE MANUFACTURE OF COSMETICS; HIGHER FATTY ACIDS FOR INDUSTRIAL PURPOSES (U.S. CLS. 1, 5, 6, 10, 26 AND 46).

DAVID TAYLOR, EXAMINING ATTORNEY

#### CLASS 1—(Continued).

SN 76-670,362. AQUARIUM PHARMACEUTICALS, INC., CHALFONT, PA. FILED 12-12-2006.

**THE HEALING POWER OF ALOE VERA**

THE MARK CONSISTS OF STANDARD CHARACTERS WITHOUT CLAIM TO ANY PARTICULAR FONT, STYLE, SIZE, OR COLOR.

NO CLAIM IS MADE TO THE EXCLUSIVE RIGHT TO USE "ALOE VERA", APART FROM THE MARK AS SHOWN.

FOR WATER TREATMENT CHEMICALS IN THE NATURE OF AQUARIUM WATER CONDITIONERS (U.S. CLS. 1, 5, 6, 10, 26 AND 46).

FIRST USE 9-0-1998; IN COMMERCE 9-0-1998.

MICHAEL TANNER, EXAMINING ATTORNEY

SN 77-028,960. THE DOW CHEMICAL COMPANY, MIDLAND, MI. FILED 10-25-2006.

**HUMAN ELEMENT**

THE MARK CONSISTS OF STANDARD CHARACTERS WITHOUT CLAIM TO ANY PARTICULAR FONT, STYLE, SIZE, OR COLOR.

FOR CHEMICALS USED IN THE MANUFACTURE OF PLASTICS, RESINS AND POLYMERS (U.S. CLS. 1, 5, 6, 10, 26 AND 46).

BERNICE HOWSE, EXAMINING ATTORNEY

**CLASS 1—(Continued).**

SN 77-046,298. ARCH PERSONAL CARE PRODUCTS, L.P.,  
SOUTH PLAINFIELD, NJ. FILED 11-17-2006.

# EYEPRO

THE MARK CONSISTS OF STANDARD CHARACTERS  
WITHOUT CLAIM TO ANY PARTICULAR FONT, STYLE,  
SIZE, OR COLOR.

FOR COSMETIC ADDITIVES, NAMELY, CHEMICALS  
FOR USE IN THE MANUFACTURE OF COSMETICS  
(U.S. CLS. 1, 5, 6, 10, 26 AND 46).

KRISTIN DAHLING, EXAMINING ATTORNEY

**CLASS 1—(Continued).**

SN 78-837,804. W.R. GRACE & CO.-CONN., COLUMBIA, MD.  
FILED 3-15-2006.

# TOP-CAST

THE MARK CONSISTS OF STANDARD CHARACTERS  
WITHOUT CLAIM TO ANY PARTICULAR FONT, STYLE,  
SIZE, OR COLOR.

FOR CHEMICALS USED TO RETARD THE SETTING  
OF CAST AND MOLDED CONCRETE PRODUCTS (U.S.  
CLS. 1, 5, 6, 10, 26 AND 46).

FIRST USE 1-1-2001; IN COMMERCE 1-1-2001.

INGRID C. EULIN, EXAMINING ATTORNEY

SN 77-064,069. LOVELAND PRODUCTS, INC., GREELEY,  
CO. FILED 12-14-2006.

# ALLEVIATE

THE MARK CONSISTS OF STANDARD CHARACTERS  
WITHOUT CLAIM TO ANY PARTICULAR FONT, STYLE,  
SIZE, OR COLOR.

OWNER OF U.S. REG. NO. 2,684,100.  
FOR SOIL CONDITIONERS FOR HORTICULTURAL  
USE (U.S. CLS. 1, 5, 6, 10, 26 AND 46).

FIRST USE 6-5-2002; IN COMMERCE 6-5-2002.

CHARISMA HAMPTON, EXAMINING ATTORNEY

SN 78-840,659. BIOMATRICA, INC, SAN DIEGO, CA. FILED  
3-18-2006.

SN 78-769,408. CASITE INTRACO, L.L.C., TROY, MI. FILED  
12-8-2005.

# ENGINE TUNE UP+

THE MARK CONSISTS OF STANDARD CHARACTERS  
WITHOUT CLAIM TO ANY PARTICULAR FONT, STYLE,  
SIZE, OR COLOR.

NO CLAIM IS MADE TO THE EXCLUSIVE RIGHT TO  
USE "ENGINE", APART FROM THE MARK AS SHOWN.

FOR CHEMICAL ADDITIVES FOR USE IN CONNEC-  
TION WITH INTERNAL COMBUSTION ENGINE  
FLUIDS (U.S. CLS. 1, 5, 6, 10, 26 AND 46).

FIRST USE 3-0-2005; IN COMMERCE 3-0-2005.

STEVEN PEREZ, EXAMINING ATTORNEY

# SAMPLEMATRIX

THE MARK CONSISTS OF STANDARD CHARACTERS  
WITHOUT CLAIM TO ANY PARTICULAR FONT, STYLE,  
SIZE, OR COLOR.

FOR STORAGE MEDIUM FOR SCIENTIFIC OR RE-  
SEARCH USE, NAMELY REAGENTS AND MEDIA FOR  
USE IN THE BIOTECHNOLOGY, MEDICAL, DIAGNOS-  
TIC, PHARMACEUTICAL AND FORENSICS INDUS-  
TRIES (U.S. CLS. 1, 5, 6, 10, 26 AND 46).

FIRST USE 4-1-2004; IN COMMERCE 4-1-2004.

LA TONIA FISHER, EXAMINING ATTORNEY



**CLASS 1—(Continued).**

SN 78-880,159. WELSUM TECHNOLOGY CORPORATION, TAIPEI, TAIWAN, FILED 5-10-2006.

NOSEN

THE MARK CONSISTS OF STANDARD CHARACTERS WITHOUT CLAIM TO ANY PARTICULAR FONT, STYLE, SIZE, OR COLOR.

FOR CHEMICAL COMPOSITION FOR USE IN NEGATIVE ION PROCESSING; CHEMICAL COMPOSITION FOR INFRARED HEATING; CHEMICAL COMPOSITION FOR USE IN ANTI-ULTRAVIOLET PROCESSING; CHEMICAL COMPOSITION FOR USE IN REPELLING WATER, OIL AND STAINS; CHEMICAL COMPOSITION FOR MOISTURE ABSORPTION AND STAIN RELEASE; FRAGRANCES FOR USE IN CHEMICAL COMPOSITIONS FOR USE IN THE MANUFACTURE OF ESSENTIAL OILS; CHEMICAL COMPOSITION FOR USE IN ULTRAVIOLET CATALYST PROCESSING; FIREPROOFING PREPARATIONS (U.S. CLS. 1, 5, 6, 10, 26 AND 46).  
FIRST USE 1-20-2003; IN COMMERCE 4-20-2003.  
EDWARD NELSON, EXAMINING ATTORNEY

SN 78-882,192. STAR-BRITE DISTRIBUTING, INC., FORT LAUDERDALE, FL. FILED 5-12-2006.

STAR COOL

THE MARK CONSISTS OF STANDARD CHARACTERS WITHOUT CLAIM TO ANY PARTICULAR FONT, STYLE, SIZE, OR COLOR.

NO CLAIM IS MADE TO THE EXCLUSIVE RIGHT TO USE "COOL", APART FROM THE MARK AS SHOWN.  
FOR ANTIFREEZE (U.S. CLS. 1, 5, 6, 10, 26 AND 46).  
HENRY S. ZAK, EXAMINING ATTORNEY

**CLASS 1—(Continued).**

SN 78-894,390. CHEM TECHNOLOGIES, LTD, MIDDLEFIELD, OH. FILED 5-26-2006.

ADVANCURE

THE MARK CONSISTS OF STANDARD CHARACTERS WITHOUT CLAIM TO ANY PARTICULAR FONT, STYLE, SIZE, OR COLOR.

FOR DUSTLESS, FREE-FLOWING, POWDER DISPERSION USED IN CURING OR PROCESSING OF ELASTOMERIC MATERIALS (U.S. CLS. 1, 5, 6, 10, 26 AND 46).  
FIRST USE 4-1-2006; IN COMMERCE 4-1-2006.  
SCOTT SISUN, EXAMINING ATTORNEY

SN 78-900,400. AGRILIANCE, LLC., ST. PAUL, MN. FILED 6-5-2006.

COMPLETE COMPATIBILITY

THE MARK CONSISTS OF STANDARD CHARACTERS WITHOUT CLAIM TO ANY PARTICULAR FONT, STYLE, SIZE, OR COLOR.

NO CLAIM IS MADE TO THE EXCLUSIVE RIGHT TO USE "COMPATIBILITY", APART FROM THE MARK AS SHOWN.

FOR CHEMICAL AGENTS TO BLEND LIQUID FERTILIZER WITH PESTICIDES AND PESTICIDE TANK MIXES (U.S. CLS. 1, 5, 6, 10, 26 AND 46).

FIRST USE 3-25-1992; IN COMMERCE 3-25-1992.  
ALAIN LAPTER, EXAMINING ATTORNEY

SN 78-911,428. ICS BUILDING TECHNOLOGIES CORP, CLEVELAND, OH. FILED 6-19-2006.

I-SEAL

THE MARK CONSISTS OF STANDARD CHARACTERS WITHOUT CLAIM TO ANY PARTICULAR FONT, STYLE, SIZE, OR COLOR.

FOR SEALERS IN THE NATURE OF WATERPROOFING CHEMICAL COMPOSITIONS FOR INDUSTRIAL FLOORING (U.S. CLS. 1, 5, 6, 10, 26 AND 46).  
ADA HAN, EXAMINING ATTORNEY

**CLASS 1—(Continued).**

SN 78-924,319. ANODAMINE (PROPRIETARY) LIMITED, HALFWAY HOUSE, GAUTENG, SOUTH AFRICA, FILED 7-7-2006.

**ANODAMINE**

THE MARK CONSISTS OF STANDARD CHARACTERS WITHOUT CLAIM TO ANY PARTICULAR FONT, STYLE, SIZE, OR COLOR.

FOR CHEMICALS FOR USE IN INDUSTRY AND SCIENCE; CHEMICAL PREPARATIONS FOR SCALE, RUST AND CORROSION CONTROL AND PREVENTION IN BOILERS AND COOLING TOWERS (U.S. CLS. 1, 5, 6, 10, 26 AND 46).

FIRST USE 11-10-2005; IN COMMERCE 11-10-2005.  
CHRISTINE COOPER, EXAMINING ATTORNEY

SN 78-934,121. DEL PRETE, MICHAEL J., BELMONT, CA. FILED 7-20-2006.

**EcoSea**

THE MARK CONSISTS OF STANDARD CHARACTERS WITHOUT CLAIM TO ANY PARTICULAR FONT, STYLE, SIZE, OR COLOR.

FOR MIXTURE OF MINERALS, NAMELY, SODIUM, CHLORIDE, CALCIUM, MAGNESIUM, SULFUR, CARBONATE, STRONTIUM, BORATE, BROMINE, AND SYNTHETIC SEA SALTS FOR THE TREATMENT OF WATER TO CREATE SYNTHETIC SEAWATER FOR USE IN AQUA CULTURE, AQUARIUMS AND SEAFOOD TANKS (U.S. CLS. 1, 5, 6, 10, 26 AND 46).

FIRST USE 10-12-2006; IN COMMERCE 10-12-2006.  
ODESSA BIBBINS, EXAMINING ATTORNEY

SN 78-948,183. ASAHI GLASS SI-TECH CO., LTD., FUKUOKA, JAPAN, FILED 8-9-2006.

**SOLESPIHERE**

THE MARK CONSISTS OF STANDARD CHARACTERS WITHOUT CLAIM TO ANY PARTICULAR FONT, STYLE, SIZE, OR COLOR.

FOR SILICA GEL POWDER, USED AS RAW MATERIALS FOR COSMETICS MANUFACTURE AND FILLER FOR RESIN (U.S. CLS. 1, 5, 6, 10, 26 AND 46).

DAVID COLLIER, EXAMINING ATTORNEY

**CLASS 1—(Continued).**

SN 78-956,869. ENZYMES INCORPORATED, WAUCONDA, IL. FILED 8-21-2006.

**BLINGCLEAN**

THE MARK CONSISTS OF STANDARD CHARACTERS WITHOUT CLAIM TO ANY PARTICULAR FONT, STYLE, SIZE, OR COLOR.

FOR ENZYME PREPARATIONS, NAMELY ENZYME CONCENTRATE PRODUCTS USED FOR THE PREPARATION OF JEWELRY CLEANER (U.S. CLS. 1, 5, 6, 10, 26 AND 46).

JENNIFER MCROBBIE, EXAMINING ATTORNEY

SN 78-960,161. BIAGRO WESTERN SALES, INC., VISALIA, CA. FILED 8-24-2006.

**TAKE OFF**

THE MARK CONSISTS OF STANDARD CHARACTERS WITHOUT CLAIM TO ANY PARTICULAR FONT, STYLE, SIZE, OR COLOR.

FOR METABOLIC PLANT FERTILIZERS AND GROWTH REGULATORS FOR AGRICULTURAL USE (U.S. CLS. 1, 5, 6, 10, 26 AND 46).

MICHELLE DUBOIS, EXAMINING ATTORNEY

SN 78-960,816. JOHNSON MATTHEY PUBLIC LIMITED COMPANY, LONDON, UNITED KINGDOM, FILED 8-25-2006.

**LANCASTER SYNTHESIS**

THE MARK CONSISTS OF STANDARD CHARACTERS WITHOUT CLAIM TO ANY PARTICULAR FONT, STYLE, SIZE, OR COLOR.

OWNER OF ERPN CMNTY TM OFC REG. NO. 004086088, DATED 6-19-2006, EXPIRES 10-25-2014.

FOR CHEMICALS FOR USE IN INDUSTRY AND SCIENCE, NAMELY, RESEARCH CHEMICALS, FINE CHEMICALS, ORGANIC COMPOUNDS, ORGANOMETALLIC COMPOUNDS, INORGANIC COMPOUNDS (U.S. CLS. 1, 5, 6, 10, 26 AND 46).

GRETTA YAO, EXAMINING ATTORNEY

**CLASS 1—(Continued).**

SN 78-961,507. AGRILIANCE LLC., ST. PAUL, MN. FILED S.R. 8-28-2006; AM. P.R. 2-2-2007.

# GRADUAL-N

THE MARK CONSISTS OF STANDARD CHARACTERS WITHOUT CLAIM TO ANY PARTICULAR FONT, STYLE, SIZE, OR COLOR.

FOR FERTILIZER (U.S. CLS. 1, 5, 6, 10, 26 AND 46).  
FIRST USE 1-31-2005; IN COMMERCE 1-31-2005.  
KIM SAITO, EXAMINING ATTORNEY

---

SN 78-961,976. DIRECT RESPONSE HOLDINGS, LLC, BREA, CA. FILED 8-28-2006.

# FLAT FORMULA 37

THE MARK CONSISTS OF STANDARD CHARACTERS WITHOUT CLAIM TO ANY PARTICULAR FONT, STYLE, SIZE, OR COLOR.

NO CLAIM IS MADE TO THE EXCLUSIVE RIGHT TO USE "FLAT FORMULA", APART FROM THE MARK AS SHOWN.

FOR ADHESIVE FOR PREVENTING FLAT TIRES; SEALANT TO SEAL PUNCTURES IN TIRE TUBES AND TUBELESS TIRES (U.S. CLS. 1, 5, 6, 10, 26 AND 46).  
LAURA KOVALSKY, EXAMINING ATTORNEY

---

SN 78-963,825. ACORN INGREDIENT TECHNOLOGIES, INC., SAN FRANCISCO, CA. FILED 8-30-2006.

# CHEESEWELL

THE MARK CONSISTS OF STANDARD CHARACTERS WITHOUT CLAIM TO ANY PARTICULAR FONT, STYLE, SIZE, OR COLOR.

FOR BACTERIA FOR USE IN FOOD MANUFACTURE (U.S. CLS. 1, 5, 6, 10, 26 AND 46).  
BENJAMIN ALLEN, EXAMINING ATTORNEY

**CLASS 1—(Continued).**

SN 78-964,257. BIOSAFE, INC., PITTSBURG, PA. FILED 8-30-2006.



THE COLOR(S) BLACK, WHITE, AND GREEN IS/ARE CLAIMED AS A FEATURE OF THE MARK.

THE MARK CONSISTS OF THE WORDING BIOSAFE IN BLACK AND THE DESIGN FEATURE CONSISTING OF THREE CIRCLES IS IN GREEN WITH THE CENTER OF EACH OF THE CIRCLES IN WHITE.

FOR ANTIMICROBIAL, ANTIBACTERIAL, AND ANTIFUNGAL CHEMICAL ADDITIVES FOR INCORPORATION INTO AND MANUFACTURE OF PLASTIC RESINS AND PRODUCTS MADE FROM SUCH ADDITIVES, NAMELY, FIBERS, FABRICS, AND A WIDE VARIETY OF PLASTIC RESIN CONSUMER GOODS; ANTIMICROBIAL, ANTIBACTERIAL, AND ANTIFUNGAL CHEMICAL ADDITIVES FOR INCORPORATION INTO AND MANUFACTURE OF CLEANING PREPARATIONS; ANTIMICROBIAL, ANTIBACTERIAL, AND ANTIFUNGAL CHEMICAL ADDITIVES FOR INCORPORATION INTO AND MANUFACTURE OF COATINGS FOR METALS; ANTIMICROBIAL, ANTIBACTERIAL, AND ANTIFUNGAL CHEMICAL ADDITIVES FOR INCORPORATION INTO AND MANUFACTURE OF NATURAL AND SYNTHETIC BUILDING MATERIALS, NAMELY, PANELING, SIDING, SHINGLES, ROOFING, CABINETRY DECKING AND STRUCTURAL SUPPORTS; ANTIMICROBIAL, ANTIBACTERIAL, AND ANTIFUNGAL CHEMICAL ADDITIVES FOR INCORPORATION INTO AND MANUFACTURE OF CERAMICS, TEXTILES, THERMOPLASTIC AND THERMOSET POLYMERS; ANTIMICROBIAL, ANTIBACTERIAL, AND ANTIFUNGAL CHEMICAL ADDITIVES FOR INCORPORATION INTO AND MANUFACTURE OF COSMETICS; ANTIMICROBIAL, ANTIBACTERIAL, AND ANTIFUNGAL CHEMICAL ADDITIVES FOR INCORPORATION INTO AND MANUFACTURE OF TWO-DIMENSIONAL AND THREE-DIMENSIONAL ARTICLES, NAMELY, SHEETS, FILMS, LAMINATES, COATINGS, FIBERS, FOAMS AND SHAPED PARTS MADE OF THERMOPLASTIC AND THERMOSET POLYMERS; AND ANTIMICROBIAL, ANTIBACTERIAL, AND ANTIFUNGAL CHEMICAL ADDITIVES FOR INCORPORATION INTO AND MANUFACTURE OF NATURAL AND SYNTHETIC POLYMERS FOR USE IN MEDICAL DEVICES NAMELY INSERTABLES AND IMPLANTABLES (U.S. CLS. 1, 5, 6, 10, 26 AND 46).

HOWARD B. LEVINE, EXAMINING ATTORNEY

---

SN 78-964,636. ARCH PERSONAL CARE PRODUCTS, L.P., SOUTH PLAINFIELD, NJ. FILED 8-31-2006.

# DERMA-FLUX

THE MARK CONSISTS OF STANDARD CHARACTERS WITHOUT CLAIM TO ANY PARTICULAR FONT, STYLE, SIZE, OR COLOR.

FOR COSMETIC APPLICATIONS, NAMELY, CHEMICAL ADDITIVES FOR USE IN THE MANUFACTURE OF COSMETICS (U.S. CLS. 1, 5, 6, 10, 26 AND 46).

KRISTIN DAHLING, EXAMINING ATTORNEY

**CLASS 1—(Continued).**

SN 78-965,809. LARGO, COLLIERVILLE, TN. FILED 9-1-2006.

**Largo**

THE MARK CONSISTS OF STANDARD CHARACTERS WITHOUT CLAIM TO ANY PARTICULAR FONT, STYLE, SIZE, OR COLOR.

FOR FERTILIZERS FOR AGRICULTURAL USE (U.S. CLS. 1, 5, 6, 10, 26 AND 46).

FIRST USE 0-0-1989; IN COMMERCE 0-0-1989.

BARBARA A. GOLD, EXAMINING ATTORNEY

**CLASS 1—(Continued).**

SN 78-967,270. AMERITYRE, BOULDER CITY, NV. FILED 9-5-2006.

**AMERIFILL**

THE MARK CONSISTS OF STANDARD CHARACTERS WITHOUT CLAIM TO ANY PARTICULAR FONT, STYLE, SIZE, OR COLOR.

FOR CHEMICAL COMPOUNDS FOR USE AS A TIRE FILL TO FILL THE VOID IN A PNEUMATIC TIRE (U.S. CLS. 1, 5, 6, 10, 26 AND 46).

MARGERY A. TIERNEY, EXAMINING ATTORNEY

SN 78-966,164. ZINSSER BRANDS COMPANY, CLEVELAND, OH. FILED 9-1-2006.

**MICROPLUG**

THE MARK CONSISTS OF STANDARD CHARACTERS WITHOUT CLAIM TO ANY PARTICULAR FONT, STYLE, SIZE, OR COLOR.

FOR CHEMICAL THAT IMPARTS WATER REPELLENCY TO SEALERS, COATINGS, AND TREATMENTS FOR CONCRETE, WOOD, AND TEXTILES (U.S. CLS. 1, 5, 6, 10, 26 AND 46).

MELVIN AXILBUND, EXAMINING ATTORNEY

SN 78-968,355. AJAY NORTH AMERICA L.L.C., POWDER SPRINGS, GA. FILED 9-6-2006.

**iodeal**

THE MARK CONSISTS OF STANDARD CHARACTERS WITHOUT CLAIM TO ANY PARTICULAR FONT, STYLE, SIZE, OR COLOR.

FOR CATALYSTS FOR CHEMICAL AND BIOCHEMICAL PROCESSES; CATALYSTS FOR USE IN THE MANUFACTURE OF INDUSTRIAL CHEMICALS; CHEMICAL PREPARATIONS FOR SCIENTIFIC PURPOSES; CHEMICALS FOR USE IN INDUSTRY AND SCIENCE (U.S. CLS. 1, 5, 6, 10, 26 AND 46).

EVELYN BRADLEY, EXAMINING ATTORNEY

SN 78-966,226. FRANCIS DRILLING FLUIDS, LTD., CROWLEY, LA. FILED 9-1-2006.

**FRANCIS DRILLING FLUIDS**

THE MARK CONSISTS OF STANDARD CHARACTERS WITHOUT CLAIM TO ANY PARTICULAR FONT, STYLE, SIZE, OR COLOR.

NO CLAIM IS MADE TO THE EXCLUSIVE RIGHT TO USE "DRILLING FLUIDS", APART FROM THE MARK AS SHOWN.

FOR DRILLING MUDS FOR USE IN OIL WELL DRILLING; CHEMICAL ADDITIVES FOR OIL WELL DRILLING FLUID; AND DETERGENTS FOR INDUSTRIAL USE (U.S. CLS. 1, 5, 6, 10, 26 AND 46).

HEATHER THOMPSON, EXAMINING ATTORNEY

SN 78-968,560. KEI STYLIST, RICHMOND, CA. FILED 9-6-2006.

THE MARK CONSISTS OF STYLIZED TEXT OF THE WORDING "KEI".

FOR ADHESIVES FOR EXTERNAL DECORATIVE USE (U.S. CLS. 1, 5, 6, 10, 26 AND 46).

FIRST USE 4-11-2006; IN COMMERCE 4-11-2006.

KEVON CHISOLM, EXAMINING ATTORNEY

**CLASS 1—(Continued).**

SN 78-968,967. KNOX FERTILIZER COMPANY, INC.,  
KNOX, IN. FILED 9-7-2006.

**TPUN**

THE MARK CONSISTS OF STANDARD CHARACTERS  
WITHOUT CLAIM TO ANY PARTICULAR FONT, STYLE,  
SIZE, OR COLOR.  
FOR FERTILIZERS FOR DOMESTIC AND AGRICUL-  
TURAL USE (U.S. CLS. 1, 5, 6, 10, 26 AND 46).  
DEBRA LEE, EXAMINING ATTORNEY

**CLASS 1—(Continued).**

SN 78-968,979. KNOX FERTILIZER COMPANY, INC.,  
KNOX, IN. FILED 9-7-2006.

**TPAN**

THE MARK CONSISTS OF STANDARD CHARACTERS  
WITHOUT CLAIM TO ANY PARTICULAR FONT, STYLE,  
SIZE, OR COLOR.  
FOR FERTILIZERS FOR DOMESTIC AND AGRICUL-  
TURAL USE (U.S. CLS. 1, 5, 6, 10, 26 AND 46).  
DEBRA LEE, EXAMINING ATTORNEY

SN 78-968,972. KNOX FERTILIZER COMPANY, INC.,  
KNOX, IN. FILED 9-7-2006.

**TPMP**

THE MARK CONSISTS OF STANDARD CHARACTERS  
WITHOUT CLAIM TO ANY PARTICULAR FONT, STYLE,  
SIZE, OR COLOR.  
FOR FERTILIZERS FOR DOMESTIC AND AGRICUL-  
TURAL USE (U.S. CLS. 1, 5, 6, 10, 26 AND 46).  
DEBRA LEE, EXAMINING ATTORNEY

SN 78-968,983. KNOX FERTILIZER COMPANY, INC.,  
KNOX, IN. FILED 9-7-2006.

**TPNP**

THE MARK CONSISTS OF STANDARD CHARACTERS  
WITHOUT CLAIM TO ANY PARTICULAR FONT, STYLE,  
SIZE, OR COLOR.  
FOR FERTILIZERS FOR DOMESTIC AND AGRICUL-  
TURAL USE (U.S. CLS. 1, 5, 6, 10, 26 AND 46).  
DEBRA LEE, EXAMINING ATTORNEY

SN 78-968,976. KNOX FERTILIZER COMPANY, INC.,  
KNOX, IN. FILED 9-7-2006.

**TPSP**

THE MARK CONSISTS OF STANDARD CHARACTERS  
WITHOUT CLAIM TO ANY PARTICULAR FONT, STYLE,  
SIZE, OR COLOR.  
FOR FERTILIZERS FOR DOMESTIC AND AGRICUL-  
TURAL USE (U.S. CLS. 1, 5, 6, 10, 26 AND 46).  
DEBRA LEE, EXAMINING ATTORNEY

SN 78-969,234. AMERITYRE, BOULDER CITY, NV. FILED 9-  
7-2006.

**ELASTOTHANE**

THE MARK CONSISTS OF STANDARD CHARACTERS  
WITHOUT CLAIM TO ANY PARTICULAR FONT, STYLE,  
SIZE, OR COLOR.  
FOR CHEMICALS, SPECIFICALLY POLYURETHANE  
(U.S. CLS. 1, 5, 6, 10, 26 AND 46).  
MARGERY A. TIERNEY, EXAMINING ATTORNEY

**CLASS 1—(Continued).**

SN 78-969,484. CHEMPLEX AUTOMOTIVE GROUP, INC., FULLERTON, CA. FILED 9-7-2006.

# DYNO-TAB

THE MARK CONSISTS OF STANDARD CHARACTERS WITHOUT CLAIM TO ANY PARTICULAR FONT, STYLE, SIZE, OR COLOR.

OWNER OF U.S. REG. NO. 2,879,435.  
FOR CHEMICAL GASOLINE AND DIESEL FUEL ADDITIVES (U.S. CLS. 1, 5, 6, 10, 26 AND 46).  
ANDREA K. NADELMAN, EXAMINING ATTORNEY

---

SN 78-969,618. REDEX LIMITED, CHESHIRE, UNITED KINGDOM, FILED 9-7-2006.

# REDEX

THE MARK CONSISTS OF STANDARD CHARACTERS WITHOUT CLAIM TO ANY PARTICULAR FONT, STYLE, SIZE, OR COLOR.

FOR CHEMICAL ADDITIVES FOR ENHANCING THE PERFORMANCE OF LUBRICATING OILS AND INTERNAL COMBUSTION FUELS (U.S. CLS. 1, 5, 6, 10, 26 AND 46).

C. DIONNE CLYBURN, EXAMINING ATTORNEY

---

SN 78-970,068. LANDIS, JAMES W., NEW BEACH, CA. FILED 9-8-2006.

# DURA ROAD

THE MARK CONSISTS OF STANDARD CHARACTERS WITHOUT CLAIM TO ANY PARTICULAR FONT, STYLE, SIZE, OR COLOR.

NO CLAIM IS MADE TO THE EXCLUSIVE RIGHT TO USE "ROAD", APART FROM THE MARK AS SHOWN.

FOR SYNTHETIC POLYMER MODIFIED RESIN COMPOUND FOR USE IN CEMENTITIOUS REPAIRS; SYNTHETIC RESINS THAT ARE USED TO REPAIR AND FILL HOLES AND CRACKS. ADHERE TO SURROUNDING MATERIALS AND SEAL SURFACES FOR USE IN HARSH ENVIRONMENTS (U.S. CLS. 1, 5, 6, 10, 26 AND 46).

ESTHER BELENKER, EXAMINING ATTORNEY

**CLASS 1—(Continued).**

SN 78-970,120. LANDIS, JAMES W., NEWPORT BEACH, CA. FILED 9-8-2006.



# DuraRoad

FOR SYNTHETIC POLYMER MODIFIED RESIN COMPOUND FOR USE IN CEMENTITIOUS REPAIRS; SYNTHETIC RESINS THAT ARE USED TO REPAIR AND FILL HOLES AND CRACKS. ADHERE TO SURROUNDING MATERIALS AND SEAL SURFACES FOR USE IN HARSH ENVIRONMENTS (U.S. CLS. 1, 5, 6, 10, 26 AND 46).

ESTHER BELENKER, EXAMINING ATTORNEY

---

SN 78-972,161. NEALANDERS INTERNATIONAL INC., MISSISSAUGA, ONTARIO, CANADA, FILED 9-12-2006.

# DADEX BOOST

THE MARK CONSISTS OF STANDARD CHARACTERS WITHOUT CLAIM TO ANY PARTICULAR FONT, STYLE, SIZE, OR COLOR.

FOR ANTIOXIDANT FOR USE WITH BIODIESEL FUEL TO HELP MAINTAIN THE ENERGY PROFILE AND TO ASSIST IN THE PREVENTION OF GUMMING (U.S. CLS. 1, 5, 6, 10, 26 AND 46).

JAMES A. RAUEN, EXAMINING ATTORNEY

---

SN 78-972,890. XCELACORP, HOUSTON, TX. FILED 9-12-2006.

# Octanium

THE MARK CONSISTS OF STANDARD CHARACTERS WITHOUT CLAIM TO ANY PARTICULAR FONT, STYLE, SIZE, OR COLOR.

FOR GASOLINE OCTANE BOOSTER ADDITIVE (U.S. CLS. 1, 5, 6, 10, 26 AND 46).

DEIRDRE ROBERTSON, EXAMINING ATTORNEY

**CLASS 1—(Continued).**

SN 79-020,627. DSM IP ASSETS B.V., NETHERLANDS,  
FILED 12-16-2005.

# CLAVITESSE

THE MARK CONSISTS OF STANDARD CHARACTERS  
WITHOUT CLAIM TO ANY PARTICULAR FONT, STYLE,  
SIZE, OR COLOR.

PRIORITY DATE OF 7-28-2005 IS CLAIMED.  
OWNER OF INTERNATIONAL REGISTRATION 0876212  
DATED 12-16-2005, EXPIRES 12-16-2015.

FOR CHEMICALS AND BIOCHEMICALS FOR USE AS  
RAW MATERIAL IN THE MANUFACTURE OF PHAR-  
MACEUTICALS (U.S. CLS. 1, 5, 6, 10, 26 AND 46).  
KRISTINA KLOIBER, EXAMINING ATTORNEY

**CLASS 2—PAINTS**

SN 78-955,301. KILLAM, RICHARD T, ST. PETERSBURG,  
FL. FILED 8-18-2006.

# CeramiFLEX

THE MARK CONSISTS OF STANDARD CHARACTERS  
WITHOUT CLAIM TO ANY PARTICULAR FONT, STYLE,  
SIZE, OR COLOR.

FOR CERAMIC ENAMELS FOR INDUSTRIAL CHE-  
MICAL TANKS AND PIPING; CLEAR AND PIGMEN-  
TED COATINGS USED IN THE NATURE OF PAINT;  
COATING COMPOSITION IN THE NATURE OF PAINT  
FOR INDUSTRIAL APPLICATIONS; ELASTOMERIC-  
BASED COATINGS FOR USE ON ROOFS, WALLS AND  
BUILDING FOUNDATIONS (U.S. CLS. 6, 11 AND 16).  
FIRST USE 1-20-2002; IN COMMERCE 6-1-2002.

PETER B. BROMAGHIM, EXAMINING ATTORNEY

SN 79-023,410. CAMPINE, NAAMLOZE VENNOOTSCHAP,  
BELGIUM, FILED 2-14-2006.

# MASTERTEK

OWNER OF INTERNATIONAL REGISTRATION 0522842  
DATED 3-31-1988, EXPIRES 3-31-2008.

FOR FLAME RETARDANT CONCENTRATES AND  
MASTER BATCHES FOR THE ELECTRICAL AND  
ELECTRONIC CABLE AND BUILDING INDUSTRY  
(U.S. CLS. 1, 5, 6, 10, 26 AND 46).

ELI HELLMAN, EXAMINING ATTORNEY

SN 78-958,652. FOSTA-TEK OPTICS, INC., LEOMINSTER,  
MA. FILED 8-23-2006.

# Fosta Fog-Free

THE MARK CONSISTS OF STANDARD CHARACTERS  
WITHOUT CLAIM TO ANY PARTICULAR FONT, STYLE,  
SIZE, OR COLOR.

NO CLAIM IS MADE TO THE EXCLUSIVE RIGHT TO  
USE "FOG-FREE", APART FROM THE MARK AS SHOWN.  
FOR ANTI-FOG OPTICAL COATINGS FOR PLASTIC  
LENSES AND OPTICS (U.S. CLS. 6, 11 AND 16).

REBECCA POVARCHUK, EXAMINING ATTORNEY

SN 79-026,955. MERCK KGAA, FED REP GERMANY, FILED  
5-18-2006.

# LICRIVUE

THE MARK CONSISTS OF STANDARD CHARACTERS  
WITHOUT CLAIM TO ANY PARTICULAR FONT, STYLE,  
SIZE, OR COLOR.

PRIORITY DATE OF 11-30-2005 IS CLAIMED.  
OWNER OF INTERNATIONAL REGISTRATION 0893480  
DATED 5-18-2006, EXPIRES 5-18-2016.

FOR CHEMICALS FOR USE IN INDUSTRY AND  
SCIENCE (U.S. CLS. 1, 5, 6, 10, 26 AND 46).

STEPHANIE DAVIS, EXAMINING ATTORNEY

SN 78-959,182. BASF CORPORATION, FLORHAM PARK, NJ,  
FILED 8-24-2006.

# UNO-HD

THE MARK CONSISTS OF STANDARD CHARACTERS  
WITHOUT CLAIM TO ANY PARTICULAR FONT, STYLE,  
SIZE, OR COLOR.

FOR REFINISH PAINTS TO BE USED IN THE AUTO-  
MOBILE INDUSTRY (U.S. CLS. 6, 11 AND 16).

FIRST USE 9-30-1996; IN COMMERCE 9-30-1996.

DOMINIC FATHY, EXAMINING ATTORNEY

**CLASS 2—(Continued).**

SN 78-962,684. ECOSIL TECHNOLOGIES, LLC, CINCINNATI, OH. FILED 8-29-2006.

**ECOSIL**

THE MARK CONSISTS OF STANDARD CHARACTERS WITHOUT CLAIM TO ANY PARTICULAR FONT, STYLE, SIZE, OR COLOR.  
FOR SILANE CONTAINING PROTECTIVE COATINGS FOR METAL SURFACES (U.S. CLS. 6, 11 AND 16).  
PRISCILLA MILTON, EXAMINING ATTORNEY

SN 78-962,766. THOMAS, MELISSA, FAIRLAWN, OH. FILED 8-29-2006.

**Colour Leather Mate**

THE MARK CONSISTS OF STANDARD CHARACTERS WITHOUT CLAIM TO ANY PARTICULAR FONT, STYLE, SIZE, OR COLOR.  
NO CLAIM IS MADE TO THE EXCLUSIVE RIGHT TO USE "COLOUR LEATHER", APART FROM THE MARK AS SHOWN.  
FOR PAINTS FOR LEATHER AND VINYL (U.S. CLS. 6, 11 AND 16).  
ALICE SUE CARRUTHERS, EXAMINING ATTORNEY

SN 78-966,863. ENGLERT, INC., PERTH AMBOY, NJ. FILED 9-5-2006.

**DURAMATTE**

THE MARK CONSISTS OF STANDARD CHARACTERS WITHOUT CLAIM TO ANY PARTICULAR FONT, STYLE, SIZE, OR COLOR.  
FOR PAINT FINISH FOR RAIN GUTTER PRODUCTS (U.S. CLS. 6, 11 AND 16).  
SETH A. RAPPAPORT, EXAMINING ATTORNEY

**CLASS 2—(Continued).**

SN 78-969,334. MILNE, RICHARD B., HURRICANE, UT. FILED 9-7-2006.

**SPRAY RIGHT**

THE MARK CONSISTS OF STANDARD CHARACTERS WITHOUT CLAIM TO ANY PARTICULAR FONT, STYLE, SIZE, OR COLOR.  
FOR HOUSE PAINT (U.S. CLS. 6, 11 AND 16).  
THOMAS MANOR, EXAMINING ATTORNEY

SN 79-029,464. MERCK KGAA, FED REP GERMANY, FILED 7-25-2006.

**RONAFLAKE**

THE MARK CONSISTS OF STANDARD CHARACTERS WITHOUT CLAIM TO ANY PARTICULAR FONT, STYLE, SIZE, OR COLOR.  
PRIORITY DATE OF 5-5-2006 IS CLAIMED.  
OWNER OF INTERNATIONAL REGISTRATION 0899912 DATED 7-25-2006, EXPIRES 7-25-2016.  
FOR ORGANIC OR INORGANIC COLORANTS, NAMELY PAINTS, DYES, PIGMENTS AND PEARL-LUSTRE PIGMENTS (U.S. CLS. 6, 11 AND 16).  
TARAH HARDY, EXAMINING ATTORNEY

**CLASS 3—COSMETICS AND CLEANING PREPARATIONS**

SN 76-594,131. LAURICE EL BADRY RAHME LTD., DBA LAURICE & CO., NEW YORK, NY. FILED 5-25-2004.

**BLEECKER STREET**

THE MARK CONSISTS OF STANDARD CHARACTERS WITHOUT CLAIM TO ANY PARTICULAR FONT, STYLE, SIZE, OR COLOR.  
SEC. 2(F).  
FOR FRAGRANCES FOR PERSONAL USE, NAMELY, PERFUMES (U.S. CLS. 1, 4, 6, 50, 51 AND 52).  
FIRST USE 11-0-2005; IN COMMERCE 11-0-2005.  
THEODORE MCBRIDE, EXAMINING ATTORNEY



**CLASS 3—(Continued).**

SN 76-622,506. INTER-MARK USA, INC., ARMONK, NY. FILED 11-29-2004.

**PLASTIQUE**

THE MARK CONSISTS OF STANDARD CHARACTERS WITHOUT CLAIM TO ANY PARTICULAR FONT, STYLE, SIZE, OR COLOR.  
FOR LIPSTICK, LIQUID LIPSTICK, LIP GLOSS (U.S. CLS. 1, 4, 6, 50, 51 AND 52).  
WILLIAM P. SHANAHAN, EXAMINING ATTORNEY

**CLASS 3—(Continued).**

SN 76-666,816. SPPC PARIS BLEU, SAS, 75017 PARIS, FRANCE, FILED 9-29-2006.

**YVES DE SISTELLE**

THE MARK CONSISTS OF STANDARD CHARACTERS WITHOUT CLAIM TO ANY PARTICULAR FONT, STYLE, SIZE, OR COLOR.  
FOR PERFUMERY (U.S. CLS. 1, 4, 6, 50, 51 AND 52).  
FIRST USE 1-0-2005; IN COMMERCE 1-0-2006.  
NAAKWAMA ANKRAH, EXAMINING ATTORNEY

SN 76-633,340. INTERNATIONAL BEAUTY EXCHANGE, MIAMI, FL. FILED 3-15-2005.

**DR. JACKSON**

THE MARK CONSISTS OF STANDARD CHARACTERS WITHOUT CLAIM TO ANY PARTICULAR FONT, STYLE, SIZE, OR COLOR.  
THE NAME DR. JACKSON DOES NOT IDENTIFY A LIVING INDIVIDUAL.  
SEC. 2(F).  
FOR COSMETICS, NAMELY, NON-MEDICATED HAND AND BODY SOAPS, SKIN CREAMS AND GELS AND LIGHTENING BODY LOTION (U.S. CLS. 1, 4, 6, 50, 51 AND 52).  
FIRST USE 12-14-1999; IN COMMERCE 12-14-1999.  
RAY THOMAS, EXAMINING ATTORNEY

SN 76-668,615. SPPC PARIS BLEU, SAS, 75017 PARIS, FRANCE, FILED 11-6-2006.

**MIRIANA**

THE MARK CONSISTS OF STANDARD CHARACTERS WITHOUT CLAIM TO ANY PARTICULAR FONT, STYLE, SIZE, OR COLOR.  
FOR PERFUMERY (U.S. CLS. 1, 4, 6, 50, 51 AND 52).  
FIRST USE 8-0-1996; IN COMMERCE 9-0-1996.  
NAAKWAMA ANKRAH, EXAMINING ATTORNEY

SN 76-665,878. SPPC PARIS BLEU, SAS, 75017 PARIS, FRANCE, FILED 9-11-2006.

**CASAMANCE**

THE MARK CONSISTS OF STANDARD CHARACTERS WITHOUT CLAIM TO ANY PARTICULAR FONT, STYLE, SIZE, OR COLOR.  
FOR PERFUMERY (U.S. CLS. 1, 4, 6, 50, 51 AND 52).  
FIRST USE 8-0-2001; IN COMMERCE 8-0-2001.  
NAAKWAMA ANKRAH, EXAMINING ATTORNEY

SN 76-668,616. SPPC PARIS BLEU, SAS, 75017 PARIS, FRANCE, FILED 11-6-2006.

**LUDIANA**

THE MARK CONSISTS OF STANDARD CHARACTERS WITHOUT CLAIM TO ANY PARTICULAR FONT, STYLE, SIZE, OR COLOR.  
FOR PERFUMERY (U.S. CLS. 1, 4, 6, 50, 51 AND 52).  
FIRST USE 6-0-1997; IN COMMERCE 7-0-1997.  
NAAKWAMA ANKRAH, EXAMINING ATTORNEY

**CLASS 3—(Continued).**

SN 76-668,617. SPPC PARIS BLEU, SAS, 75017 PARIS, FRANCE, FILED 11-6-2006.

# ELEGANCE

THE MARK CONSISTS OF STANDARD CHARACTERS WITHOUT CLAIM TO ANY PARTICULAR FONT, STYLE, SIZE, OR COLOR.  
FOR PERFUMERY (U.S. CLS. 1, 4, 6, 50, 51 AND 52).  
FIRST USE 3-0-1995; IN COMMERCE 4-0-1995.  
NAAKWAMA ANKRAH, EXAMINING ATTORNEY

**CLASS 3—(Continued).**

SN 76-668,937. SPPC PARIS BLEU, SAS, 75017 PARIS, FRANCE, FILED 11-13-2006.

# PREDILECTION

THE MARK CONSISTS OF STANDARD CHARACTERS WITHOUT CLAIM TO ANY PARTICULAR FONT, STYLE, SIZE, OR COLOR.  
FOR PERFUMERY (U.S. CLS. 1, 4, 6, 50, 51 AND 52).  
FIRST USE 4-0-2006; IN COMMERCE 8-0-2006.  
NAAKWAMA ANKRAH, EXAMINING ATTORNEY

SN 76-668,935. SPPC PARIS BLEU, SAS, 75017 PARIS, FRANCE, FILED 11-13-2006.

# ADAGE

THE MARK CONSISTS OF STANDARD CHARACTERS WITHOUT CLAIM TO ANY PARTICULAR FONT, STYLE, SIZE, OR COLOR.  
FOR PERFUMERY (U.S. CLS. 1, 4, 6, 50, 51 AND 52).  
FIRST USE 12-0-2001; IN COMMERCE 1-0-2002.  
NAAKWAMA ANKRAH, EXAMINING ATTORNEY

SN 77-003,439. BASE 10, INC., WAIALUA, HI. FILED 9-20-2006.

# KUKUI ESSENTIAL

SN 76-668,936. SPPC PARIS BLEU, SAS, 75017 PARIS, FRANCE, FILED 11-13-2006.

# GALICE

THE MARK CONSISTS OF STANDARD CHARACTERS WITHOUT CLAIM TO ANY PARTICULAR FONT, STYLE, SIZE, OR COLOR.  
FOR PERFUMERY (U.S. CLS. 1, 4, 6, 50, 51 AND 52).  
FIRST USE 1-0-1997; IN COMMERCE 9-0-1997.  
NAAKWAMA ANKRAH, EXAMINING ATTORNEY

THE MARK CONSISTS OF STANDARD CHARACTERS WITHOUT CLAIM TO ANY PARTICULAR FONT, STYLE, SIZE, OR COLOR.  
NO CLAIM IS MADE TO THE EXCLUSIVE RIGHT TO USE "KUKUI", APART FROM THE MARK AS SHOWN.  
FOR AFTER SUN CREAMS; AFTER-SUN LOTIONS; BODY OIL; NON-MEDICATED SUN CARE PREPARATIONS; SUN CARE LOTIONS (U.S. CLS. 1, 4, 6, 50, 51 AND 52).  
FIRST USE 4-0-2006; IN COMMERCE 4-0-2006.  
JAY FLOWERS, EXAMINING ATTORNEY

**CLASS 3—(Continued).**

SN 77-009,388. NOVENA COSMECEUTICALS INC., CORAL GABLES, FL. FILED 9-28-2006.



NO CLAIM IS MADE TO THE EXCLUSIVE RIGHT TO USE "MATERNAL SKIN CARE", APART FROM THE MARK AS SHOWN.

THE FOREIGN WORDING IN THE MARK TRANSLATES INTO ENGLISH AS NINE.

FOR NON-MEDICATED SKIN CARE PREPARATIONS AND NON-MEDICATED PRE AND POST NATAL SKIN CARE PREPARATIONS; SKIN CARE PRODUCTS FOR WOMEN WHO ARE PREGNANT, NAMELY, COSMETICS, CREAMS, LOTIONS, MOISTURIZERS, TONERS, CLEANSERS, SUNSCREEN, SOAPS, MAKEUP REMOVER, FACIAL CLAY MASKS (U.S. CLS. 1, 4, 6, 50, 51 AND 52).

HENRY S. ZAK, EXAMINING ATTORNEY

SN 77-020,714. LYMARI LLC, HONOLULU, HI. FILED 10-13-2006.

# Lymari

THE MARK CONSISTS OF STANDARD CHARACTERS WITHOUT CLAIM TO ANY PARTICULAR FONT, STYLE, SIZE, OR COLOR.

THE NAME(S), PORTRAIT(S), AND/OR SIGNATURE(S) SHOWN IN THE MARK IDENTIFIES LYMARI HUGHES, WHOSE CONSENT(S) TO REGISTER IS SUBMITTED.

FOR COSMETICS, COSMETIC CREAMS, COSMETIC PREPARATIONS FOR SKIN RENEWAL, COSMETIC PREPARATIONS FOR BODY CARE, COLORING PREPARATIONS FOR COSMETIC PURPOSES, COSMETIC ROUGES (U.S. CLS. 1, 4, 6, 50, 51 AND 52).

FIRST USE 10-30-1977; IN COMMERCE 0-0-2002.  
JOHN WILKE, EXAMINING ATTORNEY

**CLASS 3—(Continued).**

SN 77-033,460. VICTORIA PRINCIPAL PRODUCTIONS, INC., LOS ANGELES, CA. FILED 10-31-2006.

# EYEMIGHTY

THE MARK CONSISTS OF STANDARD CHARACTERS WITHOUT CLAIM TO ANY PARTICULAR FONT, STYLE, SIZE, OR COLOR.

FOR SKIN AND BODY CARE PREPARATIONS NAMELY, SKIN CLEANSERS, SKIN MOISTURIZERS, SKIN LOTIONS, SKIN SOAPS, SUN SCREEN PREPARATIONS, COSMETICS, NON-MEDICATED HAIR CARE PREPARATIONS, NAIL CARE PREPARATIONS, NON-MEDICATED SKIN CARE PREPARATIONS, COLOGNES, PERFUMES AND TOOTH WHITENING PREPARATIONS (U.S. CLS. 1, 4, 6, 50, 51 AND 52).

TINA KUAN, EXAMINING ATTORNEY

SN 77-048,974. THE PROCTER & GAMBLE COMPANY, CINCINNATI, OH. FILED 11-21-2006.

# POWERDRY

THE MARK CONSISTS OF STANDARD CHARACTERS WITHOUT CLAIM TO ANY PARTICULAR FONT, STYLE, SIZE, OR COLOR.

FOR DISH DETERGENT (U.S. CLS. 1, 4, 6, 50, 51 AND 52).

ALEX KEAM, EXAMINING ATTORNEY

SN 77-057,579. VICTORIA PRINCIPAL PRODUCTIONS, INC., LOS ANGELES, CA. FILED 12-5-2006.

# CALMING AND CONTOURING

THE MARK CONSISTS OF STANDARD CHARACTERS WITHOUT CLAIM TO ANY PARTICULAR FONT, STYLE, SIZE, OR COLOR.

FOR SKIN AND BODY CARE PREPARATIONS NAMELY, SKIN CLEANSERS, SKIN MOISTURIZERS, SKIN LOTIONS, SKIN SOAPS, SUN SCREEN PREPARATIONS, COSMETICS, NON-MEDICATED HAIR CARE PREPARATIONS, NAIL CARE PREPARATIONS, NON-MEDICATED SKIN CARE PREPARATIONS, COLOGNES, PERFUMES AND TOOTH WHITENING PREPARATIONS (U.S. CLS. 1, 4, 6, 50, 51 AND 52).

TINA KUAN, EXAMINING ATTORNEY

**CLASS 3—(Continued).**

SN 77-057,605. VICTORIA PRINCIPAL PRODUCTIONS, INC., LOS ANGELES, CA. FILED 12-5-2006.

**CLASS 3—(Continued).**

SN 78-361,360. PEREZ, MARCOS, CORAL GABLES, FL. FILED 2-2-2004.

**THIGHS TO SIGH FOR**

THE MARK CONSISTS OF STANDARD CHARACTERS WITHOUT CLAIM TO ANY PARTICULAR FONT, STYLE, SIZE, OR COLOR.

FOR SKIN AND BODY CARE PREPARATIONS NAMELY, SKIN CLEANSERS, SKIN MOISTURIZERS, SKIN LOTIONS, SKIN SOAPS, SUN SCREEN PREPARATIONS, COSMETICS, NON-MEDICATED HAIR CARE PREPARATIONS, NAIL CARE PREPARATIONS, NON-MEDICATED SKIN CARE PREPARATIONS, COLOGNES, PERFUMES AND TOOTH WHITENING PREPARATIONS (U.S. CLS. 1, 4, 6, 50, 51 AND 52).

TINA KUAN, EXAMINING ATTORNEY

FOR SKIN CARE PRODUCTS, NAMELY, NON-MEDICATED SKIN CARE PREPARATIONS (U.S. CLS. 1, 4, 6, 50, 51 AND 52).

ALICE BENMAMAN, EXAMINING ATTORNEY

SN 77-069,549. PHILOSOPHY, INC., PHOENIX, AZ. FILED 12-21-2006.

SN 78-379,138. SYNERGISTIC SOLUTIONS GROUP, INC., MIAMI, FL. FILED 3-5-2004.

**THE ANTI MAKE-UP ARTIST KIT****DERMODEX**

THE MARK CONSISTS OF STANDARD CHARACTERS WITHOUT CLAIM TO ANY PARTICULAR FONT, STYLE, SIZE, OR COLOR.

NO CLAIM IS MADE TO THE EXCLUSIVE RIGHT TO USE "KIT", APART FROM THE MARK AS SHOWN.

FOR BABY LOTION; BABY POWDER; BABY SHAMPOO; BODY SCRUB; COSMETIC FACIAL BLOTTER PERS; COSMETIC PADS; COSMETIC PENCILS; COSMETIC PREPARATIONS FOR THE CARE OF MOUTH AND TEETH; COSMETICS; DEPILATORIES; FACIAL SCRUBS; FRAGRANCES FOR PERSONAL USE; HAIR CARE PREPARATIONS; NAIL CARE PREPARATIONS; NON-MEDICATED BATH PREPARATIONS; NON-MEDICATED FOOT CREAM; NON-MEDICATED LIP CARE PREPARATIONS; NON-MEDICATED SKIN CARE PREPARATIONS; NON-MEDICATED SUN CARE PREPARATIONS; NON-MEDICATED TOILETRIES; PERFUMED POWDER; PERSONAL DEODORANTS; SCENTED ROOM SPRAYS; SHAVING PREPARATIONS; SHOWER AND BATH GEL (U.S. CLS. 1, 4, 6, 50, 51 AND 52).

LINDA ORNDORFF, EXAMINING ATTORNEY

THE MARK CONSISTS OF STANDARD CHARACTERS WITHOUT CLAIM TO ANY PARTICULAR FONT, STYLE, SIZE, OR COLOR.

FOR COSMETICS; NON-MEDICATED SKIN CARE PREPARATIONS FOR THE FACE, EYES AND BODY IN THE NATURE OF WRINKLE CREAMS; LIQUID MAKE-UP; NECK CREAMS (U.S. CLS. 1, 4, 6, 50, 51 AND 52).

ANN E. SAPPENFIELD, EXAMINING ATTORNEY

**CLASS 3—(Continued).**

SN 78-508,265. RECKITT BENCKISER INC., PARSIPPANY, NJ. FILED 10-29-2004.

**NANOCARE**

THE MARK CONSISTS OF STANDARD CHARACTERS WITHOUT CLAIM TO ANY PARTICULAR FONT, STYLE, SIZE, OR COLOR.

FOR LAUNDRY PREPARATIONS, NAMELY LAUNDRY DETERGENTS, LAUNDRY SOAP AND LAUNDRY BLEACH; POLISHING, SCOURING AND ABRASIVE PREPARATIONS FOR HOUSEHOLD USE; DETERGENTS, NAMELY DISHWASHING SOAP, DISHWASHING DETERGENTS; LAUNDRY ADDITIVES, NAMELY, LAUNDRY BLUING AND PRE-SOAK; STAIN REMOVING PREPARATIONS, NAMELY STAIN REMOVERS; CARPET CLEANERS; CARPET SHAMPOOS; LAUNDRY ADDITIVES, NAMELY FABRIC SOFTENERS; STAIN REMOVING PREPARATION; ALL AFOREMENTIONED GOODS WITH OR WITHOUT A DISINFECTIVE COMPONENT (U.S. CLS. 1, 4, 6, 50, 51 AND 52).

ROBERT C. CLARK JR., EXAMINING ATTORNEY

SN 78-604,662. THE YANKEE CANDLE COMPANY, INC., SOUTH DEERFIELD, MA. FILED 4-8-2005.

**YANKEE CANDLE**

THE MARK CONSISTS OF STANDARD CHARACTERS WITHOUT CLAIM TO ANY PARTICULAR FONT, STYLE, SIZE, OR COLOR.

OWNER OF U.S. REG. NOS. 2,800,377, 2,998,930 AND OTHERS.

FOR FABRIC SOFTENER, FABRIC SOFTENER SHEETS, FABRIC REFRESHENER, LAUNDRY DETERGENT, DISH WASHING DETERGENT, LIQUID SOAP, SKIN CLEANSING GEL, BATH SALTS, SKIN LOTION, ROOM FRAGRANCES, POTPOURRI, POTPOURRI REFRESHER OIL, ELECTRIC FRAGRANCE DISPENSER REFILLS, SACHETS, SCENTED LINEN SPRAY, ALL PURPOSE CLEANING PREPARATIONS, DISPOSABLE WIPES IMPREGNATED WITH CHEMICALS OR COMPOUNDS FOR HOUSEHOLD USE, INCENSE, AND AROMATHERAPY PILLOWS COMPRISING POTPOURRI IN FABRIC CONTAINERS (U.S. CLS. 1, 4, 6, 50, 51 AND 52).

MYRIAH HABEEB, EXAMINING ATTORNEY

**CLASS 3—(Continued).**

SN 78-617,215. SEXY HAIR CONCEPTS, LLC, CHATSWORTH, CA. FILED 4-26-2005.

**SEXY LIPS**

THE MARK CONSISTS OF STANDARD CHARACTERS WITHOUT CLAIM TO ANY PARTICULAR FONT, STYLE, SIZE, OR COLOR.

OWNER OF U.S. REG. NOS. 2,403,396 AND 2,486,702. NO CLAIM IS MADE TO THE EXCLUSIVE RIGHT TO USE "LIPS", APART FROM THE MARK AS SHOWN. FOR LIP GLOSS (U.S. CLS. 1, 4, 6, 50, 51 AND 52). WARREN L. OLANDRIA, EXAMINING ATTORNEY

SN 78-676,441. HENKEL KGAA, DUESSELDORF, FED REP GERMANY, FILED 7-22-2005.

**OIL THERAPY REPAIR BLASTS**

THE MARK CONSISTS OF STANDARD CHARACTERS WITHOUT CLAIM TO ANY PARTICULAR FONT, STYLE, SIZE, OR COLOR.

NO CLAIM IS MADE TO THE EXCLUSIVE RIGHT TO USE "OIL THERAPY REPAIR", APART FROM THE MARK AS SHOWN.

FOR HAIR CARE AND STYLING PREPARATIONS (U.S. CLS. 1, 4, 6, 50, 51 AND 52).

TASNEEM HUSSAIN, EXAMINING ATTORNEY

SN 78-752,179. SWAGGER CO., LTD, TOKYO, JAPAN, FILED 11-11-2005.

**SNEEKAKLEENA**

THE MARK CONSISTS OF STANDARD CHARACTERS WITHOUT CLAIM TO ANY PARTICULAR FONT, STYLE, SIZE, OR COLOR.

PRIORITY CLAIMED UNDER SEC. 44(D) ON JAPAN APPLICATION NO. 2005-68834, FILED 7-26-2005, REG. NO. 4935818, DATED 3-10-2006, EXPIRES 3-10-2016.

FOR BATH SOAPS IN LIQUID, SOLID OR GEL FORM; BODY CREAM SOAP; COSMETIC SOAPS; CREAM SOAPS; DEODORANT SOAP; DETERGENT SOAP; GRANULATED SOAPS; HAIR SHAMPOO; HAND CLEANERS; HAND SOAPS; INDUSTRIAL SOAP; LAUNDRY SOAP; LIQUID SOAPS; LIQUID SOAPS FOR HANDS, FACE AND BODY; MEDICATED SOAPS; PERFUMED SOAPS; SHAVING SOAP; SKIN SOAP; SOAP POWDER; SOAPS AND DETERGENTS; SOAPS FOR BODY CARE; SOAPS FOR HOUSEHOLD USE; SOAPS FOR PERSONAL USE; SOAPS FOR TOILET PURPOSES; TOILET SOAPS (U.S. CLS. 1, 4, 6, 50, 51 AND 52).

IRENE D. WILLIAMS, EXAMINING ATTORNEY

**CLASS 3—(Continued).**

SN 78-779,959. MAVERICK BRANDS LLC, NEW YORK, NY.  
FILED 12-22-2005.

**CHIC SIMPLE**

THE MARK CONSISTS OF STANDARD CHARACTERS WITHOUT CLAIM TO ANY PARTICULAR FONT, STYLE, SIZE, OR COLOR.

FOR COSMETICS, LIPSTICKS, LIP BALM, EYELINER, MASCARA, BLUSHER, ROUGE, LIP LINER, EYE SHADOW, FOUNDATION MAKEUP, CONCEALER MAKEUP, FACE POWDER, BRONZER, LIP GLOSS, NAIL POLISH, NAIL POLISH REMOVER, BODY SOAP, FACIAL CLEANSERS, FACIAL SOAPS, BODY CLEANSERS, SKIN TONER, BODY AND FACIAL MOISTURIZERS, SKIN, FACIAL, HAND, MASSAGE, FOOT AND BODY LOTION, AFTER SUN MOISTURIZERS, SUN BLOCK, SUNSCREEN, SKIN MASKS, HAIR REMOVING PREPARATIONS, BODY CREAM, EYE CREAM, EYE GEL, HAND CREAM, SHAVING CREAM, PERSONAL DEODORANTS AND ANTIPERSPIRANTS, PERFUMES, COLOGNE, EAU DE TOILETTE, EAU DE PARFUM, POTPOURRI, INCENSE, HAIR SHAMPOO, HAIR CONDITIONERS, HAIR GELS, HAIR MOUSSE, HAIR SPRAY, BATH OILS, BATH BUBBLES, BATH SALTS, MILK BATH, BATH BEADS, BODY SPLASH, BODY SCRUBS, TOOTHPASTE, ALL PURPOSE HOUSEHOLD CLEANING PREPARATIONS (U.S. CLS. 1, 4, 6, 50, 51 AND 52).  
ESTHER BELENKER, EXAMINING ATTORNEY

SN 78-783,606. SKINUTRIENTS, LLC, CELEBRATION, FL.  
FILED 1-2-2006.

**DR. GOODSKIN**

THE MARK CONSISTS OF STANDARD CHARACTERS WITHOUT CLAIM TO ANY PARTICULAR FONT, STYLE, SIZE, OR COLOR.

FOR COSMETICS (U.S. CLS. 1, 4, 6, 50, 51 AND 52).  
ESTHER BELENKER, EXAMINING ATTORNEY

SN 78-785,784. N. V. PERRICONE LLC, MERIDEN, CT.  
FILED 1-5-2006.

**NUTRIENT FACE FORTIFIER**

THE MARK CONSISTS OF STANDARD CHARACTERS WITHOUT CLAIM TO ANY PARTICULAR FONT, STYLE, SIZE, OR COLOR.

SEC. 2(F).  
FOR SKIN CREAMS (U.S. CLS. 1, 4, 6, 50, 51 AND 52).  
FIRST USE 12-0-2001; IN COMMERCE 12-0-2001.  
MARY ROSSMAN, EXAMINING ATTORNEY

**CLASS 3—(Continued).**

SN 78-795,312. NATERRA INTERNATIONAL, INC., DALLAS, TX. FILED 1-19-2006.

**MINERAL ART**

THE MARK CONSISTS OF STANDARD CHARACTERS WITHOUT CLAIM TO ANY PARTICULAR FONT, STYLE, SIZE, OR COLOR.

NO CLAIM IS MADE TO THE EXCLUSIVE RIGHT TO USE "MINERAL", APART FROM THE MARK AS SHOWN.  
FOR COSMETICS; HAIR CARE PREPARATIONS; NON-MEDICATED SKIN CARE PREPARATIONS (U.S. CLS. 1, 4, 6, 50, 51 AND 52).  
LEIGH LOWRY, EXAMINING ATTORNEY

SN 78-795,322. NATERRA INTERNATIONAL, INC., DALLAS, TX. FILED 1-19-2006.

**MINERAL PALETTE**

THE MARK CONSISTS OF STANDARD CHARACTERS WITHOUT CLAIM TO ANY PARTICULAR FONT, STYLE, SIZE, OR COLOR.

NO CLAIM IS MADE TO THE EXCLUSIVE RIGHT TO USE "MINERAL", APART FROM THE MARK AS SHOWN.  
FOR COSMETICS; HAIR CARE PREPARATIONS; NON-MEDICATED SKIN CARE PREPARATIONS (U.S. CLS. 1, 4, 6, 50, 51 AND 52).  
LEIGH LOWRY, EXAMINING ATTORNEY

SN 78-803,243. BASICNET SPA, TURIN, ITALY, FILED 1-31-2006.

**K WAY**

THE MARK CONSISTS OF STANDARD CHARACTERS WITHOUT CLAIM TO ANY PARTICULAR FONT, STYLE, SIZE, OR COLOR.

OWNER OF ITALY REG. NO. 952309, DATED 1-19-2005, EXPIRES 6-8-2014.

FOR SKIN SOAPS, TOILET SOAPS, LIQUID SOAPS FOR HANDS, BODY AND FACE; PERFUMES, TOILET WATERS, EAU DE COLOGNE; ESSENTIAL OILS FOR PERSONAL USE; COSMETIC CREAMS AND LOTIONS FOR HANDS, BODY AND FACE; PRE-SHAVE, SHAVING AND AFTER-SHAVE CREAM, LOTIONS, FOAM AND GELS; TANNING CREAMS AND LOTIONS; SUN CARE CREAMS AND LOTIONS; SHAMPOOS, DEODORANTS FOR PERSONAL USE; MAKE-UP PREPARATIONS (U.S. CLS. 1, 4, 6, 50, 51 AND 52).  
JAMES STEIN, EXAMINING ATTORNEY

**CLASS 3—(Continued).**

SN 78-805,247. MORGAN MOTOR COMPANY LIMITED, WORCESTERSHIRE, UNITED KINGDOM, FILED 2-2-2006.



The logo for Morgan VINTAGE features the word "Morgan" in a stylized, cursive script font. Below it, the word "VINTAGE" is written in a clean, sans-serif, all-caps font. A horizontal line is positioned below the word "VINTAGE".

OWNER OF U.S. REG. NO. 1,715,474.  
FOR BODY LOTION, BODY OIL, BODY CREAM, BODY SCRUB, BODY SMOOTHER, BATH AND SHOWER GEL, BATH AND SHOWER OIL, BODY POWDER, SOAP, DEODORANT, SHAMPOO, FACE MOISTURIZER, LIP MOISTURIZER, SUN PROTECTION LOTION, SUNTAN PREPARATIONS, TAN ACCELERATING CREAM, COLOGNE, AND PERFUME (U.S. CLS. 1, 4, 6, 50, 51 AND 52).  
JILL C. ALT, EXAMINING ATTORNEY

**CLASS 3—(Continued).**

SN 78-809,582. ZOYA COMPANY, BEDFORD, OH. FILED 2-8-2006.

# VALOS

THE MARK CONSISTS OF STANDARD CHARACTERS WITHOUT CLAIM TO ANY PARTICULAR FONT, STYLE, SIZE, OR COLOR.

THE ENGLISH TRANSLATION OF VALOS IS SEE THEM. FOR BATH SOAPS IN LIQUID, SOLID OR GEL FORM; BODY AND BEAUTY CARE PREPARATIONS; BODY CREAM SOAP; BODY MASK LOTION; COSMETICS; EXFOLIANTS FOR HANDS AND FEET; HAIR CARE CREAMS; HAIR CARE LOTIONS; HAIR CARE PREPARATIONS; HAIR CONDITIONERS; HAIR SHAMPOO; HAND CREAMS; HAND SOAPS; LIP BALM; LIP GLOSS; LIPSTICK; LOTIONS FOR STRENGTHENING THE NAILS; NAIL CARE PREPARATIONS; NAIL POLISH REMOVER; NAIL POLISH TOP COAT (U.S. CLS. 1, 4, 6, 50, 51 AND 52).

REBECCA EISINGER, EXAMINING ATTORNEY

SN 78-814,256. ANTIPODES NEW ZEALAND LIMITED, WELLINGTON, NEW ZEALAND, FILED 2-14-2006.

# ANTIPODES

THE MARK CONSISTS OF STANDARD CHARACTERS WITHOUT CLAIM TO ANY PARTICULAR FONT, STYLE, SIZE, OR COLOR.

PRIORITY CLAIMED UNDER SEC. 44(D) ON NEW ZEALAND APPLICATION NO. 734895, FILED 8-29-2005, REG. NO. 734895, DATED 8-29-2005, EXPIRES 8-29-2015.

FOR COSMETIC PREPARATIONS FOR BODY CARE; SKIN LOTIONS, SKIN CLEANSER AND SKIN CREAMS; COSMETIC CREAMS INCLUDING SKIN WHITENING CREAMS, EYE CREAM, NIGHT CREAM, DAY CREAM, COSMETIC BODY LOTION, TONING LOTION FOR THE FACE, BODY AND HANDS; FACIAL TONER; PRE-MOISTENED COSMETIC TISSUES; FACE AND BODY LOTIONS; SKIN MOISTURIZERS; FACE AND BODY TREATMENTS, NAMELY, FACIAL BEAUTY MASKS, FACIAL CLEANSING MILK, BODY MASK LOTION, BODY MILK AND BODY SCRUB; SOAP AND CAKES OF SOAP; OILS FOR COSMETIC PURPOSES; ALMOND MILK FOR COSMETIC PURPOSES; COSMETIC OILS, NAMELY, FACE OIL, BODY OIL, AVOCADO OIL AND ALMOND OIL; ALMOND SOAP; NON-MEDICATED TOILETRIES; MAKE-UP, MAKE-UP POWDER, MAKE-UP PREPARATIONS, MAKE-UP REMOVING PREPARATIONS, MINERAL FOUNDATIONS, MASCARA, LIPSTICKS, COSMETIC PENCILS, EYEBROW PENCILS, EYESHADOW, EYELINER, BEAUTY MASKS AND COSMETICS; COSMETICS FOR ANIMALS; COSMETIC KITS COMPRISED OF COSMETIC PREPARATIONS FOR BODY CARE, SKIN LOTIONS, SKIN CLEANSER AND

# WEI EAST SILK

THE MARK CONSISTS OF STANDARD CHARACTERS WITHOUT CLAIM TO ANY PARTICULAR FONT, STYLE, SIZE, OR COLOR.

OWNER OF U.S. REG. NO. 2,363,228.  
NO CLAIM IS MADE TO THE EXCLUSIVE RIGHT TO USE "SILK", APART FROM THE MARK AS SHOWN.

FOR SKIN CARE PRODUCTS, NAMELY SKIN CONDITIONERS, NON-MEDICATED SKIN SERUMS, SKIN CREAMS, BODY LOTION, EMULSIONS FOR USE AS A MOISTURIZER FOR THE HANDS, BODY EMULSIONS, BODY OIL, SKIN CLEANSER, EYE MAKEUP, EYE MAKEUP REMOVER, EYE GELS AND LIP MOISTURIZER (U.S. CLS. 1, 4, 6, 50, 51 AND 52).

BILL DAWE, EXAMINING ATTORNEY

SN 78-807,838. WEI EAST HOLDINGS, INC., NEWTOWN SQUARE, PA. FILED 2-6-2006.

**CLASS 3—(Continued).**

SKIN CREAMS, COSMETIC BODY LOTION, TONING LOTION FOR THE FACE, BODY AND HANDS, FACIAL TONER, FACE AND BODY LOTIONS, SKIN MOISTURIZERS, FACE AND BODY TREATMENTS, NAMELY, FACIAL BEAUTY MASKS, FACIAL CLEANSING MILK, BODY MASK LOTION, BODY MILK AND BODY SCRUB, SOAP AND CAKES OF SOAP AND OILS FOR COSMETIC PURPOSES; HAIR CARE PREPARATIONS INCLUDING SHAMPOOS, CONDITIONERS AND HAIR CARE TREATMENTS, NAMELY, HAIR OILS, HAIR COLORANTS AND HAIR DYES; SHAMPOOS FOR PETS; PERFUMES, PERFUMERY, PERFUME OILS AND PERFUME OILS FOR THE MANUFACTURE OF COSMETIC PREPARATIONS, NAMELY, FLOWER SCENTED PERFUMES, JASMINE OIL, LAVENDER OIL, ROSE OIL, LAVENDER TOILET WATER AND SCENTED TOILET WATER, AND LEMON OIL; INCENSE; BATH SALTS, NOT FOR MEDICAL PURPOSES; SUN TAN GEL, SUN TAN LOTION, SUN TAN OIL, COSMETIC SUN-TANNING PREPARATIONS AND SELF-TANNING SUNTAN CREAMS (U.S. CLS. 1, 4, 6, 50, 51 AND 52).  
 MEGAN WHITNEY, EXAMINING ATTORNEY

**CLASS 3—(Continued).**

SKIN CREAMS, COSMETIC BODY LOTION, TONING LOTION FOR THE FACE, BODY AND HANDS, FACIAL TONER, FACE AND BODY LOTIONS, SKIN MOISTURIZERS, FACE AND BODY TREATMENTS, NAMELY, FACIAL BEAUTY MASKS, FACIAL CLEANSING MILK, BODY MASK LOTION, BODY MILK AND BODY SCRUB, SOAP AND CAKES OF SOAP AND OILS FOR COSMETIC PURPOSES; HAIR CARE PREPARATIONS INCLUDING SHAMPOOS, CONDITIONERS AND HAIR CARE TREATMENTS, NAMELY, HAIR OILS, HAIR COLORANTS AND HAIR DYES; SHAMPOOS FOR PETS; PERFUMES, PERFUMERY, PERFUME OILS AND PERFUME OILS FOR THE MANUFACTURE OF COSMETIC PREPARATIONS, NAMELY, FLOWER SCENTED PERFUMES, JASMINE OIL, LAVENDER OIL, ROSE OIL, LAVENDER TOILET WATER AND SCENTED TOILET WATER, AND LEMON OIL; INCENSE; BATH SALTS, NOT FOR MEDICAL PURPOSES; SUN TAN GEL, SUN TAN LOTION, SUN TAN OIL, COSMETIC SUN-TANNING PREPARATIONS AND SELF-TANNING SUNTAN CREAMS (U.S. CLS. 1, 4, 6, 50, 51 AND 52).  
 MEGAN WHITNEY, EXAMINING ATTORNEY

---

SN 78-814,456. ANTIPODES NEW ZEALAND LIMITED, WELLINGTON, NEW ZEALAND, FILED 2-14-2006.

---

SN 78-818,149. DJF ENTERPRISES, INC., CULVER CITY, CA. FILED 2-17-2006.

**CONNECT WITH NATURE**

THE MARK CONSISTS OF STANDARD CHARACTERS WITHOUT CLAIM TO ANY PARTICULAR FONT, STYLE, SIZE, OR COLOR.

PRIORITY CLAIMED UNDER SEC. 44(D) ON NEW ZEALAND APPLICATION NO. 734896, FILED 8-29-2005, REG. NO. 734896, DATED 8-29-2005, EXPIRES 8-29-2015.

FOR COSMETIC PREPARATIONS FOR BODY CARE; SKIN LOTIONS, SKIN CLEANSER AND SKIN CREAMS; COSMETIC CREAMS INCLUDING SKIN WHITENING CREAMS, EYE CREAM, NIGHT CREAM, DAY CREAM, COSMETIC BODY LOTION, TONING LOTION FOR THE FACE, BODY AND HANDS; FACIAL TONER; PRE-MOISTENED COSMETIC TISSUES; FACE AND BODY LOTIONS; SKIN MOISTURIZERS; FACE AND BODY TREATMENTS, NAMELY, FACIAL BEAUTY MASKS, FACIAL CLEANSING MILK, BODY MASK LOTION, BODY MILK AND BODY SCRUB; SOAP AND CAKES OF SOAP; OILS FOR COSMETIC PURPOSES; ALMOND MILK FOR COSMETIC PURPOSES; COSMETIC OILS, NAMELY, FACE OIL, BODY OIL, AVOCADO OIL AND ALMOND OIL; ALMOND SOAP; NON-MEDICATED TOILETRIES; MAKE-UP, MAKE-UP POWDER, MAKE-UP PREPARATIONS, MAKE-UP REMOVING PREPARATIONS, MINERAL FOUNDATIONS, MASCARA, LIP-STICKS, COSMETIC PENCILS, EYEBROW PENCILS, EYESHADOW, EYELINER, BEAUTY MASKS AND COSMETICS; COSMETICS FOR ANIMALS; COSMETIC KITS COMPRISED OF COSMETIC PREPARATIONS FOR BODY CARE, SKIN LOTIONS, SKIN CLEANSER AND

**OUR KNOWLEDGE, YOUR BEAUTY**

THE MARK CONSISTS OF STANDARD CHARACTERS WITHOUT CLAIM TO ANY PARTICULAR FONT, STYLE, SIZE, OR COLOR.

FOR COSMETICS AND NON-MEDICATED SKIN CARE PREPARATIONS (U.S. CLS. 1, 4, 6, 50, 51 AND 52).  
 G. MAYERSCHOFF, EXAMINING ATTORNEY

---

SN 78-823,282. TOLLIVER, CELA, LOS ANGELES, CA. FILED 2-24-2006.

*C' Laii*  
*Let it do what it do!!*

FOR HAIR CARE PRODUCTS, NAMELY, HAIR POMADES, HAIR OILS, HAIR SHAMPOOS, HAIR CONDITIONER, AND HAIR MOISTURIZERS (U.S. CLS. 1, 4, 6, 50, 51 AND 52).  
 MARY MUNSON, EXAMINING ATTORNEY



**CLASS 3—(Continued).**

SN 78-849,337. THE PROCTER & GAMBLE COMPANY, CINCINNATI, OH. FILED 3-29-2006.



THE COLOR(S) GRAY, PURPLE, BROWN, BLACK AND WHITE IS/ARE CLAIMED AS A FEATURE OF THE MARK. THE MARK CONSISTS OF THE WORD DEFINITY IN PURPLE ON A GRAY BACKGROUND, ABOVE A GEOMETRIC-SHAPED WINDOW LINED IN BLACK AND PURPLE, ALL OF WHICH APPEARS ABOVE A SERIES OF MULTI-COLOR PIXELS (IN GRAY, PURPLE, BROWN, BLACK AND WHITE).

FOR NON-MEDICATED SKIN CARE PREPARATIONS (U.S. CLS. 1, 4, 6, 50, 51 AND 52).

KATHERINE M. DUBRAY, EXAMINING ATTORNEY

SN 78-857,353. HOBART, JAMES, D, VENTURA, CA. FILED 4-9-2006.



THE COLOR(S) BLACK, LIGHT GREEN, AND DARK GREEN IS/ARE CLAIMED AS A FEATURE OF THE MARK. THE COLOR BLACK APPEARS IN THE LETTERS OF THE WORD SIMETRE; THE COLOR LIGHT GREEN APPEARS IN THE LETTERS OF THE WORD BALANCE AND THE LEAF DESIGN; THE COLOR DARK GREEN APPEARS ON THE DESIGN OF THE OFFSET CIRCLE WITH TWO SPINNING ORBS.

THE MARK CONSISTS OF THE WORDING SIMETRE BALANCE OVER A DESIGN OF A LEAF IN THE MIDDLE OF AN OFFSET CIRCLE WITH TWO SPINNING ORBS AROUND THE PERIMETER OF THE LEAF.

FOR ALOE VERA GEL FOR COSMETIC PURPOSES; CONDITIONERS; HAIR RINSES; HAIR SHAMPOO; SHAMPOO-CONDITIONERS; SHAMPOOS (U.S. CLS. 1, 4, 6, 50, 51 AND 52).

SAMUEL E. SHARPER JR., EXAMINING ATTORNEY

**CLASS 3—(Continued).**

SN 78-865,168. ELIZABETH ARDEN, INC., MIRAMAR, FL. FILED 4-19-2006.

**LITTLE WHITE LIES**

THE MARK CONSISTS OF STANDARD CHARACTERS WITHOUT CLAIM TO ANY PARTICULAR FONT, STYLE, SIZE, OR COLOR.

FOR FRAGRANCE PRODUCTS FOR PERSONAL USE, NAMELY, PERFUME, EAU DE PARFUM, EAU DE TOILETTE, SCENTED BODY LOTIONS AND CREAMS, BATH AND SHOWER GELS (U.S. CLS. 1, 4, 6, 50, 51 AND 52).

SUE LAWRENCE, EXAMINING ATTORNEY

SN 78-874,453. L'OREAL, PARIS, FRANCE, FILED 5-2-2006.

**MEXORYL**

THE MARK CONSISTS OF STANDARD CHARACTERS WITHOUT CLAIM TO ANY PARTICULAR FONT, STYLE, SIZE, OR COLOR.

FOR CHEMICAL INGREDIENTS SOLD AS AN INTEGRAL COMPONENT OF SUNTANNING, SUN CARE, SUNLESS AND SKIN CARE PRODUCTS (U.S. CLS. 1, 4, 6, 50, 51 AND 52).

DAWN HAN, EXAMINING ATTORNEY

SN 78-893,028. GIAN COMERCIO, IMPORTACAO E EXPORTACAO LTDA., HAMBURGO/RS, BRAZIL, FILED 5-25-2006.



OWNER OF BRAZIL REG. NO. 0816554137, DATED 10-13-1993, EXPIRES 10-13-2013.

THE ENGLISH TRANSLATION OF THE WORD ESSENZIALI IN THE MARK IS ESSENTIAL.

FOR BODY LOTION, MASSAGE OIL, HAIR SHAMPOO, HAIR CONDITIONER, FACIAL WASH, BODY POLISH, MOUTHWASH, LIP BALM, FACIAL AND SKIN TONER, FACIAL MOISTURIZING CREAM, HAND LOTION, ALOE GEL, ANTI-AGING CREAM, BATH OIL, BODY MOISTURIZERS, BODY OIL, BODY MISTS, AND PERSONAL DEODORANTS, FRAGRANCES, NAMELY, COLOGNES, PERFUMES AND EAU DE TOILETTE (U.S. CLS. 1, 4, 6, 50, 51 AND 52).

JILL C. ALT, EXAMINING ATTORNEY

**CLASS 3—(Continued).**

SN 78-896,213. JAN MARINI SKIN RESEARCH, INC., SAN JOSE, CA. FILED 5-30-2006.

**MASSES OF LASHES**

THE MARK CONSISTS OF STANDARD CHARACTERS WITHOUT CLAIM TO ANY PARTICULAR FONT, STYLE, SIZE, OR COLOR.

NO CLAIM IS MADE TO THE EXCLUSIVE RIGHT TO USE "LASHES", APART FROM THE MARK AS SHOWN.

FOR COSMETIC PREPARATIONS FOR EYE LASHES (U.S. CLS. 1, 4, 6, 50, 51 AND 52).

DORITT L. CARROLL, EXAMINING ATTORNEY

SN 78-901,466. BLISS WORLD LLC, NEW YORK, NY. FILED 6-6-2006.

**CHANGE YOUR SPOTS**

THE MARK CONSISTS OF STANDARD CHARACTERS WITHOUT CLAIM TO ANY PARTICULAR FONT, STYLE, SIZE, OR COLOR.

FOR COSMETICS, NAMELY, LOTIONS FOR THE FACE AND SKIN, SKIN TONERS, SKIN AND BODY CREAMS, MASKS FOR THE FACE AND SKIN AND EXFOLIANTS FOR SKIN (U.S. CLS. 1, 4, 6, 50, 51 AND 52).

JAMES LOVELACE, EXAMINING ATTORNEY

SN 78-901,823. WTFN, INC., CHATSWORTH, CA. FILED 6-6-2006.

**Smooth -n- Sexy**

THE MARK CONSISTS OF STANDARD CHARACTERS WITHOUT CLAIM TO ANY PARTICULAR FONT, STYLE, SIZE, OR COLOR.

FOR NON-MEDICATED PREPARATIONS FOR SENSUOUS SKIN CARE, NAMELY, SPECIFICALLY FORMULATED SHAVE CREAMS AND SKIN CONDITIONERS (U.S. CLS. 1, 4, 6, 50, 51 AND 52).

FIRST USE 5-1-2006; IN COMMERCE 6-5-2006.

KELLY MCCOY, EXAMINING ATTORNEY

**CLASS 3—(Continued).**

SN 78-906,285. NATURAL SCENTS DE MEXICO, S.A. DE C.V., GUADALAJARA, JALISCO, MEXICO, FILED 6-12-2006.

**BEL-XÁ**

THE MARK CONSISTS OF STANDARD CHARACTERS WITHOUT CLAIM TO ANY PARTICULAR FONT, STYLE, SIZE, OR COLOR.

FOR SOAPS, LIQUID HAND SOAP, COSMETICS, COSMETIC CREAMS, TOWELS IMPREGNATED WITH COSMETIC LOTIONS, PERFUMERY, HAIR FIXING GEL (U.S. CLS. 1, 4, 6, 50, 51 AND 52).

JUSTINE D. PARKER, EXAMINING ATTORNEY

SN 78-913,262. THE W.E. BASSETT COMPANY, INC., SHELTON, CT. FILED 6-21-2006.

**CITRUS COOLER**

THE MARK CONSISTS OF STANDARD CHARACTERS WITHOUT CLAIM TO ANY PARTICULAR FONT, STYLE, SIZE, OR COLOR.

NO CLAIM IS MADE TO THE EXCLUSIVE RIGHT TO USE "CITRUS", APART FROM THE MARK AS SHOWN.

FOR FOOT CARE PRODUCTS, NAMELY, FOOT LOTIONS, FOOT GELS, FOOT CREAMS, FOOT SPRAYS, FOOT SOAKS, FOOT DEODORANTS, FOOT SCRUBS, FOOT BALMS, FOOT MASKS, FOOT POWDERS, FOOT OILS, HEEL CREAMS AND PEDICURE LOTIONS (U.S. CLS. 1, 4, 6, 50, 51 AND 52).

ALICIA COLLINS, EXAMINING ATTORNEY

SN 78-915,862. PARFUMS CHRISTIAN DIOR, PARIS, FRANCE, FILED 6-23-2006.

**MIDNIGHT POISON**

THE MARK CONSISTS OF STANDARD CHARACTERS WITHOUT CLAIM TO ANY PARTICULAR FONT, STYLE, SIZE, OR COLOR.

PRIORITY CLAIMED UNDER SEC. 44(D) ON FRANCE APPLICATION NO. 063435758, FILED 6-20-2006.

OWNER OF U.S. REG. NOS. 1,304,580 AND 2,771,657.

FOR PERFUMES, PERFUMERY, EAUX DE TOILETTE, PERFUMED SOAPS FOR BODY CARE, PERFUMED MILKS FOR BODY CARE, PERFUMED LOTIONS FOR BODY CARE, PERFUMED GELS FOR BODY CARE, PERFUMED CREAMS FOR BODY CARE, PERFUMED SHOWER GELS FOR BODY CARE (U.S. CLS. 1, 4, 6, 50, 51 AND 52).

JOHN SCHUYLER YARD, EXAMINING ATTORNEY

**CLASS 3—(Continued).**

SN 78-921,709. KLAMER, ANDREW LOREN, LOS ANGELES, CA. FILED 7-2-2006.

**HOLLYWOOD DREAMS**

THE MARK CONSISTS OF STANDARD CHARACTERS WITHOUT CLAIM TO ANY PARTICULAR FONT, STYLE, SIZE, OR COLOR.

FOR PERSONAL CARE COSMETICS, NAMELY, SHOWER AND BATH PRODUCTS, NAMELY, SHAMPOO, HAIR CONDITIONER, BATH GELS, BUBBLE BATH, BATH SALTS, BATH SCRUBS, HAIR PRODUCTS NAMELY HAIR GEL AND STYLING MOUSSE; HAND CREAMS, SKIN LOTIONS, LIP BALMS, SKIN MOISTURIZERS, BODY SOAPS, FACE SOAPS, AND SUNTAN LOTIONS CONTAINING SUNSCREEN; PERSONAL DEODORANTS AND BODY SPRAYS, PERSONAL WATER MISTING SPRAYS IN THE NATURE OF BODY SPRAYS, NAMELY WATER IN ATOMIZED CONTAINERS USED TO PRODUCE A COOLING EFFECT; AROMATHERAPY PRODUCTS, NAMELY, AROMATHERAPY CREAMS, OILS AND LOTIONS (U.S. CLS. 1, 4, 6, 50, 51 AND 52).

ANDREA K. NADELMAN, EXAMINING ATTORNEY

**CLASS 3—(Continued).**

SN 78-923,209. L'OREAL, PARIS, FRANCE, FILED 7-6-2006.

**KERALIGHT**

THE MARK CONSISTS OF STANDARD CHARACTERS WITHOUT CLAIM TO ANY PARTICULAR FONT, STYLE, SIZE, OR COLOR.

OWNER OF FRANCE REG. NO. 063403728, DATED 1-17-2006, EXPIRES 1-17-2016.

FOR SHAMPOOS; GELS, SPRAYS, MOUSSES AND BALMS FOR HAIR STYLING AND HAIR CARE; HAIR LACQUERS; HAIR COLORING AND HAIR DECOLORANT PREPARATIONS; PERMANENT WAVING AND CURLING PREPARATIONS; HAIR RELAXERS (U.S. CLS. 1, 4, 6, 50, 51 AND 52).

LINDA ESTRADA, EXAMINING ATTORNEY

SN 78-921,710. KLAMER, ANDREW LOREN, LOS ANGELES, CA. FILED 7-2-2006.

**VEGAS NIGHTS**

THE MARK CONSISTS OF STANDARD CHARACTERS WITHOUT CLAIM TO ANY PARTICULAR FONT, STYLE, SIZE, OR COLOR.

FOR PERSONAL CARE COSMETICS, NAMELY, SHOWER AND BATH PRODUCTS, NAMELY, SHAMPOO, HAIR CONDITIONER, BATH GELS, BUBBLE BATH, BATH SALTS, BATH SCRUBS, HAIR PRODUCTS NAMELY HAIR GEL AND STYLING MOUSSE; HAND CREAMS, SKIN LOTIONS, LIP BALMS, SKIN MOISTURIZERS, BODY SOAPS, FACE SOAPS, AND SUNTAN LOTIONS CONTAINING SUNSCREEN; PERSONAL DEODORANTS AND BODY SPRAYS, PERSONAL WATER MISTING SPRAYS IN THE NATURE OF BODY SPRAYS, NAMELY WATER IN ATOMIZED CONTAINERS USED TO PRODUCE A COOLING EFFECT; AROMATHERAPY PRODUCTS, NAMELY, AROMATHERAPY CREAMS, OILS AND LOTIONS (U.S. CLS. 1, 4, 6, 50, 51 AND 52).

ANDREA K. NADELMAN, EXAMINING ATTORNEY

SN 78-925,306. MIXED CHICKS LLC, ENCINO, CA. FILED 7-10-2006.



THE MARK CONSISTS OF THE WORD "OFFSPRING" WHEREAS THE "R" AND "I" APPEAR TO BE A MOTHER AND CHILD.

FOR 3-IN-1 HAIR CONDITIONERS; 3-IN-1 HAIR SHAMPOOS; HAIR CARE CREAMS; HAIR CARE LOTIONS; HAIR GELS; HAIR LOTIONS; HAIR MOUSSES; HAIR POMADES; HAIR RINSES; HAIR SHAMPOO; HAIR STYLING GEL; HAIR STYLING PREPARATIONS; HAIR STYLING SPRAY; HAIR WAVING LOTION; SHAMPOOS (U.S. CLS. 1, 4, 6, 50, 51 AND 52).

SANI KHOURI, EXAMINING ATTORNEY

**CLASS 3—(Continued).**

SN 78-931,790. KAGE ENTERPRISES LLC, AURORA, IL.  
FILED 7-18-2006.

# MELADERM

THE MARK CONSISTS OF STANDARD CHARACTERS WITHOUT CLAIM TO ANY PARTICULAR FONT, STYLE, SIZE, OR COLOR.

FOR COSMETICS; NON-MEDICATED SKIN CARE PREPARATIONS (U.S. CLS. 1, 4, 6, 50, 51 AND 52).

FIRST USE 5-3-2006; IN COMMERCE 5-3-2006.  
BRIAN PINO, EXAMINING ATTORNEY

---

SN 78-933,767. SHABINSKY, MELISSA, OTTAWA, CANADA,  
FILED 7-20-2006.

# ORGANIC REVOLUTION

THE MARK CONSISTS OF STANDARD CHARACTERS WITHOUT CLAIM TO ANY PARTICULAR FONT, STYLE, SIZE, OR COLOR.

NO CLAIM IS MADE TO THE EXCLUSIVE RIGHT TO USE "ORGANIC", APART FROM THE MARK AS SHOWN.

FOR ORGANIC BEAUTY AND BODY CARE PRODUCTS, NAMELY, COSMETICS, BATH OILS, COSMETIC CREAMS, CLEANSING CREAMS, SKIN CARE CREAMS, FACE CREAMS, PERFUMED CREAMS, COSMETIC OILS, COSMETIC PENCILS, ROUGES, LIPSTICK, LIP GLOSS, LIP BALM, LIP STAIN, CREAM EYE SHADOWS, POWDER EYE SHADOWS, FOUNDATIONS, LOOSE FACE POWDER, PRESSED FACE POWDER, MASCARA, SOAPS, PERFUMED SOAPS, SUNSCREEN, SUN-PROTECTING PREPARATIONS, SUN-TANNING PREPARATIONS, SUNTAN LOTIONS, DISINFECTING PERFUMED SOAPS, EAU DE PERFUME, PERFUME, PERFUME OILS, ESSENTIAL OILS AS PERFUME FOR LAUNDRY PURPOSES, LIQUID PERFUMES, NAIL VARNISH AND NUTRITIONAL OILS FOR COSMETIC PURPOSES, PERFUMED TALCUM POWDER, PERFUMING SACHETS, PRE-MOISTENED COSMETIC TOWELLETTES, PRE-MOISTENED COSMETIC WIPES, ROSE OIL FOR COSMETIC PURPOSES, SHAMPOOS, TONERS, TOPICAL SKIN SPRAYS FOR COSMETIC PURPOSES, COSMETIC BEAUTY MASKS, COSMETIC SKIN MASKS, COSMETIC FACIAL MASKS, COSMETIC BODY MASKS, HAIR CONDITIONERS AND HAIR TREATMENTS, NAMELY, HAIR CARE PREPARATIONS, HAIR DYE, HAIR NOURISHERS, HAIR TONIC AND HAIR STYLING GEL, AND MAKE-UP KITS COMPRISED OF COMBINATIONS OF THE AFOREMENTIONED GOODS (U.S. CLS. 1, 4, 6, 50, 51 AND 52).

MARC LEIPZIG, EXAMINING ATTORNEY

**CLASS 3—(Continued).**

SN 78-937,828. FANTASY TAN GLOBAL ENTERPRISES, LTD., BATAVIA, IL. FILED 7-26-2006.



OWNER OF U.S. REG. NO. 2,756,130.

NO CLAIM IS MADE TO THE EXCLUSIVE RIGHT TO USE "TAN", APART FROM THE MARK AS SHOWN.

THE MARK CONSISTS OF THE STYLIZED WORDS FANTASY TAN UNDER A STYLIZED SUN WITH FIVE GRADUATED RAYS EMANATING FROM THE CENTER; AND A SWOOSH UNDER THE WORDS REMINISCENT OF A BEACH.

FOR SUNLESS TANNING SPRAYS, LOTIONS, AND CREAMS; NON-MEDICATED SKIN CARE PREPARATIONS; SKIN COLORANTS; SKIN MOISTURIZERS; COSMETICS; SUNLESS TANNING POWDERS; AND SUN SCREEN (U.S. CLS. 1, 4, 6, 50, 51 AND 52).

FIRST USE 1-1-2003; IN COMMERCE 1-1-2003.

MARGERY A. TIERNEY, EXAMINING ATTORNEY

---

SN 78-938,775. BUENOS AIRES CORP, MIAMI, FL. FILED 7-27-2006.

# Monique Arnold

THE MARK CONSISTS OF STANDARD CHARACTERS WITHOUT CLAIM TO ANY PARTICULAR FONT, STYLE, SIZE, OR COLOR.

THE NAME MONIQUE ARNOLD DOES NOT IDENTIFY A LIVING INDIVIDUAL.

FOR AGE RETARDANT LOTION; ALOE VERA GEL FOR COSMETIC PURPOSES; AROMATHERAPY LOTIONS; ASTRINGENTS FOR COSMETIC PURPOSES; BATH OILS FOR COSMETIC PURPOSES; BEAUTY LOTIONS; BODY LOTION; BODY MASK LOTION; COSMETIC CREAMS; COSMETIC CREAMS FOR SKIN CARE; COSMETIC MILKS; COSMETIC OILS; COSMETIC OILS FOR THE EPIDERMIS; COSMETIC PREPARATIONS FOR SKIN RENEWAL; COSMETIC SOAPS; FACE AND BODY LOTIONS; FACE CREAMS FOR COSMETIC USE; FACE MILK AND LOTIONS; FACIAL LOTION; LOTIONS FOR FACE AND BODY CARE; MASSAGE OIL; NUTRITIONAL OILS FOR COSMETIC PURPOSES; SCENTED OILS USED TO PRODUCE AROMAS WHEN HEATED; SOAPS; TOPICAL SKIN SPRAYS FOR COSMETIC PURPOSES (U.S. CLS. 1, 4, 6, 50, 51 AND 52).

CHRISIE B. KING, EXAMINING ATTORNEY

**CLASS 3—(Continued).**

SN 78-939,606. STEILMANN, BRITTA, RATINGEN, FED REP GERMANY, FILED 7-28-2006.

**BRITTA STEILMANN**

THE MARK CONSISTS OF STANDARD CHARACTERS WITHOUT CLAIM TO ANY PARTICULAR FONT, STYLE, SIZE, OR COLOR.

OWNER OF U.S. REG. NO. 2,029,515. THE NAME BRITTA STEILMANN IDENTIFIES A LIVING INDIVIDUAL WHOSE CONSENT IS OF RECORD.

FOR PERFUME, EAU DE TOILETTE, PERFUME OILS AND ESSENTIAL OILS FOR PERSONAL USE AND USE IN THE MANUFACTURE OF COSMETICS; COSMETICS, NAMELY DEODORANTS FOR PERSONAL USE, BODY CREAMS, EYE CREAMS, SKIN CREAMS; HAIR LOTIONS, NAMELY HAIR COLORING AND TINTING PRODUCTS AND SHAMPOOS; DENTRIFICES (U.S. CLS. 1, 4, 6, 50, 51 AND 52).

FIRST USE 0-0-1994; IN COMMERCE 0-0-1996. JOANNA DUKOVIC, EXAMINING ATTORNEY

**CLASS 3—(Continued).**

SN 78-949,923. ERBASOL S.R.L., MONFALCONE (GO), ITALY, FILED 8-11-2006.

**NATURISSIMA**

THE MARK CONSISTS OF STANDARD CHARACTERS WITHOUT CLAIM TO ANY PARTICULAR FONT, STYLE, SIZE, OR COLOR.

FOR CLEANSING CREAMS; COSMETICS; ESSENTIAL OILS FOR PERSONAL USE; ESSENTIAL OILS FOR USE IN MANUFACTURING OF COSMETICS; FACIAL CLEANSERS; FACIAL MASKS; MAKE-UP REMOVING MILK, GEL, LOTIONS AND CREAMS; MOISTURIZING MILKS; NON-MEDICATED SKIN CARE PREPARATIONS; PERFUMERY; SKIN CARE PRODUCTS, NAMELY, NON-MEDICATED SKIN SERUM; SKIN CREAMS; SKIN LOTIONS; SKIN TONERS (U.S. CLS. 1, 4, 6, 50, 51 AND 52).

FIRST USE 3-31-2004; IN COMMERCE 3-31-2004. ROBERT C. CLARK JR., EXAMINING ATTORNEY

SN 78-945,176. NATURAL DENTIST, INC., ENGLEWOOD CLIFFS, NJ. FILED 8-4-2006.

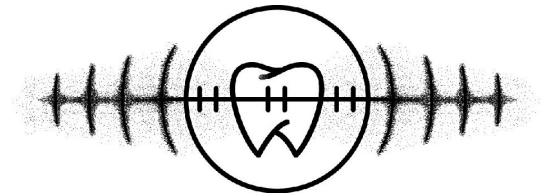

FOR NON-MEDICATED ORAL HEALTH CARE PRODUCTS, NAMELY, MOUTH RINSES, MOUTH WASHES, TOOTH PASTES AND TOOTH GELS (U.S. CLS. 1, 4, 6, 50, 51 AND 52).

DAWN HAN, EXAMINING ATTORNEY

SN 78-952,233. NATURAL DENTIST, INC., ENGLEWOOD CLIFFS, NJ. FILED 8-15-2006.

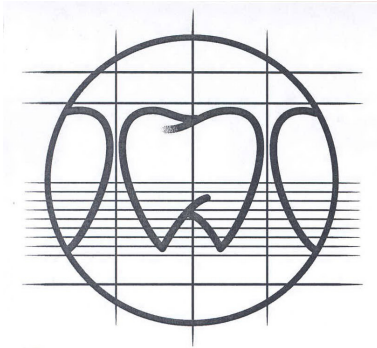

FOR NON-MEDICATED ORAL HEALTH CARE PRODUCTS, NAMELY, MOUTH RINSES, MOUTH WASHES, DENTRIFICES IN THE FORM OF CHEWING GUM FOR FRESHENING BREATH, TOOTH PASTES AND TOOTH GELS FOR ORAL CARE (U.S. CLS. 1, 4, 6, 50, 51 AND 52).

FIRST USE 12-5-2005; IN COMMERCE 12-5-2005. DAWN HAN, EXAMINING ATTORNEY

SN 78-946,480. PENNZOIL-QUAKER STATE COMPANY, HOUSTON, TX. FILED 8-7-2006.

**URBAN NIGHTS**

THE MARK CONSISTS OF STANDARD CHARACTERS WITHOUT CLAIM TO ANY PARTICULAR FONT, STYLE, SIZE, OR COLOR.

FOR FRAGRANCES FOR AUTOMOBILES (U.S. CLS. 1, 4, 6, 50, 51 AND 52).

NAPOLEN SHARMA, EXAMINING ATTORNEY

SN 78-954,512. NORDSTROM, INC., SEATTLE, WA. FILED 8-17-2006.

**TILDON**

THE MARK CONSISTS OF STANDARD CHARACTERS WITHOUT CLAIM TO ANY PARTICULAR FONT, STYLE, SIZE, OR COLOR.

FOR COSMETICS, PERFUMES AND SKIN LOTIONS (U.S. CLS. 1, 4, 6, 50, 51 AND 52).

ROBIN CHOSID, EXAMINING ATTORNEY

**CLASS 3—(Continued).**

SN 78-956,856. ENZYMES INCORPORATED, WAUCONDA, IL. FILED 8-21-2006.

**DISCOVER THE ENZYME**

THE MARK CONSISTS OF STANDARD CHARACTERS WITHOUT CLAIM TO ANY PARTICULAR FONT, STYLE, SIZE, OR COLOR.

NO CLAIM IS MADE TO THE EXCLUSIVE RIGHT TO USE ENZYME, APART FROM THE MARK AS SHOWN.

FOR CLEANING AND WASHING PREPARATIONS, NAMELY ENZYME BASED CLEANING AND WASHING PREPARATIONS FOR USE ON FLOORS, CARPETS, JEWELRY, GLASS SURFACES, WOOD SURFACES, CONCRETE SURFACES, RESTAURANT EQUIPMENT, CHEMICAL REACTORS, NAMELY HYDROCARBON PROCESSING EQUIPMENT, VEHICLES, NAMELY MOTOR VEHICLES, MARINE CRAFT AND AIRCRAFT, AND METAL AND PLASTIC PARTS, NAMELY MACHINE PARTS; ENZYME BASED WATER CLARIFIER, NAMELY POOL AND POND CLEANER; ENZYME BASED DRAIN AND SEPTIC CLEANER (U.S. CLS. 1, 4, 6, 50, 51 AND 52).

JENNIFER MCROBBIE, EXAMINING ATTORNEY

SN 78-958,270. AMOREPACIFIC CORPORATION, SEOUL, REPUBLIC OF KOREA, FILED 8-23-2006.

**SHINECLASSIC**

THE MARK CONSISTS OF STANDARD CHARACTERS WITHOUT CLAIM TO ANY PARTICULAR FONT, STYLE, SIZE, OR COLOR.

FOR SOLID MAKE-UP POWDER FOR COMPACTS; LIQUID FOUNDATION; CREAMY FOUNDATION; ROUGE; LIPSTICKS; NON-MEDICATED NOURISHING CREAMS FOR THE SKIN; NAIL POLISH REMOVERS; EYEBROW PENCILS; MASCARAS; FACIAL PACK CONSISTING OF COSMETIC MATERIAL IMPREGNATED WITH COSMETICS AND APPLIED TO THE FACE FOR SOFTENING AND PURIFYING THE SKIN OF THE FACE; BODY GELS FOR MASSAGE USE; MASSAGE OIL; NAIL POLISH; NAIL ENAMELS; HAIR OILS; HAIR CARE PREPARATIONS; HAIR COLOR; HAIR WAVING LOTIONS; HAIR BLEACHES; ADDITIVES FOR COSMETIC BATHS, NAMELY, BUBBLE BATH AND BATH BEADS; VANISHING CREAMS; BATH OIL FOR COSMETIC PURPOSES; BAY RUMS; BABY OIL; BABY POWDER; BLUSHERS; PERFUMED POWDER; NON-MEDICATED BATH SALTS; NON-MEDICATED FRAGRANCE, NAMELY, FRAGRANCES FOR PERSONAL USE AND ROOM FRAGRANCES; COSMETIC SUN-PROTECTING PREPARATIONS; SUNSCREEN LOTIONS; SUNSCREEN CREAMS; SUN TAN OIL; SUN-TANNING PREPARATIONS FOR COSMETIC PURPOSES; SHAVING CREAMS; BEAUTY MILK; SKIN MOISTURIZER; EYELINERS; EYE MAKEUP REMOVERS; EYE SHADOW; AFTER SHAVE LOTIONS; EAU DE COLOGNE; DEODORANTS FOR PERSONAL USE; NON-MEDICATED SKIN CARE PREPARATIONS, NAMELY, SKIN TONERS, SKIN LOTIONS, SKIN EMOLLIENTS AND SKIN CLARIFIERS; LIP POLISHER; NON-MEDICATED LIP PROTECTOR; NON-MEDICATED LIP CARE PREPARATIONS; NONMEDICATED COSMETIC PREPARATIONS FOR BODY SLIMMING PURPOSES, NAMELY, BODY SLIMMING CREAMS, BODY SLIMMING LOTIONS, BODY

**CLASS 3—(Continued).**

SLIMMING GELS AND BODY SLIMMING OILS; COLD CREAMS; COLD WAVING SOLUTIONS; MUSTACHE WAX; SKIN CLEANSING CREAM FOR COSMETIC PURPOSES; DEPILATORY WAX; DEPILATORIES; PERMANENT WAVE PREPARATIONS; MAKE-UP FOUNDATIONS; FACE POWDER; POTPOURRI; SKIN WHITENING CREAMS; HAND CREAMS; PERFUMES; HAIR GELS; HAIR LACQUERS; HAIR LOTIONS; HAIR MOUSSE; HAIR SPRAY; HAIR CONDITIONERS; HAIR CREAMS; HAIR TONIC; MAKE-UP POWDER; HYDROGEN PEROXIDE FOR USE ON THE HAIR; ASTRINGENTS FOR COSMETIC PURPOSES; PENCILS FOR COSMETIC PURPOSES; MINERAL SALT IN THE NATURE OF BATH SALTS NOT FOR MEDICAL PURPOSES; SKIN CLEANSING MILK; TALCUM POWDERS; LAVENDER OIL FOR COSMETIC PURPOSES; BERGAMOT OIL FOR COSMETIC PURPOSES; AMBERGRIS; JASMINE OIL FOR COSMETIC PURPOSES; ROSE OIL FOR COSMETIC PURPOSES; SYNTHETIC PERFUMERY; INCENSE STICKS; FUMIGATING INCENSES; ADHESIVES FOR AFFIXING FALSE HAIR; FALSE EYELASHES; ADHESIVES FOR AFFIXING FALSE EYELASHES; FALSE NAILS; PRE-MOISTENED TISSUES IMPREGNATED WITH COSMETIC LOTIONS; MAKE-UP REMOVAL DISPOSABLE WIPES IMPREGNATED WITH CHEMICALS FOR PERSONAL HYGIENE; COTTON STICKS FOR COSMETIC PURPOSES; BEAUTY MASKS; ADHESIVES FOR COSMETIC USE; COTTON SWABS FOR COSMETIC PURPOSES; SOAP POWDER; DETERGENTS PREPARED FROM PETROLEUM FOR HOUSEHOLD USE; INDUSTRIAL SOAPS; DRY CLEANING FLUIDS; SHAVING SOAP; LIQUID SOAPS; DEODORANT SOAP; CLEANING PREPARATIONS FOR CLEANING WASTE PIPES; SOAP FOR BRIGHTENING TEXTILE; SKIN POLISHING RICE BRAN; NON-MEDICATED DOUCHES; LAUNDRY SOAPS; DISINFECTANT SOAP; ALMOND SOAP; GLASS CLEANING PREPARATIONS; FABRIC SOFTENERS FOR LAUNDRY USE; WINDSHIELD WASHING FLUID; TOILET BOWL DETERGENTS; BATH SOAPS; SKIN SOAPS; HAIR SHAMPOOS; CREAM SOAPS; HAIR RINSES; COSMETIC SOAPS; NON-MEDICATED MOUTH WASH AND RINSE; NONMEDICATED DENTAL RINSE; DENTURE CLEANING PREPARATIONS, NAMELY, DENTURE POLISH AND DENTURE CLEANER; TOOTH POWDERS; TOOTH PASTE; MOISTURIZING ESSENCE IN THE NATURE OF MILKY LOTION; BODY CREAMS; BODY LOTIONS; FACIAL CLEANSING FOAMS; SKIN CLEANSING LOTION; SKIN CLEANSING OILS; LIP GLOSS; NONMEDICATED CREAMS FOR MASSAGE USE; LIP LINER; NON-MEDICATED LIP BALM; COLOGNE WATER; EAU DE TOILETTE; SKIN CLEANSERS; TOOTH WHITENING PREPARATIONS, NAMELY, TOOTH WHITENING CREAMS, TOOTH WHITENING GELS AND TOOTH WHITENING PASTES; NONMEDICATED MOISTURIZING NUTRITIONAL SERUMS, NAMELY, NONMEDICATED SKIN SERUMS, NON-MEDICATED EYE SERUMS AND BEAUTY SERUMS (U.S. CLS. 1, 4, 6, 50, 51 AND 52).

THOMAS MANOR, EXAMINING ATTORNEY

SN 78-959,172. PARKSIDE PROFESSIONAL PRODUCTS LTD., NIAGARA FALLS, ONTARIO, CANADA, FILED 8-24-2006.

**CITRA SENSE**

THE MARK CONSISTS OF STANDARD CHARACTERS WITHOUT CLAIM TO ANY PARTICULAR FONT, STYLE, SIZE, OR COLOR.

OWNER OF CANADA REG. NO. TMA613302, DATED 6-21-2004, EXPIRES 6-21-2019.

FOR DISHWASHING DETERGENTS; LAUNDRY DETERGENT (U.S. CLS. 1, 4, 6, 50, 51 AND 52).

JENNY PARK, EXAMINING ATTORNEY

**CLASS 3—(Continued).**

SN 78-961,452. VICTORIA'S SECRET STORES BRAND MANAGEMENT, INC., REYNOLDSBURG, OH. FILED 8-28-2006.

**BLOSSOMING ROMANCE**

THE MARK CONSISTS OF STANDARD CHARACTERS WITHOUT CLAIM TO ANY PARTICULAR FONT, STYLE, SIZE, OR COLOR.

FOR PERSONAL CARE PRODUCTS NAMELY BODY WASH, SMOOTHING BODY SCRUB, WHIPPED BODY CREAM, BODY BUTTER, BODY LOTIONS, HAND CREAM, ASTRINGENT FOR THE FACE, ASTRINGENT FOR THE SKIN, BATH BEADS, BATH OIL, BATH SALTS, BLUSH, BODY GLITTER, BODY MIST, BODY OIL, BODY SCRUB, BODY WASH, BUBBLE BATH, COLOGNE, CREAM FOR THE BODY, CREAM FOR THE CUTICLES, CREAM FOR THE EYES, CREAM FOR THE FACE, CREAM FOR THE FEET, CREAM FOR THE HANDS, ESSENTIAL OILS FOR PERSONAL USE, EXFOLIATING PREPARATIONS FOR THE SKIN, EYE GELS, EYE MAKEUP PENCILS, EYE MASKS, EYE SHADOW, FACE HIGHLIGHTER, FACE MASKS, FACE MIST, FACE SCRUB, NON-MEDICATED FOOT SOAKS, FACE TONERS, FOUNDATION, FRAGRANT BODY SPLASH, FRAGRANT BODY MIST, HAIR CONDITIONER, HAIR HIGHLIGHTER, HAIR RINSES, HAIR SHAMPOO, HAIR SPRAY, HAIR STRAIGHTENING PREPARATIONS, HAIR STYLING GEL, HAIR STYLING MOUSSE, LOTION FOR THE BODY, LOTION FOR THE FACE, LOTION FOR THE FEET, LOTION FOR THE HANDS, LIP BALM, LIP GLOSS, LIP LINER, LIP MAKEUP PENCILS, LIPSTICK, MAKEUP FOR THE BODY, MAKEUP FOR THE FACE, MAKEUP REMOVER, MASCARA, MASSAGE CREAM, MASSAGE LOTION, MASSAGE OIL, NAIL POLISH, NAIL POLISH REMOVER, NAIL STENCILS, NON-MEDICATED BLEMISH STICK, NON-MEDICATED CLEANSER FOR THE FACE, NON-MEDICATED FOOT SPRAY, NON-MEDICATED MASSAGE OINTMENT, OIL BLOTTING SHEETS FOR THE SKIN, PERFUME, POWDER FOR THE BODY, POWDER FOR THE FACE, POWDER FOR THE FEET, PUMICE STONES FOR PERSONAL USE, SALT SCRUBS FOR THE SKIN, SHAVING CREAM, SHAVING GELS, SHOWER CREAM, SHOWER GEL, SKIN BRONZING CREAM, SOAP FOR THE BODY, SOAP FOR THE FACE, SOAP FOR THE HANDS, SUN BLOCK FOR THE BODY, SUN BLOCK FOR THE FACE, SUNTAN LOTION FOR THE BODY, SUNTAN LOTION FOR THE FACE, SUNLESS TANNING LOTION FOR THE BODY, SUNLESS TANNING LOTION FOR THE FACE, PRE-SUNTANNING LOTION FOR THE BODY, POST-SUNTANNING LOTION FOR THE FACE, POST-SUNTANNING LOTION FOR THE BODY, TOILET SOAPS, HAIR SHAMPOOS, SCENTED DRAWER SACHETS, PERSONAL FRAGRANCES, NAMELY COLOGNE, PERFUME, TOILET WATER, AND ESSENTIAL OILS FOR PERSONAL USE; BATH POWDER, NON-MEDICATED FOOT POWDER, BODY POWDER; BATH, HAND AND BODY LOTIONS, HOME FRAGRANCES (U.S. CLS. 1, 4, 6, 50, 51 AND 52). ELIZABETH PIGNATELLO, EXAMINING ATTORNEY

**CLASS 3—(Continued).**

SN 78-961,609. U.S. NONWOVENS CORP., BRENTWOOD, NY. FILED 8-28-2006.

**BREEZY ENJOYABLES**

THE MARK CONSISTS OF STANDARD CHARACTERS WITHOUT CLAIM TO ANY PARTICULAR FONT, STYLE, SIZE, OR COLOR.

FOR FABRIC SOFTENERS; FABRIC SOFTENERS FOR LAUNDRY USE (U.S. CLS. 1, 4, 6, 50, 51 AND 52). WON TEAK OH, EXAMINING ATTORNEY

SN 78-961,727. AMOREPACIFIC CORPORATION, SEOUL, REPUBLIC OF KOREA, FILED 8-28-2006.

**LANEIGE DESIGNING PEARL PACT**

THE MARK CONSISTS OF STANDARD CHARACTERS WITHOUT CLAIM TO ANY PARTICULAR FONT, STYLE, SIZE, OR COLOR.

OWNER OF U.S. REG. NOS. 2,110,811, 2,408,553 AND 3,087,975.

FOR SOLID MAKE-UP POWDER FOR COMPACTS; LIQUID FOUNDATION; CREAMY FOUNDATION; ROUGE; LIPSTICKS; NON-MEDICATED NOURISHING CREAMS FOR THE SKIN; NAIL POLISH REMOVERS; EYEBROW PENCILS; MASCARAS; FACIAL PACK CONSISTING OF COSMETIC MATERIAL IMPREGNATED WITH COSMETICS AND APPLIED TO THE FACE FOR SOFTENING AND PURIFYING THE SKIN OF THE FACE; BODY GELS FOR MASSAGE USE; MASSAGE OIL; NAIL POLISH; NAIL ENAMELS; HAIR OILS; HAIR CARE PREPARATIONS; HAIR COLOR; HAIR WAVING LOTIONS; HAIR BLEACHES; ADDITIVES FOR COSMETIC BATHS, NAMELY, BUBBLE BATH AND BATH BEADS; VANISHING CREAMS; BATH OIL FOR COSMETIC PURPOSES; BATH POWDER FOR COSMETIC PURPOSES; BAY RUMS; BABY OIL; BABY POWDER; BLUSHERS; PERFUMED POWDER; NON-MEDICATED BATH SALTS; NON-MEDICATED FRAGRANCE, NAMELY, FRAGRANCES FOR PERSONAL USE AND ROOM FRAGRANCES; COSMETIC SUN-PROTECTING PREPARATIONS; SUNSCREEN LOTIONS; SUNSCREEN CREAMS; SUN TAN OIL; SUN-TANNING PREPARATIONS FOR COSMETIC PURPOSES; SHAVING CREAMS; BEAUTY MILK; SKIN MOISTURIZER; EYELINERS; EYE MAKE-UP REMOVERS; EYE SHADOW; AFTER SHAVE LOTIONS; EAU DE COLOGNE; DEODORANTS FOR PERSONAL USE; NON-MEDICATED SKIN CARE PREPARATIONS, NAMELY, SKIN TONERS, SKIN LOTIONS, SKIN EMOLLIENTS AND SKIN CLARIFIERS; LIP POLISHER; NON-MEDICATED LIP PROTECTOR; NON-MEDICATED LIP CARE PREPARATIONS; NON-MEDICATED COSMETIC PREPARATIONS FOR BODY SLIMMING PURPOSES, NAMELY, BODY SLIMMING CREAMS, BODY SLIMMING LOTIONS, BODY SLIMMING GELS AND BODY SLIMMING OILS; COLD CREAMS; COLD WAVING SOLUTIONS; MUSTACHE WAX; SKIN CLEANSING CREAM FOR COSMETIC PURPOSES; DEPILATORY WAX; DEPILATORIES; PERMANENT WAVE PREPARATIONS; MAKE-UP FOUNDATIONS; FACE POWDER; POTPOURRI; SKIN WHITENING CREAMS; HAND CREAMS; PERFUMES; HAIR GELS; HAIR LACQUERS; HAIR LOTIONS; HAIR MOUSSE; HAIR SPRAY; HAIR CONDITIONERS; HAIR CREAMS; HAIR TONIC; MAKE-UP POWDER; HYDROGEN PEROXIDE FOR USE ON THE HAIR; ASTRIN-

**CLASS 3—(Continued).**

GENTS FOR COSMETIC PURPOSES; PENCILS FOR COSMETIC PURPOSES; MINERAL SALT IN THE NATURE OF BATH SALTS NOT FOR MEDICAL PURPOSES; SKIN CLEANSING MILK; TALCUM POWDERS; LAVENDER OIL FOR COSMETIC PURPOSES; BERGAMOT OIL FOR COSMETIC PURPOSES; AMBERGRIS; JASMINE OIL FOR COSMETIC PURPOSES; ROSE OIL FOR COSMETIC PURPOSES; SYNTHETIC PERFUMERY; INCENSE STICKS; FUMIGATING INCENSES; ADHESIVES FOR AFFIXING FALSE HAIR; FALSE EYELASHES; ADHESIVES FOR AFFIXING FALSE EYELASHES; FALSE NAILS; PRE-MOISTENED TISSUES IMPREGNATED WITH COSMETIC LOTIONS; MAKE-UP REMOVAL DISPOSABLE WIPES IMPREGNATED WITH CHEMICALS FOR PERSONAL HYGIENE; COTTON STICKS FOR COSMETIC PURPOSES; BEAUTY MASKS; ADHESIVES FOR COSMETIC USE; COTTON SWABS FOR COSMETIC PURPOSES; SOAP POWDER; DETERGENTS PREPARED FROM PETROLEUM FOR HOUSEHOLD USE; INDUSTRIAL SOAPS; DRY CLEANING FLUIDS; SHAVING SOAP; LIQUID SOAPS; DEODORANT SOAP; CLEANING PREPARATIONS FOR CLEANING WASTE PIPES; SOAP FOR BRIGHTENING TEXTILE; SKIN POLISHING RICE BRAN; NON-MEDICATED DOUCHES; LAUNDRY SOAPS; DISINFECTANT SOAP; ALMOND SOAP; GLASS CLEANING PREPARATIONS; FABRIC SOFTENERS FOR LAUNDRY USE; WINDSHIELD WASHING FLUID; TOILET BOWL DETERGENTS; BATH SOAPS; SKIN SOAPS; HAIR SHAMPOOS; CREAM SOAPS; HAIR RINSES; COSMETIC SOAPS; NON-MEDICATED MOUTH WASH AND RINSE; NON-MEDICATED DENTAL RINSE; DENTURE CLEANING PREPARATIONS, NAMELY, DENTURE POLISH AND DENTURE CLEANER; TOOTH POWDERS; TOOTH PASTE; MOISTURIZING ESSENCE IN THE NATURE OF MILKY LOTION; BODY CREAMS; BODY LOTIONS; FACIAL CLEANSING FOAMS; SKIN CLEANSING LOTION; SKIN CLEANSING OILS; LIP GLOSS; NON-MEDICATED CREAMS FOR MASSAGE USE; LIP LINER; NON-MEDICATED LIP BALM; COLOGNE WATER; EAU DE TOILETTE; SKIN CLEANSERS; TOOTH WHITENING PREPARATIONS, NAMELY, TOOTH WHITENING CREAMS, TOOTH WHITENING GELS AND TOOTH WHITENING PASTES; NON-MEDICATED MOISTURIZING NUTRITIONAL SERUMS, NAMELY, NON-MEDICATED SKIN SERUMS, NON-MEDICATED EYE SERUMS AND BEAUTY SERUMS (U.S. CLS. 1, 4, 6, 50, 51 AND 52).

THOMAS MANOR, EXAMINING ATTORNEY

**CLASS 3—(Continued).**

SN 78-962,705. THE PROCTER & GAMBLE COMPANY, CINCINNATI, OH. FILED 8-29-2006.

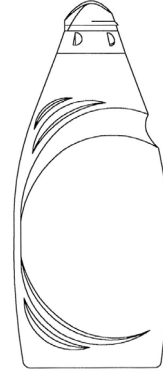

THE MARK CONSISTS OF THE DESIGN OF A BOTTLE WITH A WIDE BOTTOM TAPERING TO A MORE NARROW TOP WITH SWIRL DESIGN INDENTATIONS ON THE FRONT AND BACK FACES OF THE BOTTLE.

FOR DISH DETERGENT (U.S. CLS. 1, 4, 6, 50, 51 AND 52).

ELIZABETH BEYER, EXAMINING ATTORNEY

SN 78-962,675. MUSEUM PIECES OF NORTH AMERICA, INC., CORAL SPRINGS, FL. FILED 8-29-2006.

**INYE**

THE MARK CONSISTS OF STANDARD CHARACTERS WITHOUT CLAIM TO ANY PARTICULAR FONT, STYLE, SIZE, OR COLOR.

THE FOREIGN WORDING IN THE MARK TRANSLATES INTO ENGLISH AS ONE.

FOR BATH GELS; BODY POWDER; DEODORANT FOR PERSONAL USE; FACE AND BODY LOTIONS; HAIR CONDITIONER; HAIR SHAMPOO; NON-MEDICATED MOUTHWASH AND GARGLE; SHAVING CREAM; SOAPS FOR PERSONAL USE; TOOTHPASTE (U.S. CLS. 1, 4, 6, 50, 51 AND 52).

RAUL CORDOVA, EXAMINING ATTORNEY

SN 78-962,896. IN VENTURES LTD, GLENDALE, CA. FILED 8-29-2006.

**DERMAPRACTICA**

THE MARK CONSISTS OF STANDARD CHARACTERS WITHOUT CLAIM TO ANY PARTICULAR FONT, STYLE, SIZE, OR COLOR.

FOR BODY AND BEAUTY CARE COSMETICS (U.S. CLS. 1, 4, 6, 50, 51 AND 52).

TOBY BULLOFF, EXAMINING ATTORNEY



**CLASS 3—(Continued).**

SN 78-963,017. PHILOSOPHY, INC., PHOENIX, AZ. FILED 8-29-2006.

**PHILOSOPHY REVERSE  
CONDITIONER**

THE MARK CONSISTS OF STANDARD CHARACTERS WITHOUT CLAIM TO ANY PARTICULAR FONT, STYLE, SIZE, OR COLOR.

OWNER OF U.S. REG. NOS. 2,016,208, 2,769,211 AND OTHERS.

NO CLAIM IS MADE TO THE EXCLUSIVE RIGHT TO USE "CONDITIONER", APART FROM THE MARK AS SHOWN.

FOR BABY LOTION; BABY POWDER; BABY SHAM-POO; BODY SCRUB; COSMETIC FACIAL BLOTting PAPERS; COSMETIC PADS; COSMETIC PENCILS; COSMETIC PREPARATIONS FOR THE CARE OF MOUTH AND TEETH; COSMETICS; DEPILATORIES; FACIAL SCRUBS; FRAGRANCES FOR PERSONAL USE; HAIR CARE PREPARATIONS; NAIL CARE PREPARATIONS; NON-MEDICATED BATH PREPARATIONS; NON-MEDICATED FOOT CREAM; NON-MEDICATED LIP CARE PREPARATIONS; NON-MEDICATED SKIN CARE PREPARATIONS; NON-MEDICATED SUN CARE PREPARATIONS; NON-MEDICATED TOILETRIES; PERFUMED POWDER; PERSONAL DEODORANTS; SCENTED ROOM SPRAYS; SHAVING PREPARATIONS; SHOWER AND BATH GEL (U.S. CLS. 1, 4, 6, 50, 51 AND 52).

NAKIA HENRY, EXAMINING ATTORNEY

**CLASS 3—(Continued).**

SN 78-963,405. SUZANNE M. TYLER, SULPHUR, LA. FILED 8-29-2006.

**groupie**

THE MARK CONSISTS OF STANDARD CHARACTERS WITHOUT CLAIM TO ANY PARTICULAR FONT, STYLE, SIZE, OR COLOR.

FOR COSMETICS, SOAPS, PERFUMERY, ESSENTIAL OILS, AND NON-MEDICATED SKINCARE PREPARATIONS (U.S. CLS. 1, 4, 6, 50, 51 AND 52).

SHARON MEIER, EXAMINING ATTORNEY

SN 78-963,428. PHILLIPS, HOWARD, MILLERTON, OK. FILED 8-30-2006.

**IvyMed**

THE MARK CONSISTS OF STANDARD CHARACTERS WITHOUT CLAIM TO ANY PARTICULAR FONT, STYLE, SIZE, OR COLOR.

FOR SKIN CLEANSERS (U.S. CLS. 1, 4, 6, 50, 51 AND 52).

FIRST USE 5-15-2006; IN COMMERCE 5-15-2006.

CAROLINE WOOD, EXAMINING ATTORNEY

SN 78-963,026. LEVY, PHYLLIS, SHERMAN OAKS, CA. AND MUNAO, SUSAN, SHERMAN OAKS, CA. FILED 8-29-2006.



FOR ANTI-AGING CREAM; ANTI-WRINKLE CREAMS; BEAUTY SERUMS; BODY AND BEAUTY CARE COSMETICS; BODY CREAMS; BODY SCRUB; COSMETIC CREAMS FOR SKIN CARE; EAU DE PERFUME; EAU DE TOILETTE; EXFOLIANT CREAMS; EXFOLIANTS FOR BODY AND FACE; EYE CREAM; FACIAL BEAUTY MASKS; FACIAL CLEANSERS; FACIAL MASKS; FACIAL SCRUBS; FACIAL WASHES; FRAGRANCES FOR PERSONAL USE; HAIR CARE CREAMS; HAIR CARE LOTIONS; HAIR CARE PREPARATIONS; HAIR CONDITIONERS; HAIR SHAMPOO; HAND CREAMS; LIP BALM; LIP CREAM; LIP GLOSS; LIP LINER; LIPSTICKS; LIQUID SOAPS FOR HANDS, FACE AND BODY; NAIL CARE PREPARATIONS; NAIL POLISH; NAIL POLISH BASE COAT; NAIL POLISH REMOVERS; NAIL POLISH TOP COAT; NIGHT CREAM; NON-MEDICATED FOOT CREAM; NON-MEDICATED LIP PROTECTOR; NON-MEDICATED SKIN CARE PREPARATIONS; PERFUMES; SHOWER AND BATH GEL; SKIN CARE PRODUCTS, NAMELY, NON-MEDICATED SKIN SERUM; SKIN CREAMS; SKIN MOISTURIZER; SOAPS FOR BODY CARE (U.S. CLS. 1, 4, 6, 50, 51 AND 52).

BENJAMIN ALLEN, EXAMINING ATTORNEY

SN 78-963,498. GOOCH, MICHAEL, RUMSON, NJ. FILED 8-30-2006.

**STINKING RICH**

THE MARK CONSISTS OF STANDARD CHARACTERS WITHOUT CLAIM TO ANY PARTICULAR FONT, STYLE, SIZE, OR COLOR.

FOR PERFUMES AND COLOGNE (U.S. CLS. 1, 4, 6, 50, 51 AND 52).

AMY MCMENAMIN, EXAMINING ATTORNEY

**CLASS 3—(Continued).**

SN 78-963,649. PREGNANT & PAMPERED LLC, SAN RAMON, CA. FILED 8-30-2006.



FOR GIFT BASKETS FOR EXPECTANT MOTHERS, COMPRISED OF NON-MEDICATED SKIN CARE LOTIONS, OILS, RUBS, BALMS, LIP BALM, SHAMPOO, BODY WASH, SOAPS, TOILETRIES, BOOKS, TEAS, CANDLES, LABOR AND DELIVERY AIDS, EXERCISE DVD, DUMBBELLS, SOFTBALL, MINIBALL, BIRTH BALL, PUMP, CARRY STRAP, POSTER, NAUSEA BAG, IMPORTANT HOSPITAL DOCUMENTS RELATED TO THE BABY'S DELIVERY, MASSAGE ROLLERS, BOOK-MARK AND CERTIFICATES FOR MASSAGE SERVICES, 3D SONOGRAM AND BELLY CASTING (U.S. CLS. 1, 4, 6, 50, 51 AND 52).

ELISSA GARBER KON, EXAMINING ATTORNEY

SN 78-964,906. AMOREPACIFIC CORPORATION, YONGSAN-KU, REPUBLIC OF KOREA, FILED 8-31-2006.

LANEIGE ONE COLOR EYESHADOW

THE MARK CONSISTS OF STANDARD CHARACTERS WITHOUT CLAIM TO ANY PARTICULAR FONT, STYLE, SIZE, OR COLOR.

OWNER OF U.S. REG. NOS. 2,110,811, 3,077,324 AND OTHERS.

NO CLAIM IS MADE TO THE EXCLUSIVE RIGHT TO USE "ONE COLOR EYESHADOW", APART FROM THE MARK AS SHOWN.

FOR EYE SHADOW; SOLID MAKE-UP POWDER FOR COMPACTS; LIQUID FOUNDATION; CREAMY FOUNDATION; ROUGE; LIPSTICKS; NON-MEDICATED NOURISHING CREAMS FOR THE SKIN; NAIL POLISH REMOVERS; EYEBROW PENCILS; MASCARAS; FACIAL PACK CONSISTING OF COSMETIC MATERIAL IMPREGNATED WITH COSMETICS AND APPLIED TO THE FACE FOR SOFTENING AND PURIFYING THE SKIN OF THE FACE; BODY GELS FOR MASSAGE USE; MASSAGE OIL; NAIL POLISH; NAIL ENAMELS; HAIR OILS; HAIR CARE PREPARATIONS; HAIR COLOR; HAIR WAVING LOTIONS; HAIR BLEACHES; ADDITIVES FOR COSMETIC BATHS, NAMELY, BUBBLE BATH AND BATH BEADS; VANISHING CREAMS; BATH OIL FOR COSMETIC PURPOSES; BATH POWDER FOR COSMETIC PURPOSES; BAY RUMS; BABY OIL; BABY POWDER; BLUSHERS; PERFUMED POWDER; NON-MEDICATED BATH SALTS; NON-MEDICATED FRAGRANCE, NAMELY, FRAGRANCES FOR PERSONAL USE AND ROOM FRAGRANCES; COSMETIC SUN-PROTECTING PREPARATIONS; SUNSCREEN LOTIONS; SUNSCREEN CREAMS; SUN TAN OIL; SUN TANNING PREPARATIONS FOR COSMETIC PURPOSES; SHAVING CREAMS; BEAUTY MILK; SKIN

**CLASS 3—(Continued).**

MOISTURIZERS; EYELINERS; EYE MAKE-UP REMOVERS; AFTER SHAVE LOTIONS; EAU DE COLOGNE; DEODORANTS FOR PERSONAL USE; NON-MEDICATED SKIN CARE PREPARATIONS, NAMELY, SKIN TONERS, SKIN LOTIONS, SKIN EMOLLIENTS AND SKIN CLARIFIERS; LIP POLISHER; NON-MEDICATED LIP PROTECTOR; NON-MEDICATED LIP CARE PREPARATIONS; NON-MEDICATED COSMETIC PREPARATIONS FOR BODY SLIMMING PURPOSES, NAMELY, BODY SLIMMING CREAMS, BODY SLIMMING LOTIONS, BODY SLIMMING GELS AND BODY SLIMMING OILS; COLD CREAMS; COLD WAVING SOLUTIONS; MUSTACHE WAX; SKIN CLEANSING CREAM FOR COSMETIC PURPOSES; DEPILATORY WAX; DEPILATORIES; PERMANENT WAVE PREPARATIONS; MAKE-UP FOUNDATIONS; FACE POWDER; POTPOURRI; SKIN WHITENING CREAMS; HAND CREAMS; PERFUMES; HAIR GELS; HAIR LACQUERS; HAIR LOTIONS; HAIR MOUSSE; HAIR SPRAY; HAIR CONDITIONERS; HAIR CREAMS; HAIR TONIC; MAKE-UP POWDER; HYDROGEN PEROXIDE FOR USE ON THE HAIR; ASTRINGENTS FOR COSMETIC PURPOSES; PENCILS FOR COSMETIC PURPOSES; MINERAL SALT IN THE NATURE OF BATH SALTS NOT FOR MEDICAL PURPOSES; SKIN CLEANSING MILK; TALCUM POWDERS; LAVENDER OIL FOR COSMETIC PURPOSES; BERGAMOT OIL FOR COSMETIC PURPOSES; AMBERGRIS; JASMINE OIL FOR COSMETIC PURPOSES; ROSE OIL FOR COSMETIC PURPOSES; SYNTHETIC PERFUMERY; INCENSE STICKS; FUMIGATING INCENSES; ADHESIVES FOR AFFIXING FALSE HAIR; FALSE EYELASHES; ADHESIVES FOR AFFIXING FALSE EYELASHES; FALSE NAILS; PRE-MOISTENED TISSUES IMPREGNATED WITH COSMETIC LOTIONS; MAKE-UP REMOVAL DISPOSABLE WIPES IMPREGNATED WITH CHEMICALS FOR PERSONAL HYGIENE; COTTON STICKS FOR COSMETIC PURPOSES; BEAUTY MASKS; ADHESIVES FOR COSMETIC USE; COTTON SWABS FOR COSMETIC PURPOSES; SOAP POWDER; DETERGENTS PREPARED FROM PETROLEUM FOR HOUSEHOLD USE; INDUSTRIAL SOAPS; DRY CLEANING FLUIDS; SHAVING SOAP; LIQUID SOAPS; DEODORANT SOAP; CLEANING PREPARATIONS FOR CLEANING WASTE PIPES; SOAP FOR BRIGHTENING TEXTILE; SKIN POLISHING RICE BRAN; NON-MEDICATED DOUCHES; LAUNDRY SOAPS; DISINFECTANT SOAP; ALMOND SOAP; GLASS CLEANING PREPARATIONS; FABRIC SOFTENERS FOR LAUNDRY USE; WINDSHIELD WASHING FLUID; TOILET BOWL DETERGENTS; BATH SOAPS; SKIN SOAPS; HAIR SHAMPOOS; CREAM SOAPS; HAIR RINSES; COSMETIC SOAPS; NON-MEDICATED MOUTH WASH AND RISE; NON-MEDICATED DENTAL RINSE; DENTURE CLEANING PREPARATIONS, NAMELY, DENTURE POLISH AND DENTURE CLEANER; TOOTH POWDERS; TOOTH PASTE; MOISTURIZING ESSENCE IN THE NATURE OF MILKY LOTION; BODY CREAMS; BODY LOTIONS; FACIAL CLEANSING FOAMS; SKIN CLEANSING LOTION; SKIN CLEANSING OILS; LIP GLOSS; NON-MEDICATED CREAMS FOR MASSAGE USE; LIP LINER; NON-MEDICATED LIP BALM; COLOGNE WATER; EAU DE TOILETTE; SKIN CLEANSERS; TOOTH WHITENING PREPARATIONS, NAMELY, TOOTH WHITENING CREAMS, TOOTH WHITENING GELS AND TOOTH WHITENING PASTES; NON-MEDICATED MOISTURIZING NUTRITIONAL SERUMS, NAMELY, NON-MEDICATED SKIN SERUMS, NON-MEDICATED EYE SERUMS AND BEAUTY SERUMS (U.S. CLS. 1, 4, 6, 50, 51 AND 52).

THOMAS MANOR, EXAMINING ATTORNEY

**CLASS 3—(Continued).**

SN 78-964,912. U.S. NONWOVENS CORP., BRENTWOOD, NY. FILED 8-31-2006.

# Peaceful Expressions

THE MARK CONSISTS OF STANDARD CHARACTERS WITHOUT CLAIM TO ANY PARTICULAR FONT, STYLE, SIZE, OR COLOR.  
FOR FABRIC SOFTENERS; FABRIC SOFTENERS FOR LAUNDRY USE (U.S. CLS. 1, 4, 6, 50, 51 AND 52).  
WON TEAK OH, EXAMINING ATTORNEY

SN 78-965,227. L. C. LICENSING, INC., NEW YORK, NY. FILED 8-31-2006.

# SWEET DESIRE BY REALITIES

THE MARK CONSISTS OF STANDARD CHARACTERS WITHOUT CLAIM TO ANY PARTICULAR FONT, STYLE, SIZE, OR COLOR.  
OWNER OF U.S. REG. NO. 1,663,741.  
FOR COSMETICS, NAMELY, NAIL POLISH AND LIPSTICK, PERFUMES, COLOGNES, TOILET SOAP, POTPOURRI; PERSONAL CLEANING AND BATH PRODUCTS, NAMELY, SOAPS, FACE AND BODY POWDERS; PERSONAL CARE PRODUCTS, NAMELY SKIN MOISTURIZER, BATH OILS, SKIN CLEANSERS, SKIN SCRUBS, SHOWER GELS, BUBBLE BATH, AFTER SHAVE LOTION, DEODORANT; HAIR CARE PRODUCTS, NAMELY, SHAMPOO, CONDITIONER, STYLING COMPOUNDS; TANNING AND SUN PRODUCTS, NAMELY SUN TAN LOTION (U.S. CLS. 1, 4, 6, 50, 51 AND 52).  
COLLEEN DOMBROW, EXAMINING ATTORNEY

SN 78-965,242. FORD MOTOR COMPANY, DEARBORN, MI. FILED 8-31-2006.



FOR COLOGNE, PERFUME, SHAMPOO, HAIR CONDITIONER, SKIN LOTION, FACE LOTION, HAND LOTION AND SOAP (U.S. CLS. 1, 4, 6, 50, 51 AND 52).  
KEVIN DINALLO, EXAMINING ATTORNEY

**CLASS 3—(Continued).**

SN 78-965,281. VICTORIA PRINCIPAL PRODUCTIONS, INC., LOS ANGELES, CA. FILED 8-31-2006.

# BRIGHT & EVEN RE-TEXTURIZER

THE MARK CONSISTS OF STANDARD CHARACTERS WITHOUT CLAIM TO ANY PARTICULAR FONT, STYLE, SIZE, OR COLOR.  
FOR SKIN AND BODY CARE PREPARATIONS NAMELY, SKIN CLEANSERS, SKIN MOISTURIZERS, SKIN LOTIONS, SKIN SOAPS, SUN SCREEN PREPARATIONS, COSMETICS, NON-MEDICATED HAIR CARE PREPARATIONS, NAIL CARE PREPARATIONS, NON-MEDICATED SKIN CARE PREPARATIONS, COLOGNES, PERFUMES AND TOOTH WHITENING PREPARATIONS (U.S. CLS. 1, 4, 6, 50, 51 AND 52).  
TINA KUAN, EXAMINING ATTORNEY

SN 78-965,315. JABONES Y PRODUCTOS ESPECIALIZADOS SA DE CV, GUADALAJARA, MEXICO, FILED 8-31-2006.

# BIOGENA

THE MARK CONSISTS OF STANDARD CHARACTERS WITHOUT CLAIM TO ANY PARTICULAR FONT, STYLE, SIZE, OR COLOR.  
FOR ANTIBACTERIAL SKIN SOAPS; ANTIBACTERIAL SOAP; DETERGENT SOAP; HAND SOAPS; LAUNDRY SOAP (U.S. CLS. 1, 4, 6, 50, 51 AND 52).  
JENNIFER MCROBBIE, EXAMINING ATTORNEY

SN 78-965,344. ZOTMAN, MIKHAIL, SAN FRANCISCO, CA. FILED 8-31-2006.

# SOYCERA

THE MARK CONSISTS OF STANDARD CHARACTERS WITHOUT CLAIM TO ANY PARTICULAR FONT, STYLE, SIZE, OR COLOR.  
FOR SKIN AND BODY EMULSIFYING PREPARATIONS FOR BEAUTY, SPA AND THERAPEUTIC TREATMENTS (U.S. CLS. 1, 4, 6, 50, 51 AND 52).  
FIRST USE 8-25-2006; IN COMMERCE 8-30-2006.  
JANICE KIM, EXAMINING ATTORNEY

**CLASS 3—(Continued).**

SN 78-965,488. AMARTÉ USA HOLDINGS, INC., SAN FRANCISCO, CA. FILED 8-31-2006.

# AMARTÉ

THE MARK CONSISTS OF STANDARD CHARACTERS WITHOUT CLAIM TO ANY PARTICULAR FONT, STYLE, SIZE, OR COLOR.

FOR COSMETICS; SKIN CARE PRODUCTS, NAMELY, SKIN CREAMS, ANTI-AGING CREAMS AND LOTIONS, LOTIONS, CLEANSERS, CLARIFIERS, MOISTURIZERS, NON-MEDICATED SKIN SERUM, SKIN MASKS, SKIN TONERS, AND NON-MEDICATED SKIN CARE PREPARATIONS FOR TOPICAL APPLICATION (U.S. CLS. 1, 4, 6, 50, 51 AND 52).

SUSAN STIGLITZ, EXAMINING ATTORNEY

SN 78-965,682. COMPLETELY BARE ACCESSORIES, NEW YORK, NY. FILED 9-1-2006.

## completely smooth

THE MARK CONSISTS OF STANDARD CHARACTERS WITHOUT CLAIM TO ANY PARTICULAR FONT, STYLE, SIZE, OR COLOR.

FOR HAIR INHIBITOR BODY LOTION (U.S. CLS. 1, 4, 6, 50, 51 AND 52).

MARILYN IZZI, EXAMINING ATTORNEY

SN 78-965,855. SUN GREEN INTERNATIONAL, INC., RICHARDSON, TX. FILED 9-1-2006.

# GENTOX

THE MARK CONSISTS OF STANDARD CHARACTERS WITHOUT CLAIM TO ANY PARTICULAR FONT, STYLE, SIZE, OR COLOR.

FOR ANTI-WRINKLE CREAM (U.S. CLS. 1, 4, 6, 50, 51 AND 52).

FIRST USE 3-4-2004; IN COMMERCE 3-4-2004.

HEATHER BIDDULPH, EXAMINING ATTORNEY

**CLASS 3—(Continued).**

SN 78-965,995. SUN GREEN INTERNATIONAL, INC., RICHARDSON, TX. FILED 9-1-2006.

# BIOPEAUFA

THE MARK CONSISTS OF STANDARD CHARACTERS WITHOUT CLAIM TO ANY PARTICULAR FONT, STYLE, SIZE, OR COLOR.

FOR EXFOLIANT CREAMS (U.S. CLS. 1, 4, 6, 50, 51 AND 52).

HEATHER BIDDULPH, EXAMINING ATTORNEY

SN 78-966,076. COMPLETELY BARE ACCESSORIES, NEW YORK, NY. FILED 9-1-2006.

## ouchless wax

THE MARK CONSISTS OF STANDARD CHARACTERS WITHOUT CLAIM TO ANY PARTICULAR FONT, STYLE, SIZE, OR COLOR.

NO CLAIM IS MADE TO THE EXCLUSIVE RIGHT TO USE "WAX", APART FROM THE MARK AS SHOWN.

FOR HAIR REMOVAL WAX (U.S. CLS. 1, 4, 6, 50, 51 AND 52).

MARILYN IZZI, EXAMINING ATTORNEY

SN 78-966,285. CHEMRITE COPAC, LANNON, WI. FILED 9-1-2006.

# RACE GLAZE

THE MARK CONSISTS OF STANDARD CHARACTERS WITHOUT CLAIM TO ANY PARTICULAR FONT, STYLE, SIZE, OR COLOR.

OWNER OF U.S. REG. NOS. 1,221,368, 2,003,920 AND 2,678,450.

NO CLAIM IS MADE TO THE EXCLUSIVE RIGHT TO USE "GLAZE", APART FROM THE MARK AS SHOWN.

FOR PREPARATIONS FOR WASHING, CLEANING, POLISHING, SEALING, SHINING AND/OR PROTECTING THE EXTERIOR SURFACES OF LAND VEHICLES, MARINE CRAFT AND AIR CRAFT; AND PREPARATIONS FOR CLEANING RUBBER, VINYL, LEATHER, WOOD AND PLASTIC SURFACES (U.S. CLS. 1, 4, 6, 50, 51 AND 52).

FIRST USE 1-18-1980; IN COMMERCE 3-18-1980.

DAVID I, EXAMINING ATTORNEY

**CLASS 3—(Continued).**

SN 78-966,306. WATSON, TUESDAY, LINDALE, TX. FILED 9-1-2006.



NO CLAIM IS MADE TO THE EXCLUSIVE RIGHT TO USE "SOAP COMPANY", APART FROM THE MARK AS SHOWN.

THE MARK CONSISTS OF THE WORDS "SHINEY HINEY SOAP COMPANY" IN A CIRCULAR ARC WITHIN A DOUBLE CIRCLE, AND A STYLIZED IMAGE OF A SUN WITH A HUMAN FACE WEARING SUNGLASSES WITHIN THE DOUBLE CIRCLES BELOW THE WORDS "SHINEY HINEY".

FOR COSMETIC SOAPS (U.S. CLS. 1, 4, 6, 50, 51 AND 52).

FIRST USE 3-31-2005; IN COMMERCE 3-31-2005.  
KIMBERLY FRYE, EXAMINING ATTORNEY

SN 78-966,472. DELLE GRAZIE, VADUZ, LIECHTENSTEIN, FILED 9-2-2006.

## Sex'n Candy

THE MARK CONSISTS OF STANDARD CHARACTERS WITHOUT CLAIM TO ANY PARTICULAR FONT, STYLE, SIZE, OR COLOR.

FOR PERFUMES, COSMETICS, COSMETIC SOAPS, ESSENTIAL OILS, HAIR LOTIONS (U.S. CLS. 1, 4, 6, 50, 51 AND 52).

KATHLEEN LORENZO, EXAMINING ATTORNEY

**CLASS 3—(Continued).**

SN 78-966,894. PHILOSOPHY, INC., PHOENIX, AZ. FILED 9-5-2006.

## MAGNA DELIVERY PEEL

THE MARK CONSISTS OF STANDARD CHARACTERS WITHOUT CLAIM TO ANY PARTICULAR FONT, STYLE, SIZE, OR COLOR.

NO CLAIM IS MADE TO THE EXCLUSIVE RIGHT TO USE "PEEL", APART FROM THE MARK AS SHOWN.

FOR BODY SCRUB; COSMETIC FACIAL BLOTTER PAPER; COSMETIC PADS; COSMETICS; DEPILATORIES; FACIAL SCRUBS; NON-MEDICATED FOOT CREAM; NON-MEDICATED LIP CARE PREPARATIONS; NON-MEDICATED SKIN CARE PREPARATIONS; NON-MEDICATED SUN CARE PREPARATIONS; NON-MEDICATED TOILETRIES (U.S. CLS. 1, 4, 6, 50, 51 AND 52).

LINDA ORNDORFF, EXAMINING ATTORNEY

SN 78-967,191. ECONATURA, INC., DEER PARK, NY. FILED 9-5-2006.

## OCEAN ORGANICS

THE MARK CONSISTS OF STANDARD CHARACTERS WITHOUT CLAIM TO ANY PARTICULAR FONT, STYLE, SIZE, OR COLOR.

NO CLAIM IS MADE TO THE EXCLUSIVE RIGHT TO USE "ORGANICS", APART FROM THE MARK AS SHOWN.

FOR NATURAL AND ORGANIC PERSONAL CARE ITEMS, NAMELY, LOTIONS FOR THE HAND, BODY, AND HAIR; EYE CREAM, SHAMPOOS, HAIR CONDITIONERS, SHOWER GELS, BATH SALTS, BODY OILS, SACHET-LIKE EYE PILLOWS CONTAINING FRAGRANCES, SKIN CLEANING MOISTURIZING BARS (U.S. CLS. 1, 4, 6, 50, 51 AND 52).

FIRST USE 10-25-2005; IN COMMERCE 10-25-2005.  
SANI KHOURI, EXAMINING ATTORNEY

SN 78-967,430. RUDZEWICZ, STEPHANIE ANN, STERLING HEIGHTS, MI. FILED 9-5-2006.

## 2 CHICKS

THE MARK CONSISTS OF STANDARD CHARACTERS WITHOUT CLAIM TO ANY PARTICULAR FONT, STYLE, SIZE, OR COLOR.

FOR FACIAL CLEANSERS; FACIAL CREAMS; FACIAL LOTION; FACIAL WASHES; MAKE-UP; MAKE-UP REMOVER (U.S. CLS. 1, 4, 6, 50, 51 AND 52).

STEPHEN AQUILA, EXAMINING ATTORNEY

**CLASS 3—(Continued).**

SN 78-967,584. LIFETECH RESOURCES LLC, CHATSWORTH, CA. FILED 9-5-2006.

# NeuLash

THE MARK CONSISTS OF STANDARD CHARACTERS WITHOUT CLAIM TO ANY PARTICULAR FONT, STYLE, SIZE, OR COLOR.

FOR COSMETICS, NAMELY, EYE LASH VOLUMIZER, EYE LASH LINER, AN EYE LASH CONDITIONING TREATMENT (U.S. CLS. 1, 4, 6, 50, 51 AND 52).

JEFF DEFORD, EXAMINING ATTORNEY

SN 78-970,180. CUCCIO, ROBERTA, VALENCIA, CA. FILED 9-8-2006.

# Cuccio Naturale

THE MARK CONSISTS OF STANDARD CHARACTERS WITHOUT CLAIM TO ANY PARTICULAR FONT, STYLE, SIZE, OR COLOR.

NO CLAIM IS MADE TO THE EXCLUSIVE RIGHT TO USE "NATURALE", APART FROM THE MARK AS SHOWN. THE TERM "NATURALE" TRANSLATES INTO ENGLISH AS "NATURAL".

FOR NATURAL NAIL CARE PREPARATIONS; COSMETICS, NAMELY, CUTICLE REMOVING PREPARATIONS, NAIL STRENGTHENERS, HAND LOTION, SKIN LIGHTENERS AND SKIN REVITALIZERS (U.S. CLS. 1, 4, 6, 50, 51 AND 52).

PAUL F. GAST, EXAMINING ATTORNEY

SN 78-971,058. MERCANTIL DE COMERCIO, S.A., GUATEMALA CITY, GUATEMALA, FILED 9-11-2006.

# Tamy de Familia

THE MARK CONSISTS OF STANDARD CHARACTERS WITHOUT CLAIM TO ANY PARTICULAR FONT, STYLE, SIZE, OR COLOR.

THE FOREIGN WORDING IN THE MARK TRANSLATES INTO ENGLISH AS TAMY OF FAMILY.

FOR BODY CREAMS; BODY LOTIONS; SHAMPOOS; SOAPS (U.S. CLS. 1, 4, 6, 50, 51 AND 52).

STEVEN JACKSON, EXAMINING ATTORNEY

**CLASS 3—(Continued).**

SN 78-971,107. L. C. LICENSING, INC., NEW YORK, NY. FILED 9-11-2006.

# CURVE KICKS

THE MARK CONSISTS OF STANDARD CHARACTERS WITHOUT CLAIM TO ANY PARTICULAR FONT, STYLE, SIZE, OR COLOR.

OWNER OF U.S. REG. NOS. 2,027,829, 2,171,423 AND OTHERS.

FOR COSMETICS, NAMELY, NAIL POLISH AND LIPSTICK, PERFUMES, COLOGNES, TOILET SOAP, POTPOURRI; PERSONAL CLEANING AND BATH PRODUCTS, NAMELY, SOAPS, FACE AND BODY POWDERS; PERSONAL CARE PRODUCTS, NAMELY SKIN MOISTURIZER, BATH OILS, SKIN CLEANSERS, SKIN SCRUBS, SHOWER GELS, BUBBLE BATH, AFTER SHAVE LOTION, DEODORANT; HAIR CARE PRODUCTS, NAMELY, SHAMPOO, CONDITIONER, STYLING COMPOUNDS; TANNING AND SUN PRODUCTS, NAMELY SUN TAN LOTION (U.S. CLS. 1, 4, 6, 50, 51 AND 52).

COLLEEN DOMBROW, EXAMINING ATTORNEY

SN 78-972,653. BB COSMETICS LLC, LOS ANGELES, CA. FILED 9-12-2006.

# HARD-ON

THE MARK CONSISTS OF STANDARD CHARACTERS WITHOUT CLAIM TO ANY PARTICULAR FONT, STYLE, SIZE, OR COLOR.

FOR PROTEIN FORMULA TO STRENGTHEN BRITTLE FINGERNAILS (U.S. CLS. 1, 4, 6, 50, 51 AND 52).

ELLEN B. AWRICH, EXAMINING ATTORNEY

SN 78-972,679. BB COSMETICS LLC, LOS ANGELES, CA. FILED 9-12-2006.

# MINUTE-WONDER

THE MARK CONSISTS OF STANDARD CHARACTERS WITHOUT CLAIM TO ANY PARTICULAR FONT, STYLE, SIZE, OR COLOR.

FOR ADVANCED FORMULA TO DRY FINGERNAIL POLISH FAST, LEAVING GLOSS FINISH (U.S. CLS. 1, 4, 6, 50, 51 AND 52).

ELLEN B. AWRICH, EXAMINING ATTORNEY

**CLASS 3—(Continued).**

SN 78-978,030. L'OREAL, PARIS, FRANCE, FILED 2-22-2006.

**PRO-CALCIUM**

THE MARK CONSISTS OF STANDARD CHARACTERS WITHOUT CLAIM TO ANY PARTICULAR FONT, STYLE, SIZE, OR COLOR.

FOR COSMETICS, NAMELY, CREAMS FOR THE FACE (U.S. CLS. 1, 4, 6, 50, 51 AND 52).

FIRST USE 6-25-2006; IN COMMERCE 6-25-2006.  
NAKIA HENRY, EXAMINING ATTORNEY

---

SN 78-978,064. ARCTURUS, INC., LAS VEGAS, NV. FILED 12-23-2005.

**FUSION FORMULAS**

THE MARK CONSISTS OF STANDARD CHARACTERS WITHOUT CLAIM TO ANY PARTICULAR FONT, STYLE, SIZE, OR COLOR.

NO CLAIM IS MADE TO THE EXCLUSIVE RIGHT TO USE "FORMULAS", APART FROM THE MARK AS SHOWN.

FOR AROMATHERAPY SPRAYS (U.S. CLS. 1, 4, 6, 50, 51 AND 52).

JAMES GRIFFIN, EXAMINING ATTORNEY

---

SN 79-019,496. CASTER, FRANCE, FILED 11-15-2005.

**AQUA PULSE**

THE MARK CONSISTS OF STANDARD CHARACTERS WITHOUT CLAIM TO ANY PARTICULAR FONT, STYLE, SIZE, OR COLOR.

PRIORITY DATE OF 5-18-2005 IS CLAIMED.

OWNER OF INTERNATIONAL REGISTRATION 0872951 DATED 11-15-2005, EXPIRES 11-15-2015.

FOR SOAPS FOR PERSONAL USE; PERFUMERY PRODUCTS, NAMELY, TOILET WATER, PERFUMES; ESSENTIAL OILS; COSMETICS; SKIN COSMETIC TREATMENTS FOR NON-MEDICAL USE, NAMELY, SKIN MASKS, SKIN CREAMS AND SKIN LOTIONS; PRE-SHAVE PRODUCTS, NAMELY, PRE-SHAVE CREAMS; AFTER-SHAVE PRODUCTS, NAMELY, AFTER-SHAVE LOTIONS; MAKE-UP REMOVER; BEAUTY MASKS; NON-MEDICAL HAIR CLEANING AND HAIR CARE PREPARATIONS; SHAMPOOS; DYES FOR HAIR USE (U.S. CLS. 1, 4, 6, 50, 51 AND 52).

MONIQUE MILLER, EXAMINING ATTORNEY

**CLASS 3—(Continued).**

SN 79-025,045. JULIE ELIZABETH FOSTER, WOODBRIDGE IP12 4NY, UNITED KINGDOM, FILED 11-17-2005.

**JULIE FOSTER**

THE MARK CONSISTS OF STANDARD CHARACTERS WITHOUT CLAIM TO ANY PARTICULAR FONT, STYLE, SIZE, OR COLOR.

PRIORITY DATE OF 5-19-2005 IS CLAIMED.

OWNER OF INTERNATIONAL REGISTRATION 0888005 DATED 11-17-2005, EXPIRES 11-17-2015.

THE NAME JULIE FOSTER IDENTIFIES A LIVING INDIVIDUAL WHOSE CONSENT IS OF RECORD.

FOR SOAP, NAMELY, SOAP FOR PERSONAL USE; PERFUMERY; COSMETICS; NON-MEDICATED TOILETRIES; AROMATIC ESSENTIAL OILS; ESSENTIAL OILS, NAMELY, ALMOND OIL, BASIL OIL, BENZOIN OIL, BERGAMOT OIL, BLACK PEPPER OIL, CEDARWOOD OIL, CHAMOMILE OIL, CINNAMON LEAF OIL, CITRONELLA OIL, CLARY SAGE OIL, CYPRESS OIL, EUCALYPTUS OIL, FENNEL OIL, FRANKINCENSE OIL, GERANIUM OIL, GINGER OIL, GRAPEFRUIT OIL, GREEN MANDARIN OIL, JASMINE OIL, JUNIPER OIL, LAVENDER OIL, LEMON OIL, EUCALYPTUS OIL, LEMONGRASS OIL, LIME OIL, MAY CHANG OIL, MINT ESSENCE OIL, MYRRH OIL, NEROLI OIL, ORANGE OIL, PALMAROSA OIL, PATCHOULI OIL, PEPPERMINT OIL, PETITGRAIN OIL, ROMAN CHAMOMILE OIL, ROSE OIL, ROSEMARY OIL, SANDALWOOD OIL, SPEARMINT OIL, SWEET MARJORAM OIL, TEA TREE OIL, THYME OIL, VETIVERT OIL, YLANG YLANG OIL; CAKES OF SOAP, DEODORANT SOAP, MEDICATED SOAP; SOAP AND BATH OILS SOLD AS A UNIT; SHAMPOOS; HAIR LOTIONS; BATH SALTS, NOT FOR MEDICAL PURPOSES; LOTIONS FOR COSMETIC PURPOSES, NAMELY, BODY LOTIONS, FACIAL LOTIONS, HAND LOTIONS, FOOT LOTIONS; COSMETIC CREAMS; SCENTED WATER, NAMELY, SCENTED TOILET WATER, SCENTED LINEN WATER; PREPARATIONS FOR USE ON THE HAIR, NAMELY, HAIR CARE PREPARATIONS, HAIR STYLING PREPARATIONS; NON-MEDICATED SKIN CARE PREPARATIONS; DEODORANTS FOR USE ON THE PERSON (U.S. CLS. 1, 4, 6, 50, 51 AND 52).

DEBRA LEE, EXAMINING ATTORNEY

---

SN 79-029,396. SOCIÉTÉ ANONYME DE; SAVONNERIE ET DENTIFRICE "SED", MONACO, FILED 9-4-2006.

**HELIQSIR**

THE MARK CONSISTS OF STANDARD CHARACTERS WITHOUT CLAIM TO ANY PARTICULAR FONT, STYLE, SIZE, OR COLOR.

PRIORITY DATE OF 3-14-2006 IS CLAIMED.

OWNER OF INTERNATIONAL REGISTRATION 0899732 DATED 9-4-2006, EXPIRES 9-4-2016.

FOR SOAPS, PERFUMERY, ESSENTIAL OILS, COSMETICS AND FACE, BODY, HAND AND FEET CARE AND BEAUTY COSMETICS, OILS FOR COSMETIC PURPOSES, DRY OILS FOR THE FACE AND BODY, HAIR LOTIONS, DENTIFRICES (U.S. CLS. 1, 4, 6, 50, 51 AND 52).

KIMBERLY PERRY, EXAMINING ATTORNEY

**CLASS 4—LUBRICANTS AND FUELS**

SN 76-665,239. VOTIVO, LTD., SEATTLE, WA. FILED 8-28-2006.

**AMBER ESSENCE**

THE MARK CONSISTS OF STANDARD CHARACTERS WITHOUT CLAIM TO ANY PARTICULAR FONT, STYLE, SIZE, OR COLOR.

NO CLAIM IS MADE TO THE EXCLUSIVE RIGHT TO USE "AMBER", APART FROM THE MARK AS SHOWN. FOR CANDLES (U.S. CLS. 1, 6 AND 15). FIRST USE 6-13-2006; IN COMMERCE 6-13-2006. ELLEN B. AWRICH, EXAMINING ATTORNEY

SN 77-022,468. KENT FEEDS, INC., MUSCATINE, IA. FILED 10-17-2006.

**Heat Wave**

THE MARK CONSISTS OF STANDARD CHARACTERS WITHOUT CLAIM TO ANY PARTICULAR FONT, STYLE, SIZE, OR COLOR.

FOR FUEL PELLETS (U.S. CLS. 1, 6 AND 15). EVELYN BRADLEY, EXAMINING ATTORNEY

SN 77-058,485. RIATA ENERGY, INC., OKLAHOMA CITY, OK. FILED 12-6-2006.



NO CLAIM IS MADE TO THE EXCLUSIVE RIGHT TO USE "ENERGY", APART FROM THE MARK AS SHOWN.

THE APPLICANT CLAIMS COLOR AS A FEATURE OF THE MARK, NAMELY, BLACK AND RED.

THE MARK CONSISTS OF THE WORDS SANDRIDGE ENERGY IN STYLIZED BLACK LETTERS AND A BLACK CURVED LINE AND A RED CURVED LINE.

FOR CRUDE OIL AND NATURAL GAS (U.S. CLS. 1, 6 AND 15).

JIM RINGLE, EXAMINING ATTORNEY

**CLASS 4—(Continued).**

SN 78-710,511. HAPPY PAWS HAVEN, INC., ARAB, AL. FILED 9-10-2005.



NO CLAIM IS MADE TO THE EXCLUSIVE RIGHT TO USE "CANDLES", APART FROM THE MARK AS SHOWN.

THE COLOR(S) TEAL, YELLOW, RED, BLACK AND WHITE IS/ARE CLAIMED AS A FEATURE OF THE MARK.

THE MARK CONSISTS OF THE PHRASE SAVE A LIFE CANDLES IN THE COLOR TEAL WITH A BLACK AND WHITE COLOR OUTLINE. THE MARK CONTAINS A FLAME OVER THE LETTER I IN LIFE. THE FLAME IS IN THE COLOR YELLOW WITH A RED COLORED CENTER.

FOR CANDLES; PERFUMED CANDLES; SCENTED CANDLES (U.S. CLS. 1, 6 AND 15).

FIRST USE 1-1-2005; IN COMMERCE 1-3-2005.

TANYA AMOS, EXAMINING ATTORNEY

SN 78-852,940. FIL-TECH WEST INC., PLEASANTON, CA. FILED 4-3-2006.

**TEC-LUBE**

THE MARK CONSISTS OF STANDARD CHARACTERS WITHOUT CLAIM TO ANY PARTICULAR FONT, STYLE, SIZE, OR COLOR.

FOR LUBRICANTS FOR SEMI-CONDUCTORS; LUBRICANTS FOR HIGH VACUUM APPLICATIONS (U.S. CLS. 1, 6 AND 15).

FIRST USE 9-30-1997; IN COMMERCE 9-30-1997.

ALICE BENMAMAN, EXAMINING ATTORNEY

SN 78-956,165. AMERICA YA MEI LI CHEMICAL ENGINEERING LIMITED, GUANGZHOU, CHINA, FILED 8-21-2006.



FOR INDUSTRIAL LUBRICANTS; DUST BINDING COMPOSITIONS; ALL PURPOSE LUBRICANTS; GRANULAR ABSORBENT OIL-BASED COMPOSITION FOR ABSORBING SPILLS FROM FLOORS; BELT DRESSINGS; MOTOR OIL; INDUSTRIAL OILS; CUTTING FLUIDS; MINERAL OIL FOR USE IN THE MANUFACTURE OF PAINT; SOYBEAN OIL FOR USE IN THE MANUFACTURE OF PAINTS AND OTHER COATINGS; INDUSTRIAL GREASES (U.S. CLS. 1, 6 AND 15).

ELIZABETH KAJUBI, EXAMINING ATTORNEY



**CLASS 4—(Continued).**

SN 78-964,283. RIATA ENERGY, INC., OKLAHOMA CITY, OK. FILED 8-30-2006.

SANDRIDGE ENERGY

THE MARK CONSISTS OF STANDARD CHARACTERS WITHOUT CLAIM TO ANY PARTICULAR FONT, STYLE, SIZE, OR COLOR.

NO CLAIM IS MADE TO THE EXCLUSIVE RIGHT TO USE "ENERGY", APART FROM THE MARK AS SHOWN.

FOR CRUDE OIL AND NATURAL GAS (U.S. CLS. 1, 6 AND 15).

JIM RINGLE, EXAMINING ATTORNEY

**CLASS 4—(Continued).**

SN 78-971,141. CAW COWIE, INC., DBA COLIN COWIE LIFESTYLE, NEW YORK, NY. FILED 9-11-2006.



**squared**

BY COLIN COWIE

OWNER OF U.S. REG. NOS. 3,001,704, 3,001,711 AND OTHERS.

THE NAME COLIN COWIE IDENTIFIES A LIVING INDIVIDUAL WHOSE CONSENT IS OF RECORD.

THE MARK CONSISTS OF A CIRCULAR BORDER INSIDE WHICH ARE TWO STYLIZED "C'S", BENEATH WHICH IS THE WORD "SQUARED" AND UNDERNEATH ARE THE WORDS "BY COLIN COWIE".

FOR CANDLES; SCENTED CANDLES (U.S. CLS. 1, 6 AND 15).

RAMONA ORTIGA, EXAMINING ATTORNEY

SN 78-966,234. FRANCIS DRILLING FLUIDS, LTD., CROWLEY, LA. FILED 9-1-2006.

FRANCIS DRILLING FLUIDS

THE MARK CONSISTS OF STANDARD CHARACTERS WITHOUT CLAIM TO ANY PARTICULAR FONT, STYLE, SIZE, OR COLOR.

NO CLAIM IS MADE TO THE EXCLUSIVE RIGHT TO USE "DRILLING FLUIDS", APART FROM THE MARK AS SHOWN.

FOR DRILLING LUBRICANTS (U.S. CLS. 1, 6 AND 15).

HEATHER THOMPSON, EXAMINING ATTORNEY

SN 79-033,464. BRUGAROLAS, S.A., SPAIN, FILED 8-3-2006.

**BESLUX**

OWNER OF INTERNATIONAL REGISTRATION 0515644 DATED 9-29-1987, EXPIRES 9-29-2007.

FOR LUBRICATING OILS AND GREASES (U.S. CLS. 1, 6 AND 15).

ROBERT STRUCK, EXAMINING ATTORNEY

**CLASS 5—PHARMACEUTICALS**

SN 76-632,529. DOUBLE A BEVERAGE, LLC, BOCA RATON, FL. FILED 3-2-2005.

# W20

THE MARK CONSISTS OF STANDARD CHARACTERS WITHOUT CLAIM TO ANY PARTICULAR FONT, STYLE, SIZE, OR COLOR.

FOR NUTRITIONALLY FORTIFIED BEVERAGES (U.S. CLS. 6, 18, 44, 46, 51 AND 52).  
MARC LEIPZIG, EXAMINING ATTORNEY

SN 76-659,705. MOLD-B-GONE, LLC, NAMPA, ID. FILED 5-8-2006.



NO CLAIM IS MADE TO THE EXCLUSIVE RIGHT TO USE MOLD INHIBITOR, APART FROM THE MARK AS SHOWN.

THE LINING IS FOR SHADING PURPOSES ONLY. FOR MOLD GROWTH INHIBITOR PRODUCT FOR APPLICATION TO STRUCTURES DURING CONSTRUCTION (U.S. CLS. 6, 18, 44, 46, 51 AND 52).

FIRST USE 1-31-2004; IN COMMERCE 1-31-2004.  
LINDA MICKLEBURGH, EXAMINING ATTORNEY

SN 76-661,366. VAN ANDEL INSTITUTE, GRAND RAPIDS, MI. FILED 6-9-2006.

# LEPIMAT

THE MARK CONSISTS OF STANDARD CHARACTERS WITHOUT CLAIM TO ANY PARTICULAR FONT, STYLE, SIZE, OR COLOR.

FOR PHARMACEUTICALS FOR THE TREATMENT OF CANCER AND MACULAR DEGENERATION (U.S. CLS. 6, 18, 44, 46, 51 AND 52).

STEVEN JACKSON, EXAMINING ATTORNEY

**CLASS 5—(Continued).**

SN 76-664,658. LEINER HEALTH SERVICES CORP., CARSON, CA. FILED 8-16-2006.

# SLIDESATIONALS

THE MARK CONSISTS OF STANDARD CHARACTERS WITHOUT CLAIM TO ANY PARTICULAR FONT, STYLE, SIZE, OR COLOR.

FOR TABLET COATING SOLD AS AN INTEGRAL COMPONENT OF VITAMINS, DIETARY FOOD SUPPLEMENTS AND OVER-THE-COUNTER PHARMACEUTICALS (U.S. CLS. 6, 18, 44, 46, 51 AND 52).

JOHN KELLY, EXAMINING ATTORNEY

SN 76-665,032. VITAMEC USA, INC., VAN NUYS, CA. FILED 8-24-2006.

# PRIMO

THE MARK CONSISTS OF STANDARD CHARACTERS WITHOUT CLAIM TO ANY PARTICULAR FONT, STYLE, SIZE, OR COLOR.

FOR VITAMINS FOR USE BY CHILDREN; VITAMIN TABLETS FOR USE BY CHILDREN; VITAMIN SUPPLEMENTS FOR USE BY CHILDREN; VITAMIN PREPARATIONS FOR USE BY CHILDREN; VITAMIN AND MINERAL SUPPLEMENTS FOR USE BY CHILDREN; MULTI-VITAMIN PREPARATIONS FOR USE BY CHILDREN; MIXED VITAMIN PREPARATIONS FOR USE BY CHILDREN (U.S. CLS. 6, 18, 44, 46, 51 AND 52).

MYRIAH HABEEB, EXAMINING ATTORNEY

SN 76-665,423. ADVANCIS PHARMACEUTICAL CORPORATION, GERMANTOWN, MD. FILED 8-31-2006.

# AMOXONE

THE MARK CONSISTS OF STANDARD CHARACTERS WITHOUT CLAIM TO ANY PARTICULAR FONT, STYLE, SIZE, OR COLOR.

FOR ANTIBIOTICS (U.S. CLS. 6, 18, 44, 46, 51 AND 52).

REBECCA GILBERT, EXAMINING ATTORNEY

**CLASS 5—(Continued).**

SN 76-665,625. UNIVERSAL MARKETING CORPORATION  
2, PORTLAND, OR. FILED 9-5-2006.

# TOBACQUIT

THE MARK CONSISTS OF STANDARD CHARACTERS WITHOUT CLAIM TO ANY PARTICULAR FONT, STYLE, SIZE, OR COLOR.

FOR HERBAL TREATED CIGARETTES USED IN THE TREATMENT OF CONTROLLING NICOTINE ADDICTION ASSOCIATED WITH CIGARETTE SMOKING (U.S. CLS. 6, 18, 44, 46, 51 AND 52).

FIRST USE 3-29-1997; IN COMMERCE 4-15-1997.  
WILLIAM P. SHANAHAN, EXAMINING ATTORNEY

**CLASS 5—(Continued).**

SN 76-670,776. ADVANCIS PHARMACEUTICAL CORPORATION, GERMANTOWN, MD. FILED 12-26-2006.



OWNER OF U.S. REG. NO. 881,598.  
NO CLAIM IS MADE TO THE EXCLUSIVE RIGHT TO USE "250 MG" AND THE SHAPE OF THE CAPSULE, APART FROM THE MARK AS SHOWN.

THE COLOR(S) GREEN, WHITE AND BLACK IS/ARE CLAIMED AS A FEATURE OF THE MARK.

THE MARK CONSISTS OF A THREE-DIMENSIONAL DESIGN OF A CAPSULE WITH GREEN CAP AND WHITE BODY WHICH INCLUDES THE WORDING "KEFLEX 250 MG" IN BLACK LETTERING.

FOR ANTIBIOTICS (U.S. CLS. 6, 18, 44, 46, 51 AND 52).  
FIRST USE 9-0-1971; IN COMMERCE 9-0-1971.  
REBECCA GILBERT, EXAMINING ATTORNEY

SN 76-667,333. SILVERADE LLC, EAST BRUNSWICK, NJ.  
FILED 10-10-2006.

# SILVERADE

THE MARK CONSISTS OF STANDARD CHARACTERS WITHOUT CLAIM TO ANY PARTICULAR FONT, STYLE, SIZE, OR COLOR.

FOR MINERAL SUPPLEMENT (U.S. CLS. 6, 18, 44, 46, 51 AND 52).

BRENDAN MCCAULEY, EXAMINING ATTORNEY

SN 76-670,777. ADVANCIS PHARMACEUTICAL CORPORATION, GERMANTOWN, MD. FILED 12-26-2006.



OWNER OF U.S. REG. NO. 881,598.  
NO CLAIM IS MADE TO THE EXCLUSIVE RIGHT TO USE "500 MG" AND THE SHAPE OF THE CAPSULE, APART FROM THE MARK AS SHOWN.

THE COLOR(S) DARK GREEN, LIGHT GREEN AND BLACK IS/ARE CLAIMED AS A FEATURE OF THE MARK.

THE MARK CONSISTS OF A THREE-DIMENSIONAL DESIGN OF A CAPSULE WITH DARK GREEN CAP AND LIGHT GREEN BODY WHICH INCLUDES THE WORDING "KEFLEX 500 MG" IN BLACK LETTERING.

FOR ANTIBIOTICS (U.S. CLS. 6, 18, 44, 46, 51 AND 52).  
FIRST USE 1-0-1972; IN COMMERCE 1-0-1972.  
REBECCA GILBERT, EXAMINING ATTORNEY

SN 76-670,775. ADVANCIS PHARMACEUTICAL CORPORATION, GERMANTOWN, MD. FILED 12-26-2006.



OWNER OF U.S. REG. NO. 881,598.  
NO CLAIM IS MADE TO THE EXCLUSIVE RIGHT TO USE "333 MG" AND THE SHAPE OF THE CAPSULE, APART FROM THE MARK AS SHOWN.

THE COLOR(S) GREEN AND BLACK IS/ARE CLAIMED AS A FEATURE OF THE MARK.

THE MARK CONSISTS OF A THREE-DIMENSIONAL DESIGN OF A CAPSULE WHICH IS GREEN WITH THE WORDING "KEFLEX 333 MG" IN BLACK LETTERING.

FOR ANTIBIOTICS (U.S. CLS. 6, 18, 44, 46, 51 AND 52).  
REBECCA GILBERT, EXAMINING ATTORNEY

SN 76-670,823. ADVANCIS PHARMACEUTICAL CORPORATION, GERMANTOWN, MD. FILED 12-26-2006.



OWNER OF U.S. REG. NO. 881,598.  
NO CLAIM IS MADE TO THE EXCLUSIVE RIGHT TO USE "750 MG" AND THE SHAPE OF THE CAPSULE, APART FROM THE MARK AS SHOWN.

THE COLOR(S) GREEN AND WHITE IS/ARE CLAIMED AS A FEATURE OF THE MARK.

THE MARK CONSISTS OF A THREE-DIMENSIONAL DESIGN OF A CAPSULE WHICH IS GREEN WITH THE WORDING "KEFLEX 750 MG" IN WHITE LETTERING.

FOR ANTIBIOTICS (U.S. CLS. 6, 18, 44, 46, 51 AND 52).  
FIRST USE 7-0-2006; IN COMMERCE 7-0-2006.  
REBECCA GILBERT, EXAMINING ATTORNEY

**CLASS 5—(Continued).**

SN 77-000,720. FEDERAL LABORATORIES CORPORATION, ALDEN, NY. FILED 9-15-2006.

**CARATRIM**

THE MARK CONSISTS OF STANDARD CHARACTERS WITHOUT CLAIM TO ANY PARTICULAR FONT, STYLE, SIZE, OR COLOR.

FOR DIETARY SUPPLEMENTS, NAMELY DIETARY SUPPLEMENTS TO PROMOTE APPETITE SUPPRESSION, WEIGHT LOSS, AND THE LOWERING OF BLOOD SUGAR LEVELS (U.S. CLS. 6, 18, 44, 46, 51 AND 52).

KRISTINA KLOIBER, EXAMINING ATTORNEY

**CLASS 5—(Continued).**

SN 77-011,678. MEDTECH PRODUCTS, INC., IRVINGTON, NY. FILED 10-2-2006.

**CHLORASEPTIC**

THE MARK CONSISTS OF STANDARD CHARACTERS WITHOUT CLAIM TO ANY PARTICULAR FONT, STYLE, SIZE, OR COLOR.

OWNER OF U.S. REG. NOS. 837,014, 2,975,799 AND 2,985,067.

FOR DIETARY AND NUTRITIONAL SUPPLEMENTS FOR HUMAN CONSUMPTION (U.S. CLS. 6, 18, 44, 46, 51 AND 52).

FIRST USE 8-7-2006; IN COMMERCE 8-7-2006.

JENNIFER MARTIN, EXAMINING ATTORNEY

SN 77-002,411. SYNGENTA PARTICIPATIONS AG, BASEL, SWITZERLAND, FILED 9-19-2006.

**AXORIS**

THE MARK CONSISTS OF STANDARD CHARACTERS WITHOUT CLAIM TO ANY PARTICULAR FONT, STYLE, SIZE, OR COLOR.

FOR PREPARATIONS FOR DESTROYING VERMIN, AND PREPARATIONS FOR PROTECTING PLANTS AGAINST PATHOGENS FOR HOME AND GARDEN USE (U.S. CLS. 6, 18, 44, 46, 51 AND 52).

WON TEAK OH, EXAMINING ATTORNEY

SN 77-011,689. MEDTECH PRODUCTS, INC., IRVINGTON, NY. FILED 10-2-2006.

**CHLORASEPTIC DEFENSE**

THE MARK CONSISTS OF STANDARD CHARACTERS WITHOUT CLAIM TO ANY PARTICULAR FONT, STYLE, SIZE, OR COLOR.

OWNER OF U.S. REG. NOS. 837,014, 2,985,067 AND OTHERS.

FOR DIETARY AND NUTRITIONAL SUPPLEMENTS FOR HUMAN CONSUMPTION (U.S. CLS. 6, 18, 44, 46, 51 AND 52).

FIRST USE 8-7-2006; IN COMMERCE 8-7-2006.

JENNIFER MARTIN, EXAMINING ATTORNEY

SN 77-010,520. TRINITY THERAPEUTICS, INC., WESTLAKE VILLAGE, CA. FILED 9-29-2006.



Trinity Therapeutics, Inc.

SN 77-013,003. VETERINARY DIAGNOSTICS INSTITUTE, INC., IRVINE, CA. FILED 10-3-2006.

**Feline CardioStat**

NO CLAIM IS MADE TO THE EXCLUSIVE RIGHT TO USE "THERAPEUTICS, INC.", APART FROM THE MARK AS SHOWN.

THE MARK CONSISTS OF THE WORDS TRINITY THERAPEUTICS, INC. AND A STYLIZED REPRESENTATION OF A HUMAN ANTIBODY OR A IMMUNOGLOBULIN ANTIBODY.

FOR PHARMACEUTICAL PREPARATIONS FOR THE TREATMENT OF AUTOIMMUNE DISEASES (U.S. CLS. 6, 18, 44, 46, 51 AND 52).

SUSAN RICHARDS, EXAMINING ATTORNEY

THE MARK CONSISTS OF STANDARD CHARACTERS WITHOUT CLAIM TO ANY PARTICULAR FONT, STYLE, SIZE, OR COLOR.

NO CLAIM IS MADE TO THE EXCLUSIVE RIGHT TO USE "FELINE", APART FROM THE MARK AS SHOWN.

FOR DIAGNOSTIC PREPARATIONS TO DETECT LEVELS OF HORMONES IN ANIMALS FOR DIAGNOSIS AND TREATMENT (U.S. CLS. 6, 18, 44, 46, 51 AND 52).

RAUL CORDOVA, EXAMINING ATTORNEY

**CLASS 5—(Continued).**

SN 77-019,431. BIO-NUTRA TECHNOLOGIES, LLC, VENICE, FL. FILED 10-12-2006.

# NANO-C

THE MARK CONSISTS OF STANDARD CHARACTERS WITHOUT CLAIM TO ANY PARTICULAR FONT, STYLE, SIZE, OR COLOR.  
FOR DIETARY AND NUTRITIONAL SUPPLEMENTS (U.S. CLS. 6, 18, 44, 46, 51 AND 52).  
KIMBERLY PERRY, EXAMINING ATTORNEY

**CLASS 5—(Continued).**

SN 77-036,146. KENT FEEDS, INC., MUSCATINE, IA. FILED 11-3-2006.

# DOWN HOME

THE MARK CONSISTS OF STANDARD CHARACTERS WITHOUT CLAIM TO ANY PARTICULAR FONT, STYLE, SIZE, OR COLOR.  
FOR LIVESTOCK FEED SUPPLEMENTS AND MINERALS FOR USE AS ANIMAL FEED SUPPLEMENTS (U.S. CLS. 6, 18, 44, 46, 51 AND 52).  
EVELYN BRADLEY, EXAMINING ATTORNEY

SN 77-023,136. PUMP FORMULATIONS LTD., MISSISSAUGA, ON, CANADA, FILED 10-17-2006.

# NANOVAPOR

THE MARK CONSISTS OF STANDARD CHARACTERS WITHOUT CLAIM TO ANY PARTICULAR FONT, STYLE, SIZE, OR COLOR.  
FOR FOOD SUPPLEMENTS, NUTRITIONAL SUPPLEMENTS, VITAMIN SUPPLEMENTS, DIETARY SUPPLEMENTS; INGREDIENTS FOR FOOD SUPPLEMENTS, NUTRITIONAL SUPPLEMENTS, VITAMIN SUPPLEMENTS AND DIETARY SUPPLEMENTS (U.S. CLS. 6, 18, 44, 46, 51 AND 52).  
ALICIA COLLINS, EXAMINING ATTORNEY

SN 77-040,936. VETERINARY DIAGNOSTICS INSTITUTE, INC., IRVINE, CA. FILED 11-9-2006.

# Canine CardioStat

THE MARK CONSISTS OF STANDARD CHARACTERS WITHOUT CLAIM TO ANY PARTICULAR FONT, STYLE, SIZE, OR COLOR.  
NO CLAIM IS MADE TO THE EXCLUSIVE RIGHT TO USE "CANINE", APART FROM THE MARK AS SHOWN.  
FOR DIAGNOSTIC PREPARATIONS TO DETECT LEVELS OF HORMONES IN ANIMALS FOR DIAGNOSIS AND TREATMENT (U.S. CLS. 6, 18, 44, 46, 51 AND 52).  
RAUL CORDOVA, EXAMINING ATTORNEY

SN 77-026,829. KENT FEEDS, INC., MUSCATINE, IA. FILED 10-23-2006.

# Winning Fill

THE MARK CONSISTS OF STANDARD CHARACTERS WITHOUT CLAIM TO ANY PARTICULAR FONT, STYLE, SIZE, OR COLOR.  
FOR LIVESTOCK FEED SUPPLEMENTS (U.S. CLS. 6, 18, 44, 46, 51 AND 52).  
EVELYN BRADLEY, EXAMINING ATTORNEY

SN 77-042,210. BRECKENRIDGE PHARMACEUTICAL, INC., BOCA RATON, FL. FILED 11-13-2006.

# Rhinabid

THE MARK CONSISTS OF STANDARD CHARACTERS WITHOUT CLAIM TO ANY PARTICULAR FONT, STYLE, SIZE, OR COLOR.  
FOR PHARMACEUTICAL PREPARATIONS FOR THE TREATMENT OF COUGH AND COLD CONDITIONS (U.S. CLS. 6, 18, 44, 46, 51 AND 52).  
LAURA HAMMEL, EXAMINING ATTORNEY

**CLASS 5—(Continued).**

SN 77-047,788. ALLERGAN, INC., IRVINE, CA. FILED 11-20-2006.

**AQUAVANCE**

THE MARK CONSISTS OF STANDARD CHARACTERS WITHOUT CLAIM TO ANY PARTICULAR FONT, STYLE, SIZE, OR COLOR.

FOR PHARMACEUTICAL FORMULATION WHICH ASSISTS WITH HYDRATION OF THE CORNEAL EPITHELIAL CELLS TO PROTECT THEM FROM OSMOTIC STRESS, SOLD AS AN INTEGRAL COMPONENT OF OPHTHALMIC PREPARATIONS (U.S. CLS. 6, 18, 44, 46, 51 AND 52).

ALEX KEAM, EXAMINING ATTORNEY

SN 77-048,815. OSMEGEN, INC., LEHIGH VALLEY, PA. FILED 11-21-2006.

**Odor Air-Magnet**

THE MARK CONSISTS OF STANDARD CHARACTERS WITHOUT CLAIM TO ANY PARTICULAR FONT, STYLE, SIZE, OR COLOR.

NO CLAIM IS MADE TO THE EXCLUSIVE RIGHT TO USE ODOR, APART FROM THE MARK AS SHOWN.

FOR DEODORIZING PRODUCTS; NAMELY, ALL PURPOSE DEODORIZER PREPARATIONS FOR HOUSEHOLD, COMMERCIAL AND INDUSTRIAL USE (U.S. CLS. 6, 18, 44, 46, 51 AND 52).

FIRST USE 2-2-1998; IN COMMERCE 2-2-1998.  
AMY GEARIN, EXAMINING ATTORNEY

SN 77-055,120. MEDICIS PHARMACEUTICAL CORPORATION, SCOTTSDALE, AZ. FILED 12-1-2006.

**ZIANA**

THE MARK CONSISTS OF A SWIRL.  
FOR PHARMACEUTICAL PREPARATIONS FOR DERMATOLOGIC USE, NAMELY, TOPICAL PREPARATIONS FOR THE TREATMENT OF ACNE AND TOPICAL PREPARATIONS FOR THE TREATMENT OF STEROID-RESPONSIVE DERMATOSES, EXCLUDING PREPARATIONS FOR THE TREATMENT, OR ALLEVIATION OF VIRAL INFECTIONS, REGARDLESS OF THEIR DOSAGE FORM (U.S. CLS. 6, 18, 44, 46, 51 AND 52).

SCOTT BIBB, EXAMINING ATTORNEY

**CLASS 5—(Continued).**

SN 77-057,126. PUMP FORMULATIONS LTD., MISSISSAUGA, ONTARIO, CANADA, FILED 12-5-2006.

**VASOPRIME**

THE MARK CONSISTS OF STANDARD CHARACTERS WITHOUT CLAIM TO ANY PARTICULAR FONT, STYLE, SIZE, OR COLOR.

FOR INGREDIENT BLEND SOLD AS A COMPONENT OF NUTRITIONAL SUPPLEMENTS (U.S. CLS. 6, 18, 44, 46, 51 AND 52).

ALICIA COLLINS, EXAMINING ATTORNEY

SN 77-057,152. PUMP FORMULATIONS LTD., MISSISSAUGA, ONTARIO, CANADA, FILED 12-5-2006.

**MYOGF**

THE MARK CONSISTS OF STANDARD CHARACTERS WITHOUT CLAIM TO ANY PARTICULAR FONT, STYLE, SIZE, OR COLOR.

FOR INGREDIENT BLEND SOLD AS A COMPONENT OF NUTRITIONAL SUPPLEMENTS (U.S. CLS. 6, 18, 44, 46, 51 AND 52).

ALICIA COLLINS, EXAMINING ATTORNEY

SN 77-062,460. CELGENE CORPORATION, SUMMIT, NJ. FILED 12-12-2006.

**MODUMID**

THE MARK CONSISTS OF STANDARD CHARACTERS WITHOUT CLAIM TO ANY PARTICULAR FONT, STYLE, SIZE, OR COLOR.

PRIORITY CLAIMED UNDER SEC. 44(D) ON SWITZERLAND APPLICATION NO. 58381/2006, FILED 9-18-2006, REG. NO. 551906, DATED 9-18-2006, EXPIRES 9-18-2016.

FOR PHARMACEUTICAL PREPARATIONS THAT MODULATE THE IMMUNE SYSTEM; PHARMACEUTICAL PREPARATIONS, NAMELY CYTOKINE INHIBITORY DRUGS; PHARMACEUTICAL PREPARATIONS FOR THE TREATMENT OF ONCOLOGY, INFLAMMATION, DERMATOLOGY AND OPHTHALMOLOGY DISEASES AND ILLNESSES (U.S. CLS. 6, 18, 44, 46, 51 AND 52).

JAY FLOWERS, EXAMINING ATTORNEY

**CLASS 5—(Continued).**

SN 77-063,735. NUFARM AMERICAS INC., BURR RIDGE, IL. FILED 12-13-2006.

# NUPHATE

THE MARK CONSISTS OF STANDARD CHARACTERS WITHOUT CLAIM TO ANY PARTICULAR FONT, STYLE, SIZE, OR COLOR.

FOR FUNGICIDES; HERBICIDES FOR AGRICULTURAL USE; HERBICIDES FOR DOMESTIC USE; INSECTICIDES; PESTICIDES (U.S. CLS. 6, 18, 44, 46, 51 AND 52).

DAYNA BROWNE, EXAMINING ATTORNEY

**CLASS 5—(Continued).**

SN 78-109,776. ALTANA PHARMA AG, KONSTANZ, FED REP GERMANY, FILED 2-19-2002.

# AZAZA

OWNER OF FED REP GERMANY REG. NO. 30208425, DATED 3-22-2002, EXPIRES 2-28-2012.

FOR PHARMACEUTICAL PREPARATIONS FOR THE TREATMENT OF RESPIRATORY DISEASES AND CONDITIONS. PHARMACEUTICAL PREPARATIONS FOR THE TREATMENT OF GASTRO-INTESTINAL DISEASES AND CONDITIONS (U.S. CLS. 6, 18, 44, 46, 51 AND 52).

ROBIN CHOSID, EXAMINING ATTORNEY

SN 77-064,072. LOVELAND PRODUCTS, INC., GREELEY, CO. FILED 12-14-2006.

# PREY

THE MARK CONSISTS OF STANDARD CHARACTERS WITHOUT CLAIM TO ANY PARTICULAR FONT, STYLE, SIZE, OR COLOR.

FOR INSECTICIDES (U.S. CLS. 6, 18, 44, 46, 51 AND 52).

FIRST USE 7-0-2006; IN COMMERCE 7-0-2006.

CHARISMA HAMPTON, EXAMINING ATTORNEY

SN 78-109,780. ALTANA PHARMA AG, KONSTANZ, FED REP GERMANY, FILED 2-19-2002.

# FREATHE

OWNER OF FED REP GERMANY REG. NO. 30208427, DATED 3-22-2002, EXPIRES 3-22-2012.

FOR PHARMACEUTICAL PREPARATIONS FOR THE TREATMENT OF RESPIRATORY DISEASES AND CONDITIONS (U.S. CLS. 6, 18, 44, 46, 51 AND 52).

KIMBERLY PERRY, EXAMINING ATTORNEY

SN 77-069,364. DOW AGROSCIENCES LLC, INDIANAPOLIS, IN. FILED 12-21-2006.

# SPLAT-MAT

THE MARK CONSISTS OF STANDARD CHARACTERS WITHOUT CLAIM TO ANY PARTICULAR FONT, STYLE, SIZE, OR COLOR.

FOR PESTICIDES AND PREPARATIONS FOR DESTROYING VERMIN, NAMELY HERBICIDES, INSECTICIDES AND FUNGICIDES FOR AGRICULTURE, HORTICULTURE, FORESTRY, TURF AND ORNAMENTAL, COMMERCIAL, INDUSTRIAL AND DOMESTIC USE (U.S. CLS. 6, 18, 44, 46, 51 AND 52).

AISHA CLARKE, EXAMINING ATTORNEY

SN 78-262,433. S.A.N. CORPORATION, OXNARD, CA. FILED 6-13-2003.

# FUEL INJECTION V-12

FOR DIETARY SUPPLEMENT USED IN CONJUNCTION WITH DIET AND EXERCISE PROGRAM (U.S. CLS. 6, 18, 44, 46, 51 AND 52).

FIRST USE 3-1-2002; IN COMMERCE 6-29-2002.

ZHALEH DELANEY, EXAMINING ATTORNEY

**CLASS 5—(Continued).**

SN 78-388,016. PHOENIX LABORATORIES, INC., HICKSVILLE, NY. FILED 3-20-2004.

# CYENCE LABS

THE MARK CONSISTS OF STANDARD CHARACTERS WITHOUT CLAIM TO ANY PARTICULAR FONT, STYLE, SIZE, OR COLOR.

NO CLAIM IS MADE TO THE EXCLUSIVE RIGHT TO USE "LABS", APART FROM THE MARK AS SHOWN.

FOR DIETARY AND NUTRITIONAL SUPPLEMENTS, DIETARY AND NUTRITIONAL SUPPLEMENT DRINK MIXES, MEAL REPLACEMENT DRINK MIXES, MEAL REPLACEMENT POWDERS, MEAL REPLACEMENT DRINKS, AND NUTRITIONAL DRINK MIX FOR USE AS A MEAL REPLACEMENT (U.S. CLS. 6, 18, 44, 46, 51 AND 52).

SHAUNIA WALLACE, EXAMINING ATTORNEY

SN 78-423,934. C.P. PHARMACEUTICALS INTERNATIONAL C.V., NEW YORK, NY. FILED 5-24-2004.

# LYRICA

THE MARK CONSISTS OF STANDARD CHARACTERS WITHOUT CLAIM TO ANY PARTICULAR FONT, STYLE, SIZE, OR COLOR.

FOR PHARMACEUTICAL PREPARATIONS FOR THE TREATMENT OF CENTRAL NERVOUS SYSTEM DISEASES AND DISORDERS, NEUROLOGICAL DISORDERS, UROLOGICAL DISORDERS, UROGENITAL DISORDERS, GASTROINTESTINAL DISORDERS, MUSCULOSKELETAL DISORDERS, ALLERGIES, DIABETES, HYPERTENSION, ERECTILE DYSFUNCTION, SEXUAL DYSFUNCTION, STROKE, CANCER, MIGRAINES, PAIN, OBESITY, INFLAMMATION, INFLAMMATORY DISEASES, RESPIRATORY DISEASES, INFECTIOUS DISEASES, IMMUNOLOGICAL DISORDERS, VIRAL DISORDERS, FUNGAL DISORDERS; PHARMACEUTICAL PREPARATIONS, NAMELY, CHOLESTEROL PREPARATIONS, SMOKING CESSATION PREPARATIONS, DERMATOLOGICAL PREPARATIONS, GYNECOLOGICAL PREPARATIONS, OSTEOPOROSIS PREPARATIONS, OPHTHALMOLOGICAL PREPARATIONS, PREPARATIONS FOR THE TREATMENT OF HIV AND AIDS (U.S. CLS. 6, 18, 44, 46, 51 AND 52).

STEVEN R. FINE, EXAMINING ATTORNEY

**CLASS 5—(Continued).**

SN 78-608,262. NGUYEN, TUONG, LOS ANGELES, CA. FILED 4-13-2005.

# ARTHRI-GEL

THE MARK CONSISTS OF STANDARD CHARACTERS WITHOUT CLAIM TO ANY PARTICULAR FONT, STYLE, SIZE, OR COLOR.

FOR NUTRITIONAL SUPPLEMENT (U.S. CLS. 6, 18, 44, 46, 51 AND 52).

GINA HAYES, EXAMINING ATTORNEY

SN 78-608,277. NGUYEN, TUONG, LOS ANGELES, CA. FILED 4-13-2005.

# IMMUNE EXCEL

THE MARK CONSISTS OF STANDARD CHARACTERS WITHOUT CLAIM TO ANY PARTICULAR FONT, STYLE, SIZE, OR COLOR.

NO CLAIM IS MADE TO THE EXCLUSIVE RIGHT TO USE "IMMUNE", APART FROM THE MARK AS SHOWN.

FOR NUTRITIONAL SUPPLEMENT (U.S. CLS. 6, 18, 44, 46, 51 AND 52).

GINA HAYES, EXAMINING ATTORNEY

SN 78-609,435. GLAXO GROUP LIMITED, GREENFORD, UNITED KINGDOM, FILED 4-15-2005.

# PROAVAN

THE MARK CONSISTS OF STANDARD CHARACTERS WITHOUT CLAIM TO ANY PARTICULAR FONT, STYLE, SIZE, OR COLOR.

PRIORITY CLAIMED UNDER SEC. 44(D) ON ERPNCMNTY TM OFC APPLICATION NO. 004212874, FILED 12-22-2004.

FOR PHARMACEUTICAL PREPARATIONS AND SUBSTANCES FOR THE TREATMENT OF INFECTIOUS DISEASES, PAIN, INFLAMMATION, SEPSIS, ALOPECIA AND OBESITY, AND FOR THE TREATMENT OF VIRAL, METABOLIC, MUSCULOSKELETAL, CARDIOPULMONARY, GENITOURINARY, ONCOLOGICAL, RESPIRATORY, NEUROLOGICAL, GASTROINTESTINAL, HORMONAL, DERMATOLOGICAL AND PSYCHIATRIC RELATED DISEASES AND DISORDERS AND SKIN AND TISSUE REPAIR PREPARATIONS (U.S. CLS. 6, 18, 44, 46, 51 AND 52).

KATHRYN COWARD, EXAMINING ATTORNEY



**CLASS 5—(Continued).**

SN 78-616,074. UNITED STATES NUTRITION, INC., BOHEMIA, NY. FILED 4-25-2005.



THE STIPPLING IS FOR SHADING PURPOSES ONLY.  
THE MARK CONSISTS OF STYLIZED LETTERS WHICH COMPRISE THE ONE WORD TRADEMARK "AIRRAIDERS" TOGETHER WITH A DESIGN DEPICTING A RADAR SCREEN.  
FOR VITAMINS, MINERAL SUPPLEMENTS AND NUTRITIONAL SUPPLEMENTS (U.S. CLS. 6, 18, 44, 46, 51 AND 52).  
WON TEAK OH, EXAMINING ATTORNEY

SN 78-621,953. BRISTOL-MYERS SQUIBB & GILEAD SCIENCES, LLC, FOSTER CITY, CA. FILED 5-3-2005.

# OTRICA

THE MARK CONSISTS OF STANDARD CHARACTERS WITHOUT CLAIM TO ANY PARTICULAR FONT, STYLE, SIZE, OR COLOR.  
FOR PHARMACEUTICAL PREPARATIONS FOR THE TREATMENT OF INFECTIOUS DISEASES, DISORDERS AND CONDITIONS FOR HUMAN USE (U.S. CLS. 6, 18, 44, 46, 51 AND 52).  
JEFF DEFORD, EXAMINING ATTORNEY

SN 78-652,535. INNOVATIVE HEALTH PRODUCTS, INC., LARGO, FL. FILED 6-16-2005.

# Air Defense

THE MARK CONSISTS OF STANDARD CHARACTERS WITHOUT CLAIM TO ANY PARTICULAR FONT, STYLE, SIZE, OR COLOR.  
FOR DIETARY AND NUTRITIONAL SUPPLEMENT (U.S. CLS. 6, 18, 44, 46, 51 AND 52).  
SEAN CROWLEY, EXAMINING ATTORNEY

**CLASS 5—(Continued).**

SN 78-770,599. PRIME HEALTH DIETARY SUPPLEMENTS, INC., VENTURA, CA. FILED 12-9-2005.

# Think!

THE MARK CONSISTS OF STANDARD CHARACTERS WITHOUT CLAIM TO ANY PARTICULAR FONT, STYLE, SIZE, OR COLOR.  
FOR DIETARY FOOD SUPPLEMENTS; FOOD SUPPLEMENTS; MEAL REPLACEMENT BARS (U.S. CLS. 6, 18, 44, 46, 51 AND 52).  
FIRST USE 8-5-1994; IN COMMERCE 8-5-1994.  
MARGERY A. TIERNEY, EXAMINING ATTORNEY

SN 78-773,501. MALEK, S. SHANE, LAS VEGAS, NV. FILED 12-14-2005.

# SCALPMED

THE MARK CONSISTS OF STANDARD CHARACTERS WITHOUT CLAIM TO ANY PARTICULAR FONT, STYLE, SIZE, OR COLOR.  
FOR MEDICATED TOPICAL HAIR LOSS CONTROL LOTIONS, MOUSSES, GELS, SPRAYS, CREAMS, SHAMPOOS, CONDITIONERS, RINSES, AND OINTMENTS (U.S. CLS. 6, 18, 44, 46, 51 AND 52).  
FIRST USE 4-1-2002; IN COMMERCE 9-1-2003.  
KIMBERLY FRYE, EXAMINING ATTORNEY

SN 78-788,830. TUONG VAN NGUYEN, LOS ANGELES, CA. FILED 1-10-2006.

# INFINITE HERBAL

THE MARK CONSISTS OF STANDARD CHARACTERS WITHOUT CLAIM TO ANY PARTICULAR FONT, STYLE, SIZE, OR COLOR.  
NO CLAIM IS MADE TO THE EXCLUSIVE RIGHT TO USE "HERBAL", APART FROM THE MARK AS SHOWN.  
FOR NUTRITIONAL SUPPLEMENTS (U.S. CLS. 6, 18, 44, 46, 51 AND 52).  
MELISSA VALLILLO, EXAMINING ATTORNEY

**CLASS 5—(Continued).**

SN 78-805,068. FIRMAGEN NUTRACEUTICALS, INC., BOCA RATON, FL. FILED 2-2-2006.

**ALPHADERMALENE-PBF**

THE MARK CONSISTS OF STANDARD CHARACTERS WITHOUT CLAIM TO ANY PARTICULAR FONT, STYLE, SIZE, OR COLOR.

FOR ANTIOXIDANT INGREDIENTS IN A DIGESTIBLE DIETARY SUPPLEMENT (U.S. CLS. 6, 18, 44, 46, 51 AND 52).

FIRST USE 5-11-2003; IN COMMERCE 5-11-2003.  
DAVID STERKIN, EXAMINING ATTORNEY

SN 78-806,231. TRIDENT SCIENCES, LLC., VIENNA, VA. FILED 2-3-2006.

**BIOACTIN**

THE MARK CONSISTS OF STANDARD CHARACTERS WITHOUT CLAIM TO ANY PARTICULAR FONT, STYLE, SIZE, OR COLOR.

FOR MEDICATED LOTIONS AND OINTMENTS FOR THE TREATMENT OF ACNE, MALE PATTERNED BALDNESS, KELOIDS, ADHESIONS, ELASTIN SYNTHESIS, WRINKLES, OSTEOARTHRITIS, AND CONDITIONS MEDIATED BY ANDROGEN RECEPTORS, NAMELY ACNE, MALE PATTERNED BALDNESS, KELOID SCARRING, ABDOMINAL ADHESIONS, HEREDITARY DEAFNESS AND PEYRONI'S DISEASE (U.S. CLS. 6, 18, 44, 46, 51 AND 52).

RON FAIRBANKS, EXAMINING ATTORNEY

SN 78-809,427. CELL GENESYS, INC., SOUTH SAN FRANCISCO, CA. FILED 2-7-2006.

**CIRZEDE**

THE MARK CONSISTS OF STANDARD CHARACTERS WITHOUT CLAIM TO ANY PARTICULAR FONT, STYLE, SIZE, OR COLOR.

FOR PHARMACEUTICAL PREPARATIONS FOR IMMUNOTHERAPY AND FOR THE TREATMENT OF CANCER, PROSTATE DISEASES, PANCREATIC DISEASES, AND LEUKEMIA (U.S. CLS. 6, 18, 44, 46, 51 AND 52).

HANNO RITTNER, EXAMINING ATTORNEY

**CLASS 5—(Continued).**

SN 78-810,487. CONNETICS CORPORATION, PALO ALTO, CA. FILED 2-8-2006.

**CORE**

THE MARK CONSISTS OF STANDARD CHARACTERS WITHOUT CLAIM TO ANY PARTICULAR FONT, STYLE, SIZE, OR COLOR.

FOR PHARMACEUTICAL PREPARATIONS FOR DERMATOLOGICAL USE; DRUG DELIVERY SYSTEMS IN THE NATURE OF TOPICAL APPLICATIONS, NAMELY, FOAMS, GELS, LIQUIDS, OINTMENTS, CREAMS AND LOTIONS, FOR ADMINISTERING DRUG PREPARATIONS TO THE SKIN (U.S. CLS. 6, 18, 44, 46, 51 AND 52).  
CAROLYN CATALDO, EXAMINING ATTORNEY

SN 78-813,480. CERAGENIX PHARMACEUTICALS, INC., DENVER, CO. FILED 2-13-2006.

**CERACIDE**

THE MARK CONSISTS OF STANDARD CHARACTERS WITHOUT CLAIM TO ANY PARTICULAR FONT, STYLE, SIZE, OR COLOR.

FOR ANTI-BACTERIAL, ANTI-VIRAL, AND ANTI-FUNGAL COATINGS FOR MEDICAL DEVICES TO HELP PREVENT BACTERIAL COLONIZATION AND INFECTION (U.S. CLS. 6, 18, 44, 46, 51 AND 52).

NAKIA HENRY, EXAMINING ATTORNEY

SN 78-817,480. MEDPOINTE HEALTHCARE INC., SOMERSET, NJ. FILED 2-17-2006.

**ASTELIN**

THE MARK CONSISTS OF STANDARD CHARACTERS WITHOUT CLAIM TO ANY PARTICULAR FONT, STYLE, SIZE, OR COLOR.

OWNER OF U.S. REG. NOS. 1,395,499, 2,070,525 AND 2,130,525.

FOR ANTIHISTAMINE SPRAY USED TO TREAT NASAL SYMPTOMS CAUSED BY ALLERGENS AND IRRITANTS (U.S. CLS. 6, 18, 44, 46, 51 AND 52).

FIRST USE 2-10-2006; IN COMMERCE 2-10-2006.

MICHAEL KAZAZIAN, EXAMINING ATTORNEY

**CLASS 5—(Continued).**

SN 78-817,861. MEDPOINTE HEALTHCARE INC., SOMERSET, NJ. FILED 2-17-2006.



OWNER OF U.S. REG. NOS. 1,395,499, 2,070,525 AND 2,130,525.

THE COLOR(S) BLUE, WHITE IS/ARE CLAIMED AS A FEATURE OF THE MARK.

THE MARK CONSISTS OF BLUE AND WHITE BOTTLE, THE WORD ASTELIN IN SPECIAL FORM IN BLUE WITH A BLUE TRIANGLE. THE OUTLINE PORTION OF THE BOTTLE IS PRESENTED IN DOTTED LINES TO INDICATE THAT IT IS NOT A PART OF THE MARK.

FOR ANTIHISTAMINE SPRAY USED TO TREAT NASAL SYMPTOMS CAUSED BY ALLERGENS AND IRRITANTS (U.S. CLS. 6, 18, 44, 46, 51 AND 52).

FIRST USE 2-10-2006; IN COMMERCE 2-10-2006. MICHAEL KAZAZIAN, EXAMINING ATTORNEY



SN 78-861,364. A.C. GRACE COMPANY, BIG SANDY, TX. FILED 4-13-2006.

# Unique Omega E

THE MARK CONSISTS OF STANDARD CHARACTERS WITHOUT CLAIM TO ANY PARTICULAR FONT, STYLE, SIZE, OR COLOR.

OWNER OF U.S. REG. NO. 2,288,889. NO CLAIM IS MADE TO THE EXCLUSIVE RIGHT TO USE "OMEGA E", APART FROM THE MARK AS SHOWN. SEC. 2(F) AS TO "UNIQUE".

FOR NUTRITIONAL SUPPLEMENTS, NAMELY, CAPSULES FOR NATURAL VITAMIN E (U.S. CLS. 6, 18, 44, 46, 51 AND 52).

GILBERT SWIFT, EXAMINING ATTORNEY

**CLASS 5—(Continued).**

SN 78-865,065. FOSTER & SMITH, INC., RHINELANDER, WI. FILED 4-19-2006.

# MEDI-BITES

THE MARK CONSISTS OF STANDARD CHARACTERS WITHOUT CLAIM TO ANY PARTICULAR FONT, STYLE, SIZE, OR COLOR.

FOR VETERINARY PREPARATION FOR AIDING IN THE ORAL ADMINISTRATION OF PRESCRIPTION MEDICINES TO ANIMALS, NAMELY, BISCUITS THAT CAN BE USED WITH A WIDE VARIETY OF TABLET-FORM OR LIQUID MEDICINES TO INCREASE THE PALATABILITY OF THE MEDICINES TO PETS (U.S. CLS. 6, 18, 44, 46, 51 AND 52).

SETH A. RAPPAPORT, EXAMINING ATTORNEY



SN 78-868,985. BRISTOL-MYERS SQUIBB COMPANY, NEW YORK, NY. FILED 4-25-2006.

# FIMITAR

THE MARK CONSISTS OF STANDARD CHARACTERS WITHOUT CLAIM TO ANY PARTICULAR FONT, STYLE, SIZE, OR COLOR.

FOR PHARMACEUTICAL PREPARATIONS FOR HUMAN USE FOR THE TREATMENT AND PREVENTION OF OBESITY, DIABETES, INCONTINENCE, CARDIOVASCULAR DISEASES, CENTRAL NERVOUS SYSTEM DISEASES AND DISORDERS, METABOLIC DISORDERS, STROKE, CANCER, INFLAMMATION AND INFLAMMATORY DISEASES, RESPIRATORY AND INFECTIOUS DISEASES, AUTO-IMMUNE DISEASES, SOLID ORGAN TRANSPLANT REJECTION; PHARMACEUTICAL PREPARATIONS FOR HUMAN USE, NAMELY, ANTIBIOTICS, ANTI-FUNGALS, ANTI-VIRALS, IMMUNOSUPPRESSANTS, AND PHARMACEUTICAL ANTIBODIES; DIAGNOSTIC PHARMACEUTICAL PREPARATIONS FOR HUMAN USE; PHARMACEUTICAL PREPARATIONS FOR HUMAN USE, NAMELY, DIAGNOSTIC IMAGING AND ULTRASOUND CONTRAST AGENTS; PHARMACEUTICAL PREPARATIONS FOR HUMAN USE FOR IDENTIFYING AND DIAGNOSING CARDIOVASCULAR DISEASES AND CONDITIONS; DIAGNOSTIC PHARMACEUTICAL PREPARATIONS FOR HUMAN USE, NAMELY, PREPARATIONS FOR INCREASING THE HEART RATE FOR DIAGNOSTIC PURPOSES (U.S. CLS. 6, 18, 44, 46, 51 AND 52).

LINDA ORNDORFF, EXAMINING ATTORNEY

**CLASS 5—(Continued).**

SN 78-869,008. BRISTOL-MYERS SQUIBB COMPANY, NEW YORK, NY. FILED 4-25-2006.

**BREGLIV**

THE MARK CONSISTS OF STANDARD CHARACTERS WITHOUT CLAIM TO ANY PARTICULAR FONT, STYLE, SIZE, OR COLOR.

FOR PHARMACEUTICAL PREPARATIONS FOR HUMAN USE FOR THE TREATMENT AND PREVENTION OF OBESITY, DIABETES, INCONTINENCE, CARDIOVASCULAR DISEASES, CENTRAL NERVOUS SYSTEM DISEASES AND DISORDERS, METABOLIC DISORDERS, STROKE, CANCER, INFLAMMATION AND INFLAMMATORY DISEASES, RESPIRATORY AND INFECTIOUS DISEASES, AUTO-IMMUNE DISEASES, SOLID ORGAN TRANSPLANT REJECTION; PHARMACEUTICAL PREPARATIONS FOR HUMAN USE, NAMELY, ANTIBIOTICS, ANTI-FUNGALS, ANTI-VIRALS, IMMUNOSUPPRESSANTS, AND PHARMACEUTICAL ANTIBODIES; DIAGNOSTIC PHARMACEUTICAL PREPARATIONS FOR HUMAN USE; PHARMACEUTICAL PREPARATIONS FOR HUMAN USE, NAMELY, DIAGNOSTIC IMAGING AND ULTRASOUND CONTRAST AGENTS; PHARMACEUTICAL PREPARATIONS FOR HUMAN USE FOR IDENTIFYING AND DIAGNOSING CARDIOVASCULAR DISEASES AND CONDITIONS; DIAGNOSTIC PHARMACEUTICAL PREPARATIONS FOR HUMAN USE, NAMELY, PREPARATIONS FOR INCREASING THE HEART RATE FOR DIAGNOSTIC PURPOSES (U.S. CLS. 6, 18, 44, 46, 51 AND 52).

LINDA ORNDORFF, EXAMINING ATTORNEY

SN 78-870,265. ALTANA PHARMA AG, KONSTANZ, FED REP GERMANY, FILED 4-26-2006.

**LIBERTEK**

THE MARK CONSISTS OF STANDARD CHARACTERS WITHOUT CLAIM TO ANY PARTICULAR FONT, STYLE, SIZE, OR COLOR.

OWNER OF FED REP GERMANY REG. NO. 30576855, DATED 2-2-2006, EXPIRES 12-22-2015.

FOR PHARMACEUTICAL PRODUCTS, NAMELY, PREPARATIONS FOR THE TREATMENT OF RESPIRATORY DISEASES AND CONDITIONS, ANTI-INFLAMMATORY PREPARATIONS, ANTI-ALLERGIC PREPARATIONS (U.S. CLS. 6, 18, 44, 46, 51 AND 52).

ROBERT C. CLARK JR., EXAMINING ATTORNEY

**CLASS 5—(Continued).**

SN 78-870,486. CLUBNATURAL, INC., IRVINE, CA. FILED 4-26-2006.

**Osteozyme**

THE MARK CONSISTS OF STANDARD CHARACTERS WITHOUT CLAIM TO ANY PARTICULAR FONT, STYLE, SIZE, OR COLOR.

FOR DIETARY AND NUTRITIONAL SUPPLEMENTS (U.S. CLS. 6, 18, 44, 46, 51 AND 52).

FIRST USE 1-1-2004; IN COMMERCE 1-1-2004.  
DAVID HOFFMAN, EXAMINING ATTORNEY

SN 78-882,286. HEALTH INTERNATIONAL CORPORATION, ST. PETERSBURG, FL. FILED 5-12-2006.

**CARBCONSCIOUS**

THE MARK CONSISTS OF STANDARD CHARACTERS WITHOUT CLAIM TO ANY PARTICULAR FONT, STYLE, SIZE, OR COLOR.

FOR PROTEIN SHAKES FOR USE AS DIETARY SUPPLEMENTS; MEAL REPLACEMENT SHAKES (U.S. CLS. 6, 18, 44, 46, 51 AND 52).

ALICE BENMAMAN, EXAMINING ATTORNEY

SN 78-882,426. QUATRX PHARMACEUTICALS COMPANY, ANN ARBOR, MI. FILED 5-12-2006.

**OPHENA**

THE MARK CONSISTS OF STANDARD CHARACTERS WITHOUT CLAIM TO ANY PARTICULAR FONT, STYLE, SIZE, OR COLOR.

FOR PHARMACEUTICAL PREPARATIONS FOR USE IN THE TREATMENT OF MENOPAUSAL DISORDERS AND OTHER DISORDERS OF AGING WOMEN (U.S. CLS. 6, 18, 44, 46, 51 AND 52).

SALLY SHIH, EXAMINING ATTORNEY

**CLASS 5—(Continued).**

SN 78-882,682. BELL AUTOMOTIVE PRODUCTS, INC., SCOTTSDALE, AZ. FILED 5-12-2006.

**CLASS 5—(Continued).**

SN 78-910,457. BIOLITEC, INC., EAST LONGMEADOW, MA. FILED 6-16-2006.

## SHOWROOM FRESH

THE MARK CONSISTS OF STANDARD CHARACTERS WITHOUT CLAIM TO ANY PARTICULAR FONT, STYLE, SIZE, OR COLOR.

NO CLAIM IS MADE TO THE EXCLUSIVE RIGHT TO USE "FRESH", APART FROM THE MARK AS SHOWN.

FOR VEHICLE AIR FRESHENERS (U.S. CLS. 6, 18, 44, 46, 51 AND 52).

FIRST USE 3-31-2006; IN COMMERCE 3-31-2006.  
LINDA LAVACHE, EXAMINING ATTORNEY



SN 78-895,936. NANO DITECH CORPORATION, MONMOUTH JUNCTION, NJ. FILED 5-30-2006.

## Lab on a Film Chip

THE MARK CONSISTS OF STANDARD CHARACTERS WITHOUT CLAIM TO ANY PARTICULAR FONT, STYLE, SIZE, OR COLOR.

NO CLAIM IS MADE TO THE EXCLUSIVE RIGHT TO USE "FILM CHIP", APART FROM THE MARK AS SHOWN.

FOR MEDICAL DIAGNOSTIC IMMUNOASSAYS FOR TESTING OF BODY FLUIDS (U.S. CLS. 6, 18, 44, 46, 51 AND 52).

WILLIAM P. SHANAHAN, EXAMINING ATTORNEY



SN 78-910,301. PRISM PHARMACEUTICALS, INC., KING OF PRUSSIA, PA. FILED 6-16-2006.

## NEXTERONE

THE MARK CONSISTS OF STANDARD CHARACTERS WITHOUT CLAIM TO ANY PARTICULAR FONT, STYLE, SIZE, OR COLOR.

FOR INJECTABLE PHARMACEUTICAL PREPARATION FOR USE IN ACUTE CARDIAC AND CIRCULATORY DISORDERS (U.S. CLS. 6, 18, 44, 46, 51 AND 52).

KATHERINE M. DUBRAY, EXAMINING ATTORNEY



OWNER OF U.S. REG. NOS. 2,789,692, 3,121,482 AND OTHERS.

NO CLAIM IS MADE TO THE EXCLUSIVE RIGHT TO USE "BIOMEDICAL TECHNOLOGY", APART FROM THE MARK AS SHOWN.

FOR LIGHT-ACTIVATED, PHOTO-ACTIVATED, AND LASER-ACTIVATED PREPARATIONS FOR TREATING MACULAR DEGENERATION, FOR CARDIOVASCULAR PLAQUE REMOVAL, FOR DETECTING AND TREATING CANCER, FOR DETECTING AND TREATING LESIONS, FOR RESTENOSES PREVENTION, FOR TREATING PSORIASIS, FOR TREATING BARRETS MUCOSA, FOR PERIODONTAL TREATMENT, FOR TREATING EPILATION, AND FOR NECROTIZING BIOLOGICAL TISSUE; PHARMACEUTICAL AND COSMETIC PREPARATIONS FOR THE TREATMENT AND DIAGNOSIS OF DISEASES RELATING TO DENTISTRY, ONCOLOGY, OPHTHALMOLOGY, UROLOGY, DERMATOLOGY, GYNECOLOGY, CARDIOLOGY, AND IMMUNOLOGY (U.S. CLS. 6, 18, 44, 46, 51 AND 52).

HENRY S. ZAK, EXAMINING ATTORNEY

**CLASS 5—(Continued).**

SN 78-917,373. NICOLES, INC., CHICAGO, IL. FILED 6-26-2006.



NO CLAIM IS MADE TO THE EXCLUSIVE RIGHT TO USE "TOMATO", APART FROM THE MARK AS SHOWN.

THE COLOR(S) THE APPLICANT CLAIMS COLOR AS A FEATURE OF THE MARK, NAMELY, WHITE AND PURPLE IS/ARE CLAIMED AS A FEATURE OF THE MARK.

THE MARK CONSISTS OF A HORIZONTALLY-ORIENTED OVAL, THE INTERIOR OF WHICH IS WHITE AND THE BORDER FOR WHICH IS PURPLE. WITHIN AND ALONG THE TOP BORDER OF THE OVAL APPEAR THE WORDS "LET'S MAKE THE WHOLE THING LAST!" IN PURPLE TEXT AND BELOW WHICH APPEAR THE WORDS (CENTERED LEFT TO RIGHT AND TOP TO BOTTOM), "TOMATO-TOMAHTO!" AND BELOW WHICH APPEARS A HORIZONTAL PURPLE LINE WITHIN THE OUTLINE OF THE LOWER PORTION OF THE OVAL.

FOR BISCUITS, BREAD, BREAD ROLLS, CAKES, CEREAL PRODUCTS, CONFECTIONERY, CRACKERS, NOODLES, FISH SAUCE, RELISH, SAUCES, CEREAL-BASED SNACK-FOODS AND PREPARED DIETARY ITEMS THAT ARE GLUTEN-FREE TO ACCOMMODATE SPECIAL MEDICAL AND HEALTH CONDITIONS (U.S. CLS. 6, 18, 44, 46, 51 AND 52).

FIRST USE 5-1-2006; IN COMMERCE 5-1-2006.  
RENEE MCCRAY, EXAMINING ATTORNEY

**CLASS 5—(Continued).**

SN 78-938,338. JARROW FORMULAS, INC., LOS ANGELES, CA. FILED 7-26-2006.

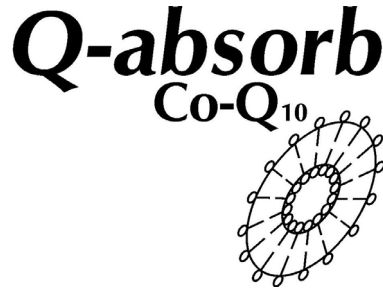

NO CLAIM IS MADE TO THE EXCLUSIVE RIGHT TO USE "COQ10", APART FROM THE MARK AS SHOWN.

THE MARK CONSISTS OF THE WORDING "Q-ABSORB" AT THE TOP OF THE MARK. UNDERNEATH THAT WORDING SITS THE WORDING "CO-Q10" WITH THE "10" AS THE SUBSCRIPT TO THE LETTER "Q". BELOW AND TO THE RIGHT OF THIS WORDING IS THE DESIGN ELEMENT OF THE MARK, WHICH CONSISTS OF TWO CONCENTRIC HOLLOW CIRCLES. THE INNER CIRCLE HAS SMALLER HOLLOW CIRCLES ALONG ITS INNER PERIPHERY, AND THE LARGER CIRCLE HAS SMALL HOLLOW CIRCLES SPACED AROUND ITS OUTER PERIPHERY. BROKEN LINES EXTEND BETWEEN THE SMALL CIRCLES OF THE INNER AND OUTER CIRCLES. THE ENTIRE DESIGN IS ANGLED TO THE RIGHT.

FOR DIETARY AND NUTRITIONAL SUPPLEMENTS (U.S. CLS. 6, 18, 44, 46, 51 AND 52).

FIRST USE 6-14-1999; IN COMMERCE 7-14-1999.  
SETH A. RAPPAPORT, EXAMINING ATTORNEY

SN 78-936,825. UCB, S.A., BRUXELLES, BELGIUM, FILED 7-25-2006.

**KEPPRA XR**

THE MARK CONSISTS OF STANDARD CHARACTERS WITHOUT CLAIM TO ANY PARTICULAR FONT, STYLE, SIZE, OR COLOR.

OWNER OF U.S. REG. NOS. 2,454,519 AND 2,726,258.

NO CLAIM IS MADE TO THE EXCLUSIVE RIGHT TO USE "XR", APART FROM THE MARK AS SHOWN.

FOR PHARMACEUTICAL PREPARATIONS ACTING ON THE CENTRAL NERVOUS SYSTEM (U.S. CLS. 6, 18, 44, 46, 51 AND 52).

LINDA M. KING, EXAMINING ATTORNEY

SN 78-943,803. LEE, YONG H., NORTHRIDGE, CA. FILED 8-3-2006.

**LEPTINO**

THE MARK CONSISTS OF STANDARD CHARACTERS WITHOUT CLAIM TO ANY PARTICULAR FONT, STYLE, SIZE, OR COLOR.

FOR DIETARY SUPPLEMENT TO ASSIST IN INCREASING METABOLISM AND IN WEIGHT CONTROL (U.S. CLS. 6, 18, 44, 46, 51 AND 52).

FIRST USE 6-1-2006; IN COMMERCE 9-1-2006.  
JILL C. ALT, EXAMINING ATTORNEY

**CLASS 5—(Continued).**

SN 78-945,149. NATURAL DENTIST, INC., ENGLEWOOD CLIFFS, NJ. FILED 8-4-2006.

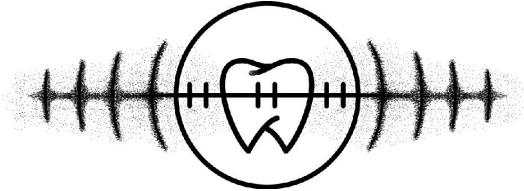

FOR MEDICATED ORAL HEALTH CARE PRODUCTS, NAMELY, MOUTH RINSES, MOUTH WASHES, TOOTH PASTES, TOOTH GELS AND DENTIFRICES, FOR ORAL HEALTH CARE (U.S. CLS. 6, 18, 44, 46, 51 AND 52).  
DAWN HAN, EXAMINING ATTORNEY

**CLASS 5—(Continued).**

SN 78-948,360. PHARMELLE LLC, GILBERT, AZ. FILED 8-9-2006.

**OraSal**

THE MARK CONSISTS OF STANDARD CHARACTERS WITHOUT CLAIM TO ANY PARTICULAR FONT, STYLE, SIZE, OR COLOR.  
FOR MEDICINAL PREPARATIONS FOR THE MOUTH AND AS SPRAYS (U.S. CLS. 6, 18, 44, 46, 51 AND 52).  
PETER CHENG, EXAMINING ATTORNEY

SN 78-945,604. SCIENTIFIC PHARMACEUTICALS, INC., POMONA, CA. FILED 8-4-2006.

**TEMPO-REX**

FOR TEMPORARY DENTAL RESTORATIVE COMPOUNDS (U.S. CLS. 6, 18, 44, 46, 51 AND 52).  
FIRST USE 11-22-1996; IN COMMERCE 11-22-1996.  
JENNIFER KRISP, EXAMINING ATTORNEY

SN 78-948,404. TESSENDERLO KERLEY, INC., PHOENIX, AZ. FILED 8-9-2006.

**SECTAGON-K54**

THE MARK CONSISTS OF STANDARD CHARACTERS WITHOUT CLAIM TO ANY PARTICULAR FONT, STYLE, SIZE, OR COLOR.  
OWNER OF U.S. REG. NOS. 1,577,268 AND 1,813,365.  
FOR AGRICULTURAL CHEMICALS, NAMELY, SOIL FUMIGANTS (U.S. CLS. 6, 18, 44, 46, 51 AND 52).  
FIRST USE 9-1-2006; IN COMMERCE 9-1-2006.  
JUSTINE D. PARKER, EXAMINING ATTORNEY

SN 78-947,922. TOTAL HEALTH ADVANCED NUTRITION, INC., FRIDLEY, MN. FILED 8-8-2006.



NO CLAIM IS MADE TO THE EXCLUSIVE RIGHT TO USE "RX" AND "NUTRITION", APART FROM THE MARK AS SHOWN.  
FOR DIETARY SUPPLEMENTS; FOOD SUPPLEMENTS; HERBAL SUPPLEMENTS; NUTRITIONAL SUPPLEMENTS (U.S. CLS. 6, 18, 44, 46, 51 AND 52).  
FIRST USE 9-10-1998; IN COMMERCE 9-10-1998.  
DAWN HAN, EXAMINING ATTORNEY

SN 78-948,663. DWD CONSUMER PRODUCTS, INC., WEST ORANGE, NJ. FILED 8-9-2006.

**IBSuppress**

THE MARK CONSISTS OF STANDARD CHARACTERS WITHOUT CLAIM TO ANY PARTICULAR FONT, STYLE, SIZE, OR COLOR.  
FOR DIETETIC FOODS ADAPTED FOR MEDICAL USE; NUTRITIONAL SUPPLEMENTS (U.S. CLS. 6, 18, 44, 46, 51 AND 52).  
FIRST USE 1-5-2007; IN COMMERCE 1-5-2007.  
KAPIL BHANOT, EXAMINING ATTORNEY

**CLASS 5—(Continued).**

SN 78-952,231. NATURAL DENTIST, INC., ENGLEWOOD CLIFFS, MA. FILED 8-15-2006.

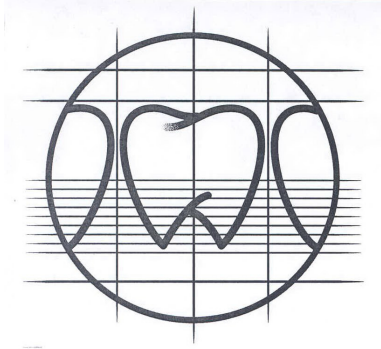

FOR MEDICATED ORAL HEALTH CARE PRODUCTS, NAMELY, MOUTH RINSES, MOUTH WASHES, BREATH-FRESHENING CHEWING GUM IN STICKS FOR MEDICINAL PURPOSES, TOOTH PASTES, TOOTH GELS AND MOUTH DISSOLVABLE FLAVORED EDIBLE FILMS, FOR ORAL HEALTH CARE (U.S. CLS. 6, 18, 44, 46, 51 AND 52).

FIRST USE 12-5-2005; IN COMMERCE 12-5-2005.  
DAWN HAN, EXAMINING ATTORNEY

SN 78-952,509. BOARDROOM, INC., STAMFORD, CT. FILED 8-15-2006.

**BOTTOM LINE PRODUCTS**

THE MARK CONSISTS OF STANDARD CHARACTERS WITHOUT CLAIM TO ANY PARTICULAR FONT, STYLE, SIZE, OR COLOR.

OWNER OF U.S. REG. NOS. 2,148,643 AND 3,057,998.  
NO CLAIM IS MADE TO THE EXCLUSIVE RIGHT TO USE "PRODUCTS", APART FROM THE MARK AS SHOWN.  
FOR VITAMIN AND NUTRITIONAL SUPPLEMENTS (U.S. CLS. 6, 18, 44, 46, 51 AND 52).  
KAREN BRACEY, EXAMINING ATTORNEY

SN 78-952,512. BOARDROOM, INC., STAMFORD, CT. FILED 8-15-2006.

**BOTTOM LINE NUTRITIONALS**

THE MARK CONSISTS OF STANDARD CHARACTERS WITHOUT CLAIM TO ANY PARTICULAR FONT, STYLE, SIZE, OR COLOR.

OWNER OF U.S. REG. NOS. 2,148,643 AND 3,057,998.  
NO CLAIM IS MADE TO THE EXCLUSIVE RIGHT TO USE "NUTRITIONALS", APART FROM THE MARK AS SHOWN.  
FOR VITAMIN AND NUTRITIONAL SUPPLEMENTS (U.S. CLS. 6, 18, 44, 46, 51 AND 52).  
KAREN BRACEY, EXAMINING ATTORNEY

**CLASS 5—(Continued).**

SN 78-953,317. RELIANT PHAMACEUTICALS, INC., LIBERTY CORNER, NJ. FILED 8-16-2006.

**PROVEN. POTENT. PURE.**

THE MARK CONSISTS OF STANDARD CHARACTERS WITHOUT CLAIM TO ANY PARTICULAR FONT, STYLE, SIZE, OR COLOR.

FOR PHARMACEUTICAL PREPARATIONS, NAMELY VITAMIN PREPARATIONS AND NUTRACEUTICALS USED TO TREAT CARDIOVASCULAR ILLNESSES THAT CONTAIN FATTY ACIDS; NUTRACEUTICALS FOR THE TREATMENT OF CARDIOVASCULAR ILLNESS; VITAMIN PREPARATIONS (U.S. CLS. 6, 18, 44, 46, 51 AND 52).

SEAN CROWLEY, EXAMINING ATTORNEY

SN 78-956,436. WHITE GAPS INC., GRAND PRAIRIE, TX. FILED 8-21-2006.

**Sock It**

THE MARK CONSISTS OF STANDARD CHARACTERS WITHOUT CLAIM TO ANY PARTICULAR FONT, STYLE, SIZE, OR COLOR.

FOR DENTAL PRODUCTS IN THE NATURE OF PHARMACEUTICAL GELS USED FOR TREATMENT OF PAIN AND PROTECTION OF WOUND SITES IN THE MOUTH, IN PARTICULAR, FOR USE AS SURGICAL DRESSINGS, TOPICAL WOUND AND ITCH DRESSINGS, DENTURE ADHESIVES, AND TOPICAL PAIN RELIEVERS (U.S. CLS. 6, 18, 44, 46, 51 AND 52).

REBECCA EISINGER, EXAMINING ATTORNEY

SN 78-956,673. ICASACOR, INC., BLUE BELL, PA. FILED 8-21-2006.

**Serious Protection Against Aging**

THE MARK CONSISTS OF STANDARD CHARACTERS WITHOUT CLAIM TO ANY PARTICULAR FONT, STYLE, SIZE, OR COLOR.

OWNER OF U.S. REG. NO. 2,944,690.  
NO CLAIM IS MADE TO THE EXCLUSIVE RIGHT TO USE "PROTECTION AGAINST AGING", APART FROM THE MARK AS SHOWN.  
FOR DIETARY AND NUTRITIONAL SUPPLEMENTS; MIXED VITAMIN PREPARATIONS; VITAMINS (U.S. CLS. 6, 18, 44, 46, 51 AND 52).

WILLIAM BRECKENFELD, EXAMINING ATTORNEY



**CLASS 5—(Continued).**

SN 78-959,433. MALABAR PRODUCTOS NATURALES, L.L.C., SAN ANTONIO, TX. FILED 8-24-2006.

**ALTAPRESS**

THE MARK CONSISTS OF STANDARD CHARACTERS WITHOUT CLAIM TO ANY PARTICULAR FONT, STYLE, SIZE, OR COLOR.

FOR HERB TEAS FOR MEDICINAL PURPOSES; HERBAL SUPPLEMENTS; HERBAL TEAS FOR MEDICINAL PURPOSES; MEDICINAL HERB EXTRACTS; MEDICINAL HERBAL EXTRACTS FOR MEDICAL PURPOSES; MEDICINAL HERBS IN DRIED OR PRESERVED FORM; MIXED VITAMIN PREPARATIONS; MULTI-VITAMIN PREPARATIONS; VITAMIN AND MINERAL PREPARATIONS FOR MEDICAL USE; VITAMIN AND MINERAL SUPPLEMENTS; VITAMIN B PREPARATIONS; VITAMIN PREPARATIONS; VITAMIN SUPPLEMENTS; VITAMIN TABLETS; VITAMINS (U.S. CLS. 6, 18, 44, 46, 51 AND 52).

FIRST USE 1-15-1994; IN COMMERCE 1-15-1994. THOMAS MANOR, EXAMINING ATTORNEY

**CLASS 5—(Continued).**

SN 78-959,728. COLORSTAR HOLDING B.V., AMSTERDAM, NETHERLANDS, FILED 8-24-2006.

**ConGaZ**

THE MARK CONSISTS OF STANDARD CHARACTERS WITHOUT CLAIM TO ANY PARTICULAR FONT, STYLE, SIZE, OR COLOR.

FOR MINERAL NUTRITIONAL SUPPLEMENTS; MINERAL SUPPLEMENTS; NUTRITIONALLY FORTIFIED BEVERAGES (U.S. CLS. 6, 18, 44, 46, 51 AND 52). KAREN SEVERSON, EXAMINING ATTORNEY

SN 78-961,175. NUTRI88, INC., ORANGE, CA. FILED 8-26-2006.

SN 78-959,698. COLORSTAR HOLDING B.V., AMSTERDAM, NETHERLANDS, FILED 8-24-2006.

**SpruDello**

THE MARK CONSISTS OF STANDARD CHARACTERS WITHOUT CLAIM TO ANY PARTICULAR FONT, STYLE, SIZE, OR COLOR.

FOR MINERAL NUTRITIONAL SUPPLEMENTS; MINERAL SUPPLEMENTS; NUTRITIONALLY FORTIFIED BEVERAGES (U.S. CLS. 6, 18, 44, 46, 51 AND 52). KAREN SEVERSON, EXAMINING ATTORNEY

**MySleep**

THE MARK CONSISTS OF STANDARD CHARACTERS WITHOUT CLAIM TO ANY PARTICULAR FONT, STYLE, SIZE, OR COLOR.

FOR DIETARY AND NUTRITIONAL SUPPLEMENTS (U.S. CLS. 6, 18, 44, 46, 51 AND 52). KEVIN CORWIN, EXAMINING ATTORNEY

SN 78-961,729. MEDICAL PRODUCTS LABORATORIES, INC., PHILADELPHIA, PA. FILED 8-28-2006.

SN 78-959,712. COLORSTAR HOLDING B.V., AMSTERDAM, NETHERLANDS, FILED 8-24-2006.

**SurZ**

THE MARK CONSISTS OF STANDARD CHARACTERS WITHOUT CLAIM TO ANY PARTICULAR FONT, STYLE, SIZE, OR COLOR.

FOR MINERAL NUTRITIONAL SUPPLEMENTS; MINERAL SUPPLEMENTS; NUTRITIONALLY FORTIFIED BEVERAGES (U.S. CLS. 6, 18, 44, 46, 51 AND 52). KAREN SEVERSON, EXAMINING ATTORNEY

**TOPICALE**

THE MARK CONSISTS OF STANDARD CHARACTERS WITHOUT CLAIM TO ANY PARTICULAR FONT, STYLE, SIZE, OR COLOR.

FOR TOPICAL ANESTHETICS APPLIED TO ORAL TISSUE (U.S. CLS. 6, 18, 44, 46, 51 AND 52). FIRST USE 7-30-1969; IN COMMERCE 7-30-1969. PAUL E. FAHRENKOPF, EXAMINING ATTORNEY

**CLASS 5—(Continued).**

SN 78-962,201. CHEMCO INDUSTRIES, INC., LOS ANGELES, CA. FILED 8-28-2006.

# ISOMAX

THE MARK CONSISTS OF STANDARD CHARACTERS WITHOUT CLAIM TO ANY PARTICULAR FONT, STYLE, SIZE, OR COLOR.

FOR DIETARY AND NUTRITIONAL SUPPLEMENTS; DIETARY SUPPLEMENTS FOR HUMAN CONSUMPTION (U.S. CLS. 6, 18, 44, 46, 51 AND 52).

ALEXANDER L. POWERS, EXAMINING ATTORNEY

---

SN 78-962,392. PHOTOCURE ASA, OSLO, NORWAY, FILED 8-29-2006.

# METVIXIA

THE MARK CONSISTS OF STANDARD CHARACTERS WITHOUT CLAIM TO ANY PARTICULAR FONT, STYLE, SIZE, OR COLOR.

FOR PHARMACEUTICAL PREPARATIONS AND SUBSTANCES FOR USE IN THE TREATMENT OF CANCER, EXCEPT GENE THERAPY PRODUCTS FOR USE IN RELATION TO CANCER; DERMATOLOGICAL PHARMACEUTICAL PREPARATIONS FOR USE IN THE TREATMENT OF CANCER, EXCEPT GENE THERAPY PRODUCTS FOR USE IN RELATION TO CANCER (U.S. CLS. 6, 18, 44, 46, 51 AND 52).

ANN E. SAPPENFIELD, EXAMINING ATTORNEY

---

SN 78-962,908. NUFARM AMERICAS INC., BURR RIDGE, IL. FILED 8-29-2006.

# GIZMO

THE MARK CONSISTS OF STANDARD CHARACTERS WITHOUT CLAIM TO ANY PARTICULAR FONT, STYLE, SIZE, OR COLOR.

FOR HERBICIDES FOR AGRICULTURAL USE; HERBICIDES FOR DOMESTIC USE; HERBICIDES, INSECTICIDES, PESTICIDES AND FUNGICIDES FOR HOME, GARDEN AND LAWN USE AND FOR PROFESSIONAL USE; INSECTICIDES; PESTICIDES FOR AGRICULTURAL, DOMESTIC, AND COMMERCIAL USE (U.S. CLS. 6, 18, 44, 46, 51 AND 52).

DAYNA BROWNE, EXAMINING ATTORNEY

**CLASS 5—(Continued).**

SN 78-964,382. MALABAR PRODUCTOS NATURALES, L.L.C., SAN ANTONIO, TX. FILED 8-30-2006.



# GRIPTE

THE MARK CONSISTS OF THE WORD "GRIPTE" IN STYLIZED LETTERS WITH A DRAWING THAT REPRESENTS A LEAF OVER THE TOP OF THE LETTER "I".

FOR COLD SORE TREATMENT PREPARATIONS; DIETARY SUPPLEMENTS; DIETARY SUPPLEMENTS FOR HUMAN CONSUMPTION; HERB TEAS FOR MEDICINAL PURPOSES; HERBAL SUPPLEMENTS; HERBAL TEAS FOR MEDICINAL PURPOSES; MEDICINAL HERB EXTRACTS; MEDICINAL HERBAL EXTRACTS FOR MEDICAL PURPOSES; PHARMACEUTICAL ANTIVIRAL-COLD PREPARATIONS; PREPARATIONS FOR TREATING COLDS; SWEETS FOR MEDICINAL PURPOSES (U.S. CLS. 6, 18, 44, 46, 51 AND 52).

FIRST USE 6-29-1994; IN COMMERCE 6-29-1994.

JAMES LOVELACE, EXAMINING ATTORNEY

---

SN 78-964,393. GRANT, DONOVAN W., GOODLETTSVILLE, TN. FILED 8-30-2006.

# BAG-R-BUCK

THE MARK CONSISTS OF STANDARD CHARACTERS WITHOUT CLAIM TO ANY PARTICULAR FONT, STYLE, SIZE, OR COLOR.

FOR MINERAL FEED SUPPLEMENT FOR DEER, NAMELY, MINERAL FEED SUPPLEMENT FOR DEER HERDS TO ASSIST IN BUCK DEVELOPMENT AND FOR A HEALTHIER DEER HERD (U.S. CLS. 6, 18, 44, 46, 51 AND 52).

JAY BESCH, EXAMINING ATTORNEY

---

SN 78-964,599. BIO-NUTRA TECHNOLOGIES, LLC, VENICE, FL. FILED 8-31-2006.

# BERRY-MAX

THE MARK CONSISTS OF STANDARD CHARACTERS WITHOUT CLAIM TO ANY PARTICULAR FONT, STYLE, SIZE, OR COLOR.

FOR DIETARY AND NUTRITIONAL SUPPLEMENTS (U.S. CLS. 6, 18, 44, 46, 51 AND 52).

KIMBERLY PERRY, EXAMINING ATTORNEY

**CLASS 5—(Continued).**

SN 78-964,735. SPHERICS, INC., MANSFIELD, MA. FILED 8-31-2006.

# SPHERICS

THE MARK CONSISTS OF STANDARD CHARACTERS WITHOUT CLAIM TO ANY PARTICULAR FONT, STYLE, SIZE, OR COLOR.

FOR PHARMACEUTICALS FOR THE TREATMENT OF CARDIOVASCULAR DISEASES, DISEASES OF THE CENTRAL NERVOUS SYSTEM, METABOLIC DISEASES, DIABETES, AND CANCER; PHARMACEUTICALS, NAMELY, ANTI-INFECTIVES; VACCINES (U.S. CLS. 6, 18, 44, 46, 51 AND 52).  
RON FAIRBANKS, EXAMINING ATTORNEY

**CLASS 5—(Continued).**

SN 78-965,328. FEDERAL LABORATORIES CORPORATION, ALDEN, NY. FILED 8-31-2006.

THE STUFF DREAMS ARE MADE OF

THE MARK CONSISTS OF STANDARD CHARACTERS WITHOUT CLAIM TO ANY PARTICULAR FONT, STYLE, SIZE, OR COLOR.

FOR DIETARY SUPPLEMENTS, NAMELY, SUPPLEMENTS FOR THE ENHANCEMENT OF DREAMS (U.S. CLS. 6, 18, 44, 46, 51 AND 52).  
KRISTINA KLOIBER, EXAMINING ATTORNEY

SN 78-964,743. SPHERICS, INC., MANSFIELD, MA. FILED 8-31-2006.



FOR PHARMACEUTICALS FOR THE TREATMENT OF CARDIOVASCULAR DISEASES, DISEASES OF THE CENTRAL NERVOUS SYSTEM, METABOLIC DISEASES, DIABETES, AND CANCER; PHARMACEUTICALS, NAMELY, ANTI-INFECTIVES; VACCINES (U.S. CLS. 6, 18, 44, 46, 51 AND 52).  
RON FAIRBANKS, EXAMINING ATTORNEY

SN 78-965,408. MALCOMSON, RONALD, MARYSVILLE, WA. FILED 8-31-2006.



SN 78-964,968. U.S. NONWOVENS, BRENTWOOD, NY. FILED 8-31-2006.

# Peaceful Expressions

THE MARK CONSISTS OF STANDARD CHARACTERS WITHOUT CLAIM TO ANY PARTICULAR FONT, STYLE, SIZE, OR COLOR.

FOR AIR FRESHENERS (U.S. CLS. 6, 18, 44, 46, 51 AND 52).  
ANDREA EVANS, EXAMINING ATTORNEY

THE COLOR(S) BLUE AND RED IS/ARE CLAIMED AS A FEATURE OF THE MARK.

THE FORMATIVE GLUCA IS BLUE AND THE FORMATIVE STAT IS ITALICIZED AND RED.

FOR INJECTABLE PHARMACEUTICALS FOR TREATMENT OF HYPOGLYCEMIC REACTIONS OR CONDITIONS (U.S. CLS. 6, 18, 44, 46, 51 AND 52).  
NAKIA HENRY, EXAMINING ATTORNEY

**CLASS 5—(Continued).**

SN 78-965,634. JIANGZHONG PHARMACEUTICAL CO., LTD, NANCHANG CITY, JIANGXI, CHINA, FILED 8-31-2006.



FOR AMINO ACIDS FOR MEDICAL OR VETERINARY PURPOSES; ANTIBACTERIAL PHARMACEUTICALS; ANTIBACTERIAL SPRAY; ANTIBIOTIC CREAMS; ANTIBIOTIC OINTMENTS; ANTIBIOTIC PREPARATIONS; ANTIBIOTIC TABLETS; ANTIBIOTICS; ANTI-COUGH DROPS; ANTI-DERMOINFECTIVES; ANTI-ITCH CREAM; CALCIUM SUPPLEMENTS; CARDIOVASCULAR PHARMACEUTICALS; COUGH EXPECTORANTS; COUGH LOZENGES; COUGH DROPS; COUGH SYRUPS; COUGH TREATMENT PREPARATIONS; DERMATOLOGICAL PHARMACEUTICAL PRODUCTS; DERMATOLOGICALS; EXPECTORANTS; FUNGAL MEDICATIONS; GASTRO-INTESTINAL TREATMENT PREPARATIONS; MEDICINAL CREAMS FOR SKIN CARE; MEDICINES FOR THE TREATMENT OF GASTROINTESTINAL DISEASES; MINERAL NUTRITIONAL SUPPLEMENTS; MULTIVITAMIN PREPARATIONS; NUTRITIONAL SUPPLEMENTS; PENICILLIN PREPARATIONS; PHARMACEUTICAL ANTITUSSIVE-COLD PREPARATIONS; PHARMACEUTICAL PREPARATIONS AND SUBSTANCES FOR THE TREATMENT OF GASTRO-INTESTINAL DISEASES; PHARMACEUTICAL PREPARATIONS FOR USE IN DERMATOLOGY; THROAT LOZENGES; VITAMIN AND MINERAL SUPPLEMENTS; MEDICATED CANDIES; MEDICINES FOR THE TREATMENT OF GASTROINTESTINAL DISEASES; BABY FOOD; VITAMIN PREPARATIONS; DIETARY AND NUTRITIONAL SUPPLEMENTS; MEDICINAL HERBS IN DRIED OR PRESERVED FORM; HERB TEAS FOR MEDICINAL PURPOSES; GELATIN CAPSULES SOLD EMPTY FOR PHARMACEUTICALS; MEDICINAL ALCOHOL (U.S. CLS. 6, 18, 44, 46, 51 AND 52).

MICHAEL KAZAZIAN, EXAMINING ATTORNEY

SN 78-965,658. NUTRACEUTICAL SCIENCES INSTITUTE, INC., BOYNTON BEACH, FL. FILED 9-1-2006.

## ULTRASORB-C

THE MARK CONSISTS OF STANDARD CHARACTERS WITHOUT CLAIM TO ANY PARTICULAR FONT, STYLE, SIZE, OR COLOR.

OWNER OF U.S. REG. NO. 2,257,056.  
FOR DIETARY AND NUTRITIONAL SUPPLEMENTS (U.S. CLS. 6, 18, 44, 46, 51 AND 52).

PRISCILLA MILTON, EXAMINING ATTORNEY

**CLASS 5—(Continued).**

SN 78-965,787. MERCOR SERVICES, INC., CLEARWATER, FL. FILED 9-1-2006.

## FALL ASLEEP

THE MARK CONSISTS OF STANDARD CHARACTERS WITHOUT CLAIM TO ANY PARTICULAR FONT, STYLE, SIZE, OR COLOR.

FOR NATURAL DIETARY SUPPLEMENT MADE WITH HERBS (U.S. CLS. 6, 18, 44, 46, 51 AND 52).

FIRST USE 5-22-2006; IN COMMERCE 5-22-2006.

RENEE MCCRAY, EXAMINING ATTORNEY

SN 78-965,875. TECHMIX INC., STEWART, MN. FILED 9-1-2006.



NO CLAIM IS MADE TO THE EXCLUSIVE RIGHT TO USE "K9 OR CANINE", APART FROM THE MARK AS SHOWN.

THE COLOR(S) BLUE, WHITE AND BLACK IS/ARE CLAIMED AS A FEATURE OF THE MARK.

THE COLOR BLUE APPEARS IN BOTH THE CIRCLE DESIGN AND IN THE LOWER HALF OF THE DESIGNATION "K9". THE COLOR WHITE APPEARS IN ALL THE WORDING AND IN THE UPPER HALF OF THE DESIGNATION "K9". THE COLOR BLACK APPEARS AS AN OUTLINE IN ALL THE WORDING AND IN THE OUTLINE OF THE CIRCLE DESIGN.

THE MARK CONSISTS OF "K9" PORTION OF THE MARK IS IN A CIRCLE ABOVE REMAINDER OF MARK.

FOR ANIMAL FEED SUPPLEMENTS FOR DOGS (U.S. CLS. 6, 18, 44, 46, 51 AND 52).

FIRST USE 8-12-2006; IN COMMERCE 8-12-2006.

RUSS HERMAN, EXAMINING ATTORNEY

SN 78-966,168. SUN GREEN INTERNATIONAL, INC., RICHARDSON, TX. FILED 9-1-2006.

## Everal

THE MARK CONSISTS OF STANDARD CHARACTERS WITHOUT CLAIM TO ANY PARTICULAR FONT, STYLE, SIZE, OR COLOR.

FOR DIETARY AND NUTRITIONAL SUPPLEMENTS (U.S. CLS. 6, 18, 44, 46, 51 AND 52).

FIRST USE 12-2-2004; IN COMMERCE 2-15-2005.

HEATHER BIDDULPH, EXAMINING ATTORNEY

**CLASS 5—(Continued).**

SN 78-966,178. SUN GREEN INTERNATIONAL, INC., RICHARDSON, TX. FILED 9-1-2006.

# BRITILEEN

THE MARK CONSISTS OF STANDARD CHARACTERS WITHOUT CLAIM TO ANY PARTICULAR FONT, STYLE, SIZE, OR COLOR.  
FOR DIETARY AND NUTRITIONAL SUPPLEMENTS (U.S. CLS. 6, 18, 44, 46, 51 AND 52).  
HEATHER BIDDULPH, EXAMINING ATTORNEY

**CLASS 5—(Continued).**

SN 78-966,222. SUN GREEN INTERNATIONAL, INC., RICHARDSON, TX. FILED 9-1-2006.

# ACADAMINE

THE MARK CONSISTS OF STANDARD CHARACTERS WITHOUT CLAIM TO ANY PARTICULAR FONT, STYLE, SIZE, OR COLOR.  
FOR DIETARY AND NUTRITIONAL SUPPLEMENTS (U.S. CLS. 6, 18, 44, 46, 51 AND 52).  
HEATHER BIDDULPH, EXAMINING ATTORNEY

SN 78-966,185. SUN GREEN INTERNATIONAL, INC., RICHARDSON, TX. FILED 9-1-2006.

# SG POWER

THE MARK CONSISTS OF STANDARD CHARACTERS WITHOUT CLAIM TO ANY PARTICULAR FONT, STYLE, SIZE, OR COLOR.  
FOR POWDERED NUTRITIONAL SUPPLEMENT DRINK MIX (U.S. CLS. 6, 18, 44, 46, 51 AND 52).  
HEATHER BIDDULPH, EXAMINING ATTORNEY

SN 78-966,223. PROKOZ, INC., ALPHARETTA, GA. FILED 9-1-2006.

# GLACIER

THE MARK CONSISTS OF STANDARD CHARACTERS WITHOUT CLAIM TO ANY PARTICULAR FONT, STYLE, SIZE, OR COLOR.  
FOR PESTICIDES FOR AGRICULTURAL AND NON-AGRICULTURAL USE (U.S. CLS. 6, 18, 44, 46, 51 AND 52).  
IRENE D. WILLIAMS, EXAMINING ATTORNEY

SN 78-966,199. SUN GREEN INTERNATIONAL, INC., RICHARDSON, TX. FILED 9-1-2006.

# BOOSTERMIN

THE MARK CONSISTS OF STANDARD CHARACTERS WITHOUT CLAIM TO ANY PARTICULAR FONT, STYLE, SIZE, OR COLOR.  
FOR DIETARY AND NUTRITIONAL SUPPLEMENTS (U.S. CLS. 6, 18, 44, 46, 51 AND 52).  
HEATHER BIDDULPH, EXAMINING ATTORNEY

SN 78-966,230. PROKOZ, INC., ALPHARETTA, GA. FILED 9-1-2006.

# MAINSAIL

THE MARK CONSISTS OF STANDARD CHARACTERS WITHOUT CLAIM TO ANY PARTICULAR FONT, STYLE, SIZE, OR COLOR.  
FOR PESTICIDES FOR AGRICULTURAL AND NON-AGRICULTURAL USE (U.S. CLS. 6, 18, 44, 46, 51 AND 52).  
IRENE D. WILLIAMS, EXAMINING ATTORNEY

**CLASS 5—(Continued).**

SN 78-966,232. SUN GREEN INTERNATIONAL, INC., RICHARDSON, TX. FILED 9-1-2006.

**VIEWGETIC**

THE MARK CONSISTS OF STANDARD CHARACTERS WITHOUT CLAIM TO ANY PARTICULAR FONT, STYLE, SIZE, OR COLOR.  
FOR DIETARY AND NUTRITIONAL SUPPLEMENTS (U.S. CLS. 6, 18, 44, 46, 51 AND 52).  
HEATHER BIDDULPH, EXAMINING ATTORNEY

**CLASS 5—(Continued).**

SN 78-966,530. DANIEL M. STUART MD, PHD, INC., CORONADO, CA. FILED 9-2-2006.

**THE PAIN TAMER**

THE MARK CONSISTS OF STANDARD CHARACTERS WITHOUT CLAIM TO ANY PARTICULAR FONT, STYLE, SIZE, OR COLOR.  
FOR MIXED VITAMINS PREPARATION (U.S. CLS. 6, 18, 44, 46, 51 AND 52).  
LINDA E. BLOHM, EXAMINING ATTORNEY

SN 78-966,258. SUN GREEN INTERNATIONAL, INC., RICHARDSON, TX. FILED 9-1-2006.

**LIPOCARDIO**

THE MARK CONSISTS OF STANDARD CHARACTERS WITHOUT CLAIM TO ANY PARTICULAR FONT, STYLE, SIZE, OR COLOR.  
FOR DIETARY AND NUTRITIONAL SUPPLEMENTS (U.S. CLS. 6, 18, 44, 46, 51 AND 52).  
HEATHER BIDDULPH, EXAMINING ATTORNEY

SN 78-966,623. DAVIDSON, DANIEL L., MIAMI BEACH, FL. FILED 9-3-2006.

**LIFE'S A FIGHT**

THE MARK CONSISTS OF STANDARD CHARACTERS WITHOUT CLAIM TO ANY PARTICULAR FONT, STYLE, SIZE, OR COLOR.  
FOR VITAMINS AND DIETARY SUPPLEMENTS (U.S. CLS. 6, 18, 44, 46, 51 AND 52).  
JOHN GARTNER, EXAMINING ATTORNEY

SN 78-966,527. DANIEL M. STUART MD, PHD, INC., CORONADO, CA. FILED 9-2-2006.

**TAME YOUR PAIN**

THE MARK CONSISTS OF STANDARD CHARACTERS WITHOUT CLAIM TO ANY PARTICULAR FONT, STYLE, SIZE, OR COLOR.  
FOR MIXED VITAMIN PREPARATIONS (U.S. CLS. 6, 18, 44, 46, 51 AND 52).  
LINDA E. BLOHM, EXAMINING ATTORNEY

SN 78-966,866. CAROLINA BEVERAGE CORPORATION, SALISBURY, NC. FILED 9-5-2006.

**VITAMINAIDE**

THE MARK CONSISTS OF STANDARD CHARACTERS WITHOUT CLAIM TO ANY PARTICULAR FONT, STYLE, SIZE, OR COLOR.  
FOR VITAMIN ENRICHED WATER (U.S. CLS. 6, 18, 44, 46, 51 AND 52).  
AISHA SALEM, EXAMINING ATTORNEY

**CLASS 5—(Continued).**

SN 78-966,948. HUDSON LIVESTOCK SUPPLEMENTS, INC., MILES, TX. FILED 9-5-2006.

**EQUINE MAX**

THE MARK CONSISTS OF STANDARD CHARACTERS WITHOUT CLAIM TO ANY PARTICULAR FONT, STYLE, SIZE, OR COLOR.

NO CLAIM IS MADE TO THE EXCLUSIVE RIGHT TO USE "EQUINE", APART FROM THE MARK AS SHOWN.

FOR DIETARY SUPPLEMENTS FOR ANIMALS (U.S. CLS. 6, 18, 44, 46, 51 AND 52).

FIRST USE 9-14-2000; IN COMMERCE 9-14-2000.  
DAVID TOOLEY, EXAMINING ATTORNEY

---

SN 78-967,200. QUATRUX PHARMACEUTICALS COMPANY, ANN ARBOR, MI. FILED 9-5-2006.

**ASORD**

THE MARK CONSISTS OF STANDARD CHARACTERS WITHOUT CLAIM TO ANY PARTICULAR FONT, STYLE, SIZE, OR COLOR.

FOR PHARMACEUTICAL PREPARATIONS IN THE NATURE OF TOPICAL TREATMENTS FOR SKIN DISEASES (U.S. CLS. 6, 18, 44, 46, 51 AND 52).

JESSICA A. POWERS, EXAMINING ATTORNEY

---

SN 78-967,416. WANZHU, LI, ARCADIA, CA. FILED 9-5-2006.

**RENA BIOTECHNOLOGY**

THE MARK CONSISTS OF STANDARD CHARACTERS WITHOUT CLAIM TO ANY PARTICULAR FONT, STYLE, SIZE, OR COLOR.

NO CLAIM IS MADE TO THE EXCLUSIVE RIGHT TO USE "BIOTECHNOLOGY", APART FROM THE MARK AS SHOWN.

FOR DIETARY AND NUTRITIONAL SUPPLEMENTS; DIETARY FIBER AS AN ADDITIVE FOR FOOD PRODUCTS; DIETARY FOOD SUPPLEMENTS; DIETARY SUPPLEMENTAL DRINKS; FOOD FOR DIABETICS; FOOD FOR INFANTS; FOOD FOR MEDICALLY RESTRICTED DIETS; FOOD SUPPLEMENTS; FOOD SUPPLEMENTS, NAMELY, ANTI-OXIDANTS; MULTIVITAMIN PREPARATIONS; NUTRITIONAL ADDITIVES FOR USE IN FOODS AND DIETARY SUPPLEMENTS FOR HUMAN CONSUMPTION (U.S. CLS. 6, 18, 44, 46, 51 AND 52).

JAY FLOWERS, EXAMINING ATTORNEY

**CLASS 5—(Continued).**

SN 78-967,736. PUJALT FERNANDO E, DEVON, PA. FILED 9-6-2006.

**MACXA**

THE MARK CONSISTS OF STANDARD CHARACTERS WITHOUT CLAIM TO ANY PARTICULAR FONT, STYLE, SIZE, OR COLOR.

FOR DIETARY SUPPLEMENTS; DIETARY SUPPLEMENTS FOR ANIMALS; DIETARY SUPPLEMENTS FOR HUMAN CONSUMPTION; FOOD SUPPLEMENTS; HERBAL SUPPLEMENTS; MEAL REPLACEMENT AND DIETARY SUPPLEMENT DRINK MIXES; MINERAL NUTRITIONAL SUPPLEMENTS; MINERAL SUPPLEMENTS; MIXED VITAMIN PREPARATIONS; MULTI-VITAMIN PREPARATIONS; NUTRITIONAL ADDITIVES FOR USE IN FOODS AND DIETARY SUPPLEMENTS FOR HUMAN CONSUMPTION; NUTRITIONAL SUPPLEMENTS (U.S. CLS. 6, 18, 44, 46, 51 AND 52).

MARK T. MULLEN, EXAMINING ATTORNEY

---

SN 78-967,801. JIGSAW HEALTH, LLC, SCOTTSDALE, AZ. FILED 9-6-2006.

**JIGSAW**

THE MARK CONSISTS OF STANDARD CHARACTERS WITHOUT CLAIM TO ANY PARTICULAR FONT, STYLE, SIZE, OR COLOR.

OWNER OF U.S. REG. NO. 3,175,134.  
FOR DIETARY AND NUTRITIONAL SUPPLEMENTS (U.S. CLS. 6, 18, 44, 46, 51 AND 52).

TASHIA BUNCH, EXAMINING ATTORNEY

---

SN 78-967,837. EQUIVALENT PHARMACEUTICAL INDUSTRIES CORPORATION, WESTBURY, NY. FILED 9-6-2006.



FOR NUTRITIONAL SUPPLEMENTS (U.S. CLS. 6, 18, 44, 46, 51 AND 52).

GRETTA YAO, EXAMINING ATTORNEY

**CLASS 5—(Continued).**

SN 78-968,008. PROCTER & GAMBLE PHARMACEUTICALS INC., CINCINNATI, OH. FILED 9-6-2006.

# AZIMICOR

THE MARK CONSISTS OF STANDARD CHARACTERS WITHOUT CLAIM TO ANY PARTICULAR FONT, STYLE, SIZE, OR COLOR.

FOR PRESCRIPTION CARDIOVASCULAR PHARMACEUTICAL PREPARATION (U.S. CLS. 6, 18, 44, 46, 51 AND 52).

JENNIFER WILLISTON, EXAMINING ATTORNEY

SN 78-968,026. PROCTER & GAMBLE PHARMACEUTICALS INC., CINCINNATI, OH. FILED 9-6-2006.



FOR PRESCRIPTION CARDIOVASCULAR PHARMACEUTICAL PREPARATION (U.S. CLS. 6, 18, 44, 46, 51 AND 52).

JENNIFER WILLISTON, EXAMINING ATTORNEY

SN 78-968,268. TSI HEALTH SCIENCES, INC., MISSOULA, MT. FILED 9-6-2006.

# RECALICIN

THE MARK CONSISTS OF STANDARD CHARACTERS WITHOUT CLAIM TO ANY PARTICULAR FONT, STYLE, SIZE, OR COLOR.

FOR DIETARY AND NUTRITIONAL SUPPLEMENTS (U.S. CLS. 6, 18, 44, 46, 51 AND 52).

DOMINIC FATHY, EXAMINING ATTORNEY

**CLASS 5—(Continued).**

SN 78-968,671. UPSHER-SMITH LABORATORIES, INC., MAPLE GROVE, MN. FILED 9-7-2006.

# TROTEX

THE MARK CONSISTS OF STANDARD CHARACTERS WITHOUT CLAIM TO ANY PARTICULAR FONT, STYLE, SIZE, OR COLOR.

FOR PHARMACEUTICAL PREPARATION, NAMELY TESTOSTERONE LOTION/GEL TO TREAT TESTOSTERONE DEFICIENCY (U.S. CLS. 6, 18, 44, 46, 51 AND 52).

JASON ROTH, EXAMINING ATTORNEY

SN 78-968,713. DOW AGROSCIENCES LLC, INDIANAPOLIS, IN. FILED 9-7-2006.

# SONIC

THE MARK CONSISTS OF STANDARD CHARACTERS WITHOUT CLAIM TO ANY PARTICULAR FONT, STYLE, SIZE, OR COLOR.

FOR PESTICIDES AND PREPARATIONS FOR DESTROYING VERMIN, NAMELY HERBICIDES, INSECTICIDES AND FUNGICIDES FOR AGRICULTURE, HORTICULTURE, FORESTRY, TURF AND ORNAMENTAL, COMMERCIAL, INDUSTRIAL AND DOMESTIC USE (U.S. CLS. 6, 18, 44, 46, 51 AND 52).

AISHA CLARKE, EXAMINING ATTORNEY

SN 78-968,718. DOW AGROSCIENCES LLC, INDIANAPOLIS, IN. FILED 9-7-2006.

# OPENSIGHT

THE MARK CONSISTS OF STANDARD CHARACTERS WITHOUT CLAIM TO ANY PARTICULAR FONT, STYLE, SIZE, OR COLOR.

FOR PESTICIDES AND PREPARATIONS FOR DESTROYING VERMIN, NAMELY HERBICIDES, INSECTICIDES AND FUNGICIDES FOR AGRICULTURE, HORTICULTURE, FORESTRY, TURF AND ORNAMENTAL, COMMERCIAL, INDUSTRIAL AND DOMESTIC USE (U.S. CLS. 6, 18, 44, 46, 51 AND 52).

AISHA CLARKE, EXAMINING ATTORNEY



**CLASS 5—(Continued).**

SN 78-968,721. DOW AGROSCIENCES LLC, INDIANAPOLIS, IN. FILED 9-7-2006.

# SHERIFF

THE MARK CONSISTS OF STANDARD CHARACTERS WITHOUT CLAIM TO ANY PARTICULAR FONT, STYLE, SIZE, OR COLOR.

FOR PESTICIDES AND PREPARATIONS FOR DESTROYING VERMIN, NAMELY HERBICIDES, INSECTICIDES AND FUNGICIDES FOR AGRICULTURE, HORTICULTURE, FORESTRY, TURF AND ORNAMENTAL, COMMERCIAL, INDUSTRIAL AND DOMESTIC USE (U.S. CLS. 6, 18, 44, 46, 51 AND 52).

AISHA CLARKE, EXAMINING ATTORNEY

**CLASS 5—(Continued).**

SN 78-969,193. DOW AGROSCIENCES LLC, INDIANAPOLIS, IN. FILED 9-7-2006.

# HIREDHAND

THE MARK CONSISTS OF STANDARD CHARACTERS WITHOUT CLAIM TO ANY PARTICULAR FONT, STYLE, SIZE, OR COLOR.

FOR PESTICIDES AND PREPARATIONS FOR DESTROYING VERMIN, NAMELY HERBICIDES, INSECTICIDES AND FUNGICIDES FOR AGRICULTURE, HORTICULTURE, FORESTRY, TURF AND ORNAMENTAL, COMMERCIAL, INDUSTRIAL AND DOMESTIC USE (U.S. CLS. 6, 18, 44, 46, 51 AND 52).

AISHA CLARKE, EXAMINING ATTORNEY

SN 78-969,189. DOW AGROSCIENCES LLC, INDIANAPOLIS, IN. FILED 9-7-2006.

# BRONCO

THE MARK CONSISTS OF STANDARD CHARACTERS WITHOUT CLAIM TO ANY PARTICULAR FONT, STYLE, SIZE, OR COLOR.

FOR PESTICIDES AND PREPARATIONS FOR DESTROYING VERMIN, NAMELY HERBICIDES, INSECTICIDES AND FUNGICIDES FOR AGRICULTURE, HORTICULTURE, FORESTRY, TURF AND ORNAMENTAL, COMMERCIAL, INDUSTRIAL AND DOMESTIC USE (U.S. CLS. 6, 18, 44, 46, 51 AND 52).

AISHA CLARKE, EXAMINING ATTORNEY

SN 78-970,065. 1682864 ONTARIO LIMITED, TORONTO, ONTARIO, CANADA, FILED 9-8-2006.

# LIQUICUT HARDCORE

THE MARK CONSISTS OF STANDARD CHARACTERS WITHOUT CLAIM TO ANY PARTICULAR FONT, STYLE, SIZE, OR COLOR.

FOR DIETARY SUPPLEMENTS; NUTRITIONAL SUPPLEMENTS; INGREDIENT BLEND FOR DIETARY SUPPLEMENTS; INGREDIENT BLEND FOR NUTRITIONAL SUPPLEMENTS (U.S. CLS. 6, 18, 44, 46, 51 AND 52).

KEVON CHISOLM, EXAMINING ATTORNEY

SN 78-969,190. DOW AGROSCIENCES LLC, INDIANAPOLIS, IN. FILED 9-7-2006.

# LOCKUP

THE MARK CONSISTS OF STANDARD CHARACTERS WITHOUT CLAIM TO ANY PARTICULAR FONT, STYLE, SIZE, OR COLOR.

FOR PESTICIDES AND PREPARATIONS FOR DESTROYING VERMIN, NAMELY HERBICIDES, INSECTICIDES AND FUNGICIDES FOR AGRICULTURE, HORTICULTURE, FORESTRY, TURF AND ORNAMENTAL, COMMERCIAL, INDUSTRIAL AND DOMESTIC USE (U.S. CLS. 6, 18, 44, 46, 51 AND 52).

AISHA CLARKE, EXAMINING ATTORNEY

SN 78-970,090. 1682864 ONTARIO LIMITED, TORONTO, ONTARIO, CANADA, FILED 9-8-2006.

# LIQUID-CUTS HARDCORE

THE MARK CONSISTS OF STANDARD CHARACTERS WITHOUT CLAIM TO ANY PARTICULAR FONT, STYLE, SIZE, OR COLOR.

FOR DIETARY SUPPLEMENTS; NUTRITIONAL SUPPLEMENTS; INGREDIENT BLEND FOR DIETARY SUPPLEMENTS; INGREDIENT BLEND FOR NUTRITIONAL SUPPLEMENTS (U.S. CLS. 6, 18, 44, 46, 51 AND 52).

KEVON CHISOLM, EXAMINING ATTORNEY

**CLASS 5—(Continued).**

SN 78-970,292. DOW AGROSCIENCES LLC, INDIANAPOLIS, IN. FILED 9-8-2006.

**BUCKBOARD**

THE MARK CONSISTS OF STANDARD CHARACTERS WITHOUT CLAIM TO ANY PARTICULAR FONT, STYLE, SIZE, OR COLOR.

FOR PESTICIDES AND PREPARATIONS FOR DESTROYING VERMIN, NAMELY HERBICIDES, INSECTICIDES AND FUNGICIDES FOR AGRICULTURE, HORTICULTURE, FORESTRY, TURF AND ORNAMENTAL, COMMERCIAL, INDUSTRIAL AND DOMESTIC USE (U.S. CLS. 6, 18, 44, 46, 51 AND 52).

RICHARD WHITE, EXAMINING ATTORNEY

**CLASS 5—(Continued).**

SN 78-970,462. AMERICAN SILVER, LLC, ALPINE, UT. FILED 9-8-2006.

**ASAP WOUND CARE**

THE MARK CONSISTS OF STANDARD CHARACTERS WITHOUT CLAIM TO ANY PARTICULAR FONT, STYLE, SIZE, OR COLOR.

OWNER OF U.S. REG. NOS. 2,541,007 AND 3,020,415. NO CLAIM IS MADE TO THE EXCLUSIVE RIGHT TO USE "WOUND CARE", APART FROM THE MARK AS SHOWN.

FOR PHARMACEUTICAL PREPARATIONS, NAMELY ANTIMICROBIAL HYDROGELS FOR THE TREATMENT OF WOUNDS (U.S. CLS. 6, 18, 44, 46, 51 AND 52). CHARLES L. JENKINS, EXAMINING ATTORNEY

SN 78-970,298. DOW AGROSCIENCES LLC, INDIANAPOLIS, IN. FILED 9-8-2006.

**DEPUTY**

THE MARK CONSISTS OF STANDARD CHARACTERS WITHOUT CLAIM TO ANY PARTICULAR FONT, STYLE, SIZE, OR COLOR.

FOR PESTICIDES AND PREPARATIONS FOR DESTROYING VERMIN, NAMELY HERBICIDES, INSECTICIDES AND FUNGICIDES FOR AGRICULTURE, HORTICULTURE, FORESTRY, TURF AND ORNAMENTAL, COMMERCIAL, INDUSTRIAL AND DOMESTIC USE (U.S. CLS. 6, 18, 44, 46, 51 AND 52).

RICHARD WHITE, EXAMINING ATTORNEY

SN 78-970,478. ALLERGAN, INC., IRVINE, CA. FILED 9-8-2006.

**VOLUMILASH**

THE MARK CONSISTS OF STANDARD CHARACTERS WITHOUT CLAIM TO ANY PARTICULAR FONT, STYLE, SIZE, OR COLOR.

FOR PHARMACEUTICAL PREPARATIONS USED TO TREAT EYELASHES (U.S. CLS. 6, 18, 44, 46, 51 AND 52). MIDGE BUTLER, EXAMINING ATTORNEY

SN 78-970,456. BARR LABORATORIES, INC., WOODCLIFF LAKE, NJ. FILED 9-8-2006.

**BALZIVA**

THE MARK CONSISTS OF STANDARD CHARACTERS WITHOUT CLAIM TO ANY PARTICULAR FONT, STYLE, SIZE, OR COLOR.

FOR ORAL CONTRACEPTIVES (U.S. CLS. 6, 18, 44, 46, 51 AND 52).

DAVID TOOLEY, EXAMINING ATTORNEY

SN 78-971,144. VIRGINIA BIONUTRIENTS, LLC, GLEN ALLEN, VA. FILED 9-11-2006.

**IT'S NOT THE SIZE OF THE BAR . . . IT'S THE MOTION**

THE MARK CONSISTS OF STANDARD CHARACTERS WITHOUT CLAIM TO ANY PARTICULAR FONT, STYLE, SIZE, OR COLOR.

FOR NUTRITIONAL SUPPLEMENTS, HERBAL SUPPLEMENTS, VITAMIN SUPPLEMENTS, MINERAL SUPPLEMENTS, VITAMIN AND MINERAL SUPPLEMENTS, DIETARY SUPPLEMENTS, DIETARY FOOD SUPPLEMENTS, AND FOOD SUPPLEMENTS, ALL IN BAR FORM (U.S. CLS. 6, 18, 44, 46, 51 AND 52).

JOHN DALIER, EXAMINING ATTORNEY

**CLASS 5—(Continued).**

SN 78-971,254. MIDLOTHIAN LABORATORIES, LLC, MONTGOMERY, AL. FILED 9-11-2006.

# D-TANN

THE MARK CONSISTS OF STANDARD CHARACTERS WITHOUT CLAIM TO ANY PARTICULAR FONT, STYLE, SIZE, OR COLOR.

FOR COUGH EXPECTORANTS; COUGH TREATMENT PREPARATIONS; PHARMACEUTICAL ANTI-TUSSIVE-COLD PREPARATIONS; PREPARATIONS FOR TREATING COLDS (U.S. CLS. 6, 18, 44, 46, 51 AND 52).

GIANCARLO CASTRO, EXAMINING ATTORNEY

**CLASS 5—(Continued).**

SN 78-971,740. ASCEND THERAPEUTICS, INC., HERNDON, VA. FILED 9-11-2006.

# Keloderm

THE MARK CONSISTS OF STANDARD CHARACTERS WITHOUT CLAIM TO ANY PARTICULAR FONT, STYLE, SIZE, OR COLOR.

FOR TOPICAL GEL FOR MEDICAL AND THERAPEUTIC TREATMENT OF SCARS (U.S. CLS. 6, 18, 44, 46, 51 AND 52).

LINDA MICKLEBURGH, EXAMINING ATTORNEY

SN 78-971,381. ARGINTEANU, RONIT, CRESSKILL, NJ. FILED 9-11-2006.

# Zolacet

THE MARK CONSISTS OF STANDARD CHARACTERS WITHOUT CLAIM TO ANY PARTICULAR FONT, STYLE, SIZE, OR COLOR.

FOR ANTI-INFLAMMATORY PAIN RELIEF MEDICATION (U.S. CLS. 6, 18, 44, 46, 51 AND 52).

RAUL CORDOVA, EXAMINING ATTORNEY

SN 78-971,555. LILLY ICOS LLC, WILMINGTON, DE. FILED 9-11-2006.

# CIALIS

THE MARK CONSISTS OF STANDARD CHARACTERS WITHOUT CLAIM TO ANY PARTICULAR FONT, STYLE, SIZE, OR COLOR.

OWNER OF U.S. REG. NO. 2,724,589.

FOR PHARMACEUTICAL PREPARATIONS FOR THE TREATMENT AND PREVENTION OF HYPERTENSION, UROLOGICAL DISEASES AND DISORDERS, AND BENIGN PROSTATE HYPERPLASIA (U.S. CLS. 6, 18, 44, 46, 51 AND 52).

ELIZABETH PIGNATELLO, EXAMINING ATTORNEY

SN 78-972,337. ADAMS RESPIRATORY OPERATIONS, INC., FORT WORTH, TX. FILED 9-12-2006.

# Jr. Mucus

THE MARK CONSISTS OF STANDARD CHARACTERS WITHOUT CLAIM TO ANY PARTICULAR FONT, STYLE, SIZE, OR COLOR.

OWNER OF U.S. REG. NOS. 3,088,179 AND 3,116,483.

FOR PHARMACEUTICAL PREPARATIONS FOR THE TREATMENT OF RESPIRATORY AND PULMONARY CONDITIONS (U.S. CLS. 6, 18, 44, 46, 51 AND 52).

JOHN HWANG, EXAMINING ATTORNEY

SN 78-972,587. KAMADA LTD., REHOVOT, ISRAEL, FILED 9-12-2006.

# KAMRAB

THE MARK CONSISTS OF STANDARD CHARACTERS WITHOUT CLAIM TO ANY PARTICULAR FONT, STYLE, SIZE, OR COLOR.

FOR RABIES VACCINE (U.S. CLS. 6, 18, 44, 46, 51 AND 52).

GEORGE LORENZO, EXAMINING ATTORNEY

**CLASS 5—(Continued).**

SN 78-972,826. PREMIER ALIVE, INC., CEDAR CITY, UT.  
FILED 9-12-2006.

**PREMIER ALIVE**

THE MARK CONSISTS OF STANDARD CHARACTERS  
WITHOUT CLAIM TO ANY PARTICULAR FONT, STYLE,  
SIZE, OR COLOR.

FOR DIETARY AND NUTRITIONAL SUPPLEMENTS  
(U.S. CLS. 6, 18, 44, 46, 51 AND 52).

SCOTT BALDWIN, EXAMINING ATTORNEY

SN 78-974,335. UPSHER-SMITH LABORATORIES, INC.,  
MAPLE GROVE, MN. FILED 9-14-2006.

**TROTEXTIN**

THE MARK CONSISTS OF STANDARD CHARACTERS  
WITHOUT CLAIM TO ANY PARTICULAR FONT, STYLE,  
SIZE, OR COLOR.

FOR PHARMACEUTICAL PREPARATION, NAMELY  
TESTOSTERONE LOTION/GEL TO TREAT TESTOSTER-  
ONE DEFICIENCY (U.S. CLS. 6, 18, 44, 46, 51 AND 52).  
JASON ROTH, EXAMINING ATTORNEY

SN 78-978,065. ARCTURUS, INC., LAS VEGAS, NV. FILED  
12-23-2005.

**FUSION FORMULAS**

THE MARK CONSISTS OF STANDARD CHARACTERS  
WITHOUT CLAIM TO ANY PARTICULAR FONT, STYLE,  
SIZE, OR COLOR.

NO CLAIM IS MADE TO THE EXCLUSIVE RIGHT TO  
USE "FORMULAS", APART FROM THE MARK AS  
SHOWN.

FOR DIETARY SUPPLEMENTS AND NUTRITIONAL  
SUPPLEMENTS (U.S. CLS. 6, 18, 44, 46, 51 AND 52).  
JAMES GRIFFIN, EXAMINING ATTORNEY

**CLASS 5—(Continued).**

SN 79-025,075. SANOFI-AVENTIS, FRANCE, FILED 4-21-  
2006.

**CILTYRI**

THE MARK CONSISTS OF STANDARD CHARACTERS  
WITHOUT CLAIM TO ANY PARTICULAR FONT, STYLE,  
SIZE, OR COLOR.

PRIORITY DATE OF 11-9-2005 IS CLAIMED.

OWNER OF INTERNATIONAL REGISTRATION 0888081  
DATED 4-21-2006, EXPIRES 4-21-2016.

FOR PHARMACEUTICAL PREPARATIONS FOR PRE-  
VENTING AND TREATING DISORDERS OF THE CEN-  
TRAL NERVOUS SYSTEM (U.S. CLS. 6, 18, 44, 46, 51  
AND 52).

HEATHER SAPP, EXAMINING ATTORNEY

**CLASS 6—METAL GOODS**

SN 78-614,548. INNOVATIVE METALS COMPANY, INC.,  
TUCKER, GA. FILED 4-22-2005.

**PERM-LOC**

THE MARK CONSISTS OF STANDARD CHARACTERS  
WITHOUT CLAIM TO ANY PARTICULAR FONT, STYLE,  
SIZE, OR COLOR.

FOR ARCHITECTURAL WALL PANELS OF METAL  
(U.S. CLS. 2, 12, 13, 14, 23, 25 AND 50).

FIRST USE 0-0-1994; IN COMMERCE 0-0-1994.

TEJBIR SINGH, EXAMINING ATTORNEY

**CLASS 6—(Continued).**

SN 78-640,259. PF MANAGEMENT HOLDING APS, VILDBJERG, DENMARK, FILED 5-31-2005.

# LHD

THE MARK CONSISTS OF STANDARD CHARACTERS WITHOUT CLAIM TO ANY PARTICULAR FONT, STYLE, SIZE, OR COLOR.

PRIORITY CLAIMED UNDER SEC. 44(D) ON ERPN CMNTY TM OFC APPLICATION NO. 004147931, FILED 12-1-2004, REG. NO. 004147931, DATED 4-11-2006, EXPIRES 12-1-2014.

FOR COMMON METALS AND THEIR ALLOYS; METAL BUILDING MATERIALS, NAMELY, GRATINGS, GRATING STEPS FOR FLOORS, WALKWAYS, STAIRS, BALCONIES, AND PLATFORMS; HEAT SHIELD DECKS FOR INDUSTRIAL FACILITIES, NAMELY METAL GRATINGS; METAL GRATINGS FOR FACADE DECORATION; METAL GRATINGS FOR VENTILATION DUCTS AND CONDUITS, PERFORATED SHEETS, LOADING RAMPS AND STAIR TREADS; IRONMONGERY AND SMALL ITEMS OF METAL HARDWARE, NAMELY, HINGES, CLAMPS, SCREWS, AND SCREW FITTINGS, NAMELY, NUTS, BOLTS AND WASHERS; PIPES AND TUBES OF METAL; METAL SAFES (U.S. CLS. 2, 12, 13, 14, 23, 25 AND 50).

BRENDAN MCCAULEY, EXAMINING ATTORNEY

SN 78-663,835. KUBOTA MATSUSHITADENKO EXTERIOR WORKS, LTD., OSAKA-SHI, JAPAN, FILED 7-5-2005.

# CERACLAD

THE MARK CONSISTS OF STANDARD CHARACTERS WITHOUT CLAIM TO ANY PARTICULAR FONT, STYLE, SIZE, OR COLOR.

FOR IRONS AND STEELS; NONFERROUS METALS AND THEIR ALLOYS FOR FURTHER MANUFACTURING; ORES OF METAL, NAMELY, ZINC ORES, CHROME IRON ORES, COBALT ORES, TIN ORES, TUNGSTEN ORES, IRON ORES, COPPER ORES, LEAD ORES, NICKEL ORES, MANGANESE ORES, MOLYBDENUM ORES, IRON PYRITES; METAL MATERIALS FOR BUILDING OR CONSTRUCTION, NAMELY, CHIMNEY SHAFTS, STAIR TREADS, FASTENERS FOR CASEMENT WINDOWS, GUARDRAILS, WALL LININGS, PILINGS, GRATINGS, TUNNELING MATERIALS, FENCES, SHUTTERS, WATER-PIPES, TILES, STEEL FRAMES FOR BUILDING, SHELF BOARDS, HINGES, HANDRAILS, GABIONS OF STEEL WIRE, CEILING BOARDS, CEILING DECORATIONS, ELECTRIC POLES, DOOR KNOCKERS, GUTTERS, GUTTER BRACKETS, SLIDING DOOR PULLEYS, SLIDING DOOR ROLLERS, DOORS, DOOR HANDLES, DOOR CLOSERS, PILLARS, WAINSCOTINGS, BEAMS, GRILLES, WIRE FENCES, FIRE RETARDING DOORS, FLOOR PAVINGS, WINDOWS, WINDOW KNOBS, WINDOW FRAMES, WINDOW PULLEYS, MANHOLE COVERS, GATES, BARBED WIRES, FLOOR BOARDS, LOUVER DOORS, ROCK SLIDE RETENTION WIRE NETS, LATHS, WIRE MATERIALS, RIDGES FOR VENTILATION, THROATING PLATES; PREFABRICATED BUILDING ASSEMBLY KITS OF METAL CONSISTING PRIMARILY OF ALUMINUM, IRON, STAINLESS STEEL, STEEL PLATE FOR USE IN CONSTRUCTING AVIARIES; LOADING AND UNLOADING PALLETS OF METAL; TURN-TABLES OF METAL FOR LOAD HANDLING; TRAVERSERS OF

**CLASS 6—(Continued).**

METAL FOR LOAD HANDLING; ARTIFICIAL FISH REEFS OF METAL; POULTRY CAGES OF METAL; PAINT SPRAYING BOOTHS OF METAL; METAL MOULDS FOR FORMING CEMENT PRODUCTS; PULLEYS OF METAL, NOT MACHINE ELEMENTS; SPRINGS OF METAL, NOT MACHINE ELEMENTS; VALVES OF METAL, NOT MACHINE ELEMENTS; METAL JUNCTIONS FOR PIPES METAL FLANGES; METAL COTTER PINS; METAL RAILWAY POINTS; NON-LUMINOUS AND NON-MECHANICAL ROAD SIGNS OF METAL; NON-LUMINOUS BEACONS OF METAL; LIQUID STORAGE TANKS OR RESERVOIRS MADE OF METAL; INDUSTRIAL WATER STORAGE TANKS OF METAL; LIQUEFIED GAS STORAGE TANKS OF METAL; GAS STORAGE TANKS OF METAL; INTERNAL FLOATING LIDS OF ALUMINUM FOR USE WITH GAS OR LIQUEFIED GAS STORAGE TANKS; CURING TANK OF METAL; METAL FASTENING ANCHORS; MOORING BITTS OF METAL; MOORING BOLLARDS OF METAL; CONTAINERS OF METAL FOR TRANSPORTATION OF GOODS; ANVILS; SWAGE BLOCKS; METAL HARDWARE, NAMELY, CUT NAILS, NAILS, WEDGES AND PEGS, WASHERS, NUTS, SCREWS, TACKS, PLUGS, BOLTS, RIVETS, RINGS, CHAINS, SECURITY LOCKS, KEYS FOR LOCKS, RINGS OF METAL FOR KEYS, PADLOCKS, CASTERS, HORSESHOES, METAL FIXTURES FOR ROPES FOR USES WITH SWIMMING POOLS; WIRE ROPES; WIRE NETS AND GAUZES; INDUSTRIAL PACKAGING CONTAINERS OF METAL FOR TRANSPORTATION OF GOODS; METAL STOPPERS FOR INDUSTRIAL PACKAGING CONTAINERS; METAL LIDS AND CAPS FOR INDUSTRIAL PACKAGING CONTAINERS; METAL NAMEPLATES AND DOOR NAMEPLATES; METAL CHAINS FOR DOGS; METAL STEPLADDERS AND LADDERS; LETTER BOXES OF METAL; HAT-HANGING HOOKS OF METAL; MONEY BOXES OF METAL; WATER TANKS OF METAL FOR HOUSEHOLD PURPOSES; TOOL BOXES OF METAL; TOWEL DISPENSERS OF METAL; METAL JOINERY FITTINGS; METAL SAFES; UPRIGHT SIGNBOARDS OF METAL; TRANSPORTABLE GREENHOUSES OF METAL FOR HOUSEHOLD USE; METAL TOMBS AND METAL TOMB PLAQUES; FERRULES OF METAL FOR CANES AND WALKING-STICKS; DIVING PLATFORMS OF METAL; STIRRUPS OF METAL; SPURS; AND SCULPTURES OF METAL (U.S. CLS. 2, 12, 13, 14, 23, 25 AND 50).

MICHAEL SOUDERS, EXAMINING ATTORNEY

SN 78-728,856. EXPANSION JOINT SYSTEMS, INC., SANTEE, CA. FILED 10-7-2005.

# CODEFLEX

THE MARK CONSISTS OF STANDARD CHARACTERS WITHOUT CLAIM TO ANY PARTICULAR FONT, STYLE, SIZE, OR COLOR.

FOR METAL EXPANSION JOINT FOR CONNECTING PIPING TO HEAT EXCHANGER (U.S. CLS. 2, 12, 13, 14, 23, 25 AND 50).

FIRST USE 9-5-2002; IN COMMERCE 9-5-2002.

SKYE YOUNG, EXAMINING ATTORNEY

**CLASS 6—(Continued).**

SN 78-802,733. TRACKOUT CONTROL, LLC, TEMPE, AZ.  
FILED 1-30-2006.

# GRIZZLY

THE MARK CONSISTS OF STANDARD CHARACTERS WITHOUT CLAIM TO ANY PARTICULAR FONT, STYLE, SIZE, OR COLOR.

FOR DEVICES AND CONTROL EQUIPMENT FOR REMOVAL OF DUST AND DEBRIS FROM VEHICLE CHASSIS, WHEELS AND TIRES BEFORE THE VEHICLE ENTERS A PAVED PUBLIC ROAD, NAMELY STEEL GRATES AND PIPING (U.S. CLS. 2, 12, 13, 14, 23, 25 AND 50).

ALAIN LAPTER, EXAMINING ATTORNEY

**CLASS 6—(Continued).**

SN 78-958,180. JACOBS, JANA MARIE, OKARCHE, OK.  
FILED 8-23-2006.

# college**space**

THE MARK CONSISTS OF THE TWO WORDS TOGETHER TO SPELL COLLEGESPACE. "COLLEGE" IS IN THE FONT: MONOTYPE CORSIVA, AND "SPACE" IS IN THE FONT: IMPACT.

FOR GENERAL PURPOSE METAL STORAGE CONTAINERS; GENERAL PURPOSE METAL STORAGE UNITS; METAL CONTAINERS FOR THE STORAGE AND TRANSPORTATION OF GOODS (U.S. CLS. 2, 12, 13, 14, 23, 25 AND 50).

THOMAS MANOR, EXAMINING ATTORNEY

SN 78-915,707. GARDEN NECESSITIES, LLC, SANDY, UT.  
FILED 6-23-2006.

# TUSCAN GARDEN WORKS

THE MARK CONSISTS OF STANDARD CHARACTERS WITHOUT CLAIM TO ANY PARTICULAR FONT, STYLE, SIZE, OR COLOR.

NO CLAIM IS MADE TO THE EXCLUSIVE RIGHT TO USE "GARDEN WORKS", APART FROM THE MARK AS SHOWN.

FOR WROUGHT IRON DECORATIVE ARTWORK; GAZEBOS PRIMARILY OF METAL; METAL GATES AND FENCING; ARCHES PRIMARILY OF METAL; PREFABRICATED METAL BRIDGES (U.S. CLS. 2, 12, 13, 14, 23, 25 AND 50).

FIRST USE 3-0-2002; IN COMMERCE 3-0-2002.  
DAWN FELDMAN, EXAMINING ATTORNEY

SN 78-962,294. NINGBO YUNHAO FASTENER MANUFACTURING CO., LTD., NINGBO, CHINA, FILED 8-28-2006.

# YHC

THE MARK CONSISTS OF STANDARD CHARACTERS WITHOUT CLAIM TO ANY PARTICULAR FONT, STYLE, SIZE, OR COLOR.

FOR METAL FASTENERS, NAMELY, SCREWS, NUTS, BOLTS, WASHERS, AND THREADED RODS AND STUDS (U.S. CLS. 2, 12, 13, 14, 23, 25 AND 50).

ESTHER BELENKER, EXAMINING ATTORNEY

SN 78-935,610. SPEED PAINTING, INC., AMARILLO, TX.  
FILED 7-24-2006.

# DOOR DECKERS

THE MARK CONSISTS OF STANDARD CHARACTERS WITHOUT CLAIM TO ANY PARTICULAR FONT, STYLE, SIZE, OR COLOR.

NO CLAIM IS MADE TO THE EXCLUSIVE RIGHT TO USE "DOOR", APART FROM THE MARK AS SHOWN.

FOR METAL HARDWARE FOR HOLDING A DOOR WHILE IT IS BEING PAINTED AND FOR USE IN STACKING PAINTED DOORS (U.S. CLS. 2, 12, 13, 14, 23, 25 AND 50).

FIRST USE 2-0-2002; IN COMMERCE 2-0-2002.  
MARGERY A. TIERNEY, EXAMINING ATTORNEY

SN 78-963,696. AMERICAN NEVADA HOLDINGS, LLC,  
HENDERSON, NV. FILED 8-30-2006.

# AVENUE33

THE MARK CONSISTS OF STANDARD CHARACTERS WITHOUT CLAIM TO ANY PARTICULAR FONT, STYLE, SIZE, OR COLOR.

FOR METAL KEY CHAINS; METAL KEY RINGS; METAL KEY CHAIN TAGS; METAL JEWELRY BOXES; METAL MONEY CLIPS; AND STATUETTES OF NON-PRECIOUS METAL (U.S. CLS. 2, 12, 13, 14, 23, 25 AND 50).

INGRID C. EULIN, EXAMINING ATTORNEY

**CLASS 6—(Continued).**

SN 78-963,764. AMERICAN NEVADA HOLDINGS, LLC, HENDERSON, NV. FILED 8-30-2006.

*Avenue33*

FOR METAL KEY CHAINS; METAL KEY RINGS; METAL KEY CHAIN TAGS; METAL JEWELRY BOXES; METAL MONEY CLIPS; AND STATUETTES OF NON-PRECIOUS METAL (U.S. CLS. 2, 12, 13, 14, 23, 25 AND 50).

INGRID C. EULIN, EXAMINING ATTORNEY

**CLASS 6—(Continued).**

SN 78-964,373. AMERICAN NEVADA HOLDINGS, LLC, HENDERSON, NV. FILED 8-30-2006.

AVENUE33 BROWNSTONES AT THE DISTRICT

THE MARK CONSISTS OF STANDARD CHARACTERS WITHOUT CLAIM TO ANY PARTICULAR FONT, STYLE, SIZE, OR COLOR.

FOR METAL KEY CHAINS; METAL KEY RINGS; METAL KEY CHAIN TAGS; METAL JEWELRY BOXES; METAL MONEY CLIPS; AND STATUETTES OF NON-PRECIOUS METAL (U.S. CLS. 2, 12, 13, 14, 23, 25 AND 50).

THEODORE MCBRIDE, EXAMINING ATTORNEY

SN 78-963,863. ISOTECH LABORATORIES, INC., CHAMPAIGN, IL. FILED 8-30-2006.

**Isotube**

OWNER OF U.S. REG. NO. 2,838,483. FOR METAL CONTAINERS FOR THE HARVESTING AND TRANSPORTATION OF GASEOUS OR LIQUID SAMPLES FOR TESTING (U.S. CLS. 2, 12, 13, 14, 23, 25 AND 50).

WILLIAM VERHOSEK, EXAMINING ATTORNEY

SN 78-966,628. CITY OF HENDERSON REDEVELOPMENT AGENCY, HENDERSON, NV. FILED 9-3-2006.



NO CLAIM IS MADE TO THE EXCLUSIVE RIGHT TO USE "WATER STREET DISTRICT HENDERSON", APART FROM THE MARK AS SHOWN.

THE MARK CONSISTS OF WATER STREET DISTRICT HENDERSON IN STYLIZED LETTERS.

FOR GOODS MADE FROM NON-PRECIOUS METAL, NAMELY, KEY CHAINS, COIN BANKS, BOXES AND JEWELRY BOXES, MONEY CLIPS AND SCULPTURE; STATUES OF NON-PRECIOUS METAL (U.S. CLS. 2, 12, 13, 14, 23, 25 AND 50).

SUSAN STIGLITZ, EXAMINING ATTORNEY

SN 78-964,324. AMERICAN NEVADA HOLDINGS, LLC, HENDERSON, NV. FILED 8-30-2006.

AVENUE33 AT THE DISTRICT

THE MARK CONSISTS OF STANDARD CHARACTERS WITHOUT CLAIM TO ANY PARTICULAR FONT, STYLE, SIZE, OR COLOR.

FOR METAL KEY CHAINS; METAL KEY RINGS; METAL KEY CHAIN TAGS; METAL JEWELRY BOXES; METAL MONEY CLIPS; AND STATUETTES OF NON-PRECIOUS METAL (U.S. CLS. 2, 12, 13, 14, 23, 25 AND 50).

THEODORE MCBRIDE, EXAMINING ATTORNEY

SN 78-966,833. SENCO PRODUCTS, INC., CINCINNATI, OH. FILED 9-5-2006.

**MASTERFIT**

THE MARK CONSISTS OF STANDARD CHARACTERS WITHOUT CLAIM TO ANY PARTICULAR FONT, STYLE, SIZE, OR COLOR.

OWNER OF U.S. REG. NO. 2,010,946. FOR COLLATED METAL FASTENERS, NAMELY NAILS, SCREWS AND STAPLES, FOR USE IN POWER FASTENING TOOLS (U.S. CLS. 2, 12, 13, 14, 23, 25 AND 50).

PRISCILLA MILTON, EXAMINING ATTORNEY

**CLASS 6—(Continued).**

SN 78-968,114. NORSE INC., TORRINGTON, CT. FILED 9-6-2006.

**SHUTTERUP**

THE MARK CONSISTS OF STANDARD CHARACTERS WITHOUT CLAIM TO ANY PARTICULAR FONT, STYLE, SIZE, OR COLOR.

FOR METAL FASTENERS FOR SECURING PANELS COMPRISED OF A SLOTTED METAL BASE AND A HOLDING CAM (U.S. CLS. 2, 12, 13, 14, 23, 25 AND 50).  
JENNIFER WILLISTON, EXAMINING ATTORNEY

SN 78-968,502. FWU KUANG ENTERPRISES CO., LTD., ERH-TAIWAN, CHINA, FILED 9-6-2006.



FOR METAL FASTENERS, NAMELY, BOLTS, NUTS AND SCREWS (U.S. CLS. 2, 12, 13, 14, 23, 25 AND 50).  
FIRST USE 4-27-2006; IN COMMERCE 4-27-2006.  
KEVON CHISOLM, EXAMINING ATTORNEY

SN 78-970,299. TRINITY INDUSTRIES, INCL., DALLAS, TX. FILED 9-8-2006.

**BUILDING TOMORROW'S  
HIGHWAY SAFETY SOLUTIONS  
TODAY**

THE MARK CONSISTS OF STANDARD CHARACTERS WITHOUT CLAIM TO ANY PARTICULAR FONT, STYLE, SIZE, OR COLOR.

FOR HIGHWAY SAFETY DEVICES OF METAL, NAMELY, GUARDRAILS; VEHICLE ENERGY-ABSORBING SYSTEMS, NAMELY, CRASH-ATTENUATING GUARDRAILS, NOSE SECTIONS, AND SUPPORTS THEREFOR; BRIDGE RAILS; METAL RETAINING WALLS; METALLIC SOUND BARRIER PANELS; FABRICATED METAL SHAPES, NAMELY, ANGLES, CHANNELS, AND SHEET PILING; CUSTOM-ROLLED FORM PRODUCTS, NAMELY, L-SHAPES, Z-SHAPES, U-SHAPES, AND CORRUGATED SHEETS FOR USE IN CONSTRUCTION (U.S. CLS. 2, 12, 13, 14, 23, 25 AND 50).  
ALICE SUE CARRUTHERS, EXAMINING ATTORNEY

**CLASS 6—(Continued).**

SN 79-011,996. PIVAB INTERNATIONAL AB, SE-430 20 VEDDIGE, SWEDEN, FILED 4-13-2005.

**PIVAB**

THE MARK CONSISTS OF STANDARD CHARACTERS WITHOUT CLAIM TO ANY PARTICULAR FONT, STYLE, SIZE, OR COLOR.

OWNER OF INTERNATIONAL REGISTRATION 0769227 DATED 11-5-2001, EXPIRES 11-5-2011.  
OWNER OF U.S. REG. NO. 2,015,977.  
FOR METAL SPRAY PAINTING BOOTHS (U.S. CLS. 2, 12, 13, 14, 23, 25 AND 50).  
ALEXANDER L. POWERS, EXAMINING ATTORNEY

**CLASS 7—MACHINERY**

SN 76-598,258. HALDEX AB, SE10388 STOCKHOLM, SWEDEN, FILED 6-21-2004.



OWNER OF U.S. REG. NOS. 1,455,157 AND 2,420,384.  
THE COLOR(S) BLUE AND WHITE IS/ARE CLAIMED AS A FEATURE OF THE MARK.

THE MARK CONSISTS OF THE STYLIZED WORDING HALDEX WITHIN A BLUE RECTANGLE. THE WORDING HALDEX IS DISPLAYED IN THE COLOR WHITE.

FOR ENGINES FOR MACHINES; MOTORS FOR MACHINES; HYDRAULIC ENGINES FOR MACHINES; PUMPS USED IN MOTORS AND ENGINES; AIR COMPRESSORS; AXLES FOR MACHINES; COUPLINGS FOR MACHINES; TRANSMISSION COMPONENTS, NOT FOR LAND VEHICLES, NAMELY, BELTS, BEARINGS, POWER TRANSMISSION BELTS, TRANSMISSION BELTS, AND TRANSMISSION GEARS AND GEARINGS; BRAKES FOR MACHINES; MACHINE BREAKING ELEMENTS NOT FOR LAND VEHICLES, NAMELY, BLOCK BRAKES, BAND BRAKES, BRAKE LININGS, AND BRAKE SEGMENTS; SUSPENSION SYSTEMS FOR MACHINES; DRIVE TRAINS FOR MACHINES; POWER TRANSMISSIONS FOR MACHINES; TORQUE CONVERTERS, NOT FOR LAND VEHICLES, NAMELY, TORQUE TRANSFER PNEUMATIC SYSTEMS; FUEL SYSTEMS FOR MACHINES, NAMELY, FUEL LINES, FUEL FILTERS, FUEL PUMPS AND FUEL INJECTORS; EMISSION REDUCTION UNITS FOR MACHINES, NAMELY, EGR VALVES, PCV VALES AND CATALYTIC CONVERTERS; MACHINE ENGINE PARTS, NAMELY, CRANKCASE VENTILATORS; MACHINE PARTS, NAMELY, EXHAUST GAS RECIRCULATORS; PARTS AND FITTINGS FOR THE LISTED GOODS (U.S. CLS. 13, 19, 21, 23, 31, 34 AND 35).

FIRST USE 12-0-2001; IN COMMERCE 12-0-2001.  
BRIAN PINO, EXAMINING ATTORNEY



**CLASS 7—(Continued).**

SN 76-636,635. NATURE TECHNOLOGIES INTERNATIONAL LLC, SONOMA, CA. FILED 4-22-2005.

NATURE TECHNOLOGIES INTERNATIONAL LLC

THE MARK CONSISTS OF STANDARD CHARACTERS WITHOUT CLAIM TO ANY PARTICULAR FONT, STYLE, SIZE, OR COLOR.

NO CLAIM IS MADE TO THE EXCLUSIVE RIGHT TO USE "TECHNOLOGIES INTERNATIONAL LLC", APART FROM THE MARK AS SHOWN.

FOR MACHINES, NAMELY, COMPOST TEA EXTRACTORS FOR PRODUCING ACTIVELY AERATED COMPOST TEA (U.S. CLS. 13, 19, 21, 23, 31, 34 AND 35).

FIRST USE 4-19-2004; IN COMMERCE 4-19-2004.

JULIE GUTTADAURO, EXAMINING ATTORNEY

**CLASS 7—(Continued).**

SN 77-025,048. LG ELECTRONICS INC., SEOUL, REPUBLIC OF KOREA, FILED 10-19-2006.

**IllumiTub**

SN 76-656,656. KIM, JAY S., SANTA FE SPRINGS, CA. FILED 3-15-2006.

**TWISTER INSIDE**

THE MARK CONSISTS OF STANDARD CHARACTERS WITHOUT CLAIM TO ANY PARTICULAR FONT, STYLE, SIZE, OR COLOR.

FOR MOTOR VEHICLE COMPONENTS AND ACCESSORIES, NAMELY MOTOR INTAKE AND EXHAUST SYSTEMS AND PARTS THEREFOR, NAMELY, AIR INTAKE MANIFOLDS, AIR INTAKE TUBES, AIR INTAKE DUCTS, AIR CLEANER HOUSINGS AND EXHAUST MANIFOLDS, EXHAUST TUBES, EXHAUST DUCTS AND MUFFLERS, ALSO COMPRISED OF INTAKE AND EXHAUST FLUID DEVICE FOR MODIFICATION OF MOVEMENT OF AIR FLOWING THROUGH THE INTAKE SYSTEM AND EXHAUST SYSTEM FOR USE IN INTERNAL COMBUSTION ENGINES AND PARTS THEREFOR (U.S. CLS. 13, 19, 21, 23, 31, 34 AND 35).

MICHAEL KEATING, EXAMINING ATTORNEY

THE MARK CONSISTS OF STANDARD CHARACTERS WITHOUT CLAIM TO ANY PARTICULAR FONT, STYLE, SIZE, OR COLOR.

FOR DISH WASHING MACHINES FOR HOUSEHOLD PURPOSES; FOOD WASTE DISPOSALS; ELECTRIC MIXERS FOR HOUSEHOLD PURPOSES; ELECTRIC FOOD GRINDERS FOR DOMESTIC USE; CLOTHES WASHING MACHINES; VACUUM CLEANERS; BRUSHES FOR VACUUM CLEANERS (U.S. CLS. 13, 19, 21, 23, 31, 34 AND 35).

KATHLEEN M. VANSTON, EXAMINING ATTORNEY

SN 77-050,219. GENERAL ATOMICS, SAN DIEGO, CA. FILED 11-22-2006.

**DC LINK**

SN 76-666,835. TRIEXE MANAGEMENT GROUP INC., FONTHILL, ONTARIO L0S 1E6, CANADA, FILED 9-29-2006.

**TURF TURTLE**

THE MARK CONSISTS OF STANDARD CHARACTERS WITHOUT CLAIM TO ANY PARTICULAR FONT, STYLE, SIZE, OR COLOR.

NO CLAIM IS MADE TO THE EXCLUSIVE RIGHT TO USE "TURF", APART FROM THE MARK AS SHOWN.

FOR MACHINES DESIGNED FOR THE MAINTENANCE OF ARTIFICIAL TURF SURFACES (U.S. CLS. 13, 19, 21, 23, 31, 34 AND 35).

DEIRDRE ROBERTSON, EXAMINING ATTORNEY

THE MARK CONSISTS OF STANDARD CHARACTERS WITHOUT CLAIM TO ANY PARTICULAR FONT, STYLE, SIZE, OR COLOR.

NO CLAIM IS MADE TO THE EXCLUSIVE RIGHT TO USE "DC", APART FROM THE MARK AS SHOWN.

FOR ELECTRIC POWER GENERATORS AND SYSTEMS AND ACCESSORIES FOR USE IN ELECTRIC POWER DISTRIBUTION SYSTEMS, PARTICULARLY FOR USE ON SHIPS, COMPRISED OF ELECTRICAL SUBSTATIONS, ELECTRICAL POWER DISTRIBUTION BLOCKS, ELECTRICAL SWITCHGEAR, TRANSFORMERS, CONVERTERS, AND REGULATORS (U.S. CLS. 13, 19, 21, 23, 31, 34 AND 35).

FIRST USE 12-7-2004; IN COMMERCE 12-7-2004.

TAMARA LEE, EXAMINING ATTORNEY

**CLASS 7—(Continued).**

SN 78-590,295. TUVIM, DORY, FRANKVILLE, ONTARIO, FILED 3-18-2005.

## DORY CONTAINER TRAVELER

THE MARK CONSISTS OF STANDARD CHARACTERS WITHOUT CLAIM TO ANY PARTICULAR FONT, STYLE, SIZE, OR COLOR.

PRIORITY CLAIMED UNDER SEC. 44(D) ON CANADA APPLICATION NO. 1231035, FILED 9-21-2004, REG. NO. TMA676,505, DATED 11-7-2006, EXPIRES 11-7-2021.

NO CLAIM IS MADE TO THE EXCLUSIVE RIGHT TO USE "CONTAINER TRAVELER", APART FROM THE MARK AS SHOWN.

FOR CONTAINER HANDLERS, NAMELY, POWER-OPERATED MACHINES FOR MOVING, LIFTING AND LOADING COMMERCIAL CONTAINERS (U.S. CLS. 13, 19, 21, 23, 31, 34 AND 35).

TRACY WHITTAKER-BROWN, EXAMINING ATTORNEY

**CLASS 7—(Continued).**

SN 78-697,176. FENNER DUNLOP HOLDINGS, INC., CHARLOTTE, NC. FILED 8-22-2005.

## GRANITE

THE MARK CONSISTS OF STANDARD CHARACTERS WITHOUT CLAIM TO ANY PARTICULAR FONT, STYLE, SIZE, OR COLOR.

FOR CHEMICAL COMPOUNDS SOLD AS AN INTEGRAL COMPONENT OF CONVEYOR BELTS FOR THE PURPOSE OF INCREASED ABRASION RESISTANCE (U.S. CLS. 13, 19, 21, 23, 31, 34 AND 35).

FIRST USE 6-30-2005; IN COMMERCE 6-30-2005.  
TRICIA SONNEBORN, EXAMINING ATTORNEY

SN 78-702,391. FENNER DUNLOP HOLDINGS, INC., CHARLOTTE, NC. FILED 8-29-2005.

## GUARDIAN

THE MARK CONSISTS OF STANDARD CHARACTERS WITHOUT CLAIM TO ANY PARTICULAR FONT, STYLE, SIZE, OR COLOR.

FOR CHEMICAL COMPOUNDS SOLD AS AN INTEGRAL COMPONENT OF CONVEYOR BELTS FOR THE PURPOSE OF INCREASED ABRASION, CHEMICAL AND DUST RESISTANCE (U.S. CLS. 13, 19, 21, 23, 31, 34 AND 35).

FIRST USE 12-23-2003; IN COMMERCE 12-23-2003.  
HOWARD B. LEVINE, EXAMINING ATTORNEY

SN 78-696,057. BSH BOSCH UND SIEMENS HAUSGERAETE GMBH, MUNICH, FED REP GERMANY, FILED 8-19-2005.



PRIORITY CLAIMED UNDER SEC. 44(D) ON FED REP GERMANY APPLICATION NO. 30514131.7/0, FILED 3-10-2005, REG. NO. 30514131, DATED 4-21-2005, EXPIRES 3-31-2015.

NO CLAIM IS MADE TO THE EXCLUSIVE RIGHT TO USE BAGLESS, APART FROM THE MARK AS SHOWN.

FOR HOUSEHOLD AND KITCHEN MACHINES AND EQUIPMENT, NAMELY, ELECTRIC CLEANING EQUIPMENT FOR HOUSEHOLD USE, NAMELY, VACUUM CLEANERS; PARTS OF ALL AFOREMENTIONED GOODS (U.S. CLS. 13, 19, 21, 23, 31, 34 AND 35).

BRIDGETT SMITH, EXAMINING ATTORNEY

SN 78-750,028. STANDARD AERO ACQUISITIONS HOLDINGS, INC., WILMINGTON, DE. FILED 11-9-2005.

# STANDARD AERO

PRIORITY CLAIMED UNDER SEC. 44(D) ON CANADA APPLICATION NO. 1268099, FILED 7-1-2005.

NO CLAIM IS MADE TO THE EXCLUSIVE RIGHT TO USE "AERO", APART FROM THE MARK AS SHOWN.

THE COLOR(S) BLUE IS/ARE CLAIMED AS A FEATURE OF THE MARK.

THE ENTIRE MARK IS BLUE.  
FOR AIRCRAFT ENGINES (U.S. CLS. 13, 19, 21, 23, 31, 34 AND 35).

FIRST USE 1-31-1983; IN COMMERCE 1-31-1983.  
PAUL F. GAST, EXAMINING ATTORNEY

**CLASS 7—(Continued).**

SN 78-753,475. ECHO, INCORPORATED, LAKE ZURICH, IL. FILED 11-14-2005.

# POWER PRUNER

THE MARK CONSISTS OF STANDARD CHARACTERS WITHOUT CLAIM TO ANY PARTICULAR FONT, STYLE, SIZE, OR COLOR.

OWNER OF U.S. REG. NO. 2,301,071.  
NO CLAIM IS MADE TO THE EXCLUSIVE RIGHT TO USE "PRUNER", APART FROM THE MARK AS SHOWN. SEC. 2(F).

FOR GAS-POWERED TREE, HEDGE, BUSH AND OTHER VEGETATION PRUNING TOOLS AND PARTS AND ACCESSORIES THEREFORE, NAMELY, EXTENSION ATTACHMENTS, EDGER ATTACHMENTS, CIRCULAR SAW ATTACHMENTS AND HEDGE CLIPPER ATTACHMENTS, WHICH MAY BE EITHER FIXED OR TELESCOPING IN OPERATION (U.S. CLS. 13, 19, 21, 23, 31, 34 AND 35).

FIRST USE 12-21-1988; IN COMMERCE 12-21-1988.  
AMY BROZENIC, EXAMINING ATTORNEY

**CLASS 7—(Continued).**

SN 78-842,142. HY-LIFT HUNTING BLINDS, INC., KENNE-DALE, TX. FILED 3-21-2006.

# Hy-Watch

THE MARK CONSISTS OF STANDARD CHARACTERS WITHOUT CLAIM TO ANY PARTICULAR FONT, STYLE, SIZE, OR COLOR.

FOR SELF-CONTAINED POWER-OPERATED LIFT UNIT USED BY POLICE OFFICERS, SECURITY PERSONNEL AND OTHER LAY PERSONS FOR SURVEILLANCE AND SECURITY PURPOSES IN PARKING LOTS, AT SHOPPING MALLS, AT SPECIAL EVENTS, OR OTHER CROWDED AREAS, USED FOR HELP WITH CROWD SUPERVISION, CROWD CONTROL AND AS A THEFT DETERRENT (U.S. CLS. 13, 19, 21, 23, 31, 34 AND 35).

MICHAEL SOUDERS, EXAMINING ATTORNEY

SN 78-901,809. GR8 G.E.T. PTY LTD, ELANORA, QUEENSLAND, AUSTRALIA, FILED 6-6-2006.



SN 78-822,523. PUREM ABGASSYSTEME GMBH & CO. KG, 59423 UNNA, FED REP GERMANY, FILED 2-24-2006.

# ADS

THE MARK CONSISTS OF STANDARD CHARACTERS WITHOUT CLAIM TO ANY PARTICULAR FONT, STYLE, SIZE, OR COLOR.

PRIORITY CLAIMED UNDER SEC. 44(D) ON ERPNCMNTY TM OFC APPLICATION NO. 004615753, FILED 9-1-2005, REG. NO. 004615753, DATED 7-25-2006, EXPIRES 9-1-2015.

FOR EXHAUST GAS PURIFYING UNITS; INDIVIDUAL COMPONENTS FOR EXHAUST GAS PURIFYING UNITS, NAMELY, CATALYTIC CONVERTERS, DIESEL PARTICLE FILTERS, SINTERED METAL FILTERS, AND REPLACEMENT PARTS THEREFOR; CARBURETORS FOR REGULATING THE MIXTURE STRENGTH OF FUEL-AIR MIXTURES, ALL FOR COMBUSTION ENGINES FOR LAND VEHICLES (U.S. CLS. 13, 19, 21, 23, 31, 34 AND 35).

KAREN K. BUSH, EXAMINING ATTORNEY

PRIORITY CLAIMED UNDER SEC. 44(D) ON AUSTRALIA APPLICATION NO. 1096245, FILED 1-30-2006, REG. NO. 1096245, DATED 1-30-2006, EXPIRES 1-30-2016.

THE COLOR(S) BLUE, RED AND WHITE IS/ARE CLAIMED AS A FEATURE OF THE MARK.

THE COLOUR BLUE APPEARS IN THE WORDING GR8 AND THE COLOUR RED APPEARS IN THE GET AND THE COLOUR WHITE APPEARS AS A DIAGONAL STRIPE BETWEEN THE "8" AND THE SECOND "G" IN THE CENTRE OF THE MARK.

FOR REPLACEMENT PARTS AND REPLACEMENT PART ASSEMBLIES COMMONLY KNOWN AS GROUND ENGAGING TOOLS FOR EARTHMOVING, ROAD BUILDING, WASTE AND SOIL COMPACTING, LAND CLEARING AND RECLAMATION, MINING AND QUARRYING AND AGRICULTURAL EQUIPMENT, NAMELY, WEAR PARTS AND WEAR PART ASSEMBLIES FOR SUCH EQUIPMENT NAMELY BUCKET, SCARIFIER AND ROLLER TIPS, TEETH, POINTS OR BOOTS AND BLADE ATTACHING HARDWARE (U.S. CLS. 13, 19, 21, 23, 31, 34 AND 35).

MARK PILARO, EXAMINING ATTORNEY

**CLASS 7—(Continued).**

SN 78-934,246. EMERSON ELECTRIC CO., ST. LOUIS, MO.  
FILED 7-20-2006.

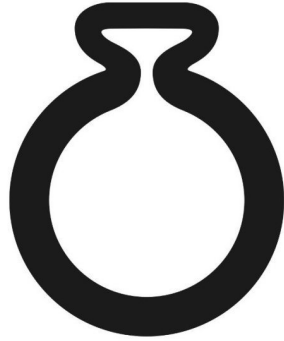

THE MARK CONSISTS OF THE SILHOUETTE OF A ROUND VASE-TYPE FIGURE WITH A NARROW NECK AND A WIDE LIP AT THE NECK SURROUNDED BY A DARK LINE OUTLINING THE FIGURE.

FOR POWER TOOLS, NAMELY, POWER OPERATED PRESSING TOOLS FOR MAKING CONNECTIONS ON PIPES AND TUBING (U.S. CLS. 13, 19, 21, 23, 31, 34 AND 35).

ESTHER BELENKER, EXAMINING ATTORNEY

SN 78-938,034. FANTASY TAN GLOBAL ENTERPRISES,  
LTD., BATAVIA, IL. FILED 7-26-2006.

## FANTASY TAN

THE MARK CONSISTS OF STANDARD CHARACTERS WITHOUT CLAIM TO ANY PARTICULAR FONT, STYLE, SIZE, OR COLOR.

OWNER OF U.S. REG. NO. 2,756,130.

NO CLAIM IS MADE TO THE EXCLUSIVE RIGHT TO USE "TAN", APART FROM THE MARK AS SHOWN.

FOR AIR BRUSHES, SPRAYERS, AND SPRAY GUNS FOR APPLYING SUNLESS TANNING PRODUCTS, SKIN COLORANTS, COSMETICS, SUN SCREEN; SPRAY SYSTEMS COMPRISED OF PUMPS, PUMP CONTROLLERS, NOZZLES, TUBING, AND VALVES; POWER OPERATED EQUIPMENT FOR APPLYING SUNLESS TANNING PRODUCTS, SKIN COLORANTS, COSMETICS, TATTOOS, AND SUNSCREEN (U.S. CLS. 13, 19, 21, 23, 31, 34 AND 35).

FIRST USE 5-1-1997; IN COMMERCE 5-1-1997.

MARGERY A. TIERNEY, EXAMINING ATTORNEY

**CLASS 7—(Continued).**

SN 78-938,083. FANTASY TAN GLOBAL ENTERPRISES,  
LTD., BATAVIA, IL. FILED 7-26-2006.



OWNER OF U.S. REG. NO. 2,756,130.

NO CLAIM IS MADE TO THE EXCLUSIVE RIGHT TO USE "TAN", APART FROM THE MARK AS SHOWN.

THE MARK CONSISTS OF THE STYLIZED WORDS FANTASY TAN UNDER A STYLIZED SUN WITH FIVE GRADUATED RAYS EMANATING FROM THE CENTER; AND A SWOOSH UNDER THE WORDS REMINISCENT OF A BEACH.

FOR AIR BRUSHES, SPRAYERS, AND SPRAY GUNS FOR APPLYING SUNLESS TANNING PRODUCTS, SKIN COLORANTS, COSMETICS, SUN SCREEN; SPRAY SYSTEMS COMPRISED OF PUMPS, PUMP CONTROLLERS, NOZZLES, TUBING, AND VALVES; POWER OPERATED EQUIPMENT FOR APPLYING SUNLESS TANNING PRODUCTS, SKIN COLORANTS, COSMETICS, TATTOOS, AND SUNSCREEN (U.S. CLS. 13, 19, 21, 23, 31, 34 AND 35).

FIRST USE 1-1-2003; IN COMMERCE 1-1-2003.

MARGERY A. TIERNEY, EXAMINING ATTORNEY

SN 78-954,547. J.H. FENNER & CO. LIMITED, EAST YORKSHIRE, ENGLAND, FILED 8-17-2006.

## PSR

THE MARK CONSISTS OF STANDARD CHARACTERS WITHOUT CLAIM TO ANY PARTICULAR FONT, STYLE, SIZE, OR COLOR.

FOR CONVEYOR BELTING (U.S. CLS. 13, 19, 21, 23, 31, 34 AND 35).

ALEXANDER L. POWERS, EXAMINING ATTORNEY

SN 78-954,971. PROPETRO SERVICES, INCORPORATED,  
MIDLAND, TX. FILED 8-18-2006.

## PRO DIV

THE MARK CONSISTS OF STANDARD CHARACTERS WITHOUT CLAIM TO ANY PARTICULAR FONT, STYLE, SIZE, OR COLOR.

NO CLAIM IS MADE TO THE EXCLUSIVE RIGHT TO USE "PRO", APART FROM THE MARK AS SHOWN.

FOR SEPARATING MACHINES (U.S. CLS. 13, 19, 21, 23, 31, 34 AND 35).

LINDSEY RUBIN, EXAMINING ATTORNEY

**CLASS 7—(Continued).**

SN 78-955,027. XALOY INCORPORATED, NEW CASTLE, PA.  
FILED 8-18-2006.

# BM-63

THE MARK CONSISTS OF STANDARD CHARACTERS WITHOUT CLAIM TO ANY PARTICULAR FONT, STYLE, SIZE, OR COLOR.

OWNER OF U.S. REG. NOS. 2,041,799 AND 2,041,800.  
FOR MACHINE PARTS, NAMELY, BACKING STEEL FOR BIMETALLIC CYLINDERS FOR USE IN EXTRUSION AND INJECTION MOLDING MACHINES (U.S. CLS. 13, 19, 21, 23, 31, 34 AND 35).

FIRST USE 4-17-2001; IN COMMERCE 4-17-2001.  
LINDA E. BLOHM, EXAMINING ATTORNEY

---

SN 78-957,512. STAR3COM CO., LTD, FONGYUAN CITY, TAIWAN, FILED 8-22-2006.

# YANGCNC

THE MARK CONSISTS OF STANDARD CHARACTERS WITHOUT CLAIM TO ANY PARTICULAR FONT, STYLE, SIZE, OR COLOR.

FOR METAL WORKING MACHINES, LATHES, METAL PROCESSING LATHES, MACHINING CENTERS, GRINDING MACHINES, DRILLING MACHINES, MILLING MACHINES, INDUSTRIAL ROBOTS, INDUSTRIAL ROBOT ARMS (U.S. CLS. 13, 19, 21, 23, 31, 34 AND 35).

JOHN WILKE, EXAMINING ATTORNEY

---

SN 78-959,351. NASCENT DESIGN INC., BARDONIA, NY.  
FILED 8-24-2006.



NO CLAIM IS MADE TO THE EXCLUSIVE RIGHT TO USE "SHIFTER", APART FROM THE MARK AS SHOWN.

THE MARK CONSISTS OF THE TWO WORDS POWER AND SHIFTER IN A STYLIZED FONT SEPARATED BY A GAP WHICH CONTAINS A CIRCULAR GRAPHIC FEATURING A CONTRASTING ARROW POINTING TOWARD THE WORD SHIFTER.

FOR ENGINE MOUNTS FOR SMALL INTERNAL COMBUSTION ENGINES (U.S. CLS. 13, 19, 21, 23, 31, 34 AND 35).

HEATHER BIDDULPH, EXAMINING ATTORNEY

**CLASS 7—(Continued).**

SN 78-959,480. DUREX PRODUCTS, INC., LUCK, WI. FILED 8-24-2006.

# SNAPDECK

THE MARK CONSISTS OF STANDARD CHARACTERS WITHOUT CLAIM TO ANY PARTICULAR FONT, STYLE, SIZE, OR COLOR.

FOR MACHINE PARTS, NAMELY, MODULAR SCREEN PANELS, SUPPORT FRAMES AND PARTS FOR USE ON MINING MATERIAL SORTING MACHINES (U.S. CLS. 13, 19, 21, 23, 31, 34 AND 35).

MARK T. MULLEN, EXAMINING ATTORNEY

---

SN 78-962,840. MATSUSHITA ELECTRIC WORKS, LTD., OSAKA, JAPAN, FILED 8-29-2006.

# REVOLITHIUM

THE MARK CONSISTS OF STANDARD CHARACTERS WITHOUT CLAIM TO ANY PARTICULAR FONT, STYLE, SIZE, OR COLOR.

FOR METALWORKING MACHINE TOOLS; BENDING MACHINES FOR METALWORKING; BORING MACHINES FOR METALWORKING; CUTTING MACHINES FOR METALWORKING; DRILLING MACHINES FOR METALWORKING; GRINDING MACHINES FOR METALWORKING; HORNING MACHINES FOR METALWORKING; LAPPING MACHINES FOR METALWORKING; MILLING MACHINES FOR METALWORKING; PERFORATING MACHINES FOR METALWORKING; PLANING MACHINES FOR METALWORKING; SHAPING MACHINES FOR METALWORKING; SHEARING MACHINES FOR METALWORKING; SLOTTING MACHINES FOR METALWORKING; SANDING MACHINES FOR WOODWORKING; SAW TOOTH SETTING MACHINES FOR LUMBERING OR WOODWORKING SAWS; WOODWORKING SAW TOOTH SETTING MACHINES; PLYWOOD CLIPPING MACHINES; PLYWOOD DRYING MACHINES; PLYWOOD FINISHING MACHINES; PLYWOOD GLUING MACHINES; PLYWOOD JOINTING MACHINES; ELECTRIC DRIVERS; POWER OPERATED VIBRATION DRILLS; POWER OPERATED WRENCHES; POWER OPERATED ELECTRIC DRILLS; POWER TOOLS, NAMELY, IMPACT DRIVERS; ROTARY HAMMER DRILLS; POWER OPERATED CIRCULAR SAWS; ELECTRIC SANDERS; RECIPROCATING SAWS; POWER OPERATED CAULKING GUNS; GEAR CUTTERS; GRINDING MACHINES FOR METALWORKING; POWER OPERATED RIVET GUNS; JIG SAWS; POWER OPERATED CRIMPING IRONS (U.S. CLS. 13, 19, 21, 23, 31, 34 AND 35).

LINDA LAVACHE, EXAMINING ATTORNEY

**CLASS 7—(Continued).**

SN 78-963,482. DYNA TECHNOLOGY, INC., LE CENTER, MN. FILED 8-30-2006.

**WEATHR-PAK**

THE MARK CONSISTS OF STANDARD CHARACTERS WITHOUT CLAIM TO ANY PARTICULAR FONT, STYLE, SIZE, OR COLOR.

FOR INTERNAL COMBUSTION ENGINE-DRIVE ELECTRIC GENERATOR SETS, ELECTRIC GENERATORS, AND PARTS THEREOF (U.S. CLS. 13, 19, 21, 23, 31, 34 AND 35).

BRIDGETT SMITH, EXAMINING ATTORNEY

SN 78-963,488. DYNA TECHNOLOGY, INC., LE CENTER, MN. FILED 8-30-2006.

**SOUND-PAK**

THE MARK CONSISTS OF STANDARD CHARACTERS WITHOUT CLAIM TO ANY PARTICULAR FONT, STYLE, SIZE, OR COLOR.

FOR INTERNAL COMBUSTION ENGINE-DRIVE ELECTRIC GENERATOR SETS, ELECTRIC GENERATORS, AND PARTS THEREOF (U.S. CLS. 13, 19, 21, 23, 31, 34 AND 35).

BRIDGETT SMITH, EXAMINING ATTORNEY

SN 78-963,571. SEJINIGB CO., LTD., KYUNGGI-DO, REPUBLIC OF KOREA, FILED 8-30-2006.

***Xeno-Quadro***



THE MARK CONSISTS IN PART OF A STYLIZED GEAR AND CIRCLE DESIGN.

FOR GEAR BOXES FOR MACHINES; TRANSMISSION GEARS FOR MACHINES; INDUSTRIAL ROBOTS (U.S. CLS. 13, 19, 21, 23, 31, 34 AND 35).

FRED MANDIR, EXAMINING ATTORNEY

**CLASS 7—(Continued).**

SN 78-966,830. VITA-MIX CORPORATION, OLMSTED FALLS, OH. FILED 9-5-2006.

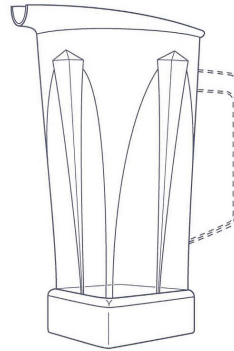

THE MARK CONSISTS OF THE OVERALL CONFIGURATION OF A BLENDING CONTAINER. THE MATTER SHOWN IN BROKEN LINES IS NOT PART OF THE MARK. SEC. 2(F).

FOR ELECTRIC FOOD PROCESSORS AND ELECTRIC FOOD BLENDERS FOR DOMESTIC AND COMMERCIAL USE (U.S. CLS. 13, 19, 21, 23, 31, 34 AND 35).

FIRST USE 5-0-1992; IN COMMERCE 6-0-1992.  
FRED MANDIR, EXAMINING ATTORNEY

SN 78-966,831. VITA-MIX CORPORATION, OLMSTED FALLS, OH. FILED 9-5-2006.

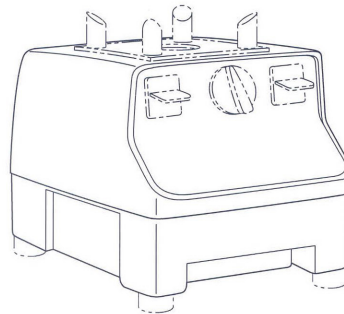

THE MARK CONSISTS OF THE OVERALL CONFIGURATION OF A BLENDER BASE. THE MATTER SHOWN IN BROKEN LINES IS NOT PART OF THE MARK. SEC. 2(F).

FOR ELECTRIC FOOD PROCESSORS AND ELECTRIC FOOD BLENDERS FOR DOMESTIC AND COMMERCIAL USE (U.S. CLS. 13, 19, 21, 23, 31, 34 AND 35).

FIRST USE 5-0-1992; IN COMMERCE 6-0-1992.  
FRED MANDIR, EXAMINING ATTORNEY

**CLASS 7—(Continued).**

SN 78-966,903. HARVEST INVESTMENT PARTNERS, INC.,  
MADISON, AL. FILED 9-5-2006.

**LIBERTY SWEEPERS**

THE MARK CONSISTS OF STANDARD CHARACTERS  
WITHOUT CLAIM TO ANY PARTICULAR FONT, STYLE,  
SIZE, OR COLOR.

NO CLAIM IS MADE TO THE EXCLUSIVE RIGHT TO  
USE "SWEEPERS", APART FROM THE MARK AS SHOWN.

FOR LAND VEHICLES, NAMELY INDUSTRIAL SIZE  
PAVEMENT, PARKING LOT, STREET AND ROAD  
SWEEPERS AND VACUUMS AND STRUCTURAL  
PARTS THEREFOR (U.S. CLS. 13, 19, 21, 23, 31, 34 AND  
35).

MIDGE BUTLER, EXAMINING ATTORNEY

**CLASS 7—(Continued).**

SN 78-968,418. HSU, ERIC, TAIPEI COUNTY 220, TAIWAN,  
FILED 9-6-2006.

**ACERTEX**

THE MARK CONSISTS OF STANDARD CHARACTERS  
WITHOUT CLAIM TO ANY PARTICULAR FONT, STYLE,  
SIZE, OR COLOR.

FOR METAL WORKING MACHINES, NAMELY, MA-  
CHINING CENTERS, ELECTRICAL DISCHARGE MA-  
CHINES AND WIRE CUT ELECTRICAL DISCHARGE  
MACHINES (U.S. CLS. 13, 19, 21, 23, 31, 34 AND 35).

FIRST USE 7-1-2006; IN COMMERCE 7-1-2006.

REBECCA EISINGER, EXAMINING ATTORNEY

SN 78-968,428. ERIC HSU, TAIPEI COUNTY 220, TAIWAN,  
FILED 9-6-2006.

**ACERTECH**

THE MARK CONSISTS OF STANDARD CHARACTERS  
WITHOUT CLAIM TO ANY PARTICULAR FONT, STYLE,  
SIZE, OR COLOR.

FOR METAL WORKING MACHINES, NAMELY, MA-  
CHINING CENTERS, ELECTRICAL DISCHARGE MA-  
CHINES AND WIRE CUT ELECTRICAL DISCHARGE  
MACHINES (U.S. CLS. 13, 19, 21, 23, 31, 34 AND 35).

FIRST USE 7-1-2006; IN COMMERCE 7-1-2006.

REBECCA EISINGER, EXAMINING ATTORNEY

SN 78-970,935. BARRY, DONALD L., HOUSTON, TX. FILED  
9-10-2006.

**ELEC-TRAK**

THE MARK CONSISTS OF STANDARD CHARACTERS  
WITHOUT CLAIM TO ANY PARTICULAR FONT, STYLE,  
SIZE, OR COLOR.

FOR ELECTRIC CHAIN SAWS; ELECTRIC LAWN  
TRIMMERS; ELECTRIC LAWNMOWERS; LAWN  
MOWERS; MECHANICAL LAWN MOWERS; POWER  
OPERATED LAWN AND GARDEN TOOLS, NAMELY,  
CULTIVATORS; RIDING LAWN MOWERS; SNOW  
BLOWERS; SNOW PLOWS; TRACTOR TOWED AGRIC-  
ULTURAL IMPLEMENTS, NAMELY, PLOWS (U.S.  
CLS. 13, 19, 21, 23, 31, 34 AND 35).

VERNA BETH RIRIE, EXAMINING ATTORNEY

SN 78-968,289. SHAANXI BLOWER (GROUP) CO., LTD.,  
XI'AN CITY, CHINA, FILED 9-6-2006.



THE FOREIGN WORDING IN THE MARK TRANSLATES  
INTO ENGLISH AS "SHAN XI" AND "DRUM".

THE NON-LATIN CHARACTER(S) IN THE MARK  
TRANSLITERATES INTO "SHAN GU", AND THIS MEANS  
NOTHING IN ENGLISH.

FOR CENTRIFUGAL GRINDING MACHINES; AIR  
CONDENSERS; ELECTRIC COMPRESSORS; COMPRES-  
SORS FOR MACHINES; COMPRESSORS FOR DEHUMI-  
DIFYING MACHINES; COMPRESSORS FOR AIR  
CONDITIONERS; AIR COMPRESSORS FOR VEHICLES;  
AIR COMPRESSORS; FANS FOR MACHINE ENGINES;  
CENTRIFUGAL FAN CONDENSERS; FORGE BEL-  
LWS; COMPRESSORS FOR REFRIGERATORS (U.S.  
CLS. 13, 19, 21, 23, 31, 34 AND 35).

FIRST USE 7-1-1997; IN COMMERCE 7-1-1997.

ADA HAN, EXAMINING ATTORNEY

**CLASS 7—(Continued).**

SN 79-026,655. DSB MASCHINENBAU GMBH, AUSTRIA, FILED 4-26-2006.

# INNOSCREEN

THE MARK CONSISTS OF STANDARD CHARACTERS WITHOUT CLAIM TO ANY PARTICULAR FONT, STYLE, SIZE, OR COLOR.

PRIORITY DATE OF 11-2-2005 IS CLAIMED.

OWNER OF INTERNATIONAL REGISTRATION 0892650 DATED 4-26-2006, EXPIRES 4-26-2016.

FOR SIFTING MACHINE INSTALLATIONS FOR SCREENING AND SEPARATING NATURAL STONE AND RECYCLING MATERIAL (U.S. CLS. 13, 19, 21, 23, 31, 34 AND 35).

NAKIA HENRY, EXAMINING ATTORNEY

**CLASS 8—(Continued).**

SN 77-007,436. UNISOURCE WORLDWIDE, INC., NORCROSS, GA. FILED 9-26-2006.

# CHEMTROLMINI

FOR HAND OPERATED CHEMICAL DISPENSING SPRAYER USED TO SPRAY CLEANING CHEMICALS IN AND AROUND BUILDINGS (U.S. CLS. 23, 28 AND 44).

FIRST USE 12-1-2005; IN COMMERCE 12-1-2005.

JORDAN BAKER, EXAMINING ATTORNEY

**CLASS 8—HAND TOOLS**

SN 76-665,568. RAM PRODUCTS, INC., EAST BRUNSWICK, NJ. FILED 9-5-2006.

# MYSTISA

THE MARK CONSISTS OF STANDARD CHARACTERS WITHOUT CLAIM TO ANY PARTICULAR FONT, STYLE, SIZE, OR COLOR.

FOR HAND-HELD MANICURE DRILLS FOR FINGER NAILS AND TOE NAILS SOLD TO MANICURISTS (U.S. CLS. 23, 28 AND 44).

CHRISTOPHER BUONGIORNO, EXAMINING ATTORNEY

SN 78-358,320. GMCA PTY LTD., VICTORIA, AUSTRALIA, FILED 1-27-2004.

# DIESEL

THE MARK CONSISTS OF STANDARD CHARACTERS WITHOUT CLAIM TO ANY PARTICULAR FONT, STYLE, SIZE, OR COLOR.

FOR MANUALLY OPERATED TOOLS, NAMELY RAKES, SHOVELS, AXES, PICKS, HOES, CHOPPERS, CULTIVATORS, RIPPING BARS, CHISELS, PUNCHES, SCRAPERS, SCREWDRIVERS, DRILLS, WRENCHES, PLIERS, HAMMERS, FILES, SAWS, GRINDERS, SHEARS, EDGERS, ABRADING TOOLS, MOWERS, TRIMMERS, AND CUTTERS (U.S. CLS. 23, 28 AND 44).

LINDA ESTRADA, EXAMINING ATTORNEY

SN 77-007,422. UNISOURCE WORLDWIDE, INC., NORCROSS, GA. FILED 9-26-2006.

# CHEMTROLMINI

THE MARK CONSISTS OF STANDARD CHARACTERS WITHOUT CLAIM TO ANY PARTICULAR FONT, STYLE, SIZE, OR COLOR.

FOR HAND OPERATED CHEMICAL DISPENSING SPRAYER USED TO SPRAY CLEANING CHEMICALS IN AND AROUND BUILDINGS (U.S. CLS. 23, 28 AND 44).

FIRST USE 4-1-2005; IN COMMERCE 4-1-2005.

JORDAN BAKER, EXAMINING ATTORNEY

SN 78-793,181. ICC INNOVATIVE CONCEPTS CORPORATION, TORRINGTON, CT. FILED 1-17-2006.

# GEAR GRIP

THE MARK CONSISTS OF STANDARD CHARACTERS WITHOUT CLAIM TO ANY PARTICULAR FONT, STYLE, SIZE, OR COLOR.

NO CLAIM IS MADE TO THE EXCLUSIVE RIGHT TO USE "GRIP", APART FROM THE MARK AS SHOWN.

FOR HAND TOOLS, NAMELY, WRENCHES (U.S. CLS. 23, 28 AND 44).

CHRISIE B. KING, EXAMINING ATTORNEY



**CLASS 8—(Continued).**

SN 78-821,330. FEUERZEIG, CRAIG L., EAST ORANGE, NJ.  
FILED 2-23-2006.

**BOWCLAMP**

THE MARK CONSISTS OF STANDARD CHARACTERS WITHOUT CLAIM TO ANY PARTICULAR FONT, STYLE, SIZE, OR COLOR.

FOR CARPENTER'S CLAMPS, NAMELY, CAUL CLAMPS, SPECIFICALLY, AN ELONGATED MEMBER USED WHEN CLAMPING OBJECTS TOGETHER (U.S. CLS. 23, 28 AND 44).

FIRST USE 6-25-2005; IN COMMERCE 7-5-2005.  
TINA BROWN, EXAMINING ATTORNEY

SN 78-866,455. ZELINKO, SHARON, JANE, WINTER HAVEN, FL. FILED 4-21-2006.

**GRIPSORS**

THE MARK CONSISTS OF STANDARD CHARACTERS WITHOUT CLAIM TO ANY PARTICULAR FONT, STYLE, SIZE, OR COLOR.

FOR SCISSORS (U.S. CLS. 23, 28 AND 44).  
FIRST USE 10-3-2005; IN COMMERCE 10-15-2005.  
CHRISTINE COOPER, EXAMINING ATTORNEY

SN 78-866,461. ZELINKO, SHARON, JANE, WINTER HAVEN, FL. FILED 4-21-2006.

Get a grip in your  
scissors!

THE MARK CONSISTS OF STANDARD CHARACTERS WITHOUT CLAIM TO ANY PARTICULAR FONT, STYLE, SIZE, OR COLOR.

FOR SCISSORS (U.S. CLS. 23, 28 AND 44).  
FIRST USE 3-21-2006; IN COMMERCE 3-23-2006.  
CHRISTINE COOPER, EXAMINING ATTORNEY

**CLASS 8—(Continued).**

SN 78-960,494. XM INTERNATIONAL, INC., EAST RUTHERFORD, NJ. FILED 8-25-2006.

**X<sup>o</sup>CELL**   
**Lawn & Garden**  
*A standard of "ex-cell-ence".*

NO CLAIM IS MADE TO THE EXCLUSIVE RIGHT TO USE "LAWN & GARDEN", APART FROM THE MARK AS SHOWN.

THE COLOR(S) BLACK AND GREEN IS/ARE CLAIMED AS A FEATURE OF THE MARK.

THE COLOR BLACK APPEARS IN THE OUTLINE OF THE RAINDROP BETWEEN "X" AND "CELL." THE WORDING "X-CELL," THE OUTLINE OF THE STYLIZED WORDING "LAWN & GARDEN," AND THE PHRASE "A STANDARD OF 'EX-CELL-ENCE.'" THE COLOR GREEN APPEARS IN THE SHADING OF THE RAINDROP AND VEINED LEAF DESIGN AND THE SHADING OF THE STYLIZED WORDING "LAWN & GARDEN."

FOR GARDENING TOOLS, NAMELY HAND TROWELS, SHOVELS, SPADES, HOES, RAKES, CULTIVATORS (U.S. CLS. 23, 28 AND 44).

MEGAN WHITNEY, EXAMINING ATTORNEY

SN 78-961,672. PETER J. LISTRO ASSOCIATES, LTD., NEW YORK, NEW YORK, NY. FILED 8-28-2006.

**LiteUps**

FOR SCISSORS, TWEEZERS AND NAIL CLIPPERS (U.S. CLS. 23, 28 AND 44).

DAYNA BROWNE, EXAMINING ATTORNEY

SN 78-965,766. TANG CHOU INDUSTRIAL CO., LTD., NANTOU CITY, TAIWAN, FILED 9-1-2006.

**TONSCO**

OWNER OF U.S. REG. NO. 1,407,400.  
FOR HAND TOOLS, NAMELY, SOCKET SETS, WRENCHES, SCREWDRIVERS, RATCHETS, PLIERS, LOCKING PLIERS, AND IMPACT DRIVERS, ALL OF THE ABOVE ITEMS SOLD INDIVIDUALLY OR PACKAGED KITS (U.S. CLS. 23, 28 AND 44).

FIRST USE 5-12-1984; IN COMMERCE 5-12-1984.  
MARILYN IZZI, EXAMINING ATTORNEY

**CLASS 8—(Continued).**

SN 78-967,154. VI-TEC MANUFACTURING, INC., LIVERMORE, CA. FILED 9-5-2006.

# DADOWIZ

THE MARK CONSISTS OF STANDARD CHARACTERS WITHOUT CLAIM TO ANY PARTICULAR FONT, STYLE, SIZE, OR COLOR.

FOR HAND TOOLS NAMELY, JIGS (U.S. CLS. 23, 28 AND 44).

KATHERINE CONNOLLY, EXAMINING ATTORNEY

**CLASS 8—(Continued).**

SN 78-971,110. WATERFALL, INC., DETROIT, MI. FILED 9-11-2006.

# R1000

THE MARK CONSISTS OF STANDARD CHARACTERS WITHOUT CLAIM TO ANY PARTICULAR FONT, STYLE, SIZE, OR COLOR.

FOR HAND-OPERATED TOOL FOR USE IN PLUMBING REPAIRS, NAMELY, A FLEXIBLE GASKET ATTACHED TO A HOLLOW SHAFT OR TUBE FOR DIVERTING WATER IN PIPES (U.S. CLS. 23, 28 AND 44).

KATHRYN COWARD, EXAMINING ATTORNEY

SN 78-967,167. VI-TEC MANUFACTURING, INC., LIVERMORE, CA. FILED 9-5-2006.

# DADOWIZPRO

THE MARK CONSISTS OF STANDARD CHARACTERS WITHOUT CLAIM TO ANY PARTICULAR FONT, STYLE, SIZE, OR COLOR.

FOR HAND TOOLS NAMELY, JIGS (U.S. CLS. 23, 28 AND 44).

KATHERINE CONNOLLY, EXAMINING ATTORNEY

**CLASS 9—ELECTRICAL AND SCIENTIFIC APPARATUS**

SN 76-138,819. SATYAM COMPUTER SERVICES LTD., ANDHRA PRADESH, INDIA, FILED 9-29-2000.

# SATYAM

THE ENGLISH TRANSLATION OF "SATYAM" IS "TRUTH".

FOR HOUSE MARK FOR COMPUTER SOFTWARE IN THE FIELD OF BUSINESS AND INFORMATION TECHNOLOGY (U.S. CLS. 21, 23, 26, 36 AND 38).

FIRST USE 0-0-1988; IN COMMERCE 0-0-1988.

MATTHEW PAPPAS, EXAMINING ATTORNEY

SN 78-971,067. WATERFALL, INC., DETROIT, MI. FILED 9-11-2006.

# WATERFALL

THE MARK CONSISTS OF STANDARD CHARACTERS WITHOUT CLAIM TO ANY PARTICULAR FONT, STYLE, SIZE, OR COLOR.

FOR HAND-OPERATED TOOL FOR USE IN PLUMBING REPAIRS, NAMELY, A FLEXIBLE GASKET ATTACHED TO A HOLLOW SHAFT OR TUBE FOR DIVERTING WATER IN PIPES (U.S. CLS. 23, 28 AND 44).

KATHRYN COWARD, EXAMINING ATTORNEY

SN 76-513,923. KABUSHIKI KAISHA TOSHIBA, TA TOSHIBA CORPORATION, TOKYO, JAPAN, FILED 5-14-2003.

# AODVD

OWNER OF JAPAN REG. NO. 4683284, DATED 6-20-2003, EXPIRES 6-20-2013.

FOR BLANK OPTICAL DISCS FOR RECORDING AND REPRODUCING OF SOUND, IMAGE, COMPUTER GAMES, COMPUTER PROGRAMS AND MAP INFORMATION; OPTICAL DISCS PRE-RECORDED IN THE AREAS OF ENTERTAINMENT, THE ARTS, SCIENCE, EDUCATION, BUSINESS AND MAP INFORMATION; OPTICAL DISC PLAYERS; OPTICAL DISC RECORDERS; OPTICAL DISC PLAYERS AND RECORDERS FOR NAVIGATION SYSTEMS; COLOR TELEVISION SETS; COMPUTERS; MACHINES FOR RECORDING, REPRODUCING AND SEARCHING DOCUMENTS ON OPTICAL DISCS; PRERECORDED OPTICAL DISCS OF COMPUTER GAMES (U.S. CLS. 21, 23, 26, 36 AND 38).

CAROLYN CATALDO, EXAMINING ATTORNEY

**CLASS 9—(Continued).**

SN 76-563,595. SOLARWINDS.NET, L.L.C., AUSTIN, TX. FILED 11-24-2003.

# ORION

FOR COMPUTER SOFTWARE FOR USE IN MONITORING COMPUTER NETWORKING EQUIPMENT AND NETWORK TRAFFIC (U.S. CLS. 21, 23, 26, 36 AND 38).

FIRST USE 10-0-2001; IN COMMERCE 10-0-2001.  
SUE LAWRENCE, EXAMINING ATTORNEY

SN 76-622,083. UNILINE SAFETY SYSTEMS LIMITED, WORCESTERSHIRE B60 3DU, UNITED KINGDOM, FILED 11-24-2004.

# EASYCLIMBER

THE MARK CONSISTS OF STANDARD CHARACTERS WITHOUT CLAIM TO ANY PARTICULAR FONT, STYLE, SIZE, OR COLOR.

PRIORITY CLAIMED UNDER SEC. 44(D) ON UNITED KINGDOM APPLICATION NO. 2364467, FILED 5-27-2004, REG. NO. 2364467, DATED 5-27-2004, EXPIRES 5-24-2014.

FOR INDUSTRIAL APPARATUS FOR PROTECTING WORKERS FROM FALLING WHILE WORKING AT HEIGHTS, NAMELY, STRUCTURAL ANCHORS FOR SUPPORTING A SAFETY CABLE OR THE LIKE, ENERGY ABSORBING ELEMENTS, NAMELY, ANCHORAGE CONNECTORS, AND INTERMEDIATE SUPPORTS FOR CABLE OR THE LIKE, NAMELY, INTERMEDIATE BRACKETS, TENSION INDICATORS, AND AN ATTACHMENT DEVICE FOR FACILITATING CLIMBING OF THE SAFETY APPARATUS BY A PERSON OR PERSONS, AND PARTS THEREFOR (U.S. CLS. 21, 23, 26, 36 AND 38).

TONI HICKEY, EXAMINING ATTORNEY

SN 76-627,585. AUTO F/X CORPORATION, DBA AUTO FX, BIRMINGHAM, AL. FILED 1-11-2005.

# AUTO FX

THE MARK CONSISTS OF STANDARD CHARACTERS WITHOUT CLAIM TO ANY PARTICULAR FONT, STYLE, SIZE, OR COLOR.

SEC. 2(F).

FOR COMPUTER SOFTWARE FOR USE IN IMAGING FOR GRAPHICS, PHOTOGRAPHY, ANIMATION, VIDEO AND WEB DESIGN AND PRODUCTION (U.S. CLS. 21, 23, 26, 36 AND 38).

FIRST USE 6-15-1995; IN COMMERCE 6-15-1995.  
MARCIE MILONE, EXAMINING ATTORNEY

**CLASS 9—(Continued).**

SN 76-630,484. INTERMOTIVE, INC., AUBURN, CA. FILED 2-4-2005.

## INTERMITTENT FAULT FILTER

THE MARK CONSISTS OF STANDARD CHARACTERS WITHOUT CLAIM TO ANY PARTICULAR FONT, STYLE, SIZE, OR COLOR.

NO CLAIM IS MADE TO THE EXCLUSIVE RIGHT TO USE "FILTER", APART FROM THE MARK AS SHOWN.

SEC. 2(F).  
FOR SIGNAL PROCESSORS FOR SENSING ELECTRICAL SIGNAL TIME DURATION IN EQUIPMENT CONTROLLERS SOLD AS A COMPONENT OF CENTRAL PROCESSING UNITS (U.S. CLS. 21, 23, 26, 36 AND 38).

FIRST USE 11-30-1999; IN COMMERCE 11-30-1999.  
TONI HICKEY, EXAMINING ATTORNEY

SN 76-649,831. PCX HOLDINGS, LLC, CLAYTON, NC. FILED 11-4-2005.

# PCX

THE MARK CONSISTS OF STANDARD CHARACTERS WITHOUT CLAIM TO ANY PARTICULAR FONT, STYLE, SIZE, OR COLOR.

FOR PRE-MANUFACTURED POWER AND DATA DISTRIBUTION SYSTEMS AND MODULES FOR INDOOR AND OUTDOOR USE COMPRISED PRIMARILY OF ELECTRICAL POWER SUPPLIES AND ELECTRICAL POWER DISTRIBUTION BLOCKS (U.S. CLS. 21, 23, 26, 36 AND 38).

FIRST USE 9-1-2002; IN COMMERCE 9-1-2002.  
SEAN CROWLEY, EXAMINING ATTORNEY

SN 76-649,832. PCX HOLDINGS, LLC, CLAYTON, NC. FILED 11-4-2005.



# PCX

*Pre-Manufactured Electrical Solutions*

NO CLAIM IS MADE TO THE EXCLUSIVE RIGHT TO USE "PRE-MANUFACTURED ELECTRICAL", APART FROM THE MARK AS SHOWN.

FOR PRE-MANUFACTURED POWER AND DATA DISTRIBUTION SYSTEMS AND MODULES FOR INDOOR AND OUTDOOR USE COMPRISED PRIMARILY OF ELECTRICAL POWER SUPPLIES AND ELECTRICAL POWER DISTRIBUTION BLOCKS (U.S. CLS. 21, 23, 26, 36 AND 38).

FIRST USE 7-30-2003; IN COMMERCE 7-30-2003.  
SEAN CROWLEY, EXAMINING ATTORNEY

**CLASS 9—(Continued).**

SN 76-653,767. AMERICAN PSYCHOLOGICAL ASSOCIATION, WASHINGTON, DC. FILED 1-20-2006.

**PSYCSCAN: BEHAVIOR ANALYSIS AND THERAPY**

THE MARK CONSISTS OF STANDARD CHARACTERS WITHOUT CLAIM TO ANY PARTICULAR FONT, STYLE, SIZE, OR COLOR.

OWNER OF U.S. REG. NOS. 1,398,486 AND 2,710,613.

NO CLAIM IS MADE TO THE EXCLUSIVE RIGHT TO USE "BEHAVIOR ANALYSIS AND THERAPY", APART FROM THE MARK AS SHOWN.

FOR ELECTRONIC DOWNLOADABLE SUMMARIES PERTAINING TO THE PSYCHOLOGICAL AND SOCIAL SCIENCES (U.S. CLS. 21, 23, 26, 36 AND 38).

FIRST USE 6-0-1995; IN COMMERCE 6-0-1995.

SHANNON TWOHIG, EXAMINING ATTORNEY

SN 76-655,343. HIE ELECTRONICS, INC., MCKINNEY, TX. FILED 2-15-2006.

# TERASTACK

THE MARK CONSISTS OF STANDARD CHARACTERS WITHOUT CLAIM TO ANY PARTICULAR FONT, STYLE, SIZE, OR COLOR.

FOR DISK MEDIA STORAGE MAGAZINE, NAMELY, A STORAGE CHAMBER, WITH USB MEMORY DEVICE, USED FOR HOLDING, SECURING, STORING AND TRANSPORTING OPTICAL MEDIA DISKS (U.S. CLS. 21, 23, 26, 36 AND 38).

FIRST USE 12-15-2005; IN COMMERCE 1-20-2006.

JESSICA A. POWERS, EXAMINING ATTORNEY

SN 76-661,599. HIGH TECH COMPUTER CORPORATION, TAO YUAN 330, TAIWAN, FILED 6-14-2006.

# TyTN

THE MARK CONSISTS OF STANDARD CHARACTERS WITHOUT CLAIM TO ANY PARTICULAR FONT, STYLE, SIZE, OR COLOR.

FOR MOBILE PHONES; PERSONAL DIGITAL ASSISTANTS; PERSONAL DIGITAL ASSISTANTS WITH WIRELESS COMMUNICATION FUNCTIONS; ACCESSORIES FOR THE ABOVE GOODS, NAMELY, SYNCHRONIZATION CABLES, HEADSETS, HEADSETS WITH WIRELESS TRANSMISSION FUNCTION, CHARGERS, CRADLES, AC ADAPTORS, AND IN-CAR CHARGERS AND IN-CAR HOLDERS FOR MOBILE PHONES AND PERSONAL DIGITAL ASSISTANTS (U.S. CLS. 21, 23, 26, 36 AND 38).

GIANCARLO CASTRO, EXAMINING ATTORNEY

**CLASS 9—(Continued).**

SN 76-662,499. NTT ELECTRONICS KABUSHIKI KAISHA, DBA NTT ELECTRONICS CORPORATION, SHIBUYA-KU, TOKYO, JAPAN, FILED 6-30-2006.

# LibraENC

PRIORITY CLAIMED UNDER SEC. 44(D) ON JAPAN APPLICATION NO. 2006-024283, FILED 3-17-2006, REG. NO. 5000792, DATED 11-2-2006, EXPIRES 11-2-2016.

FOR MPEG-2 ENCODER (U.S. CLS. 21, 23, 26, 36 AND 38).

STEVEN R. FINE, EXAMINING ATTORNEY

SN 76-663,063. GAMELOFT S.A., 75009 PARIS, FRANCE, FILED 7-14-2006.

**AIRSTRIKE 1944: FLIGHT FOR FREEDOM**

THE MARK CONSISTS OF STANDARD CHARACTERS WITHOUT CLAIM TO ANY PARTICULAR FONT, STYLE, SIZE, OR COLOR.

FOR COMPUTER SOFTWARE FOR ELECTRONIC GAMES AND ENTERTAINMENT, NAMELY, COMPUTER GAME SOFTWARE USED AND PLAYED ON MOBILE AND CELLULAR TELEPHONES, HANDHELD COMPUTERS, PERSONAL COMPUTERS AND PERSONAL DIGITAL ASSISTANTS; COMPUTER SOFTWARE THAT IS DOWNLOADABLE FROM A REMOTE COMPUTER SITE, NAMELY, ELECTRONIC GAME PROGRAMS, RING TONES AND VOICE RINGERS FOR MOBILE TELECOMMUNICATIONS DEVICES, WALL PAPERS, SCREEN SAVERS, ANIMATED IMAGES AND PROGRAMS FOR DOWNLOADING IMAGES; AND COMPUTER SOFTWARE FOR USE IN THE DESIGN, DEVELOPMENT AND EXECUTION OF WIRELESS COMPUTER GAMES, AND COMPUTER GAMES FOR CONSOLE GAMING DEVICES AND PERSONAL COMPUTERS (U.S. CLS. 21, 23, 26, 36 AND 38).

REBECCA GAN, EXAMINING ATTORNEY

**CLASS 9—(Continued).**

SN 76-663,860. GAMELOFT S.A., 75009 PARIS, FRANCE, FILED 7-31-2006.

**NAVAL BATTLE: MISSION COMMANDER**

THE MARK CONSISTS OF STANDARD CHARACTERS WITHOUT CLAIM TO ANY PARTICULAR FONT, STYLE, SIZE, OR COLOR.

FOR COMPUTER SOFTWARE FOR ELECTRONIC GAMES AND ENTERTAINMENT, NAMELY, COMPUTER GAME SOFTWARE USED AND PLAYED ON MOBILE AND CELLULAR TELEPHONES, HANDHELD COMPUTERS, PERSONAL COMPUTERS AND PERSONAL DIGITAL ASSISTANTS; DOWNLOADABLE ELECTRONIC GAME PROGRAMS; RING TONES; VOICE RINGERS; WALL PAPERS, NAMELY, STILL IMAGES FOR BACKGROUNDS ON PHONE SCREENS; SCREEN SAVERS; ANIMATED IMAGES FOR USE ON PHONE SCREENS; AND PROGRAMS FOR DOWNLOADING IMAGES FOR MOBILE TELECOMMUNICATION DEVICES, NAMELY, MOBILE AND CELLULAR TELEPHONES, HANDHELD COMPUTERS, PERSONAL COMPUTERS AND PERSONAL DIGITAL ASSISTANTS VIA THE GLOBAL COMPUTER NETWORK AND WIRELESS DEVICES; AND COMPUTER SOFTWARE FOR USE IN THE DESIGN, DEVELOPMENT AND EXECUTION OF WIRELESS COMPUTER GAMES (U.S. CLS. 21, 23, 26, 36 AND 38).  
REBECCA GAN, EXAMINING ATTORNEY

SN 76-664,091. ISECURUETRAC INC., OMAHA, NE. FILED 8-3-2006.

**IntelliCuff**

FOR PERSONAL TRACKING AND MONITORING SYSTEM COMPRISED OF ELECTRONIC RECEIVERS, TRANSMITTERS, AND SOFTWARE INSTALLED IN A BRACELET (U.S. CLS. 21, 23, 26, 36 AND 38).  
REGINA DRUMMOND, EXAMINING ATTORNEY

SN 76-664,735. OPTIMA, INC., STRATFORD, CT. FILED 8-17-2006.

**VUE POINT TECHNOLOGY**

THE MARK CONSISTS OF STANDARD CHARACTERS WITHOUT CLAIM TO ANY PARTICULAR FONT, STYLE, SIZE, OR COLOR.

NO CLAIM IS MADE TO THE EXCLUSIVE RIGHT TO USE "TECHNOLOGY", APART FROM THE MARK AS SHOWN.  
FOR OPTICAL LENSES FOR EYEGLASSES (U.S. CLS. 21, 23, 26, 36 AND 38).  
FIRST USE 7-28-2006; IN COMMERCE 7-28-2006.  
TINA BROWN, EXAMINING ATTORNEY

**CLASS 9—(Continued).**

SN 76-665,248. THREE RIVERS MARINE & RAIL TERMINALS, L.P., CHARLEROI, PA. FILED 8-29-2006.

**HOME OF THE HONEST YARD**

THE MARK CONSISTS OF STANDARD CHARACTERS WITHOUT CLAIM TO ANY PARTICULAR FONT, STYLE, SIZE, OR COLOR.

NO CLAIM IS MADE TO THE EXCLUSIVE RIGHT TO USE "YARD", APART FROM THE MARK AS SHOWN.  
FOR MEASURING DEVICE, NAMELY, A PLASTIC BOX THAT MEASURES BULK MATERIAL (U.S. CLS. 21, 23, 26, 36 AND 38).  
FIRST USE 2-0-2005; IN COMMERCE 2-0-2005.  
ALLISON SCHRODY, EXAMINING ATTORNEY

SN 76-665,533. THE BLENDERS, INC., SARASOTA, FL. FILED 9-1-2006.

**THE BLENDERS**

FOR MUSICAL SOUND RECORDINGS (U.S. CLS. 21, 23, 26, 36 AND 38).  
FIRST USE 1-1-1992; IN COMMERCE 1-1-1992.  
MARGERY A. TIERNEY, EXAMINING ATTORNEY

SN 76-665,605. ASPEN NETWORKS INC., SANTA CLARA, CA. FILED 9-5-2006.

**365-VOIP**

THE MARK CONSISTS OF STANDARD CHARACTERS WITHOUT CLAIM TO ANY PARTICULAR FONT, STYLE, SIZE, OR COLOR.

FOR CUSTOMER-PREMISE COMPUTER HARDWARE AND TELECOMMUNICATION SWITCHES THAT PROVIDE INTELLIGENT MANAGEMENT OF REDUNDANT WAN LINKS TO ENABLE VOICE OVER INTERNET PROTOCOL (VOIP) TO RUN WITHOUT INTERRUPTION (U.S. CLS. 21, 23, 26, 36 AND 38).  
DAVID YONTEF, EXAMINING ATTORNEY

**CLASS 9—(Continued).**

SN 76-665,679. SURGIPATH MEDICAL INDUSTRIES, INC., RICHMOND, IL. FILED 9-5-2006.

**POP-UPS**

THE MARK CONSISTS OF STANDARD CHARACTERS WITHOUT CLAIM TO ANY PARTICULAR FONT, STYLE, SIZE, OR COLOR.

FOR BASE MOLDS MADE OF METAL FOR LABORATORY USE IN EMBEDDING TISSUE IN PARAFFIN (U.S. CLS. 21, 23, 26, 36 AND 38).

FIRST USE 5-26-1995; IN COMMERCE 5-26-1995.

ALICE SUE CARRUTHERS, EXAMINING ATTORNEY

**CLASS 9—(Continued).**

SN 76-665,938. GAMELOFT S.A., 75009 PARIS, FRANCE, FILED 9-13-2006.

**PLATINUM KAKURO**

THE MARK CONSISTS OF STANDARD CHARACTERS WITHOUT CLAIM TO ANY PARTICULAR FONT, STYLE, SIZE, OR COLOR.

OWNER OF U.S. REG. NO. 3,090,839.

NO CLAIM IS MADE TO THE EXCLUSIVE RIGHT TO USE "KAKURO", APART FROM THE MARK AS SHOWN.

FOR COMPUTER SOFTWARE FOR ELECTRONIC GAMES AND ENTERTAINMENT, NAMELY, COMPUTER GAME SOFTWARE USED AND PLAYED ON MOBILE AND CELLULAR TELEPHONES, HANDHELD COMPUTERS, PERSONAL COMPUTERS AND PERSONAL DIGITAL ASSISTANTS; DOWNLOADABLE ELECTRONIC GAME PROGRAMS; DOWNLOADABLE RING TONES; DOWNLOADABLE VOICE RINGERS FOR MOBILE TELECOMMUNICATIONS DEVICES; COMPUTER SOFTWARE FOR WALL PAPERS, NAMELY, STILL IMAGES FOR USE IN BACKGROUNDS ON MOBILE PHONE SCREENS; COMPUTER SCREEN SAVER SOFTWARE; COMPUTER SOFTWARE FOR PROCESSING ANIMATED IMAGES FOR USE ON MOBILE PHONE SCREENS; AND PROGRAMS FOR DOWNLOADING IMAGES TO MOBILE TELECOMMUNICATION DEVICES, NAMELY, MOBILE AND CELLULAR TELEPHONES, HANDHELD COMPUTERS, PERSONAL COMPUTERS AND PERSONAL DIGITAL ASSISTANTS VIA THE GLOBAL COMPUTER NETWORK AND WIRELESS DEVICES; AND COMPUTER SOFTWARE FOR USE IN THE DESIGN, DEVELOPMENT AND EXECUTION OF WIRELESS COMPUTER GAMES (U.S. CLS. 21, 23, 26, 36 AND 38).

REBECCA GAN, EXAMINING ATTORNEY

SN 76-665,797. GRIFFIN TECHNOLOGY, INC., NASHVILLE, TN. FILED 9-11-2006.

**DIRECTDECK**

THE MARK CONSISTS OF STANDARD CHARACTERS WITHOUT CLAIM TO ANY PARTICULAR FONT, STYLE, SIZE, OR COLOR.

FOR CASSETTE ADAPTOR FOR INTERFACING A HANDHELD ELECTRONIC DEVICE WITH THE SOUND SYSTEM OF A VEHICLE (U.S. CLS. 21, 23, 26, 36 AND 38).

FIRST USE 9-1-2006; IN COMMERCE 9-1-2006.

JERI J. FICKES, EXAMINING ATTORNEY

SN 76-670,441. EDGAR RICE BURROUGHS, INC., TARZANA, CA. FILED 12-18-2006.

**NO DRAWING-SENSORY MARK**

OWNER OF U.S. REG. NO. 2,210,506.

THE MARK CONSISTS OF THE SOUND OF THE FAMOUS TARZAN YELL. THE MARK IS A YELL CONSISTING OF A SERIES OF APPROXIMATELY TEN SOUNDS, ALTERNATING BETWEEN THE CHEST AND FALSETTO REGISTERS OF THE VOICE, AS FOLLOW - 1) A SEMI-LONG SOUND IN THE CHEST REGISTER, 2) A SHORT SOUND UP AN INTERVAL OF ONE OCTAVE PLUS A FIFTH FROM THE PRECEDING SOUND, 3) A SHORT SOUND DOWN A MAJOR 3RD FROM THE PRECEDING SOUND, 4) A SHORT SOUND UP A MAJOR 3RD FROM THE PRECEDING SOUND, 5) A LONG SOUND DOWN ONE OCTAVE PLUS A MAJOR 3RD FROM THE PRECEDING SOUND, 6) A SHORT SOUND UP ONE OCTAVE FROM THE PRECEDING SOUND, 7) A SHORT SOUND UP A MAJOR 3RD FROM THE PRECEDING SOUND, 8) A SHORT SOUND DOWN A MAJOR 3RD FROM THE PRECEDING SOUND, 9) A SHORT SOUND UP A MAJOR 3RD FROM THE PRECEDING SOUND, 10) A LONG SOUND DOWN AN OCTAVE PLUS A FIFTH FROM THE PRECEDING SOUND.

FOR SLOT MACHINES (U.S. CLS. 21, 23, 26, 36 AND 38).

JASON BLAIR, EXAMINING ATTORNEY

**CLASS 9—(Continued).**

SN 77-003,318. DIEBOLD, INCORPORATED, NORTH CANTON, OH. FILED 9-20-2006.

**DIEBOLD CASHSPOT**

THE MARK CONSISTS OF STANDARD CHARACTERS WITHOUT CLAIM TO ANY PARTICULAR FONT, STYLE, SIZE, OR COLOR.

OWNER OF U.S. REG. NOS. 684,006, 2,802,243 AND OTHERS.

FOR CASH DISPENSERS (U.S. CLS. 21, 23, 26, 36 AND 38).

FRED MANDIR, EXAMINING ATTORNEY

**CLASS 9—(Continued).**

SN 77-015,742. WALTICAL SOLUTIONS, INC., BELLEVUE, WA. FILED 10-6-2006.

**Cable-Fi**

THE MARK CONSISTS OF STANDARD CHARACTERS WITHOUT CLAIM TO ANY PARTICULAR FONT, STYLE, SIZE, OR COLOR.

FOR COMPUTER HARDWARE AND COMPUTER SOFTWARE PROGRAMS FOR THE INTEGRATION OF TEXT, AUDIO, GRAPHICS, STILL IMAGE AND MOVING PICTURES INTO AN INTERACTIVE DELIVERY FOR MULTIMEDIA APPLICATIONS; COMPUTER HARDWARE FOR TELECOMMUNICATIONS; COMPUTER SOFTWARE AND FIRMWARE FOR GAMES OF CHANCE ON ANY COMPUTERIZED PLATFORM, INCLUDING DEDICATED GAMING CONSOLES, VIDEO BASED SLOT MACHINES, REEL BASED SLOT MACHINES, AND VIDEO LOTTERY TERMINALS; TELECOMMUNICATIONS AND DATA NETWORKING HARDWARE, NAMELY DEVICES FOR TRANSPORTING AND AGGREGATING VOICE, DATA, AND VIDEO COMMUNICATIONS ACROSS MULTIPLE NETWORK INFRASTRUCTURES AND COMMUNICATIONS PROTOCOLS (U.S. CLS. 21, 23, 26, 36 AND 38).

LA TONIA FISHER, EXAMINING ATTORNEY

SN 77-013,141. GO CAMPAIGNS, INC., SAN RAFAEL, CA. FILED 10-4-2006.

**LeadMiner**

THE MARK CONSISTS OF STANDARD CHARACTERS WITHOUT CLAIM TO ANY PARTICULAR FONT, STYLE, SIZE, OR COLOR.

FOR COMPUTER SOFTWARE THAT MAY BE DOWNLOADED FROM A GLOBAL COMPUTER NETWORK FOR LEAD GENERATION, NAMELY, FOR IDENTIFYING PROSPECTIVE CUSTOMERS AND BUSINESS LEADS, DIRECT MAIL MARKETING, AND FOR PRINTING, MAILING AND FULFILLING ORDERS FOR SPECIFIC ADVERTISING MATERIALS (U.S. CLS. 21, 23, 26, 36 AND 38).

FIRST USE 7-1-2006; IN COMMERCE 7-1-2006.

JENNIFER KRISP, EXAMINING ATTORNEY

SN 77-017,481. HIP KIDDY, INC., PIERMONT, NY. FILED 10-10-2006.



OWNER OF U.S. REG. NO. 3,111,045.

NO CLAIM IS MADE TO THE EXCLUSIVE RIGHT TO USE "KIDDY", APART FROM THE MARK AS SHOWN.

THE COLOR(S) LIGHT BLUE, RED, BLACK AND GRAY IS/ARE CLAIMED AS A FEATURE OF THE MARK.

THE MARK CONSISTS OF THE WORDS "HIP KIDDY" IN A THREE DIMENSIONAL, GRAFITTI-STYLE FORMAT, WHERE THE FRONT FACING PORTIONS OF THE LETTERS ARE LIGHT BLUE, THE SIDES OF THE LETTERS ARE BLACK AND RED AND THE SURROUNDING BACKGROUND IS GRAY.

FOR CHILDREN'S EDUCATIONAL MUSIC CDS AND DVDS; MUSICAL SOUND RECORDINGS (U.S. CLS. 21, 23, 26, 36 AND 38).

FIRST USE 8-1-2004; IN COMMERCE 8-1-2004.

ALICE BENMAMAN, EXAMINING ATTORNEY

**CLASS 9—(Continued).**

SN 77-024,159. CARBON PROJECT, INC., BURLINGTON, MA. FILED 10-18-2006.

**CARBONNET**

THE MARK CONSISTS OF STANDARD CHARACTERS WITHOUT CLAIM TO ANY PARTICULAR FONT, STYLE, SIZE, OR COLOR.

FOR COMPUTER SOFTWARE FOR MANAGING, MODELING, VISUALIZING AND MAPPING CONNECTIONS BETWEEN CYBER AND PHYSICAL INFRASTRUCTURES AND EXCHANGE REAL-TIME INFORMATION BETWEEN MULTIPLE SYSTEM NODES (U.S. CLS. 21, 23, 26, 36 AND 38).

LINDA M. KING, EXAMINING ATTORNEY

SN 77-027,541. PHOENIX INTERNATIONAL, IRVINE, CA. FILED 10-23-2006.

**OUTRO**

THE MARK CONSISTS OF STANDARD CHARACTERS WITHOUT CLAIM TO ANY PARTICULAR FONT, STYLE, SIZE, OR COLOR.

FOR BAGS FOR CAMERAS AND PHOTOGRAPHIC EQUIPMENT; CAMERA CASES; PROTECTIVE CARRYING CASES FOR PORTABLE MUSIC PLAYERS NAMELY MP3 PLAYERS (U.S. CLS. 21, 23, 26, 36 AND 38).

TIMOTHY FINNEGAN, EXAMINING ATTORNEY

SN 77-029,518. DEI HEADQUARTERS, INC., VISTA, CA. FILED 10-25-2006.

*direct*  
**Link**

NO CLAIM IS MADE TO THE EXCLUSIVE RIGHT TO USE "DIRECT LINK", APART FROM THE MARK AS SHOWN.

THE MARK CONSISTS OF THE STYLIZED WORDS DIRECT LINK AND THE DESIGN OF OVERLAPPING RECTANGLES WITH ROUNDED CORNERS.

FOR DOWNLOADABLE SOFTWARE AND A HARDWARE BRIDGE THAT PROVIDES CONNECTIVITY BETWEEN A COMPUTER AND A VEHICLE BYPASS MODULE FOR RECONFIGURING THE BYPASS MODULE FOR USE IN A PLURALITY OF VEHICLES (U.S. CLS. 21, 23, 26, 36 AND 38).

JOHN WILKE, EXAMINING ATTORNEY

**CLASS 9—(Continued).**

SN 77-031,739. ATP ELECTRONICS, INC., SUNNYVALE, CA. FILED 10-29-2006.

**SNS**  
**Smart and Secure**

NO CLAIM IS MADE TO THE EXCLUSIVE RIGHT TO USE "SMART AND SECURE", APART FROM THE MARK AS SHOWN.

THE MARK CONSISTS OF THE LETTERS SNS WITH THE SMALL LETTER N BEING THE HASP OF A LOCK, WITH THE WORDS SMART AND SECURE UNDERNEATH.

FOR MEMORY ACCESS CONTROL SYSTEM, NAMELY, MICRO-PROCESSOR BASED HARDWARE AND SOFTWARE USED TO CONTROL ACCESS TO DATA ON PORTABLE STORAGE DEVICES (U.S. CLS. 21, 23, 26, 36 AND 38).

JASON BLAIR, EXAMINING ATTORNEY

SN 77-035,079. ANSELL LIMITED, RICHMOND, VICTORIA, AUSTRALIA, FILED 11-2-2006.

**Ansell**  
**GRIP**  
**TECHNOLOGY**

OWNER OF U.S. REG. NO. 1,349,071.

NO CLAIM IS MADE TO THE EXCLUSIVE RIGHT TO USE "GRIP TECHNOLOGY", APART FROM THE MARK AS SHOWN.

THE MARK CONSISTS OF THE WORDS ANSELL GRIP TECHNOLOGY WITH THE IMAGE OF A GECKO.

FOR GLOVES FOR PROTECTION AGAINST ACCIDENTS; PROTECTIVE GLOVES FOR INDUSTRIAL USE; PROTECTIVE WORK GLOVES (U.S. CLS. 21, 23, 26, 36 AND 38).

FIRST USE 10-24-2005; IN COMMERCE 10-24-2005.

FLORENTINA BLANDU, EXAMINING ATTORNEY

SN 77-037,980. PORTABLE SOUND LABORATORIES, LLC, CHATSWORTH, CA. FILED 11-6-2006.

**iMainGo...do you?**

THE MARK CONSISTS OF IMAINGO...DO YOU?. FOR SOUND AMPLIFIERS (U.S. CLS. 21, 23, 26, 36 AND 38).

FIRST USE 11-5-2006; IN COMMERCE 11-5-2006.

TAMARA FRAZIER, EXAMINING ATTORNEY



**CLASS 9—(Continued).**

SN 77-042,041. NOPEC, INC., PASADENA, CA. FILED 11-11-2006.

# Run on Sun

THE MARK CONSISTS OF STANDARD CHARACTERS WITHOUT CLAIM TO ANY PARTICULAR FONT, STYLE, SIZE, OR COLOR.

FOR APPARATUS FOR CONVERTING ELECTRONIC RADIATION TO ELECTRICAL ENERGY, NAMELY PHOTOVOLTAIC ROOFING MEMBERS; APPARATUS FOR CONVERTING ELECTRONIC RADIATION TO ELECTRICAL ENERGY, NAMELY PHOTOVOLTAIC SOLAR MODULES; SOLAR CELLS (U.S. CLS. 21, 23, 26, 36 AND 38).

SUSAN LESLIE DUBOIS, EXAMINING ATTORNEY

**CLASS 9—(Continued).**

SN 77-049,464. LEAPFROG ENTERPRISES, INC., EMERYVILLE, CA. FILED 11-22-2006.

# FLY

THE MARK CONSISTS OF STANDARD CHARACTERS WITHOUT CLAIM TO ANY PARTICULAR FONT, STYLE, SIZE, OR COLOR.

OWNER OF U.S. REG. NO. 3,194,994.  
FOR COMPUTER SOFTWARE, NAMELY AN AUTHORIZING AND PUBLISHING SOFTWARE APPLICATION THAT ENABLES USERS TO DEVELOP AND ADAPT INTERACTIVE PRE-PRINT CONTENT FOR PROPRIETARY PENTOP COMPUTER (U.S. CLS. 21, 23, 26, 36 AND 38).

MORGAN WYNNE, EXAMINING ATTORNEY

SN 77-046,942. SCHOLASTIC INC., NEW YORK, NY. FILED 11-17-2006.

# CRITTER RIVER

THE MARK CONSISTS OF STANDARD CHARACTERS WITHOUT CLAIM TO ANY PARTICULAR FONT, STYLE, SIZE, OR COLOR.

FOR INTERACTIVE MULTIMEDIA COMPUTER GAME PROGRAMS; INTERACTIVE VIDEO GAME PROGRAMS; MULTIMEDIA SOFTWARE RECORDED ON CD-ROM FEATURING VIDEO AND COMPUTER GAMES; COMPUTER AND VIDEO GAMES DISCS; ELECTRONIC GAME SOFTWARE FOR HANDHELD ELECTRONIC DEVICES (U.S. CLS. 21, 23, 26, 36 AND 38).

NAKIA HENRY, EXAMINING ATTORNEY

SN 77-059,760. IGT, RENO, NV. FILED 12-8-2006.

# VISUAL SLOT PERFORMANCE

THE MARK CONSISTS OF STANDARD CHARACTERS WITHOUT CLAIM TO ANY PARTICULAR FONT, STYLE, SIZE, OR COLOR.

SEC. 2(F).  
FOR COMPUTER SOFTWARE THAT GATHERS DATA FROM GAMING MACHINES AND SLOT ACCOUNTING DATABASES FOR ANALYZING BY CASINO EMPLOYEES IN GRAPHICAL AND REPORT FORMATS (U.S. CLS. 21, 23, 26, 36 AND 38).

FIRST USE 3-1-1999; IN COMMERCE 12-1-1999.  
SUE LAWRENCE, EXAMINING ATTORNEY

SN 77-047,344. DIEBOLD, INCORPORATED, NORTH CANTON, OH. FILED 11-19-2006.

# DIEBOLD SITE SECURE

THE MARK CONSISTS OF STANDARD CHARACTERS WITHOUT CLAIM TO ANY PARTICULAR FONT, STYLE, SIZE, OR COLOR.

OWNER OF U.S. REG. NOS. 682,872, 1,701,403 AND OTHERS.  
FOR ACCESS CONTROL AND ALARM MONITORING SYSTEMS (U.S. CLS. 21, 23, 26, 36 AND 38).

FRED MANDIR, EXAMINING ATTORNEY

SN 77-059,868. EAST PENN MANUFACTURING CO., LYON STATION, PA. FILED 12-8-2006.

# E-Z LINK

THE MARK CONSISTS OF STANDARD CHARACTERS WITHOUT CLAIM TO ANY PARTICULAR FONT, STYLE, SIZE, OR COLOR.

FOR ELECTRIC STORAGE BATTERIES (U.S. CLS. 21, 23, 26, 36 AND 38).

FIRST USE 1-15-1988; IN COMMERCE 1-15-1988.  
LINDA ORNDORFF, EXAMINING ATTORNEY

**CLASS 9—(Continued).**

SN 77-059,873. EAST PENN MANUFACTURING CO., LYON STATION, PA. FILED 12-8-2006.

# GEL-MATE

THE MARK CONSISTS OF STANDARD CHARACTERS WITHOUT CLAIM TO ANY PARTICULAR FONT, STYLE, SIZE, OR COLOR.

FOR ELECTRIC STORAGE BATTERIES (U.S. CLS. 21, 23, 26, 36 AND 38).

FIRST USE 6-25-1996; IN COMMERCE 6-25-1996.  
NAKIA HENRY, EXAMINING ATTORNEY

**CLASS 9—(Continued).**

SN 77-065,189. SCHOLASTIC INC., NEW YORK, NY. FILED 12-15-2006.

# ZIP INTO LANGUAGE. ZOOM INTO READING!

THE MARK CONSISTS OF STANDARD CHARACTERS WITHOUT CLAIM TO ANY PARTICULAR FONT, STYLE, SIZE, OR COLOR.

FOR PRE-RECORDED AUDIO AND VIDEO CASSETTES AND CHILDREN'S EDUCATIONAL SOFTWARE IN THE FIELDS OF READING, WRITING, PHONICS, PHONEMIC AWARENESS, COMPREHENSION, FLUENCY, VOCABULARY, AND CONTENT AREA KNOWLEDGE (U.S. CLS. 21, 23, 26, 36 AND 38).

FIRST USE 3-23-2006; IN COMMERCE 3-23-2006.  
NAKIA HENRY, EXAMINING ATTORNEY

SN 77-063,961. INTERSCAPE, INC., BRASELTON, GA. FILED 12-14-2006.



OWNER OF U.S. REG. NO. 2,531,807.

THE COLOR(S) LIGHT BLUE, DARK BLUE, GRAY, WHITE, AND BLACK IS/ARE CLAIMED AS A FEATURE OF THE MARK.

THE COLOR LIGHT BLUE APPEARS IN THE INSIDE OF THE CIRCLE OF THE DESIGN ELEMENT; THE COLOR DARK BLUE APPEARS IN THE INSIDE OF THE CIRCLE OF THE DESIGN ELEMENT AND IN THE LETTERS "MA"; THE COLOR GRAY APPEARS IN THE LETTERS "DIGA" AND IN THE CIRCLE AND FILM REEL DESIGN ELEMENTS; THE COLOR WHITE APPEARS IN THE LETTER "I" IN THE DESIGN ELEMENT AND IN THE INSIDE OF THE DESIGN ELEMENT; AND THE COLOR BLACK APPEARS IN THE OUTLINE OF THE DESIGN ELEMENT AND IN THE WORDING "AN INTERSCAPE SOLUTION."

THE MARK CONSISTS OF A MOVIE WHEEL WITH THE LETTER "I" INSIDE IT, BELOW WHICH IS THE WORD "DIGAMA" AND BELOW WHICH ARE THE WORDS "AN INTERSCAPE SOLUTION."

FOR COMPUTER HARDWARE AND COMPUTER SOFTWARE PROGRAMS FOR THE INTEGRATION OF TEXT, AUDIO, GRAPHICS, STILL IMAGE AND MOVING PICTURES INTO AN INTERACTIVE DELIVERY FOR MULTIMEDIA APPLICATIONS (U.S. CLS. 21, 23, 26, 36 AND 38).

ATTIYA MALIK, EXAMINING ATTORNEY

SN 77-068,051. HONEYWELL INTERNATIONAL INC., MORRISTOWN, NJ. FILED 12-20-2006.

# MEDPARTNER

THE MARK CONSISTS OF STANDARD CHARACTERS WITHOUT CLAIM TO ANY PARTICULAR FONT, STYLE, SIZE, OR COLOR.

FOR MEDICATION REMINDER, NAMELY AN ELECTRONIC DEVICE THAT REMINDS PATIENT TO TAKE MEDICATION AND MONITORS COMPLIANCE (U.S. CLS. 21, 23, 26, 36 AND 38).

NAKIA HENRY, EXAMINING ATTORNEY

SN 77-069,105. SONY KABUSHIKI KAISHA, TA SONY CORPORATION, TOKYO, JAPAN, FILED 12-21-2006.

# sface

THE MARK CONSISTS OF STANDARD CHARACTERS WITHOUT CLAIM TO ANY PARTICULAR FONT, STYLE, SIZE, OR COLOR.

FOR DVD RECORDERS WITH HARD DISC DRIVE, DIGITAL STILL CAMERAS, CAMCORDERS, COMPUTER SERVERS, SET-TOP BOXES, PRINTERS, VIDEO GAME MACHINES FOR USE WITH TELEVISIONS (U.S. CLS. 21, 23, 26, 36 AND 38).

SCOTT SISUN, EXAMINING ATTORNEY

**CLASS 9—(Continued).**

SN 77-069,184. SPIELO MANUFACTURING ULC, MONCTON, NEW BRUNSWICK, CANADA, FILED 12-21-2006.

## STARS OF FATE

THE MARK CONSISTS OF STANDARD CHARACTERS WITHOUT CLAIM TO ANY PARTICULAR FONT, STYLE, SIZE, OR COLOR.

FOR RECONFIGURABLE CASINO AND LOTTERY GAMING EQUIPMENT, NAMELY SLOT MACHINES AND VIDEO LOTTERY TERMINALS AND OPERATIONAL COMPUTER GAME SOFTWARE THEREFOR (U.S. CLS. 21, 23, 26, 36 AND 38).

KAREN SEVERSON, EXAMINING ATTORNEY

**CLASS 9—(Continued).**

SN 77-069,218. SPIELO MANUFACTURING ULC, MONCTON, NEW BRUNSWICK, CANADA, FILED 12-21-2006.

## WINNER'S PARADISE

THE MARK CONSISTS OF STANDARD CHARACTERS WITHOUT CLAIM TO ANY PARTICULAR FONT, STYLE, SIZE, OR COLOR.

FOR RECONFIGURABLE CASINO AND LOTTERY GAMING EQUIPMENT, NAMELY SLOT MACHINES AND VIDEO LOTTERY TERMINALS AND OPERATIONAL COMPUTER GAME SOFTWARE THEREFOR (U.S. CLS. 21, 23, 26, 36 AND 38).

KAREN SEVERSON, EXAMINING ATTORNEY

---

SN 77-069,193. SPIELO MANUFACTURING ULC, MONCTON, NEW BRUNSWICK, CANADA, FILED 12-21-2006.

## MAXIMUS BETUS

THE MARK CONSISTS OF STANDARD CHARACTERS WITHOUT CLAIM TO ANY PARTICULAR FONT, STYLE, SIZE, OR COLOR.

FOR RECONFIGURABLE CASINO AND LOTTERY GAMING EQUIPMENT, NAMELY SLOT MACHINES AND VIDEO LOTTERY TERMINALS AND OPERATIONAL COMPUTER GAME SOFTWARE THEREFOR (U.S. CLS. 21, 23, 26, 36 AND 38).

KAREN SEVERSON, EXAMINING ATTORNEY

---

SN 77-069,232. SPIELO MANUFACTURING ULC, MONCTON, NEW BRUNSWICK, CANADA, FILED 12-21-2006.

## MONEY MAKEOVER

THE MARK CONSISTS OF STANDARD CHARACTERS WITHOUT CLAIM TO ANY PARTICULAR FONT, STYLE, SIZE, OR COLOR.

FOR RECONFIGURABLE CASINO AND LOTTERY GAMING EQUIPMENT, NAMELY SLOT MACHINES AND VIDEO LOTTERY TERMINALS AND OPERATIONAL COMPUTER GAME SOFTWARE THEREFOR (U.S. CLS. 21, 23, 26, 36 AND 38).

KAREN SEVERSON, EXAMINING ATTORNEY

---

SN 77-069,202. SPIELO MANUFACTURING ULC, MONCTON, NEW BRUNSWICK, CANADA, FILED 12-21-2006.

## ALI BABA'S VAULT

THE MARK CONSISTS OF STANDARD CHARACTERS WITHOUT CLAIM TO ANY PARTICULAR FONT, STYLE, SIZE, OR COLOR.

FOR RECONFIGURABLE CASINO AND LOTTERY GAMING EQUIPMENT, NAMELY SLOT MACHINES AND VIDEO LOTTERY TERMINALS AND OPERATIONAL COMPUTER GAME SOFTWARE THEREFOR (U.S. CLS. 21, 23, 26, 36 AND 38).

KAREN SEVERSON, EXAMINING ATTORNEY

---

SN 77-069,241. SPIELO MANUFACTURING ULC, MONCTON, NEW BRUNSWICK, CANADA, FILED 12-21-2006.

## MY LUCKY GAME

THE MARK CONSISTS OF STANDARD CHARACTERS WITHOUT CLAIM TO ANY PARTICULAR FONT, STYLE, SIZE, OR COLOR.

FOR RECONFIGURABLE CASINO AND LOTTERY GAMING EQUIPMENT, NAMELY SLOT MACHINES AND VIDEO LOTTERY TERMINALS AND OPERATIONAL COMPUTER GAME SOFTWARE THEREFOR (U.S. CLS. 21, 23, 26, 36 AND 38).

KAREN SEVERSON, EXAMINING ATTORNEY

**CLASS 9—(Continued).**

SN 77-069,258. SPIELO MANUFACTURING ULC, MONCTON, NEW BRUNSWICK, CANADA, FILED 12-21-2006.

**MAID MARION**

THE MARK CONSISTS OF STANDARD CHARACTERS WITHOUT CLAIM TO ANY PARTICULAR FONT, STYLE, SIZE, OR COLOR.

FOR RECONFIGURABLE CASINO AND LOTTERY GAMING EQUIPMENT, NAMELY SLOT MACHINES AND VIDEO LOTTERY TERMINALS AND OPERATIONAL COMPUTER GAME SOFTWARE THEREFOR (U.S. CLS. 21, 23, 26, 36 AND 38).

KAREN SEVERSON, EXAMINING ATTORNEY

---

SN 77-070,306. BUSHNELL INC., OVERLAND PARK, KS. FILED 12-22-2006.

**ARES**

THE MARK CONSISTS OF STANDARD CHARACTERS WITHOUT CLAIM TO ANY PARTICULAR FONT, STYLE, SIZE, OR COLOR.

FOR OPTICAL APPARATUS AND INSTRUMENTS AND ACCESSORIES FOR USE THEREWITH, NAMELY — TELESCOPES (U.S. CLS. 21, 23, 26, 36 AND 38).

DAVID TAYLOR, EXAMINING ATTORNEY

---

SN 78-207,742. NEXTSCAN, GARDEN VALLEY, ID. FILED 1-28-2003.

**PHOENIX**

FOR MICROFILM AND MICROFICHE SCANNERS (U.S. CLS. 21, 23, 26, 36 AND 38).

FIRST USE 12-1-2002; IN COMMERCE 12-1-2002.  
JOHN DWYER, EXAMINING ATTORNEY

**CLASS 9—(Continued).**

SN 78-323,652. SPARKLE COMPUTER CO., LTD., CHUNG SHAN DISTRICT, TAIPEI, TAIWAN, FILED 11-5-2003.



FOR COMPUTER ADD-ON CARDS, NAMELY, VIDEO GRAPHIC ADAPTER CARDS, AUDIO CARDS; LAN (LOCAL AREA NETWORK) CARDS; MODEM CARDS; NETWORK CONTROL CARDS; SCSI (SMALL COMPUTER SYSTEMS INTERFACE) CARDS; BAR CODE READERS; TELEPHONES (U.S. CLS. 21, 23, 26, 36 AND 38).

STEVEN JACKSON, EXAMINING ATTORNEY

---

SN 78-496,142. EDGEMED HEALTHCARE SOLUTIONS INC., DEERFIELD BEACH, ID. FILED 10-7-2004.

THE COLOR(S) GREEN IS/ARE CLAIMED AS A FEATURE OF THE MARK.

THE SECOND "I" IN THE WORD INNOVATION CONSIST OF A GREEN DOT/CIRCLE.

FOR COMPUTER SOFTWARE FOR USE IN THE MEDICAL FIELD, NAMELY, SOFTWARE FOR ACCOUNTS RECEIVABLE BILLING, APPOINTMENT SCHEDULING, MANAGEMENT REPORTING AND PATIENT AND INSURANCE BILLING FOR USE IN DOCTORS' OFFICES (U.S. CLS. 21, 23, 26, 36 AND 38).

AMOS T. MATTHEWS, JR., EXAMINING ATTORNEY

**CLASS 9—(Continued).**

SN 78-579,774. SAMSUNG ELECTRONICS CO., LTD., SUWON-SI, REPUBLIC OF KOREA, FILED 3-3-2005.

**HANDY STATION**

THE MARK CONSISTS OF STANDARD CHARACTERS WITHOUT CLAIM TO ANY PARTICULAR FONT, STYLE, SIZE, OR COLOR.

OWNER OF REPUBLIC OF KOREA REG. NO. 0642399, DATED 12-8-2005, EXPIRES 12-8-2015.

FOR REMOTE CONTROLS TO CONTROL COMMUNICATIONS AMONG COMPUTERS, TELEPHONES AND HOUSEHOLD APPLIANCES, NAMELY, TELEVISIONS, VIDEOTAPE RECORDERS, DIGITAL VERSATILE DISC PLAYERS, SET-TOP BOXES, HOME THEATER SYSTEMS, AIR CONDITIONERS, WASHING MACHINES, REFRIGERATORS, AND BOILERS, ALL ARE CONNECTED TO HOME NETWORKING SYSTEMS (U.S. CLS. 21, 23, 26, 36 AND 38).

ANGELA M. MICHELI, EXAMINING ATTORNEY

SN 78-610,756. PHX AP ACQUISITION, LLC, PORTLAND, OR. FILED 4-18-2005.

**AUDIOSOURCE**

THE MARK CONSISTS OF STANDARD CHARACTERS WITHOUT CLAIM TO ANY PARTICULAR FONT, STYLE, SIZE, OR COLOR.

OWNER OF U.S. REG. NOS. 1,224,625 AND 1,921,674. SEC. 2(F).

FOR AUDIO AND VIDEO RECEIVERS, AUDIO AND VIDEO AMPLIFIERS, AND AUDIO AND VIDEO PROCESSORS, DVD PLAYERS, DVD RECEIVERS, AUDIO DISTRIBUTION SYSTEMS COMPRISING ONE OR MORE AUDIO DISTRIBUTION HUBS, AND CD PLAYERS (U.S. CLS. 21, 23, 26, 36 AND 38).

DEBRA LEE, EXAMINING ATTORNEY

**CLASS 9—(Continued).**

SN 78-612,091. LANISH ENTERPRISES LIMITED, DOUGLAS, ISLE OF MAN, FILED 4-19-2005.

**BLUEAX**

THE MARK CONSISTS OF STANDARD CHARACTERS WITHOUT CLAIM TO ANY PARTICULAR FONT, STYLE, SIZE, OR COLOR.

FOR APPARATUS AND INSTRUMENTS NAMELY, DATA BLANK COMPUTER STORAGE DISCS, BLACK OPTICAL STORAGE DISCS, BLANK CD-ROM STORAGE DISCS FOR THE PROCESSING, TRANSMISSION, STORAGE, LOGGING, RECEPTION AND RETRIEVAL OF DATA BEING IN THE FORM OF ENCODED DATA, TEXT, AUDIO, GRAPHIC IMAGES, VIDEO OR DIGITAL DOWNLOADABLE MUSIC PROVIDED FROM A COMPUTER DATABASE OR THE INTERNET, INCLUDING MP3 INTERNET WEBSITES OR A COMBINATION OF THESE FORMATS; APPARATUS FOR SOUND RECORDING, REPRODUCING AND FOR LISTENING TO MUSIC DOWNLOADED FROM THE INTERNET NAMELY, COMPUTERS AND MP3 PLAYERS; BATTERY CHARGERS FOR USE WITH TELECOMMUNICATIONS APPARATUS; ADAPTERS FOR USE WITH TELECOMMUNICATIONS APPARATUS; DOWNLOADABLE FILMS FEATURING ACTION, DRAMA, COMEDY OR ANIMATION; VIDEO RECORDINGS FEATURING MOVIES, AUDIO RECORDINGS FEATURING MUSIC; DOWNLOADABLE GRAPHIC IMAGES IN THE FIELD OF ENTERTAINMENT PROVIDED VIA A GLOBAL COMPUTER NETWORK AND WIRELESS DEVICES; TELEVISIONS; TELEVISION APPARATUS AND INSTRUMENTS NAMELY, MOBILE TELEPHONES FOR USE IN TRANSMITTING IMAGES AND SIGNALS FROM ONE'S COMPUTER TO ONE'S TELEVISION; PERIPHERAL EQUIPMENT FOR TELEVISIONS AND COMPUTERS NAMELY, REMOTE CONTROLS AND CONNECTORS; COMMUNICATIONS APPARATUS, EQUIPMENT AND ACCESSORIES, NAMELY, USB DONGLES, MOBILE TELEPHONE CHARGERS AND HEADPHONES; TELECOMMUNICATIONS APPARATUS, EQUIPMENT AND ACCESSORIES NAMELY, TELEPHONES AND AUDIO DONGLES; PAGING APPARATUS AND EQUIPMENT NAMELY, TELEPHONE PAGERS; COMPUTER HARDWARE; COMPUTER SOFTWARE FOR REPRODUCTION OF DIGITALLY RECORDED SOUND; DESK OR CAR MOUNTED UNITS INCORPORATING A LOUD SPEAKER WHICH PERMITS HANDS FREE USE OF A TELEPHONE HANDSET; IN-CAR TELEPHONE HANDSET CRADLES; ELECTRONIC AMUSEMENT APPARATUS NAMELY, ELECTRONIC AND VIDEO GAME CONTROLLERS; DOWNLOADABLE DIGITAL MUSIC PROVIDED VIA THE INTERNET; COMPUTER SOFTWARE AND TELECOMMUNICATIONS APPARATUS, NAMELY, MOBILE TELEPHONES TO ENABLE CONNECTION TO DATABASES AND THE INTERNET; AUDIO OR VIDEO SIGNAL TRANSMITTING OR RECEIVING APPARATUS, NAMELY, AUDIO AND VIDEO TRANSMITTERS, AUDIO AND VIDEO RECEIVERS, OR A COMBINATION THEREOF; AUDIO OR VIDEO APPARATUS AND INSTRUMENTS NAMELY, AUDIO CASSETTE PLAYERS, VIDEO RECORDERS, OR A COMBINATION THEREOF; LOUDSPEAKERS; HEADPHONES; ANTI-THEFT WARNING DEVICES NAMELY, BURGLAR ALARMS AND THEFT ALARMS; BATTERIES; MEDIA FOR STORING INFORMATION DATA, SIGNALS, IMAGES, SOUND, OR A COMBINATION THEREOF, NAMELY, BLANK CD ROMS; BLANK COMPACT DISCS; BLANK DVDS; BLANK OPTICAL DISCS; BLANK COMPUTER DISCS; BLANK AUDIO AND VIDEO CASSETTE TAPES; PHOTOGRAPHIC APPARATUS AND INSTRUMENTS NAMELY, CAMERAS; REPLACEMENT PARTS AND FITTINGS FOR ALL AFORESAID GOODS (U.S. CLS. 21, 23, 26, 36 AND 38).

ELLEN BURNS, EXAMINING ATTORNEY

**CLASS 9—(Continued).**

SN 78-629,028. POWER COSTS, INC., NORMAN, OK. FILED 5-12-2005.

**PCI GENERATION SUPPLY  
MANAGEMENT SYSTEM**

THE MARK CONSISTS OF STANDARD CHARACTERS WITHOUT CLAIM TO ANY PARTICULAR FONT, STYLE, SIZE, OR COLOR.

NO CLAIM IS MADE TO THE EXCLUSIVE RIGHT TO USE "GENERATION SUPPLY MANAGEMENT SYSTEM", APART FROM THE MARK AS SHOWN.

FOR SUITE OF DOWNLOADABLE COMPUTER SOFTWARE FEATURING COMPLETE FUNCTIONALITY FOR GENERATION ASSET OWNERS AND MARKET PARTICIPANTS TO AUTOMATE, MANAGE, AND ANALYZE ENERGY BIDDING AND SETTLEMENT; SUITE OF DOWNLOADABLE COMPUTER SOFTWARE FEATURING FUNCTIONALITY AND FEATURES FOR ANALYZING AND OPTIMIZING THE UTILIZATION OF GENERATORS AND POSITIONS; AND SUITE OF DOWNLOADABLE COMPUTER SOFTWARE FEATURING DATABASES TO SUPPORT, ENABLE AND AUTOMATE ENTERPRISE APPLICATION OF PROCESSES AND CONNECTIVITY AND INTERFACE WITH OTHER SYSTEMS (U.S. CLS. 21, 23, 26, 36 AND 38).

FIRST USE 5-15-2004; IN COMMERCE 5-15-2004.

WARREN L. OLANDRIA, EXAMINING ATTORNEY

---

SN 78-654,585. ELK PREMIUM BUILDING PRODUCTS, INC., DALLAS, TX. FILED 6-20-2005.

**SOLARIS NRG**

THE MARK CONSISTS OF STANDARD CHARACTERS WITHOUT CLAIM TO ANY PARTICULAR FONT, STYLE, SIZE, OR COLOR.

NO CLAIM IS MADE TO THE EXCLUSIVE RIGHT TO USE "ENERGY", APART FROM THE MARK AS SHOWN.

FOR SOLAR ELECTRIC GENERATING PANEL SYSTEM FOR USE ON ROOFS (U.S. CLS. 21, 23, 26, 36 AND 38).

LINDA MICKLEBURGH, EXAMINING ATTORNEY

**CLASS 9—(Continued).**

SN 78-664,310. WORLD BASEBALL CLASSIC, INC., NEW YORK, NY. FILED 7-6-2005.



NO CLAIM IS MADE TO THE EXCLUSIVE RIGHT TO USE CLASICO AND BEISBOL FOR "PRE-RECORDED VIDEOTAPES RELATING TO BASEBALL; PRE-RECORDED VIDEODISCS RELATING TO BASEBALL; PRE-RECORDED AUDIO DISCS RELATING TO BASEBALL; BASEBALL BATTING HELMETS", APART FROM THE MARK AS SHOWN.

THE MARK CONSISTS OF A STYLIZED GLOBE WITH MERIDIANS AND BASEBALL STITCHING SURROUNDED BY FOUR HALF-CIRCLES THAT SPIRAL OUTWARD IN A PINWHEEL FASHION FROM THE GLOBE ABOVE WHICH THE WORDS CLASICO MUNDIAL DE BEISBOL APPEAR.

THE FOREIGN WORDING IN THE MARK TRANSLATES INTO ENGLISH AS WORLD BASEBALL CLASSIC.

FOR ELECTRICAL AND SCIENTIFIC APPARATUS, NAMELY, RADIOS; PRE-RECORDED VIDEOTAPES RELATING TO BASEBALL; PRE-RECORDED VIDEODISCS RELATING TO BASEBALL; PRE-RECORDED AUDIO DISCS RELATING TO BASEBALL; COMPACT DISC CASES; EYEGLASS CASES, CASES FOR PERSONAL DIGITAL ASSISTANTS, CELL PHONES, CELL PHONE ACCESSORIES, NAMELY, CASES AND FACE PLATE COVERS; BINOCULARS; CALCULATORS; PHOTOGRAPHIC CAMERAS; ELECTRIC SWITCH PLATE COVERS; LUMINOUS SIGNS, NEON SIGNS; SUNGLASSES; DECORATIVE MAGNETS; PROTECTIVE HELMETS, BASEBALL BATTING HELMETS, CATCHER'S HELMETS; VIDEO AND COMPUTER GAME CARTRIDGES, VIDEO AND COMPUTER GAME DISCS, VIDEO AND COMPUTER GAME CASSETTES AND VIDEO GAME CONTROLLERS; COMPUTER ACCESSORIES, NAMELY, MOUSE PADS AND WRIST PADS, COMPUTER SOFTWARE, NAMELY, SCREEN SAVERS, COMPUTER GAME PROGRAMS, AND COMPUTER GAME PROGRAMS DOWNLOADABLE FROM A GLOBAL COMPUTER NETWORK IN THE FIELD OF BASEBALL (U.S. CLS. 21, 23, 26, 36 AND 38).

CAROLINE WOOD, EXAMINING ATTORNEY

**CLASS 9—(Continued).**

SN 78-664,370. WORLD BASEBALL CLASSIC, INC., NEW YORK, NY. FILED 7-6-2005.



NO CLAIM IS MADE TO THE EXCLUSIVE RIGHT TO USE "BASEBALL CLASSIC" FOR PRE-RECORDED VIDEOTAPES RELATING TO BASEBALL, PRE-RECORDED VIDEODISCS RELATING TO BASEBALL; PRERECORDED AUDIO DISCS RELATING TO BASEBALL; BASEBALL BATTING HELMETS, APART FROM THE MARK AS SHOWN.

THE MARK CONSISTS OF A STYLIZED GLOBE WITH MERIDIANS AND BASEBALL STITCHING SURROUNDED BY FOUR HALF-CIRCLES THAT SPIRAL OUTWARD IN A PINWHEEL FASHION FROM THE GLOBE ABOVE WHICH THE WORDS WORLD BASEBALL CLASSIC APPEAR.

FOR ELECTRICAL AND SCIENTIFIC APPARATUS, NAMELY, RADIOS; PRE-RECORDED VIDEOTAPES RELATING TO BASEBALL, PRE-RECORDED VIDEODISCS RELATING TO BASEBALL; PRE-RECORDED AUDIO DISCS RELATING TO BASEBALL; COMPACT DISC CASES; EYEGLASS CASES, CASES FOR PERSONAL DIGITAL ASSISTANTS, CELL PHONES, CELL PHONE ACCESSORIES, NAMELY, CASES AND FACE PLATE COVERS; BINOCULARS; CALCULATORS; PHOTOGRAPHIC CAMERAS; ELECTRIC SWITCH PLATE COVERS; LUMINOUS SIGNS, NEON SIGNS; SUNGLASSES; DECORATIVE MAGNETS; PROTECTIVE HELMETS, BASEBALL BATTING HELMETS, CATCHER'S HELMETS; VIDEO AND COMPUTER GAME CARTRIDGES, VIDEO AND COMPUTER GAME DISCS, VIDEO AND COMPUTER GAME CASSETTES AND VIDEO GAME CONTROLLERS; COMPUTER ACCESSORIES, NAMELY, MOUSE PADS AND WRIST PADS, COMPUTER SOFTWARE, NAMELY, SCREEN SAVERS, COMPUTER GAME PROGRAMS, COMPUTER GAME PROGRAMS DOWNLOADABLE FROM A GLOBAL COMPUTER NETWORK IN THE FIELD OF BASEBALL (U.S. CLS. 21, 23, 26, 36 AND 38).

CAROLINE WOOD, EXAMINING ATTORNEY

**CLASS 9—(Continued).**

SN 78-675,637. DEVORE, JOHN, NEW YORK, NY. FILED 7-21-2005.

# KOALA

THE MARK CONSISTS OF STANDARD CHARACTERS WITHOUT CLAIM TO ANY PARTICULAR FONT, STYLE, SIZE, OR COLOR.

FOR CONSUMER ELECTRONIC PRODUCTS, NAMELY, STEREOS; AUDIO AND VIDEO DISC PLAYERS, AUDIO SPEAKERS, AMPLIFIERS, PREAMPLIFIERS, SUBWOOFERS, PHONOGRAPH TURNTABLES, AND PHONOGRAPH TONEARMS; HOUSINGS, ENCLOSURES, RACKS AND STANDS, FOR USE WITH STEREOS, AUDIO AND VIDEO DISC PLAYERS, SPEAKERS, AMPLIFIERS, PREAMPLIFIERS, SUBWOOFERS, TURNTABLES, AND TONEARMS; ELECTRIC WIRE; ELECTRIC CABLES (U.S. CLS. 21, 23, 26, 36 AND 38).

FIRST USE 10-1-2003; IN COMMERCE 10-1-2003.  
JASON BLAIR, EXAMINING ATTORNEY

SN 78-677,274. CB TM CORP., MISSION VIEJO, CA. FILED 7-22-2005.

# MARKETCONNECT

THE MARK CONSISTS OF STANDARD CHARACTERS WITHOUT CLAIM TO ANY PARTICULAR FONT, STYLE, SIZE, OR COLOR.

FOR DOWNLOADABLE ELECTRONIC PUBLICATIONS, NAMELY, ELECTRONIC NEWSLETTERS, GRAPHICS AND SOUND POSTCARDS, AND INSTRUCTIONAL MARKETING BROCHURE IN THE FIELD OF COMMERCIAL REAL ESTATE BROKERAGE (U.S. CLS. 21, 23, 26, 36 AND 38).

FIRST USE 2-28-2004; IN COMMERCE 2-28-2004.  
CAROL SPILS, EXAMINING ATTORNEY

SN 78-683,697. WMS GAMING INC., WAUKEGAN, IL. FILED 8-2-2005.

# HOT HOT SUPER JACKPOT

THE MARK CONSISTS OF STANDARD CHARACTERS WITHOUT CLAIM TO ANY PARTICULAR FONT, STYLE, SIZE, OR COLOR.

OWNER OF U.S. REG. NO. 3,016,293.

NO CLAIM IS MADE TO THE EXCLUSIVE RIGHT TO USE "SUPER JACKPOT", APART FROM THE MARK AS SHOWN.

FOR GAMING MACHINES (U.S. CLS. 21, 23, 26, 36 AND 38).

WILLIAM BRECKENFELD, EXAMINING ATTORNEY

**CLASS 9—(Continued).**

SN 78-714,956. MAXUM STUDIOS, LLC., BOYNTON BEACH, FL. FILED 9-16-2005.

**MAXUM GAMES**

THE MARK CONSISTS OF STANDARD CHARACTERS WITHOUT CLAIM TO ANY PARTICULAR FONT, STYLE, SIZE, OR COLOR.

NO CLAIM IS MADE TO THE EXCLUSIVE RIGHT TO USE "GAMES", APART FROM THE MARK AS SHOWN.

FOR VIDEO GAME AND COMPUTER SOFTWARE, NAMELY, SOFTWARE USED TO CREATE FULL MULTIMEDIA ELECTRONIC GAMES TO BE PLAYED ON A COMPUTER OR OTHER VIDEO GAME PLATFORMS; COMPUTER AND VIDEO GAME CARTRIDGES, CASSETTES, GAME TAPES, AND DISCS; PRERECORDED VIDEOTAPES, AUDIO TAPES, CDS AND DVDS FEATURING SOUND AND VIDEO IN THE FIELDS OF MUSIC, LIVE ACTION PROGRAMS, MOTION PICTURES AND ANIMATED CARTOONS, OR FEATURING CHARACTERS, VOICES AND SOUNDTRACK FROM A VIDEO OR COMPUTER GAME (U.S. CLS. 21, 23, 26, 36 AND 38).

IRENE D. WILLIAMS, EXAMINING ATTORNEY

**CLASS 9—(Continued).**

SN 78-733,649. PARKER-MCCRORY MFG. CO., KANSAS CITY, MO. FILED 10-14-2005.



OWNER OF U.S. REG. NO. 1,704,692.

NO CLAIM IS MADE TO THE EXCLUSIVE RIGHT TO USE "PRECISION TRADEMARK OF QUALITY SINCE 1921", APART FROM THE MARK AS SHOWN.

FOR ELECTRIC FENCE CONTROLLERS; ELECTRIC CATTLE PRODS; HIGHWAY WARNING LIGHTS; ELECTRIC FENCING; BATTERIES; TRANSFORMERS; PHOTOVOLTAIC CELLS; AND ELECTRIC FENCING ACCESSORIES, NAMELY, ELECTRIC FENCE WIRE; ELECTRIC FENCE TAPE, NAMELY, FLAT WOVEN STRIPS MADE FROM STRANDS OF POLYPROPYLENE-COATED REINFORCED FIBERGLASS BRAIDED WITH STRANDS OF ALUMINUM WIRE; ELECTRIC FENCE ROPE, NAMELY, POLYPROPYLENE ROPE TWISTED WITH STRANDS OF STAINLESS STEEL OR TIN-COATED COPPER WIRE; AND ELECTRICAL CONNECTORS FOR ELECTRIC FENCES (U.S. CLS. 21, 23, 26, 36 AND 38).

FIRST USE 0-0-1931; IN COMMERCE 0-0-1931.

MICHAEL ENGEL, EXAMINING ATTORNEY

SN 78-727,551. HARBOUR INDUSTRIES, LTD., FARNHAM, QUEBEC, CANADA, FILED 10-6-2005.

**HBR LB 200**

THE MARK CONSISTS OF STANDARD CHARACTERS WITHOUT CLAIM TO ANY PARTICULAR FONT, STYLE, SIZE, OR COLOR.

PRIORITY CLAIMED UNDER SEC. 44(D) ON CANADA APPLICATION NO. 1273216, FILED 9-23-2005, REG. NO. TMA672941, DATED 9-19-2006, EXPIRES 9-19-2021.

NO CLAIM IS MADE TO THE EXCLUSIVE RIGHT TO USE 200, APART FROM THE MARK AS SHOWN.

FOR HIGH TEMPERATURE ELECTRICAL WIRES AND CABLES FOR APPLIANCES, EXCLUDING COMPUTER-RELATED EQUIPMENT (U.S. CLS. 21, 23, 26, 36 AND 38).

RAY THOMAS, EXAMINING ATTORNEY

SN 78-744,458. FIBERBYTE PTY LTD, ADELAIDE, AUSTRALIA, FILED 11-1-2005.



OWNER OF U.S. REG. NO. 3,047,379.

NO CLAIM IS MADE TO THE EXCLUSIVE RIGHT TO USE "USB", APART FROM THE MARK AS SHOWN.

FOR ELECTRICAL CONTROLLING DEVICES (U.S. CLS. 21, 23, 26, 36 AND 38).

FIRST USE 5-1-2003; IN COMMERCE 7-1-2005.

TARAH HARDY, EXAMINING ATTORNEY



**CLASS 9—(Continued).**

SN 78-744,922. TAG COMPANY (UK) LIMITED, WEST DRAYTON, MIDDLESEX, UNITED KINGDOM, FILED 11-1-2005.



OWNER OF ERPN CMNTY TM OFC REG. NO. 004381406, DATED 4-25-2006, EXPIRES 4-8-2015.

NO CLAIM IS MADE TO THE EXCLUSIVE RIGHT TO USE "SERIES", APART FROM THE MARK AS SHOWN.

THE COLOR(S) RED IS/ARE CLAIMED AS A FEATURE OF THE MARK.

THE MARK CONSISTS OF THE WORD SERIES OUTLINED IN RED FOLLOWED BY THE NUMBER 58 IN SOLID RED.

FOR PACKAGE LABELS CONTAINING ELECTRONIC, ELECTROMAGNETIC AND ACCOUSTOMAGNETIC SECURITY DEVICES; ELECTRONIC TAGGING APPARATUS AND DEVICES, NAMELY ELECTRONIC TAGS AND LABELS FOR PREVENTING LOSS OR THEFT OF RETAIL MERCHANDISE, FOR PROVIDING RETAIL SECURITY, FOR PREVENTING VENDOR FRAUD AND FOR USE IN SURVEILLANCE OF ELECTRONIC ARTICLES, AND DEVICES AND APPARATUS NAMELY ACCOUSTOMAGNETIC SYSTEMS AND DEACTIVATORS USED TO ATTACH, SECURE, ACTIVATE, DE-ACTIVATE AND REMOVE ELECTRONIC, ELECTROMAGNETIC AND ACCOUSTOMAGNETIC LABELS ON AND FROM PACKAGES, GOODS AND WARES (U.S. CLS. 21, 23, 26, 36 AND 38).

STEVEN R. FINE, EXAMINING ATTORNEY

**CLASS 9—(Continued).**

SN 78-750,366. CARON ENGINEERING, INC., WELLS, ME. FILED 11-9-2005.



NO CLAIM IS MADE TO THE EXCLUSIVE RIGHT TO USE "TOOL MONITORING ADAPTIVE CONTROL", APART FROM THE MARK AS SHOWN.

"THE COLOR(S) BLUE, SILVER, GRAY, WHITE AND BLACK ARE CLAIMED AS A FEATURE OF THE MARK IS/ARE CLAIMED AS A FEATURE OF THE MARK."

"THE MARK CONSISTS OF AN END MILL CUTTING BIT IN AN OVAL FRAME BESIDE THE POLISHED METAL LETTERS TMAC ABOVE THE WORDS TOOL MONITORING ADAPTIVE CONTROL ON A BRUSHED-METAL BACKGROUND, AND THE COLORS GRAY, BLACK AND SILVER APPEAR IN THE DESIGN OF THE CUTTING BIT, THE COLOR BLUE APPEARS IN THE OVAL DESIGN WITH A WHITE BORDER, THE COLOR SILVER APPEARS IN THE BACKGROUND AND THE WORDING TMAC, AND THE COLOR BLACK APPEARS IN THE WORDING TOOL MONITORING ADAPTIVE CONTROL."

FOR CIRCUIT BOARDS, TRANSDUCERS, OPERATING SOFTWARE, CABLING, MOUNTING HARDWARE FOR REAL-TIME PHYSICAL MONITORING AND ANALYSIS, AND AN ADAPTIVE CONTROL DEVICE FOR MONITORING CUTTING CONDITIONS AND REGULATING CUTTING PARAMETERS FOR CUTTING OPERATION FOR THE PURPOSE OF OPTIMIZING CUTTING CONDITIONS AND INCREASING TOOL LIFE, REPLACEMENT AND UPGRADE PARTS THEREFOR AND INSTRUCTION MANUALS SOLD AS A UNIT (U.S. CLS. 21, 23, 26, 36 AND 38).

FIRST USE 7-6-2005; IN COMMERCE 7-6-2005.

LESLEY LAMOTHE, EXAMINING ATTORNEY

SN 78-745,573. OLIVE MEDIA PRODUCTS INC., SAN FRANCISCO, CA. FILED 11-2-2005.

## olive Musica

THE MARK CONSISTS OF STANDARD CHARACTERS WITHOUT CLAIM TO ANY PARTICULAR FONT, STYLE, SIZE, OR COLOR.

OWNER OF U.S. REG. NOS. 3,032,935, 3,151,000 AND 3,151,002.

NO CLAIM IS MADE TO THE EXCLUSIVE RIGHT TO USE "MUSICA", APART FROM THE MARK AS SHOWN.

THE FOREIGN WORDING IN THE MARK TRANSLATES INTO ENGLISH AS MUSIC.

FOR COMPACT DISC PLAYERS (U.S. CLS. 21, 23, 26, 36 AND 38).

FIRST USE 6-1-2005; IN COMMERCE 8-24-2005.

NORA BUCHANAN WILL, EXAMINING ATTORNEY

SN 78-752,260. SEIKO EPSON KABUSHIKI KAISHA, TA SEIKO EPSON CORPORATION, TOKYO, JAPAN, FILED 11-11-2005.

## DFOLIO

THE MARK CONSISTS OF STANDARD CHARACTERS WITHOUT CLAIM TO ANY PARTICULAR FONT, STYLE, SIZE, OR COLOR.

PRIORITY CLAIMED UNDER SEC. 44(D) ON JAPAN APPLICATION NO. 2005-098855, FILED 10-21-2005, REG. NO. 4992321, DATED 9-29-2006, EXPIRES 9-29-2016.

FOR ELECTRONIC DISPLAY SYSTEM COMPRISING COMPUTER HARDWARE, COMPUTER OPERATING SOFTWARE, AND A MODULAR DISPLAY PANEL FOR STORING AND DISPLAYING SHEET INFORMATION IN THE NATURE OF WORKPLACE MATERIALS, CONFERENCE MATERIALS, ACCOUNTING DATA, HAND-OUTS, PROFESSIONAL MATERIALS IN THE FIELD OF MEDICINE, LAW, ACCOUNTING, AND THE LIKE, TEXTS, SPECIALIZED BOOKS AND TREATISES CONCERNING EDUCATIONAL RELATED MATTERS AND ELECTRONIC PUBLICATIONS SUCH AS NEWSPAPERS AND MAGAZINES (U.S. CLS. 21, 23, 26, 36 AND 38).

JOHN DWYER, EXAMINING ATTORNEY

**CLASS 9—(Continued).**

SN 78-752,269. SEIKO EPSON KABUSHIKI KAISHA, TA SEIKO EPSON CORPORATION, TOKYO, JAPAN, FILED 11-11-2005.

# DSHEET

THE MARK CONSISTS OF STANDARD CHARACTERS WITHOUT CLAIM TO ANY PARTICULAR FONT, STYLE, SIZE, OR COLOR.

PRIORITY CLAIMED UNDER SEC. 44(D) ON JAPAN APPLICATION NO. 2005098854, FILED 10-21-2005, REG. NO. 4992320, DATED 9-29-2006, EXPIRES 9-29-2016.

FOR ELECTRONIC DISPLAY SYSTEM COMPRISING COMPUTER HARDWARE, COMPUTER OPERATING SOFTWARE, AND A MODULAR DISPLAY PANEL FOR STORING AND DISPLAYING SHEET INFORMATION IN THE NATURE OF WORKPLACE MATERIALS, CONFERENCE MATERIALS, ACCOUNTING DATA, HAND-OUTS, PROFESSIONAL MATERIALS IN THE FIELD OF MEDICINE, LAW, ACCOUNTING, AND THE LIKE, TEXTS, SPECIALIZED BOOKS AND TREATISES CONCERNING EDUCATIONAL RELATED MATTERS AND ELECTRONIC PUBLICATIONS SUCH AS NEWSPAPERS AND MAGAZINES (U.S. CLS. 21, 23, 26, 36 AND 38).

JOHN DWYER, EXAMINING ATTORNEY

---

SN 78-760,656. AEI-CASC ENGINEERING, INC., DBA CES-LANDTEC, COLTON, CA. FILED 11-23-2005.

# Accu-Flo

THE MARK CONSISTS OF STANDARD CHARACTERS WITHOUT CLAIM TO ANY PARTICULAR FONT, STYLE, SIZE, OR COLOR.

FOR CONTROL VALVE AND FLOW MEASUREMENT DEVICE FOR THE ACCURATE AND REPEATABLE MEASUREMENT OF LANDFILL GAS COMPOSITION, CONCENTRATION AND FLOW USING A LANDTEC GEM GAS ANALYZER (U.S. CLS. 21, 23, 26, 36 AND 38).

FIRST USE 6-3-1992; IN COMMERCE 6-3-1992.

ASMAT KHAN, EXAMINING ATTORNEY

**CLASS 9—(Continued).**

SN 78-761,959. KERI SYSTEMS, INC., SAN JOSE, CA. FILED 11-28-2005.

# Video TeleTrak

THE MARK CONSISTS OF STANDARD CHARACTERS WITHOUT CLAIM TO ANY PARTICULAR FONT, STYLE, SIZE, OR COLOR.

NO CLAIM IS MADE TO THE EXCLUSIVE RIGHT TO USE "VIDEO", APART FROM THE MARK AS SHOWN.

FOR SECURITY ACCESS CONTROL AND ALARM MONITORING SYSTEM THAT ALLOWS ENTRY VIA USE OF A TELEPHONE FEATURING ELECTRIC AND ELECTRONIC VIDEO SURVEILLANCE INSTALLATION, SOLD AS A UNIT (U.S. CLS. 21, 23, 26, 36 AND 38).

SEAN CROWLEY, EXAMINING ATTORNEY

---

SN 78-761,976. KERI SYSTEMS, INC., SAN JOSE, CA. FILED 11-28-2005.

# VisionTrak

THE MARK CONSISTS OF STANDARD CHARACTERS WITHOUT CLAIM TO ANY PARTICULAR FONT, STYLE, SIZE, OR COLOR.

FOR SECURITY ACCESS CONTROL AND ALARM MONITORING SYSTEM COMPRISED OF CONTROLLERS, MICROPROCESSORS, MOTHERBOARDS, CODED CARDS, TAGS AND BADGES, AND READERS THEREFORE, MEMORY MODULES AND ASSOCIATED COMPUTER SOFTWARE FOR USE IN CONFIGURING AND MANAGING CARD ACCESS AND FOR PROVIDING A USER INTERFACE, FEATURING AN ELECTRIC AND ELECTRONIC VIDEO SURVEILLANCE INSTALLATION, SOLD AS A UNIT (U.S. CLS. 21, 23, 26, 36 AND 38).

SEAN CROWLEY, EXAMINING ATTORNEY

---

SN 78-770,308. MEDI GEEKS, L.L.C., MASON, OH. FILED 12-9-2005.

# MEDICFUSION. CONNECT. COLLECT. REPEAT. SIMPLE.

THE MARK CONSISTS OF STANDARD CHARACTERS WITHOUT CLAIM TO ANY PARTICULAR FONT, STYLE, SIZE, OR COLOR.

NO CLAIM IS MADE TO THE EXCLUSIVE RIGHT TO USE "CONNECT COLLECT REPEAT SIMPLE", APART FROM THE MARK AS SHOWN.

FOR COMPUTER SOFTWARE FOR MEDICAL PRACTICE MANAGEMENT, NAMELY FOR POPULATING, ACCESSING, MANAGING AND ANALYZING ELECTRONIC HEALTH RECORDS OR ELECTRONIC MEDICAL RECORDS (U.S. CLS. 21, 23, 26, 36 AND 38).

KATHERINE STOIDES, EXAMINING ATTORNEY

**CLASS 9—(Continued).**

SN 78-770,440. LIPINSKI SOUND, BETHESDA, MD. FILED 12-9-2005.

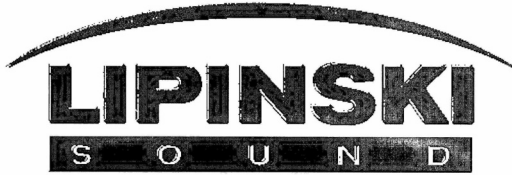

NO CLAIM IS MADE TO THE EXCLUSIVE RIGHT TO USE "SOUND", APART FROM THE MARK AS SHOWN.

FOR AUDIO EQUIPMENT, NAMELY, AMPLIFIERS, PRE-AMPLIFIERS, LOUD SPEAKER SYSTEMS, MICROPHONES, MICROPHONE PRE-AMPLIFIERS, SUB-WOOFERS, AMPLIFIED STANDS, NAMELY, A STAND CONTAINING AN AMPLIFIER, ALL FOR PROFESSIONAL AND CONSUMER USE (U.S. CLS. 21, 23, 26, 36 AND 38).

FIRST USE 10-1-2003; IN COMMERCE 10-1-2003.  
WENDY GOODMAN, EXAMINING ATTORNEY

SN 78-770,984. LINCOLN GLOBAL, INC., SANTA FE SPRINGS, CA. FILED 12-12-2005.

**POWERMAG**

THE MARK CONSISTS OF STANDARD CHARACTERS WITHOUT CLAIM TO ANY PARTICULAR FONT, STYLE, SIZE, OR COLOR.

OWNER OF U.S. REG. NOS. 615,230, 2,903,136 AND OTHERS.

FOR ELECTRIC ARC WELDERS, WELDING ELECTRODES, AND WIRE FEEDERS THEREFOR (U.S. CLS. 21, 23, 26, 36 AND 38).

DARRYL SPRUILL, EXAMINING ATTORNEY

SN 78-774,957. GAB JAMMER, INC., NEWTON, MA. FILED 12-16-2005.

**GAB JAMMER**

THE MARK CONSISTS OF STANDARD CHARACTERS WITHOUT CLAIM TO ANY PARTICULAR FONT, STYLE, SIZE, OR COLOR.

NO CLAIM IS MADE TO THE EXCLUSIVE RIGHT TO USE "JAMMER", APART FROM THE MARK AS SHOWN.

FOR COMPUTER HARDWARE AND OPERATING SOFTWARE THAT IS CAPABLE OF DETECTING THE MOTION OF A MOTOR VEHICLE AND TRANSMITTING A SIGNAL WHEN MOTION IS DETECTED TO DISABLE CELL PHONES AND WIRELESS COMMUNICATION DEVICES WITHIN THE INTERIOR OF A MOTOR VEHICLE (U.S. CLS. 21, 23, 26, 36 AND 38).

LESLEY LAMOTHE, EXAMINING ATTORNEY

**CLASS 9—(Continued).**

SN 78-775,189. CRANKING SOFTWARE INC., DAVIE, FL. FILED 12-16-2005.

**MDSSCRIPTS**

THE MARK CONSISTS OF STANDARD CHARACTERS WITHOUT CLAIM TO ANY PARTICULAR FONT, STYLE, SIZE, OR COLOR.

FOR COMPUTER SOFTWARE FOR MANAGING AND DISPENSING PRESCRIPTION PRODUCTS (U.S. CLS. 21, 23, 26, 36 AND 38).

REBECCA GAN, EXAMINING ATTORNEY

SN 78-781,430. COHEN, STUART A., KANSAS CITY, MO. FILED 12-28-2005.

**SiteCapture Pro**

THE MARK CONSISTS OF STANDARD CHARACTERS WITHOUT CLAIM TO ANY PARTICULAR FONT, STYLE, SIZE, OR COLOR.

NO CLAIM IS MADE TO THE EXCLUSIVE RIGHT TO USE "SITE CAPTURE", APART FROM THE MARK AS SHOWN.

FOR COMPUTER GRAPHICS SOFTWARE FOR CREATING SCALED DRAWINGS (U.S. CLS. 21, 23, 26, 36 AND 38).

DOMINIC FATHY, EXAMINING ATTORNEY

SN 78-787,947. LINGUASTAT, INC., PACIFICA, CA. FILED 1-9-2006.

**Virtual View**

THE MARK CONSISTS OF STANDARD CHARACTERS WITHOUT CLAIM TO ANY PARTICULAR FONT, STYLE, SIZE, OR COLOR.

NO CLAIM IS MADE TO THE EXCLUSIVE RIGHT TO USE "VIRTUAL", APART FROM THE MARK AS SHOWN.

FOR COMPUTER SOFTWARE THAT PROVIDES SOLUTIONS FOR ORGANIZING, STRUCTURING, MANAGING AND SEARCHING INFORMATION AND DATA; COMPUTER SOFTWARE FOR EXTRACTION AND RETRIEVAL OF PERSONALIZED INFORMATION; COMPUTER SOFTWARE FOR TRANSFORMING DATA AND INFORMATION INTO ALTERNATIVE REPRESENTATIONS AND PRESENTATION FORMATS FOR DISSEMINATION ON GLOBAL COMPUTER AND INFORMATION NETWORKS (U.S. CLS. 21, 23, 26, 36 AND 38).

DAWN FELDMAN, EXAMINING ATTORNEY

**CLASS 9—(Continued).**

SN 78-789,559. IGT, RENO, NV. FILED 1-11-2006.

**BONJOUR PARIS**

THE MARK CONSISTS OF STANDARD CHARACTERS WITHOUT CLAIM TO ANY PARTICULAR FONT, STYLE, SIZE, OR COLOR.

THE FOREIGN WORDING IN THE MARK TRANSLATES INTO ENGLISH AS GOOD DAY.

FOR GAMING MACHINES, NAMELY, DEVICES WHICH ACCEPT A WAGER (U.S. CLS. 21, 23, 26, 36 AND 38).

SEAN CROWLEY, EXAMINING ATTORNEY

---

SN 78-794,083. EGS, INC., WHITEHOUSE STATION, NJ. FILED 1-18-2006.

**EGAMESCORE**

THE MARK CONSISTS OF STANDARD CHARACTERS WITHOUT CLAIM TO ANY PARTICULAR FONT, STYLE, SIZE, OR COLOR.

FOR SOFTWARE FOR MANAGING, TRACKING, ANALYZING AND DISPLAYING INFORMATION RELATING TO SPORTING EVENTS AND RELATED ELECTRONIC USERS' GUIDE (U.S. CLS. 21, 23, 26, 36 AND 38).

PETER B. BROMAGHIM, EXAMINING ATTORNEY

---

SN 78-794,969. SAFFRON TECHNOLOGY, INC., MORRISVILLE, NC. FILED 1-19-2006.

**SAFFRONSCOPE**

THE MARK CONSISTS OF STANDARD CHARACTERS WITHOUT CLAIM TO ANY PARTICULAR FONT, STYLE, SIZE, OR COLOR.

OWNER OF U.S. REG. NOS. 2,870,776, 3,018,866 AND OTHERS.

FOR COMPUTER SOFTWARE APPLICATIONS AND PROGRAMS, NAMELY, COMPUTER SOFTWARE APPLICATIONS FOR DATABASE MANAGEMENT, DATA-SCRUBBING, DUPLICATE DETECTION, DATA ANALYSIS TO IDENTIFY CLUSTERS OR GROUPS OF RECORDS BASED ON SHARED CHARACTERISTICS OR ELEMENTS (U.S. CLS. 21, 23, 26, 36 AND 38).

FIRST USE 8-31-2005; IN COMMERCE 8-31-2005.  
MARIAM MAHMOUDI, EXAMINING ATTORNEY**CLASS 9—(Continued).**

SN 78-797,913. GILES, CAMERON E., NEWARK, NJ. FILED 1-24-2006.

**DIPSET**

THE MARK CONSISTS OF STANDARD CHARACTERS WITHOUT CLAIM TO ANY PARTICULAR FONT, STYLE, SIZE, OR COLOR.

FOR SERIES OF PRE-RECORDED CDS, AUDIOTAPES AND PHONOGRAPH RECORDS FEATURING MUSIC (U.S. CLS. 21, 23, 26, 36 AND 38).

FIRST USE 5-1-2002; IN COMMERCE 5-1-2002.

MELISSA VALLILLO, EXAMINING ATTORNEY

---

SN 78-798,121. SMARTSHOPPER, INC., SEVEN HILLS, OH. FILED 1-24-2006.



"THE COLOR(S) RED, BLUE, WHITE AND GRAY IS/ARE CLAIMED AS A FEATURE OF THE MARK."

"THE MARK CONSISTS OF THE LETTER 'S' IN WHITE INSIDE A BLUE CIRCLE WITH A RED OUTLINE AND THE GRAY SHADOW APPEARING UNDERNEATH THE CIRCLE."

FOR STAND ALONE COMPUTER UNITS THAT USE SPEECH RECOGNITION SOFTWARE AND COMPUTER SOFTWARE TO GENERATE AND PRINT SHOPPING LISTS (U.S. CLS. 21, 23, 26, 36 AND 38).

JENNY PARK, EXAMINING ATTORNEY

**CLASS 9—(Continued).**

SN 78-799,561. BACK BEAT, INC., IRVINE, CA. FILED 1-25-2006.



OWNER OF U.S. REG. NOS. 2,256,563 AND 2,652,247.  
FOR EYEWEAR, NAMELY, EYEGLOSS FRAMES, LENSES AND CASES, AND SUNGLASSES; PROTECTIVE EYEWEAR; SPECTACLES; EYEWEAR FOR SPORTS; PROTECTIVE AND SPORTS GOGGLES; EYEWEAR ACCESSORIES, NAMELY, STRAPS, NECK CORDS AND HEAD STRAPS FOR HOLDING SPECTACLES, AND CHAINS FOR SPECTACLES (U.S. CLS. 21, 23, 26, 36 AND 38).

ALICE SUE CARRUTHERS, EXAMINING ATTORNEY

**CLASS 9—(Continued).**

SN 78-801,358. RASH, MICHAEL B., GAMBRILLS, MD. FILED 1-27-2006.

# CIPHERDYNE

THE MARK CONSISTS OF STANDARD CHARACTERS WITHOUT CLAIM TO ANY PARTICULAR FONT, STYLE, SIZE, OR COLOR.

FOR COMPUTER SOFTWARE DEVELOPMENT TOOLS; COMPUTER SOFTWARE FOR ENCRYPTION; COMPUTER SOFTWARE FOR INTERNET FILTER LOG ANALYSIS AND INTRUSION DETECTION SYSTEM (IDS) TOOL, FOR AUTHORIZING SINGLE INTERNET PACKETS, TRANSLATING SECURITY RULES INTO EQUIVALENT INTERNET FILTER RULES, AND RECURSIVELY ENCRYPTING AND DECRYPTING WHOLE DIRECTORIES WITH ENCRYPTION SOFTWARE; DOWNLOADABLE SOFTWARE FOR INTERNET FILTER LOG ANALYSIS AND INTRUSION DETECTION SYSTEM (IDS) TOOL, FOR AUTHORIZING SINGLE INTERNET PACKETS, TRANSLATING SECURITY RULES INTO EQUIVALENT INTERNET FILTER RULES, AND RECURSIVELY ENCRYPTING AND DECRYPTING WHOLE DIRECTORIES WITH ENCRYPTION SOFTWARE (U.S. CLS. 21, 23, 26, 36 AND 38).

FIRST USE 2-24-2000; IN COMMERCE 2-24-2000.  
BRIAN PINO, EXAMINING ATTORNEY

SN 78-799,565. BACK BEAT, INC., IRVINE, CA. FILED 1-25-2006.



OWNER OF U.S. REG. NOS. 2,256,563 AND 2,652,247.  
FOR EYEWEAR, NAMELY, EYEGLOSS FRAMES, LENSES AND CASES, AND SUNGLASSES; PROTECTIVE EYEWEAR; SPECTACLES; EYEWEAR FOR SPORTS; PROTECTIVE AND SPORTS GOGGLES; EYEWEAR ACCESSORIES, NAMELY, STRAPS, NECK CORDS AND HEAD STRAPS FOR HOLDING SPECTACLES, AND CHAINS FOR SPECTACLES (U.S. CLS. 21, 23, 26, 36 AND 38).

ALICE SUE CARRUTHERS, EXAMINING ATTORNEY

SN 78-802,938. ERICKSON, MATTHEW, PAUL, LAKEWOOD, CA. FILED 1-30-2006.

# GUTTER GROOVE RECORDS

THE MARK CONSISTS OF STANDARD CHARACTERS WITHOUT CLAIM TO ANY PARTICULAR FONT, STYLE, SIZE, OR COLOR.

NO CLAIM IS MADE TO THE EXCLUSIVE RIGHT TO USE "RECORDS", APART FROM THE MARK AS SHOWN.  
FOR AUDIO RECORDINGS FEATURING MUSIC; DOWNLOADABLE MUSICAL SOUND RECORDINGS; MUSICAL SOUND RECORDINGS; PRE-RECORDED CD'S, VIDEO TAPES, LASER DISKS AND DVD'S FEATURING MUSIC (U.S. CLS. 21, 23, 26, 36 AND 38).

BARBARA BROWN, EXAMINING ATTORNEY

**CLASS 9—(Continued).**

SN 78-803,727. PESCE, KIM, WOODLAND HILLS, CA. FILED 1-31-2006.

## Kim Chambers

THE MARK CONSISTS OF STANDARD CHARACTERS WITHOUT CLAIM TO ANY PARTICULAR FONT, STYLE, SIZE, OR COLOR.

THE NAME KIM CHAMBERS IDENTIFIES A LIVING INDIVIDUAL WHOSE CONSENT IS OF RECORD.

FOR PRE-RECORDED VIDEOTAPES, AND DIGITAL VIDEO DISKS, FEATURING ADULT ORIENTED ENTERTAINMENT (U.S. CLS. 21, 23, 26, 36 AND 38).

FIRST USE 9-30-1998; IN COMMERCE 9-30-1998.

JASON BLAIR, EXAMINING ATTORNEY

---

SN 78-803,730. NOVARAD CORPORATION, AMERICAN FORK, UT. FILED 1-31-2006.

## PACS for life

THE MARK CONSISTS OF STANDARD CHARACTERS WITHOUT CLAIM TO ANY PARTICULAR FONT, STYLE, SIZE, OR COLOR.

NO CLAIM IS MADE TO THE EXCLUSIVE RIGHT TO USE "PACS", APART FROM THE MARK AS SHOWN.

FOR COMPUTER SOFTWARE FOR USE IN THE FIELDS OF MEDICAL IMAGING, RADIOLOGICAL IMAGING, DIGITAL IMAGING, MEDICAL IMAGING SYSTEMS, RADIOLOGICAL IMAGING SYSTEMS, DIGITAL IMAGING SYSTEMS, PICTURE ARCHIVING COMMUNICATION SYSTEMS, NUCLEAR MEDICINE, MAGNETIC RESONANCE IMAGING, ULTRA SOUND, COMPUTED RADIOLOGY MODALITIES, ENTERING MEDICAL AND PATIENT DATA, STORING MEDICAL AND PATIENT DATA, ARCHIVING MEDICAL AND PATIENT DATA, REPORTING MEDICAL AND PATIENT DATA, TRANSMITTING MEDICAL AND PATIENT DATA, AND ACQUIRING, CAPTURING, RETRIEVING, ORGANIZING, TRACKING, ANALYZING, VIEWING, ENLARGING, ROTATING, MODIFYING, ANNOTATING, STORING, SECURING, DUPLICATING, PRINTING AND TRANSMITTING RADIOLOGICAL IMAGES (U.S. CLS. 21, 23, 26, 36 AND 38).

GRETTA YAO, EXAMINING ATTORNEY

**CLASS 9—(Continued).**

SN 78-804,489. HILLCREST LABORATORIES, INC., ROCKVILLE, MA. FILED 2-1-2006.

## SPONTANEOUS NAVIGATION

THE MARK CONSISTS OF STANDARD CHARACTERS WITHOUT CLAIM TO ANY PARTICULAR FONT, STYLE, SIZE, OR COLOR.

NO CLAIM IS MADE TO THE EXCLUSIVE RIGHT TO USE "NAVIGATION", APART FROM THE MARK AS SHOWN.

FOR COMPUTER HARDWARE AND COMPUTER SOFTWARE FOR PROGRAMMING, SEARCHING, RECORDING, PLAYING, TRANSMITTING AND DOWNLOADING ENTERTAINMENT MEDIA FOR PERSONALIZED, INTERACTIVE ENTERTAINMENT PROGRAMMING, AND ACCOMPANYING MANUALS SOLD AS A UNIT; COMPUTER SOFTWARE FOR ORGANIZING DATA AND INFORMATION IN THE FORM OF ELECTRONIC CALENDARS AND ORGANIZERS; COMPUTER SOFTWARE AND COMPUTER PERIPHERALS FOR PERSONALIZED, INTERACTIVE ENTERTAINMENT PROGRAMMING PROMOTING THE SALE OF GOODS AND SERVICES OF OTHERS; COMPUTER SOFTWARE FOR PROVIDING AN ONLINE NETWORK GUIDE TO PERSONALIZED AND INTERACTIVE ENTERTAINMENT PROGRAMMING; COMPUTER SOFTWARE FOR PROVIDING AN ON SCREEN, INTERACTIVE GUIDE FOR SELECTING, ADMINISTERING AND MAINTAINING PERSONALIZED ENTERTAINMENT PROGRAMMING (U.S. CLS. 21, 23, 26, 36 AND 38).

JESSICA A. POWERS, EXAMINING ATTORNEY

---

SN 78-805,565. ULTRAVISION SECURITY SYSTEMS, INC., NORTH SALEM, NH. FILED 2-2-2006.

## LifeLocator

THE MARK CONSISTS OF STANDARD CHARACTERS WITHOUT CLAIM TO ANY PARTICULAR FONT, STYLE, SIZE, OR COLOR.

FOR HANDHELD COMPUTER DEVICE AND WIRELESS SENSOR USED FOR LOCATING LIVING VICTIMS IN BUILDING DEBRIS, MUDSLIDES, AVALANCHES, DISASTER WRECKAGE, AND SIMILAR CIRCUMSTANCES (U.S. CLS. 21, 23, 26, 36 AND 38).

FIRST USE 11-1-2005; IN COMMERCE 11-14-2005.

SARAH WAYDA, EXAMINING ATTORNEY

**CLASS 9—(Continued).**

SN 78-805,728. THOMAS KEYMASTER LANGUAGES LLC, NEW YORK, NY. FILED 2-2-2006.

**CLASS 9—(Continued).**

SN 78-807,145. ROBERT E HOWARD PROPERTIES INC., BEVERLY HILLS, CA. FILED 2-3-2006.

# MICHEL THOMAS

# ROBERT E. HOWARD

THE MARK CONSISTS OF STANDARD CHARACTERS WITHOUT CLAIM TO ANY PARTICULAR FONT, STYLE, SIZE, OR COLOR.

THE NAME MICHEL THOMAS DOES NOT IDENTIFY A LIVING INDIVIDUAL.

FOR EDUCATIONAL AND INSTRUCTIVE AUDIO RECORDINGS IN THE FIELD OF LANGUAGES (U.S. CLS. 21, 23, 26, 36 AND 38).

FIRST USE 11-20-2006; IN COMMERCE 11-20-2006.  
JORDAN BAKER, EXAMINING ATTORNEY

THE MARK CONSISTS OF STANDARD CHARACTERS WITHOUT CLAIM TO ANY PARTICULAR FONT, STYLE, SIZE, OR COLOR.

THE NAME(S), PORTRAIT(S), AND/OR SIGNATURE(S) SHOWN IN THE MARK DOES NOT IDENTIFY A PARTICULAR LIVING INDIVIDUAL.

FOR INTERACTIVE ELECTRONIC VIDEO GAME SOFTWARE, VIDEO GAME FIRMWARE AND COMPUTER GAME PROGRAMS; DOWNLOADABLE INTERACTIVE ELECTRONIC VIDEO GAME SOFTWARE, VIDEO GAME FIRMWARE AND COMPUTER GAME PROGRAMS; MOTION PICTURE FILMS, LIVE-ACTION AND ANIMATED, FEATURING FICTIONAL CHARACTERS IN COMIC, DRAMATIC, FANTASY, HORROR, ACTION AND ADVENTURE STORIES; MOTION PICTURE FILMS FEATURING NON-FICTIONAL CHARACTERS IN DOCUMENTARY, HISTORICAL AND DRAMATIC STORIES; PRE-RECORDED COMPACT DISCS, VIDEO TAPES, LASER DISCS, OPTICAL DISCS, DIGITAL VIDEO DISCS AND FIRMWARE FOR PLAYING AUDIOVISUAL CONTENT FEATURING FICTIONAL CHARACTERS IN LIVE-ACTION OR ANIMATED COMIC, DRAMATIC, FANTASY, HORROR, ACTION AND ADVENTURE STORIES; PRE-RECORDED COMPACT DISCS, VIDEO TAPES, LASER DISCS, OPTICAL DISCS, DIGITAL VIDEO DISCS AND FIRMWARE FOR PLAYING AUDIOVISUAL CONTENT FEATURING NON-FICTIONAL CHARACTERS IN DOCUMENTARY, HISTORICAL AND DRAMATIC STORIES; DOWNLOADABLE MULTI-MEDIA FILES CONTAINING SOUND, PICTURES, TEXT AND GRAPHIC MATERIAL, NAMELY, LIVE ACTION OR ANIMATED MOTION PICTURES, MOTION PICTURE TRAILERS, VIDEOS AND TELEVISION SHOWS FEATURING FICTIONAL CHARACTERS IN COMIC, DRAMATIC, FANTASY, HORROR, ACTION AND ADVENTURE STORIES; DOWNLOADABLE MULTI-MEDIA FILES CONTAINING SOUND, PICTURES, TEXT AND GRAPHIC MATERIAL, NAMELY, LIVE ACTION OR ANIMATED MOTION PICTURES, MOTION PICTURE TRAILERS, VIDEOS AND TELEVISION SHOWS FEATURING NON-FICTIONAL CHARACTERS IN DOCUMENTARY, HISTORICAL AND DRAMATIC STORIES; AUDIO DISCS, AUDIO TAPES, DIGITAL AUDIO TAPES, COMPACT DISCS AND DIGITAL DOWNLOADABLE AUDIO FILES FEATURING MUSIC, STORIES, POETRY AND EDUCATIONAL CONTENT RELATED TO FICTIONAL FANTASY CHARACTERS AND CREATORS OF FICTIONAL FANTASY CHARACTERS; DOWNLOADABLE ELECTRONIC PUBLICATIONS, NAMELY, BOOKS, SHORT STORIES, COMIC BOOKS, GRAPHIC NOVELS, MAGAZINES, NEWS ARTICLES, NEWSLETTERS AND ESSAYS ABOUT FICTIONAL CHARACTERS IN COMIC, DRAMATIC, FANTASY, HORROR, ACTION AND ADVENTURE STORIES; DOWNLOADABLE ELECTRONIC PUBLICATIONS, NAMELY, BOOKS, SHORT STORIES, COMIC BOOKS, GRAPHIC NOVELS, MAGAZINES, NEWS ARTICLES, NEWSLETTERS AND ESSAYS ABOUT NON-FICTIONAL CHARACTERS IN DOCUMENTARY, HISTORICAL AND DRAMATIC STORIES (U.S. CLS. 21, 23, 26, 36 AND 38).

KAREN K. BUSH, EXAMINING ATTORNEY

SN 78-806,956. 2GEEKSINALAB INC., PALMDALE, CA. FILED 2-3-2006.

# Global Garde

THE MARK CONSISTS OF STANDARD CHARACTERS WITHOUT CLAIM TO ANY PARTICULAR FONT, STYLE, SIZE, OR COLOR.

NO CLAIM IS MADE TO THE EXCLUSIVE RIGHT TO USE "GLOBAL", APART FROM THE MARK AS SHOWN.

FOR COMPUTER SOFTWARE TO CONTROL ACCESS, DUPLICATION, FILE SHARING, AND TRANSMISSION OF DIGITAL TEXT, IMAGES, MUSIC, OR DATA CONTENT (U.S. CLS. 21, 23, 26, 36 AND 38).

DANIEL CAPSHAW, EXAMINING ATTORNEY

**CLASS 9—(Continued).**

SN 78-807,185. ROBERT E HOWARD PROPERTIES INC., BEVERLY HILLS, CA. FILED 2-3-2006.

**STEVE COSTIGAN**

THE MARK CONSISTS OF STANDARD CHARACTERS WITHOUT CLAIM TO ANY PARTICULAR FONT, STYLE, SIZE, OR COLOR.

THE NAME(S), PORTRAIT(S), AND/OR SIGNATURE(S) SHOWN IN THE MARK DOES NOT IDENTIFY A PARTICULAR LIVING INDIVIDUAL.

FOR INTERACTIVE ELECTRONIC VIDEO GAME SOFTWARE, VIDEO GAME FIRMWARE AND COMPUTER GAME PROGRAMS; DOWNLOADABLE INTERACTIVE ELECTRONIC VIDEO GAME SOFTWARE, VIDEO GAME FIRMWARE AND COMPUTER GAME PROGRAMS; MOTION PICTURE FILMS, LIVE-ACTION AND ANIMATED, FEATURING FICTIONAL CHARACTERS IN COMIC, DRAMATIC, FANTASY, HORROR, ACTION AND ADVENTURE STORIES; MOTION PICTURE FILMS FEATURING NON-FICTIONAL CHARACTERS IN DOCUMENTARY, HISTORICAL AND DRAMATIC STORIES; PRE-RECORDED COMPACT DISCS, VIDEO TAPES, LASER DISCS, OPTICAL DISCS, DIGITAL VIDEO DISCS AND FIRMWARE FOR PLAYING AUDIOVISUAL CONTENT FEATURING FICTIONAL CHARACTERS IN LIVE-ACTION OR ANIMATED COMIC, DRAMATIC, FANTASY, HORROR, ACTION AND ADVENTURE STORIES; PRE-RECORDED COMPACT DISCS, VIDEO TAPES, LASER DISCS, OPTICAL DISCS, DIGITAL VIDEO DISCS AND FIRMWARE FOR PLAYING AUDIOVISUAL CONTENT FEATURING NON-FICTIONAL CHARACTERS IN DOCUMENTARY, HISTORICAL AND DRAMATIC STORIES; DOWNLOADABLE MULTI-MEDIA FILES CONTAINING SOUND, PICTURES, TEXT AND GRAPHIC MATERIAL, NAMELY, LIVE ACTION OR ANIMATED MOTION PICTURES, MOTION PICTURE TRAILERS, VIDEOS AND TELEVISION SHOWS FEATURING FICTIONAL CHARACTERS IN COMIC, DRAMATIC, FANTASY, HORROR, ACTION AND ADVENTURE STORIES; DOWNLOADABLE MULTI-MEDIA FILES CONTAINING SOUND, PICTURES, TEXT AND GRAPHIC MATERIAL, NAMELY, LIVE ACTION OR ANIMATED MOTION PICTURES, MOTION PICTURE TRAILERS, VIDEOS AND TELEVISION SHOWS FEATURING NON-FICTIONAL CHARACTERS IN DOCUMENTARY, HISTORICAL AND DRAMATIC STORIES; AUDIO DISCS, AUDIO TAPES, DIGITAL AUDIO TAPES, COMPACT DISCS AND DIGITAL DOWNLOADABLE AUDIO FILES FEATURING MUSIC, STORIES, POETRY AND EDUCATIONAL CONTENT RELATED TO FICTIONAL FANTASY CHARACTERS AND CREATORS OF FICTIONAL FANTASY CHARACTERS; DOWNLOADABLE ELECTRONIC PUBLICATIONS, NAMELY, BOOKS, SHORT STORIES, COMIC BOOKS, GRAPHIC NOVELS, MAGAZINES, NEWS ARTICLES, NEWSLETTERS AND ESSAYS ABOUT FICTIONAL CHARACTERS IN COMIC, DRAMATIC, FANTASY, HORROR, ACTION AND ADVENTURE STORIES; DOWNLOADABLE ELECTRONIC PUBLICATIONS, NAMELY, BOOKS, SHORT STORIES, COMIC BOOKS, GRAPHIC NOVELS, MAGAZINES, NEWS ARTICLES, NEWSLETTERS AND ESSAYS ABOUT NON-FICTIONAL CHARACTERS IN DOCUMENTARY, HISTORICAL AND DRAMATIC STORIES (U.S. CLS. 21, 23, 26, 36 AND 38).

KAREN K. BUSH, EXAMINING ATTORNEY

**CLASS 9—(Continued).**

SN 78-807,196. ROBERT E HOWARD PROPERTIES INC., BEVERLY HILLS, CA. FILED 2-3-2006.

**BRAN MAK MORN**

THE MARK CONSISTS OF STANDARD CHARACTERS WITHOUT CLAIM TO ANY PARTICULAR FONT, STYLE, SIZE, OR COLOR.

THE NAME(S), PORTRAIT(S), AND/OR SIGNATURE(S) SHOWN IN THE MARK DOES NOT IDENTIFY A PARTICULAR LIVING INDIVIDUAL.

FOR INTERACTIVE ELECTRONIC VIDEO GAME SOFTWARE, VIDEO GAME FIRMWARE AND COMPUTER GAME PROGRAMS; DOWNLOADABLE INTERACTIVE ELECTRONIC VIDEO GAME SOFTWARE, VIDEO GAME FIRMWARE AND COMPUTER GAME PROGRAMS; MOTION PICTURE FILMS, LIVE-ACTION AND ANIMATED, FEATURING FICTIONAL CHARACTERS IN COMIC, DRAMATIC, FANTASY, HORROR, ACTION AND ADVENTURE STORIES; MOTION PICTURE FILMS FEATURING NON-FICTIONAL CHARACTERS IN DOCUMENTARY, HISTORICAL AND DRAMATIC STORIES; PRE-RECORDED COMPACT DISCS, VIDEO TAPES, LASER DISCS, OPTICAL DISCS, DIGITAL VIDEO DISCS AND FIRMWARE FOR PLAYING AUDIOVISUAL CONTENT FEATURING FICTIONAL CHARACTERS IN LIVE-ACTION OR ANIMATED COMIC, DRAMATIC, FANTASY, HORROR, ACTION AND ADVENTURE STORIES; PRE-RECORDED COMPACT DISCS, VIDEO TAPES, LASER DISCS, OPTICAL DISCS, DIGITAL VIDEO DISCS AND FIRMWARE FOR PLAYING AUDIOVISUAL CONTENT FEATURING NON-FICTIONAL CHARACTERS IN DOCUMENTARY, HISTORICAL AND DRAMATIC STORIES; DOWNLOADABLE MULTI-MEDIA FILES CONTAINING SOUND, PICTURES, TEXT AND GRAPHIC MATERIAL, NAMELY, LIVE ACTION OR ANIMATED MOTION PICTURES, MOTION PICTURE TRAILERS, VIDEOS AND TELEVISION SHOWS FEATURING FICTIONAL CHARACTERS IN COMIC, DRAMATIC, FANTASY, HORROR, ACTION AND ADVENTURE STORIES; DOWNLOADABLE MULTI-MEDIA FILES CONTAINING SOUND, PICTURES, TEXT AND GRAPHIC MATERIAL, NAMELY, LIVE ACTION OR ANIMATED MOTION PICTURES, MOTION PICTURE TRAILERS, VIDEOS AND TELEVISION SHOWS FEATURING NON-FICTIONAL CHARACTERS IN DOCUMENTARY, HISTORICAL AND DRAMATIC STORIES; AUDIO DISCS, AUDIO TAPES, DIGITAL AUDIO TAPES, COMPACT DISCS AND DIGITAL DOWNLOADABLE AUDIO FILES FEATURING MUSIC, STORIES, POETRY AND EDUCATIONAL CONTENT RELATED TO FICTIONAL FANTASY CHARACTERS AND CREATORS OF FICTIONAL FANTASY CHARACTERS; DOWNLOADABLE ELECTRONIC PUBLICATIONS, NAMELY, BOOKS, SHORT STORIES, COMIC BOOKS, GRAPHIC NOVELS, MAGAZINES, NEWS ARTICLES, NEWSLETTERS AND ESSAYS ABOUT FICTIONAL CHARACTERS IN COMIC, DRAMATIC, FANTASY, HORROR, ACTION AND ADVENTURE STORIES; DOWNLOADABLE ELECTRONIC PUBLICATIONS, NAMELY, BOOKS, SHORT STORIES, COMIC BOOKS, GRAPHIC NOVELS, MAGAZINES, NEWS ARTICLES, NEWSLETTERS AND ESSAYS ABOUT NON-FICTIONAL CHARACTERS IN DOCUMENTARY, HISTORICAL AND DRAMATIC STORIES (U.S. CLS. 21, 23, 26, 36 AND 38).

KAREN K. BUSH, EXAMINING ATTORNEY



**CLASS 9—(Continued).**

SN 78-807,736. DISNEY ENTERPRISES, INC., BURBANK, CA. FILED 2-6-2006.

**MY FRIENDS TIGGER & POOH**

THE MARK CONSISTS OF STANDARD CHARACTERS WITHOUT CLAIM TO ANY PARTICULAR FONT, STYLE, SIZE, OR COLOR.

OWNER OF U.S. REG. NOS. 2,257,705, 3,024,286 AND OTHERS.

FOR AUDIO CASSETTE RECORDERS; AUDIO CASSETTE PLAYERS; PRE-RECORDED AUDIO CASSETTES, AUDIO DISCS AND COMPACT DISCS FEATURING MUSIC, STORIES AND GAMES FOR CHILDREN; AUDIO SPEAKERS; BINOCULARS; CALCULATORS; CAMCORDERS; CAMERAS; PRE-RECORDED CD-ROMS FEATURING COMPUTER GAMES AND ACTIVITIES FOR CHILDREN; CD-ROM DRIVES; CD-ROM WRITERS; CELLULAR TELEPHONES; CELLULAR TELEPHONE ACCESSORIES, NAMELY, BATTERIES FOR CELLULAR TELEPHONES, HEADSETS FOR CELLULAR TELEPHONES AND EARPHONES FOR CELLULAR TELEPHONES; CELLULAR TELEPHONE CASES; FACE PLATES FOR CELLULAR TELEPHONES; COMPACT DISC PLAYERS; COMPACT DISC RECORDERS; COMPUTER GAME PROGRAMS; COMPUTER GAME CARTRIDGES AND DISCS; COMPUTERS; COMPUTER HARDWARE; COMPUTER KEYBOARDS; COMPUTER MONITORS; COMPUTER MOUSE; COMPUTER DISC DRIVES; CORDLESS TELEPHONES; DECORATIVE MAGNETS; DIGITAL CAMERAS; PRE-RECORDED DVDS, VIDEO CASSETTES, DIGITAL VERSATILE DISCS AND DIGITAL VIDEO DISCS FEATURING LIVE ACTION AND ANIMATED ENTERTAINMENT FOR CHILDREN, MOTION PICTURE FILMS, AND TELEVISION SHOWS; DVD PLAYERS; DVD RECORDERS; ELECTRONIC PERSONAL ORGANIZERS; EYEGLASS CASES; EYEGLASSES; HEADPHONES; KARAOKE MACHINES; MICROPHONES; MP3 PLAYERS; COMPUTER MODEMS; MOUSE PADS; MOTION PICTURE FILMS, FEATURING ANIMATED ENTERTAINMENT, PAGERS; PERSONAL STEREO; PERSONAL DIGITAL ASSISTANTS; PRINTERS; RADIOS; SUNGLASSES; TELEPHONES; TELEVISION SETS; VIDEO CAMERAS; VIDEO CASSETTE RECORDERS; VIDEO CASSETTE PLAYERS; VIDEO GAME CARTRIDGES; VIDEO GAME DISCS; VIDEOPHONES; WALKIE-TALKIES; WRIST AND ARM RESTS FOR USE WITH COMPUTERS (U.S. CLS. 21, 23, 26, 36 AND 38).

REBECCA GAN, EXAMINING ATTORNEY

**CLASS 9—(Continued).**

SN 78-807,758. DISNEY ENTERPRISES, INC., BURBANK, CA. FILED 2-6-2006.

**PHINEAS AND FERB**

THE MARK CONSISTS OF STANDARD CHARACTERS WITHOUT CLAIM TO ANY PARTICULAR FONT, STYLE, SIZE, OR COLOR.

FOR AUDIO CASSETTE RECORDERS; AUDIO CASSETTE PLAYERS; PRE-RECORDED AUDIO CASSETTES, AUDIO DISCS AND COMPACT DISCS FEATURING MUSIC, STORIES AND GAMES FOR CHILDREN; AUDIO SPEAKERS; BINOCULARS; CALCULATORS; CAMCORDERS; CAMERAS; PRE-RECORDED CD-ROMS FEATURING COMPUTER GAMES AND ACTIVITIES FOR CHILDREN; CD-ROM DRIVES; CD-ROM WRITERS; CELLULAR TELEPHONES; CELLULAR TELEPHONE ACCESSORIES, NAMELY, BATTERIES FOR CELLULAR TELEPHONES, HEADSETS FOR CELLULAR TELEPHONES AND EARPHONES FOR CELLULAR TELEPHONES; CELLULAR TELEPHONE CASES; FACE PLATES FOR CELLULAR TELEPHONES; COMPACT DISC PLAYERS; COMPACT DISC RECORDERS; COMPUTER GAME PROGRAMS; COMPUTER GAME CARTRIDGES AND DISCS; COMPUTERS; COMPUTER HARDWARE; COMPUTER KEYBOARDS; COMPUTER MONITORS; COMPUTER MOUSE; COMPUTER DISC DRIVES; CORDLESS TELEPHONES; DECORATIVE MAGNETS; DIGITAL CAMERAS; PRE-RECORDED DVDS, VIDEO CASSETTES, DIGITAL VERSATILE DISCS AND DIGITAL VIDEO DISCS FEATURING LIVE ACTION AND ANIMATED ENTERTAINMENT FOR CHILDREN, MOTION PICTURE FILMS, AND TELEVISION SHOWS; DVD PLAYERS; DVD RECORDERS; ELECTRONIC PERSONAL ORGANIZERS; EYEGLASS CASES; EYEGLASSES; HEADPHONES; KARAOKE MACHINES; MICROPHONES; MP3 PLAYERS; MODEMS (AS PART OF A COMPUTER); MOUSE PADS; MOTION PICTURE FILMS, FEATURING ANIMATED ENTERTAINMENT, ACTION-ADVENTURE, LIVE-ACTION, COMEDY, MUSICALS, DRAMA AND DOCUMENTARIES; PAGERS; PERSONAL STEREO; PERSONAL DIGITAL ASSISTANTS; PRINTERS; RADIOS; SUNGLASSES; TELEPHONES; TELEVISION SETS; VIDEO CAMERAS; VIDEO CASSETTE RECORDERS; VIDEO CASSETTE PLAYERS; VIDEO GAME CARTRIDGES; VIDEO GAME DISCS; VIDEOPHONES; WALKIE-TALKIES; WRIST AND ARM RESTS FOR USE WITH COMPUTERS (U.S. CLS. 21, 23, 26, 36 AND 38).

REBECCA GAN, EXAMINING ATTORNEY

SN 78-807,877. TODD, EMORY, S., NEW YORK, NY, AND HODULICH, MARC, NEW YORK, NY. FILED 2-6-2006.

**Crawleeze**

THE MARK CONSISTS OF STANDARD CHARACTERS WITHOUT CLAIM TO ANY PARTICULAR FONT, STYLE, SIZE, OR COLOR.

FOR PROTECTIVE CLOTHING (U.S. CLS. 21, 23, 26, 36 AND 38).

DAVID YONTEF, EXAMINING ATTORNEY

**CLASS 9—(Continued).**

SN 78-808,290. AUTOMATION, INC., DBA PCAMERICA, PEARL RIVER, NY. FILED 2-6-2006.



NO CLAIM IS MADE TO THE EXCLUSIVE RIGHT TO USE "CASH REGISTER EXPRESS POINT OF SALE SOLUTION FOR RETAIL", APART FROM THE MARK AS SHOWN.

THE COLOR(S) BLUE, ORANGE, GREY AND WHITE IS/ ARE CLAIMED AS A FEATURE OF THE MARK.

THE MARK CONSISTS OF FOUR SQUARES COMPRISING QUARTERS OF A LARGER SQUARE— TOP LEFT SQUARE IS BLUE WITH WHITE PICTURE OF A GIFT WRAPPED BOX ICON INSIDE, TOP RIGHT SQUARE IS BLUE WITH WHITE SHOPPING CART ICON INSIDE, BOTTOM LEFT SQUARE IS BLUE WITH WHITE BOOK ICON INSIDE AND BOTTOM RIGHT SQUARE IS ORANGE WITH WHITE ARROW POINTING TO THE RIGHT. TO THE RIGHT OF THE FOUR-SQUARE AGGREGATE SQUARE IS A BLUE WORDS, "CASH REGISTER" WITH ORANGE ITALICS "EXPRESS" IMMEDIATELY TO THE RIGHT. UNDERNEATH THESE WORDS ARE THE GREY WORDS, "POINT OF SALE SOLUTION FOR RETAIL".

FOR COMPUTER HARDWARE AND SOFTWARE FOR POINT OF SALE PROCESSING FOR RETAIL STORES (U.S. CLS. 21, 23, 26, 36 AND 38).

DAVID I, EXAMINING ATTORNEY

**CLASS 9—(Continued).**

SN 78-808,640. INTERTISE INCORPORATED, WESTON, FL. FILED 2-7-2006.



THE APPLICANT CLAIMS COLOR AS A FEATURE OF THE MARK, NAMELY, DARK BLUE, CYAN.

THE MARK CONSISTS OF A DUAL BLUE ONE WORD LOGO. VISION IS DARK BLUE, CAST IS IN CYAN OR LIGHT BLUE.

FOR COMPUTER SOFTWARE FOR MANAGING AND OPERATING DIGITAL SIGNS WITH BOTH INTRANET AND INTERNET NETWORK CAPABILITIES (U.S. CLS. 21, 23, 26, 36 AND 38).

FIRST USE 3-1-2004; IN COMMERCE 10-1-2005.

TARAH HARDY, EXAMINING ATTORNEY

SN 78-809,014. 2GEEKSINALAB INC., PALMDALE, CA. FILED 2-7-2006.

SN 78-808,305. AUTOMATION, INC. D/B/A PCAMERICA, PEARL RIVER, NY. FILED 2-6-2006.



NO CLAIM IS MADE TO THE EXCLUSIVE RIGHT TO USE "RESTAURANT PRO EXPRESS POINT OF SALE SOLUTION FOR RESTAURANTS", APART FROM THE MARK AS SHOWN.

THE COLOR(S) RED, ORANGE, GREY AND WHITE IS/ ARE CLAIMED AS A FEATURE OF THE MARK.

THE MARK CONSISTS OF FOUR SQUARES COMPRISING QUARTERS OF A LARGER SQUARE— TOP LEFT SQUARE IS RED WITH WHITE COFFEE CUP ICON INSIDE, TOP RIGHT SQUARE IS RED WITH WHITE FORK AND KNIFE ICON INSIDE, BOTTOM LEFT SQUARE IS RED WITH WHITE PIZZA SLICE ICON INSIDE AND BOTTOM RIGHT SQUARE IS ORANGE WITH WHITE ARROW POINTING TO THE RIGHT. TO THE RIGHT OF THE FOUR-SQUARE AGGREGATE SQUARE ARE RED WORDS, "RESTAURANT PRO" WITH ORANGE ITALICS "EXPRESS" IMMEDIATELY TO THE RIGHT. UNDERNEATH THESE WORDS ARE THE GREY WORDS, "POINT OF SALE SOLUTION FOR RESTAURANTS".

FOR COMPUTER HARDWARE AND SOFTWARE FOR POINT OF SALE PROCESSING FOR RESTAURANTS (U.S. CLS. 21, 23, 26, 36 AND 38).

DAVID I, EXAMINING ATTORNEY



**GLOBAL GARDE**

NO CLAIM IS MADE TO THE EXCLUSIVE RIGHT TO USE "GLOBAL", APART FROM THE MARK AS SHOWN.

"THE COLOR(S) BLACK, BLUE, WHITE, AND GREY IS/ ARE CLAIMED AS A FEATURE OF THE MARK."

THE IMAGE OF THE EARTH IS BLUE AND WHITE WITHIN A LARGE GREY CIRCLE; THE INNER CIRCLE IS GREY; THE WORDING IN THE MARK IS BLACK.

THE MARK CONSISTS OF CONCENTRIC CIRCLES COMPRISING OF FIRST A NARROW SMALL GRAY CIRCLE WITHIN A LARGE WIDE CIRCLE WITH THE IMAGE OF EARTH FROM SPACE IN BLUE AND WHITE WITHIN A LARGE NARROW GRAY CIRCLE; "GLOBAL GARDE" IN ITALIC PADALOMA FONT.

FOR COMPUTER SOFTWARE TO CONTROL ACCESS, DUPLICATION, FILE SHARING, AND TRANSMISSION OF DIGITAL TEXT, IMAGES, MUSIC, OR DATA CONTENT (U.S. CLS. 21, 23, 26, 36 AND 38).

DANIEL CAPSHAW, EXAMINING ATTORNEY

**CLASS 9—(Continued).**

SN 78-811,670. EPSILON ELECTRONICS, INC., MONTEBELLO, CA. FILED 2-9-2006.

# K KOLE AUDIO

THE MARK CONSISTS OF STANDARD CHARACTERS WITHOUT CLAIM TO ANY PARTICULAR FONT, STYLE, SIZE, OR COLOR.

NO CLAIM IS MADE TO THE EXCLUSIVE RIGHT TO USE "AUDIO", APART FROM THE MARK AS SHOWN.

FOR AMPLIFIERS; AUDIO SPEAKERS; AUDIO EQUALIZERS; TWEETERS; AMPLIFIER WIRING KITS COMPRISED OF STEREO CABLES, CONNECTING ELECTRICAL CABLES, FUSES AND FUSE HOLDERS; POWER CAPACITORS; AND WOOFERS (U.S. CLS. 21, 23, 26, 36 AND 38).

FIRST USE 0-0-2002; IN COMMERCE 0-0-2002.  
TARAH HARDY, EXAMINING ATTORNEY

**CLASS 9—(Continued).**

SN 78-812,489. JUPITERBAY, INC., SCHAUMBURG, IL. FILED 2-10-2006.

# BUILDPORT

THE MARK CONSISTS OF STANDARD CHARACTERS WITHOUT CLAIM TO ANY PARTICULAR FONT, STYLE, SIZE, OR COLOR.

FOR COMPUTER SOFTWARE FOR CONSTRUCTION COLLABORATION AND PROJECT MANAGEMENT (U.S. CLS. 21, 23, 26, 36 AND 38).

FIRST USE 8-0-2003; IN COMMERCE 8-0-2003.  
JASON TURNER, EXAMINING ATTORNEY

SN 78-811,678. EPSILON ELECTRONICS, INC., MONTEBELLO, CA. FILED 2-9-2006.

# KOLE

THE MARK CONSISTS OF STANDARD CHARACTERS WITHOUT CLAIM TO ANY PARTICULAR FONT, STYLE, SIZE, OR COLOR.

FOR AMPLIFIERS; AUDIO SPEAKERS; AUDIO EQUALIZERS; TWEETERS; AMPLIFIER WIRING KITS COMPRISED OF STEREO CABLES, ELECTRICAL CONNECTING CABLES, FUSES AND FUSE HOLDERS; POWER CAPACITORS; AND WOOFERS (U.S. CLS. 21, 23, 26, 36 AND 38).

FIRST USE 0-0-2002; IN COMMERCE 0-0-2002.  
TARAH HARDY, EXAMINING ATTORNEY

SN 78-813,452. RICOH COMPANY, LTD., TOKYO, JAPAN. FILED 2-13-2006.

# OMNI CANVAS

THE MARK CONSISTS OF STANDARD CHARACTERS WITHOUT CLAIM TO ANY PARTICULAR FONT, STYLE, SIZE, OR COLOR.

OWNER OF JAPAN REG. NO. 4980012, DATED 8-18-2006, EXPIRES 8-18-2016.

FOR PERSONAL COMPUTERS WITH TOUCH PANEL DISPLAY AND OPERATING SOFTWARE (U.S. CLS. 21, 23, 26, 36 AND 38).

FLORENTINA BLANDU, EXAMINING ATTORNEY

SN 78-811,686. EPSILON ELECTRONICS, INC., MONTEBELLO, CA. FILED 2-9-2006.



FOR AMPLIFIERS; AUDIO SPEAKERS; AUDIO EQUALIZERS; TWEETERS; AMPLIFIER WIRING KITS COMPRISED OF STEREO CABLES, CONNECTING ELECTRICAL CABLES, FUSES AND FUSE HOLDERS; POWER CAPACITORS; AND WOOFERS (U.S. CLS. 21, 23, 26, 36 AND 38).

FIRST USE 0-0-2002; IN COMMERCE 0-0-2002.  
TARAH HARDY, EXAMINING ATTORNEY

SN 78-813,945. PHIL'S FONTS, INC., SANDY SPRING, MD. FILED 2-14-2006.

# FREIGHT

THE MARK CONSISTS OF STANDARD CHARACTERS WITHOUT CLAIM TO ANY PARTICULAR FONT, STYLE, SIZE, OR COLOR.

FOR DIGITIZED SCALABLE TYPEFACE FONTS RECORDED ON COMPUTER MEDIA OR DOWNLOADABLE ON GLOBAL COMPUTER NETWORK; AND COMPUTER PROGRAMS THAT PRODUCE DIGITIZED SCALABLE TYPEFACE FONTS (U.S. CLS. 21, 23, 26, 36 AND 38).

FIRST USE 9-0-2002; IN COMMERCE 7-0-2003.  
GISELLE AGOSTO, EXAMINING ATTORNEY

**CLASS 9—(Continued).**

SN 78-814,926. ROCKET GAMING SYSTEMS, LLC, LAS VEGAS, NV. FILED 2-14-2006.

# BIG RIG

THE MARK CONSISTS OF STANDARD CHARACTERS WITHOUT CLAIM TO ANY PARTICULAR FONT, STYLE, SIZE, OR COLOR.

FOR GAMING MACHINES, NAMELY, BINGO-RELATED GAMES AND SLOT MACHINES (U.S. CLS. 21, 23, 26, 36 AND 38).

ANDREA SAUNDERS, EXAMINING ATTORNEY

SN 78-815,397. CRYTEK GMBH, FRANKFURT AM MAIN, FED REP GERMANY, FILED 2-15-2006.

# CRYME

THE MARK CONSISTS OF STANDARD CHARACTERS WITHOUT CLAIM TO ANY PARTICULAR FONT, STYLE, SIZE, OR COLOR.

PRIORITY CLAIMED UNDER SEC. 44(D) ON FED REP GERMANY APPLICATION NO. 30549119.9, FILED 8-17-2005, REG. NO. 30549119, DATED 9-19-2005, EXPIRES 8-31-2015.

FOR COMPUTER SOFTWARE DEVELOPMENT TOOLS; COMPUTER SOFTWARE TO ENHANCE THE AUDIO-VISUAL CAPABILITIES OF MULTIMEDIA APPLICATIONS, NAMELY, FOR THE INTEGRATION OF TEXT, AUDIO, GRAPHICS, STILL IMAGES AND MOVING PICTURES; COMPUTER VIDEO GAMES FOR GAME CONSOLES; SOFTWARE FOR GAME CONSOLES; SOFTWARE FOR GRAPHICS DATA PROCESSING; COMPUTER GRAPHICS SOFTWARE; VIRTUAL REALITY GAME SOFTWARE; VIRTUAL REALITY SOFTWARE; PRE-RECORDED MAGNETIC OR OPTICAL DATA CARRIERS WITH COMPUTER GAME SOFTWARE, SOFTWARE FOR GAME CONSOLES AND COMPUTER VIDEO GAMES FOR GAME CONSOLES AND WITH PUBLICATIONS RELATED TO THE AFORESAID SOFTWARE; VIDEO GAME CASSETTES AND VIDEO TAPES; INTEGRATED CIRCUITS WITH SOFTWARE FOR COMPUTERS, GAME CONSOLES, VIDEO PLAYERS AND GAME AUTOMATA RECORDED THEREON; SOFTWARE FOR COMPUTER GAMES AND FOR GAMES ON GAME CONSOLES, HAND-HELD UNITS AND MOBILE PHONES PROVIDED BY MULTIMEDIA ELECTRONIC BROADCAST OR ONLINE NETWORK TRANSMISSION; DATA PROCESSING EQUIPMENT, NAMELY COMPUTERS, AND VIDEO GAME CONSOLES FOR USE WITH TELEVISIONS OR EXTERNAL DISPLAY SCREENS OR MONITORS,

**CLASS 9—(Continued).**

PRINTED MATTER IN THE NATURE OF BOOKS, BROCHURES, FLY SHEETS, LEAFLETS, INSTRUCTIONAL AND TEACHING MATERIAL CONCERNING OPERATIONAL INSTRUCTIONS AND GENERAL INFORMATION ABOUT SOFTWARE AND ELECTRONIC GOODS, SOLD AS A UNIT WITH SUCH ABOVE MENTIONED ELECTRONIC GOODS; MOTION PICTURE FILMS, NAMELY MOTION PICTURE FILMS FEATURING COMEDY, DRAMA, ACTION, ADVENTURE AND/OR ANIMATION, FOR BROADCAST ON TELEVISION, FOR PRIVATE OR HOME VIEWING ON COMPUTERS, TELEVISIONS, HAND-HELD VIEWERS OR PROJECTORS; PRERECORDED RECORDS, AUDIO-TAPES, AUDIO-VIDEO-TAPES, AUDIO-VIDEO-CASSETTES, AUDIO-VIDEO-DISCS AND DVDS WITH MUSIC, COMEDY, DRAMA, ACTION, ADVENTURE AND/OR ANIMATION; SHORT MOTION PICTURE FILMS FEATURING COMEDY, DRAMA, ACTION, ADVENTURE AND/OR ANIMATION FOR USE IN PORTABLE DISPLAY DEVICES OR PROJECTORS (U.S. CLS. 21, 23, 26, 36 AND 38).

HENRY S. ZAK, EXAMINING ATTORNEY

SN 78-816,461. UNIVERSAL CITY STUDIOS LLLP, UNIVERSAL CITY, CA. FILED 2-16-2006.

## UNIVERSAL RECORDS SOUTH

THE MARK CONSISTS OF STANDARD CHARACTERS WITHOUT CLAIM TO ANY PARTICULAR FONT, STYLE, SIZE, OR COLOR.

OWNER OF U.S. REG. NOS. 1,637,487, 2,889,475 AND OTHERS.

NO CLAIM IS MADE TO THE EXCLUSIVE RIGHT TO USE "RECORDS", APART FROM THE MARK AS SHOWN.

FOR PRE-RECORDED AUDIO TAPES, DISCS AND CASSETTES, VIDEO TAPES, DIGITAL AUDIO AND AUDIO VIDEO TAPES AND DISCS, CDS, DVDS, LASER DISCS, AND PHONOGRAPH RECORDS FEATURING MUSIC AND ENTERTAINMENT; THEATRICAL AND MUSICAL SOUND AND VIDEO RECORDINGS; VIRTUAL REALITY GAME SOFTWARE; DOWNLOADABLE RING TONES, GRAPHICS, GAMES, MUSIC, MP3 FILES, IMAGES AND VIDEOS VIA A GLOBAL COMPUTER NETWORK AND WIRELESS DEVICES; COMPUTER AND VIDEO GAME EQUIPMENT CONTAINING MEMORY DEVICES, NAMELY, COMPUTER AND VIDEO GAME SOFTWARE, PRE-RECORDED VIDEO GAME TAPES, CARTRIDGES AND CASSETTES (U.S. CLS. 21, 23, 26, 36 AND 38).

LOURDES AYALA, EXAMINING ATTORNEY

**CLASS 9—(Continued).**

SN 78-816,961. HADALA, ANTHONY J., BRECKSVILLE, OH. FILED 2-16-2006.

# Beer Strip

THE MARK CONSISTS OF STANDARD CHARACTERS WITHOUT CLAIM TO ANY PARTICULAR FONT, STYLE, SIZE, OR COLOR.

OWNER OF U.S. REG. NO. 2,772,602. NO CLAIM IS MADE TO THE EXCLUSIVE RIGHT TO USE "BEER", APART FROM THE MARK AS SHOWN.

FOR LIQUID LEVEL SENSORS (U.S. CLS. 21, 23, 26, 36 AND 38).

RONALD AIKENS, EXAMINING ATTORNEY

SN 78-817,075. ARISTOCRAT TECHNOLOGIES AUSTRALIA PTY LTD, LANE COVE, NEW SOUTH WALES, AUSTRALIA, FILED 2-16-2006.

# CASH DROP

THE MARK CONSISTS OF STANDARD CHARACTERS WITHOUT CLAIM TO ANY PARTICULAR FONT, STYLE, SIZE, OR COLOR.

PRIORITY CLAIMED UNDER SEC. 44(D) ON AUSTRALIA APPLICATION NO. 1081780, FILED 10-24-2005, REG. NO. 1081780, DATED 10-24-2005, EXPIRES 10-23-2015.

FOR GAMING DEVICES, NAMELY, GAMING MACHINES AND COMPUTER SOFTWARE USED THEREWITH TO ENABLE THE GAMING MACHINE TO RUN (U.S. CLS. 21, 23, 26, 36 AND 38).

JOHN DWYER, EXAMINING ATTORNEY

**CLASS 9—(Continued).**

SN 78-817,934. UMG RECORDINGS, INC., SANTA MONICA, CA. AND SCHUR, JORDAN, SANTA MONICA, CA. FILED 2-17-2006.

# SURETONE RECORDS

THE MARK CONSISTS OF STANDARD CHARACTERS WITHOUT CLAIM TO ANY PARTICULAR FONT, STYLE, SIZE, OR COLOR.

NO CLAIM IS MADE TO THE EXCLUSIVE RIGHT TO USE "RECORDS", APART FROM THE MARK AS SHOWN.

FOR PRE-RECORDED AUDIO TAPES, DISCS AND CASSETTES, VIDEO TAPES, DISCS AND CASSETTES, DIGITAL AUDIO AND AUDIO VIDEO TAPES AND DISCS, CDS, DVDS, LASER DISCS, AND PHONOGRAPH RECORDS FEATURING MUSIC AND ENTERTAINMENT; THEATRICAL AND MUSICAL SOUND AND VIDEO RECORDINGS; VIRTUAL REALITY GAME SOFTWARE; DOWNLOADABLE RING TONES, MUSIC, MP3S, GRAPHICS, GAMES, IMAGES AND VIDEOS FOR WIRELESS COMMUNICATION DEVICES; COMPUTER AND VIDEO GAME EQUIPMENT CONTAINING MEMORY DEVICES, NAMELY, COMPUTER GAME SOFTWARE, VIDEO GAME SOFTWARE, TAPES, CARTRIDGES, CASSETTES, JOYSTICKS AND REMOTE CONTROL UNITS; MOUSE PADS; PORTABLE AND HANDHELD DIGITAL ELECTRONIC DEVICES FOR RECORDING, ORGANIZING, TRANSMITTING, MANIPULATING, AND REVIEWING TEXT, DATA AND AUDIO FILES; AND DIGITAL ELECTRONIC DEVICES FOR RECORDING, ORGANIZING, TRANSMITTING, MANIPULATING, AND REVIEWING TEXT, DATA AND AUDIO FILES FOR VEHICLES (U.S. CLS. 21, 23, 26, 36 AND 38).

JASON BLAIR, EXAMINING ATTORNEY

SN 78-821,561. ARISTOCRAT TECHNOLOGIES AUSTRALIA PTY LTD, LANE COVE, NEW SOUTH WALES, AUSTRALIA, FILED 2-23-2006.

# EMPEROR PENGUIN

THE MARK CONSISTS OF STANDARD CHARACTERS WITHOUT CLAIM TO ANY PARTICULAR FONT, STYLE, SIZE, OR COLOR.

OWNER OF AUSTRALIA REG. NO. 1068051, DATED 8-3-2005, EXPIRES 8-13-2015.

OWNER OF U.S. REG. NOS. 2,186,586, 2,793,428 AND OTHERS.

FOR GAMING DEVICES, NAMELY, GAMING MACHINES AND COMPUTER SOFTWARE USED THEREWITH TO ENABLE THE GAMING MACHINE TO RUN (U.S. CLS. 21, 23, 26, 36 AND 38).

GEORGE LORENZO, EXAMINING ATTORNEY

**CLASS 9—(Continued).**

SN 78-824,853. BLACK & DECKER CORPORATION, THE, TOWSON, MD. FILED 2-28-2006.

# Accu-Mark

THE MARK CONSISTS OF STANDARD CHARACTERS WITHOUT CLAIM TO ANY PARTICULAR FONT, STYLE, SIZE, OR COLOR.

FOR LASER LEVEL AND TAPE MEASURING TOOLS (U.S. CLS. 21, 23, 26, 36 AND 38).

ODESSA BIBBINS, EXAMINING ATTORNEY

**CLASS 9—(Continued).**

SN 78-830,399. GLOBAL SECURITY SYSTEMS TECHNOLOGY, L.L.C., LAFAYETTE, LA. FILED 3-6-2006.

# Any Device Anywhere

THE MARK CONSISTS OF STANDARD CHARACTERS WITHOUT CLAIM TO ANY PARTICULAR FONT, STYLE, SIZE, OR COLOR.

NO CLAIM IS MADE TO THE EXCLUSIVE RIGHT TO USE "DEVICE", APART FROM THE MARK AS SHOWN.

FOR DEVICES FOR WIRELESS RADIO TRANSMISSION (U.S. CLS. 21, 23, 26, 36 AND 38).

FIRST USE 12-29-2004; IN COMMERCE 12-29-2004.  
ALYSSA PALADINO, EXAMINING ATTORNEY

SN 78-825,733. INFOBLOX, INC., SUNNYVALE, CA. FILED 2-28-2006.

# ID AWARE

THE MARK CONSISTS OF STANDARD CHARACTERS WITHOUT CLAIM TO ANY PARTICULAR FONT, STYLE, SIZE, OR COLOR.

NO CLAIM IS MADE TO THE EXCLUSIVE RIGHT TO USE "ID", APART FROM THE MARK AS SHOWN.

FOR COMPUTER HARDWARE; COMPUTER NETWORKING HARDWARE, NAMELY, AN INTERNET SERVER APPLIANCE FOR HIGH PERFORMANCE COMPUTER NETWORKING; COMPUTER SOFTWARE USED FOR NETWORK ACCESS AND MANAGEMENT OF NETWORK SECURITY; COMPUTER SOFTWARE FOR USE IN MANAGING, TRACKING, AND AUDITING NETWORK DATA; NETWORK ACCESS SERVER OPERATING SOFTWARE (U.S. CLS. 21, 23, 26, 36 AND 38).

FIRST USE 2-0-2006; IN COMMERCE 2-0-2006.  
SANJEEV VOHRA, EXAMINING ATTORNEY

SN 78-833,122. ROSS VIDEO LIMITED, IROQUOIS, ONTARIO, CANADA, FILED 3-9-2006.

# SOFT METAL

SN 78-827,237. DELSOIN, PAUL, BROOKLYN, NY. FILED 3-2-2006.

FOR DVDS FEATURING MUSIC; AND MUSIC CDS (U.S. CLS. 21, 23, 26, 36 AND 38).

FIRST USE 3-1-2005; IN COMMERCE 3-1-2005.  
CIMMERIAN COLEMAN, EXAMINING ATTORNEY

THE MARK CONSISTS OF STANDARD CHARACTERS WITHOUT CLAIM TO ANY PARTICULAR FONT, STYLE, SIZE, OR COLOR.

FOR AUDIO AND VISUAL EQUIPMENT, NAMELY, MULTI-DEFINITION VIDEO SERVERS FOR STORING AND RECALLING VIDEO AND AUDIO FILES (U.S. CLS. 21, 23, 26, 36 AND 38).

AMY HELLA, EXAMINING ATTORNEY

**CLASS 9—(Continued).**

SN 78-837,118. UMG RECORDINGS, INC., SANTA MONICA, CA. FILED 3-14-2006.

**SIENTE MUSIC**

THE MARK CONSISTS OF STANDARD CHARACTERS WITHOUT CLAIM TO ANY PARTICULAR FONT, STYLE, SIZE, OR COLOR.

NO CLAIM IS MADE TO THE EXCLUSIVE RIGHT TO USE "MUSIC", APART FROM THE MARK AS SHOWN.

THE FOREIGN WORDING IN THE MARK TRANSLATES INTO ENGLISH AS FEEL OR FEELS.

FOR PRE-RECORDED AUDIO TAPES, DISCS AND CASSETTES, VIDEO TAPES, DISCS AND CASSETTES, DIGITAL AUDIO AND AUDIO VIDEO TAPES AND DISCS, CDS, DVDS, LASER DISCS, AND PHONOGRAPH RECORDS FEATURING MUSIC AND ENTERTAINMENT; THEATRICAL AND MUSICAL SOUND AND VIDEO RECORDINGS; VIRTUAL REALITY GAME SOFTWARE; DOWNLOADABLE RING TONES, MUSIC, MP3S, GRAPHICS, GAMES, IMAGES AND VIDEOS FOR WIRELESS COMMUNICATION DEVICES; COMPUTER AND VIDEO GAME EQUIPMENT CONTAINING MEMORY DEVICES, NAMELY, COMPUTER GAME SOFTWARE, VIDEO GAME SOFTWARE, TAPES, CARTRIDGES, CASSETTES, JOYSTICKS AND REMOTE CONTROL UNITS; MOUSE PADS; PORTABLE AND HANDHELD DIGITAL ELECTRONIC DEVICES FOR RECORDING, ORGANIZING, TRANSMITTING, MANIPULATING, AND REVIEWING TEXT, DATA AND AUDIO FILES; AND DIGITAL ELECTRONIC DEVICES FOR RECORDING, ORGANIZING, TRANSMITTING, MANIPULATING, AND REVIEWING TEXT, DATA AND AUDIO FILES FOR VEHICLES (U.S. CLS. 21, 23, 26, 36 AND 38).

JASON BLAIR, EXAMINING ATTORNEY

SN 78-837,977. VAN HAUSER LLC, NEW YORK, NY. FILED 3-15-2006.

**IUNBELIEVABLE**

THE MARK CONSISTS OF STANDARD CHARACTERS WITHOUT CLAIM TO ANY PARTICULAR FONT, STYLE, SIZE, OR COLOR.

FOR AUDIO SPEAKERS; AMPLIFIERS; DOCKING STATIONS AND BATTERY CHARGERS FOR DIGITAL ELECTRONIC DEVICES FOR RECORDING, ORGANIZING, TRANSMITTING, MANIPULATING, RECEIVING AND/OR DISPLAYING TEXT, DATA, AUDIO, IMAGE AND VIDEO FILES (U.S. CLS. 21, 23, 26, 36 AND 38).

GINA HAYES, EXAMINING ATTORNEY

**CLASS 9—(Continued).**

SN 78-838,359. RYAN, ANDREW, LOS ANGELES, CA. FILED 3-15-2006.

**SUMMER OF JAM**

THE MARK CONSISTS OF STANDARD CHARACTERS WITHOUT CLAIM TO ANY PARTICULAR FONT, STYLE, SIZE, OR COLOR.

FOR PRERECORDED VIDEO CASSETTES, COMPACT DISCS, AND LASER VIDEO DISCS FEATURING MUSIC AND ENTERTAINMENT-RELATED CONTENT, NAMELY, PERFORMANCES BY MUSICAL ARTISTS AND CONCERTS (U.S. CLS. 21, 23, 26, 36 AND 38).

WILLIAM BRECKENFELD, EXAMINING ATTORNEY

SN 78-838,705. FULLTONE MUSICAL PRODUCTS, INC., CULVER CITY, CA. FILED 3-16-2006.

**FULL-DRIVE 2**

THE MARK CONSISTS OF STANDARD CHARACTERS WITHOUT CLAIM TO ANY PARTICULAR FONT, STYLE, SIZE, OR COLOR.

SEC. 2(F).

FOR ELECTRONIC EFFECTS PEDALS AND STOMP BOXES FOR USE WITH MUSICAL INSTRUMENTS AND PARTS THEREFOR AND INSTRUCTIONAL MANUALS, SOLD AS A UNIT (U.S. CLS. 21, 23, 26, 36 AND 38).

FIRST USE 1-31-1993; IN COMMERCE 1-31-1993.

BRIAN PINO, EXAMINING ATTORNEY

SN 78-843,542. PEGASUS TECHNOLOGIES, INC., KNOXVILLE, TN. FILED 3-22-2006.

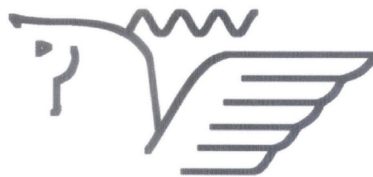

THE MARK CONSISTS OF SIDE VIEW OF A PARTIAL HORSE HEAD LINE DRAWING WITH A LINE APPROXIMATING A SINUSOID EXTENDING FROM THE TOP OF THE HEAD AND A LARGE WING EXTENDING FROM ITS SIDE.

FOR ELECTRONIC COMPONENTS, NAMELY WIRELESS RADIO TRANSMISSION AND RECEPTION DEVICES, INTEGRATED CIRCUIT MODULES, AND CIRCUIT BOARDS (U.S. CLS. 21, 23, 26, 36 AND 38).

FIRST USE 9-27-2000; IN COMMERCE 9-27-2000.

JACQUELINE A. LAVINE, EXAMINING ATTORNEY

**CLASS 9—(Continued).**

SN 78-845,015. SONY KAUBSHIKI KAISHA, TA SONY CORPORATION, TOKYO, JAPAN, FILED 3-23-2006.

**DSD**  
**Disc Format**

OWNER OF U.S. REG. NOS. 2,229,253 AND 2,251,628.  
 NO CLAIM IS MADE TO THE EXCLUSIVE RIGHT TO USE DISC FORMAT, APART FROM THE MARK AS SHOWN.

THE MARK CONSISTS OF THE WORDING DSD DISC FORMAT IN STYLIZED FORM, WITH DISC FORMAT APPEARING IN A RECTANGULAR BAR WITH ROUNDED EDGES.

FOR BLANK DIGITAL AUDIO DISCS; PRE-RECORDED DIGITAL AUDIO DISCS FEATURING MUSIC, TEXT DATA, STILL IMAGES AND MOTION PICTURES; AUDIO EQUIPMENT, NAMELY, AUDIO DISC PLAYERS AND RECORDERS; PERSONAL COMPUTERS, DIGITAL VERSATILE DISC PLAYERS, DIGITAL VERSATILE DISC RECORDERS AND VIDEO GAME MACHINES FOR USE WITH TELEVISIONS (U.S. CLS. 21, 23, 26, 36 AND 38).

SUSAN LESLIE DUBOIS, EXAMINING ATTORNEY

SN 78-846,714. WILLIAMS, ALVIN V., RIVERDALE, GA. AND CLOPTON, GRADY, RIVERDALE, GA. FILED 3-27-2006.

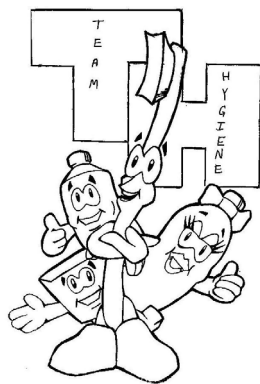

NO CLAIM IS MADE TO THE EXCLUSIVE RIGHT TO USE "HYGIENE", APART FROM THE MARK AS SHOWN.

FOR VIDEO AND DVD ANIMATION SERIES, NAMELY, VIDEOTAPES, VIDEO DISKS AND DVDS ALL RECORDED WITH ANIMATION (U.S. CLS. 21, 23, 26, 36 AND 38).

RUDY R. SINGLETON, EXAMINING ATTORNEY

**CLASS 9—(Continued).**

SN 78-846,882. BOHEMIA INTERACTIVE STUDIO S.R.O., PRAGUE 5, CZECH REPUBLIC, FILED 3-27-2006.

**VBS**

THE MARK CONSISTS OF STANDARD CHARACTERS WITHOUT CLAIM TO ANY PARTICULAR FONT, STYLE, SIZE, OR COLOR.

FOR MILITARY SIMULATION COMPUTER GAME SOFTWARE; COMPUTER SOFTWARE FOR USE IN MILITARY, LAW ENFORCEMENT, HOMELAND DEFENSE AND FIRST RESPONDER TRAINING; COMPUTER GAME DISKS (U.S. CLS. 21, 23, 26, 36 AND 38).

FIRST USE 6-1-2002; IN COMMERCE 6-1-2002.

ALEXANDER L. POWERS, EXAMINING ATTORNEY

SN 78-847,998. HADALA, ANTHONY J., BRECKSVILLE, OH. FILED 3-28-2006.

**KEG STRIP**

THE MARK CONSISTS OF STANDARD CHARACTERS WITHOUT CLAIM TO ANY PARTICULAR FONT, STYLE, SIZE, OR COLOR.

OWNER OF U.S. REG. NO. 2,772,602.  
 NO CLAIM IS MADE TO THE EXCLUSIVE RIGHT TO USE "KEG", APART FROM THE MARK AS SHOWN.

FOR LIQUID LEVEL SENSORS (U.S. CLS. 21, 23, 26, 36 AND 38).

RONALD AIKENS, EXAMINING ATTORNEY

SN 78-850,096. HONOR TRADING LTD OF FORMOSA, FREMONT, CA. FILED 3-30-2006.

**Power Dome**

THE MARK CONSISTS OF STANDARD CHARACTERS WITHOUT CLAIM TO ANY PARTICULAR FONT, STYLE, SIZE, OR COLOR.

NO CLAIM IS MADE TO THE EXCLUSIVE RIGHT TO USE "POWER", APART FROM THE MARK AS SHOWN.

FOR ELECTRICAL POWER PRODUCTS, NAMELY, POWER INVERTERS AND POWER CONVERTERS; PORTABLE POWER SUPPLIES AND BACKUP POWER SUPPLIES; AND BATTERY CHARGERS; ELECTRICAL POWER PRODUCTS, NAMELY, UNINTERRUPTIBLE POWER SUPPLIES, AND BATTERIES; ELECTRICAL POWER PRODUCTS, NAMELY, POWER INVERTERS AND POWER CONVERTERS; PORTABLE POWER SUPPLIES AND BACKUP POWER SUPPLIES; AND BATTERY CHARGERS; UNINTERRUPTIBLE POWER SUPPLIES, AND BATTERIES (U.S. CLS. 21, 23, 26, 36 AND 38).

FIRST USE 1-1-1999; IN COMMERCE 1-1-2005.

ANGELA M. MICHELI, EXAMINING ATTORNEY



**CLASS 9—(Continued).**

SN 78-851,547. NEW LINE PRODUCTIONS, INC., NEW YORK, NY. FILED 3-31-2006.

# MIMZY

THE MARK CONSISTS OF STANDARD CHARACTERS WITHOUT CLAIM TO ANY PARTICULAR FONT, STYLE, SIZE, OR COLOR.

FOR MOTION PICTURE FILMS FEATURING COMEDY, DRAMA, ACTION, ADVENTURE AND/OR ANIMATION, AND MOTION PICTURE FILMS FOR BROADCAST ON TELEVISION FEATURING COMEDY, DRAMA, ACTION, ADVENTURE AND/OR ANIMATION; PRERECORDED VINYL RECORDS, AUDIO TAPES, AUDIO-VIDEO TAPES, AUDIO VIDEO CASSETTES, AUDIO VIDEO DISCS, COMPACT DISCS, AND DIGITAL VERSATILE DISCS FEATURING MUSIC, COMEDY, DRAMA, ACTION, ADVENTURE, AND/OR ANIMATION; STEREO HEADPHONES; BATTERIES; CORDLESS TELEPHONES; HAND-HELD CALCULATORS; AUDIO CASSETTE AND CD PLAYERS; CD ROM COMPUTER GAME DISCS; HAND-HELD KARAOKE PLAYERS, TELEPHONE AND/OR RADIO PAGERS; SHORT MOTION PICTURE FILM CASSETTES FEATURING COMEDY, DRAMA, ACTION, ADVENTURE AND/OR ANIMATION TO BE USED WITH HAND-HELD VIEWERS OR PROJECTORS; VIDEO CASSETTE RECORDERS AND PLAYERS, COMPACT DISC PLAYERS, DIGITAL AUDIO TAPE RECORDERS AND PLAYERS, ELECTRONIC DIARIES; RADIOS; MOUSE PADS; EYEGLASSES, SUNGLASSES AND CASES THEREFORE; AUDIO TAPES AND BOOKLETS SOLD AS A UNIT FEATURING COMEDY, DRAMA, ACTION, ADVENTURE, ANIMATION AND MUSIC INFORMATION; COMPUTER PROGRAMS, NAMELY, SOFTWARE LINKING DIGITIZED VIDEO AND AUDIO MEDIA TO A GLOBAL COMPUTER INFORMATION NETWORK; GAME EQUIPMENT SOLD AS A UNIT FOR PLAYING A PARLOR-TYPE COMPUTER GAME; VIDEO, COMPUTER AND OTHER INTERACTIVE VIDEO GAME AND COMPUTER GAME PROGRAMS; VIDEO GAME CARTRIDGES AND CASSETTES; CELLULAR TELEPHONE ACCESSORIES, NAMELY HANDS-FREE ACCESSORIES, CELLULAR TELEPHONE COVERS AND CELLULAR TELEPHONE FACE COVERS; ENCODED MAGNETIC CARDS, NAMELY, PHONE CARDS, CREDIT CARDS, CASH CARDS, DEBIT CARDS AND MAGNETIC KEY CARDS; AND DECORATIVE MAGNETS; DOWNLOADABLE RING TONES, RING BACKS, ANIMATED RINGERS, VIDEO RINGERS AND ANIMATED SCREENSAVER SOFTWARE VIA A GLOBAL COMPUTER NETWORK AND WIRELESS DEVICES (U.S. CLS. 21, 23, 26, 36 AND 38).

ROBIN MITTLER, EXAMINING ATTORNEY

**CLASS 9—(Continued).**

SN 78-852,338. SUNELL ELECTRONICS (SHENZHEN) COMPANY LIMITED, SHENZHEN, CHINA, FILED 4-3-2006.



FOR CAMERAS; CAMERA LENSES; SMOKE DETECTORS; ANTI-THEFT WARNING APPARATUS, NAMELY, A WARNING DEVICE BEING USED IN BOTH COMMERCIAL AND RESIDENTIAL PREMISES THAT GIVES A SOUND AND SENDS A CALL TO THE LOCAL POLICE; FIRE ALARMS; COMPUTER MONITORS; PHOTOGRAPHIC RACKS, NAMELY CAMERA AND CAMCORDER TRIPODS; MONITORING DEVICES FOR CLOSED-CIRCUIT TELEVISIONS; MONITORING EQUIPMENT, NAMELY, A SURVEILLANCE CAMERA THAT LINKS TO A TELEVISION MONITOR FOR CLOSED-CIRCUIT TELEVISIONS; APPARATUS AND INSTRUMENTS, NAMELY, VIDEO RECORDERS, DECODERS, PROCESSORS, LENSES, MONITORS, CAMERAS, HOUSING AND BRACKETS, FOR RECORDING, TRANSMITTING, RECEIVING AND PROCESSING OF SOUNDS, IMAGES AND DATA (U.S. CLS. 21, 23, 26, 36 AND 38).

FIRST USE 7-7-2000; IN COMMERCE 2-1-2004.

LEIGH CAROLINE CASE, EXAMINING ATTORNEY

---

SN 78-854,797. VERINT SYSTEMS INC., MELVILLE, NY. FILED 4-5-2006.

# INTELLISCREEN

THE MARK CONSISTS OF STANDARD CHARACTERS WITHOUT CLAIM TO ANY PARTICULAR FONT, STYLE, SIZE, OR COLOR.

FOR COMPUTER SOFTWARE FOR MONITORING ACTIVITY ON THE DESKTOP SCREEN OF A CONTACT CENTER AGENT OR BACK-OFFICE WORKER AND FOR TRACKING APPLICATION USAGE, DATA ENTRY, AND SCREEN CONTENT, AND INSTRUCTION MANUALS, SOLD AS A UNIT (U.S. CLS. 21, 23, 26, 36 AND 38).

ANTHONY RINKER, EXAMINING ATTORNEY

**CLASS 9—(Continued).**

SN 78-856,880. SONY KABUSHIKI KAISHA, TA SONY CORPORATION, TOKYO, JAPAN, FILED 4-7-2006.



NO CLAIM IS MADE TO THE EXCLUSIVE RIGHT TO USE "DIGITAL CINEMA AUTO CALIBRATION", APART FROM THE MARK AS SHOWN.

FOR AUDIO AMPLIFIERS; HOME THEATER SYSTEMS COMPRISED OF AUDIO/VIDEO TAPE PLAYERS/RECORDERS, AUDIO/VIDEO DISC PLAYERS/RECORDERS, TELEVISION SETS, PROJECTORS, AUDIO AMPLIFIERS, TUNERS AND LOUD-SPEAKERS (U.S. CLS. 21, 23, 26, 36 AND 38).

JOHN SCHUYLER YARD, EXAMINING ATTORNEY

SN 78-859,403. SEMICONDUCTOR COMPONENTS INDUSTRIES, LLC, PHOENIX, AZ. FILED 4-11-2006.

### FROM THE SOCKET TO THE POCKET

THE MARK CONSISTS OF STANDARD CHARACTERS WITHOUT CLAIM TO ANY PARTICULAR FONT, STYLE, SIZE, OR COLOR.

FOR SEMICONDUCTORS; MICROPROCESSORS; POWER SUPPLIES; AND OTHER SEMICONDUCTOR DEVICES, NAMELY CONTROLLERS, ADAPTERS AND INVERTERS, INTEGRATED CIRCUITS; COMPUTER CHIPSETS; COMPUTER BOARDS, NAMELY MOTHERBOARDS, ACCELERATOR BOARDS, EXPANSION BOARDS AND GRAPHIC BOARDS; PROGRAMMABLE DIGITAL PROCESSORS; AND PARTS THEREFOR (U.S. CLS. 21, 23, 26, 36 AND 38).

GIANCARLO CASTRO, EXAMINING ATTORNEY

SN 78-860,018. KABUSHIKI KAISHA PFU, DBA PFU LIMITED, ISHIKAWA, JAPAN, FILED 4-12-2006.

### EW/SysMon

PRIORITY CLAIMED UNDER SEC. 44(D) ON JAPAN APPLICATION NO. 2005-117856, FILED 12-15-2005, REG. NO. 4977553, DATED 8-11-2006, EXPIRES 8-11-2016.

FOR COMPUTER SOFTWARE FOR MONITORING HARDWARE ENVIRONMENT, NAMELY, TEMPERATURE, VOLTAGE AND FAN SPEED OF EMBEDDED CONTROLLERS (U.S. CLS. 21, 23, 26, 36 AND 38).

PETER CHENG, EXAMINING ATTORNEY

**CLASS 9—(Continued).**

SN 78-861,552. ULTRAVISION SECURITY SYSTEMS, INC., NORTH SALEM, NH. FILED 4-14-2006.

## LifeBeat

THE MARK CONSISTS OF STANDARD CHARACTERS WITHOUT CLAIM TO ANY PARTICULAR FONT, STYLE, SIZE, OR COLOR.

FOR COMPUTER SOFTWARE USED FOR LOCATING LIVING VICTIMS IN BUILDING DEBRIS, MUDSLIDES, AVALANCHES, DISASTER WRECKAGE, AND SIMILAR CIRCUMSTANCES SOLD AS AN INTEGRAL COMPONENT OF HANDHELD COMPUTER DEVICES (U.S. CLS. 21, 23, 26, 36 AND 38).

FIRST USE 10-1-2005; IN COMMERCE 10-1-2005.  
SARAH WAYDA, EXAMINING ATTORNEY

SN 78-862,300. JENIFFER GRACE THOMPSON, SAN DIEGO, CA. FILED 4-15-2006.

## Website WOW

THE MARK CONSISTS OF STANDARD CHARACTERS WITHOUT CLAIM TO ANY PARTICULAR FONT, STYLE, SIZE, OR COLOR.

NO CLAIM IS MADE TO THE EXCLUSIVE RIGHT TO USE "WEBSITE", APART FROM THE MARK AS SHOWN.

FOR ELECTRONIC PUBLICATIONS, NAMELY, BOOK FEATURING HOW TO BUILD A WEB SITE RECORDED ON COMPUTER MEDIA (U.S. CLS. 21, 23, 26, 36 AND 38).

SKYE YOUNG, EXAMINING ATTORNEY

SN 78-864,729. EZ DOESIT SOFTWARE, LLC, TAUNTON, MA. FILED 4-19-2006.

## HHC ELEMENTS

THE MARK CONSISTS OF STANDARD CHARACTERS WITHOUT CLAIM TO ANY PARTICULAR FONT, STYLE, SIZE, OR COLOR.

NO CLAIM IS MADE TO THE EXCLUSIVE RIGHT TO USE "HHC", APART FROM THE MARK AS SHOWN.

FOR SOFTWARE FOR SUPPORTING CAREGIVER INFORMATION INCLUDING EXPIRATIONS, DEMOGRAPHIC SKILLS EVALUATIONS, CONDITIONS, MEDICATIONS, CARE PLANS, CONTACTS, BILLING INFORMATION, SERVICE ORDERS AND PRIOR AUTHORIZATION AND SCHEDULING VISITS, MEDICAL PROCEDURES, SHIFTS, NURSING VISITS, STAFFING FOR HOME HEALTHCARE CENTERS AND PROVIDERS (U.S. CLS. 21, 23, 26, 36 AND 38).

FIRST USE 7-1-2004; IN COMMERCE 7-1-2004.

WILLIAM BRECKENFELD, EXAMINING ATTORNEY

**CLASS 9—(Continued).**

SN 78-866,019. INFOBLOX, INC., SUNNYVALE, CA. FILED 4-20-2006.

# ID GRID

THE MARK CONSISTS OF STANDARD CHARACTERS WITHOUT CLAIM TO ANY PARTICULAR FONT, STYLE, SIZE, OR COLOR.

NO CLAIM IS MADE TO THE EXCLUSIVE RIGHT TO USE "ID", APART FROM THE MARK AS SHOWN.

FOR COMPUTER HARDWARE; COMPUTER NETWORKING HARDWARE; NAMELY, AN INTERNET SERVER APPLIANCE FOR HIGH PERFORMANCE COMPUTER NETWORKING; COMPUTER SOFTWARE USED FOR NETWORK ACCESS AND MANAGEMENT OF NETWORK SECURITY; COMPUTER SOFTWARE FOR USE IN MANAGING, TRACKING, AND AUDITING NETWORK DATA; NETWORK ACCESS SERVER OPERATING SOFTWARE (U.S. CLS. 21, 23, 26, 36 AND 38).

SANJEEV VOHRA, EXAMINING ATTORNEY

SN 78-868,023. HOOPNOTICA CORPORATION, LONG BEACH, CA. FILED 4-24-2006.

# Hoopnotica

THE MARK CONSISTS OF STANDARD CHARACTERS WITHOUT CLAIM TO ANY PARTICULAR FONT, STYLE, SIZE, OR COLOR.

FOR DVDS FEATURING VARIOUS LEVELS OF HOOP DANCING, INCLUDING BEGINNER, INTERMEDIATE AND SPECIALIST LEVELS OF INSTRUCTION, BOTH FOR CONSUMER USE AND TEACHER TRAINING (U.S. CLS. 21, 23, 26, 36 AND 38).

RAY THOMAS, EXAMINING ATTORNEY

SN 78-868,068. HOOPNOTICA CORPORATION, LONG BEACH, CA. FILED 4-24-2006.

# Hoopnotic

THE MARK CONSISTS OF STANDARD CHARACTERS WITHOUT CLAIM TO ANY PARTICULAR FONT, STYLE, SIZE, OR COLOR.

FOR DVDS FEATURING VARIOUS LEVELS OF HOOP DANCING, INCLUDING BEGINNER, INTERMEDIATE AND SPECIALIST LEVELS OF INSTRUCTION, BOTH FOR CONSUMER USE AND TEACHER TRAINING (U.S. CLS. 21, 23, 26, 36 AND 38).

RAY THOMAS, EXAMINING ATTORNEY

**CLASS 9—(Continued).**

SN 78-868,156. HOOPNOTICA CORPORATION, LONG BEACH, CA. FILED 4-24-2006.



THE MARK CONSISTS OF THE WORD "HOOPNOTICA" ALL IN LOWER CASE LETTERS. THE SECOND "O" IN HOOPNOTICA IS A SUPERIMPOSED CARICATURE OF A WOMAN WITH A HOOP AROUND HER WAIST. THE WORDS "FIND YOURSELF IN THE HOOP" ARE POSITIONED BELOW THE WORD "HOOPNOTICA".

FOR DVDS FEATURING VARIOUS LEVELS OF HOOP DANCING, INCLUDING BEGINNER, INTERMEDIATE AND SPECIALIST LEVELS OF INSTRUCTION, BOTH FOR CONSUMER USE AND TEACHER TRAINING (U.S. CLS. 21, 23, 26, 36 AND 38).

RAY THOMAS, EXAMINING ATTORNEY

SN 78-875,204. FISO TECHNOLOGIES INC., QUEBEC, CANADA, FILED 5-3-2006.

# NORTECH

THE MARK CONSISTS OF STANDARD CHARACTERS WITHOUT CLAIM TO ANY PARTICULAR FONT, STYLE, SIZE, OR COLOR.

PRIORITY CLAIMED UNDER SEC. 44(D) ON CANADA APPLICATION NO. 1296743, FILED 4-5-2006.

FOR FIBER OPTIC TEMPERATURE MONITORING SYSTEM, CONSISTING OF A SPECTROMETRIC READ OUT DEVICE AND A SEMI-CONDUCTING CRYSTAL BONDED TO THE END OF AN OPTICAL FIBER, FOR SMALL AND MEDIUM TRANSFORMERS FOR USE IN ALL ENERGY SECTORS (U.S. CLS. 21, 23, 26, 36 AND 38).

FIRST USE 9-30-1997; IN COMMERCE 9-30-1997.

MARK PILARO, EXAMINING ATTORNEY

SN 78-877,195. AXIOMATIC SOLUTIONS SDN BHD, SERDANG, MALAYSIA, FILED 5-5-2006.



## Axiomatic Multi-Platform C

NO CLAIM IS MADE TO THE EXCLUSIVE RIGHT TO USE "AXIOMATIC MULTI-PLATFORM C", APART FROM THE MARK AS SHOWN.

FOR COMPUTER SOFTWARE AND PROGRAMS FOR TRANSLATING C SOURCE CODE INTO BYTECODES (U.S. CLS. 21, 23, 26, 36 AND 38).

JESSICA A. POWERS, EXAMINING ATTORNEY

**CLASS 9—(Continued).**

SN 78-879,128. AROA MARKETING, INC., SYLMAR, CO.  
FILED 5-8-2006.

**MUSEO**

THE MARK CONSISTS OF STANDARD CHARACTERS WITHOUT CLAIM TO ANY PARTICULAR FONT, STYLE, SIZE, OR COLOR.

THE ENGLISH TRANSLATION OF THE WORD MUSEO IN THE MARK IS "MUSEUM".

FOR JUKE BOXES (U.S. CLS. 21, 23, 26, 36 AND 38).

FIRST USE 2-28-2004; IN COMMERCE 2-28-2004.

AMY BROZENIC, EXAMINING ATTORNEY

**CLASS 9—(Continued).**

SN 78-881,461. QUIXOTE TRAFFIC CORPORATION, SANTA FE SPRINGS, CA. FILED 5-11-2006.

**AXLELIGHT**

THE MARK CONSISTS OF STANDARD CHARACTERS WITHOUT CLAIM TO ANY PARTICULAR FONT, STYLE, SIZE, OR COLOR.

FOR TRAFFIC MONITORING SYSTEM COMPRISED OF A LASER TRANSMITTER AND RECEIVER (U.S. CLS. 21, 23, 26, 36 AND 38).

JOHN WILKE, EXAMINING ATTORNEY

SN 78-879,833. MATHSPEC, INC., ARLINGTON HEIGHTS, IL. FILED 5-9-2006.

**Rational Numbers**

THE MARK CONSISTS OF STANDARD CHARACTERS WITHOUT CLAIM TO ANY PARTICULAR FONT, STYLE, SIZE, OR COLOR.

FOR COMPUTER SOFTWARE FOR ANALYZING MASS SPECTRAL DATA IN THE FIELD OF CHEMISTRY (U.S. CLS. 21, 23, 26, 36 AND 38).

REGINA DRUMMOND, EXAMINING ATTORNEY

SN 78-887,344. CHISLETT, DAVID, NATICK, MA. FILED 5-18-2006.

**TOG Productions**

THE MARK CONSISTS OF STANDARD CHARACTERS WITHOUT CLAIM TO ANY PARTICULAR FONT, STYLE, SIZE, OR COLOR.

NO CLAIM IS MADE TO THE EXCLUSIVE RIGHT TO USE "PRODUCTIONS", APART FROM THE MARK AS SHOWN.

FOR SOUND RECORDINGS FEATURING MUSIC (U.S. CLS. 21, 23, 26, 36 AND 38).

MICHAEL LEWIS, EXAMINING ATTORNEY

SN 78-880,418. BAR-AV, ZE'EV, MADISON, WI. FILED 5-10-2006.

**THE BAR-AV SYSTEM**

THE MARK CONSISTS OF STANDARD CHARACTERS WITHOUT CLAIM TO ANY PARTICULAR FONT, STYLE, SIZE, OR COLOR.

NO CLAIM IS MADE TO THE EXCLUSIVE RIGHT TO USE "SYSTEM", APART FROM THE MARK AS SHOWN.

FOR COMPUTER SOFTWARE FOR ANALYZING HANDWRITING (U.S. CLS. 21, 23, 26, 36 AND 38).

KENNETH E. SHARPERSON, EXAMINING ATTORNEY

SN 78-896,049. DIAMOND GAME ENTERPRISES, INC., CHATSWORTH, CA. FILED 5-30-2006.

**VENICE GEMS**

THE MARK CONSISTS OF STANDARD CHARACTERS WITHOUT CLAIM TO ANY PARTICULAR FONT, STYLE, SIZE, OR COLOR.

FOR GAMING EQUIPMENT, NAMELY, GAMING MACHINES (U.S. CLS. 21, 23, 26, 36 AND 38).

DORITT L. CARROLL, EXAMINING ATTORNEY

**CLASS 9—(Continued).**

SN 78-896,621. CLEAR CHANNEL MANAGEMENT SERVICES, L.P., SAN ANTONIO, TX. FILED 5-31-2006.

# NEXGEN DIGITAL

THE MARK CONSISTS OF STANDARD CHARACTERS WITHOUT CLAIM TO ANY PARTICULAR FONT, STYLE, SIZE, OR COLOR.

OWNER OF U.S. REG. NO. 2,460,953.

NO CLAIM IS MADE TO THE EXCLUSIVE RIGHT TO USE "DIGITAL", APART FROM THE MARK AS SHOWN.

FOR COMPUTER PROGRAMS UTILIZED BY RADIO STATIONS FOR AUTOMATING THE SELECTION AND PLAYING OF MUSIC, ADVERTISEMENTS AND OTHER PROGRAMMING (U.S. CLS. 21, 23, 26, 36 AND 38).

FIRST USE 2-9-1999; IN COMMERCE 2-9-1999.

MARY MUNSON, EXAMINING ATTORNEY

SN 78-898,091. DI-NAMIC RECORDS, HOLLYWOOD, CA. FILED 6-1-2006.

# DI-NAMIC RECORDS

THE MARK CONSISTS OF STANDARD CHARACTERS WITHOUT CLAIM TO ANY PARTICULAR FONT, STYLE, SIZE, OR COLOR.

NO CLAIM IS MADE TO THE EXCLUSIVE RIGHT TO USE "RECORDS", APART FROM THE MARK AS SHOWN.

FOR MUSICAL SOUND RECORDINGS; AND PRE-RECORDED COMPACT DISCS, AUDIO CASSETTES, DVDS, VIDEOTAPES, AND AUDIO/VISUAL DISCS, ALL FEATURING MUSIC (U.S. CLS. 21, 23, 26, 36 AND 38).

STEVEN JACKSON, EXAMINING ATTORNEY

**CLASS 9—(Continued).**

SN 78-899,349. ITT CORPORATION, WHITE PLAINS, NY. FILED 6-2-2006.

# EW PLUG AND PROTECT

THE MARK CONSISTS OF STANDARD CHARACTERS WITHOUT CLAIM TO ANY PARTICULAR FONT, STYLE, SIZE, OR COLOR.

NO CLAIM IS MADE TO THE EXCLUSIVE RIGHT TO USE EW, APART FROM THE MARK AS SHOWN.

FOR ELECTRONIC COUNTERMEASURES (ECM) SYSTEMS FOR PROTECTION OF AIRCRAFT, WATERCRAFT, LAND VEHICLES, OR STATIONARY STRUCTURES FROM MILITARY AND/OR TERRORIST THREATS, COMPRISING SYSTEMS FOR DETECTING, INTERCEPTING, ANALYZING AND COUNTERING AIR AND GROUND RADIO FREQUENCY (RF) SIGNALS, WITH ALL OF THE FOREGOING COMPRISED OF COMPUTER SOFTWARE AND HARDWARE; COMPUTER HARDWARE AND SOFTWARE FOR IDENTIFYING MILITARY AND/OR TERRORIST THREATS, STORING MILITARY AND/OR TERRORIST THREAT DATA, PROVIDING A DIGITAL TARGET INTERFACE, SELECTING COUNTERMEASURE RESPONSES, MAPPING BATTLEFIELD INFORMATION, GEOLOCATING MILITARY AND/OR TERRORIST THREATS, PROVIDING EVASIVE PLANS TO AVOID MILITARY AND/OR TERRORIST THREATS, DETERMINING THE MOST EFFECTIVE COUNTERMEASURE BASED ON MILITARY AND/OR TERRORIST THREATS AND MISSION REQUIREMENTS, AND CONTROLLING RF, ELECTRO-OPTIC (EO) AND INFRARED (IR) COUNTERMEASURES (U.S. CLS. 21, 23, 26, 36 AND 38).

ODESSA BIBBINS, EXAMINING ATTORNEY

SN 78-900,901. TAMOSOFT, LTD., CHRISTCHURCH, NEW ZEALAND, FILED 6-5-2006.

# COUNTRYWHOIS

THE MARK CONSISTS OF STANDARD CHARACTERS WITHOUT CLAIM TO ANY PARTICULAR FONT, STYLE, SIZE, OR COLOR.

FOR COMPUTER SOFTWARE FOR DETERMINING THE GEOGRAPHIC LOCATION OF COMPUTERS BY NETWORK ADDRESS (U.S. CLS. 21, 23, 26, 36 AND 38).

FIRST USE 5-2-2006; IN COMMERCE 5-2-2006.

JANICE KIM, EXAMINING ATTORNEY

**CLASS 9—(Continued).**

SN 78-901,245. TOTAL EXTERIORS FRANCHISE SYSTEMS, INC., CUMMING, GA. FILED 6-6-2006.

# ExoTek

THE MARK CONSISTS OF STANDARD CHARACTERS WITHOUT CLAIM TO ANY PARTICULAR FONT, STYLE, SIZE, OR COLOR.

FOR COMPUTER SOFTWARE FOR USE IN ESTIMATING COSTS OF BUILDING RENOVATION PROJECTS; CAD/CAM SOFTWARE DESIGNED FOR USE IN CONSTRUCTION AND AUTOMATED MANUFACTURING (U.S. CLS. 21, 23, 26, 36 AND 38).

ALLISON HOLTZ, EXAMINING ATTORNEY

SN 78-904,474. IPERIA, INC., NORTH BILLERICA, MA. FILED 6-9-2006.



OWNER OF U.S. REG. NOS. 2,519,890 AND 2,523,202.  
FOR COMPUTER PROGRAMS FOR USE IN STORING, RETRIEVING AND TRANSMITTING MESSAGES COMPRISING VOICE, DATA, IMAGES, VIDEO AND TEXT OVER PUBLIC TELEPHONE NETWORKS, WIRELESS TELEPHONE NETWORKS AND LOCAL, NATIONAL AND GLOBAL INFORMATION NETWORKS; COMPUTER PROGRAMS FOR USE IN ESTABLISHING CONFERENCES OVER PUBLIC TELEPHONE NETWORKS, WIRELESS TELEPHONE NETWORKS AND LOCAL, NATIONAL AND GLOBAL INFORMATION NETWORKS; COMPUTER HARDWARE, NAMELY NETWORK SWITCH; TELECOMMUNICATION EQUIPMENT FOR USE WITH VOICE OVER INTERNET PROTOCOL, NAMELY TELECOMMUNICATION SWITCHES; COMPUTER TELEPHONY SOFTWARE (U.S. CLS. 21, 23, 26, 36 AND 38).

DAHLIA GEORGE, EXAMINING ATTORNEY

**CLASS 9—(Continued).**

SN 78-904,554. IPERIA, INC., NORTH BILLERICA, MA. FILED 6-9-2006.



OWNER OF U.S. REG. NOS. 2,519,890 AND 2,523,202.

FOR COMPUTER PROGRAMS FOR USE IN STORING, RETRIEVING, AND TRANSMITTING MESSAGES COMPRISING VOICE, DATA, IMAGES, VIDEO AND TEXT OVER PUBLIC TELEPHONE NETWORKS, WIRELESS TELEPHONE NETWORKS AND LOCAL, NATIONAL AND GLOBAL INFORMATION NETWORKS; COMPUTER PROGRAMS FOR USE IN ESTABLISHING CONFERENCES OVER PUBLIC TELEPHONE NETWORKS, WIRELESS TELEPHONE NETWORKS AND LOCAL, NATIONAL AND GLOBAL INFORMATION NETWORKS; COMPUTER HARDWARE, NAMELY NETWORK SWITCH; TELECOMMUNICATION EQUIPMENT FOR USE WITH VOICE OVER INTERNET PROTOCOL, NAMELY TELECOMMUNICATION SWITCHES; COMPUTER TELEPHONY SOFTWARE (U.S. CLS. 21, 23, 26, 36 AND 38).

DAHLIA GEORGE, EXAMINING ATTORNEY

SN 78-905,948. MARUBENI ITOCHU STEEL AMERICA INC., NEW YORK, NY. FILED 6-12-2006.

# MISA

THE MARK CONSISTS OF STANDARD CHARACTERS WITHOUT CLAIM TO ANY PARTICULAR FONT, STYLE, SIZE, OR COLOR.

FOR FIRE ENGINES, FIRE BOATS; THEFT ALARMS; MAGNETIC CORES; WELDING ELECTRODES; WELDING MASKS; REGULATORS, NAMELY ACETYLENE REGULATORS, OXYGEN REGULATORS, STATIC VOLTAGE REGULATORS; WELDING TORCHES (U.S. CLS. 21, 23, 26, 36 AND 38).

AMY BROZENIC, EXAMINING ATTORNEY

**CLASS 9—(Continued).**

SN 78-906,772. PARMENIDES PUBLISHING, LAS VEGAS, NV. FILED 6-13-2006.

**PARMENIDES AUDIO**

THE MARK CONSISTS OF STANDARD CHARACTERS WITHOUT CLAIM TO ANY PARTICULAR FONT, STYLE, SIZE, OR COLOR.

OWNER OF U.S. REG. NO. 2,940,328.  
NO CLAIM IS MADE TO THE EXCLUSIVE RIGHT TO USE "AUDIO", APART FROM THE MARK AS SHOWN.  
FOR PRE-RECORDED CDS FEATURING AUDIO-BOOKS (U.S. CLS. 21, 23, 26, 36 AND 38).  
FIRST USE 5-4-2006; IN COMMERCE 5-4-2006.  
RAMONA ORTIGA, EXAMINING ATTORNEY

**CLASS 9—(Continued).**

SN 78-912,325. AZTEC PACIFIC, INC., NEWPORT BEACH, OR. FILED 6-20-2006.



FOR COMPUTER SOFTWARE USED TO TRACK, COLLECT, MEASURE, CATEGORIZE, RECORD AND STORE TIME SPECIFIC DATA AND GENERATE REPORTS FOR REVENUE CAPTURE (U.S. CLS. 21, 23, 26, 36 AND 38).  
SAIMA MAKHDOOM, EXAMINING ATTORNEY

SN 78-907,817. SAFFER, MARC, YORKTOWN HEIGHTS, NY. FILED 6-14-2006.

**intuaSell**

THE MARK CONSISTS OF STANDARD CHARACTERS WITHOUT CLAIM TO ANY PARTICULAR FONT, STYLE, SIZE, OR COLOR.

FOR COMPUTER SOFTWARE FOR USE IN CUSTOMER RELATIONSHIP MANAGEMENT (CRM) (U.S. CLS. 21, 23, 26, 36 AND 38).  
FIRST USE 11-1-2005; IN COMMERCE 11-1-2005.  
RAY THOMAS, EXAMINING ATTORNEY

SN 78-914,712. AUTOMATED SIGNATURE TECHNOLOGY, INC., STERLING, VA. FILED 6-22-2006.

**GHOSTWRITER**

THE MARK CONSISTS OF STANDARD CHARACTERS WITHOUT CLAIM TO ANY PARTICULAR FONT, STYLE, SIZE, OR COLOR.

FOR HANDWRITING DUPLICATION APPARATUS, SIGNATURE CARDS AND REPLACEMENT PARTS, SOLD AS A UNIT (U.S. CLS. 21, 23, 26, 36 AND 38).  
FIRST USE 2-0-2005; IN COMMERCE 2-0-2005.  
MICHAEL LEWIS, EXAMINING ATTORNEY

SN 78-909,293. CAMBRIDGE VISCOSITY INC., MEDFORD, MA. FILED 6-15-2006.

**VISCObot**

THE MARK CONSISTS OF STANDARD CHARACTERS WITHOUT CLAIM TO ANY PARTICULAR FONT, STYLE, SIZE, OR COLOR.

FOR AUTOMATED ELECTROMAGNETIC VISCOSITY METER (U.S. CLS. 21, 23, 26, 36 AND 38).  
FIRST USE 9-1-2005; IN COMMERCE 9-1-2005.  
WENDY GOODMAN, EXAMINING ATTORNEY

SN 78-918,044. DIAMOND GAME ENTERPRISES, INC., CHATSWORTH, CA. FILED 6-27-2006.

**REEF MADNESS**

THE MARK CONSISTS OF STANDARD CHARACTERS WITHOUT CLAIM TO ANY PARTICULAR FONT, STYLE, SIZE, OR COLOR.

FOR GAMING EQUIPMENT, NAMELY, GAMING MACHINES (U.S. CLS. 21, 23, 26, 36 AND 38).  
DORITT L. CARROLL, EXAMINING ATTORNEY

**CLASS 9—(Continued).**

SN 78-920,152. LUCRE COMPANIES, LLC, LAGUNA BEACH, CA. FILED 6-29-2006.



THE COLOR(S) RED, WHITE AND BLACK IS/ARE CLAIMED AS A FEATURE OF THE MARK.

THE MARK CONSISTS OF A RED BOX SHAPE WITH WHITE CUT OUTS ABOVE THE BLACK WORDING LUCRE.

FOR COMPUTER SOFTWARE, NAMELY, ANALYTICAL SOFTWARE FOR THE DUE DILIGENCE REVIEW OF LOANS IN THE MORTGAGE AND FINANCIAL INDUSTRY (U.S. CLS. 21, 23, 26, 36 AND 38).

WILLIAM BRECKENFELD, EXAMINING ATTORNEY

SN 78-920,822. BORDERS, HASSAN, BERWYN, IL. FILED 6-30-2006.

# MILTICKIT

THE MARK CONSISTS OF STANDARD CHARACTERS WITHOUT CLAIM TO ANY PARTICULAR FONT, STYLE, SIZE, OR COLOR.

FOR SERIES OF MUSICAL RECORDINGS, NAMELY, PRERECORDED AUDIO TAPES, AUDIO CASSETTES, COMPACT DISKS, DIGITAL VIDEO DISKS, DIGITAL AUDIO FILES, AND VIDEO CASSETTES, FEATURING PERFORMANCES BY A MUSICAL GROUP (U.S. CLS. 21, 23, 26, 36 AND 38).

FIRST USE 1-1-2005; IN COMMERCE 1-1-2005.

GEOFFREY FOSDICK, EXAMINING ATTORNEY

**CLASS 9—(Continued).**

SN 78-923,387. MEDICAL PRIORITY CONSULTANTS, INC., SALT LAKE CITY, UT. FILED 7-6-2006.

# AQUA EMD

THE MARK CONSISTS OF STANDARD CHARACTERS WITHOUT CLAIM TO ANY PARTICULAR FONT, STYLE, SIZE, OR COLOR.

NO CLAIM IS MADE TO THE EXCLUSIVE RIGHT TO USE "EMD", APART FROM THE MARK AS SHOWN.

FOR COMPUTER SOFTWARE FOR QUALITY CONTROL AND ASSURANCE IN THE FIELD OF EMERGENCY DISPATCH AND MEDICAL CARE SERVICES (U.S. CLS. 21, 23, 26, 36 AND 38).

FIRST USE 11-13-1996; IN COMMERCE 11-13-1996.

EVELYN BRADLEY, EXAMINING ATTORNEY

SN 78-924,277. ULTIMUS, INC., CARY, NC. FILED 7-7-2006.

# iBAM

THE MARK CONSISTS OF LOWER CASE LETTER I, CAPITAL LETTERS BAM.

FOR SOFTWARE FOR WORKFLOW AUTOMATION (U.S. CLS. 21, 23, 26, 36 AND 38).

MATTHEW EINSTEIN, EXAMINING ATTORNEY

SN 78-925,611. MAINSOFT CORPORATION, SAN JOSE, CA. FILED 7-10-2006.

# GRASSHOPPER

THE MARK CONSISTS OF STANDARD CHARACTERS WITHOUT CLAIM TO ANY PARTICULAR FONT, STYLE, SIZE, OR COLOR.

FOR COMPUTER SOFTWARE, NAMELY, FOR USE IN CREATING CROSS PLATFORM SOFTWARE AND FOR PORTING/MIGRATING EXISTING APPLICATIONS FROM ONE PLATFORM TO ANOTHER (U.S. CLS. 21, 23, 26, 36 AND 38).

FIRST USE 5-0-2005; IN COMMERCE 5-0-2005.

DANNEAN HETZEL, EXAMINING ATTORNEY



**CLASS 9—(Continued).**

SN 78-926,174. LEAPFROG ENTERPRISES, INC., EMERYVILLE, CA. FILED 7-10-2006.

**LEAPSTERTV**

THE MARK CONSISTS OF STANDARD CHARACTERS WITHOUT CLAIM TO ANY PARTICULAR FONT, STYLE, SIZE, OR COLOR.

OWNER OF U.S. REG. NOS. 3,030,048, 3,163,773 AND 3,172,250.

FOR CHILDREN'S EDUCATIONAL TOYS AND DEVICES, NAMELY, HANDHELD ELECTRONIC GAME UNITS ADAPTED FOR USE WITH TELEVISION RECEIVERS (U.S. CLS. 21, 23, 26, 36 AND 38).

AMY MCMENAMIN, EXAMINING ATTORNEY

**CLASS 9—(Continued).**

SN 78-942,593. MAKEPEACE, CLAYTON, SARASOTA, FL. FILED 8-1-2006.

**THE SCREAMING EAGLE**

THE MARK CONSISTS OF STANDARD CHARACTERS WITHOUT CLAIM TO ANY PARTICULAR FONT, STYLE, SIZE, OR COLOR.

FOR DOWNLOADABLE ELECTRONIC NEWSLETTERS FEATURING COPYWRITING STRATEGIES (U.S. CLS. 21, 23, 26, 36 AND 38).

NAKIA HENRY, EXAMINING ATTORNEY

SN 78-942,623. SUPERSONIC INC., LOS ANGELES, CA. FILED 8-1-2006.

SN 78-928,824. JAMMIN' SUNSHAYDES, LLC, WIXOM, MI. FILED 7-13-2006.

**SPORTBRIMZ**

THE MARK CONSISTS OF STANDARD CHARACTERS WITHOUT CLAIM TO ANY PARTICULAR FONT, STYLE, SIZE, OR COLOR.

OWNER OF U.S. REG. NO. 2,747,884.

FOR SUNGLASSES, SAFETY SHIELDS, NAMELY, FACE SHIELDS (U.S. CLS. 21, 23, 26, 36 AND 38).

FIRST USE 1-0-2005; IN COMMERCE 1-0-2005.

RENEE MCCRAY, EXAMINING ATTORNEY

SN 78-938,824. NFOCUS CONSULTING INC, LANCASTER, OH. FILED 7-27-2006.

**ResQue**

THE MARK CONSISTS OF STANDARD CHARACTERS WITHOUT CLAIM TO ANY PARTICULAR FONT, STYLE, SIZE, OR COLOR.

FOR COMPUTER SOFTWARE, NAMELY, DATABASE MANAGEMENT SOFTWARE USED TO MANAGE CONSUMER CONTACT INFORMATION FOR MAILING CAMPAIGNS, FOR USE BY COUPON MAILERS, LIST BROKERS, LETTER SHOPS, AND RETAILERS (U.S. CLS. 21, 23, 26, 36 AND 38).

FIRST USE 0-0-1999; IN COMMERCE 0-0-1999.

AMY ALFIERI, EXAMINING ATTORNEY

**IQ Sound**

THE MARK CONSISTS OF STANDARD CHARACTERS WITHOUT CLAIM TO ANY PARTICULAR FONT, STYLE, SIZE, OR COLOR.

NO CLAIM IS MADE TO THE EXCLUSIVE RIGHT TO USE "SOUND", APART FROM THE MARK AS SHOWN.

FOR AUDIO SPEAKERS; CD PLAYERS; COMPACT DISC PLAYERS; DIGITAL AUDIO PLAYERS; DIGITAL PHOTO FRAMES FOR DISPLAYING DIGITAL PICTURES, VIDEO CLIPS AND MUSIC; DVD-PLAYERS; HOME THEATER PRODUCTS, NAMELY, LCD; LCD LARGE-SCREEN DISPLAYS; LIQUID CRYSTAL DISPLAY (LCD) PROJECTORS; MEDIA PLAYERS; MP3 PLAYERS; PORTABLE LISTENING DEVICES, NAMELY, MP3 PLAYERS; PORTABLE MEDIA PLAYERS; PORTABLE RADIOS; TELEVISION RECEIVERS; TV MONITORS, PORTABLE DVD PLAYERS, MP4 PLAYERS, COLOR TV'S, BLACK AND WHITE TV'S, LCD LARGE SCREEN DISPLAYS, NAMELY LCD TFT DISPLAYS (U.S. CLS. 21, 23, 26, 36 AND 38).

FIRST USE 6-1-2006; IN COMMERCE 6-1-2006.

SETH A. RAPPAPORT, EXAMINING ATTORNEY

SN 78-942,850. TACKLE MARKETING GROUP, INC., NA-SHUA, NH. FILED 8-2-2006.

**TMGProfile**

THE MARK CONSISTS OF STANDARD CHARACTERS WITHOUT CLAIM TO ANY PARTICULAR FONT, STYLE, SIZE, OR COLOR.

FOR COMPUTER SOFTWARE FOR COLLECTING, STORING, ANALYZING AND MANAGING DATA RELATED TO FUND RAISING MANAGEMENT AND REPORTING (U.S. CLS. 21, 23, 26, 36 AND 38).

G. MAYERSCHOFF, EXAMINING ATTORNEY

**CLASS 9—(Continued).**

SN 78-945,040. KENYATTA, FLOYD, ORMOND BEACH, FL. AND MOODY, DEBBIE HENSON, ORMOND BEACH, FL. FILED 8-4-2006.

DRAMA AT THE BLACK FUNERAL

THE MARK CONSISTS OF STANDARD CHARACTERS WITHOUT CLAIM TO ANY PARTICULAR FONT, STYLE, SIZE, OR COLOR.

NO CLAIM IS MADE TO THE EXCLUSIVE RIGHT TO USE "BLACK FUNERAL", APART FROM THE MARK AS SHOWN.

FOR MOTION PICTURE FILMS ABOUT AFRICAN AMERICAN FUNERALS (U.S. CLS. 21, 23, 26, 36 AND 38).

DAVID HOFFMAN, EXAMINING ATTORNEY

**CLASS 9—(Continued).**

SN 78-947,297. VALLEY INDUSTRIES, L.L.C., LODI, CA. FILED 8-8-2006.

VALLEY INDUSTRIES ODYSSEY

THE MARK CONSISTS OF STANDARD CHARACTERS WITHOUT CLAIM TO ANY PARTICULAR FONT, STYLE, SIZE, OR COLOR.

OWNER OF U.S. REG. NO. 780,181.

NO CLAIM IS MADE TO THE EXCLUSIVE RIGHT TO USE "INDUSTRIES", APART FROM THE MARK AS SHOWN.

FOR ELECTRONIC BRAKE CONTROLS FOR LAND VEHICLE TRAILERS (U.S. CLS. 21, 23, 26, 36 AND 38).

SCOTT SISUN, EXAMINING ATTORNEY

SN 78-946,060. GSI TECHNOLOGY, INC., CORTLAND, OH. FILED 8-7-2006.

ZQ-DYNAMIC GALVANIZING

THE MARK CONSISTS OF STANDARD CHARACTERS WITHOUT CLAIM TO ANY PARTICULAR FONT, STYLE, SIZE, OR COLOR.

NO CLAIM IS MADE TO THE EXCLUSIVE RIGHT TO USE "GALVANIZING", APART FROM THE MARK AS SHOWN.

FOR GALVANIZING MACHINES (U.S. CLS. 21, 23, 26, 36 AND 38).

FIRST USE 11-13-2002; IN COMMERCE 11-13-2002.

SHARI SHEFFIELD, EXAMINING ATTORNEY

SN 78-947,523. JACO ELECTRONICS, INC., HAUPPAUGE, NY. FILED 8-8-2006.

MOPWER

THE MARK CONSISTS OF STANDARD CHARACTERS WITHOUT CLAIM TO ANY PARTICULAR FONT, STYLE, SIZE, OR COLOR.

FOR ELECTRONIC MEMORIES FOR ELECTRONIC EQUIPMENT (U.S. CLS. 21, 23, 26, 36 AND 38).

DAWN HAN, EXAMINING ATTORNEY

SN 78-946,418. WHEATON INDUSTRIES, INC., CHATTA-NOOGA, TN. FILED 8-7-2006.

E-Z EX-TRACTION

THE MARK CONSISTS OF STANDARD CHARACTERS WITHOUT CLAIM TO ANY PARTICULAR FONT, STYLE, SIZE, OR COLOR.

FOR LABORATORY STORAGE TUBES AND LABORATORY GLASSWARE, NAMELY, HIGH RECOVERY GLASS AND PLASTIC VIALS (U.S. CLS. 21, 23, 26, 36 AND 38).

FIRST USE 7-0-2004; IN COMMERCE 7-0-2004.

SKYE YOUNG, EXAMINING ATTORNEY

SN 78-948,299. UNIVERSITY PHYSICIANS NETWORK, LLC, NEW YORK, NY. FILED 8-9-2006.

RIGHT REMIT

THE MARK CONSISTS OF STANDARD CHARACTERS WITHOUT CLAIM TO ANY PARTICULAR FONT, STYLE, SIZE, OR COLOR.

NO CLAIM IS MADE TO THE EXCLUSIVE RIGHT TO USE "REMIT", APART FROM THE MARK AS SHOWN.

FOR COMPUTER SOFTWARE FOR AUTOMATED AUDITING OF PAYOR REMITTANCES IN THE FIELD OF HEALTHCARE (U.S. CLS. 21, 23, 26, 36 AND 38).

DAVID STERKIN, EXAMINING ATTORNEY

**CLASS 9—(Continued).**

SN 78-949,038. KENIA, MANEESH, OAKLAND, CA. FILED 8-10-2006.



**DHAMAAL**

THE MARK CONSISTS OF AN ELEPHANT HEAD OUTLINE, A WREATH RING DESIGN OF LEAVES, AND THE WORD "DHAMAAL".

THE ENGLISH TRANSLATION OF THE HINDI WORD DHAMAAL IN THE MARK IS FROLIC.

FOR AUDIO RECORDINGS FEATURING MUSIC (U.S. CLS. 21, 23, 26, 36 AND 38).

FIRST USE 5-30-1999; IN COMMERCE 4-30-2004.

JAMES MACFARLANE, EXAMINING ATTORNEY

SN 78-951,294. CHASE SPORTS INC., REDWOOD CITY, CA. FILED 8-14-2006.

## 803 EYEWEAR

THE MARK CONSISTS OF STANDARD CHARACTERS WITHOUT CLAIM TO ANY PARTICULAR FONT, STYLE, SIZE, OR COLOR.

NO CLAIM IS MADE TO THE EXCLUSIVE RIGHT TO USE "EYEWEAR", APART FROM THE MARK AS SHOWN. FOR SPORTS EYEWEAR (U.S. CLS. 21, 23, 26, 36 AND 38).

SANI KHOURI, EXAMINING ATTORNEY

SN 78-951,783. FUMA DIGITAL INTERNATIONAL, INC., MONTEREY PARK, CA. FILED 8-14-2006.

## HI-5 DIGITAL

THE MARK CONSISTS OF STANDARD CHARACTERS WITHOUT CLAIM TO ANY PARTICULAR FONT, STYLE, SIZE, OR COLOR.

NO CLAIM IS MADE TO THE EXCLUSIVE RIGHT TO USE "DIGITAL", APART FROM THE MARK AS SHOWN.

FOR DVD PLAYER FOR USE IN CARS, CEILING-MOUNT LCD MONITOR, PORTABLE MULTI-MEDIA PLAYER, PORTABLE DVD PLAYER, LCD TELEVISION MONITOR THAT ATTACHES TO AUTOMOBILE SUN VISORS (U.S. CLS. 21, 23, 26, 36 AND 38).

ROBERT LAVACHE, EXAMINING ATTORNEY

**CLASS 9—(Continued).**

SN 78-953,384. VISIONEERED IMAGE SYSTEMS, INC., GARDEN GROVE, CA. FILED 8-16-2006.

## VISMAX

THE MARK CONSISTS OF STANDARD CHARACTERS WITHOUT CLAIM TO ANY PARTICULAR FONT, STYLE, SIZE, OR COLOR.

FOR ELECTRONIC BILLBOARDS, NAMELY ELECTRONIC ADVERTISEMENT AND MESSAGING DISPLAY UNIT WITH MULTI-NETWORKING (TCP/IP) CAPABILITIES AND REMOTE CONNECTIVITY (U.S. CLS. 21, 23, 26, 36 AND 38).

TAMARA LEE, EXAMINING ATTORNEY

SN 78-954,430. VANCO INTERNATIONAL, INC., BATAVIA, IL. FILED 8-17-2006.



THE COLOR(S) BLACK, RED, AND GRAY IS/ARE CLAIMED AS A FEATURE OF THE MARK.

THE MARK CONSISTS OF THE COLOR BLACK APPEARS IN ALL WORDING; THE COLOR RED APPEARS IN THE OUTLINE OF THE WORDING STANDOFF SIMPLY SAVES TIME AND IN THE CONNECTOR BLOCK; THE COLOR GRAY APPEARS IN THE STRAP.

FOR STRAP ASSEMBLY FOR HOLDING COMMUNICATION CABLE IN PLACE (U.S. CLS. 21, 23, 26, 36 AND 38).

CYNTHIA SLOAN, EXAMINING ATTORNEY

SN 78-956,348. XCEIVE CORPORATION, SANTA CLARA, CA. FILED 8-21-2006.

## CHANNELVISTA

THE MARK CONSISTS OF STANDARD CHARACTERS WITHOUT CLAIM TO ANY PARTICULAR FONT, STYLE, SIZE, OR COLOR.

FOR AUDIOVISUAL RECEIVERS; TRANSCEIVERS (U.S. CLS. 21, 23, 26, 36 AND 38).

TAMARA FRAZIER, EXAMINING ATTORNEY

**CLASS 9—(Continued).**

SN 78-956,648. ELLONA INCORPORATED, CHICAGO, IL.  
FILED 8-21-2006.

**LOVENDAR**

THE MARK CONSISTS OF STANDARD CHARACTERS WITHOUT CLAIM TO ANY PARTICULAR FONT, STYLE, SIZE, OR COLOR.

FOR COMPUTER SOFTWARE FOR THE PURPOSE OF THE MANAGEMENT OF INFORMATION, NAMELY, CALENDAR, CONTACTS, NOTES, JOURNALS, AND TASKS (U.S. CLS. 21, 23, 26, 36 AND 38).

MARGARET POWER, EXAMINING ATTORNEY

**CLASS 9—(Continued).**

SN 78-957,247. SCRIPTEL CORPORATION, COLUMBUS, OH.  
FILED 8-22-2006.

**TASKSPACE**

THE MARK CONSISTS OF STANDARD CHARACTERS WITHOUT CLAIM TO ANY PARTICULAR FONT, STYLE, SIZE, OR COLOR.

FOR HAND-HELD COMPUTERS FEATURING FLAT PANEL TOUCH SENSITIVE DISPLAY SCREENS AND EXPANSION SLOTS (U.S. CLS. 21, 23, 26, 36 AND 38).

MICHAEL ENGEL, EXAMINING ATTORNEY

SN 78-956,685. VODA MUSIK, LLC, NEW YORK, NY. FILED  
8-21-2006.

**ALEXANDR K**

THE MARK CONSISTS OF STANDARD CHARACTERS WITHOUT CLAIM TO ANY PARTICULAR FONT, STYLE, SIZE, OR COLOR.

THE NAME(S), PORTRAIT(S), AND/OR SIGNATURE(S) SHOWN IN THE MARK IDENTIFIES ALEXANDER KOGAN, WHOSE CONSENT(S) TO REGISTER IS SUBMITTED.

FOR SERIES OF RECORDINGS FEATURING MUSIC, MUSICAL SOUND RECORDINGS, MUSICAL VIDEO RECORDINGS, DOWNLOADABLE MUSICAL SOUND RECORDINGS, AND DOWNLOADABLE MUSICAL VIDEO RECORDINGS (U.S. CLS. 21, 23, 26, 36 AND 38).

JUSTINE D. PARKER, EXAMINING ATTORNEY

SN 78-957,250. GOWIN, THOMAS, SANTA CLARITA, CA.  
FILED 8-22-2006.

**staying with the times**

THE MARK CONSISTS OF STANDARD CHARACTERS WITHOUT CLAIM TO ANY PARTICULAR FONT, STYLE, SIZE, OR COLOR.

FOR COMMUNICATIONS COMPUTERS (U.S. CLS. 21, 23, 26, 36 AND 38).

PAUL CROWLEY, EXAMINING ATTORNEY

SN 78-956,846. WASHINGTON MUTUAL, INC., SEATTLE, WA. FILED 8-21-2006.

**WAMU**

THE MARK CONSISTS OF STANDARD CHARACTERS WITHOUT CLAIM TO ANY PARTICULAR FONT, STYLE, SIZE, OR COLOR.

OWNER OF U.S. REG. NOS. 2,315,782, 2,498,860 AND OTHERS.

FOR MAGNETICALLY ENCODED CREDIT CARDS, CASH CARDS, CHECK CARDS, ATM CARDS, DEBIT CARDS AND STORED VALUE CARDS; ELECTRONICALLY READABLE CREDIT CARDS, CASH CARDS, CHECK CARDS, ATM CARDS, DEBIT CARDS AND STORED VALUE CARDS (U.S. CLS. 21, 23, 26, 36 AND 38).

GEORGIA CARTY, EXAMINING ATTORNEY

SN 78-957,340. COMPUTER PARTNERS, INC., CULLMAN, AL. FILED 8-22-2006.

**C-RAE**

THE MARK CONSISTS OF STANDARD CHARACTERS WITHOUT CLAIM TO ANY PARTICULAR FONT, STYLE, SIZE, OR COLOR.

FOR COMPUTER SOFTWARE FOR THE COLLECTION, EDITING, ORGANIZING, MODIFYING, BOOK MARKING, TRANSMISSION, STORAGE AND SHARING OF DATA AND INFORMATION IN THE FIELD OF WORTHLESS CHECK RECOVERY AND ENFORCEMENT FOR USE BY PROSECUTORS AND LAW ENFORCEMENT PERSONNEL (U.S. CLS. 21, 23, 26, 36 AND 38).

EMILY CHUO, EXAMINING ATTORNEY

**CLASS 9—(Continued).**

SN 78-957,361. SHEVILLE.ORG, ASHEVILLE, NC. FILED 8-22-2006.

# Sheville

THE MARK CONSISTS OF STANDARD CHARACTERS WITHOUT CLAIM TO ANY PARTICULAR FONT, STYLE, SIZE, OR COLOR.

FOR ELECTRONIC PUBLICATIONS, NAMELY, MAGAZINE FEATURING ARTS, EVENTS, HEALTH AND WELLNESS FOR WOMEN IN WESTERN NORTH CAROLINA RECORDED ON COMPUTER MEDIA (U.S. CLS. 21, 23, 26, 36 AND 38).

FIRST USE 4-6-1997; IN COMMERCE 4-6-1997.  
ALYSSA PALADINO, EXAMINING ATTORNEY

**CLASS 9—(Continued).**

SN 78-957,965. S&K OF TAMPA, INC., TAMPA, FL. FILED 8-22-2006.



THE COLOR(S) BLACK, WHITE, RED, BLUE, YELLOW, ORANGE, BROWN, BEIGE, GREEN, PINK AND GRAY IS/ARE CLAIMED AS A FEATURE OF THE MARK.

THE MARK CONSISTS OF A STYLIZED PHRASE OF THINGS IN BLACK; GRANNY USED TO DO IN RED WITH A RED MARK UNDER IT; A BLUE CRAYON WITH A RED TIP AND BLACK AND WHITE DETAIL; YELLOW BALL OF YARN WITH WHITE CROCHET STICKS WITH RED ENDS; GREEN AND YELLOW TILES IN THE BACKGROUND; A BLUE KITCHEN GLOVE WITH YELLOW AND WHITE DETAIL THAT IS OUTLINED IN BLACK; AN ORANGE AND BROWN COFFEE MUG OUTLINED IN BLACK WITH WHITE DETAIL; PINK STEAM COMING OUT OF THE COFFEE MUG; GRANNY IS WEARING A GRAY APRON OUTLINED IN BLACK, A PINK, GREEN AND WHITE SHIRT, WHITE AND BEIGE NECKLACE AND EARRING, BLACK FRAME GLASSES, BLUE EYES, GRAY, BLACK AND WHITE HAIR, WHITE TEETH, BEIGE, ORANGE AND YELLOW FACE.

FOR PRE-RECORDED CDS, VIDEO TAPES, LASER DISKS AND DVD'S FEATURING EDUCATIONAL ENTERTAINMENT FOR CHILDREN IN THE NATURE OF COOKING INSTRUCTION, ETIQUETTE INSTRUCTION, GARDENING INSTRUCTION, PARTY PLANNING INSTRUCTION, AND DOMESTIC SKILLS INSTRUCTION FOR CHILDREN (U.S. CLS. 21, 23, 26, 36 AND 38).

EMILY CHUO, EXAMINING ATTORNEY

SN 78-957,855. MORGAN BEAUMONT, INC., BRADENTON, FL. FILED 8-22-2006.



SN 78-957,973. MILLER, JILL, SANTA MONICA, CA. FILED 8-22-2006.

# YOGA TUNE UP

THE COLOR(S) YELLOW AND BLUE IS/ARE CLAIMED AS A FEATURE OF THE MARK.

THE COLOR YELLOW APPEARS IN THE INTERIOR OF THE NUMBER "3" AND THE BORDER OF THE LETTER "O". THE COLOR BLUE APPEARS IN THE BORDER OF THE NUMBER "3" AND THE INTERIOR OF THE LETTER "O".

FOR MAGNETICALLY ENCODED, PRE-PAID STORED VALUE DEBIT CARDS (U.S. CLS. 21, 23, 26, 36 AND 38).

TRAVIS WHEATLEY, EXAMINING ATTORNEY

THE MARK CONSISTS OF STANDARD CHARACTERS WITHOUT CLAIM TO ANY PARTICULAR FONT, STYLE, SIZE, OR COLOR.

NO CLAIM IS MADE TO THE EXCLUSIVE RIGHT TO USE "YOGA", APART FROM THE MARK AS SHOWN.

FOR SOUND, AUDIO AND/OR VISUAL RECORDINGS, NAMELY PRE-RECORDED DVDS, COMPACT DISCS, AND CD-ROMS FEATURING YOGA INSTRUCTION (U.S. CLS. 21, 23, 26, 36 AND 38).

FIRST USE 9-16-2004; IN COMMERCE 12-0-2004.  
EMILY CHUO, EXAMINING ATTORNEY

**CLASS 9—(Continued).**

SN 78-957,979. S&K OF TAMPA, INC., TAMPA, FL. FILED 8-22-2006.

**Things Granny used to do**

THE MARK CONSISTS OF STANDARD CHARACTERS WITHOUT CLAIM TO ANY PARTICULAR FONT, STYLE, SIZE, OR COLOR.

FOR PRE-RECORDED CDS, VIDEO TAPES, LASER DISKS AND DVD'S FEATURING EDUCATIONAL ENTERTAINMENT FOR CHILDREN IN THE NATURE OF COOKING INSTRUCTION, ETIQUETTE INSTRUCTION, GARDENING INSTRUCTION, PARTY PLANNING INSTRUCTION, AND DOMESTIC SKILLS INSTRUCTION FOR CHILDREN (U.S. CLS. 21, 23, 26, 36 AND 38).

EMILY CHUO, EXAMINING ATTORNEY

SN 78-958,169. GEORGE F. MCCULLOUGH, SAN DIEGO, CA. FILED 8-23-2006.

**GLOBAL TENNIS**

THE MARK CONSISTS OF STANDARD CHARACTERS WITHOUT CLAIM TO ANY PARTICULAR FONT, STYLE, SIZE, OR COLOR.

FOR COMPUTER SOFTWARE THAT ASSISTS COMPUTERS IN DEPLOYING PARALLEL APPLICATIONS AND PERFORMING PARALLEL COMPUTATIONS (U.S. CLS. 21, 23, 26, 36 AND 38).

THOMAS MANOR, EXAMINING ATTORNEY

SN 78-958,957. MAHR FEDERAL INC., PROVIDENCE, RI. FILED 8-23-2006.

**EASYFORM**

THE MARK CONSISTS OF STANDARD CHARACTERS WITHOUT CLAIM TO ANY PARTICULAR FONT, STYLE, SIZE, OR COLOR.

FOR SOFTWARE FOR CONTROLLING PRECISION MEASURING INSTRUMENTS (U.S. CLS. 21, 23, 26, 36 AND 38).

FIRST USE 11-3-2005; IN COMMERCE 11-3-2005.  
ALYSSA PALADINO, EXAMINING ATTORNEY

**CLASS 9—(Continued).**

SN 78-959,070. COGENT, INC., SO. PASADENA, CA. FILED 8-23-2006.

**BLUECHECK**

THE MARK CONSISTS OF STANDARD CHARACTERS WITHOUT CLAIM TO ANY PARTICULAR FONT, STYLE, SIZE, OR COLOR.

FOR SCIENTIFIC INSTRUMENT, NAMELY, BIOLOGICAL DEVICE FOR BIOMETRIC IDENTIFICATION AND VERIFICATION USED TO CAPTURE AND IDENTIFY FINGERPRINT DATA (U.S. CLS. 21, 23, 26, 36 AND 38).

FIRST USE 6-0-2006; IN COMMERCE 6-0-2006.  
ODESSA BIBBINS, EXAMINING ATTORNEY

SN 78-959,221. GROVE SOFTWARE, INC., LYNCHBURG, VA. FILED 8-24-2006.

**RADDECAY**

THE MARK CONSISTS OF STANDARD CHARACTERS WITHOUT CLAIM TO ANY PARTICULAR FONT, STYLE, SIZE, OR COLOR.

SEC. 2(F).  
FOR COMPUTER SOFTWARE FOR PROVIDING INFORMATION ON RADIATION DECAY FOR 497 RADIONUCLIDES; DOWNLOADABLE SOFTWARE FOR PROVIDING INFORMATION ON RADIATION DECAY FOR 497 RADIONUCLIDES (U.S. CLS. 21, 23, 26, 36 AND 38).

FIRST USE 11-0-1986; IN COMMERCE 11-0-1986.  
ADA HAN, EXAMINING ATTORNEY

SN 78-959,362. BARTRON, RON R., SPOKANE, WA. FILED 8-24-2006.

**SPY-LOK**

THE MARK CONSISTS OF STANDARD CHARACTERS WITHOUT CLAIM TO ANY PARTICULAR FONT, STYLE, SIZE, OR COLOR.

FOR MESH NETWORK OF TEMPERATURE PROBES WHICH MEASURES THE INTERNAL TEMPERATURES OF COMPOST PILES AND WIRELESSLY TRANSMITS THE TEMPERATURE DATA TO A COMPUTER; AN OPTICAL METROLOGY INSPECTION SYSTEM COMPRISED OF A LIGHT SOURCE, ONE OR MORE CAMERAS AND SENSORS IN COMMUNICATION WITH COMPUTER SOFTWARE AND HARDWARE; ARM RESTS FOR USE WITH COMPUTERS; BACKUP DRIVES FOR COMPUTERS; BIOS (BASIC INPUT OUTPUT SYSTEM) COMPUTER PROGRAMS; BIOS (BASIC INPUT/OUTPUT SYSTEM) COMPUTER PROGRAM; BLANK COMPUTER DISCS; BLANK DISCS FOR COMPUTERS; BLANK FLOPPY COMPUTER DISCS; BLANK

**CLASS 9—(Continued).**

HARD COMPUTER DISCS; BLANK MAGNETIC COMPUTER TAPES; BLANK TAPES FOR STORAGE OF COMPUTER DATA; CAR NAVIGATION COMPUTERS; CD DRIVES FOR COMPUTERS; CENTRAL PROCESSING UNITS (CPU); COMMUNICATIONS COMPUTERS; COMMUNICATIONS SERVERS; COMPUTER ACCELERATOR BOARD; COMPUTER APPLICATION SOFTWARE FOR MOBILE PHONES; COMPUTER BASED APPARATUS FOR DESIGNING THE LAYOUT OF ELECTRONIC CIRCUITS; COMPUTER BUFFERS; COMPUTER CABLES; COMPUTER CAMERAS; COMPUTER CARD ADAPTER; COMPUTER CARRYING CASES; COMPUTER CENTRAL PROCESSING UNITS; COMPUTER CHASSIS; COMPUTER CHIPS; COMPUTER CHIPSET FOR USE IN TRANSMITTING DATA TO AND FROM A CENTRAL PROCESSING UNIT; COMPUTER COLOR PRINTER USING HEAT SENSITIVE DRY PRINTING PROCESS; COMPUTER COMMUNICATIONS SOFTWARE TO ALLOW CUSTOMERS TO ACCESS BANK ACCOUNT INFORMATION AND TRANSACT BANK BUSINESS; COMPUTER COMPONENT TESTING AND CALIBRATING EQUIPMENT; COMPUTER CURSOR CONTROL DEVICES, NAMELY, COMPUTER MOUSE; COMPUTER CURSOR CONTROL DEVICES, NAMELY, DIGITIZER TABLETS; COMPUTER CURSOR CONTROL DEVICES, NAMELY, LIGHT PENS; COMPUTER CURSOR CONTROL DEVICES, NAMELY, TOUCH PADS; COMPUTER CURSOR CONTROL DEVICES, NAMELY, TRACKBALLS; COMPUTER DISC DRIVES; COMPUTER DOCKING STATION; COMPUTER E-COMMERCE SOFTWARE TO ALLOW USERS TO PERFORM ELECTRONIC BUSINESS TRANSACTIONS VIA A GLOBAL COMPUTER NETWORK; COMPUTER EXPANSION BOARDS; COMPUTER FAX MODEM CARDS; COMPUTER GAME CARTRIDGES; COMPUTER GAME CASSETTES; COMPUTER GAME DISCS; COMPUTER GAME EQUIPMENT CONTAINING MEMORY DEVICES NAMELY, DISCS; COMPUTER GAME JOYSTICKS; COMPUTER GAME PROGRAMS; COMPUTER GAME SOFTWARE; COMPUTER GAME SOFTWARE, NAMELY A COMPUTER CRAPS GAME; COMPUTER GAME TAPES; COMPUTER GRAPHICS BOARDS; COMPUTER GRAPHICS SOFTWARE; COMPUTER HARD DISCS; COMPUTER HARDWARE; COMPUTER HARDWARE AND COMPUTER SOFTWARE PROGRAMS FOR THE INTEGRATION OF TEXT, AUDIO, GRAPHICS, STILL IMAGE AND MOVING PICTURES INTO AN INTERACTIVE DELIVERY FOR MULTIMEDIA APPLICATIONS; COMPUTER HARDWARE FOR TELECOMMUNICATIONS; COMPUTER HARDWARE, NAMELY, FIREWALLS; COMPUTER HARDWARE, NAMELY, WIRELESS ACCESS POINT (WAP) DEVICES; COMPUTER HEAT SINKS; COMPUTER INTERFACE BOARDS; COMPUTER JOYSTICKS; COMPUTER KEYBOARDS; COMPUTER KEYPADS; COMPUTER MEMORIES; COMPUTER MEMORY HARDWARE; COMPUTER MONITOR FRAMES; COMPUTER MONITORS; COMPUTER MOUSE; COMPUTER MOUSE, NAMELY, TOUCHPADS; COMPUTER MOUSE, NAMELY, TRACKBALLS; COMPUTER NETWORK ADAPTERS; COMPUTER NETWORK HUBS, SWITCHES AND ROUTERS; COMPUTER NETWORKING HARDWARE; COMPUTER OPERATING PROGRAMS; COMPUTER OPERATING SYSTEMS; COMPUTER PARALLEL PORTS; COMPUTER PERIPHERALS; COMPUTER PRINTERS; COMPUTER PROGRAM FOR THE COMPILATION OF CREDIT REPORTING DATA; COMPUTER PROGRAMS FOR DOCUMENT MANAGEMENT; COMPUTER PROGRAMS FOR EDITING IMAGES, SOUND AND VIDEO; COMPUTER PROGRAMS FOR PRE-RECORDED GAMES; COMPUTER PROGRAMS FOR SEARCHING THE CONTENTS OF COMPUTERS AND COMPUTER NETWORKS BY REMOTE CONTROL; COMPUTER PROGRAMS FOR THE ENABLING OF ACCESS OR ENTRANCE CONTROL; COMPUTER PROGRAMS RECORDED ON DATA MEDIA (SOFTWARE) DESIGNED FOR USE IN CONSTRUCTION AND AUTOMATED MANUFACTURING (CAD/CAM); COMPUTER PROGRAMS USED FOR ELECTRONIC CASH REGISTER SYSTEMS; COMPUTER SCREEN FILTERS; COMPUTER SCREEN SAVER SOFTWARE; COMPUTER SEARCH ENGINE SOFTWARE; COMPUTER SERIAL PORTS; COMPUTER SOFTWARE AND FIRMWARE FOR GAMES OF CHANCE ON ANY COMPUTERIZED PLATFORM, INCLUDING DEDICATED GAMING CONSOLES, VIDEO BASED SLOT MACHINES, REEL BASED SLOT MACHINES, AND VIDEO LOTTERY TERMINALS; COMPUTER SOFT-

**CLASS 9—(Continued).**

WARE DEVELOPMENT TOOLS; COMPUTER SOFTWARE FOR ACCESSING INFORMATION DIRECTORIES THAT MAY BE DOWNLOADED FROM THE GLOBAL COMPUTER NETWORK; COMPUTER SOFTWARE FOR ADMINISTRATION OF COMPUTER LOCAL AREA NETWORKS; COMPUTER SOFTWARE FOR APPLICATION AND DATABASE INTEGRATION; COMPUTER SOFTWARE FOR COMMUNICATING WITH USERS OF HAND-HELD COMPUTERS; COMPUTER SOFTWARE FOR COMPUTER SYSTEM AND APPLICATION DEVELOPMENT, DEPLOYMENT AND MANAGEMENT; COMPUTER SOFTWARE FOR CONTROLLING AND MANAGING ACCESS SERVER APPLICATIONS; COMPUTER SOFTWARE FOR CONTROLLING AND MANAGING PATIENT MEDICAL INFORMATION; COMPUTER SOFTWARE FOR CONTROLLING SELF-SERVICE TERMINALS; COMPUTER SOFTWARE FOR CREATING SEARCHABLE DATABASES OF INFORMATION AND DATA; COMPUTER SOFTWARE FOR ENCRYPTION; COMPUTER SOFTWARE FOR INTERPRETATION OF NEURO AND BRAIN SCANS PROVIDED BY DIAGNOSTIC IMAGING EQUIPMENT; COMPUTER SOFTWARE FOR MANIPULATING DIGITAL AUDIO INFORMATION FOR USE IN AUDIO MEDIA APPLICATIONS; COMPUTER SOFTWARE FOR ORGANIZING AND VIEWING DIGITAL IMAGES AND PHOTOGRAPHS; COMPUTER SOFTWARE FOR PROCESSING DIGITAL MUSIC FILES; COMPUTER SOFTWARE FOR PROVIDING AN ONLINE DATABASE IN THE FIELD OF TRANSACTION PROCESSING TO UPLOAD TRANSACTIONAL DATA, PROVIDE STATISTICAL ANALYSIS, AND PRODUCE NOTIFICATIONS AND REPORTS; COMPUTER SOFTWARE FOR PULMONARY, CARDIOVASCULAR AND EDEMA ANALYSIS FOR USE IN SMALL ANIMAL RESEARCH STUDIES; COMPUTER SOFTWARE FOR SCIENTIFIC ANALYSIS OF GENETIC SEQUENCES; COMPUTER SOFTWARE FOR THE COLLECTION, EDITING, ORGANIZING, MODIFYING, BOOK MARKING, TRANSMISSION, STORAGE AND SHARING OF DATA AND INFORMATION; COMPUTER SOFTWARE FOR THE CREATION OF FIREWALLS; COMPUTER SOFTWARE FOR THE FIELD OF WAREHOUSING AND DISTRIBUTION, TO MANAGE TRANSACTIONAL DATA, PROVIDE STATISTICAL ANALYSIS, AND PRODUCE NOTIFICATIONS AND REPORTS; COMPUTER SOFTWARE FOR USE IN CUSTOMER RELATIONSHIP MANAGEMENT (CRM); COMPUTER SOFTWARE FOR USE IN PROGRAMMING FACSIMILE MACHINES; COMPUTER SOFTWARE FOR USE IN RELATION TO DIGITAL ANIMATION AND SPECIAL EFFECTS OF IMAGES; COMPUTER SOFTWARE FOR USE IN THE ENCRYPTION AND DECRYPTION OF DIGITAL FILES, INCLUDING AUDIO, VIDEO, TEXT, BINARY, STILL IMAGES, GRAPHICS AND MULTIMEDIA FILES; COMPUTER SOFTWARE FOR THE SAFEGUARDING OF DIGITAL FILES, INCLUDING AUDIO, VIDEO, TEXT, BINARY, STILL IMAGES, GRAPHICS AND MULTIMEDIA FILES; COMPUTER SOFTWARE FOR WIRELESS CONTENT DELIVERY; COMPUTER SOFTWARE THAT ASSISTS COMPUTERS IN DEPLOYING PARALLEL APPLICATIONS AND PERFORMING PARALLEL COMPUTATIONS; COMPUTER SOFTWARE THAT PROVIDES REAL-TIME, INTEGRATED BUSINESS MANAGEMENT INTELLIGENCE BY COMBINING INFORMATION FROM VARIOUS DATABASES AND PRESENTING IT IN AN EASY-TO-UNDERSTAND USER INTERFACE; COMPUTER SOFTWARE TO AUTOMATE DATA WAREHOUSING; COMPUTER SOFTWARE TO CONTROL AND IMPROVE COMPUTER AND AUDIO EQUIPMENT SOUND QUALITY; COMPUTER SOFTWARE TO ENABLE THE TRANSMISSION OF PHOTOGRAPHS TO MOBILE TELEPHONES; COMPUTER SOFTWARE TO ENHANCE THE AUDIO-VISUAL CAPABILITIES OF MULTIMEDIA APPLICATIONS, NAMELY, FOR THE INTEGRATION OF TEXT, AUDIO, GRAPHICS, STILL IMAGES AND MOVING PICTURES; COMPUTER SOFTWARE, NAMELY, AN APPLICATION ALLOWING SALES AND FIELD SERVICE EMPLOYEES TO UPDATE AND RECEIVE DATA STORED IN AN ENTERPRISE'S COMPUTER DATABASES IN REAL TIME, USING A MOBILE DEVICE, WITH FULL TELEPHONY INTEGRATION WITH THE TELEPHONE AND/OR SOFTWARE FEATURES OF THE MOBILE DEVICE; COMPUTER SOFTWARE, NAMELY, SOFTWARE DEVELOPMENT TOOLS FOR THE CREATION OF MOBILE INTERNET APPLICATIONS AND CLIENT INTERFACES; COMPU-

**CLASS 9—(Continued).**

TER STANDS SPECIALLY DESIGNED FOR HOLDING A COMPUTER, PRINTER AND ACCESSORIES; COMPUTER STORAGE DEVICES, NAMELY, FLASH DRIVES; COMPUTER STORAGE DEVICES, NAMELY, JUMP DRIVES; COMPUTER STORAGE DEVICES, NAMELY, THUMB DRIVES; COMPUTER STYLUS; COMPUTER TELEPHONY SOFTWARE; COMPUTER TERMINALS; COMPUTER UTILITY PROGRAMS; COMPUTER WHITEBOARDS; COMPUTER-CONTROLLED ELECTRONIC APPARATUS FOR ELECTROPHYSIOLOGICAL MEASUREMENT AND TESTING OF CELLS; COMPUTERS; COMPUTERS AND INSTRUCTIONAL MANUALS SOLD AS A UNIT; COMPUTERS FOR MANAGING CONTROL DEVICES FOR AIRCRAFT; CONSUMER COUPONS DOWNLOADED FROM A GLOBAL COMPUTER NETWORK; DESKTOP COMPUTERS; DOWNLOADABLE RING TONES, GRAPHICS AND MUSIC VIA A GLOBAL COMPUTER NETWORK AND WIRELESS DEVICES; DUST COVERS FOR COMPUTERS; ELECTRONIC COMPUTERS; FLOPPY DISCS DRIVES ; FRAMES FOR ATTACHMENT TO COMPUTER MONITORS; GATEWAY ROUTERS IN THE NATURE OF COMPUTER CONTROL HARDWARE; GLOBAL POSITIONING SYSTEM (GPS) CONSISTING OF COMPUTERS, COMPUTER SOFTWARE, TRANSMITTERS, RECEIVERS, AND NETWORK INTERFACE DEVICES; HANDHELD COMPUTERS; HANDHELD PERSONAL COMPUTERS; HARD DISCS FOR COMPUTERS; HARD DRIVES FOR COMPUTERS; HEADSETS FOR USE WITH COMPUTERS; HEAT SINKS FOR USE IN COMPUTERS; INDUSTRIAL PROCESSED CONTROL SOFTWARE FOR GENERATING COMPUTER READABLE MARKINGS FOR APPLICATION TO BOARD LUMBER; INTERACTIVE MULTIMEDIA COMPUTER GAME PROGRAM; INTERACTIVE VIDEO GAMES OF VIRTUAL REALITY COMPRISED OF COMPUTER HARDWARE AND SOFTWARE; INTERNAL COOLING FANS FOR COMPUTERS; JACKETS FOR COMPUTER DISKS; JUKE BOXES; LAN (LOCAL AREA NETWORK) ACCESS POINTS FOR CONNECTING NETWORK COMPUTER USERS; LAN (LOCAL AREA NETWORK) COMPUTER CARDS FOR CONNECTING PORTABLE COMPUTER DEVICES TO COMPUTER NETWORKS; LAPTOP COMPUTERS; MAGNETICALLY ENCODED KEY CARDS; MEMORY CARDS; MICRO-COMPUTER; MICRO-COMPUTERS; MICROCHIPS; MICROPROCESSORS; MOBILE COMPUTERS; MOBILE COMPUTING AND OPERATING PLATFORMS CONSISTING OF DATA TRANSCEIVERS, WIRELESS NETWORKS AND GATEWAYS FOR COLLECTION AND MANAGEMENT OF DATA; WRIST SUPPORTS FOR COMPUTER MOUSE USERS (U.S. CLS. 21, 23, 26, 36 AND 38).

PRISCILLA MILTON, EXAMINING ATTORNEY

SN 78-959,390. CRM SOFTWARE, INC., WEST PALM BEACH, FL. FILED 8-24-2006.



The logo for Junxure Clientview features the word "Junxure" in a bold, blue, sans-serif font, followed by "Clientview" in a lighter blue, sans-serif font. The text is contained within a blue rectangular border.

THE COLOR(S) BLUE, LIGHT BLUE AND WHITE IS/ARE CLAIMED AS A FEATURE OF THE MARK.

THE MARK COMPRISES A BLUE RECTANGLE IN WHICH THE TERM "JUNXURE" APPEARS IN THE COLOR WHITE ON A BLUE FIELD, AND THE TERM "CLIENTVIEW" APPEARS IN THE COLOR BLUE ON A WHITE FIELD. THE "X" IN "JUNXTURE" APPEARS IN LIGHT BLUE.

FOR COMPUTER SOFTWARE FOR CLIENT CONTACT MANAGEMENT AND OFFICE WORKFLOW AUTOMATION, AND DOWNLOADABLE SOFTWARE FOR CLIENT CONTACT MANAGEMENT AND OFFICE WORKFLOW AUTOMATION (U.S. CLS. 21, 23, 26, 36 AND 38).

FIRST USE 3-1-2006; IN COMMERCE 3-1-2006.  
GEOFFREY FOSDICK, EXAMINING ATTORNEY

**CLASS 9—(Continued).**

SN 78-959,552. EARTHLINK, INC., ATLANTA, GA. FILED 8-24-2006.



The logo for EarthLink PC Fine Tune features three interlocking gears of varying sizes to the left of the text. "EarthLink" is in a smaller, black, sans-serif font, and "PC Fine Tune" is in a larger, bold, black, sans-serif font.

OWNER OF U.S. REG. NOS. 1,950,376, 3,102,326 AND OTHERS.

THE MARK CONSISTS OF 3 INTERLOCKING COGS NEXT TO THE WORDS EARTHLINK PC FINETUNE.

FOR COMPUTER SOFTWARE THAT DIAGNOSES AND RESOLVES COMMON COMPUTER PERFORMANCE ISSUES BY DEFRAGMENTING A HARD DRIVE, ELIMINATING UNNECESSARY TEMPORARY FILES AND COOKIES, FIXES REGISTRY ERRORS, REMOVES UNUSED DEVICE DRIVERS, AND DISABLES UNNEEDED START-UP ITEMS THAT EXHAUST A COMPUTER'S MEMORY AND SLOWS DOWN A COMPUTER (U.S. CLS. 21, 23, 26, 36 AND 38).

LINDA LAVACHE, EXAMINING ATTORNEY

SN 78-959,713. L. C. LICENSING, INC., NEW YORK, NY. FILED 8-24-2006.

BORN IN THE GLAMOROUS USA

THE MARK CONSISTS OF STANDARD CHARACTERS WITHOUT CLAIM TO ANY PARTICULAR FONT, STYLE, SIZE, OR COLOR.

FOR EYEWEAR AND ACCESSORIES, NAMELY EYEGLASSES, SUNGLASSES, EYEWEAR CASES, EYEWEAR FRAMES AND CHAINS AND CORDS FOR EYEWEAR (U.S. CLS. 21, 23, 26, 36 AND 38).

COLLEEN DOMBROW, EXAMINING ATTORNEY

SN 78-959,740. SYMARK INTERNATIONAL, INC., AGOURA HILLS, CA. FILED 8-24-2006.

POWERSERIES

THE MARK CONSISTS OF STANDARD CHARACTERS WITHOUT CLAIM TO ANY PARTICULAR FONT, STYLE, SIZE, OR COLOR.

FOR SUITE OF GLOBAL COMPUTER SECURITY ADMINISTRATION SOFTWARE THAT PROVIDES ACCESS CONTROL AND IDENTITY MANAGEMENT FUNCTIONALITY TO ASSIST ORGANIZATIONS IN MEETING DATA SECURITY AND REGULATORY COMPLIANCE REQUIREMENTS FOR USE IN ARENAS EXCLUSIVE OF LOCAL AREA NETWORKS (U.S. CLS. 21, 23, 26, 36 AND 38).

PAUL F. GAST, EXAMINING ATTORNEY



**CLASS 9—(Continued).**

SN 78-960,645. OCTILOCK, INC., LANSDALE, PA. FILED 8-25-2006.

# OCTILOCK

THE MARK CONSISTS OF STANDARD CHARACTERS WITHOUT CLAIM TO ANY PARTICULAR FONT, STYLE, SIZE, OR COLOR.

FOR ELECTRONIC LOCKS (U.S. CLS. 21, 23, 26, 36 AND 38).

SCOTT SISUN, EXAMINING ATTORNEY

**CLASS 9—(Continued).**

SN 78-960,932. TRI-TRONICS, INC., TUCSON, AZ. FILED 8-25-2006.

# THE STANDARD

THE MARK CONSISTS OF STANDARD CHARACTERS WITHOUT CLAIM TO ANY PARTICULAR FONT, STYLE, SIZE, OR COLOR.

FOR REMOTE ELECTRONIC DOG TRAINING DEVICES, NAMELY, COLLAR-MOUNTED ELECTRICAL RECEIVERS AND REMOTE HAND-HELD ELECTRICAL TRANSMITTERS AND TRAINING GUIDES AND USER MANUALS SOLD AS A UNIT, AND PARTS AND FITTINGS THEREFOR, NAMELY CHARGERS AND HOLSTERS (U.S. CLS. 21, 23, 26, 36 AND 38).

ELLEN BURNS, EXAMINING ATTORNEY

SN 78-960,688. INILEX, INC., CHANDLER, AZ. FILED 8-25-2006.

# KnoWhere

THE MARK CONSISTS OF STANDARD CHARACTERS WITHOUT CLAIM TO ANY PARTICULAR FONT, STYLE, SIZE, OR COLOR.

FOR COMPUTER HARDWARE AND GPS BASED SOFTWARE SYSTEM FOR USE IN LOCATING, TRACKING, AND MONITORING VEHICLES, FLEETS, AND OTHER MOBILE ASSETS VIA TELEPHONY AND INTERNET (U.S. CLS. 21, 23, 26, 36 AND 38).

KARANENDRA S. CHHINA, EXAMINING ATTORNEY

SN 78-961,011. ATP ELECTRONICS, INC., SUNNYVALE, CA. FILED 8-25-2006.

# Shoebox of the 21st Century

THE MARK CONSISTS OF STANDARD CHARACTERS WITHOUT CLAIM TO ANY PARTICULAR FONT, STYLE, SIZE, OR COLOR.

FOR SEMICONDUCTOR MEMORY DEVICES, NAMELY, FLASH MEMORY CARDS, USB DRIVES, AND COMPUTER PERIPHERALS; PORTABLE AUDIO PLAYERS/RECORDERS WHICH USE SEMICONDUCTOR DEVICES AS RECORDING MEDIA; AND COMPUTER OPERATING PROGRAMS FOR SEMICONDUCTOR MEMORY DEVICES (U.S. CLS. 21, 23, 26, 36 AND 38).

JASON BLAIR, EXAMINING ATTORNEY

SN 78-960,923. TRI-TRONICS, INC., TUCSON, AZ. FILED 8-25-2006.

# EXP

THE MARK CONSISTS OF STANDARD CHARACTERS WITHOUT CLAIM TO ANY PARTICULAR FONT, STYLE, SIZE, OR COLOR.

FOR REMOTE ELECTRONIC DOG TRAINING DEVICES, NAMELY, COLLAR-MOUNTED ELECTRICAL RECEIVERS AND REMOTE HAND-HELD ELECTRICAL TRANSMITTERS AND TRAINING GUIDES AND USER MANUALS SOLD AS A UNIT, AND PARTS AND FITTINGS THEREFOR, NAMELY CHARGERS AND HOLSTERS (U.S. CLS. 21, 23, 26, 36 AND 38).

ELLEN BURNS, EXAMINING ATTORNEY

SN 78-961,364. ANACAZ NETWORKS, INC., SAN JOSE, CA. FILED 8-27-2006.

# PEERJET

THE MARK CONSISTS OF STANDARD CHARACTERS WITHOUT CLAIM TO ANY PARTICULAR FONT, STYLE, SIZE, OR COLOR.

FOR COMMUNICATIONS SOFTWARE FOR CONNECTING TO CONTENT PEERING MESH NETWORK; COMPUTER ACCELERATOR BOARD; DOWNLOADABLE FILMS AND TV PROGRAMS PROVIDED VIA A VIDEO-ON-DEMAND; DOWNLOADABLE MULTIMEDIA FILE CONTAINING ARTWORK, TEXT, AUDIO, VIDEO, GAMES, AND INTERNET WEB LINKS RELATING TO A CONTENT PEERING MESH NETWORK (U.S. CLS. 21, 23, 26, 36 AND 38).

TASHIA BUNCH, EXAMINING ATTORNEY

**CLASS 9—(Continued).**

SN 78-961,388. TENNRICH ELECTRONICS (SHENZHEN) CO., LTD., SHENZHEN, CHINA, FILED 8-28-2006.



FOR BATTERIES; ELECTRIC ACCUMULATORS; BATTERY CHARGERS; ELECTRIC ACCUMULATORS FOR VEHICLES; SOLAR CELLS; ELECTRIC CONVERTERS; ELECTRIC PLUGS; ELECTRIC SOCKETS; ELECTRIC WIRES AND CABLES; COMPUTER CURSOR CONTROL DEVICES, NAMELY, COMPUTER MOUSE (U.S. CLS. 21, 23, 26, 36 AND 38).  
LEIGH LOWRY, EXAMINING ATTORNEY

---

SN 78-961,617. MAGNASPHERE CORPORATION, WAUKESHA, WI. FILED 8-28-2006.

## Get More Secure

THE MARK CONSISTS OF STANDARD CHARACTERS WITHOUT CLAIM TO ANY PARTICULAR FONT, STYLE, SIZE, OR COLOR.

NO CLAIM IS MADE TO THE EXCLUSIVE RIGHT TO USE "SECURE", APART FROM THE MARK AS SHOWN. FOR MAGNETIC BALL SWITCHES FOR USE AS SECURITY AND PROXIMITY SENSORS (U.S. CLS. 21, 23, 26, 36 AND 38).

RONALD MCMORROW, EXAMINING ATTORNEY

---

SN 78-961,641. MAGNASPHERE CORPORATION, WAUKESHA, WI. FILED 8-28-2006.

## GET MORE SECURITY

THE MARK CONSISTS OF STANDARD CHARACTERS WITHOUT CLAIM TO ANY PARTICULAR FONT, STYLE, SIZE, OR COLOR.

NO CLAIM IS MADE TO THE EXCLUSIVE RIGHT TO USE "SECURITY", APART FROM THE MARK AS SHOWN. FOR MAGNETIC BALL SWITCHES FOR USE AS SECURITY AND PROXIMITY SENSORS (U.S. CLS. 21, 23, 26, 36 AND 38).

RONALD MCMORROW, EXAMINING ATTORNEY

**CLASS 9—(Continued).**

SN 78-961,750. CANTALOUPE SYSTEMS, BERKELEY, CA. FILED 8-28-2006.



THE MARK CONSISTS OF A CIRCLE WITH A DECORATIVE BORDER.

FOR REMOTE TELEMETERING MACHINES AND APPARATUS; TELEMATICS APPARATUS, NAMELY, WIRELESS INTERNET DEVICES WHICH PROVIDE TELEMATIC SERVICES AND HAVE A CELLULAR PHONE FUNCTION (U.S. CLS. 21, 23, 26, 36 AND 38).

FIRST USE 5-0-2003; IN COMMERCE 5-0-2003.  
THOMAS V. SHAW, EXAMINING ATTORNEY

---

SN 78-961,795. CARD ACCESS, INC., SALT LAKE CITY, UT. FILED 8-28-2006.

## InOffice

THE MARK CONSISTS OF STANDARD CHARACTERS WITHOUT CLAIM TO ANY PARTICULAR FONT, STYLE, SIZE, OR COLOR.

FOR WIRELESS TRANSCEIVER TO PASS SENSOR AND CONTROL INFORMATION TO AND FROM SENSORS, SWITCHES, CONTACTS, RELAYS AND CONTROL SYSTEMS (U.S. CLS. 21, 23, 26, 36 AND 38).

DAVID I, EXAMINING ATTORNEY

---

SN 78-961,831. LIFE MOXIE, INC., SAN FRANCISCO, CA. FILED 8-28-2006.

## LIFEMOXIE

THE MARK CONSISTS OF STANDARD CHARACTERS WITHOUT CLAIM TO ANY PARTICULAR FONT, STYLE, SIZE, OR COLOR.

OWNER OF U.S. REG. NO. 2,880,258. FOR PRE-RECORDED CD'S, VIDEO TAPES, LASER DISKS AND DVD'S FEATURING SPEAKERS IN THE FIELD OF LIFE SKILLS AND LIFE PLANNING (U.S. CLS. 21, 23, 26, 36 AND 38).

MATTHEW PAPPAS, EXAMINING ATTORNEY

**CLASS 9—(Continued).**

SN 78-961,922. DREW TECHNOLOGIES, INC, WHITMORE LAKE, MI. FILED 8-28-2006.

**CLASS 9—(Continued).**

SN 78-962,012. RETAILDNA, LLC, WEST PALM BEACH, FL. FILED 8-28-2006.

# DashDAQ

THE MARK CONSISTS OF STANDARD CHARACTERS WITHOUT CLAIM TO ANY PARTICULAR FONT, STYLE, SIZE, OR COLOR.

FOR LCD COMPUTER DISPLAYS AND RELATED COMPUTER SOFTWARE TO COMMUNICATE WITH MOTOR VEHICLE ONBOARD DATA EQUIPMENT, AND TO DISPLAY MOTOR VEHICLE ENGINE PARAMETERS OTHER VEHICLE DATA IN NUMERIC AND GRAPHICAL FORMATS (U.S. CLS. 21, 23, 26, 36 AND 38).

CHRISTOPHER OTT, EXAMINING ATTORNEY

# POM

THE MARK CONSISTS OF STANDARD CHARACTERS WITHOUT CLAIM TO ANY PARTICULAR FONT, STYLE, SIZE, OR COLOR.

FOR INTEGRATED COMPUTER SOFTWARE MODULES FOR USE AT RETAIL POINTS OF SALE AND ONLINE RETAIL STORES, ENABLING RETAILERS TO CREATE ELECTRONIC MASS MARKETING MESSAGES, TARGETED MARKETING MESSAGES AND INDIVIDUALIZED MARKETING MESSAGES IN THE NATURE OF COUPONS, DISCOUNTS, PROMOTIONS, OFFERS AND INCENTIVES, THIRD-PARTY SPONSOR OFFERS AND CROSS-MARKETING PROMOTIONS DELIVERED VIA CASHIERS, E-MAIL, POSTAL SERVICE MAIL, CALL CENTER OPERATORS, WAIT STAFF, VIDEO DISPLAYS, AUDIO SPEAKERS, STILL IMAGES, GRAPHICS, ICONS, ANIMATIONS, CARTOONS OR COLLAGES; LOYALTY PROGRAM SOFTWARE ENABLING RETAILERS TO MAKE SPECIAL OFFERS BASED UPON CUSTOMER PREFERENCES, ATTRIBUTES AND ORDER HISTORY; VOICE RECOGNITION SOFTWARE FOR MONITORING AND REWARDING EMPLOYEE PERFORMANCE; ELECTRONIC CUSTOMER SURVEYS AND ELECTRONIC CUSTOMER DATA STORAGE, ALL FOR USE AT POINT-OF-SALE TERMINALS, IN COMMERCIAL KITCHENS, AT KIOSKS, SELF CHECK-OUT TERMINALS AND AUTOMATED TELLER MACHINES (ATM) VIA TELEVISIONS, TELEVISION MONITORS, VIDEO DISPLAY MONITORS, E-MAIL, VENDING MACHINES, SCANNERS, SCALES, AUDIO SPEAKERS, MICROPHONES, COMPUTER TERMINALS, LAPTOP COMPUTERS, PERSONAL COMPUTERS, MODEMS, CASH REGISTERS, CELL PHONES, PERSONAL DIGITAL ASSISTANTS (PDA) AND GLOBAL POSITIONING SYSTEMS (GPS); AND COMPUTER HARDWARE AND SOFTWARE FOR UPDATING, MINING AND ANALYZING POINT-OF-SALE, OPERATIONS AND MARKETING DATA AND FOR REMOTE ORDERING, USED IN CONNECTION WITH ACTUAL RETAIL TRANSACTIONS, ON-LINE RETAIL TRANSACTIONS, CASH REGISTER AND VENDING MACHINE SYSTEMS OR AT RETAIL STORES, FAST FOOD OUTLETS AND CONVENIENCE FOOD OUTLETS; COMPUTER OPERATING PROGRAMS FOR POINT-OF-SALE TERMINALS; AND REMOTE ORDERING SYSTEMS COMPRISING CASH REGISTERS, ELECTRONIC SCANNERS, COMPUTER TERMINALS, MODEMS, AND VOICE RECOGNITION ANALYZERS (U.S. CLS. 21, 23, 26, 36 AND 38).

MARK T. MULLEN, EXAMINING ATTORNEY

---

SN 78-961,941. DREW TECHNOLOGIES, INC, WHITMORE LAKE, MI. FILED 8-28-2006.

# FlashDAQ

THE MARK CONSISTS OF STANDARD CHARACTERS WITHOUT CLAIM TO ANY PARTICULAR FONT, STYLE, SIZE, OR COLOR.

FOR LCD COMPUTER DISPLAYS AND RELATED COMPUTER SOFTWARE TO COMMUNICATE WITH MOTOR VEHICLE ONBOARD DATA EQUIPMENT, AND TO DISPLAY MOTOR VEHICLE ENGINE PARAMETERS OTHER VEHICLE DATA IN NUMERIC AND GRAPHICAL FORMATS (U.S. CLS. 21, 23, 26, 36 AND 38).

CHRISTOPHER OTT, EXAMINING ATTORNEY

**CLASS 9—(Continued).**

SN 78-962,023. RETAILDNA, LLC, WEST PALM BEACH, FL.  
FILED 8-28-2006.

**CLASS 9—(Continued).**

SN 78-962,121. SCIENTIFIC INSTRUMENTS, INC., SKOKIE,  
IL. FILED 8-28-2006.

## DYNA-SENSE

### POINT OF MARKETING

THE MARK CONSISTS OF STANDARD CHARACTERS WITHOUT CLAIM TO ANY PARTICULAR FONT, STYLE, SIZE, OR COLOR.

NO CLAIM IS MADE TO THE EXCLUSIVE RIGHT TO USE "MARKETING", APART FROM THE MARK AS SHOWN.

FOR INTEGRATED COMPUTER SOFTWARE MODULES FOR USE AT RETAIL POINTS OF SALE AND ONLINE RETAIL STORES, ENABLING RETAILERS TO CREATE ELECTRONIC MASS MARKETING MESSAGES, TARGETED MARKETING MESSAGES AND INDIVIDUALIZED MARKETING MESSAGES IN THE NATURE OF COUPONS, DISCOUNTS, PROMOTIONS, OFFERS AND INCENTIVES, THIRD-PARTY SPONSOR OFFERS AND CROSS-MARKETING PROMOTIONS DELIVERED VIA CASHIERS, E-MAIL, POSTAL SERVICE MAIL, CALL CENTER OPERATORS, WAIT STAFF, VIDEO DISPLAYS, AUDIO SPEAKERS, STILL IMAGES, GRAPHICS, ICONS, ANIMATIONS, CARTOONS OR COLLAGES; LOYALTY PROGRAM SOFTWARE ENABLING RETAILERS TO MAKE SPECIAL OFFERS BASED UPON CUSTOMER PREFERENCES, ATTRIBUTES AND ORDER HISTORY; VOICE RECOGNITION SOFTWARE FOR MONITORING AND REWARDING EMPLOYEE PERFORMANCE; ELECTRONIC CUSTOMER SURVEYS AND ELECTRONIC CUSTOMER DATA STORAGE, ALL FOR USE AT POINT-OF-SALE TERMINALS, IN COMMERCIAL KITCHENS, AT KIOSKS, SELF CHECK-OUT TERMINALS AND AUTOMATED TELLER MACHINES (ATM) VIA TELEVISIONS, TELEVISION MONITORS, VIDEO DISPLAY MONITORS, E-MAIL, VENDING MACHINES, SCANNERS, SCALES, AUDIO SPEAKERS, MICROPHONES, COMPUTER TERMINALS, LAPTOP COMPUTERS, PERSONAL COMPUTERS, MODEMS, CASH REGISTERS, CELL PHONES, PERSONAL DIGITAL ASSISTANTS (PDA) AND GLOBAL POSITIONING SYSTEMS (GPS); AND COMPUTER HARDWARE AND SOFTWARE FOR UPDATING, MINING AND ANALYZING POINT-OF-SALE, OPERATIONS AND MARKETING DATA AND FOR REMOTE ORDERING, USED IN CONNECTION WITH ACTUAL RETAIL TRANSACTIONS, ON-LINE RETAIL TRANSACTIONS, CASH REGISTER AND VENDING MACHINE SYSTEMS OR AT RETAIL STORES, FAST FOOD OUTLETS AND CONVENIENCE FOOD OUTLETS; COMPUTER OPERATING PROGRAMS FOR POINT-OF-SALE TERMINALS; AND REMOTE ORDERING SYSTEMS COMPRISING CASH REGISTERS, ELECTRONIC SCANNERS, COMPUTER TERMINALS, MODEMS, AND VOICE RECOGNITION ANALYZERS (U.S. CLS. 21, 23, 26, 36 AND 38).

MARK T. MULLEN, EXAMINING ATTORNEY

THE MARK CONSISTS OF STANDARD CHARACTERS WITHOUT CLAIM TO ANY PARTICULAR FONT, STYLE, SIZE, OR COLOR.

FOR ELECTRICAL CONTROL AND MEASURING EQUIPMENT, NAMELY, AUTOMATIC LIQUID LEVEL MAINTAINING EQUIPMENT AND TEMPERATURE CONTROLLERS (U.S. CLS. 21, 23, 26, 36 AND 38).

FIRST USE 7-0-1967; IN COMMERCE 7-0-1967.

TOBY BULLOFF, EXAMINING ATTORNEY

SN 78-962,375. NEUROSOFT LABORATORIES INC, CENTENNIAL, CO. FILED 8-29-2006.

## Ovum Computing

THE MARK CONSISTS OF STANDARD CHARACTERS WITHOUT CLAIM TO ANY PARTICULAR FONT, STYLE, SIZE, OR COLOR.

NO CLAIM IS MADE TO THE EXCLUSIVE RIGHT TO USE COMPUTING, APART FROM THE MARK AS SHOWN.

FOR COMPUTER E-COMMERCE SOFTWARE TO ALLOW USERS TO PERFORM ELECTRONIC BUSINESS TRANSACTIONS VIA A GLOBAL COMPUTER NETWORK; COMPUTER SOFTWARE DEVELOPMENT TOOLS; COMPUTER SOFTWARE FOR COMPUTER SYSTEM AND APPLICATION DEVELOPMENT, DEPLOYMENT AND MANAGEMENT; COMPUTER SOFTWARE FOR ALLOWING USERS TO PERFORM E-PURCHASEMENT OPERATIONS; COMPUTER SOFTWARE PLATFORMS FOR LARGE-SCALE AND/OR HIGH-PERFORMANCE COMPUTING; COMPUTER SOFTWARE THAT ASSISTS COMPUTERS IN DEPLOYING PARALLEL APPLICATIONS AND PERFORMING PARALLEL COMPUTATIONS; ENTERPRISE SOFTWARE IN THE NATURE OF A DATABASE FOR NON-TRANSACTIONAL DATA AND A SEARCH ENGINE FOR DATABASE CONTENT (U.S. CLS. 21, 23, 26, 36 AND 38).

LINDA E. BLOHM, EXAMINING ATTORNEY

**CLASS 9—(Continued).**

SN 78-962,378. NEUROSOFT LABORATORIES INC, CENTENNIAL, CO. FILED 8-29-2006.

## Organic Virtual Universal Machine

THE MARK CONSISTS OF STANDARD CHARACTERS WITHOUT CLAIM TO ANY PARTICULAR FONT, STYLE, SIZE, OR COLOR.

NO CLAIM IS MADE TO THE EXCLUSIVE RIGHT TO USE VIRTUAL AND UNIVERSAL MACHINE, APART FROM THE MARK AS SHOWN.

FOR COMPUTER SOFTWARE DEVELOPMENT TOOLS; COMPUTER SOFTWARE FOR COMPUTER SYSTEM AND APPLICATION DEVELOPMENT, DEPLOYMENT AND MANAGEMENT; COMPUTER SOFTWARE PLATFORMS FOR LARGE-SCALE AND/OR HIGH-PERFORMANCE COMPUTING; COMPUTER SOFTWARE THAT ASSISTS COMPUTERS IN DEPLOYING PARALLEL APPLICATIONS AND PERFORMING PARALLEL COMPUTATIONS; ENTERPRISE SOFTWARE IN THE NATURE OF A DATABASE FOR NON-TRANSACTIONAL DATA AND A SEARCH ENGINE FOR DATABASE CONTENT (U.S. CLS. 21, 23, 26, 36 AND 38).

LINDA E. BLOHM, EXAMINING ATTORNEY

SN 78-962,627. SUMMIT GROUP SOFTWARE, INC., FARGO, ND. FILED 8-29-2006.

## Summit TCM

THE MARK CONSISTS OF STANDARD CHARACTERS WITHOUT CLAIM TO ANY PARTICULAR FONT, STYLE, SIZE, OR COLOR.

NO CLAIM IS MADE TO THE EXCLUSIVE RIGHT TO USE "TCM", APART FROM THE MARK AS SHOWN.

FOR COMPUTER SOFTWARE FOR EDUCATIONAL AND TRAINING ORGANIZATIONS, NAMELY SOFTWARE FOR MARKETING TRAINING CLASSES, REGISTERING STUDENTS, PROCURING CLASSROOM SPACE AND INSTRUCTORS, AND REPORTING ON THE PROFITABILITY OF TEACHING ENGAGEMENTS (U.S. CLS. 21, 23, 26, 36 AND 38).

JIM RINGLE, EXAMINING ATTORNEY

**CLASS 9—(Continued).**

SN 78-962,746. R. A. ALLEN COMPANY, INC., VERO BEACH, FL. FILED 8-29-2006.

## ALLEN COMMUNICATOR

THE MARK CONSISTS OF STANDARD CHARACTERS WITHOUT CLAIM TO ANY PARTICULAR FONT, STYLE, SIZE, OR COLOR.

OWNER OF U.S. REG. NOS. 1,463,413 AND 2,984,828.

NO CLAIM IS MADE TO THE EXCLUSIVE RIGHT TO USE "COMMUNICATOR", APART FROM THE MARK AS SHOWN.

FOR WALKIE-TALKIE (U.S. CLS. 21, 23, 26, 36 AND 38).

PAUL CROWLEY, EXAMINING ATTORNEY

SN 78-962,751. SKYWAY SOFTWARE, INC, TAMPA, FL. FILED 8-29-2006.

## Pragmatic SOA

THE MARK CONSISTS OF STANDARD CHARACTERS WITHOUT CLAIM TO ANY PARTICULAR FONT, STYLE, SIZE, OR COLOR.

NO CLAIM IS MADE TO THE EXCLUSIVE RIGHT TO USE "SOA", APART FROM THE MARK AS SHOWN.

FOR COMPUTER SOFTWARE DEVELOPMENT TOOLS; COMPUTER SOFTWARE FOR COMPUTER SYSTEM AND APPLICATION DEVELOPMENT, DEPLOYMENT AND MANAGEMENT (U.S. CLS. 21, 23, 26, 36 AND 38).

PAUL CROWLEY, EXAMINING ATTORNEY

SN 78-963,003. MIMOSA PARTNERS, LLC, RICHMOND, VA. FILED 8-29-2006.

## jetdial

THE MARK CONSISTS OF STANDARD CHARACTERS WITHOUT CLAIM TO ANY PARTICULAR FONT, STYLE, SIZE, OR COLOR.

FOR COMPUTER SOFTWARE PROGRAMS FOR USE IN AUTOMATED TELEPHONE DIALING SYSTEMS, VIRTUAL DIALING SYSTEMS, DIRECT MARKETING, TELEMARKETING, AND IN THE CONDUCT OF TELEPHONE CAMPAIGNS (U.S. CLS. 21, 23, 26, 36 AND 38).

DAVID COLLIER, EXAMINING ATTORNEY

**CLASS 9—(Continued).**

SN 78-963,035. RED CANYON SOFTWARE, INC., DENVER, CO. FILED 8-29-2006.



NO CLAIM IS MADE TO THE EXCLUSIVE RIGHT TO USE "OPEN SAT", APART FROM THE MARK AS SHOWN. THE APPLICANT CLAIMS COLOR AS A FEATURE OF THE MARK, NAMELY, MAROON AND TURQUOISE.

THE MARK CONSISTS OF A MAROON CRESCENT MOON CENTERED WITH A TURQUOISE ARROW ORBITING 3/4 AROUND THE MAROON CRESCENT MOON. THE TEXT OPENSAT APPEARS IN A MAROON COLOR AND IS CENTERED IN THE CRESCENT MOON.

FOR DATABASE MANAGEMENT SOFTWARE FOR SATELLITES (U.S. CLS. 21, 23, 26, 36 AND 38).  
ANDREA EVANS, EXAMINING ATTORNEY

SN 78-963,149. SCHUSTER, E. MICHAEL, SCOTTSDALE, AZ. FILED 8-29-2006.

**TRUTH BASED SELLING**

THE MARK CONSISTS OF STANDARD CHARACTERS WITHOUT CLAIM TO ANY PARTICULAR FONT, STYLE, SIZE, OR COLOR.

NO CLAIM IS MADE TO THE EXCLUSIVE RIGHT TO USE SELLING, APART FROM THE MARK AS SHOWN.

FOR PRE-RECORDED CD'S, VIDEO TAPES, LASER DISKS AND DVD'S FEATURING DENTAL PROCEDURE COMMUNICATION SERVICES (U.S. CLS. 21, 23, 26, 36 AND 38).

SUE LAWRENCE, EXAMINING ATTORNEY

SN 78-963,221. GAMMA ENTERPRISE TECHNOLOGIES, WOODLAND HILLS, CA. FILED 8-29-2006.

**LIVECHRONICLE**

THE MARK CONSISTS OF STANDARD CHARACTERS WITHOUT CLAIM TO ANY PARTICULAR FONT, STYLE, SIZE, OR COLOR.

FOR SOFTWARE FOR ACCESSING AND VIEWING ARCHIVED DATA AND RELATED TRANSACTIONAL AND MASTER DATA IN PROPRIETARY COMPUTER SYSTEMS (U.S. CLS. 21, 23, 26, 36 AND 38).

KATHLEEN M. VANSTON, EXAMINING ATTORNEY

**CLASS 9—(Continued).**

SN 78-963,451. NAVARO, RICHARD PAUL, BURLINGTON, KY. FILED 8-30-2006.

**MASTERBILLER**

THE MARK CONSISTS OF STANDARD CHARACTERS WITHOUT CLAIM TO ANY PARTICULAR FONT, STYLE, SIZE, OR COLOR.

FOR COMPUTER SOFTWARE FOR MEDICAL PRACTICE MANAGEMENT USED BY PHYSICIANS, BILLING SERVICES, CLINICS AND HOSPITALS (U.S. CLS. 21, 23, 26, 36 AND 38).

ALLISON HOLTZ, EXAMINING ATTORNEY

SN 78-963,460. INTERNATIONAL DIRECT PRODUCTS, INC., ROSLYN, NY. FILED 8-30-2006.

**MAXX DEF**

THE MARK CONSISTS OF STANDARD CHARACTERS WITHOUT CLAIM TO ANY PARTICULAR FONT, STYLE, SIZE, OR COLOR.

FOR PROTECTIVE EYEWEAR, NAMELY ANTI-GLARE GLASSES AND SUNGLASSES AND THEIR PARTS AND ACCESSORIES, NAMELY REPLACEMENT LENSES, FRAMES, EARSTEMS, AND NOSE PIECES, CASES SPECIALLY ADAPTED FOR SPECTACLES AND SUNGLASSES AND THEIR PARTS AND ACCESSORIES (U.S. CLS. 21, 23, 26, 36 AND 38).

ALLISON HOLTZ, EXAMINING ATTORNEY

SN 78-963,497. DDRDRIVE LLC, LONE TREE, CO. FILED 8-30-2006.

**The drive for speed.**

THE MARK CONSISTS OF STANDARD CHARACTERS WITHOUT CLAIM TO ANY PARTICULAR FONT, STYLE, SIZE, OR COLOR.

FOR SOLID STATE STORAGE DEVICE, NAMELY, COMPUTER HARDWARE (U.S. CLS. 21, 23, 26, 36 AND 38).

BRIDGETT SMITH, EXAMINING ATTORNEY

**CLASS 9—(Continued).**

SN 78-963,694. AOL LLC, DULLES, VA. FILED 8-30-2006.

**DYNASIZER**

THE MARK CONSISTS OF STANDARD CHARACTERS WITHOUT CLAIM TO ANY PARTICULAR FONT, STYLE, SIZE, OR COLOR.

FOR COMPUTER SOFTWARE FOR DATA, TEXT, GRAPHICS, AND IMAGE TRANSMISSION; COMPUTER COMMUNICATIONS SOFTWARE TO ALLOW CUSTOMERS TO ACCESS NETWORKED COMPUTERS, COMPUTER SOFTWARE, DATABASES, COMMUNICATIONS SERVICES, AND ELECTRONIC COMMUNICATIONS NETWORKS; COMPUTER SOFTWARE FOR FACILITATING REAL-TIME INTERACTION AND COMMUNICATION BETWEEN COMPUTER USERS VIA COMPUTER NETWORKS; COMPUTER SOFTWARE FOR BROWSING AND SEARCHING AMONG ELECTRONIC COMMUNICATIONS NETWORKS, COMPUTERS, COMPUTER SOFTWARE, AND DATABASES; COMPUTER SOFTWARE THAT SYNCHRONIZES DATA AND COMPUTER SOFTWARE APPLICATIONS WITHIN A LOCAL AREA NETWORK OR ONLINE COMPUTER SYSTEM; COMPUTER SOFTWARE THAT SYNCHRONIZES DATA BETWEEN DISPARATE FORMATS; COMPUTER SOFTWARE FOR ENSURING SECURITY AND SAFETY ON COMPUTERS AND COMPUTER NETWORKS; AND INSTRUCTION AND USER MANUALS SOLD AS A UNIT WITH ALL OF THE FOREGOING SOFTWARE; FEATURE OF COMPUTER SOFTWARE THAT ALLOWS USERS TO MODIFY AND ADJUST BROWSER WINDOWS AND THAT ALLOWS ENHANCED DRAG-AND-DROP BROWSER FUNCTIONALITY (U.S. CLS. 21, 23, 26, 36 AND 38).

TRAVIS WHEATLEY, EXAMINING ATTORNEY

SN 78-963,703. ARROW PRODUCTIONS, LTD., LAS VEGAS, NV. FILED 8-30-2006.

**DEBBIE DOES DALLAS**

THE MARK CONSISTS OF STANDARD CHARACTERS WITHOUT CLAIM TO ANY PARTICULAR FONT, STYLE, SIZE, OR COLOR.

FOR PRERECORDED VIDEO CASSETTES AND DIGITAL VIDEO DISCS FEATURING ADULT ENTERTAINMENT (U.S. CLS. 21, 23, 26, 36 AND 38).

FIRST USE 0-0-1993; IN COMMERCE 0-0-1994.  
LINDA POWELL, EXAMINING ATTORNEY

**CLASS 9—(Continued).**

SN 78-963,766. DOCUSYS, INC., MOBILE, AL. FILED 8-30-2006.

**DOCUPATH**

THE MARK CONSISTS OF STANDARD CHARACTERS WITHOUT CLAIM TO ANY PARTICULAR FONT, STYLE, SIZE, OR COLOR.

FOR COMPUTER SOFTWARE FOR ASSISTING HEALTH CARE PROVIDERS IN IMPLEMENTING PATIENT CARE PROTOCOLS AIMED AT IMPROVING PATIENT CARE BY GENERATING DIGITAL CHECKLISTS, GOALS, REMINDERS, AND OUTCOMES REPORTS (U.S. CLS. 21, 23, 26, 36 AND 38).

GENE MACIOL, EXAMINING ATTORNEY

SN 78-963,794. AOL LLC, DULLES, VA. FILED 8-30-2006.

**WINAMP**

THE MARK CONSISTS OF STANDARD CHARACTERS WITHOUT CLAIM TO ANY PARTICULAR FONT, STYLE, SIZE, OR COLOR.

OWNER OF U.S. REG. NOS. 2,557,585 AND 2,734,590.

FOR COMPUTER SOFTWARE FOR USE IN ORGANIZING, MANIPULATING, CREATING, PLAYING, AND VIEWING VIDEO, AUDIO, GRAPHIC, TEXT, MULTIMEDIA CONTENT, AND OTHER DATA FILES; COMPUTER SOFTWARE FOR USE IN TRANSMITTING, DELIVERING, BROADCASTING, AND RECEIVING VIDEO, AUDIO, GRAPHIC, TEXT, MULTIMEDIA CONTENT, AND OTHER DATA FILES VIA COMPUTER AND OTHER COMMUNICATIONS NETWORKS; COMPUTER SOFTWARE FOR TRANSMITTING STREAMED AND DOWNLOADABLE AUDIO AND VIDEO FILES VIA COMPUTER AND OTHER COMMUNICATIONS NETWORKS; COMPUTER SOFTWARE FOR USE IN WRITING TO COMPACT DISCS; COMPUTER SOFTWARE FOR BROADCASTING AND TRANSMISSION OF RADIO AND TELEVISION PROGRAMS VIA COMPUTER AND OTHER COMMUNICATIONS NETWORKS; COMPUTER SOFTWARE FOR WEB CASTING; COMPUTER SOFTWARE FOR TRANSMITTING PRERECORDED MUSIC, MUSIC VIDEOS, MOVIES, AND MOVIE TRAILERS (U.S. CLS. 21, 23, 26, 36 AND 38).

FIRST USE 4-1-1997; IN COMMERCE 4-1-1997.  
TRAVIS WHEATLEY, EXAMINING ATTORNEY

**CLASS 9—(Continued).**

SN 78-963,797. IGT, RENO, NV. FILED 8-30-2006.

**EZ ROUTE**

THE MARK CONSISTS OF STANDARD CHARACTERS WITHOUT CLAIM TO ANY PARTICULAR FONT, STYLE, SIZE, OR COLOR.

OWNER OF U.S. REG. NOS. 2,671,121, 3,056,331 AND OTHERS.

FOR SYSTEM AND GAMING DEVICES, NAMELY, CLERK VALIDATION TERMINALS THAT USE A CASHLESS OR COINLESS FORMAT, NAMELY, THE PRINTING AND ACCEPTANCE OF TICKETS, COUPONS, VOUCHERS, OR OTHER PRINTED FORMATS (U.S. CLS. 21, 23, 26, 36 AND 38).

FIRST USE 1-0-1999; IN COMMERCE 3-0-2000.

ELIZABETH J. WINTER, EXAMINING ATTORNEY

---

SN 78-963,923. INFINET WIRELESS LIMITED, ROAD TOWN, BR. VIRGIN ISLANDS, FILED 8-30-2006.

**SkyMAN NG**

THE MARK CONSISTS OF STANDARD CHARACTERS WITHOUT CLAIM TO ANY PARTICULAR FONT, STYLE, SIZE, OR COLOR.

NO CLAIM IS MADE TO THE EXCLUSIVE RIGHT TO USE "NG", APART FROM THE MARK AS SHOWN.

FOR TELECOMMUNICATIONS EQUIPMENT, NAMELY, WIRELESS BRIDGES, ROUTERS AND MESH NODES (U.S. CLS. 21, 23, 26, 36 AND 38).

CHRISTINE COOPER, EXAMINING ATTORNEY

**CLASS 9—(Continued).**

SN 78-963,927. NEXTUP TECHNOLOGIES, LLC, CLEMMONS, NC. FILED 8-30-2006.

**NEXTUP TECHNOLOGIES**

THE MARK CONSISTS OF STANDARD CHARACTERS WITHOUT CLAIM TO ANY PARTICULAR FONT, STYLE, SIZE, OR COLOR.

NO CLAIM IS MADE TO THE EXCLUSIVE RIGHT TO USE "TECHNOLOGIES", APART FROM THE MARK AS SHOWN.

FOR COMPUTER SOFTWARE USED TO CONVERT TEXT OR OTHER INFORMATION INTO VOCALIZED SOUND; COMPUTER SOFTWARE THAT PLAYS DIGITAL AUDIO OF WEATHER FORECASTS AND CONDITIONS ALOUD FROM LOCATIONS WORLDWIDE; COMPUTER SOFTWARE USED TO SEARCH FOR AND RETRIEVE NEWS STORIES THAT USERS REQUEST, AND THEN CONVERT SUCH DATA INTO AUDIO WHICH IS PLAYED ALOUD; COMPUTER SOFTWARE USED TO SEARCH FOR AND RETRIEVE INFORMATION ON STOCKS AND BUSINESS INVESTMENTS, AND THEN CONVERT SUCH DATA INTO AUDIO WHICH IS PLAYED ALOUD; COMPUTER SOFTWARE WHICH ENABLES INTERNET USERS TO EXCHANGE AND CONVERT MESSAGE POSTINGS FROM TEXT INTO AUDIO WHICH IS PLAYED ALOUD; COMPUTER SOFTWARE USED BY PEOPLE WITH VOCAL IMPAIRMENTS, BY CONVERTING TEXT TYPED BY VOCALLY IMPAIRED USERS INTO AUDIO WHICH IS PLAYED ALOUD (U.S. CLS. 21, 23, 26, 36 AND 38).

FIRST USE 3-2-2000; IN COMMERCE 3-2-2000.

ALEX KEAM, EXAMINING ATTORNEY

---

SN 78-964,305. TORA TRADING SERVICES, LTD., SAN FRANCISCO, CA. FILED 8-30-2006.

**TORA**

THE MARK CONSISTS OF STANDARD CHARACTERS WITHOUT CLAIM TO ANY PARTICULAR FONT, STYLE, SIZE, OR COLOR.

FOR COMPUTER SOFTWARE FOR USE IN BUYING AND SELLING EQUITIES, FUTURES, STOCKS, BONDS AND OTHER SECURITIES; COMPUTER SOFTWARE FOR USE IN MANAGING AND TRACKING THE BUYING AND SELLING OF EQUITIES, FUTURES, STOCKS, BONDS AND OTHER SECURITIES (U.S. CLS. 21, 23, 26, 36 AND 38).

FIRST USE 3-0-2004; IN COMMERCE 3-0-2004.

JIM RINGLE, EXAMINING ATTORNEY



**CLASS 9—(Continued).**

SN 78-964,489. NAYIO MEDIA, INC., SAN MATEO, CA.  
FILED 8-30-2006.

# VMP

THE MARK CONSISTS OF STANDARD CHARACTERS WITHOUT CLAIM TO ANY PARTICULAR FONT, STYLE, SIZE, OR COLOR.

FOR COMPUTER SOFTWARE WHICH COMMUNICATES AND DISPLAYS DIGITAL CONTENT, NAMELY, DIGITAL MUSIC AND GRAPHICS, OVER LOCAL AND GLOBAL WIRELESS AND ON-LINE NETWORKS (U.S. CLS. 21, 23, 26, 36 AND 38).

TASNEEM HUSSAIN, EXAMINING ATTORNEY

SN 78-964,807. EASY WELL SOLUTIONS AS, 4021 STAVANGER, NORWAY, FILED 8-31-2006.

# SWELLSIM

THE MARK CONSISTS OF STANDARD CHARACTERS WITHOUT CLAIM TO ANY PARTICULAR FONT, STYLE, SIZE, OR COLOR.

FOR COMPUTER SOFTWARE USED FOR SIMULATION DESIGN OF STOPPING MATERIALS IN THE FORM OF RUBBER FOR USE IN OIL AND GAS WELLS (U.S. CLS. 21, 23, 26, 36 AND 38).

LOURDES AYALA, EXAMINING ATTORNEY

SN 78-964,931. BEYONDTRUST CORPORATION, PORTSMOUTH, NH. FILED 8-31-2006.

# BEYONDTRUST

THE MARK CONSISTS OF STANDARD CHARACTERS WITHOUT CLAIM TO ANY PARTICULAR FONT, STYLE, SIZE, OR COLOR.

FOR COMPUTER SOFTWARE FOR MANAGEMENT OF APPLICATION SOFTWARE CONFIGURATION SETTINGS OVER A GLOBAL COMPUTER NETWORK; AND DOWNLOADABLE SOFTWARE FOR MANAGEMENT OF APPLICATION SOFTWARE CONFIGURATION SETTINGS OVER A GLOBAL COMPUTER NETWORK (U.S. CLS. 21, 23, 26, 36 AND 38).

FIRST USE 10-1-2006; IN COMMERCE 10-1-2006.  
DARRYL SPRUILL, EXAMINING ATTORNEY

**CLASS 9—(Continued).**

SN 78-965,129. TEXTONE RECORDS, INC., AUSTIN, TX.  
FILED 8-31-2006.

# TEXTONE RECORDS

THE MARK CONSISTS OF STANDARD CHARACTERS WITHOUT CLAIM TO ANY PARTICULAR FONT, STYLE, SIZE, OR COLOR.

NO CLAIM IS MADE TO THE EXCLUSIVE RIGHT TO USE RECORDS, APART FROM THE MARK AS SHOWN. FOR COMPACT DISCS FEATURING POPULAR MUSIC; MAGNETIC TAPES FEATURING POPULAR MUSIC; PHONOGRAPHIC RECORDS FEATURING POPULAR MUSIC (U.S. CLS. 21, 23, 26, 36 AND 38).

LEIGH CAROLINE CASE, EXAMINING ATTORNEY

SN 78-965,192. ADVANCED BIOMETRIC SOLUTIONS, INC., NEW YORK, NY. FILED 8-31-2006.

# SCREEN DOORS

THE MARK CONSISTS OF STANDARD CHARACTERS WITHOUT CLAIM TO ANY PARTICULAR FONT, STYLE, SIZE, OR COLOR.

FOR SOFTWARE ENABLING BIOMETRIC SECURITY OF ELECTRONIC INFORMATION (U.S. CLS. 21, 23, 26, 36 AND 38).

THOMAS MANOR, EXAMINING ATTORNEY

SN 78-965,218. PAGEDNA, INC., REDWOOD CITY, CA.  
FILED 8-31-2006.

# PAGEDNA

THE MARK CONSISTS OF STANDARD CHARACTERS WITHOUT CLAIM TO ANY PARTICULAR FONT, STYLE, SIZE, OR COLOR.

FOR COMPUTER E-COMMERCE SOFTWARE TO ALLOW USERS TO PERFORM ELECTRONIC BUSINESS TRANSACTIONS VIA A GLOBAL COMPUTER NETWORK; COMPUTER PROGRAMMES FOR DOCUMENT MANAGEMENT; COMPUTER PROGRAMS FOR ELECTRONIC LAYOUT OF PRINTED PRODUCTS OVER THE A NETWORK (U.S. CLS. 21, 23, 26, 36 AND 38).

MATTHEW EINSTEIN, EXAMINING ATTORNEY

**CLASS 9—(Continued).**

SN 78-965,222. ADVANCED BIOMETRIC SOLUTIONS, INC.,  
NEW YORK, NY. FILED 8-31-2006.

# DoorPass

THE MARK CONSISTS OF STANDARD CHARACTERS  
WITHOUT CLAIM TO ANY PARTICULAR FONT, STYLE,  
SIZE, OR COLOR.

FOR SOFTWARE FOR HUMAN RESOURCES MAN-  
AGEMENT WITH AN INTEGRATED BIOMETRIC IDEN-  
TITY VERIFICATION SECURITY SYSTEM (U.S. CLS. 21,  
23, 26, 36 AND 38).

THOMAS MANOR, EXAMINING ATTORNEY

**CLASS 9—(Continued).**

SN 78-965,342. HYPERNET, INC., CHICAGO, IL. FILED 8-31-  
2006.

# HYPERNET

THE MARK CONSISTS OF STANDARD CHARACTERS  
WITHOUT CLAIM TO ANY PARTICULAR FONT, STYLE,  
SIZE, OR COLOR.

FOR COMPUTER SOFTWARE FOR SECURE COM-  
MUNICATIONS VIA THE INTERNET OR A LOCAL  
AREA NETWORK OR FROM MOBILE DEVICES TO  
THE INTERNET AND TO OTHER LOCAL AREA NET-  
WORKS, NAMELY AUTHENTICATION, ENCRYPTION,  
VIRUS AND SPAM SCANNING, IDENTIFICATION OF  
USERS, SECURED GATEWAYS TO THE GENERAL  
INTERNET (U.S. CLS. 21, 23, 26, 36 AND 38).

LINDA ORNDORFF, EXAMINING ATTORNEY

SN 78-965,234. ADVANCED BIOMETRIC SOLUTIONS, INC.,  
NEW YORK, NY. FILED 8-31-2006.

# DoorMaster

THE MARK CONSISTS OF STANDARD CHARACTERS  
WITHOUT CLAIM TO ANY PARTICULAR FONT, STYLE,  
SIZE, OR COLOR.

FOR BIOMETRIC SECURITY AND IDENTIFICATION  
SOFTWARE (U.S. CLS. 21, 23, 26, 36 AND 38).

THOMAS MANOR, EXAMINING ATTORNEY

SN 78-965,356. MTS MEDICATION TECHNOLOGIES, INC.,  
ST. PETERSBURG, FL. FILED 8-31-2006.

# MedTrak

THE MARK CONSISTS OF STANDARD CHARACTERS  
WITHOUT CLAIM TO ANY PARTICULAR FONT, STYLE,  
SIZE, OR COLOR.

FOR COMPUTER INTERCONNECTABLE HAND  
HELD ELECTRONIC MEDICATION DISPENSER  
WHICH STORES INFORMATION AND DOWNLOADS  
THE SAME WHICH IS RELATED TO MEDICATION  
COMPLIANCE MANAGEMENT (U.S. CLS. 21, 23, 26, 36  
AND 38).

HEATHER BIDDULPH, EXAMINING ATTORNEY

SN 78-965,296. CEACT INFORMATION SYSTEMS, INC.,  
WAYNE, WV. FILED 8-31-2006.



NO CLAIM IS MADE TO THE EXCLUSIVE RIGHT TO  
USE "GPS", APART FROM THE MARK AS SHOWN.

FOR COMPUTER MARITIME NAVIGATION SOFT-  
WARE (U.S. CLS. 21, 23, 26, 36 AND 38).

COLLEEN DOMBROW, EXAMINING ATTORNEY

SN 78-965,397. A-TRAX, INC., LOS ANGELES, CA. FILED 8-  
31-2006.

# XACTSPOT

THE MARK CONSISTS OF STANDARD CHARACTERS  
WITHOUT CLAIM TO ANY PARTICULAR FONT, STYLE,  
SIZE, OR COLOR.

FOR LOCATION AND MOVEMENT MONITORING  
AND REPORTING DEVICE IN THE NATURE OF A  
GLOBAL POSITIONING SYSTEM (GPS) (U.S. CLS. 21, 23,  
26, 36 AND 38).

ATTIYA MALIK, EXAMINING ATTORNEY

**CLASS 9—(Continued).**

SN 78-965,489. OBLONG INDUSTRIES, INC., LOS ANGELES, CA. FILED 8-31-2006.

# oblong

THE MARK CONSISTS OF STANDARD CHARACTERS WITHOUT CLAIM TO ANY PARTICULAR FONT, STYLE, SIZE, OR COLOR.

FOR COMPUTER SOFTWARE FOR ENABLING A HAND POSE AND GESTURE-BASED COMPUTER SYSTEM AND FOR DRIVING A GESTURAL INTERFACE FOR SUCH A SYSTEM (U.S. CLS. 21, 23, 26, 36 AND 38).  
KATHRYN COWARD, EXAMINING ATTORNEY

SN 78-965,547. CARTTRONICS, LLC, CARLSBAD, CA. FILED 8-31-2006.

# SMART CORRAL

THE MARK CONSISTS OF STANDARD CHARACTERS WITHOUT CLAIM TO ANY PARTICULAR FONT, STYLE, SIZE, OR COLOR.

NO CLAIM IS MADE TO THE EXCLUSIVE RIGHT TO USE "SMART", APART FROM THE MARK AS SHOWN.

FOR SHOPPING CART IDENTIFICATION AND RETURN SYSTEM COMPRISED OF IDENTIFICATION TAGS; ELECTRONIC SENSORS; ELECTROMAGNETIC, MAGNETIC AND OPTICAL READERS; COMPUTER SOFTWARE AND COMPUTER HARDWARE FOR MONITORING THE LOCATION, MOVEMENT AND RETURN OF SHOPPING CARTS, FOR REWARDING THE RETURN OF SHOPPING CARTS WITH CREDITS OR INCENTIVES, AND FOR ALLOWING THE USE OF CUSTOMER LOYALTY PROGRAMS (U.S. CLS. 21, 23, 26, 36 AND 38).

ALICE BENMAMAN, EXAMINING ATTORNEY

SN 78-965,603. HEAD LITES CORPORATION, ST. PAUL, MN. FILED 8-31-2006.

# EELS

THE MARK CONSISTS OF STANDARD CHARACTERS WITHOUT CLAIM TO ANY PARTICULAR FONT, STYLE, SIZE, OR COLOR.

FOR LIGHTED SAFETY PRODUCTS; NAMELY, MARKERS, PORTABLE DELINEATORS FOR FOOT AND/OR VEHICULAR TRAFFIC CONTROL, AND ELECTRICAL SIGNS FOR INGRESS/EGRESS, INCORPORATING ELONGATED TUBULAR LIGHT SOURCES SELECTIVELY ILLUMINATED ALONG THEIR LENGTHS (U.S. CLS. 21, 23, 26, 36 AND 38).

STEVEN R. FINE, EXAMINING ATTORNEY

**CLASS 9—(Continued).**

SN 78-965,700. KLEINERT, R. AMIL, CHARLESTOWN, IN. FILED 9-1-2006.

# LICKITY SPLIT

THE MARK CONSISTS OF STANDARD CHARACTERS WITHOUT CLAIM TO ANY PARTICULAR FONT, STYLE, SIZE, OR COLOR.

FOR DEVICE THAT DELIVERS A MILD ELECTRICAL SHOCK TO AN ANIMAL TO DETER THE ANIMAL FROM FREQUENTING A SPECIFIED LOCATION (U.S. CLS. 21, 23, 26, 36 AND 38).

ALEX KEAM, EXAMINING ATTORNEY

SN 78-965,717. TILLMAN, DENIS, LONG BEACH, CA. FILED 9-1-2006.

# DEADNUTS

THE MARK CONSISTS OF STANDARD CHARACTERS WITHOUT CLAIM TO ANY PARTICULAR FONT, STYLE, SIZE, OR COLOR.

FOR RECEIVERS FOR USE IN THE VIDEO PIPELINE INSPECTIONS (U.S. CLS. 21, 23, 26, 36 AND 38).

DOMINIC FATHY, EXAMINING ATTORNEY

SN 78-965,730. NEXT LIMIT S.L., MADRID, SPAIN, FILED 9-1-2006.

# MULTILIGHT

THE MARK CONSISTS OF STANDARD CHARACTERS WITHOUT CLAIM TO ANY PARTICULAR FONT, STYLE, SIZE, OR COLOR.

FOR COMPUTER SOFTWARE FOR CREATION OF IMAGES (U.S. CLS. 21, 23, 26, 36 AND 38).

DOMINIC FATHY, EXAMINING ATTORNEY

**CLASS 9—(Continued).**

SN 78-965,746. REHAB INFORMATION TECHNOLOGIES, LLC, ROCHESTER, NY. FILED 9-1-2006.

**O2 Tracker**

THE MARK CONSISTS OF STANDARD CHARACTERS WITHOUT CLAIM TO ANY PARTICULAR FONT, STYLE, SIZE, OR COLOR.

NO CLAIM IS MADE TO THE EXCLUSIVE RIGHT TO USE "TRACKER", APART FROM THE MARK AS SHOWN.

FOR COMPUTER SOFTWARE FOR USE AS A MEDICAL CLAIMS PROCESSING SYSTEM (U.S. CLS. 21, 23, 26, 36 AND 38).

JOHN WILKE, EXAMINING ATTORNEY

**CLASS 9—(Continued).**

SN 78-966,325. NEURAL ID, LLC, SAN MATEO, CA. FILED 9-1-2006.

**CURE**

THE MARK CONSISTS OF STANDARD CHARACTERS WITHOUT CLAIM TO ANY PARTICULAR FONT, STYLE, SIZE, OR COLOR.

FOR PATTERN RECOGNITION SYSTEMS COMPOSED OF COMPUTER CHIPS, COMPUTER HARDWARE AND SOFTWARE (U.S. CLS. 21, 23, 26, 36 AND 38).

FIRST USE 2-14-2006; IN COMMERCE 7-2-2006.

AMY ALFIERI, EXAMINING ATTORNEY

SN 78-965,882. FLANAGAN, BRIAN, POWELL, OH. FILED 9-1-2006.



THE MARK CONSISTS OF A LARGE S WITH A CIRCLE AROUND IT AND SITE IN STYLIZED LETTERING.

FOR GOGGLES FOR SPORTS, NAMELY, SKIING, SNOWBOARDING, MOTOCROSS, AND SUNGLASSES (U.S. CLS. 21, 23, 26, 36 AND 38).

FIRST USE 4-28-2006; IN COMMERCE 4-28-2006.

RUSS HERMAN, EXAMINING ATTORNEY

SN 78-966,347. SITE9, INC., PORTLAND, OR. FILED 9-1-2006.

**Site9**

THE MARK CONSISTS OF STANDARD CHARACTERS WITHOUT CLAIM TO ANY PARTICULAR FONT, STYLE, SIZE, OR COLOR.

FOR DOWNLOADABLE SOFTWARE FOR AUTOMATING WEBSITE DESIGN AND DEPLOYMENT (U.S. CLS. 21, 23, 26, 36 AND 38).

MIDGE BUTLER, EXAMINING ATTORNEY

SN 78-966,012. PSYCHOLINGUISTIC TECHNOLOGIES, INC., ELKINS PARK, PA. FILED 9-1-2006.

**SENTENCESHAPER**

THE MARK CONSISTS OF STANDARD CHARACTERS WITHOUT CLAIM TO ANY PARTICULAR FONT, STYLE, SIZE, OR COLOR.

FOR COMPUTER SOFTWARE PROGRAM DESIGNED TO PROMOTE LANGUAGE AND SPEECH SKILLS FOR INDIVIDUALS WITH APHASIA (U.S. CLS. 21, 23, 26, 36 AND 38).

FIRST USE 9-8-2004; IN COMMERCE 9-8-2004.

TANYA AMOS, EXAMINING ATTORNEY

SN 78-966,469. RUNCO INTERNATIONAL INC., UNION CITY, CA. FILED 9-2-2006.

**RADIANT**

THE MARK CONSISTS OF STANDARD CHARACTERS WITHOUT CLAIM TO ANY PARTICULAR FONT, STYLE, SIZE, OR COLOR.

FOR TELEVISION MONITORS; TELEVISION RECEIVERS; TELEVISION SETS; HOME THEATRE PRODUCTS, NAMELY, VIDEO PROJECTORS, VIDEO PROCESSORS, LCD DISPLAY MONITORS, AND PLASMA DISPLAY MONITORS (U.S. CLS. 21, 23, 26, 36 AND 38).

FIRST USE 7-18-2001; IN COMMERCE 7-19-2001.

CAROLYN CATALDO, EXAMINING ATTORNEY

**CLASS 9—(Continued).**

SN 78-966,979. PHOENIX INTERNATIONAL, IRVINE, CA. FILED 9-5-2006.

# GEARGUARD

THE MARK CONSISTS OF STANDARD CHARACTERS WITHOUT CLAIM TO ANY PARTICULAR FONT, STYLE, SIZE, OR COLOR.

FOR BAGS FOR CAMERAS AND PHOTOGRAPHIC EQUIPMENT; CAMERA CASES; CASES FOR MOBILE PHONES (U.S. CLS. 21, 23, 26, 36 AND 38).

TIMOTHY FINNEGAN, EXAMINING ATTORNEY

SN 78-966,980. CHD SOLUTIONS LLC, HOUSTON, TX. FILED 9-5-2006.



THE MARK CONSISTS OF AN ILLUSTRATION OF A SATELLITE WITH STYLIZED TEXT OF THE WORD, "TREADNET"; THE WORD TREADNET HAS A LINE THROUGH IT.

FOR SATELLITE AND MICROWAVE COMMUNICATIONS APPARATUS TO TRANSMIT COMMUNICATIONS FROM A VEHICLE TO ANOTHER VEHICLE, OR FROM A VEHICLE TO A SATELLITE; SATELLITE DISHES FOR SATELLITE TRANSMISSIONS (U.S. CLS. 21, 23, 26, 36 AND 38).

FIRST USE 6-1-2005; IN COMMERCE 6-1-2005.  
TIMOTHY FINNEGAN, EXAMINING ATTORNEY

SN 78-967,069. INTERNATIONAL CORDAGE EAST, LTD., EAST HADDAM, CT. FILED 9-5-2006.

# MEZZNET

THE MARK CONSISTS OF STANDARD CHARACTERS WITHOUT CLAIM TO ANY PARTICULAR FONT, STYLE, SIZE, OR COLOR.

OWNER OF U.S. REG. NO. 2,408,471.  
FOR MOVABLE VERTICAL SAFETY NETS THAT COVER ELEVATED SPACE OPENINGS (U.S. CLS. 21, 23, 26, 36 AND 38).

FIRST USE 3-0-1997; IN COMMERCE 3-0-1997.  
KATHERINE M. DUBRAY, EXAMINING ATTORNEY

**CLASS 9—(Continued).**

SN 78-967,098. G. HENSLER & CO., SAN FRANCISCO, CA. FILED 9-5-2006.

# 49 SQUARE MILES

THE MARK CONSISTS OF STANDARD CHARACTERS WITHOUT CLAIM TO ANY PARTICULAR FONT, STYLE, SIZE, OR COLOR.

FOR HOLDERS FOR PORTABLE AND HANDHELD DIGITAL ELECTRONIC DEVICES FOR RECORDING, ORGANIZING, TRANSMITTING, MANIPULATING, AND REVIEWING TEXT, DATA, AUDIO, IMAGE AND VIDEO FILES; HOLDERS FOR ELECTRONIC HANDHELD UNITS FOR THE WIRELESS RECEIPT AND/OR TRANSMISSION OF DATA AND/OR VOICE COMMUNICATIONS; HOLDERS FOR MOBILE TELEPHONES (U.S. CLS. 21, 23, 26, 36 AND 38).

DAVID MURRAY, EXAMINING ATTORNEY

SN 78-967,185. SPIELO MANUFACTURING ULC, MONCTON, NEW BRUNSWICK, CANADA, FILED 9-5-2006.

# PAWS & PAYS

THE MARK CONSISTS OF STANDARD CHARACTERS WITHOUT CLAIM TO ANY PARTICULAR FONT, STYLE, SIZE, OR COLOR.

FOR RECONFIGURABLE CASINO AND LOTTERY GAMING EQUIPMENT, NAMELY, SLOT MACHINES, AND OPERATIONAL COMPUTER GAME SOFTWARE THEREFOR (U.S. CLS. 21, 23, 26, 36 AND 38).

KAREN SEVERSON, EXAMINING ATTORNEY

SN 78-967,321. D3DESIGN, LLC, AUSTIN, TX. FILED 9-5-2006.



THE MARK CONSISTS OF STANDARD CHARACTERS WITHOUT CLAIM TO ANY PARTICULAR FONT, STYLE, SIZE, OR COLOR.

FOR HOLDERS FOR COMPUTER DISCS (U.S. CLS. 21, 23, 26, 36 AND 38).

GINNY ISAACSON, EXAMINING ATTORNEY

**CLASS 9—(Continued).**

SN 78-967,326. D3DESIGN, LLC, AUSTIN, TX. FILED 9-5-2006.

# QUEUE

THE MARK CONSISTS OF STANDARD CHARACTERS WITHOUT CLAIM TO ANY PARTICULAR FONT, STYLE, SIZE, OR COLOR.

FOR HOLDERS FOR COMPUTER DISCS (U.S. CLS. 21, 23, 26, 36 AND 38).

GINNY ISAACSON, EXAMINING ATTORNEY

---

SN 78-967,404. MICWRECK INC., BROOKLYN, NY. FILED 9-5-2006.



THE MARK CONSISTS OF A ROUND LOGO WITH A MICROPHONE ON ITS SIDE, WITH "SMOKE" EMANATING FROM IT. THE WORD "MIC" IS ABOVE THE HANDLE, AND "WRECK" IS BELOW THE ENTIRE LENGTH OF THE MICROPHONE. UNDERNEATH THE WORD "WRECK" IS THE WEB ADDRESS, "WWW.MICWRECK.COM".

FOR MUSICAL SOUND RECORDINGS (U.S. CLS. 21, 23, 26, 36 AND 38).

DORITT L. CARROLL, EXAMINING ATTORNEY

---

SN 78-967,432. VITAE LLC, MONONA, WI. FILED 9-5-2006.

# BIOculture

THE MARK CONSISTS OF STANDARD CHARACTERS WITHOUT CLAIM TO ANY PARTICULAR FONT, STYLE, SIZE, OR COLOR.

FOR LABORATORY EQUIPMENT AND SUPPLIES, NAMELY, INCUBATORS (U.S. CLS. 21, 23, 26, 36 AND 38).

GINNY ISAACSON, EXAMINING ATTORNEY

**CLASS 9—(Continued).**

SN 78-967,439. DAHILL DISTRIBUTORS INC, BROOKLYN, NY. FILED 9-5-2006.

# CHARGE AROUND

THE MARK CONSISTS OF STANDARD CHARACTERS WITHOUT CLAIM TO ANY PARTICULAR FONT, STYLE, SIZE, OR COLOR.

NO CLAIM IS MADE TO THE EXCLUSIVE RIGHT TO USE "CHARGE", APART FROM THE MARK AS SHOWN.

FOR BATTERY CHARGE DEVICES; CHARGING APPLIANCES FOR RECHARGEABLE EQUIPMENT (U.S. CLS. 21, 23, 26, 36 AND 38).

DANNEAN HETZEL, EXAMINING ATTORNEY

---

SN 78-967,445. BUTTERFLY SPIRITS, LTD., LISLE, IL. FILED 9-5-2006.

# SATI

THE MARK CONSISTS OF STANDARD CHARACTERS WITHOUT CLAIM TO ANY PARTICULAR FONT, STYLE, SIZE, OR COLOR.

THE ENGLISH TRANSLATION OF SATI IS "MINDFULNESS".

FOR BATTERY-OPERATED NON-MUSICAL DEVICE, ON A PROGRAMMABLE TIMER, THAT MAKES A CHIMING SOUND (U.S. CLS. 21, 23, 26, 36 AND 38).

ELLEN B. AWRICH, EXAMINING ATTORNEY

---

SN 78-967,511. KXD TECHNOLOGY INC., DBA ASTAR TECHNOLOGY, BALDWIN PARK, CA. FILED 9-5-2006.

# GOWELL

THE MARK CONSISTS OF STANDARD CHARACTERS WITHOUT CLAIM TO ANY PARTICULAR FONT, STYLE, SIZE, OR COLOR.

FOR DVD-PLAYERS; TELEVISION SETS (U.S. CLS. 21, 23, 26, 36 AND 38).

JACLYN KIDWELL, EXAMINING ATTORNEY

**CLASS 9—(Continued).**

SN 78-967,546. ZENG, VINCENT, UNION CITY, CA. FILED 9-5-2006.



THE MARK CONSISTS OF OUTLINE OF A SQUARE-SHAPED CARTOON FIGURE SMILING WITH DETACHED EYEBROWS AND WITH LEGS AND ARMS, OF WHICH ONE ARM IS RAISED HOLDING A MICROPHONE.

FOR AUDIO AMPLIFIERS; AUDIO MIXERS; AUDIO SPEAKERS; MICROPHONES; SOUND MIXERS; SOUND MIXERS WITH INTEGRATED AMPLIFIERS (U.S. CLS. 21, 23, 26, 36 AND 38).

FIRST USE 8-30-2002; IN COMMERCE 8-30-2002.  
GRETTA YAO, EXAMINING ATTORNEY

SN 78-967,570. FREMANTLE MEDIA NORTH AMERICA, INC., BURBANK, CA. FILED 9-5-2006.

# POKER FACE

THE MARK CONSISTS OF STANDARD CHARACTERS WITHOUT CLAIM TO ANY PARTICULAR FONT, STYLE, SIZE, OR COLOR.

FOR GAMING EQUIPMENT, NAMELY SLOT MACHINES, WITH OR WITHOUT VIDEO OUTPUT (U.S. CLS. 21, 23, 26, 36 AND 38).

JEFF DEFORD, EXAMINING ATTORNEY

**CLASS 9—(Continued).**

SN 78-967,680. TAK CHEONG ELECTRONICS SHANWEI CO., LTD., 516600, CHINA, FILED 9-6-2006.

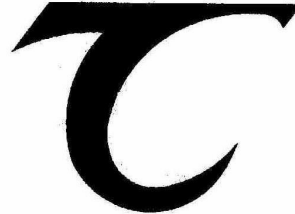

FOR ELECTRICAL APPARATUS, NAMELY, TRANSISTORS; SEMICONDUCTOR DEVICES; INTEGRATED CIRCUITS; CAPACITORS; CURRENT RECTIFIERS; ELECTRIC RELAYS; LIGHTNING ARRESTERS; ELECTRIC NAVIGATIONAL INSTRUMENTS; PORTABLE TELEPHONES; COMPUTERS; RECEIVERS FOR TELEPHONE; TELEPHONE APPARATUS; TELEPHONE ANSWERING MACHINES; VIDEO-TELEPHONES; WALKIE-TALKIES; FISHING ACCESSORIES, NAMELY, ELECTRONIC FISH LOCATORS; ELECTRONIC FISH ATTRACTORS; TELEVISION SETS; DIGITAL VIDEO RECORDERS; VIDEO TAPE RECORDERS; CAMCORDERS; NOTEBOOK COMPUTERS; COMPUTER CURSOR CONTROL DEVICES, NAMELY, COMPUTER MOUSE; COMPONENTS FOR RADIO, NAMELY, THERMIONIC VALVES; TAPE RECORDERS; CABINETS FOR LOUDSPEAKERS; LOUDSPEAKERS; BLANK AUDIO TAPES; AUDIO-VIDEO RECEIVERS; RADIOS FOR VEHICLES; VIDEO GAME MACHINES FOR USE WITH TELEVISIONS; ELECTRONIC CIRCUITS RECORDING PROGRAMS FOR AMUSEMENT APPARATUS FOR USE WITH LIQUID CRYSTAL SCREENS; MUSICAL JUKE BOXES; RADIO PAGERS; LAPTOP COMPUTERS; INSTRUMENTS AND APPARATUS FOR CONTROLLING ELECTRIC CURRENT, NAMELY, ELECTRIC COLLECTOR; ELECTRIC LIGHT DIMMERS; ELECTRONIC NOTICE BOARDS; ELECTRIC CONVERTERS (U.S. CLS. 21, 23, 26, 36 AND 38).

MARGERY A. TIERNEY, EXAMINING ATTORNEY

SN 78-967,802. COBASYS LLC, ORION, MI. FILED 9-6-2006.

# NIGUARD BRIDGE

THE MARK CONSISTS OF STANDARD CHARACTERS WITHOUT CLAIM TO ANY PARTICULAR FONT, STYLE, SIZE, OR COLOR.

OWNER OF U.S. REG. NO. 2,971,617.  
NO CLAIM IS MADE TO THE EXCLUSIVE RIGHT TO USE "BRIDGE", APART FROM THE MARK AS SHOWN.  
FOR BATTERIES (U.S. CLS. 21, 23, 26, 36 AND 38).

SUSAN STIGLITZ, EXAMINING ATTORNEY

**CLASS 9—(Continued).**

SN 78-968,132. KIMBLE ASSET MANAGEMENT, INC., VINELAND, NJ. FILED 9-6-2006.

# EZSafe

THE MARK CONSISTS OF STANDARD CHARACTERS WITHOUT CLAIM TO ANY PARTICULAR FONT, STYLE, SIZE, OR COLOR.

FOR CHROMATOGRAPHY COLUMNS (U.S. CLS. 21, 23, 26, 36 AND 38).

TARAH HARDY, EXAMINING ATTORNEY

---

SN 78-968,242. MTS SYSTEMS CORPORATION, EDEN PRAIRIE, MN. FILED 9-6-2006.

# ELASTOMEREXPRESS

THE MARK CONSISTS OF STANDARD CHARACTERS WITHOUT CLAIM TO ANY PARTICULAR FONT, STYLE, SIZE, OR COLOR.

FOR SOFTWARE FOR TESTING AND ANALYZING ELASTOMER MATERIALS AND/OR COMPONENTS (U.S. CLS. 21, 23, 26, 36 AND 38).

TARAH HARDY, EXAMINING ATTORNEY

---

SN 78-968,332. NOPEC, INC., PASADENA, CA. FILED 9-6-2006.

# NOPEC

THE MARK CONSISTS OF STANDARD CHARACTERS WITHOUT CLAIM TO ANY PARTICULAR FONT, STYLE, SIZE, OR COLOR.

FOR APPARATUS FOR CONVERTING ELECTRONIC RADIATION TO ELECTRICAL ENERGY, NAMELY PHOTOVOLTAIC ROOFING MEMBERS; APPARATUS FOR CONVERTING ELECTRONIC RADIATION TO ELECTRICAL ENERGY, NAMELY PHOTOVOLTAIC SOLAR MODULES (U.S. CLS. 21, 23, 26, 36 AND 38).

SUSAN LESLIE DUBOIS, EXAMINING ATTORNEY

**CLASS 9—(Continued).**

SN 78-968,387. NEXTHOP TECHNOLOGIES, INC., MOUNTAIN VIEW, CA. FILED 9-6-2006.

# NEXT7

THE MARK CONSISTS OF STANDARD CHARACTERS WITHOUT CLAIM TO ANY PARTICULAR FONT, STYLE, SIZE, OR COLOR.

FOR COMPUTER SOFTWARE; NAMELY COMPUTER NETWORKING SOFTWARE FOR WIRELESS AND WIRED SWITCHES; DOWNLOADABLE AND PRERECORDED COMPUTER SOFTWARE FOR ROUTING, SWITCHING, AND COORDINATING VOICE, VIDEO, AND DATA OVER NETWORKS UTILIZING THE INTERNET PROTOCOL; COMPUTER HARDWARE AND SOFTWARE FOR INTERCONNECTING AND OPERATING COMPUTER NETWORKS, NAMELY LOCAL AREA NETWORKS, WIDE AREA NETWORKS AND GLOBAL COMPUTER NETWORKS; NETWORK PROCESSOR SOFTWARE FOR USE IN COMPUTER-CONTROLLED NETWORK INFRASTRUCTURE MACHINERY; COMPUTER SOFTWARE FOR USE IN THE ARCHITECTURE OF NETWORK PROCESSING AND SOFTWARE THAT ENABLES NETWORK INTEGRATION WITH MULTIPLE SILICON TECHNOLOGIES FOR USE IN COMPUTER-CONTROLLED NETWORK INFRASTRUCTURE MACHINERY; NETWORKING SOFTWARE FOR USE IN COMPUTER-CONTROLLED NETWORK INFRASTRUCTURE SYSTEMS THAT ENABLES NETWORK COMMUNICATIONS AND THE INTEROPERATION OF NETWORK INFRASTRUCTURE PRODUCTS AND DEVICES, NAMELY, HUBS, SWITCHES, ROUTERS, ACCESS CONTROL POINTS, MULTIPLEXERS, CONCENTRATORS, AND LINE CARDS (U.S. CLS. 21, 23, 26, 36 AND 38).

KIMBERLY PERRY, EXAMINING ATTORNEY

---

SN 78-968,397. TRIACTA POWER TECHNOLOGIES INC., ALMONTE ONTARIO, CANADA, FILED 9-6-2006.



OWNER OF CANADA REG. NO. TMA658199, DATED 2-7-2006, EXPIRES 2-7-2021.

FOR HIGH-DENSITY ELECTRICITY MONITORS USED TO TRACK BREAKER-LEVEL ELECTRICITY USE FOR THE PURPOSES OF INCREASING ENERGY EFFICIENCY OR CREATING INDIVIDUAL TENANT ELECTRICITY BILLS (U.S. CLS. 21, 23, 26, 36 AND 38).

KEVIN CORWIN, EXAMINING ATTORNEY



**CLASS 9—(Continued).**

SN 78-968,421. SALAHI, YAMAN, BERKELEY, CA. FILED 9-6-2006.



THE ENGLISH TRANSLATION OF THE WORD "AKTUB" IN THE MARK IS "I WRITE".  
FOR EDUCATIONAL SOFTWARE FEATURING INSTRUCTION IN TYPING WITH THE ARABIC KEYBOARD (U.S. CLS. 21, 23, 26, 36 AND 38).  
FIRST USE 8-1-2006; IN COMMERCE 8-18-2006.  
REBECCA EISINGER, EXAMINING ATTORNEY

**CLASS 9—(Continued).**

SN 78-968,969. UNITED TELEMAGEMENT CORPORATION, DAYTON, OH. FILED 9-7-2006.

TV PASS

THE MARK CONSISTS OF STANDARD CHARACTERS WITHOUT CLAIM TO ANY PARTICULAR FONT, STYLE, SIZE, OR COLOR.  
NO CLAIM IS MADE TO THE EXCLUSIVE RIGHT TO USE "TV", APART FROM THE MARK AS SHOWN.  
FOR KIOSK MACHINE FOR VENDING A CODED TICKET FOR ENABLING A CONSUMER IN A HOSPITAL USE OF HOSPITAL TELEVISION SERVICES BY ENTERING A CODE ON THE TICKET (U.S. CLS. 21, 23, 26, 36 AND 38).  
FIRST USE 6-1-2006; IN COMMERCE 6-1-2006.  
KEVIN DINALLO, EXAMINING ATTORNEY

SN 78-968,642. SOFTMEDICAL INC, SAINT LAURENT, CANADA, FILED 9-7-2006.

see work flow

THE MARK CONSISTS OF STANDARD CHARACTERS WITHOUT CLAIM TO ANY PARTICULAR FONT, STYLE, SIZE, OR COLOR.  
FOR COMPUTER SOFTWARE FOR CONTROLLING AND MANAGING PATIENT MEDICAL INFORMATION; COMPUTER SOFTWARE FOR THE COLLECTION, EDITING, ORGANIZING, MODIFYING, BOOK MARKING, TRANSMISSION, STORAGE AND SHARING OF DATA AND INFORMATION (U.S. CLS. 21, 23, 26, 36 AND 38).  
ANNE E. GUSTASON, EXAMINING ATTORNEY

SN 78-968,986. CDM TECHNOLOGIES, INCORPORATED, SAN LUIS OBISPO, CA. FILED 9-7-2006.

KMES

SN 78-968,811. UNITED TELEMAGEMENT CORPORATION, DAYTON, OH. FILED 9-7-2006.

PHONE PASS

THE MARK CONSISTS OF STANDARD CHARACTERS WITHOUT CLAIM TO ANY PARTICULAR FONT, STYLE, SIZE, OR COLOR.  
NO CLAIM IS MADE TO THE EXCLUSIVE RIGHT TO USE "PHONE", APART FROM THE MARK AS SHOWN.  
FOR KIOSK MACHINE FOR VENDING A CODED TICKET FOR ENABLING A CONSUMER IN A HOSPITAL TO USE HOSPITAL TELEPHONE SERVICES BY ENTERING A CODE ON THE TICKET (U.S. CLS. 21, 23, 26, 36 AND 38).  
FIRST USE 6-1-2006; IN COMMERCE 6-1-2006.  
KEVIN DINALLO, EXAMINING ATTORNEY

THE MARK CONSISTS OF STANDARD CHARACTERS WITHOUT CLAIM TO ANY PARTICULAR FONT, STYLE, SIZE, OR COLOR.  
FOR COMPUTER SOFTWARE FOR MILITARY LOGISTICS DECISION SUPPORT (U.S. CLS. 21, 23, 26, 36 AND 38).  
FIRST USE 6-30-2006; IN COMMERCE 6-30-2006.  
DEBRA LEE, EXAMINING ATTORNEY

**CLASS 9—(Continued).**

SN 78-969,027. DPI, INC., ST. LOUIS, MO. FILED 9-7-2006.

**ZFI**

THE MARK CONSISTS OF STANDARD CHARACTERS WITHOUT CLAIM TO ANY PARTICULAR FONT, STYLE, SIZE, OR COLOR.

FOR CONSUMER AUDIO AND VIDEO ELECTRONIC PRODUCTS, NAMELY, PHONOGRAPHS, COMPACT DISC PLAYERS, AUDIO AND VIDEO RECEIVERS, AUDIO AND VIDEO AMPLIFIERS, WALKIE-TALKIES, AUDIO SPEAKERS, HEADPHONES, MICROPHONES, AUDIOTAPE CASSETTE PLAYERS AND RECORDERS, AUDIOTAPE DUAL CASSETTE RECORDERS, AUDIO GRAPHIC EQUALIZERS, REMOTE CONTROL UNITS FOR RADIOS, AUDIOTAPE CASSETTE PLAYERS, VIDEOTAPE CASSETTE PLAYERS, DVD PLAYERS, MP3 PLAYERS AND MP3 RECORDERS, TELEVISIONS, VIDEO CASSETTE PLAYERS, RECORDERS, AND REWINDERS; RADIOS; RADIO ANTENNAS; TELEPHONES; TELEPHONE EQUIPMENT, NAMELY, CALLER IDENTIFICATION BOXES; CITIZEN BAND RADIO TRANSCIEVERS; ELECTRONIC PERSONAL COMMUNICATION DEVICE, NAMELY, TWO-WAY RADIO FOR USE ON SPECIFIED FREQUENCY WAVES FOR COMMUNICATIONS BETWEEN FAMILIES OR SMALL GROUPS (U.S. CLS. 21, 23, 26, 36 AND 38).  
 NAAKWAMA ANKRAH, EXAMINING ATTORNEY

---

SN 78-969,032. UNITED TELEMAGEMENT CORPORATION, DAYTON, OH. FILED 9-7-2006.

**PHONE TV PASS**

THE MARK CONSISTS OF STANDARD CHARACTERS WITHOUT CLAIM TO ANY PARTICULAR FONT, STYLE, SIZE, OR COLOR.

NO CLAIM IS MADE TO THE EXCLUSIVE RIGHT TO USE "PHONE" AND "TV", APART FROM THE MARK AS SHOWN.

FOR KIOSK MACHINE FOR VENDING A CODED TICKET FOR ENABLING A CONSUMER IN A HOSPITAL USE OF HOSPITAL TELEPHONE AND/OR TELEVISION SERVICES BY ENTERING A CODE ON THE TICKET (U.S. CLS. 21, 23, 26, 36 AND 38).

FIRST USE 6-1-2006; IN COMMERCE 6-1-2006.  
 KEVIN DINALLO, EXAMINING ATTORNEY

**CLASS 9—(Continued).**

SN 78-969,199. DIGITAL INNOVATIONS, LLC, ARLINGTON HEIGHTS, IL. FILED 9-7-2006.

**ROBOMOUNT**

THE MARK CONSISTS OF STANDARD CHARACTERS WITHOUT CLAIM TO ANY PARTICULAR FONT, STYLE, SIZE, OR COLOR.

FOR APPARATUS FOR MOUNTING FLAT PANEL TELEVISIONS, NAMELY, MOTORIZED, ADJUSTABLE MOUNTS WITH REMOTE CONTROL (U.S. CLS. 21, 23, 26, 36 AND 38).

AISHA CLARKE, EXAMINING ATTORNEY

---

SN 78-969,308. ECORE SOFTWARE INC., DALLAS, TX. FILED 9-7-2006.

**ePro Scheduler**

THE MARK CONSISTS OF STANDARD CHARACTERS WITHOUT CLAIM TO ANY PARTICULAR FONT, STYLE, SIZE, OR COLOR.

NO CLAIM IS MADE TO THE EXCLUSIVE RIGHT TO USE "SCHEDULER", APART FROM THE MARK AS SHOWN.

FOR COMPUTER SOFTWARE FOR AUTOMATED SCHEDULING, TIMEKEEPING AND PAYROLL MANAGEMENT WHICH MAY BE RUN ON A LOCAL OR REMOTE FILE-SERVER (U.S. CLS. 21, 23, 26, 36 AND 38).

FIRST USE 9-1-2006; IN COMMERCE 9-1-2006.  
 AISHA SALEM, EXAMINING ATTORNEY

---

SN 78-969,324. ECORE SOFTWARE INC., DALLAS, TX. FILED 9-7-2006.

**ePro Manager**

THE MARK CONSISTS OF STANDARD CHARACTERS WITHOUT CLAIM TO ANY PARTICULAR FONT, STYLE, SIZE, OR COLOR.

NO CLAIM IS MADE TO THE EXCLUSIVE RIGHT TO USE "MANAGER", APART FROM THE MARK AS SHOWN.

FOR COMPUTER SOFTWARE FOR COMBINING RECORD MANAGEMENT, EMPLOYEE TRAINING AND TESTING, INVENTORY CONTROL, AND INCIDENT MANAGEMENT AND REPORTING WHICH MAY BE RUN ON A LOCAL OR REMOTE FILE-SERVER (U.S. CLS. 21, 23, 26, 36 AND 38).

FIRST USE 9-1-2006; IN COMMERCE 9-1-2006.  
 AISHA SALEM, EXAMINING ATTORNEY

**CLASS 9—(Continued).**

SN 78-969,375. DIEBOLD, INCORPORATED, NORTH CANTON, OH. FILED 9-7-2006.

## IDENTICENTER

THE MARK CONSISTS OF STANDARD CHARACTERS WITHOUT CLAIM TO ANY PARTICULAR FONT, STYLE, SIZE, OR COLOR.

FOR COMPUTER HARDWARE AND SOFTWARE FOR BIOMETRIC IDENTIFICATION APPLICATIONS IN THE BANKING FIELD (U.S. CLS. 21, 23, 26, 36 AND 38).

FIRST USE 9-6-2006; IN COMMERCE 9-6-2006.  
FRED MANDIR, EXAMINING ATTORNEY

SN 78-969,503. A SWEETER YOU, LLC, DBA STOP SUGAR SHOCK!, NEW YORK, NY. FILED 9-7-2006.

## ENJOY A SWEETER LIFE WITHOUT REFINED SWEETS

THE MARK CONSISTS OF STANDARD CHARACTERS WITHOUT CLAIM TO ANY PARTICULAR FONT, STYLE, SIZE, OR COLOR.

FOR AUDIO DIGITAL TAPES FEATURING THE POSITIVE EFFECTS OF ELIMINATING REFINED SUGARS AND CARBOHYDRATES FROM THE DIET AND THE POTENTIALLY DAMAGING EFFECTS OF REFINED SUGARS ON DIET, HEALTH, LIFESTYLE, AND MOOD; AUDIO DISCS FEATURING THE POSITIVE EFFECTS OF ELIMINATING REFINED SUGARS AND CARBOHYDRATES FROM THE DIET AND THE POTENTIALLY DAMAGING EFFECTS OF REFINED SUGARS ON DIET, HEALTH, LIFESTYLE, AND MOOD; AUDIO RECORDINGS FEATURING THE POSITIVE EFFECTS OF ELIMINATING REFINED SUGARS AND CARBOHYDRATES FROM THE DIET AND THE POTENTIALLY DAMAGING EFFECTS OF REFINED SUGARS ON DIET, HEALTH, LIFESTYLE, AND MOOD; AUDIO TAPES FEATURING THE POSITIVE EFFECTS OF ELIMINATING REFINED SUGARS AND CARBOHYDRATES FROM THE DIET AND THE POTENTIALLY DAMAGING EFFECTS OF REFINED SUGARS ON DIET, HEALTH, LIFESTYLE, AND MOOD; CD CASES; CD PLAYERS; DOWNLOADABLE ELECTRONIC PUBLICATIONS IN THE NATURE OF MP3 FILES, SEMINARS, TELESEMINARS, WEBSEMINARS, NEWSLETTERS, MAGAZINES IN THE FIELD OF THE POSITIVE EFFECTS OF ELIMINATING REFINED SUGARS AND CARBOHYDRATES FROM THE DIET AND THE POTENTIALLY DAMAGING EFFECTS OF REFINED SUGARS ON DIET, HEALTH, LIFESTYLE, AND MOOD; DOWNLOADABLE MULTIMEDIA FILE CONTAINING ARTWORK, TEXT, AUDIO, VIDEO, GAMES, AND INTERNET WEB LINKS RELATING TO THE POSITIVE EFFECTS OF ELIMINATING REFINED SUGARS AND CARBOHYDRATES FROM THE DIET AND THE POTENTIALLY DAMAGING EFFECTS OF REFINED SUGARS ON DIET, HEALTH, LIFESTYLE, AND MOOD; DOWNLOADABLE VIDEO RECORDINGS FEATURING THE POSITIVE EFFECTS OF ELIMINATING REFINED SUGARS AND CARBOHYDRATES FROM THE DIET AND THE POTENTIALLY DAMAGING EFFECTS OF REFINED SUGARS ON DIET, HEALTH, LIFESTYLE, AND MOOD; MULTIMEDIA SOFTWARE RECORDED ON CD-ROM FEATURING THE POSITIVE EFFECTS OF ELIMINATING REFINED SUGARS AND CARBOHYDRATES FROM THE DIET AND THE POTENTIALLY DAMAGING EFFECTS OF REFINED SUGARS ON DIET,

**CLASS 9—(Continued).**

HEALTH, LIFESTYLE, AND MOOD; PRE-RECORDED CD'S, VIDEO TAPES, LASER DISKS AND DVD'S FEATURING THE POSITIVE EFFECTS OF ELIMINATING REFINED SUGARS AND CARBOHYDRATES FROM THE DIET AND THE POTENTIALLY DAMAGING EFFECTS OF REFINED SUGARS ON DIET, HEALTH, LIFESTYLE, AND MOOD; PRERECORDED AUDIO CASSETTES FEATURING THE POSITIVE EFFECTS OF ELIMINATING REFINED SUGARS AND CARBOHYDRATES FROM THE DIET AND THE POTENTIALLY DAMAGING EFFECTS OF REFINED SUGARS ON DIET, HEALTH, LIFESTYLE, AND MOOD; PRERECORDED AUDIO TAPES FEATURING THE POSITIVE EFFECTS OF ELIMINATING REFINED SUGARS AND CARBOHYDRATES FROM THE DIET AND THE POTENTIALLY DAMAGING EFFECTS OF REFINED SUGARS ON DIET, HEALTH, LIFESTYLE, AND MOOD; PRERECORDED DIGITAL AUDIO TAPE FEATURING THE POSITIVE EFFECTS OF ELIMINATING REFINED SUGARS AND CARBOHYDRATES FROM THE DIET AND THE POTENTIALLY DAMAGING EFFECTS OF REFINED SUGARS ON DIET, HEALTH, LIFESTYLE, AND MOOD (U.S. CLS. 21, 23, 26, 36 AND 38).

SETH A. RAPPAPORT, EXAMINING ATTORNEY

SN 78-969,508. HALE, ROBERTO, BROOMFIELD, CO. FILED 9-7-2006.

## RITMONLINE

THE MARK CONSISTS OF STANDARD CHARACTERS WITHOUT CLAIM TO ANY PARTICULAR FONT, STYLE, SIZE, OR COLOR.

FOR AUDIO RECORDINGS FEATURING MUSIC (U.S. CLS. 21, 23, 26, 36 AND 38).

LOURDES AYALA, EXAMINING ATTORNEY

SN 78-969,545. ALONSO, HUMBERTO D., CHULA VISTA, CA. FILED 9-7-2006.

## Babes Go Bananas

THE MARK CONSISTS OF STANDARD CHARACTERS WITHOUT CLAIM TO ANY PARTICULAR FONT, STYLE, SIZE, OR COLOR.

FOR DOWNLOADABLE VIDEO RECORDINGS FEATURING ADULT ENTERTAINMENT; PRE-RECORDED CD'S, VIDEO TAPES, LASER DISKS AND DVD'S FEATURING ADULT ENTERTAINMENT (U.S. CLS. 21, 23, 26, 36 AND 38).

FIRST USE 10-13-2003; IN COMMERCE 6-12-2005.  
KATHRYN COWARD, EXAMINING ATTORNEY

**CLASS 9—(Continued).**

SN 78-969,605. COHERENT GMBH, GOETTINGEN, FED REP GERMANY, FILED 9-7-2006.

# PRISMA

THE MARK CONSISTS OF STANDARD CHARACTERS WITHOUT CLAIM TO ANY PARTICULAR FONT, STYLE, SIZE, OR COLOR.

FOR LASERS NOT FOR MEDICAL USE (U.S. CLS. 21, 23, 26, 36 AND 38).  
ESTHER A. BORSUK, EXAMINING ATTORNEY

---

SN 78-969,616. HONEYWELL INTERNATIONAL INC., MORRISTOWN, NJ. FILED 9-7-2006.

# ACCENTIC

THE MARK CONSISTS OF STANDARD CHARACTERS WITHOUT CLAIM TO ANY PARTICULAR FONT, STYLE, SIZE, OR COLOR.

FOR CARD READERS FOR SECURITY AND ACCESS CONTROL FOR DOORS (U.S. CLS. 21, 23, 26, 36 AND 38).  
NAKIA HENRY, EXAMINING ATTORNEY

---

SN 78-969,627. KXD TECHNOLOGY INC., DBA ASTAR TECHNOLOGY, BALDWIN PARK, CA. FILED 9-7-2006.

# TRENT

THE MARK CONSISTS OF STANDARD CHARACTERS WITHOUT CLAIM TO ANY PARTICULAR FONT, STYLE, SIZE, OR COLOR.

THE NAME(S), PORTRAIT(S), AND/OR SIGNATURE(S) SHOWN IN THE MARK DOES NOT IDENTIFY A PARTICULAR LIVING INDIVIDUAL.

FOR DVD-PLAYERS; TELEVISION SETS (U.S. CLS. 21, 23, 26, 36 AND 38).  
JACLYN KIDWELL, EXAMINING ATTORNEY

**CLASS 9—(Continued).**

SN 78-969,773. DPI, INC., ST. LOUIS, MO. FILED 9-8-2006.

# IREV

THE MARK CONSISTS OF STANDARD CHARACTERS WITHOUT CLAIM TO ANY PARTICULAR FONT, STYLE, SIZE, OR COLOR.

FOR CONSUMER AUDIO AND VIDEO ELECTRONIC PRODUCTS, NAMELY, PHONOGRAPHS, COMPACT DISC PLAYERS, AUDIO AND VIDEO RECEIVERS, AUDIO AND VIDEO AMPLIFIERS, WALKIE-TALKIES, AUDIO SPEAKERS, HEADPHONES, MICROPHONES, AUDIOTAPE CASSETTE PLAYERS AND RECORDERS, AUDIOTAPE DUAL CASSETTE RECORDERS, AUDIO GRAPHIC EQUALIZERS, REMOTE CONTROL UNITS FOR RADIOS, AUDIOTAPE CASSETTE PLAYERS, VIDEOTAPE CASSETTE PLAYERS, DVD PLAYERS, MP3 PLAYERS AND MP3 RECORDERS, TELEVISIONS, VIDEO CASSETTE PLAYERS, RECORDERS, AND REWINDERS; RADIOS; RADIO ANTENNAS; TELEPHONES; TELEPHONE EQUIPMENT, NAMELY, CALLER IDENTIFICATION BOXES; CITIZEN BAND RADIO TRANSCIEVERS; ELECTRONIC PERSONAL COMMUNICATION DEVICE, NAMELY, TWO-WAY RADIO FOR USE ON SPECIFIED FREQUENCY WAVES FOR COMMUNICATIONS BETWEEN FAMILIES OR SMALL GROUPS (U.S. CLS. 21, 23, 26, 36 AND 38).  
NAAKWAMA ANKRAH, EXAMINING ATTORNEY

---

SN 78-969,785. DPI, INC., ST. LOUIS, MO. FILED 9-8-2006.

# ZLIVE

THE MARK CONSISTS OF STANDARD CHARACTERS WITHOUT CLAIM TO ANY PARTICULAR FONT, STYLE, SIZE, OR COLOR.

FOR CONSUMER AUDIO AND VIDEO ELECTRONIC PRODUCTS, NAMELY, PHONOGRAPHS, COMPACT DISC PLAYERS, AUDIO AND VIDEO RECEIVERS, AUDIO AND VIDEO AMPLIFIERS, WALKIE-TALKIES, AUDIO SPEAKERS, HEADPHONES, MICROPHONES, AUDIOTAPE CASSETTE PLAYERS AND RECORDERS, AUDIOTAPE DUAL CASSETTE RECORDERS, AUDIO GRAPHIC EQUALIZERS, REMOTE CONTROL UNITS FOR RADIOS, AUDIOTAPE CASSETTE PLAYERS, VIDEOTAPE CASSETTE PLAYERS, DVD PLAYERS, MP3 PLAYERS AND MP3 RECORDERS, TELEVISIONS, VIDEO CASSETTE PLAYERS, RECORDERS, AND REWINDERS; RADIOS; RADIO ANTENNAS; TELEPHONES; TELEPHONE EQUIPMENT, NAMELY, CALLER IDENTIFICATION BOXES; CITIZEN BAND RADIO TRANSCIEVERS; ELECTRONIC PERSONAL COMMUNICATION DEVICE, NAMELY, TWO-WAY RADIO FOR USE ON SPECIFIED FREQUENCY WAVES FOR COMMUNICATIONS BETWEEN FAMILIES OR SMALL GROUPS (U.S. CLS. 21, 23, 26, 36 AND 38).  
NAAKWAMA ANKRAH, EXAMINING ATTORNEY

**CLASS 9—(Continued).**

SN 78-969,828. NATIVE EYEWEAR, INC., HUNTINGDON VALLEY, PA. FILED 9-8-2006.

# NATIVE

THE MARK CONSISTS OF STANDARD CHARACTERS WITHOUT CLAIM TO ANY PARTICULAR FONT, STYLE, SIZE, OR COLOR.

OWNER OF U.S. REG. NO. 2,235,338.  
FOR EYEWEAR, NAMELY, SPORTS GOGGLES FOR SNOW SPORTS AND MOTORSPORTS (U.S. CLS. 21, 23, 26, 36 AND 38).

MICHAEL KAZAZIAN, EXAMINING ATTORNEY

SN 78-969,861. VITAE LLC, MADISON, WI. FILED 9-8-2006.

# BIObath

THE MARK CONSISTS OF STANDARD CHARACTERS WITHOUT CLAIM TO ANY PARTICULAR FONT, STYLE, SIZE, OR COLOR.

FOR LABORATORY EQUIPMENT AND SUPPLIES, NAMELY, INCUBATORS (U.S. CLS. 21, 23, 26, 36 AND 38).

GINNY ISAACSON, EXAMINING ATTORNEY

SN 78-969,893. EXAGN DIAGNOSTICS, INC., ALBUQUE-  
QUE, NM. FILED 9-8-2006.

# exagenBC

FOR COMPUTER SOFTWARE FOR DIAGNOSTIC AND PROGNOSTIC PATIENT TESTING IN VARIOUS DISEASE STATES; COMPUTER SOFTWARE FOR IDENTIFYING BIOLOGICAL MARKERS FOR USE IN DIAGNOSTIC AND PROGNOSTIC PATIENT TESTING IN VARIOUS DISEASE STATES (U.S. CLS. 21, 23, 26, 36 AND 38).

TARAH HARDY, EXAMINING ATTORNEY

**CLASS 9—(Continued).**

SN 78-969,914. REMEDYMD, INC., SALT LAKE CITY, UT. FILED 9-8-2006.

## Better Data, Better Decisions, Better Outcomes

THE MARK CONSISTS OF STANDARD CHARACTERS WITHOUT CLAIM TO ANY PARTICULAR FONT, STYLE, SIZE, OR COLOR.

FOR COMPUTER SOFTWARE FOR THE ANALYSIS AND MANAGEMENT OF MEDICAL AND HEALTH-CARE INFORMATION, DECISION-MAKING PROCESSES, WORKFLOW, AND OUTCOMES (U.S. CLS. 21, 23, 26, 36 AND 38).

TONI HICKEY, EXAMINING ATTORNEY

SN 78-970,064. ELAN HOME SYSTEMS, L.L.C., LEXINGTON, KY. FILED 9-8-2006.

# PLAYROOM

THE MARK CONSISTS OF STANDARD CHARACTERS WITHOUT CLAIM TO ANY PARTICULAR FONT, STYLE, SIZE, OR COLOR.

FOR AUDIO VIDEO SOURCE CONTROLLERS, NAMELY, SPEAKER SELECTORS (U.S. CLS. 21, 23, 26, 36 AND 38).

WENDY GOODMAN, EXAMINING ATTORNEY

SN 78-970,311. HEXAGON METROLOGY AB, STOCKHOLM, SWEDEN, FILED 9-8-2006.

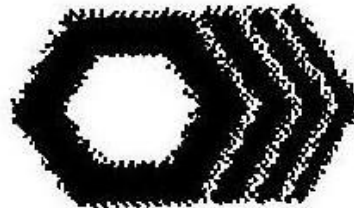

FOR COORDINATE MEASURING MACHINES AND OPERATING AND MEASUREMENT COMPUTER SOFTWARE FOR USE THEREWITH (U.S. CLS. 21, 23, 26, 36 AND 38).

FIRST USE 9-1-2004; IN COMMERCE 9-1-2004.  
RICHARD WHITE, EXAMINING ATTORNEY

**CLASS 9—(Continued).**

SN 78-970,337. CARBON PROJECT, INC., BURLINGTON, MA. FILED 9-8-2006.

**GEOSOCIAL NETWORKING**

THE MARK CONSISTS OF STANDARD CHARACTERS WITHOUT CLAIM TO ANY PARTICULAR FONT, STYLE, SIZE, OR COLOR.

NO CLAIM IS MADE TO THE EXCLUSIVE RIGHT TO USE "NETWORKING", APART FROM THE MARK AS SHOWN.

FOR COMPUTER SOFTWARE FOR COMMUNICATING, SEARCHING, INDEXING AND TRANSFERRING MAP DATA AND GEOGRAPHIC CONTENT BETWEEN COMPUTERS AND PEOPLE; COMPUTER SOFTWARE FOR SEARCHING AND RETRIEVING MAP DATA AND GEOGRAPHIC CONTENT ON LOCAL AND GLOBAL COMPUTER NETWORKS AND WITHIN NETWORKS OF PEOPLE (U.S. CLS. 21, 23, 26, 36 AND 38).

LINDA M. KING, EXAMINING ATTORNEY

SN 78-970,397. OPENLINK SOFTWARE INC., BURLINGTON, MA. FILED 9-8-2006.

**Zitgist**

THE MARK CONSISTS OF STANDARD CHARACTERS WITHOUT CLAIM TO ANY PARTICULAR FONT, STYLE, SIZE, OR COLOR.

FOR COMPUTER SOFTWARE FOR SEARCHING WEB AND INTERNET DATABASES (U.S. CLS. 21, 23, 26, 36 AND 38).

MARK T. MULLEN, EXAMINING ATTORNEY

SN 78-970,565. LUMENARE NETWORKS, SANTA CLARA, CA. FILED 9-8-2006.

**Virtualize Your Test Infrastructure**

THE MARK CONSISTS OF STANDARD CHARACTERS WITHOUT CLAIM TO ANY PARTICULAR FONT, STYLE, SIZE, OR COLOR.

FOR LAB MANAGEMENT SOFTWARE (U.S. CLS. 21, 23, 26, 36 AND 38).

JOHN WILKE, EXAMINING ATTORNEY

**CLASS 9—(Continued).**

SN 78-970,609. MICROSOFT CORPORATION, REDMOND, WA. FILED 9-8-2006.

**HDI**

THE MARK CONSISTS OF STANDARD CHARACTERS WITHOUT CLAIM TO ANY PARTICULAR FONT, STYLE, SIZE, OR COLOR.

FOR COMPUTER SOFTWARE DEVELOPMENT TOOLS FOR CREATING INTERACTIVE MULTIMEDIA CONTENT (U.S. CLS. 21, 23, 26, 36 AND 38).

DARRYL SPRULL, EXAMINING ATTORNEY

SN 78-970,622. OVERLAND, PACIFIC & CUTLER, INC., LONG BEACH, CA. FILED 9-8-2006.

**ProjectOne**

THE MARK CONSISTS OF STANDARD CHARACTERS WITHOUT CLAIM TO ANY PARTICULAR FONT, STYLE, SIZE, OR COLOR.

FOR COMPUTER SOFTWARE FOR ACQUISITION AND RELOCATION ASPECTS OF EMINENT DOMAIN PROCEEDINGS (U.S. CLS. 21, 23, 26, 36 AND 38).

DAVID H. STINE, EXAMINING ATTORNEY

SN 78-970,709. DELOR AND ASSOCIATES, INC., CLEARWATER, FL. FILED 9-9-2006.

**MPG PLUS**

THE MARK CONSISTS OF STANDARD CHARACTERS WITHOUT CLAIM TO ANY PARTICULAR FONT, STYLE, SIZE, OR COLOR.

FOR INERTIAL MASS INDICATOR FOR MOTOR VEHICLE (U.S. CLS. 21, 23, 26, 36 AND 38).

JOHN WILKE, EXAMINING ATTORNEY

**CLASS 9—(Continued).**

SN 78-970,977. WMS GAMING INC., WAUKEGAN, IL. FILED 9-11-2006.

**JEWELS OF THE NIGHT**

THE MARK CONSISTS OF STANDARD CHARACTERS WITHOUT CLAIM TO ANY PARTICULAR FONT, STYLE, SIZE, OR COLOR.

FOR GAMING MACHINES THAT GENERATE OR DISPLAY WAGER OUTCOMES; GAMING SOFTWARE THAT GENERATES OR DISPLAYS WAGER OUTCOMES OF GAMING MACHINES (U.S. CLS. 21, 23, 26, 36 AND 38).

KIMBERLY FRYE, EXAMINING ATTORNEY

SN 78-971,015. DISCOVERY DATA SYSTEMS, INC., NEWTON, NJ. FILED 9-11-2006.

**VoxWeb**

THE MARK CONSISTS OF STANDARD CHARACTERS WITHOUT CLAIM TO ANY PARTICULAR FONT, STYLE, SIZE, OR COLOR.

FOR COMPUTER HARDWARE AND SOFTWARE USED FOR THE CONTROL OF VOICE CONTROLLED INFORMATION AND COMMUNICATION DEVICES (U.S. CLS. 21, 23, 26, 36 AND 38).

LINDA MICKLEBURGH, EXAMINING ATTORNEY

SN 78-971,506. HOUSE OF BLUES BRANDS CORP., HOLLYWOOD, CA. FILED 9-11-2006.

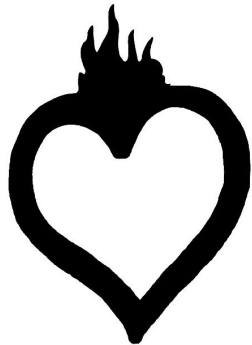

OWNER OF U.S. REG. NOS. 2,474,032, 3,084,399 AND OTHERS.

FOR PRERECORDED AUDIO AND VIDEO TAPES, CASSETTES, CARTRIDGES, COMPACT DISCS, DVDS, LASER DISCS, AND PHONOGRAPH RECORDS FEATURING MUSIC (U.S. CLS. 21, 23, 26, 36 AND 38).

ANDREA K. NADELMAN, EXAMINING ATTORNEY

**CLASS 9—(Continued).**

SN 78-971,781. TRANSFREIGHT, LLC, ERLANGER, KY. FILED 9-11-2006.

**IDS**

THE MARK CONSISTS OF STANDARD CHARACTERS WITHOUT CLAIM TO ANY PARTICULAR FONT, STYLE, SIZE, OR COLOR.

FOR LOGISTICS SOFTWARE APPLICATION THAT PROVIDES TOOLS TO DEVELOP NETWORK DESIGNS (U.S. CLS. 21, 23, 26, 36 AND 38).

CHRIS WELLS, EXAMINING ATTORNEY

SN 78-971,785. HEALTHWORKS ALLIANCE, INC., KING OF PRUSSIA, PA. FILED 9-11-2006.

**HEALTHWORKS ALLIANCE**

THE MARK CONSISTS OF STANDARD CHARACTERS WITHOUT CLAIM TO ANY PARTICULAR FONT, STYLE, SIZE, OR COLOR.

OWNER OF U.S. REG. NOS. 2,083,123 AND 3,010,148. FOR COMPUTER SOFTWARE FOR CONTROLLING AND MANAGING PATIENT MEDICAL INFORMATION (U.S. CLS. 21, 23, 26, 36 AND 38).

FIRST USE 2-4-2004; IN COMMERCE 2-4-2004. JAMES MACFARLANE, EXAMINING ATTORNEY

SN 78-971,789. TRANSFREIGHT, LLC, ERLANGER, KY. FILED 9-11-2006.

**CRO**

THE MARK CONSISTS OF STANDARD CHARACTERS WITHOUT CLAIM TO ANY PARTICULAR FONT, STYLE, SIZE, OR COLOR.

FOR LOGISTICS SOFTWARE APPLICATION THAT DETERMINES OPTIMAL SUB-ROUTE UNLOAD TIMES AND DOOR ASSIGNMENTS (U.S. CLS. 21, 23, 26, 36 AND 38).

CHRIS WELLS, EXAMINING ATTORNEY

**CLASS 9—(Continued).**

SN 78-971,798. TRANSFREIGHT, LLC, ERLANGER, KY.  
FILED 9-11-2006.

# TLCM

THE MARK CONSISTS OF STANDARD CHARACTERS WITHOUT CLAIM TO ANY PARTICULAR FONT, STYLE, SIZE, OR COLOR.

FOR LOGISTICS SOFTWARE APPLICATION DESIGNED TO CALCULATE COSTS FOR A LOGISTICS NETWORK AND A PRODUCTION SCHEDULE (U.S. CLS. 21, 23, 26, 36 AND 38).

CHRIS WELLS, EXAMINING ATTORNEY

SN 78-972,791. OBLONG INDUSTRIES, INC., LOS ANGELES, CA. FILED 9-12-2006.

# g-speak

THE MARK CONSISTS OF STANDARD CHARACTERS WITHOUT CLAIM TO ANY PARTICULAR FONT, STYLE, SIZE, OR COLOR.

FOR COMPUTER SOFTWARE FOR ENABLING A HAND POSE AND GESTURE-BASED COMPUTER SYSTEM AND FOR DRIVING A GESTURAL INTERFACE FOR SUCH A SYSTEM (U.S. CLS. 21, 23, 26, 36 AND 38).

KATHRYN COWARD, EXAMINING ATTORNEY

SN 78-973,604. ZENG, VINCENT, UNION CITY, CA. FILED 9-13-2006.



FOR AUDIO AMPLIFIERS; AUDIO MIXERS; AUDIO SPEAKERS; MICROPHONES; SOUND MIXERS; SOUND MIXERS WITH INTEGRATED AMPLIFIERS (U.S. CLS. 21, 23, 26, 36 AND 38).

GRETTA YAO, EXAMINING ATTORNEY

**CLASS 9—(Continued).**

SN 78-974,028. RUNCO INTERNATIONAL INC., UNION CITY, CA. FILED 9-14-2006.



FOR TELEVISION MONITORS; TELEVISION RECEIVERS; TELEVISION SETS; HOME THEATRE PRODUCTS, NAMELY, VIDEO PROJECTORS, VIDEO PROCESSORS, LCD DISPLAY MONITORS, AND PLASMA DISPLAY MONITORS (U.S. CLS. 21, 23, 26, 36 AND 38).

FIRST USE 7-18-2001; IN COMMERCE 7-19-2001.  
CAROLYN CATALDO, EXAMINING ATTORNEY

SN 78-974,324. CHEVRON IP INC., SAN RAMON, CA. FILED 9-14-2006.

# PROVIDUS

THE MARK CONSISTS OF STANDARD CHARACTERS WITHOUT CLAIM TO ANY PARTICULAR FONT, STYLE, SIZE, OR COLOR.

FOR SOFTWARE USED TO CREATE AND MANAGE A CENTRAL UTILITY REPOSITORY IN THE FIELD OF DRILLING ENGINEERING (U.S. CLS. 21, 23, 26, 36 AND 38).

STEPHEN AQUILA, EXAMINING ATTORNEY

SN 78-974,631. THOMSON LEARNING INC., STAMFORD, CT. FILED 9-14-2006.

# KEYCHECK

THE MARK CONSISTS OF STANDARD CHARACTERS WITHOUT CLAIM TO ANY PARTICULAR FONT, STYLE, SIZE, OR COLOR.

FOR COMPUTER SOFTWARE, NAMELY, A CD-ROM USED FOR TEACHING TYPING SKILLS TO POSTSECONDARY SCHOOL STUDENTS (U.S. CLS. 21, 23, 26, 36 AND 38).

WILLIAM P. SHANAHAN, EXAMINING ATTORNEY



**CLASS 9—(Continued).**

SN 79-013,988. KATHREIN-WERKE KG, FED REP GERMANY, FILED 6-2-2005.

# CityStar

THE MARK CONSISTS OF STANDARD CHARACTERS WITHOUT CLAIM TO ANY PARTICULAR FONT, STYLE, SIZE, OR COLOR.

OWNER OF INTERNATIONAL REGISTRATION 0858238 DATED 6-2-2005, EXPIRES 6-2-2015.

FOR APPARATUS FOR TRANSMITTING SOUND AND IMAGES; APPARATUS FOR THE TRANSMISSION OF DATA, INFORMATION, SOUNDS AND IMAGES, NAMELY; TRANSMITTER AMPLIFIER, TRANSMITTER ANTENNA, TRANSMITTER COMBINING FILTER FOR COMPLETING OR EXTENDING FM AND TV ANTENNA SYSTEMS COMPRISED OF TRANSMITTER MULTIPLEXER AND TRANSMITTER SIGNALING FILTER; TRANSMITTER INPUT AMPLIFIER; ANTENNAS AND ANTENNA SYSTEMS, NAMELY, BROADCAST ANTENNAS, CAR ANTENNAS, CAR RADIO ANTENNAS; TELEVISION ANTENNAS, SATELLITE ANTENNAS AND BASE STATION ANTENNAS FOR MOBILE COMMUNICATIONS; ANTENNA AMPLIFIERS, ANTENNA MEASURING INSTRUMENTS, NAMELY INSTRUMENTS FOR MEASURING AND TESTING CABLE TELEVISION (CATV) NETWORKS, MASTER ANTENNA TELEVISION (MATV) NETWORKS, SATELLITE MASTER TELEVISION (SMATV) NETWORKS, AND HYBRID FIBER COAX (HFC) NETWORKS; RECEIVERS FOR AUDIO AND VIDEO; RECEIVERS FOR RECEPTION OF ANALOG OR DIGITAL SIGNALS, AND RECEIVERS FOR RECEPTION OF DIGITAL DATA AND DISTRIBUTION THEREOF IN HOMES; RECEIVER AMPLIFIER, RECEIVER CIRCUITRY, RECEIVER TUNING CONTROL, AUDIO-VIDEO RECEIVER, RECEIVING CIRCUIT, RECEIVING CIRCUIT TESTER, RADIO RECEIVER, TELEVISION RECEIVER, RECORDERS, NAMELY VIDEOTAPE RECORDERS, CASSETTE RECORDERS, PERSONAL VIDEO RECORDERS, AND DIGITAL VIDEO RECORDERS, CD RECORDER, DVD RECORDER, TAPE RECORDER, MONITORS, LASER BEAM PROJECTORS, AMPLIFIERS AND SIGNAL AMPLIFIERS, SIGNAL PROCESSORS, SIGNAL CONDITIONING DEVICES FOR INDUSTRIAL PROCESS CONTROL; ELECTRONIC DEVICES, NAMELY, FREQUENCY DUPLEXERS AND POWER DIVIDERS, ALL OF THE AFORESAID GOODS FOR STATIONARY MOBILE RADIO ANTENNA INSTALLATIONS AND BASE STATIONS (U.S. CLS. 21, 23, 26, 36 AND 38).

CAROLINE WEIMER, EXAMINING ATTORNEY

SN 79-025,048. GN OTOMETRICS A/S, DENMARK, FILED 4-7-2006.

# OTOSUITE

THE MARK CONSISTS OF STANDARD CHARACTERS WITHOUT CLAIM TO ANY PARTICULAR FONT, STYLE, SIZE, OR COLOR.

PRIORITY DATE OF 10-13-2005 IS CLAIMED.

OWNER OF INTERNATIONAL REGISTRATION 0888015 DATED 4-7-2006, EXPIRES 4-7-2016.

FOR COMPUTER SOFTWARE FOR PC SUPPORTED AUDIOLOGY AND VESTIBULAR DIAGNOSTICS (U.S. CLS. 21, 23, 26, 36 AND 38).

JAMES LOVELACE, EXAMINING ATTORNEY

**CLASS 9—(Continued).**

SN 79-025,325. SOCIETE GENERALE, FRANCE, FILED 3-2-2006.

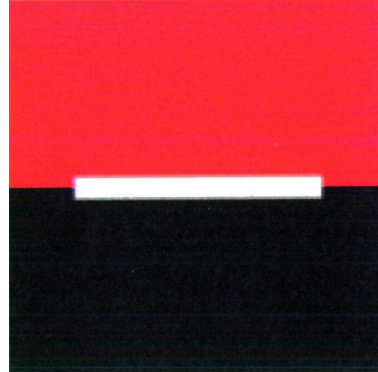

PRIORITY DATE OF 9-2-2005 IS CLAIMED.

OWNER OF INTERNATIONAL REGISTRATION 0888776 DATED 3-2-2006, EXPIRES 3-2-2016.

OWNER OF U.S. REG. NOS. 1,723,648 AND 1,734,708.

THE COLOR(S) BLACK, RED (PANTONE 185) AND WHITE IS/ARE CLAIMED AS A FEATURE OF THE MARK.

THE MARK CONSISTS OF A SQUARE. THE COLOR RED APPEARS IN THE TOP PORTION OF THE SQUARE IN THE MARK. THE COLOR BLACK APPEARS IN THE BOTTOM PORTION OF THE SQUARE IN THE MARK. THE COLOR WHITE APPEARS AS A SMALL HORIZONTAL LINE IN THE MIDDLE OF THE SQUARE IN THE MARK.

FOR MAGNETICALLY ENCODED CREDIT CARDS; MAGNETICALLY ENCODED DEBIT CARDS; MAGNETIC CARDS; MAGNETICALLY ENCODED CREDIT CARDS, NAMELY, CASH WITHDRAWAL CARDS AND PAYMENT CARDS; MEMORY CARDS; BLANK ELECTRONIC CHIP CARDS; RECORDED COMPUTER SOFTWARE USED TO SECURE TRANSACTIONS IN THE FIELD OF BANKING AND FINANCE (U.S. CLS. 21, 23, 26, 36 AND 38).

KENNETH E. SHARPERSON, EXAMINING ATTORNEY

SN 79-025,996. ARTEC S.P.A., ITALY, FILED 3-27-2006.



OWNER OF INTERNATIONAL REGISTRATION 0693506 DATED 5-5-1998, EXPIRES 5-5-2008.

OWNER OF U.S. REG. NO. 2,363,711.

THE COLOR(S) GREY, GREEN IS/ARE CLAIMED AS A FEATURE OF THE MARK.

THE MARK REPRESENTS THE NAME WAITEC IN GREY BLOCK LETTERS, PRECEDED BY TWO UPSIDE-DOWN AND SUPERIMPOSED TRIANGLES, THE FIRST IN GREY AND THE SECOND IN GREEN.

FOR COMPUTER HARDWARE, COMPACT DISC RECORDERS, COMPACT DISC WRITERS, COMPUTER DISC DRIVES, COMPUTER PRINTERS, COMPACT DISCS, NAMELY, BLANK REWRITABLE AND RECORDABLE COMPACT DISCS AND COMPACT DISC READ ONLY MEMORY, VIDEO DISCS, NAMELY, BLANK DIGITAL VIDEO DISC RANDOM ACCESS MEMORY AND DIGITAL VIDEO DISCS WHICH READ AND WRITE, ELECTRONIC CONTROLLERS, NAMELY, SMALL COMPUTER INTERFACE CONTROLLERS, COMPACT DISC CASES AND PARTS THEREFORE (U.S. CLS. 21, 23, 26, 36 AND 38).

STEVEN JACKSON, EXAMINING ATTORNEY

**CLASS 9—(Continued).**

SN 79-026,440. JIANGSU LINYANG ELECTRONICS CO., LTD., CHINA, FILED 4-12-2006.



OWNER OF INTERNATIONAL REGISTRATION 0891998 DATED 4-12-2006, EXPIRES 4-12-2016.

THE MARK CONSISTS OF "LINYANG" AND TWO CHINESE CHARACTERS WHICH HAVE NO SIGNIFICANCE IN THE TRADE, AND A DEVICE WHICH IS COMPOSED OF TWO STYLIZED LETTER "L" WITH A CIRCLE IN THE CENTER.

THE CHINESE TERMS LIN YANG TRANSLATE TO FOREST AND OCEAN IN ENGLISH.

THE TRANSLITERATION OF THE NON-LATIN CHARACTERS IN THE MARK IS: LIN YANG.

FOR ELECTRIC ENERGY METERS; ELECTRIC CURRENT METERS; AMMETERS; WATER METERS; OIL METERS; GAS METERS; ELECTRICITY DISTRIBUTION BOXES; ELECTRICITY DISTRIBUTION CONSOLES (U.S. CLS. 21, 23, 26, 36 AND 38).

CURTIS FRENCH, EXAMINING ATTORNEY

SN 79-027,170. INGRAM MACROTRON GMBH, FED REP GERMANY, FILED 5-17-2006.

# VIDEOSEVEN

THE MARK CONSISTS OF STANDARD CHARACTERS WITHOUT CLAIM TO ANY PARTICULAR FONT, STYLE, SIZE, OR COLOR.

PRIORITY DATE OF 2-1-2006 IS CLAIMED.

OWNER OF INTERNATIONAL REGISTRATION 0894069 DATED 5-17-2006, EXPIRES 5-17-2016.

OWNER OF U.S. REG. NOS. 1,390,563, 2,868,215 AND 2,868,216.

FOR GLOBAL POSITIONING SYSTEM (GPS) AND PORTABLE GLOBAL POSITIONING SYSTEM (GPS); TELEVISION SETS, NAMELY TELEVISION SETS IN DVBT TECHNOLOGY; REPLAY APPARATUS FOR SOUND AND IMAGES, NAMELY DVD PLAYERS AND MP3 PLAYERS; RECORDER FOR SOUND AND IMAGE RECORDINGS, NAMELY VIDEO TAPE RECORDERS AND HARD-DISK RECORDERS (U.S. CLS. 21, 23, 26, 36 AND 38).

ELI HELLMAN, EXAMINING ATTORNEY

**CLASS 9—(Continued).**

SN 79-027,195. INGRAM MACROTRON GMBH, FED REP GERMANY, FILED 5-17-2006.



PRIORITY DATE OF 2-1-2006 IS CLAIMED.

OWNER OF INTERNATIONAL REGISTRATION 0894123 DATED 5-17-2006, EXPIRES 5-17-2016.

OWNER OF U.S. REG. NOS. 2,868,215 AND 2,868,217.

"THE COLOR(S) RED AND BLACK IS/ARE CLAIMED AS A FEATURE OF THE MARK."

"THE MARK CONSISTS OF THE COLOR BLACK APPEARS IN THE TEXT OF THE LETTER V, WHILE THE COLOR RED APPEARS IN THE TEXT OF THE NUMBER 7."

FOR GLOBAL POSITIONING SYSTEM (GPS) AND PORTABLE GLOBAL POSITIONING SYSTEM (GPS); TELEVISION SETS, NAMELY TELEVISION SETS IN DVBT TECHNOLOGY; REPLAY APPARATUS FOR SOUND AND IMAGES, NAMELY DVD PLAYERS AND MP3 PLAYERS; RECORDER FOR SOUND AND IMAGE RECORDINGS, NAMELY VIDEO TAPE RECORDERS AND HARD-DISK RECORDERS (U.S. CLS. 21, 23, 26, 36 AND 38).

ELI HELLMAN, EXAMINING ATTORNEY

SN 79-027,202. INGRAM MACROTRON GMBH, FED REP GERMANY, FILED 5-17-2006.



PRIORITY DATE OF 2-1-2006 IS CLAIMED.

OWNER OF INTERNATIONAL REGISTRATION 0894140 DATED 5-17-2006, EXPIRES 5-17-2016.

OWNER OF U.S. REG. NOS. 1,390,563, 2,868,216 AND OTHERS.

"THE COLOR(S) RED AND BLACK IS/ARE CLAIMED AS A FEATURE OF THE MARK."

"THE MARK CONSISTS OF THE COLOR BLACK APPEARS IN THE TEXT OF THE LETTER V, AND IN THE TEXT OF THE WORDING VIDEOSEVEN. THE COLOR RED APPEARS IN THE TEXT OF THE NUMBER 7."

FOR GLOBAL POSITIONING SYSTEM (GPS) AND PORTABLE GLOBAL POSITIONING SYSTEM (GPS); TELEVISION SETS, NAMELY TELEVISION SETS IN DVBT TECHNOLOGY; REPLAY APPARATUS FOR SOUND AND IMAGES, NAMELY DVD PLAYERS AND MP3 PLAYERS; RECORDER FOR SOUND AND IMAGE RECORDINGS, NAMELY VIDEO TAPE RECORDERS AND HARD-DISK RECORDERS (U.S. CLS. 21, 23, 26, 36 AND 38).

ELI HELLMAN, EXAMINING ATTORNEY

**CLASS 9—(Continued).**

SN 79-027,377. SICHUAN TSUM TECHNOLOGY CO., LTD., CHINA, FILED 5-29-2006.

# **PISEN**

OWNER OF INTERNATIONAL REGISTRATION 0894673 DATED 5-29-2006, EXPIRES 5-29-2016.

FOR NOTEBOOK COMPUTERS; COMPUTER PERIPHERAL DEVICES; CAMCORDERS; HEADPHONES; SOLAR BATTERIES; BATTERY CHARGERS; GALVANIC CELLS; ELECTRIC ACCUMULATORS; ELECTRIC PLUGS; ELECTRIC SOCKETS; SAFETY CONTACT PLUGS; ELECTRICAL WIRES AND CABLES (U.S. CLS. 21, 23, 26, 36 AND 38).

DORITT L. CARROLL, EXAMINING ATTORNEY

SN 79-027,986. INCARD SA - STMICROELECTRONICS, SWITZERLAND, FILED 6-22-2006.

# **MOKARD**

PRIORITY DATE OF 6-19-2006 IS CLAIMED.  
OWNER OF INTERNATIONAL REGISTRATION 0896166 DATED 6-22-2006, EXPIRES 6-22-2016.

FOR OPERATING SOFTWARE FOR INTEGRATED CIRCUIT CARDS, MICROPROCESSOR CARDS, INTEGRATED CIRCUIT SEMICONDUCTOR MEMORIES; SEMICONDUCTORS, MICROPROCESSORS (U.S. CLS. 21, 23, 26, 36 AND 38).

ALLISON HOLTZ, EXAMINING ATTORNEY

SN 79-028,859. BAR-PNEUMATISCHE; STEUERUNGSSYSTEME GMBH, FED REP GERMANY, FILED 2-21-2006.

# **Vacotrol**

THE MARK CONSISTS OF STANDARD CHARACTERS WITHOUT CLAIM TO ANY PARTICULAR FONT, STYLE, SIZE, OR COLOR.

PRIORITY DATE OF 10-19-2005 IS CLAIMED.  
OWNER OF INTERNATIONAL REGISTRATION 0898399 DATED 2-21-2006, EXPIRES 2-21-2016.

FOR APPARATUS FOR THE MONITORING OF THE TORQUE DIFFERENCE BETWEEN AN ACTUATOR AND A VALVE AND DIAGNOSTICS TO IDENTIFY A POTENTIAL LACK OF FORCE FOR AUTOMATIC ARMATURES USED IN THE PROCESS-INDUSTRY E.G; IN THE FIELD OF CHEMICAL INDUSTRY, FOOD INDUSTRY OR WATER TREATMENT (U.S. CLS. 21, 23, 26, 36 AND 38).

SUZANNE BLANE, EXAMINING ATTORNEY

**CLASS 9—(Continued).**

SN 79-032,094. SAMSUNG ELECTRONICS CO., LTD., REPUBLIC OF KOREA, FILED 10-18-2006.

# **ThinGuard**

OWNER OF INTERNATIONAL REGISTRATION 0906491 DATED 10-18-2006, EXPIRES 10-18-2016.

FOR COMPUTER MONITORS; HARD DISC DRIVES; OPTICAL DISC DRIVES; COMPUTER MEMORY CARDS; NOTEBOOK COMPUTERS; COMPUTERS; COMPUTER PRINTERS; TELEVISION SETS; MOBILE PHONES; FACSIMILE MACHINES; CASH REGISTERS; DRY CELLS; BATTERIES; BATTERY CHARGERS; FIBER OPTIC CABLES; TELEPHONES; DIGITAL VERSATILE DISC PLAYERS; MP3 PLAYERS; CAMCORDERS, VIDEO CAMERAS; DIGITAL CAMERAS (U.S. CLS. 21, 23, 26, 36 AND 38).

CHRISTINA SOBRAL, EXAMINING ATTORNEY

**CLASS 10—MEDICAL APPARATUS**

SN 76-617,525. OSIM INTERNATIONAL LTD, SINGAPORE, FILED 10-26-2004.

# **IGOGO**

THE MARK CONSISTS OF STANDARD CHARACTERS WITHOUT CLAIM TO ANY PARTICULAR FONT, STYLE, SIZE, OR COLOR.

OWNER OF SINGAPORE REG. NO. T0417841J, DATED 9-27-2005, EXPIRES 10-20-2014.

FOR MESSAGE APPARATUS, NAMELY, ELECTRIC, NON-ELECTRIC, OR BATTERY OPERATED MESSAGE CHAIRS, HAND-HELD MASSAGERS, KNEADING AND MASSAGING MACHINES, EYE MASSAGERS, MANUAL MASSAGERS, BODY MASSAGERS, FOOT MASSAGERS; REFLEXOLOGY MACHINES, NAMELY, ELECTRONIC NERVE AND MUSCLE STIMULATORS FEATURING MP3 PLAYERS FOR MUSIC SYNCHRONIZATION SOLD AS A UNIT; MEDICAL REHABILITATIVE DEVICES, NAMELY, ELECTRONIC STIMULATORS FOR EXERCISING OR TONING MUSCLES (U.S. CLS. 26, 39 AND 44).

ROBERT LAVACHE, EXAMINING ATTORNEY

SN 76-656,538. BROOKS, LUCILLE S., VASSAR, MI. FILED 3-7-2006.

# **COMF-E-POUCH**

THE MARK CONSISTS OF STANDARD CHARACTERS WITHOUT CLAIM TO ANY PARTICULAR FONT, STYLE, SIZE, OR COLOR.

FOR ARM SLINGS FOR MEDICAL USE (U.S. CLS. 26, 39 AND 44).

SETH A. RAPPAPORT, EXAMINING ATTORNEY

**CLASS 10—(Continued).**

SN 76-657,290. ANSPACH EFFORT, INC., THE, PALM BEACH GARDENS, FL. FILED 3-27-2006.

# OptiBraid

THE MARK CONSISTS OF STANDARD CHARACTERS WITHOUT CLAIM TO ANY PARTICULAR FONT, STYLE, SIZE, OR COLOR.

FOR MEDICAL DEVICE FOR TYING SUTURES (U.S. CLS. 26, 39 AND 44).

MELVIN AXILBUND, EXAMINING ATTORNEY

SN 76-660,796. MOMENTUM MANAGEMENT, LLC, DBA BUSHMAN PRODUCTS, LOS ANGELES, CA. FILED 5-30-2006.



THE STIPPLING IS A FEATURE OF THE MARK.  
THE MARK CONSISTS OF THE LETTER O IN A THREE DIMENSIONAL FORMAT WITH A POSED LADY ON THE INTERIOR OF THE LETTER O ALONG WITH THE WORDS "THE BIG" RUNNING ACROSS THE BOTTOM OF THE O.  
FOR VIBRATING RUBBER RING FOR THE PENIS (U.S. CLS. 26, 39 AND 44).

FIRST USE 6-18-2005; IN COMMERCE 6-29-2005.  
RAY THOMAS, EXAMINING ATTORNEY

SN 76-665,418. STONISCH, MARY SUE, GROSSE POINTE WOODS, MI. FILED 8-31-2006.

# SMILE NOW

THE MARK CONSISTS OF STANDARD CHARACTERS WITHOUT CLAIM TO ANY PARTICULAR FONT, STYLE, SIZE, OR COLOR.

FOR DENTAL TEMPLATE FOR DEMONSTRATING AND SETTING DENTAL VENEERS AND DENTAL ONLAYS (U.S. CLS. 26, 39 AND 44).

FIRST USE 5-31-2006; IN COMMERCE 5-31-2006.  
JOHN SCHUYLER YARD, EXAMINING ATTORNEY

**CLASS 10—(Continued).**

SN 77-008,575. BTI BIOTECHNOLOGY INSTITUTE, S.L., 01005 VICTORIA (ALAVA), SPAIN, FILED 9-27-2006.

# BTI - WE KNOW HOW

THE MARK CONSISTS OF STANDARD CHARACTERS WITHOUT CLAIM TO ANY PARTICULAR FONT, STYLE, SIZE, OR COLOR.

OWNER OF U.S. REG. NOS. 2,860,581, 3,073,745 AND 3,159,607.

FOR SURGICAL DENTAL IMPLANTS COMPRISING ARTIFICIAL MATERIALS; DENTAL CROWNS (U.S. CLS. 26, 39 AND 44).

KAREN BRACEY, EXAMINING ATTORNEY

SN 77-018,029. CLARKSON UNIVERSITY, POTSDAM, NY. FILED 10-10-2006.

# NATURAL GAIT

THE MARK CONSISTS OF STANDARD CHARACTERS WITHOUT CLAIM TO ANY PARTICULAR FONT, STYLE, SIZE, OR COLOR.

FOR INVALID WALKERS (U.S. CLS. 26, 39 AND 44).

KAREN SEVERSON, EXAMINING ATTORNEY

SN 77-021,949. MEDTRONIC, INC., MINNEAPOLIS, MN. FILED 10-16-2006.

# CARELINK

THE MARK CONSISTS OF STANDARD CHARACTERS WITHOUT CLAIM TO ANY PARTICULAR FONT, STYLE, SIZE, OR COLOR.

OWNER OF U.S. REG. NOS. 2,722,626, 2,766,910 AND 2,990,678.

FOR MEDICAL APPARATUS AND EQUIPMENT FOR USE IN ELECTRONIC ACQUISITION, CAPTURE, PROCESSING, PRESENTATION, STORAGE AND TRANSMISSION OF PATIENT'S MEDICAL AND PHYSIOLOGICAL DATA FOR USE IN PROGRAMMING, MONITORING AND TESTING IMPLANTED CARDIAC DEVICES (U.S. CLS. 26, 39 AND 44).

JOHN GARTNER, EXAMINING ATTORNEY

**CLASS 10—(Continued).**

SN 77-021,960. MEDTRONIC, INC., MINNEAPOLIS, MN. FILED 10-16-2006.

# CARELINK

THE MARK CONSISTS OF STANDARD CHARACTERS WITHOUT CLAIM TO ANY PARTICULAR FONT, STYLE, SIZE, OR COLOR.

OWNER OF U.S. REG. NOS. 2,722,626, 2,766,910 AND 2,990,678.

FOR MEDICAL APPARATUS AND EQUIPMENT FOR USE IN ELECTRONIC ACQUISITION, CAPTURE, PROCESSING, PRESENTATION, STORAGE AND TRANSMISSION OF PATIENT'S MEDICAL AND PHYSIOLOGICAL DATA FOR USE IN PROGRAMMING, MONITORING AND TESTING DIABETES INSULIN PUMPS (U.S. CLS. 26, 39 AND 44).

JOHN GARTNER, EXAMINING ATTORNEY

**CLASS 10—(Continued).**

SN 77-022,863. MINOS MEDICAL, INC., IRVINE, CA. FILED 10-17-2006.

# HYSTEROYSTEM

THE MARK CONSISTS OF STANDARD CHARACTERS WITHOUT CLAIM TO ANY PARTICULAR FONT, STYLE, SIZE, OR COLOR.

FOR GYNECOLOGICAL MEDICAL INSTRUMENTS FOR EXAMINING WOMEN'S REPRODUCTIVE ORGANS; MEDICAL CUTTING DEVICES; MEDICAL INSTRUMENTS FOR CUTTING TISSUE; SURGICAL AND MEDICAL APPARATUS AND INSTRUMENTS FOR USE IN GENERAL SURGERY (U.S. CLS. 26, 39 AND 44).

BERYL GARDNER, EXAMINING ATTORNEY

SN 77-022,804. MINOS MEDICAL, INC., IRVINE, CA. FILED 10-17-2006.

# APPENDOTIE

THE MARK CONSISTS OF STANDARD CHARACTERS WITHOUT CLAIM TO ANY PARTICULAR FONT, STYLE, SIZE, OR COLOR.

FOR MEDICAL DEVICE AND SURGICAL INSTRUMENT FOR USE IN DIAGNOSIS AND SURGERY OF THE GASTRO-INTESTINAL TRACT; MEDICAL INSTRUMENTS FOR CUTTING TISSUE; SURGICAL AND MEDICAL APPARATUS AND INSTRUMENTS FOR USE IN GENERAL SURGERY (U.S. CLS. 26, 39 AND 44).

BERYL GARDNER, EXAMINING ATTORNEY

SN 77-027,943. ALLEGIANCE CORPORATION, MCGAW PARK, IL. FILED 10-24-2006.

# DURA-TRAC

THE MARK CONSISTS OF STANDARD CHARACTERS WITHOUT CLAIM TO ANY PARTICULAR FONT, STYLE, SIZE, OR COLOR.

FOR PROTECTIVE APPAREL, NAMELY, SURGICAL SHOE COVERS (U.S. CLS. 26, 39 AND 44).

FIRST USE 8-6-2004; IN COMMERCE 8-6-2004.  
RONALD AIKENS, EXAMINING ATTORNEY

SN 77-022,833. MINOS MEDICAL, INC., IRVINE, CA. FILED 10-17-2006.

# CHOLESYSTEM

THE MARK CONSISTS OF STANDARD CHARACTERS WITHOUT CLAIM TO ANY PARTICULAR FONT, STYLE, SIZE, OR COLOR.

FOR MEDICAL DEVICE AND SURGICAL INSTRUMENT FOR USE IN DIAGNOSIS AND SURGERY OF THE GASTRO-INTESTINAL TRACT; MEDICAL INSTRUMENTS FOR CUTTING TISSUE; SURGICAL AND MEDICAL APPARATUS AND INSTRUMENTS FOR USE IN GENERAL SURGERY (U.S. CLS. 26, 39 AND 44).

BERYL GARDNER, EXAMINING ATTORNEY

SN 77-053,202. BECTON, DICKINSON AND COMPANY, FRANKLIN LAKES, NJ. FILED 11-29-2006.



OWNER OF U.S. REG. NOS. 2,510,232, 2,996,913 AND OTHERS.

THE MARK CONSISTS OF IN PART, A SHADED CIRCLE WITH SUNBURST AND PARTIAL ARC DESIGN.

FOR MEDICAL INJECTION APPARATUS WITH OR WITHOUT NEEDLES (U.S. CLS. 26, 39 AND 44).

IRA J. GOODSaid, EXAMINING ATTORNEY

**CLASS 10—(Continued).**

SN 77-070,146. K2M, INC., LEESBURG, VA. FILED 12-22-2006.

**CLASS 10—(Continued).**

SN 78-465,928. NEXENSE LTD., YAVNE, ISRAEL, FILED 8-11-2004.

# SERENGETI

THE MARK CONSISTS OF STANDARD CHARACTERS WITHOUT CLAIM TO ANY PARTICULAR FONT, STYLE, SIZE, OR COLOR.

FOR SURGICAL INSTRUMENTS USED IN SPINAL SURGERY (U.S. CLS. 26, 39 AND 44).

ANTHONY RINKER, EXAMINING ATTORNEY

# NEXENSE

THE MARK CONSISTS OF STANDARD CHARACTERS WITHOUT CLAIM TO ANY PARTICULAR FONT, STYLE, SIZE, OR COLOR.

OWNER OF ISRAEL REG. NO. 170404, DATED 7-19-2005, EXPIRES 2-17-2011.

FOR RESPIRATION SENSORS, SNORING SENSORS, PULSE SENSORS, BLOOD PRESSURE SENSORS, BODY MOVEMENT SENSORS, AND GLUCOSE SENSORS (U.S. CLS. 26, 39 AND 44).

ANN E. SAPPENFIELD, EXAMINING ATTORNEY

SN 78-410,267. ALIGN TECHNOLOGY, INC., SANTA CLARA, CA. FILED 4-29-2004.

SN 78-610,251. R2 TECHNOLOGY, INC., SANTA CLARA, CA. FILED 4-15-2005.

# ALIGN

# PE

THE MARK CONSISTS OF STANDARD CHARACTERS WITHOUT CLAIM TO ANY PARTICULAR FONT, STYLE, SIZE, OR COLOR.

SEC. 2(F).  
FOR DENTAL APPARATUS, NAMELY PLASTIC ORTHODONTIC APPLIANCES (U.S. CLS. 26, 39 AND 44).  
FIRST USE 8-31-1999; IN COMMERCE 9-2-1999.

ANGELA M. MICHELI, EXAMINING ATTORNEY

THE MARK CONSISTS OF STANDARD CHARACTERS WITHOUT CLAIM TO ANY PARTICULAR FONT, STYLE, SIZE, OR COLOR.

FOR COMPUTER SOFTWARE THAT FACILITATES THE RETENTION, MAGNIFICATION, IDENTIFICATION, COMPARISON, DISPLAY, REVIEW, ANALYSIS AND HIGHLIGHTING OF ABNORMAL ANATOMICAL FEATURES IN RADIOLOGICAL IMAGES USED FOR THE DETECTION, ANALYSIS AND DIAGNOSIS OF DISEASE ABNORMALITIES (U.S. CLS. 26, 39 AND 44).

SALLY SHIH, EXAMINING ATTORNEY

**CLASS 10—(Continued).**

SN 78-645,971. ABBOTT LABORATORIES, ABBOTT PARK, IL. FILED 6-8-2005.

**RELIEFBAND**

THE MARK CONSISTS OF STANDARD CHARACTERS WITHOUT CLAIM TO ANY PARTICULAR FONT, STYLE, SIZE, OR COLOR.

SEC. 2(F).

FOR MEDICAL DEVICE, NAMELY, A WRISTBAND FOR THE PREVENTION AND TREATMENT OF NAUSEA (U.S. CLS. 26, 39 AND 44).

FIRST USE 3-15-1993; IN COMMERCE 3-15-1993.

CHARLES L. JENKINS, EXAMINING ATTORNEY

SN 78-725,836. K2M, INC., LEESBURG, VA. FILED 10-4-2005.

**NATURAL BRIDGE**

THE MARK CONSISTS OF STANDARD CHARACTERS WITHOUT CLAIM TO ANY PARTICULAR FONT, STYLE, SIZE, OR COLOR.

FOR MEDICAL APPARATUS, NAMELY, SPINAL IMPLANTS CONSISTING OF ARTIFICIAL MATERIALS (U.S. CLS. 26, 39 AND 44).

TRACY WHITTAKER-BROWN, EXAMINING ATTORNEY

SN 78-740,337. PIPEDREAM PRODUCTS, INC., CHATSWORTH, CA. FILED 10-25-2005.

**FINGER FUN**

THE MARK CONSISTS OF STANDARD CHARACTERS WITHOUT CLAIM TO ANY PARTICULAR FONT, STYLE, SIZE, OR COLOR.

FOR ELECTRIC AND NON-ELECTRIC MASSAGE DEVICES, NAMELY, DEVICES FOR MASSAGING OR VIBRATING PORTIONS OF THE FACE AND BODY AND PACIFIERS FOR MASSAGING THE LIPS; DEVICES FOR AIDING IN COPULATION AND MASTURBATION, NAMELY, REPRODUCTION OF PARTS OF THE MALE AND FEMALE ANATOMY, PENISES, VAGINAS, PUMPS, RINGS, CLAMPS, STIMULATORS, VIBRATORS, DILDOS, DONGS, BUTT PLUGS, SLEEVES ON VIBRATORS SOLD TOGETHER WITH THE MASSAGING DEVICES, HARNESSSES, MASTURBATORS, NIPPLE CLIPPERS, BODY PROSTHESES, ELECTRICAL APPLIANCES FOR MASSAGING THE BODY, KITS COMPRISED OF TWO OR MORE OF THESE PRODUCTS; LOVE DOLLS AND CONDOMS AND MINIATURE CONDOMS; PACIFIERS FOR USE BY ADULTS (U.S. CLS. 26, 39 AND 44).

FIRST USE 7-1-2004; IN COMMERCE 7-1-2004.

ALYSSA PALADINO, EXAMINING ATTORNEY

**CLASS 10—(Continued).**

SN 78-799,530. VIDAR SYSTEMS CORPORATION, HERRINGTON, VA. FILED 1-25-2006.

**VIDAR VISION**

THE MARK CONSISTS OF STANDARD CHARACTERS WITHOUT CLAIM TO ANY PARTICULAR FONT, STYLE, SIZE, OR COLOR.

OWNER OF U.S. REG. NO. 1,632,174.

FOR DIGITAL RADIOGRAPHY SYSTEMS COMPRISED OF A DIGITAL DETECTOR, ACQUISITION WORK STATION AND MULTI FUNCTIONAL STAND FOR MEDICAL PURPOSES (U.S. CLS. 26, 39 AND 44).

FIRST USE 1-1-2006; IN COMMERCE 1-1-2006.

DANNEAN HETZEL, EXAMINING ATTORNEY

SN 78-807,574. ATC TECHNOLOGIES, INC., WILMINGTON, MA. FILED 2-6-2006.

**HYDRO-SCOUT**

THE MARK CONSISTS OF STANDARD CHARACTERS WITHOUT CLAIM TO ANY PARTICULAR FONT, STYLE, SIZE, OR COLOR.

FOR SURGICAL INSTRUMENTS, NAMELY, SUCTION IRRIGATION PROBE TIPS FOR USE WITH LAPAROSCOPIC AND ENDOSCOPIC INSTRUMENTS (U.S. CLS. 26, 39 AND 44).

FIRST USE 3-0-2001; IN COMMERCE 3-0-2001.

HOWARD FRIEDMAN, EXAMINING ATTORNEY

SN 78-809,632. JCB MOBILITY, INC., ATLANTA, GA. FILED 2-8-2006.

**MOBILASER**

THE MARK CONSISTS OF STANDARD CHARACTERS WITHOUT CLAIM TO ANY PARTICULAR FONT, STYLE, SIZE, OR COLOR.

FOR LASERS FOR MEDICAL USE IN CONNECTION WITH WALKERS AND CANES (U.S. CLS. 26, 39 AND 44).

DAVID YONTEF, EXAMINING ATTORNEY

**CLASS 10—(Continued).**

SN 78-811,146. ST. JUDE MEDICAL, INC., ST. PAUL, MN.  
FILED 2-9-2006.

**TRIFECTA**

THE MARK CONSISTS OF STANDARD CHARACTERS WITHOUT CLAIM TO ANY PARTICULAR FONT, STYLE, SIZE, OR COLOR.

FOR MEDICAL DEVICES, NAMELY, HEART VALVE PROSTHESES (U.S. CLS. 26, 39 AND 44).

MIDGE BUTLER, EXAMINING ATTORNEY

**CLASS 10—(Continued).**

SN 78-835,686. TYCO HEALTHCARE GROUP LP, MANSFIELD, MA. FILED 3-13-2006.



NO CLAIM IS MADE TO THE EXCLUSIVE RIGHT TO USE "TAILOR-MADE DVT PROPHYLAXIS VASCULAR THERAPY", APART FROM THE MARK AS SHOWN.

THE COLOR(S) BLUE AND BLACK IS/ARE CLAIMED AS A FEATURE OF THE MARK.

THE MARK CONSISTS OF AN OVAL WITH A BLACK OUTLINE AND AN INTERIOR OVAL WITH BLUE OUTLINE; THE WORDS TAILOR-MADE AND VASCULAR THERAPY IN BLACK; THE WORDS DVT PROPHYLAXIS IN BLUE; THE DESIGN ELEMENT WITHIN THE "X" IN BLACK.

THE MARK CONSISTS OF TWO CONCENTRIC OVALS WITH THE WORDS TAILOR-MADE DVT PROPHYLAXIS VASCULAR THERAPY IN THE CENTER OF THE MARK AND A STYLIZED NEEDLE AND THREAD MAKING UP THE "X" IN PROPHYLAXIS.

FOR MEDICAL APPARATUS AND DEVICES, NAMELY SEQUENTIAL COMPRESSION AND THERAPEUTIC SYSTEMS CONSISTING OF CONTROLLER, SLEEVES, LINER AND TUBING SETS USED FOR REDUCING THE INCIDENCE OF DEEP VEIN THROMBOSIS; ANTI-EMBOLISM STOCKINGS (U.S. CLS. 26, 39 AND 44).

SCOTT SISUN, EXAMINING ATTORNEY

SN 78-815,063. SHERWOOD SERVICES AG, SCHAFFHAUSEN, SWITZERLAND, FILED 2-15-2006.

**PALINDROME**

THE MARK CONSISTS OF STANDARD CHARACTERS WITHOUT CLAIM TO ANY PARTICULAR FONT, STYLE, SIZE, OR COLOR.

FOR DIALYSIS CATHETER, DIALYSIS KITS COMPOSED OF DIALYSIS CATHETER, INTRODUCER NEEDLE, GUIDEWIRE, TUNNELER, TISSUE DILATOR, SYRINGE, SCALPEL, DRESSINGS, SPONGES (U.S. CLS. 26, 39 AND 44).

MARY BOAGNI, EXAMINING ATTORNEY

SN 78-836,662. VITAL SIGNS, INC., TOTOWA, NJ. FILED 3-14-2006.

SN 78-827,569. MENTOR CORPORATION, SANTA BARBARA, CA. FILED 3-2-2006.

**SILTEX**

THE MARK CONSISTS OF STANDARD CHARACTERS WITHOUT CLAIM TO ANY PARTICULAR FONT, STYLE, SIZE, OR COLOR.

OWNER OF U.S. REG. NO. 1,502,078.

FOR SURGICAL IMPLANTS COMPRISING ARTIFICIAL MATERIAL, NAMELY, TISSUE EXPANDERS (U.S. CLS. 26, 39 AND 44).

FIRST USE 12-31-1995; IN COMMERCE 12-31-1995.

GRETTA YAO, EXAMINING ATTORNEY

**T-WALL**

THE MARK CONSISTS OF STANDARD CHARACTERS WITHOUT CLAIM TO ANY PARTICULAR FONT, STYLE, SIZE, OR COLOR.

FOR MEDICAL APPARATUS, NAMELY, ENDOTRACHEAL TUBES (U.S. CLS. 26, 39 AND 44).

FIRST USE 9-0-2003; IN COMMERCE 9-0-2003.

JASON BLAIR, EXAMINING ATTORNEY



**CLASS 10—(Continued).**

SN 78-873,603. INCREDIBLE SCENTS, INC, GLEN HEAD, NY. FILED 5-1-2006.

# AROMA PRO

THE MARK CONSISTS OF STANDARD CHARACTERS WITHOUT CLAIM TO ANY PARTICULAR FONT, STYLE, SIZE, OR COLOR.

NO CLAIM IS MADE TO THE EXCLUSIVE RIGHT TO USE "AROMA", APART FROM THE MARK AS SHOWN.

FOR EXTERNAL NASAL DILATOR IN THE FORM OF A SEPTUM CLIP THAT DELIVERS VARIOUS FRAGRANCES INTENDED TO ENHANCE AEROBIC PERFORMANCE (U.S. CLS. 26, 39 AND 44).

MATTHEW MCDOWELL, EXAMINING ATTORNEY

SN 78-888,322. MEDICAL DEVICE GROUP, INC., POWAY, CA. FILED 5-19-2006.

# iapyx

THE MARK CONSISTS OF STANDARD CHARACTERS WITHOUT CLAIM TO ANY PARTICULAR FONT, STYLE, SIZE, OR COLOR.

FOR MEDICAL DEVICES, NAMELY TUBES FOR MEDICAL PURPOSES AND DEVICES FOR THE SECUREMENT AND STORAGE THEREOF, NAMELY FEEDING TUBES, J TUBES, AND DRAINAGE TUBES; CATHETERS AND DEVICES FOR THE SECUREMENT AND STORAGE THEREOF, NAMELY CLOSED SUCTION CATHETERS, YANKAUER WANDS, ARTERIAL CATHETERS, INTRAVENOUS CATHETERS, CENTRAL LINE INTRAVENOUS CATHETERS, AND CATHETER STABILIZATION DEVICES; MEDICAL HOLSTERS, NAMELY SUCTION WAND HOLSTERS (U.S. CLS. 26, 39 AND 44).

FIRST USE 6-16-2006; IN COMMERCE 6-16-2006.  
TIMOTHY FINNEGAN, EXAMINING ATTORNEY

**CLASS 10—(Continued).**

SN 78-893,979. LOWRY, GLADYS, DALLAS, TX. FILED 5-26-2006.

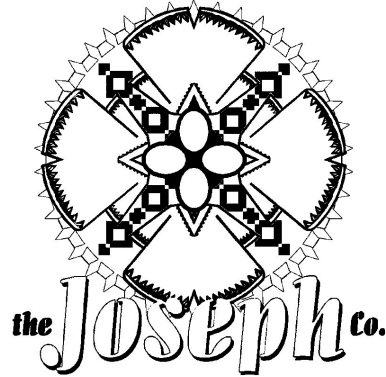

NO CLAIM IS MADE TO THE EXCLUSIVE RIGHT TO USE "CO.", APART FROM THE MARK AS SHOWN.

THE NAME JOSEPH CO. DOES NOT IDENTIFY A LIVING INDIVIDUAL.

FOR DISPOSABLE MEDICAL-SURGICAL PATIENT CARE UNDER GARMENTS (U.S. CLS. 26, 39 AND 44).

JASON TURNER, EXAMINING ATTORNEY

SN 78-902,119. EKOS CORPORATION, BOTHELL, WA. FILED 6-6-2006.

# NEUROWAVE

THE MARK CONSISTS OF STANDARD CHARACTERS WITHOUT CLAIM TO ANY PARTICULAR FONT, STYLE, SIZE, OR COLOR.

FOR CATHETERS FOR DELIVERY OF DRUGS OR FLUIDS AND CONTROLLERS AND POWER UNITS FOR INFUSION CATHETERS; ULTRASONIC DRUG DELIVERY AND DRUG ACTIVATION APPARATUS AND CONTROLLERS AND POWER UNITS THEREFOR (U.S. CLS. 26, 39 AND 44).

ALICE BENMAMAN, EXAMINING ATTORNEY

SN 78-920,088. GLOBAL SLEEP HEADQUARTERS, L.P., HOUSTON, TX. FILED 6-29-2006.

# GLOBAL SLEEP

THE MARK CONSISTS OF STANDARD CHARACTERS WITHOUT CLAIM TO ANY PARTICULAR FONT, STYLE, SIZE, OR COLOR.

NO CLAIM IS MADE TO THE EXCLUSIVE RIGHT TO USE "SLEEP", APART FROM THE MARK AS SHOWN.

FOR MEDICAL EQUIPMENT, NAMELY, PAP (POSITIVE AIRWAY PRESSURE) MACHINE (U.S. CLS. 26, 39 AND 44).

FIRST USE 1-0-2003; IN COMMERCE 1-0-2003.  
JESSICA A. POWERS, EXAMINING ATTORNEY

**CLASS 10—(Continued).**

SN 78-923,714. KCI LICENSING, INC., SAN ANTONIO, TX. FILED 7-6-2006.



The Clinical Advantage

OWNER OF U.S. REG. NOS. 1,572,615, 2,719,241 AND OTHERS.  
SEC. 2(F).

FOR THERAPEUTIC MEDICAL BEDS, OVERLAYS, MATTRESSES AND SUPPORTS FOR IMMOBILE, PULMONARY AND BARIATRIC PATIENTS; EXTERNAL PNEUMATIC COMPRESSION APPARATUS TO PROMOTE BLOOD CIRCULATION, PREVENT DEEP VEIN THROMBOSIS, REDUCE EDEMA AND IMPROVE WOUND HEALING; WOUND HEALING SYSTEMS COMPRISED OF WOUND DRESSINGS, MICROPROCESSOR-CONTROLLED PUMP UNITS, MEDICAL TUBING, RECEPTACLES FOR COLLECTING WOUND DRAINAGE, AND PARTS AND ATTACHMENTS THEREFOR (U.S. CLS. 26, 39 AND 44).

FIRST USE 7-1-2004; IN COMMERCE 7-1-2004.  
PRISCILLA MILTON, EXAMINING ATTORNEY

---

SN 78-928,907. LIFEGEAR, INC., EL MONTE, CA. FILED 7-13-2006.

# ESSENCE

THE MARK CONSISTS OF STANDARD CHARACTERS WITHOUT CLAIM TO ANY PARTICULAR FONT, STYLE, SIZE, OR COLOR.

FOR MESSAGE APPARATUS, NAMELY, MESSAGE TABLES, MESSAGE CHAIRS, MESSAGE PADS THAT ARE COMPONENT PARTS OF MESSAGE TABLES AND CHAIRS, AND HEAD RESTS FOR MESSAGE TABLES; MESSAGE ACCESSORIES, NAMELY, BOLSTERS AND LINENS SPECIFICALLY FITTED AND DESIGNED FOR USE ON MESSAGE TABLES AND CHAIRS; CARRYING CASES FOR HOLDING MESSAGE TABLES; CARRYING CASES FOR HOLDING MESSAGE CHAIRS (U.S. CLS. 26, 39 AND 44).

FIRST USE 9-3-2004; IN COMMERCE 9-3-2004.  
JEFFERY COWARD, EXAMINING ATTORNEY

**CLASS 10—(Continued).**

SN 78-932,737. TOMB, CLIFFORD III, CHICAGO, IL. FILED 7-19-2006.

# BreathEz

THE MARK CONSISTS OF STANDARD CHARACTERS WITHOUT CLAIM TO ANY PARTICULAR FONT, STYLE, SIZE, OR COLOR.

FOR HAND-HELD BREATHING FRESH-AIR APPARATUS DESIGNED FOR QUICK SPRAY INJECTIONS OF CLEAN QUALITY AIR FOR THERAPEUTIC PURPOSES (U.S. CLS. 26, 39 AND 44).

ARETHA SOMERVILLE, EXAMINING ATTORNEY

---

SN 78-943,358. ALLEGIANCE CORPORATION, MCGAW PARK, IL. FILED 8-2-2006.

# AVAPLASTY

THE MARK CONSISTS OF STANDARD CHARACTERS WITHOUT CLAIM TO ANY PARTICULAR FONT, STYLE, SIZE, OR COLOR.

OWNER OF U.S. REG. NO. 2,826,383.  
FOR BONE CEMENT DELIVERY SYSTEM, NAMELY, MEDICAL APPARATUS AND INSTRUMENTS FOR THE MIXING, APPLICATION AND INJECTION OF BONE CEMENT AND RADIOPAQUE BONE CEMENT; VERTEBRAL BODY IMPLANTS (U.S. CLS. 26, 39 AND 44).  
RONALD AIKENS, EXAMINING ATTORNEY

---

SN 78-943,393. ALLEGIANCE CORPORATION, MCGAW PARK, IL. FILED 8-2-2006.

# AVASAX

THE MARK CONSISTS OF STANDARD CHARACTERS WITHOUT CLAIM TO ANY PARTICULAR FONT, STYLE, SIZE, OR COLOR.

OWNER OF U.S. REG. NO. 2,826,383.  
FOR BONE CEMENT DELIVERY SYSTEM, NAMELY, MEDICAL APPARATUS AND INSTRUMENTS FOR THE MIXING, APPLICATION AND INJECTION OF BONE CEMENT AND RADIOPAQUE BONE CEMENT; VERTEBRAL BODY IMPLANTS (U.S. CLS. 26, 39 AND 44).  
RONALD AIKENS, EXAMINING ATTORNEY

**CLASS 10—(Continued).**

SN 78-953,357. LAERDAL MEDICAL AS, STAVANGER, NORWAY, FILED 8-16-2006.

**LAERDAL FIRST IN SUCTION**

THE MARK CONSISTS OF STANDARD CHARACTERS WITHOUT CLAIM TO ANY PARTICULAR FONT, STYLE, SIZE, OR COLOR.

FOR MEDICAL DEVICE USED TO REMOVE SOLIDS AND FLUIDS FROM WOUNDS AND TO MAINTAIN A PATIENT'S AIRWAY BY REMOVING SOLIDS AND FLUIDS FROM ORAL, NASAL AND TRACHEAL PASSAGEWAYS (U.S. CLS. 26, 39 AND 44).  
STEVEN JACKSON, EXAMINING ATTORNEY

SN 78-954,993. LHASA OMS, INC., WEYMOUTH, MA. FILED 8-18-2006.

**Pointer Pulse**

THE MARK CONSISTS OF STANDARD CHARACTERS WITHOUT CLAIM TO ANY PARTICULAR FONT, STYLE, SIZE, OR COLOR.

NO CLAIM IS MADE TO THE EXCLUSIVE RIGHT TO USE "PULSE", APART FROM THE MARK AS SHOWN.  
FOR TRANSCUTANEOUS ELECTRICAL NERVE STIMULATOR FOR USE IN PAIN RELIEF (U.S. CLS. 26, 39 AND 44).

FIRST USE 8-10-2006; IN COMMERCE 8-10-2006.  
RONALD MCMORROW, EXAMINING ATTORNEY

SN 78-957,166. MEAD JOHNSON & COMPANY, EVANSVILLE, IN. FILED 8-22-2006.

**NURSETTE**

THE MARK CONSISTS OF STANDARD CHARACTERS WITHOUT CLAIM TO ANY PARTICULAR FONT, STYLE, SIZE, OR COLOR.

OWNER OF U.S. REG. NOS. 784,892 AND 888,345.  
FOR DISPOSABLE INFANT FEEDING BOTTLES AND PARTS THEREOF FOR DISPENSING INFANT FORMULA, ORAL ELECTROLYTE SOLUTION, WATER, OR WATER WITH GLUCOSE (U.S. CLS. 26, 39 AND 44).  
JUSTINE D. PARKER, EXAMINING ATTORNEY

**CLASS 10—(Continued).**

SN 78-957,362. SWITECH MEDICAL AG, 8280 KREUZLINGEN, SWITZERLAND, FILED 8-22-2006.

**FLATWAVE**

THE MARK CONSISTS OF STANDARD CHARACTERS WITHOUT CLAIM TO ANY PARTICULAR FONT, STYLE, SIZE, OR COLOR.

FOR MEDICAL AND VETERINARY APPARATUS, NAMELY APPARATUS FOR MEDICAL AND THERAPEUTIC TREATMENT USING ACOUSTIC SHOCK WAVES (U.S. CLS. 26, 39 AND 44).

SCOTT BIBB, EXAMINING ATTORNEY

SN 78-957,882. XTENT, INC., MENLO PARK, CA. FILED 8-22-2006.

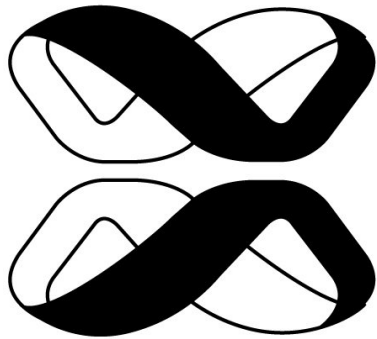

FOR MEDICAL DEVICES USED IN VASCULAR PROCEDURES, NAMELY, MEDICAL STENTS, MEDICAL STENT DELIVERY APPARATUS, CATHETERS (U.S. CLS. 26, 39 AND 44).

DAVID STERKIN, EXAMINING ATTORNEY

SN 78-958,971. COOPERVISION, INC., PLEASANTON, CA. FILED 8-23-2006.

**SENSIPOINT**

THE MARK CONSISTS OF STANDARD CHARACTERS WITHOUT CLAIM TO ANY PARTICULAR FONT, STYLE, SIZE, OR COLOR.

FOR SURGICAL INSTRUMENTS, NAMELY, AN ABDOMINAL ACCESS SYSTEM, COMPRISED OF TROCARS FOR LAPAROSCOPIC ABDOMINAL ACCESS OF VARYING DIAMETERS THAT FEATURE A REUSABLE CANNULA AND AN INTEGRATED SHIELD MECHANISM; MEDICAL INSTRUMENTS, NAMELY DISPOSABLE OBTURATOR TIPS OF VARYING DESIGNS, STYLES AND CONFIGURATIONS (U.S. CLS. 26, 39 AND 44).

KATHERINE CHANG, EXAMINING ATTORNEY

**CLASS 10—(Continued).**

SN 78-959,137. BREG, INC., VISTA, CA. FILED 8-23-2006.

**KODIAK**

THE MARK CONSISTS OF STANDARD CHARACTERS WITHOUT CLAIM TO ANY PARTICULAR FONT, STYLE, SIZE, OR COLOR.

FOR CRYOTHERAPY EQUIPMENT AND DEVICES, NAMELY, COLD THERAPY FLUID CIRCULATION SYSTEMS AND COLD THERAPY PADS AND WRAPS FOR THE TREATMENT AND REHABILITATION OF BONES, JOINTS, MUSCLES, TENDONS, AND LIGAMENTS (U.S. CLS. 26, 39 AND 44).

ALYSSA PALADINO, EXAMINING ATTORNEY

---

SN 78-959,408. APEX MEDICAL CORPORATION, SIOUX FALLS, SD. FILED 8-24-2006.

**STEP n REST**

THE MARK CONSISTS OF STANDARD CHARACTERS WITHOUT CLAIM TO ANY PARTICULAR FONT, STYLE, SIZE, OR COLOR.

FOR MOBILE SUPPORT SYSTEMS, NAMELY, WALKERS AND ROLLATORS FOR INVALIDS, INCLUDING STANDING OR SEATED DEVICES (U.S. CLS. 26, 39 AND 44).

BRIAN PINO, EXAMINING ATTORNEY

---

SN 78-960,648. XTENT, INC., MENLO PARK, CA. FILED 8-25-2006.



OWNER OF U.S. REG. NO. 3,009,289.  
FOR MEDICAL DEVICES USED IN VASCULAR PROCEDURES, NAMELY, MEDICAL STENTS, MEDICAL STENT DELIVERY APPARATUS, CATHETERS (U.S. CLS. 26, 39 AND 44).

DAVID STERKIN, EXAMINING ATTORNEY

**CLASS 10—(Continued).**

SN 78-960,983. ZWEIFLER, MICHAEL, LITTLE ROCK, AR. FILED 8-25-2006.

**ACCUPAL**

THE MARK CONSISTS OF STANDARD CHARACTERS WITHOUT CLAIM TO ANY PARTICULAR FONT, STYLE, SIZE, OR COLOR.

FOR NEEDLE GUIDES FOR PERFORMING INJECTIONS (U.S. CLS. 26, 39 AND 44).

TONJA GASKINS, EXAMINING ATTORNEY

---

SN 78-963,043. BREG, INC., VISTA, CA. FILED 8-29-2006.

**KOOL SLING**

THE MARK CONSISTS OF STANDARD CHARACTERS WITHOUT CLAIM TO ANY PARTICULAR FONT, STYLE, SIZE, OR COLOR.

NO CLAIM IS MADE TO THE EXCLUSIVE RIGHT TO USE "SLING", APART FROM THE MARK AS SHOWN.

FOR SLINGS FOR MEDICAL USE (U.S. CLS. 26, 39 AND 44).

ALYSSA PALADINO, EXAMINING ATTORNEY

---

SN 78-963,950. JONATHAN CITOW, GLENCOE, IL. FILED 8-30-2006.

**ANAL-STESIA**

THE MARK CONSISTS OF STANDARD CHARACTERS WITHOUT CLAIM TO ANY PARTICULAR FONT, STYLE, SIZE, OR COLOR.

FOR MEDICAL EQUIPMENT, NAMELY, A DEVICE FOR TREATMENT OF INFLAMED TISSUES (U.S. CLS. 26, 39 AND 44).

ALEX KEAM, EXAMINING ATTORNEY

**CLASS 10—(Continued).**

SN 78-964,605. PROFESSIONAL PRODUCTS, INC., DEFUNIAK SPRINGS, FL. FILED 8-31-2006.

# LIBERTY DSO

THE MARK CONSISTS OF STANDARD CHARACTERS WITHOUT CLAIM TO ANY PARTICULAR FONT, STYLE, SIZE, OR COLOR.

FOR ORTHOPEDIC DEVICES, NAMELY BRACES, SUPPORTS, AND WRAPS FOR THE ANKLES, KNEES AND OTHER VARIOUS LIMBS AND JOINTS OF THE BODY (U.S. CLS. 26, 39 AND 44).

FIRST USE 10-0-2003; IN COMMERCE 10-0-2003.  
KIMBERLY PERRY, EXAMINING ATTORNEY

**CLASS 10—(Continued).**

SN 78-967,261. KLEIMAN, PAUL L., CULVER CITY, CA. FILED 9-5-2006.

# MASSAGE U

THE MARK CONSISTS OF STANDARD CHARACTERS WITHOUT CLAIM TO ANY PARTICULAR FONT, STYLE, SIZE, OR COLOR.

NO CLAIM IS MADE TO THE EXCLUSIVE RIGHT TO USE "MASSAGE", APART FROM THE MARK AS SHOWN. FOR NON-ELECTRIC AND ELECTRIC MASSAGE APPARATUSES (U.S. CLS. 26, 39 AND 44).

ODESSA BIBBINS, EXAMINING ATTORNEY

SN 78-965,767. SIGNAL INVESTMENT & MANAGEMENT CO., WILMINGTON, DE. FILED 9-1-2006.

# PAIN RELIEF TO THE POWER OF T.E.N.

THE MARK CONSISTS OF STANDARD CHARACTERS WITHOUT CLAIM TO ANY PARTICULAR FONT, STYLE, SIZE, OR COLOR.

FOR TRANSCUTANEOUS ELECTRICAL NERVE STIMULATORS (U.S. CLS. 26, 39 AND 44).

MARILYN IZZI, EXAMINING ATTORNEY

SN 78-967,514. DEVON SAFETY PRODUCTS, INC., KING OF PRUSSIA, PA. FILED 9-5-2006.

# SharpShield

THE MARK CONSISTS OF STANDARD CHARACTERS WITHOUT CLAIM TO ANY PARTICULAR FONT, STYLE, SIZE, OR COLOR.

FOR INJECTION INSTRUMENTS WITH NEEDLES, NEEDLES FOR MEDICAL USE, SYRINGE BARRELS FOR ATTACHMENT TO INJECTION NEEDLES, SAFETY NEEDLES FOR MEDICAL USE AND SAFETY SYRINGES WITH NEEDLES FOR MEDICAL USE (U.S. CLS. 26, 39 AND 44).

JAY BESCH, EXAMINING ATTORNEY

SN 78-966,176. IOMED, INC., SALT LAKE CITY, UT. FILED 9-1-2006.

# OptimA

THE MARK CONSISTS OF STANDARD CHARACTERS WITHOUT CLAIM TO ANY PARTICULAR FONT, STYLE, SIZE, OR COLOR.

FOR IONTOPHORETIC ELECTRODES FOR MEDICAL APPLICATIONS (U.S. CLS. 26, 39 AND 44).

FIRST USE 2-4-2004; IN COMMERCE 4-8-2004.  
INGA ERVIN, EXAMINING ATTORNEY

SN 78-967,527. DEVON SAFETY PRODUCTS, INC., KING OF PRUSSIA, PA. FILED 9-5-2006.

# Innoc-U-Loc

THE MARK CONSISTS OF STANDARD CHARACTERS WITHOUT CLAIM TO ANY PARTICULAR FONT, STYLE, SIZE, OR COLOR.

FOR INJECTION INSTRUMENTS WITH NEEDLES, NEEDLES FOR MEDICAL USE, SYRINGE BARRELS FOR ATTACHMENT TO INJECTION NEEDLES, SAFETY NEEDLES FOR MEDICAL USE AND SAFETY SYRINGES WITH NEEDLES FOR MEDICAL USE (U.S. CLS. 26, 39 AND 44).

JAY BESCH, EXAMINING ATTORNEY

**CLASS 10—(Continued).**

SN 78-967,900. ORTHOHELIX SURGICAL DESIGNS, INC., AKRON, OH. FILED 9-6-2006.

# CALCLOCK

THE MARK CONSISTS OF STANDARD CHARACTERS WITHOUT CLAIM TO ANY PARTICULAR FONT, STYLE, SIZE, OR COLOR.

FOR SPECIALIZED IMPLANTS AND INSTRUMENTS FOR FOOT AND HAND SURGERY, NAMELY PLATES, SCREWS, WIRES, FASTENERS, PLATE HOLDERS, BENDERS, CUTTERS, SCREWDRIVERS, DRILL GUIDES, GUIDE PINS, FORCEPS, RETRACTORS, DEPTH GAUGES AND SALVAGE INSTRUMENTS (U.S. CLS. 26, 39 AND 44).

ZACHARY BELLO, EXAMINING ATTORNEY

SN 78-968,427. DEVON SAFETY PRODUCTS, INC., KING OF PRUSSIA, PA. FILED 9-6-2006.



NO CLAIM IS MADE TO THE EXCLUSIVE RIGHT TO USE "SHARP" AND "SYRINGE", APART FROM THE MARK AS SHOWN.

THE COLOR(S) BLUE AND RED IS/ARE CLAIMED AS A FEATURE OF THE MARK.

THE COLOR(S) RED APPEARS IN THE STYLIZED WORDING "SHIELD", WHICH INCLUDES THE LETTER I IN THE FORM OF A SYRINGE. THE COLOR BLUE APPEARS IN THE STYLIZED WORDING "SHARP" AND "SYRINGE", IN THE DESIGN OF A SHIELD ENGLUFING THE WORDING "SHIELD" AND "SYRINGE", AND IN THE HORIZONTAL LINE BENEATH THE WORDING "SHARP".

FOR INJECTION INSTRUMENTS WITH NEEDLES, NEEDLES FOR MEDICAL USE, SYRINGE BARRELS FOR ATTACHMENT TO INJECTION NEEDLES, SAFETY NEEDLES FOR MEDICAL USE AND SAFETY SYRINGES WITH NEEDLES FOR MEDICAL USE (U.S. CLS. 26, 39 AND 44).

JAY BESCH, EXAMINING ATTORNEY

**CLASS 10—(Continued).**

SN 78-968,805. SARNOVA MEDICAL PRODUCTS, LLC, TRUMBULL, CT. FILED 9-7-2006.

## SARNOVA MEDICAL PRODUCTS

THE MARK CONSISTS OF STANDARD CHARACTERS WITHOUT CLAIM TO ANY PARTICULAR FONT, STYLE, SIZE, OR COLOR.

NO CLAIM IS MADE TO THE EXCLUSIVE RIGHT TO USE "MEDICAL PRODUCTS", APART FROM THE MARK AS SHOWN.

FOR SPINAL IMMOBILIZATION PRODUCTS, NAMELY HEADBOARDS, BACKBOARDS, AND SPINEBOARDS; HEAD, NECK, AND BACK BLOCKS FOR USE WITH BOARDS FOR IMMOBILIZING THE SPINE; ALIGNMENT PADS FOR USE WITH SPINEBOARDS FOR MAINTAINING SPINAL ALIGNMENT; STRAPS FOR USE WITH SPINEBOARDS; SPINEBOARD PADS FOR PEDIATRIC PATIENTS; CERVICAL COLLARS FOR IMMOBILIZING THE SPINE; DISPOSABLE INFLATABLE SPLINTS; ORTHOPEDIC SUPPORTS; SUPPORTS FOR HEAD, NECK, AND BACK FOR MEDICAL USE; SUPPORTS FOR GENERAL MEDICAL USE; EMERGENCY MEDICAL EQUIPMENT, NAMELY, HEADBOARDS; BRACES FOR LIMBS AND JOINTS, FOR MEDICAL USE; CERVICAL PILLOWS FOR MEDICAL USE; LOWER BODY ALIGNMENT APPARATUS FOR MEDICAL PURPOSES; MEDICAL STRETCHERS; CERVICAL COLLARS; SPLINTS FOR MEDICAL PURPOSES (U.S. CLS. 26, 39 AND 44).

ATTIYA MALIK, EXAMINING ATTORNEY

SN 78-969,842. MATERNAL CARE, INC., ALPHARETTA, GA. FILED 9-8-2006.

# Kooleez

THE MARK CONSISTS OF STANDARD CHARACTERS WITHOUT CLAIM TO ANY PARTICULAR FONT, STYLE, SIZE, OR COLOR.

FOR CHEMICALLY ACTIVATED HOT AND/OR COLD COMPRESSES (U.S. CLS. 26, 39 AND 44).

INGRID C. EULIN, EXAMINING ATTORNEY

SN 78-971,149. CORNOVA, INC., BURLINGTON, MA. FILED 9-11-2006.

# NANOFUSION

THE MARK CONSISTS OF STANDARD CHARACTERS WITHOUT CLAIM TO ANY PARTICULAR FONT, STYLE, SIZE, OR COLOR.

FOR COATINGS SOLD AS AN INTEGRAL COMPONENT OF MEDICAL STENTS AND OTHER IMPLANTABLE MEDICAL DEVICES (U.S. CLS. 26, 39 AND 44).

STEVEN JACKSON, EXAMINING ATTORNEY

**CLASS 10—(Continued).**

SN 78-971,160. ALLERGAN, INC., IRVINE, CA. FILED 9-11-2006.

# BIB

THE MARK CONSISTS OF STANDARD CHARACTERS WITHOUT CLAIM TO ANY PARTICULAR FONT, STYLE, SIZE, OR COLOR.

OWNER OF U.S. REG. NO. 2,397,535.  
FOR MEDICAL DEVICE, NAMELY AN INTRAGASTRIC BALLOON USED IN THE TREATMENT OF OBESITY (U.S. CLS. 26, 39 AND 44).

MIDGE BUTLER, EXAMINING ATTORNEY

---

SN 78-971,467. A-DEC, INC., NEWBERG, OR. FILED 9-11-2006.

# ICV

THE MARK CONSISTS OF STANDARD CHARACTERS WITHOUT CLAIM TO ANY PARTICULAR FONT, STYLE, SIZE, OR COLOR.

FOR APPARATUS FOR CLEANING VACUUM LINES IN DENTAL AND MEDICAL EQUIPMENT (U.S. CLS. 26, 39 AND 44).

JOHN HWANG, EXAMINING ATTORNEY

---

SN 78-971,709. ALLEGIANCE CORPORATION, MCGAW PARK, IL. FILED 9-11-2006.

# IT'S VERTEBROPLASTY. REDEFINED.

THE MARK CONSISTS OF STANDARD CHARACTERS WITHOUT CLAIM TO ANY PARTICULAR FONT, STYLE, SIZE, OR COLOR.

FOR BONE CEMENT DELIVERY SYSTEM, NAMELY, MEDICAL APPARATUS AND INSTRUMENTS FOR THE MIXING, APPLICATION AND INJECTION OF BONE CEMENT AND RADIOPAQUE BONE CEMENT (U.S. CLS. 26, 39 AND 44).

RONALD AIKENS, EXAMINING ATTORNEY

**CLASS 10—(Continued).**

SN 78-972,837. SILVERLEAF MEDICAL PRODUCTS, INC., SCOTTSDALE, AZ. FILED 9-12-2006.

# PROSIT

THE MARK CONSISTS OF STANDARD CHARACTERS WITHOUT CLAIM TO ANY PARTICULAR FONT, STYLE, SIZE, OR COLOR.

FOR ABDOMINAL PADS; AEROSOL DISPENSERS FOR MEDICAL USE; AIR MATTRESSES FOR MEDICAL PURPOSES; AIR PILLOWS FOR MEDICAL PURPOSES; APPARATUS FOR ARTIFICIAL RESPIRATION; APPARATUS FOR BLOOD ANALYSIS; APPARATUS FOR CARDIAC DEFIBRILLATION; APPARATUS FOR CELLULITE TREATMENT, REDUCTION AND ELIMINATION; APPARATUS FOR CLINICAL DIAGNOSIS; APPARATUS FOR TAKING BLOOD; APPARATUS FOR TAKING BLOOD SAMPLES; APPARATUS FOR VIBRATIONAL THERAPY, NAMELY, TUNING FORKS; ARCH SUPPORTS FOR BOOTS OR SHOES; ARTIFICIAL BONE PARTS TO BE IMPLANTED IN NATURAL BONES; ARTIFICIAL BONES FOR IMPLANTATION; ARTIFICIAL CARTILAGE; ARTIFICIAL EYES; ARTIFICIAL JAWS; ARTIFICIAL JOINTS; ARTIFICIAL LIMBS; ARTIFICIAL SKIN FOR SURGICAL PURPOSES; ARTIFICIAL TEETH; ARTIFICIAL TEETH AND CAPS; ARTIFICIAL TEETH AND PROTECTIVE CUPS; ARTIFICIAL TYMPANIC MEMBRANES; BALLOONS FOR USE IN ARTHROSCOPY; BANDAGES FOR ANATOMICAL JOINTS; BLOOD DRAWING APPARATUS; BLOOD FILTERS; BLOOD TESTING APPARATUS; BLOOD TRANSFUSION APPARATUS; BLUNT CURETTES; BONE FORCEPS; BONE IMPLANTS COMPOSED OF ARTIFICIAL MATERIALS; BONE RETRACTORS; BONE SCRAPERS; BONE SCREWS; BONE SUBSTITUTES FOR SURGICAL USE; BRACES FOR LIMBS AND JOINTS, FOR MEDICAL USE; BREAST SHIELDS; CAPILLARY DRAINAGE TUBES; CAPILLARY REAGENT TUBES; CAPILLARY TUBES FOR BLOOD; CAPILLARY TUBES FOR SAMPLES; CATGUT FOR SURGICAL USE; CERVICAL COLLARS; CERVICAL PILLOWS FOR MEDICAL USE; CHEMICALLY ACTIVATED HOT AND COLD GEL PACKS FOR MEDICAL PURPOSES; CHEMICALLY ACTIVATED HOT AND/OR COLD COMPRESSES; COMPRESSION BANDAGES; CPR MASKS; CURETTES; CUSHION LINERS FOR PROSTHETIC LIMBS; DERMABRADERS; DIAPHYSEAL PLUGS; DISPOSABLE MEDICAL STERILIZATION POUCHES; DISPOSABLE SYRINGES; DISPOSABLE TEATS; DRAINAGE APPLIANCES FOR SURGICAL PROCEDURES; DRAINAGE TUBES FOR MEDICAL PURPOSES; DRESSING FORCEPS ; ELASTIC BANDAGES; ELASTIC STOCKINGS ; ELASTIC STOCKINGS FOR SURGICAL USE; EYE PROTECTORS FOR POST-SURGERY EYE PROTECTION; FINGER SPLINTS; GLOVES FOR MASSAGE; GLOVES FOR MEDICAL USE; GLOVES FOR USE IN HOSPITALS; HEALTH TRUSSES; HEATING CUSHIONS FOR MEDICAL PURPOSES; HEATING PADS FOR MEDICAL PURPOSES; HYPODERMIC NEEDLES; HYPODERMIC SYRINGES; IDENTIFICATION MARKERS, NAMELY A SELF-ADHESIVE SUBSTRATE THAT IS ATTACHED TO THE SKIN FOR USE WITH RADIOGRAPHIC PROCEDURES; IMPLANTS CONSISTING OF ARTIFICIAL MATERIALS; INCONTINENCE BED PADS; INCONTINENCE SHEETS; INJECTION DEVICE FOR PHARMACEUTICALS; INJECTION INSTRUMENTS WITH NEEDLES; INJECTION INSTRUMENTS WITHOUT NEEDLES; INJECTION NEEDLES; INJECTION NEEDLES FOR MEDICAL USE; INJECTION SYRINGES; IRRIGATORS FOR MEDICAL USE; LANCETS; LATEX MEDICAL GLOVES; MASKS FOR USE BY MEDICAL PERSONNEL; MEDICAL COMPRESSION STOCKINGS AND TIGHTS; MEDICAL GOWNS; MEDICAL HOSIERY, NAMELY, LEOTARDS; MEDICAL HOSIERY, NAMELY, SUPPORT PANTYHOSE; MEDICAL ICE PACKS; MEDICAL INSTRUMENTS FOR INTERSTITIAL THERMOTHERAPY OF BIOLOGICAL TISSUE; MEDICAL INSTRUMENTS FOR PERCUTANEOUS TRACHEOSTOMY; MEDICAL INSTRUMENTS FOR USE IN PER-

**CLASS 10—(Continued).**

FORMING BIOPSIES; MEDICAL PATIENT TREATMENT CHAIRS; MEDICAL PRODUCTS, NAMELY THERAPEUTIC MATTRESS SUPPORT; MEDICAL PRODUCTS, NAMELY, BIOFEEDBACK SENSORS; MEDICAL SCREW CONNECTIONS; MEDICAL SKIN ABRADERS; MEDICAL SPECIMEN CUPS; MEDICAL SPITTOONS; MEDICAL STENTS; MEDICAL STRETCHERS; MEDICAL SYRINGES; MEDICAL TEST KITS FOR DIABETES MONITORING FOR HOME USE; MEDICAL TREATMENT APPAREL; MEDICAL VENTILATORS; MEDICAL X-RAY FILM; MERCURY ARC LAMP UNITS FOR THERAPEUTIC PURPOSES; MICROSCOPES FOR OPERATIONS; MITTENS FOR MEDICAL USE; MOUNTS FOR MEDICAL X-RAY NEGATIVES; MOUNTS FOR X-RAY NEGATIVES FOR MEDICAL PURPOSES; MOUTH EXERCISER FOR USE IN EXERCISING AND STRENGTHENING MOUTH AND FACIAL MUSCLES FOR MEDICAL AND BEAUTY BENEFITS; MOUTH GUARDS FOR MEDICAL PURPOSES; NEBULIZERS FOR RESPIRATION THERAPY; NEEDLE-BASED AND NEEDLE-FREE INJECTION SYSTEMS; NEEDLES FOR INJECTIONS; NEEDLES FOR MEDICAL USE; NERVE STIMULATOR APPARATUS; NIPPLE BREAST COVERS FOR PROTECTION WHILE SUN TANNING; NIPPLES FOR BABY BOTTLES; NON-MEDICATED COMPRESSES; NUCLEAR MEDICINE DIAGNOSTIC IMAGING APPARATUS; NURSING BOTTLES; OCULAR IMPLANTS; OPERATING ROOM APPAREL; OPERATING TABLES; OPHTHALMOMETERS; ORTHOPEDIC JOINT IMPLANTS; ORTHOPEDIC SUPPORT BANDAGES; OSSEOUS IMPLANTS; PADDING FOR ORTHOPEDIC CASTS; PERMEABLE PLASTIC FILMS FOR MEDICAL USE; POST-OPERATIVE PRESSURE GARMENTS; PROSTHETIC AND FILLING MATERIALS, NAMELY, ARTIFICIAL MATERIALS FOR USE IN THE REPLACEMENT OF BONES; PROSTHETIC AND FILLING MATERIALS, NAMELY, PUTTY FOR USE IN THE REPLACEMENT OF BONES; PROSTHETIC LIGAMENTS; PROSTHETIC SOCKETS USED TO FASTEN PROSTHETIC LIMBS TO THE BODY; PROSTHETIC TISSUES FOR PARIETAL, VISCERAL AND VASCULAR USE; SILICONE GEL SHEETING FOR THE TREATMENT OF SCARS; SLINGS FOR MEDICAL USE; SPLINTS; STERILIZATION UNITS FOR MEDICAL INSTRUMENTS; STERILIZATION UNITS FOR MEDICAL PURPOSES; SUBSTITUTES FOR BONES, CARTILAGE, LIGAMENTS AND TENDONS; SURGICAL AND MEDICAL APPARATUS AND INSTRUMENTS FOR USE IN GENERAL SURGERY; SURGICAL CATGUTS; SURGICAL DRAPES; SURGICAL EXAMINATION DRAPES; SURGICAL GLOVES; SURGICAL GLUES; SURGICAL IMPLANTS COMPRISING ARTIFICIAL MATERIAL; SURGICAL MASKS; SURGICAL SKIN STAPLERS; SURGICAL SPONGES; SURGICAL STAPLERS; SURGICAL SUTURES; SURGICAL THREAD; SUTURES; SYNTHETIC FILLER AND EXTENDER MATERIAL TO SERVE AS REPLACEMENT FOR BONE; TEMPLATES FOR ORTHOPEDIC PURPOSES; THERMAL PACKS FOR FIRST AID PURPOSES; THREAD FOR MEDICAL USE; TRUSSES; VASCULAR ACCESS PORTS FOR MEDICAL USE; VETERINARY PROTECTIVE BOOTS FOR HORSES AFTER A SURGICAL PROCEDURE; WOUND DRAINAGE APPARATUS; WOUND SUCTION APPARATUS (U.S. CLS. 26, 39 AND 44).

ELLEN PERKINS, EXAMINING ATTORNEY

**CLASS 11—ENVIRONMENTAL CONTROL APPARATUS**

SN 76-641,667. LUSA LIGHTING, INC., VALENCIA, CA. FILED 6-27-2005.

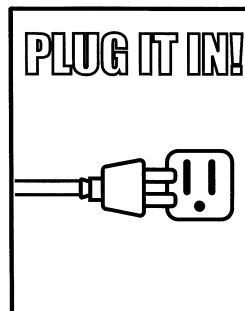

NO CLAIM IS MADE TO THE EXCLUSIVE RIGHT TO USE "PLUG IT IN", APART FROM THE MARK AS SHOWN. FOR LIGHTING FIXTURES (U.S. CLS. 13, 21, 23, 31 AND 34).

FIRST USE 5-0-2000; IN COMMERCE 5-0-2000.  
MONIQUE MILLER, EXAMINING ATTORNEY

SN 76-665,544. MICROSWEPT CORP., SARASOTA, FL. FILED 9-5-2006.

# Viraclean

THE MARK CONSISTS OF STANDARD CHARACTERS WITHOUT CLAIM TO ANY PARTICULAR FONT, STYLE, SIZE, OR COLOR.

FOR AIR PURIFIER (U.S. CLS. 13, 21, 23, 31 AND 34).  
TRICIA SONNEBORN, EXAMINING ATTORNEY

SN 77-000,399. MASCO CORPORATION OF INDIANA, INDIANAPOLIS, IN. FILED 9-15-2006.

# TOUCH<sub>2</sub>O

FOR PLUMBING PRODUCTS, NAMELY FAUCETS (U.S. CLS. 13, 21, 23, 31 AND 34).  
SARAH WAYDA, EXAMINING ATTORNEY



**CLASS 11—(Continued).**

SN 77-003,208. DOLPHIN HEATERS, INC., ST. PETERSBURG, FL. FILED 9-20-2006.



NO CLAIM IS MADE TO THE EXCLUSIVE RIGHT TO USE HEATERS, INC., APART FROM THE MARK AS SHOWN.

THE MARK CONSISTS OF A DOLPHIN ENCIRCLED IN THE WORDS DOLPHIN HEATERS, INC.

FOR WATER HEATERS FOR DOMESTIC AND COMMERCIAL USE (U.S. CLS. 13, 21, 23, 31 AND 34).  
LINDA E. BLOHM, EXAMINING ATTORNEY

SN 77-007,629. HUNTER FAN COMPANY, MEMPHIS, TN. FILED 9-26-2006.

**GRAND VISTA**

THE MARK CONSISTS OF STANDARD CHARACTERS WITHOUT CLAIM TO ANY PARTICULAR FONT, STYLE, SIZE, OR COLOR.

OWNER OF U.S. REG. NO. 2,394,718.  
FOR CEILING FANS (U.S. CLS. 13, 21, 23, 31 AND 34).  
SARA THOMAS, EXAMINING ATTORNEY

SN 77-044,742. ALLIANCE TRADING, INC., COVINGTON, LA. FILED 11-15-2006.

**COSMIC SPAS**

THE MARK CONSISTS OF STANDARD CHARACTERS WITHOUT CLAIM TO ANY PARTICULAR FONT, STYLE, SIZE, OR COLOR.

NO CLAIM IS MADE TO THE EXCLUSIVE RIGHT TO USE "SPAS", APART FROM THE MARK AS SHOWN.

FOR SPAS IN THE NATURE OF HEATED POOLS (U.S. CLS. 13, 21, 23, 31 AND 34).

TASHIA BUNCH, EXAMINING ATTORNEY

**CLASS 11—(Continued).**

SN 77-044,760. ALLIANCE TRADING, INC., COVINGTON, LA. FILED 11-15-2006.



NO CLAIM IS MADE TO THE EXCLUSIVE RIGHT TO USE "SPAS", APART FROM THE MARK AS SHOWN.

FOR SPAS IN THE NATURE OF HEATED POOLS (U.S. CLS. 13, 21, 23, 31 AND 34).

TASHIA BUNCH, EXAMINING ATTORNEY

SN 77-055,354. CONAIR CORPORATION, STAMFORD, CT. FILED 12-1-2006.

**CURLS 'N CURLS**

THE MARK CONSISTS OF STANDARD CHARACTERS WITHOUT CLAIM TO ANY PARTICULAR FONT, STYLE, SIZE, OR COLOR.

OWNER OF U.S. REG. NO. 1,156,202.  
FOR HAND-HELD ELECTRIC HAIR DRYERS (U.S. CLS. 13, 21, 23, 31 AND 34).

DOMINIC FATHY, EXAMINING ATTORNEY

SN 77-064,066. RECKITT BENCKISER INC., PARSIPPANY, NJ. FILED 12-14-2006.

**GLOWING SCENTS**

THE MARK CONSISTS OF STANDARD CHARACTERS WITHOUT CLAIM TO ANY PARTICULAR FONT, STYLE, SIZE, OR COLOR.

NO CLAIM IS MADE TO THE EXCLUSIVE RIGHT TO USE "SCENTS", APART FROM THE MARK AS SHOWN.

FOR ELECTRIC AND BATTERY POWERED DISPENSING UNITS FOR SCENTING, PURIFYING OR FRESHENING THE ATMOSPHERE; PARTS AND FITTINGS FOR ALL THE AFORESAID GOODS (U.S. CLS. 13, 21, 23, 31 AND 34).

LESLEY LAMOTHE, EXAMINING ATTORNEY

**CLASS 11—(Continued).**

SN 78-645,821. SHINING GROUP CO., LTD., FENGXIANG, CHINA, FILED 6-7-2005.



FOR AIR CONDITIONERS, HUMIDIFIERS AND DEHUMIDIFIERS FOR DOMESTIC USE (U.S. CLS. 13, 21, 23, 31 AND 34).  
SAMUEL E. SHARPER JR., EXAMINING ATTORNEY

SN 78-645,827. SHANGHAI SHUANGLU AIR CONDITIONER MANUFACTURE CO., LTD., FENGXIANG, CHINA, FILED 6-7-2005.



FOR AIR CONDITIONERS, HUMIDIFIERS, DEHUMIDIFIERS (U.S. CLS. 13, 21, 23, 31 AND 34).  
SAMUEL E. SHARPER JR., EXAMINING ATTORNEY

SN 78-662,716. KOHLER CO., KOHLER, WI. FILED 7-1-2005.

**WINDWARD**

THE MARK CONSISTS OF STANDARD CHARACTERS WITHOUT CLAIM TO ANY PARTICULAR FONT, STYLE, SIZE, OR COLOR.

FOR BATHTUBS, WHIRLPOOL BATHS; BATH INSTALLATIONS, NAMELY, BATH VALVES, BATH DRAINS AND MIXING VALVES; AND PARTS AND FITTINGS THEREFOR (U.S. CLS. 13, 21, 23, 31 AND 34).  
FIRST USE 4-0-2006; IN COMMERCE 4-0-2006.  
CHRISIE B. KING, EXAMINING ATTORNEY

**CLASS 11—(Continued).**

SN 78-796,309. MIDEA USA INC., GRAND PRAIRIE, TX. FILED 1-20-2006.

**High Point**

THE MARK CONSISTS OF STANDARD CHARACTERS WITHOUT CLAIM TO ANY PARTICULAR FONT, STYLE, SIZE, OR COLOR.  
FOR MICROWAVE OVENS FOR COOKING (U.S. CLS. 13, 21, 23, 31 AND 34).  
ODESSA BIBBINS, EXAMINING ATTORNEY

SN 78-809,303. MOST DEPENDABLE FOUNTAINS, INC., ARLINGTON, TN. FILED 2-7-2006.

**MOST DEPENDABLE FOUNTAINS**

THE MARK CONSISTS OF STANDARD CHARACTERS WITHOUT CLAIM TO ANY PARTICULAR FONT, STYLE, SIZE, OR COLOR.

NO CLAIM IS MADE TO THE EXCLUSIVE RIGHT TO USE "FOUNTAINS", APART FROM THE MARK AS SHOWN.

SEC. 2(F).  
FOR APPARATUS FOR WATER SUPPLY OR WATER DELIVERY, NAMELY, WATER FOUNTAINS, PET DRINKING FOUNTAINS, SHOWERS, SPRINKLERS AND MISTERS, NAMELY, WATER SPRINKLERS AND MISTERS FOR USE OUTDOORS TO COOL PEOPLE AND PETS, HYDRANTS NOT BEING FIRE HYDRANTS, JUG FILLERS, NAMELY, SPOUTS, FAUCETS AND SPIGOTS, HAND WASH STATIONS COMPRISED OF PEDESTALS, RECEPTOR BOWLS, FAUCETS, PUSH BARS, CONTROL VALVES AND DRAINS; BARBEQUE GRILLS (U.S. CLS. 13, 21, 23, 31 AND 34).

FIRST USE 5-7-1986; IN COMMERCE 5-7-1986.  
MARY CRAWFORD, EXAMINING ATTORNEY

SN 78-814,658. KOHLER CO., KOHLER, WI. FILED 2-14-2006.

**SURPRISE**

THE MARK CONSISTS OF STANDARD CHARACTERS WITHOUT CLAIM TO ANY PARTICULAR FONT, STYLE, SIZE, OR COLOR.

FOR TOILET SEATS (U.S. CLS. 13, 21, 23, 31 AND 34).  
FIRST USE 4-0-2006; IN COMMERCE 4-0-2006.  
WOODROW HARTZOG, EXAMINING ATTORNEY

**CLASS 11—(Continued).**

SN 78-814,665. KOHLER CO., KOHLER, WI. FILED 2-14-2006.

# HAIKU

THE MARK CONSISTS OF STANDARD CHARACTERS WITHOUT CLAIM TO ANY PARTICULAR FONT, STYLE, SIZE, OR COLOR.

FOR TOILET SEATS (U.S. CLS. 13, 21, 23, 31 AND 34).  
FIRST USE 4-0-2006; IN COMMERCE 4-0-2006.  
WOODROW HARTZOG, EXAMINING ATTORNEY

SN 78-817,738. KOHLER CO., KOHLER, WI. FILED 2-17-2006.

# TRANSITIONS

THE MARK CONSISTS OF STANDARD CHARACTERS WITHOUT CLAIM TO ANY PARTICULAR FONT, STYLE, SIZE, OR COLOR.

FOR TOILET SEATS (U.S. CLS. 13, 21, 23, 31 AND 34).  
WOODROW HARTZOG, EXAMINING ATTORNEY

SN 78-822,768. NJUN LLC, ATLANTA, GA. FILED 2-24-2006.

# DISTRIBUTED SEWER

THE MARK CONSISTS OF STANDARD CHARACTERS WITHOUT CLAIM TO ANY PARTICULAR FONT, STYLE, SIZE, OR COLOR.

NO CLAIM IS MADE TO THE EXCLUSIVE RIGHT TO USE "SEWER", APART FROM THE MARK AS SHOWN.

FOR SEWAGE TREATMENT INSTALLATIONS, NAMELY, INDIVIDUAL RESIDENTIAL SEPTIC SYSTEMS COMPRISED OF TANKS FOR RECEIVING AND TREATING WASTEWATER AND PROCESSORS FOR MONITORING AND CONTROLLING THAT TREATMENT (U.S. CLS. 13, 21, 23, 31 AND 34).  
PAUL CROWLEY, EXAMINING ATTORNEY

**CLASS 11—(Continued).**

SN 78-835,437. KOHLER CO., KOHLER, WI. FILED 3-13-2006.

# OSTERA

THE MARK CONSISTS OF STANDARD CHARACTERS WITHOUT CLAIM TO ANY PARTICULAR FONT, STYLE, SIZE, OR COLOR.

FOR TOILET SEATS (U.S. CLS. 13, 21, 23, 31 AND 34).  
FIRST USE 4-0-2006; IN COMMERCE 4-0-2006.  
WOODROW HARTZOG, EXAMINING ATTORNEY

SN 78-838,780. SCHONBEK WORLDWIDE LIGHTING, INC., PLATTSBURGH, NY. FILED 3-16-2006.

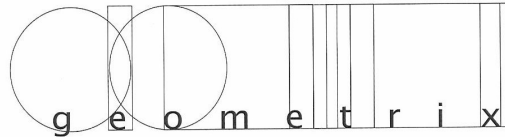

OWNER OF U.S. REG. NO. 3,188,694.  
SEC. 2(F) AS TO "GEOMETRIX".  
FOR ORNAMENTAL ELECTRIC LIGHTING FIXTURE (U.S. CLS. 13, 21, 23, 31 AND 34).  
FIRST USE 8-31-2004; IN COMMERCE 8-31-2004.  
MARY CRAWFORD, EXAMINING ATTORNEY

SN 78-849,660. GRILLI MÃN GRILLS, LTD. CO., HOUSTON, TX. FILED 3-30-2006.

# GRILLI-MÔN

THE MARK CONSISTS OF STANDARD CHARACTERS WITHOUT CLAIM TO ANY PARTICULAR FONT, STYLE, SIZE, OR COLOR.

FOR BARBEQUE GRILLS (U.S. CLS. 13, 21, 23, 31 AND 34).  
LESLEY LAMOTHE, EXAMINING ATTORNEY

SN 78-849,663. GRILLI MÃN GRILLS, LTD. CO., HOUSTON, TX. FILED 3-30-2006.



FOR BARBEQUE GRILLS (U.S. CLS. 13, 21, 23, 31 AND 34).  
LESLEY LAMOTHE, EXAMINING ATTORNEY

**CLASS 11—(Continued).**

SN 78-936,094. FULHAM COMPANY, INC., HAWTHORNE, CA. FILED 7-24-2006.

# LEDLABS

THE MARK CONSISTS OF STANDARD CHARACTERS WITHOUT CLAIM TO ANY PARTICULAR FONT, STYLE, SIZE, OR COLOR.

FOR HIGH INTENSITY DISCHARGE LAMPS; CAPACITIVE COUPLING FLUORESCENT LAMPS; EXTERNAL ELECTRODE FLUORESCENT LAMPS; AND FLUORESCENT LAMPS (U.S. CLS. 13, 21, 23, 31 AND 34).  
DAVID C. REIHNER, EXAMINING ATTORNEY

---

SN 78-948,126. BARCLAY PRODUCTS LIMITED, GURNEE, IL. FILED 8-9-2006.



OWNER OF U.S. REG. NO. 2,752,444.  
FOR PLUMBING FIXTURES, NAMELY, BATHTUBS, SHOWER HEADS, FAUCETS, SINKS, TOILETS, AND LAVATORY BASINS (U.S. CLS. 13, 21, 23, 31 AND 34).  
FRANK LATTUCA, EXAMINING ATTORNEY

**CLASS 11—(Continued).**

SN 78-957,157. SUCHITA, PERTI, WAYNE, NJ. FILED 8-22-2006.

# OVERDRIVE

THE MARK CONSISTS OF STANDARD CHARACTERS WITHOUT CLAIM TO ANY PARTICULAR FONT, STYLE, SIZE, OR COLOR.

FOR ARC LAMPS; ELECTRIC LIGHT BULBS; ELECTRIC LIGHTING FIXTURES; ELECTRIC LIGHTING FIXTURES, NAMELY POWER FAILURE BACKUP SAFETY LIGHTING; ELECTRIC LIGHTING FIXTURES, NAMELY, SCONCES; ELECTRIC LIGHTS FOR CHRISTMAS TREES; ELECTRIC NIGHT LIGHTS; ELECTRICAL MAGNIFYING LIGHT FIXTURES; FIXTURES FOR INCANDESCENT LIGHT BULBS; FLUORESCENT ELECTRIC LIGHT BULBS; FLUORESCENT LIGHTING TUBES; HALOGEN LIGHT BULBS; HIGH INTENSITY SEARCH LIGHTS; INCANDESCENT LIGHT BULBS; LAMP WHOSE LIGHT CAN BE TURNED IN ALL DIRECTIONS; LANDSCAPE LIGHTING INSTALLATIONS; LED LIGHT BULBS; LIGHT BULBS; LIGHTING FIXTURES; LIGHTING FIXTURES FOR USE IN PARKING DECKS AND GARAGES; LIGHTING TUBES; LIGHTS FOR VEHICLES; MINIATURE LIGHT BULBS; OUTDOOR LIGHTED CHRISTMAS ORNAMENTS; OUTDOOR LIGHTING, NAMELY, PAVER LIGHTS; PEN LIGHTS; SOLAR LIGHT FIXTURES, NAMELY, INDOOR AND OUTDOOR SOLAR POWERED LIGHTING UNITS AND FIXTURES; TAIL LIGHTS FOR LAND VEHICLES; WALL LIGHTS (U.S. CLS. 13, 21, 23, 31 AND 34).  
KYLE PEETE, EXAMINING ATTORNEY

---

SN 78-957,732. CFM BRANDS, LLC, CHICAGO, IL. FILED 8-22-2006.

# Breeze Frame

THE MARK CONSISTS OF STANDARD CHARACTERS WITHOUT CLAIM TO ANY PARTICULAR FONT, STYLE, SIZE, OR COLOR.

NO CLAIM IS MADE TO THE EXCLUSIVE RIGHT TO USE "FRAME", APART FROM THE MARK AS SHOWN.

FOR CEILING FANS; ELECTRIC FANS; ELECTRIC FANS; ELECTRIC HEATING FANS; ELECTRIC WINDOW FANS; PORTABLE ELECTRIC FANS; VENTILATING EXHAUST FANS; VENTILATING FANS FOR COMMERCIAL AND INDUSTRIAL USE (U.S. CLS. 13, 21, 23, 31 AND 34).

FIRST USE 2-15-2001; IN COMMERCE 2-15-2001.  
JIM RINGLE, EXAMINING ATTORNEY

**CLASS 11—(Continued).**

SN 78-958,640. MTI WHIRLPOOLS, INC., SUGAR HILL, GA. FILED 8-23-2006.

**MTI**

THE MARK CONSISTS OF STANDARD CHARACTERS WITHOUT CLAIM TO ANY PARTICULAR FONT, STYLE, SIZE, OR COLOR.  
OWNER OF U.S. REG. NOS. 2,463,570 AND 2,930,559.  
FOR BATH TUBS; WHIRLPOOL BATHS; WHIRLPOOLS (U.S. CLS. 13, 21, 23, 31 AND 34).  
FIRST USE 2-28-1994; IN COMMERCE 2-28-1994.  
JULIE GUTTADAURO, EXAMINING ATTORNEY

SN 78-959,526. SUREFIRE, LLC, FOUNTAIN VALLEY, CA. FILED 8-24-2006.

**TITAN**

THE MARK CONSISTS OF STANDARD CHARACTERS WITHOUT CLAIM TO ANY PARTICULAR FONT, STYLE, SIZE, OR COLOR.  
FOR FLASHLIGHTS (U.S. CLS. 13, 21, 23, 31 AND 34).  
FIRST USE 1-5-2007; IN COMMERCE 1-5-2007.  
ROBIN CHOSID, EXAMINING ATTORNEY

SN 78-959,554. ENERGYLOGIC, LLC, ANTIOCH, TN. FILED 8-24-2006.

**Energylogic**

THE MARK CONSISTS OF STANDARD CHARACTERS WITHOUT CLAIM TO ANY PARTICULAR FONT, STYLE, SIZE, OR COLOR.  
FOR USED OIL FURNACES AND BOILERS (U.S. CLS. 13, 21, 23, 31 AND 34).  
FIRST USE 12-14-2001; IN COMMERCE 12-14-2001.  
ANNE MADDEN, EXAMINING ATTORNEY

**CLASS 11—(Continued).**

SN 78-959,783. CSK AUTO, INC., PHOENIX, AZ. FILED 8-24-2006.

**PROXONE**

THE MARK CONSISTS OF STANDARD CHARACTERS WITHOUT CLAIM TO ANY PARTICULAR FONT, STYLE, SIZE, OR COLOR.  
FOR SPOTLIGHTS (U.S. CLS. 13, 21, 23, 31 AND 34).  
FIRST USE 5-22-2006; IN COMMERCE 5-22-2006.  
SETH A. RAPPAPORT, EXAMINING ATTORNEY

SN 78-961,841. TDC FILTER/MIDWESCO, CICERO, IL. FILED 8-28-2006.

**Platinum Series**

NO CLAIM IS MADE TO THE EXCLUSIVE RIGHT TO USE "SERIES", APART FROM THE MARK AS SHOWN.  
THE COLOR(S) GRAY IS/ARE CLAIMED AS A FEATURE OF THE MARK.  
THE MARK CONSISTS OF GRAY LETTERS EMBOSSED.  
FOR AIR FILTERS FOR INDUSTRIAL INSTALLATIONS (U.S. CLS. 13, 21, 23, 31 AND 34).  
FIRST USE 8-25-2006; IN COMMERCE 8-25-2006.  
JILL C. ALT, EXAMINING ATTORNEY

SN 78-962,809. SHAT-R-SHIELD, INC., SALISBURY, NC. FILED 8-29-2006.

**FLICK-R-SAFE**

THE MARK CONSISTS OF STANDARD CHARACTERS WITHOUT CLAIM TO ANY PARTICULAR FONT, STYLE, SIZE, OR COLOR.  
FOR CANDLE-SIMULATING LIGHT BULBS (U.S. CLS. 13, 21, 23, 31 AND 34).  
PAUL CROWLEY, EXAMINING ATTORNEY

**CLASS 11—(Continued).**

SN 78-963,782. SUNROC LLC, COLUMBUS, OH. FILED 8-30-2006.

# SUNROC

THE MARK CONSISTS OF STANDARD CHARACTERS WITHOUT CLAIM TO ANY PARTICULAR FONT, STYLE, SIZE, OR COLOR.

OWNER OF U.S. REG. NO. 1,938,734.  
FOR DRINKING FOUNTAINS; REFRIGERATED DISPENSING UNITS FOR BEVERAGES; WATER COOLERS; WATER FILTERS (U.S. CLS. 13, 21, 23, 31 AND 34).  
FIRST USE 9-10-1947; IN COMMERCE 9-10-1947.  
GENE MACIOL, EXAMINING ATTORNEY

---

SN 78-963,889. LIGHTWEDGE, LLC, NANTUCKET, MA. FILED 8-30-2006.

# MR. BRIGHTSIDE

THE MARK CONSISTS OF STANDARD CHARACTERS WITHOUT CLAIM TO ANY PARTICULAR FONT, STYLE, SIZE, OR COLOR.

FOR BOOK LIGHTS (U.S. CLS. 13, 21, 23, 31 AND 34).  
CHARISMA HAMPTON, EXAMINING ATTORNEY

---

SN 78-965,916. THE RICHARDS CORPORATION, STERLING, VA. FILED 9-1-2006.

# TIA

THE MARK CONSISTS OF STANDARD CHARACTERS WITHOUT CLAIM TO ANY PARTICULAR FONT, STYLE, SIZE, OR COLOR.

OWNER OF U.S. REG. NO. 2,032,076.  
FOR MICROWAVE OVENS (U.S. CLS. 13, 21, 23, 31 AND 34).  
FIRST USE 10-31-1998; IN COMMERCE 9-3-1999.  
MARTHA FROMM, EXAMINING ATTORNEY

**CLASS 11—(Continued).**

SN 78-966,729. SUNWORKS INCORPORATED, DALLAS, TX. FILED 9-4-2006.

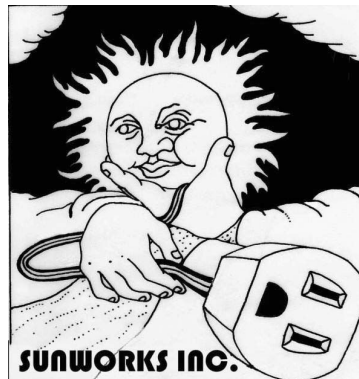

NO CLAIM IS MADE TO THE EXCLUSIVE RIGHT TO USE "INC.", APART FROM THE MARK AS SHOWN.

THE MARK CONSISTS OF A SUN WITH A HUMAN FACE AND BODY HOLDING A GROUNDED ELECTRICAL PLUG. THE WORDS SUNWORKS INC. IS DISPLAYED WITHIN THE IMAGE.

FOR SOLAR COLLECTORS; SOLAR HEAT COLLECTION PANELS; SOLAR WATER HEATERS (U.S. CLS. 13, 21, 23, 31 AND 34).

MARGARET POWER, EXAMINING ATTORNEY

---

SN 78-967,192. NEO-NEON INTERNATIONAL LIMITED, HONG KONG, CHINA, FILED 9-5-2006.

# Neon-Flex

FOR ELECTRIC LIGHTING FIXTURES; ELECTRIC LIGHTING FIXTURES, NAMELY, SCONCES; ELECTRIC TRACK LIGHTING UNITS; FIBER OPTIC LIGHTING FIXTURES USED IN CONJUNCTION WITH ELECTRICAL ILLUMINATORS; FILTERS FOR PHOTOGRAPHIC, CINEMATOGRAPHIC, VIDEO AND PERFORMING ARTS LIGHTING; FLUORESCENT LIGHTING TUBES; LIGHTERS PRIMARILY FOR LIGHTING GRILLS, FIREPLACES AND CANDLES; LIGHTING DEVICES FOR SHOWCASES; LIGHTING TRACKS; BICYCLE LAMPS; FLUORESCENT LAMPS; INCANDESCENT LAMPS AND THEIR FITTINGS; LAMPS IN GENERAL; LAMPS FOR OUTDOOR USE; SAFETY LAMPS FOR UNDERGROUND USE; TAIL LIGHTS FOR VEHICLES; TRAILER LIGHTS FOR BOATS; VEHICLE TURN-SIGNAL LIGHTS; WALL LIGHTS; AQUARIUM LIGHTS; BICYCLE LIGHTS; DIVING LIGHTS; ELECTRIC HOLIDAY LIGHTS; ELECTRIC LIGHTS FOR CHRISTMAS TREES; ELECTRIC NIGHT LIGHTS; LIGHTS FOR VEHICLES; PEN LIGHTS; POCKET SEARCH LIGHTS; REAR LIGHTS FOR VEHICLES; RUNNING LIGHTS FOR BOATS; RUNNING LIGHTS FOR LAND VEHICLES (U.S. CLS. 13, 21, 23, 31 AND 34).

FIRST USE 5-0-2004; IN COMMERCE 5-0-2004.

FLORENTINA BLANDU, EXAMINING ATTORNEY

**CLASS 11—(Continued).**

SN 78-967,714. DOLPHIN HEATERS, INC., ST. PETERSBURG, FL. FILED 9-6-2006.

# Dolphin Heaters

THE MARK CONSISTS OF STANDARD CHARACTERS WITHOUT CLAIM TO ANY PARTICULAR FONT, STYLE, SIZE, OR COLOR.

NO CLAIM IS MADE TO THE EXCLUSIVE RIGHT TO USE HEATERS, APART FROM THE MARK AS SHOWN. FOR WATER HEATERS FOR DOMESTIC AND COMMERCIAL USE (U.S. CLS. 13, 21, 23, 31 AND 34).  
LINDA E. BLOHM, EXAMINING ATTORNEY

SN 78-967,844. SOLER & PALAU, JACKSONVILLE, FL. FILED 9-6-2006.

# iVent

FOR RESIDENTIAL AND/OR LIGHT COMMERCIAL VENTILATION FAN (U.S. CLS. 13, 21, 23, 31 AND 34).  
TARAH HARDY, EXAMINING ATTORNEY

SN 78-968,985. MCDANIEL, MARY L., FORT LAUDERDALE, FL. FILED 9-7-2006.

# NICE RACK

THE MARK CONSISTS OF STANDARD CHARACTERS WITHOUT CLAIM TO ANY PARTICULAR FONT, STYLE, SIZE, OR COLOR.

FOR BARBECUE GRILLS (U.S. CLS. 13, 21, 23, 31 AND 34).  
DEBRA LEE, EXAMINING ATTORNEY

**CLASS 11—(Continued).**

SN 78-970,001. SLOAN VALVE COMPANY, FRANKLIN PARK, IL. FILED 9-8-2006.

# ROYAL CLASSIC

THE MARK CONSISTS OF STANDARD CHARACTERS WITHOUT CLAIM TO ANY PARTICULAR FONT, STYLE, SIZE, OR COLOR.

OWNER OF U.S. REG. NOS. 410,682 AND 2,286,617.  
FOR FLUSH VALVES FOR WATER SUPPLY SYSTEMS, FLUSH VALVES FOR TOILETS AND URINALS AND REPAIR PARTS THEREFOR (U.S. CLS. 13, 21, 23, 31 AND 34).  
RONALD MCMORROW, EXAMINING ATTORNEY

SN 78-970,172. LITEX INDUSTRIES, LIMITED, GRAND PRAIRIE, TX. FILED 9-8-2006.

# ELEVATING STYLE

THE MARK CONSISTS OF STANDARD CHARACTERS WITHOUT CLAIM TO ANY PARTICULAR FONT, STYLE, SIZE, OR COLOR.

FOR CEILING FANS, CEILING FANS WITH ELECTRIC LIGHT FIXTURES, ELECTRIC LIGHT FIXTURES FOR CEILING FANS, AND CEILING FAN KITS COMPRISED OF CEILING FANS, ELECTRIC LIGHT FIXTURES, WIRING AND MOUNTING BRACKETS SOLD AS A UNIT; AND ELECTRIC LIGHTING, NAMELY, WALL, CEILING AND PENDANT LIGHTING FIXTURES (U.S. CLS. 13, 21, 23, 31 AND 34).  
FRANK LATTUCA, EXAMINING ATTORNEY

SN 78-971,199. AMMM PATENT HOLDINGS, LLC, ST. LOUIS, MO. FILED 9-11-2006.

# PURELOCK

THE MARK CONSISTS OF STANDARD CHARACTERS WITHOUT CLAIM TO ANY PARTICULAR FONT, STYLE, SIZE, OR COLOR.

FOR CONVERSION DEVICES, NAMELY, ADAPTERS TO RETROFIT EXISTING WATER COOLERS TO DISPENSE BAGGED FLUIDS (U.S. CLS. 13, 21, 23, 31 AND 34).  
TINA KUAN, EXAMINING ATTORNEY

**CLASS 11—(Continued).**

SN 78-972,219. CAPP, RAND, HENDERSON, NV. FILED 9-12-2006.

**STIR LESS**

THE MARK CONSISTS OF STANDARD CHARACTERS WITHOUT CLAIM TO ANY PARTICULAR FONT, STYLE, SIZE, OR COLOR.

FOR SELF-STIRRING ELECTRIC COOKING POTS (U.S. CLS. 13, 21, 23, 31 AND 34).

ELIZABETH BEYER, EXAMINING ATTORNEY

**CLASS 11—(Continued).**

SN 78-973,695. LIGHTWEDGE, LLC, NANTUCKET, MA. FILED 9-13-2006.

**SPIKE LIGHT**

THE MARK CONSISTS OF STANDARD CHARACTERS WITHOUT CLAIM TO ANY PARTICULAR FONT, STYLE, SIZE, OR COLOR.

NO CLAIM IS MADE TO THE EXCLUSIVE RIGHT TO USE "LIGHT", APART FROM THE MARK AS SHOWN.

FOR BOOK LIGHTS (U.S. CLS. 13, 21, 23, 31 AND 34).

FIRST USE 1-0-2006; IN COMMERCE 1-0-2006.

CHARISMA HAMPTON, EXAMINING ATTORNEY

SN 78-972,398. SHADOW MANAGEMENT, L.L.C., BARRINGTON, IL. FILED 9-12-2006.

**HULA SKIRT**

THE MARK CONSISTS OF STANDARD CHARACTERS WITHOUT CLAIM TO ANY PARTICULAR FONT, STYLE, SIZE, OR COLOR.

FOR REMOVABLE SHADES FOR HIGH-BAY LIGHTING FIXTURES (U.S. CLS. 13, 21, 23, 31 AND 34).

INGRID C. EULIN, EXAMINING ATTORNEY

SN 78-973,702. LIGHTWEDGE, LLC, NANTUCKET, MA. FILED 9-13-2006.

**RELIGHT**

THE MARK CONSISTS OF STANDARD CHARACTERS WITHOUT CLAIM TO ANY PARTICULAR FONT, STYLE, SIZE, OR COLOR.

FOR BOOK LIGHTS (U.S. CLS. 13, 21, 23, 31 AND 34).

FIRST USE 7-0-2006; IN COMMERCE 7-0-2006.

CHARISMA HAMPTON, EXAMINING ATTORNEY

SN 78-972,474. STACK, PATRICK G., PLYMOUTH, MI. FILED 9-12-2006.

**PENGUIN**

THE MARK CONSISTS OF STANDARD CHARACTERS WITHOUT CLAIM TO ANY PARTICULAR FONT, STYLE, SIZE, OR COLOR.

FOR TOILETS; URINALS (U.S. CLS. 13, 21, 23, 31 AND 34).

MICHAEL WIENER, EXAMINING ATTORNEY

**CLASS 12—VEHICLES**

SN 76-654,771. SONEX AIRCRAFT, LLC, OSHKOSH, WI. FILED 2-8-2006.

**xenos**

THE MARK CONSISTS OF STANDARD CHARACTERS WITHOUT CLAIM TO ANY PARTICULAR FONT, STYLE, SIZE, OR COLOR.

FOR AIRCRAFT, AND AIRCRAFT KITS COMPRISED OF AIRCRAFT PARTS AND PLANS TO BUILD COMPLETE AIRCRAFT (U.S. CLS. 19, 21, 23, 31, 35 AND 44).

FIRST USE 12-30-2000; IN COMMERCE 12-30-2000.

JOHN DWYER, EXAMINING ATTORNEY



**CLASS 12—(Continued).**

SN 76-654,773. SONEX AIRCRAFT, LLC, OSHKOSH, WI. FILED 2-8-2006.

**waiaex**

THE MARK CONSISTS OF STANDARD CHARACTERS WITHOUT CLAIM TO ANY PARTICULAR FONT, STYLE, SIZE, OR COLOR.

FOR AIRCRAFT, AND AIRCRAFT KITS COMPRISED OF AIRCRAFT PARTS AND PLANS TO BUILD COMPLETE AIRCRAFT (U.S. CLS. 19, 21, 23, 31, 35 AND 44). FIRST USE 7-21-2003; IN COMMERCE 7-21-2003. JOHN DWYER, EXAMINING ATTORNEY

**CLASS 12—(Continued).**

SN 77-028,954. FORCE PROTECTION INDUSTRIES, INC., LADSON, SC. FILED 10-25-2006.

**COUGAR**

THE MARK CONSISTS OF STANDARD CHARACTERS WITHOUT CLAIM TO ANY PARTICULAR FONT, STYLE, SIZE, OR COLOR.

FOR ARMORED VEHICLES AND STRUCTURAL PARTS THEREFOR (U.S. CLS. 19, 21, 23, 31, 35 AND 44). FIRST USE 9-30-2000; IN COMMERCE 9-30-2000. LINDA ORNDORFF, EXAMINING ATTORNEY

SN 76-664,788. DAMITECH INC, CAMP SPRINGS, MD. FILED 8-17-2006.

**RIM COVERUP**

THE MARK CONSISTS OF STANDARD CHARACTERS WITHOUT CLAIM TO ANY PARTICULAR FONT, STYLE, SIZE, OR COLOR.

FOR AUTOMOTIVE PARTS, NAMELY, FITTED PLASTIC COVER THAT COVERS A TIRE RIM IN ORDER TO PREVENT TIRE DRESSING OVERSPRAY (U.S. CLS. 19, 21, 23, 31, 35 AND 44). MORENO, PAUL, EXAMINING ATTORNEY

SN 77-043,703. BASS PRO TRADEMARKS, L.L.C., SPRINGFIELD, MO. FILED 11-14-2006.

**WEATHERSAFE**

THE MARK CONSISTS OF STANDARD CHARACTERS WITHOUT CLAIM TO ANY PARTICULAR FONT, STYLE, SIZE, OR COLOR.

FOR FITTED BOAT COVERS (U.S. CLS. 19, 21, 23, 31, 35 AND 44). DAVID YONTEF, EXAMINING ATTORNEY

SN 77-007,887. RADIO FLYER, INC., CHICAGO, IL. FILED 9-26-2006.

**STEADY START SCOOTER**

THE MARK CONSISTS OF STANDARD CHARACTERS WITHOUT CLAIM TO ANY PARTICULAR FONT, STYLE, SIZE, OR COLOR.

NO CLAIM IS MADE TO THE EXCLUSIVE RIGHT TO USE "SCOOTER", APART FROM THE MARK AS SHOWN. FOR NON-MOTORIZED SCOOTERS (U.S. CLS. 19, 21, 23, 31, 35 AND 44). BRENDAN REGAN, EXAMINING ATTORNEY

SN 78-178,814. GIANT BICYCLE, INC., NEWBURY PARK, CA. FILED 10-27-2002.

**SHADOW**

FOR BICYCLE PARTS, NAMELY, TIRES (U.S. CLS. 19, 21, 23, 31, 35 AND 44). FIRST USE 9-1-1999; IN COMMERCE 9-1-1999. TRICIA SONNEBORN, EXAMINING ATTORNEY

**CLASS 12—(Continued).**

SN 78-633,439. BRUNO INDEPENDENT LIVING AIDS, INC.,  
OCONOMOWOC, WI. FILED 5-19-2005.

# ORBIT

THE MARK CONSISTS OF STANDARD CHARACTERS WITHOUT CLAIM TO ANY PARTICULAR FONT, STYLE, SIZE, OR COLOR.

FOR VEHICLE PARTS, NAMELY, SEATING SYSTEMS AND PARTS AND ACCESSORIES THEREFOR COMPRISED OF VEHICLE SEATS, BACKRESTS, HEADRESTS, ARMRESTS, FOOTRESTS, AND POWER CONTROLLERS, POWER SWITCHES AND POWER AND POSITION SENSORS SOLD AS A UNIT; SEATBELTS AND SEATBELT COMPONENTS, ROTATABLE AND EXTENDABLE BASES, ELEVATING MECHANISMS, TILTING MECHANISMS, AND MOBILITY DEVICE BASES FOR SELF-PROPELLED, PUSH, TRANSPORT AND POWERED WHEELCHAIRS (U.S. CLS. 19, 21, 23, 31, 35 AND 44).

FIRST USE 10-26-2004; IN COMMERCE 10-26-2004.  
ARETHA SOMERVILLE, EXAMINING ATTORNEY

---

SN 78-649,640. CHEN, XIUQIN, QINGDAO, SHANDONG,  
CHINA, FILED 6-13-2005.

# FULLRUN

THE MARK CONSISTS OF STANDARD CHARACTERS WITHOUT CLAIM TO ANY PARTICULAR FONT, STYLE, SIZE, OR COLOR.

FOR TIRES FOR AUTOMOBILES, TIRES; PNEUMATIC TIRES AND INNER TUBES FOR AUTOMOBILES, INNER TUBES FOR AUTOMOBILE TIRES, TREADS FOR RETREADING TIRES FOR FORESTRY VEHICLES, NAMELY TRACTORS, BICYCLE TIRES, CASINGS FOR PNEUMATIC TIRES, INNER TUBES FOR VEHICLE TIRES, REPAIR OUTFITS, NAMELY, ADHESIVE RUBBER PLUGS AND PATCHES FOR REPAIRING INNER TUBES OR TIRES (U.S. CLS. 19, 21, 23, 31, 35 AND 44).

FIRST USE 6-12-2003; IN COMMERCE 6-12-2003.  
PAULA MAHONEY, EXAMINING ATTORNEY

**CLASS 12—(Continued).**

SN 78-649,645. CHEN, XIUQIN, QINGDAO, SHANDONG,  
CHINA, FILED 6-13-2005.

# CLEAR

THE MARK CONSISTS OF STANDARD CHARACTERS WITHOUT CLAIM TO ANY PARTICULAR FONT, STYLE, SIZE, OR COLOR.

FOR TIRES FOR AUTOMOBILES, TIRES; PNEUMATIC TIRES AND INNER TUBES FOR AUTOMOBILES, INNER TUBES FOR AUTOMOBILE TIRES, TREADS FOR RETREADING TIRES FOR FORESTRY VEHICLES, NAMELY TRACTORS; BICYCLE TIRES, CASINGS FOR PNEUMATIC TIRES, INNER TUBES FOR VEHICLE TIRES, REPAIR OUTFITS, NAMELY, ADHESIVE RUBBER PLUGS AND PATCHES FOR REPAIRING INNER TUBES OR TIRES (U.S. CLS. 19, 21, 23, 31, 35 AND 44).

FIRST USE 1-14-2003; IN COMMERCE 1-14-2003.  
PAULA MAHONEY, EXAMINING ATTORNEY

---

SN 78-653,753. LEHMAN TRIKES, INC., WESTLOCK, ALBERTA, CANADA, FILED 6-19-2005.

# TRAMP

THE MARK CONSISTS OF STANDARD CHARACTERS WITHOUT CLAIM TO ANY PARTICULAR FONT, STYLE, SIZE, OR COLOR.

OWNER OF CANADA REG. NO. TMA665,073, DATED 5-26-2006, EXPIRES 5-26-2021.

FOR MOTORIZED TRICYCLES, KITS FOR CONVERTING MOTORCYCLES INTO TRICYCLES (U.S. CLS. 19, 21, 23, 31, 35 AND 44).

FIRST USE 12-31-2004; IN COMMERCE 12-31-2004.  
ALAIN LAPTEY, EXAMINING ATTORNEY

---

SN 78-721,398. DAIMLERCHRYSLER AG, STUTTGART, FED REP GERMANY, FILED 9-27-2005.

# SSKL

THE MARK CONSISTS OF STANDARD CHARACTERS WITHOUT CLAIM TO ANY PARTICULAR FONT, STYLE, SIZE, OR COLOR.

OWNER OF FED REP GERMANY REG. NO. 39709131, DATED 4-23-1997, RENEWED AS REG. NO. 39709131, DATED 3-9-2007, EXPIRES 2-28-2017.

FOR AUTOMOBILES AND THEIR STRUCTURAL PARTS (U.S. CLS. 19, 21, 23, 31, 35 AND 44).

H. M. FISHER, EXAMINING ATTORNEY

**CLASS 12—(Continued).**

SN 78-755,751. SANDRO MENTASTI S.R.L., VARESE, ITALY, FILED 11-17-2005.



THE MARK CONSISTS OF THE LITERAL ELEMENT OF THE MARK IN FANCIFUL LETTERS AND UNDERSCORED, THE LITERAL ELEMENT BEING CONFINED IN A NARROW, HORIZONTALLY ORIENTED ELLIPSE.

FOR ACCESSORIES FOR CYCLES, MOTORCYCLES, PERSONAL JET BOATS, AND SNOWMOBILES, NAMELY, HANDLEBAR GRIPS, WIND SCREENS IN THE NATURE OF WINDSHIELDS, SPOILERS, FUEL TANK COVERS, SPARK PLUG COVERS, FOOTBOARDS, FOOTREST PEGS, REARVIEW MIRRORS (U.S. CLS. 19, 21, 23, 31, 35 AND 44).

FIRST USE 6-14-2002; IN COMMERCE 6-14-2002.  
MARCIE MILONE, EXAMINING ATTORNEY

SN 78-863,588. IKO SPORTARTIKEL-HANDELS-GMBH, RAUBLING, FED REP GERMANY, FILED 4-18-2006.



THE MARK CONSISTS OF STANDARD CHARACTERS WITHOUT CLAIM TO ANY PARTICULAR FONT, STYLE, SIZE, OR COLOR.

FOR BICYCLES AND PARTS THEREOF (U.S. CLS. 19, 21, 23, 31, 35 AND 44).

MARK SPARACINO, EXAMINING ATTORNEY

SN 78-914,078. CAMP, ROBERT J, JUPITER, FL. FILED 6-22-2006.



THE MARK CONSISTS OF STANDARD CHARACTERS WITHOUT CLAIM TO ANY PARTICULAR FONT, STYLE, SIZE, OR COLOR.

NO CLAIM IS MADE TO THE EXCLUSIVE RIGHT TO USE "BARGE", APART FROM THE MARK AS SHOWN. FOR BOATS (U.S. CLS. 19, 21, 23, 31, 35 AND 44).

ELLEN B. AWRICH, EXAMINING ATTORNEY

**CLASS 12—(Continued).**

SN 78-916,675. VETTER UMFORMTECHNIK GMBH, BURBACH, FED REP GERMANY, FILED 6-26-2006.

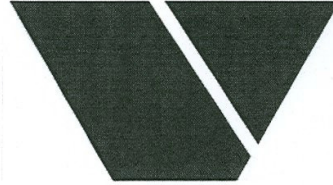

FOR PARTS FOR FORK LIFT TRUCKS, NAMELY, FORK ARMS (U.S. CLS. 19, 21, 23, 31, 35 AND 44). FIRST USE 2-28-1997; IN COMMERCE 2-28-1997.

CHARISMA HAMPTON, EXAMINING ATTORNEY

SN 78-939,198. DAIMLERCHRYSLER AG, D-70567 STUTTGART, FED REP GERMANY, FILED 7-27-2006.



THE MARK CONSISTS OF STANDARD CHARACTERS WITHOUT CLAIM TO ANY PARTICULAR FONT, STYLE, SIZE, OR COLOR.

PRIORITY CLAIMED UNDER SEC. 44(D) ON FED REP GERMANY APPLICATION NO. 30617212.7/1, FILED 3-15-2006, REG. NO. 30617212, DATED 4-27-2006, EXPIRES 4-27-2016.

OWNER OF U.S. REG. NOS. 3,100,859 AND 3,100,860. NO CLAIM IS MADE TO THE EXCLUSIVE RIGHT TO USE "350", APART FROM THE MARK AS SHOWN.

FOR AUTOMOBILES AND THEIR STRUCTURAL PARTS (U.S. CLS. 19, 21, 23, 31, 35 AND 44).

JOHN E. MICHOS, EXAMINING ATTORNEY

SN 78-942,586. AA DADDYO'S, INC., ROSEVILLE, CA. FILED 8-1-2006.

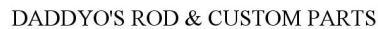

THE MARK CONSISTS OF STANDARD CHARACTERS WITHOUT CLAIM TO ANY PARTICULAR FONT, STYLE, SIZE, OR COLOR.

NO CLAIM IS MADE TO THE EXCLUSIVE RIGHT TO USE "ROD & CUSTOM PARTS", APART FROM THE MARK AS SHOWN.

FOR AUTOMOBILES AND STRUCTURAL PARTS THEREFOR; STRUCTURAL PARTS FOR AUTOMOBILES (U.S. CLS. 19, 21, 23, 31, 35 AND 44).

ELIZABETH KAJUBI, EXAMINING ATTORNEY

**CLASS 12—(Continued).**

SN 78-945,153. PENNZOIL-QUAKER STATE COMPANY, HOUSTON, TX. FILED 8-4-2006.

**BLUE CORAL**

THE MARK CONSISTS OF STANDARD CHARACTERS WITHOUT CLAIM TO ANY PARTICULAR FONT, STYLE, SIZE, OR COLOR.

OWNER OF U.S. REG. NOS. 562,745 AND 1,591,307. FOR VEHICLE WINDSHIELD WIPERS AND BLADES THEREOF (U.S. CLS. 19, 21, 23, 31, 35 AND 44).  
NAPOLLEN SHARMA, EXAMINING ATTORNEY

**CLASS 12—(Continued).**

SN 78-960,397. ADVANCED SPORTS, INC., PHILADELPHIA, PA. FILED 8-25-2006.

**DRAFT**

THE MARK CONSISTS OF STANDARD CHARACTERS WITHOUT CLAIM TO ANY PARTICULAR FONT, STYLE, SIZE, OR COLOR.

FOR BICYCLES AND STRUCTURAL PARTS AND FITTINGS THEREFOR (U.S. CLS. 19, 21, 23, 31, 35 AND 44).  
KATHLEEN M. VANSTON, EXAMINING ATTORNEY

SN 78-959,222. FORCE PROTECTION INDUSTRIES, INC., LADSON, SC. FILED 8-24-2006.

**BUFFALO**

THE MARK CONSISTS OF STANDARD CHARACTERS WITHOUT CLAIM TO ANY PARTICULAR FONT, STYLE, SIZE, OR COLOR.

FOR ARMORED VEHICLES AND STRUCTURAL PARTS THEREFOR (U.S. CLS. 19, 21, 23, 31, 35 AND 44).  
FIRST USE 8-15-2000; IN COMMERCE 8-15-2000.  
LINDA ORNDORFF, EXAMINING ATTORNEY

SN 78-960,422. COOK, MARK E., LUFKIN, TX. FILED 8-25-2006.

**LAZY LOADER**

THE MARK CONSISTS OF STANDARD CHARACTERS WITHOUT CLAIM TO ANY PARTICULAR FONT, STYLE, SIZE, OR COLOR.

FOR TRAILER FOR TRANSPORTING TIRES AND OTHER DELIVERABLES (U.S. CLS. 19, 21, 23, 31, 35 AND 44).  
JENNIFER WILLISTON, EXAMINING ATTORNEY

SN 78-959,578. WHITE, DANA LARUE, WATKINS, CO. FILED 8-24-2006.

**Rat Racing**

THE MARK CONSISTS OF STANDARD CHARACTERS WITHOUT CLAIM TO ANY PARTICULAR FONT, STYLE, SIZE, OR COLOR.

NO CLAIM IS MADE TO THE EXCLUSIVE RIGHT TO USE "RACING", APART FROM THE MARK AS SHOWN.  
FOR STRUCTURAL PARTS FOR MOTORCYCLES (U.S. CLS. 19, 21, 23, 31, 35 AND 44).  
REBECCA GAN, EXAMINING ATTORNEY

SN 78-962,997. WILSON, DEAN B., WINTHROP, WA. FILED 8-29-2006.

**BIKE BIKINI**

THE MARK CONSISTS OF STANDARD CHARACTERS WITHOUT CLAIM TO ANY PARTICULAR FONT, STYLE, SIZE, OR COLOR.

NO CLAIM IS MADE TO THE EXCLUSIVE RIGHT TO USE BIKE, APART FROM THE MARK AS SHOWN.  
FOR BICYCLE RACKS FOR VEHICLES (U.S. CLS. 19, 21, 23, 31, 35 AND 44).  
CHRIS WELLS, EXAMINING ATTORNEY

**CLASS 12—(Continued).**

SN 78-963,489. CARBON MOTORS CORPORATION, ATLANTA, GA. FILED 8-30-2006.

**CARBON MOTORS**

THE MARK CONSISTS OF STANDARD CHARACTERS WITHOUT CLAIM TO ANY PARTICULAR FONT, STYLE, SIZE, OR COLOR.

NO CLAIM IS MADE TO THE EXCLUSIVE RIGHT TO USE "MOTORS", APART FROM THE MARK AS SHOWN.

FOR AUTOMOBILES AND STRUCTURAL PARTS THEREFOR (U.S. CLS. 19, 21, 23, 31, 35 AND 44).  
ROSELLE HERRERA, EXAMINING ATTORNEY

SN 78-963,491. CARBON MOTORS CORPORATION, ATLANTA, GA. FILED 8-30-2006.

**PURE RELENTLESS DRIVE**

THE MARK CONSISTS OF STANDARD CHARACTERS WITHOUT CLAIM TO ANY PARTICULAR FONT, STYLE, SIZE, OR COLOR.

FOR AUTOMOBILES AND STRUCTURAL PARTS THEREFOR (U.S. CLS. 19, 21, 23, 31, 35 AND 44).  
ROSELLE HERRERA, EXAMINING ATTORNEY

SN 78-963,747. NEW CONCEPTS DEVELOPMENT GROUP, LLC, PHILIPSBURG, MT. FILED 8-30-2006.

**GrizHide**

THE MARK CONSISTS OF STANDARD CHARACTERS WITHOUT CLAIM TO ANY PARTICULAR FONT, STYLE, SIZE, OR COLOR.

FOR BICYCLE SADDLE COVERS; BICYCLE SADDLES; SADDLE COVERS FOR BICYCLES; SADDLES FOR BICYCLES; TRUCK BED LINERS (U.S. CLS. 19, 21, 23, 31, 35 AND 44).  
KYLE PEETE, EXAMINING ATTORNEY

**CLASS 12—(Continued).**

SN 78-964,048. JR TRADING GROUP, INC., MIAMI, FL. FILED 8-30-2006.



THE MARK CONSISTS OF THE STYLIZED LETTERS RTM ABOVE A DESIGN OF A CONVEX TRIANGLE INTERNALLY DIVIDED BY THREE LINES WITH SAID TRIANGLE OVERLAPPING A RING ELEMENT.

FOR ALL-TERRAIN VEHICLES, 3-WHEELED MOTORCYCLES, MOTORCYCLES, AND SCOOTERS (U.S. CLS. 19, 21, 23, 31, 35 AND 44).

MELISSA VALLILLO, EXAMINING ATTORNEY

SN 78-965,137. KWANG YANG MOTOR CO., LTD., KAOHSIUNG, TAIWAN, FILED 8-31-2006.

**KPW**

THE MARK CONSISTS OF STANDARD CHARACTERS WITHOUT CLAIM TO ANY PARTICULAR FONT, STYLE, SIZE, OR COLOR.

FOR TIRES, AUTOMOBILES, ELECTRIC AUTOMOBILES, MOTORCYCLES, ELECTRIC MOTORCYCLES, ALL TERRAIN VEHICLES, BEACH VEHICLES, OFF-ROAD VEHICLES, ELECTRIC ALL TERRAIN VEHICLES, MOTORIZED AND NON-MOTORIZED MOBILITY SCOOTERS, ELECTRIC MOTORIZED AND NON-MOTORIZED MOBILITY SCOOTERS, BICYCLES, ELECTRIC BICYCLES, TRICYCLES, ELECTRIC TRICYCLES, WHEELCHAIRS, ELECTRIC WHEELCHAIRS (U.S. CLS. 19, 21, 23, 31, 35 AND 44).

HENRY S. ZAK, EXAMINING ATTORNEY

**CLASS 12—(Continued).**

SN 78-967,002. FORCE PROTECTION INDUSTRIES, INC.,  
LADSON, SC. FILED 9-5-2006.

# CHEETAH

THE MARK CONSISTS OF STANDARD CHARACTERS  
WITHOUT CLAIM TO ANY PARTICULAR FONT, STYLE,  
SIZE, OR COLOR.

FOR ARMORED VEHICLES AND STRUCTURAL  
PARTS THEREFOR (U.S. CLS. 19, 21, 23, 31, 35 AND 44).  
FIRST USE 9-15-2006; IN COMMERCE 9-15-2006.  
NAKIA HENRY, EXAMINING ATTORNEY

---

SN 78-967,541. SPEEDPLAY, INC., SAN DIEGO, CA. FILED 9-  
5-2006.

# SYZR

THE MARK CONSISTS OF STANDARD CHARACTERS  
WITHOUT CLAIM TO ANY PARTICULAR FONT, STYLE,  
SIZE, OR COLOR.

FOR BICYCLE PEDALS (U.S. CLS. 19, 21, 23, 31, 35  
AND 44).  
GRETTA YAO, EXAMINING ATTORNEY

---

SN 78-967,792. INTERNATIONAL GROUP OF COMPANIES,  
LLC, MELROSE PARK, IL. FILED 9-6-2006.

# PASCO

THE MARK CONSISTS OF STANDARD CHARACTERS  
WITHOUT CLAIM TO ANY PARTICULAR FONT, STYLE,  
SIZE, OR COLOR.

FOR HAND TRUCKS (U.S. CLS. 19, 21, 23, 31, 35 AND  
44).  
BONNIE LUKEN, EXAMINING ATTORNEY

**CLASS 12—(Continued).**

SN 78-967,805. INTERNATIONAL GROUP OF COMPANIES,  
LLC, CHICAGO, IL. FILED 9-6-2006.

# INTERNATIONAL

THE MARK CONSISTS OF STANDARD CHARACTERS  
WITHOUT CLAIM TO ANY PARTICULAR FONT, STYLE,  
SIZE, OR COLOR.

FOR HAND TRUCKS (U.S. CLS. 19, 21, 23, 31, 35 AND  
44).

BONNIE LUKEN, EXAMINING ATTORNEY

---

SN 78-968,119. AMERICAN PACIFIC INDUSTRIES, INC.,  
VALENCIA, CA. FILED 9-6-2006.

---



FOR PASSENGER CAR AND LIGHT TRUCK TIRES  
(U.S. CLS. 19, 21, 23, 31, 35 AND 44).

LOURDES AYALA, EXAMINING ATTORNEY

---

SN 78-970,495. OLIVER RUBBER COMPANY, FINDLAY,  
OH. FILED 9-8-2006.

# MCL

THE MARK CONSISTS OF STANDARD CHARACTERS  
WITHOUT CLAIM TO ANY PARTICULAR FONT, STYLE,  
SIZE, OR COLOR.

FOR TREAD RUBBER FOR THE RETREADING OF  
VEHICLE TIRES (U.S. CLS. 19, 21, 23, 31, 35 AND 44).

JENNIFER MARTIN, EXAMINING ATTORNEY

---

SN 78-970,501. OLIVER RUBBER COMPANY, FINDLAY,  
OH. FILED 9-8-2006.

# MCL-DU

THE MARK CONSISTS OF STANDARD CHARACTERS  
WITHOUT CLAIM TO ANY PARTICULAR FONT, STYLE,  
SIZE, OR COLOR.

FOR TREAD RUBBER FOR THE RETREADING OF  
VEHICLE TIRES (U.S. CLS. 19, 21, 23, 31, 35 AND 44).  
JENNIFER MARTIN, EXAMINING ATTORNEY

**CLASS 12—(Continued).**

SN 78-970,837. REINOSO RODRIGUEZ, CESAR TULIO, BOGOTA, COLOMBIA, FILED 9-10-2006.

INR

THE MARK CONSISTS OF STANDARD CHARACTERS WITHOUT CLAIM TO ANY PARTICULAR FONT, STYLE, SIZE, OR COLOR.

FOR LAND VEHICLES; LAND VEHICLE PARTS, NAMELY, SUSPENSION BUSHINGS; WHEEL RIMS; PNEUMATIC TYRES (U.S. CLS. 19, 21, 23, 31, 35 AND 44).

KATHERINE CHANG, EXAMINING ATTORNEY

SN 78-971,070. HUFFY CORPORATION, MIAMISBURG, OH. FILED 9-11-2006.

SAVANNAH

THE MARK CONSISTS OF STANDARD CHARACTERS WITHOUT CLAIM TO ANY PARTICULAR FONT, STYLE, SIZE, OR COLOR.

FOR BICYCLES AND STRUCTURAL PARTS THERE-OF (U.S. CLS. 19, 21, 23, 31, 35 AND 44).

CURTIS FRENCH, EXAMINING ATTORNEY

SN 78-971,293. SRI USA, INC., AMHERST, NY. FILED 9-11-2006.

ECORUT

THE MARK CONSISTS OF STANDARD CHARACTERS WITHOUT CLAIM TO ANY PARTICULAR FONT, STYLE, SIZE, OR COLOR.

FOR TIRES (U.S. CLS. 19, 21, 23, 31, 35 AND 44).  
MATTHEW PAPPAS, EXAMINING ATTORNEY

SN 79-021,347. EUROPEAN BICYCLE IMPORTS B.V., NETHERLANDS, FILED 12-9-2005.

 *Van Nicholas*

PRIORITY DATE OF 12-2-2005 IS CLAIMED.  
OWNER OF INTERNATIONAL REGISTRATION 0878100 DATED 12-9-2005, EXPIRES 12-9-2015.  
FOR BICYCLES (U.S. CLS. 19, 21, 23, 31, 35 AND 44).  
DAYNA BROWNE, EXAMINING ATTORNEY

**CLASS 12—(Continued).**

SN 79-022,165. SANDRO MENTASTI S.R.L., ITALY, FILED 12-5-2005.

 ariete

OWNER OF INTERNATIONAL REGISTRATION 0537010 DATED 3-28-1989, EXPIRES 3-28-2009.

THE ITALIAN WORD "ARIETE" OF THE TRADEMARK CORRESPONDS TO THE ENGLISH WORD "RAM (ARIES)".  
FOR ACCESSORIES AND SPARE PARTS OF RUBBER AND THERMOPLASTIC FOR MOTORCYCLES, NAMELY, GRIPS FOR THE HANDLEBAR AND FOR PEDALS, SLEEVES FOR BRAKE AND CLUTCH CONTROL LEVERS, BELLOWS-LIKE RUBBER GASKETS FOR SHOCK ABSORBERS (U.S. CLS. 19, 21, 23, 31, 35 AND 44).

MARCIE MILONE, EXAMINING ATTORNEY

SN 79-023,543. SUZUKI MOTOR CORPORATION, JAPAN, FILED 10-28-2005.

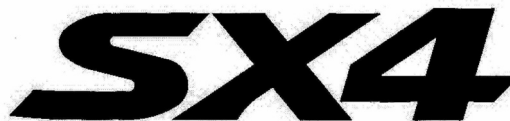
 SX4

PRIORITY DATE OF 9-26-2005 IS CLAIMED.  
OWNER OF INTERNATIONAL REGISTRATION 0883872 DATED 10-28-2005, EXPIRES 10-28-2015.

OWNER OF U.S. REG. NO. 2,984,591.  
FOR BOATS AND PERSONAL WATER CRAFT, EXCLUDING AIR CUSHION VEHICLES, AUTOMOBILES, MOTORCYCLES, BICYCLES, ELECTRIC TRICYCLES FOR TRANSPORTATION, STRUCTURAL PARTS AND FITTINGS FOR MOTORCYCLES AND ELECTRIC TRICYCLES; ADHESIVE RUBBER PATCHES FOR REPAIRING TIRES OR TUBES (U.S. CLS. 19, 21, 23, 31, 35 AND 44).

ERNEST SHOSHO, EXAMINING ATTORNEY

SN 79-024,416. JUNJIN HEAVY INDUSTRY CO., LTD., REPUBLIC OF KOREA, FILED 3-20-2006.

 JUNJIN

OWNER OF INTERNATIONAL REGISTRATION 0886346 DATED 3-20-2006, EXPIRES 3-20-2016.

THE COLOR(S) RED AND BLACK IS/ARE CLAIMED AS A FEATURE OF THE MARK.

THE COLOR RED APPEARS IN THE DESIGN ELEMENT, THE COLOR BLACK APPEARS IN THE WORDING JUNJIN.  
FOR DUMP TRUCKS; CONCRETE MIXING TRUCKS, TRUCKS FOR PUMPING CONCRETE; TRUCKS FOR PUMPING MORTAR; CONCRETE SPREADING TRUCKS (U.S. CLS. 19, 21, 23, 31, 35 AND 44).

ALLISON HOLTZ, EXAMINING ATTORNEY

**CLASS 12—(Continued).**

SN 79-027,822. TAIZHOU WANGJIN ECONOMIC; TRADE CO., LTD, CHINA, FILED 5-31-2006.



OWNER OF INTERNATIONAL REGISTRATION 0895875 DATED 5-31-2006, EXPIRES 5-31-2016.

FOR MOTORCYCLES; MOTORCYCLE FRAMES; MOTORS FOR MOTORCYCLES; REARVIEW MIRRORS; CYCLE CARS (U.S. CLS. 19, 21, 23, 31, 35 AND 44).  
ELI HELLMAN, EXAMINING ATTORNEY

SN 79-028,723. PIRELLI TYRE S.P.A., ITALY, FILED 6-29-2006.



OWNER OF INTERNATIONAL REGISTRATION 0789819 DATED 9-4-2002, EXPIRES 9-4-2012.

THE TRADEMARK CONSISTS IN A STYLIZED AND SLIGHTLY CURVED BAND WITH CONTINUOUS NON-SOLID AND SOLID LINES IN THE OUTER PART AND IN THE INNER PART, WHICH IS WIDER, THERE IS A STYLIZED REPRESENTATION OF TRIANGULAR PRINTS WITH CURVED SIDES.

FOR PNEUMATIC TIRES; SOLID, PNEUMATIC AND SEMI-PNEUMATIC TIRES FOR VEHICLE WHEELS OF ALL TYPES; WHEELS FOR VEHICLES OF ALL TYPES; INNER TUBES, RIMS, PARTS AND SPARE PARTS FOR VEHICLE WHEELS OF ALL TYPES (U.S. CLS. 19, 21, 23, 31, 35 AND 44).  
THOMAS MANOR, EXAMINING ATTORNEY

**CLASS 12—(Continued).**

SN 79-029,414. STILL GMBH, FED REP GERMANY, FILED 9-5-2006.

# RX 70

THE MARK CONSISTS OF STANDARD CHARACTERS WITHOUT CLAIM TO ANY PARTICULAR FONT, STYLE, SIZE, OR COLOR.

PRIORITY DATE OF 6-14-2006 IS CLAIMED.

OWNER OF INTERNATIONAL REGISTRATION 0899776 DATED 9-5-2006, EXPIRES 9-5-2016.

FOR FORKLIFT TRUCKS (U.S. CLS. 19, 21, 23, 31, 35 AND 44).

KIMBERLY PERRY, EXAMINING ATTORNEY

SN 79-029,415. STILL GMBH, FED REP GERMANY, FILED 9-5-2006.

# RX 60

THE MARK CONSISTS OF STANDARD CHARACTERS WITHOUT CLAIM TO ANY PARTICULAR FONT, STYLE, SIZE, OR COLOR.

OWNER OF INTERNATIONAL REGISTRATION 0899777 DATED 9-5-2006, EXPIRES 9-5-2016.

FOR FORKLIFT TRUCKS (U.S. CLS. 19, 21, 23, 31, 35 AND 44).

KIMBERLY PERRY, EXAMINING ATTORNEY

SN 79-029,416. STILL GMBH, FED REP GERMANY, FILED 9-5-2006.

# RX 20

THE MARK CONSISTS OF STANDARD CHARACTERS WITHOUT CLAIM TO ANY PARTICULAR FONT, STYLE, SIZE, OR COLOR.

OWNER OF INTERNATIONAL REGISTRATION 0899778 DATED 9-5-2006, EXPIRES 9-5-2016.

FOR FORKLIFT TRUCKS (U.S. CLS. 19, 21, 23, 31, 35 AND 44).

KIMBERLY PERRY, EXAMINING ATTORNEY



**CLASS 12—(Continued).**

SN 79-029,419. STILL GMBH, FED REP GERMANY, FILED 9-5-2006.

# RX 50

THE MARK CONSISTS OF STANDARD CHARACTERS WITHOUT CLAIM TO ANY PARTICULAR FONT, STYLE, SIZE, OR COLOR.

OWNER OF INTERNATIONAL REGISTRATION 0899791 DATED 9-5-2006, EXPIRES 9-5-2016.

FOR FORKLIFT TRUCKS (U.S. CLS. 19, 21, 23, 31, 35 AND 44).

KIMBERLY PERRY, EXAMINING ATTORNEY

**CLASS 13—FIREARMS**

SN 77-009,308. DYNO NOBEL INC., SALT LAKE CITY, UT. FILED 9-28-2006.

# SQUELCHER

THE MARK CONSISTS OF STANDARD CHARACTERS WITHOUT CLAIM TO ANY PARTICULAR FONT, STYLE, SIZE, OR COLOR.

FOR INERT STEMMING FOR BLASTING, NAMELY, A NON-EXPLOSIVE GEL USED TO INCREASE THE EFFICIENCY OF EXPLOSIVES (U.S. CLS. 2 AND 9).

FIRST USE 5-3-2006; IN COMMERCE 5-3-2006.

WENDY GOODMAN, EXAMINING ATTORNEY

SN 78-595,057. SMITH, KYLE S., WICHITA, KS. FILED 3-25-2005.

# TUNGSTEN SUPER SHOT

THE MARK CONSISTS OF STANDARD CHARACTERS WITHOUT CLAIM TO ANY PARTICULAR FONT, STYLE, SIZE, OR COLOR.

NO CLAIM IS MADE TO THE EXCLUSIVE RIGHT TO USE "SUPER SHOT", APART FROM THE MARK AS SHOWN.

FOR SHOTGUN PELLETS FOR HUNTING (U.S. CLS. 2 AND 9).

FIRST USE 3-1-2005; IN COMMERCE 7-1-2005.

CHRISIE B. KING, EXAMINING ATTORNEY

**CLASS 13—(Continued).**

SN 78-794,839. HALE FIREWORKS, LLC, BUFFALO, MO. FILED 1-19-2006.



NO CLAIM IS MADE TO THE EXCLUSIVE RIGHT TO USE "FIREWORKS LLC" AND "PYRO", APART FROM THE MARK AS SHOWN.

THE MARK CONSISTS OF WORDING AND A PICTURE OF A BOB CAT.

FOR FIREWORKS (U.S. CLS. 2 AND 9).

RUSS HERMAN, EXAMINING ATTORNEY

SN 78-922,540. BOYT HARNESS COMPANY, LLC, OSCEOLA, IA. FILED 7-5-2006.

# GUN SHIELD

THE MARK CONSISTS OF STANDARD CHARACTERS WITHOUT CLAIM TO ANY PARTICULAR FONT, STYLE, SIZE, OR COLOR.

NO CLAIM IS MADE TO THE EXCLUSIVE RIGHT TO USE "GUN", APART FROM THE MARK AS SHOWN.

FOR GUN CLEANING PATCHES, GUN CLEANING RODS, GUN CLEANING BRUSHES; GUN CLEANING KITS, COMPRISED OF GUN CLEANING PATCHES, GUN CLEANING RODS, BRUSHES, BORE CLEANER, SOLVENTS AND LUBRICANTS (U.S. CLS. 2 AND 9).

MARK RADEMACHER, EXAMINING ATTORNEY

SN 78-968,520. DYNO NOBEL INC., SALT LAKE CITY, UT. FILED 9-6-2006.

# FIRELINE

THE MARK CONSISTS OF STANDARD CHARACTERS WITHOUT CLAIM TO ANY PARTICULAR FONT, STYLE, SIZE, OR COLOR.

FOR INITIATING EXPLOSIVES (U.S. CLS. 2 AND 9).

FIRST USE 1-10-2004; IN COMMERCE 1-10-2004.

WENDY GOODMAN, EXAMINING ATTORNEY

**CLASS 13—(Continued).**

SN 78-968,883. BALLARD RIFLE & CARTRIDGE CO.,  
POWELL, WY. FILED 9-7-2006.

**LONESOME DOVE**

THE MARK CONSISTS OF STANDARD CHARACTERS  
WITHOUT CLAIM TO ANY PARTICULAR FONT, STYLE,  
SIZE, OR COLOR.  
FOR FIREARMS (U.S. CLS. 2 AND 9).  
JENNY PARK, EXAMINING ATTORNEY

SN 78-969,266. BLACK RAM ENGINEERING SERVICES  
LLC, KIRKLAND, WA. FILED 9-7-2006.

**CSCARS**

THE MARK CONSISTS OF STANDARD CHARACTERS  
WITHOUT CLAIM TO ANY PARTICULAR FONT, STYLE,  
SIZE, OR COLOR.  
FOR BOMB RELEASER (U.S. CLS. 2 AND 9).  
KARANENDRA S. CHHINA, EXAMINING ATTORNEY

SN 79-015,980. JIANG SU XIN SU MACHINERY MANU-  
FACTING CO., LTD., CHINA, FILED 7-29-2005.



OWNER OF INTERNATIONAL REGISTRATION 0863941  
DATED 7-29-2005, EXPIRES 7-29-2015.  
FOR AIR GUN, SHORT GUN, NAMELY, PISTOLS,  
RIFLES AND SPORTING RIFLES (U.S. CLS. 2 AND 9).  
ANDREA K. NADELMAN, EXAMINING ATTORNEY

**CLASS 14—JEWELRY**

SN 77-016,120. TIMEPIECES DIRECT INC., TEMECULA, CA.  
FILED 10-6-2006.

**WICKED WATCHES**

THE MARK CONSISTS OF STANDARD CHARACTERS  
WITHOUT CLAIM TO ANY PARTICULAR FONT, STYLE,  
SIZE, OR COLOR.  
NO CLAIM IS MADE TO THE EXCLUSIVE RIGHT TO  
USE "WATCHES", APART FROM THE MARK AS SHOWN.  
FOR WATCH BANDS AND STRAPS; WATCH BOXES;  
WATCH CASES; WATCHES (U.S. CLS. 2, 27, 28 AND 50).  
JENNIFER KRISP, EXAMINING ATTORNEY

SN 77-031,021. M. Z. BERGER & CO., INC., LONG ISLAND  
CITY, NY. FILED 10-27-2006.

**Embassy**

THE MARK CONSISTS OF STANDARD CHARACTERS  
WITHOUT CLAIM TO ANY PARTICULAR FONT, STYLE,  
SIZE, OR COLOR.  
FOR WATCHES AND CLOCKS (U.S. CLS. 2, 27, 28  
AND 50).  
FIRST USE 12-1-1931; IN COMMERCE 12-1-1931.  
SUNG IN, EXAMINING ATTORNEY

SN 77-057,963. FOSSIL, INC., RICHARDSON, TX. FILED 12-  
6-2006.

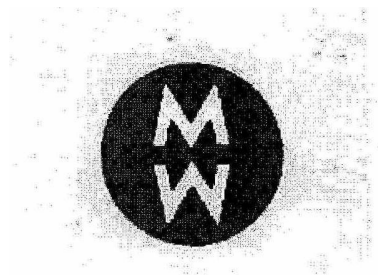

OWNER OF U.S. REG. NOS. 2,129,527, 2,925,951 AND  
OTHERS.  
THE MARK CONSISTS OF THE LETTERS MW WITHIN A  
CIRCLE.  
FOR JEWELRY (U.S. CLS. 2, 27, 28 AND 50).  
FIRST USE 2-13-2006; IN COMMERCE 2-13-2006.  
WILLIAM P. SHANAHAN, EXAMINING ATTORNEY

**CLASS 14—(Continued).**

SN 78-088,498. STARR, MICHAEL, LOS ANGELES, CA. FILED 10-15-2001.

**GENIUS**

FOR WATCHES, CLOCKS, TIMEPIECES (U.S. CLS. 2, 27, 28 AND 50).  
ANN E. SAPPENFIELD, EXAMINING ATTORNEY

SN 78-630,041. MOVADO LLC, WILMINGTON, DE. FILED 5-13-2005.

**CENTURION**

THE MARK CONSISTS OF STANDARD CHARACTERS WITHOUT CLAIM TO ANY PARTICULAR FONT, STYLE, SIZE, OR COLOR.  
FOR HOROLOGICAL AND CHRONOMETRIC INSTRUMENTS (U.S. CLS. 2, 27, 28 AND 50).  
FIRST USE 9-0-2003; IN COMMERCE 9-0-2003.  
NORA BUCHANAN WILL, EXAMINING ATTORNEY

SN 78-751,872. HAMLIN, DENNY, HUNTERSVILLE, NC. FILED 11-11-2005.

**DENNY HAMLIN**

THE MARK CONSISTS OF STANDARD CHARACTERS WITHOUT CLAIM TO ANY PARTICULAR FONT, STYLE, SIZE, OR COLOR.  
THE NAME DENNY HAMLIN IDENTIFIES A LIVING INDIVIDUAL WHOSE CONSENT IS OF RECORD.  
FOR JEWELRY NOT INCLUDING WATCHES SOLD AT PROFESSIONAL AUTOMOBILE RACING EVENTS (U.S. CLS. 2, 27, 28 AND 50).  
JUDITH HELFMAN, EXAMINING ATTORNEY

**CLASS 14—(Continued).**

SN 78-756,014. LUZ MARIA'S NATURAL STONE COLLECTION, INC., PALMETTO BAY, FL. FILED 11-17-2005.



THE NAME LUZ MARIA IDENTIFIES A LIVING INDIVIDUAL WHOSE CONSENT IS OF RECORD.  
THE MARK IS NOT IN COLOR.  
FOR JEWELRY, NAMELY, RINGS, NECKLACES, EARRINGS, WATCHES, BRACELETS, AND PINS (U.S. CLS. 2, 27, 28 AND 50).  
FIRST USE 10-1-2005; IN COMMERCE 10-1-2005.  
MARK T. MULLEN, EXAMINING ATTORNEY

SN 78-810,643. DOPP, PAUL S., MIAMI, FL. FILED 2-9-2006.



**"FIRST IN CREATION"**

THE MARK CONSISTS OF A FIG LEAF WITH THE NUMBER "1" AS ITS STEM.  
FOR JEWELRY, NAMELY, NECKLACES, EARRINGS, BRACELETS, RINGS, PINS, BELT BUCKLES OF PRECIOUS METALS, AND CUFF-LINKS (U.S. CLS. 2, 27, 28 AND 50).  
MICHELE SWAIN, EXAMINING ATTORNEY

SN 78-818,097. DIAMOND HARMONY LLC, NEW YORK, NY. FILED 2-17-2006.

**DIAMOND HARMONY**

THE MARK CONSISTS OF STANDARD CHARACTERS WITHOUT CLAIM TO ANY PARTICULAR FONT, STYLE, SIZE, OR COLOR.  
NO CLAIM IS MADE TO THE EXCLUSIVE RIGHT TO USE "DIAMOND", APART FROM THE MARK AS SHOWN.  
FOR JEWELRY (U.S. CLS. 2, 27, 28 AND 50).  
FIRST USE 6-1-2004; IN COMMERCE 1-1-2005.  
THOMAS MANOR, EXAMINING ATTORNEY

**CLASS 14—(Continued).**

SN 78-823,466. DREAM 23, LLC, TINLEY PARK, IL. FILED 2-25-2006.

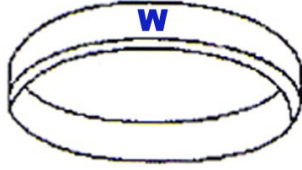

NO CLAIM IS MADE TO THE EXCLUSIVE RIGHT TO USE THE REPRESENTATION OF THREE-DIMENSIONAL DESIGN OF A RUBBER WRISTBAND, APART FROM THE MARK AS SHOWN.

THE COLOR(S) BLUE AND WHITE IS/ARE CLAIMED AS A FEATURE OF THE MARK.

THE MARK CONSISTS OF THE APPEARANCE AND THREE-DIMENSIONAL DESIGN OF A RUBBER WRISTBAND WITH THE LETTER W IMPRESSED ON THE BAND. THE COLORS BLUE AND WHITE ARE CLAIMED AS A FEATURE OF THE MARK. BLUE: THE W IMPRESSED ON THE BAND; WHITE: BACKGROUND.

FOR JEWELRY (U.S. CLS. 2, 27, 28 AND 50).  
SUSAN STIGLITZ, EXAMINING ATTORNEY

---

SN 78-867,837. DIAMOND DIRECT, LLC, NEW YORK, NY. FILED 4-24-2006.



**DIAMOND DIRECT**

NO CLAIM IS MADE TO THE EXCLUSIVE RIGHT TO USE "DIAMOND", APART FROM THE MARK AS SHOWN. THE COLOR(S) PINK AND ORANGE IS/ARE CLAIMED AS A FEATURE OF THE MARK.

THE MARK CONSISTS OF A STYLIZED ORANGE D WITH A SOLID PINK D INSIDE THE ORANGE D ABOVE THE WORDS "DIAMOND DIRECT" IN BLACK.

FOR JEWELRY FEATURING DIAMONDS AND PRECIOUS STONES; DIAMONDS AND PRECIOUS STONES (U.S. CLS. 2, 27, 28 AND 50).  
DAVID TAYLOR, EXAMINING ATTORNEY

---

SN 78-876,144. TIMEPIECES INTERNATIONAL INC., NEW BARNET, GREAT BRITAIN, FILED 5-4-2006.

**RALPH CHRISTIAN**

THE MARK CONSISTS OF STANDARD CHARACTERS WITHOUT CLAIM TO ANY PARTICULAR FONT, STYLE, SIZE, OR COLOR.

OWNER OF U.S. REG. NO. 3,108,078.  
THE NAME RALPH CHRISTIAN DOES NOT IDENTIFY A LIVING INDIVIDUAL.

FOR JEWELRY, NAMELY RINGS, NECKLACES, BRACELETS AND EARRINGS (U.S. CLS. 2, 27, 28 AND 50).  
STEVEN R. FINE, EXAMINING ATTORNEY

**CLASS 14—(Continued).**

SN 78-876,149. HAZZARD, SUSAN, O, FREEPORT, ME. FILED 5-4-2006.



**Island Grove Arts**

OWNER OF U.S. REG. NO. 3,139,078.  
NO CLAIM IS MADE TO THE EXCLUSIVE RIGHT TO USE "ARTS", APART FROM THE MARK AS SHOWN.

THE MARK CONSISTS OF THE WORDS ISLAND GROVE ARTS IN A STYLIZED FORM, TOGETHER WITH A FEMALE FORM WITH HANDS RAISED ABOVE THE HEAD.

FOR JEWELRY (U.S. CLS. 2, 27, 28 AND 50).  
FIRST USE 12-2-2005; IN COMMERCE 12-2-2005.  
STEVEN R. FINE, EXAMINING ATTORNEY

---

SN 78-890,458. KAVIAR, LLC, BEVERLY HILLS, CA. FILED 5-23-2006.

**KATHERINE AZARMI-ROSE**

THE MARK CONSISTS OF STANDARD CHARACTERS WITHOUT CLAIM TO ANY PARTICULAR FONT, STYLE, SIZE, OR COLOR.

THE NAME(S), PORTRAIT(S), AND/OR SIGNATURE(S) SHOWN IN THE MARK IDENTIFIES KATHERINE AZARMI-ROSE, WHOSE CONSENT(S) TO REGISTER IS SUBMITTED.

FOR JEWELRY, NAMELY RINGS, EARRINGS, BRACELETS, WATCHES, CUFF LINKS, PINS, NECKLACES AND BELT BUCKLES OR PRECIOUS METAL (U.S. CLS. 2, 27, 28 AND 50).  
FIRST USE 10-1-2005; IN COMMERCE 10-1-2005.  
CURTIS FRENCH, EXAMINING ATTORNEY

**CLASS 14—(Continued).**

SN 78-918,001. TXDC, L.P., IRVING, TX. FILED 6-27-2006.



NO CLAIM IS MADE TO THE EXCLUSIVE RIGHT TO USE "JEWELERS" AND "COLLECTION", APART FROM THE MARK AS SHOWN.  
FOR JEWELRY (U.S. CLS. 2, 27, 28 AND 50).  
RICHARD WHITE, EXAMINING ATTORNEY

SN 78-923,414. PYKETT, MAIJA, BRISTOL, UNITED KINGDOM, FILED 7-6-2006.

**SMALLPRINT**

THE MARK CONSISTS OF STANDARD CHARACTERS WITHOUT CLAIM TO ANY PARTICULAR FONT, STYLE, SIZE, OR COLOR.

OWNER OF UNITED KINGDOM REG. NO. 2370764, DATED 2-4-2005, EXPIRES 8-16-2014.

FOR JEWELRY MADE FROM PRECIOUS METAL, NAMELY NECKLACES, BRACELETS, RINGS, EARRINGS, DECORATIVE JEWELRY PINS AND BROOCHES, DRESS ORNAMENTS, CHARMS, PENDANTS, MEDALLIONS AND AMULETS; IMITATION JEWELRY; DECORATIVE ARTICLES, TRINKETS OR JEWELRY FOR PERSONAL USE ALL MADE OF PRECIOUS METALS, NAMELY, HAT PINS, HAT ORNAMENTS, LAPEL PINS, TRINKET RINGS, BONNET PINS OF PRECIOUS METALS, DECORATIVE BOXES OF PRECIOUS METALS; BELT BUCKLES MADE OF PRECIOUS METAL; ORNAMENTAL BUTTONS MADE OF PRECIOUS METALS; HAT AND SHOE ORNAMENTS MADE OF PRECIOUS METALS; BOXES, NAMELY, CIGAR AND CIGARETTE BOXES OF PRECIOUS METAL, JEWELRY BOXES OF PRECIOUS METAL, SNUFF BOXES OF PRECIOUS METAL, DECORATIVE BOXES MADE OF PRECIOUS METAL, WATCH BOXES, BOXES OF PRECIOUS METAL FOR SWEETS; BASKETS MADE OF PRECIOUS METALS; CASES, NAMELY, CIGAR AND CIGARETTE CASES OF PRECIOUS METAL, JEWELRY CASES OF PRECIOUS METAL, SNUFF CASES OF PRECIOUS METAL; WATCH CASES; DECORATIVE DISHES MADE

**CLASS 14—(Continued).**

OF PRECIOUS METAL; BOWLS MADE OF PRECIOUS METAL; TANKARDS MADE OF PRECIOUS METAL; DRINKING CUPS AND FLASKS OF PRECIOUS METAL; BUSINESS CARD CASES MADE OF PRECIOUS METAL; CUFF LINKS, TIE CLIPS, TIE PINS; EGG CUPS MADE OF PRECIOUS METAL; HOUSEHOLD UTENSILS MADE OF PRECIOUS METAL, NAMELY TEA INFUSERS OF PRECIOUS METAL, CRUET STANDS MADE OF PRECIOUS METAL, COFFEE POTS OF PRECIOUS METAL, NAPKIN RINGS OF PRECIOUS METAL, SERVING TRAYS OF PRECIOUS METAL, TEA BALLS OF PRECIOUS METAL; FIGURINES OF PRECIOUS METALS; KEY RINGS MADE OF PRECIOUS METALS; HOROLOGICAL AND CHRONOMETRIC INSTRUMENTS; PRECIOUS METALS AND THEIR ALLOYS; GOODS MADE OF PRECIOUS METALS OR COATED THEREWITH, NAMELY TIEPINS, CANDLESTICKS MADE OF PRECIOUS METALS, ASHTRAYS MADE OF PRECIOUS METAL, BUSTS OF PRECIOUS METALS, LETTER OPENERS OF PRECIOUS METAL (U.S. CLS. 2, 27, 28 AND 50).

MICHAEL TANNER, EXAMINING ATTORNEY

SN 78-941,308. SICURA DESIGNS, INC., BROOKLYN, NY. FILED 7-31-2006.

**ARGENTO SC**

NO CLAIM IS MADE TO THE EXCLUSIVE RIGHT TO USE "ARGENTO", APART FROM THE MARK AS SHOWN. THE MARK CONSISTS OF THE WORDS ARGENTO SC IN THE STYLIZED FONT SHOWN.

THE FOREIGN WORDING IN THE MARK TRANSLATES INTO ENGLISH AS SILVER.

FOR PICTURE FRAMES OF PRECIOUS METAL (U.S. CLS. 2, 27, 28 AND 50).

FIRST USE 4-1-2003; IN COMMERCE 4-1-2003.  
KELLY BOULTON, EXAMINING ATTORNEY

SN 78-944,824. MILWAUKEE BREWERS BASEBALL CLUB, MILWAUKEE, WI. FILED 8-4-2006.



OWNER OF U.S. REG. NOS. 2,542,640, 2,623,286 AND OTHERS.

NO CLAIM IS MADE TO THE EXCLUSIVE RIGHT TO USE "MILWAUKEE", APART FROM THE MARK AS SHOWN.

THE FOREIGN WORDING IN THE MARK TRANSLATES INTO ENGLISH AS BREWERS.

FOR JEWELRY, NAMELY, BRACELETS, CHARMS, EARRINGS, RINGS, BELLY RINGS, NECKLACES, PENDANTS, WATCHES, COSTUME JEWELRY, RUBBER OR SILICONE BRACELETS AND /OR RUBBER OR SILICONE WRISTBANDS IN THE NATURE OF BRACELETS, MEDALLIONS, ORNAMENTAL METAL PINS, LAPEL PINS, TIE CLIPS, TIE FASTENERS, CUFF LINKS, METAL BELT BUCKLES OF PRECIOUS METAL, TIE TACKS, TIE PINS, MONEY CLIPS OF PRECIOUS METAL, KEY CHAINS AND KEY RINGS MADE OF PRECIOUS METAL, CLOCKS, WALL CLOCKS, ALARM CLOCKS, FOB WATCHES, CLOCK KEY CHAINS, AND NON-MONETARY COINS OF PRECIOUS METAL (U.S. CLS. 2, 27, 28 AND 50).

C. DIONNE CLYBURN, EXAMINING ATTORNEY

**CLASS 14—(Continued).**

SN 78-953,749. CUTSHALL, LOGAN O., PURCELLVILLE, VA. FILED 8-16-2006.



FOR PRECIOUS METAL JEWELRY, DIAMONDS, GEMSTONES, WATCHES, AND COSTUME JEWELRY (U.S. CLS. 2, 27, 28 AND 50).  
DAVID HOFFMAN, EXAMINING ATTORNEY

SN 78-953,922. CUTSHALL, LOGAN O., PURCELLVILLE, VA. FILED 8-16-2006.

**Lynx Designs**

THE MARK CONSISTS OF STANDARD CHARACTERS WITHOUT CLAIM TO ANY PARTICULAR FONT, STYLE, SIZE, OR COLOR.  
NO CLAIM IS MADE TO THE EXCLUSIVE RIGHT TO USE "DESIGNS", APART FROM THE MARK AS SHOWN.  
FOR COSTUME JEWELRY, PRECIOUS METAL JEWELRY, DIAMONDS, GEMSTONES, AND WATCHES (U.S. CLS. 2, 27, 28 AND 50).  
DAVID HOFFMAN, EXAMINING ATTORNEY

**CLASS 14—(Continued).**

SN 78-955,746. SANRIO COMPANY, LTD., TOKYO, JAPAN, FILED 8-18-2006.

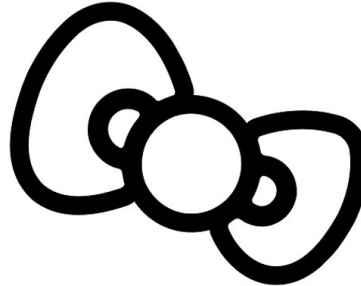

OWNER OF U.S. REG. NOS. 1,200,083, 1,370,105 AND OTHERS.  
THE MARK CONSISTS OF A BOW.  
FOR CLOCKS, ALARM CLOCKS, WALL CLOCKS, CLOCKS INCORPORATING RADIOS, JEWELRY, COSTUME JEWELRY, CHARMS, WRIST WATCHES, WATCH BANDS, WATCH STRAPS, ORNAMENTS FOR WIRELESS TELEPHONES MADE PRIMARILY OF PRECIOUS METALS (U.S. CLS. 2, 27, 28 AND 50).  
FIRST USE 11-1-2004; IN COMMERCE 11-1-2004.  
MICHAEL WIENER, EXAMINING ATTORNEY

SN 78-959,721. L. C. LICENSING, INC., NEW YORK, NY. FILED 8-24-2006.

BORN IN THE GLAMOROUS USA

THE MARK CONSISTS OF STANDARD CHARACTERS WITHOUT CLAIM TO ANY PARTICULAR FONT, STYLE, SIZE, OR COLOR.  
FOR CLOCKS AND WATCHES; JEWELRY, NAMELY: NECKLACES, BRACELETS, EARRINGS, JEWELRY PINS, RINGS, ANKLETS, CUFFLINKS, PENDANTS; PILLBOXES OF PRECIOUS METAL (U.S. CLS. 2, 27, 28 AND 50).  
COLLEEN DOMBROW, EXAMINING ATTORNEY

SN 78-959,781. L. C. LICENSING, INC., NEW YORK, NY. FILED 8-24-2006.

FOR NICE GIRLS WHO LIKE STUFF

THE MARK CONSISTS OF STANDARD CHARACTERS WITHOUT CLAIM TO ANY PARTICULAR FONT, STYLE, SIZE, OR COLOR.  
FOR CLOCKS AND WATCHES; JEWELRY, NAMELY: NECKLACES, BRACELETS, EARRINGS, JEWELRY PINS, RINGS, ANKLETS, CUFFLINKS, PENDANTS; PILLBOXES OF PRECIOUS METAL (U.S. CLS. 2, 27, 28 AND 50).  
COLLEEN DOMBROW, EXAMINING ATTORNEY

**CLASS 14—(Continued).**

SN 78-961,931. KIMAR ENTERPRISES, LLC., NEW HAVEN, CT. FILED 8-28-2006.

**ARPAIA**

THE MARK CONSISTS OF STANDARD CHARACTERS WITHOUT CLAIM TO ANY PARTICULAR FONT, STYLE, SIZE, OR COLOR.  
FOR JEWELRY (U.S. CLS. 2, 27, 28 AND 50).  
RAUL CORDOVA, EXAMINING ATTORNEY

**CLASS 14—(Continued).**

SN 78-964,166. MICHELLE RODRIGUEZ AND DARA YOUNG PARTNERSHIP, THE, DBA ISHKADADA ENTERPRISES, SANTA MONICA, CA. FILED 8-30-2006.

**ISHKADADA**

THE MARK CONSISTS OF STANDARD CHARACTERS WITHOUT CLAIM TO ANY PARTICULAR FONT, STYLE, SIZE, OR COLOR.  
FOR JEWELRY (U.S. CLS. 2, 27, 28 AND 50).  
JOHN DALIER, EXAMINING ATTORNEY

SN 78-963,241. RENE BARGUEIRAS INC., LOS ANGELES, CA. FILED 8-29-2006.

**Religious Treasures**

THE MARK CONSISTS OF STANDARD CHARACTERS WITHOUT CLAIM TO ANY PARTICULAR FONT, STYLE, SIZE, OR COLOR.  
NO CLAIM IS MADE TO THE EXCLUSIVE RIGHT TO USE "RELIGIOUS", APART FROM THE MARK AS SHOWN.  
FOR JEWELRY (U.S. CLS. 2, 27, 28 AND 50).  
MIDGE BUTLER, EXAMINING ATTORNEY

SN 78-963,732. AMERICAN NEVADA HOLDINGS, LLC, HENDERSON, NV. FILED 8-30-2006.

**AVENUE33**

THE MARK CONSISTS OF STANDARD CHARACTERS WITHOUT CLAIM TO ANY PARTICULAR FONT, STYLE, SIZE, OR COLOR.  
FOR CLOCKS; COLLECTIBLE COINS; COMMEMORATIVE COINS; JEWELRY; ORNAMENTAL PINS; PRECIOUS METAL MONEY CLIPS; WATCHES (U.S. CLS. 2, 27, 28 AND 50).  
INGRID C. EULIN, EXAMINING ATTORNEY

SN 78-964,688. HEARTS ON FIRE COMPANY, LLC, BOSTON, MA. FILED 8-31-2006.

**FEELS LIKE NO OTHER DIAMOND**

THE MARK CONSISTS OF STANDARD CHARACTERS WITHOUT CLAIM TO ANY PARTICULAR FONT, STYLE, SIZE, OR COLOR.  
NO CLAIM IS MADE TO THE EXCLUSIVE RIGHT TO USE "DIAMOND", APART FROM THE MARK AS SHOWN.  
FOR JEWELRY; PRECIOUS GEMSTONES (U.S. CLS. 2, 27, 28 AND 50).  
ESTHER A. BORSUK, EXAMINING ATTORNEY

SN 78-964,694. HEARTS ON FIRE COMPANY, LLC, BOSTON, MA. FILED 8-31-2006.

**PROMISES LIKE NO OTHER DIAMOND**

THE MARK CONSISTS OF STANDARD CHARACTERS WITHOUT CLAIM TO ANY PARTICULAR FONT, STYLE, SIZE, OR COLOR.  
NO CLAIM IS MADE TO THE EXCLUSIVE RIGHT TO USE "DIAMOND", APART FROM THE MARK AS SHOWN.  
FOR JEWELRY; PRECIOUS GEMSTONES (U.S. CLS. 2, 27, 28 AND 50).  
ESTHER A. BORSUK, EXAMINING ATTORNEY

**CLASS 14—(Continued).**

SN 78-964,704. HEARTS ON FIRE COMPANY, LLC, BOSTON, MA. FILED 8-31-2006.

**THRILLS LIKE NO OTHER  
DIAMOND**

THE MARK CONSISTS OF STANDARD CHARACTERS WITHOUT CLAIM TO ANY PARTICULAR FONT, STYLE, SIZE, OR COLOR.

NO CLAIM IS MADE TO THE EXCLUSIVE RIGHT TO USE "DIAMOND", APART FROM THE MARK AS SHOWN. FOR JEWELRY; PRECIOUS GEMSTONES (U.S. CLS. 2, 27, 28 AND 50).

ESTHER A. BORSUK, EXAMINING ATTORNEY

---

SN 78-966,490. SCHULTZ, KAREN L., CODY, WY. FILED 9-2-2006.

**ROCKSTAR COWGIRL**

THE MARK CONSISTS OF STANDARD CHARACTERS WITHOUT CLAIM TO ANY PARTICULAR FONT, STYLE, SIZE, OR COLOR.

FOR JEWELRY (U.S. CLS. 2, 27, 28 AND 50).  
MARTHA FROMM, EXAMINING ATTORNEY

---

SN 78-967,047. GURIAN, DAVID, COLUMBIA CITY, OR. FILED 9-5-2006.

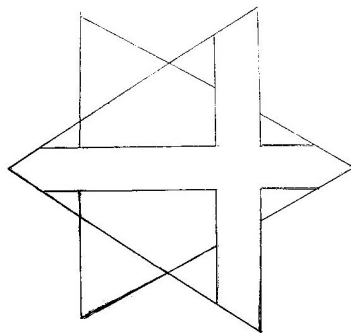

THE MARK CONSISTS OF AN ABSTRACT DESIGN. FOR JEWELRY (U.S. CLS. 2, 27, 28 AND 50).  
KATHERINE CONNOLLY, EXAMINING ATTORNEY

**CLASS 14—(Continued).**

SN 78-967,106. G. HENSLER & CO., SAN FRANCISCO, CA. FILED 9-5-2006.

**49 SQUARE MILES**

THE MARK CONSISTS OF STANDARD CHARACTERS WITHOUT CLAIM TO ANY PARTICULAR FONT, STYLE, SIZE, OR COLOR.

FOR JEWELRY (U.S. CLS. 2, 27, 28 AND 50).  
DAVID MURRAY, EXAMINING ATTORNEY

---

SN 78-967,704. OPEX S.A., PARIS, FRANCE, FILED 9-6-2006.

**OPEX**

THE MARK CONSISTS OF STANDARD CHARACTERS WITHOUT CLAIM TO ANY PARTICULAR FONT, STYLE, SIZE, OR COLOR.

OWNER OF U.S. REG. NO. 1,909,935.  
FOR JEWELRY (U.S. CLS. 2, 27, 28 AND 50).  
ALICIA COLLINS, EXAMINING ATTORNEY

---

SN 78-967,739. SOCKETOME, LLC, CHICAGO, IL. FILED 9-6-2006.

**SOCKETOME**

THE MARK CONSISTS OF STANDARD CHARACTERS WITHOUT CLAIM TO ANY PARTICULAR FONT, STYLE, SIZE, OR COLOR.

FOR JEWELRY (U.S. CLS. 2, 27, 28 AND 50).  
ANDREA EVANS, EXAMINING ATTORNEY



**CLASS 14—(Continued).**

SN 78-969,295. PRODESSO LTD., GIVATAYIM, ISRAEL, FILED 9-7-2006.

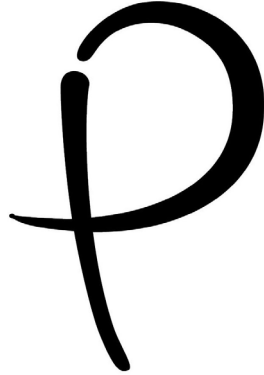

THE MARK CONSISTS OF A STYLIZED REPRESENTATION OF THE LETTER P.  
FOR JEWELRY (U.S. CLS. 2, 27, 28 AND 50).  
FIRST USE 1-0-2004; IN COMMERCE 1-0-2004.  
DAVID YONTEF, EXAMINING ATTORNEY

SN 78-969,966. LEONARD, KELBY, THOMPSONTOWN, PA. AND KEPNER, DWAYNE, CARLISLE, PA. FILED 9-8-2006.



FOR TIME AND TEMPERATURE SELF ADHESIVE CLOCK THAT WILL BE USED TO STICK ON A BOW (U.S. CLS. 2, 27, 28 AND 50).  
MARK PILARO, EXAMINING ATTORNEY

SN 78-970,150. ROLEX WATCH U.S.A., INC., NEW YORK, NY. FILED 9-8-2006.

# EVEROSE

THE MARK CONSISTS OF STANDARD CHARACTERS WITHOUT CLAIM TO ANY PARTICULAR FONT, STYLE, SIZE, OR COLOR.

FOR WATCHES AND PARTS THEREOF, WATCH CASES, BUCKLES OF PRECIOUS METAL FOR WATCHES, WATCH BRACELETS, WATCHSTRAPS, DIALS FOR CLOCK AND WATCH MAKING, WATCH CHAINS, CHRONOGRAPHS FOR USE AS WATCHES, CHRONOMETERS, CHRONOMETRIC INSTRUMENTS (U.S. CLS. 2, 27, 28 AND 50).  
JACLYN KIDWELL, EXAMINING ATTORNEY

**CLASS 14—(Continued).**

SN 78-970,436. MARK SILVERSTEIN, DBA MARK SILVERSTEIN IMAGINES, WOODLAND HILLS, CA. FILED 9-8-2006.

# Ceremony

THE MARK CONSISTS OF STANDARD CHARACTERS WITHOUT CLAIM TO ANY PARTICULAR FONT, STYLE, SIZE, OR COLOR.  
FOR JEWELRY (U.S. CLS. 2, 27, 28 AND 50).  
ATTIYA MALIK, EXAMINING ATTORNEY

SN 78-971,041. CAW COWIE, INC., DBA COLIN COWIE LIFESTYLE, NEW YORK, NY. FILED 9-11-2006.

# COLIN COWIE

THE MARK CONSISTS OF STANDARD CHARACTERS WITHOUT CLAIM TO ANY PARTICULAR FONT, STYLE, SIZE, OR COLOR.  
OWNER OF U.S. REG. NOS. 3,001,704, 3,001,711 AND OTHERS.  
THE NAME COLIN COWIE IDENTIFIES A LIVING INDIVIDUAL WHOSE CONSENT IS OF RECORD.  
FOR JEWELRY (U.S. CLS. 2, 27, 28 AND 50).  
RAMONA ORTIGA, EXAMINING ATTORNEY

SN 78-971,053. GEORGE, RANDY L, LAWRENCEBURG, IN. FILED 9-11-2006.

# KNEEKO

THE MARK CONSISTS OF STANDARD CHARACTERS WITHOUT CLAIM TO ANY PARTICULAR FONT, STYLE, SIZE, OR COLOR.  
FOR JEWELRY (U.S. CLS. 2, 27, 28 AND 50).  
WILLIAM P. SHANAHAN, EXAMINING ATTORNEY

**CLASS 14—(Continued).**

SN 79-015,333. OBCHTCHESTVO S OGRANITCHENNOY OTVETSTVENNOSTYOU "AVANDAJ", RU-125422 MOSCOU MOSCOW, RUSSIAN FED., FILED 6-1-2005.



PRIORITY DATE OF 12-7-2004 IS CLAIMED.  
OWNER OF INTERNATIONAL REGISTRATION 0862151 DATED 6-1-2005, EXPIRES 6-1-2015.

"THE MARK CONSISTS OF THE LETTERS EK APPEAR IN SPECIAL FONT ON A SQUARE."

FOR JEWELRY, ARTICLES MADE OF PRECIOUS METALS OR COATED THEREWITH NOT INCLUDED IN OTHER CLASSES, NAMELY, TUMBLERS, TABLEWARE, NAMELY, PLATTERS, DISHES, SAUCERS, NAPKIN RINGS, COFFEEPOTS, JUGS, TRAYS, CRUET STANDS FOR OIL AND VINEGAR, SALAD BOWLS, SUGAR BOWLS, COFFEE SERVICES, TEA SERVICES, TEA STRAINERS, SALT CELLARS, SOUP BOWLS, TABLE PLATES, TEAPOTS, CUPS; VASES, CANDY BOXES, CUFFLINKS, TIE PINS, ORNAMENTS FOR SHOES AND CLOTHING, MEDALS, INSIGNIA; CASES EXCLUSIVELY FOR JEWELRY; CLOCKS, WATCHES, WALL CLOCKS AND CHRONOMETRIC INSTRUMENTS (U.S. CLS. 2, 27, 28 AND 50).

JENNIFER VASQUEZ, EXAMINING ATTORNEY

SN 79-021,107. WASKOLL, FRANCE, FILED 1-6-2006.

**LOVE-INSIDE**

THE MARK CONSISTS OF STANDARD CHARACTERS WITHOUT CLAIM TO ANY PARTICULAR FONT, STYLE, SIZE, OR COLOR.

PRIORITY DATE OF 7-7-2005 IS CLAIMED.  
OWNER OF INTERNATIONAL REGISTRATION 0877466 DATED 1-6-2006, EXPIRES 1-6-2016.

FOR PRECIOUS METALS AND ALLOYS THEREOF; JEWELRY, PRECIOUS STONES, FASHION JEWELRY; TIMEPIECES AND CHRONOMETRIC INSTRUMENTS; EARRINGS, BRACELETS, WRISTWATCHES, WATCHBANDS; BROOCHES; PEARLS; NECKLACES; MEDALLIONS; DIAMONDS; JEWEL CASES OF PRECIOUS METAL; WATCH CASES; STATUES OR FIGURINES OF PRECIOUS METAL; BADGES OF PRECIOUS METAL; CUFF LINKS (U.S. CLS. 2, 27, 28 AND 50).

ELI HELLMAN, EXAMINING ATTORNEY

**CLASS 14—(Continued).**

SN 79-024,596. PINKROSA B.V., NETHERLANDS, FILED 2-10-2006.



OWNER OF INTERNATIONAL REGISTRATION 0886852 DATED 2-10-2006, EXPIRES 2-10-2016.

FOR WATCHES (U.S. CLS. 2, 27, 28 AND 50).  
AMY BROZENIC, EXAMINING ATTORNEY

SN 79-024,968. RICHARD RONALD KIES H.O.D.N. DWF NEDERLAND, NETHERLANDS, FILED 4-13-2006.

**KIBER**

THE MARK CONSISTS OF STANDARD CHARACTERS WITHOUT CLAIM TO ANY PARTICULAR FONT, STYLE, SIZE, OR COLOR.

OWNER OF INTERNATIONAL REGISTRATION 0887872 DATED 4-13-2006, EXPIRES 4-13-2016.

FOR HOROLOGICAL AND CHRONOMETRIC INSTRUMENTS, NAMELY WATCHES (U.S. CLS. 2, 27, 28 AND 50).

ELI HELLMAN, EXAMINING ATTORNEY

SN 79-026,651. MONTRES CORUM SÀRL, SWITZERLAND, FILED 7-26-2006.

**CORUM STEEL BRIDGE**

THE MARK CONSISTS OF STANDARD CHARACTERS WITHOUT CLAIM TO ANY PARTICULAR FONT, STYLE, SIZE, OR COLOR.

PRIORITY DATE OF 5-31-2006 IS CLAIMED.  
OWNER OF INTERNATIONAL REGISTRATION 0892640 DATED 7-26-2006, EXPIRES 7-26-2016.

OWNER OF U.S. REG. NOS. 1,080,321 AND 3,187,662.  
NO CLAIM IS MADE TO THE EXCLUSIVE RIGHT TO USE "STEEL BRIDGE", APART FROM THE MARK AS SHOWN.

FOR PRECIOUS METALS AND THEIR ALLOYS SOLD IN BULK; JEWELRY, PRECIOUS STONES; TIMEPIECES AND CHRONOMETRIC INSTRUMENTS, NAMELY CLOCKS, WATCHES, TABLE CLOCKS, CHRONOMETERS (U.S. CLS. 2, 27, 28 AND 50).

JOHN SCHUYLER YARD, EXAMINING ATTORNEY

**CLASS 16—PAPER GOODS AND PRINTED MATTER**

SN 74-711,091. PARK, YOUNG SAENG, GMJUNG-KU, PUSAN, REPUBLIC OF KOREA, FILED 8-4-1995.

**PARTIS**

FOR STATIONERY, WRITING IMPLEMENTS AND OFFICE REQUISITES, NAMELY, BALL POINT PENS, ROLLER BALL PENS, MARKER PENS, JELLING PENS, CORRECTION PENS, MECHANICAL PENCILS, FOUNTAIN PENS, PENCILS, CRAYONS, PASTEL CRAYONS, OIL COLORS, WATER COLORS, PENCIL SHARPENERS, FIBRE PENS, HIGHLIGHTING PENS, SIGN PENS, AND WRITING AND DRAWING INKS (U.S. CLS. 2, 5, 22, 23, 29, 37, 38 AND 50).

FIRST USE 10-31-1994; IN COMMERCE 7-31-1995.  
MARGERY A. TIERNEY, EXAMINING ATTORNEY

SN 76-007,886. SB PHARMCO PUERTO RICO INC., SAN JUAN, PUERTO RICO, FILED 3-21-2000.

**I CAN**

FOR PRINTED MATERIALS, NAMELY, PAMPHLETS AND BROCHURES, RELATING TO THE HEALTHCARE AND DIETARY CONCERNS OF DIABETIC PATIENTS, DISTRIBUTED TO MEDICAL PROFESSIONALS AND TO PATIENTS PARTICIPATING IN A MEMBERSHIP-BASED DIABETES TREATMENT PROGRAM (U.S. CLS. 2, 5, 22, 23, 29, 37, 38 AND 50).

ARETHA SOMERVILLE, EXAMINING ATTORNEY

SN 76-617,549. DOMINION ENTERPRISES, NORFOLK, VA. FILED 10-26-2004.

**TRAVEL COUPON GUIDE**

THE MARK CONSISTS OF STANDARD CHARACTERS WITHOUT CLAIM TO ANY PARTICULAR FONT, STYLE, SIZE, OR COLOR.

NO CLAIM IS MADE TO THE EXCLUSIVE RIGHT TO USE "GUIDE", APART FROM THE MARK AS SHOWN. SEC. 2(F).

FOR PERIODICAL PUBLICATIONS, NAMELY, MAGAZINES FEATURING TRAVEL INFORMATION AND TRAVEL-RELATED PROMOTIONAL DISCOUNTS (U.S. CLS. 2, 5, 22, 23, 29, 37, 38 AND 50).

FIRST USE 12-18-2000; IN COMMERCE 12-18-2000.  
BRENDAN MCCAULEY, EXAMINING ATTORNEY

**CLASS 16—(Continued).**

SN 76-648,473. LAZAR, TAMAR BORENSTEIN, PETACH-TIKVA 4950, ISRAEL, FILED 10-14-2005.



OWNER OF U.S. REG. NO. 2,352,925.

THE ENGLISH TRANSLATION OF THE FOREIGN WORDING IN THE MARK IS "AN ENDEARING FORM FOR MONKEY", KNOWN AS "A LITTLE MONKEY" OR "A CUTE MONKEY".

THE FOREIGN WORDING IN THE MARK TRANSLITERATES TO KOFIKO IN ENGLISH.

FOR POSTERS, A SERIES OF FICTION BOOKS AND A SERIES OF NON-FICTION BOOKS IN THE FIELD OF CHILDREN'S INTERESTS; COMIC BOOKS, BUMPER STICKERS, STICKERS, CALENDARS, ELECTRICAL AND MECHANICAL PENCIL SHARPENERS; PENCIL CASES, CHILDREN'S ACTIVITY BOOKS, 3-RING BINDERS, NOTEBOOKS, STATIONERY CONSISTING OF WRITING PAPER AND ENVELOPES, MEMO PADS, WRITING TABLETS, PAPER TABLE CLOTHS, PAPER NAPKINS, PENCILS, CHALK, ELECTRIC AND NON-ELECTRIC ERASERS; COLORING BOOKS, WRITING PENS, NON-CALIBRATED RULERS, PAPER WEIGHTS, PAPER COASTERS, AND PAPER MATS (U.S. CLS. 2, 5, 22, 23, 29, 37, 38 AND 50).

FIRST USE 12-31-1970; IN COMMERCE 12-31-1994.  
JORDAN BAKER, EXAMINING ATTORNEY

SN 76-659,567. LEADER, LINDON GRAY, PARK CITY, UT. FILED 5-4-2006.



NO CLAIM IS MADE TO THE EXCLUSIVE RIGHT TO USE "PARK CITY", APART FROM THE MARK AS SHOWN.

FOR PRINTED MATTER, NAMELY, POSTERS, NOTE CARDS, POST CARDS, LETTERHEAD PAPER; RUBBER STAMPS; STICKERS; INK STAMPS (U.S. CLS. 2, 5, 22, 23, 29, 37, 38 AND 50).

LAURA KOVALSKY, EXAMINING ATTORNEY

**CLASS 16—(Continued).**

SN 76-661,011. KFC CORPORATION, LOUISVILLE, KY. FILED 6-5-2006.



OWNER OF U.S. REG. NOS. 806,104, 2,218,808 AND OTHERS.

THE INDIVIDUAL IN THE DESIGN IS A REPRESENTATION OF AN ACTUAL PERSON, NAMELY, HARLAND SANDERS, NOW DECEASED, WHOSE CONSENT IS OF RECORD.

FOR PAPER FOR PACKAGING; CARDBOARD FOR PACKAGING; AND PLASTIC BAGS FOR PACKAGING (U.S. CLS. 2, 5, 22, 23, 29, 37, 38 AND 50).

THEODORE MCBRIDE, EXAMINING ATTORNEY

SN 76-665,623. QUATTROCCHI, ALLISON, DBA FAMILY MEDIATION CENTER PUBLISHING CO., LLC, SCOTTSDALE, AZ. FILED 9-5-2006.

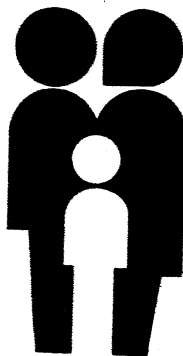

THIS DESIGN MARK CONSISTS OF A STYLIZED DEPICTION OF PARENTS WITH A CHILD.

FOR SERIES OF BOOKS TO HELP INDIVIDUALS AND FAMILIES MANAGE AND HANDLE THE PROCESS OF DIVORCE AND ISSUES RELATED TO DIVORCE (U.S. CLS. 2, 5, 22, 23, 29, 37, 38 AND 50).

FIRST USE 4-29-2005; IN COMMERCE 4-29-2005.

ALICE SUE CARRUTHERS, EXAMINING ATTORNEY

**CLASS 16—(Continued).**

SN 77-019,103. SOCIETE BIC, CLICHY, FRANCE, FILED 10-11-2006.

**D-FLEXION**

THE MARK CONSISTS OF STANDARD CHARACTERS WITHOUT CLAIM TO ANY PARTICULAR FONT, STYLE, SIZE, OR COLOR.

FOR SHOCK-ABSORBING AND CUSHIONING SPRING UNIT USED IN WRITING INSTRUMENTS, NAMELY PENS AND PENCILS (U.S. CLS. 2, 5, 22, 23, 29, 37, 38 AND 50).

JILL C. ALT, EXAMINING ATTORNEY

SN 77-020,726. UNITED TELECARD ALLIANCE, INC., PHILADELPHIA, PA. FILED 10-13-2006.

**CALABAZA**

THE MARK CONSISTS OF STANDARD CHARACTERS WITHOUT CLAIM TO ANY PARTICULAR FONT, STYLE, SIZE, OR COLOR.

THE FOREIGN WORDING IN THE MARK TRANSLATES INTO ENGLISH AS SQUASH.

FOR PRE-PAID TELEPHONE CALLING CARDS, NOT MAGNETICALLY ENCODED; TELEPHONE CALLING CARDS, NOT MAGNETICALLY ENCODED (U.S. CLS. 2, 5, 22, 23, 29, 37, 38 AND 50).

FIRST USE 10-16-2006; IN COMMERCE 10-16-2006.

SETH A. RAPPAPORT, EXAMINING ATTORNEY

SN 77-023,614. KERI BEYER INC, STILLWATER, MN. FILED 10-18-2006.



THE MARK CONSISTS OF AN OVAL WITH THE STYLIZED TEXT OF THE WORDING "URBANFARM" AND FLOWERS.

FOR COFFEE TABLE BOOKS FEATURING INSPIRATION AND LIFESTYLE; GIFT CARDS; GIFT WRAP PAPER; GREETING CARDS; INVITATION CARDS; PAPER; PAPER NAPKINS; PAPER TABLE CLOTHS; STATIONERY (U.S. CLS. 2, 5, 22, 23, 29, 37, 38 AND 50).

HEATHER BIDDULPH, EXAMINING ATTORNEY

**CLASS 16—(Continued).**

SN 77-037,274. THE CARTOON NETWORK, INC., ATLANTA, GA. FILED 11-6-2006.

**WILLIAMS STREET**

THE MARK CONSISTS OF STANDARD CHARACTERS WITHOUT CLAIM TO ANY PARTICULAR FONT, STYLE, SIZE, OR COLOR.

FOR PRINTED MATTER AND PAPER GOODS NAMELY, BOOKS FEATURING CHARACTERS FROM ANIMATED, ACTION ADVENTURE, COMEDY AND/OR DRAMA FEATURES, COMIC BOOKS, CHILDREN'S BOOKS, MAGAZINES FEATURING CHARACTERS FROM ANIMATED, ACTION ADVENTURE, COMEDY AND/OR DRAMA FEATURES, COLORING BOOKS, CHILDREN'S ACTIVITY BOOKS; STATIONERY, WRITING PAPER, ENVELOPES, NOTEBOOKS, DIARIES, NOTE CARDS, GREETING CARDS; TRADING CARDS, LITHOGRAPHS AND ANIMATION CELLS; PENS, PENCILS, CASES THEREFOR, ERASERS, CRAYONS, MARKERS, COLORED PENCILS, PAINTING SETS, CHALK AND CHALKBOARDS; DECALS, HEAT TRANSFERS; POSTERS; MOUNTED AND/OR UNMOUNTED PHOTOGRAPHS; BOOK COVERS, BOOK MARKS, CALENDARS, GIFT WRAPPING PAPER; PAPER PARTY FAVORS AND PAPER PARTY DECORATIONS - NAMELY PAPER NAPKINS, PAPER DOILIES, PAPER PLACE MATS, CREPE PAPER, PAPER HATS, INVITATIONS, PAPER TABLE CLOTHS, PAPER CAKE DECORATIONS; PRINTED TRANSFERS FOR EMBROIDERY OR FABRIC APPLIQUES; PRINTED PATTERNS FOR COSTUMES, PAJAMAS, SWEATSHIRTS AND T-SHIRTS; PASSPORT CASES (U.S. CLS. 2, 5, 22, 23, 29, 37, 38 AND 50).

LINDA ORNDORFF, EXAMINING ATTORNEY

SN 77-038,810. BUNZL DISTRIBUTION USA, INC., ST. LOUIS, MO. FILED 11-7-2006.

**PRIME SOURCE**

THE MARK CONSISTS OF STANDARD CHARACTERS WITHOUT CLAIM TO ANY PARTICULAR FONT, STYLE, SIZE, OR COLOR.

OWNER OF U.S. REG. NOS. 1,962,781, 2,439,722 AND OTHERS.

FOR PAPER GUEST CHECKS (U.S. CLS. 2, 5, 22, 23, 29, 37, 38 AND 50).

FIRST USE 12-31-2005; IN COMMERCE 12-31-2005.

MICHELE SWAIN, EXAMINING ATTORNEY

**CLASS 16—(Continued).**

SN 77-043,362. TIME4 MEDIA, INC., NEW YORK, NY. FILED 11-14-2006.

**FIELD & STREAM**

THE MARK CONSISTS OF STANDARD CHARACTERS WITHOUT CLAIM TO ANY PARTICULAR FONT, STYLE, SIZE, OR COLOR.

OWNER OF U.S. REG. NOS. 1,301,639, 2,033,655 AND OTHERS.

FOR CALENDARS; PRINTED CALENDARS (U.S. CLS. 2, 5, 22, 23, 29, 37, 38 AND 50).

FIRST USE 4-30-1995; IN COMMERCE 4-30-1995.

NATALIE POLZER, EXAMINING ATTORNEY

SN 77-053,072. DIXON TICONDEROGA COMPANY, HEATHROW, FL. FILED 11-29-2006.

**TRI-CONDEROGA**

THE MARK CONSISTS OF STANDARD CHARACTERS WITHOUT CLAIM TO ANY PARTICULAR FONT, STYLE, SIZE, OR COLOR.

OWNER OF U.S. REG. NOS. 131,087 AND 1,481,548.

FOR PENCILS (U.S. CLS. 2, 5, 22, 23, 29, 37, 38 AND 50).

FIRST USE 4-0-2005; IN COMMERCE 4-0-2005.

MARILYN IZZI, EXAMINING ATTORNEY

SN 77-059,771. ADVANSTAR COMMUNICATIONS INC., DULUTH, MN. FILED 12-8-2006.

**JOURNAL OF VALIDATION  
TECHNOLOGY**

THE MARK CONSISTS OF STANDARD CHARACTERS WITHOUT CLAIM TO ANY PARTICULAR FONT, STYLE, SIZE, OR COLOR.

OWNER OF U.S. REG. NO. 2,046,800.

NO CLAIM IS MADE TO THE EXCLUSIVE RIGHT TO USE "JOURNAL", APART FROM THE MARK AS SHOWN. SEC. 2(F).

FOR JOURNAL IN THE FIELD OF VALIDATION AND COMPLIANCE FOR FOOD AND DRUG ADMINISTRATION REGULATED INDUSTRIES (U.S. CLS. 2, 5, 22, 23, 29, 37, 38 AND 50).

FIRST USE 10-1-1994; IN COMMERCE 10-1-1994.

KEVIN DINALLO, EXAMINING ATTORNEY

**CLASS 16—(Continued).**

SN 77-064,015. FE-LINES, INC., FORT WORTH, TX. FILED 12-14-2006.



FOR ADHESIVE STRIPS FOR PLACEMENT ON FURNITURE AND IN POTTED PLANTS TO DETER CATS FROM SCRATCHING ON FURNITURE OR DIGGING IN POTTED PLANTS (U.S. CLS. 2, 5, 22, 23, 29, 37, 38 AND 50).

FIRST USE 9-24-1996; IN COMMERCE 9-24-1996.  
TASHIA BUNCH, EXAMINING ATTORNEY

**CLASS 16—(Continued).**

SN 78-495,497. HERITAGE FINANCIAL LIMITED OF JACKSONVILLE, LLLP, JACKSONVILLE, FL. FILED 10-6-2004.

**FAST CASH  
GENERATOR**

THE MARK CONSISTS OF STANDARD CHARACTERS WITHOUT CLAIM TO ANY PARTICULAR FONT, STYLE, SIZE, OR COLOR.

FOR HOME STUDY INSTRUCTION AND TRAINING KITS CONTAINING MANUALS, PRINTED INSTRUCTIONAL AND TEACHING MATERIALS, IN THE FIELD OF REAL ESTATE INVESTMENTS, ON THE SUBJECTS OF; HOW TO BUY AND SELL REAL ESTATE FOR ACHIEVING PERSONAL WEALTH, HOW TO USE THE INTERNET TO PROVIDE INFORMATION TO PROSPECTIVE CLIENTS, HOW TO MARKET NEW PRODUCTS, AND HOW TO LICENSE PRODUCTS (U.S. CLS. 2, 5, 22, 23, 29, 37, 38 AND 50).

FIRST USE 4-0-2004; IN COMMERCE 4-0-2004.  
MARCIE MILONE, EXAMINING ATTORNEY

SN 78-429,453. VOCAL MINDS, INC., CAPE CORAL, FL. FILED 6-3-2004.

**BALLYHOO**

THE MARK CONSISTS OF STANDARD CHARACTERS WITHOUT CLAIM TO ANY PARTICULAR FONT, STYLE, SIZE, OR COLOR.

FOR MAGAZINE IN THE FIELDS OF ADVERTISING AND MARKETING (U.S. CLS. 2, 5, 22, 23, 29, 37, 38 AND 50).

FIRST USE 11-1-2003; IN COMMERCE 4-1-2004.  
TONJA GASKINS, EXAMINING ATTORNEY

SN 78-547,818. FREES, JESSIE LYNCH, FLORHAM PARK, NJ. FILED 1-14-2005.

**Jackie Winquackey**

THE MARK CONSISTS OF STANDARD CHARACTERS WITHOUT CLAIM TO ANY PARTICULAR FONT, STYLE, SIZE, OR COLOR.

THE NAME "JACKIE WINQUACKEY" DOES NOT IDENTIFY A LIVING INDIVIDUAL.

FOR SERIES OF CHILDREN'S FICTIONAL BOOKS (U.S. CLS. 2, 5, 22, 23, 29, 37, 38 AND 50).

FIRST USE 11-1-2004; IN COMMERCE 11-1-2004.  
SUZANNE BLANE, EXAMINING ATTORNEY

**CLASS 16—(Continued).**

SN 78-565,830. CURTCO ROBB MEDIA, LLC, MALIBU, CA. FILED 2-11-2005.

**CLASS 16—(Continued).**

SN 78-629,960. WORLD BASEBALL CLASSIC, INC., NEW YORK, NY. FILED 5-13-2005.

**ROBB REPORT HEALTH & WELLNESS**

THE MARK CONSISTS OF STANDARD CHARACTERS WITHOUT CLAIM TO ANY PARTICULAR FONT, STYLE, SIZE, OR COLOR.

OWNER OF U.S. REG. NOS. 1,750,085, 3,001,164 AND OTHERS.

NO CLAIM IS MADE TO THE EXCLUSIVE RIGHT TO USE REPORT HEALTH & WELLNESS, APART FROM THE MARK AS SHOWN.

FOR MAGAZINES FEATURING TOPICS RELATED TO LIFESTYLES, HEALTH, MENTAL AND EMOTIONAL WELL BEING, PHYSICAL FITNESS, ANTI-AGING, NUTRITION, DIETING, PREVENTATIVE MEDICINE, AND MEDICAL BREAKTHROUGHS AND TECHNOLOGY (U.S. CLS. 2, 5, 22, 23, 29, 37, 38 AND 50).

KATHERINE STOIDES, EXAMINING ATTORNEY

**WORLD BASEBALL CLASSIC**

THE MARK CONSISTS OF STANDARD CHARACTERS WITHOUT CLAIM TO ANY PARTICULAR FONT, STYLE, SIZE, OR COLOR.

NO CLAIM IS MADE TO THE EXCLUSIVE RIGHT TO USE BASEBALL CLASSIC FOR "SCORE BOOKS, SCORE CARDS, PRINTED BASEBALL GAME PROGRAMS, MAGAZINES AND BOOKS FEATURING BASEBALL, NEWSLETTERS, BROCHURES AND PAMPHLETS FEATURING BASEBALL, BASEBALL CARD ALBUMS, PLASTIC BASEBALL CARD HOLDERS, COLLECTORS CASES AND TRADING CARDS", APART FROM THE MARK AS SHOWN.

FOR PAPER GOODS AND PRINTED MATTER, NAMELY, TRADING CARDS, POSTERS, STICKERS, DECALS, TEMPORARY TATTOOS, BUMPER STICKERS, SCORE BOOKS, SCORECARDS, PRINTED BASEBALL GAME PROGRAMS, MAGAZINES AND BOOKS FEATURING BASEBALL, NEWSLETTERS, BROCHURES AND PAMPHLETS FEATURING BASEBALL, WRITING PADS, NOTE PAPER, NOTEBOOKS, BINDERS, STATIONERY-TYPE PORTFOLIOS, STATIONERY FOLDERS, STATIONERY SETS, NAMELY, WRITING PAPER, CARDS, AND ENVELOPES, COMMEMORATIVE ENVELOPES, FLIP BOOKS, PREPRINTED AGENDA ORGANIZERS, MEMO BOARDS, SCRAPBOOKS, AUTOGRAPH BOOKS, BASEBALL CARD ALBUMS, BOOK COVERS, BOOKMARKS, BOOKENDS, CALENDARS, GREETING CARDS, POSTCARDS, PRINTED BANK CHECKBOOKS, CHECKBOOK COVERS, COLLECTIBLE STAMPS, RUBBER STAMPS, INK STAMPS, COMMEMORATIVE STAMPS, PAPER PENNANTS, GIFT WRAPPING PAPER, PAPER GIFT AND PARTY BAGS, PAPER PARTY GOODS IN THE NATURE OF PAPER PARTY DECORATIONS; PAPER COASTERS, PAPER NAPKINS, FACIAL TISSUE, PAPER TABLECLOTHS, MOUNTED AND UN-MOUNTED PHOTOGRAPHS, PHOTOGRAPH ALBUMS, LITHOGRAPHS, PLASTIC BASEBALL CARD HOLDERS AND COLLECTORS CASES, PAPERWEIGHTS, LETTER OPENERS, PENS, PENCILS, PENCIL TOP ORNAMENTS, CRAYONS, MARKERS, NON-ELECTRIC ERASERS, PENCIL SHARPENERS, PENCIL CASES, UN-GRADUATED RULERS, PAPER TICKET HOLDERS AND NON-METAL LANYARDS FOR PAPER TICKET HOLDERS SOLD AS A UNIT, ART PICTURES, ART PRINTS (U.S. CLS. 2, 5, 22, 23, 29, 37, 38 AND 50).

CAROLINE WOOD, EXAMINING ATTORNEY

SN 78-602,447. BABY PAGES, LLC, BRONX, NY. FILED 4-5-2005.



NO CLAIM IS MADE TO THE EXCLUSIVE RIGHT TO USE "BABY", APART FROM THE MARK AS SHOWN.

THE MARK CONSISTS OF THE PHRASE "BABY PAGES" AS WRITTEN; THEY WORDS WILL ALWAYS APPEAR NEXT TO ONE ANOTHER AS SHOWN.

FOR A PRINTED SHOPPER'S GUIDE IN THE FORM OF A MAGAZINE LISTING ALL KNOWN AND RELEVANT MATERNITY AND CHILDREN'S STORES, IN THE AREA WHERE PUBLISHED, WHEREIN THOSE STORES MAY CHOOSE TO ADVERTISE THEIR GOODS (U.S. CLS. 2, 5, 22, 23, 29, 37, 38 AND 50).

FIRST USE 10-15-2005; IN COMMERCE 10-15-2005.

C. DIONNE CLYBURN, EXAMINING ATTORNEY

**CLASS 16—(Continued).**

SN 78-629,978. WORLD BASEBALL CLASSIC, INC., NEW YORK, NY. FILED 5-13-2005.

**CLASS 16—(Continued).**

SN 78-640,844. MORRISON, JOHN L., ARGYLL, UNITED KINGDOM, FILED 5-31-2005.

CLÁSICO MUNDIAL DE BÉISBOL

**JOLOMO**

THE MARK CONSISTS OF STANDARD CHARACTERS WITHOUT CLAIM TO ANY PARTICULAR FONT, STYLE, SIZE, OR COLOR.

NO CLAIM IS MADE TO THE EXCLUSIVE RIGHT TO USE CLASICO AND BEISBOL FOR "SCORE BOOKS, SCORECARDS, PRINTED BASEBALL GAME PROGRAMS, MAGAZINES AND BOOKS FEATURING BASEBALL, NEWSLETTERS, BROCHURES AND PAMPHLETS FEATURING BASEBALL, BASEBALL CARD ALBUMS, PLASTIC BASEBALL CARD HOLDERS, COLLECTORS CASES AND TRADING CARDS", APART FROM THE MARK AS SHOWN.

THE FOREIGN WORDING IN THE MARK TRANSLATES INTO ENGLISH AS WORLD BASEBALL CLASSIC.

FOR PAPER GOODS AND PRINTED MATTER, NAMELY, TRADING CARDS, POSTERS, STICKERS, DECALS, TEMPORARY TATTOOS, BUMPER STICKERS, SCORE BOOKS, SCORECARDS, PRINTED BASEBALL GAME PROGRAMS, MAGAZINES AND BOOKS FEATURING BASEBALL, NEWSLETTERS, BROCHURES AND PAMPHLETS FEATURING BASEBALL, WRITING PADS, NOTE PAPER, NOTEBOOKS, BINDERS, STATIONERY-TYPE PORTFOLIOS, STATIONERY FOLDERS, STATIONERY SETS, NAMELY, WRITING PAPER, CARDS, AND ENVELOPES, COMMEMORATIVE ENVELOPES, FLIP BOOKS, PREPRINTED AGENDA ORGANIZERS, MEMO BOARDS, SCRAPBOOKS, AUTOGRAPH BOOKS, BASEBALL CARD ALBUMS, BOOK COVERS, BOOKMARKS, BOOKENDS, CALENDARS, GREETING CARDS, POSTCARDS, PRINTED BANK CHECKBOOKS, CHECKBOOK COVERS, COLLECTIBLE STAMPS, RUBBER STAMPS, INK STAMPS, COMMEMORATIVE STAMPS, PAPER PENNANTS, GIFT WRAPPING PAPER, PAPER GIFT AND PARTY BAGS, PAPER PARTY GOODS IN THE NATURE OF PAPER PARTY DECORATIONS; PAPER COASTERS, PAPER NAPKINS, FACIAL TISSUE, PAPER TABLECLOTHS, MOUNTED AND UN-MOUNTED PHOTOGRAPHS, PHOTOGRAPH ALBUMS, LITHOGRAPHS, PLASTIC BASEBALL CARD HOLDERS AND COLLECTORS CASES, PAPER-WEIGHTS, LETTER OPENERS, PENS, PENCILS, PENCIL TOP ORNAMENTS, CRAYONS, MARKERS, NON-ELECTRIC ERASERS, PENCIL SHARPENERS, PENCIL CASES, UN-GRADUATED RULERS, PAPER TICKET HOLDERS AND NON-METAL LANYARDS FOR PAPER TICKET HOLDERS SOLD AS A UNIT, ART PICTURES, ART PRINTS (U.S. CLS. 2, 5, 22, 23, 29, 37, 38 AND 50).

CAROLINE WOOD, EXAMINING ATTORNEY

THE MARK CONSISTS OF STANDARD CHARACTERS WITHOUT CLAIM TO ANY PARTICULAR FONT, STYLE, SIZE, OR COLOR.

OWNER OF UNITED KINGDOM REG. NO. 2378122A, DATED 6-24-2005, EXPIRES 11-16-2014.

FOR PRINTED MATTER, NAMELY, PRINTS AND ART PRINTS, PAINTINGS, DRAWINGS, SKETCHES, SCRAPBOOKS, CALENDARS, ENVELOPES, PICTURES, POSTERS, ADDRESS BOOKS, APPOINTMENT BOOKS AND DIARIES; PHOTOGRAPHS; ARTISTS MATERIALS, NAMELY, BRUSHES, WRITING TABLETS, CANVASES, PASTELS AND CHALK BOARDS; PRINTED INSTRUCTIONAL AND TEACHING MATERIALS IN THE FIELD OF ART, NAMELY, BOOKS, BOOKLETS, BROCHURES, CASE STUDIES AND CHARTS; ALBUMS, NAMELY, PAINTING ALBUMS, PICTURE ALBUMS, PHOTOGRAPHIC ALBUMS, AND STAMP ALBUMS; WRITING INSTRUMENTS, NAMELY, PENS, PENCILS, MARKERS, HIGHLIGHTERS, CALLIGRAPHY PENS, CHALK AND CRAYONS; STATIONERY; BOOKMARKS; CALENDARS; CARDS, NAMELY, POSTCARDS, PLACE CARDS AND WRITING CARDS; CATALOGUES, NAMELY, CATALOGUES OF ARTISTS' MATERIALS AND CATALOGUES OF ARTWORK FOR RETAIL PURPOSES AND FOR RECORD KEEPING PURPOSES; DECALCOMANIAS; GRAPHIC ART REPRODUCTIONS; GREETING CARDS; PRINTED PAPER LABELS; LITHOGRAPHS; BOOKS, BOOKLETS AND BROCHURES IN THE FIELD OF ART; MANUALS IN THE FIELD OF ART FOR INSTRUCTIONAL PURPOSES; PRINTED PUBLICATIONS, NAMELY, MAGAZINES, BROCHURES AND NEWSLETTERS IN THE FIELD OF ART; MODELING MATERIALS, NAMELY, MODELING CLAY AND COMPOUNDS; PHOTOGRAPHIC MOUNTS; EASELS; FRAMED AND UNFRAMED PAINTINGS; PAINTING PALETTES AND PAPER; PHOTOGRAPH STANDS; PAPER TOWELS; PAPER NAPKINS; PAPER TRANSPARENCIES; WRAPPING PAPER; DRAWING AND PAINTING BOOKS; WRITING MATERIALS, NAMELY, JOURNALS, WRITING PAPER AND NOTEPADS (U.S. CLS. 2, 5, 22, 23, 29, 37, 38 AND 50).

ALLISON HOLTZ, EXAMINING ATTORNEY



**CLASS 16—(Continued).**

SN 78-664,339. WORLD BASEBALL CLASSIC, INC., NEW YORK, NY. FILED 7-6-2005.



NO CLAIM IS MADE TO THE EXCLUSIVE RIGHT TO USE "BASEBALL CLASSIC" FOR SCORE BOOKS, SCORECARDS, PRINTED BASEBALL GAME PROGRAMS, MAGAZINES AND BOOKS FEATURING BASEBALL, NEWSLETTERS, BROCHURES AND PAMPHLETS FEATURING BASEBALL, BASEBALL CARD ALBUMS, PLASTIC BASEBALL CARD HOLDERS, COLLECTORS CASES AND TRADING CARDS, APART FROM THE MARK AS SHOWN.

THE MARK CONSISTS OF A STYLIZED GLOBE WITH MERIDIANS AND BASEBALL STITCHING SURROUNDED BY FOUR HALF-CIRCLES THAT SPIRAL OUTWARD IN A PINWHEEL FASHION FROM THE GLOBE ABOVE WHICH THE WORDS WORLD BASEBALL CLASSIC APPEAR.

FOR PAPER GOODS AND PRINTED MATTER, NAMELY, TRADING CARDS, POSTERS, STICKERS, DECALS, TEMPORARY TATTOOS, BUMPER STICKERS, SCORE BOOKS, SCORECARDS, PRINTED BASEBALL GAME PROGRAMS, MAGAZINES AND BOOKS FEATURING BASEBALL, NEWSLETTERS, BROCHURES AND PAMPHLETS FEATURING BASEBALL, WRITING PADS, NOTE PAPER, NOTEBOOKS, BINDERS, STATIONERY-TYPE PORTFOLIOS, STATIONERY FOLDERS, STATIONERY SETS, NAMELY, WRITING PAPER, CARDS, AND ENVELOPES, COMMEMORATIVE ENVELOPES, FLIP BOOKS, PREPRINTED AGENDA ORGANIZERS, MEMO BOARDS, SCRAPBOOKS, AUTOGRAPH BOOKS, BASEBALL CARD ALBUMS, BOOK COVERS, BOOKMARKS, BOOKENDS, CALENDARS, GREETING CARDS, POSTCARDS, PRINTED BANK CHECKBOOKS, CHECKBOOK COVERS, COLLECTIBLE STAMPS, RUBBER STAMPS, INK STAMPS, COMMEMORATIVE STAMPS, PAPER PENNANTS, GIFT WRAPPING PAPER, PAPER GIFT AND PARTY BAGS, PAPER PARTY GOODS IN THE NATURE OF PAPER PARTY DECORATIONS; PAPER COASTERS, PAPER NAPKINS, FACIAL TISSUE, PAPER TABLECLOTHS, MOUNTED AND UN-MOUNTED PHOTOGRAPHS, PHOTOGRAPH ALBUMS, LITHOGRAPHS, PLASTIC BASEBALL CARD HOLDERS AND COLLECTORS CASES, PAPER-WEIGHTS, LETTER OPENERS, PENS, PENCILS, PENCIL TOP ORNAMENTS, CRAYONS, MARKERS, NON-ELECTRIC ERASERS, PENCIL SHARPENERS, PENCIL CASES, UN-GRADUATED RULERS, PAPER TICKET HOLDERS AND NON-METAL LANYARDS FOR PAPER TICKET HOLDERS SOLD AS A UNIT, ART PICTURES, ART PRINTS (U.S. CLS. 2, 5, 22, 23, 29, 37, 38 AND 50).

CAROLINE WOOD, EXAMINING ATTORNEY

**CLASS 16—(Continued).**

SN 78-706,939. FOLTYN, JASON C., FORT WORTH, TX. FILED 9-6-2005.

# DADDYTIME

THE MARK CONSISTS OF STANDARD CHARACTERS WITHOUT CLAIM TO ANY PARTICULAR FONT, STYLE, SIZE, OR COLOR.

FOR SERIES OF CHILDREN'S PICTURE BOOKS (U.S. CLS. 2, 5, 22, 23, 29, 37, 38 AND 50).

JERI J. FICKES, EXAMINING ATTORNEY

SN 78-719,319. BUBBA'S WORLD, L.L.C., SAGINAW, MI. FILED 9-23-2005.

# Bubba's World

THE MARK CONSISTS OF STANDARD CHARACTERS WITHOUT CLAIM TO ANY PARTICULAR FONT, STYLE, SIZE, OR COLOR.

FOR ADDRESS BOOKS; ANNIVERSARY BOOKS; APPOINTMENT BOOKS; ART PRINTS; AUTOGRAPH BOOKS; BABY BOOKS; BLANK JOURNAL BOOKS; BRAG BOOKS; CARTOON PRINTS; COLOR PRINTS; COMIC BOOKS; COMPOSITION BOOKS; LITHOGRAPHIC PRINTS; MEMORY BOOKS; PHOTOGRAPHIC PRINTS; PICTORIAL PRINTS; PICTURE BOOKS; PRINTED ART REPRODUCTIONS; PRINTED AWARD CERTIFICATES; PRINTED AWARDS; PRINTED CALENDARS; PRINTED CERTIFICATES; PRINTED CHARTS; PRINTED GRAPHS; PRINTED GREETING CARDS WITH ELECTRONIC INFORMATION STORED THEREIN; PRINTED INVITATIONS; PRINTING PAPER; PRINTING PAPERS; SERIES OF FICTION BOOKS; SKETCH BOOKS; STORY BOOKS; TELEPHONE NUMBER BOOKS (U.S. CLS. 2, 5, 22, 23, 29, 37, 38 AND 50).

FIRST USE 8-15-2005; IN COMMERCE 8-15-2005.

ODESSA BIBBINS, EXAMINING ATTORNEY

**CLASS 16—(Continued).**

SN 78-743,088. MAURICE, SKILLERN, MEMPHIS, TN.  
FILED 10-29-2005.



NO CLAIM IS MADE TO THE EXCLUSIVE RIGHT TO USE "INTERNATIONAL", APART FROM THE MARK AS SHOWN.

THE COLOR(S) BLACK AND GRAY IS/ARE CLAIMED AS A FEATURE OF THE MARK.

THE MARK CONSISTS OF GRAY BACKGROUND WITH BLACK AND GRAY CIRCLE. THE BIGGEST CIRCLE(TOP) HAS LETTERS (B) AND (I) WITHIN IT. ALSO INCLUDES SQUARE LINES CONNECTING ALL.

FOR SERIES OF FICTION AND NON-FICTION BOOKS ON A VARIETY OF TOPICS, NAMELY, POETRY, NOVELS, CHILDREN'S BOOKS, SCIENCE FICTION, PLAYS, AND MOVIE SCRIPTS (U.S. CLS. 2, 5, 22, 23, 29, 37, 38 AND 50).

FIRST USE 5-10-1994; IN COMMERCE 1-20-2000.  
STEVEN JACKSON, EXAMINING ATTORNEY

SN 78-770,472. TRIBUTE PUBLISHING INC., TORONTO,  
ONTARIO, CANADA, FILED 12-9-2005.

**KIDS TRIBUTE**

THE MARK CONSISTS OF STANDARD CHARACTERS WITHOUT CLAIM TO ANY PARTICULAR FONT, STYLE, SIZE, OR COLOR.

NO CLAIM IS MADE TO THE EXCLUSIVE RIGHT TO USE "KIDS", APART FROM THE MARK AS SHOWN.

FOR PRINTED MATERIALS, NAMELY, MAGAZINES, NEWSLETTERS, EVENT PROGRAMS, SOUVENIR PROGRAMS, PROMOTIONAL MATERIALS AND PHOTOGRAPHS ABOUT ENTERTAINMENT, MOVIES, TELEVISION, MUSIC, CELEBRITIES, POP-CULTURE, LIFESTYLE AND LEISURE ACTIVITIES, SPORTS, FITNESS, DINING, NIGHTLIFE, TOYS, GAMES, FASHION, WEBSITES AND EDUCATIONAL AND SOCIAL ISSUES (U.S. CLS. 2, 5, 22, 23, 29, 37, 38 AND 50).

FIRST USE 11-1-1989; IN COMMERCE 11-1-1989.  
REBECCA EISINGER, EXAMINING ATTORNEY

**CLASS 16—(Continued).**

SN 78-770,473. TRIBUTE PUBLISHING INC., TORONTO,  
ONTARIO, CANADA, FILED 12-9-2005.

**TEEN TRIBUTE**

THE MARK CONSISTS OF STANDARD CHARACTERS WITHOUT CLAIM TO ANY PARTICULAR FONT, STYLE, SIZE, OR COLOR.

NO CLAIM IS MADE TO THE EXCLUSIVE RIGHT TO USE "TEEN", APART FROM THE MARK AS SHOWN.

FOR PRINTED MATERIALS, NAMELY, MAGAZINES, NEWSLETTERS, EVENT PROGRAMS, SOUVENIR PROGRAMS, PROMOTIONAL MATERIALS AND PHOTOGRAPHS ABOUT ENTERTAINMENT, MOVIES, TELEVISION, MUSIC, CELEBRITIES, POP-CULTURE, LIFESTYLE AND LEISURE ACTIVITIES, SPORTS, FITNESS, DINING, NIGHTLIFE, TOYS, GAMES, FASHION, WEBSITES AND EDUCATIONAL AND SOCIAL ISSUES (U.S. CLS. 2, 5, 22, 23, 29, 37, 38 AND 50).

FIRST USE 3-1-1998; IN COMMERCE 3-1-1998.

REBECCA EISINGER, EXAMINING ATTORNEY

SN 78-780,267. RAGDOLL LTD., IVER HEATH, BUCKINGHAMSHIRE, UNITED KINGDOM, FILED 12-23-2005.

**TRONJI**

THE MARK CONSISTS OF STANDARD CHARACTERS WITHOUT CLAIM TO ANY PARTICULAR FONT, STYLE, SIZE, OR COLOR.

FOR PAPER GOODS AND PRINTED MATERIAL, NAMELY, PAPER AND PAPER ARTICLES SUCH AS NOTE PAPER, ART PAPER, WRITING PAPER, CONSTRUCTION PAPER; STATIONERY, PRINTING PAPER, PHOTOCOPY PAPER, OFFSET PAPER, PRINTED PAPER FORMS, NAMELY, PARTY INVITATIONS, NAME BADGES, LABELS, CERTIFICATES AND ENVELOPES THEREFOR, CARDBOARD AND PHOTOGRAPHS, NAMELY PICTURE-MOUNTS OF CARDBOARD; CARDBOARD ARTICLES, NAMELY, BOXES AND CONTAINERS; BOOKS FEATURING STORIES, GAMES AND ACTIVITIES FOR CHILDREN; CHILDREN'S ACTIVITY BOOKS; CHILDREN'S READING BOOKS; NOTE PADS; NOTEBOOKS; DECALS; PAPER BANNERS; COMIC BOOKS; SONG BOOKS; MAGAZINES FEATURING ENTERTAINMENT AND ACTIVITIES FOR CHILDREN; NEWSLETTERS AND NEWSPAPERS FEATURING ENTERTAINMENT AND ACTIVITIES FOR CHILDREN; MEMORY BOOK PHOTO ALBUMS; PERIODICALS FEATURING ENTERTAINMENT AND ACTIVITIES FOR CHILDREN; JOURNALS IN THE NATURE OF A DIARY; MAPS; POSTERS; PAPER LABELS; OFFICE REQUI-

**CLASS 16—(Continued).**

SITES, NAMELY, PAPER CLIPS, STAPLERS, PAPER HOLE PUNCHES, PENS AND PENCILS; TELEPHONE CALLING CARDS, NOT MAGNETICALLY ENCODED; DRAWING AND PAINTING MATERIALS, NAMELY ARTS AND CRAFTS PAINT KITS; WRITING INSTRUMENTS; INSTRUCTIONAL AND TEACHING MATERIALS IN THE FORM OF GAMES, NAMELY, FLASH CARDS; BOOK COVERS; BOOK MARKS; DRAWINGS; PAINTINGS; PRINTS; PENCIL TOP ORNAMENTS; PAINTBRUSHES; PAPER GIFT WRAP; GIFT CARDS; GIFT WRAP TISSUE PAPER; PAPER GIFT BOXES; PAPER TAGS; WRAPPING PAPER; INVITATION PADS; PAPER NAPKINS; PAPER PARTY GOODS NAMELY HATS, BAGS AND FAVORS, PAPER PARTY DECORATIONS; PAPER TABLECLOTHS AND TABLE COVERS IN THE NATURE OF TABLE CLOTHS; PAPER MATS; PAPER HATS; EMBROIDERY PATTERNS; STICKERS; DRAWING RULERS; ERASERS; GREETING CARDS; PRINTED PAPER SIGNS; PRINTED GROWTH CHARTS; AND NON-FUNCTIONING TEACHING CLOCKS OF CARDBOARD (U.S. CLS. 2, 5, 22, 23, 29, 37, 38 AND 50).  
JILL C. ALT, EXAMINING ATTORNEY

SN 78-792,880. CRAVE TATTOO MAGAZINE INC., FORT DODGE, IA. FILED 1-17-2006.



NO CLAIM IS MADE TO THE EXCLUSIVE RIGHT TO USE "TATTOOING AND BODY MODIFICATION", APART FROM THE MARK AS SHOWN.

FOR NOTE PADS, BUSINESS CARDS, BROCHURES, NEWSLETTERS AND TRADE PUBLICATIONS IN THE FORM OF MAGAZINES IN THE TATTOO AND BODY PIERCING INDUSTRY (U.S. CLS. 2, 5, 22, 23, 29, 37, 38 AND 50).

FIRST USE 1-16-2005; IN COMMERCE 3-7-2005.  
DOMINICK J. SALEMI, EXAMINING ATTORNEY

SN 78-793,373. AHOLA, ROBERT J., MALIBU, CA. FILED 1-17-2006.

## Invisible Quarterly

THE MARK CONSISTS OF STANDARD CHARACTERS WITHOUT CLAIM TO ANY PARTICULAR FONT, STYLE, SIZE, OR COLOR.

NO CLAIM IS MADE TO THE EXCLUSIVE RIGHT TO USE "QUARTERLY", APART FROM THE MARK AS SHOWN.

FOR MAGAZINE PUBLISHED QUARTERLY AND FEATURING ECOLOGY, THERMOGRAPHY, GLOBAL WARMING, ENVIRONMENTAL MEDICINE, ENVIRONMENTAL PRODUCTS, WILDLIFE, PETS, INDUSTRIAL TECHNOLOGIES, COMMUNICATIONS TECHNOLOGIES AND HEALTH AND WELLNESS ISSUES (U.S. CLS. 2, 5, 22, 23, 29, 37, 38 AND 50).

REBECCA EISINGER, EXAMINING ATTORNEY

**CLASS 16—(Continued).**

SN 78-794,280. SIGNATURE WORLD CLASS CANVAS, LLC, KANSAS CITY, MO. FILED 1-18-2006.

## Avant-Garde

THE MARK CONSISTS OF STANDARD CHARACTERS WITHOUT CLAIM TO ANY PARTICULAR FONT, STYLE, SIZE, OR COLOR.

FOR CANVAS FOR PAINTING (U.S. CLS. 2, 5, 22, 23, 29, 37, 38 AND 50).

FIRST USE 1-5-2006; IN COMMERCE 1-5-2006.  
GILBERT SWIFT, EXAMINING ATTORNEY

SN 78-797,780. FUQUA, KELLI N., OCALA, FL. FILED 1-24-2006.

## CANVERSES

THE MARK CONSISTS OF STANDARD CHARACTERS WITHOUT CLAIM TO ANY PARTICULAR FONT, STYLE, SIZE, OR COLOR.

FOR PAINTINGS AND GREETING CARDS (U.S. CLS. 2, 5, 22, 23, 29, 37, 38 AND 50).

FIRST USE 12-12-2004; IN COMMERCE 12-12-2004.  
CHRISTOPHER OTT, EXAMINING ATTORNEY

SN 78-798,941. POLYNESIAN CULTURAL CENTER, HONOLULU, HI. FILED 1-25-2006.



OWNER OF U.S. REG. NO. 1,372,513.

NO CLAIM IS MADE TO THE EXCLUSIVE RIGHT TO USE "POLYNESIA", APART FROM THE MARK AS SHOWN.

FOR VISITOR GUIDE BOOKS FEATURING INFORMATION ABOUT POLYNESIA (U.S. CLS. 2, 5, 22, 23, 29, 37, 38 AND 50).

FIRST USE 5-1-2005; IN COMMERCE 5-1-2005.

KATHLEEN M. VANSTON, EXAMINING ATTORNEY

**CLASS 16—(Continued).**

SN 78-799,453. SOTKA, LAURA L., KINGWOOD, TX. AND KLAY, HOLLY A., BLOOMINGTON, IN. FILED 1-25-2006.

# Puggerfly

THE MARK CONSISTS OF STANDARD CHARACTERS WITHOUT CLAIM TO ANY PARTICULAR FONT, STYLE, SIZE, OR COLOR.

SEC. 2(F).

FOR ART PICTURES; ART PRINTS; GRAPHIC ART REPRODUCTIONS; PHOTOGRAPHIC OR ART MOUNTS; PRINTED ART REPRODUCTIONS (U.S. CLS. 2, 5, 22, 23, 29, 37, 38 AND 50).

FIRST USE 1-23-2006; IN COMMERCE 1-23-2006.

H. M. FISHER, EXAMINING ATTORNEY

SN 78-802,133. ALPINIST, LLC, JACKSON, WY. FILED 1-30-2006.

# WILD

THE MARK CONSISTS OF STANDARD CHARACTERS WITHOUT CLAIM TO ANY PARTICULAR FONT, STYLE, SIZE, OR COLOR.

FOR PRINTED PUBLICATIONS, NAMELY MAGAZINES WITH PARTICULAR EMPHASIS ON OUTDOOR ACTIVITIES, ACTIVE SPORTS, ADVENTURE, EXPLORATION AND DISCOVERY (U.S. CLS. 2, 5, 22, 23, 29, 37, 38 AND 50).

JOANNA DUKOVIC, EXAMINING ATTORNEY

**CLASS 16—(Continued).**

SN 78-804,934. MORGAN MOTOR COMPANY LIMITED, WORCESTERSHIRE, UNITED KINGDOM, FILED 2-1-2006.



OWNER OF U.S. REG. NO. 1,715,474.

FOR ADHESIVE LABELS TO BE APPLIED TO CLOTHING ITEMS, NOT MADE OF FABRIC; STICKERS; FLAGS MADE FROM PAPERS; CALENDARS; CATALOGS FEATURING PERFUMES, COSMETICS, SAFETY HELMETS, METAL BADGES AND TROPHIES, PINS, VIDEOCASSETTES, CD-ROMS, VIDEO GAMES, CELLULAR TELEPHONES, MASKS FOR CELLULAR TELEPHONES, WATCHES, JEWELRY, WATCHES, STATIONERY AND WRITING INSTRUMENTS, STAMPS FOR COLLECTORS, MEMORABILIA FROM RACING CAR EXHIBITIONS, LEATHER ITEMS, SPORT BAGS, TOWELS, FLAGS, CLOTHING, FOOTWEAR AND HEADGEAR, TOYS, AND ASHTRAYS; BROCHURES, PERIODICALS, BOOKS AND BOOKLETS ON THE SUBJECTS OF AUTOMOBILES, AUTOMOBILE MAINTENANCE AND REPAIR, AUTOMOBILE RACING AND AUTOMOBILE COMPETITIONS, AND THE HISTORY OF MORGAN MOTOR COMPANY AND ITS PARTICIPATION IN AUTOMOBILE RACING AND COMPETITIONS; PENS, FOUNTAIN PENS, ROLLING PENS, PENCILS, FELT PENS, WRITING PENS, PEN-HOLDERS NOT IN PRECIOUS METAL; PAPER CUTTERS; DOCUMENT FOLDERS FOR CARDS AND DOCUMENTS; PHOTOGRAPHIC PRINTS, POSTERS, POSTCARDS; RUBBERS, NAMELY, ERASERS; SQUARES FOR DRAWING, DRAWING RULERS, ALBUMS FOR DRAWINGS; CARDBOARD BOXES; AGENDAS; NOTEPAPERS; PHOTO ALBUMS; GREETING CARDS; WRAPPING PAPERS; PENCIL SHARPENERS, SMALL BLACKBOARDS; NOTE PADS; AND STAMPS FOR COLLECTORS (U.S. CLS. 2, 5, 22, 23, 29, 37, 38 AND 50).

JILL C. ALT, EXAMINING ATTORNEY

SN 78-807,048. MICROSOFT CORPORATION, REDMOND, WA. FILED 2-3-2006.

# NINETY-NINE NIGHTS

THE MARK CONSISTS OF STANDARD CHARACTERS WITHOUT CLAIM TO ANY PARTICULAR FONT, STYLE, SIZE, OR COLOR.

FOR PUBLICATIONS, NAMELY, STRATEGY GUIDES, USER MANUALS, COMIC BOOKS, SERIES OF FICTION BOOKS, MAGAZINES AND NEWSLETTERS ALL IN THE FIELD OF SCIENCE FICTION AND COMPUTER GAMES UNRELATED TO AUTO RACING; PENS, PENCILS, MARKERS, STATIONERY, STATIONERY-TYPE PORTFOLIOS, CLIPBOARDS, DESK SETS, PEN AND PENCIL HOLDERS, MOUNTED AND UNMOUNTED PHOTOGRAPHS, POSTERS, MAGNETIC BOARDS, MEMO PADS, BINDERS, STAPLERS, PAPERWEIGHTS, PAPER COASTERS, CALENDARS, NOTEBOOKS, BOOK COVERS, STICKER BOOKS, GREETING CARDS AND NOTE CARDS, ALL IN THE FIELD OF SCIENCE FICTION AND COMPUTER GAMES UNRELATED TO AUTO RACING (U.S. CLS. 2, 5, 22, 23, 29, 37, 38 AND 50).

KELLY CHOE, EXAMINING ATTORNEY

**CLASS 16—(Continued).**

SN 78-807,146. ROBERT E HOWARD PROPERTIES INC., BEVERLY HILLS, CA. FILED 2-3-2006.

**CLASS 16—(Continued).**

SN 78-807,189. ROBERT E HOWARD PROPERTIES INC., BEVERLY HILLS, CA. FILED 2-3-2006.

**ROBERT E. HOWARD**

**STEVE COSTIGAN**

THE MARK CONSISTS OF STANDARD CHARACTERS WITHOUT CLAIM TO ANY PARTICULAR FONT, STYLE, SIZE, OR COLOR.

THE NAME(S), PORTRAIT(S), AND/OR SIGNATURE(S) SHOWN IN THE MARK DOES NOT IDENTIFY A PARTICULAR LIVING INDIVIDUAL.

FOR BOOKS, NAMELY, NOVELS, GRAPHIC NOVELS AND COFFEE TABLE BOOKS RELATING TO COMIC, DRAMATIC, ACTION AND ADVENTURE WORKS; CHILDREN'S BOOKS, NAMELY, COMIC BOOKS, CHILDREN'S BOOKS SOLD AS A UNIT WITH TAPES, CD'S OR DVD'S, PUZZLE BOOKS, CHILDREN'S HOBBY AND PLAY BOOKS, CHILDREN'S COLORING AND ACTIVITY BOOKS, PICTURE BOOKS AND STORYBOOKS; PERIODICALS, NAMELY, MAGAZINES, JOURNALS AND NEWSLETTERS RELATING TO COMIC, DRAMATIC, ACTION AND ADVENTURE WORKS; REFERENCE AND INSTRUCTIONAL BOOKS AND MATERIALS, NAMELY, MANUALS, GAMING HINT BOOKS, STRATEGY GUIDES, HOBBY BOOKS, ROLE PLAYING BOOKS, MUSIC BOOKS, DICTIONARIES, DIRECTORIES, CATALOGUES AND BROCHURES RELATING TO COMIC, DRAMATIC, ACTION, AND ADVENTURE WORKS; DIARIES; NOTEBOOKS; PAPER AND CARDBOARD PADS, NAMELY, WRITING PADS, NOTE PADS, MEMO PADS, DESK PADS AND GAME SCORE PADS; PAPER AND CARDBOARD CARDS, NAMELY, BLANK CARDS, GREETING CARDS, OCCASION CARDS, POST CARDS, HOLIDAY CARDS, TRIVIA CARDS, TRADING CARDS, GAME SCORE CARDS, AND GIFT CARDS NOT MAGNETICALLY ENCODED; PAPER AND CARDBOARD GIFT AND PARTY GOODS, NAMELY, WRAPPING PAPER, BOWS, RIBBONS, COASTERS, HATS, BAGS, FLAGS, BANNERS AND PENNANTS, PAPER DECORATIONS, PAPER ORNAMENTS, FAVORS AND INVITATIONS; PAPER AND CARDBOARD GRAPHIC REPRODUCTIONS, NAMELY, PHOTOGRAPHIC PRINTS, GRAPHIC ART PRINTS, COLLECTABLE STAMPS, STICKERS, DECALS, CALENDARS, POSTERS, MAPS, WALL CHARTS AND DIAGRAMS; WRITING AND READING GOODS ACCESSORIES INCLUDED IN THIS CLASS, NAMELY, BOOKMARKS, PENS, PENCILS, PEN AND PENCIL CASES AND BOXES, DECORATIONS FOR PENCILS, STATIONERY AND PAPER ENVELOPES; ART AND CRAFT GOODS INCLUDED IN THIS CLASS, NAMELY, PAPER PATTERNS FOR COSTUMES, PAINT BRUSHES AND TEMPORARY TATTOOS; CARDBOARD CUT-OUT CHARACTER STANDS FOR DECORATION; COMIC STRIPS AND PRINTS; BANK CHECKS; PAPERWEIGHTS; AND GLOBES (U.S. CLS. 2, 5, 22, 23, 29, 37, 38 AND 50).

KAREN K. BUSH, EXAMINING ATTORNEY

THE MARK CONSISTS OF STANDARD CHARACTERS WITHOUT CLAIM TO ANY PARTICULAR FONT, STYLE, SIZE, OR COLOR.

THE NAME(S), PORTRAIT(S), AND/OR SIGNATURE(S) SHOWN IN THE MARK DOES NOT IDENTIFY A PARTICULAR LIVING INDIVIDUAL.

FOR BOOKS, NAMELY, NOVELS, GRAPHIC NOVELS AND COFFEE TABLE BOOKS RELATING TO COMIC, DRAMATIC, ACTION AND ADVENTURE WORKS; CHILDREN'S BOOKS, NAMELY, COMIC BOOKS, CHILDREN'S BOOKS SOLD AS A UNIT WITH TAPES, CD'S OR DVD'S, PUZZLE BOOKS, CHILDREN'S HOBBY AND PLAY BOOKS, CHILDREN'S COLORING AND ACTIVITY BOOKS, PICTURE BOOKS AND STORYBOOKS; PERIODICALS, NAMELY, MAGAZINES, JOURNALS AND NEWSLETTERS RELATING TO COMIC, DRAMATIC, ACTION AND ADVENTURE WORKS; REFERENCE AND INSTRUCTIONAL BOOKS AND MATERIALS, NAMELY, MANUALS, GAMING HINT BOOKS, STRATEGY GUIDES, HOBBY BOOKS, ROLE PLAYING BOOKS, MUSIC BOOKS, DICTIONARIES, DIRECTORIES, CATALOGUES AND BROCHURES RELATING TO COMIC, DRAMATIC, ACTION, AND ADVENTURE WORKS; DIARIES; NOTEBOOKS; PAPER AND CARDBOARD PADS, NAMELY, WRITING PADS, NOTE PADS, MEMO PADS, DESK PADS AND GAME SCORE PADS; PAPER AND CARDBOARD CARDS, NAMELY, BLANK CARDS, GREETING CARDS, OCCASION CARDS, POST CARDS, HOLIDAY CARDS, TRIVIA CARDS, TRADING CARDS, GAME SCORE CARDS, AND GIFT CARDS NOT MAGNETICALLY ENCODED; PAPER AND CARDBOARD GIFT AND PARTY GOODS, NAMELY, WRAPPING PAPER, BOWS, RIBBONS, COASTERS, HATS, BAGS, FLAGS, BANNERS AND PENNANTS, PAPER DECORATIONS, PAPER ORNAMENTS, FAVORS AND INVITATIONS; PAPER AND CARDBOARD GRAPHIC REPRODUCTIONS, NAMELY, PHOTOGRAPHIC PRINTS, GRAPHIC ART PRINTS, COLLECTABLE STAMPS, STICKERS, DECALS, CALENDARS, POSTERS, MAPS, WALL CHARTS AND DIAGRAMS; WRITING AND READING GOODS ACCESSORIES INCLUDED IN THIS CLASS, NAMELY, BOOKMARKS, PENS, PENCILS, PEN AND PENCIL CASES AND BOXES, DECORATIONS FOR PENCILS, STATIONERY AND PAPER ENVELOPES; ART AND CRAFT GOODS INCLUDED IN THIS CLASS, NAMELY, PAPER PATTERNS FOR COSTUMES, PAINT BRUSHES AND TEMPORARY TATTOOS; CARDBOARD CUT-OUT CHARACTER STANDS FOR DECORATION; COMIC STRIPS AND PRINTS; BANK CHECKS; PAPERWEIGHTS; AND GLOBES (U.S. CLS. 2, 5, 22, 23, 29, 37, 38 AND 50).

KAREN K. BUSH, EXAMINING ATTORNEY

**CLASS 16—(Continued).**

SN 78-807,195. ROBERT E HOWARD PROPERTIES INC., BEVERLY HILLS, CA. FILED 2-3-2006.

**CLASS 16—(Continued).**

SN 78-807,737. DISNEY ENTERPRISES, INC., BURBANK, CA. FILED 2-6-2006.

## BRAN MAK MORN

## MY FRIENDS TIGGER & POOH

THE MARK CONSISTS OF STANDARD CHARACTERS WITHOUT CLAIM TO ANY PARTICULAR FONT, STYLE, SIZE, OR COLOR.

THE NAME(S), PORTRAIT(S), AND/OR SIGNATURE(S) SHOWN IN THE MARK DOES NOT IDENTIFY A PARTICULAR LIVING INDIVIDUAL.

FOR BOOKS, NAMELY, NOVELS, GRAPHIC NOVELS AND COFFEE TABLE BOOKS RELATING TO COMIC, DRAMATIC, ACTION AND ADVENTURE WORKS; CHILDREN'S BOOKS, NAMELY, COMIC BOOKS, CHILDREN'S BOOKS SOLD AS A UNIT WITH TAPES, CD'S OR DVD'S, PUZZLE BOOKS, CHILDREN'S HOBBY AND PLAY BOOKS, CHILDREN'S COLORING AND ACTIVITY BOOKS, PICTURE BOOKS AND STORYBOOKS; PERIODICALS, NAMELY, MAGAZINES, JOURNALS AND NEWSLETTERS RELATING TO COMIC, DRAMATIC, ACTION AND ADVENTURE WORKS; REFERENCE AND INSTRUCTIONAL BOOKS AND MATERIALS, NAMELY, MANUALS, GAMING HINT BOOKS, STRATEGY GUIDES, HOBBY BOOKS, ROLE PLAYING BOOKS, MUSIC BOOKS, DICTIONARIES, DIRECTORIES, CATALOGUES AND BROCHURES RELATING TO COMIC, DRAMATIC, ACTION, AND ADVENTURE WORKS; DIARIES; NOTEBOOKS; PAPER AND CARDBOARD PADS, NAMELY, WRITING PADS, NOTE PADS, MEMO PADS, DESK PADS AND GAME SCORE PADS; PAPER AND CARDBOARD CARDS, NAMELY, BLANK CARDS, GREETING CARDS, OCCASION CARDS, POST CARDS, HOLIDAY CARDS, TRIVIA CARDS, TRADING CARDS, GAME SCORE CARDS, AND GIFT CARDS NOT MAGNETICALLY ENCODED; PAPER AND CARDBOARD GIFT AND PARTY GOODS, NAMELY, WRAPPING PAPER, BOWS, RIBBONS, COASTERS, HATS, BAGS, FLAGS, BANNERS AND PENNANTS, PAPER DECORATIONS, PAPER ORNAMENTS, FAVORS AND INVITATIONS; PAPER AND CARDBOARD GRAPHIC REPRODUCTIONS, NAMELY, PHOTOGRAPHIC PRINTS, GRAPHIC ART PRINTS, COLLECTABLE STAMPS, STICKERS, DECALS, CALENDARS, POSTERS, MAPS, WALL CHARTS AND DIAGRAMS; WRITING AND READING GOODS ACCESSORIES INCLUDED IN THIS CLASS, NAMELY, BOOKMARKS, PENS, PENCILS, PEN AND PENCIL CASES AND BOXES, DECORATIONS FOR PENCILS, STATIONERY AND PAPER ENVELOPES; ART AND CRAFT GOODS INCLUDED IN THIS CLASS, NAMELY, PAPER PATTERNS FOR COSTUMES, PAINT BRUSHES AND TEMPORARY TATTOOS; CARDBOARD CUT-OUT CHARACTER STANDS FOR DECORATION; COMIC STRIPS AND PRINTS; BANK CHECKS; PAPER-WEIGHTS; AND GLOBES (U.S. CLS. 2, 5, 22, 23, 29, 37, 38 AND 50).

KAREN K. BUSH, EXAMINING ATTORNEY

THE MARK CONSISTS OF STANDARD CHARACTERS WITHOUT CLAIM TO ANY PARTICULAR FONT, STYLE, SIZE, OR COLOR.

OWNER OF U.S. REG. NOS. 2,257,705, 3,024,286 AND OTHERS.

FOR ADDRESS BOOKS; ALMANACS; APPLIQUES IN THE FORM OF DECALS; APPOINTMENT BOOKS; ART PRINTS; ARTS AND CRAFT PAINT KITS; AUTOGRAPH BOOKS; BABY BOOKS; BALL POINT PENS; BASEBALL CARDS; BINDERS; BOOKENDS; BOOKMARKS; BOOKS; BUMPER STICKERS; CALENDARS; CARTOON STRIPS; CHRISTMAS CARDS; CHALK; CHILDREN'S ACTIVITY BOOKS; COASTERS MADE OF PAPER; COIN ALBUMS; COLORING BOOKS; COLOR PENCILS; COMIC BOOKS; COMIC STRIPS; COUPON BOOKS; DECALS; DECORATIVE PAPER CENTERPIECES; DIARIES; DISPOSABLE DIAPERS FOR BABIES; DRAWING RULERS; ENVELOPES; ERASERS; FELT PENS; FLASH CARDS; GIFT CARDS; GIFT WRAPPING PAPER; GLOBES; GREETING CARDS; GUEST BOOKS; MAGAZINES; MAPS; MEMO PADS; MODELING CLAY; NEWSLETTERS; NEWSPAPERS; NOTE PAPER; NOTEBOOKS; NOTEBOOK PAPER; PAINTINGS; PAPER FLAGS; PAPER PARTY FAVORS; PAPER PARTY HATS; PAPER CAKE DECORATIONS; PAPER PARTY DECORATIONS; PAPER NAPKINS; PAPER PARTY BAGS; PAPER WEIGHTS; PAPER GIFT WRAP BOWS; PAPER PENNANTS; PAPER PLACE MATS; PAPER TABLE CLOTHS; PEN OR PENCIL HOLDERS; PENCILS; PENCIL SHARPENERS; PEN AND PENCIL CASES AND BOXES; PENS; PERIODICALS; PHOTOGRAPH ALBUMS; PHOTOGRAPHS; PHOTO-ENGRAVINGS; PICTORIAL PRINTS; PICTURE BOOKS; PORTRAITS; POSTCARDS; POSTERS; PRINTED AWARDS; PRINTED CERTIFICATES; PRINTED INVITATIONS; PRINTED MENUS; RECIPE BOOKS; RUBBER STAMPS; SCORE CARDS; STAMP ALBUMS; STATIONERY; STAPLERS; STICKERS; TRADING CARDS; UNGRADUATED RULERS; WRITING PAPER; WRITING IMPLEMENTS (U.S. CLS. 2, 5, 22, 23, 29, 37, 38 AND 50).

REBECCA HAN, EXAMINING ATTORNEY

**CLASS 16—(Continued).**

SN 78-807,762. DISNEY ENTERPRISES, INC., BURBANK, CA. FILED 2-6-2006.

**PHINEAS AND FERB**

THE MARK CONSISTS OF STANDARD CHARACTERS WITHOUT CLAIM TO ANY PARTICULAR FONT, STYLE, SIZE, OR COLOR.

FOR ADDRESS BOOKS; ALMANACS; APPLIQUES IN THE FORM OF DECALS; APPOINTMENT BOOKS; ART PRINTS; ARTS AND CRAFT PAINT KITS; AUTOGRAPH BOOKS; BABY BOOKS; BALL POINT PENS; BASEBALL CARDS; BINDERS; BOOKENDS; BOOKMARKS; BOOKS; BUMPER STICKERS; CALENDARS; CARTOON STRIPS; CHRISTMAS CARDS; CHALK; CHILDREN'S ACTIVITY BOOKS; COASTERS MADE OF PAPER; COIN ALBUMS; COLORING BOOKS; COLOR PENCILS; COMIC BOOKS; COMIC STRIPS; COUPON BOOKS; DECALS; DECORATIVE PAPER CENTERPIECES; DIARIES; DISPOSABLE DIAPERS FOR BABIES; DRAWING RULERS; ENVELOPES; ERASERS; FELT PENS; FLASH CARDS; GIFT CARDS; GIFT WRAPPING PAPER; GLOBES; GREETING CARDS; GUEST BOOKS; MAGAZINES; MAPS; MEMO PADS; MODELING CLAY; NEWSLETTERS; NEWSPAPERS; NOTE PAPER; NOTEBOOKS; NOTEBOOK PAPER; PAINTINGS; PAPER FLAGS; PAPER PARTY FAVORS; PAPER PARTY HATS; PAPER CAKE DECORATIONS; PAPER PARTY DECORATIONS; PAPER NAPKINS; PAPER PARTY BAGS; PAPERWEIGHTS; PAPER GIFT WRAP BOWS; PAPER PENNANTS; PAPER PLACE MATS; PAPER TABLE CLOTHS; PEN OR PENCIL HOLDERS; PENCILS; PENCIL SHARPENERS; PEN AND PENCIL CASES AND BOXES; PENS; PERIODICALS; PHOTOGRAPH ALBUMS; PHOTOGRAPHS; PHOTO-ENGRAVINGS; PICTORIAL PRINTS; PICTURE BOOKS; PORTRAITS; POSTCARDS; POSTERS; PRINTED AWARDS; PRINTED CERTIFICATES; PRINTED INVITATIONS; PRINTED MENUS; RECIPE BOOKS; RUBBER STAMPS; SCORE CARDS; STAMP ALBUMS; STATIONERY; STAPLERS; STICKERS; TRADING CARDS; UNGRADUATED RULERS; WRITING PAPER; WRITING IMPLEMENTS (U.S. CLS. 2, 5, 22, 23, 29, 37, 38 AND 50).  
REBECCA GAN, EXAMINING ATTORNEY

SN 78-809,973. BOEHRINGER INGELHEIM VETMEDICA, INC., ST. JOSEPH, MO. FILED 2-8-2006.

**DEDICATED TO THE EQUINE PRACTITIONER**

THE MARK CONSISTS OF STANDARD CHARACTERS WITHOUT CLAIM TO ANY PARTICULAR FONT, STYLE, SIZE, OR COLOR.

NO CLAIM IS MADE TO THE EXCLUSIVE RIGHT TO USE "THE EQUINE PRACTITIONER", APART FROM THE MARK AS SHOWN.

FOR PRINTED INSTRUCTIONAL, EDUCATIONAL, AND TEACHING MATERIALS FOR VETERINARY PRACTITIONERS REGARDING THE USE OF VACCINES, MEDICAMENTS FOR EQUINE DISEASES, AND PROPHYLACTIC OINTMENTS AND SPRAYS (U.S. CLS. 2, 5, 22, 23, 29, 37, 38 AND 50).  
PETER B. BROMAGHIM, EXAMINING ATTORNEY

**CLASS 16—(Continued).**

SN 78-810,409. MULLENHOUR, ROGER S., GOLETA, CA. AND FULCHER, CAROL, LOS BANOS, CA. FILED 2-8-2006.

**M.T. "PENNY" ROSS**

THE MARK CONSISTS OF STANDARD CHARACTERS WITHOUT CLAIM TO ANY PARTICULAR FONT, STYLE, SIZE, OR COLOR.

THE NAME M.T. "PENNY" ROSS DOES NOT IDENTIFY A LIVING INDIVIDUAL.

FOR FINE ART PRINTS, GREETING CARDS, NOTE CARDS AND BOOKMARKS, MADE OF PAPER (U.S. CLS. 2, 5, 22, 23, 29, 37, 38 AND 50).

FIRST USE 1-30-2006; IN COMMERCE 1-30-2006.  
COLLEEN KEARNEY, EXAMINING ATTORNEY

SN 78-811,491. MCLAUGHLIN, JOANNA KAY, MINOT, ND. FILED 2-9-2006.

**Compleat Mother**

THE MARK CONSISTS OF STANDARD CHARACTERS WITHOUT CLAIM TO ANY PARTICULAR FONT, STYLE, SIZE, OR COLOR.

NO CLAIM IS MADE TO THE EXCLUSIVE RIGHT TO USE MOTHER, APART FROM THE MARK AS SHOWN.

FOR PRINTED MAGAZINES FEATURING TOPICS ABOUT PREGNANCY, BIRTH AND BREAST FEEDING (U.S. CLS. 2, 5, 22, 23, 29, 37, 38 AND 50).

FIRST USE 1-31-1985; IN COMMERCE 1-31-1985.  
G. MAYERSCHOFF, EXAMINING ATTORNEY

**CLASS 16—(Continued).**

SN 78-818,387. SPANGLISH DISEÑO, MILWAUKEE, WI. FILED 2-18-2006.



NO CLAIM IS MADE TO THE EXCLUSIVE RIGHT TO USE "LA REVISTA", APART FROM THE MARK AS SHOWN.

THE COLOR(S) RED, WHITE AND BLACK IS/ARE CLAIMED AS A FEATURE OF THE MARK.

THE MARK CONSISTS OF THE WORD "SPANGLISH" IN BOLD CAPITALIZED RED LETTERS WITH A WHITE OUTLINING AND A BLACK SHADOW. THERE IS A DRAWING ON THE UPPER RIGHT HAND SIDE OF THE WORD SPANGLISH, THIS DRAWING CONSISTS OF A WHITE SMILEY FACE WITH TWO TONGUES AND TWO WINGS WITH FOUR FEATHERS ON EACH SIDE WITH A RED BOX AS A BACKGROUND. THE WORDS "LA REVISTA" APPEAR ON THE BOTTOM RIGHT CORNER IN BLACK.

THE FOREIGN WORDING IN THE MARK TRANSLATES INTO ENGLISH AS SPANGLISH THE MAGAZINE.

FOR GENERAL INTEREST BILINGUAL MAGAZINE TARGETED TO THE HISPANIC MARKET (U.S. CLS. 2, 5, 22, 23, 29, 37, 38 AND 50).

FIRST USE 10-1-2005; IN COMMERCE 2-0-2006.  
THOMAS MANOR, EXAMINING ATTORNEY

---

SN 78-825,971. WHITE, HAROLD W, LITHONIA, GA. FILED 3-1-2006.

Jazèl

THE MARK CONSISTS OF STANDARD CHARACTERS WITHOUT CLAIM TO ANY PARTICULAR FONT, STYLE, SIZE, OR COLOR.

FOR FASHION MAGAZINES (U.S. CLS. 2, 5, 22, 23, 29, 37, 38 AND 50).

LAURA HAMMEL, EXAMINING ATTORNEY

**CLASS 16—(Continued).**

SN 78-829,954. KIMBERLY-CLARK WORLDWIDE, INC., NEENAH, WI. FILED 3-6-2006.

WHAT TO DO WHEN YOU ACHOO

THE MARK CONSISTS OF STANDARD CHARACTERS WITHOUT CLAIM TO ANY PARTICULAR FONT, STYLE, SIZE, OR COLOR.

FOR PRINTED EDUCATIONAL AND INSTRUCTIONAL MATERIALS ON VARIOUS TOPICS FOR CHILDREN, PARENTS AND TEACHERS, NAMELY, COLDS AND FLU; FACIAL TISSUE (U.S. CLS. 2, 5, 22, 23, 29, 37, 38 AND 50).

FIRST USE 2-13-2001; IN COMMERCE 2-13-2001.  
FLORENTINA BLANDU, EXAMINING ATTORNEY

---

SN 78-837,180. HOVDE, BRYN ROBERT, BRADENTON, FL. FILED 3-14-2006.

SELEDOR

FOR BOOKS ABOUT SCIENCE FICTION; GRAPHIC NOVELS; PRINTS; STICKERS (U.S. CLS. 2, 5, 22, 23, 29, 37, 38 AND 50).

FIRST USE 3-15-2006; IN COMMERCE 1-10-2007.  
SUSAN STIGLITZ, EXAMINING ATTORNEY

---

SN 78-838,658. LINECO, INC., HOLYOKE, MA. FILED 3-16-2006.

d:book

THE MARK CONSISTS OF STANDARD CHARACTERS WITHOUT CLAIM TO ANY PARTICULAR FONT, STYLE, SIZE, OR COLOR.

FOR ALBUMS FOR DIGITAL PHOTOS, NAMELY, ALBUMS USING INKJET COATED PAPERS FOR PRINTING DIGITAL IMAGES CREATING ALBUM PAGES; ALBUM FOR DIGITAL PHOTOS KIT COMPRISING PHOTO ALBUMS, PHOTO ALBUM PAGES, AND PHOTO SOFTWARE; PHOTO ALBUMS; PHOTO ALBUM PAGES (U.S. CLS. 2, 5, 22, 23, 29, 37, 38 AND 50).

ALLISON SCHRODY, EXAMINING ATTORNEY



**CLASS 16—(Continued).**

SN 78-846,124. NICKEL PLATE ROAD HISTORICAL & TECHNICAL SOCIETY, INC., NEW HAVEN, IN. FILED 3-25-2006.

**Nickel Plate Road**

THE MARK CONSISTS OF STANDARD CHARACTERS WITHOUT CLAIM TO ANY PARTICULAR FONT, STYLE, SIZE, OR COLOR.

SEC. 2(F).

FOR GENERAL FEATURE MAGAZINES; LETTER-HEAD PAPER; MAGAZINES FEATURING RAILROAD HISTORY; NEWSLETTERS IN THE FIELD OF RAILROAD HISTORY (U.S. CLS. 2, 5, 22, 23, 29, 37, 38 AND 50).

FIRST USE 6-30-1968; IN COMMERCE 6-30-1968.  
DAVID TAYLOR, EXAMINING ATTORNEY

**CLASS 16—(Continued).**

SN 78-869,887. SPICERS PAPER, INC., SANTA FE SPRINGS, CA. FILED 4-26-2006.

**SPICERS**

THE MARK CONSISTS OF STANDARD CHARACTERS WITHOUT CLAIM TO ANY PARTICULAR FONT, STYLE, SIZE, OR COLOR.

OWNER OF U.S. REG. NOS. 1,984,072 AND 1,984,073.

FOR PAPER AND PRINTED MATERIALS, NAMELY, COATED AND UNCOATED COMMERCIAL PRINTING PAPER, FINE PRINTING PAPER, BOND PAPER, PAPERBOARD, WRITING PAPER, BRISTOL BOARD PAPER, VELLUM PAPER, BOOK-COVER PAPER, TEXT PAPER AND ENVELOPES (U.S. CLS. 2, 5, 22, 23, 29, 37, 38 AND 50).

CARYN GLASSER, EXAMINING ATTORNEY

SN 78-852,426. KRAUSE PUBLICATIONS, INC., IOLA, WI. FILED 4-3-2006.

**COTTON & QUAIL ANTIQUE  
GAZETTE**

THE MARK CONSISTS OF STANDARD CHARACTERS WITHOUT CLAIM TO ANY PARTICULAR FONT, STYLE, SIZE, OR COLOR.

OWNER OF U.S. REG. NO. 2,473,017.

NO CLAIM IS MADE TO THE EXCLUSIVE RIGHT TO USE "GAZETTE", APART FROM THE MARK AS SHOWN.

FOR MAGAZINES PUBLISHED PERIODICALLY RELATING TO ALL ASPECTS OF ANTIQUES AND COLLECTIBLES (U.S. CLS. 2, 5, 22, 23, 29, 37, 38 AND 50).

FIRST USE 12-0-2001; IN COMMERCE 12-0-2001.  
INGA ERVIN, EXAMINING ATTORNEY

SN 78-891,732. MAYO FOUNDATION FOR MEDICAL EDUCATION AND RESEARCH, ROCHESTER, MN. FILED 5-24-2006.

**EMBODY HEALTH**

THE MARK CONSISTS OF STANDARD CHARACTERS WITHOUT CLAIM TO ANY PARTICULAR FONT, STYLE, SIZE, OR COLOR.

NO CLAIM IS MADE TO THE EXCLUSIVE RIGHT TO USE "HEALTH", APART FROM THE MARK AS SHOWN.

FOR NEWSLETTERS AND BROCHURES IN THE FIELD OF HEALTH CARE (U.S. CLS. 2, 5, 22, 23, 29, 37, 38 AND 50).

KAREN K. BUSH, EXAMINING ATTORNEY

SN 78-856,291. MEADWESTVACO CORPORATION, STAMFORD, CT. FILED 4-7-2006.

**CENTURIA**

THE MARK CONSISTS OF STANDARD CHARACTERS WITHOUT CLAIM TO ANY PARTICULAR FONT, STYLE, SIZE, OR COLOR.

FOR PAPERBOARD PACKAGING FOR PHARMACEUTICALS AND DRUGS, HEALTHCARE GOODS, MEDIA AND ENTERTAINMENT GOODS, TOBACCO PRODUCTS, COSMETICS, PERFUME AND PERSONAL CARE PRODUCTS (U.S. CLS. 2, 5, 22, 23, 29, 37, 38 AND 50).

SCOTT SISUN, EXAMINING ATTORNEY

SN 78-904,823. SAGE GROUP INTERNATIONAL LLC, SEATTLE, WA. FILED 6-9-2006.

**SPECIALTY TEA IS "HOT"  
REPORT**

THE MARK CONSISTS OF STANDARD CHARACTERS WITHOUT CLAIM TO ANY PARTICULAR FONT, STYLE, SIZE, OR COLOR.

NO CLAIM IS MADE TO THE EXCLUSIVE RIGHT TO USE "SPECIALTY TEA", APART FROM THE MARK AS SHOWN.

FOR REFERENCE BOOKS IN THE FIELD OF BEVERAGES (U.S. CLS. 2, 5, 22, 23, 29, 37, 38 AND 50).

FIRST USE 4-1-2006; IN COMMERCE 4-1-2006.  
SANJEEV VOHRA, EXAMINING ATTORNEY

**CLASS 16—(Continued).**

SN 78-912,895. PACIFIC PAPER PRODUCTS INCORPORATED, TACOMA, WA. FILED 6-21-2006.

**BELFAIR**

THE MARK CONSISTS OF STANDARD CHARACTERS WITHOUT CLAIM TO ANY PARTICULAR FONT, STYLE, SIZE, OR COLOR.

FOR PAPER PRODUCTS, NAMELY, PAPER TOWELS, AND TISSUE PAPER (U.S. CLS. 2, 5, 22, 23, 29, 37, 38 AND 50).

JIM RINGLE, EXAMINING ATTORNEY

SN 78-930,128. GLOBAL TRAINING TECHNOLOGIES, INC., LAS VEGAS, NV. FILED 7-14-2006.

**EVITAL**

THE MARK CONSISTS OF STANDARD CHARACTERS WITHOUT CLAIM TO ANY PARTICULAR FONT, STYLE, SIZE, OR COLOR.

FOR WRITING INSTRUMENTS; BINDERS; BOOK COVERS; BOOKMARKS; BUMPER STICKERS; CALENDARS; CARDS NOT MAGNETICALLY CODED FOR USE IN BUSINESS TRANSACTIONS; CLIP BOARDS; DECALS; DOCUMENT COVERS; DOCUMENT HOLDERS; DOCUMENT PORTFOLIOS; ERASERS; FLASH CARDS; FOLDERS; MARKERS; MANUALS IN THE FIELDS OF BUSINESS, INVESTMENTS, MARKETING, SALES, FINANCE, TECHNOLOGY, BANKING, REAL ESTATE, INSURANCE, LAW, SAFETY, AND HUMAN RESOURCES; NOTE PADS; NOTEBOOKS; PAPER; ENVELOPES; PERIODICALS, MAGAZINES, NEWSLETTERS, BOOKS, CATALOGUES, PAMPHLETS, AND HAND-OUTS IN THE FIELDS OF BUSINESS, INVESTMENTS, MARKETING, SALES, FINANCE, TECHNOLOGY, BANKING, REAL ESTATE, INSURANCE, LAW, SAFETY, AND HUMAN RESOURCES; STATIONERY; PRINTED AWARDS; PRINTED CERTIFICATES; PRINTED CHARTS; PRINTED FORMS; PRINTED LECTURES; PRINTED INFORMATIONAL, EDUCATIONAL, AND TEACHING MATERIALS IN THE FIELDS OF BUSINESS, INVESTMENTS, MARKETING, SALES, FINANCE, TECHNOLOGY, BANKING, REAL ESTATE, INSURANCE, LAW, SAFETY, AND HUMAN RESOURCES; STICKERS; AND STUDY GUIDES (U.S. CLS. 2, 5, 22, 23, 29, 37, 38 AND 50).

HENRY S. ZAK, EXAMINING ATTORNEY

**CLASS 16—(Continued).**

SN 78-933,538. STEVEN J. DYKSTRA, PALMER, MA. FILED 7-20-2006.

**Word Forging**

THE MARK CONSISTS OF STANDARD CHARACTERS WITHOUT CLAIM TO ANY PARTICULAR FONT, STYLE, SIZE, OR COLOR.

FOR PAPER TEACHING MATERIALS IN THE FIELD OF WRITTEN EXPRESSION (U.S. CLS. 2, 5, 22, 23, 29, 37, 38 AND 50).

FIRST USE 6-1-2004; IN COMMERCE 6-1-2006.

KATHLEEN M. VANSTON, EXAMINING ATTORNEY

SN 78-934,805. THE NATIONAL AUTOMOTIVE RADIATOR SERVICE ASSOCIATION, MT. LAUREL, NJ. FILED 7-21-2006.

**THE COOLING JOURNAL**

THE MARK CONSISTS OF STANDARD CHARACTERS WITHOUT CLAIM TO ANY PARTICULAR FONT, STYLE, SIZE, OR COLOR.

NO CLAIM IS MADE TO THE EXCLUSIVE RIGHT TO USE "JOURNAL", APART FROM THE MARK AS SHOWN.

FOR TRADE MAGAZINE IN THE FIELD OF RADIATORS, HEAT TRANSFER AND AIR CONDITIONING (U.S. CLS. 2, 5, 22, 23, 29, 37, 38 AND 50).

KHANH LE, EXAMINING ATTORNEY

SN 78-944,073. RUGGIERI, MARY JO, COLUMBUS, OH. FILED 8-3-2006.

**Energetic Structural  
Integration**

THE MARK CONSISTS OF STANDARD CHARACTERS WITHOUT CLAIM TO ANY PARTICULAR FONT, STYLE, SIZE, OR COLOR.

NO CLAIM IS MADE TO THE EXCLUSIVE RIGHT TO USE "ENERGETIC", APART FROM THE MARK AS SHOWN.

FOR PRINTED INSTRUCTIONAL, EDUCATIONAL, AND TEACHING MATERIALS IN THE FIELD OF ENERGETIC BODYWORK THAT ALLOWS FOR POLARITY THERAPY TRAINING IN ORDER TO BRING SYMMETRY BALANCE TO THE BODY THROUGH A SYSTEM OF SPECIFIC ACUPRESSURE POINTS WITH EDUCATIONAL CDS IN CONNECTION THEREWITH (U.S. CLS. 2, 5, 22, 23, 29, 37, 38 AND 50).

FIRST USE 6-15-2006; IN COMMERCE 6-15-2006.

TAMARA FRAZIER, EXAMINING ATTORNEY

**CLASS 16—(Continued).**

SN 78-944,823. MILWAUKEE BREWERS BASEBALL CLUB, MILWAUKEE, WI. FILED 8-4-2006.



OWNER OF U.S. REG. NOS. 2,542,640, 2,623,286 AND OTHERS.

NO CLAIM IS MADE TO THE EXCLUSIVE RIGHT TO USE "MILWAUKEE", APART FROM THE MARK AS SHOWN.

THE FOREIGN WORDING IN THE MARK TRANSLATES INTO ENGLISH AS BREWERS.

FOR PAPER GOODS AND PRINTED MATTER, NAMELY, TRADING CARDS, POSTERS, STICKERS, DECALS, TEMPORARY TATTOOS, BUMPER STICKERS, SCORE BOOKS, SCORECARDS, PRINTED BASEBALL GAME PROGRAMS, MAGAZINES AND BOOKS FEATURING BASEBALL, NEWSLETTERS, BROCHURES AND PAMPHLETS FEATURING BASEBALL, WRITING PADS, NOTE PAPER, NOTEBOOKS, BINDERS, STATIONERY-TYPE PORTFOLIOS, STATIONERY FOLDERS, STATIONERY SETS, NAMELY, WRITING PAPER, CARDS, AND ENVELOPES, COMMEMORATIVE ENVELOPES, FLIP BOOKS, PREPRINTED AGENDA ORGANIZERS, MEMO BOARDS, SCRAPBOOKS, AUTOGRAPH BOOKS, BASEBALL CARD ALBUMS, BOOK COVERS, BOOKMARKS, BOOKENDS, CALENDARS, GREETING CARDS, POSTCARDS, PRINTED BANK CHECKBOOKS, CHECKBOOK COVERS, COLLECTIBLE STAMPS, RUBBER STAMPS, INK STAMPS, COMMEMORATIVE STAMPS, PAPER PENNANTS, GIFT WRAPPING PAPER, PAPER GIFT AND PARTY BAGS, PAPER PARTY GOODS IN THE NATURE OF PAPER PARTY DECORATIONS; PAPER COASTERS, PAPER NAPKINS, FACIAL TISSUE, PAPER TABLECLOTHS, MOUNTED AND UN-MOUNTED PHOTOGRAPHS, PHOTOGRAPH ALBUMS, LITHOGRAPHS, PLASTIC BASEBALL CARD HOLDERS AND COLLECTORS CASES, PAPERWEIGHTS, LETTER OPENERS, PENS, PENCILS, PENCIL TOP ORNAMENTS, CRAYONS, MARKERS, NON-ELECTRIC ERASERS, PENCIL SHARPENERS, PENCIL CASES, UN-GRADUATED RULERS, PAPER TICKET HOLDERS AND NON-METAL LANYARDS FOR PAPER TICKET HOLDERS SOLD AS A UNIT, ART PICTURES, ART PRINTS (U.S. CLS. 2, 5, 22, 23, 29, 37, 38 AND 50).

C. DIONNE CLYBURN, EXAMINING ATTORNEY

SN 78-946,539. HANLEY-WOOD, LLC, WASHINGTON, DC. FILED 8-7-2006.

**DREAM FACILITIES**

THE MARK CONSISTS OF STANDARD CHARACTERS WITHOUT CLAIM TO ANY PARTICULAR FONT, STYLE, SIZE, OR COLOR.

NO CLAIM IS MADE TO THE EXCLUSIVE RIGHT TO USE FACILITIES, APART FROM THE MARK AS SHOWN.

FOR MAGAZINE SUPPLEMENT PERTAINING TO OWNERS AND ADMINISTRATORS OF WATER-RELATED FACILITIES (U.S. CLS. 2, 5, 22, 23, 29, 37, 38 AND 50).

FIRST USE 7-0-2004; IN COMMERCE 7-0-2004.  
PAULA MAHONEY, EXAMINING ATTORNEY

**CLASS 16—(Continued).**

SN 78-947,520. 24 HOUR FITNESS USA, INC., SAN RAMON, CA. FILED 8-8-2006.

**you<sup>24</sup>**

OWNER OF U.S. REG. NOS. 2,525,659 AND 2,997,726.  
FOR PRINTED MATERIALS, NAMELY, MAGAZINES IN THE FIELD OF HEALTH, FITNESS, AND EXERCISE INSTRUCTION (U.S. CLS. 2, 5, 22, 23, 29, 37, 38 AND 50).  
DAWN HAN, EXAMINING ATTORNEY

SN 78-947,698. DIXON, PHYLLIS S, STEVENSVILLE, MD. FILED 8-8-2006.

**ZILLBEAR**

THE MARK CONSISTS OF STANDARD CHARACTERS WITHOUT CLAIM TO ANY PARTICULAR FONT, STYLE, SIZE, OR COLOR.

FOR ART PICTURES (U.S. CLS. 2, 5, 22, 23, 29, 37, 38 AND 50).

CHRISTOPHER BUONGIORNO, EXAMINING ATTORNEY

SN 78-949,604. HEALTHCARE SERVICES BY A.C.T.N.T., LLC, MINERAL WELLS, TX. FILED 8-10-2006.

**PEDI SLIDE CHART**

THE MARK CONSISTS OF STANDARD CHARACTERS WITHOUT CLAIM TO ANY PARTICULAR FONT, STYLE, SIZE, OR COLOR.

NO CLAIM IS MADE TO THE EXCLUSIVE RIGHT TO USE "PEDI" AND "CHART", APART FROM THE MARK AS SHOWN.

FOR PEDIATRIC MEASURING AND MEDICATION DOSAGE INFORMATION CHARTS (U.S. CLS. 2, 5, 22, 23, 29, 37, 38 AND 50).

INGA ERVIN, EXAMINING ATTORNEY

**CLASS 16—(Continued).**

SN 78-950,416. THE DEVEREUX FOUNDATION, VILLANOVA, PA. FILED 8-11-2006.

**DBRS**

THE MARK CONSISTS OF STANDARD CHARACTERS WITHOUT CLAIM TO ANY PARTICULAR FONT, STYLE, SIZE, OR COLOR.

FOR PRINTED MANUALS AND FORMS FEATURING A RATING SCALE FOR RATINGS IN THE FIELD OF BEHAVIORAL HEALTH (U.S. CLS. 2, 5, 22, 23, 29, 37, 38 AND 50).

LORETTA C. BECK, EXAMINING ATTORNEY

**CLASS 16—(Continued).**

SN 78-953,237. PERMACHARGE CORPORATION, RIO RANCHO, NM. FILED 8-16-2006.

**VERSALINER**

THE MARK CONSISTS OF STANDARD CHARACTERS WITHOUT CLAIM TO ANY PARTICULAR FONT, STYLE, SIZE, OR COLOR.

FOR COATED PAPER RELEASE LINER FOR USE WITH ELECTROSTATICALLY CHARGED FILM (U.S. CLS. 2, 5, 22, 23, 29, 37, 38 AND 50).

JOHN WILKE, EXAMINING ATTORNEY

SN 78-951,714. FOX RIVER PAPER COMPANY LLC, APPLETON, WI. FILED 8-14-2006.

**ESTATE LABEL**

THE MARK CONSISTS OF STANDARD CHARACTERS WITHOUT CLAIM TO ANY PARTICULAR FONT, STYLE, SIZE, OR COLOR.

OWNER OF U.S. REG. NO. 992,007.

NO CLAIM IS MADE TO THE EXCLUSIVE RIGHT TO USE "LABEL", APART FROM THE MARK AS SHOWN.

FOR PAPER FOR WINE, BEVERAGE, AND FOOD LABELS (U.S. CLS. 2, 5, 22, 23, 29, 37, 38 AND 50).

FIRST USE 6-12-1973; IN COMMERCE 6-12-1973.

PAUL CROWLEY, EXAMINING ATTORNEY

SN 78-954,338. MELITTA HAUSHALTSPRODUKTE GMBH & CO. KG, MINDEN, FED REP GERMANY, FILED 8-17-2006.

**FLAVOR ENHANCERS**

THE MARK CONSISTS OF STANDARD CHARACTERS WITHOUT CLAIM TO ANY PARTICULAR FONT, STYLE, SIZE, OR COLOR.

OWNER OF U.S. REG. NO. 2,349,107.

FOR COFFEE FILTER PAPER; PAPER FILTERS FOR COFFEE MAKERS (U.S. CLS. 2, 5, 22, 23, 29, 37, 38 AND 50).

JAMES MACFARLANE, EXAMINING ATTORNEY

SN 78-953,034. BAPTIST HEALTHCARE SYSTEM, INC., LOUISVILLE, KY. FILED 8-16-2006.

**TRADITIONS & VISIONS IN HEALTH**

THE MARK CONSISTS OF STANDARD CHARACTERS WITHOUT CLAIM TO ANY PARTICULAR FONT, STYLE, SIZE, OR COLOR.

NO CLAIM IS MADE TO THE EXCLUSIVE RIGHT TO USE "HEALTH", APART FROM THE MARK AS SHOWN.

FOR MAGAZINES FEATURING HEALTH CARE INFORMATION AND NEWS ITEMS ABOUT HOSPITAL AND ITS SURROUNDING COMMUNITY (U.S. CLS. 2, 5, 22, 23, 29, 37, 38 AND 50).

FIRST USE 0-0-1997; IN COMMERCE 0-0-1997.

TIMOTHY FINNEGAN, EXAMINING ATTORNEY

SN 78-954,344. GREENBERG, KENNETH R., SILVER SPRING, MD. FILED 8-17-2006.

**TUSKY**

THE MARK CONSISTS OF STANDARD CHARACTERS WITHOUT CLAIM TO ANY PARTICULAR FONT, STYLE, SIZE, OR COLOR.

FOR SERIES OF FICTION BOOKS (U.S. CLS. 2, 5, 22, 23, 29, 37, 38 AND 50).

MICHELE SWAIN, EXAMINING ATTORNEY

**CLASS 16—(Continued).**

SN 78-955,460. DARDEN CONCEPTS, INC., ORLANDO, FL.  
FILED 8-18-2006.

**CLASS 16—(Continued).**

SN 78-956,339. FRAME SPECIALTIES, INC., ELKHART, IN.  
FILED 8-21-2006.

# Ollie & Friends

THE MARK CONSISTS OF STANDARD CHARACTERS WITHOUT CLAIM TO ANY PARTICULAR FONT, STYLE, SIZE, OR COLOR.

FOR CHILDREN'S ACTIVITY AND/OR COLORING BOOKS AND PAGES (U.S. CLS. 2, 5, 22, 23, 29, 37, 38 AND 50).

FIRST USE 6-0-2003; IN COMMERCE 6-0-2003.  
RONALD MCMORROW, EXAMINING ATTORNEY

# Perfect Care

THE MARK CONSISTS OF STANDARD CHARACTERS WITHOUT CLAIM TO ANY PARTICULAR FONT, STYLE, SIZE, OR COLOR.

FOR PICTURE FRAMING MAT BOARDS AND FOAM CENTER BOARDS (U.S. CLS. 2, 5, 22, 23, 29, 37, 38 AND 50).

DORITT L. CARROLL, EXAMINING ATTORNEY

SN 78-955,538. ODS-PETRODATA, INC., HOUSTON, TX.  
FILED 8-18-2006.

## THE OFFSHORE INTERNATIONAL NEWSLETTER

THE MARK CONSISTS OF STANDARD CHARACTERS WITHOUT CLAIM TO ANY PARTICULAR FONT, STYLE, SIZE, OR COLOR.

OWNER OF U.S. REG. NO. 2,454,291.

NO CLAIM IS MADE TO THE EXCLUSIVE RIGHT TO USE "NEWSLETTER", APART FROM THE MARK AS SHOWN.

SEC. 2(F).

FOR PRINTED MATTER, NAMELY, NEWSLETTERS PUBLISHED WEEKLY FOR THE OIL, GAS AND PETROL INDUSTRY (U.S. CLS. 2, 5, 22, 23, 29, 37, 38 AND 50).

FIRST USE 7-1-1991; IN COMMERCE 7-1-1991.  
LAURIE KAUFMAN, EXAMINING ATTORNEY

SN 78-956,427. BUTTERS, MARYJANE, MOSCOW, ID.  
FILED 8-21-2006.

## MARYJANE'S AMEN DIET

SN 78-956,187. GOLDEN GATE ANCILLARY LLC, FORT SMITH, AR. FILED 8-21-2006.

# CERELEAN

THE MARK CONSISTS OF STANDARD CHARACTERS WITHOUT CLAIM TO ANY PARTICULAR FONT, STYLE, SIZE, OR COLOR.

FOR PERIODICALS REGARDING PURCHASING FOOD AND CATERING SERVICES FOR HEALTHCARE FACILITIES (U.S. CLS. 2, 5, 22, 23, 29, 37, 38 AND 50).

CHRIS WELLS, EXAMINING ATTORNEY

THE MARK CONSISTS OF STANDARD CHARACTERS WITHOUT CLAIM TO ANY PARTICULAR FONT, STYLE, SIZE, OR COLOR.

NO CLAIM IS MADE TO THE EXCLUSIVE RIGHT TO USE "DIET", APART FROM THE MARK AS SHOWN.

FOR COOKBOOKS; BOOKS, PRINTED GUIDES AND BROCHURES FEATURING TOPICS RELATING TO WEIGHT LOSS, WEIGHT CONTROL, WEIGHT MAINTENANCE, NUTRITION, NUTRITIONAL CONTENT OF FOODS AND BEVERAGES, MENU PLANNING, RECIPES, FITNESS, HEALTH, LIFESTYLE AND EMOTIONAL WELL-BEING, AND DIET AND NUTRITION INFORMATION (U.S. CLS. 2, 5, 22, 23, 29, 37, 38 AND 50).

REBECCA EISINGER, EXAMINING ATTORNEY

**CLASS 16—(Continued).**

SN 78-956,852. WASHINGTON MUTUAL, INC., SEATTLE, WA. FILED 8-21-2006.

# WAMU

THE MARK CONSISTS OF STANDARD CHARACTERS WITHOUT CLAIM TO ANY PARTICULAR FONT, STYLE, SIZE, OR COLOR.

OWNER OF U.S. REG. NOS. 2,315,782, 2,498,860 AND OTHERS.

FOR PRINTED MATERIALS, NAMELY, MAGAZINES, TRADE JOURNALS, BROCHURES, FLYERS, PAMPHLETS, PROGRAM GUIDES, ARTICLES AND REPORTS PROVIDED TO BANK CUSTOMERS CONTAINING INFORMATION ON TOPICS OF GENERAL INTEREST; PRINTED MATTER, NAMELY, BOOKS, NEWSLETTERS, FLYERS, BROCHURES, PAPER BANNERS AND PROGRAM GUIDES ABOUT FINANCIAL, LENDING AND BANKING INFORMATION AND SAVINGS AND INVESTMENT ACCOUNTS; NEWSLETTERS IN THE FIELD OF MUTUAL FUNDS, ANNUITIES, INVESTMENT SECURITIES, INVESTMENT ADVICE, FINANCIAL PLANNING, FINANCIAL PORTFOLIO MANAGEMENT AND RELATED NEWS; NEWSLETTERS PROVIDED TO FINANCIAL ADVISORS CONTAINING INFORMATION RELATING TO MUTUAL FUNDS, ANNUITIES AND RELATED NEWS; NON-MAGNETICALLY ENCODED CREDIT CARDS, CASH CARDS, CHECK CARDS, ATM CARDS, DEBIT CARDS AND STORED VALUE CARDS (U.S. CLS. 2, 5, 22, 23, 29, 37, 38 AND 50).

GEORGIA CARTY, EXAMINING ATTORNEY

---

SN 78-957,249. THE LAUREL OF ASHEVILLE, LLC, ASHEVILLE, NC. FILED 8-22-2006.

# THE LAUREL OF ASHEVILLE

THE MARK CONSISTS OF STANDARD CHARACTERS WITHOUT CLAIM TO ANY PARTICULAR FONT, STYLE, SIZE, OR COLOR.

NO CLAIM IS MADE TO THE EXCLUSIVE RIGHT TO USE "ASHEVILLE", APART FROM THE MARK AS SHOWN.

FOR MAGAZINES FEATURING ARTS, CULTURE, EVENTS, ACTIVITIES, ACCOMMODATIONS AND RESTAURANTS IN AND AROUND ASHEVILLE, NORTH CAROLINA AND INFORMATION CONCERNING THE ASHEVILLE, NORTH CAROLINA AREA (U.S. CLS. 2, 5, 22, 23, 29, 37, 38 AND 50).

FIRST USE 10-0-2004; IN COMMERCE 10-0-2004.  
PAUL CROWLEY, EXAMINING ATTORNEY

**CLASS 16—(Continued).**

SN 78-957,613. HARCOURT, INC., ORLANDO, FL. FILED 8-22-2006.

# CIVICS IN PRACTICE

THE MARK CONSISTS OF STANDARD CHARACTERS WITHOUT CLAIM TO ANY PARTICULAR FONT, STYLE, SIZE, OR COLOR.

NO CLAIM IS MADE TO THE EXCLUSIVE RIGHT TO USE "CIVICS", APART FROM THE MARK AS SHOWN.

FOR PRINTED ASSESSMENT EDUCATIONAL, INSTRUCTIONAL AND ASSESSMENT MATERIALS IN THE SUBJECT AREA OF GOVERNMENT AND CITIZENSHIP (U.S. CLS. 2, 5, 22, 23, 29, 37, 38 AND 50).

FIRST USE 3-30-2006; IN COMMERCE 3-30-2006.  
JULIE WATSON, EXAMINING ATTORNEY

---

SN 78-958,423. DIXON TICONDEROGA COMPANY, HEATHROW, FL. FILED 8-23-2006.

# VIS-AID

THE MARK CONSISTS OF STANDARD CHARACTERS WITHOUT CLAIM TO ANY PARTICULAR FONT, STYLE, SIZE, OR COLOR.

FOR OVERHEAD PROJECTION MARKERS (U.S. CLS. 2, 5, 22, 23, 29, 37, 38 AND 50).

FIRST USE 8-5-1968; IN COMMERCE 11-11-1969.  
MARILYN IZZI, EXAMINING ATTORNEY

---

SN 78-959,501. BATH & BODY WORKS BRAND MANAGEMENT, INC., REYNOLDSBURG, OH. FILED 8-24-2006.

# LOVE POTIONS

THE MARK CONSISTS OF STANDARD CHARACTERS WITHOUT CLAIM TO ANY PARTICULAR FONT, STYLE, SIZE, OR COLOR.

FOR PAPER AND FABRIC GIFT BAGS SOLD EMPTY (U.S. CLS. 2, 5, 22, 23, 29, 37, 38 AND 50).

WILLIAM ROSSMAN, EXAMINING ATTORNEY

**CLASS 16—(Continued).**

SN 78-960,621. TRIVETTE, PAMELA, ROCKLEDGE, FL.  
FILED 8-25-2006.

**FIREBALL ROBERTS**

THE MARK CONSISTS OF STANDARD CHARACTERS WITHOUT CLAIM TO ANY PARTICULAR FONT, STYLE, SIZE, OR COLOR.

THE NAME, PORTRAIT, AND/OR SIGNATURE SHOWN IN THE MARK DOES NOT IDENTIFY A PARTICULAR LIVING INDIVIDUAL.

FOR PAPER GOODS, NAMELY, CALENDARS, TRADING CARDS, STICKERS AND POSTERS (U.S. CLS. 2, 5, 22, 23, 29, 37, 38 AND 50).

FIRST USE 1-8-2006; IN COMMERCE 1-8-2006.  
KATHY DE JONGE, EXAMINING ATTORNEY

SN 78-960,805. FLANIGAN, JENNIFER K., BOZEMAN, MT.  
FILED 8-25-2006.

**Boz Angeles, Montucky**

THE MARK CONSISTS OF STANDARD CHARACTERS WITHOUT CLAIM TO ANY PARTICULAR FONT, STYLE, SIZE, OR COLOR.

FOR BUMPER STICKERS; POSTCARDS (U.S. CLS. 2, 5, 22, 23, 29, 37, 38 AND 50).

ELLEN PERKINS, EXAMINING ATTORNEY

SN 78-960,831. UNBORN MEDIA, INC., BOSTON, MA. FILED  
8-25-2006.

**VIRB**

THE MARK CONSISTS OF STANDARD CHARACTERS WITHOUT CLAIM TO ANY PARTICULAR FONT, STYLE, SIZE, OR COLOR.

FOR BUMPER STICKERS; EVENT PROGRAMS; PENS; POSTCARDS; POSTERS; STICKERS (U.S. CLS. 2, 5, 22, 23, 29, 37, 38 AND 50).

TIMOTHY FINNEGAN, EXAMINING ATTORNEY

**CLASS 16—(Continued).**

SN 78-961,465. J. WILLIAMS DESIGN LLC, GRAND RAPIDS, MI. FILED 8-28-2006.

**FL!P !T**

THE MARK CONSISTS OF STANDARD CHARACTERS WITHOUT CLAIM TO ANY PARTICULAR FONT, STYLE, SIZE, OR COLOR.

FOR GREETING CARDS (U.S. CLS. 2, 5, 22, 23, 29, 37, 38 AND 50).

ELIZABETH PIGNATELLO, EXAMINING ATTORNEY

SN 78-961,550. PEARSON EDUCATION, INC., UPPER SADDLE RIVER, NJ. FILED 8-28-2006.

**WORDS THEIR WAY**

THE MARK CONSISTS OF STANDARD CHARACTERS WITHOUT CLAIM TO ANY PARTICULAR FONT, STYLE, SIZE, OR COLOR.

FOR PRINTED MATERIALS, NAMELY, TEXTBOOKS, ACTIVITY BOOKS, ACTIVITY GUIDES, TEACHER'S GUIDES, AND WORKBOOKS IN THE FIELD OF PHONICS, VOCABULARY, AND SPELLING (U.S. CLS. 2, 5, 22, 23, 29, 37, 38 AND 50).

FIRST USE 1-1-1991; IN COMMERCE 1-1-1991.

TINA KUAN, EXAMINING ATTORNEY

SN 78-961,818. LIFE MOXIE, INC., SAN FRANCISCO, CA.  
FILED 8-28-2006.

**MOXIE MOMENT**

THE MARK CONSISTS OF STANDARD CHARACTERS WITHOUT CLAIM TO ANY PARTICULAR FONT, STYLE, SIZE, OR COLOR.

OWNER OF U.S. REG. NO. 2,880,258.

FOR BLANK JOURNAL BOOKS; BLANK NOTE CARDS; DATE BOOKS; NON-FICTION BOOKS ON A VARIETY OF TOPICS; NOTE CARDS; SOCIAL NOTE CARDS (U.S. CLS. 2, 5, 22, 23, 29, 37, 38 AND 50).

MATTHEW PAPPAS, EXAMINING ATTORNEY

**CLASS 16—(Continued).**

SN 78-961,911. PACEWALKERS OF AMERICA, INC., DBA THOMAS JEFFERSON PRESS, SETAUKET, NY. FILED 8-28-2006.

**ORDINARY MORTALS**

THE MARK CONSISTS OF STANDARD CHARACTERS WITHOUT CLAIM TO ANY PARTICULAR FONT, STYLE, SIZE, OR COLOR.

FOR PRINTED MATTER, NAMELY, BOOKS, PERIODICALS, MAGAZINES, NEWSLETTERS, PAMPHLETS AND SYNDICATED COLUMNS ON THE SUBJECT OF HEALTH, WELLNESS, FITNESS, NUTRITION, STRESS MANAGEMENT, SCIENCE AND LIFESTYLES (U.S. CLS. 2, 5, 22, 23, 29, 37, 38 AND 50).

MARILYN IZZI, EXAMINING ATTORNEY

---

SN 78-962,216. WAVE SOUTH FLORIDA LLC, MIAMI, FL. FILED 8-28-2006.

**ON, IN, AROUND THE WATER**

THE MARK CONSISTS OF STANDARD CHARACTERS WITHOUT CLAIM TO ANY PARTICULAR FONT, STYLE, SIZE, OR COLOR.

FOR MAGAZINES FEATURING LIFE AROUND WATER ACTIVITIES, NAMELY BOATING, FISHING, DIVING, WATERFRONT LIVING, AND WATER SPORTS (U.S. CLS. 2, 5, 22, 23, 29, 37, 38 AND 50).

FIRST USE 12-31-2003; IN COMMERCE 12-31-2003.  
ELIZABETH J. WINTER, EXAMINING ATTORNEY

---

SN 78-962,219. WAVE SOUTH FLORIDA LLC, MIAMI, FL. FILED 8-28-2006.



THE MARK CONSISTS, IN PART, OF A STYLIZED REPRESENTATION OF A WATER WAVE.

FOR MAGAZINES FEATURING LIFE AROUND WATER ACTIVITIES, NAMELY, RECREATIONAL BOATING, FISHING, DIVING, WATERFRONT LIVING, AND WATER SPORTS (U.S. CLS. 2, 5, 22, 23, 29, 37, 38 AND 50).

FIRST USE 12-31-2003; IN COMMERCE 12-31-2003.  
ELIZABETH J. WINTER, EXAMINING ATTORNEY

**CLASS 16—(Continued).**

SN 78-962,590. WALK THRU THE BIBLE MINISTRIES, INC., ATLANTA, GA. FILED 8-29-2006.

**GROW IN A GROUP**

THE MARK CONSISTS OF STANDARD CHARACTERS WITHOUT CLAIM TO ANY PARTICULAR FONT, STYLE, SIZE, OR COLOR.

FOR PAPER GOODS AND PRINTED MATTER, NAMELY, SEMINAR WORKBOOKS, BOOKS, BOOKLETS, PAMPHLETS, AND PERIODICAL PUBLICATIONS, NAMELY, MAGAZINES, ALL FEATURING SPIRITUAL OR INSPIRATIONAL CONTENT (U.S. CLS. 2, 5, 22, 23, 29, 37, 38 AND 50).

ROBIN CHOSID, EXAMINING ATTORNEY

---

SN 78-962,744. O'ROURKE, IAN, SAN RAFAEL, CA. FILED 8-29-2006.

**TAKERITE**

THE MARK CONSISTS OF STANDARD CHARACTERS WITHOUT CLAIM TO ANY PARTICULAR FONT, STYLE, SIZE, OR COLOR.

FOR STICKERS USED FOR LABELING MEDICATION CONTAINERS (U.S. CLS. 2, 5, 22, 23, 29, 37, 38 AND 50).

PAUL CROWLEY, EXAMINING ATTORNEY

---

SN 78-962,783. WALK THRU THE BIBLE MINISTRIES, INC., ATLANTA, GA. FILED 8-29-2006.

**GROW**

THE MARK CONSISTS OF STANDARD CHARACTERS WITHOUT CLAIM TO ANY PARTICULAR FONT, STYLE, SIZE, OR COLOR.

FOR PERIODICAL PUBLICATIONS, NAMELY MAGAZINES WITH SPIRITUAL OR INSPIRATIONAL CONTENT (U.S. CLS. 2, 5, 22, 23, 29, 37, 38 AND 50).

ROBIN CHOSID, EXAMINING ATTORNEY



**CLASS 16—(Continued).**

SN 78-963,078. ZLOMEK, THOMAS PETER, NEW HARTFORD, NY. FILED 8-29-2006.

**GGPLS (God Guides People Like Sheep)**

THE MARK CONSISTS OF STANDARD CHARACTERS WITHOUT CLAIM TO ANY PARTICULAR FONT, STYLE, SIZE, OR COLOR.  
FOR CALENDARS, CARTOON STRIPS, CARTOON PRINTS, BOOKS IN THE FIELD OF RELIGIOUS CARTOONS AND BOOKS IN THE FIELD OF RELIGION (U.S. CLS. 2, 5, 22, 23, 29, 37, 38 AND 50).  
FRED CARL, EXAMINING ATTORNEY

SN 78-963,406. ANDRADE, DIANE L., TAMPA, FL. FILED 8-29-2006.

**Hankies from Heaven**

THE MARK CONSISTS OF STANDARD CHARACTERS WITHOUT CLAIM TO ANY PARTICULAR FONT, STYLE, SIZE, OR COLOR.  
FOR SERIES OF NON-FICTION BOOKS IN THE FIELD OF INSPIRATION (U.S. CLS. 2, 5, 22, 23, 29, 37, 38 AND 50).  
SHARON MEIER, EXAMINING ATTORNEY

SN 78-963,418. SOMMER, DIANE M, OCEANSIDE, CA. FILED 8-30-2006.

**A Cheer for Charlie**

THE MARK CONSISTS OF STANDARD CHARACTERS WITHOUT CLAIM TO ANY PARTICULAR FONT, STYLE, SIZE, OR COLOR.  
FOR CHILDREN'S BOOK (U.S. CLS. 2, 5, 22, 23, 29, 37, 38 AND 50).  
CAROLINE WOOD, EXAMINING ATTORNEY

**CLASS 16—(Continued).**

SN 78-963,547. KIDSBOKS LLC, NEWBURYPORT, MA. FILED 8-30-2006.

**SEARCH & STICK**

THE MARK CONSISTS OF STANDARD CHARACTERS WITHOUT CLAIM TO ANY PARTICULAR FONT, STYLE, SIZE, OR COLOR.  
OWNER OF U.S. REG. NOS. 3,079,766 AND 3,079,768.  
FOR CHILDREN'S BOOKS (U.S. CLS. 2, 5, 22, 23, 29, 37, 38 AND 50).  
JOHN E. MICHOS, EXAMINING ATTORNEY

SN 78-964,352. CIAMPA DANIEL, DIX HILLS, NY. FILED 8-30-2006.



THE COLOR(S) BLUE, GREEN, AND PURPLE IS/ARE CLAIMED AS A FEATURE OF THE MARK.  
THE TOP HALF OF THE WORDING ORACLE ODYSSEY IS GREEN, THE BOTTOM HALF OF THE WORDING IS BLUE, AND THE MARK IS OUTLINED IN PURPLE.  
FOR CHILDREN'S STORYBOOKS; GRAPHIC ART REPRODUCTIONS; STORIES IN ILLUSTRATED FORM (U.S. CLS. 2, 5, 22, 23, 29, 37, 38 AND 50).  
AMY BROZENIC, EXAMINING ATTORNEY

SN 78-964,554. BITTONE, ODELIA, WOODLAND HILLS, CA. FILED 8-30-2006.

**Sex and the City of Angels**

THE MARK CONSISTS OF STANDARD CHARACTERS WITHOUT CLAIM TO ANY PARTICULAR FONT, STYLE, SIZE, OR COLOR.  
FOR PRINTED PUBLICATIONS, NAMELY COLUMNS, MAGAZINE ARTICLES, AND BOOKS IN THE FIELD OF RELATIONSHIPS, LOVE, SEX, AND LIVING IN LOS ANGELES, CA (U.S. CLS. 2, 5, 22, 23, 29, 37, 38 AND 50).  
ALAIN LAPTER, EXAMINING ATTORNEY

**CLASS 16—(Continued).**

SN 78-964,654. SMITH-GETMAN, JAYE J., AUSTIN, TX. FILED 8-31-2006.

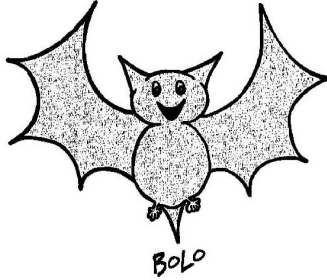

THE STIPPLING IS FOR SHADING PURPOSES ONLY. FOR BOOKS, NAMELY, CHILDREN'S ACTIVITY BOOKS, CHILDREN'S COLORING BOOKS, CHILDREN'S STORYBOOKS, COMIC BOOKS AND STORY BOOKS; STICKERS (U.S. CLS. 2, 5, 22, 23, 29, 37, 38 AND 50).

DAVID YONTEF, EXAMINING ATTORNEY

**CLASS 16—(Continued).**

SN 78-965,207. MEDIA THAT DEELIVERS, INC., SCOTTSDALE, AZ. FILED 8-31-2006.

**LUXURY COLLECTION**

THE MARK CONSISTS OF STANDARD CHARACTERS WITHOUT CLAIM TO ANY PARTICULAR FONT, STYLE, SIZE, OR COLOR.

FOR LIFESTYLE MAGAZINE FEATURING ARTICLES ON TRAVEL DESTINATIONS, RESTAURANTS, STATE EVENTS, INDIVIDUALS, TRAVELING TIPS ON VACATIONS, LOCAL AND NATIONAL STORIES AND EVENTS, HOME INTERIORS, ARCHITECTURE, LOCAL BUSINESSES, CHEFS, WINES AND SPIRITS AND RECREATIONAL ACTIVITIES (U.S. CLS. 2, 5, 22, 23, 29, 37, 38 AND 50).

LEIGH LOWRY, EXAMINING ATTORNEY

SN 78-964,924. MCLEAN, RITA C, GARLAND, TX. FILED 8-31-2006.



THE MARK CONSISTS OF AN OVAL SHAPE LYING HORIZONTALLY. A FEMALE SILHOUETTE IS ON THE TOP CENTER OF THE OVAL IN A SITTING POSITION WITH BOTH KNEES RAISED, ARMS ARE EXTENDED AND THE HANDS ARE RESTING ON THE KNEES. THE FEMALE'S HAIR IS PULLED BACK INTO A PONYTAIL. ONLY A SIDE VIEW OF THE FEMALE SILHOUETTE IS VISIBLE. INSIDE THE OVAL ARE THE WORDS PRIVATE DAYS IN A STYLIZED FONT. THE LETTER P AND THE LETTER D ARE CAPITALIZED.

FOR GARBAGE BAGS OF PLASTIC (U.S. CLS. 2, 5, 22, 23, 29, 37, 38 AND 50).

FIRST USE 11-1-2005; IN COMMERCE 4-20-2006. DARRYL SPRUILL, EXAMINING ATTORNEY

SN 78-965,525. ALLGOOD JERMAINE ROY, EAGAN, MN. AND ALLGOOD SIDDEEQUA ZAKIYAH, EAGAN, MN. FILED 8-31-2006.



SoULookDeep

THE MARK CONSISTS OF THE LITERAL ELEMENT "SO U LOOK DEEP" WITH THE WORD "LOOK" MADE TO LOOK LIKE AN EYE INSIDE OF THE LETTER U.

FOR GREETING CARDS (U.S. CLS. 2, 5, 22, 23, 29, 37, 38 AND 50).

KATHERINE CONNOLLY, EXAMINING ATTORNEY

**CLASS 16—(Continued).**

SN 78-965,725. INTERNATIONAL MASTERS PUBLISHERS AB, MALMO, SWEDEN, FILED 9-1-2006.

**GRANDMA'S KITCHEN**

THE MARK CONSISTS OF STANDARD CHARACTERS WITHOUT CLAIM TO ANY PARTICULAR FONT, STYLE, SIZE, OR COLOR.

OWNER OF U.S. REG. NO. 2,666,500.

NO CLAIM IS MADE TO THE EXCLUSIVE RIGHT TO USE "KITCHEN", APART FROM THE MARK AS SHOWN.

FOR PRINTED MATERIAL, NAMELY, A SERIES OF CONTINUITY CARDS ON THE SUBJECT OF COOKING AND RECIPES FOR INSERTION INTO A BOX, AND A BOX FOR USE IN CONNECTION THEREWITH (U.S. CLS. 2, 5, 22, 23, 29, 37, 38 AND 50).

FIRST USE 3-20-2000; IN COMMERCE 3-20-2000.  
DOMINIC FATHY, EXAMINING ATTORNEY

SN 78-966,084. UNISOURCE WORLDWIDE, INC., NORCROSS, GA. FILED 9-1-2006.

**nordic+**

OWNER OF U.S. REG. NOS. 2,000,251 AND 2,850,954.  
FOR COATED PAPER (U.S. CLS. 2, 5, 22, 23, 29, 37, 38 AND 50).

FIRST USE 8-30-2006; IN COMMERCE 8-30-2006.  
JORDAN BAKER, EXAMINING ATTORNEY

SN 78-966,310. JORDEN BURT LLP, MIAMI, FL. FILED 9-1-2006.

**EXPECT FOCUS**

THE MARK CONSISTS OF STANDARD CHARACTERS WITHOUT CLAIM TO ANY PARTICULAR FONT, STYLE, SIZE, OR COLOR.

OWNER OF U.S. REG. NO. 3,080,549.

FOR NEWSLETTERS FEATURING LEGAL, BUSINESS AND OTHER DEVELOPMENTS IN THE FIELDS OF LIFE AND HEALTH INSURANCE, REINSURANCE, PROPERTY AND CASUALTY INSURANCE, CONSUMER FINANCE, BANKING, CREDIT, BANKRUPTCY, BROKER-DEALERS, FINANCIAL PRODUCT DISTRIBUTION, MUTUAL FUNDS, INVESTMENT BANKS, INVESTMENT ADVICE AND ADVISORS, AND INVESTMENT MANAGEMENT AND MANAGERS, TAX, ERISA, LABOR, EMPLOYMENT, CORPORATE LAW, SECURITIES, INTELLECTUAL PROPERTY, TECHNOLOGY, REAL ESTATE, CONSTITUTIONAL LAW, WHITE COLLAR DEFENSE, AND COMMERCIAL TRIAL, APPELLATE AND CLASS ACTION LITIGATION, PROVIDED PARTICULARLY, BUT NOT EXCLUSIVELY, TO DOMESTIC, MULTINATIONAL AND FOREIGN BUSINESSES IN THE FINANCIAL SERVICES INDUSTRIES (U.S. CLS. 2, 5, 22, 23, 29, 37, 38 AND 50).

KIMBERLY FRYE, EXAMINING ATTORNEY

**CLASS 16—(Continued).**

SN 78-966,631. CITY OF HENDERSON REDEVELOPMENT AGENCY, HENDERSON, NV. FILED 9-3-2006.



NO CLAIM IS MADE TO THE EXCLUSIVE RIGHT TO USE "WATER STREET DISTRICT HENDERSON", APART FROM THE MARK AS SHOWN.

THE MARK CONSISTS OF WATER STREET DISTRICT HENDERSON IN STYLIZED LETTERS.

FOR PENS, PENCILS, STATIONERY, NOTE CARDS, NOTE PADS, NOTE BOOKS, APPOINTMENT BOOKS, POSTCARDS, CHILDREN'S ACTIVITY BOOKS, COLORING BOOKS, PEN AND PENCIL HOLDERS, RUBBER STAMPS, COASTERS MADE OF PAPER; PRINTED MATERIALS, NAMELY, MAPS, NEWSLETTERS ABOUT TRAVEL AND COMMUNITY EVENTS, AND CITY DIRECTORIES (U.S. CLS. 2, 5, 22, 23, 29, 37, 38 AND 50).  
SUSAN STIGLITZ, EXAMINING ATTORNEY

SN 78-966,748. GAMING INTERNATIONAL INC., STATELINE, NV. FILED 9-4-2006.

**WIN CARDS**

THE MARK CONSISTS OF STANDARD CHARACTERS WITHOUT CLAIM TO ANY PARTICULAR FONT, STYLE, SIZE, OR COLOR.

NO CLAIM IS MADE TO THE EXCLUSIVE RIGHT TO USE "CARDS", APART FROM THE MARK AS SHOWN.

FOR PRINTED INSTRUCTIONAL, EDUCATIONAL, AND TEACHING MATERIALS IN THE FIELD OF GAMES (U.S. CLS. 2, 5, 22, 23, 29, 37, 38 AND 50).

FIRST USE 9-14-1986; IN COMMERCE 10-15-1986.  
RENEE MCCRAY, EXAMINING ATTORNEY

SN 78-967,247. MEDIATEC PUBLISHING, INC., CHICAGO, IL. FILED 9-5-2006.

**CLOmedia.com**

THE MARK CONSISTS OF STANDARD CHARACTERS WITHOUT CLAIM TO ANY PARTICULAR FONT, STYLE, SIZE, OR COLOR.

FOR PUBLICATIONS, NAMELY, MAGAZINES AND NEWSLETTERS IN THE FIELD OF CORPORATE TRAINING AND EDUCATION (U.S. CLS. 2, 5, 22, 23, 29, 37, 38 AND 50).

FIRST USE 2-0-2004; IN COMMERCE 2-0-2004.  
G. MAYERSCHOFF, EXAMINING ATTORNEY

**CLASS 16—(Continued).**

SN 78-967,279. RAYBURN, PAMELA I., FESTUS, MO. FILED 9-5-2006.

**RHYME RASCALS**

THE MARK CONSISTS OF STANDARD CHARACTERS WITHOUT CLAIM TO ANY PARTICULAR FONT, STYLE, SIZE, OR COLOR.

FOR CHILDREN'S BOOKS (U.S. CLS. 2, 5, 22, 23, 29, 37, 38 AND 50).

KATHLEEN M. VANSTON, EXAMINING ATTORNEY

SN 78-967,437. HARBERTS, BERNIE, SOUTHERN PINES, NC. FILED 9-5-2006.

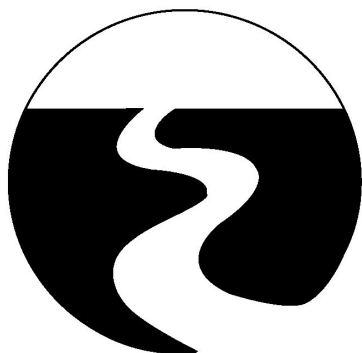

THE MARK CONSISTS OF BLACK CIRCLE WITH SINGLE OPENING. CIRCLE FILLED BY GEOMETRIC DESIGN.

FOR CHILDREN'S BOOKS FEATURING STORIES ABOUT TRAVELING (U.S. CLS. 2, 5, 22, 23, 29, 37, 38 AND 50).

FIRST USE 2-1-2006; IN COMMERCE 8-6-2006.

JENNIFER MARTIN, EXAMINING ATTORNEY

SN 78-967,651. WOLICKI, SYLVIA J, MURRIETA, CA. FILED 9-5-2006.

**Dream Guardian**

THE MARK CONSISTS OF STANDARD CHARACTERS WITHOUT CLAIM TO ANY PARTICULAR FONT, STYLE, SIZE, OR COLOR.

FOR BOOKMARKS; BUMPER STICKERS; BUSINESS CARDS; CALENDARS; GREETING CARDS; LITHOGRAPHS; POSTCARDS; POSTERS; PRINTS; SERIES OF FICTION BOOKS (U.S. CLS. 2, 5, 22, 23, 29, 37, 38 AND 50).

SUSAN LESLIE DUBOIS, EXAMINING ATTORNEY

**CLASS 16—(Continued).**

SN 78-967,770. HIDDEN TREASURES INC., TOLEDO, OH. FILED 9-6-2006.

**JULIUS SQUEEZER**

THE MARK CONSISTS OF STANDARD CHARACTERS WITHOUT CLAIM TO ANY PARTICULAR FONT, STYLE, SIZE, OR COLOR.

FOR CHILDREN'S BOOKS (U.S. CLS. 2, 5, 22, 23, 29, 37, 38 AND 50).

MICHAEL SOUDERS, EXAMINING ATTORNEY

SN 78-968,048. STUMPTOWN INCORPORATED, PORTLAND, OR. FILED 9-6-2006.

**CHERRY**

THE MARK CONSISTS OF STANDARD CHARACTERS WITHOUT CLAIM TO ANY PARTICULAR FONT, STYLE, SIZE, OR COLOR.

FOR MAGAZINES FEATURING COFFEE, COFFEE CULTURE AND THE COFFEE INDUSTRY (U.S. CLS. 2, 5, 22, 23, 29, 37, 38 AND 50).

HANNO RITTNER, EXAMINING ATTORNEY

SN 78-968,227. LEVY, CYNTHIA F., OVERLAND PARK, KS. FILED 9-6-2006.

**THE KINDERHOOK CABIN**

THE MARK CONSISTS OF STANDARD CHARACTERS WITHOUT CLAIM TO ANY PARTICULAR FONT, STYLE, SIZE, OR COLOR.

FOR ART PRINTS; COLOR PRINTS; LITHOGRAPHIC PRINTS; PAINTINGS; PAINTINGS AND THEIR REPRODUCTIONS; PHOTOGRAPHIC PRINTS; PICTORIAL PRINTS; PRINTED ART REPRODUCTIONS; PRINTS (U.S. CLS. 2, 5, 22, 23, 29, 37, 38 AND 50).

FIRST USE 7-4-2005; IN COMMERCE 7-4-2005.

ROBERT LAVACHE, EXAMINING ATTORNEY

**CLASS 16—(Continued).**

SN 78-968,281. LEVY, CYNTHIA F., OVERLAND PARK, KS.  
FILED 9-6-2006.

CINDY OF KINDERHOOK CABIN

THE MARK CONSISTS OF STANDARD CHARACTERS WITHOUT CLAIM TO ANY PARTICULAR FONT, STYLE, SIZE, OR COLOR.  
FOR CHRISTMAS CARDS; GREETING CARDS; HOLIDAY CARDS; MOTIVATIONAL CARDS (U.S. CLS. 2, 5, 22, 23, 29, 37, 38 AND 50).  
FIRST USE 7-4-2005; IN COMMERCE 7-4-2005.  
ROBERT LAVACHE, EXAMINING ATTORNEY

SN 78-968,407. GULF POWER COMPANY, PENSACOLA, FL.  
FILED 9-6-2006.

# Selectricity

THE MARK CONSISTS OF STANDARD CHARACTERS WITHOUT CLAIM TO ANY PARTICULAR FONT, STYLE, SIZE, OR COLOR.  
FOR NEWSLETTER FOR USE BY CUSTOMERS OF THE GOODCENTS SELECT PROGRAM FEATURING INFORMATION ON THE SUBJECT OF ENERGY EFFICIENCY (U.S. CLS. 2, 5, 22, 23, 29, 37, 38 AND 50).  
FIRST USE 6-1-2006; IN COMMERCE 6-1-2006.  
MIDGE BUTLER, EXAMINING ATTORNEY

SN 78-968,484. FARRIS, REX L., ARROYO GRANDE, CA.  
FILED 9-6-2006.

# Moistette

THE MARK CONSISTS OF STANDARD CHARACTERS WITHOUT CLAIM TO ANY PARTICULAR FONT, STYLE, SIZE, OR COLOR.  
FOR TOILET PAPER (U.S. CLS. 2, 5, 22, 23, 29, 37, 38 AND 50).  
GIANCARLO CASTRO, EXAMINING ATTORNEY

**CLASS 16—(Continued).**

SN 78-968,624. CATANIA, MICHAEL A, CARLSBAD, CA.  
FILED 9-6-2006.

# CLAUSE 8

THE MARK CONSISTS OF STANDARD CHARACTERS WITHOUT CLAIM TO ANY PARTICULAR FONT, STYLE, SIZE, OR COLOR.  
OWNER OF U.S. REG. NO. 3,024,514.  
FOR CALENDARS; CHILDREN'S ACTIVITY BOOKS; CHILDREN'S BOOKS; CHILDREN'S STORYBOOKS; CHRISTMAS CARDS; COLORING BOOKS; COMIC BOOKS; GIFT WRAPPING PAPER; NON-FICTION BOOKS ON THE SUBJECT OF HISTORICAL FIGURES AND HISTORICAL CALIFORNIA (U.S. CLS. 2, 5, 22, 23, 29, 37, 38 AND 50).  
LAURA KOVALSKY, EXAMINING ATTORNEY

SN 78-968,754. SMURFIT-STONE CONTAINER ENTERPRISES, INC., CHICAGO, IL. FILED 9-7-2006.

# LITTLE JOE

THE MARK CONSISTS OF STANDARD CHARACTERS WITHOUT CLAIM TO ANY PARTICULAR FONT, STYLE, SIZE, OR COLOR.  
THE NAME(S), PORTRAIT(S), AND/OR SIGNATURE(S) SHOWN IN THE MARK DOES NOT IDENTIFY A PARTICULAR LIVING INDIVIDUAL.  
FOR CORRUGATED CONTAINERS, CONTAINERBOARD AND PAPERBOARD PACKAGING (U.S. CLS. 2, 5, 22, 23, 29, 37, 38 AND 50).  
INGA ERVIN, EXAMINING ATTORNEY

SN 78-968,907. SMURFIT-STONE CONTAINER ENTERPRISES, INC., CHICAGO, IL. FILED 9-7-2006.

# BIG JOE

THE MARK CONSISTS OF STANDARD CHARACTERS WITHOUT CLAIM TO ANY PARTICULAR FONT, STYLE, SIZE, OR COLOR.  
FOR CORRUGATED CONTAINERS, CONTAINERBOARD AND PAPERBOARD PACKAGING (U.S. CLS. 2, 5, 22, 23, 29, 37, 38 AND 50).  
EMILY CARLSEN, EXAMINING ATTORNEY

**CLASS 16—(Continued).**

SN 78-968,912. SMURFIT-STONE CONTAINER ENTERPRISES, INC., CHICAGO, IL. FILED 9-7-2006.

**JOEBOX**

THE MARK CONSISTS OF STANDARD CHARACTERS WITHOUT CLAIM TO ANY PARTICULAR FONT, STYLE, SIZE, OR COLOR.

THE NAME(S), PORTRAIT(S), AND/OR SIGNATURE(S) SHOWN IN THE MARK DOES NOT IDENTIFY A PARTICULAR LIVING INDIVIDUAL.

FOR CORRUGATED CONTAINERS, CONTAINERBOARD AND PAPERBOARD PACKAGING (U.S. CLS. 2, 5, 22, 23, 29, 37, 38 AND 50).

INGA ERVIN, EXAMINING ATTORNEY

**CLASS 16—(Continued).**

SN 78-969,387. BUNGALOW MEDIA, INC., IRVINE, CA. FILED 9-7-2006.

**PARABLES FROM POP CULTURE**

THE MARK CONSISTS OF STANDARD CHARACTERS WITHOUT CLAIM TO ANY PARTICULAR FONT, STYLE, SIZE, OR COLOR.

NO CLAIM IS MADE TO THE EXCLUSIVE RIGHT TO USE "PARABLES", APART FROM THE MARK AS SHOWN.

FOR PRINTED MATTER, NAMELY, A SERIES OF FICTION AND NON-FICTION BOOKS ON THE SUBJECT OF MORAL AND RELIGIOUS LESSONS (U.S. CLS. 2, 5, 22, 23, 29, 37, 38 AND 50).

MARIAM MAHMOUDI, EXAMINING ATTORNEY

SN 78-969,041. ATICO INTERNATIONAL USA INC, FORT LAUDERDALE, FL. FILED 9-7-2006.

**Power Flex**

THE MARK CONSISTS OF STANDARD CHARACTERS WITHOUT CLAIM TO ANY PARTICULAR FONT, STYLE, SIZE, OR COLOR.

FOR TRASH BAG (U.S. CLS. 2, 5, 22, 23, 29, 37, 38 AND 50).

TARAH HARDY, EXAMINING ATTORNEY

SN 78-969,993. ALABAMA BUSINESS FORMS, HUNTSVILLE, AL. FILED 9-8-2006.

**VALU-POKET**

THE MARK CONSISTS OF STANDARD CHARACTERS WITHOUT CLAIM TO ANY PARTICULAR FONT, STYLE, SIZE, OR COLOR.

FOR PAPER FORMS, NAMELY PRINTED BUSINESS FORMS AND ENVELOPES (U.S. CLS. 2, 5, 22, 23, 29, 37, 38 AND 50).

DAVID C. REIHNER, EXAMINING ATTORNEY

SN 78-969,328. NOVA MARKETING, INC., QUINCY, MA. FILED 9-7-2006.

**metroboomer**

THE MARK CONSISTS OF STANDARD CHARACTERS WITHOUT CLAIM TO ANY PARTICULAR FONT, STYLE, SIZE, OR COLOR.

FOR MAGAZINES FEATURING INFORMATION, ADVERTISEMENTS AND ARTICLES SPECIFICALLY GEARED TOWARDS ACTIVE, MATURING ADULTS AGE 42-60 (U.S. CLS. 2, 5, 22, 23, 29, 37, 38 AND 50).

PETER B. BROMAGHIM, EXAMINING ATTORNEY

SN 78-971,056. ALBERTSON, MILES, S., PRESCOTT, AZ. FILED 9-11-2006.

**Scrabbles Babbles**

THE MARK CONSISTS OF STANDARD CHARACTERS WITHOUT CLAIM TO ANY PARTICULAR FONT, STYLE, SIZE, OR COLOR.

FOR CHILDREN'S BOOKS (U.S. CLS. 2, 5, 22, 23, 29, 37, 38 AND 50).

WILLIAM P. SHANAHAN, EXAMINING ATTORNEY

**CLASS 16—(Continued).**

SN 78-971,930. SOCIETE BIC, CLICHY, FRANCE, FILED 9-11-2006.

**CLASS 16—(Continued).**

SN 78-973,636. DIRECTV, INC., EL SEGUNDO, CA. FILED 9-13-2006.

# CLIC LINER

THE MARK CONSISTS OF STANDARD CHARACTERS WITHOUT CLAIM TO ANY PARTICULAR FONT, STYLE, SIZE, OR COLOR.

FOR CORRECTION TAPE FOR TYPE AND INK AND DISPENSERS SOLD AS A UNIT (U.S. CLS. 2, 5, 22, 23, 29, 37, 38 AND 50).

JILL C. ALT, EXAMINING ATTORNEY

# PROJECT MYWORLD

THE MARK CONSISTS OF STANDARD CHARACTERS WITHOUT CLAIM TO ANY PARTICULAR FONT, STYLE, SIZE, OR COLOR.

FOR ADDRESS BOOKS; BINDERS; BLANK WRITING JOURNALS; BOOK COVERS; BOOKMARKS; BUMPER STICKERS; CALENDARS; DATE BOOKS; DECALS; DESK CALENDARS; DIARIES; ENVELOPES; GREETING CARDS; LOOSE LEAF BINDERS; MEMO PADS; NOTE BOOKS; NOTE PAPER; PAPER BANNERS; PENCILS; PENS; POSTERS; SPIRAL NOTEBOOKS; STICKERS; TEMPORARY TATTOOS; THREE-RING BINDERS; TRADING CARDS; WALL CALENDARS; WRITING PAPER (U.S. CLS. 2, 5, 22, 23, 29, 37, 38 AND 50).

BERNICE HOWSE, EXAMINING ATTORNEY

SN 78-972,142. BINNEY & SMITH LLC, EASTON, PA. FILED 9-12-2006.

# COLORS MAGICALLY APPEAR

THE MARK CONSISTS OF STANDARD CHARACTERS WITHOUT CLAIM TO ANY PARTICULAR FONT, STYLE, SIZE, OR COLOR.

FOR CREATIVITY KITS COMPRISING MARKERS, ART PAPER, TRACING PAPER, COLORING PAPER, STENCILS, SCISSORS, AND DECORATIVE GLITTER; ARTS AND CRAFT KITS USING A LIQUID TO DEVELOP UNIQUE PATTERNS ON COLORED ROTATING CARDS (U.S. CLS. 2, 5, 22, 23, 29, 37, 38 AND 50).

FIRST USE 8-7-2005; IN COMMERCE 8-7-2005.  
MARGARET POWER, EXAMINING ATTORNEY

SN 78-974,598. INTERNATIONAL GROUP OF COMPANIES, LLC, MELROSE PARK, IL. FILED 9-14-2006.

# TAX CUT

SN 78-972,410. JEWISH RENAISSANCE MEDIA, LLC, SOUTHFIELD, MI. FILED 9-12-2006.

# JULEP

THE MARK CONSISTS OF STANDARD CHARACTERS WITHOUT CLAIM TO ANY PARTICULAR FONT, STYLE, SIZE, OR COLOR.

FOR GENERAL FEATURE MAGAZINE (U.S. CLS. 2, 5, 22, 23, 29, 37, 38 AND 50).

ROBIN CHOSID, EXAMINING ATTORNEY

THE MARK CONSISTS OF STANDARD CHARACTERS WITHOUT CLAIM TO ANY PARTICULAR FONT, STYLE, SIZE, OR COLOR.

FOR PAPER SHREDDERS (U.S. CLS. 2, 5, 22, 23, 29, 37, 38 AND 50).

BONNIE LUKEN, EXAMINING ATTORNEY

**CLASS 16—(Continued).**

SN 79-023,297. FESTINA LOTUS, S.A., SPAIN, FILED 10-27-2005.



PRIORITY DATE OF 7-1-2005 IS CLAIMED.  
OWNER OF INTERNATIONAL REGISTRATION 0883450 DATED 10-27-2005, EXPIRES 10-27-2015.  
OWNER OF U.S. REG. NOS. 1,472,167, 1,953,931 AND OTHERS.

FOR PRINTED MATTER, NAMELY, PAMPHLETS, BROCHURES, CATALOGS, NEWSLETTERS AND MAGAZINES IN THE FIELD OF JEWELRY, WATCHES, CLOCKS AND OTHER HOROLOGICAL INSTRUMENTS; PRINTED INSTRUCTIONAL MATERIAL IN THE FIELD OF JEWELRY, WATCHES, CLOCKS AND OTHER HOROLOGICAL INSTRUMENTS; BALLPOINT PENS, HOLDERS FOR PAPER CLIPS, WRITING MATERIALS, NAMELY, WRITING IMPLEMENTS, PEN NIBS, PEN NIBS OF GOLD, STYLOGRAPHIC PENS, PENHOLDERS; PENCILS; PENCIL HOLDERS; BOXES FOR PENS (U.S. CLS. 2, 5, 22, 23, 29, 37, 38 AND 50).

KRISTINA KLOIBER, EXAMINING ATTORNEY

**CLASS 17—RUBBER GOODS**

SN 77-059,752. INTEPLAST GROUP LTD., LIVINGSTON, NJ. FILED 12-8-2006.

**World of Films**

THE MARK CONSISTS OF STANDARD CHARACTERS WITHOUT CLAIM TO ANY PARTICULAR FONT, STYLE, SIZE, OR COLOR.

FOR PLASTIC FILM FOR INDUSTRIAL AND COMMERCIAL PACKING USE (U.S. CLS. 1, 5, 12, 13, 35 AND 50).

FIRST USE 12-1-2006; IN COMMERCE 12-1-2006.  
ROBIN MITTLER, EXAMINING ATTORNEY

**CLASS 17—(Continued).**

SN 78-553,054. WANG, DAVE H., MONTEREY PARK, CA. FILED 1-24-2005.



THE COLOR(S) TAN, BLACK AND WHITE IS/ARE CLAIMED AS A FEATURE OF THE MARK.

THE COLOR TAN APPEARS IN THE LETTER "O", THE COLOR BLACK APPEARS IN THE HYPHEN AND THE WORD "TAPE", AND THE COLOR WHITE APPEARS IN THE BACKGROUND OF THE MARK.

THE MARK CONSISTS OF THE WORDING "O-TAPE" IN WHICH THE LETTER "O" IS FORMED BY A ROLL OF TAPE THAT IS BEGINNING TO UNWIND.

FOR ADHESIVE TAPE FOR INDUSTRIAL AND COMMERCIAL USE (U.S. CLS. 1, 5, 12, 13, 35 AND 50).

FIRST USE 1-24-2005; IN COMMERCE 1-24-2005.  
MICHAEL GAAFAR, EXAMINING ATTORNEY

SN 78-750,133. MAPEI CORPORATION, DEERFIELD BEACH, FL. FILED 11-9-2005.

**EASY PLACE**

THE MARK CONSISTS OF STANDARD CHARACTERS WITHOUT CLAIM TO ANY PARTICULAR FONT, STYLE, SIZE, OR COLOR.

FOR CONCRETE PATCH, NAMELY, A POLYMER BASED CONCRETE PATCHING COMPOUND (U.S. CLS. 1, 5, 12, 13, 35 AND 50).

TRAVIS WHEATLEY, EXAMINING ATTORNEY

SN 78-819,190. EARTHWORKS SYSTEMS, LLC, SOLON, OH. FILED 2-20-2006.

**GOODSHEET**

THE MARK CONSISTS OF STANDARD CHARACTERS WITHOUT CLAIM TO ANY PARTICULAR FONT, STYLE, SIZE, OR COLOR.

FOR PLASTIC MATERIAL COMPOSED OF POLYVINYL CHLORIDE SHEETING FOR USE IN MAKING TRANSACTION, INFORMATION AND IDENTIFICATION CARDS AND SIGNS (U.S. CLS. 1, 5, 12, 13, 35 AND 50).

GINNY ISAACSON, EXAMINING ATTORNEY



**CLASS 17—(Continued).**

SN 78-936,326. GEALAN FENSTER-SYSTEME GMBH, OBERKOTZAU, FED REP GERMANY, FILED 7-24-2006.



THE MARK CONSISTS OF A STYLIZED CIRCULAR BORDER, WITH A WAVE-LIKE BAND FLOWING UPWARD INSIDE THE CIRCULAR BAND. THE CIRCLE IS FOLLOWED BY THE WORD "GEALAN".

FOR EXTRUDED PLASTIC MATERIAL IN THE FORM OF DOOR AND WINDOW PROFILES FOR USE IN MANUFACTURING; SYNTHETIC PLASTIC AS SEMI-FINISHED PRODUCTS IN FORM OF FOILS, PLATES, RODS, PROFILES, HOSES, TUBES, BLOCKS (U.S. CLS. 1, 5, 12, 13, 35 AND 50).  
JOHN KELLY, EXAMINING ATTORNEY

SN 78-960,017. STRAIGHT LINE INSULATION I, LP, SOUTH HOUSTON, TX. FILED 8-24-2006.

## STRONGSEAM

THE MARK CONSISTS OF STANDARD CHARACTERS WITHOUT CLAIM TO ANY PARTICULAR FONT, STYLE, SIZE, OR COLOR.

FOR BUILDING INSULATION SYSTEM CONSISTING OF INTERLOCKING COMPOSITE PANELS CREATED FROM A METALLIC OUTER SKIN LAMINATED TO THERMAL INSULATION (U.S. CLS. 1, 5, 12, 13, 35 AND 50).

ELISSA GARBER KON, EXAMINING ATTORNEY

SN 78-968,637. ROY CRICK, SURREY, BC, CANADA, FILED 9-7-2006.

## Scor-Pal

THE MARK CONSISTS OF STANDARD CHARACTERS WITHOUT CLAIM TO ANY PARTICULAR FONT, STYLE, SIZE, OR COLOR.

FOR PLASTICS IN EXTRUDED FORM USED IN PRODUCTION (U.S. CLS. 1, 5, 12, 13, 35 AND 50).

ATTIYA MALIK, EXAMINING ATTORNEY

**CLASS 17—(Continued).**

SN 78-969,311. FOAMWORKS, INC., CLEVELAND, TN. FILED 9-7-2006.

## Memory Cool

THE MARK CONSISTS OF STANDARD CHARACTERS WITHOUT CLAIM TO ANY PARTICULAR FONT, STYLE, SIZE, OR COLOR.

NO CLAIM IS MADE TO THE EXCLUSIVE RIGHT TO USE "MEMORY", APART FROM THE MARK AS SHOWN.

FOR OPEN-CELLED VISCO-ELASTIC MEMORY FOAM WITH SLOW RECOVERY, ENHANCED AIR FLOW, AND SHAPE FORMING PROPERTIES FOR USE IN PILLOW TOPS, PILLOWS, AND MATTRESSES (U.S. CLS. 1, 5, 12, 13, 35 AND 50).

ANDREA K. NADELMAN, EXAMINING ATTORNEY

SN 78-970,296. FENIELLO, PETER, J., PARK RIDGE, NJ. AND FENIELLO, PETER, A., ORADELL, NJ. AND LUTZ, FERDINAND, FIELDKIRCH, AUSTRIA, FILED 9-8-2006.

## PRIMETAC

THE MARK CONSISTS OF STANDARD CHARACTERS WITHOUT CLAIM TO ANY PARTICULAR FONT, STYLE, SIZE, OR COLOR.

FOR ADHESIVE PACKING TAPE FOR INDUSTRIAL OR COMMERCIAL USE; ADHESIVE TAPE FOR INDUSTRIAL AND COMMERCIAL USE; ADHESIVE TAPE FOR INDUSTRIAL OR COMMERCIAL PACKING USE; ADHESIVE TAPE FOR SEALING CARTONS FOR INDUSTRIAL OR COMMERCIAL USE (U.S. CLS. 1, 5, 12, 13, 35 AND 50).

FIRST USE 2-1-1992; IN COMMERCE 2-1-1992.

JERI J. FICKES, EXAMINING ATTORNEY

SN 79-025,344. NOVAPLAST PLASTIK; SANAYI VE TICARET A.S., TURKEY, FILED 3-28-2006.



OWNER OF INTERNATIONAL REGISTRATION 0888826 DATED 3-28-2006, EXPIRES 3-28-2016.

"THE COLOR(S) BLACK, WHITE, AND RED IS/ARE CLAIMED AS A FEATURE OF THE MARK."

"THE MARK CONSISTS OF THE WORDING NOVATHERM, IN WHICH THE COLOR BLACK APPEARS IN THE WORD NOVA, THE COLOR WHITE APPEARS IN THE WORD THERM, AND THE COLOR RED APPEARS AS AN OUTLINE IN THE WORD THERM."

FOR FLEXIBLE PLASTIC PIPES AND FITTINGS MADE OF PLASTIC, NAMELY COMPRESSED AIR PIPE FITTINGS, CYLINDER JOINTINGS, NON METAL JUNCTIONS FOR USE WITH WATER PIPES, NON METAL PIPE MUFFS FOR USE WITH WATER PIPES, JOINT PACKINGS FOR USE WITH WATER PIPES, RUBBER STOPPERS FOR USE WITH WATER PIPES (U.S. CLS. 1, 5, 12, 13, 35 AND 50).

MICHAEL TANNER, EXAMINING ATTORNEY

**CLASS 18—LEATHER GOODS**

SN 76-639,286. GRANDWAY USA CORPORATION, SALT LAKE CITY, UT. FILED 5-23-2005.



NO CLAIM IS MADE TO THE EXCLUSIVE RIGHT TO USE "ORIGINAL" AND "ALBUM HANDBAG", APART FROM THE MARK AS SHOWN.

THE MARK CONSISTS OF THE STYLIZED WORDING SPINS WITH AN ARC ABOVE AND BELOW THE LETTERS P, I, AND N. THE STYLIZED WORDING THE ORIGINAL IN AN ARC SHAPED ORIENTATION ABOVE THE TERM SPINS AND THE STYLIZED WORDING ALBUM HANDBAG IN AN ARC SHAPED ORIENTATION BELOW THE TERM SPINS. THE WORDING THE ORIGINAL ALBUM HANDBAG CREATES A CIRCLE FORMING THE OUTER EDGE OF AN ALBUM WITH THE ARCS ABOVE THE LETTERS P, I, AND N IN THE TERM SPINS CREATING THE INNER PART OF THE ALBUM.

FOR HAND BAGS, CARRYING CASES AND PURSES (U.S. CLS. 1, 2, 3, 22 AND 41).  
JAY BESCH, EXAMINING ATTORNEY

SN 76-647,342. FAN, JUN, CHINO HILLS, CA. FILED 9-23-2005.

# TULLÉMOSS

THE MARK CONSISTS OF STANDARD CHARACTERS WITHOUT CLAIM TO ANY PARTICULAR FONT, STYLE, SIZE, OR COLOR.

FOR GOODS OF LEATHER OR IMITATION LEATHER, NAMELY, SUITCASES, HANDBAGS, WALLET, SCHOOL BAGS, TRAVELING BAGS; CANVAS LUGGAGE AND TRAVELING BAGS (U.S. CLS. 1, 2, 3, 22 AND 41).  
ROBERT LAVACHE, EXAMINING ATTORNEY

**CLASS 18—(Continued).**

SN 76-669,444. GOLFSMITH INTERNATIONAL, INC., AUSTIN, TX. FILED 11-24-2006.

# SNAKE EYES

THE MARK CONSISTS OF STANDARD CHARACTERS WITHOUT CLAIM TO ANY PARTICULAR FONT, STYLE, SIZE, OR COLOR.

OWNER OF U.S. REG. NO. 1,889,946.

FOR BAGS, NAMELY, ALL PURPOSE CARRYING BAGS, BAGS FOR UMBRELLAS, ATHLETIC BAGS; BELT BAGS, TOTE BAGS, SMALL BAGS FOR MEN, HANDBAGS; SPORTS BAGS, SHOE BAGS FOR TRAVEL, UMBRELLAS, GOLF UMBRELLAS (U.S. CLS. 1, 2, 3, 22 AND 41).

FIRST USE 0-0-2000; IN COMMERCE 0-0-2000.  
JAY BESCH, EXAMINING ATTORNEY

SN 77-001,359. SAMSONITE CORPORATION, DENVER, CO. FILED 9-18-2006.

# SERENGETI

THE MARK CONSISTS OF STANDARD CHARACTERS WITHOUT CLAIM TO ANY PARTICULAR FONT, STYLE, SIZE, OR COLOR.

FOR LUGGAGE (U.S. CLS. 1, 2, 3, 22 AND 41).  
SCOTT SISUN, EXAMINING ATTORNEY

SN 77-010,424. SAMSONITE CORPORATION, DENVER, CO. FILED 9-29-2006.

# TOSCANI

THE MARK CONSISTS OF STANDARD CHARACTERS WITHOUT CLAIM TO ANY PARTICULAR FONT, STYLE, SIZE, OR COLOR.

OWNER OF U.S. REG. NO. 2,681,916.  
THE ENGLISH TRANSLATION OF TOSCANI IS TUSCANY.  
FOR LUGGAGE (U.S. CLS. 1, 2, 3, 22 AND 41).  
SCOTT SISUN, EXAMINING ATTORNEY

**CLASS 18—(Continued).**

SN 77-010,428. SAMSONITE CORPORATION, DENVER, CO.  
FILED 9-29-2006.

**CLASS 18—(Continued).**

SN 77-022,534. SAMSONITE CORPORATION, DENVER, CO.  
FILED 10-17-2006.

# WESTGATE

# WANDER-LITE

THE MARK CONSISTS OF STANDARD CHARACTERS WITHOUT CLAIM TO ANY PARTICULAR FONT, STYLE, SIZE, OR COLOR.  
FOR LUGGAGE (U.S. CLS. 1, 2, 3, 22 AND 41).  
SCOTT SISUN, EXAMINING ATTORNEY

THE MARK CONSISTS OF STANDARD CHARACTERS WITHOUT CLAIM TO ANY PARTICULAR FONT, STYLE, SIZE, OR COLOR.  
FOR LUGGAGE (U.S. CLS. 1, 2, 3, 22 AND 41).  
SCOTT SISUN, EXAMINING ATTORNEY

SN 77-013,036. POMARE, LTD., HONOLULU, HI. FILED 10-3-2006.

SN 77-025,563. SAMSONITE CORPORATION, DENVER, CO.  
FILED 10-20-2006.

# HAWAIIAN PALMS

# ENCHANTMENT

THE MARK CONSISTS OF STANDARD CHARACTERS WITHOUT CLAIM TO ANY PARTICULAR FONT, STYLE, SIZE, OR COLOR.  
NO CLAIM IS MADE TO THE EXCLUSIVE RIGHT TO USE "HAWAIIAN", APART FROM THE MARK AS SHOWN.  
FOR BEACH BAGS; CARRY-ALL BAGS; MAKE-UP BAGS SOLD EMPTY; PURSES; SOUVENIR BAGS; TOTE BAGS (U.S. CLS. 1, 2, 3, 22 AND 41).  
DAVID HOFFMAN, EXAMINING ATTORNEY

THE MARK CONSISTS OF STANDARD CHARACTERS WITHOUT CLAIM TO ANY PARTICULAR FONT, STYLE, SIZE, OR COLOR.  
FOR LUGGAGE (U.S. CLS. 1, 2, 3, 22 AND 41).  
SCOTT SISUN, EXAMINING ATTORNEY

SN 77-013,138. SAMSONITE CORPORATION, DENVER, CO.  
FILED 10-4-2006.

SN 78-806,655. SL&E TRAINING STABLE, INC., NEW FAIR-FILED, CT. FILED 2-3-2006.

# GRAVITON

# S.E. BOUTIQUE

THE MARK CONSISTS OF STANDARD CHARACTERS WITHOUT CLAIM TO ANY PARTICULAR FONT, STYLE, SIZE, OR COLOR.  
FOR LUGGAGE (U.S. CLS. 1, 2, 3, 22 AND 41).  
SCOTT SISUN, EXAMINING ATTORNEY

THE MARK CONSISTS OF STANDARD CHARACTERS WITHOUT CLAIM TO ANY PARTICULAR FONT, STYLE, SIZE, OR COLOR.  
NO CLAIM IS MADE TO THE EXCLUSIVE RIGHT TO USE "BOUTIQUE", APART FROM THE MARK AS SHOWN.  
FOR LUGGAGE, HANDBAGS, PURSES, WALLETS, ALL-PURPOSE TOTE BAGS, ALL-PURPOSE SPORTS BAGS, BACKPACKS (U.S. CLS. 1, 2, 3, 22 AND 41).  
GEORGE LORENZO, EXAMINING ATTORNEY

**CLASS 18—(Continued).**

SN 78-812,328. HOLZKNECHT, JAYNE, MOUNTAIN VIEW, CA. FILED 2-10-2006.

**HERRICK LOM**

THE MARK CONSISTS OF STANDARD CHARACTERS WITHOUT CLAIM TO ANY PARTICULAR FONT, STYLE, SIZE, OR COLOR.

THE NAME(S), PORTRAIT(S), AND/OR SIGNATURE(S) SHOWN IN THE MARK DOES NOT IDENTIFY A PARTICULAR LIVING INDIVIDUAL.

FOR HANDBAGS (U.S. CLS. 1, 2, 3, 22 AND 41).  
KAREN K. BUSH, EXAMINING ATTORNEY

SN 78-824,820. HINDS, DOUG WESLEY, SANTA MONICA, CA. FILED 2-28-2006.



THE MARK CONSISTS OF SOLID ELONGATED RECTANGLE.

FOR HANDBAGS (U.S. CLS. 1, 2, 3, 22 AND 41).  
DAVID MILLER, EXAMINING ATTORNEY

SN 78-843,837. NOMADIC INC., TOKYO, JAPAN, FILED 3-22-2006.

**WISE-WALKER**

THE MARK CONSISTS OF STANDARD CHARACTERS WITHOUT CLAIM TO ANY PARTICULAR FONT, STYLE, SIZE, OR COLOR.

FOR TOTE BAGS; WAIST BAGS; SHOULDER BAGS; TRAVEL BAGS; BACKPACKS AND WAIST PACKS (U.S. CLS. 1, 2, 3, 22 AND 41).

FIRST USE 6-1-1998; IN COMMERCE 6-1-1998.  
DANIEL CAPSHAW, EXAMINING ATTORNEY

**CLASS 18—(Continued).**

SN 78-918,062. KICK PRODUCTIONS, INC., LOS ANGELES, CA. FILED 6-27-2006.

**PERFECT BY CARSON KRESSLEY**

THE MARK CONSISTS OF STANDARD CHARACTERS WITHOUT CLAIM TO ANY PARTICULAR FONT, STYLE, SIZE, OR COLOR.

FOR ALL-PURPOSE SPORTS AND ATHLETIC BAGS; BEACH, BOOK, CARRY-ON, DUFFEL, DIAPER, GYM, LEATHER SHOPPING, SHOULDER, TOTE AND TRAVEL BAGS; FANNY PACKS AND WAIST PACKS; BACKPACKS; KNAPSACKS; PURSES; GARMENT BAGS FOR TRAVEL; SATCHELS; LUGGAGE; LUGGAGE TAGS; TRUNKS; SUITCASES; COSMETIC CASES AND BAGS SOLD EMPTY; TOILETRY AND VANITY CASES SOLD EMPTY; TOOL BAGS SOLD EMPTY; ATTACHE CASES; BRIEFCASES; BRIEFCASE-TYPE PORTFOLIOS; MEN'S CLUTCHES; BUSINESS CASES; BUSINESS CARD CASES; CALLING AND CREDIT CARD CASES; KEY CASES; LEATHER KEY CHAINS; WALLETS; BANK-NOTE HOLDERS; BILLFOLDS; UMBRELLAS; PARASOLS (U.S. CLS. 1, 2, 3, 22 AND 41).  
VIVIAN MICZNIK FIRST, EXAMINING ATTORNEY

SN 78-922,167. ONBOARD OUTFITTERS LLC, CALABASAS, CA. FILED 7-4-2006.

**Clene**

THE MARK CONSISTS OF STANDARD CHARACTERS WITHOUT CLAIM TO ANY PARTICULAR FONT, STYLE, SIZE, OR COLOR.

FOR BABY BACKPACKS; BABY CARRIERS WORN ON THE BODY; BABY CARRYING BAGS; BAGS FOR CARRYING BABIES' ACCESSORIES; INFANT CARRIERS WORN ON THE BODY (U.S. CLS. 1, 2, 3, 22 AND 41).

FIRST USE 5-25-2006; IN COMMERCE 7-3-2006.  
CHERYL CLAYTON, EXAMINING ATTORNEY

SN 78-952,253. ROBINSON, MARK, AMHERST, NH. FILED 8-15-2006.

**Peepers**

THE MARK CONSISTS OF STANDARD CHARACTERS WITHOUT CLAIM TO ANY PARTICULAR FONT, STYLE, SIZE, OR COLOR.

FOR DISPOSABLE PET DIAPERS (U.S. CLS. 1, 2, 3, 22 AND 41).

ELISSA GARBER KON, EXAMINING ATTORNEY

**CLASS 18—(Continued).**

SN 78-953,919. POMARE, LTD., HONOLULU, HI. FILED 8-16-2006.

# LEI Z'S

THE MARK CONSISTS OF STANDARD CHARACTERS WITHOUT CLAIM TO ANY PARTICULAR FONT, STYLE, SIZE, OR COLOR.

THE FOREIGN WORDING IN THE MARK TRANSLATES INTO ENGLISH AS NECKLACE OF FLOWERS, LEAVES, SHELLS, IVORY, FEATHERS, OR PAPER, GIVEN AS A SYMBOL OF AFFECTION; OR FIGURATIVELY.

FOR BEACH BAGS; CARRY-ALL BAGS; MAKE-UP BAGS SOLD EMPTY; PURSES; SOUVENIR BAGS; TOTE BAGS (U.S. CLS. 1, 2, 3, 22 AND 41).

DAVID HOFFMAN, EXAMINING ATTORNEY

**CLASS 18—(Continued).**

SN 78-955,609. POMARE, LTD., HONOLULU, HI. FILED 8-18-2006.

# COCONUT MOON

THE MARK CONSISTS OF STANDARD CHARACTERS WITHOUT CLAIM TO ANY PARTICULAR FONT, STYLE, SIZE, OR COLOR.

FOR BEACH BAGS; CARRY-ALL BAGS; MAKE-UP BAGS SOLD EMPTY; PURSES; SOUVENIR BAGS; TOTE BAGS (U.S. CLS. 1, 2, 3, 22 AND 41).

DAVID HOFFMAN, EXAMINING ATTORNEY

SN 78-954,509. NORDSTROM, INC., SEATTLE, WA. FILED 8-17-2006.

# TROUVE

THE MARK CONSISTS OF STANDARD CHARACTERS WITHOUT CLAIM TO ANY PARTICULAR FONT, STYLE, SIZE, OR COLOR.

THE FOREIGN WORDING IN THE MARK TRANSLATES INTO ENGLISH AS FOUND.

FOR HANDBAGS, WALLETS, TRAVEL BAGS, KEY CASES, LIPSTICK CASES, LUGGAGE, ALL-PURPOSE CARRYING BAGS, COIN PURSES, PURSES, BRIEF-CASES, VANITY CASES SOLD EMPTY AND COSMETIC CASES SOLD EMPTY (U.S. CLS. 1, 2, 3, 22 AND 41).

ANGELA M. MICHELI, EXAMINING ATTORNEY

SN 78-955,620. POMARE, LTD., HONOLULU, HI. FILED 8-18-2006.

# ALOHA DAYS

THE MARK CONSISTS OF STANDARD CHARACTERS WITHOUT CLAIM TO ANY PARTICULAR FONT, STYLE, SIZE, OR COLOR.

THE FOREIGN WORDING IN THE MARK TRANSLATES INTO ENGLISH AS "GREETINGS" OR LOVE.

FOR BEACH BAGS; CARRY-ALL BAGS; PURSES; SOUVENIR BAGS; TOTE BAGS (U.S. CLS. 1, 2, 3, 22 AND 41).

DAVID HOFFMAN, EXAMINING ATTORNEY

SN 78-954,513. NORDSTROM, INC., SEATTLE, WA. FILED 8-17-2006.

# TILDON

THE MARK CONSISTS OF STANDARD CHARACTERS WITHOUT CLAIM TO ANY PARTICULAR FONT, STYLE, SIZE, OR COLOR.

FOR HANDBAGS, WALLETS, TRAVEL BAGS, KEY CASES, LIPSTICK CASES SOLD EMPTY, LUGGAGE, TRAVEL SACKS, ALL-PURPOSE CARRYING BAGS, COIN PURSES, PURSES, BRIEFCASES, VANITY CASES SOLD EMPTY AND COSMETIC CASES SOLD EMPTY (U.S. CLS. 1, 2, 3, 22 AND 41).

ROBIN CHOSID, EXAMINING ATTORNEY

SN 78-955,633. POMARE, LTD., HONOLULU, HI. FILED 8-18-2006.

# ALI'I PALMS

THE MARK CONSISTS OF STANDARD CHARACTERS WITHOUT CLAIM TO ANY PARTICULAR FONT, STYLE, SIZE, OR COLOR.

THE FOREIGN WORDING IN THE MARK TRANSLATES INTO ENGLISH AS CHIEFLY, NOBLE OR ARISTOCRATIC. FOR BEACH BAGS; CARRY-ALL BAGS; MAKE-UP BAGS SOLD EMPTY; PURSES; SOUVENIR BAGS; TOTE BAGS (U.S. CLS. 1, 2, 3, 22 AND 41).

DAVID HOFFMAN, EXAMINING ATTORNEY

**CLASS 18—(Continued).**

SN 78-959,793. L. C. LICENSING, INC., NEW YORK, NY.  
FILED 8-24-2006.

FOR NICE GIRLS WHO LIKE  
STUFF

THE MARK CONSISTS OF STANDARD CHARACTERS WITHOUT CLAIM TO ANY PARTICULAR FONT, STYLE, SIZE, OR COLOR.

FOR HANDBAGS, PURSES, WALLETS, KEY CASES, CREDIT CARD CASES, COSMETIC CASES SOLD EMPTY, BACKPACKS, SPORT BAGS, BRIEFCASES, LUGGAGE, UMBRELLAS (U.S. CLS. 1, 2, 3, 22 AND 41).  
COLLEEN DOMBROW, EXAMINING ATTORNEY

SN 78-960,978. LOCKHEART ACCESSORIES, LLC, LOS ANGELES, CA. FILED 8-25-2006.

LOCKHEART

FOR HANDBAGS, PURSES, DAY BAGS, WALLETS, LEATHER BAGS AND IMITATION LEATHER BAGS (U.S. CLS. 1, 2, 3, 22 AND 41).

FIRST USE 8-15-2006; IN COMMERCE 8-15-2006.  
GEORGE LORENZO, EXAMINING ATTORNEY

SN 78-962,468. ROBERTS, DEBBIE, SEMINOLE, FL. FILED 8-29-2006.

PINK FLORIDA THREADS

THE MARK CONSISTS OF STANDARD CHARACTERS WITHOUT CLAIM TO ANY PARTICULAR FONT, STYLE, SIZE, OR COLOR.

NO CLAIM IS MADE TO THE EXCLUSIVE RIGHT TO USE "FLORIDA", APART FROM THE MARK AS SHOWN.

FOR EVENING HANDBAGS; PURSES; SMALL PURSES (U.S. CLS. 1, 2, 3, 22 AND 41).

KATHLEEN LORENZO, EXAMINING ATTORNEY

**CLASS 18—(Continued).**

SN 78-963,833. MAYA WRAP, INC, YADKINVILLE, NC.  
FILED 8-30-2006.

Maya

THE MARK CONSISTS OF STANDARD CHARACTERS WITHOUT CLAIM TO ANY PARTICULAR FONT, STYLE, SIZE, OR COLOR.

OWNER OF U.S. REG. NO. 2,567,509.  
FOR BABY CARRIERS WORN ON THE BODY (U.S. CLS. 1, 2, 3, 22 AND 41).

FIRST USE 10-1-1996; IN COMMERCE 10-1-1996.  
JEFF DEFORD, EXAMINING ATTORNEY

SN 78-964,130. AMERICAN NEVADA HOLDINGS, LLC, HENDERSON, NV. FILED 8-30-2006.

Avenue33  
AT THE DISTRICT

FOR LEATHER KEY CHAINS; LEATHER KEY CHAIN TAGS; BRIEFCASES; LEATHER AND IMITATION LEATHER BAGS; TOTE BAGS; TRAVEL BAGS; ALL PURPOSE SPORT BAGS; BACKPACKS; WALLETS; PURSES; HANDBAGS; SOUVENIR BAGS; FANNY PACKS; MESH SHOPPING BAGS; TEXTILE SHOPPING BAGS; AND UMBRELLAS (U.S. CLS. 1, 2, 3, 22 AND 41).  
HEATHER SAPP, EXAMINING ATTORNEY

SN 78-964,185. THE MICHELLE RODRIGUEZ AND DARA YOUNG PARTNERSHIP, DBA ISHKADADA ENTERPRISES, SANTA MONICA, CA. FILED 8-30-2006.

ISHKADADA

THE MARK CONSISTS OF STANDARD CHARACTERS WITHOUT CLAIM TO ANY PARTICULAR FONT, STYLE, SIZE, OR COLOR.

FOR LEATHER BAGS, SUITCASES AND WALLETS (U.S. CLS. 1, 2, 3, 22 AND 41).

JOHN DALIER, EXAMINING ATTORNEY

**CLASS 18—(Continued).**

SN 78-964,509. AMERICAN NEVADA HOLDINGS, LLC, HENDERSON, NV. FILED 8-30-2006.

*Avenue33*

BROWNSTONES AT THE DISTRICT

FOR LEATHER KEY CHAINS; LEATHER KEY CHAIN TAGS; BRIEFCASES; LEATHER AND IMITATION LEATHER BAGS; TOTE BAGS; TRAVEL BAGS; ALL PURPOSE SPORT BAGS; BACKPACKS; WALLETS; PURSES; HANDBAGS; SOUVENIR BAGS; FANNY PACKS; MESH SHOPPING BAGS; TEXTILE SHOPPING BAGS; AND UMBRELLAS (U.S. CLS. 1, 2, 3, 22 AND 41).  
HEATHER SAPP, EXAMINING ATTORNEY

SN 78-964,881. SOCIETE DES PRODUITS NESTLE S.A., VEVEY, SWITZERLAND, FILED 8-31-2006.

**HOLD ME**

THE MARK CONSISTS OF STANDARD CHARACTERS WITHOUT CLAIM TO ANY PARTICULAR FONT, STYLE, SIZE, OR COLOR.  
FOR COLLARS FOR PETS (U.S. CLS. 1, 2, 3, 22 AND 41).  
MATTHEW PAPPAS, EXAMINING ATTORNEY

SN 78-965,221. BARBARA K. ENTERPRISES, INC., NEW YORK, NY. FILED 8-31-2006.

**BARBARA K**

THE MARK CONSISTS OF STANDARD CHARACTERS WITHOUT CLAIM TO ANY PARTICULAR FONT, STYLE, SIZE, OR COLOR.  
OWNER OF U.S. REG. NOS. 2,967,632, 3,005,510 AND OTHERS.  
FOR TOOL BAGS SOLD EMPTY; ALL-PURPOSE SPORTS AND ATHLETIC BAGS; BEACH, BOOK, CARRY-ON, DUFFEL, DIAPER, GYM, LEATHER SHOPPING, SHOULDER, TOTE AND TRAVEL BAGS; FANNY PACKS AND WAIST PACKS; BACKPACKS; KNAPSACKS; PURSES; GARMENT BAGS FOR TRAVEL; SATCHELS; LUGGAGE; LUGGAGE TAGS; TRUNKS; SUITCASES; HAT BOXES FOR TRAVEL NOT OF PAPER OR CARDBOARD; COSMETIC CASES AND BAGS SOLD EMPTY; TOILETRY AND VANITY CASES SOLD EMPTY; ATTACHE CASES; BRIEFCASES; BRIEFCASE-TYPE PORTFOLIOS; DOCUMENT CASES; CLUTCH BAGS FOR MEN; BUSINESS CASES; BUSINESS CARD CASES; CALLING AND CREDIT CARD CASES; KEY CASES; LEATHER KEY CHAINS; WALLETS; BANK-NOTE HOLDERS; BILLFOLDS; UMBRELLAS; PARASOLS; WALKING STICKS (U.S. CLS. 1, 2, 3, 22 AND 41).  
EDWARD FENNESSY, EXAMINING ATTORNEY

**CLASS 18—(Continued).**

SN 78-966,515. BOUCKAERT INDUSTRIAL TEXTILES, INC., WOONSOCKET, RI. FILED 9-2-2006.

GENGHIS KHAN CAMEL HAIR PAD

THE MARK CONSISTS OF STANDARD CHARACTERS WITHOUT CLAIM TO ANY PARTICULAR FONT, STYLE, SIZE, OR COLOR.  
NO CLAIM IS MADE TO THE EXCLUSIVE RIGHT TO USE "CAMEL HAIR PAD", APART FROM THE MARK AS SHOWN.  
FOR HORSE BLANKETS; PADS FOR HORSE SADDLES (U.S. CLS. 1, 2, 3, 22 AND 41).  
RENEE MCCRAY, EXAMINING ATTORNEY

SN 78-966,526. KU, ROSEMARY, VESTAL, NY. FILED 9-2-2006.

**RoZCoo New York Be  
yourself . . . be yourself  
in style**

THE MARK CONSISTS OF STANDARD CHARACTERS WITHOUT CLAIM TO ANY PARTICULAR FONT, STYLE, SIZE, OR COLOR.  
NO CLAIM IS MADE TO THE EXCLUSIVE RIGHT TO USE "NEW YORK", APART FROM THE MARK AS SHOWN.  
FOR ALL PURPOSE SPORT BAGS; ALL-PURPOSE ATHLETIC BAGS; ALL-PURPOSE CARRYING BAGS; ATHLETIC BAGS; BAGS AND HOLDALLS FOR SPORTS CLOTHING; BOOK BAGS; CARRY-ALL BAGS; CARRY-ON BAGS; CHARM BAGS; CLUTCH BAGS; COSMETIC BAGS SOLD EMPTY; DUFFEL BAGS; DUFFEL BAGS FOR TRAVEL; EVENING HANDBAGS; FLEXIBLE BAGS FOR GARMENTS; GARMENT BAGS FOR TRAVEL; GENERAL PURPOSE BAGS FOR CARRYING YOGA EQUIPMENT; GYM BAGS; LEATHER AND IMITATION LEATHER BAGS; MAKE-UP BAGS SOLD EMPTY; MESSENGER BAGS; OVERNIGHT BAGS; ROLL BAGS; SCHOOL BAGS; SCHOOL BOOK BAGS; SHOULDER BAGS; SMALL BAGS FOR MEN; SPORTS BAGS; SUIT BAGS; TOTE BAGS; TRAVEL BAGS; WAIST BAGS; WINE BAGS WITH HANDLES FOR CARRYING OR HOLDING WINE; WRIST MOUNTED CARRYALL BAGS; WRISTLET BAGS (U.S. CLS. 1, 2, 3, 22 AND 41).  
FIRST USE 10-1-2004; IN COMMERCE 1-28-2005.  
CHRISTOPHER BUONGIORNO, EXAMINING ATTORNEY

**CLASS 18—(Continued).**

SN 78-966,632. CITY OF HENDERSON REDEVELOPMENT AGENCY, HENDERSON, NV. FILED 9-3-2006.



NO CLAIM IS MADE TO THE EXCLUSIVE RIGHT TO USE "WATER STREET DISTRICT HENDERSON", APART FROM THE MARK AS SHOWN.

THE MARK CONSISTS OF WATER STREET DISTRICT HENDERSON IN STYLIZED LETTERS.

FOR TOTE BAGS, DUFFEL BAGS, BACK PACKS, BEACH BAGS, FANNY PACKS, HANDBAGS, WALLETS, BILLFOLDS, BUSINESS CARD CASES, TOILETRY CASES SOLD EMPTY, GARMENT BAGS FOR TRAVEL AND UMBRELLAS (U.S. CLS. 1, 2, 3, 22 AND 41).

SUSAN STIGLITZ, EXAMINING ATTORNEY

**CLASS 18—(Continued).**

SN 78-969,142. MASCOT METROPOLITAN INC, SOUTH SAN FRANCISCO, CA. FILED 9-7-2006.

**BALLOTS ON WHEELS**

THE MARK CONSISTS OF STANDARD CHARACTERS WITHOUT CLAIM TO ANY PARTICULAR FONT, STYLE, SIZE, OR COLOR.

OWNER OF U.S. REG. NOS. 2,802,228, 2,974,647 AND OTHERS.

NO CLAIM IS MADE TO THE EXCLUSIVE RIGHT TO USE "BALLOTS", APART FROM THE MARK AS SHOWN.

FOR LUGGAGE PRIMARILY FOR VOTING EQUIPMENT AND SUPPLIES (U.S. CLS. 1, 2, 3, 22 AND 41).

FIRST USE 4-6-2006; IN COMMERCE 6-6-2006.

CYNTHIA SLOAN, EXAMINING ATTORNEY

SN 78-967,110. G. HENSLER & CO., SAN FRANCISCO, CA. FILED 9-5-2006.

**49 SQUARE MILES**

THE MARK CONSISTS OF STANDARD CHARACTERS WITHOUT CLAIM TO ANY PARTICULAR FONT, STYLE, SIZE, OR COLOR.

FOR ALL PURPOSE SPORT BAGS; BACKPACKS; BEACH BAGS; BOOK BAGS; BRIEFCASES; BUSINESS CARD CASES; COIN PURSES; COSMETIC BAGS SOLD EMPTY; DIAPER BAGS; GARMENT BAGS FOR TRAVEL; KEY CASES; LUGGAGE TAGS; OVERNIGHT CASES; OVERNIGHT SUITCASES; PURSES; SCHOOL BAGS; SHOULDER BAGS; SUITCASES; TOTE BAGS; TRAVEL BAGS; VANITY CASES SOLD EMPTY; WAIST PACKS; WALLETS (U.S. CLS. 1, 2, 3, 22 AND 41).

DAVID MURRAY, EXAMINING ATTORNEY

SN 78-969,451. TREBBIANNO, LLC, NEW YORK, NY. FILED 9-7-2006.

**MORA MARA**

THE MARK CONSISTS OF STANDARD CHARACTERS WITHOUT CLAIM TO ANY PARTICULAR FONT, STYLE, SIZE, OR COLOR.

FOR HANDBAGS, WALLETS, BILLFOLDS, SHOULDER BAGS, PURSES, LUGGAGE AND SUITCASES (U.S. CLS. 1, 2, 3, 22 AND 41).

ANDREA EVANS, EXAMINING ATTORNEY

SN 78-967,318. TELLONE, LAWRENCE, LONG ISLAND CITY, NY. FILED 9-5-2006.

**JESUS REIGNS**

THE MARK CONSISTS OF STANDARD CHARACTERS WITHOUT CLAIM TO ANY PARTICULAR FONT, STYLE, SIZE, OR COLOR.

FOR UMBRELLAS (U.S. CLS. 1, 2, 3, 22 AND 41).

FIRST USE 6-1-2006; IN COMMERCE 7-1-2006.

FLORENTINA BLANDU, EXAMINING ATTORNEY

SN 78-970,387. PET-AG, INC., HAMPSHIRE, IL. FILED 9-8-2006.

**SAFETY-KNOT**

THE MARK CONSISTS OF STANDARD CHARACTERS WITHOUT CLAIM TO ANY PARTICULAR FONT, STYLE, SIZE, OR COLOR.

FOR DENTAL RAWHIDE CHEW FOR ANIMALS (U.S. CLS. 1, 2, 3, 22 AND 41).

GRETTA YAO, EXAMINING ATTORNEY



**CLASS 19—NON-METALLIC BUILDING MATERIALS**

SN 77-056,920. BIO-NUTRA TECHNOLOGIES, LLC, VENICE, FL. FILED 12-5-2006.

**SMART TIMBER**

THE MARK CONSISTS OF STANDARD CHARACTERS WITHOUT CLAIM TO ANY PARTICULAR FONT, STYLE, SIZE, OR COLOR.

NO CLAIM IS MADE TO THE EXCLUSIVE RIGHT TO USE "TIMBER", APART FROM THE MARK AS SHOWN.

FOR TIMBER (U.S. CLS. 1, 12, 33 AND 50).  
KIMBERLY PERRY, EXAMINING ATTORNEY

SN 78-818,148. SINGER, RALPH, M., CITY OF INDUSTRY, CA. FILED 2-17-2006.

**The Millstone Collection**

THE MARK CONSISTS OF STANDARD CHARACTERS WITHOUT CLAIM TO ANY PARTICULAR FONT, STYLE, SIZE, OR COLOR.

NO CLAIM IS MADE TO THE EXCLUSIVE RIGHT TO USE "COLLECTION", APART FROM THE MARK AS SHOWN.

FOR FLOOR MATERIAL, NAMELY FLOOR BOARDS AND FLOOR TILES OF HARDWOOD AND SOLID WOOD (U.S. CLS. 1, 12, 33 AND 50).

FIRST USE 11-7-2004; IN COMMERCE 11-7-2004.  
KEVIN CORWIN, EXAMINING ATTORNEY

SN 78-855,315. 5TH WALL DESIGN, LLC, BLAINE, MN. FILED 4-6-2006.

**FIFTH WALL DESIGNS**

NO CLAIM IS MADE TO THE EXCLUSIVE RIGHT TO USE "FIFTH WALL DESIGNS", APART FROM THE MARK AS SHOWN.

THE MARK CONSISTS OF THE WORDS 5TH FIFTH WALL DESIGNS IN A STYLIZED FORMAT WITH CRISS-CROSSING LINES APPEARING AROUND THE NUMBER 5. FOR CEILING PANELS, NOT OF METAL; WALL PANELS NOT OF METAL (U.S. CLS. 1, 12, 33 AND 50).

FIRST USE 8-1-2004; IN COMMERCE 8-1-2004.  
MATTHEW MCDOWELL, EXAMINING ATTORNEY

**CLASS 19—(Continued).**

SN 78-941,453. OWEN SOUND LEDGEROCK LIMITED, OWEN SOUND, ONTARIO, CANADA, FILED 7-31-2006.

**EROSAN PAVERS**

THE MARK CONSISTS OF STANDARD CHARACTERS WITHOUT CLAIM TO ANY PARTICULAR FONT, STYLE, SIZE, OR COLOR.

PRIORITY CLAIMED UNDER SEC. 44(D) ON CANADA APPLICATION NO. 1288151, FILED 1-31-2006, REG. NO. TMA680228, DATED 1-24-2007, EXPIRES 1-24-2022.

NO CLAIM IS MADE TO THE EXCLUSIVE RIGHT TO USE "PAVERS", APART FROM THE MARK AS SHOWN.

FOR EXTERIOR LANDSCAPE PAVING UNITS, NAMELY, ERAMOSA LIMESTONE PAVERS (U.S. CLS. 1, 12, 33 AND 50).

KATHERINE CHANG, EXAMINING ATTORNEY

SN 78-949,068. PROPEX INC., CHATTANOOGA, TN. FILED 8-10-2006.

**ARVS**

THE MARK CONSISTS OF STANDARD CHARACTERS WITHOUT CLAIM TO ANY PARTICULAR FONT, STYLE, SIZE, OR COLOR.

FOR EROSION CONTROL PRODUCTS, NAMELY VEGETATIVE REINFORCEMENT AND SOIL STABILIZATION SYSTEMS COMPRISING WOVEN NON-METALLIC GEOTEXTILE MATTING AND ANCHORS FOR EROSION CONTROL (U.S. CLS. 1, 12, 33 AND 50).

DEBRA LEE, EXAMINING ATTORNEY

SN 78-958,228. MARBELITE INTERNATIONAL CORP., SARASOTA, FL. FILED 8-23-2006.

**Screed Crete Coat**

THE MARK CONSISTS OF STANDARD CHARACTERS WITHOUT CLAIM TO ANY PARTICULAR FONT, STYLE, SIZE, OR COLOR.

NO CLAIM IS MADE TO THE EXCLUSIVE RIGHT TO USE "SCREED" OR "COAT", APART FROM THE MARK AS SHOWN.

FOR DRY BAG CEMENT MIXTURES COMBINED WITH A LIQUID ACRYLIC POLYMER FOR USE IN COATING EXPANDED POLYSTYRENE FOAM (U.S. CLS. 1, 12, 33 AND 50).

PETER B. BROMAGHIM, EXAMINING ATTORNEY

**CLASS 19—(Continued).**

SN 78-959,270. INDUSTRIAS AUXILIARES FAUS S.L., VELENIA, SPAIN, FILED 8-24-2006.

# UltraClarity

THE MARK CONSISTS OF STANDARD CHARACTERS WITHOUT CLAIM TO ANY PARTICULAR FONT, STYLE, SIZE, OR COLOR.

FOR LAMINATE FLOORING (U.S. CLS. 1, 12, 33 AND 50).

LAURIE KAUFMAN, EXAMINING ATTORNEY

**CLASS 19—(Continued).**

SN 78-961,445. SUN SHADE, INC., CORAL SPRINGS, FL. FILED 8-28-2006.

# PolyShelters

FOR DURABLE, RIBBED, MOLDED THERMOPLASTIC AND FIBERGLASS MODULAR SECTIONS, WHICH ARE USED AS SUBSTITUTE ROOFS, WALLS AND FLOORS, RESISTANT TO ALL WEATHER CONDITIONS, USED TO CREATE SHEDS, GARAGES AND STORAGE (U.S. CLS. 1, 12, 33 AND 50).

THOMAS MANOR, EXAMINING ATTORNEY

SN 78-960,444. XM INTERNATIONAL, INC., EAST RUTHERFORD, NJ. FILED 8-25-2006.



**X-CELL**  
building materials  
*A standard of "ex-cell-ence" in quality hardware.*

NO CLAIM IS MADE TO THE EXCLUSIVE RIGHT TO USE "BUILDING MATERIALS", APART FROM THE MARK AS SHOWN.

THE COLOR(S) BLACK, PURPLE, AND WHITE IS/ARE CLAIMED AS A FEATURE OF THE MARK.

THE COLOR BLACK APPEARS IN THE WORDING "X-CELL" AND THE PHRASE "A STANDARD OF 'EX-CELL-ENCE' IN QUALITY HARDWARE." THE COLOR PURPLE APPEARS IN THE SHADING OF THE PARTIALLY SHADED RECTANGLE. THE COLOR WHITE APPEARS IN THE WORDING "BUILDING MATERIALS." THE COLOR WHITE IS NOT A FEATURE OF THE BACKGROUND OF THE MARK AS THE WHITE BEHIND THE MARK MERELY REPRESENTS A TRANSPARENCY.

FOR NON-METAL CLADDING FOR CONSTRUCTION AND BUILDING (U.S. CLS. 1, 12, 33 AND 50).

MEGAN WHITNEY, EXAMINING ATTORNEY

SN 78-961,938. PERMA-BILT INDUSTRIES, INC., LYNNWOOD, WA. FILED 8-28-2006.

# PERMABILT

THE MARK CONSISTS OF STANDARD CHARACTERS WITHOUT CLAIM TO ANY PARTICULAR FONT, STYLE, SIZE, OR COLOR.

FOR PREFABRICATED BUILDINGS CONSISTING OF PRIMARILY NON-METAL PARTS (U.S. CLS. 1, 12, 33 AND 50).

FIRST USE 0-0-1982; IN COMMERCE 5-5-2006.

KATHRYN COWARD, EXAMINING ATTORNEY

SN 78-960,507. INDUSTRIAS AUXILIARES FAUS S.L., VELENIA, SPAIN, FILED 8-25-2006.

# UltraClarity

THE MARK CONSISTS OF STANDARD CHARACTERS WITHOUT CLAIM TO ANY PARTICULAR FONT, STYLE, SIZE, OR COLOR.

FOR HARDWOOD FLOORING (U.S. CLS. 1, 12, 33 AND 50).

LAURIE KAUFMAN, EXAMINING ATTORNEY

SN 78-962,034. MOSARTE INDÚSTRIA E COMÉRCIO DE MOSAICOS LTDA., SANTA CATARINA, BRAZIL, FILED 8-28-2006.

# MOSARTE

THE MARK CONSISTS OF STANDARD CHARACTERS WITHOUT CLAIM TO ANY PARTICULAR FONT, STYLE, SIZE, OR COLOR.

FOR MOSAIC TILES NOT OF METAL, USED IN BUILDING MADE OF NATURAL STONES, MARBLE, GLASS, CERAMICS, SLATE, GLASS AND WOOD (U.S. CLS. 1, 12, 33 AND 50).

BONNIE LUKEN, EXAMINING ATTORNEY

**CLASS 19—(Continued).**

SN 78-962,429. VINYL WINDOW TECHNOLOGIES, INC., PADUCAH, KY. FILED 8-29-2006.



**SHORELINE**  
WIND ZONE RATED WINDOWS & DOORS

NO CLAIM IS MADE TO THE EXCLUSIVE RIGHT TO USE WIND ZONE RATED WINDOWS & DOORS, APART FROM THE MARK AS SHOWN.

FOR VINYL WINDOWS AND DOORS AND PARTS THEREFOR (U.S. CLS. 1, 12, 33 AND 50).

FIRST USE 8-18-2006; IN COMMERCE 8-18-2006.  
PATRICIA EVANKO, EXAMINING ATTORNEY

**CLASS 19—(Continued).**

SN 78-967,394. TRI-STATE WINDOW & SIDING CORP., STANHOPE, NJ. FILED 9-5-2006.

**RESISTANCE**

THE MARK CONSISTS OF STANDARD CHARACTERS WITHOUT CLAIM TO ANY PARTICULAR FONT, STYLE, SIZE, OR COLOR.

FOR GLASS SYSTEM, NAMELY, DOUBLE OR TRIPLE GLAZED GLASS SYSTEM SOLD AS A UNIT COMPRISING AT LEAST TWO PANES OF GLASS SEALED TOGETHER WITH AN EDGE SPACER, FOR USE WITH A NON-METALLIC WINDOW OR DOOR FOR BUILDING CONSTRUCTION (U.S. CLS. 1, 12, 33 AND 50).

SOPHIA S. KIM, EXAMINING ATTORNEY

SN 78-962,440. VINYL WINDOW TECHNOLOGIES, INC., PADUCAH, KY. FILED 8-29-2006.



**SHORELINE**

FOR VINYL WINDOWS AND DOORS AND PARTS THEREFOR (U.S. CLS. 1, 12, 33 AND 50).

FIRST USE 8-18-2006; IN COMMERCE 8-18-2006.  
PATRICIA EVANKO, EXAMINING ATTORNEY

SN 78-967,413. KNAUF USA POLYSTYRENE, INC., LEBA-NON, OH. FILED 9-5-2006.

**WEBLOK**

THE MARK CONSISTS OF STANDARD CHARACTERS WITHOUT CLAIM TO ANY PARTICULAR FONT, STYLE, SIZE, OR COLOR.

FOR CONSTRUCTION MATERIALS, NAMELY, NON-METAL PERMANENT INSULATING CASTING FORMS FOR CONCRETE (U.S. CLS. 1, 12, 33 AND 50).

FIRST USE 4-17-2006; IN COMMERCE 4-17-2006.  
DORITT L. CARROLL, EXAMINING ATTORNEY

SN 78-962,442. VINYL WINDOW TECHNOLOGIES, INC., PADUCAH, KY. FILED 8-29-2006.

**SHORELINE**

THE MARK CONSISTS OF STANDARD CHARACTERS WITHOUT CLAIM TO ANY PARTICULAR FONT, STYLE, SIZE, OR COLOR.

FOR VINYL WINDOWS AND DOORS AND PARTS THEREFOR (U.S. CLS. 1, 12, 33 AND 50).

FIRST USE 5-0-2004; IN COMMERCE 5-0-2004.  
PATRICIA EVANKO, EXAMINING ATTORNEY

SN 78-968,816. INTERCERAMIC, INC., GARLAND, TX. FILED 9-7-2006.

**OXIDE**

THE MARK CONSISTS OF STANDARD CHARACTERS WITHOUT CLAIM TO ANY PARTICULAR FONT, STYLE, SIZE, OR COLOR.

FOR TILES OF CLAY, GLASS, GYPSUM, CERAMIC OR EARTHENWARE (U.S. CLS. 1, 12, 33 AND 50).

KENNETH E. SHARPERSON, EXAMINING ATTORNEY

**CLASS 19—(Continued).**

SN 78-969,202. BUILDING MATERIALS INVESTMENT CORPORATION, WILMINGTON, DE. FILED 9-7-2006.

# COBRA

THE MARK CONSISTS OF STANDARD CHARACTERS WITHOUT CLAIM TO ANY PARTICULAR FONT, STYLE, SIZE, OR COLOR.

FOR ATTIC VENTILATION MATERIALS, NAMELY, NON-METAL RIDGE AND HIP ROOF VENTS AND SOFFIT VENTILATION (U.S. CLS. 1, 12, 33 AND 50).

FIRST USE 8-28-1991; IN COMMERCE 8-28-1991.  
AISHA CLARKE, EXAMINING ATTORNEY

SN 78-969,204. BUILDING MATERIALS INVESTMENT CORPORATION, WILMINGTON, DE. FILED 9-7-2006.



FOR ATTIC VENTILATION MATERIALS, NAMELY, NON-METAL RIDGE AND HIP ROOF VENTS AND SOFFIT VENTILATION (U.S. CLS. 1, 12, 33 AND 50).

FIRST USE 8-28-1991; IN COMMERCE 8-28-1991.  
AISHA CLARKE, EXAMINING ATTORNEY

SN 78-971,030. JUMPSTART CONSULTANTS, WILLMINGTON, NC. FILED 9-11-2006.

# DAWSON'S MILL

THE MARK CONSISTS OF STANDARD CHARACTERS WITHOUT CLAIM TO ANY PARTICULAR FONT, STYLE, SIZE, OR COLOR.

FOR INJECTION MOLDED POLYMERIC SIDING MATERIAL (U.S. CLS. 1, 12, 33 AND 50).

KIMBERLY FRYE, EXAMINING ATTORNEY

**CLASS 19—(Continued).**

SN 79-022,347. KREHER BETON GMBH, FED REP GERMANY, FILED 1-10-2006.

# Delgado+

THE MARK CONSISTS OF STANDARD CHARACTERS WITHOUT CLAIM TO ANY PARTICULAR FONT, STYLE, SIZE, OR COLOR.

PRIORITY DATE OF 7-29-2005 IS CLAIMED.

OWNER OF INTERNATIONAL REGISTRATION 0881011 DATED 1-10-2006, EXPIRES 1-10-2016.

FOR BUILDING MATERIALS AND PRODUCTS, NOT OF METAL, NAMELY, CONCRETE, PUMICE STONE, GRAVEL, ASPHALT, PITCH AND BITUMEN ASPHALT; GOODS MADE OF THE FOREMENTIONED MATERIALS, NAMELY, READY-MIXED CONCRETE, BRICKS, PAVING BLOCKS, KERB STONES, ROAD MAKING STONES, CAVITY BLOCK STONES, STONES FOR SLOPE STABILIZING, PALISADES; RIGID PIPES, NOT OF METAL, FOR BUILDING; TRANSPORTABLE BUILDINGS, NOT OF METAL; MONUMENTS, NOT OF METAL, OF STONE AND CONCRETE (U.S. CLS. 1, 12, 33 AND 50).

DAVID HOFFMAN, EXAMINING ATTORNEY

SN 79-027,675. SOCIEDAD ESPAÑOLA DE VIDRIOS; ARTISTICOS, S.A., SPAIN, FILED 5-25-2006.

# SEVASA

THE MARK CONSISTS OF STANDARD CHARACTERS WITHOUT CLAIM TO ANY PARTICULAR FONT, STYLE, SIZE, OR COLOR.

PRIORITY DATE OF 12-13-2005 IS CLAIMED.

OWNER OF INTERNATIONAL REGISTRATION 0895359 DATED 5-25-2006, EXPIRES 5-25-2016.

FOR PLATE GLASS WINDOWS FOR BUILDING (U.S. CLS. 1, 12, 33 AND 50).

SANDRA MANIOS, EXAMINING ATTORNEY

**CLASS 20—FURNITURE AND ARTICLES NOT OTHERWISE CLASSIFIED**

SN 76-665,718. LEE SNIJDERS DESIGNS, PORTER RANCH, CA. FILED 9-7-2006.

# LEE SNIJDERS DESIGNS

THE MARK CONSISTS OF STANDARD CHARACTERS WITHOUT CLAIM TO ANY PARTICULAR FONT, STYLE, SIZE, OR COLOR.

NO CLAIM IS MADE TO THE EXCLUSIVE RIGHT TO USE DESIGNS, APART FROM THE MARK AS SHOWN.

THE NAME LEE SNIJDERS IDENTIFIES A LIVING INDIVIDUAL WHOSE CONSENT IS OF RECORD.

FOR FURNITURE (U.S. CLS. 2, 13, 22, 25, 32 AND 50).  
BRIDGETT SMITH, EXAMINING ATTORNEY

**CLASS 20—(Continued).**

SN 77-061,386. JESSICA MCCLINTOCK, INC., SAN FRANCISCO, CA. FILED 12-11-2006.

**Jessica McClintock Home**

THE MARK CONSISTS OF STANDARD CHARACTERS WITHOUT CLAIM TO ANY PARTICULAR FONT, STYLE, SIZE, OR COLOR.

OWNER OF U.S. REG. NOS. 1,801,339, 3,171,071 AND OTHERS.

NO CLAIM IS MADE TO THE EXCLUSIVE RIGHT TO USE "HOME", APART FROM THE MARK AS SHOWN.

THE NAME(S), PORTRAIT(S), AND/OR SIGNATURE(S) SHOWN IN THE MARK IDENTIFIES JESSICA MCCLINTOCK, WHOSE CONSENT(S) TO REGISTER IS SUBMITTED.

FOR SEATING FURNITURE, NAMELY, CHAIRS; DINING CHAIRS; LOUNGE CHAIRS; LOVESEATS; CHAISES; COUCHES AND SOFAS (U.S. CLS. 2, 13, 22, 25, 32 AND 50).

FIRST USE 5-26-2006; IN COMMERCE 5-26-2006.  
MICHAEL KEATING, EXAMINING ATTORNEY

**CLASS 20—(Continued).**

SN 77-068,643. DRAKE-BLUESTEIN, INC., SACRAMENTO, CA. FILED 12-20-2006.

**DOMESTIC SOLUTIONS**

THE MARK CONSISTS OF STANDARD CHARACTERS WITHOUT CLAIM TO ANY PARTICULAR FONT, STYLE, SIZE, OR COLOR.

FOR PLASTIC AND ELASTIC FASTENERS FOR HOLDING BED SHEETS, LINENS AND LINERS IN PLACE (U.S. CLS. 2, 13, 22, 25, 32 AND 50).

FIRST USE 9-30-1999; IN COMMERCE 9-30-1999.  
MICHAEL WIENER, EXAMINING ATTORNEY

SN 77-069,817. STEELCASE DEVELOPMENT CORPORATION, CALEDONIA, MI. FILED 12-21-2006.

**LOVE HOW YOU WORK**

SN 77-061,640. JESSICA MCCLINTOCK, INC., SAN FRANCISCO, CA. FILED 12-11-2006.



OWNER OF U.S. REG. NOS. 2,436,757, 2,687,021 AND OTHERS.

THE MARK CONSISTS OF THE LETTERS "JMC" ENCLOSED WITHIN AN OVAL BACKGROUND BORDERED BY TWO CONCENTRIC CIRCLES.

FOR SEATING FURNITURE, NAMELY, CHAIRS; DINING CHAIRS; LOUNGE CHAIRS; LOVESEATS; CHAISES; COUCHES AND SOFAS (U.S. CLS. 2, 13, 22, 25, 32 AND 50).

FIRST USE 5-26-2006; IN COMMERCE 5-26-2006.  
MICHAEL KEATING, EXAMINING ATTORNEY

THE MARK CONSISTS OF STANDARD CHARACTERS WITHOUT CLAIM TO ANY PARTICULAR FONT, STYLE, SIZE, OR COLOR.

FOR FURNITURE (U.S. CLS. 2, 13, 22, 25, 32 AND 50).  
CHRISTINA SOBRAL, EXAMINING ATTORNEY

SN 78-605,541. INTERPLANET PRODUCTIONS LIMITED, BEVERLY HILLS, CA. FILED 4-9-2005.

**"SOMETHING WONDERFUL IS ABOUT TO HAPPEN" ELIZABETH TAYLOR**

THE MARK CONSISTS OF STANDARD CHARACTERS WITHOUT CLAIM TO ANY PARTICULAR FONT, STYLE, SIZE, OR COLOR.

THE NAME ELIZABETH TAYLOR IDENTIFIES A LIVING INDIVIDUAL WHOSE CONSENT IS OF RECORD.

FOR BEDS, MATTRESSES AND FURNITURE (U.S. CLS. 2, 13, 22, 25, 32 AND 50).

SUE LAWRENCE, EXAMINING ATTORNEY

**CLASS 20—(Continued).**

SN 78-770,325. GILL METAL FABRICATION, INC., BROCKTON, MA. FILED 12-9-2005.

**MODULINE**

THE MARK CONSISTS OF STANDARD CHARACTERS WITHOUT CLAIM TO ANY PARTICULAR FONT, STYLE, SIZE, OR COLOR.

FOR MODULAR STORAGE CABINETS, DRAWERS, AND SHELVING (U.S. CLS. 2, 13, 22, 25, 32 AND 50).

FIRST USE 3-1-1998; IN COMMERCE 3-1-1998.  
PAM WILLIS, EXAMINING ATTORNEY

---

SN 78-810,720. BLINDS TO GO (U.S.) INC., ISELIN, NJ. FILED 2-9-2006.

**PERFECTWOOD**

THE MARK CONSISTS OF STANDARD CHARACTERS WITHOUT CLAIM TO ANY PARTICULAR FONT, STYLE, SIZE, OR COLOR.

FOR WINDOW BLINDS (U.S. CLS. 2, 13, 22, 25, 32 AND 50).

MICHELE SWAIN, EXAMINING ATTORNEY

---

SN 78-818,180. TREASURE HUT, INC., DEDEDO, GUAM, FILED 2-17-2006.

**COCO-LUCK**

THE MARK CONSISTS OF STANDARD CHARACTERS WITHOUT CLAIM TO ANY PARTICULAR FONT, STYLE, SIZE, OR COLOR.

FOR COCONUT SHELL FIGURINES, NAMELY, A MAN AND WOMAN FIGURINE ATTACHED AT THE TOPS OF THEIR HEADS BY A STRING THAT RUNS THROUGH A COCONUT SHELL HEART; A CARD ATTACHED TO THE FIGURES EXPLAINS THEIR UNDERLYING MEANING AND TELLS THEIR STORY (U.S. CLS. 2, 13, 22, 25, 32 AND 50).

FIRST USE 8-0-2005; IN COMMERCE 8-0-2005.  
JILL C. ALT, EXAMINING ATTORNEY

**CLASS 20—(Continued).**

SN 78-826,206. RAYMOND J. LITZAU, HANNAH R. LITZAU, & ALEXANDER J. LITZAU, DORSEY, IL. FILED 3-1-2006.

**PEDIGREED PYRAMID**

THE MARK CONSISTS OF STANDARD CHARACTERS WITHOUT CLAIM TO ANY PARTICULAR FONT, STYLE, SIZE, OR COLOR.

NO CLAIM IS MADE TO THE EXCLUSIVE RIGHT TO USE "PYRAMID", APART FROM THE MARK AS SHOWN.

FOR DISPLAY BOARDS; DISPLAY CASES; DISPLAY CASES FOR MERCHANDISE; DISPLAY HEAD PANELS FOR CASKETS FOR DISPLAYING PICTURES AND INFORMATION ABOUT DECEASED; DISPLAY RACKS; METAL DISPLAY STANDS (U.S. CLS. 2, 13, 22, 25, 32 AND 50).

VERNA BETH RIRIE, EXAMINING ATTORNEY

---

SN 78-899,916. INTERMARKET TECHNOLOGY, INC., WAYNE, NJ. FILED 6-3-2006.

**MASTER BLASTER**

THE MARK CONSISTS OF STANDARD CHARACTERS WITHOUT CLAIM TO ANY PARTICULAR FONT, STYLE, SIZE, OR COLOR.

FOR POINT OF PURCHASE DISPLAYS, NAMELY, OUTDOOR PROMOTION BOXES WHICH MAY OR MAY NOT CONTAIN PALLETIZED PRODUCTS AND WHICH HAVE CHANGEABLE GRAPHICS AND PRICING INFORMATION (U.S. CLS. 2, 13, 22, 25, 32 AND 50).

FIRST USE 3-22-2002; IN COMMERCE 3-22-2002.  
CHRISTOPHER OTT, EXAMINING ATTORNEY

---

SN 78-899,921. INTERMARKET TECHNOLOGY, INC., WAYNE, NJ. FILED 6-3-2006.

**BUMP BLASTER**

THE MARK CONSISTS OF STANDARD CHARACTERS WITHOUT CLAIM TO ANY PARTICULAR FONT, STYLE, SIZE, OR COLOR.

FOR POINT OF PURCHASE DISPLAYS, NAMELY, COVERS FOR GAS ISLAND BOLLARDS, AND OUTDOOR DISPLAY BOARDS FOR PROVIDING VISUAL MESSAGES (U.S. CLS. 2, 13, 22, 25, 32 AND 50).

FIRST USE 3-31-2004; IN COMMERCE 3-31-2004.  
CHRISTOPHER OTT, EXAMINING ATTORNEY

**CLASS 20—(Continued).**

SN 78-937,944. SUMO LOUNGE INTERNATIONAL CORP., PANAMA CITY, PANAMA, FILED 7-26-2006.



OWNER OF CANADA REG. NO. TMA653275, DATED 11-23-2005, EXPIRES 11-23-2020.

FOR FURNITURE, NAMELY, CHAIRS, CUSHIONS AND OTTOMANS; FURNITURE, NAMELY, BEDROOM, DINING ROOM AND LIVING ROOM FURNITURE; PET FURNITURE AND CUSHIONS (U.S. CLS. 2, 13, 22, 25, 32 AND 50).

FIRST USE 2-0-2004; IN COMMERCE 2-0-2004.  
MATTHEW EINSTEIN, EXAMINING ATTORNEY

SN 78-955,763. SANRIO COMPANY, LTD., TOKYO, JAPAN, FILED 8-18-2006.

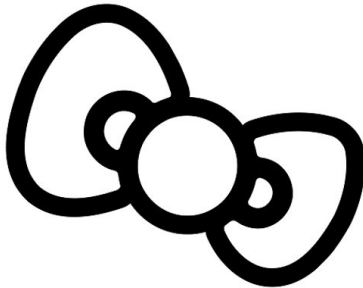

OWNER OF U.S. REG. NOS. 1,200,083, 1,370,105 AND OTHERS.

THE MARK CONSISTS OF A BOW.

FOR FURNITURE, BEDROOM FURNITURE, OUTDOOR FURNITURE, JUVENILE FURNITURE, FOAM-FILLED FURNITURE, INFLATABLE FURNITURE, SLEEPING BAGS, CUSHIONS, PILLOWS, HAMPERS, DRAWER PULLS MADE OF PLASTIC AND WOOD, DOOR STOPS MADE OF PLASTIC AND WOOD, NON-METAL CLOTHES HOOKS, NON-METAL CLOTHES HANGERS, COAT RACKS, SHOWER CURTAIN HOOKS, NON-METAL CHRISTMAS STOCKING HOOKS, PICTURE FRAMES, PERSONAL COMPACT MIRRORS, HAND MIRRORS, WOODEN HOLIDAY ORNAMENTS, PLASTIC HOLIDAY ORNAMENTS, NON-METAL KEY CHAINS, NON-METAL KEY RINGS, NON-METAL KEY HOLDERS, PLASTIC KEY CHAIN TAGS, NON-METAL JEWELRY BOXES, NON-METAL JEWELRY STANDS, NON-METAL LOCK BOXES, FABRIC STORAGE BOXES, PLASTIC BOXES, PLASTIC PILLBOXES, DISPENSERS FOR PILLS OR CAPSULES SOLD EMPTY, PLASTIC GIFT PACKAGE DECORATIONS, PLASTIC FIGURINES, PLASTIC CAKE DECORATIONS, FANS FOR PERSONAL USE, VINYL APPLIQUES FOR ATTACHMENT TO WINDOWS, MIRRORS AND OTHER SOLID SURFACES; BEDS FOR HOUSEHOLD PETS, PET CUSHIONS; FOAM TOE SEPARATORS FOR USE IN PEDICURES (U.S. CLS. 2, 13, 22, 25, 32 AND 50).

FIRST USE 9-1-2004; IN COMMERCE 9-1-2004.  
REGINA DRUMMOND, EXAMINING ATTORNEY

**CLASS 20—(Continued).**

SN 78-956,220. PDQ SUPPLY COMPANY, LINDENHURST, NY, FILED 8-21-2006.

**THE GRIPPER SYSTEMS**

THE MARK CONSISTS OF STANDARD CHARACTERS WITHOUT CLAIM TO ANY PARTICULAR FONT, STYLE, SIZE, OR COLOR.

NO CLAIM IS MADE TO THE EXCLUSIVE RIGHT TO USE "SYSTEMS", APART FROM THE MARK AS SHOWN.

FOR ORGANIZING SYSTEMS FOR AUTOMOTIVE SUPPLIES AND PARTS, NAMELY, A METAL RACK CONTAINING NUMEROUS CORRUGATED DRAWERS FOR AUTO BODY AND AUTOMOTIVE CLIPS, FASTENERS, BULBS, FUSES, AND OTHER AUTOMOTIVE SUPPLIES (U.S. CLS. 2, 13, 22, 25, 32 AND 50).

FIRST USE 4-5-2004; IN COMMERCE 4-5-2004.  
JENNY PARK, EXAMINING ATTORNEY

SN 78-957,210. JRW PROPERTIES, INC., OCALA, FL, FILED 8-22-2006.

**INFO-4-U**

THE MARK CONSISTS OF STANDARD CHARACTERS WITHOUT CLAIM TO ANY PARTICULAR FONT, STYLE, SIZE, OR COLOR.

FOR PLASTIC CONTAINERS FOR COMMERCIAL USE, NAMELY TO STORE AND DISTRIBUTE REAL ESTATE INFORMATION (U.S. CLS. 2, 13, 22, 25, 32 AND 50).

ALYSSA PALADINO, EXAMINING ATTORNEY

SN 78-957,964. WEST DECOR, LLC, ROSEVILLE, CA, FILED 8-22-2006.

**WEST DECOR**

THE MARK CONSISTS OF STANDARD CHARACTERS WITHOUT CLAIM TO ANY PARTICULAR FONT, STYLE, SIZE, OR COLOR.

NO CLAIM IS MADE TO THE EXCLUSIVE RIGHT TO USE "DECOR", APART FROM THE MARK AS SHOWN.

FOR FRAMES FOR OIL PAINTINGS; FRAMES FOR PAINTINGS; GLASS FOR USE IN FRAMING ART; LEATHER PICTURE FRAMES; MIRROR FRAMES; MIRRORS; PAPER PHOTO FRAMES; PAPER PICTURE FRAMES; PICTURE FRAME MOLDINGS; PICTURE FRAMES (U.S. CLS. 2, 13, 22, 25, 32 AND 50).

WON TEAK OH, EXAMINING ATTORNEY

**CLASS 20—(Continued).**

SN 78-958,010. WEST DECOR, LLC, ROSEVILLE, CA. FILED 8-22-2006.

**WEST DECOR HOME**

THE MARK CONSISTS OF STANDARD CHARACTERS WITHOUT CLAIM TO ANY PARTICULAR FONT, STYLE, SIZE, OR COLOR.

NO CLAIM IS MADE TO THE EXCLUSIVE RIGHT TO USE "DECOR HOME", APART FROM THE MARK AS SHOWN.

FOR FRAMES FOR OIL PAINTINGS; FRAMES FOR PAINTINGS; GLASS FOR USE IN FRAMING ART; LEATHER PICTURE FRAMES; MIRROR FRAMES; MIRRORS; PAPER PHOTO FRAMES; PAPER PICTURE FRAMES; PICTURE FRAME MOLDINGS; PICTURE FRAMES (U.S. CLS. 2, 13, 22, 25, 32 AND 50).

WON TEAK OH, EXAMINING ATTORNEY

**CLASS 20—(Continued).**

SN 78-960,456. ANTHRO CORPORATION, TUALATIN, OR. FILED 8-25-2006.

**E.L.T.2**

THE MARK CONSISTS OF STANDARD CHARACTERS WITHOUT CLAIM TO ANY PARTICULAR FONT, STYLE, SIZE, OR COLOR.

FOR COMPUTER WORKSTATIONS COMPRISED OF ADJUSTABLE WORK SURFACES, ADJUSTABLE SHELVES, ADJUSTABLE LEGS, PRIVACY PANELS, SOUND ABSORPTION PANELS, COMPUTER KEYBOARD TRAYS, COMPUTER MOUSE SHELVES, CABINETS, DRAWERS, DOCUMENT HOLDERS, AND CASTORS, SOLD AS A UNIT (U.S. CLS. 2, 13, 22, 25, 32 AND 50).

PRISCILLA MILTON, EXAMINING ATTORNEY

SN 78-959,818. BROWN, MELINDA, OCEANSIDE, CA. FILED 8-24-2006.

**INSPIRED WHIMS**

THE MARK CONSISTS OF STANDARD CHARACTERS WITHOUT CLAIM TO ANY PARTICULAR FONT, STYLE, SIZE, OR COLOR.

FOR CARVED WOODEN HOME DECORATIONS NAMELY WALL HANGINGS (U.S. CLS. 2, 13, 22, 25, 32 AND 50).

FIRST USE 8-22-2006; IN COMMERCE 8-22-2006.  
LINDA LAVACHE, EXAMINING ATTORNEY

SN 78-961,395. HOMER TLC, INC., CLAYMONT, DE. FILED 8-28-2006.

**Calabria**

THE MARK CONSISTS OF STANDARD CHARACTERS WITHOUT CLAIM TO ANY PARTICULAR FONT, STYLE, SIZE, OR COLOR.

FOR OUTDOOR FURNITURE (U.S. CLS. 2, 13, 22, 25, 32 AND 50).

KATHRYN COWARD, EXAMINING ATTORNEY

SN 78-960,433. PAWLING CORPORATION, PAWLING, NY. FILED 8-25-2006.

**CEPURE**

THE MARK CONSISTS OF STANDARD CHARACTERS WITHOUT CLAIM TO ANY PARTICULAR FONT, STYLE, SIZE, OR COLOR.

FOR PLASTIC CLOSURES FOR CONTAINERS (U.S. CLS. 2, 13, 22, 25, 32 AND 50).

SUNG IN, EXAMINING ATTORNEY

SN 78-961,398. HOMER TLC, INC., CLAYMONT, DE. FILED 8-28-2006.

**Lucerne**

THE MARK CONSISTS OF STANDARD CHARACTERS WITHOUT CLAIM TO ANY PARTICULAR FONT, STYLE, SIZE, OR COLOR.

FOR OUTDOOR FURNITURE (U.S. CLS. 2, 13, 22, 25, 32 AND 50).

KATHRYN COWARD, EXAMINING ATTORNEY



**CLASS 20—(Continued).**

SN 78-961,399. HOMER TLC, INC., CLAYMONT, DE. FILED 8-28-2006.

# Dana Point

THE MARK CONSISTS OF STANDARD CHARACTERS WITHOUT CLAIM TO ANY PARTICULAR FONT, STYLE, SIZE, OR COLOR.  
FOR OUTDOOR FURNITURE (U.S. CLS. 2, 13, 22, 25, 32 AND 50).  
KATHRYN COWARD, EXAMINING ATTORNEY

SN 78-962,630. IOLA GLOBAL DESIGNS, LLC, LOS GATOS, CA. FILED 8-29-2006.

# DRINK DADDY

THE MARK CONSISTS OF STANDARD CHARACTERS WITHOUT CLAIM TO ANY PARTICULAR FONT, STYLE, SIZE, OR COLOR.  
NO CLAIM IS MADE TO THE EXCLUSIVE RIGHT TO USE "DRINK", APART FROM THE MARK AS SHOWN.  
FOR FURNITURE IN THE NATURE OF A COLLAPSIBLE TABLE WITH INSETS DESIGNED TO HOLD BEVERAGES (U.S. CLS. 2, 13, 22, 25, 32 AND 50).  
FIRST USE 5-3-2006; IN COMMERCE 5-3-2006.  
DAVID I, EXAMINING ATTORNEY

SN 78-963,677. INTERNATIONAL CRATING & LOGISTICS, LLC, LARGO, FL. FILED 8-30-2006.

# GLOBAL CARGO

NO CLAIM IS MADE TO THE EXCLUSIVE RIGHT TO USE CARGO, APART FROM THE MARK AS SHOWN.  
FOR WOODEN CRATES FOR HOME AND PATIO USE (U.S. CLS. 2, 13, 22, 25, 32 AND 50).  
WILLIAM VERHOSEK, EXAMINING ATTORNEY

**CLASS 20—(Continued).**

SN 78-964,156. AMERICAN NEVADA HOLDINGS, LLC, HENDERSON, NV. FILED 8-30-2006.

# Avenue33

AT THE DISTRICT

FOR JEWELRY BOXES NOT OF METAL; NON-METAL AND NON-LEATHER KEY CHAINS; NON-METAL MONEY CLIPS; PICTURE FRAMES; PLASTIC FLAGS; PLASTIC KEY CHAIN TAGS; PLASTIC NOVELTY LICENSE PLATES (U.S. CLS. 2, 13, 22, 25, 32 AND 50).  
MICHAEL ENGEL, EXAMINING ATTORNEY

SN 78-964,664. ALEX KONTOS FRUIT CO., INC., BIRMINGHAM, AL. FILED 8-31-2006.

# Mountain Pride Premium Red Potatoes

THE MARK CONSISTS OF STANDARD CHARACTERS WITHOUT CLAIM TO ANY PARTICULAR FONT, STYLE, SIZE, OR COLOR.  
NO CLAIM IS MADE TO THE EXCLUSIVE RIGHT TO USE "PREMIUM RED POTATOES", APART FROM THE MARK AS SHOWN.  
FOR PLASTIC LABELS FOR PACKAGED POTATOES (U.S. CLS. 2, 13, 22, 25, 32 AND 50).  
JASON BLAIR, EXAMINING ATTORNEY

SN 78-965,629. TOLLESON, THOMAS DANIEL, HOUSTON, TX. FILED 8-31-2006.



# Coelacanth

THE MARK CONSISTS OF THE WORD COELACANTH BELOW A FISH.  
FOR FURNITURE FOR HOUSE, OFFICE AND GARDEN (U.S. CLS. 2, 13, 22, 25, 32 AND 50).  
DAHLIA GEORGE, EXAMINING ATTORNEY

**CLASS 20—(Continued).**

SN 78-965,966. LIFETIME BRANDS, INC., WESTBURY, NY. FILED 9-1-2006.

**THE PERFECT FRAME**

THE MARK CONSISTS OF STANDARD CHARACTERS WITHOUT CLAIM TO ANY PARTICULAR FONT, STYLE, SIZE, OR COLOR.

NO CLAIM IS MADE TO THE EXCLUSIVE RIGHT TO USE "FRAME", APART FROM THE MARK AS SHOWN. FOR PHOTO FRAMES (U.S. CLS. 2, 13, 22, 25, 32 AND 50).

BRIDGETT SMITH, EXAMINING ATTORNEY

SN 78-967,064. C.W.W., INC., ANN ARBOR, MI. FILED 9-5-2006.

**OPENLIGHT**

THE MARK CONSISTS OF STANDARD CHARACTERS WITHOUT CLAIM TO ANY PARTICULAR FONT, STYLE, SIZE, OR COLOR.

FOR WINDOW BLINDS (U.S. CLS. 2, 13, 22, 25, 32 AND 50).

MORENO, PAUL, EXAMINING ATTORNEY

SN 78-967,180. BOSSMATE, LLC, CHATTANOOGA, TN. FILED 9-5-2006.

**MIGHTYMATE**

THE MARK CONSISTS OF STANDARD CHARACTERS WITHOUT CLAIM TO ANY PARTICULAR FONT, STYLE, SIZE, OR COLOR.

FOR WORK SURFACES (U.S. CLS. 2, 13, 22, 25, 32 AND 50).

CYNTHIA SLOAN, EXAMINING ATTORNEY

**CLASS 20—(Continued).**

SN 78-967,980. LOUNGE 22 LLC, GLENDALE, CA. FILED 9-6-2006.

**GLOSOFA**

THE MARK CONSISTS OF STANDARD CHARACTERS WITHOUT CLAIM TO ANY PARTICULAR FONT, STYLE, SIZE, OR COLOR.

FOR SOFAS, OTTOMANS, CHAIRS, AND INFLATABLE FURNITURE (U.S. CLS. 2, 13, 22, 25, 32 AND 50).

HANNO RITTNER, EXAMINING ATTORNEY

SN 78-968,123. ANGEL'S EMBRACE, SOCORRO, NM. FILED 9-6-2006.

Angel's  Embrace

THE STIPPLING IS FOR SHADING PURPOSES ONLY. THE MARK CONSISTS OF THE WORDS "ANGEL'S" AND "EMBRACE" ARE TO EITHER SIDE OF AN UPRIGHT SHADOWED RECTANGLE WITH A BLOCK FIGURE OF A STYLIZED ANGEL SHAPE CONTAINING AN OUTLINE HEART IN THE FIGURE'S CHEST.

FOR FIGURES OF BONE, IVORY, PLASTER, PLASTIC, WAX, WOOD (U.S. CLS. 2, 13, 22, 25, 32 AND 50).

TARAH HARDY, EXAMINING ATTORNEY

SN 78-968,327. SUMMER INFANT, INC., NORTH SMITHFIELD, RI. FILED 9-6-2006.

**QUIET COMFORT**

THE MARK CONSISTS OF STANDARD CHARACTERS WITHOUT CLAIM TO ANY PARTICULAR FONT, STYLE, SIZE, OR COLOR.

FOR INFANT BOUNCERS (U.S. CLS. 2, 13, 22, 25, 32 AND 50).

KEVIN DINALLO, EXAMINING ATTORNEY

**CLASS 20—(Continued).**

SN 78-969,005. FE-LINES, INC., FORT WORTH, TX. FILED 9-7-2006.

# BUSY PAWS

THE MARK CONSISTS OF STANDARD CHARACTERS WITHOUT CLAIM TO ANY PARTICULAR FONT, STYLE, SIZE, OR COLOR.

FOR PET PRODUCTS, NAMELY SCRATCH MATS AND POSTS FOR CATS (U.S. CLS. 2, 13, 22, 25, 32 AND 50).

TASHIA BUNCH, EXAMINING ATTORNEY

**CLASS 20—(Continued).**

SN 79-024,793. ZALF INDUSTRIA MOBILI; COMONIBILI S.P.A., ITALY, FILED 2-9-2006.



OWNER OF INTERNATIONAL REGISTRATION 0649572 DATED 2-8-1996, EXPIRES 2-8-2016.

THE MARK CONSISTS OF A SPIRAL DESIGN.

FOR FURNITURE, FURNITURE OF METAL AND OFFICE FURNITURE, BEDS, CUPBOARDS, CHESTS OF DRAWERS, DRAWERS, DIVANS, ARMCHAIRS, CHAIRS, CHAISE LONGUES, EASY-CHAIRS, DECK CHAIRS, DESKS; HAND-HELD MIRRORS; HAND MIRRORS, BEING A PART OF A DRESSER; MIRRORS, BEING FURNITURE; MIRRORS, BEING LOOKING GLASSES NOT FOR CARRYING WITH; TABLES, BEING FURNITURE; MODULE KITCHEN FURNITURE (U.S. CLS. 2, 13, 22, 25, 32 AND 50).

GINA HAYES, EXAMINING ATTORNEY

SN 78-969,293. FOAMWORKS, INC., CLEVELAND, TN. FILED 9-7-2006.

# Memory Fresh

THE MARK CONSISTS OF STANDARD CHARACTERS WITHOUT CLAIM TO ANY PARTICULAR FONT, STYLE, SIZE, OR COLOR.

NO CLAIM IS MADE TO THE EXCLUSIVE RIGHT TO USE "MEMORY", APART FROM THE MARK AS SHOWN.

FOR VISCO-ELASTIC MEMORY FOAM SOLD AS AN INTEGRAL PART OF MATTRESSES (U.S. CLS. 2, 13, 22, 25, 32 AND 50).

ANDREA K. NADELMAN, EXAMINING ATTORNEY

SN 79-025,373. OIKOS SPA, ITALY, FILED 12-14-2005.



SN 78-969,723. VENDOR'S EQUIPMENT, INC., WATERBURY, CT. FILED 9-8-2006.



FOR PRE-CUT PLASTIC PANELS FOR VENDING MACHINES (U.S. CLS. 2, 13, 22, 25, 32 AND 50).

TARAH HARDY, EXAMINING ATTORNEY

PRIORITY DATE OF 8-16-2005 IS CLAIMED. OWNER OF INTERNATIONAL REGISTRATION 0888926 DATED 12-14-2005, EXPIRES 12-14-2015.

FOR KITCHEN FURNITURE, TABLES, CHAIRS, ARMCHAIRS, DIVANS, DESKS, BOOKCASES, WARDROBES, SHELVING, DECK CHAIRS, SERVING TROLLEYS, DRAWER-UNITS, DRAWERS; BOX SPRINGS, MATTRESSES, PILLOWS, BEDSIDE TABLES, CHEST OF DRAWERS, MIRRORS (U.S. CLS. 2, 13, 22, 25, 32 AND 50).

GRETTA YAO, EXAMINING ATTORNEY

**CLASS 21—HOUSEWARES AND GLASS**

SN 76-551,255. BONGIOVI, JOHN, LOS ANGELES, CA.  
FILED 9-24-2003.



THE MARK CONSISTS OF A STYLIZED WINGED FOOT-BALL.

FOR MUGS; JUGS; PORTABLE BEVERAGE COOLERS; BEVERAGE GLASSWARE; PORTABLE BEVERAGE DISPENSERS; BEVERAGEWARE; BOTTLE OPENERS; CORK SCREWS; WINE BUCKETS; HAIR COMB CASES; PAPER CUPS; PLASTIC CUPS; DECANTERS; DECORATIVE PLATES; DINNERWARE DISHES; NAPKIN HOLDERS; HOUSEHOLD HOLDERS, NAMELY, HOLDERS FOR HOUSEHOLD IRONS; ICE BUCKETS; PORTABLE ICE CHESTS FOR FOOD AND BEVERAGES; DECORATIVE CUPS; WINE BUCKETS; VACUUM BOTTLES; COMMEMORATIVE PLATES; ALL-PURPOSE PORTABLE HOUSEHOLD CONTAINERS; TOOTHBRUSHES AND WASTEPAPER BASKETS (U.S. CLS. 2, 13, 23, 29, 30, 33, 40 AND 50).

NELSON SNYDER, EXAMINING ATTORNEY

SN 76-656,138. TRECE, INC., ADAIR, OK. FILED 3-7-2006.



NO CLAIM IS MADE TO THE EXCLUSIVE RIGHT TO USE "MULTI-GENDER ATTRACTANT", APART FROM THE MARK AS SHOWN.

FOR INSECT TRAP (U.S. CLS. 2, 13, 23, 29, 30, 33, 40 AND 50).

FIRST USE 5-5-2005; IN COMMERCE 6-18-2005.  
ANTHONY RINKER, EXAMINING ATTORNEY

**CLASS 21—(Continued).**

SN 77-007,341. UNISOURCE WORLDWIDE, INC., NORCROSS, GA. FILED 9-26-2006.

# CHEMTROL

THE MARK CONSISTS OF STANDARD CHARACTERS WITHOUT CLAIM TO ANY PARTICULAR FONT, STYLE, SIZE, OR COLOR.

FOR DISPENSERS FOR CLEANING AND DISINFECTING SOLUTIONS (U.S. CLS. 2, 13, 23, 29, 30, 33, 40 AND 50).

FIRST USE 2-21-1985; IN COMMERCE 2-21-1985.  
JORDAN BAKER, EXAMINING ATTORNEY

SN 77-007,393. UNISOURCE WORLDWIDE, INC., NORCROSS, GA. FILED 9-26-2006.

# CHEMTROL

FOR DISPENSERS FOR CLEANING AND DISINFECTING SOLUTIONS (U.S. CLS. 2, 13, 23, 29, 30, 33, 40 AND 50).

FIRST USE 12-1-2005; IN COMMERCE 12-1-2005.  
JORDAN BAKER, EXAMINING ATTORNEY

SN 77-007,936. PAN AWAY, L.L.C., HOUSTON, TX. FILED 9-26-2006.



NO CLAIM IS MADE TO THE EXCLUSIVE RIGHT TO USE PAN, APART FROM THE MARK AS SHOWN.

FOR METAL PAN COOKING SYSTEM, NAMELY, DISPOSABLE NON-STICK PANS, LIDS AND HANDLES THAT CAN BE USED FOR COOKING AND STORING FOOD (U.S. CLS. 2, 13, 23, 29, 30, 33, 40 AND 50).

FIRST USE 5-30-2003; IN COMMERCE 5-30-2003.  
LINDA ORNDORFF, EXAMINING ATTORNEY

**CLASS 21—(Continued).**

SN 78-456,853. ANGELSTAR INSPIRED PRODUCTS, INC., MORGAN HILL, CA. FILED 7-26-2004.

**SERENITY HEART**

THE MARK CONSISTS OF STANDARD CHARACTERS WITHOUT CLAIM TO ANY PARTICULAR FONT, STYLE, SIZE, OR COLOR.

FOR VASES; CANDLE HOLDERS NOT MADE OF PRECIOUS METAL; DECORATIVE CERAMIC BOXES; ORNAMENTAL CERAMIC CROSSES AND ANGELS; HOLIDAY ORNAMENTS OF CERAMIC OR PORCELAIN; HOLIDAY ORNAMENTS MADE FROM CHINA, CRYSTAL, GLASS, PORCELAIN AND TERRACOTTA; DECORATIVE STATUES MADE OF PORCELAIN OR CERAMIC; DECORATIVE LAWN AND GARDEN ART, NAMELY, GARDEN SCULPTURES AND GARDEN OR HOLIDAY ORNAMENTS, NOT BEING TREE ORNAMENTS, ALL MADE OF GLASS, PORCELAIN AND TERRACOTTA (U.S. CLS. 2, 13, 23, 29, 30, 33, 40 AND 50).  
FIRST USE 1-15-1997; IN COMMERCE 1-15-1997.

JENNIFER KRISP, EXAMINING ATTORNEY

**CLASS 21—(Continued).**

SN 78-704,062. BUILT NY, INC., NEW YORK, NY. FILED 8-31-2005.



OWNER OF U.S. REG. NOS. 2,984,681, 3,148,238 AND OTHERS.

NO CLAIM IS MADE TO THE EXCLUSIVE RIGHT TO USE "BABY", APART FROM THE MARK AS SHOWN.

THE MARK CONSISTS OF THE WORD BUILT, UNDERLINED, WITH THE LETTERS NY UNDERNEATH, BOTH INSIDE A RECTANGLE. DIRECTLY UNDER THE LETTERS NY IS THE WORD BABY INSIDE A RECTANGLE.

SEC. 2(F) AS TO "NY".

FOR THERMALLY INSULATED TOTE BAGS AND CONTAINERS FOR FOOD AND BEVERAGES (U.S. CLS. 2, 13, 23, 29, 30, 33, 40 AND 50).

FIRST USE 8-11-2005; IN COMMERCE 8-11-2005.

JOHN DALIER, EXAMINING ATTORNEY

SN 78-676,456. URBAN TRENDS LLC, IRVINE, CA. FILED 7-22-2005.



NO CLAIM IS MADE TO THE EXCLUSIVE RIGHT TO USE "CHEF", APART FROM THE MARK AS SHOWN.

FOR COOKWARE, NAMELY, POTS, PANS, FOOD PREPARATION WARE AND COMPLETE SETS THEREOF; HOUSEHOLD UTENSILS, NAMELY SPATULAS, LADLES, FORKS, SPOONS, KNIVES, WHISKS; PLATES; SERVINGWARE FOR SERVING FOOD (U.S. CLS. 2, 13, 23, 29, 30, 33, 40 AND 50).

DOMINICK J. SALEMI, EXAMINING ATTORNEY

SN 78-761,880. KN LTD., SAN RAFAEL, CA. FILED 11-28-2005.



KAREN NEUBURGER

OWNER OF U.S. REG. NOS. 2,259,410, 2,722,732 AND OTHERS.

NO CLAIM IS MADE TO THE EXCLUSIVE RIGHT TO USE "HOME", APART FROM THE MARK AS SHOWN.

THE NAME(S), PORTRAIT(S), AND/OR SIGNATURE(S) SHOWN IN THE MARK IDENTIFIES KAREN NEUBURGER, WHOSE CONSENT(S) TO REGISTER IS SUBMITTED.

FOR CERAMIC AND METAL TABLEWARE, NAMELY, PLATES, BOWLS, CUPS, MUGS, AND BAKEWARE, GLASSWARE, NAMELY, CANISTERS, BEVERAGE GLASSES, VASES, METAL COOKWARE, NAMELY, FRYING, GRILL, SAUTE', STIR FRY PANS AND CASSEROLES, CASUAL TABLEWARE, NAMELY, MELAMINE PLATES AND BEVERAGE GLASSES (U.S. CLS. 2, 13, 23, 29, 30, 33, 40 AND 50).

DAVID STERKIN, EXAMINING ATTORNEY

**CLASS 21—(Continued).**

SN 78-779,963. MAVERICK BRANDS LLC, NEW YORK, NY.  
FILED 12-22-2005.

**CHIC SIMPLE**

THE MARK CONSISTS OF STANDARD CHARACTERS WITHOUT CLAIM TO ANY PARTICULAR FONT, STYLE, SIZE, OR COLOR.

FOR POT AND PAN SCRAPERS, ROLLING PINS, SPATULAS, TURNERS, WHISKS, AND HAIRBRUSHES, HAIR COMBS, TOOTHBRUSHES, COSMETIC BRUSHES, NAIL BRUSHES, DRINKING VESSELS, DISHES, PLATES, SERVING PLATTERS, COFFEE MUGS, TEA KETTLES, VASES, BEVERAGE GLASSWARE, WINE RACKS, PICNIC BASKETS, LUNCH BOXES, CONTAINERS FOR HOUSEHOLD PURPOSES, ELECTRIC TOOTHBRUSHES, BODY SPONGES, NAPKIN HOLDERS AND DRAWER ORGANIZERS FOR JEWELRY AND SILVERWARE (U.S. CLS. 2, 13, 23, 29, 30, 33, 40 AND 50).

ESTHER BELENKER, EXAMINING ATTORNEY

**CLASS 21—(Continued).**

SN 78-804,938. MORGAN MOTOR COMPANY LIMITED, WORCESTERSHIRE, UNITED KINGDOM, FILED 2-1-2006.



OWNER OF U.S. REG. NO. 1,715,474.

FOR BATH ACCESSORIES, NAMELY, EMPTY PERFUME ATOMIZERS, PLASTIC BATH RACKS, SOAP BOXES, SOAP DISPENSERS, PAPER TOWEL DISPENSERS, SHAVING BRUSHES, SHAVING BRUSH STANDS, FOOTWEAR BRUSHES, COSMETIC BRUSHES, HAIR BRUSHES, ELECTRIC AND NON-ELECTRIC TOOTH BRUSHES, FITTED VANITY CASES, CLEANING COTTON, COMB CASES, HAIR COMBS, SPONGE HOLDERS, TOILET TISSUES HOLDERS, HOUSEHOLD SPONGES, POWDER PUFFS, TOWEL BARS AND RINGS, WASH BASINS; BAKEWARE AND COOKWARE, NAMELY NON-ELECTRIC STEEL METALLIC GRILLS, CONFECTIONER'S DECORATING BAGS, SERVING SPOONS, SLOTTED SPOONS, BASTING SPOONS, MIXING SPOONS, CUTTING BOARDS, BREAD BOXES, CAKE SERVERS, CASSEROLES, STRAINERS, SIEVES AND COLANDERS FOR HOUSEHOLD USE, COOKERY MOLDS, COOKIE CUTTERS, CORN COB HOLDERS, CRUETS NOT OF PRECIOUS METALS FOR OIL AND VINEGAR, GARLIC PRESSES, PEPPER GRINDERS, NON-ELECTRIC GRIDDLES, GRATERS, SPATULAS, TURNERS, WHISKS, ICE CUBE MOLDS FOR REFRIGERATORS, KITCHEN LADLES, LEMON SQUEEZERS, SCOOPS, SALT AND PEPPER SHAKERS, BASINS FOR HOLDING AND STORING FOOD ITEMS AND BEVERAGES, BOWLS, CANISTER SETS, CHINA ORNAMENTS, CONTAINERS FOR FOOD, INSULATING JARS, PITCHERS, POTS, VASES NOT OF PRECIOUS METAL, GRAVYBOATS, COVERS FOR DISHES AND POTS, BUTTER DISHES, NAPKIN HOLDERS, TOOTH-PICK HOLDERS, NON-ELECTRIC KETTLES, NON-ELECTRIC PRESSURE COOKERS, PANS, PLATES, SERVING PLATTERS, SAUCEPANS, SAUCERS, SOUP TUREENS, SERVING TRAYS NOT OF PRECIOUS METALS; BARWARE, NAMELY, SELTZER BOTTLES, CAVIAR COOLERS, COCKTAIL PICKS, COCKTAIL SHAKERS, DECANTERS, BEVERAGE STIRRERS, SWIZZLE STICKS, WINE TASTERS SIPHONS; BEVERAGEWARE, NAMELY, WINE BOTTLE CRADLES, BOTTLE OPENERS, ICE BUCKETS, CUPS, CORK SCREWS, JUGS, MUGS, DRINKING GLASSES, DRINKING VESSELS, REAMERS FOR FRUIT JUICES, NON-ELECTRIC JUICERS, TEA AND COFFEE SERVICES NOT OF PRECIOUS METAL, COFFEE STIRRERS, HANDOPERATED COFFEE GRINDERS, DOMESTIC COFFEE MEASURES, NON-ELECTRIC COFFEE PERCOLATORS AND POTS, TEA BALLS NOT OF PRECIOUS METALS, TEA INFUSERS AND TEA POTS NOT PRECIOUS METALS, TEA CADDIES; NON-ELECTRIC CARPET BEATERS AND CARPET CLEANERS, WASTEPAPER BASKETS, DUST BINS, IRONING BOARDS AND SHAPED COVERS THEREFOR, DECORATIVE BOXES MADE OF GLASS OR PORCELAIN, DECORATIVE PLATES, CLOTHES BRUSHES, CRUMB BRUSHES, DISHWASHING BRUSHES, STOVE BURNER COVERS, NON-ELECTRIC CANDELABRAS NOT OF PRECIOUS METAL, CANDLESTICKS NOT OF PRECIOUS METALS, FLOWER POTS, FLOWER POT HOLDERS; GLASS, PORCELAIN OR EARTHENWARE DOORKNOBS AND DOOR HANDLES, CLOTHES DRYING RACKS, ALL PURPOSE PORTABLE

SN 78-801,179. FOOD EQUIPMENT TECHNOLOGIES COMPANY, INC., LAKE ZURICH, IL. FILED 1-27-2006.

**Volume  
Indicator**

NO CLAIM IS MADE TO THE EXCLUSIVE RIGHT TO USE "VOLUME" AND "INDICATOR", APART FROM THE MARK AS SHOWN.

THE LINING IS FOR SHADING PURPOSES.

THE MARK CONSISTS OF THE WORDS VOLUME INDICATOR IN STYLIZED FONT IN COMBINATION WITH A FANCIFUL FUNNEL-SHAPED OBJECT THE INTERIOR OF WHICH IS LINED TO DESIGNATE A LIGHTER SHADE THAN THE REMAINING PORTION OF THE MARK BUT NOT DESIGNATING ANY PARTICULAR COLOR.

FOR PORTABLE BEVERAGE DISPENSERS (U.S. CLS. 2, 13, 23, 29, 30, 33, 40 AND 50).

CATHERINE FAINT, EXAMINING ATTORNEY

**CLASS 21—(Continued).**

HOUSEHOLD CONTAINERS, ENAMELED GLASS, OPA-  
LINE GLASS, STAINED GLASS, UNWROUGHT GLASS,  
GLASS TUBES FOR NON-SCIENTIFIC PURPOSES, CIN-  
DER SIFTERS FOR HOUSEHOLD USE, COAL SCUT-  
TLES, DUTCH OVENS, PLASTIC COASTERS,  
DECORATIVE CRYSTAL PRISMS, PORCELAIN EGGS;  
EARTHENWARE AND CRYSTAL VASES, BOWLS,  
MUGS, CUPS, DISHES, PITCHERS, PLATTERS, SER-  
VING TRAYS AND PICTURE FRAMES; PORCELAIN  
FIGURES, FUNNELS, GARDENING GLOVES, LAWN  
SPRINKLERS, AND PAILS (U.S. CLS. 2, 13, 23, 29, 30,  
33, 40 AND 50).

JILL C. ALT, EXAMINING ATTORNEY

**CLASS 21—(Continued).**

SN 78-811,382. PILMANIS, PAULA, RANCHO PALOS  
VERDES, CA. FILED 2-9-2006.

**STAMP ME FABULOUS**

THE MARK CONSISTS OF STANDARD CHARACTERS  
WITHOUT CLAIM TO ANY PARTICULAR FONT, STYLE,  
SIZE, OR COLOR.

FOR COSMETIC AND PERSONAL CARE PRODUCTS,  
NAMELY STAMPING AND IMPRINTING IMPLEMENTS  
FOR APPLYING EYEBROWS AND IMAGES TO BODY  
PARTS USING COSMETICS INKS AND COSMETIC  
PRODUCTS; ARTIFICIAL EYEBROW STAMPING IM-  
PLEMENTS; MAKE-UP KITS CONSISTING OF IM-  
PRINTING IMPLEMENTS AND COSMETIC INKS FOR  
USE IN STAMPING ARTIFICIAL EYEBROWS; MAKE-  
UP KITS CONSISTING OF IMPRINTING IMPLEMENTS  
AND STAMPING IMPLEMENTS AND COSMETIC INKS  
FOR USE IN STAMPING ARTIFICIAL EYEBROWS;  
MAKE-UP KITS CONSISTING OF IMPRINTING AND  
STAMPING IMPLEMENTS, COSMETIC INKS AND EYE-  
BROW BRUSHES FOR USE IN STAMPING ARTIFICIAL  
EYEBROWS; MAKE-UP KITS CONSISTING OF IM-  
PRINTING AND STAMPING IMPLEMENTS, COSMETIC  
INKS AND EYEBROW BRUSHES FOR USE IN APPLY-  
ING ARTIFICIAL EYELINER (U.S. CLS. 2, 13, 23, 29, 30,  
33, 40 AND 50).

CHRISTINE COOPER, EXAMINING ATTORNEY

SN 78-811,244. PILMANIS, PAULA, RANCHO PALOS  
VERDES, CA. FILED 2-9-2006.

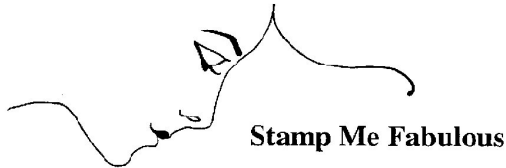

SN 78-817,855. SHISEIDO COMPANY, LTD., TOKYO, JA-  
PAN, FILED 2-17-2006.

**ELIXIR  
SUPERIEUR**

OWNER OF U.S. REG. NOS. 1,794,073 AND 1,969,311.  
NO CLAIM IS MADE TO THE EXCLUSIVE RIGHT TO  
USE "SUPERIEUR", APART FROM THE MARK AS  
SHOWN.

THE MARK CONSISTS OF THE WORD ELIXIR WITH  
THE WORD SUPERIEUR CENTERED DIRECTLY BELOW.

FOR PERSONAL CARE AND COSMETIC ACCES-  
SORIES, NAMELY, AEROSOL DISPENSERS, ATOMI-  
ZERS, SPRAYERS AND VAPORIZERS FOR PERFUME,  
COLOGNE AND TOILET WATER ALL SOLD EMPTY;  
SOAP BOXES, SOAP HOLDERS AND SOAP CONTAIN-  
ERS; SOAP DISPENSERS; COSMETIC BRUSHES; DUST-  
ING BRUSHES, EYEBROW BRUSHES, NAIL BRUSHES,  
SHAVING BRUSHES AND HAIR BRUSHES; HAIR  
COMBS, FITTED VANITY CASES FOR USE AS COMB  
CASES; SPONGE-TIP APPLICATORS FOR MAKEUP;  
COTTON BALLS; POWDER PUFFS AND COSMETIC  
SPONGES FOR APPLYING MAKEUP; EXFOLIATING  
MITTS AND EXFOLIATING PADS; COMPACTS SOLD  
EMPTY; PORTABLE VANITY CASES; GLASS BODY  
CREAM JARS; COMPACTS SOLD EMPTY FOR POW-  
DER; CANDLE HOLDERS NOT OF PRECIOUS METAL  
(U.S. CLS. 2, 13, 23, 29, 30, 33, 40 AND 50).

AMOS T. MATTHEWS, JR., EXAMINING ATTORNEY

FOR COSMETIC AND PERSONAL CARE PRODUCTS,  
NAMELY STAMPING AND IMPRINTING IMPLEMENTS  
FOR APPLYING EYEBROWS AND IMAGES TO BODY  
PARTS USING COSMETICS INKS AND COSMETIC  
PRODUCTS; ARTIFICIAL EYEBROW STAMPING IM-  
PLEMENTS; MAKE-UP KITS CONSISTING OF IM-  
PRINTING IMPLEMENTS AND COSMETIC INKS FOR  
USE IN STAMPING ARTIFICIAL EYEBROWS; MAKE-  
UP KITS CONSISTING OF IMPRINTING IMPLEMENTS  
AND STAMPING IMPLEMENTS AND COSMETIC INKS  
FOR USE IN STAMPING ARTIFICIAL EYEBROWS;  
MAKE-UP KITS CONSISTING OF IMPRINTING AND  
STAMPING IMPLEMENTS, COSMETIC INKS AND EYE-  
BROW BRUSHES FOR USE IN STAMPING ARTIFICIAL  
EYEBROWS; MAKE-UP KITS CONSISTING OF IM-  
PRINTING AND STAMPING IMPLEMENTS, COSMETIC  
INKS AND EYEBROW BRUSHES FOR USE IN APPLY-  
ING ARTIFICIAL EYELINER (U.S. CLS. 2, 13, 23, 29, 30,  
33, 40 AND 50).

CHRISTINE COOPER, EXAMINING ATTORNEY

**CLASS 21—(Continued).**

SN 78-820,647. WILLIE POTS LLC, BOSTON, VA. FILED 2-22-2006.

# Willie Pots

THE MARK CONSISTS OF STANDARD CHARACTERS WITHOUT CLAIM TO ANY PARTICULAR FONT, STYLE, SIZE, OR COLOR.

NO CLAIM IS MADE TO THE EXCLUSIVE RIGHT TO USE POTS, APART FROM THE MARK AS SHOWN.

FOR CERAMIC SCULPTURES, VASES, VESSELS, BOWLS, PLATES AND POTS (U.S. CLS. 2, 13, 23, 29, 30, 33, 40 AND 50).

FIRST USE 10-15-2004; IN COMMERCE 10-15-2004.  
LA TONIA FISHER, EXAMINING ATTORNEY

**CLASS 21—(Continued).**

SN 78-910,867. SCHNEIDER SADDLERY CO., INC., CHAGRIN FALLS, OH. FILED 6-19-2006.

# SAFEGUARDS

THE MARK CONSISTS OF STANDARD CHARACTERS WITHOUT CLAIM TO ANY PARTICULAR FONT, STYLE, SIZE, OR COLOR.

FOR PROTECTIVE SLEEVE-TYPE COVERINGS FOR THE HOOK-ENDS OF BUCKET OR PAIL HANDLES TO PREVENT INJURY TO ANIMALS AND HUMANS (U.S. CLS. 2, 13, 23, 29, 30, 33, 40 AND 50).

CHARISMA HAMPTON, EXAMINING ATTORNEY

SN 78-867,105. COOKSEY, BARBARA, IMOGENE, RENO, NV. FILED 4-21-2006.

# BINK

THE MARK CONSISTS OF STANDARD CHARACTERS WITHOUT CLAIM TO ANY PARTICULAR FONT, STYLE, SIZE, OR COLOR.

FOR HOUSEHOLD CONTAINERS FOR STORING AND PRESERVING FOODS (U.S. CLS. 2, 13, 23, 29, 30, 33, 40 AND 50).

FIRST USE 4-5-2006; IN COMMERCE 4-5-2006.  
MATTHEW MCDOWELL, EXAMINING ATTORNEY

SN 78-936,011. 7-ELEVEN, INC., DALLAS, TX. FILED 7-24-2006.

SN 78-872,594. INSULAIR, INC., VERNALIS, CA. FILED 4-28-2006.



The logo for INSULAIR features the word "INSULAIR" in a bold, sans-serif font. A stylized, curved graphic element, resembling a swoosh or a partial circle, is positioned above the letter "I" and extends to the right, partially overlapping the letters "S" and "U".

OWNER OF U.S. REG. NOS. 2,127,523 AND 2,139,779.  
THE MARK CONSISTS OF THE WORD INSULAIR WITH SHORT CURVED LINES ABOVE AND BELOW THE "U".

FOR DISPOSABLE CUPS AND THERMAL INSULATED CONTAINERS FOR FOOD OR BEVERAGE (U.S. CLS. 2, 13, 23, 29, 30, 33, 40 AND 50).

FIRST USE 4-1-2006; IN COMMERCE 4-1-2006.  
SCOTT BALDWIN, EXAMINING ATTORNEY

# SLURPEE

THE MARK CONSISTS OF STANDARD CHARACTERS WITHOUT CLAIM TO ANY PARTICULAR FONT, STYLE, SIZE, OR COLOR.

OWNER OF U.S. REG. NOS. 829,177, 2,236,874 AND OTHERS.

FOR BEVERAGE CONTAINERS, NAMELY, REUSABLE PLASTIC CUPS AND MUGS (U.S. CLS. 2, 13, 23, 29, 30, 33, 40 AND 50).

MICHAEL KAZAZIAN, EXAMINING ATTORNEY



**CLASS 21—(Continued).**

SN 78-948,822. DIAMOND FIRE GLASS, INC., SAN CLEMENTE, CA. FILED 8-9-2006.



OWNER OF U.S. REG. NO. 3,191,275.  
NO CLAIM IS MADE TO THE EXCLUSIVE RIGHT TO USE "FIRE", APART FROM THE MARK AS SHOWN.  
FOR CRUSHED TEMPERED GLASS USED IN FIREPLACE AND/OR FIRE PIT; HEAT RESISTANT GLASS FOR FIREPLACE AND/OR FIRE PIT; HEAT RESISTANT GLASS CRYSTALS FOR FIREPLACE AND/OR FIRE PIT; DECORATIVE GLASS CRYSTALS FOR FIREPLACE AND/OR FIRE PIT (U.S. CLS. 2, 13, 23, 29, 30, 33, 40 AND 50).  
FIRST USE 3-1-2004; IN COMMERCE 3-1-2004.  
TRICIA SONNEBORN, EXAMINING ATTORNEY

SN 78-952,767. MAEZ, MELISSA LUNA, ALBUQUERQUE, NM. FILED 8-15-2006.

# Turquoise Maiden

THE MARK CONSISTS OF STANDARD CHARACTERS WITHOUT CLAIM TO ANY PARTICULAR FONT, STYLE, SIZE, OR COLOR.  
NO CLAIM IS MADE TO THE EXCLUSIVE RIGHT TO USE "TURQUOISE", APART FROM THE MARK AS SHOWN.  
FOR FIGURINES OF STONE (U.S. CLS. 2, 13, 23, 29, 30, 33, 40 AND 50).  
STEVEN JACKSON, EXAMINING ATTORNEY

**CLASS 21—(Continued).**

SN 78-953,803. SUMMER INFANT, INC., NORTH SMITHFIELD, RI. FILED 8-16-2006.

# STEP BY STEP

THE MARK CONSISTS OF STANDARD CHARACTERS WITHOUT CLAIM TO ANY PARTICULAR FONT, STYLE, SIZE, OR COLOR.  
FOR POTTIES FOR CHILDREN; POTTY TRAINING SYSTEMS COMPRISING A CHILD POTTY WITH A REMOVABLE ADAPTER SEAT, AN INTEGRATED TISSUE DISPENSER, AND AN INTEGRATED WIPES HOLDER; POTTY TRAINING SYSTEMS COMPRISING A CHILD POTTY AND POTTY TRAINING MANUAL SOLD AS A UNIT; BABY TRAINERS (U.S. CLS. 2, 13, 23, 29, 30, 33, 40 AND 50).  
KEVIN DINALLO, EXAMINING ATTORNEY

SN 78-956,181. LANDMARK PLASTIC CORPORATION, AKRON, OH. FILED 8-21-2006.

# NURTURE.GROW.THRIVE.

THE MARK CONSISTS OF STANDARD CHARACTERS WITHOUT CLAIM TO ANY PARTICULAR FONT, STYLE, SIZE, OR COLOR.  
FOR PLASTIC CONTAINERS FOR PLANTS AND SEEDLINGS; FLATS, CELL PACKS, AND TRAYS USED FOR GERMINATING SEEDS AND PLANTS (U.S. CLS. 2, 13, 23, 29, 30, 33, 40 AND 50).  
JENNY PARK, EXAMINING ATTORNEY

SN 78-960,280. GMZ ASSOCIATES, LTD., BRENTWOOD, NY. FILED 8-25-2006.

# WET 'N BRUSH

THE MARK CONSISTS OF STANDARD CHARACTERS WITHOUT CLAIM TO ANY PARTICULAR FONT, STYLE, SIZE, OR COLOR.  
FOR TOOTHBRUSHES (U.S. CLS. 2, 13, 23, 29, 30, 33, 40 AND 50).  
MICHELLE DUBOIS, EXAMINING ATTORNEY

**CLASS 21—(Continued).**

SN 78-960,283. GMZ ASSOCIATES, LTD., BRENTWOOD, NY.  
FILED 8-25-2006.

**READYBRUSH**

THE MARK CONSISTS OF STANDARD CHARACTERS  
WITHOUT CLAIM TO ANY PARTICULAR FONT, STYLE,  
SIZE, OR COLOR.

FOR TOOTHBRUSHES (U.S. CLS. 2, 13, 23, 29, 30, 33, 40  
AND 50).

FIRST USE 1-1-1994; IN COMMERCE 1-1-1994.

MICHELLE DUBOIS, EXAMINING ATTORNEY

SN 78-960,802. CARROLL SALES AGENCY, INC., AVON,  
OH. FILED 8-25-2006.

**FLAVORSEAL**

THE MARK CONSISTS OF STANDARD CHARACTERS  
WITHOUT CLAIM TO ANY PARTICULAR FONT, STYLE,  
SIZE, OR COLOR.

FOR DISPOSABLE PLASTIC GLOVES FOR USE IN  
THE FOOD SERVICE INDUSTRY (U.S. CLS. 2, 13, 23, 29,  
30, 33, 40 AND 50).

ELLEN PERKINS, EXAMINING ATTORNEY

SN 78-961,651. JACQUART FABRIC PRODUCTS, INC.,  
IRONWOOD, MI. FILED 8-28-2006.

**WEEKEND WARRIOR**

THE MARK CONSISTS OF STANDARD CHARACTERS  
WITHOUT CLAIM TO ANY PARTICULAR FONT, STYLE,  
SIZE, OR COLOR.

FOR COLLAPSIBLE FABRIC STORAGE CONTAINERS  
FOR DOMESTIC USE (U.S. CLS. 2, 13, 23, 29, 30, 33, 40  
AND 50).

RONALD MCMORROW, EXAMINING ATTORNEY

**CLASS 21—(Continued).**

SN 78-962,174. ESTES, LARRY R., HOOVER, AL. FILED 8-28-  
2006.

**SPORTSTIVITIES**

THE MARK CONSISTS OF STANDARD CHARACTERS  
WITHOUT CLAIM TO ANY PARTICULAR FONT, STYLE,  
SIZE, OR COLOR.

FOR THERMAL INSULATED CONTAINERS FOR  
FOOD OR BEVERAGE (U.S. CLS. 2, 13, 23, 29, 30, 33, 40  
AND 50).

B. PARADEWELAI, EXAMINING ATTORNEY

SN 78-962,797. BRADLEY, ANDUJAR, BROOKLYN, NY.  
FILED 8-29-2006.

**TEAM REVOLUTION**

THE MARK CONSISTS OF STANDARD CHARACTERS  
WITHOUT CLAIM TO ANY PARTICULAR FONT, STYLE,  
SIZE, OR COLOR.

FOR PLASTIC WATER BOTTLES SOLD EMPTY (U.S.  
CLS. 2, 13, 23, 29, 30, 33, 40 AND 50).

WILLIAM ROSSMAN, EXAMINING ATTORNEY

SN 78-962,804. MUSHEN, JAMES G, LAS VEGAS, NV. FILED  
8-29-2006.



THE COLOR(S) WHITE, BLUE, RED AND PINK IS/ARE  
CLAIMED AS A FEATURE OF THE MARK.

THE MARK CONSISTS OF A STYLIZED DESIGN OF A  
DOG. THE COLOR WHITE APPEARS IN THE BACK-  
GROUND TO THE MARK; THE COLOR BLUE APPEARS  
IN THE OUTLINE OF THE DOG, IN THE COLLAR OF THE  
DOG AND IN THE EYE OF THE DOG; THE COLOR RED  
APPEARS IN THE HIND QUARTER, ON THE BACK, IN  
THE FRONT PAW AND AROUND THE EYE OF THE DOG;  
AND THE COLOR PINK APPEARS IN THE TONGUE OF  
THE DOG.

FOR DRINKING VESSELS; FEEDING VESSELS FOR  
PETS; PET FEEDING DISHES (U.S. CLS. 2, 13, 23, 29, 30,  
33, 40 AND 50).

FIRST USE 12-1-2005; IN COMMERCE 1-25-2006.

PAUL CROWLEY, EXAMINING ATTORNEY

**CLASS 21—(Continued).**

SN 78-962,925. BRADLEY, ANDUJAR, BROOKLYN, NY.  
FILED 8-29-2006.

THE BEST WAY TO PREDICT  
THE FUTURE IS TO CREATE IT

THE MARK CONSISTS OF STANDARD CHARACTERS  
WITHOUT CLAIM TO ANY PARTICULAR FONT, STYLE,  
SIZE, OR COLOR.  
FOR PLASTIC WATER BOTTLES SOLD EMPTY (U.S.  
CLS. 2, 13, 23, 29, 30, 33, 40 AND 50).  
WILLIAM ROSSMAN, EXAMINING ATTORNEY

SN 78-963,260. ENLIGHT-10, LTD., SANTA FE, NM. FILED 8-  
29-2006.

# HÖSIG DI

THE MARK CONSISTS OF AN UMLAUT APPEARS OVER  
THE "O" IN HOSIG.  
THE FOREIGN WORDING IN THE MARK TRANSLATES  
INTO ENGLISH AS HANDCRAFTED WOUNAAN TRIBAL  
BASKETS MADE FROM CHUNGA PALM FIBERS.  
SEC. 2(F).  
FOR BASKETS OF PALM FIBERS (U.S. CLS. 2, 13, 23,  
29, 30, 33, 40 AND 50).  
FIRST USE 8-1-2002; IN COMMERCE 8-1-2002.  
DEZMONA MIZELLE, EXAMINING ATTORNEY

SN 78-963,582. RANGE KLEEN MFG., INC., LIMA, OH.  
FILED 8-30-2006.

# GO GO SALAD

THE MARK CONSISTS OF STANDARD CHARACTERS  
WITHOUT CLAIM TO ANY PARTICULAR FONT, STYLE,  
SIZE, OR COLOR.  
NO CLAIM IS MADE TO THE EXCLUSIVE RIGHT TO  
USE "SALAD". APART FROM THE MARK AS SHOWN.  
FOR CONTAINERS FOR HOUSEHOLD OR KITCHEN  
USE; HOUSEHOLD CONTAINERS FOR FOODS (U.S.  
CLS. 2, 13, 23, 29, 30, 33, 40 AND 50).  
SCOTT BALDWIN, EXAMINING ATTORNEY

**CLASS 21—(Continued).**

SN 78-963,716. LOOPA, LLC, CHARLOTTE, NC. FILED 8-30-  
2006.



THE MARK CONSISTS OF A FIRST CIRCLE HAVING A  
SECOND CIRCLE CONTAINED THEREIN AND A THIRD  
CIRCLE CONTAINED WITHIN THE SECOND CIRCLE, THE  
THIRD CIRCLE BEING COMPLETELY FILLED-IN, AND A  
PARTIAL OVAL PARTITIONING AND EXTENDING BE-  
YOND THE FIRST CIRCLE. AT THE BOTTOM OF THE  
FIRST CIRCLE ARE THREE SMALL CIRCLES THAT ARE  
COMPLETELY SHADED. THE DESIGN ELEMENT IS  
ABOVE THE STYLIZED WORDING LOOPA.  
FOR BOWLS (U.S. CLS. 2, 13, 23, 29, 30, 33, 40 AND 50).  
LINDA POWELL, EXAMINING ATTORNEY

SN 78-964,176. LLOYD, KENNETH L., ENCINO, CA. FILED  
8-30-2006.



FOR COFFEE CUPS, TEA CUPS, AND MUGS, BEV-  
ERAGE GLASSWARE AND DINNERWARE (U.S. CLS. 2,  
13, 23, 29, 30, 33, 40 AND 50).  
TANYA AMOS, EXAMINING ATTORNEY

**CLASS 21—(Continued).**

SN 78-964,177. AMERICAN NEVADA HOLDINGS, LLC, HENDERSON, NV. FILED 8-30-2006.

**Avenue33**  
AT THE DISTRICT

FOR BEVERAGEWARE; BUCKETS; COASTERS NOT OF PAPER AND NOT BEING TABLE LINEN; CONTAINERS FOR HOUSEHOLD OR KITCHEN USE; DISHES; FLASKS; FLOWER BASKETS; SPORTS BOTTLES SOLD EMPTY; STATUETTES OF CHINA, CRYSTAL, GLASS, PORCELAIN AND EARTHENWARE; VASES (U.S. CLS. 2, 13, 23, 29, 30, 33, 40 AND 50).

MICHAEL ENGEL, EXAMINING ATTORNEY

SN 78-964,646. PAN AWAY, L.L.C., HOUSTON, TX. FILED 8-31-2006.

**Flex Lock**

THE MARK CONSISTS OF STANDARD CHARACTERS WITHOUT CLAIM TO ANY PARTICULAR FONT, STYLE, SIZE, OR COLOR.

NO CLAIM IS MADE TO THE EXCLUSIVE RIGHT TO USE "LOCK", APART FROM THE MARK AS SHOWN.

FOR NON-METAL HANDLE FOR A REPLACEABLE COOKING PAN SYSTEM (U.S. CLS. 2, 13, 23, 29, 30, 33, 40 AND 50).

LINDA ORNDORFF, EXAMINING ATTORNEY

SN 78-965,162. WHOLESALE & RETAIL DISTRIBUTION, INC., ARROYO GRANDE, CA. FILED 8-31-2006.

**CHARGE**

THE MARK CONSISTS OF STANDARD CHARACTERS WITHOUT CLAIM TO ANY PARTICULAR FONT, STYLE, SIZE, OR COLOR.

FOR LIQUID OR POWDER DISPENSER FOR USE IN A BEVERAGE CONTAINER (U.S. CLS. 2, 13, 23, 29, 30, 33, 40 AND 50).

LEIGH CAROLINE CASE, EXAMINING ATTORNEY

**CLASS 21—(Continued).**

SN 78-966,636. CITY OF HENDERSON REDEVELOPMENT AGENCY, HENDERSON, NV. FILED 9-3-2006.



NO CLAIM IS MADE TO THE EXCLUSIVE RIGHT TO USE "WATER STREET DISTRICT HENDERSON", APART FROM THE MARK AS SHOWN.

THE MARK CONSISTS OF WATER STREET DISTRICT HENDERSON IN STYLIZED LETTERS.

FOR BEVERAGE GLASSWARE, DRINKING MUGS, DRINKING STEINS, CUPS, PLATES, SERVING TRAYS NOT OF PRECIOUS METAL, COOKIE JARS, PLASTIC WATER BOTTLES SOLD EMPTY, INSULATING SLEEVE HOLDERS FOR BEVERAGE CANS, VASES, STATUES AND STATUETTES OF GLASS, CHINA, CRYSTAL, TERRACOTTA, PORCELAIN AND EARTHENWARE, NON-METAL CANDLESTICK HOLDERS; PLASTIC COASTERS AND COASTERS NOT OF PAPER AND NOT BEING TABLE LINEN; BOTTLE OPENERS, CORK SCREWS; GLASS BOXES, RECIPE BOXES, LUNCH BOXES, SANDWICH BOXES, SOAP BOXES; HAIR BRUSHES, HAIR COMBS; NON-METAL COIN BANKS; MANUAL TOOTHBRUSHES (U.S. CLS. 2, 13, 23, 29, 30, 33, 40 AND 50).

SUSAN STIGLITZ, EXAMINING ATTORNEY

SN 78-967,330. JODY COYOTE LLC, EUGENE, OR. FILED 9-5-2006.

**Poker Pup**

THE MARK CONSISTS OF STANDARD CHARACTERS WITHOUT CLAIM TO ANY PARTICULAR FONT, STYLE, SIZE, OR COLOR.

FOR CERAMIC / EARTHENWARE BOWLS AND CANISTERS (U.S. CLS. 2, 13, 23, 29, 30, 33, 40 AND 50).

SOPHIA S. KIM, EXAMINING ATTORNEY

SN 78-967,340. ART CRAFT TROPHIES INC., SPRINGFIELD, MO. FILED 9-5-2006.

**THE MUSIC CAN**

THE MARK CONSISTS OF STANDARD CHARACTERS WITHOUT CLAIM TO ANY PARTICULAR FONT, STYLE, SIZE, OR COLOR.

FOR MUSICAL CAN HOLDER, NAMELY, AN INSULATING HOLDER FOR BEVERAGE CANS THAT PLAYS MUSIC WHEN ACTIVATED (U.S. CLS. 2, 13, 23, 29, 30, 33, 40 AND 50).

TRAVIS WHEATLEY, EXAMINING ATTORNEY

**CLASS 21—(Continued).**

SN 78-967,342. ROCKLINE INDUSTRIES, INC., SHEBOYGAN, WI. FILED 9-5-2006.

# WIDGET

THE MARK CONSISTS OF STANDARD CHARACTERS WITHOUT CLAIM TO ANY PARTICULAR FONT, STYLE, SIZE, OR COLOR.  
FOR PLASTIC LIDS FOR WIPES CONTAINERS (U.S. CLS. 2, 13, 23, 29, 30, 33, 40 AND 50).  
TRAVIS WHEATLEY, EXAMINING ATTORNEY

SN 78-967,385. JODY COYOTE LLC, EUGENE, OR. FILED 9-5-2006.

# Barkarita

THE MARK CONSISTS OF STANDARD CHARACTERS WITHOUT CLAIM TO ANY PARTICULAR FONT, STYLE, SIZE, OR COLOR.  
FOR CERAMIC DOG BOWL (U.S. CLS. 2, 13, 23, 29, 30, 33, 40 AND 50).  
SOPHIA S. KIM, EXAMINING ATTORNEY

SN 78-967,845. INTERNATIONAL GROUP OF COMPANIES, LLC, MELROSE PARK, IL. FILED 9-6-2006.

# PASCO

THE MARK CONSISTS OF STANDARD CHARACTERS WITHOUT CLAIM TO ANY PARTICULAR FONT, STYLE, SIZE, OR COLOR.  
FOR AUTOMATIC SOAP DISPENSERS AND AUTOMATIC TOOTH PASTE DISPENSERS (U.S. CLS. 2, 13, 23, 29, 30, 33, 40 AND 50).  
BONNIE LUKEN, EXAMINING ATTORNEY

**CLASS 21—(Continued).**

SN 78-967,856. INTERNATIONAL GROUP OF COMPANIES, LLC, CHICAGO, IL. FILED 9-6-2006.

# INTERNATIONAL

THE MARK CONSISTS OF STANDARD CHARACTERS WITHOUT CLAIM TO ANY PARTICULAR FONT, STYLE, SIZE, OR COLOR.  
FOR AUTOMATIC SOAP DISPENSERS AND AUTOMATIC TOOTH PASTE DISPENSERS (U.S. CLS. 2, 13, 23, 29, 30, 33, 40 AND 50).  
BONNIE LUKEN, EXAMINING ATTORNEY

SN 78-968,485. ROBINSON, DANE Q., TEMPE, AZ. FILED 9-6-2006.

# TIFINITY

THE MARK CONSISTS OF STANDARD CHARACTERS WITHOUT CLAIM TO ANY PARTICULAR FONT, STYLE, SIZE, OR COLOR.  
FOR TOOTHBRUSHES, BATH BRUSHES, BRUSHES FOR BASTING MEAT, HAIR BRUSHES, POT CLEANING BRUSHES, SCRUBBING BRUSHES AND WIRE BRUSHES, NOT BEING MACHINE PARTS (U.S. CLS. 2, 13, 23, 29, 30, 33, 40 AND 50).  
GIANCARLO CASTRO, EXAMINING ATTORNEY

SN 78-968,487. ROBINSON, DANE Q., TEMPE, AZ. FILED 9-6-2006.



THE MARK CONSISTS OF AN INFINITY SYMBOL WITH TWO "T" SHAPED SYMBOLS INTERTWINED. A SMALL CIRCLE LIES DIRECTLY BENEATH EACH "T" SHAPED SYMBOL.  
FOR TOOTHBRUSHES, BATH BRUSHES, BRUSHES FOR BASTING MEAT, HAIR BRUSHES, POT CLEANING BRUSHES, SCRUBBING BRUSHES AND WIRE BRUSHES, NOT BEING MACHINE PARTS (U.S. CLS. 2, 13, 23, 29, 30, 33, 40 AND 50).  
GIANCARLO CASTRO, EXAMINING ATTORNEY

**CLASS 21—(Continued).**

SN 78-969,708. POLYCLEAN INNOVATIONS, LLC, ST. LOUIS, MO. FILED 9-8-2006.

WE HAVE THE SOLUTIONS

THE MARK CONSISTS OF STANDARD CHARACTERS WITHOUT CLAIM TO ANY PARTICULAR FONT, STYLE, SIZE, OR COLOR.

FOR BROOMS (U.S. CLS. 2, 13, 23, 29, 30, 33, 40 AND 50).

KHANH LE, EXAMINING ATTORNEY

SN 78-971,454. AVERY, DEVON, HOUSTON, TX. FILED 9-11-2006.

WAIST-CAN

THE MARK CONSISTS OF STANDARD CHARACTERS WITHOUT CLAIM TO ANY PARTICULAR FONT, STYLE, SIZE, OR COLOR.

FOR WAIST-HELD PLASTIC DOG WASTE RECEPTACLE (U.S. CLS. 2, 13, 23, 29, 30, 33, 40 AND 50).

JILL C. ALT, EXAMINING ATTORNEY

SN 78-974,236. BLITZ U.S.A., INC., MIAMI, OK. FILED 9-14-2006.

DISPOS-OIL

THE MARK CONSISTS OF STANDARD CHARACTERS WITHOUT CLAIM TO ANY PARTICULAR FONT, STYLE, SIZE, OR COLOR.

FOR NON-METAL CONTAINERS FOR HOUSEHOLD USE IN COLLECTING RECYCLED MOTOR OIL (U.S. CLS. 2, 13, 23, 29, 30, 33, 40 AND 50).

YONG KIM, EXAMINING ATTORNEY

**CLASS 21—(Continued).**

SN 78-977,496. BINN AND PARTNERS LLC, NEW YORK, NY. FILED 2-1-2006.

XPRESSPA

THE MARK CONSISTS OF STANDARD CHARACTERS WITHOUT CLAIM TO ANY PARTICULAR FONT, STYLE, SIZE, OR COLOR.

FOR HAIR BRUSH (U.S. CLS. 2, 13, 23, 29, 30, 33, 40 AND 50).

FIRST USE 2-25-2004; IN COMMERCE 2-25-2004.

DOMINIC J. FERRAIUOLO, EXAMINING ATTORNEY

SN 79-029,248. XIAMEN FIVE CONTINENTS INT'L TRADING; CO., LTD., CHINA, FILED 3-10-2006.



OWNER OF INTERNATIONAL REGISTRATION 0899304 DATED 3-10-2006, EXPIRES 3-10-2016.

FOR CONTAINERS FOR HOUSEHOLD OR KITCHEN USE; KITCHEN UTENSILS, NOT OF PRECIOUS METAL, NAMELY, BOWLS, PLATES, KETTLES, CUPS, AND BOTTLES; ENAMEL AND PLASTIC WARE FOR EVERY DAY USE, NAMELY, BASINS, BOWLS, PLATES, KETTLES, AND CUPS; CERAMICS FOR HOUSEHOLD PURPOSES, NAMELY, PLATES, BOWLS, KETTLES AND CUPS; PORCELAIN WARE, NAMELY, PLATES, BOWLS, KETTLES, CUPS, AND BOTTLES; POTTERY FOR EVERY DAY USE, NAMELY, BASINS, BOWLS, PLATES, JARS, JUG, POTS, COOKING POTS, KETTLES, AND CERAMIC TABLEWARE; CHINA ORNAMENTS; PORCELAIN, TERRA-COTTA AND GLASS WORKS OF ART, NAMELY, GLASS BOWLS, GLASS CUPS, GLASS BOTTLES; STATUETTES OF PORCELAIN, TERRA-COTTA AND GLASS; DRINKING VESSELS; TOILET PAPER HOLDERS; FLOWER POTS; DISHES FOR SOAP; TOILET UTENSILS, NAMELY, TOILET BRUSHES, TOILET SPONGES, AND TOILET PAPER DISPENSERS (U.S. CLS. 2, 13, 23, 29, 30, 33, 40 AND 50).

ELI HELLMAN, EXAMINING ATTORNEY

**CLASS 21—(Continued).**

SN 79-029,638. SEISHIN TOUGEI CO., LTD., JAPAN, FILED 6-30-2005.

eggling

THE MARK CONSISTS OF STANDARD CHARACTERS WITHOUT CLAIM TO ANY PARTICULAR FONT, STYLE, SIZE, OR COLOR.

PRIORITY DATE OF 5-23-2005 IS CLAIMED.

OWNER OF INTERNATIONAL REGISTRATION 0900568 DATED 6-30-2005, EXPIRES 6-30-2015.

FOR DENTAL FLOSS; UNWORKED OR SEMI-WORKED GLASS; MANGERS FOR ANIMALS; POULTRY RINGS; COOKING SKEWERS; TUB BRUSHES; METAL BRUSHES; BRUSHES FOR PIPES; INDUSTRIAL BRUSHES; SHIP-SCRUBBING BRUSHES; GLOVES FOR HOUSEHOLD PURPOSES; CONTAINERS OF GLASS OR CERAMICS FOR HOUSEHOLD OR KITCHEN USE; NON-ELECTRIC ALUMINUM OR ENAMEL COOKING POTS AND PANS; NON-ELECTRIC CERAMIC COFFEE-POTS; NON-ELECTRIC JAPANESE CAST IRON KETTLES (TETSUBIN); NON-ELECTRIC ALUMINUM OR ENAMEL KETTLES; NON-ELECTRIC PORTABLE COLDBOXES; PLASTIC RICE STORAGE CONTAINERS; FOOD PRESERVING JARS OF GLASS; DRINKING FLASKS; VACUUM BOTTLES; ICE PAILS; NON-ELECTRIC WHISKS; COOKING STRAINERS; PEPPER POTS, SUGAR BOWLS AND SALT SHAKERS NOT OF PRECIOUS METAL; EGG CUPS NOT OF PRECIOUS METAL; NAPKIN HOLDERS AND NAPKIN RINGS NOT OF PRECIOUS METAL; TRAYS NOT OF PRECIOUS METAL; TOOTHPICK HOLDERS NOT OF PRECIOUS METAL; COLANDERS; SHAKERS; JAPANESE-STYLE COOKED RICE SCOOPS (SHAMOJI); HAND-OPERATED COFFEE GRINDERS AND PEPPER MILLS; COOKING FUNNELS; JAPANESE-STYLE PERSONAL DINING TRAYS OR STANDS (ZEN); BOTTLE OPENERS; COOKING GRATERS; TART SCOOPS; TRIVETS; CHOPSTICKS; CHOPSTICK CASES; COOKING UTENSILS, NAMELY, LADLES AND DIPPERS; COOKING SIEVES AND SIFTERS; CHOPPING BOARDS FOR KITCHEN USE; ROLLING PINS FOR COOKING PURPOSES; COOKING UTENSILS, NAMELY, GRILLS; TOOTHPICKS; LEMON SQUEEZERS; NON-ELECTRIC WAFFLE IRONS; CLEANING TOOLS AND WASHING UTENSILS, NAMELY, CLEANING BRUSHES, CLEANING SPONGES, CLEANING CLOTHS; IRONING BOARDS; ATOMIZERS FOR USE WHEN IRONING; IRONING BOARDS (KOTEDAI); STIRRERS FOR HOT BATHTUB WATER (YUKAKIBO); BATHROOM PAILS; CANDLE EXTINGUISHERS AND CANDLESTICKS NOT OF PRECIOUS METAL; CINDER SIFTERS FOR HOUSEHOLD PURPOSES; COAL SCUTTLES; FLY SWATTERS; MOUSE TRAPS; FLOWER POTS; POTS USED FOR SOIL-LESS HOME GARDENING; WATERING CANS; FEEDING VESSELS FOR PETS; BRUSHES FOR PETS; BIRD CAGES; BIRD BATHS; CLOTHES BRUSHES; CHAMBER POTS; TOILET PAPER HOLDERS; PIGGY BANKS NOT OF METAL; POTTERY FOR CONTAINING SACRED LOTTERIES (OMIKUJI) IN THE FORM OF RANDOM FORTUNES WRITTEN ON STRIPS OF PAPER; BOXES OF METAL FOR DISPENSING PAPER TOWELS; BOOT JACKS; SOAP DISPENSERS; FLOWER VASES AND BOWLS NOT OF PRECIOUS METAL; UPRIGHT SIGNBOARDS OF GLASS OR CERAMICS; PERFUME BURNERS; COSMETIC AND TOILET UTENSILS; SHOE BRUSHES; SHOE HORNS; SHOE SHINE CLOTHS; HANDY SHOE SHINER BRUSHES; SHOE TREES STRETCHERS; PORTABLE COOKING KITS FOR OUTDOOR USE CONSISTING OF SMALL PANS, PLATES AND BOWLS; PIG BRISTLES FOR BRUSHES (U.S. CLS. 2, 13, 23, 29, 30, 33, 40 AND 50).

CURTIS FRENCH, EXAMINING ATTORNEY

**CLASS 22—CORDAGE AND FIBERS**

SN 78-823,253. NEMO EQUIPMENT, INC., NASHUA, NH. FILED 2-24-2006.



THE MARK CONSISTS OF THE LETTER "N" FORMING A SHIELD.

FOR CAMPING ACCESSORIES, NAMELY, TENTS (U.S. CLS. 1, 2, 7, 19, 22, 42 AND 50).

KELLEY WELLS, EXAMINING ATTORNEY

SN 78-951,132. THE COLEMAN COMPANY, INC., WICHITA, KS. FILED 8-14-2006.

COLETHERM

THE MARK CONSISTS OF STANDARD CHARACTERS WITHOUT CLAIM TO ANY PARTICULAR FONT, STYLE, SIZE, OR COLOR.

FOR TEXTILE FIBERS FOR SLEEPING BAGS, AND SYNTHETIC FIBERS (U.S. CLS. 1, 2, 7, 19, 22, 42 AND 50).

FIRST USE 2-15-1999; IN COMMERCE 2-15-1999. GIANCARLO CASTRO, EXAMINING ATTORNEY

**CLASS 22—(Continued).**

SN 78-955,770. SANRIO COMPANY, LTD., TOKYO, JAPAN, FILED 8-18-2006.

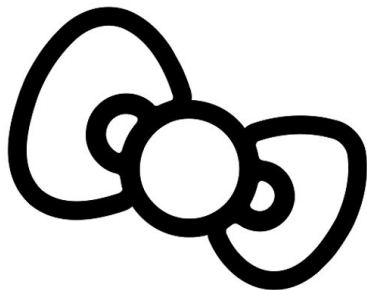

OWNER OF U.S. REG. NOS. 1,200,083, 1,370,105 AND OTHERS.

THE MARK CONSISTS OF A BOW FOR MULTI-PURPOSE CLOTH BAGS, LAUNDRY BAGS, SHOE BAGS FOR STORAGE, LANYARDS FOR HOLDING BADGES, EYEGLASSES, AND KEYS, TENTS (U.S. CLS. 1, 2, 7, 19, 22, 42 AND 50).

FIRST USE 11-1-2004; IN COMMERCE 11-1-2004.  
MICHAEL WIENER, EXAMINING ATTORNEY

SN 78-955,961. SCHOLLE CORPORATION, IRVINE, CA. FILED 8-19-2006.



THE MARK CONSISTS OF THE WORD GRIP IN STYLIZED LETTERING, WITH A BRACKET HANGING OVER THE LETTER "G".

FOR FLEXIBLE PLASTIC BAG WITH HANDLES AND ROD-INSERTION OPENING USED TO HOLD AND CONTAIN A VARIETY OF LIQUID PRODUCTS FOR PURPOSES OF PORTABILITY, HANGING OR DISPENSING CONTENTS FOR USE (U.S. CLS. 1, 2, 7, 19, 22, 42 AND 50).

DANIEL RUSSELL, EXAMINING ATTORNEY

SN 78-955,962. SCHOLLE CORPORATION, IRVINE, CA. FILED 8-19-2006.

**SCHOLLE RELINER**

THE MARK CONSISTS OF STANDARD CHARACTERS WITHOUT CLAIM TO ANY PARTICULAR FONT, STYLE, SIZE, OR COLOR.

OWNER OF U.S. REG. NOS. 705,202 AND 2,422,671. FOR PLASTIC BAG THAT IS INSTALLED IN BOTTLE-IN-CAGE PRODUCTS FOR TRANSPORT (U.S. CLS. 1, 2, 7, 19, 22, 42 AND 50).

DANIEL RUSSELL, EXAMINING ATTORNEY

**CLASS 22—(Continued).**

SN 78-959,788. CSK AUTO, INC., PHOENIX, AZ. FILED 8-24-2006.

**PROXONE**

THE MARK CONSISTS OF STANDARD CHARACTERS WITHOUT CLAIM TO ANY PARTICULAR FONT, STYLE, SIZE, OR COLOR.

FOR BUNGEE CORDS AND TIE DOWN STRAPS (U.S. CLS. 1, 2, 7, 19, 22, 42 AND 50).

FIRST USE 11-11-2005; IN COMMERCE 11-11-2005.  
SETH A. RAPPAPORT, EXAMINING ATTORNEY

SN 78-961,597. TNI PACKAGING, INC., WEST CHICAGO, IL. FILED 8-28-2006.

**TINSEL NET**

THE MARK CONSISTS OF STANDARD CHARACTERS WITHOUT CLAIM TO ANY PARTICULAR FONT, STYLE, SIZE, OR COLOR.

NO CLAIM IS MADE TO THE EXCLUSIVE RIGHT TO USE "NET", APART FROM THE MARK AS SHOWN.

FOR WOVEN PLASTIC MESH USED FOR PACKAGING GOODS AND CONTAINERS FOR GOODS (U.S. CLS. 1, 2, 7, 19, 22, 42 AND 50).

MATTHEW KLINE, EXAMINING ATTORNEY

SN 78-961,610. TNI PACKAGING, INC., WEST CHICAGO, IL. FILED 8-28-2006.

**TINSEL TIE**

THE MARK CONSISTS OF STANDARD CHARACTERS WITHOUT CLAIM TO ANY PARTICULAR FONT, STYLE, SIZE, OR COLOR.

NO CLAIM IS MADE TO THE EXCLUSIVE RIGHT TO USE "TIE", APART FROM THE MARK AS SHOWN.

FOR WOVEN PLASTIC MESH USED FOR PACKAGING GOODS AND CONTAINERS FOR GOODS (U.S. CLS. 1, 2, 7, 19, 22, 42 AND 50).

MATTHEW KLINE, EXAMINING ATTORNEY



**CLASS 22—(Continued).**

SN 79-025,426. VELERIA MARCO HOLM S.R.L., ITALY,  
FILED 4-14-2006.



PRIORITY DATE OF 12-21-2005 IS CLAIMED.  
OWNER OF INTERNATIONAL REGISTRATION 0889101  
DATED 4-14-2006, EXPIRES 4-14-2016.

NO CLAIM IS MADE TO THE EXCLUSIVE RIGHT TO  
USE "SAIL TECHNOLOGY", APART FROM THE MARK AS  
SHOWN.

FOR SAILS (U.S. CLS. 1, 2, 7, 19, 22, 42 AND 50).  
HENRY S. ZAK, EXAMINING ATTORNEY

**CLASS 23—(Continued).**

SN 77-045,394. ANSELL LIMITED, RICHMOND, VICTORIA,  
AUSTRALIA, FILED 11-16-2006.

# TEXTEK

THE MARK CONSISTS OF STANDARD CHARACTERS  
WITHOUT CLAIM TO ANY PARTICULAR FONT, STYLE,  
SIZE, OR COLOR.

FOR MIXED SPUN THREADS AND YARNS; SPUN  
YARN; SYNTHETIC FIBER THREAD AND YARN;  
SYNTHETIC YARN (U.S. CL. 43).

FLORENTINA BLANDU, EXAMINING ATTORNEY

SN 78-857,448. J. & P. COATS, LIMITED, GLASGOW, SCOT-  
LAND, FILED 4-10-2006.

# TOP SOFT

**CLASS 23—YARNS AND THREADS**

SN 76-570,777. BROS HOLDING LIMITED, TSUEN WAN,  
NEW TERRITORIES, HONG KONG, FILED 1-20-2004.

# BROS

THE MARK IS IN BLACK AND WHITE AND COLOR IS  
NOT A FEATURE OF THE MARK.

THE MARK CONSISTS OF ONE TERM "BROS" IN A  
STYLIZED FONT.

FOR COIR THREAD AND YARN, COTTON THREAD  
AND YARN, DARNING THREAD AND YARN, ELASTIC  
THREAD AND YARN FOR TEXTILE USE, EMBROI-  
DERY THREAD AND YARN, FIBERGLASS THREAD  
FOR TEXTILE USE, HEMP THREAD AND YARN, JUTE  
THREAD AND YARN, LINEN THREAD AND YARN,  
RAYON THREAD AND YARN, SEWING THREAD AND  
YARN, SPUN COTTON, SPUN THREAD AND YARN,  
SPUN WOOL, THREAD, WOOL THREAD AND YARN,  
WORSTED YARN (U.S. CL. 43).

FIRST USE 12-0-1999; IN COMMERCE 12-0-1999.  
NAAKWAMA ANKRAH, EXAMINING ATTORNEY

THE MARK CONSISTS OF STANDARD CHARACTERS  
WITHOUT CLAIM TO ANY PARTICULAR FONT, STYLE,  
SIZE, OR COLOR.

NO CLAIM IS MADE TO THE EXCLUSIVE RIGHT TO  
USE SOFT, APART FROM THE MARK AS SHOWN.

FOR HANDKNITTING YARNS (U.S. CL. 43).  
FIRST USE 10-19-2005; IN COMMERCE 10-19-2005.

WON TEAK OH, EXAMINING ATTORNEY

SN 78-964,608. J. & P. COATS, LIMITED, GLASGOW G2 5PA,  
SCOTLAND, FILED 8-31-2006.

# INDRA

THE MARK CONSISTS OF STANDARD CHARACTERS  
WITHOUT CLAIM TO ANY PARTICULAR FONT, STYLE,  
SIZE, OR COLOR.

FOR HANDKNITTING YARNS (U.S. CL. 43).  
FIRST USE 5-22-2006; IN COMMERCE 5-22-2006.

KRISTIN DAHLING, EXAMINING ATTORNEY

**CLASS 23—(Continued).**

SN 78-969,449. NORTH AMERICAN FIRE HOSE CORPORATION, SANTA MARIA, CA. FILED 9-7-2006.

**DURA-CORD**

THE MARK CONSISTS OF STANDARD CHARACTERS WITHOUT CLAIM TO ANY PARTICULAR FONT, STYLE, SIZE, OR COLOR.

FOR NYLON SYNTHETIC YARN USED TO PRODUCE FIRE HOSE (U.S. CL. 43).

CHRISIE B. KING, EXAMINING ATTORNEY

**CLASS 24—(Continued).**

SN 78-721,328. MOONSOFT INTERNATIONAL INC., MICA, WA. FILED 9-27-2005.



FOR WASH MITTS (U.S. CLS. 42 AND 50).  
FIRST USE 8-1-2004; IN COMMERCE 11-1-2004.  
FRED CARL, EXAMINING ATTORNEY

SN 78-759,235. INVERSIONES INDUSTRIALES SERPIS, S.L., ALCOY, ALICANTE, SPAIN, FILED 11-22-2005.

**CLASS 24—FABRICS**

SN 76-551,256. BONGIOVI, JOHN, LOS ANGELES, CA. FILED 9-24-2003.



THE MARK CONSISTS OF A STYLIZED WINGED FOOTBALL.

FOR BATH TOWELS; BEACH TOWELS; BEDDING, NAMELY, BED BLANKETS, COMFORTERS, BED SPREADS AND BED LINEN; BATH LINEN, HOUSEHOLD LINENS, CLOTH COASTERS, PLASTIC PLACE MATS, TEXTILE PLACE MATS, VINYL PLACE MATS, TEXTILE NAPKINS, POT HOLDERS, CLOTH PENNANTS, FELT PENNANTS AND TEXTILE WALL HANGINGS (U.S. CLS. 42 AND 50).

NELSON SNYDER, EXAMINING ATTORNEY

**AQUA CLEAN**

THE MARK CONSISTS OF STANDARD CHARACTERS WITHOUT CLAIM TO ANY PARTICULAR FONT, STYLE, SIZE, OR COLOR.

PRIORITY CLAIMED UNDER SEC. 44(D) ON ERPNCMNTY TM OFC APPLICATION NO. 4735551, FILED 11-22-2005, REG. NO. 004735551, DATED 11-27-2006, EXPIRES 11-22-2015.

FOR TEXTILES AND TEXTILE GOODS, NAMELY, UPHOLSTERY FABRIC AND TEXTILE WALL HANGING; CURTAINS MADE OF TEXTILE FABRIC; NET CURTAINS, AND BED AND TABLE LINEN (U.S. CLS. 42 AND 50).

ELIZABETH BEYER, EXAMINING ATTORNEY

SN 78-779,964. MAVERICK BRANDS LLC, NEW YORK, NY. FILED 12-22-2005.

SN 77-051,998. HEB GROCERY COMPANY, LP, SAN ANTONIO, TX. FILED 11-28-2006.

**HOLIDAY MARKET**

THE MARK CONSISTS OF STANDARD CHARACTERS WITHOUT CLAIM TO ANY PARTICULAR FONT, STYLE, SIZE, OR COLOR.

FOR TABLE LINEN, NAMELY, TABLE RUNNERS, PLACE MATS AND NAPKINS (U.S. CLS. 42 AND 50).

WILLIAM P. SHANAHAN, EXAMINING ATTORNEY

**CHIC SIMPLE**

THE MARK CONSISTS OF STANDARD CHARACTERS WITHOUT CLAIM TO ANY PARTICULAR FONT, STYLE, SIZE, OR COLOR.

FOR WASH CLOTHS, TOWELS, WINDOW CURTAINS, POT HOLDERS, DISH CLOTHS, CLOTH NAPKINS, BED SHEETS, DUVETS, PILLOW SHAMS, COMFORTERS, PILLOW CASES, PILLOW COVERS, MATTRESS COVERS, MATTRESS PADS, QUILTS, BEDSPREADS, BED SKIRTS, CRIB BUMPERS, CRIB CANOPIES, FABRIC FOR MAKING CLOTHING AND HANDKERCHIEFS, SHOWER CURTAINS AND WINDOW BLINDS, DRAPES AND OTHER COVERINGS (U.S. CLS. 42 AND 50).

ESTHER BELENKER, EXAMINING ATTORNEY

**CLASS 24—(Continued).**

SN 78-854,691. SABTEX LTD., CARLSTADT, NJ. FILED 4-5-2006.

# MAGIC

THE MARK CONSISTS OF STANDARD CHARACTERS WITHOUT CLAIM TO ANY PARTICULAR FONT, STYLE, SIZE, OR COLOR.

FOR BATH PRODUCT, NAMELY A BALL-SHAPED WASHCLOTH (U.S. CLS. 42 AND 50).  
GIANCARLO CASTRO, EXAMINING ATTORNEY

**CLASS 24—(Continued).**

SN 78-961,762. HUFF-HRENYA, SHELYA L., HINCKLEY, OH. AND WASHINGTON, CHARMAINE, LACKAWANNA, NY. FILED 8-28-2006.

# Sheet Snob

THE MARK CONSISTS OF STANDARD CHARACTERS WITHOUT CLAIM TO ANY PARTICULAR FONT, STYLE, SIZE, OR COLOR.

NO CLAIM IS MADE TO THE EXCLUSIVE RIGHT TO USE "SHEET", APART FROM THE MARK AS SHOWN.  
FOR BED LINEN; BED SHEETS (U.S. CLS. 42 AND 50).  
BENJAMIN OKEKE, EXAMINING ATTORNEY

SN 78-960,401. WLR CONE MILLS IP, INC., GREENSBORO, NC. FILED 8-25-2006.

# BLACK SEED

THE MARK CONSISTS OF STANDARD CHARACTERS WITHOUT CLAIM TO ANY PARTICULAR FONT, STYLE, SIZE, OR COLOR.

FOR DENIM FABRICS; JEANS FABRIC; FABRIC FOR USE IN THE MANUFACTURE OF CLOTHING; FABRICS FOR USE IN UPHOLSTERY AND IN THE MANUFACTURE OF HOME, INDUSTRIAL AND COMMERCIAL FURNISHINGS (U.S. CLS. 42 AND 50).  
SUNG IN, EXAMINING ATTORNEY

SN 78-964,421. PROJECT CC, LLC, LAS VEGAS, NV. FILED 8-30-2006.

# VDARA

THE MARK CONSISTS OF STANDARD CHARACTERS WITHOUT CLAIM TO ANY PARTICULAR FONT, STYLE, SIZE, OR COLOR.

FOR BEACH TOWELS (U.S. CLS. 42 AND 50).  
GEORGE LORENZO, EXAMINING ATTORNEY

SN 78-960,411. BERKSHIRE BLANKET INC., WARE, MA. FILED 8-25-2006.

# CUDDL Y CREATURES

THE MARK CONSISTS OF STANDARD CHARACTERS WITHOUT CLAIM TO ANY PARTICULAR FONT, STYLE, SIZE, OR COLOR.

FOR BED BLANKETS AND THROWS (U.S. CLS. 42 AND 50).  
JENNIFER WILLISTON, EXAMINING ATTORNEY

SN 78-964,773. WYLA, INC., JACKSONVILLE, FL. FILED 8-31-2006.

# STUDIO D'ARTS DECORATIFS

THE MARK CONSISTS OF STANDARD CHARACTERS WITHOUT CLAIM TO ANY PARTICULAR FONT, STYLE, SIZE, OR COLOR.

NO CLAIM IS MADE TO THE EXCLUSIVE RIGHT TO USE "D'ARTS DECORATIFS", APART FROM THE MARK AS SHOWN.

THE FOREIGN WORDING IN THE MARK TRANSLATES INTO ENGLISH AS STUDIO OF DECORATIVE ARTS.

FOR COTTON FABRIC; SYNTHETIC FIBER FABRICS (U.S. CLS. 42 AND 50).  
AMY GEARIN, EXAMINING ATTORNEY

**CLASS 24—(Continued).**

SN 78-966,655. CASBO HOLDING COMPANY, INC., VENICE, CA. FILED 9-3-2006.

## SEW HAPPY

THE MARK CONSISTS OF STANDARD CHARACTERS WITHOUT CLAIM TO ANY PARTICULAR FONT, STYLE, SIZE, OR COLOR.

FOR BATH GLOVES; BATH TOWELS; BEACH TOWELS; BED BLANKETS; BED LINEN; BED SKIRTS; BED SPREADS; CHENILLE FABRIC; COTTON BASE MIXED FABRICS; COTTON FABRIC; CRIB BUMPER PADS; CRIB BUMPERS; CRIB CANOPIES; CURTAINS MADE OF TEXTILE FABRICS; DIAPER CHANGING MATS; DUVET COVERS; FABRICS FOR THE MANUFACTURE OF CLOTHING; FLANNEL; HAND TOWELS; HOODED TOWELS; JERSEY MATERIAL; KIT COMPRISED OF FABRICS FOR MAKING QUILTS; KNITTED FABRICS; MIXED FIBER FABRICS; PILLOW COVERS; POLYESTER FABRIC; SHOWER CURTAINS; TEXTILE FABRICS FOR HOME AND COMMERCIAL INTERIORS; TEXTILE FABRICS FOR THE MANUFACTURE OF CLOTHING; TOWELS; WOVEN FABRICS (U.S. CLS. 42 AND 50).

ALICIA COLLINS, EXAMINING ATTORNEY

SN 78-966,743. DANAHER, THOMAS C., NEW YORK, NY. FILED 9-4-2006.

## The House of Home Fashion

THE MARK CONSISTS OF STANDARD CHARACTERS WITHOUT CLAIM TO ANY PARTICULAR FONT, STYLE, SIZE, OR COLOR.

NO CLAIM IS MADE TO THE EXCLUSIVE RIGHT TO USE "HOME FASHION", APART FROM THE MARK AS SHOWN.

FOR BARBECUE MITTS; BATH MITTS; BATH SHEETS; BATH TOWELS; BEACH TOWELS; BED BLANKETS; BED CANOPIES; BED LINEN; BED SHEETS; BED SKIRTS; BED SPREADS; BEDSHEETS; BLANKET THROWS; CLOTH BANNERS; CLOTH COASTERS; COMFORTERS; CONTOUR SHEETS; COVERS FOR CUSHIONS; CURTAINS; CURTAINS MADE OF TEXTILE FABRICS; DRAPERIES; DUVET COVERS; DUVETS; FABRIC WINDOW COVERINGS AND TREATMENTS, NAMELY CURTAINS, DRAPERIES, SHEERS, SWAGS AND VALANCES; HAND TOWELS OF TEXTILE; HOODED TOWELS; KITCHEN TOWELS; LAP-ROBES; PILLOW CASES; PILLOW COVERS; PILLOW SHAMS; PILLOWCASES; QUILTS; QUILTS OF TEXTILE; SHOWER CURTAINS; TABLE LINEN, NAMELY PLACE MATS; TABLE LINEN, NAMELY, COASTERS; TEA TOWELS; TERRY TOWELS; TEXTILE NAPKINS; THROWS; TOWEL SETS; TOWELS; WINDOW CURTAINS (U.S. CLS. 42 AND 50).

MARK PILARO, EXAMINING ATTORNEY

**CLASS 24—(Continued).**

SN 78-967,275. MARSTON, JANIS CLARE, GLENWOOD, NM. FILED 9-5-2006.



THE MARK CONSISTS OF YIN YANG SYMBOL INSIDE ZIA SYMBOL.

FOR FABRIC FLAGS (U.S. CLS. 42 AND 50).

FIRST USE 2-5-2006; IN COMMERCE 5-15-2006.

MARGERY A. TIERNEY, EXAMINING ATTORNEY

SN 78-967,734. EXCLUSIVE SPORT SALES@MARKETING, INC., BOISE, ID. FILED 9-6-2006.

## END ZONE TOWEL

THE MARK CONSISTS OF STANDARD CHARACTERS WITHOUT CLAIM TO ANY PARTICULAR FONT, STYLE, SIZE, OR COLOR.

NO CLAIM IS MADE TO THE EXCLUSIVE RIGHT TO USE "TOWEL", APART FROM THE MARK AS SHOWN.

FOR MULTIPURPOSE TOWEL FOR USE AT SPORTING EVENTS (U.S. CLS. 42 AND 50).

KEVIN DINALLO, EXAMINING ATTORNEY

SN 78-969,575. CHEMTEK POLY & PACKAGING CORP., LONG BEACH, CA. FILED 9-7-2006.

## MaxBond

THE MARK CONSISTS OF STANDARD CHARACTERS WITHOUT CLAIM TO ANY PARTICULAR FONT, STYLE, SIZE, OR COLOR.

FOR NONWOVEN AND WOVEN FABRICS INTERLINING IN THE FORM OF ROLLS, BANDS, PUNCHED-OUT AND CUT PIECES AS SEMI-FINISHED PRODUCT FOR THE MANUFACTURE OF GARMENTS, FOOTWEAR AND TEXTILE FABRICS FOR HOUSEHOLD USE; LAMINATED TEXTILE INTERLININGS FOR GARMENTS AND FOOTWEAR (U.S. CLS. 42 AND 50).

FIRST USE 3-0-2003; IN COMMERCE 3-0-2003.

ZACHARY BELLO, EXAMINING ATTORNEY

**CLASS 24—(Continued).**

SN 78-970,602. SOBEL WESTEX, INC., LAS VEGAS, NV.  
FILED 9-8-2006.



THE MARK CONSISTS OF THE WORD CARINA WITH SWIRLS BELOW THE NAME AND AN IMAGE OF AN UPPER FEMALE HEAD.

THE FOREIGN WORDING IN THE MARK TRANSLATES INTO ENGLISH AS PRETTY.

FOR TOWELS (U.S. CLS. 42 AND 50).  
ADA HAN, EXAMINING ATTORNEY

**CLASS 24—(Continued).**

SN 79-022,421. SINOTEXTILES CORPORATION LIMITED,  
CHINA, FILED 2-21-2006.

# CLEANCOOL

OWNER OF INTERNATIONAL REGISTRATION 0881127  
DATED 2-21-2006, EXPIRES 2-21-2016.

FOR UPHOLSTERY FABRICS; FELT AND NON-WOVEN TEXTILE FABRICS; HEMP CLOTH; COTTON FABRIC; GAUZE FABRIC; JERSEY FABRIC; TOWELS OF TEXTILE; FIBERGLASS FABRICS FOR TEXTILE USE; WOOLEN CLOTH; BED COVERS (U.S. CLS. 42 AND 50).

WILLIAM VERHOSEK, EXAMINING ATTORNEY

SN 78-970,608. SOBEL WESTEX, INC., LAS VEGAS, NV.  
FILED 9-8-2006.



THE MARK CONSISTS OF THE WORDS DOLCE NOTTE WITH A QUARTER MOON AND STARS.

THE FOREIGN WORDING IN THE MARK TRANSLATES INTO ENGLISH AS SWEET NIGHT.

FOR BED SHEETS (U.S. CLS. 42 AND 50).  
ADA HAN, EXAMINING ATTORNEY

SN 79-024,545. SAINT-GOBAIN VETROTEX FRANCE S.A.;  
SOCIÉTÉ ANONYME, F-73000 CHAMBERY, FRANCE,  
FILED 7-1-2005.

# MULTICORE

PRIORITY DATE OF 1-28-2005 IS CLAIMED.

OWNER OF INTERNATIONAL REGISTRATION 0886702  
DATED 7-1-2005, EXPIRES 7-1-2015.

FOR FIBERGLASS REINFORCEMENT FABRIC FOR USE IN LAND, SEA AND AEROSPACE APPLICATIONS; RESIN-SATURATED FIBERGLASS FABRIC FOR USE IN TRANSPORTATION, ARMORING, STRUCTURAL REINFORCEMENT AND STRUCTURAL REPAIRS (U.S. CLS. 42 AND 50).

KATHERINE M. DUBRAY, EXAMINING ATTORNEY

SN 78-970,620. SOBEL WESTEX, INC., LAS VEGAS, NV.  
FILED 9-8-2006.



THE MARK CONSISTS OF THE WORD SOBELLINA BETWEEN SCROLLS.

FOR BED SHEETS; TOWELS (U.S. CLS. 42 AND 50).  
ADA HAN, EXAMINING ATTORNEY

SN 79-029,437. JUNKERS + MÜLLERS GMBH, FED REP  
GERMANY, FILED 8-31-2006.

# MEDIATEX

THE MARK CONSISTS OF STANDARD CHARACTERS WITHOUT CLAIM TO ANY PARTICULAR FONT, STYLE, SIZE, OR COLOR.

OWNER OF INTERNATIONAL REGISTRATION 0899837  
DATED 8-31-2006, EXPIRES 8-31-2016.

FOR WOVEN FABRICS FOR INK-JET PRINTING (U.S. CLS. 42 AND 50).

KENNETH E. SHARPERSON, EXAMINING ATTORNEY

**CLASS 25—CLOTHING**

SN 75-079,249. KYARRA INSPIRES INCORPORATED, CLIFFSIDE PARK, NJ. FILED 3-27-1996.



OWNER OF U.S. REG. NO. 2,074,086.  
NO CLAIM IS MADE TO THE EXCLUSIVE RIGHT TO USE "SUPREME", APART FROM THE MARK AS SHOWN, FOR CLOTHING, NAMELY, TOPS, BOTTOMS, UNDERWEAR, SOCKS AND SHOES (U.S. CLS. 22 AND 39).  
FIRST USE 5-1-1995; IN COMMERCE 5-1-1995.  
ELLEN B. AWRICH, EXAMINING ATTORNEY

SN 75-572,125. SIMON, DUANE RICHARD, TEMECULA, CA. FILED 10-16-1998.

## DAWG POUND MUD PUPPIES

FOR CLOTHING, NAMELY, T-SHIRTS, SHIRTS, SWEATSHIRTS, HATS, GLOVES, JACKETS, SOCKS AND SCARFS (U.S. CLS. 22 AND 39).  
LINDA E. BLOHM, EXAMINING ATTORNEY

**CLASS 25—(Continued).**

SN 76-286,514. HUGO BOSS TRADE MARKS MANAGEMENT GMBH & CO. KG, METZINGEN, FED REP GERMANY, FILED 7-17-2001.



PRIORITY CLAIMED UNDER SEC. 44(D) ON FED REP GERMANY APPLICATION NO. 30103710.8, FILED 1-19-2001, REG. NO. 30103710, DATED 7-12-2001, EXPIRES 1-30-2011.

OWNER OF U.S. REG. NO. 2,459,324.  
THE MARK CONSISTS OF A STITCHING DESIGN WHICH APPEARS ON THE CLOTHING ARTICLES.  
FOR ARTICLES OF CLOTHING FOR LADIES, GENTLEMEN AND CHILDREN, NAMELY, BEACHWEAR, BLOUSES, BOTTOMS, DRESSES, GOLF WEAR, NAMELY, SHIRTS, PANTS, SWEATERS, JACKETS, VESTS, HATS, SOCKS AND SHOES; HOSIERY, JACKETS, LINGERIE, LOUNGEWEAR, NECKWEAR, PANTS, RAINWEAR, SHIRTS, SHORTS, SKIRTS, SKIWEAR, SLEEPWEAR, SOCKS, SUITS, SWEATERS, SWEATSHIRTS, TENNIS WEAR, TOPS, TUXEDOS; SOCKS AND STOCKINGS; HEADWEAR; UNDERWEAR; NIGHTWEAR; SWIMWEAR; BATHROBES; BELTS; SCARVES AND SHAWLS; ACCESSORIES, NAMELY HEAD SCARVES, NECK SCARVES, SHOULDER SCARVES, POCKET KERCHIEFS; TIES; GLOVES; FOOTWEAR (U.S. CLS. 22 AND 39).

HENRY S. ZAK, EXAMINING ATTORNEY

SN 76-551,257. BONGIOVI, JOHN, LOS ANGELES, CA. FILED 9-24-2003.



THE MARK CONSISTS OF A STYLIZED WINGED FOOTBALL.

FOR MEN'S, WOMEN'S AND CHILDREN'S WEARING APPAREL, NAMELY, PANTS, SHIRTS, SLACKS, DRESSES, SKIRTS AND BLOUSES; HEADWEAR, FOOTWEAR; SPORTSWEAR, NAMELY, SWEAT SHIRTS, SWEAT PANTS, WARM-UP SUITS, T-SHIRTS, SHORTS, SPORT SHIRTS, SPORT COATS AND POLO SHIRTS; SWIMWEAR AND BEACHWEAR, NAMELY, BATHING SUITS, ROBES AND COVER-UPS; AND OUTERWEAR, NAMELY, JACKETS, SWEATERS, COATS AND VESTS (U.S. CLS. 22 AND 39).

NELSON SNYDER, EXAMINING ATTORNEY

SN 76-560,139. ACCORD TRADEMARKS, INC., NEW YORK, NY. FILED 10-29-2003.

## VALLEY BY ALVIN VALLEY

THE NAME ALVIN VALLEY IDENTIFIES A LIVING INDIVIDUAL WHOSE CONSENT IS OF RECORD.  
FOR APPAREL, NAMELY, JEANS, SKIRTS, TOPS, JACKETS, DRESSES AND COATS (U.S. CLS. 22 AND 39).  
STACY WAHLBERG, EXAMINING ATTORNEY

**CLASS 25—(Continued).**

SN 76-601,689. SIMON INTERNATIONAL TRADING CORP., NEW YORK, NY. FILED 7-12-2004.

# 2-YOU BABY

THE MARK CONSISTS OF STANDARD CHARACTERS WITHOUT CLAIM TO ANY PARTICULAR FONT, STYLE, SIZE, OR COLOR.

NO CLAIM IS MADE TO THE EXCLUSIVE RIGHT TO USE "BABY", APART FROM THE MARK AS SHOWN.

FOR CLOTHING, NAMELY, SHIRTS, PANTS, SHORTS, SKIRTS, BABY SHOES, HATS, SOCKS, ROMPERS AND OVERALLS (U.S. CLS. 22 AND 39).

SALLY SHIH, EXAMINING ATTORNEY

**CLASS 25—(Continued).**

SN 76-653,074. ASICS CORPORATION, CHUO-KU, KOBE 650-8555, JAPAN, FILED 1-6-2006.

# WHIZZER

THE MARK CONSISTS OF STANDARD CHARACTERS WITHOUT CLAIM TO ANY PARTICULAR FONT, STYLE, SIZE, OR COLOR.

FOR FOOTWEAR (U.S. CLS. 22 AND 39). FIRST USE 5-20-2005; IN COMMERCE 5-20-2005.

INGRID C. EULIN, EXAMINING ATTORNEY

SN 76-647,343. FAN, JUN, CHINO HILLS, CA. FILED 9-23-2005.

# TULLÉMOSS

THE MARK CONSISTS OF STANDARD CHARACTERS WITHOUT CLAIM TO ANY PARTICULAR FONT, STYLE, SIZE, OR COLOR.

FOR CLOTHING FOR MEN AND WOMEN, NAMELY, COATS, TIES, BELTS, CAPS, SHOES, AND SOCKS; CHILDREN'S CLOTHING, NAMELY SHIRTS, PANTS, SHORTS (U.S. CLS. 22 AND 39).

ROBERT LAVACHE, EXAMINING ATTORNEY

SN 76-660,165. PAUL, CHRISTOPHER E., MCLEAN, VA. FILED 5-10-2006.

# CP3

THE MARK CONSISTS OF STANDARD CHARACTERS WITHOUT CLAIM TO ANY PARTICULAR FONT, STYLE, SIZE, OR COLOR.

FOR CLOTHING, NAMELY FOOTWEAR, SHIRTS, SWEATSHIRTS, PANTS, WRISTBANDS, SHORTS, JACKETS, WARM-UP SUITS, SKIRTS, SWEATERS, HEADWEAR, T-SHIRTS, SOCKS, HEADBANDS AND TOPS (U.S. CLS. 22 AND 39).

BARBARA GAYNOR, EXAMINING ATTORNEY

SN 76-652,221. TAHITI FEETIES, LOS ANGELES, CA. FILED 12-20-2005.



THE MARK CONSISTS OF TROPICAL FLOWERS ON THE LEFT SIDE OF THE WORDS "TAHITI FEETIES" IN A STYLIZED FONT.

FOR FOOTWEAR, NAMELY FLIP-FLOPS, SANDALS, THONGS (U.S. CLS. 22 AND 39).

FIRST USE 5-1-2005; IN COMMERCE 5-1-2005. ALEX KEAM, EXAMINING ATTORNEY

SN 76-664,882. STRICKLAND, JOSHUA W., MIDLAND, TX. AND STRICKLAND, ROBERT, MIDLAND, TX. FILED 8-21-2006.

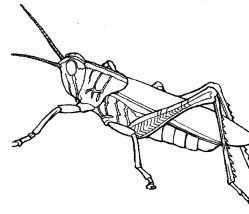

TBAAS

FOR SHIRTS (U.S. CLS. 22 AND 39). BRIDGETT SMITH, EXAMINING ATTORNEY

**CLASS 25—(Continued).**

SN 76-665,592. VIBES BASE GROUP CORP., EL MONTE, CA.  
FILED 9-5-2006.

**VIBRANT**

THE MARK CONSISTS OF STANDARD CHARACTERS WITHOUT CLAIM TO ANY PARTICULAR FONT, STYLE, SIZE, OR COLOR.

FOR MEN'S, WOMEN'S AND CHILDREN'S CLOTHING, NAMELY, SHIRTS, TOPS, SWEATERS, PANTS, JEANS, SHORTS, SKIRTS, DRESSES, SPORTS JACKETS, JACKETS, SUITS, OUTERWEAR, NAMELY, COATS, JACKETS, SWIMWEAR, SLEEPWEAR, LOUNGEWEAR, LINGERIE, UNDERGARMENTS, NAMELY, UNDERWEAR, PANTIES, BRASSIERES, FOOTWEAR, HOSIERY, BELTS AND HATS (U.S. CLS. 22 AND 39).

FIRST USE 1-1-2006; IN COMMERCE 1-1-2006.  
CURTIS FRENCH, EXAMINING ATTORNEY

SN 76-665,646. O'QUINN, INC., HUNTINGTON BEACH, CA.  
FILED 9-5-2006.

**SANDPAPER**

THE MARK CONSISTS OF STANDARD CHARACTERS WITHOUT CLAIM TO ANY PARTICULAR FONT, STYLE, SIZE, OR COLOR.

FOR MEN'S AND BOY'S WEARING APPAREL, NAMELY, T-SHIRTS, SWEATSHIRTS, TANK TOPS, WOVEN SHIRTS, SWEATERS, CARDIGANS, VESTS, JACKETS, PANTS, SWEATPANTS, JEANS, SHORTS, HATS, CAPS, COATS, SCARVES, NECKERCHIEFS, NECK BANDS, WRIST BANDS, HEAD BANDS, GLOVES, BELTS, PAJAMAS, SHOES, SOCKS, UNDERWEAR, SWIM WEAR, AND TRUNKS; AND WOMEN'S AND GIRL'S WEARING APPAREL, NAMELY, T-SHIRTS, SWEATSHIRTS, TANK TOPS, WOVEN SHIRTS, SWEATERS, CARDIGANS, VESTS, JACKETS, PANTS, SWEATPANTS, JEANS, SHORTS, HATS, CAPS, COATS, BELTS, NECKERCHIEFS, NECK BANDS, WRIST BANDS, HEAD BANDS, GLOVES, PAJAMAS, SHOES, SOCKS, UNDERWEAR, FOUNDATION GARMENTS, PANTYHOSE, TEDDIES, BRAS, SKIRTS, DRESSES, BLOUSES, SWIM WEAR, AND BIKINIS (U.S. CLS. 22 AND 39).

DAVID TOOLEY, EXAMINING ATTORNEY

**CLASS 25—(Continued).**

SN 76-665,762. THE ANTIGUA GROUP, INC., PEORIA, AZ.  
FILED 9-8-2006.

**DESERT DRY**

THE MARK CONSISTS OF STANDARD CHARACTERS WITHOUT CLAIM TO ANY PARTICULAR FONT, STYLE, SIZE, OR COLOR.

NO CLAIM IS MADE TO THE EXCLUSIVE RIGHT TO USE "DRY", APART FROM THE MARK AS SHOWN.

FOR CLOTHING MADE FROM FABRIC SPECIALLY TREATED TO WICK AWAY MOISTURE AND BODY PERSPIRATION (U.S. CLS. 22 AND 39).

FIRST USE 4-1-2002; IN COMMERCE 4-1-2002.

MELVIN AXILBUND, EXAMINING ATTORNEY

SN 76-668,732. GOLFSMITH INTERNATIONAL, INC., AUSTIN, TX. FILED 11-8-2006.

**SNAKE EYES**

THE MARK CONSISTS OF STANDARD CHARACTERS WITHOUT CLAIM TO ANY PARTICULAR FONT, STYLE, SIZE, OR COLOR.

OWNER OF U.S. REG. NO. 1,889,946.

FOR CLOTHING, NAMELY, TOPS, BOTTOMS, SHIRTS, GOLF SHIRTS, T-SHIRTS, WIND SHIRTS, JACKETS, PULLOVERS, SHORTS, PANTS, SOCKS, SHOES, GOLF SHOES, GLOVES, CAPS, HATS, VISORS, RAIN SUITS, AND VESTS (U.S. CLS. 22 AND 39).

FIRST USE 9-16-1993; IN COMMERCE 9-16-1993.

JAY BESCH, EXAMINING ATTORNEY

SN 77-006,646. BRADLEY, ANDUJAR, BROOKLYN, NY.  
FILED 9-25-2006.

**TEAM REVOLUTION**

THE MARK CONSISTS OF STANDARD CHARACTERS WITHOUT CLAIM TO ANY PARTICULAR FONT, STYLE, SIZE, OR COLOR.

OWNER OF U.S. REG. NO. 3,126,418.

FOR CLOTHING, NAMELY, SHORTS, PANTS, T-SHIRTS, SHIRTS, TANK TOPS, SOCKS, GLOVES, JACKETS, PONCHOS, SWIMWEAR, SWEATERS, FLEECE PULLOVERS, SWEATSUITS, HATS, CAPS, VISORS, HEAD BANDS, UNDERGARMENTS, SLEEPWEAR, AND LOUNGEWEAR (U.S. CLS. 22 AND 39).

FIRST USE 12-0-2002; IN COMMERCE 12-0-2002.

WILLIAM ROSSMAN, EXAMINING ATTORNEY



**CLASS 25—(Continued).**

SN 77-011,019. MUNSHI, SHERI, PARKER, CO. AND MUNSHI, KAIZAD, PARKER, CO. AND MUNSHI, CYRUS, ALEXANDRIA, VA. FILED 9-29-2006.

**LOVE ME LOVE MY**

THE MARK CONSISTS OF STANDARD CHARACTERS WITHOUT CLAIM TO ANY PARTICULAR FONT, STYLE, SIZE, OR COLOR.

FOR BANDANAS, BATHING SUITS, BELTS, BRIEFS, BOOTS, CAMISOLES, CAPRIS, CAPS, CLOTH BIBS, COATS, DRESSES, FLIP FLOPS, FOOTWEAR, GLOVES, HATS, HEAD BANDS, HEAD WEAR, JACKETS, JEANS, LEG WARMERS, NECKTIES, NECKWEAR, NIGHT-GOWNS, NIGHT SHIRTS, PAJAMAS, PULLOVERS, RAINCOATS, RAIN JACKETS, RAINWEAR, SCARVES, SHAWLS, SHIRTS, SHOES, SHORTS, SLIPPERS, SOCKS, SUSPENDERS, SWEATERS, SWEATSHIRTS, SWEATPANTS, SWIMWEAR, TANK TOPS, T-SHIRTS, TROUSERS, UNDERWEAR, AND VESTS (U.S. CLS. 22 AND 39).

KAELIE KUNG, EXAMINING ATTORNEY

**CLASS 25—(Continued).**

SN 77-013,038. POMARE, LTD., HONOLULU, HI. FILED 10-3-2006.

**HAWAIIAN PALMS**

THE MARK CONSISTS OF STANDARD CHARACTERS WITHOUT CLAIM TO ANY PARTICULAR FONT, STYLE, SIZE, OR COLOR.

NO CLAIM IS MADE TO THE EXCLUSIVE RIGHT TO USE "HAWAIIAN", APART FROM THE MARK AS SHOWN. FOR BEACH COVERUPS; BEACH FOOTWEAR; BLOUSES; DRESSES; EVENING DRESSES; HATS; JACKETS; LOUNGWEAR; NECKTIES; PANTS; SANDALS; SARONGS; SCARVES; SHIRTS; SHOES; SHORT-SLEEVED OR LONG-SLEEVED T-SHIRTS; SHORTS; SKIRTS; SOCKS; SWIMMING TRUNKS; SWIMSUITS; TANK TOPS; WAIST BELTS (U.S. CLS. 22 AND 39).

DAVID HOFFMAN, EXAMINING ATTORNEY

SN 77-013,702. HBI BRANDED APPAREL LIMITED, INC., WINSTON-SALEM, NC. FILED 10-4-2006.

**HANES TUGFREE**

THE MARK CONSISTS OF STANDARD CHARACTERS WITHOUT CLAIM TO ANY PARTICULAR FONT, STYLE, SIZE, OR COLOR.

OWNER OF U.S. REG. NOS. 719,339, 1,409,560 AND OTHERS.

FOR UNDERWEAR (U.S. CLS. 22 AND 39).

KATHERINE CONNOLLY, EXAMINING ATTORNEY

SN 77-012,957. RUBY DESIGNS, MESQUITE, NV. FILED 10-3-2006.

**Slick Chicks Racing**

THE MARK CONSISTS OF STANDARD CHARACTERS WITHOUT CLAIM TO ANY PARTICULAR FONT, STYLE, SIZE, OR COLOR.

FOR BEANIES; BOARD SHORTS; BOXER SHORTS; CHILDREN'S HEADWEAR; HATS; HEADBANDS; HEADWEAR; JACKETS; JOGGING PANTS; LADIES' UNDERWEAR; PANTIES, SHORTS AND BRIEFS; PANTS; SHIRTS; SHORT-SLEEVED OR LONG-SLEEVED T-SHIRTS; SLEEP SHIRTS; SPORTS SHIRTS WITH SHORT SLEEVES; SWEAT PANTS; SWEAT SHIRTS; SWEAT SHORTS; THONGS; TOBOGGAN HATS, PANTS AND CAPS; UNDERWEAR; VESTS; VISORS; WALKING SHORTS; WOMEN'S UNDERWEAR (U.S. CLS. 22 AND 39).

JENNIFER KRISP, EXAMINING ATTORNEY

SN 77-018,226. CASTRO, MARYANN, HUGHSON, CA. FILED 10-10-2006.

**My Daddy's Faster**

THE MARK CONSISTS OF STANDARD CHARACTERS WITHOUT CLAIM TO ANY PARTICULAR FONT, STYLE, SIZE, OR COLOR.

FOR T-SHIRTS (U.S. CLS. 22 AND 39).

MARGERIE A. TIERNEY, EXAMINING ATTORNEY

**CLASS 25—(Continued).**

SN 77-020,105. LEBA, CHRIS, BROOKLYN, NY. FILED 10-12-2006.

## SONS OF LIBERTY

THE MARK CONSISTS OF STANDARD CHARACTERS WITHOUT CLAIM TO ANY PARTICULAR FONT, STYLE, SIZE, OR COLOR.

FOR CLOTHING, NAMELY, TEE SHIRTS, SHIRTS, SWEATERS, JEANS, JACKETS, COATS, SKIRTS, DRESSES, SWEAT SHIRTS, HATS, SWIMWEAR AND SOCKS (U.S. CLS. 22 AND 39).

BARBARA BROWN, EXAMINING ATTORNEY

SN 77-025,296. JESSICA MCCLINTOCK, INC., SAN FRANCISCO, CA. FILED 10-19-2006.

## Jessica by Jessica McClintock

THE MARK CONSISTS OF STANDARD CHARACTERS WITHOUT CLAIM TO ANY PARTICULAR FONT, STYLE, SIZE, OR COLOR.

OWNER OF U.S. REG. NOS. 1,801,339, 3,171,071 AND OTHERS.

THE NAME(S), PORTRAIT(S), AND/OR SIGNATURE(S) SHOWN IN THE MARK IDENTIFIES JESSICA MCCLINTOCK, WHOSE CONSENT(S) TO REGISTER IS SUBMITTED.

FOR WOMEN'S SLEEPWEAR AND LOUNGE WEAR; PAJAMAS, SLEEP SHIRTS, ROBES, TAP SHORTS WITH CAMISOLE/T-SHIRT SETS, CHEMISES, LOUNGE PANTS, AND TOPS (U.S. CLS. 22 AND 39).

MICHAEL KEATING, EXAMINING ATTORNEY

**CLASS 25—(Continued).**

SN 77-026,532. @WEBO, COTO DE CAZA, CA. FILED 10-21-2006.

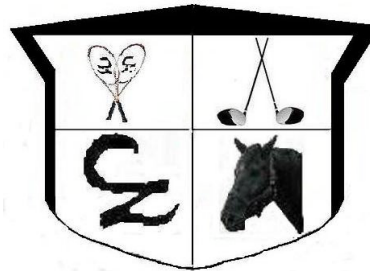

THE MARK CONSISTS OF A DESIGN ELEMENT COMPRISED OF A CREST DIVIDED INTO FOUR SECTIONS, WITH A PAIR OF CROSSING TENNIS RACKETS IN THE UPPER LEFT SECTION, A STYLIZED CZ IN THE LOWER LEFT SECTION, TWO CROSSING GOLF CLUBS IN THE UPPER RIGHT SECTION, AND THE HEAD OF A HORSE IN THE LOWER RIGHT SECTION.

FOR CAMP SHIRTS; CAPRI PANTS; CARGO PANTS; DENIMS; DRESS SHIRTS; GOLF CAPS; GOLF CLEATS; GOLF SHIRTS; GOLF SHOES; GOLF SPIKES; GOLF TROUSERS; JOGGING PANTS; KNIT SHIRTS; LEATHER PANTS; NIGHT SHIRTS; NON-DISPOSABLE CLOTH TRAINING PANTS; NURSE PANTS; OPEN-NECKED SHIRTS; PANTS; PETTI-PANTS; PIQUE SHIRTS; POLO SHIRTS; SHIRT FRONTS; SHIRT YOKES; SHIRTS; SHIRTS FOR SUITS; SHORT-SLEEVED OR LONG-SLEEVED T-SHIRTS; SHORT-SLEEVED SHIRTS; SKI PANTS; SLEEP SHIRTS; SNOW PANTS; SNOWBOARD PANTS; SPORT SHIRTS; SPORTS SHIRTS; SPORTS SHIRTS WITH SHORT SLEEVES; SWEAT PANTS; SWEAT SHIRTS; T-SHIRTS; TAP PANTS; TOBOGGAN HATS, PANTS AND CAPS; TRACK PANTS; WATERPROOF JACKETS AND PANTS; WIND SHIRTS (U.S. CLS. 22 AND 39).

FIRST USE 6-22-2005; IN COMMERCE 6-22-2005.

JUDITH HELFMAN, EXAMINING ATTORNEY

SN 77-029,850. SHANK, KEN, GLENDALE, CA. FILED 10-26-2006.

## Villain Academy

THE MARK CONSISTS OF STANDARD CHARACTERS WITHOUT CLAIM TO ANY PARTICULAR FONT, STYLE, SIZE, OR COLOR.

FOR HATS, SHIRTS, PANTS, SHOES, JACKETS, SWEAT SUITS, LINGERIE, GLOVES, BELTS AND UNDERWEAR; SPORT WEAR, NAMELY, BASEBALL JERSEYS, HOCKEY JERSEYS, FOOTBALL JERSEYS, SPORT TANK SHIRTS, AND BASKETBALL SHIRTS; SKATE WEAR, NAMELY, SWEAT PANTS, BIKE SHORTS, BMX PANTS, BMX SHIRTS, SWEAT SHIRTS, T-SHIRTS, SHORTS, FOOTWEAR, GLOVES, AND TANK TOPS (U.S. CLS. 22 AND 39).

TAMARA LEE, EXAMINING ATTORNEY

**CLASS 25—(Continued).**

SN 77-029,860. SHANK, KEN, GLENDALE, CA. FILED 10-26-2006.

**S.V.I.T. / Super Villain  
in Training**

THE MARK CONSISTS OF STANDARD CHARACTERS WITHOUT CLAIM TO ANY PARTICULAR FONT, STYLE, SIZE, OR COLOR.

FOR HATS, SHIRTS, PANTS, SHOES, JACKETS, SWEAT SUITS, LINGERIE, GLOVES, BELTS AND UNDERWEAR; SPORT WEAR, NAMELY, BASEBALL JERSEYS, HOCKEY JERSEYS, FOOTBALL JERSEYS, SPORT TANK SHIRTS, AND BASKETBALL SHIRTS; SKATE WEAR, NAMELY, SWEAT PANTS, BIKE SHORTS, BMX PANTS, BMX SHIRTS, SWEAT SHIRTS, T-SHIRTS, SHORTS, FOOTWEAR, GLOVES, AND TANK TOPS (U.S. CLS. 22 AND 39).

TAMARA LEE, EXAMINING ATTORNEY

---

SN 77-034,199. SMITH-GETMAN, J. JAYE, AUSTIN, TX. FILED 11-1-2006.

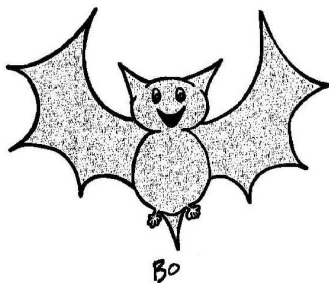

THE STIPPLING IS FOR SHADING PURPOSES ONLY. FOR CLOTHING, NAMELY, SHIRTS, T-SHIRTS, SWEATSHIRTS, SPORTS SHIRTS, COLLARED SHIRTS, SWEATERS, BASEBALL HATS, SHORTS, PANTS, UNDERWEAR AND HALLOWEEN COSTUMES (U.S. CLS. 22 AND 39).

DAVID YONTEF, EXAMINING ATTORNEY

**CLASS 25—(Continued).**

SN 77-036,518. BDSRCO, INC., WILMINGTON, DE. FILED 11-3-2006.

**BRISAS**

THE MARK CONSISTS OF STANDARD CHARACTERS WITHOUT CLAIM TO ANY PARTICULAR FONT, STYLE, SIZE, OR COLOR.

THE FOREIGN WORDING IN THE MARK TRANSLATES INTO ENGLISH AS BREEZES.

FOR SHORTS; CAPRIS; BOTTOMS; SWEATERS; SCREENED TEES; FLEECE WEAR, NAMELY, PONCHOS, JACKETS, SWEATERS AND SWEATSHIRTS; OUTERWEAR, NAMELY, COATS, PARKAS, RAINCOATS AND JACKETS; KNIT AND WOVEN TOPS; TANK TOPS; COVER-UPS (U.S. CLS. 22 AND 39).

PETER B. BROMAGHIM, EXAMINING ATTORNEY

---

SN 77-037,101. SIMMS FISHING PRODUCTS CORPORATION, BOZEMAN, MT. FILED 11-5-2006.

**EXSTREAM**

THE MARK CONSISTS OF STANDARD CHARACTERS WITHOUT CLAIM TO ANY PARTICULAR FONT, STYLE, SIZE, OR COLOR.

OWNER OF U.S. REG. NOS. 2,107,681 AND 2,695,985. FOR CLOTHING FOR FISHING, NAMELY, UNDERWEAR (U.S. CLS. 22 AND 39).

CHARISMA HAMPTON, EXAMINING ATTORNEY

---

SN 77-037,275. THE CARTOON NETWORK, INC., ATLANTA, GA. FILED 11-6-2006.

**WILLIAMS STREET**

THE MARK CONSISTS OF STANDARD CHARACTERS WITHOUT CLAIM TO ANY PARTICULAR FONT, STYLE, SIZE, OR COLOR.

FOR CLOTHING FOR MEN, WOMEN AND CHILDREN FEATURING CHARACTERS FROM ANIMATED, ACTION ADVENTURE, COMEDY AND/OR DRAMA FEATURES, NAMELY, SHIRTS, T-SHIRTS, SWEATSHIRTS, JOGGING SUITS, TROUSERS, PANTS, SHORTS, TANK TOPS, RAINWEAR, CLOTH BABY BIBS, SKIRTS, BLOUSES, DRESSES, SUSPENDERS, SWEATERS, JACKETS, COATS, RAINCOATS, SNOW SUITS, TIES, ROBES, HATS, CAPS, SUNVISORS, BELTS, SCARVES, SLEEPWEAR, PAJAMAS, LINGERIE, UNDERWEAR, BOOTS, SHOES, SNEAKERS, SANDALS, BOOTIES, SLIPPER SOCKS, SWIMWEAR AND MASQUERADE AND HALLOWEEN COSTUMES AND MASKS SOLD IN CONNECTION THEREWITH (U.S. CLS. 22 AND 39).

LINDA ORNDORFF, EXAMINING ATTORNEY

**CLASS 25—(Continued).**

SN 77-039,084. WILD MARKS, INC., LAS VEGAS, NV. FILED 11-7-2006.

# WILD OATS

THE MARK CONSISTS OF STANDARD CHARACTERS WITHOUT CLAIM TO ANY PARTICULAR FONT, STYLE, SIZE, OR COLOR.

FOR CLOTHING, NAMELY T-SHIRTS, POLO SHIRTS, DRESS SHIRTS, DENIM SHIRTS, SWEAT SHIRTS, JACKETS, WIND RESISTANT JACKETS, WOOL JACKETS, FLEECE VESTS, FLEECE PULLOVERS, APRONS, HATS (U.S. CLS. 22 AND 39).

FIRST USE 0-0-1997; IN COMMERCE 0-0-1997.  
KEVIN CORWIN, EXAMINING ATTORNEY

---

SN 77-040,262. DISGUISE, INC., POWAY, CA. FILED 11-9-2006.

# OPERATION RAPID STRIKE

THE MARK CONSISTS OF STANDARD CHARACTERS WITHOUT CLAIM TO ANY PARTICULAR FONT, STYLE, SIZE, OR COLOR.

FOR HALLOWEEN AND MASQUERADE COSTUMES AND MASKS SOLD IN CONNECTION THEREWITH; HEADWEAR, FOOTWEAR AND GLOVES (U.S. CLS. 22 AND 39).

BERYL GARDNER, EXAMINING ATTORNEY

---

SN 77-057,198. OXFORD INDUSTRIES, INC., ATLANTA, GA. FILED 12-5-2006.

# CYE

THE MARK CONSISTS OF STANDARD CHARACTERS WITHOUT CLAIM TO ANY PARTICULAR FONT, STYLE, SIZE, OR COLOR.

FOR SHIRTS (U.S. CLS. 22 AND 39).  
ELIZABETH PIGNATELLO, EXAMINING ATTORNEY

**CLASS 25—(Continued).**

SN 77-072,364. L.C. LICENSING, INC., NEW YORK, NY. FILED 12-28-2006.



THE MARK CONSISTS OF STYLIZED LETTERS R, S, R AND V.

FOR BELTS; COATS; DRESSES MADE FROM SKINS; FOOTWEAR; HEADWEAR; HOSIERY; LINGERIE; NECKTIES; PANTS; RAINWEAR; SHIRTS; SKIRTS; SLEEPWEAR; SOCKS; SUITS; SWEATERS; SWIM WEAR FOR GENTLEMEN AND LADIES; T-SHIRTS; UNDERWEAR (U.S. CLS. 22 AND 39).

COLLEEN DOMBROW, EXAMINING ATTORNEY

---

SN 77-072,372. L.C. LICENSING, INC., NEW YORK, NY. FILED 12-28-2006.



THE MARK CONSISTS OF A SQUIRREL HOLDING A BAT.

FOR BELTS; COATS; DRESSES; FOOTWEAR; HEADWEAR; HOSIERY; LINGERIE; NECKTIES; PANTS; RAINWEAR; SHIRTS; SKIRTS; SLEEPWEAR; SOCKS; SUITS; SWEATERS; SWIM WEAR; T-SHIRTS; UNDERWEAR (U.S. CLS. 22 AND 39).

COLLEEN DOMBROW, EXAMINING ATTORNEY

**CLASS 25—(Continued).**

SN 77-072,380. L.C. LICENSING, INC., NEW YORK, NY.  
FILED 12-28-2006.



THE MARK CONSISTS OF STYLIZED LETTERS R, S, R AND V WITH TWO BATS CROSSED IN BETWEEN THE LETTERS.

FOR BELTS; COATS; DRESSES; FOOTWEAR; HEADWEAR; HOSIERY; JEANS; LINGERIE; NECKTIES; PANTS; RAINWEAR; SHIRTS; SKIRTS; SLEEPWEAR; SOCKS; SUITS; SWEATERS; SWIM WEAR; T-SHIRTS; UNDERWEAR (U.S. CLS. 22 AND 39).

COLLEEN DOMBROW, EXAMINING ATTORNEY

**CLASS 25—(Continued).**

SN 77-072,422. L.C. LICENSING, INC., NEW YORK, NY.  
FILED 12-28-2006.

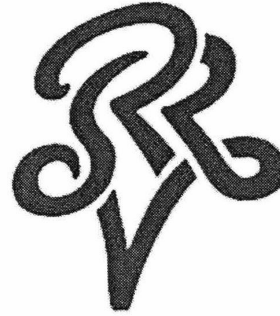

THE MARK CONSISTS OF STYLIZED LETTERS R, R AND V.

FOR BELTS; COATS; DRESSES; FOOTWEAR; HEADWEAR; HOSIERY; JEANS; LINGERIE; NECKTIES; PANTS; RAINWEAR; SHIRTS; SKIRTS; SLEEPWEAR; SOCKS; SUITS; SWEATERS; SWIM WEAR; T-SHIRTS; UNDERWEAR (U.S. CLS. 22 AND 39).

COLLEEN DOMBROW, EXAMINING ATTORNEY

SN 77-072,409. L.C. LICENSING, INC., NEW YORK, NY.  
FILED 12-28-2006.



THE MARK CONSISTS OF STYLIZED LETTERS R,S,R,V AND A DIAMOND SHAPE WITH LINES AND BARS.

FOR BELTS; COATS; DRESSES; FOOTWEAR; HEADWEAR; HOSIERY; JEANS; LINGERIE; NECKTIES; PANTS; RAINWEAR; SHIRTS; SKIRTS; SLEEPWEAR; SOCKS; SUITS; SWEATERS; SWIM WEAR; T-SHIRTS; UNDERWEAR (U.S. CLS. 22 AND 39).

COLLEEN DOMBROW, EXAMINING ATTORNEY

SN 78-192,684. FORUS S.A., SANTIAGO, CHILE, FILED 12-9-2002.

**CALPANY**

OWNER OF CHILE REG. NO. 1945607, DATED 8-13-2003, EXPIRES 8-13-2013.

FOR CLOTHING, NAMELY PANTS, TROUSERS, SHIRTS, SKIRTS, SOCKS, SWEATERS, T-SHIRTS, PULL-OVERS, UNDERWEAR; AND HEADWEAR, NAMELY, HATS AND CAPS (U.S. CLS. 22 AND 39).

KELLY BOULTON, EXAMINING ATTORNEY

**CLASS 25—(Continued).**

SN 78-581,000. KING, MARGARET NAPLES, MORRISON, CO. FILED 3-5-2005.

Me-T's

THE MARK CONSISTS OF STANDARD CHARACTERS WITHOUT CLAIM TO ANY PARTICULAR FONT, STYLE, SIZE, OR COLOR.  
FOR SHIRTS, PANTS, SHOES AND SHORTS (U.S. CLS. 22 AND 39).  
MONIQUE MILLER, EXAMINING ATTORNEY

**CLASS 25—(Continued).**

SN 78-645,525. ELLIS, ZACHARY B., VALRICO, FL. AND ELLIS, KELLY R., VALRICO, FL. FILED 6-7-2005.



THE COLOR(S) RED AND BLUE IS/ARE CLAIMED AS A FEATURE OF THE MARK.  
THE MARK CONSISTS OF A TRIANGLE WITH THE WORD URBANWEARZ IN THE MIDDLE. THE TRIANGLE IS RED AND THE WORD URBANWEARZ IS BLUE.  
SEC. 2(F).  
FOR SHIRTS, HATS, PANTS, SHOES (U.S. CLS. 22 AND 39).  
FIRST USE 7-25-2005; IN COMMERCE 8-1-2005.  
KAREN BRACEY, EXAMINING ATTORNEY

SN 78-658,999. MERCADO, MARIO, NEW YORK, NY. FILED 6-27-2005.

DOUBLE

SN 78-591,211. LETARTE, LLC, FAIRFIELD, CT. FILED 3-21-2005.



OWNER OF U.S. REG. NO. 2,501,999.  
NO CLAIM IS MADE TO THE EXCLUSIVE RIGHT TO USE "MAUI, HAWAII", APART FROM THE MARK AS SHOWN.  
FOR WOMEN'S AND CHILDREN'S CLOTHING AND FOOTWEAR, NAMELY; BATHING SUITS, TEE SHIRTS, SHIRTS, SHORTS, SKIRTS, CAFTANS, COVER-UPS, HATS AND SANDALS (U.S. CLS. 22 AND 39).  
FIRST USE 7-1-1997; IN COMMERCE 7-1-1997.  
JENNIFER VASQUEZ, EXAMINING ATTORNEY

THE MARK CONSISTS OF STANDARD CHARACTERS WITHOUT CLAIM TO ANY PARTICULAR FONT, STYLE, SIZE, OR COLOR.  
FOR ATHLETIC APPAREL, NAMELY COMPETITION, EXERCISE AND TRAINING GEAR, NAMELY, ATHLETIC UNIFORMS, BOTTOMS, CLOTHING FOR WEAR IN JUDO, CLOTHING FOR WEAR IN WRESTLING, GYM SHORTS, GYM SUITS, HEAD WEAR, JUDO SUITS, KARATE SUITS, MARTIAL ARTS UNIFORMS, MUSCLE TOPS, PANTS, PERSPIRATION ABSORBENT UNDERWEAR CLOTHING, RASH GUARDS, SHORT SLEEVED OR LONG SLEEVED TEE SHIRTS, SHORTS, SHIRTS, UNDERWEAR, WARM UP SUITS, WRESTLING UNIFORMS, JIU-JITSU UNIFORMS, SOMBO UNIFORMS, CYCLING UNIFORMS, CROSS TRAINING UNIFORMS, TRACK AND FIELD UNIFORMS, RUGBY UNIFORMS, SOCCER UNIFORMS, VOLLEY BALL UNIFORMS AND GRAPPLING UNIFORMS FOR ACTIVITIES, SUCH AS WRESTLING, TRIATHLON, JUDO, KARATE, JIU-JITSU, BOXING, MIXED MARTIAL ARTS, YOGA, SOMBO, AND AEROBICS (U.S. CLS. 22 AND 39).  
HENRY S. ZAK, EXAMINING ATTORNEY

**CLASS 25—(Continued).**

SN 78-662,187. NBA PROPERTIES, INC., NEW YORK, NY. FILED 6-30-2005.



OWNER OF U.S. REG. NOS. 2,168,038 AND 2,263,358. NO CLAIM IS MADE TO THE EXCLUSIVE RIGHT TO USE "FINALS", APART FROM THE MARK AS SHOWN. THE MARK CONSISTS OF THE WORDS "THE FINALS" IN SCRIPT ALONG WITH A SILHOUETTE OF A BASKETBALL PLAYER OVER THE LETTER "NBA" WITH A TROPHY DESIGN DEPICTING A BASKETBALL AND BASKETBALL NET.

FOR CLOTHING, NAMELY HOSIERY, FOOTWEAR, BASKETBALL SHOES, BASKETBALL SNEAKERS, T-SHIRTS, SHIRTS, POLO SHIRTS, SWEATSHIRTS, SWEATPANTS, PANTS, TANK TOPS, JERSEYS, SHORTS, PAJAMAS, SPORT SHIRTS, RUGBY SHIRTS, SWEATERS, BELTS, TIES, NIGHTSHIRTS, HATS, CAPS, VISORS, WARM-UP SUITS, WARM-UP PANTS, WARM-UP TOPS, SHOOTING SHIRTS, JACKETS, WIND RESISTANT JACKETS, PARKAS, COATS, BABY BIBS NOT OF PAPER, HEAD BANDS, WRIST BANDS, APRONS, UNDERGARMENTS, BOXER SHORTS, SLACKS, EAR MUFFS, GLOVES, MITTENS, SCARVES, WOVEN AND KNIT SHIRTS, JERSEY DRESSES, DRESSES, CHEERLEADING DRESSES AND UNIFORMS, SWIM WEAR, BATHING SUITS, SWIMSUITS, BIKINIS, TANKINIS, SWIM TRUNKS, BATHING TRUNKS, BOARD SHORTS, WET SUITS, BEACH COVER-UPS, BATHING SUIT COVER-UPS, BATHING SUIT WRAPS, SANDALS, BEACH SANDALS, BEACH HATS, SUN VISORS, SWIM CAPS, BATHING CAPS, NOVELTY HEADWEAR WITH ATTACHED WIGS (U.S. CLS. 22 AND 39).

BERYL GARDNER, EXAMINING ATTORNEY

SN 78-662,285. MOTHWING CAMO TECHNOLOGIES, INC., HELENWOOD, TN. FILED 6-30-2005.

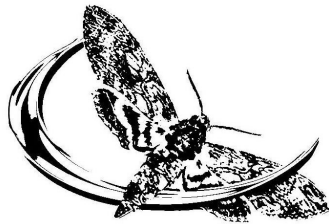

THE MARK CONSISTS OF A DESIGN OF A MOTH WITH A CURVED LINE EXTENDING FROM BEHIND THE MOTH'S TOP LEFT WING AND OVER THE MOTH'S RIGHT WING. ARROW-LIKE IMAGES APPEAR ON THE CURVED LINE PORTION OF THE DESIGN.

FOR CLOTHING, NAMELY, SHIRTS, PANTS, TOPS, BOTTOMS, ROBES, CAPS, JACKETS, COATS, VESTS, BIB OVERALLS, COVERALLS, SOCKS, NECK COVERINGS IN THE NATURE OF NECK GAITERS AND SCARVES, LEG COVERINGS IN THE NATURE OF LEG GAITERS, FACE COVERINGS IN THE NATURE OF BANDANAS AND FACEMASKS, HEAD COVERINGS IN THE NATURE OF DO-RAGS AND CAPS, AND GHILLIE SUITS (U.S. CLS. 22 AND 39).

FIRST USE 1-1-2005; IN COMMERCE 1-1-2005.

KAELIE KUNG, EXAMINING ATTORNEY

**CLASS 25—(Continued).**

SN 78-664,875. SELLERS, DAVID R., WARD, CO. FILED 7-6-2005.



FOR SKI BOOT ACCESSORY, NAMELY, AN ATTACHMENT TO SKI BOOT SOLES TO ENHANCE THE USERS MOBILITY (U.S. CLS. 22 AND 39).

SALLY SHIH, EXAMINING ATTORNEY

SN 78-684,784. MERCADO, MARIO, NEW YORK, NY. FILED 8-3-2005.

**DOUBLET**

THE MARK CONSISTS OF STANDARD CHARACTERS WITHOUT CLAIM TO ANY PARTICULAR FONT, STYLE, SIZE, OR COLOR.

FOR ATHLETIC APPAREL, NAMELY COMPETITION, EXERCISE AND TRAINING CLOTHING, NAMELY, ATHLETIC UNIFORMS, BOTTOMS, CLOTHING FOR WEAR IN JUDO PRACTICES, CLOTHING FOR WEAR IN WRESTLING MEETS, GYM SHORTS, GYM SUITS, HEAD WEAR, JUDO SUITS, KARATE SUITS, MARTIAL ARTS UNIFORMS, MUSCLE TOPS, PANTS, PERSPIRATION ABSORBENT UNDERWEAR CLOTHING, RASH GUARDS, SHORT SLEEVED OR LONG SLEEVED TEE SHIRTS, SHORTS, SHIRTS, UNDERWEAR, WARM UP SUITS, WRESTLING UNIFORMS, JIU-JITSU UNIFORMS, SOMBO UNIFORMS, CYCLING UNIFORMS, CROSS TRAINING UNIFORMS, TRACK AND FIELD UNIFORMS, RUGBY UNIFORMS, SOCCER UNIFORMS, VOLLEY BALL UNIFORMS AND GRAPPLING UNIFORMS FOR ACTIVITIES, SUCH AS WRESTLING, TRIATHLON, JUDO, KARATE, JIU-JITSU, BOXING, MIXED MARTIAL ARTS, YOGA, SOMBO, AND AEROBICS (U.S. CLS. 22 AND 39).

GINNY ISAACSON, EXAMINING ATTORNEY

**CLASS 25—(Continued).**

SN 78-721,932. HUA XIN INTERNATIONAL, INC., NEW YORK, NY. FILED 9-28-2005.



THE MARK CONSISTS OF STYLIZED LETTERS N AND H IN WITH LEFT SIDE CONNECTED TOGETHER AS MIRROR IMAGE; THE BEGINNING AND THE ENDING STYLIZED LETTERS A, C, E, G, I, M, N, AND R; THE MIDDLE STYLIZED LETTERS A AND C; THE UP-RIGHT HAND BAR; AND THE LOWER-LEFT HAND BAR.

FOR DRESS SUITS; JACKETS; JEANS; LEATHER JACKETS; MEN AND WOMEN JACKETS, COATS, TROUSERS, VESTS; MEN'S SUITS, WOMEN'S SUITS; OVERCOATS; PAJAMAS; PANTS; SCARVES; SHIRTS; SHIRTS FOR SUITS; SKIRT SUITS; SUIT COATS; SUITS; SUITS OF LEATHER; SWEAT SUITS; SWEATERS; T-SHIRTS; VESTED SUITS (U.S. CLS. 22 AND 39).

KATHRYN COWARD, EXAMINING ATTORNEY

SN 78-727,053. PRODUCE APPAREL, INC, LAGUNA HILLS, CA. FILED 10-5-2005.

## Produce Company

THE MARK CONSISTS OF STANDARD CHARACTERS WITHOUT CLAIM TO ANY PARTICULAR FONT, STYLE, SIZE, OR COLOR.

NO CLAIM IS MADE TO THE EXCLUSIVE RIGHT TO USE "COMPANY", APART FROM THE MARK AS SHOWN. FOR BLAZERS; BLOUSES; DRESSES; JACKETS; JOGGING SUITS; JUMPSUITS; KNIT SHIRTS; LOUNGEWEAR; OVERALLS; PANTS; SHORTS; SKIRTS; SWEATERS; T-SHIRTS; TOPS; WARM UP SUITS (U.S. CLS. 22 AND 39).

FIRST USE 3-10-1985; IN COMMERCE 3-10-1985.

DAVID MURRAY, EXAMINING ATTORNEY

SN 78-729,202. DAVID LIN, HONOLULU, HI. FILED 10-7-2005.

## BitterSweet

THE MARK CONSISTS OF STANDARD CHARACTERS WITHOUT CLAIM TO ANY PARTICULAR FONT, STYLE, SIZE, OR COLOR.

FOR APPAREL, NAMELY, T-SHIRTS, CREW NECK SWEATSHIRTS, HOODED SWEATSHIRTS, WIND RESISTANT JACKETS, TRACK JACKETS, POLO SHIRTS, KNIT WOVEN SHIRTS, AND BASEBALL CAPS (U.S. CLS. 22 AND 39).

FIRST USE 4-5-2004; IN COMMERCE 4-5-2004.

SANDRA MANIOS, EXAMINING ATTORNEY

**CLASS 25—(Continued).**

SN 78-731,594. GIRLS GOLF, LLC, BLOOMFIELD HILLS, MI. FILED 10-12-2005.



NO CLAIM IS MADE TO THE EXCLUSIVE RIGHT TO USE "GIRLS GOLF", APART FROM THE MARK AS SHOWN.

THE COLOR(S) DARK PINK, LIGHT PINK, AND ORANGE IS/ARE CLAIMED AS A FEATURE OF THE MARK.

THE MARK CONSISTS OF THE WORDS GIRLS GOLF AND A DEPICTION OF A BIRD, THE COLOR LIGHT PINK APPEARS IN THE BIRD'S BODY; THE COLOR DARK PINK APPEARS IN THE WORDING GIRLS GOLF, THE BIRD'S EYE, THE BIRD'S WING AND IN THE BIRD'S BREAST FEATHERS; THE COLOR ORANGE APPEARS IN THE BIRD'S FEET AND BEAK.

FOR WOMEN'S GOLF APPAREL, NAMELY SHIRTS, PANTS, SHORTS, DRESSES, SKIRTS, HATS, BELTS, SOCKS, SWEATERS, SCARVES, VESTS, JACKETS, GLOVES, COATS AND FOOTWEAR (U.S. CLS. 22 AND 39).

FIRST USE 8-1-2005; IN COMMERCE 8-1-2005.

ADA HAN, EXAMINING ATTORNEY

SN 78-735,410. BROWN, YOLANDA, HARTFORD CITY, IN. AND ALLEN, DANN, HARTFORD CITY, IN. FILED 10-18-2005.

## BUCK SHOT BLUES

THE MARK CONSISTS OF STANDARD CHARACTERS WITHOUT CLAIM TO ANY PARTICULAR FONT, STYLE, SIZE, OR COLOR.

NO CLAIM IS MADE TO THE EXCLUSIVE RIGHT TO USE "BLUES", APART FROM THE MARK AS SHOWN.

FOR CLOTHING, NAMELY, BEACHWEAR, BLOUSES, COATS, COVERALLS, DENIM WEAR, NAMELY JACKETS, PANTS, DRESSES, JEANS, SHIRTS, AND SKIRTS, DRESSES, INFANT WEAR, JACKETS, JEANS, OVERALLS, PANTS, PEDAL PUSHERS, PONCHOS, PULL-OVERS, VESTS, AND WAISTCOATS (U.S. CLS. 22 AND 39).

FIRST USE 8-13-2005; IN COMMERCE 8-13-2005.

ELLEN PERKINS, EXAMINING ATTORNEY



**CLASS 25—(Continued).**

SN 78-762,554. QVC, INC., WEST CHESTER, PA. FILED 11-29-2005.

**REFINEDSTRETCH**

THE MARK CONSISTS OF STANDARD CHARACTERS WITHOUT CLAIM TO ANY PARTICULAR FONT, STYLE, SIZE, OR COLOR.

FOR WOOL BLEND FABRIC COMPONENT OF WOMEN'S FINISHED CLOTHING, NAMELY, PANTS, JACKETS AND SKIRTS (U.S. CLS. 22 AND 39).

FIRST USE 5-12-2006; IN COMMERCE 5-12-2006.  
RICHARD WHITE, EXAMINING ATTORNEY

SN 78-771,049. STAR OF TEXAS FAIR & RODEO, AUSTIN, TX. FILED 12-12-2005.

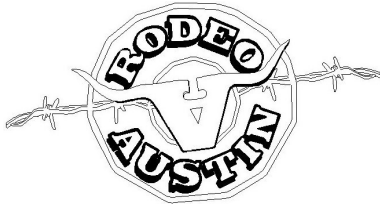

OWNER OF U.S. REG. NO. 2,327,833.  
NO CLAIM IS MADE TO THE EXCLUSIVE RIGHT TO USE "RODEO", APART FROM THE MARK AS SHOWN.  
SEC. 2(F) AS TO "RODEO AUSTIN".

FOR CLOTHING, NAMELY, T-SHIRTS, GOLF SHIRTS, SWEAT SHIRTS, SHIRTS, JERSEYS, JACKETS, PANTS, SHORTS, SWEAT PANTS, HEADBANDS, SUN VISORS, CAPS, BASEBALL CAPS, HATS, AND BELT BUCKLES NOT OF PRECIOUS METAL (U.S. CLS. 22 AND 39).

FIRST USE 7-0-2002; IN COMMERCE 10-0-2002.  
BERYL GARDNER, EXAMINING ATTORNEY

SN 78-784,184. IFITKILLSYOU LLC, NEW YORK, NY. FILED 1-3-2006.



FOR T-SHIRTS, POLO SHIRTS, DRESS SHIRTS, JEANS, TROUSERS, JACKETS/COATS, HATS, SHORTS, SWEATSHIRTS/JACKETS, SCARVES, GLOVES (U.S. CLS. 22 AND 39).

FIRST USE 10-31-2001; IN COMMERCE 10-31-2001.  
ROBIN CHOSID, EXAMINING ATTORNEY

**CLASS 25—(Continued).**

SN 78-784,324. GUILFORD COLLEGE, GREENSBORO, NC. FILED 1-3-2006.

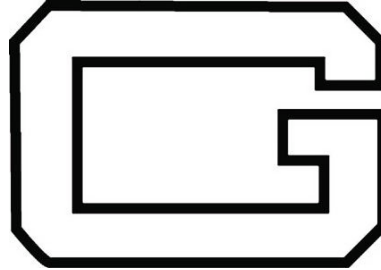

THE MARK CONSISTS OF STYLIZED LETTER G. FOR CLOTHING, NAMELY, ATHLETIC UNIFORMS, CAPS, SHORTS, T-SHIRTS, SWEATSHIRTS AND HEADWEAR (U.S. CLS. 22 AND 39).

FIRST USE 12-31-2003; IN COMMERCE 12-31-2003.  
MARTHA SANTOMARTINO, EXAMINING ATTORNEY

SN 78-786,459. CROOKED INK INC., NEW YORK, NY. FILED 1-6-2006.



FOR BELTS; BLOUSES; CAPS; DRESSES; FOOTWEAR; HATS; HEADBANDS; HOSIERY; JACKETS; PAJAMAS; PANTS; RAINWEAR; SCARVES; SHIRTS; SHOES; SHORTS; SLEEPWEAR; SOCKS; SWEAT SHIRTS; SWEATERS; SWIM WEAR; VESTS (U.S. CLS. 22 AND 39).

FIRST USE 10-1-2005; IN COMMERCE 10-1-2005.  
ALYSSA PALADINO, EXAMINING ATTORNEY

SN 78-793,450. ACA CORPORATION, SAIPAN, NORTH MARIANA ISLANDS, GUAM, FILED 1-17-2006.



THE MARK CONSISTS OF ACA WITHIN A SHADED OVAL AREA.

FOR BATHING CAPS; BEACH SHOES; BELTS; DRESSES; HAT BANDS; HATS; JACKETS; JEANS; KNIT SHIRTS; LEATHER SHOES; MEN AND WOMEN JACKETS; COATS; TROUSERS; VESTS; MEN'S SOCKS; MEN'S SUITS; POLO SHIRTS; RAIN JACKETS; SANDALS; SHIRTS; SHOES; SHORT-SLEEVED SHIRTS; SOCKS; SPORT SHIRTS; T-SHIRTS; TIES (U.S. CLS. 22 AND 39).

FIRST USE 5-11-2004; IN COMMERCE 5-11-2004.  
RICHARD WHITE, EXAMINING ATTORNEY

**CLASS 25—(Continued).**

SN 78-793,545. INTERMARKETING EXPRESS USA, LLC., MIAMI, FL. FILED 1-18-2006.

## MOLDING UP

THE MARK CONSISTS OF STANDARD CHARACTERS WITHOUT CLAIM TO ANY PARTICULAR FONT, STYLE, SIZE, OR COLOR.

FOR CLOTHING ARTICLES, NAMELY, GIRDLES (U.S. CLS. 22 AND 39).

FIRST USE 8-16-2004; IN COMMERCE 8-16-2004.  
ROBERT STRUCK, EXAMINING ATTORNEY

SN 78-794,929. MERABI PATARKATSI, NEW CITY, NY. FILED 1-19-2006.

## Brigad

THE MARK CONSISTS OF STANDARD CHARACTERS WITHOUT CLAIM TO ANY PARTICULAR FONT, STYLE, SIZE, OR COLOR.

FOR BLOUSES; BOARD SHORTS; BOXER SHORTS; CAMP SHIRTS; CAPRI PANTS; COATS; COATS FOR MEN AND WOMEN; COATS MADE OF COTTON; COATS OF DENIM; DENIM JACKETS; DENIMS; DOWN JACKETS; DRESS SHIRTS; DRESS SUITS; DRESSES; DRESSES MADE FROM SKINS; DRESSING GOWNS; DUST COATS; EVENING DRESSES; FLEECE SHORTS; FUR COATS; FUR COATS AND JACKETS; FUR HATS; FUR JACKETS; GOLF SHIRTS; GOLF TROUSERS; GYM SHORTS; HAT BANDS; HATS; HEAD SCARVES; HEAVY JACKETS; HUNTING VESTS; INFANTS' TROUSERS; JACKETS; JEANS; JOGGING PANTS; KNIT SHIRTS; LEATHER COATS; LEATHER JACKETS; LEATHER PANTS; LIGHT-REFLECTING COATS; LIGHT-REFLECTING JACKETS; LONG JACKETS; LONG SLEEVED VESTS; MEN AND WOMEN JACKETS; COATS, TROUSERS, VESTS; MOCK TURTLE-NECK SWEATERS; MORNING COATS; NIGHT SHIRTS; OPEN-NECKED SHIRTS; OVER COATS; OVER-TROUSERS; PANTIES, SHORTS AND BRIEFS; PANTS; PIQUET SHIRTS; POLO SHIRTS; QUILTED VESTS; RAIN COATS; RAIN JACKETS; RAIN TROUSERS; RAINPROOF JACKETS; RIDING COATS; RUGBY SHORTS; SCARVES; SHIRT FRONTS; SHIRTS; SHIRTS FOR SUITS; SHORT PETTICOATS; SHORT SETS; SHORT TROUSERS; SHORT-SLEEVED OR LONG-SLEEVED T-SHIRTS; SHORT-SLEEVED SHIRTS; SHORTS; SHOULDER SCARVES; SILK SCARVES; SKI JACKETS; SKI PANTS; SKIRT SUITS; SKIRTS; SKIRTS AND DRESSES; SLEEP SHIRTS; SLEEVED OR SLEEVELESS JACKETS; SMOKING JACKETS; SNOW PANTS; SNOWBOARD PANTS; SPORT COATS; SPORT SHIRTS; SPORTS JACKETS; SPORTS SHIRTS; SPORTS SHIRTS WITH SHORT SLEEVES; SUEDE JACKETS; SUIT COATS; SWEAT PANTS; SWEAT SHIRTS; SWEAT SHORTS; SWEATERS; T-SHIRTS; TAP PANTS; TOBOGGAN HATS, PANTS AND CAPS; TOP COATS; TRACK PANTS; TRENCH COATS; TROUSERS; TROUSERS FOR SWEATING; TROUSERS OF LEATHER; TURTLENECK SWEATERS; V-NECK SWEATERS; VESTED SUITS; VESTS; WALKING SHORTS; WATERPROOF JACKETS AND PANTS; WIND COATS; WIND RESISTANT JACKETS; WIND SHIRTS; WIND VESTS; WIND-JACKETS; WOMEN'S CEREMONIAL DRESSES (U.S. CLS. 22 AND 39).

FIRST USE 4-1-2005; IN COMMERCE 4-1-2005.  
ELLEN PERKINS, EXAMINING ATTORNEY

**CLASS 25—(Continued).**

SN 78-796,519. MARSHALL, ANTHONY G, PORTLAND, OR. FILED 1-21-2006.

## Mad Anthony

THE MARK CONSISTS OF STANDARD CHARACTERS WITHOUT CLAIM TO ANY PARTICULAR FONT, STYLE, SIZE, OR COLOR.

OWNER OF U.S. REG. NO. 2,509,427.

FOR CLOTHING, FOOTWEAR AND HEADGEAR NAMELY T-SHIRTS, SWEATSHIRTS, TANKTOPS, JACKETS, PANTS, SWEATPANTS, SNEAKERS, FLIP-FLOPS, BEANIES AND CAPS (U.S. CLS. 22 AND 39).

FIRST USE 1-1-1993; IN COMMERCE 1-1-1999.

WENDY JUN, EXAMINING ATTORNEY

SN 78-802,432. COAT CONCEPT, PARIS, FRANCE, FILED 1-30-2006.



THE COLOR(S) RED AND BLACK IS/ARE CLAIMED AS A FEATURE OF THE MARK.

THE MARK CONSISTS OF A RED STYLIZED K WITH A STYLIZED LINE OUTWARD FROM THE TOP OF THE LETTER AND .BAL IN BLACK LETTERS.

FOR READY-MADE CLOTHING FOR MEN, WOMEN AND CHILDREN, NAMELY, HOSIERY, LINGERIE, UNDERWEAR, PAJAMAS, DRESSING GOWNS, PEIGNOIRS, SWEATERS, SKIRTS, DRESSES, BRIEFS, TROUSERS, JACKETS, COATS; LEATHER AND IMITATION LEATHER GARMENTS, NAMELY, TROUSERS, BELTS, DRESSES, COATS, GLOVES, JACKETS; FURS, NAMELY, JACKETS AND COATS; SHIRTS, LAYETTES, TIES, SHAWLS, FOULARDS, STOLAS, SCARVES, BELTS, GLOVES, HATS, HEADWEAR, CAPS, SOCKS, STOCKINGS, TIGHTS, FOOTWEAR NOT INCLUDING ORTHOPEDIC FOOTWEAR, BOOT LINERS, SLIPPERS, BOOTS (U.S. CLS. 22 AND 39).

JENNIFER KRISP, EXAMINING ATTORNEY

**CLASS 25—(Continued).**

SN 78-802,655. LIU, BOJIA, ROSLINDALE, MA. FILED 1-30-2006.



OWNER OF CHINA REG. NO. 809636, DATED 1-21-1996, EXPIRES 1-20-2016.

THE MARK CONSISTS OF A WHITE DOG, WITH BLACK BLOTCHES, WITH THE NAME DANBO UNDERNEATH THE DOG.

FOR CLEATS FOR ATTACHMENT TO SPORTS SHOES; HEEL PIECES FOR SHOES; INSOLES; LEATHER SHOES; PROTECTIVE METAL MEMBERS FOR SHOES AND BOOTS; SHOE DOWELS; SHOE INSERTS FOR PRIMARILY NON-ORTHOPEDIC PURPOSES; SHOE PEGS; SHOE SOLES; SHOES; SHOES SOLES FOR REPAIR; TONGUE OR PULLSTRAP FOR SHOES AND BOOTS; WOMEN'S SHOES (U.S. CLS. 22 AND 39).

STEVEN R. FINE, EXAMINING ATTORNEY

SN 78-804,476. TALKING EVOLUTION, L.L.C., LOS ANGELES, CA. FILED 2-1-2006.

**FLOCK OF DODOS**

THE MARK CONSISTS OF STANDARD CHARACTERS WITHOUT CLAIM TO ANY PARTICULAR FONT, STYLE, SIZE, OR COLOR.

FOR T-SHIRTS, SHIRTS, SWEATSHIRTS, SWEATPANTS, PAJAMAS, HATS, CAPS, TIES, SOCKS, JACKETS, TANK TOPS, APRONS, SHORTS, PANTS, SUSPENDERS, SWEATERS, VESTS, BELTS, UNDERWEAR, SHOES AND FOOTWEAR (U.S. CLS. 22 AND 39).

SEAN CROWLEY, EXAMINING ATTORNEY

**CLASS 25—(Continued).**

SN 78-806,955. UCHINO CO., LTD., TOKYO, JAPAN, FILED 2-3-2006.

**AIR ROBE**

THE MARK CONSISTS OF STANDARD CHARACTERS WITHOUT CLAIM TO ANY PARTICULAR FONT, STYLE, SIZE, OR COLOR.

NO CLAIM IS MADE TO THE EXCLUSIVE RIGHT TO USE ROBE, APART FROM THE MARK AS SHOWN.

FOR ROBES (U.S. CLS. 22 AND 39).

SANI KHOURI, EXAMINING ATTORNEY

SN 78-807,149. ROBERT E HOWARD PROPERTIES INC., BEVERLY HILLS, CA. FILED 2-3-2006.

**ROBERT E. HOWARD**

THE MARK CONSISTS OF STANDARD CHARACTERS WITHOUT CLAIM TO ANY PARTICULAR FONT, STYLE, SIZE, OR COLOR.

THE NAME(S), PORTRAIT(S), AND/OR SIGNATURE(S) SHOWN IN THE MARK DOES NOT IDENTIFY A PARTICULAR LIVING INDIVIDUAL.

FOR COSTUMES, NAMELY, COSTUMES FOR USE IN ROLE PLAYING GAMES, HALLOWEEN COSTUMES, MASQUERADE COSTUMES AND MASKS SOLD IN CONNECTION THEREWITH; HEADWEAR, NAMELY, CAPS, HATS, HEADBANDS, VISORS, AND BANDANAS; FOOTWEAR, NAMELY, SOCKS, BOOTS, STREET SHOES, GYM SHOES, SLIPPERS, SNEAKERS, SANDALS, AND SPECIAL SPORTING AND GYMNASTIC FOOTWEAR; SPORT, EXERCISE AND GYMNASTIC CLOTHING, NAMELY, SWEAT SUITS, SWEAT SHIRTS, SWEAT PANTS, AND SWEAT JACKETS; OTHER CLOTHING AND ACCESSORIES INCLUDED IN THIS CLASS, NAMELY, BELTS, CAPS, GLOVES, JACKETS, MITTENS, SHIRTS, SHORTS, SLEEPWEAR, TANK TOPS, TIES, MUSCLE SHIRTS, T-SHIRTS, UNDERWEAR, AND WRISTBANDS (U.S. CLS. 22 AND 39).

KAREN K. BUSH, EXAMINING ATTORNEY

**CLASS 25—(Continued).**

SN 78-809,851. SAWYERS, MICHAEL JR., OAKLAND, CA. FILED 2-8-2006.

**OPEN EYEZ**

THE MARK CONSISTS OF STANDARD CHARACTERS WITHOUT CLAIM TO ANY PARTICULAR FONT, STYLE, SIZE, OR COLOR.

FOR BELTS; BOOTS; CAPS; CHILDREN'S AND INFANTS' CLOTH BIBS; COATS; DRESSES; HATS; JACKETS; JEANS; JOGGING SUITS; OVERALLS; PAJAMAS; PANTS; RAIN COATS; ROBES; SANDALS; SCARVES; SHIRTS; SHOES; SHORTS; SKIRTS; SLEEPWEAR; SUN VISORS; SUSPENDERS; SWEAT SHIRTS; SWEATERS; SWIM WEAR; T-SHIRTS; TANK TOPS; TIES; UNDERWEAR (U.S. CLS. 22 AND 39).

RON FAIRBANKS, EXAMINING ATTORNEY

**CLASS 25—(Continued).**

SN 78-810,388. T-TOWN, L.L.C., TUCSON, AZ. FILED 2-8-2006.



THE MARK DOES NOT IDENTIFY A LIVING INDIVIDUAL.

FOR CLOTHING, NAMELY, SHIRTS, HATS, BEANIES, AND UNDERGARMENTS (U.S. CLS. 22 AND 39).  
RICHARD A. STRASER, EXAMINING ATTORNEY

SN 78-810,033. GLOBAL CO., LTD., HINO-SHI, JAPAN, FILED 2-8-2006.

**FIT PILLOW**

THE MARK CONSISTS OF STANDARD CHARACTERS WITHOUT CLAIM TO ANY PARTICULAR FONT, STYLE, SIZE, OR COLOR.

NO CLAIM IS MADE TO THE EXCLUSIVE RIGHT TO USE "PILLOW", APART FROM THE MARK AS SHOWN.

FOR FOOTWEAR, NAMELY SLIPPERS, MULES, SANDALS AND SHOES HAVING A RAISED STIMULATING PORTION; AND FOOTWEAR INSOLES AND INSERTS FOR PRIMARILY NON-ORTHOPEDIC PURPOSES, HAVING A RAISED STIMULATING PORTION (U.S. CLS. 22 AND 39).

EVELYN BRADLEY, EXAMINING ATTORNEY

SN 78-811,079. ROAD RAGE MOTORCYCLES, CAMPBELL, CA. FILED 2-9-2006.

**RAGING ANGEL**

THE MARK CONSISTS OF STANDARD CHARACTERS WITHOUT CLAIM TO ANY PARTICULAR FONT, STYLE, SIZE, OR COLOR.

FOR CAPS; JACKETS; T-SHIRTS; VESTS (U.S. CLS. 22 AND 39).

FIRST USE 12-16-2005; IN COMMERCE 12-16-2005.

ROBIN CHOSID, EXAMINING ATTORNEY

SN 78-811,556. THE ASHKO GROUP LLC, NEW YORK, NY. FILED 2-9-2006.

**ZAND**

SN 78-810,201. K-2 CORPORATION, VASHON, WA. FILED 2-8-2006.

**FT**

THE MARK CONSISTS OF STANDARD CHARACTERS WITHOUT CLAIM TO ANY PARTICULAR FONT, STYLE, SIZE, OR COLOR.

FOR SKI BOOTS (U.S. CLS. 22 AND 39).

GEORGE LORENZO, EXAMINING ATTORNEY

THE MARK CONSISTS OF STANDARD CHARACTERS WITHOUT CLAIM TO ANY PARTICULAR FONT, STYLE, SIZE, OR COLOR.

FOR ATHLETIC FOOTWEAR; ATHLETIC SHOES; BEACH FOOTWEAR; FLIP FLOPS; FOOTWEAR; FOOTWEAR FOR MEN AND WOMEN; SANDALS; SHOES; SLIPPER SOLES; SLIPPERS; SNEAKERS; SOCKS; THONGS (U.S. CLS. 22 AND 39).

FIRST USE 12-1-2005; IN COMMERCE 12-1-2005.

TANYA AMOS, EXAMINING ATTORNEY

**CLASS 25—(Continued).**

SN 78-812,053. OFFICIAL BUGLE BOY, LLC, COLUMBUS, OH. FILED 2-10-2006.

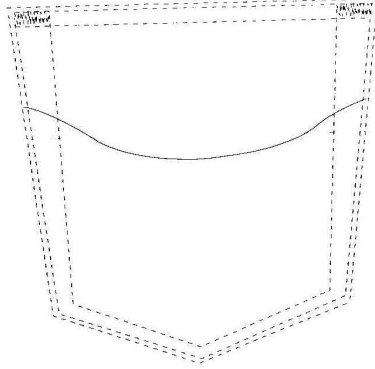

OWNER OF U.S. REG. NO. 2,403,006.  
THE MARK CONSISTS OF A SHALLOW UPWARDLY FACING CONCAVE LINE ON THE CENTER OF THE BACK POCKET OF THE GOODS. THE DOTTED LINES ARE USED TO INDICATE THE POSITIONING OF THE MARK AND ARE NOT A FEATURE OF THE MARK.  
FOR CLOTHING, NAMELY, JEANS AND SHORTS (U.S. CLS. 22 AND 39).  
SHARON MEIER, EXAMINING ATTORNEY

SN 78-812,644. BELLA DIOSA MATERNITY, VISTA, CA. FILED 2-10-2006.



NO CLAIM IS MADE TO THE EXCLUSIVE RIGHT TO USE "MATERNITY", APART FROM THE MARK AS SHOWN.  
THE ENGLISH TRANSLATION OF BELLA DIOSA IN THE MARK IS BEAUTIFUL GODDESS.  
FOR MATERNITY LINGERIE, NAMELY NURSING GOWNS, NURSING BRAS, UNDERWEAR, AND ROBES; CHILDREN AND BABY CLOTHING, NAMELY TSHIRTS AND HATS (U.S. CLS. 22 AND 39).  
REBECCA EISINGER, EXAMINING ATTORNEY

**CLASS 25—(Continued).**

SN 78-812,677. JESUSINME UNLTD. LLC, GILROY, CA. FILED 2-10-2006.

# JesusInMe Unltd.

THE MARK CONSISTS OF STANDARD CHARACTERS WITHOUT CLAIM TO ANY PARTICULAR FONT, STYLE, SIZE, OR COLOR.  
NO CLAIM IS MADE TO THE EXCLUSIVE RIGHT TO USE "UNLTD.", APART FROM THE MARK AS SHOWN.  
FOR DENIM JACKETS; DENIMS; DRESS SHIRTS; GOLF SHIRTS; JACKETS; JEANS; LONG JACKETS; PANTS; POLO SHIRTS; SHIRTS; SHORT TROUSERS; SHORTS; SLACKS; SLEEVED OR SLEEVELESS JACKETS; SPORT SHIRTS; SWEAT SHIRTS; SWEATERS; T-SHIRTS; TROUSERS (U.S. CLS. 22 AND 39).  
FIRST USE 9-1-2003; IN COMMERCE 6-1-2005.  
JAMES STEIN, EXAMINING ATTORNEY

SN 78-813,641. JB INTELLECTUAL PROPERTY, LLC, PALM BEACH, FL. FILED 2-13-2006.

# FINS TO THE LEFT, FINS TO THE RIGHT

THE MARK CONSISTS OF STANDARD CHARACTERS WITHOUT CLAIM TO ANY PARTICULAR FONT, STYLE, SIZE, OR COLOR.  
FOR T-SHIRTS (U.S. CLS. 22 AND 39).  
FIRST USE 2-1-1985; IN COMMERCE 2-1-1985.  
LA TONIA FISHER, EXAMINING ATTORNEY

SN 78-813,652. MARGARITAVILLE ENTERPRISES, LLC, PALM BEACH, FL. FILED 2-13-2006.

# FRUITCAKES

THE MARK CONSISTS OF STANDARD CHARACTERS WITHOUT CLAIM TO ANY PARTICULAR FONT, STYLE, SIZE, OR COLOR.  
FOR T-SHIRTS (U.S. CLS. 22 AND 39).  
FIRST USE 3-1-2001; IN COMMERCE 3-1-2001.  
LA TONIA FISHER, EXAMINING ATTORNEY

**CLASS 25—(Continued).**

SN 78-813,708. JB INTELLECTUAL PROPERTY, LLC, PALM BEACH, FL. FILED 2-13-2006.

IF WE WEREN'T ALL CRAZY .  
.. WE'D ALL GO INSANE!

THE MARK CONSISTS OF STANDARD CHARACTERS WITHOUT CLAIM TO ANY PARTICULAR FONT, STYLE, SIZE, OR COLOR.

FOR T-SHIRTS (U.S. CLS. 22 AND 39).  
FIRST USE 6-1-1990; IN COMMERCE 6-1-1990.  
LA TONIA FISHER, EXAMINING ATTORNEY

SN 78-814,571. PACIFIC CONNECTIONS OF CALIFORNIA, INC., ONTARIO, CA. FILED 2-14-2006.

## TESS

THE MARK CONSISTS OF STANDARD CHARACTERS WITHOUT CLAIM TO ANY PARTICULAR FONT, STYLE, SIZE, OR COLOR.

FOR WOMEN'S CLOTHING, NAMELY, TOPS, BLOUSES AND JACKETS (U.S. CLS. 22 AND 39).  
FIRST USE 4-14-1981; IN COMMERCE 4-14-1981.  
ERNEST SHOSHO, EXAMINING ATTORNEY

SN 78-818,556. POLAR EVOLUTION, INC., DENVER, CO. FILED 2-19-2006.

**POLAR**  
**EVOLUTION**



THE MARK CONSISTS OF THE TEXT POLAR EVOLUTION WHERE THE O OF EVOLUTION IS STYLIZED AS AN OFF-AXIS 8-POINT COMPASS SYMBOL.

FOR GLOVES; HATS; JACKETS; MEN AND WOMEN JACKETS, COATS, TROUSERS, VESTS; MEN'S SOCKS; SHORTS; SNOW PANTS; SNOW SUITS; SPORT SHIRTS; UNDERWEAR; WIND SHIRTS (U.S. CLS. 22 AND 39).  
FIRST USE 12-17-2005; IN COMMERCE 1-15-2006.  
ELIZABETH PIGNATELLO, EXAMINING ATTORNEY

**CLASS 25—(Continued).**

SN 78-818,576. JENNINGS, JAMES, A, SANTA BARBARA, CA. FILED 2-19-2006.

## republic of surfers

THE MARK CONSISTS OF STANDARD CHARACTERS WITHOUT CLAIM TO ANY PARTICULAR FONT, STYLE, SIZE, OR COLOR.

FOR BASEBALL CAPS; BATHING TRUNKS; BEACHWEAR; BOARDSHORTS; CAP VISORS; SWIM TRUNKS; T-SHIRTS; TANK-TOPS; TRUNKS (U.S. CLS. 22 AND 39).  
FIRST USE 4-1-2005; IN COMMERCE 8-1-2005.  
BRENDAN REGAN, EXAMINING ATTORNEY

SN 78-822,950. BEATO, RAMON, NEW YORK, NY. FILED 2-24-2006.

## De Exodic

THE MARK CONSISTS OF STANDARD CHARACTERS WITHOUT CLAIM TO ANY PARTICULAR FONT, STYLE, SIZE, OR COLOR.

FOR SHORT-SLEEVED OR LONG-SLEEVED T-SHIRTS (U.S. CLS. 22 AND 39).  
PAUL E. FAHRENKOPF, EXAMINING ATTORNEY

SN 78-823,702. CAPLEE CORPORATION, IRVINE, CA. FILED 2-27-2006.

## RUSTIC JEANS

THE MARK CONSISTS OF STANDARD CHARACTERS WITHOUT CLAIM TO ANY PARTICULAR FONT, STYLE, SIZE, OR COLOR.

NO CLAIM IS MADE TO THE EXCLUSIVE RIGHT TO USE "JEANS", APART FROM THE MARK AS SHOWN.  
FOR CAPRIS; JACKETS; JEANS; KNIT SHIRTS; PANTS; SKIRTS; SWEATERS; T-SHIRTS; VESTS (U.S. CLS. 22 AND 39).  
FIRST USE 2-18-2006; IN COMMERCE 2-18-2006.  
AMY ALFIERI, EXAMINING ATTORNEY

**CLASS 25—(Continued).**

SN 78-825,042. QUADRARO SRL, 50055 LASTRA A SIGNA (FLORENCE), ITALY, FILED 2-28-2006.



OWNER OF ITALY REG. NO. 00740940, DATED 10-10-1995, EXPIRES 10-10-2015.

THE MARK CONSISTS OF OF THE WORD QUADRARO ENCLOSED IN AN OVAL WITH THE DESIGN OF A HOUSE.

FOR CLOTHING FOR MEN, WOMEN AND CHILDREN, NAMELY COATS, RAINCOATS, JACKETS, TROUSERS, SKIRTS, DRESSES, SUITS, SHIRTS AND CHEMISES, T-SHIRTS, SWEATERS, UNDERWEAR, SWIMWEAR, BEACHWEAR, SOCKS AND STOCKINGS, GLOVES, TIES, SCARVES, FOULARDS, HATS AND CAPS; BOOTS, SHOES AND SLIPPERS; BELTS, FABRIC BELTS, LEATHER BELTS (U.S. CLS. 22 AND 39).

INGA ERVIN, EXAMINING ATTORNEY

**CLASS 25—(Continued).**

SN 78-833,323. VON DUTCH ORIGINALS, LLC., LOS ANGELES, CA. FILED 3-9-2006.



NO CLAIM IS MADE TO THE EXCLUSIVE RIGHT TO USE "CHEAP CHINOS WORLDWIDE", APART FROM THE MARK AS SHOWN.

THE MARK CONSISTS OF CHEAP CHINOS WORLDWIDE WITH DOLLARS SIGNS AND MAN'S FACE.

FOR ANKLE SOCKS; ATHLETIC FOOTWEAR; BALLOON PANTS; BEACH FOOTWEAR; BELTS; BOARD SHORTS; BOXER SHORTS; CAPRI PANTS; COATS FOR MEN AND WOMEN; COATS OF DENIM; DENIMS; FLEECE SHORTS; FLIP FLOPS; FOOTWEAR; FOOTWEAR FOR MEN AND WOMEN; FOOTWEAR NOT FOR SPORTS; FUR COATS AND JACKETS; GARTER BELTS; GYM SHORTS; JOGGING PANTS; KNIT SHIRTS; LEATHER BELTS; LEATHER PANTS; MEN AND WOMEN JACKETS, COATS, TROUSERS, VESTS; MEN'S SOCKS; NIGHT SHIRTS; OVER COATS; PANTIES, SHORTS AND BRIEFS; PANTS; PIQUET SHIRTS; POLO SHIRTS; RAIN COATS; SHIRTS; SHORT SETS; SHORT-SLEEVED OR LONG-SLEEVED T-SHIRTS; SHORT-SLEEVED SHIRTS; SHORTS; SKI PANTS; SLEEP SHIRTS; SNOW PANTS; SNOWBOARD PANTS; SOCKS; SPORT COATS; SPORT SHIRTS; SPORTS SHIRTS WITH SHORT SLEEVES; SUIT COATS; SUSPENDER BELTS FOR MEN; SUSPENDER BELTS FOR WOMEN; SWEAT PANTS; SWEAT SHIRTS; SWEAT SHORTS; THONGS; TRACK PANTS; TRENCH COATS; WALKING SHORTS; WATERPROOF JACKETS AND PANTS; WIND COATS (U.S. CLS. 22 AND 39).

MONIQUE MILLER, EXAMINING ATTORNEY

SN 78-835,789. OMEGA APPAREL LIMITED, NEW YORK, NY. FILED 3-13-2006.

**TRUE URBAN**

THE MARK CONSISTS OF STANDARD CHARACTERS WITHOUT CLAIM TO ANY PARTICULAR FONT, STYLE, SIZE, OR COLOR.

FOR MEN'S, WOMEN'S, CHILDREN'S AND INFANT'S CLOTHING, NAMELY, JEANS, PANTS, SHIRTS, DRESS SHIRTS, SWEATSHIRTS, T-SHIRTS AND UNDERWEAR; GIRLS' JUMPERS, BLOUSES AND SKIRTS; SWIMWEAR, SHORTS, DRESSES, PAJAMAS, NIGHTSHIRTS, GOWNS, ROBES, BLANKET SLEEPERS, LAYETTES, LEGGINGS, SOCKS, BELTS, HATS, SCARVES, GLOVES, SWEATERS, SNOWSUITS, JACKETS, FOOTWEAR, SHOES, SLIPPERS AND SNEAKERS (U.S. CLS. 22 AND 39).

LESLEY LAMOTHE, EXAMINING ATTORNEY

**CLASS 25—(Continued).**

SN 78-836,611. BELK STORES SERVICES, INC., CHARLOTTE, NC. FILED 3-14-2006.

**STAY @ HOME**

THE MARK CONSISTS OF STANDARD CHARACTERS WITHOUT CLAIM TO ANY PARTICULAR FONT, STYLE, SIZE, OR COLOR.

FOR WOMEN'S AND GIRLS' APPAREL, NAMELY, SOCKS, ROBES, SLEEPWEAR AND SLIPPERS; FOOTWEAR (U.S. CLS. 22 AND 39).

AMOS T. MATTHEWS, JR., EXAMINING ATTORNEY

---

SN 78-838,393. ALLEN, ALBERT, ANZA, CA. AND ALLEN, SHERRY, ANZA, CA. FILED 3-15-2006.

**REBEL WARRIOR**

THE MARK CONSISTS OF STANDARD CHARACTERS WITHOUT CLAIM TO ANY PARTICULAR FONT, STYLE, SIZE, OR COLOR.

FOR CLOTHING, NAMELY, JACKETS, T-SHIRTS, VESTS, SWEAT SHIRTS, SWEAT PANTS; FOOTWEAR; HEADGEAR, NAMELY HATS, CAPS, AND BANDANAS; ALL PRIMARILY FOR USE AS MOTORCYCLE WEAR (U.S. CLS. 22 AND 39).

MARK PILARO, EXAMINING ATTORNEY

---

SN 78-845,317. JASSO, BERNARDO CUEVA, GUADALAJARA, MEXICO, FILED 3-24-2006.

**SQUALO PUERTO ESCONDIDO**

THE MARK CONSISTS OF STANDARD CHARACTERS WITHOUT CLAIM TO ANY PARTICULAR FONT, STYLE, SIZE, OR COLOR.

NO CLAIM IS MADE TO THE EXCLUSIVE RIGHT TO USE "PUERTO ESCONDIDO", APART FROM THE MARK AS SHOWN.

THE FOREIGN WORDING IN THE MARK TRANSLATES INTO ENGLISH AS 'SHARK' FOR SQUALO AND 'HIDDEN PORT' FOR PUERTO ESCONDIDO.

FOR CLOTHING NAMELY BEACHWEAR, SHORTS, SKIRTS, PANTS, SHIRTS, BLOUSES, TOPS, TAN TOPS, T SHIRTS, SWEATSHIRTS AND SWIMWEAR; HEADWEAR NAMELY HATS AND CAPS; FOOTWEAR NAMELY SANDALS AND SHOES (U.S. CLS. 22 AND 39).

PETER B. BROMAGHIM, EXAMINING ATTORNEY

**CLASS 25—(Continued).**

SN 78-851,545. NEW LINE PRODUCTIONS, INC., NEW YORK, NY. FILED 3-31-2006.

**MIMZY**

THE MARK CONSISTS OF STANDARD CHARACTERS WITHOUT CLAIM TO ANY PARTICULAR FONT, STYLE, SIZE, OR COLOR.

FOR FULL LINES OF CLOTHING, FOOTWEAR AND HEADWEAR (U.S. CLS. 22 AND 39).

ROBIN MITTLER, EXAMINING ATTORNEY

---

SN 78-856,669. TANAKA UNIVERSAL CO., LTD., TENNOJIKU, OSAKA, JAPAN, FILED 4-7-2006.



OWNER OF U.S. REG. NO. 2,757,240.

THE COLOR(S) BLACK, RED AND GREEN IS/ARE CLAIMED AS A FEATURE OF THE MARK.

THE MARK CONSISTS OF A VERTICAL RED ANGLED BAND. TO THE RIGHT OF THE BAND ARE THREE GREEN HORIZONTAL BANDS STACKED VERTICALLY. TO THE RIGHT OF THE THREE BANDS IS A VERTICAL GREEN ANGLED BAND. ABOVE THE BANDS IS BLACK LETTERING.

FOR SHIRTS, SWEATERS, JACKETS, SLACKS, PANTS, SKIRTS, TROUSERS, HATS, SHOES, BOOTS, SANDALS, SLIPPERS, SPORTS SHOES (U.S. CLS. 22 AND 39).

KAPIL BHANOT, EXAMINING ATTORNEY



**CLASS 25—(Continued).**

SN 78-857,994. AS\*I\*B, INC., TAMPA, FL. FILED 4-10-2006.

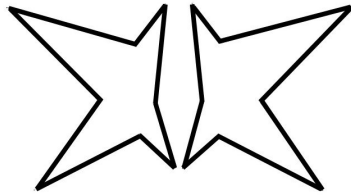

THE MARK CONSISTS OF AN EIGHT-POINTED STAR SPLIT DOWN THE CENTER INTO TWO PARTS SEPARATED BY A SPACE.  
FOR CAPS; SHIRTS; TOPS (U.S. CLS. 22 AND 39).  
FIRST USE 3-15-2005; IN COMMERCE 3-15-2005.  
JEFF DEFORD, EXAMINING ATTORNEY

**CLASS 25—(Continued).**

SN 78-862,558. T-TOWN, L.L.C., TUCSON, AZ. FILED 4-17-2006.

# SMILY GREEN

THE MARK CONSISTS OF STANDARD CHARACTERS WITHOUT CLAIM TO ANY PARTICULAR FONT, STYLE, SIZE, OR COLOR.  
NO CLAIM IS MADE TO THE EXCLUSIVE RIGHT TO USE "GREEN", APART FROM THE MARK AS SHOWN.  
THE NAME SHOWN IN THE MARK DOES NOT IDENTIFY A LIVING INDIVIDUAL.  
FOR CLOTHING, NAMELY, SHIRTS, HATS, BEANIES, AND UNDERGARMENTS (U.S. CLS. 22 AND 39).  
RICHARD A. STRASER, EXAMINING ATTORNEY

SN 78-858,001. LESLIE B. HENSHAW, BEDFORD, NY. FILED 4-10-2006.



NO CLAIM IS MADE TO THE EXCLUSIVE RIGHT TO USE "SHIRT", APART FROM THE MARK AS SHOWN.  
FOR T-SHIRTS (U.S. CLS. 22 AND 39).  
JEFF DEFORD, EXAMINING ATTORNEY

SN 78-871,461. DIVERSE 15 VENTURES, LLC, COSTA MESA, CA. FILED 4-27-2006.

# BRANDLESS

SN 78-858,617. THAT BUSINESS THING, LLC, MONTAGUE, NJ. FILED 4-11-2006.



THE MARK CONSISTS, IN PART, OF A STYLIZED P AND C INTENDED TO FORM THE BODY OF A WOMAN.  
FOR CAPS AND CLOTHING, NAMELY, SHIRTS, SWEATSHIRTS, PANTS AND UNDERGARMENTS (U.S. CLS. 22 AND 39).  
FIRST USE 4-1-2006; IN COMMERCE 4-1-2006.  
TRICIA SONNEBORN, EXAMINING ATTORNEY

THE MARK CONSISTS OF STANDARD CHARACTERS WITHOUT CLAIM TO ANY PARTICULAR FONT, STYLE, SIZE, OR COLOR.  
FOR CASUAL, LEISURE, SPORTS AND BEACH CLOTHING, NAMELY, SHIRTS, T-SHIRTS, SWEATSHIRTS, JACKETS, PANTS, SHORTS, BELTS, HATS, CAPS, SWIM WEAR AND FOOTWEAR (U.S. CLS. 22 AND 39).  
FIRST USE 3-19-2006; IN COMMERCE 3-19-2006.  
PATRICIA EVANKO, EXAMINING ATTORNEY

**CLASS 25—(Continued).**

SN 78-898,680. @WEBO, COTO DE CAZA, CA. FILED 6-1-2006.

Life Never Looked So Good!

THE MARK CONSISTS OF STANDARD CHARACTERS WITHOUT CLAIM TO ANY PARTICULAR FONT, STYLE, SIZE, OR COLOR.

FOR BALLOON PANTS; CAMP SHIRTS; CAPRI PANTS; DENIMS; DRESS SHIRTS; GOLF CAPS; GOLF CLEATS; GOLF SHIRTS; GOLF SHOES; GOLF SPIKES; GOLF TROUSERS; JOGGING PANTS; KNIT SHIRTS; LEATHER PANTS; NIGHT SHIRTS; NON-DISPOSABLE CLOTH TRAINING PANTS; NURSE PANTS; OPEN-NECKED SHIRTS; PANTS; PETTI-PANTS; PIQUET SHIRTS; POLO SHIRTS; SHIRT FRONTS; SHIRT YOKES; SHIRTS; SHIRTS FOR SUITS; SHORT-SLEEVED OR LONG-SLEEVED T-SHIRTS; SHORT-SLEEVED SHIRTS; SKI PANTS; SLEEP SHIRTS; SNOW PANTS; SNOWBOARD PANTS; SPORTS SHIRTS; SPORTS SHIRTS WITH SHORT SLEEVES; SWEAT PANTS; SWEAT SHIRTS; T-SHIRTS; TAP PANTS; TOBOGGAN HATS, PANTS AND CAPS; TRACK PANTS; WATERPROOF JACKETS AND PANTS; WIND SHIRTS (U.S. CLS. 22 AND 39).

FIRST USE 6-6-2000; IN COMMERCE 6-1-2006.  
KELLY CHOE, EXAMINING ATTORNEY

SN 78-900,792. NILLA SHIELDS, LLC, ST. PETERSBURG, FL. FILED 6-5-2006.



OWNER OF U.S. REG. NO. 2,871,331.  
FOR CLOTHING, NAMELY, WOMEN'S PANTS, SHIRTS, THONGS, SWIMSUITS AND SHORTS; CHILDREN'S SWIMSUITS, PANTS, SHIRTS, AND SHORTS; HATS (U.S. CLS. 22 AND 39).

FIRST USE 6-0-2003; IN COMMERCE 6-0-2003.  
G. MAYERSCHOFF, EXAMINING ATTORNEY

**CLASS 25—(Continued).**

SN 78-905,326. ARCHRIVAL, LOS ANGELES, CA. FILED 6-9-2006.



FOR CLOTHING, NAMELY T-SHIRTS, SHIRTS, PANTS, JACKETS; FLEECE SWEATSHIRTS, KNIT SHIRTS, SHORTS, HATS, AND CAPS (U.S. CLS. 22 AND 39).

TINA L. SNAPP, EXAMINING ATTORNEY

SN 78-907,569. ROSENDO S. RAYMUNDO, EAST IRVINE, CA. FILED 6-14-2006.

WAGADOO

THE MARK CONSISTS OF STANDARD CHARACTERS WITHOUT CLAIM TO ANY PARTICULAR FONT, STYLE, SIZE, OR COLOR.

FOR ANKLE SOCKS; ANKLETS ; ANTI-PERSPIRANT SOCKS; ATHLETIC SHOES; ATHLETIC UNIFORMS; BASEBALL CAPS; BASEBALL SHOES; BATHING CAPS; BEACH SHOES; BERMUDA SHORTS; BOARD SHORTS; BOXER SHORTS; CAP VISORS; CAPRI PANTS; CAPS ; CAPS WITH VISORS; DENIM JACKETS; DENIMS ; DOWN JACKETS; DRESS SHIRTS; FLEECE SHORTS; FOOTBALL SHOES; GOLF CAPS; GOLF SHIRTS; GOLF SHOES; GYM SHORTS; HANDBALL SHOES; HATS; HEADBANDS AGAINST SWEATING; HEAVY JACKETS; JACKETS; JERSEYS; JOGGING PANTS; KNIT SHIRTS; LIGHT-REFLECTING JACKETS; LONG JACKETS; MEN AND WOMEN JACKETS, COATS, TROUSERS, VESTS; MEN'S SOCKS; NIGHT SHIRTS; NON-DISPOSABLE CLOTH TRAINING PANTS; OPEN-NECKED SHIRTS; PANTIES, SHORTS AND BRIEFS; PANTS; POLO SHIRTS; RAIN JACKETS; RAINPROOF JACKETS; RUBBER SHOES; RUGBY SHOES; RUGBY SHORTS; RUNNING SHOES; SCHOOL UNIFORMS; SHIRT FRONTS;

**CLASS 25—(Continued).**

SHIRTS; SHOES; SHORT SETS; SHORT TROUSERS; SHORT-SLEEVED OR LONG-SLEEVED T-SHIRTS; SHORT-SLEEVED SHIRTS; SHORTS; SKI JACKETS; SLEEVED OR SLEEVELESS JACKETS; SLEEVELESS JERSEYS; SLIDING SHORTS; SOCCER SHOES; SOCK SUSPENDERS; SOCKS; SOCKS AND STOCKINGS; SPORT SHIRTS; SPORTS JACKETS; SPORTS JERSEYS; SPORTS JERSEYS AND BREECHES FOR SPORTS; SPORTS SHIRTS; SPORTS SHIRTS WITH SHORT SLEEVES; STOCKINGS; SWEAT BANDS; SWEAT PANTS; SWEAT SHIRTS; SWEAT SHORTS; SWEAT SUITS; SWIM CAPS; SWIMMING CAPS; SWIMMING CAPS; T-SHIRTS; TENNIS SHOES; THERMAL SOCKS; TOBOGGAN HATS, PANTS AND CAPS; TRACK AND FIELD SHOES; TRACK PANTS; TRAINING SHOES; TROUSERS FOR SWEATING; UNIFORMS; VOLLEYBALL SHOES; WALKING SHORTS; WATER SOCKS; WATERPROOF JACKETS AND PANTS; WIND RESISTANT JACKETS; WIND SHIRTS; WIND-JACKETS; WOMEN'S SHOES; WOOLLEN SOCKS (U.S. CLS. 22 AND 39).

FIRST USE 7-29-2005; IN COMMERCE 8-26-2005.  
LOURDES AYALA, EXAMINING ATTORNEY

SN 78-908,653. TWEEN BRANDS INVESTMENT, LLC, NEW ALBANY, OH. FILED 6-15-2006.

## Daddy's Angel

THE MARK CONSISTS OF STANDARD CHARACTERS WITHOUT CLAIM TO ANY PARTICULAR FONT, STYLE, SIZE, OR COLOR.

FOR CLOTHING, NAMELY, TOPS, T-SHIRTS AND SWEATSHIRTS, COATS AND JACKETS, DRESSES, FOOTWEAR, HATS AND HEAD WEAR, PANTS, SHORTS, SKORTS, SKIRTS, SLEEPWEAR, SOCKS, UNDERGARMENTS, SCARVES, BELTS, AND BEACHWEAR (U.S. CLS. 22 AND 39).

JESSICA A. POWERS, EXAMINING ATTORNEY

SN 78-911,842. SIDECAR DESIGNS LLC, SEATTLE, WA. FILED 6-20-2006.



THE MARK CONSISTS OF A STYLIZED ILLUSTRATION OF A WOMAN ON A MOTORCYCLE WITH A CHILD IN THE SIDECAR.

FOR BABY APPAREL, NAMELY, PANTS, SHIRTS, UNDERGARMENTS AND SHOES (U.S. CLS. 22 AND 39).  
KATINA MISTER, EXAMINING ATTORNEY

**CLASS 25—(Continued).**

SN 78-918,694. CHARLES O'ROURKE, BELFORD, NJ. FILED 6-28-2006.



NO CLAIM IS MADE TO THE EXCLUSIVE RIGHT TO USE "CLOTHING", APART FROM THE MARK AS SHOWN. FOR BEANIES; CAPS; FOOTWEAR; HATS; HEADBANDS; HEADWEAR; JACKETS; JOGGING SUITS; PAJAMAS; POLO SHIRTS; PULLOVERS; SHORT-SLEEVED OR LONG-SLEEVED T-SHIRTS; SHORTS; SUITS; SWEAT PANTS; SWEAT SHIRTS; SWIMSUITS; T-SHIRTS; TANK TOPS; TRUNKS; UNDERWEAR; WRISTBANDS (U.S. CLS. 22 AND 39).

FIRST USE 5-1-2006; IN COMMERCE 5-1-2006.  
RONALD AIKENS, EXAMINING ATTORNEY

SN 78-925,449. AMERILAB TECHNOLOGIES, INC., PLYMOUTH, MN. FILED 7-10-2006.



THE COLOR(S) RED, ORANGE, YELLOW, GREEN, BLUE, INDIGO, VIOLET, LIGHT BLUE AND WHITE IS/ARE CLAIMED AS A FEATURE OF THE MARK.

THE COLORS RED, ORANGE, YELLOW, GREEN, BLUE, INDIGO AND VIOLET APPEAR, IN THAT ORDER, BEHIND THE WORDING IN THE MARK; THE COLOR WHITE APPEARS IN THE WORDING "FIZZIES;" THE COLOR BLUE APPEARS IN THE WORDING "DRINK TABLETS;" AND THE COLOR LIGHT BLUE APPEARS IN THE BACKGROUND OF THE DESIGN.

FOR SHIRTS; T-SHIRTS; HATS; JACKETS; SWEATSHIRTS (U.S. CLS. 22 AND 39).

JUSTINE D. PARKER, EXAMINING ATTORNEY

SN 78-931,699. RUHL, GREGORY J., GOLDSBORO, NC. AND MEYER, JEFFEREY W., JR. AUBURN HILLS, MI. AND PLILER, JEFFREY S., DES MOINES, IA. AND JORGENSEN, BENT H., SPRING VALLEY, MN. FILED 7-18-2006.

## CrownieHQ

THE MARK CONSISTS OF STANDARD CHARACTERS WITHOUT CLAIM TO ANY PARTICULAR FONT, STYLE, SIZE, OR COLOR.

FOR T-SHIRTS (U.S. CLS. 22 AND 39).

FIRST USE 5-22-2006; IN COMMERCE 5-22-2006.

KELLY BOULTON, EXAMINING ATTORNEY

**CLASS 25—(Continued).**

SN 78-932,506. CAROLINE MARY, LLC, MCLEAN, VA. FILED 7-19-2006.

# Caroline Mary

THE MARK CONSISTS OF STANDARD CHARACTERS WITHOUT CLAIM TO ANY PARTICULAR FONT, STYLE, SIZE, OR COLOR.

FOR CLOTHING, NAMELY- BELTS, TOPS, SKIRTS, HATS, SCARVES, PANTS, DRESSES, TIES (U.S. CLS. 22 AND 39).

KEVIN CORWIN, EXAMINING ATTORNEY

**CLASS 25—(Continued).**

SN 78-942,306. THE YOGA STUDIO, LLC, MILL VALLEY, CA. FILED 8-1-2006.

# YOGASPIRE

THE MARK CONSISTS OF STANDARD CHARACTERS WITHOUT CLAIM TO ANY PARTICULAR FONT, STYLE, SIZE, OR COLOR.

FOR CLOTHING, NAMELY, MEN'S AND WOMEN'S SPORTS JERSEYS, T-SHIRTS, SWEATSHIRTS, SWEATPANTS, WARM-UP SUITS, JACKETS, SHORTS, LEOTARDS, HATS, VISORS (U.S. CLS. 22 AND 39).

CAROL SPILS, EXAMINING ATTORNEY

SN 78-932,542. CAROLINE MARY, LLC, MCLEAN, VA. FILED 7-19-2006.



THE MARK CONSISTS OF A SIGNATURE USING THE INITIALS: CML.

FOR CLOTHING, NAMELY- BELTS, TOPS, SKIRTS, HATS, SCARVES, PANTS, DRESSES, TIES (U.S. CLS. 22 AND 39).

KEVIN CORWIN, EXAMINING ATTORNEY

SN 78-943,075. PRODUCTOS MEXICANOS DON JOSE, INC., TIFTON, GA. FILED 8-2-2006.

SN 78-941,457. ROLLINS, JOHN S., GAINESVILLE, FL. FILED 7-31-2006.



# DAKOTA LEATHER CO.

THE COLOR(S) BLUE AND WHITE IS/ARE CLAIMED AS A FEATURE OF THE MARK.

THE MARK CONSISTS OF AN OVAL WITH THREE RINGS IN VARIOUS SHADES OF BLUE FORMING THE OUTLINE; WITHIN THE OUTLINE IS A BACKGROUND OF GRADATIONS OF BLUE; ON THE LEFT PART OF OVAL IS A GLOBE IN TWO DIFFERENT SHADES OF BLUE; TO THE RIGHT OF THE GLOBE APPEARS THE WORDING UR IMPT IN WHITE AND OUTLINED IN BLUE, WITH A BLUE STAR WITH A WHITE OUTLINE APPEARING BETWEEN THE LETTERS U AND R.

FOR CLOTHING, NAMELY SHIRTS AND HATS (U.S. CLS. 22 AND 39).

KATHERINE CHANG, EXAMINING ATTORNEY

THE MARK CONSISTS OF STANDARD CHARACTERS WITHOUT CLAIM TO ANY PARTICULAR FONT, STYLE, SIZE, OR COLOR.

NO CLAIM IS MADE TO THE EXCLUSIVE RIGHT TO USE "LEATHER CO.", APART FROM THE MARK AS SHOWN.

FOR LEATHER BELTS; LEATHER COATS; LEATHER HEADWEAR; LEATHER JACKETS; LEATHER PANTS; LEATHER SHOES; LEATHER SLIPPERS; SUITS OF LEATHER; TROUSERS OF LEATHER (U.S. CLS. 22 AND 39).

KIM SAITO, EXAMINING ATTORNEY

**CLASS 25—(Continued).**

SN 78-944,784. JESUSINME UNLIMITED LLC, GILROY, CA. FILED 8-4-2006.

**CLASS 25—(Continued).**

SN 78-952,424. HARROW STREET, LTD., HONG KONG, HONG KONG, FILED 8-15-2006.



OWNER OF U.S. REG. NOS. 3,187,202 AND 3,193,219.  
NO CLAIM IS MADE TO THE EXCLUSIVE RIGHT TO USE "UNLTD" AND "UNLIMITED", APART FROM THE MARK AS SHOWN.

THE MARK CONSISTS OF THE WORD JESUSINME UNLTD USED WITH THE CIRCULAR SHAPED SYMBOL AT THE END OF THE WORD SLIGHTLY BELOW IT - CIRCULAR SHAPE INCLUDES THE WORD UNLIMITED CENTERED AND JESUSINME WRITTEN ABOVE IT AND BELOW IT 360 DEGREES FULL CIRCLE.

FOR CAPRI PANTS; DENIM JACKETS; DENIMS; DRESS SHIRTS; GOLF SHIRTS; GYM SHORTS; HEAVY JACKETS; JACKETS; JEANS; KNIT SHIRTS; LEATHER JACKETS; LONG JACKETS; MEN AND WOMEN JACKETS, COATS, TROUSERS, VESTS; OPEN-NECKED SHIRTS; PANTS; POLO SHIRTS; SHIRTS; SHIRTS FOR SUITS; SHORT TROUSERS; SHORT-SLEEVED OR LONG-SLEEVED T-SHIRTS; SHORT-SLEEVED SHIRTS; SHORTS; SLACKS; SLEEVED OR SLEEVELESS JACKETS; SPORT SHIRTS; SPORTS JACKETS; SPORTS SHIRTS; SPORTS SHIRTS WITH SHORT SLEEVES; SUEDE JACKETS; SWEAT PANTS; SWEAT SHIRTS; SWEAT SHORTS; SWEATERS; T-SHIRTS; TROUSERS; TROUSERS OF LEATHER; V-NECK SWEATERS (U.S. CLS. 22 AND 39).

KAREN SEVERSON, EXAMINING ATTORNEY



OWNER OF U.S. REG. NOS. 1,922,160, 1,935,966 AND 2,210,850.

THE MARK CONSISTS OF "SHARKMAN" FIGURE ON BEACH WITH SURFBOARD.

FOR CLOTHING, NAMELY, TEE SHIRTS, TANK TOPS, SHIRTS, PANTS, SHORTS, SWEAT SHIRTS, SWEAT PANTS, JACKETS, SOCKS, HATS AND FOOTWEAR (U.S. CLS. 22 AND 39).

FIRST USE 2-0-1981; IN COMMERCE 6-0-1992.

GRETTA YAO, EXAMINING ATTORNEY

SN 78-953,917. POMARE, LTD., HONOLULU, HI. FILED 8-16-2006.

SN 78-951,467. THE SARA BLAKELY FOUNDATION, ATLANTA, GA. FILED 8-14-2006.

# LEI Z'S

## Give A Damn

THE MARK CONSISTS OF STANDARD CHARACTERS WITHOUT CLAIM TO ANY PARTICULAR FONT, STYLE, SIZE, OR COLOR.

FOR T-SHIRTS, SWEAT SHIRTS, JACKETS, PANTS, SOCKS, SHORTS, SKIRTS (U.S. CLS. 22 AND 39).

LEIGH LOWRY, EXAMINING ATTORNEY

THE MARK CONSISTS OF STANDARD CHARACTERS WITHOUT CLAIM TO ANY PARTICULAR FONT, STYLE, SIZE, OR COLOR.

THE FOREIGN WORDING IN THE MARK TRANSLATES INTO ENGLISH AS NECKLACE OF FLOWERS, LEAVES, SHELLS, IVORY, FEATHERS, OR PAPER, GIVEN AS A SYMBOL OF AFFECTION; OR FIGURATIVELY.

FOR BATHING SUITS; BATHROBES; BEACH COVER-UPS; BRASSIERES; GYM SUITS; LOUNGEWEAR; PAJAMAS; SHORTS; SLIPPERS; T-SHIRTS; TANK TOPS; UNDERWEAR (U.S. CLS. 22 AND 39).

DAVID HOFFMAN, EXAMINING ATTORNEY

**CLASS 25—(Continued).**

SN 78-953,930. LEE, HAN LIM, CERRITOS, CA. FILED 8-16-2006.



THE COLOR(S) BLACK, PINK, WHITE, AND YELLOW IS/ARE CLAIMED AS A FEATURE OF THE MARK.

THE MARK CONSISTS OF THE STYLIZED WORD "MISKITS," WITH THE LETTERS "M," "K," AND THE ENDING "S" IN PINK, THE TWO LETTER "I'S" IN WHITE, AND THE THIRD LETTER "S" AND LETTER "T" IN YELLOW, ALL LETTERS IN INDIVIDUAL UNEVEN BLACK SQUARES, AND TWO CAT'S HEAD SHAPES OVER THE TWO LETTER "I'S," WITH THE ONE OVER THE FIRST "I" IN PINK, AND THE SECOND IN YELLOW.

FOR CAPRI PANTS; DENIM JACKETS; DENIMS; DOWN JACKETS; HATS; JACKETS; JEANS; KNIT SHIRTS; LONG JACKETS; LOUNGEWEAR; PAJAMAS; PANTS; POLO SHIRTS; SHIRTS; SHORT-SLEEVED OR LONG-SLEEVED T-SHIRTS; SHORT-SLEEVED SHIRTS; SLEEP SHIRTS; SOCKS; SWEAT PANTS; T-SHIRTS; TRACK PANTS; UNDERWEAR (U.S. CLS. 22 AND 39).

MARK PILARO, EXAMINING ATTORNEY

SN 78-953,945. KUO, ALAN CHUN-LIANG, TORRANCE, CA. FILED 8-16-2006.



NO CLAIM IS MADE TO THE EXCLUSIVE RIGHT TO USE "SLIPPER", APART FROM THE MARK AS SHOWN.

FOR HATS; SANDALS; SLIPPERS (U.S. CLS. 22 AND 39).

DAVID HOFFMAN, EXAMINING ATTORNEY

**CLASS 25—(Continued).**

SN 78-954,398. LANE, KEVIN, SPRING VALLEY, CA. FILED 8-17-2006.



NO CLAIM IS MADE TO THE EXCLUSIVE RIGHT TO USE "CAP", APART FROM THE MARK AS SHOWN.

THE MARK CONSISTS OF THE WORDS ACTION CAP TO THE RIGHT OF A TORNADO-SHAPED DESIGN OF HORIZONTAL BARS.

FOR CAPS; JERSEYS; PANTS; SHIRTS; SHORTS; SWEAT PANTS; SWEAT SHIRTS; SWEAT SHORTS; SWIM WEAR; T-SHIRTS; TOPS; TRACK PANTS; WALKING SHORTS (U.S. CLS. 22 AND 39).

FIRST USE 6-1-2006; IN COMMERCE 6-1-2006.

SHAUNIA WALLACE, EXAMINING ATTORNEY

SN 78-955,616. POMARE, LTD., HONOLULU, HI. FILED 8-18-2006.

## COCONUT MOON

THE MARK CONSISTS OF STANDARD CHARACTERS WITHOUT CLAIM TO ANY PARTICULAR FONT, STYLE, SIZE, OR COLOR.

FOR BEACH COVERUPS; BEACH FOOTWEAR; BLOUSES; CHILDREN'S HEADWEAR; DRESSES; EVENING DRESSES; HATS; JACKETS; LOUNGEWEAR; NECKTIES; PANTS; SANDALS; SARONGS; SCARVES; SHIRTS; SHOES; SHORT-SLEEVED OR LONG-SLEEVED T-SHIRTS; SHORTS; SKIRTS; SOCKS; SWIMMING TRUNKS; SWIMSUITS; TANK TOPS; WAIST BELTS (U.S. CLS. 22 AND 39).

DAVID HOFFMAN, EXAMINING ATTORNEY

SN 78-955,640. POMARE, LTD., HONOLULU, HI. FILED 8-18-2006.

## ALI'I PALMS

THE MARK CONSISTS OF STANDARD CHARACTERS WITHOUT CLAIM TO ANY PARTICULAR FONT, STYLE, SIZE, OR COLOR.

THE FOREIGN WORDING IN THE MARK TRANSLATES INTO ENGLISH AS ARISTOCRATIC, NOBLE OR CHIEFLY.

FOR BEACH COVERUPS; BEACH FOOTWEAR; BLOUSES; DRESSES; EVENING DRESSES; HATS; JACKETS; LOUNGEWEAR; NECKTIES; PANTS; SANDALS; SARONGS; SCARVES; SHIRTS; SHOES; SHORT-SLEEVED OR LONG-SLEEVED T-SHIRTS; SHORTS; SKIRTS; SOCKS; SWIMMING TRUNKS; SWIMSUITS; TANK TOPS; WAIST BELTS (U.S. CLS. 22 AND 39).

DAVID HOFFMAN, EXAMINING ATTORNEY

**CLASS 25—(Continued).**

SN 78-956,133. HASTINGS, JASON, FLOWER MOUND, TX. FILED 8-20-2006.

# Shameless Thought

THE MARK CONSISTS OF STANDARD CHARACTERS WITHOUT CLAIM TO ANY PARTICULAR FONT, STYLE, SIZE, OR COLOR.

FOR BELTS; JACKETS; PANTS; SHIRTS; SHOES; T-SHIRTS; TANK TOPS; TOPS (U.S. CLS. 22 AND 39).  
MICHAEL ENGEL, EXAMINING ATTORNEY

SN 78-956,144. YANG, WENJING, PORTLAND, OR. FILED 8-21-2006.

# Wenjing Yang

THE MARK CONSISTS OF STANDARD CHARACTERS WITHOUT CLAIM TO ANY PARTICULAR FONT, STYLE, SIZE, OR COLOR.

THE NAME(S), PORTRAIT(S), AND/OR SIGNATURE(S) SHOWN IN THE MARK IDENTIFIES WENJING YANG, WHOSE CONSENT(S) TO REGISTER IS MADE OF RECORD.

THE FOREIGN WORDING IN THE MARK TRANSLATES INTO ENGLISH AS WENJING YANG (A PERSON'S NAME).

FOR BEACHWEAR; BELTS MADE OF LEATHER; BELTS OF TEXTILE; BLOUSES; BOTTOMS; CAMISOLES; CAPES; CAPRI PANTS; CARDIGANS; COATS; DENIM JACKETS; DENIMS; DRESS SHIRTS; DRESS SUITS; DRESSES; EVENING DRESSES; EVENING GOWNS; FUR COATS AND JACKETS; HALTER TOPS; HOSIERY; JACKETS; JEANS; JERSEYS; KNIT SHIRTS; KNITTED CAPS; LEATHER JACKETS; LEATHER PANTS; LEATHER SHOES; MEN AND WOMEN JACKETS; COATS, TROUSERS, VESTS; PANTS; SCARVES; SHAWLS; SHIRTS; SKIRTS AND DRESSES; SWEATERS; T-SHIRTS; TANK TOPS; TOPS; WEDDING DRESSES; WRAPS (U.S. CLS. 22 AND 39).

CHRISTOPHER BUONGIORNO, EXAMINING ATTORNEY

**CLASS 25—(Continued).**

SN 78-956,301. RUGGIERO, JOHN, DBA DOMINANS GOLF ESSENTIALS, MANLIUS, NY. FILED 8-21-2006.



THE MARK CONSISTS OF A MALE GOLFING FIGURE. FOR GOLF CAPS; GOLF SHIRTS; JACKETS; SWEATERS (U.S. CLS. 22 AND 39).

FIRST USE 7-21-2006; IN COMMERCE 7-21-2006.  
GEOFFREY FOSDICK, EXAMINING ATTORNEY

SN 78-956,329. JOHN RUGGIERO, DBA DOMINANS GOLF ESSENTIALS, MANLIUS, NY. FILED 8-21-2006.



THE MARK CONSISTS OF A FEMALE GOLFING FIGURE. FOR GOLF CAPS; GOLF SHIRTS; JACKETS; SWEATERS (U.S. CLS. 22 AND 39).

FIRST USE 6-18-2006; IN COMMERCE 6-18-2006.  
GEOFFREY FOSDICK, EXAMINING ATTORNEY

**CLASS 25—(Continued).**

SN 78-956,346. MONTALVO, SANTINO JOSE, TUCSON, AZ. FILED 8-21-2006.



THE MARK CONSISTS OF LOGO AND SLOGAN. FOR CAPS ; HOODS ; INFANT AND TODDLER ONE PIECE CLOTHING; TOPS (U.S. CLS. 22 AND 39). NAAKWAMA ANKRAH, EXAMINING ATTORNEY

**CLASS 25—(Continued).**

SN 78-957,956. CHOI, BYUNG MOON, LOS ANGELES, CA. FILED 8-22-2006.

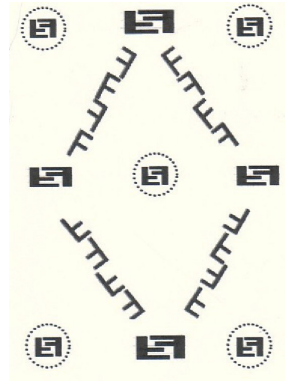

OWNER OF U.S. REG. NO. 3,108,204. THE MARK CONSISTS OF THE LETTERS "F" IN THE SHAPE OF A DIAMOND, AND FIVE CIRCLES WITH DOTS FORMING THE BORDER OF THE CIRCLES, CONTAINING THE LETTERS FF WITHIN THE CIRCLES, WITH ONE CIRCLE LOCATED INSIDE THE TRIANGLE, AND ONE CIRCLE IN EACH CORNER OUTSIDE THE TRIANGLE. FOR BELTS; BLOUSES; CAPS; DRESSES; HATS; JACKETS; PANTS; SCARVES; SHIRTS; SHORTS; SKIRTS; SWEATERS; TANK TOPS; TOPS (U.S. CLS. 22 AND 39). MICHELE SWAIN, EXAMINING ATTORNEY

SN 78-956,510. LEAVER, EDWARD S., HINGHAM, MA. FILED 8-21-2006.

**HEAL GOOD DOG**

THE MARK CONSISTS OF STANDARD CHARACTERS WITHOUT CLAIM TO ANY PARTICULAR FONT, STYLE, SIZE, OR COLOR. FOR JACKETS; SHIRTS; SPORTS SHIRTS; SWEAT SHIRTS; T-SHIRTS (U.S. CLS. 22 AND 39). CATHERINE FAINT, EXAMINING ATTORNEY

SN 78-958,212. BERLE MANUFACTURING COMPANY, CHARLESTON, SC. FILED 8-23-2006.

**DOLCE NETTARE**

SN 78-957,373. SANTOS, ANTHONY, GRANITE BAY, CA. FILED 8-22-2006.

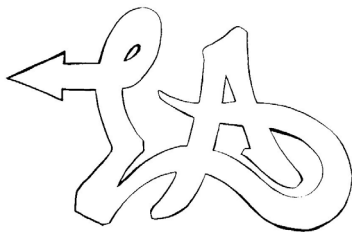

THE MARK CONSISTS OF STYLIZED TEXT. FOR HATS; SWEAT SHIRTS; T-SHIRTS (U.S. CLS. 22 AND 39). WILLIAM ROSSMAN, EXAMINING ATTORNEY

THE MARK CONSISTS OF STANDARD CHARACTERS WITHOUT CLAIM TO ANY PARTICULAR FONT, STYLE, SIZE, OR COLOR. THE FOREIGN WORDING IN THE MARK TRANSLATES INTO ENGLISH AS SWEET NECTAR. FOR COATS; PANTS; SUITS (U.S. CLS. 22 AND 39). PRISCILLA MILTON, EXAMINING ATTORNEY



**CLASS 25—(Continued).**

SN 78-959,143. JAMES, JEFF L, CAMARILLO, CA. FILED 8-23-2006.

# TWISTED RIDE

THE MARK CONSISTS OF STANDARD CHARACTERS WITHOUT CLAIM TO ANY PARTICULAR FONT, STYLE, SIZE, OR COLOR.

FOR BASEBALL CAPS; BEANIES; BELTS; BOOTS; CAPS; DENIM JACKETS; DRESS SHIRTS; G-STRINGS; GOLF SHIRTS; HATS; JACKETS; KNIT SHIRTS; KNITTED CAPS; LEATHER BELTS; LEATHER JACKETS; LONG JACKETS; MEN AND WOMEN JACKETS; COATS, TROUSERS, VESTS; POLO SHIRTS; SHIRTS; SHOES; SHORT-SLEEVED SHIRTS; SKULL CAPS; SPORT SHIRTS; SPORTS JACKETS; SUEDE JACKETS; SWEAT SHIRTS; T-SHIRTS (U.S. CLS. 22 AND 39).  
ALYSSA PALADINO, EXAMINING ATTORNEY

SN 78-959,803. L. C. LICENSING, INC., NEW YORK, NY. FILED 8-24-2006.

# FOR NICE GIRLS WHO LIKE STUFF

THE MARK CONSISTS OF STANDARD CHARACTERS WITHOUT CLAIM TO ANY PARTICULAR FONT, STYLE, SIZE, OR COLOR.

FOR CLOTHING NAMELY, SHIRTS, PANTS, SWEATERS, SKIRTS, DRESSES, COATS, SUITS, NECKTIES, BELTS, SWIMWEAR, RAINWEAR, SLEEPWEAR; NAMELY, NIGHTGOWNS, PAJAMAS AND ROBES, LINGERIE, UNDERWEAR, BRAS, SOCKS, HOSIERY, GLOVES, MITTENS AND SCARVES; FOOTWEAR; HEADWEAR (U.S. CLS. 22 AND 39).  
COLLEEN DOMBROW, EXAMINING ATTORNEY

**CLASS 25—(Continued).**

SN 78-960,216. BLB, INC., LOS ANGELES, CA. FILED 8-25-2006.



THE MARK CONSISTS OF THE WORD "FLIRTY" IN LOWER CASE, STYLIZED FORMAT WITH THE NUMBER "30" IN STYLIZED FORMAT APPEARING WITHIN A HEART DESIGN TO LOWER RIGHT OF THE WORD "FLIRTY".

FOR BALLOON PANTS; BELTS; CAPRI PANTS; CAPS; CHILDREN'S AND INFANTS' CLOTH BIBS; CHILDREN'S CLOTH EATING BIBS; COATS; COATS FOR MEN AND WOMEN; COATS OF DENIM; DENIMS; DRESS SHIRTS; GOLF SHIRTS; HATS; INFANT AND TODDLER ONE PIECE CLOTHING; JERSEYS; JOGGING PANTS; KNIT SHIRTS; LEATHER BELTS; LEATHER PANTS; MEN AND WOMEN JACKETS, COATS, TROUSERS, VESTS; NIGHT SHIRTS; OPEN-NECKED SHIRTS; PANTS; PARTS OF CLOTHING, NAMELY, GUSSETS FOR TIGHTS, GUSSETS FOR STOCKINGS, GUSSETS FOR BATHING SUITS, GUSSETS FOR UNDERWEAR, GUSSETS FOR LEOTARDS AND GUSSETS FOR FOOTLETS; PIQUE SHIRTS; POLO SHIRTS; RAIN COATS; SHIRT FRONTS; SHIRTS; SHIRTS FOR SUITS; SHORT SETS; SHORT-SLEEVED OR LONG-SLEEVED T-SHIRTS; SHORT-SLEEVED SHIRTS; SHOULDER WRAPS; SLEEP SHIRTS; SPORT COATS; SPORT SHIRTS; SPORTS SHIRTS; SPORTS SHIRTS WITH SHORT SLEEVES; SUI COATS; SWEAT PANTS; SWEAT SHIRTS; T-SHIRTS; TOBOGGAN HATS, PANTS AND CAPS; TOPS; TRACK PANTS; TRENCH COATS; WATERPROOF JACKETS AND PANTS; WIND COATS; WIND SHIRTS; WOOLLY HATS; WRAPS (U.S. CLS. 22 AND 39).  
ELI HELLMAN, EXAMINING ATTORNEY

SN 78-960,365. A & F APPAREL USA INC., VENICE, CA. FILED 8-25-2006.



FOR COATS; DENIM JACKETS; DENIMS; DRESSES; JACKETS; PANTS; SCARVES; SHIRTS; T-SHIRTS (U.S. CLS. 22 AND 39).  
MARC LEIPZIG, EXAMINING ATTORNEY

**CLASS 25—(Continued).**

SN 78-960,599. TRIVETTE, PAMELA, ROCKLEDGE, FL.  
FILED 8-25-2006.

**FIREBALL ROBERTS**

THE MARK CONSISTS OF STANDARD CHARACTERS WITHOUT CLAIM TO ANY PARTICULAR FONT, STYLE, SIZE, OR COLOR.

THE NAME, PORTRAIT, AND/OR SIGNATURE SHOWN IN THE MARK DOES NOT IDENTIFY A PARTICULAR LIVING INDIVIDUAL.

FOR CLOTHING, NAMELY, SHIRTS, T-SHIRTS, CAPS AND SWEATSHIRTS (U.S. CLS. 22 AND 39).

FIRST USE 11-0-1988; IN COMMERCE 11-0-1988.  
KATHY DE JONGE, EXAMINING ATTORNEY

**CLASS 25—(Continued).**

SN 78-960,667. GRUNDENS USA, LTD., POULSBO, WA.  
FILED 8-25-2006.

**EAT CRAB**

THE MARK CONSISTS OF STANDARD CHARACTERS WITHOUT CLAIM TO ANY PARTICULAR FONT, STYLE, SIZE, OR COLOR.

FOR BOOTS; COATS; FISHERMEN'S JACKETS; HATS; HEAVY JACKETS; JACKETS; MEN AND WOMEN JACKETS, COATS, TROUSERS, VESTS; OPEN-NECKED SHIRTS; PANTS; RAIN BOOTS; RAIN COATS; RAIN JACKETS; RAINPROOF JACKETS; SHIRTS; SHOES; SWEATERS; T-SHIRTS; VESTS (U.S. CLS. 22 AND 39).  
TANYA AMOS, EXAMINING ATTORNEY

SN 78-960,625. GRUNDENS USA, LTD., POULSBO, WA.  
FILED 8-25-2006.

**EAT SCALLOPS**

THE MARK CONSISTS OF STANDARD CHARACTERS WITHOUT CLAIM TO ANY PARTICULAR FONT, STYLE, SIZE, OR COLOR.

FOR BOOTS; COATS; FISHERMEN'S JACKETS; FISHING VESTS; HEAVY JACKETS; JACKETS; MEN AND WOMEN JACKETS, COATS, TROUSERS, VESTS; OPEN-NECKED SHIRTS; PANTS; RAIN BOOTS; RAIN COATS; RAIN JACKETS; RAINPROOF JACKETS; SHIRTS; SWEATERS; T-SHIRTS; VESTS (U.S. CLS. 22 AND 39).  
TANYA AMOS, EXAMINING ATTORNEY

SN 78-960,663. THE MOUNTAIN CORPORATION, KEENE, NH. FILED 8-25-2006.

**SKULBONE**

THE MARK CONSISTS OF STANDARD CHARACTERS WITHOUT CLAIM TO ANY PARTICULAR FONT, STYLE, SIZE, OR COLOR.

FOR T-SHIRTS (U.S. CLS. 22 AND 39).  
JAMES STEIN, EXAMINING ATTORNEY

SN 78-960,828. UNBORN MEDIA, INC., BOSTON, MA. FILED 8-25-2006.

**VIRB**

THE MARK CONSISTS OF STANDARD CHARACTERS WITHOUT CLAIM TO ANY PARTICULAR FONT, STYLE, SIZE, OR COLOR.

FOR BASEBALL CAPS; HATS; JACKETS; SHIRTS; SHORT-SLEEVED SHIRTS; SWEAT SHIRTS; T-SHIRTS; WIND RESISTANT JACKETS; WRIST BANDS (U.S. CLS. 22 AND 39).

TIMOTHY FINNEGAN, EXAMINING ATTORNEY

SN 78-961,073. HUNEEUS VINTNERS LLC, RUTHERFORD, CA. FILED 8-25-2006.

**QUINTESSA**

THE MARK CONSISTS OF STANDARD CHARACTERS WITHOUT CLAIM TO ANY PARTICULAR FONT, STYLE, SIZE, OR COLOR.

OWNER OF U.S. REG. NO. 1,933,427.  
FOR CLOTHING, NAMELY T-SHIRTS, POLO SHIRTS, COLLARED SHIRTS, TANK TOPS, SWEATSHIRTS AND HATS; APRONS (U.S. CLS. 22 AND 39).

JAMES MACFARLANE, EXAMINING ATTORNEY

**CLASS 25—(Continued).**

SN 78-961,097. LEWIS, JOHN N., OCEANSIDE, CA. AND LEWIS, ANNE K., OCEANSIDE, CA. FILED 8-25-2006.

# Click Flops

THE MARK CONSISTS OF STANDARD CHARACTERS WITHOUT CLAIM TO ANY PARTICULAR FONT, STYLE, SIZE, OR COLOR.

FOR SANDALS, FLIP FLOPS, THONGS, JAPANESE STYLE SANDALS (ZORI), AND JAPANESE STYLE SANDALS OF LEATHER (U.S. CLS. 22 AND 39).

ROBIN CHOSID, EXAMINING ATTORNEY

**CLASS 25—(Continued).**

SN 78-961,800. LIFE MOXIE, INC., SAN FRANCISCO, CA. FILED 8-28-2006.

# MOXIE MOMENT

THE MARK CONSISTS OF STANDARD CHARACTERS WITHOUT CLAIM TO ANY PARTICULAR FONT, STYLE, SIZE, OR COLOR.

OWNER OF U.S. REG. NO. 2,880,258.  
FOR CAPS; HATS; POLO SHIRTS; SPORT SHIRTS; SWEAT SHIRTS; T-SHIRTS (U.S. CLS. 22 AND 39).

MATTHEW PAPPAS, EXAMINING ATTORNEY

SN 78-961,177. BUBBLING CRUDE, INC., BEVERLY HILLS, CA. FILED 8-26-2006.

# PEANUTS CORN AND HAIR

THE MARK CONSISTS OF STANDARD CHARACTERS WITHOUT CLAIM TO ANY PARTICULAR FONT, STYLE, SIZE, OR COLOR.

FOR T-SHIRTS, SHIRTS, PANTS, CAPS, HATS, VISORS, FOOTWEAR, UNDERWEAR, BELTS, BANDANNAS, SOCKS, AND PAJAMAS; OUTERWEAR, NAMELY, JACKETS AND COATS (U.S. CLS. 22 AND 39).

LINDSEY RUBIN, EXAMINING ATTORNEY

SN 78-961,820. BOUWER, MARC, NEW YORK, NY. FILED 8-28-2006.

# Marc Bouwer

THE MARK CONSISTS OF STANDARD CHARACTERS WITHOUT CLAIM TO ANY PARTICULAR FONT, STYLE, SIZE, OR COLOR.

FOR DRESSES; EVENING DRESSES; EVENING GOWNS; WEDDING GOWNS (U.S. CLS. 22 AND 39).

FIRST USE 1-1-1990; IN COMMERCE 1-1-1990.  
MICHAEL LITZAU, EXAMINING ATTORNEY

SN 78-961,454. OXFORD INDUSTRIES, INC., ATLANTA, GA. FILED 8-28-2006.

# Shirt Guard

THE MARK CONSISTS OF STANDARD CHARACTERS WITHOUT CLAIM TO ANY PARTICULAR FONT, STYLE, SIZE, OR COLOR.

NO CLAIM IS MADE TO THE EXCLUSIVE RIGHT TO USE "SHIRT", APART FROM THE MARK AS SHOWN.  
FOR SHIRTS (U.S. CLS. 22 AND 39).

ELIZABETH PIGNATELLO, EXAMINING ATTORNEY

SN 78-962,902. FUNHAT, LLC, AKRON, OH. FILED 8-29-2006.

# FUNhat

THE MARK CONSISTS OF STANDARD CHARACTERS WITHOUT CLAIM TO ANY PARTICULAR FONT, STYLE, SIZE, OR COLOR.

FOR CLOTHING AND CLOTHING ACCESSORIES, NAMELY HATS, SCARVES, SWEAT SHIRTS, T-SHIRTS, MITTENS, AND GLOVES (U.S. CLS. 22 AND 39).

MIDGE BUTLER, EXAMINING ATTORNEY

**CLASS 25—(Continued).**

SN 78-962,974. GARCIA, JEAN-CLAUDE, TENAFLY, NJ. AND MCNAMARA, PATRICK R., WYCKOFF, NJ. FILED 8-29-2006.

DON'T THREATEN ME WITH A  
GOOD TIME

THE MARK CONSISTS OF STANDARD CHARACTERS WITHOUT CLAIM TO ANY PARTICULAR FONT, STYLE, SIZE, OR COLOR.

FOR CLOTHING, NAMELY T-SHIRTS, CAPS, PANTS, SHORTS, ATHLETIC UNIFORMS, DRESS SHIRTS, POLO SHIRTS, SWEATPANTS, SWEATSHIRTS, JACKETS, SKIRTS (U.S. CLS. 22 AND 39).

SARAH WAYDA, EXAMINING ATTORNEY

SN 78-963,064. A H CONFECQUES LTDA, SAO PAULO - SP, BRAZIL, FILED 8-29-2006.

HERCHCOVITCH; JEANS

THE MARK CONSISTS OF STANDARD CHARACTERS WITHOUT CLAIM TO ANY PARTICULAR FONT, STYLE, SIZE, OR COLOR.

NO CLAIM IS MADE TO THE EXCLUSIVE RIGHT TO USE "JEANS", APART FROM THE MARK AS SHOWN.

FOR PANTS, SHIRTS, DRESSES, BLOUSES, JACKETS, COATS, SKIRTS, SOCKS, HOSIERY, FOOTWEAR, HEADWEAR, VESTS, BELTS, GLOVES, BOOTS, CAPS, HATS, KNITWEAR, NAMELY, SWEATERS, SCARVES, VESTS; PULLOVERS, SHOES, SUITS, UNDERWEAR (U.S. CLS. 22 AND 39).

FIRST USE 9-15-2003; IN COMMERCE 9-15-2003.  
SETH A. RAPPAPORT, EXAMINING ATTORNEY

SN 78-963,069. QUEEN BEE ENTERTAINMENT, INC., NEW YORK, NY. FILED 8-29-2006.

24-7 STAR

THE MARK CONSISTS OF STANDARD CHARACTERS WITHOUT CLAIM TO ANY PARTICULAR FONT, STYLE, SIZE, OR COLOR.

FOR CLOTHING, NAMELY, HATS, SCARVES, SWEATERS, JEANS, GLOVES, TANK TOPS, HALTER TOPS; SWIM WEAR, NAMELY, BATHING SUITS AND BIKINIS; ATHLETIC WEAR, NAMELY, JOGGING SUITS, BODY SUITS, RUNNING SHORTS, RUNNING PANTS, SWEAT PANTS, SWEAT SHIRTS; WOMEN'S WEAR, NAMELY, BLOUSES, DRESSES, SKIRTS, COATS, JACKETS, RAIN COATS; FOOTWEAR; HEAD WEAR; CHILDREN'S CLOTHING, NAMELY, T-SHIRTS, SHORTS, PANTS, JEANS, FOOTWEAR, SOCKS, HOSIERY; OUTERWEAR, NAMELY, JACKETS; SLEEP WEAR, NAMELY, PAJAMAS (U.S. CLS. 22 AND 39).

JULIE THOMAS, EXAMINING ATTORNEY

**CLASS 25—(Continued).**

SN 78-963,224. WONG, DANIEL, ARCADIA, CA. AND KWOK, FLORINDA, ARCADIA, CA. AND YU, LO LEE, WEST COVINA, CA. FILED 8-29-2006.



THE MARK CONSISTS OF STYLIZED LETTERS AND NUMBERS JP AND 21 SEPARATED BY A HEART SHAPE WITH THE PHRASE JACKPOT 21 WITHIN THE HEART.

FOR BEACHWEAR; BLOUSES; CAMISOLES; CAPRI PANTS; CAPS; CARDIGANS; COATS; DENIM JACKETS; DENIMS; DRESS SHIRTS; DRESS SUITS; DRESSES; DUSTERS; GOWNS; HALTER TOPS; HOODS; JACKETS; JEANS; JERSEYS; JOGGING OUTFITS; JUMPERS; LADIES' SUITS; LINGERIE; MEN AND WOMEN JACKETS, COATS, TROUSERS, VESTS; MINISKIRTS; MUSCLE TOPS; NIGHTWEAR; OVER COATS; OVERALLS; OVERCOATS; PAJAMAS; PANTIES; PANTIES, SHORTS AND BRIEFS; PANTS; POLO SHIRTS; PULLOVERS; SCARVES; SHAWLS; SHIRTS; SHIRTS FOR SUITS; SHORTS; SKIRT SUITS; SKIRTS; SKIRTS AND DRESSES; SKORTS; SLEEPING GARMENTS; SLEEPWEAR; SUIT COATS; SUITS; SWEAT PANTS; SWEAT SHIRTS; SWEAT SHORTS; SWEATERS; T-SHIRTS; TANK TOPS; TANKINIS; TROUSERS; TURTLENECKS; UNDERCLOTHES; UNDERGARMENTS; UNDERPANTS; UNDERSHIRTS; UNDERSKIRTS; UNDERWEAR (U.S. CLS. 22 AND 39).

CHARLOTTE CORWIN, EXAMINING ATTORNEY

SN 78-963,250. FRACAS LLC, SCOTTDALE, AZ. FILED 8-29-2006.

Fracas

THE MARK CONSISTS OF STANDARD CHARACTERS WITHOUT CLAIM TO ANY PARTICULAR FONT, STYLE, SIZE, OR COLOR.

FOR CLOTHING FOR WEAR IN JUDO PRACTICES; SHORT SETS; SPORTS JERSEYS; SPORTS SHIRTS; SPORTS SHIRTS WITH SHORT SLEEVES; TOPS (U.S. CLS. 22 AND 39).

FIRST USE 8-3-2006; IN COMMERCE 8-3-2006.  
MARY MUNSON, EXAMINING ATTORNEY

**CLASS 25—(Continued).**

SN 78-963,693. ESPINOSA, GREG, RANCHO MIRAGE, CA. FILED 8-30-2006.

# Sex Wood

THE MARK CONSISTS OF STANDARD CHARACTERS WITHOUT CLAIM TO ANY PARTICULAR FONT, STYLE, SIZE, OR COLOR.

FOR CLOTHING NAMELY T-SHIRTS, TANK TOPS, SWEATSHIRTS, BOXER SHORTS; FOOTWEAR AND HEADWEAR (U.S. CLS. 22 AND 39).

JOHN HWANG, EXAMINING ATTORNEY

SN 78-964,193. AMERICAN NEVADA HOLDINGS, LLC, HENDERSON, NV. FILED 8-30-2006.



FOR CLOTHING AND CLOTHING ACCESSORIES, NAMELY, INFANTWEAR, SHIRTS, T-SHIRTS, POLO SHIRTS, TANK TOPS, COATS, JACKETS, VESTS, SLEEPWEAR, SWEATERS, SWEATSHIRTS, SWEATPANTS, HEADWEAR, ROBES, JOGGING SUITS, SHORTS, PANTS, JEANS, SKIRTS, DRESSES, UNDERGARMENTS, LINGERIE, SOCKS, SWIMWEAR, BELTS, WRIST BANDS, TIES, OVERALLS, BLOUSES, SCARVES, GLOVES, FOUL WEATHER GEAR, FOOTWEAR AND CLEATS FOR ATTACHMENT TO SPORTS SHOES (U.S. CLS. 22 AND 39).

MICHAEL ENGEL, EXAMINING ATTORNEY

SN 78-964,202. LLOYD, KENNETH L., ENCINO, CA. FILED 8-30-2006.



FOR CLOTHING, NAMELY, T-SHIRTS, POLO SHIRTS, SWEATSHIRTS, TANK TOPS, HATS AND BASEBALL CAPS (U.S. CLS. 22 AND 39).

TANYA AMOS, EXAMINING ATTORNEY

**CLASS 25—(Continued).**

SN 78-964,230. THE MICHELLE RODRIGUEZ AND DARA YOUNG PARTNERSHIP, DBA ISHKADADA ENTERPRISES, SANTA MONICA, CA. FILED 8-30-2006.

# ISHKADADA

THE MARK CONSISTS OF STANDARD CHARACTERS WITHOUT CLAIM TO ANY PARTICULAR FONT, STYLE, SIZE, OR COLOR.

FOR CLOTHING, NAMELY JEANS, PANTS, TROUSERS, SHIRTS, T-SHIRTS, POLO SHIRTS, BLOUSES, SWEATERS, CARDIGANS, KNIT TOPS, TANK TOPS, CAMISOLES, CROP TOPS, BUSTIERS, JACKETS, COATS, VESTS, LINGERIE, UNDERWEAR, UNDERSHIRTS, SLEEPWEAR, ROBES, PAJAMAS, SWIMMING SUITS, BATHING SUITS, BEACH SHIRTS, SWEATPANTS, SWEATSHIRTS, SWEAT JACKETS, OVERALLS, JUMPSUITS, DRESSES, SKIRTS, SHORTS, SUIT, SCARVES, HEADWEAR, SOCKS, TIGHTS, HOSIERY, LEG WARMERS, FOOTWEAR (U.S. CLS. 22 AND 39).

JOHN DALIER, EXAMINING ATTORNEY

SN 78-964,318. DAVID R. LOPEZ, CORSICANA, TX. FILED 8-30-2006.

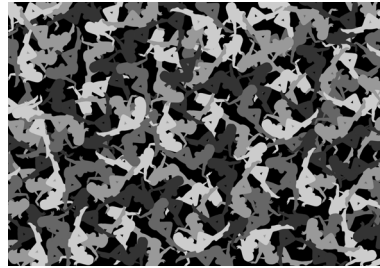

FOR BALLOON PANTS; BERMUDA SHORTS; BOARD SHORTS; BOXER SHORTS; CAMP SHIRTS; CAPRI PANTS; DENIMS; DRESS SHIRTS; FLEECE SHORTS; GOLF SHIRTS; GYM SHORTS; JOGGING PANTS; KNIT SHIRTS; LEATHER PANTS; NIGHT SHIRTS; NON-DISPOSABLE CLOTH TRAINING PANTS; NURSE PANTS; OPEN-NECKED SHIRTS; PANTIES, SHORTS AND BRIEFS; PANTS; PETTI-PANTS; PIQUE SHIRTS; POLO SHIRTS; RUGBY SHORTS; SHIRT FRONTS; SHIRT YOKES; SHIRTS; SHIRTS FOR SUITS; SHORT OVERCOAT FOR KIMONO (HAORI); SHORT PETTICOATS; SHORT SETS; SHORT TROUSERS; SHORT-SLEEVED OR LONG-SLEEVED T-SHIRTS; SHORT-SLEEVED SHIRTS; SHORTS; SKI PANTS; SLEEP SHIRTS; SLIDING SHORTS; SNOW PANTS; SNOWBOARD PANTS; SPORT SHIRTS; SPORTS SHIRTS; SPORTS SHIRTS WITH SHORT SLEEVES; SWEAT PANTS; SWEAT SHIRTS; SWEAT SHORTS; T-SHIRTS; TAP PANTS; TOBOGGAN HATS, PANTS AND CAPS; TRACK PANTS; WALKING SHORTS; WATERPROOF JACKETS AND PANTS; WIND SHIRTS (U.S. CLS. 22 AND 39).

COLLEEN DOMBROW, EXAMINING ATTORNEY

**CLASS 25—(Continued).**

SN 78-964,383. GOLFSMITH INTERNATIONAL, INC., AUSTIN, TX. FILED 8-30-2006.

# DRY18

THE MARK CONSISTS OF STANDARD CHARACTERS WITHOUT CLAIM TO ANY PARTICULAR FONT, STYLE, SIZE, OR COLOR.

FOR CLOTHING, NAMELY, TOPS, BOTTOMS, SHIRTS, GOLF SHIRTS, T-SHIRTS, WIND SHIRTS, JACKETS, PULLOVERS, SHORTS, PANTS, SOCKS, SHOES, GOLF SHOES, GLOVES, RAIN SUITS, VESTS, WIND RESISTANT JACKETS; FOOTWEAR; HEADGEAR, NAMELY, HATS, CAPS, VISORS; CLOTHING FOR SPORTS, NAMELY, SPORT SHIRTS, SPORTS BRAS, SPORT COATS, SPORTS JACKETS, SPORTS JERSEYS, UNDERWEAR (U.S. CLS. 22 AND 39).

JAY BESCH, EXAMINING ATTORNEY

SN 78-964,396. CARSON GAMING, L.L.C., LAS VEGAS, NV. FILED 8-30-2006.

# CASINO FANDANGO

THE MARK CONSISTS OF STANDARD CHARACTERS WITHOUT CLAIM TO ANY PARTICULAR FONT, STYLE, SIZE, OR COLOR.

OWNER OF U.S. REG. NOS. 2,968,485 AND 2,973,537.

FOR MEN'S, WOMEN'S, AND CHILDREN'S WEARING APPAREL, NAMELY SHIRTS, PANTS, VESTS, GOLF SHIRTS, SKIRTS, BLOUSES, COATS, JACKETS, T-SHIRTS, TANK TOPS, INFANT WEAR, SWEATSHIRTS, SWEAT SUITS, SWEATERS, JOGGING SUITS, SHORTS, SWIMWEAR, TIES, DRESSES, HATS, CAPS, BANDANNAS, SUSPENDERS, ROBES, SLEEPWEAR, ROMPERS, SCARVES, SOCKS, AND SLIPPERS (U.S. CLS. 22 AND 39).

MORGAN WYNNE, EXAMINING ATTORNEY

**CLASS 25—(Continued).**

SN 78-964,398. MILLIGAN, JAMES L., GORHAM, ME. FILED 8-30-2006.



NO CLAIM IS MADE TO THE EXCLUSIVE RIGHT TO USE "APPAREL COMPANY", APART FROM THE MARK AS SHOWN.

THE STIPPLING IS FOR SHADING PURPOSES ONLY.

THE MARK CONSISTS OF A CIRCLE AND THREE PALM TREES ON TOP WITH STYLIZED TEXT OF THE WORDS, "BIRTHDAY SUIT APPAREL COMPANY".

FOR HATS; SHIRTS; VISORS (U.S. CLS. 22 AND 39).

FIRST USE 4-1-2006; IN COMMERCE 4-1-2006.

JAY BESCH, EXAMINING ATTORNEY

SN 78-964,410. DI GIANNANTONIO, KEITH, W., GLENDALE, NY. FILED 8-30-2006.

# URBANACID

THE MARK CONSISTS OF STANDARD CHARACTERS WITHOUT CLAIM TO ANY PARTICULAR FONT, STYLE, SIZE, OR COLOR.

FOR APPAREL, NAMELY, TOPS, BOTTOMS, FOOTWEAR, HEADWEAR, UNDERWEAR, BEACHWEAR, SWIMWEAR, BELTS, COATS, JACKETS, DRESSES, SUITS, NECKWEAR, GLOVES, HOSIERY, LINGERIE, UNIFORMS, JERSEYS, MUFFS, ROBES, SASHES, PONCHOS (U.S. CLS. 22 AND 39).

JAY BESCH, EXAMINING ATTORNEY

SN 78-964,644. SMITH-GETMAN, JAYE J., AUSTIN, TX. FILED 8-31-2006.

# BATTY ABOUT AUSTIN

THE MARK CONSISTS OF STANDARD CHARACTERS WITHOUT CLAIM TO ANY PARTICULAR FONT, STYLE, SIZE, OR COLOR.

NO CLAIM IS MADE TO THE EXCLUSIVE RIGHT TO USE "AUSTIN", APART FROM THE MARK AS SHOWN.

FOR CLOTHING, NAMELY, SHIRTS, T-SHIRTS, SWEATSHIRTS, SPORTS SHIRTS, COLLARED SHIRTS, SWEATERS, BASEBALL HATS, SHORTS, PANTS, UNDERWEAR AND HALLOWEEN COSTUMES (U.S. CLS. 22 AND 39).

DAVID YONTEF, EXAMINING ATTORNEY

**CLASS 25—(Continued).**

SN 78-964,645. WARD, RODERICK A., EAST NORRITON, PA. FILED 8-31-2006.

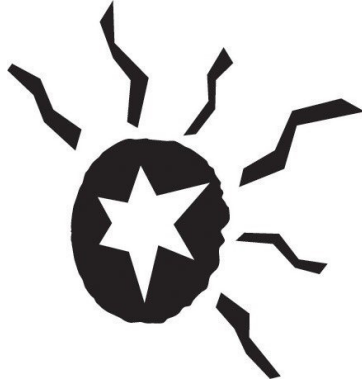

THE MARK CONSISTS OF A STYLIZED LETTER "O" WITH ASYMMETRICAL LINES AROUND HALF OF THE LETTER "O" REPRESENTING RAYS OF SUNSHINE. THE CENTER OF THE LETTER "O" IS AN ASYMMETRICAL SIX-SIDED STAR.

FOR MEN'S, WOMEN'S AND CHILDREN'S CLOTHING AND FASHION ACCESSORIES, NAMELY SHIRTS, DRESS SHIRTS, T-SHIRTS, SWEATERS, SWEATSHIRTS, SWEATPANTS, PANTS, COATS, JACKETS, PAJAMAS, UNDERGARMENTS, HATS, HEADWEAR, AND FOOTWEAR (U.S. CLS. 22 AND 39).

KRISTIN DAHLING, EXAMINING ATTORNEY



SN 78-964,658. SMITH-GETMAN, JAYE J., AUSTIN, TX. FILED 8-31-2006.

**BATTY ABOUT TEXAS**

THE MARK CONSISTS OF STANDARD CHARACTERS WITHOUT CLAIM TO ANY PARTICULAR FONT, STYLE, SIZE, OR COLOR.

NO CLAIM IS MADE TO THE EXCLUSIVE RIGHT TO USE "TEXAS", APART FROM THE MARK AS SHOWN.

FOR CLOTHING, NAMELY, SHIRTS, T-SHIRTS, SWEATSHIRTS, SPORTS SHIRTS, COLLARED SHIRTS, SWEATERS, BASEBALL HATS, SHORTS, PANTS, UNDERWEAR AND HALLOWEEN COSTUMES (U.S. CLS. 22 AND 39).

DAVID YONTEF, EXAMINING ATTORNEY

**CLASS 25—(Continued).**

SN 78-964,817. WORD ACTIVE WEAR, FRISCO, TX. FILED 8-31-2006.



THE MARK CONSISTS OF WORDACTIVEWEAR. WORDACTIVEWEAR IN THE DESIGN OF A CIRCLE AND INSIDE OF THE CIRCLE WA.

FOR T-SHIRTS (U.S. CLS. 22 AND 39).  
CURTIS FRENCH, EXAMINING ATTORNEY



SN 78-964,876. 24 STANDARD CLOTHING COMPANY CORP., NEW YORK, NY. FILED 8-31-2006.



THE MARK CONSISTS OF A WINGED KNIGHT WITH A SCEPTER ON A HORSE.

FOR CLOTHING, NAMELY, COATS, BLAZERS, JACKETS, CARDIGANS, BOLEROS, SPORT COATS, FUR STOLE, WIND RESISTANT JACKETS, SUITS, VESTS, DRESSES, EVENING GOWNS, JUMPERS, SKIRTS, PANTS, SLACKS, TROUSERS, JEANS, JUMPSUITS, SWEAT PANTS, THERMAL UNDERWEAR, SHORTS, SWEATERS, PULLOVERS, JERSEYS, SHIRTS, BLOUSES, TUNICS, SWEATSHIRTS, T-SHIRTS, HALTER TOPS, TANK TOPS, BODYSUITS, CAMISOLES, CHEMISES, UNDERSHIRTS, SLIPS, BRASSIERES, PANTIES, LINGERIE, NIGHTGOWNS, NEGLIGEEES, FOUNDATION GARMENTS, BODY SHAPERS, BUSTIERS, GARTER BELTS, ROBES, PAJAMAS, HOSE, PANTY HOSE, TIGHTS, KNEE HIGH STOCKINGS, SOCKS, BRIEFS, BOXER SHORTS, LOUNGEWEAR, NIGHT SHIRTS, TIGHTS, LEG WARMERS, LEGGINGS, SOCKS, HEAD WEAR, HATS, CAPS, HOODS, HEAD BANDS, BERETS, EARMUFFS, NECKTIES, SCARVES, SHAWLS, NECKERCHIEFS, GLOVES, MITTENS, BELTS, SASHES, BEACHWEAR, BEACH COVERUPS, SWIMWEAR, SARONGS, SKI WEAR, SKI SUITS, SKI PANTS, SKI GLOVES, THERMAL SOCKS, INFANT WEAR, PLAYSUITS, SARONGS, SHOES, FOOTWEAR, BOOTS, ATHLETIC SHOES, ATHLETIC FOOTWEAR, GALOSHES, SANDALS, BOOTS, HIGH BOOTS, AND SLIPPERS (U.S. CLS. 22 AND 39).

SCOTT BIBB, EXAMINING ATTORNEY

**CLASS 25—(Continued).**

SN 78-965,295. TAYLOR, JEFFREY C., LA QUINTA, CA.  
FILED 8-31-2006.



THE MARK CONSISTS OF A SKELETON FISH DRAWN WITHIN A ROUND CIRCLE. THE WORD " FISHGILLZ" SURROUNDS THE OUTER PART OF THE CIRCLE.

FOR BATH SLIPPERS; BATHING CAPS; BATHING COSTUMES; BATHING COSTUMES FOR WOMEN; BATHING SUITS; BATHING SUITS FOR MEN; BATHING TRUNKS; BERMUDA SHORTS; BOARD SHORTS; BODY SUITS; BOXER SHORTS; CAMP SHIRTS; CHEF'S HATS; DRESS SHIRTS; DRESS SUITS; DRY SUITS; FISHING VESTS; FITTED SWIMMING COSTUMES WITH BRA CUPS; FLEECE SHORTS; FLIGHT SUITS; FUR HATS; GOLF SHIRTS; GYM SHORTS; GYM SUITS; HAT BANDS; HATS; HEAD SCARVES; HUNTING VESTS; JOGGING SUITS; JUDO SUITS; KARATE SUITS; KNIT SHIRTS; LADIES' SUITS; LONG SLEEVED VESTS; MEN AND WOMEN JACKETS, COATS, TROUSERS, VESTS; MEN'S SUITS; MEN'S SUITS, WOMEN'S SUITS; NECK BANDS; NIGHT SHIRTS; OPEN-NECKED SHIRTS; PANTIES, SHORTS AND BRIEFS; PARTS OF CLOTHING, NAMELY, GUSSETS FOR TIGHTS, GUSSETS FOR STOCKINGS, GUSSETS FOR BATHING SUITS, GUSSETS FOR UNDERWEAR, GUSSETS FOR LEOTARDS AND GUSSETS FOR FOOTLETS; PIQUE SHIRTS; PLAY SUITS; POLO SHIRTS; RAIN SUITS; RUGBY SHORTS; SCARVES; SEDGE HATS (SUGEGASA); SHIRT FRONTS; SHIRT YOKES; SHIRTS; SHIRTS FOR SUITS; SHORT OVERCOAT FOR KIMONO (HAORI); SHORT PETTICOATS; SHORT SETS; SHORT TROUSERS; SHORT-SLEEVED OR LONG-SLEEVED T-SHIRTS; SHORT-SLEEVED SHIRTS; SHORTS; SHOULDER SCARVES; SILK SCARVES; SKI SUITS; SKI SUITS FOR COMPETITION; SKIRT SUITS; SLEEP SHIRTS; SLIDING SHORTS; SMALL HATS; SNOW BOARDING SUITS; SNOW SUITS; SPORT SHIRTS; SPORTS SHIRTS; SPORTS SHIRTS WITH SHORT SLEEVES; SUIT COATS; SUITS; SWEAT BANDS; SWEAT SHIRTS; SWEAT SHORTS; SWEAT SUITS; SWIM CAPS; SWIM TRUNKS; SWIM WEAR; SWIM WEAR FOR GENTLEMEN AND LADIES; SWIMMING CAPS; SWIMMING CAPS; SWIMMING COSTUMES; SWIMMING TRUNKS; T-SHIRTS; TOBOGGAN HATS, PANTS AND CAPS; TRACK SUITS; TRAINING SUITS; TRUNKS; VESTED SUITS; VESTS; WALKING SHORTS; WARM UP SUITS; WET SUIT GLOVES; WET SUITS; WET SUITS FOR WATER-SKIING AND SUB-AQUA; WIND SHIRTS; WIND VESTS; WOOLLY HATS; WRIST BANDS; WRISTBANDS; WRISTBANDS CONTAINING A COOLING SUBSTANCE TO COOL THE WEARER (U.S. CLS. 22 AND 39).

KATHERINE M. DUBRAY, EXAMINING ATTORNEY

**CLASS 25—(Continued).**

SN 78-965,415. ERICKSEN, COOPER, DANVILLE, CA. AND LOWER, LEWIS, JACKSONVILLE, FL. FILED 8-31-2006.

## BEACH TIME

THE MARK CONSISTS OF STANDARD CHARACTERS WITHOUT CLAIM TO ANY PARTICULAR FONT, STYLE, SIZE, OR COLOR.

FOR CLOTHING, NAMELY, T-SHIRTS, SHIRTS, HEADWEAR, TANK TOPS, SHORTS, SWEAT SHIRTS, SWEAT PANTS, AND BOXER SHORTS (U.S. CLS. 22 AND 39).

KATHERINE CHANG, EXAMINING ATTORNEY

SN 78-965,466. TRELISE COOPER LIMITED, AUCKLAND, NEW ZEALAND, FILED 8-31-2006.

## TRELISE

THE MARK CONSISTS OF STANDARD CHARACTERS WITHOUT CLAIM TO ANY PARTICULAR FONT, STYLE, SIZE, OR COLOR.

FOR CLOTHING NAMELY PANTS, SHIRTS, T-SHIRTS, SWEATSHIRTS, SHORTS, SKIRTS, SUITS, TROUSERS, DRESSES, BELTS IN THIS CLASS, SWEATSHIRTS, SCARVES, SHAWLS, GLOVES, SWIMSUITS, JUMPSUITS, COATS, JACKETS, TOPS, SWEATERS, BLOUSES, VESTS, HOSIERY, BRAS, NIGHTGOWNS, DRESSING GOWNS, PYJAMAS; LINGERIE; FOOTWEAR; HEADWEAR (U.S. CLS. 22 AND 39).

ROBERT LAVACHE, EXAMINING ATTORNEY

SN 78-965,571. TRUTHS APPAREL, INC., FULLERTON, CA. FILED 8-31-2006.

## MK2K

THE MARK CONSISTS OF STANDARD CHARACTERS WITHOUT CLAIM TO ANY PARTICULAR FONT, STYLE, SIZE, OR COLOR.

FOR DRESSES; JACKETS; JEANS; PANTS; SHIRTS; SHORTS; SKIRTS; T-SHIRTS; TANK TOPS (U.S. CLS. 22 AND 39).

IRA J. GOODSaid, EXAMINING ATTORNEY



**CLASS 25—(Continued).**

SN 78-965,601. MCINERNEY, STEVEN P., CAVE CREEK, AZ.  
FILED 8-31-2006.

# VERRADO

THE MARK CONSISTS OF STANDARD CHARACTERS  
WITHOUT CLAIM TO ANY PARTICULAR FONT, STYLE,  
SIZE, OR COLOR.

FOR BELTS; SHOES (U.S. CLS. 22 AND 39).  
STEVEN R. FINE, EXAMINING ATTORNEY

SN 78-965,721. PEGGS, ALEXIS C., WEST PALM BEACH, FL.  
FILED 9-1-2006.



FOR BALLOON PANTS; BERMUDA SHORTS; BOARD  
SHORTS; BOXER SHORTS; CAMP SHIRTS; CAPRI  
PANTS; CARGO PANTS; CHEF'S HATS; CROP TOPS;  
DENIMS ; DRESS SHIRTS; FLEECE SHORTS; FUR  
HATS; GOLF SHIRTS; GYM SHORTS; HALTER TOPS;  
HAT BANDS; HATS; JOGGING PANTS; KNIT SHIRTS;  
LEATHER PANTS; MUSCLE TOPS; NIGHT SHIRTS;  
NON-DISPOSABLE CLOTH TRAINING PANTS; NURSE  
PANTS; OPEN-NECKED SHIRTS; PANTIES, SHORTS  
AND BRIEFS; PANTS; PETTI-PANTS; PIQUE SHIRTS;  
POLO SHIRTS; RUGBY SHORTS; RUGBY TOPS; SEDGE  
HATS (SUGE-GASA); SHIRT FRONTS; SHIRT YOKES;  
SHIRTS; SHIRTS FOR SUITS; SHORT OVERCOAT FOR  
KIMONO (HAORI); SHORT PETTICOATS; SHORT SETS;  
SHORT TROUSERS; SHORT-SLEEVED OR LONG-  
SLEEVED T-SHIRTS; SHORT-SLEEVED SHIRTS;  
SHORTS; SKI PANTS; SLEEP SHIRTS; SLIDING  
SHORTS; SMALL HATS; SNOW PANTS; SNOWBOARD  
PANTS; SPORT SHIRTS; SPORTS SHIRTS; SPORTS  
SHIRTS WITH SHORT SLEEVES; SWEAT PANTS;  
SWEAT SHIRTS; SWEAT SHORTS; T-SHIRTS; TANK  
TOPS; TANK-TOPS; TAP PANTS; TOBOGGAN HATS,  
PANTS AND CAPS; TOP COATS; TOPS; TRACK PANTS;  
WALKING SHORTS; WATERPROOF JACKETS AND  
PANTS; WIND SHIRTS; WOOLLY HATS (U.S. CLS. 22  
AND 39).

FIRST USE 8-28-2006; IN COMMERCE 8-28-2006.  
DOMINIC FATHY, EXAMINING ATTORNEY

**CLASS 25—(Continued).**

SN 78-965,727. AITZO CORPORATION, OSAKA, JAPAN,  
FILED 9-1-2006.

# AZITO

THE MARK CONSISTS OF STANDARD CHARACTERS  
WITHOUT CLAIM TO ANY PARTICULAR FONT, STYLE,  
SIZE, OR COLOR.

FOR APRONS; BELTS; BLAZERS; BLOUSES; CARDI-  
GANS; CLOTHING, NAMELY, ARM WARMERS;  
COATS; COLLARS; GLOVES; HEADGEAR, NAMELY,  
HATS AND CAPS; HOODS; JACKETS; JERSEYS ; JUM-  
PERS; OVERALLS; PANTS; PARKAS; POLO SHIRTS;  
PONCHOS; RAIN COATS; RAIN SUITS; SHIRTS;  
SKIRTS; SLACKS; SMOCKS; SOCKS; STOCKINGS;  
SUITS; SUN VISORS; SWEAT SHIRTS; SWEATERS; T-  
SHIRTS; TROUSERS; UNIFORMS; VESTS (U.S. CLS. 22  
AND 39).

DOMINIC FATHY, EXAMINING ATTORNEY

SN 78-965,994. HENRI, MATTHEW, SAN FRANCISCO, CA.  
FILED 9-1-2006.

# FREE GOLD WATCH

THE MARK CONSISTS OF STANDARD CHARACTERS  
WITHOUT CLAIM TO ANY PARTICULAR FONT, STYLE,  
SIZE, OR COLOR.

FOR BANDANAS; HATS; JACKETS; JEANS; SHIRTS;  
SHORT-SLEEVED OR LONG-SLEEVED T-SHIRTS;  
SWEAT SUITS (U.S. CLS. 22 AND 39).

FIRST USE 3-1-2006; IN COMMERCE 3-1-2006.  
SCOTT SISUN, EXAMINING ATTORNEY

SN 78-966,049. PARENTE, ANTONIO P., NASHUA, NH. AND  
PARENTE, MARY ANN ANGELA, NASHUA, NH. FILED  
9-1-2006.

# I POOP FOR

THE MARK CONSISTS OF STANDARD CHARACTERS  
WITHOUT CLAIM TO ANY PARTICULAR FONT, STYLE,  
SIZE, OR COLOR.

FOR T-SHIRTS (U.S. CLS. 22 AND 39).  
STEVEN R. FINE, EXAMINING ATTORNEY

**CLASS 25—(Continued).**

SN 78-966,063. LEBA, CHRIS, BROOKLYN, NY. FILED 9-1-2006.



OWNER OF U.S. REG. NO. 2,833,188.  
NO CLAIM IS MADE TO THE EXCLUSIVE RIGHT TO USE "WORKWEAR INC.", APART FROM THE MARK AS SHOWN.

FOR CLOTHING, NAMELY, HATS, SHIRTS, PANTS, JEANS, SKIRTS, DRESSES, SUITS, JACKETS, SWEATERS, SWEAT PANTS, SWEAT SHIRT, T-SHIRTS, BATHING SUITS, AND FOOTWEAR (U.S. CLS. 22 AND 39).  
FIRST USE 8-15-2003; IN COMMERCE 8-15-2003.  
BARBARA BROWN, EXAMINING ATTORNEY

---

SN 78-966,393. ROBERTSON, STEVE, RAYMOND, LOS ANGELES, CA. FILED 9-1-2006.

## Sole Affirming

THE MARK CONSISTS OF STANDARD CHARACTERS WITHOUT CLAIM TO ANY PARTICULAR FONT, STYLE, SIZE, OR COLOR.

FOR SHOE INSERTS FOR PRIMARILY NON-ORTHOPEDIC PURPOSES (U.S. CLS. 22 AND 39).  
EMILY CHUO, EXAMINING ATTORNEY

---

SN 78-966,407. ROBERTSON, STEVE RAYMOND, LOS ANGELES, CA. FILED 9-1-2006.

## Sole Prayers

THE MARK CONSISTS OF STANDARD CHARACTERS WITHOUT CLAIM TO ANY PARTICULAR FONT, STYLE, SIZE, OR COLOR.

NO CLAIM IS MADE TO THE EXCLUSIVE RIGHT TO USE "SOLE", APART FROM THE MARK AS SHOWN.

FOR SHOE INSERTS FOR PRIMARILY NON-ORTHOPEDIC PURPOSES (U.S. CLS. 22 AND 39).  
MICHAEL GAAFAR, EXAMINING ATTORNEY

**CLASS 25—(Continued).**

SN 78-966,423. HART, TAMMY, LOMPOC, CA. FILED 9-1-2006.

## loungekitten

THE MARK CONSISTS OF STANDARD CHARACTERS WITHOUT CLAIM TO ANY PARTICULAR FONT, STYLE, SIZE, OR COLOR.

FOR DRESSES (U.S. CLS. 22 AND 39).  
CHRISTINE COOPER, EXAMINING ATTORNEY

---

SN 78-966,545. FUND BABEEZ LLC, LA, CA. FILED 9-2-2006.

## [bump] baby under manufacturing process

THE MARK CONSISTS OF STANDARD CHARACTERS WITHOUT CLAIM TO ANY PARTICULAR FONT, STYLE, SIZE, OR COLOR.

FOR BABY BIBS NOT OF PAPER; BABY DOLL PYJAMAS; CAPRI PANTS; CAPS; CARGO PANTS; CHILDREN'S AND INFANTS' CLOTH BIBS; CHILDREN'S CLOTH EATING BIBS; CLOTH BIBS; HATS; INFANT AND TODDLER ONE PIECE CLOTHING; JERSEYS; JOGGING PANTS; MATERNITY LINGERIE; MATERNITY SLEEPWEAR; PANTS; SHORT-SLEEVED OR LONG-SLEEVED T-SHIRTS; SMALL HATS; SWADDLING CLOTHES; SWEAT PANTS; T-SHIRTS; TOPS; TRACK PANTS; WRAPS (U.S. CLS. 22 AND 39).

FIRST USE 1-30-2006; IN COMMERCE 1-30-2006.  
ALICIA COLLINS, EXAMINING ATTORNEY

**CLASS 25—(Continued).**

SN 78-966,639. CITY OF HENDERSON REDEVELOPMENT AGENCY, HENDERSON, NV. FILED 9-3-2006.



NO CLAIM IS MADE TO THE EXCLUSIVE RIGHT TO USE "WATER STREET DISTRICT HENDERSON", APART FROM THE MARK AS SHOWN.

THE MARK CONSISTS OF WATER STREET DISTRICT HENDERSON IN STYLIZED LETTERS.

FOR WEARING APPAREL, NAMELY, SHIRTS, T-SHIRTS, POLO SHIRTS, GOLF SHIRTS, TANK TOPS, VESTS, BLOUSES, SWEATERS, PARKAS, TURTLE-NECKS, PULLOVERS, SKIRTS, SHORTS, JEANS, SLACKS, PANTS, ROBES, NIGHTSHIRTS AND NIGHT GOWNS, PAJAMAS, ROMPERS, COVERALLS, MITTENS, GLOVES, UNDERGARMENTS, JERSEYS, LEOTARDS, HOSE, SOCKS, BOOTIES, SLIPPERS, SCARVES, BELTS, BELTS NOT MADE OF LEATHER, NECKTIES, SUSPENDERS, HEADBANDS, HATS, CAPS, VISORS, BLAZERS, RAIN PONCHOS, JACKETS, WIND RESISTANT JACKETS, WARM-UP SUITS, JOGGING SUITS, SWEATSHIRTS, SWEAT PANTS, BEACH WEAR, NAMELY, BATHING SUITS, BEACH SANDALS, BEACH COVER-UPS, FOOTWEAR, NAMELY SHOES, BOOTS, SANDALS, SNEAKERS AND ATHLETIC SHOES (U.S. CLS. 22 AND 39).

SUSAN STIGLITZ, EXAMINING ATTORNEY

SN 78-966,665. HITMAN, INC., LAS VEGAS, NV. FILED 9-3-2006.

# Be Sin Free

THE MARK CONSISTS OF STANDARD CHARACTERS WITHOUT CLAIM TO ANY PARTICULAR FONT, STYLE, SIZE, OR COLOR.

FOR CAPS; POLO SHIRTS; SHORT-SLEEVED OR LONG-SLEEVED T-SHIRTS; SLEEP SHIRTS; SWEAT SHIRTS; T-SHIRTS; UNDERWEAR (U.S. CLS. 22 AND 39).

FIRST USE 3-1-2006; IN COMMERCE 5-9-2006.  
ERNEST SHOSHO, EXAMINING ATTORNEY

**CLASS 25—(Continued).**

SN 78-966,789. FRANCO, ROBERT, WHITE PLAINS, NY. FILED 9-4-2006.

# 10-3

THE MARK CONSISTS OF STANDARD CHARACTERS WITHOUT CLAIM TO ANY PARTICULAR FONT, STYLE, SIZE, OR COLOR.

FOR CLOTHING— NAMELY-SHIRTS, SWEATSHIRTS, T-SHIRTS, JACKETS, SHORTS, CAPS, HATS (U.S. CLS. 22 AND 39).

JAMES A. RAUEN, EXAMINING ATTORNEY

SN 78-966,794. WLA ENTERPRISES INC., TROY, MI. FILED 9-4-2006.

# VEECA

THE MARK CONSISTS OF STANDARD CHARACTERS WITHOUT CLAIM TO ANY PARTICULAR FONT, STYLE, SIZE, OR COLOR.

FOR ANKLE SOCKS; ANKLETS; ANTI-PERSPIRANT SOCKS; APRONS; ATHLETIC UNIFORMS; BALLOON PANTS; BASEBALL CAPS; BATHING CAPS; BED JACKETS; BELTS; BERMUDA SHORTS; BIBS NOT OF CLOTH OR PAPER; BICYCLE GLOVES; BICYCLING GLOVES; BLOUSES; BOARD SHORTS; BOXER SHORTS; CAMP SHIRTS; CAP VISORS; CAPES; CAPRI PANTS; CAPS; CAPS WITH VISORS; CARGO PANTS; CHILDREN'S AND INFANTS' CLOTH BIBS; CHILDREN'S CLOTH EATING BIBS; CLOTH BIBS; CLOTH BIBS FOR ADULT DINERS; CLOTH BIBS FOR USE BY SENIOR CITIZENS OR PHYSICALLY- OR MENTALLY-CHALLENGED PERSONS; CLOTH DIAPERS; CLOTHING FOR WEAR IN JUDO PRACTICES; CLOTHING FOR WEAR IN WRESTLING GAMES; CLOTHING, NAMELY, ARM WARMERS; CLOTHING, NAMELY, FOLK COSTUMES; CLOTHING, NAMELY, KNEE WARMERS; CLOTHING, NAMELY, NECK TUBES; CLOTHING, NAMELY, WRAP-AROUNDS; COATS; COATS FOR MEN AND WOMEN; COATS MADE OF COTTON; COATS OF DENIM; COBBLERS' APRONS; CORSETS; CROP TOPS; DENIM JACKETS; DENIMS; DOWN JACKETS; DRESS SHIELDS; DRESS SHIRTS; DRESS SUITS; DRESSES; DRESSES MADE FROM SKINS; DRESSING GOWNS; DUST COATS; DUSTERS; EVENING DRESSES; EVENING GOWNS; FIGURE SKATING CLOTHING, NAMELY, UNIFORM; FISHERMEN'S JACKETS; FISHING VESTS; FLEECE SHORTS; FOULARDS; FUR CLOAKS; FUR COATS; FUR COATS AND JACKETS; FUR HATS; FUR JACKETS; FUR MUFFS; FUR STOLEES; GLOVES; GLOVES FOR PERSONAL HAND CONDITIONING USE; GLOVES INCLUDING THOSE MADE OF SKIN, HIDE OR FUR; GOLF CAPS; GOLF SHIRTS; GOLF TROUSERS; GOWNS; GYM SHORTS; HALTER TOPS; HAT BANDS; HATS; HEAD SCARVES; HEADGEAR, NAMELY, HATS; HEAVY JACKETS; HOODS; HUNTING VESTS; INFANT AND TODDLER ONE PIECE CLOTHING; INFANT CLOTH DIAPERS; INFANTS' TROUSERS; JACKETS; JAPANESE STYLE SOCKS (TABI COVERS); JAPANESE STYLE SOCKS (TABI); JERSEYS; JOGGING PANTS; KNIT SHIRTS; KNITTED CAPS; KNITTED UNDERWEAR; LAB COATS; LEATHER BELTS; LEATHER COATS; LEATHER JACKETS; LEATHER PANTS; LIGHT-REFLECTING COATS; LIGHT-REFLECTING JACKETS; LONG JACKETS; LONG SLEEVED VESTS; MANTLES; MARTIAL ARTS UNI-

**CLASS 25—(Continued).**

FORMS; MEN AND WOMEN JACKETS, COATS, TROUSERS, VESTS; MEN'S SOCKS; MOCK TURTLE-NECK SWEATERS; MORNING COATS; MOTORCYCLE GLOVES; MUFFLERS; MUSCLE TOPS; NIGHT GOWNS; NIGHT SHIRTS; NON-DISPOSABLE CLOTH TRAINING PANTS; NURSE DRESSES; NURSE PANTS; OPEN-NECKED SHIRTS; OVER COATS; OVER-TROUSERS; PANTIES, SHORTS AND BRIEFS; PANTS; PARTS OF CLOTHING, NAMELY, GUSSETS FOR TIGHTS, GUSSETS FOR STOCKINGS, GUSSETS FOR BATHING SUITS, GUSSETS FOR UNDERWEAR, GUSSETS FOR LEOTARDS AND GUSSETS FOR FOOTLETS; PER-SPARATION ABSORBENT UNDERWEAR CLOTHING; PETTI-PANTS; PIQUE SHIRTS; PLEATED SKIRTS FOR FORMAL KIMONOS (HAKAMA); POLO SHIRTS; PONCHOS; QUILTED VESTS; RAIN COATS; RAIN JACKETS; RAIN TROUSERS; RAINPROOF JACKETS; RIDING COATS; RIDING GLOVES; RUGBY SHORTS; RUGBY TOPS; SCARVES; SCHOOL UNIFORMS; SEDGE HATS (SUGE-GASA); SHAMPOO CAPES; SHIRTS; SHIRT FRONTS; SHIRT YOKES; SHIRTS; SHIRTS FOR SUITS; SHORT OVERCOAT FOR KIMONO (HAORI); SHORT PETTICOATS; SHORT SETS; SHORT TROUSERS; SHORT-SLEEVED OR LONG-SLEEVED T-SHIRTS; SHORT-SLEEVED SHIRTS; SHORTS; SHOULDER PADS FOR CLOTHING; SHOULDER SCARVES; SHOULDER WRAPS; SHOWER CAPS; SHRUGS; SILK SCARVES; SKI GLOVES; SKI JACKETS; SKI PANTS; SKIRT SUITS; SKIRTS; SKIRTS AND DRESSES; SKULL CAPS; SLEEP SHIRTS; SLEEVED OR SLEEVELESS JACKETS; SLIDING SHORTS; SMALL HATS; SMOKING JACKETS; SNOW PANTS; SNOWBOARD GLOVES; SNOWBOARD PANTS; SOCK SUSPENDERS; SOCKS; SOCKS AND STOCKINGS; SPORT COATS; SPORT SHIRTS; SPORTS JACKETS; SPORTS SHIRTS; SPORTS SHIRTS WITH SHORT SLEEVES; SUEDE JACKETS; SUIT COATS; SWADDLING CLOTHES; SWEAT PANTS; SWEAT SHIRTS; SWEAT SHORTS; SWEATERS; SWIM CAPS; SWIMMING CAPS; SWIMMING CAPS; T-SHIRTS; TANK TOPS; TANK-TOPS; TAP PANTS; THERMAL SOCKS; TIES; TOBOGGAN HATS, PANTS AND CAPS; TOE CAPS; TOP COATS; TOPS; TRACK PANTS; TRENCH COATS; TROUSERS; TROUSERS FOR SWEATING; TROUSERS OF LEATHER; TURTLENECK SWEATERS; UNDERARM CLOTHING SHIELDS; UNIFORMS; V-NECK SWEATERS; VESTED SUITS; VESTS; WALKING SHORTS; WATER SOCKS; WATERPROOF JACKETS AND PANTS; WEDDING DRESSES; WEDDING GOWNS; WET SUIT GLOVES; WIND COATS; WIND RESISTANT JACKETS; WIND SHIRTS; WIND VESTS; WIND-JACKETS; WOMEN'S CEREMONIAL DRESSES; WOOLLEN SOCKS; WOOLLY HATS; WOVEN OR KNITTED UNDERWEAR; WRAPS (U.S. CLS. 22 AND 39).

TEJBIR SINGH, EXAMINING ATTORNEY

SN 78-966,799. HAPPY PLANET PROJECT, INC., CLAWSON, MI. FILED 9-4-2006.

**HAPPY PLANET PROJECT**

THE MARK CONSISTS OF STANDARD CHARACTERS WITHOUT CLAIM TO ANY PARTICULAR FONT, STYLE, SIZE, OR COLOR.

FOR T-SHIRTS, TANKTOPS, BASEBALL CAPS, POLO SHIRTS, BOXER SHORTS, BANDANAS, BERETS, BOARDSHORTS, BOTTOMS, BRIEFS, CAP VISORS, CLOTH BIBS, COATS, COLLARS, DENIM JACKETS, FLEECE PULLOVERS, FLEECE SHORTS, KNITTED CAPS, SHIRTS (U.S. CLS. 22 AND 39).

TEJBIR SINGH, EXAMINING ATTORNEY

**CLASS 25—(Continued).**

SN 78-966,816. CASTRO, MARYANN, HUGHSON, CA. FILED 9-5-2006.

**DIRT PRINCESS**

THE MARK CONSISTS OF STANDARD CHARACTERS WITHOUT CLAIM TO ANY PARTICULAR FONT, STYLE, SIZE, OR COLOR.

FOR HATS; PANTS; SHIRTS (U.S. CLS. 22 AND 39).  
MARGERY A. TIERNEY, EXAMINING ATTORNEY

SN 78-966,819. VASILAIUSKAS, DIANA L, PORTLAND, OR. FILED S.R. 9-5-2006; AM. P.R. 1-30-2007.



NO CLAIM IS MADE TO THE EXCLUSIVE RIGHT TO USE WEAR, APART FROM THE MARK AS SHOWN.

THE COLOR(S) PINK, BEIGE AND BLACK IS/ARE CLAIMED AS A FEATURE OF THE MARK.

THE COLOR PINK APPEARS IN THE WORDS "FOR THE BOOTY MAGNIFICENT," AND THE OVAL AROUND THE MARK; THE COLOR BEIGE APPEARS IN THE AREA INSIDE THE PINK OVAL AND THE AREA JUST OUTSIDE THE PINK OVAL; THE COLOR BLACK APPEARS IN THE WORDS MAGIDAH WEAR.

FOR WOMEN'S ACTIVEWEAR, NAMELY, PANTS, TOPS, TEES, TANKS, WARM-UPS, SHRUGS (U.S. CLS. 22 AND 39).

FIRST USE 7-1-2006; IN COMMERCE 8-13-2006.

MARGERY A. TIERNEY, EXAMINING ATTORNEY

SN 78-966,839. SCREEN INDUSTRY ART, INC., SODDY DAISY, TN. FILED 9-5-2006.

**PSYCHOTIC STATE UNIVERSITY**

THE MARK CONSISTS OF STANDARD CHARACTERS WITHOUT CLAIM TO ANY PARTICULAR FONT, STYLE, SIZE, OR COLOR.

FOR APRONS, BABY BIBS NOT OF PAPER, BANDANAS, BASEBALL CAPS, BATHROBES, BEACH COVER-UPS, BEACHWEAR, BELTS, BLOUSES, TIES, CAPRIS, PANTS, TOPS, ATHLETIC JERSEYS, COATS, FOOTWEAR, GLOVES, HATS, JACKETS, JOGGING SUITS, JEANS, HEADWEAR, MITTENS, NIGHTGOWNS, NIGHT WEAR, PAJAMAS, T-SHIRTS, TANK TOPS, PANTS, SHORTS, SOCKS, SWEATSHIRTS, SWEAT PANTS, RAINCOATS, SCARVES, SLEEP WEAR, SWIM WEAR, AND TRACKSUITS (U.S. CLS. 22 AND 39).

ELISSA GARBNER KON, EXAMINING ATTORNEY

**CLASS 25—(Continued).**

SN 78-966,973. FOSSA APPAREL, INC., FREMONT, CA. FILED 9-5-2006.



THE MARK CONSISTS OF THE WORDING "FOSSA", IN WHICH THE LETTER "F" IS PRESENTED IN THE SHAPE OF A HEAD OF A FOSSA.

FOR COATS; GOLF SHIRTS; JACKETS; PANTS; POLO SHIRTS; PULLOVERS; SHIRTS; SHORTS; SWEAT PANTS; SWEAT SHIRTS; SWEATERS; T-SHIRTS; VESTS (U.S. CLS. 22 AND 39).

MICHAEL GAAFAR, EXAMINING ATTORNEY

**CLASS 25—(Continued).**

SN 78-967,050. CRITICAL SURF COMPANY, OCEAN CITY, MD. FILED 9-5-2006.



NO CLAIM IS MADE TO THE EXCLUSIVE RIGHT TO USE "SURF COMPANY", APART FROM THE MARK AS SHOWN.

THE MARK CONSISTS OF STYLIZED TEXT OF THE WORDING "CRITICAL SURF COMPANY".

FOR HATS; JEANS; SHIRTS; SHORTS (U.S. CLS. 22 AND 39).

COLLEEN DOMBROW, EXAMINING ATTORNEY

SN 78-967,017. EGGPROJECTS, INC., BELVEDERE, CA. FILED 9-5-2006.

# Sea of Sound

THE MARK CONSISTS OF STANDARD CHARACTERS WITHOUT CLAIM TO ANY PARTICULAR FONT, STYLE, SIZE, OR COLOR.

FOR FLEECE PULLOVERS; HEADWEAR; T-SHIRTS (U.S. CLS. 22 AND 39).

FLORENTINA BLANDU, EXAMINING ATTORNEY

SN 78-967,119. G. HENSLER & CO., SAN FRANCISCO, CA. FILED 9-5-2006.

# 49 SQUARE MILES

THE MARK CONSISTS OF STANDARD CHARACTERS WITHOUT CLAIM TO ANY PARTICULAR FONT, STYLE, SIZE, OR COLOR.

FOR BELTS; GLOVES; HATS; SCARVES; SHOES (U.S. CLS. 22 AND 39).

DAVID MURRAY, EXAMINING ATTORNEY

SN 78-967,026. CALABRO, MARIA, NEW YORK, NY. FILED 9-5-2006.

# Tiferet 8

THE MARK CONSISTS OF STANDARD CHARACTERS WITHOUT CLAIM TO ANY PARTICULAR FONT, STYLE, SIZE, OR COLOR.

THE ENGLISH TRANSLATION OF THE WORD TIFERET IN THE MARK IS BEAUTY, SPLENDOR, SUSTENANCE.

FOR BOTTOMS; DRESSES; JACKETS; T-SHIRTS; TOPS (U.S. CLS. 22 AND 39).

GRETTA YAO, EXAMINING ATTORNEY

SN 78-967,239. HAZAN SHOES INC., SOUTH EL MONTE, CA. FILED 9-5-2006.



FOR SHOES (U.S. CLS. 22 AND 39).  
GINNY ISAACSON, EXAMINING ATTORNEY

**CLASS 25—(Continued).**

SN 78-967,426. RPM PERFORMANCE, L.L.C., WAUKEE, IA. FILED 9-5-2006.

**RADICAL GIRLS**

THE MARK CONSISTS OF STANDARD CHARACTERS WITHOUT CLAIM TO ANY PARTICULAR FONT, STYLE, SIZE, OR COLOR.

NO CLAIM IS MADE TO THE EXCLUSIVE RIGHT TO USE "GIRLS", APART FROM THE MARK AS SHOWN.

FOR CLOTHING, NAMELY, HATS, SHIRTS, T-SHIRTS, COATS, JACKETS, SHORTS, SWEATPANTS, SWEATSHIRTS, JEANS, UNDERWEAR SUCH AS PANTIES AND BRAS (U.S. CLS. 22 AND 39).

FIRST USE 4-21-2006; IN COMMERCE 4-21-2006.

STEPHEN AQUILA, EXAMINING ATTORNEY

SN 78-967,433. RILEY, BRYAN T., ODESSA, TX. FILED 9-5-2006.

**HEADKNOCKERS**

THE MARK CONSISTS OF STANDARD CHARACTERS WITHOUT CLAIM TO ANY PARTICULAR FONT, STYLE, SIZE, OR COLOR.

OWNER OF U.S. REG. NO. 2,680,744.

FOR APRONS; ATHLETIC SHOES; BANDANAS; BATHING SUITS; BEANIES; BELTS; BIKINIS; BLOUSES; BOOTS; BOXER SHORTS; CAPRIS; CAPS; COATS; DRESSES; FOOTWEAR; GLOVES; GOLF SHIRTS; HALTER TOPS; HATS; HEADWEAR; JACKETS; JEANS; JERSEYS; JUMPERS; LEGGINGS; OVERALLS; PAJAMAS; PANTS; ROBES; SANDALS; SHIRTS; SHOES; SHORTS; SKIRTS; SLACKS; SLIPPERS; SOCKS; SPORT COATS; SWEAT PANTS; SWEAT SHIRTS; SWEATBANDS; SWEATERS; SWIM WEAR; T-SHIRTS; TANK TOPS; TIES; TROUSERS; UNDERWEAR; VESTS; VISORS (U.S. CLS. 22 AND 39).

FIRST USE 7-15-1991; IN COMMERCE 7-15-1991.

DANNEAN HETZEL, EXAMINING ATTORNEY

**CLASS 25—(Continued).**

SN 78-967,820. MINOT, LAURA, MATTAPAN, MA. FILED 9-6-2006.

**DONDI**

THE MARK CONSISTS OF STANDARD CHARACTERS WITHOUT CLAIM TO ANY PARTICULAR FONT, STYLE, SIZE, OR COLOR.

FOR CLOTHING, NAMELY, SHIRTS, BLOUSES, T-SHIRTS, SWEATSHIRTS, SWEATERS, VESTS, JACKETS, BLAZERS, COATS, PANTS, SLACKS, SHORTS, SWEATPANTS, SKIRTS, DRESSES, MEN'S SUITS, WOMEN'S SUITS, SCARVES, TIES, SOCKS, STOCKINGS, HEADWEAR, FOOTWEAR, JUMPSUITS, AND ONE-PIECE BODY SUITS (U.S. CLS. 22 AND 39).

GEORGE LORENZO, EXAMINING ATTORNEY

SN 78-967,973. BALDWIN, ROSE C, MILL VALLEY, CA. FILED 9-6-2006.

**Coconut Rose**

THE MARK CONSISTS OF STANDARD CHARACTERS WITHOUT CLAIM TO ANY PARTICULAR FONT, STYLE, SIZE, OR COLOR.

FOR BATHING SUITS; BATHING SUITS FOR MEN; BERMUDA SHORTS; BOARD SHORTS; BODY SUITS; BOXER SHORTS; CAPRI PANTS; CARGO PANTS; DENIM JACKETS; DENIMS; DRESS SHIRTS; DRESS SUITS; DRESSES; DRY SUITS; EVENING DRESSES; FITTED SWIMMING COSTUMES WITH BRA CUPS; FLEECE SHORTS; GYM SHORTS; GYM SUITS; HEAVY JACKETS; JACKETS; JOGGING PANTS; JOGGING SUITS; KNIT SHIRTS; LADIES' SUITS; MEN AND WOMEN JACKETS, COATS, TROUSERS, VESTS; MEN'S SUITS; WOMEN'S SUITS; OPEN-NECKED SHIRTS; PANTIES, SHORTS AND BRIEFS; PANTS; PARTS OF CLOTHING, NAMELY, GUSSETS FOR TIGHTS, GUSSETS FOR STOCKINGS, GUSSETS FOR BATHING SUITS, GUSSETS FOR UNDERWEAR, GUSSETS FOR LEOTARDS AND GUSSETS FOR FOOTLETS; PLAY SUITS; RAIN JACKETS; RAIN SUITS; RAINPROOF JACKETS; SHIRTS; SHORT SETS; SHORT-SLEEVED OR LONG-SLEEVED T-SHIRTS; SHORT-SLEEVED SHIRTS; SKIRTS; SKIRTS AND DRESSES; SPORT SHIRTS; SPORTS SHIRTS WITH SHORT SLEEVES; SWEAT PANTS; SWEAT SHIRTS; SWEAT SHORTS; SWEAT SUITS; SWIM CAPS; SWIM TRUNKS; SWIM WEAR; SWIM WEAR FOR GENTLEMEN AND LADIES; SWIMMING CAPS; SWIMMING CAPS; SWIMMING COSTUMES; SWIMMING TRUNKS; SWIMSUITS; T-SHIRTS; TRACK SUITS; TRAINING SUITS; VESTED SUITS; WALKING SHORTS; WARM UP SUITS; WATERPROOF JACKETS AND PANTS; WET SUIT GLOVES; WET SUITS; WET SUITS FOR WATER-SKIING AND SUBAQUA; WIND RESISTANT JACKETS; WIND-JACKETS (U.S. CLS. 22 AND 39).

IRENE D. WILLIAMS, EXAMINING ATTORNEY

**CLASS 25—(Continued).**

SN 78-968,232. EVERLY, PHILLIP JASON, BURBANK, CA. FILED 9-6-2006.

**POSTAL MONKEY**

THE MARK CONSISTS OF STANDARD CHARACTERS WITHOUT CLAIM TO ANY PARTICULAR FONT, STYLE, SIZE, OR COLOR.

FOR ATHLETIC FOOTWEAR; ATHLETIC SHOES; ATHLETIC UNIFORMS; BELTS; BLOUSES; BRIEFS ; CAPS; COATS; DENIMS; DRESSES; FOOTWEAR; GLOVES; HATS; HEAD WEAR; HEADWEAR; JACKETS; JEANS; NECKTIES; NECKWEAR; NIGHTWEAR; PANTIES, SHORTS AND BRIEFS; PANTS; SHIRTS; SHOES; SHORTS; SKI WEAR; SKIRTS; SLEEPWEAR; SNEAKERS; SOCKS; SUITS; SWIM WEAR; T-SHIRTS; TOPS; UNDER GARMENTS; UNDERCLOTHES; UNDERGARMENTS; UNDERWEAR (U.S. CLS. 22 AND 39).  
ALICE BENMAMAN, EXAMINING ATTORNEY

**CLASS 25—(Continued).**

SN 78-968,253. DEMETRIOS LICENSING, LTD., NEW YORK, NY. FILED 9-6-2006.

**DEMETRIOS BRIDE**

THE MARK CONSISTS OF STANDARD CHARACTERS WITHOUT CLAIM TO ANY PARTICULAR FONT, STYLE, SIZE, OR COLOR.

OWNER OF U.S. REG. NOS. 1,561,060, 2,451,129 AND OTHERS.

NO CLAIM IS MADE TO THE EXCLUSIVE RIGHT TO USE "BRIDE", APART FROM THE MARK AS SHOWN.

FOR CLOTHING, NAMELY, WEDDING GOWNS, EVENING GOWNS; BLOUSES, COATS, DRESSES, JACKETS, GLOVES, LINGERIE, LOUNGE WEAR, NEGLIGEEES, PANTS, ROBES, SHIRTS, SKIRTS, SUITS, SWEATERS, TUXEDOS, VESTS; HEADWEAR, VEILS; FOOTWEAR (U.S. CLS. 22 AND 39).

TOBY BULLOFF, EXAMINING ATTORNEY

SN 78-968,310. WARREN, FRED, CHARLOTTE, NC. FILED 9-6-2006.

**KOMFROX**

THE MARK CONSISTS OF STANDARD CHARACTERS WITHOUT CLAIM TO ANY PARTICULAR FONT, STYLE, SIZE, OR COLOR.

FOR CLOTHING, NAMELY, SHOES AND SOCKS (U.S. CLS. 22 AND 39).

NATALIE POLZER, EXAMINING ATTORNEY

SN 78-968,239. LAVIZADEH, NAVID, LOS ANGELES, CA. AND LAVIZADEH, FARID, LOS ANGELES, CA. FILED 9-6-2006.

**FDG-83**

THE MARK CONSISTS OF STANDARD CHARACTERS WITHOUT CLAIM TO ANY PARTICULAR FONT, STYLE, SIZE, OR COLOR.

FOR BELTS; BLOUSES; CAPS; COATS; COATS OF DENIM; DENIM JACKETS; DENIMS; DRESSES; HATS; JACKETS; JEANS; MEN'S SUITS, WOMEN'S SUITS; NIGHTWEAR; PAJAMAS; PANTS; SHIRTS; SHOES; SHORTS; SKIRT SUITS; SKIRTS; SLACKS; SOCKS; SWEAT PANTS; SWEAT SUITS; T-SHIRTS; TIES; TOPS (U.S. CLS. 22 AND 39).  
ALICE BENMAMAN, EXAMINING ATTORNEY

SN 78-968,431. SURE FOOT CORPORATION, GRAND FORKS, ND. FILED 9-6-2006.

**DUE NORTH GRIPZ**

THE MARK CONSISTS OF STANDARD CHARACTERS WITHOUT CLAIM TO ANY PARTICULAR FONT, STYLE, SIZE, OR COLOR.

OWNER OF U.S. REG. NOS. 2,269,028 AND 3,050,470.  
FOR FOOTWEAR ACCESSORIES, NAMELY REMOVABLE ATTACHMENTS FOR NON-SLIP TRACTION WITH REPLACEABLE CLEATS (U.S. CLS. 22 AND 39).  
REBECCA EISINGER, EXAMINING ATTORNEY

**CLASS 25—(Continued).**

SN 78-968,747. NORTON, ANNE M. T., HOLLAND, MI.  
FILED 9-7-2006.

## Rusty Bumper

THE MARK CONSISTS OF STANDARD CHARACTERS WITHOUT CLAIM TO ANY PARTICULAR FONT, STYLE, SIZE, OR COLOR.

FOR CHILDREN'S AND INFANTS' CLOTH BIBS; INFANT AND TODDLER ONE PIECE CLOTHING; INFANT CLOTH DIAPERS; INFANT DIAPER COVERS; INFANT SLEEPERS; INFANTS' TROUSERS; ONE PIECE GARMENT FOR INFANTS AND TODDLERS (U.S. CLS. 22 AND 39).

CIMMERIAN COLEMAN, EXAMINING ATTORNEY

SN 78-968,773. CRITTENDEN, ROYMECUI S., YUMA, AZ.  
FILED 9-7-2006.

## What's luck got to do with it?

THE MARK CONSISTS OF STANDARD CHARACTERS WITHOUT CLAIM TO ANY PARTICULAR FONT, STYLE, SIZE, OR COLOR.

FOR PANTS; SHIRTS; SHOES (U.S. CLS. 22 AND 39).

MIDGE BUTLER, EXAMINING ATTORNEY

SN 78-968,956. DISGUISE, INC., POWAY, CA. FILED 9-7-2006.

## HEADZ & TEEZ

THE MARK CONSISTS OF STANDARD CHARACTERS WITHOUT CLAIM TO ANY PARTICULAR FONT, STYLE, SIZE, OR COLOR.

FOR T-SHIRTS; HALLOWEEN AND MASQUERADE COSTUMES AND MASKS SOLD IN CONNECTION THEREWITH; HEADWEAR, FOOTWEAR, GLOVES AND HOSIERY (U.S. CLS. 22 AND 39).

BERYL GARDNER, EXAMINING ATTORNEY

**CLASS 25—(Continued).**

SN 78-968,965. DISGUISE, INC., POWAY, CA. FILED 9-7-2006.

## ZERO 2 HERO

THE MARK CONSISTS OF STANDARD CHARACTERS WITHOUT CLAIM TO ANY PARTICULAR FONT, STYLE, SIZE, OR COLOR.

FOR HALLOWEEN AND MASQUERADE COSTUMES AND MASKS SOLD IN CONNECTION THEREWITH; HEADWEAR, FOOTWEAR, GLOVES AND HOSIERY (U.S. CLS. 22 AND 39).

BERYL GARDNER, EXAMINING ATTORNEY

SN 78-969,052. ROCHE, ANDREW J, GREELEY, CO. AND DENISON, JORDAN P, LAS VEGAS, NV. FILED 9-7-2006.

## Spuratik

THE MARK CONSISTS OF STANDARD CHARACTERS WITHOUT CLAIM TO ANY PARTICULAR FONT, STYLE, SIZE, OR COLOR.

FOR BOARD SHORTS; BOXER SHORTS; CARGO PANTS; DENIMS; DRESS SHIRTS; FLEECE SHORTS; GOLF SHIRTS; GYM SHORTS; JOGGING PANTS; PANTS; SHIRTS; SHORT-SLEEVED OR LONG-SLEEVED T-SHIRTS; SHORT-SLEEVED SHIRTS; SHORTS; T-SHIRTS; WATERPROOF JACKETS AND PANTS (U.S. CLS. 22 AND 39).

MARGARET POWER, EXAMINING ATTORNEY

SN 78-969,096. HBI BRANDED APPAREL LIMITED, INC., WINSTON-SALEM, NC. FILED 9-7-2006.

## HANES TAGLESS 6.1

THE MARK CONSISTS OF STANDARD CHARACTERS WITHOUT CLAIM TO ANY PARTICULAR FONT, STYLE, SIZE, OR COLOR.

OWNER OF U.S. REG. NOS. 847,649 AND 2,956,878.

SEC. 2(F) AS TO "TAGLESS".

FOR T-SHIRTS (U.S. CLS. 22 AND 39).

KATHERINE CONNOLLY, EXAMINING ATTORNEY



**CLASS 25—(Continued).**

SN 78-969,403. PALMER, PHILIP S, KINGSTON 19, JAMAICA, CA, FILED 9-7-2006.

# YUZIMI

THE MARK CONSISTS OF STANDARD CHARACTERS WITHOUT CLAIM TO ANY PARTICULAR FONT, STYLE, SIZE, OR COLOR.

FOR BELTS; DRESSES; FOOTWEAR; HEADWEAR; JACKETS; JEANS; LADIES' SUITS; MEN'S SUITS; POLO SHIRTS; SHIRTS; SHORT-SLEEVED OR LONG-SLEEVED T-SHIRTS; SKIRTS; SLEEPWEAR; UNDERWEAR (U.S. CLS. 22 AND 39).

CHARISMA HAMPTON, EXAMINING ATTORNEY

SN 78-969,473. AFFLICTION, LLC, SIGNAL HILL, CA, FILED 9-7-2006.

# DENIM KILLERS

THE MARK CONSISTS OF STANDARD CHARACTERS WITHOUT CLAIM TO ANY PARTICULAR FONT, STYLE, SIZE, OR COLOR.

FOR BANDANAS; BASEBALL CAPS; BEACH FOOTWEAR; BEANIES; BELTS; CAPS; COATS; DRESS SHIRTS; DRESSES; FOOTWEAR; GLOVES; HEADGEAR, NAMELY, CAP, HATS, HEADSCARVES, VISORS, BEANIES; JACKETS; JOGGING PANTS; KNIT SHIRTS; NIGHTWEAR; PAJAMAS; PANTS; POLO SHIRTS; PULL-OVERS; SHIRTS; SHOES; SHORTS; SKI WEAR; SKIRTS; SLEEPWEAR; SLIPPERS; SOCKS; SPORT SHIRTS; SWEAT PANTS; SWEAT SHIRTS; SWEAT SHORTS; SWEATERS; SWIMSUITS; T-SHIRTS; TANK TOPS; TENNIS SHOES; UNDERGARMENTS (U.S. CLS. 22 AND 39).

FIRST USE 6-15-2006; IN COMMERCE 7-15-2006.  
ANDREA HACK, EXAMINING ATTORNEY

SN 78-969,485. NEWPORT SPORTSWEAR, LLC, IRVINE, CA, FILED 9-7-2006.

# SEVEN PALM BRAND

THE MARK CONSISTS OF STANDARD CHARACTERS WITHOUT CLAIM TO ANY PARTICULAR FONT, STYLE, SIZE, OR COLOR.

NO CLAIM IS MADE TO THE EXCLUSIVE RIGHT TO USE "BRAND", APART FROM THE MARK AS SHOWN.

FOR BLOUSES; BOXER SHORTS; COVERUPS; DRESSES; FOOTWEAR; HEADWEAR; JACKETS; LINGERIE; LOUNGEWEAR; PANTS; SHIRTS; SHORTS; SKIRTS; SKORTS; SOCKS; SWEAT PANTS; SWEAT SHIRTS; SWEATERS; SWIM WEAR; T-SHIRTS; UNDERWEAR; VESTS (U.S. CLS. 22 AND 39).

ANDREA HACK, EXAMINING ATTORNEY

**CLASS 25—(Continued).**

SN 78-969,489. NEWPORT SPORTSWEAR, LLC, IRVINE, CA, FILED 9-7-2006.

# FIVE PALM BRAND

THE MARK CONSISTS OF STANDARD CHARACTERS WITHOUT CLAIM TO ANY PARTICULAR FONT, STYLE, SIZE, OR COLOR.

NO CLAIM IS MADE TO THE EXCLUSIVE RIGHT TO USE "BRAND", APART FROM THE MARK AS SHOWN.

FOR BLOUSES; BOXER SHORTS; COVERUPS; DRESSES; FOOTWEAR; HEADWEAR; JACKETS; LINGERIE; LOUNGEWEAR; PANTS; SHIRTS; SHORTS; SKIRTS; SKORTS; SOCKS; SWEAT PANTS; SWEAT SHIRTS; SWEATERS; SWIM WEAR; T-SHIRTS; UNDERWEAR; VESTS (U.S. CLS. 22 AND 39).

ANDREA HACK, EXAMINING ATTORNEY

SN 78-969,636. HITMAN, INC., LAS VEGAS, NV, FILED 9-7-2006.

# Click for Forgiveness.

THE MARK CONSISTS OF STANDARD CHARACTERS WITHOUT CLAIM TO ANY PARTICULAR FONT, STYLE, SIZE, OR COLOR.

FOR BRIEFS; CAP VISORS; CAPS; HATS; HEADGEAR, NAMELY, CAPS; LADIES' UNDERWEAR; SHORT-SLEEVED OR LONG-SLEEVED T-SHIRTS; SWEAT SHIRTS; T-SHIRTS; THONGS; UNDERWEAR; WOMEN'S UNDERWEAR (U.S. CLS. 22 AND 39).

FIRST USE 3-1-2006; IN COMMERCE 9-5-2006.  
ERNEST SHOSHO, EXAMINING ATTORNEY

SN 78-970,059. ROCHELLE, DALE A., SAN ANTONIO, TX, FILED 9-8-2006.

# BE YOUR OWN MONKEY

THE MARK CONSISTS OF STANDARD CHARACTERS WITHOUT CLAIM TO ANY PARTICULAR FONT, STYLE, SIZE, OR COLOR.

FOR CLOTHING, NAMELY, SHIRTS, T-SHIRTS, SHORTS, PANTS, AND HATS (U.S. CLS. 22 AND 39).

WENDY GOODMAN, EXAMINING ATTORNEY

**CLASS 25—(Continued).**

SN 78-970,099. SMITH, DARREL D., NEW LENOX, IL. FILED 9-8-2006.

# Veríssimo

THE MARK CONSISTS OF STANDARD CHARACTERS WITHOUT CLAIM TO ANY PARTICULAR FONT, STYLE, SIZE, OR COLOR.

THE FOREIGN WORDING IN THE MARK TRANSLATES INTO ENGLISH AS VERY TRUE.

FOR CLOTHING, NAMELY, SHIRTS, JEANS, TOPS, PANTS, JACKETS, T-SHIRTS, UNDERWEAR, SHORTS, SWEATERS, FOOTWEAR AND HEADWEAR (U.S. CLS. 22 AND 39).

WENDY GOODMAN, EXAMINING ATTORNEY

---

SN 78-970,626. DOOBENEN, DANIELE, CULVER CITY, CA. FILED 9-8-2006.

# Urban Monk

THE MARK CONSISTS OF STANDARD CHARACTERS WITHOUT CLAIM TO ANY PARTICULAR FONT, STYLE, SIZE, OR COLOR.

FOR SHORT-SLEEVED OR LONG-SLEEVED T-SHIRTS; SWEAT SHIRTS; T-SHIRTS (U.S. CLS. 22 AND 39).

KHANH LE, EXAMINING ATTORNEY

---

SN 78-970,631. DELUCA, ADAM, GLENDALE, CA. FILED 9-8-2006.

# ATOMIC STAGEDIVE

THE MARK CONSISTS OF STYLIZED TEXT OF THE WORDING "ATOMIC STAGEDIVE".

FOR HATS; SWEAT SHIRTS; T-SHIRTS (U.S. CLS. 22 AND 39).

PAULA MAYS, EXAMINING ATTORNEY

**CLASS 25—(Continued).**

SN 78-970,737. HENRY, JOHN WAYMAN III, ATLANTA, GA. FILED 9-9-2006.

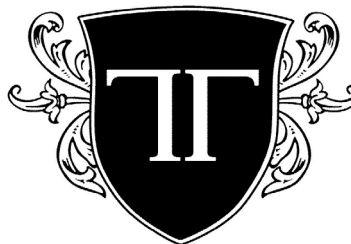

THE MARK CONSISTS OF AN EMBELLISHED SHIELD WITH A DESIGN IN THE CENTER THAT APPEARS TO BE THE LETTER "T" SPLIT DOWN THE MIDDLE VERTICALLY.

FOR BRAS; HATS; PANTIES, SHORTS AND BRIEFS; PANTS; SHIRTS; SHOES; SKIRTS; SOCKS; SWIM WEAR (U.S. CLS. 22 AND 39).

MIDGE BUTLER, EXAMINING ATTORNEY

---

SN 78-970,874. FRANCIS, JULIUS N., CAMBRIDGE, MA. FILED 9-10-2006.

# Christmode

THE MARK CONSISTS OF STANDARD CHARACTERS WITHOUT CLAIM TO ANY PARTICULAR FONT, STYLE, SIZE, OR COLOR.

FOR PANTS, SHIRTS, JACKETS, FOOTWEAR (U.S. CLS. 22 AND 39).

JENNY PARK, EXAMINING ATTORNEY

---

SN 78-970,928. WELLS, SAKURA, VENICE, CA. FILED 9-10-2006.

# Love Generation

THE MARK CONSISTS OF STANDARD CHARACTERS WITHOUT CLAIM TO ANY PARTICULAR FONT, STYLE, SIZE, OR COLOR.

FOR HATS; INFANT AND TODDLER ONE PIECE CLOTHING; PANTS; SHOES; T-SHIRTS (U.S. CLS. 22 AND 39).

JASON ROTH, EXAMINING ATTORNEY

**CLASS 25—(Continued).**

SN 78-971,222. ALLURA IMPORTS INC., NEW YORK, NY. FILED 9-11-2006.

**STREET APPROVED**

THE MARK CONSISTS OF STANDARD CHARACTERS WITHOUT CLAIM TO ANY PARTICULAR FONT, STYLE, SIZE, OR COLOR.

FOR CLOTHING NAMELY, JEANS, PANTS, SHIRTS, T-SHIRTS, SHORTS, SKIRTS, DRESSES, TANK TOPS, MUSCLE TOPS, POLOS, BATHING SUITS, FLEECE TOP AND BOTTOMS, SHORT SETS, PANT SETS, JOG SETS FOR MEN, WOMEN AND CHILDREN (U.S. CLS. 22 AND 39).

CHRIS WELLS, EXAMINING ATTORNEY

**CLASS 25—(Continued).**

SN 78-971,870. FLOWERS, ANTONIA, HAYWARD, CA. FILED 9-11-2006.



THE MARK CONSISTS OF STYLIZED TEXT OF THE WORDING "U.M.P.U. URBAN MADE PRINCESS UNITED". FOR HATS; SCARVES; T-SHIRTS (U.S. CLS. 22 AND 39).

CATHERINE FAINT, EXAMINING ATTORNEY

SN 78-971,283. STERN, KANDY L., BEVERLY HILLS, CA. FILED 9-11-2006.

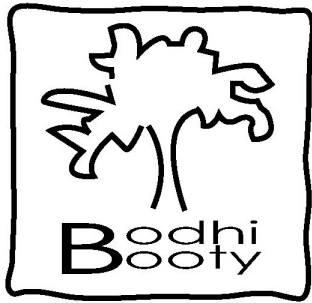

THE MARK CONSISTS OF A STYLIZED DEPICTION OF A BODHI TREE AND THE STYLIZED TEXT OF THE WORDING "BODHI BOOTY," ALL WITH IN A SQUARE DESIGN.

FOR BLOUSES; DRESSES; FOOTWEAR; HEADWEAR; JACKETS; PANTS; SCARVES; SHAWLS; SHIRTS; SHORTS; SWEAT SHIRTS; T-SHIRTS (U.S. CLS. 22 AND 39).

KARANENDRA S. CHHINA, EXAMINING ATTORNEY

SN 78-972,230. PARK, KENNY J., LOS ANGELES, CA. FILED 9-12-2006.

**HIDDEN JEANS**

THE MARK CONSISTS OF STANDARD CHARACTERS WITHOUT CLAIM TO ANY PARTICULAR FONT, STYLE, SIZE, OR COLOR.

NO CLAIM IS MADE TO THE EXCLUSIVE RIGHT TO USE "JEANS", APART FROM THE MARK AS SHOWN.

FOR BOTTOMS; JACKETS; JEANS; PANTS; SHIRTS; SHORTS; TANK-TOPS; TOPS (U.S. CLS. 22 AND 39).

JOHN DWYER, EXAMINING ATTORNEY

SN 78-971,284. CONRAD, LOUIS N. II, AURORA, CO. FILED 9-11-2006.

**MY RELIGION IS NOT A "CRUTCH" ITS MORE OF A "WALKER"**

THE MARK CONSISTS OF STANDARD CHARACTERS WITHOUT CLAIM TO ANY PARTICULAR FONT, STYLE, SIZE, OR COLOR.

FOR GOLF SHIRTS; HAT BANDS; HATS; KNIT SHIRTS; NIGHT SHIRTS; OPEN-NECKED SHIRTS; PIQUE SHIRTS; POLO SHIRTS; SHIRT FRONTS; SHIRTS; SHORT-SLEEVED OR LONG-SLEEVED T-SHIRTS; SHORT-SLEEVED SHIRTS; SLEEP SHIRTS; SPORT SHIRTS; TOBOGGAN HATS, PANTS AND CAPS; WOOLLY HATS; WRISTBANDS (U.S. CLS. 22 AND 39).

KARANENDRA S. CHHINA, EXAMINING ATTORNEY

SN 78-972,266. DWHAJ, KILOPATIE S, NEW YORK, NY. FILED 9-12-2006.

**Green Earth Clothing**

THE MARK CONSISTS OF STANDARD CHARACTERS WITHOUT CLAIM TO ANY PARTICULAR FONT, STYLE, SIZE, OR COLOR.

NO CLAIM IS MADE TO THE EXCLUSIVE RIGHT TO USE "CLOTHING", APART FROM THE MARK AS SHOWN.

FOR MENS, WOMENS CLOTHING AND FOOTWEAR, NAMELY SHIRTS, T-SHIRTS, POLO SHIRTS, SHORTS, PANTS, TOPS, BLOUSES, SKIRTS, COATS, JACKETS, SHOES, SOCKS, FOOTWEAR, UNDERWEAR, DRESSES, SUITS, TIES, HATS, CAPS, SWEATERS, TANK TOPS, SCARVES, CROP TOPS, LOUNGEWEAR (U.S. CLS. 22 AND 39).

DEIRDRE ROBERTSON, EXAMINING ATTORNEY

**CLASS 25—(Continued).**

SN 78-972,827. ARISTOCRAT DENIM, INC, LOS ANGELES, CA. FILED 9-12-2006.

**ARISTOCRAT**

THE MARK CONSISTS OF STANDARD CHARACTERS WITHOUT CLAIM TO ANY PARTICULAR FONT, STYLE, SIZE, OR COLOR.

FOR CAPRI PANTS; CAPRIS; CROP TOPS; DRESSES; GLOVES; JACKETS; KNICKERS; MINISKIRTS; OVERALLS; PANTS; SHIRTS; SHORTS; SKIRTS; SKIRTS AND DRESSES; SOCKS; TOPS ; TROUSERS (U.S. CLS. 22 AND 39).

DEZMONA MIZELLE, EXAMINING ATTORNEY

SN 78-977,859. SWAT.FAME, INC., CITY OF INDUSTRY, CA. FILED 11-30-2005.

**INDIGO ROYALTY**

THE MARK CONSISTS OF STANDARD CHARACTERS WITHOUT CLAIM TO ANY PARTICULAR FONT, STYLE, SIZE, OR COLOR.

NO CLAIM IS MADE TO THE EXCLUSIVE RIGHT TO USE INDIGO, APART FROM THE MARK AS SHOWN.

FOR CLOTHING, NAMELY JEANS (U.S. CLS. 22 AND 39).

FIRST USE 8-0-2006; IN COMMERCE 8-0-2006.

KATHERINE STOIDES, EXAMINING ATTORNEY

SN 79-021,886. AB MELKA, SWEDEN, FILED 12-5-2005.

**MELKA**

THE MARK CONSISTS OF STANDARD CHARACTERS WITHOUT CLAIM TO ANY PARTICULAR FONT, STYLE, SIZE, OR COLOR.

OWNER OF INTERNATIONAL REGISTRATION 0689600 DATED 3-18-1998, EXPIRES 3-18-2008.

FOR ARTICLES OF CLOTHING, NAMELY BLAZERS; COATS; JACKETS; SWEATERS; POLO SHIRTS, VESTS; JUMPERS; UNDERSHIRTS; SHIRTS, TROUSERS; SLACKS; SHORTS; BREECHES; KNICKERS; PANTS; WAIST COATS; WARM-UP PANTS; CLOTHING SETS COMPRISING A COMBINATION OF JACKETS, PARKAS AND WARM-UP PANTS; SWIMMING TRUNKS; SWIMMING COSTUMES; BEACH TOPS; T-SHIRTS; TANK TOPS AND BEACH JACKETS (U.S. CLS. 22 AND 39).

DEBRA LEE, EXAMINING ATTORNEY

**CLASS 25—(Continued).**

SN 79-021,990. XINWEI (FUJIAN) LIGHT; INDUSTRY CO., LTD., FUJIAN PROVINCE, CHINA, FILED 10-31-2005.



OWNER OF INTERNATIONAL REGISTRATION 0879962 DATED 10-31-2005, EXPIRES 10-31-2015.

THE ENGLISH TRANSLATION OF THE FOREIGN WORD(S) IN THE MARK IS: FEI: FLY; KE: GRAMME.

THE TRANSLITERATION OF THE NON-LATIN CHARACTERS IN THE MARK IS: FEI KE.

FOR SHORTS; SPORTS JERSEYS; TEE-SHIRTS; KNITTED CAPS; SHIRTS; LAYETTES; FOOTWEAR; SPORTS SHOES; SANDALS; SLIPPERS (U.S. CLS. 22 AND 39).

DAWN HAN, EXAMINING ATTORNEY

SN 79-022,368. AB MELKA, SWEDEN, FILED 1-24-2006.



OWNER OF INTERNATIONAL REGISTRATION 0626484 DATED 9-27-1994, EXPIRES 9-27-2014.

NO CLAIM IS MADE TO THE EXCLUSIVE RIGHT TO USE "QUALITY MEN'S WEAR", APART FROM THE MARK AS SHOWN.

FOR ARTICLES OF CLOTHING, NAMELY BLAZERS; COATS; JACKETS; SWEATERS; POLO SHIRTS, VESTS; JUMPERS; UNDERSHIRTS; SHIRTS, TROUSERS; SLACKS; SHORTS; BREECHES; KNICKERS; PANTS; WAIST COATS; WARM-UP PANTS; CLOTHING SETS COMPRISING A COMBINATION OF JACKETS, PARKAS AND WARM-UP PANTS; SWIMMING TRUNKS; SWIMMING COSTUMES; BEACH TOPS; T-SHIRTS; TANK TOPS AND BEACH JACKETS (U.S. CLS. 22 AND 39).

DEBRA LEE, EXAMINING ATTORNEY

**CLASS 25—(Continued).**

SN 79-025,735. GÜLBIYE HAN, TURKEY, FILED 3-15-2006.

**SECRET AVENUE**

OWNER OF INTERNATIONAL REGISTRATION 0889960 DATED 3-15-2006, EXPIRES 3-15-2016.

FOR CLOTHING, NAMELY, PULLOVERS, SKIRTS, DRESSES, BLOUSES, JEANS, TROUSERS, JACKETS, COATS, RAINCOATS, ANORAKS; SPORTSWEAR, NAMELY, SPORTS BRÁS, SPORTS JERSEYS, SHORTS, SHIRTS, T-SHIRTS, SWEATSHIRTS; BEACH CLOTHES, NAMELY, BEACH COVER-UPS, BATHING SUITS, BATHING TRUNKS; SHORTS, KNITWEAR, NAMELY, KNIT TOPS, KNIT DRESSES, KNIT SWEATERS; OVERALLS, UNDERCLOTHING, BODICES, BRASSIERES, CAMISOLES, UNDERPANTS, DRESSING GOWNS, BATH ROBES, BATHING SUITS, PYJAMAS, GLOVES, SKI SUITS; HEADGEAR, NAMELY, HATS, CAPS, KNITTED CAPS, BERETS; FOOTWEAR, NAMELY, SHOES EXCLUDING ORTHOPAEDIC SHOES, SLIPPERS, BOOTS, SANDALS, BEACH SHOES, SPORTS SHOES, LACE BOOTS AND PARTS THEREOF, SHOE PARTS, NAMELY, HEELPIECES, HEELS, FOOTWEAR UPPERS; STOCKINGS; BELTS; TIES, NECKTIES, SHAWLS, SCARVES, MUFFLERS, NECK SCARVES, SARONGS, COLLARS FOR DRESSES, MANIPLES, MUFFS, WRISTBANDS, SUSPENDERS, BRACES FOR CLOTHING, GARTERS, BANDANAS, HEADBANDS; CLOTHING FOR BABIES, NAMELY BABIES' DIAPERS OF TEXTILE (U.S. CLS. 22 AND 39).

AMY BROZENIC, EXAMINING ATTORNEY

SN 79-027,163. MELO E GRANO S.P.A., ITALY, FILED 11-22-2005.

OWNER OF INTERNATIONAL REGISTRATION 0894048 DATED 11-22-2005, EXPIRES 11-22-2015.

THE MARK CONSISTS OF THE WRITING M E G, THE CHARACTER USED IS "ESPECIAL KAY", THE CENTRAL E HAS THE CHARACTERISTIC OF BEING A LOGOTYPE IN THE FORM OF A SCRATCH.

FOR PULLOVERS, GLOVES, CARDIGANS, JERSEYS, NECKWEAR, SWEATERS, SOCKS, STOCKINGS, TIGHTS, TROUSERS, LEGGINGS, SKIRTS, JACKETS, JERKINS, SHIRTS, VESTS, WAISTCOATS, JUMPERS, TRACK SUITS, BLOUSES, BLOUSONS, JEANS, SWEAT PANTS, GYM SUITS, KNICKERS, PANTS, SHORTS, T-SHIRTS, SWEAT-SHIRTS, SUITS AND DRESSES, OVERCOATS, COATS, ANORAKS, RAINCOATS, BELTS, SUSPENDERS, LOUNGEWEAR, UNDERWEAR, BEACHWEAR, SLEEPWEAR, SHOES, HEADWEAR (U.S. CLS. 22 AND 39).

KEVON CHISOLM, EXAMINING ATTORNEY

**CLASS 26—FANCY GOODS**

SN 77-013,613. YKK CORPORATION OF AMERICA, MAR-LETTA, GA. FILED 10-4-2006.

**SNAP CAP**

THE MARK CONSISTS OF STANDARD CHARACTERS WITHOUT CLAIM TO ANY PARTICULAR FONT, STYLE, SIZE, OR COLOR.

NO CLAIM IS MADE TO THE EXCLUSIVE RIGHT TO USE "SNAP", APART FROM THE MARK AS SHOWN.

FOR TOP END STOPS FOR SLIDE FASTENERS (U.S. CLS. 37, 39, 40, 42 AND 50).

MICHAEL WEBSTER, EXAMINING ATTORNEY

SN 78-605,547. INTERPLANET PRODUCTIONS LIMITED, BEVERLY HILLS, CA. FILED 4-9-2005.

"SOMETHING WONDERFUL IS  
ABOUT TO HAPPEN" ELIZABETH  
TAYLOR

THE MARK CONSISTS OF STANDARD CHARACTERS WITHOUT CLAIM TO ANY PARTICULAR FONT, STYLE, SIZE, OR COLOR.

THE NAME ELIZABETH TAYLOR IDENTIFIES A LIVING INDIVIDUAL WHOSE CONSENT IS OF RECORD.

FOR HAIRPIECES, WIGS, HAIR EXTENSIONS, HAIR ORNAMENTS, RIBBONS AND BRAIDS (U.S. CLS. 37, 39, 40, 42 AND 50).

SUE LAWRENCE, EXAMINING ATTORNEY

SN 78-793,264. GENERAL WIG MANUFACTURERS, INC., MIAMI LAKES, FL. FILED 1-17-2006.

**ALTER EGO**

THE MARK CONSISTS OF STANDARD CHARACTERS WITHOUT CLAIM TO ANY PARTICULAR FONT, STYLE, SIZE, OR COLOR.

FOR WIGS AND HAIRPIECES (U.S. CLS. 37, 39, 40, 42 AND 50).

GEORGE LORENZO, EXAMINING ATTORNEY

**CLASS 26—(Continued).**

SN 78-828,251. FORD, JERE B., WASHINGTON, DC. FILED 3-3-2006.

**FLYRT**

THE MARK CONSISTS OF STANDARD CHARACTERS WITHOUT CLAIM TO ANY PARTICULAR FONT, STYLE, SIZE, OR COLOR.

FOR CLOTHING ACCESSORIES, NAMELY DECORATIVE CLASPS, CORDS AND TASSELS FOR CLOTHING (U.S. CLS. 37, 39, 40, 42 AND 50).

JEFF DEFORD, EXAMINING ATTORNEY



SN 78-860,848. MINK HAIR, LTD., LEONIA, NJ. FILED 4-13-2006.

*Sens  
Sens*

FOR HAIR PRODUCTS, NAMELY, HAIR EXTENSIONS, HAIR PIECES, WIGS, AND TOUPEES (U.S. CLS. 37, 39, 40, 42 AND 50).

SHAUNIA WALLACE, EXAMINING ATTORNEY

**CLASS 26—(Continued).**

SN 78-955,790. SANRIO COMPANY, LTD., TOKYO, JAPAN, FILED 8-18-2006.

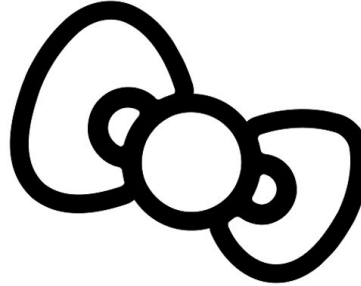

OWNER OF U.S. REG. NOS. 1,200,083, 1,370,105 AND OTHERS.

THE MARK CONSISTS OF A BOW.  
FOR HAIR BANDS, HAIR BOWS, HAIR RIBBONS, HAIR ORNAMENTS, HAIR CLIPS, FABRIC COVERED ELASTIC BANDS FOR HAIR, PONYTAIL HOLDERS, BARRETTES, ZIPPER PULLS, SHOE LACES, SHOE ORNAMENTS NOT OF PRECIOUS METAL, BELT BUCKLES NOT OF PRECIOUS METAL FOR CLOTHING, RIBBONS FOR GIFT WRAPPING, FABRIC APPLIQUES (U.S. CLS. 37, 39, 40, 42 AND 50).

FIRST USE 11-1-2004; IN COMMERCE 11-1-2004.  
MICHAEL WIENER, EXAMINING ATTORNEY



**CLASS 27—FLOOR COVERINGS**

SN 76-666,531. TRIEXE MANAGEMENT GROUP INC., FONTHILL, ONTARIO L0S 1E6, CANADA, FILED 9-21-2006.

**TURFSCAPE**

THE MARK CONSISTS OF STANDARD CHARACTERS WITHOUT CLAIM TO ANY PARTICULAR FONT, STYLE, SIZE, OR COLOR.

FOR ARTIFICIAL TURF (U.S. CLS. 19, 20, 37, 42 AND 50).

DEIRDRE ROBERTSON, EXAMINING ATTORNEY

**CLASS 27—(Continued).**

SN 78-779,971. MAVERICK BRANDS LLC, NEW YORK, NY. FILED 12-22-2005.

# CHIC SIMPLE

THE MARK CONSISTS OF STANDARD CHARACTERS WITHOUT CLAIM TO ANY PARTICULAR FONT, STYLE, SIZE, OR COLOR.

FOR BATH MATS, CARPETS, CARPET PADDING, CARPET UNDERLINING, CORK MATS, HARD SURFACE COVERING FOR FLOORS AND WALLS, DOOR MATS, RUGS, NON TEXTILE WALL HANGINGS, WALL PAPER, AND FABRIC MATS (U.S. CLS. 19, 20, 37, 42 AND 50).

ESTHER BELENKER, EXAMINING ATTORNEY

SN 78-844,049. E S ROBBINS CORPORATION, MUSCLE SHOALS, AL. FILED 3-23-2006.

# ANCHORPRO

THE MARK CONSISTS OF STANDARD CHARACTERS WITHOUT CLAIM TO ANY PARTICULAR FONT, STYLE, SIZE, OR COLOR.

FOR PLASTIC CARPET RUNNERS AND CARPET MATS (U.S. CLS. 19, 20, 37, 42 AND 50).

FIRST USE 4-27-2006; IN COMMERCE 4-27-2006.

THEODORE MCBRIDE, EXAMINING ATTORNEY

SN 78-955,795. SANRIO COMPANY, LTD., TOKYO, JAPAN, FILED 8-18-2006.

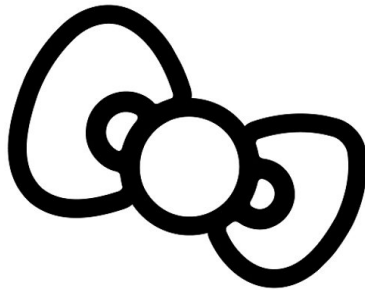

OWNER OF U.S. REG. NOS. 1,200,083, 1,370,105 AND OTHERS.

THE MARK CONSISTS OF A BOW. FOR BATH MATS, DOOR MATS, BEACH MATS, FLOOR MATS, FLOOR MATS FOR VEHICLES, RUGS, WALLPAPER, WALLPAPER BORDERS, PET FEEDING MATS (U.S. CLS. 19, 20, 37, 42 AND 50).

FIRST USE 11-1-2004; IN COMMERCE 11-1-2004.

MICHAEL WIENER, EXAMINING ATTORNEY

**CLASS 28—TOYS AND SPORTING GOODS**

SN 75-814,816. MARNICA, MIRELLA, TORONTO, ONTARIO, CANADA, FILED 10-5-1999.

# EGGROLL

PRIORITY CLAIMED UNDER SEC. 44(D) ON CANADA APPLICATION NO. 1028863, FILED 9-15-1999, REG. NO. TMA655393, DATED 12-19-2005, EXPIRES 12-19-2020.

FOR DICE GAMES AND BOARD GAMES (U.S. CLS. 22, 23, 38 AND 50).

MARGERY A. TIERNEY, EXAMINING ATTORNEY

SN 76-549,170. PLAYTIME CREATIONS, INC., ENGLEWOOD, CO. FILED 9-22-2003.

# PLAYTIME CREATIONS

FOR INDOOR AND OUTDOOR SOFT PLAYGROUND EQUIPMENT NAMELY, THEMED CLIMBING STRUCTURES, THEMED PLAY SYSTEMS, FOAM PLAY ELEMENTS, ACTIVITY PANELS, AND PLAY FLOOR MATS (U.S. CLS. 22, 23, 38 AND 50).

FIRST USE 2-1-2001; IN COMMERCE 2-1-2001.

MARC LEIPZIG, EXAMINING ATTORNEY

SN 76-636,880. CHU, YOUNG, FULLERTON, CA. FILED 4-22-2005.



FOR SPORTING GOODS, NAMELY, RAPPELLING DEVICES IN THE NATURE OF BINDING STRAPS, HOOK AND RING COMBINATIONS, HOOKS, SAFETY HARNESS FOR ROCK AND ICE CLIMBING, CHALK BAGS FOR ROCK CLIMBING, CRASH PADS, NON-METAL PITONS FOR ROCK CLIMBING, CAMMING DEVICES FOR ROCK TO PLACE PROTECTION IN CASE OF A FALL (U.S. CLS. 22, 23, 38 AND 50).

FIRST USE 10-1-2001; IN COMMERCE 10-1-2001.

DARRYL SPRUILL, EXAMINING ATTORNEY

**CLASS 28—(Continued).**

SN 76-660,198. FONSECA, JOSEPH, TEHACHAPI, CA. FILED 5-17-2006.

**RIVAL SKATEBOARDS**

THE MARK CONSISTS OF STANDARD CHARACTERS WITHOUT CLAIM TO ANY PARTICULAR FONT, STYLE, SIZE, OR COLOR.

NO CLAIM IS MADE TO THE EXCLUSIVE RIGHT TO USE "SKATEBOARDS", APART FROM THE MARK AS SHOWN.

FOR SKATEBOARD DECKS, SKATEBOARDS, BALL BEARINGS, NUTS AND BOLTS FOR SKATEBOARDS, SKATEBOARD GRIP TAPES, SKATEBOARD RISER-PADS, SKATEBOARD WHEELS, SKATEBOARD TRUCKS (U.S. CLS. 22, 23, 38 AND 50).

GINA FINK, EXAMINING ATTORNEY

SN 76-664,962. BABY ABUELITA PRODUCTIONS, INC., MIAMI, FL. FILED 8-22-2006.



OWNER OF U.S. REG. NO. 3,025,890.

NO CLAIM IS MADE TO THE EXCLUSIVE RIGHT TO USE "BABY" AND "PRODUCTIONS", APART FROM THE MARK AS SHOWN.

THE FOREIGN WORDING IN THE MARK TRANSLATES INTO ENGLISH AS LITTLE GRANDMOTHER.

FOR TOY DOLLS CAPABLE OF SINGING ETHNIC LULLABY SONGS IN THEIR ORIGINAL LANGUAGE (U.S. CLS. 22, 23, 38 AND 50).

FIRST USE 5-19-2005; IN COMMERCE 5-19-2005.

RONALD AIKENS, EXAMINING ATTORNEY

SN 76-665,435. MAHAR MANUFACTURING CORP., DBA FIESTA CONCESSION CORP., VERNON, CA. FILED 8-31-2006.

**HIGH SOCIETY**

THE MARK CONSISTS OF STANDARD CHARACTERS WITHOUT CLAIM TO ANY PARTICULAR FONT, STYLE, SIZE, OR COLOR.

FOR STUFFED PLUSH TOYS (U.S. CLS. 22, 23, 38 AND 50).

KATHLEEN LORENZO, EXAMINING ATTORNEY

**CLASS 28—(Continued).**

SN 76-665,484. PBC INTERNATIONAL, INC., OXNARD, CA. FILED 9-1-2006.



FOR STUFFED PLUSH TOY ANIMALS (U.S. CLS. 22, 23, 38 AND 50).

FIRST USE 12-30-2005; IN COMMERCE 12-30-2005.

CURTIS FRENCH, EXAMINING ATTORNEY

SN 76-665,485. PBC INTERNATIONAL, INC., OXNARD, CA. FILED 9-1-2006.



FOR STUFFED PLUSH TOY ANIMALS FOR PEOPLE (U.S. CLS. 22, 23, 38 AND 50).

FIRST USE 5-1-2006; IN COMMERCE 5-1-2006.

CURTIS FRENCH, EXAMINING ATTORNEY

SN 76-666,571. PBC INTERNATIONAL, INC., OXNARD, CA. FILED 9-25-2006.

**CHANTILLY LANE DUETS**

THE MARK CONSISTS OF STANDARD CHARACTERS WITHOUT CLAIM TO ANY PARTICULAR FONT, STYLE, SIZE, OR COLOR.

OWNER OF U.S. REG. NO. 2,972,475.

FOR PAIR OF JOINED STUFFED PLUSH TOY CHARACTERS (U.S. CLS. 22, 23, 38 AND 50).

FIRST USE 9-10-2006; IN COMMERCE 9-10-2006.

CURTIS FRENCH, EXAMINING ATTORNEY

SN 76-670,789. MAHAR MANUFACTURING CORP., DBA FIESTA CONCESSION CORP., VERNON, CA. FILED 12-26-2006.

**GOT BASEBALL**

THE MARK CONSISTS OF STANDARD CHARACTERS WITHOUT CLAIM TO ANY PARTICULAR FONT, STYLE, SIZE, OR COLOR.

FOR STUFFED PLUSH TOYS (U.S. CLS. 22, 23, 38 AND 50).

KATHLEEN LORENZO, EXAMINING ATTORNEY



**CLASS 28—(Continued).**

SN 76-671,308. GOLFSMITH INTERNATIONAL, INC., AUSTIN, TX. FILED 1-12-2007.

**SNAKE EYES**

THE MARK CONSISTS OF STANDARD CHARACTERS WITHOUT CLAIM TO ANY PARTICULAR FONT, STYLE, SIZE, OR COLOR.

OWNER OF U.S. REG. NO. 1,889,946.  
FOR SPORTING GOODS, NAMELY, GOLF CLUBS, GOLF CLUB HEADS, GOLF CLUB SHAFTS, GOLF CLUB GRIPS, GOLF BAGS, GOLF CLUB BAGS, GOLF CLUB COVERS, GOLF BALLS, GOLF CLUB FERRULES, GOLF GLOVES, AND DIVOT REPAIR TOOLS (U.S. CLS. 22, 23, 38 AND 50).

FIRST USE 9-16-1993; IN COMMERCE 9-16-1993.  
JAY BESCH, EXAMINING ATTORNEY

---

SN 77-000,303. IDEAVILLAGE PRODUCTS CORP., FAIRFIELD, NJ. FILED 9-15-2006.

**SOUTH BEACH ABS**

THE MARK CONSISTS OF STANDARD CHARACTERS WITHOUT CLAIM TO ANY PARTICULAR FONT, STYLE, SIZE, OR COLOR.

NO CLAIM IS MADE TO THE EXCLUSIVE RIGHT TO USE "ABS", APART FROM THE MARK AS SHOWN.

FOR EXERCISE EQUIPMENT, NAMELY, ABDOMINAL BOARDS; EXERCISE EQUIPMENT, NAMELY, ROTARY ABDOMINAL BOARDS; EXERCISE MACHINES; MANUALLY-OPERATED EXERCISE EQUIPMENT (U.S. CLS. 22, 23, 38 AND 50).

ALICE BENMAMAN, EXAMINING ATTORNEY

---

SN 77-022,627. KABUSHIKI KAISHA SQUARE ENIX, TA SQUARE ENIX CO., LTD., TOKYO, JAPAN, FILED 10-17-2006.

**VALKYRIE PROFILE**

THE MARK CONSISTS OF STANDARD CHARACTERS WITHOUT CLAIM TO ANY PARTICULAR FONT, STYLE, SIZE, OR COLOR.

OWNER OF U.S. REG. NOS. 2,514,477 AND 2,831,101.  
FOR DOLLS AND TOY FIGURES (U.S. CLS. 22, 23, 38 AND 50).

CHRISTINE COOPER, EXAMINING ATTORNEY

**CLASS 28—(Continued).**

SN 77-037,276. THE CARTOON NETWORK, INC., ATLANTA, GA. FILED 11-6-2006.

**WILLIAMS STREET**

THE MARK CONSISTS OF STANDARD CHARACTERS WITHOUT CLAIM TO ANY PARTICULAR FONT, STYLE, SIZE, OR COLOR.

FOR TOYS AND SPORTING GOODS INCLUDING GAMES AND PLAYTHINGS FEATURING CHARACTERS FROM ANIMATED, ACTION ADVENTURE, COMEDY AND/OR DRAMA FEATURES, NAMELY, ACTION FIGURES AND ACCESSORIES THEREFOR, PLUSH TOYS, BALLOONS, BATHTUB TOYS, RIDE-ON TOYS, PLAYING CARDS, EQUIPMENT SOLD AS A UNIT FOR PLAYING CARD GAMES, TOY VEHICLES, DOLLS, FLYING DISCS, ELECTRONIC HAND-HELD GAME UNIT, GAME EQUIPMENT SOLD AS A UNIT FOR PLAYING A BOARD GAME, A MANIPULATIVE GAME, A PARLOR GAME AND AN ACTION TYPE TARGET GAME, STAND ALONE VIDEO OUTPUT GAME MACHINES, JIGSAW AND MANIPULATIVE PUZZLES, PAPER FACE MASKS, SKATEBOARDS, ICE SKATES, WATER SQUIRTING TOYS, BALLS, NAMELY, PLAYGROUND BALLS, SOCCER BALLS, BASEBALLS, BASKETBALLS, BASEBALL GLOVES, SWIMMING FLOATS FOR RECREATIONAL USE, KICK BOARD FLOTATION DEVICES FOR RECREATIONAL USE, SURFBOARDS, SWIM BOARDS FOR RECREATIONAL USE, SWIM FINS, TOY BAKEWARE AND TOY COOKWARE, TOY BANKS, AND CHRISTMAS TREE ORNAMENTS, NOT BEING ILLUMINATED AND NOT BEING MADE OF CONFECTIONERY (U.S. CLS. 22, 23, 38 AND 50).

LINDA ORNDORFF, EXAMINING ATTORNEY

---

SN 77-063,220. JAKKS PACIFIC, INC., MALIBU, CA. FILED 12-13-2006.

**TINY DREAMERZ**

THE MARK CONSISTS OF STANDARD CHARACTERS WITHOUT CLAIM TO ANY PARTICULAR FONT, STYLE, SIZE, OR COLOR.

FOR TOYS, GAMES AND PLAYTHINGS, NAMELY, DOLLS, TOY FIGURES, AND PLAY SETS AND ACCESSORIES FOR ALL OF THE AFOREMENTIONED; TOY FIGURE MOLDS, INFANT TOYS, PLUSH TOYS, CHILDREN'S MULTIPLE ACTIVITY TOYS, CONSTRUCTION TOYS, ELECTRONIC LEARNING TOYS, STAND ALONE VIDEO GAME MACHINES (U.S. CLS. 22, 23, 38 AND 50).

JENNIFER WILLISTON, EXAMINING ATTORNEY

**CLASS 28—(Continued).**

SN 77-074,021. SHIMANO INC., SAKAI CITY, JAPAN, FILED 1-1-2007.

**ESCAPE HATCH**

THE MARK CONSISTS OF STANDARD CHARACTERS WITHOUT CLAIM TO ANY PARTICULAR FONT, STYLE, SIZE, OR COLOR.

OWNER OF U.S. REG. NO. 3,083,598.  
FOR FISHING REELS; FISHING TACKLE (U.S. CLS. 22, 23, 38 AND 50).  
FIRST USE 10-0-2004; IN COMMERCE 10-0-2004.  
SUNG IN, EXAMINING ATTORNEY

---

SN 78-247,146. HART SKI MANUFACTURING, LLC, MAPLE GROVE, MN. FILED 5-8-2003.

**HART**

FOR SKIS AND SKI ACCESSORIES, NAMELY, SKI BINDINGS, SKI POLES AND SKI BAGS (U.S. CLS. 22, 23, 38 AND 50).  
DEZMONA MIZELLE, EXAMINING ATTORNEY

---

SN 78-425,775. RIVER WEST BRANDS LLC, CHICAGO, IL. FILED 5-26-2004.

**ELECTRONIC  
QUARTERBACK**

THE MARK CONSISTS OF STANDARD CHARACTERS WITHOUT CLAIM TO ANY PARTICULAR FONT, STYLE, SIZE, OR COLOR.

NO CLAIM IS MADE TO THE EXCLUSIVE RIGHT TO USE "ELECTRONIC", APART FROM THE MARK AS SHOWN.

FOR HAND HELD UNITS FOR PLAYING ELECTRONIC GAMES (U.S. CLS. 22, 23, 38 AND 50).  
ALEXANDER L. POWERS, EXAMINING ATTORNEY

**CLASS 28—(Continued).**

SN 78-534,617. MATTEL, INC., EL SEGUNDO, CA. FILED 12-17-2004.

**FAIRYTALE  
FAVORITES**

THE MARK CONSISTS OF STANDARD CHARACTERS WITHOUT CLAIM TO ANY PARTICULAR FONT, STYLE, SIZE, OR COLOR.

FOR TOYS, GAMES AND PLAYTHINGS, NAMELY, PLUSH TOYS AND ACCESSORIES THEREFOR (U.S. CLS. 22, 23, 38 AND 50).

STEVEN R. FINE, EXAMINING ATTORNEY

---

SN 78-628,251. GRAPHITE DESIGN INTERNATIONAL INC., SAN DIEGO, CA. FILED 5-11-2005.

**GRAPHITE DESIGN**

SEC. 2(F).

FOR GOLF CLUB SHAFT (U.S. CLS. 22, 23, 38 AND 50).  
FIRST USE 5-29-1999; IN COMMERCE 5-29-1999.  
LYDIA BELZER, EXAMINING ATTORNEY

---

SN 78-648,487. HARTZ MOUNTAIN CORPORATION, THE, SECAUCUS, NJ. FILED 6-10-2005.

**HARTZ AT PLAY QUACKERS**

THE MARK CONSISTS OF STANDARD CHARACTERS WITHOUT CLAIM TO ANY PARTICULAR FONT, STYLE, SIZE, OR COLOR.

OWNER OF U.S. REG. NOS. 843,089, 2,927,650 AND OTHERS.

FOR PET TOYS (U.S. CLS. 22, 23, 38 AND 50).  
TINA L. SNAPP, EXAMINING ATTORNEY

**CLASS 28—(Continued).**

SN 78-723,426. MATTEL, INC., EL SEGUNDO, CA. FILED 9-29-2005.

**HOLIDAY RACERS**

THE MARK CONSISTS OF STANDARD CHARACTERS WITHOUT CLAIM TO ANY PARTICULAR FONT, STYLE, SIZE, OR COLOR.

NO CLAIM IS MADE TO THE EXCLUSIVE RIGHT TO USE "RACERS", APART FROM THE MARK AS SHOWN.

FOR TOYS, GAMES AND PLAYTHINGS, NAMELY, TOY VEHICLES AND ACCESSORIES THEREFOR (U.S. CLS. 22, 23, 38 AND 50).

FIRST USE 1-23-2006; IN COMMERCE 1-23-2006.  
SALLY SHIH, EXAMINING ATTORNEY

---

SN 78-771,058. STAR OF TEXAS FAIR & RODEO, AUSTIN, TX. FILED 12-12-2005.



OWNER OF U.S. REG. NO. 2,327,833.  
NO CLAIM IS MADE TO THE EXCLUSIVE RIGHT TO USE "RODEO", APART FROM THE MARK AS SHOWN.  
SEC. 2(F) AS TO "RODEO AUSTIN".

FOR SOUVENIRS, NAMELY, STUFFED DOLLS AND ANIMALS, BEAN BAG DOLLS, AND PLUSH TOYS (U.S. CLS. 22, 23, 38 AND 50).

FIRST USE 7-0-2002; IN COMMERCE 10-0-2002.  
BERYL GARDNER, EXAMINING ATTORNEY

---

SN 78-801,047. PLAYMATES TOYS INC., COSTA MESA, CA. FILED 1-27-2006.

**AMAZING ALLYSEN**

THE MARK CONSISTS OF STANDARD CHARACTERS WITHOUT CLAIM TO ANY PARTICULAR FONT, STYLE, SIZE, OR COLOR.

OWNER OF U.S. REG. NOS. 2,398,604, 2,643,100 AND OTHERS.

FOR DOLLS AND ACCESSORIES THEREFOR (U.S. CLS. 22, 23, 38 AND 50).

GENE MACIOL, EXAMINING ATTORNEY

**CLASS 28—(Continued).**

SN 78-805,221. MORGAN MOTOR COMPANY LIMITED, WORCESTERSHIRE, UNITED KINGDOM, FILED 2-2-2006.



OWNER OF U.S. REG. NO. 1,715,474.

FOR GAMES AND TOYS NAMELY, PLAYING CARDS, PLAYING CARD CASES, PARLOR-TYPE GAMES, CHESS SETS, TOY MODEL CAR RACING SETS COMPRISED OF TOY MODEL CARS, RACE TRACK, SPEED CONTROLLERS AND CRASH BARRIERS, TOY MODEL HOBBY CRAFT KITS FOR MAKING TOY CARS, TOY CARS AND TOY MODEL CARS; GYMNAS-TIC AND SPORTING ARTICLES NAMELY, TENNIS RACKETS, GOLF CLUBS, GOLF BAGS, SKIS, SNOW BOARDS, SKATE BOARDS, INLINE SKATES, JUMP ROPES, TOY NON-MOTORIZED PUSH SCOOTERS, AND GOLF BALLS (U.S. CLS. 22, 23, 38 AND 50).

JILL C. ALT, EXAMINING ATTORNEY

---

SN 78-806,082. WARE, MICHAEL J., FOLSOM, CA. FILED 2-3-2006.

**Dreamcade**

THE MARK CONSISTS OF STANDARD CHARACTERS WITHOUT CLAIM TO ANY PARTICULAR FONT, STYLE, SIZE, OR COLOR.

FOR ARCADE GAMES; ARCADE-TYPE ELECTRONIC VIDEO GAMES (U.S. CLS. 22, 23, 38 AND 50).

FIRST USE 1-1-2006; IN COMMERCE 1-1-2006.

BRIAN NEVILLE, EXAMINING ATTORNEY

**CLASS 28—(Continued).**

SN 78-807,154. ROBERT E HOWARD PROPERTIES INC., BEVERLY HILLS, CA. FILED 2-3-2006.

**ROBERT E. HOWARD**

THE MARK CONSISTS OF STANDARD CHARACTERS WITHOUT CLAIM TO ANY PARTICULAR FONT, STYLE, SIZE, OR COLOR.

THE NAME(S), PORTRAIT(S), AND/OR SIGNATURE(S) SHOWN IN THE MARK DOES NOT IDENTIFY A PARTICULAR LIVING INDIVIDUAL.

FOR GAMES, NAMELY, BOARD GAMES, PLAYING CARD GAMES, TRADING CARD GAMES, MANIPULATIVE GAMES, SKILL GAMES, ACTION SKILL GAMES, TARGET GAMES AND ACTION TARGET GAMES; MECHANICAL AND ELECTRONIC GAMES NOT INCLUDED IN OTHER CLASSES, NAMELY, PINBALL GAMES, COIN-OPERATED VIDEO GAMES, ARCADE GAMES, HAND-HELD GAMES WITH LIQUID CRYSTAL DISPLAYS, HAND-HELD UNITS FOR PLAYING VIDEO GAMES AND HAND-HELD UNITS FOR PLAYING ELECTRONIC GAMES; ROLE PLAYING GAMES; TOY WEAPONS, NAMELY, GUNS, HOLSTERS, KNIVES, SWORDS, SPEARS, SHIELDS, BOWS AND ARROWS, MISSILES AND CROSSBOWS; TOYS AND PLAYTHINGS, NAMELY, ACTION FIGURES AND ACCESSORIES THEREFOR, COLLECTABLE TOY FIGURES, SOFT SCULPTURE TOY FIGURES, MECHANICAL ACTION TOYS, ELECTRONIC ACTION TOYS, PLUSH TOYS, DOLLS, MAGIC TRICKS, PUZZLES AND PLAYING CARDS; TOY MODEL HOBBY CRAFT KITS; SPORTING AND GYMNASTIC ARTICLES NOT INCLUDED IN OTHER CLASSES, NAMELY, IN-LINE SKATES, SKATE BOARDS, SNOW BOARDS AND BAGS, CASES AND CONTAINERS SPECIALLY DESIGNED FOR SPORTS EQUIPMENT; EXERCISE EQUIPMENT, NAMELY, EXERCISE MACHINES, EXERCISE WEIGHTS, EXERCISE BENCHES, DUMBBELLS, BARBELLS AND WEIGHTLIFTING BELTS; AMUSEMENT PARK RIDES (U.S. CLS. 22, 23, 38 AND 50).  
KAREN K. BUSH, EXAMINING ATTORNEY

**CLASS 28—(Continued).**

SN 78-807,797. DISNEY ENTERPRISES, INC., BURBANK, CA. FILED 2-6-2006.

**MY FRIENDS TIGGER & POOH**

THE MARK CONSISTS OF STANDARD CHARACTERS WITHOUT CLAIM TO ANY PARTICULAR FONT, STYLE, SIZE, OR COLOR.

OWNER OF U.S. REG. NOS. 2,257,705, 3,024,286 AND OTHERS.

FOR ACTION SKILL GAMES; ACTION FIGURES AND ACCESSORIES THEREFORE; BOARD GAMES; CARD GAMES; CHILDREN'S MULTIPLE ACTIVITY TOYS; BADMINTON SETS; BALLOONS; BASKETBALLS; BATH TOYS; BASEBALLS; BEACH BALLS; BEAN BAGS; BEAN BAG DOLLS; BOARD GAMES; BUILDING BLOCKS; BOWLING BALLS; BUBBLE MAKING WANDS AND SOLUTION SETS; CHESS SETS; CHILDREN'S PLAY COSMETICS; CHRISTMAS STOCKINGS; CHRISTMAS TREE DECORATIONS; COLLECTABLE TOY FIGURES; CRIB MOBILES; CRIB TOYS; DISC TOSS TOYS; DOLLS; DOLL CLOTHING; DOLL ACCESSORIES; DOLL PLAYSETS; ELECTRIC ACTION TOYS; EQUIPMENT SOLD AS A UNIT FOR PLAYING CARD GAMES; FISHING TACKLE; GOLF BALLS; GOLF GLOVES; GOLF BALL MARKERS; HAND HELD UNIT FOR PLAYING ELECTRONIC GAMES; HOCKEY PUCKS; INFLATABLE TOYS; JIGSAW PUZZLES; JUMP ROPES; KITES; MAGIC TRICKS; MARBLES; MANIPULATIVE GAMES; MECHANICAL TOYS; MUSIC BOX TOYS; MUSICAL TOYS; PARLOR GAMES; PARTY FAVORS IN THE NATURE OF SMALL TOYS; PARTY GAMES; PLAYING CARDS; PLUSH TOYS; PUPPETS; ROLLER SKATES; RUBBER BALLS; SKATEBOARDS; SOCCER BALLS; SPINNING TOPS; SQUEEZE TOYS; STUFFED TOYS; TABLE TENNIS TABLES; TARGET GAMES; TEDDY BEARS; TENNIS BALLS; TOY ACTION FIGURES; TOY BUCKET AND SHOVEL SETS; TOY MOBILES; TOY VEHICLES; TOY SCOOTERS; TOY CARS; TOY MODEL HOBBY-CRAFT KITS; TOY FIGURES; TOY BANKS; TOY TRUCKS; TOY WATCHES; WIND-UP TOYS; YO-YOS (U.S. CLS. 22, 23, 38 AND 50).  
REBECCA GAN, EXAMINING ATTORNEY

SN 78-807,199. ROSKO, PETER J., DBA GREEN POINT LURES, NAPLES, FL. FILED 2-3-2006.

**CRIPPLED HERRING**

THE MARK CONSISTS OF STANDARD CHARACTERS WITHOUT CLAIM TO ANY PARTICULAR FONT, STYLE, SIZE, OR COLOR.

OWNER OF U.S. REG. NO. 1,861,032.

NO CLAIM IS MADE TO THE EXCLUSIVE RIGHT TO USE "HERRING", APART FROM THE MARK AS SHOWN. SEC. 2(F).

FOR FISHING LURES (U.S. CLS. 22, 23, 38 AND 50).

FIRST USE 10-0-1986; IN COMMERCE 10-0-1986.

GILBERT SWIFT, EXAMINING ATTORNEY

SN 78-811,354. ESPO ENTERTAINMENT, LLC, MIAMI, FL. FILED 2-9-2006.

**Cara Bean**

THE MARK CONSISTS OF STANDARD CHARACTERS WITHOUT CLAIM TO ANY PARTICULAR FONT, STYLE, SIZE, OR COLOR.

NO CLAIM IS MADE TO THE EXCLUSIVE RIGHT TO USE "BEAN", APART FROM THE MARK AS SHOWN.

FOR PLUSH TOYS; MORE SPECIFICALLY A PLUSH TOY FILLED WITH COFFEE BEANS (U.S. CLS. 22, 23, 38 AND 50).

STEVEN JACKSON, EXAMINING ATTORNEY

**CLASS 28—(Continued).**

SN 78-811,366. ESPO ENTERTAINMENT, LLC, MIAMI, FL.  
FILED 2-9-2006.

## Blue Mon-Ton

THE MARK CONSISTS OF STANDARD CHARACTERS WITHOUT CLAIM TO ANY PARTICULAR FONT, STYLE, SIZE, OR COLOR.

NO CLAIM IS MADE TO THE EXCLUSIVE RIGHT TO USE "BLUE", APART FROM THE MARK AS SHOWN.

FOR PLUSH TOYS; MORE SPECIFICALLY A PLUSH TOY FILLED WITH COFFEE BEANS (U.S. CLS. 22, 23, 38 AND 50).

STEVEN JACKSON, EXAMINING ATTORNEY

**CLASS 28—(Continued).**

SN 78-811,651. ESPO ENTERTAINMENT, LLC, MIAMI, FL.  
FILED 2-9-2006.

## Erin Go Bear

THE MARK CONSISTS OF STANDARD CHARACTERS WITHOUT CLAIM TO ANY PARTICULAR FONT, STYLE, SIZE, OR COLOR.

NO CLAIM IS MADE TO THE EXCLUSIVE RIGHT TO USE "BEAR", APART FROM THE MARK AS SHOWN.

FOR PLUSH TOYS; MORE SPECIFICALLY A PLUSH TOY FILLED WITH COFFEE BEANS (U.S. CLS. 22, 23, 38 AND 50).

STEVEN JACKSON, EXAMINING ATTORNEY

SN 78-811,371. ESPO ENTERTAINMENT, LLC, MIAMI, FL.  
FILED 2-9-2006.

## Momona Kona

THE MARK CONSISTS OF STANDARD CHARACTERS WITHOUT CLAIM TO ANY PARTICULAR FONT, STYLE, SIZE, OR COLOR.

"THE FOREIGN WORDING IN THE MARK TRANSLATES INTO ENGLISH AS "SWEET KONA"."

FOR PLUSH TOYS; MORE SPECIFICALLY A PLUSH TOY FILLED WITH COFFEE BEANS (U.S. CLS. 22, 23, 38 AND 50).

STEVEN JACKSON, EXAMINING ATTORNEY

SN 78-811,687. ESPO ENTERTAINMENT, LLC, MIAMI, FL.  
FILED 2-9-2006.

## Brewster Bean

THE MARK CONSISTS OF STANDARD CHARACTERS WITHOUT CLAIM TO ANY PARTICULAR FONT, STYLE, SIZE, OR COLOR.

NO CLAIM IS MADE TO THE EXCLUSIVE RIGHT TO USE "BEAN", APART FROM THE MARK AS SHOWN.

FOR PLUSH TOYS; MORE SPECIFICALLY A PLUSH TOY FILLED WITH COFFEE BEANS (U.S. CLS. 22, 23, 38 AND 50).

FIRST USE 10-15-2005; IN COMMERCE 10-15-2005.

STEVEN JACKSON, EXAMINING ATTORNEY

SN 78-811,638. ESPO ENTERTAINMENT, LLC, MIAMI, FL.  
FILED 2-9-2006.

## Carmela Macchiato

THE MARK CONSISTS OF STANDARD CHARACTERS WITHOUT CLAIM TO ANY PARTICULAR FONT, STYLE, SIZE, OR COLOR.

"THE NAME(S), PORTRAIT(S), AND/OR SIGNATURE(S) SHOWN IN THE MARK DOES NOT IDENTIFY A PARTICULAR LIVING INDIVIDUAL."

FOR PLUSH TOYS; MORE SPECIFICALLY A PLUSH TOY FILLED WITH COFFEE BEANS (U.S. CLS. 22, 23, 38 AND 50).

STEVEN JACKSON, EXAMINING ATTORNEY

SN 78-811,844. GREENBRIER INTERNATIONAL, INC.,  
CHESAPEAKE, VA. FILED 2-10-2006.

## H2O Blasters

THE MARK CONSISTS OF STANDARD CHARACTERS WITHOUT CLAIM TO ANY PARTICULAR FONT, STYLE, SIZE, OR COLOR.

NO CLAIM IS MADE TO THE EXCLUSIVE RIGHT TO USE "H2O", APART FROM THE MARK AS SHOWN.

FOR WATER PISTOLS; WATER SQUIRTING TOYS (U.S. CLS. 22, 23, 38 AND 50).

FIRST USE 9-0-2002; IN COMMERCE 11-0-2002.

ALAIN LAPTER, EXAMINING ATTORNEY

**CLASS 28—(Continued).**

SN 78-817,021. MATTEL, INC., EL SEGUNDO, CA. FILED 2-16-2006.

**INDESTRUCKTABLE**

THE MARK CONSISTS OF STANDARD CHARACTERS WITHOUT CLAIM TO ANY PARTICULAR FONT, STYLE, SIZE, OR COLOR.

FOR TOYS, GAMES AND PLAYTHINGS, NAMELY, TOY VEHICLES, TOY VEHICLE PLAYSETS, TOY VEHICLE TRACK SETS, AND ACCESSORIES FOR ALL OF THE FOREGOING (U.S. CLS. 22, 23, 38 AND 50).

ELIZABETH J. WINTER, EXAMINING ATTORNEY

SN 78-818,305. BARKING PENGUINS, LLC, PINECREST, FL. FILED 2-18-2006.

**PLAYZZLE**

THE MARK CONSISTS OF STANDARD CHARACTERS WITHOUT CLAIM TO ANY PARTICULAR FONT, STYLE, SIZE, OR COLOR.

FOR BOARD GAMES, PUZZLES (U.S. CLS. 22, 23, 38 AND 50).

FIRST USE 8-2-2005; IN COMMERCE 11-1-2005.  
LESLEY LAMOTHE, EXAMINING ATTORNEY

SN 78-818,325. BARKING PENGUINS, LLC, PINECREST, FL. FILED 2-18-2006.

**FROM THE GECKO**

THE MARK CONSISTS OF STANDARD CHARACTERS WITHOUT CLAIM TO ANY PARTICULAR FONT, STYLE, SIZE, OR COLOR.

FOR BOARD GAMES, PUZZLES (U.S. CLS. 22, 23, 38 AND 50).

FIRST USE 8-0-2004; IN COMMERCE 1-0-2006.  
LESLEY LAMOTHE, EXAMINING ATTORNEY

**CLASS 28—(Continued).**

SN 78-820,630. MATTEL, INC., EL SEGUNDO, CA. FILED 2-22-2006.

**THE POWER OF STRENGTH**

THE MARK CONSISTS OF STANDARD CHARACTERS WITHOUT CLAIM TO ANY PARTICULAR FONT, STYLE, SIZE, OR COLOR.

FOR TOYS, GAMES AND PLAYTHINGS, NAMELY, TOY ACTION FIGURES, TOY FIGURES, AND ACCESSORIES FOR ALL OF THE FOREGOING (U.S. CLS. 22, 23, 38 AND 50).

FIRST USE 6-29-2006; IN COMMERCE 6-29-2006.

WON TEAK OH, EXAMINING ATTORNEY

SN 78-824,525. MATTEL, INC., EL SEGUNDO, CA. FILED 2-27-2006.

**MOUSE'S MOUSTACHE**

THE MARK CONSISTS OF STANDARD CHARACTERS WITHOUT CLAIM TO ANY PARTICULAR FONT, STYLE, SIZE, OR COLOR.

FOR TOYS, GAMES AND PLAYTHINGS, NAMELY, TOY VEHICLES AND TOY VEHICLE ACCESSORIES (U.S. CLS. 22, 23, 38 AND 50).

FIRST USE 1-8-2007; IN COMMERCE 1-8-2007.

WON TEAK OH, EXAMINING ATTORNEY

SN 78-829,552. RIVER ROAD CREATIONS, INC., STEVENSVILLE, MT. FILED 3-5-2006.

**STP Frog**

THE MARK CONSISTS OF STANDARD CHARACTERS WITHOUT CLAIM TO ANY PARTICULAR FONT, STYLE, SIZE, OR COLOR.

NO CLAIM IS MADE TO THE EXCLUSIVE RIGHT TO USE "FROG", APART FROM THE MARK AS SHOWN.

FOR FISHING LURES; FISHING LURE PARTS, NAMELY, FLY BODIES, FLY WINGS, INSECT BODIES AND WINGS AND ANIMAL BODY PARTS USED IN FISHING, NATURAL AND SYNTHETIC MATERIALS INTENDED FOR ATTACHMENT TO FISHING HOOKS, LINES OR LEADERS USED FOR FISHING (U.S. CLS. 22, 23, 38 AND 50).

FIRST USE 9-15-2003; IN COMMERCE 12-13-2006.

TOBY BULLOFF, EXAMINING ATTORNEY

**CLASS 28—(Continued).**

SN 78-846,085. IMPERIAL TOY LLC, LOS ANGELES, CA. FILED 3-24-2006.

# WHAT ELSE?

THE MARK CONSISTS OF STANDARD CHARACTERS WITHOUT CLAIM TO ANY PARTICULAR FONT, STYLE, SIZE, OR COLOR.

FOR TOYS AND GAMES, NAMELY HAND-HELD UNITS FOR PLAYING VIDEO GAMES (U.S. CLS. 22, 23, 38 AND 50).

MARK T. MULLEN, EXAMINING ATTORNEY

**CLASS 28—(Continued).**

SN 78-868,639. LUSTBADER, SCOTT, NEW YORK, NY. FILED 4-25-2006.

# WILL POWER

THE MARK CONSISTS OF STANDARD CHARACTERS WITHOUT CLAIM TO ANY PARTICULAR FONT, STYLE, SIZE, OR COLOR.

FOR STUFFED TOYS FEATURING THE REPRESENTATION OF A FICTIONAL SUPERHERO CHARACTER AND ACCESSORIES THEREFOR (U.S. CLS. 22, 23, 38 AND 50).

AMY GEARIN, EXAMINING ATTORNEY

SN 78-853,234. MDR OUTDOOR GROUP, INC., EVANS CITY, PA. FILED 4-4-2006.

# EARLY BUCK

THE MARK CONSISTS OF STANDARD CHARACTERS WITHOUT CLAIM TO ANY PARTICULAR FONT, STYLE, SIZE, OR COLOR.

NO CLAIM IS MADE TO THE EXCLUSIVE RIGHT TO USE "BUCK", APART FROM THE MARK AS SHOWN.

FOR ANIMAL ATTRACTANT COMPOSITIONS FEATURING SCENT ENHANCEMENT GRANULES MIXED WITH A SYNTHETIC OR NATURAL ANIMAL ATTRACTANT SCENT (U.S. CLS. 22, 23, 38 AND 50).

FIRST USE 2-2-2006; IN COMMERCE 2-2-2006.  
LOURDES AYALA, EXAMINING ATTORNEY

SN 78-881,969. MATTEL, INC., EL SEGUNDO, CA. FILED 5-11-2006.



FOR TOYS, GAMES AND PLAYTHINGS, NAMELY, DOLLS, DOLL CLOTHING AND DOLL ACCESSORIES, TOY FIGURES AND ACCESSORIES THEREFOR (U.S. CLS. 22, 23, 38 AND 50).

FIRST USE 10-10-2006; IN COMMERCE 10-10-2006.  
TARAH HARDY, EXAMINING ATTORNEY

SN 78-867,982. MATTEL, INC., EL SEGUNDO, CA. FILED 4-24-2006.

# HIGHWAY HORROR

THE MARK CONSISTS OF STANDARD CHARACTERS WITHOUT CLAIM TO ANY PARTICULAR FONT, STYLE, SIZE, OR COLOR.

FOR TOYS, GAMES AND PLAYTHINGS, NAMELY, TOY VEHICLES AND ACCESSORIES THEREFOR (U.S. CLS. 22, 23, 38 AND 50).

FIRST USE 12-31-2006; IN COMMERCE 12-31-2006.  
MELVIN AXILBUND, EXAMINING ATTORNEY

SN 78-889,119. MATTEL, INC., EL SEGUNDO, CA. FILED 5-22-2006.

# N.S.E.C.T SWARM

THE MARK CONSISTS OF STANDARD CHARACTERS WITHOUT CLAIM TO ANY PARTICULAR FONT, STYLE, SIZE, OR COLOR.

FOR TOYS, GAMES, AND PLAYTHINGS, NAMELY, RADIO-CONTROLLED TOY VEHICLES, TOY VEHICLES AND ACCESSORIES FOR ALL OF THE FOREGOING (U.S. CLS. 22, 23, 38 AND 50).

ROBERT C. CLARK JR., EXAMINING ATTORNEY

**CLASS 28—(Continued).**

SN 78-899,847. THE KIMIK ENTERPRISE, INC., REDFORD, MI. FILED 6-3-2006.

**PAPER FOOTBALL LEAGUE**

THE MARK CONSISTS OF STANDARD CHARACTERS WITHOUT CLAIM TO ANY PARTICULAR FONT, STYLE, SIZE, OR COLOR.

NO CLAIM IS MADE TO THE EXCLUSIVE RIGHT TO USE "PAPER FOOTBALL", APART FROM THE MARK AS SHOWN.

FOR BOARD GAMES (U.S. CLS. 22, 23, 38 AND 50).  
ELLEN BURNS, EXAMINING ATTORNEY

SN 78-903,489. JBS FISHING LINE, LLC, PELL CITY, AL. FILED 6-8-2006.

**VICIOUS**

THE MARK CONSISTS OF STANDARD CHARACTERS WITHOUT CLAIM TO ANY PARTICULAR FONT, STYLE, SIZE, OR COLOR.

FOR FISHING LINES; FISHING LURES; FISHING TACKLE (U.S. CLS. 22, 23, 38 AND 50).  
CAROL SPILS, EXAMINING ATTORNEY

SN 78-903,564. CHRYSTAL, W. JEFF, PORTAGE, MI. FILED 6-8-2006.

**CUFF 'N CATCH**

THE MARK CONSISTS OF STANDARD CHARACTERS WITHOUT CLAIM TO ANY PARTICULAR FONT, STYLE, SIZE, OR COLOR.

FOR MULTI-SPORT ATHLETIC TRAINING DEVICE, NAMELY, A SET OF INTERCONNECTED WRIST BRACELETS (U.S. CLS. 22, 23, 38 AND 50).

CAROL SPILS, EXAMINING ATTORNEY

**CLASS 28—(Continued).**

SN 78-911,111. MATTEL, INC., EL SEGUNDO, CA. FILED 6-19-2006.

**NANO N.S.E.C.T.**

THE MARK CONSISTS OF STANDARD CHARACTERS WITHOUT CLAIM TO ANY PARTICULAR FONT, STYLE, SIZE, OR COLOR.

FOR TOYS, GAMES, AND PLAYTHINGS, NAMELY, RADIO-CONTROLLED TOY VEHICLES, TOY VEHICLES AND ACCESSORIES FOR ALL OF THE FOREGOING (U.S. CLS. 22, 23, 38 AND 50).

ROBERT C. CLARK JR., EXAMINING ATTORNEY

SN 78-927,039. DACEY, THOMAS M., BEVERLY, MA. FILED 7-11-2006.

**SIX-GUN POKER**

THE MARK CONSISTS OF STANDARD CHARACTERS WITHOUT CLAIM TO ANY PARTICULAR FONT, STYLE, SIZE, OR COLOR.

NO CLAIM IS MADE TO THE EXCLUSIVE RIGHT TO USE "POKER", APART FROM THE MARK AS SHOWN.

FOR CARD GAMES; EQUIPMENT SOLD AS A UNIT FOR PLAYING BOARD GAMES; EQUIPMENT SOLD AS A UNIT FOR PLAYING CARD GAMES; GAME EQUIPMENT, NAMELY, CHIPS; GAMING EQUIPMENT, NAMELY, POKER CHIPS; GAMING TABLES (U.S. CLS. 22, 23, 38 AND 50).

STEPHANIE DAVIS, EXAMINING ATTORNEY

SN 78-932,823. TROUT, STEVEN, TINLEY PARK, IL. FILED 7-19-2006.

**LESSON BALL**

THE MARK CONSISTS OF STANDARD CHARACTERS WITHOUT CLAIM TO ANY PARTICULAR FONT, STYLE, SIZE, OR COLOR.

NO CLAIM IS MADE TO THE EXCLUSIVE RIGHT TO USE "BALL", APART FROM THE MARK AS SHOWN.

FOR SPORT BALLS (U.S. CLS. 22, 23, 38 AND 50).

TINA KUAN, EXAMINING ATTORNEY



**CLASS 28—(Continued).**

SN 78-944,819. MILWAUKEE BREWERS BASEBALL CLUB, MILWAUKEE, WI. FILED 8-4-2006.



OWNER OF U.S. REG. NOS. 2,542,640, 2,623,286 AND OTHERS.

NO CLAIM IS MADE TO THE EXCLUSIVE RIGHT TO USE "MILWAUKEE", APART FROM THE MARK AS SHOWN.

THE FOREIGN WORDING IN THE MARK TRANSLATES INTO ENGLISH AS BREWERS.

FOR TOYS AND SPORTING GOODS, NAMELY STUFFED TOYS, PLUSH TOYS, BEAN BAG TOYS, SOFT SCULPTURE FOAM TOYS, FOAM NOVELTY ITEMS, NAMELY, FOAM FINGERS, PUPPETS; BALLOONS, CHECKER SETS, CHESS SETS, DOMINOES, CRIBBAGE GAME, BOARD GAMES, CARD GAMES, PLAYING CARDS, DART BOARDS AND DART BOARD ACCESSORIES, NAMELY, DARTS, DART SHAFTS AND DART FLIGHTS, TOY CARS AND TRUCKS, TOY MOBILES, JIGSAW AND MANIPULATIVE PUZZLES, YO-YO'S, TOY BANKS, TOY FIGURES, TOY VEHICLES, TOY AIRPLANES, DOLLS AND DOLL ACCESSORIES, BOBBING HEAD DOLLS, INFLATABLE BASEBALL BATS, DECORATIVE WIND SOCKS, FLYING DISCS, MINIATURE BASEBALL BATS, MINI BATTING HELMET REPLICAS, TOY NECKLACES, MINIATURE TOY BASEBALLS, BASEBALLS, HOLDERS FOR BASEBALLS, AUTOGRAPHED BASEBALLS, FOOTBALLS, SOFTBALLS, PLAYGROUND BALLS, RUBBER ACTION BALLS, GOLF BALLS, GOLF CLUB HEAD COVERS, GOLF CLUB BAGS, GOLF PUTTERS, BILLIARD ACCESSORIES, NAMELY, CUES, BILLIARD BALLS AND CUE CASES, BASEBALL BASES, BASEBALL BATS, CATCHER'S MASKS, GRIP TAPE FOR BASEBALL BATS, BASEBALL BATTING TEES, PINE TAR BAGS FOR BASEBALL, ROSIN BAGS FOR BASEBALL, BATTING GLOVES, BASEBALL GLOVES, BASEBALL MITTS, CHEST PROTECTORS FOR SPORTS, ATHLETIC SUPPORTERS, BASEBALL PITCHING MACHINES, INFLATABLE TOYS; BASKETBALL BACKBOARDS AND NETS; HAND HELD VIDEO AND ELECTRONIC GAMES; PARTY FAVORS IN THE NATURE OF NOISE MAKERS; COSTUME MASKS; CHRISTMAS TREE ORNAMENTS, EXCLUDING CONFECTIONERY AND ILLUMINATION ARTICLES, AND CHRISTMAS STOCKINGS (U.S. CLS. 22, 23, 38 AND 50).

C. DIONNE CLYBURN, EXAMINING ATTORNEY

SN 78-945,741. MAINSTAR, INC., WEBSTER, TX. FILED 8-5-2006.

The logo for GARFACE consists of the word "GARFACE" in a bold, serif, all-caps font. The letter "A" is significantly larger and more stylized than the other letters, with a decorative flourish extending from its base.

FOR FISHING EQUIPMENT, NAMELY FISHING TACKLE AND FISHING TACKLE CONTAINERS (U.S. CLS. 22, 23, 38 AND 50).

STEPHANIE DAVIS, EXAMINING ATTORNEY

**CLASS 28—(Continued).**

SN 78-945,978. GUAY GUAY TRADING CO., LTD., JUNGHE CITY, TAIWAN, FILED 8-7-2006.



NO CLAIM IS MADE TO THE EXCLUSIVE RIGHT TO USE "ARMAMENT", APART FROM THE MARK AS SHOWN.

THE MARK CONSIST OF THE LETTER GG WITH A RECTANGULAR DEVICE AND THE WORDS G&G ARMAMENT UNDERNEATH.

FOR PLASTIC CHARACTER TOYS; TOY GUNS; TOY PISTOLS (U.S. CLS. 22, 23, 38 AND 50).

FIRST USE 2-17-2006; IN COMMERCE 2-17-2006.

DAVID MURRAY, EXAMINING ATTORNEY

SN 78-956,036. DIVERSIFIED DYNAMICS INCORPORATED, SAN DIEGO, CA. FILED 8-20-2006.

## LITTLE BIG GYM

THE MARK CONSISTS OF STANDARD CHARACTERS WITHOUT CLAIM TO ANY PARTICULAR FONT, STYLE, SIZE, OR COLOR.

NO CLAIM IS MADE TO THE EXCLUSIVE RIGHT TO USE "GYM", APART FROM THE MARK AS SHOWN.

FOR MANUALLY-OPERATED EXERCISE EQUIPMENT (U.S. CLS. 22, 23, 38 AND 50).

JOANNA DUKOVIC, EXAMINING ATTORNEY

SN 78-957,693. HEALTHTANK, LLC, ARLINGTON, VA. FILED 8-22-2006.

## Heartdeck

THE MARK CONSISTS OF STANDARD CHARACTERS WITHOUT CLAIM TO ANY PARTICULAR FONT, STYLE, SIZE, OR COLOR.

FOR PLAYING CARDS (U.S. CLS. 22, 23, 38 AND 50).

REBECCA GAN, EXAMINING ATTORNEY

**CLASS 28—(Continued).**

SN 78-958,274. RIEBEE, LLC, CECIL, OH. FILED 8-23-2006.

**RIEBEE**

THE MARK CONSISTS OF STANDARD CHARACTERS WITHOUT CLAIM TO ANY PARTICULAR FONT, STYLE, SIZE, OR COLOR.

FOR WATER SKIPPING TOYS IN THE SHAPE OF A DISC (U.S. CLS. 22, 23, 38 AND 50).

KRISTINA KLOIBER, EXAMINING ATTORNEY

---

SN 78-958,327. MENDLESTEIN, RICHARD, ANSONIA, CT. FILED 8-23-2006.



THE COLOR(S) RED AND BLACK IS/ARE CLAIMED AS A FEATURE OF THE MARK.

THE MARK CONSISTS OF THE LETTERS AA WITH THE FIRST A IN BLACK AND THE SECOND A IN RED, IN THE CENTER OF A CIRCULAR PATTERN COMPRISED OF THE WORD DOUBLE IN RED AT THE TOP OF THE CIRCULAR PATTERN AND THE WORD ACES IN BLACK AT THE BOTTOM OF THE CIRCULAR PATTERN WITH THE WORDS CONNECTED ON EACH SIDE BY PLAYING CARD DESIGNS OF DIAMONDS AND HEARTS IN RED AND CLUBS AND SPADES IN BLACK.

FOR GAMES AND PLAYTHINGS NAMELY CASINO GAMBLING TABLE PLAYING CARD GAMES (U.S. CLS. 22, 23, 38 AND 50).

JAMES LOVELACE, EXAMINING ATTORNEY

---

SN 78-958,928. MULDER, DAVID L., WAUNAKEE, WI. FILED 8-23-2006.

**URD**

THE MARK CONSISTS OF STANDARD CHARACTERS WITHOUT CLAIM TO ANY PARTICULAR FONT, STYLE, SIZE, OR COLOR.

FOR TOY FIGURES (U.S. CLS. 22, 23, 38 AND 50).

WILLIAM ROSSMAN, EXAMINING ATTORNEY

**CLASS 28—(Continued).**

SN 78-959,414. OUT OF THE BOX PUBLISHING, INC., RICHLAND CENTER, WI. FILED 8-24-2006.

**BUMPER CROP**

THE MARK CONSISTS OF STANDARD CHARACTERS WITHOUT CLAIM TO ANY PARTICULAR FONT, STYLE, SIZE, OR COLOR.

FOR BOARD GAMES (U.S. CLS. 22, 23, 38 AND 50).

AMOS T. MATTHEWS, JR., EXAMINING ATTORNEY

---

SN 78-959,505. SIMTEC COMPANY, IRWIN, PA. FILED 8-24-2006.

**Carpet Cruisers**

THE MARK CONSISTS OF STANDARD CHARACTERS WITHOUT CLAIM TO ANY PARTICULAR FONT, STYLE, SIZE, OR COLOR.

NO CLAIM IS MADE TO THE EXCLUSIVE RIGHT TO USE "CARPET", APART FROM THE MARK AS SHOWN.

FOR FOOT SLIDES FOR RECREATIONAL USE, NAMELY FOAM AND PLASTIC DEVICES THAT ARE STRAPPED TO THE FOOT ENABLING A PERSON TO SLIDE ON CARPETED SURFACES (U.S. CLS. 22, 23, 38 AND 50).

TRAVIS WHEATLEY, EXAMINING ATTORNEY

---

SN 78-959,570. PENN FISHING TACKLE MFG. CO., PHILADELPHIA, PA. FILED 8-24-2006.

**INTERNATIONAL TORQUE**

THE MARK CONSISTS OF STANDARD CHARACTERS WITHOUT CLAIM TO ANY PARTICULAR FONT, STYLE, SIZE, OR COLOR.

OWNER OF U.S. REG. NOS. 1,016,079, 1,675,235 AND 2,987,746.

FOR FISHING TACKLE, NAMELY FISHING REELS (U.S. CLS. 22, 23, 38 AND 50).

DAVID ELTON, EXAMINING ATTORNEY

**CLASS 28—(Continued).**

SN 78-959,591. HIT THE PIT, LLC, WEST HOLLYWOOD, CA.  
FILED 8-24-2006.

**HIT THE PIT**

THE MARK CONSISTS OF STANDARD CHARACTERS WITHOUT CLAIM TO ANY PARTICULAR FONT, STYLE, SIZE, OR COLOR.

FOR TARGET GAMES, BOARD GAMES, CARD GAMES, AND PLAYING CARDS; KITES; TOY ACTION FIGURES, TOY FIGURES, NAMELY MINIATURE ARTICULATED FIGURES, PINBALL MACHINES, BOBBING HEAD DOLLS, SNOWBOARDS, SURFBOARDS AND SNOW SLEDS USED FOR RECREATION; DISC TYPE TOSS TOYS; TOY BOWS AND ARROWS; FOOTBALLS AND BASEBALLS; DOLLS, DOLL PLAYSETS, PLUSH TOYS; TOY VEHICLES, TOY CARS, TOY TRUCKS, TOY BUCKET AND SHOVEL SETS, ROLLER SKATES, TOY MODEL HOBBYCRAFT KITS, TOY ROCKETS, TOY GUNS, TOY HOLSTERS, MUSICAL TOYS, JIGSAW PUZZLES, BADMINTON SETS, BUBBLE MAKING WANDS AND SOLUTION SETS, TOY BANKS, PUPPETS, TOY BALLOONS, SKATEBOARDS, TOY SCOOTERS, STAND ALONE VIDEO GAME MACHINES; LCD GAME MACHINES; HAND-HELD COMPUTER GAMES AND HAND HELD UNIT FOR PLAYING ELECTRONIC GAMES (U.S. CLS. 22, 23, 38 AND 50).

DAVID ELTON, EXAMINING ATTORNEY

**CLASS 28—(Continued).**

SN 78-961,430. STEVEN C LINDLOF, FORT WORTH, TX.  
FILED 8-28-2006.

**Poker Weight**

THE MARK CONSISTS OF STANDARD CHARACTERS WITHOUT CLAIM TO ANY PARTICULAR FONT, STYLE, SIZE, OR COLOR.

NO CLAIM IS MADE TO THE EXCLUSIVE RIGHT TO USE "POKER", APART FROM THE MARK AS SHOWN.

FOR POKER CARD GUARDS (U.S. CLS. 22, 23, 38 AND 50).

FIRST USE 5-23-2006; IN COMMERCE 5-23-2006.

ZACHARY BELLO, EXAMINING ATTORNEY

SN 78-960,160. ARAUJO, JALMAR C., WINTHROP, MA.  
FILED 8-24-2006.

**FLEXIBRACE**

FOR ATHLETIC SPORTING GOODS, NAMELY, ATHLETIC WRIST AND JOINT SUPPORTS (U.S. CLS. 22, 23, 38 AND 50).

REBECCA POVARCHUK, EXAMINING ATTORNEY

SN 78-962,211. BAUM, JARED M., ASHTON, ID. FILED 8-28-2006.

**WHITE KNUCKLE**

SN 78-960,935. BATES, GLENDA, WEST PALM BEACH, FL.  
FILED 8-25-2006.

**RX FOR SOULMATES**

THE MARK CONSISTS OF STANDARD CHARACTERS WITHOUT CLAIM TO ANY PARTICULAR FONT, STYLE, SIZE, OR COLOR.

FOR EQUIPMENT SOLD AS A UNIT FOR PLAYING A BOARD GAME (U.S. CLS. 22, 23, 38 AND 50).

ELLEN BURNS, EXAMINING ATTORNEY

THE MARK CONSISTS OF A STYLIZED REPRESENTATION OF A HAND GRASPING A FISH BY THE MOUTH ENCLOSED WITHIN A CIRCLE AND THE WORDING WHITE KNUCKLE.

FOR ARTIFICIAL FISHING LURES; FISHING CREELS; FISHING LINES; FISHING LURES; FISHING ROD HOLDERS; FISHING SPINNERS; FISHING TACKLE; FISHING TACKLE BOXES; LURES FOR FISHING (U.S. CLS. 22, 23, 38 AND 50).

AMY ALFIERI, EXAMINING ATTORNEY

**CLASS 28—(Continued).**

SN 78-962,276. ELEMENT 21 CORPORATION, TORONTO, CANADA, FILED 8-28-2006.

# EMC2

THE MARK CONSISTS OF STANDARD CHARACTERS WITHOUT CLAIM TO ANY PARTICULAR FONT, STYLE, SIZE, OR COLOR.

FOR SPORTING GOODS NAMELY, LACROSSE STICKS, BASEBALL AND SOFTBALL BATS, TENNIS RACKETS, RACQUETBALL RACKETS, BADMINTON RACKETS, POLE VAULT POLES, FISHING POLES, SKI POLES, SKI AND SNOWBOARD EDGING, SNOW SLEDS FOR RECREATIONAL USE, FENCING HARNESSSES, PARAGLIDING FRAMES, SAIL BOARD FOOT RESTRAINTS, SAIL BOARD FOOT STRAPS, SAIL BOARD LEASHES, SAIL BOARD MASTS, SAIL BOARDS, AND SAILS AND SAILBOARDS FOR BOARDSAILING; GOLF EQUIPMENT NAMELY, GOLF CLUBS, GOLF CLUB COVERS, AND GOLF BAGS; GOLF PUTTING AIDS NAMELY, PRACTICE PUTTERS, CLUB HEAD GUIDE ATTACHMENTS, PRACTICE MATS, AND ELECTRIC PUTTING CUPS; GOLF SWING AIDS NAMELY, PRACTICE CLUBS, WEIGHTED CLUBS, HINGED CLUBS, LASER SWING TRAINERS, SWING FRAMES, PRACTICE MATS, AND PRACTICE NETS; GOLF ACCESSORIES, NAMELY, GOLF BALLS, GOLF BALL MARKERS, GOLF BALL SLEEVES, GOLF TEES, DIVOT REPAIR TOOLS, GOLF BAG PEGS, GOLF BAG TAGS, GOLF TOWEL CLIPS FOR ATTACHMENT TO GOLF BAGS, AND GOLF ACCESSORY POUCHES; HOCKEY EQUIPMENT NAMELY, HOCKEY STICKS; HOCKEY SKATE COMPONENTS, NAMELY, SKATE BLADES, SKATE FRAMES, SKATE WHEELS, SKATE WHEEL HUBS, SKATE WHEEL BALL BEARINGS, SKATE WHEEL AXLES, AND SKATE BRAKES; SKATEBOARD COMPONENTS, NAMELY, SKATEBOARD DECKS, SKATEBOARD SKIDS, SKATEBOARD TRUCKS, SKATEBOARD WHEELS, SKATEBOARD WHEEL HUBS, SKATEBOARD WHEEL BALL BEARINGS, AND SKATEBOARD WHEEL AXLES; EXERCISE EQUIPMENT AND COMPONENTS NAMELY, EXERCISE MACHINES, ROWING MACHINES, STATIONARY CYCLES, TREADMILLS, AND ELLIPTICAL TRAINERS (U.S. CLS. 22, 23, 38 AND 50).

JUSTINE D. PARKER, EXAMINING ATTORNEY

**CLASS 28—(Continued).**

SN 78-962,277. ELEMENT 21 CORPORATION, TORONTO, CANADA, FILED 8-28-2006.

# V12

THE MARK CONSISTS OF STANDARD CHARACTERS WITHOUT CLAIM TO ANY PARTICULAR FONT, STYLE, SIZE, OR COLOR.

FOR SPORTING GOODS NAMELY, LACROSSE STICKS, BASEBALL AND SOFTBALL BATS, TENNIS RACKETS, RACQUETBALL RACKETS, BADMINTON RACKETS, POLE VAULT POLES, FISHING POLES, SKI POLES, SKI AND SNOWBOARD EDGING, SNOW SLEDS FOR RECREATIONAL USE, FENCING HARNESSSES, PARAGLIDING FRAMES, SAIL BOARD FOOT RESTRAINTS, SAIL BOARD FOOT STRAPS, SAIL BOARD LEASHES, SAIL BOARD MASTS, SAIL BOARDS, AND SAILS AND SAILBOARDS FOR BOARDSAILING; GOLF EQUIPMENT NAMELY, GOLF CLUBS, GOLF CLUB COVERS, AND GOLF BAGS; GOLF PUTTING AIDS NAMELY, PRACTICE PUTTERS, CLUB HEAD GUIDE ATTACHMENTS, PRACTICE MATS, AND ELECTRIC PUTTING CUPS; GOLF SWING AIDS NAMELY, PRACTICE CLUBS, WEIGHTED CLUBS, HINGED CLUBS, LASER SWING TRAINERS, SWING FRAMES, PRACTICE MATS, AND PRACTICE NETS; GOLF ACCESSORIES, NAMELY, GOLF BALLS, GOLF BALL MARKERS, GOLF BALL SLEEVES, GOLF TEES, DIVOT REPAIR TOOLS, GOLF BAG PEGS, GOLF BAG TAGS, GOLF TOWEL CLIPS FOR ATTACHMENT TO GOLF BAGS, AND GOLF ACCESSORY POUCHES; HOCKEY EQUIPMENT NAMELY, HOCKEY STICKS; HOCKEY SKATE COMPONENTS, NAMELY, SKATE BLADES, SKATE FRAMES, SKATE WHEELS, SKATE WHEEL HUBS, SKATE WHEEL BALL BEARINGS, SKATE WHEEL AXLES, AND SKATE BRAKES; SKATEBOARD COMPONENTS, NAMELY, SKATEBOARD DECKS, SKATEBOARD SKIDS, SKATEBOARD TRUCKS, SKATEBOARD WHEELS, SKATEBOARD WHEEL HUBS, SKATEBOARD WHEEL BALL BEARINGS, AND SKATEBOARD WHEEL AXLES; EXERCISE EQUIPMENT AND COMPONENTS NAMELY, EXERCISE MACHINES, ROWING MACHINES, STATIONARY CYCLES, TREADMILLS, AND ELLIPTICAL TRAINERS (U.S. CLS. 22, 23, 38 AND 50).

JUSTINE D. PARKER, EXAMINING ATTORNEY

SN 78-962,379. BUNGEE DO BRASIL LTDA., SAO PAULO, BRAZIL, FILED 8-29-2006.

# ETERNITY HEROES

THE MARK CONSISTS OF STANDARD CHARACTERS WITHOUT CLAIM TO ANY PARTICULAR FONT, STYLE, SIZE, OR COLOR.

FOR MINIATURE TOY HELMETS; TOY ACTION FIGURES; TOY BOWS AND ARROWS; TOY SWORDS (U.S. CLS. 22, 23, 38 AND 50).

JUSTINE D. PARKER, EXAMINING ATTORNEY

**CLASS 28—(Continued).**

SN 78-962,949. MCCUTCHEON, GILBERT C., DECATUR, AL. FILED 8-29-2006.

## Safest Flip Up Server

THE MARK CONSISTS OF STANDARD CHARACTERS WITHOUT CLAIM TO ANY PARTICULAR FONT, STYLE, SIZE, OR COLOR.

NO CLAIM IS MADE TO THE EXCLUSIVE RIGHT TO USE "SAFEST" AND "SERVER", APART FROM THE MARK AS SHOWN.

FOR TENNIS TRAINING APPARATUS USED TO TEACH THE PROPER TECHNIQUE FOR SERVING (U.S. CLS. 22, 23, 38 AND 50).

MICHAEL GAAFAR, EXAMINING ATTORNEY



SN 78-963,456. DAVINCI EXPERIENCE, FALMOUTH, ME. FILED 8-30-2006.

## DAVINCI EXPERIENCE

THE MARK CONSISTS OF STANDARD CHARACTERS WITHOUT CLAIM TO ANY PARTICULAR FONT, STYLE, SIZE, OR COLOR.

FOR TOY SCIENCE KITS FOR EDUCATIONAL PURPOSES (U.S. CLS. 22, 23, 38 AND 50).

ALLISON HOLTZ, EXAMINING ATTORNEY



SN 78-963,751. THOUGHT STATION INC., ORLANDO, FL. FILED 8-30-2006.

## Thought Station

THE MARK CONSISTS OF STANDARD CHARACTERS WITHOUT CLAIM TO ANY PARTICULAR FONT, STYLE, SIZE, OR COLOR.

FOR CARD GAMES (U.S. CLS. 22, 23, 38 AND 50).

FIRST USE 5-15-2006; IN COMMERCE 6-15-2006.

ROBERT LAVACHE, EXAMINING ATTORNEY

**CLASS 28—(Continued).**

SN 78-963,762. AMERICAN NEVADA HOLDINGS, LLC, HENDERSON, NV. FILED 8-30-2006.

## AVENUE33

THE MARK CONSISTS OF STANDARD CHARACTERS WITHOUT CLAIM TO ANY PARTICULAR FONT, STYLE, SIZE, OR COLOR.

FOR MULTIPLE ACTIVITY TOYS; TOY FIGURES AND ACCESSORIES THEREFOR; SOFT SCULPTURE TOYS; TOY VEHICLES AND ACCESSORIES THEREFOR; PLUSH TOYS; TALKING TOYS; WATER SQUIRTING TOYS; WIND-UP TOYS; BENDABLE TOYS; PET TOYS; DOLLS; DOLL CLOTHING AND ACCESSORIES; ART AND DRAWING TOYS; FANTASY CHARACTER TOYS; INFANT TOYS; INFLATABLE TOYS; MUSICAL TOYS; PARTY FAVORS IN THE NATURE OF SMALL TOYS; CARD GAMES; HAND HELD UNITS FOR PLAYING VIDEO AND ELECTRONIC GAMES; DOMINOES; DARTS; DART BOARDS; BALLOONS; PROMOTIONAL GAME MATERIALS; BOWLING BALLS; BOWLING BAGS; BOWLING GLOVES; BOWLING BALL COVERS; BOWLING PINS; ATHLETIC WRIST AND JOINT SUPPORTERS; COIN-OPERATED AMUSEMENT MACHINES; ARCADE GAMES; ACTION SKILL GAMES; BOARD GAMES; JIGSAW PUZZLES; PARLOR GAMES; PARTY GAMES; GAMING EQUIPMENT, NAMELY CHIPS AND DICE; GAMING TABLES; RUBBER BALLS; SPORT BALLS; SWIM FLOATS FOR RECREATIONAL USE; AND KICK BOARD FLOTATION DEVICES FOR RECREATIONAL USE (U.S. CLS. 22, 23, 38 AND 50).

INGRID C. EULIN, EXAMINING ATTORNEY



SN 78-964,151. AMERICAN NEVADA HOLDINGS, LLC, HENDERSON, NV. FILED 8-30-2006.

## Avenue33

THE MARK CONSISTS OF AVENUE33 STYLIZED.

FOR MULTIPLE ACTIVITY TOYS; TOY FIGURES AND ACCESSORIES THEREFOR; SOFT SCULPTURE TOYS; TOY VEHICLES AND ACCESSORIES THEREFOR; PLUSH TOYS; TALKING TOYS; WATER SQUIRTING TOYS; WIND-UP TOYS; BENDABLE TOYS; PET TOYS; DOLLS; DOLL CLOTHING AND ACCESSORIES; ART AND DRAWING TOYS; FANTASY CHARACTER TOYS; INFANT TOYS; INFLATABLE TOYS; MUSICAL TOYS; PARTY FAVORS IN THE NATURE OF SMALL TOYS; CARD GAMES; HAND HELD UNITS FOR PLAYING VIDEO AND ELECTRONIC GAMES; DOMINOES; DARTS; DART BOARDS; BALLOONS; PROMOTIONAL GAME MATERIALS; BOWLING BALLS; BOWLING BAGS; BOWLING GLOVES; BOWLING BALL COVERS; BOWLING PINS; ATHLETIC WRIST AND JOINT SUPPORTERS; COIN-OPERATED AMUSEMENT MACHINES; ARCADE GAMES; ACTION SKILL GAMES; BOARD GAMES; JIGSAW PUZZLES; PARLOR GAMES; PARTY GAMES; GAMING EQUIPMENT, NAMELY CHIPS AND DICE; GAMING TABLES; RUBBER BALLS; SPORT BALLS; SWIM FLOATS FOR RECREATIONAL USE; AND KICK BOARD FLOTATION DEVICES FOR RECREATIONAL USE (U.S. CLS. 22, 23, 38 AND 50).

MICHAEL ENGEL, EXAMINING ATTORNEY

**CLASS 28—(Continued).**

SN 78-964.204. AMERICAN NEVADA HOLDINGS, LLC, HENDERSON, NV. FILED 8-30-2006.

**Avenue33**  
AT THE DISTRICT

FOR MULTIPLE ACTIVITY TOYS; TOY FIGURES AND ACCESSORIES THEREFOR; SOFT SCULPTURE TOYS; TOY VEHICLES AND ACCESSORIES THEREFOR; PLUSH TOYS; TALKING TOYS; WATER SQUIRTING TOYS; WIND-UP TOYS; BENDABLE TOYS; PET TOYS; DOLLS; DOLL CLOTHING AND ACCESSORIES; ART AND DRAWING TOYS; FANTASY CHARACTER TOYS; INFANT TOYS; INFLATABLE TOYS; MUSICAL TOYS; PARTY FAVORS IN THE NATURE OF SMALL TOYS; CARD GAMES; HAND HELD UNITS FOR PLAYING VIDEO AND ELECTRONIC GAMES; DOMINOES; DARTS; DART BOARDS; BALLOONS; PROMOTIONAL GAME MATERIALS; BOWLING BALLS; BOWLING BAGS; BOWLING GLOVES; BOWLING BALL COVERS; BOWLING PINS; ATHLETIC WRIST AND JOINT SUPPORTERS; COIN-OPERATED AMUSEMENT MACHINES; ARCADE GAMES; ACTION SKILL GAMES; BOARD GAMES; JIGSAW PUZZLES; PARLOR GAMES; PARTY GAMES; GAMING EQUIPMENT, NAMELY CHIPS AND DICE; GAMING TABLES; RUBBER BALLS; SPORT BALLS; SWIM FLOATS FOR RECREATIONAL USE; AND KICK BOARD FLOTATION DEVICES FOR RECREATIONAL USE (U.S. CLS. 22, 23, 38 AND 50).  
MICHAEL ENGEL, EXAMINING ATTORNEY

**CLASS 28—(Continued).**

SN 78-964.397. AMERICAN NEVADA HOLDINGS, LLC, HENDERSON, NV. FILED 8-30-2006.

AVENUE33 AT THE DISTRICT

THE MARK CONSISTS OF STANDARD CHARACTERS WITHOUT CLAIM TO ANY PARTICULAR FONT, STYLE, SIZE, OR COLOR.

FOR MULTIPLE ACTIVITY TOYS; TOY FIGURES AND ACCESSORIES THEREFOR; SOFT SCULPTURE TOYS; TOY VEHICLES AND ACCESSORIES THEREFOR; PLUSH TOYS; TALKING TOYS; WATER SQUIRTING TOYS; WIND-UP TOYS; BENDABLE TOYS; PET TOYS; DOLLS; DOLL CLOTHING AND ACCESSORIES; ART AND DRAWING TOYS; FANTASY CHARACTER TOYS; INFANT TOYS; INFLATABLE TOYS; MUSICAL TOYS; PARTY FAVORS IN THE NATURE OF SMALL TOYS; CARD GAMES; HAND HELD UNITS FOR PLAYING VIDEO AND ELECTRONIC GAMES; DOMINOES; DARTS; DART BOARDS; BALLOONS; PROMOTIONAL GAME MATERIALS; BOWLING BALLS; BOWLING BAGS; BOWLING GLOVES; BOWLING BALL COVERS; BOWLING PINS; ATHLETIC WRIST AND JOINT SUPPORTERS; COIN-OPERATED AMUSEMENT MACHINES; ARCADE GAMES; ACTION SKILL GAMES; BOARD GAMES; JIGSAW PUZZLES; PARLOR GAMES; PARTY GAMES; GAMING EQUIPMENT, NAMELY CHIPS AND DICE; GAMING TABLES; RUBBER BALLS; SPORT BALLS; SWIM FLOATS FOR RECREATIONAL USE; AND KICK BOARD FLOTATION DEVICES FOR RECREATIONAL USE (U.S. CLS. 22, 23, 38 AND 50).

THEODORE MCBRIDE, EXAMINING ATTORNEY

SN 78-964.441. AMERICAN NEVADA HOLDINGS, LLC, HENDERSON, NV. FILED 8-30-2006.

AVENUE33 BROWNSTONES AT THE DISTRICT

THE MARK CONSISTS OF STANDARD CHARACTERS WITHOUT CLAIM TO ANY PARTICULAR FONT, STYLE, SIZE, OR COLOR.

FOR MULTIPLE ACTIVITY TOYS; TOY FIGURES AND ACCESSORIES THEREFOR; SOFT SCULPTURE TOYS; TOY VEHICLES AND ACCESSORIES THEREFOR; PLUSH TOYS; TALKING TOYS; WATER SQUIRTING TOYS; WIND-UP TOYS; BENDABLE TOYS; PET TOYS; DOLLS; DOLL CLOTHING AND ACCESSORIES; ART AND DRAWING TOYS; FANTASY CHARACTER TOYS; INFANT TOYS; INFLATABLE TOYS; MUSICAL TOYS; PARTY FAVORS IN THE NATURE OF SMALL TOYS; CARD GAMES; HAND HELD UNITS FOR PLAYING VIDEO AND ELECTRONIC GAMES; DOMINOES; DARTS; DART BOARDS; BALLOONS; PROMOTIONAL GAME MATERIALS; BOWLING BALLS; BOWLING BAGS; BOWLING GLOVES; BOWLING BALL COVERS; BOWLING PINS; ATHLETIC WRIST AND JOINT SUPPORTERS; COIN-OPERATED AMUSEMENT MACHINES; ARCADE GAMES; ACTION SKILL GAMES; BOARD GAMES; JIGSAW PUZZLES; PARLOR GAMES; PARTY GAMES; GAMING EQUIPMENT, NAMELY CHIPS AND DICE; GAMING TABLES; RUBBER BALLS; SPORT BALLS; SWIM FLOATS FOR RECREATIONAL USE; AND KICK BOARD FLOTATION DEVICES FOR RECREATIONAL USE (U.S. CLS. 22, 23, 38 AND 50).

THEODORE MCBRIDE, EXAMINING ATTORNEY

SN 78-964.267. LOVIN, KENNETH P., DELPHOS, OH. FILED 8-30-2006.

**NIVOLK**

THE MARK CONSISTS OF STANDARD CHARACTERS WITHOUT CLAIM TO ANY PARTICULAR FONT, STYLE, SIZE, OR COLOR.

FOR BASEBALL GLOVES; BASEBALL MITTS; SOFTBALL GLOVES (U.S. CLS. 22, 23, 38 AND 50).

CHRISTINA SOBRAL, EXAMINING ATTORNEY

**CLASS 28—(Continued).**

SN 78-964,530. AMERICAN NEVADA HOLDINGS, LLC, HENDERSON, NV. FILED 8-30-2006.

*Avenue33*

BROWNSTONES AT THE DISTRICT

FOR MULTIPLE ACTIVITY TOYS; TOY FIGURES AND ACCESSORIES THEREFOR; SOFT SCULPTURE TOYS; TOY VEHICLES AND ACCESSORIES THEREFOR; PLUSH TOYS; TALKING TOYS; WATER SQUIRTING TOYS; WIND-UP TOYS; BENDABLE TOYS; PET TOYS; DOLLS; DOLL CLOTHING AND ACCESSORIES; ART AND DRAWING TOYS; FANTASY CHARACTER TOYS; INFANT TOYS; INFLATABLE TOYS; MUSICAL TOYS; PARTY FAVORS IN THE NATURE OF SMALL TOYS; CARD GAMES; HAND HELD UNITS FOR PLAYING VIDEO AND ELECTRONIC GAMES; DOMINOES; DARTS; DART BOARDS; BALLOONS; PROMOTIONAL GAME MATERIALS; BOWLING BALLS; BOWLING BAGS; BOWLING GLOVES; BOWLING BALL COVERS; BOWLING PINS; ATHLETIC WRIST AND JOINT SUPPORTERS; COIN-OPERATED AMUSEMENT MACHINES; ARCADE GAMES; ACTION SKILL GAMES; BOARD GAMES; JIGSAW PUZZLES; PARLOR GAMES; PARTY GAMES; GAMING EQUIPMENT, NAMELY CHIPS AND DICE; GAMING TABLES; RUBBER BALLS; SPORT BALLS; SWIM FLOATS FOR RECREATIONAL USE; AND KICK BOARD FLOTATION DEVICES FOR RECREATIONAL USE (U.S. CLS. 22, 23, 38 AND 50).  
MICHAEL ENGEL, EXAMINING ATTORNEY

SN 78-964,784. EXTREME TECHNOLOGIES, INC., DBA BOWTECH, EUGENE, OR. FILED 8-31-2006.

**AIROW GUN**

THE MARK CONSISTS OF STANDARD CHARACTERS WITHOUT CLAIM TO ANY PARTICULAR FONT, STYLE, SIZE, OR COLOR.

NO CLAIM IS MADE TO THE EXCLUSIVE RIGHT TO USE GUN, APART FROM THE MARK AS SHOWN.

FOR ARCHERY EQUIPMENT, NAMELY, A PNEUMATIC DEVICE ATTACHED TO AN ARCHERY BOW FOR SHOOTING SMALL PROJECTILES (U.S. CLS. 22, 23, 38 AND 50).

AMY GEARIN, EXAMINING ATTORNEY

SN 78-965,150. PINNACLE SPORTS EQUIPMENT INC., STATEN ISLAND, NY. FILED 8-31-2006.

**QUALITY FROM THE CORE**

THE MARK CONSISTS OF STANDARD CHARACTERS WITHOUT CLAIM TO ANY PARTICULAR FONT, STYLE, SIZE, OR COLOR.

FOR BASEBALL BATS AND SOFTBALL BATS (U.S. CLS. 22, 23, 38 AND 50).

JAY FLOWERS, EXAMINING ATTORNEY

**CLASS 28—(Continued).**

SN 78-965,163. GSI OPERATIONS LTD., CENTRAL, HONG KONG, FILED 8-31-2006.



THE MARK CONSISTS OF THE WORD BLUE AND AN ABSTRACT DESIGN AN X OR OF A FLOWER.

FOR SURFBOARDS (U.S. CLS. 22, 23, 38 AND 50).

FIRST USE 7-0-2006; IN COMMERCE 7-0-2006.

LINDSEY RUBIN, EXAMINING ATTORNEY

SN 78-965,382. WISNIEWSKI, ADAM ARTHUR, EVANSTON, IL. FILED 8-31-2006.

*HOTTIES*

FOR CARD GAMES; PLAYING CARD GAMES; PLAYING CARDS, PARTICULARLY CELEBRITY IMAGE PLAYING CARDS; CARD GAMES FEATURING PLAYING CARDS AND DISPOSABLE SCORE SHEETS SOLD TOGETHER AS A UNIT; GAME MATERIALS, NAMELY PROMOTIONAL GAME MATERIALS, DICE, PLAYING CARD SHUFFLING MACHINES; EQUIPMENT SOLD AS A UNIT FOR PLAYING CARD GAMES; EXPANSION PACKS OF PLAYING CARDS (U.S. CLS. 22, 23, 38 AND 50).

CHRISTINA SOBRAL, EXAMINING ATTORNEY

SN 78-966,062. NANO-SECOND TECHNOLOGY CO., LTD., TAIPEI, TAIWAN, FILED 9-1-2006.

**NSD**

THE MARK CONSISTS OF STANDARD CHARACTERS WITHOUT CLAIM TO ANY PARTICULAR FONT, STYLE, SIZE, OR COLOR.

FOR WRIST AND ANKLE WEIGHTS FOR EXERCISE; EXERCISE WRIST WEIGHTS; MANUALLY OPERATED GYROSCOPIC WRIST EXERCISER; SPORT BALLS FOR WRIST (U.S. CLS. 22, 23, 38 AND 50).

BARBARA BROWN, EXAMINING ATTORNEY

**CLASS 28—(Continued).**

SN 78-966,659. PORTABOARD, L.L.C., SANTA CLARITA, CA. FILED 9-3-2006.

**RIDE IT THEN HIDE IT**

THE MARK CONSISTS OF STANDARD CHARACTERS WITHOUT CLAIM TO ANY PARTICULAR FONT, STYLE, SIZE, OR COLOR.

FOR PORTABLE, BREAK-APART SKATEBOARD AND CARRYING CASE THEREFOR (U.S. CLS. 22, 23, 38 AND 50).

ERNEST SHOSHO, EXAMINING ATTORNEY

**CLASS 28—(Continued).**

SN 78-966,997. UNDERScore GOLF LLC, WESTERVILLE, OH. FILED 9-5-2006.

**UNDERScore**

THE MARK CONSISTS OF STANDARD CHARACTERS WITHOUT CLAIM TO ANY PARTICULAR FONT, STYLE, SIZE, OR COLOR.

FOR GOLF BALLS; GOLF CLUB GRIPS; GOLF CLUBS (U.S. CLS. 22, 23, 38 AND 50).

JAMES A. RAUEN, EXAMINING ATTORNEY

SN 78-966,661. PORTABOARD, L.L.C., SANTA CLARITA, CA. FILED 9-3-2006.

**GO IN PIECE**

THE MARK CONSISTS OF STANDARD CHARACTERS WITHOUT CLAIM TO ANY PARTICULAR FONT, STYLE, SIZE, OR COLOR.

FOR PORTABLE, BREAK-APART SKATEBOARD AND CARRYING CASE THEREFOR (U.S. CLS. 22, 23, 38 AND 50).

ERNEST SHOSHO, EXAMINING ATTORNEY

SN 78-967,325. SA-GE COLLECTIBLES, INC., CORONA, CA. FILED 9-5-2006.

**GEX**

THE MARK CONSISTS OF STANDARD CHARACTERS WITHOUT CLAIM TO ANY PARTICULAR FONT, STYLE, SIZE, OR COLOR.

FOR TRADING CARD GAMES (U.S. CLS. 22, 23, 38 AND 50).

GEOFFREY FOSDICK, EXAMINING ATTORNEY

SN 78-966,936. BATTERUP SPORTS TECH LTD., NOVA SCOTIA, CANADA, FILED 9-5-2006.

**AIRREP**

THE MARK CONSISTS OF STANDARD CHARACTERS WITHOUT CLAIM TO ANY PARTICULAR FONT, STYLE, SIZE, OR COLOR.

FOR SOFT-TOSS BASEBALL AND SOFTBALL PITCHING MACHINES; TENNIS BALL THROWING MACHINES; HOCKEY-PUCK EJECTING MACHINES; BASEBALL AND SOFTBALL PITCHING SCREENS; BASEBALL, SOFTBALL, TENNIS, AND HOCKEY PRACTICE SCREENS (U.S. CLS. 22, 23, 38 AND 50).

EMILY CARLSEN, EXAMINING ATTORNEY

SN 78-967,449. OWNER AMERICAN CORP., COSTA MESA, CA. FILED 9-5-2006.

**TWISTLOCK**

THE MARK CONSISTS OF STANDARD CHARACTERS WITHOUT CLAIM TO ANY PARTICULAR FONT, STYLE, SIZE, OR COLOR.

FOR FISHING HOOKS; FISHING LEADERS; FISHING LURES; FISHING LURES, NAMELY, PLASTIC WORMS; FISHING TACKLE; LURES FOR FISHING (U.S. CLS. 22, 23, 38 AND 50).

JASON TURNER, EXAMINING ATTORNEY



**CLASS 28—(Continued).**

SN 78-967,458. OWNER AMERICAN CORP., COSTA MESA, CA. FILED 9-5-2006.

# STINGER

THE MARK CONSISTS OF STANDARD CHARACTERS WITHOUT CLAIM TO ANY PARTICULAR FONT, STYLE, SIZE, OR COLOR.

FOR FISHING HOOKS; FISHING LEADERS; FISHING LURES; FISHING LURES, NAMELY, PLASTIC WORMS; FISHING TACKLE; LURES FOR FISHING (U.S. CLS. 22, 23, 38 AND 50).

JASON TURNER, EXAMINING ATTORNEY

**CLASS 28—(Continued).**

SN 78-967,625. YANAGITA, ROGER, LOS ANGELES, CA. FILED 9-5-2006.

# LOONY BLOX

THE MARK CONSISTS OF STANDARD CHARACTERS WITHOUT CLAIM TO ANY PARTICULAR FONT, STYLE, SIZE, OR COLOR.

NO CLAIM IS MADE TO THE EXCLUSIVE RIGHT TO USE "BLOCKS", APART FROM THE MARK AS SHOWN.

FOR INFLATABLE TOY BLOCKS (U.S. CLS. 22, 23, 38 AND 50).

ANDREA K. NADELMAN, EXAMINING ATTORNEY

SN 78-967,615. RANNAZZISI, JACK J, LAS VEGAS, NV. FILED 9-5-2006.

# Team Tubby

THE MARK CONSISTS OF STANDARD CHARACTERS WITHOUT CLAIM TO ANY PARTICULAR FONT, STYLE, SIZE, OR COLOR.

FOR SKATEBOARD DECKS (U.S. CLS. 22, 23, 38 AND 50).

MARK T. MULLEN, EXAMINING ATTORNEY

SN 78-967,813. MEZCO TOYZ, LLC, NEW YORK, NY. FILED 9-6-2006.

# We Belong Dead

THE MARK CONSISTS OF STANDARD CHARACTERS WITHOUT CLAIM TO ANY PARTICULAR FONT, STYLE, SIZE, OR COLOR.

FOR PLUSH TOYS; TOY ACTION FIGURES AND ACCESSORIES THEREFOR (U.S. CLS. 22, 23, 38 AND 50).

SUSAN STIGLITZ, EXAMINING ATTORNEY

SN 78-967,622. YANAGITA, ROGER, LOS ANGELES, CA. FILED 9-5-2006.

# LUNAR BLOX

THE MARK CONSISTS OF STANDARD CHARACTERS WITHOUT CLAIM TO ANY PARTICULAR FONT, STYLE, SIZE, OR COLOR.

NO CLAIM IS MADE TO THE EXCLUSIVE RIGHT TO USE "BLOCKS", APART FROM THE MARK AS SHOWN.

FOR INFLATABLE TOY BLOCKS (U.S. CLS. 22, 23, 38 AND 50).

ANDREA K. NADELMAN, EXAMINING ATTORNEY

SN 78-968,410. SUPERIOR PERFORMING ATHLETEZ, INC., GLENDALE, AZ. FILED 9-6-2006.

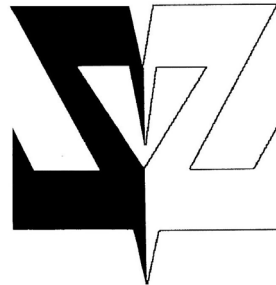

THE MARK CONSISTS OF A STYLIZED S AND Z TOUCHING ONE ANOTHER.

FOR SKATEBOARDS; SNOWBOARDS; SURFBOARDS (U.S. CLS. 22, 23, 38 AND 50).

ELISSA GARBER KON, EXAMINING ATTORNEY

**CLASS 28—(Continued).**

SN 78-969,106. MORGAN EVAN THORNE DECORATIVE PAINTING, LLC, MAPLEWOOD, MN. FILED 9-7-2006.

**CLASS 28—(Continued).**

SN 78-970,566. ATHLETIC BABY, LLC, DALLAS, TX. FILED 9-8-2006.

**STICKY PIXIES**

THE MARK CONSISTS OF STANDARD CHARACTERS WITHOUT CLAIM TO ANY PARTICULAR FONT, STYLE, SIZE, OR COLOR.

FOR HOBBY CRAFT KIT COMPRISING APPLIQUES, FABRICS, GLITTER, AND ADHESIVES (U.S. CLS. 22, 23, 38 AND 50).

TARAH HARDY, EXAMINING ATTORNEY

**LITTLE ATHLETES**

THE MARK CONSISTS OF STANDARD CHARACTERS WITHOUT CLAIM TO ANY PARTICULAR FONT, STYLE, SIZE, OR COLOR.

FOR GAMES, PLAYTHINGS AND EDUCATIONAL TOYS ALL FOR CHILDREN, NAMELY, BABY RATTLES, BOARD GAMES, CRIB MOBILES, CRIB TOYS, BABY MULTIPLE ACTIVITY TOYS, CARD GAMES, STUFFED TOY ANIMALS, CUBE, MANIPULATIVE AND JIGSAW PUZZLES, AND BATH TOYS; WATER WING SWIM AIDS FOR RECREATIONAL USE; KICKBOARD FLOTATION DEVICES FOR RECREATIONAL USE; INFLATABLE FLOTATION DEVICES FOR RECREATIONAL USE, NAMELY, TUBES AND SIMILAR-SHAPED OBJECTS; ATHLETIC EQUIPMENT, NAMELY, BALLS, GLOVES, BATS, CLUBS, RACQUETS, PROTECTIVE GUARDS AND PADS FOR BASEBALL, FOOTBALL, BASKETBALL, SOCCER, TENNIS, SWIMMING, GYMNASTICS, GOLF, ARCHERY, KARATE, AND LACROSSE; BAGS SPECIFICALLY ADAPTED FOR SPORTS EQUIPMENT; CASES FOR PLAY ACCESSORIES, EXERCISE TRAMPOLINES, INFANT DEVELOPMENTAL TOYS, INFANT EXERCISE SEATS, NAMELY, JUMPERS AND INFANT SAUCERS, JUMP ROPES, JUNGLE GYMS, PLAY MATS CONTAINING INFANT TOYS, TUMBLING MATS, AND PLAYGROUND EQUIPMENT, NAMELY, CLIMBING UNITS AND SWING SETS (U.S. CLS. 22, 23, 38 AND 50).

JOHN HWANG, EXAMINING ATTORNEY

SN 78-969,117. HOLLINGSHEAD, WYNN W., DUBLIN, OH. FILED 9-7-2006.

SN 78-970,636. BOOTON GROUP, THE, SAN JOSE, CA. FILED 9-8-2006.

**everyday people****BUTTONTONES**

THE MARK CONSISTS OF STANDARD CHARACTERS WITHOUT CLAIM TO ANY PARTICULAR FONT, STYLE, SIZE, OR COLOR.

FOR COLLECTABLE TOY FIGURES (U.S. CLS. 22, 23, 38 AND 50).

PAUL E. FAHRENKOPF, EXAMINING ATTORNEY

THE MARK CONSISTS OF STANDARD CHARACTERS WITHOUT CLAIM TO ANY PARTICULAR FONT, STYLE, SIZE, OR COLOR.

FOR TOY BUTTONS CONTAINING UPLOADABLE AND DOWNLOADABLE AUDIO CLIPS (U.S. CLS. 22, 23, 38 AND 50).

DAVID TOOLEY, EXAMINING ATTORNEY

**CLASS 28—(Continued).**

SN 78-971,504. MCPHERSON, MATTHEW A., NORWALK, WI. FILED 9-11-2006.

# MISSION

THE MARK CONSISTS OF STANDARD CHARACTERS WITHOUT CLAIM TO ANY PARTICULAR FONT, STYLE, SIZE, OR COLOR.

FOR ARCHERY BOWS (U.S. CLS. 22, 23, 38 AND 50).  
B. PARADEWELAI, EXAMINING ATTORNEY

---

SN 78-972,132. HAWKINS, LAURA JEANETTE, FAIRACRES, NM. FILED 9-12-2006.

# Gaddy Uglies

THE MARK CONSISTS OF THE WORDS CUDDLY UGLIES IN STORYBOOK TYPE.

FOR STUFFED TOYS (U.S. CLS. 22, 23, 38 AND 50).  
WENDY JUN, EXAMINING ATTORNEY

---

SN 78-974,913. AMERICAN GATEWAY MARKETING GROUP, INC., SAN JOSE, CA. FILED 9-14-2006.

# Aeromat

*#1 Mat in Fitness*

OWNER OF U.S. REG. NOS. 2,920,942 AND 2,923,427.  
NO CLAIM IS MADE TO THE EXCLUSIVE RIGHT TO USE "#1 MAT IN FITNESS", APART FROM THE MARK AS SHOWN.

THE MARK CONSISTS OF THE STYLIZED PHRASE '#1 IN FITNESS BELOW' A STYLIZED WORD 'AEROMAT' RESTING UPON A BLACK BAND WITH WHITE CIRCLES.

FOR PERSONAL EXERCISE MATS; YOGA MATS (U.S. CLS. 22, 23, 38 AND 50).

MATTHEW MCDOWELL, EXAMINING ATTORNEY

**CLASS 28—(Continued).**

SN 79-019,787. BODY SCULPTURE INTERNATIONAL EUROPE LIMITED, UNITED KINGDOM, FILED 8-30-2005.

# BODY STYLE

THE MARK CONSISTS OF STANDARD CHARACTERS WITHOUT CLAIM TO ANY PARTICULAR FONT, STYLE, SIZE, OR COLOR.

OWNER OF INTERNATIONAL REGISTRATION 0873734 DATED 8-30-2005, EXPIRES 8-30-2015.

NO CLAIM IS MADE TO THE EXCLUSIVE RIGHT TO USE "BODY", APART FROM THE MARK AS SHOWN.

FOR GYMNASTIC AND SPORTING MACHINES FOR PHYSICAL EXERCISES, NAMELY, WEIGHT LIFTING MACHINES AND BENCHES, CHEST EXPANDERS AND EXERCISERS, WRIST AND ANKLE WEIGHTS FOR EXERCISE, WEIGHT LIFTING GLOVES, TREADMILLS, BENCHES AND STAIR CLIMBERS, EXERCISE CYCLES, ROWING MACHINES; PARTS FOR THE AFORESAID GOODS (U.S. CLS. 22, 23, 38 AND 50).

RAUL CORDOVA, EXAMINING ATTORNEY

---

SN 79-022,967. PRO TACKLES S.R.L., ITALY, FILED 2-6-2006.

# molix

PRIORITY DATE OF 1-3-2006 IS CLAIMED.  
OWNER OF INTERNATIONAL REGISTRATION 0882668 DATED 2-6-2006, EXPIRES 2-6-2016.

FOR FISHING TACKLE AND EQUIPMENT NAMELY FISHING BAGS, RODS FOR FISHING, ROD HOLDERS FOR FISHING, FISHING REELS, FISHING HOOKS, ARTIFICIAL FISHING BAITS, FISHING TACKLE BAGS, FISHING TACKLE CASES, FISHING TACKLE BOXES AND FISHING TACKLE WALLETS; FISHING LINES (U.S. CLS. 22, 23, 38 AND 50).

BERYL GARDNER, EXAMINING ATTORNEY

**CLASS 28—(Continued).**

SN 79-027,901. "BALSAX" EDWARD LABOWICZ, POLAND,  
FILED 6-19-2006.



OWNER OF INTERNATIONAL REGISTRATION 0848127  
DATED 4-28-2005, EXPIRES 4-28-2015.

NO CLAIM IS MADE TO THE EXCLUSIVE RIGHT TO  
USE "CARP", APART FROM THE MARK AS SHOWN.

THE COLOR(S) YELLOW, BLACK IS/ARE CLAIMED AS  
A FEATURE OF THE MARK.

THE COLOR YELLOW APPEARS IN THE WORDING  
CARP GOLD. THE COLOR BLACK APPEARS AS LINING  
TO THE WORDING CARP GOLD.

FOR FLOATS FOR FISHING, GUTS AND LINES FOR  
FISHING, LEAD WEIGHTS FOR FISHING (U.S. CLS. 22,  
23, 38 AND 50).

TIMOTHY FINNEGAN, EXAMINING ATTORNEY

**CLASS 29—MEATS AND PROCESSED FOODS**

SN 76-370,105. EMMPAK FOODS, INC., MILWAUKEE, WI.  
FILED 2-12-2002.

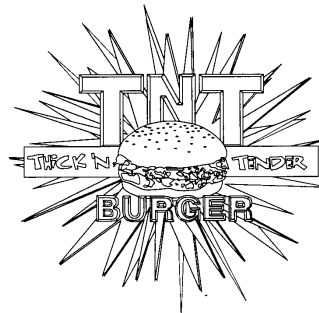

OWNER OF U.S. REG. NO. 2,189,654.

NO CLAIM IS MADE TO THE EXCLUSIVE RIGHT TO  
USE "THICK 'N TENDER BURGER" OR THE PICTORIAL  
REPRESENTATION OF THE BURGER, APART FROM THE  
MARK AS SHOWN.

THE STIPLING IS A FEATURE OF THE MARK AND  
DOES NOT INDICATE COLOR.

FOR RAW MEAT, NAMELY BEEF AND HAMBUR-  
GER, EXCLUDING MEAT SNACKS (U.S. CL. 46).  
ELIZABETH HUGHITT, EXAMINING ATTORNEY

SN 79-028,203. HEAD TECHNOLOGY GMBH, AUSTRIA,  
FILED 5-26-2006.

# METALLIX

THE MARK CONSISTS OF STANDARD CHARACTERS  
WITHOUT CLAIM TO ANY PARTICULAR FONT, STYLE,  
SIZE, OR COLOR.

PRIORITY DATE OF 1-18-2006 IS CLAIMED.

OWNER OF INTERNATIONAL REGISTRATION 0896810  
DATED 5-26-2006, EXPIRES 5-26-2016.

FOR TENNIS RACKETS AND SQUASH RACKETS;  
COVERS FOR TENNIS RACKETS AND SQUASH RACK-  
ETS (U.S. CLS. 22, 23, 38 AND 50).

LINDA POWELL, EXAMINING ATTORNEY

SN 76-655,624. KOCH FOODS INCORPORATED, PARK  
RIDGE, IL. FILED 2-24-2006.

# GAME DAY

THE MARK CONSISTS OF STANDARD CHARACTERS  
WITHOUT CLAIM TO ANY PARTICULAR FONT, STYLE,  
SIZE, OR COLOR.

FOR CHICKEN (U.S. CL. 46).

FIRST USE 9-15-2005; IN COMMERCE 9-15-2005.

ELISSA GARBER KON, EXAMINING ATTORNEY

SN 79-030,239. MARUMAN & CO., LTD., JAPAN, FILED 9-27-  
2006.

# VANQUISH

THE MARK CONSISTS OF STANDARD CHARACTERS  
WITHOUT CLAIM TO ANY PARTICULAR FONT, STYLE,  
SIZE, OR COLOR.

OWNER OF INTERNATIONAL REGISTRATION 0901894  
DATED 9-27-2006, EXPIRES 9-27-2016.

FOR GOLF CLUBS, GOLF BAGS, HEAD COVERS FOR  
GOLF CLUB (U.S. CLS. 22, 23, 38 AND 50).

CORY BOONE, EXAMINING ATTORNEY

SN 76-665,426. CAPITOL WHOLESALE MEATS, INC., CHI-  
CAGO, IL. FILED 8-30-2006.

# UNA BELLA DIFFERENZA

THE MARK CONSISTS OF STANDARD CHARACTERS  
WITHOUT CLAIM TO ANY PARTICULAR FONT, STYLE,  
SIZE, OR COLOR.

THE ENGLISH TRANSLATION OF THE ITALIAN  
WORDING "UNA BELLA DIFFERENZA" IN THE MARK  
IS "A BEAUTIFUL DIFFERENCE".

FOR PREPARED MEATS, PREPARED MEATS AND  
SAUCE SOLD AS A UNIT (U.S. CL. 46).

FIRST USE 12-1-2005; IN COMMERCE 12-1-2005.

CHARISMA HAMPTON, EXAMINING ATTORNEY

**CLASS 29—(Continued).**

SN 76-669,583. CAPITOL WHOLESALE MEATS, INC., CHICAGO, IL. FILED 11-24-2006.

**FONTANINI FARMS BABY LINKS**

THE MARK CONSISTS OF STANDARD CHARACTERS WITHOUT CLAIM TO ANY PARTICULAR FONT, STYLE, SIZE, OR COLOR.

OWNER OF U.S. REG. NOS. 1,440,340 AND 3,092,135. NO CLAIM IS MADE TO THE EXCLUSIVE RIGHT TO USE "FARMS BABY LINKS", APART FROM THE MARK AS SHOWN.

FOR SAUSAGES (U.S. CL. 46).  
CHARISMA HAMPTON, EXAMINING ATTORNEY

SN 77-007,703. J.R. SIMPLOT COMPANY, BOISE, ID. FILED 9-26-2006.

**SKINCREDIBLES**

THE MARK CONSISTS OF STANDARD CHARACTERS WITHOUT CLAIM TO ANY PARTICULAR FONT, STYLE, SIZE, OR COLOR.

FOR PROCESSED POTATOES (U.S. CL. 46).  
FIRST USE 12-9-2006; IN COMMERCE 12-9-2006.  
PETER B. BROMAGHIM, EXAMINING ATTORNEY

SN 77-042,662. STERN, BRETT, PORTLAND, OR. FILED 11-13-2006.

**ISPUDS**

THE MARK CONSISTS OF STANDARD CHARACTERS WITHOUT CLAIM TO ANY PARTICULAR FONT, STYLE, SIZE, OR COLOR.

FOR POTATO CHIPS (U.S. CL. 46).  
JENNY PARK, EXAMINING ATTORNEY

**CLASS 29—(Continued).**

SN 78-717,447. OPTIMUS, INC., MIAMI, FL. FILED 9-21-2005.



NO CLAIM IS MADE TO THE EXCLUSIVE RIGHT TO USE "FILLET", APART FROM THE MARK AS SHOWN.

THE COLOR(S) SILVER/GRAY AND BLACK IS/ARE CLAIMED AS A FEATURE OF THE MARK.

THE MARK CONSISTS OF THE WORDING FILLET ROYAL IS IN SILVER/GRAY ON BLACK BACKGROUND.

FOR SALMON (U.S. CL. 46).  
FIRST USE 9-1-2005; IN COMMERCE 9-20-2005.  
MICHELLE DUBOIS, EXAMINING ATTORNEY

SN 78-764,119. LOGAN'S ROADHOUSE, INC., NASHVILLE, TN. FILED 11-30-2005.

**ONION BREWSKI**

THE MARK CONSISTS OF STANDARD CHARACTERS WITHOUT CLAIM TO ANY PARTICULAR FONT, STYLE, SIZE, OR COLOR.

NO CLAIM IS MADE TO THE EXCLUSIVE RIGHT TO USE "ONION", APART FROM THE MARK AS SHOWN.

FOR PREPARED ENTREES CONSISTING PRIMARILY OF MEAT, FISH, POULTRY OR VEGETABLES (U.S. CL. 46).

FIRST USE 9-26-2005; IN COMMERCE 9-26-2005.  
BARBARA RUTLAND, EXAMINING ATTORNEY

SN 78-779,252. MCCAIN FOODS USA, INC., LISLE, IL. FILED 12-22-2005.

**IT'S A BEER BATTER BLITZ**

THE MARK CONSISTS OF STANDARD CHARACTERS WITHOUT CLAIM TO ANY PARTICULAR FONT, STYLE, SIZE, OR COLOR.

OWNER OF U.S. REG. NO. 2,885,173.

NO CLAIM IS MADE TO THE EXCLUSIVE RIGHT TO USE "BEER BATTER", APART FROM THE MARK AS SHOWN.

FOR PROCESSED POTATOES; BREADED AND BATTERED VEGETABLES; BREADED AND BATTERED CHEESE; BREADED AND BATTERED VEGETABLE AND CHEESE COMBINATIONS (U.S. CL. 46).

FIRST USE 8-0-2004; IN COMMERCE 8-0-2004.  
SANJEEV VOHRA, EXAMINING ATTORNEY

**CLASS 29—(Continued).**

SN 78-779,482. PREMIUM QUALITY PRODUCT, INC., LOS ANGELES, CA. FILED 12-22-2005.



NO CLAIM IS MADE TO THE EXCLUSIVE RIGHT TO USE DONKATSU AND CALIFORNIA DONKATSU, APART FROM THE MARK AS SHOWN.

THE ENGLISH TRANSLATION OF THE WORD "DONKATSU" IN THE MARK IS "PORK CUTLET".

FOR MEAT PRODUCTS THAT ARE PROCESSED, CANNED, DRIED, PRESERVED OR FERMENTED, NAMELY, BOTTLED COOKED MEAT, CANNED COOKED MEAT, DRIED MEAT, FRIED MEAT, MEAT EXTRACT, MEAT JELLIES, MEAT JUICES, MEAT PASTE, HAM, BACON, PORK CUTLETS, BOUILLON, BROTH, SAUSAGES AND HAMBURGER (U.S. CL. 46).

MONIQUE MILLER, EXAMINING ATTORNEY

SN 78-810,937. EDELSTEIN, AMNON, COMMERCE, CA. FILED 2-9-2006.

# Mr. Glatt

THE MARK CONSISTS OF STANDARD CHARACTERS WITHOUT CLAIM TO ANY PARTICULAR FONT, STYLE, SIZE, OR COLOR.

THE NAME MR. GLATT DOES NOT IDENTIFY A LIVING INDIVIDUAL.

FOR KOSHER MEAT (U.S. CL. 46).

FIRST USE 3-1-2006; IN COMMERCE 3-1-2006.

DOMINIC FATHY, EXAMINING ATTORNEY

SN 78-812,228. HERITAGE FARE, LTD., CLEVELAND, OH. FILED 2-10-2006.

# NutriGras

THE MARK CONSISTS OF STANDARD CHARACTERS WITHOUT CLAIM TO ANY PARTICULAR FONT, STYLE, SIZE, OR COLOR.

FOR EDIBLE OIL REPLACER AND FOOD ADDITIVE COMPRISING A NON-SEPARABLE STARCH LIPID COMPOSITE (U.S. CL. 46).

MICHAEL KEATING, EXAMINING ATTORNEY

**CLASS 29—(Continued).**

SN 78-833,378. THE MOODSTERS COMPANY, MINNEAPOLIS, MN. FILED 3-9-2006.

## CHUBBY BUSTERS

THE MARK CONSISTS OF STANDARD CHARACTERS WITHOUT CLAIM TO ANY PARTICULAR FONT, STYLE, SIZE, OR COLOR.

FOR FRUIT-BASED SNACK FOOD, PROCESSED VEGETABLES, PROCESSED FRUITS, SOUP, YOGURT, MILK, CHEESE, CHEESE SNACKS, NAMELY, CHEESE SLICES, CHEESE STICKS AND CHEESE NUGGETS, REFRIGERATED, FROZEN OR SHELF STABLE MEALS CONSISTING PRIMARILY OF MEAT, SEAFOOD, VEGETABLES, AND OR CHEESE (U.S. CL. 46).

BRENDAN MCCAULEY, EXAMINING ATTORNEY

SN 78-850,566. GRASAS VEGETALES SA DE CV, GUADALAJARA, MEXICO, FILED 3-30-2006.



NO CLAIM IS MADE TO THE EXCLUSIVE RIGHT TO USE "KOSHER," "PAREVE," "ACEITE COMESTIBLE PURO DE SOYA," "SIN OLOR," "CONTIENE VITAMINA E," "CONTIENE OMEGA 3 Y 6 ACIDOS GRASOS ESENCIALES," "ASOCIACION AMERICANA DE SOYA CALIDAD," AND "POR SU ORIGEN VEGETAL NO CONTIENE COLESTEROL", APART FROM THE MARK AS SHOWN.

THE COLOR(S) GREEN, WHITE, RED, GOLD, BLACK AND BLUE IS/ARE CLAIMED AS A FEATURE OF THE MARK.

THE MARK CONSISTS OF THE COLOR GREEN APPEARS AS THE BACKGROUND FOR THE ENTIRE DESIGN AND THE INSIDE OF THE SHIELD DESIGN CONTAINING THE WORD "HOGAR." THE COLOR WHITE APPEARS AS BACKGROUND OF THE FARM DESIGN IN THE CENTER OF THE MARK AND THE SOYBEAN/CHECKMARK DESIGN IN THE UPPER RIGHT OF THE MARK, IN THE WORDING "HOGAR," "CONTIENE VITAMINA E," "POR SU ORIGEN VEGETAL NO CONTIENE COLESTEROL," "ASOCIACION AMERICANA DE SOYA CALIDAD," AND AS THE OUTLINE FOR THE WORDING "CONTIENE OMEGA 3 Y 6 ACIDOS GRASOS ESENCIALES," "KOSHER" AND "PAREVE," AND AS THE OUTLINE FOR THE "VK" DESIGN ON THE RIGHT SIDE OF THE MARK, THE SHIELD DESIGN IN THE LOWER PART OF THE MARK, AND THE FARM DESIGN IN THE CENTER. THE COLOR RED APPEARS IN THE OUTLINE OF THE ENTIRE DESIGN, THE WORDING "CONTIENE OMEGA 3 Y 6 ACIDOS GRASOS ESENCIALES" (EXCEPT FOR THE "Y" AND "G") THE CHECK MARK ON THE UPPER RIGHT SIDE OF THE MARK, AND THE ELONGATED OVALS COMPRISING THE BACKGROUND FOR THE WORDING "CONTIENE VITAMINA E" AND "ACEITE COMESTIBLE PURO DE SOYA" NEAR THE TOP AND BOTTOM OF THE MARK, RESPECTIVELY. THE COLOR GOLD APPEARS IN THE FARM DESIGN, THE SOYBEAN DESIGN IN THE

**CLASS 29—(Continued).**

UPPER RIGHT SIDE OF THE MARK, THE WORDING "CONT. NET. 1 LITRO," AND THE BANNER DESIGN COMPRISING THE BACKGROUND FOR THE WORDING "SIN OLOR" IN THE UPPER LEFT SIDE OF THE MARK. THE COLOR BLACK APPEARS AS THE SHADING BENEATH THE LETTERING IN THE WORD "HOGAR." THE LETTERING IN THE WORDING "SIN OLOR," THE CIRCLE DESIGN COMPRISING THE BACKGROUND FOR THE WORDING "ASOCIACION AMERICANA DE SOYA CALDADA," AND IN THE STYLIZED "G" IN THE WORDING "OMEGA." THE COLOR BLUE APPEARS IN THE WORDING "KOSHER" AND "PAREVE," AND IN THE "VK" DESIGN ON THE RIGHT SIDE OF THE MARK, AND IN THE WORDING "Y" ON THE LEFT SIDE OF THE MARK.

THE ENGLISH TRANSLATION OF THE FOREIGN WORDING IN THE MARK IS "HOME; PURE EDIBLE SOYBEAN OIL; WITHOUT ODOR; CONTAINS VITAMIN E; CONTAINS OMEGA 3 AND 6 ESSENTIAL FATTY ACIDS; DUE TO ITS VEGETABLE ORIGIN, DOES NOT CONTAIN CHOLESTEROL; AMERICAN SOYBEAN ASSOCIATION QUALITY."

FOR EDIBLE OIL; SOYBEAN OIL (U.S. CL. 46).  
FIRST USE 1-8-1999; IN COMMERCE 1-8-1999.  
MARK PILARO, EXAMINING ATTORNEY

SN 78-904,004. ROSE ACRE FARMS, INC., SEYMOUR, IN.  
FILED 6-8-2006.

# GOOD EGG

THE MARK CONSISTS OF STANDARD CHARACTERS WITHOUT CLAIM TO ANY PARTICULAR FONT, STYLE, SIZE, OR COLOR.

OWNER OF U.S. REG. NOS. 1,237,533, 2,508,050 AND OTHERS.

FOR LIQUID EGGS AND LIQUID EGG PRODUCTS, NAMELY, NO-CHOLESTEROL EGG SUBSTITUTE AND EGG WHITES (U.S. CL. 46).

JAMES STEIN, EXAMINING ATTORNEY

SN 78-904,020. FISHERMAN'S PRIDE PROCESSOR, INC.,  
LOS ANGELES, CA. FILED 6-8-2006.



THE COLOR(S) GRAY, PURPLE, YELLOW, BLACK AND WHITE IS/ARE CLAIMED AS A FEATURE OF THE MARK.

THE COLOR GRAY APPEARS IN THE CIRCLE IN THE BACKGROUND OF THE MARK, AND THE FRAMES OF THE SHRIMP'S GLASSES. THE COLOR PURPLE APPEARS IN THE SHRIMP'S COAT, THE SHRIMP'S EYES, THE "N"

**CLASS 29—(Continued).**

IN THE SHRIMP'S CROWN, AND IN THE TIPS OF THE SHRIMP'S HAIR; THE COLOR YELLOW APPEARS IN THE SHRIMP'S CROWN, TRITON, AND TRIM OF THE SHRIMP'S COAT; THE COLOR CLACK APPEARS IN THE OUTLINE OF THE SHRIMP'S BODY AND FACE, THE OUTLINE OF THE CIRCLE IN THE BACKGROUND OF THE MARK, AND IN THE OUTLINE OF THE CROWN AND TRITON; THE COLOR WHITE APPEARS IN THE SHRIMP'S BODY, FACE, AND HANDS, AND IN THE BORDER OF THE CIRCLE IN THE BACKGROUND OF THE MARK.

THE MARK CONSISTS OF SHRIMP WITH HUMAN FACE, WEARING GLASSES, HOLDING A TRITON WITH A CROWN THAT HAS THE LETTER "N" ON IT.

FOR SHELLFISH (U.S. CL. 46).  
FIRST USE 12-1-1988; IN COMMERCE 12-1-1988.  
JUSTINE D. PARKER, EXAMINING ATTORNEY

SN 78-904,979. CUMBERLAND PACKING CORP., BROOKLYN, NY. FILED 6-9-2006.

# COCOABUTTER BUDS

THE MARK CONSISTS OF STANDARD CHARACTERS WITHOUT CLAIM TO ANY PARTICULAR FONT, STYLE, SIZE, OR COLOR.

OWNER OF U.S. REG. NOS. 2,288,378 AND 2,594,490.

NO CLAIM IS MADE TO THE EXCLUSIVE RIGHT TO USE "COCOA BUTTER", APART FROM THE MARK AS SHOWN.

FOR FOOD ADDITIVE CONTAINING COCOA BUTTER FOR USE AS A FOOD FLAVORING OR INGREDIENT (U.S. CL. 46).

FIRST USE 5-0-2004; IN COMMERCE 5-0-2004.  
FRED CARL, EXAMINING ATTORNEY

SN 78-914,123. GORTON'S INC., GLOUCESTER, MA. FILED  
6-22-2006.



OWNER OF U.S. REG. NOS. 411,843, 2,906,268 AND OTHERS.

FOR PREPACKAGED SEAFOOD DINNERS (U.S. CL. 46).

FIRST USE 6-2-2006; IN COMMERCE 6-2-2006.  
AISHA CLARKE, EXAMINING ATTORNEY

**CLASS 29—(Continued).**

SN 78-945,102. JEC CONSULTING & TRADING, INC., COLUMBIA, SC. FILED 8-4-2006.

**COLBERI FARMS**

THE MARK CONSISTS OF STANDARD CHARACTERS WITHOUT CLAIM TO ANY PARTICULAR FONT, STYLE, SIZE, OR COLOR.

NO CLAIM IS MADE TO THE EXCLUSIVE RIGHT TO USE "FARMS", APART FROM THE MARK AS SHOWN. FOR MILK; MILK PRODUCTS EXCLUDING ICE CREAM, ICE MILK AND FROZEN YOGURT (U.S. CL. 46).

FIRST USE 7-1-2006; IN COMMERCE 7-1-2006. ANTHONY RINKER, EXAMINING ATTORNEY

---

SN 78-953,560. GORTON'S INC., GLOUCESTER, MA. FILED 8-16-2006.

**FIVE STAR TILAPIA**

THE MARK CONSISTS OF STANDARD CHARACTERS WITHOUT CLAIM TO ANY PARTICULAR FONT, STYLE, SIZE, OR COLOR.

NO CLAIM IS MADE TO THE EXCLUSIVE RIGHT TO USE "TILAPIA", APART FROM THE MARK AS SHOWN. FOR PREPACKAGED SEAFOOD DINNERS (U.S. CL. 46).

AISHA CLARKE, EXAMINING ATTORNEY

---

SN 78-954,854. GORTON'S INC., GLOUCESTER, MA. FILED 8-17-2006.



OWNER OF U.S. REG. NOS. 411,843 AND 716,235. NO CLAIM IS MADE TO THE EXCLUSIVE RIGHT TO USE "TILAPIA", APART FROM THE MARK AS SHOWN. FOR PREPACKAGED SEAFOOD DINNERS (U.S. CL. 46). AISHA CLARKE, EXAMINING ATTORNEY

**CLASS 29—(Continued).**

SN 78-957,060. LYDIA TARIM URUNLERI, ALSANCAK, TURKEY, FILED 8-21-2006.

**St. Mary's**

THE MARK CONSISTS OF STANDARD CHARACTERS WITHOUT CLAIM TO ANY PARTICULAR FONT, STYLE, SIZE, OR COLOR.

FOR OLIVE OIL (U.S. CL. 46). NATALIE POLZER, EXAMINING ATTORNEY

---

SN 78-957,152. MEI YUAN PRESERVED FOODS CO., LTD., YI LAN CITY, TAIWAN, FILED 8-22-2006.



OWNER OF U.S. REG. NO. 2,086,939. THE COLOR(S) RED, WHITE AND YELLOW IS/ARE CLAIMED AS A FEATURE OF THE MARK.

THE MARK CONSISTS OF A STYLIZED WORD "MEIYUAN" AND TWO CHINESE CHARACTERS INCLUDED IN THE BODY OF A PLUM; THE WORD PART OF THE MARK IS IN THE COLOR OF WHITE, THE BODY OF THE PLUM IS IN THE COLOR OF RED, AND THE STEM OF THE PLUM IS IN THE COLOR OF YELLOW.

THE FOREIGN WORDING IN THE MARK TRANSLATES INTO ENGLISH AS BEAUTIFUL AND MONEY.

THE NON-LATIN CHARACTER(S) IN THE MARK TRANSLITERATES INTO MEI AND YUAN, AND THIS MEANS BEAUTIFUL MONEY IN ENGLISH.

FOR DEHYDRATED FRUIT SNACKS; DRIED FRUIT MIXES; DRIED FRUITS; RAISINS; DRIED FRUITS, NAMELY PRUNES, PLUMS, MANGOS, PINEAPPLES, OLIVES, BANANAS, GUAVAS, AND KUMQUATS; PROCESSED FRUITS, NAMELY PRUNES, PLUMS, MANGOS, PINEAPPLES, OLIVES, BANANAS, GUAVAS, AND KUMQUATS; PRESERVED FRUITS, NAMELY PRUNES, PLUMS, MANGOS, PINEAPPLES, OLIVES, BANANAS, GUAVAS, AND KUMQUATS (U.S. CL. 46).

FIRST USE 7-1-2001; IN COMMERCE 7-1-2006. BERNICE HOWSE, EXAMINING ATTORNEY



**CLASS 29—(Continued).**

SN 78-958,637. ASPINO INTERNATIONAL, HOUSTON, TX. FILED 8-23-2006.

# FAVOURITA

THE MARK CONSISTS OF STANDARD CHARACTERS WITHOUT CLAIM TO ANY PARTICULAR FONT, STYLE, SIZE, OR COLOR.

THE ENGLISH TRANSLATION OF THE WORD "FAVOURITA" IN THE MARK IS "FAVORITE".

FOR FROZEN FOODS, NAMELY, FROZEN MEATS, FISH, VEGETABLES AND FRUITS IMPORTED FROM INDIA (U.S. CL. 46).

JULIE GUTTADAURO, EXAMINING ATTORNEY



SN 78-959,156. STERN, BRETT, PORTLAND, OR. FILED 8-24-2006.

# Chip Shots

THE MARK CONSISTS OF STANDARD CHARACTERS WITHOUT CLAIM TO ANY PARTICULAR FONT, STYLE, SIZE, OR COLOR.

FOR POTATO CHIPS (U.S. CL. 46).

JENNY PARK, EXAMINING ATTORNEY



SN 78-959,537. DR PARSONS DAIRY, LLC, DULUTH, GA. FILED 8-24-2006.

# ORANGE SPARKLE

THE MARK CONSISTS OF STANDARD CHARACTERS WITHOUT CLAIM TO ANY PARTICULAR FONT, STYLE, SIZE, OR COLOR.

NO CLAIM IS MADE TO THE EXCLUSIVE RIGHT TO USE "ORANGE", APART FROM THE MARK AS SHOWN.

FOR CARBONATED MILK BASED BEVERAGE CONTAINING ORANGE FLAVOR PROVIDING SUPPLEMENTATION OF ESSENTIAL MINERALS TO THE HUMAN DIET (U.S. CL. 46).

JENNY PARK, EXAMINING ATTORNEY

**CLASS 29—(Continued).**

SN 78-962,232. BREWERY ON HALF MOON BAY, INC., DBA THE HALF MOON BAY BREWING COMPANY, PRINCETON-BY-THE-SEA, CA. FILED 8-28-2006.

# MAVERICKS

THE MARK CONSISTS OF STANDARD CHARACTERS WITHOUT CLAIM TO ANY PARTICULAR FONT, STYLE, SIZE, OR COLOR.

OWNER OF U.S. REG. NO. 2,532,120.

FOR OLIVE OIL (U.S. CL. 46).

CHRISTINE COOPER, EXAMINING ATTORNEY



SN 78-962,384. PRODUCTOS NATURALES DE LA SABANA S.A. ALQUERIA, CAJICA, COLOMBIA, FILED 8-29-2006.



THE COLOR(S) RED AND WHITE IS/ARE CLAIMED AS A FEATURE OF THE MARK.

THE MARK CONSISTS OF THE WORD ALQUERIA IN WHITE STYLIZED LETTERS INSIDE A RED RECTANGLE. IN THE LEFT SIDE OF THE RECTANGLE, THERE IS A RED COW'S HEAD DRAWING.

THE FOREIGN WORDING IN THE MARK TRANSLATES INTO ENGLISH AS FARMHOUSE.

FOR CREAM; DAIRY PRODUCTS EXCLUDING ICE CREAM, ICE MILK AND FROZEN YOGURT; MILK; MILK BEVERAGES CONTAINING FRUITS; MILK BEVERAGES WITH HIGH MILK CONTENT; MILK PRODUCTS EXCLUDING ICE CREAM, ICE MILK AND FROZEN YOGURT (U.S. CL. 46).

ANN E. SAPPENFIELD, EXAMINING ATTORNEY



SN 78-962,706. K S & L FOODS, RENTON, WA. FILED 8-29-2006.

# MASH POTATO SALAD

THE MARK CONSISTS OF STANDARD CHARACTERS WITHOUT CLAIM TO ANY PARTICULAR FONT, STYLE, SIZE, OR COLOR.

FOR FRIED CHICKEN (U.S. CL. 46).

TONJA GASKINS, EXAMINING ATTORNEY

**CLASS 29—(Continued).**

SN 78-962,877. TORN & GLASSER, INC., LOS ANGELES, CA.  
FILED 8-29-2006.



NO CLAIM IS MADE TO THE EXCLUSIVE RIGHT TO USE "QUALITY PRODUCTS SINCE 1928", APART FROM THE MARK AS SHOWN.

THE MARK CONSISTS OF THE WORDS TORN & GLASSER IN AN OBLONG SHAPED BANNER ACROSS A CIRCLE THAT CONTAINS BUSHES IN THE BACKGROUND OF THE PORTION OF THE CIRCLE ABOVE THE OBLONG SHAPED BANNER AND BASKETS OF APPLES, PEARS AND ORANGES AND SACKS FILLED WITH GRAIN IN THE FOREGROUND OF THE PORTION OF THE CIRCLE ABOVE THE OBLONG SHAPED BANNER ALONG WITH THE WORDS QUALITY PRODUCTS SINCE 1928 IN THE PORTION OF THE CIRCLE BELOW THE OBLONG SHAPED BANNER.

FOR PROCESSED FRUITS; PROCESSED NUTS; SNACK MIX CONSISTING PRIMARILY OF PROCESSED FRUITS, PROCESSED NUTS AND/OR RAISINS (U.S. CL. 46).

FIRST USE 1-1-1980; IN COMMERCE 1-1-1980.  
KEVON CHISOLM, EXAMINING ATTORNEY

SN 78-963,280. EL CERRITO S.A., TALCA, CHILE, FILED 8-29-2006.

**EL CERRITO**

THE MARK CONSISTS OF STANDARD CHARACTERS WITHOUT CLAIM TO ANY PARTICULAR FONT, STYLE, SIZE, OR COLOR.

THE FOREIGN WORDING IN THE MARK TRANSLATES INTO ENGLISH AS THE LITTLE HILL.

FOR OLIVE OIL (U.S. CL. 46).  
DEZMONA MIZELLE, EXAMINING ATTORNEY

**CLASS 29—(Continued).**

SN 78-963,401. SOFRITO FOOD CREATIONS, INC., EAST ORANGE, NJ. FILED 8-29-2006.



THE MARK CONSISTS OF STANDARD CHARACTERS WITHOUT CLAIM TO ANY PARTICULAR FONT, STYLE, SIZE, OR COLOR.

FOR CUT VEGETABLES (U.S. CL. 46).  
LINDA M. KING, EXAMINING ATTORNEY

SN 78-964,016. ZB IMPORTING, INC., CICERO, IL. FILED 8-30-2006.

**GREEN MEADOW**

THE MARK CONSISTS OF STANDARD CHARACTERS WITHOUT CLAIM TO ANY PARTICULAR FONT, STYLE, SIZE, OR COLOR.

FOR BUTTER (U.S. CL. 46).  
FIRST USE 4-0-2006; IN COMMERCE 4-0-2006.  
ANTHONY RINKER, EXAMINING ATTORNEY

SN 78-965,432. KOBE BEEF AMERICA, INC., REDMOND, OR. FILED 8-31-2006.

**KBA KOBE PORK**

THE MARK CONSISTS OF STANDARD CHARACTERS WITHOUT CLAIM TO ANY PARTICULAR FONT, STYLE, SIZE, OR COLOR.

OWNER OF U.S. REG. NO. 3,150,939.

NO CLAIM IS MADE TO THE EXCLUSIVE RIGHT TO USE "KOBE PORK", APART FROM THE MARK AS SHOWN.

FOR PORK (U.S. CL. 46).  
CARYN GLASSER, EXAMINING ATTORNEY

**CLASS 29—(Continued).**

SN 78-965,578. CLARKE, PATRICK, ALTAMONTE SPRINGS, FL. FILED 8-31-2006.

# Goop Dog

THE MARK CONSISTS OF STANDARD CHARACTERS WITHOUT CLAIM TO ANY PARTICULAR FONT, STYLE, SIZE, OR COLOR.

FOR SPECIALLY-SEASONED GROUND BEEF AND BAKED BEAN MIXTURE IN A SWEET/SPICY SAUCE SERVED ON A WARM POTATO ROLL WITH MELTED CHEESE (U.S. CL. 46).

HENRY S. ZAK, EXAMINING ATTORNEY

**CLASS 29—(Continued).**

SN 78-967,835. CENTRIC GROUP, LLC, ST. LOUIS, MO. FILED 9-6-2006.

# KEEFE KITCHENS

THE MARK CONSISTS OF STANDARD CHARACTERS WITHOUT CLAIM TO ANY PARTICULAR FONT, STYLE, SIZE, OR COLOR.

FOR PEANUT BUTTER (U.S. CL. 46).

FIRST USE 1-21-1997; IN COMMERCE 10-14-1997.

INGA ERVIN, EXAMINING ATTORNEY

SN 78-965,842. TURTLEBACK BRAND GROUP, LLC, LARCHMONT, NY. FILED 9-1-2006.

# ALLSWEET

THE MARK CONSISTS OF STANDARD CHARACTERS WITHOUT CLAIM TO ANY PARTICULAR FONT, STYLE, SIZE, OR COLOR.

FOR MARGARINE; MARGARINE SUBSTITUTES (U.S. CL. 46).

ROBIN MITTLER, EXAMINING ATTORNEY

SN 78-968,544. ELK RIDGE ALMONDS, INC., MADERA, CA. FILED 9-6-2006.

# LAUGHING FARMER

THE MARK CONSISTS OF STANDARD CHARACTERS WITHOUT CLAIM TO ANY PARTICULAR FONT, STYLE, SIZE, OR COLOR.

FOR PROCESSED NUTS; ROASTED NUTS (U.S. CL. 46).

RAMONA ORTIGA, EXAMINING ATTORNEY

SN 78-965,848. TURTLEBACK BRAND GROUP, LLC, LARCHMONT, NY. FILED 9-1-2006.

# LUCKY WHIP

THE MARK CONSISTS OF STANDARD CHARACTERS WITHOUT CLAIM TO ANY PARTICULAR FONT, STYLE, SIZE, OR COLOR.

NO CLAIM IS MADE TO THE EXCLUSIVE RIGHT TO USE "WHIP", APART FROM THE MARK AS SHOWN.

FOR WHIPPED TOPPING (U.S. CL. 46).  
ROBIN MITTLER, EXAMINING ATTORNEY

SN 78-968,704. AGRO.VI. M S.A., 24100 KALAMATA, GREECE, FILED 9-7-2006.

# ERATO

THE MARK CONSISTS OF STANDARD CHARACTERS WITHOUT CLAIM TO ANY PARTICULAR FONT, STYLE, SIZE, OR COLOR.

FOR OLIVE OIL AND PROCESSED OLIVES (U.S. CL. 46).

FIRST USE 11-29-2000; IN COMMERCE 11-29-2000.  
INGRID C. EULIN, EXAMINING ATTORNEY

**CLASS 29—(Continued).**

SN 78-968,800. INT'L FOODSERVICE DISTRIBUTORS CO, DBA BELLISSIMO FOODS, WALNUT CREEK, CA. FILED 9-7-2006.

# BARRY'S

THE MARK CONSISTS OF STANDARD CHARACTERS WITHOUT CLAIM TO ANY PARTICULAR FONT, STYLE, SIZE, OR COLOR.

FOR CHEESE (U.S. CL. 46).  
FIRST USE 1-1-2001; IN COMMERCE 1-1-2001.  
HOWARD B. LEVINE, EXAMINING ATTORNEY

**CLASS 30—STAPLE FOODS**

SN 76-665,108. KNAPP VENTURES, L.L.C., AUSTIN, TX. FILED 8-25-2006.

# WILLIE'S

THE MARK CONSISTS OF STANDARD CHARACTERS WITHOUT CLAIM TO ANY PARTICULAR FONT, STYLE, SIZE, OR COLOR.

FOR CONDIMENTS, NAMELY SAUCES AND SPICES (U.S. CL. 46).  
FIRST USE 1-1-2006; IN COMMERCE 1-1-2006.  
JANICE L. MCMORROW, EXAMINING ATTORNEY



SN 77-002,083. GREEN & BLACK'S CHOCOLATE LIMITED, LONDON, UNITED KINGDOM, FILED 9-19-2006.



FOR CHOCOLATE, HOT CHOCOLATE AND COCOA (U.S. CL. 46).  
FIRST USE 9-30-1997; IN COMMERCE 9-30-1997.  
RONALD MCMORROW, EXAMINING ATTORNEY

**CLASS 30—(Continued).**

SN 77-020,724. CINNABON, INC., ATLANTA, GA. FILED 10-13-2006.

# CINNABON

THE MARK CONSISTS OF STANDARD CHARACTERS WITHOUT CLAIM TO ANY PARTICULAR FONT, STYLE, SIZE, OR COLOR.

OWNER OF U.S. REG. NOS. 1,424,169, 2,137,495 AND OTHERS.

FOR BAKERY GOODS; CANDY; COOKIES; BREAKFAST CEREALS; READY-TO-EAT CEREAL DERIVED FOOD BARS; BREAD; BAGELS; MUFFINS; ICE CREAM; ICE CREAM TRUFFLES; POPPED POPCORN (U.S. CL. 46).

JASON ROTH, EXAMINING ATTORNEY



SN 77-037,262. THE CARTOON NETWORK, INC., ATLANTA, GA. FILED 11-6-2006.

# OMNITRIX

THE MARK CONSISTS OF STANDARD CHARACTERS WITHOUT CLAIM TO ANY PARTICULAR FONT, STYLE, SIZE, OR COLOR.

FOR FOODS AND BEVERAGES, NAMELY, COFFEE, TEA, COCOA, SUGAR, RICE, TAPIOCA, ARTIFICIAL COFFEE, FLOUR AND PREPARATIONS MADE FROM CEREALS, NAMELY, BREAKFAST CEREALS, READY-TO-EAT CEREAL DERIVED FOOD BARS, CEREAL-BASED SNACK FOODS, PASTRIES AND CONFECTIONERIES IN THE NATURE OF CANDIES, GUM, BUBBLE GUM, FLAVORED ICES, HONEY, BAKING POWDER, SALT, MUSTARD, VINEGAR, SAUCES EXCEPT SALAD DRESSINGS, SPICES AND ICE (U.S. CL. 46).  
LINDA ORNDORFF, EXAMINING ATTORNEY



SN 77-040,918. THE KROGER CO. OF MICHIGAN, LIVONIA, MI. FILED 11-9-2006.

# METEORITE

THE MARK CONSISTS OF STANDARD CHARACTERS WITHOUT CLAIM TO ANY PARTICULAR FONT, STYLE, SIZE, OR COLOR.

FOR FROZEN CONFECTIONS (U.S. CL. 46).  
BENJAMIN ALLEN, EXAMINING ATTORNEY

**CLASS 30—(Continued).**

SN 77-046,309. INTEGRATED BEVERAGE GROUP, LTD, FARMINGDALE, NY. FILED 11-17-2006.

# Mega Pop

THE MARK CONSISTS OF STANDARD CHARACTERS WITHOUT CLAIM TO ANY PARTICULAR FONT, STYLE, SIZE, OR COLOR.  
FOR ICE (U.S. CL. 46).  
PAULA MAYS, EXAMINING ATTORNEY

SN 77-054,151. WHITEWAVE SERVICES, INC., WILMINGTON, DE. FILED 11-30-2006.

# STOK

THE MARK CONSISTS OF STANDARD CHARACTERS WITHOUT CLAIM TO ANY PARTICULAR FONT, STYLE, SIZE, OR COLOR.  
FOR PORTION CONTROL CUP CONTAINING THE CAFFEINE EQUIVALENT OF A SHOT OF ESPRESSO FOR USE IN MAKING A COFFEE BEVERAGE (U.S. CL. 46).  
MARGERY A. TIERNEY, EXAMINING ATTORNEY

SN 77-060,093. DRAZIL FOODS, LLC, PRINCETON, NJ. FILED 12-8-2006.

# DRAZIL

THE MARK CONSISTS OF STANDARD CHARACTERS WITHOUT CLAIM TO ANY PARTICULAR FONT, STYLE, SIZE, OR COLOR.  
FOR CEREAL, CORN, AND RICE BASED SNACK FOODS (U.S. CL. 46).  
KELLY BOULTON, EXAMINING ATTORNEY

**CLASS 30—(Continued).**

SN 77-061,578. INTEGRATED BEVERAGE GROUP, LTD, FARMINGDALE, NY. FILED 12-11-2006.

# Wheezy Freezy

THE MARK CONSISTS OF STANDARD CHARACTERS WITHOUT CLAIM TO ANY PARTICULAR FONT, STYLE, SIZE, OR COLOR.  
FOR FLAVORED ICES (U.S. CL. 46).  
PAULA MAYS, EXAMINING ATTORNEY

SN 77-061,702. SOCIETE DES PRODUITS NESTLE S.A., 1800 VEVEY, SWITZERLAND, FILED 12-11-2006.

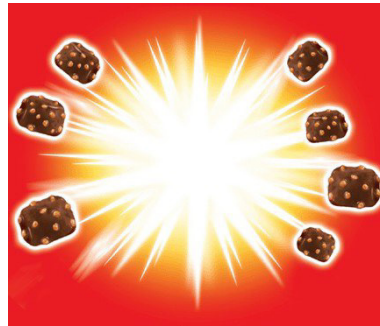

THE COLOR(S) RED, WHITE, YELLOW, AND BROWN IS/ ARE CLAIMED AS A FEATURE OF THE MARK.  
THE MARK CONSISTS OF A WHITE BURST WITH YELLOW ON A RED BACKGROUND WITH BROWN DROPS.  
FOR ICE CREAM AND FROZEN CONFECTIONS (U.S. CL. 46).  
FIRST USE 10-1-2004; IN COMMERCE 4-1-2005.  
MATTHEW PAPPAS, EXAMINING ATTORNEY

SN 77-085,450. FERRARA PAN CANDY CO., INC., FOREST PARK, IL. FILED 1-18-2007.



OWNER OF U.S. REG. NOS. 1,372,867 AND 2,693,619. NO CLAIM IS MADE TO THE EXCLUSIVE RIGHT TO USE "GUMMY BEARS", APART FROM THE MARK AS SHOWN.  
FOR CANDY (U.S. CL. 46).  
FIRST USE 6-19-2006; IN COMMERCE 6-19-2006.  
HEATHER THOMPSON, EXAMINING ATTORNEY

**CLASS 30—(Continued).**

SN 77-085,508. FERRARA PAN CANDY CO., INC., FOREST PARK, IL. FILED 1-18-2007.



OWNER OF U.S. REG. NOS. 1,372,867 AND 2,693,619.  
NO CLAIM IS MADE TO THE EXCLUSIVE RIGHT TO USE "GUMMY BEARS", APART FROM THE MARK AS SHOWN.

FOR CANDY (U.S. CL. 46).  
FIRST USE 6-19-2006; IN COMMERCE 6-19-2006.  
HEATHER THOMPSON, EXAMINING ATTORNEY

---

SN 78-070,868. MARY E. LEONARD, DBA CELESTIAL SWEETIES, ST. PAUL, MN. FILED 6-25-2001.

**CELESTIAL SWEETIES**

FOR CHOCOLATE TRUFFLES (U.S. CL. 46).  
DEZMONA MIZELLE, EXAMINING ATTORNEY

---

SN 78-362,330. YODER DAIRIES OF TIDEWATER, INC., VIRGINIA BEACH, VA. FILED 2-4-2004.



THE COLORS BLUE AND WHITE ARE CLAIMED AS A FEATURE OF THE MARK.

THE COLOR BLUE APPEARS IN THE LETTERS C, A, R, B, B, L, I, S, S AND IN THE HYPHEN. THE COLOR WHITE APPEARS IN THE TOP OF THE LETTERS C, A, R, B, B, L, I, S, S AND IN THE HYPHEN, AS WELL AS IN VARIOUS OTHER PLACES IN THE LETTERS C, A, R, B, B, L, I, S, AND S TO CREATE THE ILLUSION OF SNOW.

FOR ICE CREAM (U.S. CL. 46).  
MARC LEIPZIG, EXAMINING ATTORNEY

**CLASS 30—(Continued).**

SN 78-534,069. PRICE CHOICE FOODS, INC., BRISTOL, VA. FILED 12-16-2004.

**GO-MEX**

THE MARK CONSISTS OF STANDARD CHARACTERS WITHOUT CLAIM TO ANY PARTICULAR FONT, STYLE, SIZE, OR COLOR.

FOR MEXICAN FOOD PRODUCTS, NAMELY, TORTILLA CHIPS (U.S. CL. 46).

FIRST USE 3-15-1992; IN COMMERCE 3-15-1992.  
SALLY SHIH, EXAMINING ATTORNEY

---

SN 78-587,191. DEHMEL SALES & MARKETING INC, SUMMERSIDE, PRINCE EDWARD IS., FILED 3-15-2005.

**Kitchen Party**

THE MARK CONSISTS OF STANDARD CHARACTERS WITHOUT CLAIM TO ANY PARTICULAR FONT, STYLE, SIZE, OR COLOR.

FOR SEASONINGS FOR SEAFOOD (U.S. CL. 46).  
CAROLINE WEIMER, EXAMINING ATTORNEY

**CLASS 30—(Continued).**

SN 78-600,201. KONCERN ZA PROIZVODNJU I PROMET ZDRAVE HRANE "BAMBI" AD, 1200 POZAREVAC, SERBIA/MONTENEGRO, FILED 4-1-2005.



OWNER OF U.S. REG. NO. 2,444,662.

NO CLAIM IS MADE TO THE EXCLUSIVE RIGHT TO USE "BISCUITS 300G" AND THE PICTORIAL REPRESENTATION OF THE BISCUITS, APART FROM THE MARK AS SHOWN.

THE LIKENESS (OR, "PORTRAIT") IN THE MARK DOES NOT IDENTIFY A LIVING INDIVIDUAL.

FOR BISCUITS (U.S. CL. 46).

FIRST USE 7-1-2004; IN COMMERCE 3-12-2005.

DEBRA LEE, EXAMINING ATTORNEY

SN 78-737,582. SILKY SMOOTH, INC., LOS ANGELES, CA. FILED 10-20-2005.

**SILKYFRESH**

THE MARK CONSISTS OF STANDARD CHARACTERS WITHOUT CLAIM TO ANY PARTICULAR FONT, STYLE, SIZE, OR COLOR.

FOR ICE CREAM (U.S. CL. 46).

FIRST USE 4-28-2005; IN COMMERCE 7-25-2005.

KIMBERLY FRYE, EXAMINING ATTORNEY

SN 78-772,138. UPTON TEA IMPORTS, LLC., HOPKINTON, MA. FILED 12-13-2005.

**UPTON TEA**

THE MARK CONSISTS OF STANDARD CHARACTERS WITHOUT CLAIM TO ANY PARTICULAR FONT, STYLE, SIZE, OR COLOR.

NO CLAIM IS MADE TO THE EXCLUSIVE RIGHT TO USE "TEA", APART FROM THE MARK AS SHOWN. SEC. 2(F).

FOR BEVERAGES MADE OF TEA; BLACK TEA; FLAVORINGS FOR BEVERAGES; FLAVOURINGS OF TEA; FRUIT TEAS; GREEN TEA; HERB TEA; HERBAL INFUSIONS; HERBAL TEA; ICED TEA; JAPANESE GREEN TEA; LIME TEA; OOLONG TEA; PROCESSED HERBS; SAGE TEA; TEA; TEA FOR INFUSIONS; TEA OF PARCHED POWDER OF BARLEY WITH HUSK; TEA OF SALTY KELP POWDER; TEA PODS; TEA SUBSTITUTES; TEA-BASED BEVERAGES WITH FRUIT FLAVORING; THEINE-FREE TEA SWEETENED WITH SWEETENERS (U.S. CL. 46).

FIRST USE 9-30-1998; IN COMMERCE 9-30-1998.

MICHAEL GAFFAR, EXAMINING ATTORNEY

**CLASS 30—(Continued).**

SN 78-788,810. 200 KELSEY ASSOCIATES, LLC, NEW ROCHELLE, NY. FILED 1-10-2006.

**POM POMS**

THE MARK CONSISTS OF STANDARD CHARACTERS WITHOUT CLAIM TO ANY PARTICULAR FONT, STYLE, SIZE, OR COLOR.

FOR CANDY; CANDY BARS (U.S. CL. 46).

SCOTT BALDWIN, EXAMINING ATTORNEY

SN 78-800,066. CALIP HOLDINGS INC., BRONX, NY. FILED 1-26-2006.

**CREAM OF THE HAMPTONS**

THE MARK CONSISTS OF STANDARD CHARACTERS WITHOUT CLAIM TO ANY PARTICULAR FONT, STYLE, SIZE, OR COLOR.

OWNER OF U.S. REG. NOS. 1,511,971 AND 1,555,964.

FOR FROZEN CONFECTIONS; ICE CREAM (U.S. CL. 46).

ANNE FARRELL, EXAMINING ATTORNEY

SN 78-804,564. TRIANTAFILLOU, NICK, OMAHA, NE. FILED 2-1-2006.

**SUPER KONG**

THE MARK CONSISTS OF STANDARD CHARACTERS WITHOUT CLAIM TO ANY PARTICULAR FONT, STYLE, SIZE, OR COLOR.

OWNER OF U.S. REG. NOS. 2,536,338 AND 2,536,339.

FOR HOT SANDWICHES, NAMELY HAMBURGERS (U.S. CL. 46).

FIRST USE 5-30-1989; IN COMMERCE 12-15-1990.

JENNIFER KRISP, EXAMINING ATTORNEY

**CLASS 30—(Continued).**

SN 78-806,347. TNT HOLDINGS, LLC, ONTARIO, CA. FILED 2-3-2006.

## Pizzazz Pizza & Gelato Creamery

THE MARK CONSISTS OF STANDARD CHARACTERS WITHOUT CLAIM TO ANY PARTICULAR FONT, STYLE, SIZE, OR COLOR.

NO CLAIM IS MADE TO THE EXCLUSIVE RIGHT TO USE "PIZZA & GELATO CREAMERY", APART FROM THE MARK AS SHOWN.

FOR SPECIALTY PIZZA AND GELATO (U.S. CL. 46).  
LINDA POWELL, EXAMINING ATTORNEY

SN 78-807,157. ROBERT E HOWARD PROPERTIES INC., BEVERLY HILLS, CA. FILED 2-3-2006.

## ROBERT E. HOWARD

THE MARK CONSISTS OF STANDARD CHARACTERS WITHOUT CLAIM TO ANY PARTICULAR FONT, STYLE, SIZE, OR COLOR.

"THE NAME(S), PORTRAIT(S), AND/OR SIGNATURE(S) SHOWN IN THE MARK DOES NOT IDENTIFY A PARTICULAR LIVING INDIVIDUAL."

FOR CANDIES; EDIBLE CAKE DECORATIONS; BUBBLE GUM AND CHEWING GUM; BREAKFAST CEREALS; GRITS; OATMEAL; PANCAKES AND PANCAKE MIXES; WAFFLES AND WAFFLE MIXES; FRENCH TOAST; COFFEE, AND COFFEE SUBSTITUTES; COCOA; CHOCOLATE AND CHOCOLATE PRODUCTS, NAMELY, CHOCOLATE BARS, CHOCOLATE CANDIES, CHOCOLATE COVERED NUTS, CHOCOLATE POWDER, CHOCOLATE SYRUP, CHOCOLATE TOPPING, CHOCOLATE TRUFFLES, AND HOT CHOCOLATE; TEA, AND TEA SUBSTITUTES; HERBAL TEA; POPCORN, NAMELY, UNPOPPED POPCORN, POPPED POPCORN, MICROWAVE POPCORN, CANDY COATED POPCORN AND CARAMEL POPCORN; GRAIN BASED CHIPS, NAMELY, CORN CHIPS, PITA CHIPS, TACO CHIPS, AND TORTILLA CHIPS; CHEESE FLAVORED SNACKS, NAMELY, CHEESE CURLS, PUFFED CHEESE BALLS, AND PUFFED CHEESE CORN SNACKS; GRANOLA AND GRANOLA BARS; RICE-BASED SNACK FOODS; SNACK MIXES CONSISTING PRIMARILY OF CRACKERS, PRETZELS, CANDIED NUTS AND/OR POPPED POPCORN; DOUGHNUTS; HUSHPUPPIES; BAKED GOODS AND MIXES THEREFORE, NAMELY, CRACKERS, BISCUITS, BREAD AND BUNS, BAGELS, MUFFINS, CROISSANTS, CRUMPETS, PASTRIES, COOKIES, BROWNIES, PIES, AND CAKES; DESSERTS AND CONFECTIONS, AND MIXES THEREFORE, NAMELY, DESSERT MOUSSE, DESSERT PUDDINGS, DESSERT SOUFFLÉS, APPLE FRITTERS, CUSTARDS AND TA-

**CLASS 30—(Continued).**

PIOCA; CONDIMENTS, NAMELY, SALT, PEPPER, MUSTARD, VINEGAR, PICKLE RELISH, KETCHUP, SOY SAUCE, HOT SAUCE, PICANTE SAUCE, AND SEASONINGS; GRAVY AND GRAVY MIXES; POT PIES; ICE CREAM; ICE CREAM SUBSTITUTES; ICE CREAM CONES; ICE CREAM DRINKS; ICE-CREAM CAKES; FROZEN CUSTARD; FROZEN YOGHURT; SORBET; SHERBETS; MILKSHAKES; FLAVORED ICES; GELATO; FLAVORINGS FOR BEVERAGES; SAUCES, NAMELY, ARTICHOKE, BARBECUE, CHEESE, CHILI, PIZZA, SPAGHETTI, SALSA, AND/OR TOMATO SAUCES; SPICES, NAMELY, CINNAMON, CINNAMON POWDER, GINGER AND CRYSTALLIZED GINGER, VANILLA AND VANILLA EXTRACT; NATURAL SWEETENERS, NAMELY, SUGAR, HONEY, MOLASSES, MAPLE SYRUP AND TREACLE; DUMPLINGS; HAMBURGER SANDWICHES; HOT DOG SANDWICHES; PASTA, DRIED PASTA, NOODLES AND DRIED NOODLES; PIZZA; MARSHMALLOW AND MARSHMALLOW TOPPING; SALAD DRESSINGS AND MAYONNAISE; AND FLAVORINGS FOR TOBACCO (U.S. CL. 46).

KAREN K. BUSH, EXAMINING ATTORNEY

SN 78-818,515. BUONCAFF S.R.L., (1416) CAPITAL FEDERAL, BUENOS AIRES, ARGENTINA, FILED 2-19-2006.

## FUNDADOR

THE MARK CONSISTS OF STANDARD CHARACTERS WITHOUT CLAIM TO ANY PARTICULAR FONT, STYLE, SIZE, OR COLOR.

THE FOREIGN WORDING IN THE MARK TRANSLATES INTO ENGLISH AS FOUNDER.

FOR COFFEE; HERBAL INFUSIONS; TEA (U.S. CL. 46).

KAPIL BHANOT, EXAMINING ATTORNEY

SN 78-825,432. SOVEREIGN DEED, LLC, CHICAGO, IL. FILED 2-28-2006.

## SOVEREIGN DEED

THE MARK CONSISTS OF STANDARD CHARACTERS WITHOUT CLAIM TO ANY PARTICULAR FONT, STYLE, SIZE, OR COLOR.

FOR BAKERY GOODS; CANDIES; CEREAL BASED SNACK FOOD; CHEWING GUM; CHOCOLATE; COFFEE; FLAVORING ADDITIVES FOR NON-NUTRITIONAL PURPOSES; FLAVOURINGS; FLOUR; GRANOLA; HONEY; ICE; PASTA; POPCORN; PROCESSED CEREALS; PROCESSED GRAINS; RICE; SALT; SANDWICHES; SAUCES; SEASONINGS; SPICES; SUGAR AND SUGAR SUBSTITUTES; TEA; YEAST (U.S. CL. 46).

ZACHARY BELLO, EXAMINING ATTORNEY



**CLASS 30—(Continued).**

SN 78-828,628. AUGUST STORCK KG, BERLIN, FED REP GERMANY, FILED 3-3-2006.

# BENDICKS

THE MARK CONSISTS OF STANDARD CHARACTERS WITHOUT CLAIM TO ANY PARTICULAR FONT, STYLE, SIZE, OR COLOR.

OWNER OF ERPN CMNTY TM OFC REG. NO. 003858404, DATED 8-31-2005, EXPIRES 5-27-2014.

SEC. 2(F).  
FOR CONFECTIONERY, NAMELY, CANDY, CHOCOLATE CANDIES; CHOCOLATE; PASTRY (U.S. CL. 46).  
ELI HELLMAN, EXAMINING ATTORNEY

---

SN 78-834,082. CHEF HILLY'S KITCHEN, LLC, ATLANTA, GA. FILED 3-10-2006.

# CHEF HILLY

THE MARK CONSISTS OF STANDARD CHARACTERS WITHOUT CLAIM TO ANY PARTICULAR FONT, STYLE, SIZE, OR COLOR.

FOR FLAVORINGS FOR BEVERAGES (U.S. CL. 46).  
ALICE BENMAMAN, EXAMINING ATTORNEY

---

SN 78-840,896. MARS, INCORPORATED, MCLEAN, VA. FILED 3-20-2006.

## MORE OF WHAT YOU LIKE IN EACH BITE

THE MARK CONSISTS OF STANDARD CHARACTERS WITHOUT CLAIM TO ANY PARTICULAR FONT, STYLE, SIZE, OR COLOR.

FOR CONFECTIONERY, NAMELY, CANDY (U.S. CL. 46).  
RUSS HERMAN, EXAMINING ATTORNEY

**CLASS 30—(Continued).**

SN 78-850,794. DAVID B. SMITH, CLARKSVILLE, TN. FILED 3-31-2006.



NO CLAIM IS MADE TO THE EXCLUSIVE RIGHT TO USE BLONDIE'S SANDWICHES AND COFFEE, APART FROM THE MARK AS SHOWN.

THE COLOR(S) YELLOW, BLUE, RED, WHITE IS/ARE CLAIMED AS A FEATURE OF THE MARK.

THE COLOR YELLOW APPEARS IN THE OUTSIDE AND THIRD CIRCLE AND THE WORD BLONDIE'S, THE COLOR BLUE APPEARS IN THE SECOND RING AND THE BORDER OF THE WORDING BLONDIE'S, THE COLOR RED APPEARS IN THE BORDER OF THE WORDING SANDWICHES AND COFFEE, THE COLOR WHITE APPEARS IN THE WORDING SANDWICHES AND COFFEE AND THE CENTER CIRCLE.

FOR BAKERY DESSERTS; BEVERAGES MADE OF COFFEE; CAFFEINE-FREE COFFEE; COFFEE; COFFEE; SANDWICHES BAGEL (U.S. CL. 46).

ESTHER A. BORSUK, EXAMINING ATTORNEY

---

SN 78-855,861. SUPER BAKERY, INCORPORATED, PITTSBURGH, PA. FILED 4-6-2006.

# SUPER CEREAL

THE MARK CONSISTS OF STANDARD CHARACTERS WITHOUT CLAIM TO ANY PARTICULAR FONT, STYLE, SIZE, OR COLOR.

NO CLAIM IS MADE TO THE EXCLUSIVE RIGHT TO USE "CEREAL", APART FROM THE MARK AS SHOWN.

SEC. 2(F) AS TO "SUPER".  
FOR MIXES FOR BAKERY GOODS, BREAKFAST CEREALS AND READY-TO-EAT CEREAL DERIVED BARS (U.S. CL. 46).

BILL DAWE, EXAMINING ATTORNEY

**CLASS 30—(Continued).**

SN 78-861,356. TM, INC., STAYTON, OR. FILED 4-13-2006.

**TRIBAL MOOSE**

THE MARK CONSISTS OF STANDARD CHARACTERS WITHOUT CLAIM TO ANY PARTICULAR FONT, STYLE, SIZE, OR COLOR.

FOR FOOD PRODUCTS, NAMELY BARBECUE SAUCES, KETCHUPS, COCKTAIL SAUCES, SALAD DRESSINGS, AND SEASONINGS (U.S. CL. 46).  
SONYA STEPHENS, EXAMINING ATTORNEY

SN 78-866,130. STI AMERICA INC., BELLEVUE, WA. FILED 4-20-2006.

**TENKAI**  
**天 海**

THE MARK CONSISTS OF THE WORD "TENKAI", WHICH HAS NO ENGLISH TRANSLATION, AND JAPANESE KANJI CHARACTERS.

FOR FROZEN SUSHI, SUSHI (U.S. CL. 46).  
REBECCA HAN, EXAMINING ATTORNEY

SN 78-895,949. SIMONCIONI, FRANK, COVINGTON, LA. FILED 5-30-2006.

**SWEET CHARLOTTE'S OF NEW ORLEANS**

THE MARK CONSISTS OF STANDARD CHARACTERS WITHOUT CLAIM TO ANY PARTICULAR FONT, STYLE, SIZE, OR COLOR.

NO CLAIM IS MADE TO THE EXCLUSIVE RIGHT TO USE NEW ORLEANS, APART FROM THE MARK AS SHOWN.

FOR CANDY AND CHOCOLATE (U.S. CL. 46).  
FIRST USE 4-1-1990; IN COMMERCE 4-1-1990.  
LINDA E. BLOHM, EXAMINING ATTORNEY

**CLASS 30—(Continued).**

SN 78-902,391. AGOSTINI BAKERY, INC., OLD FORGE, PA. FILED 6-7-2006.

**ORIGINAL OLD FORGE PIZZA SHELLS**

THE MARK CONSISTS OF STANDARD CHARACTERS WITHOUT CLAIM TO ANY PARTICULAR FONT, STYLE, SIZE, OR COLOR.

NO CLAIM IS MADE TO THE EXCLUSIVE RIGHT TO USE "PIZZA SHELLS", APART FROM THE MARK AS SHOWN.

SEC. 2(F).

FOR PIZZA CRUST; PIZZA DOUGH (U.S. CL. 46).  
FIRST USE 3-15-1986; IN COMMERCE 3-15-1986.  
MARILYN IZZI, EXAMINING ATTORNEY

SN 78-904,401. MUSZYNSKI, RICHARD, NEW YORK, NY. FILED 6-8-2006.



NO CLAIM IS MADE TO THE EXCLUSIVE RIGHT TO USE "CHOCOLAT", APART FROM THE MARK AS SHOWN. THE ENGLISH TRANSLATION OF "CHOCOLAT" IS "CHOCOLATE".

FOR CHOCOLATE CANDIES (U.S. CL. 46).  
FIRST USE 10-27-1999; IN COMMERCE 10-27-1999.  
JOHN GARTNER, EXAMINING ATTORNEY

SN 78-907,120. FAMIGLIA CATERING SERVICES, INC., BOCA RATON, FL. FILED 6-13-2006.

**JOSEPHINE'S**

THE MARK CONSISTS OF STANDARD CHARACTERS WITHOUT CLAIM TO ANY PARTICULAR FONT, STYLE, SIZE, OR COLOR.

FOR SALAD DRESSINGS (U.S. CL. 46).  
SANJEEV VOHRA, EXAMINING ATTORNEY

**CLASS 30—(Continued).**

SN 78-931,578. SIGNATURE CAKES, L.L.C., BROKEN ARROW, OK. FILED 7-18-2006.



FOR CAKES, FROSTINGS, CREAMS, FANCY DESSERTS, NAMELY, BAKERY DESSERTS, DESSERT MOUSSE, CHOCOLATE MOUSSE, DESSERT PUDDINGS, PASTRIES, ECLAIRS, DESSERT SOUFFLES, CHEESECAKES, CANDIES, COOKIES, CHOCOLATES, TORTES, PIES, TIRAMISU, CARAMEL APPLES, CHOCOLATE DIPPED PRETZELS, ALL SOLD IN RETAIL STORE LOCATIONS (U.S. CL. 46).

JOANNA DUKOVIC, EXAMINING ATTORNEY

**CLASS 30—(Continued).**

SN 78-955,799. SANRIO COMPANY, LTD., TOKYO, JAPAN, FILED 8-18-2006.

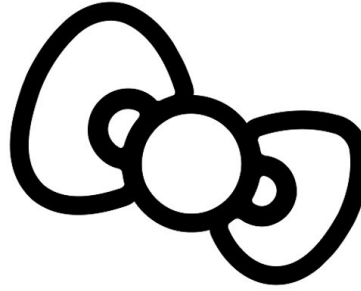

OWNER OF U.S. REG. NOS. 1,200,083, 1,370,105 AND OTHERS.

THE MARK CONSISTS OF A BOW. FOR CANDY, CHOCOLATE CANDIES, MARSHMALLOWS, CHEWING GUM, COOKIES (U.S. CL. 46). FIRST USE 11-1-2004; IN COMMERCE 11-1-2004. MICHAEL WIENER, EXAMINING ATTORNEY

SN 78-931,719. FAITH TRADING CO., ALHAMBRA, CA. FILED 7-18-2006.



NO CLAIM IS MADE TO THE EXCLUSIVE RIGHT TO USE "SWEET AROMA SPICE", APART FROM THE MARK AS SHOWN.

THE MARK CONSISTS OF AN OVAL WITH THE STYLIZED TEXT OF THE WORDING "SWEET AROMA SPICE" AND A FLOWER.

FOR COFFEE; SEASONINGS; SPICES; TEA; VANILLA BEANS (U.S. CL. 46).

PETER CHENG, EXAMINING ATTORNEY

SN 78-956,284. BEAR NAKED, INC., DARIEN, CT. FILED 8-21-2006.



OWNER OF U.S. REG. NOS. 2,800,495 AND 3,161,484. THE MARK CONSISTS OF THE WORDS BEAR NAKED WITH THE LETTER E SHOWN AS A BEAR CLAW.

FOR BREAKFAST CEREALS; OATMEAL; ROLLED OATS (U.S. CL. 46).

FIRST USE 11-1-2005; IN COMMERCE 11-1-2005.

LINDA POWELL, EXAMINING ATTORNEY

**CLASS 30—(Continued).**

SN 78-958,340. PIMENTA, ADELINO, CAPE CANAVERAL, FL. AND PIMENTA, DEBRA, CAPE CANAVERAL, FL. FILED 8-23-2006.



NO CLAIM IS MADE TO THE EXCLUSIVE RIGHT TO USE "BAKED PIZZA SANDWICH", APART FROM THE MARK AS SHOWN.

FOR BAKED AND UNBAKED, MICROWAVEABLE AND NON-MICROWAVEABLE, PACKAGED AND UNPACKAGED, FROZEN AND UNFROZEN SANDWICHES, POCKET SANDWICHES, PIZZA WITH OR WITHOUT TOPPING, CALZONE, STROMBOLI, COMBINED PIZZA AND STROMBOLI AND CALZONE SANDWICHES, BRUSCHETTE-TOPPED BREAD, LASAGNA, TORTELLINI, RAVIOLI, TAGLIARINI, HOAGIES, SUBS, HEROS, FOOD WRAPS, POT PIES, BURRITOS, TACOS, PASTAS, BREADSTICKS, ROLLS, BAGELS, PITA BREADS, TORTILLA BREADS, GARLIC BREADS, GARLIC KNOTS, DIPPING SAUCES; DESSERTS NAMELY PASTRIES, MUFFINS, SCONES, CAKES, COOKIES, AND PIES (U.S. CL. 46).  
TRAVIS WHEATLEY, EXAMINING ATTORNEY

SN 78-958,613. JUDY'S CANDY COMPANY, BERKELEY, CA. FILED 8-23-2006.



OWNER OF U.S. REG. NO. 2,533,954.  
NO CLAIM IS MADE TO THE EXCLUSIVE RIGHT TO USE "CANDY COMPANY"; "HANDMADE" AND "THE OLD-FASHIONED WAY", APART FROM THE MARK AS SHOWN.

THE MARK CONSISTS OF THE WORDS JUDY'S CANDY COMPANY HANDMADE THE OLD-FASHIONED WAY WITHIN AN OVAL CIRCLE.  
FOR CANDY (U.S. CL. 46).  
KATHLEEN LORENZO, EXAMINING ATTORNEY

**CLASS 30—(Continued).**

SN 78-958,898. INTERSTATE BAKERIES CORPORATION, KANSAS CITY, MO. FILED 8-23-2006.



OWNER OF U.S. REG. NOS. 126,368, 1,890,064 AND OTHERS.

THE COLOR(S) RED, BLUE AND WHITE IS/ARE CLAIMED AS A FEATURE OF THE MARK.

THE MARK CONSISTS OF THE WORD HOSTESS IN BLUE WITHIN A RED OVAL, THE H OF HOSTESS PARTIALLY EXTENDING OUT OF THE BORDER OF THE OVAL, AND A RED HEART ON THE UPPER PART OF THE OVAL AND SLIGHTLY OFFCENTERED FROM THE MIDPOINT. THE COLOR WHITE APPEARS IN THE OUTLINE AND SHADING OF THE WORDING HOSTESS AND IN THE SHADING OF THE OVAL AND HEART DESIGN.

FOR BAKERY GOODS (U.S. CL. 46).  
FIRST USE 7-0-2005; IN COMMERCE 7-0-2005.  
LINDA ORNDORFF, EXAMINING ATTORNEY

SN 78-959,487. DON MIGUEL MEXICAN FOODS, INC., ANAHEIM, CA. FILED 8-24-2006.

**CANTINA GRILL**

THE MARK CONSISTS OF STANDARD CHARACTERS WITHOUT CLAIM TO ANY PARTICULAR FONT, STYLE, SIZE, OR COLOR.

FOR PREPARED APPETIZERS CONSISTING PRIMARILY OF CORN AND FLOUR TORTILLA SNACKS FILLED WITH MEAT, CHICKEN, CHEESE, AND SPICES; TACOS, FLAUTAS, TAQUITOS, AND QUESADILLAS; STUFFED DOUGHS FILLED PRIMARILY WITH MEAT, CHEESE, AND SPICES (U.S. CL. 46).  
ALEXANDER L. POWERS, EXAMINING ATTORNEY

SN 78-959,534. TO YOUR HEART'S CONTENT, SHERMAN OAKS, CA. FILED 8-24-2006.

**PLUSH PUFFS**

THE MARK CONSISTS OF STANDARD CHARACTERS WITHOUT CLAIM TO ANY PARTICULAR FONT, STYLE, SIZE, OR COLOR.

FOR CANDIES; MARSHMALLOWS (U.S. CL. 46).  
FIRST USE 1-1-2005; IN COMMERCE 3-1-2005.  
KATHERINE M. DUBRAY, EXAMINING ATTORNEY

**CLASS 30—(Continued).**

SN 78-960,520. DUTCH GOLD HONEY, INC., LANCASTER, PA. FILED 8-25-2006.

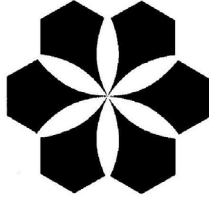

THE MARK CONSISTS OF A SIX-PETALLED FLORET IN A HONEYCOMB STYLIZED DESIGN.  
FOR HONEY (U.S. CL. 46).  
JULIE GUTTADAURO, EXAMINING ATTORNEY

SN 78-960,999. MICHEL ET MERE, INC., DBA MONT BLANC GOURMET, DENVER, CO. FILED 8-25-2006.

# OLATTE

THE MARK CONSISTS OF STANDARD CHARACTERS WITHOUT CLAIM TO ANY PARTICULAR FONT, STYLE, SIZE, OR COLOR.  
FOR COFFEE-BASED BEVERAGE CONTAINING MILK (U.S. CL. 46).  
SHAILA SETTLES, EXAMINING ATTORNEY

SN 78-961,866. MOO TECHNOLOGIES, LLC, BATAVIA, OH. FILED 8-28-2006.

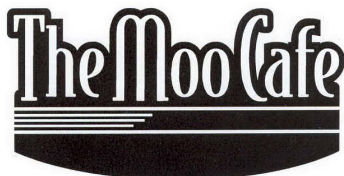

OWNER OF U.S. REG. NOS. 3,187,462 AND 3,189,217.  
THE ENGLISH TRANSLATION OF THE WORD CAFE IN THE MARK IS COFFEE.  
FOR BEVERAGES MADE OF COFFEE (U.S. CL. 46).  
FIRST USE 4-13-2006; IN COMMERCE 4-13-2006.  
CHRISTINA SOBRAL, EXAMINING ATTORNEY

**CLASS 30—(Continued).**

SN 78-961,875. MOO TECHNOLOGIES, LLC, BATAVIA, OH. FILED 8-28-2006.

# THE MOO CAFE

THE MARK CONSISTS OF STANDARD CHARACTERS WITHOUT CLAIM TO ANY PARTICULAR FONT, STYLE, SIZE, OR COLOR.  
OWNER OF U.S. REG. NOS. 3,187,462 AND 3,189,217.  
NO CLAIM IS MADE TO THE EXCLUSIVE RIGHT TO USE "CAFE", APART FROM THE MARK AS SHOWN.  
THE ENGLISH TRANSLATION OF THE WORD CAFE IN THE MARK IS COFFEE.  
FOR BEVERAGES MADE OF COFFEE (U.S. CL. 46).  
FIRST USE 4-13-2006; IN COMMERCE 4-13-2006.  
CHRISTINA SOBRAL, EXAMINING ATTORNEY

SN 78-963,252. GOTTLIEB, TED, NEW YORK, NY. FILED 8-29-2006.

# Push with a Smile

THE MARK CONSISTS OF STANDARD CHARACTERS WITHOUT CLAIM TO ANY PARTICULAR FONT, STYLE, SIZE, OR COLOR.  
FOR CEREAL-BASED SNACK FOODS (U.S. CL. 46).  
MARY MUNSON, EXAMINING ATTORNEY

SN 78-963,610. DIPIN' DONUTS, LLC, PAMPANO BEACH, FL. FILED 8-30-2006.

# GRANDMA'S ICE CREAM

THE MARK CONSISTS OF STANDARD CHARACTERS WITHOUT CLAIM TO ANY PARTICULAR FONT, STYLE, SIZE, OR COLOR.  
NO CLAIM IS MADE TO THE EXCLUSIVE RIGHT TO USE "ICE CREAM", APART FROM THE MARK AS SHOWN.  
FOR ICE CREAM (U.S. CL. 46).  
SCOTT SISUN, EXAMINING ATTORNEY

**CLASS 30—(Continued).**

SN 78-964,071. PIZZA HUT, INC., DALLAS, TX. FILED 8-30-2006.

**CRUST SENSATIONS PIZZA**

THE MARK CONSISTS OF STANDARD CHARACTERS WITHOUT CLAIM TO ANY PARTICULAR FONT, STYLE, SIZE, OR COLOR.

NO CLAIM IS MADE TO THE EXCLUSIVE RIGHT TO USE CRUST AND PIZZA, APART FROM THE MARK AS SHOWN.

FOR PIZZA (U.S. CL. 46).

JENNIFER MCROBBIE, EXAMINING ATTORNEY

SN 78-964,168. AMERICAN NEVADA HOLDINGS, LLC, HENDERSON, NV. FILED 8-30-2006.

FOR COFFEE; TEA; COCOA; PREPARED COFFEE AND COFFEE BASED BEVERAGES; BEVERAGES MADE OF TEA, NAMELY, PREPARED TEA AND TEA BASED BEVERAGES; PREPARED COCOA AND COCOA BASED BEVERAGES; CHOCOLATE FOOD BEVERAGES NOT BEING DAIRY-BASED OR VEGETABLE BASED; POWDERED MIXES FOR MAKING COFFEE BASED BEVERAGES, BEVERAGES MADE OF TEA, NAMELY, TEA BASED BEVERAGES, COCOA BASED BEVERAGES AND CHOCOLATE FOOD BEVERAGES NOT BEING DAIRY-BASED OR VEGETABLE BASED; CHOCOLATE; COOKIES; PASTRIES; BAKERY GOODS; BISCOTTI; CANDIES; AND CANDY MINTS (U.S. CL. 46).

MICHAEL ENGEL, EXAMINING ATTORNEY

SN 78-964,215. AMERICAN NEVADA HOLDINGS, LLC, HENDERSON, NV. FILED 8-30-2006.

AT THE DISTRICT

FOR COFFEE; TEA; COCOA; PREPARED COFFEE AND COFFEE BASED BEVERAGES; BEVERAGES MADE OF TEA, NAMELY, PREPARED TEA AND TEA BASED BEVERAGES; PREPARED COCOA AND COCOA BASED BEVERAGES; CHOCOLATE FOOD BEVERAGES NOT BEING DAIRY-BASED OR VEGETABLE BASED; POWDERED MIXES FOR MAKING COFFEE BASED BEVERAGES, BEVERAGES MADE OF TEA, NAMELY, TEA BASED BEVERAGES, COCOA BASED BEVERAGES AND CHOCOLATE FOOD BEVERAGES NOT BEING DAIRY-BASED OR VEGETABLE BASED; CHOCOLATE; COOKIES; PASTRIES; BAKERY GOODS; BISCOTTI; CANDIES; AND CANDY MINTS (U.S. CL. 46).

MICHAEL ENGEL, EXAMINING ATTORNEY

**CLASS 30—(Continued).**

SN 78-964,464. AMERICAN NEVADA HOLDINGS, LLC, HENDERSON, NV. FILED 8-30-2006.

**AVENUE33 BROWNSTONES AT THE DISTRICT**

THE MARK CONSISTS OF STANDARD CHARACTERS WITHOUT CLAIM TO ANY PARTICULAR FONT, STYLE, SIZE, OR COLOR.

FOR COFFEE; TEA; COCOA; PREPARED COFFEE AND COFFEE BASED BEVERAGES; BEVERAGES MADE OF TEA, NAMELY, PREPARED TEA AND TEA BASED BEVERAGES; PREPARED COCOA AND COCOA BASED BEVERAGES; CHOCOLATE FOOD BEVERAGES NOT BEING DAIRY-BASED OR VEGETABLE BASED; POWDERED MIXES FOR MAKING COFFEE BASED BEVERAGES, BEVERAGES MADE OF TEA, NAMELY, TEA BASED BEVERAGES, COCOA BASED BEVERAGES AND CHOCOLATE FOOD BEVERAGES NOT BEING DAIRY-BASED OR VEGETABLE BASED; CHOCOLATE; COOKIES; PASTRIES; BAKERY GOODS; BISCOTTI; CANDIES; AND CANDY MINTS (U.S. CL. 46).

KAREN BRACEY, EXAMINING ATTORNEY

SN 78-964,828. SCARPELLI'S, INC., HYGIENE, CO. FILED 8-31-2006.

THE MARK CONSISTS OF STANDARD CHARACTERS WITHOUT CLAIM TO ANY PARTICULAR FONT, STYLE, SIZE, OR COLOR.

FOR SANDWICHES (U.S. CL. 46).

FIRST USE 1-1-2000; IN COMMERCE 1-1-2000.

KATHERINE CHANG, EXAMINING ATTORNEY

SN 78-965,036. MEI, YUE QIN WILLIAM, CHICAGO, IL. FILED 8-31-2006.

**GOOD-HARVEST**

THE MARK CONSISTS OF STANDARD CHARACTERS WITHOUT CLAIM TO ANY PARTICULAR FONT, STYLE, SIZE, OR COLOR.

FOR RICE, RICE CRACKERS, DRIED POWDER POTATOES AND DRIED POWDER RICE (U.S. CL. 46).

JILL C. ALT, EXAMINING ATTORNEY

**CLASS 30—(Continued).**

SN 78-965,404. HALEY, VAN D., ALISO VIEJO, CA. FILED 8-31-2006.

# ZENTOPIA

THE MARK CONSISTS OF STANDARD CHARACTERS WITHOUT CLAIM TO ANY PARTICULAR FONT, STYLE, SIZE, OR COLOR.  
FOR TEAS AND PASTRIES (U.S. CL. 46).  
NAKIA HENRY, EXAMINING ATTORNEY

**CLASS 30—(Continued).**

SN 78-966,439. LOBEFARO, TRISHA, TARZANA, CA. FILED 9-1-2006.

# NO UDDER DESSERTS

NO CLAIM IS MADE TO THE EXCLUSIVE RIGHT TO USE "DESSERTS", APART FROM THE MARK AS SHOWN. THE COLOR(S) BLACK AND PINK IS/ARE CLAIMED AS A FEATURE OF THE MARK.  
THE LETTER "U" IS PINK. THE REST OF THE WORD-ING IS BLACK.  
THE MARK CONSISTS OF THE "U" IN UDDER IS PINK. FOR VEGAN BAKERY GOODS AND DESSERTS (U.S. CL. 46).  
IRA J. GOODSaid, EXAMINING ATTORNEY

SN 78-965,719. QUEEN EXOTIC BRAND, BLACKSBURG, VA. FILED 9-1-2006.

# QUEEN EXOTIC BRAND

THE MARK CONSISTS OF STANDARD CHARACTERS WITHOUT CLAIM TO ANY PARTICULAR FONT, STYLE, SIZE, OR COLOR.  
NO CLAIM IS MADE TO THE EXCLUSIVE RIGHT TO USE "BRAND", APART FROM THE MARK AS SHOWN.  
FOR BREAD; COFFEE BEANS; SAUCES (U.S. CL. 46).  
DOMINIC FATHY, EXAMINING ATTORNEY

SN 78-966,441. NEW CASCADIA LLC, PORTLAND, OR. FILED 9-1-2006.

# NEW CASCADIA TRADITIONAL

THE MARK CONSISTS OF STANDARD CHARACTERS WITHOUT CLAIM TO ANY PARTICULAR FONT, STYLE, SIZE, OR COLOR.  
FOR GLUTEN-FREE BAKERY GOODS AND PRODUCTS; FROZEN, REFRIGERATED, PARTIALLY PREPARED AND READY-TO-EAT GLUTEN-FREE QUICK BREADS, YEAST BREADS, PIZZA CRUSTS, COOKIES AND PASTRIES; GLUTEN-FREE FROZEN CONFECTIONS; GLUTEN-FREE SAUCES AND SPICES (U.S. CL. 46).  
IRA J. GOODSaid, EXAMINING ATTORNEY

SN 78-965,926. ESM FOOD MANAGEMENT INC., GOLDEN VALLEY, MN. FILED 9-1-2006.

# COFFEE'S ON US!

THE MARK CONSISTS OF STANDARD CHARACTERS WITHOUT CLAIM TO ANY PARTICULAR FONT, STYLE, SIZE, OR COLOR.  
FOR PACKAGED COFFEE (U.S. CL. 46).  
JOHN HWANG, EXAMINING ATTORNEY

SN 78-967,103. CARAVAN TRADING CO., UNION CITY, CA. FILED 9-5-2006.

# MI COLONIA

THE MARK CONSISTS OF STANDARD CHARACTERS WITHOUT CLAIM TO ANY PARTICULAR FONT, STYLE, SIZE, OR COLOR.  
THE FOREIGN WORDING IN THE MARK TRANSLATES INTO ENGLISH AS "MY NEIGHBORHOOD".  
FOR BREADS, PASTRIES AND CAKES (U.S. CL. 46).  
FIRST USE 4-30-1992; IN COMMERCE 4-30-1992.  
DORITT L. CARROLL, EXAMINING ATTORNEY

**CLASS 30—(Continued).**

SN 78-967,127. CARAVAN TRADING CO., UNION CITY, CA.  
FILED 9-5-2006.

**PANADERIA MI COLONIA**

THE MARK CONSISTS OF STANDARD CHARACTERS WITHOUT CLAIM TO ANY PARTICULAR FONT, STYLE, SIZE, OR COLOR.

NO CLAIM IS MADE TO THE EXCLUSIVE RIGHT TO USE "PANADERIA, THE ENGLISH TRANSLATION OF WHICH IS "BAKERY", APART FROM THE MARK AS SHOWN.

THE FOREIGN WORDING IN THE MARK TRANSLATES INTO ENGLISH AS "MY NEIGHBORHOOD BAKERY".  
FOR BREADS, PASTRIES AND CAKES (U.S. CL. 46).  
FIRST USE 1-0-1993; IN COMMERCE 1-0-1993.  
DORITT L. CARROLL, EXAMINING ATTORNEY

SN 78-967,528. DEMIEL MÉXICO, SA DE CV, CUAUTITLÁN IZCALLI, ESTADO DE MÉXICO, MEXICO, FILED 9-5-2006.

**COBÁ THE LAND OF HONEY**

THE MARK CONSISTS OF STANDARD CHARACTERS WITHOUT CLAIM TO ANY PARTICULAR FONT, STYLE, SIZE, OR COLOR.

NO CLAIM IS MADE TO THE EXCLUSIVE RIGHT TO USE "COBA" AND "HONEY", APART FROM THE MARK AS SHOWN.

FOR HONEY (U.S. CL. 46).  
FIRST USE 1-8-2006; IN COMMERCE 1-8-2006.  
AMY GEARIN, EXAMINING ATTORNEY

SN 78-968,109. FLOWERS BAKERIES BRANDS, INC., WILMINGTON, DE. FILED 9-6-2006.



OWNER OF U.S. REG. NOS. 1,326,230 AND 1,991,258.  
THE MARK CONSISTS OF THE WORDS COBBLESTONE MILL AND A DRAWING DEPICTING A WATER WHEEL.  
FOR BAKERY PRODUCTS (U.S. CL. 46).  
FIRST USE 6-25-2006; IN COMMERCE 6-25-2006.  
GISELLE AGOSTO, EXAMINING ATTORNEY

**CLASS 30—(Continued).**

SN 78-968,249. SMUCKER BRANDS, INC., ORRVILLE, OH.  
FILED 9-6-2006.

**Martha White**

THE MARK CONSISTS OF STANDARD CHARACTERS WITHOUT CLAIM TO ANY PARTICULAR FONT, STYLE, SIZE, OR COLOR.

OWNER OF U.S. REG. NOS. 726,321, 2,860,043 AND OTHERS.

THE NAME MARTHA WHITE DOES NOT IDENTIFY A LIVING INDIVIDUAL.

FOR FROZEN CORNBREAD (U.S. CL. 46).  
ELISSA GARBER KON, EXAMINING ATTORNEY

SN 78-968,693. HDIP, INC., MINNEAPOLIS, MN. FILED 9-7-2006.

**HÄAGEN-DAZS RESERVE**

THE MARK CONSISTS OF STANDARD CHARACTERS WITHOUT CLAIM TO ANY PARTICULAR FONT, STYLE, SIZE, OR COLOR.

OWNER OF U.S. REG. NOS. 737,244, 1,360,895 AND 1,696,350.

FOR ICE CREAM (U.S. CL. 46).  
JIM RINGLE, EXAMINING ATTORNEY

SN 78-969,343. HANSEN BEVERAGE COMPANY, CORONA, CA. FILED 9-7-2006.

**IMPORTED FROM NATURE**

THE MARK CONSISTS OF STANDARD CHARACTERS WITHOUT CLAIM TO ANY PARTICULAR FONT, STYLE, SIZE, OR COLOR.

FOR TEA, ICED TEA AND TEA PRODUCTS, NAMELY READY TO DRINK TEA, ICED TEA AND TEA BASED BEVERAGES; READY TO DRINK FLAVORED TEA, ICED TEA AND TEA BASED BEVERAGES; FLAVORED AND UNFLAVORED TEA MIX; READY TO DRINK COFFEE BASED BEVERAGES (U.S. CL. 46).

DAVID COLLIER, EXAMINING ATTORNEY



**CLASS 30—(Continued).**

SN 78-970,940. SYKES, DANNA C., FAYETTEVILLE, NC.  
FILED 9-10-2006.

**Danna's SLAM**

THE MARK CONSISTS OF STANDARD CHARACTERS  
WITHOUT CLAIM TO ANY PARTICULAR FONT, STYLE,  
SIZE, OR COLOR.

FOR SPICE BLENDS (U.S. CL. 46).  
DAVID C. REIHNER, EXAMINING ATTORNEY

---

SN 78-971,343. GREEN & BLACK'S CHOCOLATE LIMITED,  
LONDON, UNITED KINGDOM, FILED 9-11-2006.

**GREEN & BLACK'S**

THE MARK CONSISTS OF STANDARD CHARACTERS  
WITHOUT CLAIM TO ANY PARTICULAR FONT, STYLE,  
SIZE, OR COLOR.

OWNER OF U.S. REG. NO. 2,736,107.  
FOR ICE CREAM (U.S. CL. 46).  
RONALD MCMORROW, EXAMINING ATTORNEY

---

SN 78-972,346. UBIQUITY BRANDS, LLC, CHICAGO, IL.  
FILED 9-12-2006.

**O-KE-DOKE CRUNCHEESE**

THE MARK CONSISTS OF STANDARD CHARACTERS  
WITHOUT CLAIM TO ANY PARTICULAR FONT, STYLE,  
SIZE, OR COLOR.

FOR SNACK FOODS, NAMELY BAKED AND FRIED  
CHEESE CURLS (U.S. CL. 46).  
REBECCA POVARCHUK, EXAMINING ATTORNEY

**CLASS 30—(Continued).**

SN 78-973,135. SOVEREIGN DEED, LLC, VERNON HILLS,  
IL. FILED 9-13-2006.

**ADVERSE CONSEQUENCE  
PLANNING**

THE MARK CONSISTS OF STANDARD CHARACTERS  
WITHOUT CLAIM TO ANY PARTICULAR FONT, STYLE,  
SIZE, OR COLOR.

FOR BAKERY GOODS; CANDIES; CEREAL BASED  
SNACK FOOD; CHEWING GUM; CHOCOLATE; COFFEE;  
FLAVORING ADDITIVES FOR NON-NUTRITIONAL  
PURPOSES; FLAVOURINGS; FLOUR;  
GRANOLA; HONEY; ICE; PASTA; POPCORN; PROCESSED  
CEREALS; PROCESSED GRAINS; RICE; SALT;  
SANDWICHES; SAUCES; SEASONINGS; SPICES; SUGAR  
AND SUGAR SUBSTITUTES; TEA; YEAST (U.S. CL. 46).  
PETER B. BROMAGHIM, EXAMINING ATTORNEY

---

SN 78-974,381. FLOWERS BAKERIES BRANDS, INC., WIL-  
MINGTON, DE. FILED 9-14-2006.



OWNER OF U.S. REG. NOS. 1,098,271 AND 1,843,098.  
NO CLAIM IS MADE TO THE EXCLUSIVE RIGHT TO  
USE BAKERIES, APART FROM THE MARK AS SHOWN.

THE MARK CONSISTS OF A STYLIZED FACE OF A  
BIRD IN AN OVAL SHAPE WITH THE WORD BLUE ON  
THE LEFT AND THE WORD BIRD ON THE RIGHT, EACH  
IN A STYLIZED RIBBON SHAPE AND THE WORD  
BAKERIES UNDERNEATH THE BIRD'S FACE.

FOR BAKERY PRODUCTS (U.S. CL. 46).  
FIRST USE 9-4-2006; IN COMMERCE 9-4-2006.  
GISELLE AGOSTO, EXAMINING ATTORNEY

**CLASS 30—(Continued).**

SN 79-027,071. YAN LI FANG, CHINA, AND ZHU WEN SHENG, CHINA, FILED 4-24-2006.



OWNER OF INTERNATIONAL REGISTRATION 0893780 DATED 4-24-2006, EXPIRES 4-24-2016.

THE TRANSLITERATION OF THE NON-LATIN CHARACTERS IN THE MARK IS ZHU.

FOR WHEAT FLOUR; RICE FLOUR; SOYA SAUCE; SOYA FLOUR; NOODLES; SUGAR CANDY; CUBIC SUGAR; GLUTINOUS RICE FLOUR; FLAVORING ADDITIVES FOR NON-NUTRITIONAL PURPOSES, NAMELY, MONOSODIUM GLUTAMATE; INSTANT NOODLE (U.S. CL. 46).

TOBY BULLOFF, EXAMINING ATTORNEY

**CLASS 31—NATURAL AGRICULTURAL PRODUCTS**

SN 76-640,105. HAAS OUTDOORS, INC., WEST POINT, MS. FILED 6-3-2005.

**BIO LOGIC HOT SPOT**

THE MARK CONSISTS OF STANDARD CHARACTERS WITHOUT CLAIM TO ANY PARTICULAR FONT, STYLE, SIZE, OR COLOR.

OWNER OF U.S. REG. NOS. 2,278,961 AND 2,688,441. SEC. 2(F) "BIO LOGIC".

FOR PLANT SEED FOR GROWING PLANTS INTENDED AND DESIGNED FOR CONSUMPTION BY WILDLIFE, EXCLUDING PEPPERS AND/OR ORCHIDS (U.S. CLS. 1 AND 46).

KARANENDRA S. CHHINA, EXAMINING ATTORNEY

SN 77-003,300. SYNGENTA PARTICIPATIONS AG, BASEL, SWITZERLAND, FILED 9-20-2006.

**RESOLVE**

THE MARK CONSISTS OF STANDARD CHARACTERS WITHOUT CLAIM TO ANY PARTICULAR FONT, STYLE, SIZE, OR COLOR.

FOR UNPROCESSED, RAW AND FRESH FRUITS, VEGETABLES AND SEEDS THEREOF; AGRICULTURAL SEEDS, LIVE SEEDLINGS, LIVE NATURAL PLANTS; FIELD CROP SEEDS AND FIELD SEEDS (U.S. CLS. 1 AND 46).

WON TEAK OH, EXAMINING ATTORNEY

**CLASS 31—(Continued).**

SN 77-009,564. THE IAMS COMPANY, CINCINNATI, OH. FILED 9-28-2006.



OWNER OF U.S. REG. NOS. 1,433,161, 2,392,936 AND OTHERS.

NO CLAIM IS MADE TO THE EXCLUSIVE RIGHT TO USE "PREMIUM PERFORMANCE", APART FROM THE MARK AS SHOWN.

THE MARK CONSISTS OF EUKANUBA WITH A CIRCULAR PAW PRINT AFTER AND THE WORDS PREMIUM PERFORMANCE UNDERNEATH THE WORD EUKANUBA.

FOR FOOD STUFFS FOR ANIMALS (U.S. CLS. 1 AND 46).

MARGERY A. TIERNEY, EXAMINING ATTORNEY

SN 77-009,619. THE IAMS COMPANY, CINCINNATI, OH. FILED 9-28-2006.



OWNER OF U.S. REG. NOS. 1,433,161, 2,392,936 AND OTHERS.

NO CLAIM IS MADE TO THE EXCLUSIVE RIGHT TO USE "BREED SPECIFIC", APART FROM THE MARK AS SHOWN.

THE MARK CONSISTS OF THE WORK EUKANUBA FOLLOWED BY A PAW PRINT WITH THE WORDS BREED SPECIFIC UNDERNEATH.

FOR FOOD STUFFS FOR ANIMALS (U.S. CLS. 1 AND 46).

MARGERY A. TIERNEY, EXAMINING ATTORNEY

SN 77-009,643. THE IAMS COMPANY, CINCINNATI, OH. FILED 9-28-2006.



OWNER OF U.S. REG. NOS. 1,433,161, 2,392,936 AND OTHERS.

NO CLAIM IS MADE TO THE EXCLUSIVE RIGHT TO USE "NATURAL", APART FROM THE MARK AS SHOWN.

THE MARK CONSISTS OF EUKANUBA FOLLOWED BY A PAW PRINT WITH THE WORD NATURAL UNDER THE WORD EUKANUBA.

FOR FOOD STUFFS FOR ANIMALS (U.S. CLS. 1 AND 46).

MARGERY A. TIERNEY, EXAMINING ATTORNEY

**CLASS 31—(Continued).**

SN 77-019,416. THE IAMS COMPANY, CINCINNATI, OH. FILED 10-12-2006.

POUR NOURRIR CHAQUE RACE

THE MARK CONSISTS OF STANDARD CHARACTERS WITHOUT CLAIM TO ANY PARTICULAR FONT, STYLE, SIZE, OR COLOR.  
OWNER OF U.S. REG. NOS. 1,433,161, 2,392,936 AND OTHERS.

NO CLAIM IS MADE TO THE EXCLUSIVE RIGHT TO USE "NOURRIR", APART FROM THE MARK AS SHOWN. THE ENGLISH TRANSLATION OF POUR NOURRIR CHAQUE RACE IS TO NOURISH EACH RACE.

FOR FOOD STUFFS FOR ANIMALS (U.S. CLS. 1 AND 46).  
MARGERY A. TIERNEY, EXAMINING ATTORNEY



SN 77-024,701. KENT FEEDS, INC., MUSCATINE, IA. FILED 10-19-2006.

Native

THE MARK CONSISTS OF STANDARD CHARACTERS WITHOUT CLAIM TO ANY PARTICULAR FONT, STYLE, SIZE, OR COLOR.

FOR PET FOODS (U.S. CLS. 1 AND 46).  
EVELYN BRADLEY, EXAMINING ATTORNEY



SN 77-066,518. THE IAMS COMPANY, CINCINNATI, OH. FILED 12-18-2006.

PREMIUM PROTECTION

THE MARK CONSISTS OF STANDARD CHARACTERS WITHOUT CLAIM TO ANY PARTICULAR FONT, STYLE, SIZE, OR COLOR.

FOR FOODSTUFFS FOR ANIMALS (U.S. CLS. 1 AND 46).  
MARGERY A. TIERNEY, EXAMINING ATTORNEY

**CLASS 31—(Continued).**

SN 78-517,411. CARGILL INCORPORATED, WAYZATA, MN. FILED 11-16-2004.

PAYBACK

THE MARK CONSISTS OF STANDARD CHARACTERS WITHOUT CLAIM TO ANY PARTICULAR FONT, STYLE, SIZE, OR COLOR.

SUBJECT TO CONCURRENT USE PROCEEDING WITH U.S. APPLICATION SERIAL NO. 76573047. APPLICANT CLAIMS THE EXCLUSIVE RIGHT TO USE THE MARK IN THE AREA COMPRISING MAINE, NEW HAMPSHIRE, MASSACHUSETTS, DELAWARE, NEW YORK, NEW JERSEY, CONNECTICUT, MARYLAND, RHODE ISLAND, ALABAMA, ALASKA, ARIZONA, ARKANSAS, CALIFORNIA, FLORIDA, GEORGIA, HAWAII, ILLINOIS, KENTUCKY, LOUISIANA, MICHIGAN, MISSISSIPPI, NEVADA, NEW MEXICO, PENNSYLVANIA, NORTH CAROLINA, SOUTH CAROLINA, TENNESSEE, TEXAS, UTAH, VERMONT, VIRGINIA, AND WEST VIRGINIA.

FOR ANIMAL FEED (U.S. CLS. 1 AND 46).  
FIRST USE 6-1-1995; IN COMMERCE 6-1-1995.  
ALLISON SCHRODY, EXAMINING ATTORNEY



SN 78-547,652. GEEP L.L.C., GAINESVILLE, GA. FILED 1-14-2005.

HYE

THE MARK CONSISTS OF STANDARD CHARACTERS WITHOUT CLAIM TO ANY PARTICULAR FONT, STYLE, SIZE, OR COLOR.

FOR GENETICALLY ALTERED LIVE HATCHING EGGS; AND GENETICALLY ALTERED LIVE ANIMALS, NAMELY, CHICKS (U.S. CLS. 1 AND 46).  
RAY THOMAS, EXAMINING ATTORNEY

**CLASS 31—(Continued).**

SN 78-679,548. HENDRIKS GREENHOUSES, BEAMSVILLE, ONTARIO, CANADA, FILED 7-27-2005.

**PURE GREEN**

THE MARK CONSISTS OF STANDARD CHARACTERS WITHOUT CLAIM TO ANY PARTICULAR FONT, STYLE, SIZE, OR COLOR.

PRIORITY CLAIMED UNDER SEC. 44(D) ON CANADA APPLICATION NO. 1259593, FILED 6-1-2005, REG. NO. TMA667327, DATED 7-11-2006, EXPIRES 7-11-2021.

NO CLAIM IS MADE TO THE EXCLUSIVE RIGHT TO USE "GREEN", APART FROM THE MARK AS SHOWN, FOR LIVE PLANTS AND LIVE PLANT ARRANGEMENTS (U.S. CLS. 1 AND 46).

DAVID YONTEF, EXAMINING ATTORNEY

---

SN 78-748,760. WESTLAND FLORAL COMPANY, CARPINTERIA, CA. FILED 11-7-2005.

*Pacific*  
**coast**  
**bouquet**

NO CLAIM IS MADE TO THE EXCLUSIVE RIGHT TO USE "BOUQUET", APART FROM THE MARK AS SHOWN. THE COLOR(S) BLUE, YELLOW, ORANGE, AND BURGUNDY IS/ARE CLAIMED AS A FEATURE OF THE MARK.

THE MARK CONSISTS OF A BLUE CURSIVE TYPE FOR THE WORD PACIFIC, ORANGE AND YELLOW BLOCK STYLE TYPE FACE FOR THE WORD COAST, AND BURGUNDY FOR THE SERIF STYLE TYPE FACE OF THE WORD BOUQUET.

FOR CUT FLOWERS (U.S. CLS. 1 AND 46).  
FIRST USE 1-1-1995; IN COMMERCE 1-1-1995.  
CARRIE ACHEN, EXAMINING ATTORNEY

**CLASS 31—(Continued).**

SN 78-794,628. BROWN, THOMAS, KANSAS CITY, MO. FILED 1-19-2006.

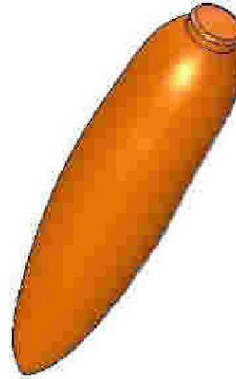

THE COLOR(S) ORANGE IS/ARE CLAIMED AS A FEATURE OF THE MARK.

THE MARK IS ORANGE.

THE MARK CONSISTS OF A CONFIGURATION OF AN ANIMAL CHEW IN THE SHAPE OF A CARROT.

FOR EDIBLE CHEWS FOR ANIMALS (U.S. CLS. 1 AND 46).

ALICE SUE CARRUTHERS, EXAMINING ATTORNEY

---

SN 78-810,156. GRASSHOPPER PACKING COMPANY, LLC, PITTSBURG, KS. FILED 2-8-2006.

 **NaturalLife**  
Nutritional Pet Products

OWNER OF U.S. REG. NOS. 1,469,297 AND 1,747,321. NO CLAIM IS MADE TO THE EXCLUSIVE RIGHT TO USE "NUTRITIONAL PET PRODUCTS", APART FROM THE MARK AS SHOWN.

FOR PET FOOD (U.S. CLS. 1 AND 46).  
FIRST USE 3-10-2006; IN COMMERCE 3-10-2006.  
LEIGH LOWRY, EXAMINING ATTORNEY

**CLASS 31—(Continued).**

SN 78-816,019. FLAVORTEK, INC., OLDSMAR, FL. FILED 2-16-2006.

**FLAVOR-DOH**

THE MARK CONSISTS OF STANDARD CHARACTERS WITHOUT CLAIM TO ANY PARTICULAR FONT, STYLE, SIZE, OR COLOR.

FOR NUTRITIONAL PET TREATS FOR FACILITATING PILL INGESTION IN DOGS AND CATS (U.S. CLS. 1 AND 46).

KEVIN DINALLO, EXAMINING ATTORNEY

SN 78-821,160. AGROMOD, S.A. DE C.V., SAN PEDRO GARZA GARCIA, N.L., MEXICO, FILED 2-22-2006.



FOR FRESH FRUIT, NAMELY, PAPAYA (U.S. CLS. 1 AND 46).

CATHERINE FAINT, EXAMINING ATTORNEY

SN 78-868,334. STOKES & LOMBARDI FARMS LLC, LODI, CA. FILED 4-24-2006.

**RIVER DOG**

THE MARK CONSISTS OF STANDARD CHARACTERS WITHOUT CLAIM TO ANY PARTICULAR FONT, STYLE, SIZE, OR COLOR.

FOR FRESH FRUITS; FRESH VEGETABLES (U.S. CLS. 1 AND 46).

SETH A. RAPPAPORT, EXAMINING ATTORNEY

**CLASS 31—(Continued).**

SN 78-896,666. BROWN, BRUCE W., FAIRHOPE, AL. FILED 5-31-2006.

**GATO GO**

THE MARK CONSISTS OF STANDARD CHARACTERS WITHOUT CLAIM TO ANY PARTICULAR FONT, STYLE, SIZE, OR COLOR.

NO CLAIM IS MADE TO THE EXCLUSIVE RIGHT TO USE "GATO", APART FROM THE MARK AS SHOWN.

THE FOREIGN WORDING IN THE MARK TRANSLATES INTO ENGLISH AS CAT.

FOR KITS CONSISTING PRIMARILY OF CAT LITTER, SCRATCHING PAD, FOOD AND TOYS SOLD TOGETHER AS A UNIT FOR USE TO ALLOW PET OWNERS TO TRAVEL WITH THEIR PETS WITH EASE (U.S. CLS. 1 AND 46).

DAVID STERKIN, EXAMINING ATTORNEY

SN 78-928,870. SCHELL & KAMPETER, INC., META, MO. FILED 7-13-2006.

**DIAMOND NATURALS**

THE MARK CONSISTS OF STANDARD CHARACTERS WITHOUT CLAIM TO ANY PARTICULAR FONT, STYLE, SIZE, OR COLOR.

OWNER OF U.S. REG. NOS. 637,256, 1,792,835 AND 1,882,415.

NO CLAIM IS MADE TO THE EXCLUSIVE RIGHT TO USE "NATURALS", APART FROM THE MARK AS SHOWN. FOR PET FOODS (U.S. CLS. 1 AND 46).

FIRST USE 4-27-2006; IN COMMERCE 4-27-2006.

JUSTINE D. PARKER, EXAMINING ATTORNEY

SN 78-940,867. D & D COMMODITIES LIMITED, STEPHEN, MN. FILED 7-31-2006.

**NUT N' BERRY**

THE MARK CONSISTS OF STANDARD CHARACTERS WITHOUT CLAIM TO ANY PARTICULAR FONT, STYLE, SIZE, OR COLOR.

OWNER OF U.S. REG. NO. 2,315,063.

SEC. 2(F).

FOR FOOD FOR BIRDS (U.S. CLS. 1 AND 46).

FIRST USE 8-24-1998; IN COMMERCE 8-24-1998.

BRENDAN MCCAULEY, EXAMINING ATTORNEY

**CLASS 31—(Continued).**

SN 78-948,418. ANDERSON, HARLAN R., COKATO, MN. FILED 8-9-2006.

## SENIOR SUPPER

THE MARK CONSISTS OF STANDARD CHARACTERS WITHOUT CLAIM TO ANY PARTICULAR FONT, STYLE, SIZE, OR COLOR.

NO CLAIM IS MADE TO THE EXCLUSIVE RIGHT TO USE "SENIOR", APART FROM THE MARK AS SHOWN. FOR FOOD FOR HORSES, NAMELY ALFALFA BASED NUTRITIONAL FEED FOR MATURE HORSES (U.S. CLS. 1 AND 46).

JULIE GUTTADAURO, EXAMINING ATTORNEY

**CLASS 31—(Continued).**

SN 78-957,662. AGRICULTURAL SYSTEMS INTERNATIONAL, INC., SALUNGA, PA. FILED 8-22-2006.

## Agri-Veal System

THE MARK CONSISTS OF STANDARD CHARACTERS WITHOUT CLAIM TO ANY PARTICULAR FONT, STYLE, SIZE, OR COLOR.

OWNER OF U.S. REG. NO. 3,160,540. FOR WATER MODIFIED WITH ELOPTIC ENERGY SPECIALLY FORMULATED FOR VEAL CALVES (U.S. CLS. 1 AND 46).

DANIEL RUSSELL, EXAMINING ATTORNEY

---

SN 78-957,654. AGRICULTURAL SYSTEMS INTERNATIONAL, INC., SALUNGA, PA. FILED 8-22-2006.

## Agri-Ducks System

THE MARK CONSISTS OF STANDARD CHARACTERS WITHOUT CLAIM TO ANY PARTICULAR FONT, STYLE, SIZE, OR COLOR.

OWNER OF U.S. REG. NO. 3,160,540. FOR WATER MODIFIED WITH ELOPTIC ENERGY SPECIALLY FORMULATED FOR DUCKS (U.S. CLS. 1 AND 46).

DANIEL RUSSELL, EXAMINING ATTORNEY

---

SN 78-957,666. AGRICULTURAL SYSTEMS INTERNATIONAL, INC., SALUNGA, PA. FILED 8-22-2006.

## Agri-Dairy System

THE MARK CONSISTS OF STANDARD CHARACTERS WITHOUT CLAIM TO ANY PARTICULAR FONT, STYLE, SIZE, OR COLOR.

OWNER OF U.S. REG. NO. 3,160,540. FOR WATER MODIFIED WITH ELOPTIC ENERGY SPECIALLY FORMULATED FOR DAIRY ANIMALS (U.S. CLS. 1 AND 46).

DANIEL RUSSELL, EXAMINING ATTORNEY

---

SN 78-957,658. AGRICULTURAL SYSTEMS INTERNATIONAL, INC., SALUNGA, PA. FILED 8-22-2006.

## Agri-Pork System

THE MARK CONSISTS OF STANDARD CHARACTERS WITHOUT CLAIM TO ANY PARTICULAR FONT, STYLE, SIZE, OR COLOR.

OWNER OF U.S. REG. NO. 3,160,540. FOR WATER MODIFIED WITH ELOPTIC ENERGY SPECIALLY FORMULATED FOR PIGS (U.S. CLS. 1 AND 46).

DANIEL RUSSELL, EXAMINING ATTORNEY

---

SN 78-957,671. AGRICULTURAL SYSTEMS INTERNATIONAL, INC., SALUNGA, PA. FILED 8-22-2006.

## Agri-Beef System

THE MARK CONSISTS OF STANDARD CHARACTERS WITHOUT CLAIM TO ANY PARTICULAR FONT, STYLE, SIZE, OR COLOR.

OWNER OF U.S. REG. NO. 3,160,540. FOR WATER MODIFIED WITH ELOPTIC ENERGY SPECIALLY FORMULATED FOR CATTLE (U.S. CLS. 1 AND 46).

DANIEL RUSSELL, EXAMINING ATTORNEY

**CLASS 31—(Continued).**

SN 78-963,453. LISDAN COMPANY, GAINESVILLE, FL.  
FILED 8-30-2006.



NO CLAIM IS MADE TO THE EXCLUSIVE RIGHT TO USE "CAT FOOD", APART FROM THE MARK AS SHOWN. THE COLOR(S) BLACK AND ORANGE IS/ARE CLAIMED AS A FEATURE OF THE MARK.

THE MARK CONSISTS OF TWO CAT FACES, IN BLACK AND ORANGE, RESPECTIVELY, ABOVE THE TWO WORDS BROTHERS AND BLEND, IN ORANGE AND BLACK, RESPECTIVELY, AND THE WORDS CAT FOOD.

FOR CAT FOOD (U.S. CLS. 1 AND 46).  
FIRST USE 5-31-2004; IN COMMERCE 5-31-2004.  
ALLISON HOLTZ, EXAMINING ATTORNEY

SN 78-963,921. GEORGE W. RADEBAUGH & SONS, INC.,  
TOWSON, MD. FILED 8-30-2006.

**ONLY NATURE HAS MORE  
EXPERIENCE**

THE MARK CONSISTS OF STANDARD CHARACTERS WITHOUT CLAIM TO ANY PARTICULAR FONT, STYLE, SIZE, OR COLOR.

FOR CUT FLOWERS; DRIED FLOWER ARRANGEMENTS; DRIED FLOWER WREATHS; DRIED FLOWERS; FLOWERS; LIVE FLOWER ARRANGEMENTS; LIVE FLOWER WREATHS; LIVE FLOWERING PLANTS; LIVE FLOWERS; LIVE PLANTS (U.S. CLS. 1 AND 46).

FIRST USE 10-1-1978; IN COMMERCE 10-1-1978.  
TRICIA SONNEBORN, EXAMINING ATTORNEY

SN 78-964,196. GENSLER, DON, WHITE SALMON, WA. AND  
GENSLER, KRISTIE, WHITE SALMON, WA. FILED 8-30-  
2006.

**WINDWALKER**

THE MARK CONSISTS OF STANDARD CHARACTERS WITHOUT CLAIM TO ANY PARTICULAR FONT, STYLE, SIZE, OR COLOR.

FOR FRUITS, NAMELY, FRESH GRAPES AND UN-  
PROCESSED GRAPES (U.S. CLS. 1 AND 46).

CHRISTINA SOBRAL, EXAMINING ATTORNEY

**CLASS 31—(Continued).**

SN 78-965,106. BKC I, LAS VEGAS, NV. FILED 8-31-2006.

**SHRIMPIES**

THE MARK CONSISTS OF STANDARD CHARACTERS WITHOUT CLAIM TO ANY PARTICULAR FONT, STYLE, SIZE, OR COLOR.

FOR LIVE SHRIMP FOR USE IN AQUARIUMS AND  
OTHER AQUATIC DISPLAYS (U.S. CLS. 1 AND 46).  
LEIGH CAROLINE CASE, EXAMINING ATTORNEY

SN 78-965,120. WEST COAST TURF, PALM DESERT, CA.  
FILED 8-31-2006.

**BAYSIDE PLUS**

THE MARK CONSISTS OF STANDARD CHARACTERS WITHOUT CLAIM TO ANY PARTICULAR FONT, STYLE, SIZE, OR COLOR.

FOR GRASS SEED, GRASS STOLONS, AND SOD (U.S.  
CLS. 1 AND 46).

ELLEN PERKINS, EXAMINING ATTORNEY

SN 78-965,630. YANTAI CHINA PET FOODS CO., LTD.,  
LAISHAN DISTRICT, CHINA, FILED 8-31-2006.

**WANPY**

THE MARK CONSISTS OF STANDARD CHARACTERS WITHOUT CLAIM TO ANY PARTICULAR FONT, STYLE, SIZE, OR COLOR.

FOR PET FOOD (U.S. CLS. 1 AND 46).

DAHLIA GEORGE, EXAMINING ATTORNEY

**CLASS 31—(Continued).**

SN 78-967,113. THE IAMS COMPANY, CINCINNATI, OH.  
FILED 9-5-2006.

EUKANUBA NATURAL LAMB &  
RICE FORMULA

THE MARK CONSISTS OF STANDARD CHARACTERS  
WITHOUT CLAIM TO ANY PARTICULAR FONT, STYLE,  
SIZE, OR COLOR.

OWNER OF U.S. REG. NOS. 1,433,161, 2,392,936 AND  
OTHERS.

NO CLAIM IS MADE TO THE EXCLUSIVE RIGHT TO  
USE "NATURAL LAMB & RICE FORMULA", APART  
FROM THE MARK AS SHOWN.

FOR FOODSTUFFS FOR ANIMALS (U.S. CLS. 1 AND  
46).

MARGERY A. TIERNEY, EXAMINING ATTORNEY

**CLASS 31—(Continued).**

SN 78-969,608. PEPIN HEIGHTS ORCHARD, INC., LAKE  
CITY, MN. FILED 9-7-2006.

HONEY BABIES BUS

THE MARK CONSISTS OF STANDARD CHARACTERS  
WITHOUT CLAIM TO ANY PARTICULAR FONT, STYLE,  
SIZE, OR COLOR.

FOR PACKAGED FRESH APPLES (U.S. CLS. 1 AND  
46).

JILL PRATER, EXAMINING ATTORNEY

SN 78-968,219. ONISHI, MASAMI, POTOMAC, MD. FILED 9-  
6-2006.



THE MARK CONSISTS OF THE LETTER F AND THE  
LETTER L ARE ON THE THE BIG LETTER X.

FOR DRIED FLOWER ARRANGEMENTS (U.S. CLS. 1  
AND 46).

MICHAEL SOUDERS, EXAMINING ATTORNEY

SN 78-972,121. BACKYARD FARMS, LLC, LEXINGTON,  
MA. FILED 9-12-2006.

GROWN NOT TOO FAR FROM HERE

THE MARK CONSISTS OF STANDARD CHARACTERS  
WITHOUT CLAIM TO ANY PARTICULAR FONT, STYLE,  
SIZE, OR COLOR.

FOR FRESH VEGETABLES (U.S. CLS. 1 AND 46).  
KEVON CHISOLM, EXAMINING ATTORNEY

SN 78-968,523. TERRA NOVA NURSERIES, INC., CANBY,  
OR. FILED 9-6-2006.

TASMANIAN ANGEL

THE MARK CONSISTS OF STANDARD CHARACTERS  
WITHOUT CLAIM TO ANY PARTICULAR FONT, STYLE,  
SIZE, OR COLOR.

NO CLAIM IS MADE TO THE EXCLUSIVE RIGHT TO  
USE "TASMANIAN", APART FROM THE MARK AS  
SHOWN.

FOR LIVE PLANTS (U.S. CLS. 1 AND 46).  
WENDY GOODMAN, EXAMINING ATTORNEY

SN 79-028,542. HAPPY YAPPERS BISCUITS FOR YOUR  
POOCH PTY LTD, AUSTRALIA. FILED 8-30-2006.



OWNER OF INTERNATIONAL REGISTRATION 0897639  
DATED 8-30-2006, EXPIRES 8-30-2016.  
FOR DOG BISCUITS (U.S. CLS. 1 AND 46).  
DANIEL CAPSHAW, EXAMINING ATTORNEY



**CLASS 32—LIGHT BEVERAGES**

SN 75-491,478. SUMMIT INVESTMENTS, INC., COLORADO SPRINGS, CO. FILED 5-27-1998.

**BACK WOODS**

FOR BEER (U.S. CLS. 45, 46 AND 48).  
PAUL F. GAST, EXAMINING ATTORNEY

SN 76-372,078. SOUTH BEACH BEVERAGE COMPANY, INC., NORWALK, CT. FILED 2-15-2002.

**LIZKIDS**

FOR NON-ALCOHOLIC BEVERAGES, NAMELY, CARBONATED SOFT DRINKS, FRUIT-FLAVORED SOFT DRINKS, AND COLAS; LOW CALORIE SOFT DRINKS; NON-CARBONATED SOFT DRINKS; AND SYRUPS, CONCENTRATES, POWDERS AND OTHER PREPARATIONS FOR MAKING SOFT DRINKS AND COLAS (U.S. CLS. 45, 46 AND 48).  
CAROLYN CATALDO, EXAMINING ATTORNEY

SN 76-381,008. SOUTH BEACH BEVERAGE COMPANY, INC., NORWALK, CT. FILED 3-12-2002.

**LIZKIDZ**

FOR NON-ALCOHOLIC BEVERAGES, NAMELY, CARBONATED SOFT DRINKS, FRUIT-FLAVORED SOFT DRINKS, AND COLAS; LOW CALORIE SOFT DRINKS; NON-CARBONATED SOFT DRINKS; AND SYRUPS, CONCENTRATES, POWDERS AND OTHER PREPARATIONS FOR MAKING SOFT DRINKS AND COLAS (U.S. CLS. 45, 46 AND 48).  
CAROLYN CATALDO, EXAMINING ATTORNEY

SN 77-030,925. CAROLINA BEVERAGE CORPORATION, SALISBURY, NC. FILED 10-27-2006.

**THE CHERRY DIFFERENT SOFT DRINK**

THE MARK CONSISTS OF STANDARD CHARACTERS WITHOUT CLAIM TO ANY PARTICULAR FONT, STYLE, SIZE, OR COLOR.

NO CLAIM IS MADE TO THE EXCLUSIVE RIGHT TO USE "CHERRY" AND "SOFT DRINK", APART FROM THE MARK AS SHOWN.

FOR SOFT DRINKS (U.S. CLS. 45, 46 AND 48).  
AISHA SALEM, EXAMINING ATTORNEY

**CLASS 32—(Continued).**

SN 77-037,264. THE CARTOON NETWORK, INC., ATLANTA, GA. FILED 11-6-2006.

**OMNITRIX**

THE MARK CONSISTS OF STANDARD CHARACTERS WITHOUT CLAIM TO ANY PARTICULAR FONT, STYLE, SIZE, OR COLOR.

FOR VEGETABLE JUICE FOR BEVERAGES; FRUIT POWDER FOR MAKING FRUIT JUICES; FRUIT SYRUP FOR MAKING FRUIT JUICES; CONCENTRATED FRUIT JUICE; LEMONADES AND SYRUP FOR MAKING LEMONADE; COLA SYRUP FOR MAKING SOFT DRINKS; POWDERS AND PASTILLES FOR USE IN MAKING EFFERVESCING BEVERAGES; NON-ALCOHOLIC BEVERAGES, NAMELY SOFT DRINKS, FRUIT NECTARS, FRUIT JUICES, FRUIT DRINKS, FRUIT FLAVORED SOFT DRINKS, FRUIT PUNCH, SELTZER WATER (U.S. CLS. 45, 46 AND 48).

LINDA ORNDORFF, EXAMINING ATTORNEY

SN 77-077,743. NEW CENTURY BEVERAGE COMPANY, SAN FRANCISCO, CA. FILED 1-8-2007.

**YOU DESERVE A PEOPLE TREAT**

THE MARK CONSISTS OF STANDARD CHARACTERS WITHOUT CLAIM TO ANY PARTICULAR FONT, STYLE, SIZE, OR COLOR.

FOR SOFT DRINKS (U.S. CLS. 45, 46 AND 48).  
JIM RINGLE, EXAMINING ATTORNEY

SN 78-497,697. TOAST BEVERAGES, INC., CARSON CITY, NV. FILED 10-11-2004.



PRIORITY CLAIMED UNDER SEC. 44(D) ON ERP CMNTY TM OFC APPLICATION NO. 003973013, FILED 8-5-2004, REG. NO. 003973013, DATED 12-1-2005, EXPIRES 8-5-2014.

NO CLAIM IS MADE TO THE EXCLUSIVE RIGHT TO USE GOURMET BEVERAGE, APART FROM THE MARK AS SHOWN.

THE MARK CONSISTS OF A HEART, BROKEN AT THE TOP AND BOTTOM, INSIDE A TWO-CONCENTRIC LINED SHIELD-LIKE BORDER WITH THE WORD GOURMET TO THE BOTTOM LEFT AND THE WORD BEVERAGE TO THE BOTTOM RIGHT.

FOR NON-ALCOHOLIC BEVERAGES, NAMELY, WINE-FLAVORED FRUIT DRINKS, CARBONATED WATER, SODA, FLAVORED WATER, FRUIT FLAVORED DRINKS AND NON-ALCOHOLIC WINE (U.S. CLS. 45, 46 AND 48).

KRISTINA KLOIBER, EXAMINING ATTORNEY

**CLASS 32—(Continued).**

SN 78-640,331. FAYROUZ INTERNATIONAL A.G., 1628  
VUADENS, SWITZERLAND, FILED 5-31-2005.

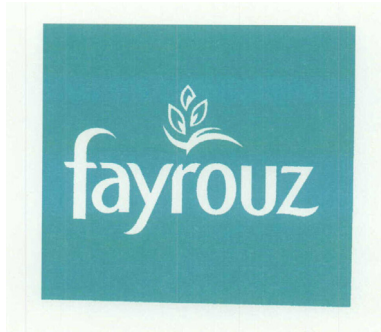

PRIORITY CLAIMED UNDER SEC. 44(D) ON IRAN  
APPLICATION NO. 83090679, FILED 12-1-2004, REG. NO.  
124641, DATED 10-3-2006, EXPIRES 12-1-2014.

OWNER OF U.S. REG. NO. 2,502,411.

THE COLORS WHITE AND TURQUOISE ARE CLAIMED  
AS A FEATURE OF THE MARK.

THE WORDING "FAYROUZ" AND THE DESIGN OF A  
FLOWER, WHICH IS ABOVE THE LITERAL ELEMENT,  
APPEAR IN THE COLOR WHITE. THE BACKGROUND  
APPEARS IN THE COLOR TURQUOISE.

THE MARK CONSISTS OF THE LITERAL ELEMENT  
"FAYROUZ" AND DESIGN.

THE FOREIGN WORDING IN THE MARK TRANSLATES  
INTO ENGLISH AS TURQUOISE.

FOR NONALCOHOLIC BEVERAGES, CONSISTING  
OF NONALCOHOLIC APERITIFS, NONALCOHOLIC  
MALT BEVERAGES, NONALCOHOLIC FRUIT DRINKS  
AND JUICES, MINERAL AND AERATED WATERS,  
CARBONATED SOFT DRINKS, AND SYRUPS AND  
OTHER PREPARATIONS FOR MAKING ALL OF THE  
FOREGOING BEVERAGES (U.S. CLS. 45, 46 AND 48).

JUDITH HELFMAN, EXAMINING ATTORNEY

SN 78-771,565. INTERNATIONAL GOLDEN FOODS, INC.,  
BENSENVILLE, IL. FILED 12-12-2005.

# Nar

THE MARK CONSISTS OF STANDARD CHARACTERS  
WITHOUT CLAIM TO ANY PARTICULAR FONT, STYLE,  
SIZE, OR COLOR.

FOR FRUIT JUICES (U.S. CLS. 45, 46 AND 48).

FIRST USE 2-12-2003; IN COMMERCE 2-12-2003.

CHRISTOPHER BUONGIORNO, EXAMINING ATTORNEY

**CLASS 32—(Continued).**

SN 78-798,135. LA WEIGHT LOSS FRANCHISE COMPANY,  
HORSHAM, DE. FILED 1-24-2006.

## SPLASH PACKS

THE MARK CONSISTS OF STANDARD CHARACTERS  
WITHOUT CLAIM TO ANY PARTICULAR FONT, STYLE,  
SIZE, OR COLOR.

NO CLAIM IS MADE TO THE EXCLUSIVE RIGHT TO  
USE PACKS, APART FROM THE MARK AS SHOWN.

FOR PRE-PACKAGED SUGAR-FREE POWDER MIXES  
USED IN PREPARATION OF FRUIT DRINKS (U.S. CLS.  
45, 46 AND 48).

FIRST USE 12-3-2005; IN COMMERCE 12-3-2005.

HANNO RITTNER, EXAMINING ATTORNEY

SN 78-815,025. COMPANHIA DE BEBIDAS DAS AMERICAS -  
AMBEV, ITAIM BIBI - SAO PAULO, BRAZIL, FILED 2-15-  
2006.

## GUARANA AMAZONIA

THE MARK CONSISTS OF STANDARD CHARACTERS  
WITHOUT CLAIM TO ANY PARTICULAR FONT, STYLE,  
SIZE, OR COLOR.

NO CLAIM IS MADE TO THE EXCLUSIVE RIGHT TO  
USE "GUARANA", APART FROM THE MARK AS SHOWN.

FOR BEVERAGES, NAMELY, CARBONATED AND  
NON-CARBONATED SOFT DRINKS, FRUIT OR VEGETABLE  
BASED DRINKS, MINERAL AND CARBONATED WATERS (U.S. CLS. 45, 46 AND 48).

MARTHA SANTOMARTINO, EXAMINING ATTORNEY

**CLASS 32—(Continued).**

SN 78-816,924. EDWARDS, LAWRENCE A., LIVINGSTON, MT. FILED 2-16-2006.



NO CLAIM IS MADE TO THE EXCLUSIVE RIGHT TO USE "ALE" OR "MADE FROM GENUINE MONTANA WATER" OR "1890" OR "BIG TIMBER, MONTANA", APART FROM THE MARK AS SHOWN.

THE COLOR(S) YELLOW, BLUE, LIGHT BLUE, BLACK, RED, TAN, WHITE, ORANGE, AND BROWN IS/ARE CLAIMED AS A FEATURE OF THE MARK.

THE MARK CONSISTS OF A STYLIZED, MULTI-COLORED BUT ESSENTIALLY BROWN TROUT, OUTLINED IN RED, WITH YELLOW EYES, BLACK PUPILS, RED LIPS AND WHITE TEETH; THE TROUT IS HOLDING A MUG FEATURING YELLOW BEER WITH WHITE FOAM. THE WORDS "TROUT LIPS ALE" APPEAR IN RED ON A RED-OUTLINED TAN BANNER SUPERIMPOSED OVER AN OVAL SHAPED BACKGROUND. THE OUTERMOST OUTLINE OF THE OVAL IS BLACK, SUCCEEDED BY BLUE INSIDE THAT, SUCCEEDED BY YELLOW INSIDE THAT WITH THE WORDING "MADE FROM GENUINE MONTANA WATER" ON THE LEFT SIDE, "RISE TO THE OCCASION" ON THE RIGHT SIDE, AND "BIG TIMBER, MONTANA" ON THE BOTTOM, ALL SUCH TEXT BEING IN BLACK; THE NEXT CONCENTRIC OVAL IS LIGHT BLUE WITH THE WORDING "1890 GRAND SALOON" APPEARING ON THE BOTTOM IN BLACK; THE NEXT CONCENTRIC OVAL IS BLACK, SUCCEEDED BY RED INSIDE THAT, WITH AN ORANGE BACKGROUND INSIDE THAT UNDERNEATH WHITE MOUNTAINS OUTLINED ON THE BOTTOM IN BROWN AND ON TOP IN BLACK, UNDERNEATH A BLUE SKY. ABOVE THAT IS AN INSET BLACK-OUTLINED ORANGE OVAL FEATURING THE HEAD OF A MOSTLY BROWN LONGHORN STEER WITH BLACK MARKINGS.

FOR MALT LIQUOR (U.S. CLS. 45, 46 AND 48).  
FIRST USE 4-3-2004; IN COMMERCE 4-3-2004.  
BRENDAN REGAN, EXAMINING ATTORNEY

**CLASS 32—(Continued).**

SN 78-839,197. WAULDRON CORPORATION, NORTH ROSE CITY, MI. FILED 3-16-2006.

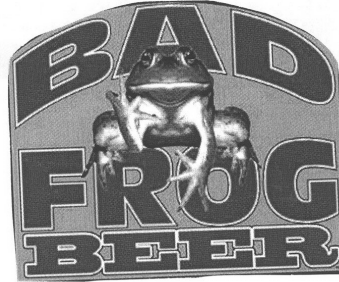

NO CLAIM IS MADE TO THE EXCLUSIVE RIGHT TO USE "BEER", APART FROM THE MARK AS SHOWN. FOR ALCOHOLIC BEVERAGES, NAMELY, BEER (U.S. CLS. 45, 46 AND 48).  
KATHERINE M. DUBRAY, EXAMINING ATTORNEY

SN 78-885,558. CHERRYPHARM, INC., GENEVA, NY. FILED 5-17-2006.



THE MARK CONSISTS OF THE TERM CHERRYPHARM WHICH IS DISPLAYED AT AN UPWARD ANGLE ACROSS THE OPENING OF AN UPWARD TILTED STYLIZED LETTER C RESEMBLING A CHERRY WITH A STEM AND A LEAF ATTACHED ABOVE.

FOR CHERRY JUICE BASED BEVERAGE (U.S. CLS. 45, 46 AND 48).  
LAURA HAMMEL, EXAMINING ATTORNEY

**CLASS 32—(Continued).**

SN 78-935,639. CORAL PROPERTIES, INC., MIAMI, FL.  
FILED 7-24-2006.

**COCO**  
**FIESTA**

NO CLAIM IS MADE TO THE EXCLUSIVE RIGHT TO USE "COCO", APART FROM THE MARK AS SHOWN.

THE COLOR(S) ORANGE, BLACK AND WHITE IS/ARE CLAIMED AS A FEATURE OF THE MARK.

THE MARK CONSISTS OF THE WORDS COCO AND FIESTA. THE WORD FIESTA IS IN ORANGE. THE OUTLINE OF THE LETTERS IN COCO ARE BLACK AND THE INTERIOR OF THE LETTERS ARE WHITE.

FOR NON-ALCOHOLIC COCTAIL MIXES (U.S. CLS. 45, 46 AND 48).

FIRST USE 9-1-2005; IN COMMERCE 9-1-2005.  
DOMINICK J. SALEMI, EXAMINING ATTORNEY

SN 78-941,099. DRAZIL FOODS, LLC, PRINCETON, NJ.  
FILED 7-31-2006.

**Drazil**

THE MARK CONSISTS OF STANDARD CHARACTERS WITHOUT CLAIM TO ANY PARTICULAR FONT, STYLE, SIZE, OR COLOR.

FOR BEVERAGES, NAMELY FRUIT BASED DRINKS, AND FRUIT JUICES (U.S. CLS. 45, 46 AND 48).  
KELLY BOULTON, EXAMINING ATTORNEY

SN 78-953,386. ARCTIC NATURAL WATERS LIMITED,  
LONDON, ENGLAND, FILED 8-16-2006.

**LIQUID ASSETS**

THE MARK CONSISTS OF STANDARD CHARACTERS WITHOUT CLAIM TO ANY PARTICULAR FONT, STYLE, SIZE, OR COLOR.

FOR BOTTLED DRINKING WATER; PREPACKAGED DRINKING WATER (U.S. CLS. 45, 46 AND 48).  
LINDSEY RUBIN, EXAMINING ATTORNEY

**CLASS 32—(Continued).**

SN 78-955,267. LONGHEDGES ESTATE LLC, ORRVILLE,  
OH. FILED 8-18-2006.

**Purely Amish**

THE MARK CONSISTS OF STANDARD CHARACTERS WITHOUT CLAIM TO ANY PARTICULAR FONT, STYLE, SIZE, OR COLOR.

NO CLAIM IS MADE TO THE EXCLUSIVE RIGHT TO USE "AMISH", APART FROM THE MARK AS SHOWN.

FOR DRINKING WATER; MINERAL WATER (U.S. CLS. 45, 46 AND 48).

WARREN L. OLANDRIA, EXAMINING ATTORNEY

SN 78-958,609. FABRICA DE BEBIDAS GASEOSAS SALVAVIDAS, S.A., GUATEMALA CITY, GUATEMALA, FILED 8-23-2006.

**SALVAVIDAS**

THE MARK CONSISTS OF STANDARD CHARACTERS WITHOUT CLAIM TO ANY PARTICULAR FONT, STYLE, SIZE, OR COLOR.

THE FOREIGN WORDING IN THE MARK TRANSLATES INTO ENGLISH AS LIFEGUARD.

FOR NON-ALCOHOLIC BEVERAGES, NAMELY PURIFIED STILL WATER, SODA POP AND FLAVORED WATER (U.S. CLS. 45, 46 AND 48).

FIRST USE 12-0-2004; IN COMMERCE 12-0-2004.  
RENEE SERVANCE, EXAMINING ATTORNEY

SN 78-958,722. THE COCA-COLA COMPANY, ATLANTA,  
GA. FILED 8-23-2006.

**HAPPINESS FACTORY**

THE MARK CONSISTS OF STANDARD CHARACTERS WITHOUT CLAIM TO ANY PARTICULAR FONT, STYLE, SIZE, OR COLOR.

FOR NON-ALCOHOLIC BEVERAGES, NAMELY, CARBONATED SOFT DRINKS; SYRUPS AND CONCENTRATES FOR MAKING BEVERAGES, NAMELY, CARBONATED SOFT DRINKS (U.S. CLS. 45, 46 AND 48).

JESSICA FATHY, EXAMINING ATTORNEY

**CLASS 32—(Continued).**

SN 78-959,107. SB NORTHWEST LLC, SEATTLE, WA. FILED 8-23-2006.

# FIRESTATION 5

THE MARK CONSISTS OF STANDARD CHARACTERS WITHOUT CLAIM TO ANY PARTICULAR FONT, STYLE, SIZE, OR COLOR.  
FOR ALE; BEER (U.S. CLS. 45, 46 AND 48).  
FIRST USE 6-15-2002; IN COMMERCE 6-15-2002.  
ALYSSA PALADINO, EXAMINING ATTORNEY

SN 78-959,109. SB NORTHWEST LLC, SEATTLE, WA. FILED 8-23-2006.

# KICKERS

THE MARK CONSISTS OF STANDARD CHARACTERS WITHOUT CLAIM TO ANY PARTICULAR FONT, STYLE, SIZE, OR COLOR.  
FOR ALE; BEER (U.S. CLS. 45, 46 AND 48).  
ALYSSA PALADINO, EXAMINING ATTORNEY

SN 78-959,637. FOX & HOUND RESTAURANT GROUP, WICHITA, KS. FILED 8-24-2006.

# RED FOX AMBER ALE

THE MARK CONSISTS OF STANDARD CHARACTERS WITHOUT CLAIM TO ANY PARTICULAR FONT, STYLE, SIZE, OR COLOR.  
NO CLAIM IS MADE TO THE EXCLUSIVE RIGHT TO USE "AMBER ALE", APART FROM THE MARK AS SHOWN.  
FOR BEER, NAMELY, AMBER ALE (U.S. CLS. 45, 46 AND 48).  
LINDSEY RUBIN, EXAMINING ATTORNEY

**CLASS 32—(Continued).**

SN 78-961,120. SODA V BEVERAGES, FT. LAUDERDALE, FL. FILED 8-26-2006.

# Soda V

THE MARK CONSISTS OF STANDARD CHARACTERS WITHOUT CLAIM TO ANY PARTICULAR FONT, STYLE, SIZE, OR COLOR.  
NO CLAIM IS MADE TO THE EXCLUSIVE RIGHT TO USE "SODA", APART FROM THE MARK AS SHOWN.  
FOR NON-ALCOHOLIC BEVERAGES, NAMELY, CARBONATED BEVERAGES (U.S. CLS. 45, 46 AND 48).  
TASHIA BUNCH, EXAMINING ATTORNEY

SN 78-961,639. TURNER, RENITA S., EPWORTH, GA. FILED 8-28-2006.

# Nature's Purest True Georgia Mountain Spring Water

THE MARK CONSISTS OF STANDARD CHARACTERS WITHOUT CLAIM TO ANY PARTICULAR FONT, STYLE, SIZE, OR COLOR.  
NO CLAIM IS MADE TO THE EXCLUSIVE RIGHT TO USE "PUREST" AND "GEORGIA MOUNTAIN SPRING WATER", APART FROM THE MARK AS SHOWN.  
FOR SPRING WATER (U.S. CLS. 45, 46 AND 48).  
RONALD MCMORROW, EXAMINING ATTORNEY

SN 78-961,653. TURNER, RENITA S., EPWORTH, GA. FILED 8-28-2006.

# Nature's Purest Tennessee True Mountain Spring Water

THE MARK CONSISTS OF STANDARD CHARACTERS WITHOUT CLAIM TO ANY PARTICULAR FONT, STYLE, SIZE, OR COLOR.  
NO CLAIM IS MADE TO THE EXCLUSIVE RIGHT TO USE "PUREST TENNESSEE" AND "MOUNTAIN SPRING WATER", APART FROM THE MARK AS SHOWN.  
FOR SPRING WATER (U.S. CLS. 45, 46 AND 48).  
RONALD MCMORROW, EXAMINING ATTORNEY

**CLASS 32—(Continued).**

SN 78-962,560. OE WET LLC, SCOTTSDALE, AZ. FILED 8-29-2006.

**OE WET**

THE MARK CONSISTS OF STANDARD CHARACTERS WITHOUT CLAIM TO ANY PARTICULAR FONT, STYLE, SIZE, OR COLOR.

FOR IOTONIC DRINKS, SPORTS DRINKS, FRUIT FLAVORED WATER, FRUIT FLAVORED DRINKS, ENERGY DRINKS, COFFEE-FLAVORED SOFT DRINKS, SPARKLING WATER, SODA WATER, BOTTLED DRINKING WATER (U.S. CLS. 45, 46 AND 48).  
ATTIYA MALIK, EXAMINING ATTORNEY

SN 78-963,248. DC BRANDS INTERNATIONAL, WHEAT RIDGE, CO. FILED 8-29-2006.

**TURN LEFT**

THE MARK CONSISTS OF STANDARD CHARACTERS WITHOUT CLAIM TO ANY PARTICULAR FONT, STYLE, SIZE, OR COLOR.

FOR NON-ALCOHOLIC BEVERAGES, NAMELY ENERGY DRINKS (U.S. CLS. 45, 46 AND 48).  
MARY MUNSON, EXAMINING ATTORNEY

SN 78-964,191. AMERICAN NEVADA HOLDINGS, LLC, HENDERSON, NV. FILED 8-30-2006.

*Avenue33*

FOR BOTTLED DRINKING WATER; SOFT DRINKS; FRUIT DRINKS; FRUIT JUICES; AND CONCENTRATES, SYRUPS OR POWDERS USED IN THE PREPARATION OF FRUIT JUICES, FRUIT DRINKS AND SOFT DRINKS (U.S. CLS. 45, 46 AND 48).  
MICHAEL ENGEL, EXAMINING ATTORNEY

**CLASS 32—(Continued).**

SN 78-964,229. AMERICAN NEVADA HOLDINGS, LLC, HENDERSON, NV. FILED 8-30-2006.

*Avenue33*  
AT THE DISTRICT

FOR BOTTLED DRINKING WATER; SOFT DRINKS; FRUIT DRINKS; FRUIT JUICES; AND CONCENTRATES, SYRUPS OR POWDERS USED IN THE PREPARATION OF FRUIT JUICES, FRUIT DRINKS AND SOFT DRINKS (U.S. CLS. 45, 46 AND 48).

MICHAEL ENGEL, EXAMINING ATTORNEY

SN 78-964,458. AMERICAN NEVADA HOLDINGS, LLC, HENDERSON, NV. FILED 8-30-2006.

AVENUE33 BROWNSTONES AT THE DISTRICT

THE MARK CONSISTS OF STANDARD CHARACTERS WITHOUT CLAIM TO ANY PARTICULAR FONT, STYLE, SIZE, OR COLOR.

FOR BOTTLED DRINKING WATER; SOFT DRINKS; FRUIT DRINKS; FRUIT JUICES; AND CONCENTRATES, SYRUPS OR POWDERS USED IN THE PREPARATION OF FRUIT JUICES, FRUIT DRINKS AND SOFT DRINKS (U.S. CLS. 45, 46 AND 48).

KAREN BRACEY, EXAMINING ATTORNEY

SN 78-964,979. NORTHERN FALLS, LLC, GRAND RAPIDS, MI. FILED 8-31-2006.

**CALIBRATE**

THE MARK CONSISTS OF STANDARD CHARACTERS WITHOUT CLAIM TO ANY PARTICULAR FONT, STYLE, SIZE, OR COLOR.

FOR DRINKING WATER (U.S. CLS. 45, 46 AND 48).  
MICHAEL KAZAZIAN, EXAMINING ATTORNEY

**CLASS 32—(Continued).**

SN 78-964,988. NORTHERN FALLS, LLC, GRAND RAPIDS, MI. FILED 8-31-2006.



THE MARK CONSISTS OF A STYLIZED WATER DROPLET SURROUNDED BY A STYLIZED AND INCOMPLETE SQUARE WITH ROUNDED EDGES.  
FOR DRINKING WATER (U.S. CLS. 45, 46 AND 48).  
MICHAEL KAZAZIAN, EXAMINING ATTORNEY

SN 78-965,455. BULL, GEORGE E., SANTA ROSA, CA. FILED 8-31-2006.

## Bull's Hit

THE MARK CONSISTS OF STANDARD CHARACTERS WITHOUT CLAIM TO ANY PARTICULAR FONT, STYLE, SIZE, OR COLOR.  
FOR BEER (U.S. CLS. 45, 46 AND 48).  
LINDA E. BLOHM, EXAMINING ATTORNEY

SN 78-965,678. THE COCA-COLA COMPANY, ATLANTA, GA. FILED 9-1-2006.

## FANTA WORLD

THE MARK CONSISTS OF STANDARD CHARACTERS WITHOUT CLAIM TO ANY PARTICULAR FONT, STYLE, SIZE, OR COLOR.

OWNER OF U.S. REG. NOS. 513,565, 3,011,381 AND OTHERS.

FOR NON-ALCOHOLIC BEVERAGES, NAMELY, SOFT DRINKS; SYRUPS AND CONCENTRATES FOR MAKING BEVERAGES, NAMELY, SOFT DRINKS (U.S. CLS. 45, 46 AND 48).

JESSICA FATHY, EXAMINING ATTORNEY

**CLASS 32—(Continued).**

SN 78-966,180. THIRSTY DOG BREWING COMPANY, INDEPENDENCE, OH. FILED 9-1-2006.

## AIRSHIP

THE MARK CONSISTS OF STANDARD CHARACTERS WITHOUT CLAIM TO ANY PARTICULAR FONT, STYLE, SIZE, OR COLOR.

FOR MALT LIQUOR (U.S. CLS. 45, 46 AND 48).  
RICHARD WHITE, EXAMINING ATTORNEY

SN 78-966,363. HAROUNIAN, KAVEH, LOS ANGELES, CA. AND HAROUNIAN, KOUROSH, LOS ANGELES, CA. FILED 9-1-2006.

## rocky

THE MARK CONSISTS OF STANDARD CHARACTERS WITHOUT CLAIM TO ANY PARTICULAR FONT, STYLE, SIZE, OR COLOR.

FOR ENERGY DRINKS AND SPORTS DRINKS (U.S. CLS. 45, 46 AND 48).  
REBECCA GILBERT, EXAMINING ATTORNEY

SN 78-966,392. STEINSSON, JON, ENCINO, CA. FILED 9-1-2006.

## ENERGO

THE MARK CONSISTS OF STANDARD CHARACTERS WITHOUT CLAIM TO ANY PARTICULAR FONT, STYLE, SIZE, OR COLOR.

FOR ALOE VERA DRINKS; COFFEE-FLAVORED SOFT DRINK; COLAS; CONCENTRATES, SYRUPS OR POWDERS USED IN THE PREPARATION OF SOFT DRINKS; ENERGY DRINKS; ESSENCES FOR USE IN MAKING SOFT DRINKS; FRUIT FLAVORED SOFT DRINKS; FRUIT-FLAVORED DRINKS; ISOTONIC DRINKS; PREPARATIONS FOR MAKING ENERGY DRINKS; SOFT DRINKS; SYRUPS FOR MAKING SOFT DRINKS; SYRUPS FOR MAKING ENERGY DRINKS (U.S. CLS. 45, 46 AND 48).

EMILY CHUO, EXAMINING ATTORNEY

**CLASS 32—(Continued).**

SN 78-966,431. THE NASH GROUP SERIES 2, LLC, DBA THINK IT, DRINK IT, BE IT, CARLSBAD, CA. FILED 9-1-2006.



NO CLAIM IS MADE TO THE EXCLUSIVE RIGHT TO USE "WATER", APART FROM THE MARK AS SHOWN.  
THE MARK CONSISTS OF THINK IT, DRINK IT, BE IT OVER THE WORD WATER.  
FOR BOTTLED WATER (U.S. CLS. 45, 46 AND 48).  
MICHAEL TANNER, EXAMINING ATTORNEY

---

SN 78-966,507. HAROUNIAN, KAVEH, LOS ANGELES, CA. AND HAROUNIAN, KOUROSH, LOS ANGELES, CA. FILED 9-2-2006.

vice

THE MARK CONSISTS OF STANDARD CHARACTERS WITHOUT CLAIM TO ANY PARTICULAR FONT, STYLE, SIZE, OR COLOR.  
FOR ENERGY DRINKS AND SPORTS DRINKS (U.S. CLS. 45, 46 AND 48).  
REBECCA GILBERT, EXAMINING ATTORNEY

---

SN 78-967,225. WINEXPERT INC., ONTARIO, CANADA, FILED 9-5-2006.

CRUSHENDO

THE MARK CONSISTS OF STANDARD CHARACTERS WITHOUT CLAIM TO ANY PARTICULAR FONT, STYLE, SIZE, OR COLOR.  
OWNER OF U.S. REG. NO. 3,050,016.  
FOR WINE MAKING KITS CONSISTING PRIMARILY OF FRUIT JUICE OR FRUIT JUICE CONCENTRATES AND CHEMICAL ADDITIVES, AND WHICH MAY CONTAIN DRIED FLOWERS AND HERBS, WOOD CHIPS, ACTIVE DRY WINE YEAST, CLARIFYING AGENTS, FINING AGENTS, STABILIZERS, SULPHUR DIOXIDE, LIQUID INVERT SUGAR, DIAMMONIUM PHOSPHATE, CITRIC ACID, MALIC ACID, TARTARIC ACID, BENTONITE, POTASSIUM SORBATE, YEAST, POTASSIUM METABISULPHITE, OAK EXTRACT, OAK CHIPS, ELDERFLOWERS, ELDERBERRIES, TANNIN, SODIUM BENZOATE, GLUCOSE, ISINGLASS, CHITOSAN, KIESELSOL, LABELS, GRAPE JUICE, CRUSHED GRAPES (U.S. CLS. 45, 46 AND 48).  
FIRST USE 9-21-2004; IN COMMERCE 9-27-2004.  
CHRISTINA SOBRAL, EXAMINING ATTORNEY

**CLASS 32—(Continued).**

SN 78-967,381. ONE WATER SOURCE, LLC, AUSTIN, TX. FILED 9-5-2006.



NO CLAIM IS MADE TO THE EXCLUSIVE RIGHT TO USE "BABY", APART FROM THE MARK AS SHOWN.  
THE COLOR(S) BLUE, RED, GREEN, YELLOW, PINK, PURPLE IS/ARE CLAIMED AS A FEATURE OF THE MARK.  
THE MARK CONSISTS OF STYLIZED BLUE LETTER B, STYLIZED RED LETTER A, STYLIZED GREEN LETTER B, STYLIZED YELLOW LETTER Y, STYLIZED PINK LETTER P, STYLIZED BLUE LETTER U, STYLIZED YELLOW LETTER R, STYLIZED PURPLE LETTER E.  
FOR DRINKING WATER (U.S. CLS. 45, 46 AND 48).  
SOPHIA S. KIM, EXAMINING ATTORNEY

---

SN 78-967,819. YOUNG, JARROD, SAN BRUNO, CA. FILED 9-6-2006.

THUGS PASSION

THE MARK CONSISTS OF STANDARD CHARACTERS WITHOUT CLAIM TO ANY PARTICULAR FONT, STYLE, SIZE, OR COLOR.  
FOR ENERGY DRINKS (U.S. CLS. 45, 46 AND 48).  
MICHAEL GAFFAR, EXAMINING ATTORNEY

---

SN 78-968,463. DEL BARRIO, JON, LOS ANGELES, CA. FILED 9-6-2006.

YOU NEED A TRANSPHUSION

THE MARK CONSISTS OF STANDARD CHARACTERS WITHOUT CLAIM TO ANY PARTICULAR FONT, STYLE, SIZE, OR COLOR.  
FOR SOFT DRINKS (U.S. CLS. 45, 46 AND 48).  
RONALD MCMORROW, EXAMINING ATTORNEY



**CLASS 32—(Continued).**

SN 78-968,689. NEW CENTURY BEVERAGE COMPANY, SAN FRANCISCO, CA. FILED 9-7-2006.

# DIET MUG

THE MARK CONSISTS OF STANDARD CHARACTERS WITHOUT CLAIM TO ANY PARTICULAR FONT, STYLE, SIZE, OR COLOR.

OWNER OF U.S. REG. NOS. 1,552,194, 3,033,800 AND OTHERS.

NO CLAIM IS MADE TO THE EXCLUSIVE RIGHT TO USE "DIET", APART FROM THE MARK AS SHOWN.

FOR SOFT DRINKS, AND SYRUPS AND CONCENTRATES FOR MAKING THE SAME (U.S. CLS. 45, 46 AND 48).

FIRST USE 0-0-1981; IN COMMERCE 0-0-1981.  
JIM RINGLE, EXAMINING ATTORNEY



SN 78-968,706. BARTON BEERS, LTD., CHICAGO, IL. FILED 9-7-2006.

# DROP-DEAD REFRESHING

THE MARK CONSISTS OF STANDARD CHARACTERS WITHOUT CLAIM TO ANY PARTICULAR FONT, STYLE, SIZE, OR COLOR.

FOR BEER (U.S. CLS. 45, 46 AND 48).  
INGRID C. EULIN, EXAMINING ATTORNEY



SN 78-969,357. HANSEN BEVERAGE COMPANY, CORONA, CA. FILED 9-7-2006.

# IMPORTED FROM NATURE

THE MARK CONSISTS OF STANDARD CHARACTERS WITHOUT CLAIM TO ANY PARTICULAR FONT, STYLE, SIZE, OR COLOR.

FOR FRUIT JUICES; FRUIT JUICE DRINKS; LEMONADES; AERATED AND NON-AERATED WATERS; CARBONATED SODAS; COFFEE FLAVORED SOFT DRINKS AND TEA FLAVORED SOFT DRINKS (U.S. CLS. 45, 46 AND 48).  
DAVID COLLIER, EXAMINING ATTORNEY

**CLASS 32—(Continued).**

SN 78-970,736. KALBEN INC., LAS VEGAS, NV. FILED 9-9-2006.

# H2WOW

THE MARK CONSISTS OF STANDARD CHARACTERS WITHOUT CLAIM TO ANY PARTICULAR FONT, STYLE, SIZE, OR COLOR.

FOR DRINKING WATER (U.S. CLS. 45, 46 AND 48).  
MICHAEL KEATING, EXAMINING ATTORNEY



SN 78-971,189. AMMM PATENT HOLDINGS, LLC, TECUMSEH, MO. FILED 9-11-2006.

# PURELOCK

THE MARK CONSISTS OF STANDARD CHARACTERS WITHOUT CLAIM TO ANY PARTICULAR FONT, STYLE, SIZE, OR COLOR.

FOR DRINKING WATER AND FLAVORED DRINKING WATER AND FLEXIBLE PLASTIC CONTAINERS THEREFOR, SOLD AS A UNIT (U.S. CLS. 45, 46 AND 48).  
TINA KUAN, EXAMINING ATTORNEY



SN 78-971,737. SMOUHA FABRICS PTY LIMITED, WATERLOO NSW, AUSTRALIA, FILED 9-11-2006.

# LUCKY BUDDHA

THE MARK CONSISTS OF STANDARD CHARACTERS WITHOUT CLAIM TO ANY PARTICULAR FONT, STYLE, SIZE, OR COLOR.

FOR BEER (U.S. CLS. 45, 46 AND 48).  
SETH A. RAPPAPORT, EXAMINING ATTORNEY



SN 78-972,754. MAVERIK, INC., NORTH SALT LAKE, UT. FILED 9-12-2006.

# RUSTR TAIL

THE MARK CONSISTS OF STANDARD CHARACTERS WITHOUT CLAIM TO ANY PARTICULAR FONT, STYLE, SIZE, OR COLOR.

FOR ENERGY DRINK (U.S. CLS. 45, 46 AND 48).  
TASHIA BUNCH, EXAMINING ATTORNEY

**CLASS 32—(Continued).**

SN 79-024,075. GERHARD-PETER REITER, FED REP GERMANY, FILED 9-30-2005.

# TSUNAMI

THE MARK CONSISTS OF STANDARD CHARACTERS WITHOUT CLAIM TO ANY PARTICULAR FONT, STYLE, SIZE, OR COLOR.

OWNER OF INTERNATIONAL REGISTRATION 0885508 DATED 9-30-2005, EXPIRES 9-30-2015.

FOR BEERS; MINERAL AND AERATED WATERS; OTHER NON-ALCOHOLIC DRINKS, NAMELY, SOFT DRINKS, SPORT DRINKS, ENERGY DRINKS, FRUIT FLAVORED BEVERAGES; FRUIT DRINKS AND FRUIT JUICES; SYRUPS FOR BEVERAGES; SYRUPS AND PREPARATIONS FOR MAKING BEVERAGES, NAMELY, ENERGY DRINKS, SOFT DRINKS, FRUIT DRINKS AND FRUIT JUICES (U.S. CLS. 45, 46 AND 48).

ESTHER BELENKER, EXAMINING ATTORNEY

**CLASS 33—(Continued).**

SN 77-023,928. VITIVINICOLA PEREZ CRUZ LIMITADA, PAINE, CHILE, FILED 10-18-2006.

# WAIKI

THE MARK CONSISTS OF STANDARD CHARACTERS WITHOUT CLAIM TO ANY PARTICULAR FONT, STYLE, SIZE, OR COLOR.

FOR WINES (U.S. CLS. 47 AND 49).

WENDY GOODMAN, EXAMINING ATTORNEY

SN 77-047,706. CORE GROUPE, LLC, MIAMI BEACH, FL. FILED 11-20-2006.

# LAQUISE VODKA

**CLASS 33—WINES AND SPIRITS**

SN 76-602,305. SCOPINARO, HORACIO ARTURO, CORDOBA, ARGENTINA, FILED 7-14-2004.

# SUELO A

THE MARK CONSISTS OF STANDARD CHARACTERS WITHOUT CLAIM TO ANY PARTICULAR FONT, STYLE, SIZE, OR COLOR.

OWNER OF ARGENTINA REG. NO. 2067280, DATED 2-17-2006, EXPIRES 2-16-2016.

THE ENGLISH TRANSLATION OF SUELO IS "FLOOR".

FOR WINES (U.S. CLS. 47 AND 49).

KEVON CHISOLM, EXAMINING ATTORNEY

THE MARK CONSISTS OF STANDARD CHARACTERS WITHOUT CLAIM TO ANY PARTICULAR FONT, STYLE, SIZE, OR COLOR.

NO CLAIM IS MADE TO THE EXCLUSIVE RIGHT TO USE "VODKA", APART FROM THE MARK AS SHOWN.

FOR ALCOHOLIC BEVERAGES, NAMELY VODKA (U.S. CLS. 47 AND 49).

STEPHANIE DAVIS, EXAMINING ATTORNEY

SN 78-231,578. JACK DANIEL'S PROPERTIES, INC., SAN RAFAEL, CA. FILED 3-28-2003.

# BLACK JACK

FOR ALCOHOLIC BEVERAGES, NAMELY, PREMIXED ALCOHOLIC COCKTAILS (U.S. CLS. 47 AND 49).

FIRST USE 4-19-2004; IN COMMERCE 4-19-2004.

CURTIS FRENCH, EXAMINING ATTORNEY

SN 76-665,467. ENLIGHTENED BRANDS, INC., NYACK, NY. FILED 9-1-2006.

# ECLIPTIC

SN 78-239,377. TASTE OF RUSSIA LIMITED, BRISTOL, UNITED KINGDOM, FILED 4-18-2003.

# SPUTNIK

THE MARK CONSISTS OF STANDARD CHARACTERS WITHOUT CLAIM TO ANY PARTICULAR FONT, STYLE, SIZE, OR COLOR.

FOR VODKA (U.S. CLS. 47 AND 49).

PRISCILLA MILTON, EXAMINING ATTORNEY

OWNER OF UNITED KINGDOM REG. NO. 2320335, DATED 6-20-2003, EXPIRES 11-1-2013.

FOR VODKA (U.S. CLS. 47 AND 49).

PAULA MAHONEY, EXAMINING ATTORNEY

**CLASS 33—(Continued).**

SN 78-488,732. SOUTHCORP BRANDS PTY LIMITED, AR-TARMON NSW 2064, AUSTRALIA, FILED 9-23-2004.



**SECRET STONE**

OWNER OF AUSTRALIA REG. NO. 1022141, DATED 7-22-2004, EXPIRES 7-22-2014.

THE COLOR(S) GREEN IS/ARE CLAIMED AS A FEATURE OF THE MARK.

THE MARK CONSISTS OF THE WORDS SECRET STONE BELOW A DESIGN THAT APPEARS IN THE COLOR GREEN.

FOR WINES (U.S. CLS. 47 AND 49).

ARETHA SOMERVILLE, EXAMINING ATTORNEY

**CLASS 33—(Continued).**

SN 78-766,837. ALPHAWOLF RANCH LLC, NAPA, CA. FILED 12-5-2005.

**VOLUPTUOUS**

THE MARK CONSISTS OF STANDARD CHARACTERS WITHOUT CLAIM TO ANY PARTICULAR FONT, STYLE, SIZE, OR COLOR.

FOR WINE (U.S. CLS. 47 AND 49).

FIRST USE 3-16-2006; IN COMMERCE 11-10-2006.

KAELIE KUNG, EXAMINING ATTORNEY

SN 78-777,885. IAN MACLEOD DISTILLERS LIMITED, BROXBURN, UNITED KINGDOM, FILED 12-21-2005.

**CHIEFTAIN'S**

THE MARK CONSISTS OF STANDARD CHARACTERS WITHOUT CLAIM TO ANY PARTICULAR FONT, STYLE, SIZE, OR COLOR.

OWNER OF ERPN CMNTY TM OFC REG. NO. 003907011, DATED 11-4-2004, EXPIRES 7-1-2014.

FOR WINES, LIQUEURS, DISTILLED SPIRITS, WHISKEY AND SCOTCH WHISKEY (U.S. CLS. 47 AND 49).

REBECCA EISINGER, EXAMINING ATTORNEY

SN 78-682,344. SCHWARTZ, NORMAN S, NEW YORK, NY. FILED 8-1-2005.

**Whoops**

THE MARK CONSISTS OF STANDARD CHARACTERS WITHOUT CLAIM TO ANY PARTICULAR FONT, STYLE, SIZE, OR COLOR.

FOR WINE (U.S. CLS. 47 AND 49).

DAVID HOFFMAN, EXAMINING ATTORNEY

SN 78-804,920. GUSTAVO, OROZCO TRUJILLO, GUADAJAJARA, MEXICO, FILED 2-1-2006.



SN 78-763,690. LUNA SPIRITS, LLC, MIAMI BEACH, FL. FILED 11-30-2005.

**LUNA SUEÑO**

THE MARK CONSISTS OF STANDARD CHARACTERS WITHOUT CLAIM TO ANY PARTICULAR FONT, STYLE, SIZE, OR COLOR.

THE ENGLISH TRANSLATION OF "LUNA SUEÑO" IS "MOON DREAM".

FOR TEQUILA (U.S. CLS. 47 AND 49).

CURTIS FRENCH, EXAMINING ATTORNEY

NO CLAIM IS MADE TO THE EXCLUSIVE RIGHT TO USE "PENCAS", APART FROM THE MARK AS SHOWN.

THE MARK CONSISTS OF THE WORDS MIL PENCAS, IN THE MIDDLE BETWEEN EACH WORD OF THE MARK A PULPY LEAF, AND A STYLIZED DESIGN OF A LINE ACROSS THE WORDS AND THE PULPY LEAF.

THE FOREIGN WORDING IN THE MARK TRANSLATES INTO ENGLISH AS THOUSAND PULPY LEAFS.

FOR TEQUILA (U.S. CLS. 47 AND 49).

FIRST USE 11-7-1997; IN COMMERCE 11-7-1997.

DANNEAN HETZEL, EXAMINING ATTORNEY

**CLASS 33—(Continued).**

SN 78-810,094. M.T. BOTTLES, LLC, ST. HELENA, CA. FILED 2-8-2006.

**Côte d' Helena**

THE MARK CONSISTS OF STANDARD CHARACTERS WITHOUT CLAIM TO ANY PARTICULAR FONT, STYLE, SIZE, OR COLOR.

FOR WINES (U.S. CLS. 47 AND 49).  
TRACY WHITTAKER-BROWN, EXAMINING ATTORNEY

SN 78-815,505. BRASSFIELD, ROBERT, SCOTT'S VALLEY, CA. FILED 2-15-2006.

**HEART O' THE MOUNTAIN**

THE MARK CONSISTS OF STANDARD CHARACTERS WITHOUT CLAIM TO ANY PARTICULAR FONT, STYLE, SIZE, OR COLOR.

FOR WINES (U.S. CLS. 47 AND 49).  
DAWN FELDMAN, EXAMINING ATTORNEY

SN 78-817,199. IMPERIAL SPIRITS S.A., FRIBOURG, SWITZERLAND, FILED 2-17-2006.

**ТЕЙКА**

OWNER OF RUSSIAN FED. REG. NO. 204984, DATED 9-13-2001, EXPIRES 1-20-2010.

THE NON-LATIN CHARACTER(S) IN THE MARK TRANSLITERATES INTO TENKA, AND THIS MEANS HEIFER IN ENGLISH.

FOR APERITIFS; ARAK; BRANDY; WINE; WHISKEY; GIN; VODKA; PREPARED ALCOHOLIC COCKTAILS; LIQUEURS; ALCOHOLIC BEVERAGES, NAMELY ALCOHOLIC COFFEE-BASED BEVERAGE; ALCOHOLIC TEA-BASED BEVERAGE; ALCOHOLIC PUNCH; CALVADOS; CHAMPAGNE; COGNAC; CURACAO; HERB LIQUEURS; OUZO; SCHNAPPS; TEQUILA; ALCOHOLIC BEVERAGES CONTAINING FRUIT; DISTILLED SPIRITS; MEAD; PEPPERMINT LIQUEURS; ALCOHOLIC BITTERS; RUM; SAKE; HARD CIDER; RICE ALCOHOL (U.S. CLS. 47 AND 49).

EUGENIA MARTIN, EXAMINING ATTORNEY

**CLASS 33—(Continued).**

SN 78-838,005. TRAVASSOS, EMANUEL M., FALL RIVER, MA. FILED 3-15-2006.

**Mother Russia**

THE MARK CONSISTS OF STANDARD CHARACTERS WITHOUT CLAIM TO ANY PARTICULAR FONT, STYLE, SIZE, OR COLOR.

NO CLAIM IS MADE TO THE EXCLUSIVE RIGHT TO USE "RUSSIA", APART FROM THE MARK AS SHOWN.  
FOR RUSSIAN VODKA (U.S. CLS. 47 AND 49).  
FIRST USE 4-5-2005; IN COMMERCE 4-5-2005.  
ANGELA M. MICHELI, EXAMINING ATTORNEY

SN 78-847,166. SCOTT, MICHAEL J., EAST WENATCHEE, WA. FILED 3-27-2006.

**NEEDLEROCK WINERY**

THE MARK CONSISTS OF STANDARD CHARACTERS WITHOUT CLAIM TO ANY PARTICULAR FONT, STYLE, SIZE, OR COLOR.

NO CLAIM IS MADE TO THE EXCLUSIVE RIGHT TO USE "WINERY", APART FROM THE MARK AS SHOWN.  
FOR WINE (U.S. CLS. 47 AND 49).  
DAYNA BROWNE, EXAMINING ATTORNEY

SN 78-859,082. GGN ALFORT SARL, ALFORTVILLE, FRANCE, FILED 4-11-2006.



PRIORITY CLAIMED UNDER SEC. 44(D) ON FRANCE APPLICATION NO. 06/3410256, FILED 2-15-2006, REG. NO. 063410256, DATED 7-21-2006, EXPIRES 7-21-2016.

NO CLAIM IS MADE TO THE EXCLUSIVE RIGHT TO USE "VODKA", APART FROM THE MARK AS SHOWN.

FOR ALCOHOLIC BEVERAGES, NAMELY, VODKA (U.S. CLS. 47 AND 49).

KIMBERLY FRYE, EXAMINING ATTORNEY

**CLASS 33—(Continued).**

SN 78-904,582. DIAGEO BRANDS B.V., AMSTERDAM, NETHERLANDS, FILED 6-9-2006.

**KING GEORGE V**

THE MARK CONSISTS OF STANDARD CHARACTERS WITHOUT CLAIM TO ANY PARTICULAR FONT, STYLE, SIZE, OR COLOR.

OWNER OF U.S. REG. NO. 537,992.  
FOR ALCOHOLIC BEVERAGES, NAMELY, WHISKY AND WHISKY BASED BEVERAGES (U.S. CLS. 47 AND 49).

ANDREA EVANS, EXAMINING ATTORNEY

**CLASS 33—(Continued).**

SN 78-922,767. COLLINS, LANCE, ENGLEWOOD CLIFFS, NJ. FILED 7-5-2006.

**Vodka Plus**

THE MARK CONSISTS OF STANDARD CHARACTERS WITHOUT CLAIM TO ANY PARTICULAR FONT, STYLE, SIZE, OR COLOR.

NO CLAIM IS MADE TO THE EXCLUSIVE RIGHT TO USE "VODKA", APART FROM THE MARK AS SHOWN.  
FOR VODKA (U.S. CLS. 47 AND 49).

LA TONIA FISHER, EXAMINING ATTORNEY

SN 78-926,062. RENATO RATTI ANTICHE CANTINE DELL'ABBAZIA DELL'ANNUNZIATA S.A.S., 12064 LA MORRA, CUNEO, ITALY, FILED 7-10-2006.

**RENATO RATTI**

THE MARK CONSISTS OF STANDARD CHARACTERS WITHOUT CLAIM TO ANY PARTICULAR FONT, STYLE, SIZE, OR COLOR.

THE NAME(S), PORTRAIT(S), AND/OR SIGNATURE(S) SHOWN IN THE MARK DOES NOT IDENTIFY A PARTICULAR LIVING INDIVIDUAL.

FOR WINES (U.S. CLS. 47 AND 49).

FIRST USE 12-31-1969; IN COMMERCE 12-31-1969.

CYNTHIA SLOAN, EXAMINING ATTORNEY

SN 78-927,069. CORE GROUPE LLC, MIAMI BEACH, FL. FILED 7-11-2006.

**DZIAQ LIQUEUR**

THE MARK CONSISTS OF STANDARD CHARACTERS WITHOUT CLAIM TO ANY PARTICULAR FONT, STYLE, SIZE, OR COLOR.

NO CLAIM IS MADE TO THE EXCLUSIVE RIGHT TO USE "LIQUEUR", APART FROM THE MARK AS SHOWN.

FOR ALCOHOLIC BEVERAGES, NAMELY LIQUEURS, VODKA-BASED LIQUEURS, VODKA (U.S. CLS. 47 AND 49).

STEPHANIE DAVIS, EXAMINING ATTORNEY

SN 78-905,725. YERING ESTATE PTY LTD, VICTORIA, AUSTRALIA, FILED 6-12-2006.

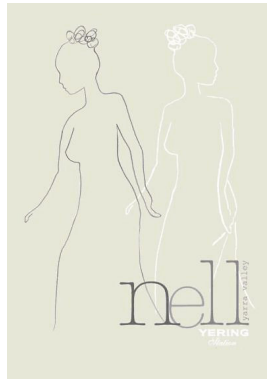

NO CLAIM IS MADE TO THE EXCLUSIVE RIGHT TO USE "YARRA VALLEY" OR "YERING", APART FROM THE MARK AS SHOWN.

THE COLOR(S) BLACK, WHITE, GRAY, AND LIGHT GREEN-GRAY IS/ARE CLAIMED AS A FEATURE OF THE MARK.

THE MARK CONSISTS OF THE WORDS NELL AND YARRA VALLEY IN BLACK AND GRAY, THE WORDS YERING STATION IN WHITE, A STYLIZED FORM OF A WOMAN IN BLACK, A STYLIZED FORM OF A WOMAN IN WHITE, ALL AGAINST A LIGHT GREEN/GRAY BACKGROUND.

FOR ALCOHOLIC BEVERAGES, NAMELY, WINES (U.S. CLS. 47 AND 49).

RONALD MCMORROW, EXAMINING ATTORNEY

**CLASS 33—(Continued).**

SN 78-933,413. DAWSON, SAMUEL GIVENS, DULZURA, CA. FILED 7-20-2006.

**FLYING KITE**

THE MARK CONSISTS OF STANDARD CHARACTERS WITHOUT CLAIM TO ANY PARTICULAR FONT, STYLE, SIZE, OR COLOR.

FOR WINE (U.S. CLS. 47 AND 49).  
TIMOTHY FINNEGAN, EXAMINING ATTORNEY

**CLASS 33—(Continued).**

SN 78-959,796. VINOCOPIA INC., MINNEAPOLIS, MN. FILED 8-24-2006.

**MAGELLAN**

THE MARK CONSISTS OF STANDARD CHARACTERS WITHOUT CLAIM TO ANY PARTICULAR FONT, STYLE, SIZE, OR COLOR.

FOR RED WINES; WHITE WINES; AND WINES (U.S. CLS. 47 AND 49).  
JIM RINGLE, EXAMINING ATTORNEY

SN 78-953,921. DANCING STALLION VINEYARDS, PASO ROBLES, CA. FILED 8-16-2006.

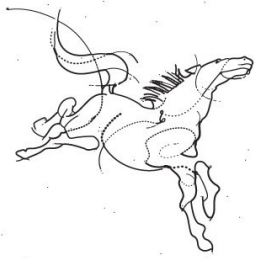

*Dancing Stallion*  
VINEYARDS

NO CLAIM IS MADE TO THE EXCLUSIVE RIGHT TO USE "VINEYARDS", APART FROM THE MARK AS SHOWN.

FOR WINES (U.S. CLS. 47 AND 49).  
DAVID HOFFMAN, EXAMINING ATTORNEY

SN 78-960,208. CHAIKEN, BARRY PAUL, BOSTON, MA. FILED 8-24-2006.

**Vinnez**

THE MARK CONSISTS OF STANDARD CHARACTERS WITHOUT CLAIM TO ANY PARTICULAR FONT, STYLE, SIZE, OR COLOR.

FOR APERITIF WINES; COOKING WINE; FRUIT WINE; GRAPE WINE; NATURAL SPARKLING WINES; PORT WINES; PREPARED WINE COCKTAILS; RED WINE; SPARKLING FRUIT WINE; SPARKLING GRAPE WINE; SPARKLING WINE; STRAWBERRY WINE; SWEET WINES; TABLE WINES; WHITE WINE; WINE; WINE COOLERS; WINE PUNCH; WINE PUNCHES; WINES (U.S. CLS. 47 AND 49).

COLLEEN KEARNEY, EXAMINING ATTORNEY

SN 78-955,603. LOZANO, JOSE EDUARDO, GUADALAJARA, MEXICO, FILED 8-18-2006.

**EMPREDEDOR TEQUILERO**

THE MARK CONSISTS OF STANDARD CHARACTERS WITHOUT CLAIM TO ANY PARTICULAR FONT, STYLE, SIZE, OR COLOR.

NO CLAIM IS MADE TO THE EXCLUSIVE RIGHT TO USE "TEQUILERO", APART FROM THE MARK AS SHOWN.

THE FOREIGN WORDING IN THE MARK TRANSLATES INTO ENGLISH AS ENTERPRISING TEQUILA PRODUCER.

FOR TEQUILA (U.S. CLS. 47 AND 49).  
ELLEN BURNS, EXAMINING ATTORNEY

SN 78-960,445. OLD BRIDGE CELLARS, NAPA, CA. FILED 8-25-2006.



THE MARK CONSISTS OF THE IMAGE OF A HOUSE FLY.

FOR WINE (U.S. CLS. 47 AND 49).  
FIRST USE 5-20-2005; IN COMMERCE 5-20-2005.  
STANLEY I. OSBORNE, EXAMINING ATTORNEY

**CLASS 33—(Continued).**

SN 78-960,861. HILL-MAR LLC, CAMINO, CA. FILED 8-25-2006.

# MOMENTUM

THE MARK CONSISTS OF STANDARD CHARACTERS WITHOUT CLAIM TO ANY PARTICULAR FONT, STYLE, SIZE, OR COLOR.

FOR WINE (U.S. CLS. 47 AND 49).  
MATTHEW MCDOWELL, EXAMINING ATTORNEY

SN 78-960,907. EAGLE CREST VINEYARD, LLC, NAPA, CA. FILED 8-25-2006.

# ROSEROCK

THE MARK CONSISTS OF STANDARD CHARACTERS WITHOUT CLAIM TO ANY PARTICULAR FONT, STYLE, SIZE, OR COLOR.

FOR WINE (U.S. CLS. 47 AND 49).  
JAMES MACFARLANE, EXAMINING ATTORNEY

SN 78-961,036. BARREL STOP WINERY, LLC, NAPA, CA. FILED 8-25-2006.



THE COLOR(S) GOLD AND BROWN IS/ARE CLAIMED AS A FEATURE OF THE MARK.

THE APPLICANT CLAIMS COLOR AS A FEATURE OF THE MARK, NAMELY, THE LETTER B IN MIRROR IMAGE, THE LETTER B, AND A FANCIFUL DESIGN, ALL IN GOLD, WITH A GOLD AND BROWN STRIPED BACKGROUND.

THE MARK CONSISTS OF THE LETTER B IN MIRROR IMAGE, THE LETTER B, AND A FANCIFUL DESIGN.

FOR WINE (U.S. CLS. 47 AND 49).  
FIRST USE 2-22-2004; IN COMMERCE 10-6-2005.  
JOHN E. MICHOS, EXAMINING ATTORNEY

**CLASS 33—(Continued).**

SN 78-961,067. HUNEEUS VINTNERS LLC, RUTHERFORD, CA. FILED 8-25-2006.

# QUINTESSA

OWNER OF U.S. REG. NO. 1,933,427.  
FOR WINE (U.S. CLS. 47 AND 49).  
FIRST USE 1-4-1995; IN COMMERCE 1-4-1995.  
JAMES MACFARLANE, EXAMINING ATTORNEY

SN 78-961,833. GO IMPORTS, INC., NEW YORK, NY. FILED 8-28-2006.

# GO WODKA

THE MARK CONSISTS OF STANDARD CHARACTERS WITHOUT CLAIM TO ANY PARTICULAR FONT, STYLE, SIZE, OR COLOR.

NO CLAIM IS MADE TO THE EXCLUSIVE RIGHT TO USE WODKA, APART FROM THE MARK AS SHOWN.

THE ENGLISH TRANSLATION OF THE WORDING WODKA IS VODKA.

FOR VODKA AND ALCHOLIC BEVERAGES CONTAINING VODKA (U.S. CLS. 47 AND 49).

DANIEL RUSSELL, EXAMINING ATTORNEY

SN 78-961,858. TEQUILAS RANCHO VIEJO SA DE CV, TEPATITLAN, MEXICO, FILED 8-28-2006.



THE COLOR(S) BROWN AND GOLD IS/ARE CLAIMED AS A FEATURE OF THE MARK.

THE NAME COMISARIO IN BROWN, WITH THE LETTERS OUTLINED IN GOLD. IN THE LETTER C APPEARS AN AGAVE PLANT ALSO IN BROWN. ABOVE THE WORD APPEARS A MEXICAN WITH A BIG HAT ALSO IN BROWN.

THE FOREIGN WORDING IN THE MARK TRANSLATES INTO ENGLISH AS SHERIFF, COMISSARY, COMISIONER.

FOR TEQUILA (U.S. CLS. 47 AND 49).  
PETER B. BROMAGHIM, EXAMINING ATTORNEY

**CLASS 33—(Continued).**

SN 78-964,209. GENSLER, DON, WHITE SALMON, WA. AND GENSLER, KRISTIE, WHITE SALMON, WA. FILED 8-30-2006.

**WINDWALKER VINEYARD**

THE MARK CONSISTS OF STANDARD CHARACTERS WITHOUT CLAIM TO ANY PARTICULAR FONT, STYLE, SIZE, OR COLOR.

NO CLAIM IS MADE TO THE EXCLUSIVE RIGHT TO USE "VINEYARD", APART FROM THE MARK AS SHOWN. FOR WINES (U.S. CLS. 47 AND 49).

CHRISTINA SOBRAL, EXAMINING ATTORNEY

SN 78-964,633. TAYLOR, JANET KAY, WEMBLEY, AUSTRALIA, AND TAYLOR, ALEXANDER, WEMBLEY, AUSTRALIA, FILED 8-31-2006.

**POACHER'S RIDGE**

THE MARK CONSISTS OF STANDARD CHARACTERS WITHOUT CLAIM TO ANY PARTICULAR FONT, STYLE, SIZE, OR COLOR.

FOR WINES (U.S. CLS. 47 AND 49).  
FIRST USE 4-15-2003; IN COMMERCE 7-27-2006.  
KRISTIN DAHLING, EXAMINING ATTORNEY

SN 78-964,726. ARNOLD PALMER ENTERPRISES, INC., CLEVELAND, OH. FILED 8-31-2006.



OWNER OF U.S. REG. NO. 2,255,513.  
THE MARK CONSISTS OF A SILHOUETTE OF A GOLFER COMPLETING A GOLF SWING SURROUNDED BY AN OVAL DESIGN.  
FOR WINE (U.S. CLS. 47 AND 49).  
KARANENDRA S. CHHINA, EXAMINING ATTORNEY

**CLASS 33—(Continued).**

SN 78-965,014. WINGARD, INC., NEW HYDE PARK, NY. FILED 8-31-2006.

**LADY JANE**

THE MARK CONSISTS OF STANDARD CHARACTERS WITHOUT CLAIM TO ANY PARTICULAR FONT, STYLE, SIZE, OR COLOR.

FOR LIQUEURS; DISTILLED SPIRITS; DISTILLED SPIRIT SPECIALTIES, NAMELY PREPARED ALCOHOLIC COCKTAILS; AND RUM LIQUEUR WITH PINK LEMONADE FLAVOR (U.S. CLS. 47 AND 49).

JORDAN BAKER, EXAMINING ATTORNEY

SN 78-965,027. TREFETHEN VINEYARDS WINERY, INC., NAPA, CA. FILED 8-31-2006.

**DRAGON'S TOOTH**

THE MARK CONSISTS OF STANDARD CHARACTERS WITHOUT CLAIM TO ANY PARTICULAR FONT, STYLE, SIZE, OR COLOR.

FOR WINE (U.S. CLS. 47 AND 49).  
FRANK LATTUCA, EXAMINING ATTORNEY

SN 78-965,401. VIÑA CARTA VIEJA S.A., VILLA ALEGRE, CHILE, FILED 8-31-2006.

**CRAZY BOB**

THE MARK CONSISTS OF STANDARD CHARACTERS WITHOUT CLAIM TO ANY PARTICULAR FONT, STYLE, SIZE, OR COLOR.

FOR WINES (U.S. CLS. 47 AND 49).  
KEVIN DINALLO, EXAMINING ATTORNEY



**CLASS 33—(Continued).**

SN 78-965,435. CODORNIU NAPA, INC., NAPA, CA. FILED 8-31-2006.

**CLASS 33—(Continued).**

SN 78-965,507. CODORNIU NAPA, INC., NAPA, CA. FILED 8-31-2006.

# HONEST WINE

# MOON MEADOW VINEYARD

THE MARK CONSISTS OF STANDARD CHARACTERS WITHOUT CLAIM TO ANY PARTICULAR FONT, STYLE, SIZE, OR COLOR.  
NO CLAIM IS MADE TO THE EXCLUSIVE RIGHT TO USE "WINE", APART FROM THE MARK AS SHOWN.  
FOR WINE (U.S. CLS. 47 AND 49).  
SARAH WAYDA, EXAMINING ATTORNEY

THE MARK CONSISTS OF STANDARD CHARACTERS WITHOUT CLAIM TO ANY PARTICULAR FONT, STYLE, SIZE, OR COLOR.  
NO CLAIM IS MADE TO THE EXCLUSIVE RIGHT TO USE "VINEYARD", APART FROM THE MARK AS SHOWN.  
FOR WINE (U.S. CLS. 47 AND 49).  
SARAH WAYDA, EXAMINING ATTORNEY

SN 78-965,498. CODORNIU NAPA, INC., NAPA, CA. FILED 8-31-2006.

SN 78-965,570. HARRIS, JEFFREY P., HEALDSBURG, CA. FILED 8-31-2006.

# TURKEY ROOST VINEYARD

# BEDARRA VINEYARDS

THE MARK CONSISTS OF STANDARD CHARACTERS WITHOUT CLAIM TO ANY PARTICULAR FONT, STYLE, SIZE, OR COLOR.  
NO CLAIM IS MADE TO THE EXCLUSIVE RIGHT TO USE "VINEYARD", APART FROM THE MARK AS SHOWN.  
FOR WINE (U.S. CLS. 47 AND 49).  
SARAH WAYDA, EXAMINING ATTORNEY

THE MARK CONSISTS OF STANDARD CHARACTERS WITHOUT CLAIM TO ANY PARTICULAR FONT, STYLE, SIZE, OR COLOR.  
NO CLAIM IS MADE TO THE EXCLUSIVE RIGHT TO USE "VINEYARDS", APART FROM THE MARK AS SHOWN.  
FOR WINES (U.S. CLS. 47 AND 49).  
IRA J. GOODSID, EXAMINING ATTORNEY

SN 78-965,502. CODORNIU NAPA, INC., NAPA, CA. FILED 8-31-2006.

SN 78-965,580. VOGT, DONALD O., KENWOOD, CA. FILED 8-31-2006.

# LONE PINE VINEYARD

# CLAJEUX

THE MARK CONSISTS OF STANDARD CHARACTERS WITHOUT CLAIM TO ANY PARTICULAR FONT, STYLE, SIZE, OR COLOR.  
NO CLAIM IS MADE TO THE EXCLUSIVE RIGHT TO USE "VINEYARD", APART FROM THE MARK AS SHOWN.  
FOR WINE (U.S. CLS. 47 AND 49).  
SARAH WAYDA, EXAMINING ATTORNEY

THE MARK CONSISTS OF STANDARD CHARACTERS WITHOUT CLAIM TO ANY PARTICULAR FONT, STYLE, SIZE, OR COLOR.  
THE FOREIGN WORDING IN THE MARK TRANSLATES INTO ENGLISH AS BLUE FLAG IRIS.  
FOR WINES (U.S. CLS. 47 AND 49).  
HENRY S. ZAK, EXAMINING ATTORNEY

**CLASS 33—(Continued).**

SN 78-966,033. CODORNIU NAPA, INC., NAPA, CA. FILED 9-1-2006.

PRESTON OVERLOOK VINEYARD

THE MARK CONSISTS OF STANDARD CHARACTERS WITHOUT CLAIM TO ANY PARTICULAR FONT, STYLE, SIZE, OR COLOR.

NO CLAIM IS MADE TO THE EXCLUSIVE RIGHT TO USE "VINEYARD", APART FROM THE MARK AS SHOWN.

THE NAME(S), PORTRAIT(S), AND/OR SIGNATURE(S) SHOWN IN THE MARK DOES NOT IDENTIFY A PARTICULAR LIVING INDIVIDUAL.

FOR WINE (U.S. CLS. 47 AND 49).  
RICHARD A. STRASER, EXAMINING ATTORNEY

SN 78-966,871. AUSTRALIAN COMMERCIAL WINES PTY LTD, MONASH, S. AUSTRALIA, AUSTRALIA, FILED 9-5-2006.

**HOUND DOG**

THE MARK CONSISTS OF STANDARD CHARACTERS WITHOUT CLAIM TO ANY PARTICULAR FONT, STYLE, SIZE, OR COLOR.

OWNER OF AUSTRALIA REG. NO. 1067193, DATED 7-28-2005, EXPIRES 7-28-2015.

FOR WINE (U.S. CLS. 47 AND 49).  
EVELYN BRADLEY, EXAMINING ATTORNEY

SN 78-967,467. TRAGO INTERNATIONAL, INC., SAN JUAN CAPISTRANO, CA. FILED 9-5-2006.

**TRAGOTINI**

THE MARK CONSISTS OF STANDARD CHARACTERS WITHOUT CLAIM TO ANY PARTICULAR FONT, STYLE, SIZE, OR COLOR.

FOR TEQUILA (U.S. CLS. 47 AND 49).  
TRAVIS WHEATLEY, EXAMINING ATTORNEY

**CLASS 33—(Continued).**

SN 78-967,473. TRAGO INTERNATIONAL, INC., SAN JUAN CAPISTRANO, CA. FILED 9-5-2006.

**TRAGORITA**

THE MARK CONSISTS OF STANDARD CHARACTERS WITHOUT CLAIM TO ANY PARTICULAR FONT, STYLE, SIZE, OR COLOR.

FOR TEQUILA (U.S. CLS. 47 AND 49).  
TRAVIS WHEATLEY, EXAMINING ATTORNEY

SN 78-967,506. SUNBELT VINEYARDS, OXNARD, CA. FILED 9-5-2006.

**Autumn Hills**

THE MARK CONSISTS OF STANDARD CHARACTERS WITHOUT CLAIM TO ANY PARTICULAR FONT, STYLE, SIZE, OR COLOR.

FOR WINE (U.S. CLS. 47 AND 49).  
G. MAYERSCHOFF, EXAMINING ATTORNEY

SN 78-967,976. FAIRPLAY FARMS, LLC, SACRAMENTO, CA. FILED 9-6-2006.

**ZIN MAN**

THE MARK CONSISTS OF STANDARD CHARACTERS WITHOUT CLAIM TO ANY PARTICULAR FONT, STYLE, SIZE, OR COLOR.

FOR WINE (U.S. CLS. 47 AND 49).  
FIRST USE 7-1-1997; IN COMMERCE 7-1-1997.  
NORA BUCHANAN WILL, EXAMINING ATTORNEY

SN 78-968,342. TEECE, DAVID, EMERYVILLE, CA. FILED 9-6-2006.

**SWING BRIDGE**

THE MARK CONSISTS OF STANDARD CHARACTERS WITHOUT CLAIM TO ANY PARTICULAR FONT, STYLE, SIZE, OR COLOR.

FOR WINE (U.S. CLS. 47 AND 49).  
ALLISON HOLTZ, EXAMINING ATTORNEY

**CLASS 33—(Continued).**

SN 78-968,376. TEECE, DAVID, EMERYVILLE, CA. FILED 9-6-2006.

**ZEALAND PEAK**

THE MARK CONSISTS OF STANDARD CHARACTERS WITHOUT CLAIM TO ANY PARTICULAR FONT, STYLE, SIZE, OR COLOR.  
FOR WINE (U.S. CLS. 47 AND 49).  
ALLISON HOLTZ, EXAMINING ATTORNEY

**CLASS 33—(Continued).**

SN 78-969,538. SALINAS, ALBERTO MATURANA, SANTIAGO RM, CHILE, FILED 9-7-2006.

**CU**

THE MARK CONSISTS OF STANDARD CHARACTERS WITHOUT CLAIM TO ANY PARTICULAR FONT, STYLE, SIZE, OR COLOR.  
FOR WINE (U.S. CLS. 47 AND 49).  
KATHERINE CHANG, EXAMINING ATTORNEY

SN 78-969,120. GONZALEZ, HENRY W., IONE, CA. FILED 9-7-2006.

**FOSTERING THE ARTS**

THE MARK CONSISTS OF STANDARD CHARACTERS WITHOUT CLAIM TO ANY PARTICULAR FONT, STYLE, SIZE, OR COLOR.  
FOR WINE (U.S. CLS. 47 AND 49).  
PAUL E. FAHRENKOPF, EXAMINING ATTORNEY

SN 78-969,574. PREMIER WINE BROKERS, LTD., NAPA, CA. FILED 9-7-2006.

**Centerpiece**

THE MARK CONSISTS OF STANDARD CHARACTERS WITHOUT CLAIM TO ANY PARTICULAR FONT, STYLE, SIZE, OR COLOR.  
FOR WINE (U.S. CLS. 47 AND 49).  
ZACHARY BELLO, EXAMINING ATTORNEY

SN 78-969,313. BONARRIGO, PAUL, BRYAN, TX. AND BONARRIGO, MERRILL, BRYAN, TX. FILED 9-7-2006.

**Texas Hold'Em Wine**

THE MARK CONSISTS OF STANDARD CHARACTERS WITHOUT CLAIM TO ANY PARTICULAR FONT, STYLE, SIZE, OR COLOR.  
NO CLAIM IS MADE TO THE EXCLUSIVE RIGHT TO USE "TEXAS" AND "WINE", APART FROM THE MARK AS SHOWN.  
FOR WINE (U.S. CLS. 47 AND 49).  
JOHN DWYER, EXAMINING ATTORNEY

SN 78-969,611. LIMBO, INC., SEBASTOPOL, CA. FILED 9-7-2006.

**FOG CREST**

THE MARK CONSISTS OF STANDARD CHARACTERS WITHOUT CLAIM TO ANY PARTICULAR FONT, STYLE, SIZE, OR COLOR.  
FOR WINES (U.S. CLS. 47 AND 49).  
JILL PRATER, EXAMINING ATTORNEY

**CLASS 33—(Continued).**

SN 78-969,670. HUGH HAMILTON WINES PTY LTD, MCLAREN VALE, AUSTRALIA, FILED 9-8-2006.

# Crikey

THE MARK CONSISTS OF STANDARD CHARACTERS WITHOUT CLAIM TO ANY PARTICULAR FONT, STYLE, SIZE, OR COLOR.

FOR APERITIF WINES; APERITIFS WITH A WINE BASE; COOKING WINE; FRUIT WINE; GRAPE WINE; KITS FOR MAKING WINE; NATURAL SPARKLING WINES; PORT WINES; PREPARED WINE COCKTAILS; RED WINE; SPARKLING FRUIT WINE; SPARKLING GRAPE WINE; SPARKLING WINE; STRAWBERRY WINE; SWEET WINES; TABLE WINES; TONIC SWEET GRAPE WINE CONTAINING EXTRACTS FROM GINSENG AND CONCHONA BARK (NINJIN-KINATETSU WINE); WHITE WINE; WINE; WINE COOLERS; WINE PUNCH; WINE PUNCHES; WINES (U.S. CLS. 47 AND 49).  
CHARISMA HAMPTON, EXAMINING ATTORNEY

---

SN 78-969,911. THE IRISHMAN LIMITED, URGLIN, CARLOW, IRELAND, FILED 9-8-2006.

# THE IRISHMAN

THE MARK CONSISTS OF STANDARD CHARACTERS WITHOUT CLAIM TO ANY PARTICULAR FONT, STYLE, SIZE, OR COLOR.

OWNER OF U.S. REG. NO. 2,857,324.  
FOR WHISKEY (U.S. CLS. 47 AND 49).  
REBECCA GILBERT, EXAMINING ATTORNEY

---

SN 78-969,923. BACCHUS IMPORTS, LLC, LONGVIEW, TX, FILED 9-8-2006.

# DON GENTINA

THE MARK CONSISTS OF STANDARD CHARACTERS WITHOUT CLAIM TO ANY PARTICULAR FONT, STYLE, SIZE, OR COLOR.

THE NAME DON GENTINA DOES NOT IDENTIFY A LIVING INDIVIDUAL.  
FOR WINE (U.S. CLS. 47 AND 49).  
REBECCA GILBERT, EXAMINING ATTORNEY

**CLASS 33—(Continued).**

SN 78-969,961. HEARTLAND WINE & SPIRITS GROUP, INC., SPRINGBORO, OH. FILED 9-8-2006.

# PUT A SPIN ON IT

THE MARK CONSISTS OF STANDARD CHARACTERS WITHOUT CLAIM TO ANY PARTICULAR FONT, STYLE, SIZE, OR COLOR.

FOR ALCOHOLIC BEVERAGES, NAMELY, VODKA (U.S. CLS. 47 AND 49).  
DAVID TOOLEY, EXAMINING ATTORNEY

---

SN 78-970,324. DEL BARRIO, JON, LOS ANGELES, CA, FILED 9-8-2006.

# TRANSPHUSION

THE MARK CONSISTS OF STANDARD CHARACTERS WITHOUT CLAIM TO ANY PARTICULAR FONT, STYLE, SIZE, OR COLOR.

FOR ALCOHOLIC MALT COOLERS; PREPARED ALCOHOLIC COCKTAIL (U.S. CLS. 47 AND 49).  
RONALD MCMORROW, EXAMINING ATTORNEY

---

SN 78-970,747. SAZERAC COMPANY, INC., NEW ORLEANS, LA. FILED 9-9-2006.

# CHARTER COUNTRY

THE MARK CONSISTS OF STANDARD CHARACTERS WITHOUT CLAIM TO ANY PARTICULAR FONT, STYLE, SIZE, OR COLOR.

OWNER OF U.S. REG. NOS. 1,309,275 AND 1,825,377.  
FOR ALCOHOLIC BEVERAGES, NAMELY WHISKEY (U.S. CLS. 47 AND 49).  
SCOTT BALDWIN, EXAMINING ATTORNEY

**CLASS 33—(Continued).**

SN 78-972,381. MARK ANTHONY PROPERTIES LTD., VAN-  
COUVER, BRITISH COLUMBIA, CANADA, FILED 9-12-  
2006.

# PERPETUA

THE MARK CONSISTS OF STANDARD CHARACTERS  
WITHOUT CLAIM TO ANY PARTICULAR FONT, STYLE,  
SIZE, OR COLOR.

FOR WINES (U.S. CLS. 47 AND 49).

JUDITH HELFMAN, EXAMINING ATTORNEY

SN 78-972,426. DROWN CORP., EAST AMHERST, NY. FILED  
9-12-2006.

# UPSIDE DOWN

THE MARK CONSISTS OF STANDARD CHARACTERS  
WITHOUT CLAIM TO ANY PARTICULAR FONT, STYLE,  
SIZE, OR COLOR.

FOR WINES (U.S. CLS. 47 AND 49).

DEBRA LEE, EXAMINING ATTORNEY

SN 79-008,979. DISTILLEERDERIJ EN LIKEURSTOKERIJ  
HERMAN JANSEN B.V., ALSO TRADING AS F.J. SON-  
NEMA TE SCHIEDAM, NETHERLANDS, FILED 12-13-  
2004.



OWNER OF INTERNATIONAL REGISTRATION 0695883  
DATED 7-10-1998, EXPIRES 7-10-2008.

NO CLAIM IS MADE TO THE EXCLUSIVE RIGHT TO  
USE 0.5 LITRE OR 30% VOL., APART FROM THE MARK AS  
SHOWN.

THE LIKENESS (OR, "PORTRAIT") IN THE MARK DOES  
NOT IDENTIFY A LIVING INDIVIDUAL. THE NAME F. J.  
SONNEMA DOES NOT IDENTIFY A LIVING INDIVIDUAL.

THE COLOR(S) RED, WHITE, BLACK AND BEIGE IS/  
ARE CLAIMED AS A FEATURE OF THE MARK.

THE COLOR RED APPEARS IN THE BACKGROUND OF  
THE RECTANGULAR DESIGN AT THE TOP OF THE  
MARK, IN THE "B" OF "BERENBURG," IN THE HAND-  
WRITTEN SCRIPT VERSION OF "SONNEMA" THAT

**CLASS 33—(Continued).**

FORMS PART OF THE MARK, IN THE SEAL AT THE  
LOWER PORTION OF THE MARK, AND IN THE UPPER  
PORTION OF THE STRIPE THAT FORMS THE BACK-  
GROUND OF THE SEAL; THE COLOR BLACK APPEARS IN  
THE PICTURE TO DEFINE THE OUTLINE AND FEAT-  
URES OF EACH OBJECT, IN ALL BUT THE LETTER "B"  
OF "BERENBURG;" IN THE LOWER PORTION OF THE  
STRIPE WHICH FORMS A BACKGROUND OF THE SEAL,  
IN THE WRITING "F.J. SONNEMA" BELOW THE HAND-  
WRITTEN SCRIPT VERSION OF "SONNEMA", IN THE  
OUTLINES OF THE LOWER-MOST RECTANGLE AND IN  
THE WORDING 0.5 LITRE 30% VOL.; THE COLOR BEIGE  
APPEARS IN THE BOX BELOW THE SEAL AND AS  
SHADING IN THE HAT, SCARF, AND MOUNTAINS IN  
THE PICTURE; AND THE COLOR WHITE APPEARS IN  
THE SKY/CLOUDS, THE TREES, THE FLOWERS AND IN  
THE FACE AND BEARD OF THE MAN IN THE PICTURE,  
AND FOR THE BLOCK PRINT VERSION OF THE WORD  
"SONNEMA" AT THE TOP OF THE MARK.

THE MARK CONSISTS PRINCIPALLY OF A SERIES OF  
RECTANGULAR DESIGNS. IN THE UPPERMOST REC-  
TANGLE IS THE WORD "SONNEMA". IN THE NEXT  
LOWER RECTANGLE THERE IS A STYLIZED RENDITION  
OF A BEARDED MAN WEARING A HAT AND CARRYING  
A WALKING STICK. HE IS STANDING IN FRONT OF A  
RANGE OF MOUNTAINS AND SOME EVERGREEN  
TREES, AND IN FRONT AND TO HIS LEFT SIDE ARE  
SOME WILDFLOWERS. BENEATH THIS RECTANGLE IS  
THE WORDING "BERENBURG" AND UNDERNEATH  
THAT AND TO THE RIGHT IS A HANDWRITTEN SCRIPT  
VERSION OF "SONNEMA" AND THE TYPED WORDS "F. J.  
SONNEMA". BELOW THIS IS A RECTANGLE WITH A  
SEAL OVER-LAPPING THE LAST RECTANGLE. THIS SEAL  
ALSO OVERLAPS THE LAST RECTANGLE, WHICH  
FORMS PART OF THE DESIGN AND WHICH CONTAINS  
THE WORDING 0.5 LITRE 30% VOL.

FOR ALCOHOLIC BITTERS, INCLUDING HERB BIT-  
TERS (U.S. CLS. 47 AND 49).

NANCY CLARKE, EXAMINING ATTORNEY

SN 79-012,184. PROTOS BODEGA RIBERA DUERO DE  
PENAFIEL, S.L., SPAIN, FILED 5-31-2005.



OWNER OF INTERNATIONAL REGISTRATION 0853544  
DATED 5-31-2005, EXPIRES 5-31-2015.

OWNER OF U.S. REG. NO. 2,536,090.

NO CLAIM IS MADE TO THE EXCLUSIVE RIGHT TO  
USE "BODEGAS, PROTOS S.A., FUNDADA EN 1927, COSE-  
CHA 1997, DENOMINACION DE ORIGEN, EMBOTELLADO  
POR, S.A., SPAIN, 13% VOL., 75 CLE", APART FROM THE  
MARK AS SHOWN.

THE COLOR(S) RED, BLACK, WHITE AND GOLD IS/  
ARE CLAIMED AS A FEATURE OF THE MARK.

THE COLOR RED APPEARS IN THE WORDING PROTOS,  
THE BOTTOM OF THE SEAL ABOVE PROTOS, AND THE  
BOTTOM LINE OF THE LABEL. THE COLOR BLACK  
APPEARS IN THE WORDING RIBERA DUERO, 1997,  
RIBERA DEL DUERO DENOMINACION DE ORIGEN,  
13% VOL., EMBOTELLADO POR BODEGAS PROTOS, S.A.,  
PENAFIEL, VALLADOLID, ESPAÑA, 75 CLE AND THE

**CLASS 33—(Continued).**

COLOR BLACK APPEARS IN THE OUTLINE OF THE WORD PROTOS AND THE WORDING RIBERA DUERO, 1997, RIBERA DEL DUERO DENOMINACION DE ORIGEN, 13% VOL., EMBOTELLADO POR BODEGAS PROTOS, S.A., PEÑAFIEL, VALLADOLID, ESPAÑA, 75 CL. THE COLOR WHITE APPEARS IN THE BACKGROUND OF THE LABEL. THE COLOR GOLD APPEARS IN THE WORDING BODEGAS PROTOS S.A. FUNDANDA EN 1927 AND COSECHA, THE CROWN ABOVE THE SEAL, AND THE TOP LINE OF THE LABEL.

THE FOREIGN WORDING IN THE MARK TRANSLATES INTO ENGLISH AS FIRST RIVIERA DUERO VINTAGE 1997; FUNDADA EN 1927 TRANSLATES INTO ENGLISH AS FOUNDED IN 1927, AND COSECHA 1997 TRANSLATES INTO ENGLISH AS VINTAGE 1997; RIBERA DEL DUERO DENOMINACION DE ORIGEN TRANSLATES INTO ENGLISH AS RIBERA DEL DUERO GUARANTEE OF ORIGIN; AND EMBOTELLADO POR BODEGAS PROTOS S.A. PEÑAFIEL VALLADOLID ESPAÑA TRANSLATES INTO ENGLISH AS BOTTLED BY BODEGAS PROTOS S.A. PEÑAFIEL VALLADOLID SPAIN. THE TERM "PROTOS" TRANSLATES TO "FIRST" AND THE TERM "BODEGAS" TRANSLATES TO "WINE CELLAR".

FOR WINE (U.S. CLS. 47 AND 49).  
DOMINIC J. FERRAIUOLO, EXAMINING ATTORNEY

SN 79-013,434. PERNOD RICARD, SOCIÉTÉ ANONYME, FRANCE, FILED 4-19-2005.



PRIORITY DATE OF 12-13-2004 IS CLAIMED.  
OWNER OF INTERNATIONAL REGISTRATION 0856878  
DATED 4-19-2005, EXPIRES 4-19-2015.

OWNER OF U.S. REG. NOS. 759,342 AND 794,175.  
THE COLOR(S) NAVY BLUE, WHITE, SILVER, GREY, YELLOW AND RED IS/ARE CLAIMED AS A FEATURE OF THE MARK.

UPPER CARTOUCHE NAVY BLUE, RICARD IN WHITE LETTERS, FOLIAGE MOTIF IN GREY-SCALE AND SILVER, RED CIRCLE, FINE OBLIQUE SILVER LINES; SIDES OF THE RECTANGLE EDGED WITH NAVY BLUE, GREY AND YELLOW.

THE MARK COMPRISES TWO CARTOUCHES AND IS CHARACTERISED BY THE SEPARATION BETWEEN THE UPPER NAVY BLUE CARTOUCHE WITH THE NAME RICARD IN WHITE LETTERS AND THE CENTRAL RECTANGLE WHICH COMPRISES A FOLIAGE MOTIF IN GREY-SCALE AND SILVER WITH A RED CIRCLE IN ITS CENTRE; FINE OBLIQUE SILVER LINES SURROUND THE ABOVE MOTIF; THE SIDES OF THE RECTANGLE ARE EDGED WITH NAVY BLUE, GREY AND YELLOW.

FOR ALCOHOLIC BEVERAGES, NAMELY APERITIFS AND PREPARED COCKTAILS MADE WITH APERITIFS (U.S. CLS. 47 AND 49).

MATTHEW MCDOWELL, EXAMINING ATTORNEY

**CLASS 33—(Continued).**

SN 79-023,875. FERNANDO BANUS RICOMA -; ESTEBAN BANUS RICOMA, SPAIN, FILED 11-2-2005.



PRIORITY DATE OF 10-21-2005 IS CLAIMED.  
OWNER OF INTERNATIONAL REGISTRATION 0885019  
DATED 11-2-2005, EXPIRES 11-2-2015.

THE MARK CONSISTS OF CONFIGURATION OF THE CONTAINER FOR THE GOODS. THE CONFIGURATION DESIGN OF THE MARK IS A BOTTLE SHAPE FROM BOTTOM TO TOP, CONSISTING OF 6 RECESSES AROUND THE LOWER PART OF THE BOTTLE ENDING CURVED ON THE UPPER PART; THE DOTTED LINES IN THE DRAWING REPRESENT THE CAP AND ARE NOT PART OF THE MARK.

FOR WINE, SPARKLING WINES, LIQUEURS, DISTILLED SPIRITS, ALCOHOLIC BEVERAGES, NAMELY, ALCOHOLIC BEVERAGES PRODUCED FROM A BREWED MALT BASE WITH NATURAL FLAVORS (U.S. CLS. 47 AND 49).

PAULA MAHONEY, EXAMINING ATTORNEY

SN 79-025,427. CORSINI DUCCIO, ITALY, FILED 4-14-2006.

# DON TOMMASO

THE MARK CONSISTS OF STANDARD CHARACTERS WITHOUT CLAIM TO ANY PARTICULAR FONT, STYLE, SIZE, OR COLOR.

PRIORITY DATE OF 12-7-2005 IS CLAIMED.  
OWNER OF INTERNATIONAL REGISTRATION 0889102  
DATED 4-14-2006, EXPIRES 4-14-2016.

THE FOREIGN WORDING IN THE MARK TRANSLATES INTO ENGLISH AS MR.

FOR WINES, DISTILLED SPIRITS AND DISTILLED LIQUORS (U.S. CLS. 47 AND 49).

HENRY S. ZAK, EXAMINING ATTORNEY

**CLASS 33—(Continued).**

SN 79-027,688. CHAMPAGNE CHARLES LAFITTE.; SUC-  
CESSEUR DE GEORGES GOULET.; MAISON FONDÉE  
EN 1834, FRANCE, FILED 6-19-2006.



PRIORITY DATE OF 12-30-2005 IS CLAIMED.  
OWNER OF INTERNATIONAL REGISTRATION 0895399  
DATED 6-19-2006, EXPIRES 6-19-2016.  
OWNER OF U.S. REG. NOS. 1,975,970, 2,349,728 AND  
2,464,898.

NO CLAIM IS MADE TO THE EXCLUSIVE RIGHT TO  
USE "SUCESSEUR DE LA MAISON GEORGE GOULET  
FONDEE EN 1834" AND "1999", APART FROM THE MARK  
AS SHOWN.

THE NAME(S), PORTRAIT(S), AND/OR SIGNATURE(S)  
SHOWN IN THE MARK IDENTIFIES CHARLES LAFITTE,  
WHOSE CONSENT(S) TO REGISTER IS SUBMITTED.

THE COLOR(S) BLACK, GOLD AND BLUE IS/ARE  
CLAIMED AS A FEATURE OF THE MARK.

THE MARK CONSISTS OF A BLUE, GOLD AND BLACK  
NECK LABEL ON WHICH THE WORDS CHARLES LA-  
FITTE ARE PRINTED TWICE IN BLACK AGAINST A BLUE  
BACKGROUND. A CREST IS PRINTED IN BLUE AND  
GOLD AGAINST A GOLD BACKGROUND AND IS EN-  
CIRCLED BY THE WORDS CHARLES LAFITTE 1834 IN  
BLACK, AND A CREST IS PRINTED IN GOLD ABOVE THE  
PHRASE SUCESSEUR DE LA MAISON GEORGE GOULET  
FONDEE EN 1834, PRINTED IN WHITE, ON A BLACK  
BACKGROUND; AND A BOTTLE LABEL WITH THE  
WORDS CHARLES LAFITTE IN WHITE LETTERS AND  
THE LETTERS E.O PRINTED TWICE IN GOLD AGAINST  
THE BACKGROUND OF A BLACK CARTOUCHE AND  
THIS CARTOUCHE IS AGAINST A BACKGROUND OF  
ALTERNATING BLUE AND GOLD VERTICAL STRIPES.

THE FOREIGN WORDING IN THE MARK TRANSLATES  
INTO ENGLISH AS SUCCESSOR OF THE HOUSE GEORGE  
GOULET FOUNDED IN.

FOR ALCOHOLIC BEVERAGES, NAMELY, WINES,  
SPARKLING WINES, WINES WITH THE PROTECTED  
APPELLATION OF ORIGIN CHAMPAGNE (U.S. CLS. 47  
AND 49).

GINA HAYES, EXAMINING ATTORNEY

SN 79-027,708. BATASIOLO SPA, ITALY, FILED 7-5-2006.

**BATASIOLO**

THE MARK CONSISTS OF STANDARD CHARACTERS  
WITHOUT CLAIM TO ANY PARTICULAR FONT, STYLE,  
SIZE, OR COLOR.

OWNER OF INTERNATIONAL REGISTRATION 0895469  
DATED 7-5-2006, EXPIRES 7-5-2016.

FOR WINES, LIQUORS, SPIRITS, NAMELY DIS-  
TILLED, POTABLE AND BRANDY SPIRITS (U.S. CLS.  
47 AND 49).

ALAIN LAPTER, EXAMINING ATTORNEY

**CLASS 33—(Continued).**

SN 79-030,428. AMBROGIO E GIOVANNI; FOLONARI  
TENUTE SOCIETA AGRICOLA; A RESPONSABILITA  
LIMITATA, ITALY, FILED 8-31-2006.

**F O L O**

THE MARK CONSISTS OF STANDARD CHARACTERS  
WITHOUT CLAIM TO ANY PARTICULAR FONT, STYLE,  
SIZE, OR COLOR.

PRIORITY DATE OF 7-19-2006 IS CLAIMED.  
OWNER OF INTERNATIONAL REGISTRATION 0902286  
DATED 8-31-2006, EXPIRES 8-31-2016.  
FOR WINES (U.S. CLS. 47 AND 49).  
TASNEEM HUSSAIN, EXAMINING ATTORNEY

**CLASS 34—SMOKERS' ARTICLES**

SN 76-459,015. POTOMAC TOBACCO COMPANY, LTD,  
ROAD TOWN, TORTOLA, BR.VIRGIN ISLANDS, FILED  
10-9-2002.

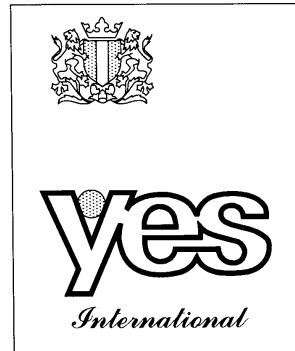

NO CLAIM IS MADE TO THE EXCLUSIVE RIGHT TO  
USE "INTERNATIONAL", APART FROM THE MARK AS  
SHOWN.

THE DOT IN THE Y OF THE WORD "YES" IS RED AS IS  
THE SCRIPT WORD "INTERNATIONAL". THE OUTLINE  
OF THE WORD "YES", THE OUTLINE OF THE DOT AND  
THE ICON IN THE UPPER LEFT CORNER IS IN BLACK.  
THE ICON INCLUDES A SHIELD WITH THREE VERTICAL  
COLUMNS, THE OUTER TWO ARE RED. THE ENTIRE  
BACKGROUND IS GOLD.

FOR TOBACCO, CIGARETTES AND CIGARS;  
MATCHES (U.S. CLS. 2, 8, 9 AND 17).

KAREN K. BUSH, EXAMINING ATTORNEY

**CLASS 34—(Continued).**

SN 78-525,498. FUENTE MARKETING LTD., WASHINGTON, DC. FILED 12-1-2004.

**PERFECCION X**

THE MARK CONSISTS OF STANDARD CHARACTERS WITHOUT CLAIM TO ANY PARTICULAR FONT, STYLE, SIZE, OR COLOR.

FOR CIGARS (U.S. CLS. 2, 8, 9 AND 17).

FIRST USE 11-30-1996; IN COMMERCE 11-30-1996.

LEIGH CAROLINE CASE, EXAMINING ATTORNEY

SN 78-805,609. BRITISH AMERICAN TOBACCO (BRANDS) LIMITED, LONDON, UNITED KINGDOM, FILED 2-2-2006.



NO CLAIM IS MADE TO THE EXCLUSIVE RIGHT TO USE "CLASSIC," "FLAVOUR" AND "LA SAVEUR CLASSIQUE", APART FROM THE MARK AS SHOWN.

"THE STIPPLING IS FOR SHADING PURPOSES ONLY."

"THE MARK CONSISTS OF A RECTANGLE DIVIDED INTO A LARGER, UPPER PORTION AND A SMALLER, LOWER PORTION, DIVIDED BY A WAVY LINE. THE UPPER PORTION CONTAINS THE WORDS CLASSIC DUMAURIER FLAVOUR, FOLLOWED BY THE FRENCH TRANSLATION THEREFOR, LA SAVEUR CLASSIQUE DUMAURIER. TO THE RIGHT OF THE WORDS CLASSIC DUMAURIER FLAVOUR APPEARS A BORDERED BOX CONTAINING THE LETTERS D, U AND M IN LOWER CASE, STYLIZED LETTERS."

"THE FOREIGN WORDING IN THE MARK TRANSLATES INTO ENGLISH AS CLASSIC FLAVOUR."

FOR CIGARETTES, TOBACCO, CIGARETTE CASES NOT OF PRECIOUS METAL, ASHTRAYS NOT OF PRECIOUS METAL, TOBACCO PIPES NOT OF PRECIOUS METAL, LIGHTERS NOT OF PRECIOUS METAL, MATCHES (U.S. CLS. 2, 8, 9 AND 17).

FIRST USE 2-0-2005; IN COMMERCE 2-0-2005.

GILBERT SWIFT, EXAMINING ATTORNEY

**CLASS 34—(Continued).**

SN 78-805,615. BRITISH AMERICAN TOBACCO (BRANDS) LIMITED, LONDON, UNITED KINGDOM, FILED 2-2-2006.

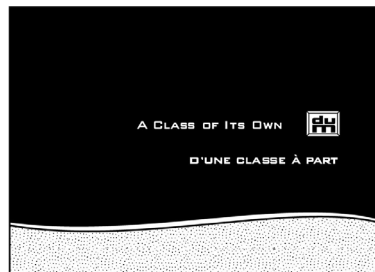

"THE STIPPLING IS FOR SHADING PURPOSES ONLY."

"THE MARK CONSISTS OF A RECTANGLE DIVIDED INTO A LARGER, UPPER PORTION AND A SMALLER, LOWER PORTION, DIVIDED BY A WAVY LINE. THE UPPER PORTION CONTAINS THE WORDS A CLASS OF ITS OWN, FOLLOWED BY THE FRENCH TRANSLATION THEREFOR, D'UNE CLASSE A PART. TO THE RIGHT OF THE WORDS A CLASS OF ITS OWN APPEARS A BORDERED BOX CONTAINING THE LETTERS D, U AND M IN LOWER CASE, STYLIZED LETTERS."

"THE FOREIGN WORDING IN THE MARK TRANSLATES INTO ENGLISH AS A CLASS OF ITS OWN."

FOR CIGARETTES, TOBACCO, CIGARETTE CASES NOT OF PRECIOUS METAL, ASHTRAYS NOT OF PRECIOUS METAL, TOBACCO PIPES NOT OF PRECIOUS METAL, LIGHTERS NOT OF PRECIOUS METAL, MATCHES (U.S. CLS. 2, 8, 9 AND 17).

FIRST USE 2-0-2005; IN COMMERCE 2-0-2005.

GILBERT SWIFT, EXAMINING ATTORNEY

SN 78-805,620. BRITISH AMERICAN TOBACCO (BRANDS) LIMITED, LONDON, UNITED KINGDOM, FILED 2-2-2006.



"THE STIPPLING IS FOR SHADING PURPOSES ONLY."

"THE MARK CONSISTS OF A RECTANGLE DIVIDED INTO A LARGER, UPPER PORTION AND A SMALLER, LOWER PORTION, DIVIDED BY A WAVY LINE. THE UPPER PORTION CONTAINS THE WORD DUMAURIER, TO THE RIGHT OF WHICH APPEARS A BORDERED BOX CONTAINING THE LETTERS D, U AND M IN LOWER CASE STYLIZED LETTERS."

FOR CIGARETTES, TOBACCO, CIGARETTE CASES NOT OF PRECIOUS METAL, ASHTRAYS NOT OF PRECIOUS METAL, TOBACCO PIPES NOT OF PRECIOUS METAL, LIGHTERS NOT OF PRECIOUS METAL, MATCHES (U.S. CLS. 2, 8, 9 AND 17).

FIRST USE 2-0-2005; IN COMMERCE 2-0-2005.

GILBERT SWIFT, EXAMINING ATTORNEY



**CLASS 34—(Continued).**

SN 78-844,476. SANTA CLARA, INC., WHIPPANY, NJ. FILED 3-23-2006.

**FLOR DE BALONEY**

THE MARK CONSISTS OF STANDARD CHARACTERS WITHOUT CLAIM TO ANY PARTICULAR FONT, STYLE, SIZE, OR COLOR.

"THE FOREIGN WORDING IN THE MARK TRANSLATES INTO ENGLISH AS FLOWER OF BALONEY."

FOR CIGARS (U.S. CLS. 2, 8, 9 AND 17).

MICHAEL KAZAZIAN, EXAMINING ATTORNEY

SN 78-844,485. SANTA CLARA, INC., WHIPPANY, NJ. FILED 3-23-2006.

**FLOR DE BOLOGNA**

THE MARK CONSISTS OF STANDARD CHARACTERS WITHOUT CLAIM TO ANY PARTICULAR FONT, STYLE, SIZE, OR COLOR.

"THE FOREIGN WORDING IN THE MARK TRANSLATES INTO ENGLISH AS FLOWER OF BOLOGNA."

FOR CIGARS (U.S. CLS. 2, 8, 9 AND 17).

MICHAEL KAZAZIAN, EXAMINING ATTORNEY

SN 78-852,295. BRITISH AMERICAN TOBACCO (BRANDS) LIMITED, LONDON, UNITED KINGDOM, FILED 4-3-2006.

**DU MAURIER LUXE**

THE MARK CONSISTS OF STANDARD CHARACTERS WITHOUT CLAIM TO ANY PARTICULAR FONT, STYLE, SIZE, OR COLOR.

NO CLAIM IS MADE TO THE EXCLUSIVE RIGHT TO USE "LUXE", APART FROM THE MARK AS SHOWN.

FOR MANUFACTURED TOBACCO PRODUCTS, NAMELY, CIGARS AND CIGARILLOS (U.S. CLS. 2, 8, 9 AND 17).

GILBERT SWIFT, EXAMINING ATTORNEY

**CLASS 34—(Continued).**

SN 78-906,892. CAMEO INC., MONTREAL, QUEBEC, CANADA, FILED 6-13-2006.

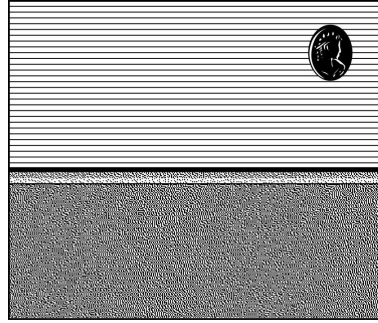

NO CLAIM IS MADE TO THE EXCLUSIVE RIGHT TO USE THE RECTANGULAR SHAPE OF THE PACKAGE ON WHICH THE MARK APPEARS, APART FROM THE MARK AS SHOWN.

THE STIPPLING IS FOR SHADING PURPOSES ONLY. THE LINING IS A FEATURE OF THE MARK AND DOES NOT INDICATE COLOR.

THE NAME(S), PORTRAIT(S), AND/OR SIGNATURE(S) SHOWN IN THE MARK DOES NOT IDENTIFY A PARTICULAR LIVING INDIVIDUAL.

THE MARK CONSISTS OF THE BUST OF A WOMAN IN AN OVAL RESEMBLING A CAMEO IN THE UPPER RIGHT HAD CORNER OF A RECTANGLE THAT IS DIVIDED INTO TWO AREAS. THE BOTTOM HALF OF THE RECTANGLE IS SHADED, AND THE UPPER PORTION OF THE RECTANGLE DISPLAYS HORIZONTAL EVENLY SPACED LINING, WITH THREE HEAVIER AND SHADED LINES SEPARATING THE TWO PORTIONS OF THE RECTANGLE.

FOR MANUFACTURED TOBACCO PRODUCTS, NAMELY, CIGARETTES (U.S. CLS. 2, 8, 9 AND 17).

FIRST USE 9-0-2001; IN COMMERCE 9-0-2001.

LINDA POWELL, EXAMINING ATTORNEY

SN 78-920,202. XIKAR, INC., KANSAS CITY, MO. FILED 6-29-2006.

**THE BEST THING TO HAPPEN TO CIGARS SINCE FIRE**

THE MARK CONSISTS OF STANDARD CHARACTERS WITHOUT CLAIM TO ANY PARTICULAR FONT, STYLE, SIZE, OR COLOR.

FOR CIGAR CUTTERS; NON-ELECTRIC CIGAR LIGHTERS NOT OF PRECIOUS METAL; HUMIDORS; AND CIGAR CARRYING CASES NOT OF PRECIOUS METAL (U.S. CLS. 2, 8, 9 AND 17).

FIRST USE 5-1-2006; IN COMMERCE 5-1-2006.

KATHRYN COWARD, EXAMINING ATTORNEY

**CLASS 34—(Continued).**

SN 78-950,524. CONNECTICUT VALLEY TOBACCONIST LLC, ENFIELD, CT. FILED 8-11-2006.

**MYSTERIOSO**

THE MARK CONSISTS OF STANDARD CHARACTERS WITHOUT CLAIM TO ANY PARTICULAR FONT, STYLE, SIZE, OR COLOR.

FOR CIGARS (U.S. CLS. 2, 8, 9 AND 17).  
FIRST USE 1-4-2003; IN COMMERCE 1-4-2004.  
YONG KIM, EXAMINING ATTORNEY

SN 78-958,023. MARTINELLIE, INC., SAN JOSE, CA. FILED 8-22-2006.

**ENERGY DRINK**

THE MARK CONSISTS OF STANDARD CHARACTERS WITHOUT CLAIM TO ANY PARTICULAR FONT, STYLE, SIZE, OR COLOR.

FOR CHEWING TOBACCO; SMOKELESS TOBACCO; SNUFF (U.S. CLS. 2, 8, 9 AND 17).  
SANI KHOURI, EXAMINING ATTORNEY

SN 78-967,271. GENERAL CIGAR CO., INC., RICHMOND, VA. FILED 9-5-2006.

**BALTAZAR**

THE MARK CONSISTS OF STANDARD CHARACTERS WITHOUT CLAIM TO ANY PARTICULAR FONT, STYLE, SIZE, OR COLOR.

FOR CIGARS (U.S. CLS. 2, 8, 9 AND 17).  
TIMOTHY FINNEGAN, EXAMINING ATTORNEY

SN 78-967,278. GENERAL CIGAR CO., INC., RICHMOND, VA. FILED 9-5-2006.

**GASPAR**

THE MARK CONSISTS OF STANDARD CHARACTERS WITHOUT CLAIM TO ANY PARTICULAR FONT, STYLE, SIZE, OR COLOR.

FOR CIGARS (U.S. CLS. 2, 8, 9 AND 17).  
TIMOTHY FINNEGAN, EXAMINING ATTORNEY

**CLASS 34—(Continued).**

SN 78-967,292. GENERAL CIGAR CO., INC., RICHMOND, VA. FILED 9-5-2006.

**THREE KINGS**

THE MARK CONSISTS OF STANDARD CHARACTERS WITHOUT CLAIM TO ANY PARTICULAR FONT, STYLE, SIZE, OR COLOR.

FOR CIGARS (U.S. CLS. 2, 8, 9 AND 17).  
TIMOTHY FINNEGAN, EXAMINING ATTORNEY

SN 78-972,292. COASTAL DISTRIBUTING GROUP, L.L.C., ROCKINGHAM, NC. FILED 9-12-2006.

**LUMBEE**

THE MARK CONSISTS OF STANDARD CHARACTERS WITHOUT CLAIM TO ANY PARTICULAR FONT, STYLE, SIZE, OR COLOR.

FOR CIGARETTES; CIGARS; CHEWING TOBACCO; HAND-ROLLING TOBACCO; PIPE TOBACCO; SMOKELESS TOBACCO; SNUFF (U.S. CLS. 2, 8, 9 AND 17).  
GEORGE LORENZO, EXAMINING ATTORNEY

SN 79-021,331. DISEÑO INDUSTRIAL DEL NOROESTE, S.L., SPAIN, FILED 1-19-2006.



OWNER OF INTERNATIONAL REGISTRATION 0878057 DATED 1-19-2006, EXPIRES 1-19-2016.

FOR SIMULATED CIGARETTES CONTAINING TOBACCO SUBSTITUTES NOT FOR MEDICAL PURPOSES (U.S. CLS. 2, 8, 9 AND 17).

KRISTINA KLOIBER, EXAMINING ATTORNEY

**CLASS 34—(Continued).**

SN 79-025,781. KARELIA TOBACCO COMPANY INC, GREECE, FILED 6-1-2006.

**CLASS 35—(Continued).**

SN 76-645,159. KINGSKY TECHNOLOGY LTD., FREEHOLD, NJ. FILED 8-18-2005.

**GEORGE KARELIAS AND SONS EXCELLENCE**

PRIORITY DATE OF 12-1-2005 IS CLAIMED. OWNER OF INTERNATIONAL REGISTRATION 0890083 DATED 6-1-2006, EXPIRES 6-1-2016.

OWNER OF U.S. REG. NOS. 2,102,843 AND 2,102,844. NO CLAIM IS MADE TO THE EXCLUSIVE RIGHT TO USE "EXCELLENCE", APART FROM THE MARK AS SHOWN.

FOR CIGARETTES, CIGARS AND TOBACCO; TOBACCO PRODUCTS AND SMOKERS' REQUISITES, NAMELY, CIGARETTE AND CIGAR LIGHTERS NOT OF PRECIOUS METALS, MATCHES, TOBACCO PIPES, AND ASHTRAYS NOT OF PRECIOUS METALS (U.S. CLS. 2, 8, 9 AND 17).

RONALD MCMORROW, EXAMINING ATTORNEY

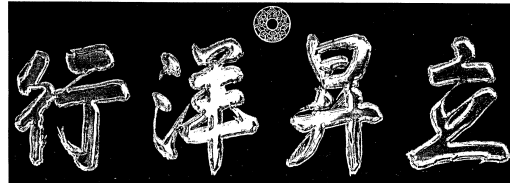

NO CLAIM IS MADE TO THE EXCLUSIVE RIGHT TO USE THE NON-LATIN CHARACTERS MEANING TECHNOLOGY LIMITED, APART FROM THE MARK AS SHOWN.

THE GRAY TONES IN THE DRAWING ARE NOT INTENDED TO INDICATE THE COLOR GRAY.

THE MARK IS DISPLAYED IN CHINESE CHARACTERS WHICH TRANSLATE IN ENGLISH AS KINGSKY TECHNOLOGY LIMITED.

THE NON-LATIN CHARACTERS IN THE MARK TRANSLITERATE TO "LIH SHENG YANG HANG".

FOR WHOLESALE DISTRIBUTORSHIPS FEATURING TOYS (U.S. CLS. 100, 101 AND 102).

FIRST USE 7-1-2001; IN COMMERCE 7-1-2001.

BARBARA BROWN, EXAMINING ATTORNEY

**SERVICE MARKS**

**CLASS 35—ADVERTISING AND BUSINESS**

SN 76-640,409. CS INFORMATION TECHNOLOGIES, INC., NEEDHAM, MA. FILED 6-8-2005.

SN 76-655,033. BARANRIZ, HAMID, LOS GATOS, CA. FILED 2-13-2006.

**PLATINUM DATA**

**YAS**

THE MARK CONSISTS OF STANDARD CHARACTERS WITHOUT CLAIM TO ANY PARTICULAR FONT, STYLE, SIZE, OR COLOR.

NO CLAIM IS MADE TO THE EXCLUSIVE RIGHT TO USE "DATA", APART FROM THE MARK AS SHOWN.

FOR PROVIDING AN ONLINE DATABASE FEATURING BUSINESS AND CORPORATE PROFILES FOR USE BY OTHERS FOR SALES AND MARKETING PURPOSES (U.S. CLS. 100, 101 AND 102).

AMY MCMENAMIN, EXAMINING ATTORNEY

FOR IMPORT AND EXPORT AGENCIES IN THE FIELD OF FOOD (U.S. CLS. 100, 101 AND 102).

SAMUEL E. SHARPER JR., EXAMINING ATTORNEY

**CLASS 35—(Continued).**

SN 76-662,760. RENAL PATHOLOGY SOCIETY, ST. LOUIS, MO. FILED 7-10-2006.

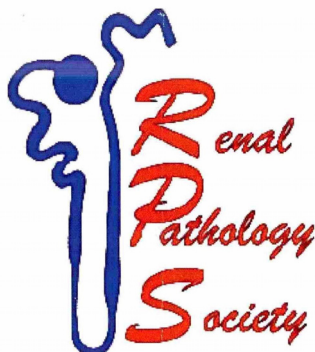

NO CLAIM IS MADE TO THE EXCLUSIVE RIGHT TO USE "RENAL PATHOLOGY SOCIETY", APART FROM THE MARK AS SHOWN.

THE COLOR(S) RED AND BLUE IS/ARE CLAIMED AS A FEATURE OF THE MARK.

THE COLOR BLUE APPEARS IN THE DESIGN OF THE KIDNEY OUTLINE AND THE COLOR RED APPEARS IN THE WORDING "RENAL PATHOLOGY SOCIETY".

THE MARK CONSISTS OF THE OUTLINE OF THE SHAPE OF A HUMAN KIDNEY TO THE LEFT OF THE WORDING "RENAL PATHOLOGY SOCIETY" IN STYLIZED LETTERING.

FOR ASSOCIATION SERVICES, NAMELY, PROMOTING THE INTERESTS OF PROFESSIONALS IN THE FIELD OF RENAL PATHOLOGY (U.S. CLS. 100, 101 AND 102).

FIRST USE 1-1-1986; IN COMMERCE 1-1-1986.

HEATHER THOMPSON, EXAMINING ATTORNEY

SN 76-662,816. RICHMOND ASSOCIATES, LLC, CHEVY CHASE, MD. FILED 7-10-2006.



FOR SHOPPING CENTER SERVICES, NAMELY, BUSINESS MANAGEMENT SERVICES FOR SHOPPING MALLS AND PROMOTING THE GOODS AND SERVICES OF OTHERS BY MEANS OF OPERATING A SHOPPING MALL (U.S. CLS. 100, 101 AND 102).

FIRST USE 7-1-1997; IN COMMERCE 7-1-1997.

BARNEY CHARLON, EXAMINING ATTORNEY

**CLASS 35—(Continued).**

SN 76-664,056. VERTASOURCE, LLC, BUFFALO, NY. FILED 8-3-2006.

**ATLANTAATHOME**

THE MARK CONSISTS OF STANDARD CHARACTERS WITHOUT CLAIM TO ANY PARTICULAR FONT, STYLE, SIZE, OR COLOR.

FOR PROVIDING ADVERTISING AND PUBLICITY SERVICES FOR OTHERS FEATURING INFORMATION ABOUT THE GOODS, SERVICES, EVENTS, ACTIVITIES, AND ATTRACTIONS OF OTHERS, IN A PARTICULAR GEOGRAPHIC REGION, NAMELY ATLANTA, GEORGIA, VIA WEBSITE ON A GLOBAL COMPUTER NETWORK (U.S. CLS. 100, 101 AND 102).

ODESSA BIBBINS, EXAMINING ATTORNEY

SN 76-664,057. VERTASOURCE, LLC, BUFFALO, NY. FILED 8-3-2006.

**PHILADELPHIAATHOME**

THE MARK CONSISTS OF STANDARD CHARACTERS WITHOUT CLAIM TO ANY PARTICULAR FONT, STYLE, SIZE, OR COLOR.

FOR PROVIDING ADVERTISING AND PUBLICITY SERVICES FOR OTHERS FEATURING INFORMATION ABOUT THE GOODS, SERVICES, EVENTS, ACTIVITIES, AND ATTRACTIONS OF OTHERS, IN A PARTICULAR GEOGRAPHIC REGION, NAMELY PHILADELPHIA, PENNSYLVANIA, VIA A WEBSITE ON A GLOBAL COMPUTER NETWORK (U.S. CLS. 100, 101 AND 102).

ODESSA BIBBINS, EXAMINING ATTORNEY

SN 76-665,626. IMEDEX, INC., ALPHARETTA, GA. FILED 9-5-2006.

**MEDEXTRA**

THE MARK CONSISTS OF STANDARD CHARACTERS WITHOUT CLAIM TO ANY PARTICULAR FONT, STYLE, SIZE, OR COLOR.

FOR BUSINESS CONSULTING SERVICES TO PHARMACEUTICAL MANUFACTURERS TO DEVELOP LONG TERM PLANS FOR INTRODUCING NEW PRODUCTS TO HEALTH PROFESSIONALS VIA SEMINARS AND EVENTS (U.S. CLS. 100, 101 AND 102).

WILLIAM P. SHANAHAN, EXAMINING ATTORNEY

**CLASS 35—(Continued).**

SN 76-665,656. BROWN, JOHN, LAGUNA BEACH, CA.  
FILED 9-6-2006.

**EXPERIENCE LAGUNA**

THE MARK CONSISTS OF STANDARD CHARACTERS WITHOUT CLAIM TO ANY PARTICULAR FONT, STYLE, SIZE, OR COLOR.

NO CLAIM IS MADE TO THE EXCLUSIVE RIGHT TO USE "LAGUNA", APART FROM THE MARK AS SHOWN, FOR ADVERTISING SERVICES FOR ART SHOWS, MUSICAL SHOWS, PERFORMANCE ART EVENTS, HOTELS AND RESTAURANTS (U.S. CLS. 100, 101 AND 102).  
REBECCA GILBERT, EXAMINING ATTORNEY

**CLASS 35—(Continued).**

SN 76-665,708. ON-LINE TAXES, INC., ST. JOSEPH, MO.  
FILED 9-7-2006.

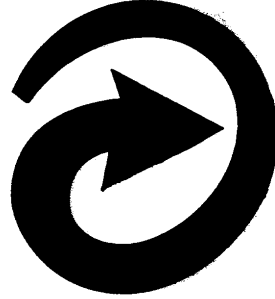

THE MARK CONSISTS OF A STYLIZED REPRESENTATION OF AN "AT SIGN" (@) WITH A CURVED ARROW, FOR INTERNET TAX FILING SERVICES (U.S. CLS. 100, 101 AND 102).  
FIRST USE 12-0-2005; IN COMMERCE 12-0-2005.  
STEVEN JACKSON, EXAMINING ATTORNEY

SN 76-665,709. ON-LINE TAXES, INC., ST. JOSEPH, MO.  
FILED 9-7-2006.

**OLT**

THE MARK CONSISTS OF STANDARD CHARACTERS WITHOUT CLAIM TO ANY PARTICULAR FONT, STYLE, SIZE, OR COLOR.

FOR INTERNET TAX FILING SERVICES (U.S. CLS. 100, 101 AND 102).  
FIRST USE 12-0-2005; IN COMMERCE 12-0-2005.  
STEVEN JACKSON, EXAMINING ATTORNEY

SN 76-665,668. ALLIANCE ABROAD GROUP, L.P., AUSTIN, TX. FILED 9-6-2006.



SN 76-665,744. SAHLGREN, MYLES R., TALLAHASSEE, FL.  
FILED 9-8-2006.

**HIGHER TASTE**

THE MARK CONSISTS OF STANDARD CHARACTERS WITHOUT CLAIM TO ANY PARTICULAR FONT, STYLE, SIZE, OR COLOR.

FOR FRANCHISING, NAMELY, OFFERING TECHNICAL ASSISTANCE IN THE ESTABLISHMENT AND/OR OPERATION OF RETAIL FOOD STORES (U.S. CLS. 100, 101 AND 102).  
FIRST USE 9-7-2006; IN COMMERCE 9-7-2006.  
JOHN DWYER, EXAMINING ATTORNEY

FOR RECRUITING, PLACEMENT, STAFFING AND CAREER NETWORKING SERVICES FOR INTERNSHIP, EMPLOYMENT, TEACHING AND VOLUNTEER OPPORTUNITIES IN THE UNITED STATES AND INTERNATIONALLY (U.S. CLS. 100, 101 AND 102).  
FIRST USE 1-0-2003; IN COMMERCE 1-0-2003.  
KATINA MISTER, EXAMINING ATTORNEY

**CLASS 35—(Continued).**

SN 76-665,745. SAHLGREN, MYLES R., TALLAHASSEE, FL.  
FILED 9-8-2006.

**HIGHER TASTE**

THE MARK CONSISTS OF STANDARD CHARACTERS WITHOUT CLAIM TO ANY PARTICULAR FONT, STYLE, SIZE, OR COLOR.  
FOR RESTAURANT FRANCHISING (U.S. CLS. 100, 101 AND 102).  
FIRST USE 9-7-2006; IN COMMERCE 9-7-2006.  
JOHN DWYER, EXAMINING ATTORNEY

SN 76-665,893. AMERICAN SOCIETY OF HOME INSPECTORS, INC, DES PLAINES, IL. FILED 9-7-2006.

**WE SPEAK HOUSE**

THE MARK CONSISTS OF STANDARD CHARACTERS WITHOUT CLAIM TO ANY PARTICULAR FONT, STYLE, SIZE, OR COLOR.  
FOR DISSEMINATION OF ADVERTISING FOR OTHERS IN THE FIELD OF PROFESSIONAL HOME INSPECTION SERVICES (U.S. CLS. 100, 101 AND 102).  
FIRST USE 11-10-2003; IN COMMERCE 11-10-2003.  
MICHAEL SOUDERS, EXAMINING ATTORNEY

SN 76-666,351. BAND AID TRUST TRUSTEE, AUSTIN, TX.  
FILED 9-20-2006.

**LONGHORN FLEA MARKET**

THE MARK CONSISTS OF STANDARD CHARACTERS WITHOUT CLAIM TO ANY PARTICULAR FONT, STYLE, SIZE, OR COLOR.  
NO CLAIM IS MADE TO THE EXCLUSIVE RIGHT TO USE FLEA MARKET, APART FROM THE MARK AS SHOWN.  
FOR FLEA MARKET (U.S. CLS. 100, 101 AND 102).  
BRIDGETT SMITH, EXAMINING ATTORNEY

**CLASS 35—(Continued).**

SN 76-666,613. SAHLGREN, MYLES R., TALLAHASSEE, FL.  
FILED 9-26-2006.

**ANIMAL KINGDOM**

THE MARK CONSISTS OF STANDARD CHARACTERS WITHOUT CLAIM TO ANY PARTICULAR FONT, STYLE, SIZE, OR COLOR.  
FOR FRANCHISING, NAMELY, OFFERING TECHNICAL ASSISTANCE IN THE ESTABLISHMENT AND/OR OPERATION OF RETAIL FOOD STORES (U.S. CLS. 100, 101 AND 102).  
FIRST USE 12-5-2003; IN COMMERCE 9-21-2006.  
JOHN DWYER, EXAMINING ATTORNEY

SN 76-668,006. ALOHA PETROLEUM, LTD., HONOLULU, HI. FILED 10-25-2006.

**MAHALO**

THE MARK CONSISTS OF STANDARD CHARACTERS WITHOUT CLAIM TO ANY PARTICULAR FONT, STYLE, SIZE, OR COLOR.  
OWNER OF U.S. REG. NO. 3,202,682.  
"MAHALO" IS A HAWAIIAN WORD MEANING "THANK YOU".  
FOR RETAIL GASOLINE SUPPLY SERVICES (U.S. CLS. 100, 101 AND 102).  
FIRST USE 10-17-2003; IN COMMERCE 10-17-2003.  
LINDA LAVACHE, EXAMINING ATTORNEY

SN 77-000,533. NEWEDGE, INC., RICHLAND, WA. FILED 9-15-2006.

**DISRUPTIVE MARKET ACTION**

THE MARK CONSISTS OF STANDARD CHARACTERS WITHOUT CLAIM TO ANY PARTICULAR FONT, STYLE, SIZE, OR COLOR.  
OWNER OF U.S. REG. NO. 3,023,320.  
NO CLAIM IS MADE TO THE EXCLUSIVE RIGHT TO USE "DISRUPTIVE MARKET", APART FROM THE MARK AS SHOWN.  
FOR BUSINESS CONSULTATION AND MANAGEMENT REGARDING MARKETING ACTIVITIES AND LAUNCHING OF NEW PRODUCTS; BUSINESS MARKETING CONSULTING SERVICES; CREATION OF MARKETING TOOLS DESIGNED TO INCREASE A CLIENT COMPANY'S KNOWLEDGE OF CUSTOMER NEEDS, AND ITS COMPETITORS' PRODUCTS AND SERVICES. PRICING, ADVERTISING STRATEGY AND SALES STRATEGY (U.S. CLS. 100, 101 AND 102).  
FIRST USE 3-0-2006; IN COMMERCE 3-0-2006.  
ROSELLE HERRERA, EXAMINING ATTORNEY

**CLASS 35—(Continued).**

SN 77-000,974. NEWEDGE, INC., RICHLAND, WA. FILED 9-15-2006.

**FRONT END INSIGHTS**

THE MARK CONSISTS OF STANDARD CHARACTERS WITHOUT CLAIM TO ANY PARTICULAR FONT, STYLE, SIZE, OR COLOR.  
FOR BUSINESS MARKETING CONSULTING SERVICES; MARKET RESEARCH CONSULTATION; MARKET RESEARCH STUDIES (U.S. CLS. 100, 101 AND 102).  
FIRST USE 6-16-2006; IN COMMERCE 6-16-2006.  
ROSELLE HERRERA, EXAMINING ATTORNEY

SN 77-000,980. NEWEDGE, INC., RICHLAND, WA. FILED 9-15-2006.

**DISRUPTIVE STRATEGY MAPPING**

THE MARK CONSISTS OF STANDARD CHARACTERS WITHOUT CLAIM TO ANY PARTICULAR FONT, STYLE, SIZE, OR COLOR.  
OWNER OF U.S. REG. NO. 3,023,320.  
NO CLAIM IS MADE TO THE EXCLUSIVE RIGHT TO USE "DISRUPTIVE STRATEGY", APART FROM THE MARK AS SHOWN.  
FOR ADVERTISING SERVICES, NAMELY, CREATING CORPORATE AND BRAND IDENTITY FOR OTHERS; BUSINESS MARKETING CONSULTING SERVICES; CREATION OF MARKETING TOOLS DESIGNED TO INCREASE A CLIENT COMPANY'S KNOWLEDGE OF CUSTOMER NEEDS, AND ITS COMPETITORS' PRODUCTS AND SERVICES, PRICING, ADVERTISING STRATEGY AND SALES STRATEGY; MARKET RESEARCH STUDIES; PROVIDING BUSINESS MANAGEMENT INFORMATION IN CONNECTION WITH CONSULTING AND ADVISORY SERVICES IN THE FIELD OF STRATEGIC PLANNING (U.S. CLS. 100, 101 AND 102).  
FIRST USE 9-21-2005; IN COMMERCE 9-21-2005.  
ROSELLE HERRERA, EXAMINING ATTORNEY

SN 77-000,984. NEWEDGE, INC., RICHLAND, WA. FILED 9-15-2006.

**UNMET NEEDS INSIGHTS**

THE MARK CONSISTS OF STANDARD CHARACTERS WITHOUT CLAIM TO ANY PARTICULAR FONT, STYLE, SIZE, OR COLOR.  
FOR BUSINESS MARKETING CONSULTING SERVICES; MARKET RESEARCH CONSULTATION; MARKET RESEARCH STUDIES (U.S. CLS. 100, 101 AND 102).  
FIRST USE 6-16-2006; IN COMMERCE 6-16-2006.  
ROSELLE HERRERA, EXAMINING ATTORNEY

**CLASS 35—(Continued).**

SN 77-001,255. LEE, MICHAEL S., TAMUNING, GUAM, FILED 9-18-2006.



NO CLAIM IS MADE TO THE EXCLUSIVE RIGHT TO USE "HAWAII", APART FROM THE MARK AS SHOWN.  
THE APPLICANT CLAIMS COLOR AS A FEATURE OF THE MARK, NAMELY, BLACK, SILVER, AND RED.  
THE MARK CONSISTS OF THE CAPITAL LETTER S IN BLACK COLOR FOLLOW BY SMALL LETTERS E, A, R, C, H IN SILVER COLOR WHICH IS FOLLOWED BY CAPITAL LETTER M IN BLACK COLOR FOLLOW BY SMALL LETTER E IN SILVER COLOR AND THAT THE CAPITAL LETTER M WITH BLACK COLOR IS WITHIN INSIDE THE CIRCLE THAT IS IN SILVER COLOR FOLLOW BY THE SMALL LETTER E IN SILVER COLOR AND THAT THE CAPITAL LETTER H IN RED COLOR IS ABOVE THE SMALL LETTER E WITH SILVER COLOR AND THAT THE LETTER H IS FOLLOWED BY SMALLER LETTERS A, W, A, I, I IN RED COLOR THAT ARE SURROUNDED WITHIN INSIDE THE SILVER CIRCLE.

FOR ADMINISTRATION OF A DISCOUNT PROGRAM FOR ENABLING PARTICIPANTS TO OBTAIN DISCOUNTS ON GOODS AND SERVICES THROUGH USE OF A DISCOUNT MEMBERSHIP CARD; ADMINISTRATION OF A PROGRAM FOR ENABLING PARTICIPANTS TO OBTAIN DISCOUNTS ON GOODS AND RECEIVE IMPROVED SERVICES; ADVERTISING AGENCIES; ADVERTISING AGENCIES, NAMELY, PROMOTING THE GOODS AND SERVICES OF OTHERS; ADVERTISING AND ADVERTISEMENT SERVICES; ADVERTISING AND BUSINESS ADVICE RELATING TO TELEMATICS' SERVICES; ADVERTISING AND BUSINESS MANAGEMENT CONSULTANCY; ADVERTISING AND BUSINESS SERVICES, NAMELY SECURING AIR-TIME ON ALL FORMS OF MEDIA COMMUNICATIONS STATIONS, SYSTEMS, NETWORKS, AND SERVICES FOR THE PURPOSE OF PROMOTING THE GOODS AND SERVICES OF OTHERS; ADVERTISING AND COMMERCIAL INFORMATION SERVICES, VIA THE INTERNET; ADVERTISING AND MARKETING; ADVERTISING AND PROMOTION SERVICES AND RELATED CONSULTING; ADVERTISING AND PUBLICITY SERVICES, NAMELY, PROMOTING THE GOODS, SERVICES, BRAND IDENTITY AND COMMERCIAL INFORMATION AND NEWS OF THIRD PARTIES THROUGH PRINT, AUDIO, VIDEO, DIGITAL AND ON-LINE MEDIUM; ADVERTISING BUSINESS ESPECIALLY IN THE FIELD OF TELEMATIC AND TELEPHONE NETWORKS; ADVERTISING CONSULTATION; ADVERTISING FLYER DISTRIBUTION; ADVERTISING, MARKETING AND PROMOTION SERVICES; AGENCIES FOR ADVERTISING TIME AND SPACE; COMPUTERIZED ON-LINE RETAIL STORE SERVICES IN THE FIELD OF MUSIC FEATURING AUDIO AND VIDEO RECORD, TAPES, CDS, BOOKS, VIDEO AND MAGAZINE; COOPERATIVE ADVERTISING AND MARKETING; CREATING AND UPDATING ADVERTISING MATERIAL; DISPLAYING ADVERTISEMENTS FOR OTHERS; DISSEMINATION OF ADVERTISING FOR OTHERS VIA AN ON-LINE COMMUNICATIONS NETWORK ON THE INTERNET; DISSEMINATION OF ADVERTISING FOR OTHERS VIA THE INTERNET; MARKETING SERVICES, NAMELY PROVIDING INFORMATIONAL WEB PAGES DESIGNED TO GENERATE SALES TRAFFIC VIA HYPERLINKS TO OTHER WEB SITES; ON-LINE ADVERTISING AND MARKETING SERVICES; ON-LINE ADVERTISING ON COMPUTER COMMUNICATION NETWORKS; ON-LINE CONSIGNMENT SERVICES WHEREBY GOODS ARE RECEIVED ON CONSIGNMENT FOR AUCTION ON AN ONLINE AUCTION SITE; ONLINE BUSINESS NETWORKING SERVICES; PLACING ADVERTISEMENTS FOR OTHERS; PREPARATION AND REALIZATION OF MEDIA AND ADVERTISING PLANS AND CONCEPTS; PREPARING ADVERTISEMENTS FOR OTHERS; PREPARING AND PLACING ADVERTISEMENTS FOR

**CLASS 35—(Continued).**

OTHERS; PROMOTING THE GOODS AND SERVICES OF OTHERS BY DISTRIBUTING ADVERTISING MATERIALS THROUGH A VARIETY OF METHODS; PROMOTING THE GOODS AND SERVICES OF OTHERS BY MEANS OF OPERATING AN ON-LINE SHOPPING MALL WITH LINKS TO THE RETAIL WEB SITES OF OTHERS; PROMOTING THE GOODS AND SERVICES OF OTHERS BY PREPARING AND PLACING ADVERTISEMENTS IN AN ELECTRONIC MAGAZINE ACCESSED THROUGH A GLOBAL COMPUTER NETWORK; PROMOTING THE GOODS AND SERVICES OF OTHERS THROUGH THE DISTRIBUTION OF DISCOUNT CARDS; PROMOTING THE SALE OF CREDIT CARD ACCOUNTS THROUGH THE ADMINISTRATION OF INCENTIVE AWARD PROGRAMS; PROMOTING, ADVERTISING AND MARKETING OF THE ON-LINE WEBSITES OF OTHERS; PROVIDING A SEARCHABLE ONLINE ADVERTISING GUIDE FEATURING THE GOODS AND SERVICES OF OTHER ON-LINE VENDORS ON THE INTERNET; PROVIDING A WEB SITE AT WHICH USERS CAN OFFER GOODS FOR SALE AND BUY GOODS OFFERED BY OTHERS; PROVIDING A WEB SITE THAT ENABLES USERS TO POST ITEMS FOR SALE THROUGH ON-LINE CLASSIFIED ADVERTISEMENTS; PROVIDING A WEB SITE WHICH FEATURES ADVERTISEMENTS FOR THE GOODS AND SERVICES OF OTHERS ON A GLOBAL COMPUTER NETWORK; PROVIDING AN ON-LINE SEARCHABLE DATABASE FEATURING CLASSIFIED AD LISTINGS AND EMPLOYMENT OPPORTUNITIES; PROVIDING AND RENTAL OF ADVERTISING SPACE ON THE INTERNET; PROVIDING SPACE AT A WEB SITE FOR THE ADVERTISEMENT OF THE GOODS AND SERVICES OF OTHERS; PROVISION OF ADVERTISING SPACE BY ELECTRONIC MEANS AND GLOBAL INFORMATION NETWORKS; REAL ESTATE ADVERTISING SERVICES; RENTAL OF ADVERTISING SPACE ON WEB SITES; SALES PROMOTION FOR OTHERS PROVIDED THROUGH THE DISTRIBUTION AND THE ADMINISTRATION OF PRIVILEGED USER CARDS (U.S. CLS. 100, 101 AND 102).

JAY FLOWERS, EXAMINING ATTORNEY

SN 77-001,980. INTERLOCKING CONCRETE PAVEMENT INSTITUTE, WASHINGTON, DC. FILED 9-19-2006.



NO CLAIM IS MADE TO THE EXCLUSIVE RIGHT TO USE "HARDSCAPE NORTH AMERICA", APART FROM THE MARK AS SHOWN.

FOR ARRANGING AND CONDUCTING TRADE SHOWS IN THE FIELD OF LANDSCAPING (U.S. CLS. 100, 101 AND 102).

FIRST USE 7-10-2006; IN COMMERCE 7-10-2006.  
TAMARA LEE, EXAMINING ATTORNEY

**CLASS 35—(Continued).**

SN 77-005,148. UNITED STATES POSTAL SERVICE, WASHINGTON, DC. FILED 9-22-2006.

## AEC II

THE MARK CONSISTS OF STANDARD CHARACTERS WITHOUT CLAIM TO ANY PARTICULAR FONT, STYLE, SIZE, OR COLOR.

FOR PROVIDING ADDRESS CORRECTION AND UPDATING SERVICES FOR MAILERS (U.S. CLS. 100, 101 AND 102).

FIRST USE 10-0-2004; IN COMMERCE 10-0-2004.  
JEFFERY COWARD, EXAMINING ATTORNEY

SN 77-008,244. CITI-ADVERTISING, INC., GLENDALE, CA. FILED 9-27-2006.

## CITI-MOBILE

THE MARK CONSISTS OF STANDARD CHARACTERS WITHOUT CLAIM TO ANY PARTICULAR FONT, STYLE, SIZE, OR COLOR.

FOR ADVERTISING SERVICES; DISPLAYING ADVERTISEMENTS FOR OTHERS (U.S. CLS. 100, 101 AND 102).

FIRST USE 6-3-2003; IN COMMERCE 6-3-2003.  
RAUL CORDOVA, EXAMINING ATTORNEY

SN 77-011,074. MARKETERS BEEHIVE, LLC, OCEAN BEACH, NY. FILED 9-29-2006.

## Marketers Beehive

THE MARK CONSISTS OF STANDARD CHARACTERS WITHOUT CLAIM TO ANY PARTICULAR FONT, STYLE, SIZE, OR COLOR.

NO CLAIM IS MADE TO THE EXCLUSIVE RIGHT TO USE "MARKETERS", APART FROM THE MARK AS SHOWN.

FOR PROVIDING A WEBSITE FEATURING INFORMATION IN THE FIELD OF PERSONNEL RECRUITMENT AND MARKETING (U.S. CLS. 100, 101 AND 102).  
KAELIE KUNG, EXAMINING ATTORNEY



**CLASS 35—(Continued).**

SN 77-011,085. MARKETERS BEEHIVE, LLC, OCEAN BEACH, NY. FILED 9-29-2006.

**CLASS 35—(Continued).**

SN 77-020,290. SHOPPING STAND, INC., SANTA ROSA, CA. FILED 10-12-2006.



## Catch the Buzz

THE MARK CONSISTS OF STANDARD CHARACTERS WITHOUT CLAIM TO ANY PARTICULAR FONT, STYLE, SIZE, OR COLOR.

FOR PROVIDING ONLINE INFORMATION IN THE FIELD OF PERSONNEL RECRUITMENT AND MARKETING (U.S. CLS. 100, 101 AND 102).

KAELIE KUNG, EXAMINING ATTORNEY

NO CLAIM IS MADE TO THE EXCLUSIVE RIGHT TO USE "WEDDING", APART FROM THE MARK AS SHOWN.

THE MARK CONSISTS OF THE STYLIZED WORDS "WEDDING STAND" AND THE DESIGN OF A GIFT BOX.

FOR ON-LINE RETAIL STORE SERVICES FEATURING MERCHANDISE, GIFTS AND ACCESSORIES FOR BRIDES, BRIDESMAIDS, GROOMSMEN, BRIDAL SHOWERS, WEDDINGS, AND WEDDING PARTIES, NAMELY, BATH AND SPA ACCESSORIES, CANDLES, WEDDING FAVORS, FAVOR BOXES, FAVOR BAGS, TABLEWARE, GLASSWARE, CDS, DVDS, DECORATIVE MAGNETS, JEWELRY, JEWELRY BOXES, CUFFLINKS, PICTURE FRAMES, KEY HOLDERS, FLASHLIGHTS, POCKET TOOLS, FLASKS, WINE BOXES, BAR AND WINE ACCESSORIES, WEDDING CARDS, GIFT CARDS, GREETING CARDS, BINGO AND PLAYING CARDS, PHOTO ALBUMS, BOOKS, STATIONERY, STICKERS, NOTEBOOKS, JOURNAL BOOKS, TISSUE PAPER, GIFT BAGS, TOILETRY BAGS, TRAVEL BAGS, CARRYING BAGS, PURSES, BACKPACKS, LUGGAGE ACCESSORIES, HANGERS, BASKETS, FLOWER BASKETS, GIFT BASKETS, FURNITURE, COMPACT MIRRORS, PILLOWS, PERSONAL GROOMING ITEMS, COMBS, CLOTHING, FOOTWEAR, HEADGEAR, HANDKERCHIEFS, HAIR PINS, GAMES, AND SPORTING GOODS (U.S. CLS. 100, 101 AND 102).

FIRST USE 5-31-2002; IN COMMERCE 5-31-2002.

KATHLEEN M. VANSTON, EXAMINING ATTORNEY

SN 77-012,152. LIME MEDIA LLC, ROWLETT, TX. FILED 10-3-2006.

SN 77-021,928. SUNSHINE, CATHY S, DENVER, CO. FILED 10-16-2006.

## Advertise Out of the Box

THE MARK CONSISTS OF STANDARD CHARACTERS WITHOUT CLAIM TO ANY PARTICULAR FONT, STYLE, SIZE, OR COLOR.

FOR ADVERTISING SERVICES IN THE NATURE OF PROMOTING THE GOODS AND SERVICES OF OTHERS BY MEANS OF MOVABLE OR MOBILE BILLBOARDS MOUNTED ON TRUCKS, SCOOTERS, SEGWAYS AND/OR OTHER MOBILE DEVICES ALONG TRAFFIC ROUTES AND AT PUBLIC EVENTS (U.S. CLS. 100, 101 AND 102).

FIRST USE 9-10-2006; IN COMMERCE 9-10-2006.

SETH A. RAPPAPORT, EXAMINING ATTORNEY

THE MARK CONSISTS OF STANDARD CHARACTERS WITHOUT CLAIM TO ANY PARTICULAR FONT, STYLE, SIZE, OR COLOR.

NO CLAIM IS MADE TO THE EXCLUSIVE RIGHT TO USE "BUSINESS", APART FROM THE MARK AS SHOWN.

FOR ADVERTISING AND BUSINESS MANAGEMENT CONSULTANCY; BUSINESS MANAGEMENT CONSULTANCY AND ADVISORY SERVICES; BUSINESS MANAGEMENT CONSULTANCY AS WELL AS DEVELOPMENT OF PROCESSES FOR THE ANALYSIS AND THE IMPLEMENTATION OF STRATEGY PLANS AND MANAGEMENT PROJECTS; BUSINESS MANAGEMENT CONSULTANCY SERVICES; BUSINESS MANAGEMENT CONSULTATION; BUSINESS MANAGEMENT CONSULTATION IN THE FIELD OF EXECUTIVE AND LEADERSHIP DEVELOPMENT; BUSINESS MANAGEMENT CONSULTING AND ADVISORY SERVICES; BUSINESS MANAGEMENT CONSULTING WITH RELATION TO STRATEGY, MARKETING, PRODUCTION, PERSONNEL AND RETAIL SALE MATTERS; BUSINESS ORGANISATION AND MANAGEMENT CONSULTING SERVICES (U.S. CLS. 100, 101 AND 102).

BRIAN NEVILLE, EXAMINING ATTORNEY

## Throughput Business

**CLASS 35—(Continued).**

SN 77-022,280. TAYLOR CHEMICAL COMPANY, DBA TAYLOR SCIENTIFIC, ST. LOUIS, MO. FILED 10-16-2006.

### Your Partner in Tomorrow's Scientific Future

THE MARK CONSISTS OF STANDARD CHARACTERS WITHOUT CLAIM TO ANY PARTICULAR FONT, STYLE, SIZE, OR COLOR.

FOR DISTRIBUTORSHIPS IN THE FIELD OF LABORATORY SUPPLIES, EQUIPMENT AND CHEMICALS (U.S. CLS. 100, 101 AND 102).

ALEX KEAM, EXAMINING ATTORNEY

---

SN 77-025,080. HILBIG, CARLA, THE WOODLANDS, TX. FILED 10-19-2006.

### PERFORMANCE COURT COUTURE

THE MARK CONSISTS OF STANDARD CHARACTERS WITHOUT CLAIM TO ANY PARTICULAR FONT, STYLE, SIZE, OR COLOR.

NO CLAIM IS MADE TO THE EXCLUSIVE RIGHT TO USE COUTURE, APART FROM THE MARK AS SHOWN.

FOR ON-LINE RETAIL STORE SERVICES FEATURING WOMEN'S ATHLETIC CLOTHING (U.S. CLS. 100, 101 AND 102).

GINNY ISAACSON, EXAMINING ATTORNEY

---

SN 77-025,454. SARVER, JOHN T., ROSWELL, GA. FILED 10-19-2006.

### HOTEL FITNESS

THE MARK CONSISTS OF STANDARD CHARACTERS WITHOUT CLAIM TO ANY PARTICULAR FONT, STYLE, SIZE, OR COLOR.

SEC. 2(F).

FOR DISTRIBUTORSHIPS FEATURING EXERCISE EQUIPMENT, NAMELY, EXERCISE WEIGHTS, EXERCISE BARS, EXERCISE BENCHES, WEIGHT LIFTING MACHINES, STAIR-STEPPING MACHINES, JOGGING MACHINES, ROWING MACHINES, CYCLING MACHINES, TREADMILLS FOR RUNNING, AND EXERCISE EQUIPMENT FOR LATERAL MOVEMENT IN A SKATING MOTION, AND GAMES, NAMELY, BASKETBALL GOAL SETS (U.S. CLS. 100, 101 AND 102).

FIRST USE 8-0-1998; IN COMMERCE 8-0-1998.

JILL C. ALT, EXAMINING ATTORNEY

**CLASS 35—(Continued).**

SN 77-025,647. INDRIOLO DISTRIBUTORS, INC., WARRENSVILLE HEIGHTS, OH. FILED 10-20-2006.

### BRINGING OUR NEIGHBORHOOD TO YOUR KITCHEN

THE MARK CONSISTS OF STANDARD CHARACTERS WITHOUT CLAIM TO ANY PARTICULAR FONT, STYLE, SIZE, OR COLOR.

FOR VENDING IN THE FIELD OF PROCESSED FOOD, NAMELY PASTA, PASTA SAUCE, CHEESE, PIZZA, AND PIZZA SAUCE (U.S. CLS. 100, 101 AND 102).

FIRST USE 5-1-2006; IN COMMERCE 5-1-2006.

NAKWAMA ANKRAH, EXAMINING ATTORNEY

---

SN 77-028,044. RIGHT MEDIA INC., NEW YORK, NY. FILED 10-24-2006.



THE MARK CONSISTS OF STANDARD CHARACTERS WITHOUT CLAIM TO ANY PARTICULAR FONT, STYLE, SIZE, OR COLOR.

OWNER OF U.S. REG. NOS. 2,983,347, 3,194,112 AND 3,194,124.

FOR ADVERTISING SERVICES, NAMELY, PROVIDING A WEBSITE FOR THE MANAGEMENT OF ONLINE ADVERTISING CAMPAIGNS FOR OTHERS; PROVIDING ADVERTISING INFORMATION VIA A WEBSITE (U.S. CLS. 100, 101 AND 102).

FIRST USE 10-2-2006; IN COMMERCE 10-2-2006.

ANDREA EVANS, EXAMINING ATTORNEY

**CLASS 35—(Continued).**

SN 77-029,144. DAVIDSON, DANIEL L., MIAMI BEACH, FL. FILED 10-25-2006.

**BRAND GLAND**

THE MARK CONSISTS OF STANDARD CHARACTERS WITHOUT CLAIM TO ANY PARTICULAR FONT, STYLE, SIZE, OR COLOR.

NO CLAIM IS MADE TO THE EXCLUSIVE RIGHT TO USE "BRAND", APART FROM THE MARK AS SHOWN.

FOR BUSINESS MANAGEMENT, RESEARCH AND STRATEGIC CONSULTING SERVICES IN THE FIELD OF ADVERTISING, PROMOTIONS, PUBLIC RELATIONS, MARKETING AND COMMUNICATIONS, INTERACTIVE MEDIA, DIGITAL MEDIA, DESIGN, PRODUCTION, MEDIA PLANNING AND BUYING, BRAND CONSULTING, DIRECT MARKETING ADVERTISING, CUSTOMER RELATIONSHIP MARKETING, ENTERTAINMENT MARKETING, SPORTS MARKETING AND EVENT MARKETING (U.S. CLS. 100, 101 AND 102).

JOHN GARTNER, EXAMINING ATTORNEY

SN 77-033,304. ALLIANCE TRADING, INC., COVINGTON, LA. FILED 10-31-2006.

**SCP**

THE MARK CONSISTS OF STANDARD CHARACTERS WITHOUT CLAIM TO ANY PARTICULAR FONT, STYLE, SIZE, OR COLOR.

FOR DISTRIBUTORSHIP SERVICES IN THE FIELD OF SWIMMING POOLS AND SPAS, SWIMMING POOL AND SPA COMPONENTS, SWIMMING POOL AND SPA ACCESSORIES, MAINTENANCE AND SAFETY EQUIPMENT, IRRIGATION PRODUCTS, LANDSCAPING PRODUCTS, CONSTRUCTION MATERIALS, OUTDOOR LEISURE PRODUCTS, GRILLS AND OUTDOOR FURNITURE (U.S. CLS. 100, 101 AND 102).

FIRST USE 0-0-1982; IN COMMERCE 0-0-1982.

TASHIA BUNCH, EXAMINING ATTORNEY

**CLASS 35—(Continued).**

SN 77-034,491. SUNSHINE, CATHY S, DENVER, CO. FILED 11-1-2006.

**Organizational Throughput**

THE MARK CONSISTS OF STANDARD CHARACTERS WITHOUT CLAIM TO ANY PARTICULAR FONT, STYLE, SIZE, OR COLOR.

NO CLAIM IS MADE TO THE EXCLUSIVE RIGHT TO USE "ORGANIZATIONAL", APART FROM THE MARK AS SHOWN.

FOR BUSINESS MANAGEMENT CONSULTANCY AND ADVISORY SERVICES; BUSINESS MANAGEMENT CONSULTANCY AS WELL AS DEVELOPMENT OF PROCESSES FOR THE ANALYSIS AND THE IMPLEMENTATION OF STRATEGY PLANS AND MANAGEMENT PROJECTS; BUSINESS MANAGEMENT CONSULTANCY SERVICES; BUSINESS MANAGEMENT CONSULTATION; BUSINESS MANAGEMENT CONSULTATION IN THE FIELD OF EXECUTIVE AND LEADERSHIP DEVELOPMENT; BUSINESS MANAGEMENT CONSULTING AND ADVISORY SERVICES; BUSINESS MANAGEMENT CONSULTING WITH RELATION TO STRATEGY, MARKETING, PRODUCTION, PERSONNEL AND RETAIL SALE MATTERS; BUSINESS ORGANISATION AND MANAGEMENT CONSULTING SERVICES (U.S. CLS. 100, 101 AND 102).

BRIAN NEVILLE, EXAMINING ATTORNEY

SN 77-036,478. INTERNATIONAL TRUCK INTELLECTUAL PROPERTY COMPANY, LLC, AURORA, IL. FILED 11-3-2006.



NO CLAIM IS MADE TO THE EXCLUSIVE RIGHT TO USE "PARTS AND SERVICE", APART FROM THE MARK AS SHOWN.

FOR DIRECT MARKETING SERVICES IN THE FIELD OF VEHICLE PARTS AND REPAIR (U.S. CLS. 100, 101 AND 102).

MICHELLE DUBOIS, EXAMINING ATTORNEY

SN 77-038,251. FISERV, INC., BROOKFIELD, WI. FILED 11-7-2006.

**YOU ARE THE ONLY YOU**

THE MARK CONSISTS OF STANDARD CHARACTERS WITHOUT CLAIM TO ANY PARTICULAR FONT, STYLE, SIZE, OR COLOR.

FOR PROVIDING CONSUMER CREDIT MONITORING SERVICES (U.S. CLS. 100, 101 AND 102).

LAURIE MAYES, EXAMINING ATTORNEY

**CLASS 35—(Continued).**

SN 77-039,695. PELOQUIN, MICHAEL M., PARADISE VALLEY, AZ. FILED 11-8-2006.



THE MARK CONSISTS OF A SILHOUETTE OF A PAIR OF EARPHONES WITHIN A CIRCLE.  
 FOR ON-LINE RETAIL STORE SERVICES FEATURING DOWNLOADABLE PRE-RECORDED MUSIC AND VIDEO (U.S. CLS. 100, 101 AND 102).  
 TARAH HARDY, EXAMINING ATTORNEY

**CLASS 35—(Continued).**

SN 77-049,013. CENTRIC GROUP, LLC, ST. LOUIS, MO. FILED 11-21-2006.



FOR WHOLESALE DISTRIBUTORSHIPS, WHOLESALE ORDERING SERVICES AND RETAIL STORE SERVICES IN THE FIELD OF GOODS SOLD BY INSTITUTIONAL COMMISSARIES (U.S. CLS. 100, 101 AND 102).  
 FIRST USE 5-1-2005; IN COMMERCE 5-1-2005.  
 INGA ERVIN, EXAMINING ATTORNEY

SN 77-042,667. FANNIE MAE FOUNDATION, WASHINGTON, DC. FILED 11-13-2006.

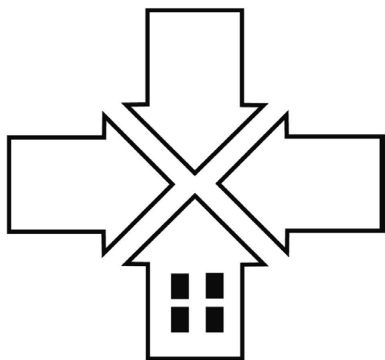

THE MARK CONSISTS OF FOUR ARROWS POINTING INWARDS WITH THE BOTTOM ARROW RESEMBLING A HOUSE.  
 FOR PROVIDING BUSINESS AND MARKET RESEARCH INFORMATION IN THE NATURE OF HOUSING AND DEMOGRAPHIC DATA (U.S. CLS. 100, 101 AND 102).  
 FIRST USE 12-1-2004; IN COMMERCE 12-1-2004.  
 ATTIYA MALIK, EXAMINING ATTORNEY

SN 77-050,403. TESSCO COMMUNICATIONS INCORPORATED, HUNT VALLEY, MD. FILED 11-24-2006.

**WIRED INTO EVERYTHING  
 WIRELESS**

THE MARK CONSISTS OF STANDARD CHARACTERS WITHOUT CLAIM TO ANY PARTICULAR FONT, STYLE, SIZE, OR COLOR.  
 NO CLAIM IS MADE TO THE EXCLUSIVE RIGHT TO USE "WIRELESS", APART FROM THE MARK AS SHOWN.  
 FOR WHOLESALE AND RETAIL DISTRIBUTORSHIPS IN THE FIELD OF TELECOMMUNICATIONS; AND BUSINESS CONSULTING SERVICES RELATING TO SUPPLY CHAIN SOLUTIONS TO THE PROFESSIONALS THAT DESIGN, BUILD, RUN, USE AND MAINTAIN WIRELESS VOICE, DATA, MESSAGING, LOCATION TRACKING AND INTERNET SYSTEMS (U.S. CLS. 100, 101 AND 102).  
 NAAKWAMA ANKRAH, EXAMINING ATTORNEY

**CLASS 35—(Continued).**

SN 77-050,810. EVO SOLUTIONS, L.P., AMARILLO, TX. FILED 11-27-2006.



NO CLAIM IS MADE TO THE EXCLUSIVE RIGHT TO USE "BUSINESS SOLUTIONS", APART FROM THE MARK AS SHOWN.

THE APPLICANT CLAIMS COLOR AS A FEATURE OF THE MARK, NAMELY, GRAY, RED, AND BLACK.

THE MARK CONSISTS OF THE WORD "EVO" INSCRIBED IN GRAY, ABOVE THE WORDS "BUSINESS SOLUTIONS" INSCRIBED IN BLACK, WITH ONE LONG RED LINE AND FOUR SHORTER RED LINES TO THE LEFT OF THE WORD "EVO" AND A GRAY ARROW BEGINNING BELOW THE LOWEST RED LINE AND POINTING UP TO THE LONG RED LINE.

FOR PROMOTING THE GOODS AND SERVICES OF OTHERS THROUGH SEARCH ENGINE REFERRAL TRAFFIC ANALYSIS AND REPORTING (U.S. CLS. 100, 101 AND 102).

FIRST USE 9-1-2006; IN COMMERCE 9-1-2006.  
CHRISIE B. KING, EXAMINING ATTORNEY

SN 77-058,539. ALLERGAN, INC., IRVINE, CA. FILED 12-6-2006.



OWNER OF U.S. REG. NOS. 3,163,917 AND 3,163,922.  
NO CLAIM IS MADE TO THE EXCLUSIVE RIGHT TO USE "REWARDS", APART FROM THE MARK AS SHOWN.  
FOR CUSTOMER INCENTIVE AWARD PROGRAM TO PROMOTE CUSTOMER LOYALTY WHICH PROVIDES INCENTIVES AND REWARDS FOR FREQUENT PURCHASES OF OPHTHALMIC RELATED PRESCRIPTION PRODUCTS (U.S. CLS. 100, 101 AND 102).  
ALEX KEAM, EXAMINING ATTORNEY

SN 77-060,007. COOPERVISION, INC., PLEASANTON, CA. FILED 12-8-2006.

## GOTLENSES.COM

THE MARK CONSISTS OF STANDARD CHARACTERS WITHOUT CLAIM TO ANY PARTICULAR FONT, STYLE, SIZE, OR COLOR.

FOR ONLINE RETAIL STORE SERVICES FEATURING CONTACT LENSES; AND ONLINE RETAIL STORE SERVICES FEATURING CONTACT LENSES IN WHICH ORDERS ARE PLACED BY TELEPHONE (U.S. CLS. 100, 101 AND 102).

FIRST USE 1-11-2004; IN COMMERCE 1-11-2004.  
KATHERINE CHANG, EXAMINING ATTORNEY

**CLASS 35—(Continued).**

SN 77-062,635. RIGHT MEDIA INC., NEW YORK, NY. FILED 12-12-2006.

## Remix Media

THE MARK CONSISTS OF STANDARD CHARACTERS WITHOUT CLAIM TO ANY PARTICULAR FONT, STYLE, SIZE, OR COLOR.

NO CLAIM IS MADE TO THE EXCLUSIVE RIGHT TO USE "MEDIA", APART FROM THE MARK AS SHOWN.

FOR ADVERTISING SERVICES, NAMELY PROVIDING AN ONLINE ADVERTISING NETWORK FOR BUYING AND SELLING ONLINE ADVERTISING IMPRESSIONS, FOR MANAGING ONLINE ADVERTISING CAMPAIGNS, AND FOR TARGETING CONSUMERS; DISSEMINATING ADVERTISING FOR OTHERS VIA THE INTERNET (U.S. CLS. 100, 101 AND 102).

FIRST USE 12-4-2006; IN COMMERCE 12-4-2006.  
ANDREA EVANS, EXAMINING ATTORNEY

SN 77-063,116. RIGHT MEDIA INC., NEW YORK, NY. FILED 12-13-2006.



NO CLAIM IS MADE TO THE EXCLUSIVE RIGHT TO USE "MEDIA", APART FROM THE MARK AS SHOWN.

THE MARK CONSISTS OF THE WORDING "REMIX MEDIA", WITH "MEDIA" APPEARING BELOW "REMIX", AND A TRIANGLE APPEARING TO THE RIGHT OF "REMIX".

FOR ADVERTISING SERVICES, NAMELY PROVIDING AN ONLINE ADVERTISING NETWORK FOR BUYING AND SELLING ONLINE ADVERTISING IMPRESSIONS, FOR MANAGING ONLINE ADVERTISING CAMPAIGNS, AND FOR TARGETING CONSUMERS; DISSEMINATING ADVERTISING FOR OTHERS VIA THE INTERNET (U.S. CLS. 100, 101 AND 102).

FIRST USE 12-4-2006; IN COMMERCE 12-4-2006.  
ANDREA EVANS, EXAMINING ATTORNEY

SN 77-069,113. MADDOCK DOUGLAS, INC., ELMHURST, IL. FILED 12-21-2006.

## MOMENTOUS

THE MARK CONSISTS OF STANDARD CHARACTERS WITHOUT CLAIM TO ANY PARTICULAR FONT, STYLE, SIZE, OR COLOR.

FOR ADVERTISING AGENCY SERVICES; ADVERTISING AGENCY SERVICES, NAMELY CREATING CORPORATE AND BRAND IDENTITIES FOR OTHERS (U.S. CLS. 100, 101 AND 102).

FIRST USE 10-0-2006; IN COMMERCE 10-0-2006.  
CHARLES L. JENKINS, EXAMINING ATTORNEY

**CLASS 35—(Continued).**

SN 78-480,678. THE MCWILLIAMS GROUP L.L.C., PITTSBURGH, PA. FILED 9-9-2004.

## The Sounding Board of TMcWG

THE MARK CONSISTS OF STANDARD CHARACTERS WITHOUT CLAIM TO ANY PARTICULAR FONT, STYLE, SIZE, OR COLOR.

FOR BUSINESS CONSULTING SERVICES FOR ENTITIES ENGAGED IN NON-PROFIT ACTIVITIES OR ENGAGED IN FUNDING NON-PROFIT ACTIVITIES (U.S. CLS. 100, 101 AND 102).

MICHELLE DUBOIS, EXAMINING ATTORNEY

**CLASS 35—(Continued).**

SN 78-531,859. LEE, CRYSTAL ANNTOINETTE, LONG BEACH, CA. FILED 12-13-2004.



NO CLAIM IS MADE TO THE EXCLUSIVE RIGHT TO USE "TOYS", APART FROM THE MARK AS SHOWN.

THE COLORS RED, BLACK AND WHITE ARE CLAIMED AS A FEATURE OF THE MARK.

THE WORDING AND THE TWO CURVED DESIGNS ARE IN RED AND WHITE. THE RECTANGULAR BACKGROUND DESIGN IS IN BLACK.

THE MARK CONSISTS OF THE WORDS PHAT TOYS AND TWO CURVED DESIGNS. THE WORDING AND THE TWO CURVED DESIGNS ARE ENCLOSED WITHIN A RECTANGULAR BACKGROUND DESIGN.

FOR RETAIL STORE SERVICES FEATURING SEXUAL AIDS, ADULT TOYS, MOVIES AND GAG GIFTS (U.S. CLS. 100, 101 AND 102).

FIRST USE 2-28-2003; IN COMMERCE 2-28-2003.

NANCY CLARKE, EXAMINING ATTORNEY

SN 78-549,702. BEVERLY ENTERPRISES, INC., FORT SMITH, AR. FILED 1-19-2005.

SN 78-521,042. CALIBER POINT BUSINESS SOLUTIONS LIMITED, MAHAPE, NAVI MUMBAI 400 710, INDIA, FILED 11-22-2004.

## CALIBER POINT

BUSINESS SOLUTIONS LTD.



NO CLAIM IS MADE TO THE EXCLUSIVE RIGHT TO USE "BUSINESS SOLUTIONS LTD.", APART FROM THE MARK AS SHOWN.

FOR OUTSOURCING IN THE FIELD OF OFFICE AND BUSINESS ADMINISTRATION SERVICES; DATA PROCESSING SERVICES; COLLECTION, PREPARATION, COMPOSITION, STORAGE, PROCESSING, ACQUISITION AND PROVISION OF BUSINESS INFORMATION, DATA, STATISTICS AND INDICES; PROVIDING STATISTICAL INFORMATION FOR BUSINESS OR COMMERCIAL PURPOSES; SERVICES COMPRISING THE RECORDING, TRANSCRIPTION, COMPOSITION, COMPILATION AND SYSTEMATIZATION OF WRITTEN COMMUNICATIONS AND RECORDINGS, AS WELL AS THE COMPILATION OF MATHEMATICAL OR STATISTICAL DATA; BUSINESS ADMINISTRATION AND MANAGEMENT (U.S. CLS. 100, 101 AND 102).

LOURDES AYALA, EXAMINING ATTORNEY

OWNER OF U.S. REG. NOS. 1,448,983, 2,358,275 AND 2,570,330.

NO CLAIM IS MADE TO THE EXCLUSIVE RIGHT TO USE "ENTERPRISES AUTOMATED CLEARINGHOUSE", APART FROM THE MARK AS SHOWN.

THE MARK CONSISTS OF TWO STYLIZED, OFFSET ARCS FOLLOWED BY LOWERCASE LETTERS "BEACH" ABOVE THE WORDS "BEVERLY ENTERPRISES AUTOMATED CLEARINGHOUSE", ALL IN LOWER CASE.

FOR PURCHASING AND PROCUREMENT SERVICES, NAMELY, PROCURING OF CONTRACTS FOR OTHERS FOR THE PURCHASE OF GOODS AND LABOR CONTRACTING SERVICES IN THE FIELD OF HEALTH-CARE (U.S. CLS. 100, 101 AND 102).

GINA HAYES, EXAMINING ATTORNEY

**CLASS 35—(Continued).**

SN 78-552,900. PRUDENTIAL OVERALL SUPPLY, IRVINE, CA. FILED 1-24-2005.

**CLASS 35—(Continued).**

SN 78-583,774. MAKO SECURITY, INC., NEW YORK, NY. FILED 3-9-2005.

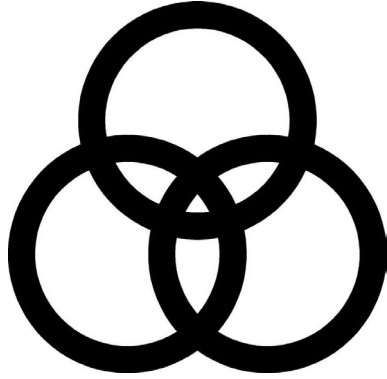

**MAKO TACTICAL**

THE MARK CONSISTS OF THREE CIRCLES, ONE ON TOP AND TWO UNDERNEATH, WITH THE ONE ON TOP BEING CENTERED BETWEEN THE TWO ON THE BOTTOM. ALL CIRCLES BEING CONNECTED.

FOR MARKETING UNIFORM RENTAL SERVICES OF OTHERS (U.S. CLS. 100, 101 AND 102).

FIRST USE 2-28-2005; IN COMMERCE 2-28-2005.  
TEJBIR SINGH, EXAMINING ATTORNEY

THE MARK CONSISTS OF STANDARD CHARACTERS WITHOUT CLAIM TO ANY PARTICULAR FONT, STYLE, SIZE, OR COLOR.

NO CLAIM IS MADE TO THE EXCLUSIVE RIGHT TO USE "TACTICAL", APART FROM THE MARK AS SHOWN.

FOR ON-LINE RETAIL STORE SERVICES FEATURING SECURITY SERVICES, WEAPONS, AND PROTECTIVE GEAR (U.S. CLS. 100, 101 AND 102).

FIRST USE 12-8-2003; IN COMMERCE 12-8-2003.  
LEIGH LOWRY, EXAMINING ATTORNEY

SN 78-562,429. SCHAFFER PARTNERS, INC., CLEVELAND, OH. FILED 2-8-2005.

SN 78-591,897. ACUITY CONSULTING, INC., CYPRESS, CA. FILED 3-21-2005.

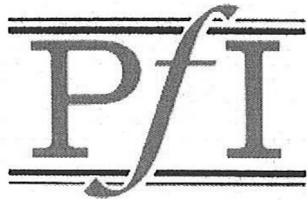

FOR CONDUCTING CONTESTS AND INCENTIVE AWARD PROGRAMS TO PROMOTE THE SALE OF GOODS AND SERVICES OF OTHERS AND CONDUCTING EMPLOYEE INCENTIVE AWARD PROGRAMS TO PROMOTE JOB SAFETY (U.S. CLS. 100, 101 AND 102).

FIRST USE 9-1-1994; IN COMMERCE 9-1-1994.  
EDWARD NELSON, EXAMINING ATTORNEY

NO CLAIM IS MADE TO THE EXCLUSIVE RIGHT TO USE "CONSULTING", APART FROM THE MARK AS SHOWN.

THE COLOR(S) RED AND BLACK IS/ARE CLAIMED AS A FEATURE OF THE MARK.

THE MARK CONSISTS OF VORTEX IN RED WITH BLACK LETTERING.

FOR BUSINESS CONSULTING SERVICES RELATING TO PRODUCT DISTRIBUTION, OPERATIONS MANAGEMENT SERVICES, LOGISTICS, SUPPLY CHAIN, PRODUCTION SYSTEMS, AND DISTRIBUTION SOLUTIONS (U.S. CLS. 100, 101 AND 102).

FIRST USE 6-1-2002; IN COMMERCE 6-1-2002.  
REBECCA EISINGER, EXAMINING ATTORNEY

**CLASS 35—(Continued).**

SN 78-605,182. PETERSON, JEFFERY L., NEWPORT BEACH, CA. FILED 4-8-2005.

**LIVE AGENT  
TRANSFER**

THE MARK CONSISTS OF STANDARD CHARACTERS WITHOUT CLAIM TO ANY PARTICULAR FONT, STYLE, SIZE, OR COLOR.

FOR ADVERTISING SERVICES; MARKETING AND PROMOTION SERVICES, NAMELY, DIRECT MARKETING SERVICES (U.S. CLS. 100, 101 AND 102).

FIRST USE 5-0-1998; IN COMMERCE 5-0-1998.  
AMOS T. MATTHEWS, JR., EXAMINING ATTORNEY

**CLASS 35—(Continued).**

SN 78-720,405. CBK STYLES, INC., UNION CITY, TN. FILED 9-26-2005.

**PINNACLE LAMPS**

THE MARK CONSISTS OF STANDARD CHARACTERS WITHOUT CLAIM TO ANY PARTICULAR FONT, STYLE, SIZE, OR COLOR.

NO CLAIM IS MADE TO THE EXCLUSIVE RIGHT TO USE "LAMPS", APART FROM THE MARK AS SHOWN.

FOR WHOLESALE DISTRIBUTORSHIP SERVICES FEATURING GIFTWARE AND HOME ACCESSORIES INTENDED FOR INTERIOR OR EXTERIOR USE, NAMELY, WALL DECOR, MIRRORS, PICTURE FRAMES, SERVEWARE, PLANTERS, VASES, OBJECTS D'ART, BOOK ENDS, BOOK RESTS, BOOK STANDS, CANDLE HOLDERS, SCONCES, PLATE RACKS, DOORSTOPS, STATUETTES, FIGURINES, FURNITURE, PILLOWS, CUSHIONS, TEXTILES, BEVERAGE RACKS, LAMPS, BASKETS, STOCKING HOLDERS, TREE ORNAMENTS, TREE SKIRTS AND STOCKING HOLDERS (U.S. CLS. 100, 101 AND 102).

FIRST USE 0-0-1988; IN COMMERCE 0-0-1988.  
DAHLIA GEORGE, EXAMINING ATTORNEY

SN 78-642,098. HOLLAND, DARRICK, BALTIMORE, MD. AND SINGLETON, NAIM, HARRISBURG, PA. FILED 6-2-2005.



FOR ARRANGING AND CONDUCTING MARKETING PROMOTIONAL EVENTS FOR OTHERS IN THE FIELD OF PHONOGRAPH RECORDS; AND DISTRIBUTORSHIP IN THE FIELD OF PHONOGRAPHIC RECORDS (U.S. CLS. 100, 101 AND 102).

DAWN HAN, EXAMINING ATTORNEY

SN 78-723,567. NESTING WITH STYLE, NAPERVILLE, IL. FILED 9-29-2005.



NO CLAIM IS MADE TO THE EXCLUSIVE RIGHT TO USE .COM, APART FROM THE MARK AS SHOWN.

FOR ONLINE RETAIL STORES SERVICES, FEATURING HOME AND GARDEN ITEMS, JEWELRY AND ACCESSORIES, GIFT ITEMS FOR CHILDREN AND ADULTS, BATH AND BODY PRODUCTS, HANDBAGS, AND CHILDREN'S BEDDING (U.S. CLS. 100, 101 AND 102).

FIRST USE 7-0-2005; IN COMMERCE 7-0-2005.  
PAULA MAHONEY, EXAMINING ATTORNEY



**CLASS 35—(Continued).**

SN 78-741,332. POSTPOOL INC., MANVILLE, NJ. FILED 10-27-2005.



THE COLORS GREEN AND BLUE ARE CLAIMED AS A FEATURE OF THE MARK.  
THE COLOR GREEN APPEARS IN THE TERM POST AND THE COLOR BLUE APPEARS IN THE TERM POOL.  
FOR PROVIDING A WEBSITE FEATURING CLASSIFIEDS THAT ALLOWS USERS TO VIEW AND POST CLASSIFIEDS VIA THE INTERNET (U.S. CLS. 100, 101 AND 102).  
FIRST USE 0-0-2005; IN COMMERCE 0-0-2005.  
SUNG IN, EXAMINING ATTORNEY

SN 78-748,278. THIRD SCREEN MEDIA, INC., PORTSMOUTH, RI. FILED 11-7-2005.



NO CLAIM IS MADE TO THE EXCLUSIVE RIGHT TO USE "THIRD SCREEN MEDIA", APART FROM THE MARK AS SHOWN.  
THE STIPPLING IS FOR SHADING PURPOSES ONLY.  
THE MARK CONSISTS OF A SQUARE DESIGN ABOVE THE WORDING "THIRDSCREENMEDIA".  
FOR PROVIDING COMMERCIAL INFORMATION IN THE FIELD OF MARKETING AND ADVERTISING; PROMOTING THE GOODS AND SERVICES OF OTHERS BY PREPARING AND PLACING ADVERTISEMENTS ON MOBILE MEDIA, NAMELY, CELLULAR TELEPHONES, PDA'S, MOBILE GAME PLAYERS AND HANDHELD ELECTRONIC DEVICES; BUSINESS MARKETING AND ADVERTISING CONSULTATION, NAMELY, MARKET RESEARCH CONSULTATION, BUSINESS ADVICE AND ANALYSIS OF MARKETS FOR TARGETING, PLACEMENT AND DISSEMINATION OF ADVERTISEMENTS (U.S. CLS. 100, 101 AND 102).  
SANDRA MANIOS, EXAMINING ATTORNEY

**CLASS 35—(Continued).**

SN 78-748,713. CARLISLE MEDICAL, INC., MOBILE, AL. FILED 11-7-2005.



NO CLAIM IS MADE TO THE EXCLUSIVE RIGHT TO USE "MEDICAL", APART FROM THE MARK AS SHOWN.  
FOR ONLINE, TELEPHONE AND MAIL ORDER RETAIL SERVICES IN THE FIELD OF DURABLE MEDICAL PRODUCTS; RETAIL PHARMACY SERVICES (U.S. CLS. 100, 101 AND 102).  
FIRST USE 1-3-1985; IN COMMERCE 1-3-1985.  
HOWARD B. LEVINE, EXAMINING ATTORNEY

SN 78-761,859. LINCARE LICENSING, INC., CLEARWATER, FL. FILED 11-28-2005.

GO WHERE YOU WANT, WHEN YOU WANT

THE MARK CONSISTS OF STANDARD CHARACTERS WITHOUT CLAIM TO ANY PARTICULAR FONT, STYLE, SIZE, OR COLOR.  
FOR RETAIL STORE SERVICES FEATURING OXYGEN SUPPLIES FOR USE IN CONNECTION WITH HOME HEALTH CARE (U.S. CLS. 100, 101 AND 102).  
FIRST USE 1-19-2004; IN COMMERCE 1-19-2004.  
RON FAIRBANKS, EXAMINING ATTORNEY

SN 78-765,380. ADVANCED ICU CARE, L.L.C., ST. LOUIS, MO. FILED 12-2-2005.



NO CLAIM IS MADE TO THE EXCLUSIVE RIGHT TO USE "ADVANCED ICU CARE", APART FROM THE MARK AS SHOWN.  
FOR MEDICAL STAFFING SERVICES, NAMELY, PROVIDING CRITICAL CARE PHYSICIANS AND INTENSIVISTS TO COMMUNITY HOSPITALS (U.S. CLS. 100, 101 AND 102).  
FIRST USE 2-0-2005; IN COMMERCE 2-0-2005.  
PAUL F. GAST, EXAMINING ATTORNEY

**CLASS 35—(Continued).**

SN 78-767,576. SPACE INNOVATORS INC., ISLIP, NY. FILED 12-6-2005.

**SPACE INNOVATORS**

THE MARK CONSISTS OF STANDARD CHARACTERS WITHOUT CLAIM TO ANY PARTICULAR FONT, STYLE, SIZE, OR COLOR.

FOR PROCUREMENT SERVICES IN THE AREAS OF MATERIALS, EQUIPMENT AND SYSTEMS FOR CONSTRUCTION PROJECTS; ASSISTING OCCUPANTS WITH MOVE-IN UPON COMPLETION OF NEW BUILDING CONSTRUCTION; ANALYSIS OF ENERGY NEEDS OF BUILDING OCCUPANTS (U.S. CLS. 100, 101 AND 102).

FIRST USE 6-8-1982; IN COMMERCE 6-8-1982.  
KIMBERLY FRYE, EXAMINING ATTORNEY

SN 78-767,624. DAVENPORT, TED M., NORTH LITTLE ROCK, AR. FILED 12-6-2005.



The logo for "Radio Memories" features the words "Radio Memories" in a stylized, bold, sans-serif font. The letters are filled with a stippled or textured pattern, giving them a three-dimensional appearance. The background is a light, slightly textured grey.

NO CLAIM IS MADE TO THE EXCLUSIVE RIGHT TO USE "RADIO", APART FROM THE MARK AS SHOWN.

THE STIPPLING IS A FEATURE OF THE MARK AND FOR SHADING PURPOSES ONLY.

FOR RETAIL STORES IN THE FIELD OF CD'S AND TAPES FEATURING NON-CURRENT RADIO PROGRAMS (U.S. CLS. 100, 101 AND 102).

FIRST USE 12-31-1999; IN COMMERCE 12-31-1999.  
WARREN L. OLANDRIA, EXAMINING ATTORNEY

SN 78-770,008. SIP WINE, LLC, NEW ORLEANS, LA. FILED 12-9-2005.



FOR RETAIL BOUTIQUE STORE SERVICES FEATURING WINE AND BEER (U.S. CLS. 100, 101 AND 102).  
FIRST USE 12-26-2004; IN COMMERCE 12-26-2004.  
DAVID HOFFMAN, EXAMINING ATTORNEY

**CLASS 35—(Continued).**

SN 78-770,027. EMIR, YUNICE, JENÁ, AUSTELL, GA. FILED 12-9-2005.

**Yunice Jená Emir**

THE MARK CONSISTS OF STANDARD CHARACTERS WITHOUT CLAIM TO ANY PARTICULAR FONT, STYLE, SIZE, OR COLOR.

THE NAME(S), PORTRAIT(S), AND/OR SIGNATURE(S) SHOWN IN THE MARK IDENTIFIES YUNICE JENA EMIR, WHOSE CONSENT(S) TO REGISTER IS MADE OF RECORD.

FOR RETAIL CLOTHING STORES (U.S. CLS. 100, 101 AND 102).  
ELIZABETH PIGNATELLO, EXAMINING ATTORNEY

SN 78-777,094. SMITH CONTENT, INC., BALTIMORE, MD. FILED 12-20-2005.



**SMITH CONTENT**

NO CLAIM IS MADE TO THE EXCLUSIVE RIGHT TO USE "CONTENT", APART FROM THE MARK AS SHOWN.

THE COLOR(S) BLACK, WHITE AND ORANGE ARE COLOR FEATURES OF THE MARK IS/ARE CLAIMED AS A FEATURE OF THE MARK.

THE MARK CONSISTS OF AN ANTIQUE BLACK TYPEWRITER WITH WHITE KEYS AND A WHITE SHEET OF BLANK PAPER IN ITS CARRIAGE ENCIRCLED BY AN ORANGE RING WITH THE WORDS "SMITH CONTENT" APPEARING BELOW THE CIRCLED TYPEWRITER IN ORANGE BLOCK LETTERING.

FOR BUSINESS MANAGEMENT AND ADVERTISING SERVICES, NAMELY MARKETING ADVISORY SERVICES, MARKETING CONSULTING, AND CONTENT DEVELOPMENT CONSISTING OF ORIGINAL COPYWRITING, NAMELY SLOGANS, HEADLINES, DIRECT MAIL PIECES, COMMERCIAL SCRIPTS AND PRESS RELEASES, AND PROJECT MANAGEMENT SERVICES FOR OTHERS FEATURING PROOFREADING; PROVISION OF MARKETING COMMUNICATION TOOLS TO COMPANIES, NAMELY THE UTILIZATION OF MARKETING TOOLS DESIGNED TO INCREASE A CLIENT COMPANY'S KNOWLEDGE OF CUSTOMER NEEDS, AND ITS COMPETITORS' PRODUCTS AND SERVICES, PRICING, ADVERTISING STRATEGY AND SALES STRATEGY (U.S. CLS. 100, 101 AND 102).

NORA BUCHANAN WILL, EXAMINING ATTORNEY

**CLASS 35—(Continued).**

SN 78-787,152. SCHNEIDER NATIONAL, INC., GREEN BAY, WI. FILED 1-8-2006.

**SCHNEIDER GLOBAL LOGISTICS**

THE MARK CONSISTS OF STANDARD CHARACTERS WITHOUT CLAIM TO ANY PARTICULAR FONT, STYLE, SIZE, OR COLOR.

OWNER OF U.S. REG. NOS. 1,150,042, 2,579,159 AND OTHERS.

NO CLAIM IS MADE TO THE EXCLUSIVE RIGHT TO USE "GLOBAL LOGISTICS", APART FROM THE MARK AS SHOWN.

THE FOREIGN WORDING IN THE MARK TRANSLATES INTO ENGLISH AS CUTTER.

SEC. 2(F) AS TO "SCHNEIDER".

FOR BUSINESS CONSULTING SERVICES RELATED TO SHIPPING AND TRANSPORTATION OF GOODS (U.S. CLS. 100, 101 AND 102).

MARGERY A. TIERNEY, EXAMINING ATTORNEY

SN 78-791,705. GARDNER, DAN, NEWBERG, OR. FILED 1-13-2006.

**"JUST ADD JESUS"**

THE MARK CONSISTS OF STANDARD CHARACTERS WITHOUT CLAIM TO ANY PARTICULAR FONT, STYLE, SIZE, OR COLOR.

FOR ADVERTISING SERVICES; BUSINESS CONSULTING SERVICES; MARKETING SERVICES; PRODUCT LICENSING SERVICES NAMELY, CLOTHING, FOOTWEAR, HEADWEAR, JEWELRY, GAMES AND PLAYTHINGS, SPORTING ARTICLES, PERISHABLE FOOD ITEMS, NONPERISHABLE FOOD ITEMS, BEVERAGES INCLUDING NONALCOHOLIC BEVERAGES, HOUSEHOLD ITEMS, PAPER ITEMS, SOFTWARE PRODUCTS, EDUCATIONAL PRODUCTS, ENTERTAINMENT PRODUCTS, CULTURAL PRODUCTS, RELIGIOUS PRODUCTS, INTERNET-RELATED PRODUCTS, CONCERTS, TELEVISION, INTERNET, RADIO, CELLULAR PHONES, BILLBOARDS, PHONE BOOKS; ADVERTISING SERVICES IN THE FIELDS OF TEXTILES AND TEXTILE GOODS, CLOTHING, FOOTWEAR, HEADWEAR, JEWELRY, GAMES AND PLAYTHINGS, SPORTING ARTICLES, PERISHABLE FOOD ITEMS, NONPERISHABLE FOOD ITEMS, BEVERAGES INCLUDING NONALCOHOLIC BEVERAGES, HOUSEHOLD ITEMS, PAPER ITEMS, SOFTWARE PRODUCTS, EDUCATIONAL PRODUCTS, ENTERTAINMENT PRODUCTS, CULTURAL PRODUCTS, RELIGIOUS PRODUCTS, INTERNET-RELATED PRODUCTS, CONCERTS, TELEVISION, INTERNET, RADIO, CELLULAR PHONES, BILLBOARDS, PHONE BOOKS, PRODUCT LICENSING, BUSINESS CONSULTING SERVICES, MARKETING SERVICES; ADVERTISING AND MARKETING SERVICES IN THE FIELDS OF TEXTILES AND TEXTILE GOODS, CLOTHING, FOOTWEAR, HEADWEAR, JEWELRY, GAMES AND PLAYTHINGS, SPORTING ARTICLES, PERISHABLE FOOD ITEMS, NONPERISHABLE FOOD ITEMS, BEVERAGES INCLUDING NONALCOHOLIC BEVERAGES, HOUSEHOLD ITEMS, PAPER ITEMS, SOFTWARE PRODUCTS, EDUCATIONAL PRODUCTS, ENTERTAINMENT PRODUCTS, CULTURAL PRODUCTS, RELIGIOUS PRODUCTS, INTERNET-RELATED PRODUCTS, CONCERTS, TELEVISION, INTERNET, RADIO, CELLU-

**CLASS 35—(Continued).**

LAR PHONES, BILLBOARDS, PHONE BOOKS, PRODUCT LICENSING, BUSINESS CONSULTING SERVICES, ADVERTISING SERVICES; BUSINESS CONSULTING SERVICES IN THE FIELDS OF TEXTILES AND TEXTILE GOODS, CLOTHING, FOOTWEAR, HEADWEAR, JEWELRY, GAMES AND PLAYTHINGS, SPORTING ARTICLES, PERISHABLE FOOD ITEMS, NONPERISHABLE FOOD ITEMS, BEVERAGES INCLUDING NONALCOHOLIC BEVERAGES, HOUSEHOLD ITEMS, PAPER ITEMS, SOFTWARE PRODUCTS, EDUCATIONAL PRODUCTS, ENTERTAINMENT PRODUCTS, CULTURAL PRODUCTS, RELIGIOUS PRODUCTS, INTERNET-RELATED PRODUCTS, CONCERTS, TELEVISION, INTERNET, RADIO, CELLULAR PHONES, BILLBOARDS, PHONE BOOKS, PRODUCT LICENSING, MARKETING SERVICES, ADVERTISING SERVICES; PRODUCT LICENSING SERVICES IN THE FIELDS OF TEXTILES AND TEXTILE GOODS, CLOTHING, FOOTWEAR, HEADWEAR, JEWELRY, GAMES AND PLAYTHINGS, SPORTING ARTICLES, PERISHABLE FOOD ITEMS, NONPERISHABLE FOOD ITEMS, BEVERAGES INCLUDING NONALCOHOLIC BEVERAGES, HOUSEHOLD ITEMS, PAPER ITEMS, SOFTWARE PRODUCTS, EDUCATIONAL PRODUCTS, ENTERTAINMENT PRODUCTS, CULTURAL PRODUCTS, RELIGIOUS PRODUCTS, INTERNET-RELATED PRODUCTS, CONCERTS, TELEVISION, INTERNET, RADIO, CELLULAR PHONES, BILLBOARDS, PHONE BOOKS, BUSINESS CONSULTING SERVICES, MARKETING SERVICES, ADVERTISING SERVICES; ALL THE ABOVE SERVICES DONE FOR OTHERS (U.S. CLS. 100, 101 AND 102).

DAVID HOFFMAN, EXAMINING ATTORNEY

SN 78-792,732. DECORA RUGS, INC., BOCA RATON, FL. FILED 1-17-2006.

**DECORA RUGS**

THE MARK CONSISTS OF STANDARD CHARACTERS WITHOUT CLAIM TO ANY PARTICULAR FONT, STYLE, SIZE, OR COLOR.

NO CLAIM IS MADE TO THE EXCLUSIVE RIGHT TO USE "RUGS", APART FROM THE MARK AS SHOWN.

FOR ONLINE WEBSITE RETAIL STORE SERVICES FEATURING SALE OF AREA RUGS AND DECORATIVE PILLOWS (U.S. CLS. 100, 101 AND 102).

FIRST USE 1-15-2006; IN COMMERCE 1-15-2006.  
JILL PRATER, EXAMINING ATTORNEY

**CLASS 35—(Continued).**

SN 78-793,613. NETWORK PODS, LLC, TROY, MI. FILED 1-18-2006.

**NETWORK PODS**

THE MARK CONSISTS OF STANDARD CHARACTERS WITHOUT CLAIM TO ANY PARTICULAR FONT, STYLE, SIZE, OR COLOR.

NO CLAIM IS MADE TO THE EXCLUSIVE RIGHT TO USE "NETWORK", APART FROM THE MARK AS SHOWN.

FOR ADVERTISING AND MARKETING; ADVERTISING, MARKETING AND PROMOTION SERVICES; ARRANGING AND CONDUCTING MARKETING PROMOTIONAL EVENTS FOR OTHERS; BUSINESS MARKETING SERVICES; COOPERATIVE ADVERTISING AND MARKETING; COOPERATIVE ADVERTISING AND MARKETING SERVICES BY WAY OF SOLICITATION, CUSTOMER SERVICE AND PROVIDING MARKETING INFORMATION VIA WEBSITES ON A GLOBAL COMPUTER NETWORK; MARKETING SERVICES, NAMELY PROVIDING INFORMATIONAL WEB PAGES DESIGNED TO GENERATE SALES TRAFFIC VIA HYPERLINKS TO OTHER WEB SITES; MULTI-LEVEL MARKETING BUSINESS SERVICES; PROMOTING, ADVERTISING AND MARKETING OF THE ON-LINE WEBSITES OF OTHERS; PROMOTION, ADVERTISING AND MARKETING OF ON-LINE WEBSITES (U.S. CLS. 100, 101 AND 102).

FIRST USE 11-1-2005; IN COMMERCE 11-1-2005.

REBECCA GAN, EXAMINING ATTORNEY

SN 78-797,384. DATA TRANSMISSION NETWORK CORPORATION, OMAHA, NE. FILED 1-23-2006.

**DTN Canada**

THE MARK CONSISTS OF STANDARD CHARACTERS WITHOUT CLAIM TO ANY PARTICULAR FONT, STYLE, SIZE, OR COLOR.

OWNER OF U.S. REG. NOS. 3,063,196, 3,070,719 AND OTHERS.

NO CLAIM IS MADE TO THE EXCLUSIVE RIGHT TO USE "CANADA", APART FROM THE MARK AS SHOWN.

FOR BUSINESS INFORMATION SERVICES, NAMELY, PROVIDING AN ON-LINE DATABASE OF NEWS, WEATHER PATTERNS, SUPPLY, AND DISTRIBUTION INFORMATION PERTINENT TO THE CANADIAN GRAIN AND LIVESTOCK MARKETS (U.S. CLS. 100, 101 AND 102).

FIRST USE 4-7-2005; IN COMMERCE 4-7-2005.

CAROLINE WOOD, EXAMINING ATTORNEY

**CLASS 35—(Continued).**

SN 78-797,644. BISH'S RV, INC., IDAHO FALLS, ID. FILED 1-23-2006.

**MEMORIES**

THE MARK CONSISTS OF STANDARD CHARACTERS WITHOUT CLAIM TO ANY PARTICULAR FONT, STYLE, SIZE, OR COLOR.

FOR RECREATIONAL VEHICLE DEALERSHIP SERVICES; PROVIDING ADVERTISING SERVICES FOR OTHERS IN THE FIELD OF RECREATIONAL VEHICLES (U.S. CLS. 100, 101 AND 102).

BRIAN NEVILLE, EXAMINING ATTORNEY

SN 78-798,818. INVENTORY LIQUIDATORS CORP., RIVER GROVE, IL. FILED 1-25-2006.

**MIDWEST MARKET DAYS**

THE MARK CONSISTS OF STANDARD CHARACTERS WITHOUT CLAIM TO ANY PARTICULAR FONT, STYLE, SIZE, OR COLOR.

NO CLAIM IS MADE TO THE EXCLUSIVE RIGHT TO USE "MIDWEST MARKET", APART FROM THE MARK AS SHOWN.

FOR ARRANGING AND CONDUCTING TRADE SHOW EXHIBITIONS IN THE FIELDS OF GENERAL MERCHANDISE, RETAIL INDUSTRY, AND DOLLAR STORES (U.S. CLS. 100, 101 AND 102).

FIRST USE 1-4-2006; IN COMMERCE 1-4-2006.

DEZMONA MIZELLE, EXAMINING ATTORNEY

SN 78-799,051. THE ADVISORY BOARD COMPANY, WASHINGTON, DC. FILED 1-25-2006.

**SURGERY COMPASS**

THE MARK CONSISTS OF STANDARD CHARACTERS WITHOUT CLAIM TO ANY PARTICULAR FONT, STYLE, SIZE, OR COLOR.

NO CLAIM IS MADE TO THE EXCLUSIVE RIGHT TO USE "SURGERY", APART FROM THE MARK AS SHOWN.

FOR HEALTH CARE MANAGEMENT CONSULTATION AND RESEARCH FOR OTHERS CONCERNING THE MANAGEMENT OF HEALTH CARE FACILITIES (U.S. CLS. 100, 101 AND 102).

FIRST USE 11-1-2005; IN COMMERCE 11-1-2005.

MICHELE SWAIN, EXAMINING ATTORNEY

**CLASS 35—(Continued).**

SN 78-799,106. BAE SYSTEMS NATIONAL SECURITY SOLUTIONS INC., SAN DIEGO, CA. FILED 1-25-2006.

**CLASS 35—(Continued).**

SN 78-807,494. BACHNER, CRAIG A., AVENTURA, FL. FILED 2-5-2006.

EFFECTS BASED INTEGRATION

THE MARK CONSISTS OF STANDARD CHARACTERS WITHOUT CLAIM TO ANY PARTICULAR FONT, STYLE, SIZE, OR COLOR.

NO CLAIM IS MADE TO THE EXCLUSIVE RIGHT TO USE "INTEGRATION", APART FROM THE MARK AS SHOWN.

FOR COMMERCIAL ASSISTANCE RELATING TO SYSTEM IMPLEMENTATION AND SYSTEM INTEGRATION (U.S. CLS. 100, 101 AND 102).

STEVEN R. FOSTER, EXAMINING ATTORNEY

YourSourceChina

SN 78-800,896. CHEAP ASS GAMER, MERRICK, NY. FILED 1-27-2006.

CHEAP ASS GAMER

THE MARK CONSISTS OF STANDARD CHARACTERS WITHOUT CLAIM TO ANY PARTICULAR FONT, STYLE, SIZE, OR COLOR.

NO CLAIM IS MADE TO THE EXCLUSIVE RIGHT TO USE "GAMER", APART FROM THE MARK AS SHOWN.

FOR PROMOTING THE GOODS AND SERVICES OF OTHERS BY PROVIDING A WEB SITE AT WHICH USERS RECEIVE INFORMATION REGARDING VIDEO GAME SALES (U.S. CLS. 100, 101 AND 102).

FIRST USE 4-28-2003; IN COMMERCE 4-28-2003.

DOMINIC FATHY, EXAMINING ATTORNEY

THE MARK CONSISTS OF STANDARD CHARACTERS WITHOUT CLAIM TO ANY PARTICULAR FONT, STYLE, SIZE, OR COLOR.

FOR ADVISORY AND CONSULTANCY SERVICES RELATING TO EXPORT, EXPORT SERVICES, EXPORT PROMOTION INFORMATION AND SERVICES; ASSISTANCE, ADVISORY SERVICES AND CONSULTANCY WITH REGARD TO BUSINESS PLANNING, BUSINESS ANALYSIS, BUSINESS MANAGEMENT, AND BUSINESS ORGANIZATION; BUSINESS ACQUISITION AND MERGER CONSULTATION; BUSINESS ADVISORY SERVICES, CONSULTANCY AND INFORMATION; BUSINESS CONSULTING AND BUSINESS INFORMATION FOR ENTERPRISES; BUSINESS CONSULTING AND INFORMATION SERVICES; BUSINESS CONSULTING SERVICES RELATING TO PRODUCT DISTRIBUTION, OPERATIONS MANAGEMENT SERVICES, LOGISTICS, REVERSE LOGISTICS, SUPPLY CHAIN, AND PRODUCTION SYSTEMS AND DISTRIBUTION SOLUTIONS; BUSINESS CONSULTING, INQUIRIES OR INFORMATION; BUSINESS CONSULTING, MANAGEMENT, PLANNING AND SUPERVISION; BUSINESS MANAGEMENT CONSULTANCY AND ADVISORY SERVICES; BUSINESS MANAGEMENT CONSULTANCY AS WELL AS DEVELOPMENT OF PROCESSES FOR THE ANALYSIS AND THE IMPLEMENTATION OF STRATEGY PLANS AND MANAGEMENT PROJECTS; BUSINESS MANAGEMENT CONSULTANCY SERVICES; BUSINESS MANAGEMENT CONSULTATION; BUSINESS MANAGEMENT CONSULTING AND ADVISORY SERVICES; BUSINESS MANAGEMENT CONSULTING WITH RELATION TO STRATEGY, MARKETING, PRODUCTION, PERSONNEL AND RETAIL SALE MATTERS; BUSINESS MARKETING CONSULTING SERVICES; BUSINESS MERGER CONSULTATION; BUSINESS ORGANISATION AND MANAGEMENT CONSULTING SERVICES; BUSINESS ORGANIZATION AND OPERATION CONSULTANCY; BUSINESS RELOCATION CONSULTING; BUSINESS RESEARCH CONSULTATION; COMMERCIAL CONSULTANCY; CONSULTANCY SERVICES REGARDING BUSINESS STRATEGIES; CONSULTATION IN THE FIELD OF BUSINESS ACQUISITIONS; CONSULTATION SERVICES IN THE FIELD OF COMPANY, BUSINESS SECTOR AND INDUSTRY DATA AND RESEARCH; CONSULTING SERVICES IN BUSINESS ORGANIZATION AND MANAGEMENT; CONSULTING SERVICES IN THE FIELD OF MANAGING INTELLECTUAL PROPERTIES; FOREIGN TRADE INFORMATION AND CONSULTATION; MARKET RESEARCH CONSULTATION; PROFESSIONAL BUSINESS CONSULTATION (U.S. CLS. 100, 101 AND 102).

FIRST USE 4-15-2005; IN COMMERCE 4-22-2005.

HANNO RITTNER, EXAMINING ATTORNEY

SN 78-804,232. WEICK AND ASSOCIATES, INC., EUSTIS, FL. FILED 2-1-2006.

THE CRABBAGE PATCH

Everything for the land hermit crab enthusiast

"THE COLOR(S) BLACK AND GREEN IS/ARE CLAIMED AS A FEATURE OF THE MARK."

"THE MARK CONSISTS OF THE WORDS 'THE CRABBAGE PATCH' IN GREEN LETTERING OUTLINED IN BLACK, AND THE WORDS 'EVERYTHING FOR THE LAND HERMIT CRAB ENTHUSIAST' IN BLACK."

FOR RETAIL STORE SERVICES FEATURING LAND HERMIT CRABS AND LAND HERMIT CRAB SUPPLIES AND GIFTS (U.S. CLS. 100, 101 AND 102).

FIRST USE 3-3-2005; IN COMMERCE 3-28-2005.

CAROLINE WEIMER, EXAMINING ATTORNEY

**CLASS 35—(Continued).**

SN 78-809,298. STONE STREET, SAN ANTONIO, TX. FILED 2-7-2006.

**LAWYERUP.COM**

THE MARK CONSISTS OF STANDARD CHARACTERS WITHOUT CLAIM TO ANY PARTICULAR FONT, STYLE, SIZE, OR COLOR.

FOR PROVIDING ATTORNEY REFERRALS, NAMELY FORWARDING INQUIRIES FROM POTENTIAL CLIENTS TO LAWYERS; ADVERTISING AND MARKETING OF LEGAL SERVICES (U.S. CLS. 100, 101 AND 102).

GISELLE AGOSTO, EXAMINING ATTORNEY

SN 78-810,078. SHELTON, JOHN, LITCHFIELD, OH. FILED 2-8-2006.



NO CLAIM IS MADE TO THE EXCLUSIVE RIGHT TO USE "VINTAGE CAR, HOT ROD, & CLASSIC TRUCK", APART FROM THE MARK AS SHOWN.

THE COLOR(S) WHITE, BEIGE SILVER, RED, GRAY, AND BLACK IS/ARE CLAIMED AS A FEATURE OF THE MARK.

THE MARK CONSISTS OF WHITE AS THE COLOR OF THE FONT USED IN THE MAIN NAME, NUTLUGS, OUTLINED IN BLACK. "NUTLUGS" IS PLACED ON TOP OF A DUAL RED STRIPE. BELOW THE STRIPE IS A SUBTITLE WORDING "THE VINTAGE CAR, HOT ROD, & CLASSIC TRUCK SUPERHIGHWAY" IN BLACK FONT. TO THE LEFT OF THE MAIN NAME (NUTLUGS) APPEARS A BLACK TIRE WITH GRAY SHADING. THE TIRE CONTAINS A RED PINSTRIPE AND IS SHOWN WITH A CENTER WHEEL WITH SHADES OF SILVER, GRAY, AND WHITE. THE ENTIRE MARK APPEARS OVER A BEIGE RECTANGULAR DESIGN.

FOR PROVIDING ONLINE DIRECTORY INFORMATION SERVICES ALSO FEATURING HYPERLINKS TO OTHER WEBSITES FEATURING INFORMATION IN THE FIELD OF AUTOMOBILE RESOTRATION (U.S. CLS. 100, 101 AND 102).

RON FAIRBANKS, EXAMINING ATTORNEY

**CLASS 35—(Continued).**

SN 78-811,992. STONE STREET, SAN ANTONIO, TX. FILED 2-10-2006.

**LAWYERUPNOW**

THE MARK CONSISTS OF STANDARD CHARACTERS WITHOUT CLAIM TO ANY PARTICULAR FONT, STYLE, SIZE, OR COLOR.

FOR PROVIDING ATTORNEY REFERRALS, NAMELY FORWARDING INQUIRIES FROM POTENTIAL CLIENTS TO LAWYERS; ADVERTISING AND MARKETING OF LEGAL SERVICES (U.S. CLS. 100, 101 AND 102).

GISELLE AGOSTO, EXAMINING ATTORNEY

SN 78-812,003. STONE STREET, SAN ANTONIO, TX. FILED 2-10-2006.

**LAWYERUPNOW.COM**

THE MARK CONSISTS OF STANDARD CHARACTERS WITHOUT CLAIM TO ANY PARTICULAR FONT, STYLE, SIZE, OR COLOR.

FOR PROVIDING ATTORNEY REFERRALS, NAMELY FORWARDING INQUIRIES FROM POTENTIAL CLIENTS TO LAWYERS; ADVERTISING AND MARKETING OF LEGAL SERVICES (U.S. CLS. 100, 101 AND 102).

GISELLE AGOSTO, EXAMINING ATTORNEY

SN 78-812,379. ONE SOURCE STAFFING AND LABOR, KANSAS CITY, KS. FILED 2-10-2006.



NO CLAIM IS MADE TO THE EXCLUSIVE RIGHT TO USE STAFFING AND LABOR, APART FROM THE MARK AS SHOWN.

THE MARK CONSISTS OF THE WORDING ONE SOURCE STAFFING AND LABOR. A STYLIZED FIGURE OF A MAN WITH A BODY IN THE SHAPE OF A "T" IS EMERGING FROM THE LETTER "O" IN THE WORD "ONE" THE "O" IN THE WORD "ONE" IS IN THE STYLE OF A GLOBE WITH MERIDIANS AND PARALLELS.

FOR EMPLOYMENT AGENCY SERVICES, NAMELY, TEMPORARY STAFFING SERVICES AND LABOR STAFFING SERVICES (U.S. CLS. 100, 101 AND 102).

FIRST USE 3-1-2005; IN COMMERCE 3-1-2005.

CHRISTINE COOPER, EXAMINING ATTORNEY

**CLASS 35—(Continued).**

SN 78-814,525. SPRINGFIELD FOAM INSULATORS L.L.C.,  
SPRINGFIELD, MO. FILED 2-14-2006.

**CLASS 35—(Continued).**

SN 78-816,880. DEUTSCHE TELEKOM AG, BONN, FED REP  
GERMANY, FILED 2-16-2006.

GET INFORMED GET FOAMED

# T.Com

THE MARK CONSISTS OF STANDARD CHARACTERS WITHOUT CLAIM TO ANY PARTICULAR FONT, STYLE, SIZE, OR COLOR.

FOR MANUFACTURERS REPRESENTATIVES IN THE FIELD OF CONSTRUCTION MATERIALS, NAMELY FOAM INSULATION AND OTHER RELATED BUILDING CONSTRUCTION MATERIALS; ESTIMATING CONTRACT WORK THEREFOR (U.S. CLS. 100, 101 AND 102).

FIRST USE 2-1-2005; IN COMMERCE 2-1-2005.  
DAVID H. STINE, EXAMINING ATTORNEY

THE MARK CONSISTS OF STANDARD CHARACTERS WITHOUT CLAIM TO ANY PARTICULAR FONT, STYLE, SIZE, OR COLOR.

OWNER OF FED REP GERMANY REG. NO. 30030567,  
DATED 6-8-2000, EXPIRES 4-30-2010.

OWNER OF U.S. REG. NOS. 2,807,616, 3,016,557 AND OTHERS.

FOR TELEPHONE DIRECTORY ASSISTANCE SERVICES; ADVERTISING SERVICES, NAMELY, PREPARING AND PLACING ADVERTISEMENTS FOR OTHERS PROMOTING THE GOODS AND SERVICES OF OTHERS THROUGH PRINTED ADVERTISING, PRINTED DIRECTORIES, THROUGH ENCODED MEDIA, THROUGH THE DISSEMINATION OF PROMOTIONAL MATERIALS, THROUGH DIRECT MAIL ADVERTISING, THROUGH ELECTRONIC BILLBOARD ADVERTISING, PREPARING AUDIO-VISUAL PRESENTATIONS FOR USE IN ADVERTISING; BUSINESS MANAGEMENT SERVICES, NAMELY, BUSINESS APPRAISALS, BUSINESS AUDITING, PROVIDING BUSINESS INFORMATION, NAMELY, PREPARING BUSINESS REPORTS AND CONDUCTING BUSINESS RESEARCH, ANALYSIS AND SURVEYS, BUSINESS MANAGEMENT PLANNING, BUSINESS MANAGEMENT CONSULTATION, BUSINESS MANAGEMENT SUPERVISION, CONDUCTING BUSINESS NETWORKING FOR OTHERS; BUSINESS MANAGEMENT AND CONSULTING SERVICES, EXCLUDING AGRICULTURAL BUSINESS MANAGEMENT AND CONSULTING SERVICES; PROVIDING INFORMATION VIA THE TELEPHONE AND THE GLOBAL COMMUNICATION NETWORKS IN THE FIELD OF ADVERTISING AND BUSINESS MARKETING; PROFESSIONAL CONSULTANCY IN THE FIELD OF DATA PROCESSING; RENTAL OF AUTOMATIC VENDING MACHINES; RENTAL OF DATA PROCESSING EQUIPMENT; ORGANIZING JOB FAIRS; ONLINE RETAIL STORE SERVICES FEATURING TELECOMMUNICATIONS AND DATA TRANSMISSION EQUIPMENT, TELECOMMUNICATIONS SERVICE PLANS AND TELECOMMUNICATIONS SERVICE ACTIVATION; RETAIL STORE SERVICES FEATURING TELECOMMUNICATIONS AND DATA TRANSMISSION EQUIPMENT, TELECOMMUNICATIONS SERVICE PLANS AND TELECOMMUNICATIONS SERVICE ACTIVATION (U.S. CLS. 100, 101 AND 102).

ANN E. SAPPENFIELD, EXAMINING ATTORNEY

SN 78-815,993. WATSON, SCOTT C., FRISCO, TX. FILED 2-15-2006.

# RealityCheck

THE MARK CONSISTS OF STANDARD CHARACTERS WITHOUT CLAIM TO ANY PARTICULAR FONT, STYLE, SIZE, OR COLOR.

FOR CONSULTATION IN THE FIELD OF DATA ANALYSIS AND COMPILATION SERVICES PROVIDED IN THE FIELD OF EMPLOYEE TRAINING EFFECTIVENESS VIA EVALUATIONS AND REPORTS; DEVELOPMENT AND ADMINISTRATION OF EMPLOYEE TRAINING EFFECTIVENESS MEASUREMENT PROGRAMS (U.S. CLS. 100, 101 AND 102).

FIRST USE 6-1-2006; IN COMMERCE 6-1-2006.  
LINDA ESTRADA, EXAMINING ATTORNEY

**CLASS 35—(Continued).**

SN 78-818,804. OWENS-CORNING FIBERGLAS TECHNOLOGY INC., TOLEDO, OH. FILED 2-20-2006.

THE GREAT AMERICAN ENERGY  
DIET

THE MARK CONSISTS OF STANDARD CHARACTERS WITHOUT CLAIM TO ANY PARTICULAR FONT, STYLE, SIZE, OR COLOR.

NO CLAIM IS MADE TO THE EXCLUSIVE RIGHT TO USE "ENERGY", APART FROM THE MARK AS SHOWN.

FOR PROVIDING INFORMATION AND ADVICE TO THE PUBLIC, NAMELY HOMEOWNERS, BUILDING CONTRACTORS, BUSINESSES, AND SCHOOLS, REGARDING HOME ENERGY CONSERVATION (U.S. CLS. 100, 101 AND 102).

LAURIE KAUFMAN, EXAMINING ATTORNEY

SN 78-819,544. WEBB, CHARLIE A., WRIGHTWOOD, CA. FILED 2-21-2006.

TERSI SCIENTIFIC

THE MARK CONSISTS OF STANDARD CHARACTERS WITHOUT CLAIM TO ANY PARTICULAR FONT, STYLE, SIZE, OR COLOR.

NO CLAIM IS MADE TO THE EXCLUSIVE RIGHT TO USE "SCIENTIFIC", APART FROM THE MARK AS SHOWN.

FOR BUSINESS MARKETING CONSULTING SERVICES; ON-LINE RETAIL STORE SERVICES FEATURING CLEANING PRODUCTS FOR USE PRIMARILY FOR THE MEDICAL AND FOOD PREPARATION INDUSTRIES; PROMOTION AND MARKETING SERVICES AND RELATED CONSULTING; WHOLESALE DISTRIBUTORSHIPS FEATURING CLEANING PRODUCTS FOR USE PRIMARILY FOR THE MEDICAL AND FOOD PREPARATION INDUSTRIES (U.S. CLS. 100, 101 AND 102).

FIRST USE 2-15-2006; IN COMMERCE 2-15-2006.

RICHARD A. STRASER, EXAMINING ATTORNEY

**CLASS 35—(Continued).**

SN 78-823,790. LIFE INSURANCE SETTLEMENT ASSOCIATION, ORLANDO, FL. FILED 2-27-2006.



THE COLORS DARK YELLOW, MIDNIGHT BLUE, BABY BLUE AND LIGHT BLUE ARE CLAIMED AS A FEATURE OF THE MARK.

THE COLOR DARK YELLOW APPEARS IN THE LETTER "L"; THE COLOR MIDNIGHT BLUE APPEARS IN THE LETTER "I"; THE COLOR BABY BLUE APPEARS IN THE LETTER "S"; THE COLOR LIGHT BLUE APPEARS IN THE LETTER "A" OF THE MARK.

FOR ASSOCIATION SERVICES, NAMELY, PROMOTING THE INTERESTS OF LIFE SETTLEMENT BROKERS, BUYERS OF LIFE INSURANCE POLICIES AND FUNDERS OF LIFE INSURANCE SETTLEMENT CONTRACTS (U.S. CLS. 100, 101 AND 102).

FIRST USE 3-1-2006; IN COMMERCE 3-1-2006.

DAWN HAN, EXAMINING ATTORNEY

SN 78-824,971. FLOORING PLUS, INC., GLEN BURNIE, MD. FILED 2-28-2006.



OWNER OF U.S. REG. NO. 2,392,135.

NO CLAIM IS MADE TO THE EXCLUSIVE RIGHT TO USE "THE FLOORING PROFESSIONALS", APART FROM THE MARK AS SHOWN.

THE MARK CONSISTS OF STYLIZED TERMS WITH AN OVAL.

SEC. 2(F) AS TO "FLOORING PLUS".

FOR COOPERATIVE ADVERTISING AND MARKETING (U.S. CLS. 100, 101 AND 102).

FIRST USE 1-1-2003; IN COMMERCE 1-1-2003.

CIMMERIAN COLEMAN, EXAMINING ATTORNEY

SN 78-825,439. SOVEREIGN DEED, LLC, CHICAGO, IL. FILED 2-28-2006.

SOVEREIGN DEED

THE MARK CONSISTS OF STANDARD CHARACTERS WITHOUT CLAIM TO ANY PARTICULAR FONT, STYLE, SIZE, OR COLOR.

FOR ADVERTISING, MARKETING AND PROMOTION SERVICES (U.S. CLS. 100, 101 AND 102).

ZACHARY BELLO, EXAMINING ATTORNEY



**CLASS 35—(Continued).**

SN 78-829,151. QPASS, INC., SEATTLE, WA. FILED 3-3-2006.



THE MARK CONSISTS OF STYLIZED LETTER Q WITH A SURROUNDING ORBIT RING.

FOR FACILITATING THE MERCHANDISING OF GOODS AND SERVICES OF OTHERS ONLINE, BY BROADBAND CABLE, SATELLITE, WAP AND WIRELESS, VIA GLOBAL COMPUTER NETWORKS THROUGH THE COMPLETION OF ONLINE RETAIL TRANSACTIONS; STATUS REPORTING, NAMELY, REPORTING THE STATUS OF ONLINE SALES TRANSACTIONS; AND PROVIDING PROMOTIONAL SERVICES TO MERCHANTS WHO PARTICIPATE IN A GLOBAL TRANSACTION NETWORK (U.S. CLS. 100, 101 AND 102).

BARBARA BROWN, EXAMINING ATTORNEY

SN 78-839,244. IMPEL CONSULTING GROUP, L.L.C., MIDDLETOWN, PA. FILED 3-16-2006.

**IMPEL CONSULTING GROUP**

THE MARK CONSISTS OF STANDARD CHARACTERS WITHOUT CLAIM TO ANY PARTICULAR FONT, STYLE, SIZE, OR COLOR.

NO CLAIM IS MADE TO THE EXCLUSIVE RIGHT TO USE CONSULTING GROUP, APART FROM THE MARK AS SHOWN.

FOR PROVIDING BUSINESS CONSULTATION AND ADVICE SERVICES TO FINANCIAL INSTITUTIONS AND OTHER COMMERCIAL ENTITIES (U.S. CLS. 100, 101 AND 102).

STEVEN PEREZ, EXAMINING ATTORNEY

SN 78-840,433. STANLEY SWAIN'S INCORPORATED, GLENDALE, CA. FILED 3-17-2006.

**SWAIN'S**

THE MARK CONSISTS OF STANDARD CHARACTERS WITHOUT CLAIM TO ANY PARTICULAR FONT, STYLE, SIZE, OR COLOR.

THE NAME, PORTRAIT, AND/OR SIGNATURE SHOWN IN THE MARK DOES NOT IDENTIFY A PARTICULAR LIVING INDIVIDUAL.

SEC. 2(F).

FOR RETAIL STORE SERVICES FEATURING STATIONERY, ARTISTS' SUPPLIES AND TOYS (U.S. CLS. 100, 101 AND 102).

FIRST USE 6-3-1963; IN COMMERCE 6-3-1963.

LINDA ORNDORFF, EXAMINING ATTORNEY

**CLASS 35—(Continued).**

SN 78-842,454. TENNESSEE FARMER'S COOPERATIVE, LAVERGNE, TN. FILED 3-21-2006.

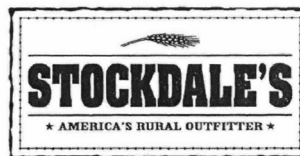

NO CLAIM IS MADE TO THE EXCLUSIVE RIGHT TO USE "AMERICA'S RURAL OUTFITTER", APART FROM THE MARK AS SHOWN.

FOR RETAIL STORES FEATURING LAWN, GARDEN, FARM SUPPLIES AND EQUIPMENT, FEED AND SEED, AND PET SUPPLIES (U.S. CLS. 100, 101 AND 102).

PAUL E. FAHRENKOPF, EXAMINING ATTORNEY

SN 78-842,960. SOVEREIGN DEED, LLC, CHICAGO, IL. FILED 3-22-2006.

**CIVIL GUARD**

THE MARK CONSISTS OF STANDARD CHARACTERS WITHOUT CLAIM TO ANY PARTICULAR FONT, STYLE, SIZE, OR COLOR.

FOR ADVERTISING, MARKETING AND PROMOTION SERVICES (U.S. CLS. 100, 101 AND 102).

CYNTHIA SLOAN, EXAMINING ATTORNEY

SN 78-843,524. FEDERATED WHOLESALE, INC., NORCROSS, GA. FILED 3-22-2006.

**Caring Matters****"It's Who We Are...It's What We do"**

THE MARK CONSISTS OF A FLAG OUTLINE IN A HEART, WHICH IS SUPPORTED BY TWO HANDS.

FOR WHOLESALE STORES FEATURING PERSONAL CARE AND PROMOTIONAL PRODUCTS, NAMELY, PERSONAL HYGIENE PRODUCTS, CLOTHING, TOTE BAGS, UMBRELLAS, LAPEL PINS, WALLETS, CANDY, LANYARDS, TELEPHONE CARDS, PENS, CLOCKS, PLAYING CARDS, BOOKS, MIRRORS, EMERGENCY FOIL RESCUE BLANKETS (U.S. CLS. 100, 101 AND 102).

MARY BOAGNI, EXAMINING ATTORNEY

**CLASS 35—(Continued).**

SN 78-854,567. EXPRESSIONS EMBROIDERY INC, LAKE WORTH, FL. FILED 4-5-2006.

## At Home in Paradise

THE MARK CONSISTS OF STANDARD CHARACTERS WITHOUT CLAIM TO ANY PARTICULAR FONT, STYLE, SIZE, OR COLOR.

FOR RETAIL FURNITURE STORES; RETAIL GIFT SHOPS (U.S. CLS. 100, 101 AND 102).

FIRST USE 8-15-2005; IN COMMERCE 2-25-2006.  
CHARLES L. JENKINS, EXAMINING ATTORNEY

SN 78-855,323. S2 HOLDING COMPANY, INC., MARIETTA, GA. FILED 4-6-2006.

## Groundwater Recharge Bank

THE MARK CONSISTS OF STANDARD CHARACTERS WITHOUT CLAIM TO ANY PARTICULAR FONT, STYLE, SIZE, OR COLOR.

NO CLAIM IS MADE TO THE EXCLUSIVE RIGHT TO USE "GROUNDWATER RECHARGE", APART FROM THE MARK AS SHOWN.

FOR NATURAL RESOURCE MANAGEMENT SERVICES (U.S. CLS. 100, 101 AND 102).

FIRST USE 2-27-2005; IN COMMERCE 2-26-2006.  
CHARISMA HAMPTON, EXAMINING ATTORNEY

SN 78-855,626. ANATOMY MEDIA, INC., NEW YORK, NY. FILED 4-6-2006.

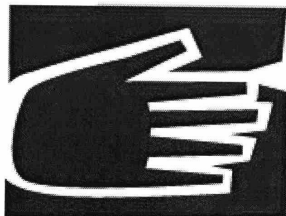

FOR MARKETING CONSULTING, FEATURING THE DESIGN OF MARKETING PRESENTATIONS FOR TELEVISION NETWORKS; CONCEPT AND BRAND DEVELOPMENT IN THE FIELD OF TELEVISION NETWORKS AND THE ENTERTAINMENT INDUSTRY; ADVERTISING SERVICES, NAMELY, CREATING CORPORATE LOGOS FOR OTHERS; PRODUCTION OF TELEVISION COMMERCIALS (U.S. CLS. 100, 101 AND 102).

FIRST USE 8-17-2002; IN COMMERCE 8-17-2002.  
GILBERT SWIFT, EXAMINING ATTORNEY

**CLASS 35—(Continued).**

SN 78-856,021. KAY HILL LTD., AUSTIN, TX. FILED 4-6-2006.



NO CLAIM IS MADE TO THE EXCLUSIVE RIGHT TO USE "TOYS.COM", APART FROM THE MARK AS SHOWN. THE COLOR(S) PINK, BLACK AND WHITE IS/ARE CLAIMED AS A FEATURE OF THE MARK.

THE MARK CONSISTS OF THE LETTERS "TABU" APPEAR IN PINK CAPITAL LETTERS, THE LETTERS "TOYS.COM" APPEAR IN STYLIZED CURSIVE BLACK LETTERS, AND "TABUTOYS.COM" APPEAR IN PINK LETTERS, THE COLOR WHITE APPEARS IN THE BACKGROUND.

FOR COMPUTERIZED ON-LINE RETAIL STORE SERVICES IN THE FIELD OF ADULT TOYS, CLOTHING, BOOKS, AND VIDEOS (U.S. CLS. 100, 101 AND 102).  
FIRST USE 6-30-2003; IN COMMERCE 6-30-2003.  
ASMAT KHAN, EXAMINING ATTORNEY

SN 78-863,876. DESCRIBE, SACRAMENTO, CA. FILED 4-18-2006.



THE COLOR(S) RED AND BLACK IS/ARE CLAIMED AS A FEATURE OF THE MARK.

THE COLOR RED APPEARS AS THE MOON SHAPED WAVES IN THE MARK WITH BLACK BEHIND THE WAVES FOR SHADOWING PURPOSES. THE TERM "DESCRIBE" APPEARS IN BLACK.

THE MARK CONSISTS OF THE WORD DESCRIBE BELOW THREE CRESENT MOON SHAPE WAVES.

FOR ADVERTISING AND PUBLICITY SERVICES, NAMELY, PROMOTING THE GOODS, SERVICES, BRAND IDENTITY AND COMMERCIAL INFORMATION AND NEWS OF THIRD PARTIES THROUGH PRINT, AUDIO, VIDEO, DIGITAL AND ON-LINE MEDIUM; ADVERTISING SERVICES, NAMELY, CREATING CORPORATE AND BRAND IDENTITY FOR OTHERS; ADVERTISING SERVICES, NAMELY, CREATING CORPORATE AND BRAND IDENTITY FOR OTHERS; SERVICES RELATING TO THE ANALYSIS, EVALUATION, CREATION AND BRAND ESTABLISHMENT OF TRADEMARKS, TRADE NAMES AND DOMAIN NAMES; PROVIDING BUSINESS MARKETING INFORMATION; PROVIDING ADVERTISING, MARKETING AND PROMOTIONAL SERVICES FOR BUSINESSES AND PROFESSIONALS; MARKETING CONSULTING; CREATION OF MARKETING TOOLS DESIGNED TO INCREASE A CLIENT COMPANY'S KNOWLEDGE OF CUSTOMER NEEDS, AND ITS COMPETITORS' PRODUCTS AND SERVICES, PRICING, ADVERTISING STRATEGY AND SALES STRATEGY; DEVELOPMENT OF MARKETING STRATEGIES AND CONCEPTS; BUSINESS MARKETING AND DIRECT MAIL CONSULTING SERVICES; BUSINESS CONSULTATION AND MANAGEMENT REGARDING MARKETING ACTIVITIES AND LAUNCHING OF NEW PRODUCTS; ADVICE IN THE FIELD OF BUSINESS MANAGEMENT AND MARKETING; DESIGN AND DEVELOPMENT OF LETTERHEAD, BUSINESS CARDS, MARKETING MATERIALS AND ADVERTISING MATERIALS FOR OTHERS (U.S. CLS. 100, 101 AND 102).

FIRST USE 2-7-2006; IN COMMERCE 4-1-2006.  
SKYE YOUNG, EXAMINING ATTORNEY

**CLASS 35—(Continued).**

SN 78-866,136. MARY POMERANTZ ADVERTISING, HIGHLAND PARK, NJ. FILED 4-20-2006.

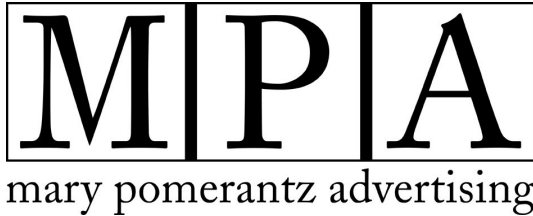

NO CLAIM IS MADE TO THE EXCLUSIVE RIGHT TO USE "ADVERTISING", APART FROM THE MARK AS SHOWN.

THE MARK CONSISTS OF THE LETTERS M, P, AND A IN CONSECUTIVE, RECTANGULAR BOXES WITH THE WORDS MARY POMERANTZ ADVERTISING APPEARING BELOW.

FOR ADVERTISING AGENCIES (U.S. CLS. 100, 101 AND 102).

FIRST USE 8-11-2003; IN COMMERCE 8-11-2003.  
REBECCA HAN, EXAMINING ATTORNEY

SN 78-871,647. HENDERSON-TOWNSEND, JUDI, OAKLAND, CA. FILED 4-27-2006.

**MANNEQUIN MADNESS**

THE MARK CONSISTS OF STANDARD CHARACTERS WITHOUT CLAIM TO ANY PARTICULAR FONT, STYLE, SIZE, OR COLOR.

NO CLAIM IS MADE TO THE EXCLUSIVE RIGHT TO USE MANNEQUIN, APART FROM THE MARK AS SHOWN.

FOR ON-LINE RETAIL STORE SERVICES, RETAIL STORE SERVICES, AND RENTAL SERVICES FEATURING STORE MANNEQUINS (U.S. CLS. 100, 101 AND 102).

FIRST USE 1-31-2001; IN COMMERCE 3-31-2001.  
PAUL E. FAHRENKOPF, EXAMINING ATTORNEY

**CLASS 35—(Continued).**

SN 78-876,885. APPELLATION ST. HELENA, ST. HELENA, CA. FILED 5-4-2006.



NO CLAIM IS MADE TO THE EXCLUSIVE RIGHT TO USE "APPELLATION ST. HELENA" AND "ST. HELENA", AS WELL AS THE DESIGN OF THE ST. HELENA APPELLATION", APART FROM THE MARK AS SHOWN.

THE COLOR(S) RED, BLACK, AND GREEN IS/ARE CLAIMED AS A FEATURE OF THE MARK.

THE MARK CONSISTS OF THE WORDS "APPELLATION ST. HELENA DISTINCTIVELY ST. HELENA" IN THE SHAPE OF A CIRCLE, WHERE THE TOP HALF OF THE CIRCLE IS COMPRISED OF THE WORDS "APPELLATION ST. HELENA" IN LARGE, CAPITAL LETTERS, WITH THE WORDS "APPELLATION" AND "HELENA" IN THE COLOR BLACK, AND THE WORD "ST." IN THE COLOR RED, AND THE BOTTOM HALF OF THE CIRCLE IS COMPRISED OF THE WORDS "DISTINCTIVELY ST. HELENA" IN LARGE, CAPITAL LETTERS, ALSO IN THE COLOR BLACK, EXCEPT FOR THE LETTERS "ST" IN THE WORD "DISTINCTIVELY" AND THE WORD "ST.", WHICH ARE IN THE COLOR RED. IN THE CENTER OF THE CIRCLE IS A RED SHAPE REPRESENTING THE GEOGRAPHICAL BORDERS OF THE ST. HELENA APPELLATION, AND IN THE CENTER OF THE RED SHAPE IS A GREEN, 5-POINTED STAR REPRESENTING THE LOCATION OF THE TOWN OF ST. HELENA WITHIN THE ST. HELENA APPELLATION.

FOR ASSOCIATION SERVICES, NAMELY PROMOTING THE INTEREST OF VINTNERS IN THE ST HELENA APPELLATION AND THE PROMOTION OF THE APPELLATION OF ORIGIN ITSELF (U.S. CLS. 100, 101 AND 102).

FIRST USE 1-6-2006; IN COMMERCE 1-6-2006.  
ALAIN LAPTER, EXAMINING ATTORNEY

SN 78-884,102. HANA BANK, CHUNG-KU SEOUL 100-191, REPUBLIC OF KOREA, FILED 5-15-2006.



NO CLAIM IS MADE TO THE EXCLUSIVE RIGHT TO USE "GROUP", APART FROM THE MARK AS SHOWN.

THE MARK CONSISTS OF A FANCIFUL IMAGE OF A PERSON TO THE LEFT OF THE LITERAL ELEMENT OF THE MARK.

FOR BUSINESS MANAGEMENT; BUSINESS MANAGEMENT PLANNING; BUSINESS MANAGEMENT SUPERVISION (U.S. CLS. 100, 101 AND 102).

ALICE BENMAMAN, EXAMINING ATTORNEY

**CLASS 35—(Continued).**

SN 78-886,482. HUMANITY OUTREACH PARTNERS ENTERPRISES, DANSVILLE, NY. FILED 5-18-2006.

## Hope Unites

THE MARK CONSISTS OF STANDARD CHARACTERS WITHOUT CLAIM TO ANY PARTICULAR FONT, STYLE, SIZE, OR COLOR.

FOR RECRUITING OF VOLUNTEERS FROM CHURCHES, COLLEGES AND SCHOOLS IN THE FIELD OF HUMANITARIAN RELIEF IN DISASTER AREAS, NAMELY, TO REBUILD HOMES, DISTRIBUTE FOOD, PROVIDE HOT MEALS TO THOSE TEMPORARILY DISPLACED AND RECRUITING MEDICAL VOLUNTEERS TO ENGAGE IN ASSISTING OF VICTIMS OF DISASTERS BY PROVIDING MEDICAL CARE AND VACCINATIONS (U.S. CLS. 100, 101 AND 102).

FIRST USE 1-1-2005; IN COMMERCE 1-1-2005.  
DEZMONA MIZELLE, EXAMINING ATTORNEY

SN 78-887,304. UGENIE, INC., MENLO PARK, CA. FILED 5-18-2006.

## ugenie

THE MARK CONSISTS OF STANDARD CHARACTERS WITHOUT CLAIM TO ANY PARTICULAR FONT, STYLE, SIZE, OR COLOR.

FOR PROVIDING INFORMATION ABOUT THE GOODS AND SERVICES OF OTHERS VIA THE INTERNET; PROVIDING INFORMATION VIA THE INTERNET FOR CONSUMERS IN THE FIELD OF LOCATING AND RECEIVING PRICE QUOTATIONS FOR GOODS AND SERVICES FROM MULTIPLE COMPETITIVE SOURCES (U.S. CLS. 100, 101 AND 102).

FIRST USE 5-1-2006; IN COMMERCE 5-1-2006.  
GIANCARLO CASTRO, EXAMINING ATTORNEY

SN 78-887,312. UGENIE, INC., MENLO PARK, CA. FILED 5-18-2006.

## UNLOCK HIDDEN SAVINGS

THE MARK CONSISTS OF STANDARD CHARACTERS WITHOUT CLAIM TO ANY PARTICULAR FONT, STYLE, SIZE, OR COLOR.

FOR PROVIDING INFORMATION ABOUT THE GOODS AND SERVICES OF OTHERS VIA THE INTERNET; PROVIDING INFORMATION VIA THE INTERNET FOR CONSUMERS IN THE FIELD OF LOCATING AND RECEIVING PRICE QUOTATIONS FOR GOODS AND SERVICES FROM MULTIPLE COMPETITIVE SOURCES (U.S. CLS. 100, 101 AND 102).

FIRST USE 5-1-2006; IN COMMERCE 5-1-2006.  
GIANCARLO CASTRO, EXAMINING ATTORNEY

**CLASS 35—(Continued).**

SN 78-888,002. BAD APPLE COMICS, INC., ORLANDO, FL. FILED 5-19-2006.



NO CLAIM IS MADE TO THE EXCLUSIVE RIGHT TO USE "COMICS", APART FROM THE MARK AS SHOWN.

THE COLOR(S) RED, GRAY, WHITE, TAN, BLACK, BROWN AND GREEN IS/ARE CLAIMED AS A FEATURE OF THE MARK.

THE MARK CONSISTS OF THE COLOR RED APPEARING ON THE WORDING BAD APPLE COMICS. THE COLORS WHITE AND GRAY LINE THE WORDING IN THE MARK. THE COLORS RED, BLACK, WHITE, TAN, BROWN AND GREEN APPEAR AS THE DESIGN OF AN APPLE EATEN TO THE CORE TO THE RIGHT OF THE WORDS IN THE MARK.

FOR RETAIL STORES FEATURING COMIC BOOKS AND COLLECTIBLES (U.S. CLS. 100, 101 AND 102).

FIRST USE 3-1-2005; IN COMMERCE 3-1-2005.  
SANDRA MANIOS, EXAMINING ATTORNEY

SN 78-892,848. SENIORS A2Z, LLC, PRINCETON, NJ. FILED 5-25-2006.

## SENIORS A2Z

THE MARK CONSISTS OF STANDARD CHARACTERS WITHOUT CLAIM TO ANY PARTICULAR FONT, STYLE, SIZE, OR COLOR.

NO CLAIM IS MADE TO THE EXCLUSIVE RIGHT TO USE "SENIORS", APART FROM THE MARK AS SHOWN.

FOR PROVIDING CONSUMER INFORMATION IN THE FIELDS OF BASIC AND GERIATRIC CARE MANAGEMENT, COMPANIONSHIP, CONCIERGE SERVICES, COUNSELING, DISEASE AND SOCIAL SUPPORT GROUPS, CRISIS AND SECURITY ASSISTANCE, PHARMACEUTICAL PROGRAMS, FINANCES, HANDYMAN SERVICES, HEALTHCARE, HOSPITAL AND HEALTHCARE, REHABILITATION AND NURSING CENTERS, ACUTE CARE CENTERS, HOUSING, INSURANCE, LEGAL SERVICES, GOVERNMENT SERVICES INCLUDING LINKS TO GOVERNMENT WEBSITES OF INTEREST TO SENIOR CITIZENS, MEDICAL EQUIPMENT, NUTRITION, SOCIAL, EDUCATIONAL AND RECREATIONAL ACTIVITIES, CONSUMER SERVICES, TECHNOLOGY FOR SENIORS, TRANSITION SERVICES, TRANSPORTATION, TRAVEL AND LEISURE, VETERAN SERVICES, VOLUNTEER AND EMPLOYMENT OPPORTUNITIES AND ASSISTANCE FOR THE CAREGIVER, AS RELATING TO SENIOR CITIZENS (U.S. CLS. 100, 101 AND 102).

KYLE PEETE, EXAMINING ATTORNEY

**CLASS 35—(Continued).**

SN 78-895,226. JOHNSON O'CONNOR LLP, MELROSE, MA. FILED 5-29-2006.



THE COLOR(S) ORANGE, BLUE AND GREEN IS/ARE CLAIMED AS A FEATURE OF THE MARK.

THE MARK CONSISTS OF AN ORANGE SQUARE, A LARGER BLUE SQUARE, AND A GREEN SQUARE THE SAME SIZE AS THE ORANGE SQUARE.

FOR ACCOUNTING SERVICES (U.S. CLS. 100, 101 AND 102).

FIRST USE 11-21-2005; IN COMMERCE 11-21-2005.  
DAVID STERKIN, EXAMINING ATTORNEY

SN 78-895,712. MORTGAGE RETRIEVER, LLC, HOCKESSIN, DE. FILED 5-30-2006.

**MORTGAGE RETRIEVER**

THE MARK CONSISTS OF STANDARD CHARACTERS WITHOUT CLAIM TO ANY PARTICULAR FONT, STYLE, SIZE, OR COLOR.

NO CLAIM IS MADE TO THE EXCLUSIVE RIGHT TO USE "MORTGAGE", APART FROM THE MARK AS SHOWN.

FOR GENERAL BUSINESS NETWORKING REFERRAL SERVICES, NAMELY, PROMOTING THE GOODS AND SERVICES OF OTHERS BY PASSING BUSINESS LEADS AND REFERRALS AMONG GROUP MEMBERS (U.S. CLS. 100, 101 AND 102).

KELLEY WELLS, EXAMINING ATTORNEY

SN 78-901,300. PALMER, CHRISTOPHER C., ANN ARBOR, MI. FILED 6-6-2006.

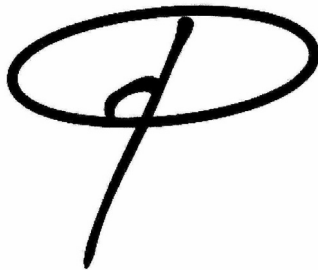

FOR ON-LINE RETAIL STORE SERVICES AND RETAIL STORE SERVICES FEATURING ART (U.S. CLS. 100, 101 AND 102).

ROBERT LAVACHE, EXAMINING ATTORNEY

**CLASS 35—(Continued).**

SN 78-901,530. NOVENTI LLC, MENLO PARK, CA. FILED 6-6-2006.

**NOVENTI**

THE MARK CONSISTS OF STANDARD CHARACTERS WITHOUT CLAIM TO ANY PARTICULAR FONT, STYLE, SIZE, OR COLOR.

THE FOREIGN WORDING IN THE MARK TRANSLATES INTO ENGLISH AS FANCIFUL IN NATURE.

FOR BUSINESS ADVISORY SERVICES AND BUSINESS MANAGEMENT SERVICES (U.S. CLS. 100, 101 AND 102).

DAVID C. REIHNER, EXAMINING ATTORNEY

SN 78-904,962. FREEDOM COMMUNICATIONS, INC., SALEM, MA. FILED 6-9-2006.

**FREEDOM COMMUNICATIONS OF  
NEW ENGLAND**

THE MARK CONSISTS OF STANDARD CHARACTERS WITHOUT CLAIM TO ANY PARTICULAR FONT, STYLE, SIZE, OR COLOR.

NO CLAIM IS MADE TO THE EXCLUSIVE RIGHT TO USE "COMMUNICATIONS OF NEW ENGLAND", APART FROM THE MARK AS SHOWN.

FOR RETAIL SHOPS FEATURING WIRELESS PERSONAL TELECOMMUNICATIONS SERVICES AND WIRELESS COMMUNICATION PRODUCTS; RETAIL STORE SERVICES FEATURING TELECOMMUNICATIONS SERVICE PLANS AND TELECOMMUNICATIONS SERVICE ACTIVATION AND RETAIL STORES FEATURING WIRELESS PERSONAL TELECOMMUNICATIONS SERVICES AND WIRELESS COMMUNICATION PRODUCTS (U.S. CLS. 100, 101 AND 102).

FIRST USE 4-26-2005; IN COMMERCE 4-26-2005.  
DEZMONA MIZELLE, EXAMINING ATTORNEY

SN 78-906,301. THE GUILD, INC., MADISON, WI. FILED 6-12-2006.

**THE ARTFUL HOME**

THE MARK CONSISTS OF STANDARD CHARACTERS WITHOUT CLAIM TO ANY PARTICULAR FONT, STYLE, SIZE, OR COLOR.

OWNER OF U.S. REG. NO. 2,762,661.

NO CLAIM IS MADE TO THE EXCLUSIVE RIGHT TO USE "HOME", APART FROM THE MARK AS SHOWN.

FOR RETAIL STORES FEATURING FINE CRAFTS, ART, WEARABLE ART, JEWELRY, GIFTS, HOME DECOR, FURNITURE, LIGHTING, ART GLASS, CERAMICS, SCULPTURE, PRINTS, AND FOOD PRODUCTS HANDMADE BY ARTISTS (U.S. CLS. 100, 101 AND 102).

RUSS HERMAN, EXAMINING ATTORNEY

**CLASS 35—(Continued).**

SN 78-910,399. LEO BURNETT USA, INC., CHICAGO, IL.  
FILED 6-16-2006.

# LeoShe

THE MARK CONSISTS OF STANDARD CHARACTERS WITHOUT CLAIM TO ANY PARTICULAR FONT, STYLE, SIZE, OR COLOR.

FOR ADVERTISING AGENCY SERVICES IN ALL MEDIA (U.S. CLS. 100, 101 AND 102).

FIRST USE 7-20-1998; IN COMMERCE 7-20-1998.

JAMES A. RAUEN, EXAMINING ATTORNEY

SN 78-913,698. DIAMOND AND JEWELRY GALLERY, INC.,  
WOODLAND HILLS, CA. FILED 6-21-2006.



NO CLAIM IS MADE TO THE EXCLUSIVE RIGHT TO USE "DIAMOND AND JEWELRY GALLERY", APART FROM THE MARK AS SHOWN.

THE MARK CONSISTS OF A HAND HOLDING A DIAMOND, AN AMPERSAND INSIDE OF A SQUARE AFTER THE WORD DIAMOND AND FOLLOWED BY THE WORDS JEWELRY GALLERY, THE WORDS BEING UNDERLINED.

FOR WHOLESALE AND RETAIL STORE SERVICES FEATURING JEWELRY (U.S. CLS. 100, 101 AND 102).

CHRISTINE COOPER, EXAMINING ATTORNEY

SN 78-918,510. CAMPFIRE MEDIA LLC, NEW YORK, NY.  
FILED 6-28-2006.

# CAMPFIRE

THE MARK CONSISTS OF STANDARD CHARACTERS WITHOUT CLAIM TO ANY PARTICULAR FONT, STYLE, SIZE, OR COLOR.

FOR ADVERTISING SERVICES, NAMELY, DEVELOPMENT OF BRANDED ENTERTAINMENT PROPERTIES AND PLATFORMS AND BRANDED CONTENT PROPERTIES AND PLATFORMS, NAMELY, INTEGRATING THE BRANDS OF OTHERS INTO THE CONTENT OF VARIOUS MEDIA PROGRAMMING AND DEVELOPING CONTENT BUILT AROUND BRANDS IN ALL MEDIA TECHNOLOGIES (U.S. CLS. 100, 101 AND 102).

FIRST USE 3-1-2006; IN COMMERCE 3-1-2006.

HOWARD SMIGA, EXAMINING ATTORNEY

**CLASS 35—(Continued).**

SN 78-920,715. RESOURCE AUTOMOTIVE, INC., CHICAGO, IL. FILED 6-30-2006.

# VIP VARIABLE INCOME PARTNERS

THE MARK CONSISTS OF STANDARD CHARACTERS WITHOUT CLAIM TO ANY PARTICULAR FONT, STYLE, SIZE, OR COLOR.

OWNER OF U.S. REG. NO. 3,019,313.

NO CLAIM IS MADE TO THE EXCLUSIVE RIGHT TO USE "VARIABLE INCOME PARTNERS", APART FROM THE MARK AS SHOWN.

FOR PROVIDING AUTOMOBILE DEALERS WITH INFORMATION IN THE FIELD OF INVENTORIES OF NEW AND USED AUTOMOBILES (U.S. CLS. 100, 101 AND 102).

FIRST USE 6-17-2004; IN COMMERCE 6-17-2004.

LAURIE MAYES, EXAMINING ATTORNEY

SN 78-922,194. ROMASH, MARLA ELLEN, SILVER SPRING, MD. FILED 7-4-2006.

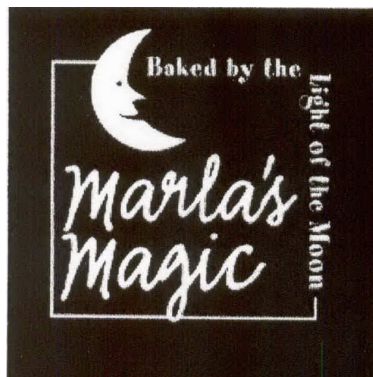

FOR RETAIL BAKERY SERVICES (U.S. CLS. 100, 101 AND 102).

FIRST USE 2-18-2003; IN COMMERCE 2-18-2003.

ELIZABETH BEYER, EXAMINING ATTORNEY

SN 78-923,951. LIEBERMAN RESEARCH WORLDWIDE, INC., LOS ANGELES, CA. FILED 7-6-2006.

# ACTIONABILITY SUITE

THE MARK CONSISTS OF STANDARD CHARACTERS WITHOUT CLAIM TO ANY PARTICULAR FONT, STYLE, SIZE, OR COLOR.

FOR MARKET RESEARCH CONSULTATION AND RELATED SERVICE, NAMELY MARKET RESEARCH STUDIES (U.S. CLS. 100, 101 AND 102).

WILLIAM VERHOSEK, EXAMINING ATTORNEY

**CLASS 35—(Continued).**

SN 78-924,340. HEALTHSTAR PHARMACY, INC., LONG-MEADOW, MA. FILED 7-7-2006.

HEALTHY LIVING PRE-PAKS

THE MARK CONSISTS OF STANDARD CHARACTERS WITHOUT CLAIM TO ANY PARTICULAR FONT, STYLE, SIZE, OR COLOR.

NO CLAIM IS MADE TO THE EXCLUSIVE RIGHT TO USE "PRE-PACKS", APART FROM THE MARK AS SHOWN. FOR ELECTRONIC PROCESSING OF ORDERS FOR OTHERS; ORDER FULFILLMENT SERVICES; AND PACKAGING ARTICLES TO THE ORDER AND SPECIFICATION OF OTHERS (U.S. CLS. 100, 101 AND 102).

FIRST USE 8-0-2006; IN COMMERCE 8-0-2006.  
BERYL GARDNER, EXAMINING ATTORNEY

**CLASS 35—(Continued).**

SN 78-925,140. MAESTRO STRATEGIES, LLC, ROSWELL, GA. FILED 7-8-2006.

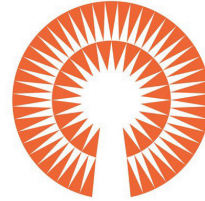

MAESTRO STRATEGIES

NO CLAIM IS MADE TO THE EXCLUSIVE RIGHT TO USE "STRATEGIES", APART FROM THE MARK AS SHOWN.

THE COLOR(S) ORANGE, WHITE, GRAY IS/ARE CLAIMED AS A FEATURE OF THE MARK.

THE MARK CONSISTS OF THREE INCOMPLETE ORANGE-COLORED CONCENTRIC CIRCLE WITH WHITE-COLORED LIGHT RAYS RADIATING FROM THE CENTER OUTWARDS AND IS DISPLAYED ABOUT THE GRAY-COLORED TEXT MAESTRO STRATEGIES.

FOR BUSINESS CONSULTING IN THE FIELD OF HEALTHCARE MANAGEMENT, NAMELY, CONSULTING WITH EXECUTIVES TO CREATE A VISION AND PLAN FOR THEIR ORGANIZATIONS (U.S. CLS. 100, 101 AND 102).

FIRST USE 6-29-2004; IN COMMERCE 6-29-2004.  
KATHLEEN LORENZO, EXAMINING ATTORNEY

SN 78-925,552. DOTHAN MOTOR COMPANY, INC., DOTHAN, AL. FILED 7-10-2006.

DealMAX

THE MARK CONSISTS OF STANDARD CHARACTERS WITHOUT CLAIM TO ANY PARTICULAR FONT, STYLE, SIZE, OR COLOR.

FOR DEALERSHIPS IN THE FIELD OF AUTOMOBILES (U.S. CLS. 100, 101 AND 102).

JAY FLOWERS, EXAMINING ATTORNEY

SN 78-924,667. BETTERGROW HYDRO, INC., LOS ANGELES, CA. FILED 7-7-2006.

BetterGrow Hydro

THE MARK CONSISTS OF STANDARD CHARACTERS WITHOUT CLAIM TO ANY PARTICULAR FONT, STYLE, SIZE, OR COLOR.

FOR RETAIL LAWN, GARDEN AND NURSERY STORES (U.S. CLS. 100, 101 AND 102).

FIRST USE 11-9-2000; IN COMMERCE 1-1-2001.  
PRISCILLA MILTON, EXAMINING ATTORNEY

SN 78-932,635. TXDC, L.P., IRVING, TX. FILED 7-19-2006.

ROMANTIC CREATION

THE MARK CONSISTS OF STANDARD CHARACTERS WITHOUT CLAIM TO ANY PARTICULAR FONT, STYLE, SIZE, OR COLOR.

NO CLAIM IS MADE TO THE EXCLUSIVE RIGHT TO USE "CREATION", APART FROM THE MARK AS SHOWN.

FOR RETAIL JEWELRY STORE SERVICES (U.S. CLS. 100, 101 AND 102).

RICHARD WHITE, EXAMINING ATTORNEY

**CLASS 35—(Continued).**

SN 78-935,503. THE ESSENCE CRAFT COMPANY LTD,  
RICHMOND HEIGHTS OHIO, OH. FILED 7-23-2006.



[www.essencecraft.com](http://www.essencecraft.com)

NO CLAIM IS MADE TO THE EXCLUSIVE RIGHT TO USE ".COM", APART FROM THE MARK AS SHOWN.  
FOR COMPUTERIZED ON-LINE RETAIL STORE SERVICES OF GOODS, NAMELY JEWELRY, BOOKS AND GIFTWARE (U.S. CLS. 100, 101 AND 102).  
FIRST USE 1-15-2005; IN COMMERCE 1-15-2005.  
LINDA ESTRADA, EXAMINING ATTORNEY

SN 78-936,290. GORGEOUS ENTERPRISES LTD, LONDON,  
UNITED KINGDOM, FILED 7-24-2006.

**GORGEOUS ENTERPRISES**

THE MARK CONSISTS OF STANDARD CHARACTERS WITHOUT CLAIM TO ANY PARTICULAR FONT, STYLE, SIZE, OR COLOR.

PRIORITY CLAIMED UNDER SEC. 44(D) ON UNITED KINGDOM APPLICATION NO. E4977054, FILED 3-23-2006.

NO CLAIM IS MADE TO THE EXCLUSIVE RIGHT TO USE "ENTERPRISES", APART FROM THE MARK AS SHOWN.

FOR ADVERTISING AND MARKETING SERVICES, NAMELY PRODUCTION OF TELEVISION COMMERCIALS; PROMOTIONAL VIDEOS; AND PROMOTIONAL CONTENT FOR THE INTERNET, MOBILE PHONES, HANDHELD COMPUTERS, PERSONAL DIGITAL ASSISTANTS, PORTABLE AND HANDHELD DIGITAL ELECTRONIC DEVICES AND ELECTRONIC ORGANIZERS (U.S. CLS. 100, 101 AND 102).

FIRST USE 1-31-1996; IN COMMERCE 1-26-1997.  
LINDA ESTRADA, EXAMINING ATTORNEY

**CLASS 35—(Continued).**

SN 78-936,635. ARCADIA GROUP BRANDS LIMITED,  
LONDON, UNITED KINGDOM, FILED 7-25-2006.

**TOP MAN**

THE MARK CONSISTS OF STANDARD CHARACTERS WITHOUT CLAIM TO ANY PARTICULAR FONT, STYLE, SIZE, OR COLOR.

OWNER OF UNITED KINGDOM REG. NO. 2017962, DATED 4-19-1995, EXPIRES 4-19-2015.

NO CLAIM IS MADE TO THE EXCLUSIVE RIGHT TO USE "MAN", APART FROM THE MARK AS SHOWN.

FOR RETAIL STORE SERVICES AND ONLINE RETAIL STORE SERVICES FEATURING CLOTHING, FOOTWEAR, HAIR ACCESSORIES, BAGS, MILLINERY, JEWELRY, IMITATION JEWELRY, WATCHES, EYE WEAR AND SPORTING GOODS; CATALOG ORDERING SERVICES FEATURING CLOTHING, FOOTWEAR, HAIR ACCESSORIES, BAGS, MILLINERY, JEWELRY, IMITATION JEWELRY, WATCHES, EYE WEAR AND SPORTING GOODS; PROVIDING HOME SHOPPING SERVICES IN THE FIELD OF CLOTHING, FOOTWEAR, HAIR ACCESSORIES, BAGS, MILLINERY, JEWELRY, IMITATION JEWELRY, WATCHES, EYE WEAR AND SPORTING GOODS BY MEANS OF TELEVISION; CUSTOMER SERVICE IN THE FIELD OF PROVIDING INFORMATION, ADVICE AND ASSISTANCE IN THE SELECTION OF GOODS IN THE FIELD OF CLOTHING, FOOTWEAR, HAIR ACCESSORIES, BAGS, MILLINERY, JEWELRY, IMITATION JEWELRY, WATCHES, EYE WEAR AND SPORTING GOODS BY MEANS OF TELEVISION (U.S. CLS. 100, 101 AND 102).

JOHN DALIER, EXAMINING ATTORNEY

SN 78-938,976. SOURCE EXECUTIVE SEARCH|CONSULTING, INC., LUTZ, FL. FILED 7-27-2006.



NO CLAIM IS MADE TO THE EXCLUSIVE RIGHT TO USE "EXECUTIVE SEARCH CONSULTING", APART FROM THE MARK AS SHOWN.

THE COLOR(S) BLUE, GRAY AND RED IS/ARE CLAIMED AS A FEATURE OF THE MARK.

THE WORD SOURCE IS IN THE COLOR BLUE, WITHIN THE LETTER "O" OF THE TERM "SOURCE" IS A GRAY TRIANGLE WHICH OVERLAPS THE UPPER RIGHT SECTION OF THE LETTER "O," AT THE NARROW END OF THE TRIANGLE DESIGN APPEARS A DARK RED DOT IN THE MIDDLE OF THE LETTER "O," THE PORTION "EXECUTIVE SEARCH | CONSULTING" IS IN THE COLOR GRAY; THE WHITE BACKGROUND IS NOT PART OF THE MARK.

FOR CONSULTANCY OF PERSONNEL RECRUITMENT; EMPLOYMENT COUNSELING AND RECRUITING; EMPLOYMENT HIRING, RECRUITING, PLACEMENT, STAFFING AND CAREER NETWORKING SERVICES; EXECUTIVE SEARCH AND PLACEMENT SERVICES; PERSONNEL PLACEMENT AND RECRUITMENT (U.S. CLS. 100, 101 AND 102).

FIRST USE 3-12-2004; IN COMMERCE 9-1-2004.  
CHRISTOPHER BUONGIORNO, EXAMINING ATTORNEY



**CLASS 35—(Continued).**

SN 78-939,578. GRAUPERA, VIDAL D., DBA VDG COMPANY, LOS ALTOS, CA. FILED 7-28-2006.

**ENCHANTUS**

THE MARK CONSISTS OF STANDARD CHARACTERS WITHOUT CLAIM TO ANY PARTICULAR FONT, STYLE, SIZE, OR COLOR.

FOR COMPILATION AND MANAGEMENT VIA THE INTERNET OF ADVERTISING AND PROMOTIONAL OFFERS DISSEMINATED BY E-MAIL AND ELECTRONIC MESSAGING; PROVIDING A WEB SITE ON THE INTERNET FEATURING INFORMATION IN THE FIELD OF COMMERCIAL PROMOTIONS FOR THE GOODS AND SERVICES OF OTHERS; PROVIDING AN ONLINE ELECTRONIC DATABASE ON THE INTERNET IN THE FIELD OF COMMERCIAL PROMOTIONS FOR THE GOODS AND SERVICES OF OTHERS; PROVIDING BUSINESS MANAGEMENT AND BUSINESS ADMINISTRATION SERVICES VIA THE INTERNET IN THE FIELD OF SCHEDULING, REPORTING, MONITORING, AND EVALUATING PROJECT PERFORMANCE (U.S. CLS. 100, 101 AND 102).

STANLEY I. OSBORNE, EXAMINING ATTORNEY

SN 78-939,938. EVO SOLUTIONS, L.P., AMARILLO, TX. FILED 7-28-2006.

**EVO DEALER SOLUTIONS**

THE MARK CONSISTS OF STANDARD CHARACTERS WITHOUT CLAIM TO ANY PARTICULAR FONT, STYLE, SIZE, OR COLOR.

NO CLAIM IS MADE TO THE EXCLUSIVE RIGHT TO USE "DEALER SOLUTIONS", APART FROM THE MARK AS SHOWN.

FOR DISSEMINATION OF ADVERTISING FOR AUTOMOBILE DEALERS VIA THE INTERNET; AND ASSOCIATION SERVICES, NAMELY, PROMOTING THE INTERESTS OF AUTOMOBILE DEALERS THROUGH SEARCH ENGINE PLACEMENT, ANALYSIS AND REPORTING (U.S. CLS. 100, 101 AND 102).

FIRST USE 8-25-2005; IN COMMERCE 8-25-2005.  
CHRISIE B. KING, EXAMINING ATTORNEY

**CLASS 35—(Continued).**

SN 78-941,142. COLUMBIA RIVER RANCH, LLC, ISSAQUAH, WA. FILED 7-31-2006.



FOR RETAIL GIFT SHOP SERVICES FEATURING CLOTHING, SOUVENIRS, FOOD AND BEVERAGES, PERSONAL CARE PRODUCTS AND RECREATIONAL EQUIPMENT AND SUPPLIES (U.S. CLS. 100, 101 AND 102).

LOURDES AYALA, EXAMINING ATTORNEY

SN 78-945,093. MODELTRAINBROKER.COM, INC., SANDPOINT, ID. FILED 8-4-2006.



NO CLAIM IS MADE TO THE EXCLUSIVE RIGHT TO USE "MODELTRAINBROKER.COM", APART FROM THE MARK AS SHOWN.

THE APPLICANT CLAIMS COLOR AS A FEATURE OF THE MARK, NAMELY, BLACK WHITE RED.

THE MARK CONSISTS OF WORD MODELTRAINBROKER.COM AND PICTURE OF TRAIN IN BLACK AND WHITE, WORDS ON TRACK 24/7 IN RED.

FOR ADVERTISING AGENCIES, NAMELY, PROMOTING THE GOODS AND SERVICES OF OTHERS; ADVERTISING AND COMMERCIAL INFORMATION SERVICES, VIA THE INTERNET; ARRANGING OF CONTRACTUAL SERVICES WITH THIRD PARTIES; CATALOG ORDERING SERVICE FEATURING MODEL TRAINS; COMPUTERIZED ON-LINE RETAIL STORE SERVICES IN THE FIELD OF MODEL TRAINS; CO-OPERATIVE ADVERTISING AND MARKETING SERVICES BY WAY OF SOLICITATION, CUSTOMER SERVICE AND PROVIDING MARKETING INFORMATION VIA WEBSITES ON A GLOBAL COMPUTER NETWORK; DIRECT MARKETING SERVICES; DISSEMINATION OF ADVERTISING FOR OTHERS VIA AN ONLINE COMMUNICATIONS NETWORK ON THE INTERNET; ELECTRONIC CATALOG SERVICES FEATURING MODEL TRAINS; ELECTRONIC COMMERCE SERVICES, NAMELY PROVIDING INFORMATION PRODUCTS VIA TELECOMMUNICATION NETWORKS FOR ADVERTISING AND SALES PURPOSES; ELECTRONIC RETAILING SERVICES VIA COMPUTER FEATURING MODEL TRAINS; ON-LINE ORDERING SERVICES FEATURING MODEL TRAINS; ON-LINE TRADING SERVICES IN WHICH SELLER POSTS PRODUCTS TO BE AUCTIONED AND BIDDING

**CLASS 35—(Continued).**

IS DONE VIA THE INTERNET; ONLINE CONSIGNMENT SERVICES WHEREBY GOODS ARE RECEIVED ON CONSIGNMENT FOR AUCTION ON AN ONLINE AUCTION SITE; ORGANISATION OF INTERNET AUCTIONS; PROMOTING THE GOODS AND SERVICES OF OTHERS BY MEANS OF OPERATING AN ON-LINE SHOPPING MALL WITH LINKS TO THE RETAIL WEB SITES OF OTHERS; PROMOTING THE GOODS AND SERVICES OF OTHERS BY PROVIDING A WEB SITE AT WHICH USERS CAN LINK TO MODEL TRAINS; PROMOTING THE GOODS AND SERVICES OF OTHERS BY PROVIDING HYPERTEXT LINKS TO THE WEB SITES OF OTHERS; PROMOTING THE GOODS AND SERVICES OF OTHERS THROUGH ON-LINE ORDERING AND CATALOGING OF THOSE GOODS AND SERVICES; PROVIDING A WEB SITE WHICH FEATURES ADVERTISEMENTS FOR THE GOODS AND SERVICES OF OTHERS ON A GLOBAL COMPUTER NETWORK; PROVIDING SPACE AT A WEB SITE FOR THE ADVERTISEMENT OF THE GOODS AND SERVICES OF OTHERS (U.S. CLS. 100, 101 AND 102).

BARBARA RUTLAND, EXAMINING ATTORNEY

---

SN 78-946,943. TRAJAH, INC., BUFFALO GROVE, IL. FILED 8-8-2006.

# TRAJAH

THE MARK CONSISTS OF STANDARD CHARACTERS WITHOUT CLAIM TO ANY PARTICULAR FONT, STYLE, SIZE, OR COLOR.

FOR ONLINE EXCHANGE SERVICES, NAMELY BARTERING OF GOODS AND SERVICES FOR OTHERS; PROVIDING AN ON-LINE SEARCHABLE DATABASE FEATURING CLASSIFIED AD LISTINGS (U.S. CLS. 100, 101 AND 102).

DEBRA LEE, EXAMINING ATTORNEY

**CLASS 35—(Continued).**

SN 78-947,295. BABYUNIVERSE, INC., JUPITER, FL. FILED 8-8-2006.

# BABYUNIVERSE

THE MARK CONSISTS OF STANDARD CHARACTERS WITHOUT CLAIM TO ANY PARTICULAR FONT, STYLE, SIZE, OR COLOR.

OWNER OF U.S. REG. NOS. 2,471,278, 2,545,925 AND 3,126,119.

FOR COMPUTERIZED ON-LINE ORDERING SERVICES FROM WHOLESALE DISTRIBUTORSHIPS, ALL FEATURING THE FOLLOWING BABY PRODUCTS, NAMELY, BATH TUBS, SEATS AND ACCESSORIES THEREFOR, BEDDING, CLOTHING, DIAPER BAGS, DIAPER PAILS AND ACCESSORIES THEREFOR, FEEDING SUPPLIES, NAMELY, BOTTLES, BOTTLE WARMERS, BREAST PUMPS AND DISHWARE, FURNITURE, NAMELY, CLOCKS, CRIBS, HAMPERS, AND LAMPS, GROOMING AIDS, NAMELY, BRUSHES, COMBS AND MANICURE INSTRUMENTS, HEALTHCARE ITEMS, NAMELY, ASPIRATORS, HUMIDIFIERS, PACIFIERS, SPOONS FOR DISPENSING MEDICINE, THERMOMETERS AND TOOTHBRUSHES; AND TOYS (U.S. CLS. 100, 101 AND 102).

FIRST USE 2-0-1999; IN COMMERCE 2-0-1999.

SCOTT SISUN, EXAMINING ATTORNEY

---

SN 78-948,164. ON THE GO SOLUTIONS, INC., SKOKIE, IL. FILED 8-9-2006.

# ON THE GO SOLUTIONS

THE MARK CONSISTS OF STANDARD CHARACTERS WITHOUT CLAIM TO ANY PARTICULAR FONT, STYLE, SIZE, OR COLOR.

FOR RETAIL STORE SERVICES AND ONLINE RETAIL STORE SERVICES FEATURING CONSUMER ELECTRONICS, PERSONAL COMMUNICATION DEVICES, COMBINATION PERSONAL DIGITAL ASSISTANTS AND COMMUNICATION DEVICES, AND ACCESSORIES AND CASES FOR THE DEVICES (U.S. CLS. 100, 101 AND 102).

FIRST USE 8-16-2002; IN COMMERCE 8-16-2002.

AISHA CLARKE, EXAMINING ATTORNEY

**CLASS 35—(Continued).**

SN 78-948,519. SLC CONSULTANTS, INC., EVANSTON, IL. FILED 8-9-2006.



FOR BUSINESS INFORMATION MANAGEMENT; INFORMATION AND DATA COMPILING AND ANALYZING RELATING TO BUSINESS MANAGEMENT (U.S. CLS. 100, 101 AND 102).  
RONALD AIKENS, EXAMINING ATTORNEY

**CLASS 35—(Continued).**

SN 78-951,272. RICHARDSON, ARTHUR H., ATLANTA, GA. FILED 8-14-2006.



NO CLAIM IS MADE TO THE EXCLUSIVE RIGHT TO USE "NEWS", APART FROM THE MARK AS SHOWN.  
FOR RETAIL STORES FEATURING CLOTHING, CANDY, SNACKS, PERIODICALS AND NOVELTIES (U.S. CLS. 100, 101 AND 102).  
FIRST USE 11-1-2005; IN COMMERCE 11-1-2005.  
DAWN HAN, EXAMINING ATTORNEY

SN 78-948,606. SK2 HOLDINGS, INC., ROSWELL, GA. FILED 8-9-2006.



NO CLAIM IS MADE TO THE EXCLUSIVE RIGHT TO USE "DRESSES FOR LESS", APART FROM THE MARK AS SHOWN.  
FOR RETAIL STORE SERVICES FOR APPAREL AND ACCESSORIES (U.S. CLS. 100, 101 AND 102).  
TRICIA SONNEBORN, EXAMINING ATTORNEY

SN 78-953,976. HUGGETT, ERICA, CHINO, CA. FILED 8-17-2006.

**Love Letters Boutique**

THE MARK CONSISTS OF STANDARD CHARACTERS WITHOUT CLAIM TO ANY PARTICULAR FONT, STYLE, SIZE, OR COLOR.  
NO CLAIM IS MADE TO THE EXCLUSIVE RIGHT TO USE "BOUTIQUE", APART FROM THE MARK AS SHOWN.  
FOR ON-LINE RETAIL STORE SERVICES FEATURING BACHELORETTE, BRIDAL AND PET BOUTIQUE ACCESSORIES, GIFTS, GIRLS NIGHT OUT, BACHELOR, PARTY SUPPLIES AND CLOTHING (U.S. CLS. 100, 101 AND 102).  
FIRST USE 4-1-2006; IN COMMERCE 6-1-2006.  
MORENO, PAUL, EXAMINING ATTORNEY

SN 78-951,264. RICHARDSON, ARTHUR H., ATLANTA, GA. FILED 8-14-2006.

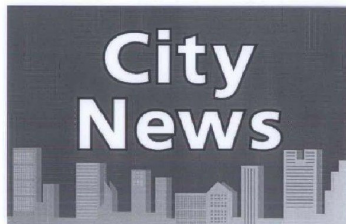

NO CLAIM IS MADE TO THE EXCLUSIVE RIGHT TO USE "NEWS", APART FROM THE MARK AS SHOWN.  
FOR RETAIL STORES FEATURING CLOTHING, CANDY, SNACKS, PERIODICALS AND NOVELTIES (U.S. CLS. 100, 101 AND 102).  
FIRST USE 11-1-2005; IN COMMERCE 11-1-2005.  
DAWN HAN, EXAMINING ATTORNEY

SN 78-954,448. BRECHER, SETH W., WASHINGTON, DC. FILED 8-17-2006.

**Scrappy Consumer**

THE MARK CONSISTS OF STANDARD CHARACTERS WITHOUT CLAIM TO ANY PARTICULAR FONT, STYLE, SIZE, OR COLOR.  
NO CLAIM IS MADE TO THE EXCLUSIVE RIGHT TO USE "CONSUMER", APART FROM THE MARK AS SHOWN.  
FOR PROVIDING A WEBSITE FEATURING SHOPPING TIPS (U.S. CLS. 100, 101 AND 102).  
STEVEN JACKSON, EXAMINING ATTORNEY

**CLASS 35—(Continued).**

SN 78-954,570. J.H. FENNER & CO. LIMITED, EAST YORKSHIRE, ENGLAND, FILED 8-17-2006.

CONVEYING PERFORMANCE TO  
THE POWER OF 3

THE MARK CONSISTS OF STANDARD CHARACTERS WITHOUT CLAIM TO ANY PARTICULAR FONT, STYLE, SIZE, OR COLOR.

FOR BUSINESS SERVICES, NAMELY, CONSULTATION, MANAGEMENT AND SALES PROMOTION SERVICES IN THE FIELD OF INDUSTRIAL CONVEYOR BELTS (U.S. CLS. 100, 101 AND 102).

FIRST USE 3-0-2006; IN COMMERCE 3-0-2006.

ALEXANDER L. POWERS, EXAMINING ATTORNEY

SN 78-955,509. RECTOR, KENNETH M., HOUSTON, TX. FILED 8-18-2006.

Barefoot Drums of Houston

THE MARK CONSISTS OF STANDARD CHARACTERS WITHOUT CLAIM TO ANY PARTICULAR FONT, STYLE, SIZE, OR COLOR.

NO CLAIM IS MADE TO THE EXCLUSIVE RIGHT TO USE "HOUSTON", APART FROM THE MARK AS SHOWN.

FOR CHARITABLE SERVICES, NAMELY ORGANIZING AND CONDUCTING VOLUNTEER PROGRAMS AND COMMUNITY SERVICE PROJECTS IN THE FIELD OF ABUSED WOMEN AND CHILDREN AND ORGANIZING WOMEN'S GROUPS TO UNDERTAKE PROJECTS WHICH BENEFIT THE HOMELESS, ABUSED, AT RISK WOMEN AND CHILDREN (U.S. CLS. 100, 101 AND 102).

ELLEN BURNS, EXAMINING ATTORNEY

SN 78-956,228. SEATONCORP, CHICAGO, IL. FILED 8-21-2006.

STUDENTSCOUT

THE MARK CONSISTS OF STANDARD CHARACTERS WITHOUT CLAIM TO ANY PARTICULAR FONT, STYLE, SIZE, OR COLOR.

OWNER OF U.S. REG. NOS. 2,522,924 AND 2,897,871.

FOR MANAGEMENT OF STUDENT ADMISSIONS PROCESS FOR EDUCATIONAL INSTITUTIONS (U.S. CLS. 100, 101 AND 102).

CHRISTOPHER BUONGIORNO, EXAMINING ATTORNEY

**CLASS 35—(Continued).**

SN 78-957,155. REAL BALANCED SOLUTIONS, INC., ORLANDO, FL. FILED 8-22-2006.

Green Lean

THE MARK CONSISTS OF STANDARD CHARACTERS WITHOUT CLAIM TO ANY PARTICULAR FONT, STYLE, SIZE, OR COLOR.

FOR BUSINESS MANAGEMENT CONSULTANCY SERVICES (U.S. CLS. 100, 101 AND 102).

KYLE PEETE, EXAMINING ATTORNEY

SN 78-957,338. COUNT US IN, INC., FT. LAUDERDALE, FL. FILED 8-22-2006.

COUNT US IN

THE MARK CONSISTS OF STANDARD CHARACTERS WITHOUT CLAIM TO ANY PARTICULAR FONT, STYLE, SIZE, OR COLOR.

FOR WEBSITE PROVIDING INFORMATION REGARDING THE US POLITICAL PROCESS FOR US SERVICEMEN AND MILITARY (U.S. CLS. 100, 101 AND 102).

EMILY CHUO, EXAMINING ATTORNEY

SN 78-957,410. BOFFI S.P.A., MILAN, ITALY, FILED 8-22-2006.

BY BOFFI

THE MARK CONSISTS OF STANDARD CHARACTERS WITHOUT CLAIM TO ANY PARTICULAR FONT, STYLE, SIZE, OR COLOR.

OWNER OF U.S. REG. NO. 1,019,084.

FOR RETAIL DEPARTMENT STORE SERVICES; RETAIL STORE SERVICES FEATURING A WIDE VARIETY OF CONSUMER GOODS OF OTHERS; RETAIL VARIETY STORES (U.S. CLS. 100, 101 AND 102).

DANNEAN HETZEL, EXAMINING ATTORNEY

**CLASS 35—(Continued).**

SN 78-958,005. PTL GLOBAL, INC., WALNUT, CA. FILED 8-22-2006.

**Fashion Aid 411**

THE MARK CONSISTS OF STANDARD CHARACTERS WITHOUT CLAIM TO ANY PARTICULAR FONT, STYLE, SIZE, OR COLOR.

FOR INTERNET AND CATALOGUE ORDERING SERVICE AND WHOLESALE DISTRIBUTORSHIP FEATURING LINGERIE AND LINGERIE ACCESSORIES, NAMELY PUSH UP BRAS, ADHESIVE BRAS, BRA PADS, INTERCHANGEABLE/REMOVABLE SHOULDER STRAPS FOR USE WITH BRASSIERES (U.S. CLS. 100, 101 AND 102).

FIRST USE 8-18-2006; IN COMMERCE 8-18-2006.  
KIMBERLY PERRY, EXAMINING ATTORNEY

SN 78-958,100. TANNER, TIFFANY N, COLLINSVILLE, OK. AND REISS, DANIELLE S, BARTLESVILLE, OK. FILED 8-22-2006.

**MISSFOXY**

THE MARK CONSISTS OF STANDARD CHARACTERS WITHOUT CLAIM TO ANY PARTICULAR FONT, STYLE, SIZE, OR COLOR.

FOR RETAIL CLOTHING BOUTIQUES (U.S. CLS. 100, 101 AND 102).

ALYSSA PALADINO, EXAMINING ATTORNEY

SN 78-958,202. ALBERDESTON, ROBERTO, ORLANDO, FL. FILED 8-23-2006.

**Pulguilla**

THE MARK CONSISTS OF STANDARD CHARACTERS WITHOUT CLAIM TO ANY PARTICULAR FONT, STYLE, SIZE, OR COLOR.

THE FOREIGN WORDING IN THE MARK TRANSLATES INTO ENGLISH AS LITTLE FLEA OR SMALL FLEA.

FOR PROVIDING A WEB SITE THAT ENABLES USERS TO POST ITEMS FOR SALE THROUGH ONLINE CLASSIFIED ADVERTISEMENTS (U.S. CLS. 100, 101 AND 102).

PRISCILLA MILTON, EXAMINING ATTORNEY

**CLASS 35—(Continued).**

SN 78-958,215. BLATT, STEPHEN, WAYNESVILLE, NC. FILED 8-23-2006.

**DOCLOC**

THE MARK CONSISTS OF STANDARD CHARACTERS WITHOUT CLAIM TO ANY PARTICULAR FONT, STYLE, SIZE, OR COLOR.

FOR TEMPORARY PHYSICIAN PLACEMENT SERVICES (U.S. CLS. 100, 101 AND 102).

PRISCILLA MILTON, EXAMINING ATTORNEY

SN 78-958,302. ALABAMA STAFF, INC., BIRMINGHAM, AL. FILED 8-23-2006.

**AMSOURCETIME**

THE MARK CONSISTS OF STANDARD CHARACTERS WITHOUT CLAIM TO ANY PARTICULAR FONT, STYLE, SIZE, OR COLOR.

OWNER OF U.S. REG. NO. 2,363,132.

FOR PROVIDING COMPUTERIZED RECORDS MANAGEMENT SERVICES, HUMAN RESOURCES MANAGEMENT SERVICES, AND BUSINESS PAYROLL ADMINISTRATION SERVICES FOR OTHERS, NAMELY, PROVIDING TIME AND ATTENDANCE RECORDKEEPING, EMPLOYEE SCHEDULING, EMPLOYEE SHIFT SWAPPING MONITORING AND RECORDKEEPING, AND PAYROLL REPORTING AND PROCESSING (U.S. CLS. 100, 101 AND 102).

FIRST USE 7-21-2006; IN COMMERCE 7-21-2006.  
LINDSEY RUBIN, EXAMINING ATTORNEY

SN 78-958,336. BARLOW AUCTION GROUP, JACKSONVILLE BEACH, FL. FILED 8-23-2006.



NO CLAIM IS MADE TO THE EXCLUSIVE RIGHT TO USE "AUCTION GROUP" AND "REAL ESTATE AUCTIONEERS", APART FROM THE MARK AS SHOWN.

THE APPLICANT CLAIMS COLOR AS A FEATURE OF THE MARK, NAMELY, GREEN, BLACK, BLUE.

THE MARK CONSISTS OF SERIES OF ATTACHED

**CLASS 35—(Continued).**

HOMES WITHIN A RECTANGULAR BORDER. THE COLOR OF THE HOMES ARE GREEN AND BLACK. THE BORDER IS BLACK WITH BANNERS AT THE TOP AND BOTTOM. THE TOP BANNERS CONSIST OF REVERSE LETTERING AND OF THE "BARLOW AUCTION GROUP" WORDING. THE BOTTOM BANNER CONSIST OF REVERSE LETTERING AND OF THE "REAL ESTATE AUCTIONEERS" WORDING. THE WORDING "BARLOW AUCTION GROUP" AND "REAL ESTATE AUCTIONEERS" IS TRANSPARENT, THAT IS, IT TAKES ON THE COLOR OF WHATEVER BACKGROUND ON WHICH THE MARK IS PLACED.

FOR REAL ESTATE AUCTIONS (U.S. CLS. 100, 101 AND 102).

TRAVIS WHEATLEY, EXAMINING ATTORNEY

---

SN 78-958,753. IDEASONE INCORPORATED, KAMUELA, HI. FILED 8-23-2006.

### Raising consciousness one life at a time

THE MARK CONSISTS OF STANDARD CHARACTERS WITHOUT CLAIM TO ANY PARTICULAR FONT, STYLE, SIZE, OR COLOR.

FOR GENERAL BUSINESS MERCHANDISING SERVICES, NAMELY, MARKETING OVER A GLOBAL COMPUTER NETWORK (U.S. CLS. 100, 101 AND 102).

MICHELLE DUBOIS, EXAMINING ATTORNEY

---

SN 78-958,765. IDEASONE INCORPORATED, KAMUELA, HI. FILED 8-23-2006.

### learning is a lifestyle

THE MARK CONSISTS OF STANDARD CHARACTERS WITHOUT CLAIM TO ANY PARTICULAR FONT, STYLE, SIZE, OR COLOR.

FOR GENERAL BUSINESS MERCHANDISING SERVICES, NAMELY, MARKETING OVER A GLOBAL COMPUTER NETWORK (U.S. CLS. 100, 101 AND 102).

MICHELLE DUBOIS, EXAMINING ATTORNEY

**CLASS 35—(Continued).**

SN 78-958,834. THE WRESTLING ROOM, INC., CORTLAND MANOR, NY. FILED 8-23-2006.



NO CLAIM IS MADE TO THE EXCLUSIVE RIGHT TO USE "WRESTLING", APART FROM THE MARK AS SHOWN.

FOR WEB-BASED ONLINE RETAIL STORE FEATURING WRESTLING EQUIPMENT (U.S. CLS. 100, 101 AND 102).

FIRST USE 4-1-2005; IN COMMERCE 4-1-2005.

HANNO RITTNER, EXAMINING ATTORNEY

---

SN 78-959,130. CZERWINSKI, STEVEN E., CHURCHVILLE, MD. FILED 8-23-2006.

### CZ's Buns & Hoses

THE MARK CONSISTS OF STANDARD CHARACTERS WITHOUT CLAIM TO ANY PARTICULAR FONT, STYLE, SIZE, OR COLOR.

FOR TRANSPORTABLE HOT DOG STAND SERVICES FEATURING HOT DOGS, POLISH SAUSAGE, BRATWURST, TAMALES AND OTHER RELATED FOOD ITEMS (U.S. CLS. 100, 101 AND 102).

JEAN IM, EXAMINING ATTORNEY

---

SN 78-959,318. MARGIE KIVETT RIPMASTER, BOULDER, CO. FILED 8-24-2006.

### Spirit of Provence

THE MARK CONSISTS OF STANDARD CHARACTERS WITHOUT CLAIM TO ANY PARTICULAR FONT, STYLE, SIZE, OR COLOR.

OWNER OF U.S. REG. NO. 2,406,733.

FOR COMPUTERIZED ONLINE ORDERING FEATURING GENERAL MERCHANDISE AND GENERAL CONSUMER GOODS (U.S. CLS. 100, 101 AND 102).

FIRST USE 1-25-2000; IN COMMERCE 1-25-2000.

SETH A. RAPPAPORT, EXAMINING ATTORNEY

**CLASS 35—(Continued).**

SN 78-959,506. HOT DISH ADVERTISING, LLC, MINNEAPOLIS, MN. FILED 8-24-2006.

## Franfocused

THE MARK CONSISTS OF STANDARD CHARACTERS WITHOUT CLAIM TO ANY PARTICULAR FONT, STYLE, SIZE, OR COLOR.

FOR ADVERTISING AGENCIES; ADVERTISING AGENCIES, NAMELY, PROMOTING THE SERVICES OF THE FRANCHISING INDUSTRY THROUGH THE DISTRIBUTION OF PRINTED AND AUDIO PROMOTIONAL MATERIALS AND BY RENDERING SALES PROMOTION ADVICE; ADVERTISING AND COMMERCIAL INFORMATION SERVICES, VIA THE INTERNET; ADVERTISING AND MARKETING; ADVERTISING CONSULTATION; ADVERTISING SERVICES; ADVERTISING THROUGH ALL PUBLIC COMMUNICATION MEANS; ADVERTISING VIA ELECTRONIC MEDIA AND SPECIFICALLY THE INTERNET; ADVERTISING, MARKETING AND PROMOTION SERVICES (U.S. CLS. 100, 101 AND 102).

TRAVIS WHEATLEY, EXAMINING ATTORNEY

---

SN 78-959,780. MARCO POLO PUBLICATIONS, INC., SAINT PETERSBURG, FL. FILED 8-24-2006.

## HDTrader

THE MARK CONSISTS OF STANDARD CHARACTERS WITHOUT CLAIM TO ANY PARTICULAR FONT, STYLE, SIZE, OR COLOR.

FOR PROVIDING A WEB SITE THAT ENABLES USERS TO POST ITEMS FOR SALE THROUGH ONLINE CLASSIFIED ADVERTISEMENTS (U.S. CLS. 100, 101 AND 102).

FIRST USE 9-5-2000; IN COMMERCE 9-5-2000.  
IRA J. GOODSaid, EXAMINING ATTORNEY

**CLASS 35—(Continued).**

SN 78-959,854. ADEPTMEDIA CORPORATION, HUNTSVILLE, AL. FILED 8-24-2006.

## AdeptMedia

THE MARK CONSISTS OF STANDARD CHARACTERS WITHOUT CLAIM TO ANY PARTICULAR FONT, STYLE, SIZE, OR COLOR.

FOR PROVIDING ADVERTISING, MARKETING AND PROMOTIONAL SERVICES, NAMELY DEVELOPMENT AND MANAGEMENT OF ADVERTISING CAMPAIGNS FOR COMMUNICATION MEDIA, NAMELY PRINT, ONLINE AND MOBILE ELECTRONIC DEVICES; MANAGEMENT AND COMPILATION OF TARGETED DIRECT ADVERTISING INFORMATION; TARGETING OF CONSUMERS TO RECEIVE ADVERTISEMENTS; PROVIDING A WEBSITE FEATURING INFORMATION IN THE FIELD OF ADVERTISING CAMPAIGNS (U.S. CLS. 100, 101 AND 102).

TARAH HARDY, EXAMINING ATTORNEY

---

SN 78-960,254. HR - OUTSIDE THE BOX, INC., WELLESLEY, MA. FILED 8-25-2006.

## HRONECALL

THE MARK CONSISTS OF STANDARD CHARACTERS WITHOUT CLAIM TO ANY PARTICULAR FONT, STYLE, SIZE, OR COLOR.

FOR PROVIDING HUMAN CAPITAL MANAGEMENT CONSULTING, PERSONNEL AND GUIDANCE; HUMAN CAPITAL MANAGEMENT OUTSOURCING; PAYROLL PREPARATION; EMPLOYEE OUTPLACEMENT SERVICES (U.S. CLS. 100, 101 AND 102).

JENNIFER KRISP, EXAMINING ATTORNEY

---

SN 78-960,639. CHERRY, BEKAERT & HOLLAND, RICHMOND, VA. FILED 8-25-2006.

## CB&H

THE MARK CONSISTS OF STANDARD CHARACTERS WITHOUT CLAIM TO ANY PARTICULAR FONT, STYLE, SIZE, OR COLOR.

FOR ACCOUNTING AND BUSINESS CONSULTING SERVICES (U.S. CLS. 100, 101 AND 102).

FIRST USE 12-1-1994; IN COMMERCE 12-1-1994.  
JULIE GUTTADAURO, EXAMINING ATTORNEY

**CLASS 35—(Continued).**

SN 78-960,642. MANAGEMENT ASSOCIATION FOR PRIVATE PHOTOGRAMMETRIC SURVEYORS, RESTON, VA. FILED 8-25-2006.

MANAGEMENT ASSOCIATION FOR  
PRIVATE PHOTOGRAMMETRIC  
SURVEYORS

THE MARK CONSISTS OF STANDARD CHARACTERS WITHOUT CLAIM TO ANY PARTICULAR FONT, STYLE, SIZE, OR COLOR.

OWNER OF U.S. REG. NOS. 1,590,262 AND 2,364,612.  
FOR ASSOCIATION SERVICES, NAMELY, PROMOTING THE INTERESTS OF PRIVATE SECTOR PHOTOGRAMMETRIC SURVEYORS AND RELATED PROFESSIONALS, NAMELY, THOSE ENGAGED IN SURVEYING, PHOTOGRAMMETRY, SATELLITE REMOTE SENSING, AIRBORNE REMOTE SENSING, AERIAL PHOTOGRAPHY, HYDROGRAPHY, AERIAL AND SATELLITE IMAGE PROCESSING, GPS AND GIS DATA COLLECTION AND CONVERSION SERVICES (U.S. CLS. 100, 101 AND 102).

FIRST USE 9-21-1984; IN COMMERCE 9-21-1984.  
SETH A. RAPPAPORT, EXAMINING ATTORNEY

SN 78-960,786. PLUS DELTA CONSULTING, LLC, LOS ANGELES, CA. FILED 8-25-2006.

Improving Performance  
through Virtual Teaming

THE MARK CONSISTS OF STANDARD CHARACTERS WITHOUT CLAIM TO ANY PARTICULAR FONT, STYLE, SIZE, OR COLOR.

OWNER OF U.S. REG. NO. 2,693,149.  
FOR BUSINESS CONSULTING SERVICES (U.S. CLS. 100, 101 AND 102).  
FIRST USE 8-1-2006; IN COMMERCE 8-1-2006.  
ELLEN PERKINS, EXAMINING ATTORNEY

SN 78-960,799. PLUS DELTA CONSULTING, LLC, LOS ANGELES, CA. FILED 8-25-2006.

Improving Performance  
through Leadership  
Excellence

THE MARK CONSISTS OF STANDARD CHARACTERS WITHOUT CLAIM TO ANY PARTICULAR FONT, STYLE, SIZE, OR COLOR.

OWNER OF U.S. REG. NO. 2,693,149.  
FOR BUSINESS CONSULTING SERVICES (U.S. CLS. 100, 101 AND 102).  
FIRST USE 8-1-2006; IN COMMERCE 8-1-2006.  
ELLEN PERKINS, EXAMINING ATTORNEY

**CLASS 35—(Continued).**

SN 78-960,927. BROWN, THOMAS W., TUKWILLA, WA. FILED 8-25-2006.

MONEY DOESN'T GROW ON  
TREES, BUT IT CAN BE FOUND  
IN YOUR REAL ESTATE-THAT'S  
WHY OWNERS LOVE IT!

THE MARK CONSISTS OF STANDARD CHARACTERS WITHOUT CLAIM TO ANY PARTICULAR FONT, STYLE, SIZE, OR COLOR.

FOR FINANCIAL SERVICES, NAMELY, COST SEGREGATION ANALYSIS AND PROPERTY TAX REVIEW (U.S. CLS. 100, 101 AND 102).  
ELLEN BURNS, EXAMINING ATTORNEY

SN 78-960,972. INNOVATION MANAGEMENT PARTNERS, LLC, CHICAGO, IL. FILED 8-25-2006.

BRINGING TOMORROWS' IDEAS  
TO MARKET TODAY

THE MARK CONSISTS OF STANDARD CHARACTERS WITHOUT CLAIM TO ANY PARTICULAR FONT, STYLE, SIZE, OR COLOR.

FOR BUSINESS CONSULTATION (U.S. CLS. 100, 101 AND 102).  
FIRST USE 6-1-2006; IN COMMERCE 6-1-2006.  
FRED MANDIR, EXAMINING ATTORNEY

SN 78-961,024. THE FRANK LLOYD WRIGHT FOUNDATION, SCOTTSDALE, AZ. FILED 8-25-2006.

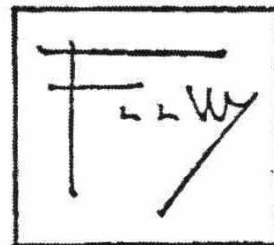

OWNER OF U.S. REG. NO. 1,022,252.  
FOR ON-LINE RETAIL STORE SERVICES, RETAIL STORE SERVICES, AND MAIL, TELEPHONE AND FACSIMILE ORDER CATALOG SERVICES IN THE FIELD OF ADDRESS BOOKS, AFGHANS, THROWS, ARCHITECTURAL HARDWARE, ARCHITECTURAL KITS, ARCHITECTURAL METALWORK, ARCHITECTURAL MOLDINGS, ARCHITECTURAL TOYS, ART GLASS PANELS, ART GLASS WINDOWS, ART PRINTS, ATRIUMS, BATH ACCESSORIES, BATH MATS, BED LINENS, BED RUNNERS, BEDS, BENCHES, BIRD BATHS, BIRD HOUSES, BLACK AND LIGHT PHOTOGRAPHY, BOOK STANDS, BOOKENDS, BOOKMARKS, BOOKPLATES, SERIES OF BOOKS, BRACELETS, BUFFETS/CHINA CABINETS, BUSINESS CARD CASES, CALENDARS, CANDLE ACCESSORIES, CANDLE



**CLASS 35—(Continued).**

HOLDERS, CANDLES, CANDLESTICKS, CAPS, CARPETS, CD HOLDERS, CDS, CERAMICS, CHAIRS, CHARMS, CHECKBOOK COVERS, CHESTS OF DRAWERS, CHILDREN'S BLOCKS, CLOCKS, CLOTHING, COASTERS, COFFEE MUGS, COMFORTERS, COMPUTER ACCESSORIES, COMPUTER SOFTWARE, COSMETIC BAGS, COVERLETS, CRYSTAL, CUFF LINKS, DECANTERS, DECORATIVE ART GLASS, DECORATIVE BOWLS, DECORATIVE BOXES, DECORATIVE FABRICS, DECORATIVE METALWORK, DECORATIVE PILLOWS, DECORATIVE PLATTERS, DECORATIVE TILE, DESK ACCESSORIES, DESK CALENDARS, DESKS, DINING ROOM TABLES, DINNERWARE, DOOR SYSTEMS, DOORMATS, DOORS, DUVET COVERS, DVDS, EARRINGS, EDUCATIONAL BLOCKS, EDUCATIONAL CARDS, ENCLOSURE CARDS, END TABLES, ENGAGEMENT BOOKS, EYEGLASS CASES, FABRIC, FACIA, FIREPLACE SCREENS, FIREPLACE TOOL SETS, FOUNTAINS, FURNITURE, GAMES, GARDEN ACCESSORIES, GAZEBOS, GIFT BAGS, GIFT WRAP, GIFT WRAP PAPER, GLASS ARCHITECTURAL ELEMENTS, GLASS PANELS FOR CABINETS, GLASSES, GLASSWARE, GREEN HOUSES, GREETING CARDS, GUEST BOOKS, HASSOCKS, HATS, HOLIDAY CARDS, HOUSE LETTERS, HOUSE NUMBERS, ICE BUCKETS, INVITATIONS, JEWELRY, JOURNAL COVERS, JOURNALS/DIARIES, KEY CHAINS, KEY TAGS, LAMP SHADES, LAMPS, LANTERNS, LETTER OPENERS, LIGHTING FIXTURES, LINENS, LUMINARIES, MAGAZINE RACKS, MAGNETS, MAGNIFYING GLASSES, MECHANICAL PENCILS, METAL AND WOOD FRAMED ART GLASS PANELS, METAL VASES, METAL WALL ART, METAL WRAPPED CANDLES, METAL WRAPPED VOTIVES, MINIATURE BUILDINGS, MINIATURE CHAIRS, MIRRORS, MOBILES, MONEY CLIPS, MUFFLERS, NECKLACES, NECKTIES, NEEDLEPOINT KITS, NIGHT LIGHTS, NOTE CADDY, NOTE PADS, NOTECARDS, OBJECTS OF INTERIOR DESIGN, ORNAMENTS, OTTOMANS, PAINT, PAINTED CANVAS NEEDLEWORK KITS, PAPER NAPKINS, PAPER WEIGHTS, PAPERCLIP BOXES, PAVERS, PEN AND PENCIL BOXES, PEN AND PENCIL CUPS, PENCILS, PENDANTS, PENS, PERSONAL ACCESSORIES, PET BOWLS, PET HOUSES, PHOTO ALBUMS, PIANOS, PICTURE FRAMES, PILL BOXES, PILLOWS, PINS, PLACEMATS, PLACQUES, PLANT STANDS, PLANTERS, PLAYING CARDS, PLUMBING FIXTURES, POCKET KNIVES, POLO SHIRTS, POSTCARD BOOKS, POSTCARDS, POSTERS, POUFS, PRE-RECORDED VIDEOTAPES, PRINTS, PURSES, PUZZLES, RIBBONS, RINGS, ROMPERS, RUBBER STAMP SETS, RUBBER STAMPS, RUGS, SALT AND PEPPER SETS, SCARVES, SCREENSAVERS, SCULPTURES, SHAWLS, SHOWER CURTAINS, SKETCH BOOKS, SOFAS, STAMP KITS, STATIONERY, STENCILS, STEPPING STONES, STITCHERY KITS, SUGAR AND CREAMER SETS, SWEATSHIRTS, SWITCH PLATES, T SHIRTS, TABLE RUNNERS, TABLES, TEAPOTS, THERMOMETERS, TIE CLIPS, TIE TACS, TOTE BAGS, TOYS, TRADING CARDS, TRELLISES, TRIVETS, TYPE FONTS, UMBRELLAS, URNS, VASES, VOTIVES, WALL ART, WALL COVERINGS, WALL MIRRORS, WALL PANELS, WALL PLACQUES, WALL SCONCES, WALL SHELVES, WALLETS, WASTEBASKETS, WATCHES, WIND CHIMES, WINDOW SHADES, WINE RACKS, WOOD SCREENS, AND WOODEN ARCHITECTURAL ELEMENTS (U.S. CLS. 100, 101 AND 102).

ASMAT KHAN, EXAMINING ATTORNEY

**CLASS 35—(Continued).**

SN 78-961,048. THE FRANK LLOYD WRIGHT FOUNDATION, SCOTTSDALE, AZ. FILED 8-25-2006.

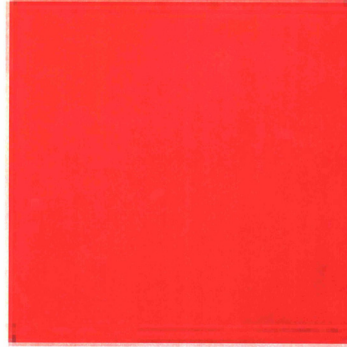

OWNER OF U.S. REG. NO. 1,460,402.  
THE COLOR(S) RED IS/ARE CLAIMED AS A FEATURE OF THE MARK.

THE MARK CONSISTS OF A RED SQUARE.  
FOR ON-LINE RETAIL STORE SERVICES, RETAIL STORE SERVICES, AND MAIL, TELEPHONE AND FACSIMILE ORDER CATALOG SERVICES IN THE FIELD OF ADDRESS BOOKS, AFGHANS, THROWS, ARCHITECTURAL HARDWARE, ARCHITECTURAL KITS, ARCHITECTURAL METALWORK, ARCHITECTURAL MOLDINGS, ARCHITECTURAL TOYS, ART GLASS PANELS, ART GLASS WINDOWS, ART PRINTS, ATRIUMS, BATH ACCESSORIES, BATH MATS, BED LINENS, BED RUNNERS, BEDS, BENCHES, BIRD BATHS, BIRD HOUSES, BLACK AND LIGHT PHOTOGRAPHY, BOOK STANDS, BOOKENDS, BOOKMARKS, BOOKPLATES, SERIES OF BOOKS, BRACELETS, BUFFETS/CHINA CABINETS, BUSINESS CARD CASES, CALENDARS, CANDLE ACCESSORIES, CANDLE HOLDERS, CANDLES, CANDLESTICKS, CAPS, CARPETS, CD HOLDERS, CDS, CERAMICS, CHAIRS, CHARMS, CHECKBOOK COVERS, CHESTS OF DRAWERS, CHILDREN'S BLOCKS, CLOCKS, CLOTHING, COASTERS, COFFEE MUGS, COMFORTERS, COMPUTER ACCESSORIES, COMPUTER SOFTWARE, COSMETIC BAGS, COVERLETS, CRYSTAL, CUFF LINKS, DECANTERS, DECORATIVE ART GLASS, DECORATIVE BOWLS, DECORATIVE BOXES, DECORATIVE FABRICS, DECORATIVE METALWORK, DECORATIVE PILLOWS, DECORATIVE PLATTERS, DECORATIVE TILE, DESK ACCESSORIES, DESK CALENDARS, DESKS, DINING ROOM TABLES, DINNERWARE, DOOR SYSTEMS, DOORMATS, DOORS, DUVET COVERS, DVDS, EARRINGS, EDUCATIONAL BLOCKS, EDUCATIONAL CARDS, ENCLOSURE CARDS, END TABLES, ENGAGEMENT BOOKS, EYEGLASS CASES, FABRIC, FACIA, FIREPLACE SCREENS, FIREPLACE TOOL SETS, FOUNTAINS, FURNITURE, GAMES, GARDEN ACCESSORIES, GAZEBOS, GIFT BAGS, GIFT WRAP, GIFT WRAP PAPER, GLASS ARCHITECTURAL ELEMENTS, GLASS PANELS FOR CABINETS, GLASSES, GLASSWARE, GREEN HOUSES, GREETING CARDS, GUEST BOOKS, HASSOCKS, HATS, HOLIDAY CARDS, HOUSE LETTERS, HOUSE NUMBERS, ICE BUCKETS, INVITATIONS, JEWELRY, JOURNAL COVERS, JOURNALS/DIARIES, KEY CHAINS, KEY TAGS, LAMP SHADES, LAMPS, LANTERNS, LETTER OPENERS, LIGHTING FIXTURES, LINENS, LUMINARIES, MAGAZINE RACKS, MAGNETS, MAGNIFYING GLASSES, MECHANICAL PENCILS, METAL AND WOOD FRAMED ART GLASS PANELS, METAL VASES, METAL WALL ART, METAL WRAPPED CANDLES, METAL WRAPPED VOTIVES, MINIATURE BUILDINGS, MINIATURE CHAIRS, MIRRORS, MOBILES, MONEY CLIPS, MUFFLERS, NECKLACES, NECKTIES, NEEDLEPOINT KITS, NIGHT LIGHTS, NOTE CADDY, NOTE PADS, NOTECARDS, OBJECTS OF INTERIOR DESIGN, ORNAMENTS, OTTOMANS, PAINT, PAINTED CANVAS NEEDLEWORK KITS, PAPER NAPKINS, PAPER WEIGHTS, PAPERCLIP BOXES, PAVERS, PEN AND PENCIL BOXES, PEN AND PENCIL CUPS, PENCILS, PENDANTS, PENS, PERSONAL ACCESSORIES, PET BOWLS,

**CLASS 35—(Continued).**

PET HOUSES, PHOTO ALBUMS, PIANOS, PICTURE FRAMES, PILL BOXES, PILLOWS, PINS, PLACEMATS, PLACQUES, PLANT STANDS, PLANTERS, PLAYING CARDS, PLUMBING FIXTURES, POCKET KNIVES, POLO SHIRTS, POSTCARD BOOKS, POSTCARDS, POSTERS, POUFS, PRE-RECORDED VIDEOTAPES, PRINTS, PURSES, PUZZLES, RIBBONS, RINGS, ROMPERS, RUBBER STAMP SETS, RUBBER STAMPS, RUGS, SALT AND PEPPER SETS, SCARVES, SCREENSAVERS, SCULPTURES, SHAWLS, SHOWER CURTAINS, SKETCH BOOKS, SOFAS, STAMP KITS, STATIONERY, STENCILS, STEPPING STONES, STITCHERY KITS, SUGAR AND CREAMER SETS, SWEATSHIRTS, SWITCH PLATES, T SHIRTS, TABLE RUNNERS, TABLES, TEAPOTS, THERMOMETERS, TIE CLIPS, TIE TACS, TOTE BAGS, TOYS, TRADING CARDS, TRELISES, TRIVETS, TYPE FONTS, UMBRELLAS, URNS, VASES, VOTIVES, WALL ART, WALL COVERINGS, WALL MIRRORS, WALL PANELS, WALL PLACQUES, WALL SCONCES, WALL SHELVES, WALLETS, WASTEBASKETS, WATCHES, WIND CHIMES, WINDOW SHADES, WINE RACKS, WOOD SCREENS, AND WOODEN ARCHITECTURAL ELEMENTS (U.S. CLS. 100, 101 AND 102).  
 ASMAT KHAN, EXAMINING ATTORNEY

---

SN 78-961,320. WALDEN, DAVID, PLEASANTON, CA. FILED 8-27-2006.

**Wealth By Strategy**

THE MARK CONSISTS OF STANDARD CHARACTERS WITHOUT CLAIM TO ANY PARTICULAR FONT, STYLE, SIZE, OR COLOR.

NO CLAIM IS MADE TO THE EXCLUSIVE RIGHT TO USE "WEALTH", APART FROM THE MARK AS SHOWN.

FOR MATCHING BORROWERS WITH POTENTIAL LENDERS IN THE FIELD OF CONSUMER AND MORTGAGE LENDING (U.S. CLS. 100, 101 AND 102).

FIRST USE 12-15-2005; IN COMMERCE 12-15-2005.

JILL PRATER, EXAMINING ATTORNEY

---

SN 78-961,603. AMERICAN WATER INSTITUTE, INC., ADA, OK. FILED 8-28-2006.



THE APPLICANT CLAIMS COLOR AS A FEATURE OF THE MARK, NAMELY, GREEN AND BLUE.

THE WORD ECO IS LIGHT GREEN FOLLOWED BY THE WORD EFFICIENCY IN BLUE AND THE SECOND F RESEMBLES A SPROUT WITH A SMALL UNCURLING LEAF WITH THE TIP OF THE LEAF APPEARING IN GREEN AND SHADING BACK TO BLUE.

THE MARK CONSISTS OF THE WORD ECO WITH THE C AND O FORMING THE INFINITY SYMBOL AND THE WORD EFFICIENCY WITH THE SECOND F RESEMBLING A SPROUT WITH A SMALL UNCURLING LEAF.

FOR EFFICIENCY EXPERTS; INFORMATION IN THE FIELD OF ENERGY EFFICIENCY (U.S. CLS. 100, 101 AND 102).

JEAN IM, EXAMINING ATTORNEY

**CLASS 35—(Continued).**

SN 78-961,657. LEWIS, CHRIS, TOWNSEND, DE. FILED 8-28-2006.

**Insulation Tools .com**

THE MARK CONSISTS OF STANDARD CHARACTERS WITHOUT CLAIM TO ANY PARTICULAR FONT, STYLE, SIZE, OR COLOR.

FOR DISTRIBUTORSHIPS IN THE FIELD OF HAND TOOLS AND MACHINERY USED IN THE APPLICATION OF THERMAL AND CRYOGENIC INSULATION IN INDUSTRIAL, COMMERCIAL AND RESIDENTIAL SETTINGS; ON-LINE RETAIL STORE SERVICES FEATURING HAND TOOLS AND MACHINERY USED IN THE APPLICATION OF THERMAL AND CRYOGENIC INSULATION IN INDUSTRIAL, COMMERCIAL AND RESIDENTIAL SETTINGS (U.S. CLS. 100, 101 AND 102).

FIRST USE 1-1-2004; IN COMMERCE 6-6-2004.

GIANCARLO CASTRO, EXAMINING ATTORNEY

---

SN 78-961,719. NATIONAL MOBILITY EQUIPMENT DEALERS ASSOCIATION, INC., TAMPA, FL. FILED 8-28-2006.

**NMEDA**

THE MARK CONSISTS OF STANDARD CHARACTERS WITHOUT CLAIM TO ANY PARTICULAR FONT, STYLE, SIZE, OR COLOR.

FOR ASSOCIATION SERVICES, NAMELY PROMOTING THE INTERESTS OF MOBILITY EQUIPMENT DEALERS, DRIVER REHABILITATION SPECIALISTS AND OTHER MOBILITY EQUIPMENT PROFESSIONALS AND THE IMPROVEMENT OF TRANSPORTATION OPTIONS FOR THOSE WITH DISABILITIES (U.S. CLS. 100, 101 AND 102).

FIRST USE 0-0-1989; IN COMMERCE 0-0-1989.

ELLEN PERKINS, EXAMINING ATTORNEY

**CLASS 35—(Continued).**

SN 78-961,920. PAJAMA REVOLUTION LLC, AUSTIN, TX.  
FILED 8-28-2006.

## Pajama Revolution

THE MARK CONSISTS OF STANDARD CHARACTERS WITHOUT CLAIM TO ANY PARTICULAR FONT, STYLE, SIZE, OR COLOR.

FOR PROVIDING A WEBSITE FEATURING BUSINESS INFORMATION ON RUNNING A HOME BASED BUSINESS; PROVIDING BUSINESS INFORMATION IN THE FIELD OF MANAGING HOME BUSINESSES, VIA THE INTERNET; PROVIDING BUSINESS INFORMATION IN THE FIELD OF HOW TO START A HOME BASED BUSINESSES; PROMOTING THE GOODS AND SERVICES OF OTHERS BY PROVIDING A WEB SITE AT WHICH USERS CAN LINK TO WEB SITES OF OTHERS FEATURING INFORMATION OF INTEREST TO OWNERS OF HOME BASED BUSINESSES; BUSINESS ADVISORY SERVICES, CONSULTANCY AND INFORMATION; PROVIDING INFORMATION IN THE FIELD OF TIME MANAGEMENT FOR BUSINESS PURPOSES; PROVIDING ORGANIZING SERVICES FOR INDIVIDUALS AT HOME, IN HOME OFFICES AND IN BUSINESS OFFICES, THAT PROVIDES HELP WITH TIME AND PAPER MANAGEMENT (U.S. CLS. 100, 101 AND 102).

FIRST USE 8-14-2006; IN COMMERCE 8-14-2006.  
ELISSA GARBER KON, EXAMINING ATTORNEY

SN 78-962,068. CLEAR CHANNEL OUTDOOR, INC., SAN ANTONIO, TX. FILED 8-28-2006.

## NY-10

THE MARK CONSISTS OF STANDARD CHARACTERS WITHOUT CLAIM TO ANY PARTICULAR FONT, STYLE, SIZE, OR COLOR.

FOR OUT-OF-HOME ADVERTISING SERVICES, NAMELY, RENTAL OF ADVERTISING SPACE AND PREPARING AND PLACING OF ADVERTISEMENTS FOR OTHERS (U.S. CLS. 100, 101 AND 102).  
SHAILA SETTLES, EXAMINING ATTORNEY

SN 78-962,667. FISERV, INC., BROOKFIELD, WI. FILED 8-29-2006.

## AlertMe

THE MARK CONSISTS OF STANDARD CHARACTERS WITHOUT CLAIM TO ANY PARTICULAR FONT, STYLE, SIZE, OR COLOR.

FOR PROVIDING CONSUMER CREDIT MONITORING SERVICES (U.S. CLS. 100, 101 AND 102).  
FIRST USE 10-0-2005; IN COMMERCE 10-0-2005.  
LAURIE MAYES, EXAMINING ATTORNEY

**CLASS 35—(Continued).**

SN 78-962,702. BLUEHIPPO FUNDING, LLC, BALTIMORE, MD. FILED 8-29-2006.

## BlueHippo

THE MARK CONSISTS OF STANDARD CHARACTERS WITHOUT CLAIM TO ANY PARTICULAR FONT, STYLE, SIZE, OR COLOR.

FOR MAIL ORDER SERVICES FEATURING AUDIO, VIDEO, AND ELECTRONIC EQUIPMENT, COMPUTER HARDWARE AND COMPUTER SOFTWARE (U.S. CLS. 100, 101 AND 102).

FIRST USE 4-1-2003; IN COMMERCE 4-1-2003.  
TONJA GASKINS, EXAMINING ATTORNEY

SN 78-963,228. MAINTENANCE SUPPLY HEADQUARTERS, LP, SUGAR LAND, TX. FILED 8-29-2006.



NO CLAIM IS MADE TO THE EXCLUSIVE RIGHT TO USE "MAINTENANCE SUPPLY", APART FROM THE MARK AS SHOWN.

FOR WHOLESALE DISTRIBUTORSHIP AND RETAIL STORE SERVICES FEATURING BUILDING MAINTENANCE SUPPLIES, PARTS, TOOLS AND ACCESSORIES (U.S. CLS. 100, 101 AND 102).

ALICE BENMAMAN, EXAMINING ATTORNEY

SN 78-963,272. ENLIGHT-10, LTD., SANTA FE, NM. FILED 8-29-2006.

## RAINFORESTBASKETS.COM

THE MARK CONSISTS OF STANDARD CHARACTERS WITHOUT CLAIM TO ANY PARTICULAR FONT, STYLE, SIZE, OR COLOR.

FOR ART GALLERIES (U.S. CLS. 100, 101 AND 102).  
FIRST USE 8-26-2002; IN COMMERCE 8-26-2002.  
DEZMONA MIZELLE, EXAMINING ATTORNEY

**CLASS 35—(Continued).**

SN 78-963,346. CLICK MEDIA ADVERTISING, INC., MIRAMAR, FL. FILED 8-29-2006.



THE MARK CONSISTS OF STYLIZED TEXT OF THE WORDING "C CLICKMEDIA" WITH AN ARROW ATTACHED TO THE "C".

FOR ADVERTISING AND ADVERTISEMENT SERVICES (U.S. CLS. 100, 101 AND 102).  
LINDA MICKLEBURGH, EXAMINING ATTORNEY

**CLASS 35—(Continued).**

SN 78-963,373. GILLENWATER, SHARON, SAN FRANCISCO, CA. FILED 8-29-2006.



THE MARK CONSISTS OF A GROUP OF PEOPLE AND THE STYLIZED TEXT OF THE WORDING "BOARDROOM INSIDERS".

FOR SUBSCRIPTION TO AN INFORMATION MEDIA PACKAGE (U.S. CLS. 100, 101 AND 102).  
WOODROW HARTZOG, EXAMINING ATTORNEY

SN 78-963,437. NATIONAL MEASUREMENT AND EVALUATION, MONTVALE, NJ. FILED 8-30-2006.

# SaleSelect

THE MARK CONSISTS OF STANDARD CHARACTERS WITHOUT CLAIM TO ANY PARTICULAR FONT, STYLE, SIZE, OR COLOR.

FOR TESTING TO DETERMINE EMPLOYMENT SKILLS (U.S. CLS. 100, 101 AND 102).  
JOHN GARTNER, EXAMINING ATTORNEY

SN 78-963,356. METROMALLS.COM, LLC, WESTLAND, MI. FILED 8-29-2006.



THE COLOR(S) BLUE, WHITE, AND BLACK IS/ARE CLAIMED AS A FEATURE OF THE MARK.

THE COLOR BLACK APPEARS IN THE WORDING "CLICK.SHOP.SAVE." THE COLOR BLUE APPEARS AS THE CORD OF THE COMPUTER MOUSE, THE OUTLINE OF THE COMPUTER MOUSE, AND THE CIRCLE SURROUNDING THE MOUSE. THE COLOR WHITE APPEARS AS THE SHADING OF THE MOUSE.

FOR ON-LINE TRADING SERVICES IN WHICH SELLER POSTS PRODUCTS TO BE AUCTIONED AND BIDDING IS DONE VIA THE INTERNET; ORGANISATION OF INTERNET AUCTIONS; PROVIDING A SEARCHABLE ONLINE ADVERTISING GUIDE FEATURING THE GOODS AND SERVICES OF OTHER ONLINE VENDORS ON THE INTERNET (U.S. CLS. 100, 101 AND 102).  
MARILYN IZZI, EXAMINING ATTORNEY

SN 78-963,723. FILLET, MITCHELL H, TOWSON, MD. FILED 8-30-2006.

## FINANCING AMERICA'S FUTURE

THE MARK CONSISTS OF STANDARD CHARACTERS WITHOUT CLAIM TO ANY PARTICULAR FONT, STYLE, SIZE, OR COLOR.

FOR BUSINESS CONSULTATION AND MANAGEMENT REGARDING MARKETING ACTIVITIES AND LAUNCHING OF NEW PRODUCTS (U.S. CLS. 100, 101 AND 102).  
LINDA POWELL, EXAMINING ATTORNEY

**CLASS 35—(Continued).**

SN 78-963,819. HUANG, LIANG, BRONX, NY. FILED 8-30-2006.



THE MARK CONSISTS OF TWO ORIENTAL FACE MASKS.

FOR RETAIL STORES FEATURING CLOTHING AND ACCESSORIES (U.S. CLS. 100, 101 AND 102). FIRST USE 3-1-1998; IN COMMERCE 3-1-1998. JEFF DEFORD, EXAMINING ATTORNEY

**CLASS 35—(Continued).**

SN 78-964,018. GIMENEZ, FRANCISCO, HIGHLAND PARK, TX. FILED 8-30-2006.

**SMARTRATINGS.COM**

THE MARK CONSISTS OF STANDARD CHARACTERS WITHOUT CLAIM TO ANY PARTICULAR FONT, STYLE, SIZE, OR COLOR.

FOR PROVIDING A WEBSITE FEATURING PRODUCT RATINGS OF THE CONSUMER GOODS OF OTHERS IN THE FIELD OF CONSUMER ELECTRONICS AND APPLIANCES, CAMERAS, COMPUTERS, PHONES, TELEVISIONS, STEREO EQUIPMENT, HOME THEATER SYSTEMS (U.S. CLS. 100, 101 AND 102). ANTHONY RINKER, EXAMINING ATTORNEY

SN 78-963,830. I'M OVER IT, WINTER PARK, FL. FILED 8-30-2006.

**I'm Over It**

THE MARK CONSISTS OF STANDARD CHARACTERS WITHOUT CLAIM TO ANY PARTICULAR FONT, STYLE, SIZE, OR COLOR.

FOR COMPUTERIZED ON-LINE RETAIL STORE SERVICES IN THE FIELD OF JEWELRY (U.S. CLS. 100, 101 AND 102). JEFF DEFORD, EXAMINING ATTORNEY

SN 78-964,088. MCGEARTY, LAWRENCE, T, PHILADELPHIA, PA. FILED 8-30-2006.

**REMEDY MARKETING**

THE MARK CONSISTS OF STANDARD CHARACTERS WITHOUT CLAIM TO ANY PARTICULAR FONT, STYLE, SIZE, OR COLOR.

NO CLAIM IS MADE TO THE EXCLUSIVE RIGHT TO USE MARKETING, APART FROM THE MARK AS SHOWN. FOR ADVERTISING CONSULTATION AND BUSINESS MARKETING CONSULTING (U.S. CLS. 100, 101 AND 102). GINNY ISAACSON, EXAMINING ATTORNEY

SN 78-963,838. ARXCEL, INC., WILLIAMSVILLE, NY. FILED 8-30-2006.

**ARXANALYSIS**

THE MARK CONSISTS OF STANDARD CHARACTERS WITHOUT CLAIM TO ANY PARTICULAR FONT, STYLE, SIZE, OR COLOR.

FOR BUSINESS SERVICES; NAMELY ADVISING OTHERS WITH RESPECT TO THE DESIGN, DEVELOPMENT, ACQUISITION AND ANALYSIS OF MANAGED HEALTH CARE AND PRESCRIPTION DRUG BENEFIT PLANS (U.S. CLS. 100, 101 AND 102). GENE MACIOL, EXAMINING ATTORNEY

SN 78-964,105. ARLINGTON INSTITUTE, ARLINGTON, VA. FILED 8-30-2006.



THE MARK CONSISTS OF A WEATHER VANE AND THE WORDS "WHETHER MAP".

FOR COLLECTION, PREPARATION, COMPOSITION, STORAGE, PROCESSING, ACQUISITION AND PROVISION OF BUSINESS INFORMATION, DATA, STATISTICS AND INDICES (U.S. CLS. 100, 101 AND 102). JAY FLOWERS, EXAMINING ATTORNEY

**CLASS 35—(Continued).**

SN 78-964,131. ARLINGTON INSTITUTE, ARLINGTON, VA. FILED 8-30-2006.



THE MARK CONSISTS OF IMAGE OF WEATHER VANE AND THE CHARACTERS "WHETHERREPORT".

FOR COLLECTION, PREPARATION, COMPOSITION, STORAGE, PROCESSING, ACQUISITION AND PROVISION OF BUSINESS INFORMATION, DATA, STATISTICS AND INDICES (U.S. CLS. 100, 101 AND 102).

JAY FLOWERS, EXAMINING ATTORNEY

SN 78-964,208. AMERICAN NEVADA HOLDINGS, LLC, HENDERSON, NV. FILED 8-30-2006.

*Avenue33*

FOR RETAIL STORE SERVICES FEATURING CONVENIENCE STORE ITEMS; RETAIL STORE SERVICES IN THE FIELDS OF KEY CHAINS, KEY RINGS, KEY CHAIN TAGS, ORNAMENTAL PINS, JEWELRY BOXES, MONEY CLIPS, STATUETTES, JEWELRY, WATCHES, COLLECTIBLE ITEMS, COMMEMORATIVE ITEMS, CLOCKS, PICTURE FRAMES, FLAGS, NOVELTY LICENSE PLATES, BEVERAGeware, BUCKETS, COASTERS, CONTAINERS, DISHES, FLASKS, FLOWERS AND FLOWER BASKETS, SPORTS BOTTLES, VASES, PERIODIC PUBLICATIONS, PRINTS, WRITING INSTRUMENTS, BUSINESS ACCESSORIES, CONSUMER ELECTRONICS, STATIONERY, POSTCARDS, CALENDARS, DAY PLANNERS, POSTERS, PAPER BANNERS, STICKERS, COUPONS, COUPON BOOKS, BRIEFCASES, BAGS, WALLETS, PURSES, FANNY PACKS, BACKPACKS, UMBRELLAS, COMPUTER PRODUCTS, ELECTRONIC EQUIPMENT, AUTOMOBILE ACCESSORIES, HOUSEWARES, HOME FURNISHINGS, TABLEWARE, CLOTHING, CLOTHING ACCESSORIES, TOYS, TOY ACCESSORIES, GAMES, DOLLS, DOLL ACCESSORIES, SPORTING GOODS, PARTY FAVORS, BALLOONS, PERSONAL-HYGIENE PRODUCTS, HEALTH CARE PRODUCTS, FITNESS PRODUCTS, SPORTS EQUIPMENT AND ACCESSORIES, GAMING EQUIPMENT AND ACCESSORIES, COIN-OPERATED AMUSEMENT MACHINES, ARCADE GAMES, FOOD ITEMS, BEVERAGE ITEMS, PET ACCESSORIES, TRAVEL ACCESSORIES, SEASONAL ITEMS, COSMETICS, LEATHER GOODS, PERFUMES, FLOWERS AND OTHER GENERAL MERCHANDISE; ISSUING GIFT CERTIFICATES WHICH MAY THEN BE REDEEMED FOR GOODS OR SERVICES; RETAIL GIFT SHOP SERVICES; CONDUCTING BONUS CARD INCENTIVE AWARD PROGRAMS TO PROMOTE HOTEL, RESORT, CASINO AND MIXED USE COMMUNITY SERVICES; ARRANGING AND CONDUCTING FAIRS, EXHIBITIONS AND CONFERENCES AND PROVIDING FACILITIES FOR BUSINESS AND ADVERTISING PURPOSES; PROVIDING INFORMATION RELATING TO BUSINESS MATTERS AND RETAIL STORE SERVICES; AND DISSEMINATION OF ADVERTISEMENTS OF THE GOODS AND SERVICES OF OTHERS (U.S. CLS. 100, 101 AND 102).

MICHAEL ENGEL, EXAMINING ATTORNEY

**CLASS 35—(Continued).**

SN 78-964,212. THE MICHELLE RODRIGUEZ AND DARA YOUNG PARTNERSHIP, DBA ISHKADADA ENTERPRISES, SANTA MONICA, CA. FILED 8-30-2006.

**ISHKADADA**

THE MARK CONSISTS OF STANDARD CHARACTERS WITHOUT CLAIM TO ANY PARTICULAR FONT, STYLE, SIZE, OR COLOR.

FOR ON-LINE RETAIL STORE SERVICES FEATURING COSMETICS, JEWELRY, LEATHER BAGS, SUITCASES, WALLETS, CLOTHING, NAMELY JEANS, PANTS, TROUSERS, SHIRTS, T-SHIRTS, POLO SHIRTS, BLOUSES, SWEATERS, CARDIGANS, KNIT TOPS, TANK TOPS, CAMISOLES, CROP TOPS, BUSTIERS, JACKETS, COATS, VESTS, LINGERIE, UNDERWEAR, UNDERSHIRTS, SLEEPWEAR, ROBES, PAJAMAS, SWIMMING SUITS, BATHING SUITS, BEACH SHIRTS, SWEATPANTS, SWEATSHIRTS, SWEAT JACKETS, OVERALLS, JUMPSUITS, DRESSES, SKIRTS, SHORTS, SUIT, SCARVES, HEADWEAR, SOCKS, TIGHTS, HOSIERY, LEG WARMERS, FOOTWEAR; RETAIL CLOTHING STORES; RETAIL JEWELRY STORES (U.S. CLS. 100, 101 AND 102).

JOHN DALIER, EXAMINING ATTORNEY

SN 78-964,242. AMERICAN NEVADA HOLDINGS, LLC, HENDERSON, NV. FILED 8-30-2006.

*Avenue33*  
AT THE DISTRICT

FOR RETAIL STORE SERVICES FEATURING CONVENIENCE STORE ITEMS; RETAIL STORE SERVICES IN THE FIELDS OF KEY CHAINS, KEY RINGS, KEY CHAIN TAGS, ORNAMENTAL PINS, JEWELRY BOXES, MONEY CLIPS, STATUETTES, JEWELRY, WATCHES, COLLECTIBLE ITEMS, COMMEMORATIVE ITEMS, CLOCKS, PICTURE FRAMES, FLAGS, NOVELTY LICENSE PLATES, BEVERAGeware, BUCKETS, COASTERS, CONTAINERS, DISHES, FLASKS, FLOWERS AND FLOWER BASKETS, SPORTS BOTTLES, VASES, PERIODIC PUBLICATIONS, PRINTS, WRITING INSTRUMENTS, BUSINESS ACCESSORIES, CONSUMER ELECTRONICS, STATIONERY, POSTCARDS, CALENDARS, DAY PLANNERS, POSTERS, PAPER BANNERS, STICKERS, COUPONS, COUPON BOOKS, BRIEFCASES, BAGS, WALLETS, PURSES, FANNY PACKS, BACKPACKS, UMBRELLAS, COMPUTER PRODUCTS, ELECTRONIC EQUIPMENT, AUTOMOBILE ACCESSORIES, HOUSEWARES, HOME FURNISHINGS, TABLEWARE, CLOTHING, CLOTHING ACCESSORIES, TOYS, TOY ACCESSORIES, GAMES, DOLLS, DOLL ACCESSORIES, SPORTING GOODS, PARTY FAVORS, BALLOONS, PER-

**CLASS 35—(Continued).**

SONAL-HYGIENE PRODUCTS, HEALTH CARE PRODUCTS, FITNESS PRODUCTS, SPORTS EQUIPMENT AND ACCESSORIES, GAMING EQUIPMENT AND ACCESSORIES, COIN-OPERATED AMUSEMENT MACHINES, ARCADE GAMES, FOOD ITEMS, BEVERAGE ITEMS, PET ACCESSORIES, TRAVEL ACCESSORIES, SEASONAL ITEMS, COSMETICS, LEATHER GOODS, PERFUMES, FLOWERS AND OTHER GENERAL MERCHANDISE; ISSUING GIFT CERTIFICATES WHICH MAY THEN BE REDEEMED FOR GOODS OR SERVICES; RETAIL GIFT SHOP SERVICES; CONDUCTING BONUS CARD INCENTIVE AWARD PROGRAMS TO PROMOTE HOTEL, RESORT, CASINO AND MIXED USE COMMUNITY SERVICES; ARRANGING AND CONDUCTING FAIRS, EXHIBITIONS AND CONFERENCES AND PROVIDING FACILITIES FOR BUSINESS AND ADVERTISING PURPOSES; PROVIDING INFORMATION RELATING TO BUSINESS MATTERS AND RETAIL STORE SERVICES; AND DISSEMINATION OF ADVERTISEMENTS OF THE GOODS AND SERVICES OF OTHERS (U.S. CLS. 100, 101 AND 102).

MICHAEL ENGEL, EXAMINING ATTORNEY

---

SN 78-964,274. OPTIVIA LLC, CINCINNATI, OH. FILED 8-30-2006.

# OPTIVIA

THE MARK CONSISTS OF STANDARD CHARACTERS WITHOUT CLAIM TO ANY PARTICULAR FONT, STYLE, SIZE, OR COLOR.

FOR TRANSPORTATION LOGISTIC SERVICES, NAMELY, ARRANGING THE TRANSPORTATION OF GOODS FOR OTHERS (U.S. CLS. 100, 101 AND 102).

TANYA AMOS, EXAMINING ATTORNEY

**CLASS 35—(Continued).**

SN 78-964,276. FIVE RIVERS, INC., BOISE, ID. FILED 8-30-2006.

# FIVE RIVERS

THE MARK CONSISTS OF STANDARD CHARACTERS WITHOUT CLAIM TO ANY PARTICULAR FONT, STYLE, SIZE, OR COLOR.

FOR RETAIL STORE SERVICES, MAIL ORDER CATALOG SERVICES AND ONLINE RETAIL SERVICES FEATURING HOUSEWARES, INDOOR AND OUTDOOR LAMPS AND LIGHTING FIXTURES, INDOOR AND OUTDOOR FURNITURE AND ACCESSORIES, TEXTILES AND PILLOWS, CURTAINS AND WINDOW COVERINGS, BEDDING, LINENS, TOWELS, DINING AND KITCHEN GOODS AND UTENSILS, BATH GOODS AND ACCESSORIES, DECORATIVE HOME FURNISHINGS AND ACCESSORIES, PICTURE FRAMES, MIRRORS, STAINED GLASS, ART AND CREATIVE ITEMS, CANDLES AND POTPOURRI AND ACCESSORIES, COMPUTER SOFTWARE, BOOKS, CDS, DVDS, TOYS, GAMES, OFFICE SUPPLIES, GREETING CARDS, WRAPPING PAPER AND GIFT BAGS AND RIBBONS, SPICES, SNACK FOODS, FOOD, BEVERAGES, COSMETICS, BEAUTY PRODUCTS AND ACCESSORIES, SHOES, HANDBAGS, SMALL LEATHER ACCESSORIES, CLOTHING AND ACCESSORIES, JEWELRY, GARDENING TOOLS AND ACCESSORIES, HARDWARE AND WIDE RANGE OF CONSUMER ELECTRONIC GOODS AND PRODUCTS (U.S. CLS. 100, 101 AND 102).

JIM RINGLE, EXAMINING ATTORNEY

---

SN 78-964,316. KENSINGTON NANNY DEVELOPMENT, ORANGE PARK, FL. FILED 8-30-2006.

# KENSINGTON NANNY & HOME SERVICES

THE MARK CONSISTS OF STANDARD CHARACTERS WITHOUT CLAIM TO ANY PARTICULAR FONT, STYLE, SIZE, OR COLOR.

NO CLAIM IS MADE TO THE EXCLUSIVE RIGHT TO USE "NANNY & HOME SERVICES", APART FROM THE MARK AS SHOWN.

FOR EMPLOYMENT HIRING, RECRUITING, PLACEMENT, STAFFING AND CAREER NETWORKING SERVICES (U.S. CLS. 100, 101 AND 102).

KATHLEEN M. VANSTON, EXAMINING ATTORNEY

**CLASS 35—(Continued).**

SN 78-964,332. VISITECH PR, INC., DENVER, CO. FILED 8-30-2006.

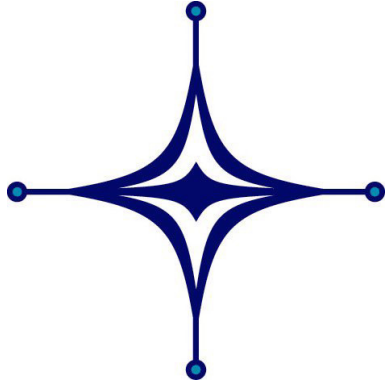

THE COLOR(S) AQUA BLUE, DARK BLUE, AND WHITE IS/ARE CLAIMED AS A FEATURE OF THE MARK.

THE COLOR AQUA BLUE APPEARS IN THE CIRCLES IN THE FOUR CORNERS OF THE STAR DESIGN, THE COLOR DARK BLUE APPEARS IN THE STAR DESIGN, AND THE COLOR WHITE APPEARS IN THE MIDDLE OF THE STAR DESIGN.

THE MARK CONSISTS OF STARBURST.  
FOR PUBLIC RELATIONS FOR HIGH-TECH CLIENTS (U.S. CLS. 100, 101 AND 102).  
ALEX KEAM, EXAMINING ATTORNEY

---

SN 78-964,459. VETCORP, FREDERICK, MD. FILED 8-30-2006.



THE MARK CONSISTS OF AN OVAL WITH THE STYLIZED TEXT OF THE WORDING "VETCORP SDVO SB".  
FOR BUSINESS MANAGEMENT AND CONSULTATION (U.S. CLS. 100, 101 AND 102).  
MORGAN WYNNE, EXAMINING ATTORNEY

**CLASS 35—(Continued).**

SN 78-964,479. JACOBSON, ADAM, GREENWICH, CT. FILED 8-30-2006.

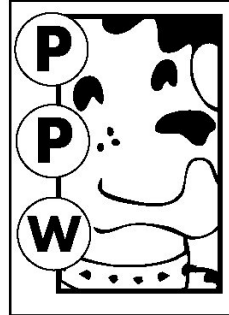

THE MARK CONSISTS OF A DOG'S FACE AND THE STYLIZED TEXT "PPW".

FOR RETAIL STORES FEATURING ANIMALS, LIVE ANIMALS, DOG COLLARS AND LEASHES, HARNESSSES, CARRIERS, APPAREL, BEAUTY AIDS, JEWELRY, BEDS, FEEDING BOWLS, STATIONERY, BOOKS, CRATES, CRATE COVERS, PICTURES, PHOTOS, COUTURE CLOTHING, FURS, PET FOOD, AND PET SUPPLIES (U.S. CLS. 100, 101 AND 102).

KEVIN CORWIN, EXAMINING ATTORNEY

---

SN 78-964,505. DELTA GALIL USA INC., SECAUCUS, NJ. FILED 8-30-2006.

**bracast**

THE MARK CONSISTS OF STANDARD CHARACTERS WITHOUT CLAIM TO ANY PARTICULAR FONT, STYLE, SIZE, OR COLOR.

NO CLAIM IS MADE TO THE EXCLUSIVE RIGHT TO USE "NETWORKS", APART FROM THE MARK AS SHOWN.

FOR ADVERTISING AND COMMERCIAL INFORMATION SERVICES, VIA THE INTERNET (U.S. CLS. 100, 101 AND 102).  
TRAVIS WHEATLEY, EXAMINING ATTORNEY

---

SN 78-964,546. LINK2 INTERGALACTIC CORPORATION, WESTCHESTER, CA. FILED 8-30-2006.

**FOODFAST NETWORKS**

THE MARK CONSISTS OF STANDARD CHARACTERS WITHOUT CLAIM TO ANY PARTICULAR FONT, STYLE, SIZE, OR COLOR.

NO CLAIM IS MADE TO THE EXCLUSIVE RIGHT TO USE "NETWORKS", APART FROM THE MARK AS SHOWN.

FOR ELECTRONIC ORDERING SERVICES VIA INTERNET AND FAX FOR RESTAURANTS (U.S. CLS. 100, 101 AND 102).

MICHAEL ENGEL, EXAMINING ATTORNEY



**CLASS 35—(Continued).**

SN 78-964,553. LINK2 INTERGALACTIC CORPORATION, WESTCHESTER, CA. FILED 8-30-2006.



FOR ELECTRONIC ORDERING SERVICES VIA INTERNET AND FAX FOR RESTAURANTS (U.S. CLS. 100, 101 AND 102).  
MICHAEL ENGEL, EXAMINING ATTORNEY

**CLASS 35—(Continued).**

SN 78-964,564. WATSON, DEAN, J, WOODBURY, CT. FILED 8-31-2006.



NO CLAIM IS MADE TO THE EXCLUSIVE RIGHT TO USE ".COM", APART FROM THE MARK AS SHOWN.  
THE PORTRAITS IN THE MARK DO NOT IDENTIFY LIVING INDIVIDUALS.  
THE APPLICANT CLAIMS COLOR AS A FEATURE OF THE MARK, NAMELY, BLUE, BLACK, WHITE, AND GREY.  
THE TWO MEN WEARING HATS AND STANDING BACK TO BACK ARE OUTLINED IN BLACK, ONE HAS BLACK SUNGLASSES OUTLINED IN GRAY; THE MEN ARE POSITIONED OVER A BLUE LICENSE PLATE WITH GRAY SCREWS OUTLINED IN BLACK AND WHITE WITH THE WORDING LOT BOYS .COM IN WHITE ON THE BLUE LICENSE PLATE.  
FOR BUSINESS MARKETING SERVICES (U.S. CLS. 100, 101 AND 102).  
FIRST USE 8-11-2006; IN COMMERCE 8-11-2006.  
PATRICIA EVANKO, EXAMINING ATTORNEY

SN 78-964,588. SARPONG, JUNE, LONDON, UNITED KINGDOM, FILED 8-31-2006.

## The Alpha Woman

THE MARK CONSISTS OF STANDARD CHARACTERS WITHOUT CLAIM TO ANY PARTICULAR FONT, STYLE, SIZE, OR COLOR.  
NO CLAIM IS MADE TO THE EXCLUSIVE RIGHT TO USE "WOMAN", APART FROM THE MARK AS SHOWN.  
FOR RETAIL APPAREL STORES (U.S. CLS. 100, 101 AND 102).  
CORY BOONE, EXAMINING ATTORNEY

SN 78-964,563. KESTEN, STEVEN, MILL VALLEY, CA. FILED 8-31-2006.

## Message Everywhere

THE MARK CONSISTS OF STANDARD CHARACTERS WITHOUT CLAIM TO ANY PARTICULAR FONT, STYLE, SIZE, OR COLOR.  
NO CLAIM IS MADE TO THE EXCLUSIVE RIGHT TO USE MESSAGE, APART FROM THE MARK AS SHOWN.  
FOR ADVERTISING THROUGH ALL PUBLIC COMMUNICATION MEANS (U.S. CLS. 100, 101 AND 102).  
PATRICIA EVANKO, EXAMINING ATTORNEY

SN 78-964,826. BRING ME A BUYER.COM, WEST CHESTER, OH. FILED 8-31-2006.

## PAY FOR PERFORMANCE. NOT LISTINGS.

THE MARK CONSISTS OF STANDARD CHARACTERS WITHOUT CLAIM TO ANY PARTICULAR FONT, STYLE, SIZE, OR COLOR.  
FOR REAL ESTATE MARKETING SERVICES IN THE FIELD OF HOMES (U.S. CLS. 100, 101 AND 102).  
BRETT J. GOLDEN, EXAMINING ATTORNEY

**CLASS 35—(Continued).**

SN 78-964,837. BURTON, HEATHER, QUARTZ HILL, CA.  
FILED 8-31-2006.



THE MARK CONSISTS OF STYLIZED TEXT OF THE WORDING "DIVA UP".

FOR ON-LINE RETAIL STORE SERVICES FEATURING BELTS, CAPS, JEANS, SCARVES, GLOVES, TANK TOPS, HALTER TOPS, SWIMWEAR, BATHING SUITS, BIKINIS, ATHLETIC WEAR, JOGGING SUITS, BODY SUITS, RUNNING SHORTS, RUNNING PANTS, SWEAT PANTS, SWEATSHIRTS, WOMEN'S BLOUSES, SKIRTS, COATS, JACKETS, PULLOVERS, T-SHIRTS, PANTS, SHORTS, SLEEPWEAR, PAJAMAS, SLIPPERS, SWEATERS, FLIP-FLOPS, POLO SHIRTS, SMOCKS, APRONS, TUNICS, PEDAL PUSHERS, BEACH COVER UPS, SOCKS, UNDERWEAR, PANTIES, BRAS, JERSEY TOPS, JEWELRY, WATCHES, BACK PACKS, DUFFEL BAGS, HAND BAGS, SHOULDER BAGS, GEAR BAGS, BEACH BAGS, SPORT BAGS, CLUTCH BAGS, BANDANNAS, LEATHER BAGS, LEATHER WALLETS, LEATHER COATS, MOTORCYCLE GEAR, MOTORCYCLE CLOTHES, DRESSES, RACING CLOTHES, VESTS, BATHROBES, STICKERS, STATIONERY, PRINTS AND PUBLICATIONS AND KEY CHAINS; STREET VENDOR SERVICES FEATURING BELTS, CAPS, JEANS, SCARVES, GLOVES, TANK TOPS, HALTER TOPS, SWIMWEAR, BATHING SUITS, BIKINIS, ATHLETIC WEAR, JOGGING SUITS, BODY SUITS, RUNNING SHORTS, RUNNING PANTS, SWEAT PANTS, SWEATSHIRTS, WOMEN'S BLOUSES, SKIRTS, COATS, JACKETS, PULLOVERS, T-SHIRTS, PANTS, SHORTS, SLEEPWEAR, PAJAMAS, SLIPPERS, SWEATERS, FLIP-FLOPS, POLO SHIRTS, SMOCKS, APRONS, TUNICS, PEDAL PUSHERS, BEACH COVER UPS, SOCKS, UNDERWEAR, PANTIES, BRAS, JERSEY TOPS, JEWELRY, WATCHES, BACK PACKS, DUFFEL BAGS, HAND BAGS, SHOULDER BAGS, GEAR BAGS, BEACH BAGS, SPORT BAGS, CLUTCH BAGS, BANDANNAS, LEATHER BAGS, LEATHER WALLETS, LEATHER COATS, MOTORCYCLE GEAR, MOTORCYCLE CLOTHES, DRESSES, RACING CLOTHES, VESTS, BATHROBES, STICKERS, STATIONERY, PRINTS AND PUBLICATIONS AND KEY CHAINS (U.S. CLS. 100, 101 AND 102).  
PRISCILLA MILTON, EXAMINING ATTORNEY

SN 78-965,022. NATIONAL ASSOCIATION FOR THE SELF EMPLOYED, INC., GRAPEVINE, TX. FILED 8-31-2006.



OWNER OF U.S. REG. NOS. 1,527,299, 2,980,550 AND OTHERS.

THE MARK CONSISTS OF STYLIZED LETTERS "NASE" WITH AN ARTISTIC REPRESENTATION OF A PERSON POSITIONED TO THE RIGHT OF THE LETTERS.

FOR ASSOCIATION SERVICES, SPECIFICALLY PROMOTING THE INTERESTS OF SELF EMPLOYED INDIVIDUALS AND SMALL BUSINESSES (U.S. CLS. 100, 101 AND 102).

FRANK LATTUCA, EXAMINING ATTORNEY

**CLASS 35—(Continued).**

SN 78-965,028. BICKFORD, LINDA, SAHUARITA, AZ.  
FILED 8-31-2006.

# Kitty Farm

THE MARK CONSISTS OF STANDARD CHARACTERS WITHOUT CLAIM TO ANY PARTICULAR FONT, STYLE, SIZE, OR COLOR.

NO CLAIM IS MADE TO THE EXCLUSIVE RIGHT TO USE "KITTY", APART FROM THE MARK AS SHOWN.

FOR MAIL ORDER AND INTERNET-BASED RETAIL STORE SERVICES FEATURING PET TOYS, PET FOOD, PET GROOMING SUPPLIES, AND HOLISTIC PET MEDICINES (U.S. CLS. 100, 101 AND 102).

FRANK LATTUCA, EXAMINING ATTORNEY

SN 78-965,048. ALTICOR INVESTMENTS, INC., ADA, MI.  
FILED 8-31-2006.

## OPPORTUNITY ZONE

THE MARK CONSISTS OF STANDARD CHARACTERS WITHOUT CLAIM TO ANY PARTICULAR FONT, STYLE, SIZE, OR COLOR.

FOR PROVIDING A WEBSITE FEATURING INFORMATION AND LINKS TO BLOGS CONCERNING MULTI-LEVEL MARKETING (U.S. CLS. 100, 101 AND 102).

ANTHONY RINKER, EXAMINING ATTORNEY

SN 78-965,276. RODDY GROUP HOLDINGS, LLC, HOUSTON, TX. FILED 8-31-2006.



THE APPLICANT CLAIMS COLOR AS A FEATURE OF THE MARK, NAMELY, RED, BLACK AND GREY.

THE MARK CONSISTS OF ALL LOWER CASE LETTERS. "I", "MOVED" AND ".COM" ARE ALL IN RED. THE WORDS: "JUST AND "TO" ARE IN BLACK. THE IMAGE

**CLASS 35—(Continued).**

PROTRAYS A BOUNCING DOT STARTING AT THE "I" AND BOUNCING TO THE "T" IN "JUST", AND THEN BOUNCING TO THE "V" IN "MOVE AND THEN BOUNCING TO THE "T" IN "TO" AND THEN LANDING RIGHT BEFORE THE "COM" TO MAKE ".COM". THE IMAGE DOES NOT SHOW MULTIPLE DOTS, HOWEVER THE BOUNCING DOT IS SHOWN TO HAVE BOUNCED BECAUSE OF ITS TRAIL, ARCHING GREY HASH MARKS BEGINNING FROM THE FIRST "I" AND ENDING AT THE ".COM".

FOR ADVERTISING AND COMMERCIAL INFORMATION SERVICES, VIA THE INTERNET; ADVERTISING VIA ELECTRONIC MEDIA AND SPECIFICALLY THE INTERNET; ADVICE AND INFORMATION ABOUT CUSTOMER SERVICES AND PRODUCT MANAGEMENT AND PRICES ON INTERNET SITES IN CONNECTION WITH PURCHASES MADE OVER THE INTERNET; DISSEMINATION OF ADVERTISING FOR OTHERS VIA AN ON-LINE COMMUNICATIONS NETWORK ON THE INTERNET; DISSEMINATION OF ADVERTISING FOR OTHERS VIA THE INTERNET; PREPARATION AND REALIZATION OF MEDIA AND ADVERTISING PLANS AND CONCEPTS; PROVIDING AN ON-LINE COMMERCIAL INFORMATION DIRECTORY ON THE INTERNET; PROVIDING AND RENTAL OF ADVERTISING SPACE ON THE INTERNET (U.S. CLS. 100, 101 AND 102).

KATHERINE CONNOLLY, EXAMINING ATTORNEY

SN 78-965,304. BELISI FASHIONS, INC, JUPITER, FL. FILED 8-31-2006.

**THE BEAUTIFUL IS YOU**

THE MARK CONSISTS OF STANDARD CHARACTERS WITHOUT CLAIM TO ANY PARTICULAR FONT, STYLE, SIZE, OR COLOR.

FOR WHOLESALE DISTRIBUTORSHIP SERVICES, RETAIL STORE SERVICES, AND ON-LINE RETAIL STORE SERVICES FEATURING FASHION ACCESSORIES, CLOTHING, FRAGRANCES, COSMETICS AND HOME DECOR (U.S. CLS. 100, 101 AND 102).

KATHERINE M. DUBRAY, EXAMINING ATTORNEY

SN 78-965,557. TEMPLE5150DESIGN, LLC, PUYALLUP, WA. FILED 8-31-2006.



THE MARK CONSISTS OF THE DEAL SUPERIMPOSED OVER THE DEPICTION OF FLAMES WITH THE WORDS EFFECTIVE ADVERTISING TARGETING YOUR BACKYARD BELOW THE DEPICTION.

FOR BUSINESS MARKETING AND DIRECT MAIL CONSULTING SERVICES; DIRECT MAIL ADVERTISING; DIRECT MARKETING ADVERTISING FOR OTHERS; DIRECT MARKETING SERVICES (U.S. CLS. 100, 101 AND 102).

FIRST USE 1-0-2005; IN COMMERCE 1-0-2005.

JESSICA A. POWERS, EXAMINING ATTORNEY

**CLASS 35—(Continued).**

SN 78-965,582. ADSCHOLARS LLC, LOS ALTOS, CA. FILED 8-31-2006.

**AdScholars**

THE MARK CONSISTS OF STANDARD CHARACTERS WITHOUT CLAIM TO ANY PARTICULAR FONT, STYLE, SIZE, OR COLOR.

FOR ADVERTISING AND MARKETING; INDEPENDENT SALES REPRESENTATIVES IN THE FIELD OF SCHOLARLY JOURNALS (U.S. CLS. 100, 101 AND 102).

HENRY S. ZAK, EXAMINING ATTORNEY

SN 78-965,592. ALOHA PETROLEUM, LTD., HONOLULU, HI. FILED 8-31-2006.

**save-a-\$club**

THE MARK CONSISTS OF THE WORDS SAVE-A-\$ CLUB IN SPECIAL TYPE FONT WITH THE \$ SYMBOL HIGHLIGHTED WITHIN A CIRCLE.

FOR ADMINISTRATION OF A DISCOUNT PROGRAM FOR ENABLING PARTICIPANTS TO OBTAIN DISCOUNTS ON GOODS AND SERVICES THROUGH USE OF A DISCOUNT MEMBERSHIP CARD (U.S. CLS. 100, 101 AND 102).

LINDA LAVACHE, EXAMINING ATTORNEY

SN 78-965,639. JAMES, LINDA, WOODBURY, MN. FILED 9-1-2006.

**EVERYDAY PRINCESS**

THE MARK CONSISTS OF STANDARD CHARACTERS WITHOUT CLAIM TO ANY PARTICULAR FONT, STYLE, SIZE, OR COLOR.

FOR ON-LINE RETAIL STORE SERVICES FEATURING HOUSEHOLD AND CONSUMER GOODS AND CLOTHING (U.S. CLS. 100, 101 AND 102).

AMY GEARIN, EXAMINING ATTORNEY

**CLASS 35—(Continued).**

SN 78-965,641. DEMIEL MÉXICO, SA DE CV, CUAUTITLÁN IZCALLI, ESTADO DE MÉXICO, MEXICO, FILED 9-1-2006.



NO CLAIM IS MADE TO THE EXCLUSIVE RIGHT TO USE "DEMIEL", APART FROM THE MARK AS SHOWN.

THE COLOR(S) YELLOW, BLACK, AND WHITE IS/ARE CLAIMED AS A FEATURE OF THE MARK.

THE MARK CONSISTS OF A YELLOW AND WHITE BEEHIVE AT THE TOP OF THE CONFIGURATION, TWO BLACK BEE WINGS WHICH OVERLAY THE YELLOW AND WHITE BEEHIVE, AND THE TERM "DEMIEL" IN BLACK LETTERS AT THE BOTTOM OF THE CONFIGURATION.

THE FOREIGN WORDING IN THE MARK TRANSLATES INTO ENGLISH AS "OF HONEY" OR "FROM HONEY".

FOR RETAIL STORE SERVICES, ONLINE STORE SERVICES AND WHOLESALE DISTRIBUTORSHIP SERVICES FEATURING FOOD, NAMELY HONEY (U.S. CLS. 100, 101 AND 102).

FIRST USE 1-9-2005; IN COMMERCE 1-9-2005.  
AMY GEARIN, EXAMINING ATTORNEY

SN 78-965,751. ALMOD DIAMONDS, LTD., NEW YORK, NY, FILED 9-1-2006.

**JOURNEY TO OUR WORLD**

THE MARK CONSISTS OF STANDARD CHARACTERS WITHOUT CLAIM TO ANY PARTICULAR FONT, STYLE, SIZE, OR COLOR.

OWNER OF U.S. REG. NOS. 2,788,275 AND 2,994,946.  
FOR ON-LINE RETAIL STORE SERVICES FEATURING JEWELRY; RETAIL JEWELRY STORES (U.S. CLS. 100, 101 AND 102).

JESSICA A. POWERS, EXAMINING ATTORNEY

**CLASS 35—(Continued).**

SN 78-965,849. TOP SHELF LICENSING EXPERTS, LLC, HOLLYWOOD, FL. FILED 9-1-2006.

# TOP SHELF

Licensing Experts, LLC

NO CLAIM IS MADE TO THE EXCLUSIVE RIGHT TO USE "LICENSING EXPERTS, LLC", APART FROM THE MARK AS SHOWN.

FOR LICENSING CONSULTATION IN CONNECTION WITH THE PRODUCTION, BOTTLING, MARKETING AND SALE OF WINE AND WINE RELATED BEVERAGES IN COMPLIANCE WITH EXISTING FEDERAL AND STATE REGULATIONS (U.S. CLS. 100, 101 AND 102).

DAYNA BROWNE, EXAMINING ATTORNEY

SN 78-966,078. ADEPTMEDIA CORPORATION, HUNTSVILLE, AL. FILED 9-1-2006.

Where Innovation  
Transforms Marketing

THE MARK CONSISTS OF STANDARD CHARACTERS WITHOUT CLAIM TO ANY PARTICULAR FONT, STYLE, SIZE, OR COLOR.

FOR PROVIDING ADVERTISING, MARKETING AND PROMOTIONAL SERVICES, NAMELY DEVELOPMENT AND MANAGEMENT OF ADVERTISING CAMPAIGNS FOR COMMUNICATION MEDIA, NAMELY PRINT, ONLINE AND MOBILE ELECTRONIC DEVICES; MANAGEMENT AND COMPILATION OF TARGETED DIRECT ADVERTISING INFORMATION; TARGETING OF CONSUMERS TO RECEIVE ADVERTISEMENTS; PROVIDING A WEBSITE FEATURING INFORMATION IN THE FIELD OF ADVERTISING CAMPAIGNS (U.S. CLS. 100, 101 AND 102).

TARAH HARDY, EXAMINING ATTORNEY

**CLASS 35—(Continued).**

SN 78-966,188. SLEEP RESEARCH SOCIETY, WESTCHESTER, IL. FILED 9-1-2006.



THE STIPLING IS A FEATURE OF THE MARK.  
FOR ASSOCIATION SERVICES, NAMELY, PROMOTING THE INTERESTS OF SCIENTISTS BY ENCOURAGING SCIENTIFIC INVESTIGATION, PROFESSIONAL EDUCATION AND CAREER DEVELOPMENT IN SLEEP RESEARCH AND ACADEMIC SLEEP MEDICINE (U.S. CLS. 100, 101 AND 102).  
FIRST USE 9-30-1988; IN COMMERCE 9-30-1988.  
JACLYN KIDWELL, EXAMINING ATTORNEY

SN 78-966,237. JEWELRY WAREHOUSE INC., WEST COLUMBIA, SC. FILED 9-1-2006.

**JEWELRY WAREHOUSE**

THE MARK CONSISTS OF STANDARD CHARACTERS WITHOUT CLAIM TO ANY PARTICULAR FONT, STYLE, SIZE, OR COLOR.

OWNER OF U.S. REG. NO. 2,136,365.  
NO CLAIM IS MADE TO THE EXCLUSIVE RIGHT TO USE "JEWELRY", APART FROM THE MARK AS SHOWN. SEC. 2(F).

FOR ON-LINE RETAIL STORE SERVICES FEATURING JEWELRY, SOUVENIRS RELATED TO UNIVERSITIES AND CLOTHING; RETAIL JEWELRY STORES (U.S. CLS. 100, 101 AND 102).

FIRST USE 3-14-1979; IN COMMERCE 3-14-1979.  
IRENE D. WILLIAMS, EXAMINING ATTORNEY

**CLASS 35—(Continued).**

SN 78-966,417. HJCV LLC, CHAPPAQUA, NY. FILED 9-1-2006.

**NEXWORKER.COM**

THE MARK CONSISTS OF STANDARD CHARACTERS WITHOUT CLAIM TO ANY PARTICULAR FONT, STYLE, SIZE, OR COLOR.

FOR PROVIDING AN ON-LINE SEARCHABLE DATABASE IN THE NATURE OF AN ADDRESS BOOK FOR MANAGING PROFESSIONAL AND PERSONAL CONTACT INFORMATION (U.S. CLS. 100, 101 AND 102).  
CHRISTINE COOPER, EXAMINING ATTORNEY

SN 78-966,425. TORRENEGRA IP, SECAUCUS, NJ. FILED 9-1-2006.

**SmartCast**

THE MARK CONSISTS OF STANDARD CHARACTERS WITHOUT CLAIM TO ANY PARTICULAR FONT, STYLE, SIZE, OR COLOR.

FOR ADVERTISING AND MARKETING; ADVERTISING BY TRANSMISSION OF ON-LINE PUBLICITY FOR THIRD PARTIES THROUGH ELECTRONIC COMMUNICATIONS NETWORKS; AUCTION MANAGEMENT SERVICES PROVIDED TO OTHERS OVER AN ON-LINE WEB SITE ACCESSED THROUGH A GLOBAL COMPUTER NETWORK; BUSINESS SERVICES, NAMELY PROVIDING COMPUTER DATABASES REGARDING THE PURCHASE AND SALE OF A WIDE VARIETY OF PRODUCTS AND SERVICES OF OTHERS; COMMERCIAL INFORMATION AND DIRECTORY AGENCY; MARKETING SERVICES, NAMELY PROVIDING INFORMATIONAL WEB PAGES DESIGNED TO GENERATE SALES TRAFFIC VIA HYPERLINKS TO OTHER WEB SITES; ON-LINE BUSINESS DIRECTORIES FEATURING VOICE TALENTS, TALENT AGENCIES, PRODUCERS, AD AGENCIES, OR OTHER MEDIA PROFESSIONALS; ON-LINE TRADING SERVICES IN WHICH SELLER POSTS PRODUCTS TO BE AUCTIONED AND BIDDING IS DONE VIA THE INTERNET; OPERATING ON-LINE MARKETPLACES FOR SELLERS OF GOODS AND/OR SERVICES; POST-PRODUCTION EDITING SERVICES FOR VIDEO AND AUDIO COMMERCIALS; PRODUCING AUDIO OR VIDEO INFO-

**CLASS 35—(Continued).**

MERCIALS; PROMOTING, ADVERTISING AND MARKETING OF THE ON-LINE WEBSITES OF OTHERS; PROMOTION, ADVERTISING AND MARKETING OF ON-LINE WEBSITES; PROVIDING A SEARCHABLE ON-LINE ADVERTISING GUIDE FEATURING THE GOODS AND SERVICES OF OTHER ON-LINE VENDORS ON THE INTERNET; PROVIDING A WEB SITE WHEREBY BUYERS OF GOODS OR SERVICES LOCATE AND RECEIVE QUOTATIONS FROM MULTIPLE COMPETITIVE SOURCES AND SELLERS OF GOODS OR SERVICES IDENTIFY AND BID ON MULTIPLE NEW SALES OPPORTUNITIES; PROVIDING AN ON-LINE COMPUTER DATABASE FEATURING TRADE INFORMATION IN THE FIELD OF COMMUNICATIONS, TALENTS, AGENCIES, AGENTS, PRODUCERS, AND OTHER MEDIA PROFESSIONALS AND SERVICES; PROVIDING ON-LINE DIRECTORY INFORMATION SERVICES ALSO FEATURING HYPERLINKS TO OTHER WEB SITES; TALENT AGENCIES; TELEPHONE DIRECTORY INFORMATION (U.S. CLS. 100, 101 AND 102).

FIRST USE 7-1-2006; IN COMMERCE 7-1-2006.

CHRISTINE COOPER, EXAMINING ATTORNEY

---

SN 78-966,522. NEXT LEVEL SPORTS MANAGEMENT, ALTA LOMA, CA. FILED 9-2-2006.

1 Car, 1 House, 1  
Girlfriend

THE MARK CONSISTS OF STANDARD CHARACTERS WITHOUT CLAIM TO ANY PARTICULAR FONT, STYLE, SIZE, OR COLOR.

FOR SPORTS MANAGEMENT, NAMELY MANAGEMENT AND REPRESENTATION OF PROFESSIONAL ATHLETES (U.S. CLS. 100, 101 AND 102).

CHRISTOPHER BUONGIORNO, EXAMINING ATTORNEY

---

SN 78-966,760. GOTTLIEB, THEODORE B., ZEPHYR COVE, NV. AND BUTLER, PAMELA L., ZEPHYR COVE, NV. FILED 9-4-2006.

KISS GAMING

THE MARK CONSISTS OF STANDARD CHARACTERS WITHOUT CLAIM TO ANY PARTICULAR FONT, STYLE, SIZE, OR COLOR.

NO CLAIM IS MADE TO THE EXCLUSIVE RIGHT TO USE "GAMING", APART FROM THE MARK AS SHOWN.

FOR MARKETING AND PROMOTION OF GAMES (U.S. CLS. 100, 101 AND 102).

CARRIE ACHEN, EXAMINING ATTORNEY

**CLASS 35—(Continued).**

SN 78-966,954. ORVY TELECOM INTERNATIONAL LLC, BEACHWOOD, OH. FILED 9-5-2006.



THE MARK CONSISTS OF ORVY WITH 3 LINES OVER THE V.

FOR MANAGEMENT AND BUSINESS CONSULTING SERVICES IN THE FIELD OF TELECOMMUNICATION SERVICES (U.S. CLS. 100, 101 AND 102).

FIRST USE 8-4-2006; IN COMMERCE 8-25-2006.

CAROLINE WOOD, EXAMINING ATTORNEY

---

SN 78-967,054. LESLIE, BRIAN, BLAINE, WA. FILED 9-5-2006.

mocommercial

THE MARK CONSISTS OF STANDARD CHARACTERS WITHOUT CLAIM TO ANY PARTICULAR FONT, STYLE, SIZE, OR COLOR.

FOR PRODUCTION AND DISTRIBUTION OF RADIO AND TELEVISION COMMERCIALS (U.S. CLS. 100, 101 AND 102).

COLLEEN DOMBROW, EXAMINING ATTORNEY

---

SN 78-967,057. SECRET IMPACT LLC, GAITHERSBURG, MD. FILED 9-5-2006.



THE STIPPLING IS FOR SHADING PURPOSES ONLY. THE MARK CONSISTS OF A CIRCLE WITH AN SI INSIDE OF IT AND NEXT TO THAT THE STYLIZED TEXT OF THE WORDING "SECRET IMPACT".

FOR ONLINE ADVERTISING AND MARKETING SERVICES (U.S. CLS. 100, 101 AND 102).

NATALIE POLZER, EXAMINING ATTORNEY

**CLASS 35—(Continued).**

SN 78-967,077. CHENG, TONY, NEW YORK, NY. FILED 9-5-2006.

# Tripfilms

THE MARK CONSISTS OF STANDARD CHARACTERS WITHOUT CLAIM TO ANY PARTICULAR FONT, STYLE, SIZE, OR COLOR.

FOR ADVERTISING AND PUBLICITY SERVICES, NAMELY, PROMOTING THE GOODS, SERVICES, BRAND IDENTITY AND COMMERCIAL INFORMATION AND NEWS OF THIRD PARTIES THROUGH PRINT, AUDIO, VIDEO, DIGITAL AND ON-LINE MEDIUM (U.S. CLS. 100, 101 AND 102).

MORENO, PAUL, EXAMINING ATTORNEY

**CLASS 35—(Continued).**

SN 78-967,485. OVERSTOCK.COM, INC., SALT LAKE CITY, UT. FILED 9-5-2006.

# FILL A TRUCK FOR A BUCK

THE MARK CONSISTS OF STANDARD CHARACTERS WITHOUT CLAIM TO ANY PARTICULAR FONT, STYLE, SIZE, OR COLOR.

FOR ONLINE WHOLESALE AND RETAIL STORE SERVICES FEATURING GENERAL CONSUMER MERCHANDISE (U.S. CLS. 100, 101 AND 102).

JAY BESCH, EXAMINING ATTORNEY

SN 78-967,489. OVERSTOCK.COM, INC., SALT LAKE CITY, UT. FILED 9-5-2006.

# YOU CAN FILL A TRUCK FOR A BUCK

THE MARK CONSISTS OF STANDARD CHARACTERS WITHOUT CLAIM TO ANY PARTICULAR FONT, STYLE, SIZE, OR COLOR.

FOR ONLINE WHOLESALE AND RETAIL STORE SERVICES FEATURING GENERAL CONSUMER MERCHANDISE (U.S. CLS. 100, 101 AND 102).

JAY BESCH, EXAMINING ATTORNEY

SN 78-967,662. POSITIVE LIVING, LLC, HONOLULU, HI. FILED 9-5-2006.

# MY RICH LIFE

THE MARK CONSISTS OF STANDARD CHARACTERS WITHOUT CLAIM TO ANY PARTICULAR FONT, STYLE, SIZE, OR COLOR.

FOR ADVERTISING, PROMOTION AND MARKETING SERVICES, NAMELY, PROMOTING THE GOODS AND SERVICES OF OTHERS VIA THE INTERNET, COMPUTER, CELLULAR, WIRELESS, FIBER-OPTIC, TELEVISION, RADIO OR OTHER COMMUNICATION NETWORKS AND SOURCES (U.S. CLS. 100, 101 AND 102).

FRANK LATTUCA, EXAMINING ATTORNEY

SN 78-967,216. QUALITY MANAGEMENT INTERNATIONAL, INC, EXTON, PA. FILED 9-5-2006.

# We fix the system.

THE MARK CONSISTS OF STANDARD CHARACTERS WITHOUT CLAIM TO ANY PARTICULAR FONT, STYLE, SIZE, OR COLOR.

FOR BUSINESS MANAGEMENT CONSULTANCY SERVICES (U.S. CLS. 100, 101 AND 102).

FIRST USE 9-5-2006; IN COMMERCE 9-5-2006.

ANN E. SAPPENFIELD, EXAMINING ATTORNEY

SN 78-967,295. PROMOSHOP, INC., LOS ANGELES, CA. FILED 9-5-2006.

# PharmaShop

THE MARK CONSISTS OF STANDARD CHARACTERS WITHOUT CLAIM TO ANY PARTICULAR FONT, STYLE, SIZE, OR COLOR.

FOR ADVERTISING, MARKETING AND PROMOTING THE SALE OF GOODS AND SERVICES OF OTHERS IN THE PHARMACEUTICAL INDUSTRY (U.S. CLS. 100, 101 AND 102).

HOWARD B. LEVINE, EXAMINING ATTORNEY

**CLASS 35—(Continued).**

SN 78-967,710. SCIENCE CENTER, PHILADELPHIA, PA. FILED 9-6-2006.

## INTERNATIONAL SOFT LANDING

THE MARK CONSISTS OF STANDARD CHARACTERS WITHOUT CLAIM TO ANY PARTICULAR FONT, STYLE, SIZE, OR COLOR.

NO CLAIM IS MADE TO THE EXCLUSIVE RIGHT TO USE "INTERNATIONAL", APART FROM THE MARK AS SHOWN.

FOR BUSINESS DEVELOPMENT SERVICES, NAMELY, PROVIDING START-UP SUPPORT FOR BUSINESSES OF OTHERS IN THE FIELDS OF LIFE SCIENCE AND TECHNOLOGY (U.S. CLS. 100, 101 AND 102).

SCOTT BIBB, EXAMINING ATTORNEY

---

SN 78-967,749. INCREMEDICAL, LLC, ST. JOHN, IN. FILED 9-6-2006.

## OPTIMIZING THE ECONOMICS OF CLINICAL EXCELLENCE

THE MARK CONSISTS OF STANDARD CHARACTERS WITHOUT CLAIM TO ANY PARTICULAR FONT, STYLE, SIZE, OR COLOR.

FOR LICENSING OF COMPUTER SOFTWARE IN THE FIELDS OF MEDICAL PRACTICE MANAGEMENT, CODING, BILLING, SCHEDULING AND CUSTOMER RELATIONSHIP MANAGEMENT; PROVIDING ONLINE INFORMATION CONCERNING CUSTOMER RELATIONSHIP MANAGEMENT (U.S. CLS. 100, 101 AND 102).

DAVID H. STINE, EXAMINING ATTORNEY

---

SN 78-967,841. PIMA DOOR & SUPPLY, INC., LAS VEGA, NV. FILED 9-6-2006.



NO CLAIM IS MADE TO THE EXCLUSIVE RIGHT TO USE "DOOR & SUPPLY, INC.", APART FROM THE MARK AS SHOWN.

FOR RETAIL SHOPS FEATURING DOORS AND TRIMS; RETAIL STORES FEATURING DOORS AND TRIMS (U.S. CLS. 100, 101 AND 102).

FIRST USE 11-1-1986; IN COMMERCE 11-1-1986.  
MICHAEL TANNER, EXAMINING ATTORNEY

**CLASS 35—(Continued).**

SN 78-967,850. MED1ONLINE, LLC, GOLDEN, CO. FILED 9-6-2006.



NO CLAIM IS MADE TO THE EXCLUSIVE RIGHT TO USE "ONLINE", APART FROM THE MARK AS SHOWN.

THE APPLICANT CLAIMS COLOR AS A FEATURE OF THE MARK, NAMELY, AQUA BLUE.

THE MARK CONSISTS OF AN AQUA BLUE SQUARE SURROUNDING THE WORDS "MED1" AND "ONLINE". MED1 AND ONLINE ARE WRITTEN IN AQUA BLUE. MED1 IS WRITTEN IN THE TOP HALF OF THE SQUARE. ONLINE IS WRITTEN IN THE BOTTOM HALF OF THE SQUARE. AN AQUA BLUE HORIZONTAL LINE DIVIDES THE SQUARE INTO HALFS AND SEPARATES THE WORDING.

FOR DISTRIBUTORSHIPS IN THE FIELD OF MEDICAL EQUIPMENT (U.S. CLS. 100, 101 AND 102).

FIRST USE 6-1-2002; IN COMMERCE 6-1-2002.

DAVID H. STINE, EXAMINING ATTORNEY

---

SN 78-968,025. ABUNGA.COM, KNOXVILLE, TN. FILED 9-6-2006.

## ABUNGA.COM

THE MARK CONSISTS OF STANDARD CHARACTERS WITHOUT CLAIM TO ANY PARTICULAR FONT, STYLE, SIZE, OR COLOR.

FOR ON-LINE RETAIL STORE SERVICES FEATURING FAMILY-FRIENDLY BOOKS, MUSIC, VIDEOTAPES, AUDIOCASSETTES, COMPACT DISCS, CD-ROMS, PRINTED MATTERS, PHONOGRAPHS, RECORDED MUSIC, GAMES, ELECTRONIC PUBLICATIONS, GREETING CARDS, CALENDARS, SOFTWARE, MERCHANDISE AND CONSUMER GOODS; ON-LINE MAIL ORDER SERVICES FEATURING FAMILY-FRIENDLY BOOKS, MUSIC, VIDEOTAPES, AUDIOCASSETTES, COMPACT DISCS, CD-ROMS, PRINTED MATTERS, PHONOGRAPHS, RECORDED MUSIC, GAMES, ELECTRONIC PUBLICATIONS, GREETING CARDS, CALENDARS, SOFTWARE, MERCHANDISE AND CONSUMER GOODS; DISTRIBUTORSHIP SERVICES FEATURING FAMILY-FRIENDLY BOOKS, MUSIC, VIDEOTAPES, AUDIOCASSETTES, COMPACT DISCS, CD-ROMS, PRINTED MATTERS, PHONOGRAPHS, RECORDED MUSIC, GAMES, ELECTRONIC PUBLICATIONS, GREETING CARDS, CALENDARS, SOFTWARE, MERCHANDISE AND CONSUMER GOODS; PROMOTION OF FAMILY-FRIENDLY GOODS AND SERVICES OF OTHERS (U.S. CLS. 100, 101 AND 102).

PAUL CROWLEY, EXAMINING ATTORNEY



**CLASS 35—(Continued).**

SN 78-968,055. FRESH SOURDOUGH EXPRESS, LLC, HOMER, AK. FILED 9-6-2006.



NO CLAIM IS MADE TO THE EXCLUSIVE RIGHT TO USE "FRESH SOURDOUGH" AND "BAKERY CAFE SINCE 1982", APART FROM THE MARK AS SHOWN.

THE MARK CONSISTS, IN PART, OF A DESIGN COMPRISING A COFFEE CUP WITH STEAM BLENDING WITH THE SUN, WHEAT STALKS, TREES AND MOUNTAINS RISING OVER A CHECKERBOARD FLOOR, STARS AND TWO BANNERS BEARING THE LITERAL ELEMENTS.

FOR RETAIL BAKERY SHOPS (U.S. CLS. 100, 101 AND 102).

FIRST USE 5-12-1982; IN COMMERCE 5-12-1982. HANNO RITTNER, EXAMINING ATTORNEY

SN 78-968,071. O' CONNELL & COMPANY, INC., COSTA MESA, CA. FILED 9-6-2006.

# FranWise

THE MARK CONSISTS OF STANDARD CHARACTERS WITHOUT CLAIM TO ANY PARTICULAR FONT, STYLE, SIZE, OR COLOR.

FOR BUSINESS CONSULTING SERVICES FOR FRANCHISED AND NON-FRANCHISED BUSINESSES (U.S. CLS. 100, 101 AND 102).

JAY FLOWERS, EXAMINING ATTORNEY

SN 78-968,083. BOWMAN, JEREMY, MILWAUKEE, WI. FILED 9-6-2006.

# SELECTIVESEATING

THE MARK CONSISTS OF STANDARD CHARACTERS WITHOUT CLAIM TO ANY PARTICULAR FONT, STYLE, SIZE, OR COLOR.

FOR INDEPENDENT SALES REPRESENTATIVES IN THE FIELD OF EVENT TICKETS (U.S. CLS. 100, 101 AND 102).

SHAUNIA WALLACE, EXAMINING ATTORNEY

**CLASS 35—(Continued).**

SN 78-968,252. EVANS, TORIANO V., FORT LAUDERDALE, FL. FILED 9-6-2006.



THE MARK CONSISTS OF THE WORD APPOINTEE, TO ITS RIGHT SIDE AN IMAGE OF A DOWNWARDLY POINTED ARROW HAVING EYES, MOUTH, AND HAIR PROTRUDING FROM A TOP SIDE.

FOR APPOINTMENT SCHEDULING SERVICES; COMPUTERIZED DATABASE MANAGEMENT; CUSTOMER RELATIONSHIP MANAGEMENT (U.S. CLS. 100, 101 AND 102).

KATHRYN COWARD, EXAMINING ATTORNEY

SN 78-968,391. THE FRESH MARKET, INC., GREENSBORO, NC. FILED 9-6-2006.

# EXPERIENCE THE FOOD!

THE MARK CONSISTS OF STANDARD CHARACTERS WITHOUT CLAIM TO ANY PARTICULAR FONT, STYLE, SIZE, OR COLOR.

FOR RETAIL GROCERY STORE SERVICES (U.S. CLS. 100, 101 AND 102).

BRENDAN REGAN, EXAMINING ATTORNEY

SN 78-968,399. THE FRESH MARKET, INC., GREENSBORO, NC. FILED 9-6-2006.

# EXPERIENCE THE FOOD

THE MARK CONSISTS OF STANDARD CHARACTERS WITHOUT CLAIM TO ANY PARTICULAR FONT, STYLE, SIZE, OR COLOR.

FOR RETAIL GROCERY STORE SERVICES (U.S. CLS. 100, 101 AND 102).

BRENDAN REGAN, EXAMINING ATTORNEY

**CLASS 35—(Continued).**

SN 78-968,464. POWELL GLOBAL ATTORNEY SEARCH, LLC, HOUSTON, TX. FILED 9-6-2006.

**POWELL GLOBAL**  
ATTORNEY SEARCH

NO CLAIM IS MADE TO THE EXCLUSIVE RIGHT TO USE "GLOBAL ATTORNEY SEARCH", APART FROM THE MARK AS SHOWN.

THE COLOR(S) MAROON AND GRAY IS/ARE CLAIMED AS A FEATURE OF THE MARK.

THE COLOR MAROON APPEARS IN THE WORDING POWELL GLOBAL ATTORNEY SEARCH AND IN THE UPPER LEFT QUADRANT OF THE CIRCULAR FOUR QUADRANT DESIGN THAT SUBSTITUTES FOR THE O IN THE TERM GLOBAL; THE COLOR GRAY APPEARS IN THE REMAINING THREE QUADRANTS AND IN THE LINE UNDER THE POWELL GLOBAL.

FOR ATTORNEY REFERRALS; CONSULTANCY OF PERSONNEL RECRUITMENT; EMPLOYMENT COUNSELING AND RECRUITING; EMPLOYMENT HIRING, RECRUITING, PLACEMENT, STAFFING AND CAREER NETWORKING SERVICES; EXECUTIVE SEARCH AND PLACEMENT SERVICES; LAWYER REFERRALS; PERSONNEL PLACEMENT AND RECRUITMENT (U.S. CLS. 100, 101 AND 102).

FIRST USE 6-1-2006; IN COMMERCE 6-1-2006.

RONALD MCMORROW, EXAMINING ATTORNEY

SN 78-968,499. URBAN COMMUNITY SERVICES CO INC, ELIZABETH, NJ. FILED 9-6-2006.

## Bringing Financial Security Back Home

THE MARK CONSISTS OF STANDARD CHARACTERS WITHOUT CLAIM TO ANY PARTICULAR FONT, STYLE, SIZE, OR COLOR.

FOR TAX PREPARATION (U.S. CLS. 100, 101 AND 102).

H. M. FISHER, EXAMINING ATTORNEY

SN 78-968,547. DEMING AND PISANO LLC, NEW YORK, NY. FILED 9-6-2006.

## THE CLIENT EXPERIENCE

THE MARK CONSISTS OF STANDARD CHARACTERS WITHOUT CLAIM TO ANY PARTICULAR FONT, STYLE, SIZE, OR COLOR.

FOR BUSINESS CONSULTATION (U.S. CLS. 100, 101 AND 102).

KEVON CHISOLM, EXAMINING ATTORNEY

**CLASS 35—(Continued).**

SN 78-968,567. CRM METRIX INC., SECAUCUS, NJ. FILED 9-6-2006.

## SITECRM

THE MARK CONSISTS OF STANDARD CHARACTERS WITHOUT CLAIM TO ANY PARTICULAR FONT, STYLE, SIZE, OR COLOR.

FOR MARKET RESEARCH (U.S. CLS. 100, 101 AND 102).

FIRST USE 2-1-2001; IN COMMERCE 2-1-2001.

LAURA KOVALSKY, EXAMINING ATTORNEY

SN 78-968,650. CLEM, BRYAN S., PHOENIX, AZ. FILED 9-7-2006.

## Fixup trader

THE MARK CONSISTS OF STANDARD CHARACTERS WITHOUT CLAIM TO ANY PARTICULAR FONT, STYLE, SIZE, OR COLOR.

NO CLAIM IS MADE TO THE EXCLUSIVE RIGHT TO USE "TRADER", APART FROM THE MARK AS SHOWN.

FOR ADVERTISING AND ADVERTISEMENT SERVICES; ADVERTISING AND COMMERCIAL INFORMATION SERVICES, VIA THE INTERNET; ADVERTISING AND MARKETING; ADVERTISING FLYER DISTRIBUTION; ADVERTISING SERVICES; ADVERTISING SERVICES, NAMELY PROVIDING ADVERTISING SPACE IN A PERIODICAL; ADVERTISING VIA ELECTRONIC MEDIA AND SPECIFICALLY THE INTERNET; ADVERTISING, MARKETING AND PROMOTION SERVICES; DISPLAYING ADVERTISEMENTS FOR OTHERS; ON-LINE ADVERTISING AND MARKETING SERVICES; ON-LINE ADVERTISING ON COMPUTER COMMUNICATION NETWORKS; PLACING ADVERTISEMENTS FOR OTHERS; PROMOTING THE GOODS AND SERVICES OF OTHERS BY PREPARING AND PLACING ADVERTISEMENTS IN AN ELECTRONIC MAGAZINE ACCESSED THROUGH A GLOBAL COMPUTER NETWORK; PROVIDING A WEB SITE WHICH FEATURES ADVERTISEMENTS FOR THE GOODS AND SERVICES OF OTHERS ON A GLOBAL COMPUTER NETWORK; PROVIDING INFORMATION ABOUT AUTOMOBILES FOR SALE BY MEANS OF THE INTERNET; PROVIDING SPACE AT A WEB SITE FOR THE ADVERTISEMENT OF THE GOODS AND SERVICES OF OTHERS (U.S. CLS. 100, 101 AND 102).

JUDITH HELFMAN, EXAMINING ATTORNEY

**CLASS 35—(Continued).**

SN 78-968,722. SKPT ENTERPRISES, LLC, DELRAY BEACH, FL. FILED 9-7-2006.

TURN YOUR PHONE INTO MONEY

THE MARK CONSISTS OF STANDARD CHARACTERS WITHOUT CLAIM TO ANY PARTICULAR FONT, STYLE, SIZE, OR COLOR.

FOR TELEMARKETING SERVICES AND LEAD GENERATING SERVICES, NAMELY ADVERTISING AND MARKETING TO GENERATE LEADS FOR THE LENDING INDUSTRY (U.S. CLS. 100, 101 AND 102).  
MARY CRAWFORD, EXAMINING ATTORNEY

SN 78-968,729. SKPT ENTERPRISES, LLC, DELRAY BEACH, FL. FILED 9-7-2006.

WANT TO TURN YOUR PHONE INTO MONEY?

THE MARK CONSISTS OF STANDARD CHARACTERS WITHOUT CLAIM TO ANY PARTICULAR FONT, STYLE, SIZE, OR COLOR.

FOR TELEMARKETING SERVICES AND LEAD GENERATING SERVICES, NAMELY ADVERTISING AND MARKETING TO GENERATE LEADS FOR THE LENDING INDUSTRY (U.S. CLS. 100, 101 AND 102).  
MARY CRAWFORD, EXAMINING ATTORNEY

SN 78-968,802. FANNIE MAE FOUNDATION, WASHINGTON, DC. FILED 9-7-2006.

**DATAPLACE**

THE MARK CONSISTS OF STANDARD CHARACTERS WITHOUT CLAIM TO ANY PARTICULAR FONT, STYLE, SIZE, OR COLOR.

FOR PROVIDING BUSINESS AND MARKET RESEARCH INFORMATION IN THE NATURE OF HOUSING AND DEMOGRAPHIC DATA (U.S. CLS. 100, 101 AND 102).  
FIRST USE 12-1-2004; IN COMMERCE 12-1-2004.  
ATTIYA MALIK, EXAMINING ATTORNEY

**CLASS 35—(Continued).**

SN 78-968,830. INFRATRAC INC., BALTIMORE, MD. FILED 9-7-2006.

**InfraTrac**

THE MARK CONSISTS OF STANDARD CHARACTERS WITHOUT CLAIM TO ANY PARTICULAR FONT, STYLE, SIZE, OR COLOR.

FOR BUSINESS CONSULTATION SERVICES (U.S. CLS. 100, 101 AND 102).  
KEVIN CORWIN, EXAMINING ATTORNEY

SN 78-968,843. TESSCO COMMUNICATIONS INCORPORATED, HUNT VALLEY, MD. FILED 9-7-2006.

**WE'RE WIRED INTO EVERYTHING WIRELESS**

THE MARK CONSISTS OF STANDARD CHARACTERS WITHOUT CLAIM TO ANY PARTICULAR FONT, STYLE, SIZE, OR COLOR.

NO CLAIM IS MADE TO THE EXCLUSIVE RIGHT TO USE "WIRELESS", APART FROM THE MARK AS SHOWN.  
FOR WHOLESALE AND RETAIL DISTRIBUTORSHIPS IN THE FIELD OF TELECOMMUNICATIONS; AND BUSINESS CONSULTING SERVICES RELATING TO SUPPLY CHAIN SOLUTIONS TO THE PROFESSIONALS THAT DESIGN, BUILD, RUN, USE AND MAINTAIN WIRELESS VOICE, DATA, MESSAGING, LOCATION TRACKING AND INTERNET SYSTEMS (U.S. CLS. 100, 101 AND 102).  
NAAKWAMA ANKRAH, EXAMINING ATTORNEY

SN 78-968,931. KENTUCKY SCHOOL PLANT MANAGEMENT ASSOCIATION, LEXINGTON, KY. FILED 9-7-2006.

**"Caretakers of the Educational Environment"**

THE MARK CONSISTS OF STANDARD CHARACTERS WITHOUT CLAIM TO ANY PARTICULAR FONT, STYLE, SIZE, OR COLOR.

FOR ASSOCIATION SERVICES, NAMELY, PROMOTING THE INTERESTS OF NON-PROFIT EDUCATION (U.S. CLS. 100, 101 AND 102).  
MICHAEL SOUDERS, EXAMINING ATTORNEY

**CLASS 35—(Continued).**

SN 78-969,466. BY ANY MEANS ENTERTAINMENT, INC., WICHITA, KS. FILED 9-7-2006.

# AUDIOCAINE

THE MARK CONSISTS OF STANDARD CHARACTERS WITHOUT CLAIM TO ANY PARTICULAR FONT, STYLE, SIZE, OR COLOR.

FOR PROMOTION AND MARKETING SERVICES AND RELATED CONSULTING (U.S. CLS. 100, 101 AND 102).

JAMES LOVELACE, EXAMINING ATTORNEY

SN 78-969,621. CITIQUEST.COM, LLC, INDIANAPOLIS, IN. FILED 9-7-2006.

# CitiQuest

THE MARK CONSISTS OF STANDARD CHARACTERS WITHOUT CLAIM TO ANY PARTICULAR FONT, STYLE, SIZE, OR COLOR.

FOR PROVIDING A WEB SITE THAT ENABLES USERS TO POST ITEMS FOR SALE THROUGH ON-LINE CLASSIFIED ADVERTISEMENTS; PROVIDING AN ON-LINE SEARCHABLE DATABASE FEATURING CLASSIFIED AD LISTINGS AND EMPLOYMENT OPPORTUNITIES (U.S. CLS. 100, 101 AND 102).

DOMINICK J. SALEMI, EXAMINING ATTORNEY

SN 78-969,689. CARMAX BUSINESS SERVICES, LLC, RICHMOND, VA. FILED 9-8-2006.

# JUST ONE OF THE GAZILLION REASONS TO SHOP AT CARMAX

THE MARK CONSISTS OF STANDARD CHARACTERS WITHOUT CLAIM TO ANY PARTICULAR FONT, STYLE, SIZE, OR COLOR.

FOR RETAIL STORE SERVICES FEATURING AUTOMOBILES AND TRUCKS (U.S. CLS. 100, 101 AND 102).

JAMES A. RAUEN, EXAMINING ATTORNEY

**CLASS 35—(Continued).**

SN 78-969,692. CARMAX BUSINESS SERVICES, LLC, RICHMOND, VA. FILED 9-8-2006.

# IT'S AMAZING NO ONE'S THOUGHT OF THIS BEFORE

THE MARK CONSISTS OF STANDARD CHARACTERS WITHOUT CLAIM TO ANY PARTICULAR FONT, STYLE, SIZE, OR COLOR.

FOR RETAIL STORE SERVICES FEATURING AUTOMOBILES AND TRUCKS (U.S. CLS. 100, 101 AND 102).

JAMES A. RAUEN, EXAMINING ATTORNEY

SN 78-969,953. ACCELLER, INC., MIAMI, FL. FILED 9-8-2006.



THE COLOR(S) GRAY, LIGHT GREEN, DARKER GREEN, LIGHT BLUE, BROWN IS/ARE CLAIMED AS A FEATURE OF THE MARK.

THE COLOR GRAY APPEARS IN THE OUTLINE OF THE HOUSE AND IN THE TERMS DIGITAL LANDING, THE COLOR LIGHT GREEN APPEARS IN THE CIRCLE IN THE UPPER LEFT CORNER OF THE HOUSE, THE COLOR BLUE APPEARS IN THE CIRCLE IN THE UPPER CORNER RIGHT OF THE HOUSE, THE COLOR BROWN APPEARS IN THE LOWER LEFT CIRCLE AND THE COLOR DARKER GREEN APPEARS IN THE LOWER RIGHT CIRCLE IN THE CORNER OF THE HOUSE.

FOR COMPARATIVE MARKETING AND ADVERTISING SERVICES FOR PROVIDERS OF RESIDENTIAL AND BUSINESS TELECOMMUNICATIONS AND OTHER DIGITAL SERVICES, NAMELY, FOR PROVIDERS OF BROADBAND CABLE, DSL, FIBER-OPTIC AND SATELLITE INTERNET ACCESS SERVICES, CABLE AND SATELLITE TELEVISION, VOICE OVER IP, AND LONG-DISTANCE TELEPHONE SERVICES; OPERATION OF TELEPHONE CALL CENTERS FOR OTHERS FOR PURPOSES OF MARKETING OF TELECOMMUNICATIONS AND OTHER DIGITAL SERVICES AND MARKETING CONSULTING RELATED THERETO (U.S. CLS. 100, 101 AND 102).

CAROLINE WOOD, EXAMINING ATTORNEY

SN 78-970,238. AKQA, INC., SAN FRANCISCO, CA. FILED 9-8-2006.

# AKQA

THE MARK CONSISTS OF STANDARD CHARACTERS WITHOUT CLAIM TO ANY PARTICULAR FONT, STYLE, SIZE, OR COLOR.

FOR ADVERTISING AND MARKETING; CONCEPT AND BRAND DEVELOPMENT IN THE FIELD OF E-COMMERCE (U.S. CLS. 100, 101 AND 102).

FIRST USE 6-8-2001; IN COMMERCE 6-8-2001.

CHRISTOPHER BUONGIORNO, EXAMINING ATTORNEY

**CLASS 35—(Continued).**

SN 78-970,429. SIGNATURE ACADEMIES, LLC, EAGLE, ID.  
FILED 9-8-2006.

# LifeSport

THE MARK CONSISTS OF STANDARD CHARACTERS  
WITHOUT CLAIM TO ANY PARTICULAR FONT, STYLE,  
SIZE, OR COLOR.

FOR REAL ESTATE MARKETING SERVICES IN THE  
FIELD OF HOMES (U.S. CLS. 100, 101 AND 102).  
MICHAEL TANNER, EXAMINING ATTORNEY

SN 78-970,482. AOL LLC, DULLES, VA. FILED 9-8-2006.

# PEOPLESPLACE

THE MARK CONSISTS OF STANDARD CHARACTERS  
WITHOUT CLAIM TO ANY PARTICULAR FONT, STYLE,  
SIZE, OR COLOR.

OWNER OF U.S. REG. NO. 2,386,795.  
FOR PROVIDING ONLINE DIRECTORY SERVICES  
FEATURING SUBSCRIBER BIOGRAPHICAL AND PERSONAL  
INFORMATION, E-MAIL ADDRESSES, AND  
WEB PAGES (U.S. CLS. 100, 101 AND 102).  
ALICE SUE CARRUTHERS, EXAMINING ATTORNEY

SN 78-970,549. JUMPSTART DIGITAL MARKETING, INC.,  
SAN FRANCISCO, CA. FILED 9-8-2006.

# JUMPSTART

THE MARK CONSISTS OF STANDARD CHARACTERS  
WITHOUT CLAIM TO ANY PARTICULAR FONT, STYLE,  
SIZE, OR COLOR.

FOR BUSINESS MARKETING AND ADVERTISING  
SERVICES, NAMELY PROVIDING MARKETING AND  
ADVERTISING SERVICES TO AUTOMOTIVE MANU-  
FACTURERS AND DEALERS IN CONNECTION WITH  
THE SALE OF AUTOMOBILES (U.S. CLS. 100, 101 AND  
102).

FIRST USE 3-1-2001; IN COMMERCE 3-1-2001.  
JULIE WATSON, EXAMINING ATTORNEY

**CLASS 35—(Continued).**

SN 78-970,681. DIGICLOSE, LLC, DBA ONEMARKETLIST-  
COM, MIAMI, FL. FILED 9-8-2006.

# One Search. Endless Value.

THE MARK CONSISTS OF STANDARD CHARACTERS  
WITHOUT CLAIM TO ANY PARTICULAR FONT, STYLE,  
SIZE, OR COLOR.

FOR MATCHING CONSUMERS WITH REAL ESTATE  
PROFESSIONALS IN THE FIELD OF REAL ESTATE  
SERVICES VIA COMPUTER NETWORK; REAL ESTATE  
ADVERTISING SERVICES; REAL ESTATE MARKETING  
SERVICES IN THE FIELD OF HOMES, CONDOMI-  
NIUMS AND DEVELOPER COMMUNITIES; REAL ES-  
TATE MARKETING SERVICES, NAMELY, ON-LINE  
SERVICES FEATURING TOURS OF RESIDENTIAL  
AND COMMERCIAL REAL ESTATE (U.S. CLS. 100, 101  
AND 102).

KATHERINE CONNOLLY, EXAMINING ATTORNEY

SN 78-970,703. MAYER, CLAUDIA, NEW YORK, NY. FILED  
9-9-2006.

# BRAND LINGUIST

THE MARK CONSISTS OF STANDARD CHARACTERS  
WITHOUT CLAIM TO ANY PARTICULAR FONT, STYLE,  
SIZE, OR COLOR.

NO CLAIM IS MADE TO THE EXCLUSIVE RIGHT TO  
USE "BRAND", APART FROM THE MARK AS SHOWN.  
FOR ADVERTISING SERVICES, FOR THIRD PAR-  
TIES, IN CONNECTION WITH THE COMMERCIALIZA-  
TION AND SALE OF PERFUMERY AND COSMETIC  
ARTICLES, PRODUCTS FOR HOUSEHOLD PURPOSES,  
OPTICAL PRODUCTS, CLOCKS AND TIMEPIECES,  
JEWELLERY, FURNISHING ARTICLES (U.S. CLS. 100,  
101 AND 102).

JOHN WILKE, EXAMINING ATTORNEY

SN 78-970,939. MANCE, CHRISTOPHER II, RIVERDALE,  
GA. FILED 9-10-2006.

# nichevertising

THE MARK CONSISTS OF STANDARD CHARACTERS  
WITHOUT CLAIM TO ANY PARTICULAR FONT, STYLE,  
SIZE, OR COLOR.

FOR PROMOTING THE GOODS AND SERVICES OF  
OTHERS BY DISTRIBUTING ADVERTISING MATERI-  
ALS THROUGH A VARIETY OF METHODS (U.S. CLS.  
100, 101 AND 102).

EDWARD NELSON, EXAMINING ATTORNEY

**CLASS 35—(Continued).**

SN 78-971,137. WASHINGTON STATE DEPARTMENT OF HEALTH, TUMWATER, WA. FILED 9-11-2006.

**No Stank You**

THE MARK CONSISTS OF STANDARD CHARACTERS WITHOUT CLAIM TO ANY PARTICULAR FONT, STYLE, SIZE, OR COLOR.

FOR ADVERTISING SLOGAN AND CARTOON CHARACTER LICENSING (U.S. CLS. 100, 101 AND 102).  
SALLY SHIH, EXAMINING ATTORNEY

SN 78-971,484. STAMY, STEPHEN, CHANHASSEN, MN. FILED 9-11-2006.

**NEXSOURCE**

THE MARK CONSISTS OF STANDARD CHARACTERS WITHOUT CLAIM TO ANY PARTICULAR FONT, STYLE, SIZE, OR COLOR.

FOR INDEPENDENT SALES REPRESENTATIVES IN THE FIELD OF CONSUMER ELECTRONICS; PROCURING OF CONTRACTS FOR THE PURCHASE AND SALE OF GOODS; AND RETAIL SERVICES BY DIRECT SOLICITATION BY SALES AGENTS IN THE FIELD OF CONSUMER ELECTRONICS; AND SALES PROMOTION SERVICES (U.S. CLS. 100, 101 AND 102).

JOHN HWANG, EXAMINING ATTORNEY

SN 78-971,595. VCFO HOLDINGS, INC., AUSTIN, TX. FILED 9-11-2006.

**VIRTUALCONTROLLER**

THE MARK CONSISTS OF STANDARD CHARACTERS WITHOUT CLAIM TO ANY PARTICULAR FONT, STYLE, SIZE, OR COLOR.

FOR BUSINESS MANAGEMENT AND CONSULTATION SERVICES IN THE NATURE OF BUDGETING, FORECASTING AND ACCOUNTING SERVICES (U.S. CLS. 100, 101 AND 102).

NICHOLAS ALTREE, EXAMINING ATTORNEY

**CLASS 35—(Continued).**

SN 78-971,608. VCFO HOLDINGS, INC, AUSTIN, TX. FILED 9-11-2006.

**VCONTROLLER**

THE MARK CONSISTS OF STANDARD CHARACTERS WITHOUT CLAIM TO ANY PARTICULAR FONT, STYLE, SIZE, OR COLOR.

FOR BUSINESS MANAGEMENT AND CONSULTATION SERVICES IN THE NATURE OF BUDGETING, FORECASTING AND ACCOUNTING SERVICES (U.S. CLS. 100, 101 AND 102).

NICHOLAS ALTREE, EXAMINING ATTORNEY

SN 78-971,908. MERCURY DIAMONDS LTD., RAMAT GAN, ISRAEL, FILED 9-11-2006.

**EPL&Co**

THE MARK CONSISTS OF A FLOWER DESIGN COMPRISED OF DIAMONDS INTO A CIRCULAR SHAPE (REPRESENTING THE FLOWER), AND TWO OVAL SHAPES (REPRESENTING THE LEAVES), WITH A VERTICAL LINE REPRESENTING THE FLOWER'S STEM. THE WORDS "EPL&CO." ARE LOCATED BELOW THE IMAGE.

FOR RETAIL JEWELRY STORES (U.S. CLS. 100, 101 AND 102).

LINDA MICKLEBURGH, EXAMINING ATTORNEY

SN 78-972,315. THE CHILDREN'S MEMORIAL MEDICAL CENTER, CHICAGO, IL. FILED 9-12-2006.

**54321GO!**

THE MARK CONSISTS OF STANDARD CHARACTERS WITHOUT CLAIM TO ANY PARTICULAR FONT, STYLE, SIZE, OR COLOR.

FOR PROMOTING PUBLIC AWARENESS REGARDING THE PREVENTION AND TREATMENT OF OBESITY IN CHILDREN (U.S. CLS. 100, 101 AND 102).

FIRST USE 1-0-2006; IN COMMERCE 1-0-2006.

ANDREA HACK, EXAMINING ATTORNEY

**CLASS 35—(Continued).**

SN 78-973,118. SOVEREIGN DEED, LLC, VERNON HILLS, IL. FILED 9-13-2006.

**ADVERSE CONSEQUENCE  
PLANNING**

THE MARK CONSISTS OF STANDARD CHARACTERS WITHOUT CLAIM TO ANY PARTICULAR FONT, STYLE, SIZE, OR COLOR.

FOR ADVERTISING, MARKETING AND PROMOTION SERVICES (U.S. CLS. 100, 101 AND 102).  
PETER B. BROMAGHIM, EXAMINING ATTORNEY

SN 78-973,546. GSD&M LP, AUSTIN, TX. FILED 9-13-2006.

**GSD&M IDEATION LAB**

THE MARK CONSISTS OF STANDARD CHARACTERS WITHOUT CLAIM TO ANY PARTICULAR FONT, STYLE, SIZE, OR COLOR.

OWNER OF U.S. REG. NO. 2,381,566.  
NO CLAIM IS MADE TO THE EXCLUSIVE RIGHT TO USE "IDEATION", APART FROM THE MARK AS SHOWN.  
FOR ADVERTISING AND MARKETING AGENCY SERVICES (U.S. CLS. 100, 101 AND 102).  
SCOTT BIBB, EXAMINING ATTORNEY

SN 78-974,503. SUNSHINE, CATHY S., DENVER, CO. FILED 9-14-2006.

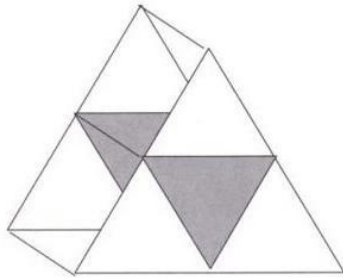

FOR BUSINESS MANAGEMENT CONSULTANCY AND ADVISORY SERVICES; BUSINESS MANAGEMENT CONSULTANCY AS WELL AS DEVELOPMENT OF PROCESSES FOR THE ANALYSIS AND THE IMPLEMENTATION OF STRATEGY PLANS AND MANAGEMENT PROJECTS; BUSINESS MANAGEMENT CONSULTANCY SERVICES; BUSINESS MANAGEMENT CONSULTATION; BUSINESS MANAGEMENT CONSULTATION IN THE FIELD OF EXECUTIVE AND LEADERSHIP DEVELOPMENT; BUSINESS MANAGEMENT CONSULTING AND ADVISORY SERVICES; BUSINESS MANAGEMENT CONSULTING WITH RELATION TO STRATEGY, MARKETING, PRODUCTION, PERSONNEL AND RETAIL SALE MATTERS (U.S. CLS. 100, 101 AND 102).  
BRIAN NEVILLE, EXAMINING ATTORNEY

**CLASS 35—(Continued).**

SN 79-029,009. THE WHOLE BOX 'N DICE PTY LTD, AUSTRALIA, FILED 2-15-2006.

THE



'n



PRIORITY DATE OF 1-5-2006 IS CLAIMED.  
OWNER OF INTERNATIONAL REGISTRATION 0898794 DATED 2-15-2006, EXPIRES 2-15-2016.

THE MARK CONSISTS OF A DESCENDING MARK WITH THE WORD THE ON TOP, A TOTALLY SHADED CIRCLE SECOND FROM THE TOP, A GIFT BOX WITH A BOW IN THE MIDDLE, THE WORDING 'N SECOND FROM THE BOTTOM, AND A DICE DESIGN AT THE BOTTOM.

FOR RETAIL STORE SERVICES FEATURING PROMOTIONAL PRODUCTS, PROMOTIONAL MERCHANDISE, PERSONALISED GIFT MERCHANDISE; BUSINESS INTERMEDIARY AND ADVISORY SERVICES IN THE FIELD OF SELLING PRODUCTS AND RENDERING SERVICES ALL IN THE FIELDS OF PROMOTIONAL PRODUCTS, PROMOTIONAL MERCHANDISE, PERSONALIZED GIFT MERCHANDISE, EXCLUSIVE DESIGNS FOR PROMOTIONAL PRODUCTS, MARKETING SERVICES, MARKETING CONSULTING AND ADVISORY SERVICES, MARKETING CAMPAIGN MANAGEMENT, DIRECT MARKETING, ANALYSIS RELATING TO MARKETING, PROVISION OF MARKETING REPORTS, RESEARCH SERVICES RELATING TO MARKETING, BUSINESS MANAGEMENT PLANNING, ADMINISTRATION AND RESEARCH, MANAGING AN INTERNET WEBSITE, SALES OF A VARIETY OF GOODS VIA AN INTERNET WEB SITE, COMPUTER NETWORK OR FROM A RETAIL OR WHOLESALE OUTLET, ENABLING CUSTOMERS TO CONVENIENTLY VIEW AND PURCHASE THOSE GOODS FROM A GENERAL MERCHANDISE INTERNET WEB SITE AND RETAIL OR WHOLESALE OUTLETS, PROVISION OF SPACE ON WEB SITES FOR ADVERTISING GOODS AND SERVICES, ADVERTISING SERVICES RELATING TO THE MARKETING INDUSTRY, ARRANGEMENT OF ADVERTISING, ARRANGING OF DEMONSTRATIONS FOR ADVERTISING AND MARKETING PURPOSES, ARRANGING OF DISPLAYS AND PRESENTATIONS FOR ADVERTISING AND MARKETING PURPOSES, PREPARING AUDIO-VISUAL DISPLAYS FOR ADVERTISING AND MARKETING PURPOSES, PRODUCTION OF VISUAL MATTER, ARRANGING EXHIBITIONS FOR MARKETING AND COMMERCIAL PURPOSES, ONLINE ADVERTISING ON A COMPUTER NETWORK, PREPARATION OF ADVERTISING AND MARKETING MATERIAL, PREPARATION OF ADVERTISING MATTER, PREPARATION OF PRINTED MATTER FOR ADVERTISING AND MARKETING, UPDATING OF INFORMATION ON A COMPUTER DATA BASE (U.S. CLS. 100, 101 AND 102).  
WARREN L. OLANDRIA, EXAMINING ATTORNEY

**CLASS 35—(Continued).**

SN 79-029,010. THE WHOLE BOX 'N DICE PTY LTD,  
ALEXANDRIA NSW 2015, AUSTRALIA, FILED 3-21-2006.

**THE WHOLE BOX 'N DICE**

THE MARK CONSISTS OF STANDARD CHARACTERS WITHOUT CLAIM TO ANY PARTICULAR FONT, STYLE, SIZE, OR COLOR.

PRIORITY DATE OF 12-30-2005 IS CLAIMED.

OWNER OF INTERNATIONAL REGISTRATION 0898795  
DATED 3-21-2006, EXPIRES 3-21-2016.

FOR RETAIL STORE SERVICES FEATURING PROMOTIONAL PRODUCTS, PROMOTIONAL MERCHANDISE, PERSONALISED GIFT MERCHANDISE; BUSINESS INTERMEDIARY AND ADVISORY SERVICES IN THE FIELD OF SELLING PRODUCTS AND RENDERING SERVICES ALL IN THE FIELDS OF PROMOTIONAL PRODUCTS, PROMOTIONAL MERCHANDISE, PERSONALIZED GIFT MERCHANDISE, EXCLUSIVE DESIGNS FOR PROMOTIONAL PRODUCTS, MARKETING SERVICES, MARKETING CONSULTING AND ADVISORY SERVICES, MARKETING CAMPAIGN MANAGEMENT, DIRECT MARKETING, ANALYSIS RELATING TO MARKETING, PROVISION OF MARKETING REPORTS, RESEARCH SERVICES RELATING TO MARKETING, BUSINESS MANAGEMENT PLANNING, ADMINISTRATION AND RESEARCH, MANAGING AN INTERNET WEBSITE, SALES OF A VARIETY OF GOODS VIA AN INTERNET WEB SITE, COMPUTER NETWORK OR FROM A RETAIL OR WHOLESALE OUTLET, ENABLING CUSTOMERS TO CONVENIENTLY VIEW AND PURCHASE THOSE GOODS FROM A GENERAL MERCHANDISE INTERNET WEB SITE AND RETAIL OR WHOLESALE OUTLETS, PROVISION OF SPACE ON WEB SITES FOR ADVERTISING GOODS AND SERVICES, ADVERTISING SERVICES RELATING TO THE MARKETING INDUSTRY, ARRANGEMENT OF ADVERTISING, ARRANGING OF DEMONSTRATIONS FOR ADVERTISING AND MARKETING PURPOSES, ARRANGING OF DISPLAYS AND PRESENTATIONS FOR ADVERTISING AND MARKETING PURPOSES, PREPARING AUDIO-VISUAL DISPLAYS FOR ADVERTISING AND MARKETING PURPOSES, PRODUCTION OF VISUAL MATTER, ARRANGING EXHIBITIONS FOR MARKETING AND COMMERCIAL PURPOSES, ONLINE ADVERTISING ON A COMPUTER NETWORK, PREPARATION OF ADVERTISING AND MARKETING MATERIAL, PREPARATION OF ADVERTISING MATTER, PREPARATION OF PRINTED MATTER FOR ADVERTISING AND MARKETING, UPDATING OF INFORMATION ON A COMPUTER DATA BASE (U.S. CLS. 100, 101 AND 102).

WARREN L. OLANDRIA, EXAMINING ATTORNEY

SN 79-030,390. PAXXION S.R.L.; C/O COMPLESSO DIREZ.  
COMMERC., ITALY, FILED 8-30-2006.

**PAXXION**

PRIORITY DATE OF 5-5-2006 IS CLAIMED.

OWNER OF INTERNATIONAL REGISTRATION 0902196  
DATED 8-30-2006, EXPIRES 8-30-2016.

FOR ADVERTISING; BUSINESS MANAGEMENT; BUSINESS ADMINISTRATION; OFFICE FUNCTIONS (U.S. CLS. 100, 101 AND 102).

ATTIYA MALIK, EXAMINING ATTORNEY

**CLASS 36—INSURANCE AND FINANCIAL**

SN 75-670,927. GRAND CANAL SHOPS MALL SUBSIDIARY,  
LLC, LAS VEGAS, NV. FILED 3-30-1999.

**GRAND CANAL SHOPPES**

NO CLAIM IS MADE TO THE EXCLUSIVE RIGHT TO USE "SHOPPES", APART FROM THE MARK AS SHOWN.  
FOR SHOPPING CENTER SERVICES (U.S. CLS. 100, 101 AND 102).

DAVID H. STINE, EXAMINING ATTORNEY

SN 76-202,068. STRATEGIC COMP, INC., METAIRIE, LA.  
FILED 1-30-2001.

**strategic  
comp**

NO CLAIM IS MADE TO THE EXCLUSIVE RIGHT TO USE "COMP", APART FROM THE MARK AS SHOWN.

THE MARK IS LINED FOR THE COLOR RED WITH BLACK LETTERING.

FOR INSURANCE BROKERAGE IN THE FIELD OF WORKERS' COMPENSATION BENEFITS (U.S. CLS. 100, 101 AND 102).

FIRST USE 12-7-2000; IN COMMERCE 12-7-2000.

PAUL F. GAST, EXAMINING ATTORNEY



**CLASS 36—(Continued).**

SN 76-641,531. CIBC WORLD MARKETS INC., TORONTO, ONTARIO, CANADA, FILED 6-23-2005.

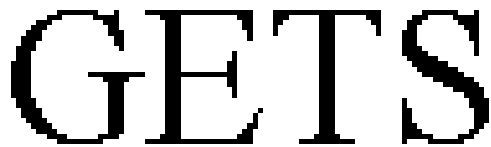

THE MARK CONSISTS OF STANDARD CHARACTERS WITHOUT CLAIM TO ANY PARTICULAR FONT, STYLE, SIZE, OR COLOR.

PRIORITY CLAIMED UNDER SEC. 44(D) ON CANADA APPLICATION NO. 1,242,601, FILED 12-23-2004, REG. NO. TMA679524, DATED 1-16-2007, EXPIRES 1-16-2022.

FOR FINANCIAL SERVICES, NAMELY BANKING SERVICES; INVESTMENT SERVICES, NAMELY THE OFFERING AND OPERATION OF INVESTMENT ACCOUNTS; FINANCIAL CONSULTING SERVICES, SECURITIES BROKERAGE SERVICES; SECURITIES TRADING PROVIDED ELECTRONICALLY AND VIA GLOBAL INFORMATION NETWORKS, NAMELY, ELECTRONICS TRADING IN SECURITIES, STOCKS, AND OPTIONS AND COMMODITIES; PROVIDING FINANCIAL AND INVESTMENT INFORMATION, FINANCIAL AND INVESTMENT NEWS, FINANCIAL AND INVESTMENT RESEARCH, FINANCIAL AND INVESTMENT DATABASES, ALL FOR USE BY INVESTORS IN THE TRADING AND ANALYSIS OF INVESTMENTS, FINANCES, AND FINANCIAL PLANNING, VIA A GLOBAL COMPUTER NETWORK (U.S. CLS. 100, 101 AND 102).

EDWARD NELSON, EXAMINING ATTORNEY

SN 76-658,217. OBRADOVICH, JOHN, RENO, NV. FILED 4-11-2006.

MORE THAN A LENDER . . . A RELATIONSHIP FOR LIFE

THE MARK CONSISTS OF STANDARD CHARACTERS WITHOUT CLAIM TO ANY PARTICULAR FONT, STYLE, SIZE, OR COLOR.

FOR FINANCIAL LENDING SERVICES (U.S. CLS. 100, 101 AND 102).

FIRST USE 8-1-2003; IN COMMERCE 8-1-2003.

HOWARD SMIGA, EXAMINING ATTORNEY

**CLASS 36—(Continued).**

SN 76-665,651. ICWI GROUP, LTD., KINGSTON, ST. ANDREW, JAMAICA, FILED 9-6-2006.



THE COLOR(S) BLUE, LIGHT BLUE, AND WHITE IS/ARE CLAIMED AS A FEATURE OF THE MARK.

THE WORDING ICWI, WHICH APPEARS IN THE COLOR BLUE, IS PRESENTED ON A RECTANGULAR BACKGROUND THAT TRANSITIONS FROM THE COLOR WHITE NEAR ITS CENTER TO THE COLOR LIGHT BLUE TOWARD ITS OUTER EDGES. THE WORDING AND BACKGROUND ARE SUPERIMPOSED ON A GLOBE DESIGN THAT APPEARS IN THE COLOR BLUE AND FEATURING A MAP OF THE CARIBBEAN REGION.

FOR INSURANCE UNDERWRITING SERVICES IN THE FIELDS OF AUTO, HOME, HEALTH, LIFE, AND FIRE (U.S. CLS. 100, 101 AND 102).

FIRST USE 5-21-1969; IN COMMERCE 5-21-1969.

KEVIN CORWIN, EXAMINING ATTORNEY

SN 76-667,323. ALTIGRO FINANCIAL GROUP, INC., WEST ORANGE, NJ. FILED 10-12-2006.



THE COLOR(S) BLACK, GRAY AND ORANGE IS/ARE CLAIMED AS A FEATURE OF THE MARK.

THE LETTERS "AL" AND "IGRO" IN THE WORD "ALTIGRO" APPEAR IN THE COLOR GRAY, WITH AN ORANGE DOT APPEARING OVER THE LETTER "I". THE STYLIZED LETTER "T" APPEARS IN BLACK.

FOR INSURANCE CONSULTATION SERVICES; FINANCIAL SERVICES, NAMELY, FINANCIAL ANALYSIS AND CONSULTATION, FINANCIAL RESEARCH, FINANCIAL PLANNING, FINANCIAL PORTFOLIO MANAGEMENT, AND FINANCIAL VALUATION OF PERSONAL PROPERTY AND REAL ESTATE (U.S. CLS. 100, 101 AND 102).

LINDA ORNDORFF, EXAMINING ATTORNEY

**CLASS 36—(Continued).**

SN 76-668,188. OPERATION BLESSING INTERNATIONAL RELIEF AND DEVELOPMENT CORPORATION, VIRGINIA BEACH, VA. FILED 10-27-2006.

**ORPHAN'S PROMISE**

THE MARK CONSISTS OF STANDARD CHARACTERS WITHOUT CLAIM TO ANY PARTICULAR FONT, STYLE, SIZE, OR COLOR.

FOR CHARITABLE SERVICES, NAMELY FUNDRAISING TO PROVIDE FINANCIAL ASSISTANCE FOR ORPHANS AND NEEDY CHILDREN, AND ORGANIZATIONS THAT PROVIDE CARE, SUPPORT, EDUCATION OR TRAINING FOR ORPHANS AND NEEDY CHILDREN (U.S. CLS. 100, 101 AND 102).

FIRST USE 9-29-2006; IN COMMERCE 9-29-2006.  
ELI HELLMAN, EXAMINING ATTORNEY

---

SN 77-002,583. THE MEMBERS GROUP, INC., DES MOINES, IA. FILED 9-19-2006.



NO CLAIM IS MADE TO THE EXCLUSIVE RIGHT TO USE "GROUP", APART FROM THE MARK AS SHOWN.

FOR FINANCIAL SERVICES PROVIDED TO CREDIT UNIONS, NAMELY, CREDIT, DEBIT AND ATM CARD PROCESSING, FINANCIAL ASSET/LIABILITY MANAGEMENT, AUTOMATED FINANCIAL CLEARING-HOUSE SERVICES, AND SHARE DRAFT FINANCIAL SERVICES, AND BANKING SERVICES (U.S. CLS. 100, 101 AND 102).

FIRST USE 6-7-2004; IN COMMERCE 6-7-2004.  
GRETTA YAO, EXAMINING ATTORNEY

**CLASS 36—(Continued).**

SN 77-011,419. HOTEL ASSET VALUE ENHANCEMENT, LLC, TIVERTON, MA. FILED 10-2-2006.

**HOTEL ASSET VALUE ENHANCEMENT**

THE MARK CONSISTS OF STANDARD CHARACTERS WITHOUT CLAIM TO ANY PARTICULAR FONT, STYLE, SIZE, OR COLOR.

NO CLAIM IS MADE TO THE EXCLUSIVE RIGHT TO USE "HOTEL ASSET VALUE", APART FROM THE MARK AS SHOWN.

FOR ADVICE RELATING TO INVESTMENTS; AGENCIES OR BROKERAGE FOR LEASING OR RENTING OF LAND; AGENCIES OR BROKERAGE FOR RENTING LAND; AGENCIES OR BROKERAGE FOR RENTING OF BUILDINGS; APPRAISAL OF REAL ESTATE; ASSESSMENT AND MANAGEMENT OF REAL ESTATE; BUILDING MANAGEMENT; CAPITAL INVESTMENT CONSULTATION; CONSULTATION RELATING TO THE APPRAISAL OF GOODS; EVALUATION OF REAL PROPERTY; FINANCIAL ANALYSIS AND CONSULTATION; FINANCIAL CONSULTATION; FINANCIAL DUE DILIGENCE; FINANCIAL EVALUATION FOR INSURANCE PURPOSES; FINANCIAL PLANNING CONSULTATION; FINANCIAL PORTFOLIO MANAGEMENT; FINANCIAL SERVICES IN THE NATURE OF AN INVESTMENT SECURITY; FINANCIAL VALUATION OF PERSONAL PROPERTY AND REAL ESTATE; INVESTMENT ADVICE; INVESTMENT ADVISORY SERVICES; INVESTMENT CONSULTATION; INVESTMENT MANAGEMENT; INVESTMENT SERVICES, NAMELY ASSET ACQUISITION, CONSULTATION, DEVELOPMENT AND MANAGEMENT SERVICES; REAL ESTATE ACQUISITION SERVICES; REAL ESTATE APPRAISAL; REAL ESTATE CONSULTANCY; REAL ESTATE MANAGEMENT; REAL ESTATE MANAGEMENT CONSULTATION; REAL ESTATE VALUATIONS (U.S. CLS. 100, 101 AND 102).

RAUL CORDOVA, EXAMINING ATTORNEY

---

SN 77-016,135. GLOBAL SERVICE SOLUTIONS GA, LLC, DORAVILLE, GA. FILED 10-6-2006.

**Got Stuck?**

THE MARK CONSISTS OF STANDARD CHARACTERS WITHOUT CLAIM TO ANY PARTICULAR FONT, STYLE, SIZE, OR COLOR.

FOR PRE-PAID PURCHASE CARD SERVICES NAMELY, PROCESSING ELECTRONIC PAYMENTS MADE THROUGH PREPAID CARDS; PREPAID CARD SERVICES IN THE NATURE OF MAKING PAYMENT FOR ADDING AIRTIME TO PREPAID OR PAY-AS-YOU-GO WIRELESS SERVICES (U.S. CLS. 100, 101 AND 102).

JENNIFER KRISP, EXAMINING ATTORNEY

**CLASS 36—(Continued).**

SN 77-019,484. HAMPSHIRE FIRST BANK, MANCHESTER, NH. FILED 10-12-2006.



NO CLAIM IS MADE TO THE EXCLUSIVE RIGHT TO USE "BANK", APART FROM THE MARK AS SHOWN.

THE MARK CONSISTS OF THE WORD "BANK" IN A STYLIZED FONT CENTERED BELOW THE WORD "HAMPSHIREFIRST" IN A STYLIZED FONT WITH AN ARCHING TRIANGLE WITH CURVED SIDES HAVING ITS CENTER POINT SLANTING SUBSTANTIALLY TO THE LEFT AND THE LEFT MOST POINT OF THE TRIANGLE BEGINNING ON THE LEFT SIDE AND STARTING AT THE BOTTOM LEVEL OF THE LETTER "H" OF THE WORD "HAMPSHIREFIRST" AND ARCHING UP AND OVER THE LETTERS "HAMP" WITH THE RIGHT MOST POINT OF THE TRIANGLE ENDING OVER THE LETTER "P" OF THE WORD "HAMPSHIREFIRST".

FOR BANKING, BANKING CONSULTATION, INVESTMENT BANKING SERVICES, MORTGAGE BANKING, MORTGAGE BANKING SERVICES, NAMELY, ORIGINATION, ACQUISITION, SERVICING, SECURITIZATION AND BROKERAGE OF MORTGAGE LOANS, AND ONLINE BANKING (U.S. CLS. 100, 101 AND 102).  
KATHLEEN LORENZO, EXAMINING ATTORNEY

SN 77-026,971. PHILADELPHIA STOCK EXCHANGE, INC., PHILADELPHIA, PA. FILED 10-23-2006.

ONE CONNECTION. THREE  
MARKETS. AND THOUSANDS OF  
PRODUCTS.

THE MARK CONSISTS OF STANDARD CHARACTERS WITHOUT CLAIM TO ANY PARTICULAR FONT, STYLE, SIZE, OR COLOR.

FOR EQUITIES, FUTURES AND OPTIONS EXCHANGE SERVICES (U.S. CLS. 100, 101 AND 102).  
FIRST USE 9-1-2006; IN COMMERCE 9-1-2006.  
GINA FINK, EXAMINING ATTORNEY

SN 77-032,969. LEVEL GLOBAL INVESTORS, L.P., GREENWICH, CT. FILED 10-31-2006.

**DUD**

THE MARK CONSISTS OF STANDARD CHARACTERS WITHOUT CLAIM TO ANY PARTICULAR FONT, STYLE, SIZE, OR COLOR.

FOR HEDGE FUND INVESTMENT AND MANAGEMENT SERVICES AND INVESTMENT ADVISORY SERVICES (U.S. CLS. 100, 101 AND 102).  
JEAN IM, EXAMINING ATTORNEY

**CLASS 36—(Continued).**

SN 77-032,997. LEVEL GLOBAL INVESTORS, L.P., GREENWICH, CT. FILED 10-31-2006.

**EWE**

THE MARK CONSISTS OF STANDARD CHARACTERS WITHOUT CLAIM TO ANY PARTICULAR FONT, STYLE, SIZE, OR COLOR.

FOR HEDGE FUND INVESTMENT AND MANAGEMENT SERVICES AND INVESTMENT ADVISORY SERVICES (U.S. CLS. 100, 101 AND 102).  
JEAN IM, EXAMINING ATTORNEY

SN 77-033,015. LEVEL GLOBAL INVESTORS, L.P., GREENWICH, CT. FILED 10-31-2006.

**GAG**

THE MARK CONSISTS OF STANDARD CHARACTERS WITHOUT CLAIM TO ANY PARTICULAR FONT, STYLE, SIZE, OR COLOR.

FOR HEDGE FUND INVESTMENT AND MANAGEMENT SERVICES AND INVESTMENT ADVISORY SERVICES (U.S. CLS. 100, 101 AND 102).  
JEAN IM, EXAMINING ATTORNEY

SN 77-033,033. LEVEL GLOBAL INVESTORS, L.P., GREENWICH, CT. FILED 10-31-2006.

**KAYAK**

THE MARK CONSISTS OF STANDARD CHARACTERS WITHOUT CLAIM TO ANY PARTICULAR FONT, STYLE, SIZE, OR COLOR.

FOR HEDGE FUND INVESTMENT AND MANAGEMENT SERVICES AND INVESTMENT ADVISORY SERVICES (U.S. CLS. 100, 101 AND 102).  
JEAN IM, EXAMINING ATTORNEY

**CLASS 36—(Continued).**

SN 77-033,044. LEVEL GLOBAL INVESTORS, L.P., GREENWICH, CT. FILED 10-31-2006.

# KOOK

THE MARK CONSISTS OF STANDARD CHARACTERS WITHOUT CLAIM TO ANY PARTICULAR FONT, STYLE, SIZE, OR COLOR.

FOR HEDGE FUND INVESTMENT AND MANAGEMENT SERVICES AND INVESTMENT ADVISORY SERVICES (U.S. CLS. 100, 101 AND 102).

JEAN IM, EXAMINING ATTORNEY

---

SN 77-033,122. LEVEL GLOBAL INVESTORS, L.P., GREENWICH, CT. FILED 10-31-2006.

# TOT

THE MARK CONSISTS OF STANDARD CHARACTERS WITHOUT CLAIM TO ANY PARTICULAR FONT, STYLE, SIZE, OR COLOR.

FOR HEDGE FUND INVESTMENT AND MANAGEMENT SERVICES AND INVESTMENT ADVISORY SERVICES (U.S. CLS. 100, 101 AND 102).

JEAN IM, EXAMINING ATTORNEY

---

SN 77-042,856. CENTURION INVESTMENT PARTNERS, LLC, COLLIERVILLE, TN. FILED 11-13-2006.

## GET BULLISH ON YOUR FAITH

THE MARK CONSISTS OF STANDARD CHARACTERS WITHOUT CLAIM TO ANY PARTICULAR FONT, STYLE, SIZE, OR COLOR.

FOR INVESTMENT OF FUNDS FOR OTHERS; MUTUAL FUND BROKERAGE; MUTUAL FUND DISTRIBUTION; MUTUAL FUND INVESTMENT (U.S. CLS. 100, 101 AND 102).

KATHY DE JONGE, EXAMINING ATTORNEY

**CLASS 36—(Continued).**

SN 77-044,651. OXONIA INSURANCE GROUP, INC., PLANTATION, FL. FILED 11-15-2006.

# BIG RED

THE MARK CONSISTS OF STANDARD CHARACTERS WITHOUT CLAIM TO ANY PARTICULAR FONT, STYLE, SIZE, OR COLOR.

FOR INSURANCE AGENCY AND BROKERAGE SERVICES (U.S. CLS. 100, 101 AND 102).

CIMMERIAN COLEMAN, EXAMINING ATTORNEY

---

SN 77-049,421. CITIZENS FINANCIAL GROUP, INC., PROVIDENCE, RI. FILED 11-22-2006.

## SAFE WITH CITIZENS

THE MARK CONSISTS OF STANDARD CHARACTERS WITHOUT CLAIM TO ANY PARTICULAR FONT, STYLE, SIZE, OR COLOR.

OWNER OF U.S. REG. NOS. 2,407,272, 3,094,046 AND OTHERS.

FOR FINANCIAL SERVICES, NAMELY, ON-LINE BANKING SERVICES FEATURING ENHANCED SECURITY FEATURES (U.S. CLS. 100, 101 AND 102).

HEATHER BIDDULPH, EXAMINING ATTORNEY

---

SN 77-049,465. CITIZENS FINANCIAL GROUP, INC., PROVIDENCE, RI. FILED 11-22-2006.

## SAFE WITH CHARTER ONE

THE MARK CONSISTS OF STANDARD CHARACTERS WITHOUT CLAIM TO ANY PARTICULAR FONT, STYLE, SIZE, OR COLOR.

OWNER OF U.S. REG. NOS. 3,094,403, 3,166,726 AND OTHERS.

FOR FINANCIAL SERVICES, NAMELY, ON-LINE BANKING SERVICES FEATURING ENHANCED SECURITY FEATURES (U.S. CLS. 100, 101 AND 102).

HEATHER BIDDULPH, EXAMINING ATTORNEY

**CLASS 36—(Continued).**

SN 77-049,520. OXONIA INSURANCE GROUP, INC., PLANTATION, FL. FILED 11-22-2006.

BE CERTAIN. BE CONFIDENT.  
BE SURE ABOUT YOUR HEALTH.

THE MARK CONSISTS OF STANDARD CHARACTERS WITHOUT CLAIM TO ANY PARTICULAR FONT, STYLE, SIZE, OR COLOR.

FOR INSURANCE AGENCY AND BROKERAGE SERVICES (U.S. CLS. 100, 101 AND 102).  
CIMMERIAN COLEMAN, EXAMINING ATTORNEY

SN 77-053,871. NAVY FEDERAL CREDIT UNION, MERRIFIELD, VA. FILED 11-30-2006.



OWNER OF U.S. REG. NOS. 2,522,415 AND 2,640,330.  
THE MARK CONSISTS OF A CIRCLE WITH "SALLIE THE BEAR" IN THE MIDDLE WITH A RING AROUND HER THAT SAYS "SALLIE SAYS YOU'RE SMART TO SAVE!"

FOR CREDIT UNION SERVICES, NAMELY, CHILDREN'S SAVINGS ACCOUNTS (U.S. CLS. 100, 101 AND 102).

FIRST USE 7-6-2003; IN COMMERCE 7-6-2003.  
DOMINICK J. SALEMI, EXAMINING ATTORNEY

SN 77-054,262. WELLS FARGO & COMPANY, MINNEAPOLIS, MN. FILED 11-30-2006.

ORGANIZE, MANAGE AND  
PROTECT ALL YOU VALUE

THE MARK CONSISTS OF STANDARD CHARACTERS WITHOUT CLAIM TO ANY PARTICULAR FONT, STYLE, SIZE, OR COLOR.

FOR INSURANCE BROKERAGE, CONSULTATION AND ADMINISTRATION SERVICES IN THE FIELDS OF UMBRELLA, ACCIDENT, AUTOMOBILE, HEALTH, HOME, RENTERS, LIABILITY AND EMPLOYER INSURANCE (U.S. CLS. 100, 101 AND 102).

SETH A. RAPPAPORT, EXAMINING ATTORNEY

**CLASS 36—(Continued).**

SN 77-060,127. KEYCORP, CLEVELAND, OH. FILED 12-8-2006.

SAVEDAY

THE MARK CONSISTS OF STANDARD CHARACTERS WITHOUT CLAIM TO ANY PARTICULAR FONT, STYLE, SIZE, OR COLOR.

FOR ADMINISTRATION OF A SAVINGS PROGRAM FOR ENABLING PARTICIPANTS TO OBTAIN SAVINGS ON A VARIETY OF FINANCIAL SERVICES, NAMELY, CHECKING ACCOUNT SERVICES; CREDIT CARD SERVICES; EDUCATION FINANCING ADVISORY SERVICES; EDUCATIONAL LENDING SERVICES; ELECTRONIC AND ON-LINE BANKING SERVICES; FINANCIAL MANAGEMENT, PLANNING AND PORTFOLIO MANAGEMENT SERVICES; HOME EQUITY LENDING SERVICES; LEASE FINANCING SERVICES; LOAN FINANCING SERVICES; MORTGAGE BANKING AND MORTGAGE LENDING SERVICES; SAVINGS ACCOUNT SERVICES; AND SMALL BUSINESS LENDING SERVICES (U.S. CLS. 100, 101 AND 102).

RONALD MCMORROW, EXAMINING ATTORNEY

SN 77-067,613. KISSTRUST, INC., WARRENTON, VA. FILED 12-19-2006.



OWNER OF U.S. REG. NO. 3,188,215.  
FOR TRUST SERVICES, NAMELY THE MANAGEMENT OF TRUST ACCOUNTS; TRUST SERVICES, NAMELY, INVESTMENT AND TRUST COMPANY SERVICES (U.S. CLS. 100, 101 AND 102).

FIRST USE 12-7-2006; IN COMMERCE 12-7-2006.  
CHRISTINA SOBRAL, EXAMINING ATTORNEY

SN 78-039,917. YES INTERNATIONAL CORP., NEW YORK, NY. FILED 12-19-2000.

#YES

FOR BROKERAGE SERVICES BETWEEN CABLE COMPANIES, ON-LINE RETAILERS, BANKS AND BROADCASTERS TO FACILITATE THE PURCHASE OF MERCHANDISE ADVERTISED ON-LINE AND OVER TELEVISION BROADCAST MEDIA (U.S. CLS. 100, 101 AND 102).

KATHERINE CHANG, EXAMINING ATTORNEY

**CLASS 36—(Continued).**

SN 78-039,922. YES INTERNATIONAL CORP., NEW YORK, NY. FILED 12-19-2000.

**\*YES**

FOR BROKERAGE SERVICES BETWEEN CABLE COMPANIES, ON-LINE RETAILERS, BANKS AND BROADCASTERS TO FACILITATE THE PURCHASE OF MERCHANDISE ADVERTISED ON-LINE AND OVER TELEVISION BROADCAST MEDIA (U.S. CLS. 100, 101 AND 102).

KATHERINE CHANG, EXAMINING ATTORNEY

SN 78-580,032. PHILANTHRIA, LLC, NEW YORK, NY. FILED 3-4-2005.

**PHILANTHRIA**

THE MARK CONSISTS OF STANDARD CHARACTERS WITHOUT CLAIM TO ANY PARTICULAR FONT, STYLE, SIZE, OR COLOR.

FOR FINANCIAL AND INVESTMENT SERVICES, NAMELY, FINANCIAL AND INVESTMENT CONSULTING, ADVISORY AND MANAGEMENT SERVICES PROVIDED TO CHARITABLE, PHILANTHROPIC, EDUCATIONAL AND OTHER "NOT-FOR-PROFIT" INSTITUTIONS, NAMELY, CREATING AND IMPLEMENTING FINANCIAL PRODUCTS ENGINEERED TO MEET THE WORKING CAPITAL AND OTHER BALANCE SHEET NEEDS OF ORGANIZATIONS BY UTILIZING TECHNIQUES SUCH AS SECURITIZING, MONETIZING AND PROVIDING FINANCIAL ADVICE REGARDING ALTERNATIVE FINANCING TECHNIQUES RELATED TO THE ON AND OFF BALANCE SHEET ASSETS OF THE ORGANIZATION, INCLUDING LEGACIES, BEQUESTS, TRUSTS AND ENDOWMENTS, ENHANCING STRATEGIC FINANCIAL PLANNING EFFORTS TO BETTER ESTABLISH AN ORGANIZATION'S MISSION AND PROVIDING FINANCIAL CONSULTING REGARDING FINANCING FOR STABILITY AND/OR GROWTH THROUGH IMPROVED BALANCE SHEET MANAGEMENT, ADDRESSING WORKING CAPITAL AND OTHER BALANCE SHEET NEEDS OR OPPORTUNITIES BY PROVIDING CREATIVE FINANCIAL SOLUTIONS, AND PROVIDING OBJECTIVE FINANCIAL ADVICE AND FINANCIAL PLANNING SERVICES TO MANAGE OPERATIONS AND ADVANCE AN ORGANIZATION'S MISSION (U.S. CLS. 100, 101 AND 102).

FIRST USE 7-21-2004; IN COMMERCE 7-21-2004.  
SANI KHOURI, EXAMINING ATTORNEY

**CLASS 36—(Continued).**

SN 78-640,291. INDEPENDENT HEALTH ASSOCIATION, INC., WILLIAMSVILLE, NY. FILED 5-31-2005.

**BENEFIT ASSISTANT**

THE MARK CONSISTS OF STANDARD CHARACTERS WITHOUT CLAIM TO ANY PARTICULAR FONT, STYLE, SIZE, OR COLOR.

NO CLAIM IS MADE TO THE EXCLUSIVE RIGHT TO USE BENEFIT, APART FROM THE MARK AS SHOWN.

FOR EMPLOYEE BENEFITS MANAGEMENT SERVICES, NAMELY, ONLINE ADMINISTRATION OF PRE-PAID HEALTH INSURANCE AND EMPLOYEE BENEFIT PLANS; PROVIDING EMPLOYER AND EMPLOYEE ACCESS TO PRE-PAID HEALTH INSURANCE BENEFIT INFORMATION, ONLINE ENROLLMENT, AND PLAN SUMMARIES OF EMPLOYEE BENEFIT PLANS AND PRE-PAID HEALTH INSURANCE PLANS (U.S. CLS. 100, 101 AND 102).

FIRST USE 3-1-2003; IN COMMERCE 3-1-2003.  
RAUL CORDOVA, EXAMINING ATTORNEY

SN 78-659,990. INTERNATIONAL FOUNDATION FOR RETIREMENT EDUCATION, LUBBOCK, TX. FILED 6-28-2005.

**CRC**

THE MARK CONSISTS OF STANDARD CHARACTERS WITHOUT CLAIM TO ANY PARTICULAR FONT, STYLE, SIZE, OR COLOR.

OWNER OF U.S. REG. NO. 2,766,972.

FOR FINANCIAL SERVICES, NAMELY, RETIREMENT PLANNING, COUNSELING, AND ADVISORY SERVICES FOR OTHERS (U.S. CLS. 100, 101 AND 102).

FIRST USE 10-0-1999; IN COMMERCE 10-0-1999.  
ANTHONY RINKER, EXAMINING ATTORNEY

SN 78-670,459. PAUL FINANCIAL, LLC, SAN RAFAEL, CA. FILED 7-14-2005.

**eBIP**

THE MARK CONSISTS OF STANDARD CHARACTERS WITHOUT CLAIM TO ANY PARTICULAR FONT, STYLE, SIZE, OR COLOR.

FOR WHOLESALE MORTGAGE LENDING AND MORTGAGE LOAN UNDERWRITING SERVICES, RESIDENTIAL REAL ESTATE LOAN FINANCING, MORTGAGE BROKERAGE, AND MORTGAGE BANKING, MORTGAGE LOAN SERVICING AND CONSUMER AND COMMERCIAL REAL ESTATE LENDING SERVICES (U.S. CLS. 100, 101 AND 102).

FIRST USE 7-14-2005; IN COMMERCE 11-15-2005.  
MAUREEN DALL, EXAMINING ATTORNEY

**CLASS 36—(Continued).**

SN 78-701,004. UBS FINANCIAL SERVICES INC., WEEHAWKEN, NJ. FILED 8-26-2005.

**CLASS 36—(Continued).**

SN 78-742,339. MIDDLELAND CAPITAL, LLC, PROVIDENCE, RI. FILED 10-28-2005.

# MiddleLand Capital

STRATEGIC WEALTH PORTFOLIOS

THE MARK CONSISTS OF STANDARD CHARACTERS WITHOUT CLAIM TO ANY PARTICULAR FONT, STYLE, SIZE, OR COLOR.

NO CLAIM IS MADE TO THE EXCLUSIVE RIGHT TO USE "PORTFOLIOS", APART FROM THE MARK AS SHOWN.

FOR STOCK BROKERAGE, MONEY MANAGEMENT, AND INVESTMENT ADVISORY SERVICES (U.S. CLS. 100, 101 AND 102).

CHRISTOPHER OTT, EXAMINING ATTORNEY

THE MARK CONSISTS OF STANDARD CHARACTERS WITHOUT CLAIM TO ANY PARTICULAR FONT, STYLE, SIZE, OR COLOR.

NO CLAIM IS MADE TO THE EXCLUSIVE RIGHT TO USE "CAPITAL", APART FROM THE MARK AS SHOWN.

FOR VENTURE CAPITAL SERVICES, NAMELY, PROVIDING FINANCING TO EMERGING AND START-UP COMPANIES (U.S. CLS. 100, 101 AND 102).

ERNEST SHOSHO, EXAMINING ATTORNEY

SN 78-756,462. ABN AMRO BANK N.V., AMSTERDAM, NETHERLANDS, FILED 11-17-2005.

SN 78-721,667. WEST CORPORATION, OMAHA, NE. FILED 9-27-2005.



NO CLAIM IS MADE TO THE EXCLUSIVE RIGHT TO USE "ASSET" AND "MORTGAGE", APART FROM THE MARK AS SHOWN.

THE MARK CONSISTS OF A HOUSE WITH SHADOW BETWEEN THE WORDS ASSET AND DIRECT WITH THE WORD MORTGAGE CENTERED BELOW.

FOR MORTGAGE BANKING SERVICES, NAMELY, MORTGAGE LENDING; MORTGAGE SERVICES, NAMELY ORIGINATION, ACQUISITION, SECURITIZATION, BROKERAGE AND SERVICING OF CONSTRUCTION MORTGAGE LOANS, BUYER PRE-QUALIFICATION OF MORTGAGES, MORTGAGE BROKERAGE, MORTGAGE PROCUREMENT FOR OTHERS, HOME EQUITY LOANS, LOAN FINANCING; ALTERNATIVE LENDING SERVICES; HOME FINANCING AND REFINANCING; AND FINANCIAL LOAN CONSULTATION; MORTGAGE BROKERAGE SERVICES (U.S. CLS. 100, 101 AND 102).

FIRST USE 5-25-2005; IN COMMERCE 5-25-2005.

PAULA MAYS, EXAMINING ATTORNEY

# TRIPLE REX

THE MARK CONSISTS OF STANDARD CHARACTERS WITHOUT CLAIM TO ANY PARTICULAR FONT, STYLE, SIZE, OR COLOR.

FOR FINANCIAL SERVICES, NAMELY, THE ISSUANCE OF INVESTMENT SECURITIES (U.S. CLS. 100, 101 AND 102).

TONI HICKEY, EXAMINING ATTORNEY

SN 78-782,980. THE JANIE SIMS CHILDREN'S FOUNDATION, INC., BIRMINGHAM, AL. FILED 12-30-2005.



Curing Childhood Cancer

NO CLAIM IS MADE TO THE EXCLUSIVE RIGHT TO USE "CURING CHILDHOOD CANCER", APART FROM THE MARK AS SHOWN.

FOR CHARITABLE FUNDRAISING SERVICES, NAMELY, FUNDRAISING, PROVIDING FINANCIAL SUPPORT, AND FUNDING RESEARCH FOR A CURE FOR PEDIATRIC CANCER (U.S. CLS. 100, 101 AND 102).

FIRST USE 8-1-2003; IN COMMERCE 8-1-2003.

MARTHA FROMM, EXAMINING ATTORNEY

**CLASS 36—(Continued).**

SN 78-791,099. NATIONAL EMPLOYEE BENEFIT COMPANIES, INC., WARWICK, RI. FILED 1-13-2006.

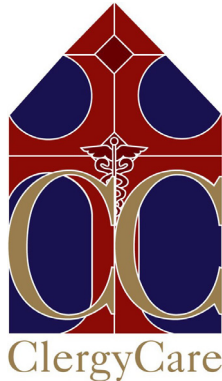

ClergyCare

THE COLOR(S) RED, DARK RED, BLUE, GOLD, AND WHITE IS/ARE CLAIMED AS A FEATURE OF THE MARK. THE MARK CONSISTS OF A GOLD, DOUBLE-LETTER "C" SHAPE, ATOP A RED COLORED, STYLIZED CROSS THAT HAS A DARKER RED COLORED CADUCEUS SYMBOL AND A DARKER RED COLORED DIAMOND SHAPE WITHIN THE CROSS SHAPE, ALL ATOP A BLUE COLORED PENTAGON SHAPE. THERE IS ADDITIONALLY A STYLIZED WORD BELOW THAT READS "CLERGYCARE" AND IS IN GOLD. THE DOUBLE-LETTER "C" SHAPE, STYLIZED CROSS, DIAMOND SHAPE, AND CADUCEUS SYMBOL ARE ALL OUTLINED IN WHITE.

FOR INSURANCE ADMINISTRATION IN THE FIELD OF RETIREE AND EMPLOYEE HEALTH AND PRESCRIPTION DRUG BENEFITS (U.S. CLS. 100, 101 AND 102).

FIRST USE 12-28-2005; IN COMMERCE 1-5-2006.  
DAVID ELTON, EXAMINING ATTORNEY

SN 78-798,389. ABN AMRO BANK N.V., AMSTERDAM, NETHERLANDS, FILED 1-24-2006.

**INDEX OUT-PERFORMANCE  
NOTES (IONS)**

THE MARK CONSISTS OF STANDARD CHARACTERS WITHOUT CLAIM TO ANY PARTICULAR FONT, STYLE, SIZE, OR COLOR.

NO CLAIM IS MADE TO THE EXCLUSIVE RIGHT TO USE "INDEX OUT-PERFORMANCE NOTES", APART FROM THE MARK AS SHOWN.

FOR FINANCIAL SERVICES, NAMELY, THE ISSUANCE OF INVESTMENT SECURITIES (U.S. CLS. 100, 101 AND 102).

FIRST USE 11-30-2005; IN COMMERCE 11-30-2005.  
TONI HICKEY, EXAMINING ATTORNEY

**CLASS 36—(Continued).**

SN 78-802,236. TB PROPRIETARY CORPORATION, WILMINGTON, DE. FILED 1-30-2006.



FOR MORTGAGE BANKING SERVICES, NAMELY ORIGINATION, ACQUISITION, SERVICING, SECURITIZATION AND BROKERAGE OF MORTGAGE LOANS (U.S. CLS. 100, 101 AND 102).

FIRST USE 9-1-2000; IN COMMERCE 9-1-2000.  
EDWARD FENNESSY, EXAMINING ATTORNEY

SN 78-803,139. BEACON CAPITAL PARTNERS LLC, BOSTON, MA. FILED 1-31-2006.

**BEACON CAPITAL PARTNERS**

THE MARK CONSISTS OF STANDARD CHARACTERS WITHOUT CLAIM TO ANY PARTICULAR FONT, STYLE, SIZE, OR COLOR.

NO CLAIM IS MADE TO THE EXCLUSIVE RIGHT TO USE "CAPITAL PARTNERS", APART FROM THE MARK AS SHOWN.

FOR REAL ESTATE INVESTMENT TRUST SERVICES (U.S. CLS. 100, 101 AND 102).

FIRST USE 1-0-1998; IN COMMERCE 1-0-1998.  
ALLISON HOLTZ, EXAMINING ATTORNEY

SN 78-811,922. NATIONAL STUDENT CONSOLIDATION CORPORATION, DBA NATIONAL STUDENT LOAN CONSOLIDATION CORPORATION, MIAMI, FL. FILED 2-10-2006.

**NSLCC**

THE MARK CONSISTS OF STANDARD CHARACTERS WITHOUT CLAIM TO ANY PARTICULAR FONT, STYLE, SIZE, OR COLOR.

FOR LOAN CONSOLIDATION SERVICES (U.S. CLS. 100, 101 AND 102).

LINDA ORNDORFF, EXAMINING ATTORNEY



**CLASS 36—(Continued).**

SN 78-819,646. IDT INSURANCE, INC., NEWARK, NJ. FILED 2-21-2006.

# CONFÍE

THE MARK CONSISTS OF STANDARD CHARACTERS WITHOUT CLAIM TO ANY PARTICULAR FONT, STYLE, SIZE, OR COLOR.

THE FOREIGN WORDING IN THE MARK TRANSLATES INTO ENGLISH AS TRUST.

FOR INSURANCE AGENCIES; INSURANCE BROKERAGE (U.S. CLS. 100, 101 AND 102).

AMY BROZENIC, EXAMINING ATTORNEY

**CLASS 36—(Continued).**

SN 78-819,716. IDT INSURANCE, INC., NEWARK, NJ. FILED 2-21-2006.

## CONFÍE INSURANCE AGENCY

THE MARK CONSISTS OF STANDARD CHARACTERS WITHOUT CLAIM TO ANY PARTICULAR FONT, STYLE, SIZE, OR COLOR.

NO CLAIM IS MADE TO THE EXCLUSIVE RIGHT TO USE "INSURANCE AGENCY", APART FROM THE MARK AS SHOWN.

"THE FOREIGN WORDING IN THE MARK TRANSLATES INTO ENGLISH AS TRUST."

FOR INSURANCE AGENCIES; INSURANCE BROKERAGE (U.S. CLS. 100, 101 AND 102).

AMY BROZENIC, EXAMINING ATTORNEY

SN 78-819,680. IDT INSURANCE, INC., NEWARK, NJ. FILED 2-21-2006.

## CONFÍE SEGUROS

THE MARK CONSISTS OF STANDARD CHARACTERS WITHOUT CLAIM TO ANY PARTICULAR FONT, STYLE, SIZE, OR COLOR.

NO CLAIM IS MADE TO THE EXCLUSIVE RIGHT TO USE "SEGUROS", APART FROM THE MARK AS SHOWN.

THE FOREIGN WORDING IN THE MARK TRANSLATES INTO ENGLISH AS TRUST INSURANCE.

FOR INSURANCE AGENCIES; INSURANCE BROKERAGE (U.S. CLS. 100, 101 AND 102).

AMY BROZENIC, EXAMINING ATTORNEY

SN 78-820,157. IDT INSURANCE, INC., NEWARK, NJ. FILED 2-21-2006.

## CONFÍE INSURANCE SERVICES

THE MARK CONSISTS OF STANDARD CHARACTERS WITHOUT CLAIM TO ANY PARTICULAR FONT, STYLE, SIZE, OR COLOR.

NO CLAIM IS MADE TO THE EXCLUSIVE RIGHT TO USE "INSURANCE SERVICES", APART FROM THE MARK AS SHOWN.

"THE FOREIGN WORDING IN THE MARK TRANSLATES INTO ENGLISH AS TRUST."

FOR INSURANCE AGENCIES; INSURANCE BROKERAGE (U.S. CLS. 100, 101 AND 102).

AMY BROZENIC, EXAMINING ATTORNEY

SN 78-819,701. IDT INSURANCE, INC., NEWARK, NJ. FILED 2-21-2006.

## CONFÍE FINANCIERA

THE MARK CONSISTS OF STANDARD CHARACTERS WITHOUT CLAIM TO ANY PARTICULAR FONT, STYLE, SIZE, OR COLOR.

NO CLAIM IS MADE TO THE EXCLUSIVE RIGHT TO USE "FINANCIERA", APART FROM THE MARK AS SHOWN.

THE FOREIGN WORDING IN THE MARK TRANSLATES INTO ENGLISH AS TRUST FINANCIAL.

FOR INSURANCE AGENCIES; INSURANCE BROKERAGE (U.S. CLS. 100, 101 AND 102).

AMY BROZENIC, EXAMINING ATTORNEY

SN 78-820,162. IDT INSURANCE, INC., NEWARK, NJ. FILED 2-21-2006.

## CONFÍE INSURANCE COMPANY

THE MARK CONSISTS OF STANDARD CHARACTERS WITHOUT CLAIM TO ANY PARTICULAR FONT, STYLE, SIZE, OR COLOR.

NO CLAIM IS MADE TO THE EXCLUSIVE RIGHT TO USE "INSURANCE COMPANY", APART FROM THE MARK AS SHOWN.

"THE FOREIGN WORDING IN THE MARK TRANSLATES INTO ENGLISH AS TRUST."

FOR INSURANCE AGENCIES; INSURANCE BROKERAGE (U.S. CLS. 100, 101 AND 102).

AMY BROZENIC, EXAMINING ATTORNEY

**CLASS 36—(Continued).**

SN 78-820,165. IDT INSURANCE, INC., NEWARK, NJ. FILED 2-21-2006.

**CONFIE FINANCIAL**

THE MARK CONSISTS OF STANDARD CHARACTERS WITHOUT CLAIM TO ANY PARTICULAR FONT, STYLE, SIZE, OR COLOR.

NO CLAIM IS MADE TO THE EXCLUSIVE RIGHT TO USE "FINANCIAL", APART FROM THE MARK AS SHOWN.

"THE FOREIGN WORDING IN THE MARK TRANSLATES INTO ENGLISH AS TRUST."

FOR INSURANCE AGENCIES; INSURANCE BROKERAGE (U.S. CLS. 100, 101 AND 102).

AMY BROZENIC, EXAMINING ATTORNEY

---

SN 78-828,478. FIFTH THIRD BANCORP, CINCINNATI, OH. FILED 3-3-2006.

**MYPRO INVESTOR SERVICES**

THE MARK CONSISTS OF STANDARD CHARACTERS WITHOUT CLAIM TO ANY PARTICULAR FONT, STYLE, SIZE, OR COLOR.

NO CLAIM IS MADE TO THE EXCLUSIVE RIGHT TO USE "INVESTOR SERVICES", APART FROM THE MARK AS SHOWN.

FOR FINANCIAL SERVICES, NAMELY, INVESTMENT ADVISORY SERVICES, INVESTMENT SERVICES, AND ACCOUNT MANAGEMENT SERVICES (U.S. CLS. 100, 101 AND 102).

LINDA POWELL, EXAMINING ATTORNEY

---

SN 78-828,999. GALEN ASSOCIATES, NEW YORK, NY. FILED 3-3-2006.

**GALEN**

THE MARK CONSISTS OF STANDARD CHARACTERS WITHOUT CLAIM TO ANY PARTICULAR FONT, STYLE, SIZE, OR COLOR.

OWNER OF U.S. REG. NOS. 2,062,670 AND 2,721,547.

FOR VENTURE CAPITAL SERVICES, NAMELY, PROVIDING FINANCING TO EMERGING AND START-UP COMPANIES (U.S. CLS. 100, 101 AND 102).

FIRST USE 0-0-1989; IN COMMERCE 0-0-1989.

KYLE PEETE, EXAMINING ATTORNEY

**CLASS 36—(Continued).**

SN 78-831,527. RELIASTAR LIFE INSURANCE COMPANY, MINNEAPOLIS, MN. FILED 3-7-2006.

**VARIABLE ACCUMULATION DESIGN**

THE MARK CONSISTS OF STANDARD CHARACTERS WITHOUT CLAIM TO ANY PARTICULAR FONT, STYLE, SIZE, OR COLOR.

OWNER OF U.S. REG. NO. 2,670,533.

NO CLAIM IS MADE TO THE EXCLUSIVE RIGHT TO USE "VARIABLE ACCUMULATION", APART FROM THE MARK AS SHOWN.

SEC. 2(F).

FOR INSURANCE BROKERAGE SERVICES IN THE FIELD OF LIFE INSURANCE; INSURANCE ADMINISTRATION SERVICES IN THE FIELD OF LIFE INSURANCE (U.S. CLS. 100, 101 AND 102).

FIRST USE 1-1-2001; IN COMMERCE 1-1-2001.

KATINA MISTER, EXAMINING ATTORNEY

---

SN 78-842,041. IDT NETHERLANDS, B.V. (PUERTO RICO BRANCH), SAN JUAN, PUERTO RICO, FILED 3-21-2006.

**DIFERENTE PHONE CARD**

THE MARK CONSISTS OF STANDARD CHARACTERS WITHOUT CLAIM TO ANY PARTICULAR FONT, STYLE, SIZE, OR COLOR.

NO CLAIM IS MADE TO THE EXCLUSIVE RIGHT TO USE "PHONE CARD", APART FROM THE MARK AS SHOWN.

THE FOREIGN WORDING IN THE MARK TRANSLATES INTO ENGLISH AS DIFFERENT.

FOR PREPAID TELEPHONE CALLING CARD AND TELEPHONE DEBIT CARD SERVICES (U.S. CLS. 100, 101 AND 102).

FIRST USE 3-16-2006; IN COMMERCE 3-16-2006.

JULIE WATSON, EXAMINING ATTORNEY

---

SN 78-847,177. THE COLLEGE COMPANY, INC., SAN MATEO, CA. FILED S.R. 3-27-2006; AM. P.R. 12-30-2006.

**TUITIONCOACH**

THE MARK CONSISTS OF STANDARD CHARACTERS WITHOUT CLAIM TO ANY PARTICULAR FONT, STYLE, SIZE, OR COLOR.

FOR PROVIDING INFORMATION IN THE FIELD OF COLLEGE FUNDING VIA THE INTERNET (U.S. CLS. 100, 101 AND 102).

FIRST USE 2-20-2006; IN COMMERCE 3-16-2006.

BARBARA RUTLAND, EXAMINING ATTORNEY

**CLASS 36—(Continued).**

SN 78-847,445. ARCAP REIT, INC., IRVING, TX. FILED 3-28-2006.

**BUY. WATCH. FIX.**

THE MARK CONSISTS OF STANDARD CHARACTERS WITHOUT CLAIM TO ANY PARTICULAR FONT, STYLE, SIZE, OR COLOR.

FOR FINANCIAL DUE DILIGENCE, SURVEILLANCE, NAMELY, ONGOING COLLECTION AND ANALYSIS OF DATA RELEVANT TO THE OPERATION OF COMMERCIAL REAL ESTATE, AND WORKOUT PROCESSES, WITH RESPECT TO COMMERCIAL MORTGAGE BACKED SECURITIES AND OTHER REAL ESTATE FINANCING ACTIVITIES AND PRODUCTS (U.S. CLS. 100, 101 AND 102).

FIRST USE 11-0-2003; IN COMMERCE 11-0-2003.  
KEVON CHISOLM, EXAMINING ATTORNEY

**CLASS 36—(Continued).**

SN 78-848,911. NOVUS CREDIT SERVICES INC., RIVERWOODS, IL. FILED 3-29-2006.

**DISCOVER BROKERAGE**

THE MARK CONSISTS OF STANDARD CHARACTERS WITHOUT CLAIM TO ANY PARTICULAR FONT, STYLE, SIZE, OR COLOR.

OWNER OF U.S. REG. NOS. 1,479,946, 3,090,532 AND OTHERS.

NO CLAIM IS MADE TO THE EXCLUSIVE RIGHT TO USE BROKERAGE, APART FROM THE MARK AS SHOWN, FOR FINANCIAL SERVICES, NAMELY, SECURITIES BROKERAGE (U.S. CLS. 100, 101 AND 102).

GILBERT SWIFT, EXAMINING ATTORNEY

SN 78-858,078. WATSON, ALDEN, SAN DIEGO, CA. FILED 4-10-2006.

**RENTALS WE GOT 'EM**

THE MARK CONSISTS OF STANDARD CHARACTERS WITHOUT CLAIM TO ANY PARTICULAR FONT, STYLE, SIZE, OR COLOR.

NO CLAIM IS MADE TO THE EXCLUSIVE RIGHT TO USE "RENTALS", APART FROM THE MARK AS SHOWN.

FOR APARTMENT LOCATING SERVICES FOR OTHERS; LEASING OF REAL ESTATE; REAL ESTATE BROKERAGE; RENTAL OF APARTMENTS (U.S. CLS. 100, 101 AND 102).

FIRST USE 9-5-1981; IN COMMERCE 9-5-1981.  
SALLY SHIH, EXAMINING ATTORNEY

SN 78-848,092. THE BANK OF NEW YORK COMPANY, INC., NEW YORK, NY. FILED 3-28-2006.

**THE BANK OF NEW YORK ADR INDEX**

THE MARK CONSISTS OF STANDARD CHARACTERS WITHOUT CLAIM TO ANY PARTICULAR FONT, STYLE, SIZE, OR COLOR.

OWNER OF U.S. REG. NOS. 841,428, 1,560,124 AND 2,354,464.

NO CLAIM IS MADE TO THE EXCLUSIVE RIGHT TO USE "BANK" OR "ADR INDEX", APART FROM THE MARK AS SHOWN.

SEC. 2(F).  
FOR FINANCIAL REPORTING SERVICES, NAMELY, CALCULATING, MEASURING, INDEXING IN RELATION TO A BASE VALUE AND REPORTING THE FLUCTUATION IN AGGREGATE MARKET VALUE OF A SELECT GROUP OF AMERICAN DEPOSITORY RECEIPTS (U.S. CLS. 100, 101 AND 102).

FIRST USE 3-23-1998; IN COMMERCE 3-23-1998.  
TRACY WHITTAKER-BROWN, EXAMINING ATTORNEY

SN 78-871,431. MONSTER (CALIFORNIA), INC., EL SEGUNDO, CA. FILED 4-27-2006.

**ASTUTE STUDENT LOAN**

THE MARK CONSISTS OF STANDARD CHARACTERS WITHOUT CLAIM TO ANY PARTICULAR FONT, STYLE, SIZE, OR COLOR.

NO CLAIM IS MADE TO THE EXCLUSIVE RIGHT TO USE "STUDENT LOAN", APART FROM THE MARK AS SHOWN.

FOR STUDENT LOAN SERVICES (U.S. CLS. 100, 101 AND 102).  
TRACY CROSS, EXAMINING ATTORNEY

**CLASS 36—(Continued).**

SN 78-873,912. CYCLE GEAR, INC., BENICIA, CA. FILED 5-1-2006.

**MOTOGUARD**

THE MARK CONSISTS OF STANDARD CHARACTERS WITHOUT CLAIM TO ANY PARTICULAR FONT, STYLE, SIZE, OR COLOR.

FOR PROVIDING EXTENDED WARRANTIES AND EXTENDED ROAD-HAZARD WARRANTIES ON TIRES (U.S. CLS. 100, 101 AND 102).

FIRST USE 8-1-2001; IN COMMERCE 8-1-2001.

MATTHEW MCDOWELL, EXAMINING ATTORNEY

---

SN 78-876,026. 2001 PENN. AVE. INVESTMENTS, LLC, WASHINGTON, DC. FILED 5-3-2006.

**PALADIN CAPITAL PARTNERS  
FUND**

THE MARK CONSISTS OF STANDARD CHARACTERS WITHOUT CLAIM TO ANY PARTICULAR FONT, STYLE, SIZE, OR COLOR.

NO CLAIM IS MADE TO THE EXCLUSIVE RIGHT TO USE "CAPITAL PARTNERS FUND", APART FROM THE MARK AS SHOWN.

FOR FINANCIAL SERVICES, NAMELY, INVESTMENT IN SECURITIES, INVESTMENT MANAGEMENT AND INVESTMENT ADVISORY SERVICES (U.S. CLS. 100, 101 AND 102).

FIRST USE 5-0-2001; IN COMMERCE 5-0-2001.

ALAIN LAPTER, EXAMINING ATTORNEY

---

SN 78-876,028. 2001 PENN. AVE. INVESTMENTS, LLC, WASHINGTON, DC. FILED 5-3-2006.

**PALADIN HOMELAND SECURITY  
FUND**

THE MARK CONSISTS OF STANDARD CHARACTERS WITHOUT CLAIM TO ANY PARTICULAR FONT, STYLE, SIZE, OR COLOR.

NO CLAIM IS MADE TO THE EXCLUSIVE RIGHT TO USE "HOMELAND SECURITY FUND", APART FROM THE MARK AS SHOWN.

FOR FINANCIAL SERVICES, NAMELY, INVESTMENT IN SECURITIES, INVESTMENT MANAGEMENT AND INVESTMENT ADVISORY SERVICES (U.S. CLS. 100, 101 AND 102).

FIRST USE 11-0-2002; IN COMMERCE 11-0-2002.

ALAIN LAPTER, EXAMINING ATTORNEY

**CLASS 36—(Continued).**

SN 78-881,625. FAIRWAY ESCAPES, LLC, ST. GEORGE, UT. FILED 5-11-2006.



NO CLAIM IS MADE TO THE EXCLUSIVE RIGHT TO USE GOLFERS RESIDENCE CLUB, APART FROM THE MARK AS SHOWN.

FOR FORMATION, BROKERAGE, AND MANAGEMENT OF MEMBERSHIP INTERESTS IN GOLF-THEMED RESIDENCE CLUBS AND GOLF CLUBS (U.S. CLS. 100, 101 AND 102).

FIRST USE 9-30-2004; IN COMMERCE 9-30-2004.

SUE LAWRENCE, EXAMINING ATTORNEY

---

SN 78-883,214. THE BRAND BANKING COMPANY, LAWRENCEVILLE, GA. FILED 5-15-2006.

**E-BRAND DIRECT**

THE MARK CONSISTS OF STANDARD CHARACTERS WITHOUT CLAIM TO ANY PARTICULAR FONT, STYLE, SIZE, OR COLOR.

NO CLAIM IS MADE TO THE EXCLUSIVE RIGHT TO USE "DIRECT", APART FROM THE MARK AS SHOWN.

FOR BANKING; ON-LINE BANKING SERVICES (U.S. CLS. 100, 101 AND 102).

DAVID H. STINE, EXAMINING ATTORNEY

---

SN 78-887,112. ALL STAR AUCTIONS LLC, RIDGEWOOD, NJ. FILED 5-18-2006.



NO CLAIM IS MADE TO THE EXCLUSIVE RIGHT TO USE "AUCTIONS", APART FROM THE MARK AS SHOWN. FOR EVALUATION AND APPRAISAL OF COMIC BOOKS AND COMIC MAGAZINES, COLLECTIBLES, AND ILLUSTRATION ARTWORK (U.S. CLS. 100, 101 AND 102).

FIRST USE 5-0-1998; IN COMMERCE 5-0-1998.

JILL C. ALT, EXAMINING ATTORNEY

**CLASS 36—(Continued).**

SN 78-890,170. M.T.J.K., INC., WEST COVINA, CA. FILED 5-23-2006.

PLEDGE INSURANCE BROKERS

THE MARK CONSISTS OF STANDARD CHARACTERS WITHOUT CLAIM TO ANY PARTICULAR FONT, STYLE, SIZE, OR COLOR.

NO CLAIM IS MADE TO THE EXCLUSIVE RIGHT TO USE "INSURANCE BROKERS", APART FROM THE MARK AS SHOWN.

FOR INSURANCE SERVICES, NAMELY, PROVIDING AUTOMOBILE, PROPERTY AND CASUALTY INSURANCE BROKERAGE SERVICES (U.S. CLS. 100, 101 AND 102).

FIRST USE 1-1-2000; IN COMMERCE 1-1-2000.  
JENNIFER KRISP, EXAMINING ATTORNEY

SN 78-902,823. GERMAN HEALTH PLANS WORLDWIDE, INC., NEW YORK, NY. FILED 6-7-2006.



THE COLOR(S) RED IS/ARE CLAIMED AS A FEATURE OF THE MARK.

THE MARK CONSISTS OF THE COLOR RED APPEARING OVER THE ENTIRE LETTER H.

FOR INSURANCE UNDERWRITING IN THE FIELD OF HEALTH TO GERMAN COMPANIES IN THE USA, INDIVIDUALS AND THEIR FAMILIES ABROAD; UNDERWRITING INSURANCE FOR PRE-PAID HEALTH CARE TO GERMAN COMPANIES IN THE USA, INDIVIDUALS AND THEIR FAMILIES ABROAD (U.S. CLS. 100, 101 AND 102).

FIRST USE 6-7-2001; IN COMMERCE 1-1-2003.  
LOURDES AYALA, EXAMINING ATTORNEY

**CLASS 36—(Continued).**

SN 78-905,985. MARUBENI ITOCHU STEEL AMERICA INC., NEW YORK, NY. FILED 6-12-2006.

MISA

THE MARK CONSISTS OF STANDARD CHARACTERS WITHOUT CLAIM TO ANY PARTICULAR FONT, STYLE, SIZE, OR COLOR.

FOR FINANCIAL GUARANTEE AND SURETY; AGENCIES IN THE FIELD OF BONDS AND OTHER SECURITIES; SECURITY AND STOCK BROKERAGE; INSURANCE AGENCIES; REAL ESTATE MANAGEMENT; REAL ESTATE ACQUISITION SERVICES; REAL ESTATE PROCUREMENT FOR OTHERS; REAL ESTATE APPRAISAL; REAL ESTATE BROKERAGE; LEASING OF REAL PROPERTY AND REAL ESTATE; PROVIDING INFORMATION IN THE FIELD OF REAL ESTATE BY MEANS OF LINKING THE WEBSITE TO OTHER WEBSITES FEATURING BUILDING AND LAND INFORMATION (U.S. CLS. 100, 101 AND 102).

AMY BROZENIC, EXAMINING ATTORNEY

SN 78-909,442. PREMIA CAPITAL MANAGEMENT, LLC, CHICAGO, IL. FILED 6-15-2006.

PREMIA CAPITAL

THE MARK CONSISTS OF STANDARD CHARACTERS WITHOUT CLAIM TO ANY PARTICULAR FONT, STYLE, SIZE, OR COLOR.

NO CLAIM IS MADE TO THE EXCLUSIVE RIGHT TO USE "CAPITAL", APART FROM THE MARK AS SHOWN.

FOR INVESTMENT ADVISORY SERVICES (U.S. CLS. 100, 101 AND 102).

FIRST USE 10-1-1998; IN COMMERCE 10-1-1998.  
MONIQUE MILLER, EXAMINING ATTORNEY

SN 78-913,131. STONWORKS ASSET MANAGEMENT LLP, LONDON, UNITED KINGDOM, FILED 6-21-2006.

Stoneworks

THE MARK CONSISTS OF STANDARD CHARACTERS WITHOUT CLAIM TO ANY PARTICULAR FONT, STYLE, SIZE, OR COLOR.

FOR FINANCIAL PORTFOLIO MANAGEMENT; FUNDS INVESTMENT; HEDGE FUND INVESTMENT SERVICES; MANAGEMENT OF PORTFOLIOS COMPRISING SECURITIES (U.S. CLS. 100, 101 AND 102).

H. M. FISHER, EXAMINING ATTORNEY

**CLASS 36—(Continued).**

SN 78-915,930. DOCUTECH CORPORATION, IDAHO FALLS, ID. FILED 6-23-2006.

**SOLEX**

THE MARK CONSISTS OF STANDARD CHARACTERS WITHOUT CLAIM TO ANY PARTICULAR FONT, STYLE, SIZE, OR COLOR.

FOR FINANCIAL AND LENDING SERVICES, NAMELY, CONSUMER LENDING SERVICES VIA INDIRECT LENDING PORTALS UTILIZING WEB-BASED SOFTWARE APPLICATIONS PROVIDING FINANCIAL INFORMATION TO CONSUMERS, LENDERS, AND DEALERS, AND UTILIZING COMPUTER NETWORKS FOR THE FINANCING OF RECREATIONAL VEHICLES (U.S. CLS. 100, 101 AND 102).

PETER CHENG, EXAMINING ATTORNEY

---

SN 78-920,313. MARSHALL, JAMES F., GERMANTOWN, WI. FILED 6-29-2006.



NO CLAIM IS MADE TO THE EXCLUSIVE RIGHT TO USE "INVESTOR", APART FROM THE MARK AS SHOWN.

THE COLOR(S) PURPLE, GREEN, RED, BLUE, LIGHT BLUE, GRAY, TAN, BROWN, YELLOW AND BLACK LETTERING IS/ARE CLAIMED AS A FEATURE OF THE MARK.

THE COLOR PURPLE APPEARS IN THE UPPER LEFT CORNER OF THE LOGO, THE COLOR GREEN APPEARS IN THE UPPER CENTER OF THE LOGO, THE COLOR RED APPEARS IN THE UPPER RIGHT CORNER OF THE LOGO, THE COLOR BLUE APPEARS IN THE MIDDLE LEFT OF THE LOGO, THE COLOR BLUE APPEARS IN THE MIDDLE OF THE LOGO, THE COLOR GRAY APPEARS IN THE RIGHT MIDDLE OF THE LOGO, THE COLOR ORANGE APPEARS IN LOWER RIGHT OF THE LOGO, THE COLOR BROWN APPEARS IN THE LOWER CENTER OF THE LOGO AND THE COLOR YELLOW APPEARS IN THE LOWER RIGHT OF THE LOGO.

FOR RETIREMENT PLAN SERVICES, NAMELY, ADMINISTRATION OF AND ADVICE WITH RESPECT TO RETIREMENT PLANS, INCLUDING 401K PLANS (U.S. CLS. 100, 101 AND 102).

DAVID TAYLOR, EXAMINING ATTORNEY

**CLASS 36—(Continued).**

SN 78-921,133. GOLDMAN, SACHS & CO., NEW YORK, NY. FILED 6-30-2006.

**GOLDMAN SACHS FXEDGE**

THE MARK CONSISTS OF STANDARD CHARACTERS WITHOUT CLAIM TO ANY PARTICULAR FONT, STYLE, SIZE, OR COLOR.

OWNER OF U.S. REG. NOS. 1,975,880, 2,444,245 AND OTHERS.

FOR FINANCIAL SERVICES, NAMELY PROVIDING FOR THE AUTOMATED TRADING OF FOREIGN CURRENCIES, SETTLEMENT SERVICES IN THE FIELD OF FOREIGN EXCHANGE, AND FOREIGN EXCHANGE RATE CALCULATION SERVICES; PROVIDING FINANCIAL INFORMATION IN THE FIELD OF FOREIGN EXCHANGE; FOREIGN EXCHANGE INFORMATION SERVICES, NAMELY MANAGING, TRACKING, AND REPORTING FOREIGN EXCHANGE PURCHASE AND SALE TRANSACTIONS; FINANCIAL ANALYSIS OF FOREIGN EXCHANGE TRANSACTIONS AND VALUES; FINANCIAL INFORMATION PROVIDED BY ELECTRONIC MEANS, NAMELY PROVIDING ONLINE DATABASES WHICH PROVIDE ACCESS TO FOREIGN EXCHANGE ACCOUNT INFORMATION; FINANCIAL RESEARCH IN THE FIELD OF FOREIGN CURRENCY EXCHANGE; FINANCIAL CONSULTATION SERVICES, NAMELY PROVIDING FOREIGN EXCHANGE FINANCIAL INFORMATION; FINANCIAL SERVICES, NAMELY PROVIDING FOR THE ONLINE TRADING OF FOREIGN CURRENCIES (U.S. CLS. 100, 101 AND 102).

JASON BLAIR, EXAMINING ATTORNEY

---

SN 78-929,255. STATION CASINOS, INC., LAS VEGAS, NV. FILED 7-13-2006.

**SUMMIT SIERRA STATION**

THE MARK CONSISTS OF STANDARD CHARACTERS WITHOUT CLAIM TO ANY PARTICULAR FONT, STYLE, SIZE, OR COLOR.

FOR LEASING OF REAL PROPERTY; LEASING OF SHOPPING MALL SPACE; ASSESSMENT AND MANAGEMENT OF REAL ESTATE; CHARITABLE FUND RAISING; EQUITY CAPITAL INVESTMENT; LEASING OR RENTING OF BUILDINGS; PHILANTHROPIC SERVICES CONCERNING MONETARY DONATIONS; REAL ESTATE MANAGEMENT (U.S. CLS. 100, 101 AND 102).

ESTHER A. BORSUK, EXAMINING ATTORNEY

**CLASS 36—(Continued).**

SN 78-931,359. VIRGINIA BEACH SCHOOLS FEDERAL CREDIT UNION, VIRGINIA BEACH, VA. FILED 7-17-2006.

## The *Smart* Financial Choice

THE COLOR(S) RED AND BLACK IS/ARE CLAIMED AS A FEATURE OF THE MARK.

THE COLOR BLACK APPEARS IN THE WORDING "THE" AND "FINANCIAL CHOICE" AND THE COLOR RED APPEARS IN THE WORDING "SMART".

FOR CREDIT UNION SERVICES (U.S. CLS. 100, 101 AND 102).

FIRST USE 9-0-2001; IN COMMERCE 9-0-2001.  
NAKIA HENRY, EXAMINING ATTORNEY

SN 78-932,449. NATIONSPLUS MORTGAGE CORPORATION, CHRISTIANSBURG, VA. FILED 7-19-2006.

## NationsPlus

THE MARK CONSISTS OF STANDARD CHARACTERS WITHOUT CLAIM TO ANY PARTICULAR FONT, STYLE, SIZE, OR COLOR.

FOR MORTGAGE BROKERING SERVICES, NAMELY, EVALUATION OF CREDIT WORTHINESS OF INDIVIDUALS; BILL CONSOLIDATION SERVICES; BUYER PREQUALIFICATION FOR HOME LOANS; PROVIDING ON-LINE FINANCIAL CALCULATORS; MORTGAGE LOAN ORIGINATION FOR HOME PURCHASE, MORTGAGE REFINANCE, SECOND MORTGAGES, CONSTRUCTION LOANS, LEASE-PURCHASE FINANCING, AND OTHERWISE, INCLUDING ALL CONVENTIONAL, FHA AND VA MORTGAGE LOANS; MORTGAGE LOAN PROCESSING, AND MORTGAGE LOAN UNDERWRITING (U.S. CLS. 100, 101 AND 102).

FIRST USE 2-28-2006; IN COMMERCE 2-28-2006.  
JENNY PARK, EXAMINING ATTORNEY

SN 78-932,451. NATIONSPLUS MORTGAGE CORPORATION, CHRISTIANSBURG, VA. FILED 7-19-2006.



THE COLOR(S) BLUE AND RED IS/ARE CLAIMED AS A FEATURE OF THE MARK.

THE MARK CONSISTS OF THE TERM NATIONSPLUS IN STYLIZED TYPE WITH THE GRAPHIC IMAGE OF TWO HOME ROOFLINES APPEARING ABOVE IT AND WITH

**CLASS 36—(Continued).**

THE "L" OF THE TERM NATIONSPLUS BEING ELEVATED SO AS TO FORM THE CHIMNEY OF ONE HOME IN THE GRAPHIC ROOFLINE IMAGE. THE WORDING "NATIONS," THE FIRST ROOFLINE IMAGE AND THE WINDOW ON THE SECOND ROOFLINE ARE BLUE, AND THE WORDING "PLUS" WITH THE LETTER "L" FORMING THE CHIMNEY ON THE SECOND HOUSE, THE LINE UNDERNEATH THE WORDING "NATIONSPLUS," THE SECOND ROOFLINE IMAGE AND THE WINDOW ON THE FIRST ROOFLINE ARE RED.

FOR MORTGAGE BROKERING SERVICES, NAMELY, EVALUATION OF CREDIT WORTHINESS OF INDIVIDUALS; BILL CONSOLIDATION SERVICES; BUYER PREQUALIFICATION FOR HOME LOANS; PROVIDING ON-LINE FINANCIAL CALCULATORS; MORTGAGE LOAN ORIGINATION FOR HOME PURCHASE, MORTGAGE REFINANCE, SECOND MORTGAGES, CONSTRUCTION LOANS, LEASE-PURCHASE FINANCING, AND OTHERWISE, INCLUDING ALL CONVENTIONAL, FHA AND VA MORTGAGE LOANS; MORTGAGE LOAN PROCESSING, AND MORTGAGE LOAN UNDERWRITING (U.S. CLS. 100, 101 AND 102).

FIRST USE 2-28-2006; IN COMMERCE 2-28-2006.  
JENNY PARK, EXAMINING ATTORNEY

SN 78-933,281. O'CONNOR, ERIN J., PEORIA, AZ. FILED 7-19-2006.



THE COLOR(S) MAROON AND WHITE IS/ARE CLAIMED AS A FEATURE OF THE MARK.

THE MARK CONSISTS OF A MAROON RECTANGLE WITH A WHITE LETTER "U" INSIDE THE RECTANGLE. THE RIGHT STEM OF THE LETTER "U" HAS SMALLER MAROON RECTANGLES IN IT DESIGNED TO LOOK LIKE WINDOWS IN A HIGH RISE BUILDING.

FOR LEASING OF REAL ESTATE; PROVIDING INFORMATION IN THE FIELD OF REAL ESTATE BY MEANS OF LINKING THE WEB SITE TO OTHER WEB SITES FEATURING REAL ESTATE INFORMATION; REAL ESTATE ACQUISITION SERVICES; REAL ESTATE AGENCIES; REAL ESTATE BROKERAGE; REAL ESTATE CONSULTANCY; REAL ESTATE CONSULTATION; REAL ESTATE INVESTMENT; REAL ESTATE LISTING; REAL ESTATE PROCUREMENT FOR OTHERS (U.S. CLS. 100, 101 AND 102).

FIRST USE 3-20-2006; IN COMMERCE 3-20-2006.  
KIM SAITO, EXAMINING ATTORNEY

**CLASS 36—(Continued).**

SN 78-933,908. MARKET AREA REAL ESTATE SERVICES, INC., HILTON HEAD ISLAND, SC. FILED 7-20-2006.

WHERE BUYERS AND SELLERS  
GO TO MARKET.

THE MARK CONSISTS OF STANDARD CHARACTERS WITHOUT CLAIM TO ANY PARTICULAR FONT, STYLE, SIZE, OR COLOR.

NO CLAIM IS MADE TO THE EXCLUSIVE RIGHT TO USE "BUYERS AND SELLERS", APART FROM THE MARK AS SHOWN.

FOR REAL ESTATE BROKERAGE SERVICES AND CONSULTING IN THE FIELD OF REAL ESTATE AND HOME PROCUREMENT (U.S. CLS. 100, 101 AND 102).

FIRST USE 11-1-2005; IN COMMERCE 11-1-2005.  
CAROLYN GRAY, EXAMINING ATTORNEY

---

SN 78-933,997. FAMILY INVESTMENT CENTER, INC., ST. JOSEPH, MO. FILED 7-20-2006.

FAMILY INVESTMENT CENTER

THE MARK CONSISTS OF STANDARD CHARACTERS WITHOUT CLAIM TO ANY PARTICULAR FONT, STYLE, SIZE, OR COLOR.

NO CLAIM IS MADE TO THE EXCLUSIVE RIGHT TO USE "INVESTMENT CENTER", APART FROM THE MARK AS SHOWN.

SEC. 2(F).  
FOR FINANCIAL ADVISORY AND MANAGEMENT SERVICES (U.S. CLS. 100, 101 AND 102).

FIRST USE 4-20-1998; IN COMMERCE 4-20-1998.  
JOANNA DUKOVIC, EXAMINING ATTORNEY

---

SN 78-935,032. THE AURORA FUNDS, INC., DURHAM, NC. FILED 7-21-2006.

AURORA FUNDS

THE MARK CONSISTS OF STANDARD CHARACTERS WITHOUT CLAIM TO ANY PARTICULAR FONT, STYLE, SIZE, OR COLOR.

NO CLAIM IS MADE TO THE EXCLUSIVE RIGHT TO USE "FUNDS", APART FROM THE MARK AS SHOWN.

FOR VENTURE CAPITAL FUNDING SERVICES TO START-UP EARLY-STAGE LIFE SCIENCES AND INFORMATION TECHNOLOGY COMPANIES (U.S. CLS. 100, 101 AND 102).

FIRST USE 8-31-1994; IN COMMERCE 8-31-1994.  
SALLY SHIH, EXAMINING ATTORNEY

**CLASS 36—(Continued).**

SN 78-936,175. THE AURORA FUNDS, INC., DURHAM, NC. FILED 7-24-2006.



NO CLAIM IS MADE TO THE EXCLUSIVE RIGHT TO USE "FUNDS", APART FROM THE MARK AS SHOWN.

THE COLOR(S) GREEN IS/ARE CLAIMED AS A FEATURE OF THE MARK.

THE MARK CONSISTS OF A HORIZONTAL CONVEX CRESCENT UNDER WHICH ARE THE WORDS AURORA FUNDS, WITH THE WORD AURORA BEING IN BOLD, BLOCK, CAPITAL LETTERS, FOLLOWED BY THE WORD FUNDS IN SMALLER, STYLIZED, CAPITAL LETTERS, ALL OF THE MARK BEING THE COLOR GREEN.

FOR VENTURE CAPITAL FUNDING SERVICES TO START-UP EARLY-STAGE LIFE SCIENCES AND INFORMATION TECHNOLOGY COMPANIES (U.S. CLS. 100, 101 AND 102).

FIRST USE 12-18-2002; IN COMMERCE 12-18-2002.  
SALLY SHIH, EXAMINING ATTORNEY

---

SN 78-936,757. KEYCORP, CLEVELAND, OH. FILED 7-25-2006.

1-800-KEY-CHECKS

THE MARK CONSISTS OF STANDARD CHARACTERS WITHOUT CLAIM TO ANY PARTICULAR FONT, STYLE, SIZE, OR COLOR.

OWNER OF U.S. REG. NOS. 1,495,327, 2,346,282 AND OTHERS.

FOR BANKING SERVICES, NAMELY, CHECKING ACCOUNT SERVICES (U.S. CLS. 100, 101 AND 102).

TIMOTHY FINNEGAN, EXAMINING ATTORNEY

---

SN 78-938,805. ASCENTIA CAPITAL PARTNERS, LLC, RENO, NV. FILED 7-27-2006.

ASCENTIA

THE MARK CONSISTS OF STANDARD CHARACTERS WITHOUT CLAIM TO ANY PARTICULAR FONT, STYLE, SIZE, OR COLOR.

FOR INVESTMENT ADVISORY SERVICES, NAMELY, PORTFOLIO MANAGEMENT, HEDGE FUND INVESTMENTS AND SEPARATELY MANAGED ACCOUNTS (U.S. CLS. 100, 101 AND 102).

FIRST USE 6-15-2005; IN COMMERCE 12-1-2005.  
ANTHONY RINKER, EXAMINING ATTORNEY



**CLASS 36—(Continued).**

SN 78-938,939. ROBERT T. BROWN, NEW YORK, NY. FILED 7-27-2006.

## Your Vision. Our Engineering.

THE MARK CONSISTS OF STANDARD CHARACTERS WITHOUT CLAIM TO ANY PARTICULAR FONT, STYLE, SIZE, OR COLOR.

FOR INSURANCE BROKERAGE, SECURITIES BROKERAGE, FINANCIAL PLANNING, RESIDENTIAL AND COMMERCIAL REAL ESTATE ADVISORY SERVICES (U.S. CLS. 100, 101 AND 102).

CAROLYN CATALDO, EXAMINING ATTORNEY

SN 78-940,777. LOPEZ, CARLOS C, SALINAS, CA. FILED 7-30-2006.



OWNER OF U.S. REG. NOS. 3,180,234 AND 3,186,317. NO CLAIM IS MADE TO THE EXCLUSIVE RIGHT TO USE "FINANCIAL GROUP" AND "REAL ESTATE & LOANS", APART FROM THE MARK AS SHOWN.

THE COLOR(S) BLACK, WHITE AND GOLD IS/ARE CLAIMED AS A FEATURE OF THE MARK.

THE COLOR BLACK APPEARS IN THE TERM LOPEZ, IN THE LETTERS IN THE WORDS REAL ESTATE & LOANS, AND IN THE HORIZONTAL LINES APPEARING ABOVE AND BELOW THE WORDING REAL ESTATE & LOANS. THE COLOR WHITE APPEARS IN THE FOUR COLUMNS AND TWO HEADERS COMPRISING THE PILLAR DESIGN IN THE MARK, AND IN THE WAVY LINE APPEARING BEHIND THE PILLAR DESIGN. THE COLOR GOLD APPEARS IN THE RECTANGULAR BACKGROUND DESIGN APPEARING BEHIND THE PILLAR DESIGN, AND IN THE LETTERS OF THE WORDS FINANCIAL GROUP. THE GOLD IN THE UPPER PORTION OF THE RECTANGULAR BACKGROUND DESIGN IS THE SAME SHADE OF GOLD THAT APPEARS IN THE WORDS FINANCIAL GROUP. THE BOTTOM HALF OF THE RECTANGULAR BACKGROUND DESIGN APPEARS IN A LIGHTER SHADE OF GOLD. THE GRAY SHADING IN THE COLUMNS AND HEADER IN THE PILLAR DESIGN IN THE MARK IS FOR SHADING AND DEPTH PURPOSES ONLY. THE GRAY SHADING IS NOT PART OF THE MARK AND THE COLOR GRAY IS NOT CLAIMED AS A FEATURE OF THE MARK.

FOR REAL ESTATE BROKERAGE AND REAL ESTATE MORTGAGE BROKERAGE SERVICES (U.S. CLS. 100, 101 AND 102).

FIRST USE 1-9-2006; IN COMMERCE 1-9-2006.

BARBARA A. LOUGHRAN, EXAMINING ATTORNEY

**CLASS 36—(Continued).**

SN 78-942,187. EQUIGUARD, INC., OAK BROOK, IL. FILED 8-1-2006.

## EquiRate

THE MARK CONSISTS OF STANDARD CHARACTERS WITHOUT CLAIM TO ANY PARTICULAR FONT, STYLE, SIZE, OR COLOR.

FOR PROVIDING EXTENDED WARRANTIES ON HEATING, VENTILATING, AIR CONDITIONING AND REFRIGERATION EQUIPMENT, AND WARRANTY CLAIMS ADMINISTRATION SERVICES, NAMELY, PROCESSING CLAIMS UNDER THE AFOREMENTIONED WARRANTIES (U.S. CLS. 100, 101 AND 102).

FIRST USE 5-1-2006; IN COMMERCE 5-1-2006.

YAT SYE, LEE, EXAMINING ATTORNEY

SN 78-945,359. EMPIRICAL WEALTH MANAGEMENT, PORTLAND, OR. FILED 8-4-2006.

## Empirical Wealth Management

THE MARK CONSISTS OF STANDARD CHARACTERS WITHOUT CLAIM TO ANY PARTICULAR FONT, STYLE, SIZE, OR COLOR.

NO CLAIM IS MADE TO THE EXCLUSIVE RIGHT TO USE "WEALTH MANAGEMENT", APART FROM THE MARK AS SHOWN.

FOR FINANCIAL PORTFOLIO MANAGEMENT; FINANCIAL SERVICES, NAMELY, A TOTAL PORTFOLIO OFFERING FOR HIGH NET WORTH CLIENTS CONSISTING OF BOTH SEPARATE ACCOUNTS AND MUTUAL FUNDS FOR EQUITY AND FIXED INCOME INVESTMENTS (U.S. CLS. 100, 101 AND 102).

FIRST USE 6-30-2006; IN COMMERCE 6-30-2006.

JASON BLAIR, EXAMINING ATTORNEY

SN 78-948,799. TRAVERSE CITY STATE BANK, TRAVERSE CITY, MI. FILED 8-9-2006.

## TRAVERSE MORTGAGE CORPORATION

THE MARK CONSISTS OF STANDARD CHARACTERS WITHOUT CLAIM TO ANY PARTICULAR FONT, STYLE, SIZE, OR COLOR.

OWNER OF U.S. REG. NOS. 2,534,949 AND 2,652,910. NO CLAIM IS MADE TO THE EXCLUSIVE RIGHT TO USE "MORTGAGE CORPORATION", APART FROM THE MARK AS SHOWN.

FOR MORTGAGE BANKING; MORTGAGE LENDING (U.S. CLS. 100, 101 AND 102).

FIRST USE 0-0-1991; IN COMMERCE 0-0-1991.

TRAVIS WHEATLEY, EXAMINING ATTORNEY

**CLASS 36—(Continued).**

SN 78-949,199. FIRST MUTUAL BANK, INC., BELLEVUE, WA. FILED 8-10-2006.

## SCANDEPOSIT

THE MARK CONSISTS OF STANDARD CHARACTERS WITHOUT CLAIM TO ANY PARTICULAR FONT, STYLE, SIZE, OR COLOR.

FOR ON-LINE BANKING SERVICES (U.S. CLS. 100, 101 AND 102).  
DAVID STERKIN, EXAMINING ATTORNEY

SN 78-949,553. HARDISON, JOSEPH H., III, DARIEN, CT. FILED 8-10-2006.

## OptiBank

THE MARK CONSISTS OF STANDARD CHARACTERS WITHOUT CLAIM TO ANY PARTICULAR FONT, STYLE, SIZE, OR COLOR.

FOR CREDIT AND CASH CARD SERVICES; CREDIT CARD SERVICES; CREDIT CARD TRANSACTION PROCESSING SERVICES; CREDIT CARD VERIFICATION; ELECTRONIC CREDIT CARD TRANSACTIONS; ISSUING CREDIT CARDS; PROVIDING ELECTRONIC PROCESSING OF CREDIT CARD TRANSACTIONS AND ELECTRONIC PAYMENTS VIA A GLOBAL COMPUTER NETWORK; DEBIT ACCOUNT SERVICES FEATURING A COMPUTER READABLE CARD; DEBIT CARD SERVICES; PAYROLL TAX DEBITING SERVICES; CHECKING ACCOUNT SERVICES; SAVINGS ACCOUNT SERVICES; MAINTAINING MORTGAGE ESCROW ACCOUNTS; FINANCIAL SERVICES, NAMELY PROVIDING ON-LINE STORED VALUE ACCOUNTS IN AN ELECTRONIC ENVIRONMENT; ISSUING STORED VALUE CARDS; ELECTRONIC TRANSFERS OF MONEY; PROVIDING REBATES AT PARTICIPATING ESTABLISHMENTS OF OTHERS THROUGH USE OF A MEMBERSHIP CARD; PROVIDING FINANCIAL INFORMATION IN THE NATURE OF INTEREST RATE AND INVESTMENT ACCOUNT RANKINGS; BILL PAYMENT SERVICES; ELECTRONIC PAYMENT, NAMELY, ELECTRONIC PROCESSING AND TRANSMISSION OF BILL PAYMENT DATA; ESTATE PLANNING SERVICES; BROKERAGE OF SHARES OR STOCKS AND OTHER SECURITIES; PROVIDING INFORMATION IN INSURANCE MATTERS; INSURANCE BROKERAGE; FINANCIAL CLEARING HOUSES; FINANCIAL CONSULTATION; FINANCIAL EXCHANGE; FINANCIAL INFORMATION IN THE NATURE OF RATES OF EXCHANGE; FINANCIAL INFORMATION PROVIDED BY ELECTRONIC MEANS; FINANCIAL INFORMATION PROCESSING; FINANCIAL MANAGEMENT; FINAN-

**CLASS 36—(Continued).**

CIAL PLANNING; FINANCIAL PORTFOLIO MANAGEMENT; FINANCIAL RESEARCH; FINANCIAL SERVICES IN THE FIELD OF MONEY LENDING; FINANCIAL SERVICES, NAMELY, INVESTMENT FUND TRANSFER AND TRANSACTION SERVICES; FINANCIAL SERVICES, NAMELY, ISSUANCE AND MANAGEMENT OF CERTIFICATES BACKED BY LOAN PORTFOLIOS WHICH ARE SUBSEQUENTLY MANAGED TO INSURE THE INTEGRITY OF THE CERTIFICATES; FINANCIAL SERVICES, NAMELY, PROVIDING FOR THE EXCHANGE OF FOREIGN CURRENCY, COMMODITIES, FINANCIAL DERIVATIVES, INTEREST RATE PRODUCTS, AND EQUITIES VIA THE INTERNET AND INTRANET SYSTEMS; FINANCIAL SERVICES, NAMELY, MORTGAGE PLANNING; PROVIDING A WEB SITE WHERE USERS CAN POST RATINGS, REVIEWS AND RECOMMENDATIONS ON STOCKS, BONDS, MUTUAL FUNDS AND OTHER FINANCIAL INSTRUMENTS; PROVIDING ON-LINE FINANCIAL CALCULATORS; MONEY LENDING (U.S. CLS. 100, 101 AND 102).

ROBERT LAVACHE, EXAMINING ATTORNEY

SN 78-949,867. WASHINGTON MUTUAL, INC., SEATTLE, WA. FILED 8-10-2006.

## WAMU EXCHANGE

THE MARK CONSISTS OF STANDARD CHARACTERS WITHOUT CLAIM TO ANY PARTICULAR FONT, STYLE, SIZE, OR COLOR.

OWNER OF U.S. REG. NOS. 2,315,782, 2,498,860 AND OTHERS.

NO CLAIM IS MADE TO THE EXCLUSIVE RIGHT TO USE "EXCHANGE", APART FROM THE MARK AS SHOWN.

FOR FINANCIAL CONSULTATION AND MANAGEMENT SERVICES RELATING TO IRS § 1031 TAX DEFERRED PROPERTY EXCHANGE TRANSACTIONS, NAMELY, SERVICES AS A QUALIFIED INTERMEDIARY, ACCOMMODATEE, TRUSTEE OR FACILITATOR IN SUCH TRANSACTIONS; BANKING SERVICES; ON-LINE BANKING SERVICES; ASSET MANAGEMENT SERVICES; MORTGAGE BANKING, BROKERAGE AND LENDING SERVICES; REAL ESTATE AND SECURITY BROKERAGE SERVICES (U.S. CLS. 100, 101 AND 102).

GEORGIA CARTY, EXAMINING ATTORNEY

**CLASS 36—(Continued).**

SN 78-949,868. WASHINGTON MUTUAL, INC., SEATTLE, WA. FILED 8-10-2006.

WAMU

THE MARK CONSISTS OF STANDARD CHARACTERS WITHOUT CLAIM TO ANY PARTICULAR FONT, STYLE, SIZE, OR COLOR.

OWNER OF U.S. REG. NOS. 2,315,782, 2,498,860 AND OTHERS.

FOR FINANCIAL CONSULTATION AND MANAGEMENT SERVICES RELATING TO IRS § 1031 TAX DEFERRED PROPERTY EXCHANGE TRANSACTIONS, NAMELY, SERVICES AS A QUALIFIED INTERMEDIARY, ACCOMMODATEE, TRUSTEE OR FACILITATOR IN SUCH TRANSACTIONS; BANKING SERVICES; ONLINE BANKING SERVICES; ASSET MANAGEMENT SERVICES; MORTGAGE BANKING, BROKERAGE AND LENDING SERVICES; REAL ESTATE AND SECURITY BROKERAGE SERVICES (U.S. CLS. 100, 101 AND 102).

GEORGIA CARTY, EXAMINING ATTORNEY

SN 78-950,090. NASDAQ STOCK MARKET, INC., THE, NEW YORK, NY. FILED 8-11-2006.



OWNER OF U.S. REG. NOS. 922,973 AND 1,259,277. NO CLAIM IS MADE TO THE EXCLUSIVE RIGHT TO USE "MARKET ANALYTICS", APART FROM THE MARK AS SHOWN.

FOR INFORMATION SERVICES, NAMELY THE PROVISION OF SECURITIES MARKET DATA (U.S. CLS. 100, 101 AND 102).

MICHELE SWAIN, EXAMINING ATTORNEY

**CLASS 36—(Continued).**

SN 78-951,276. OPPENHEIMER & CO. INC., NEW YORK, NY. FILED 8-14-2006.



OWNER OF U.S. REG. NOS. 1,239,737, 2,145,809 AND OTHERS.

FOR ADVICE RELATING TO INVESTMENTS; AGENCIES FOR BROKERAGE OF SECURITIES TRADING IN OVERSEAS SECURITIES MARKETS AND OF TRANSACTIONS ON COMMISSION OF OVERSEAS MARKET SECURITIES FUTURES; AGENCIES OR BROKERAGE FOR TRADING OF SECURITIES, SECURITIES INDEX FUTURES, SECURITIES OPTIONS, AND OVERSEAS MARKET SECURITIES FUTURES; ASSUMING FINANCIAL RISK OF OTHERS BY ENTERING INTO OPTIONS AND SWAPS; BROKERAGE HOUSES IN THE FIELD OF STOCKS, COMMODITIES, AND FUTURES; BROKERAGE OF SHARES OR STOCKS AND OTHER SECURITIES; BUSINESS BROKERAGE; CASH MANAGEMENT; COMMODITY BROKERAGE; FINANCIAL ANALYSIS AND CONSULTATION; FINANCIAL DUE DILIGENCE; FINANCIAL MANAGEMENT; FINANCIAL PLANNING CONSULTATION; FINANCIAL PLANNING, NAMELY THE CREATION OF PERSONALIZED STRATEGIES TO ACHIEVE FINANCIAL INDEPENDENCE; FINANCIAL PORTFOLIO MANAGEMENT; FINANCIAL SERVICES, NAMELY ASSISTING OTHERS WITH THE COMPLETION OF FINANCIAL TRANSACTIONS FOR STOCKS, BONDS, SECURITIES AND EQUITIES; FINANCIAL SERVICES, NAMELY, A TOTAL PORTFOLIO OFFERING FOR HIGH NET WORTH CLIENTS CONSISTING OF BOTH SEPARATE ACCOUNTS AND MUTUAL FUNDS FOR EQUITY AND FIXED INCOME INVESTMENTS; INSURANCE BROKERAGE; INVESTMENT ADVISORY SERVICES; INVESTMENT BANKING SERVICES; INVESTMENT BROKERAGE; INVESTMENT CONSULTATION; INVESTMENT MANAGEMENT; INVESTMENT OF FUNDS FOR OTHERS; INVESTMENT SERVICES, NAMELY ASSET ACQUISITION, CONSULTATION, DEVELOPMENT AND MANAGEMENT SERVICES; MANAGEMENT OF PORTFOLIOS COMPRISING SECURITIES; PROVIDING STOCK/SECURITIES MARKET INFORMATION; TRUST MANAGEMENT ACCOUNTS; TRUST SERVICES, NAMELY, INVESTMENT AND TRUST COMPANY SERVICES (U.S. CLS. 100, 101 AND 102).

FIRST USE 9-9-2003; IN COMMERCE 9-9-2003.

DAWN HAN, EXAMINING ATTORNEY

**CLASS 36—(Continued).**

SN 78-951,556. ACCURATE AUTO INSURANCE, INC., BRIDGEVIEW, IL. FILED 8-14-2006.



NO CLAIM IS MADE TO THE EXCLUSIVE RIGHT TO USE "AUTO INSURANCE", APART FROM THE MARK AS SHOWN.

THE COLOR(S) RED, WHITE AND BLACK IS/ARE CLAIMED AS A FEATURE OF THE MARK.

THE COLOR RED APPEARS IN THE OBLONG DESIGN; THE COLOR WHITE APPEARS IN THE WORDING ACCURATE; AND THE COLOR BLACK APPEARS IN THE WORDING AUTO INSURANCE.

FOR ACCIDENT INSURANCE UNDERWRITING; APPRAISALS FOR INSURANCE CLAIMS OF PERSONAL PROPERTY; INSURANCE BROKERAGE; INSURANCE CARRIER SERVICES; INSURANCE CLAIMS PROCESSING; INSURANCE CONSULTATION; INSURANCE SERVICES, NAMELY, UNDERWRITING EXTENDED WARRANTY CONTRACTS IN THE FIELD OF AUTOMOBILES; INSURANCE UNDERWRITING SERVICES FOR ALL TYPES OF INSURANCE (U.S. CLS. 100, 101 AND 102).

FIRST USE 11-1-1992; IN COMMERCE 11-1-1992.  
WILLIAM VERHOSEK, EXAMINING ATTORNEY

SN 78-951,894. M.T.J.K., INC., WEST COVINA, CA. FILED 8-14-2006.

### MORE THAN A PROMISE, A GUARANTEE

THE MARK CONSISTS OF STANDARD CHARACTERS WITHOUT CLAIM TO ANY PARTICULAR FONT, STYLE, SIZE, OR COLOR.

FOR INSURANCE SERVICES, NAMELY, PROVIDING AUTOMOBILE, PROPERTY AND CASUALTY INSURANCE BROKERAGE SERVICES (U.S. CLS. 100, 101 AND 102).

FIRST USE 1-1-2000; IN COMMERCE 1-1-2000.  
JENNIFER KRISP, EXAMINING ATTORNEY

SN 78-952,192. CABINS FOR YOU, LLC, TAYLORSVILLE, GA. FILED 8-15-2006.

### Cabins For You

THE MARK CONSISTS OF STANDARD CHARACTERS WITHOUT CLAIM TO ANY PARTICULAR FONT, STYLE, SIZE, OR COLOR.

NO CLAIM IS MADE TO THE EXCLUSIVE RIGHT TO USE "CABINS", APART FROM THE MARK AS SHOWN.

FOR REAL ESTATE MANAGEMENT (U.S. CLS. 100, 101 AND 102).

KATHERINE CHANG, EXAMINING ATTORNEY

**CLASS 36—(Continued).**

SN 78-952,308. ATALAYA CAPITAL MANAGEMENT LP, NEW YORK, NY. FILED 8-15-2006.

### ATALAYA

THE MARK CONSISTS OF STANDARD CHARACTERS WITHOUT CLAIM TO ANY PARTICULAR FONT, STYLE, SIZE, OR COLOR.

THE ENGLISH TRANSLATION OF ATALAYA IS WATCH TOWER.

FOR FINANCIAL SERVICES, NAMELY, ASSET MANAGEMENT SERVICES, INVESTMENT MANAGEMENT SERVICES AND INVESTMENT ADVISORY SERVICES (U.S. CLS. 100, 101 AND 102).

FIRST USE 4-27-2006; IN COMMERCE 6-14-2006.  
TANYA AMOS, EXAMINING ATTORNEY

SN 78-952,311. ATALAYA CAPITAL MANAGEMENT LP, NEW YORK, NY. FILED 8-15-2006.

### ATALAYA CAPITAL MANAGEMENT LP

THE MARK CONSISTS OF STANDARD CHARACTERS WITHOUT CLAIM TO ANY PARTICULAR FONT, STYLE, SIZE, OR COLOR.

NO CLAIM IS MADE TO THE EXCLUSIVE RIGHT TO USE "CAPITAL MANAGEMENT LP", APART FROM THE MARK AS SHOWN.

THE ENGLISH TRANSLATION OF THE WORD ATALAYA IN THE MARK IS WATCH TOWER.

FOR FINANCIAL SERVICES, NAMELY, ASSET MANAGEMENT SERVICES, INVESTMENT MANAGEMENT SERVICES AND INVESTMENT ADVISORY SERVICES (U.S. CLS. 100, 101 AND 102).

FIRST USE 4-27-2006; IN COMMERCE 6-14-2006.  
TANYA AMOS, EXAMINING ATTORNEY

SN 78-953,109. EX-STUDENT'S ASSOCIATION OF THE UNIVERSITY OF TEXAS, AUSTIN, TX. FILED 8-16-2006.

### SANTA RITA SOCIETY

THE MARK CONSISTS OF STANDARD CHARACTERS WITHOUT CLAIM TO ANY PARTICULAR FONT, STYLE, SIZE, OR COLOR.

NO CLAIM IS MADE TO THE EXCLUSIVE RIGHT TO USE SOCIETY, APART FROM THE MARK AS SHOWN.

THE ENGLISH TRANSLATION OF SANTA RITA IS SAINT RITA.

FOR CHARITABLE FUND RAISING SERVICES, NAMELY, RAISING FUNDS THROUGH HOTEL ROOM OR SUITE LICENSES AND SOCIAL FUNCTIONS IN SUPPORT OF THE UNIVERSITY OF TEXAS (U.S. CLS. 100, 101 AND 102).

FIRST USE 4-3-2006; IN COMMERCE 4-3-2006.  
JENNIFER MCROBBIE, EXAMINING ATTORNEY

**CLASS 36—(Continued).**

SN 78-954,735. WILSON, RORY T., RANCHO CUCAMONGA, CA. FILED 8-17-2006.



NO CLAIM IS MADE TO THE EXCLUSIVE RIGHT TO USE "LENDING TEAM", APART FROM THE MARK AS SHOWN.

THE COLOR(S) BROWN, ORANGE, GOLD, BLACK, GREY AND WHITE IS/ARE CLAIMED AS A FEATURE OF THE MARK.

THE MARK CONSISTS OF THE WORDING THE IN THE COLOR BLACK AND TEAM IN THE COLOR BLACK WITH A WHITE OUTLINE; LENDING OUTLINED IN THE COLOR GOLD; A KEY IN THE COLOR BROWN, ORANGE, GOLD WITH A HOUSE INSIDE THE KEY, AND A RECTANGULAR SHAPED BROWN BACKGROUND UNDERNEATH THE KEY WITH HORIZONTAL BARS IN THE COLORS WHITE AND GREY.

FOR CONSUMER LENDING SERVICES; FINANCIAL LOAN CONSULTATION; FINANCIAL SERVICES IN THE FIELD OF MONEY LENDING; FINANCIAL SERVICES, NAMELY MONEY LENDING; FINANCING SERVICES; HOME EQUITY LOANS; LOAN FINANCING; MORTGAGE LENDING (U.S. CLS. 100, 101 AND 102).

FIRST USE 10-0-2005; IN COMMERCE 10-0-2005. TAMARA LEE, EXAMINING ATTORNEY

**CLASS 36—(Continued).**

SN 78-956,497. DENT GROUP LLC, BATON ROUGE, LA. FILED 8-21-2006.

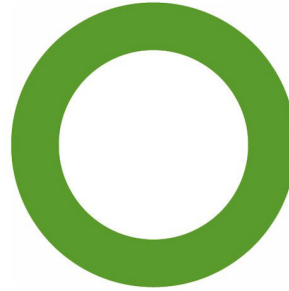

THE APPLICANT CLAIMS COLOR AS A FEATURE OF THE MARK, NAMELY, GREEN.

THE MARK CONSISTS OF A GREEN CIRCLE . FOR FINANCIAL PLANNING (U.S. CLS. 100, 101 AND 102).

FIRST USE 8-20-2006; IN COMMERCE 8-20-2006. GEORGE LORENZO, EXAMINING ATTORNEY

SN 78-956,065. WOODCOCK, CHRISTINE L., MAPLE VALLEY, WA. FILED 8-20-2006.



THE COLOR(S) DARK GREEN AND WHITE IS/ARE CLAIMED AS A FEATURE OF THE MARK.

THE COLOR DARK GREEN APPEARS IN THE CENTER OF THE OVAL. THE COLOR WHITE APPEARS IN THE WORDING, THE OUTSIDE RING OF THE OVAL AND THE DESIGN.

FOR REAL ESTATE BROKERAGE (U.S. CLS. 100, 101 AND 102).

FIRST USE 10-1-2005; IN COMMERCE 10-1-2005. ESTHER A. BORSUK, EXAMINING ATTORNEY

SN 78-957,400. AID FOR AIDS INTERNATIONAL, INC., NEW YORK, NY. FILED 8-22-2006.

**MY HERO AWARD**

THE MARK CONSISTS OF STANDARD CHARACTERS WITHOUT CLAIM TO ANY PARTICULAR FONT, STYLE, SIZE, OR COLOR.

NO CLAIM IS MADE TO THE EXCLUSIVE RIGHT TO USE "AWARD", APART FROM THE MARK AS SHOWN.

FOR CHARITABLE FUNDRAISING SERVICES AND ORGANIZING, ARRANGING AND CONDUCTING CHARITABLE FUNDRAISING EVENTS DIRECTED TOWARDS SUPPORTING ACCESS TO MEDICATIONS, HEALTH EDUCATION, AND HIV PREVENTION STRATEGIES AND ADVOCACY (U.S. CLS. 100, 101 AND 102).

FIRST USE 12-17-2001; IN COMMERCE 12-17-2001. DAVID TOOLEY, EXAMINING ATTORNEY

**CLASS 36—(Continued).**

SN 78-957,412. AID FOR AIDS INTERNATIONAL, INC.,  
NEW YORK, NY. FILED 8-22-2006.

**MY HERO GALA**

THE MARK CONSISTS OF STANDARD CHARACTERS  
WITHOUT CLAIM TO ANY PARTICULAR FONT, STYLE,  
SIZE, OR COLOR.

NO CLAIM IS MADE TO THE EXCLUSIVE RIGHT TO  
USE "GALA", APART FROM THE MARK AS SHOWN.

FOR CHARITABLE FUNDRAISING SERVICES AND  
ORGANIZING, ARRANGING AND CONDUCTING  
CHARITABLE FUNDRAISING EVENTS DIRECTED TO-  
WARDS SUPPORTING ACCESS TO MEDICATIONS,  
HEALTH EDUCATION, AND HIV PREVENTION STRA-  
TEGIES AND ADVOCACY (U.S. CLS. 100, 101 AND 102).

FIRST USE 12-17-2001; IN COMMERCE 12-17-2001.  
DAVID TOOLEY, EXAMINING ATTORNEY

**CLASS 36—(Continued).**

SN 78-959,784. BRIDGEPOINT INSURANCE GROUP, INC.,  
WAYNE, PA. FILED 8-24-2006.

**Service Without Expiration**

THE MARK CONSISTS OF STANDARD CHARACTERS  
WITHOUT CLAIM TO ANY PARTICULAR FONT, STYLE,  
SIZE, OR COLOR.

FOR BROKERAGE OF COMMERCIAL PROPERTY,  
CASUALTY, LIFE AND HEALTH INSURANCE; RISK  
MANAGEMENT FOR COMMERCIAL BUSINESSES (U.S.  
CLS. 100, 101 AND 102).

FIRST USE 8-1-2006; IN COMMERCE 8-1-2006.  
IRA J. GOODSAD, EXAMINING ATTORNEY

SN 78-959,316. DARGAN EXTENSIONS, LLC, BEAR, DE.  
FILED 8-24-2006.

**1-2-3 CASH**

THE MARK CONSISTS OF STANDARD CHARACTERS  
WITHOUT CLAIM TO ANY PARTICULAR FONT, STYLE,  
SIZE, OR COLOR.

NO CLAIM IS MADE TO THE EXCLUSIVE RIGHT TO  
USE "CASH", APART FROM THE MARK AS SHOWN.

FOR FINANCIAL SERVICES, NAMELY, MONEY  
LENDING (U.S. CLS. 100, 101 AND 102).

FIRST USE 8-30-2004; IN COMMERCE 8-30-2004.  
NAKIA HENRY, EXAMINING ATTORNEY

SN 78-959,952. ASG REAL ESTATE INC, LOS ANGELES, CA.  
FILED 8-24-2006.

**ASG Real Estate Inc.**

THE MARK CONSISTS OF STANDARD CHARACTERS  
WITHOUT CLAIM TO ANY PARTICULAR FONT, STYLE,  
SIZE, OR COLOR.

NO CLAIM IS MADE TO THE EXCLUSIVE RIGHT TO  
USE "REAL ESTATE INC.", APART FROM THE MARK AS  
SHOWN.

FOR AGENCIES OR BROKERAGE FOR LEASING OR  
RENTING OF LAND; AGENCIES OR BROKERAGE FOR  
RENTING LAND; AGENCIES OR BROKERAGE FOR  
RENTING OF BUILDINGS; APPRAISAL OF REAL  
ESTATE; ASSESSMENT AND MANAGEMENT OF REAL  
ESTATE; BUSINESS BROKERAGE; EVALUATION OF  
REAL PROPERTY; FINANCIAL INVESTMENT IN THE  
FIELD OF REAL ESTATE; FINANCIAL VALUATION OF  
PERSONAL PROPERTY AND REAL ESTATE; INVEST-  
MENT BROKERAGE; LAND ACQUISITION, NAMELY,  
REAL ESTATE BROKERAGE; LEASING OF REAL  
ESTATE; LEASING OF REAL PROPERTY; MORTGAGE  
BANKING SERVICES, NAMELY, ORIGINATION, AC-  
QUISITION, SERVICING, SECURITIZATION AND  
BROKERAGE OF MORTGAGE LOANS; MORTGAGE  
BROKERAGE; OPERATING MARKETPLACES FOR  
SELLERS OF GOODS AND/OR SERVICES; PROVIDING  
INFORMATION IN THE FIELD OF REAL ESTATE BY  
MEANS OF LINKING THE WEB SITE TO OTHER WEB  
SITES FEATURING REAL ESTATE INFORMATION;

SN 78-959,544. MONTE & CO, LLC, LONGWOOD, FL. FILED  
8-24-2006.

**PIN PRESSURE INDICATOR**

THE MARK CONSISTS OF STANDARD CHARACTERS  
WITHOUT CLAIM TO ANY PARTICULAR FONT, STYLE,  
SIZE, OR COLOR.

FOR FINANCIAL ANALYSIS, NAMELY, TECHNICAL  
INVESTMENT ANALYSIS (U.S. CLS. 100, 101 AND 102).  
TINA KUAN, EXAMINING ATTORNEY

**CLASS 36—(Continued).**

REAL ESTATE ACQUISITION SERVICES; REAL ESTATE AGENCIES; REAL ESTATE APPRAISAL; REAL ESTATE BROKERAGE; REAL ESTATE CONSULTANCY; REAL ESTATE CONSULTATION; REAL ESTATE EQUITY SHARING, NAMELY, MANAGING AND ARRANGING FOR CO-OWNERSHIP OF REAL ESTATE; REAL ESTATE ESCROW SERVICES; REAL ESTATE INVESTMENT; REAL ESTATE LISTING; REAL ESTATE MANAGEMENT; REAL ESTATE MANAGEMENT CONSULTATION; REAL ESTATE MULTIPLE LISTING SERVICES; REAL ESTATE PROCUREMENT FOR OTHERS; REAL ESTATE SERVICES, NAMELY, RENTAL OF VACATION HOMES, CONDOMINIUMS, CABINS, AND VILLAS USING PAY PER CLICK ADVERTISING ON A GLOBAL COMPUTER NETWORK; REAL ESTATE SYNDICATION; REAL ESTATE TIME-SHARING; REAL ESTATE TRUSTEE SERVICES; REAL ESTATE VALUATION SERVICES; REAL ESTATE VALUATIONS; VACATION REAL ESTATE TIME SHARE EXCHANGE SERVICES; VACATION REAL ESTATE TIME-SHARING (U.S. CLS. 100, 101 AND 102).

FIRST USE 1-1-2006; IN COMMERCE 1-1-2006.  
SANI KHOURI, EXAMINING ATTORNEY



SN 78-960,244. FEDERATED MUTUAL INSURANCE COMPANY, OWATONNA, MN. FILED 8-25-2006.



NO CLAIM IS MADE TO THE EXCLUSIVE RIGHT TO USE "CLICK", APART FROM THE MARK AS SHOWN.  
FOR INSURANCE SERVICES, NAMELY, PROVIDING ONLINE PAYMENT PROCESSING OF INSURANCE PREMIUMS (U.S. CLS. 100, 101 AND 102).  
JUDITH HELFMAN, EXAMINING ATTORNEY

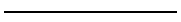

SN 78-960,336. RYDAL PARK CAPITAL MANAGEMENT, LLC, BALA CYNWYD, PA. FILED 8-25-2006.



**RYDAL PARK**

FOR FINANCIAL SERVICES, NAMELY FINANCIAL FUNDS MANAGEMENT (U.S. CLS. 100, 101 AND 102).  
LINDA E. BLOHM, EXAMINING ATTORNEY

**CLASS 36—(Continued).**

SN 78-960,618. SHOBE & ASSOCIATES, INC., BATON ROUGE, LA. FILED 8-25-2006.

**REST**

THE MARK CONSISTS OF STANDARD CHARACTERS WITHOUT CLAIM TO ANY PARTICULAR FONT, STYLE, SIZE, OR COLOR.

FOR FINANCIAL SERVICES, NAMELY, RETIREMENT PLANNING AND CONSULTATION (U.S. CLS. 100, 101 AND 102).  
KATINA MISTER, EXAMINING ATTORNEY

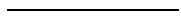

SN 78-961,109. KIDS WITH A CAUSE, INC., CULVER CITY, CA. FILED 8-25-2006.



THE MARK CONSISTS OF THE WORDS KIDS WITH A CAUSE WITHIN A STAR DESIGN.  
FOR CHARITABLE FUND RAISING (U.S. CLS. 100, 101 AND 102).  
FIRST USE 11-0-1999; IN COMMERCE 11-0-1999.  
ROBERT STRUCK, EXAMINING ATTORNEY



SN 78-961,742. UNIFI MUTUAL HOLDING COMPANY, LINCOLN, NE. FILED 8-28-2006.

**Ameritas Direct Dynamic  
No-Load Variable Annuity**

THE MARK CONSISTS OF STANDARD CHARACTERS WITHOUT CLAIM TO ANY PARTICULAR FONT, STYLE, SIZE, OR COLOR.

OWNER OF U.S. REG. NOS. 1,487,761, 3,074,529 AND OTHERS.

NO CLAIM IS MADE TO THE EXCLUSIVE RIGHT TO USE "NO-LOAD VARIABLE ANNUITY", APART FROM THE MARK AS SHOWN.

FOR INSURANCE AND FINANCIAL SERVICES, NAMELY, UNDERWRITING, ISSUANCE AND ADMINISTRATION OF VARIABLE ANNUITIES (U.S. CLS. 100, 101 AND 102).  
CURTIS FRENCH, EXAMINING ATTORNEY

**CLASS 36—(Continued).**

SN 78-961,925. BEAGLE, PATRICK B, FAIRFAX STATION, VA. FILED 8-28-2006.

## WealthCrest Financial Services

THE MARK CONSISTS OF STANDARD CHARACTERS WITHOUT CLAIM TO ANY PARTICULAR FONT, STYLE, SIZE, OR COLOR.

NO CLAIM IS MADE TO THE EXCLUSIVE RIGHT TO USE "FINANCIAL SERVICES", APART FROM THE MARK AS SHOWN.

FOR ADMINISTRATION OF EMPLOYEE BENEFIT PLANS; BROKERAGE IN THE FIELD OF INSURANCE; FINANCIAL EVALUATION FOR INSURANCE PURPOSES; FINANCIAL PLANNING CONSULTATION; FINANCIAL PLANNING, NAMELY THE CREATION OF PERSONALIZED STRATEGIES TO ACHIEVE FINANCIAL INDEPENDENCE; FINANCIAL RISK MANAGEMENT; FINANCIAL SERVICES, NAMELY ASSISTING OTHERS WITH THE COMPLETION OF FINANCIAL TRANSACTIONS FOR STOCKS, BONDS, SECURITIES AND EQUITIES; FINANCIAL SERVICES, NAMELY, A TOTAL PORTFOLIO OFFERING FOR HIGH NET WORTH CLIENTS CONSISTING OF BOTH SEPARATE ACCOUNTS AND MUTUAL FUNDS FOR EQUITY AND FIXED INCOME INVESTMENTS; FINANCIAL SERVICES, NAMELY, ISSUANCE AND MANAGEMENT OF CERTIFICATES BACKED BY LOAN PORTFOLIOS WHICH ARE SUBSEQUENTLY MANAGED TO INSURE THE INTEGRITY OF THE CERTIFICATES; INSURANCE AGENCY AND BROKERAGE; INSURANCE CONSULTATION; INVESTMENT MANAGEMENT (U.S. CLS. 100, 101 AND 102).

RAUL CORDOVA, EXAMINING ATTORNEY

SN 78-962,226. MASSMAN, DONNA, LOS ANGELES, CA. FILED 8-28-2006.

## GENEROSITY CARD

THE MARK CONSISTS OF STANDARD CHARACTERS WITHOUT CLAIM TO ANY PARTICULAR FONT, STYLE, SIZE, OR COLOR.

NO CLAIM IS MADE TO THE EXCLUSIVE RIGHT TO USE "CARD", APART FROM THE MARK AS SHOWN.

FOR CREDIT CARD SERVICES AND CHARITABLE FUNDRAISING SERVICES PERFORMED VIA USE OF A CREDIT CARD FROM WHICH A PERCENTAGE OF CHARGED AMOUNTS ARE DIRECTED TO CHARITABLE ORGANIZATIONS/CAUSES (U.S. CLS. 100, 101 AND 102).

KEVIN CORWIN, EXAMINING ATTORNEY

**CLASS 36—(Continued).**

SN 78-962,475. HAMPSHIRE FIRST BANK, MANCHESTER, NH. FILED 8-29-2006.

## Hampshire First

THE MARK CONSISTS OF STANDARD CHARACTERS WITHOUT CLAIM TO ANY PARTICULAR FONT, STYLE, SIZE, OR COLOR.

NO CLAIM IS MADE TO THE EXCLUSIVE RIGHT TO USE "FIRST", APART FROM THE MARK AS SHOWN.

FOR BANKING, BANKING CONSULTATION, INVESTMENT BANKING SERVICES, MORTGAGE BANKING, MORTGAGE BANKING SERVICES, NAMELY, ORIGINATION, ACQUISITION, SERVICING, SECURITIZATION AND BROKERAGE OF MORTGAGE LOANS, AND ONLINE BANKING (U.S. CLS. 100, 101 AND 102).

KATHLEEN LORENZO, EXAMINING ATTORNEY

SN 78-962,610. ENDIGO ENERGY LLC, DALLAS, TX. FILED 8-29-2006.

## DECLARE YOUR ENERGY INDEPENDENCE

THE MARK CONSISTS OF STANDARD CHARACTERS WITHOUT CLAIM TO ANY PARTICULAR FONT, STYLE, SIZE, OR COLOR.

FOR BROKERAGE OF ENERGY, NAMELY, GAS AND ELECTRICITY (U.S. CLS. 100, 101 AND 102).

BENJAMIN OKEKE, EXAMINING ATTORNEY

SN 78-962,689. INSPIRED CONNECTIONS, INC., PHOENIX, AZ. FILED 8-29-2006.

## HOPECONNECTS

THE MARK CONSISTS OF STANDARD CHARACTERS WITHOUT CLAIM TO ANY PARTICULAR FONT, STYLE, SIZE, OR COLOR.

FOR CHARITABLE FUND RAISING (U.S. CLS. 100, 101 AND 102).

STEVEN R. FINE, EXAMINING ATTORNEY



**CLASS 36—(Continued).**

SN 78-962,891. PIRATE CAPITAL LLC, NORWALK, CT. FILED 8-29-2006.

## PIRATE CAPITAL LLC

THE MARK CONSISTS OF STANDARD CHARACTERS WITHOUT CLAIM TO ANY PARTICULAR FONT, STYLE, SIZE, OR COLOR.

NO CLAIM IS MADE TO THE EXCLUSIVE RIGHT TO USE "CAPITAL LLC", APART FROM THE MARK AS SHOWN.

FOR HEDGE FUND INVESTMENT SERVICES (U.S. CLS. 100, 101 AND 102).

FIRST USE 5-17-2002; IN COMMERCE 7-1-2002.  
SCOTT BIBB, EXAMINING ATTORNEY

SN 78-963,090. RED AMIGA, INC., ALISO VIEJO, CA. FILED 8-29-2006.

## RED AMIGA

THE MARK CONSISTS OF STANDARD CHARACTERS WITHOUT CLAIM TO ANY PARTICULAR FONT, STYLE, SIZE, OR COLOR.

THE ENGLISH TRANSLATION OF THE WORD AMIGA IN THE MARK IS FRIEND.

FOR FINANCIAL SERVICES, NAMELY, BANKING SERVICES; MONEY TRANSFER SERVICES; ELECTRONIC FUNDS TRANSFER SERVICES; BILL PAYMENT SERVICES; MONEY ORDER SERVICES; CREDIT CARD SERVICES; AUTOMATIC TELLER MACHINE SERVICES; DEBIT CARD SERVICES; STORED VALUE CARD SERVICES, NAMELY, PROCESSING ELECTRONIC PAYMENTS THROUGH STORE-BRANDED PREPAID GIFT CARDS, ISSUING STORE-BRANDED PREPAID GIFT CARDS, AND REPLENISHING FUNDS ON STORE-BRANDED PREPAID GIFT CARDS; DIRECT DEPOSIT OF FUNDS INTO CUSTOMER BANK ACCOUNTS; PREPAID CARD SERVICES IN THE NATURE OF MAKING PAYMENT FOR ADDING AIRTIME TO PREPAID OR PAY-AS-YOU-GO WIRELESS SERVICES, RELOADING CASH ON PRE-PAID/SECURED DEBIT CARDS, AND PREPAID TELECOMMUNICATIONS CALLING CARD SERVICES, NAMELY, RECHARGING MINUTES TO PRE-PAID LONG DISTANCE CALLING CARDS; AND GIFT CHECK SERVICES IN THE NATURE OF ISSUING PERSONALIZED GIFT CHECKS AKIN TO MONEY ORDERS (U.S. CLS. 100, 101 AND 102).  
ROBIN MITTLER, EXAMINING ATTORNEY

**CLASS 36—(Continued).**

SN 78-963,444. REWARD ONE CREDIT UNION, BROOK PARK, OH. FILED 8-30-2006.

## Reward One Credit Union

THE MARK CONSISTS OF STANDARD CHARACTERS WITHOUT CLAIM TO ANY PARTICULAR FONT, STYLE, SIZE, OR COLOR.

NO CLAIM IS MADE TO THE EXCLUSIVE RIGHT TO USE "CREDIT UNION", APART FROM THE MARK AS SHOWN.

FOR CREDIT UNION SERVICES (U.S. CLS. 100, 101 AND 102).

BRIDGETT SMITH, EXAMINING ATTORNEY

SN 78-963,445. DIXON HUGHES WEALTH ADVISORS, LLC, GREENSBORO, NC. FILED 8-30-2006.

## Proactive Retirement

THE MARK CONSISTS OF STANDARD CHARACTERS WITHOUT CLAIM TO ANY PARTICULAR FONT, STYLE, SIZE, OR COLOR.

NO CLAIM IS MADE TO THE EXCLUSIVE RIGHT TO USE "RETIREMENT", APART FROM THE MARK AS SHOWN.

FOR FINANCIAL ANALYSIS AND CONSULTATION; FINANCIAL INVESTMENT IN THE FIELD OF SECURITIES; FINANCIAL PLANNING (U.S. CLS. 100, 101 AND 102).

FIRST USE 8-21-2006; IN COMMERCE 8-21-2006.  
ESTHER A. BORSUK, EXAMINING ATTORNEY

SN 78-963,475. SIMPLIFIED BUSINESS SOLUTIONS, INC., PHOENIX, AZ. FILED 8-30-2006.

## Employing Solutions

THE MARK CONSISTS OF STANDARD CHARACTERS WITHOUT CLAIM TO ANY PARTICULAR FONT, STYLE, SIZE, OR COLOR.

FOR PAYROLL TAX DEBITING SERVICES (U.S. CLS. 100, 101 AND 102).

BRIDGETT SMITH, EXAMINING ATTORNEY

**CLASS 36—(Continued).**

SN 78-963,724. NEGAUNEE VENTURES LLC, ROCKFORD, MI. FILED 8-30-2006.

## The Truckers Choice

THE MARK CONSISTS OF STANDARD CHARACTERS WITHOUT CLAIM TO ANY PARTICULAR FONT, STYLE, SIZE, OR COLOR.

NO CLAIM IS MADE TO THE EXCLUSIVE RIGHT TO USE "TRUCKERS", APART FROM THE MARK AS SHOWN. THE NAME(S), PORTRAIT(S), AND/OR SIGNATURE(S) SHOWN IN THE MARK DOES NOT IDENTIFY A PARTICULAR LIVING INDIVIDUAL.

FOR INSURANCE AGENCY SERVICES TO TRUCKERS FOR PHYSICAL DAMAGE INSURANCE, LIABILITY INSURANCE AND CARGO INSURANCE (U.S. CLS. 100, 101 AND 102).

LINDA POWELL, EXAMINING ATTORNEY

SN 78-963,883. ARCADIA MANAGEMENT GROUP, INC., SCOTTSDALE, AZ. FILED 8-30-2006.

## Arcadia Management Group

THE MARK CONSISTS OF STANDARD CHARACTERS WITHOUT CLAIM TO ANY PARTICULAR FONT, STYLE, SIZE, OR COLOR.

NO CLAIM IS MADE TO THE EXCLUSIVE RIGHT TO USE "MANAGEMENT GROUP", APART FROM THE MARK AS SHOWN.

FOR ASSESSMENT AND MANAGEMENT OF REAL ESTATE; LEASING OF REAL ESTATE; LEASING OF REAL PROPERTY; REAL ESTATE ACQUISITION SERVICES; REAL ESTATE AGENCIES; REAL ESTATE APPRAISAL; REAL ESTATE BROKERAGE; REAL ESTATE LISTING; REAL ESTATE MANAGEMENT; REAL ESTATE MANAGEMENT CONSULTATION (U.S. CLS. 100, 101 AND 102).

FIRST USE 6-1-2004; IN COMMERCE 6-1-2004.  
ROSELLE HERRERA, EXAMINING ATTORNEY

SN 78-963,909. 21ST CENTURY JET CORPORATION, RENO, NV. FILED 8-30-2006.

## Corporate Profits and Security Made Possible By Tri-Jets

THE MARK CONSISTS OF STANDARD CHARACTERS WITHOUT CLAIM TO ANY PARTICULAR FONT, STYLE, SIZE, OR COLOR.

OWNER OF U.S. REG. NO. 2,869,741.  
FOR AIRCRAFT BROKERAGE (U.S. CLS. 100, 101 AND 102).

JAMES LOVELACE, EXAMINING ATTORNEY

**CLASS 36—(Continued).**

SN 78-963,922. VALLIANCE BANK, OKLAHOMA CITY, OK. FILED 8-30-2006.

## EVERY BUSINESS NEEDS A CHAMPION

THE MARK CONSISTS OF STANDARD CHARACTERS WITHOUT CLAIM TO ANY PARTICULAR FONT, STYLE, SIZE, OR COLOR.

FOR BANKING SERVICES (U.S. CLS. 100, 101 AND 102).

FIRST USE 5-24-2006; IN COMMERCE 5-24-2006.  
TRICIA SONNEBORN, EXAMINING ATTORNEY

SN 78-964,221. AMERICAN NEVADA HOLDINGS, LLC, HENDERSON, NV. FILED 8-30-2006.



FOR REAL ESTATE MANAGEMENT; REAL ESTATE LISTING AND BROKERAGE SERVICES; LEASING OF SHOPPING SPACE AND OFFICE SPACE; PROVIDING INFORMATION ON AND THROUGH A LOCAL AND GLOBAL COMPUTER NETWORK IN THE FIELDS OF INVESTMENT, BANKING, FINANCIAL MANAGEMENT, REAL ESTATE, REAL ESTATE SERVICES, REAL ESTATE PROFESSIONALS, REAL ESTATE BROKERAGE SERVICES, INTEREST RATE INFORMATION, AND FINANCIAL INFORMATION; FINANCIAL VALUATION OF PERSONAL PROPERTY AND REAL ESTATE; FINANCIAL ANALYSIS, CONSULTATION, PLANNING AND MANAGEMENT (U.S. CLS. 100, 101 AND 102).

MICHAEL ENGEL, EXAMINING ATTORNEY

SN 78-964,284. AMERICAN NEVADA HOLDINGS, LLC, HENDERSON, NV. FILED 8-30-2006.



AT THE DISTRICT

FOR REAL ESTATE MANAGEMENT; REAL ESTATE LISTING AND BROKERAGE SERVICES; LEASING OF SHOPPING SPACE AND OFFICE SPACE; PROVIDING INFORMATION ON AND THROUGH A LOCAL AND GLOBAL COMPUTER NETWORK IN THE FIELDS OF INVESTMENT, BANKING, FINANCIAL MANAGEMENT, REAL ESTATE, REAL ESTATE SERVICES, REAL ESTATE PROFESSIONALS, REAL ESTATE BROKERAGE SERVICES, INTEREST RATE INFORMATION, AND FINANCIAL INFORMATION; FINANCIAL VALUATION OF PERSONAL PROPERTY AND REAL ESTATE; FINANCIAL ANALYSIS, CONSULTATION, PLANNING AND MANAGEMENT (U.S. CLS. 100, 101 AND 102).

MICHAEL ENGEL, EXAMINING ATTORNEY

**CLASS 36—(Continued).**

SN 78-964,418. SAMSUNG CORPORATION, CHUNG-KU, SEOUL, REPUBLIC OF KOREA, FILED 8-30-2006.



OWNER OF U.S. REG. NOS. 1,920,552, 2,660,039 AND OTHERS.

THE ENGLISH TRANSLATION OF THE WORD "SAMSUNG" IN THE MARK IS "THREE STARS".

FOR ACCIDENT INSURANCE UNDERWRITING; ACTUARIAL SERVICES; ADMINISTRATION OF PRE-PAID HEALTH CARE PLANS; APPRAISALS FOR INSURANCE CLAIMS OF REAL ESTATE; AUTOMATED SECURITIES BROKERAGE; BONDING SERVICES; BROKERAGE HOUSES IN THE FIELD OF STOCKS, COMMODITIES, AND FUTURES; CAPITAL INVESTMENT CONSULTATION; CHECK PROCESSING; COMMODITY INVESTMENT ADVICE; FACTORING AGENCIES; FINANCIAL FORECASTING; FINANCIAL GUARANTEE AND SURETY; FINANCIAL RESEARCH; FINANCIAL SERVICES, NAMELY MONEY LENDING; FIRE INSURANCE UNDERWRITING; INSURANCE ACTUARIAL SERVICES; INVESTMENT CONSULTATION; LAND ACQUISITION, NAMELY, REAL ESTATE BROKERAGE; LEASING OF REAL PROPERTY; MORTGAGE BANKING; MUTUAL FUND BROKERAGE; ORGANIZING PRE-PAID HEALTH CARE PLANS; REAL ESTATE APPRAISAL; TRUST SERVICES, NAMELY, INVESTMENT AND TRUST COMPANY SERVICES; TRUSTEESHIP REPRESENTATIVES; UNDERWRITING INSURANCE FOR PRE-PAID HEALTH CARE; VENTURE CAPITAL SERVICES, NAMELY, PROVIDING FINANCING TO EMERGING AND START-UP COMPANIES (U.S. CLS. 100, 101 AND 102).

AISHA SALEM, EXAMINING ATTORNEY

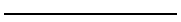

SN 78-964,436. CARSON GAMING, L.L.C., LAS VEGAS, NV. FILED 8-30-2006.

**CASINO FANDANGO**

THE MARK CONSISTS OF STANDARD CHARACTERS WITHOUT CLAIM TO ANY PARTICULAR FONT, STYLE, SIZE, OR COLOR.

OWNER OF U.S. REG. NOS. 2,968,485 AND 2,973,537. FOR REAL ESTATE INVESTMENT; REAL ESTATE MANAGEMENT; REAL ESTATE LISTING, MANAGEMENT AND BROKERAGE SERVICES; LEASING OF SHOPPING MALL SPACE; APARTMENT HOUSE AND CONDOMINIUM MANAGEMENT; AND LEASING OF REAL ESTATE (U.S. CLS. 100, 101 AND 102).

MORGAN WYNNE, EXAMINING ATTORNEY

**CLASS 36—(Continued).**

SN 78-964,452. AMERICAN NEVADA HOLDINGS, LLC, HENDERSON, NV. FILED 8-30-2006.

**AVENUE33 AT THE DISTRICT**

THE MARK CONSISTS OF STANDARD CHARACTERS WITHOUT CLAIM TO ANY PARTICULAR FONT, STYLE, SIZE, OR COLOR.

FOR REAL ESTATE MANAGEMENT; REAL ESTATE LISTING AND BROKERAGE SERVICES; LEASING OF SHOPPING SPACE AND OFFICE SPACE; PROVIDING INFORMATION ON AND THROUGH A LOCAL AND GLOBAL COMPUTER NETWORK IN THE FIELDS OF INVESTMENT, BANKING, FINANCIAL MANAGEMENT, REAL ESTATE, REAL ESTATE SERVICES, REAL ESTATE PROFESSIONALS, REAL ESTATE BROKERAGE SERVICES, INTEREST RATE INFORMATION, AND FINANCIAL INFORMATION; FINANCIAL VALUATION OF PERSONAL PROPERTY AND REAL ESTATE; FINANCIAL ANALYSIS, CONSULTATION, PLANNING AND MANAGEMENT (U.S. CLS. 100, 101 AND 102).

KAREN BRACEY, EXAMINING ATTORNEY

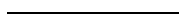

SN 78-964,525. NORTHEAST COMMUNITY BANK, WHITE PLAINS, NY. FILED 8-30-2006.

**NORTHEAST COMMUNITY BANK**

THE MARK CONSISTS OF STANDARD CHARACTERS WITHOUT CLAIM TO ANY PARTICULAR FONT, STYLE, SIZE, OR COLOR.

NO CLAIM IS MADE TO THE EXCLUSIVE RIGHT TO USE COMMUNITY BANK, APART FROM THE MARK AS SHOWN.

FOR BANKING (U.S. CLS. 100, 101 AND 102). FIRST USE 2-15-2006; IN COMMERCE 2-15-2006. STEVEN R. FINE, EXAMINING ATTORNEY

**CLASS 36—(Continued).**

SN 78-964,545. NORTHEAST COMMUNITY BANK, WHITE PLAINS, NY. FILED 8-30-2006.



THE COLOR(S) BLUE AND GOLD IS/ARE CLAIMED AS A FEATURE OF THE MARK.

THE COLOR BLUE APPEARS IN NECB AND IN THE DESIGN. THE COLOR GOLD ALSO APPEARS IN THE DESIGN.

FOR BANKING (U.S. CLS. 100, 101 AND 102).  
FIRST USE 2-15-2006; IN COMMERCE 2-15-2006.  
STEVEN R. FINE, EXAMINING ATTORNEY

SN 78-964,551. NORTHEAST COMMUNITY BANK, WHITE PLAINS, NY. FILED 8-30-2006.



NO CLAIM IS MADE TO THE EXCLUSIVE RIGHT TO USE COMMUNITY BANK, APART FROM THE MARK AS SHOWN.

THE COLOR(S) BLUE AND GOLD IS/ARE CLAIMED AS A FEATURE OF THE MARK.

THE COLOR BLUE APPEARS IN NORTHEAST AND NECB, AND IN THE DESIGN. THE COLOR GOLD APPEARS IN COMMUNITY BANK AND IN THE DESIGN.

FOR BANKING (U.S. CLS. 100, 101 AND 102).  
FIRST USE 2-15-2006; IN COMMERCE 2-15-2006.  
STEVEN R. FINE, EXAMINING ATTORNEY

**CLASS 36—(Continued).**

SN 78-964,687. KEYCORP, CLEVELAND, OH. FILED 8-31-2006.

KEYBANK HSA FDIC INSURED  
RESERVE ACCOUNT

THE MARK CONSISTS OF STANDARD CHARACTERS WITHOUT CLAIM TO ANY PARTICULAR FONT, STYLE, SIZE, OR COLOR.

OWNER OF U.S. REG. NOS. 1,722,378, 2,175,115 AND OTHERS.

NO CLAIM IS MADE TO THE EXCLUSIVE RIGHT TO USE "HSA FDIC INSURED RESERVE ACCOUNT", APART FROM THE MARK AS SHOWN.

FOR BANKING SERVICES, NAMELY, PROVIDING AN FDIC-INSURED SWEEP-TYPE CHECKING ACCOUNT IN CONJUNCTION WITH A HEALTH SAVINGS ACCOUNT (U.S. CLS. 100, 101 AND 102).

TIMOTHY FINNEGAN, EXAMINING ATTORNEY

SN 78-964,916. SATER, BENJAMIN MICHAEL, PLANO, TX. FILED 8-31-2006.

# KidSwing

THE MARK CONSISTS OF STANDARD CHARACTERS WITHOUT CLAIM TO ANY PARTICULAR FONT, STYLE, SIZE, OR COLOR.

FOR CHARITABLE FUND RAISING (U.S. CLS. 100, 101 AND 102).

FIRST USE 6-17-2003; IN COMMERCE 6-17-2003.

JAY FLOWERS, EXAMINING ATTORNEY

SN 78-965,002. VISION FINANCIAL MARKETS LLC, NEW YORK, NY. FILED 8-31-2006.

BETTER OPTIONS.  
BRIGHTER FUTURES.

THE MARK CONSISTS OF STANDARD CHARACTERS WITHOUT CLAIM TO ANY PARTICULAR FONT, STYLE, SIZE, OR COLOR.

FOR BROKERAGE HOUSES IN THE FIELD OF STOCKS, COMMODITIES, AND FUTURES; COMMODITY INVESTMENT ADVICE; FINANCIAL CLEARING HOUSES; FINANCIAL SERVICES, NAMELY, INVESTMENT FUND TRANSFER AND TRANSACTION SERVICES; INVESTMENT ADVISORY SERVICES; INVESTMENT BROKERAGE; SECURITY BROKERAGE (U.S. CLS. 100, 101 AND 102).

FIRST USE 8-31-2006; IN COMMERCE 8-31-2006.

FRANK LATTUCA, EXAMINING ATTORNEY

**CLASS 36—(Continued).**

SN 78-965,152. KISSTRUST, INC., WARRENTON, VA. FILED 8-31-2006.

**BORN TO RETIRE**

THE MARK CONSISTS OF STANDARD CHARACTERS WITHOUT CLAIM TO ANY PARTICULAR FONT, STYLE, SIZE, OR COLOR.

FOR TRUST MANAGEMENT ACCOUNTS; TRUST SERVICES, NAMELY INVESTMENT AND TRUST COMPANY SERVICES (U.S. CLS. 100, 101 AND 102).  
CHRISTINA SOBRAL, EXAMINING ATTORNEY

**CLASS 36—(Continued).**

SN 78-965,590. LEVEL GLOBAL INVESTORS, L.P., GREENWICH, CT. FILED 8-31-2006.

**LEVEL RADAR**

THE MARK CONSISTS OF STANDARD CHARACTERS WITHOUT CLAIM TO ANY PARTICULAR FONT, STYLE, SIZE, OR COLOR.

FOR HEDGE FUND INVESTMENT AND MANAGEMENT SERVICES AND INVESTMENT ADVISORY SERVICES (U.S. CLS. 100, 101 AND 102).  
JEAN IM, EXAMINING ATTORNEY

SN 78-965,379. REM CAPITAL GROUP, INC., COSTA MESA, CA. FILED 8-31-2006.

**REM CAPITAL FUNDING**

THE MARK CONSISTS OF STANDARD CHARACTERS WITHOUT CLAIM TO ANY PARTICULAR FONT, STYLE, SIZE, OR COLOR.

NO CLAIM IS MADE TO THE EXCLUSIVE RIGHT TO USE "CAPITAL FUNDING", APART FROM THE MARK AS SHOWN.

FOR MORTGAGE BANKING SERVICES, NAMELY, ORIGINATION, ACQUISITION, SERVICING, SECURITIZATION AND BROKERAGE OF MORTGAGE LOANS (U.S. CLS. 100, 101 AND 102).  
KEVIN DINALLO, EXAMINING ATTORNEY

SN 78-965,683. FORETHOUGHT FINANCIAL SERVICES, INC., BATESVILLE, IN. FILED 9-1-2006.

**FORETHOUGHT DESTINATION  
INDEXED ANNUITIES**

THE MARK CONSISTS OF STANDARD CHARACTERS WITHOUT CLAIM TO ANY PARTICULAR FONT, STYLE, SIZE, OR COLOR.

NO CLAIM IS MADE TO THE EXCLUSIVE RIGHT TO USE "INDEXED ANNUITIES", APART FROM THE MARK AS SHOWN.

FOR INVESTMENT SERVICES, NAMELY, UNDERWRITING, BROKERAGE, MANAGEMENT AND ADMINISTRATION OF ANNUITY PLANS; ADVISORY SERVICES IN THE FIELD OF ANNUITIES (U.S. CLS. 100, 101 AND 102).  
ROSELLE HERRERA, EXAMINING ATTORNEY

SN 78-965,388. THE GUARDIAN LIFE INSURANCE COMPANY OF AMERICA, NEW YORK, NY. FILED 8-31-2006.

**THE GUARDIAN RETIREMENT  
BEACON**

THE MARK CONSISTS OF STANDARD CHARACTERS WITHOUT CLAIM TO ANY PARTICULAR FONT, STYLE, SIZE, OR COLOR.

OWNER OF U.S. REG. NOS. 1,662,742, 2,268,145 AND OTHERS.

NO CLAIM IS MADE TO THE EXCLUSIVE RIGHT TO USE "RETIREMENT", APART FROM THE MARK AS SHOWN.

FOR FINANCIAL SERVICES, NAMELY, FIXED UNALLOCATED GROUP ANNUITIES (U.S. CLS. 100, 101 AND 102).  
ATTIYA MALIK, EXAMINING ATTORNEY

SN 78-966,215. CREDIT UNION CENTRAL FALLS, SMITHFIELD, RI. FILED 9-1-2006.

**NAVIGANT**

THE MARK CONSISTS OF STANDARD CHARACTERS WITHOUT CLAIM TO ANY PARTICULAR FONT, STYLE, SIZE, OR COLOR.

FOR CREDIT UNION SERVICES (U.S. CLS. 100, 101 AND 102).  
ATTIYA MALIK, EXAMINING ATTORNEY

**CLASS 36—(Continued).**

SN 78-966,224. CREDIT UNION CENTRAL FALLS, SMITH-FIELD, RI. FILED 9-1-2006.

**NAVIGANT CREDIT UNION**

THE MARK CONSISTS OF STANDARD CHARACTERS WITHOUT CLAIM TO ANY PARTICULAR FONT, STYLE, SIZE, OR COLOR.

NO CLAIM IS MADE TO THE EXCLUSIVE RIGHT TO USE "CREDIT UNION", APART FROM THE MARK AS SHOWN.

FOR CREDIT UNION SERVICES (U.S. CLS. 100, 101 AND 102).

ATTIYA MALIK, EXAMINING ATTORNEY

**CLASS 36—(Continued).**

SN 78-967,120. ONEBIGGAME, INC., SAN RAFAEL, CA. FILED 9-5-2006.

**ONEBIGGAME**

THE MARK CONSISTS OF STANDARD CHARACTERS WITHOUT CLAIM TO ANY PARTICULAR FONT, STYLE, SIZE, OR COLOR.

FOR CHARITABLE FUND RAISING SERVICES, NAMELY, DISTRIBUTING PROFITS FROM VIDEO GAME SALES TO NOT-FOR-PROFIT ORGANIZATIONS (U.S. CLS. 100, 101 AND 102).

NICHOLAS ALTREE, EXAMINING ATTORNEY

SN 78-966,386. EVAUL, DAVID H., PLANO, TX. FILED 9-1-2006.

**VALAD PLUS**

THE MARK CONSISTS OF STANDARD CHARACTERS WITHOUT CLAIM TO ANY PARTICULAR FONT, STYLE, SIZE, OR COLOR.

FOR ADVICE RELATING TO INVESTMENTS; FUNDS INVESTMENT; INVESTMENT CONSULTATION; INVESTMENT MANAGEMENT; INVESTMENT OF FUNDS FOR OTHERS (U.S. CLS. 100, 101 AND 102).

FIRST USE 8-23-2006; IN COMMERCE 8-23-2006.

KATHY DE JONGE, EXAMINING ATTORNEY

SN 78-967,228. FOUNDATION OF UMDNJ, NEW BRUNSWICK, NJ. FILED 9-5-2006.

**Endowing Health For Our Future**

THE MARK CONSISTS OF STANDARD CHARACTERS WITHOUT CLAIM TO ANY PARTICULAR FONT, STYLE, SIZE, OR COLOR.

FOR CHARITABLE FUND RAISING (U.S. CLS. 100, 101 AND 102).

JOHN DALIER, EXAMINING ATTORNEY

SN 78-966,951. DOW CAPITAL FUNDING, INC., JACKSONVILLE, FL. FILED 9-5-2006.



THE MARK CONSISTS OF A SAILING SHIP WITHIN A SEMICIRCLE FORMED OF HORIZONTAL BANDS.

FOR MORTGAGE LENDING (U.S. CLS. 100, 101 AND 102).

MATTHEW EINSTEIN, EXAMINING ATTORNEY

SN 78-967,272. HIRSCH, GUY, TEL-AVIV, ISRAEL, FILED 9-5-2006.

**INCREDITRADE**

THE MARK CONSISTS OF STANDARD CHARACTERS WITHOUT CLAIM TO ANY PARTICULAR FONT, STYLE, SIZE, OR COLOR.

FOR PROVIDING FINANCIAL INFORMATION IN THE FIELD OF INVESTMENTS, NAMELY ANALYZING, MONITORING AND COMPILING DATA, VIA A GLOBAL COMPUTER NETWORK (U.S. CLS. 100, 101 AND 102).

MARGERY A. TIERNEY, EXAMINING ATTORNEY

**CLASS 36—(Continued).**

SN 78-967,337. MIDDLESEX MUTUAL ASSURANCE COMPANY, MIDDLETOWN, CT. FILED 9-5-2006.

**WE MAKE THINGS RIGHT**

THE MARK CONSISTS OF STANDARD CHARACTERS WITHOUT CLAIM TO ANY PARTICULAR FONT, STYLE, SIZE, OR COLOR.  
FOR UNDERWRITING PROPERTY AND CASUALTY INSURANCE (U.S. CLS. 100, 101 AND 102).  
WOODROW HARTZOG, EXAMINING ATTORNEY

SN 78-967,454. WINKELMAN, ELISABETH, AUSTIN, TX. FILED 9-5-2006.

**CHALLAH FOR HUNGER**

THE MARK CONSISTS OF STANDARD CHARACTERS WITHOUT CLAIM TO ANY PARTICULAR FONT, STYLE, SIZE, OR COLOR.  
FOR CHARITABLE FUNDRAISING SERVICES (U.S. CLS. 100, 101 AND 102).  
FIRST USE 11-0-2004; IN COMMERCE 3-0-2006.  
DANNEAN HETZEL, EXAMINING ATTORNEY

SN 78-967,465. GARTMORE INVESTMENT MANAGEMENT PLC, LONDON, UNITED KINGDOM, FILED 9-5-2006.

**CRUCIS**

THE MARK CONSISTS OF STANDARD CHARACTERS WITHOUT CLAIM TO ANY PARTICULAR FONT, STYLE, SIZE, OR COLOR.  
OWNER OF UNITED KINGDOM REG. NO. 2369680, DATED 7-31-2004, EXPIRES 7-31-2014.  
THE FOREIGN WORDING IN THE MARK TRANSLATES INTO ENGLISH AS CROSS.  
FOR HEDGE FUND INVESTMENT SERVICES (U.S. CLS. 100, 101 AND 102).  
SONYA STEPHENS, EXAMINING ATTORNEY

**CLASS 36—(Continued).**

SN 78-967,548. L.A. NEW WORLD CENTER, LLC, PASADENA, CA. FILED 9-5-2006.

**NEW WORLD**

THE MARK CONSISTS OF STANDARD CHARACTERS WITHOUT CLAIM TO ANY PARTICULAR FONT, STYLE, SIZE, OR COLOR.  
FOR LEASING OF SHOPPING MALL SPACE; SHOPPING CENTER SERVICES, NAMELY, RENTAL OF SHOPPING CENTER SPACE (U.S. CLS. 100, 101 AND 102).  
GRETTA YAO, EXAMINING ATTORNEY

SN 78-967,564. GAR WOOD SECURITIES, LLC, CHICAGO, IL. FILED 9-5-2006.

**GAR WOOD SECURITIES LLC**

THE MARK CONSISTS OF STANDARD CHARACTERS WITHOUT CLAIM TO ANY PARTICULAR FONT, STYLE, SIZE, OR COLOR.  
NO CLAIM IS MADE TO THE EXCLUSIVE RIGHT TO USE "SECURITIES LLC", APART FROM THE MARK AS SHOWN.  
FOR HEDGE FUND INVESTMENT SERVICES; SECURITY BROKERAGE (U.S. CLS. 100, 101 AND 102).  
FIRST USE 1-1-2004; IN COMMERCE 2-20-2004.  
JEFF DEFORD, EXAMINING ATTORNEY

SN 78-967,616. MARKET MY SITE, INC., BOCA RATON, FL. FILED 9-5-2006.

**Your One-Stop Credit Shop**

THE MARK CONSISTS OF STANDARD CHARACTERS WITHOUT CLAIM TO ANY PARTICULAR FONT, STYLE, SIZE, OR COLOR.  
FOR CONSUMER CREDIT CONSULTATION (U.S. CLS. 100, 101 AND 102).  
FIRST USE 9-1-2006; IN COMMERCE 9-1-2006.  
MARK T. MULLEN, EXAMINING ATTORNEY

**CLASS 36—(Continued).**

SN 78-967,698. MY RENT MY CREDIT, INC., NORTH HOLLYWOOD, CA. FILED 9-6-2006.

# creditU

THE MARK CONSISTS OF STANDARD CHARACTERS WITHOUT CLAIM TO ANY PARTICULAR FONT, STYLE, SIZE, OR COLOR.

FOR CREDIT INFORMATION SERVICES FOR COLLEGE STUDENTS (U.S. CLS. 100, 101 AND 102).  
KATHY DE JONGE, EXAMINING ATTORNEY

**CLASS 36—(Continued).**

SN 78-967,898. MIDDLESEX MUTUAL ASSURANCE COMPANY, MIDDLETOWN, CT. FILED 9-6-2006.

## WE MAKE IT RIGHT

THE MARK CONSISTS OF STANDARD CHARACTERS WITHOUT CLAIM TO ANY PARTICULAR FONT, STYLE, SIZE, OR COLOR.

FOR UNDERWRITING PROPERTY AND CASUALTY INSURANCE (U.S. CLS. 100, 101 AND 102).  
WOODROW HARTZOG, EXAMINING ATTORNEY

SN 78-967,742. MERCKX, RENEE, CANTON, MI. FILED 9-6-2006.

## Living Longer and Loving It!

THE MARK CONSISTS OF STANDARD CHARACTERS WITHOUT CLAIM TO ANY PARTICULAR FONT, STYLE, SIZE, OR COLOR.

FOR INSURANCE CONSULTATION (U.S. CLS. 100, 101 AND 102).  
ANNE E. GUSTASON, EXAMINING ATTORNEY

SN 78-967,933. DRAGONFI, INC., BONITA SPRINGS, FL. FILED 9-6-2006.

## Making home finance fly

THE MARK CONSISTS OF STANDARD CHARACTERS WITHOUT CLAIM TO ANY PARTICULAR FONT, STYLE, SIZE, OR COLOR.

FOR MORTGAGE LENDING (U.S. CLS. 100, 101 AND 102).  
FIRST USE 7-1-2006; IN COMMERCE 7-1-2006.  
MICHAEL TANNER, EXAMINING ATTORNEY

SN 78-967,796. MARGATE ATLANTIC PROPERTIES LLC, NEW YORK, NY. FILED 9-6-2006.

## MARGATE ATLANTIC PROPERTIES

THE MARK CONSISTS OF STANDARD CHARACTERS WITHOUT CLAIM TO ANY PARTICULAR FONT, STYLE, SIZE, OR COLOR.

NO CLAIM IS MADE TO THE EXCLUSIVE RIGHT TO USE "PROPERTIES", APART FROM THE MARK AS SHOWN.

FOR REAL ESTATE ACQUISITION SERVICES; REAL ESTATE MANAGEMENT (U.S. CLS. 100, 101 AND 102).  
DOMINICK J. SALEMI, EXAMINING ATTORNEY

SN 78-968,019. SCHLARBAUM, MARK R., NEWTOWN SQUARE, PA. FILED 9-6-2006.

## PALLISER BAY

THE MARK CONSISTS OF STANDARD CHARACTERS WITHOUT CLAIM TO ANY PARTICULAR FONT, STYLE, SIZE, OR COLOR.

FOR FINANCIAL SERVICES, NAMELY, INVESTMENT MANAGEMENT AND ADVISORY SERVICES (U.S. CLS. 100, 101 AND 102).

NORA BUCHANAN WILL, EXAMINING ATTORNEY



**CLASS 36—(Continued).**

SN 78-968,146. BOB BADER COMPANY, INDIANAPOLIS, IN. FILED 9-6-2006.

# InsuraTRAC

THE MARK CONSISTS OF STANDARD CHARACTERS WITHOUT CLAIM TO ANY PARTICULAR FONT, STYLE, SIZE, OR COLOR.

FOR INSURANCE ADMINISTRATION IN THE FIELDS OF PROPERTY AND CASUALTY, HOMEOWNERS, RENTERS, TENANTS AND SELF STORAGE PERSONAL PROPERTY INSURANCE (U.S. CLS. 100, 101 AND 102).

NATALIE POLZER, EXAMINING ATTORNEY

**CLASS 36—(Continued).**

SN 78-968,295. INTEGRO HOLDINGS INC., WILMINGTON, DE. FILED 9-6-2006.

# INTEGRO PARTNEREXCHANGE

THE MARK CONSISTS OF STANDARD CHARACTERS WITHOUT CLAIM TO ANY PARTICULAR FONT, STYLE, SIZE, OR COLOR.

OWNER OF U.S. REG. NO. 3,115,346.  
FOR ELECTRONIC PROCESSING OF INSURANCE CLAIMS AND PAYMENT DATA, INSURANCE CLAIMS ADMINISTRATION AND INSURANCE CLAIMS PROCESSING (U.S. CLS. 100, 101 AND 102).

SUSAN LESLIE DUBOIS, EXAMINING ATTORNEY

SN 78-968,158. WOMEN'S SPORTS FOUNDATION, EAST MEADOWS, NY. FILED 9-6-2006.

# TEAM WSF

THE MARK CONSISTS OF STANDARD CHARACTERS WITHOUT CLAIM TO ANY PARTICULAR FONT, STYLE, SIZE, OR COLOR.

FOR CHARITABLE FUND RAISING SERVICES IN THE FIELD OF WOMEN'S ATHLETICS (U.S. CLS. 100, 101 AND 102).

FIRST USE 9-1-2006; IN COMMERCE 9-1-2006.  
BENJAMIN ALLEN, EXAMINING ATTORNEY

SN 78-968,522. HIMMER, RICHARD P., GIG HARBOR, WA. FILED 9-6-2006.

# Laws of Wealth

THE MARK CONSISTS OF STANDARD CHARACTERS WITHOUT CLAIM TO ANY PARTICULAR FONT, STYLE, SIZE, OR COLOR.

FOR FINANCIAL PLANNING (U.S. CLS. 100, 101 AND 102).

WENDY GOODMAN, EXAMINING ATTORNEY

SN 78-968,290. INTEGRO HOLDINGS INC., WILMINGTON, DE. FILED 9-6-2006.

# INTEGRO MARKETEXCHANGE

THE MARK CONSISTS OF STANDARD CHARACTERS WITHOUT CLAIM TO ANY PARTICULAR FONT, STYLE, SIZE, OR COLOR.

OWNER OF U.S. REG. NO. 3,115,346.  
FOR ELECTRONIC PROCESSING OF INSURANCE CLAIMS AND PAYMENT DATA, INSURANCE CLAIMS ADMINISTRATION AND INSURANCE CLAIMS PROCESSING (U.S. CLS. 100, 101 AND 102).

SUSAN LESLIE DUBOIS, EXAMINING ATTORNEY

SN 78-968,564. URBAN, GENE, PHOENIX, AZ. FILED 9-6-2006.

# The Urban Team

THE MARK CONSISTS OF STANDARD CHARACTERS WITHOUT CLAIM TO ANY PARTICULAR FONT, STYLE, SIZE, OR COLOR.

FOR REAL ESTATE BROKERAGE; REAL ESTATE CONSULTATION (U.S. CLS. 100, 101 AND 102).

FIRST USE 10-30-2001; IN COMMERCE 10-30-2001.  
KEVON CHISOLM, EXAMINING ATTORNEY

**CLASS 36—(Continued).**

SN 78-968,705. SKPT ENTERPRISES, LLC, DELRAY BEACH, FL. FILED 9-7-2006.

TURN YOUR PHONE INTO MONEY

THE MARK CONSISTS OF STANDARD CHARACTERS WITHOUT CLAIM TO ANY PARTICULAR FONT, STYLE, SIZE, OR COLOR.  
 FOR MORTGAGE BROKERAGE AND LENDING (U.S. CLS. 100, 101 AND 102).  
 MARY CRAWFORD, EXAMINING ATTORNEY

SN 78-968,737. SKPT ENTERPRISES, LLC, DELRAY BEACH, FL. FILED 9-7-2006.

WANT TO TURN YOUR PHONE INTO MONEY?

THE MARK CONSISTS OF STANDARD CHARACTERS WITHOUT CLAIM TO ANY PARTICULAR FONT, STYLE, SIZE, OR COLOR.  
 FOR MORTGAGE BROKERAGE AND LENDING (U.S. CLS. 100, 101 AND 102).  
 MARY CRAWFORD, EXAMINING ATTORNEY

SN 78-968,787. INTEGRO HOLDINGS INC., WILMINGTON, DE. FILED 9-7-2006.

INTEGRO CLIENTEXCHANGE

THE MARK CONSISTS OF STANDARD CHARACTERS WITHOUT CLAIM TO ANY PARTICULAR FONT, STYLE, SIZE, OR COLOR.  
 OWNER OF U.S. REG. NO. 3,115,346.  
 FOR ELECTRONIC PROCESSING OF INSURANCE CLAIMS AND PAYMENT DATA, INSURANCE CLAIMS ADMINISTRATION AND INSURANCE CLAIMS PROCESSING (U.S. CLS. 100, 101 AND 102).  
 SUSAN LESLIE DUBOIS, EXAMINING ATTORNEY

**CLASS 36—(Continued).**

SN 78-968,840. FIREBRAND, LLC, PROVIDENCE, RI. FILED 9-7-2006.

**FIREBRAND**

THE MARK CONSISTS OF STANDARD CHARACTERS WITHOUT CLAIM TO ANY PARTICULAR FONT, STYLE, SIZE, OR COLOR.  
 OWNER OF U.S. REG. NOS. 1,835,414, 2,499,392 AND OTHERS.  
 FOR EQUITY CAPITAL INVESTMENT; VENTURE CAPITAL FUNDING SERVICES TO EMERGING AND START-UP COMPANIES (U.S. CLS. 100, 101 AND 102).  
 FIRST USE 1-1-2001; IN COMMERCE 1-1-2001.  
 JAMES A. RAUEN, EXAMINING ATTORNEY

SN 78-968,851. CHAMPION EVERY ONE LLC, ASHEVILLE, NC. FILED 9-7-2006.

**Cash4Care**

THE MARK CONSISTS OF STANDARD CHARACTERS WITHOUT CLAIM TO ANY PARTICULAR FONT, STYLE, SIZE, OR COLOR.  
 FOR INSURANCE UNDERWRITING SERVICES FOR ALL TYPES OF INSURANCE (U.S. CLS. 100, 101 AND 102).  
 JANICE KIM, EXAMINING ATTORNEY

SN 78-968,865. VIKING ASSET MANAGEMENT, LLC, SAN FRANCISCO, CA. FILED 9-7-2006.



FOR FINANCIAL SERVICES, NAMELY, INVESTMENT ADVISORY SERVICES, INVESTMENT MANAGEMENT SERVICES AND ASSET MANAGEMENT SERVICES; TRADING OF EQUITY SECURITIES, BONDS, OPTIONS, FUTURES AND SYNTHETIC DERIVATIVE PRODUCTS IN BOTH DOMESTIC AND FOREIGN MARKETS; FINANCIAL SERVICES IN THE FIELD OF MONEY LENDING FOR INVESTMENT SUPPORT (U.S. CLS. 100, 101 AND 102).  
 NAAKWAMA ANKRAH, EXAMINING ATTORNEY

**CLASS 36—(Continued).**

SN 78-969,092. TROPIX CAPITAL MANAGEMENT LLC, WILTON, CT. FILED 9-7-2006.

# TROPIX

THE MARK CONSISTS OF STANDARD CHARACTERS WITHOUT CLAIM TO ANY PARTICULAR FONT, STYLE, SIZE, OR COLOR.

FOR FINANCIAL SERVICES, NAMELY, INVESTMENT ADVISORY SERVICES, INVESTMENT MANAGEMENT SERVICES AND ASSET MANAGEMENT SERVICES (U.S. CLS. 100, 101 AND 102).

LINDA ORNDORFF, EXAMINING ATTORNEY

SN 78-969,139. PROSHARE ADVISORS LLC, BETHESDA, MD. FILED 9-7-2006.

EXCHANGE TRADED FUNDS,  
CHAPTER TWO

THE MARK CONSISTS OF STANDARD CHARACTERS WITHOUT CLAIM TO ANY PARTICULAR FONT, STYLE, SIZE, OR COLOR.

NO CLAIM IS MADE TO THE EXCLUSIVE RIGHT TO USE "EXCHANGE TRADED FUNDS", APART FROM THE MARK AS SHOWN.

FOR FINANCIAL SERVICES, NAMELY INVESTMENT ADVISORY AND INVESTMENT MANAGEMENT SERVICES; INVESTMENTS IN THE NATURE OF EXCHANGE-TRADED FUNDS (U.S. CLS. 100, 101 AND 102).

FIRST USE 6-21-2006; IN COMMERCE 6-21-2006.  
CYNTHIA SLOAN, EXAMINING ATTORNEY

**CLASS 36—(Continued).**

SN 78-969,298. RED AMIGA, INC., ALISO VIEJO, CA. FILED 9-7-2006.

# RED AMIGA

THE MARK CONSISTS OF STANDARD CHARACTERS WITHOUT CLAIM TO ANY PARTICULAR FONT, STYLE, SIZE, OR COLOR.

THE ENGLISH TRANSLATION OF THE WORD AMIGA IN THE MARK IS FRIEND.

FOR FINANCIAL SERVICES, NAMELY, BANKING SERVICES; MONEY TRANSFER SERVICES; ELECTRONIC FUNDS TRANSFER SERVICES; BILL PAYMENT SERVICES; MONEY ORDER SERVICES; CREDIT CARD SERVICES; AUTOMATIC TELLER MACHINE SERVICES; DEBIT CARD SERVICES; STORED VALUE CARD SERVICES, NAMELY, PROCESSING ELECTRONIC PAYMENTS THROUGH STORE-BRANDED PREPAID GIFT CARDS, ISSUING STORE-BRANDED PREPAID GIFT CARDS, AND REPLENISHING FUNDS ON STORE-BRANDED PREPAID GIFT CARDS; DIRECT DEPOSIT OF FUNDS INTO CUSTOMER BANK ACCOUNTS; AUTOMATED CLEARING HOUSE DEPOSIT SERVICES; ON-LINE AUCTION PAYMENT AND SETTLEMENT SERVICES; PREPAID CARD SERVICES IN THE NATURE OF MAKING PAYMENT FOR ADDING AIRTIME TO PREPAID OR PAY-AS-YOU-GO WIRELESS SERVICES, RELOADING CASH ON PRE-PAID/SECURED DEBIT CARDS, AND PREPAID TELECOMMUNICATIONS CALLING CARD SERVICES, NAMELY, RECHARGING MINUTES TO PRE-PAID LONG DISTANCE CALLING CARDS; AND GIFT CHECK SERVICES IN THE NATURE OF ISSUING PERSONALIZED GIFT CHECKS AKIN TO MONEY ORDERS (U.S. CLS. 100, 101 AND 102).

ROBIN MITTLER, EXAMINING ATTORNEY

SN 78-969,369. COUNTRYFIELD, INC., SAN MATEO, CA. FILED 9-7-2006.

# propertix.com

THE MARK CONSISTS OF STANDARD CHARACTERS WITHOUT CLAIM TO ANY PARTICULAR FONT, STYLE, SIZE, OR COLOR.

FOR PROVIDING REAL ESTATE LISTINGS AND RELATED INFORMATION VIA A GLOBAL COMPUTER NETWORK; REAL ESTATE BROKERAGE (U.S. CLS. 100, 101 AND 102).

FIRST USE 9-6-2006; IN COMMERCE 9-6-2006.  
IRA J. GOODSaid, EXAMINING ATTORNEY

**CLASS 36—(Continued).**

SN 78-969,448. EPIPHANY, LLC, GREENWOOD VILLAGE, CO. FILED 9-7-2006.

**FINALLY, CLUB RESIDENCES  
WITH ANYTIME ACCESS**

THE MARK CONSISTS OF STANDARD CHARACTERS WITHOUT CLAIM TO ANY PARTICULAR FONT, STYLE, SIZE, OR COLOR.  
FOR REAL ESTATE INVESTMENT SERVICES, NAMELY, INVESTMENT IN RESIDENTIAL REAL ESTATE PROPERTIES (U.S. CLS. 100, 101 AND 102).  
FIRST USE 8-24-2006; IN COMMERCE 8-24-2006.  
CHRISTINE COOPER, EXAMINING ATTORNEY

SN 78-969,475. SOVEREIGN MILITARY HOSPITALLER ORDER OF ST. JOHN OF JERUSALEM OF RHODES AND OF MALTA, WESTERN ASSOCIATION U.S.A., SAN FRANCISCO, CA. FILED 9-7-2006.

**MODERN BY TRADITION**

THE MARK CONSISTS OF STANDARD CHARACTERS WITHOUT CLAIM TO ANY PARTICULAR FONT, STYLE, SIZE, OR COLOR.  
FOR CHARITABLE FUND RAISING (U.S. CLS. 100, 101 AND 102).  
DOMINIC FATHY, EXAMINING ATTORNEY

SN 78-969,864. DEDHAM INSTITUTION FOR SAVINGS, DEDHAM, MA. FILED 9-8-2006.



NO CLAIM IS MADE TO THE EXCLUSIVE RIGHT TO USE "DEDHAM" AND "SAVINGS", APART FROM THE MARK AS SHOWN.

THE MARK CONSISTS OF THE WORD LIFE BANKING IN STYLIZED TYPE PRINTED ABOVE A SHADED RECTANGLE IN WHICH ARE PRINTED THE WORDS DEDHAM SAVINGS IN SMALLER STYLIZED TYPE.  
FOR BANKING (U.S. CLS. 100, 101 AND 102).  
MIDGE BUTLER, EXAMINING ATTORNEY

**CLASS 36—(Continued).**

SN 78-969,962. DEDHAM INSTITUTION FOR SAVINGS, DEDHAM, MA. FILED 9-8-2006.

**LIFEBANKING**

THE MARK CONSISTS OF STANDARD CHARACTERS WITHOUT CLAIM TO ANY PARTICULAR FONT, STYLE, SIZE, OR COLOR.  
FOR BANKING (U.S. CLS. 100, 101 AND 102).  
MIDGE BUTLER, EXAMINING ATTORNEY

SN 78-970,069. CHAMPION EVERY ONE LLC, ASHEVILLE, NC. FILED 9-8-2006.

**Cash for Care**

THE MARK CONSISTS OF STANDARD CHARACTERS WITHOUT CLAIM TO ANY PARTICULAR FONT, STYLE, SIZE, OR COLOR.  
FOR INSURANCE UNDERWRITING SERVICES FOR ALL TYPES OF INSURANCE (U.S. CLS. 100, 101 AND 102).  
JANICE KIM, EXAMINING ATTORNEY

SN 78-970,077. SYMP, LLC, LOS ANGELES, CA. FILED 9-8-2006.

**MOVEFROG**

THE MARK CONSISTS OF STANDARD CHARACTERS WITHOUT CLAIM TO ANY PARTICULAR FONT, STYLE, SIZE, OR COLOR.

FOR PROVIDING TEXT AND PHOTOGRAPHIC INFORMATION OVER THE INTERNET CONCERNING THE AVAILABILITY, PRICE, LOCATION, AND DESCRIPTION OF RESIDENTIAL REAL PROPERTY OF OTHERS TO PROSPECTIVE RENTERS (U.S. CLS. 100, 101 AND 102).  
FIRST USE 7-0-2006; IN COMMERCE 7-0-2006.  
H. M. FISHER, EXAMINING ATTORNEY

**CLASS 36—(Continued).**

SN 78-970,297. FMR CORP., BOSTON, MA. FILED 9-8-2006.

**MYSMART CASH CENTER**

THE MARK CONSISTS OF STANDARD CHARACTERS WITHOUT CLAIM TO ANY PARTICULAR FONT, STYLE, SIZE, OR COLOR.

NO CLAIM IS MADE TO THE EXCLUSIVE RIGHT TO USE "CASH CENTER", APART FROM THE MARK AS SHOWN.

FOR INVESTMENT OF FUNDS FOR OTHERS, FEATURING THE AUTOMATIC TRANSFER AND MANAGEMENT OF FUNDS ACCORDING TO CUSTOMER-DEFINED CRITERIA (U.S. CLS. 100, 101 AND 102).

CARYN GLASSER, EXAMINING ATTORNEY

**CLASS 36—(Continued).**

SN 78-971,551. PROSHARE ADVISORS LLC, BETHESDA, MD. FILED 9-11-2006.

**THE NEXT GENERATION OF ETFs**

THE MARK CONSISTS OF STANDARD CHARACTERS WITHOUT CLAIM TO ANY PARTICULAR FONT, STYLE, SIZE, OR COLOR.

NO CLAIM IS MADE TO THE EXCLUSIVE RIGHT TO USE "ETFs", APART FROM THE MARK AS SHOWN.

FOR FINANCIAL SERVICES, NAMELY INVESTMENT ADVISORY AND INVESTMENT MANAGEMENT SERVICES; INVESTMENTS IN THE NATURE OF EXCHANGE-TRADED FUNDS (U.S. CLS. 100, 101 AND 102).

FIRST USE 6-21-2006; IN COMMERCE 6-21-2006.

CYNTHIA SLOAN, EXAMINING ATTORNEY

SN 78-970,312. MIDDLESEX MUTUAL ASSURANCE COMPANY, MIDDLETOWN, CT. FILED 9-8-2006.

**MAKING INSURANCE RIGHT**

THE MARK CONSISTS OF STANDARD CHARACTERS WITHOUT CLAIM TO ANY PARTICULAR FONT, STYLE, SIZE, OR COLOR.

FOR UNDERWRITING PROPERTY AND CASUALTY INSURANCE (U.S. CLS. 100, 101 AND 102).

WOODROW HARTZOG, EXAMINING ATTORNEY

SN 78-971,867. DEWBERRY CAPITAL CORPORATION, ATLANTA, GA. FILED 9-11-2006.

**DEWBERRY CESINGER HOLDINGS**

THE MARK CONSISTS OF STANDARD CHARACTERS WITHOUT CLAIM TO ANY PARTICULAR FONT, STYLE, SIZE, OR COLOR.

NO CLAIM IS MADE TO THE EXCLUSIVE RIGHT TO USE "HOLDINGS", APART FROM THE MARK AS SHOWN.

FOR EQUITY CAPITAL INVESTMENT; FUNDS INVESTMENT; INVESTMENT MANAGEMENT; INVESTMENT OF FUNDS FOR OTHERS (U.S. CLS. 100, 101 AND 102).

CATHERINE FAINT, EXAMINING ATTORNEY

SN 78-970,646. ARASTEH, RAY, IRVINE, CA. FILED 9-8-2006.

**Mortgage Philosophy Reloaded**

THE MARK CONSISTS OF STANDARD CHARACTERS WITHOUT CLAIM TO ANY PARTICULAR FONT, STYLE, SIZE, OR COLOR.

NO CLAIM IS MADE TO THE EXCLUSIVE RIGHT TO USE "MORTGAGE", APART FROM THE MARK AS SHOWN.

FOR MORTGAGE BROKERAGE (U.S. CLS. 100, 101 AND 102).

MIDGE BUTLER, EXAMINING ATTORNEY

SN 78-972,623. HARRIS N.A., CHICAGO, IL. FILED 9-12-2006.

**HARRIS EXPRESS LOAN PAYMENT**

THE MARK CONSISTS OF STANDARD CHARACTERS WITHOUT CLAIM TO ANY PARTICULAR FONT, STYLE, SIZE, OR COLOR.

OWNER OF U.S. REG. NOS. 1,008,229, 2,769,292 AND OTHERS.

NO CLAIM IS MADE TO THE EXCLUSIVE RIGHT TO USE "LOAN PAYMENT", APART FROM THE MARK AS SHOWN.

SEC. 2(F) AS TO HARRIS.

FOR BILL PAYMENT SERVICES (U.S. CLS. 100, 101 AND 102).

MICHAEL TANNER, EXAMINING ATTORNEY

**CLASS 36—(Continued).**

SN 78-972,637. ST. LOUIS COMMUNITY CREDIT UNION, ST. LOUIS, MO. FILED 9-12-2006.

HERE FOR YOU. HERE FOR  
LIFE.

THE MARK CONSISTS OF STANDARD CHARACTERS WITHOUT CLAIM TO ANY PARTICULAR FONT, STYLE, SIZE, OR COLOR.

FOR CREDIT UNION SERVICES (U.S. CLS. 100, 101 AND 102).

LEIGH CAROLINE CASE, EXAMINING ATTORNEY

---

SN 78-972,723. HARRIS N.A., CHICAGO, IL. FILED 9-12-2006.

**HEALTHCARE REMIT 360**

THE MARK CONSISTS OF STANDARD CHARACTERS WITHOUT CLAIM TO ANY PARTICULAR FONT, STYLE, SIZE, OR COLOR.

NO CLAIM IS MADE TO THE EXCLUSIVE RIGHT TO USE "HEALTHCARE REMIT", APART FROM THE MARK AS SHOWN.

FOR ELECTRONIC PROCESSING OF INSURANCE CLAIMS AND PAYMENT DATA (U.S. CLS. 100, 101 AND 102).

MICHAEL TANNER, EXAMINING ATTORNEY

---

SN 78-973,495. BAYLOR COLLEGE OF MEDICINE, HOUSTON, TX. FILED 9-13-2006.



NO CLAIM IS MADE TO THE EXCLUSIVE RIGHT TO USE "PINK RIBBON", APART FROM THE MARK AS SHOWN.

THE MARK CONSISTS OF A RIBBON ABOVE A BRICK WALL. BETWEEN THE RIBBON AND THE WALL ARE THE WORDS, "PINK RIBBON HOUSE", SLIGHTLY OVER-LAPING THE RIBBON.

FOR CHARITABLE FUND RAISING (U.S. CLS. 100, 101 AND 102).

TRICIA SONNEBORN, EXAMINING ATTORNEY

**CLASS 36—(Continued).**

SN 78-974,378. AMERIPRISE FINANCIAL, INC., MINNEAPOLIS, MN. FILED 9-14-2006.

**ADVICE-BUILT SOLUTIONS**

THE MARK CONSISTS OF STANDARD CHARACTERS WITHOUT CLAIM TO ANY PARTICULAR FONT, STYLE, SIZE, OR COLOR.

FOR FINANCIAL AND INVESTMENT SERVICES, NAMELY ASSET ACQUISITION, CONSULTATION, DEVELOPMENT, AND MANAGEMENT SERVICES; OFFERING WEALTH MANAGEMENT INVESTMENT PORTFOLIOS AND RELATED CONSULTATION SERVICES, ASSET MANAGEMENT SERVICES, CASH MANAGEMENT SERVICES, MUTUAL FUND INVESTMENT AND MUTUAL FUND DISTRIBUTION (U.S. CLS. 100, 101 AND 102).

LINDA MICKLEBURGH, EXAMINING ATTORNEY

**CLASS 37—CONSTRUCTION AND REPAIR**

---

SN 76-600,481. DEFENSE SUPPORT SERVICES LLC, MARLTON, NJ. FILED 7-2-2004.

DS2

THE MARK CONSISTS OF STANDARD CHARACTERS WITHOUT CLAIM TO ANY PARTICULAR FONT, STYLE, SIZE, OR COLOR.

FOR REPAIR AND MAINTENANCE OF PHYSICAL PLANTS, NAMELY BUILDINGS, ROADS, GROUNDS AND POWER PLANTS, FOR MILITARY BASES AND GOVERNMENT FACILITIES; REPAIR AND MAINTENANCE OF MILITARY AND GOVERNMENT-OWNED AIRCRAFT, GROUND EQUIPMENT, AND WEAPONS SYSTEMS; AND HOUSEKEEPING SERVICES, NAMELY CLEANING OF GOVERNMENT AND MILITARY BUILDINGS AND LAUNDRY SERVICES FOR GOVERNMENT AND MILITARY FACILITIES (U.S. CLS. 100, 103 AND 106).

DAWN HAN, EXAMINING ATTORNEY

**CLASS 37—(Continued).**

SN 76-656,739. GARCIA, CESAR O., TACOMA, WA. FILED 3-16-2006.



NO CLAIM IS MADE TO THE EXCLUSIVE RIGHT TO USE ELECTRIC, APART FROM THE MARK AS SHOWN.

THE COLOR(S) RED AND BLACK IS/ARE CLAIMED AS A FEATURE OF THE MARK.

THE WORDING NORTH POINTE IS DEPICTED IN THE COLOR BLACK AND THE STAR ABOVE THE WORDING AND THE WORD ELECTRIC ARE DEPICTED IN THE COLOR RED.

FOR ELECTRICAL CONTRACTING SERVICES FOR NEW CONSTRUCTION AND REMODELS, AND ELECTRICAL REPAIRS OF UNDERGROUND WIRING, DAMAGED OR AGING WIRING, ELECTRICAL DEVICES IN THE NATURE OF ELECTRICAL SWITCHES AND LIGHTS AND SERVICE PANELS (U.S. CLS. 100, 103 AND 106).

FIRST USE 10-1-2005; IN COMMERCE 10-1-2005. BRIDGETT SMITH, EXAMINING ATTORNEY

SN 76-664,887. LUCKY DUCT, LLC, LITTLETON, CO. FILED 8-21-2006.

**LUCKY DUCT**

THE MARK CONSISTS OF STANDARD CHARACTERS WITHOUT CLAIM TO ANY PARTICULAR FONT, STYLE, SIZE, OR COLOR.

NO CLAIM IS MADE TO THE EXCLUSIVE RIGHT TO USE "DUCT", APART FROM THE MARK AS SHOWN.

FOR AIR DUCT CLEANING SERVICES (U.S. CLS. 100, 103 AND 106).

FIRST USE 4-1-2005; IN COMMERCE 5-1-2005. GEORGIA CARTY, EXAMINING ATTORNEY

**CLASS 37—(Continued).**

SN 77-005,607. 360 BRANDS, INC., CHARLESTON, SC. FILED 9-22-2006.



NO CLAIM IS MADE TO THE EXCLUSIVE RIGHT TO USE "COMPLETE FACILITY CARE", APART FROM THE MARK AS SHOWN.

THE MARK CONSISTS OF THE NUMBER "360" IN CLOSE PROXIMITY TO THE WORD "CLEAN", ALONG WITH THE WORDS "COMPLETE FACILITY CARE" ALL SURROUNDED BY AN ELLIPSE.

FOR JANITORIAL SERVICES (U.S. CLS. 100, 103 AND 106).

FIRST USE 1-2-2006; IN COMMERCE 1-2-2006. TEJBIR SINGH, EXAMINING ATTORNEY

SN 77-058,489. RIATA ENERGY, INC., OKLAHOMA CITY, OK. FILED 12-6-2006.



NO CLAIM IS MADE TO THE EXCLUSIVE RIGHT TO USE "ENERGY", APART FROM THE MARK AS SHOWN.

THE COLOR(S) BLACK AND RED IS/ARE CLAIMED AS A FEATURE OF THE MARK.

THE MARK CONSISTS OF THE WORDS SANDRIDGE ENERGY IN STYLIZED BLACK LETTERS WITH A BLACK CURVED LINE AND A RED CURVED LINE.

FOR OIL AND GAS DRILLING (U.S. CLS. 100, 103 AND 106).

JIM RINGLE, EXAMINING ATTORNEY

SN 78-644,082. SAAB AUTOMOBILE AB, TROLHATTAN, SWEDEN, FILED 6-6-2005.

**SAAB**

THE MARK CONSISTS OF STANDARD CHARACTERS WITHOUT CLAIM TO ANY PARTICULAR FONT, STYLE, SIZE, OR COLOR.

OWNER OF U.S. REG. NOS. 2,749,313, 2,796,769 AND 2,994,144.

FOR MAINTENANCE AND REPAIR SERVICES FOR MOTOR LAND VEHICLES (U.S. CLS. 100, 103 AND 106).

FIRST USE 2-28-1957; IN COMMERCE 2-28-1957. TANYA AMOS, EXAMINING ATTORNEY

**CLASS 37—(Continued).**

SN 78-759,082. KRUEGER, KARL EVERETT, SIOUX FALLS, SD. FILED 11-22-2005.

**FOREVER SUMMER**

THE MARK CONSISTS OF STANDARD CHARACTERS WITHOUT CLAIM TO ANY PARTICULAR FONT, STYLE, SIZE, OR COLOR.

FOR LAND DEVELOPMENT SERVICES IN THE NATURE OF PLANNING AND LAYING OUT OF RURAL RESIDENTIAL COMMUNITIES FEATURING NEW RESIDENCES AND RECREATIONAL, SOCIAL AND COMMUNITY FACILITIES (U.S. CLS. 100, 103 AND 106).

KRISTINA KLOIBER, EXAMINING ATTORNEY

SN 78-774,887. ROOFERS' SUCCESS INTERNATIONAL, LLC, ST. LOUIS, MO. FILED 12-16-2005.



NO CLAIM IS MADE TO THE EXCLUSIVE RIGHT TO USE "ROOFING", APART FROM THE MARK AS SHOWN.

THE STIPPLING IS A FEATURE OF THE MARK. THE MARK CONSISTS OF A STYLIZED ROOSTER.

FOR ROOFING SERVICES (U.S. CLS. 100, 103 AND 106).

MICHAEL TANNER, EXAMINING ATTORNEY

SN 78-774,891. ROOFERS' SUCCESS INTERNATIONAL, LLC, ST. LOUIS, MO. FILED 12-16-2005.



NO CLAIM IS MADE TO THE EXCLUSIVE RIGHT TO USE "ROOFING" AND "ROOFER", APART FROM THE MARK AS SHOWN.

THE STIPPLING IS A FEATURE OF THE MARK. THE MARK CONSISTS OF A PICTURE OF ABRAHAM LINCOLN TAKING AN OATH.

FOR ROOFING SERVICES (U.S. CLS. 100, 103 AND 106).

MICHAEL TANNER, EXAMINING ATTORNEY

**CLASS 37—(Continued).**

SN 78-774,898. ROOFERS' SUCCESS INTERNATIONAL, LLC, ST. LOUIS, MO. FILED 12-16-2005.



NO CLAIM IS MADE TO THE EXCLUSIVE RIGHT TO USE "ROOF", APART FROM THE MARK AS SHOWN.

THE MARK CONSISTS OF A STYLIZED KANGAROO. FOR ROOFING SERVICES (U.S. CLS. 100, 103 AND 106).

MICHAEL TANNER, EXAMINING ATTORNEY

SN 78-793,139. WELSHCO, LLC, MINNEAPOLIS, MN. FILED 1-17-2006.



NO CLAIM IS MADE TO THE EXCLUSIVE RIGHT TO USE "DEVELOPMENT", APART FROM THE MARK AS SHOWN.

THE COLOR(S) BLACK, RED, ORANGE AND WHITE IS/ ARE CLAIMED AS A FEATURE OF THE MARK.

THE MARK CONSISTS OF THE COLOR BLACK WHICH APPEARS IN THE BACKGROUND OF THE TOP RECTANGLE AND THE WORD DEVELOPMENT. THE COLOR RED APPEARS BETWEEN THE BLACK RECTANGLE AND ORANGE RECTANGLE. THE COLOR ORANGE APPEARS IN THE RECTANGLE BELOW THE RED LINE. THE COLOR WHITE APPEARS IN THE TERM WELSH.

FOR REAL ESTATE DEVELOPMENT SERVICES (U.S. CLS. 100, 103 AND 106).

FIRST USE 10-16-1996; IN COMMERCE 10-16-1996.

AMY BROZENIC, EXAMINING ATTORNEY

SN 78-793,152. WELSHCO, LLC, MINNEAPOLIS, MN. FILED 1-17-2006.

**WELSH DEVELOPMENT**

THE MARK CONSISTS OF STANDARD CHARACTERS WITHOUT CLAIM TO ANY PARTICULAR FONT, STYLE, SIZE, OR COLOR.

NO CLAIM IS MADE TO THE EXCLUSIVE RIGHT TO USE "DEVELOPMENT", APART FROM THE MARK AS SHOWN.

FOR REAL ESTATE DEVELOPMENT SERVICES (U.S. CLS. 100, 103 AND 106).

FIRST USE 10-16-1996; IN COMMERCE 10-16-1996.

AMY BROZENIC, EXAMINING ATTORNEY



**CLASS 37—(Continued).**

SN 78-836,122. GLEN, SMITH & GLEN DEVELOPMENT  
COPMANY, LLC, LAS VEGAS, NV. FILED 3-13-2006.

SULLIVAN  SQUARE

NO CLAIM IS MADE TO THE EXCLUSIVE RIGHT TO  
USE "SQUARE", APART FROM THE MARK AS SHOWN.

THE MARK CONSISTS OF THE WORD "SULLIVAN"  
FOLLOWED BY A DESIGNED SQUARE, FOLLOWED BY  
THE WORD "SQUARE".

FOR LAND DEVELOPMENT SERVICES, NAMELY,  
PLANNING AND LAYING OUT OF RESIDENTIAL  
AND/OR COMMERCIAL COMMUNITIES (U.S. CLS.  
100, 103 AND 106).

PETER CHENG, EXAMINING ATTORNEY

---

SN 78-855,724. MOHAMMAD MALAKOUTI-ZAMIR, HOUS-  
TON, TX. FILED 4-6-2006.

AUTO CHAMP

THE MARK CONSISTS OF STANDARD CHARACTERS  
WITHOUT CLAIM TO ANY PARTICULAR FONT, STYLE,  
SIZE, OR COLOR.

NO CLAIM IS MADE TO THE EXCLUSIVE RIGHT TO  
USE "AUTO", APART FROM THE MARK AS SHOWN.

FOR VEHICLE REPAIR AND MAINTENANCE SER-  
VICES (U.S. CLS. 100, 103 AND 106).

CAROLYN GRAY, EXAMINING ATTORNEY

---

SN 78-856,677. TOUSA DELAWARE, INC., WILMINGTON,  
DE. FILED 4-7-2006.

BETTER LIVING. BY DESIGN.

THE MARK CONSISTS OF STANDARD CHARACTERS  
WITHOUT CLAIM TO ANY PARTICULAR FONT, STYLE,  
SIZE, OR COLOR.

FOR REAL ESTATE DEVELOPMENT SERVICES;  
BUILDING AND CONSTRUCTION OF HOMES (U.S.  
CLS. 100, 103 AND 106).

FIRST USE 4-7-2006; IN COMMERCE 4-7-2006.

MARC LEIPZIG, EXAMINING ATTORNEY

**CLASS 37—(Continued).**

SN 78-858,414. FERRANTE, JOHN, GAHANNA, OH. FILED  
4-11-2006.

AIRWAYS HEATING & COOLING

THE MARK CONSISTS OF STANDARD CHARACTERS  
WITHOUT CLAIM TO ANY PARTICULAR FONT, STYLE,  
SIZE, OR COLOR.

NO CLAIM IS MADE TO THE EXCLUSIVE RIGHT TO  
USE "HEATING & COOLING", APART FROM THE MARK  
AS SHOWN.

FOR INSTALLATION AND REPAIR OF HEATING,  
COOLING AND REFRIGERATION SYSTEMS (U.S. CLS.  
100, 103 AND 106).

FIRST USE 6-1-1997; IN COMMERCE 6-1-1997.

RON FAIRBANKS, EXAMINING ATTORNEY

---

SN 78-869,939. URBAN SHUTTERS, INC., INDIANAPOLIS,  
IN. FILED 4-26-2006.



NO CLAIM IS MADE TO THE EXCLUSIVE RIGHT TO  
USE "SHUTTERS", APART FROM THE MARK AS SHOWN.

THE COLOR(S) BLUE, BLACK AND WHITE IS/ARE  
CLAIMED AS A FEATURE OF THE MARK.

THE MARK CONSISTS OF AN URBAN RESIDENTIAL  
BUILDING WITH WINDOW FURNISHINGS AND A BACK-  
DROP OF THE SKY ABOVE THE PRINTED WORDS  
"URBAN SHUTTERS"; THE COLOR BLUE APPEARS IN  
THE SKY ABOVE THE BUILDING; THE COLOR BLACK  
APPEARS IN THE BUILDING AND THE BACKGROUND  
AROUND THE TEXT; THE COLOR WHITE APPEARS IN  
THE BUILDING AND THE LETTERING OF THE MARK.

FOR INSTALLATION, AND REPAIR OF WINDOW  
COVERINGS, SHUTTERS, AND TREATMENTS (U.S.  
CLS. 100, 103 AND 106).

FIRST USE 2-1-2006; IN COMMERCE 2-1-2006.

HOWARD B. LEVINE, EXAMINING ATTORNEY

**CLASS 37—(Continued).**

SN 78-887,848. MY FAVORITE PLUMBER PLUMBING & HEATING, INC., DOWNINGTOWN, PA. FILED 5-19-2006.



NO CLAIM IS MADE TO THE EXCLUSIVE RIGHT TO USE "PLUMBER" AND "PLUMBING & HEATING", APART FROM THE MARK AS SHOWN.

THE COLOR(S) GREEN, GRAY, BLACK AND WHITE IS/ ARE CLAIMED AS A FEATURE OF THE MARK.

THE MARK CONSISTS OF A STYLIZED CHARACTER AND LITERAL ELEMENT. THE STYLIZED CHARACTER'S OVERALLS AND HAT AND THE HANDLE OF THE WRENCH ARE GREEN; THE WRENCH IS GRAY COLORED; THE WORDING, THE CHARACTER'S HAIR AND THE OUTLINE OF THE CHARACTER ARE BLACK AND THE FIGURE'S BODY AND SHOES ARE WHITE.

FOR PLUMBING CONTRACTOR SERVICES; PLUMBING SERVICES; HEATING CONTRACTOR SERVICES; INSTALLATION, REPAIR AND MAINTENANCE OF HEATING EQUIPMENT; MAINTENANCE AND REPAIR OF HEATING INSTALLATIONS (U.S. CLS. 100, 103 AND 106).

FIRST USE 1-5-1992; IN COMMERCE 1-5-1992.  
RONALD MCMORROW, EXAMINING ATTORNEY

SN 78-903,055. UNIVERSAL RESTORATION SERVICES, WHEELING, IL. FILED 6-7-2006.



NO CLAIM IS MADE TO THE EXCLUSIVE RIGHT TO USE "RESTORATION SERVICES", APART FROM THE MARK AS SHOWN.

FOR CONSTRUCTION, REPAIR AND RESTORATION SERVICES FOR RESIDENTIAL, COMMERCIAL, INDUSTRIAL AND INSTITUTIONAL PROPERTIES FOLLOWING DAMAGE (U.S. CLS. 100, 103 AND 106).

FIRST USE 1-31-2005; IN COMMERCE 1-31-2005.  
ALICE BENMAMAN, EXAMINING ATTORNEY

**CLASS 37—(Continued).**

SN 78-931,796. WYNDHAM HOMES, INC., BREWSTER, NY. FILED 7-18-2006.

**UNIQUELY YOURS**

THE MARK CONSISTS OF STANDARD CHARACTERS WITHOUT CLAIM TO ANY PARTICULAR FONT, STYLE, SIZE, OR COLOR.

FOR LAND DEVELOPMENT SERVICES, NAMELY, PLANNING AND LAYING OUT OF RESIDENTIAL AND/OR COMMERCIAL COMMUNITIES; REAL ESTATE DEVELOPMENT; COMMERCIAL BUILDING CONSTRUCTION AND CONSULTING IN THE FIELD OF COMMERCIAL BUILDING CONSTRUCTION (U.S. CLS. 100, 103 AND 106).

SAIMA MAKHDOOM, EXAMINING ATTORNEY

SN 78-947,333. JEFFREY C. AUSTIN, ARVADA, CO. FILED 8-8-2006.



NO CLAIM IS MADE TO THE EXCLUSIVE RIGHT TO USE "GARAGE DOOR LLC SINCE 1985 303-422-0232", APART FROM THE MARK AS SHOWN.

THE APPLICANT CLAIMS COLOR AS A FEATURE OF THE MARK, NAMELY, BLACK, BLUE, AND GRAY.

THE MARK CONSISTS OF THE WORDS WELL HUNG IN BLACK AND BLUE PLACE OVER THE WORDS GARAGE DOOR IN BLACK. THE LETTER A IS IN GRAY AND IS LARGE IN THE BACKGROUND OF THE ENTIRE LOGO. THE PHONE NUMBER IN BLACK IS PLACED AT THE BOTTOM OF THE LOGO. SWIRL MARKS IN BLACK ARE PLACED AROUND THE WORDS WELL HUNG.

FOR INSTALLATION, MAINTENANCE AND REPAIR OF GARAGE DOORS (U.S. CLS. 100, 103 AND 106).

FIRST USE 5-1-1985; IN COMMERCE 5-1-1985.  
ROBIN MITTLER, EXAMINING ATTORNEY

**CLASS 37—(Continued).**

SN 78-951,274. LEE MYLES ASSOCIATES CORP, PARAMUS, NJ. FILED 8-14-2006.



OWNER OF U.S. REG. NOS. 1,006,492, 1,159,436 AND OTHERS.  
THE NAME "LEE MYLES" DOES NOT IDENTIFY A LIVING INDIVIDUAL.  
FOR AUTOMOBILE REPAIR AND MAINTENANCE (U.S. CLS. 100, 103 AND 106).  
FIRST USE 1-1-1996; IN COMMERCE 1-1-1996.  
DAWN HAN, EXAMINING ATTORNEY

**CLASS 37—(Continued).**

SN 78-959,830. RAY, SHANE, DBA ALOHA, COOKEVILLE, TN. FILED 8-24-2006.

**ALOHA!**

THE MARK CONSISTS OF STANDARD CHARACTERS WITHOUT CLAIM TO ANY PARTICULAR FONT, STYLE, SIZE, OR COLOR.  
THE ENGLISH TRANSLATION OF THE WORD "ALOHA" IS "HELLO, GOODBYE, OR LOVE".  
FOR INSTALLATION, REPAIR, AND MAINTENANCE OF HEATING, VENTILATING, AND AIR CONDITIONING EQUIPMENT (U.S. CLS. 100, 103 AND 106).  
LINDSEY RUBIN, EXAMINING ATTORNEY

SN 78-956,051. FUN DISH OF FLORIDA, INC., PORT CHARLOTTE, FL. FILED 8-20-2006.

**FUN DISH**

THE MARK CONSISTS OF STANDARD CHARACTERS WITHOUT CLAIM TO ANY PARTICULAR FONT, STYLE, SIZE, OR COLOR.  
NO CLAIM IS MADE TO THE EXCLUSIVE RIGHT TO USE "DISH", APART FROM THE MARK AS SHOWN.  
FOR SATELLITE SERVICES, NAMELY, SATELLITE EQUIPMENT INSTALLATION AND REPAIR (U.S. CLS. 100, 103 AND 106).  
JORDAN BAKER, EXAMINING ATTORNEY

SN 78-960,832. TB PROPRIETARY CORPORATION, WILMINGTON, DE. FILED 8-25-2006.

**ONE TEN 3RD**

THE MARK CONSISTS OF STANDARD CHARACTERS WITHOUT CLAIM TO ANY PARTICULAR FONT, STYLE, SIZE, OR COLOR.  
FOR LAND DEVELOPMENT SERVICES, NAMELY, LAYING OUT AND CONSTRUCTION OF CONDOMINIUM AND TOWN HOME DEVELOPMENTS (U.S. CLS. 100, 103 AND 106).  
FIRST USE 4-5-2006; IN COMMERCE 4-5-2006.  
TONJA GASKINS, EXAMINING ATTORNEY

SN 78-957,342. SPIKER, JOSEPH, MCHENRY, MD. FILED 8-22-2006.

**The Gleanings Village**

THE MARK CONSISTS OF STANDARD CHARACTERS WITHOUT CLAIM TO ANY PARTICULAR FONT, STYLE, SIZE, OR COLOR.  
NO CLAIM IS MADE TO THE EXCLUSIVE RIGHT TO USE "VILLAGE", APART FROM THE MARK AS SHOWN.  
FOR REAL ESTATE DEVELOPMENT (U.S. CLS. 100, 103 AND 106).  
FIRST USE 12-3-1979; IN COMMERCE 12-3-1979.  
LINDSEY RUBIN, EXAMINING ATTORNEY

SN 78-962,015. ALTA MERE INDUSTRIES, INC., MIDLOTHIAN, IL. FILED 8-28-2006.

The Choice is Clear,  
*alta mere*  
**Toys for Cars**

OWNER OF U.S. REG. NOS. 1,830,591, 2,256,450 AND 2,256,451.  
FOR AUTOMOBILE CUSTOMIZATION SERVICES (U.S. CLS. 100, 103 AND 106).  
STEVEN R. FOSTER, EXAMINING ATTORNEY

**CLASS 37—(Continued).**

SN 78-962,141. LILY'S LANDSCAPE LIGHTING, LLC, MANCHESTER, CT. FILED 8-28-2006.

THE SOFT GLOW OF  
DISTINCTION

THE MARK CONSISTS OF STANDARD CHARACTERS WITHOUT CLAIM TO ANY PARTICULAR FONT, STYLE, SIZE, OR COLOR.

FOR INSTALLATION OF LANDSCAPE LIGHTING (U.S. CLS. 100, 103 AND 106).

FIRST USE 4-1-2006; IN COMMERCE 5-1-2006.  
JASON ROTH, EXAMINING ATTORNEY

SN 78-962,479. GLENDARROCH HOMES, BURLESON, TX. FILED 8-29-2006.



NO CLAIM IS MADE TO THE EXCLUSIVE RIGHT TO USE "HOMES", APART FROM THE MARK AS SHOWN.

THE APPLICANT CLAIMS COLOR AS A FEATURE OF THE MARK, NAMELY, PURPLE, GREEN, BLACK, WHITE.

THE MARK CONSISTS OF GLENDARROCH IN PURPLE ABOVE GREEN OAK TREE WITH HOMES ALSO IN PURPLE BELOW THE GREEN OAK TREE. GLENDARROCH HOMES PURPLE LETTERING IS OUTLINED IN BLACK. WHITE BACKGROUND BEHIND WHOLE LOGO.

FOR CUSTOM CONSTRUCTION OF HOMES (U.S. CLS. 100, 103 AND 106).

FIRST USE 8-1-2006; IN COMMERCE 8-1-2006.  
KATHLEEN LORENZO, EXAMINING ATTORNEY

**CLASS 37—(Continued).**

SN 78-962,582. LEVEL ONE HVAC SERVICES, INC., WIXOM, MI. FILED 8-29-2006.



THE MARK CONSISTS OF THE WORD LEVEL OVERLAYING THE NUMERAL 1.

FOR AIR CONDITIONING CONTRACTOR SERVICES; HEATING CONTRACTOR SERVICES; HVAC CONTRACTOR SERVICES (U.S. CLS. 100, 103 AND 106).

FIRST USE 2-0-2005; IN COMMERCE 2-0-2005.  
DOMINIC FATHY, EXAMINING ATTORNEY

SN 78-964,238. AMERICAN NEVADA HOLDINGS, LLC, HENDERSON, NV. FILED 8-30-2006.



FOR PLANNING, LAYING OUT, DEVELOPMENT, REPAIR AND MAINTENANCE OF MIXED USE COMMUNITIES; PROVIDING INFORMATION REGARDING THE PLANNING, LAYING OUT, DEVELOPMENT, REPAIR AND MAINTENANCE OF MIXED USE COMMUNITIES; CLOTHING AND MATERIAL LAUNDRY, PRESS, REPAIR AND MENDING SERVICES; AND VEHICLE CLEANING, WASHING, DETAILING, REPAIR AND MAINTENANCE SERVICES (U.S. CLS. 100, 103 AND 106).

MICHAEL ENGEL, EXAMINING ATTORNEY

**CLASS 37—(Continued).**

SN 78-964,303. AMERICAN NEVADA HOLDINGS, LLC, HENDERSON, NV. FILED 8-30-2006.

**Avenue33**  
AT THE DISTRICT

FOR PLANNING, LAYING OUT, DEVELOPMENT, REPAIR AND MAINTENANCE OF MIXED USE COMMUNITIES; PROVIDING INFORMATION REGARDING THE PLANNING, LAYING OUT, DEVELOPMENT, REPAIR AND MAINTENANCE OF MIXED USE COMMUNITIES; CLOTHING AND MATERIAL LAUNDRY, PRESS, REPAIR AND MENDING SERVICES; AND VEHICLE CLEANING, WASHING, DETAILING, REPAIR AND MAINTENANCE SERVICES (U.S. CLS. 100, 103 AND 106).

MICHAEL ENGEL, EXAMINING ATTORNEY

SN 78-964,304. RIATA ENERGY, INC., OKLAHOMA CITY, OK. FILED 8-30-2006.

**SANDRIDGE ENERGY**

THE MARK CONSISTS OF STANDARD CHARACTERS WITHOUT CLAIM TO ANY PARTICULAR FONT, STYLE, SIZE, OR COLOR.

NO CLAIM IS MADE TO THE EXCLUSIVE RIGHT TO USE "ENERGY", APART FROM THE MARK AS SHOWN.

FOR OIL AND GAS DRILLING (U.S. CLS. 100, 103 AND 106).

JIM RINGLE, EXAMINING ATTORNEY

SN 78-964,443. CARSON GAMING, L.L.C., LAS VEGAS, NV. FILED 8-30-2006.

**CASINO FANDANGO**

THE MARK CONSISTS OF STANDARD CHARACTERS WITHOUT CLAIM TO ANY PARTICULAR FONT, STYLE, SIZE, OR COLOR.

OWNER OF U.S. REG. NOS. 2,968,485 AND 2,973,537.

FOR RESIDENTIAL AND COMMERCIAL BUILDING CONSTRUCTION; REAL ESTATE DEVELOPMENT; LAND DEVELOPMENT SERVICES, NAMELY, PLANNING AND LAYING OUT OF RESIDENTIAL AND/OR COMMERCIAL COMMUNITIES; BUILDING CONSTRUCTION AND REPAIR; CONSTRUCTION MANAGEMENT; CONSTRUCTION PLANNING; CONSTRUCTION SERVICES, NAMELY, PLANNING, LAYING OUT AND CUSTOM CONSTRUCTION OF RESIDENTIAL AND COMMERCIAL COMMUNITIES (U.S. CLS. 100, 103 AND 106).

MORGAN WYNNE, EXAMINING ATTORNEY

**CLASS 37—(Continued).**

SN 78-964,461. AMERICAN NEVADA HOLDINGS, LLC, HENDERSON, NV. FILED 8-30-2006.

**AVENUE33 AT THE DISTRICT**

THE MARK CONSISTS OF STANDARD CHARACTERS WITHOUT CLAIM TO ANY PARTICULAR FONT, STYLE, SIZE, OR COLOR.

FOR PLANNING, LAYING OUT, DEVELOPMENT, REPAIR AND MAINTENANCE OF MIXED USE COMMUNITIES; PROVIDING INFORMATION REGARDING THE PLANNING, LAYING OUT, DEVELOPMENT, REPAIR AND MAINTENANCE OF MIXED USE COMMUNITIES; CLOTHING AND MATERIAL LAUNDRY, PRESS, REPAIR AND MENDING SERVICES; AND VEHICLE CLEANING, WASHING, DETAILING, REPAIR AND MAINTENANCE SERVICES (U.S. CLS. 100, 103 AND 106).

KAREN BRACEY, EXAMINING ATTORNEY

SN 78-964,512. POOL PROFESSIONALS, INC., TEMPE, AZ. FILED 8-30-2006.



NO CLAIM IS MADE TO THE EXCLUSIVE RIGHT TO USE "POOL PROFESSIONALS", APART FROM THE MARK AS SHOWN.

THE COLOR(S) BLUE, COPPER AND WHITE IS/ARE CLAIMED AS A FEATURE OF THE MARK.

THE MARK CONSISTS OF A NAVY BLUE RING BORDERED IN COPPER WITH COPPER LETTERING "POOL PROFESSIONALS" SURROUNDING A YING AND YANG STYLE SWIRL OF LIGHT BLUE AND DARK BLUE, COMBINING A VERY DARK BLUE SEPARATION BAND. THE COLOR WHITE APPEARS IN THE MIDDLE OF THE SWIRLS IN THE CENTER OF THE MARK.

FOR SWIMMING POOL CLEANING SERVICES (U.S. CLS. 100, 103 AND 106).

FIRST USE 5-1-2006; IN COMMERCE 5-1-2006.

TRAVIS WHEATLEY, EXAMINING ATTORNEY

**CLASS 37—(Continued).**

SN 78-964,627. A&A CONSTRUCTION, HAVRE DE GRACE, MD. FILED 8-31-2006.

## WE CAN LAY IT...HAMMER IT...SCREW IT...

THE MARK CONSISTS OF STANDARD CHARACTERS WITHOUT CLAIM TO ANY PARTICULAR FONT, STYLE, SIZE, OR COLOR.  
FOR CUSTOM CONSTRUCTION AND BUILDING RENOVATION (U.S. CLS. 100, 103 AND 106).  
FIRST USE 9-1-2001; IN COMMERCE 9-1-2001.  
KRISTIN DAHLING, EXAMINING ATTORNEY

SN 78-964,842. SOUND ENVISIONS, LLC, ALEXANDRIA, VA. FILED 8-31-2006.

## Sound-EnVisions

THE MARK CONSISTS OF STANDARD CHARACTERS WITHOUT CLAIM TO ANY PARTICULAR FONT, STYLE, SIZE, OR COLOR.  
FOR IN-HOME INSTALLATION AND INTEGRATION OF HOME THEATER EQUIPMENT, SECURITY EQUIPMENT, AND SMART-HOME AUTOMATION EQUIPMENT (U.S. CLS. 100, 103 AND 106).  
FIRST USE 7-23-2006; IN COMMERCE 7-23-2006.  
JACLYN KIDWELL, EXAMINING ATTORNEY

SN 78-964,936. TEAM TERMITE & PEST CONTROL, INC., CORONA, CA. FILED 8-31-2006.

## TEAM TOO

THE MARK CONSISTS OF STANDARD CHARACTERS WITHOUT CLAIM TO ANY PARTICULAR FONT, STYLE, SIZE, OR COLOR.  
FOR TERMITE AND PEST CONTROL (U.S. CLS. 100, 103 AND 106).  
FIRST USE 2-7-2000; IN COMMERCE 2-7-2000.  
PETER B. BROMAGHIM, EXAMINING ATTORNEY

**CLASS 37—(Continued).**

SN 78-965,131. PN II, INC., LAS VEGAS, NV. FILED 8-31-2006.

## BRAEWELL

THE MARK CONSISTS OF STANDARD CHARACTERS WITHOUT CLAIM TO ANY PARTICULAR FONT, STYLE, SIZE, OR COLOR.  
FOR PLANNING AND LAYING OUT OF RESIDENTIAL COMMUNITIES, RECREATIONAL FACILITIES, SOCIAL AND COMMUNITY FACILITIES, OFFICE COMPLEXES, SHOPPING CENTERS AND MEETING AND CONVENTION CENTERS; AND CONSTRUCTION SERVICES, NAMELY, CONSTRUCTION OF RESIDENCES, RECREATIONAL FACILITIES, SOCIAL AND COMMUNITY FACILITIES AND COMMERCIAL BUILDINGS (U.S. CLS. 100, 103 AND 106).  
PETER B. BROMAGHIM, EXAMINING ATTORNEY

SN 78-965,945. NETCONG SERVICES LLC, DOVER, NJ. FILED 9-1-2006.

## A BETTER PLUMBER

THE MARK CONSISTS OF STANDARD CHARACTERS WITHOUT CLAIM TO ANY PARTICULAR FONT, STYLE, SIZE, OR COLOR.  
NO CLAIM IS MADE TO THE EXCLUSIVE RIGHT TO USE "PLUMBER", APART FROM THE MARK AS SHOWN.  
FOR PLUMBING SERVICES (U.S. CLS. 100, 103 AND 106).  
ATTIYA MALIK, EXAMINING ATTORNEY

SN 78-966,236. FRANCIS DRILLING FLUIDS, LTD., CROWLEY, LA. FILED 9-1-2006.

## FRANCIS DRILLING FLUIDS

THE MARK CONSISTS OF STANDARD CHARACTERS WITHOUT CLAIM TO ANY PARTICULAR FONT, STYLE, SIZE, OR COLOR.  
NO CLAIM IS MADE TO THE EXCLUSIVE RIGHT TO USE "DRILLING FLUIDS", APART FROM THE MARK AS SHOWN.  
FOR RENTAL OF OIL WELL DRILLING TOOLS/EQUIPMENT; CLEANING OF VESSELS, BARGES, TANKS, RIGS AND EQUIPMENT; CLEANING OF INDUSTRIAL PREMISES (U.S. CLS. 100, 103 AND 106).  
HEATHER THOMPSON, EXAMINING ATTORNEY

**CLASS 37—(Continued).**

SN 78-966,780. THE RESIDENCE DOCTOR, INC, SPRING, TX. FILED S.R. 9-4-2006; AM. P.R. 1-31-2007.



NO CLAIM IS MADE TO THE EXCLUSIVE RIGHT TO USE "RESIDENCE", APART FROM THE MARK AS SHOWN.

THE MARK CONSISTS OF THE WORDING "THE RESIDENCE DOCTOR" ALONG WITH A DEPICTION OF A HOUSE FEATURING A REPETITIVE DESIGN COMPRISED OF HORIZONTAL LINES ON EITHER SIDE OF THE HOUSE.

FOR HOME BUILDING AND REPAIR; REMODELING OF HOUSES (U.S. CLS. 100, 103 AND 106).

FIRST USE 2-15-2005; IN COMMERCE 2-15-2005. MICHAEL GAAFAR, EXAMINING ATTORNEY

SN 78-967,062. SAMARITAN DEVELOPMENT, ROME, GA. FILED 9-5-2006.

**Samaritan Development**

THE MARK CONSISTS OF STANDARD CHARACTERS WITHOUT CLAIM TO ANY PARTICULAR FONT, STYLE, SIZE, OR COLOR.

NO CLAIM IS MADE TO THE EXCLUSIVE RIGHT TO USE "DEVELOPMENT", APART FROM THE MARK AS SHOWN.

FOR REAL ESTATE DEVELOPMENT (U.S. CLS. 100, 103 AND 106).

MORENO, PAUL, EXAMINING ATTORNEY

SN 78-967,542. NEW AGE ELECTRONICS, INC., CARSON, CA. FILED 9-5-2006.



NO CLAIM IS MADE TO THE EXCLUSIVE RIGHT TO USE "ELECTRONICS", APART FROM THE MARK AS SHOWN.

FOR REFURBISHING AND REMANUFACTURING OF ELECTRONIC EQUIPMENT TO THE ORDER AND SPECIFICATION OF OTHERS (U.S. CLS. 100, 103 AND 106).

FIRST USE 9-30-2000; IN COMMERCE 9-30-2000. GRETTA YAO, EXAMINING ATTORNEY

**CLASS 37—(Continued).**

SN 78-968,633. KORNUTIK, CHARLES H, SCRANTON, PA. FILED 9-7-2006.



NO CLAIM IS MADE TO THE EXCLUSIVE RIGHT TO USE "NETWORKS", APART FROM THE MARK AS SHOWN.

THE COLOR(S) BLACK GREY GREEN IS/ARE CLAIMED AS A FEATURE OF THE MARK.

THE COLOR GREEN APPEARS IN THE LEAVES OF THE TREE DESIGN AND IN THE WORDING "NETWORKS". THE COLOR GRAY APPEARS IN THE TRUNK OF THE TREE DESIGN AND IN THE WORDING "IRON-TREE", AND THE COLOR BLACK APPEARS IN THE OUTLINE OF THE WORDING "IRON-TREE", IN THE UNDERLINING BELOW THE WORDING "NETWORKS", AND IN THE WORDING "GROWING STRONG SOLUTIONS FOR YOUR BUSINESS".

FOR COMPUTER SERVICES, NAMELY, INSTALLATION AND MAINTENANCE OF COMPUTER NETWORKS (U.S. CLS. 100, 103 AND 106).

ATTIYA MALIK, EXAMINING ATTORNEY

SN 78-969,223. AMERICORP HOMES, INC., NEWTOWN, PA. FILED 9-7-2006.

**YOUR SEARCH IS OVER**

THE MARK CONSISTS OF STANDARD CHARACTERS WITHOUT CLAIM TO ANY PARTICULAR FONT, STYLE, SIZE, OR COLOR.

FOR RESIDENTIAL AND COMMERCIAL BUILDING CONSTRUCTION (U.S. CLS. 100, 103 AND 106).

RONALD MCMORROW, EXAMINING ATTORNEY

**CLASS 37—(Continued).**

SN 78-970,809. RISHE, MITCHELL, LOS ANGELES, CA.  
FILED 9-9-2006.



NO CLAIM IS MADE TO THE EXCLUSIVE RIGHT TO USE "CLEANERS", APART FROM THE MARK AS SHOWN.

THE APPLICANT CLAIMS COLOR AS A FEATURE OF THE MARK, NAMELY, BLUE AND GREEN.

THE MARK CONSISTS OF AN IMAGE ELEMENT OF THREE CLOCKWISE ROTATING WATER DROPLETS OF PREDOMINATELY BLUE COLORING WITH GREEN HIGHLIGHTS, AND THE WORDS "BREATHE CLEANERS" IN LOWERCASE LETTERS, COLORED BLUE AND POSITIONED TO THE RIGHT OF THE IMAGE ELEMENT, WITH THE WORD "BREATHE" IN LARGE LETTERS AND POSITIONED ABOVE THE WORD "CLEANERS".

FOR CLEANING OF CLOTHING; DRY CLEANING; TEXTILE CLEANING (U.S. CLS. 100, 103 AND 106).  
MARC LEIPZIG, EXAMINING ATTORNEY

**CLASS 38—(Continued).**

SN 76-665,478. GOTVMAIL COMMUNICATIONS, LLC, WESTON, MA. FILED 9-1-2006.

**PHONE FAQ**

THE MARK CONSISTS OF STANDARD CHARACTERS WITHOUT CLAIM TO ANY PARTICULAR FONT, STYLE, SIZE, OR COLOR.

NO CLAIM IS MADE TO THE EXCLUSIVE RIGHT TO USE "PHONE", APART FROM THE MARK AS SHOWN.

FOR TELECOMMUNICATIONS SERVICES, NAMELY VOICE MAIL SERVICES, TOLL FREE TELEPHONE SERVICES, AND WIRELESS PBX SERVICES (U.S. CLS. 100, 101 AND 104).

COLLEEN DOMBROW, EXAMINING ATTORNEY

SN 77-051,433. COMUNIDAD HUEVO, S.A. DE C.V., COL. DE VALLE, MEXICO, D.F., MEXICO, FILED 11-27-2006.

**CLASS 38—COMMUNICATION**

SN 76-639,130. NEW HOME WATCH, L.L.C., BRIGHTON, MI.  
FILED 5-20-2005.

**New Home Photo Watch**

THE MARK CONSISTS OF STANDARD CHARACTERS WITHOUT CLAIM TO ANY PARTICULAR FONT, STYLE, SIZE, OR COLOR.

OWNER OF U.S. REG. NO. 3,102,809.

NO CLAIM IS MADE TO THE EXCLUSIVE RIGHT TO USE "NEW HOME PHOTO", APART FROM THE MARK AS SHOWN.

FOR ELECTRONIC DELIVERY OF IMAGES AND PHOTOGRAPHS VIA A GLOBAL COMPUTER NETWORK (U.S. CLS. 100, 101 AND 104).

FIRST USE 8-4-2003; IN COMMERCE 8-4-2003.

ODESSA BIBBINS, EXAMINING ATTORNEY

**LOS SUPER ESTUPENDOS**

THE MARK CONSISTS OF STANDARD CHARACTERS WITHOUT CLAIM TO ANY PARTICULAR FONT, STYLE, SIZE, OR COLOR.

OWNER OF MEXICO REG. NO. 847377, DATED 8-17-2004, EXPIRES 7-16-2014.

THE FOREIGN WORDING IN THE MARK TRANSLATES INTO ENGLISH AS THE SUPER STUPENDOUS.

FOR DATA TRANSMISSION AND RECEPTION SERVICES VIA TELECOMMUNICATION MEANS; ELECTRONIC EXCHANGE OF DATA STORED IN DATABASES ACCESSIBLE VIA TELECOMMUNICATION NETWORKS; PROVIDING ON-LINE COMMUNICATIONS LINKS WHICH TRANSFER THE WEBSITE USER TO OTHER LOCAL AND GLOBAL WEB PAGES; TRANSMISSION OF DATABASE INFORMATION VIA TELECOMMUNICATIONS NETWORKS; TRANSMISSION OF INFORMATION ON OPTICAL TELECOMMUNICATION NETWORKS (U.S. CLS. 100, 101 AND 104).

SCOTT SISUN, EXAMINING ATTORNEY



**CLASS 38—(Continued).**

SN 78-620,705. PNG TELECOMMUNICATIONS, INC., FAIRFIELD, OH. FILED 5-2-2005.

**CLASS 38—(Continued).**

SN 78-791,739. ROKU, L.L.C., PALO ALTO, CA. FILED 1-13-2006.

## CROSSCONNECT

THE MARK CONSISTS OF STANDARD CHARACTERS WITHOUT CLAIM TO ANY PARTICULAR FONT, STYLE, SIZE, OR COLOR.

FOR ENHANCED VOICE AND DATA COMMUNICATIONS SERVICES, NAMELY, TRANSMISSION OF LONG DISTANCE TELEPHONE COMMUNICATIONS, ELECTRONIC TRANSMISSION OF FACSIMILE COMMUNICATIONS AND DATA FEATURING ENCRYPTION AND DECRYPTION, ELECTRONIC VOICE MESSAGING, NAMELY, THE RECORDING, STORAGE AND SUBSEQUENT TRANSMISSION OF VOICE MESSAGES BY TELEPHONE; PROVIDING MULTIPLE USER ACCESS TO A GLOBAL COMPUTER INFORMATION NETWORK; TELECOMMUNICATIONS SERVICES, NAMELY, AUDIO TELECONFERENCING (U.S. CLS. 100, 101 AND 104).

MATTHEW MCDOWELL, EXAMINING ATTORNEY

---

SN 78-633,468. AIR MEDIA, INC., SAN FRANCISCO, CA. FILED 5-19-2005.

## AIRMEDIA

THE MARK CONSISTS OF STANDARD CHARACTERS WITHOUT CLAIM TO ANY PARTICULAR FONT, STYLE, SIZE, OR COLOR.

FOR ELECTRONIC TRANSMISSION OF MUSICAL RECORDINGS, CUSTOMIZED RING TONES, GAMES, SCREEN SAVERS AND WALLPAPER TO MOBILE COMMUNICATION DEVICES VIA THE INTERNET (U.S. CLS. 100, 101 AND 104).

FIRST USE 1-0-2004; IN COMMERCE 1-0-2004.  
 ASMAT KHAN, EXAMINING ATTORNEY

---

SN 78-687,954. AMERICAN FARM BUREAU FEDERATION, WASHINGTON, DC. FILED 8-8-2005.

## FB CONNECT

THE MARK CONSISTS OF STANDARD CHARACTERS WITHOUT CLAIM TO ANY PARTICULAR FONT, STYLE, SIZE, OR COLOR.

OWNER OF U.S. REG. NOS. 2,485,448 AND 2,573,975.  
 NO CLAIM IS MADE TO THE EXCLUSIVE RIGHT TO USE "CONNECT", APART FROM THE MARK AS SHOWN.  
 FOR INTERNET ACCESS SERVICES (U.S. CLS. 100, 101 AND 104).

LEIGH CAROLINE CASE, EXAMINING ATTORNEY

## ROKU RADIO

THE MARK CONSISTS OF STANDARD CHARACTERS WITHOUT CLAIM TO ANY PARTICULAR FONT, STYLE, SIZE, OR COLOR.

OWNER OF U.S. REG. NO. 3,177,666.  
 NO CLAIM IS MADE TO THE EXCLUSIVE RIGHT TO USE "RADIO", APART FROM THE MARK AS SHOWN.

THE FOREIGN WORDING IN THE MARK TRANSLATES INTO ENGLISH AS SIX.

FOR TELECOMMUNICATION SERVICES, NAMELY, ELECTRONIC TRANSMISSION OF STREAMED AND DOWNLOADABLE AUDIO AND VIDEO FILES VIA COMPUTER AND OTHER COMMUNICATIONS NETWORKS; WEB CASTING SERVICES; PROVISION OF CONNECTIVITY SERVICES AND ACCESS TO ELECTRONIC COMMUNICATIONS NETWORKS, FOR TRANSMISSION OR RECEPTION OF AUDIO CONTENT (U.S. CLS. 100, 101 AND 104).

ELIZABETH J. WINTER, EXAMINING ATTORNEY

**CLASS 38—(Continued).**

SN 78-792,937. SPLICE COMMUNICATIONS, INC., SAN MATEO, CA. FILED 1-17-2006.

## Splice Communications

THE MARK CONSISTS OF STANDARD CHARACTERS WITHOUT CLAIM TO ANY PARTICULAR FONT, STYLE, SIZE, OR COLOR.

NO CLAIM IS MADE TO THE EXCLUSIVE RIGHT TO USE "COMMUNICATIONS", APART FROM THE MARK AS SHOWN.

FOR VOICE OVER INTERNET PROTOCOL SERVICES; TELECOMMUNICATION SERVICES, NAMELY, TELEPHONE AND MOBILE TELEPHONE COMMUNICATION SERVICES, ELECTRONIC TRANSMISSION OF VIDEO SIGNALS AND MUSIC, WIRELESS TELEPHONE COMMUNICATION SERVICES, INTERNET TELEPHONE COMMUNICATION SERVICES, FACSIMILE SERVICES, VOICEMAIL SERVICES, ELECTRONIC TRANSMISSION OF DIGITAL VOICE AND DATA SIGNALS; LOCAL AND LONG DISTANCE TELEPHONE COMMUNICATION SERVICES FEATURING CALL-BACK AND CALLER-IDENTIFICATION; INTERNATIONAL AND MOBILE TELEPHONE COMMUNICATION SERVICES; PRE-PAID TELEPHONE COMMUNICATION SERVICES AND PRE-PAID LONG DISTANCE TELEPHONE SERVICES; ELECTRONIC TRANSMISSION OF DATA ACCESSIBLE BY ACCESS CODE OR BY COMPUTER TERMINALS; PROVIDING MULTIPLE-USER ACCESS TO THE INTERNET OR A GLOBAL COMPUTER NETWORK; ELECTRONIC TRANSMISSION OF DATA PACKETS; TELECOMMUNICATIONS SERVICES BY MEANS OF MOBILE PHONE SHORT MESSAGING, PAGING, FACSIMILE MACHINES; ELECTRONIC MAIL SERVICES; ELECTRONIC TRANSMISSION OF DATA CONTAINED IN DATA BANKS AND PICTURE BANKS; TELECOMMUNICATIONS CONSULTATION; RENTAL OF TELECOMMUNICATIONS APPARATUS AND INSTALLATIONS; PROVIDING TELECOMMUNICATION CONNECTIONS TO A GLOBAL COMPUTER NETWORK; PROVIDING ON-LINE CHAT ROOMS AND ELECTRONIC BULLETIN BOARDS FOR TRANSMISSION OF MESSAGES AMONG USERS IN THE FIELD OF GENERAL INTEREST; WIRELESS BROADBAND COMMUNICATION SERVICES; TELECOMMUNICATION GATEWAY SERVICES (U.S. CLS. 100, 101 AND 104).

FIRST USE 12-18-2002; IN COMMERCE 12-18-2002.

STEVEN R. FINE, EXAMINING ATTORNEY

SN 78-799,600. THUNDERSTORM MEDIA, INC., DALLAS, TX. FILED 1-25-2006.

## PAY PER HEAR

THE MARK CONSISTS OF STANDARD CHARACTERS WITHOUT CLAIM TO ANY PARTICULAR FONT, STYLE, SIZE, OR COLOR.

FOR LONG DISTANCE TELEPHONE COMMUNICATION SERVICES; PROVIDING VOICE COMMUNICATION SERVICES VIA THE INTERNET (U.S. CLS. 100, 101 AND 104).

RONALD MCMORROW, EXAMINING ATTORNEY

**CLASS 38—(Continued).**

SN 78-808,598. SONY KABUSHIKI KAISHA, TA SONY CORPORATION, TOKYO, JAPAN, FILED 2-7-2006.

## IPELA VC LINK

THE MARK CONSISTS OF STANDARD CHARACTERS WITHOUT CLAIM TO ANY PARTICULAR FONT, STYLE, SIZE, OR COLOR.

NO CLAIM IS MADE TO THE EXCLUSIVE RIGHT TO USE "VC LINK", APART FROM THE MARK AS SHOWN.

FOR TELECOMMUNICATION SERVICES, CONNECTING VIDEO CONFERENCING SYSTEMS USING BROADBAND INTERNET CONNECTION (U.S. CLS. 100, 101 AND 104).

JOHN SCHUYLER YARD, EXAMINING ATTORNEY

SN 78-815,972. KOLESAR, DAVID M., COLLEGE PARK, MD. FILED 2-15-2006.

## WGAY

THE MARK CONSISTS OF STANDARD CHARACTERS WITHOUT CLAIM TO ANY PARTICULAR FONT, STYLE, SIZE, OR COLOR.

FOR RADIO BROADCASTING; STREAMING OF AUDIO MATERIAL ON THE INTERNET (U.S. CLS. 100, 101 AND 104).

GISELLE AGOSTO, EXAMINING ATTORNEY

**CLASS 38—(Continued).**

SN 78-819,322. MEXICANAL, LLC, ATLANTA, GA. FILED 2-21-2006.



NO CLAIM IS MADE TO THE EXCLUSIVE RIGHT TO USE MX, APART FROM THE MARK AS SHOWN.

THE COLOR(S) RED, GREEN, AND WHITE IS/ARE CLAIMED AS A FEATURE OF THE MARK.

THE MARK CONSISTS OF AN OUTER GREEN AND ORANGE CIRCLE SURROUNDING A WHITE CIRCLE CONTAINING THE LETTERS "MX" IN ITS CENTER. THE OUTER CIRCLE IS PREDOMINATELY GREEN WITH THE RIGHT QUARTER BEING ORANGE. THE OUTER CIRCLE CONTAINS AN AZTEC DESIGN OF INTERCONNECTING LINKS. THE MX IS IN ORANGE.

FOR BROADCAST OF PROGRAMS FOR TELEVISION AND RADIO, INCLUDING REGIONAL PROGRAMMING FROM PUBLIC BROADCASTERS, INDEPENDENT PRODUCERS AND LOCAL ACCESS STATIONS FROM MEXICAN STATES (U.S. CLS. 100, 101 AND 104).

FIRST USE 8-22-2005; IN COMMERCE 8-22-2005.  
TARAH HARDY, EXAMINING ATTORNEY

SN 78-840,967. VIACOM INTERNATIONAL INC., NEW YORK, NY. FILED 3-20-2006.



FOR RADIO, TELEVISION AND CABLE TELEVISION BROADCASTING SERVICES (U.S. CLS. 100, 101 AND 104).

FIRST USE 1-1-2006; IN COMMERCE 1-1-2006.  
MICHELE SWAIN, EXAMINING ATTORNEY

SN 78-851,972. UNDERKOFER, MARK, C., HIGHLAND VILLAGE, TX. FILED 4-1-2006.

**Great Radio Ladies**

THE MARK CONSISTS OF STANDARD CHARACTERS WITHOUT CLAIM TO ANY PARTICULAR FONT, STYLE, SIZE, OR COLOR.

NO CLAIM IS MADE TO THE EXCLUSIVE RIGHT TO USE "GREAT RADIO", APART FROM THE MARK AS SHOWN.

FOR RADIO PROGRAM BROADCASTING (U.S. CLS. 100, 101 AND 104).  
SANI KHOURI, EXAMINING ATTORNEY

**CLASS 38—(Continued).**

SN 78-860,711. PROSPER MARKETPLACE, INC., MEZZANINE, CA. FILED 4-13-2006.



THE COLOR(S) BLUE AND WHITE IS/ARE CLAIMED AS A FEATURE OF THE MARK.

THE COLOR WHITE APPEARS ONLY IN THE STAR DESIGN FEATURED INSIDE THE BLUE CIRCLE DESIGN PORTION OF THE MARK.

FOR TELECOMMUNICATIONS SERVICES, NAMELY ELECTRONIC TRANSMISSION OF DATA AND MESSAGES; ONLINE INTERACTIVE BULLETIN BOARD AND CHAT ROOM FOR TRANSMISSION OF MESSAGES AMONG USERS CONCERNING FINANCIAL MATTERS (U.S. CLS. 100, 101 AND 104).

FIRST USE 2-5-2006; IN COMMERCE 2-5-2006.  
KELLY CHOE, EXAMINING ATTORNEY

SN 78-920,729. HEALTHLIFE TV LLC, NEW YORK, NY. FILED 6-30-2006.

**LEARN.SHARE.CONNECT.**

THE MARK CONSISTS OF STANDARD CHARACTERS WITHOUT CLAIM TO ANY PARTICULAR FONT, STYLE, SIZE, OR COLOR.

FOR BROADCASTING PROGRAMS VIA THE INTERNET, CABLE TELEVISION, AND HANDHELD DEVICES INCLUDING MOBILE PHONES; STREAMING OF AUDIO AND VIDEO MATERIAL ON THE INTERNET; WEBCASTING SERVICES; PODCASTING SERVICES; PROVIDING ONLINE CHAT ROOMS, ELECTRONIC BULLETIN BOARDS, ONLINE FORUMS AND LISTSERVERS FOR TRANSMISSION OF MESSAGES IN THE FIELDS OF HEALTH AND HEALTH CARE; AND TRANSMISSION OF INFORMATION, NEWS, AND MESSAGES IN THE FIELDS OF HEALTH AND HEALTH CARE OVER ELECTRONIC MEDIA (U.S. CLS. 100, 101 AND 104).

ALEX KEAM, EXAMINING ATTORNEY

**CLASS 38—(Continued).**

SN 78-922,922. ALEX H. PEREZ, FAIRFAX, VA. FILED 7-5-2006.

# Hello Familia

THE MARK CONSISTS OF STANDARD CHARACTERS WITHOUT CLAIM TO ANY PARTICULAR FONT, STYLE, SIZE, OR COLOR.

THE ENGLISH TRANSLATION OF THE WORD FAMILIA IN THE MARK IS FAMILY.

FOR LONG DISTANCE TELEPHONE COMMUNICATION SERVICES; PREPAID LONG DISTANCE TELEPHONE SERVICES; TELECOMMUNICATION SERVICES IN THE FIELD OF PROVIDING LONG DISTANCE SERVICE WITH AUDIO ADVERTISING FOR OTHERS AS A COMPONENT OF THE LONG DISTANCE SERVICE (U.S. CLS. 100, 101 AND 104).

NAKIA HENRY, EXAMINING ATTORNEY

SN 78-927,090. COMTEL TELCOM ASSETS LP, IRVING, TX. FILED 7-11-2006.



The logo for 'Excel' features the word 'Excel' in a bold, sans-serif font. A thick, black, curved line starts above the 'x', arches over the 'e' and 'l', and ends below the 'l'.

OWNER OF U.S. REG. NOS. 1,648,364 AND 2,365,269.

FOR TELECOMMUNICATION SERVICES, NAMELY, PROVIDING LOCAL, LONG DISTANCE AND INTERNATIONAL TELEPHONE SERVICES FOR RESIDENTIAL AND BUSINESS APPLICATIONS; TOLL-FREE AND TOLL-BASED TELECOMMUNICATIONS GATEWAY SERVICES; CELLULAR AND MOBILE TELEPHONE COMMUNICATIONS; VOICE OVER INTERNET PROTOCOL (VOIP) TELECOMMUNICATIONS SERVICE APPLICATIONS; AND PROVIDING MULTIPLE-USER DIAL-UP AND HIGH SPEED ACCESS TO THE INTERNET (U.S. CLS. 100, 101 AND 104).

FIRST USE 6-7-2006; IN COMMERCE 6-7-2006.

SKYE YOUNG, EXAMINING ATTORNEY

**CLASS 38—(Continued).**

SN 78-928,017. NORTH PITTSBURGH SYSTEMS, INC., GIBSONIA, PA. FILED 7-12-2006.



The logo features the letters 'NPSI' in a blue, sans-serif font at the top. Below them is a large, stylized '100' where the zeros are filled with a yellow and white striped pattern. Underneath the '100' is a blue horizontal bar with the word 'YEARS' in white, sans-serif capital letters. At the bottom, the phrase 'JUST THE BEGINNING' is written in a blue, sans-serif font.

THE COLOR(S) BLUE, YELLOW, AND WHITE IS/ARE CLAIMED AS A FEATURE OF THE MARK.

THE COLOR BLUE APPEARS IN THE WORDING NPSI 100 JUST THE BEGINNING, THE SHADED RECTANGLE, AND THE UNDERLINING. THE COLOR YELLOW APPEARS IN THE STYLIZED SKYLINE DESIGN SUPERIMPOSED ON 100. THE COLOR WHITE APPEARS IN THE WORD YEARS AND THE BACKGROUND.

FOR TELECOMMUNICATION SERVICES, NAMELY, LOCAL AND LONG DISTANCE TRANSMISSION OF VOICE, DATA, GRAPHICS BY MEANS OF TELEPHONE, TELEGRAPHIC, CABLE, AND SATELLITE TRANSMISSIONS (U.S. CLS. 100, 101 AND 104).

FIRST USE 2-1-2006; IN COMMERCE 2-1-2006.

ALLISON HOLTZ, EXAMINING ATTORNEY

SN 78-948,437. OPTIONS TECHNOLOGY LIMITED, LONDON, ENGLAND. FILED 8-9-2006.

# OPTIONS PIPE

THE MARK CONSISTS OF STANDARD CHARACTERS WITHOUT CLAIM TO ANY PARTICULAR FONT, STYLE, SIZE, OR COLOR.

OWNER OF UNITED KINGDOM REG. NO. 2397429, DATED 7-21-2005, EXPIRES 7-21-2015.

FOR COMMUNICATION SERVICES, NAMELY, ELECTRONIC TRANSMISSION OF DATA AND DOCUMENTS AMONG USERS OF COMPUTERS; ELECTRONIC DATA TRANSMISSION; AND PROVIDING ACCESS TO DATABASES (U.S. CLS. 100, 101 AND 104).

ROSELLE HERRERA, EXAMINING ATTORNEY

**CLASS 38—(Continued).**

SN 78-951,719. ROSS, TROTTER & WOLFE LLC, SEATTLE, WA. FILED 8-14-2006.

# VEGASFLUX

THE MARK CONSISTS OF STANDARD CHARACTERS WITHOUT CLAIM TO ANY PARTICULAR FONT, STYLE, SIZE, OR COLOR.

FOR PROVIDING ONLINE FACILITIES AND FORUMS FOR REAL-TIME INTERACTION AMONG USERS WITH SIMILAR INTERESTS CONCERNING TOPICS OF BUSINESS AND PERSONAL NETWORKING, BUSINESS AND PERSONAL SOCIAL INTERACTION, AND GENERAL INTEREST; PROVIDING ONLINE CHAT ROOMS AND ELECTRONIC BULLETIN AND MESSAGE BOARDS FOR TRANSMISSION OF MESSAGES AMONG USERS IN THE FIELD OF BUSINESS AND PERSONAL NETWORKING, BUSINESS AND PERSONAL SOCIAL INTERACTION, AND GENERAL INTEREST (U.S. CLS. 100, 101 AND 104).

SEAN CROWLEY, EXAMINING ATTORNEY

SN 78-957,743. BONNEVILLE INTERNATIONAL CORPORATION, SALT LAKE CITY, UT. FILED 8-22-2006.

# WDRV

THE MARK CONSISTS OF STANDARD CHARACTERS WITHOUT CLAIM TO ANY PARTICULAR FONT, STYLE, SIZE, OR COLOR.

FOR RADIO BROADCASTING SERVICES (U.S. CLS. 100, 101 AND 104).

FIRST USE 3-15-2001; IN COMMERCE 3-15-2001.  
BENJAMIN ALLEN, EXAMINING ATTORNEY

SN 78-958,380. BONNEVILLE INTERNATIONAL CORPORATION, SALT LAKE CITY, UT. FILED 8-23-2006.

# WFED

THE MARK CONSISTS OF STANDARD CHARACTERS WITHOUT CLAIM TO ANY PARTICULAR FONT, STYLE, SIZE, OR COLOR.

FOR RADIO BROADCASTING SERVICES (U.S. CLS. 100, 101 AND 104).

FIRST USE 12-13-2004; IN COMMERCE 12-13-2004.  
BENJAMIN ALLEN, EXAMINING ATTORNEY

**CLASS 38—(Continued).**

SN 78-958,410. BONNEVILLE INTERNATIONAL CORPORATION, SALT LAKE CITY, UT. FILED 8-23-2006.

# WTOP

THE MARK CONSISTS OF STANDARD CHARACTERS WITHOUT CLAIM TO ANY PARTICULAR FONT, STYLE, SIZE, OR COLOR.

FOR RADIO BROADCASTING SERVICES (U.S. CLS. 100, 101 AND 104).

FIRST USE 1-11-2006; IN COMMERCE 1-11-2006.  
BENJAMIN ALLEN, EXAMINING ATTORNEY

SN 78-958,560. MEDIA FIVE CORPORATION, VINCENNES, IN. FILED 8-23-2006.

# Hot 96 WFML

THE MARK CONSISTS OF STANDARD CHARACTERS WITHOUT CLAIM TO ANY PARTICULAR FONT, STYLE, SIZE, OR COLOR.

NO CLAIM IS MADE TO THE EXCLUSIVE RIGHT TO USE 96, APART FROM THE MARK AS SHOWN.

FOR RADIO BROADCASTING (U.S. CLS. 100, 101 AND 104).

FIRST USE 4-1-2002; IN COMMERCE 4-1-2002.  
BERNICE HOWSE, EXAMINING ATTORNEY

SN 78-964,808. RUMBERA STEREO 101.9 F.M., C.A., VALEN-  
CIA, VENEZUELA, FILED 8-31-2006.

# SI ERES FELIZ...ESTÁS AQUÍ

THE MARK CONSISTS OF STANDARD CHARACTERS WITHOUT CLAIM TO ANY PARTICULAR FONT, STYLE, SIZE, OR COLOR.

THE FOREIGN WORDING IN THE MARK TRANSLATES INTO ENGLISH AS IF YOU ARE HAPPY...YOU ARE HERE.

FOR RADIO BROADCASTING, CABLE TELEVISION BROADCASTING (U.S. CLS. 100, 101 AND 104).

JACLYN KIDWELL, EXAMINING ATTORNEY

**CLASS 38—(Continued).**

SN 78-964,998. EARTHLINK, INC., ATLANTA, GA. FILED 8-31-2006.

## EARTHLINK HOTSPOT ACCESS

THE MARK CONSISTS OF STANDARD CHARACTERS WITHOUT CLAIM TO ANY PARTICULAR FONT, STYLE, SIZE, OR COLOR.

OWNER OF U.S. REG. NOS. 2,556,818, 3,091,563 AND OTHERS.

NO CLAIM IS MADE TO THE EXCLUSIVE RIGHT TO USE "HOTSPOT ACCESS", APART FROM THE MARK AS SHOWN.

FOR TELECOMMUNICATION SERVICES, NAMELY, PROVIDING HIGH-SPEED WIRELESS INTERNET ACCESS TO END-USERS AT SPECIFIC LOCATIONS (U.S. CLS. 100, 101 AND 104).

LINDA LAVACHE, EXAMINING ATTORNEY

---

SN 78-965,910. CBS BROADCASTING INC., NEW YORK, NY. FILED 9-1-2006.

## INNERTUBE

THE MARK CONSISTS OF STANDARD CHARACTERS WITHOUT CLAIM TO ANY PARTICULAR FONT, STYLE, SIZE, OR COLOR.

FOR VIDEO BROADCASTING AND DIGITAL TRANSMISSION OF VOICE, DATA, IMAGES, SIGNALS AND MESSAGES VIA THE INTERNET AND WIRELESS COMMUNICATIONS NETWORKS (U.S. CLS. 100, 101 AND 104).

FIRST USE 5-5-2006; IN COMMERCE 5-5-2006.

CHARLES L. JENKINS, EXAMINING ATTORNEY

---

SN 78-966,023. CBS BROADCASTING INC., NEW YORK, NY. FILED 9-1-2006.



THE MARK CONSISTS OF THE WORD "INNERTUBE" ACCOMPANIED BY THE STYLIZED DESIGN OF A VIEWING SCREEN.

FOR VIDEO BROADCASTING AND DIGITAL TRANSMISSION OF VOICE, DATA, IMAGES, SIGNALS AND MESSAGES VIA THE INTERNET AND WIRELESS COMMUNICATIONS NETWORKS (U.S. CLS. 100, 101 AND 104).

FIRST USE 5-5-2006; IN COMMERCE 5-5-2006.

CHARLES L. JENKINS, EXAMINING ATTORNEY

**CLASS 38—(Continued).**

SN 78-966,079. ILLUMOBILE CORPORATION, BERKELEY, CA. FILED 9-1-2006.

## illumobile

THE MARK CONSISTS OF STANDARD CHARACTERS WITHOUT CLAIM TO ANY PARTICULAR FONT, STYLE, SIZE, OR COLOR.

FOR MOBILE MEDIA AND ENTERTAINMENT SERVICES IN THE NATURE OF ELECTRONIC TRANSMISSION OF ENTERTAINMENT MEDIA CONTENT (U.S. CLS. 100, 101 AND 104).

ATTIYA MALIK, EXAMINING ATTORNEY

---

SN 78-966,950. THE WORLD COMPANY, LAWRENCE, KS. FILED 9-5-2006.

## WAVE RUNNER

THE MARK CONSISTS OF STANDARD CHARACTERS WITHOUT CLAIM TO ANY PARTICULAR FONT, STYLE, SIZE, OR COLOR.

FOR PROVIDING WIRELESS INTERNET ACCESS SERVICES TO RURAL CUSTOMERS (U.S. CLS. 100, 101 AND 104).

FIRST USE 8-22-2006; IN COMMERCE 8-22-2006.

CAROLINE WOOD, EXAMINING ATTORNEY

---

SN 78-968,525. NETCHOICETV INC., PETALUMA, CA. FILED 9-6-2006.

## MYPATH TV

THE MARK CONSISTS OF STANDARD CHARACTERS WITHOUT CLAIM TO ANY PARTICULAR FONT, STYLE, SIZE, OR COLOR.

NO CLAIM IS MADE TO THE EXCLUSIVE RIGHT TO USE "TV", APART FROM THE MARK AS SHOWN.

FOR STREAMING OF VIDEO MATERIAL ON THE INTERNET (U.S. CLS. 100, 101 AND 104).

WENDY GOODMAN, EXAMINING ATTORNEY

**CLASS 38—(Continued).**

SN 78-970,409. V-ENABLE, INC, SAN DIEGO, CA. FILED 9-8-2006.

# SPEAK UP!

THE MARK CONSISTS OF STANDARD CHARACTERS WITHOUT CLAIM TO ANY PARTICULAR FONT, STYLE, SIZE, OR COLOR.

FOR VOICE ACTIVATED TELECOMMUNICATION SERVICES, NAMELY DATA TRANSMISSION AND RECEPTION SERVICES VIA TELECOMMUNICATION MEANS; ELECTRONIC EXCHANGE OF VOICE, DATA, AND GRAPHICS ACCESSIBLE VIA COMPUTER AND TELECOMMUNICATION NETWORKS (U.S. CLS. 100, 101 AND 104).

WILLIAM P. SHANAHAN, EXAMINING ATTORNEY

SN 78-970,500. AOL LLC, DULLES, VA. FILED 9-8-2006.

# PEOPLESPLACE

THE MARK CONSISTS OF STANDARD CHARACTERS WITHOUT CLAIM TO ANY PARTICULAR FONT, STYLE, SIZE, OR COLOR.

OWNER OF U.S. REG. NO. 2,386,795.

FOR TELECOMMUNICATIONS SERVICES, NAMELY, ELECTRONIC TRANSMISSION OF DATA, IMAGES, DOCUMENTS, AND SOUND VIA COMPUTER NETWORKS; PROVIDING ONLINE ELECTRONIC BULLETIN BOARDS AND CHAT ROOMS FOR TRANSMISSION OF MESSAGES, PHOTOS, AND NOTES AMONG A GROUP OF COMPUTER USERS CONCERNING MUSIC, MOVIES, SPORTS, EDUCATION, COMICS, COMPUTER GAMES, NEWS, AND USER-DEFINED TOPICS OF GENERAL INTEREST; PROVIDING ONLINE COMPUTER NETWORK FACILITIES FOR REAL TIME INTERACTION AND COMMUNICATION WITH OTHER COMPUTER USERS CONCERNING TOPICS OF GENERAL INTEREST; ELECTRONIC MAIL SERVICES; PROVIDING MULTIPLE USER ACCESS TO COMPUTER NETWORKS; ONLINE PAGING SERVICES; ELECTRONIC STORE-AND-FORWARD MESSAGING SERVICES (U.S. CLS. 100, 101 AND 104).

ALICE SUE CARRUTHERS, EXAMINING ATTORNEY

**CLASS 38—(Continued).**

SN 79-028,946. CARMUNITY.COM GMBH, FED REP GERMANY, FILED 8-10-2006.

# moobabes

THE MARK CONSISTS OF STANDARD CHARACTERS WITHOUT CLAIM TO ANY PARTICULAR FONT, STYLE, SIZE, OR COLOR.

OWNER OF INTERNATIONAL REGISTRATION 0898637 DATED 8-10-2006, EXPIRES 8-10-2016.

FOR TELECOMMUNICATIONS SERVICES, NAMELY, PERSONAL COMMUNICATION SERVICES, TELECOMMUNICATIONS ACCESS SERVICES, STREAMING OF VIDEO TO TELECOMMUNICATIONS DEVICES OVER A TELECOMMUNICATIONS NETWORK, DATA TRANSMISSION AND RECEPTION SERVICES VIA TELECOMMUNICATIONS MEANS (U.S. CLS. 100, 101 AND 104).

ELI HELLMAN, EXAMINING ATTORNEY

**CLASS 39—TRANSPORTATION AND STORAGE**

SN 76-308,066. JOHNSON BANK, RACINE, WI. FILED 9-4-2001.

IN-STOCK FOR  

NO CLAIM IS MADE TO THE EXCLUSIVE RIGHT TO USE "IN-STOCK FOR QUICK SHIP", APART FROM THE MARK AS SHOWN.

FOR DELIVERY SERVICES, NAMELY, EXPRESS SHIPMENT OF LIGHTING FIXTURES AND LIGHTING ACCESSORIES (U.S. CLS. 100 AND 105).

ALICIA COLLINS, EXAMINING ATTORNEY

SN 76-641,361. ROMANCE BY CANDLELIGHT, LLC, PORTSMOUTH, VA. FILED 6-22-2005.

# Romance by Candlelight St. John 14:13

THE MARK CONSISTS OF STANDARD CHARACTERS WITHOUT CLAIM TO ANY PARTICULAR FONT, STYLE, SIZE, OR COLOR.

NO CLAIM IS MADE TO THE EXCLUSIVE RIGHT TO USE "ST. JOHN 14:13", APART FROM THE MARK AS SHOWN.

FOR TRAVEL BOOKING AGENCIES, NAMELY PROVIDING GET-AWAY PACKAGES TO THE GENERAL PUBLIC (U.S. CLS. 100 AND 105).

ANTHONY RINKER, EXAMINING ATTORNEY

**CLASS 39—(Continued).**

SN 76-665,329. LAKE, ROBERT JOHN, BURLINGTON, VT. FILED 8-29-2006.

**SDL TRANSPORTATION**

THE MARK CONSISTS OF STANDARD CHARACTERS WITHOUT CLAIM TO ANY PARTICULAR FONT, STYLE, SIZE, OR COLOR.

NO CLAIM IS MADE TO THE EXCLUSIVE RIGHT TO USE TRANSPORTATION, APART FROM THE MARK AS SHOWN.

FOR TRANSPORTATION SERVICES, SPECIFICALLY, TRANSPORTATION OF GOODS BY TRUCK (U.S. CLS. 100 AND 105).

FIRST USE 8-1-2003; IN COMMERCE 8-1-2003.  
PATRICIA EVANKO, EXAMINING ATTORNEY

SN 77-058,440. RIATA ENERGY, INC., OKLAHOMA CITY, OK. FILED 12-6-2006.



NO CLAIM IS MADE TO THE EXCLUSIVE RIGHT TO USE "ENERGY", APART FROM THE MARK AS SHOWN.

THE APPLICANT CLAIMS COLOR AS A FEATURE OF THE MARK, NAMELY, BLACK AND RED.

THE MARK CONSISTS OF THE WORDS SANDRIDGE ENERGY IN STYLIZED BLACK LETTERS WITH A BLACK CURVED LINE AND A RED CURVED LINE.

FOR TRANSPORTATION BY WAY OF SHIP, BARGE, TRUCK, RAIL AND PIPELINE OF OIL AND GAS (U.S. CLS. 100 AND 105).

JIM RINGLE, EXAMINING ATTORNEY

SN 78-661,778. TIMOTHY J CASH, CENTURIA, WI. FILED 6-30-2005.

**ratemyfreight**

THE MARK CONSISTS OF STANDARD CHARACTERS WITHOUT CLAIM TO ANY PARTICULAR FONT, STYLE, SIZE, OR COLOR.

FOR FREIGHT BROKERAGE (U.S. CLS. 100 AND 105).  
FIRST USE 4-15-2005; IN COMMERCE 4-15-2005.  
MICHELE SWAIN, EXAMINING ATTORNEY

**CLASS 39—(Continued).**

SN 78-682,011. M MARKETING GROUP, INC., DELRAY BEACH, FL. FILED 7-29-2005.

MOISHE'S MOVING AND STORAGE

THE MARK CONSISTS OF STANDARD CHARACTERS WITHOUT CLAIM TO ANY PARTICULAR FONT, STYLE, SIZE, OR COLOR.

NO CLAIM IS MADE TO THE EXCLUSIVE RIGHT TO USE "MOVING AND STORAGE", APART FROM THE MARK AS SHOWN.

FOR FURNITURE MOVING; FURNITURE STORAGE (U.S. CLS. 100 AND 105).

FIRST USE 4-5-1982; IN COMMERCE 4-5-1982.  
MARTHA FROMM, EXAMINING ATTORNEY

SN 78-761,021. EXPRESS SOLUTIONS INTERNATIONAL, INC., BALTIMORE, MD. FILED 11-26-2005.

**ESI GLOBAL LOGISTICS**

THE MARK CONSISTS OF STANDARD CHARACTERS WITHOUT CLAIM TO ANY PARTICULAR FONT, STYLE, SIZE, OR COLOR.

NO CLAIM IS MADE TO THE EXCLUSIVE RIGHT TO USE "GLOBAL LOGISTICS", APART FROM THE MARK AS SHOWN.

FOR FREIGHT FORWARDING (U.S. CLS. 100 AND 105).

FIRST USE 9-4-2003; IN COMMERCE 10-27-2003.  
ALLISON HOLTZ, EXAMINING ATTORNEY

SN 78-769,440. VIAJES BARCELO, S.L., PALMA DE MAL-LORCA (BALEARES), SPAIN, FILED 12-8-2005.

**VACACIONES Barceló**

OWNER OF ERPN CMNTY TM OFC REG. NO. 3894508, DATED 10-19-2005, EXPIRES 6-28-2014.

NO CLAIM IS MADE TO THE EXCLUSIVE RIGHT TO USE "VACACIONES", APART FROM THE MARK AS SHOWN.

THE ENGLISH TRANSLATION OF THE WORD VACACIONES IN THE MARK IS VACATION.

FOR TRAVEL BOOKING AGENCIES (U.S. CLS. 100 AND 105).  
JILL PRATER, EXAMINING ATTORNEY



CLASS 39—(Continued).

SN 78-799,306. MACAU EAGLE AVIATION SERVICES LTD, EM MACAU, MACAO, FILED 1-25-2006.

VIVA MACAU

THE MARK CONSISTS OF STANDARD CHARACTERS WITHOUT CLAIM TO ANY PARTICULAR FONT, STYLE, SIZE, OR COLOR.

NO CLAIM IS MADE TO THE EXCLUSIVE RIGHT TO USE "MACAU", APART FROM THE MARK AS SHOWN.

FOR AIR TRANSPORT SERVICES; AIR PASSENGER AND CARGO TRANSPORT SERVICES; TRANSPORTATION OF BAGGAGE BY AIR; COLLECTION OF GOODS, LETTERS AND DOCUMENTS FOR TRANSPORTATION BY AIR; DELIVERY OF LETTERS, MAGAZINES, MESSAGES AND CORRESPONDENCES; DELIVERY OF GOODS BY AIR; BAGGAGE DELIVERY BY AIR; AND AIR TRANSPORTATION SERVICES OF PASSENGERS, CARGO, BAGGAGE, LETTERS, MAGAZINES, MESSAGES AND CORRESPONDENCE; MAIL AND COURIER SERVICES FOR MESSAGES AND LETTERS; LUGGAGE STORAGE SERVICES; CARGO UNLOADING SERVICES; CRATING AND DELIVERY OF AIR TRANSPORTATION GOODS; FREIGHT FORWARDING SERVICES; STORAGE OF AIR TRANSPORTATION GOODS; PARCEL DELIVERY SERVICES; ARRANGING OF TRAVEL; AIRLINE CHECK-IN SERVICES PRIOR TO TRAVEL; INFORMATION SERVICES RELATING TO TRAVEL; ISSUING OF AIRLINE TICKETS FOR TRAVEL; TRAVEL TICKET RESERVATION SERVICES; PROVISION OF INFORMATION RELATING TO AIR TRANSPORT SERVICES VIA THE INTERNET (U.S. CLS. 100 AND 105).

GRETTA YAO, EXAMINING ATTORNEY

CLASS 39—(Continued).

SN 78-799,313. MACAU EAGLE AVIATION SERVICES LTD, EM MACAU, MACAO, FILED 1-25-2006.



NO CLAIM IS MADE TO THE EXCLUSIVE RIGHT TO USE "SHYA MEN", APART FROM THE MARK AS SHOWN. THE FOREIGN WORDING IN THE MARK TRANSLATES INTO ENGLISH AS MACAU.

THE NON-LATIN CHARACTER(S) IN THE MARK TRANSLITERATES INTO SHYA MEN, AND THIS MEANS MACAU IN ENGLISH.

FOR AIR TRANSPORT SERVICES; AIR PASSENGER AND CARGO TRANSPORT SERVICES; TRANSPORTATION OF BAGGAGE BY AIR; COLLECTION OF GOODS, LETTERS AND DOCUMENTS FOR TRANSPORTATION BY AIR; DELIVERY OF LETTERS, MAGAZINES, MESSAGES AND CORRESPONDENCES; DELIVERY OF GOODS BY AIR; BAGGAGE DELIVERY BY AIR; AND AIR TRANSPORTATION SERVICES OF PASSENGERS, CARGO, BAGGAGE, LETTERS, MAGAZINES, MESSAGES AND CORRESPONDENCE; MAIL AND COURIER SERVICES FOR MESSAGES AND LETTERS; LUGGAGE STORAGE SERVICES; CARGO UNLOADING SERVICES; CRATING AND DELIVERY OF AIR TRANSPORTATION GOODS; FREIGHT FORWARDING SERVICES; STORAGE OF AIR TRANSPORTATION GOODS; PARCEL DELIVERY SERVICES; ARRANGING OF TRAVEL; AIRLINE CHECK-IN SERVICES PRIOR TO TRAVEL; INFORMATION SERVICES RELATING TO TRAVEL; ISSUING OF AIRLINE TICKETS FOR TRAVEL; TRAVEL TICKET RESERVATION SERVICES; PROVISION OF INFORMATION RELATING TO AIR TRANSPORT SERVICES VIA THE INTERNET (U.S. CLS. 100 AND 105).

GRETTA YAO, EXAMINING ATTORNEY

SN 78-810,181. GOOD, MICHAEL P., MARIETTA, GA. FILED 2-8-2006.

PET UNDERGROUND RAILROAD (P.U.R.R.)

THE MARK CONSISTS OF STANDARD CHARACTERS WITHOUT CLAIM TO ANY PARTICULAR FONT, STYLE, SIZE, OR COLOR.

FOR ANIMAL RESCUE SERVICES FOR ABUSED OR INJURED ANIMALS (U.S. CLS. 100 AND 105). SUZANNE BLANE, EXAMINING ATTORNEY

**CLASS 39—(Continued).**

SN 78-816,889. ROYAL CARIBBEAN CRUISES LTD., MIAMI, FL. FILED 2-16-2006.

## INDEPENDENCE OF THE SEAS

THE MARK CONSISTS OF STANDARD CHARACTERS WITHOUT CLAIM TO ANY PARTICULAR FONT, STYLE, SIZE, OR COLOR.

OWNER OF U.S. REG. NOS. 1,513,971, 1,955,356 AND OTHERS.

FOR CRUISE SHIP SERVICES; ARRANGING AND CONDUCTING CRUISES FOR OTHERS; TRANSPORTATION OF PASSENGERS BY SHIP (U.S. CLS. 100 AND 105).

KIMBERLY PERRY, EXAMINING ATTORNEY

SN 78-823,402. NORTHERN RHODE ISLAND SELF STORAGE INC., SMITHFIELD, RI. FILED 2-25-2006.

## SAY D Store At Your Door

THE MARK CONSISTS OF STANDARD CHARACTERS WITHOUT CLAIM TO ANY PARTICULAR FONT, STYLE, SIZE, OR COLOR.

FOR SELF STORAGE FACILITY SERVICES AND ONSITE SELF STORAGE SERVICES (U.S. CLS. 100 AND 105).

NAKIA HENRY, EXAMINING ATTORNEY

SN 78-907,177. AFFINITY CLUB NETWORK, L.L.C., PHILADELPHIA, PA. FILED 6-13-2006.



NO CLAIM IS MADE TO THE EXCLUSIVE RIGHT TO USE "CRUISE", APART FROM THE MARK AS SHOWN.

FOR ARRANGING AND PROVIDING CRUISE SHIP SERVICES (U.S. CLS. 100 AND 105).

STEPHEN AQUILA, EXAMINING ATTORNEY

**CLASS 39—(Continued).**

SN 78-920,289. SILVERJET PLC, LUTON, BEDFORDSHIRE, GREAT BRITAIN, FILED 6-29-2006.

## SILVERJET

THE MARK CONSISTS OF STANDARD CHARACTERS WITHOUT CLAIM TO ANY PARTICULAR FONT, STYLE, SIZE, OR COLOR.

PRIORITY CLAIMED UNDER SEC. 44(D) ON UNITED KINGDOM APPLICATION NO. 2412513, FILED 1-31-2006, REG. NO. 2412513, DATED 1-31-2006, EXPIRES 1-31-2016.

FOR STORAGE OF LUGGAGE AND CARGO; TRANSPORTATION OF PASSENGERS AND CARGO BY AIR, RAIL, SEA AND ROAD; TOWING SERVICES FOR AIRCRAFT; LEASING OF AIRCRAFT AND THEIR PARTS, LEASING OF AIRCRAFT ENGINES, COMPONENTS OR PARTS THEREOF; AIR TRANSPORTATION; FREIGHT AND PASSENGER TRANSPORTATION SERVICES BY MEANS OF AIR, SHIP, TRUCK, AND RAIL; VEHICLE RENTAL SERVICES; VEHICLE PARKING SERVICES; COURIER SERVICES; COURIER SERVICES FOR PACKAGES; AIRPORT PASSENGER AND BAGGAGE CHECK-IN SERVICES; PASSENGER TRANSPORTATION SERVICES, NAMELY, CHAUFFEUR SERVICES, LIMOUSINE SERVICES, TAXI TRANSPORTS, GROUND TRANSPORTATION SERVICES FOR PASSENGERS AND CARGO BY MEANS OF SHUTTLE BUS, CAR, TRUCK, AND RAIL; AIRPORT SERVICES, NAMELY, TICKETING AND BOARDING SERVICES; TRAVEL SERVICES, NAMELY, BOOKING SEATING ARRANGEMENTS FOR AIRLINE PASSENGERS; AIR TRANSPORTATION SERVICES FEATURING FREQUENT FLYER MILES AS A BONUS PROGRAM FOR FREQUENT AIR TRAVELERS; AIRCRAFT CHARTERING SERVICES; PACKAGE HOLIDAY TRAVEL BOOKING SERVICES; ARRANGING TRAVEL TOURS; TOURIST AGENCY SERVICES; TRAVEL AGENCY SERVICES, NAMELY, MAKING RESERVATIONS AND BOOKINGS FOR TRANSPORTATION; PROVIDING FLIGHT ARRIVAL AND DEPARTURE INFORMATION; TRANSPORTATION RESERVATION SERVICES; AIRLINE TRANSPORTATION SERVICES FEATURING PROVISION OF SLEEPER SEATS, DUVETS AND PILLOWS, EYE SHADES AND COMFORT KITS CONTAINING HYGIENE AND BEAUTY ITEMS (U.S. CLS. 100 AND 105).

DAVID TOOLEY, EXAMINING ATTORNEY

SN 78-939,951. DIAMOND AIRCRAFT INDUSTRIES INC., LONDON, ONTARIO, CANADA, FILED 7-28-2006.

## DIAMOND FLIGHT FOLLOWING

THE MARK CONSISTS OF STANDARD CHARACTERS WITHOUT CLAIM TO ANY PARTICULAR FONT, STYLE, SIZE, OR COLOR.

NO CLAIM IS MADE TO THE EXCLUSIVE RIGHT TO USE "FLIGHT", APART FROM THE MARK AS SHOWN.

FOR PROVIDING FLIGHT ARRIVAL AND DEPARTURE INFORMATION; PROVIDING ASSISTANCE IN BOOKING OF AVIATION FLIGHTS (U.S. CLS. 100 AND 105).

FIRST USE 11-30-2005; IN COMMERCE 11-30-2005.  
FLORENTINA BLANDU, EXAMINING ATTORNEY

**CLASS 39—(Continued).**

SN 78-941,910. CENTERPOINT ENERGY, INC., HOUSTON, TX. FILED 8-1-2006.



THE MARK CONSISTS OF A CIRCLE WITH THREE VERTICAL SWIRLED LINES DEPICTING A FLAME BEGINNING AT THE CENTER OF THE BOTTOM OF THE CIRCLE AND ONE HORIZONTAL SWIRLED LINE BENEATH THE CIRCLE.

FOR DISTRIBUTION OF NATURAL GAS (U.S. CLS. 100 AND 105).

FIRST USE 3-23-2006; IN COMMERCE 3-23-2006.  
ALEX KEAM, EXAMINING ATTORNEY

SN 78-942,534. NEW SOUTH PARKING, NEW ORLEANS, LA. FILED 8-1-2006.

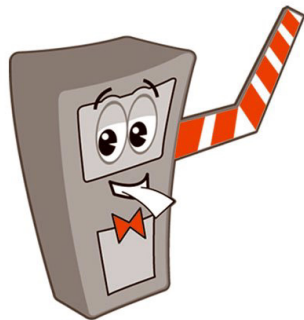

THE COLOR(S) GREY, BLACK, RED, WHITE IS/ARE CLAIMED AS A FEATURE OF THE MARK.

THE MARK CONSISTS OF A RECTANGULAR GRAY SHAPED MACHINE WITH RED AND WHITE STRIPED ARM IN THE UPRIGHT POSITION ON THE RIGHT SIDE OF THE MARK, RED BOW TIE, WHITE CIRCULAR SHAPED EYES WITH BLACK PUPILS AND EYEBROWS, MOUTH OUTLINED IN BLACK WITH WHITE TICKET COMING OUT, SQUARE SHAPED BOX AROUND EYE AND BOTTOM AREA OF MACHINE OUTLINED IN BLACK.

FOR CAR PARKING; PARKING GARAGES SERVICES; VEHICLE PARKING (U.S. CLS. 100 AND 105).  
MARY BOAGNI, EXAMINING ATTORNEY

**CLASS 39—(Continued).**

SN 78-946,379. CRUISECOMPETE, LLC, DES MOINES, IA. FILED 8-7-2006.

## CruiseCompete

THE MARK CONSISTS OF STANDARD CHARACTERS WITHOUT CLAIM TO ANY PARTICULAR FONT, STYLE, SIZE, OR COLOR.

FOR ARRANGING TRAVEL TOURS; COORDINATING TRAVEL ARRANGEMENTS FOR INDIVIDUALS AND FOR GROUPS; ORGANISATION OF TRAVEL; ORGANIZATION OF TRAVEL AND BOAT TRIPS; PROVIDING LINKS TO WEB SITES OF OTHERS FEATURING TRAVEL; TRAVEL AND TOUR INFORMATION SERVICE; TRAVEL GUIDE SERVICES; TRAVEL INFORMATION SERVICES; TRAVEL, EXCURSION AND CRUISE ARRANGEMENT (U.S. CLS. 100 AND 105).

FIRST USE 3-28-2003; IN COMMERCE 9-1-2003.  
PAM WILLIS, EXAMINING ATTORNEY

SN 78-960,959. CB TRAVEL CORP., SALT LAKE CITY, UT. FILED 8-25-2006.

## AIRBANK

THE MARK CONSISTS OF STANDARD CHARACTERS WITHOUT CLAIM TO ANY PARTICULAR FONT, STYLE, SIZE, OR COLOR.

FOR TRAVEL AGENCY SERVICES, NAMELY MAKING RESERVATIONS AND BOOKINGS FOR TRANSPORTATION (U.S. CLS. 100 AND 105).

TONJA GASKINS, EXAMINING ATTORNEY

SN 78-961,171. MAIL EXPRESS CORPORATION, SAN JUAN, PUERTO RICO, FILED 8-26-2006.

## Freez Express

THE COLOR(S) COLORS GREEN, BLUE AND GREY IS/ARE CLAIMED AS A FEATURE OF THE MARK.

THE WORD "EXPRESS" APPEARS IN THE COLOR GREEN; THE WORD "FREEZ" APPEARS WITH THE COLOR BLUE AT THE TOPS OF THE LETTERS AND THE COLOR GREY AT THE BOTTOMS OF THE LETTERS, WITH EACH COLOR MEETING THE OTHER IN A HORIZONTAL WAVY LINE AT THE MIDDLE OF THE LETTERS.

FOR PACKAGING ARTICLES FOR TRANSPORTATION (U.S. CLS. 100 AND 105).

BENJAMIN ALLEN, EXAMINING ATTORNEY

**CLASS 39—(Continued).**

SN 78-962,791. SEAFOOD LOGISTICS, INC., LOS ANGELES, CA. FILED 8-29-2006.

**PACIFIC DIAMOND**

THE MARK CONSISTS OF STANDARD CHARACTERS WITHOUT CLAIM TO ANY PARTICULAR FONT, STYLE, SIZE, OR COLOR.

FOR PACKING ARTICLES FOR TRANSPORTATION (U.S. CLS. 100 AND 105).

PAUL CROWLEY, EXAMINING ATTORNEY

SN 78-963,659. HEALTHCARE PRODUCTS INTERNATIONAL INCORPORATED, CHARLOTTESVILLE, VA. FILED 8-30-2006.

**HPI**

THE MARK CONSISTS OF STANDARD CHARACTERS WITHOUT CLAIM TO ANY PARTICULAR FONT, STYLE, SIZE, OR COLOR.

FOR BIOMEDICAL TRANSPORTATION SERVICES, NAMELY, THE STORAGE AND TRANSPORTATION OF BLOOD, BLOOD COMPONENTS, HUMAN ORGANS, AND HUMAN BIOLOGICAL PRODUCTS FOR MEDICAL AND CLINICAL USE (U.S. CLS. 100 AND 105).

ROSELLE HERRERA, EXAMINING ATTORNEY

SN 78-963,878. HEALTHCARE PRODUCTS INTERNATIONAL INCORPORATION, CHARLOTTESVILLE, VA. FILED 8-30-2006.



THE COLOR(S) BLUE, RED AND WHITE IS/ARE CLAIMED AS A FEATURE OF THE MARK.

THE MARK CONSISTS OF THE LETTERS HPI IN LOWERCASE NEXT TO A BLUE CIRCLE WITH A RED OUTLINE OF A TEARDROP AND A WHITE SNOWFLAKE.

FOR BIOMEDICAL TRANSPORTATION SERVICES, NAMELY, THE STORAGE AND TRANSPORTATION OF BLOOD, BLOOD COMPONENTS, HUMAN ORGANS, AND HUMAN BIOLOGICAL PRODUCTS FOR MEDICAL AND CLINICAL USE (U.S. CLS. 100 AND 105).

ROSELLE HERRERA, EXAMINING ATTORNEY

**CLASS 39—(Continued).**

SN 78-964,260. AMERICAN NEVADA HOLDINGS, LLC, HENDERSON, NV. FILED 8-30-2006.

*Avenue33*

FOR PROVIDING INFORMATION IN THE FIELD OF TRAVEL; TRAVEL AGENCY SERVICES, NAMELY, PROVIDING RESERVATIONS, BOOKINGS, ADVICE AND COUNSELING TO OTHERS IN THE FIELD OF TRAVEL AND TRANSPORTATION; VEHICLE VALET SERVICES; FOOD DELIVERY SERVICES; ARRANGING TRAVEL TOURS AND EXCURSIONS FOR TOURISTS; AND CHAUFFEUR SERVICES (U.S. CLS. 100 AND 105).

MICHAEL ENGEL, EXAMINING ATTORNEY

SN 78-964,296. RIATA ENERGY, INC., OKLAHOMA CITY, OK. FILED 8-30-2006.

**SANDRIDGE ENERGY**

THE MARK CONSISTS OF STANDARD CHARACTERS WITHOUT CLAIM TO ANY PARTICULAR FONT, STYLE, SIZE, OR COLOR.

NO CLAIM IS MADE TO THE EXCLUSIVE RIGHT TO USE "ENERGY", APART FROM THE MARK AS SHOWN.

FOR TRANSPORTATION BY WAY OF SHIP, BARGE, TRUCK, RAIL AND PIPELINE OF OIL AND GAS (U.S. CLS. 100 AND 105).

JIM RINGLE, EXAMINING ATTORNEY

SN 78-964,424. PROJECT CC, LLC, LAS VEGAS, NV. FILED 8-30-2006.

**VDARA**

THE MARK CONSISTS OF STANDARD CHARACTERS WITHOUT CLAIM TO ANY PARTICULAR FONT, STYLE, SIZE, OR COLOR.

FOR ARRANGING EXCURSIONS FOR TOURISTS; TRANSPORTATION OF PASSENGERS AND/OR GOODS BY CAR, VAN OR BUS; VALET PARKING (U.S. CLS. 100 AND 105).

GEORGE LORENZO, EXAMINING ATTORNEY

**CLASS 39—(Continued).**

SN 78-964,475. AMERICAN NEVADA HOLDINGS, LLC, HENDERSON, NV. FILED 8-30-2006.

**AVENUE33 AT THE DISTRICT**

THE MARK CONSISTS OF STANDARD CHARACTERS WITHOUT CLAIM TO ANY PARTICULAR FONT, STYLE, SIZE, OR COLOR.

FOR PROVIDING INFORMATION IN THE FIELD OF TRAVEL; TRAVEL AGENCY SERVICES, NAMELY, PROVIDING RESERVATIONS, BOOKINGS, ADVICE AND COUNSELING TO OTHERS IN THE FIELD OF TRAVEL AND TRANSPORTATION; VEHICLE VALET SERVICES; FOOD DELIVERY SERVICES; ARRANGING TRAVEL TOURS AND EXCURSIONS FOR TOURISTS; AND CHAUFFEUR SERVICES (U.S. CLS. 100 AND 105).  
KAREN BRACEY, EXAMINING ATTORNEY

SN 78-964,528. AMERICAN NEVADA HOLDINGS, LLC, HENDERSON, NV. FILED 8-30-2006.



FOR PROVIDING INFORMATION IN THE FIELD OF TRAVEL; TRAVEL AGENCY SERVICES, NAMELY, PROVIDING RESERVATIONS, BOOKINGS, ADVICE AND COUNSELING TO OTHERS IN THE FIELD OF TRAVEL AND TRANSPORTATION; VEHICLE VALET SERVICES; FOOD DELIVERY SERVICES; ARRANGING TRAVEL TOURS AND EXCURSIONS FOR TOURISTS; AND CHAUFFEUR SERVICES (U.S. CLS. 100 AND 105).  
MICHAEL ENGEL, EXAMINING ATTORNEY

SN 78-966,274. FRANCIS DRILLING FLUIDS, LTD., CROWLEY, LA. FILED 9-1-2006.

**FRANCIS DRILLING FLUIDS**

THE MARK CONSISTS OF STANDARD CHARACTERS WITHOUT CLAIM TO ANY PARTICULAR FONT, STYLE, SIZE, OR COLOR.

NO CLAIM IS MADE TO THE EXCLUSIVE RIGHT TO USE "DRILLING FLUIDS", APART FROM THE MARK AS SHOWN.

FOR TRANSPORTATION AND STORAGE OF DRILLING FLUIDS AND FRACTURING PROPPANTS (U.S. CLS. 100 AND 105).  
HEATHER THOMPSON, EXAMINING ATTORNEY

**CLASS 39—(Continued).**

SN 78-966,544. MINGLE WITH SINGLES, LLC, IDAHO FALLS, ID. FILED 9-2-2006.

**MINGLE WITH SINGLES**

THE MARK CONSISTS OF STANDARD CHARACTERS WITHOUT CLAIM TO ANY PARTICULAR FONT, STYLE, SIZE, OR COLOR.

FOR TRAVEL AND TOUR TICKET RESERVATION SERVICE (U.S. CLS. 100 AND 105).  
LINDA E. BLOHM, EXAMINING ATTORNEY

SN 78-966,817. HIRSCHBERG, MARK, MOONACHIE, NJ. FILED 9-5-2006.



THE MARK CONSISTS OF STANDARD CHARACTERS WITHOUT CLAIM TO ANY PARTICULAR FONT, STYLE, SIZE, OR COLOR.

FOR DELIVERY OF LIQUID MEDICATIONS AND BABY FORMULA TO AIRLINE PASSENGERS WHO CAN NOT BRING THE ITEMS ON BOARD DUE TO SECURITY OR OTHER REASONS (U.S. CLS. 100 AND 105).

ALICE SUE CARRUTHERS, EXAMINING ATTORNEY

SN 78-966,964. SOUTHERN PRIDE TRUCKING INC., LAS VEGAS, NV. FILED 9-5-2006.

**SOUTHERN PRIDE TRUCKING**

THE MARK CONSISTS OF STANDARD CHARACTERS WITHOUT CLAIM TO ANY PARTICULAR FONT, STYLE, SIZE, OR COLOR.

NO CLAIM IS MADE TO THE EXCLUSIVE RIGHT TO USE "TRUCKING", APART FROM THE MARK AS SHOWN. FOR FREIGHT TRANSPORTATION BY TRUCK (U.S. CLS. 100 AND 105).

FIRST USE 0-0-1968; IN COMMERCE 0-0-1968.  
CAROLINE WOOD, EXAMINING ATTORNEY

**CLASS 39—(Continued).**

SN 78-967,303. MOBILITY, INC., DBA FLEXCAR, WASHINGTON, DC. FILED 9-5-2006.

**OWN THE DRIVE**

THE MARK CONSISTS OF STANDARD CHARACTERS WITHOUT CLAIM TO ANY PARTICULAR FONT, STYLE, SIZE, OR COLOR.

FOR AUTOMOBILE TIMESHARING SERVICE ALLOWING INDIVIDUALS TO SHARE USE OF AUTOMOBILES, AND MAKING RESERVATIONS FOR THE USE OF AUTOMOBILES (U.S. CLS. 100 AND 105).

DAVID H. STINE, EXAMINING ATTORNEY

SN 78-967,917. PENNINGTON ENERGY CORP., MORENCI, MI. FILED 9-6-2006.

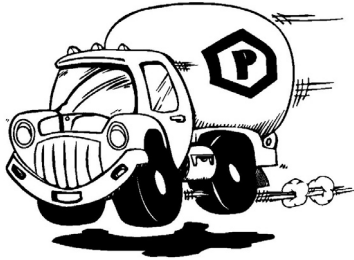

THE MARK CONSISTS OF A CARTOON ILLUSTRATION OF A TRUCK WITH STYLIZED TEXT OF THE LETTER, "P" ON THE SIDE.

FOR PROPANE GAS DELIVERY SERVICE (U.S. CLS. 100 AND 105).

FIRST USE 12-1-1984; IN COMMERCE 12-1-1984.  
EVELYN BRADLEY, EXAMINING ATTORNEY

SN 78-968,959. MOBILITY, INC., DBA FLEXCAR, WASHINGTON, DC. FILED 9-7-2006.

**SHIFT YOUR THINKING**

THE MARK CONSISTS OF STANDARD CHARACTERS WITHOUT CLAIM TO ANY PARTICULAR FONT, STYLE, SIZE, OR COLOR.

FOR AUTOMOBILE TIMESHARING SERVICE ALLOWING INDIVIDUALS TO SHARE USE OF AUTOMOBILES, AND MAKING RESERVATIONS FOR THE USE OF AUTOMOBILES (U.S. CLS. 100 AND 105).

FIRST USE 2-0-2000; IN COMMERCE 2-0-2000.  
DAVID H. STINE, EXAMINING ATTORNEY

**CLASS 39—(Continued).**

SN 78-968,961. MOBILITY, INC., DBA FLEXCAR, WASHINGTON, DC. FILED 9-7-2006.

**Flexcar**  
**SHIFT YOUR THINKING.**

OWNER OF U.S. REG. NO. 2,696,141.

THE MARK CONSISTS OF THE WORDS FLEXCAR SHIFT YOUR THINKING WITH THE LETTER "X" IN STYLIZED FORM.

FOR AUTOMOBILE TIMESHARING SERVICE ALLOWING INDIVIDUALS TO SHARE USE OF AUTOMOBILES, AND MAKING RESERVATIONS FOR THE USE OF AUTOMOBILES (U.S. CLS. 100 AND 105).

FIRST USE 2-0-2000; IN COMMERCE 2-0-2000.  
DAVID H. STINE, EXAMINING ATTORNEY

SN 78-971,861. DEWBERRY CAPITAL CORPORATION, ATLANTA, GA. FILED 9-11-2006.

**DEWBERRY PARKING**

THE MARK CONSISTS OF STANDARD CHARACTERS WITHOUT CLAIM TO ANY PARTICULAR FONT, STYLE, SIZE, OR COLOR.

NO CLAIM IS MADE TO THE EXCLUSIVE RIGHT TO USE "PARKING", APART FROM THE MARK AS SHOWN.

FOR CAR PARKING; PARKING GARAGES SERVICES; PARKING LOT SERVICES; RENTAL OF VEHICLE PARKING SPACES; VALET PARKING (U.S. CLS. 100 AND 105).

CATHERINE FAINT, EXAMINING ATTORNEY

**CLASS 40—MATERIAL TREATMENT**

SN 77-009,285. STARBUCKS U.S. BRANDS, LLC, MINDEN, NV. FILED 9-28-2006.



NO CLAIM IS MADE TO THE EXCLUSIVE RIGHT TO USE "COFFEE", APART FROM THE MARK AS SHOWN. THE MARK CONSISTS OF THE WORDING "STARBUCKS COFFEE" IN A CIRCULAR SEAL WITH TWO STARS, AND DESIGN OF A SIREN (A TWO-TAILED MERMAID) WEARING A CROWN. FOR COFFEE ROASTING AND PROCESSING (U.S. CLS. 100, 103 AND 106). FIRST USE 9-1-1992; IN COMMERCE 9-1-1992. ANGELA M. MICHELI, EXAMINING ATTORNEY

SN 78-282,790. GORDON, ANDREW W., BOCA RATON, FL. FILED 8-4-2003.

## A GLOBAL POWER SOLUTION

NO CLAIM IS MADE TO THE EXCLUSIVE RIGHT TO USE "POWER", APART FROM THE MARK AS SHOWN. FOR GENERATION OF ELECTRICITY (U.S. CLS. 100, 103 AND 106). MICHAEL ENGEL, EXAMINING ATTORNEY

SN 78-792,615. BURK, MICHAEL, LEE, TULSA, OK. FILED 1-17-2006.

## DTAGS

THE MARK CONSISTS OF STANDARD CHARACTERS WITHOUT CLAIM TO ANY PARTICULAR FONT, STYLE, SIZE, OR COLOR. FOR DIGITAL COMPRESSION OF VIDEO (U.S. CLS. 100, 103 AND 106). BRENDAN MCCAULEY, EXAMINING ATTORNEY

**CLASS 40—(Continued).**

SN 78-849,682. CUSTOM SPORTBIKE CONCEPTS, INC., WINTER GARDEN, FL. FILED 3-30-2006.

## FAST ART ON 2 WHEELS

THE MARK CONSISTS OF STANDARD CHARACTERS WITHOUT CLAIM TO ANY PARTICULAR FONT, STYLE, SIZE, OR COLOR.

FOR CUSTOM MANUFACTURE FOR OTHERS OF STRUCTURAL PARTS OF MOTORCYCLES, MOTORS AND MOTORCYCLES; METALWORK SERVICES, NAMELY, METAL FABRICATION AND FINISHING SERVICES (U.S. CLS. 100, 103 AND 106). HEATHER SAPP, EXAMINING ATTORNEY

SN 78-881,396. JAGGED EXTREME, LLC, PHOENIX, AZ. FILED 5-11-2006.

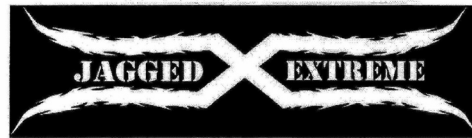

THE MARK CONSISTS OF THE WORDS JAGGED EXTREME WITH CROSSED SERRATED EDGED BLADES SURROUNDING THE WORDS.

FOR CUSTOM FABRICATION OF LAND VEHICLES AND STRUCTURAL PARTS THEREOF, NAMELY, FOR OFF-ROAD VEHICLES (U.S. CLS. 100, 103 AND 106). FIRST USE 11-20-2003; IN COMMERCE 3-24-2004. DANIEL BRODY, EXAMINING ATTORNEY

SN 78-883,932. STRATEGIC ALTERNATIVES, LLC, GERMANTOWN, TN. FILED 5-15-2006.



**BRANDED CUPS.COM**  
*customized*

NO CLAIM IS MADE TO THE EXCLUSIVE RIGHT TO USE "BRANDEDCUPS.COM", "CUSTOMIZED", AND THE FEDERAL REGISTRATION SYMBOL, APART FROM THE MARK AS SHOWN.

THE COLOR(S) BROWN AND AQUA IS/ARE CLAIMED AS A FEATURE OF THE MARK.

THE OUTLINE OF THE CUP IS IN AQUA AND BROWN; THE "R" IN A CIRCLE IS BROWN; THE WORDING "BRANDEDCUPS.COM" IS BROWN; THE WORDING "CUSTOMIZED" IS AQUA WITH AQUA UNDERLINING.

FOR CUSTOM PRINTING OF FOODSERVICE CUPS AND PACKAGING (U.S. CLS. 100, 103 AND 106). FIRST USE 1-27-2006; IN COMMERCE 1-27-2006. JEAN IM, EXAMINING ATTORNEY

**CLASS 40—(Continued).**

SN 78-934,017. TRAVEL TAGS, INC., NORTH MANKATO, MN. FILED 7-20-2006.

# EYETWIST

THE MARK CONSISTS OF STANDARD CHARACTERS WITHOUT CLAIM TO ANY PARTICULAR FONT, STYLE, SIZE, OR COLOR.

FOR CUSTOMIZED PRINTING OF COMPANY NAMES AND LOGOS ON PROMOTIONAL AND ADVERTISING PRODUCTS FOR OTHERS (U.S. CLS. 100, 103 AND 106).

FIRST USE 9-26-2006; IN COMMERCE 9-26-2006.  
LINDA ORNDORFF, EXAMINING ATTORNEY

SN 78-945,039. MOUNTAINSIDE MEDICAL, LLC, BOULDER, CO. FILED 8-4-2006.



**Mountainside Medical**

*Contract Manufacturing for Medical Products*

NO CLAIM IS MADE TO THE EXCLUSIVE RIGHT TO USE "MEDICAL" AND "CONTRACT MANUFACTURING FOR MEDICAL PRODUCTS", APART FROM THE MARK AS SHOWN.

FOR CONTRACT MANUFACTURER OF PRECISION MEDICAL DEVICE COMPONENTS AND SUB-ASSEMBLIES FOR CARDIAC SURGERY, ARTHROSCOPY, LAPAROSCOPY, OPHTHALMOLOGY, ORTHOPEDIC IMPLANTS, URO-GYNECOLOGY, ELECTRO-SURGERY AND ENDOSCOPIC-SURGERY (U.S. CLS. 100, 103 AND 106).

FIRST USE 3-1-2006; IN COMMERCE 4-1-2006.  
DAVID HOFFMAN, EXAMINING ATTORNEY

SN 78-947,925. MAINE PLASTICS, INC., ZION, IL. FILED 8-8-2006.

## One-Solution Recycling Program

THE MARK CONSISTS OF STANDARD CHARACTERS WITHOUT CLAIM TO ANY PARTICULAR FONT, STYLE, SIZE, OR COLOR.

NO CLAIM IS MADE TO THE EXCLUSIVE RIGHT TO USE "RECYCLING PROGRAM", APART FROM THE MARK AS SHOWN.

FOR RECYCLING SERVICES (U.S. CLS. 100, 103 AND 106).

FIRST USE 6-7-2006; IN COMMERCE 6-7-2006.  
DAWN HAN, EXAMINING ATTORNEY

**CLASS 40—(Continued).**

SN 78-956,981. PACIFIC COAST TECHNOLOGIES, INC., WENATCHEE, WA. FILED 8-21-2006.



FOR MANUFACTURING OF ELECTRONIC COMPONENTS AND DEVICES TO THE ORDER AND SPECIFICATIONS OF OTHERS (U.S. CLS. 100, 103 AND 106).

FIRST USE 9-1-2004; IN COMMERCE 9-1-2004.  
JUSTINE D. PARKER, EXAMINING ATTORNEY

SN 78-957,178. CL SOLUTIONS, COLD SPRING, KY. FILED 8-22-2006.



FOR BIOREMEDIATION SERVICES OF STREET DEBRIS (U.S. CLS. 100, 103 AND 106).

RAUL CORDOVA, EXAMINING ATTORNEY

SN 78-960,635. INDIVIDUALITEES, LLC, GREENSBORO, GA. FILED 8-25-2006.

## IndividualiTees

THE MARK CONSISTS OF STANDARD CHARACTERS WITHOUT CLAIM TO ANY PARTICULAR FONT, STYLE, SIZE, OR COLOR.

FOR IMPRINTING MESSAGES ON T-SHIRTS (U.S. CLS. 100, 103 AND 106).

JULIE GUTTADAURO, EXAMINING ATTORNEY



**CLASS 40—(Continued).**

SN 78-961,534. KAY ENTERPRISES, INC., OREM, UT. FILED 8-28-2006.

**RUDOLPH GYGI**

THE MARK CONSISTS OF STANDARD CHARACTERS WITHOUT CLAIM TO ANY PARTICULAR FONT, STYLE, SIZE, OR COLOR.

THE NAME RUDOLPH GYGI DOES NOT IDENTIFY A LIVING INDIVIDUAL.

FOR MANUFACTURE OF GENERAL PRODUCT LINES IN THE FIELD OF HOROLOGICAL AND CHRONOMETRIC INSTRUMENTS AND CASES THEREFOR TO THE ORDER AND SPECIFICATION OF OTHERS (U.S. CLS. 100, 103 AND 106).

HEATHER THOMPSON, EXAMINING ATTORNEY

**CLASS 40—(Continued).**

SN 78-962,159. MT. OLIVE MANUFACTURING, INC., PLAINFIELD, IN. FILED 8-28-2006.

**YOU HAVE OUR SEAL ON IT**

THE MARK CONSISTS OF STANDARD CHARACTERS WITHOUT CLAIM TO ANY PARTICULAR FONT, STYLE, SIZE, OR COLOR.

FOR CONTRACT MANUFACTURING IN THE FIELD OF MAKING HEAT SEALED BAGS, POUCHES, AND PADS (U.S. CLS. 100, 103 AND 106).

FIRST USE 5-9-2006; IN COMMERCE 5-9-2006.

ELLEN B. AWRICH, EXAMINING ATTORNEY

SN 78-962,116. CAPITAL MANAGEMENT SOLUTIONS, L.L.C., LAKE CHARLES, LA. FILED 8-28-2006.

**FLASH GUARD**

THE MARK CONSISTS OF STANDARD CHARACTERS WITHOUT CLAIM TO ANY PARTICULAR FONT, STYLE, SIZE, OR COLOR.

NO CLAIM IS MADE TO THE EXCLUSIVE RIGHT TO USE "GUARD", APART FROM THE MARK AS SHOWN.

FOR APPLYING PLATING, COATING AND UNDER-COATING METAL AND OTHER SURFACES WITH ANTI-CORROSIVE SUBSTANCES (U.S. CLS. 100, 103 AND 106).

MARGERY A. TIERNEY, EXAMINING ATTORNEY

SN 78-963,389. BAILEY, DAVID E., NORFOLK, VA. FILED 8-29-2006.

**Fisherman's Dictionary**

THE MARK CONSISTS OF STANDARD CHARACTERS WITHOUT CLAIM TO ANY PARTICULAR FONT, STYLE, SIZE, OR COLOR.

FOR CUSTOM IMPRINTING OF TEE SHIRTS AND HEADGEAR WITH DECORATIVE DESIGNS (U.S. CLS. 100, 103 AND 106).

PAMELA HIRSCHMAN, EXAMINING ATTORNEY

SN 78-962,154. MT. OLIVE MANUFACTURING, INC., PLAINFIELD, IN. FILED 8-28-2006.

**MT. OLIVE MANUFACTURING,  
INC.**

THE MARK CONSISTS OF STANDARD CHARACTERS WITHOUT CLAIM TO ANY PARTICULAR FONT, STYLE, SIZE, OR COLOR.

NO CLAIM IS MADE TO THE EXCLUSIVE RIGHT TO USE "MANUFACTURING, INC.", APART FROM THE MARK AS SHOWN.

FOR CONTRACT MANUFACTURING IN THE FIELD OF MAKING HEAT SEALED BAGS, POUCHES, AND PADS (U.S. CLS. 100, 103 AND 106).

FIRST USE 4-1-2006; IN COMMERCE 4-1-2006.

ELLEN B. AWRICH, EXAMINING ATTORNEY

SN 78-963,396. BAILEY, DAVID E., NORFOLK, VA. FILED 8-29-2006.

**Pride With Attitude**

THE MARK CONSISTS OF STANDARD CHARACTERS WITHOUT CLAIM TO ANY PARTICULAR FONT, STYLE, SIZE, OR COLOR.

FOR CUSTOM IMPRINTING OF TEE SHIRTS AND HEADGEAR WITH DECORATIVE DESIGNS (U.S. CLS. 100, 103 AND 106).

PAMELA HIRSCHMAN, EXAMINING ATTORNEY

**CLASS 40—(Continued).**

SN 78-963,435. BAILEY, DAVID E., NORFOLK, VA. FILED 8-30-2006.

**Hot Dam USA**

THE MARK CONSISTS OF STANDARD CHARACTERS WITHOUT CLAIM TO ANY PARTICULAR FONT, STYLE, SIZE, OR COLOR.

NO CLAIM IS MADE TO THE EXCLUSIVE RIGHT TO USE "USA", APART FROM THE MARK AS SHOWN.

FOR CUSTOM IMPRINTING OF TEE SHIRTS AND HEADGEAR WITH DECORATIVE DESIGNS (U.S. CLS. 100, 103 AND 106).

PAMELA HIRSCHMAN, EXAMINING ATTORNEY

**CLASS 40—(Continued).**

SN 78-966,529. WEGGEE PRODUCTIONS, INC., SANTA MONICA, CA. FILED 9-2-2006.

**Stripper Academy**

THE MARK CONSISTS OF STANDARD CHARACTERS WITHOUT CLAIM TO ANY PARTICULAR FONT, STYLE, SIZE, OR COLOR.

FOR CUSTOMIZED PRINTING OF COMPANY NAMES AND LOGOS FOR PROMOTIONAL AND ADVERTISING PURPOSES ON THE GOODS OF OTHERS (U.S. CLS. 100, 103 AND 106).

ALICIA COLLINS, EXAMINING ATTORNEY

SN 78-963,873. AIRSCAPE, LAS VEGAS, NV. FILED 8-30-2006.

**SOFT STRUCTURES**

THE MARK CONSISTS OF STANDARD CHARACTERS WITHOUT CLAIM TO ANY PARTICULAR FONT, STYLE, SIZE, OR COLOR.

NO CLAIM IS MADE TO THE EXCLUSIVE RIGHT TO USE STRUCTURES, APART FROM THE MARK AS SHOWN.

FOR CUSTOM CONSTRUCTION OF AIR SUPPORTED CABLE STRUCTURES (U.S. CLS. 100, 103 AND 106).

JOHN HWANG, EXAMINING ATTORNEY

SN 78-966,005. CASTANO, JOSEPH DOMINICK, BURBANK, CA. FILED 9-1-2006.

**WAVETRICITY**

THE MARK CONSISTS OF STANDARD CHARACTERS WITHOUT CLAIM TO ANY PARTICULAR FONT, STYLE, SIZE, OR COLOR.

FOR GENERATION OF ELECTRICITY (U.S. CLS. 100, 103 AND 106).

DAVID MURRAY, EXAMINING ATTORNEY

SN 78-968,097. REES, KELLY DEAN, VENTURA, CA. FILED 9-6-2006.

**iRBn  
i'd rather be naked**

THE MARK CONSISTS OF STANDARD CHARACTERS WITHOUT CLAIM TO ANY PARTICULAR FONT, STYLE, SIZE, OR COLOR.

FOR IMPRINTING MESSAGES ON T-SHIRTS (U.S. CLS. 100, 103 AND 106).

KATHERINE CHANG, EXAMINING ATTORNEY

SN 78-970,390. TRINITY INDUSTRIES, INC., DALLAS, TX. FILED 9-8-2006.

**BUILDING TOMORROW'S  
HIGHWAY SAFETY SOLUTIONS  
TODAY**

THE MARK CONSISTS OF STANDARD CHARACTERS WITHOUT CLAIM TO ANY PARTICULAR FONT, STYLE, SIZE, OR COLOR.

FOR CUSTOM MANUFACTURE OF METAL AND NONMETAL HIGHWAY SAFETY DEVICES (U.S. CLS. 100, 103 AND 106).

FIRST USE 5-9-2005; IN COMMERCE 5-9-2005.

ALICE SUE CARRUTHERS, EXAMINING ATTORNEY

**CLASS 40—(Continued).**

SN 78-972,844. PREMIER ALIVE, INC., CEDAR CITY, UT. FILED 9-12-2006.

# PREMIER ALIVE

THE MARK CONSISTS OF STANDARD CHARACTERS WITHOUT CLAIM TO ANY PARTICULAR FONT, STYLE, SIZE, OR COLOR.

FOR MANUFACTURE SERVICES FOR OTHERS IN THE FIELD OF DIETARY AND NUTRITIONAL SUPPLEMENTS (U.S. CLS. 100, 103 AND 106).  
SCOTT BALDWIN, EXAMINING ATTORNEY

**CLASS 41—(Continued).**

SN 76-654,599. GENE SIMMONS COMPANY, PINE BROOK, NJ. FILED 2-3-2006.

# BABY 101

THE MARK CONSISTS OF STANDARD CHARACTERS WITHOUT CLAIM TO ANY PARTICULAR FONT, STYLE, SIZE, OR COLOR.

NO CLAIM IS MADE TO THE EXCLUSIVE RIGHT TO USE "BABY", APART FROM THE MARK AS SHOWN.

FOR ENTERTAINMENT SERVICES IN THE NATURE OF AN ON-GOING LIVE-ACTION, COMEDY, DRAMA OR ANIMATED TELEVISION PROGRAMS IN THE FIELD OF PARENTING, MOTHERS AND BABIES; PRODUCTION OF LIVE-ACTION, COMEDY, DRAMA OR ANIMATED TELEVISION PROGRAMS; PRODUCTION OF LIVE-ACTION, COMEDY, DRAMA AND ANIMATED MOTION PICTURE THEATRICAL FILMS IN THE FIELD OF PARENTING, MOTHERS AND BABIES; PROVIDING INFORMATION VIA ELECTRONIC GLOBAL COMMUNICATIONS NETWORK IN THE NATURE OF LIVE-ACTION, COMEDY, DRAMA OR ANIMATED TELEVISION IN THE FIELD OF PARENTING, MOTHERS AND BABIES; ENTERTAINMENT SERVICES, NAMELY PROVIDING A LIVE-ACTION, COMEDY, DRAMA OR ANIMATED TELEVISION PROGRAM IN THE FIELD OF PARENTING, MOTHERS AND BABIES VIA ELECTRONIC GLOBAL COMMUNICATIONS NETWORK; AND PRODUCTION AND DISTRIBUTION OF LIVE-ACTION, COMEDY, ACTION OR ANIMATED MOTION PICTURE FILMS VIA A GLOBAL COMPUTER NETWORK (U.S. CLS. 100, 101 AND 107).  
ALYSSA PALADINO, EXAMINING ATTORNEY

**CLASS 41—EDUCATION AND ENTERTAINMENT**

SN 76-568,705. SMITH, JUSTIN, SECAUCUS, NJ. FILED 12-29-2003.

# JUST BLAZE

FOR RECORD PRODUCTION; AUDIO PRODUCTION, NAMELY SOUND REMIXING AND SONGWRITING (U.S. CLS. 100, 101 AND 107).

FIRST USE 1-0-1998; IN COMMERCE 1-0-1998.  
ELLEN B. AWRICH, EXAMINING ATTORNEY

SN 76-657,327. MAGS ENTERTAINMENT, LLC, GREENWOOD, SC. FILED 3-24-2006.

# BEARSHEBA J. BEAR BJ'S TEDDY BEAR CLUB AND BIBLE STORIES

THE MARK CONSISTS OF STANDARD CHARACTERS WITHOUT CLAIM TO ANY PARTICULAR FONT, STYLE, SIZE, OR COLOR.

NO CLAIM IS MADE TO THE EXCLUSIVE RIGHT TO USE "BEAR", "TEDDY BEAR", AND "BIBLE STORIES", APART FROM THE MARK AS SHOWN.

THE NAME BEARSHEBA J. BEAR DOES NOT IDENTIFY A LIVING INDIVIDUAL.

FOR ENTERTAINMENT SERVICES IN THE NATURE OF AN ANIMATED TELEVISION SERIES; ENTERTAINMENT SERVICES IN THE NATURE OF A CONTINUING ANIMATED SHOW DISTRIBUTED OVER TELEVISION, SATELLITE, AUDIO AND VIDEO MEDIA, AND THE INTERNET; ANIMATION PRODUCTION SERVICES; FILM DISTRIBUTION; PRODUCTION OF MOTION PICTURE FILMS, VIDEOTAPES, TELEVISION PROGRAMS AND CABLE TELEVISION PROGRAMS; ENTERTAINMENT SERVICES IN THE NATURE OF AN INTERNET WEBSITE FEATURING ANIMATION, STILL PICTURES AND TEXT (U.S. CLS. 100, 101 AND 107).  
FIRST USE 12-25-2005; IN COMMERCE 12-25-2005.

ROBERT STRUCK, EXAMINING ATTORNEY

SN 76-654,145. GALLO, MARC D., OTTSVILLE, PA. FILED 1-27-2006.



FOR ENTERTAINMENT, NAMELY, LIVE PERFORMANCES BY A FOUR PIECE MUSICAL BAND (U.S. CLS. 100, 101 AND 107).

FIRST USE 8-0-2000; IN COMMERCE 8-0-2000.  
REBECCA GAN, EXAMINING ATTORNEY

**CLASS 41—(Continued).**

SN 76-659,968. KNOWLEDGE ATHLETES, INC., FAIRPORT, NY. FILED 5-12-2006.

**LOGOCLICK**

THE MARK CONSISTS OF STANDARD CHARACTERS WITHOUT CLAIM TO ANY PARTICULAR FONT, STYLE, SIZE, OR COLOR.  
FOR DIGITAL IMAGING SERVICES (U.S. CLS. 100, 101 AND 107).  
MELVIN AXILBUND, EXAMINING ATTORNEY

---

SN 76-659,969. KNOWLEDGE ATHLETES, INC., FAIRPORT, NY. FILED 5-12-2006.

**IT'S ALL ONLINE!**

THE MARK CONSISTS OF STANDARD CHARACTERS WITHOUT CLAIM TO ANY PARTICULAR FONT, STYLE, SIZE, OR COLOR.  
FOR EDUCATIONAL SERVICES FOR THE ENRICHMENT OF ACADEMIC SUBJECTS, NAMELY, CONDUCTING LITERACY PRACTICE PROGRAMS IN CONJUNCTION WITH READING AND READING DISCUSSION PROGRAMS INCLUDING ONLINE BLOG-TYPE INTERACTIONS BETWEEN STUDENTS AND FACULTY (U.S. CLS. 100, 101 AND 107).  
MELVIN AXILBUND, EXAMINING ATTORNEY

---

SN 76-659,970. KNOWLEDGE ATHLETES, INC., FAIRPORT, NY. FILED 5-12-2006.

**IT'S ALL IN BOOKS!**

THE MARK CONSISTS OF STANDARD CHARACTERS WITHOUT CLAIM TO ANY PARTICULAR FONT, STYLE, SIZE, OR COLOR.  
FOR EDUCATIONAL SERVICES FOR THE ENRICHMENT OF ACADEMIC SUBJECTS, NAMELY, CONDUCTING LITERACY PRACTICE PROGRAMS IN CONJUNCTION WITH READING AND READING DISCUSSION PROGRAMS INCLUDING ONLINE BLOG-TYPE INTERACTIONS BETWEEN STUDENTS AND FACULTY (U.S. CLS. 100, 101 AND 107).  
MELVIN AXILBUND, EXAMINING ATTORNEY

**CLASS 41—(Continued).**

SN 76-663,748. ESI SERVICE CORP., CARMEL, IN. FILED 7-27-2006.



THE MARK CONSISTS OF THE LETTER "H" IN THE CENTER OF A BROKEN CIRCLE, WITH THE LETTER "S" IN THE CENTER OF THE BREAK.  
FOR EDUCATIONAL SERVICES, NAMELY PROVIDING COURSES OF INSTRUCTION IN HEALTH INFORMATION TECHNOLOGY, HEALTH INFORMATION MANAGEMENT, AND HEALTH SCIENCES AT THE COLLEGE LEVEL AND DISSEMINATION OF COURSE MATERIALS USED IN CONNECTION THEREWITH (U.S. CLS. 100, 101 AND 107).  
ODESSA BIBBINS, EXAMINING ATTORNEY

---

SN 76-664,861. BAND AID TRUST, AUSTIN, TX. FILED 8-21-2006.

**LONGHORN SPEEDWAY**

THE MARK CONSISTS OF STANDARD CHARACTERS WITHOUT CLAIM TO ANY PARTICULAR FONT, STYLE, SIZE, OR COLOR.  
NO CLAIM IS MADE TO THE EXCLUSIVE RIGHT TO USE SPEEDWAY, APART FROM THE MARK AS SHOWN.  
FOR ENTERTAINMENT IN THE NATURE OF AUTOMOBILE RACES (U.S. CLS. 100, 101 AND 107).  
BRIDGETT SMITH, EXAMINING ATTORNEY

---

SN 76-665,230. DIXON, MARGARET SPENCER, DBA SPENCER CONSULTING, KENSINGTON, MD. FILED 8-28-2006.

**SO LITTLE TIME, SO MUCH PAPER**

THE MARK CONSISTS OF STANDARD CHARACTERS WITHOUT CLAIM TO ANY PARTICULAR FONT, STYLE, SIZE, OR COLOR.  
FOR SEMINARS FOR LAWYERS AND LEGAL PROFESSIONALS IN THE FIELDS OF TIME MANAGEMENT AND STRESS MANAGEMENT, AND DISTRIBUTING COURSE MATERIALS PERTAINING TO THOSE FIELDS IN CONNECTION THEREWITH (U.S. CLS. 100, 101 AND 107).  
FIRST USE 3-15-1995; IN COMMERCE 3-15-1995.  
IRENE D. WILLIAMS, EXAMINING ATTORNEY

**CLASS 41—(Continued).**

SN 76-665,383. HECTOR, GERARD, SIMSBURY, CT. FILED 8-31-2006.

**AJALI**

THE MARK CONSISTS OF STANDARD CHARACTERS WITHOUT CLAIM TO ANY PARTICULAR FONT, STYLE, SIZE, OR COLOR.

THE ENGLISH TRANSLATION OF THE WORD AJALI IN THE MARK IS "FATE" OR "DESTINY".

FOR ENTERTAINMENT SERVICES IN THE NATURE OF LIVE MUSICAL PERFORMANCES (U.S. CLS. 100, 101 AND 107).

FIRST USE 4-15-2005; IN COMMERCE 4-15-2005.  
DANIEL RUSSELL, EXAMINING ATTORNEY

---

SN 76-665,495. HANSMIRE, JAMES KENNETH, DALLAS, TX. FILED 9-1-2006.

**TEXAS VS. THE NATION**

THE MARK CONSISTS OF STANDARD CHARACTERS WITHOUT CLAIM TO ANY PARTICULAR FONT, STYLE, SIZE, OR COLOR.

NO CLAIM IS MADE TO THE EXCLUSIVE RIGHT TO USE "TEXAS", APART FROM THE MARK AS SHOWN.

FOR ENTERTAINMENT SERVICES IN THE NATURE OF ORGANIZING AND CONDUCTING A COLLEGIATE FOOTBALL GAME AND RELATED SPORTING ACTIVITIES; ENTERTAINMENT SERVICES IN THE NATURE OF LIVE PERFORMANCES BY SINGERS, DANCERS, CHEERLEADERS, AND MARCHING BANDS (U.S. CLS. 100, 101 AND 107).

ANTHONY RINKER, EXAMINING ATTORNEY

---

SN 76-665,553. HAGSTROM, JOHN, CHICAGO, IL. FILED 9-5-2006.

**MY KIND OF SOUND**

THE MARK CONSISTS OF STANDARD CHARACTERS WITHOUT CLAIM TO ANY PARTICULAR FONT, STYLE, SIZE, OR COLOR.

FOR EDUCATION SERVICES, NAMELY, PROVIDING TUTORIAL SESSIONS IN THE FIELD OF MUSICAL INSTRUMENT INSTRUCTION (U.S. CLS. 100, 101 AND 107).

PRISCILLA MILTON, EXAMINING ATTORNEY

**CLASS 41—(Continued).**

SN 77-003,364. THE EDISON INSTITUTE, DEARBORN, MI. FILED 9-20-2006.

**THE HENRY FORD HISTORY HUNTERS**

THE MARK CONSISTS OF STANDARD CHARACTERS WITHOUT CLAIM TO ANY PARTICULAR FONT, STYLE, SIZE, OR COLOR.

OWNER OF U.S. REG. NOS. 2,064,445 AND 2,902,382.

THE NAME HENRY FORD DOES NOT IDENTIFY A LIVING INDIVIDUAL.

FOR PROVIDING INFORMATION REGARDING MUSEUM EVENTS, ACTIVITIES AND EXHIBITIONS FOR EDUCATORS TO PLAN GROUP MUSEUM TOURS (U.S. CLS. 100, 101 AND 107).

MARK T. MULLEN, EXAMINING ATTORNEY

---

SN 77-004,858. FORTNER, SANDRA L., BELLEVILLE, MI. FILED 9-21-2006.

**Sewing Steps**

THE MARK CONSISTS OF STANDARD CHARACTERS WITHOUT CLAIM TO ANY PARTICULAR FONT, STYLE, SIZE, OR COLOR.

NO CLAIM IS MADE TO THE EXCLUSIVE RIGHT TO USE "SEWING", APART FROM THE MARK AS SHOWN.

FOR TAILORING OR DRESSMAKING INSTRUCTION (U.S. CLS. 100, 101 AND 107).

KENNETH E. SHARPERSON, EXAMINING ATTORNEY

---

SN 77-005,381. INVESTMENT SEMINARS, INC., SARASOTA, FL. FILED 9-22-2006.

**MONEYSHOW UNIVERSITY**

THE MARK CONSISTS OF STANDARD CHARACTERS WITHOUT CLAIM TO ANY PARTICULAR FONT, STYLE, SIZE, OR COLOR.

NO CLAIM IS MADE TO THE EXCLUSIVE RIGHT TO USE "UNIVERSITY", APART FROM THE MARK AS SHOWN.

FOR EDUCATION SERVICES, NAMELY, PROVIDING CLASSES IN THE FIELDS OF INVESTING, TRADING AND ADVISORY MANAGEMENT VIA THE INTERNET (U.S. CLS. 100, 101 AND 107).

ROBIN MITTLER, EXAMINING ATTORNEY

**CLASS 41—(Continued).**

SN 77-006,276. BOARDROOM, INC., STAMFORD, CT. FILED 9-25-2006.

**BOTTOM LINE HEALTH**

THE MARK CONSISTS OF STANDARD CHARACTERS WITHOUT CLAIM TO ANY PARTICULAR FONT, STYLE, SIZE, OR COLOR.

OWNER OF U.S. REG. NOS. 2,146,079, 3,057,998 AND OTHERS.

NO CLAIM IS MADE TO THE EXCLUSIVE RIGHT TO USE "HEALTH", APART FROM THE MARK AS SHOWN.

FOR ENTERTAINMENT SERVICES IN THE NATURE OF ON-GOING TELEVISION PROGRAMS IN THE FIELDS OF BUSINESS, FINANCE, HEALTH, NUTRITION, PERSONAL WELL-BEING, LIFESTYLE AND SELF-IMPROVEMENT (U.S. CLS. 100, 101 AND 107).

FIRST USE 9-25-2006; IN COMMERCE 9-25-2006.

KAREN BRACEY, EXAMINING ATTORNEY

SN 77-006,958. CLEFWORKS, INC., MONTGOMERY, AL. FILED 9-25-2006.

**ClefWorks**

THE MARK CONSISTS OF STANDARD CHARACTERS WITHOUT CLAIM TO ANY PARTICULAR FONT, STYLE, SIZE, OR COLOR.

FOR ORGANIZING COMMUNITY INTER-CULTURAL EVENTS BY BRINGING INTERNATIONAL MUSICIANS TO THE MONTGOMERY, ALABAMA AREA TO COMBINE THEIR SKILLS AND TALENTS WITH PERFORMING AND VISUAL ARTISTS FROM THE CENTRAL ALABAMA REGION (U.S. CLS. 100, 101 AND 107).

FIRST USE 6-29-2006; IN COMMERCE 6-29-2006.

MONIQUE MILLER, EXAMINING ATTORNEY

SN 77-007,994. GNLV CORP., LAS VEGAS, NV. FILED 9-26-2006.

**The Tank**  
  
 THE POOL AT THE GOLDEN NUGGET

NO CLAIM IS MADE TO THE EXCLUSIVE RIGHT TO USE "TANK", APART FROM THE MARK AS SHOWN.

THE MARK CONSISTS OF THE WORDS "THE TANK" SEPARATED BY A PICTURE OF A SHARK INSIDE A CIRCLE, OVER A LINE. UNDER THE LINE ARE THE WORDS "THE POOL AT THE GOLDEN NUGGET".

FOR ENTERTAINMENT SERVICES IN THE NATURE OF AN AQUARIUM; PROVIDING SWIMMING POOLS (U.S. CLS. 100, 101 AND 107).

TOBY BULLOFF, EXAMINING ATTORNEY

**CLASS 41—(Continued).**

SN 77-025,557. PETERS, BARBARA G., SCOTTSDALE, AZ. FILED 10-20-2006.

**THE POISONED PENCIL**

THE MARK CONSISTS OF STANDARD CHARACTERS WITHOUT CLAIM TO ANY PARTICULAR FONT, STYLE, SIZE, OR COLOR.

OWNER OF U.S. REG. NOS. 2,101,697 AND 2,244,943.

FOR PUBLICATION OF A SERIES OF FICTION AND NON-FICTION BOOKS ON A VARIETY OF TOPICS (U.S. CLS. 100, 101 AND 107).

EVELYN BRADLEY, EXAMINING ATTORNEY

SN 77-039,421. VIACOM INTERNATIONAL INC., NEW YORK, NY. FILED 11-8-2006.

**TURBO NICK**

THE MARK CONSISTS OF STANDARD CHARACTERS WITHOUT CLAIM TO ANY PARTICULAR FONT, STYLE, SIZE, OR COLOR.

OWNER OF U.S. REG. NOS. 2,091,458, 3,044,795 AND OTHERS.

FOR ENTERTAINMENT SERVICES, NAMELY, PROVIDING VIDEO AND AUDIO CONTENT, NAMELY ON-GOING TELEVISION PROGRAMS IN THE NATURE OF DANCE SHOWS, MUSIC SHOWS, VIDEO AWARD SHOWS, COMEDY SHOWS, AND GAME SHOWS; LIVE MUSIC CONCERTS; TV NEWS SHOWS; PROVIDING INFORMATION IN THE FIELD OF TELEVISION PROGRAMS, DANCE SHOWS, MUSIC SHOWS AND VIDEO AWARD SHOWS, COMEDY SHOWS, AND GAME SHOWS; LIVE MUSIC CONCERTS AND TV NEWS SHOWS VIA A GLOBAL COMPUTER NETWORK (U.S. CLS. 100, 101 AND 107).

FIRST USE 7-1-2005; IN COMMERCE 7-1-2005.

TINA KUAN, EXAMINING ATTORNEY

SN 77-046,968. SCHOLASTIC INC., NEW YORK, NY. FILED 11-17-2006.

**CRITTER RIVER**

THE MARK CONSISTS OF STANDARD CHARACTERS WITHOUT CLAIM TO ANY PARTICULAR FONT, STYLE, SIZE, OR COLOR.

FOR ENTERTAINMENT SERVICES, NAMELY, PROVIDING ON-LINE COMPUTER GAMES (U.S. CLS. 100, 101 AND 107).

NAKIA HENRY, EXAMINING ATTORNEY

**CLASS 41—(Continued).**

SN 77-046,991. MID-WEST MANAGEMENT, INC., MADISON, WI. FILED 11-17-2006.

**WHAT TO WEAR WEATHER**

THE MARK CONSISTS OF STANDARD CHARACTERS WITHOUT CLAIM TO ANY PARTICULAR FONT, STYLE, SIZE, OR COLOR.

NO CLAIM IS MADE TO THE EXCLUSIVE RIGHT TO USE "WEATHER", APART FROM THE MARK AS SHOWN. FOR ENTERTAINMENT SERVICES IN THE NATURE OF AN ONGOING RADIO PROGRAM FEATURING WEATHER REPORTS AND WEATHER INFORMATION (U.S. CLS. 100, 101 AND 107).

FIRST USE 10-0-2005; IN COMMERCE 10-0-2005.  
RENEE MCCRAY, EXAMINING ATTORNEY

SN 77-048,696. NATIONAL RETAIL FEDERATION, INC., WASHINGTON, DC. FILED 11-21-2006.

**NRF UNIVERSITY WIRED**

THE MARK CONSISTS OF STANDARD CHARACTERS WITHOUT CLAIM TO ANY PARTICULAR FONT, STYLE, SIZE, OR COLOR.

OWNER OF U.S. REG. NOS. 2,261,155, 2,337,484 AND OTHERS.

NO CLAIM IS MADE TO THE EXCLUSIVE RIGHT TO USE "UNIVERSITY WIRED", APART FROM THE MARK AS SHOWN.

FOR EDUCATION SERVICES, NAMELY, PROVIDING CLASSES, CONFERENCES, AND SEMINARS IN THE FIELD OF THE RETAIL TRADE; EDUCATION SERVICES, NAMELY, PROVIDING CLASSES, CONFERENCES, AND SEMINARS IN THE FIELD OF THE RETAIL TRADE VIA WEBINARS AND WEB CASTS (U.S. CLS. 100, 101 AND 107).

FIRST USE 9-20-2006; IN COMMERCE 9-20-2006.  
MARGARET POWER, EXAMINING ATTORNEY

SN 77-059,018. FREMANTLEMEDIA NORTH AMERICA, INC., BURBANK, CA. FILED 12-7-2006.

**LIVE LIKE AN IDOL**

THE MARK CONSISTS OF STANDARD CHARACTERS WITHOUT CLAIM TO ANY PARTICULAR FONT, STYLE, SIZE, OR COLOR.

FOR ENTERTAINMENT SERVICES IN THE NATURE OF A TELEVISION REALITY SHOW; ENTERTAINMENT SERVICES IN THE NATURE OF A SWEEPSTAKES; ONLINE COMPUTER GAME (U.S. CLS. 100, 101 AND 107).

JEFF DEFORD, EXAMINING ATTORNEY

**CLASS 41—(Continued).**

SN 77-061,427. RANK, GREG J, SONOMA, CA. FILED 12-11-2006.

**Pearls of Golf**

THE MARK CONSISTS OF STANDARD CHARACTERS WITHOUT CLAIM TO ANY PARTICULAR FONT, STYLE, SIZE, OR COLOR.

FOR PROVIDING A WEBSITE THROUGH WHICH GOLFERS LOCATE INFORMATION ABOUT GOLF COURSES AND GOLF TOURNAMENTS (U.S. CLS. 100, 101 AND 107).

EDWARD NELSON, EXAMINING ATTORNEY

SN 77-062,027. AOL LLC, DULLES, VA. FILED 12-12-2006.

**DOWNLOAD SQUAD**

THE MARK CONSISTS OF STANDARD CHARACTERS WITHOUT CLAIM TO ANY PARTICULAR FONT, STYLE, SIZE, OR COLOR.

NO CLAIM IS MADE TO THE EXCLUSIVE RIGHT TO USE "DOWNLOAD", APART FROM THE MARK AS SHOWN.

FOR ONLINE JOURNALS, NAMELY, BLOGS FEATURING COMPUTERS, COMPUTER SOFTWARE, TECHNOLOGY, AND ONLINE SERVICES (U.S. CLS. 100, 101 AND 107).

FIRST USE 5-1-2004; IN COMMERCE 5-1-2004.  
TRAVIS WHEATLEY, EXAMINING ATTORNEY

SN 77-062,031. AOL LLC, DULLES, VA. FILED 12-12-2006.

**CARD SQUAD**

THE MARK CONSISTS OF STANDARD CHARACTERS WITHOUT CLAIM TO ANY PARTICULAR FONT, STYLE, SIZE, OR COLOR.

NO CLAIM IS MADE TO THE EXCLUSIVE RIGHT TO USE "CARD", APART FROM THE MARK AS SHOWN.

FOR ONLINE JOURNALS, NAMELY, BLOGS FEATURING CARD GAMES, POKER GAMES, GAME COMPETITIONS AND TOURNAMENTS, GAMING NEWS, AND GAMBLING PERSONALITIES (U.S. CLS. 100, 101 AND 107).

FIRST USE 5-1-2004; IN COMMERCE 5-1-2004.  
TRAVIS WHEATLEY, EXAMINING ATTORNEY

**CLASS 41—(Continued).**

SN 77-063,979. AOL LLC, DULLES, VA. FILED 12-14-2006.

**TV SQUAD**

THE MARK CONSISTS OF STANDARD CHARACTERS WITHOUT CLAIM TO ANY PARTICULAR FONT, STYLE, SIZE, OR COLOR.

NO CLAIM IS MADE TO THE EXCLUSIVE RIGHT TO USE "TV", APART FROM THE MARK AS SHOWN.

FOR ONLINE JOURNALS, NAMELY, BLOGS IN THE FIELD OF TELEVISION, TELEVISION PROGRAMS, AND THE TELEVISION INDUSTRY (U.S. CLS. 100, 101 AND 107).

FIRST USE 5-1-2004; IN COMMERCE 5-1-2004.  
TRAVIS WHEATLEY, EXAMINING ATTORNEY

**CLASS 41—(Continued).**

SN 78-480,381. BON LOSEE INC., PROVO, UT. FILED 9-8-2004.

**Bon Losee**

THE MARK CONSISTS OF STANDARD CHARACTERS WITHOUT CLAIM TO ANY PARTICULAR FONT, STYLE, SIZE, OR COLOR.

THE WORD BON IN THE MARK TRANSLATES INTO ENGLISH AS GOOD.

SEC. 2(F) AS TO "LOSEE".

FOR EDUCATIONAL SERVICES; NAMELY, CONDUCTING CLASSES, SEMINARS, CONFERENCES AND WORKSHOPS IN THE FIELDS OF COSMETOLOGY AND ESTHETICS AND DISTRIBUTING COURSE MATERIALS IN CONNECTION THEREWITH (U.S. CLS. 100, 101 AND 107).

FIRST USE 5-5-1987; IN COMMERCE 5-5-1987.  
NANCY CLARKE, EXAMINING ATTORNEY

SN 77-066,747. HDNET LLC, DALLAS, TX. FILED 12-18-2006.

**GREAT STORIES WELL TOLD**

THE MARK CONSISTS OF STANDARD CHARACTERS WITHOUT CLAIM TO ANY PARTICULAR FONT, STYLE, SIZE, OR COLOR.

FOR ENTERTAINMENT IN THE NATURE OF ONGOING TELEVISION PROGRAMS IN THE FIELD OF MOVIES (U.S. CLS. 100, 101 AND 107).

DAVID H. STINE, EXAMINING ATTORNEY

SN 78-522,439. AMBERT, ALBA N., CHAPEL HILL, NC. FILED 11-24-2004.

**INNER HEART INSTITUTE**

SN 77-086,753. ALTICOR INVESTMENTS, INC., ADA, MI. FILED 1-19-2007.

**ADA-TUDES**

THE MARK CONSISTS OF STANDARD CHARACTERS WITHOUT CLAIM TO ANY PARTICULAR FONT, STYLE, SIZE, OR COLOR.

FOR ON-LINE JOURNALS, NAMELY, BLOGS IN THE FIELD OF BUSINESS (U.S. CLS. 100, 101 AND 107).

ANTHONY RINKER, EXAMINING ATTORNEY

THE MARK CONSISTS OF STANDARD CHARACTERS WITHOUT CLAIM TO ANY PARTICULAR FONT, STYLE, SIZE, OR COLOR.

NO CLAIM IS MADE TO THE EXCLUSIVE RIGHT TO USE "INSTITUTE", APART FROM THE MARK AS SHOWN.

FOR EDUCATION SERVICES, NAMELY, CONDUCTING CLASSES IN THE FIELD OF PHYSICAL AND EMOTIONAL WELL-BEING AND SPIRITUAL GROWTH THROUGH VARIOUS FORMS REIKI, OPEN HEART AND OTHER METHODS; TRAINING SERVICES IN THE FIELD OF PHYSICAL AND EMOTIONAL WELL-BEING AND SPIRITUAL GROWTH USING REIKI, OPEN HEART AND OTHER METHODS (U.S. CLS. 100, 101 AND 107).

FIRST USE 8-28-2004; IN COMMERCE 8-28-2004.  
KELLY BOULTON, EXAMINING ATTORNEY



**CLASS 41—(Continued).**

SN 78-563,702. BUZZTIME ENTERTAINMENT, INC., CARLSBAD, CA. FILED 2-9-2005.

# BUZZPOINTS

THE MARK CONSISTS OF STANDARD CHARACTERS WITHOUT CLAIM TO ANY PARTICULAR FONT, STYLE, SIZE, OR COLOR.

OWNER OF U.S. REG. NOS. 2,583,460, 2,672,713 AND 2,908,923.

FOR PROVIDING A FREQUENT USER REWARDS PROGRAM IN CONNECTION WITH INTERACTIVE GAMES PLAYED VIA SATELLITE, CABLE, TELEPHONE, INTERNET, A GLOBAL COMPUTER NETWORK OR OTHER INTERACTIVE DEVICES IN THE NATURE OF PRIZE GIVEAWAYS (U.S. CLS. 100, 101 AND 107).

EUGENIA MARTIN, EXAMINING ATTORNEY



SN 78-593,437. NATIONAL CAPITAL GOLF VENTURES, LLC, DULLES, VA. FILED 3-23-2005.

# PRESIDENTIAL

THE MARK CONSISTS OF STANDARD CHARACTERS WITHOUT CLAIM TO ANY PARTICULAR FONT, STYLE, SIZE, OR COLOR.

FOR GOLF CLUB SERVICES (U.S. CLS. 100, 101 AND 107).

HENRY S. ZAK, EXAMINING ATTORNEY

**CLASS 41—(Continued).**

SN 78-608,144. NATIONAL ASSOCIATION FOR FAMILY AND COMMUNITY EDUCATION, FLORENCE, KY. FILED 4-13-2005.



NO CLAIM IS MADE TO THE EXCLUSIVE RIGHT TO USE "HOME" AND "FAMILY" AND "COMMUNITY", APART FROM THE MARK AS SHOWN.

THE MARK CONSISTS OF TWO CONCENTRIC CIRCLES. AT THE CENTER IS A HEARTH FIRE. THE SECOND CIRCLE CONSISTS OF AN OAK LEAF, A LAMP AND A SHOCK OF WHEAT. IN BETWEEN THESE SYMBOLS ARE THE WORDS: HOME FAMILY COMMUNITY.

FOR EDUCATIONAL SERVICES, NAMELY, CONDUCTING COURSES TO IMPROVE QUALITY OF FAMILY LIFE AND COURSES IN LEADERSHIP TRAINING (U.S. CLS. 100, 101 AND 107).

FIRST USE 1-0-1987; IN COMMERCE 1-0-1987.

ODESSA BIBBINS, EXAMINING ATTORNEY



SN 78-616,574. LANE, JEFFREY, INGLEWOOD, CA. FILED 4-25-2005.

# SOURCENTERTAINMENT

THE MARK CONSISTS OF STANDARD CHARACTERS WITHOUT CLAIM TO ANY PARTICULAR FONT, STYLE, SIZE, OR COLOR.

FOR MUSIC PRODUCTION (U.S. CLS. 100, 101 AND 107).

REBECCA GILBERT, EXAMINING ATTORNEY

**CLASS 41—(Continued).**

SN 78-645,065. ISOCRACY FITNESS, LLC, NASHVILLE, TN. FILED 6-7-2005.

**ISOCRACY FITNESS**

THE MARK CONSISTS OF STANDARD CHARACTERS WITHOUT CLAIM TO ANY PARTICULAR FONT, STYLE, SIZE, OR COLOR.

NO CLAIM IS MADE TO THE EXCLUSIVE RIGHT TO USE "FITNESS", APART FROM THE MARK AS SHOWN.

FOR PHYSICAL FITNESS CONSULTATION AND INSTRUCTION, NAMELY, PERSONAL TRAINER SERVICES IN THE AREAS OF CLASS EXERCISE, YOGA, PILATES, WEIGHT LIFTING AND AEROBICS; HEALTH CLUB SERVICES, NAMELY, PROVIDING INSTRUCTION AND EQUIPMENT IN THE FIELD OF PHYSICAL EXERCISE; EDUCATIONAL SERVICES, NAMELY, CONDUCTING CLASSES, WORKSHOPS AND SEMINARS IN THE FIELD OF HEALTH, NUTRITION, WEIGHT LIFTING, EXERCISE, CARDIOVASCULAR HEALTH, AND PHYSICAL FITNESS; HEALTH CLUB AND RECREATION CENTER SERVICES, NAMELY, PROVIDING FACILITIES AND ORGANIZING CLUB EVENTS, NAMELY BASKETBALL, MARTIAL ARTS, SELF DEFENSE, KICK-BOXING, SPINNING, YOGA, PILATES, AEROBICS, TREADMILL CLASSES (U.S. CLS. 100, 101 AND 107).  
JASON BLAIR, EXAMINING ATTORNEY

SN 78-655,597. DAVIDSON, TOMMY, ENCINO, CA. FILED 6-21-2005.

**The Soul Bowl**

THE MARK CONSISTS OF STANDARD CHARACTERS WITHOUT CLAIM TO ANY PARTICULAR FONT, STYLE, SIZE, OR COLOR.

FOR ENTERTAINMENT SERVICES, NAMELY, PRODUCTION OF LIVE SPECIAL EVENT SHOWS AND VARIETY MUSICAL CONCERTS (U.S. CLS. 100, 101 AND 107).  
JILL C. ALT, EXAMINING ATTORNEY

**CLASS 41—(Continued).**

SN 78-655,955. 24 HOUR FITNESS USA, INC., SAN RAMON, CA. FILED 6-22-2005.



NO CLAIM IS MADE TO THE EXCLUSIVE RIGHT TO USE "24 MINUTE WORKOUT", APART FROM THE MARK AS SHOWN.

FOR HEALTH CLUB SERVICES; INSTRUCTION SERVICES, NAMELY, INSTRUCTION IN THE FIELD OF HEALTH AND PHYSICAL EXERCISE (U.S. CLS. 100, 101 AND 107).

LESLEY LAMOTHE, EXAMINING ATTORNEY

SN 78-659,039. ORLANDO SCIENCE CENTER, INC., ORLANDO, FL. FILED 6-27-2005.

**KIDZZIBIT**

THE MARK CONSISTS OF STANDARD CHARACTERS WITHOUT CLAIM TO ANY PARTICULAR FONT, STYLE, SIZE, OR COLOR.

FOR SCIENCE MUSEUM SERVICES, NAMELY, INTERACTIVE DISPLAYS IN SCIENCE, MATH, AND TECHNOLOGY, DIRECTED TO CHILDREN AND THEIR PARENTS (U.S. CLS. 100, 101 AND 107).

FIRST USE 11-1-2004; IN COMMERCE 11-1-2004.  
LYDIA BELZER, EXAMINING ATTORNEY

**CLASS 41—(Continued).**

SN 78-664,294. WORLD BASEBALL CLASSIC, INC., NEW YORK, NY. FILED 7-6-2005.



NO CLAIM IS MADE TO THE EXCLUSIVE RIGHT TO USE "CLÁSICO" AND "BEISBOL", APART FROM THE MARK AS SHOWN.

THE MARK CONSISTS OF A STYLIZED GLOBE WITH MERIDIANS AND BASEBALL STITCHING SURROUNDED BY FOUR HALF-CIRCLES THAT SPIRAL OUTWARD IN A PINWHEEL FASHION FROM THE GLOBE ABOVE WHICH THE WORDS CLÁSICO MUNDIAL DE BEISBOL APPEAR.

THE FOREIGN WORDING IN THE MARK TRANSLATES INTO ENGLISH AS WORLD BASEBALL CLASSIC.

FOR ENTERTAINMENT SERVICES, NAMELY, BASEBALL GAMES, COMPETITIONS, TOURNAMENTS AND EXHIBITIONS RENDERED LIVE AND THROUGH BROADCAST MEDIA INCLUDING TELEVISION, RADIO, SATELLITE, WIRELESS, AUDIO AND VIDEO MEDIA, FIBER OPTICS, WI-FI AND OTHER ELECTRONIC MEDIA AND VIA A GLOBAL COMPUTER NETWORK OR A COMMERCIAL ON-LINE SERVICE; INFORMATION SERVICES, NAMELY, PROVIDING INFORMATION IN THE FIELD OF SPORTS, ENTERTAINMENT AND RELATED TOPICS, AND PROVIDING FOR INFORMATIONAL MESSAGES RELATING THERETO; ENTERTAINMENT SERVICES, NAMELY, PRODUCTION OF PROGRAMMING BROADCAST VIA TELEVISION, RADIO AND A GLOBAL COMPUTER NETWORK OR A COMMERCIAL ON-LINE SERVICE (U.S. CLS. 100, 101 AND 107).

FIRST USE 12-5-2005; IN COMMERCE 12-5-2005.  
CAROLINE WOOD, EXAMINING ATTORNEY

**CLASS 41—(Continued).**

SN 78-664,327. WORLD BASEBALL CLASSIC, INC., NEW YORK, NY. FILED 7-6-2005.



NO CLAIM IS MADE TO THE EXCLUSIVE RIGHT TO USE "BASEBALL CLASSIC", APART FROM THE MARK AS SHOWN.

THE MARK CONSISTS OF A STYLIZED GLOBE WITH MERIDIANS AND BASEBALL STITCHING SURROUNDED BY FOUR HALF-CIRCLES THAT SPIRAL OUTWARD IN A PINWHEEL FASHION FROM THE GLOBE ABOVE WHICH THE WORDS WORLD BASEBALL CLASSIC APPEAR.

FOR ENTERTAINMENT SERVICES, NAMELY, BASEBALL GAMES, COMPETITIONS, TOURNAMENTS AND EXHIBITIONS RENDERED LIVE AND THROUGH BROADCAST MEDIA INCLUDING TELEVISION, RADIO, SATELLITE, WIRELESS, AUDIO AND VIDEO MEDIA, FIBER OPTICS, WI-FI AND OTHER ELECTRONIC MEDIA AND VIA A GLOBAL COMPUTER NETWORK OR A COMMERCIAL ON-LINE SERVICE; INFORMATION SERVICES, NAMELY, PROVIDING INFORMATION IN THE FIELD OF SPORTS, ENTERTAINMENT AND RELATED TOPICS, AND PROVIDING FOR INFORMATIONAL MESSAGES RELATING THERETO; ENTERTAINMENT SERVICES, NAMELY, PRODUCTION OF PROGRAMMING BROADCAST VIA TELEVISION, RADIO AND A GLOBAL COMPUTER NETWORK OR A COMMERCIAL ON-LINE SERVICE; ORGANIZING AND CONDUCTING SPORTS CONTESTS AND SWEEPSTAKES (U.S. CLS. 100, 101 AND 107).

CAROLINE WOOD, EXAMINING ATTORNEY

**CLASS 41—(Continued).**

SN 78-680,866. UNITED STATES ANTI-DOPING AGENCY, COLORADO SPRINGS, CO. FILED 7-28-2005.



OWNER OF U.S. REG. NOS. 2,540,425, 2,638,944 AND OTHERS.

NO CLAIM IS MADE TO THE EXCLUSIVE RIGHT TO USE "AGENCY", APART FROM THE MARK AS SHOWN. SEC. 2(F) AS TO "U.S. ANTI-DOPING".

FOR DEVELOPMENT AND DISSEMINATION OF EDUCATIONAL MATERIALS OF OTHERS IN THE FIELD OF ILLEGAL OR PROHIBITED PERFORMANCE ENHANCING SUBSTANCES AND METHODS (U.S. CLS. 100, 101 AND 107).

FIRST USE 9-30-2005; IN COMMERCE 9-30-2005.  
SONYA STEPHENS, EXAMINING ATTORNEY

SN 78-683,365. AZTLAN FEST, INC., LOS ANGELES, CA. FILED 8-2-2005.



NO CLAIM IS MADE TO THE EXCLUSIVE RIGHT TO USE "LAUGHLIN", APART FROM THE MARK AS SHOWN. THE FOREIGN WORDING IN THE MARK TRANSLATES INTO ENGLISH AS LIVE.

FOR SPECIAL EVENT PLANNING AND ORGANIZING AND PROVIDING VARIOUS COMMUNITY AND CULTURAL EVENTS FEATURING ART EXHIBITIONS, THEATRICAL AND MUSICAL PERFORMANCES, AND SPORTING EVENTS (U.S. CLS. 100, 101 AND 107).

FIRST USE 3-1-2004; IN COMMERCE 7-1-2004.  
ANGELA M. MICHELI, EXAMINING ATTORNEY

**CLASS 41—(Continued).**

SN 78-714,926. MAXUM STUDIOS, LLC, BOYNTON BEACH, FL. FILED 9-16-2005.

**MAXUM STUDIOS**

THE MARK CONSISTS OF STANDARD CHARACTERS WITHOUT CLAIM TO ANY PARTICULAR FONT, STYLE, SIZE, OR COLOR.

NO CLAIM IS MADE TO THE EXCLUSIVE RIGHT TO USE "STUDIOS", APART FROM THE MARK AS SHOWN.

FOR ENTERTAINMENT SERVICES, NAMELY THE PRODUCTION FOR DISTRIBUTION OF ANIMATION, SPECIAL EFFECTS, MUSIC VIDEOS, SHORT FILMS, 3-D MODELS, COMPUTER GRAPHICS AND VIDEO GAMES FOR OTHERS (U.S. CLS. 100, 101 AND 107).

IRENE D. WILLIAMS, EXAMINING ATTORNEY

SN 78-720,790. TRIBE, LTD., CHATHAM, NJ. FILED 9-26-2005.

**Tribe**

THE MARK CONSISTS OF STANDARD CHARACTERS WITHOUT CLAIM TO ANY PARTICULAR FONT, STYLE, SIZE, OR COLOR.

FOR ENTERTAINMENT SERVICES IN THE NATURE OF TELEVISION PRODUCTION AND MOTION PICTURE FILM PRODUCTION (U.S. CLS. 100, 101 AND 107).

FIRST USE 10-1-1986; IN COMMERCE 10-1-1986.  
CAROLYN GRAY, EXAMINING ATTORNEY

SN 78-724,146. BREATH OF FRESH AIR, LLC, GLEN ALLEN, VA. FILED 9-30-2005.



THE COLOR(S) BROWN, BLACK, WHITE, RED, AND PINK IS/ARE CLAIMED AS A FEATURE OF THE MARK.

THE MARK CONSISTS OF AN IMAGE OF A WHITE FACE OUTLINED IN BLACK WITH BROWN HAIR AND PINK CHEEKS BLOWING RED HEARTS THROUGH A WHITE HEART OUTLINED IN BLACK.

FOR EDUCATIONAL SERVICES, NAMELY, PROVIDING CLASSES IN THE FIELDS OF FIRST AID AND CPR TRAINING FOR ADULTS AND CHILDREN, PET FIRST AID AND CPR, BABYSITTING, MEDICATION MANAGEMENT TRAINING, TRAINING FOR INSTRUCTORS FOR FIRST AID, CPR, BABYSITTING, AND MEDICATION MANAGEMENT CLASSES, TRAINING FOR INSTRUCTORS FOR PET FIRST AID AND CPR (U.S. CLS. 100, 101 AND 107).

ANNE FARRELL, EXAMINING ATTORNEY

**CLASS 41—(Continued).**

SN 78-733,349. COOLEY, C. MICHAEL, NEW BERLIN, WI. FILED 10-14-2005.



**WINGSHOOTING**  
A D V E N T U R E S

NO CLAIM IS MADE TO THE EXCLUSIVE RIGHT TO USE "WINGSHOOTING ADVENTURES", APART FROM THE MARK AS SHOWN.

THE COLORS TAN, BLACK, WHITE, AND BROWN ARE CLAIMED AS A FEATURE OF THIS MARK.

THE MARK CONSISTS OF A WIREHAIR DOG WITH A MALLARD IN MOUTH AND THE WORDS WINGSHOOTING ADVENTURES. THE COLOR TAN APPEARS IN THE DOG AND MALLARD DESIGNS AND IN THE WORDING WINGSHOOTING. THE COLOR BLACK APPEARS IN THE WORDING ADVENTURES. IN THE RECTANGULAR BORDER, AND IN THE DOG AND MALLARD DESIGN, THE COLOR WHITE APPEARS IN THE DOG AND MALLARD DESIGNS AND IN THE BACKGROUND OF THE RECTANGULAR BORDER, AND THE COLOR BROWN APPEARS IN THE DOG AND MALLARD DESIGNS.

FOR ENTERTAINMENT, NAMELY A CONTINUING VARIETY SHOW BROADCAST OVER TELEVISION, SATELLITE, AUDIO, AND VIDEO MEDIA (U.S. CLS. 100, 101 AND 107).

FIRST USE 1-1-2000; IN COMMERCE 1-1-2000.  
ALEX KEAM, EXAMINING ATTORNEY

SN 78-743,957. IPME, LLLP, WESTMINSTER, CO. FILED 10-31-2005.

## Master Marketing

THE MARK CONSISTS OF STANDARD CHARACTERS WITHOUT CLAIM TO ANY PARTICULAR FONT, STYLE, SIZE, OR COLOR.

NO CLAIM IS MADE TO THE EXCLUSIVE RIGHT TO USE "MARKETING", APART FROM THE MARK AS SHOWN.

FOR EDUCATIONAL SERVICES, NAMELY, CONDUCTING ONLINE CLASSES IN THE FIELDS OF BUSINESS, FINANCE, FINANCIAL IMPROVEMENT, REAL ESTATE INVESTMENTS, REAL ESTATE MORTGAGE NOTES, COMMERCIAL PAPER, LOANS, AND OTHER FINANCIAL TRANSACTIONS (U.S. CLS. 100, 101 AND 107).

FIRST USE 10-26-2005; IN COMMERCE 10-26-2005.  
MICHAEL KEATING, EXAMINING ATTORNEY

**CLASS 41—(Continued).**

SN 78-751,065. COLA, COLUMBIA, MD. FILED 11-10-2005.

## PHYSICIAN'S OFFICE LABORATORY SYMPOSIUM

THE MARK CONSISTS OF STANDARD CHARACTERS WITHOUT CLAIM TO ANY PARTICULAR FONT, STYLE, SIZE, OR COLOR.

NO CLAIM IS MADE TO THE EXCLUSIVE RIGHT TO USE "SYMPOSIUM", APART FROM THE MARK AS SHOWN.

SEC. 2(F).

FOR ARRANGING AND CONDUCTING EDUCATIONAL CONFERENCES; EDUCATION SERVICES, NAMELY, PROVIDING CONFERENCES, SEMINARS AND CERTIFICATION COURSES IN THE FIELD OF HEALTH SERVICES, NAMELY, OPERATING PHYSICIAN OFFICES AND PHYSICIAN OFFICE LABORATORIES (U.S. CLS. 100, 101 AND 107).

FIRST USE 10-1-2001; IN COMMERCE 10-1-2001.  
KAELIE KUNG, EXAMINING ATTORNEY

SN 78-752,289. DEUTSCHE TELEKOM AG, BONN, FED REP GERMANY, FILED 11-11-2005.



PRIORITY CLAIMED UNDER SEC. 44(D) ON FED REP GERMANY APPLICATION NO. 305284681, FILED 5-12-2005, REG. NO. 30528468, DATED 8-26-2005, EXPIRES 5-31-2015.

NO CLAIM IS MADE TO THE EXCLUSIVE RIGHT TO USE "WEB", APART FROM THE MARK AS SHOWN.

THE COLOR(S) GREY AND MAGENTA AND WHITE IS/ARE CLAIMED AS A FEATURE OF THE MARK.

THE MARK CONSISTS OF THE WORDING WEB'N' WALK WITH WEB AND WALK IN GREY AND "N" IN WHITE SET AGAINST A MAGENTA SQUARE. TWO MAGENTA-COLORED CURVED ARCS ARE ROTATING AROUND THE WORDS.

FOR EDUCATION AND INSTRUCTION, NAMELY, EDUCATIONAL SERVICES IN THE NATURE OF CLASSES AND SEMINARS IN THE FIELDS OF BUSINESS, TELECOMMUNICATIONS AND COMPUTERS, AND THE DISTRIBUTION OF COURSE MATERIALS THEREWITH; ENTERTAINMENT IN THE NATURE OF VISUAL AND AUDIO PERFORMANCES, NAMELY, MUSICAL BANDS, GYMNASTIC, DANCE, AND BALLET PERFORMANCES; ENTERTAINMENT SERVICES, NAMELY, PROVIDING MUSICAL, VARIETY, NEWS AND COMEDY SHOWS VIA A GLOBAL COMPUTER INFORMATION NETWORK; PROVIDING ENTERTAINMENT INFORMATION AT THE SPECIFIC REQUEST OF END-USERS BY MEANS OF TELEPHONE OR GLOBAL COMMUNICATIONS NETWORKS; ENTERTAINMENT SERVICES, NAMELY, PROVIDING ON-LINE COMPUTER GAMES FOR CHILDREN AND ADULTS; ORGANIZING COMMUNITY SPORTING AND CULTURAL EVENTS; ORGANIZING FAIRS AND EXHIBITIONS IN THE FIELD OF VISUAL AND AUDIO PERFORMANCES, NAMELY, ROCK GROUP, GYMNASTIC, DANCE, AND BALLET PERFORMANCES (U.S. CLS. 100, 101 AND 107).

DEZMONA MIZELLE, EXAMINING ATTORNEY

**CLASS 41—(Continued).**

SN 78-754,031. CHARTWELL EDUCATION GROUP LLC, NEW YORK, NY. FILED 11-15-2005.

## CHARTWELL EDUCATION GROUP

THE MARK CONSISTS OF STANDARD CHARACTERS WITHOUT CLAIM TO ANY PARTICULAR FONT, STYLE, SIZE, OR COLOR.

NO CLAIM IS MADE TO THE EXCLUSIVE RIGHT TO USE "EDUCATION GROUP", APART FROM THE MARK AS SHOWN.

FOR CONSULTING SERVICES IN THE FIELD OF THE SYSTEMATIC IMPROVEMENT IN EDUCATION PROVIDED TO NOT FOR PROFIT AND FOR PROFIT EDUCATION PROVIDERS, LOCAL SCHOOL DISTRICTS, STATE EDUCATION BOARDS, THE PHILANTHROPIC COMMUNITY AS IT RELATES TO EDUCATION, PRIVATE EQUITY FIRMS AS IT RELATES TO INVESTMENT IN THE EDUCATION SECTOR AND STATE, FEDERAL AND INTERNATIONAL GOVERNMENT EDUCATION OFFICIALS; THE SERVICES EXCLUDE CONSULTATION TO OTHERS REGARDING NUTRITIONAL COUNSELING AND FOOD SERVICES COUNSELING (U.S. CLS. 100, 101 AND 107).

FIRST USE 7-14-2005; IN COMMERCE 7-14-2005.  
FLORENTINA BLANDU, EXAMINING ATTORNEY

SN 78-766,325. BERGER, PHIL, RIVERDALE, NY. FILED 12-5-2005.



NO CLAIM IS MADE TO THE EXCLUSIVE RIGHT TO USE "PRODUCTIONS", APART FROM THE MARK AS SHOWN.

THE COLOR(S) BLUE, GREEN, YELLOW, PURPLE, BLACK, WHITE IS/ARE CLAIMED AS A FEATURE OF THE MARK.

THE COLOR(S) BLUE APPEARS IN THE FISH. THE COLOR GREEN APPEARS IN THE FISH AND THE WATER. THE COLOR YELLOW APPEARS IN THE FISH, THE CROWN AND THE WORM. THE COLOR PURPLE APPEARS IN THE FISH, THE CROWN AND THE WORDING. THE COLOR BLACK APPEARS ON THE FISH, CROWN AND THE OUTLINE OF THE WORDING. THE COLOR WHITE APPEARS ON THE FISH.

"THE MARK CONSISTS OF A FISH WEARING A CROWN UNDERNEATH THE "KINGFISH PRODUCTIONS" COMPANY NAME".

FOR MOTION PICTURE FILM PRODUCTION; TELEVISION PRODUCTION (U.S. CLS. 100, 101 AND 107).

FIRST USE 1-1-2003; IN COMMERCE 1-2-2003.  
BRENDAN MCCAULEY, EXAMINING ATTORNEY

**CLASS 41—(Continued).**

SN 78-770,129. SIP WINE, LLC, NEW ORLEANS, LA. FILED 12-9-2005.

## SIP SCHOOL

THE MARK CONSISTS OF STANDARD CHARACTERS WITHOUT CLAIM TO ANY PARTICULAR FONT, STYLE, SIZE, OR COLOR.

NO CLAIM IS MADE TO THE EXCLUSIVE RIGHT TO USE "SCHOOL", APART FROM THE MARK AS SHOWN.

FOR EDUCATIONAL SERVICES, NAMELY, PROVIDING CLASSES IN THE FIELD OF WINE AND BEER (U.S. CLS. 100, 101 AND 107).

DAVID HOFFMAN, EXAMINING ATTORNEY

SN 78-770,926. GALLMAN, JAMILLAH NICOLE, NORTH HOLLYWOOD, CA. FILED 12-11-2005.



NO CLAIM IS MADE TO THE EXCLUSIVE RIGHT TO USE HOLLYWOOD, APART FROM THE MARK AS SHOWN.

THE COLOR(S) BLACK, RED, AND SILVER IS/ARE CLAIMED AS A FEATURE OF THE MARK.

THE MARK CONSISTS OF A RED SMEAR BACKGROUND WITH THE WORDS "HOLLYWOOD REEL TO REAL" IN BLACK LETTERS WRITTEN OVER THE RED SMEAR, THE WORD "HOLLYWOOD" IS IN THICK BLACK LETTERING, THE WORDS "REEL TO REAL" ARE IN THIN BLACK LETTERING. THE FIRST "O" IN THE WORD "HOLLYWOOD" IS ACTUALLY A SILVER FILM REEL WITH BLACK FILM CASCADING FROM IT, LOOPING TOWARDS THE "R" IN THE WORD "REEL", THE LETTER "T" IN THE WORD TO IS AN OLD-FASHIONED SILVER MICROPHONE WITH A BLACK CORD, WHICH IS THE TAIL OF THE "T" CURVING UP TO THE LETTER "O". THE LAST "O" TO THE "D" IN THE WORD HOLLYWOOD HAS A PAIR OF EYE BROWS AND UNDERNEATH EACH BROW IS A SEXY VERY MADE-UP LONG-LASHED BLACK EYE, THICKLY COATED WITH BLACK EYELINER MASCARA, AND EYESHADOW.

FOR ENTERTAINMENT IN THE NATURE OF ONGOING TELEVISION PROGRAMS IN THE FIELD OF ENTERTAINMENT NEWS, CELEBRITY INTERVIEWS, FILM, FASHION, MUSIC, AND BOOK REVIEWS; ENTERTAINMENT SERVICES, NAMELY, PROVIDING A RADIO PROGRAM IN THE FIELD OF ENTERTAINMENT VIA A GLOBAL COMPUTER NETWORK; ENTERTAINMENT SERVICES, NAMELY, PROVIDING A TELEVISION PROGRAM IN THE FIELD OF ENTERTAINMENT VIA A GLOBAL COMPUTER NETWORK; ENTERTAINMENT SERVICES, NAMELY, PROVIDING ON-LINE REVIEWS OF FILM, FASHION, MUSIC, AND BOOKS; RADIO ENTERTAINMENT PRODUCTION (U.S. CLS. 100, 101 AND 107).

LA TONIA FISHER, EXAMINING ATTORNEY

**CLASS 41—(Continued).**

SN 78-771,068. STAR OF TEXAS FAIR & RODEO, AUSTIN, TX. FILED 12-12-2005.



OWNER OF U.S. REG. NO. 2,327,833.  
NO CLAIM IS MADE TO THE EXCLUSIVE RIGHT TO USE "RODEO", APART FROM THE MARK AS SHOWN.  
SEC. 2(F) AS TO "RODEO AUSTIN".  
FOR ORGANIZING AND CONDUCTING EXHIBITIONS AND SPORTING EVENTS FOR ENTERTAINMENT, NAMELY, RODEOS, ANIMAL EXHIBITIONS, HORSE SHOWINGS, STEER ROPING, TIE-DOWN ROPING, TEAM ROPING, BULL RIDING, SADDLE BRONC RIDING, BAREBACK RIDING, BARREL RACING; ENTERTAINMENT IN THE NATURE OF LIVE MUSICAL CONCERTS, AND ENTERTAINMENT IN THE NATURE OF AMUSEMENT PARK RIDES (U.S. CLS. 100, 101 AND 107).  
FIRST USE 7-0-2002; IN COMMERCE 10-0-2002.  
BERYL GARDNER, EXAMINING ATTORNEY

SN 78-776,326. MCMILLAN, LONDELL L., NEW YORK, NY. FILED 12-19-2005.

**HEAT**

THE MARK CONSISTS OF STANDARD CHARACTERS WITHOUT CLAIM TO ANY PARTICULAR FONT, STYLE, SIZE, OR COLOR.  
FOR LIVE PERFORMANCES BY A VOCAL MUSICAL GROUP (U.S. CLS. 100, 101 AND 107).  
JENNIFER WILLISTON, EXAMINING ATTORNEY

SN 78-777,982. BASEBALL CONCESSIONS, INC., DURHAM, NC. FILED 12-21-2005.



OF INDEPENDENT PROFESSIONAL BASEBALL

NO CLAIM IS MADE TO THE EXCLUSIVE RIGHT TO USE "AMERICAN ASSOCIATION OF INDEPENDENT PROFESSIONAL BASEBALL", APART FROM THE MARK AS SHOWN.  
FOR ENTERTAINMENT SERVICES IN THE NATURE OF ORGANIZING AND CONDUCTING BASEBALL GAME EXHIBITIONS AND COMPETITIONS (U.S. CLS. 100, 101 AND 107).  
FIRST USE 12-2-2005; IN COMMERCE 12-2-2005.  
KATHRYN COWARD, EXAMINING ATTORNEY

**CLASS 41—(Continued).**

SN 78-778,718. MOBLEY, DARRYL, L., AUSTIN, TX. FILED 12-21-2005.

**Strengthening the Black Family**

THE MARK CONSISTS OF STANDARD CHARACTERS WITHOUT CLAIM TO ANY PARTICULAR FONT, STYLE, SIZE, OR COLOR.  
FOR ARRANGING OF SEMINARS AND CONFERENCES (U.S. CLS. 100, 101 AND 107).  
FIRST USE 11-25-2005; IN COMMERCE 11-25-2005.  
CORY BOONE, EXAMINING ATTORNEY

SN 78-781,357. WIENER, ALLISON HARRIS, PHOENIX, AZ. FILED 12-27-2005.



NO CLAIM IS MADE TO THE EXCLUSIVE RIGHT TO USE "BEST PRACTICES IN EDUCATION", APART FROM THE MARK AS SHOWN.  
FOR EDUCATIONAL CONSULTING SERVICES, NAMELY, PROVIDING CONSULTATION TO EDUCATIONAL INSTITUTIONS IN THE AREAS OF BEST EDUCATIONAL PRACTICES, AND HOW TO DEVELOP AND IMPLEMENT PROGRAMS THAT INTEGRATE EFFECTIVE SCIENTIFIC-BASED MATERIALS AND QUALITY ASSESSMENT TOOLS (U.S. CLS. 100, 101 AND 107).  
FIRST USE 7-1-2005; IN COMMERCE 7-1-2005.  
ELI HELLMAN, EXAMINING ATTORNEY

SN 78-792,129. RAINBOW RESORT, INC., PLYMOUTH, MN. FILED 1-16-2006.

**WEST ITASCA**

THE MARK CONSISTS OF STANDARD CHARACTERS WITHOUT CLAIM TO ANY PARTICULAR FONT, STYLE, SIZE, OR COLOR.  
FOR CAMPS, FESTIVALS, AND RETREATS FEATURING A VARIETY OF ACTIVITIES, NAMELY, SPORTING EVENTS, AND EDUCATIONAL EVENTS (U.S. CLS. 100, 101 AND 107).  
FIRST USE 12-26-2005; IN COMMERCE 12-26-2005.  
KAREN K. BUSH, EXAMINING ATTORNEY

**CLASS 41—(Continued).**

SN 78-792,618. MANHATTAN DANCE PROJECT, LTD., PHOENIX, AZ. FILED 1-17-2006.

# MDP

THE MARK CONSISTS OF STANDARD CHARACTERS WITHOUT CLAIM TO ANY PARTICULAR FONT, STYLE, SIZE, OR COLOR.

FOR EDUCATIONAL SERVICES, NAMELY, PROVIDING INSTRUCTION IN THE FIELD OF DANCE, PERFORMING ARTS, HEALTH, AND NUTRITION; AND EDUCATIONAL SERVICES, NAMELY, CONDUCTING CONVENTIONS AND WORKSHOPS IN THE FIELD OF DANCE, PERFORMING ARTS, HEALTH, AND NUTRITION (U.S. CLS. 100, 101 AND 107).

FIRST USE 8-1-1997; IN COMMERCE 8-1-1997.  
BRENDAN MCCAULEY, EXAMINING ATTORNEY

---

SN 78-793,331. CROBAR TRADEMARK, INC., MIAMI BEACH, FL. FILED 1-17-2006.

**CLAIM YOUR NIGHTLIFE**

THE MARK CONSISTS OF STANDARD CHARACTERS WITHOUT CLAIM TO ANY PARTICULAR FONT, STYLE, SIZE, OR COLOR.

FOR NIGHT CLUB SERVICES (U.S. CLS. 100, 101 AND 107).

FIRST USE 12-12-2003; IN COMMERCE 12-12-2003.  
JESSICA A. POWERS, EXAMINING ATTORNEY

---

SN 78-793,798. SMITH, CAROL GREEN, SIMPSONVILLE, SC. FILED 1-18-2006.

**GENERATION EXCHANGE**

THE MARK CONSISTS OF STANDARD CHARACTERS WITHOUT CLAIM TO ANY PARTICULAR FONT, STYLE, SIZE, OR COLOR.

FOR CUSTOM WRITING SERVICES, PHOTOGRAPHIC COMPOSITIONS FOR OTHERS, EDITING FILM, PHOTO, VIDEO, AND WRITTEN TEXT FOR OTHERS (U.S. CLS. 100, 101 AND 107).

KELLY CHOE, EXAMINING ATTORNEY

**CLASS 41—(Continued).**

SN 78-795,401. GRADER, ROBERT, NEW YORK, NY. FILED 1-19-2006.

**THE CHEAP BASTARD**

THE MARK CONSISTS OF STANDARD CHARACTERS WITHOUT CLAIM TO ANY PARTICULAR FONT, STYLE, SIZE, OR COLOR.

FOR TELEVISION PROGRAM IN THE FIELD OF INEXPENSIVE LIVING, TRAVELING, SHOPPING, EATING AND BARGAINS (U.S. CLS. 100, 101 AND 107).  
DEBRA LEE, EXAMINING ATTORNEY

---

SN 78-796,080. AKTIEBOLAGET TRAV OCH GALOPP, STOCKHOLM, SWEDEN, FILED 1-20-2006.



OWNER OF SWEDEN REG. NO. 322464, DATED 3-27-1997, RENEWED AS REG. NO. 322464, DATED 3-27-2007, EXPIRES 3-27-2017.

FOR ENTERTAINMENT SERVICES, NAMELY, OPERATING AND PROVIDING LOTTERY SERVICES FOR OTHERS; CASINO GAMING SERVICES; SPORTS AND ATHLETIC ACTIVITIES, NAMELY, ARRANGING AND CONDUCTING SPORTS AND ATHLETIC COMPETITIONS; ENTERTAINMENT IN THE NATURE OF HORSE RACES; WAGERING AND BETTING SERVICES (U.S. CLS. 100, 101 AND 107).

FIRST USE 4-30-2005; IN COMMERCE 4-30-2005.  
TEJBIR SINGH, EXAMINING ATTORNEY



**CLASS 41—(Continued).**

SN 78-797,288. INTERNATIONAL SOCIETY FOR PHARMACEUTICAL ENGINEERING, INC., TAMPA, FL. FILED 1-23-2006.



OWNER OF U.S. REG. NOS. 2,176,601, 3,035,224 AND OTHERS.

NO CLAIM IS MADE TO THE EXCLUSIVE RIGHT TO USE "CERTIFIED PHARMACEUTICAL INDUSTRY PROFESSIONAL", APART FROM THE MARK AS SHOWN.

FOR EDUCATIONAL SERVICES, NAMELY DEVELOPMENT AND ADMINISTRATION OF EDUCATIONAL TESTING PROGRAMS FOR THE PURPOSES OF CERTIFICATION OF INDIVIDUALS IN THE PHARMACEUTICAL INDUSTRY (U.S. CLS. 100, 101 AND 107).

JUSTINE D. PARKER, EXAMINING ATTORNEY

SN 78-799,176. TABIBIAN, BONNIE, AUSTIN, TX. FILED 1-25-2006.

## Selah Vie

THE MARK CONSISTS OF STANDARD CHARACTERS WITHOUT CLAIM TO ANY PARTICULAR FONT, STYLE, SIZE, OR COLOR.

FOR ENTERTAINMENT IN THE NATURE OF LIVE MUSICAL PERFORMANCES (U.S. CLS. 100, 101 AND 107).

BRENDAN REGAN, EXAMINING ATTORNEY

**CLASS 41—(Continued).**

SN 78-801,067. VNU BUSINESS MEDIA, INC., NEW YORK, NY. FILED 1-27-2006.

## ICON AWARDS

THE MARK CONSISTS OF STANDARD CHARACTERS WITHOUT CLAIM TO ANY PARTICULAR FONT, STYLE, SIZE, OR COLOR.

NO CLAIM IS MADE TO THE EXCLUSIVE RIGHT TO USE "AWARDS", APART FROM THE MARK AS SHOWN.

FOR RECOGNIZING DISTINGUISHED ACHIEVEMENT IN THE ADVERTISING OF HIGH TECHNOLOGY INDUSTRIES THROUGH THE CONDUCTING OF AN AWARDS PROGRAM FEATURING AN AWARDS CEREMONY AND FESTIVITIES (U.S. CLS. 100, 101 AND 107).

JENNIFER VASQUEZ, EXAMINING ATTORNEY

SN 78-802,280. INDEPENDENT MEANS, INC., SANTA BARBARA, CA. FILED 1-30-2006.

## SUMMER \$STOCK

THE MARK CONSISTS OF STANDARD CHARACTERS WITHOUT CLAIM TO ANY PARTICULAR FONT, STYLE, SIZE, OR COLOR.

FOR EDUCATIONAL SERVICES, NAMELY, SEMINARS, WORKSHOPS AND CONFERENCES IN THE FIELDS OF FINANCIAL MANAGEMENT, FINANCIAL INDEPENDENCE, MONEY SKILLS, AND PERSONAL FINANCE (U.S. CLS. 100, 101 AND 107).

FIRST USE 7-10-2001; IN COMMERCE 7-10-2001.

PETER B. BROMAGHIM, EXAMINING ATTORNEY

SN 78-803,803. DANIELS, BRETT, BRANSON, MO. FILED 1-31-2006.

## HAND-CRAFTED MYSTERY

THE MARK CONSISTS OF STANDARD CHARACTERS WITHOUT CLAIM TO ANY PARTICULAR FONT, STYLE, SIZE, OR COLOR.

OWNER OF U.S. REG. NOS. 3,080,261, 3,183,697 AND OTHERS.

FOR ENTERTAINMENT IN THE NATURE OF MAGIC SHOWS (U.S. CLS. 100, 101 AND 107).

FIRST USE 11-10-2005; IN COMMERCE 11-10-2005.

THEODORE MCBRIDE, EXAMINING ATTORNEY

**CLASS 41—(Continued).**

SN 78-807,161. ROBERT E HOWARD PROPERTIES INC., BEVERLY HILLS, CA. FILED 2-3-2006.

ROBERT E. HOWARD

THE MARK CONSISTS OF STANDARD CHARACTERS WITHOUT CLAIM TO ANY PARTICULAR FONT, STYLE, SIZE, OR COLOR.

THE NAME(S), PORTRAIT(S), AND/OR SIGNATURE(S) SHOWN IN THE MARK DOES NOT IDENTIFY A PARTICULAR LIVING INDIVIDUAL.

FOR PRODUCTION AND DISTRIBUTION OF LIVE ACTION AND/OR ANIMATED THEATRICAL AND DIRECT TO VIDEO MOTION PICTURES, SHORTS AND TRAILERS, TELEVISION PROGRAMS, SERIES, SHORTS AND INTERSTITIALS, AND WEB CAST PROGRAMS, SERIES, SHORTS AND INTERSTITIALS; ENTERTAINMENT SERVICES, NAMELY, PROVIDING ONLINE OR WIRELESS COMPUTER GAMES FOR SINGLE PLAYER USE; ENTERTAINMENT SERVICES, NAMELY, PROVIDING ONLINE OR WIRELESS COMPUTER GAMES FOR MULTIPLE PLAYER USE; ORGANIZING AND CONDUCTING VIDEO, ON-LINE AND COMPUTER GAME CONTESTS; PRODUCTION AND PERFORMANCE OF PLAYS, MUSICALS AND THEATRICAL STAGE SHOWS; ON-LINE INFORMATION SERVICES CONCERNING THE PRODUCTION, DISTRIBUTION AND PRESENTATION OF FILM, TELEVISION, VIDEO, RADIO, INTERNET PRODUCTIONS AND PERFORMANCES, VIDEO, ON-LINE AND COMPUTER GAMES AND CONTESTS, PLAYS, MUSICALS AND THEATRICAL STAGE SHOWS; FAN CLUBS, PROVIDING FAN CLUB SERVICES VIA A WEB SITE ON A GLOBAL COMPUTER NETWORK; ARRANGING ENTERTAINMENT CONFERENCES, CONVENTIONS, FESTIVALS AND ART AND CULTURAL EVENTS FEATURING ENTERTAINMENT PERFORMANCES; ON-LINE INFORMATION SERVICES ON FAN CLUBS, FAN-WEBSITES, CONVENTIONS, CONFERENCES, FESTIVALS, ART AND CULTURAL EVENTS; ORGANIZING AND CONDUCTING ROLE PLAYING GAMES; ON-LINE INFORMATION SERVICES CONCERNING ROLE PLAYING GAMES; ON-LINE INFORMATION SERVICES CONCERNING THE LITERARY WORKS IN PRINT; PROVISION OF PERSONAL APPEARANCES BY FICTIONAL CHARACTERS AND/OR BY THE MOVIE, VIDEO AND TELEVISION ACTORS WHO PLAY THE FICTIONAL CHARACTERS IN FEATURE FILMS, VIDEO PRODUCTIONS AND TELEVISION PROGRAMS; ORGANIZING AND CONDUCTING WEIGHT LIFTING CONTESTS, AND WRESTLING CONTESTS; ON-LINE INFORMATION SERVICES CONCERNING WEIGHT LIFTING CONTESTS, BOXING CONTESTS AND WRESTLING CONTESTS; EXERCISE TRAINING AND BODY BUILDING TRAINING (U.S. CLS. 100, 101 AND 107).

KAREN K. BUSH, EXAMINING ATTORNEY

**CLASS 41—(Continued).**

SN 78-807,192. ROBERT E HOWARD PROPERTIES INC., BEVERLY HILLS, CA. FILED 2-3-2006.

STEVE COSTIGAN

THE MARK CONSISTS OF STANDARD CHARACTERS WITHOUT CLAIM TO ANY PARTICULAR FONT, STYLE, SIZE, OR COLOR.

THE NAME(S), PORTRAIT(S), AND/OR SIGNATURE(S) SHOWN IN THE MARK DOES NOT IDENTIFY A PARTICULAR LIVING INDIVIDUAL.

FOR PRODUCTION AND DISTRIBUTION OF LIVE ACTION AND/OR ANIMATED THEATRICAL AND DIRECT TO VIDEO MOTION PICTURES, SHORTS AND TRAILERS, TELEVISION PROGRAMS, SERIES, SHORTS AND INTERSTITIALS, AND WEB CAST PROGRAMS, SERIES, SHORTS AND INTERSTITIALS; ENTERTAINMENT SERVICES, NAMELY, PROVIDING ONLINE OR WIRELESS COMPUTER GAMES FOR SINGLE PLAYER USE; ENTERTAINMENT SERVICES, NAMELY, PROVIDING ONLINE OR WIRELESS COMPUTER GAMES FOR MULTIPLE PLAYER USE; ORGANIZING AND CONDUCTING VIDEO, ON-LINE AND COMPUTER GAME CONTESTS; PRODUCTION AND PERFORMANCE OF PLAYS, MUSICALS AND THEATRICAL STAGE SHOWS; ON-LINE INFORMATION SERVICES CONCERNING THE PRODUCTION, DISTRIBUTION AND PRESENTATION OF FILM, TELEVISION, VIDEO, RADIO, INTERNET PRODUCTIONS AND PERFORMANCES, VIDEO, ON-LINE AND COMPUTER GAMES AND CONTESTS, PLAYS, MUSICALS AND THEATRICAL STAGE SHOWS; FAN CLUBS, PROVIDING FAN CLUB SERVICES VIA A WEB SITE ON A GLOBAL COMPUTER NETWORK; ARRANGING ENTERTAINMENT CONFERENCES, CONVENTIONS, FESTIVALS AND ART AND CULTURAL EVENTS FEATURING ENTERTAINMENT PERFORMANCES; ON-LINE INFORMATION SERVICES ON FAN CLUBS, FAN-WEBSITES, CONVENTIONS, CONFERENCES, FESTIVALS, ART AND CULTURAL EVENTS; ORGANIZING AND CONDUCTING ROLE PLAYING GAMES; ON-LINE INFORMATION SERVICES CONCERNING ROLE PLAYING GAMES; ON-LINE INFORMATION SERVICES CONCERNING THE LITERARY WORKS IN PRINT; PROVISION OF PERSONAL APPEARANCES BY FICTIONAL CHARACTERS AND/OR BY THE MOVIE, VIDEO AND TELEVISION ACTORS WHO PLAY THE FICTIONAL CHARACTERS IN FEATURE FILMS, VIDEO PRODUCTIONS AND TELEVISION PROGRAMS; ORGANIZING AND CONDUCTING WEIGHT LIFTING CONTESTS, AND WRESTLING CONTESTS; ON-LINE INFORMATION SERVICES CONCERNING WEIGHT LIFTING CONTESTS, BOXING CONTESTS AND WRESTLING CONTESTS; EXERCISE TRAINING AND BODY BUILDING TRAINING (U.S. CLS. 100, 101 AND 107).

KAREN K. BUSH, EXAMINING ATTORNEY

**CLASS 41—(Continued).**

SN 78-807,193. ROBERT E HOWARD PROPERTIES INC., BEVERLY HILLS, CA. FILED 2-3-2006.

**BRAN MAK MORN**

THE MARK CONSISTS OF STANDARD CHARACTERS WITHOUT CLAIM TO ANY PARTICULAR FONT, STYLE, SIZE, OR COLOR.

THE NAME(S), PORTRAIT(S), AND/OR SIGNATURE(S) SHOWN IN THE MARK DOES NOT IDENTIFY A PARTICULAR LIVING INDIVIDUAL.

FOR PRODUCTION AND DISTRIBUTION OF LIVE ACTION AND/OR ANIMATED THEATRICAL AND DIRECT TO VIDEO MOTION PICTURES, SHORTS AND TRAILERS, TELEVISION PROGRAMS, SERIES, SHORTS AND INTERSTITIALS, AND WEB CAST PROGRAMS, SERIES, SHORTS AND INTERSTITIALS; ENTERTAINMENT SERVICES, NAMELY, PROVIDING ONLINE OR WIRELESS COMPUTER GAMES FOR SINGLE PLAYER USE; ENTERTAINMENT SERVICES, NAMELY, PROVIDING ONLINE OR WIRELESS COMPUTER GAMES FOR MULTIPLE PLAYER USE; ORGANIZING AND CONDUCTING VIDEO, ON-LINE AND COMPUTER GAME CONTESTS; PRODUCTION AND PERFORMANCE OF PLAYS, MUSICALS AND THEATRICAL STAGE SHOWS; ON-LINE INFORMATION SERVICES CONCERNING THE PRODUCTION, DISTRIBUTION AND PRESENTATION OF FILM, TELEVISION, VIDEO, RADIO, INTERNET PRODUCTIONS AND PERFORMANCES, VIDEO, ON-LINE AND COMPUTER GAMES AND CONTESTS, PLAYS, MUSICALS AND THEATRICAL STAGE SHOWS; FAN CLUBS, PROVIDING FAN CLUB SERVICES VIA A WEB SITE ON A GLOBAL COMPUTER NETWORK; ARRANGING ENTERTAINMENT CONFERENCES, CONVENTIONS, FESTIVALS AND ART AND CULTURAL EVENTS FEATURING ENTERTAINMENT PERFORMANCES; ON-LINE INFORMATION SERVICES ON FAN CLUBS, FAN-WEBSITES, CONVENTIONS, CONFERENCES, FESTIVALS, ART AND CULTURAL EVENTS; ORGANIZING AND CONDUCTING ROLE PLAYING GAMES; ON-LINE INFORMATION SERVICES CONCERNING ROLE PLAYING GAMES; ON-LINE INFORMATION SERVICES CONCERNING THE LITERARY WORKS IN PRINT; PROVISION OF PERSONAL APPEARANCES BY FICTIONAL CHARACTERS AND/OR BY THE MOVIE, VIDEO AND TELEVISION ACTORS WHO PLAY THE FICTIONAL CHARACTERS IN FEATURE FILMS, VIDEO PRODUCTIONS AND TELEVISION PROGRAMS; ORGANIZING AND CONDUCTING WEIGHT LIFTING CONTESTS, AND WRESTLING CONTESTS; ON-LINE INFORMATION SERVICES CONCERNING WEIGHT LIFTING CONTESTS, BOXING CONTESTS AND WRESTLING CONTESTS; EXERCISE TRAINING AND BODY BUILDING TRAINING (U.S. CLS. 100, 101 AND 107).

KAREN K. BUSH, EXAMINING ATTORNEY

**CLASS 41—(Continued).**

SN 78-807,202. ROBERT E HOWARD PROPERTIES INC., BEVERLY HILLS, CA. FILED 2-3-2006.

**BRECKINRIDGE ELKINS**

THE MARK CONSISTS OF STANDARD CHARACTERS WITHOUT CLAIM TO ANY PARTICULAR FONT, STYLE, SIZE, OR COLOR.

"THE NAME(S), PORTRAIT(S), AND/OR SIGNATURE(S) SHOWN IN THE MARK DOES NOT IDENTIFY A PARTICULAR LIVING INDIVIDUAL."

FOR PRODUCTION AND DISTRIBUTION OF LIVE ACTION AND/OR ANIMATED THEATRICAL AND DIRECT TO VIDEO MOTION PICTURES, SHORTS AND TRAILERS, TELEVISION PROGRAMS, SERIES, SHORTS AND INTERSTITIALS, AND WEB CAST PROGRAMS, SERIES, SHORTS AND INTERSTITIALS; ENTERTAINMENT SERVICES, NAMELY, PROVIDING ONLINE OR WIRELESS COMPUTER GAMES FOR SINGLE PLAYER USE; ENTERTAINMENT SERVICES, NAMELY, PROVIDING ONLINE OR WIRELESS COMPUTER GAMES FOR MULTIPLE PLAYER USE; ORGANIZING AND CONDUCTING VIDEO, ON-LINE AND COMPUTER GAME CONTESTS; PRODUCTION AND PERFORMANCE OF PLAYS, MUSICALS AND THEATRICAL STAGE SHOWS; ON-LINE INFORMATION SERVICES CONCERNING THE PRODUCTION, DISTRIBUTION AND PRESENTATION OF FILM, TELEVISION, VIDEO, RADIO, INTERNET PRODUCTIONS AND PERFORMANCES, VIDEO, ON-LINE AND COMPUTER GAMES AND CONTESTS, PLAYS, MUSICALS AND THEATRICAL STAGE SHOWS; FAN CLUBS, PROVIDING FAN CLUB SERVICES VIA A WEB SITE ON A GLOBAL COMPUTER NETWORK; ARRANGING ENTERTAINMENT CONFERENCES, CONVENTIONS, FESTIVALS AND ART AND CULTURAL EVENTS FEATURING ENTERTAINMENT PERFORMANCES; ON-LINE INFORMATION SERVICES ON FAN CLUBS, FAN-WEBSITES, CONVENTIONS, CONFERENCES, FESTIVALS, ART AND CULTURAL EVENTS; ORGANIZING AND CONDUCTING ROLE PLAYING GAMES; ON-LINE INFORMATION SERVICES CONCERNING ROLE PLAYING GAMES; ON-LINE INFORMATION SERVICES CONCERNING THE LITERARY WORKS IN PRINT; PROVISION OF PERSONAL APPEARANCES BY FICTIONAL CHARACTERS AND/OR BY THE MOVIE, VIDEO AND TELEVISION ACTORS WHO PLAY THE FICTIONAL CHARACTERS IN FEATURE FILMS, VIDEO PRODUCTIONS AND TELEVISION PROGRAMS; ORGANIZING AND CONDUCTING WEIGHT LIFTING CONTESTS, AND WRESTLING CONTESTS; ON-LINE INFORMATION SERVICES CONCERNING WEIGHT LIFTING CONTESTS, BOXING CONTESTS AND WRESTLING CONTESTS; EXERCISE TRAINING AND BODY BUILDING TRAINING (U.S. CLS. 100, 101 AND 107).

KAREN K. BUSH, EXAMINING ATTORNEY

**CLASS 41—(Continued).**

SN 78-807,218. ROBERT E HOWARD PROPERTIES INC., BEVERLY HILLS, CA. FILED 2-3-2006.

# ALMURIC

THE MARK CONSISTS OF STANDARD CHARACTERS WITHOUT CLAIM TO ANY PARTICULAR FONT, STYLE, SIZE, OR COLOR.

FOR PRODUCTION AND DISTRIBUTION OF LIVE ACTION AND/OR ANIMATED THEATRICAL AND DIRECT TO VIDEO MOTION PICTURES, SHORTS AND TRAILERS, TELEVISION PROGRAMS, SERIES, SHORTS AND INTERSTITIALS, AND WEB CAST PROGRAMS, SERIES, SHORTS AND INTERSTITIALS; ENTERTAINMENT SERVICES, NAMELY, PROVIDING ONLINE OR WIRELESS COMPUTER GAMES FOR SINGLE PLAYER USE; ENTERTAINMENT SERVICES, NAMELY, PROVIDING ONLINE OR WIRELESS COMPUTER GAMES FOR MULTIPLE PLAYER USE; ORGANIZING AND CONDUCTING VIDEO, ON-LINE AND COMPUTER GAME CONTESTS; PRODUCTION AND PERFORMANCE OF PLAYS, MUSICALS AND THEATRICAL STAGE SHOWS; ON-LINE INFORMATION SERVICES CONCERNING THE PRODUCTION, DISTRIBUTION AND PRESENTATION OF FILM, TELEVISION, VIDEO, RADIO, INTERNET PRODUCTIONS AND PERFORMANCES, VIDEO, ON-LINE AND COMPUTER GAMES AND CONTESTS, PLAYS, MUSICALS AND THEATRICAL STAGE SHOWS; FAN CLUBS, PROVIDING FAN CLUB SERVICES VIA A WEB SITE ON A GLOBAL COMPUTER NETWORK; ARRANGING ENTERTAINMENT CONFERENCES, CONVENTIONS, FESTIVALS AND ART AND CULTURAL EVENTS FEATURING ENTERTAINMENT PERFORMANCES; ON-LINE INFORMATION SERVICES ON FAN CLUBS, FAN-WEBSITES, CONVENTIONS, CONFERENCES, FESTIVALS, ART AND CULTURAL EVENTS; ORGANIZING AND CONDUCTING ROLE PLAYING GAMES; ON-LINE INFORMATION SERVICES CONCERNING ROLE PLAYING GAMES; ON-LINE INFORMATION SERVICES CONCERNING THE LITERARY WORKS IN PRINT; PROVISION OF PERSONAL APPEARANCES BY FICTIONAL CHARACTERS AND/OR BY THE MOVIE, VIDEO AND TELEVISION ACTORS WHO PLAY THE FICTIONAL CHARACTERS IN FEATURE FILMS, VIDEO PRODUCTIONS AND TELEVISION PROGRAMS; ORGANIZING AND CONDUCTING WEIGHT LIFTING CONTESTS, AND WRESTLING CONTESTS; ON-LINE INFORMATION SERVICES CONCERNING WEIGHT LIFTING CONTESTS, BOXING CONTESTS AND WRESTLING CONTESTS; EXERCISE TRAINING AND BODY BUILDING TRAINING (U.S. CLS. 100, 101 AND 107).

KAREN K. BUSH, EXAMINING ATTORNEY

**CLASS 41—(Continued).**

SN 78-808,846. SAINT LOUIS UNIVERSITY, ST. LOUIS, MO. FILED 2-7-2006.

PARKS COLLEGE OF  
ENGINEERING, AVIATION AND  
TECHNOLOGY

THE MARK CONSISTS OF STANDARD CHARACTERS WITHOUT CLAIM TO ANY PARTICULAR FONT, STYLE, SIZE, OR COLOR.

OWNER OF U.S. REG. NO. 2,316,071.

NO CLAIM IS MADE TO THE EXCLUSIVE RIGHT TO USE "COLLEGE OF ENGINEERING, AVIATION AND TECHNOLOGY", APART FROM THE MARK AS SHOWN.

FOR EDUCATIONAL SERVICES; NAMELY, PROVIDING COURSES OF INSTRUCTION AT THE COLLEGE LEVEL (U.S. CLS. 100, 101 AND 107).

FIRST USE 4-21-2004; IN COMMERCE 4-21-2004.

MATTHEW MCDOWELL, EXAMINING ATTORNEY

SN 78-808,917. HEALTHFIT 50, LLC, SEWELL, NJ. FILED 2-7-2006.



NO CLAIM IS MADE TO THE EXCLUSIVE RIGHT TO USE "50", APART FROM THE MARK AS SHOWN.

"THE COLOR(S) ORANGE AND BLUE IS/ARE CLAIMED AS A FEATURE OF THE MARK."

THE MARK CONSISTS OF THE COLOR(S) ORANGE APPEARING IN THE NUMBER "50" AND IN THE BROKEN CIRCLE SURROUNDING THE NUMBER "50" AND THE COLOR BLUE APPEARING IN THE WORDING "HEALTHFIT." THE BREAK IN THE ORANGE CIRCLE SURROUNDING THE NUMBER "50" OCCURS APPROXIMATELY AROUND THE LETTER "H," WHICH APPEARS IMMEDIATELY BEFORE THE LETTER "F" IN THE TERM "HEALTHFIT" AND THE NUMBER "50" APPEARS BELOW THE LETTERS "FIT" IN THE WORD "HEALTHFIT".

FOR HEALTH CLUB SERVICES, NAMELY PROVIDING INSTRUCTION AND EQUIPMENT IN THE FIELD OF PHYSICAL EXERCISE (U.S. CLS. 100, 101 AND 107).

C. DIONNE CLYBURN, EXAMINING ATTORNEY

SN 78-820,461. CHUMASH CASINO RESORT ENTERPRISES, SANTA YNEZ, CA. FILED 2-22-2006.



NO CLAIM IS MADE TO THE EXCLUSIVE RIGHT TO USE "COMP PLAY", APART FROM THE MARK AS SHOWN.

FOR CASINO SERVICES (U.S. CLS. 100, 101 AND 107).

RICHARD WHITE, EXAMINING ATTORNEY

**CLASS 41—(Continued).**

SN 78-823,474. LAC COMMUNICATIONS, INC., GARNERVILLE, NY. FILED 2-25-2006.

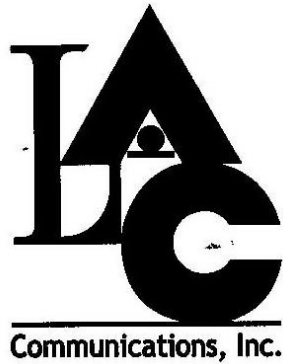

NO CLAIM IS MADE TO THE EXCLUSIVE RIGHT TO USE "COMMUNICATIONS, INC.", APART FROM THE MARK AS SHOWN.

THE MARK CONSISTS OF A STYLIZED DESIGN OF THE LETTERING "LAC" WITH THE WORDING "LAC" UNDERSCORED UNDERNEATH WITH THE WORDING "COMMUNICATIONS, INC. UNDERNEATH.

FOR PUBLISHING OF BOOKS AND MAGAZINES FOR OTHERS (U.S. CLS. 100, 101 AND 107).

FIRST USE 1-1-1994; IN COMMERCE 1-1-1994.  
LAURIE MAYES, EXAMINING ATTORNEY

**CLASS 41—(Continued).**

SN 78-826,643. KANGAROO BOB'S LLC, ATLANTA, GA. FILED 3-1-2006.



THE STIPPLING IS FOR SHADING PURPOSES ONLY. FOR PROVIDING RECREATIONAL FACILITIES IN THE NATURE OF CHILDREN'S PLAY AREAS AND RECREATIONAL AREAS FOR CHILDREN'S BIRTHDAY PARTIES AND EDUCATIONAL FACILITIES FOR CHILD LEARNING IN THE NATURE OF FACILITIES FOR MOVIES, SHOWS, PLAYS, MUSIC, AND EDUCATIONAL TRAINING (U.S. CLS. 100, 101 AND 107).

FIRST USE 3-5-2005; IN COMMERCE 12-15-2005.  
MARC LEIPZIG, EXAMINING ATTORNEY

SN 78-827,564. KELLEY, DANIEL, DBA INVISIBLE FENCE OF THE SOUTHERN TIER, HORSEHEADS, NY. FILED 3-2-2006.



THE MARK CONSISTS OF THE WORDS "SHELTERED LOVE," WITH A STYLIZED HOUSE AROUND THE LETTER "H," AND A HEART AROUND THE LETTER "V."

FOR PROVIDING A WEB SITE FOR INFORMATION AND RESOURCES REGARDING PET OWNERSHIP IN THE FIELD OF PET TRAINING AND PET EXERCISE (U.S. CLS. 100, 101 AND 107).

FIRST USE 1-31-2004; IN COMMERCE 1-31-2004.  
ELIZABETH PIGNATELLO, EXAMINING ATTORNEY

SN 78-826,240. ANCIENT MARINERS ROWING CLUB, SEATTLE, WA. FILED 3-1-2006.

ANCIENT MARINERS ROWING CLUB

THE MARK CONSISTS OF STANDARD CHARACTERS WITHOUT CLAIM TO ANY PARTICULAR FONT, STYLE, SIZE, OR COLOR.

NO CLAIM IS MADE TO THE EXCLUSIVE RIGHT TO USE "ROWING CLUB", APART FROM THE MARK AS SHOWN.

FOR ROWING CLUB SERVICES, NAMELY PROVIDING ROWING FACILITIES AND INSTRUCTION (U.S. CLS. 100, 101 AND 107).

FIRST USE 1-30-1990; IN COMMERCE 2-10-1990.  
MARIA-VICTORIA SUAREZ, EXAMINING ATTORNEY

SN 78-831,286. KANGAROO BOB'S LLC, ATLANTA, GA. FILED 3-7-2006.

Wallaby Jaq

THE MARK CONSISTS OF STANDARD CHARACTERS WITHOUT CLAIM TO ANY PARTICULAR FONT, STYLE, SIZE, OR COLOR.

FOR PROVIDING RECREATIONAL FACILITIES IN THE NATURE OF CHILDREN'S PLAY AREAS AND RECREATIONAL AREAS FOR CHILDREN'S BIRTHDAY PARTIES AND EDUCATIONAL FACILITIES FOR CHILD LEARNING IN THE NATURE OF FACILITIES FOR MOVIES, SHOWS, PLAYS, MUSIC, AND EDUCATIONAL TRAINING (U.S. CLS. 100, 101 AND 107).

FIRST USE 12-15-2005; IN COMMERCE 12-15-2005.  
MARC LEIPZIG, EXAMINING ATTORNEY

**CLASS 41—(Continued).**

SN 78-834,243. MOUNTAIN BASEBALL LLC, MISSOULA, MT. FILED 3-10-2006.

**OLLIE OSPREY**

THE MARK CONSISTS OF STANDARD CHARACTERS WITHOUT CLAIM TO ANY PARTICULAR FONT, STYLE, SIZE, OR COLOR.

OWNER OF U.S. REG. NOS. 2,639,758 AND 2,659,604. FOR ENTERTAINMENT SERVICES IN THE NATURE OF LIVE PERFORMANCES BY A BASEBALL MASCOT (U.S. CLS. 100, 101 AND 107).

FIRST USE 6-1-2002; IN COMMERCE 6-1-2002.

JEAN IM, EXAMINING ATTORNEY

SN 78-840,972. VIACOM INTERNATIONAL INC., NEW YORK, NY. FILED 3-20-2006.

**VIACOM**

OWNER OF U.S. REG. NOS. 1,008,233, 1,218,627 AND 1,703,991.

FOR PRODUCTION AND DISTRIBUTION OF MOVIES, TELEVISION MOVIES, TELEVISION PROGRAMS, CABLE TELEVISION PROGRAMMING SERVICES; PROVIDING ONLINE INFORMATION IN THE FIELD OF ENTERTAINMENT CONCERNING MOVIES, TELEVISION MOVIES, TELEVISION PROGRAMS AND CABLE TELEVISION PROGRAMMING SERVICES (U.S. CLS. 100, 101 AND 107).

FIRST USE 1-1-2006; IN COMMERCE 1-1-2006.

MICHELE SWAIN, EXAMINING ATTORNEY

SN 78-844,054. DEV8 ENTERTAINMENT LIMITED, ROAD TOWN, TORTOLA, BR.VIRGIN ISLANDS, FILED 3-23-2006.

**GIVE ME PINK**

THE MARK CONSISTS OF STANDARD CHARACTERS WITHOUT CLAIM TO ANY PARTICULAR FONT, STYLE, SIZE, OR COLOR.

FOR ENTERTAINMENT IN THE NATURE OF PROVIDING ADULT-ORIENTED MOVIES, PRERECORDED SEX-ORIENTED AUDIO AND VIDEO MESSAGES, STORIES AND PICTURES BY WAY OF TELEPHONE, TELEVISION AND A GLOBAL COMPUTER NETWORK (U.S. CLS. 100, 101 AND 107).

FIRST USE 9-30-2004; IN COMMERCE 9-30-2004.

MICHELE SWAIN, EXAMINING ATTORNEY

**CLASS 41—(Continued).**

SN 78-844,079. DEV8 ENTERTAINMENT LIMITED, ROAD TOWN, BR.VIRGIN ISLANDS, FILED 3-23-2006.

**PRIME CUPS**

THE MARK CONSISTS OF STANDARD CHARACTERS WITHOUT CLAIM TO ANY PARTICULAR FONT, STYLE, SIZE, OR COLOR.

FOR ENTERTAINMENT IN THE NATURE OF PROVIDING ADULT-ORIENTED MOVIES, PRERECORDED SEX-ORIENTED AUDIO AND VIDEO MESSAGES, STORIES AND PICTURES BY WAY OF TELEPHONE, TELEVISION AND A GLOBAL COMPUTER NETWORK (U.S. CLS. 100, 101 AND 107).

FIRST USE 11-15-2005; IN COMMERCE 11-15-2005.

MICHELE SWAIN, EXAMINING ATTORNEY

SN 78-844,187. DEV8 ENTERTAINMENT LIMITED, ROAD TOWN, BR.VIRGIN ISLANDS, FILED 3-23-2006.

**ALL INTERNAL**

THE MARK CONSISTS OF STANDARD CHARACTERS WITHOUT CLAIM TO ANY PARTICULAR FONT, STYLE, SIZE, OR COLOR.

FOR ENTERTAINMENT IN THE NATURE OF PROVIDING ADULT-ORIENTED MOVIES, PRERECORDED SEX-ORIENTED AUDIO AND VIDEO MESSAGES, STORIES AND PICTURES BY WAY OF TELEPHONE, TELEVISION AND A GLOBAL COMPUTER NETWORK (U.S. CLS. 100, 101 AND 107).

FIRST USE 8-11-2003; IN COMMERCE 8-11-2003.

MICHELE SWAIN, EXAMINING ATTORNEY

SN 78-851,540. NEW LINE PRODUCTIONS, INC., NEW YORK, NY. FILED 3-31-2006.

**MIMZY**

THE MARK CONSISTS OF STANDARD CHARACTERS WITHOUT CLAIM TO ANY PARTICULAR FONT, STYLE, SIZE, OR COLOR.

FOR ENTERTAINMENT SERVICES, NAMELY, A SERIES OF MOTION PICTURES AND TELEVISION PROGRAMS FEATURING COMEDY, DRAMA, ACTION, ADVENTURE AND/OR ANIMATION; AND FOR PROVIDING A WEBSITE FEATURING INFORMATION IN THE FIELD OF ENTERTAINMENT (U.S. CLS. 100, 101 AND 107).

ROBIN MITTLER, EXAMINING ATTORNEY

**CLASS 41—(Continued).**

SN 78-855,730. TAKKLE, INC., BROOKLYN, NY. FILED 4-6-2006.

**ONE FIELD**

THE MARK CONSISTS OF STANDARD CHARACTERS WITHOUT CLAIM TO ANY PARTICULAR FONT, STYLE, SIZE, OR COLOR.

FOR ENTERTAINMENT SERVICES FOR AMATEUR ATHLETICS, NAMELY, PROVIDING A WEB SITE ON WHICH INFORMATION REGARDING AMATEUR ATHLETE SPORTING EVENTS, PERFORMANCE STATISTICS, PHOTOS, VIDEOS, AND PERSONAL PROFILES ARE POSTED (U.S. CLS. 100, 101 AND 107).

FIRST USE 3-8-2006; IN COMMERCE 3-8-2006.  
ODESSA BIBBINS, EXAMINING ATTORNEY

SN 78-855,850. CAMBRIDGE SCIENTIFIC ABSTRACTS, LP, BETHESDA, MD. FILED 4-6-2006.

**SCHOLAR ICON**

THE MARK CONSISTS OF STANDARD CHARACTERS WITHOUT CLAIM TO ANY PARTICULAR FONT, STYLE, SIZE, OR COLOR.

FOR PROVIDING AN ON-LINE ELECTRONIC DATABASE ACCESSIBLE AND SEARCHABLE VIA A GLOBAL COMPUTER INFORMATION NETWORK PROVIDING DETAILED INFORMATION ON ACADEMIC INSTITUTIONS AND THEIR MEMBERS TO FACILITATE COLLABORATION AND RESEARCH (U.S. CLS. 100, 101 AND 107).

LOURDES AYALA, EXAMINING ATTORNEY

SN 78-866,227. CYBERHEAT, INC., TUCSON, AZ. FILED 4-20-2006.

**AllGayRealityPass**

THE MARK CONSISTS OF STANDARD CHARACTERS WITHOUT CLAIM TO ANY PARTICULAR FONT, STYLE, SIZE, OR COLOR.

FOR ADULT ENTERTAINMENT SERVICES, NAMELY, PROVIDING A WEB SITE FEATURING PERFORMANCES, RELATED FILM AND VIDEO CLIPS, AND PHOTOGRAPHS; ENTERTAINMENT SERVICES, NAMELY, PERSONAL APPEARANCES BY PERFORMERS WHO APPEAR IN MOTION PICTURES, VIDEOS OR OTHER VISUAL MEDIA IN THE FIELD OF ADULT ENTERTAINMENT (U.S. CLS. 100, 101 AND 107).

FIRST USE 11-3-2005; IN COMMERCE 11-3-2005.  
WENDY GOODMAN, EXAMINING ATTORNEY

**CLASS 41—(Continued).**

SN 78-866,982. MID-STATE SUBSTANCE ABUSE, CLARE, MI. FILED 4-21-2006.

**TAKE IT BACK**

THE MARK CONSISTS OF STANDARD CHARACTERS WITHOUT CLAIM TO ANY PARTICULAR FONT, STYLE, SIZE, OR COLOR.

FOR PUBLICATION OF PRINTED MATTER AND ON-LINE PUBLICATION OF BROCHURES AND PAMPHLETS RELATED TO ALCOHOL USE PREVENTION IN YOUTH AND OTHERS (U.S. CLS. 100, 101 AND 107).

FIRST USE 8-23-2006; IN COMMERCE 8-23-2006.  
CAROLYN GRAY, EXAMINING ATTORNEY

SN 78-870,992. NEW YORK STATE FINANCIAL AID ADMINISTRATORS ASSOCIATION, INC., SYRACUSE, NY. FILED 4-27-2006.

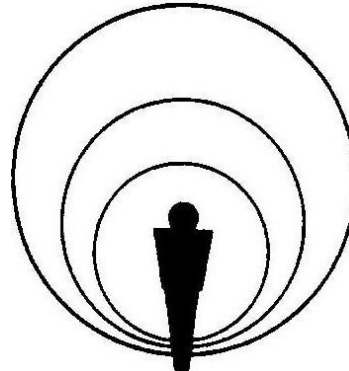

FOR PROVIDING NEWSLETTERS IN THE FIELD OF EDUCATIONAL FINANCIAL AID VIA E-MAIL; PERSONAL COACHING SERVICES IN THE FIELD OF EDUCATIONAL FINANCIAL AID; CONDUCTING WORKSHOPS AND SEMINARS IN EDUCATIONAL FINANCIAL AID; EDUCATION SERVICES NAMELY, ONE-ON-ONE MENTORING IN THE FIELD OF EDUCATIONAL FINANCIAL AID; EDUCATION SERVICES NAMELY, MENTORING IN THE FIELD OF EDUCATIONAL FINANCIAL AID; EDUCATION SERVICES, NAMELY, PROVIDING TUTORIAL SESSIONS IN THE FIELD OF EDUCATIONAL FINANCIAL AID; EDUCATION SERVICES, NAMELY, PROVIDING TUTORING IN THE FIELD OF EDUCATIONAL FINANCIAL AID; EDUCATION SERVICES, NAMELY, PROVIDING CLASSES IN THE FIELD OF EDUCATIONAL FINANCIAL AID; EDUCATION SERVICES, NAMELY PROVIDING CLASSES, SEMINARS, WORKSHOPS, TUTORING, AND MENTORING IN THE FIELD OF EDUCATIONAL FINANCIAL AID; EDUCATIONAL AND ENTERTAINMENT SERVICES, NAMELY, PROVIDING MOTIVATIONAL AND EDUCATIONAL SPEAKERS; EDUCATIONAL DEMONSTRATIONS; EDUCATIONAL RESEARCH; EDUCATIONAL SERVICES, NAMELY, PROVIDING INCENTIVES TO PEOPLE TO DEMONSTRATE EXCELLENCE IN THE FIELD OF EDUCATIONAL FINANCIAL AID THROUGH THE ISSUANCE OF AWARDS; EDUCATIONAL SERVICES, NAMELY, PROVIDING INCENTIVES TO ORGANIZATIONS TO DEMONSTRATE EXCELLENCE IN THE FIELD OF EDUCATIONAL FINANCIAL AID; EDUCATIONAL SERVICES, NAMELY, CONDUCTING SEMINARS IN

**CLASS 41—(Continued).**

THE FIELD OF EDUCATIONAL FINANCIAL AID; EDUCATIONAL SERVICES, NAMELY, CONDUCTING WORKSHOPS IN THE FIELD OF EDUCATIONAL FINANCIAL AID; EDUCATIONAL SERVICES, NAMELY, CONDUCTING CONFERENCES IN THE FIELD OF EDUCATIONAL FINANCIAL AID; EDUCATIONAL SERVICES, NAMELY, PROVIDING COURSES OF INSTRUCTION AT THE POST SECONDARY LEVEL; EDUCATIONAL SERVICES NAMELY CONDUCTING PROGRAMS IN THE FIELD OF EDUCATIONAL FINANCIAL AID; EDUCATIONAL SERVICES, NAMELY, CONDUCTING ON-LINE EXHIBITIONS AND DISPLAYS AND INTERACTIVE EXHIBITS IN THE FIELD OF EDUCATIONAL FINANCIAL AID; PUBLICATION OF BROCHURES; PUBLICATION OF ELECTRONIC NEWSPAPERS ACCESSIBLE VIA A GLOBAL COMPUTER NETWORK; TRAINING SERVICES IN THE FIELD OF EDUCATIONAL FINANCIAL AID; EDUCATION SERVICES, NAMELY, PROVIDING COURSES OF INSTRUCTION AT THE ELEMENTARY AND SECONDARY LEVEL (U.S. CLS. 100, 101 AND 107).

FIRST USE 0-0-1975; IN COMMERCE 0-0-1975.  
ANNE FARRELL, EXAMINING ATTORNEY

SN 78-871,599. ABARIS TRAINING RESOURCES, INC., RENO, NV. FILED 4-27-2006.

**ABARIS TRAINING**

THE MARK CONSISTS OF STANDARD CHARACTERS WITHOUT CLAIM TO ANY PARTICULAR FONT, STYLE, SIZE, OR COLOR.

OWNER OF U.S. REG. NO. 1,563,875.

NO CLAIM IS MADE TO THE EXCLUSIVE RIGHT TO USE "TRAINING", APART FROM THE MARK AS SHOWN. FOR EDUCATIONAL SERVICES, NAMELY, CONDUCTING CLASSES, SEMINARS, AND ONE-ON-ONE TRAINING IN THE FIELD OF COMPOSITE MATERIAL DESIGN, ENGINEERING, TOOLING, MANUFACTURE, FABRICATION, AND REPAIR (U.S. CLS. 100, 101 AND 107).

FIRST USE 1-31-1984; IN COMMERCE 1-31-1984.  
JIM RINGLE, EXAMINING ATTORNEY

SN 78-871,607. ABARIS TRAINING RESOURCES, INC., RENO, NV. FILED 4-27-2006.



OWNER OF U.S. REG. NO. 1,563,875.

NO CLAIM IS MADE TO THE EXCLUSIVE RIGHT TO USE "TRAINING", APART FROM THE MARK AS SHOWN. FOR EDUCATIONAL SERVICES, NAMELY, CONDUCTING CLASSES, SEMINARS, AND ONE-ON-ONE TRAINING IN THE FIELD OF COMPOSITE MATERIAL DESIGN, ENGINEERING, TOOLING, MANUFACTURE, FABRICATION, AND REPAIR (U.S. CLS. 100, 101 AND 107).

FIRST USE 6-30-1995; IN COMMERCE 6-30-1995.  
JIM RINGLE, EXAMINING ATTORNEY

**CLASS 41—(Continued).**

SN 78-872,982. ANDRE E. HARDY AND KENT W JORDAN PARTNERSHIP, THE, LA JOLLA, CA. FILED 4-30-2006.

**FREESTYLE MADNESS**

THE COLOR(S) PURPLE, BLACK, GRAY AND WHITE IS/ ARE CLAIMED AS A FEATURE OF THE MARK.

THE MARK CONSISTS OF THE WORDING FREESTYLE MADNESS IN PURPLE. CENTERED BELOW THE WORDING IS A BLACK AND GRAY MICROPHONE IN THE CENTER OF A LARGE PURPLE CIRCLE. ABOVE THE LARGE CIRCLE ARE FIVE MEDIUM-SIZED CIRCLES AND FOUR SMALLER CIRCLES, ALL IN PURPLE. EXTENDING OUTWARD FROM THE MEDIUM-SIZED CIRCLES ARE BLACK ARROWHEADS. THE BACKGROUND OF THE MARK IS WHITE.

FOR ARRANGING FOR TICKET RESERVATIONS FOR SHOWS AND OTHER ENTERTAINMENT EVENTS; COMPOSITION OF MUSIC FOR OTHERS; CONDUCTING AND PROVIDING FACILITIES FOR SPECIAL EVENTS FEATURING CASINO AND GAMING CONTESTS AND TOURNAMENTS; CONDUCTING EDUCATIONAL EXHIBITIONS IN THE NATURE OF FREESTYLE RAP PERFORMERS, SKATEBOARDING, VIDEO GAMES, 3 ON 3 BASKETBALL, GRAFFITI ART, BEAUTY PAGEANTS, MUSIC SEMINARS, URBAN DANCE; CONDUCTING ENTERTAINMENT EXHIBITIONS IN THE NATURE OF FREESTYLE RAP PERFORMERS, SKATEBOARDING, VIDEO GAMES, 3 ON 3 BASKETBALL, GRAFFITI ART, BEAUTY PAGEANTS, MUSIC SEMINARS, URBAN DANCE; DANCE EVENTS; DISC JOCKEYS FOR PARTIES AND SPECIAL EVENTS; EDUCATION IN THE FIELD OF FREESTYLE RAP PERFORMERS, SKATEBOARDING, VIDEO GAMES, 3 ON 3 BASKETBALL, GRAFFITI ART, BEAUTY PAGEANTS, MUSIC SEMINARS, URBAN DANCE RENDERED THROUGH CORRESPONDENCE COURSES; ENTERTAINMENT IN THE NATURE OF VISUAL AND AUDIO PERFORMANCES, AND MUSICAL, VARIETY, NEWS AND COMEDY SHOWS; ENTERTAINMENT IN THE NATURE OF VISUAL AND AUDIO PERFORMANCES, NAMELY, MUSICAL BAND, ROCK GROUP, GYMNASTIC, DANCE, AND BALLET PERFORMANCES; ENTERTAINMENT IN THE NATURE OF LIVE PERFORMANCES IN THE FIELD OF FREESTYLE RAP PERFORMERS, SKATEBOARDING, 3 ON 3 BASKETBALL, GRAFFITI ART, BEAUTY PAGEANTS, MUSIC SEMINARS, URBAN DANCE; ENTERTAINMENT, NAMELY, LIVE PERFORMANCES BY A MUSICAL BAND; ENTERTAINMENT SERVICES, NAMELY, AN ONLINE ACTIVITY WHERE YOU CREATE YOUR OWN MUSIC VIDEOS; ENTERTAINMENT SERVICES, NAMELY, PARTICIPATION IN FREESTYLE RAP PERFORMERS, SKATEBOARDING, VIDEO GAMES, 3 ON 3 BASKETBALL, GRAFFITI ART, BEAUTY PAGEANTS, MUSIC SEMINARS, URBAN DANCE; ENTERTAINMENT SERVICES, NAMELY, PROVIDING A WEB SITE FEATURING MUSICAL PERFORMANCES, MUSICAL VIDEOS, RELATED FILM CLIPS, PHOTOGRAPHS,



**CLASS 41—(Continued).**

AND OTHER MULTIMEDIA MATERIALS; ENTERTAINMENT SERVICES, NAMELY, PROVIDING ON-LINE REVIEWS OF FREESTYLE RAP PERFORMERS, SKATEBOARDING, VIDEO GAMES, 3 ON 3 BASKETBALL, GRAFFITI ART, BEAUTY PAGEANTS, MUSIC SEMINARS, URBAN DANCE; ENTERTAINMENT, NAMELY LIVE MUSIC CONCERTS; ENTERTAINMENT, NAMELY LIVE PERFORMANCES BY MUSICAL BANDS; ORGANIZATION OF DANCING EVENTS; ORGANIZING COMMUNITY FESTIVALS FEATURING A VARIETY OF ACTIVITIES, NAMELY SPORTING EVENTS, ART EXHIBITIONS, FLEA MARKETS, ETHNIC DANCES AND THE LIKE; ORGANIZING COMMUNITY SPORTING AND CULTURAL EVENTS; PLANNING ARRANGEMENT OF SHOWING MOVIES, SHOWS, PLAYS OR MUSICAL PERFORMANCES; PRESENTATION OF MUSICAL PERFORMANCE; PROVIDING RATINGS FOR TELEVISION, MOVIE, MUSIC, VIDEO AND VIDEO GAME CONTENT; SPECIAL EVENT PLANNING; SPECIAL EVENT PLANNING CONSULTATION (U.S. CLS. 100, 101 AND 107).

PAULA MAHONEY, EXAMINING ATTORNEY

SN 78-873,674. OKLAHOMA STATE FAIR, INC., OKLAHOMA CITY, OK. FILED 5-1-2006.



NO CLAIM IS MADE TO THE EXCLUSIVE RIGHT TO USE "STATE FAIR", APART FROM THE MARK AS SHOWN.

SEC. 2(F) AS TO "OKLAHOMA".

FOR ENTERTAINMENT SERVICES, NAMELY, CONDUCTING AN ANNUAL STATE FAIR INCLUDING EXHIBITIONS OF ART, CRAFTS, CONCERTS, CONCESSIONS, AMUSEMENTS, RIDES, CONTESTS, SHOWS, EDUCATIONAL DISPLAYS AND AMATEUR AND PROFESSIONAL ENTERTAINMENTS (U.S. CLS. 100, 101 AND 107).

FIRST USE 8-5-2001; IN COMMERCE 8-5-2001.  
JENNIFER KRISP, EXAMINING ATTORNEY

**CLASS 41—(Continued).**

SN 78-874,674. AMERICAN DENTAL SUPPORT, LLC, FALL CITY, WA. FILED 5-2-2006.



NO CLAIM IS MADE TO THE EXCLUSIVE RIGHT TO USE INSURANCE AND NEWSLETTER, APART FROM THE MARK AS SHOWN.

FOR EDUCATION SERVICES, NAMELY, CONDUCTING CLASSES, SEMINARS AND PRESENTATIONS FOR THE DENTAL INDUSTRY IN THE FIELD OF DENTAL INSURANCE, DENTAL INSURANCE COVERAGE, DENTAL INSURANCE CODING, MEDICARE, MEDICAID, MEDICAL AND DENTAL BENEFIT PLANS, DENTISTRY, AND DENTAL OFFICE MANAGEMENT AND ADMINISTRATION (U.S. CLS. 100, 101 AND 107).

FIRST USE 1-31-2001; IN COMMERCE 1-31-2001.  
ERNEST SHOSHO, EXAMINING ATTORNEY

SN 78-875,785. JUMPBUNCH, INC., ANNAPOLIS, MD. FILED 5-3-2006.



OWNER OF U.S. REG. NO. 2,586,608.

NO CLAIM IS MADE TO THE EXCLUSIVE RIGHT TO USE "SPORTS AND FITNESS FOR KIDS", APART FROM THE MARK AS SHOWN.

FOR EDUCATION SERVICES, NAMELY, PROVIDING RECREATIONAL CLASSES IN THE FIELD(S) OF CHILDREN'S SPORTS AND FITNESS (U.S. CLS. 100, 101 AND 107).

FIRST USE 5-1-2001; IN COMMERCE 5-1-2001.  
LINDA ORNDORFF, EXAMINING ATTORNEY

SN 78-876,018. STONE, LISA, ANN, NEWPORT BEACH, CA. FILED 5-3-2006.

**lisa ann stone**

THE MARK CONSISTS OF STANDARD CHARACTERS WITHOUT CLAIM TO ANY PARTICULAR FONT, STYLE, SIZE, OR COLOR.

FOR ENTERTAINMENT IN THE NATURE OF LIVE PERFORMANCES BY MUSICIAN OR MUSICAL GROUP (U.S. CLS. 100, 101 AND 107).

FIRST USE 2-26-2006; IN COMMERCE 4-16-2006.  
WILLIAM VERHOSEK, EXAMINING ATTORNEY

**CLASS 41—(Continued).**

SN 78-876,622. AMERICAN SOCIETY FOR INFORMATION SCIENCE AND TECHNOLOGY, SILVER SPRING, MD. FILED 5-4-2006.

**IA SUMMIT**

THE MARK CONSISTS OF STANDARD CHARACTERS WITHOUT CLAIM TO ANY PARTICULAR FONT, STYLE, SIZE, OR COLOR.

NO CLAIM IS MADE TO THE EXCLUSIVE RIGHT TO USE "SUMMIT", APART FROM THE MARK AS SHOWN. SEC. 2(F).

FOR EDUCATIONAL SERVICES, NAMELY, THE ORGANIZATION OF CONFERENCES AND SEMINARS IN THE FIELD OF INFORMATION TECHNOLOGY (U.S. CLS. 100, 101 AND 107).

FIRST USE 1-0-2003; IN COMMERCE 1-0-2003.  
GRETTA YAO, EXAMINING ATTORNEY

SN 78-880,885. NAVARRO, EFRAIN, SAN JOSE, CA. FILED 5-10-2006.

**MARCOS CASTRO**

THE MARK CONSISTS OF STANDARD CHARACTERS WITHOUT CLAIM TO ANY PARTICULAR FONT, STYLE, SIZE, OR COLOR.

THE NAME(S), PORTRAIT(S), AND/OR SIGNATURE(S) SHOWN IN THE MARK IDENTIFIES MARCOS CASTRO, WHOSE CONSENT(S) TO REGISTER IS SUBMITTED.

FOR ENTERTAINMENT, NAMELY, LIVE PERFORMANCES BY A MUSICAL BAND (U.S. CLS. 100, 101 AND 107).

KATHRYN COWARD, EXAMINING ATTORNEY

SN 78-883,318. MOBLEY, DARRYL L., AUSTIN, TX. FILED 5-15-2006.

**MegaFamily**

THE MARK CONSISTS OF STANDARD CHARACTERS WITHOUT CLAIM TO ANY PARTICULAR FONT, STYLE, SIZE, OR COLOR.

FOR ARRANGING OF SEMINARS AND CONFERENCES (U.S. CLS. 100, 101 AND 107).

FIRST USE 1-11-1995; IN COMMERCE 1-11-1995.  
CORY BOONE, EXAMINING ATTORNEY

**CLASS 41—(Continued).**

SN 78-885,309. JOHNSON & JOHNSON, NEW BRUNSWICK, NJ. FILED 5-17-2006.

**MOSAIC**

THE MARK CONSISTS OF STANDARD CHARACTERS WITHOUT CLAIM TO ANY PARTICULAR FONT, STYLE, SIZE, OR COLOR.

FOR EDUCATIONAL SERVICES, NAMELY, CONDUCTING PROGRAMS TO EDUCATE AND PROVIDE INFORMATION IN THE FIELD OF GENERAL HEALTH AND WELLNESS, MENTAL HEALTH, ALZHEIMER'S DISEASE, MIGRAINES, ANTI-INFECTIVE, GASTROINTESTINAL HEALTH, PAIN MANAGEMENT, THERAPEUTIC TREATMENT, AND WOMEN'S HEALTH, AND DISSEMINATION OF PRINTED MATERIALS TO BE USED THEREWITH (U.S. CLS. 100, 101 AND 107).

FIRST USE 9-19-2005; IN COMMERCE 9-19-2005.  
ODESSA BIBBINS, EXAMINING ATTORNEY

SN 78-886,341. GLOBAL SCIENCE BOOKS, LTD., UK, ISLEWORTH, UNITED KINGDOM, FILED 5-17-2006.



NO CLAIM IS MADE TO THE EXCLUSIVE RIGHT TO USE "GLOBAL SCIENCE BOOKS", APART FROM THE MARK AS SHOWN.

THE COLOR(S) LIGHT GREEN AND DARK GREEN IS/ ARE CLAIMED AS A FEATURE OF THE MARK.

THE MARK CONSISTS OF A YOUNG PLANTLET WITH TWO LEAVES EMERGING FROM A GREEN BOX. THE YOUNGEST LEAF IS WITHIN THE PARAMETER OF THE BOX, WHILE THE OLDER LEAF IS EXTERIOR TO THE BOX, ABOVE IT. THE BOX IS IN DARK GREEN (WITHIN), BORDERED BY A LIGHT GREEN FRAME. THE SAME/ SIMILAR TONE OF LIGHT GREEN IS USED FOR THE ENTIRE PLANT, WHILE THE LITERAL ELEMENT IS ALSO DEPICTED IN LIGHT GREEN, DIRECTLY BELOW THE "BOXED PLANT". IN TOW ROWS, THE FIRST ROW CONTAINING THE WORDS "GLOBAL SCIENCE", THE SECOND ROW "BOOKS", WORDS ALL IN CAPITAL LETTERS, AND CENTRE-ALIGNED.

FOR PUBLISHING OF BOOKS AND REVIEWS (U.S. CLS. 100, 101 AND 107).

FIRST USE 9-1-2005; IN COMMERCE 4-1-2006.  
FRANK LATTUCA, EXAMINING ATTORNEY

**CLASS 41—(Continued).**

SN 78-895,765. KYRA D SUNDANCE, LANCASTER, CA.  
FILED 5-30-2006.

## Do More With Your Dog!

THE MARK CONSISTS OF STANDARD CHARACTERS WITHOUT CLAIM TO ANY PARTICULAR FONT, STYLE, SIZE, OR COLOR.

FOR ANIMAL EXHIBITIONS; ANIMAL TRAINING; DOG SHOWS; DOG TRAINING; ENTERTAINMENT IN THE NATURE OF CIRCUSES; ENTERTAINMENT IN THE NATURE OF LIVE PERFORMANCES BY DOGS; ENTERTAINMENT IN THE NATURE OF DOG GAMES; PRESENTATION OF LIVE SHOW PERFORMANCES; TRAINING ANIMALS FOR OTHERS (U.S. CLS. 100, 101 AND 107).

FIRST USE 1-1-2001; IN COMMERCE 6-13-2003.  
AMY HELLA, EXAMINING ATTORNEY

SN 78-898,047. INVISIBLE IMAGE INC., PORT CHARLOTTE, FL. FILED 6-1-2006.

## Invisible Image

THE MARK CONSISTS OF STANDARD CHARACTERS WITHOUT CLAIM TO ANY PARTICULAR FONT, STYLE, SIZE, OR COLOR.

FOR ENTERTAINMENT IN THE NATURE OF LIVE PERFORMANCES BY A MUSICAL GROUP (U.S. CLS. 100, 101 AND 107).

FIRST USE 1-15-2003; IN COMMERCE 10-31-2005.  
KATHY DE JONGE, EXAMINING ATTORNEY

SN 78-900,388. DI-NAMIC RECORDS, HOLLYWOOD, CA.  
FILED 6-5-2006.

## DI-NAMIC RECORDS

THE MARK CONSISTS OF STANDARD CHARACTERS WITHOUT CLAIM TO ANY PARTICULAR FONT, STYLE, SIZE, OR COLOR.

NO CLAIM IS MADE TO THE EXCLUSIVE RIGHT TO USE "RECORDS", APART FROM THE MARK AS SHOWN.

FOR RECORD PRODUCTION SERVICES; MUSIC PUBLISHING SERVICES; AND PROVIDING INFORMATION RELATING TO MUSIC, MUSICAL SOUND RECORDINGS, MUSIC PUBLISHING, AND MUSICAL ARTISTS VIA A WEBSITE (U.S. CLS. 100, 101 AND 107).

STEVEN JACKSON, EXAMINING ATTORNEY

**CLASS 41—(Continued).**

SN 78-901,125. SUSAN FRIEDMANN, LAKE PLACID, NY.  
FILED 6-5-2006.

## NichePreneur

THE MARK CONSISTS OF STANDARD CHARACTERS WITHOUT CLAIM TO ANY PARTICULAR FONT, STYLE, SIZE, OR COLOR.

FOR BUSINESS COACHING AND PROVIDING SEMINARS IN THE FIELD OF ENTREPRENEURSHIP AND DISTRIBUTING COURSE MATERIAL THEREWITH (U.S. CLS. 100, 101 AND 107).

ELLEN PERKINS, EXAMINING ATTORNEY

SN 78-904,445. JACOBS, ZHYA, SOMERVILLE, MA. FILED 6-9-2006.

## CAPTURING THE INFINITE

THE MARK CONSISTS OF STANDARD CHARACTERS WITHOUT CLAIM TO ANY PARTICULAR FONT, STYLE, SIZE, OR COLOR.

FOR PUBLISHING BOOKS IN THE FIELD OF EDUCATION (U.S. CLS. 100, 101 AND 107).

JOHN DWYER, EXAMINING ATTORNEY

SN 78-904,798. BRAVO! VANCOUVER, VANCOUVER, WA.  
FILED 6-9-2006.

## VANCOUVER WINE & JAZZ FESTIVAL

THE MARK CONSISTS OF STANDARD CHARACTERS WITHOUT CLAIM TO ANY PARTICULAR FONT, STYLE, SIZE, OR COLOR.

NO CLAIM IS MADE TO THE EXCLUSIVE RIGHT TO USE "WINE & JAZZ FESTIVAL", APART FROM THE MARK AS SHOWN.

SEC. 2(F).  
FOR CONDUCTING ENTERTAINMENT EXHIBITIONS IN THE NATURE OF FESTIVALS FEATURING WINE, JAZZ, FOOD AND ART (U.S. CLS. 100, 101 AND 107).

FIRST USE 9-0-1998; IN COMMERCE 9-0-1998.  
BARBARA GAYNOR, EXAMINING ATTORNEY

**CLASS 41—(Continued).**

SN 78-906,348. FIELDSTONE ALLIANCE, INC., ST. PAUL, MN. FILED 6-12-2006.

## FIELDSTONE ALLIANCE

THE MARK CONSISTS OF STANDARD CHARACTERS WITHOUT CLAIM TO ANY PARTICULAR FONT, STYLE, SIZE, OR COLOR.

FOR PUBLISHING OF BOOKS, WORKBOOKS, NEWSLETTERS AND OTHER PRINTED MATTER, IN PRINT AND ELECTRONIC FORM AND ACCESSIBLE VIA THE INTERNET (U.S. CLS. 100, 101 AND 107).

FIRST USE 6-1-2005; IN COMMERCE 6-1-2005.  
JEFF DEFORD, EXAMINING ATTORNEY

**CLASS 41—(Continued).**

SN 78-915,165. SPORTS CLUB MANAGEMENT, L.L.C., ALEXANDRIA, VA. FILED 6-23-2006.



SN 78-906,979. RIPE DIGITAL ENTERTAINMENT, INC., LOS ANGELES, CA. FILED 6-13-2006.

## Girl vs Girl

THE MARK CONSISTS OF STANDARD CHARACTERS WITHOUT CLAIM TO ANY PARTICULAR FONT, STYLE, SIZE, OR COLOR.

FOR PROVISION OF NON-DOWNLOADABLE ONGOING AUDIO VISUAL FILM AND TELEVISION PROGRAMS VIA VIDEO ON DEMAND, TELEVISION BROADCAST, CABLE TELEVISION, BROADBAND, INTERNET AND MOBILE DEVICE SERVICES (U.S. CLS. 100, 101 AND 107).

JAMES A. RAUEN, EXAMINING ATTORNEY

THE COLOR(S) GREEN AND PURPLE AND ORANGE IS/ARE CLAIMED AS A FEATURE OF THE MARK.

THE COLOR PURPLE APPEARS AS THE COLOR OF PANTS AND SHOES OF THE BOY FIGURE ON THE LEFT AND AS THE SHIRT OF THE GIRL FIGURE ON THE RIGHT; AND APPEARS AS THE COLOR OF THE WORD "KINDER" AND APPEARS AS THE COLOR OF A PORTION OF THE DOT OVER THE "I"; AND APPEARS AS THE COLOR PURPLE OF THE WORD "IT"; AND APPEARS AS THE COLOR PURPLE OF A PORTION OF THE DOT OVER THE "I" IN THE WORD "KICK". THE COLOR ORANGE APPEARS AS THE COLOR OF THE FACE, ARMS AND THIGHS OF THE BOY FIGURE ON THE LEFT; AND THE COLOR ORANGE APPEARS AS THE COLOR OF THE FACE, HANDS AND FEET OF THE GIRL FIGURE ON THE RIGHT. THE COLOR GREEN APPEARS AS THE COLOR OF THE SHIRT AND SOCKS OF THE BOY FIGURE ON THE LEFT; AND APPEARS AS THE COLOR OF THE HAIR AND PANTS OF THE GIRL FIGURE ON THE RIGHT; AND APPEARS AS THE COLOR OF A PORTION OF THE DOT OVER THE "I"; AND APPEARS AS THE COLOR GREEN OF THE WORD "IT"; AND APPEARS AS THE COLOR GREEN OF A PORTION OF THE DOT OVER THE "I" IN THE WORD "KICK".

THE ENGLISH TRANSLATION OF THE WORD KINDER IN THE MARK IS CHILDREN.

FOR EDUCATIONAL SERVICES, NAMELY CONDUCTING CLINICS, COURSES, CAMPS, TRAINING SESSIONS AND SEMINARS IN THE FIELD OF SOCCER AND DISTRIBUTING COURSE MATERIALS IN CONNECTION THEREWITH— PERSONAL TRAINING SERVICES, NAMELY, SOCCER INSTRUCTION; SOCCER CAMPS; SOCCER TRAINING AND PERSONAL COACHING SERVICES IN THE FIELD OF SOCCER; PERSONAL TRAINING SERVICES, NAMELY, STRENGTH AND CONDITIONING TRAINING; EDUCATION SERVICES, NAMELY, MENTORING IN THE FIELD OF SOCCER; EDUCATIONAL AND ENTERTAINMENT SERVICES, NAMELY, CONDUCTING SOCCER CLINICS, CAMPS, TOURNAMENTS, SEMINARS AND ONLINE MULTIMEDIA SOCCER DRILLS AND ACTIVITIES; PROVIDING INFORMATION IN THE FIELD OF SOCCER, NAMELY, PRINCIPLES OF PLAY, TACTICS, TECHNICAL SKILLS, MENTAL TRAINING, DRILLS, ACTIVITIES, RULES, TECHNIQUES AND NEWS VIA THE INTERNET, COMPUTERS, AND OTHER ELECTRONIC DISTRIBUTIVE DEVICES, NAMELY PERSONAL DIGITAL ASSISTANTS AND WIRELESS COMMUNICATION DEVICES (U.S. CLS. 100, 101 AND 107).

JEFF DEFORD, EXAMINING ATTORNEY

SN 78-910,346. EHRlich, TODD R., AUSTIN, TX. FILED 6-16-2006.

## cerecology

THE MARK CONSISTS OF STANDARD CHARACTERS WITHOUT CLAIM TO ANY PARTICULAR FONT, STYLE, SIZE, OR COLOR.

FOR MEDICAL TRAINING AND TEACHING; TEACHING IN THE FIELD OF DENTISTRY (U.S. CLS. 100, 101 AND 107).

FIRST USE 9-15-2005; IN COMMERCE 9-15-2005.  
RICHARD A. STRASER, EXAMINING ATTORNEY

**CLASS 41—(Continued).**

SN 78-917,670. LAKE, JESSE SCOTT, MILTON, WA. FILED 6-27-2006.



NO CLAIM IS MADE TO THE EXCLUSIVE RIGHT TO USE "NATIVE AMERICAN MARTIAL ARTS ASC.", APART FROM THE MARK AS SHOWN.

FOR NATIVE AMERICAN CULTURAL EDUCATION, NAMELY, PROVIDING INSTRUCTION IN POWWOW DANCING, DRUM MAKING, ANIMAL TRACKING, SWEAT LODGE CEREMONIES, NATIVE AMERICAN CULTURAL CEREMONIES, NATIVE AMERICAN WEAPONS, BASIC SURVIVAL SKILLS, HAND-TO-HAND COMBAT, VISION QUESTING, SPIRITUAL GUIDANCE, LEADERSHIP SKILLS, PHYSICAL FITNESS, NATIVE AMERICAN HERBAL STUDIES, AND NATIVE AMERICAN PHILOSOPHY (U.S. CLS. 100, 101 AND 107).  
FIRST USE 11-0-2004; IN COMMERCE 4-0-2005.

ALICE SUE CARRUTHERS, EXAMINING ATTORNEY

SN 78-918,112. HEALDSBURG PERFORMING ARTS THEATER, HEALDSBURG, CA. FILED 6-27-2006.



THE MARK CONSISTS OF A BIRD IN TOP HAT WITH CANE PERCHED OVER THE WORD RAVEN.

FOR CINEMA THEATERS; ENTERTAINMENT IN THE NATURE OF DANCE PERFORMANCES; ENTERTAINMENT IN THE NATURE OF LIVE PERFORMANCES BY THEATER GROUPS AND MUSICIANS; ENTERTAINMENT IN THE NATURE OF THEATER PRODUCTIONS; ENTERTAINMENT IN THE NATURE OF VISUAL AND AUDIO PERFORMANCES, NAMELY, MUSICAL BAND, ROCK GROUP, GYMNASTIC, DANCE, AND BALLET PERFORMANCES; ENTERTAINMENT NAMELY, LIVE PERFORMANCES BY A MUSICAL BAND; ENTERTAINMENT, NAMELY LIVE MUSIC CONCERTS (U.S. CLS. 100, 101 AND 107).

FIRST USE 0-0-1988; IN COMMERCE 0-0-1988.  
STEVEN JACKSON, EXAMINING ATTORNEY

**CLASS 41—(Continued).**

SN 78-921,316. CALIFORNIA DIVING COMPANY, LLC, SANTA CLARITA, CA. FILED 6-30-2006.

**GRAVITY SUCKS**

THE MARK CONSISTS OF STANDARD CHARACTERS WITHOUT CLAIM TO ANY PARTICULAR FONT, STYLE, SIZE, OR COLOR.

FOR EDUCATIONAL SERVICES, NAMELY PROVIDING CLASSES, WORKSHOPS, SEMINARS IN THE FIELDS OF SCUBA DIVING (U.S. CLS. 100, 101 AND 107).

FIRST USE 9-15-2005; IN COMMERCE 9-15-2005.  
STEVEN R. FINE, EXAMINING ATTORNEY

SN 78-921,712. MARCHINI, DANIEL J., MULICA HILL, NJ. FILED 7-2-2006.

**ADDER**

THE MARK CONSISTS OF STANDARD CHARACTERS WITHOUT CLAIM TO ANY PARTICULAR FONT, STYLE, SIZE, OR COLOR.

FOR AUDIO RECORDING AND PRODUCTION; ENTERTAINMENT, NAMELY, LIVE PERFORMANCES BY ROCK GROUPS (U.S. CLS. 100, 101 AND 107).

FIRST USE 4-14-2004; IN COMMERCE 6-16-2005.  
KATHERINE CONNOLLY, EXAMINING ATTORNEY

SN 78-923,909. LIEBERMAN RESEARCH WORLDWIDE, INC., LOS ANGELES, CA. FILED 7-6-2006.

**ACTIONABILITY WORKSHOPS**

THE MARK CONSISTS OF STANDARD CHARACTERS WITHOUT CLAIM TO ANY PARTICULAR FONT, STYLE, SIZE, OR COLOR.

NO CLAIM IS MADE TO THE EXCLUSIVE RIGHT TO USE "WORKSHOPS", APART FROM THE MARK AS SHOWN.

FOR CONDUCTING WORKSHOPS AND SEMINARS IN MARKETING (U.S. CLS. 100, 101 AND 107).

CAROLYN CATALDO, EXAMINING ATTORNEY

**CLASS 41—(Continued).**

SN 78-924,095. AVYX, INC., HIGHLANDS RANCH, CO.  
FILED 7-6-2006.

# AVYX

THE MARK CONSISTS OF STANDARD CHARACTERS WITHOUT CLAIM TO ANY PARTICULAR FONT, STYLE, SIZE, OR COLOR.

FOR PUBLISHING SERVICES, NAMELY, PUBLICATION OF STUDENT MANUALS, TEACHER MANUALS, DAILY LESSON PLANS, EDUCATOR GUIDES, FLASH CARDS, WORKBOOKS, POSTERS, ACADEMIC TEXTS, CHILDREN'S BOOKS, CHILDREN'S ACTIVITY BOOKS, COLORING BOOKS, JOURNALS, NEWSLETTERS, MAGAZINES, FICTION BOOKS, AND NONFICTION BOOKS FEATURING EDUCATIONAL TOPICS IN THE AREAS OF MATH, READING, WRITING, SCIENCE, SOCIAL STUDIES, RELIGION, MUSIC, ART, FOREIGN LANGUAGES, AND PHYSICAL EDUCATION; ELECTRONIC PUBLISHING SERVICES, NAMELY, PUBLICATION OF TEXT AND GRAPHIC WORKS OF OTHERS ON CD AND DVD FEATURING EDUCATIONAL TOPICS IN THE AREAS OF MATH, READING, WRITING, SCIENCE, SOCIAL STUDIES, RELIGION, MUSIC, ART, FOREIGN LANGUAGES, AND PHYSICAL EDUCATION (U.S. CLS. 100, 101 AND 107).

EMILY CHUO, EXAMINING ATTORNEY

---

SN 78-928,713. ELMORE, WILLIAM J., LAKEWOOD, CO.  
FILED 7-13-2006.

# Aitch Eye

THE MARK CONSISTS OF STANDARD CHARACTERS WITHOUT CLAIM TO ANY PARTICULAR FONT, STYLE, SIZE, OR COLOR.

FOR ENTERTAINMENT SERVICES, NAMELY, PROVIDING A WEBSITE FEATURING PHOTOGRAPHIC PRESENTATIONS FEATURING PEOPLE, ANIMALS, BUILDINGS, RECORDING ARTISTS, BILLBOARDS AND OTHER SIGNAGE, GRAFFITI, STREET SCENES, TRAVEL DESTINATIONS, STADIUMS, MODES OF TRANSPORTATION, SPORTING EVENTS, SPORTS EQUIPMENT AND NATURAL SETTINGS (U.S. CLS. 100, 101 AND 107).

FIRST USE 5-22-2006; IN COMMERCE 5-22-2006.  
AMY ALFIERI, EXAMINING ATTORNEY

**CLASS 41—(Continued).**

SN 78-929,089. MED-SURGE HOLDINGS, INC., DALLAS, TX. FILED 7-13-2006.

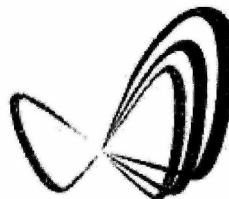

THE MARK CONSISTS OF STYLIZED BUTTERFLY. FOR EDUCATIONAL SERVICES, NAMELY, PROVIDING MEDICAL EDUCATIONAL CLINICS AND MEDICAL TRAINING (U.S. CLS. 100, 101 AND 107).

JOHN GARTNER, EXAMINING ATTORNEY

---

SN 78-929,291. STATION CASINOS, INC., LAS VEGAS, NV.  
FILED 7-13-2006.

# SUMMIT SIERRA STATION

THE MARK CONSISTS OF STANDARD CHARACTERS WITHOUT CLAIM TO ANY PARTICULAR FONT, STYLE, SIZE, OR COLOR.

FOR CASINOS; ENTERTAINMENT, NAMELY LIVE MUSIC DANCE AND COMIC PERFORMANCES; THEATRICAL AND MUSICAL FLOOR SHOWS PROVIDED AT NIGHTCLUBS (U.S. CLS. 100, 101 AND 107).

ESTHER A. BORSUK, EXAMINING ATTORNEY

---

SN 78-932,396. THE TODD PHILLIPS COMPANY, BEVERLY HILLS, CA. FILED 7-18-2006.

# A PICKED LAST PRODUCTION

THE MARK CONSISTS OF STANDARD CHARACTERS WITHOUT CLAIM TO ANY PARTICULAR FONT, STYLE, SIZE, OR COLOR.

NO CLAIM IS MADE TO THE EXCLUSIVE RIGHT TO USE "PRODUCTION", APART FROM THE MARK AS SHOWN.

FOR MOTION PICTURE PRODUCTION SERVICES (U.S. CLS. 100, 101 AND 107).

SKYE YOUNG, EXAMINING ATTORNEY

**CLASS 41—(Continued).**

SN 78-934,114. ANTOGNOLI, ERIN ALETHEA, GERMANTOWN, MD. FILED 7-20-2006.

## Halo Photographic

THE MARK CONSISTS OF STANDARD CHARACTERS WITHOUT CLAIM TO ANY PARTICULAR FONT, STYLE, SIZE, OR COLOR.

NO CLAIM IS MADE TO THE EXCLUSIVE RIGHT TO USE "PHOTOGRAPHIC", APART FROM THE MARK AS SHOWN.

FOR PHOTOGRAPHY SERVICES (U.S. CLS. 100, 101 AND 107).

FIRST USE 5-13-2002; IN COMMERCE 5-13-2002.  
ODESSA BIBBINS, EXAMINING ATTORNEY

SN 78-935,321. NEDERLANDER ALLIANCES LLC, NEW YORK, NY. FILED 7-21-2006.



THE MARK CONSISTS OF THE LETTER N IN SPECIAL FORM WITH AN ARBITRARY DESIGN.

FOR ENTERTAINMENT SERVICES, NAMELY THE PRESENTATION OF THEATRICAL, MUSICAL AND PERFORMING ARTS PRODUCTIONS (U.S. CLS. 100, 101 AND 107).

FIRST USE 0-0-1996; IN COMMERCE 0-0-1996.  
DAVID TAYLOR, EXAMINING ATTORNEY

**CLASS 41—(Continued).**

SN 78-937,452. MARINELAND OF THE PACIFIC, LLC, FALLBROOK, CA. FILED 7-25-2006.



THE COLOR(S) BLACK, WHITE AND GRAY IS/ARE CLAIMED AS A FEATURE OF THE MARK.

THE COLOR BLACK APPEARS IN THE LETTERING FOR THE WORDING "MARINELAND OF THE PACIFIC" AND IN THE TOP PORTION OF THE DOLPHIN IN THE DESIGN ELEMENT. THE COLOR WHITE APPEARS IN THE MID-SECTION PORTION OF THE DOLPHIN IN THE DESIGN ELEMENT. THE COLOR GRAY APPEARS IN OUTLINING OF THE DOLPHIN DESIGN AND IN THE LINING OF THE WATER DESIGN THAT SITS BELOW THE DOLPHIN DESIGN.

THE MARK CONSISTS OF THE WORDING "MARINELAND OF THE PACIFIC" IN BLACK LETTERING. THIS SITS ABOVE A DESIGN OF A DOLPHIN COMING OUT OF THE WATER AND THEN DIVING BACK INTO THE WATER.

FOR ENTERTAINMENT SERVICES, NAMELY PROVIDING A WEBSITE FEATURING PHOTOGRAPHIC, AUDIO AND PROSE PRESENTATIONS FEATURING PUBLIC AQUARIUM SERVICES AND OCEANARIUM SERVICES (U.S. CLS. 100, 101 AND 107).

FIRST USE 4-30-1950; IN COMMERCE 8-27-1954.  
SETH A. RAPPAPORT, EXAMINING ATTORNEY

SN 78-939,709. GAGE ACADEMY OF ART, SEATTLE, WA. FILED 7-28-2006.

## GAGE

THE MARK CONSISTS OF STANDARD CHARACTERS WITHOUT CLAIM TO ANY PARTICULAR FONT, STYLE, SIZE, OR COLOR.

THE NAME(S), PORTRAIT(S), AND/OR SIGNATURE(S) SHOWN IN THE MARK DOES NOT IDENTIFY A PARTICULAR LIVING INDIVIDUAL.

FOR EDUCATIONAL SERVICES IN THE NATURE OF FINE ART SCHOOLS; GUIDED TOURS OF ART MUSEUMS AND ART EXHIBITIONS; ART EXHIBITIONS AND PUBLIC EVENTS, NAMELY, ORGANIZING COMMUNITY FESTIVALS FEATURING A VARIETY OF ACTIVITIES, NAMELY, ART EXHIBITIONS, DANCE AND MUSIC PERFORMANCES AND PAINTING, SCULPTING AND DRAWING ACTIVITIES FOR THE PUBLIC (U.S. CLS. 100, 101 AND 107).

FIRST USE 4-15-2006; IN COMMERCE 5-8-2006.  
WARREN L. OLANDRIA, EXAMINING ATTORNEY

**CLASS 41—(Continued).**

SN 78-939,725. GAGE ACADEMY OF ART, SEATTLE, WA. FILED 7-28-2006.



NO CLAIM IS MADE TO THE EXCLUSIVE RIGHT TO USE "ACADEMY OF ART", APART FROM THE MARK AS SHOWN.

THE NAME(S), PORTRAIT(S), AND/OR SIGNATURE(S) SHOWN IN THE MARK DOES NOT IDENTIFY A PARTICULAR LIVING INDIVIDUAL.

THE MARK CONSISTS OF THE WORDING G GAGE ACADEMY OF ART WITH THE STYLIZED LETTER G ABOVE SLIGHTLY OVERLAPPING THE WORD GAGE.

FOR EDUCATIONAL SERVICES IN THE NATURE OF FINE ART SCHOOLS; GUIDED TOURS OF ART MUSEUMS AND ART EXHIBITIONS; ART EXHIBITIONS AND PUBLIC EVENTS, NAMELY, ORGANIZING COMMUNITY FESTIVALS FEATURING A VARIETY OF ACTIVITIES, NAMELY, ART EXHIBITIONS, DANCE AND MUSIC PERFORMANCES AND PAINTING, SCULPTING AND DRAWING ACTIVITIES FOR THE PUBLIC (U.S. CLS. 100, 101 AND 107).

FIRST USE 4-15-2006; IN COMMERCE 5-8-2006.  
WARREN L. OLANDRIA, EXAMINING ATTORNEY

SN 78-941,239. ANSWERS IN GENESIS OF KENTUCKY, INC., HEBRON, KY. FILED 7-31-2006.

**ANSWERS WORLDWIDE**

THE MARK CONSISTS OF STANDARD CHARACTERS WITHOUT CLAIM TO ANY PARTICULAR FONT, STYLE, SIZE, OR COLOR.

NO CLAIM IS MADE TO THE EXCLUSIVE RIGHT TO USE "WORLDWIDE", APART FROM THE MARK AS SHOWN.

FOR TRANSLATION SERVICES, NAMELY TRANSLATION OF RELIGIOUS MATERIAL FROM ENGLISH INTO NON-ENGLISH LANGUAGES. (U.S. CLS. 100, 101 AND 107).

SETH A. RAPPAPORT, EXAMINING ATTORNEY

**CLASS 41—(Continued).**

SN 78-943,363. UNBORN MEDIA, INC., BOSTON, MA. FILED 8-2-2006.

**ONE BIG SPARK**

THE MARK CONSISTS OF STANDARD CHARACTERS WITHOUT CLAIM TO ANY PARTICULAR FONT, STYLE, SIZE, OR COLOR.

FOR ENTERTAINMENT SERVICES IN THE NATURE OF ORGANIZING AND CONDUCTING LIVE MUSICAL EVENTS, NAMELY LIVE PERFORMANCES BY MUSICAL ARTISTS; ENTERTAINMENT NAMELY, PRODUCTION OF MUSIC CONCERTS; ENTERTAINMENT SERVICES NAMELY PROVIDING A WEBSITE FEATURING, PHOTOGRAPHIC, AUDIO, VIDEO AND PROSE PRESENTATIONS FEATURING MUSIC; ENTERTAINMENT SERVICES, NAMELY, PROVIDING A WEB SITE FEATURING MUSICAL PERFORMANCES, MUSICAL VIDEOS, RELATED FILM CLIPS, PHOTOGRAPHS, AND OTHER MULTIMEDIA MATERIALS; ENTERTAINMENT SERVICES, NAMELY, PROVIDING PRERECORDED MUSIC, INFORMATION IN THE FIELD OF MUSIC, AND COMMENTARY AND ARTICLES ABOUT MUSIC, ALL ON-LINE VIA A GLOBAL COMPUTER NETWORK; ENTERTAINMENT, NAMELY LIVE PERFORMANCES BY MUSICAL BANDS (U.S. CLS. 100, 101 AND 107).

TIMOTHY FINNEGAN, EXAMINING ATTORNEY

SN 78-944,525. TLC4DOGS, INC., CAMARILLO, CA. FILED 8-3-2006.



NO CLAIM IS MADE TO THE EXCLUSIVE RIGHT TO USE "INC." AND "THE LEARNING CENTER FOR DOGS", APART FROM THE MARK AS SHOWN.

THE COLOR(S) BLUE, NAVY BLUE, YELLOW AND BLACK IS/ARE CLAIMED AS A FEATURE OF THE MARK. THE MARK CONSISTS OF A BLUE RECTANGLE WITH THE NAME "TLC4DOGS, INC.", AND THE WORDS "THE LEARNING CENTER FOR DOGS". THE CHARACTERS T L C ARE YELLOW, OUTLINED IN BLACK, AND RUN DIAGONALLY FROM THE UPPER LEFT TO JUST ABOVE THE CENTER OF THE MARK. THE NUMBER 4, IN NAVY BLUE AND OUTLINED IN YELLOW, IS IN THE CENTER OF THE MARK. TO THE RIGHT AND OF, AND LOWER THAN, THE YELLOW "C". THE WORD "DOGS" IS IN LARGE NAVY BLUE LETTERING OUTLINED IN YELLOW AND RUNS HORIZONTALLY UNDER THE 4, WITH THE 4 BEING DIRECTLY ABOVE THE "G" IN "DOGS". THE WORD "DOGS", IS FOLLOWED BY A NAVY BLUE COMMA WITH A YELLOW ACCENT. THE LETTERS "INC" ARE YELLOW WITH BLACK ACCENT AND POSITIONED DIRECTLY TO THE RIGHT OF THE COMMA AFTER "DOGS". "INC" IS FOLLOWED BY A YELLOW PERIOD



**CLASS 41—(Continued).**

WITH BLACK ACCENT. UNDERNEATH THE WORDS "DOGS, INC." RUNNING HORIZONTALLY, ARE THE WORDS, "THE LEARNING CENTER FOR DOGS". THESE WORDS ARE IN NAVY BLUE LETTERING WITH THE EXCEPTION OF THE FIRST LETTERS IN EACH OF THE FIRST THREE WORDS ("T" "L" "C"), WHICH ARE YELLOW AND OUTLINED IN BLACK. IN ADDITION, THERE ARE TWO YELLOW PAW PRINTS ON THE MARK: ONE TO THE LEFT OF THE LARGE LETTER "D" "DOGS" AND ONE TO THE RIGHT OF, AND SLIGHTLY ABOVE, THE "4".

FOR DOG TRAINING (U.S. CLS. 100, 101 AND 107).  
FIRST USE 7-14-2004; IN COMMERCE 7-14-2004.  
DOMINIC FATHY, EXAMINING ATTORNEY

**CLASS 41—(Continued).**

SN 78-947,473. LOVE ONE ON PRODUCTIONS, LLC, RIVERSIDE, CA. FILED 8-8-2006.

# Flip View

THE MARK CONSISTS OF STANDARD CHARACTERS WITHOUT CLAIM TO ANY PARTICULAR FONT, STYLE, SIZE, OR COLOR.

FOR ENTERTAINMENT, NAMELY, PRODUCTION OF CABLE TELEVISION, TELEVISION, RADIO AND TELEVISION AND RADIO INTERNET SHOWS; PRODUCTION OF RADIO AND TELEVISION PROGRAMS (U.S. CLS. 100, 101 AND 107).

TAMARA FRAZIER, EXAMINING ATTORNEY

SN 78-945,195. YAOI HOUSE LLC, BLOOMINGTON, IN. FILED 8-4-2006.

# Yaoi House

THE MARK CONSISTS OF STANDARD CHARACTERS WITHOUT CLAIM TO ANY PARTICULAR FONT, STYLE, SIZE, OR COLOR.

NO CLAIM IS MADE TO THE EXCLUSIVE RIGHT TO USE "HOUSE", APART FROM THE MARK AS SHOWN.

THE FOREIGN WORDING IN THE MARK TRANSLATES INTO ENGLISH AS NO CLIMAX, NO MEANING.

FOR PUBLISHING OF BOOKS, MAGAZINES (U.S. CLS. 100, 101 AND 107).

FIRST USE 1-0-2006; IN COMMERCE 3-0-2006.  
PAULA MAYS, EXAMINING ATTORNEY

SN 78-947,526. 24 HOUR FITNESS USA, INC., SAN RAMON, CA. FILED 8-8-2006.

# you<sup>24</sup>

OWNER OF U.S. REG. NOS. 2,525,659 AND 2,997,726.

FOR PROVIDING ON-LINE PUBLICATIONS IN THE NATURE OF A MAGAZINE IN THE FIELD OF HEALTH, FITNESS AND EXERCISE INSTRUCTION (U.S. CLS. 100, 101 AND 107).

DAWN HAN, EXAMINING ATTORNEY

SN 78-946,692. DRIVERTV, LLC, NEW YORK, NY. FILED 8-7-2006.



OWNER OF U.S. REG. NOS. 3,098,687 AND 3,127,445.

FOR PRODUCTION OF VIDEO PROGRAMS FOR OTHERS, FOR USE ON VIDEO-ON-DEMAND TELEVISION CHANNELS, WEB SITES, IN-ROOM HOTEL NETWORKS, ON-DEMAND SATELLITE CHANNELS, ON-DEMAND TELEPHONE COMPANY VIDEO SERVICES AND WIRELESS NETWORKS, SUCH VIDEOS FEATURING INFORMATION ABOUT THE ATTRIBUTES, FEATURES AND SPECIFICATIONS OF MODEL AUTOMOBILES FROM ALL MAJOR MANUFACTURERS AS WELL AS OTHER INFORMATION THAT WILL HELP CONSUMERS MAKE INFORMED PURCHASING DECISIONS REGARDING AUTOMOBILES AND ANCILLARY AUTOMOTIVE PRODUCTS (U.S. CLS. 100, 101 AND 107).

EVELYN BRADLEY, EXAMINING ATTORNEY

SN 78-947,626. JACOBS ENTERTAINMENT, INC., GOLDEN, CO. FILED 8-8-2006.

# Pennies & Poker

THE MARK CONSISTS OF STANDARD CHARACTERS WITHOUT CLAIM TO ANY PARTICULAR FONT, STYLE, SIZE, OR COLOR.

NO CLAIM IS MADE TO THE EXCLUSIVE RIGHT TO USE "POKER", APART FROM THE MARK AS SHOWN.

FOR GAMBLING SERVICES (U.S. CLS. 100, 101 AND 107).

DOMINICK J. SALEMI, EXAMINING ATTORNEY

**CLASS 41—(Continued).**

SN 78-947,678. JACOBS ENTERTAINMENT, INC., GOLDEN, CO. FILED 8-8-2006.

## Pennies Poker & More

THE MARK CONSISTS OF STANDARD CHARACTERS WITHOUT CLAIM TO ANY PARTICULAR FONT, STYLE, SIZE, OR COLOR.

NO CLAIM IS MADE TO THE EXCLUSIVE RIGHT TO USE "POKER", APART FROM THE MARK AS SHOWN, FOR GAMBLING SERVICES (U.S. CLS. 100, 101 AND 107).

DOMINICK J. SALEMI, EXAMINING ATTORNEY

---

SN 78-949,284. DR. LISA COONEY, SEBASTOPOL, CA. FILED 8-10-2006.

## BREATHWORK SUNDAY

THE MARK CONSISTS OF STANDARD CHARACTERS WITHOUT CLAIM TO ANY PARTICULAR FONT, STYLE, SIZE, OR COLOR.

FOR CONDUCTING WORKSHOPS AND SEMINARS IN SELF AWARENESS THERAPY (U.S. CLS. 100, 101 AND 107).

FIRST USE 1-1-2001; IN COMMERCE 1-1-2001.

ROSELLE HERRERA, EXAMINING ATTORNEY

---

SN 78-950,893. HORNICK, JIMMY M, SCOTTSDALE, AZ. FILED 8-12-2006.

## Psychobilly Rodeo Band

THE MARK CONSISTS OF STANDARD CHARACTERS WITHOUT CLAIM TO ANY PARTICULAR FONT, STYLE, SIZE, OR COLOR.

NO CLAIM IS MADE TO THE EXCLUSIVE RIGHT TO USE RODEO BAND, APART FROM THE MARK AS SHOWN.

FOR ENTERTAINMENT IN THE NATURE OF LIVE PERFORMANCES BY PSYCHOBILLY RODEO BAND, A MUSICAL GROUP (U.S. CLS. 100, 101 AND 107).

FIRST USE 0-0-1999; IN COMMERCE 0-0-1999.

DANIEL RUSSELL, EXAMINING ATTORNEY

**CLASS 41—(Continued).**

SN 78-953,971. CARR, DARRELL, ALAMOGORDO, NM. FILED 8-17-2006.



THE COLOR(S) BLUE AND WHITE IS/ARE CLAIMED AS A FEATURE OF THE MARK.

THE COLORS BLUE AND WHITE ARE CLAIMED AS A FEATURE OF THE MARK. THE COLOR BLUE APPEARS IN AN OVAL DESIGN, IN THE WORDS MOVEMENT TO MUSCLES, IN A DESIGN OF A WOMEN RUNNING, AND A DESIGN OF A SQUARE OUTLINING A MAN FLEXING HIS BICEP. THE COLOR WHITE APPEARS WITHIN THE OVAL DESIGN AND CREATES THE SHAPE OF THE MAN FLEXING HIS BICEP.

FOR PERSONAL TRAINING SERVICES, NAMELY, STRENGTH AND CONDITIONING TRAINING (U.S. CLS. 100, 101 AND 107).

MORENO, PAUL, EXAMINING ATTORNEY

---

SN 78-954,073. AMERICAN GASTROENTEROLOGICAL ASSOCIATION INSTITUTE, BETHESDA, MD. FILED 8-17-2006.

AGA INSTITUTE  
GASTROENTEROLOGY TRAINING  
EXAMINATION

THE MARK CONSISTS OF STANDARD CHARACTERS WITHOUT CLAIM TO ANY PARTICULAR FONT, STYLE, SIZE, OR COLOR.

NO CLAIM IS MADE TO THE EXCLUSIVE RIGHT TO USE "INSTITUTE" AND "GASTROENTEROLOGY TRAINING EXAMINATION", APART FROM THE MARK AS SHOWN.

FOR EDUCATIONAL EXAMINATION SERVICES; AND ON-LINE PUBLICATION OF TESTS AND TEST BOOKLETS IN THE FIELD OF GASTROENTEROLOGY (U.S. CLS. 100, 101 AND 107).

SETH A. RAPPAPORT, EXAMINING ATTORNEY

**CLASS 41—(Continued).**

SN 78-955,275. AMERICAN ASSOCIATION OF NURSE ASSESSMENT COORDINATORS, DENVER, CO. FILED 8-18-2006.

# RAC-CT

THE MARK CONSISTS OF STANDARD CHARACTERS WITHOUT CLAIM TO ANY PARTICULAR FONT, STYLE, SIZE, OR COLOR.

OWNER OF U.S. REG. NO. 3,006,189.

FOR EDUCATIONAL SERVICES, NAMELY, DEVELOPING, ARRANGING, AND CONDUCTING EDUCATIONAL CONFERENCES AND PROGRAMS AND PROVIDING COURSES OF INSTRUCTION IN THE FIELD OF NURSE ASSESSMENT COORDINATION IN THE LONG-TERM CARE INDUSTRY, LEADING TO CERTIFICATION (U.S. CLS. 100, 101 AND 107).

DANIEL RUSSELL, EXAMINING ATTORNEY

SN 78-955,552. RECTOR, KENNETH M., HOUSTON, TX. FILED 8-18-2006.

## "The Barefoot Drummer"

THE MARK CONSISTS OF STANDARD CHARACTERS WITHOUT CLAIM TO ANY PARTICULAR FONT, STYLE, SIZE, OR COLOR.

NO CLAIM IS MADE TO THE EXCLUSIVE RIGHT TO USE "DRUMMER", APART FROM THE MARK AS SHOWN.

FOR ENTERTAINMENT SERVICES, NAMELY, LIVE PERFORMANCES BY A MUSICAL ENTERTAINER (U.S. CLS. 100, 101 AND 107).

ELLEN BURNS, EXAMINING ATTORNEY

SN 78-955,800. MARQUEZ, MARIANO III, SAN FRANCISCO, CA. FILED 8-18-2006.

## LIGHTNING RAY PICTURES

THE MARK CONSISTS OF STANDARD CHARACTERS WITHOUT CLAIM TO ANY PARTICULAR FONT, STYLE, SIZE, OR COLOR.

NO CLAIM IS MADE TO THE EXCLUSIVE RIGHT TO USE "PICTURES", APART FROM THE MARK AS SHOWN.

FOR PRODUCTION AND DISTRIBUTION OF MOTION PICTURES (U.S. CLS. 100, 101 AND 107).

MICHAEL WIENER, EXAMINING ATTORNEY

**CLASS 41—(Continued).**

SN 78-955,904. PEOPLES INCOME TAX, INC., RICHMOND, VA. FILED 8-19-2006.



NO CLAIM IS MADE TO THE EXCLUSIVE RIGHT TO USE "CHARTERED TAX PROFESSIONAL", APART FROM THE MARK AS SHOWN.

THE COLOR(S) BLUE IS/ARE CLAIMED AS A FEATURE OF THE MARK.

THE COLOR BLUE APPEARS IN THE ENTIRE MARK.

FOR EDUCATIONAL SERVICES, NAMELY LIVE AND ONLINE AND SEMINARS IN THE FIELD OF INCOME TAX; TRAINING SERVICES NAMELY LIVE AND ONLINE CLASSES AND SEMINARS IN THE FIELD OF INCOME TAX PREPARATION (U.S. CLS. 100, 101 AND 107).

FIRST USE 8-14-2006; IN COMMERCE 8-14-2006.

GRETTA YAO, EXAMINING ATTORNEY

SN 78-955,925. JURIS PRODUCTIONS, INC., PASADENA, CA. FILED 8-19-2006.

## expert storytellers

THE MARK CONSISTS OF STANDARD CHARACTERS WITHOUT CLAIM TO ANY PARTICULAR FONT, STYLE, SIZE, OR COLOR.

FOR PRODUCTION OF VIDEO AND CREATION OF COMPUTER-GENERATED VIDEO EFFECTS FOR OTHERS FOR USE IN DVDS TO BE USED AS EXHIBITS FOR LEGAL PROCEEDINGS, AND CONSULTATION IN CONNECTION THEREWITH (U.S. CLS. 100, 101 AND 107).

FIRST USE 6-1-2006; IN COMMERCE 6-1-2006.

LINDA M. KING, EXAMINING ATTORNEY

**CLASS 41—(Continued).**

SN 78-956,422. CARATTI, PAUL, IONE, CA. FILED 8-21-2006.

# One Partner

THE MARK CONSISTS OF STANDARD CHARACTERS WITHOUT CLAIM TO ANY PARTICULAR FONT, STYLE, SIZE, OR COLOR.

FOR EDUCATIONAL SERVICES, NAMELY, CONDUCTING PROGRAMS IN THE FIELD OF MARITAL FIDELITY; EDUCATIONAL SERVICES, NAMELY, CONDUCTING CLASSES, SEMINARS, AND WORKSHOPS IN THE FIELD OF ABSTINENCE, FIDELITY, SAFE SEX, AND AIDS AWARENESS AND DISTRIBUTION OF COURSE MATERIAL IN CONNECTION THEREWITH (U.S. CLS. 100, 101 AND 107).

FIRST USE 5-25-2006; IN COMMERCE 5-26-2006.  
REBECCA EISINGER, EXAMINING ATTORNEY

---

SN 78-956,738. VODA MUSIK, LLC, NEW YORK, NY. FILED 8-21-2006.

# ALEXANDR K

THE MARK CONSISTS OF STANDARD CHARACTERS WITHOUT CLAIM TO ANY PARTICULAR FONT, STYLE, SIZE, OR COLOR.

THE NAME(S), PORTRAIT(S), AND/OR SIGNATURE(S) SHOWN IN THE MARK IDENTIFIES ALEXANDER KOGAN, WHOSE CONSENT(S) TO REGISTER IS SUBMITTED.

FOR ENTERTAINMENT SERVICES, NAMELY, LIVE MUSICAL PERFORMANCES AND MUSICAL TOURS; ENTERTAINMENT SERVICES, NAMELY, PROVIDING A WEBSITE FEATURING INFORMATION ON MUSIC, PERFORMANCES, SOUND AND VIDEO RECORDINGS, APPEARANCES, BIOGRAPHICAL AND OTHER INFORMATION ON A MUSIC PERFORMER OR GROUP VIA A WEBSITE ON A GLOBAL COMPUTER NETWORK (U.S. CLS. 100, 101 AND 107).

JUSTINE D. PARKER, EXAMINING ATTORNEY

---

SN 78-956,758. ARKANSAS CHILDREN'S HOSPITAL, LITTLE ROCK, AR. FILED 8-21-2006.

# mouseclick.md

THE MARK CONSISTS OF STANDARD CHARACTERS WITHOUT CLAIM TO ANY PARTICULAR FONT, STYLE, SIZE, OR COLOR.

FOR PROVIDING ON-LINE PUBLICATIONS IN THE NATURE OF A PEDIATRIC GUIDE THAT IS NOT INTENDED TO BE DOWNLOADED (U.S. CLS. 100, 101 AND 107).

FIRST USE 4-28-2006; IN COMMERCE 5-15-2006.  
TASNEEM HUSSAIN, EXAMINING ATTORNEY

**CLASS 41—(Continued).**

SN 78-957,476. DAVENPORT UNIVERSITY, GRAND RAPIDS, MI. FILED 8-22-2006.

# START. STAY. SUCCEED.

THE MARK CONSISTS OF STANDARD CHARACTERS WITHOUT CLAIM TO ANY PARTICULAR FONT, STYLE, SIZE, OR COLOR.

FOR EDUCATIONAL SERVICES, NAMELY, PROVIDING COURSE OF INSTRUCTION AT THE COLLEGE LEVEL (U.S. CLS. 100, 101 AND 107).

LINDA LAVACHE, EXAMINING ATTORNEY

---

SN 78-958,916. TIMEOUT SERVICES, INC., CUPERTINO, CA. FILED 8-23-2006.

# COMMUNITY BOOTCAMP

THE MARK CONSISTS OF STANDARD CHARACTERS WITHOUT CLAIM TO ANY PARTICULAR FONT, STYLE, SIZE, OR COLOR.

NO CLAIM IS MADE TO THE EXCLUSIVE RIGHT TO USE "BOOT CAMP", APART FROM THE MARK AS SHOWN.

FOR PHYSICAL FITNESS INSTRUCTION AND PHYSICAL FITNESS CLASSES (U.S. CLS. 100, 101 AND 107).

FIRST USE 1-0-1997; IN COMMERCE 1-0-1997.

KATHERINE M. DUBRAY, EXAMINING ATTORNEY

---

SN 78-958,970. FESTIVAL FUN PARKS, LLC, NEWPORT BEACH, CA. FILED 8-23-2006.

# MORE FUN THAN A DAY AT THE BEACH

THE MARK CONSISTS OF STANDARD CHARACTERS WITHOUT CLAIM TO ANY PARTICULAR FONT, STYLE, SIZE, OR COLOR.

FOR ENTERTAINMENT SERVICES IN THE NATURE OF WATER PARKS FEATURING WATER RIDES, WATER SLIDES, BODY SURFING POOLS AND SWIMMING POOLS (U.S. CLS. 100, 101 AND 107).

JUSTINE D. PARKER, EXAMINING ATTORNEY

**CLASS 41—(Continued).**

SN 78-959,567. NUPTIAL ESSENTIALS CURRICULUM & INSTRUCTION, LLC, AUSTIN, TX. FILED 8-24-2006.

## Nuptial Essentials

THE MARK CONSISTS OF STANDARD CHARACTERS WITHOUT CLAIM TO ANY PARTICULAR FONT, STYLE, SIZE, OR COLOR.

NO CLAIM IS MADE TO THE EXCLUSIVE RIGHT TO USE "NUPTIAL", APART FROM THE MARK AS SHOWN.

FOR TRAINING AND EDUCATION SERVICES, NAMELY, PROVIDING CLASSES, SEMINARS AND WORKSHOPS IN THE FIELD OF WEDDING CONSULTING; EDUCATIONAL AND CAREER WORKSHOPS AND SEMINARS FOR PROFESSIONALS IN THE FIELD OF WEDDING CONSULTING; PUBLICATION OF EDUCATIONAL MANUALS IN THE FIELD OF WEDDING CONSULTING (U.S. CLS. 100, 101 AND 107).

FIRST USE 9-23-2003; IN COMMERCE 10-7-2003.  
MICHAEL LEWIS, EXAMINING ATTORNEY

---

SN 78-959,600. TEXAS CHRISTIAN UNIVERSITY, FORT WORTH, TX. FILED 8-24-2006.

## IT'S MORE THAN BUSINESS. IT'S PERSONAL.

THE MARK CONSISTS OF STANDARD CHARACTERS WITHOUT CLAIM TO ANY PARTICULAR FONT, STYLE, SIZE, OR COLOR.

FOR EDUCATIONAL PROGRAMS, ACTIVITIES AND DEGREES OFFERED AT AN INSTITUTION OF HIGHER LEARNING, NAMELY, CLASSES LEADING TO MBA, BBA, EXECUTIVE BBA DEGREES AS WELL AS NON-DEGREE EXECUTIVE EDUCATION CLASSES (U.S. CLS. 100, 101 AND 107).

DAVID ELTON, EXAMINING ATTORNEY

---

SN 78-959,789. TSUJIUCHI, JANELLE M., SOUTH SAN FRANCISCO, CA. FILED 8-24-2006.

## The Mixtress

THE MARK CONSISTS OF STANDARD CHARACTERS WITHOUT CLAIM TO ANY PARTICULAR FONT, STYLE, SIZE, OR COLOR.

FOR ENTERTAINMENT SERVICES, NAMELY, PERSONAL APPEARANCES BY A MULTI-MEDIA ENTERTAINER IN THE NATURE OF A CELEBRITY DISC JOCKEY AND RECORDING ARTIST/PRODUCER (U.S. CLS. 100, 101 AND 107).

FIRST USE 1-1-1994; IN COMMERCE 1-1-1994.  
ELLEN B. AWRICH, EXAMINING ATTORNEY

**CLASS 41—(Continued).**

SN 78-959,993. BERMAN INVESTMENT GROUP, NEWPORT BEACH, CA. FILED 8-24-2006.

## EASY AS EMAIL

THE MARK CONSISTS OF STANDARD CHARACTERS WITHOUT CLAIM TO ANY PARTICULAR FONT, STYLE, SIZE, OR COLOR.

FOR EDUCATIONAL SERVICES, NAMELY, CONDUCTING CLASSES, SEMINARS, CONFERENCES, MENTORING, AND WORKSHOPS IN THE FIELD OF PERSONAL IMPROVEMENT (U.S. CLS. 100, 101 AND 107).

SUSAN RICHARDS, EXAMINING ATTORNEY

---

SN 78-960,480. FISHER, ARIANE, DBA REELTIME DVD, OAK PARK, IL. AND FISHER, MICHAEL, DBA REELTIME DVD, OAK PARK, IL. FILED 8-25-2006.



NO CLAIM IS MADE TO THE EXCLUSIVE RIGHT TO USE "DVD", APART FROM THE MARK AS SHOWN.

THE MARK CONSISTS OF THE WORDS REELTIME DVD AND THE IMAGE OF A FILM AND A STYLIZED IMAGE OF A DISK.

FOR PRODUCTION OF VIDEO DISCS FOR OTHERS (U.S. CLS. 100, 101 AND 107).

MATTHEW MCDOWELL, EXAMINING ATTORNEY

---

SN 78-960,506. SCENE & HEARD PRODUCTIONS, INC., MINDEN, NV. FILED 8-25-2006.

## Scene & Heard Productions

THE MARK CONSISTS OF STANDARD CHARACTERS WITHOUT CLAIM TO ANY PARTICULAR FONT, STYLE, SIZE, OR COLOR.

NO CLAIM IS MADE TO THE EXCLUSIVE RIGHT TO USE "PRODUCTIONS", APART FROM THE MARK AS SHOWN.

FOR SPECIAL EVENT PLANNING (U.S. CLS. 100, 101 AND 107).

MATTHEW MCDOWELL, EXAMINING ATTORNEY

**CLASS 41—(Continued).**

SN 78-960,689. OREGON BREWING COMPANY, NEWPORT, OR. FILED 8-25-2006.

**GREAT AMERICAN DISTILLERS  
FESTIVAL**

THE MARK CONSISTS OF STANDARD CHARACTERS WITHOUT CLAIM TO ANY PARTICULAR FONT, STYLE, SIZE, OR COLOR.

NO CLAIM IS MADE TO THE EXCLUSIVE RIGHT TO USE "DISTILLERS FESTIVAL", APART FROM THE MARK AS SHOWN.

FOR ARRANGING AND CONDUCTING ENTERTAINMENT EXHIBITIONS IN THE NATURE OF FESTIVALS FEATURING DISTILLERIES AND THEIR PRODUCTS (U.S. CLS. 100, 101 AND 107).

FIRST USE 7-0-2005; IN COMMERCE 7-0-2005.  
KARANENDRA S. CHHINA, EXAMINING ATTORNEY

SN 78-960,806. UNBORN MEDIA, INC., BOSTON, MA. FILED 8-25-2006.

**VIRB**

THE MARK CONSISTS OF STANDARD CHARACTERS WITHOUT CLAIM TO ANY PARTICULAR FONT, STYLE, SIZE, OR COLOR.

FOR ENTERTAINMENT, NAMELY LIVE MUSIC CONCERTS (U.S. CLS. 100, 101 AND 107).  
TIMOTHY FINNEGAN, EXAMINING ATTORNEY

**CLASS 41—(Continued).**

SN 78-961,471. PEAK FITNESS, LLC, NEWTON, MA. FILED 8-28-2006.

**FIT FAMILIES - HEALTHY  
COMMUNITIES**

THE MARK CONSISTS OF STANDARD CHARACTERS WITHOUT CLAIM TO ANY PARTICULAR FONT, STYLE, SIZE, OR COLOR.

FOR ARRANGING AND CONDUCTING ATHLETIC COMPETITIONS; BALLET SCHOOLS; BASEBALL CAMPS; BASKETBALL CAMPS; CHILDREN'S ENTERTAINMENT AND AMUSEMENT CENTERS, NAMELY, INTERACTIVE PLAY AREAS; DANCE EVENTS; DANCE INSTRUCTION; DANCE SCHOOLS; DANCE STUDIOS; ENTERTAINMENT SERVICES, NAMELY, CONDUCTING PARTIES; GYMNASIUMS; HEALTH CLUB SERVICES, NAMELY PROVIDING INSTRUCTION AND EQUIPMENT IN THE FIELD OF PHYSICAL EXERCISE; MARTIAL ARTS INSTRUCTION; OPERATING OF MARTIAL ARTS' SCHOOLS; OPERATION OF SPORTS CAMPS; ORGANIZATION OF DANCING EVENTS; PERSONAL TRAINER SERVICES; PERSONAL TRAINING SERVICES, NAMELY, STRENGTH AND CONDITIONING TRAINING; PHYSICAL EDUCATION SERVICES; PHYSICAL FITNESS CONSULTATION; PHYSICAL FITNESS INSTRUCTION; PRODUCTION OF VIDEO CASSETTES; PRODUCTION OF VIDEO DISCS FOR OTHERS; PROVIDING A WEBSITE FEATURING SPORTING INFORMATION; PROVIDING GYMNASIUMS; PROVIDING GYMNASIUM FACILITIES; PROVIDING INFORMATION IN THE FIELD OF EXERCISE TRAINING; PROVIDING RECREATIONAL AREAS IN THE NATURE OF CHILDREN'S PLAY AREAS; PROVIDING SPORTS FACILITIES; PROVIDING SPORTS INFORMATION BY MEANS OF TELEPHONE PRERECORDED MESSAGES; SOCCER CAMPS; SPORT CAMPS; SUMMER CAMPS; YOGA INSTRUCTION (U.S. CLS. 100, 101 AND 107).

ELIZABETH PIGNATELLO, EXAMINING ATTORNEY

SN 78-961,618. RUBY JAMES, LLC, ENCINO, CA. FILED 8-28-2006.

**RUBY JAMES**

THE MARK CONSISTS OF STANDARD CHARACTERS WITHOUT CLAIM TO ANY PARTICULAR FONT, STYLE, SIZE, OR COLOR.

THE NAME "RUBY JAMES" DOES NOT IDENTIFY A LIVING INDIVIDUAL.

FOR ENTERTAINMENT, NAMELY LIVE MUSIC CONCERTS; ENTERTAINMENT, NAMELY LIVE PERFORMANCES BY MUSICAL BANDS; ENTERTAINMENT, NAMELY, LIVE PERFORMANCES BY ROCK GROUPS; PRESENTATION OF LIVE SHOW PERFORMANCES; PRESENTATION OF MUSICAL PERFORMANCE (U.S. CLS. 100, 101 AND 107).

FIRST USE 1-1-2000; IN COMMERCE 1-1-2000.  
WON TEAK OH, EXAMINING ATTORNEY

**CLASS 41—(Continued).**

SN 78-961,783. BRILLIANCE ACADEMY, INC., NORTH-BROOK, IL. FILED 8-28-2006.

**BRILLIANCE ACADEMY**

THE MARK CONSISTS OF STANDARD CHARACTERS WITHOUT CLAIM TO ANY PARTICULAR FONT, STYLE, SIZE, OR COLOR.

NO CLAIM IS MADE TO THE EXCLUSIVE RIGHT TO USE "ACADEMY", APART FROM THE MARK AS SHOWN.

FOR EDUCATIONAL SERVICES IN THE NATURE OF TUTORING STUDENTS IN MATHEMATICS AND ENGLISH FOR USE AT SCHOOLS (U.S. CLS. 100, 101 AND 107).

FIRST USE 2-29-2004; IN COMMERCE 2-29-2004.  
RUSS HERMAN, EXAMINING ATTORNEY

**CLASS 41—(Continued).**

SN 78-961,810. RETHINK HIGHER EDUCATION CONSULTING, LLC, ISSAQUAH, WA. FILED 8-28-2006.

**RETHINK HIGHER ED**

THE MARK CONSISTS OF STANDARD CHARACTERS WITHOUT CLAIM TO ANY PARTICULAR FONT, STYLE, SIZE, OR COLOR.

FOR EDUCATION CONSULTING SERVICES, NAMELY, ADVISING POST-SECONDARY SCHOOLS, INSTITUTIONS AND ORGANIZATIONS IN THE DEVELOPMENT AND IMPLEMENTATION OF CURRICULUM AND PROGRAMS FOR INDIVIDUALS WITH LEARNING, COGNITIVE AND INTELLECTUAL DISABILITIES (U.S. CLS. 100, 101 AND 107).

VERNA BETH RIRIE, EXAMINING ATTORNEY

SN 78-961,932. IMAGETAG, INC., CHANDLER, AZ. FILED 8-28-2006.

**KWIKEYS**

THE MARK CONSISTS OF STANDARD CHARACTERS WITHOUT CLAIM TO ANY PARTICULAR FONT, STYLE, SIZE, OR COLOR.

FOR EDUCATION SERVICES, NAMELY, PROVIDING ON-LINE SEMINARS IN THE FIELD OF DOCUMENT IMAGING (U.S. CLS. 100, 101 AND 107).

FIRST USE 4-5-2006; IN COMMERCE 4-5-2006.

JASON ROTH, EXAMINING ATTORNEY

SN 78-962,363. OLIVERAS, JOSE LUIS, MCGUIRE AFB, NJ. FILED 8-29-2006.

**Just4Christ**

THE MARK CONSISTS OF STANDARD CHARACTERS WITHOUT CLAIM TO ANY PARTICULAR FONT, STYLE, SIZE, OR COLOR.

FOR ENTERTAINMENT, NAMELY LIVE MUSIC CONCERTS MOBILE MEDIA AND ENTERTAINMENT SERVICES IN THE NATURE OF CONTENT PREPARATION, POST-PRODUCTION (U.S. CLS. 100, 101 AND 107).

FIRST USE 6-1-1999; IN COMMERCE 6-1-1999.

ANN E. SAPPENFIELD, EXAMINING ATTORNEY

SN 78-961,803. LAMANS, KRIS, STUDIO CITY, CA. FILED 8-28-2006.



NO CLAIM IS MADE TO THE EXCLUSIVE RIGHT TO USE "USA", APART FROM THE MARK AS SHOWN.

THE COLOR(S) BRASS AND DARK GREY IS/ARE CLAIMED AS A FEATURE OF THE MARK.

THE MARK CONSISTS OF AN OLD STYLE MICROPHONE WITH LETTERING ON THE FACE PLATE. THE COLOR BRASS APPEARS IN THE LETTERING, THE TOP AND BOTTOM RIBBED PORTIONS OF THE MICROPHONE, THE SIDE PIVOT DISC, AND THE MICROPHONE SUPPORT RING. THE COLOR DARK GREY APPEARS IN THE MICROPHONE FACE PLATE, THE MICROPHONE PIVOT POINTS, AND THE MICROPHONE STAND.

FOR ENTERTAINMENT SERVICES, NAMELY, PROVIDING A SERIES OF TELEVISION PROGRAMS RELATING TO AFRO-AMERICAN MUSICIANS WHO HAVE INFLUENCED OTHER MUSICAL STYLES IN AMERICA AND THE WORLD (U.S. CLS. 100, 101 AND 107).

DAVID I, EXAMINING ATTORNEY

**CLASS 41—(Continued).**

SN 78-962,417. ELBERGER, SETH R., MARIETTA, GA.  
FILED 8-29-2006.

**CLASS 41—(Continued).**

SN 78-963,459. DAVINCI EXPERIENCE, FALMOUTH, ME.  
FILED 8-30-2006.

## TABLE TALK

THE MARK CONSISTS OF STANDARD CHARACTERS WITHOUT CLAIM TO ANY PARTICULAR FONT, STYLE, SIZE, OR COLOR.

FOR ENTERTAINMENT SERVICES, NAMELY, A WEBSITE FEATURING COMIC STRIPS (U.S. CLS. 100, 101 AND 107).

ANN E. SAPPENFIELD, EXAMINING ATTORNEY

---

SN 78-962,697. ESQUIVEL, ARMANDO, OAKLAND, CA.  
AND LÓPEZ, MARIA, OAKLAND, CA. FILED 8-29-2006.

## CERTEZA

THE MARK CONSISTS OF STANDARD CHARACTERS WITHOUT CLAIM TO ANY PARTICULAR FONT, STYLE, SIZE, OR COLOR.

THE FOREIGN WORDING IN THE MARK TRANSLATES INTO ENGLISH AS CERTAINTY.

FOR ENTERTAINMENT NAMELY, LIVE PERFORMANCES BY A MUSICAL BAND (U.S. CLS. 100, 101 AND 107).

FIRST USE 3-31-2005; IN COMMERCE 3-31-2005.  
PAUL CROWLEY, EXAMINING ATTORNEY

---

SN 78-963,390. SYED, SEEMA, BEVERLY HILLS, CA. FILED  
8-29-2006.

## EVENT DIVA

THE MARK CONSISTS OF STANDARD CHARACTERS WITHOUT CLAIM TO ANY PARTICULAR FONT, STYLE, SIZE, OR COLOR.

NO CLAIM IS MADE TO THE EXCLUSIVE RIGHT TO USE "EVENT", APART FROM THE MARK AS SHOWN.

FOR SPECIAL EVENT AND ENTERTAINMENT SERVICES, NAMELY, SPECIAL EVENT PLANNING AND CONSULTATION IN CONNECTION THEREWITH (U.S. CLS. 100, 101 AND 107).

FIRST USE 1-31-2001; IN COMMERCE 1-31-2001.  
LINDA M. KING, EXAMINING ATTORNEY

## THE DAVINCI EXPERIENCE

THE MARK CONSISTS OF STANDARD CHARACTERS WITHOUT CLAIM TO ANY PARTICULAR FONT, STYLE, SIZE, OR COLOR.

FOR SUMMER DAY CAMP SERVICES AND EDUCATIONAL OUTREACH SERVICES THROUGH CLASSES TAUGHT AT THE CAMP AND TO CHILDREN THROUGHOUT LOCAL COMMUNITIES THROUGH HANDS-ON ACTIVITIES AND EXPERIMENTS FOCUSING IN ARTS AND SCIENCES (U.S. CLS. 100, 101 AND 107).

FIRST USE 5-1-1999; IN COMMERCE 5-1-1999.  
ALLISON HOLTZ, EXAMINING ATTORNEY

---

SN 78-963,545. SCHENK, CHRISTINE, HAMBURG, FED REP  
GERMANY, FILED 8-30-2006.



NO CLAIM IS MADE TO THE EXCLUSIVE RIGHT TO USE PRACTITIONER AND TECHNIQUE, APART FROM THE MARK AS SHOWN.

THE LINING IS A FEATURE OF THE MARK AND DOES NOT INDICATE COLOR.

THE MARK CONSISTS OF A GLOBE WITH LEAFY BRANCHES BENEATH IT REPRESENTING PEACE.

FOR WORKSHOPS AND SEMINARS IN THE FIELDS OF PSYCHOPHYSIOLOGY, EXTRA-SENSORY PERCEPTION, SELF-AWARENESS, SELF-HELP, HOLISTIC AND TRADITIONAL MEDICINE, MASSAGE, PSYCHOTHERAPY, PSYCHOLOGY, PSYCHOPHYSICS AND BIOPHYSICS, NONE OF WHICH INVOLVE WEIGHT MANAGEMENT OR PROVIDING CONSULTATION TO THE HEALTH CARE PROFESSION (U.S. CLS. 100, 101 AND 107).

JOHN E. MICHOS, EXAMINING ATTORNEY



**CLASS 41—(Continued).**

SN 78-963,635. M.A.S.S. EUPHORIA ENTERTAINMENT, TEMPLE HILL, MD. FILED 8-30-2006.

**M.A.S.S. EUPHORIA  
Entertainment**

THE MARK CONSISTS OF STANDARD CHARACTERS WITHOUT CLAIM TO ANY PARTICULAR FONT, STYLE, SIZE, OR COLOR.

NO CLAIM IS MADE TO THE EXCLUSIVE RIGHT TO USE "ENTERTAINMENT", APART FROM THE MARK AS SHOWN.

FOR ENTERTAINMENT SERVICES, NAMELY, CONDUCTING PARTIES; PARTY PLANNING; SPECIAL EVENT PLANNING (U.S. CLS. 100, 101 AND 107).  
JOHN DWYER, EXAMINING ATTORNEY

SN 78-963,654. PRIOVOLOS, NICHOLAS, NORTH HOLLYWOOD, CA. FILED 8-30-2006.

***the muts***

THE MARK CONSISTS OF STYLIZED TEXT OF THE WORDING "THE MUTS" AND "THE MOST UNLIKELY TO SUCCEED."

FOR ENTERTAINMENT NAMELY, LIVE PERFORMANCES BY A MUSICAL BAND (U.S. CLS. 100, 101 AND 107).  
DANIEL RUSSELL, EXAMINING ATTORNEY

SN 78-964,225. JIPC MANAGEMENT, INC., LAKE FOREST, CA. FILED 8-30-2006.

**ACCOLADES FOR GOOD GRADES**

THE MARK CONSISTS OF STANDARD CHARACTERS WITHOUT CLAIM TO ANY PARTICULAR FONT, STYLE, SIZE, OR COLOR.

FOR EDUCATIONAL SERVICES, NAMELY, PROVIDING INCENTIVES FOR STUDENTS TO DEMONSTRATE EXCELLENCE IN THE FIELD OF EDUCATION THROUGH THE ISSUANCE OF CERTIFICATES AND COUPONS REDEEMABLE FOR REGISTRANT'S RESTAURANT AND ENTERTAINMENT SERVICES (U.S. CLS. 100, 101 AND 107).  
GINNY ISAACSON, EXAMINING ATTORNEY

**CLASS 41—(Continued).**

SN 78-964,280. AMERICAN NEVADA HOLDINGS, LLC, HENDERSON, NV. FILED 8-30-2006.

***Avenue33***

FOR ARRANGING OF CONTESTS, EXHIBITIONS, SEMINARS AND CONFERENCES; ARRANGING AND CONDUCTING CASINO AND GAMING CONTESTS AND TOURNAMENTS; ARRANGING AND CONDUCTING ATHLETIC COMPETITIONS; CONDUCTING OF CONTESTS; CONDUCTING OF EXHIBITIONS, SEMINARS AND CONFERENCES FOR CULTURAL, EDUCATIONAL, SPORTING AND ENTERTAINMENT PURPOSES; PROVIDING FACILITIES FOR EXHIBITIONS, SEMINARS AND CONFERENCES FOR CULTURAL, EDUCATIONAL, SPORTS AND ENTERTAINMENT PURPOSES; PROVIDING FACILITIES FOR SPECIAL EVENTS FEATURING CASINO AND GAMING CONTESTS AND TOURNAMENTS; PROVIDING FACILITIES FOR SPORTS TOURNAMENTS; ENTERTAINMENT SERVICES IN THE NATURE OF MUSICAL, DRAMATIC, MAGIC, DANCE, ACROBATIC AND COMEDIC PERFORMANCES; PLANNING AND ARRANGEMENT OF SHOWING MOVIES AND SHOWS; HEALTH CLUB SERVICES, NAMELY PROVIDING INSTRUCTION AND EQUIPMENT IN THE FIELD OF PHYSICAL EXERCISE; PROVIDING RESERVATIONS, BOOKINGS, AND ADVICE TO OTHERS IN THE FIELDS OF SHOWS, SPORTING EVENTS AND OTHER ENTERTAINMENT; PROVIDING INFORMATION AND GENERAL AND LOCAL NEWS FEATURING SPORTS, HEALTH, FITNESS, ART, LEISURE, ENTERTAINMENT AND GAMING; AND NIGHT CLUBS (U.S. CLS. 100, 101 AND 107).

MICHAEL ENGEL, EXAMINING ATTORNEY

SN 78-964,354. DIMAANO ENTERPRISES, LLC, PEARLAND, TX. FILED 8-30-2006.

**FLO'CAINE**

THE MARK CONSISTS OF STANDARD CHARACTERS WITHOUT CLAIM TO ANY PARTICULAR FONT, STYLE, SIZE, OR COLOR.

FOR ENTERTAINMENT SERVICES, NAMELY, LIVE PERFORMANCES AND APPEARANCES BY A MUSICAL GROUP; PROVIDING AN INTERNET WEB SITE FEATURING MUSICAL PERFORMANCES, MUSICAL VIDEOS, RELATED FILM CLIPS, PHOTOGRAPHS, AND OTHER MULTIMEDIA MATERIALS; FAN CLUB SERVICES (U.S. CLS. 100, 101 AND 107).  
JAY BESCH, EXAMINING ATTORNEY

**CLASS 41—(Continued).**

SN 78-964,456. CARSON GAMING, L.L.C., LAS VEGAS, NV.  
FILED 8-30-2006.

**CASINO FANDANGO**

THE MARK CONSISTS OF STANDARD CHARACTERS WITHOUT CLAIM TO ANY PARTICULAR FONT, STYLE, SIZE, OR COLOR.

OWNER OF U.S. REG. NOS. 2,968,485 AND 2,973,537.

FOR ENTERTAINMENT SERVICES IN THE NATURE OF ARRANGING, CONDUCTING, AND PROVIDING FACILITIES FOR CONCERTS AND LIVE PERFORMANCES; AND ENTERTAINMENT SERVICES, NAMELY LIVE PERFORMANCES FEATURING LIVE AND PRERECORDED MUSIC AND VIDEO, SINGERS, MUSIC GROUPS, DANCERS, MAGICIANS, ACTORS, ACROBATS AND COMEDIANS; RECREATIONAL SERVICES IN THE NATURE OF GOLF, TENNIS, SWIMMING, SPA, AEROBICS AND WEIGHT TRAINING (U.S. CLS. 100, 101 AND 107).

MORGAN WYNNE, EXAMINING ATTORNEY

---

SN 78-964,511. NAYIO MEDIA, INC., SAN MATEO, CA.  
FILED 8-30-2006.

**MUGENE**

THE MARK CONSISTS OF STANDARD CHARACTERS WITHOUT CLAIM TO ANY PARTICULAR FONT, STYLE, SIZE, OR COLOR.

FOR ENTERTAINMENT SERVICES, NAMELY, PROVIDING MUSIC SEARCH, MUSIC RETRIEVAL, AND DOWNLOADABLE DIGITAL MUSIC BASED ON USER-GENERATED INPUT, OVER LOCAL AND GLOBAL WIRELESS AND ON-LINE NETWORKS (U.S. CLS. 100, 101 AND 107).

TASNEEM HUSSAIN, EXAMINING ATTORNEY

---

SN 78-964,557. COONEY, SEAN, PHOENIX, AZ. FILED 8-30-2006.

**3 LEAF PRODUCTIONS**

THE MARK CONSISTS OF STANDARD CHARACTERS WITHOUT CLAIM TO ANY PARTICULAR FONT, STYLE, SIZE, OR COLOR.

NO CLAIM IS MADE TO THE EXCLUSIVE RIGHT TO USE "PRODUCTIONS", APART FROM THE MARK AS SHOWN.

FOR AUDIO EDITING AND PRODUCTION SERVICES; MUSICAL COMPOSITION FOR OTHERS; SOUND DESIGN SERVICES (U.S. CLS. 100, 101 AND 107).

FIRST USE 9-5-2002; IN COMMERCE 5-10-2004.  
ALAIN LAPTEY, EXAMINING ATTORNEY

**CLASS 41—(Continued).**

SN 78-964,701. THE PROFESSIONAL GOLFERS' ASSOCIATION OF AMERICA, PALM BEACH GARDENS, FL.  
FILED 8-31-2006.

**PGA PNC**

THE MARK CONSISTS OF STANDARD CHARACTERS WITHOUT CLAIM TO ANY PARTICULAR FONT, STYLE, SIZE, OR COLOR.

OWNER OF U.S. REG. NOS. 578,653, 1,331,309 AND OTHERS.

FOR ENTERTAINMENT SERVICES, NAMELY, ORGANIZING AND CONDUCTING GOLF TOURNAMENTS (U.S. CLS. 100, 101 AND 107).

DAVID COLLIER, EXAMINING ATTORNEY

---

SN 78-964,713. THE PROFESSIONAL GOLFERS' ASSOCIATION OF AMERICA, PALM BEACH GARDENS, FL.  
FILED 8-31-2006.

**SPNC**

THE MARK CONSISTS OF STANDARD CHARACTERS WITHOUT CLAIM TO ANY PARTICULAR FONT, STYLE, SIZE, OR COLOR.

FOR ENTERTAINMENT SERVICES, NAMELY, ORGANIZING AND CONDUCTING GOLF TOURNAMENTS (U.S. CLS. 100, 101 AND 107).

DAVID COLLIER, EXAMINING ATTORNEY

---

SN 78-964,717. THE PROFESSIONAL GOLFERS' ASSOCIATION OF AMERICA, PALM BEACH GARDENS, FL.  
FILED 8-31-2006.

**PNC**

THE MARK CONSISTS OF STANDARD CHARACTERS WITHOUT CLAIM TO ANY PARTICULAR FONT, STYLE, SIZE, OR COLOR.

FOR ENTERTAINMENT SERVICES, NAMELY, ORGANIZING AND CONDUCTING GOLF TOURNAMENTS (U.S. CLS. 100, 101 AND 107).

DAVID COLLIER, EXAMINING ATTORNEY

**CLASS 41—(Continued).**

SN 78-964,727. WILSON, MARK, MODESTO, CA. FILED 8-31-2006.

## CLOSER\$ GET PAID

THE MARK CONSISTS OF STANDARD CHARACTERS WITHOUT CLAIM TO ANY PARTICULAR FONT, STYLE, SIZE, OR COLOR.  
FOR TRAINING SERVICES IN THE FIELD OF SALES (U.S. CLS. 100, 101 AND 107).  
FIRST USE 6-27-2006; IN COMMERCE 6-27-2006.  
KARANENDRA S. CHHINA, EXAMINING ATTORNEY

---

SN 78-964,785. ANDERSON, MARY BETH, GILROY, CA. FILED 8-31-2006.

## extraneoussubculture.com

THE MARK CONSISTS OF STANDARD CHARACTERS WITHOUT CLAIM TO ANY PARTICULAR FONT, STYLE, SIZE, OR COLOR.  
FOR ENTERTAINMENT SERVICES NAMELY PROVIDING A WEBSITE FEATURING, PHOTOGRAPHIC, AUDIO, VIDEO AND PROSE PRESENTATIONS FEATURING VARIOUS ART WORKS (U.S. CLS. 100, 101 AND 107).  
TRICIA SONNEBORN, EXAMINING ATTORNEY

---

SN 78-964,794. BERRY, JANICE M, SOMERSWORTH, NH. FILED 8-31-2006.

## United Regal Miss Pageant

THE MARK CONSISTS OF STANDARD CHARACTERS WITHOUT CLAIM TO ANY PARTICULAR FONT, STYLE, SIZE, OR COLOR.  
NO CLAIM IS MADE TO THE EXCLUSIVE RIGHT TO USE "PAGEANT", APART FROM THE MARK AS SHOWN.  
FOR ENTERTAINMENT IN THE NATURE OF BEAUTY PAGEANTS; ENTERTAINMENT SERVICES, NAMELY, CONDUCTING CONTESTS (U.S. CLS. 100, 101 AND 107).  
DOMINIC FATHY, EXAMINING ATTORNEY

**CLASS 41—(Continued).**

SN 78-964,822. VIRTUOSO MUSIC, INC., MARIETTA, GA. FILED 8-31-2006.

## VIRTUOSO MUSIC

THE MARK CONSISTS OF STANDARD CHARACTERS WITHOUT CLAIM TO ANY PARTICULAR FONT, STYLE, SIZE, OR COLOR.  
NO CLAIM IS MADE TO THE EXCLUSIVE RIGHT TO USE "MUSIC", APART FROM THE MARK AS SHOWN.  
FOR INSTRUCTION IN THE FIELD OF MUSIC (U.S. CLS. 100, 101 AND 107).  
FIRST USE 5-26-2004; IN COMMERCE 5-26-2004.  
MATTHEW PAPPAS, EXAMINING ATTORNEY

---

SN 78-964,832. DAS HEALTH & FITNESS LLC, PHOENIX, AZ. FILED 8-31-2006.



NO CLAIM IS MADE TO THE EXCLUSIVE RIGHT TO USE "SCHOOL OF EXERCISE TRAINING & SCIENCE", APART FROM THE MARK AS SHOWN.  
FOR EDUCATION SERVICES, NAMELY, PROVIDING SEMINARS, CLASSES, AND LECTURES IN THE FIELDS OF ANATOMY, PHYSIOLOGY, KINESIOLOGY, NUTRITION, PHYSICAL FITNESS, ADVERTISING, PLANNING AND DESIGN FOR EXERCISE FACILITIES, EXERCISE AND FITNESS PROGRAM DESIGN, PERSONAL TRAINING, AND BUSINESS MANAGEMENT; PHYSICAL FITNESS CONSULTATION; PHYSICAL FITNESS INSTRUCTION (U.S. CLS. 100, 101 AND 107).  
KATHERINE CHANG, EXAMINING ATTORNEY

---

SN 78-964,971. MINORITY CORPORATE COUNSEL ASSOCIATION, WASHINGTON, DC. FILED 8-31-2006.

## EMPOWERING PEOPLE INSPIRING LEADERSHIP

THE MARK CONSISTS OF STANDARD CHARACTERS WITHOUT CLAIM TO ANY PARTICULAR FONT, STYLE, SIZE, OR COLOR.  
FOR EDUCATIONAL SERVICES, NAMELY, ARRANGING AND CONDUCTING EDUCATIONAL CONFERENCES, PROGRAMS, SEMINARS, WORKSHOPS AND TRAINING SESSIONS FOR PROMOTING AND FOSTERING DIVERSITY IN THE WORK PLACE; CONDUCTING CONTINUING LEGAL EDUCATION PROGRAMS, SEMINARS AND CONFERENCES; DISTRIBUTING COURSE MATERIALS IN CONNECTION THEREWITH (U.S. CLS. 100, 101 AND 107).  
ALICE SUE CARRUTHERS, EXAMINING ATTORNEY

**CLASS 41—(Continued).**

SN 78-965,068. ARCARO, GLORIA J, OLD BRIDGE, NJ. FILED 8-31-2006.

Money Smart\$ for Teens

NO CLAIM IS MADE TO THE EXCLUSIVE RIGHT TO USE "FOR TEENS", APART FROM THE MARK AS SHOWN. THE COLOR(S) GREEN IS/ARE CLAIMED AS A FEATURE OF THE MARK.

THE MARK CONSISTS OF LETTERS THAT ARE GREEN. AND THE SECOND S OF SMARTS IS A DOLLAR SIGN.

FOR DEVELOPMENT AND DISSEMINATION OF EDUCATIONAL MATERIALS OF OTHERS IN THE FIELD OF FINANCE, CREDIT, ENTREPRENEURSHIP; EDUCATING AT SENIOR HIGH SCHOOLS; EDUCATING AT UNIVERSITY OR COLLEGES; EDUCATION SERVICES, NAMELY, PROVIDING TUTORIAL SESSIONS IN THE FIELD(S) OF FINANCE, CREDIT, ENTREPRENEURSHIP; EDUCATIONAL SERVICES NAMELY CONDUCTING PROGRAMS IN THE FIELD OF FINANCE, CREDIT, ENTREPRENEURSHIP; EDUCATIONAL SERVICES, NAMELY, CONDUCTING DISTANCE LEARNING INSTRUCTION AT THE SECONDARY, COLLEGE AND GRADUATE LEVELS; EDUCATIONAL SERVICES, NAMELY, CONDUCTING INFORMAL ON-LINE PROGRAMS IN THE FIELDS OF FINANCE, CREDIT, ENTREPRENEURSHIP, AND PRINTABLE MATERIALS DISTRIBUTED THEREWITH, EDUCATIONAL SERVICES, NAMELY, CONDUCTING CLASSES, TELESEMINARS, WORKSHOPS IN THE FIELD OF FINANCE, CREDIT, ENTREPRENEURSHIP (U.S. CLS. 100, 101 AND 107).

NAKIA HENRY, EXAMINING ATTORNEY

SN 78-965,588. MOSIG, RALF, SANTA MONICA, CA. FILED 8-31-2006.

 ECOFIT

THE MARK CONSISTS OF A PERSON RUNNING AND THE STYLIZED TEXT OF THE WORDING "ECOFIT." FOR PROVIDING FITNESS AND EXERCISE FACILITIES (U.S. CLS. 100, 101 AND 107).

JOHN DALIER, EXAMINING ATTORNEY

**CLASS 41—(Continued).**

SN 78-965,608. LAUGHBAUM, LISA ANDREA, SAN MARCOS, CA. FILED 8-31-2006.



NO CLAIM IS MADE TO THE EXCLUSIVE RIGHT TO USE CHILDREN'S MUSIC, APART FROM THE MARK AS SHOWN.

THE MARK CONSISTS OF A CD (COMPACT DISC) WITH A MUSIC STAFF ACROSS THE MIDDLE.

FOR ENTERTAINMENT, NAMELY A CONTINUING CHILDREN'S MUSIC EDUCATION SHOW BROADCAST OVER TELEVISION, SATELLITE, AUDIO, AND VIDEO MEDIA (U.S. CLS. 100, 101 AND 107).

STEVEN R. FINE, EXAMINING ATTORNEY

SN 78-965,666. ACTUALITY PRODUCTIONS, INC., NEW YORK, NY. FILED 9-1-2006.

**BRUTALLY HONEST PERSONALS**

THE MARK CONSISTS OF STANDARD CHARACTERS WITHOUT CLAIM TO ANY PARTICULAR FONT, STYLE, SIZE, OR COLOR.

NO CLAIM IS MADE TO THE EXCLUSIVE RIGHT TO USE "PERSONALS", APART FROM THE MARK AS SHOWN.

FOR ENTERTAINMENT SERVICES IN THE NATURE OF ON-GOING TELEVISION PROGRAMS ON THE SUBJECT OF DATING (U.S. CLS. 100, 101 AND 107).

TRACY WHITTAKER-BROWN, EXAMINING ATTORNEY

SN 78-965,692. NCME HOLDING CORP., SECAUCUS, NJ. FILED 9-1-2006.

STRIVE

THE MARK CONSISTS OF STANDARD CHARACTERS WITHOUT CLAIM TO ANY PARTICULAR FONT, STYLE, SIZE, OR COLOR.

FOR EDUCATION SERVICES, NAMELY, PROVIDING LECTURES IN THE FIELD OF MEDICAL CONDITIONS (U.S. CLS. 100, 101 AND 107).

FIRST USE 11-1-2000; IN COMMERCE 11-2-2000.

JESSICA FATHY, EXAMINING ATTORNEY

**CLASS 41—(Continued).**

SN 78-965,907. CBS BROADCASTING INC., NEW YORK, NY.  
FILED 9-1-2006.

**INNERTUBE**

THE MARK CONSISTS OF STANDARD CHARACTERS WITHOUT CLAIM TO ANY PARTICULAR FONT, STYLE, SIZE, OR COLOR.

FOR EDUCATION AND ENTERTAINMENT SERVICES, NAMELY, PRODUCTION AND DISTRIBUTION OF COMEDY, MUSICAL, DRAMATIC, AND REALITY TELEVISION SERIES AND NEWS VIA THE INTERNET AND WIRELESS COMMUNICATION NETWORKS; PROVIDING INFORMATION IN THE FIELDS OF CURRENT EVENTS, SPORTS, NEWS, AND ENTERTAINMENT, NAMELY, TELEVISION PROGRAMS AND VIDEO CLIPS VIA THE INTERNET AND WIRELESS COMMUNICATION DEVICES; PROVIDING A WEB SITE FEATURING TELEVISION PROGRAMS, VIDEO CLIPS, AND OTHER MULTIMEDIA MATERIALS (U.S. CLS. 100, 101 AND 107).

FIRST USE 5-5-2006; IN COMMERCE 5-5-2006.  
CHARLES L. JENKINS, EXAMINING ATTORNEY

SN 78-965,909. COLONY LAKE BOOKS, SCHAUMBURG, IL.  
FILED 9-1-2006.

**COLONY LAKE BOOKS**

THE MARK CONSISTS OF STANDARD CHARACTERS WITHOUT CLAIM TO ANY PARTICULAR FONT, STYLE, SIZE, OR COLOR.

NO CLAIM IS MADE TO THE EXCLUSIVE RIGHT TO USE "BOOKS", APART FROM THE MARK AS SHOWN.

FOR BOOK AND REVIEW PUBLISHING (U.S. CLS. 100, 101 AND 107).

KATHERINE CHANG, EXAMINING ATTORNEY

SN 78-965,954. JEFFREYS, RYAN M, AVENTURA, FL.  
FILED 9-1-2006.

**RAPID FITNESS FOR WOMEN ON  
THE GO**

THE MARK CONSISTS OF STANDARD CHARACTERS WITHOUT CLAIM TO ANY PARTICULAR FONT, STYLE, SIZE, OR COLOR.

FOR EXERCISE AND FITNESS CLUB SERVICES, NAMELY, PROVIDING FITNESS AND EXERCISE FACILITIES; HEALTH CLUB SERVICES, NAMELY, PROVIDING INSTRUCTION AND EQUIPMENT IN THE FIELD OF EXERCISE (U.S. CLS. 100, 101 AND 107).

DANNEAN HETZEL, EXAMINING ATTORNEY

**CLASS 41—(Continued).**

SN 78-966,227. SANDIFER, JON MARC, LOS ANGELES, CA.  
FILED 9-1-2006.

**Whips & Chains**

THE MARK CONSISTS OF STANDARD CHARACTERS WITHOUT CLAIM TO ANY PARTICULAR FONT, STYLE, SIZE, OR COLOR.

FOR ENTERTAINMENT IN THE NATURE OF VISUAL AND AUDIO PERFORMANCES, NAMELY A PROGRAM PROFILING AND SHOWCASING AUTOMOBILES AND JEWELRY (U.S. CLS. 100, 101 AND 107).

ATTIYA MALIK, EXAMINING ATTORNEY

SN 78-966,228. ADVANSTAR COMMUNICATIONS INC.,  
DULUTH, MN. FILED 9-1-2006.

**OFF-ROAD NATION**

THE MARK CONSISTS OF STANDARD CHARACTERS WITHOUT CLAIM TO ANY PARTICULAR FONT, STYLE, SIZE, OR COLOR.

NO CLAIM IS MADE TO THE EXCLUSIVE RIGHT TO USE "OFF-ROAD", APART FROM THE MARK AS SHOWN.

FOR PROVIDING AN ONLINE NEWSLETTER IN THE FIELD OF OFF-ROAD MOTORSPORTS (U.S. CLS. 100, 101 AND 107).

KEVIN DINALLO, EXAMINING ATTORNEY

SN 78-966,229. DANOFF, HOPE FOX, BRYN MAWR, PA.  
FILED 9-1-2006.

**IMPRESS FOR LESS**

THE MARK CONSISTS OF STANDARD CHARACTERS WITHOUT CLAIM TO ANY PARTICULAR FONT, STYLE, SIZE, OR COLOR.

FOR ENTERTAINMENT SERVICES, NAMELY, ONGOING TELEVISION SHOWS IN THE FIELD OF COOKING (U.S. CLS. 100, 101 AND 107).

ATTIYA MALIK, EXAMINING ATTORNEY

**CLASS 41—(Continued).**

SN 78-966,313. JORDEN BURT LLP, MIAMI, FL. FILED 9-1-2006.

## EXPECT FOCUS

THE MARK CONSISTS OF STANDARD CHARACTERS WITHOUT CLAIM TO ANY PARTICULAR FONT, STYLE, SIZE, OR COLOR.

OWNER OF U.S. REG. NO. 3,080,549.

FOR ONLINE PUBLICATIONS IN THE NATURE OF NEWSLETTERS AND BULLETINS FEATURING LEGAL, BUSINESS AND OTHER DEVELOPMENTS IN THE FIELDS OF LIFE AND HEALTH INSURANCE, REINSURANCE, PROPERTY AND CASUALTY INSURANCE, CONSUMER FINANCE, BANKING, CREDIT, BANKRUPTCY, BROKER-DEALERS, FINANCIAL PRODUCT DISTRIBUTION, MUTUAL FUNDS, INVESTMENT BANKS, INVESTMENT ADVICE AND ADVISORS, AND INVESTMENT MANAGEMENT AND MANAGERS, TAX, ERISA, LABOR, EMPLOYMENT, CORPORATE LAW, SECURITIES, INTELLECTUAL PROPERTY, TECHNOLOGY, REAL ESTATE, CONSTITUTIONAL LAW, WHITE COLLAR DEFENSE, AND COMMERCIAL TRIAL, APPELLATE AND CLASS ACTION LITIGATION, PROVIDED PARTICULARLY, BUT NOT EXCLUSIVELY, TO DOMESTIC, MULTINATIONAL AND FOREIGN BUSINESSES IN THE FINANCIAL SERVICES INDUSTRIES VIA THE INTERNET, GLOBAL NETWORKS, E-MAIL AND/OR OTHER MEANS (U.S. CLS. 100, 101 AND 107).  
KIMBERLY FRYE, EXAMINING ATTORNEY

**CLASS 41—(Continued).**

SN 78-966,398. LEWIS, JONATHAN M., OAKLAND, CA. FILED 9-1-2006.



NO CLAIM IS MADE TO THE EXCLUSIVE RIGHT TO USE "FILMS", APART FROM THE MARK AS SHOWN.

THE MARK CONSISTS OF A WOMAN'S FACE NEXT TO A CHURCH WITH A GROUP OF PEOPLE STANDING IN FRONT OF IT AND BELOW THAT THE STYLIZED TEXT OF THE WORDING "BLACKSUNDAY FILMS".

FOR CONDUCTING ENTERTAINMENT EXHIBITIONS IN THE NATURE OF FILM FESTIVALS; MOTION PICTURE FILM PRODUCTION (U.S. CLS. 100, 101 AND 107).

EMILY CHUO, EXAMINING ATTORNEY

SN 78-966,411. BUILDING HEALTHY CHURCHES, LLC, HARRISONVILLE, MO. FILED 9-1-2006.

## BUILDING HEALTHY CHURCHES

THE MARK CONSISTS OF STANDARD CHARACTERS WITHOUT CLAIM TO ANY PARTICULAR FONT, STYLE, SIZE, OR COLOR.

NO CLAIM IS MADE TO THE EXCLUSIVE RIGHT TO USE "CHURCHES", APART FROM THE MARK AS SHOWN.

FOR EDUCATIONAL SERVICES, NAMELY, CONDUCTING LECTURES, WORKSHOPS AND SEMINARS FOR AND OF INTEREST TO CHURCHES AND RELIGIOUS ORGANIZATIONS IN THE FIELDS OF PERSONAL AND CHURCH FINANCIAL MANAGEMENT, CHURCH CONFLICT RESOLUTION AND MEDIATION, CHURCH ADMINISTRATION, GROWTH AND DEVELOPMENT, DEVELOPING COUNSELING PROGRAMS IN CHURCHES, DEVELOPING WOMEN'S MINISTRIES, YOUTH MINISTRIES, CHILDREN'S MINISTRIES, ADULT MINISTRIES, FAMILY MINISTRIES, CHURCH WORSHIP AND MUSIC MINISTRIES, CHRISTIAN EDUCATION AND DISCIPLESHIP, EVANGELISM AND OUTREACH, PASTORAL TRAINING AND SUPPORT, DEVELOPING PLANS FOR INTERIM AND TRANSITIONAL MINISTRIES, CHURCH LEADERSHIP, STRATEGIC PLANNING FOR CHURCHES, AND INTENTIONAL MINISTRY PLACEMENT (U.S. CLS. 100, 101 AND 107).

CHRISTINE COOPER, EXAMINING ATTORNEY

SN 78-966,379. THE RED EYES, SIERRA MADRE, CA. FILED 9-1-2006.

## The Red Eyes

THE MARK CONSISTS OF STANDARD CHARACTERS WITHOUT CLAIM TO ANY PARTICULAR FONT, STYLE, SIZE, OR COLOR.

FOR ENTERTAINMENT IN THE NATURE OF VISUAL AND AUDIO PERFORMANCES, NAMELY, MUSICAL BAND, ROCK GROUP, GYMNASTIC, DANCE, AND BALLET PERFORMANCES; ENTERTAINMENT NAMELY, LIVE PERFORMANCES BY A MUSICAL BAND; ENTERTAINMENT, NAMELY LIVE PERFORMANCES BY MUSICAL BANDS; PRESENTATION OF MUSICAL PERFORMANCE (U.S. CLS. 100, 101 AND 107).

FIRST USE 10-3-2005; IN COMMERCE 10-27-2005.

JAY FLOWERS, EXAMINING ATTORNEY

**CLASS 41—(Continued).**

SN 78-966,416. EVOLVING U CORPORATION, LONGMONT, CO. FILED 9-1-2006.

# Evolving U

THE MARK CONSISTS OF STANDARD CHARACTERS WITHOUT CLAIM TO ANY PARTICULAR FONT, STYLE, SIZE, OR COLOR.

FOR PRODUCTION OF VIDEO CASSETTES; PRODUCTION OF VIDEO DISCS FOR OTHERS; VIDEO EDITING; VIDEO MASTERING SERVICES (U.S. CLS. 100, 101 AND 107).

FIRST USE 6-30-2006; IN COMMERCE 6-30-2006.  
CHRISTINE COOPER, EXAMINING ATTORNEY

---

SN 78-966,420. JERRELL, MARK, LOS ANGELES, CA. FILED 9-1-2006.

# HIPOLITIX

THE MARK CONSISTS OF STANDARD CHARACTERS WITHOUT CLAIM TO ANY PARTICULAR FONT, STYLE, SIZE, OR COLOR.

FOR ENTERTAINMENT IN THE NATURE OF ONGOING TELEVISION PROGRAMS IN THE FIELD OF POLITICS AND SOCIAL ISSUES; RADIO ENTERTAINMENT SERVICES, NAMELY RADIO PROGRAMS FEATURING PERFORMANCES BY A RADIO PERSONALITY (U.S. CLS. 100, 101 AND 107).

CHRISTINE COOPER, EXAMINING ATTORNEY

---

SN 78-966,424. MANDICH, MICHAEL, SAN PEDRO, CA. FILED 9-1-2006.

# Burden On Society

THE MARK CONSISTS OF STANDARD CHARACTERS WITHOUT CLAIM TO ANY PARTICULAR FONT, STYLE, SIZE, OR COLOR.

FOR ENTERTAINMENT, NAMELY LIVE MUSIC CONCERTS; ENTERTAINMENT, NAMELY, LIVE PERFORMANCES BY ROCK GROUPS (U.S. CLS. 100, 101 AND 107).

CHRISTINE COOPER, EXAMINING ATTORNEY

**CLASS 41—(Continued).**

SN 78-966,643. CITY OF HENDERSON REDEVELOPMENT AGENCY, HENDERSON, NV. FILED 9-3-2006.



NO CLAIM IS MADE TO THE EXCLUSIVE RIGHT TO USE "WATER STREET DISTRICT HENDERSON", APART FROM THE MARK AS SHOWN.

THE MARK CONSISTS OF WATER STREET DISTRICT HENDERSON IN STYLIZED LETTERS.

FOR ORGANIZING COMMUNITY FESTIVALS FEATURING A VARIETY OF ACTIVITIES, NAMELY SPORTING EVENTS, ART EXHIBITIONS, FLEA MARKETS, WINE FESTIVALS, ETHNIC DANCES, LIVE MUSICAL PERFORMANCES, PARADES AND THE LIKE (U.S. CLS. 100, 101 AND 107).

SUSAN STIGLITZ, EXAMINING ATTORNEY

---

SN 78-966,788. PEECHER, JOHN W, LA HABRA, CA. FILED 9-4-2006.

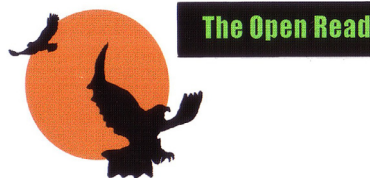

THE COLOR(S) ORANGE, GREEN AND BLACK IS/ARE CLAIMED AS A FEATURE OF THE MARK.

THE MARK CONSISTS OF ON THE RIGHT SIDE, IN GREEN LETTERING, THE PHRASE, THE OPEN READ, ENCLOSED WITHIN A BLACK RECTANGULAR CARRIER. TO THE LEFT OF THE CARRIER, THERE IS AN ORANGE SUN (WITHOUT RAYS), AND IN THE UPPER LEFT OF THE SUN, FACING TO LEFT, THERE IS A SMALL BLACK SILHOUETTE OF A HAWK WITH SPREAD WINGS. IN THE LOWER RIGHT OF THE SUN, A LARGER BLACK SILHOUETTE, FACING DOWN AND TO THE RIGHT, OF A HAWK READY TO SEIZE ITS PREY.

FOR EDUCATION SERVICES, NAMELY, PROVIDING TUTORING IN THE FIELD OF READING (U.S. CLS. 100, 101 AND 107).

FIRST USE 9-0-2006; IN COMMERCE 9-0-2006.

JAMES A. RAUEN, EXAMINING ATTORNEY

**CLASS 41—(Continued).**

SN 78-966,982. STRONGOX INC., CHOCTAW, OK. FILED 9-5-2006.

# Strongox

THE MARK CONSISTS OF STANDARD CHARACTERS WITHOUT CLAIM TO ANY PARTICULAR FONT, STYLE, SIZE, OR COLOR.

FOR EDUCATING AT SENIOR HIGH SCHOOLS; EDUCATING AT UNIVERSITY OR COLLEGES; EDUCATION IN THE FIELD OF SELF PROTECTION RENDERED THROUGH CORRESPONDENCE COURSES; EDUCATIONAL SERVICES, NAMELY, PROVIDING COURSES OF INSTRUCTION AT THE COLLEGE LEVEL AND DISTRIBUTION OF COURSE MATERIAL IN CONNECTION THEREWITH; EDUCATIONAL SERVICES, NAMELY, CONDUCTING CLASSES IN THE FIELD OF INVESTIGATIONS; PHYSICAL EDUCATION SERVICES; VOCATIONAL EDUCATION IN THE FIELDS OF HYPNOSIS AND SELF PROTECTION (U.S. CLS. 100, 101 AND 107).

TIMOTHY FINNEGAN, EXAMINING ATTORNEY

SN 78-967,001. BUCKTOWN PROMOTIONS, INC., CHICAGO, IL. FILED 9-5-2006.

# ARTNOSH

THE MARK CONSISTS OF STANDARD CHARACTERS WITHOUT CLAIM TO ANY PARTICULAR FONT, STYLE, SIZE, OR COLOR.

FOR ENTERTAINMENT SERVICES, NAMELY, CONDUCTING PARTIES (U.S. CLS. 100, 101 AND 107).

FIRST USE 9-1-2006; IN COMMERCE 9-1-2006.  
JAMES A. RAUEN, EXAMINING ATTORNEY

SN 78-967,183. GEORGIA GAME DEVELOPERS ASSOCIATION, INC., SUWANEE, GA. FILED 9-5-2006.

# SIEGE

THE MARK CONSISTS OF STANDARD CHARACTERS WITHOUT CLAIM TO ANY PARTICULAR FONT, STYLE, SIZE, OR COLOR.

FOR ARRANGING OF EXHIBITIONS, SEMINARS AND CONFERENCES TO PROMOTE THE VIDEO GAME AND ELECTRONIC ENTERTAINMENT INDUSTRIES IN GEORGIA (U.S. CLS. 100, 101 AND 107).

DANIEL RUSSELL, EXAMINING ATTORNEY

**CLASS 41—(Continued).**

SN 78-967,232. WELLS, JAMES W. JR., BESSEMER, AL. FILED 9-5-2006.

# BB WOLF

THE MARK CONSISTS OF STANDARD CHARACTERS WITHOUT CLAIM TO ANY PARTICULAR FONT, STYLE, SIZE, OR COLOR.

FOR ENTERTAINMENT, NAMELY, LIVE PERFORMANCES BY A MUSICAL BAND; RECORDING STUDIO (U.S. CLS. 100, 101 AND 107).

FIRST USE 9-4-2006; IN COMMERCE 9-4-2006.  
JOHN DALIER, EXAMINING ATTORNEY

SN 78-967,476. CANTRELL, MICHAEL P., NEWARK, CA. FILED 9-5-2006.

# The Just Six

THE MARK CONSISTS OF STANDARD CHARACTERS WITHOUT CLAIM TO ANY PARTICULAR FONT, STYLE, SIZE, OR COLOR.

FOR ENTERTAINMENT IN THE NATURE OF VISUAL AND AUDIO PERFORMANCES, NAMELY, MUSICAL BAND, ROCK GROUP, GYMNASTIC, DANCE, AND BALLET PERFORMANCES; ENTERTAINMENT, NAMELY LIVE PERFORMANCES BY MUSICAL BANDS (U.S. CLS. 100, 101 AND 107).

JESSICA FATHY, EXAMINING ATTORNEY

SN 78-967,500. MOLIN-SKELTON, JOHN MICHAEL, LOS ANGELES, CA. FILED 9-5-2006.

# spiritweaves

THE MARK CONSISTS OF STANDARD CHARACTERS WITHOUT CLAIM TO ANY PARTICULAR FONT, STYLE, SIZE, OR COLOR.

FOR ORGANIZATION OF DANCING EVENTS (U.S. CLS. 100, 101 AND 107).

FIRST USE 2-14-2004; IN COMMERCE 2-14-2004.  
BARBARA GAYNOR, EXAMINING ATTORNEY



**CLASS 41—(Continued).**

SN 78-967,508. EMAP METRO, LLC, NEW YORK, NY. FILED 9-5-2006.

**DIGITAL DARLINGS**

THE MARK CONSISTS OF STANDARD CHARACTERS WITHOUT CLAIM TO ANY PARTICULAR FONT, STYLE, SIZE, OR COLOR.

FOR PROVIDING ON-LINE INFORMATION AND ENTERTAINMENT IN THE NATURE OF BEAUTY PAGEANTS (U.S. CLS. 100, 101 AND 107).

FIRST USE 7-26-2006; IN COMMERCE 7-26-2006.  
G. MAYERSCHOFF, EXAMINING ATTORNEY

---

SN 78-967,697. WOODWARD ACADEMY, INC., COLLEGE PARK, GA. FILED 9-6-2006.

**EXCELLENCE CHARACTER OPPORTUNITY**

THE MARK CONSISTS OF STANDARD CHARACTERS WITHOUT CLAIM TO ANY PARTICULAR FONT, STYLE, SIZE, OR COLOR.

FOR EDUCATIONAL SERVICES, NAMELY, PROVIDING CLASSES, WORKSHOPS AND COURSES OF INSTRUCTION AT THE PRIMARY THROUGH SECONDARY LEVELS AND ENTERTAINMENT SERVICES, NAMELY, ORGANIZING AND CONDUCTING ATHLETIC AND SPORTS EVENTS, CONCERTS, SYMPOSIA AND THEATER PRODUCTIONS (U.S. CLS. 100, 101 AND 107).

FIRST USE 5-0-2002; IN COMMERCE 5-0-2002.  
GRETTA YAO, EXAMINING ATTORNEY

---

SN 78-967,915. PETERS, BARBARA G., SCOTTSDALE, AZ. FILED 9-6-2006.

**POISONED PENCIL PRESS**

THE MARK CONSISTS OF STANDARD CHARACTERS WITHOUT CLAIM TO ANY PARTICULAR FONT, STYLE, SIZE, OR COLOR.

OWNER OF U.S. REG. NOS. 2,101,697 AND 2,244,943.

NO CLAIM IS MADE TO THE EXCLUSIVE RIGHT TO USE "PRESS", APART FROM THE MARK AS SHOWN.

FOR PUBLICATION OF A SERIES OF FICTION AND NON-FICTION BOOKS ON A VARIETY OF TOPICS (U.S. CLS. 100, 101 AND 107).

EVELYN BRADLEY, EXAMINING ATTORNEY

**CLASS 41—(Continued).**

SN 78-968,122. THIS OLD HOUSE VENTURES, INC., NEW YORK, NY. FILED 9-6-2006.

**AROUND THE YARD**

THE MARK CONSISTS OF STANDARD CHARACTERS WITHOUT CLAIM TO ANY PARTICULAR FONT, STYLE, SIZE, OR COLOR.

OWNER OF U.S. REG. NO. 2,236,341.

FOR ON-LINE PUBLICATION OF MAGAZINE SECTIONS DEALING WITH NEWS, PRODUCTS AND ANSWERS TO QUESTIONS REGARDING THE AREA OUTSIDE THE HOME (U.S. CLS. 100, 101 AND 107).

FIRST USE 12-31-1998; IN COMMERCE 12-31-1998.  
NATALIE POLZER, EXAMINING ATTORNEY

---

SN 78-968,174. ARBUCKLE & OZARKS DEVELOPMENT COMPANY, MARSHFIELD, MO. FILED 9-6-2006.

**EXOTIC ANIMAL PARADISE**

THE MARK CONSISTS OF STANDARD CHARACTERS WITHOUT CLAIM TO ANY PARTICULAR FONT, STYLE, SIZE, OR COLOR.

NO CLAIM IS MADE TO THE EXCLUSIVE RIGHT TO USE "EXOTIC ANIMAL", APART FROM THE MARK AS SHOWN.

FOR ANIMAL EXHIBITIONS (U.S. CLS. 100, 101 AND 107).

FIRST USE 8-30-1971; IN COMMERCE 8-30-1971.  
MICHAEL TANNER, EXAMINING ATTORNEY

---

SN 78-968,269. RUBIN, JEFF, PINOLE, CA. FILED 9-6-2006.

**PUNCTUATION PLAYTIME**

THE MARK CONSISTS OF STANDARD CHARACTERS WITHOUT CLAIM TO ANY PARTICULAR FONT, STYLE, SIZE, OR COLOR.

NO CLAIM IS MADE TO THE EXCLUSIVE RIGHT TO USE "PUNCTUATION", APART FROM THE MARK AS SHOWN.

FOR EDUCATION SERVICES, NAMELY A PROGRAM TO PROMOTE THE USE OF PROPER PUNCTUATION TO SCHOOL AGE CHILDREN (U.S. CLS. 100, 101 AND 107).

FIRST USE 7-1-2006; IN COMMERCE 7-1-2006.  
DOMINIC FATHY, EXAMINING ATTORNEY

**CLASS 41—(Continued).**

SN 78-968,551. TOKUMI, SHAUNA, LOS ANGELES, CA. FILED 9-6-2006.

**NAUTICA THORN**

THE MARK CONSISTS OF STANDARD CHARACTERS WITHOUT CLAIM TO ANY PARTICULAR FONT, STYLE, SIZE, OR COLOR.

THE NAME(S), PORTRAIT(S), AND/OR SIGNATURE(S) SHOWN IN THE MARK IDENTIFIES SHAUNA TOKUMI, WHOSE CONSENT(S) TO REGISTER IS SUBMITTED.

FOR ENTERTAINMENT SERVICES IN THE NATURE OF LIVE ACTING, DANCING PERFORMANCES AND MODELING FOR ADULT PERFORMANCES, AND PUBLIC APPEARANCES OF A STAR OF ADULT MOVIES; ENTERTAINMENT SERVICES, NAMELY PROVIDING VISUAL PICTURES AND IMAGES IN THE FIELD OF ADULT ENTERTAINMENT VIA THE INTERNET (U.S. CLS. 100, 101 AND 107).

FIRST USE 1-1-2003; IN COMMERCE 1-15-2003.  
KEVON CHISOLM, EXAMINING ATTORNEY

SN 78-968,712. SCHOEN, AMY, ROCKVILLE, MD. FILED 9-7-2006.

**MOTIVATED TO MARRY**

THE MARK CONSISTS OF STANDARD CHARACTERS WITHOUT CLAIM TO ANY PARTICULAR FONT, STYLE, SIZE, OR COLOR.

FOR EDUCATIONAL AND COACHING SERVICES, NAMELY ONE-ON-ONE COACHING, AND CONDUCTING CLASSES, WORKSHOPS AND SEMINARS IN THE FIELD OF DATING, MARRIAGE, FAMILY AND LIFESTYLE (U.S. CLS. 100, 101 AND 107).

FIRST USE 3-30-2005; IN COMMERCE 5-11-2005.  
SANI KHOURI, EXAMINING ATTORNEY

SN 78-968,807. EARL G. GRAVES, LTD., NEW YORK, NY. FILED 9-7-2006.

**OUR WORLD WITH BLACK ENTERPRISE**

THE MARK CONSISTS OF STANDARD CHARACTERS WITHOUT CLAIM TO ANY PARTICULAR FONT, STYLE, SIZE, OR COLOR.

OWNER OF U.S. REG. NOS. 1,032,295, 2,671,873 AND OTHERS.

FOR ENTERTAINMENT IN THE NATURE OF A TELEVISION SERIES IN THE FIELD OF LIFESTYLE, CULTURE, COMMENTARY, HUMAN INTEREST FEATURES, INTERVIEWS AND DISCUSSIONS, CURRENT EVENTS, AND NEWS (U.S. CLS. 100, 101 AND 107).

FIRST USE 8-19-2006; IN COMMERCE 8-19-2006.  
ATTIYA MALIK, EXAMINING ATTORNEY

**CLASS 41—(Continued).**

SN 78-968,911. NINJA ACADEMY, ROSEMEAD, CA. FILED 9-7-2006.



THE MARK CONSISTS OF STYLIZED TEXT OF THE WORDING "NINJA ACADEMY".

FOR ENTERTAINMENT NAMELY, LIVE PERFORMANCES BY A MUSICAL BAND (U.S. CLS. 100, 101 AND 107).

FIRST USE 3-0-2003; IN COMMERCE 7-0-2005.  
INGA ERVIN, EXAMINING ATTORNEY

SN 78-969,084. ECOTAINMENT L.L.C., SALT LAKE CITY, UT. FILED 9-7-2006.

**Ecotainment**

THE MARK CONSISTS OF STANDARD CHARACTERS WITHOUT CLAIM TO ANY PARTICULAR FONT, STYLE, SIZE, OR COLOR.

FOR ENTERTAINMENT IN THE NATURE OF ONGOING TELEVISION PROGRAMS IN THE FIELD OF ENVIRONMENTAL DRAMA; ENTERTAINMENT, NAMELY, PRODUCTION OF TELEVISION SHOWS (U.S. CLS. 100, 101 AND 107).

LINDA ORNDORFF, EXAMINING ATTORNEY

SN 78-969,373. NOVATE MEDIA, FREDERICK, MD. FILED 9-7-2006.



THE MARK CONSISTS OF STYLIZED LETTERFORMS THAT ARE VERTICALLY STAGGERED TO SUGGEST THE MOTION OF WAVES.

FOR ENTERTAINMENT SERVICES, NAMELY, PROVIDING ON-LINE COMPUTER GAMES (U.S. CLS. 100, 101 AND 107).

FIRST USE 3-1-2006; IN COMMERCE 6-1-2006.  
IRA J. GOODSaid, EXAMINING ATTORNEY

**CLASS 41—(Continued).**

SN 78-969,527. AR DIVINE ENTERPRISES, LOS ANGELES, CA. FILED 9-7-2006.

**VIP SCHEDULE OF EVENTS**

THE MARK CONSISTS OF STANDARD CHARACTERS WITHOUT CLAIM TO ANY PARTICULAR FONT, STYLE, SIZE, OR COLOR.

NO CLAIM IS MADE TO THE EXCLUSIVE RIGHT TO USE "SCHEDULE OF EVENTS", APART FROM THE MARK AS SHOWN.

FOR PROVIDING INFORMATION IN THE FORM OF AN ON-LINE EVENTS SCHEDULE AND CALENDAR IN THE FOLLOWING FIELDS OF INTEREST; CELEBRITY EVENTS, ENTERTAINMENT INDUSTRY LAUNCH PARTIES, ENTERTAINMENT INDUSTRY PRIVATE PARTIES, ENTERTAINMENT PERFORMANCES, MOVIE PREMIERES, ENTERTAINMENT INDUSTRY GALAS AND RECEPTIONS, MUSIC FESTIVALS, FILM FESTIVALS, FUNDRAISERS, AND CHARITY EVENTS (U.S. CLS. 100, 101 AND 107).

KATHRYN COWARD, EXAMINING ATTORNEY



SN 78-969,603. KENNETH, EDWARD OLIN, LOS ANGELES, CA. FILED 9-7-2006.

**AFTER PORTSMOUTH**

THE MARK CONSISTS OF STANDARD CHARACTERS WITHOUT CLAIM TO ANY PARTICULAR FONT, STYLE, SIZE, OR COLOR.

FOR TELEVISION PRODUCTION SERVICES (U.S. CLS. 100, 101 AND 107).

JILL PRATER, EXAMINING ATTORNEY



SN 78-969,661. ANDERSON, DARCY E., SAN JOSE, CA. FILED 9-8-2006.



THE MARK CONSISTS OF THE STYLIZED WORD DAZZ. FOR COMPOSITION OF MUSIC FOR OTHERS; MUSIC PUBLISHING SERVICES (U.S. CLS. 100, 101 AND 107).

KATHERINE CONNOLLY, EXAMINING ATTORNEY

**CLASS 41—(Continued).**

SN 78-969,832. RUCKUS HOUSE IP, LLC, CONCORD, NC. FILED 9-8-2006.

**CAMP RUCKUS**

THE MARK CONSISTS OF STANDARD CHARACTERS WITHOUT CLAIM TO ANY PARTICULAR FONT, STYLE, SIZE, OR COLOR.

NO CLAIM IS MADE TO THE EXCLUSIVE RIGHT TO USE CAMP, APART FROM THE MARK AS SHOWN.

FOR DAY CAMP AND SUMMER CAMP SERVICES (U.S. CLS. 100, 101 AND 107).

DANIEL CAPSHAW, EXAMINING ATTORNEY



SN 78-969,920. MEDED RESOURCES, LLC, ELLICOTT CITY, MD. FILED 9-8-2006.

**QUESTMEDED**

THE MARK CONSISTS OF STANDARD CHARACTERS WITHOUT CLAIM TO ANY PARTICULAR FONT, STYLE, SIZE, OR COLOR.

FOR PROVIDING CONTINUING MEDICAL EDUCATION COURSES FOR HEALTHCARE PROFESSIONALS; EDUCATION SERVICES, NAMELY CONDUCTING PROGRAMS IN THE FIELD OF QUALITY IMPROVEMENT IN HEALTHCARE (U.S. CLS. 100, 101 AND 107).

ADA HAN, EXAMINING ATTORNEY



SN 78-970,319. GROSS, HERB, CHARLOTTE, NC. FILED 9-8-2006.

**HERB GROSS & THE INVICTAS**

THE MARK CONSISTS OF STANDARD CHARACTERS WITHOUT CLAIM TO ANY PARTICULAR FONT, STYLE, SIZE, OR COLOR.

FOR ENTERTAINMENT NAMELY, LIVE PERFORMANCES BY A MUSICAL BAND (U.S. CLS. 100, 101 AND 107).

FIRST USE 6-30-2005; IN COMMERCE 6-30-2005. LINDA M. KING, EXAMINING ATTORNEY

**CLASS 41—(Continued).**

SN 78-970,539. NEWTON BUSINESS PROGRAMS LLC, NEW YORK, NY. FILED 9-8-2006.

**PUTTING OUT FIRES**

THE MARK CONSISTS OF STANDARD CHARACTERS WITHOUT CLAIM TO ANY PARTICULAR FONT, STYLE, SIZE, OR COLOR.

FOR CONDUCTING WORKSHOPS AND SEMINARS IN THE FIELD OF CORPORATE TRAINING (U.S. CLS. 100, 101 AND 107).

FIRST USE 1-1-2006; IN COMMERCE 1-1-2006.  
MELVIN AXILBUND, EXAMINING ATTORNEY

**CLASS 41—(Continued).**

SN 78-970,800. INSTITUTE OF CONSUMER FINANCIAL EDUCATION, INC., SAN DIEGO, CA. FILED 9-9-2006.

**Certified Credit Report  
Reviewer (CCRR)**

THE MARK CONSISTS OF STANDARD CHARACTERS WITHOUT CLAIM TO ANY PARTICULAR FONT, STYLE, SIZE, OR COLOR.

NO CLAIM IS MADE TO THE EXCLUSIVE RIGHT TO USE "CERTIFIED CREDIT REPORT REVIEWER", APART FROM THE MARK AS SHOWN.

FOR TRAINING SERVICES IN THE FIELD OF CREDIT REPORT REVIEWING (U.S. CLS. 100, 101 AND 107).  
IRA J. GOODSaid, EXAMINING ATTORNEY

SN 78-970,679. FREMANTLEMEDIA NORTH AMERICA, INC., BURBANK, CA. FILED 9-8-2006.

**IN SEARCH OF PARADISE**

THE MARK CONSISTS OF STANDARD CHARACTERS WITHOUT CLAIM TO ANY PARTICULAR FONT, STYLE, SIZE, OR COLOR.

FOR ENTERTAINMENT SERVICES, NAMELY PRODUCTION AND DISTRIBUTION OF A SERIES OF TELEVISION PROGRAMS (U.S. CLS. 100, 101 AND 107).

JEFF DEFORD, EXAMINING ATTORNEY

SN 78-970,803. INSTITUTE OF CONSUMER FINANCIAL EDUCATION, INC., SAN DIEGO, CA. FILED 9-9-2006.

**Certified Identity Theft Risk  
Management Specialist  
(CITRMS)**

THE MARK CONSISTS OF STANDARD CHARACTERS WITHOUT CLAIM TO ANY PARTICULAR FONT, STYLE, SIZE, OR COLOR.

NO CLAIM IS MADE TO THE EXCLUSIVE RIGHT TO USE "CERTIFIED IDENTITY THEFT RISK MANAGEMENT", APART FROM THE MARK AS SHOWN.

FOR TRAINING SERVICES IN THE FIELD OF IDENTITY THEFT RISK MANAGEMENT (U.S. CLS. 100, 101 AND 107).

IRA J. GOODSaid, EXAMINING ATTORNEY

SN 78-970,710. WORTON, BARBARA, GLEN ROCK, NJ. FILED 9-9-2006.

**watchthisbook.com**

THE MARK CONSISTS OF STANDARD CHARACTERS WITHOUT CLAIM TO ANY PARTICULAR FONT, STYLE, SIZE, OR COLOR.

FOR ENTERTAINMENT SERVICES, NAMELY PROVIDING A WEB SITE FEATURING MUSICAL PERFORMANCE, MUSICAL VIDEOS, RELATED FILM CLIPS, PHOTOGRAPHS, AND OTHER MULTIMEDIA MATERIALS (U.S. CLS. 100, 101 AND 107).

MIDGE BUTLER, EXAMINING ATTORNEY

SN 78-970,816. BARBARA WORTON, GLEN ROCK, NJ. FILED 9-9-2006.

**watch this book**

THE MARK CONSISTS OF STANDARD CHARACTERS WITHOUT CLAIM TO ANY PARTICULAR FONT, STYLE, SIZE, OR COLOR.

FOR PRODUCTION OF VIDEO AND CREATION OF VISUAL EFFECTS FOR USE IN DVDS, TELEVISION PROGRAMS AND ON WEBSITES (U.S. CLS. 100, 101 AND 107).

MIDGE BUTLER, EXAMINING ATTORNEY

**CLASS 41—(Continued).**

SN 78-970,818. BARBARA WORTON, GLEN ROCK, NJ. FILED 9-9-2006.

# VideoLit

THE MARK CONSISTS OF STANDARD CHARACTERS WITHOUT CLAIM TO ANY PARTICULAR FONT, STYLE, SIZE, OR COLOR.

FOR ELECTRONIC PUBLISHING SERVICES, NAMELY, PUBLICATION OF TEXT AND GRAPHIC WORKS OF OTHERS ON DVD AND ONLINE FEATURING LITERATURE AND GRAPHICS AND PERFORMANCE; PUBLISHING AND DISTRIBUTION OF BOOKS, REVIEWS AND OTHER PRINTED MATTER AS WELL AS RELATED ELECTRONIC DATA CARRIERS; PUBLISHING OF BOOKS AND REVIEWS; PUBLISHING OF ELECTRONIC PUBLICATIONS (U.S. CLS. 100, 101 AND 107).

MIDGE BUTLER, EXAMINING ATTORNEY

SN 78-970,924. HILL, ANTHONY, NEW YORK, NY. FILED 9-10-2006.

# DigitHill

THE MARK CONSISTS OF STANDARD CHARACTERS WITHOUT CLAIM TO ANY PARTICULAR FONT, STYLE, SIZE, OR COLOR.

FOR PHOTOGRAPHY SERVICES (U.S. CLS. 100, 101 AND 107).

WILLIAM P. SHANAHAN, EXAMINING ATTORNEY

SN 78-970,933. HAMMERLE, JUDE K., WARWICK, NY. FILED 9-10-2006.

# RINGBAHN

THE MARK CONSISTS OF STANDARD CHARACTERS WITHOUT CLAIM TO ANY PARTICULAR FONT, STYLE, SIZE, OR COLOR.

FOR PROVIDING THEME PARK SERVICES (U.S. CLS. 100, 101 AND 107).

SHAUNIA WALLACE, EXAMINING ATTORNEY

**CLASS 41—(Continued).**

SN 78-972,458. CEC HOLDINGS I, INC., HOFFMAN ESTATES, IL. FILED 9-12-2006.

# FAUX ROCKS

THE MARK CONSISTS OF STANDARD CHARACTERS WITHOUT CLAIM TO ANY PARTICULAR FONT, STYLE, SIZE, OR COLOR.

FOR ARRANGING AND CONDUCTING FASHION EXHIBITIONS (U.S. CLS. 100, 101 AND 107).

DEIRDRE ROBERTSON, EXAMINING ATTORNEY

SN 78-972,532. IVILLAGE, INC., NEW YORK, NY. FILED 9-12-2006.

# STUFF WE LOVE

THE MARK CONSISTS OF STANDARD CHARACTERS WITHOUT CLAIM TO ANY PARTICULAR FONT, STYLE, SIZE, OR COLOR.

FOR ENTERTAINMENT SERVICES IN THE NATURE OF AN ON-GOING REALITY-BASED TELEVISION PROGRAM DISTRIBUTED VIA TELEVISION, SATELLITE, CABLE, GLOBAL COMPUTER NETWORK AND MOBILE COMMUNICATION DEVICES; ENTERTAINMENT SERVICES, NAMELY, PROVIDING A WEBSITE FEATURING INFORMATION ABOUT A REALITY-BASED TELEVISION PROGRAM BY MEANS OF A GLOBAL COMPUTER NETWORK (U.S. CLS. 100, 101 AND 107).

WENDY GOODMAN, EXAMINING ATTORNEY

SN 78-973,631. WELLS FARGO & COMPANY, MINNEAPOLIS, MN. FILED 9-13-2006.

# PAYROLL UNIVERSITY

THE MARK CONSISTS OF STANDARD CHARACTERS WITHOUT CLAIM TO ANY PARTICULAR FONT, STYLE, SIZE, OR COLOR.

NO CLAIM IS MADE TO THE EXCLUSIVE RIGHT TO USE "PAYROLL", APART FROM THE MARK AS SHOWN.

FOR EDUCATIONAL SERVICES, NAMELY PROVIDING TRAINING AND CLASSES, SEMINARS, WORKSHOPS, CONFERENCES, AND ONLINE TRAINING AND CLASSES, SEMINARS, WORKSHOPS, CONFERENCES IN THE FIELDS OF BUSINESS PAYROLL SERVICES (U.S. CLS. 100, 101 AND 107).

SETH A. RAPPAPORT, EXAMINING ATTORNEY

**CLASS 42—SCIENTIFIC, COMPUTER AND LEGAL SERVICES**

SN 76-607,079. ACS TECHNOLOGIES GROUP, INC., FLORENCE, SC. FILED 8-16-2004.

# ACCESS ACS

THE MARK CONSISTS OF STANDARD CHARACTERS WITHOUT CLAIM TO ANY PARTICULAR FONT, STYLE, SIZE, OR COLOR.

OWNER OF U.S. REG. NO. 2,628,153.

NO CLAIM IS MADE TO THE EXCLUSIVE RIGHT TO USE "ACCESS", APART FROM THE MARK AS SHOWN.

FOR PROVIDING TEMPORARY USE OF ON-LINE NON-DOWNLOADABLE COMPUTER SOFTWARE FOR USE IN DELIVERING AND DEPLOYING SOFTWARE APPLICATIONS AND DATA OVER COMPUTER NETWORKS AND/OR TO REMOTE USERS; PROVIDING TEMPORARY USE OF ON-LINE NON-DOWNLOADABLE COMPUTER SOFTWARE FOR USE IN ACCESSING AND USING REMOTE COMPUTER SYSTEMS, NETWORKS AND SOFTWARE (U.S. CLS. 100 AND 101). FIRST USE 12-31-2003; IN COMMERCE 12-31-2003. ELLEN PERKINS, EXAMINING ATTORNEY

SN 76-656,997. FORM WERKS STUDIOS, PHOENIX, AZ. FILED 3-21-2006.

## SITE SPECIFIC ARCHITECTURE

THE MARK CONSISTS OF STANDARD CHARACTERS WITHOUT CLAIM TO ANY PARTICULAR FONT, STYLE, SIZE, OR COLOR.

NO CLAIM IS MADE TO THE EXCLUSIVE RIGHT TO USE "ARCHITECTURE", APART FROM THE MARK AS SHOWN.

FOR ARCHITECTURAL DESIGN SERVICES; LAND USE PLANNING SERVICES; SITE PLANNING SERVICES, NAMELY, LANDSCAPE ARCHITECTURAL DESIGN SERVICES; INTERIOR DECORATING; INTERIOR DECORATING FOCUSING ON LIGHTING; DESIGN FOR OTHERS OF SPECIALIZED LIGHTING; LANDSCAPE ARCHITECTURE DESIGN SERVICES; AND ARCHITECTURAL DESIGN SERVICES WHERE THE DESIGN IS SHOWN IN PHYSICAL AND COMPUTER RENDERED MODELS (U.S. CLS. 100 AND 101).

FIRST USE 10-8-2002; IN COMMERCE 10-8-2002. CAROLYN CATALDO, EXAMINING ATTORNEY

**CLASS 42—(Continued).**

SN 76-662,973. GRAVITY TECHNOLOGIES, SAN FRANCISCO, CA. FILED 7-13-2006.

# NEWTON

THE MARK CONSISTS OF STANDARD CHARACTERS WITHOUT CLAIM TO ANY PARTICULAR FONT, STYLE, SIZE, OR COLOR.

FOR PROVIDING TEMPORARY USE OF ONLINE, NON-DOWNLOADABLE SOFTWARE FOR TRACKING EMPLOYEES, PERFORMANCE MANAGEMENT, TESTING EMPLOYEES, AND DATABASE MANAGEMENT, ALL IN THE FIELDS OF EMPLOYMENT HIRING, RECRUITING, PLACEMENT AND STAFFING (U.S. CLS. 100 AND 101).

ERNEST SHOSH0, EXAMINING ATTORNEY

SN 76-664,047. AVESTAR-IP, LLC, SAN FRANCISCO, CA. FILED 8-2-2006.

## STRENGTHENING INTELLECTUAL PROPERTY THROUGH INTELLIGENCE

THE MARK CONSISTS OF STANDARD CHARACTERS WITHOUT CLAIM TO ANY PARTICULAR FONT, STYLE, SIZE, OR COLOR.

FOR COMPUTER SERVICES, NAMELY, PROVIDING NON-DOWNLOADABLE SOFTWARE INTERFACES AVAILABLE OVER A NETWORK IN ORDER TO CREATE A PERSONALIZED ON-LINE INFORMATION SERVICE; EXTRACTION AND RETRIEVAL OF INFORMATION AND DATA MINING BY MEANS OF GLOBAL COMPUTER NETWORKS; CREATING INDEXES OF INFORMATION, INDEXES OF WEB SITES AND INDEXES OF OTHER INFORMATION SOURCES IN CONNECTION WITH GLOBAL COMPUTER NETWORKS; PROVIDING SEARCH ENGINES FOR SEARCHING USER-DEFINED INDEXES AND DATABASES OF INFORMATION, INCLUDING TEXT, ELECTRONIC DOCUMENTS, DATABASES, GRAPHICS AND AUDIO VISUAL INFORMATION, BY MEANS OF GLOBAL COMPUTER INFORMATION NETWORKS (U.S. CLS. 100 AND 101).

FIRST USE 5-14-2006; IN COMMERCE 5-14-2006. MICHAEL WIENER, EXAMINING ATTORNEY

**CLASS 42—(Continued).**

SN 76-664,049. AVESTAR-IP, LLC, SAN FRANCISCO, CA. FILED 8-2-2006.

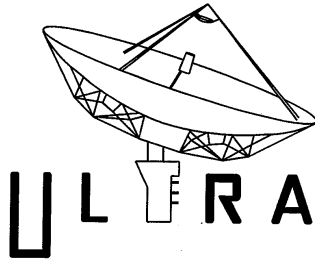

FOR COMPUTER SERVICES, NAMELY, PROVIDING NON-DOWNLOADABLE SOFTWARE INTERFACES AVAILABLE OVER A NETWORK IN ORDER TO CREATE A PERSONALIZED ON-LINE INFORMATION SERVICE; EXTRACTION AND RETRIEVAL OF INFORMATION AND DATA MINING BY MEANS OF GLOBAL COMPUTER NETWORKS; CREATING INDEXES OF INFORMATION, INDEXES OF WEB SITES AND INDEXES OF OTHER INFORMATION SOURCES IN CONNECTION WITH GLOBAL COMPUTER NETWORKS; PROVIDING SEARCH ENGINES FOR SEARCHING USER-DEFINED INDEXES AND DATABASES OF INFORMATION, INCLUDING TEXT, ELECTRONIC DOCUMENTS, DATABASES, GRAPHICS AND AUDIO VISUAL INFORMATION, BY MEANS OF GLOBAL COMPUTER INFORMATION NETWORKS (U.S. CLS. 100 AND 101).

FIRST USE 5-14-2006; IN COMMERCE 5-14-2006.  
MICHAEL WIENER, EXAMINING ATTORNEY

SN 76-665,555. M SHIP CO., LLC., SAN DIEGO, CA. FILED 9-5-2006.

**REI**

THE MARK CONSISTS OF STANDARD CHARACTERS WITHOUT CLAIM TO ANY PARTICULAR FONT, STYLE, SIZE, OR COLOR.

FOR DESIGN AND DEVELOPMENT OF POWERED AND UN-POWERED WATERCRAFT FOR GOVERNMENT, COMMERCIAL, AND MILITARY MARKETS (U.S. CLS. 100 AND 101).

FIRST USE 10-1-2006; IN COMMERCE 10-1-2006.  
PRISCILLA MILTON, EXAMINING ATTORNEY

**CLASS 42—(Continued).**

SN 77-008,544. ISOLAGEN TECHNOLOGIES, INC., EXTON, PA. FILED 9-27-2006.

CHANGING THE FACE OF TIME

THE MARK CONSISTS OF STANDARD CHARACTERS WITHOUT CLAIM TO ANY PARTICULAR FONT, STYLE, SIZE, OR COLOR.

FOR SCIENTIFIC RESEARCH AND DEVELOPMENT; COSMETIC, PERSONAL CARE AND PHARMACEUTICAL PRODUCT RESEARCH AND DEVELOPMENT; CHEMICAL, BIOCHEMICAL AND BIOLOGICAL RESEARCH AND ANALYSIS; MEDICAL LABORATORY SERVICES, NAMELY, GROWING AND PROVIDING A SUPPLY OF HISTOCOMPATIBLE FIBROBLAST CELLS FOR USE IN MEDICAL, DENTAL AND/OR COSMETIC PROCEDURES (U.S. CLS. 100 AND 101).

FIRST USE 8-27-1999; IN COMMERCE 8-27-1999.  
DEIRDRE ROBERTSON, EXAMINING ATTORNEY

SN 77-011,306. YOKLEY, TIMOTHY D., PHOENIX, AZ. FILED 10-1-2006.

**PORTALPIG**

THE MARK CONSISTS OF STANDARD CHARACTERS WITHOUT CLAIM TO ANY PARTICULAR FONT, STYLE, SIZE, OR COLOR.

FOR COMPUTER SERVICES, NAMELY, PROVIDING SEARCH ENGINES FOR OBTAINING DATA ON A GLOBAL COMPUTER NETWORK (U.S. CLS. 100 AND 101).

JENNIFER KRISP, EXAMINING ATTORNEY

SN 77-015,778. GREYBROOKE CONSULTING, INC., ORLANDO, FL. FILED 10-6-2006.

**GREYBROOKE**

THE MARK CONSISTS OF STANDARD CHARACTERS WITHOUT CLAIM TO ANY PARTICULAR FONT, STYLE, SIZE, OR COLOR.

FOR CONSULTING SERVICES IN THE FIELD OF DESIGN, SELECTION, IMPLEMENTATION AND USE OF COMPUTER HARDWARE AND SOFTWARE SYSTEMS FOR OTHERS (U.S. CLS. 100 AND 101).

FIRST USE 12-30-2005; IN COMMERCE 12-30-2005.  
JESSICA A. POWERS, EXAMINING ATTORNEY

**CLASS 42—(Continued).**

SN 77-050,817. EVO SOLUTIONS, L.P., AMARILLO, TX. FILED 11-27-2006.



NO CLAIM IS MADE TO THE EXCLUSIVE RIGHT TO USE "BUSINESS SOLUTIONS", APART FROM THE MARK AS SHOWN.

THE APPLICANT CLAIMS COLOR AS A FEATURE OF THE MARK, NAMELY, GRAY, RED, AND BLACK.

THE MARK CONSISTS OF THE WORD "EVO" INSCRIBED IN GRAY, ABOVE THE WORDS "BUSINESS SOLUTIONS" INSCRIBED IN BLACK, WITH ONE LONG RED LINE AND FOUR SHORTER RED LINES TO THE LEFT OF THE WORD "EVO" AND A GRAY ARROW BEGINNING BELOW THE LOWEST RED LINE AND POINTING UP TO THE LONG RED LINE.

FOR DESIGN, CREATION, HOSTING, MAINTENANCE OF WEBSITES FOR OTHERS (U.S. CLS. 100 AND 101).

FIRST USE 9-1-2006; IN COMMERCE 9-1-2006.  
CHRISIE B. KING, EXAMINING ATTORNEY

**CLASS 42—(Continued).**

SN 78-534,407. ARKANSAS BUSINESS LIMITED PARTNERSHIP, LITTLE ROCK, AR. FILED 12-17-2004.

**FLEX360**

THE MARK CONSISTS OF STANDARD CHARACTERS WITHOUT CLAIM TO ANY PARTICULAR FONT, STYLE, SIZE, OR COLOR.

FOR CONSULTATION SERVICES IN THE FIELD OF WEB SITE DESIGN AND DEVELOPMENT, COMPUTER APPLICATION DEVELOPMENT, AND COMPUTER PROJECT MANAGEMENT SERVICES; CONSULTATION SERVICES IN THE FIELD OF INTERNET MARKETING, NAMELY, CONSULTING WITH OTHERS ABOUT THE DESIGN OF HOMEPAGES AND WEB-SITES THAT WILL BE USED TO MARKET CLIENTS' GOODS AND SERVICES (U.S. CLS. 100 AND 101).

FIRST USE 6-1-2004; IN COMMERCE 6-1-2004.  
NANCY CLARKE, EXAMINING ATTORNEY

SN 78-599,024. MANHATTAN PRIDE DIGITAL, LLC, NEW YORK, NY. FILED 3-31-2005.

**MANHATTAN PRIDE  
DIGITAL**

THE MARK CONSISTS OF STANDARD CHARACTERS WITHOUT CLAIM TO ANY PARTICULAR FONT, STYLE, SIZE, OR COLOR.

NO CLAIM IS MADE TO THE EXCLUSIVE RIGHT TO USE "MANHATTAN AND DIGITAL", APART FROM THE MARK AS SHOWN.

FOR COMPUTER CODE CONVERSION FOR OTHERS; COMPUTER CONSULTATION; COMPUTER DIAGNOSTIC SERVICES; COMPUTER DISASTER RECOVERY PLANNING; COMPUTER GRAPHICS SERVICES; COMPUTER HARDWARE DEVELOPMENT; COMPUTER NETWORK DESIGN FOR OTHERS; COMPUTER PROGRAMMING FOR OTHERS; COMPUTER SERVICES, NAMELY, CREATING AND MAINTAINING WEB SITES FOR OTHERS; COMPUTER SERVICES, NAMELY, DATA RECOVERY SERVICES; COMPUTER SERVICES, NAMELY, DESIGNING AND IMPLEMENTING NETWORK WEB PAGES FOR OTHERS; COMPUTER SERVICES, NAMELY, DESIGNING AND IMPLEMENTING WEB SITES FOR OTHERS; COMPUTER SITE DESIGN; COMPUTER SOFTWARE CONSULTATION; COMPUTER SOFTWARE DESIGN FOR OTHERS; COMPUTER SOFTWARE DEVELOPMENT; COMPUTER SOFTWARE DE-

SN 77-058,442. RIATA ENERGY, INC., OKLAHOMA CITY, OK. FILED 12-6-2006.



NO CLAIM IS MADE TO THE EXCLUSIVE RIGHT TO USE "ENERGY", APART FROM THE MARK AS SHOWN.

THE APPLICANT CLAIMS COLOR AS A FEATURE OF THE MARK, NAMELY, BLACK AND RED.

THE MARK CONSISTS OF THE WORDS SANDRIDGE ENERGY IN STYLIZED BLACK LETTERS WITH A BLACK CURVED LINE AND A RED CURVED LINE.

FOR EXPLORATION AND SEARCHING OF OIL AND GAS (U.S. CLS. 100 AND 101).

JIM RINGLE, EXAMINING ATTORNEY



**CLASS 42—(Continued).**

SIGN, COMPUTER PROGRAMMING, OR MAINTENANCE OF COMPUTER SOFTWARE; COMPUTER SYSTEMS ANALYSIS; CONSULTING SERVICES IN THE FIELD OF DESIGN, SELECTION, IMPLEMENTATION AND USE OF COMPUTER HARDWARE AND SOFTWARE SYSTEMS FOR OTHERS; CUSTOMIZATION OF COMPUTER HARDWARE AND SOFTWARE; INSTALLATION OF COMPUTER SOFTWARE; INTEGRATION OF COMPUTER SYSTEMS AND NETWORKS; MONITORING THE COMPUTER SYSTEMS OF OTHERS FOR TECHNICAL PURPOSES AND PROVIDING BACK-UP COMPUTER PROGRAMS AND FACILITIES; RECOVERY OF COMPUTER DATA; REPAIR OF DAMAGED COMPUTER PROGRAMS; TECHNICAL SUPPORT SERVICES, NAMELY, TROUBLESHOOTING OF COMPUTER HARDWARE AND SOFTWARE PROBLEMS; TECHNICAL SUPPORT, NAMELY, PROVIDING BACK-UP COMPUTER PROGRAMS AND FACILITIES; RENTAL OF COMPUTERS; RENTAL OF COMPUTERS AND SOFTWARE; LEASING COMPUTER FACILITIES; LEASING OF COMPUTERS (U.S. CLS. 100 AND 101).

FIRST USE 3-22-2005; IN COMMERCE 3-22-2005.  
ROBERT C. CLARK JR., EXAMINING ATTORNEY

---

SN 78-612,170. YOUR COLOR SOURCE STUDIOS, INC., MONTCLAIR, NJ. FILED 4-19-2005.

**YOUR COLOR SOURCE**

THE MARK CONSISTS OF STANDARD CHARACTERS WITHOUT CLAIM TO ANY PARTICULAR FONT, STYLE, SIZE, OR COLOR.

FOR CONSULTING SERVICES IN THE FIELD OF HOME AND OFFICE INTERIOR AND EXTERIOR DESIGN (U.S. CLS. 100 AND 101).

FIRST USE 5-0-2001; IN COMMERCE 5-0-2001.  
PAMELA HIRSCHMAN, EXAMINING ATTORNEY

---

SN 78-622,400. UNITED BOBOV INTERNATIONAL, INC., BROOKLYN, NY. FILED 5-4-2005.

**AV'DAK BOBOV**

THE MARK CONSISTS OF STANDARD CHARACTERS WITHOUT CLAIM TO ANY PARTICULAR FONT, STYLE, SIZE, OR COLOR.

THE NAME AV'DAK BOBOV DOES NOT IDENTIFY A LIVING INDIVIDUAL.

THE TERM "AV'DAK" TRANSLATES TO "HEAD OF THE HOLY RABBINICAL COURT." THUS, THE TERM "AV'DAK BOBOV" TRANSLATES TO "HEAD OF THE HOLY RABBINICAL COURT OF BOBOV."

FOR LEGAL SERVICES, NAMELY, MEDIATION SERVICES (U.S. CLS. 100 AND 101).

JENNIFER WILLISTON, EXAMINING ATTORNEY

**CLASS 42—(Continued).**

SN 78-633,470. AIR MEDIA, INC, SAN FRANCISCO, CA. FILED 5-19-2005.

**AIRMEDIA**

THE MARK CONSISTS OF STANDARD CHARACTERS WITHOUT CLAIM TO ANY PARTICULAR FONT, STYLE, SIZE, OR COLOR.

FOR DEVELOPMENT OF ENTERTAINMENT SOFTWARE APPLICATIONS FOR WIRELESS MOBILE COMMUNICATION DEVICES (U.S. CLS. 100 AND 101).

FIRST USE 1-0-2004; IN COMMERCE 1-0-2004.  
ASMAT KHAN, EXAMINING ATTORNEY

---

SN 78-678,979. STRAIGHT LINE THEORY, SAINT PAUL, MN. FILED 7-26-2005.

**Straight Line Theory**

THE MARK CONSISTS OF STANDARD CHARACTERS WITHOUT CLAIM TO ANY PARTICULAR FONT, STYLE, SIZE, OR COLOR.

FOR TECHNOLOGY CONSULTING IN THE FIELD OF WEBSITE APPLICATIONS, NAMELY, TESTING, ANALYZING AND MODELING WEBSITE USABILITY AND DESIGN ISSUES TO AID BUSINESSES IN DELIVERING MORE USER FRIENDLY WEBSITES (U.S. CLS. 100 AND 101).

FIRST USE 10-24-2002; IN COMMERCE 10-24-2002.  
WENDY GOODMAN, EXAMINING ATTORNEY

---

SN 78-688,934. ADAPTIVE SPECTRUM AND SIGNAL ALIGNMENT, INC., REDWOOD CITY, CA. FILED 8-9-2005.

**CHORALE**

THE MARK CONSISTS OF STANDARD CHARACTERS WITHOUT CLAIM TO ANY PARTICULAR FONT, STYLE, SIZE, OR COLOR.

FOR TECHNICAL CONSULTATION SERVICES RELATED TO DESIGNING, IMPLEMENTING, OPERATING, MANAGING, CONTROLLING, USING, OPTIMIZING AND EVALUATING DSL SYSTEMS (U.S. CLS. 100 AND 101).

ANN E. SAPPENFIELD, EXAMINING ATTORNEY

**CLASS 42—(Continued).**

SN 78-702,156. THE FOURTH UTILITY, LLC, CHARLOTTE, NC. FILED 8-29-2005.



NO CLAIM IS MADE TO THE EXCLUSIVE RIGHT TO USE "INTELLIGENT BUILDINGS", APART FROM THE MARK AS SHOWN.

FOR DESIGNING AND IMPLEMENTING INTERNET PROTOCOL-BASED WIRE AND WIRELESS COMMUNICATION NETWORKS FOR COMMERCIAL AND REAL ESTATE CUSTOMERS; TECHNICAL SUPPORT, NAMELY, MONITORING OF INTERNET PROTOCOL-BASED WIRE AND WIRELESS COMMUNICATION NETWORKS FOR COMMERCIAL AND REAL ESTATE CUSTOMERS (U.S. CLS. 100 AND 101).

FIRST USE 3-31-2005; IN COMMERCE 3-31-2005.  
DANIEL RUSSELL, EXAMINING ATTORNEY

SN 78-745,312. DIGITAL FORENSICS PROFESSIONALS, INC., TULSA, OK. FILED 11-2-2005.



FOR PROVIDING TECHNOLOGY SERVICES AND CONSULTING IN THE FIELDS OF FORENSIC DATA ANALYSIS, COMPUTER SECURITY, AND EXAMINATION AND ANALYSIS OF COMPUTERS, DIGITAL DEVICES, COMPUTER SOFTWARE, COMPUTER NETWORKS, INTERNET TRAFFIC AND COMPUTER RECORDS; RETRIEVING, ANALYZING, AND RE-FORMATTING DIGITAL INFORMATION FROM ELECTRONIC HARDWARE AND SOFTWARE; DATA AUTOMATION AND COLLECTION SERVICE USING PROPRIETARY OR NON-PROPRIETARY SOFTWARE TO EVALUATE, ANALYZE AND COLLECT SERVICE DATA; PROVIDING CONTENT-CONTROL SERVICES FOR THE WEBSITES OF OTHERS; PROVIDING CONVERSION OF DIGITAL DATA; ENHANCEMENT, RESTORATION, AND/OR DUPLICATION OF COMPUTER DATA; RESEARCH IN THE FIELDS OF INTELLIGENCE AND SECURITY (U.S. CLS. 100 AND 101).

FIRST USE 10-19-2005; IN COMMERCE 10-19-2005.  
REBECCA EISINGER, EXAMINING ATTORNEY

**CLASS 42—(Continued).**

SN 78-750,291. AIONEX, INC., GOODLETTSVILLE, TN. FILED 11-9-2005.

# AIONEX

THE MARK CONSISTS OF STANDARD CHARACTERS WITHOUT CLAIM TO ANY PARTICULAR FONT, STYLE, SIZE, OR COLOR.

FOR COMPUTER CONSULTING SERVICES, NAMELY, IMPLEMENTATION AND CONFIGURATION OF COMPUTER HARDWARE AND SOFTWARE AND MAINTENANCE OF COMPUTER SOFTWARE FOR USE IN MANAGING INFORMATION RELATED TO HOSPITAL AND PATIENT ADMINISTRATION (U.S. CLS. 100 AND 101).

SHANNON TWOHIG, EXAMINING ATTORNEY

SN 78-750,299. AIONEX, INC., GOODLETTSVILLE, TN. FILED 11-9-2005.



FOR COMPUTER CONSULTING SERVICES, NAMELY, IMPLEMENTATION AND CONFIGURATION OF COMPUTER HARDWARE AND SOFTWARE AND MAINTENANCE OF COMPUTER SOFTWARE FOR USE IN MANAGING INFORMATION RELATED TO HOSPITAL AND PATIENT ADMINISTRATION (U.S. CLS. 100 AND 101).

SHANNON TWOHIG, EXAMINING ATTORNEY

**CLASS 42—(Continued).**

SN 78-752,290. DEUTSCHE TELEKOM AG, BONN, FED REP GERMANY, FILED 11-11-2005.



PRIORITY CLAIMED UNDER SEC. 44(D) ON FED REP GERMANY APPLICATION NO. 305284681, FILED 5-12-2005, REG. NO. 30528468. DATED 8-26-2005, EXPIRES 5-31-2015.

NO CLAIM IS MADE TO THE EXCLUSIVE RIGHT TO USE "WEB", APART FROM THE MARK AS SHOWN.

THE COLOR(S) GRAY AND MAGENTA AND WHITE IS/ARE CLAIMED AS A FEATURE OF THE MARK.

THE MARK CONSISTS OF THE WORDING WEB'N' WALK WITH WEB AND WALK IN GREY AND "N" IN WHITE SET AGAINST A MAGENTA SQUARE. TWO MAGENTA-COLORED CURVED ARCS ARE ROTATING AROUND THE WORDS.

FOR COMPUTER PROGRAMMING SERVICES FOR OTHERS; RENTAL OF COMPUTER SOFTWARE AND HARDWARE FOR ONLINE ACCESS; DATA ENCRYPTION SERVICES; APPLICATION SERVICE PROVIDER, NAMELY, HOSTING COMPUTER SOFTWARE APPLICATIONS FOR OTHERS, HOSTING OF DIGITAL CONTENT ON THE INTERNET; HOSTING THE WEBSITES OF OTHERS ON A COMPUTER SERVER FOR A GLOBAL COMPUTER NETWORK; COMPUTER SERVICES, NAMELY, CREATING INDEXES OF INFORMATION AVAILABLE ON COMPUTER NETWORKS; CONSULTING SERVICES IN THE FIELD OF DESIGN, SELECTION, IMPLEMENTATION AND USE OF COMPUTER HARDWARE AND SOFTWARE SYSTEMS FOR OTHERS; TECHNICAL PROJECT PLANNING SERVICES RELATED TO TELECOMMUNICATIONS EQUIPMENT; PROVIDING TEMPORARY USE OF ONLINE NON-DOWNLOADABLE TELECOMMUNICATIONS SOFTWARE FOR PROVIDING MULTIPLE USER ACCESS TO THE GLOBAL COMPUTER NETWORK (U.S. CLS. 100 AND 101).

DEZMONA MIZELLE, EXAMINING ATTORNEY

SN 78-769,811. MORK, TRACY, P., FREDERICKSBURG, VA. FILED 12-8-2005.



NO CLAIM IS MADE TO THE EXCLUSIVE RIGHT TO USE DESIGN, APART FROM THE MARK AS SHOWN.

THE COLOR(S) RED, GOLD, GREEN, TAN, AND BLACK IS/ARE CLAIMED AS A FEATURE OF THE MARK.

THE MARK CONSISTS OF MORK DESIGN, IS THE COMPANY NAME, THE INK IS BLACK AND THE FONT USED IS GILL SAN-BOLD FOR MORK AND GIL SANS-REGULAR FOR DESIGN. THE GRAPHIC ELEMENT ABOVE THE WORD "DESIGN" HAS THREE SLANTING LINES, THE FIRST IS IN RED, THE SECOND IS IN TAN AND THE THIRD IS IN GREEN. THE TEXT UNDER "MORK DESIGN" IS, "IMAGINE THE POSSIBILITIES. WE DO.", THE INK IS RED AND THE FONT IS COCHIN-REGULAR. THE MARK IS USED AS ONE PIECE OF ART, COMBINING THE GRAPHIC ELEMENT ON TOP WITH THE COMPANY NAME AND THE COMPANY SLOGAN.

FOR GRAPHIC DESIGN SERVICES (U.S. CLS. 100 AND 101).

FIRST USE 1-1-1999; IN COMMERCE 6-1-2005.  
KELLY BOULTON, EXAMINING ATTORNEY

**CLASS 42—(Continued).**

SN 78-776,221. HEALTHCARE PERFORMANCE CONSULTING, INC., GREEN COVE SPRINGS, FL. FILED 12-19-2005.

## Planned Change Assessment

THE MARK CONSISTS OF STANDARD CHARACTERS WITHOUT CLAIM TO ANY PARTICULAR FONT, STYLE, SIZE, OR COLOR.

NO CLAIM IS MADE TO THE EXCLUSIVE RIGHT TO USE ASSESSMENT, APART FROM THE MARK AS SHOWN.

FOR PROVIDING MEASUREMENT EVALUATIONS IN THE OUTCOMES OF MEDICAL EDUCATION FOR OTHERS (U.S. CLS. 100 AND 101).

FIRST USE 12-12-2005; IN COMMERCE 12-12-2005.  
ODESSA BIBBINS, EXAMINING ATTORNEY

SN 78-800,084. SIGNATURES NETWORK, INC., SAN FRANCISCO, CA. FILED 1-26-2006.

# FANPOWER

THE MARK CONSISTS OF STANDARD CHARACTERS WITHOUT CLAIM TO ANY PARTICULAR FONT, STYLE, SIZE, OR COLOR.

FOR DEVELOPMENT, MAINTENANCE AND HOSTING OF WEBSITES FOR THIRD PARTIES, NAMELY, DEVELOPMENT, MAINTENANCE, AND HOSTING OF ENTERTAINER-AUTHORIZED WEBSITES AND FAN APPRECIATION WEBSITES THAT INCLUDE THE TRANSMISSION OF ENTERTAINER-RELATED NEWS AND INFORMATION, AS WELL AS THE SALE OF FAN CLUB MEMBERSHIPS, CONCERT TICKETS AND TICKET PACKAGES, AND ENTERTAINER-RELATED MERCHANDISE AND MEMORABILIA; DEVELOPING, HOSTING AND OPERATING WEBSITES FOR THIRD PARTIES, NAMELY, DEVELOPING, HOSTING AND OPERATING ENTERTAINER-AUTHORIZED WEBSITES AND FAN APPRECIATION WEBSITES ON A COMPUTER SERVER ON A GLOBAL NETWORK (U.S. CLS. 100 AND 101).

ROBERT LAVACHE, EXAMINING ATTORNEY

**CLASS 42—(Continued).**

SN 78-810,338. MACDIARMID INSTITUTE FOR GLOBAL RESEARCH EXCELLENCE, WILMINGTON, DE. FILED 2-8-2006.

MACDIARMID INSTITUTE FOR  
GLOBAL RESEARCH EXCELLENCE

THE MARK CONSISTS OF STANDARD CHARACTERS WITHOUT CLAIM TO ANY PARTICULAR FONT, STYLE, SIZE, OR COLOR.

NO CLAIM IS MADE TO THE EXCLUSIVE RIGHT TO USE "INSTITUTE FOR GLOBAL RESEARCH", APART FROM THE MARK AS SHOWN.

FOR SCIENTIFIC CONSULTING AND RESEARCH SERVICES FEATURING THE EXCHANGE OF SCIENTIFIC INFORMATION AMONG SCIENTIFIC INSTITUTES AND SCIENTISTS (U.S. CLS. 100 AND 101).

DANNEAN HETZEL, EXAMINING ATTORNEY

---

SN 78-829,814. RESUN LEASING, INCORPORATED, DULLES, VA. FILED 3-6-2006.

**EXBUILD**

THE MARK CONSISTS OF STANDARD CHARACTERS WITHOUT CLAIM TO ANY PARTICULAR FONT, STYLE, SIZE, OR COLOR.

FOR DESIGN FOR OTHERS IN THE FIELD OF ENGINEERING; DESIGN/PLANNING AND ENGINEERING OF MODULAR UNITS; NAMELY, MODULAR BUILDINGS AND OFFICES; ENGINEERING (U.S. CLS. 100 AND 101).

CHARISMA HAMPTON, EXAMINING ATTORNEY

**CLASS 42—(Continued).**

SN 78-852,040. ENVIROIRRIGATION ENGINEERING INC., GUELPH, ONTARIO, CANADA, FILED 4-1-2006.

**ENVIROIRRIGATION**

THE MARK CONSISTS OF STANDARD CHARACTERS WITHOUT CLAIM TO ANY PARTICULAR FONT, STYLE, SIZE, OR COLOR.

PRIORITY CLAIMED UNDER SEC. 44(D) ON CANADA APPLICATION NO. 1274367, FILED 10-3-2005, REG. NO. TMA678,652, DATED 12-20-2006, EXPIRES 12-20-2021.

FOR CONSULTING SERVICES DIRECTED TO THE LANDSCAPE INDUSTRY TO EVALUATE AND MANAGE EFFICIENT WATER USE FOR EXISTING AND NEW IRRIGATION SYSTEMS, INCLUDING ALTERNATIVE WATER SOURCES, WATER DEMAND MANAGEMENT, AND WATER REDUCTION AND WATER REUSAGE STRATEGIES; WATER EFFICIENCY USE SERVICES THROUGH IRRIGATION SYSTEM ASSESSMENTS, WATER AUDITING AND WATER MONITORING OF RESIDENTIAL, COMMERCIAL AND GOLF IRRIGATION SYSTEMS; AND PROFESSIONAL ENGINEERING SERVICES BY PROVIDING DESIGNS, SPECIFICATIONS, CONSTRUCTION ADMINISTRATION AND COMMISSIONING FOR INTEGRATED RAINWATER AND IRRIGATION SYSTEMS (U.S. CLS. 100 AND 101).

PATRICIA EVANKO, EXAMINING ATTORNEY

---

SN 78-852,987. CLEAN SYSTEMS LLC, PORTLAND, OR. FILED 4-3-2006.

**Clean Systems**

THE MARK CONSISTS OF STANDARD CHARACTERS WITHOUT CLAIM TO ANY PARTICULAR FONT, STYLE, SIZE, OR COLOR.

NO CLAIM IS MADE TO THE EXCLUSIVE RIGHT TO USE "SYSTEMS", APART FROM THE MARK AS SHOWN.

FOR TECHNICAL SUPPORT SERVICES, NAMELY, TROUBLESHOOTING OF COMPUTER HARDWARE AND SOFTWARE PROBLEMS (U.S. CLS. 100 AND 101).

FIRST USE 11-1-2005; IN COMMERCE 11-1-2005.  
ASMAT KHAN, EXAMINING ATTORNEY

**CLASS 42—(Continued).**

SN 78-857,515. CLEARTRIAL, LLC, BURR RIDGE, IL. FILED 4-10-2006.

**ADVANCED VISIBILITY TO  
YOUR CLINICAL TRIALS**

THE MARK CONSISTS OF STANDARD CHARACTERS WITHOUT CLAIM TO ANY PARTICULAR FONT, STYLE, SIZE, OR COLOR.

FOR COMPUTER SERVICES, NAMELY, APPLICATION SERVICE PROVIDER (ASP) FEATURING SOFTWARE FOR PLANNING AND OPERATIONS MANAGEMENT IN THE FIELD OF CLINICAL TRIALS (U.S. CLS. 100 AND 101).

FIRST USE 1-1-2006; IN COMMERCE 1-1-2006.

DEIRDRE ROBERTSON, EXAMINING ATTORNEY

SN 78-858,627. PIEPER, KENNETH, C., EVERGREEN, CO. FILED 4-11-2006.

*When an Extraordinary Design Counts*

THE MARK CONSISTS OF THE PHRASE "WHEN AN EXTRAORDINARY DESIGN COUNTS" IN STANDARD FONT OVIDIUS IN THE COLOR BLACK.

FOR ARCHITECTURAL DESIGN (U.S. CLS. 100 AND 101).

FIRST USE 1-1-2000; IN COMMERCE 1-1-2000.

DAVID TAYLOR, EXAMINING ATTORNEY

**CLASS 42—(Continued).**

SN 78-864,044. SOUTHERN INSURANCE UNDERWRITER'S INC., ALPHARETTA, GA. FILED 4-18-2006.



NO CLAIM IS MADE TO THE EXCLUSIVE RIGHT TO USE "HIGH DENSITY HOSTING, INC", APART FROM THE MARK AS SHOWN.

THE COLOR(S) BLUE IS/ARE CLAIMED AS A FEATURE OF THE MARK.

THE COLOR BLUE APPEARS IN THE WORDING AND THE DESIGN.

FOR APPLICATION SERVICE PROVIDER (ASP), NAMELY, HOSTING COMPUTER SOFTWARE APPLICATIONS OF OTHERS; COMPUTER SERVICE, NAMELY, ACTING AS AN APPLICATION SERVICE PROVIDER IN THE FIELD OF KNOWLEDGE MANAGEMENT TO HOST COMPUTER APPLICATION SOFTWARE FOR CREATING SEARCHABLE DATABASES OF INFORMATION AND DATA; COMPUTER SERVICE, NAMELY, ACTING AS AN APPLICATION SERVICE PROVIDER IN THE FIELD OF KNOWLEDGE MANAGEMENT TO HOST COMPUTER APPLICATION SOFTWARE FOR SEARCHING AND RETRIEVING INFORMATION FROM DATABASES AND COMPUTER NETWORKS; COMPUTER SERVICE, NAMELY, ACTING AS AN APPLICATION SERVICE PROVIDER IN THE FIELD OF KNOWLEDGE MANAGEMENT TO HOST COMPUTER APPLICATION SOFTWARE FOR THE COLLECTION, EDITING, ORGANIZING, MODIFYING, BOOK MARKING, TRANSMISSION, STORAGE AND SHARING OF DATA AND INFORMATION; DESIGN, CREATION, HOSTING AND MAINTENANCE OF INTERNET SITES FOR THIRD PARTIES; DESIGN, CREATION, HOSTING, MAINTENANCE OF WEBSITES FOR OTHERS; HOSTING OF DIGITAL CONTENT ON THE INTERNET; HOSTING THE WEB SITES OF OTHERS ON A COMPUTER SERVER FOR A GLOBAL COMPUTER NETWORK (U.S. CLS. 100 AND 101).

FIRST USE 3-1-2006; IN COMMERCE 3-1-2006.

KRISTINA KLOIBER, EXAMINING ATTORNEY

SN 78-870,312. INTERTHINX, INC., SACRAMENTO, CA. FILED 4-26-2006.

# PredProtect

THE MARK CONSISTS OF STANDARD CHARACTERS WITHOUT CLAIM TO ANY PARTICULAR FONT, STYLE, SIZE, OR COLOR.

FOR COMPUTER SOFTWARE, NAMELY, PROVIDING TEMPORARY USE OF NON-DOWNLOADABLE SOFTWARE AVAILABLE OVER A GLOBAL COMMUNICATIONS NETWORK FOR USE BY RESIDENTIAL MORTGAGE LOAN ORIGINATORS IN LOAN ORIGINATION QUALITY CONTROL TO ENSURE COMPLIANCE WITH A VARIETY OF FEDERAL, STATE AND LOCAL MORTGAGE LENDING LAWS, RULES AND REGULATIONS ON A LOAN-LEVEL BASIS (U.S. CLS. 100 AND 101).

FIRST USE 1-0-2003; IN COMMERCE 1-0-2003.

BRENDAN MCCAULEY, EXAMINING ATTORNEY

**CLASS 42—(Continued).**

SN 78-882,259. 20/20 FORESIGHT, INC., GRAND RAPIDS, MN. FILED 5-12-2006.

# SystemEyes

THE MARK CONSISTS OF STANDARD CHARACTERS WITHOUT CLAIM TO ANY PARTICULAR FONT, STYLE, SIZE, OR COLOR.

FOR PROVIDING TEMPORARY USE OF NON-DOWNLOADABLE SOFTWARE FOR WEB-BASED REPORTING OF KEY PERFORMANCE INDICATORS (U.S. CLS. 100 AND 101).

PAUL E. FAHRENKOPF, EXAMINING ATTORNEY

SN 78-901,403. EQUITITLE, LLC, VIENNA, VA. FILED 6-6-2006.

# EquiTitle

THE MARK CONSISTS OF STANDARD CHARACTERS WITHOUT CLAIM TO ANY PARTICULAR FONT, STYLE, SIZE, OR COLOR.

FOR REAL ESTATE CLOSING SERVICES, AND REAL ESTATE SETTLEMENT SERVICES (U.S. CLS. 100 AND 101).

FIRST USE 1-29-1998; IN COMMERCE 4-10-1998.  
JOHN SCHUYLER YARD, EXAMINING ATTORNEY

SN 78-906,807. PHEASANTS FOREVER, INC., ST. PAUL, MN. FILED 6-13-2006.

# HABITAT FOREVER

THE MARK CONSISTS OF STANDARD CHARACTERS WITHOUT CLAIM TO ANY PARTICULAR FONT, STYLE, SIZE, OR COLOR.

OWNER OF U.S. REG. NOS. 1,362,717, 1,616,257 AND 3,038,465.

NO CLAIM IS MADE TO THE EXCLUSIVE RIGHT TO USE "HABITAT", APART FROM THE MARK AS SHOWN.

FOR LAND MANAGEMENT, NAMELY, LAND USE PLANNING SERVICES REGARDING THE USE OF PRESERVATION EASEMENTS; CONSULTING IN THE FIELD OF LAND CONSERVATION OF AGRICULTURAL AND NATURAL LAND FOR WILDLIFE HABITAT (U.S. CLS. 100 AND 101).

ANDREW RHIM, EXAMINING ATTORNEY

**CLASS 42—(Continued).**

SN 78-910,131. BRIDGER CONWAY Y ASOCIADOS S.C., BUENOS AIRES, ARGENTINA, FILED 6-16-2006.

# BRIDGER | CONWAY

FOR GRAPHIC DESIGN SERVICES (U.S. CLS. 100 AND 101).

BENJAMIN OKEKE, EXAMINING ATTORNEY

SN 78-912,619. ISO PROPERTIES, INC., WILMINGTON, DE. FILED 6-20-2006.

# ISOPAX

THE MARK CONSISTS OF STANDARD CHARACTERS WITHOUT CLAIM TO ANY PARTICULAR FONT, STYLE, SIZE, OR COLOR.

OWNER OF U.S. REG. NOS. 2,662,173 AND 2,673,902.  
FOR COMPUTER SERVICES, NAMELY, PROVIDING NON-DOWNLOADABLE COMPUTER SOFTWARE, ACCESSIBLE AND USABLE OVER A GLOBAL INFORMATION NETWORK, FOR OUTSOURCING INSURANCE PREMIUM AUDITS AND FOR LINKING USERS OF INSURANCE PREMIUM AUDIT SERVICES TO HIGH-QUALITY VENDORS (U.S. CLS. 100 AND 101).

FIRST USE 12-1-1998; IN COMMERCE 12-1-1998.  
SCOTT BIBB, EXAMINING ATTORNEY

SN 78-918,938. PEDIATRIX MEDICAL GROUP, INC., SUNRISE, FL. FILED 6-28-2006.

# SoundGene)))

THE COLOR(S) DARK BLUE, LIGHT BLUE AND GREEN IS/ARE CLAIMED AS A FEATURE OF THE MARK.

THE TERM SOUND IS DARK BLUE. THE TERM GENE IS GREEN. THE SOUND WAVES ARE LIGHT BLUE.

FOR LABORATORY RESEARCH IN THE FIELD OF EARLY DETECTION AND INTERVENTION FOR PRE-LINGUAL HEARING LOSS (U.S. CLS. 100 AND 101).

MICHAEL KEATING, EXAMINING ATTORNEY

**CLASS 42—(Continued).**

SN 78-924,360. WASHINGTON & ERNSTER, HOUSTON, TX.  
FILED 7-7-2006.

In the fight for justice,

W●E

never rest.

THE MARK CONSISTS OF COMBINATION OF WORDS IN THE FIGHT FOR JUSTICE, WE NEVER REST WHEREIN THE WORD "WE" COMPRISES THE LETTERS "W" AND "E" WITH A TILTED SQUARE GEOMETRIC SHAPE THEREBETWEEN.

FOR LEGAL SERVICES (U.S. CLS. 100 AND 101).  
FIRST USE 6-1-2006; IN COMMERCE 6-1-2006.  
TARAH HARDY, EXAMINING ATTORNEY

**CLASS 42—(Continued).**

SN 78-937,353. ELECTRIC POWER RESEARCH INSTITUTE, INC., PALO ALTO, CA. FILED 7-25-2006.

Prices to Devices

THE MARK CONSISTS OF STANDARD CHARACTERS WITHOUT CLAIM TO ANY PARTICULAR FONT, STYLE, SIZE, OR COLOR.

FOR RESEARCH AND DEVELOPMENT AND CONSULTATION RELATED THERETO IN THE FIELD OF ENERGY COSTS AND EFFICIENCY OF ELECTRICITY-CONSUMING DEVICES AND TECHNOLOGY (U.S. CLS. 100 AND 101).

FIRST USE 7-20-2006; IN COMMERCE 7-20-2006.  
JOHN WILKE, EXAMINING ATTORNEY

SN 78-927,651. BLOODGOOD GROUP, INC., THE, WEST DES MOINES, IA. FILED 7-12-2006.

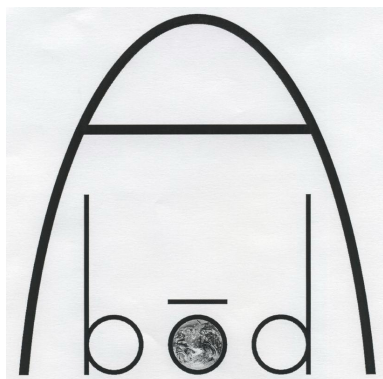

THE MARK CONSISTS OF A STYLIZED "A" WITH THE LETTERS "BOD" UNDER THE CROSS BAR OF THE "A". THERE IS A LINE OVER THE LETTER "O". THE INSIDE OF THE LETTER "O" CONTAINS A SATELLITE PHOTOGRAPH OF EARTH.

FOR ARCHITECTURAL DESIGN, LANDSCAPE ARCHITECTURAL DESIGN AND LAND USE PLANNING SERVICES (U.S. CLS. 100 AND 101).

STEVEN JACKSON, EXAMINING ATTORNEY

SN 78-943,101. CROWSEY, BILL, DALLAS, TX. FILED 8-2-2006.

TEC VAULT

THE MARK CONSISTS OF STANDARD CHARACTERS WITHOUT CLAIM TO ANY PARTICULAR FONT, STYLE, SIZE, OR COLOR.

FOR INFORMATION TECHNOLOGY SERVICES IN THE NATURE OF TECHNICAL SUPPORT, NAMELY, PROVIDING BACK-UP COMPUTER PROGRAMS (U.S. CLS. 100 AND 101).

DAVID TAYLOR, EXAMINING ATTORNEY

SN 78-944,280. VOKE MEDIA, LLC, JACKSON, WY. FILED 7-28-2006.

voke

THE MARK CONSISTS OF STANDARD CHARACTERS WITHOUT CLAIM TO ANY PARTICULAR FONT, STYLE, SIZE, OR COLOR.

FOR INFORMATION, ADVISORY AND CONSULTANCY SERVICES RELATING TO TECHNOLOGY (U.S. CLS. 100 AND 101).

RON FAIRBANKS, EXAMINING ATTORNEY

**CLASS 42—(Continued).**

SN 78-946,134. WEALTH2K, INC., HINGHAM, MA. FILED 8-7-2006.

# Compliance2K

THE MARK CONSISTS OF STANDARD CHARACTERS WITHOUT CLAIM TO ANY PARTICULAR FONT, STYLE, SIZE, OR COLOR.

FOR TECHNOLOGY CONSULTATION IN THE FIELD OF FINANCIAL SERVICES SALES PRACTICES AND COMPLIANCE (U.S. CLS. 100 AND 101).

FIRST USE 6-1-2005; IN COMMERCE 6-1-2005.  
SHARI SHEFFIELD, EXAMINING ATTORNEY

**CLASS 42—(Continued).**

SN 78-948,694. DZYN WERKES LLC, WATERFORD, MI. FILED 8-9-2006.



**DZYN WERKES**

NO CLAIM IS MADE TO THE EXCLUSIVE RIGHT TO USE "DESIGN" AND "WERKES", APART FROM THE MARK AS SHOWN.

THE MARK CONSISTS OF SPECIFICALLY DESIGNED LETTER 'D' WITH A LINE BETWEEN, THEN A SPECIFICALLY DESIGNED 'W' WITH THE COMPANY NAME SPELLED DZYN WERKES UNDERNEATH.

FOR INDUSTRIAL DESIGN; PRODUCT DEVELOPMENT (U.S. CLS. 100 AND 101).  
TAMARA LEE, EXAMINING ATTORNEY

SN 78-954,376. THEUEGROUP, LLC, SAN JOSE, CA. FILED 8-17-2006.

## DESIGN FOR HUMANS RESULTS FOR BUSINESS

THE MARK CONSISTS OF STANDARD CHARACTERS WITHOUT CLAIM TO ANY PARTICULAR FONT, STYLE, SIZE, OR COLOR.

FOR PACKAGING DESIGN SERVICES FOR OTHERS; COMPUTER NETWORK DESIGN FOR OTHERS, NAMELY, COMPUTER USER INTERFACE DESIGN SERVICES; COMPUTER SERVICES, NAMELY CREATING, MAINTAINING AND IMPLEMENTING WEB SITES FOR OTHERS; RESEARCH AND DEVELOPMENT OF NEW PRODUCTS FOR OTHERS; PRINT AND GRAPHIC DESIGN; COMPUTER SERVICES, NAMELY CREATING WEBSITES FOR OTHERS; COMPUTER SOFTWARE DESIGN AND DEVELOPMENT; CONSULTING SERVICES IN THE FIELD OF DESIGN, SELECTION, IMPLEMENTATION, AND USE OF COMPUTER HARDWARE AND SOFTWARE SYSTEMS FOR OTHERS, NAMELY, EXTRANET AND INTRANET COMPUTER USER INTERFACE DESIGN CONSULTING SERVICES RELATING TO THE CREATION, DESIGN, DEVELOPMENT AND IMPLEMENTATION OF WEBSITES AND INTERACTIVE COMPUTER DATABASES; DESIGN FOR OTHERS IN THE FIELD OF COMPUTER NETWORKS AND SOFTWARE, NAMELY, CUSTOM SOFTWARE AND USER INTERFACE DESIGN SERVICES FOR OTHERS; GRAPHIC DESIGN SERVICES FOR OTHERS; PACKAGING DESIGN AND PRODUCT DESIGN FOR OTHERS; COMPUTER SOFTWARE SYSTEMS DESIGN SERVICES UTILIZING HISTORICAL CONTEXT INFORMATION TO IMPROVE THE EFFICIENCY AND EFFECTIVENESS OF PROCESSES AND SYSTEMS; CONSULTING SER-

SN 78-948,296. ADVENTNET, INC., PLEASANTON, CA. FILED 8-9-2006.

# ZOHO

THE MARK CONSISTS OF STANDARD CHARACTERS WITHOUT CLAIM TO ANY PARTICULAR FONT, STYLE, SIZE, OR COLOR.

FOR PROVIDING TEMPORARY USE OF ON-LINE NON-DOWNLOADABLE SOFTWARE FOR WORDPROCESSING, SPREADSHEETS, CALENDAR, E-MAILING, INSTANT MESSAGING, GROUP WARE, DOCUMENT SHARING, ORGANIZER, MANAGING DATA, CUSTOMER RELATIONSHIP MANAGEMENT, ONLINE POLLING, AND TO EDIT, CREATE, PUBLISH AND DESIGN PRESENTATIONS (U.S. CLS. 100 AND 101).

FIRST USE 1-26-2005; IN COMMERCE 8-15-2005.  
IRENE D. WILLIAMS, EXAMINING ATTORNEY



**CLASS 42—(Continued).**

VICES IN THE FIELD OF DESIGN, SELECTION, IMPLEMENTATION, AND USE OF COMPUTER HARDWARE AND SOFTWARE SYSTEMS FOR OTHERS, NAMELY, COMPUTER CONSULTING SERVICES FOR IMPROVING USER EXPERIENCE FOR CONTEXT-AWARE AND LOCATION-AWARE COMPUTING SYSTEMS FOR MOBILE COMPUTERS AND COMMUNICATIONS DEVICES TO IMPROVE THE USER EXPERIENCE THROUGH INCORPORATION OF LOCATION, IDENTITY, ROLE, ENVIRONMENT, SPEED, DIRECTION, HABITS, TIME OF DAY, AND ACTIVITIES OF THE USER; COMPUTER SOFTWARE MAINTENANCE SERVICES; DESIGN AND TESTING OF NEW COMPUTER SOFTWARE USER INTERFACES FOR OTHERS; TESTING OF THE EASE OF THE USE OF THE COMPUTER SOFTWARE PRODUCTS OF OTHERS; PRODUCT RESEARCH AND DEVELOPMENT, NAMELY, THE DEVELOPMENT OF COMPUTER USER RESEARCH METHODS, COMPUTER USABILITY INSPECTION METHODS, AND COMPUTER END USER TESTING METHODS (U.S. CLS. 100 AND 101).

FIRST USE 8-2-2003; IN COMMERCE 8-2-2003.  
LINDSEY RUBIN, EXAMINING ATTORNEY

---

SN 78-957,976. PURINTON, ANTHONY, OCEANSIDE, CA. FILED 8-22-2006.

# AIR-TITE

THE MARK CONSISTS OF STANDARD CHARACTERS WITHOUT CLAIM TO ANY PARTICULAR FONT, STYLE, SIZE, OR COLOR.

FOR TESTING, ANALYSIS AND EVALUATION OF THE GOODS AND SERVICES OF OTHERS FOR THE PURPOSE OF CERTIFICATION (U.S. CLS. 100 AND 101).  
FIRST USE 3-1-2006; IN COMMERCE 5-24-2006.  
EMILY CHUO, EXAMINING ATTORNEY

---

SN 78-958,472. RUTTER HOBBS & DAVIDOFF INCORPORATED, LOS ANGELES, CA. FILED 8-23-2006.

# NEED A DIRECT RESPONSE LAWYER WHO RESPONDS DIRECTLY?

THE MARK CONSISTS OF STANDARD CHARACTERS WITHOUT CLAIM TO ANY PARTICULAR FONT, STYLE, SIZE, OR COLOR.

FOR LEGAL SERVICES (U.S. CLS. 100 AND 101).  
FIRST USE 8-11-2006; IN COMMERCE 8-11-2006.  
MICHAEL LITZAU, EXAMINING ATTORNEY

**CLASS 42—(Continued).**

SN 78-959,997. PROVENTURE CONSULTING, INC., REDONDO BEACH, CA. FILED 8-24-2006.

# provenSuite

THE MARK CONSISTS OF STANDARD CHARACTERS WITHOUT CLAIM TO ANY PARTICULAR FONT, STYLE, SIZE, OR COLOR.

FOR COMPUTER SOFTWARE DESIGN, COMPUTER PROGRAMMING, OR MAINTENANCE OF COMPUTER SOFTWARE (U.S. CLS. 100 AND 101).  
MEGAN WHITNEY, EXAMINING ATTORNEY

---

SN 78-960,797. UNBORN MEDIA, INC., BOSTON, MA. FILED 8-25-2006.

# VIRB

THE MARK CONSISTS OF STANDARD CHARACTERS WITHOUT CLAIM TO ANY PARTICULAR FONT, STYLE, SIZE, OR COLOR.

FOR COMPUTER SERVICES IN THE NATURE OF CUSTOMIZED WEB PAGES FEATURING USER-DEFINED INFORMATION, PERSONAL PROFILES AND INFORMATION; COMPUTER SERVICES, NAMELY, HOSTING ONLINE WEB FACILITIES FOR OTHERS FOR ORGANIZING AND CONDUCTING ONLINE MEETINGS, GATHERINGS, AND INTERACTIVE DISCUSSIONS (U.S. CLS. 100 AND 101).  
TIMOTHY FINNEGAN, EXAMINING ATTORNEY

---

SN 78-960,853. OCELOT SOLUTIONS, INC., MANHATTAN BEACH, CA. FILED 8-25-2006.

# TechForward

THE MARK CONSISTS OF STANDARD CHARACTERS WITHOUT CLAIM TO ANY PARTICULAR FONT, STYLE, SIZE, OR COLOR.

FOR LEASING OF COMPUTERS (U.S. CLS. 100 AND 101).  
PETER B. BROMAGHIM, EXAMINING ATTORNEY

**CLASS 42—(Continued).**

SN 78-960,886. LNH, INC., DBA HOSTMYSITE.COM, NEWARK, DE. FILED 8-25-2006.



THE MARK CONSISTS OF A STYLIZED H FOLLOWED BY THE WORDS HOSTMYSITE.COM.

FOR APPLICATION SERVICE PROVIDER (ASP), NAMELY, HOSTING COMPUTER SOFTWARE APPLICATIONS OF OTHERS; HOSTING OF DIGITAL CONTENT ON THE INTERNET; HOSTING THE WEB SITES OF OTHERS ON A COMPUTER SERVER FOR A GLOBAL COMPUTER NETWORK; PROVIDING ONLINE NON-DOWNLOADABLE SOFTWARE FOR WEBSITE DESIGN, WEBSITE CREATION, WEBSITE MANAGEMENT, MESSAGING, COLLABORATION AND DOCUMENT MANAGEMENT; WEB SITE HOSTING SERVICES (U.S. CLS. 100 AND 101).

FIRST USE 8-12-1998; IN COMMERCE 8-12-1998.  
CHARLES L. JENKINS, EXAMINING ATTORNEY

SN 78-961,062. MICHEL ET MERE, INC., DBA MONT BLANC GOURMET, DENVER, CO. FILED 8-25-2006.



NO CLAIM IS MADE TO THE EXCLUSIVE RIGHT TO USE "BEVERAGE SOLUTIONS", APART FROM THE MARK AS SHOWN.

THE MARK CONSISTS OF A DOG WEARING A COAT AND GLASSES AND CARRYING A FLASK, AND THE WORDS "THE CHOCOLATE LAB BEVERAGE SOLUTIONS COFFEE'S BEST FRIEND".

FOR RESEARCH AND DEVELOPMENT FOR NEW PRODUCTS FOR OTHERS (U.S. CLS. 100 AND 101).

FIRST USE 4-30-2006; IN COMMERCE 4-30-2006.  
SHAILA SETTLES, EXAMINING ATTORNEY

**CLASS 42—(Continued).**

SN 78-961,272. BERRIMAN, JAMES, BOSTON, MA. FILED 8-27-2006.

# EVIDOX

THE MARK CONSISTS OF STANDARD CHARACTERS WITHOUT CLAIM TO ANY PARTICULAR FONT, STYLE, SIZE, OR COLOR.

FOR ATTORNEY SERVICES; CONSULTING AND LEGAL SERVICES IN THE FIELD OF PRIVACY AND SECURITY LAWS, REGULATIONS, AND REQUIREMENTS; CONSULTING SERVICES CONCERNING LEGAL MATTERS IN THE MEDICAL FIELD; COPYRIGHT MANAGEMENT; COPYRIGHT MANAGEMENT CONSULTATION; INTELLECTUAL PROPERTY CONSULTATION; JURY CONSULTANCY; LEGAL DOCUMENT PREPARATION AND RESEARCH SERVICES FOR ATTORNEYS; LEGAL RESEARCH; LEGAL SERVICES; LEGAL SERVICES, NAMELY, PROCESS SERVING; LICENSING OF INTELLECTUAL PROPERTY; LITIGATION CONSULTANCY; LITIGATION SUPPORT SERVICES; MEDIATION; NOTARY PUBLIC SERVICES; PARALEGAL SERVICES; PATENT AGENCY AND INDUSTRIAL PROPERTY CONSULTATION; PATENT LICENSING; PREPARING AND FILING INCORPORATION PAPERS; PREPARING AND ORGANIZING LOAN CLOSING DOCUMENTS; PROVIDING INFORMATION RELATING TO LEGAL AFFAIRS; RETRIEVING PUBLIC DOCUMENTS; TITLE SEARCHING; TRADEMARK WATCH SERVICES (U.S. CLS. 100 AND 101).

SHARON MEIER, EXAMINING ATTORNEY

SN 78-962,041. BERRIMAN, JAMES, BOSTON, MA. FILED 8-28-2006.



THE MARK CONSISTS OF A RECTANGULAR SHAPE WITHIN WHICH IS THE WORD EVIDOX WITH A DOT IN THE CENTER OF THE "O".

FOR ATTORNEY SERVICES; CONSULTING AND LEGAL SERVICES IN THE FIELD OF PRIVACY AND SECURITY LAWS, REGULATIONS, AND REQUIREMENTS; CONSULTING SERVICES CONCERNING LEGAL MATTERS IN THE MEDICAL FIELD; COPYRIGHT MANAGEMENT; COPYRIGHT MANAGEMENT CONSULTATION; INTELLECTUAL PROPERTY CONSULTATION; JURY CONSULTANCY; LEGAL DOCUMENT PREPARATION AND RESEARCH SERVICES FOR ATTORNEYS; LEGAL RESEARCH; LEGAL SERVICES; LEGAL SERVICES, NAMELY, PROCESS SERVING; LICENSING OF INTELLECTUAL PROPERTY; LITIGATION CONSULTANCY; LITIGATION SUPPORT SERVICES; MEDIATION; NOTARY PUBLIC SERVICES; PARALEGAL SERVICES; PATENT AGENCY AND INDUSTRIAL PROPERTY CONSULTATION; PATENT LICENSING; PREPARING AND FILING INCORPORATION PAPERS; PREPARING AND ORGANIZING LOAN CLOSING DOCUMENTS; PROVIDING INFORMATION RELATING TO LEGAL AFFAIRS; RETRIEVING PUBLIC DOCUMENTS; TITLE SEARCHING; TRADEMARK WATCH SERVICES (U.S. CLS. 100 AND 101).

SHARON MEIER, EXAMINING ATTORNEY

**CLASS 42—(Continued).**

SN 78-962,612. LAW OFFICES OF SAM BERNSTEIN, FARM-  
INGTON HILLS, MI. FILED 8-29-2006.

**CLASS 42—(Continued).**

SN 78-963,706. AOL LLC, DULLES, VA. FILED 8-30-2006.

# DYNASIZER

## BERNSTEIN ADVANTAGE

THE MARK CONSISTS OF STANDARD CHARACTERS  
WITHOUT CLAIM TO ANY PARTICULAR FONT, STYLE,  
SIZE, OR COLOR.  
FOR LEGAL SERVICES (U.S. CLS. 100 AND 101).  
FIRST USE 2-1-2005; IN COMMERCE 2-1-2005.  
BENJAMIN OKEKE, EXAMINING ATTORNEY

THE MARK CONSISTS OF STANDARD CHARACTERS  
WITHOUT CLAIM TO ANY PARTICULAR FONT, STYLE,  
SIZE, OR COLOR.

FOR PROVIDING A WIDE RANGE OF INFORMA-  
TION IN THE FIELDS OF COMPUTER TECHNOLOGY  
AND OTHER TECHNOLOGY VIA COMPUTER NET-  
WORKS; COMPUTER VIRUS PROTECTION SERVICES;  
COMPUTER SECURITY SERVICES, NAMELY, RE-  
STRICTING ACCESS TO AND BY COMPUTER NET-  
WORKS TO AND OF UNDESIRED WEBSITES, MEDIA,  
INDIVIDUALS, AND FACILITIES; APPLICATION SER-  
VICE PROVIDER FEATURING SOFTWARE FOR THE  
DETECTION AND REMOVAL OF COMPUTER VIRUSES  
AND THREATS, PROTECTING AND SECURING COM-  
PUTER NETWORKS AND APPLICATIONS, AND DE-  
TECTING AND REPAIRING COMPUTER SOFTWARE  
AND HARDWARE PROBLEMS; PROVIDING INFORMA-  
TION IN THE FIELDS OF NETWORK, DATA, AND  
COMPUTER SECURITY; APPLICATION SERVICE PRO-  
VIDER (ASP) FEATURING SOFTWARE FOR SYNCHRO-  
NIZING, BROWSING, AND TRACKING WEB DATA ON  
A HANDHELD DEVICE AND GLOBAL COMPUTER  
NETWORK; COMPUTER SERVICES, NAMELY, A FEAT-  
URE OF ONLINE COMPUTER SERVICES THAT AL-  
LWS USERS TO MODIFY AND ADJUST BROWSER  
WINDOWS AND THAT ALLOWS ENHANCED DRAG-  
AND-DROP BROWSER FUNCTIONALITY (U.S. CLS. 100  
AND 101).

TRAVIS WHEATLEY, EXAMINING ATTORNEY

SN 78-962,822. METAMORPHIX, INC., BELTSVILLE, MD.  
FILED 8-29-2006.

SN 78-964,270. RIATA ENERGY, INC., OKLAHOMA CITY,  
OK. FILED 8-30-2006.

# PawPrint

## SANDRIDGE ENERGY

THE MARK CONSISTS OF STANDARD CHARACTERS  
WITHOUT CLAIM TO ANY PARTICULAR FONT, STYLE,  
SIZE, OR COLOR.  
FOR ANALYSIS OF ANIMAL DNA TO IDENTIFY  
ANIMALS AND ESTABLISH SPECIES, BREED, AND  
PEDIGREE (U.S. CLS. 100 AND 101).  
PAUL CROWLEY, EXAMINING ATTORNEY

THE MARK CONSISTS OF STANDARD CHARACTERS  
WITHOUT CLAIM TO ANY PARTICULAR FONT, STYLE,  
SIZE, OR COLOR.

NO CLAIM IS MADE TO THE EXCLUSIVE RIGHT TO  
USE "ENERGY", APART FROM THE MARK AS SHOWN.  
FOR EXPLORATION AND SEARCHING OF OIL AND  
GAS (U.S. CLS. 100 AND 101).  
JIM RINGLE, EXAMINING ATTORNEY

**CLASS 42—(Continued).**

SN 78-964,684. GOTTLIEB, RACKMAN & REISMAN, P.C.,  
NEW YORK, NY. FILED 8-31-2006.

GOTTLIEB, RACKMAN & REISMAN

THE MARK CONSISTS OF STANDARD CHARACTERS  
WITHOUT CLAIM TO ANY PARTICULAR FONT, STYLE,  
SIZE, OR COLOR.

FOR LEGAL SERVICES (U.S. CLS. 100 AND 101).  
FIRST USE 0-0-1970; IN COMMERCE 0-0-1970.  
JOHN GARTNER, EXAMINING ATTORNEY

SN 78-964,714. CHESSON & SCHWEICKERT LLC, MIL-  
FORD, CT. FILED 8-31-2006.

# Get the rent

THE MARK CONSISTS OF STANDARD CHARACTERS  
WITHOUT CLAIM TO ANY PARTICULAR FONT, STYLE,  
SIZE, OR COLOR.

FOR LEGAL SERVICES (U.S. CLS. 100 AND 101).  
KARANENDRA S. CHHINA, EXAMINING ATTORNEY

SN 78-964,728. CHESSON & SCHWEICKERT LLC, MIL-  
FORD, CT. FILED 8-31-2006.

# Get the rent or get them out.

THE MARK CONSISTS OF STANDARD CHARACTERS  
WITHOUT CLAIM TO ANY PARTICULAR FONT, STYLE,  
SIZE, OR COLOR.

FOR LEGAL SERVICES (U.S. CLS. 100 AND 101).  
KARANENDRA S. CHHINA, EXAMINING ATTORNEY

**CLASS 42—(Continued).**

SN 78-965,202. NATIONAL ASSOCIATION OF COUNTY  
AND CITY HEALTH OFFICIALS, WASHINGTON, DC.  
FILED 8-31-2006.



THE COLOR(S) TAN AND BLUE AND WHITE IS/ARE  
CLAIMED AS A FEATURE OF THE MARK.

THE COLOR BLUE APPEARS IN THE OUTLINES OF THE  
SHIELD AND THE CROSS; THE COLOR TAN APPEARS  
WITHIN THE SHIELD; THE COLOR WHITE APPEARS  
WITHIN THE CROSS.

THE MARK CONSISTS OF A THREE-SIDED TAN  
SHIELD WITH A BLUE BORDER ENCLOSING A WHITE  
STYLIZED CROSS OR TREE FORM WITH A BLUE BOR-  
DER.

FOR CONSUMER PRODUCT SAFETY TESTING AND  
CONSULTATION; FOOD SAFETY TESTING AND CON-  
SULTATION (U.S. CLS. 100 AND 101).  
DAVID MURRAY, EXAMINING ATTORNEY

SN 78-965,398. CDH ENTERPRISES, LLC, RIVER VALE, NJ.  
FILED 8-31-2006.

# YouBuildIt!

THE MARK CONSISTS OF STANDARD CHARACTERS  
WITHOUT CLAIM TO ANY PARTICULAR FONT, STYLE,  
SIZE, OR COLOR.

FOR DESIGN OF HOME PAGES, COMPUTER SOFT-  
WARE AND WEB SITES; PROVIDING TEMPORARY  
USE OF ON-LINE NON-DOWNLOADABLE SOFTWARE  
FOR WEBSITE CREATION (U.S. CLS. 100 AND 101).

ATTIYA MALIK, EXAMINING ATTORNEY

**CLASS 42—(Continued).**

SN 78-965,569. PRECYDENT LLC, JAMUL, CA. FILED 8-31-2006.

**PRECYDENT**

THE MARK CONSISTS OF STANDARD CHARACTERS WITHOUT CLAIM TO ANY PARTICULAR FONT, STYLE, SIZE, OR COLOR.

FOR COMPUTER SERVICE, NAMELY, ACTING AS AN APPLICATION SERVICE PROVIDER IN THE FIELD OF KNOWLEDGE MANAGEMENT TO HOST COMPUTER APPLICATION SOFTWARE FOR SEARCHING AND RETRIEVING INFORMATION FROM DATABASES AND COMPUTER NETWORKS (U.S. CLS. 100 AND 101).

IRA J. GOODSaid, EXAMINING ATTORNEY

**CLASS 42—(Continued).**

SN 78-966,120. DEI HEADQUARTERS, INC., VISTA, CA. FILED 9-1-2006.

**DIRECTECHS.COM**

THE MARK CONSISTS OF STANDARD CHARACTERS WITHOUT CLAIM TO ANY PARTICULAR FONT, STYLE, SIZE, OR COLOR.

FOR TECHNICAL SUPPORT SERVICES, NAMELY PROVIDING ON-LINE TECHNICAL SUPPORT AND WIRING DIAGRAMS RELATED TO INSTALLATION OF CONSUMER ELECTRONICS PRODUCTS (U.S. CLS. 100 AND 101).

FIRST USE 5-24-2000; IN COMMERCE 5-24-2000.  
JOHN WILKE, EXAMINING ATTORNEY

SN 78-965,720. BENCHMARK LIFE SCIENCES, INC., PRAIRIE VILLAGE, KS. FILED 9-1-2006.

**BENCHMARK LIFE SCIENCES**

THE MARK CONSISTS OF STANDARD CHARACTERS WITHOUT CLAIM TO ANY PARTICULAR FONT, STYLE, SIZE, OR COLOR.

NO CLAIM IS MADE TO THE EXCLUSIVE RIGHT TO USE LIFE SCIENCES, APART FROM THE MARK AS SHOWN.

FOR RESEARCH AND DEVELOPMENT IN THE LIFE SCIENCES AND BIOTECH AREA, PRIMARILY FOR ANIMAL HEALTH (U.S. CLS. 100 AND 101).

DOMINIC FATHY, EXAMINING ATTORNEY

SN 78-966,277. FRANCIS DRILLING FLUIDS, LTD., CROWLEY, LA. FILED 9-1-2006.

**FRANCIS DRILLING FLUIDS**

THE MARK CONSISTS OF STANDARD CHARACTERS WITHOUT CLAIM TO ANY PARTICULAR FONT, STYLE, SIZE, OR COLOR.

NO CLAIM IS MADE TO THE EXCLUSIVE RIGHT TO USE "DRILLING FLUIDS", APART FROM THE MARK AS SHOWN.

FOR DESIGN FOR OTHERS IN THE FIELD OF DRILLING FLUID SYSTEMS, ENGINEERING; TECHNOLOGY CONSULTATION AND RESEARCH IN THE FIELD OF DRILLING FLUID SYSTEMS; AND TECHNOLOGY CONSULTATION IN THE FIELD OF DRILLING FLUID SYSTEMS (U.S. CLS. 100 AND 101).

HEATHER THOMPSON, EXAMINING ATTORNEY

SN 78-966,098. GEE WHIZ LABS, INC., SAN FRANCISCO, CA. FILED 9-1-2006.

**KEEPANDSHARE**

THE MARK CONSISTS OF STANDARD CHARACTERS WITHOUT CLAIM TO ANY PARTICULAR FONT, STYLE, SIZE, OR COLOR.

FOR NON-DOWNLOADABLE WEB-BASED COMPUTER SOFTWARE FOR CONTROLLING ACCESS RIGHTS AND FOR CREATING, STORING AND SHARING USER INFORMATION (U.S. CLS. 100 AND 101).

FIRST USE 8-0-2005; IN COMMERCE 8-0-2005.  
SCOTT SISUN, EXAMINING ATTORNEY

SN 78-966,341. SITE9, INC., PORTLAND, OR. FILED 9-1-2006.

**Site9**

THE MARK CONSISTS OF STANDARD CHARACTERS WITHOUT CLAIM TO ANY PARTICULAR FONT, STYLE, SIZE, OR COLOR.

FOR DESIGN, CREATION, HOSTING, AND MAINTENANCE OF WEBSITES FOR OTHERS (U.S. CLS. 100 AND 101).

FIRST USE 1-25-2001; IN COMMERCE 1-25-2001.  
MIDGE BUTLER, EXAMINING ATTORNEY

**CLASS 42—(Continued).**

SN 78-966,497. NFSN, LLC, HOUSTON, TX. FILED 9-2-2006.

## NearlyFreeSpeech

THE MARK CONSISTS OF STANDARD CHARACTERS WITHOUT CLAIM TO ANY PARTICULAR FONT, STYLE, SIZE, OR COLOR.

FOR HOSTING OF DIGITAL CONTENT ON THE INTERNET (U.S. CLS. 100 AND 101).

FIRST USE 1-18-2002; IN COMMERCE 1-18-2002.  
MARTHA FROMM, EXAMINING ATTORNEY

---

SN 78-966,598. HONINGFORD, JASON M, CAPE CORAL, FL.  
FILED 9-3-2006.

## PortVista

THE MARK CONSISTS OF STANDARD CHARACTERS WITHOUT CLAIM TO ANY PARTICULAR FONT, STYLE, SIZE, OR COLOR.

FOR COMPUTER SOFTWARE DESIGN, COMPUTER PROGRAMMING, OR MAINTENANCE OF COMPUTER SOFTWARE; DESIGN, CREATION, HOSTING, MAINTENANCE OF WEBSITES FOR OTHERS (U.S. CLS. 100 AND 101).

ESTHER A. BORSUK, EXAMINING ATTORNEY

---

SN 78-967,399. BIO-REFERENCE LABORATORIES, INC.,  
ELMWOOD PARK, NJ. FILED 9-5-2006.

## GENPAP

THE MARK CONSISTS OF STANDARD CHARACTERS WITHOUT CLAIM TO ANY PARTICULAR FONT, STYLE, SIZE, OR COLOR.

FOR MEDICAL LABORATORY SERVICES, NAMELY, PROVIDING WOMEN'S MEDICAL LABORATORY TEST RESULTS ANALYSIS AND EVALUATION FOR THE HEALTH CARE AND HEALTH CARE INSURANCE INDUSTRIES (U.S. CLS. 100 AND 101).

SOPHIA S. KIM, EXAMINING ATTORNEY

**CLASS 42—(Continued).**

SN 78-968,004. OBUNWIRED, SAN DIEGO, CA. FILED 9-6-2006.

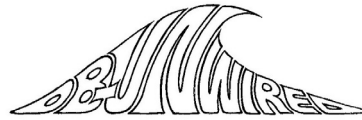

THE MARK CONSISTS OF THE LETTERS OB-UNWIRED STYLIZED TO FORM A WAVE.

FOR DESIGN, DEVELOPMENT AND IMPLEMENTATION OF SOFTWARE (U.S. CLS. 100 AND 101).

JENNIFER WILLISTON, EXAMINING ATTORNEY

---

SN 78-968,640. GEONAMIC SYSTEMS, INC., DULUTH, GA.  
FILED 9-7-2006.

## Geonamic

THE MARK CONSISTS OF STANDARD CHARACTERS WITHOUT CLAIM TO ANY PARTICULAR FONT, STYLE, SIZE, OR COLOR.

FOR COMPUTER SERVICES RELATING TO MAPPING AND GEOGRAPHIC INFORMATION, NAMELY, COMPUTER SOFTWARE CONSULTATION SERVICES AND COMPUTER SOFTWARE PROGRAMMING FOR OTHERS (U.S. CLS. 100 AND 101).

DAVID H. STINE, EXAMINING ATTORNEY

---

SN 78-968,884. SPONGEFISH, INC., SAN FRANCISCO, CA.  
FILED 9-7-2006.

## What You Know

THE MARK CONSISTS OF STANDARD CHARACTERS WITHOUT CLAIM TO ANY PARTICULAR FONT, STYLE, SIZE, OR COLOR.

FOR HOSTING OF DIGITAL CONTENT ON THE INTERNET; PROVIDING SPECIFIC INFORMATION AS REQUESTED BY CUSTOMERS VIA THE INTERNET (U.S. CLS. 100 AND 101).

TRAVIS WHEATLEY, EXAMINING ATTORNEY

**CLASS 42—(Continued).**

SN 78-969,268. GILBERT SYSTEMS, NEW YORK, NY. FILED 9-7-2006.

# PROCLIVITY

THE MARK CONSISTS OF STANDARD CHARACTERS WITHOUT CLAIM TO ANY PARTICULAR FONT, STYLE, SIZE, OR COLOR.

FOR APPLICATION SERVICE PROVIDER (ASP) FEATURING SOFTWARE FOR USE IN DATABASE MANAGEMENT, FOR USE AS A SPREADSHEET, AND FOR WORD PROCESSING IN THE FIELD OF MARKETING (U.S. CLS. 100 AND 101).

H. M. FISHER, EXAMINING ATTORNEY

**CLASS 42—(Continued).**

SN 78-969,566. INDYBUDGET LLC, SAN ANTONIO, TX. FILED 9-7-2006.

# INDYBUDGET

THE MARK CONSISTS OF STANDARD CHARACTERS WITHOUT CLAIM TO ANY PARTICULAR FONT, STYLE, SIZE, OR COLOR.

FOR APPLICATION SERVICE PROVIDER (ASP) FEATURING SOFTWARE FOR USE IN DOCUMENTING, TRACKING AND FORECASTING OF PERSONAL FINANCIAL ACCOUNTS AND ACTIVITY (U.S. CLS. 100 AND 101).

ANDREA EVANS, EXAMINING ATTORNEY

SN 78-969,486. ATTORNEY CONSULTANT, INC., CLEVELAND, OH. FILED 9-7-2006.

# Dedicated to helping the disabled

THE MARK CONSISTS OF STANDARD CHARACTERS WITHOUT CLAIM TO ANY PARTICULAR FONT, STYLE, SIZE, OR COLOR.

FOR LEGAL SERVICES (U.S. CLS. 100 AND 101).  
MIDGE BUTLER, EXAMINING ATTORNEY

SN 78-970,244. AKQA, INC., SAN FRANCISCO, CA. FILED 9-8-2006.

# AKQA

THE MARK CONSISTS OF STANDARD CHARACTERS WITHOUT CLAIM TO ANY PARTICULAR FONT, STYLE, SIZE, OR COLOR.

FOR DESIGN, CREATION, AND MAINTENANCE OF WEBSITES FOR OTHERS; WEBSITE HOSTING SERVICES; AND COMPUTER SOFTWARE DESIGN IN THE FIELD OF ONLINE MARKETING AND ADVERTISING (U.S. CLS. 100 AND 101).

FIRST USE 6-8-2001; IN COMMERCE 6-8-2001.  
CHRISTOPHER BUONGIORNO, EXAMINING ATTORNEY

SN 78-969,515. INTERNET TRUCKSTOP, LLC, NEW PLYMOUTH, ID. FILED 9-7-2006.

# RATEMATE

THE MARK CONSISTS OF STANDARD CHARACTERS WITHOUT CLAIM TO ANY PARTICULAR FONT, STYLE, SIZE, OR COLOR.

FOR PROVIDING TEMPORARY USE OF ON-LINE, NON-DOWNLOADABLE SOFTWARE FOR USE IN FORMULATING COMPETITIVE FREIGHT-HAULING RATES AND IMPROVING THE PROFITABILITY OF HAULING FREIGHT (U.S. CLS. 100 AND 101).

FIRST USE 9-5-2006; IN COMMERCE 9-5-2006.  
MIDGE BUTLER, EXAMINING ATTORNEY

SN 78-970,343. TRINITY INDUSTRIES, INC., DALLAS, TX. FILED 9-8-2006.

# BUILDING TOMORROW'S HIGHWAY SAFETY SOLUTIONS TODAY

THE MARK CONSISTS OF STANDARD CHARACTERS WITHOUT CLAIM TO ANY PARTICULAR FONT, STYLE, SIZE, OR COLOR.

FOR RESEARCH, DESIGN, ENGINEERING AND DEVELOPMENT IN THE FIELD OF METAL FABRICATION AND HIGHWAY SAFETY DEVICES (U.S. CLS. 100 AND 101).

FIRST USE 5-9-2005; IN COMMERCE 5-9-2005.  
ALICE SUE CARRUTHERS, EXAMINING ATTORNEY

**CLASS 42—(Continued).**

SN 78-970,494. AOL LLC, DULLES, VA. FILED 9-8-2006.

**PEOPLESPLACE**

THE MARK CONSISTS OF STANDARD CHARACTERS WITHOUT CLAIM TO ANY PARTICULAR FONT, STYLE, SIZE, OR COLOR.

OWNER OF U.S. REG. NO. 2,386,795.

FOR COMPUTER SERVICES, NAMELY, PROVIDING SUBSCRIBERS ONLINE WEB SITE DEVELOPMENT SOFTWARE FOR CREATING PERSONAL WEB PAGES; COMPUTER SERVICES, NAMELY, PROVIDING SEARCH ENGINES FOR OBTAINING DATA ON COMPUTER NETWORKS; HOSTING THE WEB SITES OF OTHERS ON A COMPUTER SERVER FOR A GLOBAL COMPUTER NETWORK; PROVIDING A WIDE RANGE OF INFORMATION IN THE FIELDS OF COMPUTERS AND TECHNOLOGY, VIA COMPUTER NETWORKS; COMPUTER VIRUS PROTECTION SERVICES; COMPUTER SECURITY SERVICES, NAMELY, RESTRICTING ACCESS TO AND BY COMPUTER NETWORKS TO AND OF UNDESIREED WEBSITES, MEDIA, INDIVIDUALS, AND FACILITIES; APPLICATION SERVICE PROVIDER FEATURING SOFTWARE FOR THE DETECTION AND REMOVAL OF COMPUTER VIRUSES AND THREATS, PROTECTING AND SECURING COMPUTER NETWORKS AND APPLICATIONS, AND DETECTING AND REPAIRING COMPUTER SOFTWARE AND HARDWARE PROBLEMS; PROVIDING INFORMATION IN THE FIELDS OF NETWORK, DATA, AND COMPUTER SECURITY; APPLICATION SERVICE PROVIDER (ASP) FEATURING SOFTWARE FOR SYNCHRONIZING, BROWSING, AND TRACKING WEB DATA ON A HANDHELD DEVICE AND GLOBAL COMPUTER NETWORK (U.S. CLS. 100 AND 101).

ALICE SUE CARRUTHERS, EXAMINING ATTORNEY

**CLASS 42—(Continued).**

SN 78-971,857. COOPER, KEVIN D., CLEVELAND, OH. FILED 9-11-2006.

**LIFEDERMNET**

THE MARK CONSISTS OF STANDARD CHARACTERS WITHOUT CLAIM TO ANY PARTICULAR FONT, STYLE, SIZE, OR COLOR.

FOR MEDICAL AND SCIENTIFIC RESEARCH IN THE FIELD OF DERMATOLOGY (U.S. CLS. 100 AND 101).

ERNEST SHOSHO, EXAMINING ATTORNEY

SN 78-972,015. COBASYS LLC, ORION, MI. FILED 9-12-2006.

SN 78-970,671. SMITH, MICHAEL J., WESTWOOD, NJ. FILED 9-8-2006.

**THE FIRST NAME IN ADVANCED  
ENERGY STORAGE SYSTEM  
SOLUTIONS**

FOR GRAPHIC DESIGN SERVICES GRAPHIC ART DESIGN (U.S. CLS. 100 AND 101).  
MICHAEL WEBSTER, EXAMINING ATTORNEY

THE MARK CONSISTS OF STANDARD CHARACTERS WITHOUT CLAIM TO ANY PARTICULAR FONT, STYLE, SIZE, OR COLOR.

OWNER OF U.S. REG. NO. 3,054,565.

NO CLAIM IS MADE TO THE EXCLUSIVE RIGHT TO USE "ENERGY STORAGE SYSTEM", APART FROM THE MARK AS SHOWN.

FOR RESEARCH AND DEVELOPMENT SERVICES FEATURING MATERIALS, CHEMICALS, PRODUCTS AND PROCESSES FOR THE PRODUCTION, OPERATION AND DISTRIBUTION OF BATTERIES, BATTERY SYSTEMS AND BATTERY PACKS TO END USERS, RETAILERS, INTERMEDIATES, WHOLESALERS AND ORIGINAL EQUIPMENT MANUFACTURERS (U.S. CLS. 100 AND 101).

FIRST USE 9-12-2006; IN COMMERCE 9-12-2006.

SUSAN STIGLITZ, EXAMINING ATTORNEY



**CLASS 42—(Continued).**

SN 78-972,300. BLUELOCK, LLC, WESTFIELD, IN. FILED 9-12-2006.

# BLUELOCK

THE MARK CONSISTS OF STANDARD CHARACTERS WITHOUT CLAIM TO ANY PARTICULAR FONT, STYLE, SIZE, OR COLOR.

FOR APPLICATION SERVICE PROVIDER (ASP), NAMELY, HOSTING COMPUTER SOFTWARE APPLICATIONS OF OTHERS; COMPUTER NETWORK DESIGN FOR OTHERS; CONSULTATION SERVICES IN THE FIELDS OF SELECTION, IMPLEMENTATION AND USE OF COMPUTER HARDWARE AND SOFTWARE SYSTEMS FOR OTHERS; HOSTING THE WEB SITES OF OTHERS ON A COMPUTER SERVER FOR A GLOBAL COMPUTER NETWORK; INFORMATION TECHNOLOGY CONSULTATION; INTEGRATION OF COMPUTER SYSTEMS AND NETWORKS; RENTING OUT HARDWARE AND SOFTWARE; TECHNICAL SUPPORT SERVICES, NAMELY, TROUBLESHOOTING OF COMPUTER HARDWARE AND SOFTWARE PROBLEMS; TECHNICAL SUPPORT, NAMELY, MONITORING OF NETWORK SYSTEMS (U.S. CLS. 100 AND 101).  
KHANH LE, EXAMINING ATTORNEY

SN 78-972,574. SPILOTRO, MARK A., GEORGETOWN, TX. FILED 9-12-2006.

# WE'RE ALL BUSINESS

THE MARK CONSISTS OF STANDARD CHARACTERS WITHOUT CLAIM TO ANY PARTICULAR FONT, STYLE, SIZE, OR COLOR.

FOR COMPUTER SERVICES, NAMELY DESIGNING, DEVELOPING, IMPLEMENTING, INSTALLING, MAINTAINING, UPGRADING, AND CONFIGURING COMPUTER SOFTWARE FOR OTHERS, AND CONSULTING RELATED THERETO; PROVIDING TEMPORARY USE OF ONLINE NON-DOWNLOADABLE SOFTWARE FOR ORGANIZING, MANAGING, STORING, TRACKING, INSTANT MESSAGING, ELECTRONIC STORE-AND-FORWARD MESSAGING, MULTIMEDIA MESSAGING, WEB MESSAGING, WIRELESS DIGITAL MESSAGING, PRESENCE MANAGEMENT, ANALYZING AND CREATING REPORTS ON INFORMATION RELATED TO RELATIONSHIP MANAGEMENT, SUPPLY CHAIN MANAGEMENT, ENTERPRISE RESOURCE PLANNING, WIRELESS CARRIER CONNECTION, VOICE OVER INTERNET PROTOCOL, CALL CENTER INTEGRATION, SALES, PROMOTION AND MARKETING; PROVIDING TECHNICAL SUPPORT, NAMELY, TROUBLESHOOTING SOFTWARE PROBLEMS; PRO-

**CLASS 42—(Continued).**

VIDING ONLINE INFORMATION REGARDING COMPUTER SOFTWARE, NAMELY OPTIMAL USE OF AND TECHNICAL INFORMATION ON COMPUTER SOFTWARE FOR ORGANIZING, MANAGING, STORING, TRACKING, INSTANT MESSAGING, ELECTRONIC STORE-AND-FORWARD MESSAGING, MULTIMEDIA MESSAGING, WEB MESSAGING, WIRELESS DIGITAL MESSAGING, PRESENCE MANAGEMENT, ANALYZING AND CREATING REPORTS ON INFORMATION RELATED TO RELATIONSHIP MANAGEMENT, SUPPLY CHAIN MANAGEMENT, ENTERPRISE RESOURCE PLANNING, WIRELESS CARRIER CONNECTION, VOICE OVER INTERNET PROTOCOL, CALL CENTER INTEGRATION, SALES, PROMOTION AND MARKETING; PROVIDING ONLINE INFORMATION REGARDING COMPUTER SERVICES, NAMELY OPTIMAL USE OF AND TECHNICAL INFORMATION ON DESIGNING, DEVELOPING, IMPLEMENTING, INSTALLING, MAINTAINING, UPGRADING, AND CONFIGURING COMPUTER SOFTWARE FOR OTHERS, AND CONSULTING RELATED THERETO (U.S. CLS. 100 AND 101).

JOHN WILKE, EXAMINING ATTORNEY

SN 79-016,507. AGARE S.R.L., ITALY, FILED 8-28-2005.



PRIORITY DATE OF 7-27-2005 IS CLAIMED.  
OWNER OF INTERNATIONAL REGISTRATION 0865398 DATED 8-28-2005, EXPIRES 8-28-2015.

NO CLAIM IS MADE TO THE EXCLUSIVE RIGHT TO USE "TECH", APART FROM THE MARK AS SHOWN.

THE COLOR(S) LIGHT GREY, DARK GREY AND RED IS/ARE CLAIMED AS A FEATURE OF THE MARK.

THE MARK CONSISTS OF THE WORDING TECH GAP WRITTEN IN DARK GREY FANCIFUL CHARACTERS HAVING A THIN RED UNDERLINE; ABOVE THIS WORDING THERE IS SOME RED AND LIGHT GREY CURVILINEAR ELEMENTS.

FOR SCIENTIFIC AND TECHNOLOGICAL SERVICES, NAMELY SCIENTIFIC RESEARCH AND DESIGN SERVICES IN THE FIELD OF COMPUTER SOFTWARE AND HARDWARE ARCHITECTURE; DESIGN AND DEVELOPMENT OF COMPUTER HARDWARE AND SOFTWARE (U.S. CLS. 100 AND 101).

STACY WAHLBERG, EXAMINING ATTORNEY

SN 79-024,702. ANDROME N.V., BELGIUM, FILED 3-15-2006.

# INTELLIVIC

THE MARK CONSISTS OF STANDARD CHARACTERS WITHOUT CLAIM TO ANY PARTICULAR FONT, STYLE, SIZE, OR COLOR.

PRIORITY DATE OF 9-23-2005 IS CLAIMED.  
OWNER OF INTERNATIONAL REGISTRATION 0887151 DATED 3-15-2006, EXPIRES 3-15-2016.

FOR DESIGN AND DEVELOPMENT OF COMPUTER HARDWARE AND SOFTWARE FOR OTHERS, FOR AUDIO CONFERENCES AND VIDEO CONFERENCES (U.S. CLS. 100 AND 101).

ANDREA K. NADELMAN, EXAMINING ATTORNEY

**CLASS 43—HOTEL AND RESTAURANT SERVICES**

SN 76-630,502. DREAM DINNERS, INC., SNOHOMISH, WA. FILED 2-7-2005.



NO CLAIM IS MADE TO THE EXCLUSIVE RIGHT TO USE "DINNERS", APART FROM THE MARK AS SHOWN.

THE COLOR(S) RED, GREEN AND GRAY IS/ARE CLAIMED AS A FEATURE OF THE MARK.

THE MARK IS COMPRISED OF THE STYLIZED WORDS DREAM DINNERS IN PANTONE 180 - TERRACOTTA RED; A DESIGN OF A DOVE IN PANTONE 583 - GREEN; WING IN PANTONE 624 - BLUE; AND A FORK IN PANTONE 583 - GREEN. THE BEAK OF THE DOVE TOUCHES THE UPRIGHT FORK.

THE MARK CONSISTS OF A DESIGN OF A DOVE IN THE COLOR GREEN WITH THE UPPER WING OF THE DOVE APPEARING IN THE COLOR GRAY. THE DINNER FORK IS SHOWN IN THE COLOR GREEN. THE BEAK OF THE DOVE TOUCHES THE UPRIGHT DINNER FORK IN THE COLOR GREEN. THE WORDS DREAM DINNERS IS IN THE COLOR RED.

FOR PERSONALIZED MENU AND FOOD PREPARATION AND FOOD CATERING FOR THE GENERAL PUBLIC (U.S. CLS. 100 AND 101).

KATHERINE CONNOLLY, EXAMINING ATTORNEY

SN 76-652,939. JAW RESTAURANT MANAGEMENT, LLC, DBA THE COUNTER, SANTA MONICA, CA. FILED 1-4-2006.

**THE COUNTER BURGER**

THE MARK CONSISTS OF STANDARD CHARACTERS WITHOUT CLAIM TO ANY PARTICULAR FONT, STYLE, SIZE, OR COLOR.

NO CLAIM IS MADE TO THE EXCLUSIVE RIGHT TO USE BURGER, APART FROM THE MARK AS SHOWN.

FOR RESTAURANT SERVICES NOT FEATURING VEGETARIAN CUISINE (U.S. CLS. 100 AND 101).

JAMES STEIN, EXAMINING ATTORNEY

**CLASS 43—(Continued).**

SN 76-663,900. KIM, JE SEEK, LOS ANGELES, CA. FILED 8-1-2006.



NO CLAIM IS MADE TO THE EXCLUSIVE RIGHT TO USE "BOBA" AND "COFFEE & SMOOTHIE", APART FROM THE MARK AS SHOWN.

THE COLOR(S) RED, BLUE, WHITE AND BLACK IS/ARE CLAIMED AS A FEATURE OF THE MARK.

THE COLOR RED APPEARS IN THE DESIGN OF A HEART AND THE BACKGROUND OF THE RECTANGLE UNDER THE WORD BOBA; THE COLOR BLUE APPEARS IN THE WORDS "I" AND "BOBA"; THE COLOR WHITE APPEARS IN THE WORDS "COFFEE & SMOOTHIE" AND THE COLOR BLACK IN THE OUTER RECTANGULAR BORDER DESIGN".

THE MARK CONSISTS OF: A LETTER "I" WITH A SHAPE OF A HEART FOLLOWED BY A WORD "BOBA"; "COFFEE & SMOOTHIE" APPEAR UNDERNEATH.

FOR RESTAURANT SERVICES, FEATURING BEVERAGES, SOFT DRINKS, AND CONFECTIONS (U.S. CLS. 100 AND 101).

FIRST USE 11-1-2001; IN COMMERCE 11-1-2001.

HENRY S. ZAK, EXAMINING ATTORNEY

SN 76-664,632. MORSELS, L.P., AUSTIN, TX. FILED 8-15-2006.

# BESS

THE MARK CONSISTS OF STANDARD CHARACTERS WITHOUT CLAIM TO ANY PARTICULAR FONT, STYLE, SIZE, OR COLOR.

FOR RESTAURANT, BAR AND CATERING SERVICES (U.S. CLS. 100 AND 101).

FIRST USE 11-14-2006; IN COMMERCE 11-14-2006.

MARY CRAWFORD, EXAMINING ATTORNEY

SN 77-011,603. MADISON HOLDINGS, INC. SEATTLE, WA. FILED 10-2-2006.

# Sempai

THE MARK CONSISTS OF STANDARD CHARACTERS WITHOUT CLAIM TO ANY PARTICULAR FONT, STYLE, SIZE, OR COLOR.

THE FOREIGN WORDING IN THE MARK TRANSLATES INTO ENGLISH AS "SENIOR".

FOR RESTAURANTS (U.S. CLS. 100 AND 101).

HOWARD FRIEDMAN, EXAMINING ATTORNEY

**CLASS 43—(Continued).**

SN 77-042,055. LAUGHING GRAVY PARTNERS INC., HONOLULU, HI. FILED 11-12-2006.

**Caliente del Sol**

THE MARK CONSISTS OF STANDARD CHARACTERS WITHOUT CLAIM TO ANY PARTICULAR FONT, STYLE, SIZE, OR COLOR.

THE ENGLISH TRANSLATION OF CALIENTE DEL SOL IS "HEAT OF THE SUN" OR "WARMTH OF THE SUN".

FOR CAFE-RESTAURANTS; CARRY-OUT RESTAURANTS; DELICATESSENS; FAST FOOD AND NON-STOP RESTAURANT SERVICES; FAST-FOOD RESTAURANTS; FAST-FOOD RESTAURANTS AND SNACK-BARS; HOTEL, BAR AND RESTAURANT SERVICES; RESTAURANT AND BAR SERVICES; RESTAURANT SERVICES; RESTAURANTS; RESTAURANTS FEATURING HOME DELIVERY; SELF SERVICE RESTAURANTS; SELF-SERVICE RESTAURANTS; TAKE-OUT RESTAURANT SERVICES (U.S. CLS. 100 AND 101).

LAURA KOVALSKY, EXAMINING ATTORNEY

SN 77-064,012. MORRISON HOLDING COMPANY, LAS VEGAS, NV. FILED 12-14-2006.

**CARING FOR THE CAREGIVERS**

THE MARK CONSISTS OF STANDARD CHARACTERS WITHOUT CLAIM TO ANY PARTICULAR FONT, STYLE, SIZE, OR COLOR.

FOR CONTRACT FOOD SERVICES; PREPARATION OF FOOD AND BEVERAGES (U.S. CLS. 100 AND 101).

WON TEAK OH, EXAMINING ATTORNEY

SN 77-064,372. MORRISON HOLDING COMPANY, LAS VEGAS, NV. FILED 12-14-2006.

**DAILY SPICE**

THE MARK CONSISTS OF STANDARD CHARACTERS WITHOUT CLAIM TO ANY PARTICULAR FONT, STYLE, SIZE, OR COLOR.

FOR CONTRACT FOOD SERVICES AND FOOD PREPARATION SERVICES, ALL IN THE FIELD OF HEALTH CARE (U.S. CLS. 100 AND 101).

WON TEAK OH, EXAMINING ATTORNEY

**CLASS 43—(Continued).**

SN 77-066,956. MORRISON HOLDING COMPANY, LAS VEGAS, NV. FILED 12-19-2006.

**BERRY SMOOTH**

THE MARK CONSISTS OF STANDARD CHARACTERS WITHOUT CLAIM TO ANY PARTICULAR FONT, STYLE, SIZE, OR COLOR.

FOR RESTAURANT SERVICES FEATURING SMOOTHIES, JUICE DRINKS AND JUICE BASED BEVERAGES, FOR CONSUMPTION ON OR OFF THE PREMISES (U.S. CLS. 100 AND 101).

WON TEAK OH, EXAMINING ATTORNEY

SN 78-689,207. FUNARI'S ITALIAN CREAMERY, INC., JACKSONVILLE BEACH, FL. FILED 8-9-2005.

**WHAT FUN TASTES LIKE**

THE MARK CONSISTS OF STANDARD CHARACTERS WITHOUT CLAIM TO ANY PARTICULAR FONT, STYLE, SIZE, OR COLOR.

FOR RESTAURANT SERVICES (U.S. CLS. 100 AND 101).

FIRST USE 11-1-2004; IN COMMERCE 11-1-2004.  
EUGENIA MARTIN, EXAMINING ATTORNEY

SN 78-702,660. MAPCO EXPRESS, INC., FRANKLIN, TN. FILED 8-29-2005.

**GRILLE MARX**

THE MARK CONSISTS OF STANDARD CHARACTERS WITHOUT CLAIM TO ANY PARTICULAR FONT, STYLE, SIZE, OR COLOR.

NO CLAIM IS MADE TO THE EXCLUSIVE RIGHT TO USE "GRILLE", APART FROM THE MARK AS SHOWN.

FOR RESTAURANT SERVICES (U.S. CLS. 100 AND 101).

KATHLEEN M. VANSTON, EXAMINING ATTORNEY

**CLASS 43—(Continued).**

SN 78-707,143. SCHUMACHER PAINTING INC., YAKIMA, WA. FILED 9-6-2005.

SUPERSAVER-HOTELS.COM

THE MARK CONSISTS OF STANDARD CHARACTERS WITHOUT CLAIM TO ANY PARTICULAR FONT, STYLE, SIZE, OR COLOR.

SEC. 2(F).

FOR TRAVEL AGENCY SERVICES, NAMELY, MAKING RESERVATIONS AND BOOKING FOR TEMPORARY LODGING AT HOTELS VIA AN INTERNET WEBSITE (U.S. CLS. 100 AND 101).

FIRST USE 1-1-2002; IN COMMERCE 1-1-2002.  
MARCIE MILONE, EXAMINING ATTORNEY

SN 78-737,638. SIGNATURE CHEF COMPANY, LLC, GRAFTON, WI. FILED 10-20-2005.



NO CLAIM IS MADE TO THE EXCLUSIVE RIGHT TO USE "GRAFTON, WISCONSIN", APART FROM THE MARK AS SHOWN.

THE COLOR(S) BLUE, GOLD, BLACK AND WHITE IS/ARE CLAIMED AS A FEATURE OF THE MARK.

THE MARK CONSISTS OF A GOLD EAGLE OVER A GOLD GLOBE AT THE CREST OF A BLUE CIRCLE, WHICH IS ENCIRCLED BY A GOLD BAND FOLLOWED BY TWO BLACK BANDS NEAR THE OUTER EDGE OF THE BLUE CIRCLE. AT THE BOTTOM CENTER ARE THE WORDS, "GRAFTON, WISCONSIN" IN GOLD LETTERING, THROUGH THE MIDDLE OF THE BLUE CIRCLE, EXTENDING PAST THE EDGES OF THE CIRCLE IS THE "PARAMOUNT" NAME IN BLACK. A SMALL WHITE CIRCLE IN THE MIDDLE OF THE LARGER BLUE CIRCLE APPEARS IN WHITE.

FOR BAR AND RESTAURANT SERVICES (U.S. CLS. 100 AND 101).

FIRST USE 10-1-2005; IN COMMERCE 1-10-2006.  
MARIA-VICTORIA SUAREZ, EXAMINING ATTORNEY

**CLASS 43—(Continued).**

SN 78-744,451. ATLAS PARTNERS, LLC, ARLINGTON, WA. FILED 11-1-2005.

OVERWOOD

THE MARK CONSISTS OF STANDARD CHARACTERS WITHOUT CLAIM TO ANY PARTICULAR FONT, STYLE, SIZE, OR COLOR.

FOR CAFE-RESTAURANTS; CARRY-OUT RESTAURANTS; DELICATESSENS; FAST FOOD AND NON-STOP RESTAURANT SERVICES; SNACK BARS; HOTEL, BAR AND RESTAURANT SERVICES; PROVIDING ONLINE REVIEWS OF RESTAURANTS AND HOTELS; RESERVATION OF RESTAURANTS; RESTAURANTS FEATURING HOME DELIVERY; SELF SERVICE RESTAURANTS; TAKE-OUT RESTAURANT SERVICES (U.S. CLS. 100 AND 101).

FIRST USE 10-1-2005; IN COMMERCE 10-1-2005.  
BRIDGETT SMITH, EXAMINING ATTORNEY

SN 78-746,614. 1469 SOUTH PEARL STREET, LLC, BOULDER, CO. FILED 11-3-2005.

LOLA

THE MARK CONSISTS OF STANDARD CHARACTERS WITHOUT CLAIM TO ANY PARTICULAR FONT, STYLE, SIZE, OR COLOR.

FOR RESTAURANT SERVICES (U.S. CLS. 100 AND 101).

FIRST USE 8-20-2002; IN COMMERCE 8-20-2002.  
CHRISTOPHER BUONGIORNO, EXAMINING ATTORNEY

**CLASS 43—(Continued).**

SN 78-759,686. KOBEISSI INC, LONG BEACH, CA. FILED 11-22-2005.



NO CLAIM IS MADE TO THE EXCLUSIVE RIGHT TO USE MEDITERRANEAN GRILL AND AUTHENTIC LEBANESE CUISINE, APART FROM THE MARK AS SHOWN.

"THE COLOR(S) MUSTARD YELLOW (PMS 117), RED (PMS 180 OR PMS 1805), BROWN (PMS 732) AND WHITE IS/ARE CLAIMED AS A FEATURE OF THE MARK."

"THE MARK CONSISTS OF STYLIZED WORDS OPEN IN MUSTARD YELLOW AND SESAME IN RED AND MUSTARD YELLOW. THE STYLIZED S HAS TASSELS ON THE END AND CONSISTS OF TWO COLORS A RED OUTLINE AND A MUSTARD YELLOW INTERIOR. THE WORDING MEDITERRANEAN GRILL IS IN WHITE SURROUNDED BY A RECTANGULAR CARRIER IN THE COLOR BROWN. THE WORDING AUTHENTIC LEBANESE CUISINE IS IN BROWN."

FOR RESTAURANTS (U.S. CLS. 100 AND 101).  
FIRST USE 10-1-2005; IN COMMERCE 11-19-2005.  
SHARON MEIER, EXAMINING ATTORNEY

**CLASS 43—(Continued).**

SN 78-783,111. BISTRO FOODS, INC., NORCROSS, GA. FILED 12-30-2005.

# LE PETIT BISTRO

THE MARK CONSISTS OF STANDARD CHARACTERS WITHOUT CLAIM TO ANY PARTICULAR FONT, STYLE, SIZE, OR COLOR.

OWNER OF U.S. REG. NO. 1,935,146.

NO CLAIM IS MADE TO THE EXCLUSIVE RIGHT TO USE "BISTRO", APART FROM THE MARK AS SHOWN.

THE FOREIGN WORDING IN THE MARK TRANSLATES INTO ENGLISH AS THE SMALL BAR.

FOR RESTAURANTS (U.S. CLS. 100 AND 101).

FIRST USE 8-31-1992; IN COMMERCE 8-31-1992.

AMY ALFIERI, EXAMINING ATTORNEY

SN 78-789,396. FRESHWAY FOOD SYSTEMS, INC., SIOUX FALLS, SD. FILED 1-11-2006.



NO CLAIM IS MADE TO THE EXCLUSIVE RIGHT TO USE "CHICKEN & SPUDS", APART FROM THE MARK AS SHOWN.

THE COLOR(S) GRAY, BLACK, WHITE AND BROWN IS/ARE CLAIMED AS A FEATURE OF THE MARK.

THE COLOR BROWN APPEARS IN THE COMB OF THE STYLIZED CHICKEN AND IN THE FRONT OF THE FARMHOUSE. THE COLOR BLACK APPEARS IN THE OVAL SHAPED BORDER, THE PICKET FENCE, THE COUNTRY ROAD, THE OUTLINE OF THE STYLIZED CHICKEN, THE OUTLINE OF THE FARM HOUSE, THE SHADOW OF THE FARMHOUSE, IN THE FIVE STYLIZED CHICKENS, IN THE STYLIZED SUNRISE AND IN THE WORDING "EMILY'S CHICKEN & SPUDS". THE COLOR WHITE APPEARS IN THE BACKGROUND OF THE MARK, IN THE BODY AND HEAD OF THE CHICKEN, THE DESIGN OF A WINDOW ON THE FARMHOUSE, IN THE LAND SURROUNDING THE FARMHOUSE, IN THE SKY, AS A SHADOW ELEMENT IN THE WORDING "EMILY'S" AND IN THE FORM OF MISSHAPED DOTS IN THE BLACK OVAL BORDER. THE COLOR GRAY APPEARS IN THE BORDER OF THE SUNBEAMS OF THE SUNRISE AND IN THE FORM OF A SHADOW OF THE FIVE STYLIZED CHICKENS.

THE MARK CONSISTS OF A FARM SCENE CONTAINING A STYLIZED CHICKEN, A FARMHOUSE, A PICKET FENCE, A SUNRISE, FIVE SMALL-STYLIZED CHICKENS AND A COUNTRY ROAD ALL CENTERED IN A STYLIZED OVAL THAT CONTAINS THE TEXT "EMILY'S CHICKEN & SPUDS".

FOR RESTAURANT SERVICES (U.S. CLS. 100 AND 101).

SEAN CROWLEY, EXAMINING ATTORNEY

SN 78-782,997. MONTEX FINANCIAL SERVICES CORP., TORONTO, ONTARIO, CANADA, FILED 12-30-2005.

# GEOHOLIDAY

THE MARK CONSISTS OF STANDARD CHARACTERS WITHOUT CLAIM TO ANY PARTICULAR FONT, STYLE, SIZE, OR COLOR.

FOR PLANNING OF VACATIONS FOR INDIVIDUALS AND GROUPS, NAMELY, MAKING RESERVATIONS FOR TEMPORARY LODGING; THE PROVISION OF VACATION PREMISES, NAMELY, MAKING HOTEL AND LODGING RESERVATIONS FOR OTHERS (U.S. CLS. 100 AND 101).

FIRST USE 0-0-1991; IN COMMERCE 0-0-1991.  
SEAN CROWLEY, EXAMINING ATTORNEY

**CLASS 43—(Continued).**

SN 78-795,294. BISTRO FOODS, INC., NORCROSS, GA.  
FILED 1-19-2006.

**LE PETIT BISTRO EXPRESS**

THE MARK CONSISTS OF STANDARD CHARACTERS WITHOUT CLAIM TO ANY PARTICULAR FONT, STYLE, SIZE, OR COLOR.

OWNER OF U.S. REG. NO. 1,935,146.

NO CLAIM IS MADE TO THE EXCLUSIVE RIGHT TO USE "BISTRO EXPRESS", APART FROM THE MARK AS SHOWN.

"THE FOREIGN WORDING IN THE MARK TRANSLATES INTO ENGLISH AS THE SMALL BAR."

FOR CATERING; RESTAURANTS (U.S. CLS. 100 AND 101).

FIRST USE 8-31-1992; IN COMMERCE 8-31-1992.  
AMY ALFIERI, EXAMINING ATTORNEY

SN 78-811,636. PANINO SPORTIVO TRADEMARK, LLC,  
WATERMILL, NY. FILED 2-9-2006.



NO CLAIM IS MADE TO THE EXCLUSIVE RIGHT TO USE "PANINO" AND "GROUP", APART FROM THE MARK AS SHOWN.

THE COLOR(S) RED, ORANGE, YELLOW, BLACK, WHITE, BURGUNDY IS/ARE CLAIMED AS A FEATURE OF THE MARK.

THE MARK CONSISTS OF BLACK, RED, ORANGE AND YELLOW SOCCER BALL IN THE MIDDLE OF A BURGUNDY CIRCLE OUTLINED IN ORANGE WITH WHITE LETTERS IN A CIRCULAR MOTION AROUND THE SOCCER BALL IN THE BURGUNDY CIRCLE.

THE FOREIGN WORDING IN THE MARK TRANSLATES INTO ENGLISH AS SPORTING .

FOR RESTAURANT AND CARRY OUT RESTAURANT SERVICES (U.S. CLS. 100 AND 101).

FIRST USE 7-1-2003; IN COMMERCE 7-1-2003.  
ELLEN PERKINS, EXAMINING ATTORNEY

**CLASS 43—(Continued).**

SN 78-815,526. DIABLOS ROJOS, MILWAUKEE, WI. FILED  
2-15-2006.

**REDLIGHT**

THE MARK CONSISTS OF STANDARD CHARACTERS WITHOUT CLAIM TO ANY PARTICULAR FONT, STYLE, SIZE, OR COLOR.

FOR BAR AND RESTAURANT SERVICES (U.S. CLS. 100 AND 101).

FIRST USE 11-20-2003; IN COMMERCE 11-20-2003.

PETER B. BROMAGHIM, EXAMINING ATTORNEY

SN 78-815,535. DIABLOS ROJOS, MILWAUKEE, WI. FILED  
2-15-2006.

**TROCADERO**

THE MARK CONSISTS OF STANDARD CHARACTERS WITHOUT CLAIM TO ANY PARTICULAR FONT, STYLE, SIZE, OR COLOR.

FOR BAR AND RESTAURANT SERVICES (U.S. CLS. 100 AND 101).

FIRST USE 9-20-2001; IN COMMERCE 9-20-2001.

PETER B. BROMAGHIM, EXAMINING ATTORNEY

SN 78-821,812. LONE STAR STEAKHOUSE & SALOON, INC.,  
WICHITA, KS. FILED 2-23-2006.



OWNER OF U.S. REG. NO. 1,949,689.

NO CLAIM IS MADE TO THE EXCLUSIVE RIGHT TO USE "ITALIAN GRILLE", APART FROM THE MARK AS SHOWN.

THE MARK CONSISTS OF THE WORDS FRANKIE'S ITALIAN GRILLE IN STYLIZED LETTERS.

FOR RESTAURANT AND BAR SERVICES (U.S. CLS. 100 AND 101).

FIRST USE 3-20-1995; IN COMMERCE 3-20-1995.  
SALLY SHIH, EXAMINING ATTORNEY

**CLASS 43—(Continued).**

SN 78-822,548. PICK UP STIX, INC., SAN CLEMENTE, CA. FILED 2-24-2006.

**PICK UP STIX FRESH ASIAN FLAVORS**

THE MARK CONSISTS OF STANDARD CHARACTERS WITHOUT CLAIM TO ANY PARTICULAR FONT, STYLE, SIZE, OR COLOR.

OWNER OF U.S. REG. NOS. 1,719,646, 2,465,228 AND OTHERS.

NO CLAIM IS MADE TO THE EXCLUSIVE RIGHT TO USE "FRESH ASIAN FLAVORS", APART FROM THE MARK AS SHOWN.

FOR RESTAURANT SERVICES, TAKE-OUT FOOD SERVICES, AND CATERING SERVICES (U.S. CLS. 100 AND 101).

MARY CRAWFORD, EXAMINING ATTORNEY

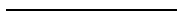

SN 78-840,550. RELAY INTERNATIONAL CO., LTD., MAPO-KU, SEOUL, REPUBLIC OF KOREA, FILED 3-17-2006.

**REDMANGO**

THE MARK CONSISTS OF STANDARD CHARACTERS WITHOUT CLAIM TO ANY PARTICULAR FONT, STYLE, SIZE, OR COLOR.

OWNER OF REPUBLIC OF KOREA REG. NO. 0100820, DATED 5-14-2004, EXPIRES 5-14-2014.

FOR RESTAURANT AND CAFE SERVICES (U.S. CLS. 100 AND 101).

CHARISMA HAMPTON, EXAMINING ATTORNEY



SN 78-849,510. COOL RESTAURANT CORP., NEW YORK, NY. FILED 3-29-2006.

**GONZO**

THE MARK CONSISTS OF STANDARD CHARACTERS WITHOUT CLAIM TO ANY PARTICULAR FONT, STYLE, SIZE, OR COLOR.

FOR RESTAURANT SERVICES (U.S. CLS. 100 AND 101).

FIRST USE 8-7-2002; IN COMMERCE 8-7-2002.

TINA L. SNAPP, EXAMINING ATTORNEY

**CLASS 43—(Continued).**

SN 78-852,706. TURGEL, JONATHAN, ADAMSTOWN, MD. AND HARTUNG, GEORGE, JR., GERMANTOWN, MD. FILED 4-3-2006.

**Beers & Cheers**

THE MARK CONSISTS OF STANDARD CHARACTERS WITHOUT CLAIM TO ANY PARTICULAR FONT, STYLE, SIZE, OR COLOR.

FOR RESTAURANT SERVICES FEATURING BEER AND WINE (U.S. CLS. 100 AND 101).

FIRST USE 10-21-2000; IN COMMERCE 10-21-2000.

AMY GEARIN, EXAMINING ATTORNEY



SN 78-855,499. BRINKER INTERNATIONAL HOLDINGS, L.P., DALLAS, TX. FILED 4-6-2006.



OWNER OF U.S. REG. NOS. 1,104,978, 2,093,049 AND OTHERS.

THE COLOR(S) RED AND GREEN IS/ARE CLAIMED AS A FEATURE OF THE MARK.

THE MARK CONSISTS OF THE WORD "CHILI'S" IN A STYLIZED FONT. THE APOSTROPHE BETWEEN THE LETTER I AND THE LETTER S IS A PEPPER DESIGN. THE WORD CHILI, THE PEPPER BODY AND THE S ARE CLAIMED IN THE COLOR RED. THE PEPPER STEM AND LEAF CAP OF THE PEPPER LOGO ARE CLAIMED IN THE COLOR GREEN.

FOR RESTAURANT, BAR AND CATERING SERVICES (U.S. CLS. 100 AND 101).

FIRST USE 4-1-2001; IN COMMERCE 4-1-2001.

JUSTINE D. PARKER, EXAMINING ATTORNEY

**CLASS 43—(Continued).**

SN 78-855,647. BRINKER INTERNATIONAL HOLDINGS, L.P., DALLAS, TX. FILED 4-6-2006.



OWNER OF U.S. REG. NOS. 1,104,978, 2,093,049 AND OTHERS.

THE COLOR(S) GREEN AND RED IS/ARE CLAIMED AS A FEATURE OF THE MARK.

THE MARK CONSISTS OF THE WORD "CHILI'S" IN A STYLIZED FONT. THE APOSTROPHE BETWEEN THE LETTER I AND THE LETTER S IS A PEPPER DESIGN. THE PEPPER BODY IS CLAIMED IN THE COLOR RED. THE WORD CHILI, THE S, THE PEPPER STEM AND LEAF CAP OF THE PEPPER LOGO ARE CLAIMED IN THE COLOR GREEN.

FOR RESTAURANT, BAR AND CATERING SERVICES (U.S. CLS. 100 AND 101).

FIRST USE 4-1-2001; IN COMMERCE 4-1-2001.

JUSTINE D. PARKER, EXAMINING ATTORNEY

SN 78-856,909. LONE STAR STEAKHOUSE & SALOON, INC., WICHITA, KS. FILED 4-7-2006.



OWNER OF U.S. REG. NOS. 1,958,923 AND 1,962,699. NO CLAIM IS MADE TO THE EXCLUSIVE RIGHT TO USE "STEAK HOUSE U.S.D.A. PRIME", APART FROM THE MARK AS SHOWN.

THE MARK CONSISTS OF THE WORDS DEL FRISCO'S DOUBLE EAGLE STEAK HOUSE U.S.D.A. PRIME IN STYLIZED LETTERS WITH THE DESIGN OF A ROSE.

FOR RESTAURANT AND BAR SERVICES (U.S. CLS. 100 AND 101).

FIRST USE 4-1-1981; IN COMMERCE 4-1-1981.

SALLY SHIH, EXAMINING ATTORNEY

**CLASS 43—(Continued).**

SN 78-896,603. COOKING DEVELOPMENT LIMITED, LONDON, UNITED KINGDOM, FILED 5-31-2006.

**BENOIT**

THE MARK CONSISTS OF STANDARD CHARACTERS WITHOUT CLAIM TO ANY PARTICULAR FONT, STYLE, SIZE, OR COLOR.

OWNER OF ERPN CMNTY TM OFC REG. NO. 004419859, DATED 5-17-2006, EXPIRES 3-5-2015.

FOR RESTAURANT, BAR AND CATERING SERVICES (U.S. CLS. 100 AND 101).

REBECCA GAN, EXAMINING ATTORNEY

SN 78-901,251. HOSPITALITY EXCELLENCE, INC., FT. LAUDERDALE, FL. FILED 6-6-2006.

**HOSPITALITY EXCELLENCE**

THE MARK CONSISTS OF STANDARD CHARACTERS WITHOUT CLAIM TO ANY PARTICULAR FONT, STYLE, SIZE, OR COLOR.

NO CLAIM IS MADE TO THE EXCLUSIVE RIGHT TO USE "HOSPITALITY", APART FROM THE MARK AS SHOWN.

SEC. 2(F).

FOR CONSULTING SERVICES IN THE FIELD OF HOSPITALITY (U.S. CLS. 100 AND 101).

FIRST USE 5-1-1999; IN COMMERCE 5-1-1999.

DAWN FELDMAN, EXAMINING ATTORNEY

SN 78-904,234. FIESTA PALMS, LLC, LAS VEGAS, NV. FILED 6-8-2006.

**THE PEARL AT THE PALMS**

THE MARK CONSISTS OF STANDARD CHARACTERS WITHOUT CLAIM TO ANY PARTICULAR FONT, STYLE, SIZE, OR COLOR.

OWNER OF U.S. REG. NOS. 2,736,239 AND 2,819,261.

FOR ARENA SERVICES, NAMELY PROVIDING FACILITIES FOR SPORTS, CONCERTS, CONVENTIONS AND EXHIBITIONS (U.S. CLS. 100 AND 101).

ANDREA SAUNDERS, EXAMINING ATTORNEY



**CLASS 43—(Continued).**

SN 78-934,762. CAFFENOVA, INC., CHICAGO, IL. FILED 7-21-2006.



THE COLOR(S) RED, WHITE AND BLACK IS/ARE CLAIMED AS A FEATURE OF THE MARK.

THE COLOR BLACK APPEARS IN THE OUTERMOST CIRCLE AND IN THE BAR LOCATED ABOVE THE LETTER "O". THE COLOR WHITE APPEARS IN THE WORDING, "ROM" AND IN THE CIRCLE BETWEEN THE OUTERMOST BLACK CIRCLE AND RED CENTER CIRCLE. THE COLOR RED APPEARS IN THE INNERMOST CIRCLE, WHICH CONTAINS THE WORDING, "ROM".

THE FOREIGN WORDING IN THE MARK TRANSLATES INTO ENGLISH AS ROME.

FOR CAFE-RESTAURANTS, RESTAURANTS (U.S. CLS. 100 AND 101).

FIRST USE 6-7-2006; IN COMMERCE 6-7-2006.  
LINDSEY RUBIN, EXAMINING ATTORNEY

**CLASS 43—(Continued).**

SN 78-939,884. M.M. FRENCH-PARADOX, LTD., NEW YORK, NY. FILED 7-28-2006.

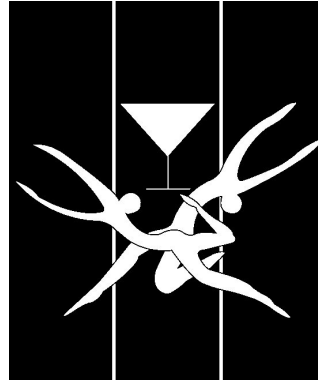

THE MARK CONSISTS OF A MARTINI GLASS, TWO ABSTRACT DANCERS, AND PARALLEL LINES.

FOR CAFES; CATERING; RESTAURANT SERVICES (U.S. CLS. 100 AND 101).

CARYN GLASSER, EXAMINING ATTORNEY

SN 78-952,583. VENTURE CONCEPTS HOLDINGS, LLC, MEMPHIS, TN. FILED 8-15-2006.

# MADRE

THE MARK CONSISTS OF STANDARD CHARACTERS WITHOUT CLAIM TO ANY PARTICULAR FONT, STYLE, SIZE, OR COLOR.

THE FOREIGN WORDING IN THE MARK TRANSLATES INTO ENGLISH AS MOTHER.

FOR RESTAURANT SERVICES; BAR SERVICES; WINE AND CIGAR BAR SERVICES; PROVIDING ADVICE ON WINE AND WINE AND FOOD PAIRING; PROVIDING RECIPES FOR FOOD, NAMELY, PROVIDING AN ONLINE DATABASE IN THE FIELD OF RECIPES (U.S. CLS. 100 AND 101).

JENNIFER MARTIN, EXAMINING ATTORNEY

SN 78-935,955. WALL STREET CAFE, INC., FARMINGTON HILLS, MI. FILED 7-24-2006.



THE COLORS BROWN, GREEN AND WHITE ARE CLAIMED AS A FEATURE OF THE MARK.

THE COLOR WHITE APPEARS IN THE OUTLINE OF THE COFFEE CUP, THE COLOR BROWN APPEARS IN THE COFFEE IN THE CUP AND THE WORDS THE AND EXCHANGE, AND THE COLOR GREEN APPEARS IN THE OUTLINE OF THE COFFEE CUP AND THE WORDS JAVA AND CAFE.

FOR COFFEE SHOP SERVING FOOD AND DRINKS (U.S. CLS. 100 AND 101).

SANI KHOURI, EXAMINING ATTORNEY

SN 78-954,174. GREAT TEXAS RESTAURANTS, INC., MONTGOMERY, TX. FILED 8-17-2006.



NO CLAIM IS MADE TO THE EXCLUSIVE RIGHT TO USE "FAJITA" AND "MEXICAN GRILL & CANTINA", APART FROM THE MARK AS SHOWN.

THE MARK CONSISTS OF STYLIZED TEXT OF THE WORDING "FAJITA JACKS MEXICAN GRILL & CANTINA".

FOR RESTAURANT AND BAR SERVICES (U.S. CLS. 100 AND 101).

FIRST USE 10-1-2004; IN COMMERCE 10-1-2004.  
CATHERINE FAINT, EXAMINING ATTORNEY

**CLASS 43—(Continued).**

SN 78-955,625. RECTOR, KENNETH M., HOUSTON, TX.  
FILED 8-18-2006.

"Barefoot'in"

THE MARK CONSISTS OF STANDARD CHARACTERS WITHOUT CLAIM TO ANY PARTICULAR FONT, STYLE, SIZE, OR COLOR.

FOR EMERGENCY SHELTER SERVICES, NAMELY, PROVIDING TEMPORARY HOUSING FOR ABUSED WOMEN AND CHILDREN; CHARITABLE SERVICES, NAMELY, PROVIDING FOOD TO ABUSED WOMEN AND CHILDREN (U.S. CLS. 100 AND 101).  
ELLEN BURNS, EXAMINING ATTORNEY

SN 78-956,344. CHIPPENDALES USA, LLC, PLAINVIEW, NY.  
FILED 8-21-2006.

CHIPPENDALES

THE MARK CONSISTS OF STANDARD CHARACTERS WITHOUT CLAIM TO ANY PARTICULAR FONT, STYLE, SIZE, OR COLOR.

OWNER OF U.S. REG. NOS. 1,197,438, 2,802,430 AND OTHERS.

FOR CATERING SERVICES FOR PROVIDING FOOD AND DRINK; WAITER SERVICES FOR SERVING FOOD AND DRINK; BAR AND RESTAURANT SERVICES (U.S. CLS. 100 AND 101).  
MIDGE BUTLER, EXAMINING ATTORNEY

**CLASS 43—(Continued).**

SN 78-956,379. PICKLEMAN'S LLC, COLUMBIA, MO. FILED 8-21-2006.



OWNER OF U.S. REG. NO. 3,134,420.  
NO CLAIM IS MADE TO THE EXCLUSIVE RIGHT TO USE "GOURMET CAFE", APART FROM THE MARK AS SHOWN.

THE COLOR(S) LIGHT GREEN, DARK GREEN, GOLDEN YELLOW, LIGHT ORANGE, PALE YELLOW AND BLACK IS/ARE CLAIMED AS A FEATURE OF THE MARK.

GREEN PICKLE OUTLINED IN BLACK, WITH LIGHTER AND DARKER SHADING THROUGHOUT THE GREEN TO SHOW DEPTH AND VARIATION. THE WORD "PICKLEMAN'S" AND THE SEMI-CIRCLE BELOW THE WORD ARE GOLDEN YELLOW COLOR, WITH VARIATIONS OF LIGHT ORANGE AND PALE YELLOW TO SHOW VARIATION AND DEPTH. THE WORDS "GOURMET CAFE" ARE BLACK.

THE MARK CONSISTS OF A PICKLE BACKGROUND FEATURING THE STYLIZED WORD "PICKLEMAN'S" AND A SEMI-CIRCLE BELOW THE WORD "PICKLEMAN'S" FEATURING THE WORDS "GOURMET CAFE".

FOR RESTAURANTS (U.S. CLS. 100 AND 101).  
FIRST USE 9-30-2005; IN COMMERCE 9-30-2005.  
GEORGE LORENZO, EXAMINING ATTORNEY

SN 78-958,038. VALIANT GROUP, INC., SANTA BARBARA, CA. FILED 8-22-2006.

RECIPES FOR DAILY LIVING

THE MARK CONSISTS OF STANDARD CHARACTERS WITHOUT CLAIM TO ANY PARTICULAR FONT, STYLE, SIZE, OR COLOR.

FOR RESTAURANT SERVICES AND CARRY OUT RESTAURANT SERVICES (U.S. CLS. 100 AND 101).  
CHARLOTTE CORWIN, EXAMINING ATTORNEY

SN 78-958,057. VALIANT GROUP, INC., SANTA BARBARA, CA. FILED 8-22-2006.

PRESCRIPTIONS FOR DAILY LIVING

THE MARK CONSISTS OF STANDARD CHARACTERS WITHOUT CLAIM TO ANY PARTICULAR FONT, STYLE, SIZE, OR COLOR.

FOR RESTAURANT SERVICES AND CARRY OUT RESTAURANT SERVICES (U.S. CLS. 100 AND 101).  
CHARLOTTE CORWIN, EXAMINING ATTORNEY

**CLASS 43—(Continued).**

SN 78-959,563. PT HOSPITALITY, LLC, JENKS, OK. FILED 8-24-2006.

**JooJooBee's Club & Deli**

THE MARK CONSISTS OF STANDARD CHARACTERS WITHOUT CLAIM TO ANY PARTICULAR FONT, STYLE, SIZE, OR COLOR.

NO CLAIM IS MADE TO THE EXCLUSIVE RIGHT TO USE "CLUB & DELI", APART FROM THE MARK AS SHOWN.

FOR DELICATESSENS; RESTAURANT AND BAR SERVICES; RESTAURANT SERVICES; RESTAURANTS; RESTAURANTS FEATURING HOME DELIVERY; TAKE-OUT RESTAURANT SERVICES (U.S. CLS. 100 AND 101).

MICHAEL LEWIS, EXAMINING ATTORNEY

**CLASS 43—(Continued).**

SN 78-961,079. HUNEEUS VINTNERS LLC, RUTHERFORD, CA. FILED 8-25-2006.

**QUINTESSA**

THE MARK CONSISTS OF STANDARD CHARACTERS WITHOUT CLAIM TO ANY PARTICULAR FONT, STYLE, SIZE, OR COLOR.

OWNER OF U.S. REG. NO. 1,933,427.

FOR HOTEL, BAR AND RESTAURANT SERVICES; CATERING; WINE BARS; PROVIDING INFORMATION ABOUT WINE CHARACTERISTICS; SOMMELIER SERVICES, NAMELY, PROVIDING ADVICE ON WINE AND WINE AND FOOD PAIRING (U.S. CLS. 100 AND 101).

JAMES MACFARLANE, EXAMINING ATTORNEY

SN 78-959,996. MATSUHISA, NOBUYUKI, BEVERLY HILLS, CA. FILED 8-24-2006.

**NOBU**

THE MARK CONSISTS OF STANDARD CHARACTERS WITHOUT CLAIM TO ANY PARTICULAR FONT, STYLE, SIZE, OR COLOR.

OWNER OF U.S. REG. NOS. 1,959,250, 2,338,877 AND 2,646,468.

FOR HOTELS (U.S. CLS. 100 AND 101).  
SUSAN RICHARDS, EXAMINING ATTORNEY

SN 78-961,774. FRONTERA FRESCO, LLC, CHICAGO, IL. FILED 8-28-2006.

**FRONTERA FRESCO**

THE MARK CONSISTS OF STANDARD CHARACTERS WITHOUT CLAIM TO ANY PARTICULAR FONT, STYLE, SIZE, OR COLOR.

THE ENGLISH TRANSLATION OF THE WORDING FRONTERA FRESCO IS "FRONTIER FRESH".  
FOR RESTAURANT SERVICES (U.S. CLS. 100 AND 101).

WILLIAM VERHOSEK, EXAMINING ATTORNEY

SN 78-960,233. ROCK & REPUBLIC ENTERPRISES, INC., CULVER CITY, CA. FILED 8-25-2006.



FOR HOTEL, BAR AND RESTAURANT SERVICES (U.S. CLS. 100 AND 101).  
WILLIAM P. SHANAHAN, EXAMINING ATTORNEY

SN 78-961,939. FLEISCHMAN, MARK, LOS ANGELES, CA. FILED 8-28-2006.

**Tatou Supper Club**

THE MARK CONSISTS OF STANDARD CHARACTERS WITHOUT CLAIM TO ANY PARTICULAR FONT, STYLE, SIZE, OR COLOR.

NO CLAIM IS MADE TO THE EXCLUSIVE RIGHT TO USE "SUPPER CLUB", APART FROM THE MARK AS SHOWN.

FOR COCKTAIL LOUNGES; RESTAURANT AND BAR SERVICES (U.S. CLS. 100 AND 101).  
TASHIA BUNCH, EXAMINING ATTORNEY

**CLASS 43—(Continued).**

SN 78-961,958. FLEISCHMAN, MARK, LOS ANGELES, CA.  
FILED 8-28-2006.

## Mark Fleischman's Tatou Supper Club

THE MARK CONSISTS OF STANDARD CHARACTERS  
WITHOUT CLAIM TO ANY PARTICULAR FONT, STYLE,  
SIZE, OR COLOR.

NO CLAIM IS MADE TO THE EXCLUSIVE RIGHT TO  
USE "SUPPER CLUB", APART FROM THE MARK AS  
SHOWN.

FOR COCKTAIL LOUNGES; RESTAURANT AND BAR  
SERVICES (U.S. CLS. 100 AND 101).

TASHIA BUNCH, EXAMINING ATTORNEY

**CLASS 43—(Continued).**

SN 78-963,010. ATLANTA NORTH INDIAN CATERING,  
INC., ATLANTA, GA. FILED 8-29-2006.

## BHOJANIC

THE MARK CONSISTS OF STANDARD CHARACTERS  
WITHOUT CLAIM TO ANY PARTICULAR FONT, STYLE,  
SIZE, OR COLOR.

FOR RESTAURANT SERVICES (U.S. CLS. 100 AND  
101).

FIRST USE 6-12-2000; IN COMMERCE 7-30-2003.

BRIAN PINO, EXAMINING ATTORNEY

SN 78-962,982. LODGE MANAGEMENT, INC., DECATUR,  
GA. FILED 8-29-2006.

## Metro Extended Stay

THE MARK CONSISTS OF STANDARD CHARACTERS  
WITHOUT CLAIM TO ANY PARTICULAR FONT, STYLE,  
SIZE, OR COLOR.

NO CLAIM IS MADE TO THE EXCLUSIVE RIGHT TO  
USE "EXTENDED STAY", APART FROM THE MARK AS  
SHOWN.

FOR PROVIDING TEMPORARY HOUSING ACCOM-  
MODATIONS (U.S. CLS. 100 AND 101).

KATHERINE M. DUBRAY, EXAMINING ATTORNEY

SN 78-963,505. WALL HOUSE CAFÉ, LTD., MILLERSBURG,  
OH. FILED 8-30-2006.

## Wall House Café

THE MARK CONSISTS OF STANDARD CHARACTERS  
WITHOUT CLAIM TO ANY PARTICULAR FONT, STYLE,  
SIZE, OR COLOR.

NO CLAIM IS MADE TO THE EXCLUSIVE RIGHT TO  
USE CAFE, APART FROM THE MARK AS SHOWN.

FOR CAFE-RESTAURANTS (U.S. CLS. 100 AND 101).

BRIDGETT SMITH, EXAMINING ATTORNEY

SN 78-962,983. DEMIRGIL, SUAT LEVENT, BROOKLYN,  
NY. FILED 8-29-2006.

## KEBAB GARDEN

THE MARK CONSISTS OF STANDARD CHARACTERS  
WITHOUT CLAIM TO ANY PARTICULAR FONT, STYLE,  
SIZE, OR COLOR.

NO CLAIM IS MADE TO THE EXCLUSIVE RIGHT TO  
USE "KEBAB", APART FROM THE MARK AS SHOWN.

FOR RESTAURANT SERVICES (U.S. CLS. 100 AND  
101).

FIRST USE 8-18-2006; IN COMMERCE 8-18-2006.

KATHERINE M. DUBRAY, EXAMINING ATTORNEY

SN 78-963,828. THE ENLIGHTENED DINER, LLC, TUCSON,  
AZ. FILED 8-30-2006.

## The Enlightened Diner

THE MARK CONSISTS OF STANDARD CHARACTERS  
WITHOUT CLAIM TO ANY PARTICULAR FONT, STYLE,  
SIZE, OR COLOR.

FOR RESTAURANTS (U.S. CLS. 100 AND 101).

JEFF DEFORD, EXAMINING ATTORNEY

**CLASS 43—(Continued).**

SN 78-963,870. BLUM ENTERPRISES, LLC, WINTER PARK, FL. FILED 8-30-2006.

**GOOD FOOD FOR THE PLANET**

THE MARK CONSISTS OF STANDARD CHARACTERS WITHOUT CLAIM TO ANY PARTICULAR FONT, STYLE, SIZE, OR COLOR.

FOR RESTAURANT SERVICES (U.S. CLS. 100 AND 101).

BENJAMIN ALLEN, EXAMINING ATTORNEY

SN 78-964,114. AMERICAN NEVADA HOLDINGS, LLC, HENDERSON, NV. FILED 8-30-2006.

**AVENUE33**

THE MARK CONSISTS OF STANDARD CHARACTERS WITHOUT CLAIM TO ANY PARTICULAR FONT, STYLE, SIZE, OR COLOR.

FOR TRAVEL AGENCY SERVICES, NAMELY, RESERVATIONS AND BOOKING SERVICES FOR TEMPORARY LODGING AND DINING; PROVIDING INFORMATION IN THE FIELDS OF RESORTS, HOTELS, RESTAURANTS, BARS AND COCKTAIL LOUNGES; PROVIDING CONFERENCE AND MEETING FACILITIES; AND PROVIDING FACILITIES FOR FAIRS, EXHIBITIONS AND CONVENTIONS (U.S. CLS. 100 AND 101).

HEATHER SAPP, EXAMINING ATTORNEY

SN 78-964,353. CARSON GAMING, L.L.C., LAS VEGAS, NV. FILED 8-30-2006.

**CASINO FANDANGO**

THE MARK CONSISTS OF STANDARD CHARACTERS WITHOUT CLAIM TO ANY PARTICULAR FONT, STYLE, SIZE, OR COLOR.

OWNER OF U.S. REG. NOS. 2,968,485 AND 2,973,537. FOR HOTELS; RESORT HOTELS; AND HOTEL, BAR AND RESTAURANT SERVICES; RESTAURANTS; PROVIDING CONVENTION FACILITIES AND PROVIDING BANQUET AND SOCIAL FUNCTION FACILITIES FOR SPECIAL OCCASIONS (U.S. CLS. 100 AND 101).

MORGAN WYNNE, EXAMINING ATTORNEY

**CLASS 43—(Continued).**

SN 78-964,487. AMERICAN NEVADA HOLDINGS, LLC, HENDERSON, NV. FILED 8-30-2006.

**AVENUE33 AT THE DISTRICT**

THE MARK CONSISTS OF STANDARD CHARACTERS WITHOUT CLAIM TO ANY PARTICULAR FONT, STYLE, SIZE, OR COLOR.

FOR TRAVEL AGENCY SERVICES, NAMELY, RESERVATIONS AND BOOKING SERVICES FOR TEMPORARY LODGING AND DINING; PROVIDING INFORMATION IN THE FIELDS OF RESORTS, HOTELS, RESTAURANTS, BARS AND COCKTAIL LOUNGES; PROVIDING CONFERENCE AND MEETING FACILITIES; AND PROVIDING FACILITIES FOR FAIRS, EXHIBITIONS AND CONVENTIONS (U.S. CLS. 100 AND 101).

HEATHER SAPP, EXAMINING ATTORNEY

SN 78-964,502. AMERICAN NEVADA HOLDINGS, LLC, HENDERSON, NV. FILED 8-30-2006.

**AVENUE33 BROWNSTONES AT THE DISTRICT**

THE MARK CONSISTS OF STANDARD CHARACTERS WITHOUT CLAIM TO ANY PARTICULAR FONT, STYLE, SIZE, OR COLOR.

FOR TRAVEL AGENCY SERVICES, NAMELY, RESERVATIONS AND BOOKING SERVICES FOR TEMPORARY LODGING AND DINING; PROVIDING INFORMATION IN THE FIELDS OF RESORTS, HOTELS, RESTAURANTS, BARS AND COCKTAIL LOUNGES; PROVIDING CONFERENCE AND MEETING FACILITIES; AND PROVIDING FACILITIES FOR FAIRS, EXHIBITIONS AND CONVENTIONS (U.S. CLS. 100 AND 101).

HEATHER SAPP, EXAMINING ATTORNEY

SN 78-964,624. HMR INTERNATIONAL, INC., INVER GROVE HEIGHTS, MN. FILED 8-31-2006.

**SNAP PEA**

THE MARK CONSISTS OF STANDARD CHARACTERS WITHOUT CLAIM TO ANY PARTICULAR FONT, STYLE, SIZE, OR COLOR.

FOR RESTAURANT SERVICES; MEALS PREPARED FOR OFF-PREMISES COOKING AND CONSUMPTION; TAKE-OUT RESTAURANT SERVICES (U.S. CLS. 100 AND 101).

LAURA KOVALSKY, EXAMINING ATTORNEY

**CLASS 43—(Continued).**

SN 78-964,703. RICHMOND INTERNATIONAL RACEWAY, INC., DAYTONA BEACH, FL. FILED 8-31-2006.

# TORQUE

THE MARK CONSISTS OF STANDARD CHARACTERS WITHOUT CLAIM TO ANY PARTICULAR FONT, STYLE, SIZE, OR COLOR.

FOR HOSPITALITY SERVICES, NAMELY, PROVIDING FOOD AND BEVERAGES FOR GUESTS AT MOTORSPORTS EVENTS (U.S. CLS. 100 AND 101).

RONALD MCMORROW, EXAMINING ATTORNEY

**CLASS 43—(Continued).**

SN 78-965,618. GNLV, CORP., LAS VEGAS, NV. FILED 8-31-2006.

# RUSH LOUNGE

THE MARK CONSISTS OF STANDARD CHARACTERS WITHOUT CLAIM TO ANY PARTICULAR FONT, STYLE, SIZE, OR COLOR.

NO CLAIM IS MADE TO THE EXCLUSIVE RIGHT TO USE "LOUNGE", APART FROM THE MARK AS SHOWN.

FOR RESTAURANT, BAR, AND COCKTAIL LOUNGE SERVICES (U.S. CLS. 100 AND 101).

TOBY BULLOFF, EXAMINING ATTORNEY

SN 78-964,801. DAOU, JONATHAN, NEW YORK, NY. FILED 8-31-2006.

# UNORTHODOX JUICE

THE MARK CONSISTS OF STANDARD CHARACTERS WITHOUT CLAIM TO ANY PARTICULAR FONT, STYLE, SIZE, OR COLOR.

NO CLAIM IS MADE TO THE EXCLUSIVE RIGHT TO USE "JUICE", APART FROM THE MARK AS SHOWN.

FOR RESTAURANT SERVICES (U.S. CLS. 100 AND 101).

BENJAMIN OKEKE, EXAMINING ATTORNEY

SN 78-966,184. LEE, TROY E., GEORGETOWN, KY. FILED 9-1-2006.

# coffea

THE MARK CONSISTS OF STANDARD CHARACTERS WITHOUT CLAIM TO ANY PARTICULAR FONT, STYLE, SIZE, OR COLOR.

FOR COFFEE SHOPS (U.S. CLS. 100 AND 101).

ALICIA COLLINS, EXAMINING ATTORNEY

SN 78-966,590. DAWKINS, MARILYN SMITH, AUSTIN, TX. FILED 9-3-2006.

# Aqua Serene

SN 78-965,020. GILGAL ROCKS HOLDING, INC., LILBURN, GA. FILED 8-31-2006.

# A WONKY KUP A JO

THE MARK CONSISTS OF STANDARD CHARACTERS WITHOUT CLAIM TO ANY PARTICULAR FONT, STYLE, SIZE, OR COLOR.

FOR CAFE-RESTAURANTS; COFFEE SHOPS (U.S. CLS. 100 AND 101).

KAREN SEVERSON, EXAMINING ATTORNEY

THE MARK CONSISTS OF STANDARD CHARACTERS WITHOUT CLAIM TO ANY PARTICULAR FONT, STYLE, SIZE, OR COLOR.

FOR PROVIDING TEMPORARY HOUSING ACCOMMODATIONS; GUESTHOUSE; ARRANGING TEMPORARY HOUSING ACCOMMODATIONS; OPERATION OF A TOURIST HOME; RENTAL OF FURNITURE AND HOUSEHOLD FURNISHINGS IN THE NATURE OF APPLIANCES AND ELECTRONIC EQUIPMENT FOR USE IN TEMPORARY HOUSING ACCOMMODATIONS (U.S. CLS. 100 AND 101).

ESTHER A. BORSUK, EXAMINING ATTORNEY

**CLASS 43—(Continued).**

SN 78-966,837. ZERO'S MR. SUBMARINE INC., VIRGINIA BEACH, VA. FILED 9-5-2006.

WE'RE HOT AND ON A ROLL!

THE MARK CONSISTS OF STANDARD CHARACTERS WITHOUT CLAIM TO ANY PARTICULAR FONT, STYLE, SIZE, OR COLOR.  
FOR FAST-FOOD RESTAURANTS (U.S. CLS. 100 AND 101).  
FIRST USE 11-0-1996; IN COMMERCE 11-0-1996.  
PRISCILLA MILTON, EXAMINING ATTORNEY

SN 78-967,339. LESTER'S, LLC, ST. LOUIS, MO. FILED 9-5-2006.

**LESTER'S**

THE MARK CONSISTS OF STANDARD CHARACTERS WITHOUT CLAIM TO ANY PARTICULAR FONT, STYLE, SIZE, OR COLOR.  
FOR RESTAURANT AND BAR SERVICES (U.S. CLS. 100 AND 101).  
TRAVIS WHEATLEY, EXAMINING ATTORNEY

SN 78-967,469. DASA HOSPITALITY, LP, PHILADELPHIA, PA. FILED 9-5-2006.



THE MARK CONSISTS OF THE LETTERS "RAE" SURROUNDED BY A CIRCULAR DESIGN CONSISTING OF STYLIZED LINES.  
FOR RESTAURANT SERVICES (U.S. CLS. 100 AND 101).  
KHANH LE, EXAMINING ATTORNEY

**CLASS 43—(Continued).**

SN 78-967,791. HOSPITALITY TOO LLC, WEST ORANGE, NJ. FILED 9-6-2006.

**Hospitality Too**

THE MARK CONSISTS OF STANDARD CHARACTERS WITHOUT CLAIM TO ANY PARTICULAR FONT, STYLE, SIZE, OR COLOR.  
NO CLAIM IS MADE TO THE EXCLUSIVE RIGHT TO USE "HOSPITALITY", APART FROM THE MARK AS SHOWN.  
FOR HOTEL SERVICES; HOTEL SERVICES FOR PREFERRED CUSTOMERS; MAKING HOTEL RESERVATIONS FOR OTHERS; RESERVATION OF HOTEL ROOMS FOR TRAVELLERS (U.S. CLS. 100 AND 101).  
FIRST USE 12-1-1990; IN COMMERCE 12-1-1990.  
RENEE MCCRAY, EXAMINING ATTORNEY

SN 78-968,154. GOODWILL INDUSTRIES OF SANTA CLARA COUNTY, SAN JOSE, CA. FILED 9-6-2006.

**STANMOOR PREP**

THE MARK CONSISTS OF STANDARD CHARACTERS WITHOUT CLAIM TO ANY PARTICULAR FONT, STYLE, SIZE, OR COLOR.  
NO CLAIM IS MADE TO THE EXCLUSIVE RIGHT TO USE "PREP", APART FROM THE MARK AS SHOWN.  
FOR PROVIDING SHORT AND LONG TERM TEMPORARY HOUSING ACCOMMODATIONS FOR STUDENTS (U.S. CLS. 100 AND 101).  
REBECCA GILBERT, EXAMINING ATTORNEY

SN 78-968,183. THE COCA-COLA COMPANY, ATLANTA, GA. FILED 9-6-2006.

**ADVENTURES BY THE CUP**

THE MARK CONSISTS OF STANDARD CHARACTERS WITHOUT CLAIM TO ANY PARTICULAR FONT, STYLE, SIZE, OR COLOR.  
FOR SERVICES FOR PROVIDING FOOD AND DRINK, NAMELY RESTAURANT, BAR, COFFEE SHOP, CAFE AND CAFETERIA SERVICES (U.S. CLS. 100 AND 101).  
JESSICA FATHY, EXAMINING ATTORNEY

**CLASS 43—(Continued).**

SN 78-968,465. TAP OF POLK INCORPORATED, WINTER HAVEN, FL. FILED 9-6-2006.

## A lotta food for a little booty

THE MARK CONSISTS OF STANDARD CHARACTERS WITHOUT CLAIM TO ANY PARTICULAR FONT, STYLE, SIZE, OR COLOR.  
FOR RESTAURANTS (U.S. CLS. 100 AND 101).  
RONALD MCMORROW, EXAMINING ATTORNEY

SN 78-968,592. THE GROWING TREE CHILDREN'S ACADEMY LLC, TINTON FALLS, NJ. FILED 9-6-2006.



NO CLAIM IS MADE TO THE EXCLUSIVE RIGHT TO USE "CHILDRENS ACADEMY", APART FROM THE MARK AS SHOWN.

THE MARK CONSISTS OF AN ILLUSTRATION OF TWO CHILDREN HOLDING HANDS NEXT TO A TREE WITH STYLIZED TEXT OF THE WORDS, "THE GROWING TREE CHILDRENS ACADEMY".

FOR CHILD CARE CENTERS (U.S. CLS. 100 AND 101).  
LAURA KOVALSKY, EXAMINING ATTORNEY

SN 78-968,657. WAKELING, KEVIN S., ORELAND, PA. FILED 9-7-2006.

## Zaps Easy

THE MARK CONSISTS OF STANDARD CHARACTERS WITHOUT CLAIM TO ANY PARTICULAR FONT, STYLE, SIZE, OR COLOR.  
FOR CONTRACT FOOD SERVICES (U.S. CLS. 100 AND 101).  
JAY FLOWERS, EXAMINING ATTORNEY

**CLASS 43—(Continued).**

SN 78-968,676. LIFESTYLE HOLIDAYS VACATION CLUB, INC., MIAMI, FL. FILED 9-7-2006.

## VIP WORLD

THE MARK CONSISTS OF STANDARD CHARACTERS WITHOUT CLAIM TO ANY PARTICULAR FONT, STYLE, SIZE, OR COLOR.  
FOR COCKTAIL LOUNGES; RESTAURANT AND BAR SERVICES; RESTAURANTS (U.S. CLS. 100 AND 101).  
JIM RINGLE, EXAMINING ATTORNEY

SN 78-968,685. LIFESTYLE HOLIDAYS VACATION CLUB, INC., MIAMI, FL. FILED 9-7-2006.

## TELL IT ONLY TO YOUR BEST FRIENDS

THE MARK CONSISTS OF STANDARD CHARACTERS WITHOUT CLAIM TO ANY PARTICULAR FONT, STYLE, SIZE, OR COLOR.  
FOR COCKTAIL LOUNGES; RESTAURANT AND BAR SERVICES; RESTAURANTS (U.S. CLS. 100 AND 101).  
JIM RINGLE, EXAMINING ATTORNEY

SN 78-968,975. U.S.A. FAMOUS ORIGINAL RAY'S LICENSING CORPORATION, MASPETH, NY. FILED 9-7-2006.

## THE ORIGINAL RAY'S PIZZA

THE MARK CONSISTS OF STANDARD CHARACTERS WITHOUT CLAIM TO ANY PARTICULAR FONT, STYLE, SIZE, OR COLOR.  
OWNER OF U.S. REG. NOS. 1,918,483, 2,196,830 AND OTHERS.

NO CLAIM IS MADE TO THE EXCLUSIVE RIGHT TO USE "PIZZA", APART FROM THE MARK AS SHOWN.  
FOR RESTAURANT SERVICES (U.S. CLS. 100 AND 101).  
FIRST USE 6-24-1959; IN COMMERCE 6-24-1959.  
REBECCA GILBERT, EXAMINING ATTORNEY



**CLASS 43—(Continued).**

SN 78-969,613. LAUGHING GRAVY PARTNERS INC., HONOLULU, HI. FILED 9-7-2006.

**NUEVO CALIENTE**

THE MARK CONSISTS OF STANDARD CHARACTERS WITHOUT CLAIM TO ANY PARTICULAR FONT, STYLE, SIZE, OR COLOR.

THE ENGLISH TRANSLATION OF NUEVO CALIENTE IS "NEW HEAT" OR "NEW WARMTH".

FOR RESTAURANTS (U.S. CLS. 100 AND 101).  
LAURA KOVALSKY, EXAMINING ATTORNEY

SN 78-971,321. S & D COFFEE, INC., CONCORD, NC. FILED 9-11-2006.

**BREW LAGOON**

THE MARK CONSISTS OF STANDARD CHARACTERS WITHOUT CLAIM TO ANY PARTICULAR FONT, STYLE, SIZE, OR COLOR.

FOR COFFEE-HOUSE AND SNACK BAR SERVICES (U.S. CLS. 100 AND 101).

ANN E. SAPPENFIELD, EXAMINING ATTORNEY

SN 78-972,838. AHMADI, PABLO T, SEATTLE, WA. FILED 9-12-2006.



Pomegranate  
The Persian Cuisine

NO CLAIM IS MADE TO THE EXCLUSIVE RIGHT TO USE "THE PERSIAN CUISINE", APART FROM THE MARK AS SHOWN.

THE COLOR(S) RED, BLACK AND PINK IS/ARE CLAIMED AS A FEATURE OF THE MARK.

THE COLOR RED APPEARS IN THE POMEGRANATE, THE COLOR BLACK APPEARS IN THE BACKGROUND AND IN THE LETTERING, AND THE COLOR PINK APPEARS AT THE TOP OF THE POMEGRANATE.

FOR RESTAURANT AND BAR SERVICES; RESTAURANTS (U.S. CLS. 100 AND 101).

MARY ROSSMAN, EXAMINING ATTORNEY

**CLASS 44—MEDICAL, BEAUTY AND AGRICULTURAL SERVICES**

SN 76-643,702. ILLINOIS COLLEGE OF OPTOMETRY, CHICAGO, IL. FILED 7-28-2005.

**ILLINOIS EYE INSTITUTE**

THE MARK CONSISTS OF STANDARD CHARACTERS WITHOUT CLAIM TO ANY PARTICULAR FONT, STYLE, SIZE, OR COLOR.

NO CLAIM IS MADE TO THE EXCLUSIVE RIGHT TO USE "EYE INSTITUTE", APART FROM THE MARK AS SHOWN.

SEC. 2(F).  
FOR MEDICAL SERVICES, NAMELY OPTOMETRY AND AMBULANT OPHTHALMOLOGY SERVICES (U.S. CLS. 100 AND 101).

FIRST USE 1-1-1984; IN COMMERCE 1-1-1984.  
BERYL GARDNER, EXAMINING ATTORNEY

SN 76-660,195. BUBBLES, INC., VIENNA, VA. FILED 5-17-2006.

**TALK WITH YOUR HAIR**

THE MARK CONSISTS OF STANDARD CHARACTERS WITHOUT CLAIM TO ANY PARTICULAR FONT, STYLE, SIZE, OR COLOR.

FOR BEAUTY SALONS; HAIRDRESSING SALONS; HEALTH SPA SERVICES, NAMELY COSMETIC BODY CARE SERVICES AND HAIR CARE SERVICES; HAIR SALONS; HAIR SALON SERVICES (U.S. CLS. 100 AND 101).

FIRST USE 8-1-2005; IN COMMERCE 8-1-2005.  
GINA FINK, EXAMINING ATTORNEY

SN 77-040,953. VETERINARY DIAGNOSTICS INSTITUTE, INC., IRVINE, CA. FILED 11-9-2006.

**Feline CardioScore**

THE MARK CONSISTS OF STANDARD CHARACTERS WITHOUT CLAIM TO ANY PARTICULAR FONT, STYLE, SIZE, OR COLOR.

NO CLAIM IS MADE TO THE EXCLUSIVE RIGHT TO USE "FELINE", APART FROM THE MARK AS SHOWN.

FOR VETERINARY SERVICES, NAMELY, PROVIDING A RATING FOR A CAT FOR RISK OF HEART DISEASE (U.S. CLS. 100 AND 101).

RAUL CORDOVA, EXAMINING ATTORNEY

**CLASS 44—(Continued).**

SN 77-040,972. VETERINARY DIAGNOSTICS INSTITUTE, INC., IRVINE, CA. FILED 11-9-2006.

**Canine CardioScore**

THE MARK CONSISTS OF STANDARD CHARACTERS WITHOUT CLAIM TO ANY PARTICULAR FONT, STYLE, SIZE, OR COLOR.

NO CLAIM IS MADE TO THE EXCLUSIVE RIGHT TO USE "CANINE", APART FROM THE MARK AS SHOWN. FOR VETERINARY SERVICES, NAMELY, PROVIDING A RATING FOR A DOG FOR RISK OF HEART DISEASE (U.S. CLS. 100 AND 101).

RAUL CORDOVA, EXAMINING ATTORNEY

---

SN 77-068,776. ALLERGAN, INC., IRVINE, CA. FILED 12-20-2006.

**TAME YOUR HUNGER**

THE MARK CONSISTS OF STANDARD CHARACTERS WITHOUT CLAIM TO ANY PARTICULAR FONT, STYLE, SIZE, OR COLOR.

FOR PROVIDING INFORMATION DIRECTED TO CONSUMERS CONCERNING OBESITY TREATMENTS (U.S. CLS. 100 AND 101).

MIDGE BUTLER, EXAMINING ATTORNEY

---

SN 78-561,163. RED LETTER DAYS LIMITED, LONDON, UNITED KINGDOM, FILED 2-4-2005.

**RED LETTER**

THE MARK CONSISTS OF STANDARD CHARACTERS WITHOUT CLAIM TO ANY PARTICULAR FONT, STYLE, SIZE, OR COLOR.

OWNER OF UNITED KINGDOM REG. NO. 2205212, DATED 8-8-2003, EXPIRES 8-6-2009.

FOR BEAUTY SALONS; HEALTH SPA SERVICES FOR HEALTH AND WELLNESS OF BODY AND SPIRIT; HAIRDRESSING SERVICES (U.S. CLS. 100 AND 101).

JAMES GRIFFIN, EXAMINING ATTORNEY

**CLASS 44—(Continued).**

SN 78-647,080. MEDEXPRESS URGENT CARE HOLDING CO., INC., MORGANTOWN, WV. FILED S.R. 6-9-2005; AM. P.R. 1-16-2007.

**MEDEXPRESS**

THE MARK CONSISTS OF STANDARD CHARACTERS WITHOUT CLAIM TO ANY PARTICULAR FONT, STYLE, SIZE, OR COLOR.

FOR OUTPATIENT MEDICAL CLINICS SPECIALIZING IN URGENT PHYSICIAN CARE AND TREATMENT, EXCLUDING, DISCOUNT PROGRAMS FOR MEDICAL EQUIPMENT AND PRESCRIPTIONS, ON-LINE COMPUTER DATABASES FOR DISCOUNT HEALTH PROGRAMS, DISCOUNTED MEDICAL AND HEALTHCARE PROVIDED THROUGH THIRD-PARTY PROVIDERS, AIR AMBULANCE TRANSPORT SERVICES, AEROMEDICAL MEDICAL SERVICES, MAIL ORDER PHARMACY SERVICES, PHARMACEUTICAL PREPARATIONS NAMELY RESPIRATORY MEDICATIONS AND INSULIN, AND INCONTINENCE SUPPLIES, MEDICAL AND HEALTH CARE SUPPLIES, NAMELY RESPIRATORY MEDICATION DELIVERY DEVICES, GLUCOMETERS, LANCETS, BLOOD HEMOGLOBIN, TESTING SUPPLIES, DISTRIBUTORSHIP SERVICES FEATURING MEDICAL PRODUCTS AND PHARMACEUTICALS FOR USE BY RETAIL STORES, PHYSICIANS, HOSPITALS, CLINICS, PHARMACIES AND INDUSTRIAL SERVICES, DISTRIBUTION AND RENTAL OF MEDICAL EQUIPMENT, AND LABORATORY TESTING SERVICES (U.S. CLS. 100 AND 101).

FIRST USE 9-10-2001; IN COMMERCE 9-10-2001.

TONJA GASKINS, EXAMINING ATTORNEY

---

SN 78-680,871. UNITED STATES ANTI-DOPING AGENCY, COLORADO SPRINGS, CO. FILED 7-28-2005.



OWNER OF U.S. REG. NOS. 2,540,425, 2,638,944 AND OTHERS.

NO CLAIM IS MADE TO THE EXCLUSIVE RIGHT TO USE "AGENCY", APART FROM THE MARK AS SHOWN. SEC. 2(F) AS TO "U.S. ANTI-DOPING".

FOR DRUG TESTING FOR THE USE OF ILLEGAL OR PROHIBITED PERFORMANCE ENHANCING SUBSTANCES OR METHODS BY PARTICIPANTS IN VARIOUS SPORTS (U.S. CLS. 100 AND 101).

FIRST USE 9-30-2005; IN COMMERCE 9-30-2005.

PRISCILLA MILTON, EXAMINING ATTORNEY

**CLASS 44—(Continued).**

SN 78-766,301. CANCER WELLNESS PROTOCOL, AUSTIN, TX. FILED 12-5-2005.

**Cancer Wellness Protocol**

THE MARK CONSISTS OF STANDARD CHARACTERS WITHOUT CLAIM TO ANY PARTICULAR FONT, STYLE, SIZE, OR COLOR.

NO CLAIM IS MADE TO THE EXCLUSIVE RIGHT TO USE "CANCER" AND "PROTOCOL", APART FROM THE MARK AS SHOWN.

FOR PROVIDING HEALTH CARE INFORMATION BY TELEPHONE AND THE INTERNET; PROVIDING HEALTH INFORMATION; PROVIDING INFORMATION ABOUT DIETARY SUPPLEMENTS AND NUTRITION; PROVIDING MEDICAL INFORMATION (U.S. CLS. 100 AND 101).

LESLEY LAMOTHE, EXAMINING ATTORNEY

**CLASS 44—(Continued).**

SN 78-794,344. SEIGEL, HARVEY LEWIS, CORNWALL ON HUDSON, NY. FILED 1-18-2006.

**Trust the doctors your doctor trusts.**

THE MARK CONSISTS OF STANDARD CHARACTERS WITHOUT CLAIM TO ANY PARTICULAR FONT, STYLE, SIZE, OR COLOR.

FOR PRACTICE OF ORTHOPEDIC SURGERY, OBSTETRICS AND GYNECOLOGY (U.S. CLS. 100 AND 101).

TIMOTHY FINNEGAN, EXAMINING ATTORNEY

SN 78-771,841. FAVORITE, BLANCA, EL PASO, TX. FILED 12-13-2005.

**MILLENIUM HAIR SALON**

THE MARK CONSISTS OF STANDARD CHARACTERS WITHOUT CLAIM TO ANY PARTICULAR FONT, STYLE, SIZE, OR COLOR.

NO CLAIM IS MADE TO THE EXCLUSIVE RIGHT TO USE "HAIR SALON", APART FROM THE MARK AS SHOWN.

FOR HAIR SALON SERVICES, NAMELY, HAIRDRESSING SALONS; AND BEAUTY SALONS (U.S. CLS. 100 AND 101).

FIRST USE 6-1-2002; IN COMMERCE 6-1-2002.  
GEORGE LORENZO, EXAMINING ATTORNEY

SN 78-815,948. NORTHEAST MANAGEMENT SYSTEMS, LLC, SOUTH SALEM, NY. FILED 2-15-2006.

**gotomyob**

THE MARK CONSISTS OF STANDARD CHARACTERS WITHOUT CLAIM TO ANY PARTICULAR FONT, STYLE, SIZE, OR COLOR.

FOR PROVIDING GENERAL INFORMATION TO CONSUMERS, PROVIDERS, ADMINISTRATORS AND OTHER PARTICIPANTS IN THE HEALTH CARE INDUSTRY VIA AN ON-LINE COMPUTER NETWORK IN THE FIELDS OF OBGYN, NUTRITION, DIETING, WELLNESS AND SEXUALITY (U.S. CLS. 100 AND 101).

AMOS T. MATTHEWS, JR., EXAMINING ATTORNEY

SN 78-773,938. PHOTO THERAPEUTICS LIMITED, ALTRINCHAM, CHESHIRE WA14 1EP, UNITED KINGDOM, FILED 12-15-2005.

**LUMIÈRE**

THE MARK CONSISTS OF STANDARD CHARACTERS WITHOUT CLAIM TO ANY PARTICULAR FONT, STYLE, SIZE, OR COLOR.

THE ENGLISH TRANSLATION OF "LUMIÈRE" IS "LIGHT, DAYLIGHT OR DAY".

FOR PROVIDING COSMETIC, PHARMACEUTICAL AND MEDICAL INFORMATION AND CONSULTING SERVICES (U.S. CLS. 100 AND 101).

PAUL F. GAST, EXAMINING ATTORNEY

SN 78-822,215. KIRBY, ADRIAN G., DALLAS, TX. FILED 2-23-2006.

**Adrian "the DreamWeaver"**

THE MARK CONSISTS OF STANDARD CHARACTERS WITHOUT CLAIM TO ANY PARTICULAR FONT, STYLE, SIZE, OR COLOR.

FOR HAIR STYLING SERVICES NAMELY HAIR EXTENSIONS (U.S. CLS. 100 AND 101).

FIRST USE 0-0-1996; IN COMMERCE 0-0-1996.  
MATTHEW MCDOWELL, EXAMINING ATTORNEY

**CLASS 44—(Continued).**

SN 78-828,259. FORD, JERE B., WASHINGTON, DC. FILED 3-3-2006.

**DO YOUR SHOES A FAVOR**

THE MARK CONSISTS OF STANDARD CHARACTERS WITHOUT CLAIM TO ANY PARTICULAR FONT, STYLE, SIZE, OR COLOR.

FOR PROVIDING SERVICES, NAMELY WEIGHT REDUCTION DIET PLANNING AND SUPERVISION RELATED TO WEIGHT REDUCTION AND WEIGHT CONTROL; PROVIDING ADVICE, CONSULTATION, AND INFORMATION IN THE FIELD OF WEIGHT REDUCTION AND CONTROL; SUPERVISING WEIGHT REDUCTION AND WEIGHT CONTROL PROGRAMS; PROVIDING MEDICAL COUNSELING SUPPORT FOR WEIGHT REDUCTION AND WEIGHT CONTROL (U.S. CLS. 100 AND 101).

JEFF DEFORD, EXAMINING ATTORNEY

SN 78-844,392. LOVING CARE ANGENCY, INC., NEWARK, NJ. FILED 3-23-2006.

**THE AGENCY WITH A HEART**

THE MARK CONSISTS OF STANDARD CHARACTERS WITHOUT CLAIM TO ANY PARTICULAR FONT, STYLE, SIZE, OR COLOR.

NO CLAIM IS MADE TO THE EXCLUSIVE RIGHT TO USE "AGENCY", APART FROM THE MARK AS SHOWN.

FOR PEDIATRIC NURSING SERVICES FEATURING CARE COORDINATION; MEDICAL SERVICES FEATURING CLINICAL MANAGEMENT OF HEALTH CONDITIONS; PRIVATE DUTY AND EXTENDED HOURS NURSING CARE; SKILLED NURSING VISITS; PHYSICAL, OCCUPATIONAL AND SPEECH THERAPY; CLINICAL SOCIAL WORKER CONSULTATIONS; MEDICAL SERVICES, FEATURING PATIENT CASE MANAGEMENT; HOME HEALTH CARE SERVICES PROVIDED BY HOME HEALTH AIDES, FEATURING HOSPITAL TO HOME COORDINATION (U.S. CLS. 100 AND 101).

THOMAS MANOR, EXAMINING ATTORNEY

**CLASS 44—(Continued).**

SN 78-845,636. LOVING CARE AGENCY, INC., FORT LEE, NJ. FILED 3-24-2006.

**HELP BRING THE CHILDREN HOME...**

THE MARK CONSISTS OF STANDARD CHARACTERS WITHOUT CLAIM TO ANY PARTICULAR FONT, STYLE, SIZE, OR COLOR.

FOR PEDIATRIC NURSING SERVICES FEATURING CARE COORDINATION; MEDICAL SERVICES FEATURING CLINICAL MANAGEMENT OF HEALTH CONDITIONS; PRIVATE DUTY AND EXTENDED HOURS NURSING CARE; SKILLED NURSING VISITS; PHYSICAL, OCCUPATIONAL AND SPEECH THERAPY; CLINICAL SOCIAL WORKER CONSULTATIONS; MEDICAL SERVICES, FEATURING PATIENT CASE MANAGEMENT; HOME HEALTH CARE SERVICES PROVIDED BY HOME HEALTH AIDES, FEATURING HOSPITAL TO HOME COORDINATION (U.S. CLS. 100 AND 101).

FIRST USE 11-0-1998; IN COMMERCE 11-0-1998.

THOMAS MANOR, EXAMINING ATTORNEY

SN 78-861,840. LOVING CARE AGENCY, INC., FORT LEE, NJ. FILED 4-14-2006.



NO CLAIM IS MADE TO THE EXCLUSIVE RIGHT TO USE "CARE" AND "PEDIATRIC HOMECARE", APART FROM THE MARK AS SHOWN.

THE COLOR(S) TEAL, PINK AND BLACK IS/ARE CLAIMED AS A FEATURE OF THE MARK.

THE MARK CONSISTS OF THE LITERAL ELEMENT: LOVING CARE PEDIATRIC HOMECARE. A PINK SHADED HEART WITHIN WHICH ARE ONE HAND EACH OF A BABY AND AN ADULT OVERLAPPING, BOTH HANDS DRAWN WITH BLACK OUTLINE THE HEART APPEARING ABOVE AND TO THE RIGHT OF THE WORD "LOVING" AND ABOVE AND TO THE LEFT OF THE WORD "CARE". THE WORDS "LOVING" AND "CARE" ARE TEAL IN COLOR. THE WORDING "PEDIATRIC HOMECARE" APPEARS BELOW "LOVING" AND "CARE", AND ARE THE COLOR TEAL.

FOR PEDIATRIC NURSING SERVICES FEATURING CARE COORDINATION; MEDICAL SERVICES FEATURING CLINICAL MANAGEMENT OF HEALTH CONDITIONS; PRIVATE DUTY AND EXTENDED HOURS NURSING CARE; SKILLED NURSING VISITS; PHYSICAL, OCCUPATIONAL AND SPEECH THERAPY; CLINICAL SOCIAL WORKER CONSULTATIONS; MEDICAL SERVICES, FEATURING PATIENT CASE MANAGEMENT; HOME HEALTH CARE SERVICES PROVIDED BY HOME HEALTH AIDES, FEATURING HOSPITAL TO HOME COORDINATION (U.S. CLS. 100 AND 101).

FIRST USE 11-0-1998; IN COMMERCE 11-0-1998.

THOMAS MANOR, EXAMINING ATTORNEY

**CLASS 44—(Continued).**

SN 78-891,776. MAYO FOUNDATION FOR MEDICAL EDUCATION AND RESEARCH, ROCHESTER, MN. FILED 5-24-2006.

**EMBODY HEALTH**

THE MARK CONSISTS OF STANDARD CHARACTERS WITHOUT CLAIM TO ANY PARTICULAR FONT, STYLE, SIZE, OR COLOR.

NO CLAIM IS MADE TO THE EXCLUSIVE RIGHT TO USE "HEALTH", APART FROM THE MARK AS SHOWN.

FOR PROVIDING ONLINE NEWS AND INFORMATION IN THE FIELDS OF HEALTH CARE, PHARMACOLOGY, MEDICAL DISEASES AND CONDITIONS, AGING, FIRST AID, NUTRITION, WELLNESS AND LIFESTYLE MANAGEMENT; PROVIDING ONLINE INTERACTIVE HEALTH RISK ASSESSMENTS AND TREATMENT GUIDES; PROVIDING ONLINE INTERACTIVE PLANNERS FOR HEALTHY LIFESTYLES; WEBSITES FEATURING INFORMATION IN THE FIELD OF HEALTH CARE, PHARMACOLOGY, MEDICAL DISEASES AND CONDITIONS, AGING, FIRST AID, NUTRITION, WELLNESS AND LIFESTYLE MANAGEMENT (U.S. CLS. 100 AND 101).

KAREN K. BUSH, EXAMINING ATTORNEY

**CLASS 44—(Continued).**

SN 78-899,283. UNIVERSITY OF NORTH CAROLINA AT CHAPEL HILL, CHAPEL HILL, NC. FILED 6-2-2006.

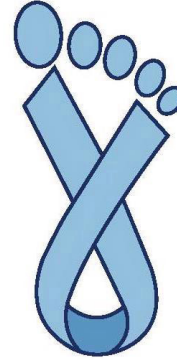

"THE COLOR(S) LIGHT BLUE AND DARK BLUE IS/ARE CLAIMED AS A FEATURE OF THE MARK."

THE COLOR LIGHT BLUE APPEARS IN THE FOOT DESIGN ELEMENT CONSISTING OF A RIBBON, AND THE COLOR DARK BLUE OUTLINES THE ENTIRE MARK.

THE MARK CONSISTS OF A STYLIZED FOOT, WITH PART OF THE FOOT CONSISTING OF A RIBBON.

FOR HEALTH CARE AND HOSPITAL SERVICES (U.S. CLS. 100 AND 101).

ALLISON SCHRODY, EXAMINING ATTORNEY

SN 78-899,818. RED & WHITE HOLISTIC HEALTH CARE CENTER, INC., WESTMINSTER, CO. FILED 6-2-2006.

SN 78-898,407. SPECIALTY DISEASE MANAGEMENT SERVICES, INC., JACKSONVILLE, FL. FILED 6-1-2006.

**EXPERIENCE HEALTH365**

THE MARK CONSISTS OF STANDARD CHARACTERS WITHOUT CLAIM TO ANY PARTICULAR FONT, STYLE, SIZE, OR COLOR.

FOR HEALTH CARE SERVICES, MANAGED HEALTH CARE SERVICES, AND DISEASE MANAGEMENT SERVICES, INCLUDING CARE COORDINATION; MANAGEMENT OF CO-MORBID CONDITIONS; ASSESSMENTS, NAMELY, MEDICAL TESTING; MONITORING OF DATA INDICATIVE OF THE HEALTH OR CONDITION OF AN INDIVIDUAL OR GROUP OF INDIVIDUALS; PROVIDING MEDICAL AND HEALTH INFORMATION VIA DIRECT MAIL, EMAIL AND THE INTERNET (U.S. CLS. 100 AND 101).

FIRST USE 2-0-2006; IN COMMERCE 2-0-2006.

CHRISTOPHER OTT, EXAMINING ATTORNEY

NO CLAIM IS MADE TO THE EXCLUSIVE RIGHT TO USE "HOLISTIC HEALTHCARE CENTER, INC.", APART FROM THE MARK AS SHOWN.

THE FOREIGN WORDING IN THE MARK TRANSLATES INTO ENGLISH AS RED WHITE.

THE NON-LATIN CHARACTER(S) IN THE MARK TRANSLITERATES INTO "CHI" AND "BAI", AND THIS MEANS "RED" AND "WHITE" IN ENGLISH.

FOR TRADITIONAL CHINESE MEDICINE THERAPY AND COUNSELING; ACUPUNCTURE THERAPY AND COUNSELING; ALLERGY ELIMINATION ACUPUNCTURE THERAPY AND COUNSELING; HERBAL MEDICINE THERAPY AND COUNSELING; MASSAGE THERAPY AND COUNSELING; HOMEOPATHY THERAPY AND COUNSELING; ACUPRESSURE THERAPY AND COUNSELING; AND NUTRITION THERAPY AND COUNSELING (U.S. CLS. 100 AND 101).

FIRST USE 5-15-1998; IN COMMERCE 5-15-1998.

ELIZABETH PIGNATELLO, EXAMINING ATTORNEY

**CLASS 44—(Continued).**

SN 78-916,907. GLOBAL SLEEP HEADQUARTERS, L.P., HOUSTON, TX. FILED 6-26-2006.

**GLOBAL SLEEP**

THE MARK CONSISTS OF STANDARD CHARACTERS WITHOUT CLAIM TO ANY PARTICULAR FONT, STYLE, SIZE, OR COLOR.

NO CLAIM IS MADE TO THE EXCLUSIVE RIGHT TO USE "SLEEP", APART FROM THE MARK AS SHOWN.

FOR MEDICAL SERVICES RELATING TO SLEEP DISORDERS (U.S. CLS. 100 AND 101).

FIRST USE 1-1-2002; IN COMMERCE 1-1-2002.

JESSICA A. POWERS, EXAMINING ATTORNEY

SN 78-918,904. PEDIATRIX MEDICAL GROUP, INC., SUNRISE, FL. FILED 6-28-2006.



THE COLOR(S) DARK BLUE, LIGHT BLUE AND GREEN IS/ARE CLAIMED AS A FEATURE OF THE MARK.

THE TERM SOUND IS DARK BLUE. THE TERM GENE IS GREEN. THE SOUND WAVES ARE LIGHT BLUE.

FOR PROVIDING ANALYTICAL TESTING SERVICES FOR PRE-LINGUAL HEARING LOSS USING ANALYSIS OF DNA MUTATIONS ASSOCIATED WITH HEARING LOSS (U.S. CLS. 100 AND 101).

MICHAEL KEATING, EXAMINING ATTORNEY

SN 78-919,031. MEDICAL RECORDS REVIEW SERVICE, INC., GRIMES, IA. FILED 6-28-2006.



OWNER OF U.S. REG. NO. 1,909,026. NO CLAIM IS MADE TO THE EXCLUSIVE RIGHT TO USE "MEDICAL RECORDS REVIEW SERVICE INCORPORATED", APART FROM THE MARK AS SHOWN.

FOR CONSULTATION IN THE FIELD OF MEDICAL INFORMATION FOR LAWYERS (U.S. CLS. 100 AND 101).

FIRST USE 8-1-2002; IN COMMERCE 8-1-2002.

CHRISTINA SOBRAL, EXAMINING ATTORNEY

**CLASS 44—(Continued).**

SN 78-923,971. MIXON, MICHAEL ANDREW, SAN ANTONIO, TX. FILED 7-6-2006.



THE COLOR(S) ORANGE, ROYAL BLUE AND WHITE ARE CLAIMED AS A FEATURE OF THE MARK.

THE MARK CONSISTS OF AN ORANGE "V" AND THE ROYAL BLUE PAW OF AN ANIMAL AND A WHITE HUMAN HAND WITH ROYAL BLUE TRIM.

FOR VETERINARY SERVICES (U.S. CLS. 100 AND 101).

FIRST USE 7-15-2003; IN COMMERCE 7-15-2003.

TRACY WHITTAKER-BROWN, EXAMINING ATTORNEY

SN 78-924,911. ATLANTA URGENT CARE CENTER, P.C., ATLANTA, GA. FILED 7-7-2006.



NO CLAIM IS MADE TO THE EXCLUSIVE RIGHT TO USE "ATLANTA" AND "URGENT CARE CENTER" AND THE CADUCEUS SYMBOL, APART FROM THE MARK AS SHOWN.

THE COLOR(S) BLUE, RED, GREY AND BLACK IS/ARE CLAIMED AS A FEATURE OF THE MARK.

THE MARK CONSISTS OF THE COLORS BLUE, RED, GREY AND BLACK. THE COLOR BLUE APPEARS IN THE LITERAL ELEMENTS ATLANTA AND CENTER. ATLANTA IS UNDERLINED IN BLUE. THE COLOR BLUE ALSO APPEARS IN A TRIANGLE DESIGN WITH A CADUCEUS SYMBOL IN GRAY AND BLACK, ABOVE A RED CURVED ARROW. THE LITERAL ELEMENTS URGENT CARE APPEAR IN RED, BETWEEN THE LITERAL ELEMENTS ATLANTA AND CENTER.

FOR URGENT MEDICAL CARE CENTERS (U.S. CLS. 100 AND 101).

DAVID HOFFMAN, EXAMINING ATTORNEY

**CLASS 44—(Continued).**

SN 78-929,257. NGUYEN, DIANE, HOUSTON, TX. FILED 7-13-2006.

bebe

THE MARK CONSISTS OF STANDARD CHARACTERS WITHOUT CLAIM TO ANY PARTICULAR FONT, STYLE, SIZE, OR COLOR.

THE FOREIGN WORDING IN THE MARK TRANSLATES INTO ENGLISH AS BABY.

FOR BEAUTY SALONS; HAIR SALON SERVICES, NAMELY, TREATMENTS TO PROTECT HAIR FROM AFFECTS OF EXPOSURE TO SUNLIGHT, HEAT, HUMIDITY AND CHLORINATED WATER; NAIL CARE SALONS; SALON SERVICES, NAMELY, FACIALS, MANICURES AND MASSAGES THAT ARE PROVIDED IN A TRAILER OUTFITTED WITH CHAIR, TABLE AND SINK ACCESSORIES (U.S. CLS. 100 AND 101).

FIRST USE 12-1-1998; IN COMMERCE 12-1-1998.  
REBECCA POVARCHUK, EXAMINING ATTORNEY

**CLASS 44—(Continued).**

SN 78-940,461. TITAN HEALTH CORPORATION, SACRAMENTO, CA. FILED 7-28-2006.



NO CLAIM IS MADE TO THE EXCLUSIVE RIGHT TO USE "HEALTH CORPORATION", APART FROM THE MARK AS SHOWN.

THE COLOR(S) RED AND BLUE IS/ARE CLAIMED AS A FEATURE OF THE MARK.

THE WORDS TITAN HEALTH CORPORATION ARE IN BLUE. THE DOT OF THE "I" IN TITAN IS RED.

FOR HEALTH CARE (U.S. CLS. 100 AND 101).

FIRST USE 1-1-2001; IN COMMERCE 1-1-2001.

MICHAEL KEATING, EXAMINING ATTORNEY

SN 78-940,674. AFFINITY HEALTH SYSTEM, MENASHA, WI. FILED 7-30-2006.



NO CLAIM IS MADE TO THE EXCLUSIVE RIGHT TO USE "HEALTH SYSTEM", APART FROM THE MARK AS SHOWN.

FOR HEALTH CARE SERVICES, NAMELY, HOSPITALS AND MEDICAL CLINICS AND RELATED HEALTH CARE PROVIDERS, NAMELY, SKILLED NURSING FACILITIES AND HEALTH MAINTENANCE ORGANIZATION (U.S. CLS. 100 AND 101).

FIRST USE 3-0-1995; IN COMMERCE 3-0-1995.

STEPHANIE DAVIS, EXAMINING ATTORNEY

SN 78-930,209. BILES, DAVID, SANTA CRUZ, CA. FILED 7-14-2006.

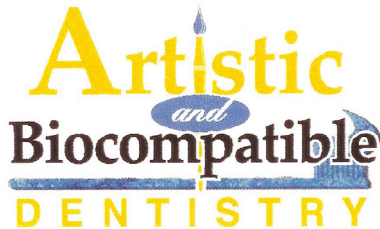

NO CLAIM IS MADE TO THE EXCLUSIVE RIGHT TO USE "DENTISTRY", APART FROM THE MARK AS SHOWN.

THE COLOR(S) BLACK, GOLD, WHITE AND BLUE IS/ARE CLAIMED AS A FEATURE OF THE MARK.

THE MARK CONSISTS OF STYLIZED BLACK LETTERING "BIOCOMPATIBLE", STYLIZED GOLD LETTERING "ARTISTIC" AND "DENTISTRY", STYLIZED WHITE LETTERING "AND", A STYLIZED VERTICAL GOLD PAINTBRUSH WITH BLUE TIP, A HORIZONTAL BLUE OVAL, AND A HORIZONTAL STYLIZED BLUE TOOTHBRUSH WITH TOOTHPASTE.

FOR DENTIST SERVICES (U.S. CLS. 100 AND 101).  
FIRST USE 4-1-1998; IN COMMERCE 4-1-1998.  
RAUL CORDOVA, EXAMINING ATTORNEY

SN 78-940,682. AFFINITY HEALTH SYSTEM, MENASHA, WI. FILED 7-30-2006.



OWNER OF U.S. REG. NO. 2,536,320.

NO CLAIM IS MADE TO THE EXCLUSIVE RIGHT TO USE NETWORK HEALTH PLAN AND HEALTH SYSTEM, APART FROM THE MARK AS SHOWN.

FOR HEALTH CARE IN THE NATURE OF HEALTH MAINTENANCE ORGANIZATIONS (U.S. CLS. 100 AND 101).

FIRST USE 2-0-1987; IN COMMERCE 2-0-1987.  
STEPHANIE DAVIS, EXAMINING ATTORNEY

**CLASS 44—(Continued).**

SN 78-940,807. AFFINITY HEALTH SYSTEM, MENASHA, WI. FILED 7-31-2006.



OWNER OF U.S. REG. NO. 2,536,320.  
NO CLAIM IS MADE TO THE EXCLUSIVE RIGHT TO USE NETWORK AND HEALTH SYSTEM, APART FROM THE MARK AS SHOWN.

FOR HEALTH CARE IN THE NATURE OF HEALTH MAINTENANCE ORGANIZATIONS (U.S. CLS. 100 AND 101).

FIRST USE 2-0-2006; IN COMMERCE 2-0-2006.  
STEPHANIE DAVIS, EXAMINING ATTORNEY

**CLASS 44—(Continued).**

SN 78-942,891. CHENNY TROUPE, INC., CHICAGO, IL. FILED 8-2-2006.

## Chenny Troupe

THE MARK CONSISTS OF STANDARD CHARACTERS WITHOUT CLAIM TO ANY PARTICULAR FONT, STYLE, SIZE, OR COLOR.

NO CLAIM IS MADE TO THE EXCLUSIVE RIGHT TO USE "TROUPE", APART FROM THE MARK AS SHOWN.

FOR PROVISION OF THERAPY, NAMELY, RECREATIONAL, OCCUPATIONAL, PHYSICAL, PSYCHOSOCIAL, BEHAVIORAL, SPEECH AND LANGUAGE, AND SUBSTANCE ABUSE REHABILITATION, USING ANIMAL ASSISTED THERAPY (U.S. CLS. 100 AND 101).

FIRST USE 0-0-1991; IN COMMERCE 0-0-1991.  
KATHERINE CHANG, EXAMINING ATTORNEY

SN 78-942,278. OPTIMAL READING SERVICES GROUP, INC., BIRMINGHAM, AL. FILED 8-1-2006.



NO CLAIM IS MADE TO THE EXCLUSIVE RIGHT TO USE "READINGS", APART FROM THE MARK AS SHOWN.  
THE MARK CONSISTS OF TWO FACES IN SILHOUETTE WITH OPPOSING ARROWS TRAVERSING A STYLIZED "O".

FOR MEDICAL RADIOLOGY SERVICES, NAMELY TELERADIOLOGY SERVICES (U.S. CLS. 100 AND 101).  
CAROL SPILS, EXAMINING ATTORNEY

SN 78-943,244. CHENNY TROUPE, INC., CHICAGO, IL. FILED 8-2-2006.

## Heeling Hearts

THE MARK CONSISTS OF STANDARD CHARACTERS WITHOUT CLAIM TO ANY PARTICULAR FONT, STYLE, SIZE, OR COLOR.

FOR PROVISION OF ANIMAL-ASSISTED THERAPY SERVICES, NAMELY, RECREATIONAL, OCCUPATIONAL, PHYSICAL, PSYCHOSOCIAL, BEHAVIORAL, SPEECH AND LANGUAGE AND SUBSTANCE ABUSE REHABILITATION (U.S. CLS. 100 AND 101).

FIRST USE 0-0-2002; IN COMMERCE 0-0-2002.  
KATHERINE CHANG, EXAMINING ATTORNEY

SN 78-942,301. OPTIMAL READING SERVICES GROUP, INC., BIRMINGHAM, AL. FILED 8-1-2006.

## OPTIMAL READINGS

THE MARK CONSISTS OF STANDARD CHARACTERS WITHOUT CLAIM TO ANY PARTICULAR FONT, STYLE, SIZE, OR COLOR.

NO CLAIM IS MADE TO THE EXCLUSIVE RIGHT TO USE "READINGS", APART FROM THE MARK AS SHOWN.

FOR MEDICAL RADIOLOGY SERVICES, NAMELY TELERADIOLOGY SERVICES (U.S. CLS. 100 AND 101).  
CAROL SPILS, EXAMINING ATTORNEY

SN 78-943,266. LIFEHEALTH LLC, LITTLETON, CO. FILED 8-2-2006.

## LifeHealth Good health is good business

THE MARK CONSISTS OF STANDARD CHARACTERS WITHOUT CLAIM TO ANY PARTICULAR FONT, STYLE, SIZE, OR COLOR.

FOR HEALTH CARE (U.S. CLS. 100 AND 101).

FIRST USE 6-1-2004; IN COMMERCE 6-1-2004.

SAMUEL E. SHARPER JR., EXAMINING ATTORNEY



**CLASS 44—(Continued).**

SN 78-947,045. TMS HEALTH, LLC, BOCA RATON, FL.  
FILED 8-8-2006.

# FORMALERT

THE MARK CONSISTS OF STANDARD CHARACTERS WITHOUT CLAIM TO ANY PARTICULAR FONT, STYLE, SIZE, OR COLOR.

FOR PROVIDING HEALTH CARE INFORMATION IN THE NATURE OF NOTIFICATIONS AND ANNOUNCEMENTS FROM PHARMACEUTICAL COMPANIES TO PHARMACIES AND HEALTHCARE PROVIDERS REGARDING FORMULARY STATUS CHANGES AND NEW FORMULARIES (U.S. CLS. 100 AND 101).  
CAROLINE WOOD, EXAMINING ATTORNEY

---

SN 78-950,938. ECOETERNITY, LLC, CENTREVILLE, VA.  
FILED 8-12-2006.



THE COLOR(S) BLACK AND GREEN IS/ARE CLAIMED AS A FEATURE OF THE MARK.

THE MARK CONSISTS OF BLACK LETTERING WITH A GREEN TREE SPLITTING THE WORD ECOETERNITY BETWEEN ECO AND ETERNITY; LEAVES SPREAD ABOVE THE WORD AND ROOTS SPREAD BELOW THE WORD.

FOR CEMETERY PLOT BEAUTIFICATION AND MAINTENANCE AND CONTINUAL UPKEEP OF FAMILY CEMETERY PLOTS (U.S. CLS. 100 AND 101).  
SOPHIA S. KIM, EXAMINING ATTORNEY

---

SN 78-951,960. JASON ENTERPRISES, INC., DALLAS, TX.  
FILED 8-15-2006.

# LIFE IN MOTION

THE MARK CONSISTS OF STANDARD CHARACTERS WITHOUT CLAIM TO ANY PARTICULAR FONT, STYLE, SIZE, OR COLOR.

FOR DISEASE, WEIGHT, WELLNESS, AND HEALTH MANAGEMENT THROUGH THE USE OF WEIGHT REDUCTION, DIET PLANNING, AND HEALTH AND WELLNESS SERVICES (U.S. CLS. 100 AND 101).  
FIRST USE 3-31-2006; IN COMMERCE 3-31-2006.  
PETER B. BROMAGHIM, EXAMINING ATTORNEY

**CLASS 44—(Continued).**

SN 78-956,438. BUTTERS, MARYJANE, MOSCOW, ID.  
FILED 8-21-2006.

# MARYJANE'S AMEN DIET

THE MARK CONSISTS OF STANDARD CHARACTERS WITHOUT CLAIM TO ANY PARTICULAR FONT, STYLE, SIZE, OR COLOR.

NO CLAIM IS MADE TO THE EXCLUSIVE RIGHT TO USE "DIET", APART FROM THE MARK AS SHOWN.

FOR PROVIDING A WEB SITE FEATURING INFORMATION ABOUT WEIGHT LOSS, WEIGHT CONTROL AND MAINTENANCE, DIET, RECIPES AND MEAL PLANNING, EXERCISE, NUTRITION, HEALTH, LIFESTYLE AND EMOTIONAL WELL-BEING, AND INTERACTIVE WEIGHT LOSS FEATURES, NAMELY, WEIGHT TRACKERS, SHOPPING LIST GENERATORS AND ONLINE DIET DIARIES; WEIGHT REDUCTION DIET PLANNING AND SUPERVISION SERVICES, NAMELY, PROVIDING WEIGHT LOSS, WEIGHT CONTROL AND WEIGHT MAINTENANCE SERVICES, MENU PLANNING, AND NUTRITION COUNSELING SERVICES; WEIGHT CONTROL EVALUATION SERVICES; WEIGHT CONTROL TREATMENT SERVICES; ADVICE AND COUNSELING SERVICES FOR DIET AND EMOTIONAL WELL-BEING; COUNSELING SERVICES IN THE FIELD OF WEIGHT LOSS, WEIGHT CONTROL, WEIGHT MAINTENANCE, NUTRITION, MENU PLANNING, AND HEALTHY LIFESTYLE AND EMOTIONAL WELL-BEING (U.S. CLS. 100 AND 101).  
REBECCA EISINGER, EXAMINING ATTORNEY

---

SN 78-957,054. AL-BIN-ALI, FAHD KHALAF, TUCSON, AZ.  
FILED 8-21-2006.



THE MARK CONSISTS OF A STYLIZED SILHOUETTE OF A PREGNANT WOMAN WITH THE WORDING OVUMATE APPEARING TO THE RIGHT.

FOR ONLINE REMOTE MONITORING OF FERTILITY DATA INDICATIVE OF THE HEALTH OR CONDITION OF AN INDIVIDUAL; PROVIDING HEALTH INFORMATION RELATING TO FERTILITY MONITORING AND OVULATION PREDICTION (U.S. CLS. 100 AND 101).  
DANIEL RUSSELL, EXAMINING ATTORNEY

**CLASS 44—(Continued).**

SN 78-959,754. BEVERLY ENTERPRISES, INC., FORT SMITH, AR. FILED 8-24-2006.

ALZHEIMER'S CARE BY BEVERLY

THE MARK CONSISTS OF STANDARD CHARACTERS WITHOUT CLAIM TO ANY PARTICULAR FONT, STYLE, SIZE, OR COLOR.

OWNER OF U.S. REG. NOS. 2,352,493, 3,184,577 AND OTHERS.

NO CLAIM IS MADE TO THE EXCLUSIVE RIGHT TO USE "ALZHEIMER'S CARE", APART FROM THE MARK AS SHOWN.

FOR MEDICAL COUNSELING, NAMELY, PROVIDING SUPPORT IN THE NATURE OF MEDICAL AND PSYCHOLOGICAL COUNSELING; NUTRITION COUNSELING; FACILITIES, NAMELY, HOSPITALS; PROVIDING MENTAL REHABILITATION FACILITIES; PROVIDING PHYSICAL REHABILITATION FACILITIES FOR LONG-TERM CARE FOR INDIVIDUALS WITH ALZHEIMER'S AND RELATED DEMENTIA (U.S. CLS. 100 AND 101).

CHARISMA HAMPTON, EXAMINING ATTORNEY

SN 78-959,759. BEVERLY ENTERPRISES, INC., FORT SMITH, AR. FILED 8-24-2006.

BEVERLY LIVING COMMUNITIES

THE MARK CONSISTS OF STANDARD CHARACTERS WITHOUT CLAIM TO ANY PARTICULAR FONT, STYLE, SIZE, OR COLOR.

OWNER OF U.S. REG. NOS. 2,352,492, 2,388,256 AND OTHERS.

NO CLAIM IS MADE TO THE EXCLUSIVE RIGHT TO USE "LIVING COMMUNITIES", APART FROM THE MARK AS SHOWN.

FOR HEALTH CARE SERVICES (U.S. CLS. 100 AND 101).

CHARISMA HAMPTON, EXAMINING ATTORNEY

**CLASS 44—(Continued).**

SN 78-959,766. BEVERLY LIVING CENTERS, FORT SMITH, DE. FILED 8-24-2006.

BEVERLY LIVING CENTERS

THE MARK CONSISTS OF STANDARD CHARACTERS WITHOUT CLAIM TO ANY PARTICULAR FONT, STYLE, SIZE, OR COLOR.

OWNER OF U.S. REG. NOS. 2,352,492, 2,388,256 AND OTHERS.

NO CLAIM IS MADE TO THE EXCLUSIVE RIGHT TO USE "LIVING CENTERS", APART FROM THE MARK AS SHOWN.

FOR HEALTH CARE SERVICES (U.S. CLS. 100 AND 101).

CHARISMA HAMPTON, EXAMINING ATTORNEY

SN 78-961,749. VIECARE, INC., CRANBERRY TOWNSHIP, PA. FILED 8-28-2006.

VieCare

THE MARK CONSISTS OF STANDARD CHARACTERS WITHOUT CLAIM TO ANY PARTICULAR FONT, STYLE, SIZE, OR COLOR.

FOR MANAGED HEALTHCARE SERVICES FOR THE ELDERLY (U.S. CLS. 100 AND 101).

YAT SYE, LEE, EXAMINING ATTORNEY

SN 78-962,519. BLUE CROSS BLUE SHIELD OF NORTH CAROLINA, DURHAM, NC. FILED 8-29-2006.

STICK IT TO THE FLU

THE MARK CONSISTS OF STANDARD CHARACTERS WITHOUT CLAIM TO ANY PARTICULAR FONT, STYLE, SIZE, OR COLOR.

NO CLAIM IS MADE TO THE EXCLUSIVE RIGHT TO USE FLU, APART FROM THE MARK AS SHOWN.

FOR HEALTH CARE PROGRAM, NAMELY, PROVIDING HEALTH INFORMATION RELATING TO THE FLU, FLU SHOTS, AND THE HOSTING OF FLU SHOT CLINICS, AND THE PROVISION OF FLU SHOTS IN CONNECTION WITH HEALTH CARE COVERAGE PLANS (U.S. CLS. 100 AND 101).

ZHALEH DELANEY, EXAMINING ATTORNEY

**CLASS 44—(Continued).**

SN 78-963,096. MMMM RANCH, LTD., DBA 4M WHITETAILS, FORT WORTH, TX. FILED 8-29-2006.



NO CLAIM IS MADE TO THE EXCLUSIVE RIGHT TO USE "WHITETAILS", APART FROM THE MARK AS SHOWN.

THE COLOR(S) RED WHITE BLUE AND BLACK IS/ARE CLAIMED AS A FEATURE OF THE MARK.

THE MARK CONSISTS OF AN EIGHT-POINT STAR FILLED WITH A RED, WHITE AND BLUE TEXAS FLAG. THE LEFT PORTION OF THE FLAG IS BLUE, THE TOP RIGHT IS WHITE, THE BOTTOM RIGHT IS RED, AND THE FIVE-POINT STAR IS WHITE. THE EIGHT-POINT STAR IS OUTLINED IN BLACK. BLACK SOLID DEER ANTLERS COME OUT OF THE TOP OF THE EIGHT-POINT STAR. THE WORDS "4M WHITETAILS" ARE IN SOLID BLACK ABOVE THE STAR, AND ARE SUPERIMPOSED OVER THE ANTLERS.

FOR BREEDING OF DEER (U.S. CLS. 100 AND 101).  
ROBIN MITTLER, EXAMINING ATTORNEY

**CLASS 44—(Continued).**

SN 78-963,770. KIDS TIME PEDIATRICS, LLC, MADISON, GA. FILED 8-30-2006.

**KIDS TIME PEDIATRICS**

THE MARK CONSISTS OF STANDARD CHARACTERS WITHOUT CLAIM TO ANY PARTICULAR FONT, STYLE, SIZE, OR COLOR.

NO CLAIM IS MADE TO THE EXCLUSIVE RIGHT TO USE "KIDS" AND "PEDIATRICS", APART FROM THE MARK AS SHOWN.

FOR MEDICAL SERVICES (U.S. CLS. 100 AND 101).  
ROBERT LAVACHE, EXAMINING ATTORNEY

SN 78-963,398. CALVIN N. TSAO, HOUSTON, TX. FILED 8-29-2006.



LASER | COSMETICS | MEDSPA

NO CLAIM IS MADE TO THE EXCLUSIVE RIGHT TO USE LASER AND COSMETICS AND MEDSPA, APART FROM THE MARK AS SHOWN.

THE COLOR(S) LIGHT GREEN, WHITE, GREEN AND BLACK IS/ARE CLAIMED AS A FEATURE OF THE MARK.

THE COLOR LIGHT GREEN APPEARS IN THE CIRCLE. THE COLOR WHITE APPEARS IN THE LETTER "I" WITHIN THE CIRCLE. THE COLOR GREEN APPEARS IN THE WORDING "IMPRESSIONS" SUPERIMPOSED OVER THE CIRCLE AND LETTER "I". THE COLOR BLACK APPEARS IN THE WORDING "LASER", "COSMETICS", AND "MEDSPA" AND THE TWO VERTICAL LINES IN BETWEEN THE WORDING "LASER" AND "COSMETICS" AND "COSMETICS" AND "MEDSPA".

FOR MEDICAL CLINICS (U.S. CLS. 100 AND 101).  
DANIEL RUSSELL, EXAMINING ATTORNEY

SN 78-964,137. AMERICAN NEVADA HOLDINGS, LLC, HENDERSON, NV. FILED 8-30-2006.

**AVENUE33**

THE MARK CONSISTS OF STANDARD CHARACTERS WITHOUT CLAIM TO ANY PARTICULAR FONT, STYLE, SIZE, OR COLOR.

FOR HEALTH SPA SERVICES, NAMELY, COSMETIC BODY AND FACE CARE SERVICES, PROVIDING SAUNA AND STEAM ROOM FACILITIES, NUTRITIONAL COUNSELING, MASSAGE THERAPY AND AROMATHERAPY; BEAUTY SALON SERVICES; PROVIDING RESERVATIONS, BOOKINGS, ADVICE AND COUNSELING SERVICES TO OTHERS IN THE FIELDS OF HEALTH SPAS AND BEAUTY SALONS; AND PROVIDING HEALTH SPA AND BEAUTY INFORMATION (U.S. CLS. 100 AND 101).

MICHAEL ENGEL, EXAMINING ATTORNEY

**CLASS 44—(Continued).**

SN 78-964,289. SPA WHERE YOU ARE, LLC, CHICAGO, IL.  
FILED 8-30-2006.



NO CLAIM IS MADE TO THE EXCLUSIVE RIGHT TO USE "SPA", APART FROM THE MARK AS SHOWN.

THE COLOR(S) LILAC, BLACK AND WHITE IS/ARE CLAIMED AS A FEATURE OF THE MARK.

THE MARK CONSISTS OF A WAVY LILAC COLORED SHAPE CONTAINING THE WHITE FACE OF WOMAN WITH BLACK HAIR AND LILAC LIPS IN UPPER LEFT CORNER, THE WORDS "SPA WHERE YOU ARE" IN CURLY BLACK LETTERS WITH WHITE SHADING AND THREE BLACK STARS - ONE ON TOP AND TWO ON THE SIDES.

FOR HEALTH SPA SERVICES, NAMELY, COSMETIC BODY CARE SERVICES (U.S. CLS. 100 AND 101).

FIRST USE 3-13-2006; IN COMMERCE 3-13-2006.

TANYA AMOS, EXAMINING ATTORNEY

SN 78-964,301. FIVE RIVERS, INC., BOISE, ID. FILED 8-30-2006.

## FIVE RIVERS

THE MARK CONSISTS OF STANDARD CHARACTERS WITHOUT CLAIM TO ANY PARTICULAR FONT, STYLE, SIZE, OR COLOR.

FOR LANDSCAPE GARDENING, CONSULTATION AND DESIGN SERVICES (U.S. CLS. 100 AND 101).

JIM RINGLE, EXAMINING ATTORNEY

**CLASS 44—(Continued).**

SN 78-964,337. AMERICAN NEVADA HOLDINGS, LLC, HENDERSON, NV. FILED 8-30-2006.

# Avenue33

FOR HEALTH SPA SERVICES, NAMELY, COSMETIC BODY AND FACE CARE SERVICES, PROVIDING SAUNA AND STEAM ROOM FACILITIES, NUTRITIONAL COUNSELING, MASSAGE THERAPY AND AROMATHERAPY; BEAUTY SALON SERVICES; PROVIDING RESERVATIONS, BOOKINGS, ADVICE AND COUNSELING SERVICES TO OTHERS IN THE FIELDS OF HEALTH SPAS AND BEAUTY SALONS; AND PROVIDING HEALTH SPA AND BEAUTY INFORMATION (U.S. CLS. 100 AND 101).

THEODORE MCBRIDE, EXAMINING ATTORNEY

SN 78-964,370. CARSON GAMING, L.L.C., LAS VEGAS, NV. FILED 8-30-2006.

## CASINO FANDANGO

THE MARK CONSISTS OF STANDARD CHARACTERS WITHOUT CLAIM TO ANY PARTICULAR FONT, STYLE, SIZE, OR COLOR.

OWNER OF U.S. REG. NOS. 2,968,485 AND 2,973,537.

FOR HEALTH SPA SERVICES, NAMELY, COSMETIC BODY CARE SERVICES; HEALTH SPA SERVICES FOR HEALTH AND WELLNESS OF THE BODY AND SPIRIT OFFERED AT A HEALTH RESORT; BEAUTY SALONS (U.S. CLS. 100 AND 101).

MORGAN WYNNE, EXAMINING ATTORNEY

SN 78-964,440. AMERICAN NEVADA HOLDINGS, LLC, HENDERSON, NV. FILED 8-30-2006.

# Avenue33

AT THE DISTRICT

FOR HEALTH SPA SERVICES, NAMELY, COSMETIC BODY AND FACE CARE SERVICES, PROVIDING SAUNA AND STEAM ROOM FACILITIES, NUTRITIONAL COUNSELING, MASSAGE THERAPY AND AROMATHERAPY; BEAUTY SALON SERVICES; PROVIDING RESERVATIONS, BOOKINGS, ADVICE AND COUNSELING SERVICES TO OTHERS IN THE FIELDS OF HEALTH SPAS AND BEAUTY SALONS; AND PROVIDING HEALTH SPA AND BEAUTY INFORMATION (U.S. CLS. 100 AND 101).

THEODORE MCBRIDE, EXAMINING ATTORNEY

**CLASS 44—(Continued).**

SN 78-964,494. AMERICAN NEVADA HOLDINGS, LLC, HENDERSON, NV. FILED 8-30-2006.

AVENUE33 AT THE DISTRICT

THE MARK CONSISTS OF STANDARD CHARACTERS WITHOUT CLAIM TO ANY PARTICULAR FONT, STYLE, SIZE, OR COLOR.

FOR HEALTH SPA SERVICES, NAMELY, COSMETIC BODY AND FACE CARE SERVICES, PROVIDING SAUNA AND STEAM ROOM FACILITIES, NUTRITIONAL COUNSELING, MASSAGE THERAPY AND AROMATHERAPY; BEAUTY SALON SERVICES; PROVIDING RESERVATIONS, BOOKINGS, ADVICE AND COUNSELING SERVICES TO OTHERS IN THE FIELDS OF HEALTH SPAS AND BEAUTY SALONS; AND PROVIDING HEALTH SPA AND BEAUTY INFORMATION (U.S. CLS. 100 AND 101).

HEATHER SAPP, EXAMINING ATTORNEY

SN 78-964,508. AMERICAN NEVADA HOLDINGS, LLC, HENDERSON, NV. FILED 8-30-2006.

AVENUE33 BROWNSTONES AT THE DISTRICT

THE MARK CONSISTS OF STANDARD CHARACTERS WITHOUT CLAIM TO ANY PARTICULAR FONT, STYLE, SIZE, OR COLOR.

FOR HEALTH SPA SERVICES, NAMELY, COSMETIC BODY AND FACE CARE SERVICES, PROVIDING SAUNA AND STEAM ROOM FACILITIES, NUTRITIONAL COUNSELING, MASSAGE THERAPY AND AROMATHERAPY; BEAUTY SALON SERVICES; PROVIDING RESERVATIONS, BOOKINGS, ADVICE AND COUNSELING SERVICES TO OTHERS IN THE FIELDS OF HEALTH SPAS AND BEAUTY SALONS; AND PROVIDING HEALTH SPA AND BEAUTY INFORMATION (U.S. CLS. 100 AND 101).

HEATHER SAPP, EXAMINING ATTORNEY

SN 78-964,699. GEORGE WEST MENTAL HEALTH FOUNDATION, INC., ATLANTA, GA. FILED 8-31-2006.

SKYLAND TRAIL

THE MARK CONSISTS OF STANDARD CHARACTERS WITHOUT CLAIM TO ANY PARTICULAR FONT, STYLE, SIZE, OR COLOR.

FOR MENTAL HEALTH SERVICES (U.S. CLS. 100 AND 101). FIRST USE 5-1-1989; IN COMMERCE 5-1-1989. RONALD MCMORROW, EXAMINING ATTORNEY

**CLASS 44—(Continued).**

SN 78-964,804. BECTON, DICKINSON AND COMPANY, FRANKLIN LAKES, NJ. FILED 8-31-2006.



OWNER OF U.S. REG. NOS. 2,510,232, 2,711,880 AND OTHERS.

NO CLAIM IS MADE TO THE EXCLUSIVE RIGHT TO USE "FLUSTOCK", APART FROM THE MARK AS SHOWN. THE MARK CONSISTS OF IN PART, A SHADED CIRCLE WITH SUNBURST AND PARTIAL ARC DESIGN.

FOR HEALTH CARE SERVICES, NAMELY, A PROGRAM FOR ASSISTING HOSPITALS WITH FLU PANDEMIC PREPAREDNESS (U.S. CLS. 100 AND 101). BENJAMIN OKEKE, EXAMINING ATTORNEY

SN 78-965,102. ADG, INC., BLOOMFIELD HILLS, MI. FILED 8-31-2006.

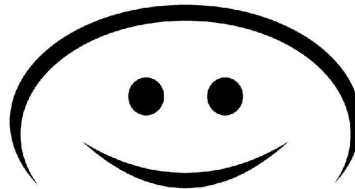

FOR DENTISTRY (U.S. CLS. 100 AND 101). FIRST USE 1-0-2000; IN COMMERCE 1-0-2000. GRETTA YAO, EXAMINING ATTORNEY

**CLASS 44—(Continued).**

SN 78-965,198. NATIONAL ASSOCIATION OF COUNTY AND CITY HEALTH OFFICIALS, WASHINGTON, DC. FILED 8-31-2006.



THE COLOR(S) TAN AND BLUE AND WHITE IS/ARE CLAIMED AS A FEATURE OF THE MARK.

THE COLOR BLUE APPEARS IN THE OUTLINES OF THE SHIELD AND THE CROSS; THE COLOR TAN APPEARS WITHIN THE SHIELD; THE COLOR WHITE APPEARS WITHIN THE CROSS.

THE MARK CONSISTS OF THREE-SIDED TAN SHIELD WITH A BLUE BORDER ENCLOSING A WHITE STYLIZED CROSS OR TREE FORM WITH A BLUE BORDER.

FOR PROVIDING HEALTH INFORMATION IN AN EFFORT TO PREVENT DISEASE AND PROMOTE GOOD HEALTH (U.S. CLS. 100 AND 101).

FIRST USE 7-26-2006; IN COMMERCE 7-26-2006.  
DAVID MURRAY, EXAMINING ATTORNEY

SN 78-965,947. JOSEPH MERLO LLC, SAN DIEGO, CA. FILED 9-1-2006.

## Good Vibrations Chiropractic

THE MARK CONSISTS OF STANDARD CHARACTERS WITHOUT CLAIM TO ANY PARTICULAR FONT, STYLE, SIZE, OR COLOR.

NO CLAIM IS MADE TO THE EXCLUSIVE RIGHT TO USE "CHIROPRACTIC", APART FROM THE MARK AS SHOWN.

FOR CHIROPRACTIC SERVICES; HEALTH CARE SERVICES, NAMELY WELLNESS PROGRAMS (U.S. CLS. 100 AND 101).

ATTIYA MALIK, EXAMINING ATTORNEY

**CLASS 44—(Continued).**

SN 78-966,403. DALEO, DAVID V., LOS ANGELES, CA. FILED 9-1-2006.

## Specializing in Psychology for the Future

THE MARK CONSISTS OF STANDARD CHARACTERS WITHOUT CLAIM TO ANY PARTICULAR FONT, STYLE, SIZE, OR COLOR.

FOR PSYCHOLOGICAL COUNSELING (U.S. CLS. 100 AND 101).

MICHAEL SOUDERS, EXAMINING ATTORNEY

SN 78-966,463. BINGHAM, TODD, CARLSBAD, CA. FILED 9-2-2006.

## CEDAR: Creating Effective Domestic Abuse Resolutions

THE MARK CONSISTS OF STANDARD CHARACTERS WITHOUT CLAIM TO ANY PARTICULAR FONT, STYLE, SIZE, OR COLOR.

FOR MENTAL HEALTH COUNSELING AND PSYCHOTHERAPY AS IT RELATES TO RELATIONSHIPS; MENTAL HEALTH SERVICES; PSYCHOLOGICAL CONSULTATION; PSYCHOLOGICAL COUNSELING (U.S. CLS. 100 AND 101).

FIRST USE 8-15-2002; IN COMMERCE 8-15-2002.  
ALICIA COLLINS, EXAMINING ATTORNEY

SN 78-966,920. PASCHE, BORIS C., CHICAGO, IL. FILED 9-5-2006.

## TheraBionic

THE MARK CONSISTS OF STANDARD CHARACTERS WITHOUT CLAIM TO ANY PARTICULAR FONT, STYLE, SIZE, OR COLOR.

FOR MEDICAL CONSULTATIONS; MEDICAL INFORMATION; MEDICAL SERVICES (U.S. CLS. 100 AND 101).

JOHN E. MICHOS, EXAMINING ATTORNEY

**CLASS 44—(Continued).**

SN 78-966,929. ASSOCIATED PLASTIC SURGEONS, INC., CARMEL, IN. FILED 9-5-2006.



NO CLAIM IS MADE TO THE EXCLUSIVE RIGHT TO USE "PHYSICIAN-DIRECTED SKIN CARE AND COSMECEUTICALS", APART FROM THE MARK AS SHOWN. FOR HEALTH SPA SERVICES, NAMELY COSMETIC BODY CARE SERVICES (U.S. CLS. 100 AND 101). EMILY CARLSEN, EXAMINING ATTORNEY

SN 78-967,822. NEVEU, MARK J, MIAMI BEACH, FL. FILED 9-6-2006.

# Wellome

THE MARK CONSISTS OF STANDARD CHARACTERS WITHOUT CLAIM TO ANY PARTICULAR FONT, STYLE, SIZE, OR COLOR. FOR HEALTH CARE SERVICES, NAMELY WELLNESS PROGRAMS (U.S. CLS. 100 AND 101). DANIEL RUSSELL, EXAMINING ATTORNEY

SN 78-967,833. NEVEU, MARK J, MIAMI BEACH, FL. FILED 9-6-2006.

# Wellgenie

THE MARK CONSISTS OF STANDARD CHARACTERS WITHOUT CLAIM TO ANY PARTICULAR FONT, STYLE, SIZE, OR COLOR. FOR PROVIDING HEALTH CARE INFORMATION BY TELEPHONE AND THE INTERNET (U.S. CLS. 100 AND 101). DANIEL RUSSELL, EXAMINING ATTORNEY

**CLASS 44—(Continued).**

SN 78-968,296. SARKISSIAN DENTAL CORPORATION, PALMDALE, CA. FILED 9-6-2006.

# We Take Care of the Uninsured

THE MARK CONSISTS OF STANDARD CHARACTERS WITHOUT CLAIM TO ANY PARTICULAR FONT, STYLE, SIZE, OR COLOR. FOR DENTIST SERVICES (U.S. CLS. 100 AND 101). STEVEN JACKSON, EXAMINING ATTORNEY

SN 78-968,322. SARKISSIAN DENTAL CORPORATION, PALMDALE, CA. FILED 9-6-2006.

# We Are The Dental Solution to the Healthcare Crisis

THE MARK CONSISTS OF STANDARD CHARACTERS WITHOUT CLAIM TO ANY PARTICULAR FONT, STYLE, SIZE, OR COLOR. FOR DENTIST SERVICES (U.S. CLS. 100 AND 101). STEVEN JACKSON, EXAMINING ATTORNEY

SN 78-968,626. BECK, WENDY, ROSLYN, NY. AND GOOD, PENELOPE, BALDWIN, NY. FILED 9-6-2006.

# Licebeaters

THE MARK CONSISTS OF STANDARD CHARACTERS WITHOUT CLAIM TO ANY PARTICULAR FONT, STYLE, SIZE, OR COLOR. FOR HEAD LICE REMOVAL SERVICES (U.S. CLS. 100 AND 101). FIRST USE 0-0-1997; IN COMMERCE 0-0-1997. LAURA KOVALSKY, EXAMINING ATTORNEY

**CLASS 44—(Continued).**

SN 78-970,316. NITROMED, INC., LEXINGTON, MA. FILED 9-8-2006.

**MORE LIFE TO LIVE**

THE MARK CONSISTS OF STANDARD CHARACTERS WITHOUT CLAIM TO ANY PARTICULAR FONT, STYLE, SIZE, OR COLOR.

FOR HEALTH CARE SERVICES, NAMELY, PROVIDING INFORMATION ON THE TOPIC OF HEALTH ISSUES AND HEALTH AWARENESS (U.S. CLS. 100 AND 101).

ANDREA HACK, EXAMINING ATTORNEY

SN 78-971,885. JOHNSTONE, DEBRA H., CAVE CREEK, AZ. FILED 9-11-2006.

**Wellness Effect**

THE MARK CONSISTS OF STANDARD CHARACTERS WITHOUT CLAIM TO ANY PARTICULAR FONT, STYLE, SIZE, OR COLOR.

NO CLAIM IS MADE TO THE EXCLUSIVE RIGHT TO USE "WELLNESS", APART FROM THE MARK AS SHOWN.

FOR HEALTH CONSULTING SERVICES UTILIZING COLOR, SOUND, AND LIGHT THERAPY (U.S. CLS. 100 AND 101).

AMY ALFIERI, EXAMINING ATTORNEY

SN 78-972,368. ADAMS RESPIRATORY OPERATIONS, INC., FORT WORTH, TX. FILED 9-12-2006.

**Jr. Mucus**

THE MARK CONSISTS OF STANDARD CHARACTERS WITHOUT CLAIM TO ANY PARTICULAR FONT, STYLE, SIZE, OR COLOR.

OWNER OF U.S. REG. NOS. 3,088,179 AND 3,116,483.

FOR PROVIDING INFORMATION, NAMELY NEWS AND ITEMS OF INTEREST CONCERNING RESPIRATORY AND PULMONARY CONDITIONS VIA A GLOBAL NETWORK (U.S. CLS. 100 AND 101).

JOHN HWANG, EXAMINING ATTORNEY

**CLASS 45—PERSONAL SERVICES**

SN 77-020,693. THE MAGI ASSOCIATES, INC., NEW YORK, NY. FILED 10-13-2006.

**LoveOracle**

THE MARK CONSISTS OF STANDARD CHARACTERS WITHOUT CLAIM TO ANY PARTICULAR FONT, STYLE, SIZE, OR COLOR.

FOR ASTROLOGY BASED COMPATIBILITY ANALYSIS TO DETERMINE RELATIONSHIP COMPARABILITY (U.S. CLS. 100 AND 101).

FIRST USE 12-31-2001; IN COMMERCE 12-31-2001.

JEFFERY COWARD, EXAMINING ATTORNEY

SN 78-577,883. CAMPBELL CONCERTS, INC., PEABODY, MA. FILED 3-1-2005.

THE COLOR(S) YELLOW, GRAY AND BLACK IS/ARE CLAIMED AS A FEATURE OF THE MARK.

THE MARK CONSISTS OF THE COLOR YELLOW, WHICH APPEARS IN THE CIRCLE NEXT TO THE FIRST LETTER "C" IN "CATHOLIC" AND AS A DARKER YELLOW CROSS INTERSECTING IN THE MIDDLE OF THE CIRCLE; THE COLOR GRAY APPEARS IN THE WORDING ".COM" AS WELL AS AN EXTENSION OF THE LOWER OPENING OF THE FIRST LETTER "C" IN "CATHOLIC" CONTINUING UPWARDS TOWARD THE UPPER OPENING OF THE LETTER; THE COLOR BLACK APPEARS IN THE WORDING "PROUD2BCATHOLIC".

FOR YOUTH MINISTERIAL SERVICES TO ENCOURAGE CATHOLIC PRIDE; MINISTERIAL SERVICES (U.S. CLS. 100 AND 101).

FIRST USE 7-1-2000; IN COMMERCE 2-1-2001.

SOPHIA S. KIM, EXAMINING ATTORNEY

SN 78-778,904. VERTICAL SCREEN, INC., SOUTHAMPTON, PA. FILED 12-22-2005.

**HRMS Toolbox**

THE MARK CONSISTS OF STANDARD CHARACTERS WITHOUT CLAIM TO ANY PARTICULAR FONT, STYLE, SIZE, OR COLOR.

NO CLAIM IS MADE TO THE EXCLUSIVE RIGHT TO USE "HRMS", APART FROM THE MARK AS SHOWN.

FOR PROVIDING EMPLOYEE BACKGROUND SCREENING SERVICES THROUGH CUSTOM INTEGRATION OF SCREENING REPORTING SERVICES WITH THIRD PARTY HUMAN RESOURCES MANAGEMENT SYSTEMS AND APPLICANT TRACKING SYSTEMS (U.S. CLS. 100 AND 101).

FIRST USE 10-6-2004; IN COMMERCE 10-6-2004.

HANNO RITTNER, EXAMINING ATTORNEY



**CLASS 45—(Continued).**

SN 78-785,203. FIND MY SPECIALIST, INC., COSTA MESA, CA. FILED 1-4-2006.

# SCREENNAME

THE MARK CONSISTS OF STANDARD CHARACTERS WITHOUT CLAIM TO ANY PARTICULAR FONT, STYLE, SIZE, OR COLOR.

FOR SOCIAL INTRODUCTION AGENCIES; PROVIDING INFORMATION REGARDING SOCIAL INTRODUCTION AND SOCIAL NETWORKING (U.S. CLS. 100 AND 101).

TRACY CROSS, EXAMINING ATTORNEY

**CLASS 45—(Continued).**

SN 78-940,804. US INVESTIGATIONS SERVICES, LLC, ANNANDALE, PA. FILED 7-31-2006.

# DVA

THE MARK CONSISTS OF STANDARD CHARACTERS WITHOUT CLAIM TO ANY PARTICULAR FONT, STYLE, SIZE, OR COLOR.

FOR INVESTIGATION SERVICES, NAMELY, MONITORING DRIVING RECORDS FOR VIOLATIONS (U.S. CLS. 100 AND 101).

BERNICE HOWSE, EXAMINING ATTORNEY

SN 78-855,871. CHOICEPOINT ASSET COMPANY, ALPHARETTA, GA. FILED 4-6-2006.

# RESIDENT DATA

THE MARK CONSISTS OF STANDARD CHARACTERS WITHOUT CLAIM TO ANY PARTICULAR FONT, STYLE, SIZE, OR COLOR.

OWNER OF U.S. REG. NO. 2,308,060. SEC. 2(F).

FOR RESIDENTIAL APARTMENT HOUSING INFORMATION MANAGEMENT, NAMELY, PRE-EMPLOYMENT AND BACKGROUND INVESTIGATION SERVICES AND TENANT BACKGROUND INVESTIGATION SERVICES, NAMELY, CRIMINAL BACKGROUND CHECKS (U.S. CLS. 100 AND 101).

FIRST USE 9-0-1998; IN COMMERCE 9-0-1998.

WILLIAM BRECKENFELD, EXAMINING ATTORNEY

SN 78-946,428. HIGHTECHNIQUE, INC., NEEDHAM, MA. FILED 8-7-2006.

# HighTechnique

THE MARK CONSISTS OF STANDARD CHARACTERS WITHOUT CLAIM TO ANY PARTICULAR FONT, STYLE, SIZE, OR COLOR.

FOR CONSULTING SERVICES IN THE FIELD OF MAINTAINING THE SECURITY AND INTEGRITY OF DATABASES; MONITORING OF COMPUTER SYSTEMS FOR SECURITY PURPOSES (U.S. CLS. 100 AND 101).

FIRST USE 12-1-1999; IN COMMERCE 12-1-1999.

TONJA GASKINS, EXAMINING ATTORNEY

SN 78-887,101. STULTZ, STEVEN K., CHICAGO, IL. AND STULTZ, BRENITA, CHICAGO, IL. FILED 5-18-2006.

# Teen-Town Chosen Generation Leadership Corps

THE MARK CONSISTS OF STANDARD CHARACTERS WITHOUT CLAIM TO ANY PARTICULAR FONT, STYLE, SIZE, OR COLOR.

NO CLAIM IS MADE TO THE EXCLUSIVE RIGHT TO USE "LEADERSHIP CORPS", APART FROM THE MARK AS SHOWN.

FOR CHARITABLE SERVICES, NAMELY, ORGANIZING YOUTH GROUPS TO UNDERTAKE PROJECTS TO BENEFIT THE NEEDY AND THE COMMUNITY TO ENCOURAGE LEADERSHIP, CHARACTER, COMPASSION, AND GOOD CITIZENSHIP (U.S. CLS. 100 AND 101).

JULIE WATSON, EXAMINING ATTORNEY

SN 78-953,037. FOU, AUGUSTINE C, NEW YORK, NY. FILED 8-16-2006.

# TrustedRx

THE MARK CONSISTS OF STANDARD CHARACTERS WITHOUT CLAIM TO ANY PARTICULAR FONT, STYLE, SIZE, OR COLOR.

FOR SECURITY PRINTING, NAMELY, ENCODING IDENTIFICATION INFORMATION ON VALUABLE DOCUMENTS AND PRODUCTS (U.S. CLS. 100 AND 101).

FIRST USE 7-27-2006; IN COMMERCE 7-27-2006.

JUSTINE D. PARKER, EXAMINING ATTORNEY

**CLASS 45—(Continued).**

SN 78-953,736. CENTARA LEGAL GROUP, APC, SAN DIEGO, CA. FILED 8-16-2006.

# Centara

THE MARK CONSISTS OF STANDARD CHARACTERS WITHOUT CLAIM TO ANY PARTICULAR FONT, STYLE, SIZE, OR COLOR.

FOR LEGAL SERVICES (U.S. CLS. 100 AND 101).  
FIRST USE 2-14-2003; IN COMMERCE 2-14-2003.  
BARBARA BROWN, EXAMINING ATTORNEY

---

SN 78-955,523. RADIO SYSTEMS CORPORATION, KNOXVILLE, TN. FILED 8-18-2006.

## PETSAFE RESCUE SERVICE

THE MARK CONSISTS OF STANDARD CHARACTERS WITHOUT CLAIM TO ANY PARTICULAR FONT, STYLE, SIZE, OR COLOR.

OWNER OF U.S. REG. NOS. 2,502,307 AND 2,618,673.  
NO CLAIM IS MADE TO THE EXCLUSIVE RIGHT TO USE "RESCUE SERVICE", APART FROM THE MARK AS SHOWN.

FOR ASSISTING IN LOCATING LOST PETS (U.S. CLS. 100 AND 101).  
PAMELA HIRSCHMAN, EXAMINING ATTORNEY

---

SN 78-955,584. RECTOR, KENNETH M., HOUSTON, TX. FILED 8-18-2006.

## Child Advocate Lifer

THE MARK CONSISTS OF STANDARD CHARACTERS WITHOUT CLAIM TO ANY PARTICULAR FONT, STYLE, SIZE, OR COLOR.

NO CLAIM IS MADE TO THE EXCLUSIVE RIGHT TO USE "CHILD ADVOCATE", APART FROM THE MARK AS SHOWN.

FOR CHILD ADVOCACY SERVICES, NAMELY, CASE MANAGEMENT COORDINATION OF LEGAL, SOCIAL AND PSYCHOLOGICAL SERVICES FOR ABUSED CHILDREN (U.S. CLS. 100 AND 101).  
ELLEN BURNS, EXAMINING ATTORNEY

**CLASS 45—(Continued).**

SN 78-960,440. YUANGBHANICH, DANNY, NORTHRIDGE, CA. FILED 8-25-2006.



THE MARK CONSISTS OF A BUILDING WITH PALM TREES ON EITHER SIDE AND BELOW THAT THE STYLIZED TEXT OF THE WORDING "FLIXDATES.COM". FOR INTERNET BASED SOCIAL NETWORKING, INTRODUCTION, AND DATING SERVICES (U.S. CLS. 100 AND 101).

FIRST USE 7-19-2006; IN COMMERCE 8-0-2006.  
STANLEY I. OSBORNE, EXAMINING ATTORNEY

---

SN 78-960,692. INILEX, INC., CHANDLER, AZ. FILED 8-25-2006.

# KnoWhere

THE MARK CONSISTS OF STANDARD CHARACTERS WITHOUT CLAIM TO ANY PARTICULAR FONT, STYLE, SIZE, OR COLOR.

FOR THEFT SECURITY SERVICES, NAMELY, LOCATING, TRACKING, MONITORING, AND RECOVERY OF VEHICLES, FLEETS, AND OTHER MOBILE ASSETS (U.S. CLS. 100 AND 101).

KARANENDRA S. CHHINA, EXAMINING ATTORNEY

---

SN 78-963,616. STERNE, KESSLER, GOLDSTEIN & FOX P.L.L.C., WASHINGTON, DC. FILED 8-30-2006.

## HOW POTENT IS YOUR PATENT?

THE MARK CONSISTS OF STANDARD CHARACTERS WITHOUT CLAIM TO ANY PARTICULAR FONT, STYLE, SIZE, OR COLOR.

FOR LEGAL SERVICES (U.S. CLS. 100 AND 101).  
JENNIFER KRISP, EXAMINING ATTORNEY

**CLASS 45—(Continued).**

SN 78-963,645. BALEOUT, PLANT CITY, FL. FILED 8-30-2006.



THE MARK CONSISTS OF THE TERM BALEOUT AND A BALL AND CHAIN RESTRAINT ON A RECTANGULAR BACKGROUND.

FOR REMINDER SERVICES IN THE AREA OF UPCOMING IMPORTANT DATES AND EVENTS (U.S. CLS. 100 AND 101).

JOHN DWYER, EXAMINING ATTORNEY

**CLASS 45—(Continued).**

SN 78-967,959. COMELLA, CHRISTOPHER, CAMBRIDGE, MD. FILED 9-6-2006.

the world is your party

THE MARK CONSISTS OF STANDARD CHARACTERS WITHOUT CLAIM TO ANY PARTICULAR FONT, STYLE, SIZE, OR COLOR.

FOR INTERNET BASED SOCIAL NETWORKING, INTRODUCTION, AND DATING SERVICES (U.S. CLS. 100 AND 101).

PAM WILLIS, EXAMINING ATTORNEY

SN 78-966,667. BOYD, WALLACE BASS, WASHINGTON, DC. FILED 9-3-2006.

Electric Shaman

THE MARK CONSISTS OF STANDARD CHARACTERS WITHOUT CLAIM TO ANY PARTICULAR FONT, STYLE, SIZE, OR COLOR.

FOR PROVIDING INFORMATION ON TECHNIQUES FOR IMPROVING PERSONAL CREATIVITY (U.S. CLS. 100 AND 101).

MATTHEW MCDOWELL, EXAMINING ATTORNEY

SN 78-969,292. SILVA, DAVE, BOISE, ID. FILED 9-7-2006.

FORESTARY

THE MARK CONSISTS OF STANDARD CHARACTERS WITHOUT CLAIM TO ANY PARTICULAR FONT, STYLE, SIZE, OR COLOR.

FOR FUNERAL ARRANGEMENT SERVICES FEATURING CREMATION AND BURIAL FACILITIES (U.S. CLS. 100 AND 101).

DAVID YONTEF, EXAMINING ATTORNEY

SN 78-967,608. LORI D. HOLMES AND DURAY OUBRE PARTNERSHIP, THE, PRAIRIEVILLE, LA. FILED 9-5-2006.

Sitters-R-Us

THE MARK CONSISTS OF STANDARD CHARACTERS WITHOUT CLAIM TO ANY PARTICULAR FONT, STYLE, SIZE, OR COLOR.

FOR BABY SITTING (U.S. CLS. 100 AND 101).  
HOWARD SMIGA, EXAMINING ATTORNEY

SN 78-971,037. SILVA, DAVE, BOISE, ID. FILED 9-11-2006.

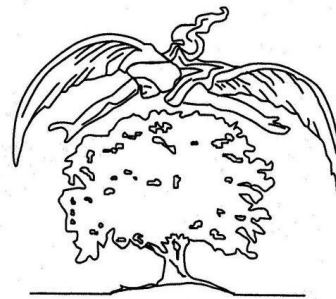

FOR FUNERAL ARRANGEMENT SERVICES FEATURING CREMATION AND BURIAL FACILITIES (U.S. CLS. 100 AND 101).

DAVID YONTEF, EXAMINING ATTORNEY

**CLASS 45—(Continued).**

SN 78-972,897, NOBLE GRACE LLC, NEW YORK, NY.  
FILED 9-12-2006.

# LoveByDNA

THE MARK CONSISTS OF STANDARD CHARACTERS WITHOUT CLAIM TO ANY PARTICULAR FONT, STYLE, SIZE, OR COLOR.

FOR ASTROLOGICAL FORECASTING; ASTROLOGY CONSULTATION; HOROSCOPE FORECASTING; HOROSCOPES; PROVIDING HOROSCOPE INFORMATION VIA COMPUTER NETWORKS; ZODIAC CONSULTATION (U.S. CLS. 100 AND 101).

RICHARD A. STRASER, EXAMINING ATTORNE

\* \* \* \* \*

SECTION 3.—PRIOR UNITED STATES CLASSIFICATION

APPLICATION IN MORE THAN ONE CLASS

SN 78-570,390. PARENTS' CHOICE FOUNDATION, COMPRISING CLAIRE S. GREEN, SARA R. PASTERNAK, SUSAN P. BEACHAM, AND DIANA HUSS GREEN, ALL U.S. CITIZENS, TIMONIUM, MD. FILED 2-18-2005.

THE CERTIFICATION MARK AS USED BY AUTHORIZED PERSONS CERTIFIES THAT THE GOODS AND SERVICES HAVE BEEN REVIEWED AND THAT THEIR CONTENT MEETS THE CERTIFIER'S STANDARDS AS TO ABILITY TO STIMULATE IMAGINATION, ENCOURAGING LOGICAL THINKING, ENTERTAIN AND TEACH; VERSATILITY, PURPOSEFULNESS, SAFETY, LACK OF RACIST, SEXIST AND AGIST CONTENT, ATTRACTIVENESS AND CHILD APPEAL.



THE MARK CONSISTS OF THE DESIGN OF A WOMAN SURROUNDED BY CHILDREN.

**CLASS A—GOODS**

FOR MOTION PICTURE FILMS, AUDIOVISUAL RECORDINGS, BOOKS, TOYS, MUSICAL SOUND RECORDINGS, SOFTWARE, MAGAZINES, VIDEOS, PRERECORDED DVDS, VIDEO GAMES, ELECTRONIC GAMES.

FIRST USE 12-0-1981; IN COMMERCE 12-0-1981.

**CLASS B—SERVICES**

FOR TELEVISION PROGRAMS AND WEBSITES.

FIRST USE 12-0-1981; IN COMMERCE 12-0-1981.

BARBARA GAYNOR, EXAMINING ATTORNE

\* \* \* \* \*

SECTION 4.—PRIOR UNITED STATES CLASSIFICATION

APPLICATION IN ONE CLASS

COLLECTIVE MEMBERSHIP MARKS

CLASS 200—COLLECTIVE MEMBERSHIP  
SN 78-804,295. PI BETA PHI, TOWN & COUNTRY, MO.  
FILED 2-1-2006.



OWNER OF U.S. REG. NOS. 244,812 AND 617,299.  
THE MARK CONSISTS OF DIAMOND SHAPED BORDER  
AROUND A BIRD GRASPING A ARROW IN ONE TALON.  
FOR INDICATING MEMBERSHIP IN A COLLEGIATE  
SORORITY.  
FIRST USE 0-0-1912; IN COMMERCE 0-0-1912.  
ANN E. SAPPENFIELD, EXAMINING ATTORNEY

CERTIFICATION MARKS

CLASS A—GOODS

SN 78-432,688. WIMAX FORUM, MOUNTAIN VIEW, CA.  
FILED 6-9-2004.



OWNER OF U.S. REG. NO. 3,182,504.

TM 854

NO CLAIM IS MADE TO THE EXCLUSIVE RIGHT TO  
USE "CERTIFIED", APART FROM THE MARK AS SHOWN.  
THE CERTIFICATION MARK, AS USED BY PERSONS  
AUTHORIZED BY THE CERTIFIER, CERTIFIES THE  
INTEROPERABILITY OF THE GOODS BASED ON THE  
802.16 STANDARD.

SEC. 2(F) AS TO "WIMAX" AND "WIMAX FORUM".  
FOR BROADBAND WIRELESS EQUIPMENT AND  
HARDWARE, NAMELY, NETWORKING PRODUCTS.  
VERNA BETH RIRIE, EXAMINING ATTORNEY

SN 78-729,786. DIGITAL ASSURANCE CERTIFICATION,  
LLC, ORLANDO, FL. FILED 10-10-2005.

DAC BOND

THE MARK CONSISTS OF STANDARD CHARACTERS  
WITHOUT CLAIM TO ANY PARTICULAR FONT, STYLE,  
SIZE, OR COLOR.

NO CLAIM IS MADE TO THE EXCLUSIVE RIGHT TO  
USE BOND, APART FROM THE MARK AS SHOWN.

THE CERTIFICATION MARK, AS USED BY PERSONS  
AUTHORIZED BY THE CERTIFIER, CERTIFIES THAT THE  
MUNICIPAL SECURITIES PROVIDED HAVE COMPLIED  
WITH THE U.S. SECURITIES AND EXCHANGE COMMISS-  
SION'S DISCLOSURE AND REPORTING REQUIREMENTS  
AS SET FORTH IN SEC RULE 15C2-12.

FOR MUNICIPAL SECURITIES.  
GISELLE AGOSTO, EXAMINING ATTORNEY

CLASS B—SERVICES

SN 78-425,026. MERELINDA FARMS, LLC, DBA ALPACA.-  
COM LLC, WHITMORE LAKE, MI. FILED 5-25-2004.

ALPACAMARK

THE MARK CONSISTS OF STANDARD CHARACTERS  
WITHOUT CLAIM TO ANY PARTICULAR FONT, STYLE,  
SIZE, OR COLOR.

APRIL 24, 2007

U.S. PATENT AND TRADEMARK OFFICE

TM 855

THE CERTIFICATION MARK, AS USED BY AUTHORIZED PERSONS, CERTIFIES THE HEALTH AND PHYSICAL CHARACTERISTICS OF ANIMALS.  
FOR LIVE ANIMALS.  
FIRST USE 3-29-2002; IN COMMERCE 5-25-2004.

LESLEY LAMOTHE, EXAMINING ATTORNE

\* \* \* \* \*

# TRADEMARK REGISTRATIONS ISSUED

## PRINCIPAL REGISTER

### SECTION 1.— INTERNATIONAL CLASSIFICATION

The short titles associated below with the international class numbers are terms designed merely for quick identification and are not an official part of the international classification. The full names of international classes are given in section 6.1 of the trademark rules of practice.

The designation "U.S. Cl." appearing in this section refers to the U.S. class in effect prior to Sep. 1, 1973 rather than the international class which applies to applications filed on or after that date. For adoption of international classification see notice in the OFFICIAL GAZETTE of Jun. 26, 1973 (911 O.G. TM 210).

#### CLASS 1—CHEMICALS

- 3,232,073. **MISCELLANEOUS DESIGN**. IMPERIAL CHEMICAL INDUSTRIES PLC, MULTIPLE CLASS, (INT. CLS. 1, 2, 3, 5, 16, 30, 35, 40 AND 42), (U.S. CLS. 1, 2, 4, 5, 6, 10, 11, 16, 18, 22, 23, 26, 29, 37, 38, 44, 46, 50, 51, 52, 100, 101, 102, 103 AND 106). SN 76-445,562. PUB. 2-6-2007. FILED 8-30-2002.
- 3,232,176. **CORRO TRIBLUE (BLOCK FORM)**. ATOTECH DEUTSCHLAND GMBH. (U.S. CLS. 1, 5, 6, 10, 26 AND 46). SN 76-651,122. PUB. 2-6-2007. FILED 11-28-2005.
- 3,232,692. **D-OX (BLOCK FORM)**. DUNLOP AEROSPACE LIMITED, MULTIPLE CLASS, (INT. CLS. 1, 2 AND 12), (U.S. CLS. 1, 5, 6, 10, 11, 16, 19, 21, 23, 26, 31, 35, 44 AND 46). SN 78-751,773. PUB. 2-6-2007. FILED 11-10-2005.
- 3,232,693. **NEXUSPHARMA (BLOCK FORM)**. WEBER, LUTZ, MULTIPLE CLASS, (INT. CLS. 1, 5 AND 42), (U.S. CLS. 1, 5, 6, 10, 18, 26, 44, 46, 51, 52, 100 AND 101). SN 78-751,879. PUB. 2-6-2007. FILED 11-11-2005.
- 3,232,704. **SEPTI-FREE (BLOCK FORM)**. A & V, INC., (U.S. CLS. 1, 5, 6, 10, 26 AND 46). SN 78-754,189. PUB. 2-6-2007. FILED 11-15-2005.
- 3,232,758. **KF POLYMER L AND DESIGN**. KUREHA CORPORATION, (U.S. CLS. 1, 5, 6, 10, 26 AND 46). SN 78-774,796. PUB. 2-6-2007. FILED 12-16-2005.
- 3,232,774. **LACTISWEET (BLOCK FORM)**. DANISCO A/S, MULTIPLE CLASS, (INT. CLS. 1 AND 30), (U.S. CLS. 1, 5, 6, 10, 26 AND 46). SN 78-784,028. PUB. 2-6-2007. FILED 1-3-2006.
- 3,232,808. **DUROSLIDE (BLOCK FORM)**. FENNER DUNLOP AMERICAS, INC., (U.S. CLS. 1, 5, 6, 10, 26 AND 46). SN 78-808,141. PUB. 2-6-2007. FILED 2-6-2006.
- 3,232,879. **SEQUEST-ALL (BLOCK FORM)**. SPER CHEMICAL CORPORATION, (U.S. CLS. 1, 5, 6, 10, 26 AND 46). SN 78-838,380. PUB. 2-6-2007. FILED 3-15-2006.
- 3,232,996. **BLS (BLOCK FORM)**. MAYZO, INC., (U.S. CLS. 1, 5, 6, 10, 26 AND 46). SN 78-879,682. PUB. 2-6-2007. FILED 5-9-2006.
- 3,233,136. **PRIMACT (BLOCK FORM)**. NALCO COMPANY, (U.S. CLS. 1, 5, 6, 10, 26 AND 46). SN 78-907,106. PUB. 2-6-2007. FILED 6-13-2006.
- 3,233,196. **ELEFAC (BLOCK FORM)**. ALZO INTERNATIONAL INC., DBA BERNEI CHEMICAL COMPANY INC., (U.S. CLS. 1, 5, 6, 10, 26 AND 46). SN 78-910,203. PUB. 2-6-2007. FILED 6-16-2006.
- 3,233,411. **EASY ACID (BLOCK FORM)**. UNITED CHEMICAL CORPORATION, (U.S. CLS. 1, 5, 6, 10, 26 AND 46). SN 78-918,009. PUB. 2-6-2007. FILED 6-27-2006.
- 3,233,412. **SUPER STAIN TREAT (BLOCK FORM)**. UNITED CHEMICAL CORPORATION, (U.S. CLS. 1, 5, 6, 10, 26 AND 46). SN 78-918,014. PUB. 2-6-2007. FILED 6-27-2006.
- 3,233,465. **ENPURE (BLOCK FORM)**. ENCOM, INC., (U.S. CLS. 1, 5, 6, 10, 26 AND 46). SN 78-921,820. PUB. 2-6-2007. FILED 7-3-2006.
- 3,233,467. **ENFOAM (BLOCK FORM)**. ENCOM, INC., (U.S. CLS. 1, 5, 6, 10, 26 AND 46). SN 78-921,828. PUB. 2-6-2007. FILED 7-3-2006.
- 3,233,469. **CHEMBLEND (BLOCK FORM)**. ENCOM, INC., (U.S. CLS. 1, 5, 6, 10, 26 AND 46). SN 78-921,838. PUB. 2-6-2007. FILED 7-3-2006.
- 3,233,520. **FIFA CLUB WORLD CHAMPIONSHIP (BLOCK FORM)**. FÉDÉRATION INTERNATIONALE DE FOOTBALL ASSOCIATION (FIFA), MULTIPLE CLASS, (INT. CLS. 1, 3, 4, 5, 6, 7, 8, 9, 10, 11, 12, 14, 15, 16, 18, 20, 21, 24, 25, 26, 27, 28, 29, 30, 31, 32, 33, 34, 35, 36, 37, 38, 39, 40, 41, 42 AND 43), (U.S. CLS. 1, 2, 3, 4, 5, 6, 8, 9, 10, 12, 13, 14, 15, 17, 18, 19, 20, 21, 22, 23, 25, 26, 27, 28, 29, 30, 31, 32, 33, 34, 35, 36, 37, 38, 39, 40, 41, 42, 44, 45, 46, 47, 48, 49, 50, 51, 52, 100, 101, 102, 103, 104, 105, 106 AND 107). SN 79-004,476. PUB. 2-6-2007. FILED 6-25-2004.
- 3,233,541. **RASCO (BLOCK FORM)**. RASCOR SPEZIALBAU GMBH, MULTIPLE CLASS, (INT. CLS. 1, 7, 17, 19, 37 AND 42), (U.S. CLS. 1, 5, 6, 10, 12, 13, 19, 21, 23, 26, 31, 33, 34, 35, 46, 50, 100, 101, 103 AND 106). SN 79-015,184. PUB. 2-6-2007. FILED 10-6-2004.
- 3,233,577. **IMR (BLOCK FORM)**. IMR INTERNATIONAL MINERAL RESOURCES B.V., MULTIPLE CLASS, (INT. CLS. 1, 6, 7, 37 AND 40), (U.S. CLS. 1, 2, 5, 6, 10, 12, 13, 14, 19, 21, 23, 25, 26, 31, 34, 35, 46, 50, 100, 103 AND 106). SN 79-018,013. PUB. 2-6-2007. FILED 10-25-2005.
- 3,233,584. **ENVINOX (BLOCK FORM)**. UHDE GMBH, MULTIPLE CLASS, (INT. CLS. 1, 7, 37 AND 42), (U.S. CLS. 1, 5, 6, 10, 13, 19, 21, 23, 26, 31, 34, 35, 46, 100, 101, 103 AND 106). SN 79-018,398. PUB. 2-6-2007. FILED 11-10-2004.
- 3,233,595. **JUST ADD KEMIRA (BLOCK FORM)**. KEMIRA OYJ, MULTIPLE CLASS, (INT. CLS. 1, 2, 16 AND 42), (U.S. CLS. 1, 2, 5, 6, 10, 11, 16, 22, 23, 26, 29, 37, 38, 46, 50, 100 AND 101). SN 79-019,050. PUB. 2-6-2007. FILED 8-22-2005.
- 3,233,612. **ECOCOOL (BLOCK FORM)**. FUCHS PETROLUB AG, (U.S. CLS. 1, 5, 6, 10, 26 AND 46). SN 79-019,824. PUB. 2-6-2007. FILED 11-24-2005.
- 3,233,638. **RENOFORM (BLOCK FORM)**. FUCHS PETROLUB AG, MULTIPLE CLASS, (INT. CLS. 1, 2, 3 AND 4), (U.S. CLS. 1, 4, 5, 6, 10, 11, 15, 16, 26, 46, 50, 51 AND 52). SN 79-020,843. PUB. 2-6-2007. FILED 11-28-2005.
- 3,233,652. **MISCELLANEOUS DESIGN**. ZAKRYTOE AKTIONERNOE OBSHCHESTVO: "RUSSKAYA MEDNAYA KOMPANIA", MULTIPLE CLASS, (INT. CLS. 1, 6 AND 14), (U.S. CLS. 1, 2, 5, 6, 10, 12, 13, 14, 23, 25, 26, 27, 28, 46 AND 50). SN 79-021,398. PUB. 2-6-2007. FILED 8-9-2005.
- 3,233,654. **TFC (BLOCK FORM)**. JACOB COMPOSITE GMBH, MULTIPLE CLASS, (INT. CLS. 1 AND 17), (U.S. CLS. 1, 5, 6, 10, 12, 13, 26, 35, 46 AND 50). SN 79-021,420. PUB. 2-6-2007. FILED 11-3-2005.
- 3,233,672. **THERMISOL (STYLIZED)**. FUCHS PETROLUB AG, MULTIPLE CLASS, (INT. CLS. 1 AND 4), (U.S. CLS. 1, 5, 6, 10, 15, 26 AND 46). SN 79-022,172. PUB. 2-6-2007. FILED 12-2-2005.
- 3,233,679. **MISCELLANEOUS DESIGN**. SHANDONG DONGGYUE CHEMICAL CO., LTD., (U.S. CLS. 1, 5, 6, 10, 26 AND 46). SN 79-022,514. PUB. 2-6-2007. FILED 12-5-2005.
- 3,233,681. **PICASSIAN (BLOCK FORM)**. STAHL INTERNATIONAL B.V., (U.S. CLS. 1, 5, 6, 10, 26 AND 46). SN 79-022,694. PUB. 2-6-2007. FILED 1-18-2006.
- 3,233,684. **UNLOCKING THE MAGIC OF NATURE (BLOCK FORM)**. NOVOZYMES A/S, MULTIPLE CLASS, (INT. CLS. 1, 41 AND 42), (U.S. CLS. 1, 5, 6, 10, 26, 46, 100, 101 AND 107). SN 79-022,791. PUB. 2-6-2007. FILED 3-30-2006.
- 3,233,735. **DOTTIKON EXCLUSIVE SYNTHESIS AND DESIGN**. DOTTIKON ES HOLDING AG, MULTIPLE CLASS,



(INT. CLS. 1, 5 AND 42), (U.S. CLS. 1, 5, 6, 10, 18, 26, 44, 46, 51, 52, 100 AND 101). SN 79-025,747. PUB. 2-6-2007. FILED 4-21-2006.

## CLASS 2—PAINTS

- 3,232,073 ( *See Class 1 for this trademark* ).  
 3,232,199. **GREEN DEVICE AND DESIGN**. TAIWAN GREEN DEVICE CO., LTD., (U.S. CLS. 6, 11 AND 16). SN 76-655,554. PUB. 1-23-2007. FILED 2-22-2006.  
 3,232,342. **LIQUITITE (BLOCK FORM)**. LIQUIGUARD TECHNOLOGIES, INC., (U.S. CLS. 6, 11 AND 16). SN 78-339,809. PUB. 9-14-2004. FILED 12-11-2003.  
 3,232,610. **CORTEC (BLOCK FORM)**. CORTEC CORPORATION, MULTIPLE CLASS, (INT. CLS. 2 AND 3), (U.S. CLS. 1, 4, 6, 11, 16, 50, 51 AND 52). SN 78-731,707. PUB. 2-6-2007. FILED 10-12-2005.  
 3,232,692 ( *See Class 1 for this trademark* ).  
 3,232,971. **THOMPSON'S (BLOCK FORM)**. SWIMC, INC., (U.S. CLS. 6, 11 AND 16). SN 78-869,614. PUB. 2-6-2007. FILED 4-26-2006.  
 3,232,990. **LASERNETWORKS (BLOCK FORM)**. LASERNETWORKS INC, MULTIPLE CLASS, (INT. CLS. 2, 35 AND 37), (U.S. CLS. 6, 11, 16, 100, 101, 102, 103 AND 106). SN 78-877,524. PUB. 2-6-2007. FILED 5-5-2006.  
 3,233,128. **BIOCORR (BLOCK FORM)**. CORTEC CORPORATION, (U.S. CLS. 6, 11 AND 16). SN 78-906,134. PUB. 2-6-2007. FILED 6-12-2006.  
 3,233,149. **CLEAR DEFENSE (BLOCK FORM)**. SPECIALTY CONSTRUCTION BRANDS, INC., (U.S. CLS. 6, 11 AND 16). SN 78-907,808. PUB. 2-6-2007. FILED 6-14-2006.  
 3,233,595 ( *See Class 1 for this trademark* ).  
 3,233,638 ( *See Class 1 for this trademark* ).  
 3,233,743. **ADGREENCOAT (BLOCK FORM)**. NIHON YAKU-HIN KENYUJYO; KABUSHIKI KAISHA, (U.S. CLS. 6, 11 AND 16). SN 79-026,421. PUB. 2-6-2007. FILED 6-12-2006.

## CLASS 3—COSMETICS AND CLEANING PREPARATIONS

- 3,232,073 ( *See Class 1 for this trademark* ).  
 3,232,121. **THICK VOLUMIZER (BLOCK FORM)**. ALAGIO CORP., (U.S. CLS. 1, 4, 6, 50, 51 AND 52). SN 76-635,743. PUB. 2-6-2007. FILED 4-11-2005.  
 3,232,123. **BASKETS ON THE RUN (BLOCK FORM)**. BASKETS ON THE RUN, (U.S. CLS. 1, 4, 6, 50, 51 AND 52). SN 76-635,948. PUB. 2-6-2007. FILED 4-13-2005.  
 3,232,194. **NATURE'S GATE ORGANICS ADVANCED CARE (STYLIZED)**. LEVLAD, INCORPORATED, (U.S. CLS. 1, 4, 6, 50, 51 AND 52). SN 76-653,614. PUB. 2-6-2007. FILED 1-13-2006.  
 3,232,214. **LIGHT DEFENSE (BLOCK FORM)**. FALLIEN COSMECEUTICALS, LTD., DBA FALLENE LTD., (U.S. CLS. 1, 4, 6, 50, 51 AND 52). SN 76-659,645. PUB. 2-6-2007. FILED 5-5-2006.  
 3,232,375. **OFF SHORE AND DESIGN**. OFF SHORE GLOBAL LICENSING CORP., DBA OFF SHORE OF CALIFORNIA, INC., MULTIPLE CLASS, (INT. CLS. 3, 9, 18, 24 AND 28), (U.S. CLS. 1, 2, 3, 4, 6, 21, 22, 23, 26, 36, 38, 41, 42, 50, 51 AND 52). SN 78-499,454. PUB. 2-6-2007. FILED 10-13-2004.  
 3,232,389. **BOSS SKIN (BLOCK FORM)**. HUGO BOSS TRADE MARK MANAGEMENT, (U.S. CLS. 1, 4, 6, 50, 51 AND 52). SN 78-534,632. PUB. 2-6-2007. FILED 12-17-2004.  
 3,232,467. **THE SOAP STORY (BLOCK FORM)**. THE SOAP STORY N.V., MULTIPLE CLASS, (INT. CLS. 3 AND 35), (U.S. CLS. 1, 4, 6, 50, 51, 52, 100, 101 AND 102). SN 78-618,028. PUB. 10-31-2006. FILED 4-27-2005.  
 3,232,483. **SUNRISE SKINCARE AND DESIGN**. SUNRISE SKINCARE, LLC, (U.S. CLS. 1, 4, 6, 50, 51 AND 52). SN 78-632,603. PUB. 2-6-2007. FILED 5-18-2005.  
 3,232,502. **MILLER ET BERTAUX (BLOCK FORM)**. MILLER, FRANCIS, AND BERTAUX, PATRICK, (U.S. CLS. 1, 4, 6, 50, 51 AND 52). SN 78-655,768. PUB. 2-6-2007. FILED 6-22-2005.  
 3,232,536. **METALLINE (BLOCK FORM)**. METALLINE CORPORATION, (U.S. CLS. 1, 4, 6, 50, 51 AND 52). SN 78-682,692. PUB. 2-6-2007. FILED 8-1-2005.  
 3,232,549. **BÜJI BLOCK (BLOCK FORM)**. CADE LABORATORIES, LLC, MULTIPLE CLASS, (INT. CLS. 3 AND 5), (U.S. CLS. 1, 4, 6, 18, 44, 46, 50, 51 AND 52). SN 78-692,497. PUB. 2-6-2007. FILED 8-15-2005.  
 3,232,562. **COLOR FEVER (BLOCK FORM)**. LANCOME PARFUMS ET BEAUTE & CIE, (U.S. CLS. 1, 4, 6, 50, 51 AND 52). SN 78-699,681. PUB. 2-6-2007. FILED 8-24-2005.  
 3,232,610 ( *See Class 2 for this trademark* ).  
 3,232,675. **RIPS KLEAN THROUGH! (BLOCK FORM)**. W.M. BARR AND COMPANY INC., (U.S. CLS. 1, 4, 6, 50, 51 AND 52). SN 78-748,548. PUB. 2-6-2007. FILED 11-7-2005.  
 3,232,714. **RV PRO 200 (STYLIZED)**. A & V, INC., (U.S. CLS. 1, 4, 6, 50, 51 AND 52). SN 78-756,782. PUB. 2-6-2007. FILED 11-18-2005.  
 3,232,744. **ME SUÁ (BLOCK FORM)**. MENENDEZ, JORGE SUAREZ, MULTIPLE CLASS, (INT. CLS. 3 AND 5), (U.S. CLS. 1, 4, 6, 18, 44, 46, 50, 51 AND 52). SN 78-768,301. PUB. 2-6-2007. FILED 12-7-2005.  
 3,232,810. **ORATEC (BLOCK FORM)**. ORATEC CORPORATION, MULTIPLE CLASS, (INT. CLS. 3 AND 10), (U.S. CLS. 1, 4, 6, 26, 39, 44, 50, 51 AND 52). SN 78-808,998. PUB. 2-6-2007. FILED 2-7-2006.  
 3,232,816. **IN YOUR OWN SKIN (BLOCK FORM)**. IN YOUR OWN SKIN SKIN THERAPY CENTER, INC., MULTIPLE CLASS, (INT. CLS. 3 AND 44), (U.S. CLS. 1, 4, 6, 50, 51, 52, 100 AND 101). SN 78-811,005. PUB. 2-6-2007. FILED 2-9-2006.  
 3,232,933. **TRACY ELLEN TRACY (BLOCK FORM)**. L. C. LICENSING, INC., (U.S. CLS. 1, 4, 6, 50, 51 AND 52). SN 78-859,553. PUB. 2-6-2007. FILED 4-12-2006.  
 3,232,984. **WECHEM AND DESIGN**. WEICHEM INC, (U.S. CLS. 1, 4, 6, 50, 51 AND 52). SN 78-875,175. PUB. 2-6-2007. FILED 5-3-2006.  
 3,232,988. **SMELL GOODIES (BLOCK FORM)**. HAWAIIAN ORGANICS, L.L.C., (U.S. CLS. 1, 4, 6, 50, 51 AND 52). SN 78-877,003. PUB. 2-6-2007. FILED 5-4-2006.  
 3,232,999. **SOMADERM (BLOCK FORM)**. SOMALIFE INTERNATIONAL, INC., (U.S. CLS. 1, 4, 6, 50, 51 AND 52). SN 78-880,076. PUB. 2-6-2007. FILED 5-9-2006.  
 3,233,000. **HURRISAFE POWERFUL AQUEOUS CLEANING SOLUTIONS AND DESIGN**. PCI OF AMERICA, INC., (U.S. CLS. 1, 4, 6, 50, 51 AND 52). SN 78-880,112. PUB. 2-6-2007. FILED 5-9-2006.  
 3,233,010. **EAU DE REGLISSE CARON (BLOCK FORM)**. PARFUMS CARON, (U.S. CLS. 1, 4, 6, 50, 51 AND 52). SN 78-882,346. PUB. 2-6-2007. FILED 5-12-2006.  
 3,233,058. **ERRE-DUE (BLOCK FORM)**. AROMCA S.A., (U.S. CLS. 1, 4, 6, 50, 51 AND 52). SN 78-892,636. PUB. 2-6-2007. FILED 5-25-2006.  
 3,233,100. **DIVINE RESPONSE HEAL ONE-EIGHTY° AND DESIGN**. GLINN-TANNER, DARYL, (U.S. CLS. 1, 4, 6, 50, 51 AND 52). SN 78-902,833. PUB. 2-6-2007. FILED 6-7-2006.  
 3,233,142. **AEROPOSTALE (BLOCK FORM)**. AEROPOSTALE WEST, INC., (U.S. CLS. 1, 4, 6, 50, 51 AND 52). SN 78-907,234. PUB. 2-6-2007. FILED 6-13-2006.  
 3,233,188. **THE DIFFERENCE IS REAL (BLOCK FORM)**. LUMINOSO STUDIOS, INC., (U.S. CLS. 1, 4, 6, 50, 51 AND 52). SN 78-909,973. PUB. 2-6-2007. FILED 6-16-2006.  
 3,233,189. **SIMPLE. EFFECTIVE. RESULTS. (BLOCK FORM)**. LUMINOSO STUDIOS, INC., (U.S. CLS. 1, 4, 6, 50, 51 AND 52). SN 78-909,980. PUB. 2-6-2007. FILED 6-16-2006.  
 3,233,201. **INSTA-GLAZE (BLOCK FORM)**. GEORGE TAUB PRODUCTS AND FUSION CO., INC., (U.S. CLS. 1, 4, 6, 50, 51 AND 52). SN 78-910,508. PUB. 2-6-2007. FILED 6-16-2006.  
 3,233,202. **TRUE BLUE (BLOCK FORM)**. GEORGE TAUB PRODUCTS AND FUSION CO., INC., (U.S. CLS. 1, 4, 6, 50, 51 AND 52). SN 78-910,554. PUB. 2-6-2007. FILED 6-16-2006.  
 3,233,210. **PELICAN (BLOCK FORM)**. PELICAN SOAP CO., LTD., (U.S. CLS. 1, 4, 6, 50, 51 AND 52). SN 78-910,968. PUB. 2-6-2007. FILED 6-19-2006.  
 3,233,277. **WIPEOUT (BLOCK FORM)**. CLEANING SYSTEMS, INC., (U.S. CLS. 1, 4, 6, 50, 51 AND 52). SN 78-914,229. PUB. 2-6-2007. FILED 6-22-2006.  
 3,233,353. **GLOSS FX (BLOCK FORM)**. J.LYNNE COSMETICS, LLC, (U.S. CLS. 1, 4, 6, 50, 51 AND 52). SN 78-

- 916,263. PUB. 2-6-2007. FILED 6-24-2006.
- 3,233,387. **SNAPPLE (BLOCK FORM)**. SNAPPLE BEVERAGE CORP., (U.S. CLS. 1, 4, 6, 50, 51 AND 52). SN 78-917,297. PUB. 2-6-2007. FILED 6-26-2006.
- 3,233,394. **EW AND DESIGN**. ABLEMAN, CORINNE. (U.S. CLS. 1, 4, 6, 50, 51 AND 52). SN 78-917,382. PUB. 2-6-2007. FILED 6-26-2006.
- 3,233,520 ( *See Class 1 for this trademark*).
- 3,233,523. **EUROWELLNESS (STYLIZED)**. STEFAN EBELING, MULTIPLE CLASS, (INT. CLS. 3, 14, 18 AND 25), (U.S. CLS. 1, 2, 3, 4, 6, 22, 27, 28, 39, 41, 50, 51 AND 52). SN 79-009,310. PUB. 2-6-2007. FILED 1-28-2005.
- 3,233,546. **DANIEL SWAROVSKI (BLOCK FORM)**. SWAROVSKI AKTIENGESELLSCHAFT, MULTIPLE CLASS, (INT. CLS. 3, 14, 16, 18, 21, 25 AND 41), (U.S. CLS. 1, 2, 3, 4, 5, 6, 13, 22, 23, 27, 28, 29, 30, 33, 37, 38, 39, 40, 41, 50, 51, 52, 100, 101 AND 107). SN 79-015,804. PUB. 2-6-2007. FILED 11-3-2004.
- 3,233,574. **LA MERCIS (BLOCK FORM)**. LIDL STIFTUNG & CO. KG, (U.S. CLS. 1, 4, 6, 50, 51 AND 52). SN 79-017,948. PUB. 2-6-2007. FILED 11-3-2005.
- 3,233,575. **EUGENE PERMA PARIS ESSENTIEL AND DESIGN**. EUGENE PERMA FRANCE, (U.S. CLS. 1, 4, 6, 50, 51 AND 52). SN 79-017,965. PUB. 2-6-2007. FILED 11-2-2005.
- 3,233,591. **K MARKIARO (STYLIZED)**. DELTA S.R.L., MULTIPLE CLASS, (INT. CLS. 3, 9, 14, 16, 18 AND 25), (U.S. CLS. 1, 2, 3, 4, 5, 6, 21, 22, 23, 26, 27, 28, 29, 36, 37, 38, 39, 41, 50, 51 AND 52). SN 79-018,839. PUB. 2-6-2007. FILED 10-6-2005.
- 3,233,616. **COLOR BY PHYTOSPECIFIC (BLOCK FORM)**. CASTER, (U.S. CLS. 1, 4, 6, 50, 51 AND 52). SN 79-019,965. PUB. 2-6-2007. FILED 12-21-2005.
- 3,233,622. **TRICHOVITAL (BLOCK FORM)**. CASTER, (U.S. CLS. 1, 4, 6, 50, 51 AND 52). SN 79-020,287. PUB. 2-6-2007. FILED 12-26-2005.
- 3,233,629. **MISCELLANEOUS DESIGN**. CAI RU QING, (U.S. CLS. 1, 4, 6, 50, 51 AND 52). SN 79-020,539. PUB. 2-6-2007. FILED 1-9-2006.
- 3,233,638 ( *See Class 1 for this trademark*).
- 3,233,663. **ACQUA DELL'ELBA AND DESIGN**. FABIO MURZI, MULTIPLE CLASS, (INT. CLS. 3, 4 AND 31), (U.S. CLS. 1, 4, 6, 15, 46, 50, 51 AND 52). SN 79-021,898. PUB. 2-6-2007. FILED 11-28-2005.
- 3,233,667. **PHILOSYKOS (STYLIZED)**. DIPTYQUE S.A.S., (U.S. CLS. 1, 4, 6, 50, 51 AND 52). SN 79-022,072. PUB. 2-6-2007. FILED 4-14-2005.
- 3,233,682. **INDULT (BLOCK FORM)**. GANEM CARL, (U.S. CLS. 1, 4, 6, 50, 51 AND 52). SN 79-022,701. PUB. 2-6-2007. FILED 2-27-2006.
- 3,233,685. **MHT AND DESIGN**. DE TAILLAC, MARIE-HÉLÈNE, MULTIPLE CLASS, (INT. CLS. 3, 14, 40 AND 42), (U.S. CLS. 1, 2, 4, 6, 27, 28, 50, 51, 52, 100, 101, 103 AND 106). SN 79-022,810. PUB. 2-6-2007. FILED 9-14-2005.
- 3,233,701. **MISCELLANEOUS DESIGN**. KLINGSPOR AG, MULTIPLE CLASS, (INT. CLS. 3, 7 AND 8), (U.S. CLS. 1, 4, 6, 13, 19, 21, 23, 28, 31, 34, 35, 44, 50, 51 AND 52). SN 79-023,532. PUB. 2-6-2007. FILED 1-2-2006.
- 3,233,737. **ICEDENT (BLOCK FORM)**. OBSHCESTVO S OGRANICHENNOY; OTVETSTVENNOSTYU "KONTSEPT", MULTIPLE CLASS, (INT. CLS. 3 AND 21), (U.S. CLS. 1, 2, 4, 6, 13, 23, 29, 30, 33, 40, 50, 51 AND 52). SN 79-025,952. PUB. 2-6-2007. FILED 4-6-2006.
- 3,233,746. **DERMATIS (BLOCK FORM)**. MARKLINE S.A., (U.S. CLS. 1, 4, 6, 50, 51 AND 52). SN 79-026,666. PUB. 2-6-2007. FILED 6-22-2006.
- 3,233,753. **ROCK ME (BLOCK FORM)**. MÜLHENS GMBH & CO. KG, (U.S. CLS. 1, 4, 6, 50, 51 AND 52). SN 79-028,031. PUB. 2-6-2007. FILED 6-22-2006.
- 3,233,758. **OCEAN SUN (BLOCK FORM)**. MÜLHENS GMBH & CO. KG, (U.S. CLS. 1, 4, 6, 50, 51 AND 52). SN 79-028,825. PUB. 2-6-2007. FILED 7-17-2006.

#### CLASS 4—LUBRICANTS AND FUELS

- 3,232,181. **ULTIMATE BLUE (BLOCK FORM)**. JENNY PRODUCTS, INCORPORATED, (U.S. CLS. 1, 6 AND 15). SN 76-652,268. PUB. 10-24-2006. FILED 12-21-2005.

- 3,232,224. **ARCHIPELAGO (BLOCK FORM)**. CKLA, LLC, (U.S. CLS. 1, 6 AND 15). SN 76-661,395. PUB. 2-6-2007. FILED 6-9-2006.
- 3,232,225. **ARCHIPELAGO BOTANICALS (BLOCK FORM)**. CKLA, LLC, (U.S. CLS. 1, 6 AND 15). SN 76-661,396. PUB. 2-6-2007. FILED 6-9-2006.
- 3,232,293. **FLAME (BLOCK FORM)**. INSIGHT IMPORTS, (U.S. CLS. 1, 6 AND 15). SN 77-011,145. PUB. 2-6-2007. FILED 9-29-2006.
- 3,232,245. **TEA LEAVES (BLOCK FORM)**. BANANA REPUBLIC (APPAREL), LLC, (U.S. CLS. 1, 6 AND 15). SN 78-912,752. PUB. 2-6-2007. FILED 6-20-2006.
- 3,232,246. **SPRING PARTY (BLOCK FORM)**. BANANA REPUBLIC (APPAREL), LLC, (U.S. CLS. 1, 6 AND 15). SN 78-912,755. PUB. 2-6-2007. FILED 6-20-2006.
- 3,233,520 ( *See Class 1 for this trademark*).
- 3,233,573. **MULTIPRESS (STYLIZED)**. ZELLER + GMELIN GMBH & CO, (U.S. CLS. 1, 6 AND 15). SN 79-017,893. PUB. 2-6-2007. FILED 9-5-2005.
- 3,233,638 ( *See Class 1 for this trademark*).
- 3,233,663 ( *See Class 3 for this trademark*).
- 3,233,672 ( *See Class 1 for this trademark*).
- 3,233,673. **ELECTROSYNTEC (BLOCK FORM)**. FUCHS PETROLUB AG, (U.S. CLS. 1, 6 AND 15). SN 79-022,180. PUB. 2-6-2007. FILED 11-24-2005.

#### CLASS 5—PHARMACEUTICALS

- 3,232,073 ( *See Class 1 for this trademark*).
- 3,232,084. **DARI CAL**. U.S. FOODS & PHARMACEUTICALS, INC., (U.S. CLS. 6, 18, 44, 46, 51 AND 52). SN 76-552,118. PUB. 2-6-2007. FILED 10-17-2003.
- 3,232,088. **FERRING PHARMACEUTICALS (BLOCK FORM)**. FERRING B.V., MULTIPLE CLASS, (INT. CLS. 5, 9, 16 AND 41), (U.S. CLS. 2, 5, 6, 18, 21, 22, 23, 26, 29, 36, 37, 38, 44, 46, 50, 51, 52, 100, 101 AND 107). SN 76-591,167. PUB. 2-6-2007. FILED 5-10-2004.
- 3,232,132. **MISCELLANEOUS DESIGN**. LUCKY MART, INC., (U.S. CLS. 6, 18, 44, 46, 51 AND 52). SN 76-644,356. PUB. 2-6-2007. FILED 8-8-2005.
- 3,232,159. **DEO' GREY (BLOCK FORM)**. MENELAUS B.V., (U.S. CLS. 6, 18, 44, 46, 51 AND 52). SN 76-649,638. PUB. 2-6-2007. FILED 11-2-2005.
- 3,232,204. **AVIANATURAL REMEDIES (BLOCK FORM)**. KING, ANDREW, (U.S. CLS. 6, 18, 44, 46, 51 AND 52). SN 76-657,062. PUB. 2-6-2007. FILED 3-22-2006.
- 3,232,207. **ALLOOSS (STYLIZED)**. ACE SURGICAL SUPPLY CO, INC., (U.S. CLS. 6, 18, 44, 46, 51 AND 52). SN 76-658,555. PUB. 2-6-2007. FILED 4-17-2006.
- 3,232,266. **WAL-PHOSPHATE (BLOCK FORM)**. WALGREEN CO., (U.S. CLS. 6, 18, 44, 46, 51 AND 52). SN 76-663,056. PUB. 2-6-2007. FILED 7-14-2006.
- 3,232,280. **KRE-GENERATOR (BLOCK FORM)**. ALL AMERICAN PHARMACEUTICAL & NATURAL FOODS CORPORATION, (U.S. CLS. 6, 18, 44, 46, 51 AND 52). SN 77-000,874. PUB. 2-6-2007. FILED 9-15-2006.
- 3,232,281. **KRE-A-FEM (BLOCK FORM)**. ALL AMERICAN PHARMACEUTICAL & NATURAL FOODS CORPORATION, (U.S. CLS. 6, 18, 44, 46, 51 AND 52). SN 77-000,893. PUB. 2-6-2007. FILED 9-15-2006.
- 3,232,316. **PVRIX**. GLAXOSMITHKLINE BIOLOGICALS S.A., (U.S. CLS. 6, 18, 44, 46, 51 AND 52). SN 78-036,784. PUB. 12-30-2003. FILED 11-28-2000.
- 3,232,325. **XXL SUPPORT**. ADVANCED BOTANICALS LTD., (U.S. CLS. 6, 18, 44, 46, 51 AND 52). SN 78-217,676. PUB. 5-23-2006. FILED 2-21-2003.
- 3,232,341. **MISCELLANEOUS DESIGN**. WESTRIDGE LABORATORIES, INC., (U.S. CLS. 6, 18, 44, 46, 51 AND 52). SN 78-339,778. PUB. 2-6-2007. FILED 12-11-2003.
- 3,232,343. **NINAPHARM AND DESIGN**. NINAPHARM, (U.S. CLS. 6, 18, 44, 46, 51 AND 52). SN 78-341,681. PUB. 2-6-2007. FILED 12-16-2003.
- 3,232,347. **OREXIS (BLOCK FORM)**. OREXIS, LLC, (U.S. CLS. 6, 18, 44, 46, 51 AND 52). SN 78-359,442. PUB. 2-6-2007. FILED 1-29-2004.
- 3,232,361. **MULTIGUARD PROTECT (BLOCK FORM)**. AGRICULTURAL

- GUARD COMPANY, LLC, (U.S. CLS. 6, 18, 44, 46, 51 AND 52). SN 78-445,584. PUB. 6-14-2005. FILED 7-2-2004.
- 3,232,376. **SYNERGEX (BLOCK FORM)**. NEXAGEN USA, LLC, (U.S. CLS. 6, 18, 44, 46, 51 AND 52). SN 78-506,228. PUB. 2-21-2006. FILED 10-26-2004.
- 3,232,384. **PULMOCAPS (BLOCK FORM)**. INNOVATA BIOMED LIMITED, (U.S. CLS. 6, 18, 44, 46, 51 AND 52). SN 78-521,146. PUB. 2-6-2007. FILED 11-22-2004.
- 3,232,418. **FORTITECH STRATEGIC NUTRITION AND DESIGN**. FORTITECH INC., MULTIPLE CLASS, (INT. CLS. 5, 42 AND 44), (U.S. CLS. 6, 18, 44, 46, 51, 52, 100 AND 101). SN 78-575,131. PUB. 2-6-2007. FILED 2-25-2005.
- 3,232,447. **REDLINE (BLOCK FORM)**. VITAL PHARMACEUTICALS, INC., (U.S. CLS. 6, 18, 44, 46, 51 AND 52). SN 78-598,015. PUB. 6-13-2006. FILED 3-30-2005.
- 3,232,475. **BONEGEN CALCIUM SULFATE HEMIHYDRATE (BLOCK FORM)**. BIO-LOK INTERNATIONAL, INC., (U.S. CLS. 6, 18, 44, 46, 51 AND 52). SN 78-626,843. PUB. 2-6-2007. FILED 5-10-2005.
- 3,232,491. **ORONINE (BLOCK FORM)**. OTSUKA PHARMACEUTICAL FACTORY INC., (U.S. CLS. 6, 18, 44, 46, 51 AND 52). SN 78-643,209. PUB. 8-1-2006. FILED 6-3-2005.
- 3,232,535. **CLADEVA (BLOCK FORM)**. GLAXO GROUP LIMITED, (U.S. CLS. 6, 18, 44, 46, 51 AND 52). SN 78-682,363. PUB. 2-6-2007. FILED 8-1-2005.
- 3,232,549 ( *See Class 3 for this trademark*).
- 3,232,582. **METAL-BITE (BLOCK FORM)**. R-DENTAL DENTALERZEUGNISSE GMBH, (U.S. CLS. 6, 18, 44, 46, 51 AND 52). SN 78-721,124. PUB. 2-6-2007. FILED 9-27-2005.
- 3,232,633. **OREGAIN (BLOCK FORM)**. MIDWEST VETERINARY SERVICES, INC., (U.S. CLS. 6, 18, 44, 46, 51 AND 52). SN 78-740,361. PUB. 2-6-2007. FILED 10-25-2005.
- 3,232,648. **DEXADA (BLOCK FORM)**. SCHWARZ PHARMA AG, (U.S. CLS. 6, 18, 44, 46, 51 AND 52). SN 78-744,220. PUB. 10-24-2006. FILED 11-1-2005.
- 3,232,669. **GLUCALMAX (BLOCK FORM)**. BOMAC LABORATORIES LIMITED, (U.S. CLS. 6, 18, 44, 46, 51 AND 52). SN 78-747,634. PUB. 2-6-2007. FILED 11-4-2005.
- 3,232,670. **GLUCALPHOS (BLOCK FORM)**. BOMAC LABORATORIES LIMITED, (U.S. CLS. 6, 18, 44, 46, 51 AND 52). SN 78-747,639. PUB. 2-6-2007. FILED 11-4-2005.
- 3,232,678. **QUIK-ID (BLOCK FORM)**. GENETIC TESTING INSTITUTE, (U.S. CLS. 6, 18, 44, 46, 51 AND 52). SN 78-749,223. PUB. 2-6-2007. FILED 11-8-2005.
- 3,232,693 ( *See Class 1 for this trademark*).
- 3,232,744 ( *See Class 3 for this trademark*).
- 3,232,765. **MOZIRO (BLOCK FORM)**. SCHWARZ PHARMA AG, (U.S. CLS. 6, 18, 44, 46, 51 AND 52). SN 78-778,084. PUB. 10-24-2006. FILED 12-21-2005.
- 3,232,766. **BERVELA (BLOCK FORM)**. SCHWARZ PHARMA AG, (U.S. CLS. 6, 18, 44, 46, 51 AND 52). SN 78-778,102. PUB. 10-24-2006. FILED 12-21-2005.
- 3,232,767. **ELZERIO (BLOCK FORM)**. SCHWARZ PHARMA AG, (U.S. CLS. 6, 18, 44, 46, 51 AND 52). SN 78-778,195. PUB. 10-24-2006. FILED 12-21-2005.
- 3,232,769. **MAXI-BLUE (BLOCK FORM)**. CARGILL, INCORPORATED, (U.S. CLS. 6, 18, 44, 46, 51 AND 52). SN 78-779,659. PUB. 2-6-2007. FILED 12-22-2005.
- 3,232,862. **ALL NATURAL STOP HELPS STOP SMOKING AND DESIGN**. OMEGA TECH LABS, LLC, (U.S. CLS. 6, 18, 44, 46, 51 AND 52). SN 78-833,422. PUB. 2-6-2007. FILED 3-9-2006.
- 3,232,929. **TYENNE (BLOCK FORM)**. ARES TRADING S.A., (U.S. CLS. 6, 18, 44, 46, 51 AND 52). SN 78-856,760. PUB. 2-6-2007. FILED 4-7-2006.
- 3,232,931. **HIMALAYAN GOJI JUICE AND DESIGN**. FREE-LIFE INTERNATIONAL, LLC, (U.S. CLS. 6, 18, 44, 46, 51 AND 52). SN 78-857,664. PUB. 11-28-2006. FILED 4-10-2006.
- 3,233,014. **IMAGENETIX (BLOCK FORM)**. IMAGENETIX, (U.S. CLS. 6, 18, 44, 46, 51 AND 52). SN 78-882,768. PUB. 2-6-2007. FILED 5-12-2006.
- 3,233,018. **LIVER FORCE (BLOCK FORM)**. NEW CHAPTER, INC., (U.S. CLS. 6, 18, 44, 46, 51 AND 52). SN 78-884,600. PUB. 2-6-2007. FILED 5-16-2006.
- 3,233,034. **APLICARE ADVANTAGE (BLOCK FORM)**. APLICARE, INC., (U.S. CLS. 6, 18, 44, 46, 51 AND 52). SN 78-886,386. PUB. 2-6-2007. FILED 5-18-2006.
- 3,233,052. **APLICARE ADVANTAGE AND DESIGN**. APLICARE, INC., (U.S. CLS. 6, 18, 44, 46, 51 AND 52). SN 78-890,278. PUB. 2-6-2007. FILED 5-23-2006.
- 3,233,054. **MI ANGELITO AND DESIGN**. KRAMER LABORATORIES, INC., (U.S. CLS. 6, 18, 44, 46, 51 AND 52). SN 78-891,013. PUB. 2-6-2007. FILED 5-24-2006.
- 3,233,059. **UMEKEN (STYLIZED)**. UMEKEN USA, INC., (U.S. CLS. 6, 18, 44, 46, 51 AND 52). SN 78-892,773. PUB. 2-6-2007. FILED 5-25-2006.
- 3,233,125. **SUPPLEGENT (BLOCK FORM)**. ADVANCED FOODS NUTRITION LLC, (U.S. CLS. 6, 18, 44, 46, 51 AND 52). SN 78-905,625. PUB. 2-6-2007. FILED 6-12-2006.
- 3,233,127. **TRAINER PLUS (BLOCK FORM)**. BODYWORKS BY NICHOLAS SMITH INC., (U.S. CLS. 6, 18, 44, 46, 51 AND 52). SN 78-905,963. PUB. 2-6-2007. FILED 6-12-2006.
- 3,233,153. **MEDERMA (BLOCK FORM)**. MERZ PHARMACEUTICALS, LLC, (U.S. CLS. 6, 18, 44, 46, 51 AND 52). SN 78-908,193. PUB. 2-6-2007. FILED 6-14-2006.
- 3,233,170. **PHARMACEUTICAL GRADE CAFFEINE AND DESIGN**. DICKEY INVESTMENTS, LLC, (U.S. CLS. 6, 18, 44, 46, 51 AND 52). SN 78-909,114. PUB. 2-6-2007. FILED 6-15-2006.
- 3,233,185. **SUPER HEALER (BLOCK FORM)**. ENVIROSAFE CORPORATION, (U.S. CLS. 6, 18, 44, 46, 51 AND 52). SN 78-909,736. PUB. 2-6-2007. FILED 6-16-2006.
- 3,233,186. **SEA HEARTS (BLOCK FORM)**. COASTSIDE BIO RESOURCES, (U.S. CLS. 6, 18, 44, 46, 51 AND 52). SN 78-909,803. PUB. 2-6-2007. FILED 6-16-2006.
- 3,233,231. **VOGREZ (BLOCK FORM)**. NOVARTIS AG, (U.S. CLS. 6, 18, 44, 46, 51 AND 52). SN 78-912,308. PUB. 2-6-2007. FILED 6-20-2006.
- 3,233,307. **SEXYMENOPAUSE AND DESIGN**. MILLENIUM2HEALTH, INC., (U.S. CLS. 6, 18, 44, 46, 51 AND 52). SN 78-914,938. PUB. 2-6-2007. FILED 6-22-2006.
- 3,233,361. **EZ-KILL (BLOCK FORM)**. RIDDELL & ASSOCIATES, INC., (U.S. CLS. 6, 18, 44, 46, 51 AND 52). SN 78-916,802. PUB. 2-6-2007. FILED 6-26-2006.
- 3,233,393. **GOLDENZYMES (BLOCK FORM)**. DR. JIM SMITH, D.O., INC., (U.S. CLS. 6, 18, 44, 46, 51 AND 52). SN 78-917,378. PUB. 2-6-2007. FILED 6-22-2006.
- 3,233,409. **GROW FROM WITHIN (BLOCK FORM)**. ABS GLOBAL, INC., (U.S. CLS. 6, 18, 44, 46, 51 AND 52). SN 78-917,989. PUB. 2-6-2007. FILED 6-27-2006.
- 3,233,453. **DIVINE CRACKERS (BLOCK FORM)**. NICOLE'S, INC., MULTIPLE CLASS, (INT. CLS. 5 AND 30), (U.S. CLS. 6, 18, 44, 46, 51 AND 52). SN 78-920,018. PUB. 2-6-2007. FILED 6-29-2006.
- 3,233,520 ( *See Class 1 for this trademark*).
- 3,233,529. **GUIDAGE (BLOCK FORM)**. SOCIÉTÉ DE CONSEILS DE RECHERCHES ET D'APPLICATIONS SCIENTIFIQUES (S.C.R.A.S.), MULTIPLE CLASS, (INT. CLS. 5, 16, 38, 41, 42 AND 44), (U.S. CLS. 2, 5, 6, 18, 22, 23, 29, 37, 38, 44, 46, 50, 51, 52, 100, 101, 104 AND 107). SN 79-012,743. PUB. 2-6-2007. FILED 3-2-2005.
- 3,233,556. **UCBEYOND (BLOCK FORM)**. UCB, SOCIÉTÉ ANONYME, MULTIPLE CLASS, (INT. CLS. 5, 16, 41, 42 AND 44), (U.S. CLS. 2, 5, 6, 18, 22, 23, 29, 37, 38, 44, 46, 50, 51, 52, 100, 101 AND 107). SN 79-016,959. PUB. 2-6-2007. FILED 10-11-2005.
- 3,233,570. **LEUKOFIX (STYLIZED)**. BSN MEDICAL GMBH, (U.S. CLS. 6, 18, 44, 46, 51 AND 52). SN 79-017,540. PUB. 2-6-2007. FILED 8-16-2005.
- 3,233,608. **SCANBAG (BLOCK FORM)**. GUERBET, MULTIPLE CLASS, (INT. CLS. 5 AND 16), (U.S. CLS. 2, 5, 6, 18, 22, 23, 29, 37, 38, 44, 46, 50, 51 AND 52). SN 79-019,584. PUB. 2-6-2007. FILED 11-29-2005.
- 3,233,623. **QUINORAL (BLOCK FORM)**. PIERRE FABRE DERMO-COSMETIQUE, (U.S. CLS. 6, 18, 44, 46, 51 AND 52). SN 79-020,350. PUB. 2-6-2007. FILED 10-28-2005.
- 3,233,655. **XACTAVE (BLOCK FORM)**. CENES LIMITED, (U.S. CLS. 6, 18, 44, 46, 51 AND 52). SN 79-021,442. PUB. 2-6-2007. FILED 10-7-2005.
- 3,233,690. **PHYTOVIR (BLOCK FORM)**. PARSENN-PRODUKTE AG, (U.S. CLS. 6, 18, 44, 46, 51 AND 52). SN 79-023,022. PUB. 2-6-2007. FILED 2-20-2006.
- 3,233,720. **RINIVA (BLOCK FORM)**. SCHWARZ PHARMA AKTIENGESELLSCHAFT, (U.S. CLS. 6, 18, 44, 46, 51 AND 52). SN 79-024,894. PUB. 2-6-2007. FILED 4-5-2006.
- 3,233,721. **ZILIANT (BLOCK FORM)**. NOVARTIS AG, (U.S.

- CLS. 6, 18, 44, 46, 51 AND 52). SN 79-024,977. PUB. 2-6-2007. FILED 6-2-2006.
- 3,233,735 ( *See Class 1 for this trademark*).
- 3,233,736. **GIMEGA (BLOCK FORM)**. NEWLIFE RESEARCH LIMITED, (U.S. CLS. 6, 18, 44, 46, 51 AND 52). SN 79-025,887. PUB. 2-6-2007. FILED 5-16-2006.
- 3,233,759. **FOXTROT (BLOCK FORM)**. CHEMINOVA A/S, (U.S. CLS. 6, 18, 44, 46, 51 AND 52). SN 79-028,908. PUB. 2-6-2007. FILED 6-22-2006.
- 3,233,761. **ORINURZA (BLOCK FORM)**. SANOFI-AVENTIS, (U.S. CLS. 6, 18, 44, 46, 51 AND 52). SN 79-029,835. PUB. 2-6-2007. FILED 9-27-2006.

---

### CLASS 6—METAL GOODS

- 3,232,060. **COMMANDOS AND DESIGN**. PYRO STUDIOS, S.L., MULTIPLE CLASS, (INT. CLS. 6, 9, 14, 16, 18, 25, 28, 34, 41 AND 42), (U.S. CLS. 1, 2, 3, 5, 8, 9, 12, 13, 14, 17, 21, 22, 23, 25, 26, 27, 28, 29, 36, 37, 38, 39, 41, 50, 100, 101 AND 107). SN 76-064,261. PUB. 10-24-2006. FILED 6-6-2000.
- 3,232,131. **WELCO (BLOCK FORM)**. W.C. HERAEUS GMBH, (U.S. CLS. 2, 12, 13, 14, 23, 25 AND 50). SN 76-643,631. PUB. 10-31-2006. FILED 7-26-2005.
- 3,232,145. **ECV (BLOCK FORM)**. FUJIKIN INCORPORATED, MULTIPLE CLASS, (INT. CLS. 6, 7 AND 9), (U.S. CLS. 2, 12, 13, 14, 19, 21, 23, 25, 26, 31, 34, 35, 36, 38 AND 50). SN 76-647,319. PUB. 2-6-2007. FILED 9-22-2005.
- 3,232,215. **CARTER FENCE CO. INC. (BLOCK FORM)**. CARTER FENCE CO. INC., MULTIPLE CLASS, (INT. CLS. 6 AND 19), (U.S. CLS. 1, 2, 12, 13, 14, 23, 25, 33 AND 50). SN 76-659,922. PUB. 2-6-2007. FILED 5-11-2006.
- 3,232,216. **STORM-BUSTERS FASTRAC (BLOCK FORM)**. STORM DEPOT OF AMERICA, INC., DBA STORM-BUSTERS, (U.S. CLS. 2, 12, 13, 14, 23, 25 AND 50). SN 76-660,402. PUB. 2-6-2007. FILED 5-22-2006.
- 3,232,246. **HEADLOK (BLOCK FORM)**. HANDY & HARMAN, (U.S. CLS. 2, 12, 13, 14, 23, 25 AND 50). SN 76-661,913. PUB. 2-6-2007. FILED 6-21-2006.
- 3,232,411. **CHF CHERFORD (STYLIZED)**. CHERFORD INTERNATIONAL INC., (U.S. CLS. 2, 12, 13, 14, 23, 25 AND 50). SN 78-566,232. PUB. 2-6-2007. FILED 2-12-2005.
- 3,232,589. **ECLIPSE ARCHITECTURAL (STYLIZED)**. A. K. DRAFT SEAL LTD., MULTIPLE CLASS, (INT. CLS. 6 AND 19), (U.S. CLS. 1, 2, 12, 13, 14, 23, 25, 33 AND 50). SN 78-724,130. PUB. 2-6-2007. FILED 9-30-2005.
- 3,232,864. **WWW.AUTOGOLD.COM (BLOCK FORM)**. AUTOMOTIVE GOLD, INC., MULTIPLE CLASS, (INT. CLS. 6, 12 AND 20), (U.S. CLS. 2, 12, 13, 14, 19, 21, 22, 23, 25, 31, 32, 35, 44 AND 50). SN 78-834,136. PUB. 2-6-2007. FILED 3-10-2006.
- 3,232,886. **CONFORM (BLOCK FORM)**. BWE LIMITED, MULTIPLE CLASS, (INT. CLS. 6, 7, 9 AND 40), (U.S. CLS. 2, 12, 13, 14, 19, 21, 23, 25, 26, 31, 34, 35, 36, 38, 50, 100, 103 AND 106). SN 78-841,276. PUB. 2-6-2007. FILED 3-20-2006.
- 3,232,968. **TSP (BLOCK FORM)**. CENTURY INDUSTRIES, LLC, (U.S. CLS. 2, 12, 13, 14, 23, 25 AND 50). SN 78-868,685. PUB. 2-6-2007. FILED 4-25-2006.
- 3,232,969. **TRANSPORT (BLOCK FORM)**. CENTURY INDUSTRIES, LLC, (U.S. CLS. 2, 12, 13, 14, 23, 25 AND 50). SN 78-868,692. PUB. 2-6-2007. FILED 4-25-2006.
- 3,233,082. **AH NEE MÄHL (BLOCK FORM)**. SALARTI ENTERPRISES, INC., MULTIPLE CLASS, (INT. CLS. 6, 18 AND 25), (U.S. CLS. 1, 2, 3, 12, 13, 14, 22, 23, 25, 39, 41 AND 50). SN 78-899,022. PUB. 2-6-2007. FILED 6-2-2006.
- 3,233,101. **HUNTER ANCHORS (BLOCK FORM)**. HUNTER BOAT ANCHORS, LLC, (U.S. CLS. 2, 12, 13, 14, 23, 25 AND 50). SN 78-902,916. PUB. 2-6-2007. FILED 6-7-2006.
- 3,233,204. **ELBO AND DESIGN**. WILLIAMS, LEONARD M, (U.S. CLS. 2, 12, 13, 14, 23, 25 AND 50). SN 78-910,625. PUB. 2-6-2007. FILED 6-16-2006.
- 3,233,312. **G AND DESIGN**. GENCOR INDUSTRIES, INC., MULTIPLE CLASS, (INT. CLS. 6, 7, 9 AND 11), (U.S. CLS. 2, 12, 13, 14, 19, 21, 23, 25, 26, 31, 34, 35, 36, 38 AND 50). SN 78-915,168. PUB. 2-6-2007. FILED 6-23-2006.
- 3,233,402. **MISCELLANEOUS DESIGN**. BOLTS & NUTS, INC., (U.S. CLS. 2, 12, 13, 14, 23, 25 AND 50). SN 78-917,615. PUB. 2-6-2007. FILED 6-27-2006.
- 3,233,520 ( *See Class 1 for this trademark*).
- 3,233,545. **NEXT AND DESIGN**. EUROTUNGSTENE POUDRES, (U.S. CLS. 2, 12, 13, 14, 23, 25 AND 50). SN 79-015,790. PUB. 2-6-2007. FILED 6-3-2005.
- 3,233,548. **UNIBRIDGE AND DESIGN**. SOCIETE CIVILE DE BREVETS MATIERE, MULTIPLE CLASS, (INT. CLS. 6 AND 19), (U.S. CLS. 1, 2, 12, 13, 14, 23, 25, 33 AND 50). SN 79-015,897. PUB. 2-6-2007. FILED 12-14-2004.
- 3,233,557. **H AND DESIGN**. HERMES INTERNATIONAL, MULTIPLE CLASS, (INT. CLS. 6, 14, 18, 25 AND 26), (U.S. CLS. 1, 2, 3, 12, 13, 14, 22, 23, 25, 27, 28, 37, 39, 40, 41, 42 AND 50). SN 79-017,059. PUB. 2-6-2007. FILED 9-13-2005.
- 3,233,558. **H (STYLIZED)**. HERMES INTERNATIONAL, MULTIPLE CLASS, (INT. CLS. 6, 14, 18, 25 AND 26), (U.S. CLS. 1, 2, 3, 12, 13, 14, 22, 23, 25, 27, 28, 37, 39, 40, 41, 42 AND 50). SN 79-017,060. PUB. 2-6-2007. FILED 9-13-2005.
- 3,233,577 ( *See Class 1 for this trademark*).
- 3,233,588. **DSG (BLOCK FORM)**. MHP MANNESMANN PRÄZISROHR GMBH, (U.S. CLS. 2, 12, 13, 14, 23, 25 AND 50). SN 79-018,609. PUB. 2-6-2007. FILED 10-21-2005.
- 3,233,593. **MISCELLANEOUS DESIGN**. ZINGERLE METAL SPA, MULTIPLE CLASS, (INT. CLS. 6, 19 AND 22), (U.S. CLS. 1, 2, 7, 12, 13, 14, 19, 22, 23, 25, 33, 42 AND 50). SN 79-018,928. PUB. 2-6-2007. FILED 12-2-2005.
- 3,233,606. **K AND DESIGN**. KOCKS TECHNIK GMBH & CO.KG, MULTIPLE CLASS, (INT. CLS. 6, 7, 9, 11 AND 42), (U.S. CLS. 2, 12, 13, 14, 19, 21, 23, 25, 26, 31, 34, 35, 36, 38, 50, 100 AND 101). SN 79-019,508. PUB. 2-6-2007. FILED 1-31-2005.
- 3,233,617. **MISCELLANEOUS DESIGN**. HEROSE GMBH ARMATUREN UND METALLE, MULTIPLE CLASS, (INT. CLS. 6, 7, 11, 17, 19 AND 20), (U.S. CLS. 1, 2, 5, 12, 13, 14, 19, 21, 22, 23, 25, 31, 32, 33, 34, 35 AND 50). SN 79-019,986. PUB. 2-6-2007. FILED 2-24-2005.
- 3,233,635. **OCSA AND DESIGN**. OCSA OFFICINE DI CRO-CETTA S.P.A., (U.S. CLS. 2, 12, 13, 14, 23, 25 AND 50). SN 79-020,712. PUB. 2-6-2007. FILED 12-29-2005.
- 3,233,642. **RITTAL LIQUID COOLING PACKAGE (BLOCK FORM)**. RITTAL GMBH & CO. KG, MULTIPLE CLASS, (INT. CLS. 6, 9, 11 AND 20), (U.S. CLS. 2, 12, 13, 14, 21, 22, 23, 25, 26, 31, 32, 34, 36, 38 AND 50). SN 79-020,959. PUB. 2-6-2007. FILED 3-23-2005.
- 3,233,644. **EDARD (STYLIZED)**. ANCIENS ETABLISSEMENTS EDARD, MULTIPLE CLASS, (INT. CLS. 6 AND 20), (U.S. CLS. 2, 12, 13, 14, 22, 23, 25, 32 AND 50). SN 79-020,998. PUB. 2-6-2007. FILED 1-20-2006.
- 3,233,646. **RAMOR (STYLIZED)**. RAUTARUUKKI OYJ, (U.S. CLS. 2, 12, 13, 14, 23, 25 AND 50). SN 79-021,119. PUB. 2-6-2007. FILED 9-22-2005.
- 3,233,647. **SPECIAL SPRINGS AND DESIGN**. SPECIAL SPRINGS S.R.L., MULTIPLE CLASS, (INT. CLS. 6 AND 7), (U.S. CLS. 2, 12, 13, 14, 19, 21, 23, 25, 31, 34, 35 AND 50). SN 79-021,231. PUB. 2-6-2007. FILED 10-28-2005.
- 3,233,652 ( *See Class 1 for this trademark*).
- 3,233,739. **BAOTI (STYLIZED)**. BAOJI TITANIUM INDUSTRY CO., LTD, (U.S. CLS. 2, 12, 13, 14, 23, 25 AND 50). SN 79-026,104. PUB. 2-6-2007. FILED 5-11-2006.

---

### CLASS 7—MACHINERY

- 3,232,076. **GARDIEN WATERWORKS**. CONSOLIDATED FOAM INC., MULTIPLE CLASS, (INT. CLS. 7, 17 AND 21), (U.S. CLS. 1, 2, 5, 12, 13, 19, 21, 23, 29, 30, 31, 33, 34, 35, 40 AND 50). SN 76-471,181. PUB. 3-30-2004. FILED 11-29-2002.
- 3,232,086. **AGRO XML (BLOCK FORM)**. KURATORIUM FUER TECHNIK UND BAUWESEN IN DER LANDWIRTSCHAFT E.V. (KTBL), MULTIPLE CLASS, (INT. CLS. 7, 9, 12, 42 AND 44), (U.S. CLS. 13, 19, 21, 23, 26, 31, 34, 35, 36, 38, 44, 100 AND 101). SN 76-581,447. PUB. 2-6-2007. FILED 3-17-2004.
- 3,232,145 ( *See Class 6 for this trademark*).
- 3,232,226. **1158 (BLOCK FORM)**. PAXAR AMERICAS, INC., (U.S. CLS. 13, 19, 21, 23, 31, 34 AND 35). SN 76-661,424. PUB. 2-6-2007. FILED 6-8-2006.
- 3,232,234. **COMPUVAC (BLOCK FORM)**. SCOTT FETZER

- COMPANY, THE, (U.S. CLS. 13, 19, 21, 23, 31, 34 AND 35). SN 76-661,718. PUB. 2-6-2007. FILED 6-16-2006.
- 3,232,237. **AIRCRAFTERS (BLOCK FORM)**. AIRCRAFTERS, INC., MULTIPLE CLASS, (INT. CLS. 7, 9 AND 12), (U.S. CLS. 13, 19, 21, 23, 26, 31, 34, 35, 36, 38 AND 44). SN 76-661,771. PUB. 2-6-2007. FILED 6-19-2006.
- 3,232,329. **FUNK AND DESIGN**. KARL FUNK GMBH & CO., MULTIPLE CLASS, (INT. CLS. 7, 9, 19, 28, 37 AND 41), (U.S. CLS. 1, 12, 13, 19, 21, 22, 23, 26, 31, 33, 34, 35, 36, 38, 50, 100, 101, 103, 106 AND 107). SN 78-252,580. PUB. 5-9-2006. FILED 5-21-2003.
- 3,232,388. **ACTI-TRAP (BLOCK FORM)**. PYROBAN GROUP LIMITED, (U.S. CLS. 13, 19, 21, 23, 31, 34 AND 35). SN 78-532,225. PUB. 8-22-2006. FILED 12-14-2004.
- 3,232,427. **AIR TURBINE TOOLS (BLOCK FORM)**. AIR TURBINE TECHNOLOGY, INC., (U.S. CLS. 13, 19, 21, 23, 31, 34 AND 35). SN 78-582,627. PUB. 2-6-2007. FILED 3-8-2005.
- 3,232,516. **VICTORY MACHINES (BLOCK FORM)**. VICTORY MACHINES, LLC, (U.S. CLS. 13, 19, 21, 23, 31, 34 AND 35). SN 78-665,326. PUB. 2-6-2007. FILED 7-7-2005.
- 3,232,521. **PREDATOR (BLOCK FORM)**. DELTA INDUSTRIAL SERVICES, INC., (U.S. CLS. 13, 19, 21, 23, 31, 34 AND 35). SN 78-672,292. PUB. 2-6-2007. FILED 7-18-2005.
- 3,232,545. **ASI (STYLIZED)**. ADDITIVE SYSTEMS INC., MULTIPLE CLASS, (INT. CLS. 7 AND 37), (U.S. CLS. 13, 19, 21, 23, 31, 34, 35, 100, 103 AND 106). SN 78-688,353. PUB. 2-6-2007. FILED 8-9-2005.
- 3,232,583. **EXCALIBUR AND DESIGN**. EXCALIBUR BAGEL & BAKERY EQUIPMENT, INC., MULTIPLE CLASS, (INT. CLS. 7 AND 11), (U.S. CLS. 13, 19, 21, 23, 31, 34 AND 35). SN 78-721,636. PUB. 2-6-2007. FILED 9-27-2005.
- 3,232,739. **MORE POWER, LESS WEIGHT, BETTER ENGINEERING (BLOCK FORM)**. MAKITA U.S.A., INC., (U.S. CLS. 13, 19, 21, 23, 31, 34 AND 35). SN 78-767,288. PUB. 2-6-2007. FILED 12-6-2005.
- 3,232,802. **FLETCHER MINING EQUIPMENT AND DESIGN**. J.H. FLETCHER & CO., INC., MULTIPLE CLASS, (INT. CLS. 7, 12 AND 37), (U.S. CLS. 13, 19, 21, 23, 31, 34, 35, 44, 100, 103 AND 106). SN 78-803,060. PUB. 2-6-2007. FILED 1-31-2006.
- 3,232,803. **FLETCHER (BLOCK FORM)**. J.H. FLETCHER & CO., INC., MULTIPLE CLASS, (INT. CLS. 7, 12 AND 37), (U.S. CLS. 13, 19, 21, 23, 31, 34, 35, 44, 100, 103 AND 106). SN 78-803,070. PUB. 2-6-2007. FILED 1-31-2006.
- 3,232,833. **HEIDELBERG QUICKMASTER (BLOCK FORM)**. HEIDELBERGER DRUCKMASCHINEN AG, (U.S. CLS. 13, 19, 21, 23, 31, 34 AND 35). SN 78-816,165. PUB. 2-6-2007. FILED 2-16-2006.
- 3,232,871. **SOLAROLA (BLOCK FORM)**. VETERANS ENERGY TECHNOLOGIES, INC., MULTIPLE CLASS, (INT. CLS. 7 AND 9), (U.S. CLS. 13, 19, 21, 23, 26, 31, 34, 35, 36 AND 38). SN 78-836,112. PUB. 2-6-2007. FILED 3-13-2006.
- 3,232,886 ( *See Class 6 for this trademark*).
- 3,232,923. **VARIO SPEED L AND DESIGN**. BSH BOSCH UND SIEMENS HAUSGERAETE GMBH, (U.S. CLS. 13, 19, 21, 23, 31, 34 AND 35). SN 78-856,257. PUB. 2-6-2007. FILED 4-7-2006.
- 3,233,004. **TRITAN (BLOCK FORM)**. AERO-MOD INCORPORATED, (U.S. CLS. 13, 19, 21, 23, 31, 34 AND 35). SN 78-880,572. PUB. 12-19-2006. FILED 5-10-2006.
- 3,233,015. **ULTRATIP (BLOCK FORM)**. MASTER APPLIANCE CORP., (U.S. CLS. 13, 19, 21, 23, 31, 34 AND 35). SN 78-883,896. PUB. 2-6-2007. FILED 5-15-2006.
- 3,233,040. **OGIHARA AND DESIGN**. OGIHARA CORPORATION, MULTIPLE CLASS, (INT. CLS. 7 AND 12), (U.S. CLS. 13, 19, 21, 23, 31, 34, 35 AND 44). SN 78-887,790. PUB. 2-6-2007. FILED 5-19-2006.
- 3,233,195. **AIRPLACO (BLOCK FORM)**. AIRPLACO EQUIPMENT COMPANY, (U.S. CLS. 13, 19, 21, 23, 31, 34 AND 35). SN 78-910,195. PUB. 2-6-2007. FILED 6-16-2006.
- 3,233,218. **POWER WALK (BLOCK FORM)**. THE TRUSTEES OF THE MELVIN LOYD CHILCOAT FAMILY TRUST, (U.S. CLS. 13, 19, 21, 23, 31, 34 AND 35). SN 78-911,546. PUB. 2-6-2007. FILED 6-19-2006.
- 3,233,242. **MF MAXIFORJA AND DESIGN**. MAXIFORJA SA FORJARIA METALURIGIA, MULTIPLE CLASS, (INT. CLS. 7 AND 12), (U.S. CLS. 13, 19, 21, 23, 31, 34, 35 AND 44). SN 78-912,638. PUB. 2-6-2007. FILED 6-20-2006.
- 3,233,308. **FOX (BLOCK FORM)**. HINIKER COMPANY, (U.S. CLS. 13, 19, 21, 23, 31, 34 AND 35). SN 78-915,005. PUB. 2-6-2007. FILED 6-22-2006.
- 3,233,312 ( *See Class 6 for this trademark*).
- 3,233,413. **FORWARD (BLOCK FORM)**. DELAWARE CAPITAL FORMATION, INC., (U.S. CLS. 13, 19, 21, 23, 31, 34 AND 35). SN 78-918,065. PUB. 2-6-2007. FILED 6-27-2006.
- 3,233,495. **WHEATEENA (BLOCK FORM)**. LINK.ALDEN, (U.S. CLS. 13, 19, 21, 23, 31, 34 AND 35). SN 78-944,849. PUB. 2-6-2007. FILED 8-4-2006.
- 3,233,499. **ST.E.P. PLUS (STYLIZED)**. STA-RITE INDUSTRIES, LLC, (U.S. CLS. 13, 19, 21, 23, 31, 34 AND 35). SN 78-949,643. PUB. 2-6-2007. FILED 8-10-2006.
- 3,233,520 ( *See Class 1 for this trademark*).
- 3,233,526. **APEX AND DESIGN**. EURO-APEX B.V., (U.S. CLS. 13, 19, 21, 23, 31, 34 AND 35). SN 79-010,597. PUB. 2-6-2007. FILED 3-17-2005.
- 3,233,531. **FOPOWER (BLOCK FORM)**. FOBOX AS, MULTIPLE CLASS, (INT. CLS. 7, 9, 39, 40 AND 44), (U.S. CLS. 13, 19, 21, 23, 26, 31, 34, 35, 36, 38, 100, 101, 103, 105 AND 106). SN 79-013,329. PUB. 2-6-2007. FILED 8-26-2004.
- 3,233,534. **SATO (STYLIZED)**. KABUSHIKI KAISHA SATO, MULTIPLE CLASS, (INT. CLS. 7, 9, 16, 20, 37 AND 42), (U.S. CLS. 2, 5, 13, 19, 21, 22, 23, 25, 26, 29, 31, 32, 34, 35, 36, 37, 38, 50, 100, 101, 103 AND 106). SN 79-013,778. PUB. 2-6-2007. FILED 4-23-2004.
- 3,233,541 ( *See Class 1 for this trademark*).
- 3,233,544. **CANFLEX (BLOCK FORM)**. EHB ELECTRONICS GMBH, MULTIPLE CLASS, (INT. CLS. 7, 9 AND 12), (U.S. CLS. 13, 19, 21, 23, 26, 31, 34, 35, 36, 38 AND 44). SN 79-015,689. PUB. 2-6-2007. FILED 6-15-2005.
- 3,233,559. **PREFINER (BLOCK FORM)**. BÜHLER AG, MULTIPLE CLASS, (INT. CLS. 7, 9, 11 AND 42), (U.S. CLS. 13, 19, 21, 23, 26, 31, 34, 35, 36, 38, 100 AND 101). SN 79-017,117. PUB. 2-6-2007. FILED 7-21-2005.
- 3,233,560. **DEBAC (BLOCK FORM)**. BÜHLER AG, MULTIPLE CLASS, (INT. CLS. 7, 9, 11 AND 42), (U.S. CLS. 13, 19, 21, 23, 26, 31, 34, 35, 36, 38, 100 AND 101). SN 79-017,119. PUB. 2-6-2007. FILED 7-21-2005.
- 3,233,577 ( *See Class 1 for this trademark*).
- 3,233,580. **SHADOW DATA (BLOCK FORM)**. VESTAS CONTROL SYSTEMS A/S, MULTIPLE CLASS, (INT. CLS. 7, 9 AND 42), (U.S. CLS. 13, 19, 21, 23, 26, 31, 34, 35, 36, 38, 100 AND 101). SN 79-018,284. PUB. 2-6-2007. FILED 8-23-2004.
- 3,233,584 ( *See Class 1 for this trademark*).
- 3,233,592. **FU ER DA AND DESIGN**. TAIZHOU ZHEDONG MACHINE TOOL ACCESSORY FACTORY CO., LTD, (U.S. CLS. 13, 19, 21, 23, 31, 34 AND 35). SN 79-018,845. PUB. 2-6-2007. FILED 9-20-2005.
- 3,233,606 ( *See Class 6 for this trademark*).
- 3,233,607. **MISCELLANEOUS DESIGN**. OFFICINE MECCANICHE GALLETTI O.M.G. SRL, (U.S. CLS. 13, 19, 21, 23, 31, 34 AND 35). SN 79-019,575. PUB. 2-6-2007. FILED 10-6-2005.
- 3,233,617 ( *See Class 6 for this trademark*).
- 3,233,619. **DESSALATOR (BLOCK FORM)**. DESSALATOR S.A.R.L., MULTIPLE CLASS, (INT. CLS. 7, 11 AND 37), (U.S. CLS. 13, 19, 21, 23, 31, 34, 35, 100, 103 AND 106). SN 79-020,196. PUB. 2-6-2007. FILED 10-20-2005.
- 3,233,647 ( *See Class 6 for this trademark*).
- 3,233,653. **SIEMENS SGCC (BLOCK FORM)**. SIEMENS AKTIENGESELLSCHAFT, (U.S. CLS. 13, 19, 21, 23, 31, 34 AND 35). SN 79-021,404. PUB. 2-6-2007. FILED 1-13-2006.
- 3,233,669. **GROB AND DESIGN**. GROB-WERKE BURKHART GROB E.K., MULTIPLE CLASS, (INT. CLS. 7 AND 12), (U.S. CLS. 13, 19, 21, 23, 31, 34, 35 AND 44). SN 79-022,078. PUB. 2-6-2007. FILED 12-12-2005.
- 3,233,700. **SUNING (STYLIZED)**. JIANGSU SUNING APPLIANCE; COMPANY LIMITED, MULTIPLE CLASS, (INT. CLS. 7, 9, 11, 35 AND 37), (U.S. CLS. 13, 19, 21, 23, 26, 31, 34, 35, 36, 38, 100, 101, 102, 103 AND 106). SN 79-023,507. PUB. 2-6-2007. FILED 3-28-2006.
- 3,233,701 ( *See Class 3 for this trademark*).
- 3,233,703. **MISCELLANEOUS DESIGN**. JIANGSU SUNING APPLIANCE; COMPANY LIMITED, MULTIPLE CLASS, (INT. CLS. 7, 9, 11, 35 AND 37), (U.S. CLS. 13, 19, 21, 23, 26, 31, 34, 35, 36, 38, 100, 101, 102, 103 AND 106). SN 79-023,612. PUB. 2-6-2007. FILED 3-28-2006.

- 3,233,710. **ARDO MADE FOR YOU. AND DESIGN.** ANTONIO MERLONI S.P.A., MULTIPLE CLASS, (INT. CLS. 7 AND 11), (U.S. CLS. 13, 19, 21, 23, 31, 34 AND 35). SN 79-024,181. PUB. 2-6-2007. FILED 12-21-2005.
- 3,233,748. **HAARUP MIXER (BLOCK FORM).** HAARUP MASKINFABRIK A/S, (U.S. CLS. 13, 19, 21, 23, 31, 34 AND 35). SN 79-026,690. PUB. 2-6-2007. FILED 3-2-2006.
- 3,233,756. **A ANYCUT AND DESIGN.** ZHENGZHOU HI-TECH ABRASIVES; COMPANY LTD., (U.S. CLS. 13, 19, 21, 23, 31, 34 AND 35). SN 79-028,536. PUB. 2-6-2007. FILED 6-15-2006.

---

### CLASS 8—HAND TOOLS

- 3,232,137. **BLACK RHINO (BLOCK FORM).** NEWELL INTERNATIONAL, INC., MULTIPLE CLASS, (INT. CLS. 8, 9 AND 18), (U.S. CLS. 1, 2, 3, 21, 22, 23, 26, 28, 36, 38, 41 AND 44). SN 76-646,043. PUB. 2-6-2007. FILED 9-1-2005.
- 3,232,180. **EXPECT A MIRACLE (BLOCK FORM).** GRACE MANUFACTURING INC., (U.S. CLS. 23, 28 AND 44). SN 76-652,070. PUB. 2-6-2007. FILED 12-19-2005.
- 3,232,459. **PONY (BLOCK FORM).** ADJUSTABLE CLAMP COMPANY, (U.S. CLS. 23, 28 AND 44). SN 78-612,459. PUB. 2-6-2007. FILED 4-20-2005.
- 3,232,563. **BIG JACK (BLOCK FORM).** BUTLER PRODUCTS CORPORATION, (U.S. CLS. 23, 28 AND 44). SN 78-699,952. PUB. 2-6-2007. FILED 8-24-2005.
- 3,232,586. **KS KANZAWA SAMURAI AND DESIGN.** KANZAWA SEIKO CO., LTD., (U.S. CLS. 23, 28 AND 44). SN 78-722,454. PUB. 2-6-2007. FILED 9-28-2005.
- 3,233,039. **NS AND DESIGN.** GAUGHAN, RICK L., (U.S. CLS. 23, 28 AND 44). SN 78-887,782. PUB. 2-6-2007. FILED 5-19-2006.
- 3,233,284. **EXTEND-A-HAND (BLOCK FORM).** VERSATILE HOUSEWARES & GARDENING SYSTEMS, INC., (U.S. CLS. 23, 28 AND 44). SN 78-914,525. PUB. 2-6-2007. FILED 6-22-2006.
- 3,233,520 ( *See Class 1 for this trademark*).
- 3,233,554. **BY (BLOCK FORM).** ORFEVRERIE CHRISTOFLE, MULTIPLE CLASS, (INT. CLS. 8, 14 AND 21), (U.S. CLS. 2, 13, 23, 27, 28, 29, 30, 33, 40, 44 AND 50). SN 79-016,593. PUB. 2-6-2007. FILED 5-20-2005.
- 3,233,695. **YPERION (BLOCK FORM).** A & M TECHNOLOGY, (U.S. CLS. 23, 28 AND 44). SN 79-023,374. PUB. 2-6-2007. FILED 12-6-2005.
- 3,233,701 ( *See Class 3 for this trademark*).

---

### CLASS 9—ELECTRICAL AND SCIENTIFIC APPARATUS

- 3,232,060 ( *See Class 6 for this trademark*).
- 3,232,067. **UNISANTIS.** UNISANTIS HOLDING COMPANY PTE, LTD., THE, MULTIPLE CLASS, (INT. CLS. 9 AND 10), (U.S. CLS. 21, 23, 26, 36, 38, 39 AND 44). SN 76-384,328. PUB. 2-6-2007. FILED 3-20-2002.
- 3,232,075. **ID WITNESS AND DESIGN.** SEGUTRONIC INTERNATIONAL, INC., (U.S. CLS. 21, 23, 26, 36 AND 38). SN 76-460,571. PUB. 8-29-2006. FILED 10-18-2002.
- 3,232,078. **COOL CATCH.** ATRONIC INTERNATIONAL GMBH, MULTIPLE CLASS, (INT. CLS. 9 AND 28), (U.S. CLS. 21, 22, 23, 26, 36, 38 AND 50). SN 76-497,256. PUB. 5-16-2006. FILED 3-14-2003.
- 3,232,079. **MAGAZINE (STYLIZED).** MAGA SHOP S.R.L., (U.S. CLS. 21, 23, 26, 36 AND 38). SN 76-519,379. PUB. 2-6-2007. FILED 6-4-2003.
- 3,232,085. **INSIGHT THROUGH IN VIVO IMAGING (BLOCK FORM).** VISUALSONICS INC., MULTIPLE CLASS, (INT. CLS. 9 AND 10), (U.S. CLS. 21, 23, 26, 36, 38, 39 AND 44). SN 76-566,636. PUB. 11-8-2005. FILED 12-22-2003.
- 3,232,086 ( *See Class 7 for this trademark*).
- 3,232,087. **MOST AND DESIGN.** MSC EUROPE GMBH, MULTIPLE CLASS, (INT. CLS. 9, 41 AND 42), (U.S. CLS. 21, 23, 26, 36, 38, 100, 101 AND 107). SN 76-584,908. PUB. 8-15-2006. FILED 4-2-2004.

- 3,232,088 ( *See Class 5 for this trademark*).
- 3,232,089. **I-VU (STYLIZED).** I-VU USA, INC., MULTIPLE CLASS, (INT. CLS. 9, 35 AND 41), (U.S. CLS. 21, 23, 26, 36, 38, 100, 101, 102 AND 107). SN 76-596,616. PUB. 2-6-2007. FILED 6-4-2004.
- 3,232,091. **W WORLD VIDEO & SUPPLY, INC. AND DESIGN.** WORLD VIDEO & SUPPLY, INC., MULTIPLE CLASS, (INT. CLS. 9, 35 AND 41), (U.S. CLS. 21, 23, 26, 36, 38, 100, 101, 102 AND 107). SN 76-600,731. PUB. 2-6-2007. FILED 7-6-2004.
- 3,232,095. **VOCA (BLOCK FORM).** VOCA LIMITED, MULTIPLE CLASS, (INT. CLS. 9, 36, 42 AND 45), (U.S. CLS. 21, 23, 26, 36, 38, 100, 101 AND 102). SN 76-609,278. PUB. 8-15-2006. FILED 8-30-2004.
- 3,232,096. **NATURAL DISPLAY (BLOCK FORM).** CASIO KEISANKI KABUSHIKI KAISHA, DBA CASIO COMPUTER CO., LTD., (U.S. CLS. 21, 23, 26, 36 AND 38). SN 76-609,495. PUB. 8-22-2006. FILED 8-31-2004.
- 3,232,113. **THE ED BENGUIAT FONT COLLECTION (BLOCK FORM).** BRAND DESIGN COMPANY, INC., DBA HOUSE INDUSTRIES, (U.S. CLS. 21, 23, 26, 36 AND 38). SN 76-629,584. PUB. 2-6-2007. FILED 1-27-2005.
- 3,232,117. **TURKEY MOUNTAIN AND DESIGN.** WILLIAM C HANCOCK & DALE G HANCOCK, (U.S. CLS. 21, 23, 26, 36 AND 38). SN 76-630,684. PUB. 2-6-2007. FILED 2-8-2005.
- 3,232,118. **SCOTSMAN GUIDE (BLOCK FORM).** SCOTSMAN PUBLISHING, INC., MULTIPLE CLASS, (INT. CLS. 9 AND 16), (U.S. CLS. 2, 5, 21, 22, 23, 26, 29, 36, 37, 38 AND 50). SN 76-631,913. PUB. 2-6-2007. FILED 2-22-2005.
- 3,232,119. **IGNITE AND DESIGN.** TIME-O-MATIC, INC., (U.S. CLS. 21, 23, 26, 36 AND 38). SN 76-633,484. PUB. 2-6-2007. FILED 3-10-2005.
- 3,232,128. **CHALK & WIRE AND DESIGN.** CHALK & WIRE PROFESSIONAL DEVELOPMENT CANADA INC., (U.S. CLS. 21, 23, 26, 36 AND 38). SN 76-639,431. PUB. 2-6-2007. FILED 5-25-2005.
- 3,232,137 ( *See Class 8 for this trademark*).
- 3,232,139. **FLYABILITY (BLOCK FORM).** THOT TECHNOLOGIES, (U.S. CLS. 21, 23, 26, 36 AND 38). SN 76-646,624. PUB. 2-6-2007. FILED 9-8-2005.
- 3,232,145 ( *See Class 6 for this trademark*).
- 3,232,167. **MISCELLANEOUS DESIGN.** HYPERPHYSICS RESEARCH, LLC, (U.S. CLS. 21, 23, 26, 36 AND 38). SN 76-650,325. PUB. 2-6-2007. FILED 11-15-2005.
- 3,232,168. **HYPERPHYSICS RESEARCH (BLOCK FORM).** HYPERPHYSICS RESEARCH, LLC, (U.S. CLS. 21, 23, 26, 36 AND 38). SN 76-650,327. PUB. 2-6-2007. FILED 11-15-2005.
- 3,232,188. **CCS CHARGE CARD SYSTEMS, INC AND DESIGN.** CHARGE CARD SYSTEMS, INC., MULTIPLE CLASS, (INT. CLS. 9 AND 36), (U.S. CLS. 21, 23, 26, 36, 38, 100, 101 AND 102). SN 76-652,568. PUB. 2-6-2007. FILED 12-27-2005.
- 3,232,196. **MISCELLANEOUS DESIGN.** THE UNITED METHODIST PUBLISHING HOUSE, MULTIPLE CLASS, (INT. CLS. 9, 16 AND 35), (U.S. CLS. 2, 5, 21, 22, 23, 26, 29, 36, 37, 38, 50, 100, 101 AND 102). SN 76-654,325. PUB. 2-6-2007. FILED 1-25-2006.
- 3,232,203. **TITANIUM POWER (BLOCK FORM).** YONI DISTRIBUTORS, INC., (U.S. CLS. 21, 23, 26, 36 AND 38). SN 76-657,014. PUB. 2-6-2007. FILED 3-21-2006.
- 3,232,208. **MOBILYST (BLOCK FORM).** RADIANT SOFTWARE, INC., (U.S. CLS. 21, 23, 26, 36 AND 38). SN 76-658,715. PUB. 2-6-2007. FILED 4-19-2006.
- 3,232,237 ( *See Class 7 for this trademark*).
- 3,232,274. **OPTIFILTER (STYLIZED).** MINE SAFETY APPLIANCES COMPANY, (U.S. CLS. 21, 23, 26, 36 AND 38). SN 76-667,113. PUB. 2-6-2007. FILED 10-10-2006.
- 3,232,275. **BROADMAN & HOLMAN (BLOCK FORM).** LIFE-WAY CHRISTIAN RESOURCES OF THE SOUTHERN BAPTIST CONVENTION, MULTIPLE CLASS, (INT. CLS. 9 AND 16), (U.S. CLS. 2, 5, 21, 22, 23, 26, 29, 36, 37, 38 AND 50). SN 76-667,792. PUB. 2-6-2007. FILED 10-20-2006.
- 3,232,279. **NIKITA (BLOCK FORM).** CYBERSCAN TECHNOLOGY, (U.S. CLS. 21, 23, 26, 36 AND 38). SN 77-000,508. PUB. 2-6-2007. FILED 9-15-2006.
- 3,232,287. **FREEVERSE AND DESIGN.** FREEVERSE CORPORATION, (U.S. CLS. 21, 23, 26, 36 AND 38). SN 77-003,589. PUB. 2-6-2007. FILED 9-20-2006.

- 3,232,288. **WEBLEGS (BLOCK FORM)**. EXODUS WEB, INC., (U.S. CLS. 21, 23, 26, 36 AND 38). SN 77-005,546. PUB. 2-6-2007. FILED 9-22-2006.
- 3,232,290. **VE (BLOCK FORM)**. CERWIN VEGA, INC., (U.S. CLS. 21, 23, 26, 36 AND 38). SN 77-010,281. PUB. 2-6-2007. FILED 9-29-2006.
- 3,232,292. **STROKER PRO (BLOCK FORM)**. CERWIN VEGA, INC., (U.S. CLS. 21, 23, 26, 36 AND 38). SN 77-010,864. PUB. 2-6-2007. FILED 9-29-2006.
- 3,232,296. **DIGIMODEL (BLOCK FORM)**. VIRTUALCAST, LLC, (U.S. CLS. 21, 23, 26, 36 AND 38). SN 77-019,479. PUB. 2-6-2007. FILED 10-12-2006.
- 3,232,297. **KINEMATRICS (BLOCK FORM)**. KINEMATRICS, INC., (U.S. CLS. 21, 23, 26, 36 AND 38). SN 77-019,916. PUB. 2-6-2007. FILED 10-12-2006.
- 3,232,301. **SPLASH TUNES (BLOCK FORM)**. IQ HONG KONG, LTD, (U.S. CLS. 21, 23, 26, 36 AND 38). SN 77-025,079. PUB. 2-6-2007. FILED 10-19-2006.
- 3,232,308. **DIGGING FOR THE TRUTH (BLOCK FORM)**. A&E TELEVISION NETWORKS, MULTIPLE CLASS, (INT. CLS. 9 AND 41), (U.S. CLS. 21, 23, 26, 36, 38, 100, 101 AND 107). SN 77-030,243. PUB. 2-6-2007. FILED 10-26-2006.
- 3,232,310. **G3 (BLOCK FORM)**. BILL GOOD MARKETING, (U.S. CLS. 21, 23, 26, 36 AND 38). SN 77-035,409. PUB. 2-6-2007. FILED 11-2-2006.
- 3,232,311. **TREADSTAT (BLOCK FORM)**. BFS BRANDS, LLC, (U.S. CLS. 21, 23, 26, 36 AND 38). SN 77-038,248. PUB. 2-6-2007. FILED 11-7-2006.
- 3,232,329 ( *See Class 7 for this trademark*).
- 3,232,335. **H2O (STYLIZED)**. WILSON, DEREK J, MULTIPLE CLASS, (INT. CLS. 9, 18, 25 AND 28), (U.S. CLS. 1, 2, 3, 21, 22, 23, 26, 36, 38, 39, 41 AND 50). SN 78-287,111. PUB. 2-6-2007. FILED 8-13-2003.
- 3,232,339. **DIGIDYN**. SENNHEISER ELECTRONIC GMBH & CO. KG, (U.S. CLS. 21, 23, 26, 36 AND 38). SN 78-305,952. PUB. 3-7-2006. FILED 9-26-2003.
- 3,232,345. **AJB SOFTWARE (BLOCK FORM)**. AJB SOFTWARE DESIGN INC., MULTIPLE CLASS, (INT. CLS. 9 AND 42), (U.S. CLS. 21, 23, 26, 36, 38, 100 AND 101). SN 78-352,586. PUB. 6-27-2006. FILED 1-15-2004.
- 3,232,346. **ECAMPUS NAVIGATOR (BLOCK FORM)**. DECISION ACADEMIC INC., (U.S. CLS. 21, 23, 26, 36 AND 38). SN 78-358,083. PUB. 2-6-2007. FILED 1-27-2004.
- 3,232,350. **GYPSY FORTUNE (BLOCK FORM)**. ATRONIC INTERNATIONAL GMBH, MULTIPLE CLASS, (INT. CLS. 9 AND 28), (U.S. CLS. 21, 22, 23, 26, 36, 38 AND 50). SN 78-381,506. PUB. 2-7-2006. FILED 3-10-2004.
- 3,232,357. **MINSTITUTIONAL (BLOCK FORM)**. PYXIS MOBILE, INC., (U.S. CLS. 21, 23, 26, 36 AND 38). SN 78-422,664. PUB. 2-6-2007. FILED 5-20-2004.
- 3,232,365. **XOFTSPY (BLOCK FORM)**. PARETOLOGIC INC., (U.S. CLS. 21, 23, 26, 36 AND 38). SN 78-462,851. PUB. 2-6-2007. FILED 8-5-2004.
- 3,232,366. **DUPAGE CHILDREN'S MUSEUM AND DESIGN**. DUPAGE CHILDREN'S MUSEUM, MULTIPLE CLASS, (INT. CLS. 9 AND 16), (U.S. CLS. 2, 5, 21, 22, 23, 26, 29, 36, 37, 38 AND 50). SN 78-471,962. PUB. 2-6-2007. FILED 8-23-2004.
- 3,232,369. **MAKING MORE POSSIBLE AND DESIGN**. ABN AMRO BANK N.V., MULTIPLE CLASS, (INT. CLS. 9, 35, 36 AND 41), (U.S. CLS. 21, 23, 26, 36, 38, 100, 101, 102 AND 107). SN 78-482,362. PUB. 7-4-2006. FILED 9-13-2004.
- 3,232,375 ( *See Class 3 for this trademark*).
- 3,232,381. **OVERFINCH BESPOKE VEHICLES AND DESIGN**. OVERFINCH HOLDINGS LIMITED, MULTIPLE CLASS, (INT. CLS. 9, 12, 35 AND 40), (U.S. CLS. 19, 21, 23, 26, 31, 35, 36, 38, 44, 100, 101, 102, 103 AND 106). SN 78-512,245. PUB. 2-6-2007. FILED 11-5-2004.
- 3,232,383. **PRAIRIE FARM REPORT (BLOCK FORM)**. AG-COM PRODUCTIONS LTD., MULTIPLE CLASS, (INT. CLS. 9, 25 AND 41), (U.S. CLS. 21, 22, 23, 26, 36, 38, 39, 100, 101 AND 107). SN 78-520,663. PUB. 2-6-2007. FILED 11-21-2004.
- 3,232,390. **KIVA SYSTEMS AND DESIGN**. KIVA SYSTEMS, INC., (U.S. CLS. 21, 23, 26, 36 AND 38). SN 78-539,116. PUB. 2-6-2007. FILED 12-28-2004.
- 3,232,400. **MOBITRONIC (STYLIZED)**. MOBICOOL INTERNATIONAL LIMITED, (U.S. CLS. 21, 23, 26, 36 AND 38). SN 78-554,209. PUB. 5-9-2006. FILED 1-26-2005.
- 3,232,402. **LINX TECHNOLOGY (BLOCK FORM)**. ABLE PLANET, INCORPORATED, (U.S. CLS. 21, 23, 26, 36 AND 38). SN 78-556,233. PUB. 2-6-2007. FILED 1-28-2005.
- 3,232,412. **DARCYLOG (BLOCK FORM)**. INSTITUT FRANCAIS DU PÉTROLE, MULTIPLE CLASS, (INT. CLS. 9 AND 42), (U.S. CLS. 21, 23, 26, 36, 38, 100 AND 101). SN 78-567,340. PUB. 11-15-2005. FILED 2-15-2005.
- 3,232,413. **WNI AND DESIGN**. WEATHERNEWS AMERICAS INC., (U.S. CLS. 21, 23, 26, 36 AND 38). SN 78-568,966. PUB. 2-6-2007. FILED 2-16-2005.
- 3,232,414. **TRANSITIONS LIFESTYLE SYSTEM (BLOCK FORM)**. MARKET AMERICA, INC., MULTIPLE CLASS, (INT. CLS. 9 AND 16), (U.S. CLS. 2, 5, 21, 22, 23, 26, 29, 36, 37, 38 AND 50). SN 78-570,812. PUB. 2-6-2007. FILED 2-18-2005.
- 3,232,423. **ELITEMICRO (BLOCK FORM)**. AUDIO & VIDEO LABS, INC./DISC MAKERS, (U.S. CLS. 21, 23, 26, 36 AND 38). SN 78-578,279. PUB. 2-6-2007. FILED 3-2-2005.
- 3,232,426. **MONDEX (BLOCK FORM)**. MONDEX INTERNATIONAL LIMITED, MULTIPLE CLASS, (INT. CLS. 9 AND 36), (U.S. CLS. 21, 23, 26, 36, 38, 100, 101 AND 102). SN 78-582,597. PUB. 2-6-2007. FILED 3-8-2005.
- 3,232,431. **KIBA AND DESIGN**. DREAM RANCH INC., MULTIPLE CLASS, (INT. CLS. 9 AND 28), (U.S. CLS. 21, 22, 23, 26, 36, 38 AND 50). SN 78-587,428. PUB. 2-6-2007. FILED 3-15-2005.
- 3,232,432. **STEWART (BLOCK FORM)**. STEWART TITLE GUARANTY COMPANY, MULTIPLE CLASS, (INT. CLS. 9 AND 36), (U.S. CLS. 21, 23, 26, 36, 38, 100, 101 AND 102). SN 78-588,317. PUB. 2-6-2007. FILED 3-16-2005.
- 3,232,434. **ULTRALITE (BLOCK FORM)**. SUNTIGER, INC., (U.S. CLS. 21, 23, 26, 36 AND 38). SN 78-589,467. PUB. 2-6-2007. FILED 3-17-2005.
- 3,232,458. **ELECTROSONIC (BLOCK FORM)**. ELECTROSONIC LIMITED, (U.S. CLS. 21, 23, 26, 36 AND 38). SN 78-609,763. PUB. 2-6-2007. FILED 4-15-2005.
- 3,232,461. **FRONTENDWARE (BLOCK FORM)**. MAVERICK DATA SYSTEMS, INC., (U.S. CLS. 21, 23, 26, 36 AND 38). SN 78-612,721. PUB. 2-6-2007. FILED 4-20-2005.
- 3,232,473. **PRECISION (BLOCK FORM)**. ADVANCED BIONICS CORPORATION, MULTIPLE CLASS, (INT. CLS. 9, 10 AND 16), (U.S. CLS. 2, 5, 21, 22, 23, 26, 29, 36, 37, 38, 39, 44 AND 50). SN 78-623,413. PUB. 2-6-2007. FILED 5-5-2005.
- 3,232,478. **SSM (BLOCK FORM)**. ESTEREL TECHNOLOGIES, (U.S. CLS. 21, 23, 26, 36 AND 38). SN 78-630,347. PUB. 2-6-2007. FILED 5-16-2005.
- 3,232,480. **BOBBY VALENTINO (BLOCK FORM)**. BECKINGHAM, ROBERT JAMES, (U.S. CLS. 21, 23, 26, 36 AND 38). SN 78-631,746. PUB. 2-6-2007. FILED 5-17-2005.
- 3,232,486. **KIDSKOUNT (BLOCK FORM)**. APPLIED COMPUTER SYSTEMS, INCORPORATED, (U.S. CLS. 21, 23, 26, 36 AND 38). SN 78-634,636. PUB. 2-6-2007. FILED 5-5-2005.
- 3,232,492. **DYNAMICSIQ (BLOCK FORM)**. APPLIED ENTERPRISE DYNAMICS, INC., (U.S. CLS. 21, 23, 26, 36 AND 38). SN 78-644,756. PUB. 2-6-2007. FILED 6-6-2005.
- 3,232,501. **PURSUIT OUTCOMES (BLOCK FORM)**. BRAEBON MEDICAL CORPORATION, (U.S. CLS. 21, 23, 26, 36 AND 38). SN 78-652,242. PUB. 10-31-2006. FILED 6-16-2005.
- 3,232,519. **KUNDALA (BLOCK FORM)**. MAIER, CHARLES E. III, MULTIPLE CLASS, (INT. CLS. 9 AND 41), (U.S. CLS. 21, 23, 26, 36, 38, 100, 101 AND 107). SN 78-669,680. PUB. 2-6-2007. FILED 7-13-2005.
- 3,232,520. **AQUA ZONE (BLOCK FORM)**. ORVAR S.A. DE C.V., MULTIPLE CLASS, (INT. CLS. 9, 25 AND 28), (U.S. CLS. 21, 22, 23, 26, 36, 38, 39 AND 50). SN 78-672,103. PUB. 2-6-2007. FILED 7-18-2005.
- 3,232,530. **VIRTUAL MACRO (BLOCK FORM)**. APPROPRIATE SOLUTIONS PTY LTD, (U.S. CLS. 21, 23, 26, 36 AND 38). SN 78-678,037. PUB. 2-6-2007. FILED 7-26-2005.
- 3,232,531. **IMT.LAB AND DESIGN**. BIOSOUND ESAOTE, INC., (U.S. CLS. 21, 23, 26, 36 AND 38). SN 78-678,122. PUB. 2-6-2007. FILED 7-26-2005.
- 3,232,542. **ICORE (BLOCK FORM)**. ZODIAC U.S. CORPORATION, (U.S. CLS. 21, 23, 26, 36 AND 38). SN 78-685,571. PUB. 2-6-2007. FILED 8-4-2005.
- 3,232,559. **SPLICED NETWORKS (BLOCK FORM)**. SPLICED NETWORKS LLC, (U.S. CLS. 21, 23, 26, 36 AND 38). SN 78-697,432. PUB. 2-6-2007. FILED 8-22-2005.
- 3,232,565. **ADVANCED SYSTEM OPTIMIZER AND DESIGN**.

- RANA, SHRISHAIL, (U.S. CLS. 21, 23, 26, 36 AND 38). SN 78-705,944. PUB. 2-6-2007. FILED 9-2-2005.
- 3,232,587. **VELOCITY AND DESIGN. MALCOLM & CO. LLC**, (U.S. CLS. 21, 23, 26, 36 AND 38). SN 78-722,661. PUB. 2-6-2007. FILED 9-28-2005.
- 3,232,590. **CAMPUSVUE COLLEGIATE (BLOCK FORM). CAMPUS MANAGEMENT CORPORATION**, (U.S. CLS. 21, 23, 26, 36 AND 38). SN 78-724,244. PUB. 2-6-2007. FILED 9-30-2005.
- 3,232,591. **CAMPUSVUE (BLOCK FORM). CAMPUS MANAGEMENT CORPORATION**, (U.S. CLS. 21, 23, 26, 36 AND 38). SN 78-724,260. PUB. 2-6-2007. FILED 9-30-2005.
- 3,232,596. **DENTAL HEALTH COACH (BLOCK FORM). POWERS, MARK A., MULTIPLE CLASS, (INT. CLS. 9 AND 41)**, (U.S. CLS. 21, 23, 26, 36, 38, 100, 101 AND 107). SN 78-727,030. PUB. 2-6-2007. FILED 10-5-2005.
- 3,232,603. **TANC (STYLIZED). PORTWELL, INC.**, (U.S. CLS. 21, 23, 26, 36 AND 38). SN 78-729,010. PUB. 2-6-2007. FILED 10-7-2005.
- 3,232,608. **CADCAPTURE (BLOCK FORM). TRINITY TECHNOLOGIES CORPORATION**, (U.S. CLS. 21, 23, 26, 36 AND 38). SN 78-731,020. PUB. 2-6-2007. FILED 10-11-2005.
- 3,232,629. **THE VIDEO ENCYCLOPEDIA OF THE 20TH CENTURY (BLOCK FORM). SUNRISE MEDIA LLC**, (U.S. CLS. 21, 23, 26, 36 AND 38). SN 78-739,095. PUB. 2-6-2007. FILED 10-24-2005.
- 3,232,631. **JUNXION BOX (BLOCK FORM). JUNXION, INC.**, (U.S. CLS. 21, 23, 26, 36 AND 38). SN 78-739,482. PUB. 2-6-2007. FILED 10-24-2005.
- 3,232,666. **HORSELAND (BLOCK FORM). HORSELAND, LLC, MULTIPLE CLASS, (INT. CLS. 9, 14 AND 16)**, (U.S. CLS. 2, 5, 21, 22, 23, 26, 27, 28, 29, 36, 37, 38 AND 50). SN 78-747,397. PUB. 9-19-2006. FILED 11-4-2005.
- 3,232,667. **CAB POWER (BLOCK FORM). PHILLIPS & TEMRO INDUSTRIES INC.**, (U.S. CLS. 21, 23, 26, 36 AND 38). SN 78-747,405. PUB. 2-6-2007. FILED 11-4-2005.
- 3,232,672. **CINEPLEX (BLOCK FORM). PLEXON INCORPORATED**, (U.S. CLS. 21, 23, 26, 36 AND 38). SN 78-748,206. PUB. 2-6-2007. FILED 11-7-2005.
- 3,232,682. **LR DUPLEX (BLOCK FORM). LEUPOLD & STEVENS, INC.**, (U.S. CLS. 21, 23, 26, 36 AND 38). SN 78-749,678. PUB. 2-6-2007. FILED 11-8-2005.
- 3,232,683. **RX (BLOCK FORM). LEUPOLD & STEVENS, INC.**, (U.S. CLS. 21, 23, 26, 36 AND 38). SN 78-749,769. PUB. 2-6-2007. FILED 11-8-2005.
- 3,232,690. **FON AND DESIGN. FON WIRELESS LIMITED**, (U.S. CLS. 21, 23, 26, 36 AND 38). SN 78-751,577. PUB. 2-6-2007. FILED 11-10-2005.
- 3,232,694. **FUTURE SOLDIER TRAINER (BLOCK FORM). LASER SHOT, INC.**, (U.S. CLS. 21, 23, 26, 36 AND 38). SN 78-751,912. PUB. 2-6-2007. FILED 11-11-2005.
- 3,232,699. **SIMPLIFY LOCKDOWN (BLOCK FORM). TRICERAT, INC.**, (U.S. CLS. 21, 23, 26, 36 AND 38). SN 78-753,023. PUB. 10-31-2006. FILED 11-14-2005.
- 3,232,701. **INTELLAPATCH (BLOCK FORM). APCON, INC.**, (U.S. CLS. 21, 23, 26, 36 AND 38). SN 78-753,272. PUB. 2-6-2007. FILED 11-14-2005.
- 3,232,712. **DIGIFLOW (BLOCK FORM). DIGITOT (PTY) LTD**, (U.S. CLS. 21, 23, 26, 36 AND 38). SN 78-756,299. PUB. 2-6-2007. FILED 11-17-2005.
- 3,232,726. **PATCHVIEW (BLOCK FORM). RIT TECHNOLOGIES, LTD.**, (U.S. CLS. 21, 23, 26, 36 AND 38). SN 78-762,252. PUB. 2-6-2007. FILED 11-29-2005.
- 3,232,735. **BJORN\* EYEWEAR (BLOCK FORM). BJORN EYEWEAR, INC.**, (U.S. CLS. 21, 23, 26, 36 AND 38). SN 78-764,562. PUB. 2-6-2007. FILED 12-1-2005.
- 3,232,736. **BJORN EYEWEAR (BLOCK FORM). BJORN EYEWEAR, INC.**, (U.S. CLS. 21, 23, 26, 36 AND 38). SN 78-764,626. PUB. 2-6-2007. FILED 12-1-2005.
- 3,232,737. **MEDICORDER (BLOCK FORM). OFIELD, ANDREW FRANK**, (U.S. CLS. 21, 23, 26, 36 AND 38). SN 78-765,298. PUB. 2-6-2007. FILED 12-2-2005.
- 3,232,750. **THE ART OF THE PICKUP AND DESIGN. LEARN THE SKILLS CORPORATION**, (U.S. CLS. 21, 23, 26, 36 AND 38). SN 78-770,195. PUB. 2-6-2007. FILED 12-9-2005.
- 3,232,752. **3AAA (STYLIZED). HUA, YANG JIAN**, (U.S. CLS. 21, 23, 26, 36 AND 38). SN 78-770,725. PUB. 2-6-2007. FILED 12-10-2005.
- 3,232,755. **QPM (BLOCK FORM). IATIA LIMITED**, (U.S. CLS. 21, 23, 26, 36 AND 38). SN 78-771,837. PUB. 2-6-2007. FILED 12-13-2005.
- 3,232,761. **TRICERAT (BLOCK FORM). TRICERAT, INC.**, (U.S. CLS. 21, 23, 26, 36 AND 38). SN 78-777,485. PUB. 2-6-2007. FILED 12-20-2005.
- 3,232,763. **ILYNX (BLOCK FORM). SCIENTIFIC-ATLANTA EUROPE NV**, (U.S. CLS. 21, 23, 26, 36 AND 38). SN 78-777,833. PUB. 8-29-2006. FILED 12-21-2005.
- 3,232,764. **ENDPOINT-LINK PRO (BLOCK FORM). ITRON, INC.**, (U.S. CLS. 21, 23, 26, 36 AND 38). SN 78-778,079. PUB. 2-6-2007. FILED 12-21-2005.
- 3,232,771. **VOICESECUREIT (BLOCK FORM). VOICEIT TECHNOLOGIES, LLC**, (U.S. CLS. 21, 23, 26, 36 AND 38). SN 78-780,024. PUB. 8-22-2006. FILED 12-23-2005.
- 3,232,775. **VALVETRAIN AMPLIFICATION AND DESIGN. GESSNER, RICHARD J JR.**, (U.S. CLS. 21, 23, 26, 36 AND 38). SN 78-785,654. PUB. 2-6-2007. FILED 1-5-2006.
- 3,232,778. **LEARNING PLUS (BLOCK FORM). LEARNING PLUS ASSOCIATES**, (U.S. CLS. 21, 23, 26, 36 AND 38). SN 78-786,796. PUB. 2-6-2007. FILED 1-6-2006.
- 3,232,779. **LEARNING PLUS ASSOCIATES POWERFUL LEARNING USING STANDARDS AND DESIGN. LEARNING PLUS ASSOCIATES**, (U.S. CLS. 21, 23, 26, 36 AND 38). SN 78-786,801. PUB. 2-6-2007. FILED 1-6-2006.
- 3,232,780. **DIGI-LAB LABORATORY GRADE FOR PRECISION ACCURACY AND DESIGN. TRANSWORLD AQUATIC ENTERPRISES INCORPORATED**, (U.S. CLS. 21, 23, 26, 36 AND 38). SN 78-787,153. PUB. 2-6-2007. FILED 1-8-2006.
- 3,232,783. **POSITIVE IDENTITY SOLUTIONS AND DESIGN. RSH PROTECTION, INC.**, (U.S. CLS. 21, 23, 26, 36 AND 38). SN 78-787,912. PUB. 2-6-2007. FILED 1-9-2006.
- 3,232,809. **MARK 5 (BLOCK FORM). KONINKLIJKE PHILIPS ELECTRONICS N.V.**, (U.S. CLS. 21, 23, 26, 36 AND 38). SN 78-808,869. PUB. 2-6-2007. FILED 2-7-2006.
- 3,232,811. **HOW SAFE (BLOCK FORM). ASSOCIATED ELECTRIC & GAS INSURANCE SERVICES LIMITED, MULTIPLE CLASS, (INT. CLS. 9 AND 41)**, (U.S. CLS. 21, 23, 26, 38, 100, 101 AND 107). SN 78-809,257. PUB. 2-6-2007. FILED 2-7-2006.
- 3,232,825. **MONTIUM (BLOCK FORM). RECORE SYSTEMS B.V.**, (U.S. CLS. 21, 23, 26, 36 AND 38). SN 78-813,583. PUB. 2-6-2007. FILED 2-13-2006.
- 3,232,829. **STARENT NETWORKS AND DESIGN. STARENT NETWORKS CORP.**, (U.S. CLS. 21, 23, 26, 36 AND 38). SN 78-815,384. PUB. 2-6-2007. FILED 2-15-2006.
- 3,232,830. **AFF (BLOCK FORM). BASIS TECHNOLOGY CORPORATION, AND GARFINKEL, SIMSON**, (U.S. CLS. 21, 23, 26, 36 AND 38). SN 78-815,577. PUB. 2-6-2007. FILED 2-15-2006.
- 3,232,831. **AFFLIB (BLOCK FORM). BASIS TECHNOLOGY CORPORATION, AND GARFINKEL, SIMSON**, (U.S. CLS. 21, 23, 26, 36 AND 38). SN 78-815,583. PUB. 2-6-2007. FILED 2-15-2006.
- 3,232,835. **SAVVYPACK (BLOCK FORM). ALLIED DEVELOPMENT CORPORATION, MULTIPLE CLASS, (INT. CLS. 9 AND 42)**, (U.S. CLS. 21, 23, 26, 38, 100 AND 101). SN 78-817,126. PUB. 2-6-2007. FILED 2-16-2006.
- 3,232,841. **ATLANTIC SECURITY AND DESIGN. ATLANTIC COMPANIES, INC., MULTIPLE CLASS, (INT. CLS. 9, 37 AND 45)**, (U.S. CLS. 21, 23, 26, 36, 38, 100, 101, 103 AND 106). SN 78-822,566. PUB. 2-6-2007. FILED 2-24-2006.
- 3,232,861. **TURBOSPEECH (BLOCK FORM). ECTACO INC.**, (U.S. CLS. 21, 23, 26, 36 AND 38). SN 78-833,191. PUB. 2-6-2007. FILED 3-9-2006.
- 3,232,871 ( *See Class 7 for this trademark*).
- 3,232,886 ( *See Class 6 for this trademark*).
- 3,232,894. **MISCELLANEOUS DESIGN. THE BURTON CORPORATION, MULTIPLE CLASS, (INT. CLS. 9, 25 AND 28)**, (U.S. CLS. 21, 22, 23, 26, 36, 38, 39 AND 50). SN 78-843,499. PUB. 2-6-2007. FILED 3-22-2006.
- 3,232,895. **SWIFT AND DESIGN. SOFTEL-USA**, (U.S. CLS. 21, 23, 26, 36 AND 38). SN 78-844,522. PUB. 2-6-2007. FILED 3-23-2006.
- 3,232,899. **PLANVIEW AND DESIGN. PLANVIEW, INC.**, (U.S. CLS. 21, 23, 26, 36 AND 38). SN 78-847,099. PUB. 10-24-2006. FILED 3-27-2006.
- 3,232,905. **FUSIONVM (BLOCK FORM). ACHILLES GUARD**,



- INC., DBA CRITICAL WATCH, MULTIPLE CLASS, (INT. CLS. 9 AND 45), (U.S. CLS. 21, 23, 26, 36, 38, 100 AND 101). SN 78-849,256. PUB. 2-6-2007. FILED 3-29-2006.
- 3,232,907. **HAIX AND DESIGN**. HAIX-SCHUHE PRODUKTIONS UND VERTIEBS GMBH, MULTIPLE CLASS, (INT. CLS. 9 AND 25), (U.S. CLS. 21, 22, 23, 26, 36, 38 AND 39). SN 78-850,103. PUB. 2-6-2007. FILED 3-30-2006.
- 3,232,908. **HAIX SHOES FOR PROFESSIONALS AND DESIGN**. HAIX-SCHUHE PRODUKTIONS UND VERTIEBS GMBH, MULTIPLE CLASS, (INT. CLS. 9 AND 25), (U.S. CLS. 21, 22, 23, 26, 36, 38 AND 39). SN 78-850,212. PUB. 2-6-2007. FILED 3-30-2006.
- 3,232,912. **IBT INTELLIGENT BRIGHTNESS TECHNOLOGY (BLOCK FORM)**. FOURSTAR GROUP, INC., (U.S. CLS. 21, 23, 26, 36 AND 38). SN 78-853,296. PUB. 2-6-2007. FILED 4-4-2006.
- 3,232,924. **ICION (BLOCK FORM)**. DECISION ANALYST, INC., (U.S. CLS. 21, 23, 26, 36 AND 38). SN 78-856,397. PUB. 2-6-2007. FILED 4-7-2006.
- 3,232,930. **GRIP 'N' CHECK (BLOCK FORM)**. BAILEY, KEN, (U.S. CLS. 21, 23, 26, 36 AND 38). SN 78-857,207. PUB. 2-6-2007. FILED 4-8-2006.
- 3,232,954. **MCAFFEE PROVEN SECURITY (BLOCK FORM)**. MCAFFEE, INC., (U.S. CLS. 21, 23, 26, 36 AND 38). SN 78-866,151. PUB. 2-6-2007. FILED 4-20-2006.
- 3,232,955. **BLACKHAWK! THE WORLD'S FINEST TACTICAL GEAR AND DESIGN**. BLACKHAWK INDUSTRIES PRODUCT GROUP UNLIMITED LLC, (U.S. CLS. 21, 23, 26, 36 AND 38). SN 78-866,505. PUB. 2-6-2007. FILED 4-21-2006.
- 3,232,966. **SIMONS VOSS (BLOCK FORM)**. SIMONSSVOSS TECHNOLOGIES AG, MULTIPLE CLASS, (INT. CLS. 9, 16 AND 42), (U.S. CLS. 2, 5, 21, 22, 23, 26, 29, 36, 37, 38, 50, 100 AND 101). SN 78-868,035. PUB. 2-6-2007. FILED 4-24-2006.
- 3,232,970. **ISMAP (BLOCK FORM)**. HARBINGER TECHNOLOGIES GROUP, INC., (U.S. CLS. 21, 23, 26, 36 AND 38). SN 78-869,018. PUB. 2-6-2007. FILED 4-25-2006.
- 3,232,972. **CENTICE (BLOCK FORM)**. OPTOPO, INC., DBA CENTICE CORPORATION, (U.S. CLS. 21, 23, 26, 36 AND 38). SN 78-869,642. PUB. 2-6-2007. FILED 4-26-2006.
- 3,232,973. **CLEARSHOT (BLOCK FORM)**. OPTOPO, INC., DBA CENTICE CORPORATION, (U.S. CLS. 21, 23, 26, 36 AND 38). SN 78-869,647. PUB. 2-6-2007. FILED 4-26-2006.
- 3,232,981. **FAT BOY SERIES (BLOCK FORM)**. KEY DIGITAL SYSTEMS, INC., (U.S. CLS. 21, 23, 26, 36 AND 38). SN 78-873,980. PUB. 2-6-2007. FILED 5-2-2006.
- 3,232,982. **ACCIO (BLOCK FORM)**. ULTRALINGUA, INC., (U.S. CLS. 21, 23, 26, 36 AND 38). SN 78-874,135. PUB. 2-6-2007. FILED 5-2-2006.
- 3,232,994. **PUREPOINT GOLF (BLOCK FORM)**. INNOVATIVE SOLUTIONS, INC., (U.S. CLS. 21, 23, 26, 36 AND 38). SN 78-878,812. PUB. 2-6-2007. FILED 5-8-2006.
- 3,233,009. **CODE 242 AND DESIGN**. IRIZARRY, JOSEPH, P, (U.S. CLS. 21, 23, 26, 36 AND 38). SN 78-881,843. PUB. 2-6-2007. FILED 5-11-2006.
- 3,233,022. **PIX + CLICK (BLOCK FORM)**. DIGITAL BLUE, (U.S. CLS. 21, 23, 26, 36 AND 38). SN 78-884,809. PUB. 2-6-2007. FILED 5-16-2006.
- 3,233,080. **SHOWRACK (BLOCK FORM)**. VISSER SOFTWARE SERVICES, INC., (U.S. CLS. 21, 23, 26, 36 AND 38). SN 78-898,695. PUB. 2-6-2007. FILED 6-1-2006.
- 3,233,093. **WELLARCHITECT WA (STYLIZED)**. DYNAMIC GRAPHICS, INC., (U.S. CLS. 21, 23, 26, 36 AND 38). SN 78-900,891. PUB. 2-6-2007. FILED 6-6-2006.
- 3,233,112. **EVIN (BLOCK FORM)**. MERRICK SYSTEMS, INC., (U.S. CLS. 21, 23, 26, 36 AND 38). SN 78-903,986. PUB. 2-6-2007. FILED 6-8-2006.
- 3,233,113. **TIBO (BLOCK FORM)**. CARPOINT SYSTEM CO. LTD., (U.S. CLS. 21, 23, 26, 36 AND 38). SN 78-904,160. PUB. 2-6-2007. FILED 6-8-2006.
- 3,233,121. **TRADESHAPES (BLOCK FORM)**. MARKET CONTOURS, LLC, (U.S. CLS. 21, 23, 26, 36 AND 38). SN 78-905,054. PUB. 2-6-2007. FILED 6-9-2006.
- 3,233,123. **PRODUCTIVITY SOLUTIONS, INC. HELPING TO POWER THE VIRTUAL CLOSE AND DESIGN**. PRODUCTIVITY SOLUTIONS, INC., (U.S. CLS. 21, 23, 26, 36 AND 38). SN 78-905,412. PUB. 2-6-2007. FILED 6-10-2006.
- 3,233,134. **S AND DESIGN**. ROBROY INDUSTRIES, INC., (U.S. CLS. 21, 23, 26, 36 AND 38). SN 78-906,792. PUB. 2-6-2007. FILED 6-13-2006.
- 3,233,144. **SUPPORT NET (BLOCK FORM)**. KIDS WITH FOOD ALLERGIES, INC., (U.S. CLS. 21, 23, 26, 36 AND 38). SN 78-907,453. PUB. 2-6-2007. FILED 6-13-2006.
- 3,233,148. **HAMMER SCANNER (BLOCK FORM)**. MICROTRAIN INTERNATIONAL, INC., (U.S. CLS. 21, 23, 26, 36 AND 38). SN 78-907,772. PUB. 2-6-2007. FILED 6-14-2006.
- 3,233,157. **ROADTRIP (BLOCK FORM)**. WINEGARD COMPANY, (U.S. CLS. 21, 23, 26, 36 AND 38). SN 78-908,527. PUB. 2-6-2007. FILED 6-14-2006.
- 3,233,167. **VIKEM (BLOCK FORM)**. BEL-ART PRODUCTS, (U.S. CLS. 21, 23, 26, 36 AND 38). SN 78-908,746. PUB. 2-6-2007. FILED 6-15-2006.
- 3,233,168. **PETROREGS (BLOCK FORM)**. MERRICK SYSTEMS, INC., (U.S. CLS. 21, 23, 26, 36 AND 38). SN 78-908,855. PUB. 2-6-2007. FILED 6-15-2006.
- 3,233,191. **MPHASE TECHNOLOGIES AND DESIGN**. MPHASE TECHNOLOGIES, INC., (U.S. CLS. 21, 23, 26, 36 AND 38). SN 78-910,116. PUB. 2-6-2007. FILED 6-16-2006.
- 3,233,198. **XOTIC AND DESIGN**. SOUTHWESTERN FIREARMS, INC., (U.S. CLS. 21, 23, 26, 36 AND 38). SN 78-910,322. PUB. 2-6-2007. FILED 6-16-2006.
- 3,233,199. **QVIS (STYLIZED)**. ADVANTAGE BUSINESS SOLUTIONS LIMITED, (U.S. CLS. 21, 23, 26, 36 AND 38). SN 78-910,462. PUB. 2-6-2007. FILED 6-16-2006.
- 3,233,207. **RUNE STONE READER (BLOCK FORM)**. FLARB LLC, (U.S. CLS. 21, 23, 26, 36 AND 38). SN 78-910,846. PUB. 2-6-2007. FILED 6-19-2006.
- 3,233,213. **CHIROSUITE (BLOCK FORM)**. LIFE SYSTEMS, INC., (U.S. CLS. 21, 23, 26, 36 AND 38). SN 78-911,289. PUB. 2-6-2007. FILED 6-19-2006.
- 3,233,215. **CHIRO (BLOCK FORM)**. LIFE SYSTEMS, INC., (U.S. CLS. 21, 23, 26, 36 AND 38). SN 78-911,361. PUB. 2-6-2007. FILED 6-19-2006.
- 3,233,220. **OPTICAL AFFAIRS (BLOCK FORM)**. ROTH, CHRISTIAN, (U.S. CLS. 21, 23, 26, 36 AND 38). SN 78-911,713. PUB. 2-6-2007. FILED 6-19-2006.
- 3,233,229. **CERTIFITRAC+ (BLOCK FORM)**. DATATRACPLUS, LLC, (U.S. CLS. 21, 23, 26, 36 AND 38). SN 78-912,193. PUB. 2-6-2007. FILED 6-20-2006.
- 3,233,230. **SERENE SAVER (BLOCK FORM)**. AMUSE, INC., (U.S. CLS. 21, 23, 26, 36 AND 38). SN 78-912,227. PUB. 2-6-2007. FILED 6-20-2006.
- 3,233,250. **CONFORM, PERFORM & EXCEL (BLOCK FORM)**. VALID8.COM, INC., (U.S. CLS. 21, 23, 26, 36 AND 38). SN 78-912,870. PUB. 2-6-2007. FILED 6-21-2006.
- 3,233,264. **APCV (BLOCK FORM)**. PETROQUIP ENERGY SERVICES, (U.S. CLS. 21, 23, 26, 36 AND 38). SN 78-913,260. PUB. 2-6-2007. FILED 6-21-2006.
- 3,233,285. **COMP PRO (BLOCK FORM)**. JOHN MEZZALINGUA ASSOCIATES, INC., (U.S. CLS. 21, 23, 26, 36 AND 38). SN 78-914,530. PUB. 2-6-2007. FILED 6-22-2006.
- 3,233,312 ( *See Class 6 for this trademark*).
- 3,233,324. **DOSIMETER (STYLIZED)**. ANDERSEN STERILIZERS, INC., (U.S. CLS. 21, 23, 26, 36 AND 38). SN 78-915,494. PUB. 2-6-2007. FILED 6-23-2006.
- 3,233,325. **IWATCH (BLOCK FORM)**. VIVA VISION, INC., (U.S. CLS. 21, 23, 26, 36 AND 38). SN 78-915,534. PUB. 2-6-2007. FILED 6-23-2006.
- 3,233,343. **NETBURNER (BLOCK FORM)**. NETBURNER, MULTIPLE CLASS, (INT. CLS. 9 AND 42), (U.S. CLS. 21, 23, 26, 36, 38, 100 AND 101). SN 78-915,986. PUB. 2-6-2007. FILED 6-23-2006.
- 3,233,374. **BLACK BAR (BLOCK FORM)**. MORAVEC, DANIEL, (U.S. CLS. 21, 23, 26, 36 AND 38). SN 78-917,106. PUB. 2-6-2007. FILED 6-26-2006.
- 3,233,380. **WINDHAM HILL (BLOCK FORM)**. BMG MUSIC, (U.S. CLS. 21, 23, 26, 36 AND 38). SN 78-917,210. PUB. 2-6-2007. FILED 6-26-2006.
- 3,233,398. **MAYBERRY (BLOCK FORM)**. ASCENDER CORPORATION, (U.S. CLS. 21, 23, 26, 36 AND 38). SN 78-917,484. PUB. 2-6-2007. FILED 6-27-2006.
- 3,233,418. **POWERED BY SAM AND DESIGN**. SCHOLASTIC INC., (U.S. CLS. 21, 23, 26, 36 AND 38). SN 78-918,170. PUB. 2-6-2007. FILED 6-27-2006.
- 3,233,448. **RCM ADAPTER (BLOCK FORM)**. THE FORCE, INC., (U.S. CLS. 21, 23, 26, 36 AND 38). SN 78-919,546. PUB. 2-6-2007. FILED 6-29-2006.

- 3,233,455. **RCMA (BLOCK FORM)**. THE FORCE, INC., MULTIPLE CLASS, (INT. CLS. 9 AND 41), (U.S. CLS. 21, 23, 26, 36, 38, 100, 101 AND 107). SN 78-920,380. PUB. 2-6-2007. FILED 6-29-2006.
- 3,233,464. **DEMODOC (BLOCK FORM)**. MICROSTRAIN, INC., (U.S. CLS. 21, 23, 26, 36 AND 38). SN 78-921,714. PUB. 2-6-2007. FILED 7-2-2006.
- 3,233,466. **VULTURE (BLOCK FORM)**. SHELTERED WINGS, INC., (U.S. CLS. 21, 23, 26, 36 AND 38). SN 78-921,825. PUB. 2-6-2007. FILED 7-3-2006.
- 3,233,468. **SEO INFORMER AND DESIGN**. QUALITY CUBE, LLC, (U.S. CLS. 21, 23, 26, 36 AND 38). SN 78-921,829. PUB. 2-6-2007. FILED 7-3-2006.
- 3,233,480. **N (STYLIZED)**. THE CRUCIBLE GROUP, INC., (U.S. CLS. 21, 23, 26, 36 AND 38). SN 78-925,371. PUB. 2-6-2007. FILED 7-10-2006.
- 3,233,481. **PANTERA (BLOCK FORM)**. AVENUES IN LEATHER, INC., (U.S. CLS. 21, 23, 26, 36 AND 38). SN 78-925,545. PUB. 2-6-2007. FILED 7-10-2006.
- 3,233,496. **VIVA! BUZZ (BLOCK FORM)**. VIVA VISION, INC., (U.S. CLS. 21, 23, 26, 36 AND 38). SN 78-947,372. PUB. 2-6-2007. FILED 8-8-2006.
- 3,233,500. **TRUTH & TRAINING CLUBS (BLOCK FORM)**. AWANA CLUBS INTERNATIONAL, MULTIPLE CLASS, (INT. CLS. 9 AND 16), (U.S. CLS. 2, 5, 21, 22, 23, 26, 29, 36, 37, 38 AND 50). SN 78-951,253. PUB. 2-6-2007. FILED 8-14-2006.
- 3,233,509. **GOARCHIVE (BLOCK FORM)**. THOMSON PROFESSIONAL & REGULATORY INC., (U.S. CLS. 21, 23, 26, 36 AND 38). SN 78-968,818. PUB. 2-6-2007. FILED 9-7-2006.
- 3,233,514. **ONE TOUCH AND DESIGN**. ONE TOUCH GMBH CO. KG, MULTIPLE CLASS, (INT. CLS. 9, 14, 18, 23, 25 AND 26), (U.S. CLS. 1, 2, 3, 21, 22, 23, 26, 27, 28, 36, 37, 38, 39, 40, 41, 42, 43 AND 50). SN 78-975,742. PUB. 2-6-2007. FILED 9-25-2003.
- 3,233,516. **RENGOKU (BLOCK FORM)**. KABUSHIKI KAISHA HUDSON, (U.S. CLS. 21, 23, 26, 36 AND 38). SN 78-977,611. PUB. 2-6-2007. FILED 6-14-2006.
- 3,233,520 ( *See Class 1 for this trademark*).
- 3,233,525. **DIGITIME (BLOCK FORM)**. CONSTRUCTION DIFFUSION VENUE INTERNATIONALE, (U.S. CLS. 21, 23, 26, 36 AND 38). SN 79-010,512. PUB. 2-6-2007. FILED 1-18-2005.
- 3,233,527. **TIRE WATCH (STYLIZED)**. LDL TECHNOLOGY S.A.S., MULTIPLE CLASS, (INT. CLS. 9, 12 AND 38), (U.S. CLS. 19, 21, 23, 26, 31, 35, 36, 38, 44, 100, 101 AND 104). SN 79-011,098. PUB. 2-6-2007. FILED 4-12-2005.
- 3,233,531 ( *See Class 7 for this trademark*).
- 3,233,534 ( *See Class 7 for this trademark*).
- 3,233,535. **ORSYP AND DESIGN**. ORGANISATION SYSTEME PRODUCTIVITE, MULTIPLE CLASS, (INT. CLS. 9, 16, 35, 38, 41 AND 42), (U.S. CLS. 2, 5, 21, 22, 23, 26, 29, 36, 37, 38, 50, 100, 101, 102, 104 AND 107). SN 79-014,031. PUB. 2-6-2007. FILED 6-20-2005.
- 3,233,536. **LAICA (STYLIZED)**. LAICA S.P.A., MULTIPLE CLASS, (INT. CLS. 9 AND 21), (U.S. CLS. 2, 13, 21, 23, 26, 29, 30, 33, 36, 38, 40 AND 50). SN 79-014,100. PUB. 2-6-2007. FILED 1-18-2005.
- 3,233,539. **ORSYP (BLOCK FORM)**. ORGANISATION SYSTEME PRODUCTIVITE, MULTIPLE CLASS, (INT. CLS. 9, 16, 35, 41 AND 42), (U.S. CLS. 2, 5, 21, 22, 23, 26, 29, 36, 37, 38, 50, 100, 101, 102 AND 107). SN 79-014,607. PUB. 2-6-2007. FILED 10-14-2004.
- 3,233,542. **SLEEP DISCOVERY (BLOCK FORM)**. COMPUMEDICS LIMITED, MULTIPLE CLASS, (INT. CLS. 9 AND 10), (U.S. CLS. 21, 23, 26, 36, 38, 39 AND 44). SN 79-015,264. PUB. 2-6-2007. FILED 7-21-2004.
- 3,233,543. **MISCELLANEOUS DESIGN**. SPRINGER-VERLAG GMBH, MULTIPLE CLASS, (INT. CLS. 9, 16 AND 41), (U.S. CLS. 2, 5, 21, 22, 23, 26, 29, 36, 37, 38, 50, 100, 101 AND 107). SN 79-015,479. PUB. 2-6-2007. FILED 5-17-2005.
- 3,233,544 ( *See Class 7 for this trademark*).
- 3,233,550. **MISCELLANEOUS DESIGN**. POPULAR HOLDINGS LIMITED, MULTIPLE CLASS, (INT. CLS. 9, 16, 41 AND 42), (U.S. CLS. 2, 5, 21, 22, 23, 26, 29, 36, 37, 38, 50, 100, 101 AND 107). SN 79-016,098. PUB. 2-6-2007. FILED 9-6-2005.
- 3,233,555. **RESEPT (BLOCK FORM)**. TRUST INTEGRATION SERVICES B.V., MULTIPLE CLASS, (INT. CLS. 9, 38 AND 42), (U.S. CLS. 21, 23, 26, 36, 38, 100, 101 AND 104). SN 79-016,806. PUB. 2-6-2007. FILED 7-4-2005.
- 3,233,559 ( *See Class 7 for this trademark*).
- 3,233,560 ( *See Class 7 for this trademark*).
- 3,233,565. **OPENBC (STYLIZED)**. OPEN BUSINESS CLUB AG, MULTIPLE CLASS, (INT. CLS. 9, 35, 38 AND 42), (U.S. CLS. 21, 23, 26, 36, 38, 100, 101, 102 AND 104). SN 79-017,286. PUB. 2-6-2007. FILED 2-15-2005.
- 3,233,569. **POWERZOOM (BLOCK FORM)**. PICSEL (RESEARCH) LIMITED, MULTIPLE CLASS, (INT. CLS. 9 AND 42), (U.S. CLS. 21, 23, 26, 36, 38, 100 AND 101). SN 79-017,479. PUB. 2-6-2007. FILED 10-20-2005.
- 3,233,578. **LABRAM ARAMIS (BLOCK FORM)**. HORIBA JOBIN YVON SAS, (U.S. CLS. 21, 23, 26, 36 AND 38). SN 79-018,175. PUB. 2-6-2007. FILED 10-6-2005.
- 3,233,579. **LABRAM (BLOCK FORM)**. HORIBA JOBIN YVON SAS, (U.S. CLS. 21, 23, 26, 36 AND 38). SN 79-018,176. PUB. 2-6-2007. FILED 10-6-2005.
- 3,233,580 ( *See Class 7 for this trademark*).
- 3,233,581. **MISCELLANEOUS DESIGN**. TIMEDOMAIN CORPORATION, MULTIPLE CLASS, (INT. CLS. 9 AND 16), (U.S. CLS. 2, 5, 21, 22, 23, 26, 29, 36, 37, 38 AND 50). SN 79-018,352. PUB. 2-6-2007. FILED 9-28-2005.
- 3,233,582. **TIME DOMAIN AND DESIGN**. TIMEDOMAIN CORPORATION, (U.S. CLS. 21, 23, 26, 36 AND 38). SN 79-018,353. PUB. 2-6-2007. FILED 9-28-2005.
- 3,233,590. **XCARECROWS (BLOCK FORM)**. COMPAGNIE GENERALE D'INFORMATIQUE ET DE TELECOMMUNICATIONS, MULTIPLE CLASS, (INT. CLS. 9, 38 AND 42), (U.S. CLS. 21, 23, 26, 36, 38, 100, 101 AND 104). SN 79-018,717. PUB. 2-6-2007. FILED 9-30-2005.
- 3,233,591 ( *See Class 3 for this trademark*).
- 3,233,597. **C AND DESIGN**. CINNOBER FINANCIAL TECHNOLOGY AB (PUBL), MULTIPLE CLASS, (INT. CLS. 9, 35, 36, 37, 38 AND 42), (U.S. CLS. 21, 23, 26, 36, 38, 100, 101, 102, 103, 104 AND 106). SN 79-019,202. PUB. 2-6-2007. FILED 10-17-2005.
- 3,233,598. **JAYBEAM (STYLIZED)**. JAYBEAM LTD, (U.S. CLS. 21, 23, 26, 36 AND 38). SN 79-019,273. PUB. 2-6-2007. FILED 11-22-2005.
- 3,233,605. **WENGO (STYLIZED)**. WENGO, MULTIPLE CLASS, (INT. CLS. 9, 35 AND 38), (U.S. CLS. 21, 23, 26, 36, 38, 100, 101, 102 AND 104). SN 79-019,481. PUB. 2-6-2007. FILED 11-14-2005.
- 3,233,606 ( *See Class 6 for this trademark*).
- 3,233,610. **LYNCEE (BLOCK FORM)**. LYNCEE TEC S.A., MULTIPLE CLASS, (INT. CLS. 9, 10 AND 42), (U.S. CLS. 21, 23, 26, 36, 38, 39, 44, 100 AND 101). SN 79-019,769. PUB. 2-6-2007. FILED 12-8-2005.
- 3,233,613. **TRAC AND DESIGN**. KONINKLIJKE PHILIPS ELECTRONICS N.V., (U.S. CLS. 21, 23, 26, 36 AND 38). SN 79-019,881. PUB. 2-6-2007. FILED 11-10-2005.
- 3,233,614. **HORUS (STYLIZED)**. FORMULACTION, (U.S. CLS. 21, 23, 26, 36 AND 38). SN 79-019,924. PUB. 2-6-2007. FILED 10-28-2005.
- 3,233,630. **DOUBLE BUNGAH (BLOCK FORM)**. LIGHTNING BOX GAMES PTY LIMITED, MULTIPLE CLASS, (INT. CLS. 9 AND 28), (U.S. CLS. 21, 22, 23, 26, 36, 38 AND 50). SN 79-020,571. PUB. 2-6-2007. FILED 10-28-2005.
- 3,233,631. **BANANA SMOOTHIE (BLOCK FORM)**. LIGHTNING BOX GAMES PTY LIMITED, MULTIPLE CLASS, (INT. CLS. 9 AND 28), (U.S. CLS. 21, 22, 23, 26, 36, 38 AND 50). SN 79-020,636. PUB. 2-6-2007. FILED 10-28-2005.
- 3,233,636. **SUPERSENSE (BLOCK FORM)**. U-BLOX AG, MULTIPLE CLASS, (INT. CLS. 9, 16, 38 AND 42), (U.S. CLS. 2, 5, 21, 22, 23, 26, 29, 36, 37, 38, 50, 100, 101 AND 104). SN 79-020,724. PUB. 2-6-2007. FILED 10-17-2005.
- 3,233,640. **TAGSYS (BLOCK FORM)**. TAG TRACK & ID, MULTIPLE CLASS, (INT. CLS. 9, 38, 39 AND 42), (U.S. CLS. 21, 23, 26, 36, 38, 100, 101, 104 AND 105). SN 79-020,897. PUB. 2-6-2007. FILED 5-27-2005.
- 3,233,641. **B FIRE + ICE AND DESIGN**. WILLY BOGNER GMBH & CO.; KOMMANDITGESELLSCHAFT AUF AKTIEN, MULTIPLE CLASS, (INT. CLS. 9, 18, 25 AND 28), (U.S. CLS. 1, 2, 3, 21, 22, 23, 26, 36, 38, 39, 41 AND 50). SN 79-020,952. PUB. 2-6-2007. FILED 11-2-2005.
- 3,233,642 ( *See Class 6 for this trademark*).
- 3,233,643. **SOLIDBURN AND DESIGN**. KONINKLIJKE PHILIPS ELECTRONICS N.V., (U.S. CLS. 21, 23, 26, 36 AND 38).

- SN 79-020,990. PUB. 2-6-2007. FILED 12-22-2005.
- 3,233,645. **B AND DESIGN**. WILLY BOGNER GMBH & CO.; KOMMANDITGESELLSCHAFT AUF AKTIEN, MULTIPLE CLASS, (INT. CLS. 9, 18 AND 25), (U.S. CLS. 1, 2, 3, 21, 22, 23, 26, 36, 38, 39 AND 41). SN 79-021,062. PUB. 2-6-2007. FILED 10-31-2005.
- 3,233,648. **PIPETMAN CLASSIC (BLOCK FORM)**. GILSON SAS, (U.S. CLS. 21, 23, 26, 36 AND 38). SN 79-021,291. PUB. 2-6-2007. FILED 11-4-2005.
- 3,233,649. **ENFC ENHANCED NFC AND DESIGN**. INSIDE CONTACTLESS, MULTIPLE CLASS, (INT. CLS. 9 AND 42), (U.S. CLS. 21, 23, 26, 36, 38, 100 AND 101). SN 79-021,295. PUB. 1-23-2007. FILED 8-26-2005.
- 3,233,658. **LUPOS AND DESIGN**. LUPOS SCHUHFABRIK GMBH, (U.S. CLS. 21, 23, 26, 36 AND 38). SN 79-021,558. PUB. 2-6-2007. FILED 11-4-2005.
- 3,233,671. **PILAR (BLOCK FORM)**. 01 DB-METRAVIB, (U.S. CLS. 21, 23, 26, 36 AND 38). SN 79-022,126. PUB. 2-6-2007. FILED 1-13-2006.
- 3,233,677. **HB HOFBRÄUHAUS AND DESIGN**. STAATLICHES HOFBRÄUHAUS IN MÜNCHEN, MULTIPLE CLASS, (INT. CLS. 9, 14, 16, 18, 21, 24, 25, 28, 32, 42 AND 43), (U.S. CLS. 1, 2, 3, 5, 13, 21, 22, 23, 26, 27, 28, 29, 30, 33, 36, 37, 38, 39, 40, 41, 42, 45, 46, 48, 50, 100 AND 101). SN 79-022,417. PUB. 2-6-2007. FILED 6-3-2005.
- 3,233,689. **MISCELLANEOUS DESIGN**. JOS VAN HEMERT INKOOOPPUNT B.V., MULTIPLE CLASS, (INT. CLS. 9 AND 25), (U.S. CLS. 21, 22, 23, 26, 36, 38 AND 39). SN 79-023,003. PUB. 2-6-2007. FILED 6-22-2006.
- 3,233,694. **QUICKLAB (BLOCK FORM)**. SIEMENS AKTIENGESELLSCHAFT, MULTIPLE CLASS, (INT. CLS. 9 AND 16), (U.S. CLS. 2, 5, 21, 22, 23, 26, 29, 36, 37, 38 AND 50). SN 79-023,251. PUB. 2-6-2007. FILED 3-17-2006.
- 3,233,700 ( *See Class 7 for this trademark* ).
- 3,233,703 ( *See Class 7 for this trademark* ).
- 3,233,704. **ANOCYSYS (BLOCK FORM)**. ANOCYSYS AG, MULTIPLE CLASS, (INT. CLS. 9 AND 42), (U.S. CLS. 21, 23, 26, 36, 38, 100 AND 101). SN 79-023,676. PUB. 2-6-2007. FILED 2-9-2006.
- 3,233,717. **CAREMAT (STYLIZED)**. BIRCHER REGLOMAT AG, (U.S. CLS. 21, 23, 26, 36 AND 38). SN 79-024,589. PUB. 2-6-2007. FILED 3-30-2006.
- 3,233,723. **MEDIAEVAL KINGDOMS (STYLIZED)**. RUNNING GAMES AS, MULTIPLE CLASS, (INT. CLS. 9 AND 41), (U.S. CLS. 21, 23, 26, 36, 38, 100, 101 AND 107). SN 79-025,137. PUB. 2-6-2007. FILED 9-8-2005.
- 3,233,740. **YUN YUNHUAN AND DESIGN**. NINGBO YUNHUAN ELECTRONIC GROUP CO. LTD., (U.S. CLS. 21, 23, 26, 36 AND 38). SN 79-026,132. PUB. 2-6-2007. FILED 3-22-2006.
- 3,233,741. **TVD AND DESIGN**. MEDIAMOTION EUROPE GMBH, (U.S. CLS. 21, 23, 26, 36 AND 38). SN 79-026,155. PUB. 2-6-2007. FILED 4-26-2006.
- 3,233,744. **KRAFTWERK (STYLIZED)**. RALF HÜTTER, AND FLORIAN SCHNEIDER, MULTIPLE CLASS, (INT. CLS. 9, 18 AND 41), (U.S. CLS. 1, 2, 3, 21, 22, 23, 26, 36, 38, 41, 100, 101 AND 107). SN 79-026,533. PUB. 2-6-2007. FILED 3-8-2006.
- 3,233,747. **PARAGON SOFTWARE (BLOCK FORM)**. PARAGON TECHNOLOGIE GMBH; SYSTEMPROGRAMMIERUNG, (U.S. CLS. 21, 23, 26, 36 AND 38). SN 79-026,668. PUB. 2-6-2007. FILED 1-31-2006.
- 3,233,750. **MINGYUE AND DESIGN**. SHANGHAI MINGYUE OPTICAL; GLASSES CO., LTD, (U.S. CLS. 21, 23, 26, 36 AND 38). SN 79-027,342. PUB. 2-6-2007. FILED 5-25-2006.
- 3,233,751. **TRAY-IT (BLOCK FORM)**. MASRON BV, MULTIPLE CLASS, (INT. CLS. 9, 20 AND 21), (U.S. CLS. 2, 13, 21, 22, 23, 25, 26, 29, 30, 32, 33, 36, 38, 40 AND 50). SN 79-027,434. PUB. 2-6-2007. FILED 4-28-2006.
- 3,233,760. **SUNIS (BLOCK FORM)**. SOMFY SAS, (U.S. CLS. 21, 23, 26, 36 AND 38). SN 79-029,545. PUB. 2-6-2007. FILED 10-4-2006.
- 3,232,135. **PULMOLIFE (BLOCK FORM)**. MICRO MEDICAL LIMITED, (U.S. CLS. 26, 39 AND 44). SN 76-645,664. PUB. 9-19-2006. FILED 8-26-2005.
- 3,232,170. **SIGNUS AND DESIGN**. SIGNUS MEDIZINTECHNIK GMBH, (U.S. CLS. 26, 39 AND 44). SN 76-650,523. PUB. 2-6-2007. FILED 11-17-2005.
- 3,232,175. **TRUTEC (BLOCK FORM)**. TRUTEC LLC, (U.S. CLS. 26, 39 AND 44). SN 76-651,120. PUB. 2-6-2007. FILED 11-21-2005.
- 3,232,228. **EZ KEY (BLOCK FORM)**. GREAT LAKES ORTHODONTICS, LTD., (U.S. CLS. 26, 39 AND 44). SN 76-661,465. PUB. 2-6-2007. FILED 6-12-2006.
- 3,232,251. **BEACONMEDAES (BLOCK FORM)**. BEACON MEDICAL PRODUCTS LLC, (U.S. CLS. 26, 39 AND 44). SN 76-662,019. PUB. 2-6-2007. FILED 6-22-2006.
- 3,232,408. **SAVING THE WORLD, ONE ORGASM AT A TIME! (BLOCK FORM)**. BONK DESIGNS, INC., (U.S. CLS. 26, 39 AND 44). SN 78-564,049. PUB. 2-6-2007. FILED 2-9-2005.
- 3,232,473 ( *See Class 9 for this trademark* ).
- 3,232,507. **V VIBRADERM AND DESIGN**. VIBRADERM, INC., (U.S. CLS. 26, 39 AND 44). SN 78-658,120. PUB. 2-6-2007. FILED 6-24-2005.
- 3,232,622. **TRILINE AND DESIGN**. TRILINE MEDICAL LLC, (U.S. CLS. 26, 39 AND 44). SN 78-737,607. PUB. 2-6-2007. FILED 10-20-2005.
- 3,232,720. **DERMAGLIDE (BLOCK FORM)**. ADVANCED LASER & ANTI-AGING CENTER, INC., (U.S. CLS. 26, 39 AND 44). SN 78-759,487. PUB. 2-6-2007. FILED 11-22-2005.
- 3,232,721. **MICROGLIDE (BLOCK FORM)**. ADVANCED LASER & ANTI-AGING CENTER, INC., (U.S. CLS. 26, 39 AND 44). SN 78-759,497. PUB. 2-6-2007. FILED 11-22-2005.
- 3,232,784. **FOLD-N-HOLD AND DESIGN**. GENERAL HOSPITAL SUPPLY CORPORATION, (U.S. CLS. 26, 39 AND 44). SN 78-789,472. PUB. 2-6-2007. FILED 1-11-2006.
- 3,232,810 ( *See Class 3 for this trademark* ).
- 3,232,836. **SUTUROSCOPE (STYLIZED)**. KARL STORZ GMBH & CO. KG, MULTIPLE CLASS, (INT. CLS. 10 AND 16), (U.S. CLS. 2, 5, 22, 23, 26, 29, 37, 38, 39, 44 AND 50). SN 78-819,359. PUB. 2-6-2007. FILED 2-21-2006.
- 3,232,958. **LEVITOR (BLOCK FORM)**. PROGRESSIVE APPLIANCE CORPORATION, (U.S. CLS. 26, 39 AND 44). SN 78-867,072. PUB. 2-6-2007. FILED 4-21-2006.
- 3,232,967. **HEADBED (BLOCK FORM)**. LAERDAL MEDICAL AS, (U.S. CLS. 26, 39 AND 44). SN 78-868,247. PUB. 2-6-2007. FILED 4-24-2006.
- 3,233,011. **ACCLI-MATE (BLOCK FORM)**. RESMED LIMITED, (U.S. CLS. 26, 39 AND 44). SN 78-882,551. PUB. 2-6-2007. FILED 5-12-2006.
- 3,233,046. **AVICENNA - LASER THERAPY CENTERS OF EXCELLENCE- REVOLUTIONIZING PAIN MANAGEMENT AND DESIGN**. AVICENNA LASER TECHNOLOGY, INC., MULTIPLE CLASS, (INT. CLS. 10 AND 44), (U.S. CLS. 26, 39, 44, 100 AND 101). SN 78-888,315. PUB. 2-6-2007. FILED 5-19-2006.
- 3,233,494. **VEINVIEWER BY LUMINETX (BLOCK FORM)**. LUMINETX TECHNOLOGIES CORPORATION, (U.S. CLS. 26, 39 AND 44). SN 78-941,654. PUB. 2-6-2007. FILED 7-31-2006.
- 3,233,507. **SAVINA (BLOCK FORM)**. DRÄGER MEDICAL AG & CO. KG, (U.S. CLS. 26, 39 AND 44). SN 78-964,838. PUB. 2-6-2007. FILED 8-31-2006.
- 3,233,520 ( *See Class 1 for this trademark* ).
- 3,233,542 ( *See Class 9 for this trademark* ).
- 3,233,547. **PRIOCLIP (BLOCK FORM)**. PRIONICS AG, (U.S. CLS. 26, 39 AND 44). SN 79-015,891. PUB. 2-6-2007. FILED 9-15-2005.
- 3,233,551. **EMTY (BLOCK FORM)**. ROLLAX GMBH & CO. KG, (U.S. CLS. 26, 39 AND 44). SN 79-016,105. PUB. 2-6-2007. FILED 8-12-2005.
- 3,233,553. **MAMBO (STYLIZED)**. ULRICH GMBH & CO. KG, MULTIPLE CLASS, (INT. CLS. 10 AND 44), (U.S. CLS. 26, 39, 44, 100 AND 101). SN 79-016,574. PUB. 2-6-2007. FILED 9-22-2005.
- 3,233,594. **CIELO (BLOCK FORM)**. SIEMENS AUDIOLOGISCHE TECHNIK GMBH, (U.S. CLS. 26, 39 AND 44). SN 79-018,984. PUB. 2-6-2007. FILED 11-18-2005.
- 3,233,604. **PAPCONE (BLOCK FORM)**. OTTO BOCK SCHAUMSTOFFWERKE GMBH, (U.S. CLS. 26, 39 AND

---

#### CLASS 10—MEDICAL APPARATUS

- 3,232,067 ( *See Class 9 for this trademark* ).
- 3,232,085 ( *See Class 9 for this trademark* ).

- 44). SN 79-019,480. PUB. 2-6-2007. FILED 12-8-2005.  
3,233,610 ( *See Class 9 for this trademark* ).  
3,233,664. **BTO BRADY TACHY OVERLAP (STYLIZED)**. ELA MEDICAL. (U.S. CLS. 26, 39 AND 44). SN 79-021,966. PUB. 2-6-2007. FILED 10-24-2005.  
3,233,686. **MRP-TITAN (BLOCK FORM)**. PETER BREHM. (U.S. CLS. 26, 39 AND 44). SN 79-022,889. PUB. 2-6-2007. FILED 12-20-2005.  
3,233,692. **ASTRA ASTRA TECH AND DESIGN**. ASTRA TECH AB, MULTIPLE CLASS. (INT. CLS. 10 AND 44). (U.S. CLS. 26, 39, 44, 100 AND 101). SN 79-023,208. PUB. 2-6-2007. FILED 2-2-2006.  
3,233,702. **ENERTEC POWER AROUSER (BLOCK FORM)**. PHILIP ALLAN POTTER. (U.S. CLS. 26, 39 AND 44). SN 79-023,561. PUB. 2-6-2007. FILED 8-23-2005.  
3,233,731. **V.V.T. (BLOCK FORM)**. OMRON HEALTHCARE CO., LTD. (U.S. CLS. 26, 39 AND 44). SN 79-025,421. PUB. 2-6-2007. FILED 4-28-2006.  
3,233,733. **AI AUGMENTATION INDEX AND DESIGN**. OMRON HEALTHCARE CO., LTD. (U.S. CLS. 26, 39 AND 44). SN 79-025,556. PUB. 2-6-2007. FILED 4-28-2006.  
3,233,745. **FATCHER (BLOCK FORM)**. ASTRA TECH AB. (U.S. CLS. 26, 39 AND 44). SN 79-026,653. PUB. 2-6-2007. FILED 3-2-2006.

#### CLASS 11—ENVIRONMENTAL CONTROL APPARATUS

- 3,232,125. **AEROMATIC OVEN (BLOCK FORM)**. MIRAMA ENTERPRISES INC., (U.S. CLS. 13, 21, 23, 31 AND 34). SN 76-637,646. PUB. 2-6-2007. FILED 5-2-2005.  
3,232,186. **10N1 (BLOCK FORM)**. MORGAN STANLEY SENIOR FUNDING, INC., AS THE ADMINISTRATIVE AGENT, (U.S. CLS. 13, 21, 23, 31 AND 34). SN 76-652,464. PUB. 2-6-2007. FILED 12-27-2005.  
3,232,221. **SONORAN (BLOCK FORM)**. SOUTHWEST FIRE-BIRD, INC., (U.S. CLS. 13, 21, 23, 31 AND 34). SN 76-661,171. PUB. 2-6-2007. FILED 6-6-2006.  
3,232,302. **WHISPERWIND (BLOCK FORM)**. HUNTER FAN COMPANY, (U.S. CLS. 13, 21, 23, 31 AND 34). SN 77-025,534. PUB. 2-6-2007. FILED 10-20-2006.  
3,232,372. **CLARIFLOW (BLOCK FORM)**. DOMNICK HUNTER ADVANCED FILTRATION INC., (U.S. CLS. 13, 21, 23, 31 AND 34). SN 78-492,048. PUB. 2-6-2007. FILED 9-30-2004.  
3,232,395. **BLACKHAWK! THE WORLD'S FINEST TACTICAL GEAR AND DESIGN**. BLACKHAWK INDUSTRIES PRODUCT GROUP UNLIMITED LLC, (U.S. CLS. 13, 21, 23, 31 AND 34). SN 78-551,783. PUB. 2-6-2007. FILED 1-21-2005.  
3,232,436. **SINK SCENTS (BLOCK FORM)**. BATH SOLUTIONS, INC., (U.S. CLS. 13, 21, 23, 31 AND 34). SN 78-592,822. PUB. 2-6-2007. FILED 3-22-2005.  
3,232,505. **NEWAIR (BLOCK FORM)**. PFLEIDERER WATER SYSTEMS GMBH, (U.S. CLS. 13, 21, 23, 31 AND 34). SN 78-657,346. PUB. 12-26-2006. FILED 6-23-2005.  
3,232,546. **ST RUBINETTERIE (STYLIZED)**. F. LLI SAGLIO TROMBONE S.R.L., (U.S. CLS. 13, 21, 23, 31 AND 34). SN 78-689,171. PUB. 2-6-2007. FILED 8-9-2005.  
3,232,583 ( *See Class 7 for this trademark* ).  
3,232,647. **NANO MAGNETIC (BLOCK FORM)**. HELEN OF TROY LIMITED, (U.S. CLS. 13, 21, 23, 31 AND 34). SN 78-744,151. PUB. 2-6-2007. FILED 11-1-2005.  
3,232,768. **BBQ PRO (BLOCK FORM)**. KMART OF MICHIGAN, INC., (U.S. CLS. 13, 21, 23, 31 AND 34). SN 78-778,433. PUB. 2-6-2007. FILED 12-21-2005.  
3,232,837. **EXECUTIVE EDITION (BLOCK FORM)**. BSH BOSCH UND SIEMENS HAUSGERAETE GMBH, (U.S. CLS. 13, 21, 23, 31 AND 34). SN 78-819,756. PUB. 2-6-2007. FILED 2-21-2006.  
3,232,872. **BGO AND DESIGN**. BGO INC., MULTIPLE CLASS, (INT. CLS. 11 AND 20). (U.S. CLS. 2, 13, 21, 22, 23, 25, 31, 32, 34 AND 50). SN 78-836,156. PUB. 10-24-2006. FILED 3-13-2006.  
3,232,915. **S S-SUN AND DESIGN**. SHIH SANYO ENTERPRISE CO., LTD., (U.S. CLS. 13, 21, 23, 31 AND 34). SN 78-854,842. PUB. 2-6-2007. FILED 4-5-2006.  
3,232,987. **DELANY AND DESIGN**. COYNE & DELANY COMPANY, (U.S. CLS. 13, 21, 23, 31 AND 34). SN 78-876,825. PUB. 2-6-2007. FILED 5-4-2006.  
3,233,001. **MISCELLANEOUS DESIGN**. GRAND HALL ENTERPRISE CO., LTD., (U.S. CLS. 13, 21, 23, 31 AND 34). SN 78-880,158. PUB. 2-6-2007. FILED 5-10-2006.  
3,233,023. **MISCELLANEOUS DESIGN**. MOO TECHNOLOGIES, LLC, MULTIPLE CLASS, (INT. CLS. 11 AND 29). (U.S. CLS. 13, 21, 23, 31, 34 AND 46). SN 78-884,863. PUB. 2-6-2007. FILED 5-16-2006.  
3,233,088. **PLUSRITE (BLOCK FORM)**. QIAN, SONG, (U.S. CLS. 13, 21, 23, 31 AND 34). SN 78-899,756. PUB. 2-6-2007. FILED 6-2-2006.  
3,233,312 ( *See Class 6 for this trademark* ).  
3,233,381. **SAUNAGEN (BLOCK FORM)**. KINGSTON GLOBAL, INC., (U.S. CLS. 13, 21, 23, 31 AND 34). SN 78-917,235. PUB. 2-6-2007. FILED 6-26-2006.  
3,233,382. **FIRE & ICE (BLOCK FORM)**. PLASMA INDUSTRIES INC, (U.S. CLS. 13, 21, 23, 31 AND 34). SN 78-917,239. PUB. 2-6-2007. FILED 6-26-2006.  
3,233,417. **TRUEAIR AND DESIGN**. HAMILTON BEACH/PROCTOR-SILEX, INC., (U.S. CLS. 13, 21, 23, 31 AND 34). SN 78-918,169. PUB. 2-6-2007. FILED 6-27-2006.  
3,233,505. **CHINOOK VALUE VENTILATION AND DESIGN**. DELAWARE CAPITAL FORMATION, INC., (U.S. CLS. 13, 21, 23, 31 AND 34). SN 78-960,854. PUB. 2-6-2007. FILED 8-25-2006.  
3,233,520 ( *See Class 1 for this trademark* ).  
3,233,521. **KREON TOOLS OF LIGHT (STYLIZED)**. KREON, NAAMLOZE VENNOOTSCHAP, (U.S. CLS. 13, 21, 23, 31 AND 34). SN 79-007,509. PUB. 2-6-2007. FILED 10-21-2004.  
3,233,559 ( *See Class 7 for this trademark* ).  
3,233,560 ( *See Class 7 for this trademark* ).  
3,233,606 ( *See Class 6 for this trademark* ).  
3,233,617 ( *See Class 6 for this trademark* ).  
3,233,619 ( *See Class 7 for this trademark* ).  
3,233,628. **SURROUND NO FROST (STYLIZED)**. INDESIT COMPANY SPA, (U.S. CLS. 13, 21, 23, 31 AND 34). SN 79-020,483. PUB. 2-6-2007. FILED 11-10-2005.  
3,233,632. **I CARE (STYLIZED)**. INDESIT COMPANY SPA, (U.S. CLS. 13, 21, 23, 31 AND 34). SN 79-020,665. PUB. 2-6-2007. FILED 11-7-2005.  
3,233,642 ( *See Class 6 for this trademark* ).  
3,233,656. **C AND DESIGN**. COPAT S.P.A., MULTIPLE CLASS, (INT. CLS. 11 AND 20). (U.S. CLS. 2, 13, 21, 22, 23, 25, 31, 32, 34 AND 50). SN 79-021,459. PUB. 2-6-2007. FILED 10-21-2005.  
3,233,668. **MISCELLANEOUS DESIGN**. DONGGUAN QINGXI JINWONIU; INDUSTRIAL CO., LTD., (U.S. CLS. 13, 21, 23, 31 AND 34). SN 79-022,074. PUB. 2-6-2007. FILED 11-17-2005.  
3,233,700 ( *See Class 7 for this trademark* ).  
3,233,703 ( *See Class 7 for this trademark* ).  
3,233,710 ( *See Class 7 for this trademark* ).  
3,233,711. **ECM AND DESIGN**. ETUDES ET CONSTRUCTIONS MECANIKES, MULTIPLE CLASS, (INT. CLS. 11 AND 40). (U.S. CLS. 13, 21, 23, 31, 34, 100, 103 AND 106). SN 79-024,209. PUB. 2-6-2007. FILED 3-14-2006.  
3,233,730. **MIDIPOLL (BLOCK FORM)**. ERCO LEUCHTEN GMBH, (U.S. CLS. 13, 21, 23, 31 AND 34). SN 79-025,292. PUB. 2-6-2007. FILED 3-10-2006.  
3,233,742. **4ARXS HCD (BLOCK FORM)**. OSRAM; GESELLSCHAFT MIT BESCHRÄNKTER HAFTUNG, (U.S. CLS. 13, 21, 23, 31 AND 34). SN 79-026,250. PUB. 2-6-2007. FILED 5-9-2006.  
3,233,755. **PICKWICK (BLOCK FORM)**. SARA LEE/DE N.V., (U.S. CLS. 13, 21, 23, 31 AND 34). SN 79-028,474. PUB. 2-6-2007. FILED 7-7-2006.

#### CLASS 12—VEHICLES

- 3,232,065. **BONDIOLI & PAVESI**. BONDIOLI & PAVESI S.P.A., (U.S. CLS. 19, 21, 23, 31, 35 AND 44). SN 76-333,060. PUB. 2-6-2007. FILED 11-1-2001.  
3,232,086 ( *See Class 7 for this trademark* ).  
3,232,222. **PLATELOCK (BLOCK FORM)**. PLATELOCK LLC, (U.S. CLS. 19, 21, 23, 31, 35 AND 44). SN 76-661,309. PUB. 2-6-2007. FILED 6-9-2006.

- 3,232,237 ( *See Class 7 for this trademark* ).  
 3,232,358. **NEVER STOP EXPLORING (BLOCK FORM)**. THE NORTH FACE APPAREL CORP., (U.S. CLS. 19, 21, 23, 31, 35 AND 44). SN 78-427,785. PUB. 5-17-2005. FILED 6-1-2004.  
 3,232,381 ( *See Class 9 for this trademark* ).  
 3,232,476. **ARI LEGACY (BLOCK FORM)**. AMERICAN RELIANCE INDUSTRIES, CO., (U.S. CLS. 19, 21, 23, 31, 35 AND 44). SN 78-626,907. PUB. 8-29-2006. FILED 5-10-2005.  
 3,232,497. **MASQUE (BLOCK FORM)**. PHILIPPS, IGOR JOHN, MULTIPLE CLASS, (INT. CLS. 12 AND 22), (U.S. CLS. 1, 2, 7, 19, 21, 22, 23, 31, 35, 42, 44 AND 50). SN 78-649,923. PUB. 2-6-2007. FILED 6-14-2005.  
 3,232,517. **DLB AND DESIGN**. SHANDONG DOUBLE LINK BRAKE MATERIAL CO., LTD., (U.S. CLS. 19, 21, 23, 31, 35 AND 44). SN 78-665,612. PUB. 2-6-2007. FILED 7-7-2005.  
 3,232,692 ( *See Class 1 for this trademark* ).  
 3,232,796. **DIRECT HYBRID (BLOCK FORM)**. DAIMLER-CHRYSLER AG, (U.S. CLS. 19, 21, 23, 31, 35 AND 44). SN 78-797,782. PUB. 2-6-2007. FILED 1-24-2006.  
 3,232,802 ( *See Class 7 for this trademark* ).  
 3,232,803 ( *See Class 7 for this trademark* ).  
 3,232,842. **INDEPENDENT CYCLE, INC. (BLOCK FORM)**. INDEPENDENT CYCLE, INC., (U.S. CLS. 19, 21, 23, 31, 35 AND 44). SN 78-823,437. PUB. 2-6-2007. FILED 2-25-2006.  
 3,232,864 ( *See Class 6 for this trademark* ).  
 3,232,902. **FISHUNTER (BLOCK FORM)**. GENMAR INDUSTRIES, INC., (U.S. CLS. 19, 21, 23, 31, 35 AND 44). SN 78-847,478. PUB. 2-6-2007. FILED 3-28-2006.  
 3,233,040 ( *See Class 7 for this trademark* ).  
 3,233,233. **EXOMOS (BLOCK FORM)**. EXOMOS FZCO, (U.S. CLS. 19, 21, 23, 31, 35 AND 44). SN 78-912,330. PUB. 2-6-2007. FILED 6-20-2006.  
 3,233,242 ( *See Class 7 for this trademark* ).  
 3,233,253. **BUILT TO FISH (BLOCK FORM)**. BLUEWATER MARINE GROUP, INC., (U.S. CLS. 19, 21, 23, 31, 35 AND 44). SN 78-912,920. PUB. 2-6-2007. FILED 6-21-2006.  
 3,233,520 ( *See Class 1 for this trademark* ).  
 3,233,527 ( *See Class 9 for this trademark* ).  
 3,233,544 ( *See Class 7 for this trademark* ).  
 3,233,599. **FREEK (STYLIZED)**. SELLE ROYAL S.P.A., MULTIPLE CLASS, (INT. CLS. 12 AND 25), (U.S. CLS. 19, 21, 22, 23, 31, 35, 39 AND 44). SN 79-019,280. PUB. 2-6-2007. FILED 11-3-2005.  
 3,233,669 ( *See Class 7 for this trademark* ).  
 3,233,719. **BLIZZARD (BLOCK FORM)**. OTTO BOCK HEALTHCARE GMBH, (U.S. CLS. 19, 21, 23, 31, 35 AND 44). SN 79-024,859. PUB. 2-6-2007. FILED 4-4-2006.

---

### CLASS 13—FIREARMS

- 3,232,468. **PERFORMANCE RULES! (BLOCK FORM)**. BLACKHAWK INDUSTRIES PRODUCT GROUP UNLIMITED LLC, (U.S. CLS. 2 AND 9). SN 78-618,630. PUB. 2-6-2007. FILED 4-28-2005.  
 3,232,561. **POLY TECH (BLOCK FORM)**. KENG'S FIREARMS SPECIALTY, INC., (U.S. CLS. 2 AND 9). SN 78-698,767. PUB. 2-6-2007. FILED 8-23-2005.  
 3,232,814. **LAR-15 (BLOCK FORM)**. ROCK RIVER ARMS, INC., (U.S. CLS. 2 AND 9). SN 78-810,314. PUB. 2-6-2007. FILED 2-8-2006.  
 3,233,050. **Z ZIPDET (STYLIZED)**. UNION ESPANOLA DE EXPLOSIVOS-MINING SERVICES INTERNATIONAL S.A., (U.S. CLS. 2 AND 9). SN 78-889,416. PUB. 2-6-2007. FILED 5-22-2006.

---

### CLASS 14—JEWELRY

- 3,232,060 ( *See Class 6 for this trademark* ).  
 3,232,367. **WCJ (BLOCK FORM)**. WCJ HOLDINGS CO., LTD., (U.S. CLS. 2, 27, 28 AND 50). SN 78-479,235. PUB. 2-6-2007. FILED 9-7-2004.  
 3,232,387. **LUXE . JEWELS . (STYLIZED)**. LUXE JEWELS, LLC, MULTIPLE CLASS, (INT. CLS. 14 AND 41), (U.S. CLS. 2, 27, 28, 50, 100, 101 AND 107). SN 78-526,188. PUB. 2-6-2007. FILED 12-2-2004.  
 3,232,409. **MINE JEWELRY NEW YORK AND DESIGN**. NA, SEHTI, (U.S. CLS. 2, 27, 28 AND 50). SN 78-566,047. PUB. 2-6-2007. FILED 2-11-2005.  
 3,232,618. **ARTOGEIA BRYONI (BLOCK FORM)**. OCTOBIA LLC, (U.S. CLS. 2, 27, 28 AND 50). SN 78-736,727. PUB. 2-6-2007. FILED 10-19-2005.  
 3,232,666 ( *See Class 9 for this trademark* ).  
 3,232,873. **PRICEGEMS (BLOCK FORM)**. PRICEGEMS, LLC, (U.S. CLS. 2, 27, 28 AND 50). SN 78-836,236. PUB. 2-6-2007. FILED 3-14-2006.  
 3,232,920. **CAPITAL GLOBAL OUTLOOK DAILY (BLOCK FORM)**. THE CAPITAL GOLD GROUP, MULTIPLE CLASS, (INT. CLS. 14 AND 36), (U.S. CLS. 2, 27, 28, 50, 100, 101 AND 102). SN 78-856,142. PUB. 2-6-2007. FILED 4-6-2006.  
 3,232,921. **AS SAFE AS GOLD QUARTERLY (BLOCK FORM)**. THE CAPITAL GOLD GROUP, MULTIPLE CLASS, (INT. CLS. 14 AND 36), (U.S. CLS. 2, 27, 28, 50, 100, 101 AND 102). SN 78-856,145. PUB. 2-6-2007. FILED 4-6-2006.  
 3,232,922. **EYE ON PRECIOUS METALS (BLOCK FORM)**. THE CAPITAL GOLD GROUP, MULTIPLE CLASS, (INT. CLS. 14 AND 36), (U.S. CLS. 2, 27, 28, 50, 100, 101 AND 102). SN 78-856,146. PUB. 2-6-2007. FILED 4-6-2006.  
 3,232,964. **UNFADING AND DESIGN**. LEON TECH CO., LTD., (U.S. CLS. 2, 27, 28 AND 50). SN 78-867,404. PUB. 2-6-2007. FILED 4-22-2006.  
 3,233,005. **PERSEVERING IN PURITY (BLOCK FORM)**. CTA, INC., MULTIPLE CLASS, (INT. CLS. 14 AND 16), (U.S. CLS. 2, 5, 22, 23, 27, 28, 29, 37, 38 AND 50). SN 78-880,586. PUB. 2-6-2007. FILED 5-10-2006.  
 3,233,019. **LOKELANI (BLOCK FORM)**. LOKELANI DESIGNS, LLC, (U.S. CLS. 2, 27, 28 AND 50). SN 78-884,667. PUB. 2-6-2007. FILED 5-16-2006.  
 3,233,030. **NAUTICA (BLOCK FORM)**. NAUTICA APPAREL, INC., (U.S. CLS. 2, 27, 28 AND 50). SN 78-885,472. PUB. 2-6-2007. FILED 5-17-2006.  
 3,233,090. **DIAMONDSDEAL.COM CORP AND DESIGN**. DIAMONDSDEAL.COM CORP., (U.S. CLS. 2, 27, 28 AND 50). SN 78-900,404. PUB. 2-6-2007. FILED 6-5-2006.  
 3,233,108. **THE BEAUTY OF SHORTHAND WRITTEN ESPECIALLY FOR YOU (BLOCK FORM)**. WANCHESE POTTERY, INC., (U.S. CLS. 2, 27, 28 AND 50). SN 78-903,454. PUB. 2-6-2007. FILED 6-8-2006.  
 3,233,135. **MARCELLO C. (BLOCK FORM)**. MATTHIAS H. VAN DOORN, (U.S. CLS. 2, 27, 28 AND 50). SN 78-906,947. PUB. 2-6-2007. FILED 6-13-2006.  
 3,233,282. **MISCELLANEOUS DESIGN**. CATHEDRAL ART METAL CO., INC., (U.S. CLS. 2, 27, 28 AND 50). SN 78-914,464. PUB. 2-6-2007. FILED 6-22-2006.  
 3,233,323. **1928 SPARKLE AND DESIGN**. MEL BERNIE AND COMPANY, INC., (U.S. CLS. 2, 27, 28 AND 50). SN 78-915,490. PUB. 2-6-2007. FILED 6-23-2006.  
 3,233,350. **JKO (BLOCK FORM)**. OLSEN, JUDITH K., (U.S. CLS. 2, 27, 28 AND 50). SN 78-916,168. PUB. 2-6-2007. FILED 6-24-2006.  
 3,233,443. **MONTESINO DESTINATION BRACELET COLLECTION AND DESIGN**. MONTESINO INTERNATIONAL CORP., (U.S. CLS. 2, 27, 28 AND 50). SN 78-919,506. PUB. 2-6-2007. FILED 6-29-2006.  
 3,233,508. **DISNEYLAND (BLOCK FORM)**. DISNEY ENTERPRISES, INC., (U.S. CLS. 2, 27, 28 AND 50). SN 78-967,979. PUB. 2-6-2007. FILED 9-6-2006.  
 3,233,514 ( *See Class 9 for this trademark* ).  
 3,233,520 ( *See Class 1 for this trademark* ).  
 3,233,523 ( *See Class 3 for this trademark* ).  
 3,233,546 ( *See Class 3 for this trademark* ).  
 3,233,554 ( *See Class 8 for this trademark* ).  
 3,233,557 ( *See Class 6 for this trademark* ).  
 3,233,558 ( *See Class 6 for this trademark* ).  
 3,233,564. **VIATOR AND DESIGN**. VIATOR SA, MULTIPLE CLASS, (INT. CLS. 14, 16 AND 18), (U.S. CLS. 1, 2, 3, 5, 22, 23, 27, 28, 29, 37, 38, 41 AND 50). SN 79-017,272. PUB. 2-6-2007. FILED 8-19-2005.  
 3,233,567. **SUPA'GLEM AND DESIGN**. DOMINGO SANDRA, MARIE, ENAGNON, MULTIPLE CLASS, (INT. CLS. 14, 18 AND 25), (U.S. CLS. 1, 2, 3, 22, 27, 28, 39, 41 AND 50). SN 79-

- 017,376. PUB. 2-6-2007. FILED 10-17-2005.
- 3,233,571. **NEOLOG (BLOCK FORM)**, SCOPETIME GMBH, (U.S. CLS. 2, 27, 28 AND 50). SN 79-017,609. PUB. 2-6-2007. FILED 10-17-2005.
- 3,233,591 ( *See Class 3 for this trademark*).
- 3,233,633. **0 1 2 3 4 5 6 7 8 9 10 11 12 13 14 15 16 17 18 19 20 21 22 23 AND DESIGN**, NEUF, MULTIPLE CLASS, (INT. CLS. 14 AND 25), (U.S. CLS. 2, 22, 27, 28, 39 AND 50). SN 79-020,679. PUB. 2-6-2007. FILED 11-18-2005.
- 3,233,634. **0 1 2 3 4 5 6 7 8 9 10 11 12 13 14 15 16 17 18 19 20 21 22 23 AND DESIGN**, NEUF, MULTIPLE CLASS, (INT. CLS. 14 AND 18), (U.S. CLS. 1, 2, 3, 22, 27, 28, 41 AND 50). SN 79-020,684. PUB. 2-6-2007. FILED 11-18-2005.
- 3,233,652 ( *See Class 1 for this trademark*).
- 3,233,677 ( *See Class 9 for this trademark*).
- 3,233,685 ( *See Class 3 for this trademark*).
- 3,233,712. **EVERFLOW (STYLIZED)**, SOGESPRÖM SA, MULTIPLE CLASS, (INT. CLS. 14, 16 AND 18), (U.S. CLS. 1, 2, 3, 5, 22, 23, 27, 28, 29, 37, 38, 41 AND 50). SN 79-024,289. PUB. 2-6-2007. FILED 4-10-2006.
- 3,233,728. **DRIES VAN NOTEN (BLOCK FORM)**, VAN NOTEN ANDRIES, NAAAMLOZE VENNOOTSCHAP, MULTIPLE CLASS, (INT. CLS. 14, 18, 25 AND 35), (U.S. CLS. 1, 2, 3, 22, 27, 28, 39, 41, 50, 100, 101 AND 102). SN 79-025,248. PUB. 2-6-2007. FILED 1-25-2006.
- 3,233,732. **MASTER DECIDER (BLOCK FORM)**, FRANCK MULLER WATCHLAND SA, (U.S. CLS. 2, 27, 28 AND 50). SN 79-025,478. PUB. 2-6-2007. FILED 6-13-2006.

---

#### CLASS 15—MUSICAL INSTRUMENTS

- 3,232,391. **MISCELLANEOUS DESIGN**, CENTERLINE GUITARS, LLC, (U.S. CLS. 2, 21 AND 36). SN 78-544,243. PUB. 2-6-2007. FILED 1-7-2005.
- 3,233,520 ( *See Class 1 for this trademark*).
- 3,233,624. **V JAZZ (STYLIZED)**, VARLEPIC PARTICIPATIONS, MULTIPLE CLASS, (INT. CLS. 15 AND 41), (U.S. CLS. 2, 21, 36, 100, 101 AND 107). SN 79-020,383. PUB. 2-6-2007. FILED 12-16-2005.
- 3,233,726. **B45 AND DESIGN**, VARLEPIC PARTICIPATIONS, (U.S. CLS. 2, 21 AND 36). SN 79-025,190. PUB. 2-6-2007. FILED 4-14-2006.
- 3,233,727. **B40 (BLOCK FORM)**, VARLEPIC PARTICIPATIONS, (U.S. CLS. 2, 21 AND 36). SN 79-025,236. PUB. 2-6-2007. FILED 4-28-2006.

---

#### CLASS 16—PAPER GOODS AND PRINTED MATTER

- 3,232,049. **VARGA GIRL**, ESQUIRE MAGAZINE GROUP, INC., (U.S. CL. 38). SN 73-572,719. PUB. 11-23-1993. FILED 12-10-1985.
- 3,232,054. **PPD**, TOTAL ADMINISTRATIVE BENEFIT SYSTEMS, INC., MULTIPLE CLASS, (INT. CLS. 16, 41 AND 42), (U.S. CLS. 2, 5, 22, 23, 29, 37, 38, 50, 100, 101 AND 107). SN 75-625,899. PUB. 2-6-2007. FILED 1-25-1999.
- 3,232,060 ( *See Class 6 for this trademark*).
- 3,232,061. **CUB CASH**, BUILD-A-BEAR WORKSHOP, INC., (U.S. CLS. 2, 5, 22, 23, 29, 37, 38 AND 50). SN 76-110,408. PUB. 1-8-2002. FILED 8-14-2000.
- 3,232,073 ( *See Class 1 for this trademark*).
- 3,232,074. **MALIBU FILM FESTIVAL**, MALIBU FILM FOUNDATION, MULTIPLE CLASS, (INT. CLS. 16, 25 AND 41), (U.S. CLS. 2, 5, 22, 23, 29, 37, 38, 39, 50, 100, 101 AND 107). SN 76-457,765. PUB. 2-6-2007. FILED 10-10-2002.
- 3,232,088 ( *See Class 5 for this trademark*).
- 3,232,118 ( *See Class 9 for this trademark*).
- 3,232,144. **LVE HUNTING DECALS, LLC (BLOCK FORM)**, LVE HUNTING DECALS, LLC, (U.S. CLS. 2, 5, 22, 23, 29, 37, 38 AND 50). SN 76-647,311. PUB. 2-6-2007. FILED 9-23-2005.
- 3,232,164. **INTERNATIONAL ACCOUNTING STANDARDS BOARD AND DESIGN**, INTERNATIONAL ACCOUNTING STANDARDS COMMITTEE FOUNDATION, MULTIPLE

- CLASS, (INT. CLS. 16, 35 AND 41), (U.S. CLS. 2, 5, 22, 23, 29, 37, 38, 50, 100, 101, 102 AND 107). SN 76-650,139. PUB. 2-6-2007. FILED 11-10-2005.
- 3,232,169. **CHARACTER CHARACTERISTIC (BLOCK FORM)**, BE A DREAMER PRODUCTIONS, INC., (U.S. CLS. 2, 5, 22, 23, 29, 37, 38 AND 50). SN 76-650,356. PUB. 2-6-2007. FILED S.R. 11-15-2005; AM. P.R. 12-12-2006.
- 3,232,196 ( *See Class 9 for this trademark*).
- 3,232,205. **POKER LIFE (BLOCK FORM)**, POKER LIFE MAGAZINE, LLC, (U.S. CLS. 2, 5, 22, 23, 29, 37, 38 AND 50). SN 76-657,743. PUB. 2-6-2007. FILED 4-3-2006.
- 3,232,231. **PRESS-REGISTER (BLOCK FORM)**, THE MOBILE PRESS REGISTER, INC., (U.S. CLS. 2, 5, 22, 23, 29, 37, 38 AND 50). SN 76-661,586. PUB. 2-6-2007. FILED 6-15-2006.
- 3,232,264. **T.R.G.T. (BLOCK FORM)**, U.S. TACTICAL SUPPLY, INC., (U.S. CLS. 2, 5, 22, 23, 29, 37, 38 AND 50). SN 76-662,792. PUB. 2-6-2007. FILED 7-10-2006.
- 3,232,275 ( *See Class 9 for this trademark*).
- 3,232,278. **BEST DISHES (BLOCK FORM)**, PAULA DEEN ENTERPRISES, LLC, (U.S. CLS. 2, 5, 22, 23, 29, 37, 38 AND 50). SN 77-000,183. PUB. 2-6-2007. FILED 9-15-2006.
- 3,232,309. **¡DISFRÚTALO! (BLOCK FORM)**, PEPSICO, INC., (U.S. CLS. 2, 5, 22, 23, 29, 37, 38 AND 50). SN 77-031,046. PUB. 2-6-2007. FILED 10-27-2006.
- 3,232,364. **ITALIAN DESIGNS EDIZIONE NB SIMEONE COLLECTORS SERIES AUTHENTIC REPRODUCTIONS AND DESIGN**, SAN FRANCIS IMPORTS, (U.S. CLS. 2, 5, 22, 23, 29, 37, 38 AND 50). SN 78-461,800. PUB. 2-6-2007. FILED 8-4-2004.
- 3,232,366 ( *See Class 9 for this trademark*).
- 3,232,393. **BAR SECRETS (BLOCK FORM)**, SHOPPING SECRETS PTY. LTD., (U.S. CLS. 2, 5, 22, 23, 29, 37, 38 AND 50). SN 78-547,107. PUB. 2-6-2007. FILED 1-13-2005.
- 3,232,399. **DRAGON TAROT (BLOCK FORM)**, U.S. GAMES SYSTEMS, INC., (U.S. CLS. 2, 5, 22, 23, 29, 37, 38 AND 50). SN 78-553,699. PUB. 2-6-2007. FILED 1-25-2005.
- 3,232,414 ( *See Class 9 for this trademark*).
- 3,232,419. **HEALTHY TOGETHER...TAKE CONTROL! (BLOCK FORM)**, APS HEALTHCARE BETHESDA, INC., MULTIPLE CLASS, (INT. CLS. 16, 41 AND 44), (U.S. CLS. 2, 5, 22, 23, 29, 37, 38, 50, 100, 101 AND 107). SN 78-575,276. PUB. 2-6-2007. FILED 2-25-2005.
- 3,232,448. **PROJECT MANAGEMENT GOLD (BLOCK FORM)**, SOFTWARE NUGGETS, INC., (U.S. CLS. 2, 5, 22, 23, 29, 37, 38 AND 50). SN 78-598,112. PUB. 2-6-2007. FILED 3-30-2005.
- 3,232,449. **SOPHIZTICATES (STYLIZED)**, EMBREY INK, INC., (U.S. CLS. 2, 5, 22, 23, 29, 37, 38 AND 50). SN 78-598,471. PUB. 2-6-2007. FILED 3-30-2005.
- 3,232,451. **WHEN DOES A SNAPSHOT BECOME A MEMORY? WHEN DOES A MEMORY BECOME A STORY? (BLOCK FORM)**, PUSH BUTTON MEMORIES, LLC, (U.S. CLS. 2, 5, 22, 23, 29, 37, 38 AND 50). SN 78-599,477. PUB. 2-6-2007. FILED 3-31-2005.
- 3,232,470. **RELIABILITY (BLOCK FORM)**, RELIABILITY MAGAZINE, LLC, (U.S. CLS. 2, 5, 22, 23, 29, 37, 38 AND 50). SN 78-620,089. PUB. 2-6-2007. FILED 4-29-2005.
- 3,232,473 ( *See Class 9 for this trademark*).
- 3,232,482. **UPTIME (BLOCK FORM)**, NETEXPRESSUSA INC., (U.S. CLS. 2, 5, 22, 23, 29, 37, 38 AND 50). SN 78-632,281. PUB. 2-6-2007. FILED 5-18-2005.
- 3,232,524. **LIGHTHOUSE ACADEMIES SELF-DISCIPLINE HUMILITY INTELLIGENCE NOBILITY EXCELLENCE AND DESIGN**, LIGHTHOUSE ACADEMIES, INC., (U.S. CLS. 2, 5, 22, 23, 29, 37, 38 AND 50). SN 78-674,091. PUB. 2-6-2007. FILED 7-20-2005.
- 3,232,544. **LIVE AND RAW (BLOCK FORM)**, CCLR INTERNET, LLC, MULTIPLE CLASS, (INT. CLS. 16 AND 41), (U.S. CLS. 2, 5, 22, 23, 29, 37, 38, 50, 100, 101 AND 107). SN 78-686,069. PUB. 2-6-2007. FILED 8-4-2005.
- 3,232,550. **PRISMACOLOR PREMIER (BLOCK FORM)**, SANFORD, L.P., (U.S. CLS. 2, 5, 22, 23, 29, 37, 38 AND 50). SN 78-693,288. PUB. 2-6-2007. FILED 8-16-2005.
- 3,232,551. **PRISMACOLOR PREMIER (BLOCK FORM)**, SANFORD, L.P., (U.S. CLS. 2, 5, 22, 23, 29, 37, 38 AND 50). SN 78-693,438. PUB. 2-6-2007. FILED 8-16-2005.
- 3,232,557. **HEALTHY COMPUTING (BLOCK FORM)**, HEALTHY COMPUTING.COM, MULTIPLE CLASS, (INT.

- CLS. 16 AND 41), (U.S. CLS. 2, 5, 22, 23, 29, 37, 38, 50, 100, 101 AND 107). SN 78-696,771. PUB. 2-6-2007. FILED 8-19-2005.
- 3,232,574. **NANTUCKET TIMES (BLOCK FORM)**, N, LLC, (U.S. CLS. 2, 5, 22, 23, 29, 37, 38 AND 50). SN 78-712,970. PUB. 2-6-2007. FILED 9-14-2005.
- 3,232,576. **KCO (BLOCK FORM)**, LI, ALEX, (U.S. CLS. 2, 5, 22, 23, 29, 37, 38 AND 50). SN 78-714,195. PUB. 2-6-2007. FILED 9-15-2005.
- 3,232,595. **TRANSPLIT (BLOCK FORM)**, ONE STEP PAPERS, L.L.C., (U.S. CLS. 2, 5, 22, 23, 29, 37, 38 AND 50). SN 78-726,980. PUB. 2-6-2007. FILED 10-5-2005.
- 3,232,616. **PRISMSTIX (BLOCK FORM)**, BEROL CORPORATION, (U.S. CLS. 2, 5, 22, 23, 29, 37, 38 AND 50). SN 78-735,514. PUB. 2-6-2007. FILED 10-18-2005.
- 3,232,617. **MEXICO CIEN (BLOCK FORM)**, UNION TELECOM, INC., (U.S. CLS. 2, 5, 22, 23, 29, 37, 38 AND 50). SN 78-736,033. PUB. 1-23-2007. FILED 10-19-2005.
- 3,232,620. **BLG AND DESIGN**, BORDEN LADNER GERVAIS, LLP, MULTIPLE CLASS, (INT. CLS. 16 AND 42), (U.S. CLS. 2, 5, 22, 23, 29, 37, 38, 50, 100 AND 101). SN 78-737,332. PUB. 2-6-2007. FILED 10-20-2005.
- 3,232,666 ( *See Class 9 for this trademark*).
- 3,232,832. **THE NATIONAL TEACHERS HALL OF FAME PRESERVING A HERITAGE ... BUILDING A LEGACY AND DESIGN**, THE NATIONAL TEACHERS HALL OF FAME, INC., (U.S. CLS. 2, 5, 22, 23, 29, 37, 38 AND 50). SN 78-816,100. PUB. 2-6-2007. FILED 2-16-2006.
- 3,232,836 ( *See Class 10 for this trademark*).
- 3,232,888. **A TINY BIT OF GOD (BLOCK FORM)**, BARONE, ADRIANA, (U.S. CLS. 2, 5, 22, 23, 29, 37, 38 AND 50). SN 78-842,065. PUB. 2-6-2007. FILED 3-21-2006.
- 3,232,889. **ZANDERS TREVI (BLOCK FORM)**, M-REAL ZANDERS GMBH, (U.S. CLS. 2, 5, 22, 23, 29, 37, 38 AND 50). SN 78-842,180. PUB. 2-6-2007. FILED 3-21-2006.
- 3,232,909. **BRIK PAK AND DESIGN**, MEADWESTVACO CORPORATION, (U.S. CLS. 2, 5, 22, 23, 29, 37, 38 AND 50). SN 78-850,774. PUB. 2-6-2007. FILED 3-31-2006.
- 3,232,914. **CVT PREPAID SOLUTIONS (BLOCK FORM)**, CVT PREPAID SOLUTIONS, INC., MULTIPLE CLASS, (INT. CLS. 16, 36 AND 38), (U.S. CLS. 2, 5, 22, 23, 29, 37, 38, 50, 100, 101, 102 AND 104). SN 78-854,711. PUB. 2-6-2007. FILED 4-5-2006.
- 3,232,916. **CVT PREPAID SOLUTIONS, INC. AND DESIGN**, CVT PREPAID SOLUTIONS, INC., MULTIPLE CLASS, (INT. CLS. 16, 36 AND 38), (U.S. CLS. 2, 5, 22, 23, 29, 37, 38, 50, 100, 101, 102 AND 104). SN 78-854,926. PUB. 2-6-2007. FILED 4-5-2006.
- 3,232,928. **PAPER DAISY (BLOCK FORM)**, PAPER DAISY, L.L.C., MULTIPLE CLASS, (INT. CLS. 16 AND 35), (U.S. CLS. 2, 5, 22, 23, 29, 37, 38, 50, 100, 101 AND 102). SN 78-856,673. PUB. 2-6-2007. FILED 4-7-2006.
- 3,232,932. **DEALMEMO (BLOCK FORM)**, THE DEAL, LLC, (U.S. CLS. 2, 5, 22, 23, 29, 37, 38 AND 50). SN 78-859,498. PUB. 2-6-2007. FILED 4-12-2006.
- 3,232,966 ( *See Class 9 for this trademark*).
- 3,233,005 ( *See Class 14 for this trademark*).
- 3,233,025. **JERUSALEM YORK (BLOCK FORM)**, VOIP SERVICES, INC, (U.S. CLS. 2, 5, 22, 23, 29, 37, 38 AND 50). SN 78-884,956. PUB. 2-6-2007. FILED 5-16-2006.
- 3,233,026. **PUEBLA YORK (BLOCK FORM)**, VOIP SERVICES, INC, (U.S. CLS. 2, 5, 22, 23, 29, 37, 38 AND 50). SN 78-884,961. PUB. 2-6-2007. FILED 5-16-2006.
- 3,233,060. **DESTINATION SAN DIEGO (BLOCK FORM)**, INFORMEDIA PUBLICATIONS, INC., (U.S. CLS. 2, 5, 22, 23, 29, 37, 38 AND 50). SN 78-892,942. PUB. 2-6-2007. FILED 5-25-2006.
- 3,233,061. **THE TRAVELING FORK (BLOCK FORM)**, CARDILLO, JOHN P., (U.S. CLS. 2, 5, 22, 23, 29, 37, 38 AND 50). SN 78-892,986. PUB. 2-6-2007. FILED 5-25-2006.
- 3,233,077. **EMIKO (BLOCK FORM)**, VOIP SERVICES, INC, (U.S. CLS. 2, 5, 22, 23, 29, 37, 38 AND 50). SN 78-897,419. PUB. 2-6-2007. FILED 5-31-2006.
- 3,233,084. **ZHENG (BLOCK FORM)**, VOIP SERVICES, INC, (U.S. CLS. 2, 5, 22, 23, 29, 37, 38 AND 50). SN 78-899,529. PUB. 2-6-2007. FILED 6-2-2006.
- 3,233,085. **ZINDZHI (BLOCK FORM)**, VOIP SERVICES, INC, (U.S. CLS. 2, 5, 22, 23, 29, 37, 38 AND 50). SN 78-899,539. PUB. 2-6-2007. FILED 6-2-2006.
- 3,233,086. **DE CAJON (BLOCK FORM)**, VOIP SERVICES, INC, (U.S. CLS. 2, 5, 22, 23, 29, 37, 38 AND 50). SN 78-899,546. PUB. 2-6-2007. FILED 6-2-2006.
- 3,233,087. **LATINO YORK (BLOCK FORM)**, VOIP SERVICES, INC, (U.S. CLS. 2, 5, 22, 23, 29, 37, 38 AND 50). SN 78-899,553. PUB. 2-6-2007. FILED 6-2-2006.
- 3,233,118. **THE FAIRY CHRONICLES (BLOCK FORM)**, SWEET, JOANNE, (U.S. CLS. 2, 5, 22, 23, 29, 37, 38 AND 50). SN 78-904,913. PUB. 2-6-2007. FILED 6-9-2006.
- 3,233,131. **LABTALK (BLOCK FORM)**, FRAMES DATA INC., (U.S. CLS. 2, 5, 22, 23, 29, 37, 38 AND 50). SN 78-906,557. PUB. 2-6-2007. FILED 6-13-2006.
- 3,233,164. **THE ARTERY (BLOCK FORM)**, HEMOPHILIA FOUNDATION OF MICHIGAN, (U.S. CLS. 2, 5, 22, 23, 29, 37, 38 AND 50). SN 78-908,689. PUB. 2-6-2007. FILED 6-15-2006.
- 3,233,165. **THE BLOODY TRUTH (BLOCK FORM)**, HEMOPHILIA FOUNDATION OF MICHIGAN, (U.S. CLS. 2, 5, 22, 23, 29, 37, 38 AND 50). SN 78-908,691. PUB. 2-6-2007. FILED 6-15-2006.
- 3,233,197. **SANDERS MCNEAL (BLOCK FORM)**, MCNEAL, SANDERS, (U.S. CLS. 2, 5, 22, 23, 29, 37, 38 AND 50). SN 78-910,281. PUB. 2-6-2007. FILED 6-16-2006.
- 3,233,266. **LIFE TAKES PLACE. (BLOCK FORM)**, KEIM, KEVIN P., (U.S. CLS. 2, 5, 22, 23, 29, 37, 38 AND 50). SN 78-913,428. PUB. 2-6-2007. FILED 6-21-2006.
- 3,233,271. **JOURNEYS IN PARADISE (BLOCK FORM)**, LITTLE SWITZERLAND, INC., (U.S. CLS. 2, 5, 22, 23, 29, 37, 38 AND 50). SN 78-913,616. PUB. 2-6-2007. FILED 6-21-2006.
- 3,233,286. **PAPERBACKADDY AND DESIGN**, BRIEE, YVES, (U.S. CLS. 2, 5, 22, 23, 29, 37, 38 AND 50). SN 78-914,532. PUB. 2-6-2007. FILED 6-22-2006.
- 3,233,289. **COUNT ON IT (BLOCK FORM)**, PEOPLES EDUCATION, INC., THE, MULTIPLE CLASS, (INT. CLS. 16 AND 41), (U.S. CLS. 2, 5, 22, 23, 29, 37, 38, 50, 100, 101 AND 107). SN 78-914,565. PUB. 2-6-2007. FILED 6-22-2006.
- 3,233,290. **KEEP ON READING (BLOCK FORM)**, PEOPLES EDUCATION, INC., THE, MULTIPLE CLASS, (INT. CLS. 16 AND 41), (U.S. CLS. 2, 5, 22, 23, 29, 37, 38, 50, 100, 101 AND 107). SN 78-914,588. PUB. 2-6-2007. FILED 6-22-2006.
- 3,233,351. **SPREAD (BLOCK FORM)**, SPREAD MAGAZINE, (U.S. CLS. 2, 5, 22, 23, 29, 37, 38 AND 50). SN 78-916,188. PUB. 2-6-2007. FILED 6-24-2006.
- 3,233,391. **BELLISIMO (STYLIZED)**, CHARTWELL STUDIO, INC., (U.S. CLS. 2, 5, 22, 23, 29, 37, 38 AND 50). SN 78-917,333. PUB. 2-6-2007. FILED 6-26-2006.
- 3,233,395. **YOUR TOWN MONTHLY AND DESIGN**, S & J ADVERTISING, INC., (U.S. CLS. 2, 5, 22, 23, 29, 37, 38 AND 50). SN 78-917,389. PUB. 2-6-2007. FILED 6-26-2006.
- 3,233,408. **AAA AND DESIGN**, AMERICAN AUTOMOBILE ASSOCIATION, INC., (U.S. CLS. 2, 5, 22, 23, 29, 37, 38 AND 50). SN 78-917,908. PUB. 2-6-2007. FILED 6-27-2006.
- 3,233,416. **CLUBHOUSE LIVING (STYLIZED)**, TRAVEL-HOST, INC., (U.S. CLS. 2, 5, 22, 23, 29, 37, 38 AND 50). SN 78-918,154. PUB. 2-6-2007. FILED 6-27-2006.
- 3,233,438. **HOBBY OUTLOOK (BLOCK FORM)**, HOBBY TOWN UNLIMITED, INC., MULTIPLE CLASS, (INT. CLS. 16 AND 41), (U.S. CLS. 2, 5, 22, 23, 29, 37, 38, 50, 100, 101 AND 107). SN 78-919,226. PUB. 2-6-2007. FILED 6-28-2006.
- 3,233,475. **MISCELLANEOUS DESIGN**, THE OFFICER DOWN MEMORIAL PAGE, INC., (U.S. CLS. 2, 5, 22, 23, 29, 37, 38 AND 50). SN 78-922,391. PUB. 2-6-2007. FILED 7-5-2006.
- 3,233,500 ( *See Class 9 for this trademark*).
- 3,233,504. **THE AUTOMOTIVE LUXURY LIFESTYLE (BLOCK FORM)**, AMERICAN DRIVER MEDIA, INC., (U.S. CLS. 2, 5, 22, 23, 29, 37, 38 AND 50). SN 78-958,283. PUB. 2-6-2007. FILED 8-23-2006.
- 3,233,510. **BUTTONED UP AND DESIGN**, BUTTONED UP, INC., MULTIPLE CLASS, (INT. CLS. 16 AND 18), (U.S. CLS. 1, 2, 3, 5, 22, 23, 29, 37, 38, 41 AND 50). SN 78-971,617. PUB. 2-6-2007. FILED 9-11-2006.
- 3,233,520 ( *See Class 1 for this trademark*).
- 3,233,529 ( *See Class 5 for this trademark*).
- 3,233,534 ( *See Class 7 for this trademark*).
- 3,233,535 ( *See Class 9 for this trademark*).
- 3,233,539 ( *See Class 9 for this trademark*).

3,233,543 ( *See Class 9 for this trademark.*)  
 3,233,546 ( *See Class 3 for this trademark.*)  
 3,233,550 ( *See Class 9 for this trademark.*)  
 3,233,556 ( *See Class 5 for this trademark.*)  
 3,233,564 ( *See Class 14 for this trademark.*)  
 3,233,581 ( *See Class 9 for this trademark.*)  
 3,233,589. **MISCELLANEOUS DESIGN.** CARAN D'ACHE S.A., (U.S. CLS. 2, 5, 22, 23, 29, 37, 38 AND 50). SN 79-018,645. PUB. 2-6-2007. FILED 10-13-2005.  
 3,233,591 ( *See Class 3 for this trademark.*)  
 3,233,595 ( *See Class 1 for this trademark.*)  
 3,233,600. **GLOW ZONE AND DESIGN.** TOY POLLOI PTY LTD, AND P FALK & CO PTY LTD, MULTIPLE CLASS, (INT. CLS. 16 AND 28), (U.S. CLS. 2, 5, 22, 23, 29, 37, 38 AND 50). SN 79-019,410. PUB. 10-24-2006. FILED 11-12-2004.  
 3,233,608 ( *See Class 5 for this trademark.*)  
 3,233,636 ( *See Class 9 for this trademark.*)  
 3,233,677 ( *See Class 9 for this trademark.*)  
 3,233,694 ( *See Class 9 for this trademark.*)  
 3,233,712 ( *See Class 14 for this trademark.*)  
 3,233,716. **CHOCOLAT MICHEL CLUIZEL AND DESIGN.** CHOCOLATS CLUIZEL, MULTIPLE CLASS, (INT. CLS. 16, 30 AND 43), (U.S. CLS. 2, 5, 22, 23, 29, 37, 38, 46, 50, 100 AND 101). SN 79-024,511. PUB. 2-6-2007. FILED 2-3-2006.  
 3,233,749. **CLIFTER (STYLIZED).** MITSUBISHI PENCIL CO., LTD., (U.S. CLS. 2, 5, 22, 23, 29, 37, 38 AND 50). SN 79-027,173. PUB. 2-6-2007. FILED 6-19-2006.

---

### CLASS 17—RUBBER GOODS

3,232,076 ( *See Class 7 for this trademark.*)  
 3,232,245. **SUR BOND BARRIER MATERIALS AND DESIGN.** GRAHAM PACKAGING PET TECHNOLOGIES INC., (U.S. CLS. 1, 5, 12, 13, 35 AND 50). SN 76-661,891. PUB. 2-6-2007. FILED 6-19-2006.  
 3,232,377. **FXT (BLOCK FORM).** FREUDENBERG-NOK GENERAL PARTNERSHIP, (U.S. CLS. 1, 5, 12, 13, 35 AND 50). SN 78-508,316. PUB. 2-6-2007. FILED 10-29-2004.  
 3,233,338. **NAILBOARD (BLOCK FORM).** JOHNS MANVILLE, (U.S. CLS. 1, 5, 12, 13, 35 AND 50). SN 78-915,935. PUB. 2-6-2007. FILED 6-23-2006.  
 3,233,342. **HUBTRON (BLOCK FORM).** MITSUBOSHI CO., LTD., (U.S. CLS. 1, 5, 12, 13, 35 AND 50). SN 78-915,982. PUB. 2-6-2007. FILED 6-23-2006.  
 3,233,541 ( *See Class 1 for this trademark.*)  
 3,233,617 ( *See Class 6 for this trademark.*)  
 3,233,654 ( *See Class 1 for this trademark.*)  
 3,233,715. **ELOFIT (BLOCK FORM).** GECO SYSTEM S.P.A., MULTIPLE CLASS, (INT. CLS. 17 AND 19), (U.S. CLS. 1, 5, 12, 13, 33, 35 AND 50). SN 79-024,453. PUB. 2-6-2007. FILED 2-16-2006.  
 3,233,734. **HEVEAFLEX (BLOCK FORM).** LATEXCO N.V., MULTIPLE CLASS, (INT. CLS. 17 AND 20), (U.S. CLS. 1, 2, 5, 12, 13, 22, 25, 32, 35 AND 50). SN 79-025,586. PUB. 2-6-2007. FILED 3-16-2006.

---

### CLASS 18—LEATHER GOODS

3,232,060 ( *See Class 6 for this trademark.*)  
 3,232,103. **J-4 (BLOCK FORM).** FASHION PARK S.R.L., MULTIPLE CLASS, (INT. CLS. 18 AND 25), (U.S. CLS. 1, 2, 3, 22, 39 AND 41). SN 76-617,369. PUB. 9-5-2006. FILED 10-22-2004.  
 3,232,124. **L H L AND DESIGN.** MCCLAIN, JANECE LUND, (U.S. CLS. 1, 2, 3, 22 AND 41). SN 76-636,825. PUB. 2-6-2007. FILED 4-22-2005.  
 3,232,137 ( *See Class 8 for this trademark.*)  
 3,232,217. **TRACY & CO. (BLOCK FORM).** ZHOU, WANGJIAN, (U.S. CLS. 1, 2, 3, 22 AND 41). SN 76-660,581. PUB. 2-6-2007. FILED 5-25-2006.  
 3,232,315. **ROOSTER (BLOCK FORM).** ROOSTER PRODUCTS INTERNATIONAL, INC., (U.S. CLS. 1, 2, 3, 22 AND 41). SN 77-043,560. PUB. 2-6-2007. FILED 11-14-2006.

3,232,335 ( *See Class 9 for this trademark.*)  
 3,232,375 ( *See Class 3 for this trademark.*)  
 3,232,469. **PERFORMANCE RULES! (BLOCK FORM).** BLACKHAWK INDUSTRIES PRODUCT GROUP UNLIMITED LLC, (U.S. CLS. 1, 2, 3, 22 AND 41). SN 78-618,643. PUB. 2-6-2007. FILED 4-28-2005.  
 3,232,575. **CK BRADLEY (BLOCK FORM).** TALLY HO DESIGNS, LTD., MULTIPLE CLASS, (INT. CLS. 18 AND 25), (U.S. CLS. 1, 2, 3, 22, 39 AND 41). SN 78-714,049. PUB. 2-6-2007. FILED 9-15-2005.  
 3,232,668. **SOFT-GRIP (BLOCK FORM).** RHODE ISLAND TEXTILE COMPANY, (U.S. CLS. 1, 2, 3, 22 AND 41). SN 78-747,449. PUB. 2-6-2007. FILED 11-4-2005.  
 3,232,759. **MIKE'S HARD LIME (BLOCK FORM).** MARK ANTHONY INTERNATIONAL SRL, MULTIPLE CLASS, (INT. CLS. 18, 25, 32 AND 33), (U.S. CLS. 1, 2, 3, 22, 39, 41, 45, 46, 47, 48 AND 49). SN 78-775,380. PUB. 6-6-2006. FILED 12-16-2005.  
 3,232,773. **NO DRIP UMBRELLA AND DESIGN.** GEE! TECHNOLOGIES LLC, (U.S. CLS. 1, 2, 3, 22 AND 41). SN 78-783,334. PUB. 2-6-2007. FILED 12-30-2005.  
 3,232,801. **BKAED (BLOCK FORM).** LAVINIA LOBO, DBA BABY KAED, (U.S. CLS. 1, 2, 3, 22 AND 41). SN 78-800,349. PUB. 2-6-2007. FILED 1-26-2006.  
 3,232,805. **A AND DESIGN.** KMART OF MICHIGAN, INC., MULTIPLE CLASS, (INT. CLS. 18, 25 AND 28), (U.S. CLS. 1, 2, 3, 22, 23, 38, 39, 41 AND 50). SN 78-803,773. PUB. 2-6-2007. FILED 1-31-2006.  
 3,232,827. **NAUTICA PERFORMANCE TRAVEL GEAR (BLOCK FORM).** NAUTICA APPAREL, INC., (U.S. CLS. 1, 2, 3, 22 AND 41). SN 78-814,361. PUB. 2-6-2007. FILED 2-14-2006.  
 3,232,859. **BO (STYLIZED).** NUFOLD, INC., (U.S. CLS. 1, 2, 3, 22 AND 41). SN 78-832,194. PUB. 10-24-2006. FILED 3-8-2006.  
 3,232,866. **BETSEY JOHNSON (BLOCK FORM).** B.J. VINES, INC., (U.S. CLS. 1, 2, 3, 22 AND 41). SN 78-834,547. PUB. 2-6-2007. FILED 3-10-2006.  
 3,232,890. **MARC BUCHANAN (BLOCK FORM).** PELLE PELLE, INC., MULTIPLE CLASS, (INT. CLS. 18 AND 25), (U.S. CLS. 1, 2, 3, 22, 39 AND 41). SN 78-842,469. PUB. 2-6-2007. FILED 3-21-2006.  
 3,232,917. **DRESSED TO THE K-NINES AND DESIGN.** DRESSED TO THE K-NINES, INC., (U.S. CLS. 1, 2, 3, 22 AND 41). SN 78-855,497. PUB. 2-6-2007. FILED 4-6-2006.  
 3,232,997. **HYDE (BLOCK FORM).** HYDE TOOLS, INC., (U.S. CLS. 1, 2, 3, 22 AND 41). SN 78-879,750. PUB. 2-6-2007. FILED 5-9-2006.  
 3,233,082 ( *See Class 6 for this trademark.*)  
 3,233,124. **BROWN TOES (BLOCK FORM).** YOUNG, ANTHONY LORICK, MULTIPLE CLASS, (INT. CLS. 18 AND 35), (U.S. CLS. 1, 2, 3, 22, 41, 100, 101 AND 102). SN 78-905,501. PUB. 2-6-2007. FILED 6-11-2006.  
 3,233,276. **BANDHA (STYLIZED).** MICHELE DAIGNAULT, (U.S. CLS. 1, 2, 3, 22 AND 41). SN 78-913,951. PUB. 2-6-2007. FILED 6-22-2006.  
 3,233,510 ( *See Class 16 for this trademark.*)  
 3,233,514 ( *See Class 9 for this trademark.*)  
 3,233,520 ( *See Class 1 for this trademark.*)  
 3,233,523 ( *See Class 3 for this trademark.*)  
 3,233,538. **RICARDA M. (STYLIZED).** HOFMANN, RICARDA M., MULTIPLE CLASS, (INT. CLS. 18, 24 AND 25), (U.S. CLS. 1, 2, 3, 22, 39, 41, 42 AND 50). SN 79-014,487. PUB. 2-6-2007. FILED 5-23-2005.  
 3,233,546 ( *See Class 3 for this trademark.*)  
 3,233,557 ( *See Class 6 for this trademark.*)  
 3,233,558 ( *See Class 6 for this trademark.*)  
 3,233,562. **MACRON AND DESIGN.** MACRON S.P.A., MULTIPLE CLASS, (INT. CLS. 18, 25 AND 28), (U.S. CLS. 1, 2, 3, 22, 38, 39, 41 AND 50). SN 79-017,257. PUB. 2-6-2007. FILED 9-9-2005.  
 3,233,563. **MISCELLANEOUS DESIGN.** MACRON S.P.A., MULTIPLE CLASS, (INT. CLS. 18, 25 AND 28), (U.S. CLS. 1, 2, 3, 22, 23, 38, 39, 41 AND 50). SN 79-017,258. PUB. 2-6-2007. FILED 9-9-2005.  
 3,233,564 ( *See Class 14 for this trademark.*)  
 3,233,567 ( *See Class 14 for this trademark.*)  
 3,233,583. **EVER EON (STYLIZED).** LEE MIN KUNG, (U.S. CLS. 1, 2, 3, 22 AND 41). SN 79-018,359. PUB. 2-6-2007.



FILED 11-21-2005.  
 3,233,585. **MISCELLANEOUS DESIGN**. NYNKE FENNEMA, MULTIPLE CLASS, (INT. CLS. 18 AND 25), (U.S. CLS. 1, 2, 3, 22, 39 AND 41). SN 79-018,465. PUB. 2-6-2007. FILED 11-14-2005.  
 3,233,587. **ZEIS HOUSE (STYLIZED)**. ZEIS EXCELSA SPA, MULTIPLE CLASS, (INT. CLS. 18 AND 25), (U.S. CLS. 1, 2, 3, 22, 39 AND 41). SN 79-018,591. PUB. 2-6-2007. FILED 10-6-2005.  
 3,233,591 ( *See Class 3 for this trademark*).  
 3,233,634 ( *See Class 14 for this trademark*).  
 3,233,641 ( *See Class 9 for this trademark*).  
 3,233,645 ( *See Class 9 for this trademark*).  
 3,233,660. **MISCELLANEOUS DESIGN**. SKATEBOARD WORLD INDUSTRIES INC, MULTIPLE CLASS, (INT. CLS. 18, 25 AND 28), (U.S. CLS. 1, 2, 3, 22, 23, 38, 39, 41 AND 50). SN 79-021,599. PUB. 2-6-2007. FILED 9-9-2005.  
 3,233,677 ( *See Class 9 for this trademark*).  
 3,233,678. **DEHA (STYLIZED)**. MEETING GROUP S.P.A., MULTIPLE CLASS, (INT. CLS. 18 AND 25), (U.S. CLS. 1, 2, 3, 22, 39 AND 41). SN 79-022,485. PUB. 2-6-2007. FILED 6-21-2005.  
 3,233,712 ( *See Class 14 for this trademark*).  
 3,233,728 ( *See Class 14 for this trademark*).  
 3,233,744 ( *See Class 9 for this trademark*).

#### CLASS 19—NON-METALLIC BUILDING MATERIALS

3,232,215 ( *See Class 6 for this trademark*).  
 3,232,257. **JUMBO RESERVE (BLOCK FORM)**. GREEN RIVER LOG SALES LTD., (U.S. CLS. 1, 12, 33 AND 50). SN 76-662,426. PUB. 2-6-2007. FILED 6-30-2006.  
 3,232,258. **RESERVE CUT (BLOCK FORM)**. GREEN RIVER LOG SALES LTD., (U.S. CLS. 1, 12, 33 AND 50). SN 76-662,427. PUB. 2-6-2007. FILED 6-30-2006.  
 3,232,259. **PREMIUM RESERVE (BLOCK FORM)**. GREEN RIVER LOG SALES LTD., (U.S. CLS. 1, 12, 33 AND 50). SN 76-662,428. PUB. 2-6-2007. FILED 6-30-2006.  
 3,232,329 ( *See Class 7 for this trademark*).  
 3,232,354. **OPTIMUM SERIES (BLOCK FORM)**. COUNTY MATERIALS CORPORATION, (U.S. CLS. 1, 12, 33 AND 50). SN 78-404,678. PUB. 2-6-2007. FILED 4-20-2004.  
 3,232,420. **GENIUS SERIES (BLOCK FORM)**. PREVERCO INC., (U.S. CLS. 1, 12, 33 AND 50). SN 78-575,562. PUB. 2-6-2007. FILED 2-25-2005.  
 3,232,454. **BARMAC (BLOCK FORM)**. METSO MINERALS (MATAMATA) LIMITED, (U.S. CLS. 1, 12, 33 AND 50). SN 78-603,861. PUB. 10-31-2006. FILED 4-7-2005.  
 3,232,471. **SUN TUNNEL SKYLIGHTS (BLOCK FORM)**. VKR HOLDING A/S, (U.S. CLS. 1, 12, 33 AND 50). SN 78-623,244. PUB. 2-6-2007. FILED 5-4-2005.  
 3,232,494. **THE RUMP SIGN AND DESIGN**. ROGERS, DEBORAH M., (U.S. CLS. 1, 12, 33 AND 50). SN 78-647,781. PUB. 2-6-2007. FILED 6-10-2005.  
 3,232,529. **ISLAND QUARTZ (BLOCK FORM)**. BND PLASTERING, INC., (U.S. CLS. 1, 12, 33 AND 50). SN 78-677,894. PUB. 2-6-2007. FILED 7-25-2005.  
 3,232,589 ( *See Class 6 for this trademark*).  
 3,232,813. **HAKATAI (BLOCK FORM)**. HAKATAI ENTERPRISES, INC., MULTIPLE CLASS, (INT. CLS. 19 AND 42), (U.S. CLS. 1, 12, 33, 50, 100 AND 101). SN 78-809,399. PUB. 2-6-2007. FILED 2-7-2006.  
 3,232,865. **SAFETCORK (BLOCK FORM)**. ROPPE CORPORATION, (U.S. CLS. 1, 12, 33 AND 50). SN 78-834,378. PUB. 2-6-2007. FILED 3-10-2006.  
 3,233,405. **SOPHIASTONE (BLOCK FORM)**. JUN PACIFIC LLC, AND JUN CORPORATION, INC., (U.S. CLS. 1, 12, 33 AND 50). SN 78-917,753. PUB. 2-6-2007. FILED 6-27-2006.  
 3,233,476. **SYSSCRIBE (BLOCK FORM)**. GULF COAST GLASS & ERECTION CO., (U.S. CLS. 1, 12, 33 AND 50). SN 78-923,919. PUB. 2-6-2007. FILED 7-6-2006.  
 3,233,541 ( *See Class 1 for this trademark*).  
 3,233,548 ( *See Class 6 for this trademark*).  
 3,233,593 ( *See Class 6 for this trademark*).  
 3,233,617 ( *See Class 6 for this trademark*).

3,233,665. **ALIEX (STYLIZED)**. SHANGHAI FORTUNE CERAMIC CO., LTD., (U.S. CLS. 1, 12, 33 AND 50). SN 79-021,989. PUB. 2-6-2007. FILED 10-13-2005.  
 3,233,715 ( *See Class 17 for this trademark*).  
 3,233,718. **ICEBOX (BLOCK FORM)**. AST EIS- UND SOLAR-TECHNIK; GMBH & CO KG, (U.S. CLS. 1, 12, 33 AND 50). SN 79-024,734. PUB. 2-6-2007. FILED 12-19-2005.

#### CLASS 20—FURNITURE AND ARTICLES NOT OTHERWISE CLASSIFIED

3,232,141. **MINI-DAM (BLOCK FORM)**. THE ELDRD CORPORATION, DBA FOL-DA-TANK COMPANY, (U.S. CLS. 2, 13, 22, 25, 32 AND 50). SN 76-647,035. PUB. 2-6-2007. FILED 9-15-2005.  
 3,232,165. **KCARE (BLOCK FORM)**. KIU HUNG INDUSTRIES LTD., MULTIPLE CLASS, (INT. CLS. 20 AND 28), (U.S. CLS. 2, 13, 22, 23, 25, 32, 38 AND 50). SN 76-650,267. PUB. 2-6-2007. FILED 11-14-2005.  
 3,232,192. **CLOSED CORNER CASUALS BY PLATTE RIVER ART SERVICES AND DESIGN**. PLATTE RIVER ART SERVICES, INC., (U.S. CLS. 2, 13, 22, 25, 32 AND 50). SN 76-653,396. PUB. 2-6-2007. FILED 1-17-2006.  
 3,232,232. **EVERGREEN (BLOCK FORM)**. LAIDLAW COMPANY LLC, (U.S. CLS. 2, 13, 22, 25, 32 AND 50). SN 76-661,617. PUB. 2-6-2007. FILED 6-15-2006.  
 3,232,273. **EVERGREEN AND DESIGN**. LAIDLAW COMPANY LLC, (U.S. CLS. 2, 13, 22, 25, 32 AND 50). SN 76-664,595. PUB. 2-6-2007. FILED 8-14-2006.  
 3,232,306. **SLEEPSATIONS (BLOCK FORM)**. LOUISVILLE BEDDING COMPANY, (U.S. CLS. 2, 13, 22, 25, 32 AND 50). SN 77-028,024. PUB. 2-6-2007. FILED 10-24-2006.  
 3,232,318. **GAMMA ARREDAMENTI AND DESIGN**. GAMMA ARREDAMENTI INTERNATIONAL S.P.A., (U.S. CLS. 2, 13, 22, 25, 32 AND 50). SN 78-090,175. PUB. 2-6-2007. FILED 10-25-2001.  
 3,232,443. **NO CLUTTER SIMPLY ORGANIZED LLC WE'LL GIVE YOU YOUR SPACE AND DESIGN**. O'CONNOR, MICHAEL, (U.S. CLS. 2, 13, 22, 25, 32 AND 50). SN 78-594,338. PUB. 10-31-2006. FILED 3-24-2005.  
 3,232,543. **NOMITE (BLOCK FORM)**. VERBAND DER EUROPAISCHEN BETTFEDERN- UND BETTWARENINDUSTRIE E.V., MULTIPLE CLASS, (INT. CLS. 20 AND 24), (U.S. CLS. 2, 13, 22, 25, 32, 42 AND 50). SN 78-685,801. PUB. 2-6-2007. FILED 8-4-2005.  
 3,232,788. **PRIVATE RETREAT (BLOCK FORM)**. AMBELLA HOME COLLECTION, INC., (U.S. CLS. 2, 13, 22, 25, 32 AND 50). SN 78-792,063. PUB. 2-6-2007. FILED 1-15-2006.  
 3,232,789. **NATURESOURCE (BLOCK FORM)**. MEADWESTVACO CORPORATION, (U.S. CLS. 2, 13, 22, 25, 32 AND 50). SN 78-792,682. PUB. 2-6-2007. FILED 1-17-2006.  
 3,232,838. **ALLERGYKIDS (BLOCK FORM)**. ALLERGY KIDS LLC, (U.S. CLS. 2, 13, 22, 25, 32 AND 50). SN 78-819,953. PUB. 10-24-2006. FILED 2-21-2006.  
 3,232,860. **KATTBANK (BLOCK FORM)**. TRAVIS LEE WEEDMAN, (U.S. CLS. 2, 13, 22, 25, 32 AND 50). SN 78-832,711. PUB. 2-6-2007. FILED 3-8-2006.  
 3,232,864 ( *See Class 6 for this trademark*).  
 3,232,872 ( *See Class 11 for this trademark*).  
 3,233,076. **HAMILTON SORTER (BLOCK FORM)**. WORKSTREAM, INC., (U.S. CLS. 2, 13, 22, 25, 32 AND 50). SN 78-897,061. PUB. 2-6-2007. FILED 5-31-2006.  
 3,233,451. **POWER PLUS IGNITOR (BLOCK FORM)**. POWER PLUS IGNITOR, LLC, (U.S. CLS. 2, 13, 22, 25, 32 AND 50). SN 78-919,744. PUB. 2-6-2007. FILED 6-29-2006.  
 3,233,520 ( *See Class 1 for this trademark*).  
 3,233,534 ( *See Class 7 for this trademark*).  
 3,233,617 ( *See Class 6 for this trademark*).  
 3,233,642 ( *See Class 6 for this trademark*).  
 3,233,644 ( *See Class 6 for this trademark*).  
 3,233,656 ( *See Class 11 for this trademark*).  
 3,233,680. **CYRUS COMPANY (BLOCK FORM)**. CYRUS COMPANY S.R.L., (U.S. CLS. 2, 13, 22, 25, 32 AND 50). SN 79-022,599. PUB. 2-6-2007. FILED 1-13-2006.  
 3,233,693. **LA MAISON DE LA LITERIE AND DESIGN**. MDL FRANCE, MULTIPLE CLASS, (INT. CLS. 20, 22 AND 24),

(U.S. CLS. 1, 2, 7, 13, 19, 22, 25, 32, 42 AND 50). SN 79-023,237. PUB. 2-6-2007. FILED 2-2-2006.  
 3,233,734 ( *See Class 17 for this trademark*).  
 3,233,751 ( *See Class 9 for this trademark*).  
 3,233,752. **BAPILLOVE (BLOCK FORM)**. BEAUTY ZONE, MULTIPLE CLASS, (INT. CLS. 20, 24 AND 28), (U.S. CLS. 2, 13, 22, 23, 25, 32, 38, 42 AND 50). SN 79-027,751. PUB. 2-6-2007. FILED 5-29-2006.

---

### CLASS 21—HOUSEWARES AND GLASS

3,232,076 ( *See Class 7 for this trademark*).  
 3,232,104. **SCENTSATIONAL (BLOCK FORM)**. SCENTSATIONAL TECHNOLOGIES, (U.S. CLS. 2, 13, 23, 29, 30, 33, 40 AND 50). SN 76-618,722. PUB. 2-6-2007. FILED 10-28-2004.  
 3,232,156. **SOUTHERN BLOOMER MFG. CO. AND DESIGN**. SOUTHERN BLOOMER, MFG. CO., MULTIPLE CLASS, (INT. CLS. 21 AND 25), (U.S. CLS. 2, 13, 22, 23, 29, 30, 33, 39, 40 AND 50). SN 76-649,055. PUB. 2-6-2007. FILED 10-24-2005.  
 3,232,244. **TUFF-BLOCK (BLOCK FORM)**. THE MALISH CORPORATION, (U.S. CLS. 2, 13, 23, 29, 30, 33, 40 AND 50). SN 76-661,844. PUB. 2-6-2007. FILED 6-19-2006.  
 3,232,267. **REMOVE THE LINE, YOUR BROOM LEAVES BEHIND (BLOCK FORM)**. SCOTT FETZER COMPANY, THE, (U.S. CLS. 2, 13, 23, 29, 30, 33, 40 AND 50). SN 76-663,129. PUB. 2-6-2007. FILED 7-17-2006.  
 3,232,465. **TUFFBOX (BLOCK FORM)**. KILLGERM GROUP LIMITED, (U.S. CLS. 2, 13, 23, 29, 30, 33, 40 AND 50). SN 78-617,165. PUB. 5-9-2006. FILED 4-26-2005.  
 3,232,560. **MISCELLANEOUS DESIGN**. BUSINESS SERVICES CORPORATION, MULTIPLE CLASS, (INT. CLS. 21, 25 AND 41), (U.S. CLS. 2, 13, 22, 23, 29, 30, 33, 39, 40, 50, 100, 101 AND 107). SN 78-698,040. PUB. 2-6-2007. FILED 8-23-2005.  
 3,232,703. **MISCELLANEOUS DESIGN**. GIANTMICROBES, INC., (U.S. CLS. 2, 13, 23, 29, 30, 33, 40 AND 50). SN 78-753,749. PUB. 2-6-2007. FILED 11-14-2005.  
 3,232,718. **TOSTOBUENO THE ULTIMATE TOSTONERA AND DESIGN**. AND WHY NOT US, (U.S. CLS. 2, 13, 23, 29, 30, 33, 40 AND 50). SN 78-758,404. PUB. 2-6-2007. FILED 11-21-2005.  
 3,232,913. **ROYAL PRESTIGE AND DESIGN**. HY CITE CORPORATION, (U.S. CLS. 2, 13, 23, 29, 30, 33, 40 AND 50). SN 78-853,905. PUB. 2-6-2007. FILED 4-4-2006.  
 3,232,945. **HYDRASTORM HYDRATION SYSTEMS AND DESIGN**. BLACKHAWK INDUSTRIES PRODUCT GROUP UNLIMITED LLC, (U.S. CLS. 2, 13, 23, 29, 30, 33, 40 AND 50). SN 78-864,471. PUB. 2-6-2007. FILED 4-19-2006.  
 3,233,132. **BAKER'S SECRET (BLOCK FORM)**. WORLD KITCHEN, LLC, (U.S. CLS. 2, 13, 23, 29, 30, 33, 40 AND 50). SN 78-906,625. PUB. 2-6-2007. FILED 6-13-2006.  
 3,233,305. **SCRUBBIEZ (BLOCK FORM)**. SKF GLOBAL, INC., (U.S. CLS. 2, 13, 23, 29, 30, 33, 40 AND 50). SN 78-914,896. PUB. 2-6-2007. FILED 6-22-2006.  
 3,233,349. **SUNNY PATCH (BLOCK FORM)**. CALLAWAY ARTS AND ENTERTAINMENT, (U.S. CLS. 2, 13, 23, 29, 30, 33, 40 AND 50). SN 78-916,079. PUB. 2-6-2007. FILED 6-23-2006.  
 3,233,520 ( *See Class 1 for this trademark*).  
 3,233,524. **W (STYLIZED)**. GUANGDONG WEIYE CERAMICS INDUSTRIAL CO., LTD., (U.S. CLS. 2, 13, 23, 29, 30, 33, 40 AND 50). SN 79-010,091. PUB. 2-6-2007. FILED 10-22-2004.  
 3,233,536 ( *See Class 9 for this trademark*).  
 3,233,546 ( *See Class 3 for this trademark*).  
 3,233,554 ( *See Class 8 for this trademark*).  
 3,233,601. **CERAMICPLUS VILLEROY & BOCH AND DESIGN**. VILLEROY & BOCH AG, (U.S. CLS. 2, 13, 23, 29, 30, 33, 40 AND 50). SN 79-019,455. PUB. 2-6-2007. FILED 8-26-2005.  
 3,233,625. **LITTERSHARK (BLOCK FORM)**. BRÜCO SWISS AG, MULTIPLE CLASS, (INT. CLS. 21 AND 35), (U.S. CLS. 2, 13, 23, 29, 30, 33, 40, 50, 100, 101 AND 102). SN 79-020,390. PUB. 2-6-2007. FILED 1-4-2006.  
 3,233,637. **POHRI RO (STYLIZED)**. S.D.R. BIOTEC; VERFAHRENSTECHNIK GMBH, MULTIPLE CLASS, (INT. CLS. 21 AND 23), (U.S. CLS. 2, 13, 23, 29, 30, 33, 40, 43 AND

50). SN 79-020,757. PUB. 2-6-2007. FILED 7-1-2005.  
 3,233,677 ( *See Class 9 for this trademark*).  
 3,233,737 ( *See Class 3 for this trademark*).  
 3,233,751 ( *See Class 9 for this trademark*).

---

### CLASS 22—CORDAGE AND FIBERS

3,232,497 ( *See Class 12 for this trademark*).  
 3,233,593 ( *See Class 6 for this trademark*).  
 3,233,693 ( *See Class 20 for this trademark*).

---

### CLASS 23—YARNS AND THREADS

3,233,514 ( *See Class 9 for this trademark*).  
 3,233,615. **Q QUINTESSANCE (STYLIZED)**. EMILCOTONI S.P.A., MULTIPLE CLASS, (INT. CLS. 23 AND 24), (U.S. CLS. 42, 43 AND 50). SN 79-019,939. PUB. 2-6-2007. FILED 10-28-2005.  
 3,233,637 ( *See Class 21 for this trademark*).

---

### CLASS 24—FABRICS

3,232,162. **OUR FABRICS ARE NEVER DISCONTINUED (BLOCK FORM)**. C.O.M. CUSTOM, LLC, (U.S. CLS. 42 AND 50). SN 76-649,962. PUB. 2-6-2007. FILED 11-8-2005.  
 3,232,178. **THE PANTHER PITT AND DESIGN**. UNIVERSITY OF PITTSBURGH - OF THE COMMONWEALTH SYSTEM OF HIGHER EDUCATION, (U.S. CLS. 42 AND 50). SN 76-651,313. PUB. 2-6-2007. FILED 12-5-2005.  
 3,232,375 ( *See Class 3 for this trademark*).  
 3,232,485. **COLLEGIATE PACIFIC (BLOCK FORM)**. WOOL FELT PRODUCTS, INC., MULTIPLE CLASS, (INT. CLS. 24 AND 40), (U.S. CLS. 42, 50, 100, 103 AND 106). SN 78-633,699. PUB. 2-6-2007. FILED 5-20-2005.  
 3,232,543 ( *See Class 20 for this trademark*).  
 3,232,642. **ROLLEE POLLEE (BLOCK FORM)**. REEVES, BRIAN, (U.S. CLS. 42 AND 50). SN 78-742,931. PUB. 2-6-2007. FILED 10-28-2005.  
 3,232,649. **UTAX CO., LTD. (BLOCK FORM)**. UTAX CO., LTD., MULTIPLE CLASS, (INT. CLS. 24 AND 26), (U.S. CLS. 37, 39, 40, 42 AND 50). SN 78-744,293. PUB. 2-6-2007. FILED 11-1-2005.  
 3,232,918. **EMILY GREEN A BRAND OF IMAGINATION (BLOCK FORM)**. GREEN, EMILY, (U.S. CLS. 42 AND 50). SN 78-855,931. PUB. 2-6-2007. FILED 4-6-2006.  
 3,233,219. **SPLASH GUARD (BLOCK FORM)**. KENNEDY INTERNATIONAL INC., (U.S. CLS. 42 AND 50). SN 78-911,663. PUB. 2-6-2007. FILED 6-19-2006.  
 3,233,298. **LL LINENS LIMITED (STYLIZED)**. LINENS LIMITED, LLC, (U.S. CLS. 42 AND 50). SN 78-914,691. PUB. 2-6-2007. FILED 6-22-2006.  
 3,233,479. **KISSY KISSY PREMIER (BLOCK FORM)**. TATIANA AND COMPANY, INC., MULTIPLE CLASS, (INT. CLS. 24 AND 25), (U.S. CLS. 22, 39, 42 AND 50). SN 78-924,324. PUB. 2-6-2007. FILED 7-7-2006.  
 3,233,517. **GABEL (BLOCK FORM)**. GABEL INDUSTRIA TESSILE S.P.A., (U.S. CLS. 42 AND 50). SN 79-001,888. PUB. 2-6-2007. FILED 2-25-2004.  
 3,233,520 ( *See Class 1 for this trademark*).  
 3,233,538 ( *See Class 18 for this trademark*).  
 3,233,586. **YINGZIDA AND DESIGN**. TAIZHOU YINGZIDA PLASTICS INDUSTRY CO., LTD, (U.S. CLS. 42 AND 50). SN 79-018,525. PUB. 2-6-2007. FILED 9-20-2005.  
 3,233,615 ( *See Class 23 for this trademark*).  
 3,233,618. **ANTICO COTONIFICIO VENEZIANO AND DESIGN**. OPERA S.R.L., (U.S. CLS. 42 AND 50). SN 79-020,176. PUB. 2-6-2007. FILED 11-3-2005.  
 3,233,676. **MENDALE SINCE 1956 (STYLIZED)**. MENDALE HOUSEHOLD TEXTILES CO., LTD, (U.S. CLS. 42 AND 50). SN 79-022,340. PUB. 2-6-2007. FILED 10-27-2005.  
 3,233,677 ( *See Class 9 for this trademark*).

3,233,693 ( *See Class 20 for this trademark.* )  
 3,233,706. **NINA LISA CORTI HOME TEXTILE EMPORIUM BAMBINO BAMBINA AND DESIGN.** SANTINI ANNA LUISA, MULTIPLE CLASS, (INT. CLS. 24 AND 25), (U.S. CLS. 22, 39, 42 AND 50). SN 79-023,854. PUB. 2-6-2007. FILED 8-24-2005.  
 3,233,713. **UNIWAX (STYLIZED).** VLISCO B.V., (U.S. CLS. 42 AND 50). SN 79-024,373. PUB. 2-6-2007. FILED 1-31-2006.  
 3,233,752 ( *See Class 20 for this trademark.* )

## CLASS 25—CLOTHING

3,232,057. **JESUS.** BASIC TRADEMARK S.A., (U.S. CLS. 22 AND 39). SN 75-866,210. PUB. 9-27-2005. FILED 12-7-1999.  
 3,232,059. **ASHLEY BY 26 INTERNATIONAL U.S.A. AND DESIGN.** 26 INTERNATIONAL, INC., (U.S. CLS. 22 AND 39). SN 75-936,684. PUB. 2-6-2007. FILED 3-4-2000.  
 3,232,060 ( *See Class 6 for this trademark.* )  
 3,232,064. **0001961 COSMONAUT AND DESIGN.** THE COSMONAUT CORP., (U.S. CLS. 22 AND 39). SN 76-245,497. PUB. 2-15-2005. FILED 4-23-2001.  
 3,232,074 ( *See Class 16 for this trademark.* )  
 3,232,077. **YA-YA.** YA-YA BRAND INCORPORATED, (U.S. CLS. 22 AND 39). SN 76-481,132. PUB. 2-6-2007. FILED 1-9-2003.  
 3,232,103 ( *See Class 18 for this trademark.* )  
 3,232,106. **CONCEPTS CONRAD C (BLOCK FORM).** COLLECTION CONRAD C INC., (U.S. CLS. 22 AND 39). SN 76-621,312. PUB. 2-6-2007. FILED 11-18-2004.  
 3,232,122. **LUXE LIFESTYLE WEAR FOR YOGA AND BEYOND (BLOCK FORM).** TRANQUIL SPACE, LLC, (U.S. CLS. 22 AND 39). SN 76-635,872. PUB. 2-6-2007. FILED 4-8-2005.  
 3,232,156 ( *See Class 21 for this trademark.* )  
 3,232,161. **MIBOY (BLOCK FORM).** MIBOY, INC., (U.S. CLS. 22 AND 39). SN 76-649,811. PUB. 2-6-2007. FILED 11-4-2005.  
 3,232,189. **JAPAN LITE-NING (BLOCK FORM).** ASICS CORPORATION, (U.S. CLS. 22 AND 39). SN 76-653,008. PUB. 2-6-2007. FILED 1-6-2006.  
 3,232,193. **MI BOY AND DESIGN.** MIBOY, INC., (U.S. CLS. 22 AND 39). SN 76-653,404. PUB. 2-6-2007. FILED 1-11-2006.  
 3,232,220. **HH HILTON HOLLIS (STYLIZED).** HILTON HOLLIS DESIGNS, INC., (U.S. CLS. 22 AND 39). SN 76-661,058. PUB. 2-6-2007. FILED 6-5-2006.  
 3,232,233. **PROPHET (BLOCK FORM).** PARTS INTERNATIONAL INC., (U.S. CLS. 22 AND 39). SN 76-661,667. PUB. 2-6-2007. FILED 6-15-2006.  
 3,232,285. **THE BRICKYARD (BLOCK FORM).** BRICKYARD TRADEMARKS, INC., (U.S. CLS. 22 AND 39). SN 77-002,631. PUB. 2-6-2007. FILED 9-19-2006.  
 3,232,319. **I LOVE ALPACA.COM AND DESIGN.** MERELINDA FARMS L.L.C., DBA ALPACA.COM L.L.C., (U.S. CLS. 22 AND 39). SN 78-094,226. PUB. 2-11-2003. FILED 11-20-2001.  
 3,232,335 ( *See Class 9 for this trademark.* )  
 3,232,383 ( *See Class 9 for this trademark.* )  
 3,232,397. **FAVEUR (BLOCK FORM).** FAVEUR, INC., (U.S. CLS. 22 AND 39). SN 78-551,920. PUB. 2-6-2007. FILED 1-21-2005.  
 3,232,425. **NINO DANIELI (BLOCK FORM).** F.LLI CLAUDIO & CARLALBERTO CORNELIANI SPA, (U.S. CLS. 22 AND 39). SN 78-580,399. PUB. 10-31-2006. FILED 3-4-2005.  
 3,232,428. **YAMATO TOKOROTANI AND DESIGN.** YAMATO CO., LTD., (U.S. CLS. 22 AND 39). SN 78-583,075. PUB. 8-8-2006. FILED 3-8-2005.  
 3,232,437. **THE SHAVE EST. 2005 AND DESIGN.** THE SHAVE, INC., MULTIPLE CLASS, (INT. CLS. 25, 35 AND 44), (U.S. CLS. 22, 39, 100, 101 AND 102). SN 78-593,186. PUB. 2-6-2007. FILED 3-23-2005.  
 3,232,441. **CALIFORNIA COSTUME COLLECTIONS, INC. AND DESIGN.** CALIFORNIA COSTUME COLLECTIONS, INC., MULTIPLE CLASS, (INT. CLS. 25 AND 26), (U.S. CLS. 22, 37, 39, 40, 42 AND 50). SN 78-593,527. PUB. 2-6-2007. FILED 3-23-2005.  
 3,232,445. **ALL FOR ONE. ONE FOR ALL (BLOCK FORM).** CAVALIERS OPERATING COMPANY, LLC, (U.S. CLS. 22 AND 39). SN 78-597,158. PUB. 2-6-2007. FILED 3-29-2005.  
 3,232,460. **H1 (BLOCK FORM).** GENERAL MOTORS CORPORATION, (U.S. CLS. 22 AND 39). SN 78-612,682. PUB. 2-6-2007. FILED 4-20-2005.  
 3,232,499. **HEAD GONE (BLOCK FORM).** ANDREW, SINCLAIR M., (U.S. CLS. 22 AND 39). SN 78-650,806. PUB. 3-28-2006. FILED 6-15-2005.  
 3,232,520 ( *See Class 9 for this trademark.* )  
 3,232,539. **ALL AXCES (STYLIZED).** ALL AXCES, LLC., (U.S. CLS. 22 AND 39). SN 78-684,572. PUB. 10-24-2006. FILED 8-3-2005.  
 3,232,552. **TWISTED FIBER (BLOCK FORM).** TWISTED FIBER, INC., (U.S. CLS. 22 AND 39). SN 78-693,839. PUB. 2-6-2007. FILED 8-16-2005.  
 3,232,560 ( *See Class 21 for this trademark.* )  
 3,232,569. **B (STYLIZED).** RYLEN, INC., (U.S. CLS. 22 AND 39). SN 78-710,446. PUB. 2-6-2007. FILED 9-9-2005.  
 3,232,573. **RENÉE OF HOLLYWOOD SINCE 1934 AND DESIGN.** ROBERTS, ELIOT, (U.S. CLS. 22 AND 39). SN 78-712,397. PUB. 2-6-2007. FILED 9-14-2005.  
 3,232,575 ( *See Class 18 for this trademark.* )  
 3,232,588. **DELAWARE STATE UNIVERSITY (BLOCK FORM).** DELAWARE STATE UNIVERSITY, (U.S. CLS. 22 AND 39). SN 78-723,268. PUB. 2-6-2007. FILED 9-29-2005.  
 3,232,628. **WEST COAST CHOPPERS AND DESIGN.** VANILLA GORILLA, L.P., (U.S. CLS. 22 AND 39). SN 78-738,736. PUB. 2-6-2007. FILED 10-23-2005.  
 3,232,658. **ROWDY REPTILES (BLOCK FORM).** UNIVERSITY ATHLETIC ASSOCIATION, (U.S. CLS. 22 AND 39). SN 78-745,415. PUB. 2-6-2007. FILED 11-2-2005.  
 3,232,686. **SODA CLUB (BLOCK FORM).** PELLE PELLE INC., (U.S. CLS. 22 AND 39). SN 78-751,118. PUB. 2-6-2007. FILED 11-10-2005.  
 3,232,732. **GATOR VISION (BLOCK FORM).** UNIVERSITY ATHLETIC ASSOCIATION INC, MULTIPLE CLASS, (INT. CLS. 25 AND 41), (U.S. CLS. 22, 39, 100, 101 AND 107). SN 78-763,863. PUB. 2-6-2007. FILED 11-30-2005.  
 3,232,757. **FEAR THE ROO AND DESIGN.** THE UNIVERSITY OF AKRON, MULTIPLE CLASS, (INT. CLS. 25 AND 41), (U.S. CLS. 22, 39, 100, 101 AND 107). SN 78-774,435. PUB. 2-6-2007. FILED 12-15-2005.  
 3,232,759 ( *See Class 18 for this trademark.* )  
 3,232,805 ( *See Class 18 for this trademark.* )  
 3,232,824. **TOTORA SURFBOARDS (STYLIZED).** TOTORA SURFBOARDS, INC., MULTIPLE CLASS, (INT. CLS. 25 AND 28), (U.S. CLS. 22, 23, 38, 39 AND 50). SN 78-812,370. PUB. 2-6-2007. FILED 2-10-2006.  
 3,232,834. **MISCELLANEOUS DESIGN.** URBAN, KEITH, (U.S. CLS. 22 AND 39). SN 78-816,609. PUB. 2-6-2007. FILED 2-16-2006.  
 3,232,839. **COIN LAUNDRY (BLOCK FORM).** ESTEPHANIAN, MARK, AND COHEN, MICHAEL, (U.S. CLS. 22 AND 39). SN 78-820,135. PUB. 2-6-2007. FILED 2-21-2006.  
 3,232,856. **USA JUDO AND DESIGN.** UNITED STATES JUDO, INC., MULTIPLE CLASS, (INT. CLS. 25, 35 AND 41), (U.S. CLS. 22, 39, 100, 101, 102 AND 107). SN 78-829,790. PUB. 10-17-2006. FILED 3-6-2006.  
 3,232,890 ( *See Class 18 for this trademark.* )  
 3,232,892. **PRO DIVA SPORTS (BLOCK FORM).** RECTOR, STEPHANIE, (U.S. CLS. 22 AND 39). SN 78-843,174. PUB. 2-6-2007. FILED 3-22-2006.  
 3,232,894 ( *See Class 9 for this trademark.* )  
 3,232,907 ( *See Class 9 for this trademark.* )  
 3,232,908 ( *See Class 9 for this trademark.* )  
 3,232,938. **R ROTHCO AND DESIGN.** MORRIS ROTHENBERG & SON, INC., (U.S. CLS. 22 AND 39). SN 78-861,741. PUB. 2-6-2007. FILED 4-14-2006.  
 3,232,940. **ERIN FETHERSTON (STYLIZED).** FETHERSTON DESIGN GROUP, THE, (U.S. CLS. 22 AND 39). SN 78-862,191. PUB. 2-6-2007. FILED 4-14-2006.  
 3,233,081. **Ä AH NEE MÄHL (STYLIZED).** SALARTI ENTERPRISES, INC., (U.S. CLS. 22 AND 39). SN 78-898,986. PUB. 2-6-2007. FILED 6-2-2006.  
 3,233,082 ( *See Class 6 for this trademark.* )  
 3,233,158. **ELIZA HUGH (BLOCK FORM).** ROETMAN, BARBARA, AND ROETMAN, EDWARD, (U.S. CLS. 22 AND 39). SN 78-908,596. PUB. 2-6-2007. FILED 6-14-2006.  
 3,233,169. **BOTTLECAPPS (STYLIZED).** J & S KIDSWEAR,

INC., (U.S. CLS. 22 AND 39), SN 78-909,089. PUB. 2-6-2007. FILED 6-15-2006.

3,233,177. **STEPS (STYLIZED)**. STEPS DELAWARE LIMITED, (U.S. CLS. 22 AND 39), SN 78-909,504. PUB. 2-6-2007. FILED 6-15-2006.

3,233,178. **SAM'S TOWN 400 TEXAS MOTOR SPEEDWAY AND DESIGN**. BOYD GAMING CORPORATION, (U.S. CLS. 22 AND 39), SN 78-909,529. PUB. 2-6-2007. FILED 6-15-2006.

3,233,203. **STEPS NEW YORK (STYLIZED)**. STEPS DELAWARE LIMITED, (U.S. CLS. 22 AND 39), SN 78-910,583. PUB. 2-6-2007. FILED 6-16-2006.

3,233,236. **IBS (BLOCK FORM)**. IBS, INC., (U.S. CLS. 22 AND 39), SN 78-912,380. PUB. 2-6-2007. FILED 6-20-2006.

3,233,310. **APOLIS (BLOCK FORM)**. APOLIS HOLDINGS, LLC, (U.S. CLS. 22 AND 39), SN 78-915,043. PUB. 2-6-2007. FILED 6-22-2006.

3,233,352. **DULCENEA LINGERIE (BLOCK FORM)**. DULCENEA, INC., (U.S. CLS. 22 AND 39), SN 78-916,247. PUB. 2-6-2007. FILED 6-24-2006.

3,233,449. **FLAT SAM (BLOCK FORM)**. E STREET DENIM CO., (U.S. CLS. 22 AND 39), SN 78-919,568. PUB. 2-6-2007. FILED 6-29-2006.

3,233,459. **BRAJA (BLOCK FORM)**. SILVER IMPRESSIONS, INC., (U.S. CLS. 22 AND 39), SN 78-920,836. PUB. 2-6-2007. FILED 6-30-2006.

3,233,462. **CALYPSO JOE (BLOCK FORM)**. DOUGLAS A. MARCHISELLO TRUST, COMPRISING DOUGLAS A. MARCHISELLO, A US CITIZEN, (U.S. CLS. 22 AND 39), SN 78-921,608. PUB. 2-6-2007. FILED 7-1-2006.

3,233,478. **TWIGS (BLOCK FORM)**. RUSSELL-NEWMAN, LTD., (U.S. CLS. 22 AND 39), SN 78-924,307. PUB. 2-6-2007. FILED 7-7-2006.

3,233,479 ( *See Class 24 for this trademark*).

3,233,490. **SPYDER VENOM (BLOCK FORM)**. SPYDER ACTIVE SPORTS, INC., (U.S. CLS. 22 AND 39), SN 78-934,934. PUB. 2-6-2007. FILED 7-21-2006.

3,233,502. **HOUSE33 (BLOCK FORM)**. BRAND DESIGN COMPANY, INC., DBA HOUSE INDUSTRIES, (U.S. CLS. 22 AND 39), SN 78-952,918. PUB. 2-6-2007. FILED 8-15-2006.

3,233,503. **DHARMA AND DESIGN**. DISNEY ENTERPRISES, INC., (U.S. CLS. 22 AND 39), SN 78-957,939. PUB. 2-6-2007. FILED 8-22-2006.

3,233,513. **SCHOONER (BLOCK FORM)**. NAUTICA APPAREL, INC., (U.S. CLS. 22 AND 39), SN 78-974,601. PUB. 2-6-2007. FILED 9-14-2006.

3,233,514 ( *See Class 9 for this trademark*).

3,233,519. **(C)STUDIO (STYLIZED)**. CINELLISTUDIO S.R.L., (U.S. CLS. 22 AND 39), SN 79-002,835. PUB. 2-6-2007. FILED 3-4-2004.

3,233,520 ( *See Class 1 for this trademark*).

3,233,523 ( *See Class 3 for this trademark*).

3,233,528. **WITH LOVE MARILYN MOORE (BLOCK FORM)**. MARILYN ROSE HAZEL MOORE, (U.S. CLS. 22 AND 39), SN 79-012,223. PUB. 2-6-2007. FILED 6-2-2005.

3,233,538 ( *See Class 18 for this trademark*).

3,233,540. **ICHO (STYLIZED)**. KING GLORY CO, LTD., (U.S. CLS. 22 AND 39), SN 79-014,729. PUB. 2-6-2007. FILED 6-13-2005.

3,233,546 ( *See Class 3 for this trademark*).

3,233,557 ( *See Class 6 for this trademark*).

3,233,558 ( *See Class 6 for this trademark*).

3,233,562 ( *See Class 18 for this trademark*).

3,233,563 ( *See Class 18 for this trademark*).

3,233,567 ( *See Class 14 for this trademark*).

3,233,585 ( *See Class 18 for this trademark*).

3,233,587 ( *See Class 18 for this trademark*).

3,233,591 ( *See Class 3 for this trademark*).

3,233,599 ( *See Class 12 for this trademark*).

3,233,602. **WOLSEY AND DESIGN**. WOLSEY LIMITED, (U.S. CLS. 22 AND 39), SN 79-019,466. PUB. 2-6-2007. FILED 12-6-2005.

3,233,603. **MISCELLANEOUS DESIGN**. WOLSEY LIMITED, (U.S. CLS. 22 AND 39), SN 79-019,468. PUB. 2-6-2007. FILED 12-6-2005.

3,233,609. **MISCELLANEOUS DESIGN**. ANDREW JAMES HOSIE, MULTIPLE CLASS, (INT. CLS. 25, 28 AND 41), (U.S. CLS. 22, 23, 38, 39, 50, 100, 101 AND 107), SN 79-019,634.

PUB. 2-6-2007. FILED 11-4-2005.

3,233,627. **EVOLAIR (BLOCK FORM)**. MELLUSO DI BENIAMINO MELLUSO; E C. S.A.S., (U.S. CLS. 22 AND 39), SN 79-020,465. PUB. 2-6-2007. FILED 11-3-2005.

3,233,633 ( *See Class 14 for this trademark*).

3,233,641 ( *See Class 9 for this trademark*).

3,233,645 ( *See Class 9 for this trademark*).

3,233,660 ( *See Class 18 for this trademark*).

3,233,677 ( *See Class 9 for this trademark*).

3,233,678 ( *See Class 18 for this trademark*).

3,233,683. **BABY GRAZIELLA (STYLIZED)**. BABY GRAZIELLA SRL, (U.S. CLS. 22 AND 39), SN 79-022,780. PUB. 2-6-2007. FILED 1-16-2006.

3,233,689 ( *See Class 9 for this trademark*).

3,233,706 ( *See Class 24 for this trademark*).

3,233,708. **TOPBI (STYLIZED)**. FUJIAN E&D GROUP., LTD., (U.S. CLS. 22 AND 39), SN 79-024,051. PUB. 2-6-2007. FILED 2-21-2006.

3,233,728 ( *See Class 14 for this trademark*).

3,233,729. **Q&X (STYLIZED)**. Q&X LTD., (U.S. CLS. 22 AND 39), SN 79-025,282. PUB. 2-6-2007. FILED 2-25-2006.

---

### CLASS 26—FANCY GOODS

3,232,056. **LOS ANGELES POLICE AND DESIGN**. CITY OF LOS ANGELES, (U.S. CLS. 37, 39, 40, 42 AND 50), SN 75-829,848. PUB. 2-6-2007. FILED 10-22-1999.

3,232,441 ( *See Class 25 for this trademark*).

3,232,649 ( *See Class 24 for this trademark*).

3,233,514 ( *See Class 9 for this trademark*).

3,233,520 ( *See Class 1 for this trademark*).

3,233,557 ( *See Class 6 for this trademark*).

3,233,558 ( *See Class 6 for this trademark*).

---

### CLASS 27—FLOOR COVERINGS

3,232,163. **C O M AND DESIGN**. C.O.M. CUSTOM, LLC, (U.S. CLS. 19, 20, 37, 42 AND 50), SN 76-649,963. PUB. 2-6-2007. FILED 11-8-2005.

3,232,731. **FIELDTURF (STYLIZED)**. FIELDTURF TARKETT INC., MULTIPLE CLASS, (INT. CLS. 27 AND 37), (U.S. CLS. 19, 20, 37, 42, 50, 100, 103 AND 106), SN 78-763,784. PUB. 2-6-2007. FILED 11-30-2005.

3,233,520 ( *See Class 1 for this trademark*).

3,233,596. **DIAMANT AND DESIGN**. SATHIS, (U.S. CLS. 19, 20, 37, 42 AND 50), SN 79-019,079. PUB. 2-6-2007. FILED 10-18-2005.

---

### CLASS 28—TOYS AND SPORTING GOODS

3,232,060 ( *See Class 6 for this trademark*).

3,232,078 ( *See Class 9 for this trademark*).

3,232,165 ( *See Class 20 for this trademark*).

3,232,254. **EASY BODY AND DESIGN**. DALPS & LEISURE PRODUCTS SUPPLY CORPORATION, (U.S. CLS. 22, 23, 38 AND 50), SN 76-662,098. PUB. 2-6-2007. FILED 6-23-2006.

3,232,262. **CHIP & COOKIE (BLOCK FORM)**. CHIP & COOKIE, LLC, (U.S. CLS. 22, 23, 38 AND 50), SN 76-662,695. PUB. 2-6-2007. FILED 7-7-2006.

3,232,268. **AIR-REST (BLOCK FORM)**. DOUBLE TAKE ARCHERY LLC., (U.S. CLS. 22, 23, 38 AND 50), SN 76-663,318. PUB. 2-6-2007. FILED 7-19-2006.

3,232,329 ( *See Class 7 for this trademark*).

3,232,330. **VEGAS. HARBRO, LLC**, (U.S. CLS. 22, 23, 38 AND 50), SN 78-253,725. PUB. 8-10-2004. FILED 5-23-2003.

3,232,331. **BURGLAR IN PARIS AND DESIGN**. ARUZE CORPORATION, (U.S. CLS. 22, 23, 38 AND 50), SN 78-257,305. PUB. 2-6-2007. FILED 6-2-2003.

3,232,335 ( *See Class 9 for this trademark*).

3,232,340. **MISS MOO-MOO THE COW**. LISA LELEU STUDIOS, INC., (U.S. CLS. 22, 23, 38 AND 50), SN 78-311,234.

- PUB. 2-6-2007. FILED 10-8-2003.  
 3,232,349. **FUNFUN AND DESIGN**. GIGLIO, MARK A. (U.S. CLS. 22, 23, 38 AND 50). SN 78-381,344. PUB. 2-6-2007. FILED 3-10-2004.  
 3,232,350 ( *See Class 9 for this trademark*).  
 3,232,375 ( *See Class 3 for this trademark*).  
 3,232,386. **SPIKEE BRAND (BLOCK FORM)**. ROCKET USA, INC. (U.S. CLS. 22, 23, 38 AND 50). SN 78-525,973. PUB. 2-6-2007. FILED 12-2-2004.  
 3,232,431 ( *See Class 9 for this trademark*).  
 3,232,450. **BALANCEFIT (BLOCK FORM)**. SISSLE INC., (U.S. CLS. 22, 23, 38 AND 50). SN 78-599,128. PUB. 2-6-2007. FILED 3-31-2005.  
 3,232,496. **ALTUS (BLOCK FORM)**. OK-1 MANUFACTURING COMPANY, (U.S. CLS. 22, 23, 38 AND 50). SN 78-648,444. PUB. 2-6-2007. FILED 6-10-2005.  
 3,232,498. **DEFA AND DESIGN**. JIEYANG DEFA TOY CO., LTD., (U.S. CLS. 22, 23, 38 AND 50). SN 78-650,083. PUB. 9-19-2006. FILED 6-14-2005.  
 3,232,504. **JUGS BY BERT (BLOCK FORM)**. JUGS BY BERT, INC., (U.S. CLS. 22, 23, 38 AND 50). SN 78-657,091. PUB. 2-6-2007. FILED 6-23-2005.  
 3,232,520 ( *See Class 9 for this trademark*).  
 3,232,523. **ESOX AND DESIGN**. MOOREHEAD MANAGEMENT, INC., DBA ESOX RODS, (U.S. CLS. 22, 23, 38 AND 50). SN 78-672,893. PUB. 2-6-2007. FILED 7-18-2005.  
 3,232,526. **HANSSON AND DESIGN**. HANSSON, INC., (U.S. CLS. 22, 23, 38 AND 50). SN 78-674,926. PUB. 2-6-2007. FILED 7-20-2005.  
 3,232,548. **TRACTOR TIPPING (BLOCK FORM)**. MATTEL, INC., (U.S. CLS. 22, 23, 38 AND 50). SN 78-691,732. PUB. 10-24-2006. FILED 8-12-2005.  
 3,232,600. **TWIN CHOPPER (BLOCK FORM)**. SPIN MASTER LTD., (U.S. CLS. 22, 23, 38 AND 50). SN 78-728,125. PUB. 2-6-2007. FILED 10-6-2005.  
 3,232,637. **THE BIRTHDAY SOCK (BLOCK FORM)**. DANNY Q. ROBERTSON, DBA NEW INDUSTRIES, (U.S. CLS. 22, 23, 38 AND 50). SN 78-742,192. PUB. 2-6-2007. FILED 10-28-2005.  
 3,232,805 ( *See Class 18 for this trademark*).  
 3,232,824 ( *See Class 25 for this trademark*).  
 3,232,876. **ALPHA BID POKER (BLOCK FORM)**. ALPHA BID POKER LLC, (U.S. CLS. 22, 23, 38 AND 50). SN 78-836,905. PUB. 2-6-2007. FILED 3-14-2006.  
 3,232,894 ( *See Class 9 for this trademark*).  
 3,232,965. **BEPONG AND DESIGN**. BEPONG LLC, (U.S. CLS. 22, 23, 38 AND 50). SN 78-867,904. PUB. 2-6-2007. FILED 4-24-2006.  
 3,233,079. **MINI GRAND TABS (BLOCK FORM)**. BONANZA PRESS, INC., (U.S. CLS. 22, 23, 38 AND 50). SN 78-898,195. PUB. 2-6-2007. FILED 6-1-2006.  
 3,233,094. **CURIOUS CAT (BLOCK FORM)**. PET APPEAL, INC., (U.S. CLS. 22, 23, 38 AND 50). SN 78-901,004. PUB. 2-6-2007. FILED 6-5-2006.  
 3,233,257. **HUG N' STUFF (BLOCK FORM)**. UNEEDA DOLL COMPANY, LTD., (U.S. CLS. 22, 23, 38 AND 50). SN 78-912,953. PUB. 2-6-2007. FILED 6-21-2006.  
 3,233,263. **MISCELLANEOUS DESIGN**. FISHING SCIENCE, INCORPORATED, (U.S. CLS. 22, 23, 38 AND 50). SN 78-913,223. PUB. 2-6-2007. FILED 6-21-2006.  
 3,233,327. **LIFESPAN (BLOCK FORM)**. PARK CITY ENTERTAINMENT, INC., (U.S. CLS. 22, 23, 38 AND 50). SN 78-915,582. PUB. 2-6-2007. FILED 6-23-2006.  
 3,233,334. **LUCKY 20 (STYLIZED)**. ROBITAILLE, LUC, (U.S. CLS. 22, 23, 38 AND 50). SN 78-915,799. PUB. 2-6-2007. FILED 6-23-2006.  
 3,233,445. **314 2 AND DESIGN**. CLAWSON CUSTOM CUES, INC. (U.S. CLS. 22, 23, 38 AND 50). SN 78-919,523. PUB. 2-6-2007. FILED 6-29-2006.  
 3,233,446. **Z 2 AND DESIGN**. CLAWSON CUSTOM CUES, INC. (U.S. CLS. 22, 23, 38 AND 50). SN 78-919,535. PUB. 2-6-2007. FILED 6-29-2006.  
 3,233,461. **HOMESCHOOLPOLY (BLOCK FORM)**. BERTHUME ENTERPRISES, LLC, (U.S. CLS. 22, 23, 38 AND 50). SN 78-921,570. PUB. 2-6-2007. FILED 7-1-2006.  
 3,233,520 ( *See Class 1 for this trademark*).  
 3,233,562 ( *See Class 18 for this trademark*).  
 3,233,563 ( *See Class 18 for this trademark*).  
 3,233,572. **PEKIP (BLOCK FORM)**. HEIKE SCHWARZ, AND ANDREAS EICHTSTETTER, (U.S. CLS. 22, 23, 38 AND 50). SN 79-017,655. PUB. 2-6-2007. FILED 10-25-2005.  
 3,233,600 ( *See Class 16 for this trademark*).  
 3,233,609 ( *See Class 25 for this trademark*).  
 3,233,626. **PLAYERZ GAMES AND DESIGN**. MADWISH B.V., (U.S. CLS. 22, 23, 38 AND 50). SN 79-020,415. PUB. 2-6-2007. FILED 10-21-2005.  
 3,233,630 ( *See Class 9 for this trademark*).  
 3,233,631 ( *See Class 9 for this trademark*).  
 3,233,641 ( *See Class 9 for this trademark*).  
 3,233,660 ( *See Class 18 for this trademark*).  
 3,233,677 ( *See Class 9 for this trademark*).  
 3,233,705. **DEE&GEE (BLOCK FORM)**. DOLCE & GABBANA S.R.L., (U.S. CLS. 22, 23, 38 AND 50). SN 79-023,769. PUB. 2-6-2007. FILED 3-20-2006.  
 3,233,752 ( *See Class 20 for this trademark*).  
 3,233,757. **E (STYLIZED)**. K.K. ENDO SEISAKUSHO, (U.S. CLS. 22, 23, 38 AND 50). SN 79-028,568. PUB. 2-6-2007. FILED 8-9-2006.
- 
- CLASS 29—MEATS AND PROCESSED FOODS**
- 3,232,093. **MCARTHUR'S 1876 AMERICAN CORNUCOPIA AND DESIGN**. M&S FINE FOODS, INC., MULTIPLE CLASS, (INT. CLS. 29, 30 AND 35), (U.S. CLS. 46, 100, 101 AND 102). SN 76-604,231. PUB. 2-6-2007. FILED 7-27-2004.  
 3,232,138. **RIQUESITO (BLOCK FORM)**. DIAZ WHOLESALE AND MANUFACTURING CO., (U.S. CL. 46). SN 76-646,053. PUB. 2-6-2007. FILED 9-2-2005.  
 3,232,177. **PHILADELPHIA GRILL BRAND (BLOCK FORM)**. ASTRA FOODS, INC., (U.S. CL. 46). SN 76-651,224. PUB. 2-6-2007. FILED 12-1-2005.  
 3,232,276. **EATING RIGHT**. SAFEWAY INC., (U.S. CL. 46). SN 76-978,271. PUB. 2-6-2007. FILED 2-26-2003.  
 3,232,333. **SNYDER OF BERLIN**. LINDEN OAKS CORPORATION, MULTIPLE CLASS, (INT. CLS. 29 AND 30), (U.S. CL. 46). SN 78-270,499. PUB. 2-6-2007. FILED 7-3-2003.  
 3,232,371. **CHEF JAMIE (BLOCK FORM)**. TASTEBUD ENTERTAINMENT, INC., MULTIPLE CLASS, (INT. CLS. 29 AND 30), (U.S. CL. 46). SN 78-490,386. PUB. 2-6-2007. FILED 9-28-2004.  
 3,232,479. **PHIL-EZE (BLOCK FORM)**. DEVAULT PACKING CO., INC., (U.S. CL. 46). SN 78-631,472. PUB. 2-28-2006. FILED 5-17-2005.  
 3,232,609. **PACIFIC CHOICE SPECIALTY FOODS AND DESIGN**. PACIFIC CHOICE SPECIALTY FOODS, INC., (U.S. CL. 46). SN 78-731,217. PUB. 2-6-2007. FILED 10-11-2005.  
 3,232,619. **FIORUCCI SINCE 1850 ITALY'S # 1 AND DESIGN**. CESARE FIORUCCI S.P.A., (U.S. CL. 46). SN 78-737,329. PUB. 2-6-2007. FILED 10-20-2005.  
 3,232,661. **VICTORINA (BLOCK FORM)**. LA CENA FINE FOODS, LTD., MULTIPLE CLASS, (INT. CLS. 29 AND 30), (U.S. CL. 46). SN 78-745,721. PUB. 1-23-2007. FILED 11-2-2005.  
 3,232,662. **MCCADAM AND DESIGN**. AGRI-MARK, INCORPORATED, (U.S. CL. 46). SN 78-746,027. PUB. 2-6-2007. FILED 11-3-2005.  
 3,232,762. **TADIM AND DESIGN**. TADIM GIDA MADDELERI SANAYI VE TICARET A.S, MULTIPLE CLASS, (INT. CLS. 29 AND 30), (U.S. CL. 46). SN 78-777,711. PUB. 2-6-2007. FILED 12-20-2005.  
 3,233,023 ( *See Class 11 for this trademark*).  
 3,233,103. **FRESH FROM THE SEA BRAND AND DESIGN**. RED CHAMBER CO., (U.S. CL. 46). SN 78-902,977. PUB. 2-6-2007. FILED 6-7-2006.  
 3,233,104. **HEALTHY ORCHARD (BLOCK FORM)**. YOAS, CHAD, (U.S. CL. 46). SN 78-902,985. PUB. 2-6-2007. FILED 6-7-2006.  
 3,233,111. **ROSSELLA (BLOCK FORM)**. CANADIAN FISH EXPORTERS, INC., (U.S. CL. 46). SN 78-903,866. PUB. 2-6-2007. FILED 6-8-2006.  
 3,233,171. **QUE SABOR (BLOCK FORM)**. CATANIA SPAGNA CORPORATION, (U.S. CL. 46). SN 78-909,161. PUB. 2-6-2007. FILED 6-15-2006.  
 3,233,243. **SNO\*E TOFU (BLOCK FORM)**. VANCE'S FOODS,

- INC., (U.S. CL. 46). SN 78-912,663. PUB. 2-6-2007. FILED 6-20-2006.
- 3,233,258. **DANTE (BLOCK FORM)**. WISCONSIN SHEEP DAIRY COOPERATIVE, (U.S. CL. 46). SN 78-912,975. PUB. 2-6-2007. FILED 6-21-2006.
- 3,233,291. **A LA DIABLA (BLOCK FORM)**. GRUPO BIMBO, S.A. DE C.V., (U.S. CL. 46). SN 78-914,602. PUB. 2-6-2007. FILED 6-22-2006.
- 3,233,383. **VEGICHECKED (BLOCK FORM)**. AHAVA FOOD CORP., (U.S. CL. 46). SN 78-917,247. PUB. 2-6-2007. FILED 6-26-2006.
- 3,233,384. **VEGICHECKED AND DESIGN**. AHAVA FOOD CORP., (U.S. CL. 46). SN 78-917,253. PUB. 2-6-2007. FILED 6-26-2006.
- 3,233,397. **BRONZE CLASSIC (BLOCK FORM)**. SUGAR CREEK PACKING CO., (U.S. CL. 46). SN 78-917,483. PUB. 2-6-2007. FILED 6-27-2006.
- 3,233,454. **CRISPY SOUTHWEST DIPPERS (BLOCK FORM)**. BUFFALO WILD WINGS, INC., (U.S. CL. 46). SN 78-920,066. PUB. 2-6-2007. FILED 6-29-2006.
- 3,233,520 ( *See Class 1 for this trademark*).
- 3,233,522. **VIONDIS (BLOCK FORM)**. A. MOKSEL AG, MULTIPLE CLASS, (INT. CLS. 29 AND 30), (U.S. CL. 46). SN 79-008,244. PUB. 2-6-2007. FILED 7-8-2004.
- 3,233,666. **CHANGHUA (BLOCK FORM)**. OCEAN INTERNATIONAL HOLDINGS LIMITED, (U.S. CL. 46). SN 79-021,995. PUB. 2-6-2007. FILED 11-24-2005.
- 3,233,691. **KWANG DONG PHARMACEUTICAL CO., LTD. (BLOCK FORM)**. KWANG DONG PHARMACEUTICAL CO., LTD., MULTIPLE CLASS, (INT. CLS. 29, 30, 32 AND 44), (U.S. CLS. 45, 46, 48, 100 AND 101). SN 79-023,044. PUB. 2-6-2007. FILED 3-7-2005.
- 
- CLASS 30—STAPLE FOODS**
- 3,232,053. **TUXEDOS**. SAFEWAY INC., (U.S. CL. 46). SN 75-512,027. PUB. 10-31-2006. FILED 7-2-1998.
- 3,232,073 ( *See Class 1 for this trademark*).
- 3,232,093 ( *See Class 29 for this trademark*).
- 3,232,107. **BON APPETIT AMERICA'S PASTRY CHEF AND DESIGN**. BON APPETIT DANISH, INC., (U.S. CL. 46). SN 76-622,444. PUB. 2-6-2007. FILED 12-1-2004.
- 3,232,187. **C THE CULTURED CUP AND DESIGN**. THE CULTURED CUP, INC., (U.S. CL. 46). SN 76-652,563. PUB. 2-6-2007. FILED 12-27-2005.
- 3,232,219. **MAX LIFE (BLOCK FORM)**. GLOBAL BRANDS, INC., (U.S. CL. 46). SN 76-660,980. PUB. 2-6-2007. FILED 6-2-2006.
- 3,232,261. **READING TAKES YOU EVERYWHERE (BLOCK FORM)**. CHIP & COOKIE, LLC, (U.S. CL. 46). SN 76-662,693. PUB. 2-6-2007. FILED 7-7-2006.
- 3,232,270. **HELLMANN'S AND DESIGN**. UNILEVER SUPPLY CHAIN, INC., (U.S. CL. 46). SN 76-663,775. PUB. 1-23-2007. FILED 7-27-2006.
- 3,232,305. **MISCELLANEOUS DESIGN**. CLIF BAR & CO., (U.S. CL. 46). SN 77-027,622. PUB. 2-6-2007. FILED 10-23-2006.
- 3,232,333 ( *See Class 29 for this trademark*).
- 3,232,362. **EMPORIA POP'ERS AND DESIGN**. ENCORE GOURMET FOOD CORPORATION, (U.S. CL. 46). SN 78-452,569. PUB. 2-6-2007. FILED 7-19-2004.
- 3,232,371 ( *See Class 29 for this trademark*).
- 3,232,392. **TUCAN AND DESIGN**. TUCAN COFFEE ESTATES AND ROASTERS, LTD., (U.S. CL. 46). SN 78-544,331. PUB. 1-10-2006. FILED 1-8-2005.
- 3,232,484. **THE HEALTHY AND TASTY ALTERNATIVE (BLOCK FORM)**. 579732 B.C. LTD., DBA ROSS CHOCOLATES, (U.S. CL. 46). SN 78-633,273. PUB. 2-6-2007. FILED 5-19-2005.
- 3,232,510. **ROOIBOS AND DESIGN**. BURKE-WATKINS, VIRGINIA, (U.S. CL. 46). SN 78-661,729. PUB. 2-6-2007. FILED 6-30-2005.
- 3,232,522. **FINGER LAKES COFFEE ROASTERS (BLOCK FORM)**. FINGER LAKES COFFEE ROASTERS, INC., MULTIPLE CLASS, (INT. CLS. 30 AND 43), (U.S. CLS. 46, 100 AND 101). SN 78-672,809. PUB. 2-6-2007. FILED 7-18-2005.
- 3,232,584. **THE UNFORGETTABLES (BLOCK FORM)**. N & H BAKER AND SANDWICH MAKER, LLC, (U.S. CL. 46). SN 78-721,762. PUB. 2-6-2007. FILED 9-27-2005.
- 3,232,606. **EVIVA COFFEE ROASTERS (BLOCK FORM)**. EVIVA COFFEE & TEA COMPANY INC., (U.S. CL. 46). SN 78-730,335. PUB. 2-6-2007. FILED 10-10-2005.
- 3,232,607. **EVIVA COFFEE ROASTERS TOAST OUR TASTE AND DESIGN**. EVIVA COFFEE & TEA COMPANY INC., (U.S. CL. 46). SN 78-730,337. PUB. 2-6-2007. FILED 10-10-2005.
- 3,232,661 ( *See Class 29 for this trademark*).
- 3,232,663. **SIMPLY BAKE (BLOCK FORM)**. THE PILLSBURY COMPANY, (U.S. CL. 46). SN 78-746,172. PUB. 2-6-2007. FILED 11-3-2005.
- 3,232,681. **BARRO'S PIZZA (BLOCK FORM)**. MJB PIZZA INC., AND A & D PIZZA INC., MULTIPLE CLASS, (INT. CLS. 30 AND 43), (U.S. CLS. 46, 100 AND 101). SN 78-749,589. PUB. 12-26-2006. FILED 11-8-2005.
- 3,232,762 ( *See Class 29 for this trademark*).
- 3,232,774 ( *See Class 1 for this trademark*).
- 3,232,823. **SANTA BARBARA CHOCOLATE CO. AND DESIGN**. PARADISE USA, LLC, (U.S. CL. 46). SN 78-811,641. PUB. 2-6-2007. FILED 2-9-2006.
- 3,232,844. **CINNAMON MELTS (BLOCK FORM)**. MCDONALD'S CORPORATION, (U.S. CL. 46). SN 78-825,444. PUB. 2-6-2007. FILED 2-28-2006.
- 3,232,963. **JEROVIA (STYLIZED)**. CANOPY, (U.S. CL. 46). SN 78-867,401. PUB. 2-6-2007. FILED 4-22-2006.
- 3,233,075. **"THE ORIGINAL" WRAPOLÉ PREMIUM QUALITY TORTILLAS AND DESIGN**. LIBFELD INC., (U.S. CL. 46). SN 78-897,055. PUB. 2-6-2007. FILED 5-31-2006.
- 3,233,172. **KHAYELITSHA COOKIES CREATING OPPORTUNITY ONE BITE AT A TIME AND DESIGN**. POLAK, ALICIA DANIELLE, (U.S. CL. 46). SN 78-909,210. PUB. 2-6-2007. FILED 6-15-2006.
- 3,233,216. **BJ'S BREAK BAR (BLOCK FORM)**. ELIZABETH J. CORPENING, (U.S. CL. 46). SN 78-911,456. PUB. 2-6-2007. FILED 6-19-2006.
- 3,233,228. **KRAUSE (BLOCK FORM)**. KRAUSE COMPANIES, INC., (U.S. CL. 46). SN 78-912,152. PUB. 2-6-2007. FILED 6-20-2006.
- 3,233,255. **MAKE AN IMPRESSION! (BLOCK FORM)**. MARS, INCORPORATED, (U.S. CL. 46). SN 78-912,942. PUB. 2-6-2007. FILED 6-21-2006.
- 3,233,273. **FEED GRANOLA CO. (BLOCK FORM)**. OSBORN, N. JASON, (U.S. CL. 46). SN 78-913,647. PUB. 2-6-2007. FILED 6-21-2006.
- 3,233,344. **AZUCAR GLASS (BLOCK FORM)**. ZUCRUM FOODS, L.L.C., (U.S. CL. 46). SN 78-916,012. PUB. 2-6-2007. FILED 6-23-2006.
- 3,233,375. **ALL THE TASTE WITHOUT THE GUILT (BLOCK FORM)**. JENNISON, DAVID, (U.S. CL. 46). SN 78-917,133. PUB. 2-6-2007. FILED 6-26-2006.
- 3,233,396. **8 MATE AND DESIGN**. NISHIMOTO TRADING CO., LTD., (U.S. CL. 46). SN 78-917,403. PUB. 2-6-2007. FILED 6-26-2006.
- 3,233,419. **HAVASU (BLOCK FORM)**. NIELSEN, ROBERT, (U.S. CL. 46). SN 78-918,199. PUB. 2-6-2007. FILED 6-27-2006.
- 3,233,453 ( *See Class 5 for this trademark*).
- 3,233,518. **SONNENTOR AND DESIGN**. SONNENTOR KRÄUTERHANDELS GESELLSCHAFT M.B.H., (U.S. CL. 46). SN 79-002,060. PUB. 10-18-2005. FILED 4-5-2004.
- 3,233,520 ( *See Class 1 for this trademark*).
- 3,233,522 ( *See Class 29 for this trademark*).
- 3,233,661. **PART DES ANGES AND DESIGN**. BUOB LAURENT, MULTIPLE CLASS, (INT. CLS. 30, 32 AND 33), (U.S. CLS. 45, 46, 47, 48 AND 49). SN 79-021,762. PUB. 2-6-2007. FILED 12-30-2005.
- 3,233,675. **MISCELLANEOUS DESIGN**. TOSCHI VIGNOLA S.R.L., (U.S. CL. 46). SN 79-022,282. PUB. 2-6-2007. FILED 11-25-2005.
- 3,233,691 ( *See Class 29 for this trademark*).
- 3,233,716 ( *See Class 16 for this trademark*).

**CLASS 31—NATURAL AGRICULTURAL PRODUCTS**

- 3,232,055. **SUNRIPE**. PACIFIC TOMATO GROWERS, LTD., (U.S. CLS. 1 AND 46). SN 75-756,555. PUB. 2-6-2007. FILED 7-21-1999.
- 3,232,081. **EAST COAST FRESH CUTS**. EAST COAST FRESH CUTS COMPANY, MULTIPLE CLASS, (INT. CLS. 31 AND 35), (U.S. CLS. 1, 46, 100, 101 AND 102). SN 76-533,538. PUB. 2-6-2007. FILED 7-30-2003.
- 3,232,101. **AYELEN (BLOCK FORM)**. SALENTEIN ARGENTINA B.V., (U.S. CLS. 1 AND 46). SN 76-615,617. PUB. 2-6-2007. FILED 10-13-2004.
- 3,232,127. **PINK CANDY POPS MINT (BLOCK FORM)**. WESTERFIELD, JAMES, (U.S. CLS. 1 AND 46). SN 76-639,398. PUB. 2-6-2007. FILED 5-24-2005.
- 3,232,197. **SWEET TREET (BLOCK FORM)**. FARMER'S SUPPLY CO. OF DINUBA, INC., (U.S. CLS. 1 AND 46). SN 76-655,214. PUB. 2-6-2007. FILED 2-16-2006.
- 3,232,206. **GURDA GARDENS AND DESIGN**. GURDA GARDENS LTD., (U.S. CLS. 1 AND 46). SN 76-658,496. PUB. 2-6-2007. FILED 4-14-2006.
- 3,232,291. **THE DIFFERENCE IS REAL (BLOCK FORM)**. SOCIETE DES PRODUITS NESTLE S.A., (U.S. CLS. 1 AND 46). SN 77-010,684. PUB. 2-6-2007. FILED 9-29-2006.
- 3,232,363. **SUN KING (BLOCK FORM)**. COMPANIA FRUTERA DEL NORTE, S. A., (U.S. CLS. 1 AND 46). SN 78-459,700. PUB. 2-6-2007. FILED 7-30-2004.
- 3,232,421. **DENVER GOLD (BLOCK FORM)**. DENVER BOTANIC GARDENS, INC., AND COLORADO STATE UNIVERSITY, (U.S. CLS. 1 AND 46). SN 78-576,586. PUB. 2-6-2007. FILED 2-28-2005.
- 3,232,506. **CADAWG (BLOCK FORM)**. NANHALL MANUFACTURING CO., INC., (U.S. CLS. 1 AND 46). SN 78-658,052. PUB. 2-6-2007. FILED 6-24-2005.
- 3,232,570. **EMALON (BLOCK FORM)**. BENTOLI, INC., (U.S. CLS. 1 AND 46). SN 78-710,709. PUB. 2-6-2007. FILED 9-12-2005.
- 3,232,572. **EARTH BUDDY (BLOCK FORM)**. SPIN MASTER LTD., (U.S. CLS. 1 AND 46). SN 78-712,135. PUB. 2-6-2007. FILED 9-13-2005.
- 3,232,793. **PRO CITRUS NETWORK AND DESIGN**. PRO CITRUS NETWORK, (U.S. CLS. 1 AND 46). SN 78-795,244. PUB. 2-6-2007. FILED 1-19-2006.
- 3,233,021. **STRONG ROOTS. STRONG YIELDS. (BLOCK FORM)**. DEKALB GENETICS CORPORATION, (U.S. CLS. 1 AND 46). SN 78-884,741. PUB. 2-6-2007. FILED 5-16-2006.
- 3,233,071. **RAGIN' CAJUN RUELLIA (BLOCK FORM)**. DUPONT NURSERY, INC., (U.S. CLS. 1 AND 46). SN 78-895,962. PUB. 2-6-2007. FILED 5-30-2006.
- 3,233,095. **NATURAL ULTRAMIX (BLOCK FORM)**. PET APPEAL, INC., (U.S. CLS. 1 AND 46). SN 78-901,030. PUB. 2-6-2007. FILED 6-5-2006.
- 3,233,297. **CHOP HOUSE ORIGINALS (BLOCK FORM)**. SOCIETE DES PRODUITS NESTLE S.A., (U.S. CLS. 1 AND 46). SN 78-914,689. PUB. 2-6-2007. FILED 6-22-2006.
- 3,233,457. **FOR A BETTER 'DOG'S LIFE'... (BLOCK FORM)**. RODGERS, JODY, (U.S. CLS. 1 AND 46). SN 78-920,657. PUB. 2-6-2007. FILED 6-30-2006.
- 3,233,520 ( *See Class 1 for this trademark*).
- 3,233,663 ( *See Class 3 for this trademark*).
- 3,233,696. **ANIMALUS (BLOCK FORM)**. MARION FÜRMETZ, MULTIPLE CLASS, (INT. CLS. 31 AND 38), (U.S. CLS. 1, 46, 100, 101 AND 104). SN 79-023,383. PUB. 2-6-2007. FILED 2-13-2006.

**CLASS 32—LIGHT BEVERAGES**

- 3,232,069. **CHILLER BEACH PARTY**. MOLSON CANADA 2005, (U.S. CLS. 45, 46 AND 48). SN 76-394,738. PUB. 7-1-2003. FILED 4-11-2002.
- 3,232,352. **ACTIGO (BLOCK FORM)**. INBEV S.A., (U.S. CLS. 45, 46 AND 48). SN 78-396,400. PUB. 10-10-2006. FILED 4-5-2004.
- 3,232,566. **RIO GRANDE (BLOCK FORM)**. RIO GRANDE FOOD PRODUCTS, INC., (U.S. CLS. 45, 46 AND 48). SN 78-

- 706,138. PUB. 2-6-2007. FILED 9-2-2005.
- 3,232,567. **NATURE'S PUREST TRUE MOUNTAIN SPRING WATER (BLOCK FORM)**. TURNER, RENITA S, (U.S. CLS. 45, 46 AND 48). SN 78-707,973. PUB. 2-6-2007. FILED 9-7-2005.
- 3,232,602. **MISCELLANEOUS DESIGN**. THE COCA-COLA COMPANY, (U.S. CLS. 45, 46 AND 48). SN 78-728,673. PUB. 2-6-2007. FILED 10-7-2005.
- 3,232,640. **SAN MIG AND DESIGN**. SAN MIGUEL CORPORATION, (U.S. CLS. 45, 46 AND 48). SN 78-742,540. PUB. 2-6-2007. FILED 10-28-2005.
- 3,232,641. **SAN MIGUEL (BLOCK FORM)**. SAN MIGUEL CORPORATION, (U.S. CLS. 45, 46 AND 48). SN 78-742,598. PUB. 2-6-2007. FILED 10-28-2005.
- 3,232,653. **BERRY CREAM SENSATION (BLOCK FORM)**. BOOSTER JUICE LIMITED PARTNERSHIP, (U.S. CLS. 45, 46 AND 48). SN 78-744,949. PUB. 2-6-2007. FILED 11-1-2005.
- 3,232,689. **NIGHT OF THE LIVING DEAD (BLOCK FORM)**. MAGIC HAT BREWING COMPANY AND PERFORMING ARTS CENTER, INC., (U.S. CLS. 45, 46 AND 48). SN 78-751,499. PUB. 2-6-2007. FILED 11-10-2005.
- 3,232,753. **JIVITA ESSENCE INFUSED WATER. AND DESIGN**. JIVITA LLC, (U.S. CLS. 45, 46 AND 48). SN 78-771,760. PUB. 2-6-2007. FILED 12-12-2005.
- 3,232,759 ( *See Class 18 for this trademark*).
- 3,233,035. **G (STYLIZED)**. VOSS OF NORWAY ASA, (U.S. CLS. 45, 46 AND 48). SN 78-886,895. PUB. 2-6-2007. FILED 5-18-2006.
- 3,233,056. **M METROMINT AND DESIGN**. SOMA BEVERAGE COMPANY, LLC, (U.S. CLS. 45, 46 AND 48). SN 78-891,691. PUB. 2-6-2007. FILED 5-24-2006.
- 3,233,067. **TSINGTAO PURE DRAFT (BLOCK FORM)**. TSINGTAO BREWERY COMPANY LIMITED, (U.S. CLS. 45, 46 AND 48). SN 78-895,468. PUB. 2-6-2007. FILED 5-30-2006.
- 3,233,068. **TSINGTAO BEER AND DESIGN**. TSINGTAO BREWERY COMPANY LIMITED, (U.S. CLS. 45, 46 AND 48). SN 78-895,489. PUB. 2-6-2007. FILED 5-30-2006.
- 3,233,069. **TSINGTAO PURE DRAFT BEER AND DESIGN**. TSINGTAO BREWERY COMPANY LIMITED, (U.S. CLS. 45, 46 AND 48). SN 78-895,535. PUB. 2-6-2007. FILED 5-30-2006.
- 3,233,486. **LIVE AT FULL TILT (BLOCK FORM)**. ANHEUSER-BUSCH, INCORPORATED, (U.S. CLS. 45, 46 AND 48). SN 78-929,416. PUB. 2-6-2007. FILED 7-14-2006.
- 3,233,520 ( *See Class 1 for this trademark*).
- 3,233,533. **MISCELLANEOUS DESIGN**. RED BULL GMBH, (U.S. CLS. 45, 46 AND 48). SN 79-013,593. PUB. 6-27-2006. FILED 10-7-2004.
- 3,233,661 ( *See Class 30 for this trademark*).
- 3,233,677 ( *See Class 9 for this trademark*).
- 3,233,691 ( *See Class 29 for this trademark*).
- 3,233,714. **VIRGA PURE TASMANIAN WATER AND DESIGN**. BELLE-RIVE FUNCTIONAL; WATERS PTY LTD, (U.S. CLS. 45, 46 AND 48). SN 79-024,449. PUB. 2-6-2007. FILED 4-4-2006.

**CLASS 33—WINES AND SPIRITS**

- 3,232,090. **RON ZACAPA CENTENARIO AND DESIGN**. LICORERA ZACAPANECA, SOCIEDAD ANÓNIMA, (U.S. CLS. 47 AND 49). SN 76-600,158. PUB. 1-23-2007. FILED 7-1-2004.
- 3,232,097. **COYOTE'S RUN (BLOCK FORM)**. CONCESSION 5 CELLARS LIMITED PARTNERSHIP, (U.S. CLS. 47 AND 49). SN 76-610,072. PUB. 2-6-2007. FILED 9-3-2004.
- 3,232,143. **DESILVER WHITE RUM WITH SECRET SPICES FROM ST-BARTHS AND DESIGN**. DESILVER, (U.S. CLS. 47 AND 49). SN 76-647,064. PUB. 2-6-2007. FILED 9-19-2005.
- 3,232,229. **EXOTIC RUSH (STYLIZED)**. SHEVOKAS, WAYNE R., (U.S. CLS. 47 AND 49). SN 76-661,471. PUB. 2-6-2007. FILED 6-12-2006.
- 3,232,252. **SWEET LUCY (BLOCK FORM)**. PRICHARD'S DISTILLERY, INC., (U.S. CLS. 47 AND 49). SN 76-662,022. PUB. 2-6-2007. FILED 6-22-2006.
- 3,232,353. **THEA'S SELECTION (BLOCK FORM)**. LEMELSON

WINERY LLC, (U.S. CLS. 47 AND 49). SN 78-396,766. PUB. 2-6-2007. FILED 4-5-2004.

3,232,368. **STONEFISH AND DESIGN**. LE GRAND IMPORTS EXPORTS PTY LIMITED, (U.S. CLS. 47 AND 49). SN 78-479,275. PUB. 10-31-2006. FILED 9-7-2004.

3,232,422. **MISCELLANEOUS DESIGN**. DIAGEO NORTH AMERICA, INC., (U.S. CLS. 47 AND 49). SN 78-576,953. PUB. 2-6-2007. FILED 2-28-2005.

3,232,440. **ALTO MONCAYO (BLOCK FORM)**. BODEGAS ALTO MONCAYO, S.A., (U.S. CLS. 47 AND 49). SN 78-593,353. PUB. 2-6-2007. FILED 3-23-2005.

3,232,453. **WOKKA SAKI (STYLIZED)**. EXTREME SPIRITS LTD, (U.S. CLS. 47 AND 49). SN 78-600,835. PUB. 2-6-2007. FILED 4-4-2005.

3,232,457. **FRA GUERAU (BLOCK FORM)**. VIÑAS DEL MONTSANT, SL, (U.S. CLS. 47 AND 49). SN 78-607,694. PUB. 2-6-2007. FILED 4-13-2005.

3,232,488. **GALA ROUGE (BLOCK FORM)**. BROWN-FORMAN CORPORATION, (U.S. CLS. 47 AND 49). SN 78-638,129. PUB. 2-6-2007. FILED 5-26-2005.

3,232,568. **MISCELLANEOUS DESIGN**. NEVIS BLUFF WINES LIMITED, (U.S. CLS. 47 AND 49). SN 78-710,081. PUB. 2-6-2007. FILED 9-9-2005.

3,232,627. **RED BARN CIDER (BLOCK FORM)**. SKAGIT BEVERAGE LLC, (U.S. CLS. 47 AND 49). SN 78-738,721. PUB. 2-6-2007. FILED 10-23-2005.

3,232,717. **ATHESIA AND DESIGN**. ATHESIA VINI S.R.L., (U.S. CLS. 47 AND 49). SN 78-758,209. PUB. 2-6-2007. FILED 11-21-2005.

3,232,759 ( *See Class 18 for this trademark*).

3,232,855. **MISCELLANEOUS DESIGN**. THOUSAND ISLANDS WINERY, LLC, (U.S. CLS. 47 AND 49). SN 78-829,754. PUB. 2-6-2007. FILED 3-6-2006.

3,232,901. **MISCELLANEOUS DESIGN**. JACKSON FAMILY FARMS, LLC, (U.S. CLS. 47 AND 49). SN 78-847,452. PUB. 10-24-2006. FILED 3-28-2006.

3,233,032. **DON JOSE LOPEZ PORTILLO (BLOCK FORM)**. PRODUCTORA DE TEQUILA GEMINIS, S.A. DE C.V., (U.S. CLS. 47 AND 49). SN 78-885,897. PUB. 2-6-2007. FILED 5-17-2006.

3,233,043. **RICH & RARE (BLOCK FORM)**. SAZERAC COMPANY, INC., (U.S. CLS. 47 AND 49). SN 78-888,228. PUB. 2-6-2007. FILED S.R. 5-19-2006; AM. P.R. 11-27-2006.

3,233,225. **ERATH (BLOCK FORM)**. STE. MICHELLE WINE ESTATES LTD., (U.S. CLS. 47 AND 49). SN 78-912,131. PUB. 2-6-2007. FILED 6-20-2006.

3,233,262. **MILES OF MAGIC (BLOCK FORM)**. DISNEY ENTERPRISES, INC., (U.S. CLS. 47 AND 49). SN 78-913,168. PUB. 2-6-2007. FILED 6-21-2006.

3,233,293. **HILLCREST DURBANVILLE (BLOCK FORM)**. HILLCREST ESTATE DURBANVILLE (PTY) LIMITED, (U.S. CLS. 47 AND 49). SN 78-914,649. PUB. 2-6-2007. FILED 6-22-2006.

3,233,489. **HI. (BLOCK FORM)**. PASQUINI, OLIVIER, (U.S. CLS. 47 AND 49). SN 78-931,055. PUB. 2-6-2007. FILED 7-17-2006.

3,233,520 ( *See Class 1 for this trademark*).

3,233,561. **ASKANELI, ASKANELI BROTHERS AND DESIGN**. OBSHESTVO S OGRANICHENNOY OTVETSTVENNOSTJU "ASKANELI", MULTIPLE CLASS, (INT. CLS. 33, 35 AND 43), (U.S. CLS. 47, 49, 100, 101 AND 102). SN 79-017,130. PUB. 2-6-2007. FILED 9-1-2005.

3,233,566. **SIRECH (STYLIZED)**. SIRECH & CO S.A.S., (U.S. CLS. 47 AND 49). SN 79-017,339. PUB. 2-6-2007. FILED 10-12-2005.

3,233,611. **LES FOLIES PAR LE MARQUIS DE CHASSE (BLOCK FORM)**. MAISON GINESTET, (U.S. CLS. 47 AND 49). SN 79-019,798. PUB. 2-6-2007. FILED 11-25-2005.

3,233,650. **LEGARIS CREATIUM (STYLIZED)**. LEGARIS S.L., (U.S. CLS. 47 AND 49). SN 79-021,301. PUB. 2-6-2007. FILED 2-6-2006.

3,233,657. **ST-RÉMY NAPOLEON BRANDY FRENCH BRANDY BRANDY FRANCAIS VSOP AND DESIGN**. E. REMY MARTIN & C, (U.S. CLS. 47 AND 49). SN 79-021,503. PUB. 1-23-2007. FILED 12-23-2005.

3,233,661 ( *See Class 30 for this trademark*).

3,233,688. **"ALABANZA" (STYLIZED)**. JOSE MARIA RUIZ-ALEJOS HERRERO, (U.S. CLS. 47 AND 49). SN 79-022,908.

PUB. 2-6-2007. FILED 9-20-2005.

3,233,707. **G SHOT AND DESIGN**. G-SHOTS B.V., (U.S. CLS. 47 AND 49). SN 79-024,001. PUB. 2-6-2007. FILED 4-27-2006.

3,233,722. **KRIMART (BLOCK FORM)**. CLOSE JOINT STOCK COMPANY "ARTYOMOVSK WINERY", (U.S. CLS. 47 AND 49). SN 79-024,999. PUB. 2-6-2007. FILED 3-21-2006.

3,233,738. **HILL SAIDE (BLOCK FORM)**. BENT KARLSEN TRADING SCANDINAVIA AB, (U.S. CLS. 47 AND 49). SN 79-025,967. PUB. 2-6-2007. FILED 5-8-2006.

---

### CLASS 34—SMOKERS' ARTICLES

3,232,060 ( *See Class 6 for this trademark*).

3,232,745. **EL INCOMPARABLE (BLOCK FORM)**. POZDEREC, SUSANNE, (U.S. CLS. 2, 8, 9 AND 17). SN 78-769,383. PUB. 2-6-2007. FILED 12-8-2005.

3,233,110. **CYCLONES PRE ROLLED CONE BLUNTS AND DESIGN**. HBI INTERNATIONAL, (U.S. CLS. 2, 8, 9 AND 17). SN 78-903,857. PUB. 2-6-2007. FILED 6-8-2006.

3,233,292. **VERONA'S COURT (BLOCK FORM)**. MAX ROHR, INC., (U.S. CLS. 2, 8, 9 AND 17). SN 78-914,642. PUB. 2-6-2007. FILED 6-22-2006.

3,233,520 ( *See Class 1 for this trademark*).

---

### SERVICE MARKS

### CLASS 35—ADVERTISING AND BUSINESS

3,232,052. **GARDEN GATE DESIGNS (BLOCK FORM)**. JO-ANN STORES SUPPLY CHAIN MANAGEMENT, INC., (U.S. CLS. 100, 101 AND 102). SN 75-355,600. PUB. 2-6-2007. FILED 9-12-1997.

3,232,063. **MISCELLANEOUS DESIGN**. GENESCO INC., (U.S. CLS. 100, 101 AND 102). SN 76-238,378. PUB. 8-14-2001. FILED 4-10-2001.

3,232,066. **GOOD LIFE APPAREL AND DESIGN**. MANCELLO, JOSEPH, (U.S. CLS. 100, 101 AND 102). SN 76-378,756. PUB. 2-6-2007. FILED 3-6-2002.

3,232,068. **M AND DESIGN**. LEMANS CORPORATION, (U.S. CLS. 100, 101 AND 102). SN 76-387,520. PUB. 2-6-2007. FILED 3-27-2002.

3,232,071. **RXCROSSROADS**. RXCROSSROADS, LLC, (U.S. CLS. 100, 101 AND 102). SN 76-414,784. PUB. 2-6-2007. FILED 5-30-2002.

3,232,072. **HYPHEN**. INNOVATIVE HOSPITALITY SOLUTIONS CORPORATION, MULTIPLE CLASS, (INT. CLS. 35 AND 42), (U.S. CLS. 100, 101 AND 102). SN 76-437,489. PUB. 2-7-2006. FILED 8-5-2002.

3,232,073 ( *See Class 1 for this trademark*).

3,232,081 ( *See Class 31 for this trademark*).

3,232,082. **SIXDEGREES OF SEPARATION AND DESIGN**. GILBERT, TREVOR, (U.S. CLS. 100, 101 AND 102). SN 76-546,181. PUB. 6-27-2006. FILED 9-22-2003.

3,232,089 ( *See Class 9 for this trademark*).

3,232,091 ( *See Class 9 for this trademark*).

3,232,093 ( *See Class 29 for this trademark*).

3,232,094. **THE SCIENCE OF TALENT (BLOCK FORM)**. TALENT PLUS, INC., DBA TALENT+, (U.S. CLS. 100, 101 AND 102). SN 76-608,634. PUB. 2-6-2007. FILED 8-25-2004.

3,232,098. **INFLECTION POINT VENTURES (BLOCK FORM)**. IPV SBIC MANAGEMENT, LLC, MULTIPLE CLASS, (INT. CLS. 35 AND 36), (U.S. CLS. 100, 101 AND 102). SN 76-610,522. PUB. 2-6-2007. FILED 9-2-2004.

3,232,109. **WILD HORSEFEATHERS (BLOCK FORM)**. WILD HORSEFEATHERS LLC, (U.S. CLS. 100, 101 AND 102). SN 76-625,248. PUB. 2-6-2007. FILED 12-21-2004.

3,232,110. **UNITED STATES ENVIROFUELS LLC AND DESIGN**. UNITED STATES ENVIROFUELS, LLC, (U.S. CLS. 100, 101 AND 102). SN 76-626,190. PUB. 2-6-2007. FILED 12-28-2004.

3,232,115. **S I M A N AND DESIGN**. ALMACENES SIMAN,



- SOCIEDAD ANONIMA DE CAPITAL VARIABLE, (U.S. CLS. 100, 101 AND 102). SN 76-630,609. PUB. 8-1-2006. FILED 2-7-2005.
- 3,232,116. **SIMAN (BLOCK FORM)**. ALMACENES SIMAN, SOCIEDAD ANONIMA DE CAPITAL VARIABLE, (U.S. CLS. 100, 101 AND 102). SN 76-630,613. PUB. 8-1-2006. FILED 2-7-2005.
- 3,232,120. **TRANSAXIONAL (BLOCK FORM)**. RED X HOLDINGS, LLC, MULTIPLE CLASS, (INT. CLS. 35 AND 41), (U.S. CLS. 100, 101, 102 AND 107). SN 76-635,393. PUB. 2-6-2007. FILED 4-7-2005.
- 3,232,129. **SHARP GROWTH AND DESIGN**. BRIEN, SIDNEY, (U.S. CLS. 100, 101 AND 102). SN 76-639,634. PUB. 2-6-2007. FILED 5-26-2005.
- 3,232,134. **LIFESTYLES (BLOCK FORM)**. FLINT POOL & PATIO, INC., DBA LIFESTYLES SPAS & POOLS, (U.S. CLS. 100, 101 AND 102). SN 76-645,394. PUB. 10-24-2006. FILED 8-22-2005.
- 3,232,142. **SEAFOOD CITY (BLOCK FORM)**. FORTUNE COMMERCIAL CORPORATION, (U.S. CLS. 100, 101 AND 102). SN 76-647,056. PUB. 2-6-2007. FILED 9-19-2005.
- 3,232,151. **WINBROOK HELPING YOU DO BUSINESS, BETTER AND DESIGN**. WINBROOK COMMUNICATIONS, INC., (U.S. CLS. 100, 101 AND 102). SN 76-648,245. PUB. 2-6-2007. FILED 10-11-2005.
- 3,232,154. **J&S BEST PRICE COMMITMENT (STYLIZED)**. JAMES AND SONS, LTD., (U.S. CLS. 100, 101 AND 102). SN 76-648,614. PUB. 2-6-2007. FILED 10-17-2005.
- 3,232,164 ( *See Class 16 for this trademark*).
- 3,232,173. **U-REV (BLOCK FORM)**. LEGACY MARKETING PARTNERS, L.L.C., (U.S. CLS. 100, 101 AND 102). SN 76-650,878. PUB. 2-6-2007. FILED 11-23-2005.
- 3,232,174. **U-REV AND DESIGN**. LEGACY MARKETING PARTNERS, L.L.C., (U.S. CLS. 100, 101 AND 102). SN 76-650,879. PUB. 2-6-2007. FILED 11-23-2005.
- 3,232,179. **EJK AND DESIGN**. APPLE HILL HOLDINGS, LLC, (U.S. CLS. 100, 101 AND 102). SN 76-651,731. PUB. 2-6-2007. FILED 12-12-2005.
- 3,232,182. **WHAT BRINGS YOU? (BLOCK FORM)**. GENERAL GROWTH PROPERTIES, INC., MULTIPLE CLASS, (INT. CLS. 35 AND 36), (U.S. CLS. 100, 101 AND 102). SN 76-652,308. PUB. 2-6-2007. FILED 12-22-2005.
- 3,232,183. **WELCOME TO THE MALL, MOM (BLOCK FORM)**. GENERAL GROWTH PROPERTIES, INC., MULTIPLE CLASS, (INT. CLS. 35 AND 36), (U.S. CLS. 100, 101 AND 102). SN 76-652,312. PUB. 2-6-2007. FILED 12-22-2005.
- 3,232,184. **IMAGINE GETTING IT DONE (BLOCK FORM)**. GENERAL GROWTH PROPERTIES, INC., MULTIPLE CLASS, (INT. CLS. 35 AND 36), (U.S. CLS. 100, 101 AND 102). SN 76-652,314. PUB. 2-6-2007. FILED 12-22-2005.
- 3,232,185. **TAKE THE FEELING WITH YOU (BLOCK FORM)**. GENERAL GROWTH PROPERTIES, INC., MULTIPLE CLASS, (INT. CLS. 35 AND 36), (U.S. CLS. 100, 101 AND 102). SN 76-652,375. PUB. 2-6-2007. FILED 12-22-2005.
- 3,232,196 ( *See Class 9 for this trademark*).
- 3,232,201. **POSTCOM AND DESIGN**. ASSOCIATION FOR POSTAL COMMERCE, (U.S. CLS. 100, 101 AND 102). SN 76-655,951. PUB. 2-6-2007. FILED 3-1-2006.
- 3,232,209. **BLUE (BLOCK FORM)**. LACY SYMONS, INC., (U.S. CLS. 100, 101 AND 102). SN 76-658,818. PUB. 2-6-2007. FILED 4-21-2006.
- 3,232,210. **NEW REVOLUTION PARTY (BLOCK FORM)**. PENCE, CAIN M., (U.S. CLS. 100, 101 AND 102). SN 76-658,926. PUB. 2-6-2007. FILED 4-24-2006.
- 3,232,211. **HONEST FLORIST (BLOCK FORM)**. BENON, ARON, (U.S. CLS. 100, 101 AND 102). SN 76-658,973. PUB. 2-6-2007. FILED 4-24-2006.
- 3,232,235. **SAFE SONG USA (BLOCK FORM)**. SAFE SONG USA, L.L.C., (U.S. CLS. 100, 101 AND 102). SN 76-661,755. PUB. 2-6-2007. FILED 6-19-2006.
- 3,232,236. **BOATWRENCH INC. (BLOCK FORM)**. BOATWRENCH, INC., (U.S. CLS. 100, 101 AND 102). SN 76-661,766. PUB. 2-6-2007. FILED 6-19-2006.
- 3,232,284. **ARI INSIGHTS (STYLIZED)**. AUTOMOTIVE RENTALS, INC., (U.S. CLS. 100, 101 AND 102). SN 77-002,629. PUB. 2-6-2007. FILED 9-19-2006.
- 3,232,299. **PINK SUNDAY (BLOCK FORM)**. THE SUSAN G. KOMEN BREAST CANCER FOUNDATION, INC., (U.S. CLS. 100, 101 AND 102). SN 77-021,022. PUB. 2-6-2007. FILED 10-13-2006.
- 3,232,317. **THE MOST PERFECTLY CUT DIAMOND IN THE WORLD**. HEARTS ON FIRE COMPANY LLC, (U.S. CLS. 100, 101 AND 102). SN 78-078,313. PUB. 2-1-2005. FILED S.R. 8-8-2001; AM. P.R. 9-18-2002.
- 3,232,321. **NOVI HOME IMPROVEMENT SHOW**. BUILDING INDUSTRY ASSOCIATION OF SOUTHEASTERN MICHIGAN, (U.S. CLS. 100, 101 AND 102). SN 78-146,677. PUB. 2-6-2007. FILED 7-23-2002.
- 3,232,323. **ACXIOM (STYLIZED)**. ACXIOM CORPORATION, MULTIPLE CLASS, (INT. CLS. 35 AND 42), (U.S. CLS. 100, 101 AND 102). SN 78-179,376. PUB. 2-6-2007. FILED 10-29-2002.
- 3,232,328. **T AND DESIGN**. DEUTSCHE TELEKOM AG, (U.S. CLS. 100, 101 AND 102). SN 78-245,849. PUB. 9-12-2006. FILED 5-5-2003.
- 3,232,332. **NATIONAL TRUST FORUM**. NATIONAL TRUST FOR HISTORIC PRESERVATION IN THE UNITED STATES, MULTIPLE CLASS, (INT. CLS. 35 AND 37), (U.S. CLS. 100, 101, 102, 103 AND 106). SN 78-258,720. PUB. 7-5-2005. FILED 6-5-2003.
- 3,232,369 ( *See Class 9 for this trademark*).
- 3,232,378. **IQ DIGITAL STUDIOS (BLOCK FORM)**. VARSITY GROUP, INC., MULTIPLE CLASS, (INT. CLS. 35, 38 AND 41), (U.S. CLS. 100, 101, 102, 104 AND 107). SN 78-509,015. PUB. 2-6-2007. FILED 11-1-2004.
- 3,232,379. **Z ZOOMSHARE (STYLIZED)**. DW DATA, INCORPORATED, (U.S. CLS. 100, 101 AND 102). SN 78-510,631. PUB. 7-4-2006. FILED 11-3-2004.
- 3,232,381 ( *See Class 9 for this trademark*).
- 3,232,396. **CHESAPEAKE WILDLIFE HERITAGE (BLOCK FORM)**. CHESAPEAKE WILDLIFE HERITAGE, INC., MULTIPLE CLASS, (INT. CLS. 35 AND 37), (U.S. CLS. 100, 101, 102, 103 AND 106). SN 78-551,807. PUB. 2-6-2007. FILED 1-21-2005.
- 3,232,416. **KITCHEN UNIVERSE AND DESIGN**. VEGA RIBAS, CARINA, (U.S. CLS. 100, 101 AND 102). SN 78-574,857. PUB. 2-6-2007. FILED 2-25-2005.
- 3,232,424. **LIQUIDITY ALTERNATIVES (BLOCK FORM)**. ARIA CAPITAL ADVISORS, LLC, MULTIPLE CLASS, (INT. CLS. 35 AND 36), (U.S. CLS. 100, 101 AND 102). SN 78-580,137. PUB. 2-6-2007. FILED 3-4-2005.
- 3,232,429. **BRAINPLC (BLOCK FORM)**. BOHAN GROUP LLC, MULTIPLE CLASS, (INT. CLS. 35, 36 AND 42), (U.S. CLS. 100, 101 AND 102). SN 78-586,172. PUB. 2-6-2007. FILED 3-13-2005.
- 3,232,437 ( *See Class 25 for this trademark*).
- 3,232,456. **BROEN (BLOCK FORM)**. BROEN A/S, MULTIPLE CLASS, (INT. CLS. 35, 37 AND 40), (U.S. CLS. 100, 101, 102, 103 AND 106). SN 78-606,119. PUB. 2-6-2007. FILED 4-11-2005.
- 3,232,463. **CONSTANT COMMITMENT, CONSTANT RESULTS, GUARANTEED (BLOCK FORM)**. MODERN DISPLAY SERVICES, INC., (U.S. CLS. 100, 101 AND 102). SN 78-615,323. PUB. 2-6-2007. FILED 4-23-2005.
- 3,232,466. **AIC AND DESIGN**. AIC LIMITED, MULTIPLE CLASS, (INT. CLS. 35 AND 36), (U.S. CLS. 100, 101 AND 102). SN 78-617,280. PUB. 9-19-2006. FILED 4-26-2005.
- 3,232,467 ( *See Class 3 for this trademark*).
- 3,232,481. **WISCONSIN DELLS (STYLIZED)**. WISCONSIN DELLS VISITOR AND CONVENTION BUREAU, INC., MULTIPLE CLASS, (INT. CLS. 35, 39, 41 AND 43), (U.S. CLS. 100, 101, 102, 105 AND 107). SN 78-631,832. PUB. 2-6-2007. FILED 5-17-2005.
- 3,232,490. **MINYARD (BLOCK FORM)**. MINYARD FOOD STORES, INC., MULTIPLE CLASS, (INT. CLS. 35, 40 AND 43), (U.S. CLS. 100, 101, 102, 103 AND 106). SN 78-639,851. PUB. 2-6-2007. FILED 5-31-2005.
- 3,232,509. **TRC THE RETROFIT COMPANIES LIGHTING RETROFIT RETROFIT RECYCLING RETROFIT SUPPLY RETROFIT ELECTRIC AND DESIGN**. THE RETROFIT COMPANIES, INC., MULTIPLE CLASS, (INT. CLS. 35, 37 AND 40), (U.S. CLS. 100, 101, 102, 103 AND 106). SN 78-659,884. PUB. 2-6-2007. FILED 6-28-2005.
- 3,232,511. **PIRATE FIREWORKS (BLOCK FORM)**. ROSE CREEK FARMS, INC., (U.S. CLS. 100, 101 AND 102). SN 78-662,467. PUB. 2-6-2007. FILED 7-1-2005.

- 3,232,512. **APPROACH AND RESPONSE MANAGEMENT (ARM) (BLOCK FORM)**. O'NEILL, ROSALINDA, MULTIPLE CLASS, (INT. CLS. 35 AND 41), (U.S. CLS. 100, 101, 102 AND 107). SN 78-662,949. PUB. 2-6-2007. FILED 7-1-2005.
- 3,232,532. **ATLASBOOKS (BLOCK FORM)**. BOOKMASTERS, INC., (U.S. CLS. 100, 101 AND 102). SN 78-679,368. PUB. 2-6-2007. FILED 7-27-2005.
- 3,232,533. **PERSONALHEALTH RX (BLOCK FORM)**. MED-IMPACT HEALTHCARE SYSTEMS, INC., MULTIPLE CLASS, (INT. CLS. 35, 36 AND 42), (U.S. CLS. 100, 101 AND 102). SN 78-680,020. PUB. 2-6-2007. FILED 7-27-2005.
- 3,232,534. **CASESCRIBE (BLOCK FORM)**. TECH S2, INC., (U.S. CLS. 100, 101 AND 102). SN 78-682,063. PUB. 2-6-2007. FILED 7-30-2005.
- 3,232,537. **WHOLISTIC PLANET AND DESIGN**. WHOLISTIC PLANET, LLC, (U.S. CLS. 100, 101 AND 102). SN 78-683,316. PUB. 2-6-2007. FILED 8-2-2005.
- 3,232,547. **THE BEST WAY TO PREDICT THE FUTURE IS TO CREATE IT (BLOCK FORM)**. BRADLEY, ANDUJAR, (U.S. CLS. 100, 101 AND 102). SN 78-689,921. PUB. 2-6-2007. FILED 8-10-2005.
- 3,232,554. **T JOBS AND DESIGN**. DEUTSCHE TELEKOM AG, (U.S. CLS. 100, 101 AND 102). SN 78-695,600. PUB. 10-31-2006. FILED 8-18-2005.
- 3,232,579. **AVIANCASH (BLOCK FORM)**. AEROVIAS DEL CONTINENTE AMERICANO S.A. AVIANCA, MULTIPLE CLASS, (INT. CLS. 35 AND 36), (U.S. CLS. 100, 101 AND 102). SN 78-718,951. PUB. 2-6-2007. FILED 9-22-2005.
- 3,232,585. **BUY GROMMETS.COM AND DESIGN**. POMFRET, STEVE, (U.S. CLS. 100, 101 AND 102). SN 78-721,953. PUB. 2-6-2007. FILED 9-28-2005.
- 3,232,594. **INTERSTRAT (BLOCK FORM)**. INTERSTRAT CORPORATION, MULTIPLE CLASS, (INT. CLS. 35 AND 41), (U.S. CLS. 100, 101, 102 AND 107). SN 78-726,903. PUB. 2-6-2007. FILED 10-5-2005.
- 3,232,601. **LINKING BUSINESS NEEDS TO FINANCIAL SOLUTIONS (BLOCK FORM)**. CAPITAL REGION FINANCIAL GROUP, L.L.C., (U.S. CLS. 100, 101 AND 102). SN 78-728,305. PUB. 2-6-2007. FILED 10-6-2005.
- 3,232,604. **HD HIGH DEF EXPO AND DESIGN**. HIGH DEF EXPO, INC., MULTIPLE CLASS, (INT. CLS. 35 AND 41), (U.S. CLS. 100, 101, 102 AND 107). SN 78-729,048. PUB. 2-6-2007. FILED 10-7-2005.
- 3,232,605. **GET YOUR TICKETS IN A FLASH (BLOCK FORM)**. FLASH SEATS, LLC, (U.S. CLS. 100, 101 AND 102). SN 78-729,253. PUB. 2-6-2007. FILED 10-7-2005.
- 3,232,613. **KNOW WHAT TO DO (BLOCK FORM)**. EVOLUTIONARY STRATEGIC PLANNING, INC., MULTIPLE CLASS, (INT. CLS. 35, 36 AND 41), (U.S. CLS. 100, 101, 102 AND 107). SN 78-734,302. PUB. 2-6-2007. FILED 10-17-2005.
- 3,232,614. **GOTCHA! THE DO'S & DON'TS OF CAR BUYING AND DESIGN**. AUTOMOTIVE.COM, INC., (U.S. CLS. 100, 101 AND 102). SN 78-734,789. PUB. 2-6-2007. FILED 10-17-2005.
- 3,232,615. **NATIONAL LEAGUE FOR NURSING (BLOCK FORM)**. NATIONAL LEAGUE FOR NURSING, MULTIPLE CLASS, (INT. CLS. 35 AND 41), (U.S. CLS. 100, 101, 102 AND 107). SN 78-735,452. PUB. 2-6-2007. FILED 10-18-2005.
- 3,232,624. **TXU ENERGY REWARDS+ (BLOCK FORM)**. TXU ENERGY RETAIL COMPANY LP, (U.S. CLS. 100, 101 AND 102). SN 78-738,209. PUB. 2-6-2007. FILED 10-21-2005.
- 3,232,625. **MEMBERSNOW (BLOCK FORM)**. EDI TECHNOLOGIES CORPORATION, (U.S. CLS. 100, 101 AND 102). SN 78-738,299. PUB. 2-6-2007. FILED 10-21-2005.
- 3,232,626. **BABY GIFT CLOUDS (BLOCK FORM)**. PITCHER, BRIAN, (U.S. CLS. 100, 101 AND 102). SN 78-738,477. PUB. 2-6-2007. FILED 10-21-2005.
- 3,232,634. **VYTOL BIOSYSTEMS (BLOCK FORM)**. MIDWEST VETERINARY SERVICES, INC., (U.S. CLS. 100, 101 AND 102). SN 78-740,367. PUB. 2-6-2007. FILED 10-25-2005.
- 3,232,635. **CUSTOMERS ARE AN INVESTMENT, MAXIMIZE YOUR RETURN (BLOCK FORM)**. MEDIATRAC, LLC, MULTIPLE CLASS, (INT. CLS. 35 AND 38), (U.S. CLS. 100, 101, 102 AND 104). SN 78-741,182. PUB. 2-6-2007. FILED 10-26-2005.
- 3,232,643. **GLOBE EXPRESS SERVICES AND DESIGN**. GLOBE EXPRESS SERVICES, LTD., (U.S. CLS. 100, 101 AND 102). SN 78-743,354. PUB. 2-6-2007. FILED 10-31-2005.
- 3,232,644. **ALYN-WEISS & ASSOCIATES, INC. (BLOCK FORM)**. ALYN-WEISS AND ASSOCIATES, INC., (U.S. CLS. 100, 101 AND 102). SN 78-743,417. PUB. 2-6-2007. FILED 10-31-2005.
- 3,232,645. **ASID FOUNDATION AND DESIGN**. AMERICAN SOCIETY OF INTERIOR DESIGNERS, INC., (U.S. CLS. 100, 101 AND 102). SN 78-743,808. PUB. 2-6-2007. FILED 10-31-2005.
- 3,232,650. **TDI (BLOCK FORM)**. CBS OUTDOOR INC., (U.S. CLS. 100, 101 AND 102). SN 78-744,636. PUB. 2-6-2007. FILED 11-1-2005.
- 3,232,652. **MERCH SOURCE (BLOCK FORM)**. MERCH-SOURCE, LLC, (U.S. CLS. 100, 101 AND 102). SN 78-744,858. PUB. 2-6-2007. FILED 11-1-2005.
- 3,232,654. **FUNDING READINESS LEVEL (FRL) (BLOCK FORM)**. COMMERCIALIZATION FUNDING COACH, INC., THE, (U.S. CLS. 100, 101 AND 102). SN 78-744,982. PUB. 2-6-2007. FILED 11-1-2005.
- 3,232,665. **TICKET2FAME (BLOCK FORM)**. CHANCE ENTERTAINMENT, LLC, (U.S. CLS. 100, 101 AND 102). SN 78-746,602. PUB. 2-6-2007. FILED 11-3-2005.
- 3,232,671. **SPOKESMANNEQUIN (BLOCK FORM)**. SULLIVANT, WAYNE A., MULTIPLE CLASS, (INT. CLS. 35 AND 41), (U.S. CLS. 100, 101, 102 AND 107). SN 78-747,856. PUB. 2-6-2007. FILED 11-4-2005.
- 3,232,673. **RTCRM (BLOCK FORM)**. WPP PROPERTIES, (U.S. CLS. 100, 101 AND 102). SN 78-748,418. PUB. 2-6-2007. FILED 11-7-2005.
- 3,232,674. **RTC (BLOCK FORM)**. WPP PROPERTIES, (U.S. CLS. 100, 101 AND 102). SN 78-748,462. PUB. 2-6-2007. FILED 11-7-2005.
- 3,232,676. **LINCOLN FINANCIAL SPORTS (BLOCK FORM)**. LINCOLN NATIONAL CORPORATION, (U.S. CLS. 100, 101 AND 102). SN 78-748,622. PUB. 2-6-2007. FILED 11-7-2005.
- 3,232,684. **PLAY LIKE THE BIG DOGS. (BLOCK FORM)**. HARRAH'S LICENSE COMPANY, LLC, MULTIPLE CLASS, (INT. CLS. 35 AND 41), (U.S. CLS. 100, 101, 102 AND 107). SN 78-750,151. PUB. 7-18-2006. FILED 11-9-2005.
- 3,232,685. **BLUE SQUARE STUDIOS (BLOCK FORM)**. BLUE SQUARE STUDIOS, LLC, MULTIPLE CLASS, (INT. CLS. 35 AND 42), (U.S. CLS. 100, 101 AND 102). SN 78-750,600. PUB. 2-6-2007. FILED 11-9-2005.
- 3,232,687. **SEE SPOT RUN (BLOCK FORM)**. ADVANTA CORP., (U.S. CLS. 100, 101 AND 102). SN 78-751,236. PUB. 2-6-2007. FILED 11-10-2005.
- 3,232,688. **STUDIOS AND DESIGN**. BLUE SQUARE STUDIOS, LLC, MULTIPLE CLASS, (INT. CLS. 35 AND 42), (U.S. CLS. 100, 101 AND 102). SN 78-751,245. PUB. 2-6-2007. FILED 11-10-2005.
- 3,232,696. **INTELLIGENT COMMUNITY FORUM (BLOCK FORM)**. ALAN/ANTHONY, INC., MULTIPLE CLASS, (INT. CLS. 35, 41 AND 42), (U.S. CLS. 100, 101, 102 AND 107). SN 78-751,964. PUB. 2-6-2007. FILED 11-11-2005.
- 3,232,697. **FOUNDATION MEDICAL STAFFING (BLOCK FORM)**. CHG MANAGEMENT, INC., (U.S. CLS. 100, 101 AND 102). SN 78-752,297. PUB. 2-6-2007. FILED 11-11-2005.
- 3,232,710. **NOTEWORTHY (BLOCK FORM)**. RACKSPACE, LTD., MULTIPLE CLASS, (INT. CLS. 35 AND 38), (U.S. CLS. 100, 101, 102 AND 104). SN 78-755,569. PUB. 10-31-2006. FILED 11-16-2005.
- 3,232,715. **MARVIN J. PERRY (BLOCK FORM)**. MARVIN J. PERRY, INC., (U.S. CLS. 100, 101 AND 102). SN 78-756,796. PUB. 7-25-2006. FILED 11-18-2005.
- 3,232,719. **MIGHTY BIDS (BLOCK FORM)**. MIGHTY BIDS AUCTIONS INC., (U.S. CLS. 100, 101 AND 102). SN 78-758,631. PUB. 2-6-2007. FILED 11-21-2005.
- 3,232,727. **HB HOMEWARD BOUND AND DESIGN**. HOUSTON VALLEY MATERIALS LLC, (U.S. CLS. 100, 101 AND 102). SN 78-762,851. PUB. 2-6-2007. FILED 11-29-2005.
- 3,232,728. **THE BRAINS BEHIND YOUR CASH FLOW (BLOCK FORM)**. INTELACCOUNT, INC., (U.S. CLS. 100, 101 AND 102). SN 78-762,935. PUB. 2-6-2007. FILED 11-29-2005.
- 3,232,743. **BEST LAB DEALS AND DESIGN**. BEST LAB DEALS, INC., MULTIPLE CLASS, (INT. CLS. 35 AND 37), (U.S. CLS. 100, 101, 102, 103 AND 106). SN 78-768,152. PUB. 2-6-2007. FILED 12-7-2005.

- 3,232,747. **MISCELLANEOUS DESIGN**. JOHNSON, ALBERT SIDNEY, (U.S. CLS. 100, 101 AND 102). SN 78-769,940. PUB. 2-6-2007. FILED 12-9-2005.
- 3,232,748. **DELIVERING RESULTS WITH INSPIRING REWARDS (BLOCK FORM)**. CASCADE PROMOTION CORPORATION, (U.S. CLS. 100, 101 AND 102). SN 78-769,959. PUB. 2-6-2007. FILED 12-9-2005.
- 3,232,754. **FLOWERS DIRECT (BLOCK FORM)**. FLORISTS' TRANSWORLD DELIVERY, INC., MULTIPLE CLASS, (INT. CLS. 35 AND 39), (U.S. CLS. 100, 101, 102 AND 105). SN 78-771,768. PUB. 2-6-2007. FILED 12-12-2005.
- 3,232,777. **THE BUSINESS DOC (BLOCK FORM)**. CANNON, RONALD JAY, (U.S. CLS. 100, 101 AND 102). SN 78-786,673. PUB. 2-6-2007. FILED 1-6-2006.
- 3,232,781. **JENNINGS (BLOCK FORM)**. JENNINGS CHEVROLET, INC., MULTIPLE CLASS, (INT. CLS. 35, 37 AND 39), (U.S. CLS. 100, 101, 102, 103, 105 AND 106). SN 78-787,356. PUB. 2-6-2007. FILED 1-9-2006.
- 3,232,785. **CHARITYBUZZ (BLOCK FORM)**. HOLZMAN, COPPY, (U.S. CLS. 100, 101 AND 102). SN 78-789,713. PUB. 2-6-2007. FILED 1-11-2006.
- 3,232,792. **CS CS CS CS COLLEEN'S SERVICES (BLOCK FORM)**. BAINBRIDGE, BONNIE C., AND LEMONS, COLLEEN, (U.S. CLS. 100, 101 AND 102). SN 78-795,153. PUB. 2-6-2007. FILED 1-19-2006.
- 3,232,798. **FWTOOLS (BLOCK FORM)**. FWTOOLS, INC., (U.S. CLS. 100, 101 AND 102). SN 78-798,653. PUB. 2-6-2007. FILED 1-25-2006.
- 3,232,799. **HEALTHCARE EXPRESS (BLOCK FORM)**. BILLARD, CHARLES, (U.S. CLS. 100, 101 AND 102). SN 78-798,755. PUB. 2-6-2007. FILED 1-25-2006.
- 3,232,804. **S.A.C.K. (BLOCK FORM)**. SACK FOUNDATION, (U.S. CLS. 100, 101 AND 102). SN 78-803,728. PUB. 2-6-2007. FILED 1-31-2006.
- 3,232,807. **THE FUTURE OF YOUR BACK OFFICE (BLOCK FORM)**. INTELACCOUNT, INC., (U.S. CLS. 100, 101 AND 102). SN 78-806,542. PUB. 2-6-2007. FILED 2-3-2006.
- 3,232,817. **T-MOBILE HOME (BLOCK FORM)**. DEUTSCHE TELEKOM AG, (U.S. CLS. 100, 101 AND 102). SN 78-811,139. PUB. 2-6-2007. FILED 2-9-2006.
- 3,232,819. **T-MOBILE HOMESPOT (BLOCK FORM)**. DEUTSCHE TELEKOM AG, (U.S. CLS. 100, 101 AND 102). SN 78-811,192. PUB. 2-6-2007. FILED 2-9-2006.
- 3,232,822. **T-MOBILE HOMESITE (BLOCK FORM)**. DEUTSCHE TELEKOM AG, (U.S. CLS. 100, 101 AND 102). SN 78-811,305. PUB. 2-6-2007. FILED 2-9-2006.
- 3,232,826. **LEBANONCITY IT'S EASIER FROM HERE. AND DESIGN: CITY OF LEBANON**, (U.S. CLS. 100, 101 AND 102). SN 78-814,276. PUB. 2-6-2007. FILED 2-14-2006.
- 3,232,828. **WOODS FUN CENTER (BLOCK FORM)**. AMERICA'S POWERSPORTS, INC., (U.S. CLS. 100, 101 AND 102). SN 78-815,109. PUB. 2-6-2007. FILED 2-15-2006.
- 3,232,843. **SHOWCASE REALTY AND DESIGN**. SHOWCASE REALTY, (U.S. CLS. 100, 101 AND 102). SN 78-824,533. PUB. 2-6-2007. FILED 2-27-2006.
- 3,232,845. **II INNODATA ISOGEN AND DESIGN**. INNODATA ISOGEN, INC., MULTIPLE CLASS, (INT. CLS. 35, 40, 41 AND 42), (U.S. CLS. 100, 101, 102, 103, 106 AND 107). SN 78-825,472. PUB. 2-6-2007. FILED 2-28-2006.
- 3,232,846. **NAUTICA (BLOCK FORM)**. NAUTICA APPAREL, INC., (U.S. CLS. 100, 101 AND 102). SN 78-825,489. PUB. 2-6-2007. FILED 2-28-2006.
- 3,232,847. **INNODATA ISOGEN (BLOCK FORM)**. INNODATA ISOGEN, INC., MULTIPLE CLASS, (INT. CLS. 35, 40, 41 AND 42), (U.S. CLS. 100, 101, 102, 103, 106 AND 107). SN 78-825,493. PUB. 2-6-2007. FILED 2-28-2006.
- 3,232,848. **INNODATA (BLOCK FORM)**. INNODATA ISOGEN, INC., MULTIPLE CLASS, (INT. CLS. 35, 40, 41 AND 42), (U.S. CLS. 100, 101, 102, 103, 106 AND 107). SN 78-825,555. PUB. 2-6-2007. FILED 2-28-2006.
- 3,232,849. **TOTAL QUALITY INDEX (BLOCK FORM)**. DARREL EDWARDS INC., (U.S. CLS. 100, 101 AND 102). SN 78-825,756. PUB. 2-6-2007. FILED 2-28-2006.
- 3,232,856 ( *See Class 25 for this trademark*).
- 3,232,863. **SIMPLIFY WITH STYLE (BLOCK FORM)**. SENSIBLY ORGANIZED INC., (U.S. CLS. 100, 101 AND 102). SN 78-833,871. PUB. 10-31-2006. FILED 3-9-2006.
- 3,232,868. **CLUB AWARE (BLOCK FORM)**. AWARE PRODUCTIONS, (U.S. CLS. 100, 101 AND 102). SN 78-835,519. PUB. 2-6-2007. FILED 3-13-2006.
- 3,232,880. **E-SALES ADVANTAGE AND DESIGN**. E-SALES ADVANTAGE ENTERPRISES, INC., (U.S. CLS. 100, 101 AND 102). SN 78-839,068. PUB. 2-6-2007. FILED 3-16-2006.
- 3,232,881. **DRUG REHAB THAT WORKS (BLOCK FORM)**. HOLTZ, DAVID, (U.S. CLS. 100, 101 AND 102). SN 78-839,431. PUB. 2-6-2007. FILED 3-16-2006.
- 3,232,882. **MCREPS (BLOCK FORM)**. MCREPS INC., (U.S. CLS. 100, 101 AND 102). SN 78-840,051. PUB. 2-6-2007. FILED 3-17-2006.
- 3,232,883. **NEEDASPA.COM AND DESIGN**. KNJ SOLUTIONS, LLC, (U.S. CLS. 100, 101 AND 102). SN 78-840,314. PUB. 2-6-2007. FILED 3-17-2006.
- 3,232,884. **CLICK-INS WELCOME (BLOCK FORM)**. KNJ SOLUTIONS, LLC, (U.S. CLS. 100, 101 AND 102). SN 78-840,341. PUB. 2-6-2007. FILED 3-17-2006.
- 3,232,887. **ROLO REALTY (BLOCK FORM)**. ROLO DEVELOPMENT, LLC, (U.S. CLS. 100, 101 AND 102). SN 78-841,389. PUB. 2-6-2007. FILED 3-20-2006.
- 3,232,891. **PACTRAC (BLOCK FORM)**. PACCAR FINANCIAL CORP., DBA PACCAR LEASING COMPANY, (U.S. CLS. 100, 101 AND 102). SN 78-842,636. PUB. 2-6-2007. FILED 3-21-2006.
- 3,232,897. **EIB EMPLOYEE INFORMATION BOOKLET (BLOCK FORM)**. ULTAN F. FEIGHERY, (U.S. CLS. 100, 101 AND 102). SN 78-846,985. PUB. 2-6-2007. FILED 3-27-2006.
- 3,232,903. **TURN TO US (BLOCK FORM)**. VERTIS, INC., MULTIPLE CLASS, (INT. CLS. 35, 40, 41 AND 42), (U.S. CLS. 100, 101, 102, 103, 106 AND 107). SN 78-848,168. PUB. 2-6-2007. FILED 3-28-2006.
- 3,232,904. **FIRST MEDICAL MANAGEMENT (BLOCK FORM)**. FCM-MTC MEDICAL, LLC, MULTIPLE CLASS, (INT. CLS. 35 AND 44), (U.S. CLS. 100, 101 AND 102). SN 78-848,303. PUB. 2-6-2007. FILED 3-28-2006.
- 3,232,911. **FMM (BLOCK FORM)**. FCM-MTC MEDICAL, LLC, MULTIPLE CLASS, (INT. CLS. 35 AND 44), (U.S. CLS. 100, 101 AND 102). SN 78-852,290. PUB. 2-6-2007. FILED 4-3-2006.
- 3,232,925. **NOVOGRADAC & COMPANY LLP CERTIFIED PUBLIC ACCOUNTANTS AND DESIGN**. NOVOGRADAC & COMPANY LLP, (U.S. CLS. 100, 101 AND 102). SN 78-856,465. PUB. 2-6-2007. FILED 4-7-2006.
- 3,232,928 ( *See Class 16 for this trademark*).
- 3,232,934. **FASHION LINK (BLOCK FORM)**. VANITY SHOP OF GRAND FORKS, INC., (U.S. CLS. 100, 101 AND 102). SN 78-859,678. PUB. 2-6-2007. FILED 4-12-2006.
- 3,232,935. **THE WILMINGTON GROUP EXECUTIVE SEARCH AND DESIGN**. ILM PARTNERS, INC., (U.S. CLS. 100, 101 AND 102). SN 78-860,732. PUB. 2-6-2007. FILED 4-13-2006.
- 3,232,944. **MIMEO.COM AND DESIGN**. MIMEO.COM, INC., MULTIPLE CLASS, (INT. CLS. 35, 39 AND 40), (U.S. CLS. 100, 101, 102, 103, 105 AND 106). SN 78-864,382. PUB. 2-6-2007. FILED 4-19-2006.
- 3,232,947. **SATELLIC TRAFFIC MANAGEMENT (BLOCK FORM)**. DEUTSCHE TELEKOM AG, (U.S. CLS. 100, 101 AND 102). SN 78-865,121. PUB. 2-6-2007. FILED 4-19-2006.
- 3,232,953. **NEXTRIDGE (BLOCK FORM)**. NEXTRIDGE, INC., MULTIPLE CLASS, (INT. CLS. 35 AND 36), (U.S. CLS. 100, 101 AND 102). SN 78-865,826. PUB. 2-6-2007. FILED 4-20-2006.
- 3,232,961. **THE FLOOR TRADER CARPET & FLOORS FROM AROUND THE WORLD AND DESIGN**. STONE MOUNTAIN CARPET MILLS, INC., (U.S. CLS. 100, 101 AND 102). SN 78-867,174. PUB. 2-6-2007. FILED 4-21-2006.
- 3,232,962. **BOUDINOT COVENANT SOCIETY AND DESIGN**. PRESBYTERIAN CHURCH (USA) FOUNDATION, MULTIPLE CLASS, (INT. CLS. 35 AND 36), (U.S. CLS. 100, 101 AND 102). SN 78-867,218. PUB. 2-6-2007. FILED 4-21-2006.
- 3,232,978. **GREATER RICHMOND CHAMBER AND DESIGN**. GREATER RICHMOND CHAMBER OF COMMERCE, (U.S. CLS. 100, 101 AND 102). SN 78-872,497. PUB. 2-6-2007. FILED 4-28-2006.
- 3,232,979. **BLUE ROOF (BLOCK FORM)**. GORNEY, EDEN B., (U.S. CLS. 100, 101 AND 102). SN 78-873,361. PUB. 2-6-2007. FILED 5-1-2006.
- 3,232,980. **NTP NATIONAL TRADE PRODUCTIONS AND**

- DESIGN**. NATIONAL TRADE PRODUCTIONS, INC., (U.S. CLS. 100, 101 AND 102). SN 78-873,523. PUB. 2-6-2007. FILED 5-1-2006.
- 3,232,986. **TRYLON SMR STRATEGIC MEDIA RELATIONS AND DESIGN**. TRYLON COMMUNICATIONS, INC., (U.S. CLS. 100, 101 AND 102). SN 78-876,435. PUB. 2-6-2007. FILED 5-4-2006.
- 3,232,990 ( *See Class 2 for this trademark*).
- 3,232,991. **COST PER PAGE (BLOCK FORM)**. LASERNETWORKS INC. MULTIPLE CLASS, (INT. CLS. 35 AND 37), (U.S. CLS. 100, 101, 102, 103 AND 106). SN 78-877,577. PUB. 2-6-2007. FILED 5-5-2006.
- 3,232,995. **CONSELECT ONLINE CONCEPT TESTING SOLUTION (BLOCK FORM)**. MRSI (MARKETING RESEARCH SERVICES, INC.), (U.S. CLS. 100, 101 AND 102). SN 78-879,386. PUB. 2-6-2007. FILED 5-9-2006.
- 3,233,002. **WORC AND DESIGN**. WORKFORCE ORGANIZATIONS FOR REGIONAL COLLABORATION, (U.S. CLS. 100, 101 AND 102). SN 78-880,312. PUB. 2-6-2007. FILED 5-10-2006.
- 3,233,012. **GOT WICKED? (BLOCK FORM)**. EMERALD CITY WEB DESIGN, INC., MULTIPLE CLASS, (INT. CLS. 35 AND 42), (U.S. CLS. 100, 101 AND 102). SN 78-882,564. PUB. 2-6-2007. FILED 5-12-2006.
- 3,233,013. **POWERFUL PRESENCE (BLOCK FORM)**. CBS OUTDOOR INC., (U.S. CLS. 100, 101 AND 102). SN 78-882,568. PUB. 2-6-2007. FILED 5-12-2006.
- 3,233,031. **CONCEPT NINJA AND DESIGN**. MANIS, PETER J, (U.S. CLS. 100, 101 AND 102). SN 78-885,688. PUB. 2-6-2007. FILED S.R. 5-17-2006; AM. P.R. 11-21-2006.
- 3,233,042. **ANY MOUNTAIN (BLOCK FORM)**. SSI VENTURE LLC, MULTIPLE CLASS, (INT. CLS. 35 AND 41), (U.S. CLS. 100, 101, 102 AND 107). SN 78-888,216. PUB. 2-6-2007. FILED 5-19-2006.
- 3,233,044. **SAVVY EQUESTRIAN AND DESIGN**. LASALLE, REBECCA, (U.S. CLS. 100, 101 AND 102). SN 78-888,271. PUB. 2-6-2007. FILED 5-19-2006.
- 3,233,047. **CASHPAY COMPLETE (BLOCK FORM)**. BLACK DIAMOND GROUP, LLC, (U.S. CLS. 100, 101 AND 102). SN 78-888,497. PUB. 2-6-2007. FILED 5-20-2006.
- 3,233,065. **WHERE PEOPLE WITH DISABILITIES... BENEFIT (BLOCK FORM)**. RESOURCE CORPORATION OF AMERICA & RECOVERY OF TEXAS, INC., (U.S. CLS. 100, 101 AND 102). SN 78-894,325. PUB. 2-6-2007. FILED 5-26-2006.
- 3,233,072. **24 HOUR TAX SERVICES AND DESIGN**. PERGADIA, PRATIKSHA, (U.S. CLS. 100, 101 AND 102). SN 78-896,091. PUB. 2-6-2007. FILED 5-30-2006.
- 3,233,073. **LIMELITE ADVERTISING (BLOCK FORM)**. C-MOBILITY ADVERTISING, INC., (U.S. CLS. 100, 101 AND 102). SN 78-896,193. PUB. 2-6-2007. FILED 5-30-2006.
- 3,233,089. **DRAKE'S (BLOCK FORM)**. LYNN W. GENTLE TRUST OF 1990, A CALIFORNIA TRUST, THE TRUSTEES COMPRISING LYNN W. GENTLE, A CITIZEN OF THE UNITED STATES, THE, MULTIPLE CLASS, (INT. CLS. 35 AND 41), (U.S. CLS. 100, 101, 102 AND 107). SN 78-900,370. PUB. 2-6-2007. FILED 6-5-2006.
- 3,233,092. **CHK NUTRITION (BLOCK FORM)**. HINZ, MARTIN C., (U.S. CLS. 100, 101 AND 102). SN 78-900,739. PUB. 2-6-2007. FILED 6-5-2006.
- 3,233,098. **MAXPREPS (BLOCK FORM)**. MAXPREPS, INC., MULTIPLE CLASS, (INT. CLS. 35 AND 41), (U.S. CLS. 100, 101, 102 AND 107). SN 78-901,906. PUB. 2-6-2007. FILED 6-6-2006.
- 3,233,106. **WEIMAGINE (BLOCK FORM)**. MARKIE, ELIZABETH, (U.S. CLS. 100, 101 AND 102). SN 78-903,247. PUB. 2-6-2007. FILED 6-7-2006.
- 3,233,122. **S (STYLIZED)**. SIGNET SOLUTIONS, INC., (U.S. CLS. 100, 101 AND 102). SN 78-905,220. PUB. 2-6-2007. FILED 6-9-2006.
- 3,233,124 ( *See Class 18 for this trademark*).
- 3,233,130. **FRONT AGENT (BLOCK FORM)**. FEDERAL SCHEDULERS LTD, (U.S. CLS. 100, 101 AND 102). SN 78-906,484. PUB. 2-6-2007. FILED 6-13-2006.
- 3,233,133. **EXPERIENCE THE WOODLANDS (BLOCK FORM)**. FLORY, MICHELE M., (U.S. CLS. 100, 101 AND 102). SN 78-906,666. PUB. 2-6-2007. FILED 6-13-2006.
- 3,233,141. **SIX SIGMA ACADEMY (BLOCK FORM)**. SIX SIGMA ACADEMY INTERNATIONAL, LLC, (U.S. CLS. 100, 101 AND 102). SN 78-907,232. PUB. 2-6-2007. FILED 6-13-2006.
- 3,233,150. **QSP QUALITY SERVICE PROCESS AND DESIGN**. E & H DISTRIBUTING CO., (U.S. CLS. 100, 101 AND 102). SN 78-907,906. PUB. 2-6-2007. FILED 6-14-2006.
- 3,233,160. **HFM (BLOCK FORM)**. HEMOPHILIA FOUNDATION OF MICHIGAN, (U.S. CLS. 100, 101 AND 102). SN 78-908,676. PUB. 2-6-2007. FILED 6-15-2006.
- 3,233,175. **VOTE LEAVE YOUR PRINT AND DESIGN**. LT. GOVERNOR'S OFFICE OF THE STATE OF UTAH, (U.S. CLS. 100, 101 AND 102). SN 78-909,353. PUB. 2-6-2007. FILED 6-15-2006.
- 3,233,190. **PROTUO (BLOCK FORM)**. DUNAMIS COMMUNICATIONS LLC, (U.S. CLS. 100, 101 AND 102). SN 78-909,997. PUB. 2-6-2007. FILED 6-16-2006.
- 3,233,193. **AMERICA'S FAVORITE FAVORS (BLOCK FORM)**. TAYMARK, INC., (U.S. CLS. 100, 101 AND 102). SN 78-910,178. PUB. 2-6-2007. FILED 6-16-2006.
- 3,233,194. **MULTIFAMILY EXECUTIVE LEADERSHIP SUMMIT AND DESIGN**. HANLEY-WOOD, LLC, (U.S. CLS. 100, 101 AND 102). SN 78-910,187. PUB. 2-6-2007. FILED 6-16-2006.
- 3,233,200. **BACKYARD FUNSTORE (BLOCK FORM)**. ALLIANCE TRADING, INC., (U.S. CLS. 100, 101 AND 102). SN 78-910,496. PUB. 2-6-2007. FILED 6-16-2006.
- 3,233,208. **FEDORA COLLECTION (BLOCK FORM)**. FEDORA COLLECTION, INC., (U.S. CLS. 100, 101 AND 102). SN 78-910,869. PUB. 2-6-2007. FILED 6-19-2006.
- 3,233,209. **SCANDIA DOWN (BLOCK FORM)**. SCANDIA DOWN, LLC, (U.S. CLS. 100, 101 AND 102). SN 78-910,945. PUB. 2-6-2007. FILED 6-19-2006.
- 3,233,211. **BIC BAC AND DESIGN**. KEL & PARTNERS LLC, MULTIPLE CLASS, (INT. CLS. 35 AND 41), (U.S. CLS. 100, 101, 102 AND 107). SN 78-910,992. PUB. 2-6-2007. FILED 6-19-2006.
- 3,233,212. **THE TAX CAFÉ INCOME TAX PREPARATION PLUS 1 7 4 3 6 8 2 9 5 AND DESIGN**. THE TAX CAFE INC., MULTIPLE CLASS, (INT. CLS. 35 AND 43), (U.S. CLS. 100, 101 AND 102). SN 78-911,162. PUB. 2-6-2007. FILED 6-19-2006.
- 3,233,217. **SOAVE (BLOCK FORM)**. SOAVE ENTERPRISES L.L.C., MULTIPLE CLASS, (INT. CLS. 35, 36, 37, 39, 40 AND 43), (U.S. CLS. 100, 101, 102, 103, 105 AND 106). SN 78-911,484. PUB. 2-6-2007. FILED 6-19-2006.
- 3,233,223. **CUSTOMER FOR A DAY (BLOCK FORM)**. QUEST ENGINEERING CONSULTANTS INC., (U.S. CLS. 100, 101 AND 102). SN 78-911,800. PUB. 2-6-2007. FILED 6-19-2006.
- 3,233,237. **ALADEX (BLOCK FORM)**. ALADEX CORP., (U.S. CLS. 100, 101 AND 102). SN 78-912,382. PUB. 2-6-2007. FILED 6-20-2006.
- 3,233,238. **WE HELP PEOPLE REMEMBER YOUR NAME. (BLOCK FORM)**. STUCK, JAY, (U.S. CLS. 100, 101 AND 102). SN 78-912,459. PUB. 2-6-2007. FILED 6-20-2006.
- 3,233,244. **CONVERTINATOR (BLOCK FORM)**. FIDELITY ASSETS, LLC, (U.S. CLS. 100, 101 AND 102). SN 78-912,729. PUB. 2-6-2007. FILED 6-20-2006.
- 3,233,249. **WE DO YOUR JOB RIGHT - THE FIRST TIME. (BLOCK FORM)**. INTERNATIONAL BROTHERHOOD OF BOILERMAKERS, IRON SHIP BUILDERS, BLACKSMITHS, FORGERS & HELPERS, (U.S. CLS. 100, 101 AND 102). SN 78-912,824. PUB. 2-6-2007. FILED 6-20-2006.
- 3,233,251. **CONSUMERSEARCH (BLOCK FORM)**. CONSUMERSEARCH, INC., (U.S. CLS. 100, 101 AND 102). SN 78-912,908. PUB. 2-6-2007. FILED 6-21-2006.
- 3,233,259. **WE FIND A WAY (BLOCK FORM)**. INTREPID U.S.A., INC., MULTIPLE CLASS, (INT. CLS. 35 AND 44), (U.S. CLS. 100, 101 AND 102). SN 78-912,984. PUB. 2-6-2007. FILED 6-21-2006.
- 3,233,272. **IT IS JUST THE BEGINNING (BLOCK FORM)**. OMNATION CORPORATION, (U.S. CLS. 100, 101 AND 102). SN 78-913,618. PUB. 2-6-2007. FILED 6-21-2006.
- 3,233,274. **LIFE SETTLEMENT AWARENESS MONTH LSAM AND DESIGN**. NOMIS, L.P., MULTIPLE CLASS, (INT. CLS. 35 AND 41), (U.S. CLS. 100, 101, 102 AND 107). SN 78-913,744. PUB. 2-6-2007. FILED 6-21-2006.
- 3,233,283. **MAJOR (BLOCK FORM)**. THE MAJOR AUTOMOTIVE COMPANIES, INC., (U.S. CLS. 100, 101 AND 102). SN 78-914,517. PUB. 2-6-2007. FILED 6-22-2006.

- 3,233,288. **MAJOR WORLD (BLOCK FORM)**. THE MAJOR AUTOMOTIVE COMPANIES, INC., (U.S. CLS. 100, 101 AND 102). SN 78-914,542. PUB. 2-6-2007. FILED 6-22-2006.
- 3,233,296. **DAVANTE (BLOCK FORM)**. LUXURY OPTICAL HOLDINGS CO., (U.S. CLS. 100, 101 AND 102). SN 78-914,663. PUB. 2-6-2007. FILED 6-22-2006.
- 3,233,302. **ELITE MOTOR CARS (BLOCK FORM)**. MONO-GIOUDIS, NICK, (U.S. CLS. 100, 101 AND 102). SN 78-914,816. PUB. 2-6-2007. FILED 6-22-2006.
- 3,233,304. **LISTEN TO YOUR PASSION (BLOCK FORM)**. SANSOUCY, RYAN, (U.S. CLS. 100, 101 AND 102). SN 78-914,844. PUB. 2-6-2007. FILED 6-22-2006.
- 3,233,309. **SEEKWEED (BLOCK FORM)**. THELADDERS.-COM, INC., MULTIPLE CLASS, (INT. CLS. 35 AND 41), (U.S. CLS. 100, 101, 102 AND 107). SN 78-915,008. PUB. 2-6-2007. FILED 6-22-2006.
- 3,233,320. **HUFF (BLOCK FORM)**. JIM HUFF REALTY, INC., (U.S. CLS. 100, 101 AND 102). SN 78-915,431. PUB. 2-6-2007. FILED 6-23-2006.
- 3,233,331. **CABLE INNOVATES (BLOCK FORM)**. NATIONAL CABLE AND TELECOMMUNICATIONS ASSOCIATION, INC., (U.S. CLS. 100, 101 AND 102). SN 78-915,746. PUB. 2-6-2007. FILED 6-23-2006.
- 3,233,332. **CABLE PROVIDES (BLOCK FORM)**. NATIONAL CABLE AND TELECOMMUNICATIONS ASSOCIATION, INC., (U.S. CLS. 100, 101 AND 102). SN 78-915,770. PUB. 2-6-2007. FILED 6-23-2006.
- 3,233,336. **BARRETT-JACKSON (STYLIZED)**. BARRETT-JACKSON AUCTION COMPANY, LLC, (U.S. CLS. 100, 101 AND 102). SN 78-915,847. PUB. 2-6-2007. FILED 6-23-2006.
- 3,233,347. **AUBRY KREWE AND DESIGN**. M'DEAR, (U.S. CLS. 100, 101 AND 102). SN 78-916,072. PUB. 2-6-2007. FILED 6-23-2006.
- 3,233,348. **AUBRY AND DESIGN**. M'DEAR INC, (U.S. CLS. 100, 101 AND 102). SN 78-916,073. PUB. 2-6-2007. FILED 6-23-2006.
- 3,233,355. **TRUCLAIM (BLOCK FORM)**. TC3 HEALTH, LLC., MULTIPLE CLASS, (INT. CLS. 35, 42 AND 45), (U.S. CLS. 100, 101 AND 102). SN 78-916,336. PUB. 2-6-2007. FILED 6-25-2006.
- 3,233,360. **KLEENWELL (BLOCK FORM)**. G.F. LASSWELL BRUSH COMPANY, INC., (U.S. CLS. 100, 101 AND 102). SN 78-916,698. PUB. 2-6-2007. FILED 6-26-2006.
- 3,233,365. **IDEAS THAT MAKE A DIFFERENCE (BLOCK FORM)**. HUMES & BARRINGTON, LLP, (U.S. CLS. 100, 101 AND 102). SN 78-916,950. PUB. 2-6-2007. FILED 6-26-2006.
- 3,233,368. **PERFORMANCE ASSURANCE (BLOCK FORM)**. PRENOVA, INC., (U.S. CLS. 100, 101 AND 102). SN 78-917,012. PUB. 2-6-2007. FILED 6-26-2006.
- 3,233,386. **FROM FIELDS TO FUEL (BLOCK FORM)**. AMERICAN COALITION FOR ETHANOL, (U.S. CLS. 100, 101 AND 102). SN 78-917,278. PUB. 2-6-2007. FILED 6-26-2006.
- 3,233,399. **AUTOTEC (BLOCK FORM)**. AUTOTEC, LLC, (U.S. CLS. 100, 101 AND 102). SN 78-917,573. PUB. 2-6-2007. FILED 6-27-2006.
- 3,233,401. **A AUTOTEC AND DESIGN**. AUTOTEC, LLC, (U.S. CLS. 100, 101 AND 102). SN 78-917,580. PUB. 2-6-2007. FILED 6-27-2006.
- 3,233,403. **EFFICIENT EVOLUTIONS (BLOCK FORM)**. EFFICIENT EVOLUTIONS LLC, (U.S. CLS. 100, 101 AND 102). SN 78-917,675. PUB. 2-6-2007. FILED 6-27-2006.
- 3,233,421. **PAG PRIVATEBRANDS AND DESIGN**. PACIFIC ART GROUP LLC, (U.S. CLS. 100, 101 AND 102). SN 78-918,235. PUB. 2-6-2007. FILED 6-27-2006.
- 3,233,425. **YOU'VE SEEN THE SOUTH...NOW DISCOVER HER SECRETS (BLOCK FORM)**. SECRETS OF THE SOUTH MEDIA, INC., (U.S. CLS. 100, 101 AND 102). SN 78-918,459. PUB. 2-6-2007. FILED 6-28-2006.
- 3,233,426. **FLOSOURCE (BLOCK FORM)**. FLOSOURCE, INC., (U.S. CLS. 100, 101 AND 102). SN 78-918,469. PUB. 2-6-2007. FILED 6-28-2006.
- 3,233,441. **SOAVE AND DESIGN**. SOAVE ENTERPRISES L.L.C., MULTIPLE CLASS, (INT. CLS. 35, 36, 37, 39, 40 AND 43), (U.S. CLS. 100, 101, 102, 103, 105 AND 106). SN 78-919,349. PUB. 2-6-2007. FILED 6-28-2006.
- 3,233,442. **HIREWORKERS.COM AND DESIGN**. EMERGING DEMOGRAPHICS INC., (U.S. CLS. 100, 101 AND 102). SN 78-919,355. PUB. 2-6-2007. FILED 6-28-2006.
- 3,233,471. **POWER SALES JOBS (BLOCK FORM)**. POWELL, CARLTON L., (U.S. CLS. 100, 101 AND 102). SN 78-922,000. PUB. 2-6-2007. FILED 7-3-2006.
- 3,233,473. **SUGAR SUGAR AND DESIGN**. SUGAR SUGAR, INC., (U.S. CLS. 100, 101 AND 102). SN 78-922,106. PUB. 2-6-2007. FILED 7-3-2006.
- 3,233,491. **FONVILLE PRESS (BLOCK FORM)**. EBSCO INDUSTRIES, INC., (U.S. CLS. 100, 101 AND 102). SN 78-937,050. PUB. 2-6-2007. FILED 7-25-2006.
- 3,233,492. **PLANVIEW (BLOCK FORM)**. PLANVIEW, INC., (U.S. CLS. 100, 101 AND 102). SN 78-937,143. PUB. 10-31-2006. FILED 7-25-2006.
- 3,233,493. **MISCELLANEOUS DESIGN**. GSI COMMERCE SOLUTIONS, INC., MULTIPLE CLASS, (INT. CLS. 35, 36 AND 42), (U.S. CLS. 100, 101 AND 102). SN 78-941,499. PUB. 2-6-2007. FILED 7-31-2006.
- 3,233,520 ( *See Class 1 for this trademark*).
- 3,233,530. **LIVE TEST AND DESIGN**. IN-TOUCH MARKETING COMPANY, MULTIPLE CLASS, (INT. CLS. 35, 38 AND 42), (U.S. CLS. 100, 101, 102 AND 104). SN 79-012,896. PUB. 2-6-2007. FILED 12-9-2004.
- 3,233,535 ( *See Class 9 for this trademark*).
- 3,233,539 ( *See Class 9 for this trademark*).
- 3,233,561 ( *See Class 33 for this trademark*).
- 3,233,565 ( *See Class 9 for this trademark*).
- 3,233,568. **PSM (BLOCK FORM)**. FÉDÉRATION INTERNATIONALE DES INGÉNIEURS-CONSEILS (FIDIC), MULTIPLE CLASS, (INT. CLS. 35 AND 41), (U.S. CLS. 100, 101, 102 AND 107). SN 79-017,414. PUB. 2-6-2007. FILED 9-2-2005.
- 3,233,597 ( *See Class 9 for this trademark*).
- 3,233,605 ( *See Class 9 for this trademark*).
- 3,233,620. **OPEN WENGO (STYLIZED)**. WENGO, MULTIPLE CLASS, (INT. CLS. 35, 38 AND 42), (U.S. CLS. 100, 101, 102 AND 104). SN 79-020,200. PUB. 2-6-2007. FILED 11-14-2005.
- 3,233,621. **PEAK PERFORMANCE (BLOCK FORM)**. PEAK PERFORMANCE PRODUCTION AB, (U.S. CLS. 100, 101 AND 102). SN 79-020,209. PUB. 2-6-2007. FILED 12-13-2005.
- 3,233,625 ( *See Class 21 for this trademark*).
- 3,233,651. **AFFILIATEFUTURE AND DESIGN**. AFFILIATE FUTURE LIMITED, (U.S. CLS. 100, 101 AND 102). SN 79-021,392. PUB. 2-6-2007. FILED 11-14-2005.
- 3,233,662. **VITAGORA THE TASTE, NUTRITION AND HEALTH INNOVATION POLE AND DESIGN**. SYNERGENCE, MULTIPLE CLASS, (INT. CLS. 35, 36, 41 AND 42), (U.S. CLS. 100, 101, 102 AND 107). SN 79-021,858. PUB. 2-6-2007. FILED 8-31-2005.
- 3,233,697. **MISCELLANEOUS DESIGN**. INTERFACE CORPORATION, (U.S. CLS. 100, 101 AND 102). SN 79-023,392. PUB. 2-6-2007. FILED 3-3-2006.
- 3,233,698. **DOCTOR CONNIE (STYLIZED)**. INTERFACE CORPORATION, (U.S. CLS. 100, 101 AND 102). SN 79-023,395. PUB. 2-6-2007. FILED 3-3-2006.
- 3,233,699. **DIA (STYLIZED)**. RÖHM GMBH & CO. KG, (U.S. CLS. 100, 101 AND 102). SN 79-023,399. PUB. 2-6-2007. FILED 3-1-2006.
- 3,233,700 ( *See Class 7 for this trademark*).
- 3,233,703 ( *See Class 7 for this trademark*).
- 3,233,728 ( *See Class 14 for this trademark*).
- 3,233,754. **LINKME (BLOCK FORM)**. LINKME PTY LIMITED, MULTIPLE CLASS, (INT. CLS. 35 AND 45), (U.S. CLS. 100, 101 AND 102). SN 79-028,112. PUB. 2-6-2007. FILED 3-31-2006.
- 
- CLASS 36—INSURANCE AND FINANCIAL**
- 3,232,050. **ACCIDENT INSURANCE SERVICES THE PYRAMID - YOUR SHIELD OF PROTECTION AND DESIGN**. ACCIDENT INSURANCE SERVICES, INC., (U.S. CL. 102). SN 74-453,303. PUB. 2-6-2007. FILED 11-2-1993.
- 3,232,070. **MBI INTERNATIONAL & PARTNERS AND DESIGN**. MBI INTERNATIONAL, INC., (U.S. CLS. 100, 101 AND 102). SN 76-395,446. PUB. 12-20-2005. FILED 4-15-2002.
- 3,232,080. **VI AND DESIGN**. VENVEST, INCORPORATED, (U.S. CLS. 100, 101 AND 102). SN 76-522,322. PUB. 10-12-

2004. FILED 6-4-2003.  
 3,232,095 ( *See Class 9 for this trademark*).  
 3,232,098 ( *See Class 35 for this trademark*).  
 3,232,099. **MOVE PERKS NOW IT PAYS TO MOVE! AND DESIGN.** CHAMNESS RELOCATION SERVICES, INC., (U.S. CLS. 100, 101 AND 102). SN 76-611,632. PUB. 2-6-2007. FILED 9-16-2004.  
 3,232,100. **NOW IT PAYS TO MOVE! AND DESIGN.** CHAMNESS RELOCATION SERVICES, INC., (U.S. CLS. 100, 101 AND 102). SN 76-611,633. PUB. 2-6-2007. FILED 9-16-2004.  
 3,232,105. **GAMEDAY CENTERS LUXURY SPORTS CONDOMINIUMS AND DESIGN.** GAMEDAY CENTERS S.E., LLC, (U.S. CLS. 100, 101 AND 102). SN 76-621,193. PUB. 2-6-2007. FILED 11-18-2004.  
 3,232,126. **MERCANTILE-SAFE DEPOSIT AND TRUST COMPANY (BLOCK FORM).** MERCANTILE BANKSHARES CORPORATION, (U.S. CLS. 100, 101 AND 102). SN 76-637,970. PUB. 2-6-2007. FILED 5-6-2005.  
 3,232,150. **EL SERVICIO QUE USTED DESEA, LA ATENCION AL CLIENTE QUE USTED MERECE. (BLOCK FORM).** ACC CAPITAL HOLDINGS CORPORATION, (U.S. CLS. 100, 101 AND 102). SN 76-648,060. PUB. 2-6-2007. FILED 10-6-2005.  
 3,232,182 ( *See Class 35 for this trademark*).  
 3,232,183 ( *See Class 35 for this trademark*).  
 3,232,184 ( *See Class 35 for this trademark*).  
 3,232,185 ( *See Class 35 for this trademark*).  
 3,232,188 ( *See Class 9 for this trademark*).  
 3,232,200. **TOWNHOUSE TIMES (BLOCK FORM).** TOWNHOUSE TIMES LLC, (U.S. CLS. 100, 101 AND 102). SN 76-655,796. PUB. 2-6-2007. FILED 2-28-2006.  
 3,232,250. **BENEFITREADY (BLOCK FORM).** OUTSOURCEONE, INC., (U.S. CLS. 100, 101 AND 102). SN 76-661,988. PUB. 2-6-2007. FILED 6-22-2006.  
 3,232,265. **THE SMART TARGET FUNDS (BLOCK FORM).** THE INSTITUTE FOR WEALTH MANAGEMENT, LLC, (U.S. CLS. 100, 101 AND 102). SN 76-662,903. PUB. 2-6-2007. FILED 7-10-2006.  
 3,232,271. **XC+ (BLOCK FORM).** THE CINCINNATI INSURANCE COMPANY, (U.S. CLS. 100, 101 AND 102). SN 76-664,133. PUB. 2-6-2007. FILED 8-4-2006.  
 3,232,272. **NEWFIRST (BLOCK FORM).** NEWFIRST BANK, (U.S. CLS. 100, 101 AND 102). SN 76-664,568. PUB. 2-6-2007. FILED 8-14-2006.  
 3,232,286. **HEALTHSCORE (BLOCK FORM).** CANOPY FINANCIAL, INC., (U.S. CLS. 100, 101 AND 102). SN 77-002,868. PUB. 2-6-2007. FILED 9-19-2006.  
 3,232,289. **COMMISSIONLINK (BLOCK FORM).** LEHMAN BROTHERS INC., (U.S. CLS. 100, 101 AND 102). SN 77-008,345. PUB. 2-6-2007. FILED 9-27-2006.  
 3,232,304. **BUILDSTATS (BLOCK FORM).** WILLIS NORTH AMERICA INC., (U.S. CLS. 100, 101 AND 102). SN 77-027,208. PUB. 2-6-2007. FILED 10-23-2006.  
 3,232,324. **SPIES.** LEHMAN BROTHERS INC., (U.S. CLS. 100, 101 AND 102). SN 78-201,506. PUB. 2-6-2007. FILED 1-9-2003.  
 3,232,344. **MISS AMERICA'S OUTSTANDING TEEN (BLOCK FORM).** THE MISS AMERICA ORGANIZATION, MULTIPLE CLASS, (INT. CLS. 36 AND 41), (U.S. CLS. 100, 101, 102 AND 107). SN 78-344,995. PUB. 2-6-2007. FILED 12-23-2003.  
 3,232,355. **LATITUDE SUBROGATION SERVICES (BLOCK FORM).** LATITUDE SUBROGATION SERVICES LLC, (U.S. CLS. 100, 101 AND 102). SN 78-413,363. PUB. 2-6-2007. FILED 5-5-2004.  
 3,232,356. **LATITUDE SUBROGATION SERVICES AND DESIGN.** LATITUDE SUBROGATION SERVICES, LLC, (U.S. CLS. 100, 101 AND 102). SN 78-413,369. PUB. 2-6-2007. FILED 5-5-2004.  
 3,232,369 ( *See Class 9 for this trademark*).  
 3,232,382. **STOP HUNGER (BLOCK FORM).** SODEXHO OPERATIONS, LLC, (U.S. CLS. 100, 101 AND 102). SN 78-516,488. PUB. 2-6-2007. FILED S.R. 11-13-2004; AM. P.R. 3-16-2006.  
 3,232,405. **LFE (BLOCK FORM).** FRECON, LESLIE A. (U.S. CLS. 100, 101 AND 102). SN 78-558,982. PUB. 2-6-2007. FILED 2-2-2005.  
 3,232,424 ( *See Class 35 for this trademark*).  
 3,232,426 ( *See Class 9 for this trademark*).  
 3,232,429 ( *See Class 35 for this trademark*).  
 3,232,432 ( *See Class 9 for this trademark*).  
 3,232,442. **TITLE2LAND (BLOCK FORM).** TITLE2LAND LLC, MULTIPLE CLASS, (INT. CLS. 36 AND 42), (U.S. CLS. 100, 101 AND 102). SN 78-594,087. PUB. 2-6-2007. FILED 3-24-2005.  
 3,232,466 ( *See Class 35 for this trademark*).  
 3,232,474. **RESTAURANT DIRECT (BLOCK FORM).** NATIONAL RESTAURANT ASSOCIATION, (U.S. CLS. 100, 101 AND 102). SN 78-623,605. PUB. 2-6-2007. FILED 5-5-2005.  
 3,232,489. **LIVE SMART. BANK SMART. (BLOCK FORM).** MISSION FEDERAL CREDIT UNION, (U.S. CLS. 100, 101 AND 102). SN 78-639,127. PUB. 2-7-2006. FILED 5-27-2005.  
 3,232,493. **HOUSE FINDER (BLOCK FORM).** BRAIN WAREHOUSE LLC, (U.S. CLS. 100, 101 AND 102). SN 78-645,582. PUB. 2-6-2007. FILED 6-7-2005.  
 3,232,514. **SIGNATURE APPRAISALS (BLOCK FORM).** SIGNATURE APPRAISALS, UNDERWRITING AND LOSS CONTROL, INC., (U.S. CLS. 100, 101 AND 102). SN 78-663,365. PUB. 2-6-2007. FILED 7-4-2005.  
 3,232,518. **ABCF EARLY DETECTION IS THE KEY TO LIFE AND DESIGN.** THE AMERICAN BREAST CANCER FOUNDATION, INC., (U.S. CLS. 100, 101 AND 102). SN 78-667,190. PUB. 2-6-2007. FILED 7-11-2005.  
 3,232,533 ( *See Class 35 for this trademark*).  
 3,232,540. **NATIONAL FINANCIAL AND DESIGN.** FMR CORP., (U.S. CLS. 100, 101 AND 102). SN 78-684,907. PUB. 8-22-2006. FILED 8-3-2005.  
 3,232,541. **NATIONAL FINANCIAL INTEGRATED BROKERAGE SOLUTIONS A FIDELITY INVESTMENTS COMPANY AND DESIGN.** FMR CORP., (U.S. CLS. 100, 101 AND 102). SN 78-684,909. PUB. 8-22-2006. FILED 8-3-2005.  
 3,232,564. **DISABILITIES AND DESIGN.** AL SIGL CENTER FOR REHABILITATION AGENCIES, INC., (U.S. CLS. 100, 101 AND 102). SN 78-705,427. PUB. 2-6-2007. FILED 9-1-2005.  
 3,232,571. **THE HUMPHREYS GROUP (BLOCK FORM).** THE HUMPHREYS GROUP, (U.S. CLS. 100, 101 AND 102). SN 78-711,435. PUB. 2-6-2007. FILED 9-12-2005.  
 3,232,578. **THE HOME EXPERT TEAM AND DESIGN.** DIEZ, SUSAN, D. AND MCCLUSKEY, DESIREE, (U.S. CLS. 100, 101 AND 102). SN 78-717,706. PUB. 2-6-2007. FILED 9-21-2005.  
 3,232,579 ( *See Class 35 for this trademark*).  
 3,232,597. **RIDE FOR HOPE..... SPONSOR A CHILD NON-PROFIT, GOOD HOPE EQUESTRIAN TRAINING CENTER, THERAPEUTIC HORSEBACK TRAINING AND DESIGN.** GOOD HOPE EQUESTRIAN TRAINING CENTER, INC., (U.S. CLS. 100, 101 AND 102). SN 78-727,104. PUB. 2-6-2007. FILED 10-5-2005.  
 3,232,613 ( *See Class 35 for this trademark*).  
 3,232,639. **THORNBURG COMPANIES AND DESIGN.** THORNBURG, H. GARRETT, (U.S. CLS. 100, 101 AND 102). SN 78-742,529. PUB. 2-6-2007. FILED 10-28-2005.  
 3,232,664. **VISUAL RISK SOLUTIONS (BLOCK FORM).** VISUAL RISK SOLUTIONS, INC., (U.S. CLS. 100, 101 AND 102). SN 78-746,212. PUB. 2-6-2007. FILED 11-3-2005.  
 3,232,698. **LAIDLAW & COMPANY (BLOCK FORM).** DOCALONTI LLC, (U.S. CLS. 100, 101 AND 102). SN 78-752,897. PUB. 2-6-2007. FILED 11-14-2005.  
 3,232,700. **ALUMNI BENEFITS AND DESIGN.** AFFINITY DIRECT, LLC, (U.S. CLS. 100, 101 AND 102). SN 78-753,110. PUB. 2-6-2007. FILED 11-14-2005.  
 3,232,711. **CSDC (BLOCK FORM).** CHARTER SCHOOLS DEVELOPMENT CORPORATION, MULTIPLE CLASS, (INT. CLS. 36 AND 37), (U.S. CLS. 100, 101, 102, 103 AND 106). SN 78-755,868. PUB. 2-6-2007. FILED 11-17-2005.  
 3,232,722. **CALPRO APPRAISAL SERVICES AND DESIGN.** CALIFORNIA PROFESSIONAL APPRAISAL SERVICES, INC., (U.S. CLS. 100, 101 AND 102). SN 78-760,623. PUB. 2-6-2007. FILED 11-23-2005.  
 3,232,725. **KIDS 2 KIDS HEIFER INTERNATIONAL (BLOCK FORM).** HEIFER PROJECT INTERNATIONAL, (U.S. CLS. 100, 101 AND 102). SN 78-761,841. PUB. 2-6-2007. FILED 11-28-2005.  
 3,232,820. **ACCUBANC MORTGAGE (BLOCK FORM).** NATIONAL CITY CORPORATION, (U.S. CLS. 100, 101 AND 102). SN 78-811,198. PUB. 2-6-2007. FILED 2-9-2006.  
 3,232,853. **PAN-MASSACHUSETTS CHALLENGE (BLOCK FORM).** PAN-MASSACHUSETTS CHALLENGE, INC.,

- (U.S. CLS. 100, 101 AND 102). SN 78-826,392. PUB. 2-6-2007. FILED 3-1-2006.
- 3,232,854. **CLOSER BY THE MILE (BLOCK FORM)**. PAN-MASSACHUSETTS CHALLENGE, INC., (U.S. CLS. 100, 101 AND 102). SN 78-826,507. PUB. 2-6-2007. FILED 3-1-2006.
- 3,232,885. **XL REAL ESTATE AND DESIGN**. XL REAL ESTATE LLC, (U.S. CLS. 100, 101 AND 102). SN 78-840,836. PUB. 2-6-2007. FILED 3-19-2006.
- 3,232,898. **TTM (STYLIZED)**. TILTON, THOMAS & MORGAN, INC., (U.S. CLS. 100, 101 AND 102). SN 78-847,027. PUB. 2-6-2007. FILED 3-27-2006.
- 3,232,914 ( *See Class 16 for this trademark*).
- 3,232,916 ( *See Class 16 for this trademark*).
- 3,232,920 ( *See Class 14 for this trademark*).
- 3,232,921 ( *See Class 14 for this trademark*).
- 3,232,922 ( *See Class 14 for this trademark*).
- 3,232,941. **FRIPP ISLAND GOLF & BEACH RESORT AND DESIGN**. FRIPP ISLAND COMPANY, LLC, MULTIPLE CLASS, (INT. CLS. 36, 41 AND 43), (U.S. CLS. 100, 101, 102 AND 107). SN 78-863,396. PUB. 2-6-2007. FILED 4-18-2006.
- 3,232,948. **SATELLIC TRAFFIC MANAGEMENT (BLOCK FORM)**. DEUTSCHE TELEKOM AG, (U.S. CLS. 100, 101 AND 102). SN 78-865,126. PUB. 2-6-2007. FILED 4-19-2006.
- 3,232,953 ( *See Class 35 for this trademark*).
- 3,232,962 ( *See Class 35 for this trademark*).
- 3,232,977. **TOTAL LIVING COVERAGE (BLOCK FORM)**. GENWORTH FINANCIAL, INC., (U.S. CLS. 100, 101 AND 102). SN 78-872,271. PUB. 2-6-2007. FILED 4-28-2006.
- 3,232,983. **COMBINED WORKSITE SOLUTIONS (BLOCK FORM)**. COMBINED INSURANCE COMPANY OF AMERICA, (U.S. CLS. 100, 101 AND 102). SN 78-874,246. PUB. 2-6-2007. FILED 5-2-2006.
- 3,233,006. **CHARITY FOLKS AND DESIGN**. CHARITY FOLKS INC., (U.S. CLS. 100, 101 AND 102). SN 78-881,291. PUB. 2-6-2007. FILED 5-11-2006.
- 3,233,028. **BBH BUSINESS BROKERS HAWAII AND DESIGN**. BUSINESS BROKERS HAWAII, LLC, (U.S. CLS. 100, 101 AND 102). SN 78-885,116. PUB. 2-6-2007. FILED 5-16-2006.
- 3,233,037. **THORNBURG SECURITIES AND DESIGN**. THORNBURG, GARRETT H., (U.S. CLS. 100, 101 AND 102). SN 78-887,216. PUB. 2-6-2007. FILED 5-18-2006.
- 3,233,049. **MISCELLANEOUS DESIGN**. TARGET BRANDS, INC., (U.S. CLS. 100, 101 AND 102). SN 78-889,053. PUB. 2-6-2007. FILED 5-22-2006.
- 3,233,062. **FRANTZEN CAPITAL MANAGEMENT AND DESIGN**. FRANTZEN CAPITAL MANAGEMENT, INC., (U.S. CLS. 100, 101 AND 102). SN 78-893,075. PUB. 2-6-2007. FILED 5-25-2006.
- 3,233,064. **RETURN ON IDEAS (BLOCK FORM)**. ISTAR FINANCIAL INC., (U.S. CLS. 100, 101 AND 102). SN 78-894,262. PUB. 2-6-2007. FILED 5-26-2006.
- 3,233,091. **WISHTRIP (BLOCK FORM)**. MEMBERSTRAD E LLC, (U.S. CLS. 100, 101 AND 102). SN 78-900,527. PUB. 2-6-2007. FILED 6-5-2006.
- 3,233,099. **NICHOLAS FOUNDATION (BLOCK FORM)**. NICHOLAS FOUNDATION, (U.S. CLS. 100, 101 AND 102). SN 78-902,038. PUB. 2-6-2007. FILED 6-6-2006.
- 3,233,117. **AETNA AFFORDABLE HEALTH CHOICES (BLOCK FORM)**. AETNA INC., (U.S. CLS. 100, 101 AND 102). SN 78-904,813. PUB. 2-6-2007. FILED 6-9-2006.
- 3,233,120. **GREAT PRACTICES FOR GREAT FAMILIES (BLOCK FORM)**. WEALTHBRIDGE PARTNERS LLC, MULTIPLE CLASS, (INT. CLS. 36 AND 41), (U.S. CLS. 100, 101, 102 AND 107). SN 78-905,039. PUB. 2-6-2007. FILED 6-9-2006.
- 3,233,126. **COVER AMERICA (BLOCK FORM)**. MID-WEST NATIONAL LIFE INSURANCE COMPANY OF TENNESSEE, (U.S. CLS. 100, 101 AND 102). SN 78-905,853. PUB. 2-6-2007. FILED 6-12-2006.
- 3,233,147. **POLICY FUNCTION STRATEGY (BLOCK FORM)**. CAPITAL ADVISORS, INC., (U.S. CLS. 100, 101 AND 102). SN 78-907,753. PUB. 2-6-2007. FILED 6-14-2006.
- 3,233,155. **SPCA INTERNATIONAL AND DESIGN**. SPCA INTERNATIONAL, INC., (U.S. CLS. 100, 101 AND 102). SN 78-908,334. PUB. 2-6-2007. FILED 6-14-2006.
- 3,233,159. **SWINGING FOR SMILES (BLOCK FORM)**. HEMOPHILIA FOUNDATION OF MICHIGAN, (U.S. CLS. 100, 101 AND 102). SN 78-908,668. PUB. 2-6-2007. FILED 6-15-2006.
- 3,233,217 ( *See Class 35 for this trademark*).
- 3,233,221. **CAVA 4 LIFE THE FINE ART OF LOOKING GOOD... WHILE DOING GOOD! AND DESIGN**. BLACKWELL, LISA NICOLE, (U.S. CLS. 100, 101 AND 102). SN 78-911,731. PUB. 2-6-2007. FILED 6-19-2006.
- 3,233,256. **CARTRIDGES FOR A CURE (BLOCK FORM)**. KAHN, ELI B., (U.S. CLS. 100, 101 AND 102). SN 78-912,943. PUB. 2-6-2007. FILED 6-21-2006.
- 3,233,265. **MYBANKDOESNTGETIT.COM (BLOCK FORM)**. HOMESTREET, INC., (U.S. CLS. 100, 101 AND 102). SN 78-913,399. PUB. 2-6-2007. FILED 6-21-2006.
- 3,233,279. **TRIVIUM (BLOCK FORM)**. TRIVIUM CAPITAL MANAGEMENT LLC, (U.S. CLS. 100, 101 AND 102). SN 78-914,298. PUB. 2-6-2007. FILED 6-22-2006.
- 3,233,287. **I INVEST USA (BLOCK FORM)**. HASHEM, JARROD, (U.S. CLS. 100, 101 AND 102). SN 78-914,535. PUB. 2-6-2007. FILED 6-22-2006.
- 3,233,295. **AYRIE (BLOCK FORM)**. OTA ASSET MANAGEMENT LLC, (U.S. CLS. 100, 101 AND 102). SN 78-914,653. PUB. 2-6-2007. FILED 6-22-2006.
- 3,233,300. **FIT FOR AN INDEPENDENT TOMORROW (BLOCK FORM)**. FOUNDATION FOR AN INDEPENDENT TOMORROW, (U.S. CLS. 100, 101 AND 102). SN 78-914,699. PUB. 2-6-2007. FILED 6-22-2006.
- 3,233,303. **ACTING FOR A CURE (BLOCK FORM)**. HELSON, RACHEL, DBA ACTING FOR A CURE, (U.S. CLS. 100, 101 AND 102). SN 78-914,839. PUB. 2-6-2007. FILED 6-22-2006.
- 3,233,314. **IT'S THE LITTLE THINGS WE DO (BLOCK FORM)**. ERA TM CORP., (U.S. CLS. 100, 101 AND 102). SN 78-915,320. PUB. 2-6-2007. FILED 6-23-2006.
- 3,233,318. **INTOHOMES MORTGAGE SERVICES, INC. AND DESIGN**. INTOHOMES MORTGAGE SERVICES, INC., (U.S. CLS. 100, 101 AND 102). SN 78-915,413. PUB. 2-6-2007. FILED 6-23-2006.
- 3,233,328. **AMERITOR REALTY (BLOCK FORM)**. AMERITOR REALTY, INC., (U.S. CLS. 100, 101 AND 102). SN 78-915,615. PUB. 2-6-2007. FILED 6-23-2006.
- 3,233,329. **NEWFIRST BANK (BLOCK FORM)**. NEWFIRST BANK, (U.S. CLS. 100, 101 AND 102). SN 78-915,644. PUB. 2-6-2007. FILED 6-23-2006.
- 3,233,333. **CAPLEASE (BLOCK FORM)**. CAPITAL LEASE FUNDING, INC., (U.S. CLS. 100, 101 AND 102). SN 78-915,786. PUB. 2-6-2007. FILED 6-23-2006.
- 3,233,345. **LOANBYJERRY.COM (STYLIZED)**. VALENZUELA, JERRY, (U.S. CLS. 100, 101 AND 102). SN 78-916,044. PUB. 2-6-2007. FILED 6-23-2006.
- 3,233,441 ( *See Class 35 for this trademark*).
- 3,233,482. **DOUGLAS EMMETT (BLOCK FORM)**. DOUGLAS EMMETT PROPERTIES, L.P., (U.S. CLS. 100, 101 AND 102). SN 78-927,232. PUB. 2-6-2007. FILED 7-11-2006.
- 3,233,493 ( *See Class 35 for this trademark*).
- 3,233,497. **YARD BY YARD AND DESIGN**. PEPSICO, INC., (U.S. CLS. 100, 101 AND 102). SN 78-947,413. PUB. 2-6-2007. FILED 8-8-2006.
- 3,233,498. **GLOBAL VOLUNTEERS (BLOCK FORM)**. GLOBAL VOLUNTEERS, (U.S. CLS. 100, 101 AND 102). SN 78-949,269. PUB. 2-6-2007. FILED 8-10-2006.
- 3,233,501. **FIDUCIARY ASSURE (BLOCK FORM)**. HARTFORD LIFE INSURANCE COMPANY, (U.S. CLS. 100, 101 AND 102). SN 78-952,249. PUB. 2-6-2007. FILED 8-15-2006.
- 3,233,511. **HOMESTREET GETS IT (BLOCK FORM)**. HOMESTREET, INC., (U.S. CLS. 100, 101 AND 102). SN 78-971,671. PUB. 2-6-2007. FILED 9-11-2006.
- 3,233,512. **WE HELP THE MILITARY WHEN OTHERS DON'T. (BLOCK FORM)**. PIONEER LICENSING SERVICES, INC., (U.S. CLS. 100, 101 AND 102). SN 78-973,351. PUB. 2-6-2007. FILED 9-13-2006.
- 3,233,520 ( *See Class 1 for this trademark*).
- 3,233,532. **WESTLB NEW ANSWERS IN BANKING AND DESIGN**. WESTLB AG, (U.S. CLS. 100, 101 AND 102). SN 79-013,567. PUB. 2-6-2007. FILED 6-23-2005.
- 3,233,576. **THE SECOND RENAISSANCE AND DESIGN**. THE SECOND RENAISSANCE S.R.L., MULTIPLE CLASS, (INT. CLS. 36 AND 38), (U.S. CLS. 100, 101, 102 AND 104). SN 79-017,983. PUB. 10-31-2006. FILED 3-16-2005.
- 3,233,597 ( *See Class 9 for this trademark*).
- 3,233,662 ( *See Class 35 for this trademark*).

3,233,687. **CREDARIS (BLOCK FORM)**. CREDARIS PORTOFOLIO MANAGEMENT GMBH, (U.S. CLS. 100, 101 AND 102). SN 79-022,907. PUB. 2-6-2007. FILED 1-12-2006.

### CLASS 37—CONSTRUCTION AND REPAIR

3,232,108. **AW... DRY UP AND DESIGN**. ODONATA INCORPORATED, (U.S. CLS. 100, 103 AND 106). SN 76-623,729. PUB. 2-6-2007. FILED 12-9-2004.

3,232,146. **MINUTEMAN (BLOCK FORM)**. MINUTEMAN INTERNATIONAL, INC., (U.S. CLS. 100, 103 AND 106). SN 76-647,695. PUB. 2-6-2007. FILED 9-29-2005.

3,232,198. **GARAGE CONCEPTS (BLOCK FORM)**. GARAGE CONCEPTS, L.L.C., (U.S. CLS. 100, 103 AND 106). SN 76-655,383. PUB. 2-6-2007. FILED 2-21-2006.

3,232,248. **ALLOY WHEEL REPAIR SPECIALISTS (BLOCK FORM)**. ALLOY WHEEL REPAIR SPECIALIST, INC., (U.S. CLS. 100, 103 AND 106). SN 76-661,971. PUB. 2-6-2007. FILED 6-19-2006.

3,232,322. **GLOBAL PORTABLE HOUSING**. CHUCKHOUSE, INC., MULTIPLE CLASS, (INT. CLS. 37 AND 42), (U.S. CLS. 100, 101, 103 AND 106). SN 78-156,073. PUB. 2-6-2007. FILED 8-20-2002.

3,232,329 ( *See Class 7 for this trademark*).

3,232,332 ( *See Class 35 for this trademark*).

3,232,351. **TEC WELL SERVICE (BLOCK FORM)**. TEC WELL SERVICE, INC., (U.S. CLS. 100, 103 AND 106). SN 78-387,037. PUB. 2-6-2007. FILED 3-18-2004.

3,232,394. **UNIVISIONS (BLOCK FORM)**. CENTRAL NEW YORK UNIVISION VIDEO SYSTEMS, INC., MULTIPLE CLASS, (INT. CLS. 37 AND 42), (U.S. CLS. 100, 101, 103 AND 106). SN 78-548,921. PUB. 4-11-2006. FILED 1-18-2005.

3,232,396 ( *See Class 35 for this trademark*).

3,232,456 ( *See Class 35 for this trademark*).

3,232,462. **BUILDING SOLUTIONS FOR THE 21ST CENTURY (BLOCK FORM)**. CADATA CORPORATION, INC., THE, (U.S. CLS. 100, 103 AND 106). SN 78-615,126. PUB. 10-24-2006. FILED 4-22-2005.

3,232,472. **CYCLEFRAC (BLOCK FORM)**. SANJEL LIMITED PARTNERSHIP, MULTIPLE CLASS, (INT. CLS. 37 AND 40), (U.S. CLS. 100, 103 AND 106). SN 78-623,246. PUB. 10-10-2006. FILED 5-4-2005.

3,232,509 ( *See Class 35 for this trademark*).

3,232,545 ( *See Class 7 for this trademark*).

3,232,707. **MUHLER (BLOCK FORM)**. THE MUHLER COMPANY, INC., (U.S. CLS. 100, 103 AND 106). SN 78-755,201. PUB. 2-6-2007. FILED 11-16-2005.

3,232,708. **DOITYOURSELF.COM (BLOCK FORM)**. ALLIANCES ASSOCIATES, (U.S. CLS. 100, 103 AND 106). SN 78-755,273. PUB. 2-6-2007. FILED 11-16-2005.

3,232,711 ( *See Class 36 for this trademark*).

3,232,731 ( *See Class 27 for this trademark*).

3,232,740. **CONSOLIDATED GARAGE DOORS (BLOCK FORM)**. CONSOLIDATED GARAGE DOORS, LTD., (U.S. CLS. 100, 103 AND 106). SN 78-768,039. PUB. 2-6-2007. FILED 12-6-2005.

3,232,741. **SOLID SINCE 1976 (BLOCK FORM)**. CONSOLIDATED GARAGE DOORS, LTD., (U.S. CLS. 100, 103 AND 106). SN 78-768,043. PUB. 2-6-2007. FILED 12-6-2005.

3,232,742. **CONSOLIDATED GARAGE DOORS LTD. AND DESIGN**. CONSOLIDATED GARAGE DOORS, LTD., (U.S. CLS. 100, 103 AND 106). SN 78-768,051. PUB. 2-6-2007. FILED 12-7-2005.

3,232,743 ( *See Class 35 for this trademark*).

3,232,781 ( *See Class 35 for this trademark*).

3,232,802 ( *See Class 7 for this trademark*).

3,232,803 ( *See Class 7 for this trademark*).

3,232,812. **MELO DEVELOPMENT AND DESIGN**. MELO DEVELOPMENT, INC., (U.S. CLS. 100, 103 AND 106). SN 78-809,283. PUB. 2-6-2007. FILED 2-7-2006.

3,232,841 ( *See Class 9 for this trademark*).

3,232,900. **FAST AID (BLOCK FORM)**. FAST AID FRANCHISE CORPORATION, (U.S. CLS. 100, 103 AND 106). SN 78-847,277. PUB. 2-6-2007. FILED 3-27-2006.

3,232,942. **MR. SQUEAKY CAR WASH AND DESIGN**. MR. SQUEAKY CAR WASH, INC., (U.S. CLS. 100, 103 AND 106).

SN 78-864,098. PUB. 2-6-2007. FILED 4-18-2006.

3,232,946. **OPTIONS CONTINUATION PROGRAM AND DESIGN**. I.T. XCHANGE LLC, MULTIPLE CLASS, (INT. CLS. 37 AND 42), (U.S. CLS. 100, 101, 103 AND 106). SN 78-864,533. PUB. 2-6-2007. FILED 4-19-2006.

3,232,949. **SATELLIC TRAFFIC MANAGEMENT (BLOCK FORM)**. DEUTSCHE TELEKOM AG, (U.S. CLS. 100, 103 AND 106). SN 78-865,130. PUB. 2-6-2007. FILED 4-19-2006.

3,232,990 ( *See Class 2 for this trademark*).

3,232,991 ( *See Class 35 for this trademark*).

3,233,008. **REGENT AND DESIGN**. REGENT ASSET MANAGEMENT GROUP, LLC, (U.S. CLS. 100, 103 AND 106). SN 78-881,744. PUB. 2-6-2007. FILED 5-11-2006.

3,233,024. **ELITE CUSTOM (BLOCK FORM)**. ELITE CUSTOM, (U.S. CLS. 100, 103 AND 106). SN 78-884,894. PUB. 2-6-2007. FILED 5-16-2006.

3,233,109. **DESIGNER SERIES (BLOCK FORM)**. M.J.C. HOMES, INC., (U.S. CLS. 100, 103 AND 106). SN 78-903,565. PUB. 2-6-2007. FILED 6-8-2006.

3,233,116. **PERFECTION PAINTING (BLOCK FORM)**. PERFECTION PAINTING COMPANY, (U.S. CLS. 100, 103 AND 106). SN 78-904,646. PUB. 2-6-2007. FILED 6-9-2006.

3,233,173. **SHINER ROOFING (BLOCK FORM)**. SHINER ROOFING, INC., (U.S. CLS. 100, 103 AND 106). SN 78-909,275. PUB. 2-6-2007. FILED 6-15-2006.

3,233,174. **SHINER ROOFING AND DESIGN**. SHINER ROOFING, INC., (U.S. CLS. 100, 103 AND 106). SN 78-909,317. PUB. 2-6-2007. FILED 6-15-2006.

3,233,217 ( *See Class 35 for this trademark*).

3,233,313. **PESTBUSTERS (BLOCK FORM)**. PESTBUSTERS, INC., (U.S. CLS. 100, 103 AND 106). SN 78-915,205. PUB. 2-6-2007. FILED 6-23-2006.

3,233,315. **FAMILIES HELPING FAMILIES (BLOCK FORM)**. MERCEDES HOMES, INC., (U.S. CLS. 100, 103 AND 106). SN 78-915,323. PUB. 2-6-2007. FILED 6-23-2006.

3,233,356. **ON TRACK (BLOCK FORM)**. ON TRACK POWER WINDOW REPAIR, (U.S. CLS. 100, 103 AND 106). SN 78-916,354. PUB. 2-6-2007. FILED 6-25-2006.

3,233,385. **DENT-TENT (BLOCK FORM)**. DENTCRAFTER, INC., (U.S. CLS. 100, 103 AND 106). SN 78-917,265. PUB. 2-6-2007. FILED 6-26-2006.

3,233,415. **ROOF TUNE-UP (BLOCK FORM)**. BONADUCE INCORPORATED, (U.S. CLS. 100, 103 AND 106). SN 78-918,148. PUB. 2-6-2007. FILED 6-27-2006.

3,233,441 ( *See Class 35 for this trademark*).

3,233,474. **PESTBUSTERS AND DESIGN**. PESTBUSTERS, INC., (U.S. CLS. 100, 103 AND 106). SN 78-922,330. PUB. 2-6-2007. FILED 7-5-2006.

3,233,487. **NEAT-O AND DESIGN**. NEAT-O FLEET WASHING SERVICES, INC., (U.S. CLS. 100, 103 AND 106). SN 78-929,748. PUB. 2-6-2007. FILED 7-14-2006.

3,233,488. **NEAT-O (BLOCK FORM)**. NEAT-O FLEET WASHING SERVICES, INC., (U.S. CLS. 100, 103 AND 106). SN 78-929,761. PUB. 2-6-2007. FILED 7-14-2006.

3,233,520 ( *See Class 1 for this trademark*).

3,233,534 ( *See Class 7 for this trademark*).

3,233,541 ( *See Class 1 for this trademark*).

3,233,577 ( *See Class 1 for this trademark*).

3,233,584 ( *See Class 1 for this trademark*).

3,233,597 ( *See Class 9 for this trademark*).

3,233,619 ( *See Class 7 for this trademark*).

3,233,700 ( *See Class 7 for this trademark*).

3,233,703 ( *See Class 7 for this trademark*).

### CLASS 38—COMMUNICATION

3,232,300. **GAMEDAILY (BLOCK FORM)**. AOL LLC, (U.S. CLS. 100, 101 AND 104). SN 77-023,811. PUB. 2-6-2007. FILED 10-18-2006.

3,232,359. **\*22 (BLOCK FORM)**. CUSTOM TELECONNECT, INC., (U.S. CLS. 100, 101 AND 104). SN 78-437,214. PUB. 4-26-2005. FILED 6-17-2004.

3,232,360. **\*11 (BLOCK FORM)**. CUSTOM TELECONNECT, INC., (U.S. CLS. 100, 101 AND 104). SN 78-437,226. PUB. 4-26-2005. FILED 6-17-2004.

3,232,378 ( *See Class 35 for this trademark*).



- 3,232,401. **EVOICE AND DESIGN**. J2 GLOBAL COMMUNICATIONS, INC., (U.S. CLS. 100, 101 AND 104). SN 78-555,814. PUB. 2-6-2007. FILED 1-28-2005.
- 3,232,406. **HIS RADIO AND DESIGN**. RADIO TRAINING NETWORK, INC., (U.S. CLS. 100, 101 AND 104). SN 78-559,102. PUB. 2-6-2007. FILED 2-2-2005.
- 3,232,446. **ALL FOR ONE. ONE FOR ALL (BLOCK FORM)**. CAVALIERS OPERATING COMPANY, LLC, (U.S. CLS. 100, 101 AND 104). SN 78-597,202. PUB. 2-6-2007. FILED 3-29-2005.
- 3,232,500. **PERU MAGICO (BLOCK FORM)**. TELEFONICA MULTIMEDIA S.A.C., MULTIPLE CLASS, (INT. CLS. 38 AND 41), (U.S. CLS. 100, 101, 104 AND 107). SN 78-651,320. PUB. 10-3-2006. FILED 6-15-2005.
- 3,232,525. **JUSTILOVE (BLOCK FORM)**. PROKSCH, CARSTEN, MULTIPLE CLASS, (INT. CLS. 38, 42 AND 45), (U.S. CLS. 100, 101 AND 104). SN 78-674,202. PUB. 2-6-2007. FILED 7-20-2005.
- 3,232,538. **SDN (STYLIZED)**. COASTAL RESEARCH GROUP, MULTIPLE CLASS, (INT. CLS. 38 AND 41), (U.S. CLS. 100, 101, 104 AND 107). SN 78-683,674. PUB. 10-24-2006. FILED 8-2-2005.
- 3,232,555. **T JOBS AND DESIGN**. DEUTSCHE TELEKOM AG, (U.S. CLS. 100, 101 AND 104). SN 78-695,618. PUB. 10-24-2006. FILED 8-18-2005.
- 3,232,599. **MARKETPLACE TAKEOUT (BLOCK FORM)**. MINNESOTA PUBLIC RADIO, (U.S. CLS. 100, 101 AND 104). SN 78-727,284. PUB. 2-6-2007. FILED 10-5-2005.
- 3,232,635 ( *See Class 35 for this trademark* ).
- 3,232,651. **T AND DESIGN**. TELIGENCE (CANADA), INC., (U.S. CLS. 100, 101 AND 104). SN 78-744,771. PUB. 2-6-2007. FILED 11-1-2005.
- 3,232,677. **LINCOLN FINANCIAL SPORTS (BLOCK FORM)**. LINCOLN NATIONAL CORPORATION, (U.S. CLS. 100, 101 AND 104). SN 78-748,643. PUB. 2-6-2007. FILED 11-7-2005.
- 3,232,691. **FON AND DESIGN**. FON WIRELESS LIMITED, (U.S. CLS. 100, 101 AND 104). SN 78-751,591. PUB. 2-6-2007. FILED 11-10-2005.
- 3,232,710 ( *See Class 35 for this trademark* ).
- 3,232,716. **THE ESSENTIAL GLOBAL NEWS NETWORK (BLOCK FORM)**. THE ASSOCIATED PRESS, MULTIPLE CLASS, (INT. CLS. 38 AND 41), (U.S. CLS. 100, 101, 104 AND 107). SN 78-757,040. PUB. 2-6-2007. FILED 11-18-2005.
- 3,232,852. **MISCELLANEOUS DESIGN**. PODSHOW, INC., (U.S. CLS. 100, 101 AND 104). SN 78-826,128. PUB. 2-6-2007. FILED 3-1-2006.
- 3,232,914 ( *See Class 16 for this trademark* ).
- 3,232,916 ( *See Class 16 for this trademark* ).
- 3,232,950. **SATELLIC TRAFFIC MANAGEMENT (BLOCK FORM)**. DEUTSCHE TELEKOM AG, (U.S. CLS. 100, 101 AND 104). SN 78-865,131. PUB. 2-6-2007. FILED 4-19-2006.
- 3,232,960. **DAILY BLABBER (BLOCK FORM)**. IVILLAGE, INC., (U.S. CLS. 100, 101 AND 104). SN 78-867,164. PUB. 2-6-2007. FILED 4-21-2006.
- 3,233,078. **PROCESSDRIVER (BLOCK FORM)**. SAFENET CONSULTING, INC., (U.S. CLS. 100, 101 AND 104). SN 78-897,743. PUB. 2-6-2007. FILED 6-1-2006.
- 3,233,129. **MEGA MARCH MADNESS (BLOCK FORM)**. MARCH MADNESS ATHLETIC ASSOCIATION LLC, (U.S. CLS. 100, 101 AND 104). SN 78-906,214. PUB. 2-6-2007. FILED 6-12-2006.
- 3,233,143. **ALWAYS LIVE - ALWAYS PRIVATE (BLOCK FORM)**. BLUE FROG MOBILE, INC., (U.S. CLS. 100, 101 AND 104). SN 78-907,327. PUB. 2-6-2007. FILED 6-13-2006.
- 3,233,254. **MERCURY MESSAGE (BLOCK FORM)**. JOVE CORPORATION, (U.S. CLS. 100, 101 AND 104). SN 78-912,937. PUB. 2-6-2007. FILED 6-21-2006.
- 3,233,326. **BANDMIX (BLOCK FORM)**. ECHO MEDIA, INC., (U.S. CLS. 100, 101 AND 104). SN 78-915,550. PUB. 2-6-2007. FILED 6-23-2006.
- 3,233,483. **TRESSIFY (BLOCK FORM)**. O2 HOLDINGS, LLC, (U.S. CLS. 100, 101 AND 104). SN 78-928,039. PUB. 2-6-2007. FILED 7-12-2006.
- 3,233,520 ( *See Class 1 for this trademark* ).
- 3,233,527 ( *See Class 9 for this trademark* ).
- 3,233,529 ( *See Class 5 for this trademark* ).
- 3,233,530 ( *See Class 35 for this trademark* ).
- 3,233,535 ( *See Class 9 for this trademark* ).
- 3,233,537. **SMARTCO (BLOCK FORM)**. SMARTCO, MULTIPLE CLASS, (INT. CLS. 38 AND 42), (U.S. CLS. 100, 101 AND 104). SN 79-014,356. PUB. 2-6-2007. FILED 4-11-2005.
- 3,233,555 ( *See Class 9 for this trademark* ).
- 3,233,565 ( *See Class 9 for this trademark* ).
- 3,233,576 ( *See Class 36 for this trademark* ).
- 3,233,590 ( *See Class 9 for this trademark* ).
- 3,233,597 ( *See Class 9 for this trademark* ).
- 3,233,605 ( *See Class 9 for this trademark* ).
- 3,233,620 ( *See Class 35 for this trademark* ).
- 3,233,636 ( *See Class 9 for this trademark* ).
- 3,233,640 ( *See Class 9 for this trademark* ).
- 3,233,674. **VIDEO ITALIA AND DESIGN**. RADIO ITALIA S.P.A., MULTIPLE CLASS, (INT. CLS. 38 AND 41), (U.S. CLS. 100, 101, 104 AND 107). SN 79-022,272. PUB. 1-23-2007. FILED 12-12-2005.
- 3,233,696 ( *See Class 31 for this trademark* ).

---

### CLASS 39—TRANSPORTATION AND STORAGE

- 3,232,136. **PORTSIDE DISTRIBUTION (BLOCK FORM)**. AVERITT EXPRESS, (U.S. CLS. 100 AND 105). SN 76-645,706. PUB. 2-6-2007. FILED 8-26-2005.
- 3,232,155. **RUN WITH THE WINNERS AND DESIGN**. ATLAS OIL COMPANY, (U.S. CLS. 100 AND 105). SN 76-648,980. PUB. 2-6-2007. FILED 10-21-2005.
- 3,232,202. **RESTORGANIZE AND DESIGN**. RESTORGANIZE, LLC., (U.S. CLS. 100 AND 105). SN 76-656,498. PUB. 2-6-2007. FILED 3-13-2006.
- 3,232,303. **BACKUP YOUR LIFE (BLOCK FORM)**. BACKUP-RIGHT, LLC, (U.S. CLS. 100 AND 105). SN 77-025,958. PUB. 2-6-2007. FILED 10-20-2006.
- 3,232,415. **SUPERSAVER (STYLIZED)**. SCHUMACHER PAINTING INC., (U.S. CLS. 100 AND 105). SN 78-572,380. PUB. 2-6-2007. FILED 2-22-2005.
- 3,232,481 ( *See Class 35 for this trademark* ).
- 3,232,581. **DANCE THE MAGIC (BLOCK FORM)**. BARR, DEBI, MULTIPLE CLASS, (INT. CLS. 39 AND 41), (U.S. CLS. 100, 101, 105 AND 107). SN 78-720,948. PUB. 2-6-2007. FILED 9-26-2005.
- 3,232,655. **WE BEGIN WHERE OCEAN CRUISES END. (BLOCK FORM)**. VIKING RIVER CRUISES, INC., (U.S. CLS. 100 AND 105). SN 78-744,992. PUB. 2-6-2007. FILED 11-1-2005.
- 3,232,754 ( *See Class 35 for this trademark* ).
- 3,232,781 ( *See Class 35 for this trademark* ).
- 3,232,782. **CENTRAL PARK BIKE TOUR NYC AND DESIGN**. BITE OF THE APPLE TOURS INC., (U.S. CLS. 100 AND 105). SN 78-787,482. PUB. 2-6-2007. FILED 1-9-2006.
- 3,232,878. **WWW.STATRAVEL.COM AND DESIGN**. STA TRAVEL, INC., MULTIPLE CLASS, (INT. CLS. 39 AND 43), (U.S. CLS. 100, 101 AND 105). SN 78-838,226. PUB. 2-6-2007. FILED 3-15-2006.
- 3,232,926. **NSI NOVAPTUS SYSTEMS, INC. MEDICAL, HEALTH AND WELLNESS TECHNOLOGY SYSTEMS AND DESIGN**. NOVAPTUS SYSTEMS, INCORPORATED, (U.S. CLS. 100 AND 105). SN 78-856,485. PUB. 2-6-2007. FILED 4-7-2006.
- 3,232,944 ( *See Class 35 for this trademark* ).
- 3,232,998. **UP KILI (BLOCK FORM)**. TUSKER TRAIL & SAFARI CO., (U.S. CLS. 100 AND 105). SN 78-880,000. PUB. 2-6-2007. FILED 5-9-2006.
- 3,233,007. **ALTERNITY POWER AND DESIGN**. CONTI, KURT G., MULTIPLE CLASS, (INT. CLS. 39 AND 40), (U.S. CLS. 100, 103, 105 AND 106). SN 78-881,395. PUB. 2-6-2007. FILED 5-11-2006.
- 3,233,137. **HEALTHSTRING (BLOCK FORM)**. HEALTHSTRING, LLC, MULTIPLE CLASS, (INT. CLS. 39 AND 44), (U.S. CLS. 100, 101 AND 105). SN 78-907,188. PUB. 2-6-2007. FILED 6-13-2006.
- 3,233,138. **HEALTHSTRING AND DESIGN**. HEALTHSTRING, LLC, MULTIPLE CLASS, (INT. CLS. 39 AND 44), (U.S. CLS. 100, 101 AND 105). SN 78-907,206. PUB. 2-6-2007. FILED 6-13-2006.

- 3,233,140. **HELPING PATIENTS AND PROVIDERS PULL TOGETHER (BLOCK FORM)**. HEALTHSTRING, LLC, MULTIPLE CLASS, (INT. CLS. 39 AND 44), (U.S. CLS. 100, 101 AND 105). SN 78-907,222. PUB. 2-6-2007. FILED 6-13-2006.
- 3,233,217 ( *See Class 35 for this trademark*).
- 3,233,301. **BOLT (BLOCK FORM)**. BOLT EXPRESS, LLC, (U.S. CLS. 100 AND 105). SN 78-914,782. PUB. 2-6-2007. FILED 6-22-2006.
- 3,233,410. **ALTERNITY POWER (BLOCK FORM)**. CONTI, KURT G., MULTIPLE CLASS, (INT. CLS. 39 AND 40), (U.S. CLS. 100, 103, 105 AND 106). SN 78-918,007. PUB. 2-6-2007. FILED 6-27-2006.
- 3,233,422. **PERIMETER OF PROTECTION (BLOCK FORM)**. LAWRENCE, CLINT E., (U.S. CLS. 100 AND 105). SN 78-918,281. PUB. 2-6-2007. FILED 6-27-2006.
- 3,233,441 ( *See Class 35 for this trademark*).
- 3,233,515. **SANTANNA ENERGY SERVICES (BLOCK FORM)**. SANTANNA NATURAL GAS CORPORATION, (U.S. CLS. 100 AND 105). SN 78-977,594. PUB. 2-6-2007. FILED 8-9-2005.
- 3,233,520 ( *See Class 1 for this trademark*).
- 3,233,531 ( *See Class 7 for this trademark*).
- 3,233,549. **DP DOMEPICO AND DESIGN**. P.A.N.G. ITHALAT IHRACAT GIDA INSAAT TURIZM TICARET VE SANAYI LIMITED SIRKETI, MULTIPLE CLASS, (INT. CLS. 39, 40, 41 AND 43), (U.S. CLS. 100, 101, 103, 105, 106 AND 107). SN 79-015,994. PUB. 2-6-2007. FILED 7-6-2004.
- 3,233,640 ( *See Class 9 for this trademark*).
- AND 106). SN 78-856,002. PUB. 2-6-2007. FILED 4-6-2006.
- 3,232,944 ( *See Class 35 for this trademark*).
- 3,232,992. **CREATIONS BY DESIGN (BLOCK FORM)**. JEFF LAU, (U.S. CLS. 100, 103 AND 106). SN 78-878,227. PUB. 2-6-2007. FILED 5-6-2006.
- 3,233,007 ( *See Class 39 for this trademark*).
- 3,233,051. **ON-SITE AND DESIGN**. PELLERIN, BURLEY J., II, (U.S. CLS. 100, 103 AND 106). SN 78-889,534. PUB. 2-6-2007. FILED 5-22-2006.
- 3,233,182. **UNION WINE COMPANY (BLOCK FORM)**. UNION WINE COMPANY, (U.S. CLS. 100, 103 AND 106). SN 78-909,638. PUB. 2-6-2007. FILED 6-15-2006.
- 3,233,183. **UNDERWOOD CELLARS (BLOCK FORM)**. UNION WINE COMPANY, (U.S. CLS. 100, 103 AND 106). SN 78-909,644. PUB. 2-6-2007. FILED 6-15-2006.
- 3,233,217 ( *See Class 35 for this trademark*).
- 3,233,224. **SYNERGIS (BLOCK FORM)**. SYNERGIS TECHNOLOGIES GROUP CORPORATION, (U.S. CLS. 100, 103 AND 106). SN 78-911,893. PUB. 2-6-2007. FILED 6-20-2006.
- 3,233,337. **MAESTROMD (BLOCK FORM)**. ENCORE ETC., INC., (U.S. CLS. 100, 103 AND 106). SN 78-915,917. PUB. 2-6-2007. FILED 6-23-2006.
- 3,233,339. **MAESTROMD AND DESIGN**. ENCORE ETC., INC., (U.S. CLS. 100, 103 AND 106). SN 78-915,945. PUB. 2-6-2007. FILED 6-23-2006.
- 3,233,410 ( *See Class 39 for this trademark*).
- 3,233,441 ( *See Class 35 for this trademark*).
- 3,233,456. **SYNERGIS TECHNOLOGIES GROUP AND DESIGN**. SYNERGIS TECHNOLOGIES GROUP CORPORATION, (U.S. CLS. 100, 103 AND 106). SN 78-920,547. PUB. 2-6-2007. FILED 6-30-2006.
- 3,233,520 ( *See Class 1 for this trademark*).
- 3,233,531 ( *See Class 7 for this trademark*).
- 3,233,549 ( *See Class 39 for this trademark*).
- 3,233,577 ( *See Class 1 for this trademark*).
- 3,233,685 ( *See Class 3 for this trademark*).
- 3,233,711 ( *See Class 11 for this trademark*).

#### CLASS 40—MATERIAL TREATMENT

- 3,232,073 ( *See Class 1 for this trademark*).
- 3,232,160. **WW WOODY WILSON COLLECTION FINE CUSTOM CLOTHING AND DESIGN**. TURNER, WOODROW WILSON, III, (U.S. CLS. 100, 103 AND 106). SN 76-649,801. PUB. 2-6-2007. FILED 11-4-2005.
- 3,232,320. **BE SUREBEAM SAFE**. SB OPERATINGCO, LLC, (U.S. CLS. 100, 103 AND 106). SN 78-145,494. PUB. 12-30-2003. FILED 7-18-2002.
- 3,232,381 ( *See Class 9 for this trademark*).
- 3,232,452. **CUSTOM WOOD DESIGNS NATURALLY CREATIVE AND DESIGN**. CUSTOM WOOD DESIGNS, INC., MULTIPLE CLASS, (INT. CLS. 40 AND 42), (U.S. CLS. 100, 101, 103 AND 106). SN 78-600,670. PUB. 2-6-2007. FILED 4-2-2005.
- 3,232,456 ( *See Class 35 for this trademark*).
- 3,232,472 ( *See Class 37 for this trademark*).
- 3,232,485 ( *See Class 24 for this trademark*).
- 3,232,490 ( *See Class 35 for this trademark*).
- 3,232,509 ( *See Class 35 for this trademark*).
- 3,232,515. **THE REIGNING FAMILY OF PREMIUM CIGARS (BLOCK FORM)**. FUENTE MARKETING LTD., (U.S. CLS. 100, 103 AND 106). SN 78-663,975. PUB. 2-6-2007. FILED 7-5-2005.
- 3,232,612. **STRATEGIC DIAGNOSTICS INC. (BLOCK FORM)**. STRATEGIC DIAGNOSTICS INC., MULTIPLE CLASS, (INT. CLS. 40 AND 42), (U.S. CLS. 100, 101, 103 AND 106). SN 78-731,968. PUB. 2-6-2007. FILED 10-12-2005.
- 3,232,702. **WEILAND SLIDING DOORS AND WINDOWS, INC. AND DESIGN**. WEILAND SLIDING DOORS AND WINDOWS, INC., (U.S. CLS. 100, 103 AND 106). SN 78-753,527. PUB. 2-6-2007. FILED 11-14-2005.
- 3,232,840. **PERFECT OPTICS AND DESIGN**. PERFECT OPTICS, LLC, (U.S. CLS. 100, 103 AND 106). SN 78-820,884. PUB. 2-6-2007. FILED 2-22-2006.
- 3,232,845 ( *See Class 35 for this trademark*).
- 3,232,847 ( *See Class 35 for this trademark*).
- 3,232,848 ( *See Class 35 for this trademark*).
- 3,232,858. **ROCKET PRODUCTS, INC. (BLOCK FORM)**. LAZIER INDUSTRIES, INC., (U.S. CLS. 100, 103 AND 106). SN 78-831,369. PUB. 2-6-2007. FILED 3-7-2006.
- 3,232,886 ( *See Class 6 for this trademark*).
- 3,232,903 ( *See Class 35 for this trademark*).
- 3,232,919. **INEDEFILE (BLOCK FORM)**. MICRO GRAPHIC INFORMATION SERVICES CORPORATION, MULTIPLE CLASS, (INT. CLS. 40 AND 42), (U.S. CLS. 100, 101, 103

#### CLASS 41—EDUCATION AND ENTERTAINMENT

- 3,232,054 ( *See Class 16 for this trademark*).
- 3,232,060 ( *See Class 6 for this trademark*).
- 3,232,062. **BODY ONE FITNESS 1 AND DESIGN**. SIDELLA, LOUIS J, (U.S. CLS. 100, 101 AND 107). SN 76-223,440. PUB. 2-6-2007. FILED 3-12-2001.
- 3,232,074 ( *See Class 16 for this trademark*).
- 3,232,083. **R'CLUB AND DESIGN**. R'CLUB CHILD CARE, INC, MULTIPLE CLASS, (INT. CLS. 41 AND 43), (U.S. CLS. 100, 101 AND 107). SN 76-546,391. PUB. 6-22-2004. FILED 9-22-2003.
- 3,232,087 ( *See Class 9 for this trademark*).
- 3,232,088 ( *See Class 5 for this trademark*).
- 3,232,089 ( *See Class 9 for this trademark*).
- 3,232,091 ( *See Class 9 for this trademark*).
- 3,232,102. **MONARCH SERVICES FOR CHILDREN & ADOLESCENTS WITH AUTISM AT BELLEFAIREJCB AND DESIGN**. BELLEFAIRE JCB, MULTIPLE CLASS, (INT. CLS. 41, 44 AND 45), (U.S. CLS. 100, 101 AND 107). SN 76-616,891. PUB. 10-10-2006. FILED 10-19-2004.
- 3,232,111. **LE FREAK (BLOCK FORM)**. PWE PRODUCTIONS, LLC, (U.S. CLS. 100, 101 AND 107). SN 76-626,241. PUB. 2-6-2007. FILED 12-22-2004.
- 3,232,114. **MASCARA SAGRADA (BLOCK FORM)**. HERRADA, ANTONIO HIPOLITO PEÑA, (U.S. CLS. 100, 101 AND 107). SN 76-629,758. PUB. 10-3-2006. FILED 2-1-2005.
- 3,232,120 ( *See Class 35 for this trademark*).
- 3,232,153. **TRAVEL TODAY (BLOCK FORM)**. CHECK SIX PRODUCTIONS, INC., (U.S. CLS. 100, 101 AND 107). SN 76-648,518. PUB. 2-6-2007. FILED 10-14-2005.
- 3,232,157. **ASAP (BLOCK FORM)**. THE ZIG ZIGLAR CORPORATION, (U.S. CLS. 100, 101 AND 107). SN 76-649,220. PUB. 2-6-2007. FILED 10-26-2005.
- 3,232,164 ( *See Class 16 for this trademark*).
- 3,232,166. **STYLE STARS AND DESIGN**. JESSE BRIGGS AND BLANCA F. BRIGGS PARTNERSHIP, THE, (U.S. CLS. 100,

- 101 AND 107), SN 76-650,299. PUB. 2-6-2007. FILED 11-14-2005.
- 3,232,171. **CRYSTAL PALACE CASINO (BLOCK FORM)**. CABLE BEACH RESORTS LTD., (U.S. CLS. 100, 101 AND 107). SN 76-650,681. PUB. 2-6-2007. FILED 11-21-2005.
- 3,232,191. **SMOOTH JAZZ TELEVISION AND DESIGN**. SMITH, CAMERON, (U.S. CLS. 100, 101 AND 107). SN 76-653,059. PUB. 2-6-2007. FILED 1-9-2006.
- 3,232,212. **CRAZY PETS (BLOCK FORM)**. CRAZY PET, LLC, (U.S. CLS. 100, 101 AND 107). SN 76-659,427. PUB. 2-6-2007. FILED 5-2-2006.
- 3,232,213. **ATISOKANIGAMIG "LEGEND HOUSE" AND DESIGN**. BOIS FORTE BAND OF CHIPPEWA INDIANS, (U.S. CLS. 100, 101 AND 107). SN 76-659,522. PUB. 2-6-2007. FILED 5-3-2006.
- 3,232,218. **EARTHWONDERS BALANCE FOR LIFE AND LIVING (BLOCK FORM)**. EARTHWONDERS, LLC, (U.S. CLS. 100, 101 AND 107). SN 76-660,952. PUB. 2-6-2007. FILED 5-30-2006.
- 3,232,238. **MEGAFONO (BLOCK FORM)**. MEGA MEDIA HOLDINGS, INC., (U.S. CLS. 100, 101 AND 107). SN 76-661,782. PUB. 2-6-2007. FILED 6-19-2006.
- 3,232,247. **QUEENS LIBRARY ENRICH YOUR LIFE AND DESIGN**. THE QUEENS BOROUGH PUBLIC LIBRARY, (U.S. CLS. 100, 101 AND 107). SN 76-661,920. PUB. 2-6-2007. FILED 6-20-2006.
- 3,232,249. **"UNIQUELY MONIQUE" (STYLIZED)**. PURCELL, SHERRI M., (U.S. CLS. 100, 101 AND 107). SN 76-661,975. PUB. 2-6-2007. FILED 6-23-2006.
- 3,232,260. **LITERATURE ONLINE (BLOCK FORM)**. PRO-QUEST INFORMATION AND LEARNING COMPANY, (U.S. CLS. 100, 101 AND 107). SN 76-662,603. PUB. 2-6-2007. FILED 7-5-2006.
- 3,232,263. **BAHAMA MAMA (BLOCK FORM)**. SOHMER, SHARON, (U.S. CLS. 100, 101 AND 107). SN 76-662,749. PUB. 2-6-2007. FILED 7-10-2006.
- 3,232,282. **AMERICAN CHEER POWER NATIONALS (BLOCK FORM)**. TEXAS CHEERLEADING ASSOCIATION, INC., DBA TCA CORPORATION, (U.S. CLS. 100, 101 AND 107). SN 77-001,122. PUB. 2-6-2007. FILED 9-17-2006.
- 3,232,294. **MIKE'S SUPER SHORT SHOW (BLOCK FORM)**. DISNEY ENTERPRISES, INC., (U.S. CLS. 100, 101 AND 107). SN 77-019,089. PUB. 2-6-2007. FILED 10-11-2006.
- 3,232,307. **ENGADGET (BLOCK FORM)**. AOL LLC, (U.S. CLS. 100, 101 AND 107). SN 77-028,271. PUB. 2-6-2007. FILED 10-24-2006.
- 3,232,308 ( *See Class 9 for this trademark*).
- 3,232,312. **POST UNIVERSITY 1890 AND DESIGN**. POST UNIVERSITY, INC, (U.S. CLS. 100, 101 AND 107). SN 77-041,605. PUB. 2-6-2007. FILED 11-10-2006.
- 3,232,313. **POST UNIVERSITY ONLINE 1890 AND DESIGN**. POST UNIVERSITY, INC, (U.S. CLS. 100, 101 AND 107). SN 77-041,661. PUB. 2-6-2007. FILED 11-10-2006.
- 3,232,314. **POST UNIVERSITY REGIONAL LOCATIONS 1890 AND DESIGN**. POST UNIVERSITY, INC, (U.S. CLS. 100, 101 AND 107). SN 77-041,675. PUB. 2-6-2007. FILED 11-10-2006.
- 3,232,327. **HIGH ENERGY TRIVIA**. A-Z ENTERTAINMENT, LTD., (U.S. CLS. 100, 101 AND 107). SN 78-245,261. PUB. 10-17-2006. FILED 5-2-2003.
- 3,232,329 ( *See Class 7 for this trademark*).
- 3,232,344 ( *See Class 36 for this trademark*).
- 3,232,348. **ATAYDE (BLOCK FORM)**. GUZMAN, ANDRES ATAYDE, AND GUZMAN, ALFREDO ATAYDE, AND GUZMAN, ALBERTO OSCAR ATAYDE, (U.S. CLS. 100, 101 AND 107). SN 78-380,019. PUB. 2-6-2007. FILED 3-8-2004.
- 3,232,369 ( *See Class 9 for this trademark*).
- 3,232,370. **SKY SPORTS NEWS (BLOCK FORM)**. BRITISH SKY BROADCASTING GROUP PLC, (U.S. CLS. 100, 101 AND 107). SN 78-484,099. PUB. 8-30-2005. FILED 9-15-2004.
- 3,232,378 ( *See Class 35 for this trademark*).
- 3,232,383 ( *See Class 9 for this trademark*).
- 3,232,387 ( *See Class 14 for this trademark*).
- 3,232,398. **EASTGATE (BLOCK FORM)**. GREEN, DAVID G., MULTIPLE CLASS, (INT. CLS. 41 AND 42), (U.S. CLS. 100, 101 AND 107). SN 78-552,081. PUB. 2-6-2007. FILED 1-21-2005.
- 3,232,403. **LIFETIME NUTRITION BOOKS LLC AND DESIGN**. LIFETIME NUTRITION BOOKS, LLC, (U.S. CLS. 100, 101 AND 107). SN 78-556,760. PUB. 9-5-2006. FILED 11-31-2005.
- 3,232,410. **POWER RELAXATION (BLOCK FORM)**. CARNEY, WINSTON H., (U.S. CLS. 100, 101 AND 107). SN 78-566,135. PUB. 4-4-2006. FILED 2-11-2005.
- 3,232,417. **ECHOCARDIOGRAPHY IN PEDIATRIC AND ADULT CONGENITAL HEART DISEASE (BLOCK FORM)**. ULTRAECHO, LTD., (U.S. CLS. 100, 101 AND 107). SN 78-574,957. PUB. 2-6-2007. FILED 2-25-2005.
- 3,232,419 ( *See Class 16 for this trademark*).
- 3,232,433. **HEALTHY TOGETHER...LIVING WELL! (BLOCK FORM)**. APS HEALTHCARE BETHESDA, INC., MULTIPLE CLASS, (INT. CLS. 41 AND 44), (U.S. CLS. 100, 101 AND 107). SN 78-588,386. PUB. 2-6-2007. FILED 3-16-2005.
- 3,232,435. **THE NATIONS HOUR (BLOCK FORM)**. ALL NATIONS FULL GOSPEL CHURCH, (U.S. CLS. 100, 101 AND 107). SN 78-590,657. PUB. 5-30-2006. FILED 3-18-2005.
- 3,232,481 ( *See Class 35 for this trademark*).
- 3,232,500 ( *See Class 38 for this trademark*).
- 3,232,508. **9 BIG APPLE 9-BALL CHALLENGE AND DESIGN**. DYER, D. ALEXANDRA, (U.S. CLS. 100, 101 AND 107). SN 78-659,328. PUB. 2-6-2007. FILED 6-27-2005.
- 3,232,512 ( *See Class 35 for this trademark*).
- 3,232,519 ( *See Class 9 for this trademark*).
- 3,232,527. **LITTLE CHEFS (BLOCK FORM)**. LITTLE CHEFS, LTD., (U.S. CLS. 100, 101 AND 107). SN 78-676,224. PUB. 2-6-2007. FILED 7-22-2005.
- 3,232,528. **LITTLE CHEFS A CULINARY PLACE FOR CHILDREN AND DESIGN**. LITTLE CHEFS, LTD., (U.S. CLS. 100, 101 AND 107). SN 78-676,256. PUB. 2-6-2007. FILED 7-22-2005.
- 3,232,538 ( *See Class 38 for this trademark*).
- 3,232,544 ( *See Class 16 for this trademark*).
- 3,232,553. **LAZLOW (BLOCK FORM)**. RADIO LAZLOW, INC., (U.S. CLS. 100, 101 AND 107). SN 78-695,315. PUB. 2-6-2007. FILED 8-18-2005.
- 3,232,556. **T JOBS AND DESIGN**. DEUTSCHE TELEKOM AG, (U.S. CLS. 100, 101 AND 107). SN 78-695,631. PUB. 10-24-2006. FILED 8-18-2005.
- 3,232,557 ( *See Class 16 for this trademark*).
- 3,232,558. **MISCELLANEOUS DESIGN**. PRIORITY HEALTH, MULTIPLE CLASS, (INT. CLS. 41 AND 44), (U.S. CLS. 100, 101 AND 107). SN 78-697,146. PUB. 2-6-2007. FILED 8-22-2005.
- 3,232,560 ( *See Class 21 for this trademark*).
- 3,232,577. **THE SPACE SHOW (BLOCK FORM)**. LIVINGSTON, DAVID M., (U.S. CLS. 100, 101 AND 107). SN 78-716,064. PUB. 2-6-2007. FILED 9-19-2005.
- 3,232,580. **DISCOVERY MINISTRY AND DESIGN**. DEER CREEK COMMUNITY CHURCH, (U.S. CLS. 100, 101 AND 107). SN 78-720,900. PUB. 2-6-2007. FILED 9-26-2005.
- 3,232,581 ( *See Class 39 for this trademark*).
- 3,232,592. **MY CAR CHALLENGE (BLOCK FORM)**. ZIGZAG ASIA CO., LTD., (U.S. CLS. 100, 101 AND 107). SN 78-724,278. PUB. 2-6-2007. FILED 9-30-2005.
- 3,232,594 ( *See Class 35 for this trademark*).
- 3,232,596 ( *See Class 9 for this trademark*).
- 3,232,598. **CENTER FOR MARKETING EXCELLENCE ACCREDITED MARKETING PROFESSIONAL PROGRAM AND DESIGN**. CENTER FOR MARKETING EXCELLENCE, (U.S. CLS. 100, 101 AND 107). SN 78-727,213. PUB. 2-6-2007. FILED 10-5-2005.
- 3,232,604 ( *See Class 35 for this trademark*).
- 3,232,613 ( *See Class 35 for this trademark*).
- 3,232,615 ( *See Class 35 for this trademark*).
- 3,232,630. **AVALON FORTRESS SECURITY CORPORATION WORLDWIDE (BLOCK FORM)**. AVALON FORTRESS SECURITY CORPORATION, MULTIPLE CLASS, (INT. CLS. 41 AND 45), (U.S. CLS. 100, 101 AND 107). SN 78-739,141. PUB. 2-6-2007. FILED 10-24-2005.
- 3,232,656. **RC3 (BLOCK FORM)**. CHILDCAREGROUP, (U.S. CLS. 100, 101 AND 107). SN 78-745,402. PUB. 2-6-2007. FILED 11-2-2005.
- 3,232,671 ( *See Class 35 for this trademark*).
- 3,232,680. **VUONG'S TAE KWON DO AND DESIGN**. VUONG'S TAE KWON DO CENTER, LTD., (U.S. CLS. 100, 101 AND 107). SN 78-749,366. PUB. 2-6-2007. FILED 11-

- 8-2005.  
 3,232,684 ( *See Class 35 for this trademark* ).  
 3,232,695. **MAX THE MARKETING MAESTRO (BLOCK FORM)**. CLOCKWORK HOME SERVICES, INC., (U.S. CLS. 100, 101 AND 107). SN 78-751,960. PUB. 2-6-2007. FILED 11-11-2005.  
 3,232,696 ( *See Class 35 for this trademark* ).  
 3,232,705. **PCS (BLOCK FORM)**. SSPC: THE SOCIETY FOR PROTECTIVE COATINGS, (U.S. CLS. 100, 101 AND 107). SN 78-754,934. PUB. 2-6-2007. FILED 11-16-2005.  
 3,232,706. **TOTAL WELLNESS SYSTEMS, INC. AND DESIGN**. TOTAL WELLNESS SYSTEMS, INC., (U.S. CLS. 100, 101 AND 107). SN 78-755,119. PUB. 2-6-2007. FILED 11-16-2005.  
 3,232,709. **INNOVATIVE UNIVERSITY (BLOCK FORM)**. BETAZONE, INC., (U.S. CLS. 100, 101 AND 107). SN 78-755,518. PUB. 2-6-2007. FILED 11-16-2005.  
 3,232,716 ( *See Class 38 for this trademark* ).  
 3,232,723. **LIGHTNING ENTERTAINMENT AND DESIGN**. LIGHTNING ENTERTAINMENT, INC., (U.S. CLS. 100, 101 AND 107). SN 78-760,625. PUB. 2-6-2007. FILED 11-23-2005.  
 3,232,729. **US SAILING TEAM (BLOCK FORM)**. UNITED STATES SAILING ASSOCIATION, INC., (U.S. CLS. 100, 101 AND 107). SN 78-763,334. PUB. 2-6-2007. FILED 11-30-2005.  
 3,232,732 ( *See Class 25 for this trademark* ).  
 3,232,734. **NBC WEATHER PLUS + AND DESIGN**. NBC UNIVERSAL, INC., MULTIPLE CLASS, (INT. CLS. 41 AND 42), (U.S. CLS. 100, 101 AND 107). SN 78-763,996. PUB. 2-6-2007. FILED 11-30-2005.  
 3,232,746. **MCCORMICK FLAVOR ACADEMY (BLOCK FORM)**. MCCORMICK & COMPANY, INCORPORATED, (U.S. CLS. 100, 101 AND 107). SN 78-769,530. PUB. 2-6-2007. FILED 12-8-2005.  
 3,232,757 ( *See Class 25 for this trademark* ).  
 3,232,760. **FEEDBACK FORUM (STYLIZED)**. PHANTOM GOURMET, INC., MULTIPLE CLASS, (INT. CLS. 41 AND 43), (U.S. CLS. 100, 101 AND 107). SN 78-776,122. PUB. 2-6-2007. FILED 12-19-2005.  
 3,232,786. **WEST COAST UNIVERSITY (BLOCK FORM)**. ACTON EDUCATIONAL SERVICES, INC., (U.S. CLS. 100, 101 AND 107). SN 78-791,625. PUB. 2-6-2007. FILED 1-13-2006.  
 3,232,787. **SIR BOUNCEALOTS (BLOCK FORM)**. JAKOBER, DAVID, ROBERT, AND JAKOBER, AMY, LYNN, (U.S. CLS. 100, 101 AND 107). SN 78-791,640. PUB. 2-6-2007. FILED 1-13-2006.  
 3,232,791. **SYSTEMS OF UNIVERSAL LAW INSTITUTE, INC. (BLOCK FORM)**. UNIVERSAL, ESPERANZA, (U.S. CLS. 100, 101 AND 107). SN 78-794,442. PUB. 2-6-2007. FILED 1-19-2006.  
 3,232,797. **WELLSPRING AND DESIGN**. WELLSPRING LIVING, INC., MULTIPLE CLASS, (INT. CLS. 41 AND 45), (U.S. CLS. 100, 101 AND 107). SN 78-798,225. PUB. 2-6-2007. FILED 1-24-2006.  
 3,232,806. **GRANDMA THE CLOWN (BLOCK FORM)**. LUBIN, BARRY MARK, (U.S. CLS. 100, 101 AND 107). SN 78-804,145. PUB. 2-6-2007. FILED 2-1-2006.  
 3,232,811 ( *See Class 9 for this trademark* ).  
 3,232,845 ( *See Class 35 for this trademark* ).  
 3,232,847 ( *See Class 35 for this trademark* ).  
 3,232,848 ( *See Class 35 for this trademark* ).  
 3,232,856 ( *See Class 25 for this trademark* ).  
 3,232,867. **MAINLINE RELEASING (BLOCK FORM)**. MRG ENTERTAINMENT, INC., (U.S. CLS. 100, 101 AND 107). SN 78-835,024. PUB. 2-6-2007. FILED 3-11-2006.  
 3,232,869. **FIRE & ICE FESTIVAL (BLOCK FORM)**. CASA LARGA VINEYARDS, INC., (U.S. CLS. 100, 101 AND 107). SN 78-835,536. PUB. 10-24-2006. FILED 3-13-2006.  
 3,232,870. **LIGHTNING ENTERTAINMENT (BLOCK FORM)**. LIGHTNING ENTERTAINMENT, (U.S. CLS. 100, 101 AND 107). SN 78-835,656. PUB. 2-6-2007. FILED 3-13-2006.  
 3,232,874. **JUNGLE JIMBO'S AND DESIGN**. JUNGLE JIMBO'S, INC., (U.S. CLS. 100, 101 AND 107). SN 78-836,704. PUB. 2-6-2007. FILED 3-14-2006.  
 3,232,875. **EQUIP (BLOCK FORM)**. EQUIP, INC., (U.S. CLS. 100, 101 AND 107). SN 78-836,760. PUB. 10-24-2006. FILED 3-14-2006.  
 3,232,896. **PHOTOMOVERS (BLOCK FORM)**. CASCIO, KEN, (U.S. CLS. 100, 101 AND 107). SN 78-846,076. PUB. 2-6-2007. FILED 3-24-2006.  
 3,232,903 ( *See Class 35 for this trademark* ).  
 3,232,906. **LUSCIOUS LIZ (BLOCK FORM)**. PADILLA, ELIZABETH R., (U.S. CLS. 100, 101 AND 107). SN 78-850,041. PUB. 2-6-2007. FILED 3-30-2006.  
 3,232,927. **TOTALLY SOAKED (BLOCK FORM)**. SAVION, TIFFANY, (U.S. CLS. 100, 101 AND 107). SN 78-856,529. PUB. 2-6-2007. FILED S.R. 4-7-2006; AM. P.R. 11-20-2006.  
 3,232,941 ( *See Class 36 for this trademark* ).  
 3,232,943. **LOUISVILLE SUN (BLOCK FORM)**. LOUISVILLE SUN NETWORK, LLC, (U.S. CLS. 100, 101 AND 107). SN 78-864,320. PUB. 2-6-2007. FILED 4-18-2006.  
 3,232,951. **SATELLIC TRAFFIC MANAGEMENT (BLOCK FORM)**. DEUTSCHE TELEKOM AG, (U.S. CLS. 100, 101 AND 107). SN 78-865,137. PUB. 2-6-2007. FILED 4-19-2006.  
 3,232,959. **DAILY BLABBER (BLOCK FORM)**. IVILLAGE, INC., (U.S. CLS. 100, 101 AND 107). SN 78-867,146. PUB. 2-6-2007. FILED 4-21-2006.  
 3,232,974. **PAYDAY SPORTS AND DESIGN**. PAYDAY SPORTS, INC., (U.S. CLS. 100, 101 AND 107). SN 78-870,433. PUB. 2-6-2007. FILED 4-26-2006.  
 3,232,975. **MISCELLANEOUS DESIGN**. PAYDAY SPORTS, INC., (U.S. CLS. 100, 101 AND 107). SN 78-870,443. PUB. 2-6-2007. FILED 4-26-2006.  
 3,232,976. **MADFIN SHARK SERIES (BLOCK FORM)**. JM ASSOCIATES, INC., (U.S. CLS. 100, 101 AND 107). SN 78-871,336. PUB. 2-6-2007. FILED 4-27-2006.  
 3,232,985. **MOBILE MAGAZINE (BLOCK FORM)**. BROADBAND MEDIA CORPORATION, (U.S. CLS. 100, 101 AND 107). SN 78-876,183. PUB. 2-6-2007. FILED 5-4-2006.  
 3,233,003. **CASA MARINA RESORT & BEACH CLUB AND DESIGN**. CASA MARINA OWNER, LLC, MULTIPLE CLASS, (INT. CLS. 41, 43 AND 44), (U.S. CLS. 100, 101 AND 107). SN 78-880,456. PUB. 2-6-2007. FILED 5-10-2006.  
 3,233,016. **BOTH-WIN (BLOCK FORM)**. KARRASS LTD, (U.S. CLS. 100, 101 AND 107). SN 78-883,919. PUB. 2-6-2007. FILED 5-15-2006.  
 3,233,017. **THE MENTORING MANSION (BLOCK FORM)**. KINGDOM GLOBAL MINISTRIES, (U.S. CLS. 100, 101 AND 107). SN 78-884,087. PUB. 2-6-2007. FILED 5-15-2006.  
 3,233,036. **NA NAUGHTY AMERICA EST. 1776 (BLOCK FORM)**. LA TOURAIN, INC., (U.S. CLS. 100, 101 AND 107). SN 78-886,957. PUB. 2-6-2007. FILED 5-18-2006.  
 3,233,042 ( *See Class 35 for this trademark* ).  
 3,233,045. **TRIPLESTEP DANCE PRODUCTIONS AND DESIGN**. BRYAN FOSS, DBA TRIPLESTEP DANCE PRODUCTIONS, (U.S. CLS. 100, 101 AND 107). SN 78-888,299. PUB. 2-6-2007. FILED 5-19-2006.  
 3,233,048. **THE DAVE RAMSEY SHOW (BLOCK FORM)**. THE LAMPO GROUP, INC., (U.S. CLS. 100, 101 AND 107). SN 78-888,716. PUB. 2-6-2007. FILED 5-22-2006.  
 3,233,053. **ACCIDENT SCENE MANAGEMENT (BLOCK FORM)**. ACCIDENT SCENE MANAGEMENT, INC., (U.S. CLS. 100, 101 AND 107). SN 78-890,982. PUB. 2-6-2007. FILED 5-24-2006.  
 3,233,055. **ICE (BLOCK FORM)**. THE INSTITUTE OF CULINARY EDUCATION, INC., MULTIPLE CLASS, (INT. CLS. 41 AND 43), (U.S. CLS. 100, 101 AND 107). SN 78-891,401. PUB. 2-6-2007. FILED 5-24-2006.  
 3,233,066. **CUBE FABULOUS (BLOCK FORM)**. SHORN INDUSTRIES, LLC, (U.S. CLS. 100, 101 AND 107). SN 78-894,461. PUB. 2-6-2007. FILED 5-26-2006.  
 3,233,070. **WHITEBOARD WEDNESDAY (BLOCK FORM)**. DISHER DESIGN & DEVELOPMENT, (U.S. CLS. 100, 101 AND 107). SN 78-895,866. PUB. 2-6-2007. FILED 5-30-2006.  
 3,233,089 ( *See Class 35 for this trademark* ).  
 3,233,098 ( *See Class 35 for this trademark* ).  
 3,233,102. **DELAWARE LAW WEEKLY (BLOCK FORM)**. ALM PROPERTIES, INC., (U.S. CLS. 100, 101 AND 107). SN 78-902,954. PUB. 2-6-2007. FILED 6-7-2006.  
 3,233,119. **KARATE PLUS (BLOCK FORM)**. TAEKWONDO FITNESS CENTER OF DELAWARE INC., (U.S. CLS. 100, 101 AND 107). SN 78-905,001. PUB. 2-6-2007. FILED 6-9-2006.  
 3,233,120 ( *See Class 36 for this trademark* ).  
 3,233,145. **WOLFSONIAN - FLORIDA INTERNATIONAL UNIVERSITY (BLOCK FORM)**. FLORIDA INTERNATIONAL UNIVERSITY - BOARD OF TRUSTEES, (U.S.

- CLS. 100, 101 AND 107). SN 78-907,697. PUB. 2-6-2007. FILED 6-14-2006.
- 3,233,146. **WOLFSONIAN - THE MUSEUM OF THINKISM (BLOCK FORM)**. FLORIDA INTERNATIONAL UNIVERSITY - BOARD OF TRUSTEES, (U.S. CLS. 100, 101 AND 107). SN 78-907,719. PUB. 2-6-2007. FILED 6-14-2006.
- 3,233,154. **DOCTORS DEMYSTIFY AND DESIGN. MEALS**, ROY A., (U.S. CLS. 100, 101 AND 107). SN 78-908,298. PUB. 2-6-2007. FILED 6-14-2006.
- 3,233,161. **CAMP BOLD EAGLE (BLOCK FORM)**. HEMOPHILIA FOUNDATION OF MICHIGAN, (U.S. CLS. 100, 101 AND 107). SN 78-908,679. PUB. 2-6-2007. FILED 6-15-2006.
- 3,233,162. **EAGLE OUTPOST (BLOCK FORM)**. HEMOPHILIA FOUNDATION OF MICHIGAN, (U.S. CLS. 100, 101 AND 107). SN 78-908,682. PUB. 2-6-2007. FILED 6-15-2006.
- 3,233,163. **SPRINGFEST (BLOCK FORM)**. HEMOPHILIA FOUNDATION OF MICHIGAN, (U.S. CLS. 100, 101 AND 107). SN 78-908,687. PUB. 2-6-2007. FILED 6-15-2006.
- 3,233,166. **EAGLE EXPEDITION (BLOCK FORM)**. HEMOPHILIA FOUNDATION OF MICHIGAN, (U.S. CLS. 100, 101 AND 107). SN 78-908,693. PUB. 2-6-2007. FILED 6-15-2006.
- 3,233,176. **ZOOM-ZOOM LIVE! (BLOCK FORM)**. MAZDA MOTOR OF AMERICA, INC., (U.S. CLS. 100, 101 AND 107). SN 78-909,427. PUB. 2-6-2007. FILED 6-15-2006.
- 3,233,179. **PROPERLIVING (BLOCK FORM)**. BUTEN, DAVID, (U.S. CLS. 100, 101 AND 107). SN 78-909,606. PUB. 2-6-2007. FILED 6-15-2006.
- 3,233,180. **JEFF ADAMS (BLOCK FORM)**. ADAMS, JEFF, (U.S. CLS. 100, 101 AND 107). SN 78-909,610. PUB. 2-6-2007. FILED 6-15-2006.
- 3,233,211 ( See Class 35 for this trademark).
- 3,233,214. **VSN (STYLIZED)**. GIGANTE IMAGE GROUP, (U.S. CLS. 100, 101 AND 107). SN 78-911,331. PUB. 2-6-2007. FILED 6-19-2006.
- 3,233,227. **TRUMPET AWARDS (BLOCK FORM)**. TRUMPET AWARDS FOUNDATION, INC., (U.S. CLS. 100, 101 AND 107). SN 78-912,146. PUB. 2-6-2007. FILED 6-20-2006.
- 3,233,232. **D.J. BROTHER'S (BLOCK FORM)**. D.J. BROTHER'S ENTERTAINMENT CO., INC., (U.S. CLS. 100, 101 AND 107). SN 78-912,315. PUB. 2-6-2007. FILED 6-20-2006.
- 3,233,235. **ENGLISH BY THE HOUR AND DESIGN**. LINQUIST, REBECCA, (U.S. CLS. 100, 101 AND 107). SN 78-912,345. PUB. 2-6-2007. FILED 6-20-2006.
- 3,233,260. **B2 ENTERTAINMENT (BLOCK FORM)**. B2 ENTERTAINMENT, LLC, (U.S. CLS. 100, 101 AND 107). SN 78-912,992. PUB. 2-6-2007. FILED 6-21-2006.
- 3,233,261. **WVLT TV (BLOCK FORM)**. GRAY TELEVISION GROUP, INC., (U.S. CLS. 100, 101 AND 107). SN 78-913,045. PUB. 2-6-2007. FILED 6-21-2006.
- 3,233,267. **CAROLINA VISIONS (BLOCK FORM)**. OATES & COMPANY, LLC, (U.S. CLS. 100, 101 AND 107). SN 78-913,460. PUB. 2-6-2007. FILED 6-21-2006.
- 3,233,269. **INTERNATIONAL INSTITUTE OF SEWER AND PIPE CLEANING (BLOCK FORM)**. SPARTAN TOOL, L.L.C., (U.S. CLS. 100, 101 AND 107). SN 78-913,518. PUB. 2-6-2007. FILED 6-21-2006.
- 3,233,270. **IRON LORE (BLOCK FORM)**. IRON LORE ENTERTAINMENT, LTD., (U.S. CLS. 100, 101 AND 107). SN 78-913,588. PUB. 2-6-2007. FILED 6-21-2006.
- 3,233,274 ( See Class 35 for this trademark).
- 3,233,280. **TEN YEARS AFTER (BLOCK FORM)**. CHURCHILL, MICHAEL G., AND LYONS, LEO DW., AND LEE, RICHARD, (U.S. CLS. 100, 101 AND 107). SN 78-914,307. PUB. 2-6-2007. FILED 6-22-2006.
- 3,233,281. **CASEY PARKER (BLOCK FORM)**. HARP, TEREZA ANN, (U.S. CLS. 100, 101 AND 107). SN 78-914,312. PUB. 2-6-2007. FILED 6-22-2006.
- 3,233,289 ( See Class 16 for this trademark).
- 3,233,290 ( See Class 16 for this trademark).
- 3,233,294. **THESCREAMONLINE.COM AND DESIGN**. BALCOMB, STUART VAIL, (U.S. CLS. 100, 101 AND 107). SN 78-914,651. PUB. 2-6-2007. FILED 6-22-2006.
- 3,233,299. **THE XCHANGE (BLOCK FORM)**. TRENZ MUSIC, INC., (U.S. CLS. 100, 101 AND 107). SN 78-914,692. PUB. 2-6-2007. FILED 6-22-2006.
- 3,233,309 ( See Class 35 for this trademark).
- 3,233,317. **GUILLOTINE (BLOCK FORM)**. GUILLOTINE, INC., (U.S. CLS. 100, 101 AND 107). SN 78-915,377. PUB. 2-6-2007. FILED 6-23-2006.
- 3,233,319. **SPORTSBUZZ.COM (BLOCK FORM)**. PAOLIN, JOHN R., (U.S. CLS. 100, 101 AND 107). SN 78-915,414. PUB. 2-6-2007. FILED 6-23-2006.
- 3,233,322. **GUILLOTINE POST (BLOCK FORM)**. GUILLOTINE, INC., (U.S. CLS. 100, 101 AND 107). SN 78-915,473. PUB. 2-6-2007. FILED 6-23-2006.
- 3,233,346. **MARCIA MERRILL'S ECAREERCORNER.COM AND DESIGN**. MERRILL, MARCIA, (U.S. CLS. 100, 101 AND 107). SN 78-916,047. PUB. 2-6-2007. FILED 6-23-2006.
- 3,233,359. **PARKER AND DESIGN**. FRESNO BASEBALL CLUB, LLC, (U.S. CLS. 100, 101 AND 107). SN 78-916,549. PUB. 2-6-2007. FILED 6-26-2006.
- 3,233,362. **SPINAWAY (BLOCK FORM)**. THE NEW YORK RACING ASSOCIATION INC., (U.S. CLS. 100, 101 AND 107). SN 78-916,931. PUB. 2-6-2007. FILED 6-26-2006.
- 3,233,363. **FOREGO (BLOCK FORM)**. THE NEW YORK RACING ASSOCIATION INC., (U.S. CLS. 100, 101 AND 107). SN 78-916,937. PUB. 2-6-2007. FILED 6-26-2006.
- 3,233,364. **DIANA (BLOCK FORM)**. THE NEW YORK RACING ASSOCIATION INC., (U.S. CLS. 100, 101 AND 107). SN 78-916,949. PUB. 2-6-2007. FILED 6-26-2006.
- 3,233,366. **FRIZETTE (BLOCK FORM)**. THE NEW YORK RACING ASSOCIATION INC., (U.S. CLS. 100, 101 AND 107). SN 78-916,970. PUB. 2-6-2007. FILED 6-26-2006.
- 3,233,367. **MOTHER GOOSE (BLOCK FORM)**. THE NEW YORK RACING ASSOCIATION INC., (U.S. CLS. 100, 101 AND 107). SN 78-917,006. PUB. 2-6-2007. FILED 6-26-2006.
- 3,233,369. **GAZELLE (BLOCK FORM)**. THE NEW YORK RACING ASSOCIATION INC., (U.S. CLS. 100, 101 AND 107). SN 78-917,081. PUB. 2-6-2007. FILED 6-26-2006.
- 3,233,370. **KING'S BISHOP (BLOCK FORM)**. THE NEW YORK RACING ASSOCIATION INC., (U.S. CLS. 100, 101 AND 107). SN 78-917,093. PUB. 2-6-2007. FILED 6-26-2006.
- 3,233,371. **BELDAME (BLOCK FORM)**. THE NEW YORK RACING ASSOCIATION INC., (U.S. CLS. 100, 101 AND 107). SN 78-917,098. PUB. 2-6-2007. FILED 6-26-2006.
- 3,233,372. **RUFFIAN (BLOCK FORM)**. THE NEW YORK RACING ASSOCIATION INC., (U.S. CLS. 100, 101 AND 107). SN 78-917,102. PUB. 2-6-2007. FILED 6-26-2006.
- 3,233,373. **GO FOR WAND (BLOCK FORM)**. THE NEW YORK RACING ASSOCIATION INC., (U.S. CLS. 100, 101 AND 107). SN 78-917,104. PUB. 2-6-2007. FILED 6-26-2006.
- 3,233,377. **COACHING CLUB AMERICAN OAKS (BLOCK FORM)**. THE NEW YORK RACING ASSOCIATION INC., (U.S. CLS. 100, 101 AND 107). SN 78-917,138. PUB. 2-6-2007. FILED 6-26-2006.
- 3,233,388. **LIONESZ (BLOCK FORM)**. LIONESZ, (U.S. CLS. 100, 101 AND 107). SN 78-917,315. PUB. 2-6-2007. FILED 6-26-2006.
- 3,233,389. **MUSEUM OF THE BOOK (BLOCK FORM)**. LEGACY MINISTRIES INTERNATIONAL, (U.S. CLS. 100, 101 AND 107). SN 78-917,325. PUB. 2-6-2007. FILED 6-26-2006.
- 3,233,392. **YOU WANT 'EM? WE GOT 'EM! (BLOCK FORM)**. AK TICKETS, (U.S. CLS. 100, 101 AND 107). SN 78-917,376. PUB. 2-6-2007. FILED 6-26-2006.
- 3,233,406. **ROSH HODESH: IT'S A GIRL THING! (BLOCK FORM)**. MOVING TRADITIONS, (U.S. CLS. 100, 101 AND 107). SN 78-917,863. PUB. 2-6-2007. FILED 6-27-2006.
- 3,233,407. **MOVING TRADITIONS (BLOCK FORM)**. MOVING TRADITIONS, (U.S. CLS. 100, 101 AND 107). SN 78-917,869. PUB. 2-6-2007. FILED 6-27-2006.
- 3,233,414. **BREAK-IT! THINKING (BLOCK FORM)**. PATLER, LOUIS, DBA B.I.T. GROUP, (U.S. CLS. 100, 101 AND 107). SN 78-918,068. PUB. 2-6-2007. FILED 6-27-2006.
- 3,233,427. **SHUVEE (BLOCK FORM)**. THE NEW YORK RACING ASSOCIATION INC., (U.S. CLS. 100, 101 AND 107). SN 78-918,878. PUB. 2-6-2007. FILED 6-28-2006.
- 3,233,428. **GALLANT BLOOM (BLOCK FORM)**. THE NEW YORK RACING ASSOCIATION INC., (U.S. CLS. 100, 101 AND 107). SN 78-918,895. PUB. 2-6-2007. FILED 6-28-2006.
- 3,233,429. **WITHERS (BLOCK FORM)**. THE NEW YORK RACING ASSOCIATION INC., (U.S. CLS. 100, 101 AND 107). SN 78-918,897. PUB. 2-6-2007. FILED 6-28-2006.
- 3,233,430. **JAIPUR (BLOCK FORM)**. THE NEW YORK RACING ASSOCIATION INC., (U.S. CLS. 100, 101 AND 107). SN 78-918,905. PUB. 2-6-2007. FILED 6-28-2006.
- 3,233,431. **COMELY (BLOCK FORM)**. THE NEW YORK

RACING ASSOCIATION INC., (U.S. CLS. 100, 101 AND 107). SN 78-918,908. PUB. 2-6-2007. FILED 6-28-2006.

3,233,432. **DEMOISELLE (BLOCK FORM)**, THE NEW YORK RACING ASSOCIATION INC., (U.S. CLS. 100, 101 AND 107). SN 78-918,914. PUB. 2-6-2007. FILED 6-28-2006.

3,233,433. **HILL PRINCE (BLOCK FORM)**, THE NEW YORK RACING ASSOCIATION INC., (U.S. CLS. 100, 101 AND 107). SN 78-918,936. PUB. 2-6-2007. FILED 6-28-2006.

3,233,434. **POKER (BLOCK FORM)**, THE NEW YORK RACING ASSOCIATION INC., (U.S. CLS. 100, 101 AND 107). SN 78-918,947. PUB. 2-6-2007. FILED 6-28-2006.

3,233,435. **AQUEDUCT (BLOCK FORM)**, THE NEW YORK RACING ASSOCIATION INC., (U.S. CLS. 100, 101 AND 107). SN 78-919,971. PUB. 2-6-2007. FILED 6-28-2006.

3,233,436. **WESTCHESTER (BLOCK FORM)**, THE NEW YORK RACING ASSOCIATION INC., (U.S. CLS. 100, 101 AND 107). SN 78-919,024. PUB. 2-6-2007. FILED 6-28-2006.

3,233,438 ( *See Class 16 for this trademark*).

3,233,447. **FOR A BETTER 'DOG'S LIFE'... (BLOCK FORM)**, THE BARKING DOG, LTD., (U.S. CLS. 100, 101 AND 107). SN 78-919,536. PUB. 2-6-2007. FILED 6-29-2006.

3,233,450. **MY EYE HEALTH: IN THE WINK OF AN EYE (BLOCK FORM)**, (OSI) EYETECH, INC., MULTIPLE CLASS, (INT. CLS. 41 AND 44), (U.S. CLS. 100, 101 AND 107). SN 78-919,674. PUB. 2-6-2007. FILED 6-29-2006.

3,233,455 ( *See Class 9 for this trademark*).

3,233,458. **ALMOST SOBER AND DESIGN**, KUNZE, JAMES, (U.S. CLS. 100, 101 AND 107). SN 78-920,786. PUB. 2-6-2007. FILED 6-30-2006.

3,233,463. **YOUR VISION EFFORTLESSLY FULFILLED (BLOCK FORM)**, CHARLES-COLLINS, KELLY, N. H., (U.S. CLS. 100, 101 AND 107). SN 78-921,622. PUB. 2-6-2007. FILED 7-1-2006.

3,233,470. **K NICOLE AND DESIGN**, CHARLES-COLLINS, KELLY, N. H., (U.S. CLS. 100, 101 AND 107). SN 78-921,882. PUB. 2-6-2007. FILED 7-3-2006.

3,233,472. **MCCRONE RESEARCH INSTITUTE (BLOCK FORM)**, MCCRONE RESEARCH INSTITUTE, MULTIPLE CLASS, (INT. CLS. 41 AND 42), (U.S. CLS. 100, 101 AND 107). SN 78-922,036. PUB. 2-6-2007. FILED 7-3-2006.

3,233,477. **YOGAKIDS AND DESIGN**, DANCING FEET YOGA CENTER, INC., (U.S. CLS. 100, 101 AND 107). SN 78-924,283. PUB. 2-6-2007. FILED 7-7-2006.

3,233,484. **TRESSTIFY (BLOCK FORM)**, O2 HOLDINGS, LLC, (U.S. CLS. 100, 101 AND 107). SN 78-928,071. PUB. 2-6-2007. FILED 7-12-2006.

3,233,485. **TRUTH & TRAINING CLUBS (BLOCK FORM)**, AWANA CLUBS INTERNATIONAL, (U.S. CLS. 100, 101 AND 107). SN 78-928,562. PUB. 2-6-2007. FILED 7-13-2006.

3,233,520 ( *See Class 1 for this trademark*).

3,233,529 ( *See Class 5 for this trademark*).

3,233,535 ( *See Class 9 for this trademark*).

3,233,539 ( *See Class 9 for this trademark*).

3,233,543 ( *See Class 9 for this trademark*).

3,233,546 ( *See Class 3 for this trademark*).

3,233,549 ( *See Class 39 for this trademark*).

3,233,550 ( *See Class 9 for this trademark*).

3,233,552. **SPACE DANCE AND DESIGN**, SPACE BEACH CLUB, S.A., (U.S. CLS. 100, 101 AND 107). SN 79-016,358. PUB. 1-23-2007. FILED 9-14-2005.

3,233,556 ( *See Class 5 for this trademark*).

3,233,568 ( *See Class 35 for this trademark*).

3,233,609 ( *See Class 25 for this trademark*).

3,233,624 ( *See Class 15 for this trademark*).

3,233,639. **ABC COOKING STUDIO AND DESIGN**, ABC COOKING STUDIO CO., LTD., (U.S. CLS. 100, 101 AND 107). SN 79-020,849. PUB. 2-6-2007. FILED 1-27-2006.

3,233,659. **TAEPOXI (BLOCK FORM)**, SCHNITZELKÖNIG HOTEL-; UND GASTRONOMIE GES.M.B.H., MULTIPLE CLASS, (INT. CLS. 41 AND 44), (U.S. CLS. 100, 101 AND 107). SN 79-021,572. PUB. 2-6-2007. FILED 9-1-2005.

3,233,662 ( *See Class 35 for this trademark*).

3,233,674 ( *See Class 38 for this trademark*).

3,233,684 ( *See Class 1 for this trademark*).

3,233,723 ( *See Class 9 for this trademark*).

3,233,744 ( *See Class 9 for this trademark*).

## CLASS 42—SCIENTIFIC, COMPUTER AND LEGAL SERVICES

3,232,051. **THE MED LAW TEAM**, BONINA & BONINA, P.C., (U.S. CLS. 100 AND 101). SN 75-285,614. PUB. 5-23-2006. FILED 5-2-1997.

3,232,054 ( *See Class 16 for this trademark*).

3,232,058. **CAFE MARGAUX (STYLIZED)**, CHATEAU MARGAUX, INC., (U.S. CLS. 100 AND 101). SN 75-872,425. PUB. 10-31-2000. FILED 12-15-1999.

3,232,060 ( *See Class 6 for this trademark*).

3,232,072 ( *See Class 35 for this trademark*).

3,232,073 ( *See Class 1 for this trademark*).

3,232,086 ( *See Class 7 for this trademark*).

3,232,087 ( *See Class 9 for this trademark*).

3,232,095 ( *See Class 9 for this trademark*).

3,232,133. **MISCELLANEOUS DESIGN**, GLOBAL STANDARDS, LLC, (U.S. CLS. 100 AND 101). SN 76-644,890. PUB. 2-6-2007. FILED 8-15-2005.

3,232,140. **MYEASYWEBSITE (BLOCK FORM)**, MYEASYWEBSITE LLC, (U.S. CLS. 100 AND 101). SN 76-646,957. PUB. 2-6-2007. FILED 9-19-2005.

3,232,147. **EBUSINESS/MATE (BLOCK FORM)**, AUTO/MATE, INC., (U.S. CLS. 100 AND 101). SN 76-647,759. PUB. 2-6-2007. FILED 9-30-2005.

3,232,148. **SOLVE IT (BLOCK FORM)**, SOLVE IT, LLP, (U.S. CLS. 100 AND 101). SN 76-647,777. PUB. 2-6-2007. FILED 9-30-2005.

3,232,149. **SUBMITWIZARD (BLOCK FORM)**, NETWORK SOLUTIONS, LLC, (U.S. CLS. 100 AND 101). SN 76-647,778. PUB. 2-6-2007. FILED 9-30-2005.

3,232,158. **CONVERGENT TECHNOLOGIES AND DESIGN**, CONVERGENT TECHNOLOGIES DESIGN GROUP, INC., (U.S. CLS. 100 AND 101). SN 76-649,455. PUB. 2-6-2007. FILED 10-31-2005.

3,232,195. **XTEN AND DESIGN**, KELLY, AUSTIN, (U.S. CLS. 100 AND 101). SN 76-653,691. PUB. 2-6-2007. FILED 1-19-2006.

3,232,243. **M DESIGNS AND DESIGN**, MCGAHA DESIGNS, LLC, (U.S. CLS. 100 AND 101). SN 76-661,814. PUB. 2-6-2007. FILED 6-19-2006.

3,232,253. **TALK NERDY TO ME... (BLOCK FORM)**, KOENIG SOFTWARE SYSTEMS, LLC, (U.S. CLS. 100 AND 101). SN 76-662,090. PUB. 2-6-2007. FILED 6-21-2006.

3,232,283. **ARI INSIGHTS (STYLIZED)**, AUTOMOTIVE RENTALS, INC., (U.S. CLS. 100 AND 101). SN 77-002,304. PUB. 2-6-2007. FILED 9-19-2006.

3,232,298. **XCELIOR COMMUNICATIONS (BLOCK FORM)**, TY INC., (U.S. CLS. 100 AND 101). SN 77-019,936. PUB. 2-6-2007. FILED 10-12-2006.

3,232,322 ( *See Class 37 for this trademark*).

3,232,323 ( *See Class 35 for this trademark*).

3,232,336. **PRODUCT VISIONAIRES (BLOCK FORM)**, PRODUCT VISIONAIRES GMBH, (U.S. CLS. 100 AND 101). SN 78-289,415. PUB. 8-29-2006. FILED 8-19-2003.

3,232,345 ( *See Class 9 for this trademark*).

3,232,373. **JSNP (BLOCK FORM)**, JAPAN SCIENCE AND TECHNOLOGY AGENCY, (U.S. CLS. 100 AND 101). SN 78-497,027. PUB. 10-24-2006. FILED 10-8-2004.

3,232,374. **IPWATCH NETWORK ASSURANCE PROGRAM AND DESIGN**, IP LOGIC, LLC, MULTIPLE CLASS, (INT. CLS. 42 AND 45), (U.S. CLS. 100 AND 101). SN 78-498,422. PUB. 8-22-2006. FILED 10-12-2004.

3,232,394 ( *See Class 37 for this trademark*).

3,232,398 ( *See Class 41 for this trademark*).

3,232,404. **STATEDGE (BLOCK FORM)**, ASSISTANTGM, LLC, (U.S. CLS. 100 AND 101). SN 78-558,892. PUB. 12-6-2005. FILED 2-2-2005.

3,232,412 ( *See Class 9 for this trademark*).

3,232,418 ( *See Class 5 for this trademark*).

3,232,429 ( *See Class 35 for this trademark*).

3,232,430. **WEBUNE (BLOCK FORM)**, AQUINO, EDWIN A., (U.S. CLS. 100 AND 101). SN 78-586,205. PUB. 2-6-2007. FILED 3-14-2005.

3,232,442 ( *See Class 36 for this trademark*).

3,232,452 ( *See Class 40 for this trademark*).

3,232,464. **MATCAST (BLOCK FORM)**, MCLANE ADVANCED TECHNOLOGIES, (U.S. CLS. 100 AND 101). SN 78-615,400. PUB. 2-6-2007. FILED 4-23-2005.

- 3,232,477. **TURNING INNOVATIONS INTO PATENTS (BLOCK FORM)**, BERKELEY LAW & TECHNOLOGY GROUP, LLC, (U.S. CLS. 100 AND 101). SN 78-629,071. PUB. 8-22-2006. FILED 5-12-2005.
- 3,232,495. **FORTIMAX (BLOCK FORM)**, CUETO, OSCAR SOBERON, (U.S. CLS. 100 AND 101). SN 78-648,076. PUB. 2-6-2007. FILED 6-10-2005.
- 3,232,503. **PETITION BUSTER (BLOCK FORM)**, OLD ROAD SOFTWARE, INC., (U.S. CLS. 100 AND 101). SN 78-655,923. PUB. 2-6-2007. FILED 6-22-2005.
- 3,232,513. **CHIC KNITS (BLOCK FORM)**, BURNS, BONNE MARIE, (U.S. CLS. 100 AND 101). SN 78-663,121. PUB. 2-6-2007. FILED S.R. 7-1-2005; AM. P.R. 7-1-2005.
- 3,232,525 ( *See Class 38 for this trademark*).
- 3,232,533 ( *See Class 35 for this trademark*).
- 3,232,593. **STYLE AGENT AND DESIGN**, STYLE AGENT, (U.S. CLS. 100 AND 101). SN 78-726,603. PUB. 2-6-2007. FILED S.R. 10-4-2005; AM. P.R. 8-2-2006.
- 3,232,612 ( *See Class 40 for this trademark*).
- 3,232,620 ( *See Class 16 for this trademark*).
- 3,232,621. **FATHOM THE POSSIBILITIES (BLOCK FORM)**, ASTORINO, CHRISTINE, (U.S. CLS. 100 AND 101). SN 78-737,596. PUB. 2-6-2007. FILED 10-20-2005.
- 3,232,623. **SEGMENTED BOND TOOL (BLOCK FORM)**, BAKER HUGHES INCORPORATED, (U.S. CLS. 100 AND 101). SN 78-737,723. PUB. 2-6-2007. FILED 10-21-2005.
- 3,232,632. **VISUAL CLAIMS STUDIO (BLOCK FORM)**, VISUAL RISK SOLUTIONS, INC., (U.S. CLS. 100 AND 101). SN 78-739,606. PUB. 2-6-2007. FILED 10-25-2005.
- 3,232,646. **INNOVATION CENTRAL WAYNE FARMS LLC AND DESIGN**, WAYNE FARMS, LLC, (U.S. CLS. 100 AND 101). SN 78-743,979. PUB. 2-6-2007. FILED 10-31-2005.
- 3,232,657. **VISUAL LIQUID WEB (BLOCK FORM)**, VISUAL RISK SOLUTIONS, INC., (U.S. CLS. 100 AND 101). SN 78-745,413. PUB. 2-6-2007. FILED 11-2-2005.
- 3,232,659. **VISUAL IMAGE STUDIO (BLOCK FORM)**, VISUAL RISK SOLUTIONS, INC., (U.S. CLS. 100 AND 101). SN 78-745,420. PUB. 2-6-2007. FILED 11-2-2005.
- 3,232,660. **VISUAL RISK STUDIO (BLOCK FORM)**, VISUAL RISK SOLUTIONS, INC., (U.S. CLS. 100 AND 101). SN 78-745,640. PUB. 2-6-2007. FILED 11-2-2005.
- 3,232,685 ( *See Class 35 for this trademark*).
- 3,232,688 ( *See Class 35 for this trademark*).
- 3,232,693 ( *See Class 1 for this trademark*).
- 3,232,696 ( *See Class 35 for this trademark*).
- 3,232,734 ( *See Class 41 for this trademark*).
- 3,232,738. **THEA (BLOCK FORM)**, TSUNAMI INVESTMENTS, LLC, (U.S. CLS. 100 AND 101). SN 78-766,349. PUB. 2-6-2007. FILED 12-5-2005.
- 3,232,772. **SOLINTIX (BLOCK FORM)**, SOLINTIX, INC., (U.S. CLS. 100 AND 101). SN 78-781,852. PUB. 2-6-2007. FILED 12-28-2005.
- 3,232,776. **DIMAGI AND DESIGN**, DIMAGI INC., (U.S. CLS. 100 AND 101). SN 78-785,790. PUB. 2-6-2007. FILED 1-5-2006.
- 3,232,813 ( *See Class 19 for this trademark*).
- 3,232,818. **T-MOBILE HOME (BLOCK FORM)**, DEUTSCHE TELEKOM AG, (U.S. CLS. 100 AND 101). SN 78-811,159. PUB. 2-6-2007. FILED 2-9-2006.
- 3,232,821. **T-MOBILE HOMESPOT (BLOCK FORM)**, DEUTSCHE TELEKOM AG, (U.S. CLS. 100 AND 101). SN 78-811,228. PUB. 2-6-2007. FILED 2-9-2006.
- 3,232,835 ( *See Class 9 for this trademark*).
- 3,232,845 ( *See Class 35 for this trademark*).
- 3,232,847 ( *See Class 35 for this trademark*).
- 3,232,848 ( *See Class 35 for this trademark*).
- 3,232,893. **A ALPHA WOODS HOLE LABS AND DESIGN**, ALPHA ANALYTICAL, INC., (U.S. CLS. 100 AND 101). SN 78-843,381. PUB. 2-6-2007. FILED 3-22-2006.
- 3,232,903 ( *See Class 35 for this trademark*).
- 3,232,919 ( *See Class 40 for this trademark*).
- 3,232,939. **NETDRAFTER ARCHITECTS OF THE WEB AND DESIGN**, NETDRAFTER, LLC, (U.S. CLS. 100 AND 101). SN 78-862,108. PUB. 2-6-2007. FILED 4-14-2006.
- 3,232,946 ( *See Class 37 for this trademark*).
- 3,232,966 ( *See Class 9 for this trademark*).
- 3,232,993. **EGG DESIGN AND DESIGN**, DOGMATIC PRODUCTS, INC., (U.S. CLS. 100 AND 101). SN 78-878,404. PUB. 2-6-2007. FILED 5-7-2006.
- 3,233,012 ( *See Class 35 for this trademark*).
- 3,233,029. **CHIPIN AND DESIGN**, KEALOHA TECHNOLOGIES, INC., (U.S. CLS. 100 AND 101). SN 78-885,238. PUB. 2-6-2007. FILED 5-16-2006.
- 3,233,063. **GRANDPATELLME.COM PRESERVING YOUR FAMILY HERITAGE ONE STORY AT A TIME AND DESIGN**, GRANDPATELLME.COM SOFTWARE SYSTEMS, LLC, (U.S. CLS. 100 AND 101). SN 78-893,470. PUB. 2-6-2007. FILED 5-25-2006.
- 3,233,074. **IS INNOSOURCE EDOCFLOW AND DESIGN**, INNOSOURCE BUSINESS SOLUTIONS, INC., (U.S. CLS. 100 AND 101). SN 78-896,709. PUB. 2-6-2007. FILED 5-31-2006.
- 3,233,096. **NEIGHBORS TO THE RESCUE (BLOCK FORM)**, VOLUNTEER FLORIDA FOUNDATION, INC., MULTIPLE CLASS, (INT. CLS. 42 AND 43), (U.S. CLS. 100 AND 101). SN 78-901,281. PUB. 2-6-2007. FILED 6-6-2006.
- 3,233,115. **DESIGN AROUND (BLOCK FORM)**, O'LENICK, ANTHONY J., (U.S. CLS. 100 AND 101). SN 78-904,370. PUB. 2-6-2007. FILED 6-8-2006.
- 3,233,156. **WORLD WIDE NEST (BLOCK FORM)**, WORLD WIDE NEST LLC, (U.S. CLS. 100 AND 101). SN 78-908,512. PUB. 2-6-2007. FILED 6-14-2006.
- 3,233,184. **HIGH PERFORMANCE LANDSCAPING (BLOCK FORM)**, OWEN EUGENE DELL, DBA COUNTY LANDSCAPE & DESIGN, MULTIPLE CLASS, (INT. CLS. 42 AND 44), (U.S. CLS. 100 AND 101). SN 78-909,714. PUB. 2-6-2007. FILED 6-16-2006.
- 3,233,192. **LEAN FOR THE MACHINE (BLOCK FORM)**, TECHSOLVE, INC., (U.S. CLS. 100 AND 101). SN 78-910,136. PUB. 2-6-2007. FILED 6-16-2006.
- 3,233,206. **NORTH AMERICAN SEARCH AUTHORITY (NASA) (BLOCK FORM)**, IP INVESTMENT FUND, LLC, (U.S. CLS. 100 AND 101). SN 78-910,840. PUB. 2-6-2007. FILED 6-19-2006.
- 3,233,226. **COUNT5 (BLOCK FORM)**, COUNT5, LLC, (U.S. CLS. 100 AND 101). SN 78-912,141. PUB. 2-6-2007. FILED 6-20-2006.
- 3,233,239. **SHERIDAN ROSS (BLOCK FORM)**, SHERIDAN ROSS P.C., (U.S. CLS. 100 AND 101). SN 78-912,488. PUB. 2-6-2007. FILED 6-20-2006.
- 3,233,241. **RAPID LEGAL (BLOCK FORM)**, RAPID LEGAL, (U.S. CLS. 100 AND 101). SN 78-912,601. PUB. 2-6-2007. FILED 6-20-2006.
- 3,233,247. **TOP ROW (BLOCK FORM)**, WETHERILL INVESTMENT LLC, (U.S. CLS. 100 AND 101). SN 78-912,775. PUB. 2-6-2007. FILED 6-20-2006.
- 3,233,275. **CLARIT (BLOCK FORM)**, MAVENSPIRE, INC., (U.S. CLS. 100 AND 101). SN 78-913,923. PUB. 2-6-2007. FILED 6-21-2006.
- 3,233,278. **INFINITE CONTROL SYSTEMS (BLOCK FORM)**, INFINITE CONTROL SYSTEMS, INC., (U.S. CLS. 100 AND 101). SN 78-914,256. PUB. 2-6-2007. FILED 6-22-2006.
- 3,233,306. **EXCELUS (BLOCK FORM)**, SULESKE, CHRISTOPHER A., (U.S. CLS. 100 AND 101). SN 78-914,937. PUB. 2-6-2007. FILED 6-22-2006.
- 3,233,316. **CPFR AND DESIGN**, VOLUNTARY INTERINDUSTRY COMMERCE STANDARDS ASSOC., (U.S. CLS. 100 AND 101). SN 78-915,339. PUB. 2-6-2007. FILED 6-23-2006.
- 3,233,321. **HUFF (BLOCK FORM)**, JIM HUFF REALTY, INC., (U.S. CLS. 100 AND 101). SN 78-915,436. PUB. 2-6-2007. FILED 6-23-2006.
- 3,233,340. **AKC SERVICES, INC. PERMIT EXPEDITERS AND DESIGN**, AKC SERVICES, INC., (U.S. CLS. 100 AND 101). SN 78-915,961. PUB. 2-6-2007. FILED 6-23-2006.
- 3,233,341. **RAPID LEGAL FILE & SERVE SOLUTIONS! AND DESIGN**, RAPID LEGAL, (U.S. CLS. 100 AND 101). SN 78-915,969. PUB. 2-6-2007. FILED 6-23-2006.
- 3,233,343 ( *See Class 9 for this trademark*).
- 3,233,354. **VISUAL SERVICES, INC. AND DESIGN**, VISUAL SERVICES, INCORPORATED, (U.S. CLS. 100 AND 101). SN 78-916,275. PUB. 2-6-2007. FILED 6-25-2006.
- 3,233,355 ( *See Class 35 for this trademark*).
- 3,233,357. **BROOKS CENTER FOR REHABILITATION STUDIES (BLOCK FORM)**, GENESIS HEALTH, INC., (U.S. CLS. 100 AND 101). SN 78-916,413. PUB. 2-6-2007. FILED 6-26-2006.
- 3,233,358. **ANSWERS INPOWER (BLOCK FORM)**, ANSWERS

- SYSTEMS INC., (U.S. CLS. 100 AND 101), SN 78-916,423. PUB. 2-6-2007. FILED 6-26-2006.
- 3,233,378. **AWESUMATION (BLOCK FORM)**, AWESUMATION, INC., (U.S. CLS. 100 AND 101), SN 78-917,146. PUB. 2-6-2007. FILED 6-26-2006.
- 3,233,390. **NETSTEPS (BLOCK FORM)**, MYEXTENT, (U.S. CLS. 100 AND 101), SN 78-917,332. PUB. 2-6-2007. FILED 6-26-2006.
- 3,233,400. **SOFTWARE DESIGNED WITH YOU IN MIND (BLOCK FORM)**, NETROSOFT, INC., (U.S. CLS. 100 AND 101), SN 78-917,574. PUB. 2-6-2007. FILED 6-27-2006.
- 3,233,423. **PERRY IP GROUP (BLOCK FORM)**, PERRY IP GROUP A LAW CORPORATION, (U.S. CLS. 100 AND 101), SN 78-918,317. PUB. 2-6-2007. FILED 6-27-2006.
- 3,233,424. **PROTECTING THE BRANDS YOU BUILD (BLOCK FORM)**, PERRY IP GROUP A LAW CORPORATION, (U.S. CLS. 100 AND 101), SN 78-918,323. PUB. 2-6-2007. FILED 6-27-2006.
- 3,233,437. **TOMORROW'S TECHNOLOGY. TODAY'S USERS. (BLOCK FORM)**, TRITAUER, LLC, (U.S. CLS. 100 AND 101), SN 78-919,117. PUB. 2-6-2007. FILED 6-28-2006.
- 3,233,460. **SWOG (BLOCK FORM)**, SOUTHWEST ONCOLOGY GROUP, (U.S. CLS. 100 AND 101), SN 78-920,978. PUB. 2-6-2007. FILED 6-30-2006.
- 3,233,472 ( See Class 41 for this trademark).
- 3,233,493 ( See Class 35 for this trademark).
- 3,233,506. **FACILITY CHECK (BLOCK FORM)**, NALCO COMPANY, (U.S. CLS. 100 AND 101), SN 78-964,768. PUB. 2-6-2007. FILED 8-31-2006.
- 3,233,520 ( See Class 1 for this trademark).
- 3,233,529 ( See Class 5 for this trademark).
- 3,233,530 ( See Class 35 for this trademark).
- 3,233,534 ( See Class 7 for this trademark).
- 3,233,535 ( See Class 9 for this trademark).
- 3,233,537 ( See Class 38 for this trademark).
- 3,233,539 ( See Class 9 for this trademark).
- 3,233,541 ( See Class 1 for this trademark).
- 3,233,550 ( See Class 9 for this trademark).
- 3,233,555 ( See Class 9 for this trademark).
- 3,233,556 ( See Class 5 for this trademark).
- 3,233,559 ( See Class 7 for this trademark).
- 3,233,560 ( See Class 7 for this trademark).
- 3,233,565 ( See Class 9 for this trademark).
- 3,233,569 ( See Class 9 for this trademark).
- 3,233,580 ( See Class 7 for this trademark).
- 3,233,584 ( See Class 1 for this trademark).
- 3,233,590 ( See Class 9 for this trademark).
- 3,233,595 ( See Class 1 for this trademark).
- 3,233,597 ( See Class 9 for this trademark).
- 3,233,606 ( See Class 6 for this trademark).
- 3,233,610 ( See Class 9 for this trademark).
- 3,233,620 ( See Class 35 for this trademark).
- 3,233,636 ( See Class 9 for this trademark).
- 3,233,640 ( See Class 9 for this trademark).
- 3,233,649 ( See Class 9 for this trademark).
- 3,233,662 ( See Class 35 for this trademark).
- 3,233,670. **PETER MACCALLUM (BLOCK FORM)**, PETER MACCALLUM CANCER INSTITUTE, (U.S. CLS. 100 AND 101), SN 79-022,080. PUB. 2-6-2007. FILED 1-25-2006.
- 3,233,677 ( See Class 9 for this trademark).
- 3,233,684 ( See Class 1 for this trademark).
- 3,233,685 ( See Class 3 for this trademark).
- 3,233,704 ( See Class 9 for this trademark).
- 3,233,724. **INDENA LAB IND AND DESIGN**, INDENA S.P.A., (U.S. CLS. 100 AND 101), SN 79-025,166. PUB. 2-6-2007. FILED 5-2-2006.
- 3,233,725. **INDENAVET AND DESIGN**, INDENA S.P.A., (U.S. CLS. 100 AND 101), SN 79-025,183. PUB. 2-6-2007. FILED 12-28-2005.
- 3,233,735 ( See Class 1 for this trademark).
- 3,232,119. **SPLENDOR (BLOCK FORM)**, SPLENDOR FRANCHISING LTD., (U.S. CLS. 100 AND 101), SN 76-602,998. PUB. 1-17-2006. FILED 7-20-2004.
- 3,232,130. **QUARTINO (BLOCK FORM)**, LOMBARDO, STEPHEN J., (U.S. CLS. 100 AND 101), SN 76-640,283. PUB. 2-6-2007. FILED 6-6-2005.
- 3,232,152. **MISCELLANEOUS DESIGN**, MCKINNON 'S LLC, (U.S. CLS. 100 AND 101), SN 76-648,408. PUB. 2-6-2007. FILED 10-13-2005.
- 3,232,172. **BAYMONT INN & SUITES AND DESIGN**, WHG TM CORP., (U.S. CLS. 100 AND 101), SN 76-650,824. PUB. 1-23-2007. FILED 11-16-2005.
- 3,232,190. **SHOGUN (BLOCK FORM)**, SHIN NIHON KOSAN, INC., (U.S. CLS. 100 AND 101), SN 76-653,034. PUB. 2-6-2007. FILED 1-6-2006.
- 3,232,230. **XES LOUNGE AND DESIGN**, JERETON ENTERTAINMENT, INC., (U.S. CLS. 100 AND 101), SN 76-661,503. PUB. 2-6-2007. FILED 6-13-2006.
- 3,232,239. **AUDITPRO (STYLIZED)**, TRAVEL PLANNERS, INC., (U.S. CLS. 100 AND 101), SN 76-661,800. PUB. 2-6-2007. FILED 6-19-2006.
- 3,232,240. **RESASSURE (STYLIZED)**, TRAVEL PLANNERS, INC., (U.S. CLS. 100 AND 101), SN 76-661,801. PUB. 2-6-2007. FILED 6-19-2006.
- 3,232,241. **RESOPEN (STYLIZED)**, TRAVEL PLANNERS, INC., (U.S. CLS. 100 AND 101), SN 76-661,802. PUB. 2-6-2007. FILED 6-19-2006.
- 3,232,242. **YOUR MASTER PLAN FOR CONVENTION HOUSING (STYLIZED)**, TRAVEL PLANNERS, INC., (U.S. CLS. 100 AND 101), SN 76-661,804. PUB. 2-6-2007. FILED 6-19-2006.
- 3,232,295. **DISNEY'S ANIMAL KINGDOM LODGE (BLOCK FORM)**, DISNEY ENTERPRISES, INC., (U.S. CLS. 100 AND 101), SN 77-019,094. PUB. 2-6-2007. FILED 10-11-2006.
- 3,232,407. **YVONNE'S SOUTHERN CUISINE (BLOCK FORM)**, PARKER, YVONNE, AND TAYLOR, ROBERT B., (U.S. CLS. 100 AND 101), SN 78-560,889. PUB. 2-6-2007. FILED 2-4-2005.
- 3,232,444. **RUSSIAN TEA TIME (BLOCK FORM)**, KLARETTA FOODS, INC., (U.S. CLS. 100 AND 101), SN 78-595,349. PUB. 2-6-2007. FILED 3-25-2005.
- 3,232,481 ( See Class 35 for this trademark).
- 3,232,490 ( See Class 35 for this trademark).
- 3,232,522 ( See Class 30 for this trademark).
- 3,232,611. **NATIONAL CONEY ISLAND MICHIGAN'S FINEST HOT DOG! MR. POP AND DESIGN**, NATIONAL CONEY ISLAND, INC., (U.S. CLS. 100 AND 101), SN 78-731,916. PUB. 2-6-2007. FILED 10-12-2005.
- 3,232,681 ( See Class 30 for this trademark).
- 3,232,713. **MENCHANKO-TEI (BLOCK FORM)**, YONEHAMA, AKIHIDE, (U.S. CLS. 100 AND 101), SN 78-756,648. PUB. 2-6-2007. FILED 11-17-2005.
- 3,232,724. **GATEWAY TO THE WORLD (BLOCK FORM)**, SUN LLC, (U.S. CLS. 100 AND 101), SN 78-760,767. PUB. 2-6-2007. FILED 11-24-2005.
- 3,232,733. **CHOP'T (BLOCK FORM)**, CHOP'T CREATIVE SALAD COMPANY LLC, (U.S. CLS. 100 AND 101), SN 78-763,906. PUB. 11-7-2006. FILED 11-30-2005.
- 3,232,756. **MISCELLANEOUS DESIGN**, GUANGZHOU KUNGFU CATERING MANAGEMENT CO., LTD., (U.S. CLS. 100 AND 101), SN 78-774,305. PUB. 2-6-2007. FILED 12-15-2005.
- 3,232,760 ( See Class 41 for this trademark).
- 3,232,795. **REDESIGNED BY BUSINESS TRAVELERS FOR BUSINESS TRAVELERS (BLOCK FORM)**, MARRIOTT INTERNATIONAL, INC., (U.S. CLS. 100 AND 101), SN 78-795,557. PUB. 2-6-2007. FILED 1-20-2006.
- 3,232,850. **PLANET BURRITO AND DESIGN**, CAMPBELL, WILLIAM, JR., (U.S. CLS. 100 AND 101), SN 78-826,099. PUB. 2-6-2007. FILED 3-1-2006.
- 3,232,851. **PLANET BURRITO AND DESIGN**, CAMPBELL, WILLIAM, JR., (U.S. CLS. 100 AND 101), SN 78-826,102. PUB. 2-6-2007. FILED 3-1-2006.
- 3,232,857. **LIMÓN (STYLIZED)**, CALUZ, INC., (U.S. CLS. 100 AND 101), SN 78-830,904. PUB. 10-24-2006. FILED 3-7-2006.
- 3,232,877. **ANDALE MEXICAN RESTAURANT (BLOCK FORM)**, ANDALÉ LOS GATOS, (U.S. CLS. 100 AND 101), SN 78-837,848. PUB. 2-6-2007. FILED 3-15-2006.
- 3,232,878 ( See Class 39 for this trademark).

#### CLASS 43—HOTEL AND RESTAURANT SERVICES

- 3,232,083 ( See Class 41 for this trademark).
- 3,232,092. **S.P.O.L.E.T.O CULINARIA ITALIANA AND DE-**



- 3,232,910. **SNOWCAP LODGE (BLOCK FORM)**. ALPINE LODGE LLC, (U.S. CLS. 100 AND 101). SN 78-851,288. PUB. 2-6-2007. FILED 3-31-2006.
- 3,232,936. **OHELT AND DESIGN**. SONTGERATH, MELINDA, (U.S. CLS. 100 AND 101). SN 78-861,287. PUB. 2-6-2007. FILED 4-13-2006.
- 3,232,941 ( *See Class 36 for this trademark*).
- 3,232,952. **YUMMY BARTENDERS (BLOCK FORM)**. VALENTINE, KEITH W., DBA YUMMY BARTENDERS, (U.S. CLS. 100 AND 101). SN 78-865,405. PUB. 2-6-2007. FILED 4-20-2006.
- 3,233,003 ( *See Class 41 for this trademark*).
- 3,233,033. **MISCELLANEOUS DESIGN**. JOSE', INC., (U.S. CLS. 100 AND 101). SN 78-886,014. PUB. 2-6-2007. FILED 5-17-2006.
- 3,233,041. **POMODORO (STYLIZED)**. PASTA POMODORO, INC., (U.S. CLS. 100 AND 101). SN 78-888,100. PUB. 2-6-2007. FILED 5-19-2006.
- 3,233,055 ( *See Class 41 for this trademark*).
- 3,233,096 ( *See Class 42 for this trademark*).
- 3,233,107. **CARINO'S ITALIAN (BLOCK FORM)**. KONA RESTAURANT GROUP, INC., (U.S. CLS. 100 AND 101). SN 78-903,376. PUB. 2-6-2007. FILED 6-7-2006.
- 3,233,139. **OH BABY O'S (BLOCK FORM)**. BORKHUIS, DEBORAH ANN, DBA OH BABY O'S, (U.S. CLS. 100 AND 101). SN 78-907,210. PUB. 2-6-2007. FILED 6-13-2006.
- 3,233,151. **THE SASSY SANDWICH (BLOCK FORM)**. THE SASSY SANDWICH, INC., (U.S. CLS. 100 AND 101). SN 78-907,967. PUB. 2-6-2007. FILED 6-14-2006.
- 3,233,181. **25° TWENTYFIVEDEGREES AND DESIGN**. DOMAINE RESTAURANT GROUP LLC, (U.S. CLS. 100 AND 101). SN 78-909,630. PUB. 2-6-2007. FILED 6-15-2006.
- 3,233,187. **JAVA CONE AND DESIGN**. JAVA CONE LTD., (U.S. CLS. 100 AND 101). SN 78-909,844. PUB. 2-6-2007. FILED 6-16-2006.
- 3,233,212 ( *See Class 35 for this trademark*).
- 3,233,217 ( *See Class 35 for this trademark*).
- 3,233,222. **MISCELLANEOUS DESIGN**. KING'S SEAFOOD COMPANY, LLC, (U.S. CLS. 100 AND 101). SN 78-911,775. PUB. 2-6-2007. FILED 6-19-2006.
- 3,233,248. **YES, WE CAN! (BLOCK FORM)**. EMERITUS CORPORATION, MULTIPLE CLASS, (INT. CLS. 43 AND 44), (U.S. CLS. 100 AND 101). SN 78-912,801. PUB. 2-6-2007. FILED 6-20-2006.
- 3,233,252. **KIN FOLKS (BLOCK FORM)**. SPOMO INC., DBA KIN FOLKS TEXAS BBQ, (U.S. CLS. 100 AND 101). SN 78-912,909. PUB. 2-6-2007. FILED 6-21-2006.
- 3,233,420. **CREPE "N" TEARIA (BLOCK FORM)**. CREPE "N" TEARIA, INC., (U.S. CLS. 100 AND 101). SN 78-918,219. PUB. 2-6-2007. FILED 6-27-2006.
- 3,233,439. **BUBBA GUMP SHRIMP CO. RESTAURANT & MARKET AND DESIGN**. PARAMOUNT PICTURES CORPORATION, (U.S. CLS. 100 AND 101). SN 78-919,230. PUB. 2-6-2007. FILED 6-28-2006.
- 3,233,441 ( *See Class 35 for this trademark*).
- 3,233,520 ( *See Class 1 for this trademark*).
- 3,233,549 ( *See Class 39 for this trademark*).
- 3,233,561 ( *See Class 33 for this trademark*).
- 3,233,677 ( *See Class 9 for this trademark*).
- 3,233,709. **BYBLOS ART HOTEL VILLA AMISTÀ (STYLIZED)**. SWINGER INTERNATIONAL S.P.A., (U.S. CLS. 100 AND 101). SN 79-024,067. PUB. 2-6-2007. FILED 11-10-2005.
- 3,233,716 ( *See Class 16 for this trademark*).
- 3,232,256. **SONA MEDSPA (STYLIZED)**. SONA MEDSPA INTERNATIONAL, INC., (U.S. CLS. 100 AND 101). SN 76-662,306. PUB. 2-6-2007. FILED 6-29-2006.
- 3,232,269. **FHC HEALTH SYSTEMS (BLOCK FORM)**. FHC HEALTH SYSTEMS, INC., (U.S. CLS. 100 AND 101). SN 76-663,403. PUB. 2-6-2007. FILED 7-18-2006.
- 3,232,277. **SALT IN YOUR SOCK (BLOCK FORM)**. BEARD, LILLIAN, (U.S. CLS. 100 AND 101). SN 76-978,533. PUB. 9-13-2005. FILED 1-7-2004.
- 3,232,418 ( *See Class 5 for this trademark*).
- 3,232,419 ( *See Class 16 for this trademark*).
- 3,232,433 ( *See Class 41 for this trademark*).
- 3,232,437 ( *See Class 25 for this trademark*).
- 3,232,438. **STRIKE OUT CANCER (BLOCK FORM)**. GENENTECH, INC., (U.S. CLS. 100 AND 101). SN 78-593,278. PUB. 3-14-2006. FILED 3-23-2005.
- 3,232,439. **STRIKE OUT CANCER AND DESIGN**. GENENTECH, INC., (U.S. CLS. 100 AND 101). SN 78-593,304. PUB. 4-18-2006. FILED 3-23-2005.
- 3,232,487. **HELPS HEALTHY EXERCISE & LIFESTYLE PROGRAMS (BLOCK FORM)**. WAKE FOREST UNIVERSITY, (U.S. CLS. 100 AND 101). SN 78-638,046. PUB. 2-6-2007. FILED 5-26-2005.
- 3,232,558 ( *See Class 41 for this trademark*).
- 3,232,636. **INDIANA HEMOPHILIA & THROMBOSIS CENTER AND DESIGN**. INDIANA HEMOPHILIA & THROMBOSIS CENTER, INC., (U.S. CLS. 100 AND 101). SN 78-741,898. PUB. 2-6-2007. FILED 10-27-2005.
- 3,232,679. **E ESTHETIQUE (STYLIZED)**. EARL M. SCHNEIDER, D.D.S., LTD., (U.S. CLS. 100 AND 101). SN 78-749,234. PUB. 2-6-2007. FILED 11-8-2005.
- 3,232,749. **"NOTHING LIKE A GOOD NIGHT'S SLEEP." (BLOCK FORM)**. SIGSBEE REHABILITATION CORPORATION, (U.S. CLS. 100 AND 101). SN 78-769,993. PUB. 8-22-2006. FILED 12-9-2005.
- 3,232,751. **ITALK THERAPY AND DESIGN**. PM KNIGHTS, INC., (U.S. CLS. 100 AND 101). SN 78-770,718. PUB. 2-6-2007. FILED 12-10-2005.
- 3,232,770. **MARRIAGWORKS (BLOCK FORM)**. SELL, ARNOLD J., MULTIPLE CLASS, (INT. CLS. 44 AND 45), (U.S. CLS. 100 AND 101). SN 78-779,970. PUB. 2-6-2007. FILED 12-22-2005.
- 3,232,790. **METHODE TRAPEZE (BLOCK FORM)**. ON RITE CO., INC., (U.S. CLS. 100 AND 101). SN 78-792,792. PUB. 2-6-2007. FILED 1-17-2006.
- 3,232,794. **FRAGEN COSMETIC SURGERY CENTER (BLOCK FORM)**. RONALD A. FRAGEN M.D., A MEDICAL CORPORATION, (U.S. CLS. 100 AND 101). SN 78-795,336. PUB. 12-5-2006. FILED 1-19-2006.
- 3,232,815. **IN YOUR OWN SKIN SKIN THERAPY CENTER (BLOCK FORM)**. IN YOUR OWN SKIN SKIN THERAPY CENTER, INC., (U.S. CLS. 100 AND 101). SN 78-810,989. PUB. 2-6-2007. FILED 2-9-2006.
- 3,232,816 ( *See Class 3 for this trademark*).
- 3,232,904 ( *See Class 35 for this trademark*).
- 3,232,911 ( *See Class 35 for this trademark*).
- 3,232,937. **YOU'RE NEVER TOO OLD TO BE YOUNG (BLOCK FORM)**. CHARLES F. GLASSMAN MD LLC, (U.S. CLS. 100 AND 101). SN 78-861,302. PUB. 2-6-2007. FILED 4-13-2006.
- 3,232,957. **PHYSICIANS WELLNESS NETWORK (BLOCK FORM)**. DOCTALK, INC., (U.S. CLS. 100 AND 101). SN 78-866,564. PUB. 2-6-2007. FILED 4-21-2006.
- 3,232,989. **CHANGING PRISMS (BLOCK FORM)**. BOYS TOWN OF MISSOURI, (U.S. CLS. 100 AND 101). SN 78-877,237. PUB. 2-6-2007. FILED 5-5-2006.
- 3,233,003 ( *See Class 41 for this trademark*).
- 3,233,027. **MISCELLANEOUS DESIGN**. HALLMARK REHABILITATION GP, LLC, (U.S. CLS. 100 AND 101). SN 78-885,112. PUB. 2-6-2007. FILED 5-16-2006.
- 3,233,038. **MISCELLANEOUS DESIGN**. FERTILITY CENTERS OF ILLINOIS, S.C., (U.S. CLS. 100 AND 101). SN 78-887,646. PUB. 2-6-2007. FILED 5-19-2006.
- 3,233,046 ( *See Class 10 for this trademark*).
- 3,233,057. **ELIZA JENNINGS (BLOCK FORM)**. ELIZA JENNINGS SENIOR CARE NETWORK, (U.S. CLS. 100 AND 101). SN 78-892,555. PUB. 2-6-2007. FILED 5-25-2006.
- 3,233,083. **SLEEP ASSURANCE FROM ASSOCIATED**

---

#### CLASS 44—MEDICAL, BEAUTY AND AGRICULTURAL SERVICES

- 3,232,086 ( *See Class 7 for this trademark*).
- 3,232,102 ( *See Class 41 for this trademark*).
- 3,232,112. **ANSR (BLOCK FORM)**. SMITH, FRANK R., (U.S. CLS. 100 AND 101). SN 76-629,116. PUB. 2-6-2007. FILED 1-24-2005.
- 3,232,255. **SONA MEDSPA (BLOCK FORM)**. SONA MEDSPA INTERNATIONAL, INC., (U.S. CLS. 100 AND 101). SN 76-662,195. PUB. 2-6-2007. FILED 6-26-2006.

- (**BLOCK FORM**). ASSOCIATED HEALTHCARE SYSTEMS, INC., (U.S. CLS. 100 AND 101). SN 78-899,190. PUB. 2-6-2007. FILED 6-2-2006.
- 3,233,114. **MIAMI OBSTETRICS GYNECOLOGY AND DESIGN**. DEL BOCA, ADRIAN, (U.S. CLS. 100 AND 101). SN 78-904,209. PUB. 2-6-2007. FILED 6-8-2006.
- 3,233,137 ( *See Class 39 for this trademark*).
- 3,233,138 ( *See Class 39 for this trademark*).
- 3,233,140 ( *See Class 39 for this trademark*).
- 3,233,152. **CARA DONLEY PEDIATRIC DENTISTRY AND DESIGN**. DONLEY, CARA L. AND BOCH, JASON A. (U.S. CLS. 100 AND 101). SN 78-907,974. PUB. 2-6-2007. FILED 6-14-2006.
- 3,233,184 ( *See Class 42 for this trademark*).
- 3,233,234. **P AND DESIGN**. PRO-ACTIVITY ASSOCIATES, LLC, (U.S. CLS. 100 AND 101). SN 78-912,338. PUB. 2-6-2007. FILED 6-20-2006.
- 3,233,240. **PROMOTING GROWTH. CHANGING LIVES. (BLOCK FORM)**. CENTER FOR CHILD DEVELOPMENT, (U.S. CLS. 100 AND 101). SN 78-912,566. PUB. 2-6-2007. FILED 6-20-2006.
- 3,233,248 ( *See Class 43 for this trademark*).
- 3,233,259 ( *See Class 35 for this trademark*).
- 3,233,268. **BRONX PLASTIC SURGERY (BLOCK FORM)**. GOLDSTEIN, ROBERT D., (U.S. CLS. 100 AND 101). SN 78-913,477. PUB. 2-6-2007. FILED 6-21-2006.
- 3,233,311. **OIL LADY AROMATHERAPY (BLOCK FORM)**. NEWMAN, CANDACE J., (U.S. CLS. 100 AND 101). SN 78-915,072. PUB. 2-6-2007. FILED 6-22-2006.
- 3,233,330. **BROOKS REHABILITATION NETWORK (BLOCK FORM)**. GENESIS HEALTH, INC., (U.S. CLS. 100 AND 101). SN 78-915,713. PUB. 2-6-2007. FILED 6-23-2006.
- 3,233,335. **BROOKS HEALTH SYSTEM (BLOCK FORM)**. GENESIS HEALTH, INC., (U.S. CLS. 100 AND 101). SN 78-915,816. PUB. 2-6-2007. FILED 6-23-2006.
- 3,233,376. **TURF TOUCH (BLOCK FORM)**. HOUSTON, MARSHALL S., (U.S. CLS. 100 AND 101). SN 78-917,136. PUB. 2-6-2007. FILED 6-26-2006.
- 3,233,404. **BEYOND BROCCOLI (BLOCK FORM)**. MARY T. RYAN, (U.S. CLS. 100 AND 101). SN 78-917,707. PUB. 2-6-2007. FILED 6-27-2006.
- 3,233,440. **PARENT AID (BLOCK FORM)**. OREGON ASSOCIATION CHIEFS OF POLICE, (U.S. CLS. 100 AND 101). SN 78-919,319. PUB. 2-6-2007. FILED 6-28-2006.
- 3,233,444. **FOR A BETTER 'DOG'S LIFE'...** (BLOCK FORM). THE BARKING DOG, LTD., (U.S. CLS. 100 AND 101). SN 78-919,520. PUB. 2-6-2007. FILED 6-29-2006.
- 3,233,450 ( *See Class 41 for this trademark*).
- 3,233,452. **COS BAR (BLOCK FORM)**. COSBAR USA, INC., (U.S. CLS. 100 AND 101). SN 78-919,947. PUB. 2-6-2007. FILED 6-29-2006.
- 3,233,529 ( *See Class 5 for this trademark*).
- 3,233,531 ( *See Class 7 for this trademark*).
- 3,233,553 ( *See Class 10 for this trademark*).
- 3,233,556 ( *See Class 5 for this trademark*).
- 3,233,659 ( *See Class 41 for this trademark*).
- 3,233,691 ( *See Class 29 for this trademark*).
- 3,233,692 ( *See Class 10 for this trademark*).
- 3,232,374 ( *See Class 42 for this trademark*).
- 3,232,380. **CANDIDATEPRO (BLOCK FORM)**. KOEHLER, KURT E., (U.S. CLS. 100 AND 101). SN 78-511,511. PUB. 2-6-2007. FILED 11-4-2004.
- 3,232,385. **INTERNATIONAL INTELLECTUAL PROPERTY INVESTIGATORS ASSOCIATION (BLOCK FORM)**. KRISTOPHER TODD BUCKNER, (U.S. CLS. 100 AND 101). SN 78-522,642. PUB. 2-6-2007. FILED 11-24-2004.
- 3,232,455. **SPIRITUAL SPA (BLOCK FORM)**. BAKER, SUZANNE, (U.S. CLS. 100 AND 101). SN 78-605,787. PUB. 2-6-2007. FILED 4-11-2005.
- 3,232,525 ( *See Class 38 for this trademark*).
- 3,232,630 ( *See Class 41 for this trademark*).
- 3,232,770 ( *See Class 44 for this trademark*).
- 3,232,797 ( *See Class 41 for this trademark*).
- 3,232,841 ( *See Class 9 for this trademark*).
- 3,232,905 ( *See Class 9 for this trademark*).
- 3,232,956. **LIFELOCK TAKE CONTROL (BLOCK FORM)**. LIFELOCK, INC., (U.S. CLS. 100 AND 101). SN 78-866,519. PUB. 2-6-2007. FILED 4-21-2006.
- 3,233,105. **ARW ADOPTION RESOURCES OF WISCONSIN AND DESIGN**. ADOPTION RESOURCES OF WISCONSIN, (U.S. CLS. 100 AND 101). SN 78-903,173. PUB. 2-6-2007. FILED 6-7-2006.
- 3,233,205. **SAFETYWATCH AND DESIGN**. SAFETYWATCH, LLC, (U.S. CLS. 100 AND 101). SN 78-910,628. PUB. 2-6-2007. FILED 6-16-2006.
- 3,233,355 ( *See Class 35 for this trademark*).
- 3,233,379. **LITTLE COURTESIES (BLOCK FORM)**. DIANA BITTLE, (U.S. CLS. 100 AND 101). SN 78-917,180. PUB. 2-6-2007. FILED 6-26-2006.
- 3,233,754 ( *See Class 35 for this trademark*).

\* \* \* \* \*

---

#### CLASS 45—PERSONAL SERVICES

- 3,232,095 ( *See Class 9 for this trademark*).
- 3,232,102 ( *See Class 41 for this trademark*).
- 3,232,227. **LOCK WORKS LOCKSMITH COMPANY AND DESIGN**. LOCKWORKS LOCKSMITH COMPANY, LLC, (U.S. CLS. 100 AND 101). SN 76-661,435. PUB. 2-6-2007. FILED 6-12-2006.
- 3,232,334. **SURECALL**. CARDAVAN CORPORATION, (U.S. CLS. 100 AND 101). SN 78-275,499. PUB. 8-22-2006. FILED 7-17-2003.
- 3,232,337. **BEL-AIR PATROL**. ADT SERVICES AG, (U.S. CLS. 100 AND 101). SN 78-291,110. PUB. 2-6-2007. FILED 8-22-2003.
- 3,232,338. **ADT BEL-AIR PATROL**. ADT SERVICES AG, (U.S. CLS. 100 AND 101). SN 78-291,124. PUB. 2-6-2007. FILED 8-22-2003.

SECTION 2.—PRIOR UNITED STATES CLASSIFICATION

COLLECTIVE MEMBERSHIP MARKS

**CLASS 200—COLLECTIVE MEMBERSHIP**

3,232,638. **SIGMA ALPHA OMEGA (BLOCK FORM)**, SIGMA ALPHA OMEGA CHRISTIAN SORORITY, INC., SN 78-742,252. PUB. 2-6-2007. FILED 10-28-2005.

3,232,730. **US SAILING TEAM (BLOCK FORM)**, UNITED STATES SAILING ASSOCIATION, INC., SN 78-763,408. PUB. 2-6-2007. FILED 11-30-2005.

3,232,800. **NATIONAL CHILDREN'S ALLIANCE (BLOCK FORM)**, NATIONAL CHILDREN'S ALLIANCE, SN 78-800,025. PUB. 2-6-2007. FILED 1-26-2006.

3,233,020. **1% FOR THE PLANET (BLOCK FORM)**, 1% FOR THE PLANET, INC., SN 78-884,681. PUB. 2-6-2007. FILED 5-16-2006.

CERTIFICATION MARKS

CLASS A—GOODS

3,232,223. **UNION MADE IN THE U.S.A. UNITE HERE! (STYLIZED)**, UNITE HERE, SN 76-661,315. PUB. 2-6-2007. FILED 6-9-2006.

3,232,326. **100% NAPA VALLEY**, NAPA VALLEY VINTNERS ASSOCIATION, SN 78-219,418. PUB. 2-6-2007. FILED 2-26-2003.

CLASS B—SERVICES

3,233,097. **CLP CERTIFIED LEGAL PROFESSIONALS .THE ASSOCIATION FOR LEGAL PROFESSIONALS AND DESIGN**, NALS, INC., SN 78-901,550. PUB. 1-23-2007. FILED 6-6-2006.

\* \* \* \* \*

# TRADEMARK REGISTRATIONS ISSUED UNDER SECTION 1(d)

The following marks have registered on the Principal Register pursuant to the intent-to-use provisions of Section 1(d) of the Trademark Act of 1946, as amended.

## SECTION 1.— INTERNATIONAL CLASSIFICATION

The short titles associated below with the international class numbers are terms designed merely for quick identification and are not an official part of the international classification. The full names of international classes are given in section 6.1 of the trademark rules of practice.

The designation "U.S. Cl." appearing in this section refers to the U.S. class in effect prior to Sep. 1, 1973 rather than the international class which applies to applications filed on or after that date. For adoption of international classification see notice in the OFFICIAL GAZETTE of Jun. 26, 1973 (911 O.G. TM 210).

### Application in more than one class

3,233,767. RAYMOND JAMES FINANCIAL, INC., ST. PETERSBURG, FL. SN 75-712,160. PUB. 8-28-2001, FILED 5-21-1999.

3,233,768. HARRIS MYCFO, INC., CHICAGO, IL. SN 75-717,146. PUB. 7-9-2002, FILED 5-28-1999.

## RAYMOND JAMES STADIUM

NO CLAIM IS MADE TO THE EXCLUSIVE RIGHT TO USE "STADIUM", APART FROM THE MARK AS SHOWN. "RAYMOND JAMES" IS NOT THE NAME OF A REAL PERSON, LIVING OR DEAD.

### CLASS 9—ELECTRICAL AND SCIENTIFIC APPARATUS

FOR PRE-RECORDED AUDIO AND VIDEO TAPES, CASSETTES AND DISCS FEATURING FOOTBALL/SOCCER HIGHLIGHTS, MOTION PICTURE FILMS FEATURING FOOTBALL/SOCCER HIGHLIGHTS AND SUNGLASSES (U.S. CLS. 21, 23, 26, 36 AND 38).  
FIRST USE 6-26-1998; IN COMMERCE 6-26-1998.

### CLASS 16—PAPER GOODS AND PRINTED MATTER

FOR PAPER GOODS AND PRINTED MATTER, NAMELY BANNERS AND SOUVENIR PROGRAMS FOR FOOTBALL/SOCCER GAMES AND STADIUM EVENTS, DRINKING CUPS (U.S. CLS. 2, 5, 22, 23, 29, 37, 38 AND 50).  
FIRST USE 6-26-1998; IN COMMERCE 6-26-1998.

### CLASS 25—CLOTHING

FOR CLOTHING, NAMELY TEE-SHIRTS, SWEAT SHIRTS, JACKETS, HATS, HEAD BANDS, CAMP SHIRTS, SHORTS AND PANTS (U.S. CLS. 22 AND 39).  
FIRST USE 6-26-1998; IN COMMERCE 6-26-1998.

## MYCFO

### CLASS 35—ADVERTISING AND BUSINESS

FOR BUSINESS MARKETING AND BUSINESS MANAGEMENT CONSULTING SERVICES; ACCOUNTING SERVICES, TAX PREPARATION, TAX ADVISORY AND TAX CONSULTATION SERVICES; PAYROLL PREPARATION SERVICES; PROVIDING BUSINESS INFORMATION BY ELECTRONIC MEANS (U.S. CLS. 100, 101 AND 102).  
FIRST USE 1-1-2002; IN COMMERCE 1-1-2002.

### CLASS 36—INSURANCE AND FINANCIAL

FOR FINANCIAL ANALYSIS AND CONSULTATION SERVICES; INVESTMENT ADVISORY SERVICES AND INVESTMENT MANAGEMENT SERVICES; INSURANCE CONSULTING SERVICES, FINANCIAL PLANNING SERVICES; ASSET PROTECTION CONSULTING SERVICES; ESTATE PLANNING ADVISORY SERVICES; WEALTH MANAGEMENT SERVICES; FINANCIAL INFORMATION PROVIDED BY ELECTRONIC MEANS (U.S. CLS. 100, 101 AND 102).  
FIRST USE 1-1-2002; IN COMMERCE 1-1-2002.

---

3,233,772. E-KNOW, INC., ARLINGTON, VA. SN 75-818,002. PUB. 3-21-2006, FILED 10-6-1999.

## E-KNOW

### CLASS 35—ADVERTISING AND BUSINESS

FOR ANALYSIS AND CONSULTATION SERVICES IN THE FIELD OF BUSINESS INFORMATION MANAGEMENT (U.S. CLS. 100, 101 AND 102).  
FIRST USE 4-16-2000; IN COMMERCE 4-16-2000.

**CLASS 42—SCIENTIFIC, COMPUTER AND LEGAL SERVICES**

FOR ANALYSIS AND CONSULTATION SERVICES IN THE FIELD OF COMMUNICATIONS (U.S. CLS. 100 AND 101).

FIRST USE 4-16-2000; IN COMMERCE 4-16-2000.

3,233,783. BUMPER 2 BUMPER MEDIA INC., MISSISSAUGA, ONTARIO, CANADA. SN 76-359,601. PUB. 4-18-2006, FILED 1-16-2002.

3,233,778. DETROIT PLASTICOS E METAIS LTDA, DIADEMA, SAO PAULO, BRAZIL. SN 76-283,481. PUB. 2-24-2004, FILED 7-10-2001.

**D-LOK****CLASS 6—METAL GOODS**

FOR INDUSTRIAL PATTERNS MADE OF METAL, NAMELY, STAINLESS STEEL PATTERNS, CARBON STEEL PATTERNS, BRASS PATTERNS, BRASS FORGED PATTERNS AND STRAIGHT MACHINE PATTERNS, ALL FOR USE WITH MACHINES (U.S. CLS. 2, 12, 13, 14, 23, 25 AND 50).

FIRST USE 10-27-2005; IN COMMERCE 10-27-2005.

**CLASS 7—MACHINERY**

FOR FANS FOR MACHINE ENGINES; HYDRAULIC TURBINES; AIR FILTERS FOR AUTOMOBILES; CONVEYING SYSTEM EQUIPMENT, NAMELY, BLOWERS; AIR COMPRESSORS; DIES FOR USE WITH MACHINE TOOLS, NAMELY, INDUSTRIAL DIES, STAINLESS STEEL DIES, CARBON STEEL DIES, BRASS DIES, BRASS FORGED DIES, AND STRAIGHT MACHINE DIES; METAL TUBING FOR USE IN LAND VEHICLES, NAMELY, TEMPERATURE CONTROL LINES USED IN COOLING WATER SYSTEMS OF LAND VEHICLES AND FLUID FLOW CONTROL LINES USED IN FUEL INJECTION SYSTEMS OF LAND VEHICLES (U.S. CLS. 13, 19, 21, 23, 31, 34 AND 35).

FIRST USE 10-27-2005; IN COMMERCE 10-27-2005.

**CLASS 11—ENVIRONMENTAL CONTROL APPARATUS**

FOR METAL TUBING FOR USE IN LAND VEHICLES, NAMELY, HIGH PRESSURE LINES USED IN AIR CONDITIONING SYSTEMS FOR LAND VEHICLES, TEMPERATURE CONTROL LINES USED IN AIR CONDITIONING SYSTEMS OF LAND VEHICLES, AND FLUID FLOW CONTROL LINES USED IN AIR CONDITIONING SYSTEMS OF LAND VEHICLES (U.S. CLS. 13, 21, 23, 31 AND 34).

FIRST USE 10-27-2005; IN COMMERCE 10-27-2005.

**CLASS 12—VEHICLES**

FOR PARTS OF LAND VEHICLES, NAMELY, METAL FUEL LINES; HYDRAULIC TRANSMISSION SETS FOR LAND VEHICLES COMPRISED OF HYDRAULIC PUMPS, CYLINDERS, VALVES, HYDRAULIC LIFTING JACKS, HYDRAULIC CIRCUITS FOR TRANSMISSIONS AND HYDRAULIC SYSTEM CLUTCHES; TRUCKS; BUSES; STATION WAGONS; TRACTORS; PARTS OF LAND VEHICLES, NAMELY, FUEL TANKS; PARTS OF LAND VEHICLES, NAMELY, AIR BRAKE SYSTEMS COMPRISED OF MOUNTED BRAKE ASSEMBLIES, BRAKE SHOES, DISC BRAKE LINING, HOSES, COUPLINGS, FITTINGS AND BRAKE ADJUSTERS; PARTS OF LAND VEHICLES, NAMELY, FILTERING SYSTEMS FOR VEHICLES COMPRISED OF AIR ADMISSION PIPING, FILTERS AND FITTINGS FOR THE AIR BRAKE SYSTEMS AND TURBO COMPRESSOR; PARTS OF LAND VEHICLES, NAMELY, HYDRAULIC SETS COMPRISED OF HYDRAULIC PUMPS FOR POWER STEERING UNITS; METAL TUBING FOR USE IN LAND VEHICLES, NAMELY, HIGH PRESSURE LINES USED IN AIR BRAKE SYSTEMS OF LAND VEHICLES (U.S. CLS. 19, 21, 23, 31, 35 AND 44).

FIRST USE 10-27-2005; IN COMMERCE 10-27-2005.

**BUMP !**

THE MARK CONSISTS OF STANDARD CHARACTERS WITHOUT CLAIM TO ANY PARTICULAR FONT, STYLE, SIZE, OR COLOR.

PRIORITY CLAIMED UNDER SEC. 44(D) ON CANADA APPLICATION NO. 1,114,914, FILED 9-4-2001, REG. NO. TMA597119, DATED 12-10-2003, EXPIRES 12-10-2018.

**CLASS 9—ELECTRICAL AND SCIENTIFIC APPARATUS**

FOR PRE-RECORDED AUDIO AND VIDEO TAPES, CASSETTES, AND DISCS, ALL FEATURING MUSIC, MOTION PICTURE FILMS, AND TELEVISION SHOWS; PRE-RECORDED INTERACTIVE SOFTWARE PROGRAMS FEATURING ACTION/ADVENTURE MOTION PICTURE FILMS, TELEVISION PROGRAMS, AND COMPUTER GAMES; PHONOGRAPH RECORDS FEATURING MUSIC AND AUDIO SOUND TRACKS; ALL CONCERNING DRAMATIC, FACTUAL AND LIFESTYLE ENTERTAINMENT OR OTHER MATTERS, NOT ON THE SINGLE TOPIC OF DANCE (U.S. CLS. 21, 23, 26, 36 AND 38).

FIRST USE 11-0-2004; IN COMMERCE 11-0-2004.

**CLASS 41—EDUCATION AND ENTERTAINMENT**

FOR ENTERTAINMENT SERVICES IN THE NATURE OF PRODUCTION AND DISTRIBUTION OF MOTION PICTURE FILMS AND TELEVISION PROGRAMS FOR OTHERS; VIDEOTAPE PRODUCTION SERVICES; PRODUCTION OF VIDEO CASSETTES AND DISCS; AUDIO RECORDING AND PRODUCTION SERVICES; PROVIDING ON-LINE INFORMATION IN THE FIELDS OF ENTERTAINMENT AND EDUCATION, TRANSMITTED THROUGH A WEB SITE VIA INTERCONNECTED COMPUTER NETWORKS LINKED BY COMMON PROTOCOLS; ALL CONCERNING DRAMATIC, FACTUAL AND LIFESTYLE ENTERTAINMENT OR OTHER MATTERS, NOT ON THE SINGLE TOPIC OF DANCE (U.S. CLS. 100, 101 AND 107).

FIRST USE 11-0-2004; IN COMMERCE 11-0-2004.

3,233,784. MAXENS GMBH, D-83308 TROSTBERG, FED REP GERMANY. SN 76-365,410. PUB. 5-25-2004, FILED 1-31-2002.

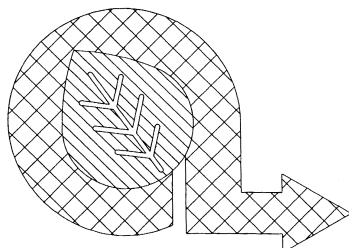

**Alfrebro**

### CLASS 1—CHEMICALS

FOR CHEMICALS BEING SYNTHETIC, NATURAL AND NATURE-IDENTICAL COMPOUNDS TO BE USED FOR THE MANUFACTURE OF FLAVORS, FLAVORING AGENTS AND FRAGRANCES, NAMELY KETONES, ALDEHYDES, SULFUR-AND OXYGEN-CONTAINING ORGANIC COMPOUNDS, ORGANIC ACIDS, THEIR SALTS AND DERIVATIVES THEREOF, ESTERS, ALCOHOLS, AND NITROGEN-, SULFUR- AND OXYGEN-CONTAINING HETEROCYCLES; EXTRACTS AND CONCENTRATES OF MILK AND MILK PRODUCTS, MEAT, FISH, SEAFOOD, POULTRY AND GAME FOR USE IN MANUFACTURING NUTRACEUTICALS, FOODS, ALCOHOLIC BEVERAGES, NON-ALCOHOLIC BEVERAGES AND OTHER MANUFACTURED AND PROCESSED GOODS, NAMELY PROCESSED FOODS; ENZYME MODIFIED INGREDIENTS, EXTRACTS AND CONCENTRATES FROM MILK AND MILK PRODUCTS FOR USE IN MANUFACTURING NUTRACEUTICALS, FOODS, ALCOHOLIC BEVERAGES, NON-ALCOHOLIC BEVERAGES AND OTHER MANUFACTURED AND PROCESSED GOODS, NAMELY PROCESSED FOODS (U.S. CLS. 1, 5, 6, 10, 26 AND 46).

FIRST USE 1-0-1999; IN COMMERCE 1-0-1999.

### CLASS 30—STAPLE FOODS

FOR MALT EXTRACTS FOR FOODS; FOOD ADDITIVES FOR NON-NUTRACEUTICAL PURPOSES FOR USE AS FLAVORING, FLAVORING AGENTS, FRAGRANCES AND FOR AROMAS, FOR USE IN NUTRACEUTICALS, FOODS, ALCOHOLIC BEVERAGES, NON-ALCOHOLIC BEVERAGES AND OTHER EDIBLE GOODS, AND FOOD FLAVORINGS, FOOD FLAVORING AGENTS, FOOD AROMAS AND FOOD FRAGRANCES, NOT BEING ESSENTIAL OILS, FOR USE IN FOODS NUTRACEUTICALS, ALCOHOLIC BEVERAGES, NON-ALCOHOLIC BEVERAGES AND OTHER EDIBLE GOODS, EXTRACTS USED AS FLAVORING, FLAVORING AGENTS, AROMAS OR FRAGRANCES THAT ARE NOT ESSENTIAL OILS (U.S. CL. 46).

FIRST USE 1-0-1999; IN COMMERCE 1-0-1999.

### CLASS 32—LIGHT BEVERAGES

FOR NATURAL, NATURE-IDENTICAL AND SYNTHETIC FLAVORS, FLAVORING AGENTS, AROMAS AND FRAGRANCES FOR MAKING BEVERAGES FOR IMPARTING FLAVORS AND AROMAS; NON-ALCOHOLIC FRUIT EXTRACTS USED IN THE PREPARATION OF BEVERAGES (U.S. CLS. 45, 46 AND 48).

FIRST USE 1-0-1999; IN COMMERCE 1-0-1999.

### CLASS 35—ADVERTISING AND BUSINESS

FOR WHOLESALE DISTRIBUTORSHIP FEATURING NATURAL, NATURE-IDENTICAL AND SYNTHETIC FLAVORS, AROMAS, FLAVORING AGENTS AND FRAGRANCES FOR USE IN MANUFACTURING NUTRACEUTICALS, FOODS, ALCOHOLIC BEVERAGES, NON-ALCOHOLIC BEVERAGES AND OTHER EDIBLE GOODS (U.S. CLS. 100, 101 AND 102).

FIRST USE 1-0-1999; IN COMMERCE 1-0-1999.

### CLASS 40—MATERIAL TREATMENT

FOR FOOD PROCESSING (U.S. CLS. 100, 103 AND 106).

FIRST USE 1-0-1999; IN COMMERCE 1-0-1999.

3,233,786. UNITERS S.P.A., VICENZA, ITALY. SN 76-379,092. PUB. 11-29-2005, FILED 3-6-2002.



OWNER OF U.S. REG. NO. 2,473,852.

NO CLAIM IS MADE TO THE EXCLUSIVE RIGHT TO USE "BOAT" AND "DEVELOPED BY", APART FROM THE MARK AS SHOWN.

### CLASS 2—PAINTS

FOR MIXTURES AND OILS FOR COLORING AND PRESERVING WOOD; LACQUERS BEING ABLE TO GIVE A WATER-REPELLENT EFFECT; TEAK OIL FOR THE PRESERVATION OF WOOD; TEAK OIL COLOR FOR THE PRESERVATION OF WOOD (U.S. CLS. 6, 11 AND 16).

FIRST USE 10-30-2003; IN COMMERCE 10-30-2003.

### CLASS 3—COSMETICS AND CLEANING PREPARATIONS

FOR GOODS, NAMELY, CLEANING PREPARATIONS FOR CLEANING AND TREATING INTERIOR AND EXTERIOR OF BOATS; GLASS CLEANING PREPARATIONS FOR BOATS; PREPARATIONS FOR CLEANING, PROTECTING AND PRESERVING BOAT SURFACES; BOAT WAX; POLISHING POWDER; TEXTILE CLEANER; TEXTILE STRONG CLEANER; PREPARATIONS FOR CLEANING, PROTECTING AND MAINTAINING TEXTILES; LEATHER STRONG CLEANER; CLEANERS TO REMOVE INK; LEATHER PROTECTION CREAM FOR CLEANING, PROTECTING AND MAINTAINING LEATHER; CLEANERS AND POLISHES FOR FIBERGLASS; POLISHING PASTES FOR METALLIC SURFACES; LIQUID CLEANERS FOR BILGES; CLEANERS FOR RUBBER FENDERS; METALS CLEANER FIBRE; SILICON WAX FOR PROTECTING SHEETS; ALL PURPOSE UNIVERSAL CLEANER; TEAK CLEANER; TEAK BRIGHTENER; CLEANERS FOR CUSHIONS MADE OF VINYL MATERIAL; CLEANERS WITH ANTI-MOLD PROPERTIES; CLEANERS FOR REMOVING MOLD AND PROTECTING FROM MOLD (U.S. CLS. 1, 4, 6, 50, 51 AND 52).

FIRST USE 10-30-2003; IN COMMERCE 10-30-2003.

3,233,787. CORUS BAUSYSTEME GMBH, 56070 KOBLENZ, FED REP GERMANY. SN 76-384,622. PUB. 5-20-2003, FILED 3-15-2002.

## KALZIP

### CLASS 6—METAL GOODS

FOR COMMON METALS AND THEIR ALLOYS IN THE FORM OF SHEETS, PLATES, FOILS, PROFILES, ALUMINUM IN ROLLS, PRESSED PARTS OF ALUMINUM; TRANSPORTABLE BUILDING PARTS OF METAL, NAMELY, METAL BUILDING FLASHING, METAL SOFFITS, METAL FASCIA, METAL CLADDING FOR CONSTRUCTION AND BUILDING; BUILDING PARTS OF METAL, NAMELY, METAL BUILDING FLASHING, METAL SOFFITS, METAL FASCIA, METAL CLADDING FOR CONSTRUCTION AND BUILDING; ALUMINUM PRODUCTS FOR THE BUILDING INDUSTRY, NAMELY, ALUMINUM SIDING; METAL IN THE FORM OF SHEETS, PLATES, PANELS, PROFILES, WHICH MAY BE PROVIDED WITH AN ORGANIC OR METAL COATING, FOR THE PANELING OF FACADES, WALLS AND ROOFS; METAL ROOFING MATERIAL, NAMELY, METAL ROOFING, METAL ROOFING HIPS, METAL ROOFING PANELS, METAL ROOFING TILES, METAL ROOF TRUSSES, METAL ROOF VENTS FOR VENTILATING RESIDENTIAL AND COMMERCIAL BUILDINGS, METAL VENT COVERS FOR ROOF DECK PROTRUSIONS, DRAINS AND PITCH PANS; PROFILED METAL SHEETS OR PROFILED METAL PANELS, WHICH MAY BE PROVIDED WITH AN ORGANIC OR METAL COATING (U.S. CLS. 2, 12, 13, 14, 23, 25 AND 50). FIRST USE 0-0-2000; IN COMMERCE 0-0-2005.

### CLASS 37—CONSTRUCTION AND REPAIR

FOR CONSTRUCTION CONSULTING OF ROOFING AND WALL PANELING MATERIAL FOR ARCHITECTS, ENGINEERS, BUILDERS, CONTRACTORS AND CONSTRUCTORS (U.S. CLS. 100, 103 AND 106). FIRST USE 0-0-2000; IN COMMERCE 0-0-2005.

3,233,792. EXCEPTIONAL SOFTWARE STRATEGIES, INC., LINTHICUM, MD. SN 76-396,458. PUB. 9-2-2003, FILED 4-16-2002.

## REITERATE

### CLASS 41—EDUCATION AND ENTERTAINMENT

FOR PRODUCTION OF VIDEO CASSETTES AND DISKS FOR OTHERS (U.S. CLS. 100, 101 AND 107). FIRST USE 9-16-2002; IN COMMERCE 9-16-2002.

### CLASS 42—SCIENTIFIC, COMPUTER AND LEGAL SERVICES

FOR SOFTWARE DEVELOPMENT AND CONSULTATION (U.S. CLS. 100 AND 101). FIRST USE 9-16-2002; IN COMMERCE 9-16-2002.

3,233,801. STARGLOW PRODUCTIONS INC., WOODLAND HILLS, CA. SN 76-433,420. PUB. 8-5-2003, FILED 7-16-2002.

## CYNDI'S SECRETS

### CLASS 9—ELECTRICAL AND SCIENTIFIC APPARATUS

FOR AUDIO TAPES, VIDEO TAPES, AND DVD'S, ALL IN THE FIELDS OF FITNESS, FASHION, BEAUTY, NUTRITION, HEALTH, STRESS REDUCTION AND MANAGEMENT AND LIFESTYLE MANAGEMENT (U.S. CLS. 21, 23, 26, 36 AND 38). FIRST USE 9-15-2006; IN COMMERCE 9-15-2006.

### CLASS 16—PAPER GOODS AND PRINTED MATTER

FOR PUBLICATIONS AND PRINTED MATTER IN THE FIELDS OF FITNESS, FASHION, BEAUTY, NUTRITION, HEALTH, STRESS REDUCTION AND MANAGEMENT AND LIFESTYLE MANAGEMENT, NAMELY, BOOKS, BOOKLETS, BROCHURES, INFORMATIONAL FLYERS, PAMPHLETS, AND PRINTED INSTRUCTIONAL, EDUCATIONAL, AND TEACHING MATERIALS (U.S. CLS. 2, 5, 22, 23, 29, 37, 38 AND 50). FIRST USE 9-15-2006; IN COMMERCE 9-15-2006.

3,233,808. ANDRADE, MARY J., SAN JOSE, CA. SN 76-457,634. PUB. 5-17-2005, FILED 10-11-2002.



THE MARK CONSISTS OF THE WORDING LA CALACA MITOTERA AND A STYLIZED REPRESENTATION OF A BURNING CANDLE AND A SKULL WITH TWO FLOWERS ON EITHER SIDE.

THE ENGLISH TRANSLATION OF LA CALACA MITOTERA IS "THE FESTIVE SKULL".

### CLASS 16—PAPER GOODS AND PRINTED MATTER

FOR BOOKS AND MAGAZINES RELATING TO THE DAY OF THE DEAD MEXICAN HOLIDAY PAPER-GOODS, NAMELY, POSTERS, GREETING CARDS, POST CARDS, BOOK COVERS, BOOKMARKS, CALENDARS AND STATIONARY; PENS; PENCILS; PEN AND PENCIL CASES; STICKERS IN THE NATURE OF SELF-STICK SEALS (U.S. CLS. 2, 5, 22, 23, 29, 37, 38 AND 50). FIRST USE 0-0-2003; IN COMMERCE 0-0-2003.

### CLASS 25—CLOTHING

FOR CLOTHING, NAMELY, T-SHIRTS, PANTS, BANDANAS, JACKETS, CAPS (U.S. CLS. 22 AND 39). FIRST USE 7-0-2005; IN COMMERCE 7-0-2005.

**CLASS 35—ADVERTISING AND BUSINESS**

FOR ONLINE RETAIL STORE SERVICES FEATURING BOOKS, POSTCARDS, AUDIO AND VIDEO CASSETTES AND DISCS AND CLOTHING ALL RELATING TO THE DAY OF THE DEAD MEXICAN HOLIDAY (U.S. CLS. 100, 101 AND 102).

FIRST USE 9-0-2005; IN COMMERCE 9-0-2005.

**CLASS 7—MACHINERY**

FOR ELECTRIC SCREW DRIVERS; ELECTRIC HAND DRILLS; COMPRESSORS, NAMELY AIR COMPRESSORS, ELECTRIC MEAT GRINDERS; ELECTRIC VACUUM CLEANERS (U.S. CLS. 13, 19, 21, 23, 31, 34 AND 35).

FIRST USE 5-31-2003; IN COMMERCE 5-31-2003.

3,233,827. PLEXTRON CORP., TORONTO, ONTARIO, CANADA. SN 76-491,214. PUB. 3-22-2005, FILED 2-19-2003.

**PLEXTRON**

PRIORITY CLAIMED UNDER SEC. 44(D) ON CANADA APPLICATION NO. 1,154,601, FILED 10-2-2002, REG. NO. TMA610,088, DATED 5-12-2004, EXPIRES 5-12-2019.

**CLASS 8—HAND TOOLS**

FOR ELECTRIC SHAVERS; BLADES FOR ELECTRIC SHAVERS; ELECTRIC HAIR CLIPPERS; ELECTRIC DEPIATORS; ELECTRIC BEARD TRIMMERS; ELECTRIC HAIR TRIMMERS; ELECTRIC NOSE TRIMMERS; ELECTRIC RAZORS (U.S. CLS. 23, 28 AND 44).

FIRST USE 5-31-2003; IN COMMERCE 5-31-2003.

**CLASS 40—MATERIAL TREATMENT**

FOR CUSTOM MANUFACTURE OF INJECTION MOLDED PLASTIC PARTS, MACHINED PARTS, FABRICATED METAL PARTS, SUBASSEMBLY OF INJECTION MOLDED PLASTIC PARTS, MACHINED PARTS AND FABRICATED METAL PARTS, AND CONTRACT ASSEMBLY OF FINISHED GOODS FOR USE IN THE FIELDS OF AGRICULTURE, POULTRY, CHEMICAL PROCESSING AND CONTAINERS, AUTOMOTIVE PARTS, BOATING, FURNITURE, GARDENING, TOYS, LARGE HOUSEHOLD APPLIANCES, NAMELY WASHING MACHINES, DRYERS, AND REFRIGERATORS, SMALL HOUSEHOLD APPLIANCES, SPORTING GOODS, COMPUTERS, COPIERS, PRINTERS, TELECOMMUNICATIONS EQUIPMENT, ELECTRONICS, CONSTRUCTION, ENTERTAINMENT, MILITARY EQUIPMENT, PACKAGING, MEDICAL DEVICES AND EQUIPMENT, PHARMACEUTICAL AND RETAIL DISPLAY (U.S. CLS. 100, 103 AND 106).

FIRST USE 7-19-2002; IN COMMERCE 7-19-2002.

**CLASS 9—ELECTRICAL AND SCIENTIFIC APPARATUS**

FOR PLAIN PAPER COPIERS; BATTERIES; DRY CELLS; RECHARGEABLE BATTERIES; BATTERY CHARGERS; SOLAR CELLS; FUEL CELLS; NICKEL CADMIUM BATTERIES; NICKEL HYDROGEN BATTERIES; LITHIUM BATTERIES LITHIUM ION BATTERIES; PUSH SWITCHES; SLIDE SWITCHES; TOUCH SWITCHES; DETECTOR SWITCHES; ACOUSTIC MACHINES AND APPARATUS, NAMELY RADIOS, CASSETTE TAPE PLAYERS AND/OR RECORDERS, RADIO CASSETTE RECORDERS, DAT RECORDERS, PORTABLE CASSETTE TAPE PLAYERS, CASES FOR CASSETTE TAPE PLAYERS, PORTABLE CASSETTE PLAYERS WITH RADIOS, COMPACT DISC PLAYERS AND/OR RECORDERS, DVD AUDIO PLAYERS AND/OR RECORDERS, SECURE DIGITAL AUDIO PLAYERS AND/OR RECORDERS, MP3 (MPEG-I AUDIO LAYER-3) PLAYERS, SPEAKERS, TUNERS, STEREO COMPONENT SYSTEM, RADIOS INCORPORATING CLOCKS, IC CHIP RECORDERS, HEADPHONES, CORDLESS HEADPHONES, EARPHONES, EARPHONES WITH MICROPHONES, CAR AUDIO SYSTEMS, MAGNETIC TAPE CLEANERS, AUDIO-VISUAL MACHINES AND APPARATUS NAMELY TELEVISION RECEIVERS, PLASMA TELEVISION RECEIVERS; PARTS AND ACCESSORIES FOR PLASMA DISPLAY NAMELY STANDS, PARTS AND ACCESSORIES FOR PLASMA DISPLAY NAMELY WALL HANGING FITTINGS, LCD TELEVISION RECEIVERS, COMBINED TELEVISION RECEIVERS WITH VIDEO TAPE RECORDERS, COMBINED TELEVISION RECEIVER WITH DISK PLAYERS, TUNERS FOR CABLE BROADCASTING, TERRESTRIAL TUNERS, TUNERS FOR TELEVISION, TUNERS FOR AUDIO BROADCASTING, INTERNET RECEIVERS, VIDEO CASSETTE RECORDERS, CAMCORDERS, CABLES FOR CAMCORDERS, CASES FOR CAMCORDERS, AC (ALTERNATING CURRENT) ADAPTERS FOR CAMCORDERS, BATTERIES FOR CAMCORDERS, TRIPODS FOR CAMERAS, DIGITAL STILL CAMERAS, BATTERIES FOR DIGITAL CAMERAS, AC (ALTERNATING CURRENT) ADAPTERS FOR DIGITAL CAMERAS, DVD VIDEO PLAYERS AND/OR RECORDERS, DIGITAL HD (HIGH DEFINITION) VIDEO CASSETTE TAPE RECORDERS, BLANK OPTICAL DISC CARTRIDGES; COMMUNICATION MACHINES AND APPARATUS, NAMELY, FACSIMILE TRANSCEIVERS, TELEPHONES, CELLULAR MOBILE TELEPHONES, TELEPHONE ANSWERING MACHINES; RADIOS FOR VEHICLES, PERSONAL HANDY-PHONES; SUPERVISION APPARATUS AND INSTRUMENTS, NAMELY, COMMUNICATION AND MONITORING SYSTEM FOR APARTMENT BUILDINGS; COMMUNICATION AND MONITORING APPARATUS FOR BUILDINGS; POWER CAPACITORS; COMPUTERS AND COMPUTER PERIPHERAL EQUIPMENT, NAMELY, GATEWAY APPARATUS FOR COMPUTER NETWORK, PC CARD ADAPTER FOR MEMORY CARDS, CD-ROM DRIVES, CARD READERS, CARD READER AND/OR WRITERS, BAR CODE READERS, DVD-RAM AND/OR ROM DRIVES; BLANK EXTERNAL STORAGE MEDIA, NAMELY BLANK VIDEO CASSETTE TAPES, BLANK CLEANING TAPES FOR TAPE DRIVES, BLANK DIGITAL VIDEO CASSETTE TAPES, BLANK AUDIO CASSETTE TAPES, BLANK FLOPPY DISCS, BLANK OPTICAL DISCS, BLANK MINI-DISCS, BLANK DVDS, BLANK SD (SECURE DIGITAL) MEMORY CARDS; SENSORS NAMELY MR (MAGNETIC RESISTANT) SENSORS, PHOTO SENSORS, POSITION SENSORS, ANGU-

**CLASS 42—SCIENTIFIC, COMPUTER AND LEGAL SERVICES**

FOR DESIGN FOR OTHERS OF INJECTION MOLDED PLASTIC PARTS, MACHINED PARTS, FABRICATED METAL PARTS FOR USE IN THE FIELDS OF AGRICULTURE, POULTRY, CHEMICAL PROCESSING AND CONTAINERS, AUTOMOTIVE PARTS, BOATING, FURNITURE, GARDENING, TOYS, LARGE HOUSEHOLD APPLIANCES, NAMELY, WASHING MACHINES, DRYERS, AND REFRIGERATORS, SMALL HOUSEHOLD APPLIANCES, SPORTING GOODS, COMPUTERS, COPIERS, PRINTERS, TELECOMMUNICATIONS EQUIPMENT, ELECTRONICS, CONSTRUCTION, ENTERTAINMENT, MILITARY EQUIPMENT, PACKAGING, MEDICAL DEVICES AND EQUIPMENT, PHARMACEUTICAL AND RETAIL DISPLAY (U.S. CLS. 100 AND 101).

FIRST USE 7-19-2002; IN COMMERCE 7-19-2002.

3,233,843. MATSUSHITA ELECTRIC INDUSTRIAL CO., LTD., OSAKA-FU, JAPAN. SN 76-502,203. PUB. 7-26-2005, FILED 3-24-2003.

**Panasonic  
ideas for life**

OWNER OF U.S. REG. NOS. 640,961, 2,451,162, AND OTHERS.



LAR RATE SENSORS, MAGNETIC SENSORS; ELECTRONIC COMPONENTS, NAMELY LIGHT EMITTING DIODES, DIODES, TRANSISTORS, IC (INTEGRATED CIRCUIT) MEMORY CARDS, LSI, ONE CHIP MICROCOMPUTERS, CCD IMAGE SENSORS, COIN VALIDATING UNITS, COIN SELECTOR UNITS, BILL VALIDATING UNITS, BILL SELECTOR UNITS, PRINTED WIRING BOARDS, SINGLE-SIDED PRINTED WIRING BOARDS, DOUBLE SIDED PRINTED WIRING BOARDS, MULTILAYER PRINTED WIRING BOARDS, PRINTED CIRCUIT SUBSTRATES, PARTS OF COPYING MACHINES AND FACSIMILE MACHINES, NAMELY MAGNET ROLLS FOR DEVELOPING AND CLEANING DEVICES, DC/DC CONVERTERS, INDUCTORS AND COILS, FIXED INDUCTORS, VARIABLE INDUCTORS, FILTERS OF ELECTRIC SIGNALS, EMI (ELECTROMAGNETIC INTERFERENCE) FILTERS, NOISE FILTERS USED TO PREVENT EXTERNAL NOISE COMING FROM THE POWER LINE OR TO REDUCE NOISE GENERATED BY THE SERVO MOTOR, SAW (SURFACE ACOUSTIC WAVE) FILTERS, CERAMIC FILTERS, LINE FILTERS, LASER DIODE MODULES, PHOTO DIODE MODULES, OPTICAL CONNECTORS, ASPHERICAL LENSES, INPUT AND OUTPUT TRANSFORMERS, PIEZOELECTRIC TRANSFORMERS, THERMISTORS, VARISTORS AND SURGE ABSORBERS, CERAMIC RESONATORS, SAW (SURFACE ACOUSTIC WAVE) RESONATORS, RESISTORS, POTENTIOMETERS, TRIMMER POTENTIOMETERS, R NETWORKS CONSISTING OF REGISTER ARRAY FOR INTERFACE CIRCUIT, ENCODERS, COILS, CHOKE COILS, PANEL SWITCHES, TOUCH PANELS, REMOTE CONTROLS FOR RADIOS, TELEVISIONS, STEREO CONTROL FOR COMPUTER, ANALOG TUNERS, DIGITAL TUNERS, ELECTRONIC TUNERS, DUPLEXERS, WIRELESS COMMUNICATION MODULES/UNITS; ELECTRIC UTENSILS FOR THE HOUSEHOLD, NAMELY ELECTRIC FLAT IRONS, ELECTRIC CURLERS FOR EYELASHES (U.S. CLS. 21, 23, 26, 36 AND 38).  
FIRST USE 5-31-2003; IN COMMERCE 5-31-2003.

#### CLASS 10—MEDICAL APPARATUS

FOR SURGICAL, MEDICAL, DENTAL AND VETERINARY APPARATUS AND INSTRUMENTS, NAMELY ELECTRONIC BLOOD PRESSURE METERS, ELECTRIC HANDY MASSAGERS, ELECTRIC MASSAGE CHAIRS, ELECTRIC MASSAGERS (U.S. CLS. 26, 39 AND 44).  
FIRST USE 5-31-2003; IN COMMERCE 5-31-2003.

#### CLASS 11—ENVIRONMENTAL CONTROL APPARATUS

FOR INSTALLATIONS FOR LIGHTING, NAMELY MINIATURE BULBS, SCREW-IN FLUORESCENT LAMPS, FLUORESCENT LAMPS, FLASH LIGHTS, HEAD LAMPS; AUTOMATIC BREAD MAKERS FOR HOME USE; ELECTRIC PRESSURE COOKERS; ELECTRIC RICE COOKERS; ELECTRIC ROASTERS; OVENS FOR COOKING; TOASTERS; MICROWAVE OVENS; ELECTRIC FREEZING SHOW CASES; VENTILATING APPARATUS AND INSTRUMENTS, NAMELY ELECTRIC FANS, VENTILATING FANS, CEILING FANS, VENTILATION FANS, ELECTRIC PORE CLEANERS FOR DOMESTIC USE (U.S. CLS. 13, 21, 23, 31 AND 34).  
FIRST USE 5-31-2003; IN COMMERCE 5-31-2003.

#### CLASS 16—PAPER GOODS AND PRINTED MATTER

FOR OFFICE REQUISITES, NAMELY ELECTRIC STAPLERS, BATTERY-OPERATED LETTER OPENERS, ELECTRIC PENCIL SHARPENERS, ELECTRIC HOLE PUNCHES (U.S. CLS. 2, 5, 22, 23, 29, 37, 38 AND 50).  
FIRST USE 5-31-2003; IN COMMERCE 5-31-2003.

#### CLASS 21—HOUSEWARES AND GLASS

FOR HOUSEHOLD UTENSILS, NAMELY WATER APPARATUS FOR CLEANING TEETH AND GUMS, ELECTRIC MOUTH WASHING AND RINSING DEVICES (U.S. CLS. 2, 13, 23, 29, 30, 33, 40 AND 50).  
FIRST USE 5-31-2003; IN COMMERCE 5-31-2003.

#### CLASS 37—CONSTRUCTION AND REPAIR

FOR CONSTRUCTION, REPAIR, MAINTENANCE, FITTING AND INSTALLATION OF ELECTRIC AND ELECTRONIC APPARATUS AND INSTRUMENTS, NAMELY INSTALLATION OF ELECTRIC APPLIANCE, REPAIR OF RADIO RECEIVERS AND TELEVISION RECEIVERS, REPAIR AND MAINTENANCE OF ELECTRICAL COMMUNICATION APPARATUS AND INSTRUMENTS, REPAIR AND MAINTENANCE OF HOUSEHOLD ELECTRIC APPLIANCE, REPAIR AND MAINTENANCE OF ELECTRIC LIGHTING APPARATUS, REPAIR AND MAINTENANCE OF MEDICAL APPARATUS AND INSTRUMENTS, REPAIR AND MAINTENANCE OF COOKING APPARATUS FOR INDUSTRIAL PURPOSES, REPAIR AND MAINTENANCE OF MUSICAL INSTRUMENTS, REPAIR OF TOILET STOOL UNITS WITH WASHING WATER SQUIRTS; INSTALLATION, MAINTENANCE AND REPAIR OF COMPUTER HARDWARE; REPAIR AND MAINTENANCE OF AIR-CONDITIONING APPARATUS; OFFICE MACHINES AND EQUIPMENT INSTALLATION, MAINTENANCE AND REPAIR; BICYCLE REPAIR; REPAIR AND MAINTENANCE OF COMPUTERS; REPAIR AND MAINTENANCE OF ELECTRONIC PRINTERS; TELEPHONE REPAIR; TELECOMMUNICATION EQUIPMENT INSTALLATION AND REPAIR (U.S. CLS. 100, 103 AND 106).

FIRST USE 5-31-2003; IN COMMERCE 5-31-2003.

3,233,845. THE SYSTEMS BIOLOGY INSTITUTE, SHIBUYA-KU, TOKYO, JAPAN. SN 76-506,668. PUB. 7-26-2005, FILED 4-14-2003.

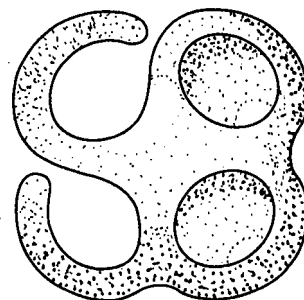

THE MARK IS A COLOR MARK COMPRISED OF THE COLOR BLUE, AND APPLICANT CLAIMS THE COLOR BLUE AS A FEATURE OF THE MARK. THE STIPPLING IN THE MARK IS NOT A FEATURE OF THE MARK, AND IS MERELY USED TO INDICATE SHADING AND THREE-DIMENSIONAL CONTOUR, WITH THE DENSER PORTIONS OF THE STIPPLING INDICATING DARKER BLUE, AND THE SPARSER PORTIONS INDICATING A LIGHTER BLUE.

THE MARK IS A SHAPE THAT APPEARS TO BE COMPRISED OF A LEFT SIDE AND A RIGHT SIDE CONNECTED TO ONE ANOTHER FROM THE MIDDLE CENTER OF THE MARK TO THE BOTTOM CENTER OF THE MARK, WITH THE LEFT SIDE FORMING A DISTORTED "S"-SHAPE IN LIGHT BLUE AND THE RIGHT SIDE FORMING A DISTORTED AND HARDLY RECOGNIZABLE "8"-SHAPE IN BLUE WITH THE UPPER PORTION CONTAINING A SPHERE APPEARING TO BE THREE-DIMENSIONAL, AND THE LOWER PORTION CONTAINING THE SAME.

**CLASS 9—ELECTRICAL AND SCIENTIFIC APPARATUS**

FOR COMPUTER SOFTWARE USED AS AN EDITOR FOR DESCRIBING INTERRELATIONSHIPS BETWEEN PROTEINS AND GENES; COMPUTER SOFTWARE USED FOR FORECASTING INTERRELATIONSHIPS AMONG GENES, METABOLISM, AND SIGNAL FLOWS; COMPUTER SOFTWARE FOR USE IN SIMULATION OF INTERRELATIONSHIPS OF GENES, METABOLISM, AND SIGNAL FLOWS; COMPUTER SOFTWARE FOR USE IN DATABASE MANAGEMENT, FOR USE AS A SPREADSHEET, FOR WORD PROCESSING, AND FOR USE IN CALCULATION; PRE-RECORDED AUDIO TAPES, VIDEO TAPES, COMPACT DISCS, AND DVDS, ALL FEATURING INFORMATION IN THE FIELD OF BIOLOGY, NAMELY, GENES AND PROTEINS; PRE-RECORDED MAGNETIC AND OPTICAL DISCS FEATURING INFORMATION IN THE FIELD OF BIOLOGY, NAMELY, GENES AND PROTEINS; DOWNLOADABLE ELECTRONIC PUBLICATIONS, NAMELY, BOOKS, MAGAZINES, NEWSPAPERS, MANUALS AND CATALOGS FEATURING INFORMATION IN THE FIELD OF BIOLOGY, NAMELY, GENES AND PROTEINS (U.S. CLS. 21, 23, 26, 36 AND 38).

FIRST USE 3-20-2003; IN COMMERCE 5-0-2003.

**CLASS 42—SCIENTIFIC, COMPUTER AND LEGAL SERVICES**

FOR COMPUTER SERVICES, NAMELY, PROVIDING TEMPORARY USE OF NON-DOWNLOADABLE ON-LINE SOFTWARE IN THE FIELD OF BIOLOGY, NAMELY, GENES AND PROTEINS; COMPUTER SERVICES, NAMELY, PROVIDING ON-LINE DATABASE AND REFERENCE MATERIALS IN THE FIELD OF BIOLOGY, NAMELY, GENES AND PROTEINS; LABORATORY RESEARCH, TESTING AND INSPECTION OF GENES AND PROTEINS IN THE FIELD OF BIOLOGY; CONSULTING SERVICES IN THE FIELD OF BIOLOGY; COMPUTER PROGRAMMING FOR OTHERS; COMPUTER SOFTWARE DESIGN FOR OTHERS; MAINTENANCE AND UPDATING OF COMPUTER SOFTWARE; COMPUTER DIAGNOSTIC SERVICES; AND RENTAL OF COMPUTERS AND SOFTWARE (U.S. CLS. 100 AND 101).

FIRST USE 6-10-2003; IN COMMERCE 6-10-2003.

3,233,849. GMFS, LLC, BATON ROUGE, LA. SN 76-516,839. PUB. 7-26-2005, FILED 5-1-2003.

**MORTGAGEMATCHER****CLASS 9—ELECTRICAL AND SCIENTIFIC APPARATUS**

FOR COMPUTER SOFTWARE FOR USE IN THE FIELD OF MORTGAGE LENDING, NAMELY, SOFTWARE FOR COLLECTING AND ANALYZING THE FINANCIAL DATA OF POTENTIAL BORROWERS AND MATCHING BORROWERS WITH LENDERS (U.S. CLS. 21, 23, 26, 36 AND 38).

FIRST USE 7-16-2001; IN COMMERCE 12-15-2003.

**CLASS 36—INSURANCE AND FINANCIAL**

FOR ON-LINE SERVICES IN THE FIELD OF MORTGAGE LENDING, NAMELY, COLLECTING FINANCIAL DATA ON POTENTIAL BORROWERS AND MATCHING BORROWERS WITH LENDERS (U.S. CLS. 100, 101 AND 102).

FIRST USE 11-0-2003; IN COMMERCE 12-15-2003.

**CLASS 42—SCIENTIFIC, COMPUTER AND LEGAL SERVICES**

FOR TECHNICAL AND CONSULTATION SERVICES RELATING TO THE IMPLEMENTATION AND UTILIZATION OF COMPUTER SOFTWARE FOR USE IN THE FIELD OF MORTGAGE LENDING (U.S. CLS. 100 AND 101).

FIRST USE 7-16-2001; IN COMMERCE 12-15-2003.

3,233,862. MILLER, MARK C., SANTA FE, NM. SN 76-548,066. PUB. 8-30-2005, FILED 9-30-2003.

**RED SAGE**

OWNER OF U.S. REG. NO. 1,792,097.

**CLASS 16—PAPER GOODS AND PRINTED MATTER**

FOR COOK BOOKS (U.S. CLS. 2, 5, 22, 23, 29, 37, 38 AND 50).

FIRST USE 1-0-1993; IN COMMERCE 12-0-1999.

**CLASS 43—HOTEL AND RESTAURANT SERVICES**

FOR RESTAURANT SERVICES (U.S. CLS. 100 AND 101).

FIRST USE 1-0-1993; IN COMMERCE 1-0-1993.

3,233,867. PFIZER INC., NEW YORK, NY. SN 76-558,887. PUB. 8-10-2004, FILED 11-10-2003.

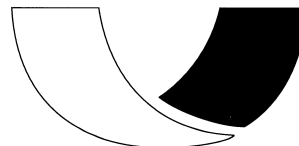
**CLASS 5—PHARMACEUTICALS**

FOR DRY POWDER FORM OF INSULIN (U.S. CLS. 6, 18, 44, 46, 51 AND 52).

FIRST USE 6-20-2006; IN COMMERCE 6-20-2006.

**CLASS 10—MEDICAL APPARATUS**

FOR EMPTY INHALERS FOR THERAPEUTIC USE, WHICH MAY BE USED FOR INHALING INSULIN (U.S. CLS. 26, 39 AND 44).

FIRST USE 6-20-2006; IN COMMERCE 6-20-2006.

3,233,889. GROOPE.COM LLC, CAMBRIDGE, MA. SN 76-581,825. PUB. 12-14-2004, FILED 3-19-2004.

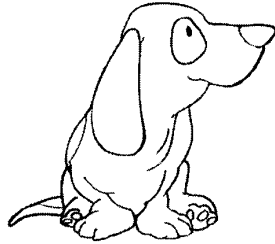

**CLASS 38—COMMUNICATION**

FOR PROVIDING ON-LINE CHAT ROOMS AND ELECTRONIC BULLETIN BOARDS FOR TRANSMISSION OF MESSAGES AMONG USERS IN THE FIELD OF GENERAL INTEREST (U.S. CLS. 100, 101 AND 104).  
FIRST USE 9-15-2006; IN COMMERCE 9-15-2006.

**CLASS 42—SCIENTIFIC, COMPUTER AND LEGAL SERVICES**

FOR PROVIDING TEMPORARY USE OF ON-LINE, NON-DOWNLOADABLE SOFTWARE, NAMELY, OFFICE PRODUCTIVITY SOFTWARE, PERSONAL PRODUCTIVITY SOFTWARE, SCHEDULING SOFTWARE, CALENDARING SOFTWARE, EVENT PLANNING SOFTWARE, PROJECT MANAGEMENT SOFTWARE AND SOFTWARE THAT ENABLES USERS TO COLLECT, PROCESS AND DISPLAY VOTES; PROVIDING CUSTOMIZED ONLINE WEB PAGES FEATURING USER-DEFINED INFORMATION, WHICH INCLUDES USER-PROVIDED DATA, PICTURES, GRAPHICS, FILES AND ONLINE WEB LINKS TO OTHER WEB SITES (U.S. CLS. 100 AND 101).  
FIRST USE 9-15-2006; IN COMMERCE 9-15-2006.

3,233,890. GROOPE.COM LLC, CAMBRIDGE, MA. SN 76-581,827. PUB. 12-14-2004, FILED 3-19-2004.

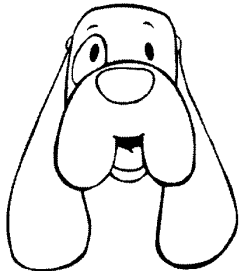

**CLASS 38—COMMUNICATION**

FOR PROVIDING ON-LINE CHAT ROOMS AND ELECTRONIC BULLETIN BOARDS FOR TRANSMISSION OF MESSAGES AMONG USERS IN THE FIELD OF GENERAL INTEREST (U.S. CLS. 100, 101 AND 104).  
FIRST USE 9-15-2006; IN COMMERCE 9-15-2006.

**CLASS 42—SCIENTIFIC, COMPUTER AND LEGAL SERVICES**

FOR PROVIDING TEMPORARY USE OF ON-LINE, NON-DOWNLOADABLE SOFTWARE, NAMELY, OFFICE PRODUCTIVITY SOFTWARE, PERSONAL PRODUCTIVITY SOFTWARE, SCHEDULING SOFTWARE, CALENDARING SOFTWARE, EVENT PLANNING SOFTWARE, PROJECT MANAGEMENT SOFTWARE AND SOFTWARE THAT ENABLES USERS TO COLLECT, PROCESS AND DISPLAY VOTES; PROVIDING CUSTOMIZED ONLINE WEB PAGES FEATURING USER-DEFINED INFORMATION, WHICH INCLUDES USER-PROVIDED DATA, PICTURES, GRAPHICS, FILES AND ONLINE WEB LINKS TO OTHER WEB SITES (U.S. CLS. 100 AND 101).  
FIRST USE 9-15-2006; IN COMMERCE 9-15-2006.

3,233,895. ULTRA PET CO., INC., ANDERSON, SC. SN 76-585,645. PUB. 9-6-2005, FILED 4-6-2004.

**ZEN PUPPY**

THE MARK CONSISTS OF STANDARD CHARACTERS WITHOUT CLAIM TO ANY PARTICULAR FONT, STYLE, SIZE, OR COLOR.  
NO CLAIM IS MADE TO THE EXCLUSIVE RIGHT TO USE PUPPY, APART FROM THE MARK AS SHOWN.

**CLASS 18—LEATHER GOODS**

FOR PET ACCESSORIES, NAMELY APPAREL, NAMELY, CLOTHING FOR PETS (U.S. CLS. 1, 2, 3, 22 AND 41).  
FIRST USE 6-30-2006; IN COMMERCE 6-30-2006.

**CLASS 28—TOYS AND SPORTING GOODS**

FOR PET TOYS (U.S. CLS. 22, 23, 38 AND 50).  
FIRST USE 6-30-2006; IN COMMERCE 6-30-2006.

3,233,897. DOMINION BEARING COMPANY, PORTLAND, OR. SN 76-585,969. PUB. 8-23-2005, FILED 4-9-2004.

**DOMINION**

THE MARK CONSISTS OF STANDARD CHARACTERS WITHOUT CLAIM TO ANY PARTICULAR FONT, STYLE, SIZE, OR COLOR.

**CLASS 6—METAL GOODS**

FOR METAL LOCKNUTS; METAL LOCK WASHERS (U.S. CLS. 2, 12, 13, 14, 23, 25 AND 50).  
FIRST USE 1-1-2005; IN COMMERCE 1-1-2005.

**CLASS 7—MACHINERY**

FOR MACHINE PARTS, NAMELY, BALL BEARINGS, DOUBLE ROW BALL BEARINGS, CYLINDRICAL ROLLER BEARINGS, SPHERICAL THRUST BEARINGS, ROLLER BEARINGS, BALL BEARING INSERTS, SPHERICAL BEARINGS, NEEDLE BEARINGS, PLAIN SPHERICAL BEARINGS, BEARING ADAPTERS, SELF ALIGNING BALL BEARINGS, THRUST BALL BEARINGS, ANGULAR CONTACT BALL BEARINGS, NEEDLE BEARINGS, THRUST NEEDLE BEARINGS, THRUST ROLLER BEARINGS, TAPERED ROLLER BEARINGS, JOURNAL BEARINGS, LINEAR BEARINGS, LINEAR SHAFTING, MAGNETO BALL BEARINGS, MOUNTED BALL BEARINGS, MOUNTED ROLLER BEARINGS, BEARING HEATERS, BEARING PULLERS, AND ALL OTHER TYPES OF ANTI-FRICTION BEARINGS; AND ROD ENDS FOR USE IN INDUSTRIAL APPLICATIONS; MAINLY, MINING, SAWMILLS, AND PULP AND PAPER MACHINERY; MACHINE PARTS, NAMELY, PILLOW BLOCKS AND FLANGE BLOCKS (U.S. CLS. 13, 19, 21, 23, 31, 34 AND 35).

FIRST USE 1-1-2005; IN COMMERCE 1-1-2005.

3,233,908. LOUNGE22, LLC, GLENDALE, CA. SN 76-592,623. PUB. 5-24-2005, FILED 5-17-2004.

**LOUNGE 22**

THE MARK CONSISTS OF STANDARD CHARACTERS WITHOUT CLAIM TO ANY PARTICULAR FONT, STYLE, SIZE, OR COLOR.

NO CLAIM IS MADE TO THE EXCLUSIVE RIGHT TO USE "LOUNGE", APART FROM THE MARK AS SHOWN.

**CLASS 35—ADVERTISING AND BUSINESS**

FOR FURNITURE RETAIL STORE SERVICES; SECOND HAND FURNITURE RESALE DEALERSHIP SERVICES; GENERAL CONSUMER MERCHANDISE RETAIL STORE SERVICES (U.S. CLS. 100, 101 AND 102). FIRST USE 8-31-2005; IN COMMERCE 8-31-2005.

3,233,907. LOUNGE22, LLC, GLENDALE, CA. SN 76-592,618. PUB. 5-24-2005, FILED 5-17-2004.



NO CLAIM IS MADE TO THE EXCLUSIVE RIGHT TO USE "LOUNGE", APART FROM THE MARK AS SHOWN.

**CLASS 35—ADVERTISING AND BUSINESS**

FOR FURNITURE RETAIL STORE SERVICES; SECOND HAND FURNITURE RESALE DEALERSHIP SERVICES; GENERAL CONSUMER MERCHANDISE RETAIL STORE SERVICES (U.S. CLS. 100, 101 AND 102). FIRST USE 5-31-2003; IN COMMERCE 5-31-2003.

**CLASS 37—CONSTRUCTION AND REPAIR**

FOR CONTRACT FURNITURE SERVICES, NAMELY, CUSTOM INSTALLATION OF FURNITURE (U.S. CLS. 100, 103 AND 106). FIRST USE 5-31-2003; IN COMMERCE 5-31-2003.

**CLASS 40—MATERIAL TREATMENT**

FOR CONTRACT FURNITURE SERVICES, NAMELY, CUSTOM FABRICATION OF FURNITURE (U.S. CLS. 100, 103 AND 106). FIRST USE 5-31-2003; IN COMMERCE 5-31-2003.

**CLASS 37—CONSTRUCTION AND REPAIR**

FOR CONTRACT FURNITURE SERVICES, NAMELY, CUSTOM INSTALLATION OF FURNITURE (U.S. CLS. 100, 103 AND 106). FIRST USE 8-31-2005; IN COMMERCE 8-31-2005.

**CLASS 40—MATERIAL TREATMENT**

FOR CONTRACT FURNITURE SERVICES, NAMELY, CUSTOM FABRICATION OF FURNITURE (U.S. CLS. 100, 103 AND 106). FIRST USE 8-31-2005; IN COMMERCE 8-31-2005.

3,233,909. PCJ FRANCHISING COMPANY LLC, WILMINGTON, NC. SN 76-592,934. PUB. 2-21-2006, FILED 5-19-2004.

**GLOBALLY GROWN. ARTISAN ROASTED.**

THE MARK CONSISTS OF STANDARD CHARACTERS WITHOUT CLAIM TO ANY PARTICULAR FONT, STYLE, SIZE, OR COLOR.

**CLASS 30—STAPLE FOODS**

FOR COFFEE, TEA, COCOA, GRAIN BASED COFFEE SUBSTITUTES, BREADS, PASTRIES, AND CANDIES (U.S. CL. 46). FIRST USE 6-1-2006; IN COMMERCE 6-1-2006.

**CLASS 43—HOTEL AND RESTAURANT SERVICES**

FOR RESTAURANT SERVICES FEATURING ESPRESSOS, SMOOTHIES, SANDWICHES, GOURMET COFFEES, CANDIES, AND JUICES (U.S. CLS. 100 AND 101). FIRST USE 6-1-2006; IN COMMERCE 6-1-2006.

3,233,914. MOTION PICTURE ASSOCIATION OF AMERICA, INC., ENCINO, CA. SN 76-595,870. PUB. 4-25-2006, FILED 6-7-2004.



NO CLAIM IS MADE TO THE EXCLUSIVE RIGHT TO USE "ILLEGAL DOWNLOADING", APART FROM THE MARK AS SHOWN.

#### CLASS 35—ADVERTISING AND BUSINESS

FOR CONDUCTING MEDIA CAMPAIGNS FOR THE PURPOSE OF EDUCATING THE PUBLIC ABOUT ILLEGAL DOWNLOADING AND THE UNLAWFUL NATURE OF MOTION PICTURE PIRACY (U.S. CLS. 100, 101 AND 102).

FIRST USE 6-15-2004; IN COMMERCE 6-15-2004.

#### CLASS 41—EDUCATION AND ENTERTAINMENT

FOR EDUCATIONAL SERVICES IN THE FIELD OF MOTION PICTURE PIRACY, NAMELY, CONDUCTING COURSES, CLASSES, INFORMATIVE AND INSTRUCTIONAL SEMINARS ON THE SUBJECT OF ILLEGAL DOWNLOADING OF COPYRIGHTED MATERIALS AND THE UNLAWFUL NATURE OF MOTION PICTURE PIRACY; PROVIDING AN EDUCATIONAL WEB SITE ON THE SUBJECT OF ILLEGAL DOWNLOADING OF COPYRIGHTED MATERIALS AND THE UNLAWFUL NATURE OF MOTION PICTURE PIRACY (U.S. CLS. 100, 101 AND 107).

FIRST USE 6-15-2004; IN COMMERCE 6-15-2004.

3,233,919. INPHARMATICA LIMITED, LONDON, W1T 2NU, UNITED KINGDOM. SN 76-597,894. PUB. 9-13-2005, FILED 6-17-2004.

# CHEMATICA

THE MARK CONSISTS OF STANDARD CHARACTERS WITHOUT CLAIM TO ANY PARTICULAR FONT, STYLE, SIZE, OR COLOR.

#### CLASS 9—ELECTRICAL AND SCIENTIFIC APPARATUS

FOR ELECTRONIC DATABASES CONTAINING PRE-PROCESSED BIOLOGICAL AND CHEMICAL DATA RECORDED ON ELECTRONIC MEDIA; COMPUTER SOFTWARE FOR ACCESSING, PROCESSING, STORAGE, RETRIEVAL AND PRESENTATION OF BIOLOGICAL, CHEMICAL AND CLINICAL DATA AND ASSOCIATED COMMERCIAL INFORMATION; SOFTWARE FOR USE IN BIOLOGICAL AND CHEMICAL MODELING, ANALYSIS AND INFORMATION MANAGEMENT; SOFTWARE FOR COMPUTER-AIDED MOLECULAR DESIGN; BIOLOGICAL AND CHEMICAL DATA ANALYSIS SOFTWARE FOR USE IN DRUG DISCOVERY DATABASE INFORMATION SYSTEMS; PRE-RECORDED CASSETTES, COMPUTER DISCS AND CD ROMS FEATURING INFORMATION RELATING TO BIOLOGY, GENOMICS, PROTEOMICS, CHEMISTRY, BIOTECHNOLOGY, PHARMACEUTICALS, DRUG DISCOVERY AND DRUG DEVELOPMENT (U.S. CLS. 21, 23, 26, 36 AND 38).

FIRST USE 7-11-2001; IN COMMERCE 4-23-2004.

#### CLASS 42—SCIENTIFIC, COMPUTER AND LEGAL SERVICES

FOR PROVIDING AN ON-LINE COMPUTER DATABASE IN THE FIELDS OF BIOLOGY, GENOMICS, PROTEOMICS, CHEMISTRY, BIOTECHNOLOGY, PHARMACEUTICALS, DRUG DISCOVERY AND DRUG DEVELOPMENT; DESIGN, UPDATING AND MAINTENANCE OF COMPUTER SOFTWARE FOR OTHERS; RENTAL OF SOFTWARE; ANALYSIS AND DEVELOPMENT OF DATABASES CONTAINING INFORMATION RELATING TO BIOLOGY, GENOMICS, PROTEOMICS, CHEMISTRY, BIOTECHNOLOGY, PHARMACEUTICALS, DRUG DISCOVERY AND DRUG DEVELOPMENT; PROVIDING ON-LINE COMPUTER DATABASES IN THE FIELD OF BIOLOGY, GENOMICS, PROTEOMICS, CHEMISTRY, BIOTECHNOLOGY, PHARMACEUTICALS, DRUG DISCOVERY AND DRUG DEVELOPMENT; BIOTECHNOLOGY AND PHARMACEUTICALS RESEARCH, PROFESSIONAL CONSULTATION IN THE FIELD OF BIOTECHNOLOGY AND DRUG DEVELOPMENT; PROVISION OF INFORMATION RELATING TO BIOLOGY, GENOMICS, PROTEOMICS, CHEMISTRY, BIOTECHNOLOGY, PHARMACEUTICALS, DRUG DISCOVERY AND DRUG DEVELOPMENT (U.S. CLS. 100 AND 101).

FIRST USE 7-11-2001; IN COMMERCE 4-23-2004.

3,233,921. ALOHA AIRLINES, INC., HONOLULU, HI. SN 76-599,092. PUB. 3-21-2006, FILED 6-24-2004.

#### ALI'I LOYALTY PROGRAM

THE MARK CONSISTS OF STANDARD CHARACTERS WITHOUT CLAIM TO ANY PARTICULAR FONT, STYLE, SIZE, OR COLOR.

NO CLAIM IS MADE TO THE EXCLUSIVE RIGHT TO USE LOYALTY PROGRAM, APART FROM THE MARK AS SHOWN.

THE ENGLISH TRANSLATION OF THE WORD ALI' I IN THE MARK IS "CHIEF, NOBILITY, ROYALTY, TO TREAT WITH ROYALTY".

**CLASS 39—TRANSPORTATION AND STORAGE**

FOR AIR TRANSPORTATION SERVICES, NAMELY, AIRLINE PASSENGER SERVICES IN THE NATURE OF A SPECIALIZED FREQUENT FLIER PROGRAM FEATURING TICKET UPGRADES, AUGMENTED FREQUENT FLIER MILEAGE, AND AIR TRANSPORTATION RESERVATION SERVICES; AIR TRANSPORTATION SERVICES FEATURING AN AWARD PROGRAM FOR FREQUENT AIR TRAVELERS (U.S. CLS. 100 AND 105).

FIRST USE 1-31-2004; IN COMMERCE 1-31-2004.

**CLASS 43—HOTEL AND RESTAURANT SERVICES**

FOR FREQUENT FLIER TRAVEL SERVICES, NAMELY PROVIDING FOOD AND BEVERAGES TO MEMBER TRAVELERS IN THE AIRPORT LOUNGE (U.S. CLS. 100 AND 101).

FIRST USE 1-31-2004; IN COMMERCE 1-31-2004.

**CLASS 45—PERSONAL SERVICES**

FOR FREQUENT FLIER TRAVEL SERVICES, NAMELY, HOSPITALITY SERVICES IN THE NATURE OF CONCIERGE SERVICES FOR OTHERS COMPRISING MAKING REQUESTED PERSONAL ARRANGEMENTS AND RESERVATIONS AND PROVIDING CUSTOMER-SPECIFIC INFORMATION TO MEET INDIVIDUAL NEEDS RENDERED TOGETHER IN AN AIRPORT ENVIRONMENT (U.S. CLS. 100 AND 101).

FIRST USE 1-31-2004; IN COMMERCE 1-31-2004.

3,233,930. GROOPE.COM LLC, CAMBRIDGE, MA. SN 76-603,190. PUB. 12-14-2004, FILED 7-20-2004.

**CLASS 38—COMMUNICATION**

FOR PROVIDING ON-LINE CHAT ROOMS AND ELECTRONIC BULLETIN BOARDS FOR TRANSMISSION OF MESSAGES AMONG USERS IN THE FIELD OF GENERAL INTEREST (U.S. CLS. 100, 101 AND 104).

FIRST USE 9-15-2006; IN COMMERCE 9-15-2006.

**CLASS 42—SCIENTIFIC, COMPUTER AND LEGAL SERVICES**

FOR PROVING TEMPORARY USE OF ON-LINE, NON-DOWNLOADABLE SOFTWARE, NAMELY, OFFICE PRODUCTIVITY SOFTWARE, PERSONAL PRODUCTIVITY SOFTWARE, SCHEDULING SOFTWARE, CALENDARING SOFTWARE, EVENT PLANNING SOFTWARE, PROJECT MANAGEMENT SOFTWARE AND SOFTWARE THAT ENABLES USERS TO COLLECT, PROCESS AND DISPLAY VOTES; PROVIDING CUSTOMIZED ONLINE WEB PAGES FEATURING USER-DEFINED INFORMATION, WHICH INCLUDES USER-PROVIDED DATA, PICTURES, GRAPHICS, FILES AND ONLINE WEB LINKS TO OTHER WEB SITES (U.S. CLS. 100 AND 101).

FIRST USE 9-15-2006; IN COMMERCE 9-15-2006.

3,233,948. GRAHAM, RICHARD A., HUNTINGTON BEACH, CA. SN 76-610,455. PUB. 10-11-2005, FILED 9-2-2004.

**DISC HYDRATOR**

THE MARK CONSISTS OF STANDARD CHARACTERS WITHOUT CLAIM TO ANY PARTICULAR FONT, STYLE, SIZE, OR COLOR.

OWNER OF U.S. REG. NOS. 2,048,172, 2,219,790, AND 2,293,915.

NO CLAIM IS MADE TO THE EXCLUSIVE RIGHT TO USE "DISC", APART FROM THE MARK AS SHOWN.

**CLASS 10—MEDICAL APPARATUS**

FOR CERVICAL TRACTION APPARATUS (U.S. CLS. 26, 39 AND 44).

FIRST USE 3-0-2006; IN COMMERCE 3-0-2006.

**CLASS 28—TOYS AND SPORTING GOODS**

FOR MANUALLY OPERATED NECK EXERCISE APPARATUS (U.S. CLS. 22, 23, 38 AND 50).

FIRST USE 3-0-2006; IN COMMERCE 3-0-2006.

3,233,950. VANI USA, INC., NEW YORK, NY. SN 76-610,813. PUB. 5-9-2006, FILED 9-10-2004.



La pagayo

OWNER OF U.S. REG. NO. 2,723,544.

THE MARK CONSISTS IN PART OF A STYLIZED DESIGN ELEMENT OF A PARROT.

THE ENGLISH TRANSLATION OF LA PAGAYO IS THE LEAF.

**CLASS 9—ELECTRICAL AND SCIENTIFIC APPARATUS**

FOR SUNGLASSES, CASES AND FRAMES FOR SPECTACLES AND SUNGLASSES, LENSES FOR SUNGLASSES AND SPORT GOGGLES FOR USE IN SCUBA DIVING, MOTORCYCLING AND SWIMMING (U.S. CLS. 21, 23, 26, 36 AND 38).

FIRST USE 2-0-2005; IN COMMERCE 10-0-2005.

**CLASS 25—CLOTHING**

FOR CLOTHING, NAMELY HEADWEAR, FOOTWEAR, JACKETS, JEANS, DRESSES, SKIRTS, SUITS, SWEATERS, JERSEY, SHIRTS, BLOUSES, VESTS, SINGLETTS, TROUSERS, PANTS, SHORTS, DUNGAREES, SOCKS, LEGGINGS, SHAWLS AND GLOVES (U.S. CLS. 22 AND 39).

FIRST USE 2-0-2005; IN COMMERCE 10-0-2005.

3,233,951. WAKEFERN FOOD CORP., ELIZABETH, NJ. SN 76-610,867. PUB. 8-16-2005, FILED 9-10-2004.

3,233,973. PHONAK HOLDING AG, CH-8712 STAEFA, SWITZERLAND. SN 76-615,303. PUB. 1-24-2006, FILED 10-12-2004.

### IT MAKES A DIFFERENCE WHERE YOU SHOP

THE MARK CONSISTS OF STANDARD CHARACTERS WITHOUT CLAIM TO ANY PARTICULAR FONT, STYLE, SIZE, OR COLOR.

#### CLASS 35—ADVERTISING AND BUSINESS

FOR RETAIL GROCERY STORE SERVICES; PROMOTING PUBLIC AWARENESS OF THE NEED FOR MONEY CONTRIBUTIONS TO LOCAL CHARITIES AND COMMUNITY ORGANIZATIONS (U.S. CLS. 100, 101 AND 102).

FIRST USE 6-0-2004; IN COMMERCE 6-0-2004.

#### CLASS 36—INSURANCE AND FINANCIAL

FOR CHARITABLE FUND RAISING SERVICES (U.S. CLS. 100, 101 AND 102).

FIRST USE 6-0-2004; IN COMMERCE 6-0-2004.

3,233,969. MI WINDOWS AND DOORS, INC., GRATZ, PA. SN 76-614,369. PUB. 12-13-2005, FILED 10-1-2004.



NO CLAIM IS MADE TO THE EXCLUSIVE RIGHT TO USE "BETTER BUILT", APART FROM THE MARK AS SHOWN.

THE COLOR(S) BLACK, WHITE AND RED IS/ARE CLAIMED AS A FEATURE OF THE MARK.

THE COLOR BLACK APPEARS IN THE RECTANGULAR CARRIER; THE LETTERS ARE IN THE COLOR WHITE; AND THE DIAMOND SHAPE THAT IS THE "DOT" FOR THE LETTER "I" IS IN THE COLOR RED.

#### CLASS 6—METAL GOODS

FOR METAL WINDOWS (U.S. CLS. 2, 12, 13, 14, 23, 25 AND 50).

FIRST USE 12-31-1999; IN COMMERCE 12-31-1999.

#### CLASS 19—NON-METALLIC BUILDING MATERIALS

FOR NON-METAL WINDOWS (U.S. CLS. 1, 12, 33 AND 50).

FIRST USE 12-31-1999; IN COMMERCE 12-31-1999.

## BassBoost

THE MARK CONSISTS OF STANDARD CHARACTERS WITHOUT CLAIM TO ANY PARTICULAR FONT, STYLE, SIZE, OR COLOR.

#### CLASS 9—ELECTRICAL AND SCIENTIFIC APPARATUS

FOR COMPUTER SOFTWARE FOR USE IN THE ADJUSTMENT OF HEARING AIDS FOR THE SPECIFIC HEARING LOSS NEEDS OF THE USER (U.S. CLS. 21, 23, 26, 36 AND 38).

FIRST USE 4-30-2004; IN COMMERCE 4-30-2004.

#### CLASS 10—MEDICAL APPARATUS

FOR HEARING AIDS (U.S. CLS. 26, 39 AND 44).

FIRST USE 4-30-2004; IN COMMERCE 4-30-2004.

3,233,976. ELECTROLUX HOME PRODUCTS, INC., CLEVELAND, OH. SN 76-615,845. PUB. 1-17-2006, FILED 10-7-2004.

## FRIGIDAIRE ELEMENTS

THE MARK CONSISTS OF STANDARD CHARACTERS WITHOUT CLAIM TO ANY PARTICULAR FONT, STYLE, SIZE, OR COLOR.

OWNER OF U.S. REG. NOS. 364,709, 2,744,799, AND OTHERS.

#### CLASS 7—MACHINERY

FOR HOUSEHOLD CLOTHES WASHING MACHINES AND DISHWASHING MACHINES, AND PARTS FOR ALL OF THE AFORESAID (U.S. CLS. 13, 19, 21, 23, 31, 34 AND 35).

FIRST USE 7-31-2006; IN COMMERCE 7-31-2006.

#### CLASS 11—ENVIRONMENTAL CONTROL APPARATUS

FOR HOUSEHOLD REFRIGERATORS AND FREEZERS; WINE COOLERS, NAMELY ELECTRIC BEVERAGE COOLING APPARATUS; HOUSEHOLD CLOTHES DRYING MACHINES; ELECTRICAL ICE MAKERS; HOUSEHOLD GAS AND ELECTRIC RANGES, COOKING OVENS, STOVES AND COOKTOPS; MICROWAVE OVENS, RANGE HOODS, ROOM AIR CONDITIONERS AND WATER PURIFYING APPARATUS (U.S. CLS. 13, 21, 23, 31 AND 34).

FIRST USE 7-31-2006; IN COMMERCE 7-31-2006.

3,233,987. GENTIVA HEALTH SERVICES, INC., MELVILLE, NY. SN 76-620,607. PUB. 3-21-2006, FILED 11-12-2004.

## GENTIVA UNIVERSITY

THE MARK CONSISTS OF STANDARD CHARACTERS WITHOUT CLAIM TO ANY PARTICULAR FONT, STYLE, SIZE, OR COLOR.

### CLASS 16—PAPER GOODS AND PRINTED MATTER

FOR EDUCATIONAL PUBLICATIONS, NAMELY, TRAINING MANUALS IN THE FIELD OF HEALTH CARE; PRINTED INSTRUCTIONAL, EDUCATIONAL, AND TEACHING MATERIALS IN THE FIELD OF HEALTH CARE (U.S. CLS. 2, 5, 22, 23, 29, 37, 38 AND 50).  
FIRST USE 7-1-2005; IN COMMERCE 7-1-2005.

### CLASS 35—ADVERTISING AND BUSINESS

FOR TESTING TO DETERMINE EMPLOYMENT SKILLS AND JOB AND PROFESSIONAL COMPETENCY; PROVIDING LINKS TO THE WEB SITES OF OTHERS IN THE FIELD OF HEALTH CARE; PROMOTING THE GOODS AND SERVICES OF OTHERS BY PROVIDING HYPERTEXT LINKS TO THE WEB SITES OF OTHERS; PROMOTING THE GOODS AND SERVICES OF OTHERS BY PROVIDING A WEB SITE AT WHICH USERS CAN LINK TO OTHER WEBSITES IN THE FIELD OF HEALTH CARE; PROVIDING INFORMATION ON THE TOPIC OF PROMOTING PATIENT, PHYSICIAN AND EMPLOYEE SATISFACTION VIA A GLOBAL COMPUTER NETWORK (U.S. CLS. 100, 101 AND 102).  
FIRST USE 7-1-2005; IN COMMERCE 7-1-2005.

### CLASS 41—EDUCATION AND ENTERTAINMENT

FOR EDUCATIONAL SERVICES FOR OTHERS IN THE FIELD OF HEALTH CARE, NAMELY, WORKSHOPS AND SEMINARS CONDUCTED IN PERSON, BY TELEPHONE, ELECTRONIC MAIL, AND THE GLOBAL COMPUTER INFORMATION NETWORK AND THE DISTRIBUTION OF COURSE MATERIAL IN CONNECTION THEREWITH; EDUCATIONAL SERVICES, NAMELY, CONDUCTING CLASSES, SEMINARS, CONFERENCES, PROGRAMS AND WORKSHOPS IN THE FIELD OF HEALTH CARE AND DISTRIBUTING COURSE MATERIALS IN CONNECTION THEREWITH; EDUCATIONAL SERVICES, NAMELY, CONDUCTING ON-LINE EXHIBITIONS AND DISPLAYS AND INTERACTIVE EXHIBITS IN THE FIELD OF HEALTH CARE; EDUCATION IN THE FIELD OF HEALTH CARE RENDERED THROUGH CORRESPONDENCE COURSES; PROVIDING CONTINUING MEDICAL AND NURSING EDUCATION COURSES; VOCATIONAL EDUCATION IN THE FIELD OF HEALTHCARE; TRAINING OF MEDICAL PERSONNEL IN THE ADMINISTRATION OF PHARMACEUTICAL PREPARATIONS AND THE USE OF MEDICAL APPARATUS; ARRANGING AND CONDUCTING EDUCATIONAL CONFERENCES; DEVELOPING EDUCATIONAL MANUALS FOR OTHERS IN THE FIELD OF HEALTH CARE; DEVELOPMENT AND DISSEMINATION OF EDUCATIONAL MATERIALS OF OTHERS IN THE FIELD OF HEALTH CARE; EDUCATIONAL DEMONSTRATIONS; ARRANGING PROFESSIONAL WORKSHOP AND TRAINING COURSES; MEDICAL TRAINING AND TEACHING; TRAINING IN THE USE AND OPERATION OF MEDICAL EQUIPMENT; TRAINING SERVICES IN THE FIELD OF HEALTH CARE; EDUCATION SERVICES NAMELY, ONE-ON-ONE MENTORING IN THE FIELD OF HEALTH CARE; EDUCATIONAL AND STANDARDIZED TESTING; ANALYZING EDUCATIONAL TESTS SCORES AND DATA FOR OTHERS; PREPARING, ADMINISTERING, AND SCORING STANDARDIZED TESTS (U.S. CLS. 100, 101 AND 107).  
FIRST USE 7-1-2005; IN COMMERCE 7-1-2005.

### CLASS 44—MEDICAL, BEAUTY AND AGRICULTURAL SERVICES

FOR PROVIDING INFORMATION IN THE FIELD OF HEALTH CARE; PROVIDING INFORMATION IN THE FIELD OF HEALTH CARE VIA THE INTERNET (U.S. CLS. 100 AND 101).  
FIRST USE 7-1-2005; IN COMMERCE 7-1-2005.

3,233,996. INVICTA WATCH COMPANY OF AMERICA, INC., HOLLYWOOD, FL. SN 76-625,756. PUB. 10-11-2005, FILED 12-21-2004.

# AIRLINK

THE MARK CONSISTS OF STANDARD CHARACTERS WITHOUT CLAIM TO ANY PARTICULAR FONT, STYLE, SIZE, OR COLOR.

### CLASS 14—JEWELRY

FOR HOROLOGICAL INSTRUMENTS, NAMELY WATCHES, WRIST-WATCHES, POCKET WATCHES; CHRONOGRAPHS FOR USE AS WATCHES; CHRONOMETERS (U.S. CLS. 2, 27, 28 AND 50).  
FIRST USE 7-27-2005; IN COMMERCE 7-27-2005.

### CLASS 18—LEATHER GOODS

FOR LUGGAGE, TOTE BAGS, WALLETS AND BACKPACKS (U.S. CLS. 1, 2, 3, 22 AND 41).  
FIRST USE 11-19-2004; IN COMMERCE 1-2-2005.

3,234,004. HELEN OF TROY LIMITED, ST. MICHAEL, BARBADOS. SN 76-627,806. PUB. 10-25-2005, FILED 1-13-2005.

# STYLIST CHOICE

THE MARK CONSISTS OF STANDARD CHARACTERS WITHOUT CLAIM TO ANY PARTICULAR FONT, STYLE, SIZE, OR COLOR.

OWNER OF U.S. REG. NO. 1,964,365.  
SEC. 2(F).

### CLASS 9—ELECTRICAL AND SCIENTIFIC APPARATUS

FOR ELECTRIC HAND-HELD HAIR STYLING IRONS; AND ELECTRIC HOT AIR HAIR BRUSHES (U.S. CLS. 21, 23, 26, 36 AND 38).  
FIRST USE 6-1-2006; IN COMMERCE 6-1-2006.

### CLASS 11—ENVIRONMENTAL CONTROL APPARATUS

FOR ELECTRIC HAND-HELD HAIR DRYERS (U.S. CLS. 13, 21, 23, 31 AND 34).  
FIRST USE 6-1-2006; IN COMMERCE 6-1-2006.



3,234,013. DILLARD'S, INC., LITTLE ROCK, AR. SN 76-630,350. PUB. 5-16-2006, FILED 2-4-2005.

# studio D

THE MARK CONSISTS OF STANDARD CHARACTERS WITHOUT CLAIM TO ANY PARTICULAR FONT, STYLE, SIZE, OR COLOR.

NO CLAIM IS MADE TO THE EXCLUSIVE RIGHT TO USE "STUDIO", APART FROM THE MARK AS SHOWN.

## CLASS 21—HOUSEWARES AND GLASS

FOR TOWEL BARS, TOWEL RINGS, TOOTHBRUSH HOLDERS, TOILET TISSUE HOLDERS, SOAP DISHES, AND BATHROOM ACCESSORIES, NAMELY, CUP HOLDERS (U.S. CLS. 2, 13, 23, 29, 30, 33, 40 AND 50).

FIRST USE 8-30-2003; IN COMMERCE 8-30-2003.

## CLASS 24—FABRICS

FOR BED LINENS, BED SPREADS, PILLOW CASES, PILLOW SHAMS, DECORATIVE PILLOWS, PILLOW COVERS, DUVETS, DUVET COVERS, COMFORTERS, BLANKETS, QUILTS AND QUILT COVERS, BED SKIRTS, DUST RUFFLES, THROWS, BED SCARVES, FABRIC WINDOW TREATMENT, NAMELY, SHEERS, WINDOW VALANCES, DRAPES, AND WINDOW CURTAINS, TOWELS, WASH CLOTHS, HAND TOWELS, WASHING MITTS, AND SHOWER CURTAINS (U.S. CLS. 42 AND 50).

FIRST USE 8-30-2003; IN COMMERCE 8-30-2003.

## CLASS 27—FLOOR COVERINGS

FOR BATH RUGS (U.S. CLS. 19, 20, 37, 42 AND 50).

FIRST USE 8-30-2003; IN COMMERCE 8-30-2003.

3,234,022. ROSSIGNOL SKI COMPANY, INC., PARK CITY, UT. SN 76-632,157. PUB. 1-31-2006, FILED 2-25-2005.

ROSSIGNOL PURE MOUNTAIN COMPANY

THE MARK CONSISTS OF STANDARD CHARACTERS WITHOUT CLAIM TO ANY PARTICULAR FONT, STYLE, SIZE, OR COLOR.

OWNER OF U.S. REG. NOS. 954,365, 1,882,352, AND OTHERS.

NO CLAIM IS MADE TO THE EXCLUSIVE RIGHT TO USE "MOUNTAIN COMPANY", APART FROM THE MARK AS SHOWN.

THE ENGLISH TRANSLATION OF THE WORD ROSSIGNOL IN THE MARK IS "NIGHTINGALE".

## CLASS 9—ELECTRICAL AND SCIENTIFIC APPARATUS

FOR HELMETS (U.S. CLS. 21, 23, 26, 36 AND 38).

FIRST USE 4-1-2004; IN COMMERCE 4-1-2004.

## CLASS 18—LEATHER GOODS

FOR BAGS, NAMELY, BACK BAGS AND SATCHELS (U.S. CLS. 1, 2, 3, 22 AND 41).

FIRST USE 4-1-2004; IN COMMERCE 4-1-2004.

## CLASS 25—CLOTHING

FOR CLOTHING, NAMELY, JACKETS, PANTS, GLOVES, SOCKS, T-SHIRTS, HATS, CAPS, MASKS, UNDERWEAR, SWEATER OVERS; BELTS; SHOES; ALPINE SKI BOOTS, NORDIC SKI BOOTS AND SNOWBOARD BOOTS (U.S. CLS. 22 AND 39).

FIRST USE 4-1-2004; IN COMMERCE 4-1-2004.

## CLASS 28—TOYS AND SPORTING GOODS

FOR SPORTS EQUIPMENT, NAMELY, ALPINE SKIS AND NORDIC SKIS; ALPINE SKI BINDINGS AND NORDIC SKI BINDINGS; SKI POLES; SNOWBOARDS AND SNOWBOARD BINDINGS; PROTECTION EQUIPMENT, NAMELY, SPEED SUITS, GAITERS, TIBIA PROTECTIONS, BACK PROTECTION, BODY PROTECTIONS, INTEGRAL JACKETS, LEG PROTECTORS AND PROTECTIVE SHORTS (U.S. CLS. 22, 23, 38 AND 50).

FIRST USE 4-1-2004; IN COMMERCE 4-1-2004.

3,234,028. VACCARO, JOHN, CALABASAS, CA. SN 76-634,508. PUB. 7-11-2006, FILED 3-28-2005.

# NEXT FACTOR

THE MARK CONSISTS OF STANDARD CHARACTERS WITHOUT CLAIM TO ANY PARTICULAR FONT, STYLE, SIZE, OR COLOR.

## CLASS 18—LEATHER GOODS

FOR SPORTS BAGS, GAME BAGS, TRAVELLING BAGS, BACKPACKS (U.S. CLS. 1, 2, 3, 22 AND 41).

FIRST USE 5-1-2005; IN COMMERCE 5-1-2005.

## CLASS 25—CLOTHING

FOR CLOTHING, NAMELY, SHIRTS, PANTS, SHORTS, UNDERWEAR, PAJAMAS, VESTS, JACKETS, WARM UP SUITS, FOOTWEAR, HEADGEAR, NAMELY, HATS, CAPS AND VISORS (U.S. CLS. 22 AND 39).

FIRST USE 5-1-2004; IN COMMERCE 5-1-2004.

3,234,031. INSTITUTE OF MANAGEMENT ACCOUNTANTS, MONTVALE, NJ. SN 76-634,928. PUB. 7-4-2006, FILED 4-4-2005.

**CERTIFIED MANAGEMENT ACCOUNTANTS.....**

**PROFESSIONALS DRIVING BUSINESS PERFORMANCE**

THE MARK CONSISTS OF STANDARD CHARACTERS WITHOUT CLAIM TO ANY PARTICULAR FONT, STYLE, SIZE, OR COLOR.

OWNER OF U.S. REG. NOS. 1,811,163, 1,895,368, AND 2,771,907.

NO CLAIM IS MADE TO THE EXCLUSIVE RIGHT TO USE "CERTIFIED MANAGEMENT ACCOUNTANTS", APART FROM THE MARK AS SHOWN.

**CLASS 35—ADVERTISING AND BUSINESS**

FOR ASSOCIATION SERVICES, NAMELY, PROMOTING THE INTERESTS OF MANAGEMENT ACCOUNTANTS; PROMOTING PUBLIC AWARENESS OF THE NEED FOR MANAGEMENT ACCOUNTANTS AND OF THE NEED FOR EDUCATIONAL PROGRAMS IN THE FIELDS OF MANAGEMENT ACCOUNTING AND FINANCIAL MANAGEMENT (U.S. CLS. 100, 101 AND 102).  
FIRST USE 12-0-2005; IN COMMERCE 12-0-2005.

**CLASS 41—EDUCATION AND ENTERTAINMENT**

FOR EDUCATIONAL PROGRAMS IN THE FINANCIAL MANAGEMENT AND MANAGEMENT ACCOUNTING FIELDS, NAMELY, EDUCATIONAL RESEARCH, ARRANGING AND CONDUCTING EDUCATIONAL CONFERENCES, EDUCATIONAL DEMONSTRATIONS, AND EDUCATIONAL TESTING (U.S. CLS. 100, 101 AND 107).  
FIRST USE 12-0-2005; IN COMMERCE 12-0-2005.

3,234,041. THE TRUSTEES OF THE UNIVERSITY OF PENNSYLVANIA, PHILADELPHIA, PA. SN 76-637,839. PUB. 1-24-2006, FILED 5-2-2005.

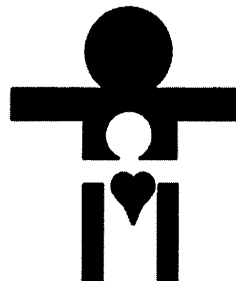
**CLASS 16—PAPER GOODS AND PRINTED MATTER**

FOR NEWSLETTERS AND PAMPHLETS ON ISSUES RELATED TO THE HUMAN HEART (U.S. CLS. 2, 5, 22, 23, 29, 37, 38 AND 50).  
FIRST USE 9-30-2004; IN COMMERCE 9-30-2004.

**CLASS 44—MEDICAL, BEAUTY AND AGRICULTURAL SERVICES**

FOR MEDICAL TREATMENT AND SURGICAL SERVICES; MEDICAL COUNSELING SERVICES; PROVIDING MEDICAL INFORMATION (U.S. CLS. 100 AND 101).  
FIRST USE 9-30-2004; IN COMMERCE 9-30-2004.

3,234,036. MCCALLUM, KENNETH G. SR., WEST MONROE, LA. SN 76-635,610. PUB. 3-14-2006, FILED 4-11-2005.

3,234,053. RED-BAN COMMUNICATIONS, LLC, SANDY, UT. SN 76-640,632. PUB. 5-9-2006, FILED 6-10-2005.



# NEXTPHONE

THE MARK CONSISTS OF STANDARD CHARACTERS WITHOUT CLAIM TO ANY PARTICULAR FONT, STYLE, SIZE, OR COLOR.

**CLASS 20—FURNITURE AND ARTICLES NOT OTHERWISE CLASSIFIED**

FOR PLASTIC NOVELTY LICENSE PLATES (U.S. CLS. 2, 13, 22, 25, 32 AND 50).  
FIRST USE 9-19-2005; IN COMMERCE 9-19-2005.

**CLASS 9—ELECTRICAL AND SCIENTIFIC APPARATUS**

FOR ELECTRICAL HARDWARE RELAY BOX AND RELATED EQUIPMENT, NAMELY SESSION INITIATED PROTOCOL SERVERS, VOIP APPLICATIONS SERVERS, GATEWAY SOFT-SWITCHES, INTEGRATED ACCESS DEVICES SUCH AS SIP (SESSION INITIATED PROTOCOL) TELEPHONES AND ANALOG TELEPHONE ADAPTERS TO PROVIDE TELEPHONE SERVICES OVER INTERNET PROTOCOL INTERNET TO TELEPHONE SERVICE (U.S. CLS. 21, 23, 26, 36 AND 38).  
FIRST USE 11-1-2005; IN COMMERCE 11-1-2005.

**CLASS 25—CLOTHING**

FOR BASEBALL CAPS AND T-SHIRTS (U.S. CLS. 22 AND 39).  
FIRST USE 9-19-2005; IN COMMERCE 9-19-2005.

**CLASS 38—COMMUNICATION**

FOR VOICE OVER INTERNET PROTOCOL INTERNET BASED TELEPHONE SERVICE (U.S. CLS. 100, 101 AND 104).  
FIRST USE 11-1-2005; IN COMMERCE 11-1-2005.

3,234,084. PENNWELL CORPORATION, TULSA, OK. SN 76-978,452. PUB. 9-13-2005, FILED 3-10-2004.

## OIL & GAS FINANCIAL JOURNAL

THE MARK CONSISTS OF STANDARD CHARACTERS WITHOUT CLAIM TO ANY PARTICULAR FONT, STYLE, SIZE, OR COLOR.

OWNER OF U.S. REG. NOS. 508,769, 2,197,086, AND 2,795,202.

NO CLAIM IS MADE TO THE EXCLUSIVE RIGHT TO USE "FINANCIAL JOURNAL", APART FROM THE MARK AS SHOWN.

SEC. 2(F) AS TO "OIL & GAS".

### CLASS 16—PAPER GOODS AND PRINTED MATTER

FOR MAGAZINE IN THE FIELD OF FINANCIAL INFORMATION RELATING TO THE OIL AND GAS INDUSTRY (U.S. CLS. 2, 5, 22, 23, 29, 37, 38 AND 50).

FIRST USE 3-0-2004; IN COMMERCE 3-0-2004.

### CLASS 36—INSURANCE AND FINANCIAL

FOR PROVIDING INFORMATION ONLINE IN THE FIELD OF FINANCIAL INFORMATION RELATING TO THE OIL AND GAS INDUSTRY (U.S. CLS. 100, 101 AND 102).

FIRST USE 5-0-2006; IN COMMERCE 5-0-2006.

3,234,090. STYLAI, LLC, MANHASSET, NY. SN 76-978,471. PUB. 2-14-2006, FILED 12-13-2004.

## ETERNAL SHAMROCKS

THE MARK CONSISTS OF STANDARD CHARACTERS WITHOUT CLAIM TO ANY PARTICULAR FONT, STYLE, SIZE, OR COLOR.

NO CLAIM IS MADE TO THE EXCLUSIVE RIGHT TO USE "SHAMROCKS", APART FROM THE MARK AS SHOWN.

### CLASS 6—METAL GOODS

FOR METAL KEY RINGS, METAL MONEY CLIPS, AND METAL ORNAMENTS FOR ATTACHMENT TO AUTOMOTIVE VISORS (U.S. CLS. 2, 12, 13, 14, 23, 25 AND 50).

FIRST USE 4-1-2005; IN COMMERCE 4-1-2005.

### CLASS 14—JEWELRY

FOR COLLECTABLE AND COMMEMORATIVE COINS MADE OF NONPRECIOUS METAL; COSTUME JEWELRY (U.S. CLS. 2, 27, 28 AND 50).

FIRST USE 4-1-2005; IN COMMERCE 4-1-2005.

### CLASS 16—PAPER GOODS AND PRINTED MATTER

FOR PAPERWEIGHTS MADE OF NONPRECIOUS METAL; GREETING CARDS; BOOKMARKS; WALLET CARDS; DESK ACCESSORIES, NAMELY, DESK PADS AND DESK FILE TRAYS (U.S. CLS. 2, 5, 22, 23, 29, 37, 38 AND 50).

FIRST USE 10-1-2005; IN COMMERCE 10-1-2005.

### CLASS 26—FANCY GOODS

FOR METAL ZIPPER PULLS (U.S. CLS. 37, 39, 40, 42 AND 50).

FIRST USE 4-1-2005; IN COMMERCE 4-1-2005.

3,234,095. GREEN BAY PACKERS, INC., GREEN BAY, WI. SN 78-061,782. PUB. 7-27-2004, FILED 5-3-2001.

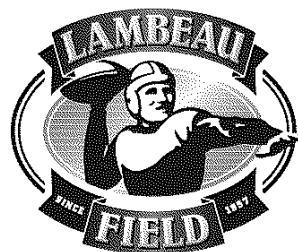

NO CLAIM IS MADE TO THE EXCLUSIVE RIGHT TO USE "LAMBEAU FIELD" AND "SINCE 1957", APART FROM THE MARK AS SHOWN.

### CLASS 24—FABRICS

FOR BLANKETS AND BEDDING (U.S. CLS. 42 AND 50).

FIRST USE 8-0-2005; IN COMMERCE 8-0-2005.

### CLASS 28—TOYS AND SPORTING GOODS

FOR GOLF ACCESSORIES, NAMELY, GOLF BALLS, GOLF TEES AND GOLF BAGS; FOOTBALLS, TOY REPLICA STADIUMS, BASEBALLS, BASKET BALLS, BEACH BALLS, VOLLEY BALLS, FOAM BALLS, RUBBER BALLS, STUFFED ANIMALS AND GAMES, NAMELY BOARD GAMES (U.S. CLS. 22, 23, 38 AND 50).

FIRST USE 9-0-2003; IN COMMERCE 9-0-2003.

3,234,096. GREEN BAY PACKERS, INC., GREEN BAY, WI. SN 78-061,785. PUB. 2-17-2004, FILED 5-3-2001.

## LAMBEAU FIELD

### CLASS 24—FABRICS

FOR BLANKETS, BEDDING (U.S. CLS. 42 AND 50).

FIRST USE 8-0-2005; IN COMMERCE 8-0-2005.

### CLASS 28—TOYS AND SPORTING GOODS

FOR GOLF ACCESSORIES, NAMELY, GOLF BALLS, GOLF TEES AND GOLF BAGS; FOOTBALLS, TOY REPLICA STADIUMS, BASEBALLS, BASKET BALLS, BEACH BALLS, VOLLEY BALLS, FOAM BALLS, RUBBER BALLS, STUFFED ANIMALS AND GAMES, NAMELY BOARD GAMES (U.S. CLS. 22, 23, 38 AND 50).

FIRST USE 9-0-2003; IN COMMERCE 9-0-2003.

3,234,097. ACL SERVICES LTD., VANCOUVER, BRITISH COLUMBIA, CANADA. SN 78-085,876. PUB. 8-30-2005, FILED 9-27-2001.



PRIORITY CLAIMED UNDER SEC. 44(D) ON CANADA APPLICATION NO. 1098422, FILED 4-3-2001, REG. NO. TMA585096, DATED 7-11-2003, EXPIRES 7-11-2018.

OWNER OF U.S. REG. NO. 1,516,233.

THE MARK CONSISTS OF A PARTIAL ELLIPSIS INTERSECTING THE LETTERS ACL.

#### **CLASS 9—ELECTRICAL AND SCIENTIFIC APPARATUS**

FOR COMPUTER SOFTWARE PROGRAMS, IN THE FIELDS OF AUDITING, ACCOUNTING AND DATA MANAGEMENT AND ANALYSIS, USED FOR ACCESSING, MANAGING, ANALYZING AND REPORTING COMPUTERIZED DATA; ELECTRONIC PUBLICATIONS RECORDED ON COMPUTER MEDIA, NAMELY, NEWSLETTERS, BOOKS, INSTRUCTION MANUALS, GUIDES AND WORKBOOKS, IN THE FIELDS OF AUDITING, ACCOUNTING AND DATA MANAGEMENT AND ANALYSIS; DOWNLOADABLE ELECTRONIC PUBLICATIONS, NAMELY NEWSLETTERS, BOOKS, INSTRUCTION MANUALS, GUIDES AND WORKBOOKS, IN THE FIELDS OF AUDITING, ACCOUNTING AND DATA MANAGEMENT AND ANALYSIS (U.S. CLS. 21, 23, 26, 36 AND 38).

FIRST USE 4-0-1997; IN COMMERCE 4-0-1997.

#### **CLASS 16—PAPER GOODS AND PRINTED MATTER**

FOR PRINTED PAPER PUBLICATIONS, NAMELY, NEWSLETTERS, BOOKS, INSTRUCTION MANUALS, GUIDES AND WORKBOOKS, IN THE FIELDS OF AUDITING, ACCOUNTING AND DATA MANAGEMENT AND ANALYSIS (U.S. CLS. 2, 5, 22, 23, 29, 37, 38 AND 50).

FIRST USE 4-0-1997; IN COMMERCE 4-0-1997.

#### **CLASS 38—COMMUNICATION**

FOR ELECTRONIC DELIVERY OF DOWNLOADABLE AND NONDOWNLOADABLE COMPUTER SOFTWARE PROGRAMS IN THE FIELDS OF AUDITING, ACCOUNTING AND DATABASE MANAGEMENT AND ANALYSIS, USED FOR ACCESSING, MANAGING, ANALYZING AND REPORTING COMPUTERIZED DATA IN THE FIELDS OF AUDITING, ACCOUNTING AND DATABASE MANAGEMENT (U.S. CLS. 100, 101 AND 104).

FIRST USE 4-0-1997; IN COMMERCE 4-0-1997.

#### **CLASS 41—EDUCATION AND ENTERTAINMENT**

FOR EDUCATIONAL AND TRAINING SERVICES IN PERSON, IN THE FIELDS OF AUDITING, ACCOUNTING AND DATA MANAGEMENT AND ANALYSIS, BY CONDUCTING SEMINARS AND CLASSES IN COMPUTER SOFTWARE PROGRAMS USED FOR ACCESSING, MANAGING, ANALYZING AND REPORTING COMPUTERIZED DATA (U.S. CLS. 100, 101 AND 107).

FIRST USE 4-0-1997; IN COMMERCE 4-0-1997.

#### **CLASS 42—SCIENTIFIC, COMPUTER AND LEGAL SERVICES**

FOR COMPUTER PROGRAMMING CONSULTATION SERVICES; COMPUTER SOFTWARE IMPLEMENTATION SERVICES; COMPUTER PROGRAMMING SERVICES FOR OTHERS; TROUBLESHOOTING OF COMPUTER HARDWARE AND SOFTWARE PROBLEMS (U.S. CLS. 100 AND 101).

FIRST USE 4-0-1997; IN COMMERCE 4-0-1997.

3,234,100. REEBOK INTERNATIONAL LIMITED, LANCASTER LA1 1GF, UNITED KINGDOM. SN 78-122,262. PUB. 8-19-2003, FILED 4-17-2002.

#### **RBK**

OWNER OF U.S. REG. NO. 2,384,091.

#### **CLASS 9—ELECTRICAL AND SCIENTIFIC APPARATUS**

FOR GOGGLES (U.S. CLS. 21, 23, 26, 36 AND 38).  
FIRST USE 7-25-2006; IN COMMERCE 7-25-2006.

#### **CLASS 18—LEATHER GOODS**

FOR LUGGAGE, ALL PURPOSE SPORTS BAGS, DUFFEL BAGS, TOTE BAGS (U.S. CLS. 1, 2, 3, 22 AND 41).  
FIRST USE 7-13-2006; IN COMMERCE 7-13-2006.

#### **CLASS 28—TOYS AND SPORTING GOODS**

FOR SPORTS EQUIPMENT, NAMELY, BASEBALLS, SOFTBALLS, VOLLEYBALLS, EXERCISE MACHINES, NAMELY, TREADMILLS; BASEBALL PROTECTIVE EQUIPMENT, NAMELY SHIN PADS; PROTECTIVE FOOTBALL EQUIPMENT, NAMELY, SHOULDER PADS, HIP AND THIGH PADS; BASEBALL BATTING GLOVES, BASEBALL AND SOFTBALL FIELDING MITTS, EXERCISE MATS, FITNESS AND RESISTANCE BANDS (U.S. CLS. 22, 23, 38 AND 50).

FIRST USE 3-2-2005; IN COMMERCE 3-2-2005.

#### **CLASS 35—ADVERTISING AND BUSINESS**

FOR RETAIL STORES AND RETAIL OUTLET STORES IN THE FIELD OF CLOTHING, SHOES, BAGS AND RELATED ACCESSORIES, SPORTS ACCESSORIES, AND AUDIO AND VIDEO TAPES (U.S. CLS. 100, 101 AND 102).

FIRST USE 10-5-2004; IN COMMERCE 10-5-2004.

#### **CLASS 36—INSURANCE AND FINANCIAL**

FOR FINANCIAL SPONSORSHIP OF SPORTS CAMPS AND ATHLETIC EVENTS (U.S. CLS. 100, 101 AND 102).  
FIRST USE 8-21-2006; IN COMMERCE 8-21-2006.

3,234,103. SONNIER, NATHANIEL GERARD, LADERA RANCH, CA. SN 78-122,620. PUB. 8-19-2003, FILED 4-18-2002.

#### **I. C. ANJULS**

THE NAME IN THE MARK DOES NOT IDENTIFY A LIVING INDIVIDUAL.

**CLASS 25—CLOTHING**

FOR CLOTHING, NAMELY, SHIRTS, CAPS, HATS (U.S. CLS. 22 AND 39).  
FIRST USE 11-10-2006; IN COMMERCE 11-10-2006.

**CLASS 35—ADVERTISING AND BUSINESS**

FOR COMPUTERIZED ON-LINE AND MAIL ORDER RETAIL SERVICES IN THE FIELD OF RELIGIOUS, SPIRITUAL, FANTASY AND OTHER ITEMS (U.S. CLS. 100, 101 AND 102).  
FIRST USE 11-10-2006; IN COMMERCE 11-10-2006.

3,234,107. TESA ENTRY SYSTEMS, S.L., GUIPUZCOA, SPAIN. SN 78-146,449. PUB. 9-27-2005, FILED 7-23-2002.



The logo for 'Unity' features the word 'Unity' in a bold, sans-serif font. The letter 'U' is stylized with a power symbol (a circle with a vertical line) integrated into its top curve.

**CLASS 6—METAL GOODS**

FOR SAFETY DEPOSIT BOXES; METAL SAFES; METAL CASH BOXES; METAL LOCKS AND BOLTS; METAL KEYS FOR LOCKS; METAL DOORS; NON-ELECTRICAL DEVICES TO OPEN DOORS OR FOR THE CONTROL OF ACCESS, NAMELY, KEY CYLINDERS, METAL LOCKING MECHANISMS, METAL LOCK SETS, METAL DOOR BOLTS, METAL LATCHES, METAL DOOR LATCHES, METAL CLASPS FOR USE AS DOOR SECURITY HARDWARE, METAL CLOSURES FOR DOORS, METAL DEAD BOLTS, METAL CHAIN DOOR GUARDS, METAL HANDLES FOR DOORS, NON-ELECTRIC METAL DOOR BELLS (U.S. CLS. 2, 12, 13, 14, 23, 25 AND 50).

FIRST USE 10-1-2002; IN COMMERCE 10-1-2002.

**CLASS 9—ELECTRICAL AND SCIENTIFIC APPARATUS**

FOR ELECTRICAL AND ELECTRONIC DEVICES FOR LOCKSMITHING, OPENING, AND CLOSING DOORS, NAMELY, ELECTRIC LOCKS; MAGNETIC CODED CARDS FOR IDENTIFICATION AND ACCESS; ELECTRONIC SAFES; ANTI-INTRUSION ALARMS; THEFT ALARMS; METAL DETECTORS; OPTICAL MAGNIFYING PEEPHOLES FOR DOORS; COMPUTER PROGRAMS TO CONTROL ACCESS TO DOORS AND LOCKS; FACILITIES MANAGEMENT SOFTWARE, NAMELY, SOFTWARE TO CONTROL BUILDING ENVIRONMENTAL, ACCESS AND SECURITY SYSTEMS; WARNING DEVICES, NAMELY, BELLS, ELECTRIC DOORBELLS; ENCODED INTEGRATED CIRCUIT CARDS CONTAINING PROGRAMMING USED FOR LOCKSMITHING AND CONTROL OF ACCESSES; THERMOSTATS; DECORATIVE DIALS FOR THERMOSTATS FOR NON-MEDICAL USE; WATER METERS; GAS METERS; ELECTRIC LIGHT SWITCHES AND DIMMERS; CLIMATE CONTROL SYSTEMS FOR HOTELS, OFFICES, SCHOOLS, RESIDENCES AND BOATS CONSISTING OF DIGITAL THERMOSTATS, AIR CONDITIONING, HEATING, VENTILATION AND DRYING CONTROL DEVICES (U.S. CLS. 21, 23, 26, 36 AND 38).

FIRST USE 10-1-2002; IN COMMERCE 10-1-2002.

**CLASS 37—CONSTRUCTION AND REPAIR**

FOR INSTALLATION, MAINTENANCE AND REPAIR OF FIRE ALARMS, BURGLAR ALARMS, SECURITY SYSTEMS, THEFT PREVENTION DEVICES, ELECTRICAL SYSTEMS, AIR CONDITIONING APPARATUS, HEATING APPARATUS AND COMPUTER SYSTEMS USED WITH FIRE ALARMS, BURGLAR ALARMS, SECURITY SYSTEMS, THEFT PREVENTION DEVICES, ELECTRICAL SYSTEMS, AIR CONDITIONING APPARATUS AND HEATING APPARATUS (U.S. CLS. 100, 103 AND 106).

FIRST USE 10-1-2002; IN COMMERCE 10-1-2002.

**CLASS 42—SCIENTIFIC, COMPUTER AND LEGAL SERVICES**

FOR INSTALLATION, MAINTENANCE AND REPAIR OF COMPUTER SOFTWARE THAT IS USED WITH FIRE ALARMS, BURGLAR ALARMS, SECURITY SYSTEMS, THEFT PREVENTION DEVICES, ELECTRICAL SYSTEMS, AIR CONDITIONING APPARATUS AND HEATING APPARATUS (U.S. CLS. 100 AND 101).

FIRST USE 10-1-2002; IN COMMERCE 10-1-2002.

3,234,108. MOTRAX MOTORCYCLE ACCESSORIES LIMITED, HIGHAM FERRERS, NORTHAMPTONSHIRE, UNITED KINGDOM. SN 78-150,463. PUB. 11-8-2005, FILED 8-2-2002.

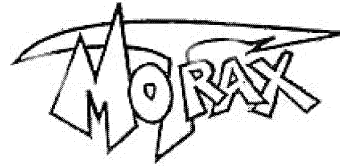

The logo for 'MOTRAX' is a stylized, blocky font with sharp, angular edges. The letters are interconnected, giving it a dynamic, mechanical appearance.

**CLASS 6—METAL GOODS**

FOR METAL GOODS, NAMELY, SECURITY LOCKS, PADLOCKS, CHAINS, KEYS, KEYRINGS, TOOLBOXES; METAL HARDWARE, NAMELY, SCREWS, BOLTS, NUTS, VALVE CAPS, AND PARTS AND FITTINGS FOR THE AFORESAID GOODS (U.S. CLS. 2, 12, 13, 14, 23, 25 AND 50).

FIRST USE 9-25-2006; IN COMMERCE 9-25-2006.

**CLASS 9—ELECTRICAL AND SCIENTIFIC APPARATUS**

FOR ELECTRIC LOCKS; CAMERA MOUNTS; DEFORMABLE EAR PLUGS FOR NON-MEDICAL USE FOR NOISE PROTECTION; PROTECTIVE CLOTHING; PROTECTIVE HEADWEAR IN THE NATURE OF HELMETS; PROTECTIVE SHOES AND BOOTS FOR MOTORCYCLISTS; WATERPROOF PROTECTIVE CLOTHING; AND LEATHER PROTECTIVE CLOTHING (U.S. CLS. 21, 23, 26, 36 AND 38).

FIRST USE 9-25-2006; IN COMMERCE 9-25-2006.

**CLASS 12—VEHICLES**

FOR MOTORCYCLE PARTS AND ACCESSORIES, NAMELY, HANDLE BARS, HANDLE BAR GRIPS, HANDLE BAR END CRASH PROTECTORS, SCREENS, SCREEN TRIMS, MIRRORS, TURN SIGNALS, TURN SIGNAL MOUNTS, FRAME PROTECTORS, FOOT PEGS, AIR PUMPS, TIRE PRESSURE GAUGES, TIRE WARMERS, LUGGAGE CARRIERS, TANK BAGS, PANNIERS, CARGO NETS, PASSENGER HANDLES, TANK PADS, TANK SHIELDS AND PROTECTORS, FUEL FITTERS, NUMBER PLATE BRACKETS, COVERS, STANDS, AND PARTS AND FITTINGS FOR THE AFORESAID GOODS (U.S. CLS. 19, 21, 23, 31, 35 AND 44).

FIRST USE 9-25-2006; IN COMMERCE 9-25-2006.

3,234,109. JRH BIOSCIENCES, INC., LENEXA, KS. SN 78-152,358. PUB. 2-17-2004, FILED 8-8-2002.

## imMEDIate ADVANTAGE

PRIORITY CLAIMED UNDER SEC. 44(D) ON AUSTRALIA APPLICATION NO. 915386, FILED 6-5-2002, REG. NO. 915386, DATED 6-5-2002, EXPIRES 6-5-2012.

### CLASS 1—CHEMICALS

FOR CHEMICAL AND BIOLOGICAL REAGENTS FOR DIAGNOSTIC, SCIENTIFIC AND RESEARCH USE; AND BIOCHEMICALS USED TO CREATE CELL CULTURES (U.S. CLS. 1, 5, 6, 10, 26 AND 46).  
FIRST USE 7-1-2001; IN COMMERCE 3-6-2002.

### CLASS 5—PHARMACEUTICALS

FOR CELL CULTURE MEDIA; AND CELL CULTURE MEDIA CONTAINED IN STERILE BAGS (U.S. CLS. 6, 18, 44, 46, 51 AND 52).  
FIRST USE 7-1-2001; IN COMMERCE 3-6-2002.

### CLASS 40—MATERIAL TREATMENT

FOR CUSTOM MANUFACTURE OF MEDIA AND REAGENTS (U.S. CLS. 100, 103 AND 106).  
FIRST USE 7-1-2001; IN COMMERCE 3-6-2002.

3,234,121. PPM ENERGY, INC., PORTLAND, OR. SN 78-198,976. PUB. 3-23-2004, FILED 12-31-2002.

## PPM ENERGY

NO CLAIM IS MADE TO THE EXCLUSIVE RIGHT TO USE "ENERGY", APART FROM THE MARK AS SHOWN.

### CLASS 35—ADVERTISING AND BUSINESS

FOR ENERGY AUDITING; MANAGING PRODUCTION OF ENERGY FOR OTHERS (U.S. CLS. 100, 101 AND 102).  
FIRST USE 1-15-2003; IN COMMERCE 1-15-2003.

### CLASS 36—INSURANCE AND FINANCIAL

FOR ELECTRICITY AND GAS COMMODITY TRADING FOR OTHERS, EXCLUDING INVESTMENT MANAGEMENT SERVICES (U.S. CLS. 100, 101 AND 102).  
FIRST USE 1-15-2003; IN COMMERCE 1-15-2003.

### CLASS 37—CONSTRUCTION AND REPAIR

FOR INSTALLATION OF ENERGY SYSTEMS (U.S. CLS. 100, 103 AND 106).  
FIRST USE 1-15-2003; IN COMMERCE 1-15-2003.

### CLASS 39—TRANSPORTATION AND STORAGE

FOR NATURAL GAS STORAGE SERVICES (U.S. CLS. 100 AND 105).  
FIRST USE 1-15-2003; IN COMMERCE 1-15-2003.

### CLASS 40—MATERIAL TREATMENT

FOR GENERATION OF ELECTRICITY (U.S. CLS. 100, 103 AND 106).  
FIRST USE 1-15-2003; IN COMMERCE 1-15-2003.

### CLASS 42—SCIENTIFIC, COMPUTER AND LEGAL SERVICES

FOR DESIGN AND ENGINEERING OF ENERGY PRODUCTION SYSTEMS; ENGINEERING SERVICES IN THE FIELD OF ENERGY; CONDUCTING FEASIBILITY STUDIES; PRODUCT RESEARCH AND DEVELOPMENT; RESEARCH IN THE ENERGY FIELD; DESIGN AND DEVELOPMENT FOR OTHERS OF ENERGY SERVICES PACKAGES (U.S. CLS. 100 AND 101).  
FIRST USE 1-15-2003; IN COMMERCE 1-15-2003.

3,234,131. COPERA, INC., MOUNTAIN VIEW, CA. SN 78-222,683. PUB. 2-21-2006, FILED 3-6-2003.

## COPERA

### CLASS 9—ELECTRICAL AND SCIENTIFIC APPARATUS

FOR COMPUTER SOFTWARE, NAMELY, VIDEO GAME SOFTWARE (U.S. CLS. 21, 23, 26, 36 AND 38).  
FIRST USE 11-0-2004; IN COMMERCE 11-0-2004.

### CLASS 42—SCIENTIFIC, COMPUTER AND LEGAL SERVICES

FOR COMPUTER SOFTWARE DEVELOPMENT SERVICES FOR OTHERS; COMPUTER SOFTWARE CONSULTATION SERVICES FOR OTHERS (U.S. CLS. 100 AND 101).  
FIRST USE 6-0-2003; IN COMMERCE 6-0-2003.

3,234,135. WINGS RESEARCH & DEVELOPMENT S.R.L., PIANORO (BO), ITALY. SN 78-241,552. PUB. 9-14-2004, FILED 4-24-2003.

## RIETVELD

OWNER OF ITALY REG. NO. 00655064, DATED 8-2-1995, RENEWED AS REG. NO. 0001006281, DATED 11-23-2006, EXPIRES 4-8-2015.

OWNER OF U.S. REG. NO. 2,000,357.  
SEC. 2(F).

### CLASS 18—LEATHER GOODS

FOR LEATHER GOODS, NAMELY, BACKPACKS, WALLETS, AND BAGS, NAMELY HANDBAGS, SPORTSBAGS, BEACHBAGS, AND TRAVELBAGS (U.S. CLS. 1, 2, 3, 22 AND 41).  
FIRST USE 4-0-1997; IN COMMERCE 4-0-1997.

### CLASS 25—CLOTHING

FOR MEN'S, WOMEN'S AND CHILDREN'S CLOTHING, NAMELY, TROUSERS, SHIRTS, T-SHIRTS, JACKETS, SKIRTS, OVERCOATS, RAINCOATS, BATHING SUITS, UNDERWEAR, SCARVES, HATS AND CAPS AND KNITWEAR, NAMELY, SWEATERS (U.S. CLS. 22 AND 39).  
FIRST USE 9-14-1995; IN COMMERCE 9-14-1995.

3,234,139. SOCIETE DES PRODUITS NESTLE S.A., 1800 VEVEY, SWITZERLAND. SN 78-250,795. PUB. 8-31-2004, FILED 5-16-2003.

## TOLL HOUSE

OWNER OF U.S. REG. NOS. 378,301, 2,324,631, AND OTHERS.

### CLASS 11—ENVIRONMENTAL CONTROL APPARATUS

FOR APPARATUS FOR COOKING, NAMELY, COMMERCIAL COOKING OVENS; ELECTRIC FOOD WARMING UNITS FOR BAKERY PRODUCTS FOR FROZEN OR PRE-BAKED COOKIES (U.S. CLS. 13, 21, 23, 31 AND 34).

FIRST USE 2-10-2001; IN COMMERCE 2-10-2001.

### CLASS 30—STAPLE FOODS

FOR COFFEE, COFFEE EXTRACTS AND COFFEE-BASED PREPARATIONS; TEA, TEA EXTRACTS AND TEA-BASED PREPARATIONS; COCOA AND PREPARATIONS HAVING A BASE OF COCOA; CHOCOLATE; SUGAR; NATURAL SWEETENERS; BAKERY PRODUCTS; PASTRY; BISCUITS; CAKES; BAKERY DESERTS; ICE CREAM; PRODUCTS FOR THE PREPARATION OF ICE CREAM, NAMELY, SALTED AND SWEETENED POWDERED OR LIQUID MIXES, FOOD FLAVORING AND SUGAR; HONEY AND (U.S. CL. 46).

FIRST USE 2-10-2001; IN COMMERCE 2-10-2001.

### CLASS 43—HOTEL AND RESTAURANT SERVICES

FOR RESTAURANT, HOTEL, CAFES, SNACK-BAR AND CANTEEN SERVICES; CATERING SERVICES (U.S. CLS. 100 AND 101).

FIRST USE 2-10-2001; IN COMMERCE 2-10-2001.

### CLASS 3—COSMETICS AND CLEANING PREPARATIONS

FOR LAUNDRY BLEACH AND LAUNDRY DETERGENT; FABRIC SOFTENERS, DISHWASHING DETERGENT; HAND SOAP; HAIR SHAMPOO, HAIR CONDITIONER; FLOOR AND CARPET CLEANING PREPARATIONS; FLOOR WAX; PERFUMERY; ESSENTIAL OILS FOR PERSONAL USE; EAU DE COLOGNE; SKIN LOTION; BEAUTY SERUMS; COSMETICS; NAIL POLISH; LIPSTICKS; EYELINERS; COSMETIC CREAMS; HAIR DYES; EYEBROW PENCILS; MASCARAS; MAKE-UP POWDER; COSMETIC PREPARATIONS FOR SKIN CARE; CLEANSING MILK FOR TOILET PURPOSES; NAIL POLISH REMOVERS AND CLEANSERS; AFTER-SHAVE LOTIONS; DEPILATORY PREPARATIONS; HENNA FOR COSMETIC PURPOSES; ANTIBACTERIAL SOAP, DISINFECTANT SOAP; MEDICATED SOAP; DENTIFRICES; DENTURE POLISHES; PREPARATIONS FOR CLEANING DENTURES; SUBSTANCES FOR REMOVING ADHESIVES; CHEMICAL CHIMNEY CLEANERS (U.S. CLS. 1, 4, 6, 50, 51 AND 52).

FIRST USE 9-0-2003; IN COMMERCE 2-0-2004.

### CLASS 9—ELECTRICAL AND SCIENTIFIC APPARATUS

FOR DATA PROCESSORS; COMPUTERS; BLANK MAGNETIC DATA CARRIERS, BLANK OPTICAL DISCS; CINEMATOGRAPHIC AND PHOTOGRAPHY CAMERAS, PARTS AND EQUIPMENTS THEREFORE; AEROMETERS; BATTERIES, BATTERY CASES; FIRE-EXTINGUISHING APPARATUS, RADAR APPARATUS (U.S. CLS. 21, 23, 26, 36 AND 38).

FIRST USE 9-0-2003; IN COMMERCE 2-0-2004.

3,234,153. SAINT-GOBAIN PERFORMANCE PLASTICS CORPORATION, AURORA, OH. SN 78-285,737. PUB. 8-30-2005, FILED 8-11-2003.

## TYGO-LINK

OWNER OF U.S. REG. NOS. 612,056, 1,505,905, AND 1,600,643.

### CLASS 10—MEDICAL APPARATUS

FOR PLASTIC FITTINGS, NAMELY, MOLDED SILICONE CONNECTION FOR USE WITH MEDICAL FLEXIBLE TUBING IN THE PHARMACEUTICAL AND MEDICAL INDUSTRIES (U.S. CLS. 26, 39 AND 44).

FIRST USE 4-16-2004; IN COMMERCE 4-16-2004.

### CLASS 20—FURNITURE AND ARTICLES NOT OTHERWISE CLASSIFIED

FOR PLASTIC FITTINGS, NAMELY, MOLDED SILICONE CONNECTION FOR USE WITH PHARMACEUTICAL FLEXIBLE TUBING IN THE PHARMACEUTICAL AND MEDICAL INDUSTRIES (U.S. CLS. 2, 13, 22, 25, 32 AND 50).

FIRST USE 4-16-2006; IN COMMERCE 4-16-2006.

3,234,144. INNCREA KIMYA MAKINA YAZILIM ELEKTRONIK SANAYI VE TICARET LIMITED SIRKETI, BESIKTAS-ISTANBUL, TURKEY. SN 78-261,860. PUB. 11-22-2005, FILED 6-12-2003.



NO CLAIM IS MADE TO THE EXCLUSIVE RIGHT TO USE "INNOVATION AND CREATION COMPANY", APART FROM THE MARK AS SHOWN.

3,234,154. PC FARM, NEWINGTON, CT. SN 78-285,967. PUB. 8-30-2005, FILED 8-11-2003.



### CLASS 9—ELECTRICAL AND SCIENTIFIC APPARATUS

FOR BIOS COMPUTER PROGRAM; BLANK COMPUTER DISCS; BLANK FLOPPY COMPUTER DISCS; BLANK HARD COMPUTER DISCS; BLANK MAGNETIC COMPUTER TAPES; BLANK TAPES FOR STORAGE OF COMPUTER DATA; COMPUTER HARDWARE, NAMELY, COMMUNICATIONS SERVERS; COMMUNICATIONS SOFTWARE FOR CONNECTING NETWORK SERVERS AND GLOBAL COMPUTER NETWORKS; COMPUTER ACCELERATOR BOARD; COMPUTER BUFFERS; COMPUTER CABLES; COMPUTER CAMERAS; COMPUTER CARD ADAPTER; COMPUTER CARRYING CASES; COMPUTER CHASSIS; COMPUTER CHIPS; COMPUTER CHIPSET FOR USE IN TRANSMITTING DATA TO AND FROM A CENTRAL PROCESSING UNIT; COMPUTER COLOR PRINTER USING HEAD SENSITIVE DRY PRINTING PROCESS; COMPUTER COMMUNICATIONS SOFTWARE TO ALLOW CUSTOMERS TO ACCESS BANK ACCOUNT INFORMATION AND TRANSACT BANK BUSINESS; COMPUTER COMPONENT TESTING AND CALIBRATING EQUIPMENT; COMPUTER CURSOR CONTROL DEVICES, NAMELY, COMPUTER MOUSE, DIGITIZER TABLETS, LIGHT PENS, TOUCH PADS, AND TRACKBALLS; COMPUTER DISC DRIVES; COMPUTER DOCKING STATION; COMPUTER EXPANSION BOARDS; COMPUTER E-COMMERCE SOFTWARE TO ALLOW USERS TO PERFORM ELECTRONIC BUSINESS TRANSACTIONS VIA A GLOBAL COMPUTER NETWORK; COMPUTER FAX MODEM CARDS; COMPUTER GAME CARTRIDGES; COMPUTER GAME CASSETTES; COMPUTER GAME DISCS; COMPUTER GAME EQUIPMENT CONTAINING MEMORY DEVICES, NAMELY, DISCS; COMPUTER GAME JOYSTICKS; COMPUTER GAME PROGRAMS; COMPUTER GAME SOFTWARE; COMPUTER GAME TAPES; COMPUTER GRAPHICS BOARDS; COMPUTER GRAPHICS SOFTWARE; COMPUTER HARDWARE; COMPUTER HEAT SINKS; COMPUTER INTERFACE BOARDS; COMPUTER JOYSTICKS; COMPUTER KEYBOARDS; COMPUTER MEMORIES; COMPUTER MEMORY HARDWARE; COMPUTER MONITOR FRAMES; COMPUTER MONITORS; COMPUTER MOUSE; COMPUTER MOUSE, NAMELY, TACK BALLS; COMPUTER MOUSE, NAMELY, TOUCH PADS; COMPUTER NETWORK ADAPTERS; COMPUTER NETWORK HUBS, SWITCHES AND ROUTERS; COMPUTER NETWORKING HARDWARE; COMPUTER OPERATING PROGRAMS; COMPUTER OPERATING SYSTEMS; COMPUTER PARALLEL PORTS; COMPUTER PERIPHERALS; COMPUTER PRINTERS; COMPUTER SCREEN FILTERS; COMPUTER SCREEN SAVER SOFTWARE; COMPUTER SEARCH ENGINE SOFTWARE; COMPUTER SERIAL PORTS; COMPUTER SOFTWARE FOR USE IN DATABASE MANAGEMENT, FOR USE AS A SPREADSHEET AND FOR WORD PROCESSING; COMPUTER SOFTWARE DEVELOPMENT TOOLS; COMPUTER SOFTWARE FOR ACCESSING INFORMATION DIRECTORIES THAT MAY BE DOWNLOADED FROM THE GLOBAL COMPUTER NETWORK; COMPUTER SOFTWARE FOR APPLICATION AND DATABASE INTEGRATION; COMPUTER SOFTWARE FOR CREATING SEARCHABLE DATABASES OF INFORMATION AND DATA; COMPUTER SOFTWARE FOR THE COLLECTION, EDITING, ORGANIZING, MODIFYING, BOOK MARKING, TRANSMISSION STORAGE AND SHARING OF DATA AND INFORMATION; COMPUTER SOFTWARE FOR COMMUNICATING WITH USERS OF HAND-HELD COMPUTERS; COMPUTER SOFTWARE THAT ASSISTS COMPUTERS IN DEPLOYING PARALLEL APPLICATIONS AND PERFORMING PARALLEL COMPUTATIONS; COMPUTER SOFTWARE TO AUTOMATE DATA WAREHOUSING; COMPUTER SOFTWARE

TO CONTROL AND IMPROVE COMPUTER AND AUDIO EQUIPMENT SOUND QUALITY; COMPUTER SOFTWARE TO ENHANCE THE AUDIO-VISUAL CAPABILITIES OF MULTIMEDIA APPLICATIONS, NAMELY, FOR THE INTEGRATION OF TEXT, AUDIO, GRAPHICS, STILL IMAGES AND MOVING PICTURES; COMPUTER STANDS SPECIALLY DESIGNED FOR HOLDING A COMPUTER, PRINTER AND ACCESSORIES; COMPUTER STYLUS, COMPUTER TELEPHONY SOFTWARE THAT ENABLES TELEPHONE ACTIVITIES TO BE PERFORMED THROUGH A COMPUTER; COMPUTER TERMINALS; COMPUTER UTILITY PROGRAMS THAT PERFORM MAINTENANCE WORK; COMPUTER WHITE BOARDS; FRAMES FOR ATTACHMENT TO COMPUTER MONITORS; GLOBAL POSITIONING SYSTEM, GPS, CONSISTING OF COMPUTERS, COMPUTER SOFTWARE, TRANSMITTERS, RECEIVERS AND NETWORK INTERFACE DEVICES; INTERACTIVE MULTIMEDIA COMPUTER GAME PROGRAM; INTERACTIVE VIDEO GAMES OF VIRTUAL REALITY COMPRISED OF COMPUTER HARDWARE AND SOFTWARE; JACKETS FOR COMPUTER DISCS; LAN ACCESS POINTS FOR CONNECTING NETWORK COMPUTER USERS; LAN COMPUTER CARDS FOR CONNECTING PORTABLE COMPUTER DEVICES TO COMPUTER NETWORKS; MEMORY CARDS; MICROCHIPS; MICROPROCESSORS; MOUNTING RACKS FOR COMPUTER HARDWARE; MOUSE PADS; WIRELESS COMPUTER PERIPHERALS; WRIST RESTS FOR COMPUTER MOUSE USERS; WRIST SUPPORTS FOR COMPUTER MOUSE USERS (U.S. CLS. 21, 23, 26, 36 AND 38).  
FIRST USE 6-15-2002; IN COMMERCE 6-15-2002.

### CLASS 37—CONSTRUCTION AND REPAIR

FOR UPGRADING OF COMPUTER HARDWARE; MAINTENANCE AND REPAIR OF COMPUTER NETWORKS; MAINTENANCE AND REPAIR OF COMPUTER HARDWARE; INSTALLATION OF COMPUTER NETWORKS; INSTALLATION OF COMPUTER SYSTEMS; COMPUTER AND TELEPHONE BATTERY RECHARGE SERVICES (U.S. CLS. 100, 103 AND 106).  
FIRST USE 6-15-2002; IN COMMERCE 6-15-2002.

3,234,157. BONDO CORPORATION, ATLANTA, GA. SN 78-293,010. PUB. 2-15-2005, FILED 8-27-2003.

## TRUCK GUARD

NO CLAIM IS MADE TO THE EXCLUSIVE RIGHT TO USE "GUARD", APART FROM THE MARK AS SHOWN.

### CLASS 2—PAINTS

FOR PROTECTIVE POLYMERIC COATINGS IN THE NATURE OF AUTOMOBILE FINISHING (U.S. CLS. 6, 11 AND 16).  
FIRST USE 12-1-2000; IN COMMERCE 12-1-2000.

### CLASS 40—MATERIAL TREATMENT

FOR APPLICATION OF PROTECTIVE POLYMERIC COATINGS (U.S. CLS. 100, 103 AND 106).  
FIRST USE 12-1-2000; IN COMMERCE 12-1-2000.

3,234,164. PRL USA HOLDINGS, INC., WILMINGTON, DE. SN 78-303,316. PUB. 8-24-2004, FILED 9-22-2003.

## RL GIRL TV

OWNER OF U.S. REG. NOS. 2,060,836, 2,312,818, AND 2,575,703.  
NO CLAIM IS MADE TO THE EXCLUSIVE RIGHT TO



USE "GIRL TV", APART FROM THE MARK AS SHOWN.

**CLASS 41—EDUCATION AND ENTERTAINMENT**

FOR ENTERTAINMENT, NAMELY, A CONTINUING FASHION AND LIFESTYLE SHOW BROADCAST OVER TELEVISION (U.S. CLS. 100, 101 AND 107).  
FIRST USE 2-1-2003; IN COMMERCE 2-1-2003.

**CLASS 44—MEDICAL, BEAUTY AND AGRICULTURAL SERVICES**

FOR PROVIDING INFORMATION IN THE FIELD OF LIFESTYLE, NAMELY, HEALTH AND BEAUTY VIA THE GLOBAL COMPUTER NETWORK (U.S. CLS. 100 AND 101).  
FIRST USE 2-1-2003; IN COMMERCE 2-1-2003.

**CLASS 45—PERSONAL SERVICES**

FOR PROVIDING INFORMATION ABOUT FASHION AND FRAGRANCE VIA THE GLOBAL COMPUTER NETWORK (U.S. CLS. 100 AND 101).  
FIRST USE 2-1-2003; IN COMMERCE 2-1-2003.

---

3,234,168. FLOWSERVE MANAGEMENT COMPANY, IRVING, TX. SN 78-306,935. PUB. 2-8-2005, FILED 9-29-2003.

**EXPERIENCE IN MOTION**

---

**CLASS 6—METAL GOODS**

FOR MANUALLY OPERATED INDUSTRIAL METAL VALVES; METAL PIPE AND FITTINGS THEREFOR (U.S. CLS. 2, 12, 13, 14, 23, 25 AND 50).  
FIRST USE 0-0-2004; IN COMMERCE 0-0-2004.

**CLASS 7—MACHINERY**

FOR CENTRIFUGAL PUMPS AND PARTS THEREFOR; STEAM TURBINES; MECHANICAL SEALS AND MECHANICAL SEAL ASSEMBLIES AND PARTS THEREFOR FOR USE WITH ROTATING MACHINERY; CYCLONE SEPARATORS; PNEUMATIC RACK AND PINION ACTUATORS, PNEUMATIC AND HYDRAULIC VALVE ACTUATORS AND POSITIONERS FOR MACHINES; ELECTRIC MOTORS FOR MACHINES; FILTERS FOR MACHINES USED IN THE CHEMICAL AND FLUID PROCESS INDUSTRIES, NAMELY, FILTERS FOR EXTERNAL FLUSHING SYSTEMS ASSOCIATED WITH MECHANICAL SEAL ASSEMBLIES (U.S. CLS. 13, 19, 21, 23, 31, 34 AND 35).  
FIRST USE 0-0-2004; IN COMMERCE 0-0-2004.

**CLASS 9—ELECTRICAL AND SCIENTIFIC APPARATUS**

FOR AUTOMATIC GATE CHECK AND GLOBE CONTROL AND ISOLATION VALVES AND PARTS THEREFOR; VALVE OPERATORS, ELECTRICAL VALVE ACTUATORS AND POSITIONERS AND ELECTRICAL PROPORTIONAL CONTROLLERS FOR VALVES FOR NON-AUTOMOTIVE APPLICATIONS; ELECTRO-PNEUMATIC POSITIONERS AND LIMIT SWITCHES FOR USE IN NON-VEHICULAR INDUSTRIAL EQUIPMENT; AND SOFTWARE USED IN THE DIAGNOSIS, MAINTENANCE AND REPAIR OF INDUSTRIAL EQUIPMENT INCLUDING PUMPS, VALVES, MECHANICAL SEALS AND RELATED EQUIPMENT (U.S. CLS. 21, 23, 26, 36 AND 38).  
FIRST USE 0-0-2004; IN COMMERCE 0-0-2004.

**CLASS 11—ENVIRONMENTAL CONTROL APPARATUS**

FOR HEAT EXCHANGERS AND AIR FIN COOLERS FOR COOLING THE COOLANT SUPPLIED TO A MECHANICAL SEAL ASSEMBLY (U.S. CLS. 13, 21, 23, 31 AND 34).  
FIRST USE 0-0-2004; IN COMMERCE 0-0-2004.

**CLASS 37—CONSTRUCTION AND REPAIR**

FOR INSTALLATION, MAINTENANCE AND REPAIR OF INDUSTRIAL EQUIPMENT, NAMELY, PUMPS, VALVES, MECHANICAL SEALS AND RELATED EQUIPMENT (U.S. CLS. 100, 103 AND 106).  
FIRST USE 0-0-2004; IN COMMERCE 0-0-2004.

**CLASS 42—SCIENTIFIC, COMPUTER AND LEGAL SERVICES**

FOR TECHNICAL CONSULTING AND ENGINEERING IN THE FIELD OF INDUSTRIAL EQUIPMENT, NAMELY, PUMPS, VALVES, MECHANICAL SEALS AND RELATED EQUIPMENT; SOFTWARE SERVICES, NAMELY, DESIGN, DEVELOPMENT AND IMPLEMENTATION OF SOFTWARE, MAINTENANCE OF SOFTWARE, UPDATING OF SOFTWARE AND SOFTWARE AUTHORIZING IN THE FIELDS OF DIAGNOSIS, MAINTENANCE AND REPAIR OF INDUSTRIAL EQUIPMENT INCLUDING PUMPS, VALVES, MECHANICAL SEALS AND RELATED EQUIPMENT, AND CONSULTATION SERVICES RELATED THERETO (U.S. CLS. 100 AND 101).  
FIRST USE 0-0-2004; IN COMMERCE 0-0-2004.

3,234,169. AMERICAN HEART ASSOCIATION, INC., DALLAS, TX. SN 78-309,051. PUB. 3-14-2006, FILED 10-3-2003.

**LEARN AND LIVE**

---

**CLASS 9—ELECTRICAL AND SCIENTIFIC APPARATUS**

FOR EDUCATIONAL COMPUTER SOFTWARE IN THE FIELD OF CARDIOVASCULAR HEALTH, FITNESS, NUTRITION, AND/OR PREVENTION OR REDUCTION OF CARDIOVASCULAR DISEASE AND STROKE (U.S. CLS. 21, 23, 26, 36 AND 38).  
FIRST USE 11-30-2004; IN COMMERCE 11-30-2004.

**CLASS 16—PAPER GOODS AND PRINTED MATTER**

FOR PRINTED PAMPHLETS, BROCHURES, MANUALS, BOOKS, COOKBOOKS, BOOKLETS, LEAFLETS, FLYERS, WALLET CARDS, POSTERS, INFORMATIONAL SHEETS AND NEWSLETTERS, RESEARCH MONOGRAPHS, JOURNAL REPRINTS, CHARTS, DIAGRAMS, POSTERS, ADHESIVE BACKED STICKERS, AND KITS COMPRISING ONE OR MORE OF THE FOREGOING MATERIALS, ALL RELATING TO THE PROMOTION OF CARDIOVASCULAR HEALTH, FITNESS AND NUTRITION, AND/OR THE PREVENTION OR REDUCTION OF CARDIOVASCULAR DISEASE AND STROKE (U.S. CLS. 2, 5, 22, 23, 29, 37, 38 AND 50).  
FIRST USE 11-30-2003; IN COMMERCE 11-30-2003.

**CLASS 35—ADVERTISING AND BUSINESS**

FOR ASSOCIATION SERVICES, NAMELY, PROMOTING CARDIOVASCULAR HEALTH, FITNESS AND NUTRITION AND/OR THE PREVENTION OR REDUCTION OF CARDIOVASCULAR DISEASE AND STROKE; PROMOTING PUBLIC AWARENESS OF THE NEED FOR COMMUNITY EDUCATION IN THE FIELD OF CARDIOVASCULAR HEALTH, FITNESS AND NUTRITION AND/OR PREVENTION OR REDUCTION OF CARDIOVASCULAR DISEASE AND STROKE; PROMOTING RESEARCH IN THE FIELD OF CARDIOVASCULAR HEALTH, FITNESS AND NUTRITION AND/OR PREVENTION OR REDUCTION OF CARDIOVASCULAR DISEASE AND STROKE; PRODUCING RADIO AND TELEVISION ADVERTISEMENTS RELATING TO CARDIOVASCULAR HEALTH, FITNESS AND NUTRITION, AND/OR PREVENTION OR REDUCTION OF CARDIOVASCULAR DISEASE AND STROKE (U.S. CLS. 100, 101 AND 102).

FIRST USE 11-30-2003; IN COMMERCE 11-30-2003.

**CLASS 36—INSURANCE AND FINANCIAL**

FOR CHARITABLE FUND RAISING SERVICES FOR PROMOTING RESEARCH, EDUCATION AND OTHER ACTIVITIES RELATING TO CARDIOVASCULAR HEALTH, FITNESS AND NUTRITION, AND/OR THE PREVENTION OR REDUCTION OF CARDIOVASCULAR DISEASE AND STROKE; CHARITABLE FUND RAISING SERVICES FOR MEMORIAL DONATIONS TO CARDIOVASCULAR CHARITY (U.S. CLS. 100, 101 AND 102).

FIRST USE 11-30-2003; IN COMMERCE 11-30-2003.

**CLASS 41—EDUCATION AND ENTERTAINMENT**

FOR EDUCATIONAL SERVICES, NAMELY, CONDUCTING SEMINARS, COURSES, CONFERENCES AND SCIENTIFIC SESSION MEETINGS, LECTURES AND WORKSHOPS RELATING TO CARDIOVASCULAR HEALTH, FITNESS AND NUTRITION, AND/OR PREVENTION OR REDUCTION OF CARDIOVASCULAR DISEASE AND STROKE (U.S. CLS. 100, 101 AND 107).

FIRST USE 11-30-2004; IN COMMERCE 11-30-2004.

3,234,174. PETERSON PACIFIC CORP., EUGENE, OR. SN 78-312,994. PUB. 6-7-2005, FILED 10-13-2003.

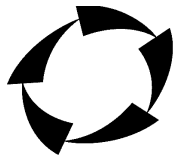

**Peterson**

**CLASS 7—MACHINERY**

FOR FORESTRY AND RECYCLING EQUIPMENT, NAMELY, WOOD CHIPPERS FOR CUTTING AND REDUCING WHOLE TREES INTO PULP CHIPS; RECYCLING EQUIPMENT, NAMELY, GRINDERS AND SHREDDERS FOR REDUCING ORGANIC MATTER INTO MULCH, FUEL AND OTHER SECONDARY PRODUCTS (U.S. CLS. 13, 19, 21, 23, 31, 34 AND 35).

FIRST USE 8-1-2003; IN COMMERCE 8-1-2003.

**CLASS 12—VEHICLES**

FOR BLOWER TRUCKS USED TO DELIVER AND APPLY ORGANIC MATERIALS, NAMELY MULCH, PLAYGROUND COVERS, ANIMAL BEDDING, COMPOST AND A WIDE VARIETY OF OTHER ORGANIC MATERIALS (U.S. CLS. 19, 21, 23, 31, 35 AND 44).

FIRST USE 8-1-2003; IN COMMERCE 8-1-2003.

3,234,175. AARON, LAWRENCE DAVID, LEDGEWOOD, NJ. SN 78-315,529. PUB. 6-14-2005, FILED 10-18-2003.

**COOKS & CRAFTS****CLASS 35—ADVERTISING AND BUSINESS**

FOR RETAIL STORE SERVICES INCLUDING ONLINE RETAIL STORE SERVICES IN THE FIELDS OF FOOD PREPARATION AND THE DECORATIVE ARTS (U.S. CLS. 100, 101 AND 102).

FIRST USE 2-12-2005; IN COMMERCE 2-12-2005.

**CLASS 41—EDUCATION AND ENTERTAINMENT**

FOR EDUCATIONAL SERVICES IN THE NATURE OF CLASSES THAT ARE STRUCTURED LIKE PARTIES THAT FOCUS ON TECHNIQUES AND SKILLS IN FOOD PREPARATION AND THE DECORATIVE ARTS (U.S. CLS. 100, 101 AND 107).

FIRST USE 2-12-2006; IN COMMERCE 2-12-2006.

3,234,176. TYPEFI SYSTEMS PTY LTD, QUEENSLAND, AUSTRALIA. SN 78-316,169. PUB. 6-21-2005, FILED 10-20-2003.

Typéfi

THE COLORS BLUE AND BLACK ARE CLAIMED AS A FEATURE OF THE MARK.

THE COLOR BLUE APPEARS IN THE LETTERS, "TYP", THE HYPHEN OVER THE LETTER "E" AND IN THE LEFT SIDE OF THE LETTER "E". THE COLOR BLACK APPEARS IN THE RIGHT SIDE OF THE LETTER "E" AND THE LETTERS "FI".

**CLASS 9—ELECTRICAL AND SCIENTIFIC APPARATUS**

FOR SOFTWARE FOR AUTOMATING THE LAYOUT OF TEXT AND GRAPHICS WITHIN A DOCUMENT (U.S. CLS. 21, 23, 26, 36 AND 38).

FIRST USE 1-1-2003; IN COMMERCE 1-1-2003.

**CLASS 40—MATERIAL TREATMENT**

FOR TYPESETTING, INCLUDING THE LAYOUT AND FORMATTING, OF TEXT AND GRAPHICS FOR DOCUMENT, BOOK, ELECTRONIC AND OTHER PUBLICATIONS; FULL SERVICE TYPESETTING, DISTRIBUTED TYPESETTING, WEB-BASED TYPESETTING; AND TYPESETTING SERVICES FOR USE BY BOOK AUTHORS AND OTHER CONTENT CREATORS (U.S. CLS. 100, 103 AND 106).

FIRST USE 1-1-2003; IN COMMERCE 1-1-2003.

3,234,184. GLOBAL-EZE INCORPORATED, ISLE OF PALMS, SC. SN 78-329,150. PUB. 9-6-2005, FILED 11-17-2003.



NO CLAIM IS MADE TO THE EXCLUSIVE RIGHT TO USE "INCORPORATED", APART FROM THE MARK AS SHOWN.

THE COLOR(S) GOLD, BLUE, TEAL, GREEN AND ORANGE IS/ARE CLAIMED AS A FEATURE OF THE MARK.

THE MARK CONSISTS OF THE NAME OF THE COMPANY AND WITH A BLUE GLOBE ON A GOLD BACKGROUND WITH TEAL AND BLUE LATITUDE AND GOLD AND ORANGE LONGITUDE LINES.

#### CLASS 35—ADVERTISING AND BUSINESS

FOR GLOBAL BUSINESS PRODUCTS AND SERVICES, NAMELY, COMPUTERIZED ON-LINE ORDERING SERVICES IN THE FIELD OF E-LEARNING BUSINESS RESEARCH, CORPORATE AND EMPLOYEE TRAINING MANUALS, E-BOOKS FEATURING STRATEGIC PLANNING FOR BUSINESS AND BUSINESS MARKETING, ADVERTISING E-TEMPLATES AND BUSINESS INFORMATION (U.S. CLS. 100, 101 AND 102).

FIRST USE 8-1-2003; IN COMMERCE 5-5-2006.

#### CLASS 41—EDUCATION AND ENTERTAINMENT

FOR GLOBAL BUSINESS SERVICES, NAMELY, EDUCATIONAL CORPORATE TRAINING AND WORKSHOPS IN THE NATURE OF INTERACTIVE E-LEARNING OVER A GLOBAL COMPUTER NETWORK IN THE FIELDS OF CULTURAL EDUCATION, REMOTE MANAGEMENT SKILLS, MANAGEMENT TACTICS, STRATEGIC PLANNING, CROSS-CULTURAL COMMUNICATIONS, MANNERS AND PROTOCOL (U.S. CLS. 100, 101 AND 107).

FIRST USE 8-1-2003; IN COMMERCE 5-5-2006.

3,234,191. APPLIED MINDS, INC., GLENDALE, CA. SN 78-333,659. PUB. 9-7-2004, FILED 11-26-2003.

MAXIMOG

THE MARK CONSISTS OF STANDARD CHARACTERS WITHOUT CLAIM TO ANY PARTICULAR FONT, STYLE, SIZE, OR COLOR.

#### CLASS 12—VEHICLES

FOR COMPUTERIZED ALL-TERRAIN VEHICLES (U.S. CLS. 19, 21, 23, 31, 35 AND 44).  
FIRST USE 11-14-2006; IN COMMERCE 11-14-2006.

#### CLASS 28—TOYS AND SPORTING GOODS

FOR CHILDREN'S TOYS, NAMELY VEHICLES AND ASSOCIATED ACCESSORIES (U.S. CLS. 22, 23, 38 AND 50).

FIRST USE 7-31-2006; IN COMMERCE 7-31-2006.

3,234,204. PREFIX CORPORATION, ROCHESTER HILLS, MI. SN 78-349,765. PUB. 8-23-2005, FILED 1-9-2004.

EXCELLENCE IS  
EXPECTED

THE MARK CONSISTS OF STANDARD CHARACTERS WITHOUT CLAIM TO ANY PARTICULAR FONT, STYLE, SIZE, OR COLOR.

#### CLASS 11—ENVIRONMENTAL CONTROL APPARATUS

FOR HEADLIGHTS, TAIL LIGHTS, TURN LIGHTS, NAMELY, LENSES, PARABOLAS, AND HOUSINGS FOR PARABOLAS AND/OR LENSES (U.S. CLS. 13, 21, 23, 31 AND 34).

FIRST USE 9-30-2004; IN COMMERCE 10-14-2004.

#### CLASS 12—VEHICLES

FOR AUTOMOBILES, NAMELY, CONCEPT VEHICLES, SHOW VEHICLES, PROTOTYPE VEHICLES; AND PROGRAMMABLE VEHICLE MODELS AND PARTS THEREFORE, NAMELY, EXTERIOR BODIES, WHEELS, GRILLES, SEATS, STEERING WHEELS, INSTRUMENT PANELS, CONSOLES, VEHICLE HEIGHT ADJUSTMENT SYSTEMS, NAMELY, AIR CYLINDERS AND JACK SCREWS, INTERIOR TRIM, AND ELECTRONIC PACKAGING FOR VEHICLE COMPUTERS, NAMELY, CASES (U.S. CLS. 19, 21, 23, 31, 35 AND 44).

FIRST USE 12-12-2003; IN COMMERCE 12-12-2003.

#### CLASS 28—TOYS AND SPORTING GOODS

FOR SCALED VEHICLE MODELS (U.S. CLS. 22, 23, 38 AND 50).

FIRST USE 11-17-2003; IN COMMERCE 11-8-2006.

#### CLASS 37—CONSTRUCTION AND REPAIR

FOR CUSTOM PAINTING OF VEHICLES (U.S. CLS. 100, 103 AND 106).

FIRST USE 10-18-2004; IN COMMERCE 8-22-2006.

**CLASS 42—SCIENTIFIC, COMPUTER AND LEGAL SERVICES**

FOR CREATING, DEVELOPING, AND ENGINEERING PRODUCTS AND PRODUCT DESIGNS FOR OTHERS, NAMELY, CUSTOM DESIGNS AND ENGINEERING OF MOTOR VEHICLE INTERIORS AND EXTERIORS, DESIGN AND DEVELOPMENT OF INTERIOR AND EXTERIOR CONCEPTS FOR MOTOR VEHICLES, DESIGN AND ENGINEERING OF AUTOMOBILE PARTS; CONSULTING SERVICES IN THE FIELD OF AUTOMOBILE DESIGN; DESIGN AND TESTING FOR NEW PRODUCT DEVELOPMENT FOR AUTOMOBILES; DESIGN AND TESTING OF NEW AUTOMOBILE PRODUCTS; INTERIOR PACKAGING OF VEHICLE COMPONENTS TAKING INTO ACCOUNT HUMAN GEOMETRY, AND MODEL SCANNING SERVICES, NAMELY, SCANNING VEHICLE MODELS, VEHICLES, VEHICLE PARTS, ASSEMBLIES, AND SUB ASSEMBLIES TO GENERATE DIMENSIONAL DATA, AND PRODUCT DESIGN DATA FOR SPECIALIZED ERGONOMIC REQUIREMENTS AND APPLICATIONS (U.S. CLS. 100 AND 101).

FIRST USE 1-27-2005; IN COMMERCE 1-27-2005.

3,234,226. USA FINANCIAL MARKETING CORPORATION, ADA, MI. SN 78-377,564. PUB. 9-13-2005, FILED 3-3-2004.

# Plug-N-Run

3,234,219. ERIDON CORPORATION, SHOREWOOD, MN. SN 78-365,159. PUB. 9-13-2005, FILED 2-9-2004.

# Eridon

THE MARK CONSISTS OF STANDARD CHARACTERS WITHOUT CLAIM TO ANY PARTICULAR FONT, STYLE, SIZE, OR COLOR.

**CLASS 9—ELECTRICAL AND SCIENTIFIC APPARATUS**

FOR INTEGRATED CIRCUITS, NAMELY, PRE-DESIGNED CIRCUIT BOARDS THAT PLUG TOGETHER; COMPUTER HARDWARE AND SOFTWARE DEVELOPMENT TOOLS COMPRISED OF COMPUTER AIDED DESIGN SOFTWARE THAT INTEGRATES CUSTOM AND PRE-DESIGNED HARDWARE CIRCUITS, SOFTWARE, AND FIRMWARE FOR USE IN DESIGNING OTHER COMPUTERS (U.S. CLS. 21, 23, 26, 36 AND 38).

FIRST USE 4-1-2006; IN COMMERCE 4-1-2006.

**CLASS 42—SCIENTIFIC, COMPUTER AND LEGAL SERVICES**

FOR COMPUTER HARDWARE, SOFTWARE, AND FIRMWARE DEVELOPMENT AND DESIGN; INTEGRATION OF COMPUTER CIRCUITS, SOFTWARE, AND FIRMWARE (U.S. CLS. 100 AND 101).

FIRST USE 4-1-2006; IN COMMERCE 4-1-2006.

THE MARK CONSISTS OF STANDARD CHARACTERS WITHOUT CLAIM TO ANY PARTICULAR FONT, STYLE, SIZE, OR COLOR.

**CLASS 16—PAPER GOODS AND PRINTED MATTER**

FOR PRINTED INSTRUCTIONAL, EDUCATIONAL, AND TEACHING MATERIALS RELATED TO FINANCIAL PLANNING, NAMELY, MANUALS, MARKET REPORTS, BINDER BOOKS, AND NOTEBOOKS ON PROFESSIONAL STRATEGIES AND TACTICS IN THE FIELD OF FINANCIAL ADVISOR PRACTICE MANAGEMENT (U.S. CLS. 2, 5, 22, 23, 29, 37, 38 AND 50).

FIRST USE 4-0-2004; IN COMMERCE 4-0-2004.

**CLASS 35—ADVERTISING AND BUSINESS**

FOR CONSULTING SERVICES FOR PROFESSIONALS, NAMELY, BUSINESS MANAGEMENT CONSULTING SERVICES FOR FINANCIAL ADVISORS AND FINANCIAL PLANNERS; CONSULTING SERVICES FOR PROFESSIONALS, NAMELY, BUSINESS MARKETING CONSULTING SERVICES FOR FINANCIAL ADVISORS AND FINANCIAL PLANNERS (U.S. CLS. 100, 101 AND 102).

FIRST USE 4-0-2004; IN COMMERCE 4-0-2004.

**CLASS 36—INSURANCE AND FINANCIAL**

FOR FINANCIAL STRATEGY SERVICES FOR FINANCIAL PROFESSIONALS, NAMELY, FINANCIAL ANALYSIS AND CONSULTATION IN THE FIELD OF RETIREMENT PLANNING AND ESTATE PLANNING (U.S. CLS. 100, 101 AND 102).

FIRST USE 4-0-2004; IN COMMERCE 4-0-2004.

**CLASS 41—EDUCATION AND ENTERTAINMENT**

FOR EDUCATIONAL PROGRAMS AND SEMINARS FOR FINANCIAL PROFESSIONALS, NAMELY, SEMINARS FEATURING PROFESSIONAL FINANCIAL INVESTMENT PLANNING STRATEGIES, TECHNIQUES, AND TACTICS FOR USE BY FINANCIAL ADVISORS AND FINANCIAL PLANNERS; PERSONAL COACHING SERVICES FOR FINANCIAL PROFESSIONALS IN THE FIELD OF RETIREMENT PLANNING AND ESTATE PLANNING; PERSONAL COACHING SERVICES FOR FINANCIAL PROFESSIONALS IN THE FIELD OF FINANCIAL INVESTMENT PLANNING STRATEGIES, TECHNIQUES, AND TACTICS (U.S. CLS. 100, 101 AND 107).

FIRST USE 4-0-2004; IN COMMERCE 4-0-2004.

3,234,228. ADVANCED HAIR STUDIOS (EUROPE) LTD, DUBLIN 2, IRELAND. SN 78-377,899. PUB. 3-21-2006, FILED 3-3-2004.



NO CLAIM IS MADE TO THE EXCLUSIVE RIGHT TO USE "LASER THERAPY", APART FROM THE MARK AS SHOWN.

THE MARK CONSISTS OF ADVANCED LASER THERAPY (AND DESIGN).

#### CLASS 16—PAPER GOODS AND PRINTED MATTER

FOR PRINTED MATERIAL, NAMELY, BROCHURES, MANUALS, PUBLICATIONS, NEWSLETTERS, PROMOTIONAL PRINTED VISUALS, PRINTED INSTRUCTIONAL AND TEACHING MATERIALS, ALL RELATING TO HAIR LOTIONS, HAIR AND SCALP REVITALISERS, HAIR THICKENING SERUMS, HAIR REPLACEMENT SERVICES AND PHARMACEUTICAL PREPARATIONS, LASERS FOR THERAPEUTIC PURPOSES, HAIR PIECES, WIGS, FALSE HAIR, HAIR FASTENERS, HAIR NETS, HAIRDRESSING AND STYLING SERVICES, HAIR REPLACEMENT SERVICES AND SERVICES IN CONNECTION WITH FIXING HAIR PIECES TO THE HEADS OF HUMAN BEINGS (U.S. CLS. 2, 5, 22, 23, 29, 37, 38 AND 50).

FIRST USE 0-0-1996; IN COMMERCE 0-0-1996.

#### CLASS 44—MEDICAL, BEAUTY AND AGRICULTURAL SERVICES

FOR HAIRDRESSING AND HAIR STYLING SERVICES, HAIR REPLACEMENT SERVICES AND SERVICES IN CONNECTION WITH FIXING HAIR PIECES TO THE HEADS OF HUMAN BEINGS (U.S. CLS. 100 AND 101).

FIRST USE 0-0-1996; IN COMMERCE 0-0-1996.

3,234,229. ABBOTT, PAUL J., YORK, PA. SN 78-377,992. PUB. 8-9-2005, FILED 3-3-2004.

Oentry

THE MARK CONSISTS OF STANDARD CHARACTERS WITHOUT CLAIM TO ANY PARTICULAR FONT, STYLE, SIZE, OR COLOR.

#### CLASS 6—METAL GOODS

FOR METAL HARDWARE ITEMS NAMELY PADLOCKS, METAL LOCKS, METAL HANDLES FOR DOORS, METAL HINGES, METAL BOLTS, METAL KEYS FOR LOCKS, METAL LOCKING MECHANISMS, METAL LOCKS AND KEYS THEREFORE, METAL KEY BLANKS, NON-ELECTRIC CABLES; DOOR HARDWARE NAMELY METAL LOCK SETS, METAL PULLS FOR DOORS, METAL KNOBS, METAL KNOCKERS, METAL LATCH BARS, METAL LATCHES, METAL DOOR KNOCKERS, METAL DOOR KICK PLATES, METAL HOUSE NUMBERS, METAL DOOR BOLTS, METAL BARS AND CHAINS, NON-MAGNIFIED METAL DOOR VIEWERS, METAL HINGES, METAL DEAD BOLTS, METAL KEYS AND KEY CYLINDERS, METAL MAIL SLOTS, METAL NAMEPLATES AND DOOR NAMEPLATES; SECURING HARDWARE NAMELY METAL CHAIN DOOR GUARDS, METAL CATCHES FOR WINDOWS, METAL CATCHES FOR PATIO DOORS, METAL CATCHES FOR CABINET DOORS, METAL BOLTS; HOME SAFETY AND SECURITY HARDWARE NAMELY METAL GUARD RAILS, METAL GATES, GATE STOPS, METAL RAILS, METAL BATHTUB RAILS, METAL BATHTUB GRAB BARS (U.S. CLS. 2, 12, 13, 14, 23, 25 AND 50).

FIRST USE 12-6-2005; IN COMMERCE 12-6-2005.

#### CLASS 9—ELECTRICAL AND SCIENTIFIC APPARATUS

FOR ELECTRONIC ENTRY SECURITY SYSTEMS AND HARDWARE NAMELY INTRUSION AND BURGLAR ALARMS, BLANK INTEGRATED CIRCUIT CARDS, BLANK SMART CARDS, CARD READING EQUIPMENT, ENCODERS, ELECTRIC DOOR OPENERS, ELECTRIC LOCKS, ELECTRICAL AND ELECTRONIC BURGLAR ALARMS, ELECTRONIC DOOR CLOSING SYSTEMS, ELECTRONIC DOOR OPENERS, ELECTRONIC LOCKS, SIRENS, GLASS BREAKAGE SENSORS, DOOR SENSORS, MOTION SENSITIVE SECURITY LIGHTS, MOTION SENSORS, SECURITY PANELS IN THE NATURE OF ELECTRONIC INDICATOR PANELS AND ELECTRIC CONTROL PANELS, AUTOMATED SECURITY GATES, ELECTRIC GATE OPERATORS, ACCESS CONTROL AND ALARM MONITORING SYSTEMS; COMPUTERIZED SOFTWARE SYSTEMS USED IN MANAGEMENT OF SECURE ENTRY, NAMELY COMPUTER SOFTWARE TO CONTROL BUILDING ACCESS AND SECURITY SYSTEMS (U.S. CLS. 21, 23, 26, 36 AND 38).

FIRST USE 12-5-2005; IN COMMERCE 12-5-2005.

3,234,234. AVERY DENNISON CORPORATION, PASADENA, CA. SN 78-379,706. PUB. 3-21-2006, FILED 3-5-2004.

AVERY DENNISON

THE MARK CONSISTS OF STANDARD CHARACTERS WITHOUT CLAIM TO ANY PARTICULAR FONT, STYLE, SIZE, OR COLOR.

OWNER OF U.S. REG. NOS. 758,062 AND 758,123.

THE NAME(S), PORTRAIT(S), AND/OR SIGNATURE(S) SHOWN IN THE MARK DOES NOT IDENTIFY A PARTICULAR LIVING INDIVIDUAL.

**CLASS 16—PAPER GOODS AND PRINTED MATTER**

FOR PLASTIC AND POLYMERIC DIGITAL IMAGING FILMS FOR COMMERCIAL AND INDUSTRIAL PRINTING USES (U.S. CLS. 2, 5, 22, 23, 29, 37, 38 AND 50).  
FIRST USE 6-0-2001; IN COMMERCE 6-0-2001.

**CLASS 17—RUBBER GOODS**

FOR REFLECTIVE TAPES FOR COMMERCIAL, TRANSPORTATION, GRAPHIC AND INDUSTRIAL USES; REFLECTIVE PLASTIC FILMS FOR COMMERCIAL, TRANSPORTATION, GRAPHIC AND INDUSTRIAL USES; GLASS BEADED AND PRISMATIC RETROREFLECTIVE PLASTIC FILM FOR COMMERCIAL, TRANSPORTATION, GRAPHIC AND INDUSTRIAL USES; GLASS BEADED AND PRISMATIC RETROREFLECTIVE PLASTIC TAPE FOR COMMERCIAL, TRANSPORTATION, GRAPHIC AND INDUSTRIAL USES (U.S. CLS. 1, 5, 12, 13, 35 AND 50).  
FIRST USE 3-0-2001; IN COMMERCE 3-0-2001.

**CLASS 20—FURNITURE AND ARTICLES NOT OTHERWISE CLASSIFIED**

FOR PLASTIC LABELS (U.S. CLS. 2, 13, 22, 25, 32 AND 50).  
FIRST USE 9-0-2000; IN COMMERCE 9-0-2000.

---

3,234,236. CONAIR CORPORATION, STAMFORD, CT. SN 78-380,312. PUB. 3-8-2005, FILED 3-8-2004.

# CONAIR

THE MARK CONSISTS OF STANDARD CHARACTERS WITHOUT CLAIM TO ANY PARTICULAR FONT, STYLE, SIZE, OR COLOR.

OWNER OF U.S. REG. NOS. 994,007, 2,248,614, AND 2,877,642.

**CLASS 7—MACHINERY**

FOR MULTI-PURPOSE STEAM CLEANING MACHINES FOR DOMESTIC USE (U.S. CLS. 13, 19, 21, 23, 31, 34 AND 35).  
FIRST USE 3-1-2004; IN COMMERCE 3-1-2004.

**CLASS 9—ELECTRICAL AND SCIENTIFIC APPARATUS**

FOR ELECTRICALLY HEATED IRONS, NAMELY DRY AND STEAM IRONS AND CLOTHES STEAMERS FOR DOMESTIC USE (U.S. CLS. 21, 23, 26, 36 AND 38).  
FIRST USE 3-1-2004; IN COMMERCE 3-1-2004.

3,234,255. MARTIN, CRAIG, TORRANCE, CA. SN 78-385,810. PUB. 9-13-2005, FILED 3-17-2004.

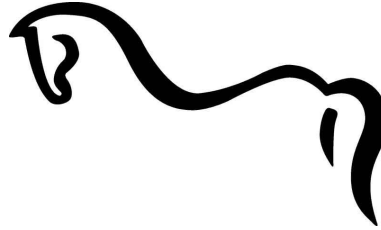
**CLASS 9—ELECTRICAL AND SCIENTIFIC APPARATUS**

FOR PRE-RECORDED VIDEO TAPES AND DVDS FEATURING EQUESTRIAN SUBJECT MATTER (U.S. CLS. 21, 23, 26, 36 AND 38).  
FIRST USE 1-1-2003; IN COMMERCE 1-1-2003.

**CLASS 25—CLOTHING**

FOR CLOTHING, NAMELY, CAPS, COATS, GOLF SHIRTS, BREECHES, RAINCOATS, OVER COATS, HATS, HEAD WEAR, HEAD BANDS, JACKETS, WIND RESISTANT JACKETS, LEATHER JACKETS, NECKTIES, POLO SHIRTS, RAIN SUITS, RAINWEAR, SHIRTS, SWEATSHIRTS, SPORT SHIRTS, SWEATERS, AND TURTLENECKS (U.S. CLS. 22 AND 39).  
FIRST USE 1-1-2003; IN COMMERCE 1-1-2003.

---

3,234,268. UNITEDHEALTH GROUP INCORPORATED, GOLDEN VALLEY, MN. SN 78-398,880. PUB. 1-24-2006, FILED 4-8-2004.

# MYRENEWELL

THE MARK CONSISTS OF STANDARD CHARACTERS WITHOUT CLAIM TO ANY PARTICULAR FONT, STYLE, SIZE, OR COLOR.

**CLASS 35—ADVERTISING AND BUSINESS**

FOR PROVIDING A WEB SITE FEATURING CONSUMER DISCOUNTS ON THE GOODS AND SERVICES OF OTHERS (U.S. CLS. 100, 101 AND 102).  
FIRST USE 9-0-2004; IN COMMERCE 9-0-2004.

**CLASS 38—COMMUNICATION**

FOR PROVIDING CHAT ROOMS USED BY INDIVIDUALS TO IDENTIFY AREAS FOR IMPROVING THEIR HEALTH AND TO ASSIST INDIVIDUALS IN MAINTAINING HEALTHY LIFESTYLE CHOICES (U.S. CLS. 100, 101 AND 104).  
FIRST USE 9-0-2004; IN COMMERCE 9-0-2004.

**CLASS 41—EDUCATION AND ENTERTAINMENT**

FOR PROVIDING ONLINE PUBLICATIONS IN THE FIELD OF HEALTHCARE, NAMELY, ARTICLES AND JOURNALS (U.S. CLS. 100, 101 AND 107).

FIRST USE 9-0-2004; IN COMMERCE 9-0-2004.

**CLASS 42—SCIENTIFIC, COMPUTER AND LEGAL SERVICES**

FOR PROVIDING TEMPORARY USE OF ONLINE NON-DOWNLOADABLE SOFTWARE FEATURING HEALTH RISK APPRAISALS, QUIZZES, SELF-ASSESSMENTS, CALCULATORS, AND GOAL TRACKING IN THE FIELD OF HEALTHCARE (U.S. CLS. 100 AND 101).

FIRST USE 9-0-2004; IN COMMERCE 9-0-2004.

**CLASS 44—MEDICAL, BEAUTY AND AGRICULTURAL SERVICES**

FOR PROVIDING INFORMATION IN THE FIELDS OF HEALTH AND WELLNESS; PROVIDING INFORMATION IN THE FIELDS OF HEALTH AND WELLNESS VIA THE INTERNET (U.S. CLS. 100 AND 101).

FIRST USE 9-0-2004; IN COMMERCE 9-0-2004.

3,234,282. FEDERAL EXPRESS CORPORATION, MEMPHIS, TN. AND KINKO'S VENTURES, INC., DALLAS, TX. SN 78-407,258. PUB. 2-1-2005, FILED 4-23-2004.



3,234,273. LYNNE ELLEN, INC., CHARLESTON, SC. SN 78-403,497. PUB. 11-15-2005, FILED 4-16-2004.

NO CLAIM IS MADE TO THE EXCLUSIVE RIGHT TO USE OFFICE AND PRINT CENTER, APART FROM THE MARK AS SHOWN.

THE MARK CONSISTS OF THE WORDS FEDEX KINKO'S OFFICE AND PRINT CENTER WITH A STAR WITH CENTER TRIANGLE.

**ME TOO, MOMMY**

THE MARK CONSISTS OF STANDARD CHARACTERS WITHOUT CLAIM TO ANY PARTICULAR FONT, STYLE, SIZE, OR COLOR.

**CLASS 16—PAPER GOODS AND PRINTED MATTER**

FOR CHILDREN'S AND BABY'S BOOKS, INCLUDING CALENDARS, KEEPSAKES, AND PHOTO ALBUMS (U.S. CLS. 2, 5, 22, 23, 29, 37, 38 AND 50).

FIRST USE 9-14-2004; IN COMMERCE 9-14-2004.

**CLASS 25—CLOTHING**

FOR INFANT AND TODDLER CLOTHING, NAMELY, INFANT BODY SUITS (U.S. CLS. 22 AND 39).

FIRST USE 2-9-2006; IN COMMERCE 2-9-2006.

**CLASS 28—TOYS AND SPORTING GOODS**

FOR CHILDREN'S AND BABY'S TOYS, STUFFED TOYS (U.S. CLS. 22, 23, 38 AND 50).

FIRST USE 9-14-2004; IN COMMERCE 9-14-2004.

**CLASS 9—ELECTRICAL AND SCIENTIFIC APPARATUS**

FOR COMPUTER WORKSTATIONS, COMPRISING MONITORS, NAMELY MONITORS WITH AND WITHOUT TOUCH SCREEN CAPABILITIES, SCANNERS, CENTRAL PROCESSING UNITS, HARD DRIVES, PRINT DRIVES, ZIP DRIVES, CD READ/WRITE BURNERS, DIGITAL CAMERA MEDIA READERS, AND COMPUTER DESKTOP SOFTWARE PROGRAMS FOR USE IN CREATING, ALTERING/MANIPULATING, PRINTING AND DISTRIBUTING DOCUMENTS (U.S. CLS. 21, 23, 26, 36 AND 38).

FIRST USE 4-26-2004; IN COMMERCE 4-26-2004.

**CLASS 16—PAPER GOODS AND PRINTED MATTER**

FOR PAPER, NAMELY WRITING, TYPING, PRINTING, DRAWING, PHOTOCOPYING, BOND, LASER, LETTERHEAD AND COLOR PAPER; PHOTOGRAPHS; STATIONERY; ENVELOPES; BUSINESS CARDS; POSTCARDS; CALENDARS; ANNOUNCEMENT CARDS; INVITATIONS; WRITING AND DRAFTING INSTRUMENTS, NAMELY PENS, PENCILS, MARKERS AND HIGHLIGHTING MARKERS; OFFICE REQUISITES, NAMELY BINDER CLIPS, BOOKMARKS, BUBBLE MAILERS, CORRECTION FLUID, GLUE STICKS, NOTEPADS, ORDER PADS, PLASTIC BAGS, PAPER CLIPS, SELF-ADHESIVE PADS, RUBBER BANDS, DRAWING RULERS AND ADHESIVE TAPE FOR HOUSEHOLD AND OFFICE USE; PRINTERS TYPE AND PRINTING BLOCKS; AND PHOTOGRAPHIC REPRODUCTION, BROCHURES RELATING TO RESUME DRAFTING, JOB INTERVIEWING AND DEVELOPING BUSINESS SKILLS; PHOTOGRAPHIC SUPPLIES, NAMELY PHOTO ALBUMS, PHOTOGRAPH MOUNTS AND PLASTIC PAGES FOR PHOTOGRAPH ALBUMS (U.S. CLS. 2, 5, 22, 23, 29, 37, 38 AND 50).

FIRST USE 4-26-2004; IN COMMERCE 4-26-2004.

3,234,305. BUCKHIESTER MANAGEMENT LIMITED, VANCOUVER, BRITISH COLUMBIA, CANADA. SN 78-418,562. PUB. 9-6-2005, FILED 5-13-2004.

# REVroadmap

## CLASS 9—ELECTRICAL AND SCIENTIFIC APPARATUS

FOR ELECTRONIC PUBLICATIONS, NAMELY TRAINING AND INSTRUCTION MANUALS AND GUIDES, PAMPHLETS, FORMS, WORKSHEETS AND BOOKS IN THE FIELD OF MANAGEMENT IN THE HOSPITALITY INDUSTRY, RECORDED ON COMPUTER MEDIA (U.S. CLS. 21, 23, 26, 36 AND 38).  
FIRST USE 8-14-2006; IN COMMERCE 8-14-2006.

## CLASS 16—PAPER GOODS AND PRINTED MATTER

FOR PRINTED PUBLICATIONS, NAMELY TRAINING AND INSTRUCTION MANUALS AND GUIDES, PAMPHLETS, FORMS, WORKSHEETS, BROCHURES AND BOOKS IN THE FIELD OF MANAGEMENT IN THE HOSPITALITY INDUSTRY (U.S. CLS. 2, 5, 22, 23, 29, 37, 38 AND 50).  
FIRST USE 8-14-2006; IN COMMERCE 8-14-2006.

## CLASS 35—ADVERTISING AND BUSINESS

FOR BUSINESS MANAGEMENT CONSULTING SERVICES RELATING TO THE HOSPITALITY INDUSTRY (U.S. CLS. 100, 101 AND 102).  
FIRST USE 8-14-2006; IN COMMERCE 8-14-2006.

## CLASS 41—EDUCATION AND ENTERTAINMENT

FOR EDUCATION COURSES AND TRAINING IN THE FIELD OF MANAGEMENT IN THE HOSPITALITY INDUSTRY (U.S. CLS. 100, 101 AND 107).  
FIRST USE 8-14-2006; IN COMMERCE 8-14-2006.

3,234,314. PLANTE, JOSEPH M., AMESBURY, MA. AND PLANTE, CHRISTOPHER L., AMESBURY, MA. AND DROUIN, DAVID, AMESBURY, MA. AND KANE, KELLY, AMESBURY, MA. SN 78-425,493. PUB. 2-28-2006, FILED 5-26-2004.

# The Brew

THE MARK CONSISTS OF STANDARD CHARACTERS WITHOUT CLAIM TO ANY PARTICULAR FONT, STYLE, SIZE, OR COLOR.

## CLASS 9—ELECTRICAL AND SCIENTIFIC APPARATUS

FOR MUSICAL SOUND RECORDINGS (U.S. CLS. 21, 23, 26, 36 AND 38).  
FIRST USE 5-1-2002; IN COMMERCE 6-1-2003.

## CLASS 41—EDUCATION AND ENTERTAINMENT

FOR LIVE PERFORMANCES BY A MUSICAL BAND (U.S. CLS. 100, 101 AND 107).  
FIRST USE 6-1-2003; IN COMMERCE 6-1-2003.

3,234,320. EBBEL, ERIKA, CAMBRIDGE, MA. SN 78-428,449. PUB. 10-11-2005, FILED 6-2-2004.

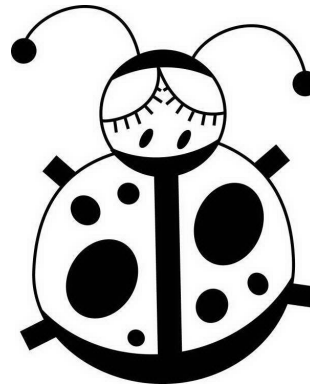

THE MARK CONSISTS OF A LADYBUG DESIGN, IN WHICH COLOR IS NOT A FEATURE OF THE MARK.

## CLASS 18—LEATHER GOODS

FOR LUNCH BOXES; SOUVENIR BAGS; TOTE BAGS; TRAVEL BAGS (U.S. CLS. 1, 2, 3, 22 AND 41).  
FIRST USE 10-23-2006; IN COMMERCE 10-23-2006.

## CLASS 25—CLOTHING

FOR KNIT SHIRTS; SHIRTS; SLEEP SHIRTS; SWEAT SHIRTS; T-SHIRTS; LONG SLEEVED T-SHIRTS; BEACH SHOES; HATS (U.S. CLS. 22 AND 39).  
FIRST USE 10-23-2006; IN COMMERCE 10-23-2006.

3,234,323. WEYERHAEUSER COMPANY, FEDERAL WAY, WA. SN 78-433,290. PUB. 11-15-2005, FILED 6-10-2004.

# WEYERHAEUSER

THE MARK CONSISTS OF STANDARD CHARACTERS WITHOUT CLAIM TO ANY PARTICULAR FONT, STYLE, SIZE, OR COLOR.

OWNER OF U.S. REG. NOS. 817,189, 823,127, AND OTHERS.  
SEC. 2(F).



**CLASS 35—ADVERTISING AND BUSINESS**

FOR ADVERTISING SERVICES, NAMELY, PROMOTING GOODS OF OTHERS; ARRANGING FOR PICKUP, DELIVERY, STORAGE AND TRANSPORTATION OF DOCUMENTS, PACKAGES, FREIGHT AND PARCELS VIA GROUND AND AIR CARRIERS (U.S. CLS. 100, 101 AND 102).

FIRST USE 9-1-2003; IN COMMERCE 9-1-2003.

**CLASS 39—TRANSPORTATION AND STORAGE**

FOR PACKING ARTICLES FOR TRANSPORTATION; STORAGE AND TRANSPORTATION OF PACKAGES VIA AIR, RAIL, SHIP OR TRUCK (U.S. CLS. 100 AND 105).

FIRST USE 9-1-2003; IN COMMERCE 9-1-2003.

**CLASS 40—MATERIAL TREATMENT**

FOR ASSEMBLY OF PRODUCTS FOR OTHERS (U.S. CLS. 100, 103 AND 106).

FIRST USE 9-1-2003; IN COMMERCE 9-1-2003.

**CLASS 42—SCIENTIFIC, COMPUTER AND LEGAL SERVICES**

FOR PACKAGING DESIGN FOR OTHERS (U.S. CLS. 100 AND 101).

FIRST USE 9-1-2003; IN COMMERCE 9-1-2003.

---

3,234,328. TOOLS THAT ROCK, LLC, WEST BEND, WI. SN 78-435,227. PUB. 9-20-2005, FILED 6-15-2004.

**TOOLS THAT ROCK**

THE MARK CONSISTS OF STANDARD CHARACTERS WITHOUT CLAIM TO ANY PARTICULAR FONT, STYLE, SIZE, OR COLOR.

**CLASS 6—METAL GOODS**

FOR METAL TOOL TRAYS (U.S. CLS. 2, 12, 13, 14, 23, 25 AND 50).

FIRST USE 11-0-2005; IN COMMERCE 11-0-2005.

**CLASS 8—HAND TOOLS**

FOR HAND-OPERATED TOOLS, NAMELY HAND-OPERATED REELS FOR DISPENSING CONDUIT, TUBING, AND THE LIKE (U.S. CLS. 23, 28 AND 44).

FIRST USE 11-5-2005; IN COMMERCE 11-5-2005.

**CLASS 25—CLOTHING**

FOR CLOTHING, NAMELY SHIRTS, PANTS, JACKETS, FOOTWEAR, AND HEADWEAR (U.S. CLS. 22 AND 39).

FIRST USE 11-0-2005; IN COMMERCE 11-0-2005.

3,234,330. THE CHEN FAMILY LIMITED PARTNERSHIP, HENDERSON, NV. SN 78-436,370. PUB. 4-11-2006, FILED 6-16-2004.

**KELVIN CHEN**

THE MARK CONSISTS OF STANDARD CHARACTERS WITHOUT CLAIM TO ANY PARTICULAR FONT, STYLE, SIZE, OR COLOR.

THE NAME KELVIN CHEN IDENTIFIES A LIVING INDIVIDUAL WHOSE CONSENT IS OF RECORD.

**CLASS 6—METAL GOODS**

FOR COLLECTIBLES MADE OF METAL AND ENAMEL, NAMELY JEWELRY BOXES (U.S. CLS. 2, 12, 13, 14, 23, 25 AND 50).

FIRST USE 5-1-1987; IN COMMERCE 5-1-1987.

**CLASS 20—FURNITURE AND ARTICLES NOT OTHERWISE CLASSIFIED**

FOR METAL PICTURE FRAMES (U.S. CLS. 2, 13, 22, 25, 32 AND 50).

FIRST USE 5-1-1987; IN COMMERCE 5-1-1987.

**CLASS 21—HOUSEWARES AND GLASS**

FOR COLLECTIBLES MADE OF METAL AND ENAMEL, NAMELY TEA POTS AND BIRD HOUSES (U.S. CLS. 2, 13, 23, 29, 30, 33, 40 AND 50).

FIRST USE 5-1-1987; IN COMMERCE 5-1-1987.

**CLASS 28—TOYS AND SPORTING GOODS**

FOR CHRISTMAS TREE ORNAMENTS (U.S. CLS. 22, 23, 38 AND 50).

FIRST USE 6-11-2004; IN COMMERCE 6-11-2004.

---

3,234,346. METACARTA, INC., CAMBRIDGE, MA. SN 78-448,521. PUB. 9-6-2005, FILED 7-9-2004.

**GEODRIVE**

THE MARK CONSISTS OF STANDARD CHARACTERS WITHOUT CLAIM TO ANY PARTICULAR FONT, STYLE, SIZE, OR COLOR.

**CLASS 9—ELECTRICAL AND SCIENTIFIC APPARATUS**

FOR COMPUTER SEARCH ENGINE SOFTWARE (U.S. CLS. 21, 23, 26, 36 AND 38).  
FIRST USE 2-0-2003; IN COMMERCE 2-0-2003.

**CLASS 42—SCIENTIFIC, COMPUTER AND LEGAL SERVICES**

FOR COMPUTER SERVICES, NAMELY, PROVIDING ONLINE NON-DOWNLOADABLE COMPUTER SEARCH ENGINE SOFTWARE FOR OBTAINING DATA ON A GLOBAL COMPUTER NETWORK (U.S. CLS. 100 AND 101).

FIRST USE 2-0-2003; IN COMMERCE 2-0-2003.

3,234,358. ARCHER-DANIELS-MIDLAND COMPANY, DECATUR, IL. SN 78-453,487. PUB. 2-21-2006, FILED 7-20-2004.



NO CLAIM IS MADE TO THE EXCLUSIVE RIGHT TO USE "BEANS", APART FROM THE MARK AS SHOWN.

THE STIPPLING IN THE DRAWING IS A FEATURE OF THE MARK.

THE ENGLISH TRANSLATION OF THE WORD "CASA" IN THE MARK IS "HOUSE".

**CLASS 29—MEATS AND PROCESSED FOODS**

FOR PINTO BEANS, NAVY BEANS, SOY BEANS, AND REFRIED BEANS, ALL DEHYDRATED AND PROCESSED (U.S. CL. 46).

FIRST USE 10-0-2004; IN COMMERCE 10-0-2004.

**CLASS 31—NATURAL AGRICULTURAL PRODUCTS**

FOR PINTO BEANS, NAVY BEANS, AND SOY BEANS, ALL UNPROCESSED (U.S. CLS. 1 AND 46).

FIRST USE 10-0-2004; IN COMMERCE 10-0-2004.

3,234,359. LOWELL MANUFACTURING COMPANY, PACIFIC, MO. SN 78-453,937. PUB. 11-8-2005, FILED 7-21-2004.

THE MARK CONSISTS OF STANDARD CHARACTERS WITHOUT CLAIM TO ANY PARTICULAR FONT, STYLE, SIZE, OR COLOR.

**CLASS 6—METAL GOODS**

FOR HARDWARE AND ELECTRICAL COMPONENTS FOR USE IN ELECTRONIC EQUIPMENT RACKS AND CABINETS, NAMELY, PANELS, DOORS, BASES, SHELVES, DRAWERS, STORAGE BOXES, SCREWS, MOUNTING RAILS, LEG LEVELERS, AND CASTERS, ALL MADE OF METAL (U.S. CLS. 2, 12, 13, 14, 23, 25 AND 50).

FIRST USE 1-0-2005; IN COMMERCE 1-0-2005.

**CLASS 9—ELECTRICAL AND SCIENTIFIC APPARATUS**

FOR PRODUCTS AND ACCESSORIES FOR USE IN ELECTRONIC EQUIPMENT RACKS AND CABINETS, NAMELY, AC POWER PANELS AND STRIPS, POWER CONDITIONERS, REMOTE POWER CONTROLS, REMOTE POWER SEQUENCERS, SWITCHES, SURGE SUPPRESSORS, AND FILTERS (U.S. CLS. 21, 23, 26, 36 AND 38).

FIRST USE 1-0-2005; IN COMMERCE 1-0-2005.

3,234,365. BARRAZA, TIMOTHY R., LOS ANGELES, CA. AND DETRICK, JOHN CHRISTOPHER, LOS ANGELES, CA. SN 78-458,509. PUB. 8-30-2005, FILED 7-29-2004.

NO CLAIM IS MADE TO THE EXCLUSIVE RIGHT TO USE "INTERACTIVE", APART FROM THE MARK AS SHOWN.

**CLASS 38—COMMUNICATION**

FOR INTERACTIVE TELEVISION TRANSMISSION SERVICES; CONTENT-ON-DEMAND TRANSMISSION SERVICES FOR INTERACTIVE TELEVISION BROADCASTS; INTERACTIVE TELEVISION BROADCAST PROJECT MANAGEMENT SERVICES; CONSULTING SERVICES IN THE FIELD OF TELEVISION BROADCASTING, NAMELY CONSULTATION SERVICES FOR THE DESIGN, SELECTION, IMPLEMENTATION, MANAGEMENT, DEPLOYMENT, AND USE OF INTERACTIVE TELEVISION (U.S. CLS. 100, 101 AND 104).

FIRST USE 9-12-2006; IN COMMERCE 9-12-2006.

**CLASS 42—SCIENTIFIC, COMPUTER AND LEGAL SERVICES**

FOR DEVELOPMENT OF NEW TECHNOLOGY FOR OTHERS IN THE FIELD OF INTERACTIVE TELEVISION (U.S. CLS. 100 AND 101).

FIRST USE 9-12-2006; IN COMMERCE 9-12-2006.

3,234,368. WITT INDUSTRIES, INC., CINCINNATI, OH. SN 78-463,440. PUB. 10-11-2005, FILED 8-6-2004.



OWNER OF U.S. REG. NOS. 867,003 AND 2,970,146.

NO CLAIM IS MADE TO THE EXCLUSIVE RIGHT TO USE "STADIUM SERIES", APART FROM THE MARK AS SHOWN.

**CLASS 20—FURNITURE AND ARTICLES NOT OTHERWISE CLASSIFIED**

FOR OUTDOOR FURNITURE AND AMENITIES, NAMELY, BENCHES (U.S. CLS. 2, 13, 22, 25, 32 AND 50). FIRST USE 4-30-2004; IN COMMERCE 4-30-2004.

**CLASS 21—HOUSEWARES AND GLASS**

FOR OUTDOOR FURNITURE AND AMENITIES, NAMELY, TRASH RECEPTACLES AND PLANTERS (U.S. CLS. 2, 13, 23, 29, 30, 33, 40 AND 50). FIRST USE 3-31-2004; IN COMMERCE 3-31-2004.

3,234,369. ERAGRAIN, LLC, NAMPA, ID. SN 78-463,540. PUB. 4-4-2006, FILED 8-6-2004.



THE COLOR(S) GOLD AND GREEN IS/ARE CLAIMED AS A FEATURE OF THE MARK.

THE MARK CONSISTS OF THE WORD "ERAGRAIN" WHICH APPEARS IN GOLD RECESSED LETTERS WITH GREEN HIGHLIGHTS, AND THE GRAIN STOCK APPEARS IN GOLD WITH A GREEN STOCK, AND A LIGHT GOLD SWIRL APPEARS BEHIND THE WORD "ERAGRAIN". THE NAME IS SHOWN IN LOWER CASE ZRNIC LETTERS. CURVED AROUND THE END OF THE WORD IS A STYLIZED GRAIN GRAPHIC.

**CLASS 30—STAPLE FOODS**

FOR FLOUR (U.S. CL. 46). FIRST USE 11-28-2006; IN COMMERCE 11-28-2006.

**CLASS 31—NATURAL AGRICULTURAL PRODUCTS**

FOR RAW CEREALS (U.S. CLS. 1 AND 46). FIRST USE 11-28-2006; IN COMMERCE 11-28-2006.

3,234,370. BUNKY'S ENTERPRISES, INC., WESTBROOK, CT. SN 78-463,586. PUB. 9-27-2005, FILED 8-6-2004.

**CELESTIAL  
COMBATANTS**

THE MARK CONSISTS OF STANDARD CHARACTERS WITHOUT CLAIM TO ANY PARTICULAR FONT, STYLE, SIZE, OR COLOR.

**CLASS 16—PAPER GOODS AND PRINTED MATTER**

FOR PUBLICATIONS AND PRINTED MATTER, NAMELY, COMIC BOOKS, COMIC MAGAZINES, AND ILLUSTRATED STORIES FEATURED IN BOOKS AND MAGAZINES, TRADING CARDS, BROCHURES AND BOOKLETS RELATING TO CARD GAME INSTRUCTIONS AND STRATEGY, PRINTED GAME INSTRUCTION SHEETS, PRINTED SCORING SHEETS, SHEETS FOR HOLDING TRADING AND PLAYING CARDS, CARD HOLDERS (U.S. CLS. 2, 5, 22, 23, 29, 37, 38 AND 50).

FIRST USE 0-0-2003; IN COMMERCE 0-0-2003.

**CLASS 28—TOYS AND SPORTING GOODS**

FOR PLAYING AND TRADING CARD GAMES, PLAYING CARDS, BOARD GAMES, ROLE-PLAYING GAMES, GAME EQUIPMENT SOLD AS A UNIT FOR PLAYING A CARD GAME (U.S. CLS. 22, 23, 38 AND 50).

FIRST USE 0-0-2003; IN COMMERCE 0-0-2003.

3,234,384. WELLNESS RESOURCES, INC., EDINA, MN. SN 78-470,995. PUB. 9-13-2005, FILED 8-20-2004.

**MASTERING**

THE MARK CONSISTS OF STANDARD CHARACTERS WITHOUT CLAIM TO ANY PARTICULAR FONT, STYLE, SIZE, OR COLOR.

**CLASS 9—ELECTRICAL AND SCIENTIFIC APPARATUS**

FOR PRERECORDED AUDIO DISCS, COMPUTER DISCS, COMPACT DISCS FEATURING INFORMATION AND INSTRUCTION IN THE FIELDS OF NUTRITION, HEALTH, WELLNESS, AND WEIGHT MANAGEMENT (U.S. CLS. 21, 23, 26, 36 AND 38).

FIRST USE 5-0-2005; IN COMMERCE 5-0-2005.

**CLASS 16—PAPER GOODS AND PRINTED MATTER**

FOR SERIES OF BOOKLETS, PAMPHLETS, GUIDES, AND NEWSLETTERS IN THE FIELDS OF NUTRITION, HEALTH, WELLNESS, AND WEIGHT MANAGEMENT (U.S. CLS. 2, 5, 22, 23, 29, 37, 38 AND 50).

FIRST USE 5-0-2005; IN COMMERCE 5-0-2005.

3,234,389. EQUITYTHINK, LLC, FOUNTAIN HILLS, AZ. SN 78-474,047. PUB. 11-29-2005, FILED 8-26-2004.

**CHARLEY BIGGS**

THE MARK CONSISTS OF STANDARD CHARACTERS WITHOUT CLAIM TO ANY PARTICULAR FONT, STYLE,

SIZE, OR COLOR.

"CHANCY BIGGS" DOES NOT IDENTIFY A LIVING INDIVIDUAL.

3,234,404. STARMARK INTERNATIONAL, INC., DANIA, FL. SN 78-480,437. PUB. 8-30-2005, FILED 9-8-2004.

#### CLASS 35—ADVERTISING AND BUSINESS

FOR WHOLESALE DISTRIBUTORSHIP SERVICES FEATURING CHICKEN AND SAUCES (U.S. CLS. 100, 101 AND 102).

FIRST USE 12-1-2004; IN COMMERCE 12-1-2004.

#### CLASS 43—HOTEL AND RESTAURANT SERVICES

FOR RESTAURANT SERVICES (U.S. CLS. 100 AND 101).

FIRST USE 12-1-2004; IN COMMERCE 12-1-2004.

## QUICKWEBPRO

THE MARK CONSISTS OF STANDARD CHARACTERS WITHOUT CLAIM TO ANY PARTICULAR FONT, STYLE, SIZE, OR COLOR.

#### CLASS 9—ELECTRICAL AND SCIENTIFIC APPARATUS

FOR SOFTWARE, NAMELY SOFTWARE USED TO EVALUATE THE EFFECTIVENESS OF DIFFERENT MARKETING AND ADVERTISING TACTICS AND MEDIA TOOLS (U.S. CLS. 21, 23, 26, 36 AND 38).

FIRST USE 1-11-2005; IN COMMERCE 1-11-2005.

3,234,397. RODAN & FIELDS INC., NEW YORK, NY. SN 78-477,593. PUB. 8-9-2005, FILED 9-2-2004.

#### CLASS 35—ADVERTISING AND BUSINESS

FOR MARKETING SERVICES, NAMELY, MARKET TRACKING ANALYSIS SERVICES USED TO EVALUATE THE EFFECTIVENESS OF DIFFERENT MARKETING AND ADVERTISING TACTICS AND MEDIA TOOLS (U.S. CLS. 100, 101 AND 102).

FIRST USE 1-11-2005; IN COMMERCE 1-11-2005.

## RODAN + FIELDS ESSENTIALS

3,234,405. ASSOCIATION OF AMERICAN MEDICAL COLLEGES, WASHINGTON, DC. SN 78-480,472. PUB. 2-21-2006, FILED 9-8-2004.

THE MARK CONSISTS OF STANDARD CHARACTERS WITHOUT CLAIM TO ANY PARTICULAR FONT, STYLE, SIZE, OR COLOR.

OWNER OF U.S. REG. NOS. 2,371,069, 2,372,867, AND 2,754,159.



#### CLASS 3—COSMETICS AND CLEANING PREPARATIONS

FOR NON-MEDICATED SKIN CARE PREPARATIONS, FACE CREAMS, FACE LOTIONS, FACIAL CLEANSERS, FACIAL MOISTURIZERS, FACIAL SOAPS, SKIN CLEANSING PREPARATIONS, SKIN BRIGHTENERS, SKIN LIGHTENERS, SUNSCREEN AND SUNBLOCK PREPARATIONS (U.S. CLS. 1, 4, 6, 50, 51 AND 52).

FIRST USE 4-30-2005; IN COMMERCE 4-30-2005.

OWNER OF U.S. REG. NOS. 2,847,336, 2,896,694, AND OTHERS.

THE MARK CONSISTS OF A STYLIZED STAFF INTERWINDEN BY A SNAKE AND THE LETTERS AAMC.

#### CLASS 5—PHARMACEUTICALS

FOR MEDICATED SKIN CARE PREPARATIONS AND MEDICATED COSMECEUTICALS, SKIN BRIGHTENING PREPARATIONS, SKIN CLEANSERS, SKIN CREAMS, SKIN LIGHTENING PREPARATIONS, SKIN MOISTURIZERS, SKIN SOAPS (U.S. CLS. 6, 18, 44, 46, 51 AND 52).

FIRST USE 4-30-2005; IN COMMERCE 4-30-2005.

#### CLASS 16—PAPER GOODS AND PRINTED MATTER

FOR PUBLICATIONS, NAMELY, MAGAZINES, NEWSLETTERS, REPORTS AND GUIDEBOOKS DEALING WITH TOPICS AND ISSUES OF MEDICAL EDUCATION AND TRAINING, BIOMEDICAL RESEARCH, HEALTH SERVICES AND CAREER PLANNING FOR MEDICAL STUDENTS (U.S. CLS. 2, 5, 22, 23, 29, 37, 38 AND 50).

FIRST USE 11-5-2004; IN COMMERCE 11-5-2004.

**CLASS 35—ADVERTISING AND BUSINESS**

FOR ASSOCIATION SERVICES, NAMELY, PROMOTING THE INTERESTS OF MEDICAL SCHOOLS AND TEACHING HOSPITALS AND PROMOTING MEDICAL EDUCATION; MEDICAL RESEARCH AND HEALTH CARE THROUGH THE IMPROVEMENT OF MEDICAL SCHOOLS AND TEACHING HOSPITALS; PROVIDING AN ONLINE COMPUTER DATABASE FOR USE IN EMPLOYMENT, HIRING, RECRUITING, PLACEMENT, AND CAREER NETWORKING BY MEDICAL PROFESSIONALS; COMPUTERIZED RESIDENCY APPLICATION SERVICES FOR MEDICAL SCHOOL GRADUATES APPLYING FOR RESIDENCY POSITIONS; DATA PROCESSING SERVICES FOR THE APPLICATION OF PROSPECTIVE MEDICAL STUDENTS FOR ADMISSION TO DESIGNATED MEDICAL SCHOOLS; PROVIDING CAREER INFORMATION TO MEDICAL STUDENTS VIA THE INTERNET (U.S. CLS. 100, 101 AND 102).

FIRST USE 11-5-2004; IN COMMERCE 11-5-2004.

**CLASS 36—INSURANCE AND FINANCIAL**

FOR LOAN ARRANGING SERVICES FOR MEDICAL SCHOOL STUDENTS (U.S. CLS. 100, 101 AND 102).

FIRST USE 11-5-2004; IN COMMERCE 11-5-2004.

**CLASS 41—EDUCATION AND ENTERTAINMENT**

FOR PROVIDING ONLINE INFORMATION IN THE FIELD OF MEDICAL PROFESSIONAL PROGRAMS AND MEDICAL EDUCATION; PROVIDING SERVICES IN CONNECTION WITH THE PREPARATION, ADMINISTRATION, AND ANALYSIS OF STANDARDIZED TESTS TO ASSESS MASTERY OF BASIC CONCEPTS IN BIOLOGY, CHEMISTRY, PHYSICS, FACILITY WITH PROBLEM SOLVING, CRITICAL THINKING AND WRITING SKILLS; CAREER COUNSELING SERVICES FEATURING CAREER PLANNING FOR MEDICAL STUDENTS (U.S. CLS. 100, 101 AND 107).

FIRST USE 11-5-2004; IN COMMERCE 11-5-2004.

**CLASS 42—SCIENTIFIC, COMPUTER AND LEGAL SERVICES**

FOR PROVIDING TEMPORARY USE OF ONLINE NONDOWNLOADABLE SOFTWARE FOR USE IN THE ADMINISTRATIVE MANAGEMENT OF DATA REGARDING CAREER PLANNING AND PREPARATION, MEDICAL EDUCATION AND RELATED MEDICAL PROFESSIONAL ACTIVITIES (U.S. CLS. 100 AND 101).

FIRST USE 11-5-2004; IN COMMERCE 11-5-2004.

3,234,409. LIFESPAN BIOSCIENCES, INC., SEATTLE, WA. SN 78-481,976. PUB. 9-13-2005, FILED 9-10-2004.

**ALIAS**

THE MARK CONSISTS OF STANDARD CHARACTERS WITHOUT CLAIM TO ANY PARTICULAR FONT, STYLE,

SIZE, OR COLOR.

**CLASS 9—ELECTRICAL AND SCIENTIFIC APPARATUS**

FOR COMPUTER SOFTWARE AND HARDWARE FOR USE IN AUTOMATED ACQUISITION AND ANALYSIS OF IMAGES OF HUMAN AND ANIMAL CELLS AND TISSUES FOR MEDICAL DIAGNOSIS AND PATHOLOGY (U.S. CLS. 21, 23, 26, 36 AND 38).

FIRST USE 3-30-2005; IN COMMERCE 3-30-2005.

**CLASS 42—SCIENTIFIC, COMPUTER AND LEGAL SERVICES**

FOR TISSUE ANALYSIS FOR OTHERS, NAMELY, TISSUE ANALYSIS USING COMPUTER IMPLEMENTED ALGORITHMS AND COMPUTERIZED IMAGE CAPTURE (U.S. CLS. 100 AND 101).

FIRST USE 3-30-2005; IN COMMERCE 3-30-2005.

3,234,437. PERFECT SMILE CORPORATION, WESTLAKE, OH. SN 78-492,117. PUB. 9-13-2005, FILED 9-30-2004.

**Q-LITOL**

THE MARK CONSISTS OF STANDARD CHARACTERS WITHOUT CLAIM TO ANY PARTICULAR FONT, STYLE, SIZE, OR COLOR.

**CLASS 3—COSMETICS AND CLEANING PREPARATIONS**

FOR FORMULA COMPRISING VITAMIN C, XYLITOL AND COQ10, SOLD AS AN INTEGRAL COMPONENT OF ORAL CARE PRODUCTS, NAMELY, TOOTHPASTES AND NON-MEDICATED MOUTH RINSES (U.S. CLS. 1, 4, 6, 50, 51 AND 52).

FIRST USE 6-20-2005; IN COMMERCE 6-20-2005.

**CLASS 5—PHARMACEUTICALS**

FOR FORMULA COMPRISING VITAMIN C, XYLITOL AND COQ10, SOLD AS AN INTEGRAL COMPONENT OF ORAL CARE PRODUCTS, NAMELY, MEDICATED ANTI-GINGIVITIS MOUTH RINSES AND BREATH-FRESHENING CHEWING GUM FOR MEDICINAL PURPOSES (U.S. CLS. 6, 18, 44, 46, 51 AND 52).

FIRST USE 5-12-2005; IN COMMERCE 5-12-2005.

3,234,454. CONAIR CORPORATION, STAMFORD, CT. SN 78-498,813. PUB. 3-14-2006, FILED 10-13-2004.

3,234,466. COOPERATIVA DE PRODUCTORES DE LECHE DOSPINOS, R.L., ALAJUELA, COSTA RICA. SN 78-503,165. PUB. 2-14-2006, FILED 10-20-2004.

## INFINITI BY CONAIR

THE MARK CONSISTS OF STANDARD CHARACTERS WITHOUT CLAIM TO ANY PARTICULAR FONT, STYLE, SIZE, OR COLOR.

OWNER OF CANADA REG. NO. TMA447835, DATED 9-15-1995, EXPIRES 9-15-2010.

OWNER OF U.S. REG. NOS. 2,248,614, 2,877,642, AND OTHERS.

### CLASS 9—ELECTRICAL AND SCIENTIFIC APPARATUS

FOR ELECTRIC HAIR APPLIANCES, NAMELY CURLING IRON AND STRAIGHTENERS; (BASED ON 44(E)) ELECTRIC CURLING IRONS AND STRAIGHTENERS (U.S. CLS. 21, 23, 26, 36 AND 38).

FIRST USE 3-1-2005; IN COMMERCE 3-1-2005.

### CLASS 11—ENVIRONMENTAL CONTROL APPARATUS

FOR ELECTRIC HAIR APPLIANCES, NAMELY HAIR DRYERS; (BASED ON 44(E)) ELECTRIC HAIR DRYERS AND HAIR DRYER DIFFUSERS (U.S. CLS. 13, 21, 23, 31 AND 34).

FIRST USE 10-1-2005; IN COMMERCE 10-1-2005.

3,234,460. HICKORY SPRINGS MANUFACTURING COMPANY, HICKORY, NC. SN 78-500,705. PUB. 11-22-2005, FILED 10-15-2004.

# VINESS

THE MARK CONSISTS OF STANDARD CHARACTERS WITHOUT CLAIM TO ANY PARTICULAR FONT, STYLE, SIZE, OR COLOR.

### CLASS 20—FURNITURE AND ARTICLES NOT OTHERWISE CLASSIFIED

FOR MATTRESS TOPPERS; FURNITURE, NAMELY, FUTONS, FOAM NOT OF RUBBER FOR USE IN FURNITURE AND BEDDING (U.S. CLS. 2, 13, 22, 25, 32 AND 50).

FIRST USE 11-27-2006; IN COMMERCE 11-27-2006.

### CLASS 24—FABRICS

FOR PILLOWS (U.S. CLS. 42 AND 50).

FIRST USE 11-27-2006; IN COMMERCE 11-27-2006.

**Dos Pinos**  
...siempre con algo mejor.

OWNER OF U.S. REG. NO. 2,894,462.

THE FOREIGN WORDING IN THE MARK TRANSLATES INTO ENGLISH AS TWO PINES ALWAYS WITH SOMETHING BETTER.

### CLASS 29—MEATS AND PROCESSED FOODS

FOR MILK, POWDERED MILK, YOGURT, CHEESE, SOUR CREAM, BUTTER AND DRINKS WITH A MILK BASE (U.S. CL. 46).

FIRST USE 1-0-1960; IN COMMERCE 12-1-1997.

### CLASS 30—STAPLE FOODS

FOR ICE CREAM (U.S. CL. 46).

FIRST USE 1-0-1960; IN COMMERCE 12-1-1997.

### CLASS 32—LIGHT BEVERAGES

FOR FRUIT JUICES, NECTARS OF FRUITS (U.S. CLS. 45, 46 AND 48).

FIRST USE 1-0-1960; IN COMMERCE 12-1-1997.

3,234,468. SURATI SWEET MART LIMITED, TORONTO, ONTARIO, CANADA. SN 78-503,380. PUB. 4-4-2006, FILED 10-21-2004.

# SHALINI

THE MARK CONSISTS OF STANDARD CHARACTERS WITHOUT CLAIM TO ANY PARTICULAR FONT, STYLE, SIZE, OR COLOR.

PRIORITY CLAIMED UNDER SEC. 44(D) ON CANADA APPLICATION NO. 1221205, FILED 6-22-2004.

**CLASS 29—MEATS AND PROCESSED FOODS**

FOR PICKLES, NAMELY PICKLED VEGETABLES AND PICKLED FRUITS; SNACK FOODS, NAMELY PREPARED READY-TO-EAT FOODS CONSISTING PRIMARILY OF CHICK-PEAS, LENTILS, BEANS, PEANUTS, POTATO AND/OR MIXED NUTS; SPICY-FLAVORED PEANUTS AND CASHEWS; DRIED TOMATO WAFERS; BANANA AND PLANTAIN CHIPS AND CASSAVA CHIPS; FOOD PACKAGE COMBINATIONS CONSISTING PRIMARILY OF COOKED VEGETABLES, YOGURT, FRIED CASSAVA AND PRESERVED FRUITS; CANNED VEGETABLES; CHUTNEY AND FRUIT PRESERVES (U.S. CL. 46).

FIRST USE 1-1-1997; IN COMMERCE 1-1-1997.

**CLASS 30—STAPLE FOODS**

FOR SNACK FOODS, NAMELY, PREPARED READY-TO-EAT FOODS CONSISTING PRIMARILY OF RICE, FLOUR, NOODLES AND SPICES; CONFECTIONERY, NAMELY CONFECTIONERY CONSISTING PRIMARILY OF CHICK-PEAS, MILK SOLIDS, YOGURT, COCONUT, FLOUR, BEAN FLOUR AND/OR ALMONDS; BAKED GOODS, NAMELY VEGETABLE-FILLED PASTRIES, CHICK-PEA-BASED PUFF PASTRIES, BISCUITS, BREAD AND ROLLS; COOKED NOODLES AND RICE; FLOUR, NAMELY RICE FLOUR, WHEAT FLOUR, AND CHICK-PEA FLOUR; CONDIMENTS, NAMELY SPICES; PASTE OF PREPARED SPICES; CHUTNEY; FOOD PACKAGE COMBINATIONS CONSISTING PRIMARILY OF NOODLES AND RICE (U.S. CL. 46).

FIRST USE 1-1-1997; IN COMMERCE 1-1-1997.

**CLASS 32—LIGHT BEVERAGES**

FOR NON-ALCOHOLIC FRUIT JUICES AND PULPS (U.S. CLS. 45, 46 AND 48).

FIRST USE 1-1-1997; IN COMMERCE 1-1-1997.

**CLASS 9—ELECTRICAL AND SCIENTIFIC APPARATUS**

FOR COMPUTER SOFTWARE FOR USE IN ACCESSING AND MIGRATING INFORMATION FROM AND TO OTHER DATA SOURCES, NAMELY, EXTRACTION, TRANSFORMATION AND LOAD (ETL) SOFTWARE; COMPUTER SOFTWARE, NAMELY, DATA INTEGRATION SOFTWARE; DATABASE MANAGEMENT SOFTWARE; SOFTWARE FOR USE IN DATA MANAGEMENT; CUSTOMER RELATIONSHIP MANAGEMENT SOFTWARE; SUPPLY CHAIN MANAGEMENT SOFTWARE; ENTERPRISE INFORMATION PORTAL SOFTWARE; INTEGRATION SOFTWARE USED FOR ACCESSING AND COMPILING INFORMATION FROM OTHER DATABASES, NAMELY, ENTERPRISE INFORMATION INTEGRATION (EII) SOFTWARE; APPLICATION INTEGRATION SOFTWARE; QUERY PROCESSING SOFTWARE, NAMELY, SOFTWARE USED TO PROCESS END-USER INQUIRIES; BUSINESS INTELLIGENCE SOFTWARE USED FOR IDENTIFYING AND HIGHLIGHTING PATTERNS AND TRENDS BASED ON INFORMATION MAPPING, ACCESSING AND QUERYING; INTEGRATION SOFTWARE USED FOR ACCESSING AND COMPILING INFORMATION FROM AND FOR OTHER DATABASES (U.S. CLS. 21, 23, 26, 36 AND 38).

FIRST USE 2-16-2006; IN COMMERCE 2-16-2006.

**CLASS 42—SCIENTIFIC, COMPUTER AND LEGAL SERVICES**

FOR COMPUTER SERVICES, NAMELY, INTEGRATION OF COMPUTER SYSTEMS AND NETWORKS FOR OTHERS SO USERS MAY MAP, ACCESS, QUERY, SEARCH, RETRIEVE, CUSTOMIZE, VIEW, PUBLISH AND SHARE DATA FROM MULTIPLE PLATFORMS AND DEVICES IN MULTIPLE FORMATS; COMPUTER AND TECHNICAL CONSULTATION SERVICES IN THE FIELDS OF ELECTRONIC COMMERCE AND BUSINESS TRANSACTIONS VIA A GLOBAL COMPUTER NETWORK; COMPUTER AND TECHNICAL CONSULTATION IN THE FIELDS OF COMPUTER SOFTWARE, INFORMATION TECHNOLOGY AND COMPUTER NETWORKS; COMPUTER SOFTWARE DESIGN FOR OTHERS; TECHNICAL SUPPORT SERVICES, NAMELY, TROUBLESHOOTING, MONITORING AND CONTROLLING COMPUTER SOFTWARE; INSTALLATION, OPERATION AND MAINTENANCE OF COMPUTER SOFTWARE; LEASING COMPUTER SOFTWARE; INFORMATION TECHNOLOGY CONSULTING SERVICES; COMPUTER SYSTEMS CONSULTING SERVICES; COMPUTER DATABASE DEVELOPMENT CONSULTATION SERVICES (U.S. CLS. 100 AND 101).

FIRST USE 2-16-2006; IN COMMERCE 2-16-2006.

3,234,475. ARBUTUS SOFTWARE INC., BURNABY, CANADA. SN 78-506,019. PUB. 6-20-2006, FILED 10-26-2004.

3,234,476. POLIMASTER LTD., MINSK, BELARUS. SN 78-506,256. PUB. 10-11-2005, FILED 10-26-2004.

**LEGACYLINK**

**POLISMART**

THE MARK CONSISTS OF STANDARD CHARACTERS WITHOUT CLAIM TO ANY PARTICULAR FONT, STYLE, SIZE, OR COLOR.

PRIORITY CLAIMED UNDER SEC. 44(D) ON CANADA APPLICATION NO. 1215356, FILED 4-26-2004, REG. NO. TMA660977, DATED 3-20-2006, EXPIRES 3-20-2021.

THE MARK CONSISTS OF STANDARD CHARACTERS WITHOUT CLAIM TO ANY PARTICULAR FONT, STYLE, SIZE, OR COLOR.

**CLASS 9—ELECTRICAL AND SCIENTIFIC APPARATUS**

FOR SCIENTIFIC MEASURING AND MONITORING INSTRUMENTS, NAMELY, ALTIMETERS, AIR COMPOSITION ANALYZERS, BAROMETERS, GAS TESTING INSTRUMENTS, GASOMETERS, PRESSURE MEASURING GAUGES, METAL DETECTORS, INTERCOMS, DOSIMETERS, TELECOMMUNICATION TRANSMITTERS, TIME CLOCKS, PRECISION THEODOLITES, SPEED INDICATORS, AND SPEEDOMETERS FOR VEHICLES (U.S. CLS. 21, 23, 26, 36 AND 38).

FIRST USE 11-6-2006; IN COMMERCE 11-6-2006.

**CLASS 42—SCIENTIFIC, COMPUTER AND LEGAL SERVICES**

FOR QUALITY CONTROL RESEARCH FOR OTHERS; INDUSTRIAL DESIGN RESEARCH; PROVIDING ANALYSIS OF REFLECTION SPECTRUM DATA REGARDING AN OBJECT EXPOSED TO AN OUTSIDE SOURCE OF RADIATION IN ORDER TO IDENTIFY THE OBJECT'S MATERIAL COMPOSITION, ALL PROVIDED VIA THE INTERNET (U.S. CLS. 100 AND 101).

FIRST USE 2-15-2006; IN COMMERCE 2-15-2006.

3,234,487. DELORME PUBLISHING COMPANY, INC., YARMOUTH, ME. SN 78-511,396. PUB. 3-14-2006, FILED 11-4-2004.

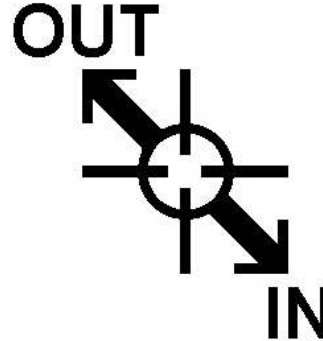

THE MARK CONSISTS OF A CIRCLE INTERSECTED BY INCOMPLETE HORIZONTAL AND VERTICAL AXES AND OBLIQUELY ORIENTED ARROWS BETWEEN THE WORDS OUT ABOVE-LEFT AND IN BELOW-RIGHT.

**CLASS 9—ELECTRICAL AND SCIENTIFIC APPARATUS**

FOR COMPUTER PROGRAMS IN SOFTWARE AND FIRMWARE FOR THE CREATION, STORAGE, RETRIEVAL, DISPLAY AND MANIPULATION OF MAPS AND GEOGRAPHIC DATABASES AND RELATED CARTOGRAPHIC, TRAVEL AND NAVIGATION DATA FOR USE IN CARTOGRAPHY, TRAVEL, AND NAVIGATION; PRERECORDED CDS AND DVDS FEATURING MAPS, ATLASES, AND GEOGRAPHIC, CARTOGRAPHIC, TRAVEL AND NAVIGATION DATA; PREPROGRAMMED ROMS FEATURING MAPS, ATLASES, AND GEOGRAPHIC, CARTOGRAPHIC, TRAVEL AND NAVIGATION DATA; GPS RECEIVERS; NAVIGATION COMPUTERS; DIGITAL CAMERAS, AND ELECTRONIC CABLES AND CONNECTORS FOR DIGITAL CAMERAS (U.S. CLS. 21, 23, 26, 36 AND 38).

FIRST USE 11-10-2006; IN COMMERCE 12-5-2006.

**CLASS 42—SCIENTIFIC, COMPUTER AND LEGAL SERVICES**

FOR APPLICATION SERVICE PROVIDER, NAMELY, PROVIDING ONLINE ACCESS TO AND USE OF COMPUTER PROGRAMS AND DATA FOR THE CREATION, STORAGE, RETRIEVAL, DISPLAY AND MANIPULATION OF MAPS AND GEOGRAPHIC DATABASES AND RELATED CARTOGRAPHIC, TRAVEL, AND NAVIGATION DATA FOR USE IN CARTOGRAPHY, TRAVEL, AND NAVIGATION (U.S. CLS. 100 AND 101).

FIRST USE 11-10-2006; IN COMMERCE 12-6-2006.

3,234,483. ZIDISIUS, INC., HOUSTON, TX. SN 78-509,362. PUB. 3-14-2006, FILED 11-1-2004.

**The Kentucky Club**

THE MARK CONSISTS OF STANDARD CHARACTERS WITHOUT CLAIM TO ANY PARTICULAR FONT, STYLE, SIZE, OR COLOR.

NO CLAIM IS MADE TO THE EXCLUSIVE RIGHT TO USE "CLUB", APART FROM THE MARK AS SHOWN.

**CLASS 25—CLOTHING**

FOR CLOTHING, NAMELY T-SHIRTS, JACKETS, HATS, AND CAPS (U.S. CLS. 22 AND 39).

FIRST USE 11-1-2004; IN COMMERCE 11-1-2004.

**CLASS 41—EDUCATION AND ENTERTAINMENT**

FOR NIGHTCLUB SERVICES (U.S. CLS. 100, 101 AND 107).

FIRST USE 11-1-2004; IN COMMERCE 11-1-2004.

**CLASS 43—HOTEL AND RESTAURANT SERVICES**

FOR RESTAURANTS; COCKTAIL LOUNGE AND BAR SERVICES (U.S. CLS. 100 AND 101).

FIRST USE 11-1-2004; IN COMMERCE 11-1-2004.

3,234,498. HEARTHSTONE SENIOR SERVICES, L.P., THE WOODLANDS, TX. SN 78-513,801. PUB. 9-13-2005, FILED 11-9-2004.

**LIVING FOR SENIORS**

THE MARK CONSISTS OF STANDARD CHARACTERS WITHOUT CLAIM TO ANY PARTICULAR FONT, STYLE, SIZE, OR COLOR.



NO CLAIM IS MADE TO THE EXCLUSIVE RIGHT TO USE "SENIORS", APART FROM THE MARK AS SHOWN.

3,234,539. MCCARNEY, KEVIN T., DBA POQUITO MAS, NO. HOLLYWOOD, CA. SN 78-523,681. PUB. 10-18-2005, FILED 11-29-2004.

#### CLASS 35—ADVERTISING AND BUSINESS

FOR MANAGEMENT AND ADMINISTRATION OF RETIREMENT, INDEPENDENT LIVING, ASSISTED LIVING, ALZHEIMER'S, ADULT DAY CARE, DEMENTIA CARE, NURSING HOME, AND LONG TERM CARE FACILITIES FOR OTHERS (U.S. CLS. 100, 101 AND 102).  
FIRST USE 1-1-2005; IN COMMERCE 1-1-2005.

#### CLASS 43—HOTEL AND RESTAURANT SERVICES

FOR ASSISTED LIVING, ADULT DAY CARE, ALZHEIMER'S AND DEMENTIA CARE CENTERS; RETIREMENT HOMES; PROVIDING INDEPENDENT LIVING, ASSISTED LIVING, LONG TERM CARE FACILITIES, AND RESPITE CARE; HOME CARE AND ADULT CARE IN THE NATURE OF PROVIDING NON-MEDICAL IN-HOME ASSISTED LIVING FACILITIES (U.S. CLS. 100 AND 101).  
FIRST USE 1-1-2005; IN COMMERCE 1-1-2005.

#### CLASS 44—MEDICAL, BEAUTY AND AGRICULTURAL SERVICES

FOR HOSPICE CARE SERVICES; MEDICAL SERVICES; SKILLED NURSING; NURSING HOME; ON-SITE MEDICAL SERVICES FOR RESIDENTS OF LONG TERM CARE FACILITIES; HOME NURSING AID SERVICES, NAMELY, MEDICATION MANAGEMENT (U.S. CLS. 100 AND 101).  
FIRST USE 1-1-2005; IN COMMERCE 1-1-2005.

3,234,537. FLOWVISION, DILLION, CO. SN 78-522,946. PUB. 11-1-2005, FILED 11-24-2004.

## FLOWVISION

THE MARK CONSISTS OF STANDARD CHARACTERS WITHOUT CLAIM TO ANY PARTICULAR FONT, STYLE, SIZE, OR COLOR.

#### CLASS 41—EDUCATION AND ENTERTAINMENT

FOR EDUCATIONAL SERVICES, NAMELY, CONDUCTING CLASSES, SEMINARS, CONFERENCES, WORKSHOPS RELATING TO THE ENGINEERING, DESIGN, IMPLEMENTATION AND CONTROL OF MANUFACTURING AND INVENTORY MANAGEMENT PROCESSES (U.S. CLS. 100, 101 AND 107).  
FIRST USE 12-31-1998; IN COMMERCE 12-31-1998.

#### CLASS 42—SCIENTIFIC, COMPUTER AND LEGAL SERVICES

FOR TECHNICAL CONSULTING SERVICES RELATING TO THE ENGINEERING, DESIGN, IMPLEMENTATION AND CONTROL OF MANUFACTURING PROCESSES (U.S. CLS. 100 AND 101).  
FIRST USE 12-31-1998; IN COMMERCE 12-31-1998.

## CHEF MEX

THE MARK CONSISTS OF STANDARD CHARACTERS WITHOUT CLAIM TO ANY PARTICULAR FONT, STYLE, SIZE, OR COLOR.

OWNER OF U.S. REG. NO. 2,057,149.

#### CLASS 8—HAND TOOLS

FOR HAND-OPERATED FOOD PROCESSORS (U.S. CLS. 23, 28 AND 44).  
FIRST USE 4-0-2003; IN COMMERCE 4-0-2003.

#### CLASS 29—MEATS AND PROCESSED FOODS

FOR FOOD PRODUCTS, NAMELY FROZEN MEALS AND ENTREES CONSISTING PRIMARILY OF MEAT (U.S. CL. 46).  
FIRST USE 6-15-2003; IN COMMERCE 6-15-2003.

#### CLASS 30—STAPLE FOODS

FOR TORTILLAS; SPICES (U.S. CL. 46).  
FIRST USE 6-0-2004; IN COMMERCE 6-0-2004.

3,234,543. OWENS, CALEB R., VENICE, CA. AND PARROTT, GEORGE, MIAMI, FL. SN 78-525,590. PUB. 9-27-2005, FILED 12-2-2004.

## mumbo jumbo

THE MARK CONSISTS OF STANDARD CHARACTERS WITHOUT CLAIM TO ANY PARTICULAR FONT, STYLE, SIZE, OR COLOR.

#### CLASS 9—ELECTRICAL AND SCIENTIFIC APPARATUS

FOR SERIES OF MUSICAL SOUND AND VIDEO RECORDINGS, SERIES OF PRERECORDED AUDIO AND VIDEO CASSETTES, TAPES, AND DISKS FEATURING DRAMATIC AND NON DRAMATIC PERFORMANCES OF MUSICAL WORKS (U.S. CLS. 21, 23, 26, 36 AND 38).  
FIRST USE 1-1-2004; IN COMMERCE 11-1-2004.

#### CLASS 25—CLOTHING

FOR CLOTHING, NAMELY T-SHIRTS, HATS, TANK TOPS, JACKETS (U.S. CLS. 22 AND 39).  
FIRST USE 1-1-2004; IN COMMERCE 11-1-2004.

3,234,546. VEGETABLE JUICES, INC., BEDFORD PARK, IL.  
SN 78-526,718. PUB. 3-21-2006, FILED 12-3-2004.

3,234,565. KABUSHIKI KAISHA G-MODE, DBA G-MODE  
CO., LTD., TOKYO, JAPAN. SN 78-530,633. PUB. 2-14-  
2006, FILED 12-10-2004.

## NATURAL INGREDIENT SOLUTIONS

THE MARK CONSISTS OF STANDARD CHARACTERS  
WITHOUT CLAIM TO ANY PARTICULAR FONT, STYLE,  
SIZE, OR COLOR.

NO CLAIM IS MADE TO THE EXCLUSIVE RIGHT TO  
USE "NATURAL INGREDIENT", APART FROM THE  
MARK AS SHOWN.

### CLASS 29—MEATS AND PROCESSED FOODS

FOR FRESH AND BOTTLED CUT VEGETABLES,  
VEGETABLE PUREE (U.S. CL. 46).  
FIRST USE 10-6-2005; IN COMMERCE 10-6-2005.

### CLASS 32—LIGHT BEVERAGES

FOR VEGETABLE JUICES (U.S. CLS. 45, 46 AND 48).  
FIRST USE 10-6-2005; IN COMMERCE 10-6-2005.

---

3,234,549. PRIMESOURCE HEALTHCARE, INC., TUCSON,  
AZ. SN 78-527,337. PUB. 10-25-2005, FILED 12-6-2004.

## LXU HEALTHCARE INC.

THE MARK CONSISTS OF STANDARD CHARACTERS  
WITHOUT CLAIM TO ANY PARTICULAR FONT, STYLE,  
SIZE, OR COLOR.

NO CLAIM IS MADE TO THE EXCLUSIVE RIGHT TO  
USE "HEALTHCARE", APART FROM THE MARK AS  
SHOWN.

### CLASS 35—ADVERTISING AND BUSINESS

FOR RETAIL SERVICES BY DIRECT SOLICITATION  
BY SALES AGENTS IN THE FIELD OF HEALTHCARE  
AND MEDICAL EQUIPMENT AND SUPPLIES FOR  
CARDIO VASCULAR AND THORACIC MEDICAL  
TREATMENT, GENERAL SURGERY, MINIMALLY IN-  
VASIVE SURGICAL PROCEDURES, GYNECOLOGICAL  
AND NEUROLOGICAL TREATMENTS, VASCULAR AC-  
CESS, INTRAVENOUS AND ARTERIAL TREATMENT;  
DISTRIBUTORSHIP SERVICES IN THE FIELD OF  
HEALTHCARE AND MEDICAL EQUIPMENT AND SUP-  
PLIES FOR CARDIO VASCULAR AND THORACIC  
MEDICAL TREATMENT, GENERAL SURGERY, MINI-  
MALLY INVASIVE SURGICAL PROCEDURES, GYNE-  
COLOGICAL AND NEUROLOGICAL TREATMENTS,  
VASCULAR ACCESS, INTRAVENOUS AND ARTERIAL  
TREATMENT (U.S. CLS. 100, 101 AND 102).  
FIRST USE 4-5-2006; IN COMMERCE 4-5-2006.

### CLASS 40—MATERIAL TREATMENT

FOR CUSTOM MANUFACTURING SERVICES IN THE  
FIELD OF HEALTHCARE AND MEDICAL EQUIPMENT  
AND SUPPLIES FOR GENERAL SURGERY (U.S. CLS.  
100, 103 AND 106).  
FIRST USE 4-5-2006; IN COMMERCE 4-5-2006.

## BURNIN' RUBBER

THE MARK CONSISTS OF STANDARD CHARACTERS  
WITHOUT CLAIM TO ANY PARTICULAR FONT, STYLE,  
SIZE, OR COLOR.

### CLASS 9—ELECTRICAL AND SCIENTIFIC APPARATUS

FOR COMPUTER VIDEO GAME PROGRAMS; DOWN-  
LOADABLE COMPUTER VIDEO GAME PROGRAMS;  
PRERECORDED COMPUTER VIDEO GAME PRO-  
GRAMS ON CARTRIDGES, CASSETTES, MAGNETIC  
CARDS, AND COMPACT DISCS (U.S. CLS. 21, 23, 26, 36  
AND 38).  
FIRST USE 10-3-2005; IN COMMERCE 10-3-2005.

### CLASS 41—EDUCATION AND ENTERTAIN- MENT

FOR ENTERTAINMENT SERVICES, NAMELY PRO-  
VIDING AN ON-LINE COMPUTER GAME (U.S. CLS.  
100, 101 AND 107).  
FIRST USE 10-3-2005; IN COMMERCE 10-3-2005.

---

3,234,566. KABUSHIKI KAISHA G-MODE, DBA G-MODE  
CO., LTD., TOKYO, JAPAN. SN 78-530,688. PUB. 3-28-  
2006, FILED 12-10-2004.

## TUMBLE POP

THE MARK CONSISTS OF STANDARD CHARACTERS  
WITHOUT CLAIM TO ANY PARTICULAR FONT, STYLE,  
SIZE, OR COLOR.

### CLASS 9—ELECTRICAL AND SCIENTIFIC APPARATUS

FOR COMPUTER VIDEO GAME PROGRAMS; DOWN-  
LOADABLE COMPUTER VIDEO GAME PROGRAMS;  
PRERECORDED COMPUTER VIDEO GAME PRO-  
GRAMS ON CARTRIDGES, CASSETTES, MAGNETIC  
CARDS, AND COMPACT DISCS (U.S. CLS. 21, 23, 26, 36  
AND 38).  
FIRST USE 10-3-2005; IN COMMERCE 10-3-2005.

### CLASS 41—EDUCATION AND ENTERTAIN- MENT

FOR ENTERTAINMENT SERVICES, NAMELY PRO-  
VIDING AN ON-LINE COMPUTER GAME (U.S. CLS.  
100, 101 AND 107).  
FIRST USE 10-3-2005; IN COMMERCE 10-3-2005.

3,234,575. VALOIS SAS, 27110 LE NEUBOURG, FRANCE. SN 78-532,344. PUB. 9-13-2005, FILED 12-14-2004.

# IMAGIN

THE MARK CONSISTS OF STANDARD CHARACTERS WITHOUT CLAIM TO ANY PARTICULAR FONT, STYLE, SIZE, OR COLOR.

OWNER OF U.S. REG. NO. 2,810,076.

#### CLASS 8—HAND TOOLS

FOR MANUALLY OPERATED HAND PUMPS FOR SPRAYING LIQUIDS (U.S. CLS. 23, 28 AND 44). FIRST USE 12-0-2005; IN COMMERCE 12-0-2005.

#### CLASS 21—HOUSEWARES AND GLASS

FOR PERFUME SPRAYERS SOLD EMPTY AND PUMP COMPONENTS OF PERFUME SPRAYERS (U.S. CLS. 2, 13, 23, 29, 30, 33, 40 AND 50). FIRST USE 12-0-2005; IN COMMERCE 12-0-2005.

3,234,596. ALLCONNECT, INC., ATLANTA, GA. SN 78-539,439. PUB. 4-11-2006, FILED 12-29-2004.

# allconnect

OWNER OF U.S. REG. NOS. 2,220,770, 2,311,828, AND 2,626,064.

#### CLASS 35—ADVERTISING AND BUSINESS

FOR BUSINESS MARKETING SERVICES IN THE NATURE OF AGENCY REPRESENTATION OF COMPANIES MARKETING A VARIETY OF SERVICES TO HOME OWNERS AND RENTERS, NAMELY, UTILITY HOOK-UPS, TELECOMMUNICATION SERVICES, HOME SECURITY SERVICES, HOME WARRANTIES, HOME AND YARD MAINTENANCE, FURNITURE AND APPLIANCE RENTAL (U.S. CLS. 100, 101 AND 102). FIRST USE 2-0-2005; IN COMMERCE 2-0-2005.

#### CLASS 38—COMMUNICATION

FOR TELECOMMUNICATIONS CONSULTATIONS RENDERED TO CONSUMERS IN THE NATURE OF THE INITIATION AND TERMINATION OF SERVICES WITH TELECOMMUNICATION PROVIDERS (U.S. CLS. 100, 101 AND 104). FIRST USE 2-0-2005; IN COMMERCE 2-0-2005.

#### CLASS 39—TRANSPORTATION AND STORAGE

FOR UTILITY SERVICES CONSULTATIONS RENDERED TO CONSUMERS IN THE NATURE OF THE INITIATION AND TERMINATION OF SERVICES WITH UTILITY PROVIDERS (U.S. CLS. 100 AND 105). FIRST USE 2-0-2005; IN COMMERCE 2-0-2005.

3,234,597. HAWKINS, TOMIKO, OAKLAND, CA. SN 78-540,283. PUB. 3-14-2006, FILED 12-30-2004.

# MIKO MARKS

THE MARK CONSISTS OF STANDARD CHARACTERS WITHOUT CLAIM TO ANY PARTICULAR FONT, STYLE, SIZE, OR COLOR.

THE NAME MIKO MARKS IDENTIFIES A LIVING INDIVIDUAL WHOSE CONSENT IS OF RECORD.

#### CLASS 9—ELECTRICAL AND SCIENTIFIC APPARATUS

FOR SERIES OF MUSICAL SOUND AND MUSICAL VIDEO RECORDINGS (U.S. CLS. 21, 23, 26, 36 AND 38). FIRST USE 9-12-2005; IN COMMERCE 9-12-2005.

#### CLASS 41—EDUCATION AND ENTERTAINMENT

FOR ENTERTAINMENT SERVICES IN THE NATURE OF LIVE MUSICAL PERFORMANCES AND AUDIO-VISUAL PERFORMANCES BY AN INDIVIDUAL MUSICAL PERFORMER; AND PROVIDING A WEBSITE ON A GLOBAL COMPUTER NETWORK FEATURING INFORMATION ABOUT PERFORMANCES, RECORDINGS, APPEARANCES, THE BIOGRAPHY, AND OTHER INFORMATION ABOUT AN INDIVIDUAL MUSICAL PERFORMER, SONG WRITER, AND RECORDING ARTIST (U.S. CLS. 100, 101 AND 107). FIRST USE 10-1-1990; IN COMMERCE 8-20-2005.

3,234,602. PALMER, A RAYMOND, GOODYEAR, AZ. SN 78-542,402. PUB. 10-4-2005, FILED 1-5-2005.



#### CLASS 16—PAPER GOODS AND PRINTED MATTER

FOR DECALS (U.S. CLS. 2, 5, 22, 23, 29, 37, 38 AND 50). FIRST USE 2-7-1997; IN COMMERCE 2-7-1997.

**CLASS 25—CLOTHING**

FOR T-SHIRTS (U.S. CLS. 22 AND 39),  
FIRST USE 2-7-1997; IN COMMERCE 2-7-1997.

3,234,626. NETCONCEPTS, MADISON, WI. SN 78-547,863.  
PUB. 11-22-2005, FILED 1-14-2005.

# Get Found

THE MARK CONSISTS OF STANDARD CHARACTERS WITHOUT CLAIM TO ANY PARTICULAR FONT, STYLE, SIZE, OR COLOR.

**CLASS 35—ADVERTISING AND BUSINESS**

FOR BUSINESS MARKETING AND MONITORING SERVICES, NAMELY, PROVIDING TRACKING AND ANALYSIS OF WEBSITES OF OTHERS TO PROVIDE DETAILS ABOUT USER CLICK TRAFFIC OR VISITS FOR THE PURPOSE OF MAXIMIZING SEARCH ENGINE TRAFFIC AND TO EXPLOIT TARGETED BRAND AWARENESS (U.S. CLS. 100, 101 AND 102).

FIRST USE 12-21-2004; IN COMMERCE 12-21-2004.

**CLASS 42—SCIENTIFIC, COMPUTER AND LEGAL SERVICES**

FOR PROCUREMENT SOLUTIONS TO MAXIMIZE SEARCH ENGINE TRAFFIC, NAMELY, UPDATING OF TELECOMMUNICATION NETWORK SEARCH ENGINES TO MAXIMIZE SEARCH ENGINE TRAFFIC AND EXPLOIT TARGETED BRAND AWARENESS (U.S. CLS. 100 AND 101).

FIRST USE 12-21-2004; IN COMMERCE 12-21-2004.

3,234,631. SMALLTOWN, INC., FOSTER CITY, CA. SN 78-553,756. PUB. 4-18-2006, FILED 1-25-2005.

# SMALLTOWN

THE MARK CONSISTS OF STANDARD CHARACTERS WITHOUT CLAIM TO ANY PARTICULAR FONT, STYLE, SIZE, OR COLOR.

**CLASS 38—COMMUNICATION**

FOR ON-LINE ELECTRONIC BULLETIN BOARDS ALLOWING MEMBERS OF A LOCAL COMMUNITY TO SHARE INFORMATION WITH OTHER MEMBERS OF THE SAME COMMUNITY OR OTHER COMMUNITIES (U.S. CLS. 100, 101 AND 104).

FIRST USE 10-10-2006; IN COMMERCE 10-10-2006.

**CLASS 42—SCIENTIFIC, COMPUTER AND LEGAL SERVICES**

FOR PROVIDING TEMPORARY USE OF NON-DOWNLOADABLE SOFTWARE FOR USE IN SCHEDULING, ADVERTISING, COMMUNICATING, NETWORKING, POSTING, SEARCHING, AND ORGANIZING MESSAGES AND DIGITAL CONTENT (U.S. CLS. 100 AND 101).

FIRST USE 10-10-2006; IN COMMERCE 10-10-2006.

3,234,643. AMAZON TECHNOLOGIES, INC., RENO, NV. SN 78-559,146. PUB. 1-3-2006, FILED 2-2-2005.

# PRIME

THE MARK CONSISTS OF STANDARD CHARACTERS WITHOUT CLAIM TO ANY PARTICULAR FONT, STYLE, SIZE, OR COLOR.

**CLASS 35—ADVERTISING AND BUSINESS**

FOR CUSTOMER LOYALTY PROGRAM SERVICES FEATURING REWARDS IN THE FORM OF DISCOUNTED SHIPPING SERVICES; RETAIL SERVICES, NAMELY, ADMINISTRATION OF A DISCOUNT PROGRAM FOR ENABLING PARTICIPANTS TO OBTAIN DISCOUNTS ON SHIPPING SERVICES THROUGH USE OF A DISCOUNT MEMBERSHIP CARD (U.S. CLS. 100, 101 AND 102).

FIRST USE 2-2-2005; IN COMMERCE 2-2-2005.

**CLASS 39—TRANSPORTATION AND STORAGE**

FOR EXPEDITED SHIPPING SERVICE FOR OTHERS (U.S. CLS. 100 AND 105).

FIRST USE 2-2-2005; IN COMMERCE 2-2-2005.

3,234,645. INTERNATIONAL HOUSE OF BLUES FOUNDATION, INC., HOLLYWOOD, CA. SN 78-560,689. PUB. 12-27-2005, FILED 2-4-2005.

## ACTION FOR THE ARTS

THE MARK CONSISTS OF STANDARD CHARACTERS WITHOUT CLAIM TO ANY PARTICULAR FONT, STYLE, SIZE, OR COLOR.

NO CLAIM IS MADE TO THE EXCLUSIVE RIGHT TO USE "ARTS", APART FROM THE MARK AS SHOWN.

### CLASS 36—INSURANCE AND FINANCIAL

FOR CHARITABLE FUNDRAISING SERVICES (U.S. CLS. 100, 101 AND 102).  
FIRST USE 9-1-2006; IN COMMERCE 9-1-2006.

### CLASS 41—EDUCATION AND ENTERTAINMENT

FOR EDUCATIONAL SERVICES, NAMELY, PROVIDING PROGRAMS, EXHIBITIONS, AND PRESENTATIONS TO RAISE INTEREST IN AND AWARENESS OF THE ARTS AND BENEFITS THERETO; ENTERTAINMENT IN THE NATURE OF LIVE ARTISTIC AND MUSICAL PERFORMANCES (U.S. CLS. 100, 101 AND 107).  
FIRST USE 7-0-2006; IN COMMERCE 7-0-2006.

3,234,655. THINKAGE, LLC, ATLANTA, GA. SN 78-564,913. PUB. 3-7-2006, FILED 2-10-2005.

## Think Decision

THE MARK CONSISTS OF STANDARD CHARACTERS WITHOUT CLAIM TO ANY PARTICULAR FONT, STYLE, SIZE, OR COLOR.

### CLASS 9—ELECTRICAL AND SCIENTIFIC APPARATUS

FOR COMPUTER SOFTWARE FOR COLLECTION, EDITING, ORGANIZING, MODIFYING, BOOK MARKING, TRANSMISSION AND SHARING OF SALES, PRODUCT, OPERATIONAL, FINANCIAL, AND SUPPLY CHAIN DATA AND INFORMATION AND PROVIDING GRAPHIC AND TABULAR DISPLAYS SUMMARIZING SUCH DATA AND INFORMATION FOR USE IN ACCOUNTING, PRODUCTION, PERSONNEL, OR SALES DATABASES (U.S. CLS. 21, 23, 26, 36 AND 38).  
FIRST USE 5-17-2005; IN COMMERCE 8-15-2005.

### CLASS 35—ADVERTISING AND BUSINESS

FOR BUSINESS CONSULTATION FOR ORGANIZATIONAL ISSUES AND BUSINESS ADMINISTRATION, WITH AND WITHOUT THE HELP OF ELECTRONIC DATABASES, NAMELY, BUSINESS CONSULTATION AND ANALYSIS CONCERNING BUSINESS EFFICIENCY AND EFFECTIVENESS FOR RESTAURANTS, RETAILERS, AND MANUFACTURERS (U.S. CLS. 100, 101 AND 102).

FIRST USE 5-17-2005; IN COMMERCE 8-15-2005.

3,234,668. O.C. TANNER COMPANY, SALT LAKE CITY, UT. SN 78-573,543. PUB. 6-6-2006, FILED 2-23-2005.

## A CARROT A DAY

THE MARK CONSISTS OF STANDARD CHARACTERS WITHOUT CLAIM TO ANY PARTICULAR FONT, STYLE, SIZE, OR COLOR.

### CLASS 9—ELECTRICAL AND SCIENTIFIC APPARATUS

FOR VIDEO DISCS AND VIDEO TAPES FEATURING CLASSES AND WORKSHOPS IN THE FIELD OF RECOGNITION AND INCENTIVE AWARD PRESENTATION TRAINING INCLUDING THE FORMAL AND INFORMAL USE OF RECOGNITION TECHNIQUES AND HELP IN IMPROVING THE EFFECTIVENESS OF AWARD PRESENTATIONS (U.S. CLS. 21, 23, 26, 36 AND 38).  
FIRST USE 5-16-2005; IN COMMERCE 5-16-2005.

### CLASS 16—PAPER GOODS AND PRINTED MATTER

FOR PRINTED TRAINING MATERIALS, CERTIFICATES, CARDS, AND BOOKS FOR USE WITH RECOGNITION AND INCENTIVE AWARD PROGRAMS, NAMELY, EMPLOYEE ACHIEVEMENT, PRODUCTIVITY, PERFORMANCE, SALES, SERVICE, CUSTOMER SATISFACTION, QUALITY, SAFETY, RETIREMENT, EVENT, AND OTHER RECOGNITION AND INCENTIVE AWARD PROGRAMS; PRINTED TRAINING MATERIALS IN THE FIELD OF RECOGNITION AND INCENTIVE AWARD PRESENTATION TRAINING INCLUDING THE FORMAL AND INFORMAL USE OF RECOGNITION TECHNIQUES AND HELP IN IMPROVING THE EFFECTIVENESS OF AWARD PRESENTATIONS; CUSTOM DESIGNED AND PRINTED TRAINING MATERIALS IN THE FIELD OF RECOGNITION AND INCENTIVE AWARD PRESENTATION TRAINING WHICH INCORPORATE THE PURCHASER'S LOGOS OR SYMBOLS (U.S. CLS. 2, 5, 22, 23, 29, 37, 38 AND 50).  
FIRST USE 2-1-2006; IN COMMERCE 2-1-2006.

### CLASS 41—EDUCATION AND ENTERTAINMENT

FOR EDUCATIONAL SERVICES, NAMELY, CONDUCTING CLASSES, SEMINARS, WORKSHOPS AND ON-LINE CLASSES AND WORKSHOPS IN THE FIELD OF RECOGNITION AND INCENTIVE AWARD PRESENTATION TRAINING INCLUDING THE FORMAL AND INFORMAL USE OF RECOGNITION TECHNIQUES AND HELP IN IMPROVING THE EFFECTIVENESS OF AWARD PRESENTATIONS (U.S. CLS. 100, 101 AND 107).  
FIRST USE 9-23-2006; IN COMMERCE 9-23-2006.

3,234,686. ICOS CORPORATION, BOTHELL, WA. SN 78-579,436. PUB. 2-21-2006, FILED 3-3-2005.

## ICOS BIOLOGICS

THE MARK CONSISTS OF STANDARD CHARACTERS WITHOUT CLAIM TO ANY PARTICULAR FONT, STYLE, SIZE, OR COLOR.

OWNER OF U.S. REG. NOS. 1,864,159, 1,876,108, AND 1,955,148.

NO CLAIM IS MADE TO THE EXCLUSIVE RIGHT TO USE "BIOLOGICS", APART FROM THE MARK AS SHOWN.

### CLASS 40—MATERIAL TREATMENT

FOR MANUFACTURING OF PHARMACEUTICALS, THERAPEUTICS AND BIOLOGICS FOR OTHERS; PROCESSING OF PHARMACEUTICALS, THERAPEUTICS AND BIOLOGICS FOR OTHERS AS PART OF THE MANUFACTURING OF THE SAME (U.S. CLS. 100, 103 AND 106).

FIRST USE 5-30-2003; IN COMMERCE 5-30-2003.

### CLASS 42—SCIENTIFIC, COMPUTER AND LEGAL SERVICES

FOR DEVELOPMENT OF PHARMACEUTICALS, THERAPEUTICS AND BIOLOGICS FOR OTHERS (U.S. CLS. 100 AND 101).

FIRST USE 5-30-2003; IN COMMERCE 5-3-2003.

3,234,689. DEMAILOLO, MARY PIPINO, CANFIELD, OH. SN 78-580,081. PUB. 7-11-2006, FILED 3-4-2005.

## FITNESST

THE MARK CONSISTS OF STANDARD CHARACTERS WITHOUT CLAIM TO ANY PARTICULAR FONT, STYLE, SIZE, OR COLOR.

### CLASS 41—EDUCATION AND ENTERTAINMENT

FOR PROVIDING INFORMATION AND COUNSELING IN THE FIELD OF PERSONAL TRAINING AND EXERCISE; PERSONAL TRAINING SERVICES, NAMELY, STRENGTH AND CONDITIONING TRAINING (U.S. CLS. 100, 101 AND 107).

FIRST USE 3-1-2006; IN COMMERCE 3-1-2006.

### CLASS 44—MEDICAL, BEAUTY AND AGRICULTURAL SERVICES

FOR NUTRITION COUNSELING; PSYCHOLOGICAL COUNSELING; PROVIDING INFORMATION ABOUT DIETARY SUPPLEMENTS AND NUTRITION; AND MEDICAL TESTING SERVICES, NAMELY, FITNESS EVALUATION (U.S. CLS. 100 AND 101).

FIRST USE 3-1-2006; IN COMMERCE 3-1-2006.

3,234,713. SKATE RANGER, BROOKLYN, NY. SN 78-588,524. PUB. 4-25-2006, FILED 3-16-2005.



THE COLOR(S) RED IS/ARE CLAIMED AS A FEATURE OF THE MARK.

THE COLOR RED APPEARS IN THE CURVED BANDS AND TRIANGULAR DESIGNS OF THE MARK.

THE MARK CONSISTS OF A STYLIZED DESIGN OF THE LETTERS S AND R CONSISTING OF CURVED BANDS AND TRIANGULAR DESIGNS.

### CLASS 25—CLOTHING

FOR CLOTHING, NAMELY, HATS, SHIRTS, T-SHIRTS, PANTS, COATS, AND UNDERWEAR (U.S. CLS. 22 AND 39).

FIRST USE 5-8-2003; IN COMMERCE 6-9-2004.

### CLASS 28—TOYS AND SPORTING GOODS

FOR TOYS, NAMELY, ACTION FIGURES (U.S. CLS. 22, 23, 38 AND 50).

FIRST USE 5-8-2003; IN COMMERCE 6-9-2004.

3,234,738. PLOWSHARES, LTD., WOODSTOCK, IL. SN 78-597,497. PUB. 4-18-2006, FILED 3-29-2005.

## MATCH ME

THE MARK CONSISTS OF STANDARD CHARACTERS WITHOUT CLAIM TO ANY PARTICULAR FONT, STYLE, SIZE, OR COLOR.

NO CLAIM IS MADE TO THE EXCLUSIVE RIGHT TO USE "MATCH", APART FROM THE MARK AS SHOWN.

### CLASS 25—CLOTHING

FOR CLOTHES, NAMELY, MATCHING OUTFITS FOR MOTHER AND DAUGHTER COMPRISED OF TOPS, SKIRTS, CAPRI PANTS, AND DRESSES (U.S. CLS. 22 AND 39).

FIRST USE 7-19-2005; IN COMMERCE 3-13-2006.

**CLASS 28—TOYS AND SPORTING GOODS**

FOR MATCHING DOLL CLOTHES (U.S. CLS. 22, 23, 38 AND 50).  
FIRST USE 7-19-2005; IN COMMERCE 3-13-2006.

3,234,754. ALIZA'S FOODS PRIVATE LTD., KARACHI, PAKISTAN. SN 78-602,946. PUB. 3-28-2006, FILED 4-6-2005.

3,234,742. TEMPLE UNIVERSITY – OF THE COMMONWEALTH SYSTEM OF HIGHER EDUCATION, PHILADELPHIA, PA. SN 78-598,936. PUB. 4-11-2006, FILED 3-31-2005.

# SAPNA

# TEMPLE UNIVERSITY

THE MARK CONSISTS OF STANDARD CHARACTERS WITHOUT CLAIM TO ANY PARTICULAR FONT, STYLE, SIZE, OR COLOR.

THE FOREIGN WORDING IN THE MARK TRANSLATES INTO ENGLISH AS DREAM.

**CLASS 29—MEATS AND PROCESSED FOODS**

FOR PICKLES AND COOKING OIL (U.S. CL. 46).  
FIRST USE 10-7-2005; IN COMMERCE 10-7-2005.

**CLASS 30—STAPLE FOODS**

FOR RICE, SPICES, CHUTNEY, TIKKA PASTES, TANDORI PASTES, KASHMIRI PASTES, CURRY PASTES, MINT SAUCE PASTES, GARLIC PASTES, GINGER PASTES, SEASONINGS, READY MIX SPICES, KETCHUP, BAKED BREAD, FROZEN PLAIN CAKES (U.S. CL. 46).

FIRST USE 10-7-2005; IN COMMERCE 10-7-2005.

**CLASS 32—LIGHT BEVERAGES**

FOR NON-ALCOHOLIC ASIAN DRINKS, NAMELY, SOFT DRINKS AND SYRUPS USED IN THE MANUFACTURE OF SOFT DRINKS (U.S. CLS. 45, 46 AND 48).  
FIRST USE 10-7-2005; IN COMMERCE 10-7-2005.

OWNER OF U.S. REG. NOS. 1,538,142, 1,608,527, AND OTHERS.

NO CLAIM IS MADE TO THE EXCLUSIVE RIGHT TO USE "UNIVERSITY", APART FROM THE MARK AS SHOWN.

THE MARK CONSISTS OF THE WORDS TEMPLE UNIVERSITY IN A STYLIZED FONT, WITH THE WORD TEMPLE APPEARING IN LARGER LETTERS ABOVE THE WORD UNIVERSITY.

**CLASS 16—PAPER GOODS AND PRINTED MATTER**

FOR NOTEBOOKS, FILLER PAPER, INK PENS, PENCILS, DECALS, STAPLERS, STATIONARY-TYPE PORTFOLIOS, BINDERS, CALENDARS, COMPOSITION BOOKS, DAILY PLANNERS, DATE BOOKS, DESK TOP ORGANIZERS, FILE FOLDERS, WRITING PADS, AND POSTERS (U.S. CLS. 2, 5, 22, 23, 29, 37, 38 AND 50).  
FIRST USE 3-16-2005; IN COMMERCE 3-16-2005.

**CLASS 25—CLOTHING**

FOR T-SHIRTS, KNIT SHIRTS, SWEAT SHIRTS, SWEAT PANTS, SWEAT BANDS, SWEAT SUITS, SWEATERS, SHORTS, BOXER SHORTS, HATS, BASEBALL CAPS, JACKETS, NECKTIES, VESTS, SLEEPWEAR, SOCKS, AND SWIM WEAR (U.S. CLS. 22 AND 39).  
FIRST USE 3-14-2006; IN COMMERCE 3-14-2006.

**CLASS 41—EDUCATION AND ENTERTAINMENT**

FOR EDUCATIONAL SERVICES, NAMELY, PROVIDING INSTRUCTION AND TRAINING AT THE UNDERGRADUATE, GRADUATE, POSTGRADUATE, AND PROFESSIONAL LEVELS; ENTERTAINMENT SERVICES, NAMELY, ARRANGING AND CONDUCTING ATHLETIC COMPETITIONS (U.S. CLS. 100, 101 AND 107).  
FIRST USE 3-1-2005; IN COMMERCE 3-1-2005.

3,234,761. KLISE MANUFACTURING COMPANY, GRAND RAPIDS, MI. SN 78-604,671. PUB. 1-10-2006, FILED 4-8-2005.

# KLISE WOOD IN DETAIL

THE MARK CONSISTS OF STANDARD CHARACTERS WITHOUT CLAIM TO ANY PARTICULAR FONT, STYLE, SIZE, OR COLOR.

NO CLAIM IS MADE TO THE EXCLUSIVE RIGHT TO USE "WOOD", APART FROM THE MARK AS SHOWN.

**CLASS 19—NON-METALLIC BUILDING MATERIALS**

FOR NON-METAL DECORATIVE MOULDINGS AND DECORATIVE TRIM FOR USE ON FURNITURE, CABINETS, BUILDING CONSTRUCTION, TOYS, CASSETS, BOATS, MUSICAL INSTRUMENTS, STORE FIXTURES, AND MANUFACTURED HOUSING; MULTI-LAYERED WOOD; NON-METAL COVE BASES; AND NON-METAL DOOR FRAMES (U.S. CLS. 1, 12, 33 AND 50).

FIRST USE 4-30-2005; IN COMMERCE 4-30-2005.

**CLASS 20—FURNITURE AND ARTICLES NOT OTHERWISE CLASSIFIED**

FOR FURNITURE MOULDINGS AND FURNITURE PARTS, NAMELY LEGS, PEDESTALS, AND TRIM; CURTAIN RODS; DOOR AND DRAWER TRIM; PEGS; PICTURE FRAMES AND WOOD CARVINGS (U.S. CLS. 2, 13, 22, 25, 32 AND 50).

FIRST USE 4-30-2005; IN COMMERCE 4-30-2005.

**CLASS 35—ADVERTISING AND BUSINESS**

FOR WHOLESALE ORDERING SERVICES FEATURING NON-METAL DECORATIVE MOULDINGS AND DECORATIVE TRIM, AND FURNITURE MOULDINGS AND FURNITURE PARTS (U.S. CLS. 100, 101 AND 102).

FIRST USE 4-30-2005; IN COMMERCE 4-30-2005.

3,234,764. INSTITUTO DE MONOCRISTALES, S.L., CARMONA, SEVILLA, SPAIN. SN 78-605,904. PUB. 3-21-2006, FILED 4-11-2005.

*Iris Gem*



*The Presence of Love*

NO CLAIM IS MADE TO THE EXCLUSIVE RIGHT TO USE "GEM", APART FROM THE MARK AS SHOWN.

THE COLOR(S) BROWN AND PURPLE IS/ARE CLAIMED AS A FEATURE OF THE MARK.

THE MARK CONSISTS OF THE TERM IRIS GEM WITH A MISCELLANEOUS DESIGN CONTAINING THE LETTER G BETWEEN THE WORDS IRIS AND GEM. THESE ELEMENTS APPEAR ABOVE THE WORDING THE PRESENCE OF LOVE. THE MISCELLANEOUS DESIGN IS BROWN AND THE REST OF THE WORDS ARE PURPLE.

**CLASS 14—JEWELRY**

FOR JEWELRY, NAMELY, SYNTHETIC DIAMONDS AND PRECIOUS STONES (U.S. CLS. 2, 27, 28 AND 50).

FIRST USE 6-1-2005; IN COMMERCE 5-22-2006.

**CLASS 35—ADVERTISING AND BUSINESS**

FOR ELECTRONIC RETAILING SERVICES VIA COMPUTER FEATURING JEWELRY, NAMELY SYNTHETIC DIAMONDS, PRECIOUS AND SEMI-PRECIOUS STONES (U.S. CLS. 100, 101 AND 102).

FIRST USE 6-1-2005; IN COMMERCE 5-22-2006.

3,234,773. INFOPIA, INC., SALT LAKE CITY, UT. SN 78-610,351. PUB. 3-14-2006, FILED 4-15-2005.

# INFOPIA

THE MARK CONSISTS OF STANDARD CHARACTERS WITHOUT CLAIM TO ANY PARTICULAR FONT, STYLE, SIZE, OR COLOR.

OWNER OF U.S. REG. NO. 2,976,608.

**CLASS 9—ELECTRICAL AND SCIENTIFIC APPARATUS**

FOR COMPUTER SOFTWARE FOR MANAGING ONLINE AUCTION TRANSFERS AND ECOMMERCE TRANSACTIONS AND MANUALS SUPPLIED THEREWITH; COMPUTER SOFTWARE FOR INITIATING, MANAGING, OPTIMIZING, TRACKING, FULFILLING, ANALYZING, AND PROVIDING REPORTS ON E-COMMERCE AND ONLINE AUCTION TRANSACTIONS, AND COMPUTER SOFTWARE FOR CONDUCTING ONLINE MARKETING, NAMELY FOR INITIATING AND TRACKING THE EFFECTIVENESS OF PAY-PER-CLICK, EMAIL, AFFILIATE, AND PRINT MARKETING CAMPAIGNS; COMPUTER SOFTWARE FOR DESIGNING AND HOSTING WEBSITES FOR OTHERS (U.S. CLS. 21, 23, 26, 36 AND 38).

FIRST USE 1-25-2001; IN COMMERCE 1-25-2001.

**CLASS 42—SCIENTIFIC, COMPUTER AND LEGAL SERVICES**

FOR COMPUTER SERVICES, NAMELY, DESIGNING, CREATING, IMPLEMENTING AND HOSTING WEBSITES FOR OTHERS; PROVIDING NON-DOWNLOADABLE SOFTWARE; PROVIDING NON-DOWNLOADABLE SOFTWARE FOR INITIATING, MANAGING, OPTIMIZING, TRACKING, FULFILLING AND ANALYZING ONLINE MARKETING AND E-COMMERCE AND ONLINE AUCTION TRANSACTIONS FOR OTHERS VIA WEBSITES ON THE INTERNET, AND FOR PROVIDING REPORTS REGARDING ONLINE MARKETING ACTIVITIES AND TRANSACTIONS; PROVIDING NON-DOWNLOADABLE SOFTWARE FOR DESIGNING AND HOSTING WEBSITES; PROVIDING NON-DOWNLOADABLE SOFTWARE FOR DESIGNING AND CREATING LOGOS, WEB PAGES, AND WEB LISTING TEMPLATES; PROVIDING NON-DOWNLOADABLE SOFTWARE FOR LISTING DETAILED PRODUCT SEARCH DATA AND RELATED PRODUCT DATA ON WEBSITES AND ONLINE MARKETPLACES; PROVIDING NON-DOWNLOADABLE SOFTWARE FOR USE IN ATTRIBUTE-BASED MERCHANDISING; PROVIDING NON-DOWNLOADABLE SOFTWARE FOR INVENTORY MANAGEMENT AND ORDER FULFILLMENT; PROVIDING NON-DOWNLOADABLE CUSTOMER RELATIONSHIP MANAGEMENT SOFTWARE; PROVIDING NON-DOWNLOADABLE SOFTWARE TO MANAGE AND EVALUATE MARKETING CAMPAIGNS; PROVIDING NON-DOWNLOADABLE SOFTWARE FOR USE IN IMPLEMENTING TRADE-IN CAPABILITIES ON WEBSITE AND AUCTION LISTINGS; CUSTOM COMPUTER PROGRAMMING AND APPLICATION DEVELOPMENT SERVICES FOR OTHERS; COMPUTER AND SOFTWARE INTEGRATION SERVICES (U.S. CLS. 100 AND 101).

FIRST USE 1-25-2001; IN COMMERCE 1-25-2001.



3,234,782. FOREMOST GROUPS, INC., EAST HANOVER, NJ.  
SN 78-614,792. PUB. 6-6-2006, FILED 4-22-2005.

## AFTERGLOW

THE MARK CONSISTS OF STANDARD CHARACTERS WITHOUT CLAIM TO ANY PARTICULAR FONT, STYLE, SIZE, OR COLOR.

### CLASS 4—LUBRICANTS AND FUELS

FOR PATIO TORCHES; COLORED FIRE TORCHES; LIQUID FUEL PATIO TORCHES THAT EMIT A LUMINOUS FLAME (U.S. CLS. 1, 6 AND 15).  
FIRST USE 9-1-2005; IN COMMERCE 11-10-2005.

### CLASS 11—ENVIRONMENTAL CONTROL APPARATUS

FOR OIL LAMPS AND THEIR FITTINGS; LAMPS FOR OUTDOOR USE (U.S. CLS. 13, 21, 23, 31 AND 34).  
FIRST USE 9-1-2005; IN COMMERCE 11-10-2005.

3,234,788. CLEANER'S SUPPLY, INC., CONKLIN, NY. SN 78-616,983. PUB. 2-28-2006, FILED 4-26-2005.



NO CLAIM IS MADE TO THE EXCLUSIVE RIGHT TO USE "QUALITY" AND "GARMENT", APART FROM THE MARK AS SHOWN.

THE COLOR(S) BLACK, WHITE AND RED IS/ARE CLAIMED AS A FEATURE OF THE MARK.

THE COLOR BLACK APPEARS IN THE RECTANGULAR BACKGROUND; THE COLOR WHITE APPEARS IN THE LETTER "Q" AND THE WORDS "QUALITY GARMENT CARE"; THE COLOR RED APPEARS IN THE INNER RECTANGLE FOUND BEHIND THE LETTER "Q".

### CLASS 16—PAPER GOODS AND PRINTED MATTER

FOR PAPER GARMENT COVERS AND TISSUE PAPER (U.S. CLS. 2, 5, 22, 23, 29, 37, 38 AND 50).  
FIRST USE 7-6-2005; IN COMMERCE 7-6-2005.

### CLASS 18—LEATHER GOODS

FOR FLEXIBLE PLASTIC BAGS FOR SWEATERS AND TIES AS GARMENTS; PAPER CARRY-ON BAGS FOR SHIRTS (U.S. CLS. 1, 2, 3, 22 AND 41).  
FIRST USE 7-6-2005; IN COMMERCE 7-6-2005.

3,234,793. ZUTRON MEDICAL, L.L.C., KANSAS CITY, MO.  
SN 78-619,465. PUB. 8-1-2006, FILED 4-28-2005.



NO CLAIM IS MADE TO THE EXCLUSIVE RIGHT TO USE "MEDICAL", APART FROM THE MARK AS SHOWN.

THE MARK CONSISTS OF STYLIZED LARGER LETTERS ZM ON A CONTRASTING BACKGROUND, AND BELOW THEM THE WORDS ZUTRON MEDICAL ALSO ON A CONTRASTING BACKGROUND.

### CLASS 3—COSMETICS AND CLEANING PREPARATIONS

FOR LIQUID DETERGENT FOR CLEANING MEDICAL AND SURGICAL INSTRUMENTS; MULTI-ENZYMATIC CLEANER FOR GENERAL HEALTH CARE EQUIPMENT (U.S. CLS. 1, 4, 6, 50, 51 AND 52).  
FIRST USE 3-6-2006; IN COMMERCE 3-6-2006.

### CLASS 9—ELECTRICAL AND SCIENTIFIC APPARATUS

FOR ENDOSCOPE LEAK DETECTOR (U.S. CLS. 21, 23, 26, 36 AND 38).  
FIRST USE 3-6-2006; IN COMMERCE 3-6-2006.

### CLASS 10—MEDICAL APPARATUS

FOR ENDOSCOPE STIFFENING DEVICE (U.S. CLS. 26, 39 AND 44).  
FIRST USE 3-6-2006; IN COMMERCE 3-6-2006.

3,234,804. PRODUCT PARTNERS, LLC, BEVERLY HILLS, CA. SN 78-622,930. PUB. 3-21-2006, FILED 5-4-2005.

## TURBO SLIM

THE MARK CONSISTS OF STANDARD CHARACTERS WITHOUT CLAIM TO ANY PARTICULAR FONT, STYLE, SIZE, OR COLOR.

### CLASS 9—ELECTRICAL AND SCIENTIFIC APPARATUS

FOR PRE-RECORDED VIDEO CASSETTES AND DVD'S FEATURING EXERCISE, FITNESS AND DIETARY INFORMATION AND INSTRUCTION (U.S. CLS. 21, 23, 26, 36 AND 38).  
FIRST USE 7-26-2005; IN COMMERCE 7-26-2005.

**CLASS 16—PAPER GOODS AND PRINTED MATTER**

FOR PRINTED INSTRUCTIONAL MATERIALS IN THE FIELD OF DIET AND FITNESS (U.S. CLS. 2, 5, 22, 23, 29, 37, 38 AND 50).

FIRST USE 7-26-2005; IN COMMERCE 7-26-2005.

3,234,833. WINGING YOUR WAY LLC, CHANTILLY, VA.  
SN 78-630,558. PUB. 2-21-2006, FILED 5-16-2005.

**CLASS 28—TOYS AND SPORTING GOODS**

FOR PET TOYS (U.S. CLS. 22, 23, 38 AND 50).  
FIRST USE 9-1-2005; IN COMMERCE 9-1-2005.

**CLASS 35—ADVERTISING AND BUSINESS**

FOR ONLINE AND RETAIL STORE SERVICES FEATURING PET TOYS AND ACCESSORIES (U.S. CLS. 100, 101 AND 102).

FIRST USE 9-1-2005; IN COMMERCE 9-1-2005.

3,234,844. HABER VISION, LLC, GOLDEN, CO. SN 78-633,373. PUB. 4-25-2006, FILED 5-19-2005.



THE COLOR(S) BLACK AND BLUE IS/ARE CLAIMED AS A FEATURE OF THE MARK.

THE MARK CONSISTS OF A STYLIZED CAPITAL "H" WITH BLACK VERTICAL SIDES THAT ARC INWARD WITH A BLUE ELONGATED "V" SHAPED DESIGN POSITIONED BETWEEN THE VERTICAL SIDES.

**CLASS 9—ELECTRICAL AND SCIENTIFIC APPARATUS**

FOR EYEWEAR; NAMELY SUNGLASSES, SUNGLASS LENSES, SUNGLASS FRAMES, EYEGLOSS CASES AND EYEGLOSS ACCESSORIES, NAMELY, HEADSTRAPS AND RETAINERS WHICH RESTRAIN EYEWEAR FROM MOVEMENT ON A WEARER, SAFETY AND TACTICAL GLASSES FOR USE BY THE MILITARY AND POLICE, SPORT GOGGLES FOR USE IN SNOW SKIING, WATER SKIING, JET BOATING, SNOW BOARDING, BICYCLING, GOLFING, KAYAKING, TENNIS, SWIMMING, MOTORCYCLING, BOATING, WINDSURFING, SURFING, FISHING, HIKING, CLIMBING, SKY DIVING, BASEBALL AND SAFETY GOGGLES (U.S. CLS. 21, 23, 26, 36 AND 38).

FIRST USE 12-23-2005; IN COMMERCE 12-23-2005.

**CLASS 18—LEATHER GOODS**

FOR BAGS, NAMELY, BACKPACKS, DUFFEL BAGS, MESH SHOPPING BAGS, HAND BAGS AND CARRYING CASES (U.S. CLS. 1, 2, 3, 22 AND 41).

FIRST USE 12-23-2005; IN COMMERCE 12-23-2005.

**CLASS 25—CLOTHING**

FOR CLOTHING, NAMELY SHIRTS, SWEATSHIRTS, T-SHIRTS, GOLF SHIRTS, JACKETS, WIND SUITS, PANTS, SHORTS, SKIRTS, HATS, CAPS, SKI JACKETS, SKI TROUSERS, SOCKS, VISORS AND SWEATERS (U.S. CLS. 22 AND 39).

FIRST USE 12-23-2005; IN COMMERCE 12-23-2005.

3,234,845. FOUNDATION FOR EARLY LEARNING, SEATTLE, WA. SN 78-633,447. PUB. 2-14-2006, FILED 5-19-2005.

 Getting School Ready!

NO CLAIM IS MADE TO THE EXCLUSIVE RIGHT TO USE "SCHOOL", APART FROM THE MARK AS SHOWN. THE STIPPLING IS A FEATURE OF THE MARK.

**CLASS 16—PAPER GOODS AND PRINTED MATTER**

FOR INFORMATIONAL MATERIALS, NAMELY, PRINTED INSTRUCTIONAL, EDUCATIONAL AND TEACHING MATERIALS, DEVELOPMENTAL CHARTS, INFORMATIONAL BOOKLETS, TIP SHEETS, BOOKMARKS, BROCHURES, POSTERS, PRINTED GUIDES, FOR USE IN THE AREA OF PROGRAMS DESIGNED TO SUPPORT PARENTS AS THEIR CHILDREN'S FIRST TEACHERS, IMPROVE ACCESS TO HIGH-QUALITY CHILD CARE AND PRESCHOOL AND CONNECT COMMUNITIES, SCHOOLS, AND FAMILIES FOR CHILDREN'S SUCCESS IN SCHOOL AND LIFE (U.S. CLS. 2, 5, 22, 23, 29, 37, 38 AND 50).

FIRST USE 11-10-2004; IN COMMERCE 3-15-2005.

**CLASS 35—ADVERTISING AND BUSINESS**

FOR ADMINISTRATION AND MANAGEMENT OF GRANTS FOR PROGRAMS DESIGNED TO SUPPORT PARENTS AS THEIR CHILDREN'S FIRST TEACHERS, IMPROVE ACCESS TO HIGH-QUALITY CHILD CARE AND PRESCHOOL AND CONNECT COMMUNITIES, SCHOOLS, AND FAMILIES FOR CHILDREN'S SUCCESS IN SCHOOL AND LIFE (U.S. CLS. 100, 101 AND 102).  
FIRST USE 5-1-2005; IN COMMERCE 5-1-2005.

3,234,873. KINGS RESTAURANT GROUP, LLC, LOS ANGELES, CA. SN 78-638,594. PUB. 3-7-2006, FILED 5-26-2005.

LOOSE LEAF SALAD COMPANY

**CLASS 36—INSURANCE AND FINANCIAL**

FOR CHARITABLE FUND RAISING AND PROVIDING GRANTS TO SCHOOLS AND COMMUNITY ORGANIZATIONS FOR PROGRAMS DESIGNED TO SUPPORT PARENTS AS THEIR CHILDREN'S FIRST TEACHERS, IMPROVE ACCESS TO HIGH-QUALITY CHILD CARE AND PRESCHOOL AND CONNECT COMMUNITIES, SCHOOLS, AND FAMILIES FOR CHILDREN'S SUCCESS IN SCHOOL AND LIFE (U.S. CLS. 100, 101 AND 102).  
FIRST USE 1-1-2005; IN COMMERCE 1-12-2005.

THE MARK CONSISTS OF STANDARD CHARACTERS WITHOUT CLAIM TO ANY PARTICULAR FONT, STYLE, SIZE, OR COLOR.

NO CLAIM IS MADE TO THE EXCLUSIVE RIGHT TO USE "COMPANY" FOR CLASS 25, OR "SALAD COMPANY" FOR CLASSES 30 AND 43, APART FROM THE MARK AS SHOWN.

**CLASS 41—EDUCATION AND ENTERTAINMENT**

FOR ARRANGING AND PLANNING OF CONFERENCES, SEMINARS, AND EVENTS DESIGNED TO SUPPORT PARENTS AS THEIR CHILDREN'S FIRST TEACHERS, IMPROVE ACCESS TO HIGH-QUALITY CHILD CARE AND PRESCHOOL AND CONNECT COMMUNITIES, SCHOOLS, AND FAMILIES FOR CHILDREN'S SUCCESS IN SCHOOL AND LIFE (U.S. CLS. 100, 101 AND 107).  
FIRST USE 10-11-2005; IN COMMERCE 3-3-2005.

**CLASS 25—CLOTHING**

FOR CLOTHING, NAMELY, T-SHIRTS, SHIRTS, SWEATSHIRTS, JACKETS, AND APRONS; FOOTWEAR; AND HEADGEAR, NAMELY, HATS AND CAPS (U.S. CLS. 22 AND 39).  
FIRST USE 7-24-2006; IN COMMERCE 7-24-2006.

**CLASS 30—STAPLE FOODS**

FOR SALAD DRESSINGS AND CONDIMENTS, NAMELY, CROUTONS (U.S. CL. 46).  
FIRST USE 7-24-2006; IN COMMERCE 7-24-2006.

**CLASS 43—HOTEL AND RESTAURANT SERVICES**

FOR RESTAURANT SERVICES (U.S. CLS. 100 AND 101).  
FIRST USE 7-24-2006; IN COMMERCE 7-24-2006.

3,234,864. AMERIGROUP CORPORATION, VIRGINIA BEACH, VA. SN 78-636,590. PUB. 3-7-2006, FILED 5-24-2005.

3,234,885. SPORTS SOURCE, INC., TORRANCE, CA. SN 78-641,664. PUB. 2-21-2006, FILED 6-1-2005.

HIP HOP 4 HEALTH

THE MARK CONSISTS OF STANDARD CHARACTERS WITHOUT CLAIM TO ANY PARTICULAR FONT, STYLE, SIZE, OR COLOR.

**CLASS 35—ADVERTISING AND BUSINESS**

FOR PROMOTING PUBLIC AWARENESS OF THE HEALTH AND WELLNESS OF CHILDREN BY PROMOTING PHYSICAL ACTIVITY, NUTRITION, EDUCATION AND EXERCISE TO CHILDREN (U.S. CLS. 100, 101 AND 102).  
FIRST USE 11-17-2005; IN COMMERCE 11-17-2005.

**CLASS 44—MEDICAL, BEAUTY AND AGRICULTURAL SERVICES**

FOR PROVIDING INFORMATION ABOUT CHILDREN'S HEALTH AND WELLNESS (U.S. CLS. 100 AND 101).  
FIRST USE 11-17-2005; IN COMMERCE 11-17-2005.

THE MARK CONSISTS OF STANDARD CHARACTERS WITHOUT CLAIM TO ANY PARTICULAR FONT, STYLE, SIZE, OR COLOR.

OWNER OF U.S. REG. NOS. 2,716,434 AND 2,716,502.

**CLASS 9—ELECTRICAL AND SCIENTIFIC APPARATUS**

FOR LIFESAVING AND TEACHING APPARATUS AND INSTRUMENTS NAMELY, FOOTBALL HELMETS, HOCKEY HELMETS, MOTORCYCLE HELMETS, BICYCLE HELMETS, HELMETS FOR USE IN AUTO AND BOAT RACING, SKATEBOARD HELMETS, SKI HELMETS, SNOWBOARD HELMETS, DIVING HELMETS, SCUBA DIVING GLOVES, SCUBA MASKS, SCUBA WEIGHT BELTS (U.S. CLS. 21, 23, 26, 36 AND 38).  
FIRST USE 1-2-2006; IN COMMERCE 1-2-2006.

DIAMOND TEK

**CLASS 25—CLOTHING**

FOR CLOTHING NAMELY, HATS, SKI JACKETS, SKI PANTS, PARKAS, SKI OVERALLS, SKI BOOTS, SKI GLOVES, WET SUITS, WET SUITS FOR BODY BOARDING, SHORTS, PANTS, TENNIS SHOES, HIKING BOOTS, RUNNING SHOES, SANDALS, BOOTIES, WALKING SHOES, WATER SHOES, SWEAT SHIRTS, SWEAT PANTS, RACING LEATHERS, NAMELY RACING SUITS, T-SHIRTS, DRESS SHIRTS, GOLF SHIRTS, GOLF SLACKS, GOLF SHOES, SOCKS AND BELTS (U.S. CLS. 22 AND 39).

FIRST USE 1-2-2006; IN COMMERCE 1-2-2006.

**CLASS 28—TOYS AND SPORTING GOODS**

FOR SPORTING GOODS NAMELY, SKIS, MINI SKIS, SKI POLES, SURFBOARDS, BODY BOARDS, WAKE BOARD, WATER SKIS, SCUBA FINS, SWIMMING FINS, SURFBOARD FINS, SURF FINS, SKATE BOARDS, SNOWBOARDS, TENNIS RACKETS, TENNIS BALLS, FOOTBALLS, FOOTBALL SHOULDER PADS, KNEE PADS FOR ATHLETIC USE, ELBOW PADS FOR ATHLETIC USE, WEIGHT LIFTING GLOVES, BARBELLS, DUMBELLS, HOCKEY PUCKS, HOCKEY STICKS, HOCKEY SKATES, INLINE SKATES, GOLF CLUBS, GOLF PUTTERS, GOLF CLUB SHAFTS, GOLF BALLS, GOLF TEES AND GOLF BAGS (U.S. CLS. 22, 23, 38 AND 50).

FIRST USE 1-2-2006; IN COMMERCE 1-2-2006.

3,234,923. AMERICAN EXPRESS MARKETING AND DEVELOPMENT CORP., NEW YORK, NY. SN 78-649,939. PUB. 3-7-2006, FILED 6-14-2005.

**CARRY THE LOVE**

THE MARK CONSISTS OF STANDARD CHARACTERS WITHOUT CLAIM TO ANY PARTICULAR FONT, STYLE, SIZE, OR COLOR.

**CLASS 36—INSURANCE AND FINANCIAL**

FOR CREDIT CARD AND CHARGE CARD SERVICES (U.S. CLS. 100, 101 AND 102).

FIRST USE 7-20-2005; IN COMMERCE 7-20-2005.

**CLASS 39—TRANSPORTATION AND STORAGE**

FOR TRAVEL AGENCY SERVICES, NAMELY, MAKING RESERVATIONS AND BOOKINGS FOR TRANSPORTATION (U.S. CLS. 100 AND 105).

FIRST USE 7-20-2005; IN COMMERCE 7-20-2005.

3,234,920. PROMETHEAN GROUP, LLC, OLATHE, KS. SN 78-649,021. PUB. 3-7-2006, FILED 6-13-2005.

3,234,924. UNITED STATES POSTAL SERVICE, WASHINGTON, DC. SN 78-650,209. PUB. 4-25-2006, FILED 6-14-2005.

**CASUAL CALORIES**

THE MARK CONSISTS OF STANDARD CHARACTERS WITHOUT CLAIM TO ANY PARTICULAR FONT, STYLE, SIZE, OR COLOR.

NO CLAIM IS MADE TO THE EXCLUSIVE RIGHT TO USE CALORIES, APART FROM THE MARK AS SHOWN.

**CLASS 41—EDUCATION AND ENTERTAINMENT**

FOR PHYSICAL FITNESS CONSULTATION AND INSTRUCTION (U.S. CLS. 100, 101 AND 107).

FIRST USE 12-0-2003; IN COMMERCE 12-0-2003.

**CLASS 44—MEDICAL, BEAUTY AND AGRICULTURAL SERVICES**

FOR FOOD NUTRITION CONSULTATION (U.S. CLS. 100 AND 101).

FIRST USE 12-0-2003; IN COMMERCE 12-0-2003.



OWNER OF U.S. REG. NOS. 2,295,192, 2,295,423, AND 2,295,478.

SEC. 2(F) "U.S. POST OFFICE".

**CLASS 35—ADVERTISING AND BUSINESS**

FOR RETAIL STORE SERVICES FEATURING STAMPS, AND VALUE-ADDED MAILING AND DELIVERY PRODUCTS AND SUPPLIES; MAIL SERVICES, NAMELY, VALUE ADDED SORTING, HANDLING AND RECEIVING OF POSTCARDS, LETTERS, PACKAGES, ADVERTISEMENTS, CATALOGS, PUBLICATIONS, INVOICES AND OTHER ITEMS OF MAIL (U.S. CLS. 100, 101 AND 102).

FIRST USE 4-1-2006; IN COMMERCE 4-1-2006.

**CLASS 39—TRANSPORTATION AND STORAGE**

FOR PICKUP, TRANSPORTATION, AND DELIVERY OF POSTCARDS, LETTERS, PACKAGES, ADVERTISEMENTS, CATALOGS, PUBLICATIONS, INVOICES, AND OTHER ITEMS OF MAIL; RENTAL OF MAIL BOXES (U.S. CLS. 100 AND 105).

FIRST USE 4-1-2006; IN COMMERCE 4-1-2006.

3,234,944. BRYANT, PAMELA, SPRINGFIELD, MA. SN 78-652,306. PUB. 2-28-2006, FILED 6-16-2005.

3,234,929. INDOPCO, INC., DBA NATIONAL STARCH AND CHEMICAL COMPANY, BRIDGEWATER, NJ. SN 78-650,862. PUB. 3-14-2006, FILED 6-15-2005.

**EASY-PAC**

THE MARK CONSISTS OF STANDARD CHARACTERS WITHOUT CLAIM TO ANY PARTICULAR FONT, STYLE, SIZE, OR COLOR.

OWNER OF U.S. REG. NOS. 1,614,526 AND 1,964,408.

**CLASS 1—CHEMICALS**

FOR HOT MELT ADHESIVE FOR USE IN THE PACKAGING, ENVELOPE, BOOKBINDING AND LABELING INDUSTRIES (U.S. CLS. 1, 5, 6, 10, 26 AND 46).

FIRST USE 1-5-2006; IN COMMERCE 1-5-2006.

**CLASS 7—MACHINERY**

FOR HOT MELT ADHESIVE APPLICATION EQUIPMENT, NAMELY, HEATED HOLDING TANKS, APPLICATION PUMPS AND APPLICATOR GUNS COMPRISED OF HOSES AND A NOZZLE FOR USE IN THE PACKAGING, ENVELOPE, BOOKBINDING AND LABELING INDUSTRIES (U.S. CLS. 13, 19, 21, 23, 31, 34 AND 35).

FIRST USE 1-5-2006; IN COMMERCE 1-5-2006.

3,234,933. PLASMATRONICS, LLC, CENTER MORICHES, NY. SN 78-651,089. PUB. 3-7-2006, FILED 6-15-2005.

**PLASMATRONICS**

THE MARK CONSISTS OF STANDARD CHARACTERS WITHOUT CLAIM TO ANY PARTICULAR FONT, STYLE, SIZE, OR COLOR.

**CLASS 7—MACHINERY**

FOR ELECTRONIC IGNITIONS IGNITION COILS (U.S. CLS. 13, 19, 21, 23, 31, 34 AND 35).

FIRST USE 11-17-2006; IN COMMERCE 11-17-2006.

**CLASS 9—ELECTRICAL AND SCIENTIFIC APPARATUS**

FOR ENGINE MANAGEMENT COMPUTERS (U.S. CLS. 21, 23, 26, 36 AND 38).

FIRST USE 11-17-2006; IN COMMERCE 11-17-2006.

**FEAST THE EYES**

THE MARK CONSISTS OF STANDARD CHARACTERS WITHOUT CLAIM TO ANY PARTICULAR FONT, STYLE, SIZE, OR COLOR.

**CLASS 16—PAPER GOODS AND PRINTED MATTER**

FOR CALENDARS, NAMELY CALENDARS FEATURING INFORMATION ON NUTRITION AND WEIGHT LOSS (U.S. CLS. 2, 5, 22, 23, 29, 37, 38 AND 50).

FIRST USE 11-1-2003; IN COMMERCE 11-1-2003.

**CLASS 25—CLOTHING**

FOR SHIRTS, NAMELY, T-SHIRTS IMPRINTED WITH IMAGES OF FOOD (U.S. CLS. 22 AND 39).

FIRST USE 11-1-2003; IN COMMERCE 11-1-2003.

3,234,949. ACTION MEDIA OPERATING, LLC, IRVINE, CA. SN 78-652,879. PUB. 3-7-2006, FILED 6-17-2005.

**VIP AUTO FASHION**

THE MARK CONSISTS OF STANDARD CHARACTERS WITHOUT CLAIM TO ANY PARTICULAR FONT, STYLE, SIZE, OR COLOR.

NO CLAIM IS MADE TO THE EXCLUSIVE RIGHT TO USE "AUTO", APART FROM THE MARK AS SHOWN.

**CLASS 35—ADVERTISING AND BUSINESS**

FOR ADVERTISING THE ENTERTAINMENT SERVICES OF OTHERS BY DISTRIBUTING PRINTED PROMOTIONAL MATERIALS (U.S. CLS. 100, 101 AND 102).

FIRST USE 4-24-2004; IN COMMERCE 5-1-2004.

**CLASS 41—EDUCATION AND ENTERTAINMENT**

FOR ENTERTAINMENT SERVICES, NAMELY, ARRANGING AND CONDUCTING AUTOMOBILE COMPETITIONS AND MUSICAL FESTIVALS AND MUSICAL EXPOSITIONS (U.S. CLS. 100, 101 AND 107).

FIRST USE 4-24-2004; IN COMMERCE 5-1-2004.

3,234,957. BIZDEV, LLC, CHEVY CHASE, MD. SN 78-653,924.  
PUB. 3-7-2006, FILED 6-20-2005.

3,234,987. YVONNE LOW, SUNNYVALE, CA. SN 78-657,462.  
PUB. 8-8-2006, FILED 6-24-2005.

## FAMILIES ONLY

THE MARK CONSISTS OF STANDARD CHARACTERS WITHOUT CLAIM TO ANY PARTICULAR FONT, STYLE, SIZE, OR COLOR.

NO CLAIM IS MADE TO THE EXCLUSIVE RIGHT TO USE "FAMILIES", APART FROM THE MARK AS SHOWN.

### CLASS 9—ELECTRICAL AND SCIENTIFIC APPARATUS

FOR CONSUMER COUPONS DOWNLOADED FROM A GLOBAL COMPUTER NETWORK (U.S. CLS. 21, 23, 26, 36 AND 38).

FIRST USE 11-30-2006; IN COMMERCE 11-30-2006.

### CLASS 35—ADVERTISING AND BUSINESS

FOR DIRECT MAIL ADVERTISING; PROMOTING THE SALE OF GOODS AND SERVICES OF OTHERS THROUGH THE DISTRIBUTION OF PRINTED MATERIAL INCLUDING COUPONS AND PROMOTIONAL CONTESTS; PROMOTING THE GOODS AND SERVICES OF OTHERS THROUGH THE DISTRIBUTION OF DISCOUNT CARDS (U.S. CLS. 100, 101 AND 102).

FIRST USE 9-1-2006; IN COMMERCE 9-1-2006.

3,234,973. THE BANDANA CO., INC., LOUISVILLE, KY. SN 78-655,268. PUB. 8-8-2006, FILED 6-21-2005.

## SPOONIES

THE MARK CONSISTS OF STANDARD CHARACTERS WITHOUT CLAIM TO ANY PARTICULAR FONT, STYLE, SIZE, OR COLOR.

### CLASS 6—METAL GOODS

FOR METAL HOOKS FOR KEYS (U.S. CLS. 2, 12, 13, 14, 23, 25 AND 50).

FIRST USE 4-16-2005; IN COMMERCE 10-24-2005.

### CLASS 9—ELECTRICAL AND SCIENTIFIC APPARATUS

FOR REFRIGERATOR MAGNETS (U.S. CLS. 21, 23, 26, 36 AND 38).

FIRST USE 4-16-2005; IN COMMERCE 10-24-2005.

### CLASS 16—PAPER GOODS AND PRINTED MATTER

FOR DESKTOP BUSINESS CARD HOLDERS (U.S. CLS. 2, 5, 22, 23, 29, 37, 38 AND 50).

FIRST USE 4-16-2005; IN COMMERCE 1-26-2006.



THE COLOR(S) WHITE, BLACK, PURPLE, PINK, RED, YELLOW, ORANGE, GREEN AND BLUE IS/ARE CLAIMED AS A FEATURE OF THE MARK.

THE COLOR PURPLE APPEARS AS THE OUTSIDE CIRCLE THAT CONTAINS THE TEXT KYODOOZ IN YELLOW, LIGHT YELLOW APPEARS AS THE BACKGROUND WITHIN THE PINK CIRCLE, THE COLORS ORANGE AND GREEN APPEARS IN THE CARROT, THE RABBIT APPEARS IN THE COLORS WHITE AND PINK WITH BLACK WHISKERS, WEARING A RED GRADUATION CAP, A RED SUIT WITH A BLUE TIE AND PURPLE COVERINGS OVER THE FEET, AND EVERYTHING HAVING A THIN OUTLINE IN THE COLOR BLACK.

### CLASS 16—PAPER GOODS AND PRINTED MATTER

FOR EDUCATIONAL BOOKS FEATURING ELEMENTARY AND HIGH SCHOOL LEVEL MATHEMATICS, CHILDREN'S BOOKS, PICTURE BOOKS, REFERENCE BOOKS IN THE FIELD OF MATHEMATICS AND COMPUTER SCIENCE, CHILDREN'S ACTIVITY BOOKS, COLORING BOOKS, STORY BOOKS, CHILDREN'S STORYBOOKS; DISPOSABLE SWIM PANTS FOR CHILDREN AND INFANTS, MODELING CLAY FOR CHILDREN, MODELING MATERIALS AND COMPOUNDS FOR USE BY CHILDREN, PAINTING SETS FOR CHILDREN, TALKING CHILDREN'S BOOKS, ACCOUNT BOOKS, ADDRESS BOOKS, APPOINTMENT BOOKS, AUTOGRAPH BOOKS, BABY BOOKS, BOOK BINDINGS, BOOK COVERS, BOOK HOLDERS, BOOK-COVER PAPER, BRAG BOOKS, BUSINESS RECORD BOOKS, CARDBOARD BACKING FOR BINDING BOOKS, CASH RECEIPT BOOKS, CHECK BOOKS, COMPOSITION BOOKS, COOK BOOKS, COPY BOOKS, COUPON BOOKS, DATA BOOKS, DATE BOOKS, DICTATION BOOKS, EXERCISE BOOKS, EXERCISE-BOOK COVERS, EXPENSE BOOKS, GUEST BOOKS, LEATHER APPOINTMENT BOOK COVERS, LEATHER BOOK COVERS, LEDGER BOOKS, LOG BOOKS, MANUSCRIPT BOOKS, MEMORANDUM BOOKS, MEMORY BOOKS, NOTE BOOKS, PICTURE BOOKS, POCKET MEMORANDUM BOOKS, PRINTED MUSIC BOOKS, PROTECTIVE COVERS FOR SHEETS OR PAPER AND PAGES OF BOOKS AND THE LIKE, PROTECTIVE COVERS FOR BOOKS, RECEIPT BOOKS, RECIPE BOOKS, REPORTERS' NOTE BOOKS, SCHOOL WRITING BOOKS, SCORE BOOKS, SCORE-BOOKS, SKETCH BOOKS, SONG BOOKS, STENOGRAPHERS' NOTE BOOKS, TELEPHONE NUMBER BOOKS, TRAVEL BOOKS, VOUCHER BOOKS, WIRE-BOUND BOOKS (U.S. CLS. 2, 5, 22, 23, 29, 37, 38 AND 50).

FIRST USE 9-1-2005; IN COMMERCE 9-1-2005.

### CLASS 25—CLOTHING

FOR T-SHIRTS, CHILDREN'S AND INFANT'S CLOTHING, CHILDREN'S AND INFANT'S PLASTIC AND CLOTH BIBS, CHILDREN'S HEADWEAR (U.S. CLS. 22 AND 39).

FIRST USE 9-1-2005; IN COMMERCE 9-1-2005.

3,234,995. PETITE MENAGERIE, INC., ATLANTA, GA. SN 78-658,795. PUB. 3-14-2006, FILED 6-27-2005.



**CLASS 3—COSMETICS AND CLEANING PREPARATIONS**

FOR SOAPS, HAND LOTION, FACE LOTION, BODY LOTION, HAND CREAMS, FACE CREAMS, BODY CREAMS, BALMS FOR USE IN MOISTURIZING THE FACE AND BODY, PERFUMES, BODY MISTS, SCENTED ROOM SPRAYS, OILS FOR THE FACE, BODY AND HAIR, HAIR SHAMPOO, CONDITIONER, BEAUTY MASKS, FACIAL AND BODY SCRUBS, BUFFS, SHOWER GELS, HAND CLEANSER, FACE CLEANSER, BODY CLEANSER, HAND TONERS, FACE TONERS, BODY TONERS, BATH SALTS, BATH SOAKS, AND POTPOURRI (U.S. CLS. 1, 4, 6, 50, 51 AND 52).  
FIRST USE 6-1-2005; IN COMMERCE 12-1-2005.

**CLASS 4—LUBRICANTS AND FUELS**

FOR CANDLES (U.S. CLS. 1, 6 AND 15).  
FIRST USE 6-1-2005; IN COMMERCE 12-1-2005.

**CLASS 25—CLOTHING**

FOR CLOTHING, NAMELY, SHIRTS, T-SHIRTS, SWEATSHIRTS, HATS (U.S. CLS. 22 AND 39).  
FIRST USE 6-1-2005; IN COMMERCE 12-1-2005.

**CLASS 30—STAPLE FOODS**

FOR PASTRIES, CRACKERS, BISCUITS, COOKIES, CAKES, PIES, TARTS, CANDIES, CANDY, CHOCOLATES, CHOCOLATE TRUFFLES, CHUTNEYS, TOPPING SYRUPS, AND SAUCES (U.S. CL. 46).  
FIRST USE 6-1-2005; IN COMMERCE 12-1-2005.

3,234,999. TEAM RESOURCES, INC., ATLANTA, GA. SN 78-659,071. PUB. 2-14-2006, FILED 6-27-2005.

**TRIAXIA PARTNERS**

THE MARK CONSISTS OF STANDARD CHARACTERS WITHOUT CLAIM TO ANY PARTICULAR FONT, STYLE, SIZE, OR COLOR.  
NO CLAIM IS MADE TO THE EXCLUSIVE RIGHT TO USE "PARTNERS", APART FROM THE MARK AS SHOWN.

**CLASS 16—PAPER GOODS AND PRINTED MATTER**

FOR PRINTED INSTRUMENTS FOR MEASURING PERSONAL BEHAVIORAL AND ORGANIZATIONAL CHARACTERISTICS, AND PRINTED REPORTS OF ORGANIZED PROFILES AND SURVEYS (U.S. CLS. 2, 5, 22, 23, 29, 37, 38 AND 50).  
FIRST USE 12-9-2005; IN COMMERCE 12-9-2005.

**CLASS 35—ADVERTISING AND BUSINESS**

FOR BUSINESS CONSULTING SERVICES IN THE FIELD OF MANAGEMENT AND ORGANIZATIONAL DEVELOPMENT, SURVEYS AND PROFILES OF ORGANIZATIONAL CHARACTERISTICS, TEAM DEVELOPMENT, LEADERSHIP DEVELOPMENT, STRATEGY DEVELOPMENT, AND ORGANIZATIONAL DESIGN AND DEVELOPMENT (U.S. CLS. 100, 101 AND 102).  
FIRST USE 12-9-2005; IN COMMERCE 12-9-2005.

3,235,003. DAD LAB, INC., AUSTIN, TX. SN 78-659,548. PUB. 3-7-2006, FILED 6-28-2005.

**DAD LABS**

THE MARK CONSISTS OF STANDARD CHARACTERS WITHOUT CLAIM TO ANY PARTICULAR FONT, STYLE, SIZE, OR COLOR.  
NO CLAIM IS MADE TO THE EXCLUSIVE RIGHT TO USE "DAD", APART FROM THE MARK AS SHOWN.

**CLASS 9—ELECTRICAL AND SCIENTIFIC APPARATUS**

FOR DOWNLOADABLE FILMS AND TELEVISION PROGRAMS PROVIDED VIA VIDEO-ON-DEMAND; VIDEO RECORDINGS AND DOWNLOADABLE VIDEO RECORDINGS FEATURING INSTRUCTIONAL AND INTERACTIVE RESOURCES FOR PARENTS; MUSICAL VIDEO RECORDINGS; PRE-RECORDED CD'S, VIDEO TAPES, LASER DISKS AND DVD'S FEATURING INSTRUCTIONAL AND INTERACTIVE RESOURCES FOR PARENTS (U.S. CLS. 21, 23, 26, 36 AND 38).  
FIRST USE 8-10-2006; IN COMMERCE 8-10-2006.

**CLASS 35—ADVERTISING AND BUSINESS**

FOR RETAIL STORE AND ON-LINE RETAIL STORE SERVICES, AVAILABLE THROUGH COMPUTER COMMUNICATIONS AND INTERACTIVE TELEVISION, FEATURING DOWNLOADABLE PRE-RECORDED MUSIC, VIDEO, INSTRUCTION MANUALS, BOOKS, CLOTHING AND ACCESSORIES; PROVIDING CONSUMER PRODUCT INFORMATION VIA THE INTERNET (U.S. CLS. 100, 101 AND 102).  
FIRST USE 8-10-2006; IN COMMERCE 8-10-2006.

**CLASS 41—EDUCATION AND ENTERTAINMENT**

FOR ENTERTAINMENT IN THE NATURE OF VISUAL AND AUDIO PERFORMANCES AND ENTERTAINMENT AND EDUCATIONAL SERVICES, NAMELY, PROVIDING INSTRUCTIONAL INFORMATION, IN PRE-RECORDED FORM, ON PARENTING AND ACTIVITIES FOR PARENTS AND CHILDREN VIA TELEVISION, RADIO, SATELLITE, AUDIO AND VIDEO COMMUNICATIONS AND VIA A GLOBAL COMPUTER NETWORK; MULTIMEDIA ENTERTAINMENT SOFTWARE PRODUCTION SERVICES (U.S. CLS. 100, 101 AND 107).

FIRST USE 8-10-2006; IN COMMERCE 8-10-2006.

3,235,008. FULLER, JASON C, LAGO VISTA, TX. SN 78-660,172. PUB. 4-25-2006, FILED 6-28-2005.

# Sexy Party

THE MARK CONSISTS OF STANDARD CHARACTERS WITHOUT CLAIM TO ANY PARTICULAR FONT, STYLE, SIZE, OR COLOR.

NO CLAIM IS MADE TO THE EXCLUSIVE RIGHT TO USE "PARTY", APART FROM THE MARK AS SHOWN.

**CLASS 25—CLOTHING**

FOR T-SHIRTS, SHORTS, LINGERIE, TANK TOPS, BATHING SUITS, HATS, SWEAT SHIRTS, UNDERWEAR, SOCKS, BLINDFOLDS (U.S. CLS. 22 AND 39).

FIRST USE 8-1-2006; IN COMMERCE 8-1-2006.

**CLASS 41—EDUCATION AND ENTERTAINMENT**

FOR PARTY/EVENT PLANNING; PARTY/EVENT HOSTING, NAMELY, CONDUCTING PARTIES AND SPECIAL EVENTS (U.S. CLS. 100, 101 AND 107).

FIRST USE 6-2-2006; IN COMMERCE 6-2-2006.

3,235,011. GENERAL ELECTRIC COMPANY, SCHENECTADY, NY. SN 78-660,604. PUB. 5-9-2006, FILED 6-29-2005.



OWNER OF U.S. REG. NOS. 986,362, 1,679,636, AND OTHERS.

**CLASS 37—CONSTRUCTION AND REPAIR**

FOR CHEMICAL CLEANING SERVICES FOR GLASS-LINED REACTOR VESSELS USED IN THE CHEMICAL AND PHARMACEUTICAL PROCESSING INDUSTRIES; MAINTENANCE SERVICES FOR HEAT TRANSFER SYSTEMS AND CONDENSERS; MAINTENANCE AND REPAIR SERVICES IN THE FIELD OF COMPUTERIZED COOLING SYSTEM EQUIPMENT (U.S. CLS. 100, 103 AND 106).

FIRST USE 1-31-2003; IN COMMERCE 1-31-2003.

**CLASS 40—MATERIAL TREATMENT**

FOR WATER AND WASTEWATER TREATMENT SERVICES (U.S. CLS. 100, 103 AND 106).

FIRST USE 1-31-2003; IN COMMERCE 1-31-2003.

3,235,025. WELLQUEST INTERNATIONAL INC., NEW YORK, NY. SN 78-662,105. PUB. 3-21-2006, FILED 6-30-2005.

# WELLQUEST

THE MARK CONSISTS OF STANDARD CHARACTERS WITHOUT CLAIM TO ANY PARTICULAR FONT, STYLE, SIZE, OR COLOR.

OWNER OF U.S. REG. NO. 2,261,517.

**CLASS 3—COSMETICS AND CLEANING PREPARATIONS**

FOR TOOTH GEL, NON-MEDICATED MOUTH WASH, BREATH FRESHENER (U.S. CLS. 1, 4, 6, 50, 51 AND 52).

FIRST USE 11-0-2006; IN COMMERCE 11-0-2006.

**CLASS 10—MEDICAL APPARATUS**

FOR INTRA-ORAL DENTAL DIODE LIGHT SYSTEM FOR TOOTH WHITENING (U.S. CLS. 26, 39 AND 44).

FIRST USE 11-30-2006; IN COMMERCE 11-30-2006.

**CLASS 21—HOUSEWARES AND GLASS**

FOR TOOTHBRUSHES (U.S. CLS. 2, 13, 23, 29, 30, 33, 40 AND 50).

FIRST USE 11-30-2006; IN COMMERCE 11-30-2006.

3,235,050. UNITED COMMUNICATIONS GROUP LIMITED PARTNERSHIP, ROCKVILLE, MD. SN 78-664,220. PUB. 3-28-2006, FILED 7-6-2005.



OWNER OF U.S. REG. NO. 2,845,877.



**CLASS 16—PAPER GOODS AND PRINTED MATTER**

FOR PUBLICATIONS, NAMELY NEWSLETTERS AND MAGAZINES IN THE FIELD OF BUSINESS MANAGEMENT AND GOVERNMENT COMPLIANCE OF HEALTH CARE PROVIDERS (U.S. CLS. 2, 5, 22, 23, 29, 37, 38 AND 50).

FIRST USE 6-27-2005; IN COMMERCE 6-27-2005.

**CLASS 35—ADVERTISING AND BUSINESS**

FOR ON LINE SERVICES ON A GLOBAL COMPUTER NETWORK PROVIDING INFORMATION RELATING TO BUSINESS MANAGEMENT AND GOVERNMENT COMPLIANCE FOR HEALTH CARE PROVIDERS (U.S. CLS. 100, 101 AND 102).

FIRST USE 1-24-2006; IN COMMERCE 1-24-2006.

**CLASS 41—EDUCATION AND ENTERTAINMENT**

FOR EDUCATIONAL SERVICES, NAMELY ORGANIZING AND CONDUCTING SEMINARS IN THE FIELD OF BUSINESS MANAGEMENT AND GOVERNMENT COMPLIANCE FOR HEALTH CARE PROVIDERS (U.S. CLS. 100, 101 AND 107).

FIRST USE 9-0-2005; IN COMMERCE 9-0-2005.

---

3,235,051. TRUMP, DONALD J., NEW YORK, NY. SN 78-664,563. PUB. 3-14-2006, FILED 7-6-2005.

TRUMP LAS OLAS BEACH RESORT

THE MARK CONSISTS OF STANDARD CHARACTERS WITHOUT CLAIM TO ANY PARTICULAR FONT, STYLE, SIZE, OR COLOR.

NO CLAIM IS MADE TO THE EXCLUSIVE RIGHT TO USE "LAS OLAS BEACH RESORT", APART FROM THE MARK AS SHOWN.

THE ENGLISH TRANSLATION OF THE SPANISH WORDING IN THE MARK, "LAS OLAS," IS "THE WAVES".

**CLASS 36—INSURANCE AND FINANCIAL**

FOR REAL ESTATE SERVICES, NAMELY, LISTING LEASING, FINANCING, AND MANAGING COMMERCIAL, RESIDENTIAL, AND HOTEL PROPERTY (U.S. CLS. 100, 101 AND 102).

FIRST USE 6-0-2006; IN COMMERCE 6-0-2006.

**CLASS 37—CONSTRUCTION AND REPAIR**

FOR REAL ESTATE DEVELOPMENT AND CONSTRUCTION OF COMMERCIAL, RESIDENTIAL, AND HOTEL PROPERTY (U.S. CLS. 100, 103 AND 106).

FIRST USE 6-0-2006; IN COMMERCE 6-0-2006.

---

3,235,057. PHARMACIA & UPJOHN COMPANY LLC, PEAPACK, NJ. SN 78-665,200. PUB. 3-21-2006, FILED 7-7-2005.

**PEDIA CARE**

THE MARK CONSISTS OF STANDARD CHARACTERS

WITHOUT CLAIM TO ANY PARTICULAR FONT, STYLE, SIZE, OR COLOR.

OWNER OF U.S. REG. NOS. 1,445,906 AND 2,911,609.

**CLASS 5—PHARMACEUTICALS**

FOR AIR FRESHENER; REFILLS FOR AIR FRESHENERS (U.S. CLS. 6, 18, 44, 46, 51 AND 52).

FIRST USE 8-11-2005; IN COMMERCE 8-11-2005.

**CLASS 10—MEDICAL APPARATUS**

FOR ELECTRIC VAPORIZER THAT EMITS MENTHOL DESIGNED TO HELP CONSUMERS MANAGE UPPER RESPIRATORY CONDITIONS (U.S. CLS. 26, 39 AND 44).

FIRST USE 8-11-2005; IN COMMERCE 8-11-2005.

**CLASS 11—ENVIRONMENTAL CONTROL APPARATUS**

FOR ELECTRICAL DISPENSER FOR AIR FRESHENER AND DEODORIZER TO BE PLUGGED INTO WALL OUTLETS (U.S. CLS. 13, 21, 23, 31 AND 34).

FIRST USE 8-11-2005; IN COMMERCE 8-11-2005.

---

3,235,079. MUIR, GLEN BECK, REXBURG, ID. SN 78-669,518. PUB. 3-28-2006, FILED 7-13-2005.

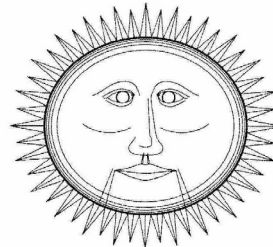
**CLASS 14—JEWELRY**

FOR RINGS, PENDANTS, COLLECTIBLE COINS, COMMEMORATIVE COINS, CHARMS, JEWELRY (U.S. CLS. 2, 27, 28 AND 50).

FIRST USE 8-0-2004; IN COMMERCE 8-0-2004.

**CLASS 25—CLOTHING**

FOR CLOTHING, NAMELY, SHIRTS, PANTS, JACKETS, AND HATS (U.S. CLS. 22 AND 39).

FIRST USE 8-0-2004; IN COMMERCE 8-0-2004.

---

3,235,086. KONDOH INDUSTRIES, LTD., TOKYO, JAPAN. SN 78-671,366. PUB. 4-11-2006, FILED 7-15-2005.

**NEO-CAP**

THE MARK CONSISTS OF STANDARD CHARACTERS WITHOUT CLAIM TO ANY PARTICULAR FONT, STYLE, SIZE, OR COLOR.

**CLASS 7—MACHINERY**

FOR AIR FILTERS FOR MECHANICAL PURPOSES (U.S. CLS. 13, 19, 21, 23, 31, 34 AND 35).  
FIRST USE 1-0-2006; IN COMMERCE 1-0-2006.

**CLASS 11—ENVIRONMENTAL CONTROL APPARATUS**

FOR AIR FILTERS FOR AIR CONDITIONING UNITS; AIR FILTERS FOR INDUSTRIAL INSTALLATIONS (U.S. CLS. 13, 21, 23, 31 AND 34).  
FIRST USE 1-0-2006; IN COMMERCE 1-0-2006.

---

3,235,108. THE MAKERY, DENVER, CO. SN 78-676,806. PUB. 5-16-2006, FILED 7-23-2005.



NO CLAIM IS MADE TO THE EXCLUSIVE RIGHT TO USE "BAKERY", APART FROM THE MARK AS SHOWN.

**CLASS 30—STAPLE FOODS**

FOR BAKERY GOODS (U.S. CL. 46).  
FIRST USE 3-17-2006; IN COMMERCE 6-21-2006.

**CLASS 35—ADVERTISING AND BUSINESS**

FOR RETAIL BAKERY SHOPS FEATURING CAKES, COOKIES, GINGERBREAD COOKIES, GINGERBREAD HOUSES, AND OTHER BAKED GOODS WHICH PATRONS CAN DECORATE THEMSELVES; RETAIL BAKERY SHOP SERVICES (U.S. CLS. 100, 101 AND 102).  
FIRST USE 7-1-2006; IN COMMERCE 7-1-2006.

---

3,235,118. COLORADO SKI COUNTRY U.S.A., INC., DENVER, CO. SN 78-679,388. PUB. 7-18-2006, FILED 7-27-2005.

ENTER A HIGHER STATE

THE MARK CONSISTS OF STANDARD CHARACTERS WITHOUT CLAIM TO ANY PARTICULAR FONT, STYLE, SIZE, OR COLOR.

**CLASS 16—PAPER GOODS AND PRINTED MATTER**

FOR PRINTS AND PUBLICATIONS, NAMELY, BROCHURES, PAMPHLETS, MAGAZINES, POSTERS, NEWSLETTERS AND FREE-STANDING INSERTS FURNISHING TRAVEL INFORMATION AND INFORMATION RELATING TO THE LOCATION AND SERVICES OF SKI AND SNOW BOARDING FACILITIES, AND PUBLICIZING COLORADO SKI AND SNOW BOARDING FACILITIES GENERALLY (U.S. CLS. 2, 5, 22, 23, 29, 37, 38 AND 50).  
FIRST USE 9-0-2005; IN COMMERCE 9-0-2005.

**CLASS 35—ADVERTISING AND BUSINESS**

FOR DISSEMINATION OF ADVERTISING MATTER FOR SKI AND SNOW BOARDING FACILITIES; ASSOCIATION SERVICES, NAMELY, PROMOTING THE INTERESTS OF SKI AND SNOW BOARD RESORTS, SKI AND SNOW BOARD AREA TOWNS AND RELATED BUSINESSES (U.S. CLS. 100, 101 AND 102).  
FIRST USE 8-0-2005; IN COMMERCE 8-0-2005.

**CLASS 39—TRANSPORTATION AND STORAGE**

FOR DISSEMINATING INFORMATION RELATIVE TO TRANSPORTATION TO THE FACILITIES, FOOD, HOUSING AND OTHER AMENITIES AT SKI AND SNOW BOARDING FACILITIES (U.S. CLS. 100 AND 105).  
FIRST USE 9-0-2005; IN COMMERCE 9-0-2005.

---

3,235,151. HARANDI, MEHDI, SPRINGFIELD, VA. SN 78-691,237. PUB. 5-2-2006, FILED 8-12-2005.

THE MARK CONSISTS OF STANDARD CHARACTERS WITHOUT CLAIM TO ANY PARTICULAR FONT, STYLE, SIZE, OR COLOR.

**CLASS 37—CONSTRUCTION AND REPAIR**

FOR INSTALLATION AND REPAIR OF COMPUTERS (U.S. CLS. 100, 103 AND 106).  
FIRST USE 4-27-2006; IN COMMERCE 5-15-2006.

**CLASS 42—SCIENTIFIC, COMPUTER AND LEGAL SERVICES**

FOR INSTALLATION AND REPAIR OF COMPUTER SOFTWARE; COMPUTER CONSULTATION SERVICES (U.S. CLS. 100 AND 101).  
FIRST USE 4-27-2006; IN COMMERCE 5-15-2006.

3,235,166. MACDONALD PAGE & CO LLC, SOUTH PORTLAND, ME. SN 78-695,205. PUB. 5-23-2006, FILED 8-18-2005.

## Simply Genuine

THE MARK CONSISTS OF STANDARD CHARACTERS WITHOUT CLAIM TO ANY PARTICULAR FONT, STYLE, SIZE, OR COLOR.

### CLASS 35—ADVERTISING AND BUSINESS

FOR AUDIT AND ACCOUNTING SERVICES, NAMELY, ACCOUNT AUDITING SERVICES; FINANCIAL STATEMENT AUDIT, REVIEW AND COMPILATION SERVICES; AND FINANCIAL STATEMENT PREPARATION AND ANALYSIS SERVICES FOR BUSINESSES; TAX AND TAX-RELATED CONSULTATION SERVICES, NAMELY, TAX ADVISORY SERVICES; TAX ASSESSMENT SERVICES; TAX RETURN PREPARATION SERVICES; TAX RETURN FILING SERVICES; TAX AND TAXATION PLANNING ADVICE, INFORMATION AND CONSULTANCY SERVICES; AND TAX REPRESENTATION SERVICES BEFORE THE INTERNAL REVENUE SERVICE; BUSINESS ADMINISTRATION AND BUSINESS MANAGEMENT CONSULTATION SERVICES, NAMELY, PROVIDING BUSINESS PROJECTIONS AND FORECASTS; BUSINESS CONSULTATION SERVICES IN THE FIELD OF MANUAL AND COMPUTERIZED BOOKKEEPING, ACCOUNTING AND OFFICE MANAGEMENT SYSTEMS; FRAUD AUDIT AND OTHER BUSINESS AUDIT SERVICES; FORENSIC ACCOUNTING SERVICES; BOOKKEEPING ASSISTANCE AND OVERSIGHT SERVICES; BUSINESS VALUATION AND APPRAISAL SERVICES; PREPARATION OF INTERNAL MANAGEMENT REPORTS; AND BUSINESS NEGOTIATION SERVICES (U.S. CLS. 100, 101 AND 102).

FIRST USE 10-15-2005; IN COMMERCE 10-15-2005.

### CLASS 36—INSURANCE AND FINANCIAL

FOR FINANCIAL ANALYSIS AND CONSULTATION SERVICES; FINANCIAL MANAGEMENT CONSULTATION SERVICES; FINANCIAL FORECASTING SERVICES; AND FINANCIAL MANAGEMENT AND PLANNING SERVICES, NAMELY, BUDGETING AND CASH FLOW ANALYSIS AND CONTROL SERVICES (U.S. CLS. 100, 101 AND 102).

FIRST USE 10-15-2005; IN COMMERCE 10-15-2005.

3,235,172. RUSSELL ENTERPRISES, INC., MILFORD, CT. SN 78-696,217. PUB. 4-25-2006, FILED 8-19-2005.

## ChessCafe

THE MARK CONSISTS OF STANDARD CHARACTERS WITHOUT CLAIM TO ANY PARTICULAR FONT, STYLE, SIZE, OR COLOR.

### CLASS 35—ADVERTISING AND BUSINESS

FOR RETAIL STORE SERVICES AVAILABLE ON A GLOBAL COMPUTER NETWORK FEATURING BOOKS AND INSTRUCTIONAL MATERIALS IN THE FIELD OF GAMES (U.S. CLS. 100, 101 AND 102).

FIRST USE 4-1-1996; IN COMMERCE 4-1-1996.

### CLASS 41—EDUCATION AND ENTERTAINMENT

FOR ENTERTAINMENT AND EDUCATIONAL SERVICES, NAMELY, PROVIDING INFORMATION VIA A WEBSITE IN THE FIELD OF GAMES (U.S. CLS. 100, 101 AND 107).

FIRST USE 4-1-1996; IN COMMERCE 4-1-1996.

3,235,190. SILICON VALLEY BANK, SANTA CLARA, CA. SN 78-704,683. PUB. 6-27-2006, FILED 8-31-2005.

## LIMELIGHT NETWORKS

THE MARK CONSISTS OF STANDARD CHARACTERS WITHOUT CLAIM TO ANY PARTICULAR FONT, STYLE, SIZE, OR COLOR.

NO CLAIM IS MADE TO THE EXCLUSIVE RIGHT TO USE "NETWORKS", APART FROM THE MARK AS SHOWN.

### CLASS 38—COMMUNICATION

FOR ELECTRONIC TRANSMISSION OF DATA, PICTURES, SOFTWARE, MUSIC, AND VIDEO, AND STREAMING OF DATA, PICTURES, SOFTWARE, MUSIC, AND VIDEO FOR OTHERS VIA GLOBAL AND LOCAL COMPUTER NETWORKS (U.S. CLS. 100, 101 AND 104).

FIRST USE 12-0-2001; IN COMMERCE 12-0-2001.

### CLASS 42—SCIENTIFIC, COMPUTER AND LEGAL SERVICES

FOR HOSTING THIRD PARTY WEB CONTENT AND SOFTWARE APPLICATIONS; COMPUTER NETWORK MANAGEMENT, NAMELY, GLOBAL TRAFFIC MANAGEMENT; WEB SITE TRAFFIC MONITORING, ANALYSIS AND REPORTING; DIGITAL RIGHTS MANAGEMENT SERVICES TO PROTECT DATA, PICTURES, SOFTWARE, MUSIC, AND VIDEO; DESIGNING COMPUTER NETWORKS AND SOFTWARE FOR OTHERS (U.S. CLS. 100 AND 101).

FIRST USE 12-0-2001; IN COMMERCE 12-0-2001.

3,235,227. OXFORD INSTRUMENTS AMERICA, INC., CONCORD, MA. SN 78-721,975. PUB. 8-1-2006, FILED 9-28-2005.

## PROSERVE

THE MARK CONSISTS OF STANDARD CHARACTERS WITHOUT CLAIM TO ANY PARTICULAR FONT, STYLE,

SIZE, OR COLOR.

3,235,273. VENTURE RESEARCH, INC., PLANO, TX. SN 78-745,174. PUB. 7-18-2006, FILED 11-2-2005.

**CLASS 35—ADVERTISING AND BUSINESS**

FOR CUSTOMER SERVICE IN THE FIELD OF SERVICE CONTRACTS AND AGREEMENTS FOR THE REPAIR AND MAINTENANCE OF SCIENTIFIC AND MEDICAL INSTRUMENTS AND EQUIPMENT; WHOLESALE DISTRIBUTORSHIP FEATURING SPARE PARTS FOR SCIENTIFIC AND MEDICAL INSTRUMENTS AND EQUIPMENT (U.S. CLS. 100, 101 AND 102).

FIRST USE 7-2-2004; IN COMMERCE 7-2-2004.

**CLASS 37—CONSTRUCTION AND REPAIR**

FOR INSTALLATION, REPAIR AND MAINTENANCE OF SCIENTIFIC AND MEDICAL INSTRUMENTS AND EQUIPMENT, AND THEIR SPARE PARTS (U.S. CLS. 100, 103 AND 106).

FIRST USE 7-2-2004; IN COMMERCE 7-2-2004.

**CLASS 41—EDUCATION AND ENTERTAINMENT**

FOR TRAINING SERVICES IN THE USE OF SCIENTIFIC AND MEDICAL INSTRUMENTS AND EQUIPMENT (U.S. CLS. 100, 101 AND 107).

FIRST USE 7-2-2004; IN COMMERCE 7-2-2004.

**Comp/  
Appliance**

**CLASS 9—ELECTRICAL AND SCIENTIFIC APPARATUS**

FOR COMPUTER HARDWARE AND SOFTWARE IN THE FIELD OF SUPPLY CHAIN MANAGEMENT THAT WILL TRACK AND MANAGE INFORMATION USING RADIO FREQUENCY IDENTIFICATION (RFID) BETWEEN A SUPPLIER'S MANUFACTURING OR DISTRIBUTION CENTER AND ITS CUSTOMER'S RECEIVING CENTER (U.S. CLS. 21, 23, 26, 36 AND 38).

FIRST USE 11-0-2003; IN COMMERCE 11-0-2003.

**CLASS 42—SCIENTIFIC, COMPUTER AND LEGAL SERVICES**

FOR APPLICATION SERVICE PROVIDER (ASP) FEATURING COMPUTER SOFTWARE IN THE FIELD OF SUPPLY CHAIN MANAGEMENT THAT WILL TRACK AND MANAGE INFORMATION USING RADIO FREQUENCY IDENTIFICATION (RFID) BETWEEN A SUPPLIER'S MANUFACTURING OR DISTRIBUTION CENTER AND ITS CUSTOMER'S RECEIVING CENTER (U.S. CLS. 100 AND 101).

FIRST USE 11-0-2003; IN COMMERCE 11-0-2003.

3,235,267. ALTIA, INC., COLORADO SPRINGS, CO. SN 78-741,133. PUB. 7-4-2006, FILED 10-26-2005.

3,235,294. AUGUSTA PROFESSIONAL BASEBALL LLC, BALTIMORE, MD. SN 78-756,713. PUB. 8-22-2006, FILED 11-18-2005.



THE COLOR(S) GREEN AND GREY IS/ARE CLAIMED AS A FEATURE OF THE MARK.

THE LETTERS APPEAR IN GREEN OUTLINED IN GREY.

OWNER OF U.S. REG. NOS. 1,764,307 AND 2,285,221.

**CLASS 9—ELECTRICAL AND SCIENTIFIC APPARATUS**

FOR COMPUTER GRAPHICS SOFTWARE FOR DEVELOPING SIMULATIONS AND EMBEDDED SYSTEMS, AS WELL AS INSTRUCTION MANUALS SOLD THEREWITH (U.S. CLS. 21, 23, 26, 36 AND 38).

FIRST USE 5-31-2005; IN COMMERCE 3-13-2006.

**CLASS 42—SCIENTIFIC, COMPUTER AND LEGAL SERVICES**

FOR COMPUTER CONSULTATION SERVICES, NAMELY, CONSULTATION IN THE AREA OF COMPUTER GRAPHICS SOFTWARE (U.S. CLS. 100 AND 101).

FIRST USE 5-31-2005; IN COMMERCE 3-13-2006.

**CLASS 25—CLOTHING**

FOR CLOTHING, NAMELY, PLAYER UNIFORMS, FOOTWEAR, CHEERLEADER UNIFORMS, REPLICA UNIFORM SHIRTS, WOOL HATS, PAINTER CAPS, BASEBALL CAPS, VISORS, HEADBANDS, WRISTBANDS, SHIRTS, TANK TOPS, JERSEY TOPS, SWEATPANTS, SWEATSHIRTS AND TEESHIRTS (U.S. CLS. 22 AND 39).

FIRST USE 12-1-2005; IN COMMERCE 12-1-2005.

**CLASS 41—EDUCATION AND ENTERTAINMENT**

FOR ENTERTAINMENT SERVICES IN THE NATURE OF BASEBALL EXHIBITIONS (U.S. CLS. 100, 101 AND 107).

FIRST USE 4-11-2006; IN COMMERCE 4-11-2006.

3,235,306. IN-PIPE TECHNOLOGY COMPANY, LLC, WHEATON, IL. SN 78-759,119. PUB. 8-15-2006, FILED 11-22-2005.



OWNER OF U.S. REG. NOS. 2,539,309 AND 2,724,822.  
NO CLAIM IS MADE TO THE EXCLUSIVE RIGHT TO USE "TECHNOLOGY", APART FROM THE MARK AS SHOWN.

#### CLASS 1—CHEMICALS

FOR BACTERIA FOR WASTE WATER TREATMENT (U.S. CLS. 1, 5, 6, 10, 26 AND 46).  
FIRST USE 10-31-2005; IN COMMERCE 10-31-2005.

#### CLASS 40—MATERIAL TREATMENT

FOR WASTE WATER TREATMENT SERVICES AND PROVIDING TECHNICAL CONSULTATION IN CONNECTION THEREWITH (U.S. CLS. 100, 103 AND 106).  
FIRST USE 10-31-2005; IN COMMERCE 10-31-2005.

---

3,235,333. GENERAL ELECTRIC COMPANY, SCHENECTADY, NY. SN 78-769,047. PUB. 5-23-2006, FILED 12-8-2005.

IMAGINATION AT WORK

THE MARK CONSISTS OF STANDARD CHARACTERS WITHOUT CLAIM TO ANY PARTICULAR FONT, STYLE, SIZE, OR COLOR.

#### CLASS 37—CONSTRUCTION AND REPAIR

FOR CHEMICAL CLEANING SERVICES FOR GLASS-LINED REACTOR VESSELS USED IN THE CHEMICAL AND PHARMACEUTICAL PROCESSING INDUSTRIES; MAINTENANCE SERVICES FOR HEAT TRANSFER SYSTEMS AND CONDENSERS; MAINTENANCE AND REPAIR SERVICES IN THE FIELD OF COMPUTERIZED COOLING SYSTEM EQUIPMENT (U.S. CLS. 100, 103 AND 106).  
FIRST USE 7-31-2005; IN COMMERCE 7-31-2005.

#### CLASS 40—MATERIAL TREATMENT

FOR WATER AND WASTEWATER TREATMENT SERVICES (U.S. CLS. 100, 103 AND 106).  
FIRST USE 7-31-2005; IN COMMERCE 7-31-2005.

3,235,341. MAC DONALD, GORDON K., STURGEON BAY, WI. AND MAC DONALD, DIANE LYNN, STURGEON BAY, WI. SN 78-770,657. PUB. 8-22-2006, FILED 12-9-2005.

LAST CHANGE

OAR HOUSE

NO CLAIM IS MADE TO THE EXCLUSIVE RIGHT TO USE "OAR HOUSE" IN INT. CLASS 039 ONLY, APART FROM THE MARK AS SHOWN.

#### CLASS 25—CLOTHING

FOR T-SHIRTS (U.S. CLS. 22 AND 39).  
FIRST USE 12-3-2006; IN COMMERCE 12-3-2006.

#### CLASS 39—TRANSPORTATION AND STORAGE

FOR DRIFT BOAT AND PONTOON BOAT RENTALS (U.S. CLS. 100 AND 105).  
FIRST USE 12-3-2006; IN COMMERCE 12-3-2006.

---

3,235,362. ZAVATA, INC., ATLANTA, GA. SN 78-782,591. PUB. 7-18-2006, FILED 12-29-2005.

ZAVATA

THE MARK CONSISTS OF STANDARD CHARACTERS WITHOUT CLAIM TO ANY PARTICULAR FONT, STYLE, SIZE, OR COLOR.

#### CLASS 35—ADVERTISING AND BUSINESS

FOR BUSINESS PROCESS OUTSOURCING SERVICES FOR CLIENTS IN THE HEALTHCARE, INSURANCE, CORPORATE, AND COMMERCIAL INDUSTRIES, AND GOVERNMENT AND PUBLIC HEALTH AGENCIES IN THE FIELD OF HEALTHCARE REVENUE CYCLE MANAGEMENT, HEALTHCARE ADMINISTRATION SERVICES, MEDICAL MANagements, PPO NETWORK AND DATABASE MANAGEMENT, CLAIMS REPRICING SERVICES, CLAIMS PROCESSING SERVICES, CLAIMS ADJUDICATION SERVICES, CUSTOMER RELATIONSHIP MANAGEMENT SERVICES, BUSINESS PROCESS RE-ENGINEERING, BUSINESS CONSULTING SERVICES, AND HEALTHCARE AND TECHNICAL HELP DESK SERVICES, VIA A GLOBAL SOURCING MODEL (U.S. CLS. 100, 101 AND 102).  
FIRST USE 12-31-2005; IN COMMERCE 12-31-2005.

**CLASS 41—EDUCATION AND ENTERTAINMENT**

FOR EDUCATIONAL SERVICES, NAMELY PROVIDING CLASSES, SEMINARS AND WORKSHOPS IN THE FIELD OF HEALTHCARE, INSURANCE, CORPORATE AND COMMERCIAL INDUSTRIES, AND GOVERNMENT AND PUBLIC HEALTH AGENCIES; TRAINING SERVICES IN THE FIELD OF HEALTHCARE, INSURANCE, CORPORATE AND COMMERCIAL INDUSTRIES, AND GOVERNMENT AND PUBLIC HEALTH AGENCIES (U.S. CLS. 100, 101 AND 107).

FIRST USE 12-31-2005; IN COMMERCE 12-31-2005.

3,235,392. EISAI INC., TEANECK, NJ. SN 78-977,895. PUB. 3-7-2006, FILED 11-16-2004.

HELPING PEOPLE BE  
MORE LIKE  
THEMSELVES  
LONGER

THE MARK CONSISTS OF STANDARD CHARACTERS WITHOUT CLAIM TO ANY PARTICULAR FONT, STYLE, SIZE, OR COLOR.

**CLASS 16—PAPER GOODS AND PRINTED MATTER**

FOR PUBLICATIONS, PERIODIC PUBLICATIONS AND EDUCATIONAL MATERIALS IN THE FIELDS OF AGING, DEMENTIA AND ALZHEIMER'S DISEASE, NAMELY, NEWSLETTERS, BROCHURES, ARTICLES, TRANSCRIPTS, BOOKLETS, LEAFLETS, BULLETINS, POSTERS, FOLDERS, CIRCULARS, AND INSERTS (U.S. CLS. 2, 5, 22, 23, 29, 37, 38 AND 50).

FIRST USE 9-0-2003; IN COMMERCE 9-0-2003.

**CLASS 44—MEDICAL, BEAUTY AND AGRICULTURAL SERVICES**

FOR PROVIDING A DISEASE MANAGEMENT PROGRAM FOR THE DIAGNOSIS, TREATMENT AND MANAGEMENT OF ALZHEIMER'S DISEASE (U.S. CLS. 100 AND 101).

FIRST USE 9-0-2003; IN COMMERCE 9-0-2003.

3,235,395. MASCOT BOOKS, INC., HERNDON, VA. SN 78-977,960. PUB. 3-21-2006, FILED 5-9-2005.

CORT THE SPORT

THE MARK CONSISTS OF STANDARD CHARACTERS WITHOUT CLAIM TO ANY PARTICULAR FONT, STYLE, SIZE, OR COLOR.

**CLASS 14—JEWELRY**

FOR MEDALS (U.S. CLS. 2, 27, 28 AND 50).  
FIRST USE 3-0-2006; IN COMMERCE 3-0-2006.

**CLASS 16—PAPER GOODS AND PRINTED MATTER**

FOR CHILDREN'S BOOKS (U.S. CLS. 2, 5, 22, 23, 29, 37, 38 AND 50).

FIRST USE 3-0-2006; IN COMMERCE 3-0-2006.

3,235,396. EISAI INC., TEANECK, NJ. SN 78-977,971. PUB. 2-21-2006, FILED 11-12-2004.

HELPING PATIENTS  
BE MORE LIKE  
THEMSELVES  
LONGER

THE MARK CONSISTS OF STANDARD CHARACTERS WITHOUT CLAIM TO ANY PARTICULAR FONT, STYLE, SIZE, OR COLOR.

**CLASS 41—EDUCATION AND ENTERTAINMENT**

FOR EDUCATIONAL SERVICES, NAMELY, CONDUCTING COURSE INSTRUCTION AND DISTRIBUTING PRINTED EDUCATIONAL MATERIALS THEREWITH, IN THE FIELD OF DIAGNOSIS, TREATMENT AND MANAGEMENT OF ALZHEIMER'S DISEASE AND DEMENTIA (U.S. CLS. 100, 101 AND 107).

FIRST USE 9-0-2003; IN COMMERCE 9-0-2003.

**CLASS 44—MEDICAL, BEAUTY AND AGRICULTURAL SERVICES**

FOR PROVIDING A DISEASE MANAGEMENT PROGRAM FOR THE DIAGNOSIS, TREATMENT AND MANAGEMENT OF ALZHEIMER'S DISEASE (U.S. CLS. 100 AND 101).

FIRST USE 9-0-2003; IN COMMERCE 9-0-2003.

3,235,397. BECK/ARNLEY WORLDPARTS CORPORATION, SMYRNA, TN. SN 78-977,977. PUB. 8-30-2005, FILED 1-26-2004.

WORLDPARTS

THE MARK CONSISTS OF STANDARD CHARACTERS

WITHOUT CLAIM TO ANY PARTICULAR FONT, STYLE, SIZE, OR COLOR.

WITHOUT CLAIM TO ANY PARTICULAR FONT, STYLE, SIZE, OR COLOR.

OWNER OF U.S. REG. NOS. 1,891,470, 2,654,981, AND OTHERS.

**CLASS 6—METAL GOODS**

FOR VEHICLE PARTS AND ACCESSORIES, NAMELY, GASKETS MADE PARTIALLY OF METAL AND METAL HOSE CLAMPS FOR VEHICLES (U.S. CLS. 2, 12, 13, 14, 23, 25 AND 50).  
FIRST USE 9-1-1972; IN COMMERCE 9-1-1972.

**CLASS 7—MACHINERY**

FOR PARTS FOR INTERNAL COMBUSTION ENGINES, NAMELY, PISTONS, PISTON RINGS, CYLINDER LINERS, ENGINE BEARINGS, CAM BEARINGS, THRUST WASHERS, CAM SHAFTS, VALVES, VALVE GUIDES, VALVE SHIMS, VALVE LIFTERS, VALVE SPRINGS, VALVE SEATS, VALVE ROCKERS, TIMING CHAINS, VALVE TENSIONERS, VALVE GUIDES, TIMING GEARS, OIL PUMPS AND OIL COOLERS, ELECTRONIC IGNITIONS, STARTERS, ALTERNATORS, STARTER DRIVES, STARTER BUSHINGS, STARTER SOLENOIDS, VEHICLE ELECTRONIC AND IGNITION PARTS, NAMELY, POINTS, CONDENSERS, IGNITION ROTORS, DISTRIBUTOR CAPS, IGNITION WIRE SETS, SPARK PLUGS, GLOW PLUGS; CATALYTIC CONVERTERS, WATER PUMPS, RADIATOR CAPS, MECHANICAL AND ELECTRIC FUEL PUMPS, FUEL INJECTORS; CARBURETORS, CARBURETOR FLOATS, NEEDLES, JETS AND DIAPHRAGMS; OIL FILTERS, AIR FILTERS, FUEL FILTERS; PCV VALVES, EGR AND GULP VALVES, EXHAUST CHECK VALVES; ENGINE BALL AND ROLLER BEARINGS; ENGINE MOUNTS; FAN BLADES, FAN MOTORS; BLOWER MOTORS; ANTI-BACKFIRE VALVES, RADIATOR, HEATER AND BY-PASS HOSES, ENGINE BELTS AND TIMING BELTS (U.S. CLS. 13, 19, 21, 23, 31, 34 AND 35).  
FIRST USE 9-1-1972; IN COMMERCE 9-1-1972.

**CLASS 9—ELECTRICAL AND SCIENTIFIC APPARATUS**

FOR VEHICLE PARTS AND ACCESSORIES, NAMELY, VOLTAGE REGULATORS, COILS, COIL RESISTORS, BRUSHES, FUSES, BATTERY CABLES, SWITCHES, FLASHERS, ELECTRICAL RELAYS; SPEEDOMETER CABLES, TACHOMETER CABLES; THERMOSTATS AND THERMOSTAT HOUSINGS; OXYGEN SENSORS; ANTENNAS (U.S. CLS. 21, 23, 26, 36 AND 38).  
FIRST USE 9-1-1972; IN COMMERCE 9-1-1972.

**CLASS 17—RUBBER GOODS**

FOR NON-METAL GASKETS AND NON-METAL OIL SEALS FOR VEHICLES (U.S. CLS. 1, 5, 12, 13, 35 AND 50).  
FIRST USE 9-1-1972; IN COMMERCE 9-1-1972.

**CLASS 9—ELECTRICAL AND SCIENTIFIC APPARATUS**

FOR CD-ROMS, AND INTERACTIVE COMPUTER GAME SOFTWARE, ALL FEATURING INFORMATION FOR FAMILIES OF CHILDREN WITH SERIOUS ILLNESS, AND INSTRUCTIONAL MANUALS SOLD AS A UNIT; ROLLING STAND CONTAINING A COMPUTER, TELEVISION, VCR, DVD PLAYER, ELECTRONIC GAME MACHINE, ELECTRONIC VIDEO GAME MACHINE FOR USE WITH A MONITOR OR A TELEVISION, AND/OR INTERACTIVE GAME MACHINE, FOR USE IN EDUCATION AND COMMUNICATION BY SERIOUSLY ILL CHILDREN IN HOSPITALS (U.S. CLS. 21, 23, 26, 36 AND 38).  
FIRST USE 4-0-2005; IN COMMERCE 4-0-2005.

**CLASS 14—JEWELRY**

FOR PINS, NAMELY, LAPEL PINS (U.S. CLS. 2, 27, 28 AND 50).  
FIRST USE 10-0-2005; IN COMMERCE 10-0-2005.

**CLASS 28—TOYS AND SPORTING GOODS**

FOR PLUSH TOYS (U.S. CLS. 22, 23, 38 AND 50).  
FIRST USE 11-0-2006; IN COMMERCE 11-0-2006.

**CLASS 35—ADVERTISING AND BUSINESS**

FOR CHARITABLE SERVICES, NAMELY ORGANIZING AND CONDUCTING VOLUNTEER PROGRAMS AND COMMUNITY SERVICE PROJECTS TO PROMOTE THE IMPROVEMENT OF THE QUALITY OF LIFE OF SERIOUSLY ILL CHILDREN AND THEIR FAMILIES THROUGH THE COLLABORATION OF ENTERTAINMENT, EDUCATIONAL AND HEALTHCARE PROFESSIONALS (U.S. CLS. 100, 101 AND 102).  
FIRST USE 9-0-2004; IN COMMERCE 9-0-2004.

**CLASS 36—INSURANCE AND FINANCIAL**

FOR CHARITABLE FUND RAISING (U.S. CLS. 100, 101 AND 102).  
FIRST USE 9-0-2004; IN COMMERCE 9-0-2004.

**CLASS 38—COMMUNICATION**

FOR PROVIDING FACILITIES AND EQUIPMENT FOR VIDEO CONFERENCING, NAMELY, FOR ALLOWING CHILDREN WHO ARE ILL TO CORRESPOND WITH OTHER CHILDREN; WEB MESSAGING AND ELECTRONIC MAIL SERVICES THAT ALLOW CHILDREN WHO ARE ILL TO CORRESPOND WITH OTHER CHILDREN; PROVIDING ON-LINE CHAT ROOMS FOR TRANSMISSION OF MESSAGES AMONG COMPUTER USERS CONCERNING CHILDREN'S MEDICAL ISSUES; ELECTRONIC MAIL SERVICES FOR CHILDREN WHO ARE ILL; PROVIDING ONLINE CHAT ROOMS AND ELECTRONIC BULLETIN BOARDS FOR TRANSMISSION OF MESSAGES, PHOTOS AND NOTES AMONG CHILDREN WITH SERIOUS ILLNESSES AND THEIR FAMILIES (U.S. CLS. 100, 101 AND 104).  
FIRST USE 6-0-2004; IN COMMERCE 6-0-2004.

3,235,399. THE STARLIGHT STARBRIGHT CHILDREN'S FOUNDATION, LOS ANGELES, CA. SN 78-977,998. PUB. 11-29-2005, FILED 6-10-2004.

**STARLIGHT  
STARBRIGHT**

THE MARK CONSISTS OF STANDARD CHARACTERS

**CLASS 41—EDUCATION AND ENTERTAINMENT**

FOR EDUCATIONAL SERVICES, NAMELY, DISPLAYING INTERACTIVE PRESENTATIONS VIA VIDEOTAPE, CD-ROM AND INTERACTIVE WEBSITES TO ASSIST IN UNDERSTANDING AND PARTICIPATING IN MEDICAL TREATMENT PROTOCOLS; EDUCATIONAL SERVICES, NAMELY GUIDED FIELD TRIPS FOR SERIOUSLY ILL CHILDREN AND THEIR FAMILIES; ENTERTAINMENT SERVICES, NAMELY, PROVIDING AN ONLINE COMPUTER GAME; PROVIDING FACILITIES FOR RECREATION ACTIVITIES, NAMELY, PROVIDING ROOMS AND OTHER ENVIRONMENTS AT HOSPITALS FOR RELAXATION AND ENTERTAINMENT; CHARITABLE SERVICES, NAMELY, ARRANGING FOR SERIOUSLY ILL CHILDREN AND THEIR FAMILIES TO ATTEND SPORTING EVENTS, AMUSEMENT PARKS, CONCERTS, THEATERS, MUSEUMS AND CELEBRITY MEETINGS; CHARITABLE SERVICES, NAMELY, PROVIDING TOYS TO SERIOUSLY ILL CHILDREN; ENTERTAINMENT SERVICES, NAMELY, ARRANGING PARTIES (U.S. CLS. 100, 101 AND 107).

FIRST USE 9-0-2004; IN COMMERCE 9-0-2004.

**CLASS 42—SCIENTIFIC, COMPUTER AND LEGAL SERVICES**

FOR PROVIDING TEMPORARY USE OF NON-DOWNLOADABLE COMPUTER SOFTWARE FEATURING INFORMATION FOR FAMILIES OF CHILDREN WITH SERIOUS ILLNESSES; COMPUTER SERVICES, NAMELY, PROVIDING SEARCH ENGINES FOR OBTAINING DATA ON A GLOBAL COMPUTER NETWORK THAT ALLOW CHILDREN WHO ARE ILL TO LOCATE OTHER CHILDREN (U.S. CLS. 100 AND 101).

FIRST USE 9-0-2004; IN COMMERCE 9-0-2004.

**CLASS 44—MEDICAL, BEAUTY AND AGRICULTURAL SERVICES**

FOR MEDICAL COUNSELING AND CONSULTATION SERVICES FOR SERIOUSLY ILL CHILDREN AND THEIR FAMILIES TO ASSIST IN UNDERSTANDING AND PARTICIPATING IN MEDICAL TREATMENT PROTOCOLS; PROVIDING A WEBSITES FEATURING MEDICAL INFORMATION FOR FAMILIES OF SERIOUSLY ILL CHILDREN (U.S. CLS. 100 AND 101).

FIRST USE 9-0-2004; IN COMMERCE 9-0-2004.

---

3,235,402. BATH & BODY WORKS, INC., REYNOLDSBURG, OH. SN 78-978,015. PUB. 9-27-2005, FILED 9-28-2004.

100% FLAVOR. 0  
CALORIES.

THE MARK CONSISTS OF STANDARD CHARACTERS WITHOUT CLAIM TO ANY PARTICULAR FONT, STYLE, SIZE, OR COLOR.

**CLASS 4—LUBRICANTS AND FUELS**

FOR CANDLES (U.S. CLS. 1, 6 AND 15).  
FIRST USE 9-15-2004; IN COMMERCE 9-15-2004.

**CLASS 35—ADVERTISING AND BUSINESS**

FOR RETAIL STORE SERVICES IN THE FIELD OF PERSONAL CARE PRODUCTS AND HOME FRAGRANCE PRODUCTS AND ACCESSORIES (U.S. CLS. 100, 101 AND 102).

FIRST USE 9-15-2004; IN COMMERCE 9-15-2004.

---

3,235,403. TICKETMASTER CORPORATION, WEST HOLLYWOOD, CA. SN 78-978,027. PUB. 4-18-2006, FILED 7-14-2005.

COTTONBLEND

THE MARK CONSISTS OF STANDARD CHARACTERS WITHOUT CLAIM TO ANY PARTICULAR FONT, STYLE, SIZE, OR COLOR.

**CLASS 35—ADVERTISING AND BUSINESS**

FOR TICKET AGENCY SERVICES FOR VENUES, SPORTING EVENTS, MUSICAL CONCERTS AND OTHER ENTERTAINMENT EVENTS, RENDERED ONLINE; PROMOTION OF VENUES, MUSICAL PERFORMERS, SPORTING EVENTS, MUSICAL CONCERTS AND OTHER ENTERTAINMENT EVENTS OF OTHERS (U.S. CLS. 100, 101 AND 102).

FIRST USE 9-30-2005; IN COMMERCE 9-30-2005.

**CLASS 42—SCIENTIFIC, COMPUTER AND LEGAL SERVICES**

FOR DESIGN, CREATION, MAINTENANCE AND HOSTING OF WEBSITES FOR OTHERS; PROVIDING ONLINE, NON-DOWNLOADABLE SOFTWARE FOR USE IN MAINTENANCE OF WEBSITES (U.S. CLS. 100 AND 101).

FIRST USE 9-30-2005; IN COMMERCE 9-30-2005.

---

3,235,404. THE STARLIGHT STARBRIGHT CHILDREN'S FOUNDATION, LOS ANGELES, CA. SN 78-978,028. PUB. 11-29-2005, FILED 6-10-2004.

STARLIGHT STARBRIGHT  
CHILDREN'S FOUNDATION

THE MARK CONSISTS OF STANDARD CHARACTERS WITHOUT CLAIM TO ANY PARTICULAR FONT, STYLE, SIZE, OR COLOR.

OWNER OF U.S. REG. NOS. 1,891,470, 2,654,981, AND OTHERS.

NO CLAIM IS MADE TO THE EXCLUSIVE RIGHT TO USE "CHILDREN'S FOUNDATION", APART FROM THE MARK AS SHOWN.



**CLASS 9—ELECTRICAL AND SCIENTIFIC APPARATUS**

FOR VIDEO TAPES, CD-ROMS, AND INTERACTIVE COMPUTER GAME SOFTWARE, ALL FEATURING INFORMATION FOR FAMILIES OF CHILDREN WITH SERIOUS ILLNESS, AND INSTRUCTIONAL MANUALS SOLD AS A UNIT; ROLLING STAND CONTAINING A COMPUTER, TELEVISION, VCR, DVD PLAYER, ELECTRONIC GAME MACHINE, ELECTRONIC VIDEO GAME MACHINE FOR USE WITH A MONITOR OR A TELEVISION, AND/OR INTERACTIVE GAME MACHINE, FOR USE IN EDUCATION AND COMMUNICATION BY SERIOUSLY ILL CHILDREN IN HOSPITALS (U.S. CLS. 21, 23, 26, 36 AND 38).

FIRST USE 4-0-2005; IN COMMERCE 4-0-2005.

**CLASS 14—JEWELRY**

FOR PINS, NAMELY, LAPEL PINS (U.S. CLS. 2, 27, 28 AND 50).

FIRST USE 10-0-2005; IN COMMERCE 10-0-2005.

**CLASS 28—TOYS AND SPORTING GOODS**

FOR PLUSH TOYS (U.S. CLS. 22, 23, 38 AND 50).

FIRST USE 11-0-2006; IN COMMERCE 11-0-2006.

**CLASS 35—ADVERTISING AND BUSINESS**

FOR CHARITABLE SERVICES, NAMELY ORGANIZING AND CONDUCTING VOLUNTEER PROGRAMS AND COMMUNITY SERVICE PROJECTS TO PROMOTE THE IMPROVEMENT OF THE QUALITY OF LIFE OF SERIOUSLY ILL CHILDREN AND THEIR FAMILIES THROUGH THE COLLABORATION OF ENTERTAINMENT, EDUCATIONAL AND HEALTHCARE PROFESSIONALS (U.S. CLS. 100, 101 AND 102).

FIRST USE 9-0-2004; IN COMMERCE 9-0-2004.

**CLASS 36—INSURANCE AND FINANCIAL**

FOR CHARITABLE FUND RAISING (U.S. CLS. 100, 101 AND 102).

FIRST USE 9-0-2004; IN COMMERCE 9-0-2004.

**CLASS 38—COMMUNICATION**

FOR PROVIDING FACILITIES AND EQUIPMENT FOR VIDEO CONFERENCING, NAMELY, FOR ALLOWING CHILDREN WHO ARE ILL TO CORRESPOND WITH OTHER CHILDREN; WEB MESSAGING AND ELECTRONIC MAIL SERVICES THAT ALLOW CHILDREN WHO ARE ILL TO CORRESPOND WITH OTHER CHILDREN; PROVIDING ON-LINE CHAT ROOMS FOR TRANSMISSION OF MESSAGES AMONG COMPUTER USERS CONCERNING CHILDREN'S MEDICAL ISSUES; ELECTRONIC MAIL SERVICES FOR CHILDREN WHO ARE ILL; PROVIDING ONLINE CHAT ROOMS AND ELECTRONIC BULLETIN BOARDS FOR TRANSMISSION OF MESSAGES, PHOTOS AND NOTES AMONG CHILDREN WITH SERIOUS ILLNESSES AND THEIR FAMILIES (U.S. CLS. 100, 101 AND 104).

FIRST USE 6-0-2004; IN COMMERCE 6-0-2004.

**CLASS 41—EDUCATION AND ENTERTAINMENT**

FOR EDUCATIONAL SERVICES, NAMELY, DISPLAYING INTERACTIVE PRESENTATIONS VIA VIDEOTAPE, CD-ROM AND INTERACTIVE WEBSITES TO ASSIST IN UNDERSTANDING AND PARTICIPATING IN MEDICAL TREATMENT PROTOCOLS; EDUCATIONAL SERVICES, NAMELY GUIDED FIELD TRIPS FOR SERIOUSLY ILL CHILDREN AND THEIR FAMILIES; ENTERTAINMENT SERVICES, NAMELY, PROVIDING AN ONLINE COMPUTER GAME; PROVIDING FACILITIES FOR RECREATION ACTIVITIES, NAMELY, PROVIDING ROOMS AND OTHER ENVIRONMENTS AT HOSPITALS FOR RELAXATION AND ENTERTAINMENT; CHARITABLE SERVICES, NAMELY, ARRANGING FOR SERIOUSLY ILL CHILDREN AND THEIR FAMILIES TO ATTEND SPORTING EVENTS, AMUSEMENT PARKS, CONCERTS, THEATERS, MUSEUMS AND CELEBRITY MEETINGS; CHARITABLE SERVICES, NAMELY, PROVIDING TOYS TO SERIOUSLY ILL CHILDREN; ENTERTAINMENT SERVICES, NAMELY, ARRANGING PARTIES (U.S. CLS. 100, 101 AND 107).

FIRST USE 9-0-2004; IN COMMERCE 9-0-2004.

**CLASS 42—SCIENTIFIC, COMPUTER AND LEGAL SERVICES**

FOR PROVIDING TEMPORARY USE OF NON-DOWNLOADABLE COMPUTER SOFTWARE FEATURING INFORMATION FOR FAMILIES OF CHILDREN WITH SERIOUS ILLNESSES; COMPUTER SERVICES, NAMELY, PROVIDING SEARCH ENGINES FOR OBTAINING DATA ON A GLOBAL COMPUTER NETWORK THAT ALLOW CHILDREN WHO ARE ILL TO LOCATE OTHER CHILDREN (U.S. CLS. 100 AND 101).

FIRST USE 9-0-2004; IN COMMERCE 9-0-2004.

**CLASS 44—MEDICAL, BEAUTY AND AGRICULTURAL SERVICES**

FOR MEDICAL COUNSELING AND CONSULTATION SERVICES FOR SERIOUSLY ILL CHILDREN AND THEIR FAMILIES TO ASSIST IN UNDERSTANDING AND PARTICIPATING IN MEDICAL TREATMENT PROTOCOLS; PROVIDING A WEBSITE FEATURING MEDICAL INFORMATION FOR FAMILIES OF SERIOUSLY ILL CHILDREN (U.S. CLS. 100 AND 101).

FIRST USE 9-0-2004; IN COMMERCE 9-0-2004.

3,235,405. TRIMACO, LLC, DURHAM, NC. SN 78-978,032.  
PUB. 9-20-2005, FILED 9-10-2003.

**TRIMACO****CLASS 9—ELECTRICAL AND SCIENTIFIC APPARATUS**

FOR PROTECTIVE WORK GLOVES; SAFETY GOGGLES; DUST MASKS AND PROTECTIVE MASKS (U.S. CLS. 21, 23, 26, 36 AND 38).

FIRST USE 7-0-2005; IN COMMERCE 7-0-2005.

**CLASS 16—PAPER GOODS AND PRINTED MATTER**

FOR PAPER PRODUCTS, NAMELY, CONTRACTOR PAPER; PAPER DROP CLOTHS; KRAFT PAPER; CONSTRUCTION PAPER; BUTCHER PAPER; AND BANNER TAPES IN THE NATURE OF PRINTED PAPER SIGNS; PAINTING SUNDRIES, NAMELY, STAINING PADS, STAINING CLOTH APPLICATORS, DISPOSABLE WIPES NOT IMPREGNATED WITH CHEMICALS; PAINT TRAYS, PAINT TRAY LINERS, PAINT ROLLER FRAMES, SPONGES FOR PAINTING; RAGS USED AS PAINT OR STAIN APPLICATORS (U.S. CLS. 2, 5, 22, 23, 29, 37, 38 AND 50).

FIRST USE 7-0-2005; IN COMMERCE 7-0-2005.

**CLASS 17—RUBBER GOODS**

FOR PLASTIC DROP CLOTHS; MASKING TAPE (U.S. CLS. 1, 5, 12, 13, 35 AND 50).  
FIRST USE 7-0-2005; IN COMMERCE 7-0-2005.

**CLASS 21—HOUSEWARES AND GLASS**

FOR RAGS FOR CLEANING, DISPOSABLE GLOVES FOR GENERAL USE, SPONGES FOR HOUSEHOLD PURPOSES, PAINT STRAINERS, PAPER TOWER DISPENSERS, BUCKETS, PAILS, CORNER GUARDS, AND WIRE BRUSHES, NOT BEING MACHINE PARTS (U.S. CLS. 2, 13, 23, 29, 30, 33, 40 AND 50).  
FIRST USE 7-0-2005; IN COMMERCE 7-0-2005.

**CLASS 22—CORDAGE AND FIBERS**

FOR CANVAS DROP CLOTHS (U.S. CLS. 1, 2, 7, 19, 22, 42 AND 50).  
FIRST USE 7-0-2005; IN COMMERCE 7-0-2005.

**CLASS 24—FABRICS**

FOR TACK CLOTHS USED TO PREPARE SURFACES FOR PAINTING, SHOP TOWELS, PAINTERS' TOWELS AND CHEESE CLOTH (U.S. CLS. 42 AND 50).  
FIRST USE 7-0-2005; IN COMMERCE 7-0-2005.

**CLASS 25—CLOTHING**

FOR PAINTER'S APPAREL, NAMELY, OVERALLS, COVERALLS, SHOE AND BOOT GUARDS, SPRAY SOCKS, PAINTERS' MITTS, SPRAY HOODS, GLOVES, APRONS, SHIRTS, PAINTER PANTS AND SHORTS, VESTS, HATS, AND PAINTERS' JACKETS (U.S. CLS. 22 AND 39).  
FIRST USE 7-0-2005; IN COMMERCE 7-0-2005.

**CLASS 9—ELECTRICAL AND SCIENTIFIC APPARATUS**

FOR COMPUTER HARDWARE, COMMUNICATIONS HARDWARE AND COMPUTER SOFTWARE, ALL FOR USE IN SINGLE-FAMILY RESIDENCES, MULTIPLE-UNIT RESIDENCES AND SMALL BUSINESSES FOR MANAGEMENT, AUTOMATION AND MONITORING OF ELECTRONIC SENSORS OF PHYSICAL ACTIVITY, PHYSICAL PREMISES SECURITY SYSTEMS, HOME ENTERTAINMENT DEVICES AND HOME ELECTRONIC DEVICES, ALL OF THE FOREGOING EXCLUDING SOFTWARE AND HARDWARE TO MANAGE AND SECURE COMMUNICATIONS TRAFFIC OVER COMPUTER NETWORKS (U.S. CLS. 21, 23, 26, 36 AND 38).  
FIRST USE 5-0-2006; IN COMMERCE 5-0-2006.

**CLASS 42—SCIENTIFIC, COMPUTER AND LEGAL SERVICES**

FOR APPLICATION SERVICE PROVIDER (ASP) FEATURING SOFTWARE IN THE FIELDS OF AUTOMATION AND MONITORING OF ELECTRONIC SENSORS OF PHYSICAL ACTIVITY, PHYSICAL PREMISES SECURITY SYSTEMS, HOME ENTERTAINMENT DEVICES AND HOME ELECTRONIC DEVICES, ALL FOR USE IN SINGLE-FAMILY RESIDENCES AND MULTIPLE-UNIT RESIDENCES AND SMALL BUSINESSES; PROVIDING SERVICES BY MEANS OF COMMUNICATIONS NETWORKS ALLOWING AUTOMATION AND CUSTOMER MONITORING OF ELECTRONIC SENSORS OF PHYSICAL ACTIVITY, PHYSICAL PREMISES SECURITY SYSTEMS, HOME ENTERTAINMENT DEVICES AND HOME ELECTRONIC DEVICES, ALL FOR USE IN SINGLE-FAMILY AND MULTIPLE-UNIT RESIDENCES AND SMALL BUSINESSES, ALL OF THE FOREGOING EXCLUDING SOFTWARE AND HARDWARE SUPPORT SERVICES TO MANAGE AND SECURE COMMUNICATIONS TRAFFIC OVER COMPUTER NETWORKS (U.S. CLS. 100 AND 101).  
FIRST USE 5-0-2006; IN COMMERCE 5-0-2006.

3,235,408. ICONTROL NETWORKS, INC., PALO ALTO, CA.  
SN 78-978,039. PUB. 8-9-2005, FILED 3-4-2004.

3,235,409. MARS, INCORPORATED, MC LEAN, VA. SN 78-978,045. PUB. 10-25-2005, FILED 6-21-2005.

# ICONTROL

THE MARK CONSISTS OF STANDARD CHARACTERS WITHOUT CLAIM TO ANY PARTICULAR FONT, STYLE, SIZE, OR COLOR.  
OWNER OF U.S. REG. NOS. 1,847,272 AND 2,407,438.

# 7 PATHS

THE MARK CONSISTS OF STANDARD CHARACTERS WITHOUT CLAIM TO ANY PARTICULAR FONT, STYLE, SIZE, OR COLOR.

**CLASS 29—MEATS AND PROCESSED FOODS**

FOR PREPARED ENTREES CONSISTING PRIMARILY OF MEAT, FISH, POULTRY OR VEGETABLES (U.S. CL. 46).  
FIRST USE 8-20-2006; IN COMMERCE 8-20-2006.

**CLASS 30—STAPLE FOODS**

FOR PREPARED ENTREES CONSISTING PRIMARILY OF PASTA OR RICE; SAUCES (U.S. CL. 46).  
FIRST USE 7-27-2006; IN COMMERCE 7-27-2006.

**CLASS 31—NATURAL AGRICULTURAL PRODUCTS**

FOR FRESH VEGETABLES (U.S. CLS. 1 AND 46).  
FIRST USE 8-20-2006; IN COMMERCE 8-20-2006.

3,235,410. MARS, INCORPORATED, MC LEAN, VA. SN 78-978,046. PUB. 10-25-2005, FILED 6-21-2005.

# SEVEN PATHS

THE MARK CONSISTS OF STANDARD CHARACTERS WITHOUT CLAIM TO ANY PARTICULAR FONT, STYLE, SIZE, OR COLOR.

## CLASS 29—MEATS AND PROCESSED FOODS

FOR PREPARED ENTREES CONSISTING PRIMARILY OF MEAT, FISH, POULTRY OR VEGETABLES (U.S. CL. 46).  
FIRST USE 8-20-2006; IN COMMERCE 8-20-2006.

## CLASS 30—STAPLE FOODS

FOR PREPARED ENTREES CONSISTING PRIMARILY OF PASTA OR RICE; SAUCES (U.S. CL. 46).  
FIRST USE 7-27-2006; IN COMMERCE 7-27-2006.

## CLASS 31—NATURAL AGRICULTURAL PRODUCTS

FOR FRESH VEGETABLES (U.S. CLS. 1 AND 46).  
FIRST USE 8-20-2006; IN COMMERCE 8-20-2006.

3,235,418. CARNIVAL CORPORATION, MIAMI, FL. SN 78-978,098. PUB. 10-11-2005, FILED 4-15-2004.

# "FUN SHIP" FREDDY

THE MARK CONSISTS OF STANDARD CHARACTERS WITHOUT CLAIM TO ANY PARTICULAR FONT, STYLE, SIZE, OR COLOR.  
OWNER OF U.S. REG. NO. 2,813,987.

## CLASS 9—ELECTRICAL AND SCIENTIFIC APPARATUS

FOR MULTIMEDIA SOFTWARE RECORDED ON CD-ROM FEATURING CHILDREN'S GAME (U.S. CLS. 21, 23, 26, 36 AND 38).  
FIRST USE 4-0-2004; IN COMMERCE 4-0-2004.

## CLASS 28—TOYS AND SPORTING GOODS

FOR INFLATABLE DOLLS AND RING BUOYS FOR RECREATIONAL USE (U.S. CLS. 22, 23, 38 AND 50).  
FIRST USE 4-0-2004; IN COMMERCE 4-0-2004.

3,235,419. CUISINE POPULAIRE, INC., CHICAGO, IL. SN 78-978,103. PUB. 4-5-2005, FILED 1-6-2004.

# CUISINE POPULAIRE

THE MARK CONSISTS OF STANDARD CHARACTERS WITHOUT CLAIM TO ANY PARTICULAR FONT, STYLE, SIZE, OR COLOR.

NO CLAIM IS MADE TO THE EXCLUSIVE RIGHT TO USE "CUISINE", APART FROM THE MARK AS SHOWN.

THE ENGLISH TRANSLATION OF THE FRENCH WORDING "CUISINE POPULAIRE" IS "POPULAR CUISINE."

## CLASS 9—ELECTRICAL AND SCIENTIFIC APPARATUS

FOR DOWNLOADABLE ELECTRONIC PUBLICATIONS, NAMELY, NEWSLETTERS IN THE FIELD OF FOOD AND WINE (U.S. CLS. 21, 23, 26, 36 AND 38).  
FIRST USE 2-0-2006; IN COMMERCE 2-0-2006.

## CLASS 43—HOTEL AND RESTAURANT SERVICES

FOR PROVIDING AN INTERACTIVE DATABASE FEATURING INFORMATION IN THE FIELD OF FOOD AND WINE PREPARATION (U.S. CLS. 100 AND 101).  
FIRST USE 2-0-2006; IN COMMERCE 2-0-2006.

\* \* \* \* \*

## SECTION 2.— INTERNATIONAL CLASSIFICATION

The short titles associated below with the international class numbers are terms designed merely for quick identification and are not an official part of the international classification. The full names of international classes are given in section 6.1 of the trademark rules of practice.

The designation "U.S. Cl." appearing in this section refers to the U.S. class in effect prior to Sep. 1, 1973 rather than the international class which applies to applications filed on or after that date. For adoption of international classification see notice in the OFFICIAL GAZETTE of Jun. 26, 1973 (911 O.G. TM 210).

### Application in one class

#### CLASS 1—CHEMICALS

3,233,809. ALDIVIA S.A., 69 561 SAINT-GENIS-LAVAL CE-DEX, FRANCE. SN 76-459,057. PUB. 9-7-2004, FILED 10-15-2002.

#### VIAZEST

FOR LIPOSOLUBLE PLANT EXTRACTS AND OIL SOLUBLE, AQUEOUS, ALCOHOLIC AND GLYCOLIC PLANT EXTRACTS, NAMELY, INTERMEDIATE OLEO-CHEMICAL SOLUTIONS FOR USE IN THE MANUFACTURE OF COSMETICS, NEUTRACEUTICS, PHARMACEUTICS, DIETETICS AND FOR USE IN VETERINARY GOODS, NAMELY EMULSIONS, SHAMPOOS, CAPSULES, SUNTAN OILS (U.S. CLS. 1, 5, 6, 10, 26 AND 46).

FIRST USE 4-11-2002; IN COMMERCE 8-30-2002.

3,233,824. KAUFMAN, KARIN, POUND RIDGE, NY. SN 76-485,351. PUB. 3-29-2005, FILED 1-27-2003.

#### NATURAL STATE RESEARCH

NO CLAIM IS MADE TO THE EXCLUSIVE RIGHT TO USE "RESEARCH", APART FROM THE MARK AS SHOWN.

FOR ORGANIC AND CHEMICAL HAZARDOUS WASTE TREATMENT PREPARATIONS FOR USE IN THE DISPOSAL OF HAZARDOUS MATERIALS (U.S. CLS. 1, 5, 6, 10, 26 AND 46).

FIRST USE 10-9-2002; IN COMMERCE 7-16-2003.

#### CLASS 1—(Continued).

3,233,837. OMS INVESTMENTS, INC., LOS ANGELES, CA. SN 76-496,457. PUB. 11-4-2003, FILED 3-4-2003.



OWNER OF U.S. REG. NOS. 668,868, 2,618,699, AND OTHERS.

THE MARK CONSISTS OF THE WORD "MIRACLE-GRO" IN A BULLSEYE LOGO WITH A GREEN LEAF DOTTING THE "I" IN "MIRACLE-GRO" AND A YELLOW RING IN THE BULLSEYE.

FOR CHARCOAL FOR HORTICULTURAL PURPOSES AND FOR USE AS A SOIL CONDITIONER; PERLITE FOR HORTICULTURAL PURPOSES AND FOR USE AS A SOIL CONDITIONER (U.S. CLS. 1, 5, 6, 10, 26 AND 46).

FIRST USE 12-0-2000; IN COMMERCE 12-0-2000.

3,233,912. BIOVERIS CORPORATION, GAITHERSBURG, MD. SN 76-595,800. PUB. 5-31-2005, FILED 6-7-2004.

#### BV-SANITIZE

THE MARK CONSISTS OF STANDARD CHARACTERS WITHOUT CLAIM TO ANY PARTICULAR FONT, STYLE, SIZE, OR COLOR.

FOR REAGENTS FOR SCIENTIFIC RESEARCH USE; RESEARCH REAGENTS FOR INDUSTRIAL USE, NAMELY, FOR FOOD TESTING (U.S. CLS. 1, 5, 6, 10, 26 AND 46).

FIRST USE 8-31-2004; IN COMMERCE 8-31-2004.

**CLASS 1—(Continued).**

3,233,913. BIOVERIS CORPORATION, GAITHERSBURG, MD. SN 76-595,801. PUB. 5-31-2005, FILED 6-7-2004.

**BV-DILUENT**

THE MARK CONSISTS OF STANDARD CHARACTERS WITHOUT CLAIM TO ANY PARTICULAR FONT, STYLE, SIZE, OR COLOR.

FOR REAGENTS FOR SCIENTIFIC RESEARCH USE; RESEARCH REAGENTS FOR INDUSTRIAL USE, NAMELY, FOR FOOD TESTING (U.S. CLS. 1, 5, 6, 10, 26 AND 46).

FIRST USE 8-11-2004; IN COMMERCE 8-11-2004.

---

3,233,945. FUJI CHEMICAL INDUSTRY CO., LTD., NAKA-NIIKAWA-GUN, TOYAMA-KEN, JAPAN. SN 76-609,483. PUB. 4-18-2006, FILED 8-31-2004.

**F-MELT**

THE MARK CONSISTS OF STANDARD CHARACTERS WITHOUT CLAIM TO ANY PARTICULAR FONT, STYLE, SIZE, OR COLOR.

FOR PHARMACEUTICAL EXCIPIENT FOR USE IN THE MANUFACTURE OF SOLID DOSAGE DRUGS, NAMELY, EXCIPIENT FOR USE IN THE MANUFACTURE OF DIRECTLY-COMPRESSIBLE OR RAPIDLY DISINTEGRATING TABLETS (U.S. CLS. 1, 5, 6, 10, 26 AND 46).

FIRST USE 10-12-2004; IN COMMERCE 2-28-2005.

---

3,233,977. WORLD WIDE IMPORTS ENTERPRISES, INC., FT. LAUDERDALE, FL. SN 76-616,281. PUB. 9-27-2005, FILED 10-18-2004.

**ALIVE**

THE MARK CONSISTS OF STANDARD CHARACTERS WITHOUT CLAIM TO ANY PARTICULAR FONT, STYLE, SIZE, OR COLOR.

FOR SALTWATER, SEAWATER, OCEAN WATER AND FRESHWATER SOLUTIONS, NAMELY SALTWATER, SEAWATER, OCEAN WATER, FRESHWATER, CONCENTRATED SALTWATER, CONCENTRATED SEAWATER, CONCENTRATED OCEAN WATER, AND CONCENTRATED FRESH WATER, EACH ENRICHED WITH PRESERVATIVES AND SOLD IN RETAIL CONTAINERS FOR USE IN FILLING AQUARIUMS DURING INITIAL SET-UP, FOR REPLACING WATER LOST TO EVAPORATION, AND FOR AQUARIUM WATER CHANGES (U.S. CLS. 1, 5, 6, 10, 26 AND 46).

FIRST USE 9-0-2003; IN COMMERCE 9-0-2003.

**CLASS 1—(Continued).**

3,234,033. I & OC OF JAPAN CO., LTD., TOKYO 113-0033, JAPAN. SN 76-635,273. PUB. 7-18-2006, FILED 4-6-2005.

**LAND LIFE**

THE MARK CONSISTS OF STANDARD CHARACTERS WITHOUT CLAIM TO ANY PARTICULAR FONT, STYLE, SIZE, OR COLOR.

FOR SOIL CONDITIONERS FOR AGRICULTURAL AND HORTICULTURAL USE (U.S. CLS. 1, 5, 6, 10, 26 AND 46).

FIRST USE 5-26-2006; IN COMMERCE 5-26-2006.

---

3,234,158. POLYONE CORPORATION, AVON LAKE, OH. SN 78-293,050. PUB. 8-31-2004, FILED 8-27-2003.

**ONFLEX**

FOR THERMOPLASTIC ELASTOMER POLYMERIC COMPOUNDS FOR USE IN PLASTIC MOLDING OR EXTRUDING OPERATIONS (U.S. CLS. 1, 5, 6, 10, 26 AND 46).

FIRST USE 9-28-2006; IN COMMERCE 9-28-2006.

---

3,234,293. TERRACYCLE, INC., TRENTON, NJ. SN 78-411,169. PUB. 3-15-2005, FILED 4-30-2004.



THE COLOR GREEN IS CLAIMED AS A FEATURE OF THE MARK.

THE MARK CONSISTS OF A DESIGN IN THE SHAPE OF A MODIFIED INFINITY SYMBOL HAVING A SOLID GREEN COLOR.

FOR FERTILIZER (U.S. CLS. 1, 5, 6, 10, 26 AND 46). FIRST USE 12-6-2006; IN COMMERCE 12-6-2006.

**CLASS 1—(Continued).**

3,234,669. BIO-BOTANICA, INC., HAUPAUGGE, NY. SN 78-573,708. PUB. 12-13-2005, FILED 2-23-2005.

## SUPRAPEIN

THE MARK CONSISTS OF STANDARD CHARACTERS WITHOUT CLAIM TO ANY PARTICULAR FONT, STYLE, SIZE, OR COLOR.

OWNER OF U.S. REG. NOS. 2,300,825, 2,352,531, AND 2,916,646.

FOR BIOTANICAL ESSENCES AND EXTRACTS AND PREPARATIONS FOR USE AS INGREDIENTS IN THE MANUFACTURE OF PHARMACEUTICALS, FOOD SUPPLEMENTS, COSMETICS AND PERSONAL CARE PREPARATIONS (U.S. CLS. 1, 5, 6, 10, 26 AND 46).

FIRST USE 9-0-2004; IN COMMERCE 7-0-2005.

3,234,687. ESM TECHNOLOGIES, L.L.C., CARTHAGE, MO. SN 78-579,668. PUB. 3-7-2006, FILED 3-3-2005.

## HA-LO

THE MARK CONSISTS OF STANDARD CHARACTERS WITHOUT CLAIM TO ANY PARTICULAR FONT, STYLE, SIZE, OR COLOR.

FOR BULK CHEMICAL FOR COMMERCIAL USE IN FURTHER MANUFACTURING, NAMELY, ALL-NATURAL, NON-IRRADIATED LOW MOLECULAR WEIGHT HYALURONIC ACID FOR USE BY MANUFACTURES IN THE MANUFACTURE OF COSMETICS, NUTRITIONAL SUPPLEMENTS, AND PHARMACEUTICALS (U.S. CLS. 1, 5, 6, 10, 26 AND 46).

FIRST USE 11-30-2006; IN COMMERCE 11-30-2006.

**CLASS 1—(Continued).**

3,234,700. MISSISSIPPI LIME COMPANY, ST. LOUIS, MO. SN 78-583,723. PUB. 12-27-2005, FILED 3-9-2005.



NO CLAIM IS MADE TO THE EXCLUSIVE RIGHT TO USE "LIME", APART FROM THE MARK AS SHOWN.

FOR CALCIUM BASED CHEMICALS (U.S. CLS. 1, 5, 6, 10, 26 AND 46).

FIRST USE 5-0-2004; IN COMMERCE 9-1-2004.

3,234,734. SIGMA-ALDRICH BIOTECHNOLOGY L.P., SAINT LOUIS, MO. SN 78-596,496. PUB. 12-20-2005, FILED 3-28-2005.

## FLUOROPROFILE

THE MARK CONSISTS OF STANDARD CHARACTERS WITHOUT CLAIM TO ANY PARTICULAR FONT, STYLE, SIZE, OR COLOR.

FOR CHEMICALS AND BIOCHEMICALS, NAMELY, FLUORESCENT SUBSTANCES FOR USE IN LABELING BIOLOGICAL AGENTS FOR LABORATORY AND RESEARCH USE (U.S. CLS. 1, 5, 6, 10, 26 AND 46).

FIRST USE 7-1-2005; IN COMMERCE 7-1-2005.

3,234,781. GRANCRETE LLC, MECHANICSVILLE, VA. SN 78-613,929. PUB. 3-14-2006, FILED 4-21-2005.

## GRANCRETE

THE MARK CONSISTS OF STANDARD CHARACTERS WITHOUT CLAIM TO ANY PARTICULAR FONT, STYLE, SIZE, OR COLOR.

FOR CHEMICAL AGENTS THAT ARE SPRAYED ONTO SYNTHETIC WALL MATERIALS THAT DRY INTO A DURABLE WALL STRUCTURE FOR USE IN THE BUILDING AND CONSTRUCTION INDUSTRY; BUILDING MATERIALS, NAMELY, PROPRIETARY CEMENT-LIKE SUBSTANCES IN THE NATURE OF CONTACT CEMENTS (U.S. CLS. 1, 5, 6, 10, 26 AND 46).

FIRST USE 1-30-2006; IN COMMERCE 1-30-2006.

**CLASS 1—(Continued).**

3,234,904. J.R. SIMPLOT COMPANY, BOISE, ID. SN 78-646,377. PUB. 3-21-2006, FILED 6-8-2005.

**SPRAY-FAST**

THE MARK CONSISTS OF STANDARD CHARACTERS WITHOUT CLAIM TO ANY PARTICULAR FONT, STYLE, SIZE, OR COLOR.

FOR ADJUVANTS AND SURFACTANTS FOR USE WITH PESTICIDES AND FERTILIZERS FOR AGRICULTURAL, TURF, AND HORTICULTURAL USE (U.S. CLS. 1, 5, 6, 10, 26 AND 46).

FIRST USE 1-24-2006; IN COMMERCE 1-24-2006.

---

3,234,912. ECONET, INC., LACEY, WA. SN 78-647,643. PUB. 2-21-2006, FILED 6-9-2005.

**ECONET**

THE MARK CONSISTS OF STANDARD CHARACTERS WITHOUT CLAIM TO ANY PARTICULAR FONT, STYLE, SIZE, OR COLOR.

FOR CHEMICAL ADDITIVES AND BOTANICAL EXTRACTS USED IN THE MANUFACTURE OF COSMETICS, LOTIONS, MEDICATIONS, PHARMACEUTICALS, NUTRICEUTICALS, DIETING AIDS, SUNSCREEN, SKIN REPAIR PREPARATIONS, AFTER SUN EXPOSURE PREPARATIONS, COSMECEUTICALS, ANTISEPTICS, DIETARY SUPPLEMENTS, HEALTH FOODS, HEALTH DRINKS, MEDICAL DRINKS AND VETERINARY DIETARY SUPPLEMENTS (U.S. CLS. 1, 5, 6, 10, 26 AND 46).

FIRST USE 4-5-2005; IN COMMERCE 4-5-2005.

---

3,234,956. STRATAGENE CALIFORNIA, LA JOLLA, CA. SN 78-653,829. PUB. 3-7-2006, FILED 6-20-2005.

**SIDESTEP**

THE MARK CONSISTS OF STANDARD CHARACTERS WITHOUT CLAIM TO ANY PARTICULAR FONT, STYLE, SIZE, OR COLOR.

FOR REAGENTS FOR SCIENTIFIC RESEARCH USE (U.S. CLS. 1, 5, 6, 10, 26 AND 46).

FIRST USE 8-4-2005; IN COMMERCE 8-4-2005.

**CLASS 1—(Continued).**

3,234,977. FLEXIBLE PRODUCTS COMPANY, MARIETTA, GA. SN 78-655,788. PUB. 4-11-2006, FILED 6-22-2005.

**INSTA STIK**

THE MARK CONSISTS OF STANDARD CHARACTERS WITHOUT CLAIM TO ANY PARTICULAR FONT, STYLE, SIZE, OR COLOR.

OWNER OF U.S. REG. NO. 1,545,937.

FOR ADHESIVES USED IN THE BUILDING, CONSTRUCTION, AND REPAIR INDUSTRIES (U.S. CLS. 1, 5, 6, 10, 26 AND 46).

FIRST USE 0-0-1981; IN COMMERCE 0-0-1981.

---

3,235,047. GRAIN PROCESSING CORPORATION, MUSCATINE, IA. SN 78-663,805. PUB. 3-21-2006, FILED 7-5-2005.

**TruBran**

THE MARK CONSISTS OF STANDARD CHARACTERS WITHOUT CLAIM TO ANY PARTICULAR FONT, STYLE, SIZE, OR COLOR.

FOR INGREDIENTS FOR USE IN THE MANUFACTURE OF FOOD PRODUCTS, NAMELY, FIBER DERIVED FROM CORN (U.S. CLS. 1, 5, 6, 10, 26 AND 46).

FIRST USE 10-1-2006; IN COMMERCE 10-1-2006.

---

3,235,054. NEWCOMER SUPPLY, INC., MIDDLETON, WI. SN 78-664,856. PUB. 4-11-2006, FILED 7-6-2005.

**FrozFix**

THE MARK CONSISTS OF STANDARD CHARACTERS WITHOUT CLAIM TO ANY PARTICULAR FONT, STYLE, SIZE, OR COLOR.

FOR HISTOLOGICAL FIXATIVES (U.S. CLS. 1, 5, 6, 10, 26 AND 46).

FIRST USE 9-19-2006; IN COMMERCE 9-19-2006.

**CLASS 1—(Continued).**

3,235,312. MIDTECH R&D, INC., FAIRMONT, MN. SN 78-761,752. PUB. 8-1-2006, FILED 11-28-2005.

**POWERHOUSE**

THE MARK CONSISTS OF STANDARD CHARACTERS WITHOUT CLAIM TO ANY PARTICULAR FONT, STYLE, SIZE, OR COLOR.

FOR ADJUVANTS FOR USE WITH PESTICIDES (U.S. CLS. 1, 5, 6, 10, 26 AND 46).  
FIRST USE 3-20-2006; IN COMMERCE 3-20-2006.

3,235,313. MIDTECH R&D, INC., FAIRMONT, MN. SN 78-761,819. PUB. 8-1-2006, FILED 11-28-2005.

**ENACT**

THE MARK CONSISTS OF STANDARD CHARACTERS WITHOUT CLAIM TO ANY PARTICULAR FONT, STYLE, SIZE, OR COLOR.

FOR ADJUVANTS FOR USE WITH PESTICIDES (U.S. CLS. 1, 5, 6, 10, 26 AND 46).  
FIRST USE 3-1-2006; IN COMMERCE 3-1-2006.

3,235,314. MIDTECH R&D, INC., FAIRMONT, MN. SN 78-762,255. PUB. 8-1-2006, FILED 11-29-2005.

**INSOURCE**

THE MARK CONSISTS OF STANDARD CHARACTERS WITHOUT CLAIM TO ANY PARTICULAR FONT, STYLE, SIZE, OR COLOR.

FOR ADJUVANTS FOR USE WITH PESTICIDES (U.S. CLS. 1, 5, 6, 10, 26 AND 46).  
FIRST USE 2-16-2006; IN COMMERCE 2-16-2006.

**CLASS 2—PAINTS****CLASS 2—(Continued).**

3,233,876. DEGUSSA CORPORATION, PARSIPPANY, NJ. SN 76-570,432. PUB. 10-19-2004, FILED 1-12-2004.

**DECOTREND**

OWNER OF U.S. REG. NO. 2,857,162.  
FOR PIGMENT DISPERSIONS FOR COLORING PAINTS AND PLASTICS; COLORANTS FOR ARCHITECTURAL AND INDUSTRIAL SURFACE COATINGS (U.S. CLS. 6, 11 AND 16).  
FIRST USE 3-22-2006; IN COMMERCE 3-22-2006.

3,233,916. PROTECTIVE COATING COMPANY, ALLENTOWN, PA. SN 76-596,044. PUB. 5-23-2006, FILED 6-7-2004.

**PC-WOOD GUARDIAN**

THE MARK CONSISTS OF STANDARD CHARACTERS WITHOUT CLAIM TO ANY PARTICULAR FONT, STYLE, SIZE, OR COLOR.

FOR WOOD PRESERVATIVE FOR PROTECTING AND TREATING WOOD AGAINST FUNGAL DECAY AND PREVENTING AND CONTROLLING WOOD DESTROYING INSECTS (U.S. CLS. 6, 11 AND 16).  
FIRST USE 10-11-2004; IN COMMERCE 10-11-2004.

3,234,353. INVISTA NORTH AMERICA S.A.R.L., WILMINGTON, DE. SN 78-451,025. PUB. 6-20-2006, FILED 7-15-2004.

**STAINMASTER**

THE MARK CONSISTS OF STANDARD CHARACTERS WITHOUT CLAIM TO ANY PARTICULAR FONT, STYLE, SIZE, OR COLOR.

FOR PAINTS (U.S. CLS. 6, 11 AND 16).  
FIRST USE 10-18-2006; IN COMMERCE 10-18-2006.



**CLASS 2—(Continued).**

3,234,531. FLINT INK CORPORATION, ANN ARBOR, MI.  
SN 78-521,736. PUB. 3-14-2006, FILED 11-23-2004.

**STARBASE**

THE MARK CONSISTS OF STANDARD CHARACTERS WITHOUT CLAIM TO ANY PARTICULAR FONT, STYLE, SIZE, OR COLOR.

FOR LITHOGRAPHIC, FLEXIGRAPHIC, AND GRAVURE INKS AND PIGMENTS FOR USE IN THE GRAPHIC ARTS INDUSTRY AND PACKAGING (U.S. CLS. 6, 11 AND 16).

FIRST USE 6-0-2004; IN COMMERCE 6-0-2004.

3,234,704. WALLCOAT, INC., WINTER PARK, FL. SN 78-585,531. PUB. 1-17-2006, FILED 3-11-2005.

**LOOKS LIKE  
PAINT...LASTS A  
LIFETIME**

THE MARK CONSISTS OF STANDARD CHARACTERS WITHOUT CLAIM TO ANY PARTICULAR FONT, STYLE, SIZE, OR COLOR.

FOR LIQUID ARCHITECTURAL WALL COVERINGS, NAMELY SEALER COATINGS FOR EXTERIOR WALL SURFACES (U.S. CLS. 6, 11 AND 16).

FIRST USE 4-30-2006; IN COMMERCE 4-30-2006.

**CLASS 2—(Continued).**

3,234,891. GERDAU AMERISTEEL US, INC., TAMPA, FL. SN 78-642,872. PUB. 2-14-2006, FILED 6-3-2005.

**ZBAR**

THE MARK CONSISTS OF STANDARD CHARACTERS WITHOUT CLAIM TO ANY PARTICULAR FONT, STYLE, SIZE, OR COLOR.

FOR ORGANIC, THERMALLY-CURED POWDER ANTI-CORROSIVE COATING FOR STRUCTURAL METAL (U.S. CLS. 6, 11 AND 16).

FIRST USE 10-18-2006; IN COMMERCE 10-18-2006.

**CLASS 3—COSMETICS AND CLEANING PREPARATIONS**

3,233,776. ROOTS CANADA LTD., TORONTO, ONTARIO, CANADA. SN 76-259,596. PUB. 9-13-2005, FILED 5-21-2001.

**ROOTS FOR HIM**

PRIORITY CLAIMED UNDER SEC. 44(D) ON CANADA APPLICATION NO. 1094,726, FILED 3-2-2001, REG. NO. TMA605126, DATED 3-15-2004, EXPIRES 3-15-2019.

NO CLAIM IS MADE TO THE EXCLUSIVE RIGHT TO USE "FOR HIM", APART FROM THE MARK AS SHOWN.

FOR AROMATHERAPY PRODUCTS, NAMELY SCENTED CREAMS, HAIR AND BODY WASHES, BATH BEADS AND HOME SCENTED PRODUCTS, NAMELY, SCENTED BURN STICKS, SCENTED ROOM SPRAYS, POTPOURRIS AND SACHETS (U.S. CLS. 1, 4, 6, 50, 51 AND 52).

FIRST USE 7-0-2002; IN COMMERCE 7-0-2002.

3,233,777. ROOTS CANADA LTD., TORONTO, ONTARIO, CANADA. SN 76-260,365. PUB. 9-13-2005, FILED 5-21-2001.

**ROOTS FOR HER**

PRIORITY CLAIMED UNDER SEC. 44(D) ON CANADA APPLICATION NO. 1096,506, FILED 3-19-2001, REG. NO. 605088, DATED 3-15-2004, EXPIRES 3-15-2019.

NO CLAIM IS MADE TO THE EXCLUSIVE RIGHT TO USE "FOR HER", APART FROM THE MARK AS SHOWN.

FOR AROMATHERAPY PRODUCTS, NAMELY, SCENTED CREAMS, HAIR AND BODY WASHES, BATH BEADS AND HOME SCENTED PRODUCTS, NAMELY, SCENTED BURN STICKS, SCENTED ROOM SPRAYS, POTPOURRIS AND SACHETS (U.S. CLS. 1, 4, 6, 50, 51 AND 52).

FIRST USE 7-0-2002; IN COMMERCE 7-0-2002.

**CLASS 3—(Continued).**

3,233,782. WILLIAMS-SONOMA, INC., SAN FRANCISCO, CA. SN 76-352,866. PUB. 7-12-2005, FILED 12-19-2001.

**PURE AND SIMPLE**

FOR BATH GELS AND ROOM FRAGRANCES (U.S. CLS. 1, 4, 6, 50, 51 AND 52).  
FIRST USE 10-10-2006; IN COMMERCE 10-10-2006.

---

3,233,852. AMOREPACIFIC CORPORATION, SEOUL, REPUBLIC OF KOREA. SN 76-525,750. PUB. 9-7-2004, FILED 6-18-2003.

**LANEIGE****EVERYDAY NEW FACE**

OWNER OF U.S. REG. NOS. 2,110,811 AND 2,408,553.  
FOR LIPSTICKS, NON-MEDICATED MOISTURIZING SKIN SERUMS, SKIN FRESHENERS, SKIN MILK LOTIONS, FACE POWDERS, POWDER FOUNDATIONS, FOUNDATIONS, NOURISHING SKIN AND FACIAL CREAMS, SUN BLOCK CREAMS, SUN TAN CREAMS, EYEBROW PENCILS, EYE SHADOWS, LIP GLOSS, SUN BLOCK LOTIONS, SUN TAN LOTIONS, SKIN CLEANSING CREAMS, BODY AND FACIAL MASSAGE CREAMS, SKIN CLEANSING LOTIONS, MASCARAS, AND COSMETIC PENCILS (U.S. CLS. 1, 4, 6, 50, 51 AND 52).

FIRST USE 1-1-2000; IN COMMERCE 1-1-2000.

---

3,233,853. FERRIS, DAVID, CHICAGO, IL. SN 76-526,139. PUB. 2-10-2004, FILED 6-13-2003.

**EKOSHAV**

FOR SHAVING SOAP (U.S. CLS. 1, 4, 6, 50, 51 AND 52).  
FIRST USE 10-20-2006; IN COMMERCE 10-20-2006.

**CLASS 3—(Continued).**

3,233,871. BUBBLES, INC., FALLS CHURCH, VA. SN 76-564,815. PUB. 8-17-2004, FILED 11-28-2003.

**TSU SHINE**

THE MARK CONSISTS OF STANDARD CHARACTERS WITHOUT CLAIM TO ANY PARTICULAR FONT, STYLE, SIZE, OR COLOR.

FOR HAIR CARE PRODUCTS, NAMELY, SHAMPOOS, CONDITIONERS AND STYLING PREPARATIONS, AND SOAPS, TOILET WATER, SKIN CREAMS AND BODY LOTIONS (U.S. CLS. 1, 4, 6, 50, 51 AND 52).

FIRST USE 5-17-2004; IN COMMERCE 5-17-2004.

---

3,233,879. CHANEL, INC., NEW YORK, NY. SN 76-574,999. PUB. 3-22-2005, FILED 2-9-2004.

**DOUCEUR SCINTILLANTE**

THE MARK CONSISTS OF STANDARD CHARACTERS WITHOUT CLAIM TO ANY PARTICULAR FONT, STYLE, SIZE, OR COLOR.

OWNER OF U.S. REG. NOS. 2,474,785 AND 2,671,909.  
THE MARK DOUCEUR SCINTILLANTE TRANSLATES AS SPARKLING SOFTNESS.

FOR FRAGRANCES FOR PERSONAL USE, NON-MEDICATED SKIN CARE PREPARATIONS (U.S. CLS. 1, 4, 6, 50, 51 AND 52).

FIRST USE 3-1-2005; IN COMMERCE 3-1-2005.

---

3,233,906. BIOTHERM, MONACO, MONACO. SN 76-592,253. PUB. 8-16-2005, FILED 5-14-2004.

**LINE PEEL**

NO CLAIM IS MADE TO THE EXCLUSIVE RIGHT TO USE "PEEL", APART FROM THE MARK AS SHOWN.

FOR COSMETICS NAMELY, LOTIONS AND GELS FOR THE FACE, THE BODY AND THE HANDS (U.S. CLS. 1, 4, 6, 50, 51 AND 52).

FIRST USE 8-0-2006; IN COMMERCE 8-0-2006.

**CLASS 3—(Continued).**

3,233,918. KOSE CORPORATION, CHUO-KU, TOKYO, JAPAN. SN 76-597,623. PUB. 5-2-2006, FILED 6-16-2004.

**A W A K E**  
**skin renovation**  
**FIRM ADVANTAGE**

OWNER OF U.S. REG. NOS. 2,576,627, 2,888,687, AND OTHERS.

NO CLAIM IS MADE TO THE EXCLUSIVE RIGHT TO USE "SKIN RENOVATION" OR "FIRM", APART FROM THE MARK AS SHOWN.

THE MARK CONSISTS OF THE WORD AWAKE IN STYLIED FORM AND THE WORDS SKIN RENOVATION IN A LOWER CASE BLOCK LETTER FORM AND THE WORDS FIRM ADVANTAGE IN AN UPPER CASE BLOCK LETTER FORM.

FOR COSMETICS, PERFUMES, COSMETIC SOAPS, COTTON FOR COSMETIC USE AND HAIR CARE PREPARATIONS (U.S. CLS. 1, 4, 6, 50, 51 AND 52).

FIRST USE 10-1-2004; IN COMMERCE 10-1-2004.

3,233,924. L'ORÉAL, PARIS, FRANCE. SN 76-600,493. PUB. 5-16-2006, FILED 7-2-2004.

**MEN'S EXPERT**

THE MARK CONSISTS OF STANDARD CHARACTERS WITHOUT CLAIM TO ANY PARTICULAR FONT, STYLE, SIZE, OR COLOR.

NO CLAIM IS MADE TO THE EXCLUSIVE RIGHT TO USE "MEN'S", APART FROM THE MARK AS SHOWN.

FOR FACE WASH, FACIAL AND EYE MOISTURIZERS, EYE CREAMS, ANTIWRINKLE AND SKIN FIRING MOISTURIZERS, AND SKIN EXFOLIATING CLEANSERS, LOTIONS AND CREAMS (U.S. CLS. 1, 4, 6, 50, 51 AND 52).

FIRST USE 2-0-2005; IN COMMERCE 2-0-2005.

3,233,944. TOMA'S, LLC, OKLAHOMA CITY, OK. SN 76-609,337. PUB. 1-10-2006, FILED 8-26-2004.

**SUN MERGE**

THE MARK CONSISTS OF STANDARD CHARACTERS WITHOUT CLAIM TO ANY PARTICULAR FONT, STYLE, SIZE, OR COLOR.

NO CLAIM IS MADE TO THE EXCLUSIVE RIGHT TO USE SUN, APART FROM THE MARK AS SHOWN.

FOR NON-MEDICATED SKIN CARE PREPARATIONS, NAMELY, INSTANT SELF TANNING CREAMS, TANNING ACCELERATORS, EXFOLIATE GELS, MOISTURIZING LOTIONS, SKIN SCRUBS, TANNING GELS, TANNING FOAMS, TANNING OILS, SUN SCREEMS, LIP BALMS, BRONZING POWDERS, FADE CREAMS, LIPSTICK AND MAKEUP (U.S. CLS. 1, 4, 6, 50, 51 AND 52).

FIRST USE 12-0-2004; IN COMMERCE 12-0-2004.

**CLASS 3—(Continued).**

3,234,052. CONOPCO, INC., DBA UNILEVER, TRUMBULL, CT. SN 76-640,118. PUB. 2-21-2006, FILED 6-3-2005.

**SUNSILK**

OWNER OF U.S. REG. NO. 2,594,734.  
FOR HAIR CARE PRODUCTS, NAMELY, SHAMPOO AND CONDITIONER (U.S. CLS. 1, 4, 6, 50, 51 AND 52).  
FIRST USE 6-18-2006; IN COMMERCE 6-18-2006.

3,234,073. JAFRA COSMETICS INTERNATIONAL, INC., WESTLAKE VILLAGE, CA. SN 76-648,246. PUB. 6-13-2006, FILED 10-11-2005.

**YITSU**

THE MARK CONSISTS OF STANDARD CHARACTERS WITHOUT CLAIM TO ANY PARTICULAR FONT, STYLE, SIZE, OR COLOR.

FOR EAU DE TOILETTE (U.S. CLS. 1, 4, 6, 50, 51 AND 52).

FIRST USE 10-10-2006; IN COMMERCE 10-10-2006.

3,234,074. BIKE BRITE, INC., MENTOR, OH. SN 76-648,335. PUB. 6-13-2006, FILED 10-12-2005.

**MOTO-SHINE**

THE MARK CONSISTS OF STANDARD CHARACTERS WITHOUT CLAIM TO ANY PARTICULAR FONT, STYLE, SIZE, OR COLOR.

FOR CLEANING AND POLISHING PREPARATIONS FOR BICYCLES AND MOTORIZED VEHICLES (U.S. CLS. 1, 4, 6, 50, 51 AND 52).

FIRST USE 1-1-2006; IN COMMERCE 1-1-2006.

**CLASS 3—(Continued).**

3,234,099. SCIENCE OF SKINCARE, LLC, GLENDALE, CA. SN 78-115,843. PUB. 8-19-2003, FILED 3-19-2002.

**IS HE**

FOR NON-MEDICATED SKINCARE TREATMENT PRODUCTS AND TOILETRIES, NAMELY, REJUVENATING LOTIONS, SERUMS, CREAMS, TONICS, ANTI-AGING SKINCARE TREATMENTS, NAMELY, CREAMS, FIRING CREAMS, MOISTURIZING SERUMS, LOTIONS, MOISTURIZERS FOR THE FACE, BODY, EYES, LIPS, AND HANDS, SKIN LIGHTENERS FOR THE FACE AND BODY, SKIN CLEANSERS, FACIAL CLEANSERS, BODY WASHES, SHAMPOOS, SHAVING PRODUCTS, NAMELY, SHAVING BALM AND GEL, HAIR GELS, HAIR SPRAYS, HAIR THICKENERS; AND FRAGRANCES, NAMELY, COLOGNES (U.S. CLS. 1, 4, 6, 50, 51 AND 52).

FIRST USE 10-24-2006; IN COMMERCE 10-24-2006.

3,234,141. WANDREY, HOWARD L. JR., CORONA, CA. SN 78-257,131. PUB. 2-17-2004, FILED 6-2-2003.

**NAILESSANCE**

FOR NAIL CARE PREPARATIONS, INCLUDING, NAIL STRENGTHENER (U.S. CLS. 1, 4, 6, 50, 51 AND 52). FIRST USE 7-0-2006; IN COMMERCE 7-0-2006.

3,234,146. THE PROCTER & GAMBLE COMPANY, CINCINNATI, OH. SN 78-269,148. PUB. 3-8-2005, FILED 7-1-2003.

**OLAY CLARITY**

OWNER OF U.S. REG. NOS. 1,109,069, 1,130,648, AND OTHERS.

FOR NON-MEDICATED SKIN CARE PREPARATIONS, NAMELY, COSMETIC DRY LATHERING CLOTHS CONTAINING SKIN SOAP (U.S. CLS. 1, 4, 6, 50, 51 AND 52). FIRST USE 7-31-2005; IN COMMERCE 7-31-2005.

3,234,163. ISTITUTO GANASSINI S.P.A. DI RICERCHE BIOCHIMICHE, MILANO, ITALY. SN 78-301,650. PUB. 1-31-2006, FILED 9-17-2003.

**HYDROTENSEUR**

PRIORITY CLAIMED UNDER SEC. 44(D) ON ERPNTY TM OFC APPLICATION NO. 003299351, FILED 7-30-2003, REG. NO. 3299351, DATED 10-29-2004, EXPIRES 7-30-2013.

FOR COSMETICS (U.S. CLS. 1, 4, 6, 50, 51 AND 52). FIRST USE 1-1-2004; IN COMMERCE 7-5-2005.

**CLASS 3—(Continued).**

3,234,186. MICRO ABRASIVES CORPORATION, WESTFIELD, MA. SN 78-329,956. PUB. 6-20-2006, FILED 11-19-2003.



OWNER OF U.S. REG. NO. 689,287.  
NO CLAIM IS MADE TO THE EXCLUSIVE RIGHT TO USE THE GREEK LETTER (MU), "ABRASIVES" AND "CORPORATION", APART FROM THE MARK AS SHOWN. SEC. 2(F).

FOR ABRASIVE GRAINS AND POWDERS CONSISTING OF FUSED AND UNFUSED ALUMINUM OXIDE AND SILICON OXIDE AND SILICON CARBIDE; INDUSTRIAL ABRASIVES FOR USE IN GRINDING, POLISHING AND REFRACTORY APPLICATIONS AND INDUSTRIES (U.S. CLS. 1, 4, 6, 50, 51 AND 52). FIRST USE 9-0-2003; IN COMMERCE 7-0-2006.

3,234,202. PHILOSOPHY, INC., PHOENIX, AZ. SN 78-348,071. PUB. 9-28-2004, FILED 1-6-2004.

**MOMMY**

THE MARK CONSISTS OF STANDARD CHARACTERS WITHOUT CLAIM TO ANY PARTICULAR FONT, STYLE, SIZE, OR COLOR.

FOR GIFT SETS COMPRISED OF FRAGRANCES, NAMELY, PERFUME, FACE AND BODY LOTION, HAIR CARE PRODUCTS, NAMELY, SHAMPOO, AND BATH CARE PRODUCTS, NAMELY, GEL (U.S. CLS. 1, 4, 6, 50, 51 AND 52).

FIRST USE 11-16-2006; IN COMMERCE 11-16-2006.

**CLASS 3—(Continued).**

3,234,231. MIRALOMA CORPORATION, ANAHEIM, CA. SN 78-378,467. PUB. 4-4-2006, FILED 3-4-2004.

**CLASS 3—(Continued).**

3,234,456. NOXELL CORPORATION, THE, HUNT VALLEY, MD. SN 78-499,250. PUB. 8-8-2006, FILED 10-13-2004.

# ANISETTE

# SMOOTHWEAR LIPTINTS

THE MARK CONSISTS OF STANDARD CHARACTERS WITHOUT CLAIM TO ANY PARTICULAR FONT, STYLE, SIZE, OR COLOR.  
FOR PERFUME, COLOGNE, SCENTED BODY SPRAY (U.S. CLS. 1, 4, 6, 50, 51 AND 52).  
FIRST USE 11-1-2004; IN COMMERCE 11-1-2004.

THE MARK CONSISTS OF STANDARD CHARACTERS WITHOUT CLAIM TO ANY PARTICULAR FONT, STYLE, SIZE, OR COLOR.  
OWNER OF U.S. REG. NO. 2,076,121.  
NO CLAIM IS MADE TO THE EXCLUSIVE RIGHT TO USE LIPTINTS, APART FROM THE MARK AS SHOWN.  
FOR COSMETICS, NAMELY, LIP GLOSS (U.S. CLS. 1, 4, 6, 50, 51 AND 52).  
FIRST USE 7-31-2005; IN COMMERCE 7-31-2005.

3,234,497. CAKE BEAUTY INC., TORONTO, ONTARIO, CANADA. SN 78-512,620. PUB. 3-7-2006, FILED 11-6-2004.

3,234,284. KISS NAIL PRODUCTS, INC., PORT WASHINGTON, NY. SN 78-407,711. PUB. 4-5-2005, FILED 4-26-2004.

# CAKE WALK

# JET DRY

THE MARK CONSISTS OF STANDARD CHARACTERS WITHOUT CLAIM TO ANY PARTICULAR FONT, STYLE, SIZE, OR COLOR.  
FOR NAIL GLUE (U.S. CLS. 1, 4, 6, 50, 51 AND 52).  
FIRST USE 1-3-2005; IN COMMERCE 1-3-2005.

THE MARK CONSISTS OF STANDARD CHARACTERS WITHOUT CLAIM TO ANY PARTICULAR FONT, STYLE, SIZE, OR COLOR.  
FOR COSMETICS AND BODY CARE PRODUCTS, NAMELY, BODY LOTIONS AND FOOT LOTIONS (U.S. CLS. 1, 4, 6, 50, 51 AND 52).  
FIRST USE 8-31-2001; IN COMMERCE 8-31-2001.

**CLASS 3—(Continued).**

3,234,519. HEALTHPOINT, LTD., SAN ANTONIO, TX. SN 78-519,354. PUB. 6-27-2006, FILED 11-18-2004.

---

**CERAVE**

THE MARK CONSISTS OF STANDARD CHARACTERS WITHOUT CLAIM TO ANY PARTICULAR FONT, STYLE, SIZE, OR COLOR.

FOR COMPLETE LINE OF SKIN CARE PREPARATIONS, NAMELY, CLEANERS, MOISTURIZERS, LOTIONS, HAND CREAMS, HAND OINTMENTS, AND SUNSCREEN CREAMS (U.S. CLS. 1, 4, 6, 50, 51 AND 52). FIRST USE 6-1-2005; IN COMMERCE 6-1-2005.

---

3,234,548. TARA'S DREAM LTD., GRAND CAYMAN, CAYMAN ISLANDS. SN 78-527,323. PUB. 3-14-2006, FILED 12-6-2004.

**PERFECTING DREAM  
CREME**

THE MARK CONSISTS OF STANDARD CHARACTERS WITHOUT CLAIM TO ANY PARTICULAR FONT, STYLE, SIZE, OR COLOR.

NO CLAIM IS MADE TO THE EXCLUSIVE RIGHT TO USE "PERFECTING" AND "CREME", APART FROM THE MARK AS SHOWN.

FOR SKIN CARE PRODUCTS, NAMELY NON-MEDICATED SKIN CREAMS, SKIN SERUMS, SKIN LOTIONS, AND NON-MEDICATED SKIN CARE PREPARATIONS (U.S. CLS. 1, 4, 6, 50, 51 AND 52).

FIRST USE 7-31-2005; IN COMMERCE 7-31-2005.

---

3,234,651. SEBASTIAN INTERNATIONAL, INC., WOODLAND HILLS, CA. SN 78-564,118. PUB. 11-8-2005, FILED 2-9-2005.

**EXOTIC EROTIC**

**CLASS 3—(Continued).**

THE MARK CONSISTS OF STANDARD CHARACTERS WITHOUT CLAIM TO ANY PARTICULAR FONT, STYLE, SIZE, OR COLOR.

FOR HAIR CARE PRODUCTS, NAMELY, HAIR STYLING GEL AND JAM IN THE NATURE OF HAIR STYLING PASTE (U.S. CLS. 1, 4, 6, 50, 51 AND 52).

FIRST USE 7-15-2005; IN COMMERCE 7-15-2005.

---

3,234,671. BRAZIL BRONZE INC., NEW YORK, NY. SN 78-574,038. PUB. 4-18-2006, FILED 2-24-2005.

**BRAZIL BRONZE GLOW  
BAR**

THE MARK CONSISTS OF STANDARD CHARACTERS WITHOUT CLAIM TO ANY PARTICULAR FONT, STYLE, SIZE, OR COLOR.

NO CLAIM IS MADE TO THE EXCLUSIVE RIGHT TO USE BRONZE, APART FROM THE MARK AS SHOWN.

FOR SUNLESS TANNING PREPARATIONS, SUNLESS AIRBRUSH TANNING SOLUTIONS AND SPRAYS; SUNLESS AIRBRUSH TANNING SOLUTIONS WHICH, WHEN APPLIED, HELP REDUCE THE APPEARANCE OF CELLULITE; SUNLESS AIRBRUSH TANNING SOLUTIONS WHICH, WHEN APPLIED, GIVES THE BODY A MORE SCULPTED APPEARANCE; FACIAL BRONZERS; FACE AND BODY LOTIONS; EXFOLIATING FACE AND BODY WASHES; SELF-TANNING LOTIONS; SUNSCREENS; SUNBLOCKS; SUNTANNING LOTIONS, GELS AND OILS, SUNLESS TANNING POWDERS; SUNLESS TAN EXTENDERS; AFTER-SUN SKIN LOTIONS; LIP BALMS; SKIN MOISTURIZERS, SKIN CLEANSERS; FACIAL MASKS; SKIN FRESHENERS AND TONICS; MAKE-UP REMOVER, FOUNDATION MAKEUP; BATH AND SHOWER SOAP, GEL AND FOAM; AND BUBBLE BATH, ALL OF THE FOREGOING NOT IN BAR FORM (U.S. CLS. 1, 4, 6, 50, 51 AND 52).

FIRST USE 5-31-2005; IN COMMERCE 5-31-2005.

---

3,234,720. ENIVA CORPORATION, MINNEAPOLIS, MN. SN 78-592,685. PUB. 3-21-2006, FILED 3-22-2005.

**Ageless Radiance**

THE MARK CONSISTS OF STANDARD CHARACTERS WITHOUT CLAIM TO ANY PARTICULAR FONT, STYLE, SIZE, OR COLOR.

FOR BODYCARE PRODUCTS, NAMELY, SHAMPOOS, CREAM RINSE, BODY WASH, SKIN MOISTURIZERS, SKIN SOAPS, SKIN CREAMS, LOTIONS AND COSMETICS (U.S. CLS. 1, 4, 6, 50, 51 AND 52).

FIRST USE 8-11-2006; IN COMMERCE 8-11-2006.

**CLASS 3—(Continued).**

3,234,726. GABRIELLE STUDIO, INC., NEW YORK, NY. SN 78-594,984. PUB. 9-6-2005, FILED 3-25-2005.

**DONNA KARAN GOLD**

THE MARK CONSISTS OF STANDARD CHARACTERS WITHOUT CLAIM TO ANY PARTICULAR FONT, STYLE, SIZE, OR COLOR.

OWNER OF U.S. REG. NOS. 1,692,152, 2,698,535, AND OTHERS.

FOR PERFUMES; BODY AND BEAUTY CARE PREPARATIONS (U.S. CLS. 1, 4, 6, 50, 51 AND 52).  
FIRST USE 9-1-2006; IN COMMERCE 9-15-2006.

**CLASS 3—(Continued).**

3,234,803. MINTZ, LEEJAY, LOS ANGELES, CA. SN 78-622,280. PUB. 2-28-2006, FILED 5-4-2005.

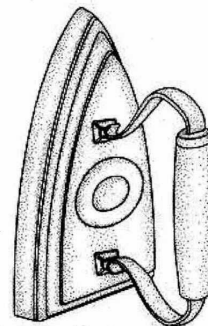

FOR COSMETICS (U.S. CLS. 1, 4, 6, 50, 51 AND 52).  
FIRST USE 11-2-2006; IN COMMERCE 11-2-2006.

3,234,854. AMOREPACIFIC CORPORATION, SEOUL 140-777, REPUBLIC OF KOREA. SN 78-634,670. PUB. 2-21-2006, FILED 5-23-2005.

**PEARL SHINING**

THE MARK CONSISTS OF STANDARD CHARACTERS WITHOUT CLAIM TO ANY PARTICULAR FONT, STYLE, SIZE, OR COLOR.

FOR HAIR SHAMPOOS, HAIR RINSES, HAIR TREATMENT CREAMS, HAIR LOTIONS, NON-MEDICATED MOISTURIZING SERUMS FOR THE HAIR (U.S. CLS. 1, 4, 6, 50, 51 AND 52).

FIRST USE 6-0-2004; IN COMMERCE 9-0-2004.

3,234,755. NIOXIN RESEARCH LABORATORIES, INC., LITHIA SPRINGS, GA. SN 78-603,010. PUB. 3-21-2006, FILED 4-6-2005.

**BioAMP**

3,234,869. BATH & BODY WORKS, INC., REYNOLDSBURG, OH. SN 78-637,249. PUB. 2-28-2006, FILED 5-25-2005.

**TANTI BACI**

THE MARK CONSISTS OF STANDARD CHARACTERS WITHOUT CLAIM TO ANY PARTICULAR FONT, STYLE, SIZE, OR COLOR.

THE ENGLISH TRANSLATION OF THE ITALIAN WORDING "TANTI BACI" IS "MANY KISSES".

FOR PERSONAL CARE PRODUCTS, NAMELY LIP GLOSS, LIP BALM, LIP STICK, LIP LINER (U.S. CLS. 1, 4, 6, 50, 51 AND 52).

FIRST USE 1-31-2005; IN COMMERCE 1-31-2005.

THE MARK CONSISTS OF STANDARD CHARACTERS WITHOUT CLAIM TO ANY PARTICULAR FONT, STYLE, SIZE, OR COLOR.

FOR HAIR CARE PREPARATIONS (U.S. CLS. 1, 4, 6, 50, 51 AND 52).

FIRST USE 6-30-2005; IN COMMERCE 6-30-2005.

**CLASS 3—(Continued).**

3,234,875. FIVE STAR FRAGRANCE COMPANY, INC., NEW YORK, NY. SN 78-638,679. PUB. 2-21-2006, FILED 5-27-2005.

**HYDRA PLUMP**

THE MARK CONSISTS OF STANDARD CHARACTERS WITHOUT CLAIM TO ANY PARTICULAR FONT, STYLE, SIZE, OR COLOR.

NO CLAIM IS MADE TO THE EXCLUSIVE RIGHT TO USE "PLUMP", APART FROM THE MARK AS SHOWN.

FOR COSMETICS AND SKIN CARE PRODUCTS, NAMELY, LIPSTICK, LIP DYE, COSMETIC LIP PREPARATION FOR MAKING FULLER LIPS, LIP GLOSS, LIP LINER, NON-MEDICATED LIP BALM, LIP MOISTURIZER, LIP CREAM, AND SCENTED LIP GLOSS (U.S. CLS. 1, 4, 6, 50, 51 AND 52).

FIRST USE 9-29-2005; IN COMMERCE 9-29-2005.

**CLASS 3—(Continued).**

3,234,903. COSMETIC DERMATOLOGY, INC., MIAMI, FL. SN 78-646,308. PUB. 2-28-2006, FILED 6-8-2005.

**LASER LIGHTNING**

THE MARK CONSISTS OF STANDARD CHARACTERS WITHOUT CLAIM TO ANY PARTICULAR FONT, STYLE, SIZE, OR COLOR.

FOR SKIN CREAMS, BODY LOTIONS, BODY SCRUBS, SKIN LOTIONS, SKIN MOISTURIZERS, SKIN EMOLLIENTS, SKIN MASKS, FACIAL MASKS, SKIN CLEANSERS, SKIN TONERS, EXFOLIATES, EYE CREAMS, SUN SCREENS AND SUN BLOCK PREPARATIONS (U.S. CLS. 1, 4, 6, 50, 51 AND 52).

FIRST USE 6-1-2006; IN COMMERCE 6-1-2006.

3,234,876. CONAIR CORPORATION, STAMFORD, CT. SN 78-639,001. PUB. 2-21-2006, FILED 5-27-2005.

**CURLSILK**

THE MARK CONSISTS OF STANDARD CHARACTERS WITHOUT CLAIM TO ANY PARTICULAR FONT, STYLE, SIZE, OR COLOR.

FOR HAIR CARE PREPARATIONS, NAMELY SHAMPOOS, CONDITIONER AND HAIR STYLING PREPARATIONS (U.S. CLS. 1, 4, 6, 50, 51 AND 52).

FIRST USE 6-1-2005; IN COMMERCE 6-1-2005.

3,234,899. CHANEL, INC., NEW YORK, NY. SN 78-645,514. PUB. 2-28-2006, FILED 6-7-2005.

**ROUGE ALLURE**

THE MARK CONSISTS OF STANDARD CHARACTERS WITHOUT CLAIM TO ANY PARTICULAR FONT, STYLE, SIZE, OR COLOR.

OWNER OF U.S. REG. NOS. 635,700, 2,598,290, AND OTHERS.

NO CLAIM IS MADE TO THE EXCLUSIVE RIGHT TO USE "ROUGE", APART FROM THE MARK AS SHOWN.

THE FOREIGN WORDING IN THE MARK TRANSLATES INTO ENGLISH AS RED.

FOR COSMETICS (U.S. CLS. 1, 4, 6, 50, 51 AND 52).  
FIRST USE 5-1-2006; IN COMMERCE 5-1-2006.

3,234,940. BUCKEYE INTERNATIONAL, INC., MARYLAND HEIGHTS, MO. SN 78-651,711. PUB. 3-7-2006, FILED 6-15-2005.

**LUCENT**

THE MARK CONSISTS OF STANDARD CHARACTERS WITHOUT CLAIM TO ANY PARTICULAR FONT, STYLE, SIZE, OR COLOR.

FOR FLOOR FINISHING PREPARATION (U.S. CLS. 1, 4, 6, 50, 51 AND 52).

FIRST USE 2-6-2006; IN COMMERCE 2-6-2006.

3,234,959. KLINGER ADVANCED AESTHETICS, INC., NORWALK, NJ. SN 78-654,067. PUB. 3-14-2006, FILED 6-20-2005.

**GLOBAL HEALTH FACE**

THE MARK CONSISTS OF STANDARD CHARACTERS WITHOUT CLAIM TO ANY PARTICULAR FONT, STYLE, SIZE, OR COLOR.

NO CLAIM IS MADE TO THE EXCLUSIVE RIGHT TO USE "FACE", APART FROM THE MARK AS SHOWN.

FOR MOISTURIZING FACE LOTION THAT CONTAINS SUNSCREEN (U.S. CLS. 1, 4, 6, 50, 51 AND 52).

FIRST USE 4-0-2006; IN COMMERCE 4-0-2006.



**CLASS 3—(Continued).**

3,234,975. CURVES INTERNATIONAL, INC., WACO, TX. SN 78-655,511. PUB. 8-22-2006, FILED 6-21-2005.

**DIANE**

THE MARK CONSISTS OF STANDARD CHARACTERS WITHOUT CLAIM TO ANY PARTICULAR FONT, STYLE, SIZE, OR COLOR.

OWNER OF U.S. REG. NO. 2,954,936. FOR COSMETICS (U.S. CLS. 1, 4, 6, 50, 51 AND 52). FIRST USE 4-1-2006; IN COMMERCE 4-1-2006.

**CLASS 3—(Continued).**

3,234,994. PARFUMS CHRISTIAN DIOR, 75008 PARIS, FRANCE. SN 78-658,633. PUB. 3-14-2006, FILED 6-27-2005.

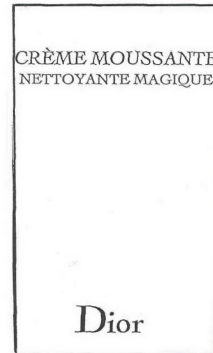

OWNER OF U.S. REG. NOS. 573,430, 886,004, AND OTHERS.

NO CLAIM IS MADE TO THE EXCLUSIVE RIGHT TO USE CRÈME MOUSSANTE NETTOYANTE, APART FROM THE MARK AS SHOWN.

THE ENGLISH TRANSLATION OF THE FRENCH PHRASE "CRÈME MOUSSANTE NETTOYANTE MAGIQUE" IN THE MARK IS "MAGICAL FOAMING CLEANSING CRÈME".

FOR CLEANSING PREPARATIONS FOR FACE CARE (U.S. CLS. 1, 4, 6, 50, 51 AND 52).

FIRST USE 6-0-2005; IN COMMERCE 6-0-2005.

3,234,993. PARFUMS CHRISTIAN DIOR, 75008 PARIS, FRANCE. SN 78-658,613. PUB. 3-14-2006, FILED 6-27-2005.

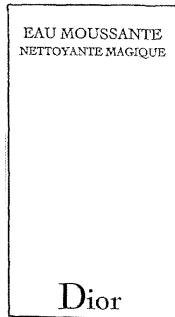

3,235,069. GROOMBADABOOM, INC., ROSEMONT, IL. SN 78-668,360. PUB. 3-14-2006, FILED 7-12-2005.

**DON'T WORRY ABOUT IT**

OWNER OF U.S. REG. NOS. 573,430, 886,004, AND OTHERS.

NO CLAIM IS MADE TO THE EXCLUSIVE RIGHT TO USE EAU MOUSSANTE NETOYANTE, APART FROM THE MARK AS SHOWN.

THE FRENCH PHRASE "EAU MOUSSANTE NETTOYANTE MAGIQUE" TRANSLATES INTO ENGLISH AS "MAGICAL FOAMING CLEANSING LIQUID".

FOR CLEANSING PREPARATIONS FOR FACE CARE (U.S. CLS. 1, 4, 6, 50, 51 AND 52).

FIRST USE 6-0-2005; IN COMMERCE 6-0-2005.

THE MARK CONSISTS OF STANDARD CHARACTERS WITHOUT CLAIM TO ANY PARTICULAR FONT, STYLE, SIZE, OR COLOR.

FOR HAIR CARE PRODUCTS, NAMELY HAIR STRAIGHTENER (U.S. CLS. 1, 4, 6, 50, 51 AND 52).

FIRST USE 6-0-2006; IN COMMERCE 6-0-2006.

**CLASS 3—(Continued).**

3,235,087. MARKMAN, LEONID, BROOKLYN, NY. SN 78-671,617. PUB. 5-23-2006, FILED 7-15-2005.



THE COLOR(S) BLACK IN THE TEXT "REJUVAHAIR" AND ORANGE IN THE "HAIR FOLLICLE IMAGE" IS/ARE CLAIMED AS A FEATURE OF THE MARK.

THE MARK CONSISTS OF THE WORD REJUVAHAIR WRITTEN COUNTERCLOCKWISE IN BLACK LETTERING WITH A DRAWING OF AN ORANGE HAIR FOLLICLE IN THE MIDDLE OF IT.

FOR HAIR CARE PRODUCTS, NAMELY, SHampoos, CONDITIONERS, STYLING SPRAY AND GEL AND OIL AND CREAM; HAIR COLORANTS AND PERMANENTS; NON-MEDICATED SCALP CARE PRODUCTS, NAMELY SCALP LOTION AND CREAM AND GEL AND BALM; NON-MEDICATED POWDERS, NAMELY TALCUM POWDER; BATH SALT, BATH OIL (U.S. CLS. 1, 4, 6, 50, 51 AND 52).

FIRST USE 6-7-2006; IN COMMERCE 8-1-2006.

3,235,095. NATERRA INTERNATIONAL, INC., DALLAS, TX. SN 78-672,916. PUB. 4-4-2006, FILED 7-18-2005.

**COLORGEN**

THE MARK CONSISTS OF STANDARD CHARACTERS WITHOUT CLAIM TO ANY PARTICULAR FONT, STYLE, SIZE, OR COLOR.

FOR HAIR BLEACH; HAIR BLEACHING PREPARATIONS; HAIR COLOR REMOVERS; HAIR CONDITIONER; HAIR DYE; HAIR EMOLLIENTS; HAIR FROSTS; HAIR GEL; HAIR LIGHTENERS; HAIR LOTIONS; HAIR MOUSSE; HAIR POMADES; HAIR RELAXING PREPARATIONS; HAIR REMOVING CREAM; HAIR SHAMPOO; HAIR SPRAY; HAIR STRAIGHTENING PREPARATIONS; HAIR STYLING PREPARATIONS; HAIR WAVING LOTION (U.S. CLS. 1, 4, 6, 50, 51 AND 52).

FIRST USE 4-1-2006; IN COMMERCE 4-1-2006.

**CLASS 3—(Continued).**

3,235,114. TOO FACED COSMETICS, INC., IRVINE, CA. SN 78-678,614. PUB. 4-11-2006, FILED 7-26-2005.

**GLAMOUR GLOSS**

THE MARK CONSISTS OF STANDARD CHARACTERS WITHOUT CLAIM TO ANY PARTICULAR FONT, STYLE, SIZE, OR COLOR.

NO CLAIM IS MADE TO THE EXCLUSIVE RIGHT TO USE "GLOSS", APART FROM THE MARK AS SHOWN. FOR COSMETICS (U.S. CLS. 1, 4, 6, 50, 51 AND 52). FIRST USE 12-1-2005; IN COMMERCE 12-1-2005.

3,235,134. WHISH BODY PRODUCTS, L.L.C., SCOTTSDALE, AZ. SN 78-684,096. PUB. 9-5-2006, FILED 8-2-2005.

**SHAVE CRAVE**

THE MARK CONSISTS OF STANDARD CHARACTERS WITHOUT CLAIM TO ANY PARTICULAR FONT, STYLE, SIZE, OR COLOR.

FOR BODY LOTIONS; SHAVING CREAMS (U.S. CLS. 1, 4, 6, 50, 51 AND 52). FIRST USE 5-9-2006; IN COMMERCE 5-9-2006.

3,235,174. CHOPRA ENTERPRISES, LLC, CARLSBAD, CA. SN 78-697,711. PUB. 4-25-2006, FILED 8-22-2005.

**ABHY**

THE MARK CONSISTS OF STANDARD CHARACTERS WITHOUT CLAIM TO ANY PARTICULAR FONT, STYLE, SIZE, OR COLOR.

FOR MASSAGE OILS (U.S. CLS. 1, 4, 6, 50, 51 AND 52). FIRST USE 11-29-2005; IN COMMERCE 11-29-2005.

**CLASS 3—(Continued).**

3,235,185. PHILOSOPHY, INC., PHOENIX, AZ. SN 78-703,120. PUB. 8-22-2006, FILED 8-30-2005.

**THE PHILOSOPHY TWO STEP**

THE MARK CONSISTS OF STANDARD CHARACTERS WITHOUT CLAIM TO ANY PARTICULAR FONT, STYLE, SIZE, OR COLOR.

OWNER OF U.S. REG. NOS. 2,016,208, 2,388,010, AND OTHERS.

NO CLAIM IS MADE TO THE EXCLUSIVE RIGHT TO USE "TWO STEP", APART FROM THE MARK AS SHOWN.

FOR SKIN CARE KITS CONTAINING NON-MEDICATED SKIN CARE PREPARATIONS, NAMELY, FACIAL CLEANSER AND MOISTURIZER (U.S. CLS. 1, 4, 6, 50, 51 AND 52).

FIRST USE 12-28-2005; IN COMMERCE 12-28-2005.

3,235,186. LARISA BART, STATEN ISLAND, NY. SN 78-703,851. PUB. 7-4-2006, FILED 8-30-2005.



THE MARK CONSISTS OF THE TERM AVELURE WITH THE LETTER L STYLIZED TO RESEMBLE A NOSE, ABOVE THE LETTER U IS AN EYE WITH AN IRIS; THE ENTIRE MARK IS SURROUNDED BY AN ELLIPSE.

FOR ASTRINGENTS FOR COSMETIC PURPOSES; BATH OILS FOR COSMETIC PURPOSES; BODY AND BEAUTY CARE COSMETICS; CLEANSING CREAMS; COCOA BUTTER FOR COSMETIC PURPOSES; CONCEALERS; COSMETIC CREAMS; COSMETIC CREAMS FOR SKIN CARE; COSMETIC MILKS; COSMETIC OILS; COSMETIC OILS FOR THE EPIDERMIS; COSMETIC PADS; COSMETIC PENCILS; COSMETIC PREPARATIONS AGAINST SUNBURN; COSMETIC PREPARATIONS FOR BODY CARE; COSMETIC PREPARATIONS FOR SKIN RENEWAL; COSMETIC PRODUCTS IN THE FORM OF AEROSOLS FOR SKINCARE; COSMETIC ROUGES; COSMETIC SOAPS; COSMETIC SUN-PROTECTING PREPARATIONS; COSMETIC SUN-TANNING PREPARATIONS; COSMETIC SUNTAN LOTIONS; COSMETICS; COTTON FOR COSMETIC PURPOSES; COTTON PUFFS FOR COSMETIC PURPOSES; COTTON STICKS FOR COSMETIC PURPOSES; COTTON SWABS FOR COSMETIC PURPOSES; DECORATIVE TRANSFERS AND SKIN JEWELS FOR COSMETIC PURPOSES; EYE COMPRESSES FOR COSMETIC PURPOSES; FACE CREAMS FOR COSMETIC USE; FOAMS CONTAINING COSMETICS AND SUNSCREENS; FOUNDATION; GAUZE FOR COSMETIC PURPOSES; MAKE-UP KITS COMPRISED OF LIPSTICK, EYE SHADOW, BLUSH, FACE POWDER, BRONZER, LIP LINER, EYE LINER, LIP GLOSS, EYE SHADOW BASE, EYE MAKEUP REMOVER, MAKEUP BRUSHES; PENCILS FOR COSMETIC PURPOSES; ROSE OIL FOR COSMETIC PURPOSES; SHAMPOOS; SOAPS; TONERS; TOPICAL SKIN SPRAYS FOR COSMETIC PURPOSES (U.S. CLS. 1, 4, 6, 50, 51 AND 52).

FIRST USE 10-10-2005; IN COMMERCE 10-10-2005.

**CLASS 3—(Continued).**

3,235,187. L'OREAL, PARIS, FRANCE. SN 78-704,151. PUB. 5-16-2006, FILED 8-31-2005.

**HEALTHY LOOK**

THE MARK CONSISTS OF STANDARD CHARACTERS WITHOUT CLAIM TO ANY PARTICULAR FONT, STYLE, SIZE, OR COLOR.

FOR FACIAL MOISTURIZER (U.S. CLS. 1, 4, 6, 50, 51 AND 52).

FIRST USE 2-0-2006; IN COMMERCE 2-0-2006.

3,235,191. PHYSICIANS FORMULA, INC., AZUSA, CA. SN 78-705,222. PUB. 7-4-2006, FILED 9-1-2005.

**BAKED TO PERFECTION**

THE MARK CONSISTS OF STANDARD CHARACTERS WITHOUT CLAIM TO ANY PARTICULAR FONT, STYLE, SIZE, OR COLOR.

FOR COSMETICS, INCLUDING EYE AND FACE MAKEUP (U.S. CLS. 1, 4, 6, 50, 51 AND 52).

FIRST USE 1-27-2006; IN COMMERCE 1-27-2006.

3,235,197. AAVEN PRODUCTS INC., FRESH MEADOWS, NY. SN 78-709,087. PUB. 8-8-2006, FILED 9-8-2005.

*Aaven*

FOR AFTER SUN CREAMS; AGE SPOT REDUCING CREAMS; ANTI-AGING CREAM; ANTI-FRECKLE CREAMS; ANTI-WRINKLE CREAMS; AROMATHERAPY CREAMS; ASTRINGENTS FOR COSMETIC PURPOSES; BATH OILS FOR COSMETIC PURPOSES; BEAUTY CREAMS; BEAUTY CREAMS FOR BODY CARE; BLEACHING PREPARATIONS FOR COSMETIC PURPOSES; BODY AND BEAUTY CARE COSMETICS; BODY CREAM; BODY CREAM SOAP; BODY MASK CREAM; CLEANER FOR COSMETIC BRUSHES; CLEANSING CREAMS; COCOA BUTTER FOR COSMETIC PURPOSES; COLD CREAM; CONGEALERS; COSMETIC BALLS; COSMETIC CREAMS; COSMETIC CREAMS FOR SKIN CARE; COSMETIC MILKS; COSMETIC OILS; COSMETIC OILS FOR THE EPIDERMIS; COSMETIC PADS; COSMETIC PENCILS; COSMETIC

**CLASS 3—(Continued).**

PREPARATIONS AGAINST SUNBURN; COSMETIC PREPARATIONS FOR BODY CARE; COSMETIC PREPARATIONS FOR EYE LASHES; COSMETIC PREPARATIONS FOR SKIN RENEWAL; COSMETIC PREPARATIONS FOR THE CARE OF MOUTH AND TEETH; COSMETIC PRODUCTS IN THE FORM OF AEROSOLS FOR SKIN CARE; COSMETIC ROUGES; COSMETIC SOAPS; COSMETIC SUN-PROTECTING PREPARATIONS; COSMETIC SUN-TANNING PREPARATIONS; COSMETIC SUNTAN LOTIONS; COSMETICS; COSMETICS NAMELY, COMPACTS; COTTON BALLS FOR COSMETIC PURPOSES; COTTON BUDS FOR COSMETIC PURPOSES; COTTON FOR COSMETIC PURPOSES; COTTON PUFFS FOR COSMETIC PURPOSES; COTTON STICKS FOR COSMETIC PURPOSES; COTTON SWABS FOR COSMETIC PURPOSES; CREAM SOAPS; CREAMS FOR CELLULITE REDUCTION; CUTICLE CREAM; DECORATIVE TRANSFERS AND SKIN JEWELS FOR COSMETIC PURPOSES; DEPILATORY CREAMS; EXFOLIANT CREAMS; EYE COMPRESSES FOR COSMETIC PURPOSES; EYE CREAM; FACE AND BODY BEAUTY CREAMS; FACE AND BODY CREAMS; FACE CREAMS; FACE CREAMS FOR COSMETIC USE; FACIAL CREAM; FAIR COMPLEXION CREAM; FOAMS CONTAINING COSMETICS AND SUNSCREENS; FOUNDATION GAUZE FOR COSMETIC PURPOSES; HAIR CARE CREAMS; HAIR CREAMS; HAIR REMOVING CREAM; HAND CREAM; HENNA FOR COSMETIC PURPOSES; LIP CREAM; MAKE-UP REMOVING MILK, GEL, LOTIONS AND CREAMS; NAIL CREAM; NAIL VARNISH FOR COSMETIC PURPOSES; NIGHT CREAM; NON-MEDICATED FOOT CREAM; NON-MEDICATED SCALP TREATMENT CREAM; NON-MEDICATED SKIN CREAMS; PENCILS FOR COSMETIC PURPOSES; PERFUME OILS FOR THE MANUFACTURE OF COSMETIC PREPARATIONS; PERFUMED CREAMS; PETROLEUM JELLY FOR COSMETIC PURPOSES; PRE-MOISTENED COSMETIC TISSUES; PRE-MOISTENED COSMETIC TOWELETTES; PRE-MOISTENED COSMETIC WIPES; ROSE OIL FOR COSMETIC PURPOSES; SHAMPOOS; SUN CREAMS; SUNSCREEN CREAM; SUNTAN CREAMS; TANNING CREAMS; TONERS; TOPICAL HERBAL CREAM FOR FIRING AND ENHANCING BREASTS; TOPICAL SKIN SPRAYS FOR COSMETIC PURPOSES; VANISHING CREAM; WRINKLE RESISTANT CREAM (U.S. CLS. 1, 4, 6, 50, 51 AND 52).

FIRST USE 1-2-2003; IN COMMERCE 1-2-2003.

3,235,205. SAINT GABRIEL PARTNERS, LLC, SULPHUR, LA. SN 78-711,868. PUB. 8-8-2006, FILED 9-13-2005.

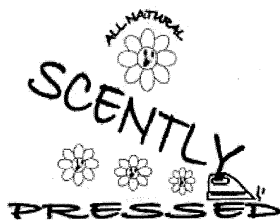

NO CLAIM IS MADE TO THE EXCLUSIVE RIGHT TO USE "ALL NATURAL", APART FROM THE MARK AS SHOWN.

FOR LAUNDRY STARCH (U.S. CLS. 1, 4, 6, 50, 51 AND 52).  
FIRST USE 1-10-2006; IN COMMERCE 1-13-2006.

**CLASS 3—(Continued).**

3,235,229. SPPC PARIS BLEU, PARIS, FRANCE. SN 78-723,706. PUB. 6-13-2006, FILED 9-29-2005.

## SILVER RING

THE MARK CONSISTS OF STANDARD CHARACTERS WITHOUT CLAIM TO ANY PARTICULAR FONT, STYLE, SIZE, OR COLOR.

OWNER OF U.S. REG. NO. 2,959,269.

FOR PERFUMERY (U.S. CLS. 1, 4, 6, 50, 51 AND 52).  
FIRST USE 4-0-2006; IN COMMERCE 6-6-2006.

3,235,241. LA DOLCE DIVA, INC., MARIETTA, GA. SN 78-727,548. PUB. 7-4-2006, FILED 10-6-2005.

## Bella Divina

THE MARK CONSISTS OF STANDARD CHARACTERS WITHOUT CLAIM TO ANY PARTICULAR FONT, STYLE, SIZE, OR COLOR.

THE FOREIGN WORDING IN THE MARK TRANSLATES INTO ENGLISH AS BEAUTIFUL DIVINE.

FOR BATH BEADS; BATH FOAMS; BATH GELS; BATH LOTION; BATH MILKS; BATH OILS; BATH POWDER; BATH SALTS; BATHING LOTIONS; BODY AND BEAUTY CARE PREPARATIONS; BODY CREAMS; BODY LOTIONS; BODY MILKS; BODY OILS; BODY SCRUB; BODY SPRAYS; BUBBLE BATH; HAIR RINSES; HAIR SHAMPOO; HAND CREAMS; HAND LOTIONS; LIP BALM; LIP GLOSS; LIQUID BATH SOAPS; LIQUID SOAPS; LIQUID SOAPS FOR HANDS AND FACE; PERFUMING SACHETS; SACHET-LIKE EYE PILLOWS CONTAINING FRAGRANCES; SACHETS; SHAMPOO-CONDITIONERS; SHOWER AND BATH FOAM; SHOWER AND BATH GEL; SHOWER GELS (U.S. CLS. 1, 4, 6, 50, 51 AND 52).

FIRST USE 1-13-2006; IN COMMERCE 2-15-2006.

**CLASS 3—(Continued).**

3,235,257. PHYSICIANS FORMULA, INC., AZUSA, CA. SN 78-735,294. PUB. 7-4-2006, FILED 10-18-2005.

**COVER 2 GO**

THE MARK CONSISTS OF STANDARD CHARACTERS WITHOUT CLAIM TO ANY PARTICULAR FONT, STYLE, SIZE, OR COLOR.

NO CLAIM IS MADE TO THE EXCLUSIVE RIGHT TO USE "COVER", APART FROM THE MARK AS SHOWN.

FOR COSMETICS, INCLUDING CONCEALERS (U.S. CLS. 1, 4, 6, 50, 51 AND 52).

FIRST USE 1-27-2006; IN COMMERCE 1-27-2006.

3,235,356. CHOPRA ENTERPRISES, LLC, CARLSBAD, CA. SN 78-780,441. PUB. 9-5-2006, FILED 12-23-2005.

**AYURVEDIC HERBAL WISDOM**

THE MARK CONSISTS OF STANDARD CHARACTERS WITHOUT CLAIM TO ANY PARTICULAR FONT, STYLE, SIZE, OR COLOR.

NO CLAIM IS MADE TO THE EXCLUSIVE RIGHT TO USE "AYURVEDIC HERBAL", APART FROM THE MARK AS SHOWN.

FOR AROMATHERAPY LOTIONS; AROMATHERAPY OILS; BATH LOTION; BATHING LOTIONS; BEAUTY LOTIONS; BODY AND BEAUTY CARE COSMETICS; BODY LOTIONS; BODY OILS; BODY SCRUB; COSMETIC CREAMS FOR SKIN CARE; COSMETIC OILS; COSMETIC PREPARATIONS FOR BODY CARE; COSMETIC PREPARATIONS FOR SKIN RENEWAL; COSMETIC SOAPS; COSMETICS; FACE CREAMS FOR COSMETIC USE; FACIAL SCRUBS; HAIR CARE LOTIONS; HAIR CONDITIONERS; HAIR RINSES; HAND LOTIONS; SHAMPOOS; SKIN CONDITIONERS; SKIN LOTIONS (U.S. CLS. 1, 4, 6, 50, 51 AND 52).

FIRST USE 11-30-2005; IN COMMERCE 11-30-2005.

3,235,368. WADSWORTH, JENNIFER, MARIETTA, GA. SN 78-790,078. PUB. 8-29-2006, FILED 1-12-2006.

**ESCAPE ARTISTE**

THE MARK CONSISTS OF STANDARD CHARACTERS WITHOUT CLAIM TO ANY PARTICULAR FONT, STYLE, SIZE, OR COLOR.

THE FOREIGN WORDING IN THE MARK TRANSLATES INTO ENGLISH AS ARTIST.

FOR AROMATHERAPY CREAMS; AROMATHERAPY LOTIONS; AROMATHERAPY OILS; COSMETIC OILS; COSMETIC PREPARATIONS FOR BODY CARE; COSMETIC PREPARATIONS FOR SKIN RENEWAL (U.S. CLS. 1, 4, 6, 50, 51 AND 52).

FIRST USE 9-6-2006; IN COMMERCE 9-6-2006.

**CLASS 3—(Continued).**

3,235,381. Y.Z.Y. INC, MIAMI, FL. SN 78-809,113. PUB. 8-29-2006, FILED 2-7-2006.

**TREATY**

THE MARK CONSISTS OF STANDARD CHARACTERS WITHOUT CLAIM TO ANY PARTICULAR FONT, STYLE, SIZE, OR COLOR.

FOR BEAUTY CREAMS FOR BODY CARE; BEAUTY LOTIONS; BODY SPRAY USED AS A PERSONAL DEODORANT AND AS FRAGRANCE; COSMETIC CREAMS FOR SKIN CARE; DEODORANT FOR PERSONAL USE; DEODORANTS AND ANTIPERSPIRANTS; EAU DE COLOGNE; EAU DE PERFUME; HAND CREAMS; HAND LOTIONS; PERFUME; PERFUMED SOAPS; PERSONAL DEODORANTS (U.S. CLS. 1, 4, 6, 50, 51 AND 52).

FIRST USE 6-1-1990; IN COMMERCE 6-1-1990.

3,235,384. REVLON CONSUMER PRODUCTS CORPORATION, NEW YORK, NY. SN 78-812,276. PUB. 9-5-2006, FILED 2-10-2006.

**BEDROOM EYES**

THE MARK CONSISTS OF STANDARD CHARACTERS WITHOUT CLAIM TO ANY PARTICULAR FONT, STYLE, SIZE, OR COLOR.

FOR COSMETICS; MAKE-UP (U.S. CLS. 1, 4, 6, 50, 51 AND 52).

FIRST USE 10-25-2006; IN COMMERCE 10-25-2006.

3,235,386. DEL LABORATORIES, INC., UNIONDALE, NY. SN 78-825,998. PUB. 8-22-2006, FILED 3-1-2006.

**FIRE OPAL NAIL GLAZE**

THE MARK CONSISTS OF STANDARD CHARACTERS WITHOUT CLAIM TO ANY PARTICULAR FONT, STYLE, SIZE, OR COLOR.

NO CLAIM IS MADE TO THE EXCLUSIVE RIGHT TO USE "NAIL GLAZE", APART FROM THE MARK AS SHOWN.

FOR NAIL CARE PREPARATIONS; NAIL POLISH (U.S. CLS. 1, 4, 6, 50, 51 AND 52).

FIRST USE 4-1-2006; IN COMMERCE 4-1-2006.

**CLASS 3—(Continued).**

3,235,401. NAMASTE LABORATORIES, L.L.C., BLUE ISLAND, IL. SN 78-978,008. PUB. 2-21-2006, FILED 6-2-2005.

**"HONORING THE BEAUTY  
WITHIN"**

THE MARK CONSISTS OF STANDARD CHARACTERS WITHOUT CLAIM TO ANY PARTICULAR FONT, STYLE, SIZE, OR COLOR.

FOR HAIR CARE PREPARATIONS (U.S. CLS. 1, 4, 6, 50, 51 AND 52).

FIRST USE 8-25-2005; IN COMMERCE 8-25-2005.

---

3,235,414. LANCOME PARFUMS ET BEAUTE & CIE, PARIS, FRANCE. SN 78-978,087. PUB. 8-15-2006, FILED 12-6-2005.

**ABSOLUE POWDER**

THE MARK CONSISTS OF STANDARD CHARACTERS WITHOUT CLAIM TO ANY PARTICULAR FONT, STYLE, SIZE, OR COLOR.

OWNER OF U.S. REG. NOS. 2,592,464 AND 2,719,719.

NO CLAIM IS MADE TO THE EXCLUSIVE RIGHT TO USE "POWDER", APART FROM THE MARK AS SHOWN.

THE FOREIGN WORDING IN THE MARK TRANSLATES INTO ENGLISH AS ABSOLUTE, COMPLETE AND TOTAL, FOR MAKEUP PRODUCTS, NAMELY, LOOSE POWDERS FOR THE FACE (U.S. CLS. 1, 4, 6, 50, 51 AND 52).  
FIRST USE 3-1-2006; IN COMMERCE 3-1-2006.

---

3,235,420. STEIN, RONALD B., BOCA RATON, FL. SN 78-978,132. PUB. 4-26-2005, FILED 5-7-2004.

**Y Tu Tambien**

THE MARK CONSISTS OF STANDARD CHARACTERS WITHOUT CLAIM TO ANY PARTICULAR FONT, STYLE, SIZE, OR COLOR.

THE ENGLISH TRANSLATION OF "Y TU TAMBIEN" IS "AND YOU TOO".

FOR WOMEN'S FRAGRANCES FOR PERSONAL USE (U.S. CLS. 1, 4, 6, 50, 51 AND 52).

FIRST USE 8-31-2006; IN COMMERCE 8-31-2006.

**CLASS 4—LUBRICANTS AND FUELS**

3,234,692. PURE POWER! INCORPORATED, HUNTINGTON BEACH, CA. SN 78-580,807. PUB. 11-29-2005, FILED 3-4-2005.

**GOT POWER?**

THE MARK CONSISTS OF STANDARD CHARACTERS WITHOUT CLAIM TO ANY PARTICULAR FONT, STYLE, SIZE, OR COLOR.

FOR ENGINE OILS, GREASES, PENETRATING SPRAYS, SPRAY LUBRICANTS, TRANSMISSION FLUIDS, 2-CYCLE ENGINE OILS AND TURBINE OIL (U.S. CLS. 1, 6 AND 15).

FIRST USE 5-0-2006; IN COMMERCE 5-0-2006.

---

3,234,784. GETTY PETROLEUM MARKETING INC., EAST MEADOW, NY. SN 78-614,958. PUB. 2-21-2006, FILED 4-22-2005.

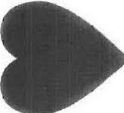
**we  cars**

FOR GASOLINE AND MOTOR OIL (U.S. CLS. 1, 6 AND 15).

FIRST USE 5-1-2006; IN COMMERCE 5-1-2006.

---

3,234,937. CHEMTOOL INC., CRYSTAL LAKE, IL. SN 78-651,603. PUB. 2-21-2006, FILED 6-15-2005.

**NUSOL**

THE MARK CONSISTS OF STANDARD CHARACTERS WITHOUT CLAIM TO ANY PARTICULAR FONT, STYLE, SIZE, OR COLOR.

FOR INDUSTRIAL LUBRICANTS AND EMULSIONS (U.S. CLS. 1, 6 AND 15).

FIRST USE 4-0-2005; IN COMMERCE 4-0-2005.

**CLASS 4—(Continued).**

3,235,415. FORTH & TOWNE (APPAREL) LLC, SAN FRANCISCO, CA. SN 78-978,088. PUB. 10-4-2005, FILED 2-16-2005.

**FORTH & TOWNE**

THE MARK CONSISTS OF STANDARD CHARACTERS WITHOUT CLAIM TO ANY PARTICULAR FONT, STYLE, SIZE, OR COLOR.

FOR CANDLES (U.S. CLS. 1, 6 AND 15).  
FIRST USE 11-13-2006; IN COMMERCE 11-13-2006.

**CLASS 5—PHARMACEUTICALS**

3,233,771. BIOSYN ARZNEIMITTEL GMBH, 70734 FELLBACH, FED REP GERMANY. SN 75-776,685. PUB. 7-1-2003, FILED 8-16-1999.

**BIOSYN**

FOR DIAGNOSTIC CHEMICAL REAGENTS AND TEST PREPARATIONS FOR MEDICAL LABORATORY AND CLINICAL USE IN THE PRODUCTION OF VACCINES; AND PHARMACEUTICAL PREPARATIONS FOR THE TREATMENT OF TUMORS, BACTERIAL AND VIRAL INFECTIONS, IMMUNE DISEASES, HEART DISEASES AND INFLAMMATORY DISEASE AND NUTRITIONAL SUPPLEMENTS (U.S. CLS. 6, 18, 44, 46, 51 AND 52).

FIRST USE 1-1-1995; IN COMMERCE 1-1-1995.

3,233,774. WN PHARMACEUTICALS LTD., BURNABY, BRITISH COLUMBIA, CANADA. SN 76-115,087. PUB. 8-15-2006, FILED 8-24-2000.

**GROWER SELECT**

PRIORITY CLAIMED UNDER SEC. 44(D) ON CANADA APPLICATION NO. 1069106, FILED 7-28-2000.

NO CLAIM IS MADE TO THE EXCLUSIVE RIGHT TO USE SELECT, APART FROM THE MARK AS SHOWN.

FOR NUTRITIONAL AND DIETARY SUPPLEMENTS CONTAINING HERBS IN THE FORM OF CAPSULES, TABLETS, LIQUIDS, AND POWDERS (U.S. CLS. 6, 18, 44, 46, 51 AND 52).

FIRST USE 4-18-2006; IN COMMERCE 4-18-2006.

**CLASS 5—(Continued).**

3,233,820. HERBACEUTICALS, INC., NAPA, CA. SN 76-480,682. PUB. 5-13-2003, FILED 1-7-2003.

**AROMASENSE**

FOR NON-PRESCRIPTION DIETARY SUPPLEMENTS NOT FOR MEDICINAL PURPOSES OR FOR DISPENSING BY A PHARMACIST UNDER PRESCRIPTION (U.S. CLS. 6, 18, 44, 46, 51 AND 52).

FIRST USE 8-1-2004; IN COMMERCE 8-1-2004.

3,233,828. L. PERRIGO COMPANY, ALLEGAN, MI. SN 76-492,319. PUB. 11-4-2003, FILED 2-25-2003.

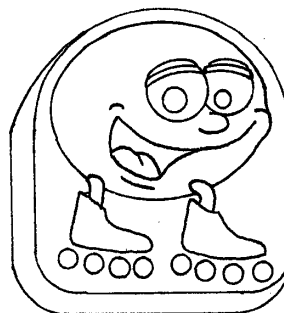

FOR DIETARY SUPPLEMENTS (U.S. CLS. 6, 18, 44, 46, 51 AND 52).

FIRST USE 10-3-2006; IN COMMERCE 10-3-2006.

3,233,829. L. PERRIGO COMPANY, ALLEGAN, MI. SN 76-492,425. PUB. 11-4-2003, FILED 2-25-2003.

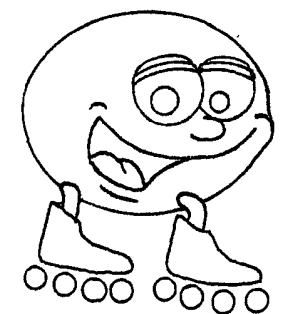

FOR DIETARY SUPPLEMENTS (U.S. CLS. 6, 18, 44, 46, 51 AND 52).

FIRST USE 10-3-2006; IN COMMERCE 10-3-2006.

**CLASS 5—(Continued).**

3,233,830. L. PERRIGO COMPANY, ALLEGAN, MI. SN 76-492,426. PUB. 11-4-2003, FILED 2-25-2003.

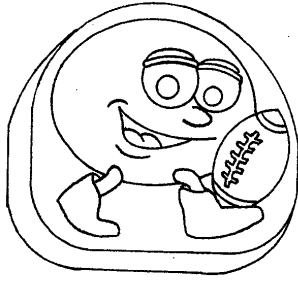

FOR DIETARY SUPPLEMENTS (U.S. CLS. 6, 18, 44, 46, 51 AND 52).  
FIRST USE 10-3-2006; IN COMMERCE 10-3-2006.

**CLASS 5—(Continued).**

3,233,832. L. PERRIGO COMPANY, ALLEGAN, MI. SN 76-492,432. PUB. 11-4-2003, FILED 2-25-2003.

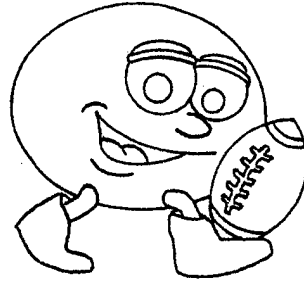

FOR DIETARY SUPPLEMENTS (U.S. CLS. 6, 18, 44, 46, 51 AND 52).  
FIRST USE 10-3-2006; IN COMMERCE 10-3-2006.

3,233,831. L. PERRIGO COMPANY, ALLEGAN, MI. SN 76-492,427. PUB. 11-4-2003, FILED 2-25-2003.

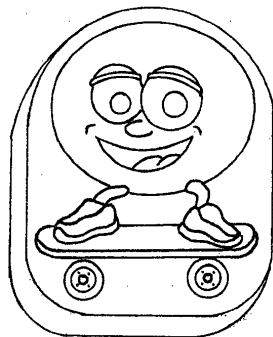

FOR DIETARY SUPPLEMENTS (U.S. CLS. 6, 18, 44, 46, 51 AND 52).  
FIRST USE 10-3-2006; IN COMMERCE 10-3-2006.

3,233,833. L. PERRIGO COMPANY, ALLEGAN, MI. SN 76-492,433. PUB. 11-4-2003, FILED 2-25-2003.

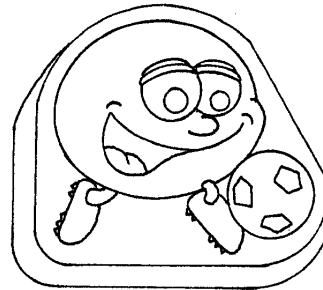

FOR DIETARY SUPPLEMENTS (U.S. CLS. 6, 18, 44, 46, 51 AND 52).  
FIRST USE 10-3-2006; IN COMMERCE 10-3-2006.



**CLASS 5—(Continued).**

3,233,834. L. PERRIGO COMPANY, ALLEGAN, MI. SN 76-492,470. PUB. 11-4-2003, FILED 2-25-2003.

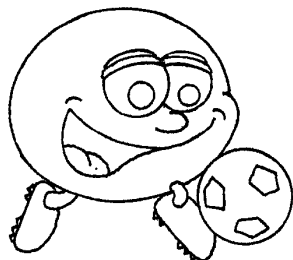

FOR DIETARY SUPPLEMENTS (U.S. CLS. 6, 18, 44, 46, 51 AND 52).  
FIRST USE 10-3-2006; IN COMMERCE 10-3-2006.

3,233,850. NUFARM AMERICAS INC., BURR RIDGE, IL. SN 76-517,889. PUB. 1-27-2004, FILED 5-29-2003.

**LAZER**

FOR HERBICIDES FOR AGRICULTURAL, COMMERCIAL AND RESIDENTIAL USE (U.S. CLS. 6, 18, 44, 46, 51 AND 52).  
FIRST USE 11-3-2005; IN COMMERCE 11-3-2005.

3,233,932. POWER3 MEDICAL PRODUCTS, INC., THE WOODLANDS, TX. SN 76-605,921. PUB. 6-28-2005, FILED 8-6-2004.

**NuroPro**

FOR REAGENTS AND DIAGNOSTIC PREPARATIONS FOR MEDICAL AND VETERINARY PURPOSES (U.S. CLS. 6, 18, 44, 46, 51 AND 52).  
FIRST USE 10-13-2005; IN COMMERCE 11-10-2006.

3,233,935. JOHNSON & JOHNSON, NEW BRUNSWICK, NJ. SN 76-608,051. PUB. 8-30-2005, FILED 8-20-2004.

**VISTAKON PHARMACEUTICALS**

**CLASS 5—(Continued).**

OWNER OF U.S. REG. NOS. 1,277,875 AND 1,409,312.  
NO CLAIM IS MADE TO THE EXCLUSIVE RIGHT TO USE "PHARMACEUTICALS", APART FROM THE MARK AS SHOWN.  
FOR MEDICATED OPHTHALMIC SOLUTIONS (U.S. CLS. 6, 18, 44, 46, 51 AND 52).  
FIRST USE 10-3-2006; IN COMMERCE 10-3-2006.

3,233,971. JACKSON, JANET A., LAYTON, UT. SN 76-614,811. PUB. 2-21-2006, FILED 10-7-2004.

**Loaded  
RX**

NO CLAIM IS MADE TO THE EXCLUSIVE RIGHT TO USE RX, APART FROM THE MARK AS SHOWN.  
FOR LIQUID AND POWDERED MEDICINAL EXTRACTS OBTAINED FROM FRUIT, BRAN, AMINO ACIDS, TRACE MINERALS, VEGETABLES AND HERBS FOR USE AS A DIETARY SUPPLEMENT (U.S. CLS. 6, 18, 44, 46, 51 AND 52).  
FIRST USE 12-0-2004; IN COMMERCE 12-0-2004.

3,234,054. SOUTHERN GROUP ENTERPRISES, LLC, MIAMI, FL. SN 76-640,808. PUB. 5-9-2006, FILED 6-14-2005.

**MAXIMUM CREA-GAIN**

THE MARK CONSISTS OF STANDARD CHARACTERS WITHOUT CLAIM TO ANY PARTICULAR FONT, STYLE, SIZE, OR COLOR.  
FOR NUTRITIONAL SUPPLEMENTS, NAMELY, DIETARY FOOD SUPPLEMENTS AND NUTRITIONAL DRINK MIXES FOR USE AS A MEAL REPLACEMENT, DIET PILLS, DIET CAPSULES, AND MEAL SUBSTITUTES FOR DIETARY PURPOSES (U.S. CLS. 6, 18, 44, 46, 51 AND 52).  
FIRST USE 11-0-2005; IN COMMERCE 11-0-2005.

3,234,119. NOVOZYMES A/S, BAGSVAERD, DENMARK. SN 78-189,668. PUB. 5-31-2005, FILED 11-27-2002.

**ECOGUARD**

FOR BIOLOGICAL FUNGICIDES FOR USE IN THE FIELDS OF LAWN TREATMENT, GOLF COURSE MAINTENANCE, AND PRE-HARVEST AGRICULTURAL USE (U.S. CLS. 6, 18, 44, 46, 51 AND 52).  
FIRST USE 9-0-2002; IN COMMERCE 9-0-2002.

**CLASS 5—(Continued).**

3,234,122. KINEMED, INC., EMERYVILLE, CA. SN 78-202,557. PUB. 9-2-2003, FILED 1-13-2003.

**KINEMED**

FOR ASSAYS TO MEASURE KINETIC ACTIVITY IN BIOCHEMICAL PATHWAYS THROUGH SURROGATE BIOMARKERS, FOR CLINICAL MEDICAL LABORATORY USE (U.S. CLS. 6, 18, 44, 46, 51 AND 52).  
FIRST USE 11-1-2003; IN COMMERCE 11-1-2003.

3,234,136. PROBIOHEALTH, LLC, BEVERLY HILLS, CA. SN 78-242,694. PUB. 7-6-2004, FILED 4-28-2003.

**PROBIOMEGA**

FOR FOOD SUPPLEMENTS AND PHARMACEUTICAL PREPARATIONS FOR THE TREATMENT OF HEART DISEASE, HYPERTENSION, RHEUMATOID ARTHRITIS, LUPUS, RAYNAUD'S DISEASE, AUTOIMMUNE DISEASE, STRESS AND TUMORS, ALL SUCH GOODS CONTAINING PROBIOTICS (U.S. CLS. 6, 18, 44, 46, 51 AND 52).  
FIRST USE 5-17-2002; IN COMMERCE 5-17-2002.

3,234,152. PHARMANEX LLC, PROVO, UT. SN 78-285,669. PUB. 4-11-2006, FILED 8-11-2003.

**IGG BOOST**

NO CLAIM IS MADE TO THE EXCLUSIVE RIGHT TO USE IGG, APART FROM THE MARK AS SHOWN.  
FOR NUTRITIONAL, DIETARY AND HERBAL SUPPLEMENT CONTAINING COLOSTRUM (U.S. CLS. 6, 18, 44, 46, 51 AND 52).  
FIRST USE 2-15-2004; IN COMMERCE 2-15-2004.

3,234,156. WARNER CHILCOTT COMPANY, INC., FAJARDO, PUERTO RICO. SN 78-292,822. PUB. 7-27-2004, FILED 8-27-2003.

**FEMCON**

OWNER OF U.S. REG. NO. 1,268,854.  
FOR PHARMACEUTICAL PREPARATIONS, NAMELY, ORAL CONTRACEPTIVES (U.S. CLS. 6, 18, 44, 46, 51 AND 52).  
FIRST USE 11-6-2006; IN COMMERCE 11-6-2006.

**CLASS 5—(Continued).**

3,234,160. WESTERN HOLDINGS, LLC, CHEYENNE, WY. SN 78-296,609. PUB. 2-28-2006, FILED 9-5-2003.

**THE FIRST AND ONLY NON-EPHEDRA DIET PILL WITH A KICK**

FOR DIETARY SUPPLEMENTS (U.S. CLS. 6, 18, 44, 46, 51 AND 52).  
FIRST USE 9-12-2003; IN COMMERCE 11-21-2006.

3,234,210. STANDARD HOMEOPATHIC COMPANY, LOS ANGELES, CA. SN 78-359,452. PUB. 3-8-2005, FILED 1-29-2004.

**SNIFFLES 'N SNEEZES**

THE MARK CONSISTS OF STANDARD CHARACTERS WITHOUT CLAIM TO ANY PARTICULAR FONT, STYLE, SIZE, OR COLOR.  
FOR HOMEOPATHIC PHARMACEUTICALS FOR THE TREATMENT OF COUGHS AND COLDS (U.S. CLS. 6, 18, 44, 46, 51 AND 52).  
FIRST USE 7-21-2006; IN COMMERCE 7-21-2006.

3,234,215. THE PROCTER & GAMBLE COMPANY, CINCINNATI, OH. SN 78-363,714. PUB. 1-11-2005, FILED 2-6-2004.

**AIR EFFECTS**

THE MARK CONSISTS OF STANDARD CHARACTERS WITHOUT CLAIM TO ANY PARTICULAR FONT, STYLE, SIZE, OR COLOR.  
NO CLAIM IS MADE TO THE EXCLUSIVE RIGHT TO USE "AIR", APART FROM THE MARK AS SHOWN.  
FOR AIR FRESHENERS (U.S. CLS. 6, 18, 44, 46, 51 AND 52).  
FIRST USE 8-16-2005; IN COMMERCE 8-16-2005.

**CLASS 5—(Continued).**

3,234,225. JOHNSON & JOHNSON, NEW BRUNSWICK, NJ.  
SN 78-376,717. PUB. 9-20-2005, FILED 3-2-2004.

**CLASS 5—(Continued).**

3,234,317. HUANG, ZIWEI, LA JOLLA, CA. SN 78-427,421.  
PUB. 7-11-2006, FILED 5-29-2004.

# BETHOGUARD

# SMM-Chemokine

THE MARK CONSISTS OF STANDARD CHARACTERS  
WITHOUT CLAIM TO ANY PARTICULAR FONT, STYLE,  
SIZE, OR COLOR.  
FOR FUNGICIDES AND ALGICIDES FOR DOMESTIC  
USE (U.S. CLS. 6, 18, 44, 46, 51 AND 52).  
FIRST USE 10-4-2006; IN COMMERCE 10-4-2006.

THE MARK CONSISTS OF STANDARD CHARACTERS  
WITHOUT CLAIM TO ANY PARTICULAR FONT, STYLE,  
SIZE, OR COLOR.  
FOR BIOCHEMICALS, NAMELY, POLYPEPTIDES  
FOR IN VITRO, IN VIVO AND BIOMEDICAL USE  
AND APPLICATIONS (U.S. CLS. 6, 18, 44, 46, 51 AND 52).  
FIRST USE 11-1-2005; IN COMMERCE 11-1-2005.

3,234,285. ATLEY PHARMACEUTICALS, INC., ASHLAND,  
VA. SN 78-408,888. PUB. 3-15-2005, FILED 4-27-2004.

3,234,357. CUTBIRTH, CATHERINE, AUSTIN, TX. SN 78-  
453,192. PUB. 6-21-2005, FILED 7-20-2004.

# SUDEX

# DYNO PACK

THE MARK CONSISTS OF STANDARD CHARACTERS  
WITHOUT CLAIM TO ANY PARTICULAR FONT, STYLE,  
SIZE, OR COLOR.  
FOR PHARMACEUTICAL PREPARATIONS, NAMELY  
DECONGESTANTS AND EXPECTORANTS (U.S. CLS. 6,  
18, 44, 46, 51 AND 52).  
FIRST USE 11-6-2006; IN COMMERCE 11-6-2006.

THE MARK CONSISTS OF STANDARD CHARACTERS  
WITHOUT CLAIM TO ANY PARTICULAR FONT, STYLE,  
SIZE, OR COLOR.  
FOR VITAMINS (U.S. CLS. 6, 18, 44, 46, 51 AND 52).  
FIRST USE 3-30-2003; IN COMMERCE 3-30-2003.

**CLASS 5—(Continued).**

3,234,448. WESTERN HOLDINGS, LLC, CHEYENNE, WY.  
SN 78-495,803. PUB. 9-20-2005, FILED 10-6-2004.

**STIM-FREE**

THE MARK CONSISTS OF STANDARD CHARACTERS WITHOUT CLAIM TO ANY PARTICULAR FONT, STYLE, SIZE, OR COLOR.

FOR DIETARY SUPPLEMENTS (U.S. CLS. 6, 18, 44, 46, 51 AND 52).

FIRST USE 10-22-2004; IN COMMERCE 11-23-2004.

**CLASS 5—(Continued).**

3,234,509. LOVELAND PRODUCTS, INC., GREELEY, CO. SN  
78-515,392. PUB. 12-20-2005, FILED 11-11-2004.

**Intensity**  
POST-EMERGENCE GRASS HERBICIDE

NO CLAIM IS MADE TO THE EXCLUSIVE RIGHT TO USE "POST-EMERGENCE GRASS HERBICIDE", APART FROM THE MARK AS SHOWN.

THE MARK CONSISTS OF THE STYLIZED WORD INTENSITY WITH THE WORDS POST-EMERGENCE GRASS HERBICIDE BELOW. THE MARK IS NOT IN COLOR.

FOR HERBICIDES FOR AGRICULTURAL USE (U.S. CLS. 6, 18, 44, 46, 51 AND 52).

FIRST USE 11-11-2004; IN COMMERCE 2-0-2005.

3,234,486. PORCELAIN-PLUS DENTAL SYSTEMS, INC,  
CRANFORD, NJ. SN 78-510,366. PUB. 4-18-2006, FILED  
11-3-2004.

**X-treme Veneers**

THE MARK CONSISTS OF STANDARD CHARACTERS WITHOUT CLAIM TO ANY PARTICULAR FONT, STYLE, SIZE, OR COLOR.

NO CLAIM IS MADE TO THE EXCLUSIVE RIGHT TO USE "VENEERS", APART FROM THE MARK AS SHOWN.

FOR PORCELAIN LAMINATE VENEERS USED IN DENTISTRY (U.S. CLS. 6, 18, 44, 46, 51 AND 52).

FIRST USE 2-14-2004; IN COMMERCE 3-23-2004.

3,234,521. ARCUS MEDICAL, LLC, CHARLOTTE, NC. SN 78-  
520,167. PUB. 4-4-2006, FILED 11-19-2004.

**GOLDEN RELIEVER**

THE MARK CONSISTS OF STANDARD CHARACTERS WITHOUT CLAIM TO ANY PARTICULAR FONT, STYLE, SIZE, OR COLOR.

FOR PERSONAL HYGIENE DEVICE IN THE NATURE OF A PLASTIC RECEPTACLE FOR WEAR BY A MALE USER FOR URINE COLLECTION AND DISPOSAL (U.S. CLS. 6, 18, 44, 46, 51 AND 52).

FIRST USE 11-14-2006; IN COMMERCE 11-14-2006.

**CLASS 5—(Continued).**

3,234,525. THE PROCTER & GAMBLE COMPANY, CINCINNATI, OH. SN 78-520,682. PUB. 9-6-2005, FILED 11-21-2004.

**FABRIC. AIR.  
FEBREZE FRESH  
EVERYWHERE.**

THE MARK CONSISTS OF STANDARD CHARACTERS WITHOUT CLAIM TO ANY PARTICULAR FONT, STYLE, SIZE, OR COLOR.

OWNER OF U.S. REG. NOS. 2,107,914, 2,924,317, AND OTHERS.

NO CLAIM IS MADE TO THE EXCLUSIVE RIGHT TO USE "FABRIC. AIR.", APART FROM THE MARK AS SHOWN.

FOR DEODORIZER FOR FABRICS, UPHOLSTERY AND CARPETS; AIR FRESHENERS AND ROOM DEODORIZERS (U.S. CLS. 6, 18, 44, 46, 51 AND 52).

FIRST USE 1-31-2005; IN COMMERCE 1-31-2005.

3,234,625. VALUE MARKETING, INC., CEDARHURST, NY. SN 78-547,850. PUB. 10-25-2005, FILED 1-14-2005.

**AMBIATOL**

THE MARK CONSISTS OF STANDARD CHARACTERS WITHOUT CLAIM TO ANY PARTICULAR FONT, STYLE, SIZE, OR COLOR.

FOR NUTRITIONAL SUPPLEMENTS; DIETARY SUPPLEMENTS; NUTRACEUTICALS FOR USE AS A DIETARY SUPPLEMENT (U.S. CLS. 6, 18, 44, 46, 51 AND 52).

FIRST USE 1-3-2004; IN COMMERCE 1-3-2004.

**CLASS 5—(Continued).**

3,234,805. LAUREN, KIM, SCOTTSDALE, AZ. SN 78-623,308. PUB. 1-24-2006, FILED 5-4-2005.

**Expert Formula**

THE MARK CONSISTS OF STANDARD CHARACTERS WITHOUT CLAIM TO ANY PARTICULAR FONT, STYLE, SIZE, OR COLOR.

NO CLAIM IS MADE TO THE EXCLUSIVE RIGHT TO USE "FORMULA", APART FROM THE MARK AS SHOWN.

FOR NUTRITIONAL AND DIETARY SUPPLEMENTS, NAMELY VITAMIN SUPPLEMENTS, MINERAL SUPPLEMENTS AND HERBAL SUPPLEMENTS (U.S. CLS. 6, 18, 44, 46, 51 AND 52).

FIRST USE 7-12-2006; IN COMMERCE 7-12-2006.

3,234,816. SCIELE PHARMA, INC., ATLANTA, GA. SN 78-625,791. PUB. 2-7-2006, FILED 5-9-2005.



FOR PHARMACEUTICAL PRODUCTS, NAMELY, LIPID AND TRIGLYCERIDE REDUCING AGENTS (U.S. CLS. 6, 18, 44, 46, 51 AND 52).

FIRST USE 6-27-2005; IN COMMERCE 6-27-2005.

3,234,821. PRIMUS PHARMACEUTICALS, INC., SCOTTSDALE, AZ. SN 78-626,170. PUB. 1-31-2006, FILED 5-9-2005.

**SAFETY THAT WORKS IN  
OSTEOARTHRITIS**

THE MARK CONSISTS OF STANDARD CHARACTERS WITHOUT CLAIM TO ANY PARTICULAR FONT, STYLE, SIZE, OR COLOR.

FOR MEDICAL FOODS FOR USE IN THE DIETARY MANAGEMENT OF PATIENTS WITH OSTEOARTHRITIS (U.S. CLS. 6, 18, 44, 46, 51 AND 52).

FIRST USE 10-0-2004; IN COMMERCE 10-0-2004.

**CLASS 5—(Continued).**

3,234,840. NATIONAL ENZYME COMPANY, FORSYTH, MO. SN 78-631,643. PUB. 2-14-2006, FILED 5-17-2005.

**PROCERELASE**

THE MARK CONSISTS OF STANDARD CHARACTERS WITHOUT CLAIM TO ANY PARTICULAR FONT, STYLE, SIZE, OR COLOR.

FOR FOOD GRADE FUNGAL ENZYME SYSTEM, CONSISTING OF A UNIQUE ENZYME MIXTURE THAT HYDROLYZES PLANT CELL WALL FIBERS AND NON-STARCH POLYSACCHARIDES (NSPS), THAT IS USED AS A COMPONENT OF DIETARY SUPPLEMENTS (U.S. CLS. 6, 18, 44, 46, 51 AND 52).

FIRST USE 11-6-2006; IN COMMERCE 11-6-2006.

**CLASS 5—(Continued).**

3,234,881. MEDEXUS INC., ONTARIO, CANADA. SN 78-641,113. PUB. 3-21-2006, FILED 6-1-2005.

**SMOOTHCHEW**

THE MARK CONSISTS OF STANDARD CHARACTERS WITHOUT CLAIM TO ANY PARTICULAR FONT, STYLE, SIZE, OR COLOR.

PRIORITY CLAIMED UNDER SEC. 44(D) ON CANADA APPLICATION NO. 1241015, FILED 12-17-2004, REG. NO. TMA650,461, DATED 10-17-2005, EXPIRES 10-17-2020.

FOR NUTRITIONAL SUPPLEMENT CONTAINING CALCIUM AND VITAMIN D3 (U.S. CLS. 6, 18, 44, 46, 51 AND 52).

FIRST USE 1-30-2006; IN COMMERCE 1-30-2006.

3,234,878. KELSEY ASSOCIATES, LLC, LEDGEWOOD, NJ. SN 78-639,244. PUB. 3-7-2006, FILED 5-27-2005.

**BUG NIX**

THE MARK CONSISTS OF STANDARD CHARACTERS WITHOUT CLAIM TO ANY PARTICULAR FONT, STYLE, SIZE, OR COLOR.

NO CLAIM IS MADE TO THE EXCLUSIVE RIGHT TO USE "BUG", APART FROM THE MARK AS SHOWN.

FOR INSECT REPELLENTS (U.S. CLS. 6, 18, 44, 46, 51 AND 52).

FIRST USE 6-15-2005; IN COMMERCE 6-30-2005.

3,234,893. ALLEGIANCE CORPORATION, MCGAW PARK, IL. SN 78-643,400. PUB. 5-23-2006, FILED 6-3-2005.

**AVA-TEX**

THE MARK CONSISTS OF STANDARD CHARACTERS WITHOUT CLAIM TO ANY PARTICULAR FONT, STYLE, SIZE, OR COLOR.

OWNER OF U.S. REG. NO. 2,826,383.

FOR RADIOPAGUE BONE CEMENT FOR USE IN VERTEBROPLASTY (U.S. CLS. 6, 18, 44, 46, 51 AND 52).

FIRST USE 7-7-2005; IN COMMERCE 7-7-2005.

3,234,879. SOUTHERN AGRICULTURAL INSECTICIDES INC., PALMETTO, FL. SN 78-640,226. PUB. 2-21-2006, FILED 5-31-2005.

**PARAFINE**

THE MARK CONSISTS OF STANDARD CHARACTERS WITHOUT CLAIM TO ANY PARTICULAR FONT, STYLE, SIZE, OR COLOR.

FOR INSECTICIDES (U.S. CLS. 6, 18, 44, 46, 51 AND 52).

FIRST USE 12-22-2005; IN COMMERCE 1-6-2006.

3,234,916. HD NUTRITION, INC., COSTA MESA, CA. SN 78-648,635. PUB. 2-28-2006, FILED 6-10-2005.

**MARIPLEX-GLM**

THE MARK CONSISTS OF STANDARD CHARACTERS WITHOUT CLAIM TO ANY PARTICULAR FONT, STYLE, SIZE, OR COLOR.

FOR DIETARY SUPPLEMENTS (U.S. CLS. 6, 18, 44, 46, 51 AND 52).

FIRST USE 3-1-2005; IN COMMERCE 3-1-2005.

**CLASS 5—(Continued).**

3,234,941. NATURAL VET LLC, THE, UNICOI, TN. SN 78-651,789. PUB. 3-21-2006, FILED 6-16-2005.

**NATURE FOR LIFE**

THE MARK CONSISTS OF STANDARD CHARACTERS WITHOUT CLAIM TO ANY PARTICULAR FONT, STYLE, SIZE, OR COLOR.

FOR FOOD SUPPLEMENTS FOR HUMANS AND ANIMALS (U.S. CLS. 6, 18, 44, 46, 51 AND 52).

FIRST USE 3-0-2005; IN COMMERCE 4-0-2005.

**CLASS 5—(Continued).**

3,235,056. DENTSPLY INTERNATIONAL INC., YORK, PA. SN 78-665,183. PUB. 5-23-2006, FILED 7-7-2005.

**SEAL-N-GLO**

THE MARK CONSISTS OF STANDARD CHARACTERS WITHOUT CLAIM TO ANY PARTICULAR FONT, STYLE, SIZE, OR COLOR.

FOR DENTAL PIT AND FISSURE SEALANT PREPARATIONS, NAMELY RESINS, ETCHANTS AND RESTORATIVE COMPOUNDS (U.S. CLS. 6, 18, 44, 46, 51 AND 52).

FIRST USE 12-6-2005; IN COMMERCE 12-6-2005.

3,235,039. ADVANCED NUTRITIONAL BIOSYSTEMS, INC., ORLANDO, FL. SN 78-662,839. PUB. 3-21-2006, FILED 7-1-2005.

**HEMO-NO**

THE MARK CONSISTS OF STANDARD CHARACTERS WITHOUT CLAIM TO ANY PARTICULAR FONT, STYLE, SIZE, OR COLOR.

FOR VITAMINS AND NUTRITIONAL SUPPLEMENTS (U.S. CLS. 6, 18, 44, 46, 51 AND 52).

FIRST USE 6-0-2006; IN COMMERCE 6-0-2006.

3,235,070. WYETH HOLDINGS CORPORATION, MADISON, NJ. SN 78-668,473. PUB. 5-2-2006, FILED 7-12-2005.



NO CLAIM IS MADE TO THE EXCLUSIVE RIGHT TO USE "8 INTERACTIVE COMBINATIONS", APART FROM THE MARK AS SHOWN.

FOR DIETARY AND NUTRITIONAL SUPPLEMENTS (U.S. CLS. 6, 18, 44, 46, 51 AND 52).

FIRST USE 4-1-2006; IN COMMERCE 4-1-2006.

3,235,043. ENZYMATIC THERAPY, INC., GREEN BAY, WI. SN 78-663,427. PUB. 7-4-2006, FILED 7-5-2005.

**PROSTATE ADVANTAGE**

THE MARK CONSISTS OF STANDARD CHARACTERS WITHOUT CLAIM TO ANY PARTICULAR FONT, STYLE, SIZE, OR COLOR.

NO CLAIM IS MADE TO THE EXCLUSIVE RIGHT TO USE "PROSTATE", APART FROM THE MARK AS SHOWN.

FOR DIETARY AND NUTRITIONAL SUPPLEMENTS (U.S. CLS. 6, 18, 44, 46, 51 AND 52).

FIRST USE 3-7-2006; IN COMMERCE 3-7-2006.

3,235,112. MED GEN INC., BOCA RATON, FL. SN 78-678,304. PUB. 4-18-2006, FILED 7-26-2005.

**WEIGHT SHIELD**

THE MARK CONSISTS OF STANDARD CHARACTERS WITHOUT CLAIM TO ANY PARTICULAR FONT, STYLE, SIZE, OR COLOR.

NO CLAIM IS MADE TO THE EXCLUSIVE RIGHT TO USE "WEIGHT", APART FROM THE MARK AS SHOWN.

FOR PHARMACEUTICAL PREPARATIONS FOR THE TREATMENT OF OVERWEIGHT (U.S. CLS. 6, 18, 44, 46, 51 AND 52).

FIRST USE 8-4-2006; IN COMMERCE 8-4-2006.

**CLASS 5—(Continued).**

3,235,126. MICHAEL S. MORRIS, MD, LLC, ROCKVILLE, MD. SN 78-681,838. PUB. 6-20-2006, FILED 7-29-2005.

**ALLERDROPS**

THE MARK CONSISTS OF STANDARD CHARACTERS WITHOUT CLAIM TO ANY PARTICULAR FONT, STYLE, SIZE, OR COLOR.

FOR REFORMULATED MEDICATED SERUMS FOR TREATMENT OF ALLERGIES (U.S. CLS. 6, 18, 44, 46, 51 AND 52).

FIRST USE 10-15-2005; IN COMMERCE 10-15-2005.

3,235,136. WYETH HOLDINGS CORPORATION, MADISON, NJ. SN 78-685,675. PUB. 4-25-2006, FILED 8-4-2005.



OWNER OF U.S. REG. NOS. 1,331,595, 1,956,858, AND 1,971,803.

THE APPLICANT CLAIMS COLOR AS A FEATURE OF THE MARK, NAMELY, BLUE, BLACK, SILVER, YELLOW AND WHITE.

THE MARK CONSISTS OF A BLUE FIELD AT THE TOP, BENEATH WHICH IS THE CALTRATE WORD MARK IN BLACK AND SHADOWED IN SILVER AGAINST A WHITE BACKGROUND INSIDE THE ARC OF A CURVED, HORSE-SHOE-SHAPED RIBBON, WHERE THE OUTSIDE EDGE OF THE RIBBON IS SILVER AND THE INSIDE EDGE IS YELLOW, THAT HAS A SILVER CURVED LINE ON THE RIGHT SIDE THAT FORMS AN OVAL BY CLOSING THE OPEN END OF THE CURVED RIBBON, BENEATH WHICH IS A THIN STRIP OF BLUE, BENEATH WHICH IS A FIELD OF WHITE THAT BLEEDS INTO BLUE TOWARD THE BOTTOM, BENEATH WHICH IS A CURVED SILVER LINE RUNNING UPWARD FROM LEFT TO RIGHT, ALL BENEATH WHICH IS A FIELD OF BLUE APPEARING AT THE BOTTOM.

FOR DIETARY SUPPLEMENTS; NUTRITIONAL SUPPLEMENTS (U.S. CLS. 6, 18, 44, 46, 51 AND 52).

FIRST USE 7-13-2006; IN COMMERCE 7-13-2006.

**CLASS 5—(Continued).**

3,235,155. INCLINE MEDICAL, LLC, LAKE OSWEGO, OR. SN 78-692,763. PUB. 5-16-2006, FILED 8-15-2005.

**ValuStrip**

THE MARK CONSISTS OF STANDARD CHARACTERS WITHOUT CLAIM TO ANY PARTICULAR FONT, STYLE, SIZE, OR COLOR.

FOR MEDICAL DIAGNOSTIC BLOOD GLUCOSE TEST STRIPS FOR USE BY DIABETICS (U.S. CLS. 6, 18, 44, 46, 51 AND 52).

FIRST USE 7-1-2006; IN COMMERCE 8-1-2006.

3,235,278. THE DOW CHEMICAL COMPANY, MIDLAND, MI. SN 78-748,967. PUB. 8-8-2006, FILED 11-8-2005.

**GLUTEX**

THE MARK CONSISTS OF STANDARD CHARACTERS WITHOUT CLAIM TO ANY PARTICULAR FONT, STYLE, SIZE, OR COLOR.

FOR BIOCIDES, DISINFECTANTS AND SANITARY PREPARATIONS FOR INDUSTRIAL USE FOR FARM ANIMAL AND POULTRY HOUSING FACILITIES (U.S. CLS. 6, 18, 44, 46, 51 AND 52).

FIRST USE 9-30-2006; IN COMMERCE 9-30-2006.

3,235,283. SELFWORX.COM LLC, DBA PREVAL, SCARBOROUGH, ME. SN 78-751,381. PUB. 7-18-2006, FILED 11-10-2005.

**WRECKING BALM**

THE MARK CONSISTS OF STANDARD CHARACTERS WITHOUT CLAIM TO ANY PARTICULAR FONT, STYLE, SIZE, OR COLOR.

NO CLAIM IS MADE TO THE EXCLUSIVE RIGHT TO USE "BALM", APART FROM THE MARK AS SHOWN.

FOR MEDICATED SKINCARE PREPARATION KIT COMPRISED PRIMARILY OF EXFOLIATING CHEMICAL SKIN PEEL, MEDICATED SKIN LIGHTENING CREAM, APPLICATOR STICKS FOR APPLYING SKIN LIGHTENING CREAM, AND CONCEALERS FOR THE SKIN (U.S. CLS. 6, 18, 44, 46, 51 AND 52).

FIRST USE 10-0-2005; IN COMMERCE 3-0-2006.



**CLASS 5—(Continued).**

3,235,289. COVENANT PHARMA INC., MARIETTA, GA. SN 78-755,383. PUB. 8-1-2006, FILED 11-16-2005.

**ISONARIF**

THE MARK CONSISTS OF STANDARD CHARACTERS WITHOUT CLAIM TO ANY PARTICULAR FONT, STYLE, SIZE, OR COLOR.

FOR PHARMACEUTICAL PREPARATION FOR THE TREATMENT OF TUBERCULOSIS (U.S. CLS. 6, 18, 44, 46, 51 AND 52).

FIRST USE 1-1-2006; IN COMMERCE 1-1-2006.

3,235,302. JENERIC/PENTRON, INC., WALLINGFORD, CT. SN 78-758,906. PUB. 8-22-2006, FILED 11-22-2005.

**ARTISTE**

THE MARK CONSISTS OF STANDARD CHARACTERS WITHOUT CLAIM TO ANY PARTICULAR FONT, STYLE, SIZE, OR COLOR.

FOR DENTAL COMPOSITE MATERIALS (U.S. CLS. 6, 18, 44, 46, 51 AND 52).

FIRST USE 1-16-2006; IN COMMERCE 1-16-2006.

3,235,343. DESTON THERAPEUTICS, INC., CHAPEL HILL, NC. SN 78-771,034. PUB. 8-15-2006, FILED 12-12-2005.

**NOVAHISTINE**

THE MARK CONSISTS OF STANDARD CHARACTERS WITHOUT CLAIM TO ANY PARTICULAR FONT, STYLE, SIZE, OR COLOR.

FOR PHARMACEUTICAL PREPARATION, NAMELY, A DECONGESTANT/ANTIHISTIMINE/COUGH SUPPRESSANT PREPARATION (U.S. CLS. 6, 18, 44, 46, 51 AND 52).

FIRST USE 11-2-2006; IN COMMERCE 11-2-2006.

**CLASS 5—(Continued).**

3,235,358. CHOPRA ENTERPRISES, LLC, CARLSBAD, CA. SN 78-780,459. PUB. 9-5-2006, FILED 12-23-2005.

**AYURVEDIC HERBAL WISDOM**

THE MARK CONSISTS OF STANDARD CHARACTERS WITHOUT CLAIM TO ANY PARTICULAR FONT, STYLE, SIZE, OR COLOR.

NO CLAIM IS MADE TO THE EXCLUSIVE RIGHT TO USE "AYURVEDIC HERBAL", APART FROM THE MARK AS SHOWN.

FOR DIETARY SUPPLEMENTS; FOOD SUPPLEMENTS; HERBAL SUPPLEMENTS; MIXED VITAMIN PREPARATIONS; MULTI-VITAMIN PREPARATIONS; NUTRITIONAL SUPPLEMENTS; VITAMIN SUPPLEMENTS; VITAMINS (U.S. CLS. 6, 18, 44, 46, 51 AND 52).

FIRST USE 11-30-2005; IN COMMERCE 11-30-2005.

3,235,376. DIAL BRANDS, INC., SCOTTSDALE, AZ. SN 78-799,467. PUB. 7-11-2006, FILED 1-25-2006.

**GENTLE CITRUS ORCHARD**

THE MARK CONSISTS OF STANDARD CHARACTERS WITHOUT CLAIM TO ANY PARTICULAR FONT, STYLE, SIZE, OR COLOR.

NO CLAIM IS MADE TO THE EXCLUSIVE RIGHT TO USE CITRUS, APART FROM THE MARK AS SHOWN.

FOR AIR FRESHENERS, AIR DEODORIZER, CAR DEODORIZER, CARPET DEODORIZER, HOUSEHOLD DEODORIZER, ROOM DEODORIZER, ROOM FRESHENER, CARPET FRESHENERS AND ODOR ELIMINATORS, ALL PURPOSE DISINFECTING AND DEODORIZING PREPARATIONS, GARBAGE DISPOSER FRESHENERS, ODOR NEUTRALIZING PREPARATIONS FOR USE ON CARPETS, TEXTILES, AND IN THE AIR (U.S. CLS. 6, 18, 44, 46, 51 AND 52).

FIRST USE 10-1-2006; IN COMMERCE 10-1-2006.

3,235,387. LOBSONS INTERNATIONAL, INC., LONG VALLEY, NJ. SN 78-869,884. PUB. 8-22-2006, FILED 4-26-2006.

**KONDROMAX**

THE MARK CONSISTS OF STANDARD CHARACTERS WITHOUT CLAIM TO ANY PARTICULAR FONT, STYLE, SIZE, OR COLOR.

FOR CHONDROITIN PREPARATIONS (U.S. CLS. 6, 18, 44, 46, 51 AND 52).

FIRST USE 8-22-2006; IN COMMERCE 8-22-2006.

**CLASS 5—(Continued).**

3,235,394. LUITPOLD PHARMACEUTICALS, INC., SHIRLEY, NY. SN 78-977,955. PUB. 8-22-2006, FILED 12-12-2005.

**CLASS 6—(Continued).**

3,234,042. CARFARO, INC., HAMILTON TOWNSHIP, NJ. SN 76-637,884. PUB. 1-24-2006, FILED 5-4-2005.

**OSTEOHEALTH**

THE MARK CONSISTS OF STANDARD CHARACTERS WITHOUT CLAIM TO ANY PARTICULAR FONT, STYLE, SIZE, OR COLOR.

OWNER OF U.S. REG. NO. 1,941,753.

FOR GROWTH FACTOR ENHANCED PHARMACEUTICAL PREPARATIONS FOR THE TREATMENT OF PERIODONTAL AND CRANIO-MAXILLOFACIAL (CMF) BONE AND SOFT TISSUE DEFECTS, NAMELY BONE AND TISSUE DEFECTS OF THE HEAD, JAW, AND FACE AND RELATED TO WOUND HEALING AND TISSUE REPAIR (U.S. CLS. 6, 18, 44, 46, 51 AND 52).

FIRST USE 4-0-2006; IN COMMERCE 4-0-2006.

**READYRAILING**

THE MARK CONSISTS OF STANDARD CHARACTERS WITHOUT CLAIM TO ANY PARTICULAR FONT, STYLE, SIZE, OR COLOR.

FOR METAL RAILINGS FOR PORCHES, BALCONIES, STAIRS AND FENCES (U.S. CLS. 2, 12, 13, 14, 23, 25 AND 50).

FIRST USE 11-3-2006; IN COMMERCE 11-3-2006.

**CLASS 6—METAL GOODS**

3,233,851. AK STEEL CORPORATION, MIDDLETOWN, OH. SN 76-524,436. PUB. 1-20-2004, FILED 6-23-2003.

3,234,406. WALLIS, JAMES W., OKLAHOMA CITY, OK. SN 78-480,811. PUB. 4-11-2006, FILED 9-9-2004.

**T2**

FOR STEEL (U.S. CLS. 2, 12, 13, 14, 23, 25 AND 50).

FIRST USE 3-0-2005; IN COMMERCE 3-0-2005.

**LOBO**

3,233,933. HIGH GEAR SPECIALTIES, INC., OAKLAND, FL. SN 76-607,338. PUB. 10-4-2005, FILED 8-17-2004.

**TECHMOUNT**

THE MARK CONSISTS OF STANDARD CHARACTERS WITHOUT CLAIM TO ANY PARTICULAR FONT, STYLE, SIZE, OR COLOR.

FOR METAL SUPPORT BRACKETS AFFIXED TO MOTORCYCLES FOR THE TRANSPORT OF ELECTRONIC EQUIPMENT, CHANGE HOLDERS AND OTHER PORTABLE ITEMS (U.S. CLS. 2, 12, 13, 14, 23, 25 AND 50).

FIRST USE 8-31-2004; IN COMMERCE 8-31-2004.

THE MARK CONSISTS OF STANDARD CHARACTERS WITHOUT CLAIM TO ANY PARTICULAR FONT, STYLE, SIZE, OR COLOR.

FOR ALUMINUM ALLOY ATTACHMENT FOR FENCE POSTS, IN THE NATURE OF A STEP, FOR THE PURPOSE OF CLIMBING WIRE FENCES SUPPORTED BY T-POSTS (U.S. CLS. 2, 12, 13, 14, 23, 25 AND 50).

FIRST USE 11-30-2004; IN COMMERCE 11-30-2004.

**CLASS 6—(Continued).**

3,234,610. WESTERN STATES WHOLESALE, INC., ONTARIO, CA. SN 78-544,193. PUB. 4-18-2006, FILED 1-7-2005.



NO CLAIM IS MADE TO THE EXCLUSIVE RIGHT TO USE "PROBACKER SCREWS", APART FROM THE MARK AS SHOWN.

THE MARK CONSISTS OF THE WORD DESIGN "PROBACKER SCREWS" IN WHICH THE FIRST SYLLABLE "PRO" IS IN ITALICS AND THE REMAINING SYLLABLES ARE IN BLOCK LETTERS. BEHIND THE WORD DESIGN IS A TILTED RECTANGLE WITH SERRATED EDGES.

FOR METAL SCREWS FOR USE WITH CEMENT BACKING BOARD (U.S. CLS. 2, 12, 13, 14, 23, 25 AND 50).

FIRST USE 9-1-2006; IN COMMERCE 9-1-2006.

**CLASS 6—(Continued).**

3,234,855. KAREN ROSSI STUDIOS, MERIDEN, CT. SN 78-634,671. PUB. 2-21-2006, FILED 5-23-2005.

**DAZZLING DAMSELLES**

THE MARK CONSISTS OF STANDARD CHARACTERS WITHOUT CLAIM TO ANY PARTICULAR FONT, STYLE, SIZE, OR COLOR.

FOR FIGURINES MADE OF COMMON METAL; GARDEN STAKES MADE OF COMMON METAL; KINETIC SCULPTURES MADE OF COMMON METAL (U.S. CLS. 2, 12, 13, 14, 23, 25 AND 50).

FIRST USE 11-4-2005; IN COMMERCE 11-4-2005.

3,234,911. MCFADDEN, CHRIS, PALM DESERT, CA. SN 78-647,587. PUB. 3-21-2006, FILED 6-9-2005.

**KLEEN-WEEP**

THE MARK CONSISTS OF STANDARD CHARACTERS WITHOUT CLAIM TO ANY PARTICULAR FONT, STYLE, SIZE, OR COLOR.

FOR BUILDING MATERIALS, NAMELY, METAL DRAINS AND METAL SCREENS FOR DRAINING MOISTURE FROM STUCCO AND EXTERIOR STUCCO PRODUCTS ON RESIDENTIAL AND COMMERCIAL BUILDINGS (U.S. CLS. 2, 12, 13, 14, 23, 25 AND 50).

FIRST USE 8-8-2006; IN COMMERCE 8-8-2006.

3,235,006. FASTWELL INDUSTRY CO. LTD, SHANGHAI, CHINA. SN 78-659,977. PUB. 5-9-2006, FILED 6-28-2005.

**EnviroMark****FW**

THE MARK CONSISTS OF STANDARD CHARACTERS WITHOUT CLAIM TO ANY PARTICULAR FONT, STYLE, SIZE, OR COLOR.

FOR SOLDER PASTE (U.S. CLS. 2, 12, 13, 14, 23, 25 AND 50).

FIRST USE 10-0-2004; IN COMMERCE 10-0-2004.

THE MARK CONSISTS OF STANDARD CHARACTERS WITHOUT CLAIM TO ANY PARTICULAR FONT, STYLE, SIZE, OR COLOR.

FOR METAL THREAD AND METAL NON-THREAD FASTENERS NAMELY BOLTS, NUTS, NAILS, RIVETS, SCREWS, AND WASHERS (U.S. CLS. 2, 12, 13, 14, 23, 25 AND 50).

FIRST USE 6-1-2006; IN COMMERCE 6-1-2006.

**CLASS 6—(Continued).**

3,235,055. WESTERN BUILDERS SUPPLY, INC., BILLINGS, MT. SN 78-665,089. PUB. 3-21-2006, FILED 7-6-2005.

**BIG TIMBER**

THE MARK CONSISTS OF STANDARD CHARACTERS WITHOUT CLAIM TO ANY PARTICULAR FONT, STYLE, SIZE, OR COLOR.

FOR METAL FASTENERS, NAMELY, SCREWS, SPIKES, STAPLES, NAILS, BOLTS AND NUTS (U.S. CLS. 2, 12, 13, 14, 23, 25 AND 50).

FIRST USE 1-11-2006; IN COMMERCE 1-11-2006.

3,235,234. O'SULLIVAN INDUSTRIES, INC., LAMAR, MO. SN 78-725,952. PUB. 9-5-2006, FILED 10-4-2005.

**SNUGTRACK**

THE MARK CONSISTS OF STANDARD CHARACTERS WITHOUT CLAIM TO ANY PARTICULAR FONT, STYLE, SIZE, OR COLOR.

FOR METAL SHELVING BRACKETS AND STANDARDS (U.S. CLS. 2, 12, 13, 14, 23, 25 AND 50).

FIRST USE 5-31-2006; IN COMMERCE 5-31-2006.

3,235,236. O'SULLIVAN INDUSTRIES, INC., LAMAR, MO. SN 78-725,966. PUB. 7-11-2006, FILED 10-4-2005.

**SHELVING SOLUTIONS**

THE MARK CONSISTS OF STANDARD CHARACTERS WITHOUT CLAIM TO ANY PARTICULAR FONT, STYLE, SIZE, OR COLOR.

NO CLAIM IS MADE TO THE EXCLUSIVE RIGHT TO USE "SHELVING", APART FROM THE MARK AS SHOWN.

FOR METAL SHELVING BRACKETS AND STANDARDS (U.S. CLS. 2, 12, 13, 14, 23, 25 AND 50).

FIRST USE 5-0-2006; IN COMMERCE 5-0-2006.

**CLASS 6—(Continued).**

3,235,374. MAZELMINTS, INC, ELDERSBURG, MD. SN 78-797,834. PUB. 4-11-2006, FILED 1-24-2006.

**ENLARGEMINTS**

THE MARK CONSISTS OF STANDARD CHARACTERS WITHOUT CLAIM TO ANY PARTICULAR FONT, STYLE, SIZE, OR COLOR.

FOR METAL BOXES (U.S. CLS. 2, 12, 13, 14, 23, 25 AND 50).

FIRST USE 12-5-2006; IN COMMERCE 12-5-2006.

**CLASS 7—MACHINERY**

3,233,822. HAGEMeyer NORTH AMERICA, INC., ALPHARETTA, GA. SN 76-482,666. PUB. 6-1-2004, FILED 1-16-2003.

**CAMBAR**

FOR ABRASIVE WHEELS FOR USE ON POWER TOOLS, NAMELY, CUT-OFF WHEELS, CENTER WHEELS, AND DEPRESSED CENTER WHEELS; GENERAL-PURPOSE ABRASIVE BELTS FOR USE ON POWER TOOLS; POWER-OPERATED PNEUMATIC DRILLS, RATCHETS, IMPACT WRENCHES, GRINDERS, SANDERS, SCALERS, AND HAMMERS; POWER-OPERATED JOBBER DRILLS AND SCREW MACHINE DRILLS; POWER-OPERATED TAPER SHANK DRILLS AND REDUCED SHANK DRILLS; DRILL SETS FOR USE ON POWER-OPERATED DRILLS; END MILLS, TAPS, PIPE TAPS, HAND TAPS, AND BURS FOR USE WITH POWER TOOLS; POWER-OPERATED FLUID MAINTENANCE EQUIPMENT, NAMELY, BELT SKIMMER AND COOLANT PREMIXER/PROPORTIONER; INDUSTRIAL MACHINE TOOL SUMP FILTRATION EQUIPMENT FOR REMOVING WASTE COOLANT, METAL CHIPS, TRAMP OILS, AND SLUDGE; BAND SAW BLADES FOR POWER-OPERATED BAND SAWS; PAINT STRIPING MACHINE; AND POWER-OPERATED DRUM PUMP (U.S. CLS. 13, 19, 21, 23, 31, 34 AND 35).

FIRST USE 3-3-2003; IN COMMERCE 3-3-2003.

3,233,839. L.J. SMITH, INC., BOWERSTON, OH. SN 76-498,862. PUB. 1-20-2004, FILED 3-12-2003.

**BALUSTER RUNNER**

NO CLAIM IS MADE TO THE EXCLUSIVE RIGHT TO USE "BALUSTER", APART FROM THE MARK AS SHOWN.

FOR CHUCKS FOR POWER DRILLS (U.S. CLS. 13, 19, 21, 23, 31, 34 AND 35).

FIRST USE 7-0-2006; IN COMMERCE 7-0-2006.

**CLASS 7—(Continued).**

3,233,885. COLLETTE, JERRY, CARROLLTON, OH. SN 76-578,649. PUB. 11-8-2005, FILED 3-1-2004.

**RAP SAVER**

THE MARK CONSISTS OF STANDARD CHARACTERS WITHOUT CLAIM TO ANY PARTICULAR FONT, STYLE, SIZE, OR COLOR.

NO CLAIM IS MADE TO THE EXCLUSIVE RIGHT TO USE "RAP", APART FROM THE MARK AS SHOWN.

FOR MACHINES AND MACHINERY FOR RECYCLING AND RESTORING MILLED ASPHALT WASTE FROM ROADS, PARKING LOTS AND DRIVEWAYS INTO REUSABLE HOT MIX ASPHALT PAVING MATERIAL (U.S. CLS. 13, 19, 21, 23, 31, 34 AND 35).

FIRST USE 9-1-2006; IN COMMERCE 9-1-2006.

3,233,893. HOMELAND HOUSEWARES, LLC, LOS ANGELES, CA. SN 76-584,753. PUB. 2-15-2005, FILED 4-5-2004.

**CYCLONIC CUTTING ZONE**

THE MARK CONSISTS OF STANDARD CHARACTERS WITHOUT CLAIM TO ANY PARTICULAR FONT, STYLE, SIZE, OR COLOR.

NO CLAIM IS MADE TO THE EXCLUSIVE RIGHT TO USE "CUTTING", APART FROM THE MARK AS SHOWN.

FOR ELECTRONIC APPLIANCES, NAMELY, KITCHEN FOOD PROCESSORS (U.S. CLS. 13, 19, 21, 23, 31, 34 AND 35).

FIRST USE 8-31-2003; IN COMMERCE 8-31-2003.

3,233,900. BICO DRILLING TOOLS, INC., HOUSTON, TX. SN 76-589,559. PUB. 1-18-2005, FILED 4-19-2004.

**SpiroStar**

THE MARK CONSISTS OF STANDARD CHARACTERS WITHOUT CLAIM TO ANY PARTICULAR FONT, STYLE, SIZE, OR COLOR.

FOR POSITIVE DISPLACEMENT DRILLING MOTOR (U.S. CLS. 13, 19, 21, 23, 31, 34 AND 35).

FIRST USE 1-1-2005; IN COMMERCE 1-1-2005.

**CLASS 7—(Continued).**

3,233,967. HARTNESS INTERNATIONAL, INC., GREENVILLE, SC. SN 76-614,239. PUB. 9-13-2005, FILED 10-1-2004.

**GLOBALFILL**

THE MARK CONSISTS OF STANDARD CHARACTERS WITHOUT CLAIM TO ANY PARTICULAR FONT, STYLE, SIZE, OR COLOR.

OWNER OF U.S. REG. NO. 2,464,484.

FOR MACHINES, NAMELY, ROTARY FILLERS FOR DISPENSING LIQUIDS INTO CONTAINERS (U.S. CLS. 13, 19, 21, 23, 31, 34 AND 35).

FIRST USE 1-31-2006; IN COMMERCE 1-31-2006.

3,233,982. KERK MOTION PRODUCTS, INC., HOLLIS, NH. SN 76-618,971. PUB. 1-10-2006, FILED 11-2-2004.

**KERK**

THE MARK CONSISTS OF STANDARD CHARACTERS WITHOUT CLAIM TO ANY PARTICULAR FONT, STYLE, SIZE, OR COLOR.

OWNER OF U.S. REG. NO. 1,345,622.

FOR MACHINE PARTS, NAMELY, LEAD SCREWS AND NUTS; LINEAR RAILS, GUIDES AND BUSHINGS, SPLINE SHAFTS AND BUSHINGS; LINEAR SLIDES; AND LINEAR ACTUATORS (U.S. CLS. 13, 19, 21, 23, 31, 34 AND 35).

FIRST USE 8-10-1978; IN COMMERCE 8-10-1978.

3,234,026. STEINEL GMBH, D-4836 HERZEBROCK 1, FED REP GERMANY. SN 76-634,353. PUB. 7-25-2006, FILED 3-25-2005.

**THERMAMELT**

THE MARK CONSISTS OF STANDARD CHARACTERS WITHOUT CLAIM TO ANY PARTICULAR FONT, STYLE, SIZE, OR COLOR.

FOR BUTANE POWERED HOT MELT GLUE GUNS (U.S. CLS. 13, 19, 21, 23, 31, 34 AND 35).

FIRST USE 9-13-2005; IN COMMERCE 9-13-2005.

**CLASS 7—(Continued).**

3,234,056. TSUKIBOSHI MFG. CO. LTD., KAGA CITY ISHIKAWA, PEF. 922, JAPAN. SN 76-641,193. PUB. 3-14-2006, FILED 6-21-2005.

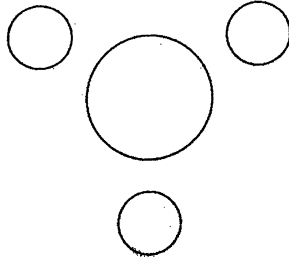

FOR CYLINDER HEAD BOLTS FOR MOTORCYCLE ENGINES (U.S. CLS. 13, 19, 21, 23, 31, 34 AND 35). FIRST USE 1-10-2006; IN COMMERCE 1-10-2006.

3,234,069. KZCO INCORPORATED, ASHLAND, NE. SN 76-646,188. PUB. 8-8-2006, FILED 9-7-2005.



FOR REMOTELY CONTROLLED ELECTRIC LINEAR ACTUATORS FOR USE IN MOVING DOORS OR STAGE PLATFORMS (U.S. CLS. 13, 19, 21, 23, 31, 34 AND 35). FIRST USE 3-22-2005; IN COMMERCE 9-1-2005.

3,234,079. GOODWAY TECHNOLOGIES CORPORATION, STAMFORD, CT. SN 76-652,785. PUB. 8-29-2006, FILED 1-3-2006.

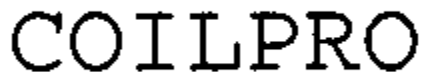

THE MARK CONSISTS OF STANDARD CHARACTERS WITHOUT CLAIM TO ANY PARTICULAR FONT, STYLE, SIZE, OR COLOR. FOR MACHINES FOR CLEANING COILS IN HVAC UNITS (U.S. CLS. 13, 19, 21, 23, 31, 34 AND 35). FIRST USE 1-15-2005; IN COMMERCE 1-15-2005.

**CLASS 7—(Continued).**

3,234,211. U. S. A. GEORGE ELEVATOR, INC., CHICAGO, IL. SN 78-361,416. PUB. 9-27-2005, FILED 2-3-2004.



THE MARK CONSISTS OF TWO TRIANGLES. FOR ELEVATORS; STAIR LIFTS; ESCALATORS; MOVING STAIRWAYS; HOISTING EQUIPMENT, NAMELY CRANES, POWER JACKS AND HYDRAULIC JACKS; LOADING EQUIPMENT, NAMELY, FRONT END LOADERS AND CONVEYERS; MOBILE CRANES; PNEUMATIC TRANSPORTERS; HOISTS (U.S. CLS. 13, 19, 21, 23, 31, 34 AND 35). FIRST USE 11-26-2002; IN COMMERCE 11-26-2002.

3,234,279. GHISLAIN, JUSTIN MARIE MAT, KRUGERS-DORP, GAUTENG, SOUTH AFRICA. SN 78-404,683. PUB. 9-13-2005, FILED 4-20-2004.



THE MARK CONSISTS OF THE WORD "SCAVENGER" AND A SLATED SQUARE, A CIRCLE CONTAINED IN THAT SQUARE AND CIRCLES POSITIONED IN THE CORNERS OF THE SQUARE. FOR MACHINES AND MACHINE TOOLS FOR USE IN CONVEYOR BELT CLEANING AND SCRAPING SYSTEMS FOR USE IN THE MINING INDUSTRY; CONVEYOR BELT MOTORS AND ENGINES; NOT INCLUDING LAND MACHINE COUPLING AND TRANSMISSION COMPONENTS, FOR USE IN THE MINING INDUSTRY; CONVEYORS AND BELTS FOR USE IN THE MINING INDUSTRY, AND ALL PARTS THEREFOR, ALL FOR USE IN THE MINING INDUSTRY (U.S. CLS. 13, 19, 21, 23, 31, 34 AND 35). FIRST USE 8-31-2004; IN COMMERCE 9-9-2004.

**CLASS 7—(Continued).**

3,234,344. BSH HOME APPLIANCES CORPORATION, HUNTINGTON BEACH, CA. SN 78-446,689. PUB. 5-31-2005, FILED 7-7-2004.

**CLASS 7—(Continued).**

3,234,444. SPP PUMPS LIMITED, READING BERKSHIRE RG31 7SP, UNITED KINGDOM. SN 78-494,465. PUB. 9-13-2005, FILED 10-5-2004.

# Vision

# SPP

THE MARK CONSISTS OF STANDARD CHARACTERS WITHOUT CLAIM TO ANY PARTICULAR FONT, STYLE, SIZE, OR COLOR.  
FOR DISHWASHERS AND PARTS THEREFOR (U.S. CLS. 13, 19, 21, 23, 31, 34 AND 35).  
FIRST USE 11-1-2004; IN COMMERCE 11-1-2004.

---

THE MARK CONSISTS OF STANDARD CHARACTERS WITHOUT CLAIM TO ANY PARTICULAR FONT, STYLE, SIZE, OR COLOR.  
FOR CENTRIFUGAL PUMPS AND PARTS THEREFOR (U.S. CLS. 13, 19, 21, 23, 31, 34 AND 35).  
FIRST USE 0-0-1947; IN COMMERCE 0-0-1980.

3,234,438. ANCHOR WALL SYSTEMS, INC., MINNETONKA, MN. SN 78-492,232. PUB. 7-25-2006, FILED 9-30-2004.

---

3,234,526. EAGLE ROCK MANUFACTURING, LLC, MIDLAND, TX. SN 78-520,954. PUB. 4-11-2006, FILED 11-22-2004.

# CRUNCH

# EAGLE ROCK

THE MARK CONSISTS OF STANDARD CHARACTERS WITHOUT CLAIM TO ANY PARTICULAR FONT, STYLE, SIZE, OR COLOR.  
FOR MACHINE PARTS, NAMELY, SPLITTING TOOLS FOR USE IN CONCRETE BLOCK SPLITTING MACHINES FOR SPLITTING CONCRETE UNITS TO CREATE DECORATIVE SURFACES ON CONCRETE BLOCKS (U.S. CLS. 13, 19, 21, 23, 31, 34 AND 35).  
FIRST USE 11-9-2006; IN COMMERCE 11-9-2006.

NO CLAIM IS MADE TO THE EXCLUSIVE RIGHT TO USE "ROCK", APART FROM THE MARK AS SHOWN.  
FOR DRILLING RIGS, NAMELY, OIL FIELD WELL DRILLING EQUIPMENT FOR USE IN EARTH DRILLING IN THE NATURE OF WELL DRILLING MACHINES (U.S. CLS. 13, 19, 21, 23, 31, 34 AND 35).  
FIRST USE 6-12-2004; IN COMMERCE 6-12-2004.

**CLASS 7—(Continued).**

3,234,604. CERIONX, INC., PENNSAUKEN, NJ. SN 78-543,330. PUB. 12-13-2005, FILED 1-6-2005.



FOR APPARATUS AND INSTRUMENTS FOR CLEANING AND SURFACE CONDITIONING SCIENTIFIC INSTRUMENTS (U.S. CLS. 13, 19, 21, 23, 31, 34 AND 35).  
FIRST USE 9-18-2006; IN COMMERCE 9-18-2006.

**CLASS 7—(Continued).**

3,234,670. BLUESHIFT TECHNOLOGIES, INC., ANDOVER, MA. SN 78-573,916. PUB. 3-7-2006, FILED 2-24-2005.

**QUICKLINK**

THE MARK CONSISTS OF STANDARD CHARACTERS WITHOUT CLAIM TO ANY PARTICULAR FONT, STYLE, SIZE, OR COLOR.

FOR SEMICONDUCTOR MANUFACTURING MACHINES AND SEMICONDUCTOR WAFER HANDLING SYSTEMS CONSISTING OF INDUSTRIAL ROBOTS AND OPERATING SOFTWARE SOLD AS AN INTEGRAL COMPONENT THEREOF (U.S. CLS. 13, 19, 21, 23, 31, 34 AND 35).  
FIRST USE 8-0-2005; IN COMMERCE 8-0-2005.

3,234,606. CERIONX, INC., PENNSAUKEN, NJ. SN 78-543,376. PUB. 12-13-2005, FILED 1-6-2005.



FOR CLEANING MACHINES FOR CLEANING AND SURFACE CONDITIONING SCIENTIFIC INSTRUMENTS, USING PLASMA (U.S. CLS. 13, 19, 21, 23, 31, 34 AND 35).  
FIRST USE 9-18-2006; IN COMMERCE 9-18-2006.

3,234,701. R.M. WADE & CO., PORTLAND, OR. SN 78-583,984. PUB. 4-25-2006, FILED 3-9-2005.

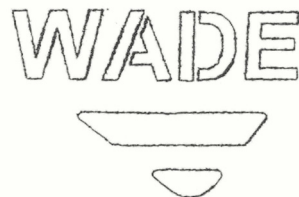

THE MARK CONSISTS OF THE WORD WADE IN BLOCK LETTERS WITH TWO WIDE LINES UNDER THE WORD.

FOR POWER OPERATED AGRICULTURAL IMPLEMENTS, NAMELY ROCK PICKERS AND ROTARY CUTTERS (U.S. CLS. 13, 19, 21, 23, 31, 34 AND 35).  
FIRST USE 1-30-2005; IN COMMERCE 1-30-2006.



**CLASS 7—(Continued).**

3,234,710. COLLETTE, JERRY R., CARROLTON, OH. SN 78-588,249. PUB. 9-13-2005, FILED 3-16-2005.



NO CLAIM IS MADE TO THE EXCLUSIVE RIGHT TO USE "RAP", APART FROM THE MARK AS SHOWN.

THE COLOR(S) RED, WHITE AND BLACK IS/ARE CLAIMED AS A FEATURE OF THE MARK.

THE MARK CONSISTS OF RAP SAVER AND AUGER IN RED, PARTICLES, OUTLINE OF THE WORDING, AUGER AND ROAD IN BLACK. THE COLOR WHITE APPEARS IN THE WORDING, AUGER AND ROAD.

FOR MACHINES AND MACHINERY FOR RECYCLING AND RESTORING MILLED ASPHALT WASTE FROM ROADS, PARKING LOTS AND DRIVEWAYS INTO REUSABLE HOT MIX ASPHALT PAVING MATERIAL (U.S. CLS. 13, 19, 21, 23, 31, 34 AND 35).

FIRST USE 9-1-2006; IN COMMERCE 9-1-2006.

3,235,210. JING LONG ENG. MACHINERY CO., LTD., GUANGZHOU CITY, CHINA. SN 78-714,241. PUB. 5-30-2006, FILED 9-15-2005.



THE MARK CONSISTS OF THE WORD GJJ. FOR ELEVATING WORK PLATFORMS; LIFTING INSTALLATIONS FOR THE TRANSPORT OF PERSONS AND GOODS; CRANES; DERRICKS; HOISTS; ELEVATORS BEING LIFTS; CONVEYORS; FRONT END LOADERS; EARTH MOVING MACHINES, NAMELY, LOADERS; BULLDOZERS; AGITATORS FOR CIRCULATING LIQUID MEDIA; CONCRETE MIXERS; POWER SHOVELS; ROAD MAKING MACHINES; MACHINES FOR USE IN CONSTRUCTION, NAMELY, RAMS; PLOUGHS (U.S. CLS. 13, 19, 21, 23, 31, 34 AND 35).

FIRST USE 7-13-1996; IN COMMERCE 8-1-2003.

3,235,268. SEALED AIR CORPORATION (US), ELMWOOD PARK, NJ. SN 78-741,673. PUB. 7-4-2006, FILED 10-27-2005.

**SEALED AIR SHORT CUT**

**CLASS 7—(Continued).**

THE MARK CONSISTS OF STANDARD CHARACTERS WITHOUT CLAIM TO ANY PARTICULAR FONT, STYLE, SIZE, OR COLOR.

OWNER OF U.S. REG. NOS. 925,912, 1,113,176, AND 1,580,890.

FOR PACKAGING MACHINERY, NAMELY A MACHINE THAT CONVERTS ROLLS OF PACKAGING FILM, FOAM AND CUSHIONING INTO SHEETS (U.S. CLS. 13, 19, 21, 23, 31, 34 AND 35).

FIRST USE 12-28-2005; IN COMMERCE 12-28-2005.

3,235,279. GOODYEAR TIRE & RUBBER COMPANY, THE, AKRON, OH. SN 78-750,109. PUB. 7-11-2006, FILED 11-9-2005.

**RAIDER**

THE MARK CONSISTS OF STANDARD CHARACTERS WITHOUT CLAIM TO ANY PARTICULAR FONT, STYLE, SIZE, OR COLOR.

FOR CONVEYOR BELTS (U.S. CLS. 13, 19, 21, 23, 31, 34 AND 35).

FIRST USE 1-6-2006; IN COMMERCE 1-6-2006.

3,235,292. ARIENS COMPANY, BRILLION, WI. SN 78-756,444. PUB. 7-25-2006, FILED 11-17-2005.

**X-FACTOR**

THE MARK CONSISTS OF STANDARD CHARACTERS WITHOUT CLAIM TO ANY PARTICULAR FONT, STYLE, SIZE, OR COLOR.

FOR OUTDOOR POWER EQUIPMENT, NAMELY MOWING DECKS FOR LAWN MOWERS (U.S. CLS. 13, 19, 21, 23, 31, 34 AND 35).

FIRST USE 1-27-2006; IN COMMERCE 1-27-2006.

**CLASS 7—(Continued).**

3,235,370. GRACO MINNESOTA INC., MINNEAPOLIS, MN.  
SN 78-793,855. PUB. 8-1-2006, FILED 1-18-2006.

**CLASS 8—(Continued).**

3,234,628. EASTWAY FAIR COMPANY LIMITED, TORTOLA, BR. VIRGIN ISLANDS. SN 78-549,826. PUB. 5-16-2006, FILED 1-19-2005.

# RAZOR

# AIRGRIP

THE MARK CONSISTS OF STANDARD CHARACTERS WITHOUT CLAIM TO ANY PARTICULAR FONT, STYLE, SIZE, OR COLOR.  
FOR AIR SPRAY/HVLP SPRAY GUNS (U.S. CLS. 13, 19, 21, 23, 31, 34 AND 35).  
FIRST USE 9-28-2006; IN COMMERCE 9-28-2006.

THE MARK CONSISTS OF STANDARD CHARACTERS WITHOUT CLAIM TO ANY PARTICULAR FONT, STYLE, SIZE, OR COLOR.

FOR HAND TOOL ACCESSORY IN THE NATURE OF A DEVICE THAT ATTACHES TO A WALL BY MEANS OF SUCTION, FOR USE AS A TOOL HANGING MOUNT, A VISE OR WORKPIECE HOLDER, AND A TEMPORARY SHELF (U.S. CLS. 23, 28 AND 44).  
FIRST USE 8-31-2004; IN COMMERCE 9-30-2004.

**CLASS 8—HAND TOOLS**

3,233,884. NAKAYAMA, TOSHIRO, RANCHO PALOS VERDES, CA. SN 76-578,648. PUB. 9-27-2005, FILED 3-1-2004.

3,235,265. PRIME TIME SOLUTIONS, INC., TORRINGTON, CT. SN 78-740,022. PUB. 7-4-2006, FILED S.R. 10-25-2005; AM. P.R. 4-27-2006.

# MIRACLE ERASER

# MOLDINGPRO

THE MARK CONSISTS OF STANDARD CHARACTERS WITHOUT CLAIM TO ANY PARTICULAR FONT, STYLE, SIZE, OR COLOR.

NO CLAIM IS MADE TO THE EXCLUSIVE RIGHT TO USE "ERASER", APART FROM THE MARK AS SHOWN.

FOR HAND TOOL FEATURING RIGID MOLDABLE BARS ADAPTABLE TO THE SHAPE OF A PARTICULAR SURFACE FOR REMOVING RUST, PAINT, VARNISH AND THE LIKE FROM WOOD AND METAL (U.S. CLS. 23, 28 AND 44).

FIRST USE 1-1-1984; IN COMMERCE 1-1-1984.

THE MARK CONSISTS OF STANDARD CHARACTERS WITHOUT CLAIM TO ANY PARTICULAR FONT, STYLE, SIZE, OR COLOR.

FOR HAND TOOL NAMELY, CROWBARS, PRY BARS, AND NAIL PULLERS (U.S. CLS. 23, 28 AND 44).  
FIRST USE 10-13-2003; IN COMMERCE 10-13-2003.

**CLASS 9—ELECTRICAL AND SCIENTIFIC APPARATUS**

**CLASS 9—(Continued).**

3,233,765. COOPER INDUSTRIES, LLC, HOUSTON, TX. SN 75-584,535. PUB. 4-3-2001, FILED 11-6-1998.

**QUIKREAD**

FOR MEASURING TAPES (U.S. CLS. 21, 23, 26, 36 AND 38).  
FIRST USE 8-29-1998; IN COMMERCE 8-29-1998.

3,233,770. TOOLZ, LTD., MONGKOK, KOWLOON, HONG KONG. SN 75-764,268. PUB. 6-13-2000, FILED 7-30-1999.

**ROBOVECTOR**

OWNER OF U.S. REG. NOS. 2,145,017 AND 2,231,068.  
FOR ELECTRONIC MEASURING AND SURVEYING TOOLS, NAMELY ELECTRONIC LEVEL (U.S. CLS. 21, 23, 26, 36 AND 38).  
FIRST USE 7-31-1999; IN COMMERCE 7-31-1999.

3,233,779. JBM LOGIC INC., LONGUEUIL, QUEBEC. SN 76-305,710. PUB. 9-6-2005, FILED 8-28-2001.

**INTEGRA E-BUSINESS**

NO CLAIM IS MADE TO THE EXCLUSIVE RIGHT TO USE "E-BUSINESS", APART FROM THE MARK AS SHOWN.

FOR INVENTORY CONTROL PROCESS SOFTWARE FOR E-COMMERCE FOR MANUFACTURERS WITH MULTIPLE SITES THAT ALLOWS THEM TO MANAGE PRODUCTION, SCHEDULING, RE-SUPPLY, AND DISTRIBUTION DATA AND TO INTEGRATE SUCH DATA INTO THEIR FINANCIAL ACCOUNTING, SOLD ONLY TO MANUFACTURERS, NOT TARGETED TO GROCERS OR RETAIL STORES (U.S. CLS. 21, 23, 26, 36 AND 38).  
FIRST USE 2-15-1991; IN COMMERCE 12-18-2000.

3,233,780. SAMSUNG ELECTRONICS CO., LTD., KYUNGKIDO, REPUBLIC OF KOREA. SN 76-350,689. PUB. 10-26-2004, FILED 12-20-2001.

**HOMEVITA**

THE FOREIGN WORDING IN THE MARK TRANSLATES INTO ENGLISH AS LIFE.

FOR PORTABLE COMPUTERS WITH MONITORS FOR DOMESTIC USE (U.S. CLS. 21, 23, 26, 36 AND 38).  
FIRST USE 9-1-2006; IN COMMERCE 9-1-2006.

3,233,789. PROPACK DATA GMBH, 76131 KARLSRUHE, FED REP GERMANY. SN 76-395,122. PUB. 3-8-2005, FILED 4-12-2002.

**PROPACK DATA****CLASS 9—(Continued).**

PRIORITY CLAIMED UNDER SEC. 44(D) ON ERPN CMNTY TM OFC APPLICATION NO. 2627073, FILED 3-22-2002, REG. NO. 2627073, DATED 7-27-2004, EXPIRES 3-22-2012.

NO CLAIM IS MADE TO THE EXCLUSIVE RIGHT TO USE "DATA", APART FROM THE MARK AS SHOWN.

FOR COMPUTER SOFTWARE, NAMELY COMPUTER SOFTWARE FOR COLLECTING, STORING, TRACKING, ANALYZING, INTEGRATING, TRANSMITTING, REPORTING, AND MANAGING DATA FOR USE IN THE CHEMICAL, BIOLOGICAL, PHARMACEUTICAL AND FOOD INDUSTRIES; COMPUTER SOFTWARE TO MANAGE THE DATA AND INFORMATION USED IN THE DEVELOPMENT, APPROVAL PROCESS, AND PRODUCTION OF PRODUCTS SUBJECT TO REGULATORY APPROVAL; NOT INCLUDING SOFTWARE FOR THE OPERATION OF CHROMATOGRAPHY COLUMNS (U.S. CLS. 21, 23, 26, 36 AND 38).  
FIRST USE 0-0-2001; IN COMMERCE 9-29-2002.

3,233,813. AGENT SOFTWARE CORPORATION, MOUNTAIN VIEW, CA. SN 76-465,784. PUB. 9-13-2005, FILED 11-12-2002.



**agentSoftware**

NO CLAIM IS MADE TO THE EXCLUSIVE RIGHT TO USE "AGENT SOFTWARE", APART FROM THE MARK AS SHOWN.

THE STIPPLING IS A FEATURE OF THE MARK.  
THE MARK CONSISTS OF STYLIZED LETTERING; A FOOT PRINT.

FOR COMPUTER SOFTWARE FOR USE IN INTERFACE, TASK, INFORMATION, AND INTERACTION SERVICES; SPECIFICALLY FOR INTERMEDIATION PURPOSES (U.S. CLS. 21, 23, 26, 36 AND 38).  
FIRST USE 10-25-2005; IN COMMERCE 10-25-2005.

3,233,826. CODIAC STUDIOS LIMITED, EYE, SUFFOLK IP 23 7AJ, UNITED KINGDOM. SN 76-489,611. PUB. 8-24-2004, FILED 2-14-2003.

**JP2-ZIP**

FOR COMPUTER SOFTWARE USED FOR THE ARCHIVING AND DISTRIBUTION OF COMPRESSED IMAGE FILES, CODE STREAMS AND RELATED METADATA; COMPUTER PROGRAMS FOR USE IN THE PACKAGING, ARCHIVING, AND DISTRIBUTION OF FILES, CODE STREAMS, COMPRESSED IMAGE FILES, AND METADATA FOR USE IN THE FIELD OF DIGITAL IMAGE COMPRESSION AND DISTRIBUTION; COMPUTER SOFTWARE AND COMPUTER PROGRAMS FOR COMPRESSION, DECOMPRESSION, ARCHIVING AND DELIVERY OF COMPRESSED DATA FILES, COMPRESSED IMAGE FILES, AND COMPUTER FILE MANAGEMENT; COMPUTER SOFTWARE AND PROGRAMS FOR CREATING, STORING, READING, RETRIEVING AND TRANSMITTING DIGITAL FILES, DOWNLOADABLE ELECTRONIC PUBLICATIONS PROVIDED ONLINE FROM THE INTERNET OR OTHER COMPUTER NETWORK IN THE FIELD OF DIGITAL IMAGE COMPRESSION AND DISTRIBUTION (U.S. CLS. 21, 23, 26, 36 AND 38).  
FIRST USE 11-15-2006; IN COMMERCE 11-15-2006.

**CLASS 9—(Continued).**

3,233,838. SEIKO INSTRUMENTS KABUSHIKI KAISHA, TA SEIKO INSTRUMENTS INC., CHIBA 261-8507, JAPAN. SN 76-498,477. PUB. 3-21-2006, FILED 3-19-2003.



PRIORITY CLAIMED UNDER SEC. 44(D) ON JAPAN APPLICATION NO. 2002-106303, FILED 12-17-2002. THE MARK CONSISTS OF IN PART OF A CHINESE CHARACTER.

THE JAPANESE TRANSLITERATION OF THIS CHARACTER IS "TAKUMI", WHICH MEANS "MISTER MAN" OR "CRAFTSMAN" WHEN TRANSLATED INTO ENGLISH.

FOR BATTERIES; ELECTRIC WIRE AND CABLES; GLASS TUBES FOR SCIENTIFIC PURPOSES; ELECTROLYSIS APPARATUS FOR ELECTROPLATING PURPOSES; ELECTRICAL CIRCUITS FOR USE IN AMUSEMENTS GAME MACHINES FOR REPRODUCING MUSIC, SPEECH, AND SPECIAL EFFECTS; ROTARY CONVERTERS; ELECTRIC FLAT IRONS; ELECTRICALLY HEATED HAIR-CURLERS; ELECTRIC DOOR BELLS; RAILWAY SAFETY LIGHTS AND SIGNAL BELLS; VEHICLE BREAKDOWN WARNING TRIANGLES; LUMINOUS OR MECHANICAL ROAD SIGNS; FIRE ALARMS; GLOVES FOR PROTECTION AGAINST ACCIDENTS; FIRE EXTINGUISHERS; FIRE HOSE NOZZLES; FIRE ENGINES; FIREBOATS; ANTI-THEFT WARNING APPARATUS; PROTECTIVE HELMETS; FIREPROOF CLOTHING; DUST MASKS; GAS MASKS; ELECTRIC CIGAR LIGHTERS FOR AUTOMOBILES; ELECTRIC RESISTANCE HEATING WIRE; WELDING ELECTRODES; WELDING MASKS; SLIDE FILM MOUNTS; VENDING MACHINES; COIN-OPERATED GATES FOR CAR PARKS OR PARKING LOTS; CASH REGISTERS; CALCULATING SCALES; COIN COUNTING AND SORTING MACHINES; EVENT RECORDERS; PHOTO-COPYING MACHINES; MANUALLY OPERATED CALCULATORS; DRAWING OR DRAFTING MACHINES; TIME STAMPING MACHINES; TIME RECORDERS; ELECTRIC CALCULATORS; PUNCH CARD MACHINES; PUNCH CLOCK MACHINES; VOTING MACHINES; AUTOMATED BILLING MACHINES; WEIGHT BELTS FOR DIVING; AIR TANKS FOR USE IN SCUBA DIVING; REGULATORS FOR USE IN SCUBA DIVING; DOG WHISTLES; ELECTRIC AUTOMATIC DOOR OPENERS; METRONOMES (U.S. CLS. 21, 23, 26, 36 AND 38).

FIRST USE 5-31-2003; IN COMMERCE 4-21-2006.

3,233,840. MECHANICAL SIMULATION CORPORATION, ANN ARBOR, MI. SN 76-499,910. PUB. 10-14-2003, FILED 3-21-2003.

**VEHICLESIM**

FOR COMPUTER SOFTWARE FOR COMPUTATIONAL VEHICLE DYNAMICS (U.S. CLS. 21, 23, 26, 36 AND 38).

FIRST USE 11-9-2006; IN COMMERCE 11-9-2006.

**CLASS 9—(Continued).**

3,233,841. ADRENALIN GAMING L.L.C., LADERA RANCH, CA. SN 76-501,152. PUB. 11-30-2004, FILED 3-19-2003.

**BALLISTIC**

FOR SLOT MACHINE (U.S. CLS. 21, 23, 26, 36 AND 38). FIRST USE 3-13-2003; IN COMMERCE 3-13-2003.

3,233,844. PHAT FASHIONS LLC, NEW YORK, NY. SN 76-502,750. PUB. 9-9-2003, FILED 3-18-2003.



OWNER OF U.S. REG. NOS. 2,240,881, 2,557,269, AND OTHERS.

FOR PROTECTIVE EYEWEAR; SUNGLASSES; EYEGLASSES; EYEGGLASS FRAMES; EYEGGLASS, SUNGLASS AND SPECTACLE CASES; EYEGGLASS, SUNGLASS AND SPECTACLE STRAPS; EYEGGLASS, SUNGLASS AND SPECTACLE CHAINS; EYEGGLASS, SUNGLASS AND SPECTACLE CLEANING CLOTHS (U.S. CLS. 21, 23, 26, 36 AND 38).

FIRST USE 1-0-2003; IN COMMERCE 1-0-2003.

3,233,861. MI-JACK PRODUCTS, INC., HAZEL CREST, IL. SN 76-547,255. PUB. 9-7-2004, FILED 9-26-2003.

**ACCUSTORE**

FOR INVENTORY CONTROL AND TRACKING SYSTEM COMPRISING COMPUTERS, COMPUTER SOFTWARE, TRANSMITTERS, RECEIVERS AND NETWORK INTERFACE DEVICES WHICH UTILIZES GPS DATA AND SENSORS FOR INDUSTRIAL WAREHOUSING (U.S. CLS. 21, 23, 26, 36 AND 38).

FIRST USE 9-30-2004; IN COMMERCE 10-7-2006.

**CLASS 9—(Continued).**

3,233,864. ENSCO, INC., FALL CHURCH, VA. SN 76-550,766.  
PUB. 4-19-2005, FILED 10-14-2003.

**DIGITALTRACK NOTEBOOK**

NO CLAIM IS MADE TO THE EXCLUSIVE RIGHT TO USE "NOTEBOOK", APART FROM THE MARK AS SHOWN.

FOR COMPUTER SOFTWARE FOR USE IN INSPECTING RAILROAD TRACKS IN THE FIELD OF FREIGHT AND PASSENGER TRAIN TRANSPORTATION (U.S. CLS. 21, 23, 26, 36 AND 38).

FIRST USE 10-0-2003; IN COMMERCE 10-0-2003.

**CLASS 9—(Continued).**

3,233,899. AMERICAN TANK GAUGE, INC., CHICKASHA, OK. SN 76-587,576. PUB. 8-30-2005, FILED 4-20-2004.

**LEVELNET**

3,233,874. JAM INDUSTRIES LTD./LTEE, QUEBEC, CANADA. SN 76-566,190. PUB. 4-26-2005, FILED 12-19-2003.

**SINCLAIR AUDIO**

THE MARK CONSISTS OF STANDARD CHARACTERS WITHOUT CLAIM TO ANY PARTICULAR FONT, STYLE, SIZE, OR COLOR.

OWNER OF U.S. REG. NO. 2,725,187.

NO CLAIM IS MADE TO THE EXCLUSIVE RIGHT TO USE AUDIO, APART FROM THE MARK AS SHOWN.

FOR MICROPHONES, MICROPHONE STANDS AND ACCESSORIES, NAMELY MICROPHONE CABLES, MICROPHONE CASES, MICROPHONE CLASPS, MICROPHONE CONNECTORS, MICROPHONE HEAD SUPPORTS, MICROPHONE PLUGS, MICROPHONE SWITCHES, MICROPHONE TUNERS, MICROPHONE WIRES, MICROPHONE TRANSMITTERS AND MICROPHONE TRANSCEIVERS (U.S. CLS. 21, 23, 26, 36 AND 38).

FIRST USE 6-15-2002; IN COMMERCE 6-15-2006.

THE MARK CONSISTS OF STANDARD CHARACTERS WITHOUT CLAIM TO ANY PARTICULAR FONT, STYLE, SIZE, OR COLOR.

FOR AUTOMATED LIQUID-LEVEL MONITORING MACHINES (U.S. CLS. 21, 23, 26, 36 AND 38).

FIRST USE 7-31-2006; IN COMMERCE 7-31-2006.

3,233,901. LOW AND INSIDE, LLC, MINNEAPOLIS, MN. SN 76-589,914. PUB. 3-1-2005, FILED 4-12-2004.

**LOW AnD inSiDE**

3,233,881. BIG O TIRES, INC., CENTENNIAL, CO. SN 76-576,412. PUB. 3-22-2005, FILED 2-17-2004.

**BIGFOOT**

THE MARK CONSISTS OF STANDARD CHARACTERS WITHOUT CLAIM TO ANY PARTICULAR FONT, STYLE, SIZE, OR COLOR.

OWNER OF U.S. REG. NOS. 1,102,058, 1,102,059, AND 1,904,955.

FOR BATTERIES (U.S. CLS. 21, 23, 26, 36 AND 38).

FIRST USE 3-21-2005; IN COMMERCE 3-21-2005.

THE MARK CONSISTS OF STANDARD CHARACTERS WITHOUT CLAIM TO ANY PARTICULAR FONT, STYLE, SIZE, OR COLOR.

FOR ELECTRONIC PUBLICATIONS NAMELY BOOKS, MAGAZINES AND ARTICLES FEATURING BASEBALL RELATED INFORMATION RECORDED ON COMPUTER MEDIA (U.S. CLS. 21, 23, 26, 36 AND 38).

FIRST USE 11-17-1988; IN COMMERCE 12-10-2004.

**CLASS 9—(Continued).**

3,233,917. CANON KABUSHIKI KAISHA, TOKYO, JAPAN.  
SN 76-596,785. PUB. 10-4-2005, FILED 6-14-2004.

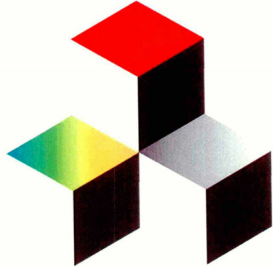

THE COLOR(S) BLUE, GREEN, YELLOW, RED, GREY, BLACK, AND WHITE IS/ARE CLAIMED AS A FEATURE OF THE MARK.

THE TOP SURFACE OF THE CUBE ON THE LEFT SIDE OF THE MARK IS BLUE, GREEN AND YELLOW; THE TOP SURFACE OF THE CENTER CUBE IS RED; AND THE TOP SURFACE OF THE CUBE ON THE RIGHT SIDE OF THE MARK IS GREY. THE REMAINDER OF THE MARK IS BLACK AND WHITE.

THE MARK CONSISTS OF A DESIGN WHICH DEPICTS THREE CUBE SHAPES IN A STEPPED FORMATION.

FOR ELECTRONIC PRINTERS; DIGITAL COPYING MACHINES; FACSIMILE MACHINES; SCANNERS; MULTIFUNCTIONAL MACHINES, NAMELY, MULTIFUNCTION DEVICES THAT PERFORM SOME OR ALL OF THE ABOVEMENTIONED FUNCTIONS, NAMELY, ELECTRONIC PRINTING, PHOTOCOPYING, FACSIMILE TRANSMISSION AND SCANNING IN ONE UNIT; COMPUTER OPERATING SOFTWARE FOR ALL OF THE ABOVEMENTIONED DEVICES AND MACHINES (U.S. CLS. 21, 23, 26, 36 AND 38).

FIRST USE 8-4-2006; IN COMMERCE 10-15-2006.

3,233,949. ATLANTIC CITY COIN & SLOT SERVICE COMPANY, INC., PLEASANTVILLE, NJ. SN 76-610,678. PUB. 8-30-2005, FILED 9-9-2004.

**PIRATES OF BONUS ISLAND**

THE MARK CONSISTS OF STANDARD CHARACTERS WITHOUT CLAIM TO ANY PARTICULAR FONT, STYLE, SIZE, OR COLOR.

FOR GAMING MACHINES, NAMELY, SLOT MACHINES WITH OR WITHOUT A VIDEO OUTPUT, AND CONVERSION KITS COMPRISED OF REPLACEMENT GLASS AND REEL STRIPS FOR SLOT MACHINES (U.S. CLS. 21, 23, 26, 36 AND 38).

FIRST USE 11-7-2006; IN COMMERCE 11-7-2006.

3,233,953. DAKA DEVELOPMENT LTD., KOWLOON, HONG KONG, CHINA. SN 76-611,701. PUB. 12-13-2005, FILED 9-13-2004.

**DAKASPORTS****CLASS 9—(Continued).**

THE MARK CONSISTS OF STANDARD CHARACTERS WITHOUT CLAIM TO ANY PARTICULAR FONT, STYLE, SIZE, OR COLOR.

FOR SPORT GOGGLES, SPORT WHISTLES, BAROMETER, ALTIMETER, DIRECTIONAL COMPASS, GLOBAL POSITIONING SYSTEM INDICATOR CONSISTING OF COMPUTERS, COMPUTER SOFTWARE, TRANSMITTERS, RECEIVERS, AND NETWORK INTERFACE DEVICES; EMERGENCY SIGNAL LIGHTS, RADIO RECEIVERS, RADIO TRANSMITTERS, RADIO TRANSCIEVERS, ELECTRONIC TIMERS FOR COMPUTING TEMPORAL MAGNITUDE; CALCULATORS; TELEPHONES; SECURITY WARNING ELECTRONICS, NAMELY SENSORS FOR DETECTING BODY HEAT, MOTION AND VIBRATIONS; ELECTRONIC PET PRODUCTS, NAMELY TRACKING COLLARS AND TRANSCIEVERS, ELECTRONIC AND ELECTRICAL INSECT TRAPS, ULTRASONIC AND ELECTROMAGNETIC CIRCUITS; ELECTRONICS DEVICES FOR WARDING OFF UNWANTED ANIMALS AND PESTS; ELECTRONIC VOICE STRESS ANALYZERS; COMPACT DISK HOLDERS AND BINOCULARS, ELECTRONIC COMPUTER FOR DISPLAYING DATA (U.S. CLS. 21, 23, 26, 36 AND 38).

FIRST USE 8-1-2006; IN COMMERCE 8-1-2006.

3,233,954. LEVITON MANUFACTURING CO., INC., LITTLE NECK, NY. SN 76-612,054. PUB. 8-30-2005, FILED 9-14-2004.

**SMARTLOCKPRO**

THE MARK CONSISTS OF STANDARD CHARACTERS WITHOUT CLAIM TO ANY PARTICULAR FONT, STYLE, SIZE, OR COLOR.

OWNER OF U.S. REG. NO. 2,725,149.

FOR ELECTRICAL WIRING DEVICES, NAMELY GROUND FAULT CIRCUIT INTERRUPTERS (U.S. CLS. 21, 23, 26, 36 AND 38).

FIRST USE 7-15-2006; IN COMMERCE 8-1-2006.

3,233,979. THQ WIRELESS INC., AGOURA HILLS, CA. SN 76-617,546. PUB. 4-4-2006, FILED 10-26-2004.

**THQ WIRELESS**

THE MARK CONSISTS OF STANDARD CHARACTERS WITHOUT CLAIM TO ANY PARTICULAR FONT, STYLE, SIZE, OR COLOR.

OWNER OF U.S. REG. NOS. 1,744,660, 2,614,259, AND OTHERS.

NO CLAIM IS MADE TO THE EXCLUSIVE RIGHT TO USE "WIRELESS", APART FROM THE MARK AS SHOWN, FOR COMPUTER SOFTWARE FOR ELECTRONIC GAMES AND ENTERTAINMENT, NAMELY, COMPUTER GAME SOFTWARE USED AND PLAYED ON MOBILE AND CELLULAR TELEPHONES, HANDHELD COMPUTERS, PERSONAL COMPUTERS AND PERSONAL DIGITAL ASSISTANTS; COMPUTER SOFTWARE THAT IS DOWNLOADABLE FROM A REMOTE COMPUTER SITE, NAMELY, ELECTRONIC GAME PROGRAMS, RING TONES AND VOICE RINGERS FOR MOBILE TELECOMMUNICATIONS DEVICES, WALL PAPERS, SCREEN SAVERS, ANIMATED IMAGES AND PROGRAMS FOR DOWNLOADING IMAGES; AND COMPUTER SOFTWARE FOR USE IN THE DESIGN, DEVELOPMENT AND EXECUTION OF WIRELESS COMPUTER GAMES (U.S. CLS. 21, 23, 26, 36 AND 38).

FIRST USE 2-5-2002; IN COMMERCE 2-5-2002.

**CLASS 9—(Continued).**

3,233,980. PIONEERING TECHNOLOGY INC., MISSISSAUGA, ONTARIO. SN 76-617,767. PUB. 4-25-2006, FILED 10-26-2004.

# POWERGRILL

THE MARK CONSISTS OF STANDARD CHARACTERS WITHOUT CLAIM TO ANY PARTICULAR FONT, STYLE, SIZE, OR COLOR.

FOR ELECTRIC OR BATTERY OPERATED REMOTE CONTROLS FOR GAS APPLIANCES AND THERMO-ELECTRIC HEAT GENERATORS FOR GAS APPLIANCES (U.S. CLS. 21, 23, 26, 36 AND 38).

FIRST USE 12-31-2004; IN COMMERCE 12-31-2004.

3,233,983. SONY KABUSHIKI KAISHA, TA SONY CORPORATION, TOKYO, JAPAN. SN 76-619,136. PUB. 10-11-2005, FILED 11-3-2004.



FOR BLANK MAGNETIC TAPES FOR AUDIO, VIDEO AND COMPUTER DATA STORAGE; MAGNETIC TAPE DRIVES FOR AUDIO, VIDEO AND COMPUTER DATA STORAGE; MAGNETIC TAPE LIBRARY SYSTEMS COMPRISED OF MAGNETIC TAPE DRIVES AND COMPUTER HARDWARE FOR AUDIO, VIDEO AND COMPUTER DATA STORAGE (U.S. CLS. 21, 23, 26, 36 AND 38).

FIRST USE 10-31-2004; IN COMMERCE 10-31-2004.

3,233,991. KELSEY, MICHAEL V., SR., GLEN DALE, MD. SN 76-622,790. PUB. 5-2-2006, FILED 12-1-2004.



THE COLORS PURPLE AND GOLD ARE CLAIMED AS A FEATURE OF THE MARK.

**CLASS 9—(Continued).**

THE COLOR OF GOLD APPEARS IN THE LETTERING AND IN THE CROSS AND THE COLOR PURPLE APPEARS IN THE BANNER.

FOR AUDIOCASSETTES AND COMPACT DISCS CONTAINING RELIGIOUS INSTRUCTION AND PRERECORDED MUSIC (U.S. CLS. 21, 23, 26, 36 AND 38).

FIRST USE 6-1-2006; IN COMMERCE 6-1-2006.

3,233,995. D2RM CORP., GARDENA, CA. SN 76-625,329. PUB. 2-21-2006, FILED 12-21-2004.

# AIRSONIC

THE MARK CONSISTS OF STANDARD CHARACTERS WITHOUT CLAIM TO ANY PARTICULAR FONT, STYLE, SIZE, OR COLOR.

FOR AUDIO AMPLIFIERS; AUDIO CIRCUIT BOARDS; AUDIO SPEAKER ENCLOSURES; COMPUTER SOFTWARE FOR USE IN CONTROLLING AND IMPROVING COMPUTER AND AUDIO EQUIPMENT SOUND QUALITY; AUDIO RECEIVERS (U.S. CLS. 21, 23, 26, 36 AND 38).

FIRST USE 10-1-2006; IN COMMERCE 10-1-2006.

3,233,998. KABUSHIKI KAISHA TOSHIBA, DBA TOSHIBA CORPORATION, MINATO-KU, TOKYO, JAPAN. SN 76-625,942. PUB. 9-27-2005, FILED 12-28-2004.

# GIGASTYLE

THE MARK CONSISTS OF STANDARD CHARACTERS WITHOUT CLAIM TO ANY PARTICULAR FONT, STYLE, SIZE, OR COLOR.

FOR DIGITAL CAMERAS HAVING FUNCTIONS OF A STILL CAMERA AND A MOVIE CAMERA (U.S. CLS. 21, 23, 26, 36 AND 38).

FIRST USE 2-22-2006; IN COMMERCE 2-22-2006.

**CLASS 9—(Continued).**

3,233,999. FOOD QUALITY SENSOR INTERNATIONAL, INC., LEXINGTON, MA. SN 76-626,310. PUB. 9-20-2005, FILED 12-23-2004.

**FQSI**

THE MARK CONSISTS OF STANDARD CHARACTERS WITHOUT CLAIM TO ANY PARTICULAR FONT, STYLE, SIZE, OR COLOR.

FOR FOOD QUALITY SENSORS (U.S. CLS. 21, 23, 26, 36 AND 38).

FIRST USE 11-10-2006; IN COMMERCE 11-10-2006.

**CLASS 9—(Continued).**

3,234,007. HILDEBRANDT, WILLIAM K., INMAN, SC. SN 76-628,491. PUB. 9-6-2005, FILED 1-20-2005.

**ADD ON TIMER**

THE MARK CONSISTS OF STANDARD CHARACTERS WITHOUT CLAIM TO ANY PARTICULAR FONT, STYLE, SIZE, OR COLOR.

NO CLAIM IS MADE TO THE EXCLUSIVE RIGHT TO USE "TIMER", APART FROM THE MARK AS SHOWN.

FOR MEDICINE DISPENSING TIMER FOR A MEDICINE VIAL OR BOTTLE (U.S. CLS. 21, 23, 26, 36 AND 38).

FIRST USE 6-1-2006; IN COMMERCE 6-1-2006.

3,234,025. THOMAS JOSEPH LENTINI, LOS ANGELES, CA. SN 76-633,412. PUB. 3-21-2006, FILED 3-14-2005.

**WHITE BARS**

FANCY DESIGN OF THE WORDS WHITE BARS, RESEMBLING SHEET MUSIC.

FOR PRERECORDED COMPACT DISCS AND DVD'S FEATURING MUSIC (U.S. CLS. 21, 23, 26, 36 AND 38).

FIRST USE 11-16-2006; IN COMMERCE 11-16-2006.

3,234,006. SARTORIUS AG, D-37075 GOTTINGEN, FED REP GERMANY. SN 76-628,348. PUB. 3-14-2006, FILED 1-19-2005.

**DOCUCLIP**

THE MARK CONSISTS OF STANDARD CHARACTERS WITHOUT CLAIM TO ANY PARTICULAR FONT, STYLE, SIZE, OR COLOR.

FOR SCIENTIFIC INSTRUMENTS, APPARATUS AND EQUIPMENT, NAMELY LABORATORY EQUIPMENT, NAMELY, COMBINATION DEVICES COMPRISED OF PH METERS, CONDUCTOMETERS, ION METERS, COMPUTER PRINTERS FOR DOCUMENTING CALIBRATION DATA, AND REPLACEMENT PARTS THEREFORE, ALL FOR USE IN PHYSICAL, CHEMICAL AND ELECTROCHEMICAL ANALYSIS (U.S. CLS. 21, 23, 26, 36 AND 38).

FIRST USE 11-1-2005; IN COMMERCE 11-1-2005.

3,234,047. AVAZ, INC., PHOENIX, AZ. SN 76-638,871. PUB. 7-25-2006, FILED 5-16-2005.

**IBDS**

THE MARK CONSISTS OF STANDARD CHARACTERS WITHOUT CLAIM TO ANY PARTICULAR FONT, STYLE, SIZE, OR COLOR.

FOR ELECTRONIC SIGNAL PROCESSING AND CONTROL APPARATUS WHICH COMBINES AND ROUTES MULTIPLE VIDEO AND AUDIO SOURCES INTO A SINGLE INTERACTIVE DISPLAY THAT IS USED AS A MILITARY TRAINING AND MISSION PLANNING TOOL (U.S. CLS. 21, 23, 26, 36 AND 38).

FIRST USE 6-14-2005; IN COMMERCE 6-8-2006.



**CLASS 9—(Continued).**

3,234,048. KAM CONTROLS INCORPORATED, HOUSTON, TX. SN 76-639,087. PUB. 3-28-2006, FILED 5-20-2005.

# OWD

THE MARK CONSISTS OF STANDARD CHARACTERS WITHOUT CLAIM TO ANY PARTICULAR FONT, STYLE, SIZE, OR COLOR.

FOR APPARATUS FOR MEASURING PHYSICAL AND CHEMICAL CHARACTERISTICS OF FLUIDS AS THEY FLOW THROUGH A PIPELINE, NAMELY MOISTURE ANALYZERS, FLUID COMPOSITION DETECTORS, AND OIL WATER DETECTORS (U.S. CLS. 21, 23, 26, 36 AND 38).

FIRST USE 10-6-2006; IN COMMERCE 10-6-2006.

3,234,050. COCHLEAR LIMITED, LANE COVE, NSW 2066, AUSTRALIA. SN 76-639,359. PUB. 2-28-2006, FILED 5-24-2005.

# AUTONRT

THE MARK CONSISTS OF STANDARD CHARACTERS WITHOUT CLAIM TO ANY PARTICULAR FONT, STYLE, SIZE, OR COLOR.

OWNER OF U.S. REG. NO. 2,896,018.  
FOR COMPUTER SOFTWARE RECORDED ON MAGNETIC AND/OR OPTICAL MEDIA TO CONTROL, OPERATE AND MODIFY THE OPERATION OF IMPLANTABLE ELECTRONIC MEDICAL DEVICES (U.S. CLS. 21, 23, 26, 36 AND 38).

FIRST USE 3-0-2005; IN COMMERCE 3-0-2005.

3,234,051. REVA SYSTEMS CORPORATION, CHELMSFORD, MA. SN 76-639,368. PUB. 3-14-2006, FILED 5-24-2005.

## TAG ACQUISITION PROCESSOR

THE MARK CONSISTS OF STANDARD CHARACTERS WITHOUT CLAIM TO ANY PARTICULAR FONT, STYLE, SIZE, OR COLOR.

NO CLAIM IS MADE TO THE EXCLUSIVE RIGHT TO USE "TAG" AND "PROCESSOR", APART FROM THE MARK AS SHOWN.

FOR COMPUTER HARDWARE AND SOFTWARE FOR ANALYZING AND PROCESSING DATA PERTAINING TO PRODUCT IDENTIFYING TAGS AND COMMUNICATING SUCH DATA OVER A DATA COMMUNICATIONS NETWORK (U.S. CLS. 21, 23, 26, 36 AND 38).

FIRST USE 6-20-2005; IN COMMERCE 6-20-2005.

**CLASS 9—(Continued).**

3,234,065. PROGRESSIVE GAMING INTERNATIONAL CORPORATION, LAS VEGAS, NV. SN 76-643,178. PUB. 4-11-2006, FILED 7-20-2005.

# MONEY FACTORY

THE MARK CONSISTS OF STANDARD CHARACTERS WITHOUT CLAIM TO ANY PARTICULAR FONT, STYLE, SIZE, OR COLOR.

FOR GAMING EQUIPMENT, NAMELY, ELECTRONIC GAMING MACHINES AND VIDEO GAME SOFTWARE (U.S. CLS. 21, 23, 26, 36 AND 38).

FIRST USE 9-13-2005; IN COMMERCE 9-13-2005.

3,234,068. UNITED CHINA ELECTRONICS (HONG KONG) COMPANY LIMITED, NEW TERRITORIES, HONG KONG. SN 76-645,646. PUB. 5-30-2006, FILED 8-25-2005.

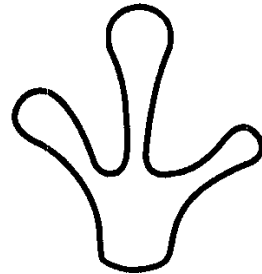

THE MARK CONSISTS OF A FROG HAND.

FOR AMPLIFIERS; RADIOS; COMPACT DISC PLAYERS AND RECORDERS; DIGITAL VIDEO DISC PLAYERS AND RECORDERS; LASER DISC PLAYERS AND RECORDERS; AUDIO CASSETTE PLAYERS AND RECORDERS; AUDIO SPEAKERS; SUBWOOFER AUDIO SPEAKERS; STEREO RECEIVERS; AUDIO AND VIDEO RECEIVERS; SIGNAL CONVERTER USED TO CONVERT DIGITAL SIGNALS TO ANALOGUE SIGNALS, ANALOGUE SIGNALS TO DIGITAL SIGNALS AND VOICE TO ANALOGUE AND DIGITAL SIGNALS; POWER CONDITIONERS USED TO PROTECT ELECTRICAL EQUIPMENT; SPEAKER COMPONENTS, NAMELY, TWEETERS, TUNERS, AND MIDRANGE AND CROSSOVER COMPONENTS; AUDIO AND VIDEO CABLES; ANTI-DAZZLE PANELS; BATTERIES FOR LIGHTING; SAFETY EQUIPMENT, NAMELY, FLASHING LIGHTS AND BEACONS THAT ARE OPERATED BY BATTERIES OR SOLAR BATTERIES; LUMINOUS OR MECHANICAL SIGNALLING PANELS; LUMINOUS OR MECHANICAL ROAD SIGNS; VEHICLE BREAKDOWN WARNING TRIANGLES; LUMINOUS OR MECHANICAL SIGNS; PAVEMENT SAFETY MARKERS; SIGNAL LANTERNS; LIGHT-EMITTING ELECTRONIC BOARDS AND PANELS; PROTECTIVE HELMETS; PROTECTIVE MASKS; SAFETY NETS; PROTECTIVE SHOES; AND PROTECTIVE GLOVES (U.S. CLS. 21, 23, 26, 36 AND 38).

FIRST USE 4-14-2006; IN COMMERCE 4-14-2006.

**CLASS 9—(Continued).**

3,234,077. CHOU, TERRY, TAINAN CITY, TAIWAN, CHINA.  
SN 76-649,214. PUB. 6-27-2006, FILED 10-26-2005.

# ENGO

THE MARK CONSISTS OF STANDARD CHARACTERS WITHOUT CLAIM TO ANY PARTICULAR FONT, STYLE, SIZE, OR COLOR.

FOR SWIM GOGGLES, SWIM MASKS, SNORKELS, SWIMMING FACE MASKS, FACE MASKS FOR DIVING, AND NOSE CLIPS FOR DIVERS AND SWIMMERS (U.S. CLS. 21, 23, 26, 36 AND 38).

FIRST USE 2-20-2006; IN COMMERCE 2-20-2006.

3,234,082. SHE-MOTO, INC, HOLLAND, MI. SN 76-978,363.  
PUB. 9-28-2004, FILED 8-26-2003.

## SHE-MOTO

FOR PROTECTIVE CLOTHING, NAMELY, JACKETS, FOR WOMEN FOR PROTECTION WHILE RIDING MOTORCYCLES (U.S. CLS. 21, 23, 26, 36 AND 38).

FIRST USE 11-9-2006; IN COMMERCE 11-9-2006.

3,234,089. IDEASTREAM CONSUMER PRODUCTS LLC, PARMA, OH. SN 76-978,468. PUB. 4-11-2006, FILED 1-9-2003.

## VAULTZ

FOR CAMERA CASES; CAMCORDER CASES (U.S. CLS. 21, 23, 26, 36 AND 38).

FIRST USE 12-31-2004; IN COMMERCE 12-31-2004.

3,234,101. EPIWORKS, INC., CHAMPAIGN, IL. SN 78-122,588.  
PUB. 10-11-2005, FILED 4-18-2002.

## EPIHBT

OWNER OF U.S. REG. NO. 2,546,066.  
FOR ELECTRONIC AND OPTOELECTRONIC COMPOUND SEMICONDUCTOR MATERIALS, NAMELY, EPITAXIAL WAFERS (U.S. CLS. 21, 23, 26, 36 AND 38).  
FIRST USE 3-1-2001; IN COMMERCE 3-1-2001.

**CLASS 9—(Continued).**

3,234,102. EPIWORKS, INC., CHAMPAIGN, IL. SN 78-122,591.  
PUB. 10-11-2005, FILED 4-18-2002.

## EPILASER

OWNER OF U.S. REG. NO. 2,546,066.  
FOR ELECTRONIC AND OPTOELECTRONIC COMPOUND SEMICONDUCTOR MATERIALS, NAMELY, EPITAXIAL WAFERS (U.S. CLS. 21, 23, 26, 36 AND 38).  
FIRST USE 3-1-2001; IN COMMERCE 3-1-2001.

3,234,104. INTERSTELLAR TECHNOLOGIES CORPORATION, MONROVIA, CA. SN 78-132,903. PUB. 9-2-2003,  
FILED 6-3-2002.

## TRANSVACER

FOR TRANSDUCERS THAT UTILIZE A CASIMIR FORCE GENERATING SYSTEM AND AN ENERGY TRANSFORMATION SYSTEM (U.S. CLS. 21, 23, 26, 36 AND 38).

FIRST USE 11-22-2006; IN COMMERCE 11-22-2006.

3,234,143. FLEETWOOD MANUFACTURING, INC., BILLINGS, MT. SN 78-259,042. PUB. 9-7-2004, FILED 6-5-2003.

## CASINO KING

NO CLAIM IS MADE TO THE EXCLUSIVE RIGHT TO USE "CASINO", APART FROM THE MARK AS SHOWN.

FOR COMPUTER SOFTWARE GAMES, SOFTWARE FOR USE IN GAMING MACHINES AND GAMING EQUIPMENT, GAMING EQUIPMENT NAMELY GAMING MACHINES, SLOT MACHINES, KENO AND POKER MACHINES AND PARTS THEREFOR, NAMELY BELLY GLASS AND TOP BOX GLASS (U.S. CLS. 21, 23, 26, 36 AND 38).

FIRST USE 4-17-2003; IN COMMERCE 10-11-2006.

3,234,145. GREEN HILLS SOFTWARE, INC., SANTA BARBARA, CA. SN 78-268,912. PUB. 9-28-2004, FILED 6-30-2003.

## TIMEMACHINE

FOR COMPUTER SOFTWARE FOR DEBUGGING EMBEDDED APPLICATION SOFTWARE PROGRAMS (U.S. CLS. 21, 23, 26, 36 AND 38).

FIRST USE 9-16-2003; IN COMMERCE 9-16-2003.

**CLASS 9—(Continued).**

3,234,148. ADRENALIN GAMING L.L.C., LADERA RANCH, CA. SN 78-276,504. PUB. 4-13-2004, FILED 7-21-2003.

**HAND OUT**

FOR GAMING MACHINE WITH OR WITHOUT VIDEO INPUT USED IN A CASINO; COMPUTERIZED TABLE GAME FOR GAMING PURPOSES USED IN A CASINO; ONLINE COMPUTER GAMING SOFTWARE THAT MAY BE DOWNLOADED FROM THE INTERNET (U.S. CLS. 21, 23, 26, 36 AND 38).

FIRST USE 9-30-2006; IN COMMERCE 9-30-2006.

3,234,150. ASUSTEK COMPUTER INCORPORATION, TAIPEI, TAIWAN. SN 78-283,882. PUB. 11-9-2004, FILED 8-6-2003.

**CentriBoard**

FOR COMPUTER MOTHERBOARDS, COMPUTER ADD-ON CARDS, NAMELY, VIDEO GRAPHIC ADAPTER CARDS, AUDIO CARDS, LAN (LOCAL AREA NETWORK) CARDS, MODEM CARDS, NETWORK CONTROL CARDS AND SCSI (SMALL COMPUTER SYSTEM INTERFACE) CARDS, COMPUTER INTERFACE BOARDS (U.S. CLS. 21, 23, 26, 36 AND 38).

FIRST USE 5-16-2004; IN COMMERCE 9-15-2006.

3,234,151. CON-CISE, LLC, SAN LEANDRO, CA. SN 78-283,896. PUB. 6-29-2004, FILED 8-6-2003.

**REVLENS**

FOR CONTACT LENSES (U.S. CLS. 21, 23, 26, 36 AND 38).

FIRST USE 9-7-2006; IN COMMERCE 9-7-2006.

3,234,161. CYBERLINK CORP., SHINDIAN CITY, TAIPEI, TAIWAN. SN 78-298,271. PUB. 3-14-2006, FILED 9-10-2003.

**CTMS**

FOR EDUCATIONAL SOFTWARE FEATURING INSTRUCTION IN PRODUCT, POLICY, AND INFORMATION OF A CORPORATION FOR USE IN FACILITATING INSTRUCTOR-LED ON-LINE LEARNING; COMPUTER SOFTWARE PLATFORMS FOR ELECTRONIC PUBLICATIONS AND COURSE SHARING FOR USE IN FACILITATING INSTRUCTOR-LED ON-LINE LEARNING (U.S. CLS. 21, 23, 26, 36 AND 38).

FIRST USE 7-10-2003; IN COMMERCE 7-10-2003.

**CLASS 9—(Continued).**

3,234,167. ADRENALIN GAMING L.L.C., LADERA RANCH, CA. SN 78-304,259. PUB. 9-21-2004, FILED 9-23-2003.

**JACKPOT IN A BOX**

NO CLAIM IS MADE TO THE EXCLUSIVE RIGHT TO USE "JACKPOT", APART FROM THE MARK AS SHOWN.

FOR GAMING MACHINES, NAMELY, SLOT MACHINES WITH OR WITHOUT VIDEO OUTPUT USED IN A CASINO; ELECTRIC OR ELECTRO-MECHANICAL GAMING TABLES WITH VIDEO OUTPUT USED IN A CASINO (U.S. CLS. 21, 23, 26, 36 AND 38).

FIRST USE 8-14-2004; IN COMMERCE 8-14-2004.

3,234,170. HOME SAFEGUARD INDUSTRIES, LLC, VERNON HILLS, IL. SN 78-310,405. PUB. 8-16-2005, FILED 10-7-2003.



**HSI FIRE**  
& Security Group

NO CLAIM IS MADE TO THE EXCLUSIVE RIGHT TO USE "FIRE & SECURITY GROUP", APART FROM THE MARK AS SHOWN.

FOR ALARM TESTING DEVICE USED TO CHECK THE FUNCTION AND EFFECTIVENESS OF SMOKE, CARBON MONOXIDE, HEAT AND OTHER FIRE ALARM DETECTORS (U.S. CLS. 21, 23, 26, 36 AND 38).

FIRST USE 6-30-2003; IN COMMERCE 6-30-2003.

3,234,179. ACUPRINT, INC, CARLSBAD, CA. SN 78-324,404. PUB. 8-23-2005, FILED 11-6-2003.

**fDexchange**

THE MARK CONSISTS OF STANDARD CHARACTERS WITHOUT CLAIM TO ANY PARTICULAR FONT, STYLE, SIZE, OR COLOR.

FOR FINANCIAL DATA EXCHANGE COMMUNICATIONS SOFTWARE FOR CONNECTING BANKS TO THEIR COMMERCIAL CLIENTS OVER THE INTERNET, FOR PURPOSES OF FILE EXCHANGE, DATA CONVERSION, DATA NORMALIZATION AND STRAIGHT-THRU-PROCESSING ("STP") (U.S. CLS. 21, 23, 26, 36 AND 38).

FIRST USE 3-26-2003; IN COMMERCE 3-26-2003.

**CLASS 9—(Continued).**

3,234,192. OLYMPUS CORPORATION, TOKYO, JAPAN. SN 78-334,599. PUB. 3-15-2005, FILED 12-1-2003.

FOR MICROSCOPES (U.S. CLS. 21, 23, 26, 36 AND 38).  
FIRST USE 12-31-2004; IN COMMERCE 12-31-2004.

3,234,195. ION OPTICS, INC., WALTHAM, MA. SN 78-338,694.  
PUB. 9-7-2004, FILED 12-10-2003.

# SensorChip

THE MARK CONSISTS OF STANDARD CHARACTERS WITHOUT CLAIM TO ANY PARTICULAR FONT, STYLE, SIZE, OR COLOR.  
FOR GAS SENSORS FOR MEASURING GAS CONCENTRATIONS (U.S. CLS. 21, 23, 26, 36 AND 38).  
FIRST USE 11-14-2006; IN COMMERCE 11-14-2006.

3,234,206. RADICA GAMES LTD., HAMILTON, BERMUDA. SN 78-352,397. PUB. 7-5-2005, FILED 1-15-2004.

# MYPHOTOBOOTH

THE MARK CONSISTS OF STANDARD CHARACTERS WITHOUT CLAIM TO ANY PARTICULAR FONT, STYLE, SIZE, OR COLOR.  
FOR NOVELTY PHOTOGRAPHY STUDIO FOR HOME USE, NAMELY AN INSTANT CAMERA SOLD TOGETHER AS A UNIT WITH INSTANT FILM (U.S. CLS. 21, 23, 26, 36 AND 38).  
FIRST USE 6-0-2004; IN COMMERCE 6-0-2004.

**CLASS 9—(Continued).**

3,234,216. SANCHEZ, EDAN C., LEESBURG, VA. SN 78-364,281. PUB. 11-16-2004, FILED 2-6-2004.

# EDAN EVERYWHERE

THE MARK CONSISTS OF STANDARD CHARACTERS WITHOUT CLAIM TO ANY PARTICULAR FONT, STYLE, SIZE, OR COLOR.

OWNER OF U.S. REG. NO. 2,699,655.  
FOR MUSICAL SOUND RECORDINGS, NAMELY, PRERECORDED COMPACT DISCS, PHONOGRAPH RECORDS, AND CASSETTES, ALL FEATURING MUSIC (U.S. CLS. 21, 23, 26, 36 AND 38).  
FIRST USE 4-1-2002; IN COMMERCE 5-1-2005.

3,234,230. AMERICAN SUPERCONDUCTOR CORPORATION, WESTBOROUGH, MA. SN 78-378,253. PUB. 9-13-2005, FILED 3-4-2004.

THE MARK CONSISTS OF STANDARD CHARACTERS WITHOUT CLAIM TO ANY PARTICULAR FONT, STYLE, SIZE, OR COLOR.

FOR ELECTRICAL POWER QUALITY SYSTEMS, NAMELY, REACTIVE POWER COMPENSATION SYSTEMS USED TO PROVIDE VOLTAGE REGULATION FOR UTILITY TRANSMISSION AND DISTRIBUTION SYSTEMS, NAMELY, VOLTAGE RESTORERS, CAPACITOR BANKS AND SHUNT REACTORS USED IN COMBINATION, UNDER THE CONTROL OF AN ELECTRONIC CONTROLLER, FOR UTILITY VOLTAGE REGULATION (U.S. CLS. 21, 23, 26, 36 AND 38).  
FIRST USE 8-17-2006; IN COMMERCE 8-17-2006.

**CLASS 9—(Continued).**

3,234,233. EZ-CAP ENTERPRISES, LLC, JEFFERSON CITY, MO. SN 78-379,574. PUB. 9-13-2005, FILED 3-5-2004.

**EZ-CAP**

THE MARK CONSISTS OF STANDARD CHARACTERS WITHOUT CLAIM TO ANY PARTICULAR FONT, STYLE, SIZE, OR COLOR.

FOR PRE-WIRE INSTALLATION KITS TO FACILITATE THE WIRING INSTALLATION OF HOME THEATER SYSTEMS, WHOLE HOUSE AUDIO SYSTEMS, HOME SECURITY SYSTEMS, OR GARAGE DOOR MOTOR CONTROL SYSTEMS, COMPRISED OF A PLASTIC COVER, A COVER SUPPORT, A SUPPORT MOUNT, AND A WIRING RETAINER (U.S. CLS. 21, 23, 26, 36 AND 38).

FIRST USE 8-15-2006; IN COMMERCE 8-15-2006.

3,234,239. THE GIRAFFE PROJECT, INC., LANGLEY, WA. SN 78-381,675. PUB. 3-15-2005, FILED 3-10-2004.



FOR SOUND RECORDINGS IN THE FIELD OF EDUCATION AND CHARACTER DEVELOPMENT (U.S. CLS. 21, 23, 26, 36 AND 38).

FIRST USE 12-31-2005; IN COMMERCE 12-31-2005.

**CLASS 9—(Continued).**

3,234,244. KONAMI DIGITAL ENTERTAINMENT CO. LTD., TOKYO, JAPAN. SN 78-383,474. PUB. 2-21-2006, FILED 3-12-2004.

**RUMBLE ROSES**

THE MARK CONSISTS OF STANDARD CHARACTERS WITHOUT CLAIM TO ANY PARTICULAR FONT, STYLE, SIZE, OR COLOR.

FOR VIDEO GAME SOFTWARE; VIDEO GAME PROGRAMS; VIDEO GAME CD-ROMS; ELECTRONIC GAME PROGRAMS; ELECTRONIC GAME CD-ROMS (U.S. CLS. 21, 23, 26, 36 AND 38).

FIRST USE 11-9-2004; IN COMMERCE 11-9-2004.

3,234,266. MELODY, TIMOTHY JOSEPH, LAKE FOREST, CA. SN 78-398,348. PUB. 9-27-2005, FILED 4-8-2004.

**Old School New Rules**

THE MARK CONSISTS OF STANDARD CHARACTERS WITHOUT CLAIM TO ANY PARTICULAR FONT, STYLE, SIZE, OR COLOR.

FOR SUNGLASSES (U.S. CLS. 21, 23, 26, 36 AND 38).

FIRST USE 1-1-2006; IN COMMERCE 1-1-2006.

3,234,267. CAPCOM CO., LTD., OSAKA, JAPAN. SN 78-398,745. PUB. 9-27-2005, FILED 4-8-2004.

**SHADOW OF ROME**

THE MARK CONSISTS OF STANDARD CHARACTERS WITHOUT CLAIM TO ANY PARTICULAR FONT, STYLE, SIZE, OR COLOR.

FOR COMPUTER GAME SOFTWARE, COMPUTER GAME CARTRIDGES, COMPUTER GAME CASSETTES, COMPUTER GAME DISCS, COMPUTER GAME TAPES, VIDEO GAME CARTRIDGES, VIDEO GAME MACHINES FOR USE WITH TELEVISION RECEIVERS, DOWNLOADABLE GAME SOFTWARE, DOWNLOADABLE COMPUTER GAMES (U.S. CLS. 21, 23, 26, 36 AND 38).

FIRST USE 2-4-2005; IN COMMERCE 2-8-2005.

**CLASS 9—(Continued).**

3,234,272. ANABOLIC VIDEO PRODUCTIONS, INC., CHATSWORTH, CA. SN 78-402,816. PUB. 9-20-2005, FILED 4-15-2004.

# ARTCORE

THE MARK CONSISTS OF STANDARD CHARACTERS WITHOUT CLAIM TO ANY PARTICULAR FONT, STYLE, SIZE, OR COLOR.

FOR SERIES OF PRERECORDED VIDEO TAPES AND DVDS FEATURING ADULT ENTERTAINMENT (U.S. CLS. 21, 23, 26, 36 AND 38).

FIRST USE 5-24-2004; IN COMMERCE 5-24-2004.

---

3,234,283. SOPHIS INC, NEW YORK, NY. SN 78-407,690. PUB. 2-1-2005, FILED 4-26-2004.

# SOPHIS

THE MARK CONSISTS OF STANDARD CHARACTERS WITHOUT CLAIM TO ANY PARTICULAR FONT, STYLE, SIZE, OR COLOR.

FOR COMPUTER PROGRAMS AND INSTRUCTION MANUALS ALL SOLD AS A UNIT FOR USE IN SPREADSHEETING AND DATABASING APPLICATIONS USED IN THE FIELD OF FINANCIAL AND MANAGEMENT SERVICES (U.S. CLS. 21, 23, 26, 36 AND 38).

FIRST USE 1-3-1985; IN COMMERCE 10-10-2002.

**CLASS 9—(Continued).**

3,234,292. VISTANT HOLDINGS, INC., DUBLIN, OH. SN 78-410,986. PUB. 3-14-2006, FILED 4-30-2004.

# CONTROLPOINT

THE MARK CONSISTS OF STANDARD CHARACTERS WITHOUT CLAIM TO ANY PARTICULAR FONT, STYLE, SIZE, OR COLOR.

FOR COMPUTER SOFTWARE FOR OPERATING, TRACKING INVENTORY AND ELECTRONIC INVENTORY TRACKING AND REORDERING IN AUTOMATED DISPENSING MACHINES FOR CONTROLLING AND DISPENSING PARTS, COMPONENTS, TOOLS, CHEMICALS, BIOLOGICALS, LIQUIDS, MATERIALS, SUPPLIES, MATERIAL AND OTHER MAINTENANCE, REPAIR AND OPERATING ITEMS USED IN ANY LABORATORY, RESEARCH, MANUFACTURING OR ASSEMBLY ENVIRONMENT (U.S. CLS. 21, 23, 26, 36 AND 38).

FIRST USE 6-30-2003; IN COMMERCE 6-30-2003.

---

3,234,294. JOHANSON DIELECTRICS, INC., SYLMAR, CA. SN 78-412,047. PUB. 3-15-2005, FILED 5-3-2004.

# POLYTERM

THE MARK CONSISTS OF STANDARD CHARACTERS WITHOUT CLAIM TO ANY PARTICULAR FONT, STYLE, SIZE, OR COLOR.

FOR CAPACITORS (U.S. CLS. 21, 23, 26, 36 AND 38).

FIRST USE 9-30-2003; IN COMMERCE 11-23-2003.

**CLASS 9—(Continued).**

3,234,308. WPT ENTERPRISES, INC., LOS ANGELES, CA. SN 78-419,344. PUB. 8-23-2005, FILED 5-14-2004.

WPT

THE MARK CONSISTS OF STANDARD CHARACTERS WITHOUT CLAIM TO ANY PARTICULAR FONT, STYLE, SIZE, OR COLOR.

FOR ELECTRICAL AND SCIENTIFIC APPARATUS, NAMELY PRE-RECORDED DIGITAL VERSATILE DISCS FEATURING TELEVISION SHOWS FEATURING POKER GAMES, POKER GAMES, INFORMATION REGARDING THE GAME OF POKER AND INSTRUCTIONAL INFORMATION REGARDING CARD GAMES AND THE GAME OF POKER; AND VIDEO GAME DISCS (U.S. CLS. 21, 23, 26, 36 AND 38).

FIRST USE 3-0-2005; IN COMMERCE 3-0-2005.

**CLASS 9—(Continued).**

3,234,312. PII LIMITED, CRAMLINGTON, NORTHUMBERLAND, UNITED KINGDOM. SN 78-425,093. PUB. 9-27-2005, FILED 5-26-2004.

LAPA

THE MARK CONSISTS OF STANDARD CHARACTERS WITHOUT CLAIM TO ANY PARTICULAR FONT, STYLE, SIZE, OR COLOR.

FOR APPARATUS AND INSTRUMENTS, NAMELY, IN LINE INSPECTION VEHICLES, PIGS AND INERTIAL MEASUREMENT UNITS FOR THE SURVEYING AND LOCATION OF TERRESTRIAL FEATURES AND STRUCTURES, FOR THE LOCATION OF PIPELINES, AND FOR THE DETECTION AND LOCATION OF DEFECTS IN PIPELINES; COMPUTER PROGRAMS FOR USE IN THE MANAGEMENT AND MANIPULATION OF DATA COLLECTED FROM THE AFORESAID APPARATUS AND INSTRUMENTS, AND FOR THE PRODUCTION OF REPORTS FROM SUCH DATA AND FROM RELATED AERIAL AND SATELLITE IMAGING OF TERRESTRIAL FEATURES AND STRUCTURES (U.S. CLS. 21, 23, 26, 36 AND 38).

FIRST USE 7-31-1996; IN COMMERCE 7-31-1996.

3,234,309. CABOT SAFETY INTERMEDIATE CORPORATION, NEWARK, DE. SN 78-421,247. PUB. 10-11-2005, FILED 5-19-2004.



OWNER OF U.S. REG. NOS. 1,435,400 AND 2,449,846.  
NO CLAIM IS MADE TO THE EXCLUSIVE RIGHT TO USE "PLUG", APART FROM THE MARK AS SHOWN.

THE COLOR(S) YELLOW IS/ARE CLAIMED AS A FEATURE OF THE MARK.

THE YELLOW PLUG SUPERIMPOSED ON A STYLIZED DESIGN OF AN EAR WITH A YELLOW CIRCLE SUGGESTIVE OF AN EARPLUG INSERTED, SAID EARPLUG FORMING THE LETTER "O" IN THE WORD "YELLOW". THE COLORS GRAY AND BLACK ARE NOT PART OF THE MARK AND ARE USED TO SHOW SHADED AREAS IN THE MARK.

SEC. 2(F) IN PART, AS TO YELLOW.  
FOR HEARING PROTECTIVE DEVICES, NAMELY, EAR PLUGS (U.S. CLS. 21, 23, 26, 36 AND 38).

FIRST USE 10-15-2005; IN COMMERCE 10-15-2005.

3,234,313. GENIUS APPLICATION DEVELOPERS, LLC, ANNAPOLIS, MD. SN 78-425,314. PUB. 6-7-2005, FILED 5-26-2004.

reACAD

THE MARK CONSISTS OF STANDARD CHARACTERS WITHOUT CLAIM TO ANY PARTICULAR FONT, STYLE, SIZE, OR COLOR.

FOR COMPUTER SOFTWARE ENHANCING THE CAPABILITIES OF COMPUTER AIDED DESIGN SOFTWARE TO DISPLAY AND ESTIMATE RENOVATION WORK IN EXISTING FACILITIES (U.S. CLS. 21, 23, 26, 36 AND 38).

FIRST USE 7-17-2006; IN COMMERCE 7-17-2006.

**CLASS 9—(Continued).**

3,234,327. SAMSONITE CORPORATION, DENVER, CO. SN 78-434,779. PUB. 6-7-2005, FILED 6-14-2004.

# iMOBILE

THE MARK CONSISTS OF STANDARD CHARACTERS WITHOUT CLAIM TO ANY PARTICULAR FONT, STYLE, SIZE, OR COLOR.

FOR TOP-LOADING COMPUTER BAGS (U.S. CLS. 21, 23, 26, 36 AND 38).

FIRST USE 6-7-2005; IN COMMERCE 6-7-2005.

3,234,333. 3VR SECURITY, INC., SAN FRANCISCO, CA. SN 78-438,556. PUB. 9-13-2005, FILED 6-21-2004.

# 3VR

THE MARK CONSISTS OF STANDARD CHARACTERS WITHOUT CLAIM TO ANY PARTICULAR FONT, STYLE, SIZE, OR COLOR.

FOR COMPUTER SOFTWARE FOR USE IN CAPTURING, ANALYZING, MANAGING AND STORING VIDEO DATA FOR USE IN ELECTRONIC AND OPTICAL SECURITY AND SURVEILLANCE; ACCESS CONTROL AND ALARM MONITORING SYSTEMS, NAMELY VIDEO RECORDERS, DIGITAL TRANSMITTERS, COMPUTER MONITORS, TELEVISION MONITORS, VIDEO MONITORS, AND VOICE DISPLAY MONITORS; FACILITIES MANAGEMENT SOFTWARE, NAMELY, SOFTWARE TO CONTROL BUILDING ENVIRONMENTAL, ACCESS AND SECURITY SYSTEMS; COMMUNICATIONS SOFTWARE FOR CONNECTING COMPUTER NETWORK USERS AND ONLINE ELECTRONIC AND OPTICAL COMMUNICATIONS NETWORKS; COMPUTER SOFTWARE FOR THE COLLECTION, EDITING, ORGANIZING, MODIFYING, BOOK MARKING, TRANSMISSION STORAGE AND SHARING OF DATA AND INFORMATION; DATA COMPRESSION AND DE-COMPRESSION SOFTWARE; COMPUTER HARDWARE; COMPUTER HARDWARE FOR USE IN ELECTRONIC AND OPTICAL SECURITY AND SURVEILLANCE; DIGITAL VIDEO RECORDERS; ELECTRONIC AND OPTICAL COMMUNICATIONS INSTRUMENTS AND COMPONENTS, NAMELY, DIGITAL TRANSMITTERS (U.S. CLS. 21, 23, 26, 36 AND 38).

FIRST USE 3-15-2006; IN COMMERCE 3-31-2006.

**CLASS 9—(Continued).**

3,234,336. TELEVISA SA. DE C.V., COLONIA ZEDEC SANTA FE, MEXICO, D.F., MEXICO. SN 78-440,859. PUB. 1-31-2006, FILED 6-24-2004.

# TELEVISA HOME ENTERTAINMENT

THE MARK CONSISTS OF STANDARD CHARACTERS WITHOUT CLAIM TO ANY PARTICULAR FONT, STYLE, SIZE, OR COLOR.

NO CLAIM IS MADE TO THE EXCLUSIVE RIGHT TO USE HOME ENTERTAINMENT, APART FROM THE MARK AS SHOWN.

THE TRANSLATION OF THE WORD TELEVISA IS "IT TELEVISES".

SEC. 2(F).

FOR PRERECORDED VIDEO TAPES, VIDEO CASSETTES, DIGITAL VIDEO DISKS (DVDS), COMPACT DISKS (CDS), AND OTHER ELECTRONIC MEDIA, NAMELY, MAGNETIC TAPES AND DIGITAL ELECTRONIC MEDIA FEATURING TELEVISION ENTERTAINMENT PROGRAMS (U.S. CLS. 21, 23, 26, 36 AND 38).

FIRST USE 12-0-2002; IN COMMERCE 12-0-2002.

3,234,345. AEON GAMING LLC, ST. PAUL, MN. SN 78-448,455. PUB. 11-22-2005, FILED 7-9-2004.

# SHAMUS OF SHAMROCK

THE MARK CONSISTS OF STANDARD CHARACTERS WITHOUT CLAIM TO ANY PARTICULAR FONT, STYLE, SIZE, OR COLOR.

FOR ELECTRONIC EQUIPMENT, NAMELY, SOFTWARE FOR USE IN OPERATING AN ELECTRONIC BINGO GAME; AND ELECTRONIC GAME EQUIPMENT, THAT IS USED AS AN AID TO THE PLAYING OF BINGO GAMES, NAMELY PORTABLE ELECTRONIC GAMING CONTROLLERS (U.S. CLS. 21, 23, 26, 36 AND 38).

FIRST USE 7-24-2004; IN COMMERCE 7-24-2004.



**CLASS 9—(Continued).**

3,234,347. KOPTIX, TORRANCE, CA. SN 78-448,571. PUB. 6-21-2005, FILED 7-9-2004.

# FULL THROTTLE

THE MARK CONSISTS OF STANDARD CHARACTERS WITHOUT CLAIM TO ANY PARTICULAR FONT, STYLE, SIZE, OR COLOR.

FOR SUN GLASSES (U.S. CLS. 21, 23, 26, 36 AND 38).  
FIRST USE 8-31-2005; IN COMMERCE 8-31-2005.

3,234,361. WEYERHAEUSER COMPANY, FEDERAL WAY, WA. SN 78-457,506. PUB. 11-8-2005, FILED 7-27-2004.

# TJ-PANELMATE

THE MARK CONSISTS OF STANDARD CHARACTERS WITHOUT CLAIM TO ANY PARTICULAR FONT, STYLE, SIZE, OR COLOR.

OWNER OF U.S. REG. NOS. 2,258,917 AND 2,361,123.  
FOR COMPUTER PROGRAMS FOR USE IN THE SELECTION AND DESIGN OF BUILDING MATERIALS (U.S. CLS. 21, 23, 26, 36 AND 38).  
FIRST USE 7-1-2004; IN COMMERCE 7-1-2004.

3,234,366. GUITAR CENTER, INC., WESTLAKE VILLAGE, CA. SN 78-460,370. PUB. 6-28-2005, FILED 8-2-2004.

# LIVE WIRE SOLUTIONS

THE MARK CONSISTS OF STANDARD CHARACTERS WITHOUT CLAIM TO ANY PARTICULAR FONT, STYLE,

**CLASS 9—(Continued).**

SIZE, OR COLOR.

OWNER OF U.S. REG. NO. 2,831,584.  
FOR PROFESSIONAL AUDIO RECORDING, SOUND REINFORCEMENT, AND PERFORMANCE HARDWARE AND ACCESSORIES FOR DIGITAL AND ANALOG APPLICATIONS, NAMELY DIRECT BOXES, IMPEDANCE CONVERTING UNITS, AUDIO SIGNAL SPLITTERS, AUDIO SIGNAL COMBINERS, PATCHBAYS, ADAPTERS, NOISE REDUCTION AND/OR ISOLATION HARDWARE, POWER SUPPLIES, TESTING EQUIPMENT, FOOT PEDALS AND SWITCHES, DIGITAL MIDI INTERFACES, HEADPHONE AMPLIFIERS, CONNECTORS AND CONVERTERS; CABLES FOR USE WITH GUITARS, MIXERS, PROAUDIO APPLICATIONS, RECORDING APPLICATIONS AND OTHER MUSICAL APPLICATIONS REQUIRING THE USE OF CABLES (U.S. CLS. 21, 23, 26, 36 AND 38).  
FIRST USE 7-1-2005; IN COMMERCE 7-1-2005.

3,234,373. SIX DISCIPLINES CORPORATION, FINDLAY, OH. SN 78-467,236. PUB. 7-12-2005, FILED 8-13-2004.

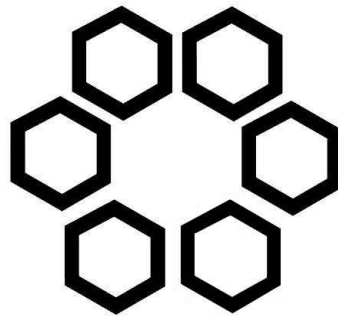

THE MARK CONSISTS OF SIX HEXAGONS.  
FOR COMPUTER SOFTWARE THAT PROVIDES TRANSACTION PROCESSING IN THE FIELD OF BUSINESS MANAGEMENT (U.S. CLS. 21, 23, 26, 36 AND 38).  
FIRST USE 8-26-2004; IN COMMERCE 8-26-2004.

**CLASS 9—(Continued).**

3,234,376. LEXAR MEDIA, INC., FREMONT, CA. SN 78-468,177. PUB. 2-28-2006, FILED 8-16-2004.



OWNER OF U.S. REG. NOS. 2,295,266 AND 2,905,053.

THE MARK CONSISTS OF THE WORD LEXAR, IN WHICH THE "X" IS MADE UP OF A SLANTED LINE AND FIVE CIRCLES.

FOR DIGITAL FILM; BLANK DIGITAL STORAGE MEDIA; REMOVABLE FLASH-BASED DIGITAL MEDIA; DIGITAL MEMORY CARDS; FLASH MEMORY CARDS; NON-VOLATILE MEMORY CARDS; SOLID STATE MEMORY CARDS; USB FLASH DRIVES; DIGITAL FILM READERS; DIGITAL STORAGE MEDIA READERS; MP3 PLAYERS; HARDWARE FOR VIEWING DIGITAL PICTURES THROUGH TELEVISION EQUIPMENT; SOFTWARE FOR RECOVERING IMAGE FILMS FROM MEMORY CARDS; COMPUTER HARDWARE AND COMPUTER SOFTWARE FOR TRANSFERRING, STORING, TRANSPORTING AND RECOVERING ELECTRONIC DATA BETWEEN ELECTRONIC STORAGE DEVICES; SOFTWARE FOR ENCODING DIGITAL FILM DATA; COMPUTER SOFTWARE, BLANK DIGITAL STORAGE MEDIA, MEMORY DRIVES, MEMORY CARDS, AND MEMORY CARD READERS FOR USE IN DOWNLOADING, TRANSMITTING, RECEIVING, EDITING, EXTRACTING, CODING, DECODING, PLAYING, STORING, PRINTING AND ORGANIZING SOUND AND IMAGE DATA; CABLES FOR TRANSFERRING ELECTRONIC IMAGES FROM A DIGITAL CAMERA TO A COMPUTER (U.S. CLS. 21, 23, 26, 36 AND 38).  
FIRST USE 6-20-2004; IN COMMERCE 6-20-2004.

**CLASS 9—(Continued).**

3,234,386. FLEXIWORLD TECHNOLOGIES, INC, PORTLAND, OR. SN 78-472,393. PUB. 9-6-2005, FILED 8-24-2004.



---

3,234,377. IGT, RENO, NV. SN 78-468,437. PUB. 7-25-2006, FILED 8-17-2004.

**GEMS WILD-TILES**

THE MARK CONSISTS OF STANDARD CHARACTERS WITHOUT CLAIM TO ANY PARTICULAR FONT, STYLE, SIZE, OR COLOR.

NO CLAIM IS MADE TO THE EXCLUSIVE RIGHT TO USE "WILD-TILES", APART FROM THE MARK AS SHOWN.

FOR GAMING MACHINES, NAMELY, DEVICES ON WHICH A WAGER IS PLACED AND COMPONENTS THEREFOR (U.S. CLS. 21, 23, 26, 36 AND 38).  
FIRST USE 12-15-2005; IN COMMERCE 1-18-2006.

THE MARK CONSISTS OF STANDARD CHARACTERS WITHOUT CLAIM TO ANY PARTICULAR FONT, STYLE, SIZE, OR COLOR.

FOR FLASH MEMORY STORAGE MODULES; COMPUTER ACCESSORY DEVICE THAT COMBINES FLASH MEMORY STORAGE MODULES WITH WIRELESS COMMUNICATION CAPABILITY IN A SINGLE UNIT; COMPUTER SOFTWARE OPERATING PROGRAMS FOR SEMICONDUCTOR MEMORY DEVICES; COMPUTER SOFTWARE OPERATING PROGRAMS FOR WIRELESS COMMUNICATION DEVICES; COMPUTER SOFTWARE APPLICATION PROGRAMS FOR PERSONAL COMPUTERS AND A WIDE VARIETY OF WIRELESS COMMUNICATION DEVICES THAT ALLOW FILE TRANSFER BETWEEN AND AMONG PERSONAL COMPUTERS AND A WIDE RANGE OF WIRELESS AND WIRED STORAGE, COMPUTER OUTPUT, DISPLAY, CAMERA, AND COMPUTER PROCESSING DEVICES (U.S. CLS. 21, 23, 26, 36 AND 38).  
FIRST USE 6-30-2006; IN COMMERCE 6-30-2006.

**CLASS 9—(Continued).**

3,234,402. PCS DIGITAL, L.L.C., SCOTTSDALE, AZ. SN 78-480,155. PUB. 12-20-2005, FILED 9-8-2004.

**CLASS 9—(Continued).**

3,234,415. CAPCOM CO., LTD., OSAKA, JAPAN. SN 78-483,826. PUB. 9-27-2005, FILED 9-15-2004.

# SUITE 16

THE MARK CONSISTS OF STANDARD CHARACTERS WITHOUT CLAIM TO ANY PARTICULAR FONT, STYLE, SIZE, OR COLOR.

FOR KEY TELEPHONE SYSTEMS CONSISTING PRINCIPALLY OF KEY TELEPHONE SETS AND A KEY SERVICE UNIT (KSU) EQUIPPED WITH PROPRIETARY HARDWARE AND SOFTWARE AS MAY BE NEEDED TO PROVIDE KEY TELEPHONE, PBX, AND/OR VOICE MAIL FUNCTIONALITY WITHIN THE CUSTOMER ENTERPRISE (U.S. CLS. 21, 23, 26, 36 AND 38).

FIRST USE 5-4-2005; IN COMMERCE 5-4-2005.

# HAUNTING GROUND

THE MARK CONSISTS OF STANDARD CHARACTERS WITHOUT CLAIM TO ANY PARTICULAR FONT, STYLE, SIZE, OR COLOR.

FOR COMPUTER GAME SOFTWARE, COMPUTER GAME CARTRIDGES, COMPUTER GAME CASSETTES, COMPUTER GAME DISCS, COMPUTER GAME TAPES, VIDEO GAME CARTRIDGES, VIDEO GAME MACHINES FOR USE WITH TELEVISION RECEIVERS, DOWNLOADABLE GAME SOFTWARE, DOWNLOADABLE COMPUTER GAMES (U.S. CLS. 21, 23, 26, 36 AND 38).

FIRST USE 4-29-2005; IN COMMERCE 5-10-2005.

3,234,423. MEDSTRAT, INC., DOWNERS GROVE, IL. SN 78-486,566. PUB. 9-6-2005, FILED 9-20-2004.

# ECHOESTATION

THE MARK CONSISTS OF STANDARD CHARACTERS WITHOUT CLAIM TO ANY PARTICULAR FONT, STYLE, SIZE, OR COLOR.

FOR COMPUTER SOFTWARE FOR LOCATING, RETRIEVING, VIEWING, PROCESSING, MEASURING, ANALYZING AND ANNOTATING ORTHOPEDIC MEDICAL IMAGES ON A LOCAL AREA NETWORK OR OVER A GLOBAL COMPUTER NETWORK (U.S. CLS. 21, 23, 26, 36 AND 38).

FIRST USE 2-1-2004; IN COMMERCE 2-1-2004.

3,234,410. ADRENALIN GAMING LLC, LADERA RANCH, CA. SN 78-482,081. PUB. 9-13-2005, FILED 9-11-2004.

# CASH INN

THE MARK CONSISTS OF STANDARD CHARACTERS WITHOUT CLAIM TO ANY PARTICULAR FONT, STYLE, SIZE, OR COLOR.

FOR GAMING MACHINES, NAMELY VIDEO AND SLOT MACHINES AND TABLE GAMES USED IN A GAMBLING ESTABLISHMENT (U.S. CLS. 21, 23, 26, 36 AND 38).

FIRST USE 10-28-2005; IN COMMERCE 10-28-2005.

3,234,424. MEDSTRAT, INC., DOWNERS GROVE, IL. SN 78-486,568. PUB. 9-6-2005, FILED 9-20-2004.

# ECHOESYSTEM

**CLASS 9—(Continued).**

THE MARK CONSISTS OF STANDARD CHARACTERS WITHOUT CLAIM TO ANY PARTICULAR FONT, STYLE, SIZE, OR COLOR.

FOR COMPUTER HARDWARE AND SOFTWARE FOR STORING, MANAGING, ORGANIZING AND RETRIEVING DIGITAL ORTHOPEDIC IMAGES AND DATA (U.S. CLS. 21, 23, 26, 36 AND 38).

FIRST USE 2-1-2004; IN COMMERCE 2-1-2004.

---

3,234,439. 4TH DAY ENTERPRISES, LLC, BANGOR, ME. SN 78-493,443. PUB. 9-13-2005, FILED 10-1-2004.

## THE FLASHLIGHT YOU CAN'T DROP

THE MARK CONSISTS OF STANDARD CHARACTERS WITHOUT CLAIM TO ANY PARTICULAR FONT, STYLE, SIZE, OR COLOR.

FOR HAND COVERING WITH INTEGRATED LIGHT EMITTING DIODES (LEDS) TO PROVIDE ILLUMINATION AT A POINT OF WORK OR INTEREST (U.S. CLS. 21, 23, 26, 36 AND 38).

FIRST USE 7-25-2006; IN COMMERCE 7-25-2006.

---

3,234,473. R/D TECH INSTRUMENTS INC., WALTHAM, MA. SN 78-505,932. PUB. 9-27-2005, FILED 10-26-2004.

## ATLAS

THE MARK CONSISTS OF STANDARD CHARACTERS WITHOUT CLAIM TO ANY PARTICULAR FONT, STYLE, SIZE, OR COLOR.

FOR ULTRASONIC TRANSDUCERS (U.S. CLS. 21, 23, 26, 36 AND 38).

FIRST USE 11-0-2004; IN COMMERCE 11-0-2004.

**CLASS 9—(Continued).**

3,234,480. AZTEC PACIFIC, INC., NEWPORT BEACH, CA. SN 78-507,102. PUB. 10-4-2005, FILED 10-27-2004.

## AZTEC PACIFIC

THE MARK CONSISTS OF STANDARD CHARACTERS WITHOUT CLAIM TO ANY PARTICULAR FONT, STYLE, SIZE, OR COLOR.

FOR COMPUTER SOFTWARE USED TO TRACK, COLLECT, MEASURE, CATEGORIZE, RECORD AND STORE TIME SPECIFIC DATA AND GENERATE REPORTS (U.S. CLS. 21, 23, 26, 36 AND 38).

FIRST USE 3-18-2004; IN COMMERCE 3-18-2004.

---

3,234,484. DATACOLOR HOLDING AG, LUZERN, SWITZERLAND. SN 78-509,833. PUB. 3-14-2006, FILED 11-2-2004.

## DATACOLOR SORT

THE MARK CONSISTS OF STANDARD CHARACTERS WITHOUT CLAIM TO ANY PARTICULAR FONT, STYLE, SIZE, OR COLOR.

NO CLAIM IS MADE TO THE EXCLUSIVE RIGHT TO USE "SORT", APART FROM THE MARK AS SHOWN.

FOR COMPUTER SORTING SOFTWARE, NAMELY, SOFTWARE FOR GROUPING TOGETHER DYED MATERIAL AND FOR SORTING THE DYED MATERIAL INTO AN ORDER OF CONTINUOUS COLOR DEVIATION SUCH THAT ANY EXISTING COLOR DEVIATION IS NOT NOTICEABLE AMONG THE SORTED GROUPS OF DYED MATERIAL (U.S. CLS. 21, 23, 26, 36 AND 38).

FIRST USE 3-30-2005; IN COMMERCE 3-30-2005.

---

3,234,485. SQUILLACE PRODUCTION STUDIOS LLC, BURBANK, CA. SN 78-510,276. PUB. 3-14-2006, FILED 11-2-2004.

## Auto-Roto-Strobe

**CLASS 9—(Continued).**

THE MARK CONSISTS OF STANDARD CHARACTERS WITHOUT CLAIM TO ANY PARTICULAR FONT, STYLE, SIZE, OR COLOR.

FOR ACCESSORIES FOR ALL TYPES OF CAMERAS, VIDEO OR STILL, EITHER BUILT INTO OR USED SEPARATELY FROM THE CAMERA BODY, THAT ASSIST, AID OR FACILITATE USERS, THAT ARE EITHER PHYSICALLY HOLDING THE CAMERA, OR ARE OPERATING THE CAMERA FROM AFAR, TO USE THE CAMERA AND IT'S ACCESSORIES, NAMELY WIRING HARNESES, FLASH UNITS, AND CAMERA FLASHES, CAMERA HOODS, FLASHLAMPS FOR CAMERAS, LIGHTS FOR USE ON VIDEO CAMERAS, LIGHTS FOR USE ON CAMERAS, AS ONE COHESIVE UNIT WITHOUT REGARD TO PLANAR ORIENTATION OF THE CAMERA AND IT'S ACCESSORIES, NAMELY LANDSCAPE OR PORTRAIT ORIENTATION (U.S. CLS. 21, 23, 26, 36 AND 38).

FIRST USE 1-1-2006; IN COMMERCE 11-1-2006.



3,234,490. LEGACY TECHNICAL GROUP, INC., SALT LAKE CITY, UT. SN 78-511,664. PUB. 3-14-2006, FILED 11-4-2004.

**ATTOSTAT**

THE MARK CONSISTS OF STANDARD CHARACTERS WITHOUT CLAIM TO ANY PARTICULAR FONT, STYLE, SIZE, OR COLOR.

FOR ELECTRICAL AND ELECTRONIC APPARATUS, DEVICES AND INSTRUMENTS FOR WEIGHING, MEASURING, COUNTING, RECORDING, MONITORING, AND TESTING OF MICROSCOPIC AND SUB-MICROSCOPIC PARTICLES NAMELY OPEN AND CLOSED-LOOP CONTROL AND SWITCHING APPARATUS; OPTICAL SWITCHGEAR AND CONTROLS; LASERS FOR WORKING WITH MICROSCOPIC AND SUB-MICROSCOPIC PARTICLES; MACHINES FOR PRODUCING PARTICLES SIZED AND TESTED IN NANOMETER AND ANGSTROM RANGES (U.S. CLS. 21, 23, 26, 36 AND 38).

FIRST USE 8-1-2006; IN COMMERCE 8-1-2006.

**CLASS 9—(Continued).**

3,234,491. LEGACY TECHNICAL GROUP, INC., SALT LAKE CITY, UT. SN 78-511,666. PUB. 3-14-2006, FILED 11-4-2004.

**NOBLE LINE  
COLLOIDS**

THE MARK CONSISTS OF STANDARD CHARACTERS WITHOUT CLAIM TO ANY PARTICULAR FONT, STYLE, SIZE, OR COLOR.

NO CLAIM IS MADE TO THE EXCLUSIVE RIGHT TO USE NOBLE AND COLLOID, APART FROM THE MARK AS SHOWN.

FOR ELECTRICAL AND ELECTRONIC APPARATUS, DEVICES AND INSTRUMENTS FOR WEIGHING, MEASURING, COUNTING, RECORDING, MONITORING, AND TESTING OF MICROSCOPIC AND SUB-MICROSCOPIC PARTICLES NAMELY OPEN AND CLOSED-LOOP CONTROL AND SWITCHING APPARATUS; OPTICAL SWITCHGEAR AND CONTROLS; LASERS FOR WORKING WITH MICROSCOPIC AND SUB-MICROSCOPIC PARTICLES; MACHINES FOR PRODUCING PARTICLES SIZED AND TESTED IN NANOMETER AND ANGSTROM RANGES (U.S. CLS. 21, 23, 26, 36 AND 38).

FIRST USE 12-1-2006; IN COMMERCE 12-1-2006.



3,234,493. NVIDIA CORPORATION, SANTA CLARA, CA. SN 78-511,793. PUB. 2-14-2006, FILED 11-5-2004.

**NVIDIA SLI**

THE MARK CONSISTS OF STANDARD CHARACTERS WITHOUT CLAIM TO ANY PARTICULAR FONT, STYLE, SIZE, OR COLOR.

OWNER OF U.S. REG. NOS. 1,895,559, 2,942,531, AND OTHERS.

NO CLAIM IS MADE TO THE EXCLUSIVE RIGHT TO USE "SLI", APART FROM THE MARK AS SHOWN.

FOR COMPUTER HARDWARE, NAMELY, INTEGRATED CIRCUITS, SEMICONDUCTORS AND CHIPSETS, AND ASSOCIATED COMPUTER SOFTWARE AND HARDWARE FOR OPERATING THE SAME (U.S. CLS. 21, 23, 26, 36 AND 38).

FIRST USE 6-28-2004; IN COMMERCE 6-28-2004.

**CLASS 9—(Continued).**

3,234,501. DATACOLOR HOLDING AG., LUZERN, SWITZERLAND. SN 78-514,726. PUB. 2-28-2006, FILED 11-10-2004.

**DATACOLOR PROCESS**

THE MARK CONSISTS OF STANDARD CHARACTERS WITHOUT CLAIM TO ANY PARTICULAR FONT, STYLE, SIZE, OR COLOR.

NO CLAIM IS MADE TO THE EXCLUSIVE RIGHT TO USE "PROCESS", APART FROM THE MARK AS SHOWN.

FOR COMPUTER SOFTWARE FOR DETERMINING ABSOLUTE AMOUNTS OF SPECIFIC DYES NEEDED TO PRODUCE A DYED MATERIAL SUCH AS A FABRIC HAVING A SPECIFIC COLOR AND SPECIFIC DYEING PARAMETERS (U.S. CLS. 21, 23, 26, 36 AND 38).

FIRST USE 1-5-2005; IN COMMERCE 1-5-2005.

3,234,502. DATACOLOR HOLDING AG., LUZERN, SWITZERLAND. SN 78-514,729. PUB. 3-14-2006, FILED 11-10-2004.

**DATACOLOR MATCH  
TEXTILE**

THE MARK CONSISTS OF STANDARD CHARACTERS WITHOUT CLAIM TO ANY PARTICULAR FONT, STYLE, SIZE, OR COLOR.

NO CLAIM IS MADE TO THE EXCLUSIVE RIGHT TO USE "MATCH TEXTILE", APART FROM THE MARK AS SHOWN.

FOR COMPUTER SOFTWARE FOR USE IN CONJUNCTION WITH A COLOR MEASURING DEVICE FOR DETERMINING ABSOLUTE AMOUNTS OF SPECIFIC DYES NEEDED TO REPRODUCE A SAMPLE DYED MATERIAL SUCH AS A FABRIC HAVING A SPECIFIC COLOR (U.S. CLS. 21, 23, 26, 36 AND 38).

FIRST USE 9-10-2004; IN COMMERCE 9-10-2004.

**CLASS 9—(Continued).**

3,234,505. DATACOLOR HOLDING AG., LUZERN, SWITZERLAND. SN 78-515,093. PUB. 2-21-2006, FILED 11-11-2004.

**DATACOLOR WEIGH**

THE MARK CONSISTS OF STANDARD CHARACTERS WITHOUT CLAIM TO ANY PARTICULAR FONT, STYLE, SIZE, OR COLOR.

NO CLAIM IS MADE TO THE EXCLUSIVE RIGHT TO USE "WEIGH", APART FROM THE MARK AS SHOWN.

FOR COMPUTER SOFTWARE FOR USE IN THE FIELD OF TEXTILES FOR PROVIDING AND DISPLAYING TO A USER A LIST OF TEXTILE LOTS TO BE DYED AND AN ACTUAL WEIGHTED AMOUNT OF DYES TO BE USED FOR EACH LOT; IN CONJUNCTION WITH WEIGHING MEANS, THE SOFTWARE PROVIDES A REAL TIME DISPLAY OF THE ACTUAL WEIGHED AMOUNT AND THE TARGET WEIGHT ALONG WITH RELEVANT MIXING INSTRUCTIONS; AN ALARM IS ALSO DISPLAYED DURING AN OVERWEIGHT CONDITION (U.S. CLS. 21, 23, 26, 36 AND 38).

FIRST USE 3-8-2005; IN COMMERCE 3-8-2005.

3,234,506. DATACOLOR HOLDING AG., LUZERN, SWITZERLAND. SN 78-515,097. PUB. 2-21-2006, FILED 11-11-2004.



NO CLAIM IS MADE TO THE EXCLUSIVE RIGHT TO USE "WEIGH", APART FROM THE MARK AS SHOWN.

THE COLOR(S) BLACK, GRAY, RED, ORANGE AND WHITE IS/ARE CLAIMED AS A FEATURE OF THE MARK.

THE COLOR BLACK APPEARS IN THE WORD "DATACOLOR" AND IN THE HORIZONTAL LINE THROUGH THE MIDDLE OF THE MARK. THE COLOR GRAY APPEARS IN THE WORDS "WEIGH". THE COLOR RED APPEARS IN THE RECTANGLE IN THE UPPER RIGHT-HAND CORNER OF THE MARK. THE COLORS ORANGE AND WHITE APPEAR IN THE SQUARE IN THE LOWER LEFT-HAND CORNER OF THE MARK.

FOR COMPUTER SOFTWARE FOR USE IN THE FIELD OF TEXTILES FOR PROVIDING AND DISPLAYING TO A USER A LIST OF TEXTILE LOTS TO BE DYED AND AN ACTUAL WEIGHTED AMOUNT OF DYES TO BE USED FOR EACH LOT; IN CONJUNCTION WITH WEIGHING MEANS, THE SOFTWARE PROVIDES A REAL TIME DISPLAY OF THE ACTUAL WEIGHED AMOUNT AND THE TARGET WEIGHT ALONG WITH RELEVANT MIXING INSTRUCTIONS; AN ALARM IS ALSO DISPLAYED DURING AN OVERWEIGHT CONDITION (U.S. CLS. 21, 23, 26, 36 AND 38).

FIRST USE 3-8-2005; IN COMMERCE 3-8-2005.

**CLASS 9—(Continued).**

3,234,528. ISYMPHONY HOLDINGS ENTERPRISES, VAN NUYS, CA. SN 78-521,394. PUB. 10-18-2005, FILED 11-22-2004.

**BRINGING AUDIO  
BACK TO LIFE**

THE MARK CONSISTS OF STANDARD CHARACTERS WITHOUT CLAIM TO ANY PARTICULAR FONT, STYLE, SIZE, OR COLOR.

FOR CONSUMER ELECTRONICS, NAMELY, RADIO RECEIVERS; AUDIO TUNERS, AUDIO AMPLIFIERS; LOUD SPEAKERS; SPEAKER-BOXES; EAR PHONES; HEAD PHONES; EMOTE CONTROLS FOR AUDIO AND VIDEO EQUIPMENT (U.S. CLS. 21, 23, 26, 36 AND 38).  
FIRST USE 7-19-2006; IN COMMERCE 7-20-2006.

3,234,529. ISYMPHONY HOLDINGS ENTERPRISES, VAN NUYS, CA. SN 78-521,404. PUB. 9-13-2005, FILED 11-22-2004.

**BRINGING AUDIO  
BACK TO LIFE**

THE MARK CONSISTS OF STANDARD CHARACTERS WITHOUT CLAIM TO ANY PARTICULAR FONT, STYLE, SIZE, OR COLOR.

FOR CONSUMER ELECTRONICS, NAMELY, RADIO RECEIVERS; AUDIO TUNERS, AUDIO AMPLIFIERS; LOUD SPEAKERS; SPEAKER-BOXES; EAR PHONES; HEAD PHONES; REMOTE CONTROLS FOR AUDIO AND VIDEO EQUIPMENT (U.S. CLS. 21, 23, 26, 36 AND 38).  
FIRST USE 7-19-2006; IN COMMERCE 7-20-2006.

**CLASS 9—(Continued).**

3,234,530. DATACOLOR HOLDING AG., LUZERN, SWITZERLAND. SN 78-521,568. PUB. 3-7-2006, FILED 11-23-2004.



OWNER OF U.S. REG. NO. 1,423,732.  
NO CLAIM IS MADE TO THE EXCLUSIVE RIGHT TO USE "TOOLS", APART FROM THE MARK AS SHOWN.

THE COLORS BLACK, GRAY, WHITE, RED AND BLUE ARE CLAIMED AS A FEATURE OF THE MARK.

THE COLOR BLACK APPEARS IN THE WORD "DATACOLOR" AND IN THE HORIZONTAL LINE IN THE CENTER OF THE MARK. THE COLOR GRAY APPEARS IN THE WORD "CHECK." THE COLOR RED APPEARS IN THE RECTANGLE IN THE UPPER RIGHT HAND CORNER OF THE MARK. THE COLORS BLUE AND WHITE APPEAR IN THE SQUARE IN THE LOWER LEFT HAND CORNER OF THE MARK.

FOR COMPUTER SOFTWARE FOR CREATING COLOR MEASUREMENT EXPERIMENTS AND FILES, SETTING UP PASS-FAIL CRITERIA FOR COLOR MEASUREMENT SCANS, DATA SHARING AND GENERATING CUSTOMIZED REPORTS FOR COLOR MEASUREMENT APPARATUSES (U.S. CLS. 21, 23, 26, 36 AND 38).  
FIRST USE 1-10-2005; IN COMMERCE 1-10-2005.

3,234,535. DATACOLOR HOLDING AG., LUZERN, SWITZERLAND. SN 78-522,340. PUB. 3-7-2006, FILED 11-24-2004.

**COLORVISION  
SPYDER2PRO STUDIO**

THE MARK CONSISTS OF STANDARD CHARACTERS WITHOUT CLAIM TO ANY PARTICULAR FONT, STYLE, SIZE, OR COLOR.

FOR COLOR MEASURING APPARATUSES, NAMELY, COLORIMETERS AND COLOR MEASURING SOFTWARE FOR COLOR EDITING, COLOR MEASUREMENT AND CALIBRATION OF COMPUTER AND VIDEO DISPLAYS SUCH AS CATHODE RAY TUBE (CRT), LIQUID CRYSTAL DISPLAY (LCD) AND LAPTOP COMPUTER DISPLAYS (U.S. CLS. 21, 23, 26, 36 AND 38).  
FIRST USE 9-24-2004; IN COMMERCE 9-24-2004.

**CLASS 9—(Continued).**

3,234,536. NAMCO BANDAI GAMES AMERICA INC., SANTA CLARA, CA. SN 78-522,942. PUB. 10-11-2005, FILED 11-24-2004.

**CLASS 9—(Continued).**

3,234,560. IGT, RENO, NV. SN 78-530,408. PUB. 10-4-2005, FILED 12-10-2004.

**THE LEGEND OF HEROES**

THE MARK CONSISTS OF STANDARD CHARACTERS WITHOUT CLAIM TO ANY PARTICULAR FONT, STYLE, SIZE, OR COLOR.

FOR VIDEO GAME AND DISKS (U.S. CLS. 21, 23, 26, 36 AND 38).

FIRST USE 11-15-2005; IN COMMERCE 11-15-2005.

**SECOND PARTY**

THE MARK CONSISTS OF STANDARD CHARACTERS WITHOUT CLAIM TO ANY PARTICULAR FONT, STYLE, SIZE, OR COLOR.

OWNER OF U.S. REG. NOS. 2,466,283, 2,813,419, AND OTHERS.

FOR GAMING MACHINES, NAMELY, DEVICES WHICH ACCEPT A WAGER AND COMPONENTS THEREFOR, NAMELY, CONTROLLERS, DISPLAYS, BUTTON PANELS, BOLSTERS, ELECTRICAL WIRING, AND COMPUTER HARDWARE AND SOFTWARE ASSOCIATED THEREWITH (U.S. CLS. 21, 23, 26, 36 AND 38).

FIRST USE 6-14-2005; IN COMMERCE 6-25-2005.

3,234,553. AGILIX LABS, INC., OREM, UT. SN 78-528,354. PUB. 2-21-2006, FILED 12-7-2004.

**InfiNotes<sup>∞</sup>**

THE MARK CONSISTS OF THE WORD INFINOTES FOLLOWED BY THE INFINITY SYMBOL.

FOR COMPUTER SOFTWARE FOR BUILDING DIGITAL INK APPLICATIONS (U.S. CLS. 21, 23, 26, 36 AND 38).

FIRST USE 12-20-2004; IN COMMERCE 12-20-2004.

3,234,561. IGT, RENO, NV. SN 78-530,410. PUB. 10-4-2005, FILED 12-10-2004.

3,234,554. AGILIX LABS, INC., OREM, UT. SN 78-528,546. PUB. 8-29-2006, FILED 12-7-2004.

**INFINOTES**

THE MARK CONSISTS OF STANDARD CHARACTERS WITHOUT CLAIM TO ANY PARTICULAR FONT, STYLE, SIZE, OR COLOR.

FOR COMPUTER SOFTWARE FOR BUILDING DIGITAL INK APPLICATIONS (U.S. CLS. 21, 23, 26, 36 AND 38).

FIRST USE 12-20-2004; IN COMMERCE 12-20-2004.

**THIRD PARTY**

THE MARK CONSISTS OF STANDARD CHARACTERS WITHOUT CLAIM TO ANY PARTICULAR FONT, STYLE, SIZE, OR COLOR.

OWNER OF U.S. REG. NOS. 2,466,283, 2,813,419, AND OTHERS.

FOR GAMING MACHINES, NAMELY, DEVICES WHICH ACCEPT A WAGER AND COMPONENTS THEREFOR, NAMELY, CONTROLLERS, DISPLAYS, BUTTON PANELS, BOLSTERS, ELECTRICAL WIRING, AND COMPUTER HARDWARE AND SOFTWARE ASSOCIATED THEREWITH (U.S. CLS. 21, 23, 26, 36 AND 38).

FIRST USE 6-14-2005; IN COMMERCE 6-25-2005.



**CLASS 9—(Continued).**

3,234,562. IGT, RENO, NV. SN 78-530,419. PUB. 10-4-2005, FILED 12-10-2004.

**CLASS 9—(Continued).**

3,234,570. DATACOLOR HOLDING AG., LUZERN, SWITZERLAND. SN 78-531,980. PUB. 3-7-2006, FILED 12-14-2004.

## SIXTH PARTY

## DATACOLOR TOOLS

THE MARK CONSISTS OF STANDARD CHARACTERS WITHOUT CLAIM TO ANY PARTICULAR FONT, STYLE, SIZE, OR COLOR.

OWNER OF U.S. REG. NOS. 2,466,283, 2,813,419, AND OTHERS.

FOR GAMING MACHINES, NAMELY, DEVICES WHICH ACCEPT A WAGER AND COMPONENTS THEREFOR, NAMELY, CONTROLLERS, DISPLAYS, BUTTON PANELS, BOLSTERS, ELECTRICAL WIRING, AND COMPUTER HARDWARE AND SOFTWARE ASSOCIATED THEREWITH (U.S. CLS. 21, 23, 26, 36 AND 38).

FIRST USE 6-14-2005; IN COMMERCE 6-25-2005.

THE MARK CONSISTS OF STANDARD CHARACTERS WITHOUT CLAIM TO ANY PARTICULAR FONT, STYLE, SIZE, OR COLOR.

OWNER OF U.S. REG. NO. 1,423,732.

NO CLAIM IS MADE TO THE EXCLUSIVE RIGHT TO USE "TOOLS", APART FROM THE MARK AS SHOWN.

FOR COMPUTER SOFTWARE FOR CREATING COLOR MEASUREMENT EXPERIMENTS AND FILES, SETTING UP PASS-FAIL CRITERIA FOR COLOR MEASUREMENT SCANS, DATA SHARING AND GENERATING CUSTOMIZED REPORTS FOR COLOR MEASUREMENT APPARATUSES (U.S. CLS. 21, 23, 26, 36 AND 38).

FIRST USE 1-10-2005; IN COMMERCE 1-10-2005.

---

3,234,563. GIGATRONIX LIMITED, PORTSMOUTH, HAMPSHIRE, ENGLAND. SN 78-530,531. PUB. 1-24-2006, FILED 12-10-2004.

---

3,234,571. DATACOLOR HOLDING AG., LUZERN, SWITZERLAND. SN 78-531,983. PUB. 3-7-2006, FILED 12-14-2004.

## CABULATOR

## DATACOLOR CHECK

THE MARK CONSISTS OF STANDARD CHARACTERS WITHOUT CLAIM TO ANY PARTICULAR FONT, STYLE, SIZE, OR COLOR.

FOR ELECTRONIC COMPONENTS, NAMELY, CONNECTORS, CABLES, CABLE ASSEMBLIES AND ADAPTORS; CABLE CONNECTION AND ADAPTORS; CUSTOM CABLE ASSEMBLIES AND COAXIAL CONNECTORS, COMPUTER AND COMPUTER SOFTWARE AND FIRMWARE ALL FOR USE IN CREATING, DRAWING, PRICING, ORGANIZING, STANDARDIZING CUSTOM SPECIFICATION AND COMPONENT KITTING IN THE CABLE AND CABLE ASSEMBLY FIELD (U.S. CLS. 21, 23, 26, 36 AND 38).

FIRST USE 12-9-2002; IN COMMERCE 12-9-2002.

THE MARK CONSISTS OF STANDARD CHARACTERS WITHOUT CLAIM TO ANY PARTICULAR FONT, STYLE, SIZE, OR COLOR.

OWNER OF U.S. REG. NO. 1,423,732.

FOR INTEGRATED MOBILE, HANDHELD COLOR MANAGEMENT SYSTEM CONSISTING OF A MOBILE, HANDHELD SPECTROPHOTOMETER AND COLOR MANAGEMENT/MEASUREMENT COMPUTER SOFTWARE FOR COLOR MEASUREMENT AND IDENTIFICATION, COLOR EVALUATION, COLOR SPECIFICATION AND COLOR QUALITY CONTROL IN BOTH LABORATORY AND PRODUCTION SETTINGS (U.S. CLS. 21, 23, 26, 36 AND 38).

FIRST USE 3-8-2005; IN COMMERCE 3-8-2005.

**CLASS 9—(Continued).**

3,234,577. WILSON AUDIO SPECIALTIES, INC., PROVO, UT.  
SN 78-532,518. PUB. 9-6-2005, FILED 12-14-2004.

## SPECIAL APPLICATION ENGINEERING

THE MARK CONSISTS OF STANDARD CHARACTERS WITHOUT CLAIM TO ANY PARTICULAR FONT, STYLE, SIZE, OR COLOR.

NO CLAIM IS MADE TO THE EXCLUSIVE RIGHT TO USE "SPECIAL APPLICATION", APART FROM THE MARK AS SHOWN.

FOR HOME THEATER PRODUCTS AND EQUIPMENT, NAMELY, STEREO LOUDSPEAKERS (U.S. CLS. 21, 23, 26, 36 AND 38).

FIRST USE 11-15-2005; IN COMMERCE 1-5-2006.

**CLASS 9—(Continued).**

3,234,598. LEATHERWOOD, JAMES M., LINGLEVILLE, TX.  
SN 78-540,457. PUB. 10-18-2005, FILED 12-31-2004.

## MALCOLM

THE MARK CONSISTS OF STANDARD CHARACTERS WITHOUT CLAIM TO ANY PARTICULAR FONT, STYLE, SIZE, OR COLOR.

FOR RIFLE SCOPES AND RIFLE SCOPE MOUNTS (U.S. CLS. 21, 23, 26, 36 AND 38).

FIRST USE 3-1-2005; IN COMMERCE 8-1-2005.

3,234,583. IGT, RENO, NV. SN 78-533,946. PUB. 10-11-2005,  
FILED 12-16-2004.

## GRAND PARTY

THE MARK CONSISTS OF STANDARD CHARACTERS WITHOUT CLAIM TO ANY PARTICULAR FONT, STYLE, SIZE, OR COLOR.

OWNER OF U.S. REG. NOS. 2,466,283, 2,813,419, AND OTHERS.

FOR GAMING MACHINES, NAMELY, DEVICES WHICH ACCEPT A WAGER AND COMPONENTS THEREFOR, NAMELY, CONTROLLERS, DISPLAYS, BUTTON PANELS, BOLSTERS, ELECTRICAL WIRING, AND COMPUTER HARDWARE AND SOFTWARE ASSOCIATED THEREWITH (U.S. CLS. 21, 23, 26, 36 AND 38).

FIRST USE 6-14-2005; IN COMMERCE 6-25-2005.

3,234,600. WILL, JEFFREY A., MAPLE GROVE, MN. SN 78-541,690. PUB. 10-11-2005, FILED 1-4-2005.

## Power Choice

3,234,594. SEIKO EPSON KABUSHIKI KAISHA, DBA SEIKO EPSON CORPORATION, TOKYO, JAPAN. SN 78-538,872. PUB. 4-18-2006, FILED 12-28-2004.



SEC. 2(F) AS TO 3LCD.  
FOR PROJECTORS FOR HOME AND OFFICE USE, NAMELY, LIQUID CRYSTAL DISPLAY (LCD) PROJECTORS; HIGH TEMPERATURE POLY-SILICON LIQUID CRYSTAL DISPLAY PANELS (U.S. CLS. 21, 23, 26, 36 AND 38).

FIRST USE 2-1-2005; IN COMMERCE 2-1-2005.

THE MARK CONSISTS OF STANDARD CHARACTERS WITHOUT CLAIM TO ANY PARTICULAR FONT, STYLE, SIZE, OR COLOR.

NO CLAIM IS MADE TO THE EXCLUSIVE RIGHT TO USE "POWER", APART FROM THE MARK AS SHOWN.

FOR HEARING AID BATTERIES (U.S. CLS. 21, 23, 26, 36 AND 38).

FIRST USE 10-1-2005; IN COMMERCE 10-1-2005.

**CLASS 9—(Continued).**

3,234,603. LESZYNSKI GROUP, INC., BELLEVUE, WA. SN 78-543,156. PUB. 2-28-2006, FILED 1-6-2005.

ININKPUT

THE MARK CONSISTS OF STANDARD CHARACTERS WITHOUT CLAIM TO ANY PARTICULAR FONT, STYLE, SIZE, OR COLOR.

FOR COMPUTER SOFTWARE, NAMELY, PROGRAMMING TOOLS AND COMPONENTS FOR INCLUSION IN CUSTOM SOFTWARE APPLICATIONS (U.S. CLS. 21, 23, 26, 36 AND 38).

FIRST USE 11-22-2006; IN COMMERCE 11-22-2006.

3,234,608. COBY ELECTRONICS CORP., MASPETH, NY. SN 78-543,716. PUB. 5-23-2006, FILED 1-7-2005.

V ZON

THE MARK CONSISTS OF STANDARD CHARACTERS WITHOUT CLAIM TO ANY PARTICULAR FONT, STYLE, SIZE, OR COLOR.

FOR PORTABLE DVD PLAYERS (U.S. CLS. 21, 23, 26, 36 AND 38).

FIRST USE 9-29-2005; IN COMMERCE 9-29-2005.

**CLASS 9—(Continued).**

3,234,623. ZOOM EYEWORKS, INC., BERKELEY, CA. SN 78-547,661. PUB. 2-14-2006, FILED 1-14-2005.



THE COLORS RED/ORANGE AND GREY ARE CLAIMED AS A FEATURE OF THE MARK.

THE WORDING G2B AND THE STYLIZED RECTANGULAR DESIGN ARE IN RED/ORANGE WITH G2B CONTAINING A GREY SHADING.

FOR READING GLASSES, SUNGLASSES, AND EYEWEAR ACCESSORIES, NAMELY, EYEGLOSS CHAINS, CORDS, CASES, LEASHES AND REPAIR KITS CONSISTING OF REPLACEMENT PARTS AND TOOLS (U.S. CLS. 21, 23, 26, 36 AND 38).

FIRST USE 5-31-2005; IN COMMERCE 5-31-2005.

3,234,627. TRS QUALITY, INC., FORT WORTH, TX. SN 78-548,622. PUB. 10-25-2005, FILED 1-17-2005.

SMART CONNECT

THE MARK CONSISTS OF STANDARD CHARACTERS WITHOUT CLAIM TO ANY PARTICULAR FONT, STYLE, SIZE, OR COLOR.

NO CLAIM IS MADE TO THE EXCLUSIVE RIGHT TO USE CONNECT, APART FROM THE MARK AS SHOWN.

FOR CABLES, NAMELY, COAXIAL CABLES, VIDEO CABLES, A/V CABLES, AUDIO CABLES, DIGITAL CABLES (U.S. CLS. 21, 23, 26, 36 AND 38).

FIRST USE 7-12-2006; IN COMMERCE 7-12-2006.

**CLASS 9—(Continued).**

3,234,630. CASE LOGIC, INC., LONGMONT, CO. SN 78-551,643. PUB. 4-4-2006, FILED 1-21-2005.

**CLASS 9—(Continued).**

3,234,644. PULSE-LINK, INC., CARLSBAD, CA. SN 78-559,259. PUB. 6-6-2006, FILED 2-2-2005.

**FAST FILE**

THE MARK CONSISTS OF STANDARD CHARACTERS WITHOUT CLAIM TO ANY PARTICULAR FONT, STYLE, SIZE, OR COLOR.

FOR CASES, ALBUMS, BAGS, STORAGE TRAYS, POCKETS, AND SLEEVES SPECIALLY ADAPTED FOR HOLDING COMPACT DISCS, COMPACT DISC PLAYERS, DVDS, DVD PLAYERS, AUDIO CASSETTES, AUDIO CASSETTE PLAYERS, MINIDISCS, MINIDISC PLAYERS, DIGITAL AUDIO TAPES, DIGITAL DISKS, DIGITAL MEDIA PLAYERS, MP3 PLAYERS, VIDEO/COMPUTER GAME DISCS, HAND HELD GAME PLAYERS, PERSONAL ORGANIZERS, CAR STEREOS, COMPUTERS, CD-ROMS, FLOPPY DISCS, SOLID STATE MEMORY CARDS, VIDEOCASSETTES, CAMERAS, PHOTOGRAPHS AND CAMCORDERS; ORGANIZERS AND HOLDERS SPECIALLY ADAPTED FOR PORTABLE VIDEO AND DVD SYSTEMS; STORAGE CABINETS, TRAYS AND RACKS SPECIALLY ADAPTED FOR COMPACT DISCS, DVDS, MINIDISCS, DIGITAL MEDIA, VIDEOCASSETTES, GAME DISCS, CD-ROMS, SOLID STATE MEMORY CARDS AND FLOPPY DISCS (U.S. CLS. 21, 23, 26, 36 AND 38).

FIRST USE 1-0-2003; IN COMMERCE 3-0-2003.

3,234,638. THE WHISTLER GROUP, INC., CHELMSFORD, MA. SN 78-557,196. PUB. 4-25-2006, FILED 1-31-2005.

**INTELLICORD**

THE MARK CONSISTS OF STANDARD CHARACTERS WITHOUT CLAIM TO ANY PARTICULAR FONT, STYLE, SIZE, OR COLOR.

FOR ELECTRICAL POWER EXTENSION CORDS FOR USE IN CONNECTION WITH RADAR DETECTOR SYSTEMS (U.S. CLS. 21, 23, 26, 36 AND 38).

FIRST USE 11-1-2004; IN COMMERCE 1-3-2005.

**CWAVE**

THE MARK CONSISTS OF STANDARD CHARACTERS WITHOUT CLAIM TO ANY PARTICULAR FONT, STYLE, SIZE, OR COLOR.

FOR COMPUTER HARDWARE AND SOFTWARE FOR ENABLING ULTRA-WIDEBAND COMMUNICATIONS, SOLD AS A UNIT; COMPUTER SOFTWARE EMBEDDED IN INTEGRATED CIRCUITS OR SEMICONDUCTORS FOR ENABLING ULTRA-WIDEBAND COMMUNICATIONS; AND INTEGRATED CIRCUITS AND SEMICONDUCTORS FOR USE IN ULTRA-WIDEBAND COMMUNICATION (U.S. CLS. 21, 23, 26, 36 AND 38).

FIRST USE 12-13-2005; IN COMMERCE 12-13-2005.

3,234,657. TAYLOR BRANDS, LLC, KINGSPORT, TN. SN 78-565,896. PUB. 2-21-2006, FILED 2-11-2005.

**UNCLE HENRY**

THE MARK CONSISTS OF STANDARD CHARACTERS WITHOUT CLAIM TO ANY PARTICULAR FONT, STYLE, SIZE, OR COLOR.

OWNER OF U.S. REG. NO. 818,241.  
FOR SAFETY GLASSES AND SHOOTING GLASSES WITH EAR SAFETY PROTECTORS (U.S. CLS. 21, 23, 26, 36 AND 38).

FIRST USE 10-28-1965; IN COMMERCE 8-20-2006.

**CLASS 9—(Continued).**

3,234,661. CLIPHANGER, LLC, KAYSVILLE, UT. SN 78-568,552. PUB. 4-4-2006, FILED 2-16-2005.

cliphanger

THE MARK CONSISTS OF STANDARD CHARACTERS WITHOUT CLAIM TO ANY PARTICULAR FONT, STYLE, SIZE, OR COLOR.

FOR ATTACHMENTS AND ACCESSORIES FOR CARRYING, CLASPING, AND SECURING PORTABLE ELECTRONIC DEVICES, NAMELY CELLULAR PHONES, PDA'S, POCKET PC'S, GPS RECEIVERS, MP3 PLAYERS AND 2-WAY RADIOS (U.S. CLS. 21, 23, 26, 36 AND 38).

FIRST USE 11-0-2004; IN COMMERCE 8-0-2005.

3,234,663. CLIPHANGER, LLC, SAN DIEGO, CA. SN 78-568,601. PUB. 11-8-2005, FILED 2-16-2005.

ARE YOU HANGIN'?

THE MARK CONSISTS OF STANDARD CHARACTERS WITHOUT CLAIM TO ANY PARTICULAR FONT, STYLE, SIZE, OR COLOR.

FOR ATTACHMENTS AND ACCESSORIES FOR CARRYING, CLASPING, AND ATTACHING PORTABLE ELECTRONIC DEVICES, NAMELY CELLULAR PHONES, PDA'S, POCKET PC'S, GPS RECEIVERS, MP3 PLAYERS AND 2-WAY RADIOS (U.S. CLS. 21, 23, 26, 36 AND 38).

FIRST USE 11-0-2004; IN COMMERCE 8-0-2005.

**CLASS 9—(Continued).**

3,234,675. MUSES LEGAL PRODUCTS, INC., PROSPECT, KY. SN 78-575,485. PUB. 11-29-2005, FILED 2-25-2005.

MUSES LEGAL GUIDE  
TO LIVING  
TOGETHER

THE MARK CONSISTS OF STANDARD CHARACTERS WITHOUT CLAIM TO ANY PARTICULAR FONT, STYLE, SIZE, OR COLOR.

NO CLAIM IS MADE TO THE EXCLUSIVE RIGHT TO USE "LEGAL GUIDE TO LIVING TOGETHER", APART FROM THE MARK AS SHOWN.

FOR ORGANIZATIONAL AND EDUCATIONAL SOFTWARE IN THE FIELD OF RELATIONSHIPS AND IN THE FIELD OF LEGAL SELF HELP (U.S. CLS. 21, 23, 26, 36 AND 38).

FIRST USE 3-31-2005; IN COMMERCE 10-31-2005.

3,234,676. MUSES LEGAL PRODUCTS, INC., PROSPECT, KY. SN 78-575,491. PUB. 11-15-2005, FILED 2-25-2005.

MUSES LEGAL  
PRODUCTS

THE MARK CONSISTS OF STANDARD CHARACTERS WITHOUT CLAIM TO ANY PARTICULAR FONT, STYLE, SIZE, OR COLOR.

NO CLAIM IS MADE TO THE EXCLUSIVE RIGHT TO USE "LEGAL PRODUCTS", APART FROM THE MARK AS SHOWN.

FOR ORGANIZATIONAL AND EDUCATIONAL SOFTWARE IN THE FIELD OF RELATIONSHIPS AND IN THE FIELD OF LEGAL SELF HELP (U.S. CLS. 21, 23, 26, 36 AND 38).

FIRST USE 1-31-2006; IN COMMERCE 1-31-2006.

**CLASS 9—(Continued).**

3,234,679. GRUSSO, EKUN LOGAN, BURBANK, CA. SN 78-576,441. PUB. 4-25-2006, FILED 2-28-2005.

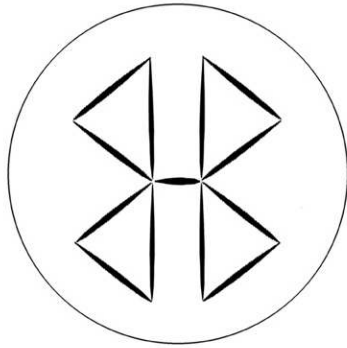

THE MARK CONSISTS OF STYLIZED LETTERS BHB. FOR PRE-RECORDED CD'S FEATURING MUSIC (U.S. CLS. 21, 23, 26, 36 AND 38). FIRST USE 1-1-2005; IN COMMERCE 10-1-2006.

3,234,680. DRANETZ TECHNOLOGIES, INC., DBA DRANETZ-BMI, EDISON, NJ. SN 78-576,574. PUB. 3-7-2006, FILED 2-28-2005.

**MEASURING PAD**

THE MARK CONSISTS OF STANDARD CHARACTERS WITHOUT CLAIM TO ANY PARTICULAR FONT, STYLE, SIZE, OR COLOR.

NO CLAIM IS MADE TO THE EXCLUSIVE RIGHT TO USE "MEASURING", APART FROM THE MARK AS SHOWN.

FOR PORTABLE ELECTRONIC RECORDER FOR MEASURING AND RECORDING MULTIPLE VOLTAGE, CURRENT AND THERMOCOUPLE READINGS FROM VARIOUS TRANSDUCERS (U.S. CLS. 21, 23, 26, 36 AND 38). FIRST USE 4-25-2005; IN COMMERCE 4-25-2005.

**CLASS 9—(Continued).**

3,234,684. E. I. DU PONT DE NEMOURS AND COMPANY, WILMINGTON, DE. SN 78-579,089. PUB. 3-28-2006, FILED 3-3-2005.

**DRYLOX**

THE MARK CONSISTS OF STANDARD CHARACTERS WITHOUT CLAIM TO ANY PARTICULAR FONT, STYLE, SIZE, OR COLOR.

FOR GETTER INTERGRATED FLAT GLASS, COVER GLASS AND GLASS LEDGES FOR USE IN THE MANUFACTURE OF LED DISPLAY SCREENS AND FOR USE AS COMPUTER DISPLAY SCREENS (U.S. CLS. 21, 23, 26, 36 AND 38). FIRST USE 8-9-2006; IN COMMERCE 8-9-2006.

3,234,696. ESI CASES & ACCESSORIES, BROOKLYN, NY. SN 78-582,784. PUB. 6-6-2006, FILED 3-8-2005.

**ITRAVELKIT**

THE MARK CONSISTS OF STANDARD CHARACTERS WITHOUT CLAIM TO ANY PARTICULAR FONT, STYLE, SIZE, OR COLOR.

FOR ACCESSORIES FOR MP3 PLAYERS, NAMELY RETRACTABLE EARPHONES, SPLITTER CABLE, REPLACEMENT COVERS FOR PLAYER AND CARRYING CASE SOLD AS A UNIT (U.S. CLS. 21, 23, 26, 36 AND 38). FIRST USE 2-28-2005; IN COMMERCE 2-28-2005.

**CLASS 9—(Continued).**

3,234,702. RALINK TECHNOLOGY CORPORATION, CUPERTINO, CA. SN 78-584,358. PUB. 11-29-2005, FILED 3-10-2005.

**Range-OVERDRIVE**

THE MARK CONSISTS OF STANDARD CHARACTERS WITHOUT CLAIM TO ANY PARTICULAR FONT, STYLE, SIZE, OR COLOR.

FOR COMPUTER CHIPS; COMPUTER HARDWARE; INTEGRATED CIRCUITS; AND COMPUTER SOFTWARE FOR CONTROLLING AND USING WIRELESS NETWORKING AND COMMUNICATION SYSTEMS, CHIPSETS AND MODULES (U.S. CLS. 21, 23, 26, 36 AND 38).

FIRST USE 9-20-2005; IN COMMERCE 9-20-2005.

3,234,730. HARVEY ENTERTAINMENT, INC., NEW YORK, NY. SN 78-596,176. PUB. 3-14-2006, FILED 3-28-2005.



OWNER OF U.S. REG. NOS. 722,258, 2,129,953, AND OTHERS.

FOR PRERECORDED VIDEO CASSETTES, PRERECORDED VIDEO TAPES, PRERECORDED DVDS, PRERECORDED CD-ROM FEATURING ANIMATED CARTOONS, AND INTERACTIVE MULTIMEDIA SOFTWARE PROGRAMS FOR ENTERTAINMENT NAMELY COMPUTER GAME SOFTWARE; PRERECORDED COMPACT DISCS, PRERECORDED AUDIO TAPES, PRERECORDED AUDIO CASSETTES, AND PHONOGRAPH RECORDS FEATURING MUSIC; COMPUTER SCREEN SAVER SOFTWARE AND WALLPAPER SOFTWARE FOR MOBILE TELEPHONES; HOME COMPUTERS; COMPUTER GAME PROGRAMS; VIDEO GAME CARTRIDGES (U.S. CLS. 21, 23, 26, 36 AND 38).

FIRST USE 8-16-2005; IN COMMERCE 8-16-2005.

**CLASS 9—(Continued).**

3,234,741. DATAVIZ, INC., MILFORD, CT. SN 78-598,022. PUB. 3-28-2006, FILED 3-30-2005.



THE COLOR(S) YELLOW AND BLACK IS/ARE CLAIMED AS A FEATURE OF THE MARK.

THE MARK CONSISTS OF DESIGN OF A YELLOW ROAD SIGN WITH BLACK ARROWS AND BLACK BORDER.

FOR COMPUTER SOFTWARE FOR TRANSFER AND EXCHANGE OF ELECTRONIC MESSAGES AND OTHER DATA BETWEEN STATIONARY COMPUTERS AND/OR SERVERS AND PORTABLE, WIRELESS COMPUTERS AND TELEPHONES (U.S. CLS. 21, 23, 26, 36 AND 38).

FIRST USE 11-1-2004; IN COMMERCE 11-19-2004.

3,234,759. PAN OCEANIC EYEWEAR, LTD., NEW YORK, NY. SN 78-604,668. PUB. 2-28-2006, FILED 4-8-2005.

**PANO NEW YORK**

THE MARK CONSISTS OF STANDARD CHARACTERS WITHOUT CLAIM TO ANY PARTICULAR FONT, STYLE, SIZE, OR COLOR.

NO CLAIM IS MADE TO THE EXCLUSIVE RIGHT TO USE "NEW YORK", APART FROM THE MARK AS SHOWN.

FOR EYEGLASSES, SUNGLASSES, EYEWEAR, NAMELY, SPORTS EYEWEAR, GOGGLES, NAMELY SWIM GOGGLES AND SNOW GOGGLES, PROTECTIVE GOGGLES, EYEWEAR ACCESSORIES, NAMELY, EYEGLASS AND SUNGLASS CASES, STRINGS, CHAINS AND CORDS (U.S. CLS. 21, 23, 26, 36 AND 38).

FIRST USE 12-20-2005; IN COMMERCE 12-20-2005.

**CLASS 9—(Continued).**

3,234,769. CINCH CONNECTORS, INC., LOMBARD, IL. SN 78-608,569. PUB. 2-14-2006, FILED 4-14-2005.

# MODICE

THE MARK CONSISTS OF STANDARD CHARACTERS WITHOUT CLAIM TO ANY PARTICULAR FONT, STYLE, SIZE, OR COLOR.

FOR ELECTRICAL ENCLOSURES, NAMELY, HOUSINGS FOR ELECTRONIC CIRCUITRY (U.S. CLS. 21, 23, 26, 36 AND 38).

FIRST USE 10-28-2004; IN COMMERCE 10-28-2004.

3,234,771. INNOVA CABLE TRAY, INC., PEMBROKE PINES, FL. SN 78-609,706. PUB. 1-10-2006, FILED 4-15-2005.



FOR ELECTRICAL PARTS, NAMELY, CABLE TRAYS (U.S. CLS. 21, 23, 26, 36 AND 38).

FIRST USE 7-22-2005; IN COMMERCE 7-22-2005.

3,234,785. MARAJ, BAL, FULLERTON, CA. SN 78-615,411. PUB. 5-9-2006, FILED 4-23-2005.

# PROOF @ WORK

THE MARK CONSISTS OF STANDARD CHARACTERS WITHOUT CLAIM TO ANY PARTICULAR FONT, STYLE, SIZE, OR COLOR.

FOR COMPUTERS, NAMELY, WIRELESS/WIRED TABLET COMPUTERS, PERSONAL DIGITAL ASSISTANTS, LAPTOPS, DESKTOPS, CELLULAR PHONES, RADIO PAGERS; PRERECORDED DIGITAL VIDEO FEATURING TRAINING AND INSTRUCTION IN THE FIELD OF SALES AND DISTRIBUTION; POINT OF SALE INTERACTIVE COMPUTER KIOSKS AND PORTABLE COMPUTER DEVICES, NAMELY LAPTOPS, HANDHELD AND POCKET COMPUTERS, FACSIMILE TRANSMITTERS AND RECEIVERS, WIRELESS FAX MACHINES, PEN TABLETS AND COMPUTERIZED CELLULAR PHONES; COMPUTER SOFTWARE FOR CONNECTING MOBILE, WIRED AND WIRELESS COMPUTER NETWORK USERS, GLOBAL COMMUNICATION NETWORKS, INTRANET AND INTERNET ACCESS AND PORTAL COMMUNICATION SOFTWARE, WEB SERVICES SOFTWARE, NAMELY, SOFTWARE FOR USE IN PROVIDING SECURE AND ENCRYPTED ONLINE PURCHASES; DOWNLOADABLE BROWSER BASED SOFTWARE FOR USE IN PROVIDING SECURE AND ENCRYPTED ONLINE PURCHASES; DOWNLOADABLE

**CLASS 9—(Continued).**

ONLINE TRAINING SOFTWARE FOR USE IN THE FIELD OF SALES AND DISTRIBUTION; TELEPHONY SOFTWARE THAT ALLOWS FOR DATA EXCHANGE, RETRIEVAL, DOWNLOAD AND UPDATES; COMPUTER SOFTWARE FOR CUSTOMER RELATION MANAGEMENT, MARKETING, SALES, CONTACT MANAGEMENT, CUSTOMER SERVICES, CALL CENTERS, HELPDESK, HUMAN RESOURCES AND PAYROLL, INVENTORY MANAGEMENT, ORDER FULFILLMENT, POINT OF SALE TRANSACTIONS, RADIO FREQUENCY IDENTIFICATION, QUALITY CONTROL, BUSINESS INTELLIGENCE, SCHEDULING, DISPATCHING, MERCHANDISING AND WORK FLOW OPTIMIZATION, TRACK FIELD SERVICES ACTIVITIES, PROVIDES SERVICE DOCUMENTATION AND BILLING AND DELIVERY OF GOODS; COMPUTER SOFTWARE FOR USE IN THE FIELDS OF FINANCE AND MANUFACTURING FOR PURCHASE ORDERS, PROCUREMENT, RECEIVER, ACCOUNTS PAYABLE, ACCOUNTS RECEIVABLE, FIXED ASSETS, AND GENERAL LEDGERS; JOB SCHEDULING, MATERIAL REQUIREMENT PLANNING, BILL OF MATERIAL, JOB COSTING, WAREHOUSE MANAGEMENT SYSTEM, LOGISTICS, DATA WAREHOUSING AND FORECASTING; COMPUTER SEARCH ENGINE SOFTWARE FOR OBTAINING DATA ON A GLOBAL COMPUTER NETWORK; INTERACTIVE MULTIMEDIA COMPUTER PROGRAM FOR USE IN THE FIELD OF ANALYSIS, MANAGEMENT, MONITORING, MODELING, MARKETING AND PROMOTION, ENABLING PEER TO PEER COMMUNICATIONS AND THE PREPARATION AND PRESENTATION OF DATA IN TEXT AND GRAPHICS FORMAT (U.S. CLS. 21, 23, 26, 36 AND 38).

FIRST USE 8-21-2006; IN COMMERCE 8-21-2006.

3,234,790. INTELENT SOFTWARE, INC., SALT LAKE CITY, UT. SN 78-617,452. PUB. 7-18-2006, FILED 4-26-2005.



NO CLAIM IS MADE TO THE EXCLUSIVE RIGHT TO USE "TODDLER TRACKER", APART FROM THE MARK AS SHOWN.

FOR ELECTRONIC COMMUNICATIONS INSTRUMENTS AND COMPONENTS, NAMELY ELECTRONIC TRANSMITTERS, RECEIVERS, AND TRANSCEIVERS (U.S. CLS. 21, 23, 26, 36 AND 38).

FIRST USE 3-13-2006; IN COMMERCE 3-13-2006.

3,234,794. THE UNLIMITED "INC." WELL, LLC, RENO, NV. SN 78-619,532. PUB. 2-21-2006, FILED 4-28-2005.

# LLC'S: IT'S TIME TO GET ORGANIZED!

THE MARK CONSISTS OF STANDARD CHARACTERS WITHOUT CLAIM TO ANY PARTICULAR FONT, STYLE, SIZE, OR COLOR.

FOR SERIES OF PRE-RECORDED DVDS ABOUT THE FORMATION OF LIMITED LIABILITY COMPANIES AND RELATED ISSUES (U.S. CLS. 21, 23, 26, 36 AND 38).

FIRST USE 9-10-2006; IN COMMERCE 9-10-2006.



**CLASS 9—(Continued).**

3,234,799. SINGER, MICHAEL G., HARRISVILLE, MI. SN 78-620,609. PUB. 1-24-2006, FILED 5-2-2005.

## PrognostiCheck

THE MARK CONSISTS OF STANDARD CHARACTERS WITHOUT CLAIM TO ANY PARTICULAR FONT, STYLE, SIZE, OR COLOR.

FOR COMPUTER SOFTWARE FOR MEDICAL CARE PURPOSES, NAMELY, SOFTWARE FOR ARCHIVING, COMPARING AND GRADING THE SUBJECT'S MEASURED PHASE ANGLE AS AN ELECTROPHYSIOLOGICAL DIAGNOSTIC TOOL FOR PREDICTING SURVIVAL (U.S. CLS. 21, 23, 26, 36 AND 38).  
FIRST USE 5-31-2003; IN COMMERCE 4-30-2005.

---

3,234,800. SCANBUY, INC., NEW YORK, NY. SN 78-620,632. PUB. 5-23-2006, FILED 5-2-2005.

## ScanLIFE

THE MARK CONSISTS OF STANDARD CHARACTERS WITHOUT CLAIM TO ANY PARTICULAR FONT, STYLE, SIZE, OR COLOR.

FOR SOFTWARE WHICH IS USED TO MANAGE AND DISTRIBUTE INFORMATION AND CONTENT FROM VENDORS AND CONTENT PROVIDERS TO USERS OF MOBILE WIRELESS DEVICES (U.S. CLS. 21, 23, 26, 36 AND 38).

FIRST USE 5-5-2005; IN COMMERCE 5-5-2005.

---

3,234,802. AMMO BOX AMPLIFIERS LLC, NEW HAVEN, CT. SN 78-621,993. PUB. 4-18-2006, FILED 5-3-2005.

## Ammo Box Amps

THE MARK CONSISTS OF STANDARD CHARACTERS WITHOUT CLAIM TO ANY PARTICULAR FONT, STYLE, SIZE, OR COLOR.

NO CLAIM IS MADE TO THE EXCLUSIVE RIGHT TO USE "AMPS", APART FROM THE MARK AS SHOWN.

FOR AMPLIFIERS FOR THE AMPLIFICATION AND PROCESSING OF SOUND OF MUSICAL INSTRUMENTS FOR USE IN MUSICAL PERFORMANCES (U.S. CLS. 21, 23, 26, 36 AND 38).

FIRST USE 7-10-2006; IN COMMERCE 7-10-2006.

**CLASS 9—(Continued).**

3,234,809. PROGRESS SOFTWARE CORPORATION, BEDFORD, MA. SN 78-624,042. PUB. 2-21-2006, FILED 5-5-2005.

## PROGRESS DATAXTEND

THE MARK CONSISTS OF STANDARD CHARACTERS WITHOUT CLAIM TO ANY PARTICULAR FONT, STYLE, SIZE, OR COLOR.

OWNER OF U.S. REG. NOS. 1,382,068, 2,788,727, AND OTHERS.

FOR COMPUTER SOFTWARE IN THE FIELD OF INFORMATION TECHNOLOGY FOR USE IN THE DEVELOPMENT, DEPLOYMENT, INTEGRATION, AND MANAGEMENT OF BUSINESS APPLICATIONS OVER LOCAL AREA, WIDE AREA, AND GLOBAL COMPUTER NETWORKS AND MANUALS SOLD TOGETHER THEREWITH (U.S. CLS. 21, 23, 26, 36 AND 38).  
FIRST USE 10-17-2005; IN COMMERCE 10-17-2005.

---

3,234,818. TONY TIME PRODUCTS, LLC, AURORA, CO. SN 78-626,009. PUB. 2-14-2006, FILED 5-9-2005.

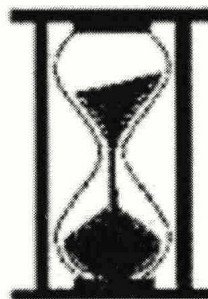

THE MARK CONSISTS OF A STYLIZED HOURGLASS DESIGN.

FOR DECORATIVE MAGNETS (U.S. CLS. 21, 23, 26, 36 AND 38).

FIRST USE 2-1-2005; IN COMMERCE 2-1-2005.

**CLASS 9—(Continued).**

3,234,819. ADRENALIN GAMING, LLC., LADERA RANCH, CA. SN 78-626,131. PUB. 2-21-2006, FILED 5-9-2005.

**CASHLAND**

THE MARK CONSISTS OF STANDARD CHARACTERS WITHOUT CLAIM TO ANY PARTICULAR FONT, STYLE, SIZE, OR COLOR.

FOR GAMING EQUIPMENT, NAMELY, SLOT MACHINES WITH OR WITHOUT VIDEO OUTPUT AND COMPUTERIZED VIDEO TABLE GAMES FOR GAMING PURPOSES (U.S. CLS. 21, 23, 26, 36 AND 38).

FIRST USE 10-28-2005; IN COMMERCE 10-28-2005.

---

3,234,832. SYNDERA CORPORATION, REDWOOD CITY, CA. SN 78-630,470. PUB. 2-7-2006, FILED 5-16-2005.

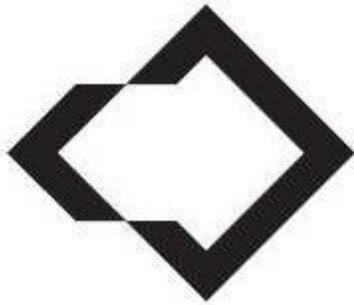

FOR BUSINESS INTELLIGENCE SOFTWARE, NAMELY, SOFTWARE THAT COLLECTS, PROCESSES, AND DELIVERS BUSINESS EVENT DATA TO END-USERS AND OTHER APPLICATIONS (U.S. CLS. 21, 23, 26, 36 AND 38).

FIRST USE 5-10-2005; IN COMMERCE 5-10-2005.

---

3,234,843. SENSIS CORPORATION, EAST SYRACUSE, NY. SN 78-632,418. PUB. 1-31-2006, FILED 5-18-2005.

**TAXIVIEW**

THE MARK CONSISTS OF STANDARD CHARACTERS WITHOUT CLAIM TO ANY PARTICULAR FONT, STYLE, SIZE, OR COLOR.

FOR COMPUTER SOFTWARE FOR USE IN VISUALIZING LIVE AND HISTORICAL MOVEMENT AND OPERATIONS OF AIRCRAFT AND VEHICLE TRAFFIC, ON AND AROUND AN AIRPORT SURFACE (U.S. CLS. 21, 23, 26, 36 AND 38).

FIRST USE 1-6-2006; IN COMMERCE 1-6-2006.

**CLASS 9—(Continued).**

3,234,848. ALLENDALE LLC, TAMPA, FL. SN 78-633,748. PUB. 4-4-2006, FILED 5-20-2005.

**BLUESKY MAST**

THE MARK CONSISTS OF STANDARD CHARACTERS WITHOUT CLAIM TO ANY PARTICULAR FONT, STYLE, SIZE, OR COLOR.

NO CLAIM IS MADE TO THE EXCLUSIVE RIGHT TO USE "MAST", APART FROM THE MARK AS SHOWN.

FOR COMBINATION STAND AND MAST FOR SUPPORTING A CAMERA, MOTION DETECTOR, SENSOR, AND/OR ANTENNA IN AN ELEVATED POSITION (U.S. CLS. 21, 23, 26, 36 AND 38).

FIRST USE 8-20-2003; IN COMMERCE 8-27-2003.

---

3,234,859. WMS GAMING INC., WAUKEGAN, IL. SN 78-635,342. PUB. 2-14-2006, FILED 5-23-2005.

**STAR OF INDIA**

THE MARK CONSISTS OF STANDARD CHARACTERS WITHOUT CLAIM TO ANY PARTICULAR FONT, STYLE, SIZE, OR COLOR.

FOR GAMING MACHINES (U.S. CLS. 21, 23, 26, 36 AND 38).

FIRST USE 9-12-2005; IN COMMERCE 9-12-2005.

---

3,234,863. OPTICHRON, INC., FREMONT, CA. SN 78-636,522. PUB. 2-21-2006, FILED 5-24-2005.

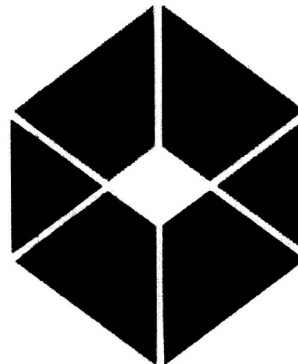

FOR INTEGRATED CIRCUITS (U.S. CLS. 21, 23, 26, 36 AND 38).

FIRST USE 3-29-2005; IN COMMERCE 3-29-2005.

**CLASS 9—(Continued).**

3,234,866. PERFORMANCE MOTION DEVICES, INC., LINCOLN, MA. SN 78-637,096. PUB. 3-21-2006, FILED 5-25-2005.

**CLASS 9—(Continued).**

3,234,886. JEDA TECHNOLOGIES, INC., MOUNTAIN VIEW, CA. SN 78-641,695. PUB. 2-21-2006, FILED 6-1-2005.

**ION**

THE MARK CONSISTS OF STANDARD CHARACTERS WITHOUT CLAIM TO ANY PARTICULAR FONT, STYLE, SIZE, OR COLOR.

FOR COMPUTER HARDWARE, NAMELY, MOTOR DRIVES, AMPLIFIERS AND CONTROLS FOR USE IN THE MOTION CONTROL INDUSTRY (U.S. CLS. 21, 23, 26, 36 AND 38).

FIRST USE 5-0-2005; IN COMMERCE 1-27-2006.

**NSCA**

THE MARK CONSISTS OF STANDARD CHARACTERS WITHOUT CLAIM TO ANY PARTICULAR FONT, STYLE, SIZE, OR COLOR.

FOR DOWNLOADABLE COMPUTER SOFTWARE FOR USE IN THE PERFORMING QUALITY CONTROL CHECKS IN THE DESIGN OF SEMICONDUCTORS AND/OR ELECTRONIC SYSTEMS (U.S. CLS. 21, 23, 26, 36 AND 38).

FIRST USE 9-15-2006; IN COMMERCE 9-15-2006.

3,234,867. PERFORMANCE MOTION DEVICES, INC., LINCOLN, MA. SN 78-637,098. PUB. 2-21-2006, FILED 5-25-2005.

**VB-MOTION**

THE MARK CONSISTS OF STANDARD CHARACTERS WITHOUT CLAIM TO ANY PARTICULAR FONT, STYLE, SIZE, OR COLOR.

FOR COMPUTER SOFTWARE, NAMELY, AN APPLICATION PROGRAM INTERFACE FOR DEVELOPING APPLICATIONS IN THE FIELD OF INTEGRATED CIRCUIT-BASED MOTION CONTROL (U.S. CLS. 21, 23, 26, 36 AND 38).

FIRST USE 5-0-2005; IN COMMERCE 5-0-2005.

3,234,887. HOANG, THANG V., FOUNTAIN VALLEY, CA. SN 78-641,773. PUB. 2-28-2006, FILED 6-2-2005.

**bTOUCH**

3,234,884. YAHOO! INC., SUNNYVALE, CA. SN 78-641,363. PUB. 2-28-2006, FILED 6-1-2005.

**DEL.ICIO.US**

THE MARK CONSISTS OF STANDARD CHARACTERS WITHOUT CLAIM TO ANY PARTICULAR FONT, STYLE, SIZE, OR COLOR.

FOR COMPUTER SOFTWARE FOR ENABLING INTERNET USERS TO CREATE AND PUBLICLY SHARE DATA (U.S. CLS. 21, 23, 26, 36 AND 38).

FIRST USE 9-30-2003; IN COMMERCE 9-30-2003.

THE MARK CONSISTS OF STANDARD CHARACTERS WITHOUT CLAIM TO ANY PARTICULAR FONT, STYLE, SIZE, OR COLOR.

FOR COMPUTER SOFTWARE TO FUNCTION AS CASH REGISTER AND TRACK INVENTORY IN THE FIELD OF POINT OF SALE SERVICE (U.S. CLS. 21, 23, 26, 36 AND 38).

FIRST USE 1-1-2006; IN COMMERCE 1-1-2006.

**CLASS 9—(Continued).**

3,234,892. CREATIVE MICROSYSTEMS, INC., ENGLEWOOD, OH. SN 78-643,122. PUB. 2-14-2006, FILED 6-3-2005.



FOR SOFTWARE FOR USE BY MUNICIPAL AND LOCAL GOVERNMENT AUTHORITIES IN THE FIELDS OF FINANCIAL MANAGEMENT, ACCOUNTING, HUMAN RESOURCES PROCESSING, PAYROLL PROCESSING, INCOME TAXES, FIXED ASSETS TRACKING AND REPORTING, UTILITY BILLING, CITY AND MUNICIPAL SERVICES BILLING, PUBLIC RECORDS MANAGEMENT, COMPUTER AIDED DISPATCH, MOBILE DATA COMPUTING, MAPPING, FRAUD DETECTION, POLICE AND FIRE OPERATIONS, POLICE AND TRAFFIC RECORDS, PARKING ADMINISTRATION, DOCUMENT MANAGEMENT, COURT OPERATIONS, COURT CASE DOCKETING AND CASE MANAGEMENT, FLEET MANAGEMENT, LIBRARY MANAGEMENT, ENVIRONMENTAL HEALTH, AND BENEFITS MANAGEMENT (U.S. CLS. 21, 23, 26, 36 AND 38).  
FIRST USE 7-27-2005; IN COMMERCE 7-27-2005.

3,234,895. DIGITAL INNOVATIONS, LLC, ARLINGTON HEIGHTS, IL. SN 78-644,120. PUB. 2-21-2006, FILED 6-6-2005.

**SECURITYDR ISPOT**

THE MARK CONSISTS OF STANDARD CHARACTERS WITHOUT CLAIM TO ANY PARTICULAR FONT, STYLE, SIZE, OR COLOR.

FOR ELECTRONIC EQUIPMENT, NAMELY, APPARATUS FOR LOCATING OBJECTS, NAMELY, A WIRELESS RADIO TRANSMITTER AND A PLURALITY OF WIRELESS AUDIO RECEIVERS ATTACHED TO OBJECTS IN THE NATURE OF SMALL SIZED PERSONAL ARTICLES, SUCH AS KEYS, EYEGLASSES, PURSES, WALLETTS AND REMOTE CONTROLS (U.S. CLS. 21, 23, 26, 36 AND 38).

FIRST USE 8-0-2005; IN COMMERCE 8-0-2005.

3,234,906. APPALACHIAN STATE UNIVERSITY, BOONE, NC. SN 78-646,884. PUB. 2-28-2006, FILED 6-9-2005.

**SPLIT RAIL RECORDS**

THE MARK CONSISTS OF STANDARD CHARACTERS WITHOUT CLAIM TO ANY PARTICULAR FONT, STYLE,

**CLASS 9—(Continued).**

SIZE, OR COLOR.

NO CLAIM IS MADE TO THE EXCLUSIVE RIGHT TO USE "RECORDS", APART FROM THE MARK AS SHOWN. FOR PRERECORDED AUDIO CASSETTE TAPES AND CD'S FEATURING MUSIC (U.S. CLS. 21, 23, 26, 36 AND 38).

FIRST USE 11-20-2006; IN COMMERCE 11-20-2006.

3,234,910. THE READER'S DIGEST ASSOCIATION, INC., PLEASANTVILLE, NY. SN 78-647,234. PUB. 3-7-2006, FILED 6-9-2005.

**READER'S DIGEST FAITH**

THE MARK CONSISTS OF STANDARD CHARACTERS WITHOUT CLAIM TO ANY PARTICULAR FONT, STYLE, SIZE, OR COLOR.

OWNER OF U.S. REG. NOS. 2,151,348, 2,929,038, AND OTHERS.

FOR AUDIO RECORDINGS FEATURING CHRISTIAN BASED MUSIC (U.S. CLS. 21, 23, 26, 36 AND 38).

FIRST USE 1-31-2006; IN COMMERCE 1-31-2006.

3,234,915. COOPER TECHNOLOGIES COMPANY, HOUSTON, TX. SN 78-648,250. PUB. 2-21-2006, FILED 6-10-2005.

**AIR-TITE**

THE MARK CONSISTS OF STANDARD CHARACTERS WITHOUT CLAIM TO ANY PARTICULAR FONT, STYLE, SIZE, OR COLOR.

FOR ELECTRIC LIGHTING FIXTURE PARTS, FITTINGS AND COMPONENTS, NAMELY, LIGHTING FIXTURE TRIM AND HOUSING ASSEMBLIES (U.S. CLS. 21, 23, 26, 36 AND 38).

FIRST USE 5-1-1996; IN COMMERCE 5-1-1996.

**CLASS 9—(Continued).**

3,234,928. PLANTRONICS, INC., SANTA CRUZ, CA. SN 78-650,593. PUB. 7-11-2006, FILED 6-14-2005.

**PLANTRONICS EXPLORER**

THE MARK CONSISTS OF STANDARD CHARACTERS WITHOUT CLAIM TO ANY PARTICULAR FONT, STYLE, SIZE, OR COLOR.

OWNER OF U.S. REG. NOS. 1,020,399, 1,278,897, AND 2,037,148.

FOR WIRELESS HEADSETS; AND ACCESSORIES, NAMELY ADAPTERS FOR WIRELESS COMMUNICATIONS, CABLES AND EAR CUSHIONS, ALL FOR USE WITH WITH MOBILE PHONES, TELEPHONES, PERSONAL DIGITAL ASSISTANTS, AND COMPUTERS (U.S. CLS. 21, 23, 26, 36 AND 38).

FIRST USE 7-24-2005; IN COMMERCE 7-24-2005.



3,234,943. MIDWAY AMUSEMENT GAMES, LLC, CHICAGO, IL. SN 78-652,201. PUB. 2-28-2006, FILED 6-16-2005.

**RAMPAGE: TOTAL DESTRUCTION**

THE MARK CONSISTS OF STANDARD CHARACTERS WITHOUT CLAIM TO ANY PARTICULAR FONT, STYLE, SIZE, OR COLOR.

OWNER OF U.S. REG. NOS. 2,579,771, 2,683,900, AND 2,825,347.

FOR COMPUTER AND VIDEO GAME PROGRAMS RECORDED ON CARTRIDGES, DISCS, CD-ROMS, CASSETTES, TAPES, AND MINI DISCS; VIDEO AND COMPUTER GAME SOFTWARE (U.S. CLS. 21, 23, 26, 36 AND 38).

FIRST USE 4-24-2006; IN COMMERCE 4-24-2006.



3,234,976. MCCARTHY, JAMES, R., TUCSON, AZ. SN 78-655,655. PUB. 3-14-2006, FILED 6-22-2005.

**OCUBAR**

THE MARK CONSISTS OF STANDARD CHARACTERS WITHOUT CLAIM TO ANY PARTICULAR FONT, STYLE, SIZE, OR COLOR.

FOR EYEGLASS FRAMES FOR AUTOMOBILE NIGHT DRIVING, WITH LOUVERS THAT DECREASE GLARE (U.S. CLS. 21, 23, 26, 36 AND 38).

FIRST USE 12-5-2006; IN COMMERCE 12-5-2006.

**CLASS 9—(Continued).**

3,234,984. ROCKET GAMING SYSTEMS, LLC, LAS VEGAS, NV. SN 78-657,435. PUB. 3-7-2006, FILED 6-23-2005.

**FORBIDDEN TREASURES**

THE MARK CONSISTS OF STANDARD CHARACTERS WITHOUT CLAIM TO ANY PARTICULAR FONT, STYLE, SIZE, OR COLOR.

FOR GAMING MACHINES, NAMELY, BINGO-RELATED GAMES AND SLOT MACHINES (U.S. CLS. 21, 23, 26, 36 AND 38).

FIRST USE 2-28-2006; IN COMMERCE 2-28-2006.



3,234,985. ROCKET GAMING SYSTEMS, LLC, LAS VEGAS, NV. SN 78-657,436. PUB. 3-7-2006, FILED 6-23-2005.

**LUCKY LOOT**

THE MARK CONSISTS OF STANDARD CHARACTERS WITHOUT CLAIM TO ANY PARTICULAR FONT, STYLE, SIZE, OR COLOR.

FOR GAMING MACHINES, NAMELY, BINGO-RELATED GAMES AND SLOT MACHINES (U.S. CLS. 21, 23, 26, 36 AND 38).

FIRST USE 5-25-2006; IN COMMERCE 5-25-2006.



3,234,986. ROCKET GAMING SYSTEMS, LLC, LAS VEGAS, NV. SN 78-657,437. PUB. 3-7-2006, FILED 6-23-2005.

**BOOTLEGGGER**

THE MARK CONSISTS OF STANDARD CHARACTERS WITHOUT CLAIM TO ANY PARTICULAR FONT, STYLE, SIZE, OR COLOR.

FOR GAMING MACHINES, NAMELY, BINGO-RELATED GAMES AND SLOT MACHINES (U.S. CLS. 21, 23, 26, 36 AND 38).

FIRST USE 5-25-2006; IN COMMERCE 5-25-2006.

**CLASS 9—(Continued).**

3,235,000. INTERWOVEN, INC., SUNNYVALE, CA. SN 78-659,213. PUB. 3-14-2006, FILED 6-27-2005.

**CONTROLHUB**

THE MARK CONSISTS OF STANDARD CHARACTERS WITHOUT CLAIM TO ANY PARTICULAR FONT, STYLE, SIZE, OR COLOR.

FOR COMPUTER PROGRAM USED BY SOFTWARE DEVELOPERS TO TRACK STATUS IN THE DEVELOPMENT OF COMPUTER APPLICATIONS (U.S. CLS. 21, 23, 26, 36 AND 38).

FIRST USE 3-31-2004; IN COMMERCE 3-31-2004.

**CLASS 9—(Continued).**

3,235,015. PULSAFEEDER, INC., ROCHESTER, NY. SN 78-661,145. PUB. 3-14-2006, FILED 6-29-2005.

**MICROTRAC**

THE MARK CONSISTS OF STANDARD CHARACTERS WITHOUT CLAIM TO ANY PARTICULAR FONT, STYLE, SIZE, OR COLOR.

FOR CONDUCTIVITY CONTROLLER FOR MONITORING AND ADJUSTING CONDUCTIVITY IN FLUIDS (U.S. CLS. 21, 23, 26, 36 AND 38).

FIRST USE 7-30-2005; IN COMMERCE 7-30-2005.

3,235,004. CRESTRON ELECTRONICS, INC., ROCKLEIGH, NJ. SN 78-659,700. PUB. 3-21-2006, FILED 6-28-2005.

**ADAGIO**

THE MARK CONSISTS OF STANDARD CHARACTERS WITHOUT CLAIM TO ANY PARTICULAR FONT, STYLE, SIZE, OR COLOR.

THE ENGLISH TRANSLATION OF "ADAGIO" IS "SLOWLY".

FOR MEDIA SERVERS, NAMELY, COMMUNICATIONS SERVERS, CONTROL DATA AND SIGNAL PROCESSORS, AUDIO DISTRIBUTION DATA AND SIGNAL PROCESSORS, AMPLIFIERS, SURROUND SOUND DECODERS, AND TOUCH PANELS (U.S. CLS. 21, 23, 26, 36 AND 38).

FIRST USE 9-0-2005; IN COMMERCE 9-0-2005.

3,235,013. THE GILLETTE COMPANY, BOSTON, MA. SN 78-660,817. PUB. 3-28-2006, FILED 6-29-2005.

**POWERPIX**

THE MARK CONSISTS OF STANDARD CHARACTERS WITHOUT CLAIM TO ANY PARTICULAR FONT, STYLE, SIZE, OR COLOR.

FOR BATTERIES AND BATTERY CHARGERS (U.S. CLS. 21, 23, 26, 36 AND 38).

FIRST USE 12-20-2005; IN COMMERCE 12-20-2005.

3,235,022. TUNGSTEN STRATEGIC LLC, FORT COLLINS, CO. SN 78-661,885. PUB. 3-14-2006, FILED 6-30-2005.

**BOOKSKINS**

THE MARK CONSISTS OF STANDARD CHARACTERS WITHOUT CLAIM TO ANY PARTICULAR FONT, STYLE, SIZE, OR COLOR.

FOR PROTECTIVE COVERS AND DECORATIVE COVERS FOR PORTABLE COMPUTERS (U.S. CLS. 21, 23, 26, 36 AND 38).

FIRST USE 8-1-2005; IN COMMERCE 8-1-2005.

3,235,058. CANBERRA INDUSTRIES, INC., MERIDEN, CT. SN 78-665,280. PUB. 4-11-2006, FILED 7-7-2005.

**Cryo-Pulse**

THE MARK CONSISTS OF STANDARD CHARACTERS WITHOUT CLAIM TO ANY PARTICULAR FONT, STYLE, SIZE, OR COLOR.

FOR ELECTRICALLY REFRIGERATED CRYOSTATS, NAMELY, ELECTRICALLY POWERED COOLERS FOR USE IN RADIATION DETECTORS (U.S. CLS. 21, 23, 26, 36 AND 38).

FIRST USE 1-19-2006; IN COMMERCE 8-2-2006.

**CLASS 9—(Continued).**

3,235,075. RESTEK CORPORATION, BELLEFONTE, PA. SN 78-669,096. PUB. 6-27-2006, FILED 7-13-2005.

# pHidelity

THE MARK CONSISTS OF STANDARD CHARACTERS WITHOUT CLAIM TO ANY PARTICULAR FONT, STYLE, SIZE, OR COLOR.

FOR HIGH PRESSURE LIQUID CHROMATOGRAPHY COLUMNS FOR CHEMICAL ANALYSIS (U.S. CLS. 21, 23, 26, 36 AND 38).

FIRST USE 6-15-2005; IN COMMERCE 6-15-2005.

---

3,235,085. COMPUTER SCIENCES CORPORATION, EL SEGUNDO, CA. SN 78-670,601. PUB. 5-23-2006, FILED 7-14-2005.

# WEALTH MANAGEMENT ACCELERATOR

THE MARK CONSISTS OF STANDARD CHARACTERS WITHOUT CLAIM TO ANY PARTICULAR FONT, STYLE, SIZE, OR COLOR.

NO CLAIM IS MADE TO THE EXCLUSIVE RIGHT TO USE "WEALTH MANAGEMENT", APART FROM THE MARK AS SHOWN.

FOR COMPUTER PROGRAM FOR USE BY INSURERS FOR ADMINISTRATION OF WEALTH MANAGEMENT INSURANCE AND ANNUITY PRODUCTS AND SERVICES (U.S. CLS. 21, 23, 26, 36 AND 38).

FIRST USE 10-1-2004; IN COMMERCE 10-1-2004.

---

3,235,097. ZMD AMERICA INC., MELVILLE, NY. SN 78-673,277. PUB. 6-13-2006, FILED 7-19-2005.

# RBic

THE MARK CONSISTS OF STANDARD CHARACTERS WITHOUT CLAIM TO ANY PARTICULAR FONT, STYLE, SIZE, OR COLOR.

FOR ELECTRONIC CIRCUITRY, NAMELY CIRCUITRY FOR PROVIDING AMPLIFICATION AND SENSOR-SPECIFIC CORRECTION OF A BRIDGE SENSOR SIGNAL AND FOR INTERFACING AN AMPLIFIED AND CORRECTED BRIDGE SENSOR SIGNAL TO EXTERNAL CIRCUITRY (U.S. CLS. 21, 23, 26, 36 AND 38).

FIRST USE 5-15-2003; IN COMMERCE 5-15-2003.

**CLASS 9—(Continued).**

3,235,098. ZMD AMERICA INC., MELVILLE, NY. SN 78-673,282. PUB. 6-13-2006, FILED 7-19-2005.

# TSic

THE MARK CONSISTS OF STANDARD CHARACTERS WITHOUT CLAIM TO ANY PARTICULAR FONT, STYLE, SIZE, OR COLOR.

FOR ELECTRONIC CIRCUITRY, NAMELY AN ELECTRIC OR ELECTRONIC TEMPERATURE SENSOR AND CIRCUITRY FOR PROVIDING A SCALED, SENSED TEMPERATURE OUTPUT SIGNAL AND INTERFACING THAT SIGNAL TO EXTERNAL CIRCUITRY (U.S. CLS. 21, 23, 26, 36 AND 38).

FIRST USE 1-29-2004; IN COMMERCE 1-29-2004.

---

3,235,107. MICROSOFT CORPORATION, REDMOND, WA. SN 78-676,707. PUB. 4-25-2006, FILED 7-22-2005.

# WINDOWS VISTA

THE MARK CONSISTS OF STANDARD CHARACTERS WITHOUT CLAIM TO ANY PARTICULAR FONT, STYLE, SIZE, OR COLOR.

PRIORITY CLAIMED UNDER SEC. 44(D) ON FED REP GERMANY APPLICATION NO. 30516986, FILED 3-22-2005, REG. NO. 30516986, DATED 4-20-2005, EXPIRES 3-31-2015.

OWNER OF U.S. REG. NOS. 1,872,264 AND 2,513,051.

FOR COMPUTER SOFTWARE, NAMELY, OPERATING SYSTEM PROGRAMS (U.S. CLS. 21, 23, 26, 36 AND 38).

FIRST USE 8-3-2005; IN COMMERCE 8-3-2005.

---

3,235,116. ROCKET GAMING SYSTEMS, LLC, LAS VEGAS, NV. SN 78-678,833. PUB. 4-18-2006, FILED 7-26-2005.

# BIRDS OF PARADISE

THE MARK CONSISTS OF STANDARD CHARACTERS WITHOUT CLAIM TO ANY PARTICULAR FONT, STYLE, SIZE, OR COLOR.

FOR GAMING MACHINES, NAMELY, BINGO-RELATED GAMES AND SLOT MACHINES (U.S. CLS. 21, 23, 26, 36 AND 38).

FIRST USE 9-14-2006; IN COMMERCE 9-14-2006.

**CLASS 9—(Continued).**

3,235,117. ROCKET GAMING SYSTEMS, LLC, LAS VEGAS, NV. SN 78-678,862. PUB. 4-18-2006, FILED 7-26-2005.

**GOLD DIGGIN' DIXIE**

THE MARK CONSISTS OF STANDARD CHARACTERS WITHOUT CLAIM TO ANY PARTICULAR FONT, STYLE, SIZE, OR COLOR.

FOR GAMING MACHINES, NAMELY, BINGO-RELATED GAMES AND SLOT MACHINES (U.S. CLS. 21, 23, 26, 36 AND 38).

FIRST USE 9-14-2006; IN COMMERCE 9-14-2006.

**CLASS 9—(Continued).**

3,235,128. PHARMACY DEVELOPMENT SERVICES, BOYNTON BEACH, FL. SN 78-682,479. PUB. 4-18-2006, FILED 8-1-2005.

**IF YOU WANT IT DONE RIGHT,  
YOU DON'T HAVE TO DO IT  
YOURSELF**

THE MARK CONSISTS OF STANDARD CHARACTERS WITHOUT CLAIM TO ANY PARTICULAR FONT, STYLE, SIZE, OR COLOR.

FOR EMPLOYEE MANAGEMENT SOFTWARE (U.S. CLS. 21, 23, 26, 36 AND 38).

FIRST USE 8-1-2005; IN COMMERCE 8-1-2005.

3,235,121. SONY KABUSHIKI KAISHA, TA SONY CORPORATION, TOKYO, JAPAN. SN 78-681,280. PUB. 4-25-2006, FILED 7-29-2005.

**FORTELION**

THE MARK CONSISTS OF STANDARD CHARACTERS WITHOUT CLAIM TO ANY PARTICULAR FONT, STYLE, SIZE, OR COLOR.

FOR LITHIUM-ION SECONDARY BATTERIES (U.S. CLS. 21, 23, 26, 36 AND 38).

FIRST USE 10-31-2006; IN COMMERCE 10-31-2006.

3,235,133. U.S. GRAPHIC ARTS, INC., TEMPE, AZ. SN 78-683,850. PUB. 6-6-2006, FILED 8-2-2005.

**T-JET**

THE MARK CONSISTS OF STANDARD CHARACTERS WITHOUT CLAIM TO ANY PARTICULAR FONT, STYLE, SIZE, OR COLOR.

FOR PRINTERS, NAMELY PRINTERS FOR PRINTING ON TEXTILES (U.S. CLS. 21, 23, 26, 36 AND 38).

FIRST USE 12-22-2004; IN COMMERCE 12-22-2004.

3,235,122. TONALSOFT, INC., RENO, NV. SN 78-681,533. PUB. 4-18-2006, FILED 7-29-2005.

**TONESCAPE**

THE MARK CONSISTS OF STANDARD CHARACTERS WITHOUT CLAIM TO ANY PARTICULAR FONT, STYLE, SIZE, OR COLOR.

FOR COMPUTER SOFTWARE FOR PROCESSING DIGITAL MUSIC; AND COMPUTER SOFTWARE IN THE FIELD OF MUSIC FOR CREATING MUSICAL COMPOSITIONS, STORING MUSICAL COMPOSITIONS, MANAGING MUSICAL COMPOSITIONS, PLAYING MUSICAL COMPOSITIONS, AND DISSEMINATING MUSICAL COMPOSITIONS (U.S. CLS. 21, 23, 26, 36 AND 38).

FIRST USE 11-2-2006; IN COMMERCE 11-2-2006.

3,235,135. CONNECTICUT COMPUTER & CONSULTING COMPANY, KENILWORTH, NJ. SN 78-685,112. PUB. 4-25-2006, FILED 8-3-2005.

**CLINTELLIGENCE**

THE MARK CONSISTS OF STANDARD CHARACTERS WITHOUT CLAIM TO ANY PARTICULAR FONT, STYLE, SIZE, OR COLOR.

FOR BUSINESS INTELLIGENCE COMPUTER SOFTWARE, NAMELY, DOWNLOADABLE PERFORMANCE MANAGEMENT SOFTWARE FOR USE BY PHARMACEUTICAL RESEARCH COMPANIES TO ASSIST WITH REPORTING AND DATA ANALYSIS OF THE DRUG DEVELOPMENT PROCESS (U.S. CLS. 21, 23, 26, 36 AND 38).

FIRST USE 10-1-2005; IN COMMERCE 10-1-2005.



**CLASS 9—(Continued).**

3,235,140. KAIDEA INNOVATION INC., BREA, CA. SN 78-687,173. PUB. 4-25-2006, FILED 8-6-2005.

**SECURED4SURE**

THE MARK CONSISTS OF STANDARD CHARACTERS WITHOUT CLAIM TO ANY PARTICULAR FONT, STYLE, SIZE, OR COLOR.

FOR COMPUTER MEMORY HARDWARE (U.S. CLS. 21, 23, 26, 36 AND 38).  
FIRST USE 12-4-2005; IN COMMERCE 5-1-2006.

**CLASS 9—(Continued).**

3,235,152. AGUILA RECORDS INC., WEST CHICAGO, IL. SN 78-691,421. PUB. 8-15-2006, FILED 8-12-2005.



NO CLAIM IS MADE TO THE EXCLUSIVE RIGHT TO USE "MUSICAL", APART FROM THE MARK AS SHOWN.

FOR SERIES OF SOUND RECORDING, NAMELY, A SERIES OF PRERECORDED COMPACT DISKS, AUDIO AND VIDEO DISKS AND CASSETTES, ALL FEATURING MUSICAL RECORDINGS (U.S. CLS. 21, 23, 26, 36 AND 38).

FIRST USE 5-0-2005; IN COMMERCE 5-0-2005.

3,235,153. ALPS AUTOMOTIVE, INC., AUBURN HILLS, MI. SN 78-691,560. PUB. 8-8-2006, FILED 8-12-2005.



FOR SOFTWARE THAT ENABLES HANDSFREE MOBILE DEVICE OPERATION AND TRANSFER AND SYNCHRONIZATION OF DATA, NAMELY, PERSONAL INFORMATION, TEXT MESSAGES, EMAIL MESSAGES, AND STREAMING AUDIO AND VIDEO BETWEEN MOBILE COMMUNICATION APPARATUS, NAMELY, HANDS-FREE PHONES, PDAS, RADIOS, PMPs, AND MP3 PLAYERS (U.S. CLS. 21, 23, 26, 36 AND 38).  
FIRST USE 8-31-2005; IN COMMERCE 8-31-2005.

3,235,141. KAIDEA INNOVATION INC., BREA, CA. SN 78-687,178. PUB. 4-18-2006, FILED 8-6-2005.



THE COLOR(S) BLACK AND METALLIC GRAY IS/ARE CLAIMED AS A FEATURE OF THE MARK.

THE MARK CONSISTS OF A BLACK RECTANGLE HAVING METALLIC GRAY BOLTS AT ALL FOUR CORNERS WITH THE WORDS "NAS VAULT" IN METALLIC GRAY HAVING A METALLIC GRAY SYMBOL FOR WATER BELOW AND A METALLIC GRAY SYMBOL FOR FIRE ABOVE SAID WORDS.

FOR COMPUTER MEMORY HARDWARE (U.S. CLS. 21, 23, 26, 36 AND 38).  
FIRST USE 12-4-2005; IN COMMERCE 5-1-2006.

3,235,163. TRUE VALUE COMPANY, CHICAGO, IL. SN 78-694,777. PUB. 5-23-2006, FILED 8-17-2005.

**COLOR INSPIRATIONS MADE SIMPLE**

THE MARK CONSISTS OF STANDARD CHARACTERS WITHOUT CLAIM TO ANY PARTICULAR FONT, STYLE, SIZE, OR COLOR.

FOR COMPUTER SOFTWARE FOR USE IN THE CUSTOM COLOR MATCHING OF PAINTS, PRIMERS, STAINS AND COATINGS (U.S. CLS. 21, 23, 26, 36 AND 38).

FIRST USE 3-0-2005; IN COMMERCE 3-0-2005.

**CLASS 9—(Continued).**

3,235,173. LEARNING RESOURCES, INC., VERNON HILLS, IL. SN 78-697,229. PUB. 6-20-2006, FILED 8-22-2005.

**ABC CHALK TALK!**

THE MARK CONSISTS OF STANDARD CHARACTERS WITHOUT CLAIM TO ANY PARTICULAR FONT, STYLE, SIZE, OR COLOR.

FOR ELECTRONIC TEACHING SYSTEM COMPRISED OF AN ELECTRONIC ACTIVITY MAT AND REMOVABLE CHALKBOARD FOR TEACHING LANGUAGE, SHAPES, NUMBERS AND COLORS (U.S. CLS. 21, 23, 26, 36 AND 38).

FIRST USE 1-30-2006; IN COMMERCE 1-30-2006.

**CLASS 9—(Continued).**

3,235,223. DILLARD'S INC., LITTLE ROCK, AR. SN 78-721,154. PUB. 7-4-2006, FILED 9-27-2005.

**MURANO**

THE MARK CONSISTS OF STANDARD CHARACTERS WITHOUT CLAIM TO ANY PARTICULAR FONT, STYLE, SIZE, OR COLOR.

OWNER OF U.S. REG. NOS. 2,272,499, 2,297,049, AND 2,826,047.

FOR SUNGLASSES (U.S. CLS. 21, 23, 26, 36 AND 38).  
FIRST USE 3-30-2006; IN COMMERCE 3-30-2006.

3,235,208. ADRENALIN GAMING LLC, LADERA RANCH, CA. SN 78-713,042. PUB. 5-23-2006, FILED 9-14-2005.

**CLUMSY KLUTZ**

THE MARK CONSISTS OF STANDARD CHARACTERS WITHOUT CLAIM TO ANY PARTICULAR FONT, STYLE, SIZE, OR COLOR.

FOR GAMING MACHINES, NAMELY, VIDEO AND SLOT MACHINES AND COMPUTERIZED VIDEO TABLE GAMES FOR GAMING PURPOSES (U.S. CLS. 21, 23, 26, 36 AND 38).

FIRST USE 10-1-2006; IN COMMERCE 10-1-2006.

3,235,240. CADILLAC JACK, INC., DULUTH, GA. SN 78-726,805. PUB. 6-6-2006, FILED 10-5-2005.

**REEL DIAMONDS**

THE MARK CONSISTS OF STANDARD CHARACTERS WITHOUT CLAIM TO ANY PARTICULAR FONT, STYLE, SIZE, OR COLOR.

FOR GAMING EQUIPMENT, NAMELY, SLOT MACHINES WITH OR WITHOUT VIDEO OUTPUT (U.S. CLS. 21, 23, 26, 36 AND 38).

FIRST USE 12-1-2006; IN COMMERCE 12-1-2006.

3,235,214. GRACE ENGINEERED PRODUCTS, INC. CORP., DAVENPORT, IA. SN 78-716,904. PUB. 5-30-2006, FILED 9-20-2005.

**INSIDE-OUTLET**

THE MARK CONSISTS OF STANDARD CHARACTERS WITHOUT CLAIM TO ANY PARTICULAR FONT, STYLE, SIZE, OR COLOR.

FOR ELECTRICAL SAFETY DEVICES, NAMELY GROUND FAULT CIRCUIT INTERRUPTERS (U.S. CLS. 21, 23, 26, 36 AND 38).

FIRST USE 9-0-2005; IN COMMERCE 9-0-2005.

3,235,269. EQAIR, LLC, GRANDVILLE, MI. SN 78-741,740. PUB. 7-4-2006, FILED 10-27-2005.

**PSICLOPS**

THE MARK CONSISTS OF STANDARD CHARACTERS WITHOUT CLAIM TO ANY PARTICULAR FONT, STYLE, SIZE, OR COLOR.

FOR TIRE PRESSURE GAUGES (U.S. CLS. 21, 23, 26, 36 AND 38).

FIRST USE 11-9-2006; IN COMMERCE 11-9-2006.

**CLASS 9—(Continued).**

3,235,276. HUEY CHIAO INTERNATIONAL CO., LTD., HSIN-CHUANG CITY, TAIPEI, TAIWAN. SN 78-747,995. PUB. 7-25-2006, FILED 11-6-2005.

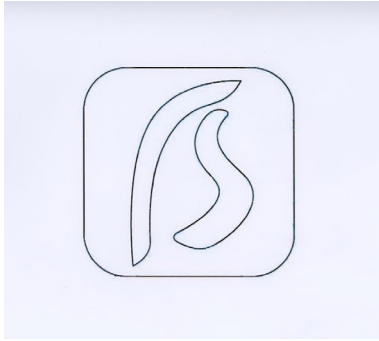

THE MARK CONSISTS OF ARCUATE BOOMERANG LIKE CONTOUR ADJACENT A STYLIZED "S" SHAPED CONTOUR ALL WITHIN A RECTANGULAR BORDER.

FOR MOBILE PHONE CASES; MOBILE PHONE BAGS; MOBILE PHONE HOLDERS; MOBILE PHONE STRAPS; MOBILE PHONE TOPPERS IN THE NATURE OF COVERS; MOBILE PHONE HOUSINGS; BELT CLIP PHONE HOLSTERS; WIRELESS HEADSETS; TELEPHONE APPARATUS; TELEPHONE WIRES (U.S. CLS. 21, 23, 26, 36 AND 38).

FIRST USE 1-9-2006; IN COMMERCE 1-9-2006.

3,235,285. MARK FELDSTEIN & ASSOCIATES, INC., MAUMEE, OH. SN 78-751,814. PUB. 8-22-2006, FILED 11-11-2005.

**AQUADOCK**

THE MARK CONSISTS OF STANDARD CHARACTERS WITHOUT CLAIM TO ANY PARTICULAR FONT, STYLE, SIZE, OR COLOR.

FOR SHOWER ENTERTAINMENT SYSTEM, NAMELY, A RADIO, AMPLIFIER AND AUDIO SPEAKERS IN A HOUSING WHICH INCLUDES A DOCKING STATION FOR A PORTABLE MP3 PLAYER (U.S. CLS. 21, 23, 26, 36 AND 38).

FIRST USE 7-15-2006; IN COMMERCE 7-15-2006.

**CLASS 9—(Continued).**

3,235,300. RESEARCH TRIANGLE SOFTWARE, INC., CARY, NC. SN 78-757,893. PUB. 7-25-2006, FILED 11-21-2005.

**CRYPTOLOCK**

THE MARK CONSISTS OF STANDARD CHARACTERS WITHOUT CLAIM TO ANY PARTICULAR FONT, STYLE, SIZE, OR COLOR.

FOR COMPUTER SOFTWARE FOR ENCRYPTION AND DECRYPTION OF COMPUTER FILES AND DATA, SOLD AS A COMPONENT OF COMPUTER HARDWARE, NAMELY, FLASH DRIVES (U.S. CLS. 21, 23, 26, 36 AND 38).

FIRST USE 11-7-2005; IN COMMERCE 1-10-2006.

3,235,304. HUGHES NETWORK SYSTEMS LLC, GERMANTOWN, MD. SN 78-758,921. PUB. 8-8-2006, FILED 11-22-2005.

**HUGHESNET**

THE MARK CONSISTS OF STANDARD CHARACTERS WITHOUT CLAIM TO ANY PARTICULAR FONT, STYLE, SIZE, OR COLOR.

OWNER OF U.S. REG. NOS. 1,288,713 AND 1,503,201.

FOR EQUIPMENT FOR RECEIVING, PROCESSING, AND TRANSMITTING VOICE, VIDEO, DATA AND INFORMATION VIA TELECOMMUNICATIONS AND WIRELESS SIGNALS, SATELLITE AND COMPUTERS, NAMELY, RECEIVERS, RECEIVER MODULES, MODULATORS, TRANSMITTERS, MULTIPLEXERS, DECODER BOXES, DATA PROCESSORS, INTEGRATED CIRCUITS, SET-TOP BOXES PRIMARILY COMPRISED OF A RECEIVER AND CIRCUITRY, COMPUTER OPERATING HARDWARE AND SOFTWARE FOR USE IN THE AFOREMENTIONED GOODS, SATELLITE DISHES, SATELLITE EARTH STATIONS, AND VERY SMALL APERTURE TERMINALS (VSAT) (U.S. CLS. 21, 23, 26, 36 AND 38).

FIRST USE 3-26-2006; IN COMMERCE 3-26-2006.

3,235,323. PLAYFIRST, INC., SAN FRANCISCO, CA. SN 78-765,055. PUB. 8-8-2006, FILED 12-1-2005.

**POKER POP**

THE MARK CONSISTS OF STANDARD CHARACTERS WITHOUT CLAIM TO ANY PARTICULAR FONT, STYLE, SIZE, OR COLOR.

**CLASS 9—(Continued).**

NO CLAIM IS MADE TO THE EXCLUSIVE RIGHT TO USE "POKER", APART FROM THE MARK AS SHOWN.  
FOR COMPUTER GAME SOFTWARE; VIDEO GAME SOFTWARE (U.S. CLS. 21, 23, 26, 36 AND 38).  
FIRST USE 4-25-2006; IN COMMERCE 4-25-2006.

---

3,235,328. REALSOFTWARE SOLUTIONS, LLC, BRADENTON, FL. SN 78-766,514. PUB. 8-22-2006, FILED 12-5-2005.

**REALPROSPECT**

THE MARK CONSISTS OF STANDARD CHARACTERS WITHOUT CLAIM TO ANY PARTICULAR FONT, STYLE, SIZE, OR COLOR.

FOR COMPUTER SOFTWARE FOR REAL ESTATE INVESTING PURPOSES (U.S. CLS. 21, 23, 26, 36 AND 38).  
FIRST USE 10-1-2005; IN COMMERCE 10-1-2005.

---

3,235,329. INFO DESIGNS, INC., TIMONIUM, MD. SN 78-766,678. PUB. 8-22-2006, FILED 12-5-2005.

**I-Stop**

THE MARK CONSISTS OF STANDARD CHARACTERS WITHOUT CLAIM TO ANY PARTICULAR FONT, STYLE, SIZE, OR COLOR.

FOR ELECTRIC SWITCHES; MICROPHONES (U.S. CLS. 21, 23, 26, 36 AND 38).  
FIRST USE 1-6-2006; IN COMMERCE 11-1-2006.

---

3,235,331. FEDERAL SIGNAL CORPORATION, OAK BROOK, IL. SN 78-768,571. PUB. 8-22-2006, FILED 12-7-2005.



The logo for SUREWARN features the word "SURE" in a bold, italicized, sans-serif font, followed by "WARN" in a similar font. The letters are white with a black outline and are set against a background of three horizontal, overlapping ellipses that create a sense of motion or depth.

THE MARK CONSISTS OF SUREWARN WITH THREE ELLIPSES IN THE BACKGROUND. THE MARK IS NOT IN COLOR

FOR COMPUTER SOFTWARE FOR DESIGN OF EMERGENCY SIREN SYSTEMS TO ENSURE SOUND COVERAGE OVER VARIOUS TERRAIN AND WEATHER CONDITIONS (U.S. CLS. 21, 23, 26, 36 AND 38).  
FIRST USE 6-10-2005; IN COMMERCE 6-10-2005.

**CLASS 9—(Continued).**

3,235,346. PRESONUS AUDIO ELECTRONIC, INC., BATON ROUGE, LA. SN 78-772,879. PUB. 8-8-2006, FILED 12-14-2005.

**FaderPort**

THE MARK CONSISTS OF STANDARD CHARACTERS WITHOUT CLAIM TO ANY PARTICULAR FONT, STYLE, SIZE, OR COLOR.

FOR SOUND MIXING AND RECORDING CONSOLES AND CONTROLLER DESKS; SOFTWARE FOR OPERATING SOUND MIXING AND RECORDING CONSOLES AND CONTROLLER DESKS; HEADPHONES FOR SOUND MIXING AND RECORDING CONSOLES AND CONTROLLER DESKS (U.S. CLS. 21, 23, 26, 36 AND 38).  
FIRST USE 9-1-2006; IN COMMERCE 9-1-2006.

---

3,235,348. TEL CONTROL, INC., HUNTSVILLE, AL. SN 78-775,272. PUB. 8-15-2006, FILED 12-16-2005.

**THE POWER OF SHARING**

THE MARK CONSISTS OF STANDARD CHARACTERS WITHOUT CLAIM TO ANY PARTICULAR FONT, STYLE, SIZE, OR COLOR.

FOR COMPUTER TELEPHONY SOFTWARE AND RELATED COMPUTER HARDWARE FOR RECEIVING AND PROCESSING EMERGENCY ASSISTANCE CALLS (U.S. CLS. 21, 23, 26, 36 AND 38).  
FIRST USE 2-23-2006; IN COMMERCE 2-23-2006.

---

3,235,366. LYNCH, GEORGE M., VALENCIA, CA. SN 78-786,002. PUB. 8-29-2006, FILED 1-5-2006.

**LYNCH BOX**

THE MARK CONSISTS OF STANDARD CHARACTERS WITHOUT CLAIM TO ANY PARTICULAR FONT, STYLE, SIZE, OR COLOR.

FOR GUITAR AMPLIFIERS (U.S. CLS. 21, 23, 26, 36 AND 38).  
FIRST USE 8-1-2006; IN COMMERCE 8-1-2006.

**CLASS 9—(Continued).**

3,235,382. BLINK TWICE LLC, NEW YORK, NY. SN 78-809,217. PUB. 8-8-2006, FILED 2-7-2006.

**CLASS 9—(Continued).**

3,235,411. GAMLA ENTERPRISES N.A. INC., NEW YORK, NY. SN 78-978,054. PUB. 3-14-2006, FILED 11-18-2004.

# TANGO!

THE MARK CONSISTS OF STANDARD CHARACTERS WITHOUT CLAIM TO ANY PARTICULAR FONT, STYLE, SIZE, OR COLOR.

FOR PORTABLE COMMUNICATION DEVICES FOR PEOPLE WITH SPEECH DISABILITIES, NAMELY TALKING MACHINES (U.S. CLS. 21, 23, 26, 36 AND 38).  
FIRST USE 3-0-2006; IN COMMERCE 3-0-2006.

# CONTINENTAL

THE MARK CONSISTS OF STANDARD CHARACTERS WITHOUT CLAIM TO ANY PARTICULAR FONT, STYLE, SIZE, OR COLOR.

FOR 35MM CAMERA CASES, APS CAMERA CASES, DIGITAL CAMERA CASES, VIDEO CAMERA CASES, DIGITAL VIDEO CAMERA CASES; DIGITAL CAMERAS; DIGITAL VIDEO CAMERAS (U.S. CLS. 21, 23, 26, 36 AND 38).  
FIRST USE 12-15-2001; IN COMMERCE 6-1-2005.

3,235,398. GUESS ?, INC., LOS ANGELES, CA. SN 78-977,990. PUB. 9-14-2004, FILED 3-17-2003.

# YES

OWNER OF U.S. REG. NOS. 1,396,894, 1,734,931, AND 1,803,778.

FOR EYEWEAR, NAMELY, EYEGLOSS FRAMES, SUNGLASSES, EYEGLOSS CASES, EYEGLOSS CHAINS (U.S. CLS. 21, 23, 26, 36 AND 38).  
FIRST USE 10-1-2006; IN COMMERCE 10-1-2006.

3,235,413. DISNEY ENTERPRISES, INC., BURBANK, CA. SN 78-978,086. PUB. 9-27-2005, FILED 9-12-2002.

# DISNEY

3,235,406. HELIO LLC, LOS ANGELES, CA. SN 78-978,035. PUB. 9-19-2006, FILED 10-18-2005.

# DON'T CALL IT A PHONE

THE MARK CONSISTS OF STANDARD CHARACTERS WITHOUT CLAIM TO ANY PARTICULAR FONT, STYLE, SIZE, OR COLOR.

FOR CONSUMER ELECTRONICS DEVICES, NAMELY PERSONAL DIGITAL ASSISTANTS (PDAS), TELEPHONES, HEADSETS FOR TELEPHONES, COMPUTERS AND CAMERAS (U.S. CLS. 21, 23, 26, 36 AND 38).  
FIRST USE 11-9-2006; IN COMMERCE 11-9-2006.

OWNER OF U.S. REG. NOS. 1,838,246, 2,832,514, AND OTHERS.

SEC. 2(F).  
FOR PRE-RECORDED COMPACT DISCS FEATURING MUSIC, STORIES AND GAMES FOR CHILDREN; PRE-RECORDED DIGITAL VIDEO DISCS AND VIDEO CASSETTES FEATURING ANIMATED CHILDREN'S ADVENTURE AND COMEDY MOVIES AND MUSIC; COMPUTER GAME PROGRAMS; MOTION PICTURE FILMS IN THE FIELD OF ANIMATED CHILDREN'S COMEDY AND ADVENTURE, LIVE-ACTION COMEDY, DRAMA AND TV SHOWS; DIGITAL AUDIO PLAYERS; DIGITAL CAMERAS; TV AND DVD COMBINATION MACHINES; DVD PLAYERS AND TELEVISION SETS (U.S. CLS. 21, 23, 26, 36 AND 38).  
FIRST USE 10-0-1980; IN COMMERCE 10-0-1980.

**CLASS 9—(Continued).**

3,235,417. V, INC., COSTA MESA, CA. SN 78-978,090. PUB. 3-21-2006, FILED 3-29-2005.

**VIZIO**

THE MARK CONSISTS OF STANDARD CHARACTERS WITHOUT CLAIM TO ANY PARTICULAR FONT, STYLE, SIZE, OR COLOR.

THE FOREIGN WORDING IN THE MARK TRANSLATES INTO ENGLISH AS FLAW, MISTAKE, ERROR, FAULTS.

FOR TELEVISIONS, LIQUID CRYSTAL DISPLAY TELEVISIONS, PLASMA TELEVISIONS, RE-MOTE CONTROL UNITS FOR TELEVISIONS RECEIVERS, TELEVISION MONITORS WITH OR WITHOUT TELEVISION TUNERS, TELEVISION ACCESSORIES NAMELY, COMPONENT CABLES AND DVI-I CABLES (U.S. CLS. 21, 23, 26, 36 AND 38).

FIRST USE 3-31-2004; IN COMMERCE 3-31-2004.

**CLASS 10—MEDICAL APPARATUS**

3,233,902. EMBO-OPTICS, LLC, BEVERLY, MA. SN 76-591,035. PUB. 9-20-2005, FILED 5-7-2004.

**FLUSH-LITE**

THE MARK CONSISTS OF STANDARD CHARACTERS WITHOUT CLAIM TO ANY PARTICULAR FONT, STYLE, SIZE, OR COLOR.

FOR LIGHTS FOR USE IN MEDICAL APPLICATIONS, NAMELY, CHEMICALLY-ACTIVATED LIGHT STICKS FOR MARKING AND HIGHLIGHTING OF INTRAVENOUS FLUIDS AND WITHDRAWAL LINES (U.S. CLS. 26, 39 AND 44).

FIRST USE 12-13-2003; IN COMMERCE 1-15-2004.

3,233,920. TOMCANY, BRIAN, STRONGSVILLE, OH. SN 76-598,896. PUB. 10-25-2005, FILED 6-23-2004.

**RAPID SEQUENCE IMMOBILIZATION**

THE MARK CONSISTS OF STANDARD CHARACTERS WITHOUT CLAIM TO ANY PARTICULAR FONT, STYLE,

**CLASS 10—(Continued).**

SIZE, OR COLOR.

NO CLAIM IS MADE TO THE EXCLUSIVE RIGHT TO USE "IMMOBILIZATION", APART FROM THE MARK AS SHOWN.

FOR MEDICAL DEVICE, NAMELY BACKBOARD WITH HEAD AND NECK RESTRAINT (U.S. CLS. 26, 39 AND 44).

FIRST USE 9-14-2006; IN COMMERCE 9-14-2006.

3,233,926. SUPERMAX, INC., AURORA, IL. SN 76-601,065. PUB. 10-11-2005, FILED 7-6-2004.

**HONEYCOMB**

THE MARK CONSISTS OF STANDARD CHARACTERS WITHOUT CLAIM TO ANY PARTICULAR FONT, STYLE, SIZE, OR COLOR.

FOR MEDICAL GLOVES (U.S. CLS. 26, 39 AND 44). FIRST USE 1-1-2003; IN COMMERCE 1-1-2003.

3,233,939. MELIVET PRODUCTS, INC., FOGELSVILLE, PA. SN 76-608,574. PUB. 9-13-2005, FILED 8-20-2004.



FOR VETERINARY PROTECTIVE BOOTS TO BE USED ON DOGS, CATS, COWS OR HORSES AS A COVERING TO AID IN HEALING AFTER INJURY OR SURGERY TO THE LIMB (U.S. CLS. 26, 39 AND 44).

FIRST USE 7-1-2004; IN COMMERCE 7-1-2004.

**CLASS 10—(Continued).**

3,234,057. GOLDA, INC., BEACHWOOD, OH. SN 76-641,254.  
PUB. 4-25-2006, FILED 6-21-2005.

**SURGI-BINDER**

THE MARK CONSISTS OF STANDARD CHARACTERS WITHOUT CLAIM TO ANY PARTICULAR FONT, STYLE, SIZE, OR COLOR.

OWNER OF U.S. REG. NOS. 1,284,184 AND 2,184,865.  
FOR ABDOMINAL BELTS; COMPRESSION BANDAGES AND WRAPS FOR ABDOMINAL AND CHEST USE; AUGMENTATION BINDERS OR BANDS (U.S. CLS. 26, 39 AND 44).

FIRST USE 3-0-2006; IN COMMERCE 3-0-2006.

3,234,091. KABUSHIKI KAISHA TOP, TOKYO, JAPAN. SN 76-978,477. PUB. 4-19-2005, FILED 5-5-2003.

**TOP**

OWNER OF U.S. REG. NO. 1,337,744.  
FOR INJECTION NEEDLES FOR NERVE BLOCK (U.S. CLS. 26, 39 AND 44).

FIRST USE 0-0-1970; IN COMMERCE 0-0-1983.

3,234,132. CNS, INC., EDEN PRAIRIE, MN. SN 78-224,018.  
PUB. 3-23-2004, FILED 3-11-2003.

**BREATHE BETTER. SLEEP  
BETTER. FEEL BETTER.**

FOR EXTERNAL NASAL DILATOR (U.S. CLS. 26, 39 AND 44).

FIRST USE 8-1-2006; IN COMMERCE 8-1-2006.

3,234,222. ARROW INTERNATIONAL INVESTMENT CORP., WILMINGTON, DE. SN 78-374,280. PUB. 11-16-2004, FILED 2-26-2004.

**HEMOSONIC****CLASS 10—(Continued).**

THE MARK CONSISTS OF STANDARD CHARACTERS WITHOUT CLAIM TO ANY PARTICULAR FONT, STYLE, SIZE, OR COLOR.

FOR MEDICAL DEVICES, NAMELY CARDIAC OUTPUT MONITORS (U.S. CLS. 26, 39 AND 44).

FIRST USE 11-9-1999; IN COMMERCE 11-9-1999.

3,234,339. THE LARYNGEAL MASK COMPANY LIMITED, VICTORIA, MAHE, SEYCHELLES. SN 78-442,798. PUB. 11-1-2005, FILED 6-29-2004.

**LMA CTRACH**

THE MARK CONSISTS OF STANDARD CHARACTERS WITHOUT CLAIM TO ANY PARTICULAR FONT, STYLE, SIZE, OR COLOR.

OWNER OF U.S. REG. NOS. 1,854,088, 2,506,914, AND OTHERS.

SEC. 2(F) AS TO "LMA".

FOR LARYNGEAL MASKS (U.S. CLS. 26, 39 AND 44).  
FIRST USE 11-19-2004; IN COMMERCE 11-29-2004.

3,234,341. LITTLE RAPIDS CORPORATION, GREEN BAY, WI. SN 78-444,915. PUB. 11-8-2005, FILED 7-1-2004.

**COMFORT1**

THE MARK CONSISTS OF STANDARD CHARACTERS WITHOUT CLAIM TO ANY PARTICULAR FONT, STYLE, SIZE, OR COLOR.

FOR DISPOSABLE BLANKET FOR MEDICAL USE (U.S. CLS. 26, 39 AND 44).

FIRST USE 12-0-2005; IN COMMERCE 3-0-2006.

**CLASS 10—(Continued).**

3,234,364. FISHER AND PAYKEL HEALTHCARE LIMITED, AUCKLAND, NEW ZEALAND. SN 78-458,012. PUB. 12-6-2005, FILED 7-28-2004.

**CLASS 10—(Continued).**

3,234,642. C. R. BARD, INC., MURRAY HILL, NJ. SN 78-558,970. PUB. 10-25-2005, FILED 2-2-2005.

# INFINITY

THE MARK CONSISTS OF STANDARD CHARACTERS WITHOUT CLAIM TO ANY PARTICULAR FONT, STYLE, SIZE, OR COLOR.

FOR MEDICAL APPARATUS AND INSTRUMENTS FOR TREATING SLEEPING DISORDERS, SNORING, APNEA, AND OBSTRUCTIVE SLEEP APNEA; MEDICAL APPARATUS AND INSTRUMENTS FOR CONTINUOUS POSITIVE AIRWAY PRESSURE, ALSO KNOWN AS CPAP, AND BI-LEVEL RESPIRATORY THERAPY; MEDICAL APPARATUS AND INSTRUMENTS, NAMELY, VENTILATION AND NON-INVASIVE VENTILATION APPARATUS AND INSTRUMENTS; MEDICAL APPARATUS, NAMELY, FACIAL MASKS, HEADGEAR, ORAL MASKS, NASAL MASKS, AND MOUTHPIECES FOR USE BY PATIENTS; MEDICAL APPARATUS AND INSTRUMENTS, NAMELY, SLEEP APNEA MONITORS; MEDICAL APPARATUS AND INSTRUMENTS, NAMELY, HUMIDIFIERS AND METERS FOR CONTINUOUS POSITIVE AIRWAY PRESSURE, ALSO KNOWN AS CAPA, AND BI-LEVEL RESPIRATORY THERAPY; PARTS AND FITTINGS FOR ALL THE AFOREMENTIONED GOODS (U.S. CLS. 26, 39 AND 44).

FIRST USE 2-28-2005; IN COMMERCE 2-28-2005.

---

3,234,477. GILTSPUR SCIENTIFIC LIMITED, BALLYCLARE, COUNTY ANTRIM, NORTHERN IRELAND. SN 78-506,327. PUB. 3-7-2006, FILED 10-26-2004.

## AMERICAN GILTSPUR

THE MARK CONSISTS OF STANDARD CHARACTERS WITHOUT CLAIM TO ANY PARTICULAR FONT, STYLE, SIZE, OR COLOR.

NO CLAIM IS MADE TO THE EXCLUSIVE RIGHT TO USE "AMERICAN", APART FROM THE MARK AS SHOWN.

FOR THERAPEUTIC SHOES FOR THE TREATMENTS OF LAMENESS IN CATTLE AND IN HORSES (U.S. CLS. 26, 39 AND 44).

FIRST USE 10-1-2003; IN COMMERCE 10-1-2003.

# TEGRESS

THE MARK CONSISTS OF STANDARD CHARACTERS WITHOUT CLAIM TO ANY PARTICULAR FONT, STYLE, SIZE, OR COLOR.

FOR URETHRAL IMPLANTS USED AS A BULKING AGENT AND URETHRAL IMPLANT NEEDLES (U.S. CLS. 26, 39 AND 44).

FIRST USE 4-18-2005; IN COMMERCE 4-18-2005.

---

3,234,756. KUEHNE, JONAS, SANTA MONICA, CA. SN 78-603,409. PUB. 12-27-2005, FILED 4-6-2005.

## FACELIFTER

THE MARK CONSISTS OF STANDARD CHARACTERS WITHOUT CLAIM TO ANY PARTICULAR FONT, STYLE, SIZE, OR COLOR.

FOR MOUTH EXERCISER FOR USE IN EXERCISING AND STRENGTHENING FACIAL MUSCLES FOR MEDICAL AND BEAUTY BENEFITS (U.S. CLS. 26, 39 AND 44).

FIRST USE 3-6-2006; IN COMMERCE 3-6-2006.



**CLASS 10—(Continued).**

3,234,783. CUSTOM PAPER TUBES, INC., CLEVELAND, OH.  
SN 78-614,820. PUB. 8-1-2006, FILED 4-22-2005.

# Brite White

THE MARK CONSISTS OF STANDARD CHARACTERS WITHOUT CLAIM TO ANY PARTICULAR FONT, STYLE, SIZE, OR COLOR.

NO CLAIM IS MADE TO THE EXCLUSIVE RIGHT TO USE "WHITE", APART FROM THE MARK AS SHOWN.

FOR TUBULAR PAPER DISPOSABLE MEDICAL MOUTHPIECES FOR USE IN MEASURING LUNG CAPACITY (U.S. CLS. 26, 39 AND 44).

FIRST USE 3-10-2005; IN COMMERCE 11-6-2006.

3,234,829. SPIRUS MEDICAL INC., STOUGHTON, MA. SN 78-629,648. PUB. 1-31-2006, FILED 5-13-2005.

# SPIRUS

THE MARK CONSISTS OF STANDARD CHARACTERS WITHOUT CLAIM TO ANY PARTICULAR FONT, STYLE, SIZE, OR COLOR.

FOR MEDICAL APPARATUS, NAMELY, INTRODUCERS FOR INTRODUCING MEDICAL INSTRUMENTATION INTO A BODILY PASSAGEWAY AND ADVANCING THE SAME ALONG THE BODILY PASSAGEWAY, WHEREIN THE MEDICAL INSTRUMENTATION COMPRISES VISUALIZATION DEVICES, BIOPSY DEVICES, IMPLANTS AND THE LIKE; COLONOSCOPES; ENDOSCOPES; DILATORS FOR INTRODUCTION INTO A BODILY PASSAGEWAY AND ADVANCEMENT ALONG THE BODILY PASSAGEWAY; AND OCCLUDERS FOR INTRODUCTION INTO A BODILY PASSAGEWAY AND ADVANCEMENT ALONG THE BODILY PASSAGEWAY (U.S. CLS. 26, 39 AND 44).

FIRST USE 8-1-2006; IN COMMERCE 8-1-2006.

**CLASS 10—(Continued).**

3,234,865. ENDOCARE, INC., IRVINE, CA. SN 78-636,972.  
PUB. 2-28-2006, FILED 5-25-2005.

# V-PROBE

THE MARK CONSISTS OF STANDARD CHARACTERS WITHOUT CLAIM TO ANY PARTICULAR FONT, STYLE, SIZE, OR COLOR.

FOR MEDICAL DEVICES AND INSTRUMENTS FOR USE IN CRYOSURGICAL PROCEDURES, NAMELY, CRYOSURGICAL APPARATUS FOR USE IN PERFORMING ABLATIVE SURGERY; CRYOSURGICAL PROBES (U.S. CLS. 26, 39 AND 44).

FIRST USE 8-31-2006; IN COMMERCE 8-31-2006.

3,235,029. NONIN MEDICAL, INC., PLYMOUTH, MN. SN 78-662,599. PUB. 4-11-2006, FILED 7-1-2005.

# FETALSAT

THE MARK CONSISTS OF STANDARD CHARACTERS WITHOUT CLAIM TO ANY PARTICULAR FONT, STYLE, SIZE, OR COLOR.

FOR MEDICAL DEVICES, NAMELY PULSE OXIMETERS (U.S. CLS. 26, 39 AND 44).

FIRST USE 1-17-2002; IN COMMERCE 4-13-2006.

3,235,146. POLYGON COMPANY, WALKERTON, IN. SN 78-688,474. PUB. 5-2-2006, FILED 8-9-2005.

# LESTRAN

THE MARK CONSISTS OF STANDARD CHARACTERS WITHOUT CLAIM TO ANY PARTICULAR FONT, STYLE, SIZE, OR COLOR.

FOR REUSABLE SURGICAL TUBING (U.S. CLS. 26, 39 AND 44).

FIRST USE 8-0-2002; IN COMMERCE 8-0-2002.

**CLASS 10—(Continued).**

3,235,195. UBIMED L.L.C., MIAMI, FL. SN 78-706,949. PUB. 5-23-2006, FILED 9-6-2005.

# CLEANOZ

THE MARK CONSISTS OF STANDARD CHARACTERS WITHOUT CLAIM TO ANY PARTICULAR FONT, STYLE, SIZE, OR COLOR.

FOR MEDICAL APPARATUS NAMELY AIR BLOWING DEVICES FOR DRYING THE AUDITORY MEATUS; ELECTRIC NASAL ASPIRATORS (U.S. CLS. 26, 39 AND 44).

FIRST USE 10-0-2006; IN COMMERCE 10-0-2006.

---

3,235,249. KENSEY NASH CORPORATION, EXTON, PA. SN 78-730,574. PUB. 3-14-2006, FILED 10-11-2005.

# ProGuard

THE MARK CONSISTS OF STANDARD CHARACTERS WITHOUT CLAIM TO ANY PARTICULAR FONT, STYLE, SIZE, OR COLOR.

FOR MEDICAL REVASCLARIZATION SYSTEMS, COMPRISED OF ONE OR MORE OF THE FOLLOWING; AN ATHERECTOMY CATHETER, A BALLOON GUIDE-WIRE, AND A CATHETER DRIVE AND DEBRIS EVACUATION SYSTEM, AND ACCESSORIES FOR SUCH SYSTEMS, NAMELY, AN INFUSATE TUBING ASSEMBLY, AN EXTRACTION TUBING ASSEMBLY, A PRESURE TRANSDUCER, AN INSUFFLATOR AND ASSOCIATED TUBING, A BALLOON INFLATION APPARATUS, A HEMOSTASIS VALVE, AND OTHER TUBING AND CATHETERS, FOR USE BY INTERVENTIONAL RADIOLOGISTS AND INTERVENTIONAL RADIOLOGISTS (U.S. CLS. 26, 39 AND 44).

FIRST USE 2-17-2006; IN COMMERCE 2-17-2006.

---

3,235,272. SPINETRONICS LLC, PARKLAND, FL. SN 78-745,165. PUB. 7-11-2006, FILED 11-2-2005.

# Antalgic-Trak

FOR TRACTION TABLES AND CHAIRS FOR THE TREATMENT AND REHABILITATION OF THE NECK, BACK OR SPINE (U.S. CLS. 26, 39 AND 44).

FIRST USE 5-4-2005; IN COMMERCE 1-3-2006.

**CLASS 10—(Continued).**

3,235,288. MEDTRONIC, INC., MINNEAPOLIS, MN. SN 78-753,134. PUB. 7-25-2006, FILED 11-14-2005.

# NEXDRIVE

THE MARK CONSISTS OF STANDARD CHARACTERS WITHOUT CLAIM TO ANY PARTICULAR FONT, STYLE, SIZE, OR COLOR.

FOR MEDICAL INSTRUMENT, NAMELY, A DISPOSABLE TOOL THAT DELIVERS A MICRO ELECTRODE INTO THE BRAIN FOR ANALYSIS OF NEURONAL ACTIVITY (U.S. CLS. 26, 39 AND 44).

FIRST USE 5-3-2005; IN COMMERCE 5-3-2005.

---

3,235,332. ARTHREX, INC., NAPLES, FL. SN 78-768,595. PUB. 8-15-2006, FILED 12-7-2005.

# RETROBUTTON

THE MARK CONSISTS OF STANDARD CHARACTERS WITHOUT CLAIM TO ANY PARTICULAR FONT, STYLE, SIZE, OR COLOR.

FOR MEDICAL DEVICES FOR USE FOR LIGAMENT FIXATION (U.S. CLS. 26, 39 AND 44).

FIRST USE 9-6-2006; IN COMMERCE 11-8-2006.

**CLASS 11—ENVIRONMENTAL CONTROL APPARATUS**

3,233,814. ARMAMENT SYSTEMS AND PROCEDURES, INC., APPLETON, WI. SN 76-466,881. PUB. 7-15-2003, FILED 11-14-2002.

# REGENCY

FOR RECHARGEABLE FLASHLIGHTS (U.S. CLS. 13, 21, 23, 31 AND 34).

FIRST USE 8-12-2006; IN COMMERCE 8-12-2006.

**CLASS 11—(Continued).**

3,233,875. DESA IP, LLC, MIAMI, FL. SN 76-567,676. PUB. 10-5-2004, FILED 12-19-2003.

# TORPEDO

THE MARK CONSISTS OF STANDARD CHARACTERS WITHOUT CLAIM TO ANY PARTICULAR FONT, STYLE, SIZE, OR COLOR.

FOR KEROSENE, LIQUID PROPANE AND NATURAL GAS-POWERED FORCED AIR HEATERS (U.S. CLS. 13, 21, 23, 31 AND 34).

FIRST USE 7-0-2006; IN COMMERCE 7-0-2006.

3,233,886. C.COO, LLC, COATESVILLE, PA. SN 76-579,791. PUB. 10-4-2005, FILED 3-5-2004.

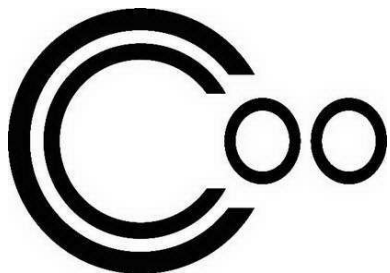

FOR REFRIGERATED WALL MOUNTED COSMETIC AND MEDICINE CABINET (U.S. CLS. 13, 21, 23, 31 AND 34).

FIRST USE 4-4-2005; IN COMMERCE 4-4-2005.

3,233,887. ELECTROLUX HOME PRODUCTS, INC., CLEVELAND, OH. SN 76-580,157. PUB. 9-13-2005, FILED 3-10-2004.

# ULTRAFREEZE

THE MARK CONSISTS OF STANDARD CHARACTERS WITHOUT CLAIM TO ANY PARTICULAR FONT, STYLE, SIZE, OR COLOR.

FOR DOMESTIC FREEZERS (U.S. CLS. 13, 21, 23, 31 AND 34).

FIRST USE 7-0-2004; IN COMMERCE 7-0-2004.

**CLASS 11—(Continued).**

3,234,027. STEINEL GMBH, D 4836 HERZEBROCK I, FED REP GERMANY. SN 76-634,392. PUB. 7-25-2006, FILED 3-25-2005.

# THERMAHEAT

THE MARK CONSISTS OF STANDARD CHARACTERS WITHOUT CLAIM TO ANY PARTICULAR FONT, STYLE, SIZE, OR COLOR.

FOR BUTANE POWERED FLAMELESS HEAT GUNS (U.S. CLS. 13, 21, 23, 31 AND 34).

FIRST USE 9-13-2005; IN COMMERCE 9-13-2005.

3,234,112. SARAMAR, L.L.C., CHICAGO, IL. SN 78-158,790. PUB. 1-6-2004, FILED 8-28-2002.



THE STIPPLING IS A FEATURE OF THE MARK. FOR FRAGRANCE AND AIR DEODORIZING DISPENSING UNITS (U.S. CLS. 13, 21, 23, 31 AND 34).

FIRST USE 1-10-2005; IN COMMERCE 1-10-2005.

3,234,155. ROHM AND HAAS COMPANY, PHILADELPHIA, PA. SN 78-291,780. PUB. 9-7-2004, FILED 8-25-2003.

# ADVANCED AMBERPACK

OWNER OF U.S. REG. NOS. 390,787, 744,807, AND OTHERS.

FOR WATER TREATMENT EQUIPMENT FOR INDUSTRIAL AND POTABLE WATER MARKETS, NAMELY ION EXCHANGE UNITS, ADSORPTION UNITS, WATER FILTRATION AND PURIFICATION UNITS, WASTEWATER TREATMENT UNITS, OIL FROM WATER SEPARATORS, CHEMICAL STERILIZATION UNITS, AND REVERSE OSMOSIS FILTRATION UNITS (U.S. CLS. 13, 21, 23, 31 AND 34).

FIRST USE 7-31-2003; IN COMMERCE 7-31-2003.

**CLASS 11—(Continued).**

3,234,172. MILLIPORE CORPORATION, BILLERICA, MA.  
SN 78-311,571. PUB. 7-20-2004, FILED 10-9-2003.

**Q-POD**

OWNER OF U.S. REG. NOS. 1,119,187, 2,637,353, AND  
OTHERS.  
FOR POINT OF USE PURIFIED WATER DISPENSER  
(U.S. CLS. 13, 21, 23, 31 AND 34).  
FIRST USE 3-16-2006; IN COMMERCE 3-16-2006.

---

3,234,209. ITOUCHLESS HOUSEWARES & PRODUCTS,  
INC., FOSTER CITY, CA. SN 78-359,063. PUB. 2-21-2006,  
FILED 1-28-2004.

**Ez Faucet**

THE MARK CONSISTS OF STANDARD CHARACTERS  
WITHOUT CLAIM TO ANY PARTICULAR FONT, STYLE,  
SIZE, OR COLOR.

NO CLAIM IS MADE TO THE EXCLUSIVE RIGHT TO  
USE "FAUCET", APART FROM THE MARK AS SHOWN.  
FOR AUTOMATIC AND ELECTRONICALLY CON-  
TROLLED FAUCETS (U.S. CLS. 13, 21, 23, 31 AND 34).  
FIRST USE 1-1-2004; IN COMMERCE 1-1-2004.

---

3,234,290. ELKAY MANUFACTURING COMPANY, OAK  
BROOK, IL. SN 78-410,610. PUB. 8-30-2005, FILED 4-29-  
2004.

**MODA**

**CLASS 11—(Continued).**

THE MARK CONSISTS OF STANDARD CHARACTERS  
WITHOUT CLAIM TO ANY PARTICULAR FONT, STYLE,  
SIZE, OR COLOR.

THE FOREIGN WORDING IN THE MARK TRANSLATES  
INTO ENGLISH AS "FASHION".  
FOR FAUCETS (U.S. CLS. 13, 21, 23, 31 AND 34).  
FIRST USE 5-0-2004; IN COMMERCE 5-0-2004.

---

3,234,335. EMISSIVE ENERGY CORPORATION, NORTH  
KINGSTON, RI. SN 78-440,691. PUB. 8-22-2006, FILED 6-  
24-2004.

**T2**

THE MARK CONSISTS OF STANDARD CHARACTERS  
WITHOUT CLAIM TO ANY PARTICULAR FONT, STYLE,  
SIZE, OR COLOR.  
FOR FLASHLIGHTS (U.S. CLS. 13, 21, 23, 31 AND 34).  
FIRST USE 8-22-2005; IN COMMERCE 8-22-2005.

**CLASS 11—(Continued).**

3,234,378. SOCIETE DES PRODUITS NESTLE S.A., 1800 VEVEY, SWITZERLAND. SN 78-468,980. PUB. 10-11-2005, FILED 8-17-2004.

# ROMEO

THE MARK CONSISTS OF STANDARD CHARACTERS WITHOUT CLAIM TO ANY PARTICULAR FONT, STYLE, SIZE, OR COLOR.

FOR MILK HEATING AND FROTHING MACHINES FOR USE IN MAKING COFFEE; MACHINES FOR MAKING AND BREWING COFFEE AND TEA AND FOR DISPENSING COFFEE, TEA AND HOT WATER; ELECTRIC COFFEE MAKING MACHINES, ELECTRIC COFFEE POTS AND ELECTRIC PERCOLATORS; PARTS AND FITTINGS FOR THE AFORESAID GOODS (U.S. CLS. 13, 21, 23, 31 AND 34).

FIRST USE 9-15-2005; IN COMMERCE 9-15-2005.

3,234,418. TRAVIS INDUSTRIES, INC., MUKILTEO, WA. SN 78-485,407. PUB. 9-6-2005, FILED 9-17-2004.

# BUNGALOW

THE MARK CONSISTS OF STANDARD CHARACTERS WITHOUT CLAIM TO ANY PARTICULAR FONT, STYLE, SIZE, OR COLOR.

FOR WOOD, GAS, AND PELLET BURNING FIREPLACE INSERTS IN THE NATURE OF HEAT EXCHANGERS AND SOLID AND GAS FUEL BURNERS; WOOD, GAS, AND PELLET BURNING FIREPLACES; WOOD, GAS, AND PELLET BURNING STOVES; ELECTRIC FIREPLACES AND FIREPLACE INSERTS; AND REPLACEMENT PARTS THEREFOR (U.S. CLS. 13, 21, 23, 31 AND 34).

FIRST USE 10-25-2004; IN COMMERCE 10-25-2004.

**CLASS 11—(Continued).**

3,234,552. ALSONS CORPORATION, HILLSDALE, MI. SN 78-528,132. PUB. 10-18-2005, FILED 12-7-2004.

# THE INCREDIBLE HEAD

THE MARK CONSISTS OF STANDARD CHARACTERS WITHOUT CLAIM TO ANY PARTICULAR FONT, STYLE, SIZE, OR COLOR.

NO CLAIM IS MADE TO THE EXCLUSIVE RIGHT TO USE "HEAD", APART FROM THE MARK AS SHOWN.

FOR PLUMBING PRODUCTS, NAMELY, SHOWER HEADS (U.S. CLS. 13, 21, 23, 31 AND 34).

FIRST USE 5-4-2004; IN COMMERCE 5-4-2004.

3,234,581. CRYSTAL FOUNTAINS INC., CONCORD, ONTARIO, CANADA. SN 78-532,928. PUB. 9-13-2005, FILED 12-15-2004.

# CHOREOSWITCH

THE MARK CONSISTS OF STANDARD CHARACTERS WITHOUT CLAIM TO ANY PARTICULAR FONT, STYLE, SIZE, OR COLOR.

FOR WATER FOUNTAIN WATER DIVERTERS FOR CREATING WATER FEATURE EFFECTS (U.S. CLS. 13, 21, 23, 31 AND 34).

FIRST USE 10-0-2006; IN COMMERCE 10-0-2006.

**CLASS 11—(Continued).**

3,234,585. MOEN INCORPORATED, NORTH OLMSTED, OH.  
SN 78-534,244. PUB. 4-11-2006, FILED 12-17-2004.

**SAGE**

THE MARK CONSISTS OF STANDARD CHARACTERS  
WITHOUT CLAIM TO ANY PARTICULAR FONT, STYLE,  
SIZE, OR COLOR.

OWNER OF U.S. REG. NO. 2,867,784.  
FOR TOILET TANK LEVERS PRIMARILY MADE  
FROM METAL (U.S. CLS. 13, 21, 23, 31 AND 34).  
FIRST USE 8-1-2004; IN COMMERCE 8-1-2004.

3,234,618. FLAX, GARY ERROL, DALLAS, TX. SN 78-547,513.  
PUB. 4-11-2006, FILED 1-14-2005.

**little luxury**

FOR WATER COOLERS; TEMPERATURE-CONTROLLED  
WATER DISPENSERS THAT CONTAIN A  
WATER FILTER (U.S. CLS. 13, 21, 23, 31 AND 34).  
FIRST USE 9-10-1994; IN COMMERCE 10-9-1996.

**CLASS 11—(Continued).**

3,234,786. MILLIPORE CORPORATION, BILLERICA, MA.  
SN 78-615,716. PUB. 3-28-2006, FILED 4-25-2005.

**SYNERGYPAK**

THE MARK CONSISTS OF STANDARD CHARACTERS  
WITHOUT CLAIM TO ANY PARTICULAR FONT, STYLE,  
SIZE, OR COLOR.

OWNER OF U.S. REG. NO. 2,730,576.  
FOR PURIFICATION UNITS FOR LABORATORY  
USE, FOR REMOVING CONTAMINANTS FROM  
WATER (U.S. CLS. 13, 21, 23, 31 AND 34).  
FIRST USE 8-31-2005; IN COMMERCE 8-31-2005.

3,234,861. DIMPLEX NORTH AMERICA LIMITED, CAM-  
BRIDGE, ONTARIO, CANADA. SN 78-636,120. PUB. 3-28-  
2006, FILED 5-24-2005.

**ELECTRALOG**

THE MARK CONSISTS OF STANDARD CHARACTERS  
WITHOUT CLAIM TO ANY PARTICULAR FONT, STYLE,  
SIZE, OR COLOR.

OWNER OF U.S. REG. NO. 2,278,266.  
FOR ELECTRIC FIREPLACES AND ELECTRIC  
STOVES (U.S. CLS. 13, 21, 23, 31 AND 34).  
FIRST USE 8-0-2005; IN COMMERCE 8-0-2005.

3,234,871. RARITAN ENGINEERING COMPANY, INC.,  
MILLVILLE, NJ. SN 78-637,273. PUB. 2-21-2006, FILED 5-  
25-2005.

**ATLANTES FREEDOM**

THE MARK CONSISTS OF STANDARD CHARACTERS  
WITHOUT CLAIM TO ANY PARTICULAR FONT, STYLE,  
SIZE, OR COLOR.

FOR TOILET SYSTEMS COMPRISING BOWLS,  
PUMPS, CONTROLS, WIRING HARNESES, PLUMBING  
FITTINGS, NAMELY, VALVES, COCKS, BIBBS, TRAPS  
AND SEATS (U.S. CLS. 13, 21, 23, 31 AND 34).  
FIRST USE 8-31-2005; IN COMMERCE 8-31-2005.

**CLASS 11—(Continued).**

3,234,938. SEYCHELLE ENVIRONMENTAL TECHNOLOGIES, INC., SAN JUAN CAPISTRANO, CA. SN 78-651,609. PUB. 8-1-2006, FILED 6-15-2005.



FOR DRINKING WATER FILTRATION AND PURIFICATION UNITS (U.S. CLS. 13, 21, 23, 31 AND 34). FIRST USE 8-4-2006; IN COMMERCE 8-4-2006.

3,234,980. CTM ENTERPRISES, INC., LAS VEGAS, NV. SN 78-656,436. PUB. 3-7-2006, FILED 6-22-2005.

**SCENTED LIVING**

THE MARK CONSISTS OF STANDARD CHARACTERS WITHOUT CLAIM TO ANY PARTICULAR FONT, STYLE, SIZE, OR COLOR.

FOR AIR FILTERS FOR DOMESTIC USE (U.S. CLS. 13, 21, 23, 31 AND 34). FIRST USE 5-1-2005; IN COMMERCE 5-1-2005.

3,235,059. AMERICAN STANDARD INTERNATIONAL INC., NEW YORK, NY. SN 78-665,325. PUB. 3-21-2006, FILED 7-7-2005.

**TRIUMPH**

THE MARK CONSISTS OF STANDARD CHARACTERS WITHOUT CLAIM TO ANY PARTICULAR FONT, STYLE, SIZE, OR COLOR.

FOR PLUMBING FITTINGS, NAMELY, FAUCETS AND PARTS THEREFOR (U.S. CLS. 13, 21, 23, 31 AND 34). FIRST USE 7-1-2005; IN COMMERCE 8-31-2006.

**CLASS 11—(Continued).**

3,235,062. VERILUX, INC., STAMFORD, CT. SN 78-666,198. PUB. 4-18-2006, FILED 7-8-2005.

**LIFE IN A BETTER LIGHT**

THE MARK CONSISTS OF STANDARD CHARACTERS WITHOUT CLAIM TO ANY PARTICULAR FONT, STYLE, SIZE, OR COLOR.

FOR LAMPS; LIGHTING FIXTURES; ELECTRIC LIGHTING SYSTEMS COMPRISED PRIMARILY OF ELECTRIC LIGHTING FIXTURES AND/OR ELECTRIC FLUORESCENT LIGHTING TUBES AND/OR ELECTRIC INCANDESCENT LIGHT BULBS AND/OR ELECTRIC LAMPS (U.S. CLS. 13, 21, 23, 31 AND 34). FIRST USE 8-15-2005; IN COMMERCE 8-15-2005.

3,235,181. ZURN INDUSTRIES, INC., ERIE, PA. SN 78-700,997. PUB. 5-16-2006, FILED 8-26-2005.

**FLO-TROL**

THE MARK CONSISTS OF STANDARD CHARACTERS WITHOUT CLAIM TO ANY PARTICULAR FONT, STYLE, SIZE, OR COLOR.

FOR POST YARD HYDRANTS (U.S. CLS. 13, 21, 23, 31 AND 34). FIRST USE 1-1-2007; IN COMMERCE 1-1-2007.

3,235,256. ARGOS TECHNOLOGIES, INC., EAST DUNDEE, IL. SN 78-735,136. PUB. 6-27-2006, FILED 10-18-2005.

**NOVA**

THE MARK CONSISTS OF STANDARD CHARACTERS WITHOUT CLAIM TO ANY PARTICULAR FONT, STYLE, SIZE, OR COLOR.

FOR LABORATORY INCINERATOR FOR STERILIZATION OF LABORATORY INSTRUMENTS (U.S. CLS. 13, 21, 23, 31 AND 34). FIRST USE 2-19-2006; IN COMMERCE 4-12-2006.

**CLASS 11—(Continued).**

3,235,261. LEDALITE ARCHITECTURAL PRODUCTS, LANGLEY, BRITISH COLUMBIA, CANADA. SN 78-737,731. PUB. 8-22-2006, FILED 10-21-2005.

**ENDEAVOR**

THE MARK CONSISTS OF STANDARD CHARACTERS WITHOUT CLAIM TO ANY PARTICULAR FONT, STYLE, SIZE, OR COLOR.

FOR ELECTRIC LIGHTING FIXTURES (U.S. CLS. 13, 21, 23, 31 AND 34).  
FIRST USE 1-30-2006; IN COMMERCE 1-30-2006.

3,235,393. FPI FIREPLACE PRODUCTS INTERNATIONAL LTD., DELTA, BRITISH COLUMBIA, CANADA. SN 78-977,914. PUB. 6-27-2006, FILED 6-22-2005.

**GREENFIRE**

THE MARK CONSISTS OF STANDARD CHARACTERS WITHOUT CLAIM TO ANY PARTICULAR FONT, STYLE, SIZE, OR COLOR.

FOR GAS STOVES AND PARTS, ACCESSORIES AND ATTACHMENTS FOR SUCH GAS STOVES, NAMELY CAST IRON AND CERAMIC PLATES, COVERS, BRACKETS, AND BURNERS SOLD AS PARTS OF STOVES (U.S. CLS. 13, 21, 23, 31 AND 34).  
FIRST USE 10-0-2006; IN COMMERCE 10-0-2006.

**CLASS 12—VEHICLES**

3,233,842. ARVIN RIDE CONTROL PRODUCTS, INC., TORONTO, ONTARIO, CANADA. SN 76-502,054. PUB. 10-21-2003, FILED 3-26-2003.

**REACT**

FOR SHOCK ABSORBERS FOR USE IN SNOWMOBILE AND ALL TERRAIN VEHICLE (ATV) SUSPENSIONS (U.S. CLS. 19, 21, 23, 31, 35 AND 44).  
FIRST USE 7-0-2002; IN COMMERCE 7-0-2002.

**CLASS 12—(Continued).**

3,233,947. TOTAL SEAL, INC., PHOENIX, AZ. SN 76-610,324. PUB. 3-7-2006, FILED 9-7-2004.

**ADVANCED PROFILING**

FOR PISTON RINGS FOR INTERNAL COMBUSTION ENGINES AND PNEUMATIC MOTORS AND PUMPS (U.S. CLS. 19, 21, 23, 31, 35 AND 44).  
FIRST USE 11-0-2005; IN COMMERCE 11-0-2005.

3,233,964. KENDA RUBBER INDUSTRIAL CO., LTD., YUANLIN JEN, CHANGHUA CHANGHUA, TAIWAN. SN 76-613,753. PUB. 9-13-2005, FILED 9-28-2004.

**WASHOUGAL**

THE MARK CONSISTS OF STANDARD CHARACTERS WITHOUT CLAIM TO ANY PARTICULAR FONT, STYLE, SIZE, OR COLOR.

FOR MOTORCYCLE TIRES (U.S. CLS. 19, 21, 23, 31, 35 AND 44).  
FIRST USE 5-12-2005; IN COMMERCE 5-12-2005.

3,233,972. GREAT AMERICAN BICYCLE, LLC, SARATOGA SPRINGS, NY. SN 76-614,976. PUB. 9-20-2005, FILED 10-7-2004.

**TORSIGNCORE**

FOR BICYCLE FRAMES AND TUBES (U.S. CLS. 19, 21, 23, 31, 35 AND 44).  
FIRST USE 12-1-2004; IN COMMERCE 11-30-2005.

3,233,986. ROCAWEAR LICENSING LLC, NEW YORK, NY. SN 76-620,454. PUB. 8-30-2005, FILED 11-15-2004.

**ROCAWEAR**

OWNER OF U.S. REG. NOS. 2,633,943 AND 2,780,202.  
FOR STROLLERS (U.S. CLS. 19, 21, 23, 31, 35 AND 44).  
FIRST USE 1-1-2005; IN COMMERCE 1-1-2005.



**CLASS 12—(Continued).**

3,233,997. PRO ALUMINUM, INC., SACRAMENTO, CA. SN 76-625,786. PUB. 10-25-2005, FILED 12-22-2004.

**V-CROSS**

THE MARK CONSISTS OF STANDARD CHARACTERS WITHOUT CLAIM TO ANY PARTICULAR FONT, STYLE, SIZE, OR COLOR.

FOR ALL-TERRAIN VEHICLE PARTS, NAMELY, BUMPERS (U.S. CLS. 19, 21, 23, 31, 35 AND 44).  
FIRST USE 10-6-2004; IN COMMERCE 10-6-2004.

---

3,234,045. JUST WHEELS & TIRES CO., HUNTINGTON BEACH, CA. SN 76-638,864. PUB. 1-31-2006, FILED 5-18-2005.

**MANDRUS WHEELS**

THE MARK CONSISTS OF STANDARD CHARACTERS WITHOUT CLAIM TO ANY PARTICULAR FONT, STYLE, SIZE, OR COLOR.

NO CLAIM IS MADE TO THE EXCLUSIVE RIGHT TO USE "WHEELS", APART FROM THE MARK AS SHOWN.

FOR LAND VEHICLE PARTS, NAMELY WHEELS (U.S. CLS. 19, 21, 23, 31, 35 AND 44).

FIRST USE 11-1-2005; IN COMMERCE 12-1-2005.

---

3,234,046. JUST WHEELS & TIRES CO., HUNTINGTON BEACH, CA. SN 76-638,866. PUB. 1-31-2006, FILED 5-18-2005.

**VICTOR EQUIPMENT**

THE MARK CONSISTS OF STANDARD CHARACTERS WITHOUT CLAIM TO ANY PARTICULAR FONT, STYLE, SIZE, OR COLOR.

NO CLAIM IS MADE TO THE EXCLUSIVE RIGHT TO USE "EQUIPMENT", APART FROM THE MARK AS SHOWN.

FOR LAND VEHICLE PARTS, NAMELY WHEELS (U.S. CLS. 19, 21, 23, 31, 35 AND 44).

FIRST USE 11-1-2005; IN COMMERCE 12-1-2005.

**CLASS 12—(Continued).**

3,234,201. TOYOTA JIDOSHA KABUSHIKI KAISHA, TA TOYOTA MOTOR CORPORATION, TOYOTA-SHI, AICHI-KEN, JAPAN. SN 78-346,153. PUB. 9-20-2005, FILED 12-29-2003.

**RELEASE SERIES**

THE MARK CONSISTS OF STANDARD CHARACTERS WITHOUT CLAIM TO ANY PARTICULAR FONT, STYLE, SIZE, OR COLOR.

NO CLAIM IS MADE TO THE EXCLUSIVE RIGHT TO USE "SERIES", APART FROM THE MARK AS SHOWN.

FOR MOTOR CARS AND STRUCTURAL PARTS THEREOF (U.S. CLS. 19, 21, 23, 31, 35 AND 44).

FIRST USE 2-24-2004; IN COMMERCE 2-24-2004.

---

3,234,262. KRINEY, JOHN V., SAN DIEGO, CA. SN 78-391,855. PUB. 9-20-2005, FILED 3-26-2004.

**SHOWOFF CARS**

THE MARK CONSISTS OF STANDARD CHARACTERS WITHOUT CLAIM TO ANY PARTICULAR FONT, STYLE, SIZE, OR COLOR.

NO CLAIM IS MADE TO THE EXCLUSIVE RIGHT TO USE "CARS", APART FROM THE MARK AS SHOWN.

FOR AFTERMARKET AUTO PARTS, NAMELY, BODY KITS COMPRISING WINGS, HOODS, FENDERS, COWLINGS, AIR DAMS, SIDE SKIRTS, AND ASSOCIATED MOUNTING HARDWARE, AND PERFORMANCE PARTS, NAMELY, WINGS, HOODS, FENDERS, COWLINGS, AIR DAMS, SIDE SKIRTS, AND ASSOCIATED MOUNTING HARDWARE, AND WHEELS, RIMS, AND SUSPENSION PARTS, NAMELY, COIL SPRINGS, LEAF SPRINGS, SHOCK ABSORBERS, STRUTS AND ASSOCIATED MOUNTING HARDWARE (U.S. CLS. 19, 21, 23, 31, 35 AND 44).

FIRST USE 1-1-2005; IN COMMERCE 1-1-2005.

**CLASS 12—(Continued).**

3,234,286. YAMAHA HATSUDOKI KABUSHIKI KAISHA, IWATA-SHI, SHIZUOKA-KEN, JAPAN. SN 78-409,373. PUB. 3-21-2006, FILED 4-28-2004.

**VX**

THE MARK CONSISTS OF STANDARD CHARACTERS WITHOUT CLAIM TO ANY PARTICULAR FONT, STYLE, SIZE, OR COLOR.

FOR PERSONAL WATERCRAFT, NAMELY, SINGLE AND MULTIPLE PASSENGER RECREATIONAL JET BOATS AND STRUCTURAL PARTS THEREFOR (U.S. CLS. 19, 21, 23, 31, 35 AND 44).

FIRST USE 7-31-2004; IN COMMERCE 7-31-2004.

**CLASS 12—(Continued).**

3,234,334. SPCN, INC., COSTA MESA, CA. SN 78-438,814. PUB. 4-26-2005, FILED 6-21-2004.

**SPCN**

THE MARK CONSISTS OF STANDARD CHARACTERS WITHOUT CLAIM TO ANY PARTICULAR FONT, STYLE, SIZE, OR COLOR.

FOR MOTORCYCLES (U.S. CLS. 19, 21, 23, 31, 35 AND 44).

FIRST USE 5-1-2004; IN COMMERCE 12-1-2005.

3,234,348. M7 AEROSPACE LP, SAN ANTONIO, TX. SN 78-448,683. PUB. 4-18-2006, FILED 7-9-2004.

**FAIRCHILD**

3,234,316. SIMPLICITY MANUFACTURING, INC., PORT WASHINGTON, WI. SN 78-427,159. PUB. 9-6-2005, FILED 5-28-2004.

**TURF CRUISER**

THE MARK CONSISTS OF STANDARD CHARACTERS WITHOUT CLAIM TO ANY PARTICULAR FONT, STYLE, SIZE, OR COLOR.

OWNER OF U.S. REG. NO. 2,090,111. NO CLAIM IS MADE TO THE EXCLUSIVE RIGHT TO USE "TURF", APART FROM THE MARK AS SHOWN.

FOR UTILITY GROUND VEHICLES, NAMELY, CARTS FOR HAULING GROUNDS MAINTENANCE EQUIPMENT (U.S. CLS. 19, 21, 23, 31, 35 AND 44).

FIRST USE 12-1-2004; IN COMMERCE 12-1-2004.

THE MARK CONSISTS OF STANDARD CHARACTERS WITHOUT CLAIM TO ANY PARTICULAR FONT, STYLE, SIZE, OR COLOR.

SEC. 2(F). FOR AIRCRAFT AND STRUCTURAL PARTS THEREFOR: AIRCRAFT PARTS, NAMELY, FUSELAGES, LANDING GEAR, EMPENNAGES, NOSE CONES, WINGS, FLAPS AND AILERONS (U.S. CLS. 19, 21, 23, 31, 35 AND 44).

FIRST USE 4-1-2003; IN COMMERCE 4-1-2003.

**CLASS 12—(Continued).**

3,234,349. M7 AEROSPACE LP, SAN ANTONIO, TX. SN 78-448,689. PUB. 4-18-2006, FILED 7-9-2004.

**CLASS 12—(Continued).**

3,234,470. FLEETWOOD ENTERPRISES, INC., RIVERSIDE, CA. SN 78-503,955. PUB. 4-18-2006, FILED 10-21-2004.

**FAIRCHILD AIRCRAFT**

**ORBIT**

THE MARK CONSISTS OF STANDARD CHARACTERS WITHOUT CLAIM TO ANY PARTICULAR FONT, STYLE, SIZE, OR COLOR.

NO CLAIM IS MADE TO THE EXCLUSIVE RIGHT TO USE "AIRCRAFT", APART FROM THE MARK AS SHOWN. SEC. 2(F).

FOR AIRCRAFT AND STRUCTURAL PARTS THEREFORE: AIRCRAFT PARTS, NAMELY, FUSELAGES, LANDING GEAR, EMPENNAGES, NOSE CONES, WINGS, FLAPS AND AILERONS (U.S. CLS. 19, 21, 23, 31, 35 AND 44).

FIRST USE 4-1-2003; IN COMMERCE 4-1-2003.

THE MARK CONSISTS OF STANDARD CHARACTERS WITHOUT CLAIM TO ANY PARTICULAR FONT, STYLE, SIZE, OR COLOR.

FOR TRAVEL TRAILERS (U.S. CLS. 19, 21, 23, 31, 35 AND 44).

FIRST USE 11-0-2004; IN COMMERCE 11-0-2004.

3,234,503. SOLAS SCIENCE & ENGINEERING CO., LTD., TAICHUNG, TAIWAN. SN 78-514,745. PUB. 3-7-2006, FILED 11-10-2004.

3,234,447. FEDERAL CORPORATION, TAOYUAN, TAIWAN. SN 78-495,491. PUB. 11-22-2005, FILED 10-6-2004.



***ECOVAN***

NO CLAIM IS MADE TO THE EXCLUSIVE RIGHT TO USE "PROPELLER", APART FROM THE MARK AS SHOWN.

THE COLOR(S) PURPLE, BLUE, YELLOW IS/ARE CLAIMED AS A FEATURE OF THE MARK.

THE MARK CONSISTS OF THE STYLIZED WORDS "LEXOR PROPELLER" IN A PURPLE-BLUE COLOR OUTLINED IN YELLOW.

FOR MARINE PROPELLERS (U.S. CLS. 19, 21, 23, 31, 35 AND 44).

FIRST USE 11-30-2004; IN COMMERCE 3-31-2005.

FOR TIRES (U.S. CLS. 19, 21, 23, 31, 35 AND 44). FIRST USE 6-10-2005; IN COMMERCE 6-10-2005.

**CLASS 12—(Continued).**

3,234,556. CASEY, DALE E., DECATUR, IL. SN 78-529,041. PUB. 9-13-2005, FILED 12-8-2004.

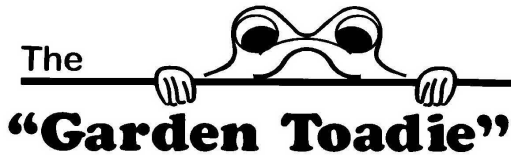

NO CLAIM IS MADE TO THE EXCLUSIVE RIGHT TO USE "GARDEN", APART FROM THE MARK AS SHOWN.  
 FOR YARD CARTS FOR TRANSPORTING MATERIALS AND FOR HOLDING WASTE BAGS (U.S. CLS. 19, 21, 23, 31, 35 AND 44).  
 FIRST USE 12-2-2006; IN COMMERCE 12-2-2006.

**CLASS 12—(Continued).**

3,234,706. WESTERN RECREATIONAL VEHICLES, INC., YAKIMA, WA. SN 78-586,970. PUB. 3-21-2006, FILED 3-14-2005.



OWNER OF U.S. REG. NO. 1,885,958.  
 THE COLORS GRAY, BLACK AND WHITE ARE CLAIMED AS A FEATURE OF THE MARK.  
 THE COLOR BLACK APPEARS IN THE WORDING ALPENLITE VOYAGER, THE COLOR GRAY APPEARS IN THE OUTLINING OF THE WORDING VOYAGER AND THE COLOR WHITE APPEARS IN THE OUTLINE OF THE WORDING VOYAGER.  
 FOR NON MOTORIZED TRAILERS, NAMELY CAMPING TRAILERS, VACATION AND TRAVEL TRAILERS, AND FIFTH WHEEL TRAILERS (U.S. CLS. 19, 21, 23, 31, 35 AND 44).  
 FIRST USE 7-1-2005; IN COMMERCE 7-1-2005.

3,234,601. E-Z HITCH, LTD., SEBRING, OH. SN 78-542,256. PUB. 9-27-2005, FILED 1-5-2005.

**HITCHMATIC**

THE MARK CONSISTS OF STANDARD CHARACTERS WITHOUT CLAIM TO ANY PARTICULAR FONT, STYLE, SIZE, OR COLOR.  
 FOR VEHICLE MOUNTED GUIDE FOR ALIGNING A TRAILER TONGUE AND A HITCH BALL DURING TRAILER ATTACHMENT TO A TOWING VEHICLE (U.S. CLS. 19, 21, 23, 31, 35 AND 44).  
 FIRST USE 10-17-2006; IN COMMERCE 10-17-2006.

3,234,736. ELECTRIC VEHICLE TECHNOLOGIES, INC., SKOKIE, IL. SN 78-597,027. PUB. 3-14-2006, FILED 3-29-2005.

**EVS**

THE MARK CONSISTS OF STANDARD CHARACTERS WITHOUT CLAIM TO ANY PARTICULAR FONT, STYLE, SIZE, OR COLOR.  
 FOR ELECTRIC POWERED BICYCLES; MOTORIZED SCOOTERS AND ALL-TERRAIN VEHICLES (U.S. CLS. 19, 21, 23, 31, 35 AND 44).  
 FIRST USE 8-7-2006; IN COMMERCE 8-7-2006.

**CLASS 12—(Continued).**

3,234,751. REGAL MARINE INDUSTRIES, INC., ORLANDO, FL. SN 78-601,428. PUB. 8-8-2006, FILED 4-4-2005.

**CLASS 12—(Continued).**

3,235,175. BALL, BOUNCE AND SPORT INCORPORATED, ASHLAND, OH. SN 78-699,125. PUB. 3-21-2006, FILED 8-24-2005.

## Window Express

# G2 WATER

THE MARK CONSISTS OF STANDARD CHARACTERS WITHOUT CLAIM TO ANY PARTICULAR FONT, STYLE, SIZE, OR COLOR.  
FOR BOAT FENDERS (U.S. CLS. 19, 21, 23, 31, 35 AND 44).  
FIRST USE 8-31-2005; IN COMMERCE 12-1-2006.

THE MARK CONSISTS OF STANDARD CHARACTERS WITHOUT CLAIM TO ANY PARTICULAR FONT, STYLE, SIZE, OR COLOR.  
NO CLAIM IS MADE TO THE EXCLUSIVE RIGHT TO USE "WINDOW", APART FROM THE MARK AS SHOWN.  
FOR BOATS (U.S. CLS. 19, 21, 23, 31, 35 AND 44).  
FIRST USE 10-31-2006; IN COMMERCE 10-31-2006.

3,235,176. INTERNATIONAL TRUCK INTELLECTUAL PROPERTY COMPANY, LLC, WARRENVILLE, IL. SN 78-699,182. PUB. 5-23-2006, FILED 8-24-2005.

# LONESTAR

3,234,796. SEEBOARD PRODUCTS LLC, POINT LOOKOUT, NY. SN 78-620,230. PUB. 4-4-2006, FILED 4-29-2005.

THE MARK CONSISTS OF STANDARD CHARACTERS WITHOUT CLAIM TO ANY PARTICULAR FONT, STYLE, SIZE, OR COLOR.  
FOR LAND VEHICLES, NAMELY, HIGHWAY TRUCKS (U.S. CLS. 19, 21, 23, 31, 35 AND 44).  
FIRST USE 11-9-2006; IN COMMERCE 11-9-2006.



3,235,217. GOODYEAR TIRE & RUBBER COMPANY, THE, AKRON, OH. SN 78-717,430. PUB. 3-21-2006, FILED 9-21-2005.

## RESPONSEEDGE TECHNOLOGY

THE COLOR(S) BLUE IS/ARE CLAIMED AS A FEATURE OF THE MARK.  
THE MARK CONSISTS OF THE STYLIZED WORD SEE-BOARDS WHICH APPEARS IN BLUE, OVER THE FANCIFUL DESIGN OF A WAVE WHICH APPEARS IN BLUE.  
FOR BOAT ACCESSORY, NAMELY, A NON-METAL PLATFORM USED WHILE STEERING BOATS, CONSISTING OF MULTIPLE LAYERS THAT CAN BE ADJUSTED TO APPROPRIATE HEIGHTS, AND PROVIDE CUSHIONING (U.S. CLS. 19, 21, 23, 31, 35 AND 44).  
FIRST USE 3-10-2006; IN COMMERCE 3-10-2006.

THE MARK CONSISTS OF STANDARD CHARACTERS WITHOUT CLAIM TO ANY PARTICULAR FONT, STYLE, SIZE, OR COLOR.  
NO CLAIM IS MADE TO THE EXCLUSIVE RIGHT TO USE "TECHNOLOGY", APART FROM THE MARK AS SHOWN.  
FOR TIRES (U.S. CLS. 19, 21, 23, 31, 35 AND 44).  
FIRST USE 4-12-2006; IN COMMERCE 4-12-2006.

**CLASS 12—(Continued).**

3,235,347. TENDAIRE INDUSTRIES, INC., BERESFORD, SD.  
SN 78-775,269. PUB. 8-22-2006, FILED 12-16-2005.

**TENDER TOW**

THE MARK CONSISTS OF STANDARD CHARACTERS WITHOUT CLAIM TO ANY PARTICULAR FONT, STYLE, SIZE, OR COLOR.

NO CLAIM IS MADE TO THE EXCLUSIVE RIGHT TO USE "TOW", APART FROM THE MARK AS SHOWN.

FOR TRAILER HITCHES (U.S. CLS. 19, 21, 23, 31, 35 AND 44).

FIRST USE 3-0-2006; IN COMMERCE 3-0-2006.

---

3,235,377. RUX, R. DAVID, LITTLETON, CO. SN 78-799,584.  
PUB. 9-12-2006, FILED 1-25-2006.



FOR MOUNTING RACKS FOR VEHICLES, NAMELY, POLE TRANSPORTS FOR LAND SURVEY EQUIPMENT (U.S. CLS. 19, 21, 23, 31, 35 AND 44).

FIRST USE 1-3-2006; IN COMMERCE 1-3-2006.

**CLASS 13—FIREARMS**

3,234,199. THE TRUSTEES OF SALISH TRUST, ANA-CORTES, WA. SN 78-343,838. PUB. 9-27-2005, FILED 12-19-2003.

**EL GRANDE DE FLAMBE**

THE MARK CONSISTS OF STANDARD CHARACTERS WITHOUT CLAIM TO ANY PARTICULAR FONT, STYLE, SIZE, OR COLOR.

THE ENGLISH TRANSLATION OF THE MARK IS "THE GREAT ONE OF FLAMBE."

FOR FIREWORKS (U.S. CLS. 2 AND 9).

FIRST USE 3-1-2004; IN COMMERCE 3-1-2004.

**CLASS 13—(Continued).**

3,234,414. DETONICS, USA, LLC, PENDERGRASS, GA. SN 78-483,310. PUB. 9-6-2005, FILED 9-14-2004.

**ScoreMaster**

THE MARK CONSISTS OF STANDARD CHARACTERS WITHOUT CLAIM TO ANY PARTICULAR FONT, STYLE, SIZE, OR COLOR.

FOR FIREARMS (U.S. CLS. 2 AND 9).

FIRST USE 6-8-2006; IN COMMERCE 6-8-2006.

---

3,234,983. AMICK, DARRYL D., ALBANY, OR. SN 78-657,079.  
PUB. 3-14-2006, FILED 6-23-2005.

**PERMA-GEL**

THE MARK CONSISTS OF STANDARD CHARACTERS WITHOUT CLAIM TO ANY PARTICULAR FONT, STYLE, SIZE, OR COLOR.

FOR SHOOTING BLOCKS AND KITS SOLD AS A UNIT FOR MAKING SHOOTING BLOCKS (U.S. CLS. 2 AND 9).

FIRST USE 9-1-2006; IN COMMERCE 9-1-2006.

---

3,235,091. HS MUNITIONS, INC., STEVENSVILLE, MT. SN 78-671,883. PUB. 3-28-2006, FILED 7-16-2005.

**Urban COPper**

THE MARK CONSISTS OF STANDARD CHARACTERS WITHOUT CLAIM TO ANY PARTICULAR FONT, STYLE, SIZE, OR COLOR.

FOR AMMUNITION (U.S. CLS. 2 AND 9).

FIRST USE 11-1-2006; IN COMMERCE 11-1-2006.

**CLASS 13—(Continued).**

3,235,244. B.J. ALAN COMPANY, YOUNGSTOWN, OH. SN 78-728,718. PUB. 8-8-2006, FILED 10-7-2005.

**CRITICAL BLAST**

THE MARK CONSISTS OF STANDARD CHARACTERS WITHOUT CLAIM TO ANY PARTICULAR FONT, STYLE, SIZE, OR COLOR.

NO CLAIM IS MADE TO THE EXCLUSIVE RIGHT TO USE "BLAST", APART FROM THE MARK AS SHOWN. FOR FIREWORKS (U.S. CLS. 2 AND 9). FIRST USE 3-4-2006; IN COMMERCE 3-13-2006.

**CLASS 14—(Continued).**

3,234,030. STULLER, INC., LAFAYETTE, LA. SN 76-634,693. PUB. 2-28-2006, FILED 3-30-2005.



NO CLAIM IS MADE TO THE EXCLUSIVE RIGHT TO USE "WHITE GOLD", APART FROM THE MARK AS SHOWN. FOR PRECIOUS METALS (U.S. CLS. 2, 27, 28 AND 50). FIRST USE 6-0-2005; IN COMMERCE 6-0-2005.

**CLASS 14—JEWELRY**

3,233,989. WIDE-EYED DESIGNS, LLC, ST. LOUIS, MO. SN 76-621,889. PUB. 6-6-2006, FILED 11-23-2004.

**ARTISTIC**

THE MARK CONSISTS OF STANDARD CHARACTERS WITHOUT CLAIM TO ANY PARTICULAR FONT, STYLE, SIZE, OR COLOR.

FOR CLOCKS, OF PRECIOUS METAL (U.S. CLS. 2, 27, 28 AND 50). FIRST USE 6-1-2006; IN COMMERCE 6-1-2006.

3,234,140. SCHENKEL, LESLIE J., BEVERLY HILLS, CA. SN 78-255,102. PUB. 2-24-2004, FILED 5-28-2003.

**LUXURY BASICS**

FOR WOMEN'S JEWELRY (U.S. CLS. 2, 27, 28 AND 50). FIRST USE 5-30-2003; IN COMMERCE 11-13-2003.

3,234,029. STULLER, INC., LAFAYETTE, LA. SN 76-634,691. PUB. 2-28-2006, FILED 3-30-2005.

**X-1 WHITE GOLD**

THE MARK CONSISTS OF STANDARD CHARACTERS WITHOUT CLAIM TO ANY PARTICULAR FONT, STYLE, SIZE, OR COLOR.

NO CLAIM IS MADE TO THE EXCLUSIVE RIGHT TO USE "WHITE GOLD", APART FROM THE MARK AS SHOWN. FOR PRECIOUS METALS (U.S. CLS. 2, 27, 28 AND 50). FIRST USE 6-0-2005; IN COMMERCE 6-0-2005.

3,234,220. ROSY BLUE, N.V., 2018 ANTWERP, BELGIUM. SN 78-372,190. PUB. 3-1-2005, FILED 2-23-2004.

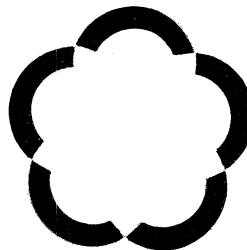

FOR DIAMONDS AND PRECIOUS AND SEMI-PRECIOUS STONES; JEWELRY, NAMELY, EARRINGS, RINGS, BRACELETS, CHARMS, NECKLACES, PENDANTS, PINS AND BROOCHES (U.S. CLS. 2, 27, 28 AND 50). FIRST USE 11-0-2003; IN COMMERCE 11-0-2003.

**CLASS 14—(Continued).**

3,234,434. KIMBERLI J. BRYAN, PINE, CO. SN 78-490,914. PUB. 9-13-2005, FILED 9-28-2004.

**CLASS 14—(Continued).**

3,234,622. AZOTIC COATING TECHNOLOGY, INC., ROCHESTER, MN. SN 78-547,656. PUB. 10-4-2005, FILED 1-14-2005.

UM

AUTUMN'S FIRE

THE MARK CONSISTS OF STANDARD CHARACTERS WITHOUT CLAIM TO ANY PARTICULAR FONT, STYLE, SIZE, OR COLOR.  
FOR JEWELRY (U.S. CLS. 2, 27, 28 AND 50).  
FIRST USE 2-18-2005; IN COMMERCE 8-23-2005.

THE MARK CONSISTS OF STANDARD CHARACTERS WITHOUT CLAIM TO ANY PARTICULAR FONT, STYLE, SIZE, OR COLOR.  
OWNER OF U.S. REG. NO. 2,187,079.  
FOR GEMSTONES (U.S. CLS. 2, 27, 28 AND 50).  
FIRST USE 10-1-2002; IN COMMERCE 10-1-2002.

---

3,234,621. AZOTIC COATING TECHNOLOGY, INC., ROCHESTER, MN. SN 78-547,643. PUB. 10-4-2005, FILED 1-14-2005.

---

3,234,659. AMERICAN GIRL, LLC, EL SEGUNDO, CA. SN 78-567,084. PUB. 4-25-2006, FILED 2-14-2005.

AZOTIC ECSTASY

 American Girl Place

THE MARK CONSISTS OF STANDARD CHARACTERS WITHOUT CLAIM TO ANY PARTICULAR FONT, STYLE, SIZE, OR COLOR.  
OWNER OF U.S. REG. NO. 2,895,072.  
NO CLAIM IS MADE TO THE EXCLUSIVE RIGHT TO USE "AZOTIC", APART FROM THE MARK AS SHOWN.  
FOR GEMSTONES (U.S. CLS. 2, 27, 28 AND 50).  
FIRST USE 1-1-2002; IN COMMERCE 5-1-2002.

OWNER OF U.S. REG. NOS. 2,136,153, 2,771,323, AND OTHERS.  
FOR GIRL'S JEWELRY, NAMELY, BRACELETS, CHARMS AND NECKLACES (U.S. CLS. 2, 27, 28 AND 50).  
FIRST USE 10-1-2006; IN COMMERCE 10-1-2006.



**CLASS 14—(Continued).**

3,234,850. BOSTON RED SOX BASEBALL CLUB LIMITED PARTNERSHIP, BOSTON, MA. SN 78-633,845. PUB. 2-7-2006, FILED 5-20-2005.

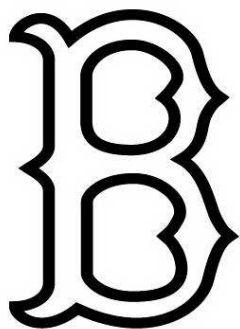

OWNER OF U.S. REG. NOS. 1,060,117, 2,504,257, AND OTHERS.

THE MARK CONSISTS OF THE LETTER "B" IN STYLIZED FORM.

FOR JEWELRY, NAMELY, BRACELETS, CHARMS, EARRINGS, RINGS, BELLY RINGS, NECKLACES, PENDANTS, WATCHES, COSTUME JEWELRY, SILICONE OR RUBBER BRACELETS AND/OR WRISTBANDS, MEDALLIONS, ORNAMENTAL METAL PINS, LAPEL PINS, CUFF LINKS, METAL BELT BUCKLES OF PRECIOUS METAL, MONEY CLIPS OF PRECIOUS METAL, KEY CHAINS OF PRECIOUS METAL, KEY RINGS OF PRECIOUS METAL, CLOCKS, WALL CLOCKS, ALARM CLOCKS, FOB WATCHES, CLOCK KEY CHAINS, AND NON-MONETARY COINS OF PRECIOUS METAL (U.S. CLS. 2, 27, 28 AND 50).

FIRST USE 0-0-1988; IN COMMERCE 0-0-1988.

3,234,913. HEARTS ON FIRE COMPANY LLC, BOSTON, MA. SN 78-647,950. PUB. 2-28-2006, FILED 6-10-2005.

## FRAGRANT

THE MARK CONSISTS OF STANDARD CHARACTERS WITHOUT CLAIM TO ANY PARTICULAR FONT, STYLE, SIZE, OR COLOR.

FOR JEWELRY AND GEMSTONES (U.S. CLS. 2, 27, 28 AND 50).

FIRST USE 11-30-2004; IN COMMERCE 11-30-2004.

**CLASS 14—(Continued).**

3,234,969. FOSTER, LINDA GRAYSON, THOUSAND OAKS, CA. SN 78-654,589. PUB. 2-21-2006, FILED 6-20-2005.

## SASS SPOKEN HERE

THE MARK CONSISTS OF STANDARD CHARACTERS WITHOUT CLAIM TO ANY PARTICULAR FONT, STYLE, SIZE, OR COLOR.

FOR JEWELRY (U.S. CLS. 2, 27, 28 AND 50).  
FIRST USE 1-7-2006; IN COMMERCE 1-7-2006.

3,235,137. EXOTIC CUSTOM JEWELRY, RICHMOND, CA. SN 78-686,668. PUB. 4-25-2006, FILED 8-5-2005.

## ICE TIME

THE MARK CONSISTS OF STANDARD CHARACTERS WITHOUT CLAIM TO ANY PARTICULAR FONT, STYLE, SIZE, OR COLOR.

FOR JEWELRY WATCHES; MECHANICAL AND AUTOMATIC WATCHES; TIMEPIECES; WATCH BANDS AND STRAPS; WATCH FACES; WATCH PARTS; WATCH STRAPS MADE OF METAL OR LEATHER OR PLASTIC; WATCHES; WRIST WATCHES (U.S. CLS. 2, 27, 28 AND 50).

FIRST USE 12-1-2005; IN COMMERCE 12-1-2005.

3,235,138. HERWITT, JENNIFER, WEST HOLLYWOOD, CA. SN 78-687,004. PUB. 4-18-2006, FILED 8-5-2005.



THE MARK CONSISTS OF THE LETTERS J AND H OVERLAYED, WITH DESIGN.

FOR JEWELRY (U.S. CLS. 2, 27, 28 AND 50).  
FIRST USE 3-0-2004; IN COMMERCE 1-15-2006.

**CLASS 14—(Continued).**

3,235,160. THE TC LANE FOUNDATION, SAPULPA, OK. SN 78-694,532. PUB. 5-9-2006, FILED 8-17-2005.

## MAKE A DIFFERENCE WWW.TCLANE.ORG

THE MARK CONSISTS OF STANDARD CHARACTERS WITHOUT CLAIM TO ANY PARTICULAR FONT, STYLE, SIZE, OR COLOR.

FOR SYNTHETIC RUBBER WRISTBANDS IN THE NATURE OF A BRACELET (U.S. CLS. 2, 27, 28 AND 50). FIRST USE 8-1-2006; IN COMMERCE 8-1-2006.

3,235,212. A. T. STORRS LTD., VANCOUVER, BRITISH COLUMBIA, CANADA. SN 78-715,033. PUB. 6-6-2006, FILED 9-16-2005.

## WILD PEARLE

THE MARK CONSISTS OF STANDARD CHARACTERS WITHOUT CLAIM TO ANY PARTICULAR FONT, STYLE, SIZE, OR COLOR.

NO CLAIM IS MADE TO THE EXCLUSIVE RIGHT TO USE "PEARL", APART FROM THE MARK AS SHOWN.

FOR JEWELLERY; BROOCHES; LAPEL PINS (U.S. CLS. 2, 27, 28 AND 50). FIRST USE 1-11-2006; IN COMMERCE 1-11-2006.

3,235,224. DILLARD'S INC., LITTLE ROCK, AR. SN 78-721,167. PUB. 7-4-2006, FILED 9-27-2005.

## ANNA & AVA

THE MARK CONSISTS OF STANDARD CHARACTERS WITHOUT CLAIM TO ANY PARTICULAR FONT, STYLE, SIZE, OR COLOR.

FOR JEWELRY (U.S. CLS. 2, 27, 28 AND 50). FIRST USE 1-30-2006; IN COMMERCE 1-30-2006.

**CLASS 14—(Continued).**

3,235,367. ESPOSITO JEWELRY, INC., PROVIDENCE, RI. SN 78-789,111. PUB. 8-29-2006, FILED 1-11-2006.

## SMART SNAP

THE MARK CONSISTS OF STANDARD CHARACTERS WITHOUT CLAIM TO ANY PARTICULAR FONT, STYLE, SIZE, OR COLOR.

NO CLAIM IS MADE TO THE EXCLUSIVE RIGHT TO USE "SNAP", APART FROM THE MARK AS SHOWN.

FOR JEWELRY, NAMELY AN ATTACHMENT FOR CLOSING A NECKLACE OR BRACELET (U.S. CLS. 2, 27, 28 AND 50).

FIRST USE 6-22-2006; IN COMMERCE 6-22-2006.

**CLASS 15—MUSICAL INSTRUMENTS**

3,233,791. KUN SHOULDER REST INC., THE, OTTAWA, ONTARIO, CANADA. SN 76-395,584. PUB. 3-14-2006, FILED 4-17-2002.

## KUN

PRIORITY CLAIMED UNDER SEC. 44(D) ON CANADA APPLICATION NO. 814061, FILED 2-26-2002, REG. NO. 528,575, DATED 3-25-2005, EXPIRES 3-25-2020.

OWNER OF U.S. REG. NO. 2,347,951. SEC. 2(F).

FOR ROSIN FOR STRINGED INSTRUMENT BOWS; AND BOWS FOR VIOLIN, VIOLA, CELLO AND BASS, VIOLINS, VIOLAS (U.S. CLS. 2, 21 AND 36).

FIRST USE 3-3-2003; IN COMMERCE 4-0-2005.

**CLASS 16—PAPER GOODS AND PRINTED MATTER**

3,233,794. SENA, MIYUKI, TORRANCE, CA. SN 76-398,421. PUB. 7-29-2003, FILED 4-22-2002.

## SID THE YELLOW BIRD

FOR MAGNETIC, CARDBOARD AND STATIONERY BOXES; GREETING CARDS, BLANK GREETING CARDS, CHILDREN'S ACTIVITY BOOKS, COLORING BOOKS, COMIC BOOKS, SERIES OF CHILDREN'S FICTION BOOKS; PENS, PENCILS, AND MARKERS; GIFT WRAPPING PAPER NOTEBOOKS, POSTERS, POSTCARDS, STICKERS, STATIONERY, WRITING PAPER AND CALENDARS (U.S. CLS. 2, 5, 22, 23, 29, 37, 38 AND 50).

FIRST USE 10-19-2006; IN COMMERCE 10-19-2006.

**CLASS 16—(Continued).**

3,233,803. ELKIND + SWEET COMMUNICATIONS, INC., SAN FRANCISCO, CA. SN 76-440,668. PUB. 9-2-2003, FILED 8-15-2002.

**POPCORN PARK**

FOR PAPER GOODS AND PRINTED MATTER, NAMELY, BOOKS FOR CHILDREN; POSTERS (U.S. CLS. 2, 5, 22, 23, 29, 37, 38 AND 50).

FIRST USE 6-2-2003; IN COMMERCE 6-2-2003.

---

3,233,806. PETESKI PRODUCTIONS, INC., IRVING, TX. SN 76-451,859. PUB. 8-12-2003, FILED 9-23-2002.

**DR. PHIL**

THE NAME "DR. PHIL" IDENTIFIES A LIVING INDIVIDUAL WHOSE CONSENT IS OF RECORD.

FOR BOOKS RELATING TO PERSONAL RELATIONSHIPS AND PARENTING, PRINTED INSTRUCTIONAL AND EDUCATIONAL MATERIALS IN THE FIELD OF PERSONAL RELATIONSHIPS AND PARENTING, POSTERS, CALENDARS, PENS, PENCILS, GREETING CARDS, CHRISTMAS CARDS, AUTOGRAPH BOOKS, POSTER BOOKS, ALBUMS, ADDRESS BOOKS, APPOINTMENT BOOKS, PAPER PLACE MATS, PAPER COASTERS, DECALS, STICKERS, NOTEBOOKS, BOOK COVERS, BINDERS, BANK CHECKS, CHECK BOOKS, BUMPER STICKERS, PEN CASES, PENCIL CASES, MAGNETIC BOARDS, NOTE PADS, GIFT WRAPPING PAPER, PAPER BANNERS, UNMOUNTED PHOTOGRAPHS, MOUNTED PHOTOGRAPHS, PRINTED MUSIC BOOKS, POSTCARDS, STATIONERY, TRADING CARDS, AND LITHOGRAPHS (U.S. CLS. 2, 5, 22, 23, 29, 37, 38 AND 50).

FIRST USE 9-30-2003; IN COMMERCE 9-30-2003.

**CLASS 16—(Continued).**

3,233,812. SOURCINGPARTNER, INC., MCKINNEY, TX. SN 76-465,760. PUB. 3-9-2004, FILED 11-12-2002.



NO CLAIM IS MADE TO THE EXCLUSIVE RIGHT TO USE "HOME SCHOOL OFFICE", APART FROM THE MARK AS SHOWN.

FOR OFFICE PRODUCTS, NAMELY, PAPER HOLE PUNCHES, STAPLES, PAPER STAPLERS, STAPLE REMOVERS, BINDER CLIPS, ADHESIVE BACKED REMOVABLE NOTES, REPORT COVERS, PAPER CLIPS, SHEET PROTECTORS, THUMB TACKS, PUSH PINS, CLIP BOARDS, LETTER OPENERS, RUBBER BANDS, DOCUMENT COPY HOLDERS, DESK FILE TRAYS, PENCIL HOLDERS, DESKTOP BUSINESS CARD HOLDERS, CORRECTION TAPE FOR PAPER, CORRECTION FLUID FOR PAPER, DOCUMENT EXPANDING FILES, STRING ENVELOPES, PAPER TRIMMERS, ENVELOPE MOISTENERS, LINED WRITING PADS, LOOSE LEAF RINGS BINDERS, FILE FOLDERS, FILE FRAMES FOR HANGING FILE FOLDERS, WRITING SURFACES IN THE NATURE OF DRY ERASE WHITE BOARDS, WHITE BOARD MARKERS, STAMP PADS, DRAWING RULERS, TRIPPLICATE COPY BOOKS, TELEPHONE MESSAGE PADS, RUBBER STAMPS, AND WRITING INSTRUMENTS (U.S. CLS. 2, 5, 22, 23, 29, 37, 38 AND 50).

FIRST USE 10-1-2004; IN COMMERCE 10-1-2004.

---

3,233,815. DEITSCH, MIRIAM K., WANTAGH, NY. AND LACKMANN, KAY F., SYOSSET, NY. SN 76-473,914. PUB. 7-29-2003, FILED 12-6-2002.

**THE BEAUTY CARE PROXY**

FOR GREETING CARDS (U.S. CLS. 2, 5, 22, 23, 29, 37, 38 AND 50).

FIRST USE 10-13-2006; IN COMMERCE 10-13-2006.

**CLASS 16—(Continued).**

3,233,855. YERETSKAYA, YEVGENIYA, MIAMI, FL. SN 76-533,422. PUB. 12-27-2005, FILED 7-30-2003.

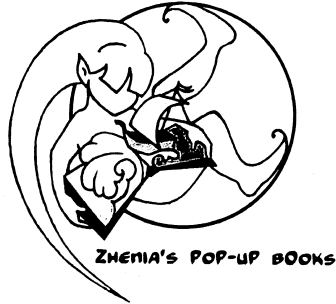

NO CLAIM IS MADE TO THE EXCLUSIVE RIGHT TO USE "POP UP BOOKS", APART FROM THE MARK AS SHOWN.

FOR POP-UP CHILDREN'S BOOKS, NAMELY, CHILDREN'S ACTIVITY BOOKS AND CHILDREN'S INTERACTIVE BOOKS (U.S. CLS. 2, 5, 22, 23, 29, 37, 38 AND 50). FIRST USE 5-17-2006; IN COMMERCE 8-31-2006.

3,233,857. DESI NETWORK, INC., AKA DNI, TUCSON, AZ. SN 76-534,997. PUB. 11-30-2004, FILED 7-24-2003.

**POSTAL BABES**

NO CLAIM IS MADE TO THE EXCLUSIVE RIGHT TO USE "BABES", APART FROM THE MARK AS SHOWN.

FOR PRINTED MATTERS AND PAPER GOODS, NAMELY DESK CALENDARS, WALL CALENDARS, POSTERS, COMIC BOOKS, TRADING CARDS, STICKERS, MAGAZINES AND NEWSLETTERS FEATURING FEMALE MODELS (U.S. CLS. 2, 5, 22, 23, 29, 37, 38 AND 50).

FIRST USE 12-0-2005; IN COMMERCE 8-11-2006.

3,233,865. FRANCE, AMY LEA, ORMOND BEACH, FL. SN 76-554,383. PUB. 9-21-2004, FILED 10-8-2003.

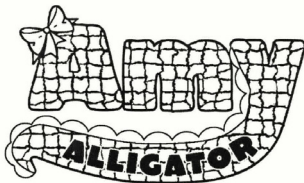

FOR CHILDREN'S BOOKS (U.S. CLS. 2, 5, 22, 23, 29, 37, 38 AND 50). FIRST USE 5-22-2006; IN COMMERCE 5-22-2006.

**CLASS 16—(Continued).**

3,233,869. SACKS, LAUREN P., KATY, TX. SN 76-561,960. PUB. 8-31-2004, FILED 11-25-2003.

**SKY MARSHALL**

FOR FICTIONAL BOOKS (U.S. CLS. 2, 5, 22, 23, 29, 37, 38 AND 50). FIRST USE 11-1-2006; IN COMMERCE 11-1-2006.

3,234,020. ESSELTE CORPORATION, MELVILLE, NY. SN 76-631,705. PUB. 8-8-2006, FILED 2-22-2005.

**OXFORD AT HAND**

FOR DISPENSER FOR PROTECTIVE COVERS FOR PLASTIC SHEETS FOR PROTECTING PAPER DOCUMENTS (U.S. CLS. 2, 5, 22, 23, 29, 37, 38 AND 50). FIRST USE 11-0-2005; IN COMMERCE 11-0-2005.

3,234,088. VANILLA GORILLA, L.P., LOS ANGELES, CA. SN 76-978,466. PUB. 10-4-2005, FILED 9-11-2002.

**FREE JESSE JAMES**

FOR STICKERS (U.S. CLS. 2, 5, 22, 23, 29, 37, 38 AND 50). FIRST USE 8-31-2002; IN COMMERCE 8-31-2002.

3,234,105. MEDBASICS LLC, NEW YORK, NY. SN 78-134,662. PUB. 8-26-2003, FILED 6-11-2002.

**MEDBASICS**

FOR SERIES OF EDUCATIONAL BOOKLETS, INFORMATIONAL CARDS, BOOKS, BROCHURES, AND LAMINATED CARDS DETAILING FIRST AID PROCEDURES FOR INFANTS, BABIES, TODDLERS, AND CHILDREN (U.S. CLS. 2, 5, 22, 23, 29, 37, 38 AND 50). FIRST USE 9-3-2003; IN COMMERCE 9-3-2003.

**CLASS 16—(Continued).**

3,234,123. HEB GROCERY COMPANY, LP, SAN ANTONIO, TX. SN 78-204,117. PUB. 9-2-2003, FILED 1-16-2003.

**WORK SOLUTIONS**

FOR BINDERS; ENVELOPES; CLASP ENVELOPES; FULL LINE OF ADHESIVE TAPES FOR HOUSEHOLD OR STATIONERY USE; OFFICE ACCESSORIES, NAMELY, DESK CALENDARS, DESK FILE TRAYS, DESK PADS, DESK SETS, DESK TOP DOCUMENT RACKS, DESKTOP PLANNERS, PEN OR PENCIL HOLDERS, PEN AND PENCIL TRAYS, ADHESIVE TAPE DISPENSERS FOR HOUSEHOLD OR STATIONERY USE, STAPLE REMOVERS, STAPLERS, PUNCHES, ADDRESS LABELS; SHIPPING LABELS; BLANK, PARTIALLY PRINTED, OR PRINTED LABELS; STICKERS; INDEX DIVIDERS; INDEX CARDS; INDEX BOOKS; REPORT COVERS; LEGAL PADS; WRITING INSTRUMENTS, NAMELY, LEAD PENCILS, MARKERS, GEL PENS, AND HIGHLIGHTERS; PROTECTIVE COVERS FOR SHEETS OF PAPER AND PAGES OF BOOKS AND THE LIKE (U.S. CLS. 2, 5, 22, 23, 29, 37, 38 AND 50).  
FIRST USE 4-0-2003; IN COMMERCE 4-0-2003.

3,234,129. NATIONAL MODEL RAILROAD ASSOCIATION, INC, CHATTANOOGA, TN. SN 78-219,983. PUB. 4-11-2006, FILED 2-28-2003.

**SCALE**  
*Rails*

FOR PRINTED MATERIALS, NAMELY, BOOKS, MAGAZINES, INFORMATION SHEETS AND PERIODICALS IN THE FIELD OF MODEL RAILROAD HOBBYING AND HISTORICAL, COMMERCIAL INDUSTRY AND TECHNICAL INFORMATION PERTAINING TO MODEL RAILROADS AND DESIGN STANDARDS FOR MODEL RAILROADS (U.S. CLS. 2, 5, 22, 23, 29, 37, 38 AND 50).  
FIRST USE 10-1-2003; IN COMMERCE 10-1-2003.

**CLASS 16—(Continued).**

3,234,177. NOVARTIS AG, BASEL, SWITZERLAND. SN 78-317,272. PUB. 6-21-2005, FILED 10-22-2003.

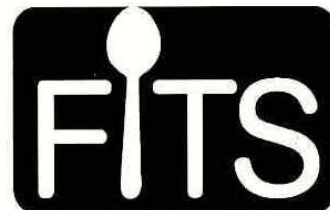

Feeding Infants and Toddlers Study

NO CLAIM IS MADE TO THE EXCLUSIVE RIGHT TO USE "FEEDING INFANTS AND TODDLERS STUDY", APART FROM THE MARK AS SHOWN.

THE MARK CONSISTS OF IN PART OF THE WORD FITS WITH A SPOON FORMING THE LETTER I.

FOR RESEARCH REPORTS FEATURING STUDY OF INFANT AND TODDLER NUTRITIONAL HABITS (U.S. CLS. 2, 5, 22, 23, 29, 37, 38 AND 50).

FIRST USE 1-30-2004; IN COMMERCE 1-30-2004.

3,234,183. PHILLIES FLORIDA LLC, CLEARWATER, FL. SN 78-327,540. PUB. 9-21-2004, FILED 11-13-2003.



NO CLAIM IS MADE TO THE EXCLUSIVE RIGHT TO USE "CLEARWATER", APART FROM THE MARK AS SHOWN.

THE MARK CONSISTS OF THE WORDS "CLEARWATER THRESHERS" STYLIZED WITH A SHARK FOLLOWING A BASEBALL.

FOR PAPER GOODS AND PRINTED MATTER, NAMELY, AUTOGRAPH BOOKS, BINDERS, BOOK-MARKS, BUMPER STICKERS, CALENDARS, CATALOGS OF INTEREST TO BASEBALL FANS, DECALS, MERCHANDISE BAGS, NEWSLETTERS OF INTEREST TO BASEBALL FANS, NOTE PADS, PAPER CONTAINERS, PAPER PENNANTS, PENS, PENCILS, POSTCARDS, POSTERS, PRINTED AWARDS, PRINTED GAME TICKETS, PRINTED GUIDES OF INTEREST TO BASEBALL FANS, REFERENCE BOOKS OF INTEREST TO BASEBALL FANS, SCORE BOOKS, SCORE CARDS, SCORE SHEETS, STATIONERY, STICKERS, STICKER ALBUMS AND TRADING CARDS (U.S. CLS. 2, 5, 22, 23, 29, 37, 38 AND 50).

FIRST USE 10-14-2003; IN COMMERCE 10-14-2003.

**CLASS 16—(Continued).**

3,234,188. NEWELL OPERATING COMPANY, ATLANTA, GA. SN 78-330,028. PUB. 2-1-2005, FILED 11-19-2003.

# PRO GRIP

THE MARK CONSISTS OF STANDARD CHARACTERS WITHOUT CLAIM TO ANY PARTICULAR FONT, STYLE, SIZE, OR COLOR.

NO CLAIM IS MADE TO THE EXCLUSIVE RIGHT TO USE "GRIP", APART FROM THE MARK AS SHOWN.

FOR PAINT APPLICATORS FOR INTERIOR AND EXTERIOR PAINTS (U.S. CLS. 2, 5, 22, 23, 29, 37, 38 AND 50).

FIRST USE 12-1-2004; IN COMMERCE 12-1-2004.

---

3,234,189. NEWELL OPERATING COMPANY, ATLANTA, GA. SN 78-330,059. PUB. 9-27-2005, FILED 11-19-2003.

# PRO TIP

THE MARK CONSISTS OF STANDARD CHARACTERS WITHOUT CLAIM TO ANY PARTICULAR FONT, STYLE, SIZE, OR COLOR.

NO CLAIM IS MADE TO THE EXCLUSIVE RIGHT TO USE "TIP", APART FROM THE MARK AS SHOWN.

FOR PAINT BRUSHES (U.S. CLS. 2, 5, 22, 23, 29, 37, 38 AND 50).

FIRST USE 2-15-2003; IN COMMERCE 2-15-2003.

**CLASS 16—(Continued).**

3,234,235. DISNEY ENTERPRISES, INC., BURBANK, CA. SN 78-380,237. PUB. 8-30-2005, FILED 3-8-2004.

# PHIL OF THE FUTURE

THE MARK CONSISTS OF STANDARD CHARACTERS WITHOUT CLAIM TO ANY PARTICULAR FONT, STYLE, SIZE, OR COLOR.

THE NAME PHIL DOES NOT IDENTIFY A PARTICULAR LIVING INDIVIDUAL.

FOR A SERIES OF FICTION BOOKS (U.S. CLS. 2, 5, 22, 23, 29, 37, 38 AND 50).

FIRST USE 9-1-2005; IN COMMERCE 9-1-2005.

---

3,234,253. INSPIRED TECHNOLOGIES, INC., LE SUEUR, MN. SN 78-385,264. PUB. 3-1-2005, FILED 3-16-2004.

# Paint Block

THE MARK CONSISTS OF STANDARD CHARACTERS WITHOUT CLAIM TO ANY PARTICULAR FONT, STYLE, SIZE, OR COLOR.

FOR ADHESIVE TAPES FOR STATIONERY OR HOUSEHOLD PURPOSES (U.S. CLS. 2, 5, 22, 23, 29, 37, 38 AND 50).

FIRST USE 6-6-2004; IN COMMERCE 11-21-2006.

**CLASS 16—(Continued).**

3,234,256. WORLD WRESTLING ENTERTAINMENT, INC., STAMFORD, CT. SN 78-386,140. PUB. 9-13-2005, FILED 3-17-2004.

# BOOKER T

THE MARK CONSISTS OF STANDARD CHARACTERS WITHOUT CLAIM TO ANY PARTICULAR FONT, STYLE, SIZE, OR COLOR.

OWNER OF U.S. REG. NO. 2,733,461.

THE NAME(S), PORTRAIT(S), AND/OR SIGNATURE(S) SHOWN IN THE MARK IDENTIFIES BOOKER T. HUFFMAN, WHOSE CONSENT(S) TO REGISTER IS SUBMITTED.

FOR PACKAGING, NAMELY BLISTER CARDS, PAPER FOR WRAPPING AND PACKAGING, PAPER POUCHES FOR PACKAGING, PLASTIC BAGS FOR PACKAGING, PLASTIC BUBBLE PACKS FOR WRAPPING OR PACKAGING; COLLECTOR ALBUMS, NAMELY, FOR STICKER COLLECTABLE CARDS, PHOTO COLLECTABLES; LABELS, NAMELY, PRINTED PAPER LABELS, PRINTED SHIPPING LABELS; FOLDERS; PLASTIC BAGS FOR GENERAL USE; PAPER TABLEWARE, NAMELY, PAPER PLACE MATS, PAPER TABLE MATS, PAPER TABLE LINENS; STICKERS; FRAMED PICTURES; PENS; PENCILS; POSTERS; NOTEBOOKS OF PAPER; TRADING CARDS; CALENDARS; PAPER TABLECLOTHS; PHOTOGRAPHS; CHALK; BROCHURES, MAGAZINES, AND NEWSPAPERS CONCERNING SPORTS ENTERTAINMENT; PHOTOGRAPHIC PRINTS; POSTCARDS; GREETING CARDS; PICTURES; DECALS; TEMPORARY TATTOO TRANSFERS; COLORING BOOKS; CHILDREN'S ACTIVITY BOOKS; SOUVENIR PROGRAMS CONCERNING SPORTS ENTERTAINMENT; BOOKS FEATURING PICTORIAL BIOGRAPHIES; COMIC BOOKS; BOOK COVERS; PAPER BOOK MARKERS; BOOKPLATES; PAPER LUNCH BAGS; PAPER NAPKINS; PICTURE BOOKS; STICKER ALBUMS; MEMO PADS; DATE BOOKS; ADDRESS BOOKS; AGENDA BOOKS; PENCIL SHARPENERS; RUBBER STAMPS; STAMP PADS; COLLECTIBLE PREPAID TELEPHONE CARDS NOT MAGNETICALLY ENCODED; COLLECTOR STAMPS, NAMELY, COMMEMORATIVE STAMP SHEETS; CUSTOMIZED PERSONAL BANK CHECKS; CHECKBOOK COVERS AND RETURN ADDRESS LABELS NOT OF TEXTILE; PAPER BANNERS; PRINTED PAPER SIGNS FOR DOORS; PENCIL CASES; DRAWING RULERS; ERASERS, NAMELY, RUBBER ERASERS, CHALK ERASERS, BLACKBOARD ERASERS; SCRIBBLE PAD; PHOTO ALBUMS; BUMPER STICKERS; WINDOW DECALS; LITHOGRAPHS; PAPER PARTY BAGS; PAPER PARTY FAVORS, NAMELY, PAPER HATS; STENCILS FOR TRACING DESIGNS ONTO PAPER; PAPER GIFT WRAP; PAPER CAKE DECORATIONS (U.S. CLS. 2, 5, 22, 29, 37, 38 AND 50).

FIRST USE 3-20-2002; IN COMMERCE 3-20-2002.

**CLASS 16—(Continued).**

3,234,289. WALSCH, TARA-JENELLE C., ASHLAND, OR. SN 78-410,421. PUB. 2-21-2006, FILED 4-29-2004.



THE MARK CONSISTS OF THE SILHOUETTE DESIGN OF A WOMAN DANCING ABOVE THE WORDING SOULEBRATE. COLOR IS NOT CLAIMED AS A FEATURE OF THE MARK.

FOR PRINTED MATTER, NAMELY, MESSAGE COUPON BOOKS TO ENCOURAGE INTERPERSONAL INTERACTION (U.S. CLS. 2, 5, 22, 23, 29, 37, 38 AND 50).

FIRST USE 2-4-2004; IN COMMERCE 9-1-2005.

3,234,298. TEACHER CREATED RESOURCES, INC., WESTMINSTER, CA. SN 78-413,356. PUB. 9-6-2005, FILED 5-5-2004.

# LEARNING TRAIN

THE MARK CONSISTS OF STANDARD CHARACTERS WITHOUT CLAIM TO ANY PARTICULAR FONT, STYLE, SIZE, OR COLOR.

NO CLAIM IS MADE TO THE EXCLUSIVE RIGHT TO USE "LEARNING", APART FROM THE MARK AS SHOWN.

FOR PRINTED EDUCATIONAL MATERIALS FOR USE BY CHILDREN, PARENTS AND TEACHERS IN THE FIELDS OF SOCIAL SCIENCE, LANGUAGE, ART AND MATH; BOOKS CONTAINING EDUCATIONAL ACTIVITIES FOR CHILDREN; LANGUAGE, WORD, MATH, DOT-TO-DOT, WORDSEARCH, MAZE AND CROSSWORD PUZZLES (U.S. CLS. 2, 5, 22, 23, 29, 37, 38 AND 50).

FIRST USE 4-30-2005; IN COMMERCE 4-30-2005.

**CLASS 16—(Continued).**

3,234,315. V.E.W., LTD., NEW YORK, NY. SN 78-426,281. PUB. 9-20-2005, FILED 5-27-2004.

VERA WANG

THE MARK CONSISTS OF STANDARD CHARACTERS WITHOUT CLAIM TO ANY PARTICULAR FONT, STYLE, SIZE, OR COLOR.

OWNER OF U.S. REG. NOS. 2,635,884 AND 2,844,080.

THE NAME VERA WANG IDENTIFIES A LIVING INDIVIDUAL WHOSE CONSENT IS OF RECORD.

FOR STATIONERY; PERSONALIZED WRITING MATERIALS, NAMELY, PERSONALIZED WRITING PAPER AND WRITING IMPLEMENTS; PRINTED INVITATIONS, ANNOUNCEMENT CARDS, PLACE CARDS; WRITING TABLETS, NOTE CARDS, GUEST BOOKS, PHOTO ALBUMS, PLACE CARDS, WRITING INSTRUMENTS, NAMELY, PEN, AND PENCILS (U.S. CLS. 2, 5, 22, 23, 29, 37, 38 AND 50).

FIRST USE 5-15-2005; IN COMMERCE 5-15-2005.

3,234,324. GUIDEPOSTS, A CHURCH CORPORATION, CARMEL, NY. SN 78-433,380. PUB. 5-23-2006, FILED 6-10-2004.

GUIDEPOSTS SWEET  
16

THE MARK CONSISTS OF STANDARD CHARACTERS WITHOUT CLAIM TO ANY PARTICULAR FONT, STYLE, SIZE, OR COLOR.

FOR MAGAZINE RELATING TO SELF IMPROVEMENT AND INSPIRATIONAL SUBJECTS (U.S. CLS. 2, 5, 22, 23, 29, 37, 38 AND 50).

FIRST USE 8-0-2004; IN COMMERCE 8-0-2004.

**CLASS 16—(Continued).**

3,234,337. DYNAMIC PAINT PRODUCTS INC., MISSISSAUGA, ONTARIO, CANADA. SN 78-442,067. PUB. 10-11-2005, FILED 6-28-2004.

STUBBY  
PRO

FOR PAINT BRUSHES (U.S. CLS. 2, 5, 22, 23, 29, 37, 38 AND 50).

FIRST USE 1-1-2005; IN COMMERCE 3-1-2005.

3,234,390. IDEASTREAM CONSUMER PRODUCTS, LLC, PARMA, OH. SN 78-474,263. PUB. 5-2-2006, FILED 8-26-2004.



FOR INK PENS; PEN INK REFILLS; INCLINED DOCUMENT SORTERS; AND DESK TOP TELEPHONE STANDS BEING DESKTOP ORGANIZERS (U.S. CLS. 2, 5, 22, 23, 29, 37, 38 AND 50).

FIRST USE 6-30-2003; IN COMMERCE 6-30-2003.

3,234,396. PRENTISS DOUTHIT, LLC, BIRMINGHAM, AL. SN 78-477,013. PUB. 7-12-2005, FILED 9-1-2004.



THE NAME PRENTISS DOUTHIT IDENTIFIES A LIVING INDIVIDUAL WHOSE CONSENT IS OF RECORD.

FOR STATIONERY, PRINTED INVITATIONS, ANNOUNCEMENT CARDS, PAPER NAPKINS, PRINTED GIFT WRAP PAPER AND PRINTED GREETING CARDS (U.S. CLS. 2, 5, 22, 23, 29, 37, 38 AND 50).

FIRST USE 1-1-2002; IN COMMERCE 1-1-2002.



**CLASS 16—(Continued).**

3,234,398. AGRI-PULSE COMMUNICATIONS, INC., ST. CHARLES, IL. SN 78-477,627. PUB. 7-19-2005, FILED 9-2-2004.

# Agri-Pulse

THE MARK CONSISTS OF STANDARD CHARACTERS WITHOUT CLAIM TO ANY PARTICULAR FONT, STYLE, SIZE, OR COLOR.

FOR NEWSLETTERS DEALING WITH CURRENT ISSUES IN THE FIELD OF AGRICULTURE (U.S. CLS. 2, 5, 22, 23, 29, 37, 38 AND 50).

FIRST USE 1-25-2005; IN COMMERCE 1-25-2005.

3,234,412. WHITFORD WORLDWIDE COMPANY, WILMINGTON, DE. SN 78-482,809. PUB. 9-6-2005, FILED 9-13-2004.

# FixitFast

THE MARK CONSISTS OF STANDARD CHARACTERS WITHOUT CLAIM TO ANY PARTICULAR FONT, STYLE, SIZE, OR COLOR.

FOR ADHESIVES FOR STATIONERY OR HOUSEHOLD PURPOSES (U.S. CLS. 2, 5, 22, 23, 29, 37, 38 AND 50).

FIRST USE 11-20-2006; IN COMMERCE 11-20-2006.

**CLASS 16—(Continued).**

3,234,436. QUESTEX MEDIA GROUP, INC., NEWTON, MA. SN 78-491,322. PUB. 2-21-2006, FILED 9-29-2004.

# LUXURY TRAVEL ADVISOR

THE MARK CONSISTS OF STANDARD CHARACTERS WITHOUT CLAIM TO ANY PARTICULAR FONT, STYLE, SIZE, OR COLOR.

NO CLAIM IS MADE TO THE EXCLUSIVE RIGHT TO USE "LUXURY TRAVEL", APART FROM THE MARK AS SHOWN.

FOR TRADE PUBLICATIONS, NAMELY MAGAZINES FEATURING INFORMATION ON TRAVEL FOR TRAVEL AGENTS (U.S. CLS. 2, 5, 22, 23, 29, 37, 38 AND 50).  
FIRST USE 4-0-2005; IN COMMERCE 4-0-2005.

3,234,474. BODYWISE HEALTH OPTIONS, INC., EVERGREEN, CO. SN 78-506,011. PUB. 10-4-2005, FILED 10-26-2004.

# ERGO ~ SOMA

THE MARK CONSISTS OF STANDARD CHARACTERS WITHOUT CLAIM TO ANY PARTICULAR FONT, STYLE, SIZE, OR COLOR.

FOR EDUCATIONAL PUBLICATIONS, NAMELY, TRAINING MANUALS IN THE FIELD OF OCCUPATIONAL HEALTH (U.S. CLS. 2, 5, 22, 23, 29, 37, 38 AND 50).

FIRST USE 6-4-2005; IN COMMERCE 6-4-2005.

3,234,500. TOWN MONEY SAVER, INC., LUCAS, OH. SN 78-514,356. PUB. 3-14-2006, FILED 11-10-2004.



THE MARK CONSISTS OF SCANNED IMAGE OF STYLIZED STOREFRONTS.

FOR PERIODICAL NEWSPAPERS AND COUPON BOOKS FOR GENERAL CIRCULATION (U.S. CLS. 2, 5, 22, 23, 29, 37, 38 AND 50).

FIRST USE 3-0-2006; IN COMMERCE 3-0-2006.

**CLASS 16—(Continued).**

3,234,516. EVERT-FRESH CORP., KATY, TX. SN 78-518,339.  
PUB. 9-13-2005, FILED 11-17-2004.

**CLASS 16—(Continued).**

3,234,564. THE MCLEAN HOSPITAL CORPORATION, BELMONT, MA. SN 78-530,625. PUB. 9-6-2005, FILED 12-10-2004.

**GREEN LOCK**

THE MARK CONSISTS OF STANDARD CHARACTERS WITHOUT CLAIM TO ANY PARTICULAR FONT, STYLE, SIZE, OR COLOR.

NO CLAIM IS MADE TO THE EXCLUSIVE RIGHT TO USE "GREEN", APART FROM THE MARK AS SHOWN.

FOR PLASTIC BAGS FOR STORING FRUITS, VEGETABLES, AND FLOWERS (U.S. CLS. 2, 5, 22, 23, 29, 37, 38 AND 50).

FIRST USE 2-1-2006; IN COMMERCE 2-1-2006.

**STOP-THINK-RELAX**

THE MARK CONSISTS OF STANDARD CHARACTERS WITHOUT CLAIM TO ANY PARTICULAR FONT, STYLE, SIZE, OR COLOR.

FOR PRINTED REPORTS IN THE FIELDS OF PSYCHIATRY, PSYCHOLOGY, MENTAL HEALTH AND SUBSTANCE ABUSE; BOOKMARKS (U.S. CLS. 2, 5, 22, 23, 29, 37, 38 AND 50).

FIRST USE 6-0-2006; IN COMMERCE 6-0-2006.

3,234,572. BRIGHT ANGLE, NEW YORK, NY. SN 78-532,197.  
PUB. 9-13-2005, FILED 12-14-2004.

**Blank You Notes**

3,234,524. CASIO KEISANKI KABUSHIKI KAISHA, DBA CASIO COMPUTER CO., LTD., SHIBUYA-KU, TOKYO, JAPAN. SN 78-520,241. PUB. 5-2-2006, FILED 11-19-2004.

THE MARK CONSISTS OF STANDARD CHARACTERS WITHOUT CLAIM TO ANY PARTICULAR FONT, STYLE, SIZE, OR COLOR.

NO CLAIM IS MADE TO THE EXCLUSIVE RIGHT TO USE "NOTES", APART FROM THE MARK AS SHOWN.

FOR NOTE CARDS (U.S. CLS. 2, 5, 22, 23, 29, 37, 38 AND 50).

FIRST USE 9-26-2005; IN COMMERCE 2-6-2006.

**LABEL-BIZ**

3,234,615. DEVELOPMENTAL STUDIES CENTER, OAKLAND, CA. SN 78-546,479. PUB. 11-8-2005, FILED 1-12-2005.

THE MARK CONSISTS OF STANDARD CHARACTERS WITHOUT CLAIM TO ANY PARTICULAR FONT, STYLE, SIZE, OR COLOR.

FOR ELECTRONIC LABEL PRINTING MACHINES; PRINTING MACHINES FOR PRINTING DISC TITLES (U.S. CLS. 2, 5, 22, 23, 29, 37, 38 AND 50).

FIRST USE 2-0-2005; IN COMMERCE 2-0-2005.

**Caring School  
Community**

**CLASS 16—(Continued).**

THE MARK CONSISTS OF STANDARD CHARACTERS WITHOUT CLAIM TO ANY PARTICULAR FONT, STYLE, SIZE, OR COLOR.

FOR BOOKS, WORKBOOKS, AND PREPRINTED CARDS RELATING TO SOCIAL AND ACADEMIC DEVELOPMENT FOR CHILDREN GRADES KINDERGARTEN THROUGH 6TH GRADE (U.S. CLS. 2, 5, 22, 23, 29, 37, 38 AND 50).

FIRST USE 12-31-1995; IN COMMERCE 12-31-1995.

**CLASS 16—(Continued).**

3,234,708. SELLARS ABSORBENT MATERIALS, INC., MILWAUKEE, WI. SN 78-587,881. PUB. 1-10-2006, FILED 3-15-2005.

3,234,619. PURDUE PRODUCTS L.P., STAMFORD, CT. SN 78-547,593. PUB. 3-7-2006, FILED 1-14-2005.

NO BODY IS  
COMPLETE WITHOUT  
IT

THE MARK CONSISTS OF STANDARD CHARACTERS WITHOUT CLAIM TO ANY PARTICULAR FONT, STYLE, SIZE, OR COLOR.

FOR PRINTED MATTER, NAMELY INFORMATIONAL BROCHURES IN THE FIELD OF NUTRITIONAL SUPPLEMENTS (U.S. CLS. 2, 5, 22, 23, 29, 37, 38 AND 50).

FIRST USE 6-30-2004; IN COMMERCE 6-30-2004.

THE MARK CONSISTS OF STANDARD CHARACTERS WITHOUT CLAIM TO ANY PARTICULAR FONT, STYLE, SIZE, OR COLOR.

FOR PAPER TOWELS COMPRISED OF WOOD PULP AND BINDING AGENTS (U.S. CLS. 2, 5, 22, 23, 29, 37, 38 AND 50).

FIRST USE 3-25-2005; IN COMMERCE 3-25-2005.

**BRAVO**

3,234,654. PIZZA HUT, INC., DALLAS, TX. SN 78-564,848. PUB. 4-25-2006, FILED 2-10-2005.

**L.A.B.**

THE MARK CONSISTS OF STANDARD CHARACTERS WITHOUT CLAIM TO ANY PARTICULAR FONT, STYLE, SIZE, OR COLOR.

FOR ACTIVITY BOOKS FOR CHILDREN, STICKERS, STICKER BOOKS, COLORING BOOKS, PAPER NAPKINS, PAPER PLACE MATS, PAPER TRAY COVERS, PAPER MENUS; CARDBOARD ARTICLES, NAMELY, CARDBOARD CONTAINERS, CARTONS AND BOXES; STATIONERY, GREETING CARDS, POSTCARDS, PRINTED INVITATIONS; PARTY SUPPLIES, NAMELY, PAPER PARTY BAGS, PAPER PARTY DECORATIONS, PAPER PARTY HATS (U.S. CLS. 2, 5, 22, 23, 29, 37, 38 AND 50).

FIRST USE 8-1-2005; IN COMMERCE 8-1-2005.

3,234,727. RYDER, TRACEY, OJAI, CA. AND TOPALIAN, CAROLE, OJAI, CA. SN 78-595,178. PUB. 12-27-2005, FILED 3-25-2005.

**Edible Chesapeake**

THE MARK CONSISTS OF STANDARD CHARACTERS WITHOUT CLAIM TO ANY PARTICULAR FONT, STYLE, SIZE, OR COLOR.

NO CLAIM IS MADE TO THE EXCLUSIVE RIGHT TO USE "CHESAPEAKE", APART FROM THE MARK AS SHOWN.

FOR PUBLICATIONS NAMELY MAGAZINES AND NEWSLETTERS RELATING TO THE TOURISM, CULINARY AND AGRICULTURE INDUSTRIES; PUBLICATIONS NAMELY MAGAZINES AND NEWSLETTERS DEALING WITH CONNECTING CONSUMERS WITH LOCAL GROWERS, FOOD RETAILERS, CHEFS AND FOOD ARTISANS (U.S. CLS. 2, 5, 22, 23, 29, 37, 38 AND 50).

FIRST USE 12-1-2005; IN COMMERCE 12-1-2005.

**CLASS 16—(Continued).**

3,234,735. EXECUTOR OF THE JOYCE JILLSON GALLAGHER ESTATE, SHERMAN OAKS, CA. SN 78-596,551. PUB. 10-25-2005, FILED 3-28-2005.

# PETROLOGY

THE MARK CONSISTS OF STANDARD CHARACTERS WITHOUT CLAIM TO ANY PARTICULAR FONT, STYLE, SIZE, OR COLOR.

FOR PAPER GOODS AND PUBLICATIONS, NAMELY, BOOKS DEALING WITH ASTROLOGY, MAGAZINE AND NEWSPAPER COLUMNS DEALING WITH ASTROLOGY (U.S. CLS. 2, 5, 22, 23, 29, 37, 38 AND 50).

FIRST USE 10-15-2005; IN COMMERCE 10-15-2005.

3,234,740. STERLING PUBLISHING CO., INC., NEW YORK, NY. SN 78-597,870. PUB. 12-27-2005, FILED 3-30-2005.

## SUPER LITTLE GIANT

THE MARK CONSISTS OF STANDARD CHARACTERS WITHOUT CLAIM TO ANY PARTICULAR FONT, STYLE, SIZE, OR COLOR.

OWNER OF U.S. REG. NO. 2,179,291.

FOR SERIES OF FICTION AND NON-FICTION BOOKS ON A VARIETY OF TOPICS (U.S. CLS. 2, 5, 22, 23, 29, 37, 38 AND 50).

FIRST USE 9-30-2005; IN COMMERCE 9-30-2005.

3,234,746. STERLING PUBLISHING CO., INC., NEW YORK, NY. SN 78-600,316. PUB. 12-27-2005, FILED 4-1-2005.



OWNER OF U.S. REG. NO. 2,179,291.

NO CLAIM IS MADE TO THE EXCLUSIVE RIGHT TO USE "BOOK", APART FROM THE MARK AS SHOWN.

FOR SERIES OF FICTION AND NON-FICTION BOOKS ON A VARIETY OF TOPICS (U.S. CLS. 2, 5, 22, 23, 29, 37, 38 AND 50).

FIRST USE 9-30-2005; IN COMMERCE 9-30-2005.

**CLASS 16—(Continued).**

3,234,748. BAHL, VALERIE WAKEFIELD, SPARKS, NV. SN 78-600,791. PUB. 4-4-2006, FILED 4-4-2005.

## Quartermoon Quilts

THE MARK CONSISTS OF STANDARD CHARACTERS WITHOUT CLAIM TO ANY PARTICULAR FONT, STYLE, SIZE, OR COLOR.

NO CLAIM IS MADE TO THE EXCLUSIVE RIGHT TO USE "QUILTS", APART FROM THE MARK AS SHOWN.

FOR PRINTED QUILT PATTERNS AND QUILTING INSTRUCTION SHEETS (U.S. CLS. 2, 5, 22, 23, 29, 37, 38 AND 50).

FIRST USE 1-1-2005; IN COMMERCE 1-12-2006.

3,234,752. CROPPORTUNITIES, MARSHFIELD, WI. SN 78-601,558. PUB. 7-18-2006, FILED 4-4-2005.



THE COLOR(S) LIGHT BLUE, DARK BLUE AND LIME GREEN ARE CLAIMED AS A FEATURE OF THE MARK.

THE COLOR(S) LIGHT BLUE APPEARS ON THE INCOMPLETE SQUARE AROUND THE CIRCLE. THE DARK BLUE APPEARS IN THE WORD "CROPPORTUNITIES" AND AROUND THE INCOMPLETE SQUARE. THE COLOR LIME GREEN APPEARS IN THE BACKGROUND AROUND THE "C".

FOR SCRAPBOOKING SUPPLIES, NAMELY, SCRAPBOOK PAGES; PAPER CRAFT SUPPLIES, NAMELY, CRAFT PAPER (U.S. CLS. 2, 5, 22, 23, 29, 37, 38 AND 50). FIRST USE 11-1-2005; IN COMMERCE 11-1-2005.

3,234,836. DENNING, SUZY C., DBA OPEN DOOR PRODUCTS, CORTE MADERA, CA. SN 78-630,824. PUB. 4-4-2006, FILED 5-16-2005.

## Denning's Treat Calendars

THE MARK CONSISTS OF STANDARD CHARACTERS WITHOUT CLAIM TO ANY PARTICULAR FONT, STYLE, SIZE, OR COLOR.

NO CLAIM IS MADE TO THE EXCLUSIVE RIGHT TO USE "TREAT CALENDAR", APART FROM THE MARK AS SHOWN.

FOR HOLIDAY CALENDARS WITH ORIGINAL ARTWORK CONTAINING COOKIES AND CANDIES FOR PETS WHERE EACH CALENDAR HAS 24 DOORS WITH EACH DOOR CONTAINING ONE TREAT (U.S. CLS. 2, 5, 22, 23, 29, 37, 38 AND 50).

FIRST USE 8-1-2005; IN COMMERCE 8-1-2005.

**CLASS 16—(Continued).**

3,234,837. IBASIS, INC., BURLINGTON, MA. SN 78-631,051.  
PUB. 2-28-2006, FILED 5-16-2005.

**CLASS 16—(Continued).**

3,234,961. PORTAL PUBLICATIONS, LTD., NOVATO, CA. SN  
78-654,191. PUB. 3-14-2006, FILED 6-20-2005.

# El General

THE MARK CONSISTS OF STANDARD CHARACTERS WITHOUT CLAIM TO ANY PARTICULAR FONT, STYLE, SIZE, OR COLOR.

THE FOREIGN WORDING IN THE MARK TRANSLATES INTO ENGLISH AS THE USUAL OR THE COMMANDER.

FOR TELEPHONE CALLING CARD, NOT MAGNETICALLY ENCODED (U.S. CLS. 2, 5, 22, 23, 29, 37, 38 AND 50).

FIRST USE 5-1-2006; IN COMMERCE 5-1-2006.

# FINISHING TOUCHES

THE MARK CONSISTS OF STANDARD CHARACTERS WITHOUT CLAIM TO ANY PARTICULAR FONT, STYLE, SIZE, OR COLOR.

FOR PRINTED GOODS AND PRINTED MATTER, NAMELY, ART PRINTS, ART REPRODUCTIONS, PHOTOGRAPHS AND PHOTOGRAPH REPRODUCTIONS (U.S. CLS. 2, 5, 22, 23, 29, 37, 38 AND 50).

FIRST USE 1-25-2006; IN COMMERCE 1-25-2006.

3,234,880. GENERAL MILLS, INC., MINNEAPOLIS, MN. SN  
78-641,072. PUB. 2-21-2006, FILED 6-1-2005.

3,234,962. PORTAL PUBLICATIONS, LTD., NOVATO, CA. SN  
78-654,232. PUB. 2-28-2006, FILED 6-20-2005.

# EZ PRO

THE MARK CONSISTS OF STANDARD CHARACTERS WITHOUT CLAIM TO ANY PARTICULAR FONT, STYLE, SIZE, OR COLOR.

FOR CARDBOARD CARTONS, PAPER CARTONS AND PLASTIC BAGS FOR PACKAGING (U.S. CLS. 2, 5, 22, 23, 29, 37, 38 AND 50).

FIRST USE 12-0-2005; IN COMMERCE 12-0-2005.

# STUDIO ACCENTS

THE MARK CONSISTS OF STANDARD CHARACTERS WITHOUT CLAIM TO ANY PARTICULAR FONT, STYLE, SIZE, OR COLOR.

FOR PRINTED GOODS AND PRINTED MATTER, NAMELY, ART PRINTS, ART REPRODUCTIONS, PHOTOGRAPHS AND PHOTOGRAPH REPRODUCTIONS (U.S. CLS. 2, 5, 22, 23, 29, 37, 38 AND 50).

FIRST USE 7-22-2005; IN COMMERCE 7-22-2005.

3,234,950. CHEVRON CORPORATION, SAN RAMON, CA.  
SN 78-652,981. PUB. 3-14-2006, FILED 6-17-2005.

3,234,982. PACON CORPORATION, APPLETON, WI. SN 78-  
656,751. PUB. 3-7-2006, FILED 6-23-2005.

FILL UP...WITH NEWS AND  
INFORMATION FROM CHEVRON  
AND TEXACO

# TANDEM TONES

THE MARK CONSISTS OF STANDARD CHARACTERS WITHOUT CLAIM TO ANY PARTICULAR FONT, STYLE, SIZE, OR COLOR.

FOR NEWSLETTER OF GENERAL INTEREST TO MOTORISTS (U.S. CLS. 2, 5, 22, 23, 29, 37, 38 AND 50).

FIRST USE 8-22-2005; IN COMMERCE 8-22-2005.

THE MARK CONSISTS OF STANDARD CHARACTERS WITHOUT CLAIM TO ANY PARTICULAR FONT, STYLE, SIZE, OR COLOR.

FOR POSTER BOARD (U.S. CLS. 2, 5, 22, 23, 29, 37, 38 AND 50).

FIRST USE 12-13-2005; IN COMMERCE 12-13-2005.

**CLASS 16—(Continued).**

3,235,018. HARPERCOLLINS PUBLISHERS L.L.C., NEW YORK, NY. SN 78-661,834. PUB. 3-21-2006, FILED 6-30-2005.



H A R P E R  
P E R E N N I A L

OWNER OF U.S. REG. NOS. 1,463,434 AND 2,578,299.  
FOR PRINTED FICTION AND NON-FICTION BOOKS  
ON A VARIETY OF TOPICS (U.S. CLS. 2, 5, 22, 23, 29, 37,  
38 AND 50).  
FIRST USE 4-30-2005; IN COMMERCE 4-30-2005.

3,235,019. DIETZ DESIGNS, HOUSTON, TX. SN 78-661,840.  
PUB. 3-28-2006, FILED 6-30-2005.

GRIPPEN

THE MARK CONSISTS OF STANDARD CHARACTERS  
WITHOUT CLAIM TO ANY PARTICULAR FONT, STYLE,  
SIZE, OR COLOR.  
FOR WRITING INSTRUMENTS, NAMELY PENS (U.S.  
CLS. 2, 5, 22, 23, 29, 37, 38 AND 50).  
FIRST USE 2-0-2006; IN COMMERCE 2-0-2006.

3,235,021. HARPERCOLLINS PUBLISHERS L.L.C., NEW  
YORK, NY. SN 78-661,860. PUB. 3-21-2006, FILED 6-30-2005.

H A R P E R  P E R E N N I A L

OWNER OF U.S. REG. NOS. 1,463,434 AND 2,578,299.  
FOR PRINTED FICTION AND NON-FICTION BOOKS  
ON A VARIETY OF TOPICS (U.S. CLS. 2, 5, 22, 23, 29, 37,  
38 AND 50).  
FIRST USE 4-30-2005; IN COMMERCE 4-30-2005.

**CLASS 16—(Continued).**

3,235,073. MORELL, ERNESTO, MIAMI, FL. SN 78-668,665.  
PUB. 4-18-2006, FILED 7-12-2005.

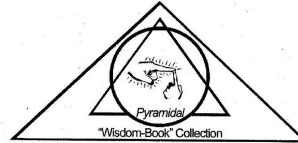

NO CLAIM IS MADE TO THE EXCLUSIVE RIGHT TO  
USE "COLLECTION", APART FROM THE MARK AS  
SHOWN.

FOR SERIES OF BOOKS IN THE FIELD OF PHILO-  
SOPHY, THEOLOGY, HISTORY AND HUMAN BEHA-  
VIOR (U.S. CLS. 2, 5, 22, 23, 29, 37, 38 AND 50).  
FIRST USE 10-3-2006; IN COMMERCE 10-3-2006.

3,235,076. HODGES, VANNIE KAY, ANN ARBOR, MI. SN 78-  
669,243. PUB. 4-4-2006, FILED 7-13-2005.

JIFF

THE MARK CONSISTS OF STANDARD CHARACTERS  
WITHOUT CLAIM TO ANY PARTICULAR FONT, STYLE,  
SIZE, OR COLOR.

FOR PRINTED MATERIALS, NAMELY, QUESTION-  
NAIRES, SURVEYS, CHECKLISTS, ANSWER SHEETS,  
INSTRUCTION MANUALS, GUIDEBOOKS, INFORMA-  
TION SHEETS, PRINTED FORMS, AND PAMPHLETS,  
ALL RELATED TO THE PSYCHOLOGICAL ASSESS-  
MENT OF CHILDREN AND ADOLESCENTS (U.S. CLS.  
2, 5, 22, 23, 29, 37, 38 AND 50).

FIRST USE 11-15-2005; IN COMMERCE 11-15-2005.

3,235,081. MITSUBISHI PENCIL CO., LTD., TOKYO, JAPAN.  
SN 78-669,731. PUB. 3-28-2006, FILED 7-13-2005.

PREMIER  
207  
▼

FOR WRITING INSTRUMENTS (U.S. CLS. 2, 5, 22, 23,  
29, 37, 38 AND 50).  
FIRST USE 4-1-2005; IN COMMERCE 4-1-2005.

**CLASS 16—(Continued).**

3,235,104. NATIONAL ASSOCIATION OF REALTORS, CHICAGO, IL. SN 78-676,117. PUB. 4-11-2006, FILED 7-22-2005.

## REAL ESTATE BROKERAGE ESSENTIALS

THE MARK CONSISTS OF STANDARD CHARACTERS WITHOUT CLAIM TO ANY PARTICULAR FONT, STYLE, SIZE, OR COLOR.

NO CLAIM IS MADE TO THE EXCLUSIVE RIGHT TO USE "REAL ESTATE BROKERAGE", APART FROM THE MARK AS SHOWN.

FOR REFERENCE BOOKS IN THE FIELD OF REAL ESTATE BROKERAGE MANAGEMENT AND OPERATION (U.S. CLS. 2, 5, 22, 23, 29, 37, 38 AND 50).

FIRST USE 10-1-2006; IN COMMERCE 10-1-2006.

---

3,235,124. JAKKS PACIFIC, INC., MALIBU, CA. SN 78-681,727. PUB. 4-11-2006, FILED 7-29-2005.

## SENSORPRO

THE MARK CONSISTS OF STANDARD CHARACTERS WITHOUT CLAIM TO ANY PARTICULAR FONT, STYLE, SIZE, OR COLOR.

FOR WRITING INSTRUMENTS (U.S. CLS. 2, 5, 22, 23, 29, 37, 38 AND 50).

FIRST USE 1-16-2003; IN COMMERCE 1-16-2003.

---

3,235,131. QUINCE MEDIA, LLC, VAN ALSTYNE, TX. SN 78-683,297. PUB. 4-11-2006, FILED 8-2-2005.

## QUINCE

THE MARK CONSISTS OF STANDARD CHARACTERS WITHOUT CLAIM TO ANY PARTICULAR FONT, STYLE, SIZE, OR COLOR.

THE FOREIGN WORDING IN THE MARK TRANSLATES INTO ENGLISH AS FIFTEEN.

FOR MAGAZINES FEATURING ENTERTAINMENT AND INFORMATION FOR TEENAGE AUDIENCE AND PARENTS (U.S. CLS. 2, 5, 22, 23, 29, 37, 38 AND 50).

FIRST USE 3-7-2006; IN COMMERCE 3-7-2006.

**CLASS 16—(Continued).**

3,235,147. JERRY F. HUTCHINS, INC., COVINGTON, GA. SN 78-689,080. PUB. 4-18-2006, FILED 8-9-2005.

## SKANVELOPE

THE MARK CONSISTS OF STANDARD CHARACTERS WITHOUT CLAIM TO ANY PARTICULAR FONT, STYLE, SIZE, OR COLOR.

FOR CUSTOMIZED PRINTED FORMS AND ENVELOPES FOR USE IN ENVELOPE-BASED DATA COLLECTION, PAYMENT COLLECTION, OFFERING COLLECTION, TITHE COLLECTION AND DATA ANALYSIS (U.S. CLS. 2, 5, 22, 23, 29, 37, 38 AND 50).

FIRST USE 7-12-2005; IN COMMERCE 7-12-2005.

---

3,235,148. WARNER BROS. ENTERTAINMENT INC., BURBANK, CA. SN 78-689,899. PUB. 5-16-2006, FILED 8-10-2005.

## THE ANT BULLY

THE MARK CONSISTS OF STANDARD CHARACTERS WITHOUT CLAIM TO ANY PARTICULAR FONT, STYLE, SIZE, OR COLOR.

FOR PRINTED MATTER AND PAPER GOODS - NAMELY, BOOKS FEATURING CHARACTERS FROM ANIMATED, ACTION ADVENTURE, COMEDY AND/OR DRAMA FEATURES, COMIC BOOKS, CHILDREN'S BOOKS, MAGAZINES FEATURING CHARACTERS FROM ANIMATED, ACTION ADVENTURE, COMEDY AND/OR DRAMA FEATURES, COLORING BOOKS, CHILDREN'S ACTIVITY BOOKS; STATIONERY, WRITING PAPER, ENVELOPES, NOTEBOOKS, DIARIES, NOTE CARDS, GREETING CARDS, TRADING CARDS; LITHOGRAPHS; PENS, PENCILS, CASES THEREFOR, ERASERS, CRAYONS, MARKERS, COLORED PENCILS, PAINTING SETS, CHALK AND CHALKBOARDS; DECALS, HEAT TRANSFERS; POSTERS; MOUNTED AND/OR UNMOUNTED PHOTOGRAPHS; BOOK COVERS, BOOK MARKS, CALENDARS, GIFT WRAPPING PAPER; PAPER PARTY FAVORS AND PAPER PARTY DECORATIONS - NAMELY, PAPER NAPKINS, PAPER DOILIES, PAPER PLACE MATS, CREPE PAPER, PAPER HATS, INVITATIONS, PAPER TABLE CLOTHS, PAPER CAKE DECORATIONS; PRINTED TRANSFERS FOR EMBROIDERY OR FABRIC APPLIQUES; PRINTED PATTERNS FOR COSTUMES, PAJAMAS, SWEATSHIRTS AND T-SHIRTS (U.S. CLS. 2, 5, 22, 23, 29, 37, 38 AND 50).

FIRST USE 7-1-2006; IN COMMERCE 7-1-2006.

**CLASS 16—(Continued).**

3,235,161. NEW TAN, INC., LOS ANGELES, CA. SN 78-694,578. PUB. 5-2-2006, FILED 8-17-2005.

### Discover Beauty Beyond The Sun

THE MARK CONSISTS OF STANDARD CHARACTERS WITHOUT CLAIM TO ANY PARTICULAR FONT, STYLE, SIZE, OR COLOR.

FOR PRINTED VISUALS IN THE NATURE OF PUBLICATIONS, NAMELY, BOOKLETS, BROCHURES, MAGAZINES, TRADE JOURNALS AND NEWSLETTERS RELATING TO SKIN CARE PRODUCTS, THE SALE AND MARKETING OF SKIN CARE PRODUCTS, THE OPERATION OF RETAIL ESTABLISHMENTS AND THE OPERATION OF DISTRIBUTORSHIPS RELATING TO SKIN CARE PRODUCTS; PRESENTATION BOARDS; AND POSTERS (U.S. CLS. 2, 5, 22, 23, 29, 37, 38 AND 50).  
FIRST USE 3-0-2006; IN COMMERCE 3-0-2006.

---

3,235,177. CLARKE AMERICAN CHECKS, INC., SAN ANTONIO, TX. SN 78-699,229. PUB. 7-18-2006, FILED 8-24-2005.

## COLLEAGUE

THE MARK CONSISTS OF STANDARD CHARACTERS WITHOUT CLAIM TO ANY PARTICULAR FONT, STYLE, SIZE, OR COLOR.

FOR CHECKBOOK COVERS AND BINDERS (U.S. CLS. 2, 5, 22, 23, 29, 37, 38 AND 50).  
FIRST USE 1-1-2006; IN COMMERCE 1-1-2006.

---

3,235,193. POTLATCH CORPORATION, SPOKANE, WA. SN 78-705,665. PUB. 7-25-2006, FILED 9-1-2005.

## SIMPLY SOFT

THE MARK CONSISTS OF STANDARD CHARACTERS WITHOUT CLAIM TO ANY PARTICULAR FONT, STYLE, SIZE, OR COLOR.

NO CLAIM IS MADE TO THE EXCLUSIVE RIGHT TO USE SOFT, APART FROM THE MARK AS SHOWN.

FOR FACIAL AND BATHROOM TISSUE (U.S. CLS. 2, 5, 22, 23, 29, 37, 38 AND 50).  
FIRST USE 2-1-2006; IN COMMERCE 2-1-2006.

**CLASS 16—(Continued).**

3,235,216. MARSHALL CAVENDISH CORPORATION, TARRYTOWN, NY. SN 78-717,312. PUB. 7-25-2006, FILED 9-21-2005.



THE COLOR(S) RED, YELLOW, AND WHITE IS/ARE CLAIMED AS A FEATURE OF THE MARK.

THE COLOR(S) RED APPEARS AS CIRCLES AT THE TOP PORTION OF THE MARK, THE COLOR YELLOW APPEARS AS THE LETTERS RE AND A SCHOOLBUS IN THE BOTTOM PORTION OF THE MARK, THE COLOR WHITE APPEARS AS LETTERING IN THE TOP PORTION OF THE MARK AND IN THE BOTTOM PORTION OF THE MARK AS WINDOWS IS/ARE CLAIMED AS A FEATURE OF THE MARK

FOR CHILDREN'S BOOKS; EDUCATIONAL BOOKS FEATURING REBUSES; SERIES OF NON-FICTION BOOKS IN THE FIELD OF CHILDREN'S STORIES (U.S. CLS. 2, 5, 22, 23, 29, 37, 38 AND 50).  
FIRST USE 9-15-2006; IN COMMERCE 9-15-2006.

---

3,235,221. HANOVER, AMBER, LAS VEGAS, NV. SN 78-720,258. PUB. 7-18-2006, FILED 9-26-2005.

## Homebuyers Helper

THE MARK CONSISTS OF STANDARD CHARACTERS WITHOUT CLAIM TO ANY PARTICULAR FONT, STYLE, SIZE, OR COLOR.

NO CLAIM IS MADE TO THE EXCLUSIVE RIGHT TO USE "HOMEBUYERS", APART FROM THE MARK AS SHOWN.

FOR MAGAZINES FEATURING GUIDANCE AND RESOURCES FOR HOMEBUYERS AND HOMEOWNERS ON MORTGAGES, HOME IMPROVEMENT LOANS, INTERIOR AND EXTERIOR DECORATING AND DESIGN, HOME IMPROVEMENTS AND REPAIRS, SELLING A HOME WITH AN AGENT, SELLING A HOME WITHOUT AN AGENT, BUYING A HOME WITH AN AGENT, AND BUYING A HOME WITHOUT AN AGENT (U.S. CLS. 2, 5, 22, 23, 29, 37, 38 AND 50).  
FIRST USE 5-3-2006; IN COMMERCE 5-3-2006.



**CLASS 16—(Continued).**

3,235,233. MEADWESTVACO CORPORATION, GLEN ALLEN, VA. SN 78-725,820. PUB. 5-30-2006, FILED 10-4-2005.

## SMART TOOLS FOR PAPER PEOPLE

THE MARK CONSISTS OF STANDARD CHARACTERS WITHOUT CLAIM TO ANY PARTICULAR FONT, STYLE, SIZE, OR COLOR.

FOR CALENDAR DESK PADS; CALENDARS; DAILY PLANNERS; DESKTOP ORGANIZERS; DESKTOP PLANNERS; PADFOLIOS; PERSONAL ORGANIZERS (U.S. CLS. 2, 5, 22, 23, 29, 37, 38 AND 50).

FIRST USE 7-31-2006; IN COMMERCE 7-31-2006.

---

3,235,243. MEDICAL WORLD BUSINESS PRESS, INC., JAMESBURG, NJ. SN 78-728,574. PUB. 7-25-2006, FILED 10-7-2005.

## CONTEMPORARY ESTHETICS

THE MARK CONSISTS OF STANDARD CHARACTERS WITHOUT CLAIM TO ANY PARTICULAR FONT, STYLE, SIZE, OR COLOR.

OWNER OF U.S. REG. NOS. 2,207,120 AND 2,401,533. NO CLAIM IS MADE TO THE EXCLUSIVE RIGHT TO USE "ESTHETICS", APART FROM THE MARK AS SHOWN. FOR MAGAZINES AND NEWSLETTERS IN THE FIELD OF DENTISTRY (U.S. CLS. 2, 5, 22, 23, 29, 37, 38 AND 50).

FIRST USE 1-0-2006; IN COMMERCE 1-0-2006.

---

3,235,317. NYP HOLDINGS, INC., NEW YORK, NY. SN 78-763,580. PUB. 1-31-2006, FILED 11-30-2005.

# PAGE SIX

THE MARK CONSISTS OF STANDARD CHARACTERS WITHOUT CLAIM TO ANY PARTICULAR FONT, STYLE, SIZE, OR COLOR.

OWNER OF U.S. REG. NOS. 1,678,509 AND 2,851,018. FOR MAGAZINE IN THE FIELD OF GOSSIP, ENTERTAINMENT, AND CELEBRITY NEWS AND EVENTS (U.S. CLS. 2, 5, 22, 23, 29, 37, 38 AND 50).

FIRST USE 2-9-2006; IN COMMERCE 2-9-2006.

**CLASS 16—(Continued).**

3,235,325. POTLATCH FOREST PRODUCTS CORPORATION, SPOKANE, WA. SN 78-765,460. PUB. 7-25-2006, FILED 12-2-2005.

## SIMPLY ELEGANT

THE MARK CONSISTS OF STANDARD CHARACTERS WITHOUT CLAIM TO ANY PARTICULAR FONT, STYLE, SIZE, OR COLOR.

FOR PAPER NAPKINS (U.S. CLS. 2, 5, 22, 23, 29, 37, 38 AND 50).

FIRST USE 6-1-2006; IN COMMERCE 6-1-2006.

---

3,235,349. THE ALLEGHENY COUNTY BAR ASSOCIATION, PITTSBURGH, PA. SN 78-775,906. PUB. 8-22-2006, FILED 12-19-2005.

## Today's Attorney

THE MARK CONSISTS OF STANDARD CHARACTERS WITHOUT CLAIM TO ANY PARTICULAR FONT, STYLE, SIZE, OR COLOR.

OWNER OF U.S. REG. NO. 3,020,706. NO CLAIM IS MADE TO THE EXCLUSIVE RIGHT TO USE "ATTORNEY", APART FROM THE MARK AS SHOWN. FOR GENERAL FEATURE MAGAZINES (U.S. CLS. 2, 5, 22, 23, 29, 37, 38 AND 50).

FIRST USE 1-1-2006; IN COMMERCE 3-1-2006.

**CLASS 17—RUBBER GOODS**

---

3,234,259. SAF-T-SCREENS, INC., COMFORT, TX. SN 78-388,855. PUB. 6-7-2005, FILED 3-23-2004.

## UNIVERSAL TAPE

THE MARK CONSISTS OF STANDARD CHARACTERS WITHOUT CLAIM TO ANY PARTICULAR FONT, STYLE, SIZE, OR COLOR.

NO CLAIM IS MADE TO THE EXCLUSIVE RIGHT TO USE "TAPE", APART FROM THE MARK AS SHOWN.

FOR ADHESIVE TAPE FOR THE ROOFING REPAIR, BUILDING MAINTENANCE AND WALL CONSTRUCTION AND REPAIR INDUSTRIES (U.S. CLS. 1, 5, 12, 13, 35 AND 50).

FIRST USE 5-8-2003; IN COMMERCE 5-8-2003.

**CLASS 17—(Continued).**

3,234,449. GRUBBLE PRODUCTS, LLC, IRVINE, CA. SN 78-496,024. PUB. 9-13-2005, FILED 10-7-2004.

**FLEX-O-BORDER**

THE MARK CONSISTS OF STANDARD CHARACTERS WITHOUT CLAIM TO ANY PARTICULAR FONT, STYLE, SIZE, OR COLOR.

FOR RUBBER LANDSCAPE EDGING USED TO CONTAIN LOOSE-FILL GROUND COVER MATERIAL IN OR NEAR PLAYGROUNDS OR WALKWAYS AND USED IN COMMERCIAL AND RESIDENTIAL LANDSCAPE APPLICATIONS (U.S. CLS. 1, 5, 12, 13, 35 AND 50).

FIRST USE 8-0-2004; IN COMMERCE 8-0-2004.

3,234,481. SAC ACQUISITION LLC, STAMFORD, CT. SN 78-508,262. PUB. 1-10-2006, FILED 10-29-2004.

**DURAFOAM**

THE MARK CONSISTS OF STANDARD CHARACTERS WITHOUT CLAIM TO ANY PARTICULAR FONT, STYLE, SIZE, OR COLOR.

FOR POLYURETHANE FOAM IN SHREDDED AND BLOCK FORM FOR USE IN THE MANUFACTURE OF UPHOLSTERED FURNITURE AND FRAMELESS FOAM-FILLED CHAIRS (U.S. CLS. 1, 5, 12, 13, 35 AND 50).

FIRST USE 1-1-2006; IN COMMERCE 1-1-2006.

**CLASS 17—(Continued).**

3,235,045. FOSTER CORPORATION, PUTNAM, CT. SN 78-663,666. PUB. 3-21-2006, FILED 7-5-2005.

**PLASTICEUTICAL**

THE MARK CONSISTS OF STANDARD CHARACTERS WITHOUT CLAIM TO ANY PARTICULAR FONT, STYLE, SIZE, OR COLOR.

FOR BIO-ACTIVE POLYMER COMPOUNDS IN PELLET FORM FOR USE IN FURTHER MANUFACTURE (U.S. CLS. 1, 5, 12, 13, 35 AND 50).

FIRST USE 9-1-2006; IN COMMERCE 9-1-2006.

3,235,046. FOSTER CORPORATION, PUTNAM, CT. SN 78-663,769. PUB. 3-28-2006, FILED 7-5-2005.

**FOSTALUBE**

THE MARK CONSISTS OF STANDARD CHARACTERS WITHOUT CLAIM TO ANY PARTICULAR FONT, STYLE, SIZE, OR COLOR.

OWNER OF U.S. REG. NOS. 2,930,811, 2,951,605, AND OTHERS.

FOR POLYMER COMPOUNDS IN PELLET FORM FOR USE IN FURTHER MANUFACTURE (U.S. CLS. 1, 5, 12, 13, 35 AND 50).

FIRST USE 9-1-2006; IN COMMERCE 9-1-2006.

3,235,123. TRUE VALUE COMPANY, CHICAGO, IL. SN 78-681,720. PUB. 7-18-2006, FILED 7-29-2005.



OWNER OF U.S. REG. NOS. 581,301, 1,457,989, AND OTHERS.

THE MARK IS NOT IN COLOR.

THE MARK CONSISTS OF THE WORDS GREEN THUMB UNDERLINED BY A CURVED LINE, IN A MISCELLANEOUS OVAL DESIGN WITH A LEAF DESIGN TO THE RIGHT OF THE WORDS GREEN THUMB.

FOR GARDEN HOSES AND NON-METAL GARDEN HOSE COUPLINGS IN THE NATURE OF NON-METAL GARDEN HOSE ADAPTERS (U.S. CLS. 1, 5, 12, 13, 35 AND 50).

FIRST USE 6-0-2005; IN COMMERCE 6-0-2005.

**CLASS 17—(Continued).**

3,235,378. AMES TRUE TEMPER PROPERTIES, INC., WILMINGTON, DE. SN 78-804,357. PUB. 8-29-2006, FILED 2-1-2006.

# JACKSON

THE MARK CONSISTS OF STANDARD CHARACTERS WITHOUT CLAIM TO ANY PARTICULAR FONT, STYLE, SIZE, OR COLOR.

OWNER OF U.S. REG. NOS. 708,354 AND 708,388. FOR GARDEN HOSES (U.S. CLS. 1, 5, 12, 13, 35 AND 50).  
FIRST USE 9-0-2005; IN COMMERCE 9-0-2005.

**CLASS 18—LEATHER GOODS**

3,234,212. WILLETT, RICHARD E., EAST HAMPTON, NY. SN 78-362,099. PUB. 1-4-2005, FILED 2-4-2004.

# WILLET... THE ORIGINAL WALLET

THE MARK CONSISTS OF STANDARD CHARACTERS WITHOUT CLAIM TO ANY PARTICULAR FONT, STYLE, SIZE, OR COLOR.

NO CLAIM IS MADE TO THE EXCLUSIVE RIGHT TO USE "THE ORIGINAL WALLET", APART FROM THE MARK AS SHOWN.

THE NAME SHOWN IN THE MARK DOES NOT IDENTIFY A PARTICULAR LIVING INDIVIDUAL.

FOR ELASTIC HOLDER FOR BILLFOLD (U.S. CLS. 1, 2, 3, 22 AND 41).  
FIRST USE 7-31-2005; IN COMMERCE 7-31-2005.

3,234,224. BAENZIGER, KASPAR, PFEFFINGEN, SWITZERLAND. SN 78-376,200. PUB. 9-6-2005, FILED 3-1-2004.

# KASPAR BÄNZIGER

THE MARK CONSISTS OF STANDARD CHARACTERS WITHOUT CLAIM TO ANY PARTICULAR FONT, STYLE, SIZE, OR COLOR.

PRIORITY CLAIMED UNDER SEC. 44(D) ON SWITZERLAND APPLICATION NO. 05311/2003, FILED 10-16-2003, REG. NO. 517622, DATED 1-29-2004, EXPIRES 1-29-2014.

THE NAME SHOWN IN THE MARK IDENTIFIES A LIVING INDIVIDUAL WHOSE CONSENT IS OF RECORD.

FOR HANDBAGS, SHOULDER BAGS, BEACH BAGS, CLUTCH BAGS, ALL PURPOSE SPORTS BAGS, BRIEFCASES, PURSES, WALLETS (U.S. CLS. 1, 2, 3, 22 AND 41).  
FIRST USE 12-31-2004; IN COMMERCE 1-31-2005.

**CLASS 18—(Continued).**

3,234,240. ALINA GROUP, INC., HOUSTON, TX. SN 78-381,797. PUB. 3-8-2005, FILED 3-10-2004.

# ALINA

THE MARK CONSISTS OF STANDARD CHARACTERS WITHOUT CLAIM TO ANY PARTICULAR FONT, STYLE, SIZE, OR COLOR.

FOR HANDBAGS, CLUTCHES, PURSES, BACKPACKS, LUGGAGE, TRAVELING BAGS, COSMETIC BAGS SOLD EMPTY, GARMENT BAGS FOR TRAVEL, NYLON SHOPPING BAGS FOR CARRYING ARTICLES, TOTE BAGS, STOWAWAY SUITCASES AND KNAPSACKS, UMBRELLAS, COMBINATION KEY CASE/COIN PURSE AND ALL-PURPOSE SPORTS BAGS (U.S. CLS. 1, 2, 3, 22 AND 41).  
FIRST USE 11-29-2006; IN COMMERCE 11-29-2006.

3,234,245. LORENZO MURILLO, DBA CALIFORNIA DIVING COMPANY, SANTA CLARITA, CA. SN 78-383,490. PUB. 9-6-2005, FILED 3-12-2004.



THE MARK CONSISTS OF THE LETTERS "C" AND "N" IN "CALIFORNIA" AND "COMPANY" FORM THE SHAPE OF THE TURTLE'S FINS.

FOR ALL PURPOSE SPORTS BAGS AND CARRYING CASES FOR A VARIETY OF USES INCLUDING, BUT NOT LIMITED TO, SCUBA DIVING EQUIPMENT AND ACCESSORIES (U.S. CLS. 1, 2, 3, 22 AND 41).  
FIRST USE 1-1-2003; IN COMMERCE 1-1-2004.

**CLASS 18—(Continued).**

3,234,416. BRASSERIE DE TAHITI S.A., PAPEETE, FRENCH POLYNESIA. SN 78-484,649. PUB. 7-12-2005, FILED 9-16-2004.



OWNER OF U.S. REG. NOS. 2,192,919 AND 2,873,493.  
 FOR UMBRELLAS, BEACH UMBRELLAS, GOLF UMBRELLAS, BEACH BAGS, CARRY-ON BAGS, TRAVEL BAGS, LUGGAGE TAGS, HANDBAGS (U.S. CLS. 1, 2, 3, 22 AND 41).  
 FIRST USE 1-0-1995; IN COMMERCE 7-0-2005.

---

3,234,614. COLUMBIA SPORTSWEAR NORTH AMERICA, INC., PORTLAND, OR. SN 78-545,793. PUB. 8-22-2006, FILED 1-11-2005.

**TITANIUM**

THE MARK CONSISTS OF STANDARD CHARACTERS WITHOUT CLAIM TO ANY PARTICULAR FONT, STYLE, SIZE, OR COLOR.  
 OWNER OF U.S. REG. NOS. 2,729,263 AND 2,908,165.  
 FOR ALL-PURPOSE SPORT, ATHLETIC AND CARRYING BAGS, EXCLUDING GOLF BAGS; TOTE BAGS, BACKPACKS; SPORTS PACKS; BRIEFCASES (U.S. CLS. 1, 2, 3, 22 AND 41).  
 FIRST USE 5-2-2005; IN COMMERCE 5-2-2005.

**CLASS 18—(Continued).**

3,234,649. TUMI, INC., SOUTH PLAINFIELD, NJ. SN 78-563,840. PUB. 12-27-2005, FILED 2-9-2005.

**FXT**

THE MARK CONSISTS OF STANDARD CHARACTERS WITHOUT CLAIM TO ANY PARTICULAR FONT, STYLE, SIZE, OR COLOR.  
 FOR FABRIC SOLD AS A COMPONENT PART OF LUGGAGE, TRAVEL BAGS, DUFFEL BAGS, SHOULDER BAGS, BACK PACKS AND SMALL LEATHER GOODS, NAMELY, WALLETS, PURSES AND KEY CASES (U.S. CLS. 1, 2, 3, 22 AND 41).  
 FIRST USE 2-25-2005; IN COMMERCE 2-25-2005.

---

3,234,673. FANCY HOLDINGS, LLC, MEMPHIS, TN. SN 78-574,317. PUB. 2-21-2006, FILED 2-24-2005.

**FEMME SUD**

THE MARK CONSISTS OF STANDARD CHARACTERS WITHOUT CLAIM TO ANY PARTICULAR FONT, STYLE, SIZE, OR COLOR.  
 NO CLAIM IS MADE TO THE EXCLUSIVE RIGHT TO USE "FEMME", APART FROM THE MARK AS SHOWN.  
 THE ENGLISH TRANSLATION OF FEMME SUD IS "SOUTHERN WOMAN".  
 FOR WOMEN'S PURSES, WALLETS, BRIEFCASES, CLUTCHES, SHOULDER BAGS, TRAVEL BAGS, POCKETBOOKS, TOTE BAGS AND CARRYALL BAGS (U.S. CLS. 1, 2, 3, 22 AND 41).  
 FIRST USE 8-30-2005; IN COMMERCE 8-30-2005.

**CLASS 18—(Continued).**

3,234,699. WILLIAMS, JOSEPH G, MILWAUKEE, WI. SN 78-583,649. PUB. 12-6-2005, FILED 3-9-2005.

# SkinnyPouch

THE MARK CONSISTS OF STANDARD CHARACTERS WITHOUT CLAIM TO ANY PARTICULAR FONT, STYLE, SIZE, OR COLOR.

FOR WALLET IN THE SHAPE OF A POUCH WITH COMPARTMENTS THAT CAN BE HUNG FROM THE REARVIEW MIRROR OF AN AUTOMOBILE AND THAT CONVERT AND EXPAND TO BE WORN BY A PERSON AROUND THE NECK, WRIST OR WAIST (U.S. CLS. 1, 2, 3, 22 AND 41).

FIRST USE 3-1-2005; IN COMMERCE 3-1-2005.

3,234,919. DRAGON FULL DEVELOPMENTS LIMITED, CAYMAN ISLANDS, BRITISH WEST INDIES, CAYMAN ISLANDS. SN 78-648,995. PUB. 3-14-2006, FILED 6-13-2005.



THE MARK CONSISTS OF THREE CHINESE CHARACTERS.

THE NON-LATIN CHARACTER(S) IN THE MARK TRANSLITERATES INTO XIANG; HUA; TIAN, AND THIS MEANS FRAGRANT; FLOWERY; SKY IN ENGLISH.

FOR SCHOOL BAGS, SUITCASES, TRAVELING BAGS, POCKET WALLET; UMBRELLAS, WALKING STICKS; COVERS FOR ANIMALS, NAMELY, PET BLANKETS AND PET CLOTHING IN THE NATURE OF COATS, PULLOVERS AND HATS; LEATHER LEASHES FOR ANIMALS; COLLARS FOR ANIMALS; CAT O' NINE TAILS; RIDING SADDLES; SADDLERY; SADDLE COVERS FOR HORSES; CLOTHING FOR PETS; BABY CARRYING BAGS; ANIMAL GAME BAGS; HUNTERS' GAME BAGS; TOOL BAGS OF LEATHER SOLD EMPTY (U.S. CLS. 1, 2, 3, 22 AND 41).

FIRST USE 11-11-2004; IN COMMERCE 12-1-2004.

**CLASS 18—(Continued).**

3,234,934. HADLEY POLLET, LLC, CAMBRIDGE, MA. SN 78-651,258. PUB. 3-7-2006, FILED 6-15-2005.

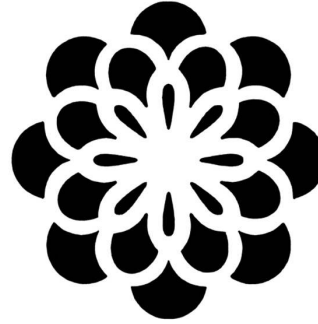

FOR LUGGAGE, HANDBAGS, CANVAS TOTE BAGS AND WALLET (U.S. CLS. 1, 2, 3, 22 AND 41).

FIRST USE 6-16-2005; IN COMMERCE 6-16-2005.

3,234,970. SHARON W. CHIANG, PASADENA, CA. SN 78-654,626. PUB. 6-6-2006, FILED 6-20-2005.

# olicoco

THE MARK CONSISTS OF STANDARD CHARACTERS WITHOUT CLAIM TO ANY PARTICULAR FONT, STYLE, SIZE, OR COLOR.

FOR HANDBAGS, ALL-PURPOSE CARRYING BAGS, TOTE BAGS, TRAVELLING BAGS, SHOULDER BAGS, CLUTCH PURSES, ALL-PURPOSE ATHLETIC BAGS, BACKPACKS, WALLET, COIN PURSES, COSMETIC BAGS SOLD EMPTY, POCKETBOOKS, LUGGAGE TAGS (U.S. CLS. 1, 2, 3, 22 AND 41).

FIRST USE 10-3-2006; IN COMMERCE 10-3-2006.

3,235,080. ASPEN PET PRODUCTS, INC., DENVER, CO. SN 78-669,649. PUB. 5-16-2006, FILED 7-13-2005.

# COMFORT CHAIN

THE MARK CONSISTS OF STANDARD CHARACTERS WITHOUT CLAIM TO ANY PARTICULAR FONT, STYLE, SIZE, OR COLOR.

NO CLAIM IS MADE TO THE EXCLUSIVE RIGHT TO USE "CHAIN", APART FROM THE MARK AS SHOWN.

FOR DOG COLLARS (U.S. CLS. 1, 2, 3, 22 AND 41).

FIRST USE 9-29-2006; IN COMMERCE 9-29-2006.

**CLASS 18—(Continued).**

3,235,192. TENG DA TRADING USA INC., NEW YORK, NY.  
SN 78-705,250. PUB. 8-15-2006, FILED 9-1-2005.

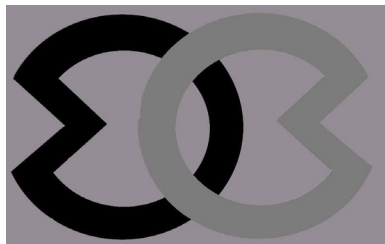

FOR HANDBAGS (U.S. CLS. 1, 2, 3, 22 AND 41).  
FIRST USE 9-1-2005; IN COMMERCE 9-1-2005.

**CLASS 19—(Continued).**

3,234,035. CARMEUSE NORTH AMERICA SERVICES, INC.,  
PITTSBURGH, PA. SN 76-635,378. PUB. 1-24-2006, FILED 4-  
7-2005.

# DRYOX

THE MARK CONSISTS OF STANDARD CHARACTERS  
WITHOUT CLAIM TO ANY PARTICULAR FONT, STYLE,  
SIZE, OR COLOR.

FOR LIMESTONE; NON-AGRICULTURAL LIME RE-  
SIDUE FOR NON-AGRICULTURAL USE (U.S. CLS. 1, 12,  
33 AND 50).

FIRST USE 5-17-2006; IN COMMERCE 5-17-2006.

3,234,049. RGM PRODUCTS, INC., FRESNO, CA. SN 76-  
639,269. PUB. 2-7-2006, FILED 5-23-2005.

# GRIP-LAP

THE MARK CONSISTS OF STANDARD CHARACTERS  
WITHOUT CLAIM TO ANY PARTICULAR FONT, STYLE,  
SIZE, OR COLOR.

FOR BUILDING MATERIALS, NAMELY NON-METAL  
ROOFING (U.S. CLS. 1, 12, 33 AND 50).

FIRST USE 6-13-2005; IN COMMERCE 6-13-2005.

3,234,182. HOMER TLC, INC., CLAYMONT, DE. SN 78-  
327,474. PUB. 9-7-2004, FILED 11-13-2003.

# MILLSTEAD

THE MARK CONSISTS OF STANDARD CHARACTERS  
WITHOUT CLAIM TO ANY PARTICULAR FONT, STYLE,  
SIZE, OR COLOR.

FOR DECKING; LUMBER; MOLDING, FENCING  
AND LATTICE (U.S. CLS. 1, 12, 33 AND 50).

FIRST USE 5-5-2005; IN COMMERCE 5-5-2005.

**CLASS 19—NON-METALLIC BUILDING MA-  
TERIALS**

3,233,858. METL-SPAN I, LTD., LEWISVILLE, DENTON  
COUNTY, TX. SN 76-538,263. PUB. 4-6-2004, FILED 8-19-  
2003.

# TUFF COTE

FOR FIBER REINFORCED POLYMER MATERIAL  
THAT IS SPRAY APPLIED AND OVEN CURED TO  
CREATE A STUCCO-LIKE APPEARANCE (U.S. CLS. 1,  
12, 33 AND 50).

FIRST USE 7-0-2006; IN COMMERCE 7-0-2006.

3,233,905. HEARTLAND BUILDING PRODUCTS, INC.,  
BOONESVILLE, MS. SN 76-592,224. PUB. 9-6-2005, FILED  
5-14-2004.

# THE HEARTLAND COLLECTION

OWNER OF U.S. REG. NOS. 1,417,463, 1,447,504, AND  
OTHERS.

NO CLAIM IS MADE TO THE EXCLUSIVE RIGHT TO  
USE "COLLECTION", APART FROM THE MARK AS  
SHOWN.

FOR NON-METALLIC WINDOWS AND DOORS AND  
PARTS THEREFORE (U.S. CLS. 1, 12, 33 AND 50).

FIRST USE 2-10-2005; IN COMMERCE 2-10-2005.

**CLASS 19—(Continued).**

3,234,261. ALLAN BLOCK CORPORATION, EDINA, MN. SN 78-391,822. PUB. 9-20-2005, FILED 3-26-2004.

**GREEN SLOPE**

THE MARK CONSISTS OF STANDARD CHARACTERS WITHOUT CLAIM TO ANY PARTICULAR FONT, STYLE, SIZE, OR COLOR.

FOR CONCRETE LANDSCAPING BLOCKS (U.S. CLS. 1, 12, 33 AND 50).

FIRST USE 4-19-2004; IN COMMERCE 11-0-2004.

3,234,304. SABLE MARCO INC., PONT-ROUGE, QUEBEC, CANADA. SN 78-418,087. PUB. 3-15-2005, FILED 5-13-2004.

**STABILIZ-O-BLOCK**

THE MARK CONSISTS OF STANDARD CHARACTERS WITHOUT CLAIM TO ANY PARTICULAR FONT, STYLE, SIZE, OR COLOR.

FOR POLYMERIC SAND (U.S. CLS. 1, 12, 33 AND 50).

FIRST USE 4-9-2002; IN COMMERCE 4-9-2002.

3,234,340. CRAFT-BILT MANUFACTURING COMPANY, SOUDERTON, PA. SN 78-443,602. PUB. 5-2-2006, FILED 6-30-2004.

**BETTERLIVING**

THE MARK CONSISTS OF STANDARD CHARACTERS WITHOUT CLAIM TO ANY PARTICULAR FONT, STYLE, SIZE, OR COLOR.

OWNER OF U.S. REG. NO. 1,630,590.

FOR NON-METAL WINDOWS (U.S. CLS. 1, 12, 33 AND 50).

FIRST USE 7-11-2001; IN COMMERCE 7-11-2001.

**CLASS 19—(Continued).**

3,234,399. VENTURE PRODUCTS, LLC, FAIRFIELD, NJ. SN 78-477,649. PUB. 10-25-2005, FILED 9-2-2004.

**SHOCK ATHLETIC**

THE MARK CONSISTS OF STANDARD CHARACTERS WITHOUT CLAIM TO ANY PARTICULAR FONT, STYLE, SIZE, OR COLOR.

NO CLAIM IS MADE TO THE EXCLUSIVE RIGHT TO USE "ATHLETIC", APART FROM THE MARK AS SHOWN. FOR GYM FLOORING (U.S. CLS. 1, 12, 33 AND 50).

FIRST USE 9-4-2004; IN COMMERCE 9-4-2004.

3,234,504. BURKE INDUSTRIES (DELAWARE), INC., SAN JOSE, CA. SN 78-514,970. PUB. 2-21-2006, FILED 11-10-2004.



NO CLAIM IS MADE TO THE EXCLUSIVE RIGHT TO USE THE REPRESENTATION OF THE CHASING ARROWS RECYCLING SYMBOL, APART FROM THE MARK AS SHOWN.

THE COLOR(S) YELLOW, GREEN, AND BLACK IS/ARE CLAIMED AS A FEATURE OF THE MARK.

THE LETTERS IN THE MARK ARE YELLOW AND ARE OUTLINED IN PALE YELLOW AND BLACK. THE TOP PORTION OF THE ARROWS IS A MEDIUM GREEN COLOR, THE UNDERSIDE OF THE ARROWS IS A LIGHTER GREEN COLOR, AND THE ARROWS HAVE A NARROW OUTLINED IN A DARKER GREEN COLOR.

THE MARK CONSISTS OF THE TERM ECOSCORE DISPLAYED ACROSS THE CENTER OF A BACKGROUND REPRESENTATION OF THE RECYCLING SYMBOL. THE REPRESENTATION OF THE RECYCLING SYMBOL CONSISTING OF THREE BROAD ARROWS FORMING A TRIANGLE AND TWISTING SO THAT THE TOP AND UNDERSIDES OF THE ARROWS SHOW AS THEY TWIST.

FOR RUBBER FLOORING TILES FOR MULTIPURPOSE USES MADE FROM RECYCLED TIRES (U.S. CLS. 1, 12, 33 AND 50).

FIRST USE 4-5-2005; IN COMMERCE 10-20-2006.

**CLASS 19—(Continued).**

3,234,611. WESTERN STATES WHOLESALE, INC., ONTARIO, CA. SN 78-544,283. PUB. 5-9-2006, FILED 1-7-2005.



THE MARK CONSISTS OF THE WORD DESIGN "PROACTIVE" IN WHICH THE FIRST SYLLABLE "PRO" IS IN ITALICS AND THE REMAINING SYLLABLES ARE IN BLOCK LETTERS. BEHIND THE WORD DESIGN IS A TILTED RECTANGLE WITH SERRATED EDGES.

FOR DRY POWDER SELF-LEVELING UNDERLAYMENT PREPARATION FOR CONCRETE SLABS OR PLYWOOD, NAMELY, MORTARS (U.S. CLS. 1, 12, 33 AND 50).

FIRST USE 3-18-2005; IN COMMERCE 3-18-2005.

3,234,662. SIMPSON DOOR COMPANY, TACOMA, WA. SN 78-568,583. PUB. 11-15-2005, FILED 2-16-2005.

## RIVERDALE

THE MARK CONSISTS OF STANDARD CHARACTERS WITHOUT CLAIM TO ANY PARTICULAR FONT, STYLE, SIZE, OR COLOR.

FOR WOOD DOORS (U.S. CLS. 1, 12, 33 AND 50).  
FIRST USE 10-26-2005; IN COMMERCE 10-26-2005.

**CLASS 19—(Continued).**

3,234,674. ATLAS BRICK COMPANY LLC, SUGAR LAND, TX. SN 78-574,856. PUB. 12-27-2005, FILED 2-25-2005.

## Nothing Else Stacks Up

THE MARK CONSISTS OF STANDARD CHARACTERS WITHOUT CLAIM TO ANY PARTICULAR FONT, STYLE, SIZE, OR COLOR.

FOR CONCRETE BUILDING MATERIALS, NAMELY, BRICKS (U.S. CLS. 1, 12, 33 AND 50).

FIRST USE 6-15-2005; IN COMMERCE 6-15-2005.

3,234,777. GUARDIAN INDUSTRIES CORP., AUBURN HILLS, MI. SN 78-611,658. PUB. 2-14-2006, FILED 4-19-2005.

## SHOWERGUARD

THE MARK CONSISTS OF STANDARD CHARACTERS WITHOUT CLAIM TO ANY PARTICULAR FONT, STYLE, SIZE, OR COLOR.

FOR GLASS FOR USE IN THE ARCHITECTURAL FIELD, NAMELY, FLAT OR CONTOURED GLASS PANELS AND SHEETS FOR USE IN SHOWER ENCLOSURES WITH AND WITHOUT A PROTECTIVE AND/OR WATER MANAGEMENT COATING (U.S. CLS. 1, 12, 33 AND 50).

FIRST USE 3-14-2005; IN COMMERCE 3-14-2005.

3,234,789. AIR VENT INC., PEORIA, IL. SN 78-617,180. PUB. 1-24-2006, FILED 4-26-2005.

FOR NON-MECHANICAL PLASTIC ROOF RIDGE VENT FOR VENTILATING ATTICS (U.S. CLS. 1, 12, 33 AND 50).

FIRST USE 9-12-2005; IN COMMERCE 9-12-2005.



**CLASS 19—(Continued).**

3,234,945. TAPCO INTERNATIONAL CORPORATION, WIXOM, MI. SN 78-652,400. PUB. 3-7-2006, FILED 6-16-2005.

## MID-AMERICA SIDING COMPONENTS

THE MARK CONSISTS OF STANDARD CHARACTERS WITHOUT CLAIM TO ANY PARTICULAR FONT, STYLE, SIZE, OR COLOR.

NO CLAIM IS MADE TO THE EXCLUSIVE RIGHT TO USE "SIDING COMPONENTS", APART FROM THE MARK AS SHOWN.

FOR NON-METALLIC BUILDING PRODUCTS, NAMELY, SHUTTERS, SHINGLES, SIDING, TRIM (U.S. CLS. 1, 12, 33 AND 50).

FIRST USE 11-0-2006; IN COMMERCE 11-0-2006.

3,234,974. FRAMERICA CORP., YAPHANK, NY. SN 78-655,277. PUB. 3-14-2006, FILED 6-21-2005.

## A CROWNING TOUCH ARCHITECTURAL MOLDING

THE MARK CONSISTS OF STANDARD CHARACTERS WITHOUT CLAIM TO ANY PARTICULAR FONT, STYLE, SIZE, OR COLOR.

NO CLAIM IS MADE TO THE EXCLUSIVE RIGHT TO USE "ARCHITECTURAL MOLDING", APART FROM THE MARK AS SHOWN.

FOR NON-METAL DECORATIVE MOLDINGS FOR USE IN BUILDING CONSTRUCTION (U.S. CLS. 1, 12, 33 AND 50).

FIRST USE 12-21-2005; IN COMMERCE 12-21-2005.

3,235,002. IDEAL PET PRODUCTS, INC., VALENCIA, CA. SN 78-659,421. PUB. 3-21-2006, FILED 6-28-2005.

## ULTRA-FLEX

THE MARK CONSISTS OF STANDARD CHARACTERS WITHOUT CLAIM TO ANY PARTICULAR FONT, STYLE, SIZE, OR COLOR.

FOR NON-METALLIC PET DOORS (U.S. CLS. 1, 12, 33 AND 50).

FIRST USE 9-0-2005; IN COMMERCE 9-0-2005.

**CLASS 19—(Continued).**

3,235,060. DIVERSIFIED BUILDER SUPPLY, INC., CHANDLER, AZ. SN 78-665,791. PUB. 3-28-2006, FILED 7-7-2005.

## eAZee

THE MARK CONSISTS OF STANDARD CHARACTERS WITHOUT CLAIM TO ANY PARTICULAR FONT, STYLE, SIZE, OR COLOR.

FOR PRE-FABRICATED MORTARLESS GLASS BLOCK WINDOWS (U.S. CLS. 1, 12, 33 AND 50).

FIRST USE 12-31-2004; IN COMMERCE 12-31-2004.

3,235,068. ANCHOR WALL SYSTEMS, INC., MINNETONKA, MN. SN 78-668,290. PUB. 3-21-2006, FILED 7-12-2005.

## HIGHLAND

THE MARK CONSISTS OF STANDARD CHARACTERS WITHOUT CLAIM TO ANY PARTICULAR FONT, STYLE, SIZE, OR COLOR.

OWNER OF U.S. REG. NO. 2,664,396.

FOR CONCRETE LANDSCAPE PRODUCTS, NAMELY, RETAINING WALL BLOCKS, FREE STANDING WALL BLOCKS, PAVERS, SLABS, EDGERS; ARCHITECTURAL CONCRETE MASONRY UNITS, NAMELY BLOCKS, BRICKS, AND VENEERS (U.S. CLS. 1, 12, 33 AND 50).

FIRST USE 5-25-2004; IN COMMERCE 5-25-2004.

3,235,115. CERTAINTEED CORPORATION, VALLEY FORGE, PA. SN 78-678,796. PUB. 4-11-2006, FILED 7-26-2005.

## NORTHWOODS

THE MARK CONSISTS OF STANDARD CHARACTERS WITHOUT CLAIM TO ANY PARTICULAR FONT, STYLE, SIZE, OR COLOR.

FOR VINYL SIDING PANELS (U.S. CLS. 1, 12, 33 AND 50).

FIRST USE 11-0-2005; IN COMMERCE 6-28-2006.

**CLASS 19—(Continued).**

3,235,254. DUY, ARTHUR H., SALT LAKE CITY, UT. SN 78-734,710. PUB. 7-4-2006, FILED 10-17-2005.

**QUARAZON**

THE MARK CONSISTS OF STANDARD CHARACTERS WITHOUT CLAIM TO ANY PARTICULAR FONT, STYLE, SIZE, OR COLOR.

FOR ROCK MATERIALS USED IN THE MANUFACTURE OF FLOORING, ROOFING, COUNTERTOPS, WALLS, CLADDING AND FIREPLACES (U.S. CLS. 1, 12, 33 AND 50).

FIRST USE 4-1-2006; IN COMMERCE 7-1-2006.

**CLASS 19—(Continued).**

3,235,342. PRODUCT DESIGN, LLC, DELAWARE, OH. SN 78-770,996. PUB. 8-29-2006, FILED 12-12-2005.

**SPOT-IT**

THE MARK CONSISTS OF STANDARD CHARACTERS WITHOUT CLAIM TO ANY PARTICULAR FONT, STYLE, SIZE, OR COLOR.

FOR SPACKLING COMPOUND WITH PIGMENTATION (U.S. CLS. 1, 12, 33 AND 50).

FIRST USE 5-13-2006; IN COMMERCE 5-13-2006.

3,235,260. BERNDT, MARGARET S, WOLCOTT, NY. SN 78-737,594. PUB. 6-27-2006, FILED 10-20-2005.

**Lake Stone Cabinetry Knobs  
Mother Nature's Hardware**

THE MARK CONSISTS OF STANDARD CHARACTERS WITHOUT CLAIM TO ANY PARTICULAR FONT, STYLE, SIZE, OR COLOR.

NO CLAIM IS MADE TO THE EXCLUSIVE RIGHT TO USE "LAKE STONE CABINETRY KNOBS", APART FROM THE MARK AS SHOWN.

FOR STONE KNOBS FOR KITCHEN, BATHROOM OR ANY DISTINCTIVE CABINETRY PIECE (U.S. CLS. 1, 12, 33 AND 50).

FIRST USE 9-1-2005; IN COMMERCE 9-1-2005.

**CLASS 20—FURNITURE AND ARTICLES NOT OTHERWISE CLASSIFIED**

3,233,870. SOUTHEAST BEDDING COMPANY, COLUMBUS, GA. SN 76-564,208. PUB. 9-21-2004, FILED 12-8-2003.

**SAVANNAH NIGHTS**

THE MARK CONSISTS OF STANDARD CHARACTERS WITHOUT CLAIM TO ANY PARTICULAR FONT, STYLE, SIZE, OR COLOR.

FOR MATTRESSES (U.S. CLS. 2, 13, 22, 25, 32 AND 50).

FIRST USE 9-0-2006; IN COMMERCE 9-0-2006.

3,235,318. HOBOKEN WOOD FLOORING LLC, WAYNE, NJ. SN 78-763,611. PUB. 2-28-2006, FILED 11-30-2005.

**GLASS OF DISTINCTION**

THE MARK CONSISTS OF STANDARD CHARACTERS WITHOUT CLAIM TO ANY PARTICULAR FONT, STYLE, SIZE, OR COLOR.

OWNER OF U.S. REG. NOS. 2,896,848, 2,918,537, AND OTHERS.

NO CLAIM IS MADE TO THE EXCLUSIVE RIGHT TO USE GLASS, APART FROM THE MARK AS SHOWN.

FOR GLASS FLOOR AND WALL TILES (U.S. CLS. 1, 12, 33 AND 50).

FIRST USE 2-0-2006; IN COMMERCE 2-0-2006.

3,233,922. MARMOT MOUNTAIN LLC, SANTA ROSA, CA. SN 76-599,258. PUB. 5-10-2005, FILED 6-25-2004.

**SPIRAFIL**

THE MARK CONSISTS OF STANDARD CHARACTERS WITHOUT CLAIM TO ANY PARTICULAR FONT, STYLE, SIZE, OR COLOR.

FOR THERMAL INSULATION MADE OF NONWOVEN SYNTHETIC FIBERS OR POLYESTER SOLD AS AN INTEGRAL COMPONENT OF SLEEPING BAGS (U.S. CLS. 2, 13, 22, 25, 32 AND 50).

FIRST USE 0-0-2005; IN COMMERCE 0-0-2005.

**CLASS 20—(Continued).**

3,233,927. JPJ INVESTMENT HOLDING CORP., CARSON CITY, NV. SN 76-602,325. PUB. 9-13-2005, FILED 7-14-2004.

# Perma-Lock

THE MARK CONSISTS OF STANDARD CHARACTERS WITHOUT CLAIM TO ANY PARTICULAR FONT, STYLE, SIZE, OR COLOR.

FOR NONMETAL HANDLE FOR STRIKING TOOLS, NAMELY, HAMMERS, PICKS, MATTOCKS, MAULS, AXES AND TAMPERS (U.S. CLS. 2, 13, 22, 25, 32 AND 50).

FIRST USE 10-10-2005; IN COMMERCE 10-10-2005.

3,233,968. DREAMWELL, LTD., LAS VEGAS, NV. SN 76-614,344. PUB. 1-17-2006, FILED 10-1-2004.

# HEALTHSMART

THE MARK CONSISTS OF STANDARD CHARACTERS WITHOUT CLAIM TO ANY PARTICULAR FONT, STYLE, SIZE, OR COLOR.

FOR MATTRESS TOPPERS (U.S. CLS. 2, 13, 22, 25, 32 AND 50).

FIRST USE 11-30-2004; IN COMMERCE 11-30-2004.

3,234,034. DISTRIBUCIONES FAJARDO S.L., 41500 SEVILLA, SPAIN. SN 76-635,316. PUB. 7-11-2006, FILED 4-7-2005.



NO CLAIM IS MADE TO THE EXCLUSIVE RIGHT TO USE ESPACIO, APART FROM THE MARK AS SHOWN.

THE COLOR RED, WHITE AND GRAY ARE CLAIMED AS A FEATURE OF THE MARK.

THE CIRCLE ON THE LEFT IS RED, AND THE RECTANGULAR SHAPE INSIDE THE CIRCLE IS WHITE; THE WORDS "DIFASA" AND "ESPACIO" ARE GRAY, AND THE DOT OVER THE "I" IN "DIFASA" IS ALSO RED.

THE ENGLISH TRANSLATION OF THE WORD ESPACIO IN THE MARK IS "SPACE".

FOR FURNITURE, MIRRORS, AND PICTURE FRAMES NOT OF PRECIOUS METAL; PORTABLE, PRE-FABRICATED CLOSETS AND WALK-IN CLOSETS MADE OF WOOD, CORK, REED, CANE, WICKER, HORN, BONE, IVORY, WHALEBONE, SHELL, AMBER, MOTHER OF PEARL, MEERSCHAUM, PLASTIC, AND SUBSTITUTES OF ALL THESE MATERIALS (U.S. CLS. 2, 13, 22, 25, 32 AND 50).

FIRST USE 5-0-1987; IN COMMERCE 9-0-2005.

**CLASS 20—(Continued).**

3,234,062. QUIKEY MANUFACTURING CO., INC., AKRON, OH. SN 76-641,788. PUB. 3-7-2006, FILED 6-27-2005.

# PICTURE ME COLORING

THE MARK CONSISTS OF STANDARD CHARACTERS WITHOUT CLAIM TO ANY PARTICULAR FONT, STYLE, SIZE, OR COLOR.

FOR MAGNETIC PICTURE FRAMES (U.S. CLS. 2, 13, 22, 25, 32 AND 50).

FIRST USE 11-16-2006; IN COMMERCE 11-16-2006.

3,234,086. AMERICAN TEXTILE COMPANY, DUQUESNE, PA. SN 76-978,463. PUB. 3-28-2006, FILED 11-9-2004.

# EVERSOFT

THE MARK CONSISTS OF STANDARD CHARACTERS WITHOUT CLAIM TO ANY PARTICULAR FONT, STYLE, SIZE, OR COLOR.

OWNER OF U.S. REG. NOS. 1,799,426 AND 1,926,497.

FOR BED PILLOWS (U.S. CLS. 2, 13, 22, 25, 32 AND 50).

FIRST USE 5-31-2006; IN COMMERCE 5-31-2006.

3,234,087. AMERICAN TEXTILE COMPANY, DUQUESNE, PA. SN 76-978,464. PUB. 3-28-2006, FILED 11-9-2004.

# ALLER-EASE

THE MARK CONSISTS OF STANDARD CHARACTERS WITHOUT CLAIM TO ANY PARTICULAR FONT, STYLE, SIZE, OR COLOR.

OWNER OF U.S. REG. NO. 2,080,165.

FOR BED PILLOWS (U.S. CLS. 2, 13, 22, 25, 32 AND 50).

FIRST USE 1-31-2006; IN COMMERCE 1-31-2006.

3,234,094. ROPAK CORPORATION, FOUNTAIN VALLEY, CA. SN 78-045,924. PUB. 9-20-2005, FILED 1-31-2001.

# EZ GRIP

NO CLAIM IS MADE TO THE EXCLUSIVE RIGHT TO USE "GRIP", APART FROM THE MARK AS SHOWN.

FOR PLASTIC HANDLE FOR BUCKETS AND PAILS (U.S. CLS. 2, 13, 22, 25, 32 AND 50).

FIRST USE 4-1-2001; IN COMMERCE 4-1-2001.

**CLASS 20—(Continued).**

3,234,130. ROBINSON & ROBINSON INC., SAN DIEGO, CA. SN 78-222,412. PUB. 5-11-2004, FILED 3-6-2003.

**VIVANTE COLLECTION**

NO CLAIM IS MADE TO THE EXCLUSIVE RIGHT TO USE "COLLECTION", APART FROM THE MARK AS SHOWN.

THE ENGLISH TRANSLATION OF THE ITALIAN WORD "VIVANTE" IS "LIVING".

FOR UPHOLSTERED FURNITURE (U.S. CLS. 2, 13, 22, 25, 32 AND 50).

FIRST USE 4-0-2003; IN COMMERCE 4-0-2003.

---

3,234,208. WOODS & ZIMMERMAN, RANCHO PALOS VERDES, CA. SN 78-358,477. PUB. 2-21-2006, FILED 1-28-2004.

**THE LUCKY LADYBEAN TREE**

THE MARK CONSISTS OF STANDARD CHARACTERS WITHOUT CLAIM TO ANY PARTICULAR FONT, STYLE, SIZE, OR COLOR.

FOR WOOD PRODUCTS MANUFACTURED FROM AN ORMOSIA TREE THAT GROWS IN THE PERUVIAN JUNGLE, NAMELY BOXES AND PICTURE FRAMES (U.S. CLS. 2, 13, 22, 25, 32 AND 50).

FIRST USE 12-4-2003; IN COMMERCE 12-4-2003.

---

3,234,371. MIDWEST REGIONAL MARKETING, INC., BURNSVILLE, MN. SN 78-466,557. PUB. 8-23-2005, FILED 8-12-2004.

**EXPRESSIONS WITH A VIEW**

THE MARK CONSISTS OF STANDARD CHARACTERS WITHOUT CLAIM TO ANY PARTICULAR FONT, STYLE, SIZE, OR COLOR.

FOR WINDOW BLINDS (U.S. CLS. 2, 13, 22, 25, 32 AND 50).

FIRST USE 3-0-2005; IN COMMERCE 3-0-2005.

**CLASS 20—(Continued).**

3,234,422. ROYAL-PEDIC MATTRESS MANUFACTURING, LLC, BEVERLY HILLS, CA. SN 78-485,767. PUB. 3-28-2006, FILED 9-17-2004.

**DREAM SPRING**

THE MARK CONSISTS OF STANDARD CHARACTERS WITHOUT CLAIM TO ANY PARTICULAR FONT, STYLE, SIZE, OR COLOR.

NO CLAIM IS MADE TO THE EXCLUSIVE RIGHT TO USE "SPRING", APART FROM THE MARK AS SHOWN.

FOR MATTRESSES, BOX SPRINGS, AND PILLOWTOP MATTRESS CUSHIONS (U.S. CLS. 2, 13, 22, 25, 32 AND 50).

FIRST USE 7-28-2006; IN COMMERCE 7-28-2006.

---

3,234,541. CLASSIC-MIDWEST DIE MOLD, INC., DBA CLASSIC M.D.M., INC., CHICAGO, IL. SN 78-524,439. PUB. 3-14-2006, FILED 11-30-2004.

**MEDISPENSE**

THE MARK CONSISTS OF STANDARD CHARACTERS WITHOUT CLAIM TO ANY PARTICULAR FONT, STYLE, SIZE, OR COLOR.

FOR PLASTIC MEDICATION CONTAINERS IN THE NATURE OF DAILY PILL BOXES, AND MINIATURE DISPENSERS FOR PILLS OR CAPSULES IN POD FORM SOLD EMPTY (U.S. CLS. 2, 13, 22, 25, 32 AND 50).

FIRST USE 12-1-2004; IN COMMERCE 12-1-2004.

**CLASS 20—(Continued).**

3,234,559. GLOBAL BRAND HOLDINGS, LLC, NEW YORK, NY. SN 78-530,059. PUB. 3-7-2006, FILED 12-9-2004.

**CLASS 20—(Continued).**

3,234,646. O'KEEFE, DANIEL J, LISLE, IL. SN 78-561,551. PUB. 7-4-2006, FILED 2-7-2005.

XOXO

Leppidio

THE MARK CONSISTS OF STANDARD CHARACTERS WITHOUT CLAIM TO ANY PARTICULAR FONT, STYLE, SIZE, OR COLOR.  
FOR BEDDING FURNITURE AND PILLOWS (U.S. CLS. 2, 13, 22, 25, 32 AND 50).  
FIRST USE 7-0-2005; IN COMMERCE 7-0-2005.

THE MARK CONSISTS OF STANDARD CHARACTERS WITHOUT CLAIM TO ANY PARTICULAR FONT, STYLE, SIZE, OR COLOR.  
FOR ORNAMENTAL BUTTERFLY DISPLAYS, NAMELY, TRANSPARENT AND NON-TRANSPARENT FRAMED BUTTERFLIES AND RESIN-ENCAPSULATED BUTTERFLIES (U.S. CLS. 2, 13, 22, 25, 32 AND 50).  
FIRST USE 4-30-2005; IN COMMERCE 4-30-2005.

3,234,568. EOS SURFACES, LLC, SUFFOLK, VA. SN 78-531,182. PUB. 3-21-2006, FILED 12-13-2004.

3,234,667. ATICO INTERNATIONAL USA, INC., FT. LAUDERDALE, FL. SN 78-573,506. PUB. 5-16-2006, FILED 2-23-2005.



Backyard Accents

NO CLAIM IS MADE TO THE EXCLUSIVE RIGHT TO USE "3CM" AND "SOLID SURFACE", APART FROM THE MARK AS SHOWN.  
THE MARK CONSISTS OF THE WORDS 3CM EOS SOLID SURFACE AND FIVE SOLID CIRCLES.  
FOR FURNITURE PARTS, NAMELY COUNTERTOPS, VANITY TOPS, AND WORK SURFACE COUNTERTOPS (U.S. CLS. 2, 13, 22, 25, 32 AND 50).  
FIRST USE 9-1-2004; IN COMMERCE 12-1-2004.

THE MARK CONSISTS OF STANDARD CHARACTERS WITHOUT CLAIM TO ANY PARTICULAR FONT, STYLE, SIZE, OR COLOR.  
OWNER OF U.S. REG. NO. 2,756,371.  
NO CLAIM IS MADE TO THE EXCLUSIVE RIGHT TO USE "BACKYARD", APART FROM THE MARK AS SHOWN.  
FOR PATIO FURNITURE (U.S. CLS. 2, 13, 22, 25, 32 AND 50).  
FIRST USE 7-30-2002; IN COMMERCE 1-30-2003.

**CLASS 20—(Continued).**

3,234,682. VAN HORN, PETER, TERRE HAUTE, IN. SN 78-578,353. PUB. 5-9-2006, FILED 3-2-2005.

**SOCKET LOGIC**

THE MARK CONSISTS OF STANDARD CHARACTERS WITHOUT CLAIM TO ANY PARTICULAR FONT, STYLE, SIZE, OR COLOR.

NO CLAIM IS MADE TO THE EXCLUSIVE RIGHT TO USE "SOCKET", APART FROM THE MARK AS SHOWN, FOR PLASTIC TOOL ORGANIZER (U.S. CLS. 2, 13, 22, 25, 32 AND 50).

FIRST USE 11-0-2005; IN COMMERCE 7-0-2006.

3,234,688. COLD SPRING GRANITE COMPANY, COLD SPRING, MN. SN 78-580,062. PUB. 4-18-2006, FILED 3-4-2005.

**SIGNATURE**

THE MARK CONSISTS OF STANDARD CHARACTERS WITHOUT CLAIM TO ANY PARTICULAR FONT, STYLE, SIZE, OR COLOR.

OWNER OF U.S. REG. NO. 2,525,886. FOR RITUAL FLOWER VASES (U.S. CLS. 2, 13, 22, 25, 32 AND 50). FIRST USE 3-1-2005; IN COMMERCE 3-1-2005.

**CLASS 20—(Continued).**

3,234,719. BOYD FLOTATION, INC., MARYLAND HEIGHTS, MO. SN 78-592,126. PUB. 3-28-2006, FILED 3-22-2005.

**EXHILARATE**

THE MARK CONSISTS OF STANDARD CHARACTERS WITHOUT CLAIM TO ANY PARTICULAR FONT, STYLE, SIZE, OR COLOR.

FOR BED PILLOWS, GEL FIBER BED PILLOWS (U.S. CLS. 2, 13, 22, 25, 32 AND 50). FIRST USE 1-1-2006; IN COMMERCE 1-1-2006.

3,234,830. MURRAY, BARBARA J., MINNETONKA, MN. SN 78-629,930. PUB. 2-21-2006, FILED 5-13-2005.

**HANGSHAPER**

THE MARK CONSISTS OF STANDARD CHARACTERS WITHOUT CLAIM TO ANY PARTICULAR FONT, STYLE, SIZE, OR COLOR.

FOR ATTACHMENTS FOR THE SHOULDER PORTION OF CLOTHES HANGERS TO PROVIDE ADDITIONAL THICKNESS (U.S. CLS. 2, 13, 22, 25, 32 AND 50). FIRST USE 4-6-2006; IN COMMERCE 4-6-2006.

3,234,856. UNITED STATIONERS SUPPLY COMPANY, DEERFIELD, IL. SN 78-634,775. PUB. 2-14-2006, FILED 5-23-2005.

**ALERA**

THE MARK CONSISTS OF STANDARD CHARACTERS WITHOUT CLAIM TO ANY PARTICULAR FONT, STYLE, SIZE, OR COLOR.

FOR OFFICE FURNITURE (U.S. CLS. 2, 13, 22, 25, 32 AND 50). FIRST USE 8-0-2005; IN COMMERCE 8-0-2005.

**CLASS 20—(Continued).**

3,234,964. AMERICAN SIGNATURE, INC., COLUMBUS, OH.  
SN 78-654,342. PUB. 3-7-2006, FILED 6-20-2005.

**PLANTATION COVE**

THE MARK CONSISTS OF STANDARD CHARACTERS WITHOUT CLAIM TO ANY PARTICULAR FONT, STYLE, SIZE, OR COLOR.

FOR FURNITURE (U.S. CLS. 2, 13, 22, 25, 32 AND 50).  
FIRST USE 2-0-2006; IN COMMERCE 2-0-2006.

---

3,234,972. CNS, INC., MINNEAPOLIS, MN. SN 78-655,216.  
PUB. 3-14-2006, FILED 6-21-2005.

**BREATHE RIGHT**

THE MARK CONSISTS OF STANDARD CHARACTERS WITHOUT CLAIM TO ANY PARTICULAR FONT, STYLE, SIZE, OR COLOR.

FOR PILLOWS (U.S. CLS. 2, 13, 22, 25, 32 AND 50).  
FIRST USE 8-1-2006; IN COMMERCE 8-1-2006.

---

3,235,083. DEECEEQ!, MIAMI, FL. SN 78-670,561. PUB. 3-14-2006, FILED 7-14-2005.

**ZOOM-ROOM**

THE MARK CONSISTS OF STANDARD CHARACTERS WITHOUT CLAIM TO ANY PARTICULAR FONT, STYLE, SIZE, OR COLOR.

FOR WALL BEDS ENCASED IN BOTH CUSTOM AND STANDARD CABINETRY AND OPERATED BY REMOTE CONTROL (U.S. CLS. 2, 13, 22, 25, 32 AND 50).  
FIRST USE 2-28-2006; IN COMMERCE 2-28-2006.

**CLASS 20—(Continued).**

3,235,132. AIDMA ENTERPRISE CO., LTD., TAIPEI HSIEN, TAIWAN. SN 78-683,829. PUB. 4-18-2006, FILED 8-2-2005.



THE COLOR(S) BLACK AND GREEN IS/ARE CLAIMED AS A FEATURE OF THE MARK.

THE MARK CONSISTS OF STYLIZED LETTERS ERGOAID WITH THE LETTER "A" SHAPED LIKE AN ARC IN COLOR OF GREEN.

FOR FURNITURE, NAMELY, CABINETS, CHAIR PADS, CHESTS OF DRAWERS, COMPUTER FURNITURE, COMPUTER KEYBOARD TRAYS, DESKS, DRAWERS, FURNITURE, HUTCHES, INDUSTRIAL WORK TABLES, MAGAZINE RACKS, OFFICE FURNITURE, SHELVES, STORAGE RACKS, AND TABLES (U.S. CLS. 2, 13, 22, 25, 32 AND 50).

FIRST USE 10-7-2004; IN COMMERCE 11-18-2004.

---

3,235,235. O'SULLIVAN INDUSTRIES, INC., LAMAR, MO.  
SN 78-725,963. PUB. 6-20-2006, FILED 10-4-2005.

**SHELVING SOLUTIONS**

THE MARK CONSISTS OF STANDARD CHARACTERS WITHOUT CLAIM TO ANY PARTICULAR FONT, STYLE, SIZE, OR COLOR.

NO CLAIM IS MADE TO THE EXCLUSIVE RIGHT TO USE "SHELVING", APART FROM THE MARK AS SHOWN.

FOR METAL AND NON-METAL SHELVING AND COMPONENT PARTS THEREOF, NAMELY, SHELVING AND BRACKETS SOLD AS A UNIT (U.S. CLS. 2, 13, 22, 25, 32 AND 50).

FIRST USE 5-31-2006; IN COMMERCE 5-31-2006.

---

3,235,248. NEMSCHOFF CHAIRS, INC., SHEBOYGAN, WI.  
SN 78-730,568. PUB. 6-13-2006, FILED 10-11-2005.

**COMPACTCOMFORT**

THE MARK CONSISTS OF STANDARD CHARACTERS WITHOUT CLAIM TO ANY PARTICULAR FONT, STYLE, SIZE, OR COLOR.

FOR RECLINERS (U.S. CLS. 2, 13, 22, 25, 32 AND 50).  
FIRST USE 6-0-2006; IN COMMERCE 6-0-2006.

**CLASS 20—(Continued).**

3,235,271. SUPERTREND INTERNATIONAL INC., TAIPEI, TAIWAN. SN 78-743,632. PUB. 8-8-2006, FILED 10-31-2005.

**SUPERTREND**

THE MARK CONSISTS OF STANDARD CHARACTERS WITHOUT CLAIM TO ANY PARTICULAR FONT, STYLE, SIZE, OR COLOR.

FOR SLEEP PRODUCTS, NAMELY, INFLATABLE AIR MATTRESSES (U.S. CLS. 2, 13, 22, 25, 32 AND 50).  
FIRST USE 11-13-2006; IN COMMERCE 11-13-2006.

3,235,286. THE KILLION CORPORATION, INDIANAPOLIS, IN. SN 78-752,082. PUB. 7-25-2006, FILED 11-11-2005.

**CRICKIT**

THE MARK CONSISTS OF STANDARD CHARACTERS WITHOUT CLAIM TO ANY PARTICULAR FONT, STYLE, SIZE, OR COLOR.

FOR NON-METAL MAGNETIC CLIPS FOR HOLDING SHEETS, SUCH AS SHEETS OF PAPERS, PHOTOGRAPHS, AND CARDS (U.S. CLS. 2, 13, 22, 25, 32 AND 50).

FIRST USE 6-15-2006; IN COMMERCE 6-15-2006.

3,235,365. KRUEGER INTERNATIONAL, INC., GREEN BAY, WI. SN 78-785,064. PUB. 8-8-2006, FILED 1-4-2006.

**MI6**

THE MARK CONSISTS OF STANDARD CHARACTERS WITHOUT CLAIM TO ANY PARTICULAR FONT, STYLE, SIZE, OR COLOR.

FOR FURNITURE (U.S. CLS. 2, 13, 22, 25, 32 AND 50).  
FIRST USE 10-19-2006; IN COMMERCE 10-19-2006.

**CLASS 20—(Continued).**

3,235,372. KOHL'S ILLINOIS, INC., AURORA, IL. SN 78-795,163. PUB. 3-21-2006, FILED 1-19-2006.

**HOMESTUDIO**

THE MARK CONSISTS OF STANDARD CHARACTERS WITHOUT CLAIM TO ANY PARTICULAR FONT, STYLE, SIZE, OR COLOR.

OWNER OF U.S. REG. NO. 2,936,720.  
FOR PILLOWS AND DECORATIVE PILLOWS (U.S. CLS. 2, 13, 22, 25, 32 AND 50).

FIRST USE 8-0-2006; IN COMMERCE 8-0-2006.

**CLASS 21—HOUSEWARES AND GLASS**

3,233,799. PROMARK BRANDS INC., MERIDIAN, ID. SN 76-415,135. PUB. 8-12-2003, FILED 5-30-2002.

**FOREVER FULL**

FOR CONTAINER FOR CONDIMENTS AND SAUCES TO BE USED WITH MEAT, POULTRY, AND/OR FISH (U.S. CLS. 2, 13, 23, 29, 30, 33, 40 AND 50).

FIRST USE 12-31-2000; IN COMMERCE 12-31-2000.

3,233,854. SPECTRUM SURGICAL INSTRUMENTS CORP., STOW, OH. SN 76-529,086. PUB. 9-6-2005, FILED 7-11-2003.

**CLEAN-N-DRY**

FOR CLEANING BRUSHES USED TO MAINTAIN SURGICAL AND VETERINARY INSTRUMENTS (U.S. CLS. 2, 13, 23, 29, 30, 33, 40 AND 50).

FIRST USE 8-27-2002; IN COMMERCE 9-0-2002.

3,234,075. HERITAGE MINT, LTD, SCOTTSDALE, AZ. SN 76-649,049. PUB. 8-29-2006, FILED 10-24-2005.

**RIVERSTONE**

THE MARK CONSISTS OF STANDARD CHARACTERS WITHOUT CLAIM TO ANY PARTICULAR FONT, STYLE, SIZE, OR COLOR.

FOR DINNERWARE (U.S. CLS. 2, 13, 23, 29, 30, 33, 40 AND 50).

FIRST USE 12-1-2005; IN COMMERCE 12-1-2005.



**CLASS 21—(Continued).**

3,234,116. PETCO ANIMAL SUPPLIES, INC., SAN DIEGO, CA. SN 78-176,127. PUB. 5-13-2003, FILED 10-18-2002.

**CLASS 21—(Continued).**

3,234,381. NILFISK-ADVANCE, INC., PLYMOUTH, MN. SN 78-470,359. PUB. 2-21-2006, FILED 8-19-2004.

**QUICK-CAGE**

FOR BIRD, SMALL ANIMAL, DOG AND CAT CAGES (U.S. CLS. 2, 13, 23, 29, 30, 33, 40 AND 50). FIRST USE 8-5-2003; IN COMMERCE 8-5-2003.

**SURFACEWORX**

3,234,118. MUNCHKIN, INC., NORTH HILLS, CA. SN 78-187,924. PUB. 9-23-2003, FILED 11-22-2002.

**BAMBOO**

FOR PET FEEDING DISHES; PET WATER BOWLS (U.S. CLS. 2, 13, 23, 29, 30, 33, 40 AND 50). FIRST USE 11-16-2006; IN COMMERCE 11-16-2006.

THE MARK CONSISTS OF STANDARD CHARACTERS WITHOUT CLAIM TO ANY PARTICULAR FONT, STYLE, SIZE, OR COLOR.

FOR CLEANING SUPPLIES, NAMELY, MOPS, SPONGES, PRE-MOISTENED TOWELETTES, CLEANING PADS, CLEANING WIPES, AND DUSTING GLOVES; MICROFIBER TEXTILE PRODUCTS FOR CLEANING, NAMELY, MOPS, CLOTHS, WIPES, SPONGES, PADS, BONNETS, PRE-MOISTENED TOWELETTES AND HOUSEHOLD GLOVES FOR CLEANING USE; PARTS FOR CLEANING SUPPLIES NAMELY, MOP HOLDERS, LIQUID DISPENSING SHAFTS AND HANDLES FOR USE WITH MOPS, SPONGES, CLEANING PADS AND CLEANING BONNETS (U.S. CLS. 2, 13, 23, 29, 30, 33, 40 AND 50). FIRST USE 8-19-2004; IN COMMERCE 8-19-2004.

3,234,128. MILLIKEN & COMPANY, NEW YORK, NY. SN 78-215,664. PUB. 9-16-2003, FILED 2-17-2003.

**PREMIRA**

OWNER OF U.S. REG. NO. 1,560,994. FOR FABRIC CLEAN ROOM WIPES (U.S. CLS. 2, 13, 23, 29, 30, 33, 40 AND 50). FIRST USE 7-23-2004; IN COMMERCE 7-23-2004.

3,234,387. QUICKIE MANUFACTURING CORPORATION, CINNAMINSON, NJ. SN 78-473,206. PUB. 7-19-2005, FILED 8-25-2004.

3,234,325. LAITNER BRUSH COMPANY, TRAVERSE CITY, MI. SN 78-433,456. PUB. 10-18-2005, FILED 6-10-2004.



**EZ-GLIDE**

NO CLAIM IS MADE TO THE EXCLUSIVE RIGHT TO USE "SWEEP", APART FROM THE MARK AS SHOWN.

THE MARK CONSISTS OF THE TERMS GREEN SWEEP WITH AN OVERSIZED LETTER S INSIDE AN OVAL WITH TIRE MARKS AND LEAVES IN THE BACKGROUND.

FOR BROOMS MADE FROM MATERIAL USING RECYCLED TIRES AND PLASTICS (U.S. CLS. 2, 13, 23, 29, 30, 33, 40 AND 50). FIRST USE 11-15-2004; IN COMMERCE 11-15-2004.

THE MARK CONSISTS OF STANDARD CHARACTERS WITHOUT CLAIM TO ANY PARTICULAR FONT, STYLE, SIZE, OR COLOR.

FOR BUCKETS (U.S. CLS. 2, 13, 23, 29, 30, 33, 40 AND 50). FIRST USE 4-30-2004; IN COMMERCE 4-30-2004.

**CLASS 21—(Continued).**

3,234,408. KIKKERLAND DESIGNS, INC., NEW YORK, NY.  
SN 78-481,931. PUB. 9-6-2005, FILED 9-10-2004.

**CLASS 21—(Continued).**

3,234,458. BASKETVILLE, INC., PUTNEY, VT. SN 78-500,298.  
PUB. 5-2-2006, FILED 10-15-2004.

**BOBBLE OPENER**

THE MARK CONSISTS OF STANDARD CHARACTERS WITHOUT CLAIM TO ANY PARTICULAR FONT, STYLE, SIZE, OR COLOR.

NO CLAIM IS MADE TO THE EXCLUSIVE RIGHT TO USE "OPENER", APART FROM THE MARK AS SHOWN.

FOR NOVELTY BOTTLE OPENER (U.S. CLS. 2, 13, 23, 29, 30, 33, 40 AND 50).

FIRST USE 8-1-2004; IN COMMERCE 8-1-2004.

**HOME THEORY**

THE MARK CONSISTS OF STANDARD CHARACTERS WITHOUT CLAIM TO ANY PARTICULAR FONT, STYLE, SIZE, OR COLOR.

NO CLAIM IS MADE TO THE EXCLUSIVE RIGHT TO USE HOME, APART FROM THE MARK AS SHOWN.

FOR BASKETS OF WOVEN NATURAL FIBERS (U.S. CLS. 2, 13, 23, 29, 30, 33, 40 AND 50).

FIRST USE 3-1-2005; IN COMMERCE 3-1-2005.

3,234,417. BRASSERIE DE TAHITI S.A., PAPEETE, FRENCH POLYNESIA. SN 78-484,651. PUB. 7-12-2005, FILED 9-16-2004.

3,234,492. VANCE, REBECCA, WILKESBORO, NC. SN 78-511,691. PUB. 3-14-2006, FILED 11-4-2004.

**"Women of the Bible" Collection**

OWNER OF U.S. REG. NOS. 2,192,919 AND 2,873,493.  
FOR MUGS, CUPS, BEER MUGS, PORTABLE COOLERS, BEVERAGE GLASSWARE, BOTTLE OPENERS, COASTERS NOT OF PAPER OR TABLE LINEN, ICE BUCKETS, DRINKING FLASKS, PITCHERS, SERVING PLATTERS (U.S. CLS. 2, 13, 23, 29, 30, 33, 40 AND 50).

FIRST USE 1-0-1995; IN COMMERCE 1-0-2004.

THE MARK CONSISTS OF STANDARD CHARACTERS WITHOUT CLAIM TO ANY PARTICULAR FONT, STYLE, SIZE, OR COLOR.

NO CLAIM IS MADE TO THE EXCLUSIVE RIGHT TO USE COLLECTION, APART FROM THE MARK AS SHOWN.

FOR EARTHENWARE POTTERY NAMELY PITCHERS, URNS AND VASES (U.S. CLS. 2, 13, 23, 29, 30, 33, 40 AND 50).

FIRST USE 3-6-2004; IN COMMERCE 11-23-2004.

**CLASS 21—(Continued).**

3,234,545. KOMODO INTERNATIONAL CORP., RANCHO DOMINGUEZ, CA. SN 78-526,655. PUB. 4-11-2006, FILED 12-3-2004.

**CREATE SPACE**

THE MARK CONSISTS OF STANDARD CHARACTERS WITHOUT CLAIM TO ANY PARTICULAR FONT, STYLE, SIZE, OR COLOR.

FOR HOUSEHOLD AND KITCHEN UTENSILS, NAMELY, KITCHEN LADLES, SERVING FORKS, SERVING KNIVES, AND SERVING SPOONS; GLASSWARE, NAMELY, CUPS, MUGS, DRINKING GLASSES, CHALICES, SUGAR BOWLS, PITCHERS, JUGS, DECANTERS, COCKTAIL SHAKERS, VINEGAR AND OIL BOTTLES SOLD EMPTY, DECORATIVE BOWLS, SALAD BOWLS, CELERY DISHES, VASES, JARS FOR STORING FOODSTUFFS, AND BEVERAGeware FOR WATER, WINE, PORT, SHERRY, BRANDY, LIQUER, AND CHAMPAGNE; COOKWARE, NAMELY, POTS, PANS, DISHES, COLANDERS, AND TEA KETTLES; BEVERAGeware; DINNERWARE; FLATWARE; PORCELAINWARE, NAMELY, CUPS, SAUCERS, DISHES, PLATES, BOWLS, PITCHERS, PITCHER CREAMERS, AND SALT AND PEPPER SHAKERS, ALL MADE OF PORCELAIN; CERAMICWARE, NAMELY, BOWLS, SERVING PLATES, AND SERVING BOWLS, ALL MADE OF CERAMIC; AND PLASTICWARE, NAMELY, KITCHEN LADLES, SERVING FORKS, SERVING KNIVES, AND SERVING SPOONS, DISHES, CUPS, AND MUGS, ALL MADE OF PLASTIC (U.S. CLS. 2, 13, 23, 29, 30, 33, 40 AND 50).

FIRST USE 2-28-2005; IN COMMERCE 2-28-2005.

3,234,593. KAY CHEMICAL CO., GREENSBORO, NC. SN 78-537,805. PUB. 10-25-2005, FILED 12-23-2004.

**QUATSMART**

THE MARK CONSISTS OF STANDARD CHARACTERS WITHOUT CLAIM TO ANY PARTICULAR FONT, STYLE, SIZE, OR COLOR.

NO CLAIM IS MADE TO THE EXCLUSIVE RIGHT TO USE "QUAT", APART FROM THE MARK AS SHOWN.

FOR CLEANING CLOTHS (U.S. CLS. 2, 13, 23, 29, 30, 33, 40 AND 50).

FIRST USE 5-12-2005; IN COMMERCE 5-12-2005.

**CLASS 21—(Continued).**

3,234,685. MATTEL, INC., EL SEGUNDO, CA. SN 78-579,297. PUB. 4-18-2006, FILED 3-3-2005.

**POTTY ON-THE-GO**

THE MARK CONSISTS OF STANDARD CHARACTERS WITHOUT CLAIM TO ANY PARTICULAR FONT, STYLE, SIZE, OR COLOR.

NO CLAIM IS MADE TO THE EXCLUSIVE RIGHT TO USE "POTTY", APART FROM THE MARK AS SHOWN.

FOR CHILDREN'S POTTIES (U.S. CLS. 2, 13, 23, 29, 30, 33, 40 AND 50).

FIRST USE 4-16-2006; IN COMMERCE 4-16-2006.

3,234,772. FOOD EQUIPMENT TECHNOLOGIES COMPANY, INC., LAKE ZURICH, IL. SN 78-610,085. PUB. 1-31-2006, FILED 4-15-2005.

**ICING FRESH COFFEE**

THE MARK CONSISTS OF STANDARD CHARACTERS WITHOUT CLAIM TO ANY PARTICULAR FONT, STYLE, SIZE, OR COLOR.

NO CLAIM IS MADE TO THE EXCLUSIVE RIGHT TO USE "COFFEE", APART FROM THE MARK AS SHOWN.

FOR COMMERCIAL PORTABLE INSULATED BEVERAGE DISPENSERS AND COMMERCIAL BEVERAGE SERVERS IN THE NATURE OF NON-ELECTRIC BEVERAGE SERVERS NOT OF PRECIOUS METALS, NON-ELECTRIC INSULATED AIRPOTS, AND THERMALLY INSULATED BEVERAGE BOTTLES, MARKETED TO RESTAURANTS, COFFEE SHOPS, CATERERS AND OTHER COMMERCIAL PROVIDERS OF LARGE QUANTITIES OF FRESHLY BREWED BEVERAGE (U.S. CLS. 2, 13, 23, 29, 30, 33, 40 AND 50).

FIRST USE 4-1-2005; IN COMMERCE 4-1-2005.

**CLASS 21—(Continued).**

3,234,890. DOBRANSKY, MICHAEL T., CARDIFF BY THE SEA, CA. SN 78-642,785. PUB. 2-7-2006, FILED 6-2-2005.

# GIDGET

THE MARK CONSISTS OF STANDARD CHARACTERS WITHOUT CLAIM TO ANY PARTICULAR FONT, STYLE, SIZE, OR COLOR.

OWNER OF U.S. REG. NOS. 2,093,572, 2,344,019, AND 2,884,815.

FOR DRINKING GLASSES, BEER MUGS, COFFEE MUGS, DISHES, PLATES, BOWLS, BOTTLE OPENERS, THERMAL INSULATED CONTAINERS FOR BEVERAGES, PLASTIC JUGS FOR BEVERAGES, CONTAINERS FOR FOOD, PITCHERS AND JARS (U.S. CLS. 2, 13, 23, 29, 30, 33, 40 AND 50).

FIRST USE 10-1-2006; IN COMMERCE 10-1-2006.

3,234,917. BALLARINI PAOLO & FIGLI S.P.A., RIVAROLO MANTOVANO, ITALY. SN 78-648,987. PUB. 3-7-2006, FILED 6-13-2005.

# iLoveCookingRisotto

FOR COOKING POTS, NON-ELECTRIC PRESSURE COOKERS, SAUCEPANS, PANS; ALL PURPOSE HOUSEHOLD CONTAINERS FOR KITCHEN USE, NAMELY, CONTAINERS FOR PRESERVING FOOD; COOKING POTS WITH ANTI-ADHERENT COATING, SAUCEPANS WITH ANTI-ADHERENT COATING, NON-ELECTRIC COOKING PANS WITH ANTI-ADHERENT COATING, ALL PURPOSE HOUSEHOLD CONTAINERS WITH ANTI-ADHERENT COATING FOR PRESERVING FOOD; COOKING POTS WITH OUTSIDE DECORATIONS, VARNISHING OR OUTSIDE PAINTING, NON-ELECTRIC PRESSURE COOKERS WITH OUTSIDE DECORATIONS, VARNISHING OR OUTSIDE PAINTING, SAUCEPANS WITH OUTSIDE DECORATIONS, VARNISHING OR OUTSIDE PAINTING, NON-ELECTRIC COOKING PANS AND ALL PURPOSE HOUSEHOLD CONTAINERS FOR KITCHEN USE WITH OUTSIDE DECORATIONS, VARNISHING OR OUTSIDE PAINTING (U.S. CLS. 2, 13, 23, 29, 30, 33, 40 AND 50).

FIRST USE 3-18-2004; IN COMMERCE 11-10-2005.

**CLASS 21—(Continued).**

3,234,918. BALLARINI PAOLO & FIGLI S.P.A., RIVAROLO MANTOVANO, ITALY. SN 78-648,988. PUB. 6-20-2006, FILED 6-13-2005.

# iLoveCookingPasta

FOR COOKING POTS, NON-ELECTRIC PRESSURE COOKERS, SAUCEPANS, PANS; ALL PURPOSE HOUSEHOLD CONTAINERS FOR KITCHEN USE, NAMELY, CONTAINERS FOR PRESERVING FOOD; COOKING POTS WITH ANTI-ADHERENT COATING, SAUCEPANS WITH ANTI-ADHERENT COATING, NON-ELECTRIC COOKING PANS WITH ANTI-ADHERENT COATING, ALL PURPOSE HOUSEHOLD CONTAINERS WITH ANTI-ADHERENT COATING FOR PRESERVING FOOD; COOKING POTS WITH OUTSIDE DECORATIONS, VARNISHING OR OUTSIDE PAINTING, NON-ELECTRIC PRESSURE COOKERS WITH OUTSIDE DECORATIONS, VARNISHING OR OUTSIDE PAINTING, SAUCEPANS WITH OUTSIDE DECORATIONS, VARNISHING OR OUTSIDE PAINTING, NON-ELECTRIC COOKING PANS AND ALL PURPOSE HOUSEHOLD CONTAINERS FOR KITCHEN USE WITH OUTSIDE DECORATIONS, VARNISHING OR OUTSIDE PAINTING (U.S. CLS. 2, 13, 23, 29, 30, 33, 40 AND 50).

FIRST USE 10-5-2004; IN COMMERCE 3-12-2006.

3,235,125. TRUE VALUE COMPANY, CHICAGO, IL. SN 78-681,766. PUB. 7-25-2006, FILED 7-29-2005.



OWNER OF U.S. REG. NOS. 581,301, 3,068,261, AND OTHERS.

FOR GRASS SPRINKLERS; LAWN SPRINKLERS; HOSE NOZZLES; SPRAYER WANDS FOR GARDEN HOSES; GUTTER CLEANERS, NAMELY, GARDEN HOSES FEATURING SPRAYER WANDS FOR CLEANING GUTTERS (U.S. CLS. 2, 13, 23, 29, 30, 33, 40 AND 50).

FIRST USE 6-0-2005; IN COMMERCE 6-0-2005.

**CLASS 21—(Continued).**

3,235,245. HELEN OF TROY LIMITED, ST. MICHAEL, BARBADOS. SN 78-728,820. PUB. 6-13-2006, FILED 10-7-2005.

**CLASS 22—(Continued).**

3,234,138. NORTHPOLE LIMITED, KOWLOON, HONG KONG. SN 78-250,226. PUB. 8-10-2004, FILED 5-15-2003.

# AMBER WAVES

THE MARK CONSISTS OF STANDARD CHARACTERS WITHOUT CLAIM TO ANY PARTICULAR FONT, STYLE, SIZE, OR COLOR.  
FOR BATH BRUSHES; HAIR BRUSHES; HAIR COMBS (U.S. CLS. 2, 13, 23, 29, 30, 33, 40 AND 50).  
FIRST USE 5-15-2006; IN COMMERCE 5-15-2006.

# CYCLONE VENTING

FOR PORTABLE SHELTERS, NAMELY TENTS, NON-METAL AWNINGS, SCREENHOUSES IN THE NATURE OF TENTS (U.S. CLS. 1, 2, 7, 19, 22, 42 AND 50).  
FIRST USE 1-0-2003; IN COMMERCE 1-0-2003.

3,235,277. DYNASTY DESIGNS LLC, ST. LOUIS, MO. SN 78-748,733. PUB. 7-11-2006, FILED 11-7-2005.

3,234,271. HICKORY SPRINGS MANUFACTURING COMPANY, HICKORY, NC. SN 78-402,283. PUB. 10-4-2005, FILED 4-15-2004.



FOR HAIR BRUSHES (U.S. CLS. 2, 13, 23, 29, 30, 33, 40 AND 50).  
FIRST USE 1-1-2006; IN COMMERCE 8-11-2006.

# IMPEDE

3,235,380. THE HOMER LAUGHLIN CHINA COMPANY, NEWELL, WV. SN 78-806,444. PUB. 8-29-2006, FILED 2-3-2006.

THE MARK CONSISTS OF STANDARD CHARACTERS WITHOUT CLAIM TO ANY PARTICULAR FONT, STYLE, SIZE, OR COLOR.  
FOR COTTON FIBERS TREATED WITH FIRE-RETARDANT MATERIALS (U.S. CLS. 1, 2, 7, 19, 22, 42 AND 50).  
FIRST USE 7-18-2006; IN COMMERCE 7-18-2006.

# RE-21

THE MARK CONSISTS OF STANDARD CHARACTERS WITHOUT CLAIM TO ANY PARTICULAR FONT, STYLE, SIZE, OR COLOR.  
FOR DINNERWARE (U.S. CLS. 2, 13, 23, 29, 30, 33, 40 AND 50).  
FIRST USE 5-20-2006; IN COMMERCE 7-8-2006.

**CLASS 22—CORDAGE AND FIBERS**

**CLASS 23—YARNS AND THREADS**

**CLASS 23—(Continued).**

3,233,904. LI PENG ENTERPRISE CO.,LTD., TAIPEI, TAIWAN. SN 76-591,968. PUB. 3-14-2006, FILED 5-13-2004.

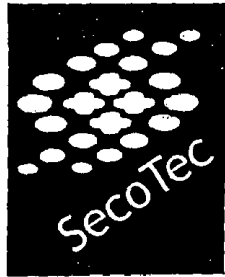

FOR YARNS AND THREADS, FOR TEXTILE USE (U.S. CL. 43).  
FIRST USE 11-28-2000; IN COMMERCE 11-28-2000.

**CLASS 24—FABRICS**

3,234,081. OFFICIAL PILLOWTEX LLC, COLUMBUS, OH. SN 76-978,321. PUB. 11-18-2003, FILED 3-27-2003.



NO CLAIM IS MADE TO THE EXCLUSIVE RIGHT TO USE "TRADE MARK U.S.A. 1887", APART FROM THE MARK AS SHOWN.  
FOR TOWELS AND TOWELING, BED SHEETS, PILLOWCASES, WASHCLOTHS AND COMFORTERS (U.S. CLS. 42 AND 50).  
FIRST USE 3-0-2006; IN COMMERCE 3-0-2006.

**CLASS 24—(Continued).**

3,234,166. PRATS, CARLOS ROYO, CASTELLON, SPAIN. SN 78-303,857. PUB. 9-13-2005, FILED 9-22-2003.

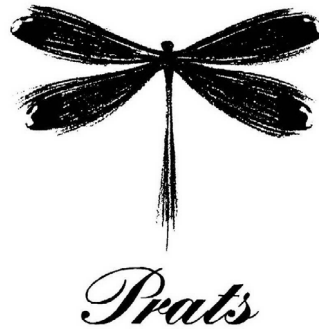

FOR TAPESTRIES OF TEXTILES; TEXTILES FABRICS FOR THE MANUFACTURE OF CLOTHING; TEXTILE LININGS FOR GARMENTS; TEXTILE NAPKINS; TEXTILE PLACE MATS; TEXTILE PRINTERS' BLANKETS; TEXTILE USED AS LINING FOR CLOTHING; TEXTILE WALL HANGINGS; BED SPREADS; AND TABLE CLOTHS NOT OF PAPER (U.S. CLS. 42 AND 50).  
FIRST USE 10-20-2006; IN COMMERCE 10-20-2006.

3,234,258. BLUE LINE PRODUCTIONS, INC., SUWANEE, GA. SN 78-388,847. PUB. 9-6-2005, FILED 3-23-2004.



THE COLOR(S) BLACK AND BLUE IS/ARE CLAIMED AS A FEATURE OF THE MARK.  
THE MARK CONSISTS OF TWO BLACK BARS, WITH A BLUE BAR DISPOSED BETWEEN THE TWO BLACK BARS, FOR CLOTH FLAGS (U.S. CLS. 42 AND 50).  
FIRST USE 7-12-2001; IN COMMERCE 7-12-2001.

3,234,331. ALEN SANDS YORK ASSOCIATES, NEW YORK, NY. SN 78-436,710. PUB. 9-27-2005, FILED 6-17-2004.



NO CLAIM IS MADE TO THE EXCLUSIVE RIGHT TO

**CLASS 24—(Continued).**

USE "KIDS", APART FROM THE MARK AS SHOWN.

THE COLORS PINK, LIGHT BLUE, GREEN AND BLACK ARE CLAIMED AS A FEATURE OF THE MARK.

THE COLOR PINK APPEARS IN THE ISLAND DESIGN, THE COLOR LIGHT BLUE APPEARS IN THE BACK GROUND OF THE MARK, THE COLOR GREEN APPEARS IN THE PALM TREE FRONDS OF THE STYLIZED LETTER "I," AND THE COLOR BLACK APPEARS IN THE WORDING ISLAND KIDS OF THE MARK.

FOR BED BLANKETS, BED LINENS, FLAT BED SHEETS, FITTED BED SHEETS, COMFORTER COVERS, DUVETS, DUVET COVERS, AND SHAMS, PILLOW-CASES, THROW BLANKETS (U.S. CLS. 42 AND 50).

FIRST USE 1-12-2005; IN COMMERCE 4-8-2005.

---

3,234,580. RARITY, INC., NEW YORK, NY. SN 78-532,763. PUB. 3-21-2006, FILED 12-15-2004.

## TY PENNINGTON STYLE

THE MARK CONSISTS OF STANDARD CHARACTERS WITHOUT CLAIM TO ANY PARTICULAR FONT, STYLE, SIZE, OR COLOR.

THE NAME(S), PORTRAIT(S), AND/OR SIGNATURE(S) SHOWN IN THE MARK IDENTIFIES TY PENNINGTON, WHOSE CONSENT(S) TO REGISTER IS SUBMITTED.

FOR BEDDING AND BEDDING ACCESSORIES, NAMELY BED SKIRTS AND BED SHEETS; BATH TOWELS; WINDOW TREATMENTS, NAMELY CURTAINS; PILLOW SHAMS, PILLOW COVERS AND PILLOW CASES; KITCHEN TOWELS; POT HOLDERS; DISH CLOTHS; TABLECLOTHS; CLOTH NAPKINS; PLASTIC AND TEXTILE PLACEMATS (U.S. CLS. 42 AND 50).

FIRST USE 4-1-2005; IN COMMERCE 4-1-2005.

---

3,234,989. FABRIC EDITIONS LLC, FORMERLY FE ACQUISITION LLC, GREENVILLE, SC. SN 78-657,573. PUB. 3-14-2006, FILED 6-24-2005.

## DESIGN BY THE PIECE

THE MARK CONSISTS OF STANDARD CHARACTERS WITHOUT CLAIM TO ANY PARTICULAR FONT, STYLE, SIZE, OR COLOR.

FOR PRE-CUT FABRICS; FABRIC PATCHWORK PIECES AND QUILT AND CRAFT KITS COMPRISED OF FABRIC PATCHWORK PIECES (U.S. CLS. 42 AND 50).

FIRST USE 8-31-2005; IN COMMERCE 8-31-2005.

**CLASS 24—(Continued).**

3,235,258. TOADEGRIP PARTNERS, LLP, UNIVERSAL CITY, TX. SN 78-735,808. PUB. 8-8-2006, FILED 10-18-2005.

## TOADEGRIP

THE MARK CONSISTS OF STANDARD CHARACTERS WITHOUT CLAIM TO ANY PARTICULAR FONT, STYLE, SIZE, OR COLOR.

FOR FABRIC BANNERS FOR ATTACHMENT TO GOLF CARTS AND OTHER MOTORIZED VEHICLES (U.S. CLS. 42 AND 50).

FIRST USE 1-6-2006; IN COMMERCE 1-6-2006.

---

3,235,371. KOHL'S ILLINOIS, INC., AURORA, IL. SN 78-795,162. PUB. 3-21-2006, FILED 1-19-2006.

## HOMESTUDIO

THE MARK CONSISTS OF STANDARD CHARACTERS WITHOUT CLAIM TO ANY PARTICULAR FONT, STYLE, SIZE, OR COLOR.

OWNER OF U.S. REG. NO. 2,936,720.

FOR BED BLANKETS; BED SHEETS; BLANKET TROWS; COMFORTERS; PILLOW CASES; TABLE LINEN, NAMELY PLACEMATS, NAPKINS, TABLE-CLOTHS, AND TABLE RUNNERS (U.S. CLS. 42 AND 50).

FIRST USE 8-0-2006; IN COMMERCE 8-0-2006.

**CLASS 25—CLOTHING**

3,233,762. BEAR U.S.A., INC., RIDGEFIELD, NJ. SN 75-063,345. PUB. 8-1-2000, FILED 2-26-1996.



FOR CLOTHING, NAMELY, PARKAS, JACKETS, COLD-WEATHER HATS, AND DENIM PRODUCTS, NAMELY, JEANS, SHORTS, SHIRTS, JACKETS AND HATS (U.S. CLS. 22 AND 39).

FIRST USE 4-0-1996; IN COMMERCE 4-0-1996.

**CLASS 25—(Continued).**

3,233,773. CONTROLLED CHAOS, INC., ORANGE PARK, FL. SN 75-931,648. PUB. 6-27-2006, FILED 2-29-2000.

**MANGO MANNY'S**

FOR CLOTHING, NAMELY, SHORTS, SHIRTS, T-SHIRTS, SWEATSHIRTS, HATS, CAPS, SANDALS, BLOUSES, SKIRTS, DRESSES AND SWIMSUITS (U.S. CLS. 22 AND 39).

FIRST USE 7-17-2000; IN COMMERCE 10-0-2001.

3,233,775. ARAWAZA EQUIPMENT INC., QUEBEC, CANADA. SN 76-240,781. PUB. 11-12-2002, FILED 4-13-2001.

**KAMIKAZE**

FOR KARATE UNIFORMS, ANY UNIFORM USED FOR MARTIAL ARTS TRAINING, NAMELY UNIFORMS FOR JUJITSU, UNIFORMS FOR JUDO (U.S. CLS. 22 AND 39).

FIRST USE 11-22-2006; IN COMMERCE 11-22-2006.

3,233,785. L.C. LICENSING, INC., NEW YORK, NY. SN 76-376,647. PUB. 8-12-2003, FILED 2-28-2002.

**JUICY BABY**

NO CLAIM IS MADE TO THE EXCLUSIVE RIGHT TO USE "BABY", APART FROM THE MARK AS SHOWN.

FOR CLOTHING, NAMELY, SHIRTS, JOGGING SUITS, SWEATSHIRTS, SWEATPANTS, PANTS (U.S. CLS. 22 AND 39).

FIRST USE 11-2-2006; IN COMMERCE 11-2-2006.

3,233,793. BAYCHAR, INC., EASTPORT, ME. SN 76-396,623. PUB. 9-2-2003, FILED 4-18-2002.

**BAYCHAR**

FOR CLOTHING, NAMELY, ATHLETIC FOOTWEAR, ATHLETIC SHOES, ATHLETIC UNIFORMS, BATH SLIPPERS, BATHING SUITS, BATHING TRUNKS, BATHROBES, BEACH COVER-UPS, BEACHWEAR, BERMUDA SHORTS, BLAZERS, BLOUSES, BOOTS, BOTTOMS, BOXER BRIEFS, BOXER SHORTS, BRAS, COATS, DENIM JACKETS, FOOTWEAR, GYM SHORTS, GYM SUITS, INNER SOLES, INSOLES, JACKETS, JEANS, JERSEYS, KNIT SHIRTS, LEATHER COATS, LEATHER JACKETS, PAJAMAS, PANTS, PULLOVERS, RAIN COATS, RAIN JACKETS, RAINWEAR, POLO SHIRTS (U.S. CLS. 22 AND 39).

FIRST USE 1-1-2003; IN COMMERCE 1-1-2003.

**CLASS 25—(Continued).**

3,233,819. MASTRION, HELEN, GREENFIELD CENTER, NY. SN 76-480,475. PUB. 9-9-2003, FILED 1-3-2003.

**PRINCESS POSSE**

FOR T-SHIRTS (U.S. CLS. 22 AND 39).  
FIRST USE 7-4-2006; IN COMMERCE 7-4-2006.

3,233,860. SPOELSTRA, DUANE, LANCASTER, CA. SN 76-546,623. PUB. 2-22-2005, FILED 9-24-2003.

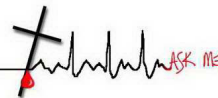

THE COLOR(S) RED IS/ARE CLAIMED AS A FEATURE OF THE MARK.

THE DROP OF BLOOD AND THE WORDS "ASK ME" APPEAR IN RED.

THE MARK CONSISTS OF A STRAIGHT LINE SUPERIMPOSED WITH A CROSS WITH A DROP OF BLOOD FOLLOWED BY THE SYMBOL OF AN EKG HEARTBEAT GRAPH WITH THE WORDS "ASK ME" AT THE END.

FOR CLOTHING, NAMELY, T-SHIRTS, HATS, SWEATSHIRTS (U.S. CLS. 22 AND 39).

FIRST USE 6-18-2006; IN COMMERCE 7-18-2006.

3,233,877. BALENCIAGA, 75006 PARIS, FRANCE. SN 76-571,456. PUB. 7-12-2005, FILED 1-22-2004.



FOR DRESS SHIRTS, SPORT SHIRTS, POLO SHIRTS (U.S. CLS. 22 AND 39).

FIRST USE 6-0-2004; IN COMMERCE 6-0-2004.



**CLASS 25—(Continued).**

3,233,878. DALLAS BASKETBALL LIMITED, DALLAS, TX.  
SN 76-574,936. PUB. 2-22-2005, FILED 2-9-2004.

# MFFL

THE MARK CONSISTS OF STANDARD CHARACTERS WITHOUT CLAIM TO ANY PARTICULAR FONT, STYLE, SIZE, OR COLOR.

FOR T-SHIRTS, SWEATSHIRTS, HATS AND JERSEYS (U.S. CLS. 22 AND 39).

FIRST USE 10-0-2000; IN COMMERCE 10-0-2000.

3,233,888. DEL MONTE CORPORATION, SAN FRANCISCO, CA. SN 76-580,854. PUB. 1-10-2006, FILED 3-15-2004.

# KEEPING KIDS HAPPY

THE MARK CONSISTS OF STANDARD CHARACTERS WITHOUT CLAIM TO ANY PARTICULAR FONT, STYLE, SIZE, OR COLOR.

FOR CLOTHING, NAMELY, SOCKS, SLIPPERS, FLIP-FLOPS, SWEATERS, BELTS, HATS, GLOVES, SCARVES, T-SHIRTS, TANK TOPS AND SWEATSHIRTS (U.S. CLS. 22 AND 39).

FIRST USE 6-1-2004; IN COMMERCE 6-1-2004.

3,233,896. AMERICAN SPORTS LICENSING, INC., WILMINGTON, DE. SN 76-585,796. PUB. 10-11-2005, FILED 4-8-2004.

# TROPHY HUNTER

THE MARK CONSISTS OF STANDARD CHARACTERS WITHOUT CLAIM TO ANY PARTICULAR FONT, STYLE, SIZE, OR COLOR.

FOR FOOTWEAR, NAMELY, SHOES AND BOOTS (U.S. CLS. 22 AND 39).

FIRST USE 9-5-2004; IN COMMERCE 9-5-2004.

**CLASS 25—(Continued).**

3,233,898. ADAMS, MARLENE, SPRINGFIELD GARDENS, NY. SN 76-587,082. PUB. 8-30-2005, FILED 4-12-2004.

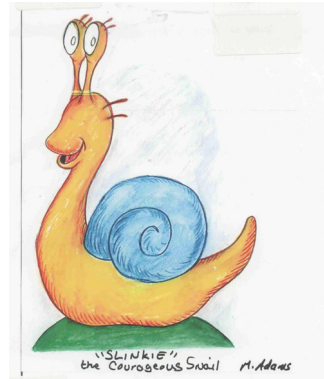

THE COLOR(S) YELLOW, BLUE, WHITE, RED, GREEN IS/ARE CLAIMED AS A FEATURE OF THE MARK.

THE BODY OF THE SNAIL IS IN YELLOW, THE SHELL IS BLUE, THE EYES ARE WHITE, THE TONGUE IS RED AND THE GRASS BASE IS GREEN.

FOR T-SHIRTS (U.S. CLS. 22 AND 39).

FIRST USE 2-2-2003; IN COMMERCE 2-2-2003.

3,233,903. LI PENG ENTERPRISE CO., LTD., TAIPEI, TAIWAN. SN 76-591,967. PUB. 3-14-2006, FILED 5-13-2004.

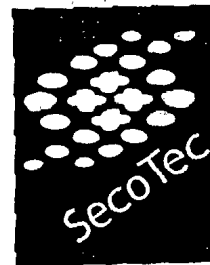

FOR CLOTHING, NAMELY, SUITS, SUIT COATS, SWEAT SUITS, SPORT SHIRTS, SPORT COATS, JACKETS, SWEAT PANTS, PANTS, SKIRTS, ATHLETIC SHOES, HATS AND CAPS (U.S. CLS. 22 AND 39).

FIRST USE 11-28-2000; IN COMMERCE 11-28-2000.

**CLASS 25—(Continued).**

3,233,946. SPANGLER, GREGORY D., CORONA, CA. SN 76-609,748. PUB. 8-23-2005, FILED 9-1-2004.

**TWISTED ADDICTION**

THE MARK CONSISTS OF STANDARD CHARACTERS WITHOUT CLAIM TO ANY PARTICULAR FONT, STYLE, SIZE, OR COLOR.

FOR CLOTHING, NAMELY, T-SHIRTS, SHIRTS, SWIMWEAR, SLEEPWEAR, PANTS, SHORTS, JACKETS, SWEATSHIRTS, HATS AND CAPS (U.S. CLS. 22 AND 39).  
FIRST USE 10-0-2006; IN COMMERCE 10-0-2006.

**CLASS 25—(Continued).**

3,233,957. PRATT, NATHAN D., SOMIS, CA. SN 76-613,132. PUB. 9-6-2005, FILED 9-21-2004.

**Z-SHOE**

THE MARK CONSISTS OF STANDARD CHARACTERS WITHOUT CLAIM TO ANY PARTICULAR FONT, STYLE, SIZE, OR COLOR.

OWNER OF U.S. REG. NOS. 2,770,125 AND 2,770,126.  
FOR SHOES (U.S. CLS. 22 AND 39).  
FIRST USE 12-31-2005; IN COMMERCE 12-31-2005.

3,233,955. TSUKIHOSHI KASEI KABUSHIKI KAISHA, KURUME-SHI, KUKUOKA-KEN, JAPAN. SN 76-612,775. PUB. 9-6-2005, FILED 9-24-2004.

**CARROT**

THE MARK CONSISTS OF STANDARD CHARACTERS WITHOUT CLAIM TO ANY PARTICULAR FONT, STYLE, SIZE, OR COLOR.

FOR FOOTWEAR (U.S. CLS. 22 AND 39).  
FIRST USE 12-11-1986; IN COMMERCE 11-9-2006.

3,233,962. BLOOM, AKIVAH, BROOKLYN, NY. AND DRATEL, JASON EVAN, BROOKLYN, NY. SN 76-613,716. PUB. 9-6-2005, FILED 9-27-2004.

3,233,956. UNIVERSAL BLUE C.V., CH-8038 ZURICH, SWITZERLAND. SN 76-612,858. PUB. 2-21-2006, FILED 9-27-2004.

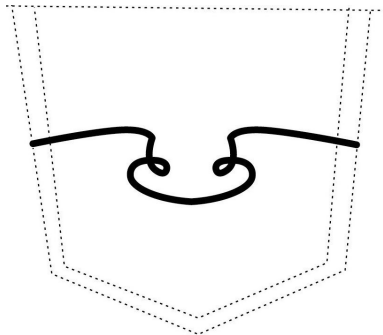

THE MARK CONSISTS OF ONE LINE OF STITCHING STRETCHING FROM THE EDGE OF A POCKET TO THE OTHER EDGE OF THE SAME POCKET, FORMING IN THE CENTER OF THE POCKET AN ABSTRACT RENDITION OF RAM'S HORNS. THE MATTER SHOWN IN DOTTED LINES IS NOT PART OF THE MARK AND SERVES ONLY TO SHOW THE POSITION OF THE MARK.

FOR JEANS, SKIRTS, AND JACKETS (U.S. CLS. 22 AND 39).  
FIRST USE 8-1-2002; IN COMMERCE 10-1-2002.



FOR BABY BIBS NOT OF PAPER, BEACHWEAR, BOTTOMS, CHILDREN'S CLOTH EATING BIBS, COVERALLS, DRESSES, HATS, HEADWEAR, INFANTWEAR, PANTS, SHIRTS, SHORTS, SKIRTS, SWEAT PANTS, SWEAT SHIRTS, TOPS, T-SHIRTS, UNDERGARMENTS (U.S. CLS. 22 AND 39).  
FIRST USE 11-17-2006; IN COMMERCE 11-17-2006.

**CLASS 25—(Continued).**

3,233,963. BLOOM, AKIVAH, BROOKLYN, NY. AND DRA-  
TEL, JASON EVAN, BROOKLYN, NY. SN 76-613,717. PUB.  
9-13-2005, FILED 9-27-2004.



THE STIPPLING AND LINING SHOWN IN THE DRAW-  
ING ARE FEATURES OF THE MARK AND NOT IN-  
TENDED TO INDICATE COLOR.

FOR BABY BIBS NOT OF PAPER, BEACHWEAR,  
BOTTOMS, CHILDREN'S CLOTH EATING BIBS, COV-  
ERALLS, HATS, PANTS, SHIRTS, SHORTS, SKIRTS,  
SWEAT PANTS, SWEAT SHIRTS, TOPS, T-SHIRTS,  
UNDERGARMENTS (U.S. CLS. 22 AND 39).

FIRST USE 11-17-2006; IN COMMERCE 11-17-2006.

**CLASS 25—(Continued).**

3,233,966. BLOOM, AKIVAH, BROOKLYN, NY. AND DRA-  
TEL, JASON EVAN, BROOKLYN, NY. SN 76-613,769. PUB.  
9-6-2005, FILED 9-28-2004.

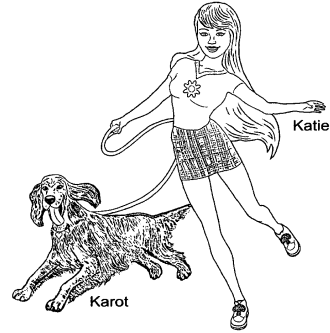

FOR BABY BIBS NOT OF PAPER, BEACHWEAR,  
BOTTOM, CHILDREN'S CLOTH EATING BIBS, COVER-  
ALLS, HATS, HEADWEAR, INFANT WEAR, PANTS,  
SHIRTS, SHORTS, SKIRTS, SWEAT PANTS, SWEAR  
SHIRTS, TOPS, T-SHIRTS, UNDERGARMENTS (U.S.  
CLS. 22 AND 39).

FIRST USE 11-17-2006; IN COMMERCE 11-17-2006.

3,233,965. BLOOM, AKIVAH, BROOKLYN, NY. AND DRA-  
TEL, JASON EVAN, BROOKLYN, NY. SN 76-613,767. PUB.  
9-13-2005, FILED 9-28-2004.

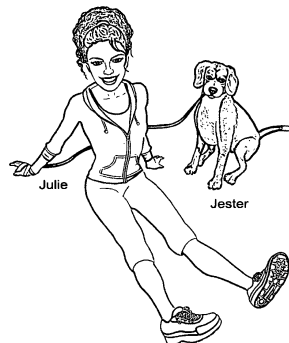

THE STIPPLING AND LINING SHOWN IN THE DRAW-  
ING ARE FEATURES OF THE MARK AND NOT IN-  
TENDED TO INDICATE COLOR.

FOR BABY BIBS NOT OF PAPER, BEACHWEAR,  
BOTTOMS, CHILDREN'S CLOTH EATING BIBS, COV-  
ERALLS, HATS, PANTS, SHIRTS, SHORTS, SKIRTS,  
SWEAT PANTS, SWEAT SHIRTS, TOP, T-SHIRTS, UN-  
DERGARMENTS (U.S. CLS. 22 AND 39).

FIRST USE 11-17-2006; IN COMMERCE 11-17-2006.

3,233,988. PEBBLE BEACH COMPANY, PEBBLE BEACH, CA.  
SN 76-620,847. PUB. 10-25-2005, FILED 11-16-2004.

### 1919 COLLECTION

THE MARK CONSISTS OF STANDARD CHARACTERS  
WITHOUT CLAIM TO ANY PARTICULAR FONT, STYLE,  
SIZE, OR COLOR.

OWNER OF U.S. REG. NO. 2,701,763.  
NO CLAIM IS MADE TO THE EXCLUSIVE RIGHT TO  
USE COLLECTION, APART FROM THE MARK AS SHOWN.  
FOR SHIRTS, POLO SHIRTS, AND SPORTS SHIRTS  
(U.S. CLS. 22 AND 39).

FIRST USE 3-1-2006; IN COMMERCE 3-1-2006.

3,233,994. NEW BALANCE ATHLETIC SHOE, INC., BOSTON,  
MA. SN 76-624,461. PUB. 9-13-2005, FILED 12-13-2004.

### RUN FASTER. JUMP HIGHER.

THE MARK CONSISTS OF STANDARD CHARACTERS  
WITHOUT CLAIM TO ANY PARTICULAR FONT, STYLE,  
SIZE, OR COLOR.

FOR FOOTWEAR (U.S. CLS. 22 AND 39).  
FIRST USE 0-0-1991; IN COMMERCE 0-0-1991.

**CLASS 25—(Continued).**

3,234,001. MILANO MANHATTAN, LLC, NEW YORK, NY. SN 76-626,598. PUB. 10-18-2005, FILED 12-30-2004.

**LLOYD WILLIAMS**

THE MARK CONSISTS OF STANDARD CHARACTERS WITHOUT CLAIM TO ANY PARTICULAR FONT, STYLE, SIZE, OR COLOR.

LLOYD WILLIAMS IS A LIVING INDIVIDUAL WHOSE CONSENT IS OF RECORD.

FOR WOMEN'S APPAREL, NAMELY, SUITS, JACKETS, COATS, SCARVES, SOCKS, BELTS, GLOVES, HATS, UNDERGARMENTS, SHIRTS, BLOUSES, SWEATERS, VESTS, DRESSES, SKIRTS, PANTS, TROUSERS, SHORTS AND SHOES (U.S. CLS. 22 AND 39).

FIRST USE 11-15-2005; IN COMMERCE 11-15-2005.

3,234,019. B.J.D., INC., BELL, CA. SN 76-631,480. PUB. 11-29-2005, FILED 2-17-2005.

**FRED & HOWARD**

THE MARK CONSISTS OF STANDARD CHARACTERS WITHOUT CLAIM TO ANY PARTICULAR FONT, STYLE, SIZE, OR COLOR.

FOR CLOTHING, NAMELY, TOPS, BOTTOMS, COATS, JACKETS, VESTS, SHOES, BELTS, SWEATERS, SWIMWEAR, UNDERWEAR AND SHORTS (U.S. CLS. 22 AND 39).

FIRST USE 11-30-2004; IN COMMERCE 11-30-2004.

3,234,024. TLB HOLDINGS, INC., MEDINA, MN. SN 76-633,139. PUB. 12-13-2005, FILED 3-10-2005.

*Lea & Nicole*

FOR SHIRTS, T-SHIRTS, SWEATERS AND JACKETS (U.S. CLS. 22 AND 39).

FIRST USE 8-25-2005; IN COMMERCE 8-25-2005.

**CLASS 25—(Continued).**

3,234,037. MCGRATH, MARK, MANALAPAN, NJ. SN 76-635,793. PUB. 3-14-2006, FILED 4-11-2005.

**COOL CHIN GEAR**

THE MARK CONSISTS OF STANDARD CHARACTERS WITHOUT CLAIM TO ANY PARTICULAR FONT, STYLE, SIZE, OR COLOR.

NO CLAIM IS MADE TO THE EXCLUSIVE RIGHT TO USE "GEAR", APART FROM THE MARK AS SHOWN.

FOR SCARVES; KNITTED COLD WEATHER FACE MASKS; FABRIC FACE COVERS FOR COLD WEATHER, NAMELY, FACE COVERS (U.S. CLS. 22 AND 39).

FIRST USE 2-16-2006; IN COMMERCE 2-16-2006.

3,234,055. DEBOURG, PHILIP, HOLLYWOOD, FL. AND BERNIER, TROY, MIAMI GARDENS, FL. SN 76-641,147. PUB. 5-23-2006, FILED 6-17-2005.

**BYKSTYLZ**

THE MARK CONSISTS OF STANDARD CHARACTERS WITHOUT CLAIM TO ANY PARTICULAR FONT, STYLE, SIZE, OR COLOR.

FOR CLOTHING, NAMELY, SHIRTS, PANTS, SHORTS, TOPS, T-SHIRTS, JERSEYS, SWEATERS, SWEATSHIRTS, JUMPSUITS, JACKETS, VESTS AND COATS (U.S. CLS. 22 AND 39).

FIRST USE 10-11-2006; IN COMMERCE 11-1-2006.

3,234,078. PAK INTERNATIONAL, INC., LOS ANGELES, CA. SN 76-651,381. PUB. 8-15-2006, FILED 12-1-2005.

**ALEXANDRA ROSATI**

THE MARK CONSISTS OF STANDARD CHARACTERS WITHOUT CLAIM TO ANY PARTICULAR FONT, STYLE, SIZE, OR COLOR.

THE MARK ALEXANDRA ROSATI DOES NOT IDENTIFY A LIVING INDIVIDUAL.

FOR LADIES AND CHILDREN'S CLOTHING, NAMELY PANTS, SHIRTS, T-SHIRTS, BLOUSES, DRESSES, JACKETS, SUITS, SWEATERS, KNITS, CAPS, HATS, LINGERIE NAMELY BRAS, PANTIES, UNDERWEAR, SOCKS AND STOCKINGS AND ACCESSORIES NAMELY SCARVES, GLOVES, AND BELTS (U.S. CLS. 22 AND 39).

FIRST USE 1-0-2006; IN COMMERCE 1-0-2006.

**CLASS 25—(Continued).**

3,234,098. ANDREAE, JOHN, C, NEWPORT BEACH, CA. SN 78-111,093. PUB. 7-22-2003, FILED 2-26-2002.

**GREEDYGEAR**

FOR CLOTHING AND APPAREL, NAMELY, T-SHIRTS, SHORTS, PANTS, JACKETS, SWEATSHIRTS, BATHING SUITS, HATS, SHIRTS, TANK TOPS, PULL-OVER SHIRTS, BUTTON UP SHIRTS, UNDERWEAR, LONG SLEEVE SHIRTS, AND SOCKS (U.S. CLS. 22 AND 39).

FIRST USE 10-6-2006; IN COMMERCE 10-6-2006.

**CLASS 25—(Continued).**

3,234,196. ASBELL, JOSEPH C., DURHAM, NC. SN 78-339,768. PUB. 5-31-2005, FILED 12-11-2003.



*one fish at a time!*

3,234,110. DILLY NORDESTE S.A., CEARA RIO GRANDE DEL SR, BRAZIL. SN 78-152,932. PUB. 8-19-2003, FILED 8-9-2002.

**TRY ON**

NO CLAIM IS MADE TO THE EXCLUSIVE RIGHT TO USE "ANGLER", APART FROM THE MARK AS SHOWN. FOR T-SHIRTS, GOLF SHIRTS, SWEAT SHIRTS, SHIRTS, HATS, VISORS, SHOES (U.S. CLS. 22 AND 39). FIRST USE 1-1-2004; IN COMMERCE 5-25-2004.

FOR SHOES FOR MAN AND WOMAN (U.S. CLS. 22 AND 39). FIRST USE 6-21-2005; IN COMMERCE 10-20-2006.

3,234,205. HEINRICH, KYLE, MALIBU, CA. SN 78-352,371. PUB. 11-2-2004, FILED 1-15-2004.

3,234,142. J. T. DESIGN STUDIO, INC., LOS ANGELES, CA. SN 78-257,747. PUB. 6-28-2005, FILED 6-3-2003.

eight ✨ sixty

**SURF SOLES**

FOR CLOTHING, HEAD WEAR AND FOOTWEAR, NAMELY, TOPS, SHIRTS, DRESSES, SKIRTS, PANTS, SWEATERS, T-SHIRTS, KNIT SHIRTS, CAPS, JACKETS, HEAD WEAR AND FOOTWEAR (U.S. CLS. 22 AND 39). FIRST USE 10-31-2003; IN COMMERCE 10-31-2003.

FOR FOOTWEAR, T-SHIRTS, SWEATSHIRTS AND HATS (U.S. CLS. 22 AND 39). FIRST USE 7-15-2006; IN COMMERCE 7-16-2006.

**CLASS 25—(Continued).**

3,234,243. EVAN J. MCKINNEY, TOLEDO, OH. SN 78-383,203.  
 PUB. 9-6-2005, FILED 3-12-2004.

**CLASS 25—(Continued).**

3,234,287. JONES, ROSETTA L., MOOREVILLE, NC. SN 78-409,849. PUB. 2-1-2005, FILED 4-28-2004.

är'dnt

Pink Dog

THE MARK CONSISTS OF STANDARD CHARACTERS WITHOUT CLAIM TO ANY PARTICULAR FONT, STYLE, SIZE, OR COLOR.  
 FOR JACKETS (U.S. CLS. 22 AND 39).  
 FIRST USE 11-10-2006; IN COMMERCE 11-10-2006.

THE MARK CONSISTS OF STANDARD CHARACTERS WITHOUT CLAIM TO ANY PARTICULAR FONT, STYLE, SIZE, OR COLOR.  
 FOR SHIRTS, BELTS, HATS (U.S. CLS. 22 AND 39).  
 FIRST USE 11-9-2006; IN COMMERCE 11-9-2006.

---

3,234,264. REDCATS USA, L.P., INDIANAPOLIS, IN. SN 78-394,059. PUB. 3-15-2005, FILED 3-31-2004.

---

3,234,299. SEBAGO USA, LLC, ROCKFORD, MI. SN 78-413,454. PUB. 9-13-2005, FILED 5-5-2004.

WILLOW LANE

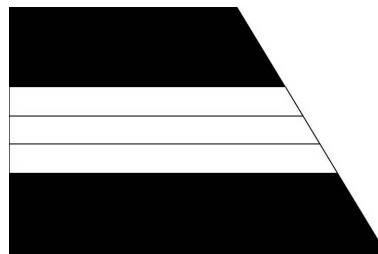

THE MARK CONSISTS OF STANDARD CHARACTERS WITHOUT CLAIM TO ANY PARTICULAR FONT, STYLE, SIZE, OR COLOR.  
 FOR CLOTHING, NAMELY, DRESSES, PANTS, SUITS, COATS, JACKETS, SKIRTS, SWEATERS, BLOUSES, KNIT TOPS (U.S. CLS. 22 AND 39).  
 FIRST USE 5-0-2005; IN COMMERCE 5-0-2005.

FOR FOOTWEAR; CLOTHING, NAMELY, SHIRTS, PANTS, SHORTS, JACKETS, COATS, SWEATERS, SWEATSHIRTS, SWIMSUITS, VESTS, GLOVES, AND SOCKS; HEADWEAR (U.S. CLS. 22 AND 39).  
 FIRST USE 6-8-2004; IN COMMERCE 6-8-2004.

**CLASS 25—(Continued).**

3,234,301. MA, DELIANG, SAN FRANCISCO, CA. SN 78-417,315. PUB. 3-21-2006, FILED 5-12-2004.

Smooth

THE MARK CONSISTS OF STANDARD CHARACTERS WITHOUT CLAIM TO ANY PARTICULAR FONT, STYLE, SIZE, OR COLOR.  
FOR SHOES (U.S. CLS. 22 AND 39).  
FIRST USE 1-1-2006; IN COMMERCE 10-27-2006.

**CLASS 25—(Continued).**

3,234,343. STOLOSKI, DANIEL, SACRAMENTO, CA. AND PHILLIPS, JOSH, SACRAMENTO, CA. SN 78-446,572. PUB. 9-6-2005, FILED 7-6-2004.

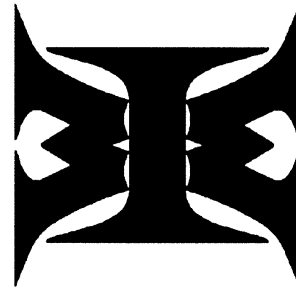

THE MARK CONSISTS OF STYLIZED LETTERING SPELLING OUT WWI.  
FOR CLOTHING, NAMELY, HEAD WEAR, SHIRTS, TANK TOPS, T-SHIRTS, CAPS, HATS, SWEATSHIRTS (U.S. CLS. 22 AND 39).  
FIRST USE 8-0-2005; IN COMMERCE 8-0-2005.

3,234,338. DERRING, DAVID, VIRGINIA BEACH, VA. SN 78-442,188. PUB. 3-21-2006, FILED 6-28-2004.



FOR HATS, T-SHIRTS, SWEATSHIRTS AND UNDERWEAR (U.S. CLS. 22 AND 39).  
FIRST USE 1-1-2000; IN COMMERCE 1-1-2001.

3,234,379. DIAGEO NORTH AMERICA, INC., NORWALK, CT. SN 78-469,725. PUB. 9-13-2005, FILED 8-18-2004.



OWNER OF U.S. REG. NOS. 1,724,742, 2,094,877, AND 2,851,028.  
THE MARK CONSISTS OF THE STYLIZED WORDS CROWN ROYAL.  
FOR ARTICLES OF CLOTHING, NAMELY, JACKETS, WIND RESISTANT JACKETS, LEATHER JACKETS, BOXER , SHIRTS, GOLF SHIRTS, POLO SHIRTS, KNIT SHIRTS, TANK TOPS, PANTS, SLEEPWEAR, SWEATSHIRTS, T-SHIRTS, CAPS, BASEBALL CAPS, VISORS, BANDANAS, HATS, APRONS, FOOTWEAR, NAMELY, SANDALS AND FLIP-FLOPS (U.S. CLS. 22 AND 39).  
FIRST USE 0-0-1989; IN COMMERCE 0-0-1989.

**CLASS 25—(Continued).**

3,234,380. RICHARD LEEDS INTERNATIONAL, INC., NEW YORK, NY. SN 78-470,320. PUB. 8-23-2005, FILED 8-19-2004.

**MAC & CHEEZE**

THE MARK CONSISTS OF STANDARD CHARACTERS WITHOUT CLAIM TO ANY PARTICULAR FONT, STYLE, SIZE, OR COLOR.

FOR WOMEN'S CLOTHING AND INTIMATE APPAREL, NAMELY, SLEEPWEAR, TANK TOPS, DORM SHIRTS, LOUNGEWEAR, BOXER SHORTS, SHORTS AND LINGERIE (U.S. CLS. 22 AND 39).

FIRST USE 1-12-2005; IN COMMERCE 1-12-2005.

3,234,388. JUST FOR WRAPS, INC., COMMERCE, CA. SN 78-473,612. PUB. 4-4-2006, FILED 8-25-2004.



THE COLOR(S) PINK, WHITE AND BLACK IS/ARE CLAIMED AS A FEATURE OF THE MARK.

THE COLOR STATEMENT MARK CONSISTS OF WHITE LETTERS, WITH A PINK HEART BETWEEN THE WORD SQUARED, ON A BLACK RECTANGLE.

FOR LADIES BETTERWEAR, NAMELY, TOPS AND BOTTOMS (U.S. CLS. 22 AND 39).

FIRST USE 9-1-2004; IN COMMERCE 9-1-2004.

3,234,394. VOLCOM, INC., COSTA MESA, CA. SN 78-476,623. PUB. 12-20-2005, FILED 8-31-2004.

**VEECO PRODUCTIONS**

THE MARK CONSISTS OF STANDARD CHARACTERS WITHOUT CLAIM TO ANY PARTICULAR FONT, STYLE, SIZE, OR COLOR.

OWNER OF U.S. REG. NO. 2,335,293.

FOR MEN'S AND WOMEN'S CLOTHING, NAMELY, SWIMWEAR, BATHING SUITS, BIKINIS, COVER-UPS, TANK TOPS, SHIRTS, SKIRTS, DRESSES, SHORTS, JUMPERS, CAPRIS, LEGGINGS, PAJAMAS, ROBES, T-SHIRTS, PANTS, SWEATPANTS, SWEATSHIRTS, SWIM-TRUNKS, JACKETS, JERSEYS, SOCKS, UNDERWEAR, GLOVES, BELTS, TIES, VESTS; HEADWEAR, NAMELY, HATS, CAPS AND VISORS; AND FOOTWEAR, NAMELY, SANDALS, SLIPPERS, BOOTS, AND ATHLETIC SHOES (U.S. CLS. 22 AND 39).

FIRST USE 6-1-1991; IN COMMERCE 6-1-1991.

**CLASS 25—(Continued).**

3,234,428. JOSEPH M. LOSPINUSO AND MARK S. LOSPINUSO PARTNERSHIP, THE, NEWTON, NJ. SN 78-488,207. PUB. 11-8-2005, FILED 9-23-2004.

**STUPID SHOULD HURT**

THE MARK CONSISTS OF STANDARD CHARACTERS WITHOUT CLAIM TO ANY PARTICULAR FONT, STYLE, SIZE, OR COLOR.

FOR SHIRTS, HATS (U.S. CLS. 22 AND 39).

FIRST USE 8-1-2005; IN COMMERCE 1-31-2006.

3,234,430. KUHLMAN, DAVE, LOMBARD, IL. AND LUTZ, STEVE, GLEN ELLYN, IL. SN 78-489,744. PUB. 8-8-2006, FILED 9-27-2004.

**ON YER LEFT!**

THE MARK CONSISTS OF STANDARD CHARACTERS WITHOUT CLAIM TO ANY PARTICULAR FONT, STYLE, SIZE, OR COLOR.

FOR CLOTHING, NAMELY, TEE-SHIRTS, SWEATSHIRTS, HATS, AND SHORTS (U.S. CLS. 22 AND 39).

FIRST USE 4-15-2005; IN COMMERCE 4-15-2005.

3,234,451. SMITH, MELANIE, WASHINGTON CROSSING, PA. SN 78-498,047. PUB. 9-13-2005, FILED 10-11-2004.

**YOGAPHORIA**

THE MARK CONSISTS OF STANDARD CHARACTERS WITHOUT CLAIM TO ANY PARTICULAR FONT, STYLE, SIZE, OR COLOR.

FOR SHIRTS, PANTS, SHOES, JACKETS, SOCKS, SWEATERS (U.S. CLS. 22 AND 39).

FIRST USE 3-1-2005; IN COMMERCE 3-1-2005.



**CLASS 25—(Continued).**

3,234,452. VANITY FAIR, INC., WILMINGTON, DE. SN 78-498,382. PUB. 4-11-2006, FILED 10-12-2004.

**CLASS 25—(Continued).**

3,234,512. CLIPPARD, BRIAN C., ROYAL OAK, MI. SN 78-516,617. PUB. 3-28-2006, FILED 11-14-2004.

**BODY SUPERIOR  
SUPPORT**

**Big Beaver Brewery**

THE MARK CONSISTS OF STANDARD CHARACTERS WITHOUT CLAIM TO ANY PARTICULAR FONT, STYLE, SIZE, OR COLOR.

NO CLAIM IS MADE TO THE EXCLUSIVE RIGHT TO USE SUPERIOR SUPPORT, APART FROM THE MARK AS SHOWN.

FOR LINGERIE (U.S. CLS. 22 AND 39).  
FIRST USE 6-7-2005; IN COMMERCE 6-7-2005.

THE MARK CONSISTS OF STANDARD CHARACTERS WITHOUT CLAIM TO ANY PARTICULAR FONT, STYLE, SIZE, OR COLOR.

FOR T-SHIRTS (U.S. CLS. 22 AND 39).  
FIRST USE 12-10-2006; IN COMMERCE 12-10-2006.

3,234,518. MAGEE, STEVEN D, LIVINGSTON, LA. SN 78-519,262. PUB. 11-8-2005, FILED 11-18-2004.

3,234,453. RYAN SEACREST PRODUCTIONS, INC., LOS ANGELES, CA. SN 78-498,747. PUB. 2-28-2006, FILED 10-12-2004.

**RYAN SEACREST**

**you think it's a  
game?**

THE MARK CONSISTS OF STANDARD CHARACTERS WITHOUT CLAIM TO ANY PARTICULAR FONT, STYLE, SIZE, OR COLOR.

THE NAME(S), PORTRAIT(S), AND/OR SIGNATURE(S) SHOWN IN THE MARK IDENTIFIES RYAN SEACREST, WHOSE CONSENT(S) TO REGISTER IS SUBMITTED.

FOR CLOTHING, NAMELY, SHIRTS (U.S. CLS. 22 AND 39).  
FIRST USE 6-0-2005; IN COMMERCE 6-0-2005.

THE MARK CONSISTS OF STANDARD CHARACTERS WITHOUT CLAIM TO ANY PARTICULAR FONT, STYLE, SIZE, OR COLOR.

FOR CLOTHING AND SPORTSWEAR, NAMELY, FOOTWEAR, UNDERWEAR, BRIEFS, PANTS, SHIRTS, JEANS, TANK TOPS, JERSEYS, SHORTS, NIGHT SHIRTS, SWEATERS, HATS, WARM-UP SUITS, JACKETS, COATS, HEADBANDS, WRISTBANDS, BOXER SHORTS, AND CAPS (U.S. CLS. 22 AND 39).

FIRST USE 5-25-1992; IN COMMERCE 9-30-2005.

**CLASS 25—(Continued).**

3,234,540. SELBACH, HANS D., BONN, FED REP GER-MANY. SN 78-523,803. PUB. 4-11-2006, FILED 11-29-2004.



NO CLAIM IS MADE TO THE EXCLUSIVE RIGHT TO USE "ARM", APART FROM THE MARK AS SHOWN.

THE COLOR(S) PURPLE, BLUE, LIGHT BLUE, GREEN, YELLOW, AND BLACK IS/ARE CLAIMED AS A FEATURE OF THE MARK.

THERE ARE FIVE LINES THROUGH THE WORDS ARM WITH THE ARROW AND POWER, BEGINNING IN THE MIDDLE OF THE WORD ARM WITH THE ARROW AND ENDING IN THE MIDDLE OF THE WORD POWER (FROM TOP TO BOTTOM). THE TOP LINE IS PURPLE, THE SECOND LINE IS BLUE, THE THIRD LINE IS LIGHT BLUE, THE FOURTH LINE IS GREEN AND THE FIFTH LINE IS YELLOW. THE WORDS ARM AND POWER APPEAR IN BLACK AS DOES THE ARROW.

FOR NOVELTY ITEMS IN THE NATURE OF FABRIC ARM BANDS TO BE WORN BY FANS AT SPORTING AND OTHER EVENTS (U.S. CLS. 22 AND 39).

FIRST USE 12-6-2006; IN COMMERCE 12-6-2006.

**CLASS 25—(Continued).**

3,234,582. NEJAD, MATTHEW, FRESNO, CA. SN 78-533,880. PUB. 2-28-2006, FILED 12-16-2004.

**BROKHELM**

THE MARK CONSISTS OF STANDARD CHARACTERS WITHOUT CLAIM TO ANY PARTICULAR FONT, STYLE, SIZE, OR COLOR.

FOR T-SHIRTS (U.S. CLS. 22 AND 39).

FIRST USE 10-5-2006; IN COMMERCE 10-5-2006.

3,234,557. REDIKER, TIM, LAS VEGAS, NV. SN 78-529,138. PUB. 3-7-2006, FILED 12-8-2004.

**COMMON GOAL**



THE MARK CONSISTS OF STANDARD CHARACTERS WITHOUT CLAIM TO ANY PARTICULAR FONT, STYLE, SIZE, OR COLOR.

FOR CLOTHING AND SPORTSWEAR, NAMELY, SHIRTS, HATS, CAPS, SPORTS JERSEYS, SWEATERS, BATHING SUITS, JACKETS, SWEATPANTS, SWEAT-SHIRTS, SHORTS, SOCKS, SHOES, ATHLETIC SHOES, DRESS SHOES, AND CASUAL SHOES, SWEATBANDS, TANK TOPS, ATHLETIC UNIFORMS (U.S. CLS. 22 AND 39).

FIRST USE 6-20-2006; IN COMMERCE 6-20-2006.

3,234,589. CAP AMERICA, INC., FREDERICKTOWN, MO. SN 78-537,334. PUB. 12-13-2005, FILED 12-22-2004.

NO CLAIM IS MADE TO THE EXCLUSIVE RIGHT TO USE "CAP BRAND", APART FROM THE MARK AS SHOWN.

FOR HEADWEAR, VISORS, CAPS (U.S. CLS. 22 AND 39).

FIRST USE 4-12-2005; IN COMMERCE 4-12-2005.

**CLASS 25—(Continued).**

3,234,590. LANDSBAUM, SCOTT L., BEVERLY HILLS, CA. SN 78-537,416. PUB. 10-25-2005, FILED 12-22-2004.

**CLASS 25—(Continued).**

3,234,620. KAN-DOO ATTITUDE, INC., KELLER, TX. SN 78-547,615. PUB. 11-1-2005, FILED 1-14-2005.

**POET BABIES**

**kan-doo**

THE MARK CONSISTS OF STANDARD CHARACTERS WITHOUT CLAIM TO ANY PARTICULAR FONT, STYLE, SIZE, OR COLOR.

NO CLAIM IS MADE TO THE EXCLUSIVE RIGHT TO USE "BABIES", APART FROM THE MARK AS SHOWN.

FOR CLOTHING, NAMELY T-SHIRTS, TOPS (U.S. CLS. 22 AND 39).

FIRST USE 6-30-2005; IN COMMERCE 3-30-2006.

THE MARK CONSISTS OF STANDARD CHARACTERS WITHOUT CLAIM TO ANY PARTICULAR FONT, STYLE, SIZE, OR COLOR.

FOR SHIRTS, T-SHIRTS AND HATS (U.S. CLS. 22 AND 39).

FIRST USE 5-1-2006; IN COMMERCE 5-1-2006.

3,234,632. NBS TRUCKING LTD., CUSTER CITY, PA. SN 78-554,988. PUB. 3-7-2006, FILED 1-27-2005.

3,234,591. LANDSBAUM, SCOTT L., BEVERLY HILLS, CA. SN 78-537,421. PUB. 10-25-2005, FILED 12-22-2004.



THE MARK CONSISTS OF A STYLIZED BABY BOTTLE CONNECTED TO A STYLIZED FOUNTAIN PEN NIB.

FOR CLOTHING, NAMELY T-SHIRTS, TOPS (U.S. CLS. 22 AND 39).

FIRST USE 6-30-2005; IN COMMERCE 3-30-2006.



OWNER OF U.S. REG. NO. 2,224,361. THE COLOR(S) RED AND BLACK IS/ARE CLAIMED AS A FEATURE OF THE MARK.

THE MARK CONSISTS OF A STYLIZED BLACK BULL INSIDE AN INTERNATIONAL PROHIBITION SYMBOL IN RED.

FOR CLOTHING, NAMELY SHIRTS, T-SHIRTS (U.S. CLS. 22 AND 39).

FIRST USE 10-26-2006; IN COMMERCE 10-26-2006.

**CLASS 25—(Continued).**

3,234,634. SAUCONY, INC., PEABODY, MA. SN 78-555,137.  
PUB. 11-8-2005, FILED 1-27-2005.

## GRID PROPEL

THE MARK CONSISTS OF STANDARD CHARACTERS WITHOUT CLAIM TO ANY PARTICULAR FONT, STYLE, SIZE, OR COLOR.

OWNER OF U.S. REG. NO. 2,663,005.  
FOR FOOTWEAR (U.S. CLS. 22 AND 39).  
FIRST USE 12-0-2004; IN COMMERCE 12-0-2004.

3,234,683. STEGER DESIGNS, INC., ELY, MN. SN 78-578,835.  
PUB. 2-7-2006, FILED 3-2-2005.



NO CLAIM IS MADE TO THE EXCLUSIVE RIGHT TO USE "MOCCASINS", APART FROM THE MARK AS SHOWN.

THE NAME STEGER IDENTIFIES A LIVING INDIVIDUAL WHOSE CONSENT IS OF RECORD.  
FOR FOOTWEAR, NAMELY, MOCCASINS AND MUKLUKS WINTER BOOTS (U.S. CLS. 22 AND 39).  
FIRST USE 5-0-2004; IN COMMERCE 5-0-2004.

3,234,697. ELECT APPAREL INC., GARDEN CITY, NY. SN 78-583,282. PUB. 3-7-2006, FILED 3-9-2005.

## Elect Apparel

THE MARK CONSISTS OF STANDARD CHARACTERS WITHOUT CLAIM TO ANY PARTICULAR FONT, STYLE,

**CLASS 25—(Continued).**

SIZE, OR COLOR.

NO CLAIM IS MADE TO THE EXCLUSIVE RIGHT TO USE "APPAREL", APART FROM THE MARK AS SHOWN.

FOR MEN'S, WOMEN'S AND CHILDREN'S CLOTHING AND FASHION ACCESSORIES, NAMELY, DRESSES, COATS, SHORTS, SHIRTS, DRESS SHIRTS, PANTS, DRESS PANTS, JEANS, SWEATERS, JACKETS, SUITS, T-SHIRTS, BLOUSES, POLO-SHIRTS, KNIT TOPS, TANK TOPS, VELOUR SUITS, VESTS, WIND RESISTANT JACKETS, JOGGING SUITS, SWEATSHIRTS, SWEATPANTS, HOODED SWEATSHIRTS, HEAD BANDS, BELTS, GLOVES, SCARVES, PONCHOS, PANTIES, BOXER, BRIEFS, SOCKS, PAJAMAS, ROBES, NIGHTGOWNS, UNDERWEAR, UNDERSHIRTS, RAINWEAR, RAINCOATS, SWIMWEAR, BATHING SUITS, AND WOMEN'S LINGERIE; FOOTWEAR; NAMELY RUNNING SNEAKERS, BASKETBALL SNEAKERS, WALKING SNEAKERS, SHOES, BOOTS, HEADWEAR, TIES, CAPS, HATS (U.S. CLS. 22 AND 39).

FIRST USE 2-0-2005; IN COMMERCE 11-27-2006.

3,234,703. GLOBAL BRAND MARKETING INC., SANTA BARBARA, CA. SN 78-585,285. PUB. 2-21-2006, FILED 3-11-2005.



OWNER OF U.S. REG. NO. 2,989,422.  
NO CLAIM IS MADE TO THE EXCLUSIVE RIGHT TO USE "SANTA BARBARA", APART FROM THE MARK AS SHOWN.

FOR FOOTWEAR, NAMELY AND CASUAL SHOES, SANDALS, SLIPPERS AND BEACH FOOTWEAR, BEACH SHOES (U.S. CLS. 22 AND 39).

FIRST USE 5-12-2005; IN COMMERCE 12-5-2005.

**CLASS 25—(Continued).**

3,234,714. CLEAN RUN PRODUCTIONS LLC, CHICOPEE, MA. SN 78-589,088. PUB. 7-18-2006, FILED 3-17-2005.



NO CLAIM IS MADE TO THE EXCLUSIVE RIGHT TO USE "GEAR", APART FROM THE MARK AS SHOWN. THE MARK CONSISTS OF A DISTINCTIVE FONT AND AN IMAGE OF A LEAPING DOG CENTERED BETWEEN THE STYLIZED WORDS "AGILE" AND "GEAR". FOR SHOES AND JOGGING SUITS USED IN CONNECTION WITH DOG AGILITY COMPETITIONS (U.S. CLS. 22 AND 39). FIRST USE 6-0-2005; IN COMMERCE 6-0-2005.

**CLASS 25—(Continued).**

3,234,724. GARNER, LATARER, JACKSON, MS. SN 78-594,618. PUB. 3-7-2006, FILED 3-24-2005.



NO CLAIM IS MADE TO THE EXCLUSIVE RIGHT TO USE "WEAR", APART FROM THE MARK AS SHOWN. FOR UNDERWEAR, PANTS, SHIRTS, CAPS, HEADBANDS, WRISTBANDS, SHORTS, SOCKS, AND SHOES (U.S. CLS. 22 AND 39). FIRST USE 11-10-2004; IN COMMERCE 11-10-2005.

3,234,731. HARVEY ENTERTAINMENT, INC., NEW YORK, NY. SN 78-596,213. PUB. 9-12-2006, FILED 3-28-2005.

3,234,722. CANTEX ENTERPRISES LIMITED, XIAN, CHINA. SN 78-593,517. PUB. 4-4-2006, FILED 3-23-2005.



FOR UNDERCLOTHES; SWEATERS; SHIRTS; SUITS; BREECHES; TROUSERS; VESTS; COATS; SKIRTS; SINGLETS; TOP COATS; PORTABLE COATS; STUFF JACKETS; JACKETS; PARKAS; TEE-SHIRTS; FISHING VESTS; CAMISOLES; WIND-RESISTANT JACKETS; BABIES' PANTS; LAYETTES; BATHING DRAWERS; BATHING TRUNKS; JUMPING SHOES; CLIMBING SHOES; SPORTS SHOES; GLOVES; MUFFS; AND MITTENS (U.S. CLS. 22 AND 39). FIRST USE 1-0-2004; IN COMMERCE 1-0-2006.



OWNER OF U.S. REG. NOS. 722,258, 2,129,953, AND OTHERS. FOR CLOTHING, NAMELY, MEN'S, WOMEN'S AND CHILDREN'S CLOTHING, NAMELY, SKIRTS, DRESSES, PANTS, BLOUSES, JEANS, JERSEYS, ROMPERS, SHIRTS, T-SHIRTS, TANK TOPS, GOLF SHIRTS, POLO SHIRTS, SWEAT SHIRTS, SWEAT PANTS, SWEAT SUITS, BLAZERS, SHORTS, COVERALLS, OVERALLS, SHORTALLS, APRONS, VESTS, BATHROBES, BATHING SUITS, BEACH WEAR, SWIM WEAR, HOSIERY, TIGHTS, SOCKS, BELTS, NECK TIES, BOW TIES, SUSPENDERS, WRISTBANDS, SCARVES, MUFFS, KERCHEFS, BANDANAS, SHAWLS, LEOTARDS, LEG WARMERS, HALLOWEEN AND MASQUERADE COSTUMES; CLOTHING FOR BABIES, NAMELY, INFANT WEAR AND CLOTH DIAPERS AND CLOTH BIBS; OUTERWEAR, NAMELY, PONCHOS, PULLOVERS, RAINWEAR, RAIN COATS, RAIN JACKETS, SNOW SUITS, SKI SUITS, SKI JACKETS, SKI PANTS, COATS, JACKETS, ANORAKS, GLOVES AND MITTENS; SLEEPWEAR AND LOUNGEWEAR, NAMELY, LONG AND SHORT TWO-PIECE SETS, GOWNS, DORM SHIRTS, LOUNGEWEAR SEPARATES, NIGHT SHIRTS, NIGHT GOWNS, ROBES, DRESSING GOWNS AND PAJAMAS; UNDERWEAR, NAMELY, PANTIES, CAMISOLES, UNDERSHIRTS, BOXERS BRIEFS; FOOTWEAR, NAMELY, SHOES, SNEAKERS, ATHLETIC SHOES, SLIPPERS, BOOTS, SANDALS, BEACH SHOES, LACE BOOTS; SHOE PARTS, NAMELY, HEELS AND FOOTWEAR UPPERS; HEADGEAR, NAMELY, HATS, CAPS, KNITTED CAPS, BASEBALL CAPS, HEADBANDS, BÉRETS AND EAR MUFFS (U.S. CLS. 22 AND 39). FIRST USE 11-1-2004; IN COMMERCE 11-1-2004.

**CLASS 25—(Continued).**

3,234,753. RICHARD C. HALPERN AND KRICKETT JONES HALPERN PARTNERSHIP, THE, ENCINO, CA. SN 78-601,601. PUB. 6-6-2006, FILED 4-4-2005.

got boobie?

THE MARK CONSISTS OF STANDARD CHARACTERS WITHOUT CLAIM TO ANY PARTICULAR FONT, STYLE, SIZE, OR COLOR.

FOR BABY CLOTHING, NAMELY, T-SHIRTS (U.S. CLS. 22 AND 39).

FIRST USE 7-15-2003; IN COMMERCE 5-13-2004.

3,234,758. ATHLETICA, INC., GENESEO, NY. SN 78-603,932. PUB. 3-7-2006, FILED 4-7-2005.

**team** cheer

OWNER OF U.S. REG. NO. 2,571,060. NO CLAIM IS MADE TO THE EXCLUSIVE RIGHT TO USE "CHEER", APART FROM THE MARK AS SHOWN.

THE MARK CONSISTS OF TEAM CHEER AND WISH-BONE DESIGN.

FOR CLOTHING, NAMELY UNIFORMS, T-SHIRTS, SWEATSHIRTS, SWEAT PANTS, SPORT SHIRTS, GOLF SHIRTS, POLO SHIRTS, SWEATERS, BELTS, TIES, NIGHTSHIRTS, COATS, CAPS, HATS, HEAD BANDS, WRIST BANDS, PANTS, SOCKS, JERSEYS, JACKETS, SHORTS, WARM-UP SUITS, SCARVES, CLOTH BIBS, APRONS, SHOES AND FOOTWEAR (U.S. CLS. 22 AND 39).

FIRST USE 1-31-2005; IN COMMERCE 1-31-2005.

**CLASS 25—(Continued).**

3,234,763. GREEN WHITE CHECKER, LLC, TORRANCE, CA. SN 78-605,444. PUB. 3-14-2006, FILED 4-9-2005.

Green White  
Checker

THE MARK CONSISTS OF STANDARD CHARACTERS WITHOUT CLAIM TO ANY PARTICULAR FONT, STYLE, SIZE, OR COLOR.

FOR CLOTHING, NAMELY, WRISTBANDS; SHIRTS; SWEATERS; SWEATSHIRTS; T-SHIRTS; TANK TOPS; UNDERSHIRTS; PANTS; JEANS; SHORTS; SWEAT-PANTS; SHOES; SNEAKERS; UNDERWEAR; BOXERS; SOCKS; SUITS; BELTS; TIES; SUSPENDERS; BANDANAS; COATS; JACKETS; SCARVES; GLOVES; AND HEADGEAR, NAMELY, HATS, BASEBALL CAPS, GOLF CAPS, SPORTS CAPS, VISORS, AND HEADBANDS (U.S. CLS. 22 AND 39).

FIRST USE 4-2-2005; IN COMMERCE 6-22-2005.

3,234,774. DDI, INC, DUBUQUE, IA. SN 78-610,376. PUB. 8-15-2006, FILED 4-16-2005.



THE COLOR(S) GOLD AND BLACK IS/ARE CLAIMED AS A FEATURE OF THE MARK.

THE COLOR GOLD APPEARS IN THE SHIELD WHICH IS THE BACKGROUND OF THE MARK UPON WHICH THE GOLDEN ARMOR APPEARS. THE COLOR BLACK APPEARS IN THE OUTLINE OF THE TEXT GOLDEN ARMOR IN THE MARK. THE COLOR BLACK APPEARS IN THE OUTLINE OF THE SHIELD OF THE BACKGROUND OF THE MARK. THE COLOR BLACK APPEARS IN THE RIVETS ON THE SHIELD IN THE BACKGROUND OF THE MARK.

FOR APPAREL, NAMELY COATS, JACKETS BIB OVERALLS, AND GLOVES (U.S. CLS. 22 AND 39).

FIRST USE 3-29-2005; IN COMMERCE 4-25-2005.

**CLASS 25—(Continued).**

3,234,811. ASIAN DISTRIBUTORS, INC., AGANA, GUAM. SN 78-624,484. PUB. 7-25-2006, FILED 5-6-2005.

TRULY NEW YORK

THE MARK CONSISTS OF STANDARD CHARACTERS WITHOUT CLAIM TO ANY PARTICULAR FONT, STYLE, SIZE, OR COLOR.

NO CLAIM IS MADE TO THE EXCLUSIVE RIGHT TO USE NEW YORK, APART FROM THE MARK AS SHOWN. FOR CLOTHING, NAMELY, T-SHIRTS, SHORTS, HATS, CAPS, FOOT WEAR, SWEAT SHIRTS, SHIRTS, PANTS (U.S. CLS. 22 AND 39).  
FIRST USE 4-14-2006; IN COMMERCE 4-14-2006.

**CLASS 25—(Continued).**

3,234,831. HENRY, SYLVESTER III, CORONA, CA. SN 78-630,213. PUB. 3-7-2006, FILED 5-16-2005.



THE COLOR(S) BLACK LETTERING WITH PINKISH RED LIPS IS/ARE CLAIMED AS A FEATURE OF THE MARK.

THE MARK CONSISTS OF STACKED LETTERING WITH THE PHRASE GIMME SOME! ABOVE THE WORD SUGA WITH THE PINKISH RED LIPS KISSING TOWARDS THE LETTER A.  
FOR TSHIRTS, HATS, SWEATSUITS, SPORTSWEAR, NAMELY, PANTS, JACKETS, AND TANK-TOPS (U.S. CLS. 22 AND 39).  
FIRST USE 7-1-2006; IN COMMERCE 7-1-2006.

3,234,812. HODGES, HOLLEY, SEFFNER, FL. SN 78-624,588. PUB. 6-20-2006, FILED 5-6-2005.

SUNNY LANE

THE MARK CONSISTS OF STANDARD CHARACTERS WITHOUT CLAIM TO ANY PARTICULAR FONT, STYLE, SIZE, OR COLOR.  
FOR CLOTHING, NAMELY WOMEN'S UNDERGARMENTS (U.S. CLS. 22 AND 39).  
FIRST USE 1-10-2006; IN COMMERCE 1-15-2006.

3,234,853. GARZA, RAYNALDO, MONARCH BEACH, CA. SN 78-634,489. PUB. 7-18-2006, FILED 5-22-2005.

ELLAY

THE MARK CONSISTS OF STANDARD CHARACTERS WITHOUT CLAIM TO ANY PARTICULAR FONT, STYLE, SIZE, OR COLOR.  
FOR APPAREL, NAMELY, T-SHIRTS, SHIRTS, JOGGING SUITS, SWEAT SUITS, PANTS; HEADWEAR, NAMELY, CAPS AND BEANIES; AND SHOES, NAMELY, ATHLETIC SHOES, SNEAKERS (U.S. CLS. 22 AND 39).  
FIRST USE 12-24-2002; IN COMMERCE 5-23-2006.

**CLASS 25—(Continued).**

3,234,860. TURNER COMMUNICATIONS CORP., FT. LAUDERDALE, FL. SN 78-636,116. PUB. 2-14-2006, FILED 5-24-2005.

**CONCHTINI**

THE MARK CONSISTS OF STANDARD CHARACTERS WITHOUT CLAIM TO ANY PARTICULAR FONT, STYLE, SIZE, OR COLOR.

FOR CLOTHING, NAMELY, T-SHIRTS, TANK TOPS, GOLF SHIRTS, HEADWEAR (U.S. CLS. 22 AND 39).  
FIRST USE 10-1-2006; IN COMMERCE 10-1-2006.

---

3,234,927. SCHERING-PLOUGH HEALTHCARE PRODUCTS, INC., MEMPHIS, TN. SN 78-650,460. PUB. 2-28-2006, FILED 6-14-2005.

**BLOCK THE SUN NOT THE FUN**

THE MARK CONSISTS OF STANDARD CHARACTERS WITHOUT CLAIM TO ANY PARTICULAR FONT, STYLE, SIZE, OR COLOR.

OWNER OF U.S. REG. NO. 2,278,479.  
FOR HEADWEAR (U.S. CLS. 22 AND 39).  
FIRST USE 2-8-2006; IN COMMERCE 2-8-2006.

---

3,234,935. HADLEY POLLET, LLC, CAMBRIDGE, MA. SN 78-651,265. PUB. 3-7-2006, FILED 6-15-2005.

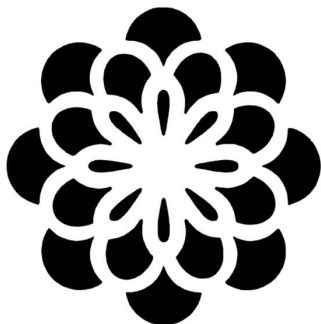

FOR BELTS MADE OF FABRIC, SUEDE OR LEATHER; HEADBANDS; FOOTWEAR FOR ADULTS AND CHILDREN; MEN, WOMEN AND CHILDREN'S CLOTHING, NAMELY, SHIRTS, PANTS, SKIRTS, TIES, SLEEP WEAR AND BATHING SUITS (U.S. CLS. 22 AND 39).

FIRST USE 6-16-2005; IN COMMERCE 6-16-2005.

**CLASS 25—(Continued).**

3,234,968. CARHARTT INC., DEARBORN, MI. SN 78-654,463. PUB. 4-11-2006, FILED 6-20-2005.

**WORK COMFORT**

THE MARK CONSISTS OF STANDARD CHARACTERS WITHOUT CLAIM TO ANY PARTICULAR FONT, STYLE, SIZE, OR COLOR.

FOR CLOTHING, NAMELY, SHORTS (U.S. CLS. 22 AND 39).  
FIRST USE 1-1-2006; IN COMMERCE 1-1-2006.

---

3,234,992. IMPRINT ALLIANCE GROUP, L.L.C., MANALAPAN, NJ. SN 78-658,576. PUB. 3-21-2006, FILED 6-27-2005.

**CHANGE IS GOOD**

THE MARK CONSISTS OF STANDARD CHARACTERS WITHOUT CLAIM TO ANY PARTICULAR FONT, STYLE, SIZE, OR COLOR.

OWNER OF U.S. REG. NO. 2,722,425.  
FOR HEADWEAR, SHIRTS (U.S. CLS. 22 AND 39).  
FIRST USE 6-0-2005; IN COMMERCE 9-0-2005.

---

3,235,023. ROSIVARA, S.L., ELCHE (ALICANTE), SPAIN. SN 78-661,901. PUB. 3-28-2006, FILED 6-30-2005.

**ROBERTO BOTELLA**

THE MARK CONSISTS OF STANDARD CHARACTERS WITHOUT CLAIM TO ANY PARTICULAR FONT, STYLE, SIZE, OR COLOR.

THE NAME(S), PORTRAIT(S), AND/OR SIGNATURE(S) SHOWN IN THE MARK IDENTIFIES ROBERTO BOTELLA PASTOR, WHOSE CONSENT(S) TO REGISTER IS SUBMITTED.

FOR FOOTWEAR NAMELY SHOES, SANDALS, SNEAKERS, CLOGS, BOOTS, SHORT BOOTS, KNEE HIGH BOOTS, STILETTO PUMPS, FLIP FLOPS, DRESS SHOES, SPORTS SHOES, BEACH SHOES, MULES, ESPADRILLES (U.S. CLS. 22 AND 39).

FIRST USE 3-14-2006; IN COMMERCE 3-14-2006.



**CLASS 25—(Continued).**

3,235,063. WPT ENTERPRISES, INC., LOS ANGELES, CA. SN 78-666,677. PUB. 9-6-2005, FILED 7-8-2005.

WPTONLINE.NET

THE MARK CONSISTS OF STANDARD CHARACTERS WITHOUT CLAIM TO ANY PARTICULAR FONT, STYLE, SIZE, OR COLOR.

FOR CLOTHING, NAMELY TOPS, T-SHIRTS AND HATS (U.S. CLS. 22 AND 39).

FIRST USE 2-0-2006; IN COMMERCE 2-0-2006.

3,235,096. 88 INTERNATIONAL, INC., ALHAMBRA, CA. SN 78-672,943. PUB. 4-4-2006, FILED 7-18-2005.

NAPOLEON SOLO

THE MARK CONSISTS OF STANDARD CHARACTERS WITHOUT CLAIM TO ANY PARTICULAR FONT, STYLE, SIZE, OR COLOR.

FOR MEN, WOMEN AND CHILDREN'S SHIRTS, VESTS, JACKETS, SKIRTS AND PANTS (U.S. CLS. 22 AND 39).

FIRST USE 12-1-1993; IN COMMERCE 12-1-1993.

**CLASS 25—(Continued).**

3,235,110. CHI, YUWEI, VALLEY STREAM, NY. SN 78-678,057. PUB. 7-4-2006, FILED 7-26-2005.



JULIA CHI  
NEW YORK

NO CLAIM IS MADE TO THE EXCLUSIVE RIGHT TO USE "NEW YORK", APART FROM THE MARK AS SHOWN. THE NAME JULIA CHI IDENTIFIES A LIVING INDIVIDUAL WHOSE CONSENT IS OF RECORD.

"THE COLOR(S) PEACH AND BLACK IS/ARE CLAIMED AS A FEATURE OF THE MARK."

THE COLOR PEACH APPEARS IN THE FLOWER. THE COLOR BLACK APPEARS AS SHADING IN THE CENTER OF THE FLOWER AND IN THE WORDING "JULIA CHI NEW YORK".

FOR LEATHER SHOES; RUBBER SHOES; SHOES; SKIING SHOES; SOCCER SHOES; TENNIS SHOES; TRACK AND FIELD SHOES; TRAINING SHOES; VOLLEYBALL SHOES; WOMEN'S SHOES; WORK SHOES AND BOOTS (U.S. CLS. 22 AND 39).

FIRST USE 5-1-2005; IN COMMERCE 5-1-2005.

3,235,120. DILLON A. DURANDO, ROHNERT PARK, CA. SN 78-681,008. PUB. 3-28-2006, FILED 7-28-2005.

WINE COUNTRY

THE MARK CONSISTS OF STANDARD CHARACTERS WITHOUT CLAIM TO ANY PARTICULAR FONT, STYLE, SIZE, OR COLOR.

FOR CAMP SHIRTS; JACKETS; COATS, TROUSERS, VESTS; SOCKS; SHORTS AND BRIEFS; PANTS; SHIRTS; SHIRTS FOR SUITS; CARGO SHORTS; LOGO T-SHIRTS, SLEEPWEAR, TIES (U.S. CLS. 22 AND 39).

FIRST USE 8-25-2005; IN COMMERCE 9-30-2005.

**CLASS 25—(Continued).**

3,235,144. MAZEH, ABBAS, WESTMINSTER, CA. SN 78-687,824. PUB. 4-18-2006, FILED 8-8-2005.

# OC STARZ

THE MARK CONSISTS OF STANDARD CHARACTERS WITHOUT CLAIM TO ANY PARTICULAR FONT, STYLE, SIZE, OR COLOR.

FOR CLOTHING AND CLOTHING ACCESSORIES, NAMELY, SHIRTS, T-SHIRTS, BLAZERS, PANTS, TROUSERS, SHORTS, JACKETS, HATS, CAPS, VESTS, SWEATERS, SWEATSHIRTS, UNDERWEAR, UNDERSHIRTS, COATS, BELTS, TIES, GLOVES, SCARVES AND SOCKS (U.S. CLS. 22 AND 39).

FIRST USE 8-12-2005; IN COMMERCE 8-12-2005.

3,235,150. THE PASADENA TOURNAMENT OF ROSES ASSOCIATION, INC., PASADENA, CA. SN 78-690,619. PUB. 4-25-2006, FILED 8-11-2005.

## GRANDDADDY OF THEM ALL

THE MARK CONSISTS OF STANDARD CHARACTERS WITHOUT CLAIM TO ANY PARTICULAR FONT, STYLE, SIZE, OR COLOR.

OWNER OF U.S. REG. NO. 1,053,762.

FOR CLOTHING, NAMELY TEE SHIRTS (U.S. CLS. 22 AND 39).

FIRST USE 1-1-2001; IN COMMERCE 1-1-2001.

3,235,196. RAVAN, REBECCA HEKMAT, BEVERLY HILLS, CA. SN 78-707,601. PUB. 8-1-2006, FILED 9-6-2005.



THE MARK CONSISTS OF A CLASSIC CREST; IN THE MIDDLE OF THE CREST A SHIELD BROKEN INTO THREE

**CLASS 25—(Continued).**

SEGMENTS WITH A CAPITAL H IN THE CENTER OF THE LARGEST SECTION; ON EACH SIDE OF THE SHIELD ARE TWO BRANCHES OF LEAVES AND ABOVE THE SHIELD IS A SCROLL INSIDE OF WHICH APPEARS THE LITERAL ELEMENT "ESTABLISHED SINCE MT. SINAI" AND ABOVE THAT THE LITERAL ELEMENT HEBREW SCHOOL; BELOW THE CREST IS ANOTHER SCROLL INSIDE OF WHICH APPEARS THE LITERAL ELEMENT "IN G-D WE TRUST" AND BELOW THE SCROLL IS THE LITERAL ELEMENT "DROP OUT".

FOR JOGGING PANTS; KNIT SHIRTS; POLO SHIRTS; SHIRT FRONTS; SHORT-SLEEVED SHIRTS; T-SHIRTS; TANK TOPS; TOPS (U.S. CLS. 22 AND 39).

FIRST USE 9-5-2005; IN COMMERCE 9-5-2005.

3,235,201. TIERNEY, MELISSA H., EVANSTON, IL. SN 78-709,858. PUB. 7-25-2006, FILED 9-9-2005.

## GRATEFUL NOT GREEDY

THE MARK CONSISTS OF STANDARD CHARACTERS WITHOUT CLAIM TO ANY PARTICULAR FONT, STYLE, SIZE, OR COLOR.

FOR SHIRTS (U.S. CLS. 22 AND 39).

FIRST USE 9-1-2005; IN COMMERCE 9-1-2005.

3,235,262. TILLEY, KERI, ESCONDIDO, CA. SN 78-738,327. PUB. 7-11-2006, FILED 10-21-2005.

## DRAMA MAMA

THE MARK CONSISTS OF STANDARD CHARACTERS WITHOUT CLAIM TO ANY PARTICULAR FONT, STYLE, SIZE, OR COLOR.

FOR WOMEN'S CLOTHING, NAMELY TANK TOPS, TSHIRTS, SHIRTS, SWEATSHIRTS, HATS, PAJAMAS, PANTS, SWEATSUITS, CAMISOLES, UNDERWEAR (U.S. CLS. 22 AND 39).

FIRST USE 7-5-2006; IN COMMERCE 8-23-2006.

3,235,264. SPERBER, JOSHUA D., BERKELEY, CA. AND MANDEL, LEV L., BERKELEY, CA. SN 78-739,500. PUB. 7-11-2006, FILED 10-24-2005.

## HYPHIE

**CLASS 25—(Continued).**

THE MARK CONSISTS OF STANDARD CHARACTERS WITHOUT CLAIM TO ANY PARTICULAR FONT, STYLE, SIZE, OR COLOR.

OWNER OF U.S. REG. NO. 3,160,379.  
FOR HEADWEAR, T-SHIRTS (U.S. CLS. 22 AND 39).  
FIRST USE 11-29-2005; IN COMMERCE 12-10-2005.

**CLASS 25—(Continued).**

3,235,336. ACORN PRODUCTS CO., INC., LEWISTON, ME.  
SN 78-769,772. PUB. 8-15-2006, FILED 12-8-2005.

3,235,270. SPENCER, COLLIN C, NEW YORK, NY. SN 78-743,087. PUB. 8-1-2006, FILED 10-29-2005.

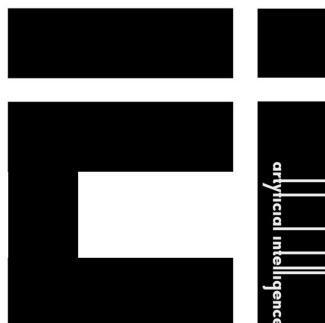

FOR CLOTHING, NAMELY SHIRTS, UNDERWEAR, HATS, PANTS, SWEATSHIRTS, SCARVES, SWIMWEAR, JACKETS, SKIRTS, SOCKS, TIES, VESTS, T-SHIRTS, PANTS, JEANS, SHORTS, SUITS, LOUNGEWEAR; ATHLETIC WEAR, NAMELY, ATHLETIC SHORTS, TANK TOPS, AND SPORTS BRAS (U.S. CLS. 22 AND 39).  
FIRST USE 10-10-2005; IN COMMERCE 9-6-2006.

**DOUBLE DUTY**

THE MARK CONSISTS OF STANDARD CHARACTERS WITHOUT CLAIM TO ANY PARTICULAR FONT, STYLE, SIZE, OR COLOR.

FOR FOOTWEAR; SOCKS (U.S. CLS. 22 AND 39).  
FIRST USE 1-31-2006; IN COMMERCE 7-31-2006.

3,235,354. BREUCKELEN NYC, INC., BROOKLYN, NY. SN 78-777,988. PUB. 9-5-2006, FILED 12-21-2005.

**EGALITARIAN UNIFORM**

3,235,301. DE VARONA, JONAS, SEATTLE, WA. SN 78-758,571. PUB. 7-25-2006, FILED 11-21-2005.

FOR WOMEN'S AND MEN'S CLOTHING, NAMELY BLOUSES, SKIRTS, DRESSES, YOGA PANTS, SLACKS, JEANS, SHORTS, T-SHIRTS, SWEATSHIRTS, SWEATERS, JACKETS, BELTS, AND SHOES (U.S. CLS. 22 AND 39).

FIRST USE 10-23-2000; IN COMMERCE 11-12-2006.

THE MARK CONSISTS OF STANDARD CHARACTERS WITHOUT CLAIM TO ANY PARTICULAR FONT, STYLE, SIZE, OR COLOR.

NO CLAIM IS MADE TO THE EXCLUSIVE RIGHT TO USE UNIFORM, APART FROM THE MARK AS SHOWN.

FOR CLOTHES FOR MEN, WOMEN, KIDS AND INFANTS, NAMELY T-SHIRTS, HATS, BASEBALL HATS, PANTS, SHORTS, JACKETS, OUTERWEAR, NAMELY JACKETS, PULLOVER SHIRTS, SWEATSHIRTS, SWEATBANDS, HEADBANDS, SOCKS, DRESSES, HEAD VISORS, UNIFORMS, SKIRTS, SCARVES, BUSINESS SUITS, COLLARED SHIRTS, SWEATERS, VEST, TIES, TANK TOPS, SWEAT PANTS, SWEAT SHIRTS, MALE UNDERWEAR, FEMALE UNDERWEAR, HOSIERY, WRAPS (U.S. CLS. 22 AND 39).

FIRST USE 8-2-2005; IN COMMERCE 8-2-2005.

**CLASS 25—(Continued).**

3,235,363. BREUCKELEN NYC, INC., BROOKLYN, NY. SN 78-782,661. PUB. 9-5-2006, FILED 12-29-2005.

**URBAN AMERICANA**

THE MARK CONSISTS OF STANDARD CHARACTERS WITHOUT CLAIM TO ANY PARTICULAR FONT, STYLE, SIZE, OR COLOR.

FOR CLOTHES FOR MEN, WOMEN, KIDS AND INFANTS, NAMELY T-SHIRTS, HATS, BASEBALL HATS, PANTS, SHORTS, JACKETS, OUTERWEAR, NAMELY JACKETS, PULLOVER SHIRTS, SWEAT-SHIRTS, SWEATBANDS, HEADBANDS, SOCKS, DRESSES, HEAD VISORS, UNIFORMS, SKIRTS, SCARVES, BUSINESS SUITS, COLLARED SHIRTS, SWEATERS, VEST, TIES, TANK TOPS, SWEAT PANTS, SWEAT SHIRTS, MALE UNDERWEAR, FEMALE UNDERWEAR, HOSIERY, WRAPS (U.S. CLS. 22 AND 39).

FIRST USE 8-2-2005; IN COMMERCE 8-2-2005.

---

3,235,364. BREUCKELEN NYC, INC., BROOKLYN, NY. SN 78-782,663. PUB. 9-5-2006, FILED 12-29-2005.

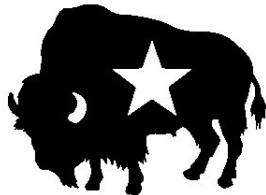

FOR CLOTHES FOR MEN, WOMEN, KIDS AND INFANTS, NAMELY T-SHIRTS, HATS, BASEBALL HATS, PANTS, SHORTS, JACKETS, OUTERWEAR, NAMELY JACKETS, PULLOVER SHIRTS, SWEAT-SHIRTS, SWEATBANDS, HEADBANDS, SOCKS, DRESSES, HEAD VISORS, UNIFORMS, SKIRTS, SCARVES, BUSINESS SUITS, COLLARED SHIRTS, SWEATERS, VEST, TIES, TANK TOPS, SWEAT PANTS, SWEAT SHIRTS, MALE UNDERWEAR, FEMALE UNDERWEAR, HOSIERY, WRAPS (U.S. CLS. 22 AND 39).

FIRST USE 8-2-2005; IN COMMERCE 8-2-2005.

**CLASS 25—(Continued).**

3,235,412. MOVA, LLC, SAN FRANCISCO, CA. SN 78-978,085. PUB. 1-24-2006, FILED 3-29-2005.

**MOVA**

THE MARK CONSISTS OF STANDARD CHARACTERS WITHOUT CLAIM TO ANY PARTICULAR FONT, STYLE, SIZE, OR COLOR.

THE FOREIGN WORDING IN THE MARK TRANSLATES INTO ENGLISH AS "IT MOVES."

FOR CLOTHING, NAMELY, JACKETS (U.S. CLS. 22 AND 39).

FIRST USE 8-2-2006; IN COMMERCE 8-2-2006.

**CLASS 26—FANCY GOODS**

---

3,234,061. L.J.L., INC., MINNEAPOLIS, MN. SN 76-641,664. PUB. 3-7-2006, FILED 6-27-2005.

**KLICINZ**

THE MARK CONSISTS OF STANDARD CHARACTERS WITHOUT CLAIM TO ANY PARTICULAR FONT, STYLE, SIZE, OR COLOR.

FOR HAIR ACCESSORIES, HAIR BANDS AND HAIR ORNAMENTS (U.S. CLS. 37, 39, 40, 42 AND 50).

FIRST USE 12-15-2005; IN COMMERCE 12-15-2005.

**CLASS 26—(Continued).**

3,235,213. JOVY ENTERPRISES LLC, NEW YORK, NY. SN 78-716,487. PUB. 5-23-2006, FILED 9-20-2005.

**CLASS 27—(Continued).**

3,233,766. PEACHTREE INTERNATIONAL LIMITED, HAMILTON HM, BERMUDA MX, BERMUDA. SN 75-631,320. PUB. 1-17-2006, FILED 2-1-1999.

**CHIC & MODE**

THE MARK CONSISTS OF STANDARD CHARACTERS WITHOUT CLAIM TO ANY PARTICULAR FONT, STYLE, SIZE, OR COLOR.

FOR HAIR ACCESSORIES, NAMELY, CLAW CLIPS; HAIR ACCESSORIES, NAMELY, SNAP CLIPS; HAIR BANDS; HAIR CLIPS; HAIR ORNAMENTS; HAIR ORNAMENTS IN THE FORM OF COMBS; HAIR PINS (U.S. CLS. 37, 39, 40, 42 AND 50).

FIRST USE 9-9-2006; IN COMMERCE 9-9-2006.



NO CLAIM IS MADE TO THE EXCLUSIVE RIGHT TO USE "INTERNATIONAL" AND "CREATIVE FLOOR COVERINGS", APART FROM THE MARK AS SHOWN.

FOR HARD SURFACE COVERING FOR FLOORS; VINYL FLOOR COVERINGS (U.S. CLS. 19, 20, 37, 42 AND 50).

FIRST USE 12-4-1998; IN COMMERCE 2-1-1999.

3,235,416. BEAUTY HOLDING COMPANY, INC., HAMILTON, BERMUDA. SN 78-978,089. PUB. 10-12-2004, FILED 12-31-2003.

**GET'N WAVES**

THE MARK CONSISTS OF STANDARD CHARACTERS WITHOUT CLAIM TO ANY PARTICULAR FONT, STYLE, SIZE, OR COLOR.

FOR HATS, CAPS AND SCARVES FOR USE IN CONNECTION WITH HAIR CARE PREPARATIONS (U.S. CLS. 37, 39, 40, 42 AND 50).

FIRST USE 5-17-2004; IN COMMERCE 5-17-2004.

3,234,958. PORTER ATHLETIC, INC., BROADVIEW, IL. SN 78-653,937. PUB. 2-28-2006, FILED 6-20-2005.

**SAFPAD**

THE MARK CONSISTS OF STANDARD CHARACTERS WITHOUT CLAIM TO ANY PARTICULAR FONT, STYLE, SIZE, OR COLOR.

OWNER OF U.S. REG. NO. 2,306,440.  
FOR PLASTIC AND VINYL COVERINGS, NAMELY, SAFETY PADDING COVERINGS FOR GYMNASIUM AND OTHER INSTITUTIONAL WALLS; SPORTS SAFETY EQUIPMENT, NAMELY, SAFETY PADS FOR GYMNASIUM WALLS (U.S. CLS. 19, 20, 37, 42 AND 50).

FIRST USE 11-3-2005; IN COMMERCE 11-3-2005.

**CLASS 27—FLOOR COVERINGS**

**CLASS 27—(Continued).**

3,234,960. PORTER ATHLETIC, INC., BROADVIEW, IL. SN 78-654,091. PUB. 2-28-2006, FILED 6-20-2005.

**HIMPACT SAFPAD**

THE MARK CONSISTS OF STANDARD CHARACTERS WITHOUT CLAIM TO ANY PARTICULAR FONT, STYLE, SIZE, OR COLOR.

OWNER OF U.S. REG. NO. 2,306,440.  
FOR PLASTIC AND VINYL COVERINGS, NAMELY, SAFETY PADDING COVERINGS FOR GYMNASIUM AND OTHER INSTITUTIONAL WALLS; SPORTS SAFETY EQUIPMENT, NAMELY, SAFETY PADS FOR GYMNASIUM WALLS (U.S. CLS. 19, 20, 37, 42 AND 50).  
FIRST USE 3-3-2006; IN COMMERCE 3-3-2006.

3,234,963. PORTER ATHLETIC, INC., BROADVIEW, IL. SN 78-654,252. PUB. 2-28-2006, FILED 6-20-2005.

**HINRG SAFPAD**

THE MARK CONSISTS OF STANDARD CHARACTERS WITHOUT CLAIM TO ANY PARTICULAR FONT, STYLE, SIZE, OR COLOR.

OWNER OF U.S. REG. NO. 2,306,440.  
FOR PLASTIC AND VINYL COVERINGS, NAMELY, SAFETY PADDING COVERINGS FOR GYMNASIUM AND OTHER INSTITUTIONAL WALLS; SPORTS SAFETY EQUIPMENT, NAMELY, SAFETY PADS FOR GYMNASIUM WALLS (U.S. CLS. 19, 20, 37, 42 AND 50).  
FIRST USE 11-3-2005; IN COMMERCE 11-3-2005.

3,234,998. BREWSTER WALLPAPER CORP., RANDOLPH, MA. SN 78-658,970. PUB. 3-14-2006, FILED 6-27-2005.

**PAPERPRO**

THE MARK CONSISTS OF STANDARD CHARACTERS WITHOUT CLAIM TO ANY PARTICULAR FONT, STYLE, SIZE, OR COLOR.

FOR WALLCOVERINGS (U.S. CLS. 19, 20, 37, 42 AND 50).  
FIRST USE 11-0-2005; IN COMMERCE 11-0-2005.

**CLASS 27—(Continued).**

3,235,204. ARMS BUILDING & MAINTENANCE, INC., LONGVIEW, TX. SN 78-711,147. PUB. 6-27-2006, FILED 9-12-2005.

**PRO PLAY**

THE MARK CONSISTS OF STANDARD CHARACTERS WITHOUT CLAIM TO ANY PARTICULAR FONT, STYLE, SIZE, OR COLOR.

FOR SYNTHETIC TURF FOR OUTDOOR FIELDS USED FOR SOCCER, FOOTBALL, BASEBALL, LACROSSE, FIELD HOCKEY AND OTHER ATHLETIC ACTIVITIES (U.S. CLS. 19, 20, 37, 42 AND 50).  
FIRST USE 7-0-2005; IN COMMERCE 7-0-2005.

3,235,322. KOHL'S ILLINOIS, INC., AURORA, IL. SN 78-764,910. PUB. 3-21-2006, FILED 12-1-2005.

**HOMESTUDIO**

THE MARK CONSISTS OF STANDARD CHARACTERS WITHOUT CLAIM TO ANY PARTICULAR FONT, STYLE, SIZE, OR COLOR.

OWNER OF U.S. REG. NO. 2,936,720.  
FOR RUGS (U.S. CLS. 19, 20, 37, 42 AND 50).  
FIRST USE 8-0-2006; IN COMMERCE 8-0-2006.

**CLASS 28—TOYS AND SPORTING GOODS**

3,233,804. ELKIND + SWEET COMMUNICATIONS, INC., SAN FRANCISCO, CA. SN 76-440,671. PUB. 9-2-2003, FILED 8-15-2002.

**POPCORN PARK**

FOR TOYS, GAMES AND PLAYTHINGS, NAMELY, PUPPETS, CARD GAMES (U.S. CLS. 22, 23, 38 AND 50).  
FIRST USE 3-31-2006; IN COMMERCE 3-31-2006.

**CLASS 28—(Continued).**

3,233,836. COHEN, LORI ADAMS, EAST HILLS, NY. SN 76-495,349. PUB. 10-21-2003, FILED 3-7-2003.

*Airanimals*

FOR INFLATABLE PLUSH TOYS (U.S. CLS. 22, 23, 38 AND 50).  
FIRST USE 7-10-2006; IN COMMERCE 7-10-2006.

3,233,868. FRONTPAIGE PRODUCTIONS, INC., LEEDS, AL. SN 76-560,995. PUB. 7-27-2004, FILED 11-3-2003.

VentriloMask

THE MARK CONSISTS OF STANDARD CHARACTERS WITHOUT CLAIM TO ANY PARTICULAR FONT, STYLE, SIZE, OR COLOR.

FOR DECORATIVE FACE MASK; COSTUME MASK (U.S. CLS. 22, 23, 38 AND 50).  
FIRST USE 7-12-2006; IN COMMERCE 7-12-2006.

3,233,958. PRATT, NATHAN D., SOMIS, CA. SN 76-613,137. PUB. 9-6-2005, FILED 9-21-2004.

Z-SKATE

THE MARK CONSISTS OF STANDARD CHARACTERS WITHOUT CLAIM TO ANY PARTICULAR FONT, STYLE, SIZE, OR COLOR.

OWNER OF U.S. REG. NOS. 2,770,125 AND 2,770,126.  
FOR TOYS AND SPORTING GOODS, NAMELY, SPORTS BOARDS, NAMELY SURFBOARDS, BODY BOARDS, SKIM BOARDS, SKATEBOARDS, SNOWBOARDS, WAKEBOARDS, AND KITEBOARDS, LEASHES, SURF FINS AND WAXES USED IN CONJUNCTION WITH SURFING, SWIM FINS AND FLIPPERS USED IN SWIMMING AND DIVING, SAILS AND SAILBOARDS FOR BOARDSAILING, BINDINGS USED WITH SNOWBOARDS, WHEELS USED ON SKATEBOARDS AND KITES (U.S. CLS. 22, 23, 38 AND 50).  
FIRST USE 12-31-2005; IN COMMERCE 12-31-2005.

**CLASS 28—(Continued).**

3,233,959. PRATT, NATHAN D., SOMIS, CA. SN 76-613,138. PUB. 9-6-2005, FILED 9-21-2004.

Z-SURF

THE MARK CONSISTS OF STANDARD CHARACTERS WITHOUT CLAIM TO ANY PARTICULAR FONT, STYLE, SIZE, OR COLOR.

OWNER OF U.S. REG. NOS. 2,770,125 AND 2,770,126.  
FOR TOYS AND SPORTING GOODS, NAMELY, SPORTS BOARDS, NAMELY SURFBOARDS, BODY BOARDS, SKIM BOARDS, SKATEBOARDS, SAILBOARDS, SNOWBOARDS, WAKEBOARDS, AND KITEBOARDS, LEASHES, SURF FINS AND WAXES USED IN CONJUNCTION WITH SURFING, SWIM FINS AND FLIPPERS USED IN SWIMMING AND DIVING, SAILS USED WITH SAILBOARDS, BINDINGS USED WITH SNOWBOARDS, WHEELS USED ON SKATEBOARDS AND KITES (U.S. CLS. 22, 23, 38 AND 50).  
FIRST USE 12-31-2005; IN COMMERCE 12-31-2005.

3,233,984. SKIS DYNASTAR, INC., PARK CITY, UT. SN 76-619,338. PUB. 10-11-2005, FILED 11-4-2004.

SWEET TROUBLE

THE MARK CONSISTS OF STANDARD CHARACTERS WITHOUT CLAIM TO ANY PARTICULAR FONT, STYLE, SIZE, OR COLOR.

OWNER OF U.S. REG. NO. 2,846,177.  
FOR SKIS (U.S. CLS. 22, 23, 38 AND 50).  
FIRST USE 1-20-2005; IN COMMERCE 3-23-2005.

3,234,002. KONAMI DIGITAL ENTERTAINMENT CO., LTD., TOKYO, JAPAN. SN 76-627,117. PUB. 4-25-2006, FILED 1-7-2005.

**STRUCTURE DECK**  
—DRAGON'S ROAR—

NO CLAIM IS MADE TO THE EXCLUSIVE RIGHT TO USE "DECK", APART FROM THE MARK AS SHOWN.  
FOR PLAYING CARDS, TRADING CARD GAMES (U.S. CLS. 22, 23, 38 AND 50).  
FIRST USE 3-0-2005; IN COMMERCE 3-0-2005.

**CLASS 28—(Continued).**

3,234,003. KONAMI DIGITAL ENTERTAINMENT CO., LTD., TOKYO, JAPAN. SN 76-627,118. PUB. 4-18-2006, FILED 1-7-2005.

**STRUCTURE DECK**  
—ZOMBIE MADNESS—

NO CLAIM IS MADE TO THE EXCLUSIVE RIGHT TO USE "DECK", APART FROM THE MARK AS SHOWN. FOR CARD GAMES (U.S. CLS. 22, 23, 38 AND 50). FIRST USE 3-0-2005; IN COMMERCE 3-0-2005.

3,234,023. KONAMI DIGITAL ENTERTAINMENT CO., LTD., TOKYO, JAPAN. SN 76-632,182. PUB. 4-18-2006, FILED 3-2-2005.

**STRUCTURE DECK**  
—BLAZE OF DESTRUCTION—

NO CLAIM IS MADE TO THE EXCLUSIVE RIGHT TO USE "DECK", APART FROM THE MARK AS SHOWN. FOR PLAYING CARDS, TRADING CARD GAMES (U.S. CLS. 22, 23, 38 AND 50). FIRST USE 3-0-2005; IN COMMERCE 3-0-2005.

3,234,058. HASBRO, INC., PAWTUCKET, RI. SN 76-641,479. PUB. 3-14-2006, FILED 6-22-2005.

**BUSY GEARS**

THE MARK CONSISTS OF STANDARD CHARACTERS WITHOUT CLAIM TO ANY PARTICULAR FONT, STYLE, SIZE, OR COLOR.

OWNER OF U.S. REG. NO. 2,935,968.  
NO CLAIM IS MADE TO THE EXCLUSIVE RIGHT TO USE GEARS, APART FROM THE MARK AS SHOWN. FOR CHILDREN'S MULTIPLE ACTIVITY TOYS (U.S. CLS. 22, 23, 38 AND 50). FIRST USE 10-28-2005; IN COMMERCE 10-28-2005.

**CLASS 28—(Continued).**

3,234,059. KONAMI DIGITAL ENTERTAINMENT CO., LTD., TOKYO, JAPAN. SN 76-641,536. PUB. 4-25-2006, FILED 6-23-2005.

**STRUCTURE DECK**  
—WARRIOR'S TRIUMPH—

NO CLAIM IS MADE TO THE EXCLUSIVE RIGHT TO USE "DECK", APART FROM THE MARK AS SHOWN. FOR PLAYING CARDS; TRADING CARD GAMES (U.S. CLS. 22, 23, 38 AND 50). FIRST USE 3-0-2005; IN COMMERCE 3-0-2005.

3,234,070. HASBRO, INC., PAWTUCKET, RI. SN 76-647,313. PUB. 6-13-2006, FILED 9-22-2005.

**BOXERS OR BRIEFS?**

THE MARK CONSISTS OF STANDARD CHARACTERS WITHOUT CLAIM TO ANY PARTICULAR FONT, STYLE, SIZE, OR COLOR. FOR BOARD GAMES (U.S. CLS. 22, 23, 38 AND 50). FIRST USE 10-13-2005; IN COMMERCE 10-13-2005.

3,234,071. WIZARDS OF THE COAST, INC., PAWTUCKET, RI. SN 76-647,532. PUB. 6-13-2006, FILED 9-27-2005.

**COLDSNAP**

THE MARK CONSISTS OF STANDARD CHARACTERS WITHOUT CLAIM TO ANY PARTICULAR FONT, STYLE, SIZE, OR COLOR. FOR TRADING CARD GAMES (U.S. CLS. 22, 23, 38 AND 50). FIRST USE 7-8-2006; IN COMMERCE 7-8-2006.



**CLASS 28—(Continued).**

3,234,111. KALAMDARYAN, VARTAN, T, BURBANK, CA.  
SN 78-157,581. PUB. 5-2-2006, FILED 8-25-2002.

**CLASS 28—(Continued).**

3,234,134. CAVALIERS OPERATING COMPANY, LLC, CLEVELAND, OH. SN 78-237,387. PUB. 9-14-2004, FILED 4-14-2003.



NO CLAIM IS MADE TO THE EXCLUSIVE RIGHT TO USE "PRODUCTS", APART FROM THE MARK AS SHOWN. FOR POOL, BILLIARD, SNOOKER SUPPLIES, NAMELY, CUE STICKS, CUE CASES, SHAFTS FOR BILLIARD CUES, CUE TIPS, FITTED CUE WRAPS, POOL AND BILLIARD ACCESSORIES, NAMELY, BILLIARD BALLS, POOL AND BILLIARD TABLE FELTS (U.S. CLS. 22, 23, 38 AND 50).  
FIRST USE 1-31-2002; IN COMMERCE 1-31-2002.



3,234,127. HERSCH AND COMPANY, LOS ANGELES, CA.  
SN 78-214,558. PUB. 9-23-2003, FILED 2-13-2003.

**SHOW ME YOURS I'LL  
SHOW YOU MINE**

FOR BOARD GAMES (U.S. CLS. 22, 23, 38 AND 50).  
FIRST USE 5-15-2006; IN COMMERCE 5-15-2006.

FOR TOYS, GAMES AND SPORTING GOODS, NAMELY BASKETBALLS, GOLF BALLS, PLAYGROUND BALLS, SPORTS BALLS, RUBBER ACTION BALLS AND FOAM ACTION BALLS, PLUSH BALLS, BASKETBALL NETS, BASKETBALL BACKBOARDS, PUMPS FOR INFLATING BASKETBALLS, AND NEEDLES THEREFOR, GOLF CLUBS, GOLF BAGS, GOLF PUTTERS, GOLF ACCESSORIES, NAMELY, DIVOT REPAIR TOOLS, TEES, BALL MARKERS, GOLF BAG COVERS, CLUB HEAD COVERS, GOLF GLOVES, GOLF BALL SLEEVES, ELECTRONIC BASKETBALL TABLE TOP GAMES, BASKETBALL TABLE TOP GAMES, BASKETBALL BOARD GAMES, ACTION SKILL GAMES, ADULT'S AND CHILDREN'S PARTY GAMES, TRIVIA INFORMATION GAMES AND ELECTRONIC VIDEO ARCADE GAME MACHINES, BASKETBALL KIT COMPRISED OF A NET AND WHISTLE, DOLLS, DECORATIVE DOLLS, COLLECTIBLE DOLLS, TOY ACTION FIGURES, BOBBLEHEAD ACTION FIGURES, STUFFED TOYS, JIGSAW PUZZLES AND CHRISTMAS TREE ORNAMENTS, CHRISTMAS STOCKINGS; TOY VEHICLES IN THE NATURE OF CARS, TRUCKS AND VANS, ALL CONTAINING BASKETBALL THEMES, TOY FINGERS IN THE NATURE OF A FOAM NOVELTY FINGER FOR USE AT SPORTING EVENTS; PLAYING CARDS (U.S. CLS. 22, 23, 38 AND 50).  
FIRST USE 10-10-2006; IN COMMERCE 10-10-2006.

**CLASS 28—(Continued).**

3,234,137. BOBCATS BASKETBALL, LLC, CHARLOTTE, NC. SN 78-244,453. PUB. 1-6-2004, FILED 5-1-2003.

**CHARLOTTE BOBCATS**

NO CLAIM IS MADE TO THE EXCLUSIVE RIGHT TO USE "CHARLOTTE", APART FROM THE MARK AS SHOWN.

FOR TOYS, GAMES AND SPORTING GOODS, NAMELY BASKETBALLS, GOLF BALLS, PLAYGROUND BALLS, SPORTS BALLS, RUBBER ACTION BALLS AND FOAM ACTION BALLS, PLUSH BALLS, BASKETBALL NETS, BASKETBALL BACKBOARDS, PUMPS FOR INFLATING BASKETBALLS, AND NEEDLES THEREFOR, GOLF CLUBS, GOLF BAGS, GOLF PUTTERS, GOLF ACCESSORIES, NAMELY, DIVOT REPAIR TOOLS, TEES, BALL MARKERS, GOLF BAG COVERS, CLUB HEAD COVERS, GOLF GLOVES, GOLF BALL SLEEVES, ELECTRONIC BASKETBALL TABLE TOP GAMES, BASKETBALL TABLE TOP GAMES, BASKETBALL BOARD GAMES, ACTION SKILL GAMES, ADULT'S AND CHILDREN'S PARTY GAMES, TRIVIA INFORMATION GAMES AND ELECTRONIC VIDEO ARCADE GAME MACHINES, BASKETBALL KIT COMPRISED OF A NET AND WHISTLE, DOLLS, DECORATIVE DOLLS, COLLECTIBLE DOLLS, TOY ACTION FIGURES, BOBBLEHEAD ACTION FIGURES, STUFFED TOYS, JIGSAW PUZZLES AND CHRISTMAS TREE ORNAMENTS, CHRISTMAS STOCKINGS; TOY VEHICLES IN THE NATURE OF CARS, TRUCKS AND VANS, ALL CONTAINING BASKETBALL THEMES, TOY FINGERS (U.S. CLS. 22, 23, 38 AND 50).  
FIRST USE 8-1-2004; IN COMMERCE 8-1-2004.

---

3,234,149. PETERS, ANDREW, GOSHEN, IN. SN 78-283,725. PUB. 5-4-2004, FILED 8-6-2003.

**STACK & STICK**

FOR TOY BUILDING BLOCKS; TOY CONSTRUCTION SETS (U.S. CLS. 22, 23, 38 AND 50).  
FIRST USE 9-1-2006; IN COMMERCE 9-1-2006.

---

3,234,180. BROWN, DAN, NEW YORK, NY. SN 78-326,560. PUB. 8-24-2004, FILED 11-12-2003.

**DA VINCI CODE**

THE MARK CONSISTS OF STANDARD CHARACTERS WITHOUT CLAIM TO ANY PARTICULAR FONT, STYLE, SIZE, OR COLOR.  
FOR BOARD GAMES, CARD GAMES AND PUZZLES (U.S. CLS. 22, 23, 38 AND 50).  
FIRST USE 3-16-2006; IN COMMERCE 3-16-2006.

**CLASS 28—(Continued).**

3,234,193. SCIENTIFIC TOYS LTD., TSIM SHA TSUI EAST, KOWLOON, HONG KONG. SN 78-338,543. PUB. 3-15-2005, FILED 12-9-2003.

**LEARNING MAGIC**

THE MARK CONSISTS OF STANDARD CHARACTERS WITHOUT CLAIM TO ANY PARTICULAR FONT, STYLE, SIZE, OR COLOR.

NO CLAIM IS MADE TO THE EXCLUSIVE RIGHT TO USE "LEARNING", APART FROM THE MARK AS SHOWN.  
FOR ELECTRONIC LEARNING AIDS, NAMELY, ELECTRONIC EDUCATIONAL GAME MACHINES FOR CHILDREN; LEARNING TOYS, NAMELY, TOY TEACHING CLOCKS, TOY TYPEWRITERS, TOY TELEPHONES, AND TOY MUSICAL INSTRUMENTS (U.S. CLS. 22, 23, 38 AND 50).

FIRST USE 10-20-2006; IN COMMERCE 10-20-2006.

---

3,234,237. MATTEL, INC., EL SEGUNDO, CA. SN 78-380,721. PUB. 10-18-2005, FILED 3-9-2004.

**BEBE DO**

THE MARK CONSISTS OF STANDARD CHARACTERS WITHOUT CLAIM TO ANY PARTICULAR FONT, STYLE, SIZE, OR COLOR.

NO CLAIM IS MADE TO THE EXCLUSIVE RIGHT TO USE "BEBE", APART FROM THE MARK AS SHOWN.  
THE FOREIGN WORDING IN THE MARK TRANSLATES INTO ENGLISH AS BABY.

FOR TOYS, GAMES AND PLAYTHINGS, NAMELY, DOLLS, DOLL CLOTHING AND DOLL ACCESSORIES (U.S. CLS. 22, 23, 38 AND 50).

FIRST USE 3-5-2006; IN COMMERCE 3-5-2006.

**CLASS 28—(Continued).**

3,234,265. AVIOTT DESIGN, INC., DETROIT, MI. SN 78-395,632. PUB. 3-29-2005, FILED 4-2-2004.

**ZOOSCAPE**

THE MARK CONSISTS OF STANDARD CHARACTERS WITHOUT CLAIM TO ANY PARTICULAR FONT, STYLE, SIZE, OR COLOR.

FOR TOYS, NAMELY, ACTIVITY KITS COMPOSED OF PLASTIC FIGURES AND BOOKS ILLUSTRATING ANIMAL HABITATS (U.S. CLS. 22, 23, 38 AND 50).

FIRST USE 11-27-2006; IN COMMERCE 11-27-2006.

\_\_\_\_\_

3,234,278. ARCHON PAINTBALL, INC., GREENVILLE, SC. SN 78-404,283. PUB. 9-6-2005, FILED 4-19-2004.

**VOODOO**

THE MARK CONSISTS OF STANDARD CHARACTERS WITHOUT CLAIM TO ANY PARTICULAR FONT, STYLE, SIZE, OR COLOR.

FOR PAINTBALLS (U.S. CLS. 22, 23, 38 AND 50). FIRST USE 9-20-2004; IN COMMERCE 9-20-2004.

**CLASS 28—(Continued).**

3,234,295. KMC ACQUISITION CORP., LAKEWOOD, CO. SN 78-412,276. PUB. 8-23-2005, FILED 5-3-2004.

**KMC**

THE MARK CONSISTS OF STANDARD CHARACTERS WITHOUT CLAIM TO ANY PARTICULAR FONT, STYLE, SIZE, OR COLOR.

FOR TOYS, GAMES AND PLAYTHINGS, NAMELY, TOY MODEL VEHICLES AND RELATED ACCESSORIES SOLD AS UNITS, DIE CAST TOY CARS, TOY TRUCKS, AND TOY VEHICLES AND RELATED ACCESSORIES SOLD AS UNITS, AND REMOTE-CONTROLLED TOY VEHICLES AND RELATED ACCESSORIES SOLD AS UNITS (U.S. CLS. 22, 23, 38 AND 50).

FIRST USE 5-3-2004; IN COMMERCE 5-3-2004.

\_\_\_\_\_

3,234,296. DEAMONE, DANIEL NEAL, HANOVER, ONTARIO. SN 78-412,847. PUB. 2-22-2005, FILED 5-4-2004.

**CAPITALIST**

THE MARK CONSISTS OF STANDARD CHARACTERS WITHOUT CLAIM TO ANY PARTICULAR FONT, STYLE, SIZE, OR COLOR.

FOR BOARD GAMES (U.S. CLS. 22, 23, 38 AND 50). FIRST USE 10-31-2006; IN COMMERCE 10-31-2006.

**CLASS 28—(Continued).**

3,234,372. MATTEL, INC., EL SEGUNDO, CA. SN 78-466,727.  
PUB. 11-29-2005, FILED 8-12-2004.

**CLASS 28—(Continued).**

3,234,463. PLAYCORE WISCONSIN, INC., CHATTANOOGA,  
TN. SN 78-502,269. PUB. 10-11-2005, FILED 10-19-2004.

**PRECIOUS PRINCESS**

THE MARK CONSISTS OF STANDARD CHARACTERS  
WITHOUT CLAIM TO ANY PARTICULAR FONT, STYLE,  
SIZE, OR COLOR.

FOR TOYS, GAMES AND PLAYTHINGS, NAMELY,  
DOLLS, DOLL CLOTHING AND DOLL ACCESSORIES  
(U.S. CLS. 22, 23, 38 AND 50).

FIRST USE 6-29-2006; IN COMMERCE 6-29-2006.

**GIZMO**

THE MARK CONSISTS OF STANDARD CHARACTERS  
WITHOUT CLAIM TO ANY PARTICULAR FONT, STYLE,  
SIZE, OR COLOR.

FOR PLAYGROUND EQUIPMENT, NAMELY ACTIV-  
ITY PANELS (U.S. CLS. 22, 23, 38 AND 50).

FIRST USE 2-0-2006; IN COMMERCE 2-0-2006.

3,234,450. GOLF EDUCATORS, LLC, ATLANTA, GA. SN 78-  
496,695. PUB. 9-27-2005, FILED 10-8-2004.

**GIMME A RULING**

THE MARK CONSISTS OF STANDARD CHARACTERS  
WITHOUT CLAIM TO ANY PARTICULAR FONT, STYLE,  
SIZE, OR COLOR.

FOR PARLOR GAMES (U.S. CLS. 22, 23, 38 AND 50).

FIRST USE 5-14-2005; IN COMMERCE 6-4-2005.

3,234,467. WINN INCORPORATED, HUNTINGTON BEACH,  
CA. SN 78-503,166. PUB. 3-14-2006, FILED 10-20-2004.

**WINN G8**

3,234,461. BONACCORSI M SHELLY, GAUTHIER J CA-  
MILLE AND LEVESQUE A NATALIE, HAMPTON, NH.  
SN 78-501,283. PUB. 9-13-2005, FILED 10-18-2004.

**CARTWHEEL KIDS**

THE MARK CONSISTS OF STANDARD CHARACTERS  
WITHOUT CLAIM TO ANY PARTICULAR FONT, STYLE,  
SIZE, OR COLOR.

NO CLAIM IS MADE TO THE EXCLUSIVE RIGHT TO  
USE "KIDS", APART FROM THE MARK AS SHOWN.

FOR STACKING CHILD'S TOY (U.S. CLS. 22, 23, 38  
AND 50).

FIRST USE 11-0-2004; IN COMMERCE 11-0-2004.

THE MARK CONSISTS OF STANDARD CHARACTERS  
WITHOUT CLAIM TO ANY PARTICULAR FONT, STYLE,  
SIZE, OR COLOR.

OWNER OF U.S. REG. NOS. 1,151,120, 2,565,037, AND  
OTHERS.

FOR SPORTING GOODS, NAMELY, GRIPS FOR  
GOLF CLUBS, HANDLE GRIPS FOR SPORTING EQUIP-  
MENT, AND GRIPS FOR FISHING POLES (U.S. CLS. 22,  
23, 38 AND 50).

FIRST USE 10-3-2005; IN COMMERCE 10-3-2005.

**CLASS 28—(Continued).**

3,234,471. GRAVES, TODD DONALD, EDMOND, OK. SN 78-504,622. PUB. 10-4-2005, FILED 10-22-2004.

**CLASS 28—(Continued).**

3,234,520. NBA PROPERTIES, INC., NEW YORK, NY. SN 78-519,361. PUB. 2-28-2006, FILED 11-18-2004.

The Feeling of  
Greatness



THE MARK CONSISTS OF STANDARD CHARACTERS WITHOUT CLAIM TO ANY PARTICULAR FONT, STYLE, SIZE, OR COLOR.  
FOR GOLF CLUB GRIPS (U.S. CLS. 22, 23, 38 AND 50).  
FIRST USE 5-31-2005; IN COMMERCE 7-1-2005.

OWNER OF U.S. REG. NOS. 1,525,782, 2,453,588, AND OTHERS.

NO CLAIM IS MADE TO THE EXCLUSIVE RIGHT TO USE "KIDS", APART FROM THE MARK AS SHOWN.

FOR TOYS, GAMES AND SPORTING GOODS, NAMELY BASKETBALLS, GOLF BALLS, PLAYGROUND BALLS, SPORTS BALLS, RUBBER ACTION BALLS AND FOAM ACTION BALLS, PLUSH BALLS, BASKETBALL NETS, BASKETBALL BACKBOARDS, MINIATURE BASKETBALL BACKBOARDS, PUMPS FOR INFLATING BASKETBALLS, NEEDLES FOR INFLATING BASKETBALLS, GOLF CLUBS, GOLF BAGS, GOLF PUTTERS, GOLF ACCESSORIES, NAMELY, DIVOT REPAIR TOOLS, TEES, BALL MARKERS, GOLF BAG COVERS, CLUB HEAD COVERS, GOLF GLOVES, GOLF BALL SLEEVES, ELECTRONIC BASKETBALL TABLE TOP GAMES, BASKETBALL TABLE TOP GAMES, BASKETBALL BOARD GAMES, ACTION SKILL GAMES, ADULT'S AND CHILDREN'S PARTY GAMES, TRIVIA INFORMATION GAMES AND ELECTRONIC VIDEO ARCADE GAME MACHINES, BASKETBALL KIT COMPRISED OF A NET AND WHISTLE, DOLLS, DECORATIVE DOLLS, COLLECTIBLE DOLLS, TOY ACTION FIGURES, BOBBLEHEAD ACTION FIGURES, STUFFED TOYS, NOVELTY PLUSH TOYS WITH WIGS, JIGSAW PUZZLES AND CHRISTMAS TREE ORNAMENTS, CHRISTMAS STOCKINGS; TOY VEHICLES IN THE NATURE OF CARS, TRUCKS AND VANS, ALL CONTAINING BASKETBALL THEMES, NOVELTY FOAM TOYS IN THE SHAPES OF FINGERS AND TROPHIES, TOY TROPHIES, PLAYING CARDS, CARD GAMES, NOISEMAKERS, PET TOYS, BEACH TOYS, POOL TOYS, BEACH BALLS, PLASTIC BALLS, INFLATABLE BALLS, TOY PAILS, TOY SHOVELS, INFLATABLE TOYS, SAND TOYS, SAND BOX TOYS, WATER-SQUIRTING TOYS; BEACH AND POOL ACCESSORIES, NAMELY SWIM FLOATS, POOL FLOATS, FOAM FLOATS, SWIM RINGS, POOL RINGS, FOAM RINGS, WATER RAFTS, BODY BOARDS, SURF BOARDS, SWIM FINS, SURF FINS, ARM FLOATS AND WATER WING SWIM AIDS FOR RECREATIONAL USE; TOY BUILDING BLOCKS, VOLLEYBALL GAME KITS COMPRISED OF BALL, NET, SIDELINES AND WHISTLE, AND WATER POLO GAME KITS COMPRISED OF BALL, NET AND WHISTLE (U.S. CLS. 22, 23, 38 AND 50).  
FIRST USE 10-31-2004; IN COMMERCE 10-31-2004.

3,234,507. STUDIO EL NINO, INC., NEW YORK, NY. SN 78-515,141. PUB. 9-27-2005, FILED 11-11-2004.

BODY PLANET

THE MARK CONSISTS OF STANDARD CHARACTERS WITHOUT CLAIM TO ANY PARTICULAR FONT, STYLE, SIZE, OR COLOR.  
FOR TOYS AND GAMES, NAMELY, DOLLS AND BOARD GAMES (U.S. CLS. 22, 23, 38 AND 50).  
FIRST USE 3-1-2006; IN COMMERCE 3-1-2006.

**CLASS 28—(Continued).**

3,234,532. TY INC., WESTMONT, IL. SN 78-521,830. PUB. 9-13-2005, FILED 11-23-2004.

**MY BABY BUNNY**

THE MARK CONSISTS OF STANDARD CHARACTERS WITHOUT CLAIM TO ANY PARTICULAR FONT, STYLE, SIZE, OR COLOR.

NO CLAIM IS MADE TO THE EXCLUSIVE RIGHT TO USE "BUNNY", APART FROM THE MARK AS SHOWN. FOR PLUSH TOYS (U.S. CLS. 22, 23, 38 AND 50). FIRST USE 2-8-2005; IN COMMERCE 2-8-2005.

3,234,677. WHEAT, CLEVELAND E., RESTON, VA. SN 78-575,921. PUB. 11-15-2005, FILED 2-27-2005.

**PUTTRUNNER**

THE MARK CONSISTS OF STANDARD CHARACTERS WITHOUT CLAIM TO ANY PARTICULAR FONT, STYLE, SIZE, OR COLOR.

FOR GOLF PUTTING PRACTICE AID; NAMELY, AN AUTOMATIC PUTT RETURN (U.S. CLS. 22, 23, 38 AND 50).

FIRST USE 3-28-2006; IN COMMERCE 3-28-2006.

3,234,694. MATTEL, INC., EL SEGUNDO, CA. SN 78-582,538. PUB. 4-11-2006, FILED 3-8-2005.

**AUTOGRFX**

THE MARK CONSISTS OF STANDARD CHARACTERS WITHOUT CLAIM TO ANY PARTICULAR FONT, STYLE, SIZE, OR COLOR.

FOR TOYS, GAMES AND PLAYTHINGS, NAMELY, TOY VEHICLES AND ACCESSORIES THEREFOR (U.S. CLS. 22, 23, 38 AND 50).

FIRST USE 11-15-2006; IN COMMERCE 11-15-2006.

**CLASS 28—(Continued).**

3,234,695. MATTEL, INC., EL SEGUNDO, CA. SN 78-582,539. PUB. 4-25-2006, FILED 3-8-2005.

**DESERT BAZAAR**

THE MARK CONSISTS OF STANDARD CHARACTERS WITHOUT CLAIM TO ANY PARTICULAR FONT, STYLE, SIZE, OR COLOR.

FOR TOYS, GAMES AND PLAYTHINGS, NAMELY, BOARD GAMES AND ACCESSORIES THEREFOR (U.S. CLS. 22, 23, 38 AND 50).

FIRST USE 11-30-2006; IN COMMERCE 11-30-2006.

3,234,723. JAKKS PACIFIC, INC., MALIBU, CA. SN 78-594,008. PUB. 12-20-2005, FILED 3-24-2005.

**CATALINA**

THE MARK CONSISTS OF STANDARD CHARACTERS WITHOUT CLAIM TO ANY PARTICULAR FONT, STYLE, SIZE, OR COLOR.

FOR FASHION DOLLS FOR GIRLS (U.S. CLS. 22, 23, 38 AND 50).

FIRST USE 11-8-2005; IN COMMERCE 11-8-2005.

3,234,732. HARVEY ENTERTAINMENT, INC., NEW YORK, NY. SN 78-596,217. PUB. 3-14-2006, FILED 3-28-2005.



OWNER OF U.S. REG. NOS. 722,258, 2,129,953, AND OTHERS.

FOR CHRISTMAS TREE ORNAMENTS AND TOYS, NAMELY, PLASTIC MECHANICAL TOYS; PERFORMANCE PUPPETS; JIGSAW PUZZLES; CARD GAMES; BATH TOYS; SAND ART TOY KITS COMPRISING OF PLAY SAND AND DECORATIVE CONTAINERS; HOBBY CRAFT KIT FOR MAKING JEWELRY AND HAIR ACCESSORIES; TOY FIGURES; COSTUME MASKS; HAND-HELD UNIT FOR PLAYING ELECTRONIC GAMES; DOLLS, DOLL ACCESSORIES; STUFFED TOYS; BENDABLE FIGURINES; TOY VEHICLES, CARDBOARD AND PLASTIC DISCS USED AS GAME PIECES FOR PLAYING A GAME AND SLAMMERS; PINBALL MACHINES; MODEL CRAFT KITS OF TOY FIGURES; BOARD GAMES; PLUSH TOYS; BALLOONS; WATER SQUIRTING DOLL HEADS; INFLATABLE TOYS IN THE NATURE OF VINYL FIGURES; AND SQUEEZE TOYS; PLAYING CARDS (U.S. CLS. 22, 23, 38 AND 50).

FIRST USE 9-1-2005; IN COMMERCE 9-1-2005.

**CLASS 28—(Continued).**

3,234,739. SHOOT THE MOON PRODUCTS II, LLC, PLEASANTON, CA. SN 78-597,775. PUB. 12-27-2005, FILED 3-29-2005.

**NOODLE DOODLES**

THE MARK CONSISTS OF STANDARD CHARACTERS WITHOUT CLAIM TO ANY PARTICULAR FONT, STYLE, SIZE, OR COLOR.

FOR TOYS AND PLAYTHINGS, NAMELY, DOLL HOUSES, DOLLS AND PLAYSETS THEREFOR AND DOLL ACCESSORIES (U.S. CLS. 22, 23, 38 AND 50).

FIRST USE 8-0-2005; IN COMMERCE 8-0-2005.

3,234,770. MATTEL, INC., EL SEGUNDO, CA. SN 78-608,710. PUB. 3-21-2006, FILED 4-14-2005.

**STAR TEAM**

THE MARK CONSISTS OF STANDARD CHARACTERS WITHOUT CLAIM TO ANY PARTICULAR FONT, STYLE, SIZE, OR COLOR.

FOR TOYS, GAMES AND PLAYTHINGS, NAMELY, DOLLS, DOLL CLOTHING AND DOLL ACCESSORIES (U.S. CLS. 22, 23, 38 AND 50).

FIRST USE 4-12-2006; IN COMMERCE 4-12-2006.

3,234,825. THOSE CHARACTERS FROM CLEVELAND, INC., CLEVELAND, OH. SN 78-627,906. PUB. 2-14-2006, FILED 5-11-2005.

**TEA BLOSSOM**

THE MARK CONSISTS OF STANDARD CHARACTERS WITHOUT CLAIM TO ANY PARTICULAR FONT, STYLE, SIZE, OR COLOR.

FOR TOY FIGURES AND DOLLS (U.S. CLS. 22, 23, 38 AND 50).

FIRST USE 6-30-2006; IN COMMERCE 6-30-2006.

**CLASS 28—(Continued).**

3,234,839. RUSSELL CORPORATION, ATLANTA, GA. SN 78-631,381. PUB. 1-31-2006, FILED 5-17-2005.

**ARENA VIEW**

THE MARK CONSISTS OF STANDARD CHARACTERS WITHOUT CLAIM TO ANY PARTICULAR FONT, STYLE, SIZE, OR COLOR.

OWNER OF U.S. REG. NO. 1,662,569.

FOR BASKETBALL EQUIPMENT, NAMELY BASKETBALL BACKBOARDS, POLES, GOALS, AND PORTABLE BASKETBALL UNITS CONTAINING A BASE, POLE, BACKBOARD AND GOAL (U.S. CLS. 22, 23, 38 AND 50).

FIRST USE 5-31-2005; IN COMMERCE 5-31-2005.

3,234,857. KARSTEN MANUFACTURING CORPORATION, PHOENIX, AZ. SN 78-634,837. PUB. 2-28-2006, FILED 5-23-2005.

**G5**

THE MARK CONSISTS OF STANDARD CHARACTERS WITHOUT CLAIM TO ANY PARTICULAR FONT, STYLE, SIZE, OR COLOR.

FOR GOLF BAGS (U.S. CLS. 22, 23, 38 AND 50).

FIRST USE 2-8-2006; IN COMMERCE 2-8-2006.

3,234,888. GILGAL GOLF, LLC, WAUNAKEE, WI. SN 78-641,983. PUB. 2-28-2006, FILED 6-2-2005.

**PRECOURSE**

THE MARK CONSISTS OF STANDARD CHARACTERS WITHOUT CLAIM TO ANY PARTICULAR FONT, STYLE, SIZE, OR COLOR.

FOR GOLF SWING AID AND TRAINING DEVICE CONSISTING OF A BELT AND A WRIST BAND CONNECTED BY RUBBER EXERCISE TUBING (U.S. CLS. 22, 23, 38 AND 50).

FIRST USE 10-1-2005; IN COMMERCE 1-15-2006.

**CLASS 28—(Continued).**

3,234,900. VANILLA GORILLA, L.P., LOS ANGELES, CA. SN 78-645,815. PUB. 3-7-2006, FILED 6-7-2005.

*Jesse James*

FOR TOYS, NAMELY, TOY VEHICLES (U.S. CLS. 22, 23, 38 AND 50).  
FIRST USE 12-19-2002; IN COMMERCE 12-19-2002.

3,234,952. THOSE CHARACTERS FROM CLEVELAND, INC., CLEVELAND, OH. SN 78-653,080. PUB. 3-14-2006, FILED 6-17-2005.

**HUCKLEBERRY HASH**

THE MARK CONSISTS OF STANDARD CHARACTERS WITHOUT CLAIM TO ANY PARTICULAR FONT, STYLE, SIZE, OR COLOR.

OWNER OF U.S. REG. NO. 2,849,544.  
THE MARK DOES NOT IDENTIFY ANY LIVING INDIVIDUAL.

FOR TOY FIGURES AND DOLLS (U.S. CLS. 22, 23, 38 AND 50).

FIRST USE 8-31-2005; IN COMMERCE 8-31-2005.

3,234,955. TULIPANI, VICTOR, SAN RAFAEL, CA. SN 78-653,492. PUB. 3-14-2006, FILED 6-17-2005.

**DUDLEY THE DUCK**

THE MARK CONSISTS OF STANDARD CHARACTERS WITHOUT CLAIM TO ANY PARTICULAR FONT, STYLE, SIZE, OR COLOR.

NO CLAIM IS MADE TO THE EXCLUSIVE RIGHT TO USE "DUCK", APART FROM THE MARK AS SHOWN.

FOR BATHTUB TOYS (U.S. CLS. 22, 23, 38 AND 50).  
FIRST USE 11-1-2005; IN COMMERCE 11-1-2005.

**CLASS 28—(Continued).**

3,234,966. NINTENDO OF AMERICA INC., REDMOND, WA. SN 78-654,396. PUB. 3-14-2006, FILED 6-20-2005.

**NINTENDOGS**

THE MARK CONSISTS OF STANDARD CHARACTERS WITHOUT CLAIM TO ANY PARTICULAR FONT, STYLE, SIZE, OR COLOR.

FOR COLLECTABLE TOY FIGURES; HAND-HELD GAMES WITH LIQUID CRYSTAL DISPLAYS; HAND-HELD UNITS FOR PLAYING ELECTRONIC GAMES; HAND-HELD UNITS FOR PLAYING ELECTRONIC GAMES IN THE NATURE OF A VIRTUAL PET; HAND-HELD UNITS FOR PLAYING VIDEO GAMES; HAND-HELD VIDEO GAME SYSTEMS, COMPRISING HAND-HELD UNITS FOR PLAYING VIDEO GAMES AND ASSOCIATED GAME CARTRIDGES PACKAGED AS A UNIT; PLUSH TOYS; PROMOTIONAL GAME CARDS; STUFFED TOYS; TRADING CARD GAMES (U.S. CLS. 22, 23, 38 AND 50).

FIRST USE 3-1-2006; IN COMMERCE 3-1-2006.

3,235,010. INTELLIGENT DUMBBELLS, INC., OWATONNA, MN. SN 78-660,486. PUB. 3-28-2006, FILED 6-29-2005.

**POWERSTATION**

THE MARK CONSISTS OF STANDARD CHARACTERS WITHOUT CLAIM TO ANY PARTICULAR FONT, STYLE, SIZE, OR COLOR.

FOR EXERCISE EQUIPMENT, NAMELY WEIGHT LIFTING MACHINES (U.S. CLS. 22, 23, 38 AND 50).

FIRST USE 1-15-2005; IN COMMERCE 10-1-2005.

3,235,017. T.F.H. PUBLICATIONS, INC., NEPTUNE CITY, NJ. SN 78-661,711. PUB. 3-21-2006, FILED 6-30-2005.

**MY LITTLE PRINCE**

THE MARK CONSISTS OF STANDARD CHARACTERS WITHOUT CLAIM TO ANY PARTICULAR FONT, STYLE, SIZE, OR COLOR.

FOR NON-EDIBLE PET CHEW TOYS (U.S. CLS. 22, 23, 38 AND 50).

FIRST USE 6-5-2006; IN COMMERCE 6-26-2006.



**CLASS 28—(Continued).**

3,235,041. WILD PLANET ENTERTAINMENT, INC., SAN FRANCISCO, CA. SN 78-663,043. PUB. 3-21-2006, FILED 7-1-2005.

**DODGE DISCS**

THE MARK CONSISTS OF STANDARD CHARACTERS WITHOUT CLAIM TO ANY PARTICULAR FONT, STYLE, SIZE, OR COLOR.

NO CLAIM IS MADE TO THE EXCLUSIVE RIGHT TO USE "DISCS", APART FROM THE MARK AS SHOWN.

FOR TOYS AND PLAYTHINGS, NAMELY AN ACTION SKILLS GAME CONSISTING OF A COMBINATION TOY DISC LAUNCHER AND SHIELD THAT PLAYERS WEAR ON THEIR ARMS AND USE TO SHOOT DISCS AND BLOCK DISCS SHOT BY OTHERS (U.S. CLS. 22, 23, 38 AND 50).

FIRST USE 5-0-2005; IN COMMERCE 11-0-2005.

3,235,042. HULL, DENNIS H., KEIZER, OR. SN 78-663,286. PUB. 3-14-2006, FILED 7-3-2005.

**Flash Rattle & Dive**

THE MARK CONSISTS OF STANDARD CHARACTERS WITHOUT CLAIM TO ANY PARTICULAR FONT, STYLE, SIZE, OR COLOR.

FOR FISHING TACKLE (U.S. CLS. 22, 23, 38 AND 50). FIRST USE 8-1-2004; IN COMMERCE 5-25-2005.

3,235,061. GEOFFREY, INC., WAYNE, NJ. SN 78-666,120. PUB. 4-11-2006, FILED 7-8-2005.

**TICKLE TUMMY BABY**

THE MARK CONSISTS OF STANDARD CHARACTERS WITHOUT CLAIM TO ANY PARTICULAR FONT, STYLE, SIZE, OR COLOR.

NO CLAIM IS MADE TO THE EXCLUSIVE RIGHT TO USE "BABY", APART FROM THE MARK AS SHOWN.

FOR DOLLS AND DOLL ACCESSORIES (U.S. CLS. 22, 23, 38 AND 50).

FIRST USE 6-0-2005; IN COMMERCE 6-0-2005.

**CLASS 28—(Continued).**

3,235,105. BURFORD, TIFFANEY L., DORCHESTER, MA. SN 78-676,411. PUB. 3-28-2006, FILED 7-22-2005.

**MATHSMIND**

THE MARK CONSISTS OF STANDARD CHARACTERS WITHOUT CLAIM TO ANY PARTICULAR FONT, STYLE, SIZE, OR COLOR.

FOR BOARD GAMES (U.S. CLS. 22, 23, 38 AND 50). FIRST USE 11-4-2002; IN COMMERCE 11-4-2002.

3,235,156. FUNDEX GAMES, LTD., INDIANAPOLIS, IN. SN 78-692,869. PUB. 5-16-2006, FILED 8-15-2005.

**SONIC SEARCH**

THE MARK CONSISTS OF STANDARD CHARACTERS WITHOUT CLAIM TO ANY PARTICULAR FONT, STYLE, SIZE, OR COLOR.

NO CLAIM IS MADE TO THE EXCLUSIVE RIGHT TO USE THE TERM "SONIC", APART FROM THE MARK AS SHOWN.

FOR OUTDOOR ACTION SKILL GAMES IN WHICH PLAYERS TRY TO LOCATE AN UNDERWATER SOUND EMITTING DEVICE (U.S. CLS. 22, 23, 38 AND 50).

FIRST USE 4-20-2006; IN COMMERCE 4-20-2006.

3,235,183. GARDNER, MERLE F., MEMPHIS, TN. SN 78-702,409. PUB. 5-23-2006, FILED 8-29-2005.

**SPIT TECH**

THE MARK CONSISTS OF STANDARD CHARACTERS WITHOUT CLAIM TO ANY PARTICULAR FONT, STYLE, SIZE, OR COLOR.

FOR DUCK CALL (U.S. CLS. 22, 23, 38 AND 50). FIRST USE 7-0-2005; IN COMMERCE 8-9-2005.

**CLASS 28—(Continued).**

3,235,246. CALLAWAY GOLF COMPANY, CARLSBAD, CA. SN 78-729,836. PUB. 6-13-2006, FILED 10-10-2005.

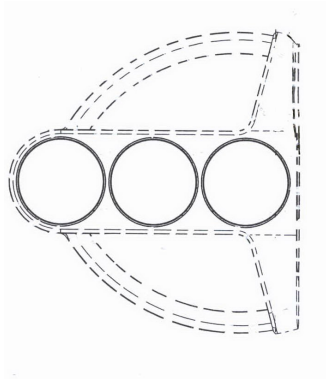

OWNER OF U.S. REG. NO. 2,663,332.  
THE APPLICANT CLAIMS COLOR AS A FEATURE OF THE MARK, NAMELY, WHITE.

THE MARK CONSISTS OF THREE WHITE CIRCLES AS PART OF THE MARK. THE DOTTED LINES DO NOT FORM PART OF THE MARK BUT ARE RATHER FOR ILLUSTRATIVE PURPOSES ONLY.

FOR GOLF CLUBS (U.S. CLS. 22, 23, 38 AND 50).  
FIRST USE 9-13-2005; IN COMMERCE 9-13-2005.

3,235,252. BRIDGESTONE SPORTS CO., LTD., TOKYO, JAPAN. SN 78-731,276. PUB. 6-13-2006, FILED 10-12-2005.

e6

THE MARK CONSISTS OF STANDARD CHARACTERS WITHOUT CLAIM TO ANY PARTICULAR FONT, STYLE, SIZE, OR COLOR.  
FOR GOLF BALLS (U.S. CLS. 22, 23, 38 AND 50).  
FIRST USE 6-0-2005; IN COMMERCE 6-0-2005.

**CLASS 28—(Continued).**

3,235,284. RAFATI, HAROON, SAN ANTONIO, TX. SN 78-751,566. PUB. 7-18-2006, FILED 11-10-2005.

**TUGS THE UNGLOVES**

THE MARK CONSISTS OF STANDARD CHARACTERS WITHOUT CLAIM TO ANY PARTICULAR FONT, STYLE, SIZE, OR COLOR.

FOR RECTANGULAR SHAPED, RUBBER HANDLE GRIPS AND HAND PADS USED FOR PROTECTING HANDS WHILE LIFTING WEIGHTS OR PERFORMING OTHER VARIOUS GYM EXERCISE ACTIVITIES (U.S. CLS. 22, 23, 38 AND 50).

FIRST USE 1-1-2006; IN COMMERCE 6-6-2006.

3,235,327. JAKKS PACIFIC, INC., MALIBU, CA. SN 78-766,263. PUB. 8-8-2006, FILED 12-4-2005.

**FUN CHAIR**

THE MARK CONSISTS OF STANDARD CHARACTERS WITHOUT CLAIM TO ANY PARTICULAR FONT, STYLE, SIZE, OR COLOR.

NO CLAIM IS MADE TO THE EXCLUSIVE RIGHT TO USE "CHAIR", APART FROM THE MARK AS SHOWN.

FOR NET SEAT THAT ATTACHES TO A SOFT FOAM TOY FOR WATER RECREATION PURPOSES (U.S. CLS. 22, 23, 38 AND 50).

FIRST USE 1-9-2004; IN COMMERCE 1-9-2004.

3,235,337. SHAKESPEARE COMPANY, LLC, COLUMBIA, SC. SN 78-770,155. PUB. 7-25-2006, FILED 12-9-2005.

**INSPINITY**

THE MARK CONSISTS OF STANDARD CHARACTERS WITHOUT CLAIM TO ANY PARTICULAR FONT, STYLE, SIZE, OR COLOR.

FOR FISHING RODS AND REELS (U.S. CLS. 22, 23, 38 AND 50).

FIRST USE 9-0-2006; IN COMMERCE 9-0-2006.

**CLASS 28—(Continued).**

3,235,339. JAKKS PACIFIC, INC., MALIBU, CA. SN 78-770,318. PUB. 8-8-2006, FILED 12-9-2005.

**TU TA BELLA**

THE MARK CONSISTS OF STANDARD CHARACTERS WITHOUT CLAIM TO ANY PARTICULAR FONT, STYLE, SIZE, OR COLOR.

FOR DOLL CLOTHING; DOLL HOUSES; DOLLS; DOLLS AND ACCESSORIES THEREFOR; DOLLS AND PLAYSETS THEREFOR; TOY VEHICLES (U.S. CLS. 22, 23, 38 AND 50).

FIRST USE 5-13-2006; IN COMMERCE 5-13-2006.

---

3,235,351. KINGMAN INTERNATIONAL CORPORATION, BALDWIN PARK, CA. SN 78-777,082. PUB. 8-29-2006, FILED 12-20-2005.

**MR2**

THE MARK CONSISTS OF STANDARD CHARACTERS WITHOUT CLAIM TO ANY PARTICULAR FONT, STYLE, SIZE, OR COLOR.

FOR PAINTBALL GUNS, AND ACCESSORIES THEREFOR IN THE NATURE OF BARRELS, GRIP FRAMES, FRAME COVERS, GRIPS, EXPANSION CHAMBERS, SIGHT RAILS, TRIGGER ASSEMBLIES, BARREL PLUGS, AND TURBULENCE BOLTS (U.S. CLS. 22, 23, 38 AND 50).

FIRST USE 12-20-2005; IN COMMERCE 12-20-2005.

---

3,235,352. KINGMAN INTERNATIONAL CORPORATION, BALDWIN PARK, CA. SN 78-777,092. PUB. 8-29-2006, FILED 12-20-2005.

**MR3**

THE MARK CONSISTS OF STANDARD CHARACTERS WITHOUT CLAIM TO ANY PARTICULAR FONT, STYLE, SIZE, OR COLOR.

FOR PAINTBALL GUNS, AND ACCESSORIES THEREFOR IN THE NATURE OF BARRELS, GRIP FRAMES, FRAME COVERS, GRIPS, EXPANSION CHAMBERS, SIGHT RAILS, TRIGGER ASSEMBLIES, BARREL PLUGS, AND TURBULENCE BOLTS (U.S. CLS. 22, 23, 38 AND 50).

FIRST USE 6-28-2006; IN COMMERCE 6-28-2006.

**CLASS 28—(Continued).**

3,235,353. BOARD OF TRUSTEES OF THE UNIVERSITY OF ARKANSAS, LITTLE ROCK, AR. SN 78-777,865. PUB. 7-4-2006, FILED 12-21-2005.



OWNER OF U.S. REG. NOS. 2,172,444, 2,172,446, AND OTHERS.

FOR PUZZLES (U.S. CLS. 22, 23, 38 AND 50).

FIRST USE 12-31-2005; IN COMMERCE 12-31-2005.

---

3,235,400. KINECT SPORTS LLC, LOVELAND, OH. SN 78-978,004. PUB. 3-21-2006, FILED 2-10-2005.

**SHOCK ATTACK**

THE MARK CONSISTS OF STANDARD CHARACTERS WITHOUT CLAIM TO ANY PARTICULAR FONT, STYLE, SIZE, OR COLOR.

FOR SPORTS TRAINING AND GAME EQUIPMENT, NAMELY, BASEBALLS, SOFTBALLS AND GOLF BALLS, BASEBALL BATS, GOLF CLUBS, BALL PITCHING MACHINES, RACQUETBALL, TENNIS, PADDLE TENNIS AND SQUASH RACKETS, CRICKET BATS, LACROSSE STICKS AND LACROSSE SHOULDER, RIB, ELBOW AND HAND PADS; FOOTBALLS AND BASKETBALLS (U.S. CLS. 22, 23, 38 AND 50).

FIRST USE 4-5-2005; IN COMMERCE 4-5-2005.

**CLASS 29—MEATS AND PROCESSED FOODS**

3,233,763. UNITED NATURAL FOODS, INC., DAYVILLE, CT. SN 75-132,043. PUB. 9-30-1997, FILED 7-10-1996.

**WOODSTOCK ORGANICS**

NO CLAIM IS MADE TO THE EXCLUSIVE RIGHT TO USE "ORGANICS", APART FROM THE MARK AS SHOWN.

FOR FROZEN SOUPS (U.S. CL. 46).

FIRST USE 0-0-1997; IN COMMERCE 0-0-1997.

**CLASS 29—(Continued).**

3,233,825. RESTAURANT BRODARD, INC., GARDEN GROVE, CA. SN 76-489,258. PUB. 11-11-2003, FILED 2-11-2003.

**BRODARD RESTAURANT**

NO CLAIM IS MADE TO THE EXCLUSIVE RIGHT TO USE "RESTAURANT", APART FROM THE MARK AS SHOWN.

FOR MEATS; PROCESSED FOODS, NAMELY, FROZEN ENTREES CONSISTING OF PRIMARILY OF MEAT, FISH, POULTRY OR VEGETABLES, AND READY-TO-EAT PREPARED MEALS CONSISTING PRIMARILY OF MEAT, FISH, POULTRY OR VEGETABLES (U.S. CL. 46).

FIRST USE 10-13-2006; IN COMMERCE 10-13-2006.

---

3,233,847. DAISY BRAND, LP, DALLAS, TX. SN 76-509,448. PUB. 9-23-2003, FILED 4-25-2003.



OWNER OF U.S. REG. NO. 1,716,092.  
FOR DAIRY PRODUCTS, NAMELY COTTAGE CHEESE (U.S. CL. 46).  
FIRST USE 11-6-2006; IN COMMERCE 11-6-2006.

---

3,233,882. MONGELLUZZI, FRANK, CLEARWATER, FL. SN 76-576,655. PUB. 9-13-2005, FILED 2-23-2004.

**FRANK'S THANKS**

FOR HOT DOGS (U.S. CL. 46).  
FIRST USE 2-23-2004; IN COMMERCE 6-4-2004.

---

3,234,173. CHICAGO IMPORTING CO., ELGIN, IL. SN 78-312,223. PUB. 1-18-2005, FILED 10-10-2003.

**10/40 FOODS**

NO CLAIM IS MADE TO THE EXCLUSIVE RIGHT TO USE FOODS, APART FROM THE MARK AS SHOWN.

FOR DRIED SHRIMP; SMOKED FISH; PROCESSED EDIBLE SEEDS, PROCESSED NUTS, PROCESSED CASAVA, SEAFOOD, PROCESSED BEANS AND PROCESSED YAMS (U.S. CL. 46).

FIRST USE 10-16-2006; IN COMMERCE 10-16-2006.

**CLASS 29—(Continued).**

3,234,200. HORIZON PRODUCTS, LLC, UNIVERSITY HEIGHTS, OH. SN 78-345,129. PUB. 6-6-2006, FILED 12-23-2003.

**IRISH BURGER**

THE MARK CONSISTS OF STANDARD CHARACTERS WITHOUT CLAIM TO ANY PARTICULAR FONT, STYLE, SIZE, OR COLOR.

NO CLAIM IS MADE TO THE EXCLUSIVE RIGHT TO USE BURGER, APART FROM THE MARK AS SHOWN.

FOR MEAT PATTIES IN THE CONFIGURATION OF A SHAMROCK (U.S. CL. 46).

FIRST USE 3-17-2005; IN COMMERCE 3-17-2005.

---

3,234,310. WAINER, JESSE ILAN, SANTA MONICA, CA. SN 78-424,852. PUB. 9-27-2005, FILED 5-25-2004.

**NEXT GENERATION GOURMET**

THE MARK CONSISTS OF STANDARD CHARACTERS WITHOUT CLAIM TO ANY PARTICULAR FONT, STYLE, SIZE, OR COLOR.

NO CLAIM IS MADE TO THE EXCLUSIVE RIGHT TO USE "GOURMET", APART FROM THE MARK AS SHOWN.

FOR FROZEN, PREPARED AND PACKAGED MEALS CONSISTING PRIMARILY OF SOY, MEAT SUBSTITUTES, POULTRY SUBSTITUTES AND FISH SUBSTITUTES MADE FROM SOY, VEGETABLES, AND GRAINS (U.S. CL. 46).

FIRST USE 8-0-2004; IN COMMERCE 8-0-2004.

---

3,234,352. ACH FOOD COMPANIES, INC., CORDOVA, TN. SN 78-450,024. PUB. 9-20-2005, FILED 7-13-2004.

**CAPULLO DE MAZOLA**

THE MARK CONSISTS OF STANDARD CHARACTERS WITHOUT CLAIM TO ANY PARTICULAR FONT, STYLE, SIZE, OR COLOR.

OWNER OF U.S. REG. NOS. 83,639, 1,172,467, AND

**CLASS 29—(Continued).**

OTHERS.

THE ENGLISH TRANSLATION OF THE MARK CAPULLO DE MAZOLA IS "COCOON OR FLOWER BUD OF MAZOLA."

FOR EDIBLE OILS (U.S. CL. 46).  
FIRST USE 9-1-2004; IN COMMERCE 9-1-2004.

---

3,234,355. ACH FOOD COMPANIES, INC., CORDOVA, TN.  
SN 78-451,494. PUB. 9-20-2005, FILED 7-15-2004.



OWNER OF U.S. REG. NOS. 721,414, 1,172,467, AND OTHERS.

THE COLORS RED, GREEN AND GOLD ARE CLAIMED AS A FEATURE OF THE MARK.

THE COLOR RED APPEARS IN THE FLOWER AND THE WORDING CAPULLO DE. THE COLOR GREEN APPEARS IN THE LEAVES AND THE WORD MAZOLA. THE COLOR GOLD APPEARS IN THE OUTLINE OF THE WORD MAZOLA.

THE ENGLISH TRANSLATION OF THE WORD CAPULLO IN THE MARK IS "COCOON OR FLOWER BUD."

FOR EDIBLE OILS (U.S. CL. 46).  
FIRST USE 9-1-2004; IN COMMERCE 9-1-2004.

---

3,234,426. PERDUE HOLDINGS, INC., WILMINGTON, DE.  
SN 78-487,560. PUB. 9-13-2005, FILED 9-22-2004.

**PERFECT ROAST**

THE MARK CONSISTS OF STANDARD CHARACTERS WITHOUT CLAIM TO ANY PARTICULAR FONT, STYLE, SIZE, OR COLOR.

NO CLAIM IS MADE TO THE EXCLUSIVE RIGHT TO USE "ROAST", APART FROM THE MARK AS SHOWN.

FOR FRESH POULTRY WITH A TEMPERATURE GAUGE INCORPORATED THEREIN (U.S. CL. 46).  
FIRST USE 3-1-2006; IN COMMERCE 3-1-2006.

**CLASS 29—(Continued).**

3,234,469. COOPERATIVA DE PRODUCTORES DE LECHE DOSPINOS, R.L., ALAJUELA, COSTA RICA. SN 78-503,448. PUB. 3-14-2006, FILED 10-21-2004.



THE FOREIGN WORDING IN THE MARK TRANSLATES INTO ENGLISH AS "TWO PINES" AND "LITTLE PINE".

FOR MILK, POWDERED MILK, AND DRINKS WITH A MILK BASE (U.S. CL. 46).  
FIRST USE 11-0-1993; IN COMMERCE 3-0-2002.

---

3,234,658. TROPICANA PRODUCTS, INC., BRADENTON, FL. SN 78-567,004. PUB. 11-15-2005, FILED 2-14-2005.

**TROPICANA  
FRUITWISE**

THE MARK CONSISTS OF STANDARD CHARACTERS WITHOUT CLAIM TO ANY PARTICULAR FONT, STYLE, SIZE, OR COLOR.

OWNER OF U.S. REG. NOS. 630,572, 2,510,655, AND OTHERS.

FOR FRUIT-BASED SNACKS (U.S. CL. 46).  
FIRST USE 9-30-2005; IN COMMERCE 9-30-2005.

---

3,234,664. HARE, SCOTT, BELLEVILLE, WI. AND HARE, LISA, BELLEVILLE, WI. SN 78-569,916. PUB. 12-27-2005, FILED 2-17-2005.

**WILD HARE**

**CLASS 29—(Continued).**

THE MARK CONSISTS OF STANDARD CHARACTERS WITHOUT CLAIM TO ANY PARTICULAR FONT, STYLE, SIZE, OR COLOR.

FOR BEEF JERKY, BEEF JERKY IN STICK FORM, DAIRY-BASED DIPS, GARLIC-BASED SPREADS, LUNCHEON MEATS, MEAT-BASED SPREADS, PORK RINDS, POTATO CHIPS, PROTEINS FOR USE AS FOOD ADDITIVES AND VEGETABLE-BASED SPREADS, SALAMI, SAUSAGES (U.S. CL. 46).

FIRST USE 4-15-2003; IN COMMERCE 11-17-2005.

---

3,234,678. SEASOURCE, INC., MORRISTOWN, NJ. SN 78-576,324. PUB. 11-29-2005, FILED 2-28-2005.

## Moon Tide The Finest Products From The Sea

THE MARK CONSISTS OF STANDARD CHARACTERS WITHOUT CLAIM TO ANY PARTICULAR FONT, STYLE, SIZE, OR COLOR.

NO CLAIM IS MADE TO THE EXCLUSIVE RIGHT TO USE THE FINEST PRODUCTS FROM THE SEA, APART FROM THE MARK AS SHOWN.

FOR FRUIT AND VEGETABLE SALADS (U.S. CL. 46).  
FIRST USE 5-1-2006; IN COMMERCE 5-1-2006.

---

3,234,801. VERDE YAG BESIN MADDELERI SANAYII VE TICARET ANONIM SIRKETI, IZMIR, TURKEY. SN 78-621,896. PUB. 1-24-2006, FILED 5-3-2005.

## VERDOLIO

THE MARK CONSISTS OF STANDARD CHARACTERS WITHOUT CLAIM TO ANY PARTICULAR FONT, STYLE, SIZE, OR COLOR.

FOR EDIBLE OILS, EDIBLE FATS, OLIVE OIL (U.S. CL. 46).

FIRST USE 7-0-2006; IN COMMERCE 7-0-2006.

**CLASS 29—(Continued).**

3,234,807. SUPREME OIL COMPANY, ENGLEWOOD, NJ. SN 78-623,774. PUB. 3-21-2006, FILED 5-5-2005.



NO CLAIM IS MADE TO THE EXCLUSIVE RIGHT TO USE "WHIPPED MARGARINE", APART FROM THE MARK AS SHOWN.

THE COLORS RED, YELLOW, WHITE AND BLUE IS/ARE CLAIMED AS A FEATURE OF THE MARK.

THE COLOR RED APPEARS IN THE WORDING SPRING LAKES WHIPPED MARGARINE, THE COLORS BLUE AND WHITE APPEAR IN THE DESIGN PORTION COMPRISING A FARM SCENE AND THE COLOR YELLOW APPEARS IN THE CIRCULAR BORDER.

FOR MARGARINE, EDIBLE OILS, BUTTER (U.S. CL. 46).

FIRST USE 12-30-2005; IN COMMERCE 12-30-2005.

---

3,235,101. THE FEDERATED GROUP, INC., ARLINGTON HEIGHTS, IL. SN 78-674,482. PUB. 3-28-2006, FILED 7-20-2005.

## SMOOTH MELT

THE MARK CONSISTS OF STANDARD CHARACTERS WITHOUT CLAIM TO ANY PARTICULAR FONT, STYLE, SIZE, OR COLOR.

FOR PROCESSED CHEESE (U.S. CL. 46).

FIRST USE 1-25-2005; IN COMMERCE 8-8-2005.

**CLASS 29—(Continued).**

3,235,145. KABUSHIKI KAISHA ONSUI, NIIGATA, JAPAN.  
SN 78-688,248. PUB. 4-25-2006, FILED 8-9-2005.

# CHO-REI-KUN

THE MARK CONSISTS OF STANDARD CHARACTERS WITHOUT CLAIM TO ANY PARTICULAR FONT, STYLE, SIZE, OR COLOR.

OWNER OF U.S. REG. NO. 2,915,719.  
FOR FISH; MEATS; PROCESSED BEANS; SLICED VEGETABLES FRESH, CANNED, OR BOTTLED; AND EGGS (U.S. CL. 46).  
FIRST USE 10-0-2005; IN COMMERCE 10-0-2005.

---

3,235,209. PIZZERIA UNO CORPORATION, WILMINGTON, DE. SN 78-713,828. PUB. 6-20-2006, FILED 9-15-2005.

# MRS. O'LEARY'S CLAM CHOWDER

THE MARK CONSISTS OF STANDARD CHARACTERS WITHOUT CLAIM TO ANY PARTICULAR FONT, STYLE, SIZE, OR COLOR.

NO CLAIM IS MADE TO THE EXCLUSIVE RIGHT TO USE "CLAM CHOWDER", APART FROM THE MARK AS SHOWN.

THE NAME SHOWN IN THE MARK DOES NOT IDENTIFY A PARTICULAR LIVING INDIVIDUAL.  
FOR CHOWDER FOR CONSUMPTION ON OR OFF THE PREMISES (U.S. CL. 46).  
FIRST USE 9-25-2005; IN COMMERCE 9-25-2005.

---

3,235,350. REMA FOODS, INC., ENGLEWOOD CLIFFS, NJ. SN 78-776,068. PUB. 8-22-2006, FILED 12-19-2005.

# REMA RESERVE

THE MARK CONSISTS OF STANDARD CHARACTERS WITHOUT CLAIM TO ANY PARTICULAR FONT, STYLE, SIZE, OR COLOR.

OWNER OF U.S. REG. NOS. 2,103,538 AND 2,215,125.  
FOR FRUITS, NAMELY, PROCESSED PINEAPPLES (U.S. CL. 46).  
FIRST USE 3-31-2006; IN COMMERCE 3-31-2006.

---

**CLASS 30—STAPLE FOODS**

**CLASS 30—(Continued).**

3,233,781. DISNEY ENTERPRISES, INC., BURBANK, CA. SN 76-351,128. PUB. 9-23-2003, FILED 12-19-2001.

# DISNEY

OWNER OF U.S. REG. NOS. 1,162,727, 2,475,160, AND OTHERS.  
SEC. 2(F).  
FOR BREAKFAST CEREALS AND PASTRY (U.S. CL. 46).  
FIRST USE 0-0-2003; IN COMMERCE 0-0-2003.

---

3,233,795. HEB GROCERY COMPANY, LP, SAN ANTONIO, TX. SN 76-402,024. PUB. 8-19-2003, FILED 5-1-2002.

# H•E•BUDDY

FOR COOKIES; GRAHAM CRACKERS; POWDERS FOR FLAVORING MILK; FLAVORED, SWEETENED GELATIN DESSERTS; PUDDING; BREAD; FLAVORING SYRUPS; COCOA MIXES; PREPARED READY-TO-EAT MEALS CONSISTING PRIMARILY OF MACARONI AND CHEESE OR PEANUT BUTTER AND JELLY SANDWICH; READY-TO-EAT AND READY-TO-COOK PASTA AND MACARONI AND CHEESE (U.S. CL. 46).  
FIRST USE 5-20-2002; IN COMMERCE 5-20-2002.

---

3,233,928. QC PROPERTIES COMPANY, LLC, CHICAGO, IL. SN 76-602,450. PUB. 10-11-2005, FILED 7-15-2004.

# QC FOODS

THE MARK CONSISTS OF STANDARD CHARACTERS WITHOUT CLAIM TO ANY PARTICULAR FONT, STYLE, SIZE, OR COLOR.

NO CLAIM IS MADE TO THE EXCLUSIVE RIGHT TO USE "FOODS", APART FROM THE MARK AS SHOWN.

FOR CROUTONS; STUFFING CONSISTING OF BREAD; SHRED WHICH IS A FORM OF BREAD STUFFING; DRIED BREAD; BREAD BATTERS; SPICES, NAMELY SPICE BLENDS FOR CROUTONS AND STUFFING NOT INCLUDING RETAIL SALES (U.S. CL. 46).  
FIRST USE 11-9-2006; IN COMMERCE 11-9-2006.

**CLASS 30—(Continued).**

3,233,985. FOOD FASHION DESIGNS, INC., SANTA MONICA, CA. SN 76-620,181. PUB. 2-14-2006, FILED 11-12-2004.

**DIM SUM ESSENCE**

THE MARK CONSISTS OF STANDARD CHARACTERS WITHOUT CLAIM TO ANY PARTICULAR FONT, STYLE, SIZE, OR COLOR.

NO CLAIM IS MADE TO THE EXCLUSIVE RIGHT TO USE DIM SUM, APART FROM THE MARK AS SHOWN. FOR SAUCES FOR ASIAN FOODS (U.S. CL. 46). FIRST USE 11-1-2005; IN COMMERCE 11-1-2005.

3,233,990. LY BROTHERS CORPORATION, SAN FRANCISCO, CA. SN 76-622,209. PUB. 9-27-2005, FILED 11-26-2004.



NO CLAIM IS MADE TO THE EXCLUSIVE RIGHT TO USE "CORPORATION", APART FROM THE MARK AS SHOWN.

FOR BAKERY GOODS (U.S. CL. 46). FIRST USE 6-22-2006; IN COMMERCE 6-22-2006.

3,234,072. SAGEE USA GROUP INC., ROWLAND HTS., CA. SN 76-648,181. PUB. 8-1-2006, FILED 10-11-2005.

**SALISS**

THE MARK CONSISTS OF STANDARD CHARACTERS WITHOUT CLAIM TO ANY PARTICULAR FONT, STYLE, SIZE, OR COLOR.

FOR DIETARY TEA FOR NON-MEDICAL PURPOSES (U.S. CL. 46). FIRST USE 11-1-2006; IN COMMERCE 11-1-2006.

**CLASS 30—(Continued).**

3,234,083. FL FOOD LION, INC., SALISBURY, NC. SN 76-978,451. PUB. 2-8-2005, FILED 8-16-2004.



THE ENGLISH TRANSLATION OF SIERRA MADRE IS "MOTHER MOUNTAIN RANGE".

FOR TACO WRAPPERS, AND BURRITO WRAPPERS (U.S. CL. 46). FIRST USE 7-23-2006; IN COMMERCE 7-23-2006.

3,234,092. CONAGRA FOODS, INC., OMAHA, NE. SN 76-978,484. PUB. 1-31-2006, FILED 9-17-2004.

**ULTRAGRAIN**

THE MARK CONSISTS OF STANDARD CHARACTERS WITHOUT CLAIM TO ANY PARTICULAR FONT, STYLE, SIZE, OR COLOR.

OWNER OF U.S. REG. NO. 2,921,828. FOR FLOUR (U.S. CL. 46). FIRST USE 7-23-2004; IN COMMERCE 7-23-2004.

3,234,124. THE KAHLUA COMPANY, WILMINGTON, DE. SN 78-207,552. PUB. 9-2-2003, FILED 1-27-2003.

**KAHLUA**

FOR SAUCES, COFFEE CONCENTRATE, CAPPUCCINO MIX (U.S. CL. 46). FIRST USE 12-31-2004; IN COMMERCE 12-31-2004.



**CLASS 30—(Continued).**

3,234,181. PIERRE, DANIEL, BUHL-LORRAINE, FRANCE.  
SN 78-327,109. PUB. 8-23-2005, FILED 11-12-2003.



THE NAME MAITRE PIERRE DOES NOT IDENTIFY A LIVING INDIVIDUAL.  
THE FOREIGN WORDING IN THE MARK TRANSLATES INTO ENGLISH AS MASTER.  
FOR TARTS, BREAKFAST CEREALS, PROCESSED CEREALS; BREAD; SALT AND SWEET PIE BASED FILLINGS FOR PIES; FLAMBEED TARTS; PIZZAS; FROZEN BAKED PIES FILLED WITH BEEF, FISH, POULTRY OR GAME; FRUIT PIES; VEGETABLE PIES (U.S. CL. 46).  
FIRST USE 11-10-2006; IN COMMERCE 11-10-2006.

3,234,275. REDDY ICE CORPORATION, DALLAS, TX. SN 78-403,918. PUB. 10-11-2005, FILED 4-19-2004.

**CRYSTAL CLASSIC  
CUBES**

THE MARK CONSISTS OF STANDARD CHARACTERS WITHOUT CLAIM TO ANY PARTICULAR FONT, STYLE, SIZE, OR COLOR.  
NO CLAIM IS MADE TO THE EXCLUSIVE RIGHT TO USE CUBES, APART FROM THE MARK AS SHOWN.  
FOR ICE (U.S. CL. 46).  
FIRST USE 5-0-2004; IN COMMERCE 5-0-2004.

**CLASS 30—(Continued).**

3,234,276. REDDY ICE CORPORATION, DALLAS, TX. SN 78-403,924. PUB. 9-27-2005, FILED 4-19-2004.



NO CLAIM IS MADE TO THE EXCLUSIVE RIGHT TO USE CUBES, ICE AND GOURMET ICE CUBES, APART FROM THE MARK AS SHOWN.  
FOR ICE (U.S. CL. 46).  
FIRST USE 5-0-2004; IN COMMERCE 5-0-2004.

3,234,391. SEATTLE'S BEST COFFEE, LLC, SEATTLE, WA. SN 78-475,750. PUB. 2-21-2006, FILED 8-30-2004.

**AUTUMN RESERVE**

THE MARK CONSISTS OF STANDARD CHARACTERS WITHOUT CLAIM TO ANY PARTICULAR FONT, STYLE, SIZE, OR COLOR.  
FOR COFFEE, WHOLE BEAN AND GROUND; NON-ALCOHOLIC BEVERAGES MADE WITH A BASE OF COFFEE (U.S. CL. 46).  
FIRST USE 9-30-2002; IN COMMERCE 9-30-2002.

3,234,441. SILVER JOE'S CORPORATION, DBA SILVER JOE'S COFFEE COMPANY, FORT SMITH, AR. SN 78-493,781. PUB. 9-13-2005, FILED 10-4-2004.

**SILVER JOE'S**

THE MARK CONSISTS OF STANDARD CHARACTERS WITHOUT CLAIM TO ANY PARTICULAR FONT, STYLE, SIZE, OR COLOR.

**CLASS 30—(Continued).**

THE NAME SILVER JOE'S DOES NOT IDENTIFY A LIVING INDIVIDUAL.  
FOR COFFEE (U.S. CL. 46).  
FIRST USE 6-26-2006; IN COMMERCE 6-26-2006.

**CLASS 30—(Continued).**

3,234,508. GRADY, PATRICIA DRUMM, SPRINGFIELD CENTER, NY. SN 78-515,306. PUB. 11-15-2005, FILED 11-11-2004.

3,234,443. FOUR U LU 2, INC, SAYVILLE, NY. SN 78-494,173.  
PUB. 3-14-2006, FILED 10-4-2004.



THE COLOR(S) RED AND YELLOW IS/ARE CLAIMED AS A FEATURE OF THE MARK.

THE MARK CONSISTS OF THE COLOR RED APPEARS IN THE WORDING OF THE MARK AND THE DESIGN OF A GIRL'S FACE, THE COLOR YELLOW APPEARS IN THE BACKGROUND OF THE MARK.

FOR BAKED PRODUCTS, NAMELY, MUFFINS, COOKIES AND BAKERY GOODS (U.S. CL. 46).  
FIRST USE 9-0-2005; IN COMMERCE 9-0-2005.



NO CLAIM IS MADE TO THE EXCLUSIVE RIGHT TO USE "COOPERSTOWN COOKIE COMPANY", APART FROM THE MARK AS SHOWN.

THE MARK CONSISTS OF AN IMAGE OF A BASEBALL WITH STITCHING FEATURING THE WORDS COOPERSTOWN COOKIE COMPANY IN THE CENTER OF THE BALL.

FOR BAKERY GOODS (U.S. CL. 46).  
FIRST USE 11-1-2004; IN COMMERCE 11-1-2004.

3,234,455. 7-ELEVEN, INC., DALLAS, TX. SN 78-499,038. PUB. 3-7-2006, FILED 10-13-2004.

## 7-PACIFIC ROAST

THE MARK CONSISTS OF STANDARD CHARACTERS WITHOUT CLAIM TO ANY PARTICULAR FONT, STYLE, SIZE, OR COLOR.

NO CLAIM IS MADE TO THE EXCLUSIVE RIGHT TO USE ROAST, APART FROM THE MARK AS SHOWN.

FOR GROUND AND WHOLE BEAN COFFEE; AND COFFEE FOR CONSUMPTION ON OR OFF THE PREMISES (U.S. CL. 46).

FIRST USE 11-8-2004; IN COMMERCE 11-8-2004.

3,234,544. CAFES RICHARD, 92230 GENNEVILLIES, FRANCE. SN 78-526,003. PUB. 3-14-2006, FILED 12-2-2004.

## FLOR FINA

THE MARK CONSISTS OF STANDARD CHARACTERS WITHOUT CLAIM TO ANY PARTICULAR FONT, STYLE, SIZE, OR COLOR.

THE FOREIGN WORDING IN THE MARK TRANSLATES INTO ENGLISH AS "EXQUISITE FLOWER".

FOR COFFEE (U.S. CL. 46).

FIRST USE 3-31-2006; IN COMMERCE 3-31-2006.

**CLASS 30—(Continued).**

3,234,595. ROSEANNE GULLO, PLANO, TX. SN 78-539,001. PUB. 10-25-2005, FILED 12-28-2004.

**CLASS 30—(Continued).**

3,234,745. SOUTHERN FRIED ICE CREAM, LLC, HOMO-SASSA, FL. SN 78-600,088. PUB. 3-7-2006, FILED 4-1-2005.

### Four Sisters and a Brother

### SOUTHERN FRIED ICE CREAM

THE MARK CONSISTS OF STANDARD CHARACTERS WITHOUT CLAIM TO ANY PARTICULAR FONT, STYLE, SIZE, OR COLOR.  
FOR FOOD PRODUCTS, NAMELY, BREAD CRUMBS (U.S. CL. 46).  
FIRST USE 1-19-2005; IN COMMERCE 7-1-2005.

THE MARK CONSISTS OF STANDARD CHARACTERS WITHOUT CLAIM TO ANY PARTICULAR FONT, STYLE, SIZE, OR COLOR.  
NO CLAIM IS MADE TO THE EXCLUSIVE RIGHT TO USE "FRIED ICE CREAM", APART FROM THE MARK AS SHOWN.  
FOR FROZEN DESSERTS, NAMELY, COATED ICE CREAM (U.S. CL. 46).  
FIRST USE 3-28-2006; IN COMMERCE 3-28-2006.

3,234,698. CHOCOLAFABRIKEN LINDT & SPRUNGLI A.G., KILCHBERG, SWITZERLAND. SN 78-583,507. PUB. 3-14-2006, FILED 3-9-2005.

3,234,765. THE KROGER CO. OF MICHIGAN, LIVONIA, MI. SN 78-606,332. PUB. 5-9-2006, FILED 4-11-2005.

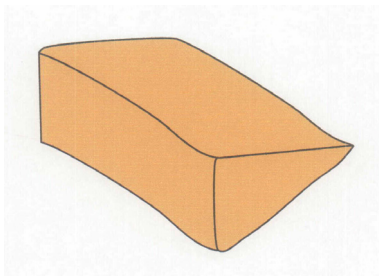

### ACTIVE LIFESTYLE

THE COLOR(S) GOLD IS/ARE CLAIMED AS A FEATURE OF THE MARK.  
THE MARK CONSISTS OF THE CONFIGURATION OF A FOIL WRAPPED CHOCOLATE CANDY. THE CONFIGURATION IS TRIANGULAR AND TENT-SHAPED. THE COLOR GOLD APPEARS OVER THE ENTIRE CONFIGURATION MARK.  
FOR CHOCOLATE (U.S. CL. 46).  
FIRST USE 10-31-1978; IN COMMERCE 10-31-1978.

THE MARK CONSISTS OF STANDARD CHARACTERS WITHOUT CLAIM TO ANY PARTICULAR FONT, STYLE, SIZE, OR COLOR.  
FOR BREAKFAST CEREALS (U.S. CL. 46).  
FIRST USE 7-10-2005; IN COMMERCE 7-10-2005.

**CLASS 30—(Continued).**

3,234,779. MINOM, INC., SAN ANTONIO, TX. SN 78-613,098.  
PUB. 2-14-2006, FILED 4-20-2005.



FOR BAKING PRODUCTS, NAMELY, FLOUR, ALL PURPOSE FLOUR, WHEAT FLOUR, FLOUR TORTILLA MIX, AND CORN TORTILLA MIX; READY TO EAT TORTILLAS; TACO SHELLS; TOSTADA SHELLS; FROZEN TORTILLA DOUGH; TAMALES; SALSA; SEASONINGS, SEASONING BLENDS, SPICES, AND SPICE BLENDS (U.S. CL. 46).

FIRST USE 6-6-2006; IN COMMERCE 6-6-2006.

**CLASS 30—(Continued).**

3,234,921. ANHEUSER-BUSCH, INCORPORATED, ST. LOUIS, MO. SN 78-649,498. PUB. 3-7-2006, FILED 6-13-2005.

## SPYKES

THE MARK CONSISTS OF STANDARD CHARACTERS WITHOUT CLAIM TO ANY PARTICULAR FONT, STYLE, SIZE, OR COLOR.

FOR FLAVORING ADDITIVES FOR MALT BEVERAGES (U.S. CL. 46).

FIRST USE 10-22-2005; IN COMMERCE 10-22-2005.

3,234,951. WM. WRIGLEY JR. COMPANY, CHICAGO, IL. SN 78-652,983. PUB. 3-14-2006, FILED 6-17-2005.

## INFERNO

THE MARK CONSISTS OF STANDARD CHARACTERS WITHOUT CLAIM TO ANY PARTICULAR FONT, STYLE, SIZE, OR COLOR.

FOR CONFECTIONERY, NAMELY, CHEWING GUM, BUBBLEGUM, CANDY AND MINTS (U.S. CL. 46).

FIRST USE 1-1-2006; IN COMMERCE 1-1-2006.

3,234,909. KRAFT FOODS HOLDINGS, INC., NORTHFIELD, IL. SN 78-646,955. PUB. 2-28-2006, FILED 6-9-2005.



OWNER OF U.S. REG. NOS. 528,074, 1,091,036, AND OTHERS.

NO CLAIM IS MADE TO THE EXCLUSIVE RIGHT TO USE "FRESH", "NUT" AND "PEANUT", APART FROM THE MARK AS SHOWN.

FOR CHOCOLATE COVERED NUTS (U.S. CL. 46).  
FIRST USE 1-0-2005; IN COMMERCE 1-0-2005.

3,234,967. FISCHER & WIESER SPECIALTY FOODS, INC., FREDERICKSBURG, TX. SN 78-654,440. PUB. 3-14-2006, FILED 6-20-2005.

## MOM'S MARTINI PASTA SAUCE

THE MARK CONSISTS OF STANDARD CHARACTERS WITHOUT CLAIM TO ANY PARTICULAR FONT, STYLE, SIZE, OR COLOR.

NO CLAIM IS MADE TO THE EXCLUSIVE RIGHT TO USE "MARTINI PASTA SAUCE", APART FROM THE MARK AS SHOWN.

FOR PASTA SAUCE (U.S. CL. 46).  
FIRST USE 1-1-2005; IN COMMERCE 7-1-2005.

**CLASS 30—(Continued).**

3,235,001. SWEET CANDY COMPANY, SALT LAKE CITY, UT. SN 78-659,319. PUB. 3-21-2006, FILED 6-27-2005.



FOR CANDY (U.S. CL. 46).  
FIRST USE 6-1-2006; IN COMMERCE 6-1-2006.

3,235,078. KELLOGG NORTH AMERICA COMPANY, BATTLE CREEK, MI. SN 78-669,487. PUB. 4-11-2006, FILED 7-13-2005.

**TOWN HOUSE TOPPERS**

THE MARK CONSISTS OF STANDARD CHARACTERS WITHOUT CLAIM TO ANY PARTICULAR FONT, STYLE, SIZE, OR COLOR.  
OWNER OF U.S. REG. NOS. 587,813 AND 2,896,257.  
FOR CRACKERS, CRACKER SANDWICHES, COOKIES (U.S. CL. 46).  
FIRST USE 6-19-2006; IN COMMERCE 6-19-2006.

3,235,142. FARLEY'S & SATHERS CANDY COMPANY, INC., ROUND LAKE, MN. SN 78-687,325. PUB. 5-2-2006, FILED 8-7-2005.



OWNER OF U.S. REG. NOS. 1,242,236 AND 2,399,062.  
NO CLAIM IS MADE TO THE EXCLUSIVE RIGHT TO USE "BUBBLE GUM BALLS" AND "ASSORTED FLAVORS", APART FROM THE MARK AS SHOWN.  
FOR BUBBLE GUM (U.S. CL. 46).  
FIRST USE 1-30-2006; IN COMMERCE 1-30-2006.

**CLASS 30—(Continued).**

3,235,143. FARLEY'S & SATHERS CANDY COMPANY, INC., ROUND LAKE, MN. SN 78-687,327. PUB. 5-2-2006, FILED 8-7-2005.

**SUPER BUBBLE XL**

THE MARK CONSISTS OF STANDARD CHARACTERS WITHOUT CLAIM TO ANY PARTICULAR FONT, STYLE, SIZE, OR COLOR.  
OWNER OF U.S. REG. NOS. 504,862 AND 882,574.  
NO CLAIM IS MADE TO THE EXCLUSIVE RIGHT TO USE "BUBBLE XL", APART FROM THE MARK AS SHOWN.  
FOR BUBBLE GUM (U.S. CL. 46).  
FIRST USE 2-0-2005; IN COMMERCE 2-0-2005.

3,235,149. FLOREZ, STAN R., BONNEY LAKE, WA. SN 78-690,223. PUB. 5-2-2006, FILED 8-11-2005.

**PURGATORY  
"the in-between state"**

THE MARK CONSISTS OF STANDARD CHARACTERS WITHOUT CLAIM TO ANY PARTICULAR FONT, STYLE, SIZE, OR COLOR.  
NO CLAIM IS MADE TO THE EXCLUSIVE RIGHT TO USE "PURGATORY", APART FROM THE MARK AS SHOWN.  
FOR CHILI POWDERS; CHILI SAUCE; CHILI SEASONING; DRIED CHILI PEPPERS FOR USE AS A SEASONING; SALSA (U.S. CL. 46).  
FIRST USE 10-25-2006; IN COMMERCE 10-25-2006.

3,235,168. UNILEVER SUPPLY CHAIN, INC., CLINTON, CT. SN 78-695,401. PUB. 5-9-2006, FILED 8-18-2005.

**SALAD SPRITZERS**

THE MARK CONSISTS OF STANDARD CHARACTERS WITHOUT CLAIM TO ANY PARTICULAR FONT, STYLE, SIZE, OR COLOR.  
NO CLAIM IS MADE TO THE EXCLUSIVE RIGHT TO USE "SALAD", APART FROM THE MARK AS SHOWN.  
FOR SALAD DRESSINGS (U.S. CL. 46).  
FIRST USE 3-0-2006; IN COMMERCE 3-0-2006.

**CLASS 30—(Continued).**

3,235,170. SHONEY'S, LLC, NASHVILLE, TN. SN 78-696,075.  
PUB. 5-2-2006, FILED 8-19-2005.

**BIG GRIZZLY**

THE MARK CONSISTS OF STANDARD CHARACTERS WITHOUT CLAIM TO ANY PARTICULAR FONT, STYLE, SIZE, OR COLOR.

FOR SANDWICHES, NAMELY, HAMBURGERS, CHEESEBURGERS AND SPECIALTY SANDWICHES (U.S. CL. 46).

FIRST USE 9-26-2005; IN COMMERCE 9-26-2005.

**CLASS 30—(Continued).**

3,235,266. CHURNY COMPANY, INC., NORTHFIELD, IL. SN 78-740,547. PUB. 7-4-2006, FILED 10-26-2005.

**ATHENOS**

THE MARK CONSISTS OF STANDARD CHARACTERS WITHOUT CLAIM TO ANY PARTICULAR FONT, STYLE, SIZE, OR COLOR.

OWNER OF U.S. REG. NOS. 2,135,096, 2,193,825, AND 2,821,307.

FOR PITA CHIPS (U.S. CL. 46).

FIRST USE 3-13-2006; IN COMMERCE 3-13-2006.

3,235,171. SHONEY'S NORTH AMERICA CORPORATION, ATLANTA, GA. SN 78-696,077. PUB. 5-2-2006, FILED 8-19-2005.

**GRIZZLY**

THE MARK CONSISTS OF STANDARD CHARACTERS WITHOUT CLAIM TO ANY PARTICULAR FONT, STYLE, SIZE, OR COLOR.

FOR SANDWICHES, NAMELY, HAMBURGERS, CHEESEBURGERS AND SPECIALTY SANDWICHES (U.S. CL. 46).

FIRST USE 9-26-2005; IN COMMERCE 9-26-2005.

3,235,275. HERSHEY CHOCOLATE & CONFECTIONERY CORP., WHEAT RIDGE, CO. SN 78-746,116. PUB. 7-4-2006, FILED 11-3-2005.

**DOUBLE BLASTS**

THE MARK CONSISTS OF STANDARD CHARACTERS WITHOUT CLAIM TO ANY PARTICULAR FONT, STYLE, SIZE, OR COLOR.

FOR CANDY (U.S. CL. 46).

FIRST USE 6-1-2006; IN COMMERCE 6-1-2006.

3,235,211. MALT-O-MEAL COMPANY, MINNEAPOLIS, MN. SN 78-714,296. PUB. 6-13-2006, FILED 9-16-2005.

**MATEYS**

THE MARK CONSISTS OF STANDARD CHARACTERS WITHOUT CLAIM TO ANY PARTICULAR FONT, STYLE, SIZE, OR COLOR.

OWNER OF U.S. REG. NO. 1,888,006.

FOR BREAKFAST CEREAL (U.S. CL. 46).

FIRST USE 10-12-1993; IN COMMERCE 10-12-1993.

3,235,290. PF BRANDS, INC., NEWARK, DE. SN 78-755,762. PUB. 8-8-2006, FILED 11-17-2005.

**THE ART OF THE COOKIE**

THE MARK CONSISTS OF STANDARD CHARACTERS WITHOUT CLAIM TO ANY PARTICULAR FONT, STYLE, SIZE, OR COLOR.

NO CLAIM IS MADE TO THE EXCLUSIVE RIGHT TO USE "COOKIE", APART FROM THE MARK AS SHOWN.

FOR COOKIES (U.S. CL. 46).

FIRST USE 3-31-2006; IN COMMERCE 3-31-2006.

**CLASS 30—(Continued).**

3,235,344. ALEXIA FOODS, INC., BROOKLYN, NY. SN 78-771,155. PUB. 6-13-2006, FILED 12-12-2005.

**ALEXIA PIZZA SNACKS**

THE MARK CONSISTS OF STANDARD CHARACTERS WITHOUT CLAIM TO ANY PARTICULAR FONT, STYLE, SIZE, OR COLOR.

NO CLAIM IS MADE TO THE EXCLUSIVE RIGHT TO USE "PIZZA SNACKS", APART FROM THE MARK AS SHOWN.

FOR PIZZA SNACKS IN THE NATURE OF PIES, TURNOVERS, POCKET SANDWICHES AND POCKET APPETIZERS, PASTRY SHELLS OF PROCESSED CHEESE, TOMATO SAUCE AND SPICES IN A FLOUR CRUST (U.S. CL. 46).

FIRST USE 7-12-2006; IN COMMERCE 7-12-2006.

3,235,345. SCHWAN'S IP, LLC, MARSHALL, MN. SN 78-771,505. PUB. 7-11-2006, FILED 12-12-2005.

**SCHWAN'S SIGNATURE**

THE MARK CONSISTS OF STANDARD CHARACTERS WITHOUT CLAIM TO ANY PARTICULAR FONT, STYLE, SIZE, OR COLOR.

FOR ICE CREAM AND ICE CREAM NOVELTIES (U.S. CL. 46).

FIRST USE 4-3-2006; IN COMMERCE 4-3-2006.

3,235,369. ZATARAIN'S PARTNERSHIP, L.P., GRETNA, LA. SN 78-791,213. PUB. 9-12-2006, FILED 1-13-2006.

**BIG & ZESTY**

THE MARK CONSISTS OF STANDARD CHARACTERS WITHOUT CLAIM TO ANY PARTICULAR FONT, STYLE, SIZE, OR COLOR.

FOR SEASONINGS (U.S. CL. 46).

FIRST USE 3-30-2006; IN COMMERCE 3-30-2006.

**CLASS 30—(Continued).**

3,235,389. SOCIETE DES PRODUITS NESTLE S.A., 1800 VEVEY, SWITZERLAND. SN 78-977,755. PUB. 1-24-2006, FILED 5-4-2005.

**ROLO**

THE MARK CONSISTS OF STANDARD CHARACTERS WITHOUT CLAIM TO ANY PARTICULAR FONT, STYLE, SIZE, OR COLOR.

OWNER OF U.S. REG. NO. 363,472.

FOR ICE CREAM (U.S. CL. 46).

FIRST USE 3-1-2006; IN COMMERCE 3-1-2006.

**CLASS 31—NATURAL AGRICULTURAL PRODUCTS**

3,233,943. SUN VALLEY GROUP, INC., THE, ARCATA, CA. SN 76-609,257. PUB. 3-14-2006, FILED 8-30-2004.



NO CLAIM IS MADE TO THE EXCLUSIVE RIGHT TO USE "LILIES", APART FROM THE MARK AS SHOWN.

THE LINING IS A FEATURE OF THE MARK.

FOR LIVING PLANTS AND CUT FLOWERS (U.S. CLS. 1 AND 46).

FIRST USE 11-6-2006; IN COMMERCE 11-6-2006.

3,233,970. WHOLE FOODS MARKET IP, L.P., AUSTIN, TX. SN 76-614,414. PUB. 9-6-2005, FILED 10-1-2004.

**WHOLE FIELDS**

THE MARK CONSISTS OF STANDARD CHARACTERS WITHOUT CLAIM TO ANY PARTICULAR FONT, STYLE, SIZE, OR COLOR.

FOR FRESH FRUITS AND VEGETABLES (U.S. CLS. 1 AND 46).

FIRST USE 1-0-2006; IN COMMERCE 1-0-2006.

**CLASS 31—(Continued).**

3,234,185. PLANT SCIENCES, INC., WATSONVILLE, CA. SN 78-329,691. PUB. 8-23-2005, FILED 11-18-2003.

# INTEGRITY

THE MARK CONSISTS OF STANDARD CHARACTERS WITHOUT CLAIM TO ANY PARTICULAR FONT, STYLE, SIZE, OR COLOR.

FOR LIVE PLANTS, FRESH FRUIT, AND ARTI-CHOKE SEED (U.S. CLS. 1 AND 46).

FIRST USE 9-27-2006; IN COMMERCE 11-5-2006.

3,234,459. BARENBRUG USA, INC., TANGENT, OR. SN 78-500,317. PUB. 9-20-2005, FILED 10-15-2004.

# HAYMASTER

THE MARK CONSISTS OF STANDARD CHARACTERS WITHOUT CLAIM TO ANY PARTICULAR FONT, STYLE, SIZE, OR COLOR.

FOR GRASS SEED (U.S. CLS. 1 AND 46).  
FIRST USE 8-0-2006; IN COMMERCE 8-0-2006.

**CLASS 31—(Continued).**

3,234,574. EAGLE PACK PET FOODS, INC., MISHAWAKA, IN. SN 78-532,229. PUB. 3-28-2006, FILED 12-14-2004.

# HOLISTIC SOLUTION

THE MARK CONSISTS OF STANDARD CHARACTERS WITHOUT CLAIM TO ANY PARTICULAR FONT, STYLE, SIZE, OR COLOR.

OWNER OF U.S. REG. NO. 2,754,276.

FOR ANIMAL FOOD (U.S. CLS. 1 AND 46).

FIRST USE 3-1-2005; IN COMMERCE 3-1-2005.

3,234,629. GOLDEN STATE BULB GROWERS, INC., MOSS LANDING, CA. SN 78-550,793. PUB. 11-8-2005, FILED 1-20-2005.



The logo for 'Callaifornia Divas' features the word 'Callaifornia' in a black, cursive script font. The letter 'D' in 'Divas' is significantly larger and stylized, with an orange outline and a green-to-yellow gradient fill. The word 'Divas' is positioned to the right of 'Callaifornia'.

NO CLAIM IS MADE TO THE EXCLUSIVE RIGHT TO USE "CALIFORNIA DIVAS", APART FROM THE MARK AS SHOWN.

THE COLOR(S) ORANGE AND GREEN IS/ARE CLAIMED AS A FEATURE OF THE MARK.

THE COLOR ORANGE APPEARS IN THE UPPER 2/3 OF THE "D" IN THE MARK AND THE COLOR GREEN APPEARS IN THE LOWER 1/3 OF THE "D" IN THE MARK.

THE MARK CONSISTS OF THE WORD CALLAFORNIA DIVAS WITH THE D IN DIVA BEING AN STYLIZED OUTLINE OF A CALLA FLOWER, WHICH IS COLORED.

FOR LIVING PLANTS, LIVE FLOWERING PLANTS, CUT FLOWERS, LIVE FLOWERS, FLOWER BULBS, FLOWER SEEDS (U.S. CLS. 1 AND 46).

FIRST USE 9-16-2005; IN COMMERCE 11-5-2005.



**CLASS 31—(Continued).**

3,234,747. ROSES FOREVER APS, DK-5600 FAABORG, DENMARK. SN 78-600,333. PUB. 2-28-2006, FILED 4-1-2005.



THE MARK IS NOT IN COLOR.  
FOR LIVING PLANTS AND NATURAL FLOWERS  
(U.S. CLS. 1 AND 46).  
FIRST USE 1-0-2002; IN COMMERCE 3-0-2004.

3,234,797. HANNA-BARBERA PRODUCTIONS, INC, BURBANK, CA. SN 78-620,417. PUB. 1-24-2006, FILED 4-29-2005.

**ROGS RUV EM**

THE MARK CONSISTS OF STANDARD CHARACTERS  
WITHOUT CLAIM TO ANY PARTICULAR FONT, STYLE,  
SIZE, OR COLOR.  
FOR PET FOOD; FOODSTUFFS FOR ANIMALS (U.S.  
CLS. 1 AND 46).  
FIRST USE 4-0-2005; IN COMMERCE 4-0-2005.

3,234,824. CHIQUITA BRANDS L.L.C., CINCINNATI, OH. SN 78-627,854. PUB. 1-31-2006, FILED 5-11-2005.

**POTASSIUM POWER**

THE MARK CONSISTS OF STANDARD CHARACTERS  
WITHOUT CLAIM TO ANY PARTICULAR FONT, STYLE,  
SIZE, OR COLOR.  
OWNER OF U.S. REG. NOS. 670,320, 2,422,224, AND  
OTHERS.  
FOR FRESH FRUIT (U.S. CLS. 1 AND 46).  
FIRST USE 12-1-2005; IN COMMERCE 12-1-2005.

**CLASS 31—(Continued).**

3,234,826. MARS, INCORPORATED, MC LEAN, VA. SN 78-627,984. PUB. 1-24-2006, FILED 5-11-2005.

**SCHMACKOS MINI BONES**

THE MARK CONSISTS OF STANDARD CHARACTERS  
WITHOUT CLAIM TO ANY PARTICULAR FONT, STYLE,  
SIZE, OR COLOR.  
NO CLAIM IS MADE TO THE EXCLUSIVE RIGHT TO  
USE MINI BONES, APART FROM THE MARK AS SHOWN.  
FOR PET FOOD (U.S. CLS. 1 AND 46).  
FIRST USE 1-0-2006; IN COMMERCE 1-0-2006.

3,234,877. T.F.H. PUBLICATIONS, INC., NEPTUNE CITY, NJ. SN 78-639,130. PUB. 2-28-2006, FILED 5-27-2005.

**360° POWER ACTION**

THE MARK CONSISTS OF STANDARD CHARACTERS  
WITHOUT CLAIM TO ANY PARTICULAR FONT, STYLE,  
SIZE, OR COLOR.  
FOR EDIBLE PET CHEWS (U.S. CLS. 1 AND 46).  
FIRST USE 12-12-2005; IN COMMERCE 12-12-2005.

3,234,914. CAYMUS VINEYARDS, RUTHERFORD, CA. SN 78-647,968. PUB. 3-21-2006, FILED 6-10-2005.

**ALL NATURAL FROM THE  
INSIDE OUT**

THE MARK CONSISTS OF STANDARD CHARACTERS  
WITHOUT CLAIM TO ANY PARTICULAR FONT, STYLE,  
SIZE, OR COLOR.  
FOR FRESH FRUITS AND VEGETABLES (U.S. CLS. 1  
AND 46).  
FIRST USE 5-30-2006; IN COMMERCE 5-30-2006.

**CLASS 31—(Continued).**

3,234,965. SUN RIVER BERRIES, LLC, YAKIMA, WA. SN 78-654,384. PUB. 3-14-2006, FILED 6-20-2005.

**CLASS 31—(Continued).**

3,235,202. VINTIMILLA ABAD, MARCELO, CUENCA, ECUADOR. SN 78-710,593. PUB. 6-13-2006, FILED 9-11-2005.

## WIND RIVER

THE MARK CONSISTS OF STANDARD CHARACTERS WITHOUT CLAIM TO ANY PARTICULAR FONT, STYLE, SIZE, OR COLOR.

FOR FRESH FRUITS AND VEGETABLES (U.S. CLS. 1 AND 46).

FIRST USE 9-13-2006; IN COMMERCE 9-13-2006.



---

3,235,065. CULLUM SEEDS, LLC, FISHER, AR. SN 78-667,260. PUB. 4-11-2006, FILED 7-11-2005.

## FATAL ATTRACTION

THE MARK CONSISTS OF STANDARD CHARACTERS WITHOUT CLAIM TO ANY PARTICULAR FONT, STYLE, SIZE, OR COLOR.

FOR GRASS SEEDS, WILDLIFE SEED MIXTURES, CROP SEEDS, SEEDS AND BULBS (U.S. CLS. 1 AND 46). FIRST USE 9-1-2006; IN COMMERCE 9-1-2006.

THE APPLICANT CLAIMS COLOR AS A FEATURE OF THE MARK, NAMELY, WHITE, NAVY BLUE, LIGHT BLUE.

THE MARK CONSISTS OF THE WORDS SNOW WHITE IN WHITE STYLIZED LETTERS ON A NAVY BLUE BACKGROUND BELOW OF WHICH APPEARS A LIGHT BLUE WAVE DESIGN. THERE ARE FOUR SNOWFLAKES, A BIGGER WHITE ONE LOCATED TO THE RIGHT OF THE WORD SNOW, A MEDIUM SIZE LIGHT BLUE ONE LOCATED TO THE RIGHT AND SLIGHTLY HIGHER THAN THE WHITE SNOWFLAKE, AND TWO SMALLER LIGHT BLUE SNOWFLAKES, ONE ABOVE THE LETTER W OF THE WORD "SNOW" AND ANOTHER ONE LOCATED TO THE LEFT SIDE OF THE WORD "WHITE".

FOR AGRICULTURAL SEEDS; CROP SEEDS; FLOWER SEEDS; FLOWERS; LIVE FLOWERING PLANTS; LIVE FLOWERS; LIVING PLANTS; PLANT SEEDS; SEEDS FOR FLOWERS (U.S. CLS. 1 AND 46). FIRST USE 8-3-2005; IN COMMERCE 8-3-2005.

**CLASS 31—(Continued).**

3,235,324. PLUM POINT OYSTERS, LLC, NORTH KINGSTOWN, RI. SN 78-765,106. PUB. 8-1-2006, FILED 12-1-2005.

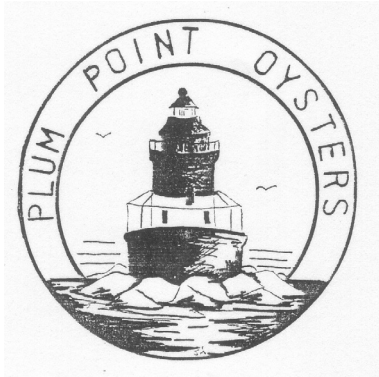

NO CLAIM IS MADE TO THE EXCLUSIVE RIGHT TO USE PLUM POINT OYSTERS, APART FROM THE MARK AS SHOWN.

THE MARK CONSISTS OF A LIGHTHOUSE ON ROCKS SURROUNDED BY WATER AND TWO BIRDS, PARTIALLY ENCLOSED BY TWO CIRCLES. THE WORDING PLUM POINT OYSTERS APPEARS BETWEEN THE TWO CIRCLES.

FOR LIVE OYSTERS (U.S. CLS. 1 AND 46).  
FIRST USE 7-26-2006; IN COMMERCE 7-28-2006.

**CLASS 32—LIGHT BEVERAGES**

3,233,802. SCOTTISH & NEWCASTLE PLC, EDINBURGH EH12 6HX, SCOTLAND. SN 76-437,037. PUB. 4-19-2005, FILED 8-1-2002.

**THE ONE AND ONLY**

FOR BEER; ALE; BITTER TYPE BEER; MILD TYPE BEER (U.S. CLS. 45, 46 AND 48).  
FIRST USE 11-0-1962; IN COMMERCE 11-0-1962.

3,233,863. GOLDEN GAMING, INC., LAS VEGAS, NV. SN 76-548,404. PUB. 3-14-2006, FILED 9-15-2003.

**SIERRA GOLD**

NO CLAIM IS MADE TO THE EXCLUSIVE RIGHT TO USE "GOLD", APART FROM THE MARK AS SHOWN.  
FOR BEER (U.S. CLS. 45, 46 AND 48).  
FIRST USE 10-13-2003; IN COMMERCE 10-13-2003.

**CLASS 32—(Continued).**

3,233,892. TONG CONG TY BIA-RUOU-NUOC GIAI KHAT HA NOI, AKA HANOI BEER-ALCOHOL BEVERAGE CORPORATION, BA DINH DISTRICT, HANOI, VIETNAM. SN 76-584,372. PUB. 6-14-2005, FILED 4-1-2004.



OWNER OF U.S. REG. NO. 3,160,740.

NO CLAIM IS MADE TO THE EXCLUSIVE RIGHT TO USE "BIA HA NOI", APART FROM THE MARK AS SHOWN.

THE WORDS BIA HA NOI, HABECO IS AN ENGLISH ABBREVIATED NAME OF APPLICANT'S BUSINESS AND PRODUCT NAME AND NOT A NAME OF AN INDIVIDUAL.

THE MARK CONSISTS OF THE WORDS BIA HA NOI, HABECO AND DESIGN. THESE WORDS ARE ARRANGED ON A BAND WITH TWO SLIGHT PARALLEL LINE ABOVE AND BELOW. ABOVE THE BAND, THERE IS A FIGURE OF ONE PILLAR PAGODA ARRANGED ON A RECTANGLE WITH THE STYLIZED BOTTOM AND ON BOTH SIDES OF THIS ARE TWO STYLIZED BEARS SHOWN WITH RAISED FRONT LEGS. ABOVE THIS RECTANGLE, THERE ARE FIVE SMALL STARS FORMING AN ARC AND BELOW OF THIS THERE IS THE WORD HABECO WHICH IS AN ABBREVIATED ENGLISH NAME OF THE COMPANY THAT IS PRESENTED ON A BAND WITH TWO ROLLED SIDES. ALL OF THE ABOVEMENTIONED WORDS AND DESIGN ARE ARRANGED WITHIN A STYLIZED SQUARE.

THE FOREIGN WORDING IN THE MARK TRANSLATES INTO ENGLISH AS BEER OF HANOI, HABECO IS AN ABBREVIATION OF THE NAME OF THE COMPANY.  
FOR BEER PRODUCED IN VIETNAM (U.S. CLS. 45, 46 AND 48).

FIRST USE 1-15-2000; IN COMMERCE 10-10-2005.

3,233,978. SANTA FE DINING, INC., SANTA FE, NM. SN 76-616,740. PUB. 9-27-2005, FILED 10-21-2004.

**SLEEPING DOG STOUT**

THE MARK CONSISTS OF STANDARD CHARACTERS WITHOUT CLAIM TO ANY PARTICULAR FONT, STYLE, SIZE, OR COLOR.

NO CLAIM IS MADE TO THE EXCLUSIVE RIGHT TO USE "STOUT", APART FROM THE MARK AS SHOWN.  
FOR BEERS AND ALES (U.S. CLS. 45, 46 AND 48).  
FIRST USE 1-24-2005; IN COMMERCE 1-24-2005.

**CLASS 32—(Continued).**

3,234,008. NATIONAL DAIRY HOLDINGS, LP, DALLAS, TX.  
SN 76-629,017. PUB. 3-14-2006, FILED 1-24-2005.

**CLASS 32—(Continued).**

3,234,085. SANRIO COMPANY, LTD., TOKYO 141, JAPAN.  
SN 76-978,462. PUB. 10-4-2005, FILED 10-6-2004.

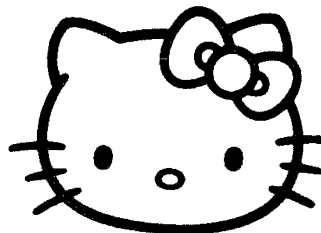
**SOL T 20**

THE MARK CONSISTS OF STANDARD CHARACTERS WITHOUT CLAIM TO ANY PARTICULAR FONT, STYLE, SIZE, OR COLOR.

NO CLAIM IS MADE TO THE EXCLUSIVE RIGHT TO USE 20, APART FROM THE MARK AS SHOWN.

FOR FRUIT DRINKS; FRUIT JUICES (U.S. CLS. 45, 46 AND 48).

FIRST USE 1-1-2006; IN COMMERCE 1-1-2006.

OWNER OF U.S. REG. NO. 2,488,126 AND OTHERS.  
FOR FRUIT DRINKS, CARBONATED AND NON-CARBONATED SOFT DRINKS (U.S. CLS. 45, 46 AND 48).  
FIRST USE 2-9-2003; IN COMMERCE 2-9-2003.

3,234,080. J & A IMPORTERS INC., VERNON, CA. SN 76-977,735. PUB. 5-2-2006, FILED 6-24-2004.



THE MARK CONSISTS OF THE LETTERS "J & A," SET IN A DISTINCTIVE OVAL LOGO.

FOR NON ALCOHOLIC BEVERAGES, NAMELY, SOY-BASED BEVERAGES NOT BEING MILK SUBSTITUTES, DRINKING WATER, MINERAL WATER, AERATED DRINKING WATER, FLAVORED DRINKING WATER, NON-ALCOHOLIC BEVERAGES, NAMELY, ENERGY DRINKS, BEVERAGES FLAVORED WITH TEAS; FRUIT-FLAVORED DRINKS; SODAS, NAMELY, SODA POPS; AND FRUIT JUICES; FLAVORED DRINKS AND JUICES NAMELY, SUGAR CANE DRINK, MANGO JUICE, COCONUT JUICE, PENNYWOTH FRUIT JUICE DRINK, GUAVA JUICE, ORANGE FLAVOR DRINK, MANGO FLAVORED DRINK, AND PEACH FLAVORED DRINK (U.S. CLS. 45, 46 AND 48).

FIRST USE 9-0-2004; IN COMMERCE 9-0-2004.

3,234,332. MH WATERS PTY. LTD., WAVERTON, NSW 2060, AUSTRALIA. SN 78-437,118. PUB. 4-26-2005, FILED 6-17-2004.

**TASMANIAN RAIN**

THE MARK CONSISTS OF STANDARD CHARACTERS WITHOUT CLAIM TO ANY PARTICULAR FONT, STYLE, SIZE, OR COLOR.

FOR CARBONATED AND NON-CARBONATED WATER; BOTTLED WATER (U.S. CLS. 45, 46 AND 48).

FIRST USE 8-22-2006; IN COMMERCE 8-22-2006.

**CLASS 32—(Continued).**

3,234,354. PECONIC DEVELOPMENT CORP., CLINTON-DALE, NY. SN 78-451,146. PUB. 6-28-2005, FILED 7-15-2004.

**CLASS 32—(Continued).**

3,234,932. UNITED BEVERAGE GROUP, LLC, ATLANTA, GA. SN 78-651,072. PUB. 3-7-2006, FILED 6-15-2005.



NO CLAIM IS MADE TO THE EXCLUSIVE RIGHT TO USE "FRUIT", APART FROM THE MARK AS SHOWN. THE COLOR(S) RED AND GREEN IS/ARE CLAIMED AS A FEATURE OF THE MARK.

THE MARK CONSISTS OF A RED APPLE WITH TWO GREEN LEAVES AND A BROWN STEM WITH THE WORDS "GOOD FRUIT" WRITTEN ACROSS THE APPLE ON A SLANT IN GREEN WITH WHITE OUTLINING OF THE LETTERS.

FOR SWEET CIDER; AND OTHER BEVERAGES THAT ARE CIDER AND FRUIT BLENDS (U.S. CLS. 45, 46 AND 48).

FIRST USE 10-1-2005; IN COMMERCE 10-1-2005.

3,234,838. NIX, GRETCHEN, WEST HOLLYWOOD, CA. SN 78-631,344. PUB. 1-31-2006, FILED 5-17-2005.

# MODMIX

THE MARK CONSISTS OF STANDARD CHARACTERS WITHOUT CLAIM TO ANY PARTICULAR FONT, STYLE, SIZE, OR COLOR.

FOR NON-ALCOHOLIC COCKTAIL MIXES (U.S. CLS. 45, 46 AND 48).

FIRST USE 2-28-2005; IN COMMERCE 2-28-2005.

# SOUTHERN SIPPERS

THE MARK CONSISTS OF STANDARD CHARACTERS WITHOUT CLAIM TO ANY PARTICULAR FONT, STYLE, SIZE, OR COLOR.

FOR FRUIT DRINKS; CARBONATED AND NON-CARBONATED BEVERAGES (U.S. CLS. 45, 46 AND 48).

FIRST USE 8-31-2005; IN COMMERCE 8-31-2005.

3,235,102. RONIN, LLC, LAKE MILLS, WI. SN 78-674,681. PUB. 4-4-2006, FILED 7-20-2005.

"WHAT KIND OF WARRIOR ARE YOU?"

THE MARK CONSISTS OF STANDARD CHARACTERS WITHOUT CLAIM TO ANY PARTICULAR FONT, STYLE, SIZE, OR COLOR.

FOR NON-ALCOHOLIC BEVERAGES, NAMELY, LIGHTLY CARBONATED BEVERAGES (U.S. CLS. 45, 46 AND 48).

FIRST USE 10-1-2004; IN COMMERCE 10-1-2004.

3,235,103. RONIN, LLC, LAKE MILLS, WI. SN 78-674,685. PUB. 4-4-2006, FILED 7-20-2005.

A WARRIOR LIES WITHIN

THE MARK CONSISTS OF STANDARD CHARACTERS WITHOUT CLAIM TO ANY PARTICULAR FONT, STYLE, SIZE, OR COLOR.

FOR NON-ALCOHOLIC BEVERAGES, NAMELY, LIGHTLY CARBONATED BEVERAGES (U.S. CLS. 45, 46 AND 48).

FIRST USE 10-1-2004; IN COMMERCE 10-1-2004.

**CLASS 32—(Continued).**

3,235,165. COORS GLOBAL PROPERTIES, INC., GOLDEN, CO. SN 78-694,879. PUB. 5-2-2006, FILED 8-17-2005.

**SILVER BULLET TRAIN**

THE MARK CONSISTS OF STANDARD CHARACTERS WITHOUT CLAIM TO ANY PARTICULAR FONT, STYLE, SIZE, OR COLOR.

OWNER OF U.S. REG. NOS. 1,264,432, 2,420,533, AND OTHERS.

FOR BEER (U.S. CLS. 45, 46 AND 48).

FIRST USE 4-30-2006; IN COMMERCE 4-30-2006.

3,235,220. ANHEUSER-BUSCH, INCORPORATED, ST. LOUIS, MO. SN 78-718,552. PUB. 3-14-2006, FILED 9-22-2005.

**STONE MILL**

THE MARK CONSISTS OF STANDARD CHARACTERS WITHOUT CLAIM TO ANY PARTICULAR FONT, STYLE, SIZE, OR COLOR.

FOR BEER (U.S. CLS. 45, 46 AND 48).

FIRST USE 4-30-2006; IN COMMERCE 4-30-2006.

3,235,334. STOKELY-VAN CAMP, INC., CHICAGO, IL. SN 78-769,155. PUB. 8-8-2006, FILED 12-8-2005.

**IT'S ON THE COURSE. IS IT  
IN YOU?**

THE MARK CONSISTS OF STANDARD CHARACTERS WITHOUT CLAIM TO ANY PARTICULAR FONT, STYLE, SIZE, OR COLOR.

OWNER OF U.S. REG. NO. 2,300,671.

FOR NON-ALCOHOLIC, NON-CARBONATED FRUIT FLAVORED DRINKS (U.S. CLS. 45, 46 AND 48).

FIRST USE 4-30-2006; IN COMMERCE 4-30-2006.

**CLASS 33—WINES AND SPIRITS****CLASS 33—(Continued).**

3,233,846. ST ANDREWS LINKS LIMITED, FIFE KY16 9SF, UNITED KINGDOM. SN 76-507,302. PUB. 2-24-2004, FILED 4-16-2003.

**THE OLD COURSE**

FOR WHISKY (U.S. CLS. 47 AND 49).

FIRST USE 2-0-2005; IN COMMERCE 2-0-2005.

3,233,931. TAIWAN TOBACCO & LIQUOR CORPORATION, TAIPEI, TAIWAN. SN 76-604,429. PUB. 4-11-2006, FILED 7-28-2004.



NO CLAIM IS MADE TO THE EXCLUSIVE RIGHT TO USE "NON-LATIN CHARACTER WHICH MEANS RICE", APART FROM THE MARK AS SHOWN.

THE NON-LATIN CHARACTERS IN THE MARK TRANSLITERATE TO DAO XLANG AND THIS MEANS SCENT OF RICE IN ENGLISH.

FOR RICE WINE (U.S. CLS. 47 AND 49).

FIRST USE 4-28-1999; IN COMMERCE 12-1-2005.

3,234,009. ATLANTIC BOTTLING, LLC, LONG BRANCH, NJ. SN 76-629,270. PUB. 12-6-2005, FILED 1-25-2005.

**ZACHLAWI**

THE MARK CONSISTS OF STANDARD CHARACTERS WITHOUT CLAIM TO ANY PARTICULAR FONT, STYLE, SIZE, OR COLOR.

FOR ALCOHOLIC BEVERAGES, NAMELY, LIQUOR AND LIQUEUR (U.S. CLS. 47 AND 49).

FIRST USE 7-15-2006; IN COMMERCE 7-15-2006.

**CLASS 33—(Continued).**

3,234,012. ATLANTIC BOTTLING, LLC, LONG BRANCH, NJ. SN 76-629,494. PUB. 11-29-2005, FILED 1-27-2005.

**CLASS 33—(Continued).**

3,234,207. L&P SPIRITS IMPORTS, LLC, SAN FRANCISCO, CA. SN 78-353,324. PUB. 10-19-2004, FILED 1-16-2004.

# MAHIA LE FIG

THE MARK CONSISTS OF STANDARD CHARACTERS WITHOUT CLAIM TO ANY PARTICULAR FONT, STYLE, SIZE, OR COLOR.

THE ENGLISH TRANSLATION OF THE MARK IS "WATER OF LIFE OF THE FIG".

FOR ALCOHOLIC BEVERAGES, NAMELY, DISTILLED LIQUOR AND LIQUEURS (U.S. CLS. 47 AND 49).

FIRST USE 7-15-2006; IN COMMERCE 7-15-2006.

# SWAN'S NECK

THE MARK CONSISTS OF STANDARD CHARACTERS WITHOUT CLAIM TO ANY PARTICULAR FONT, STYLE, SIZE, OR COLOR.

FOR DISTILLED SPIRITS, VODKA (U.S. CLS. 47 AND 49).

FIRST USE 8-24-2006; IN COMMERCE 8-24-2006.

---

3,234,114. CONSTELLATION WINES U.S., INC., CANANDAIGUA, NY. SN 78-165,071. PUB. 10-25-2005, FILED 9-17-2002.

# SEVENTH MOON

FOR WINE (U.S. CLS. 47 AND 49).  
FIRST USE 12-0-2002; IN COMMERCE 12-0-2002.

---

3,234,300. LA INVERSORA SOCIEDAD ANONIMA, COMERCIAL, INDUSTRIAL INMOBILIARIA, CONSTRUCTORA, AGROPECUARIA Y FINANCIERA, NEUQUEN, PROVINCIA DE NEUQUEN, ARGENTINA. SN 78-415,640. PUB. 8-8-2006, FILED 5-10-2004.

# POSTALES

---

3,234,194. ANDREWS, JAMES P., LONDON, UNITED KINGDOM. SN 78-338,641. PUB. 9-21-2004, FILED 12-10-2003.

# EAST MEETS WEST

THE MARK CONSISTS OF STANDARD CHARACTERS WITHOUT CLAIM TO ANY PARTICULAR FONT, STYLE, SIZE, OR COLOR.

FOR ALCOHOLIC BEVERAGES, NAMELY, WINES, GIN, VODKA, LIQUEURS, AND SPIRITS, NAMELY, BRANDY SPIRITS, POTABLE SPIRITS, DISTILLED SPIRITS MADE FROM GRAIN, AND FLAVORED DISTILLED SPIRITS (U.S. CLS. 47 AND 49).

FIRST USE 8-27-2005; IN COMMERCE 8-27-2005.

THE MARK CONSISTS OF STANDARD CHARACTERS WITHOUT CLAIM TO ANY PARTICULAR FONT, STYLE, SIZE, OR COLOR.

THE FOREIGN WORDING IN THE MARK TRANSLATES INTO ENGLISH AS POSTCARDS.

FOR WINES, DISTILLED SPIRITS, WHISKEY, BRANDY, COGNAC, CORDIALS, LIQUEURS AND APÉRITIFS WITH A WINE BASE (U.S. CLS. 47 AND 49).

FIRST USE 8-10-2004; IN COMMERCE 8-10-2004.

**CLASS 33—(Continued).**

3,234,322. DIAGEO SCOTLAND LIMITED, EDINBURGH, SCOTLAND. SN 78-430,693. PUB. 9-13-2005, FILED 6-7-2004.



FOR WINES, LIQUEURS, SCHNAPPS, WHISKY, GIN, VODKA AND RUM (U.S. CLS. 47 AND 49).  
FIRST USE 6-0-2005; IN COMMERCE 6-0-2005.

**CLASS 33—(Continued).**

3,234,403. GLOBAL STORE LTD, HONG KONG, HONG KONG. SN 78-480,297. PUB. 9-13-2005, FILED 9-8-2004.

**STILVODKA**

THE MARK CONSISTS OF STANDARD CHARACTERS WITHOUT CLAIM TO ANY PARTICULAR FONT, STYLE, SIZE, OR COLOR.

FOR ALCOHOLIC BEVERAGES, NAMELY, VODKA (U.S. CLS. 47 AND 49).  
FIRST USE 9-20-2004; IN COMMERCE 9-20-2004.

3,234,427. MENDOCINO WINE GROUP, LLC, UKIAH, CA. SN 78-487,995. PUB. 9-13-2005, FILED 9-22-2004.

3,234,392. ROSEVINE ENTERPRISES, LLC, MARIETTA, GA. SN 78-476,474. PUB. 9-13-2005, FILED 8-31-2004.

**Zig Zag Zin****CHAIRMAN'S RESERVE**

THE MARK CONSISTS OF STANDARD CHARACTERS WITHOUT CLAIM TO ANY PARTICULAR FONT, STYLE, SIZE, OR COLOR.

NO CLAIM IS MADE TO THE EXCLUSIVE RIGHT TO USE "RESERVE", APART FROM THE MARK AS SHOWN.  
FOR WINE (U.S. CLS. 47 AND 49).  
FIRST USE 3-0-2005; IN COMMERCE 3-0-2005.

THE MARK CONSISTS OF STANDARD CHARACTERS WITHOUT CLAIM TO ANY PARTICULAR FONT, STYLE, SIZE, OR COLOR.

FOR WINE, NAMELY A ZINFANDEL (U.S. CLS. 47 AND 49).  
FIRST USE 8-28-2006; IN COMMERCE 8-28-2006.



**CLASS 33—(Continued).**

3,234,496. DAVIS LEHRMITAGE, LLC, SANTA ROSA, CA. SN 78-512,553. PUB. 10-11-2005, FILED 11-5-2004.

**CLASS 33—(Continued).**

3,234,538. LUCERO, MARK, T., PITTSBURGH, PA. SN 78-523,199. PUB. 10-11-2005, FILED 11-26-2004.

**THE SPIRIT OF  
SONOMA COUNTY**

**Pink Diamond**

THE MARK CONSISTS OF STANDARD CHARACTERS WITHOUT CLAIM TO ANY PARTICULAR FONT, STYLE, SIZE, OR COLOR.

NO CLAIM IS MADE TO THE EXCLUSIVE RIGHT TO USE SONOMA COUNTY, APART FROM THE MARK AS SHOWN.

FOR ALCOHOLIC BEVERAGES, NAMELY DISTILLED SPIRITS (U.S. CLS. 47 AND 49).  
FIRST USE 11-9-2006; IN COMMERCE 11-9-2006.

THE MARK CONSISTS OF STANDARD CHARACTERS WITHOUT CLAIM TO ANY PARTICULAR FONT, STYLE, SIZE, OR COLOR.

OWNER OF U.S. REG. NO. 2,855,146.  
NO CLAIM IS MADE TO THE EXCLUSIVE RIGHT TO USE "PINK", APART FROM THE MARK AS SHOWN.  
FOR VODKA (U.S. CLS. 47 AND 49).  
FIRST USE 7-15-2006; IN COMMERCE 7-15-2006.

3,234,578. EXCELSIOR IMPORTS, LLC, ATLANTA, GA. SN 78-532,589. PUB. 7-25-2006, FILED 12-14-2004.

3,234,527. STAR BEVERAGES PTY LIMITED, SILVERDALE, AUSTRALIA. SN 78-521,001. PUB. 3-7-2006, FILED 11-22-2004.

**ICE ME DOWN UNDER**



THE MARK CONSISTS OF STANDARD CHARACTERS WITHOUT CLAIM TO ANY PARTICULAR FONT, STYLE, SIZE, OR COLOR.

FOR FLAVORED BREWED MALT BEVERAGES (U.S. CLS. 47 AND 49).  
FIRST USE 7-10-2005; IN COMMERCE 7-10-2005.

THE MARK CONSISTS OF A DIAMOND WITH A CIRCLE IN THE CENTER; IN THE CENTER OF THE CIRCLE IS THE MARK AGUA LUCA, WITH STARS VISIBLE IN THE CIRCLE, BOTH NEXT TO AND BEHIND THE MARK AGUA LUCA.

THE ENGLISH TRANSLATION OF THE WORD "AGUA" IN THE MARK IS "WATER."  
FOR DISTILLED SPIRITS (U.S. CLS. 47 AND 49).  
FIRST USE 5-0-2005; IN COMMERCE 5-0-2005.

**CLASS 33—(Continued).**

3,234,584. P38 MEDIA LLC, DENVER, CO. SN 78-534,178.  
PUB. 6-6-2006, FILED 12-17-2004.

## Green Devil

THE MARK CONSISTS OF STANDARD CHARACTERS WITHOUT CLAIM TO ANY PARTICULAR FONT, STYLE, SIZE, OR COLOR.

NO CLAIM IS MADE TO THE EXCLUSIVE RIGHT TO USE "GREEN", APART FROM THE MARK AS SHOWN.

FOR ALCOHOLIC DRINKS, NAMELY PUNCH, WINES, DISTILLED SPIRITS AND ABSINTHE (U.S. CLS. 47 AND 49).

FIRST USE 2-26-2004; IN COMMERCE 2-26-2004.

---

3,234,612. DIAGEO NORTH AMERICA, INC., NORWALK, CT. SN 78-544,899. PUB. 12-20-2005, FILED 1-10-2005.

## ORONOCO

THE MARK CONSISTS OF STANDARD CHARACTERS WITHOUT CLAIM TO ANY PARTICULAR FONT, STYLE, SIZE, OR COLOR.

FOR ALCOHOLIC BEVERAGES, NAMELY DISTILLED SPIRITS (U.S. CLS. 47 AND 49).

FIRST USE 8-9-2005; IN COMMERCE 8-9-2005.

**CLASS 33—(Continued).**

3,234,639. BECKETT, JOSHUA P., PASO ROBLES, CA. AND BECKETT, JACOB R., PASO ROBLES, CA. SN 78-557,342.  
PUB. 11-1-2005, FILED 1-31-2005.

## CHRONIC CELLARS

THE MARK CONSISTS OF STANDARD CHARACTERS WITHOUT CLAIM TO ANY PARTICULAR FONT, STYLE, SIZE, OR COLOR.

NO CLAIM IS MADE TO THE EXCLUSIVE RIGHT TO USE "CELLARS", APART FROM THE MARK AS SHOWN. FOR WINE (U.S. CLS. 47 AND 49).

FIRST USE 10-26-2006; IN COMMERCE 10-30-2006.

---

3,234,712. DIE SWARTLANDSE KOOPERATIEWE WYNKELDER LIMITED, MALMESBURY 7299, SOUTH AFRICA. SN 78-588,337. PUB. 1-17-2006, FILED 3-16-2005.

## IDELIA

THE MARK CONSISTS OF STANDARD CHARACTERS WITHOUT CLAIM TO ANY PARTICULAR FONT, STYLE, SIZE, OR COLOR.

FOR ALCOHOLIC BEVERAGES, NAMELY, WINES, DISTILLED SPIRITS, LIQUEURS AND BRANDY (U.S. CLS. 47 AND 49).

FIRST USE 10-0-2006; IN COMMERCE 10-0-2006.

**CLASS 33—(Continued).**

3,234,717. BODEGAS BORDEJE, S.L., 50570, AINZON, SPAIN. SN 78-590,901. PUB. 10-25-2005, FILED 3-18-2005.

**BORDEJÉ**

THE MARK CONSISTS OF STANDARD CHARACTERS WITHOUT CLAIM TO ANY PARTICULAR FONT, STYLE, SIZE, OR COLOR.  
FOR WINES AND SPARKLING RED AND WHITE WINES (U.S. CLS. 47 AND 49).  
FIRST USE 12-31-1974; IN COMMERCE 9-19-2005.

3,234,737. DSR IMPORTS LLC, GREAT NECK, NY. SN 78-597,315. PUB. 3-7-2006, FILED 3-29-2005.

**BUSINESS CLASS**

THE MARK CONSISTS OF STANDARD CHARACTERS WITHOUT CLAIM TO ANY PARTICULAR FONT, STYLE, SIZE, OR COLOR.  
FOR VODKA (U.S. CLS. 47 AND 49).  
FIRST USE 9-0-2005; IN COMMERCE 9-0-2005.

3,234,828. LION NATHAN WINE GROUP AUSTRALIA LIMITED, SYDNEY NSW, AUSTRALIA. SN 78-629,085. PUB. 2-14-2006, FILED 5-12-2005.

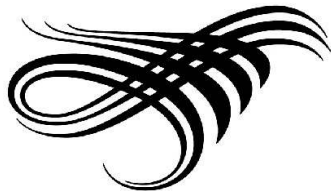

FOR WINES (U.S. CLS. 47 AND 49).  
FIRST USE 12-0-2004; IN COMMERCE 12-0-2004.

**CLASS 33—(Continued).**

3,234,897. HACIENDA LA CAPILLA S.A. DE C.V., CAPILLA DE GUADALUPE, MEXICO. SN 78-644,766. PUB. 7-11-2006, FILED 6-6-2005.

**HACIENDA LA CAPILLA**

THE MARK CONSISTS OF STANDARD CHARACTERS WITHOUT CLAIM TO ANY PARTICULAR FONT, STYLE, SIZE, OR COLOR.  
OWNER OF MEXICO REG. NO. 568931, DATED 1-29-1998, EXPIRES 12-5-2007.  
THE FOREIGN WORDING IN THE MARK TRANSLATES INTO ENGLISH AS CHAPEL RANCH.  
FOR ALCOHOLIC BEVERAGES, NAMELY TEQUILA (U.S. CLS. 47 AND 49).  
FIRST USE 8-10-2006; IN COMMERCE 8-10-2006.

3,234,902. EVENSTAD, KENNETH L., NAPLES, FL. SN 78-646,161. PUB. 8-1-2006, FILED 6-8-2005.

**COEUR BLANC**

THE MARK CONSISTS OF STANDARD CHARACTERS WITHOUT CLAIM TO ANY PARTICULAR FONT, STYLE, SIZE, OR COLOR.  
NO CLAIM IS MADE TO THE EXCLUSIVE RIGHT TO USE "BLANC", APART FROM THE MARK AS SHOWN.  
THE FOREIGN WORDING IN THE MARK TRANSLATES INTO ENGLISH AS WHITE HEART.  
FOR WINE (U.S. CLS. 47 AND 49).  
FIRST USE 9-21-2006; IN COMMERCE 9-21-2006.

3,234,905. PURPLE WINE COMPANY LLC, GRATON, CA. SN 78-646,789. PUB. 2-28-2006, FILED 6-8-2005.

**Azure Creek**

THE MARK CONSISTS OF STANDARD CHARACTERS WITHOUT CLAIM TO ANY PARTICULAR FONT, STYLE, SIZE, OR COLOR.  
FOR WINE (U.S. CLS. 47 AND 49).  
FIRST USE 1-1-2006; IN COMMERCE 1-1-2006.

**CLASS 33—(Continued).**

3,234,922. NAVREN LLC, DBA HEMINGWAY AND HALE, FORT WORTH, TX. SN 78-649,816. PUB. 2-28-2006, FILED 6-13-2005.

**RAINDANCE**

THE MARK CONSISTS OF STANDARD CHARACTERS WITHOUT CLAIM TO ANY PARTICULAR FONT, STYLE, SIZE, OR COLOR.  
FOR WINE (U.S. CLS. 47 AND 49).  
FIRST USE 3-8-2006; IN COMMERCE 3-8-2006.

3,234,925. GOOSE RIDGE, LLC, OUTLOOK, WA. SN 78-650,283. PUB. 3-7-2006, FILED 6-14-2005.

**STONECAP**

THE MARK CONSISTS OF STANDARD CHARACTERS WITHOUT CLAIM TO ANY PARTICULAR FONT, STYLE, SIZE, OR COLOR.  
FOR WINE (U.S. CLS. 47 AND 49).  
FIRST USE 9-15-2005; IN COMMERCE 1-11-2006.

3,234,990. ABB PARTNERS, LLC, LOCUST VALLEY, NY. SN 78-658,075. PUB. 3-21-2006, FILED 6-24-2005.

**CABANA CACHACA**

THE MARK CONSISTS OF STANDARD CHARACTERS WITHOUT CLAIM TO ANY PARTICULAR FONT, STYLE, SIZE, OR COLOR.  
NO CLAIM IS MADE TO THE EXCLUSIVE RIGHT TO USE "CACHACA", APART FROM THE MARK AS SHOWN.  
FOR DISTILLED SPIRITS MADE FROM SUGAR CANE (U.S. CLS. 47 AND 49).  
FIRST USE 1-1-2006; IN COMMERCE 6-1-2006.

**CLASS 33—(Continued).**

3,234,991. ABB PARTNERS, LLC, LOCUST VALLEY, NY. SN 78-658,103. PUB. 3-21-2006, FILED 6-24-2005.

**CABANA**

THE MARK CONSISTS OF STANDARD CHARACTERS WITHOUT CLAIM TO ANY PARTICULAR FONT, STYLE, SIZE, OR COLOR.  
FOR DISTILLED SPIRITS MADE FROM SUGAR CANE (U.S. CLS. 47 AND 49).  
FIRST USE 1-1-2006; IN COMMERCE 6-1-2006.

3,234,997. DAVID, NARSAI M., KENSINGTON, CA. SN 78-658,943. PUB. 3-14-2006, FILED 6-27-2005.

**Narsai**

THE MARK CONSISTS OF STANDARD CHARACTERS WITHOUT CLAIM TO ANY PARTICULAR FONT, STYLE, SIZE, OR COLOR.  
FOR WINES (U.S. CLS. 47 AND 49).  
FIRST USE 6-1-1978; IN COMMERCE 6-1-1978.

3,235,026. ESTABLISSEMENTS ROULET FRANSAC, CHERMIGNAC THENAC, FRANCE. SN 78-662,135. PUB. 3-21-2006, FILED 6-30-2005.

**APPLE XO BY BAUCHANT**

THE MARK CONSISTS OF STANDARD CHARACTERS WITHOUT CLAIM TO ANY PARTICULAR FONT, STYLE, SIZE, OR COLOR.  
OWNER OF U.S. REG. NO. 1,348,427.  
NO CLAIM IS MADE TO THE EXCLUSIVE RIGHT TO USE "APPLE XO", APART FROM THE MARK AS SHOWN.  
FOR ALCOHOLIC BEVERAGES, NAMELY, COGNAC AND LIQUEURS (U.S. CLS. 47 AND 49).  
FIRST USE 3-20-2006; IN COMMERCE 3-20-2006.

**CLASS 33—(Continued).**

3,235,198. PERNOD RICARD MEXICO S.A. DE C.V., MEXICO DF, MEXICO. SN 78-709,098. PUB. 6-13-2006, FILED 9-8-2005.

**TEVADO**

THE MARK CONSISTS OF STANDARD CHARACTERS WITHOUT CLAIM TO ANY PARTICULAR FONT, STYLE, SIZE, OR COLOR.

FOR POTABLE DISTILLED SPIRITS (U.S. CLS. 47 AND 49).  
FIRST USE 7-7-2006; IN COMMERCE 7-7-2006.

3,235,215. OPICI IMPORT CO. INC., GLEN ROCK, NJ. SN 78-716,981. PUB. 6-6-2006, FILED 9-20-2005.

**HOPPER CREEK RANCH**

THE MARK CONSISTS OF STANDARD CHARACTERS WITHOUT CLAIM TO ANY PARTICULAR FONT, STYLE, SIZE, OR COLOR.

NO CLAIM IS MADE TO THE EXCLUSIVE RIGHT TO USE "RANCH", APART FROM THE MARK AS SHOWN.  
FOR WINE (U.S. CLS. 47 AND 49).  
FIRST USE 9-9-2005; IN COMMERCE 9-9-2005.

3,235,316. HUSIC VINEYARDS, LLC, SAN FRANCISCO, CA. SN 78-762,805. PUB. 7-25-2006, FILED 11-29-2005.

**PALM TERRACE**

THE MARK CONSISTS OF STANDARD CHARACTERS WITHOUT CLAIM TO ANY PARTICULAR FONT, STYLE, SIZE, OR COLOR.

FOR WINE (U.S. CLS. 47 AND 49).  
FIRST USE 10-15-2006; IN COMMERCE 10-15-2006.

**CLASS 33—(Continued).**

3,235,338. MIDWEST WINE EXCHANGE LLC, NOVI, MI. SN 78-770,301. PUB. 8-8-2006, FILED 12-9-2005.

**CAT'S MEOW**

THE MARK CONSISTS OF STANDARD CHARACTERS WITHOUT CLAIM TO ANY PARTICULAR FONT, STYLE, SIZE, OR COLOR.

FOR WINE (U.S. CLS. 47 AND 49).  
FIRST USE 9-1-2006; IN COMMERCE 9-27-2006.

**CLASS 34—SMOKERS' ARTICLES**

3,233,835. MILLER, WENTWORTH E., SEWICKLEY, PA. SN 76-494,031. PUB. 10-12-2004, FILED 3-3-2003.

**CIGARETTESAVER**

FOR CYLINDRICAL TUBE WITH REMOVABLE CAPS AT ONE OR BOTH ENDS FOR ENCLOSING AND EXTINGUISHING BY OXYGEN DEPRIVATION A LIGHTED CIGARETTE, CIGAR, OR SIMILAR SMOKABLE PRODUCT (U.S. CLS. 2, 8, 9 AND 17).

FIRST USE 11-0-2003; IN COMMERCE 11-0-2003.

3,233,925. GONZALEZ, MELQUIADES, MIAMI, FL. SN 76-601,041. PUB. 9-6-2005, FILED 7-6-2004.

**ORISHA**

THE MARK CONSISTS OF STANDARD CHARACTERS WITHOUT CLAIM TO ANY PARTICULAR FONT, STYLE, SIZE, OR COLOR.

FOR CIGARS, CIGARILLOS, SMOKING TOBACCO AND RELATED ACCESSORIES, NAMELY CIGAR BANDS, CIGAR CUTTERS, CIGAR TUBES, CIGAR ASH RECEPTACLES, CIGAR CASES NOT OF PRECIOUS METAL, CIGAR LIGHTERS NOT FOR LAND VEHICLES AND NOT OF PRECIOUS METAL, TOBACCO POUCHES AND MATCHES (U.S. CLS. 2, 8, 9 AND 17).

FIRST USE 9-6-2006; IN COMMERCE 9-6-2006.

3,234,115. TOBACCO IMPORTS INTERNATIONAL, INC., RANDOLPH, NJ. SN 78-169,163. PUB. 5-13-2003, FILED 9-30-2002.

**PREMIUM CLASSIC**

**CLASS 34—(Continued).**

NO CLAIM IS MADE TO THE EXCLUSIVE RIGHT TO USE "PREMIUM", APART FROM THE MARK AS SHOWN. FOR CIGARETTES (U.S. CLS. 2, 8, 9 AND 17). FIRST USE 7-27-2006; IN COMMERCE 7-27-2006.

**CLASS 34—(Continued).**

3,235,088. COMMONWEALTH BRANDS, INC., BOWLING GREEN, KY. SN 78-671,622. PUB. 4-4-2006, FILED 7-15-2005.

3,234,198. NORTH FORK DAVIDOFF OF COLUMBUS CIRCLE LLC, WELLESLEY, MA. SN 78-343,078. PUB. 9-21-2004, FILED 12-18-2003.

# RHYTHM

# LA BUENA VIDA

THE MARK CONSISTS OF STANDARD CHARACTERS WITHOUT CLAIM TO ANY PARTICULAR FONT, STYLE, SIZE, OR COLOR. FOR CIGARETTES (U.S. CLS. 2, 8, 9 AND 17). FIRST USE 10-18-2006; IN COMMERCE 10-18-2006.

THE MARK CONSISTS OF STANDARD CHARACTERS WITHOUT CLAIM TO ANY PARTICULAR FONT, STYLE, SIZE, OR COLOR. THE FOREIGN WORDING IN THE MARK TRANSLATES INTO ENGLISH AS THE GOOD LIFE. FOR CIGARS (U.S. CLS. 2, 8, 9 AND 17). FIRST USE 6-0-2005; IN COMMERCE 6-0-2005.

**SERVICE MARKS****CLASS 35—ADVERTISING AND BUSINESS**

3,234,257. BLUE LINE PRODUCTIONS, INC., SUWANEE, GA. SN 78-388,844. PUB. 9-6-2005, FILED 3-23-2004.

3,233,790. ALLIANCE OF NEW STAGE ADULTS, LLC, BOULDER, CO. SN 76-395,123. PUB. 10-29-2002, FILED 4-12-2002.



# ALLIANCE OF NEW STAGE ADULTS

THE COLOR(S) BLACK AND BLUE IS/ARE CLAIMED AS A FEATURE OF THE MARK. THE MARK CONSISTS OF TWO BLACK BARS, WITH A BLUE BAR DISPOSED BETWEEN THE TWO BLACK BARS. FOR CIGARETTE LIGHTERS NOT OF PRECIOUS METAL (U.S. CLS. 2, 8, 9 AND 17). FIRST USE 3-20-2000; IN COMMERCE 3-20-2000.

FOR EMPLOYMENT COUNSELING AND RECRUITING; EMPLOYMENT PLACEMENT AND CAREER NETWORKING SERVICES; ADMINISTRATION OF A PROGRAM FOR ENABLING PARTICIPANTS TO OBTAIN INFORMATION ON JOB OPPORTUNITIES (U.S. CLS. 100, 101 AND 102). FIRST USE 1-1-2003; IN COMMERCE 9-1-2004.

**CLASS 35—(Continued).**

3,233,798. SEEGWAY, INC., BEDFORD, NH. SN 76-411,838.  
PUB. 9-9-2003, FILED 5-23-2002.

**CLASS 35—(Continued).**

3,233,805. IPX CORPORATION, EDMONTON, ALBERTA,  
CANADA. SN 76-450,642. PUB. 3-7-2006, FILED 9-18-2002.



FOR PROVIDING ADVERTISING AND MARKETING SERVICES, NAMELY, PROMOTING THE SALE OF TRANSPORTATION DEVICES IN THE NATURE OF MOTORIZED, SELF-PROPELLED, WHEELED PERSONAL MOBILITY DEVICES, NAMELY, WHEELCHAIRS, SCOOTERS, UTILITY CARTS AND CHARIOTS, AND RELATED EQUIPMENT THROUGH THE PREPARATION AND DISTRIBUTION OF PRINTED AND AUDIO-VISUAL PROMOTIONAL MATERIALS, BY RENDERING SALES PROMOTION ADVICE, AND BY PREPARING AND PLACING ADVERTISEMENTS FOR OTHERS (U.S. CLS. 100, 101 AND 102).  
FIRST USE 0-0-2005; IN COMMERCE 0-0-2005.

PRIORITY CLAIMED UNDER SEC. 44(D) ON CANADA APPLICATION NO. 1151446, FILED 9-5-2002.  
FOR PROVIDING AN ON-LINE DATA MANAGEMENT SERVICE ACCESSIBLE BY A GLOBAL COMPUTER NETWORK FOR SEARCHING, MONITORING, RETRIEVING, AND DELIVERING DATA REGARDING INTELLECTUAL PROPERTY; PROVIDING AN ON-LINE MARKETPLACE ACCESSIBLE BY A GLOBAL COMPUTER NETWORK TO FACILITATE THE BUYING, SELLING AND EXCHANGE OF INTELLECTUAL PROPERTY BY OTHERS; PROVIDING AN ON-LINE ADVERTISEMENT POSTING SERVICE ACCESSIBLE BY A GLOBAL COMPUTER NETWORK TO FACILITATE THE SALE OR LICENSING OF INTELLECTUAL PROPERTY BY OTHERS; PROVIDING AN ON-LINE AUCTION SERVICE ACCESSIBLE BY A GLOBAL COMPUTER NETWORK TO FACILITATE THE SALE OR LICENSING OF INTELLECTUAL PROPERTY BY OTHERS (U.S. CLS. 100, 101 AND 102).  
FIRST USE 11-0-2002; IN COMMERCE 11-0-2002.

**CLASS 35—(Continued).**

3,233,816. HEB GROCERY COMPANY, LP, SAN ANTONIO, TX. SN 76-476,063. PUB. 2-24-2004, FILED 12-18-2002.

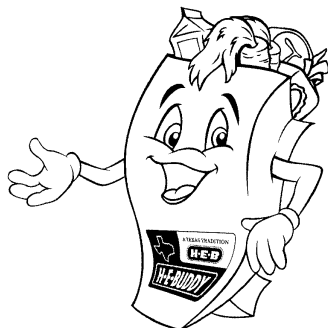

OWNER OF U.S. REG. NOS. 2,384,226, 2,407,988, AND OTHERS.

NO CLAIM IS MADE TO THE EXCLUSIVE RIGHT TO USE TEXAS AND THE REPRESENTATION OF THE OUTLINE OF TEXAS, APART FROM THE MARK AS SHOWN.

FOR PROMOTING THE SERVICES OF OTHERS BY CONDUCTING PUBLIC AWARENESS AND EDUCATION PROGRAMS CONCERNING CHARITABLE ORGANIZATIONS; PROMOTING THE GOODS OF OTHERS THROUGH THE DISTRIBUTION OF PRINTED MATERIAL FEATURING PRODUCT INFORMATION AND INFORMATION OF GENERAL INTEREST TO CONSUMERS; PROMOTING PUBLIC AWARENESS OF ISSUES CONCERNING NUTRITION, DIET, HEALTH AND THE WELFARE OF CHILDREN THROUGH PERSONAL APPEARANCES AT PUBLIC EVENTS (U.S. CLS. 100, 101 AND 102).

FIRST USE 5-0-2004; IN COMMERCE 5-0-2004.

3,233,818. LEAKE, H. MILTON, JR., BURBANK, CA. SN 76-476,428. PUB. 8-26-2003, FILED 12-18-2002.

**QUICKEASE**

FOR RETAIL SHOPS FEATURING HEALTH FOODS AND BEVERAGES, ORGANIC BODY CARE PRODUCTS, MAGAZINES, BOOKS, VIDEOS AND ASSORTED FENG SHUI ITEMS (U.S. CLS. 100, 101 AND 102).

FIRST USE 5-15-2004; IN COMMERCE 10-19-2005.

3,233,848. EBIZ GOOD STEPS, INC., TAMPA, FL. SN 76-513,980. PUB. 3-28-2006, FILED 4-22-2003.

**EBIZ GOOD STEPS**

NO CLAIM IS MADE TO THE EXCLUSIVE RIGHT TO USE "EBIZ", APART FROM THE MARK AS SHOWN.

FOR BUSINESS DEVELOPMENT SERVICES, NAMELY, PROVIDING START-UP SUPPORT FOR BUSINESSES OF OTHERS (U.S. CLS. 100, 101 AND 102).

FIRST USE 8-30-2004; IN COMMERCE 8-30-2004.

**CLASS 35—(Continued).**

3,233,873. PRECO ELECTRONICS, INC., BOISE, ID. SN 76-566,151. PUB. 8-30-2005, FILED 12-19-2003.

**PRECISE**

THE MARK CONSISTS OF STANDARD CHARACTERS WITHOUT CLAIM TO ANY PARTICULAR FONT, STYLE, SIZE, OR COLOR.

FOR TRACKING SERVICES FOR LOCATION OF TRANSPORTATION EQUIPMENT, NAMELY AIRPLANES, SHIPS, TRUCKS, TRAILERS, TRAINS, RAIL FREIGHT CARS AND AUTOMOBILES (U.S. CLS. 100, 101 AND 102).

FIRST USE 5-27-2005; IN COMMERCE 5-27-2005.

3,233,915. MOTION PICTURE ASSOCIATION OF AMERICA, INC., ENCINO, CA. SN 76-595,873. PUB. 4-4-2006, FILED 6-7-2004.

I	<b>ILLEGAL DOWNLOADING</b> Inappropriate for All Ages
---	--

NO CLAIM IS MADE TO THE EXCLUSIVE RIGHT TO USE "ILLEGAL DOWNLOADING", APART FROM THE MARK AS SHOWN.

FOR ASSOCIATION SERVICES, NAMELY, PROMOTING THE INTERESTS OF THE MOTION PICTURE INDUSTRY (U.S. CLS. 100, 101 AND 102).

FIRST USE 6-15-2004; IN COMMERCE 6-15-2004.

3,233,923. CARDONE INDUSTRIES, INC., PHILADELPHIA, PA. SN 76-599,472. PUB. 9-13-2005, FILED 6-28-2004.

**CARDONE WEBCAT**

THE MARK CONSISTS OF STANDARD CHARACTERS WITHOUT CLAIM TO ANY PARTICULAR FONT, STYLE, SIZE, OR COLOR.

OWNER OF U.S. REG. NOS. 1,215,717 AND 2,076,817. FOR WHOLESALE ORDERING SERVICES AND INTERNET-BASED CATALOG ORDERING SERVICES IN THE FIELD OF PARTS AND ACCESSORIES FOR MOTOR VEHICLES (U.S. CLS. 100, 101 AND 102).

FIRST USE 6-0-2004; IN COMMERCE 6-0-2004.



**CLASS 35—(Continued).**

3,233,992. WAL-MART STORES, INC., BENTONVILLE, AR. SN 76-622,949. PUB. 3-7-2006, FILED 12-2-2004.

SAM'S CLUB ADVANTAGE MEMBER

THE MARK CONSISTS OF STANDARD CHARACTERS WITHOUT CLAIM TO ANY PARTICULAR FONT, STYLE, SIZE, OR COLOR.

OWNER OF U.S. REG. NOS. 1,952,424, 2,658,692, AND OTHERS.

NO CLAIM IS MADE TO THE EXCLUSIVE RIGHT TO USE "CLUB" AND "MEMBER", APART FROM THE MARK AS SHOWN.

FOR RETAIL AND WHOLESALE DEPARTMENT STORE SERVICES (U.S. CLS. 100, 101 AND 102). FIRST USE 3-11-1994; IN COMMERCE 3-11-1994.

**CLASS 35—(Continued).**

3,234,038. BUNNIES, INC., BLOOMINGTON, MN. SN 76-636,051. PUB. 2-28-2006, FILED 4-13-2005.

# REALTYBUNNIES

THE MARK CONSISTS OF STANDARD CHARACTERS WITHOUT CLAIM TO ANY PARTICULAR FONT, STYLE, SIZE, OR COLOR.

FOR REAL ESTATE SERVICES, NAMELY, MARKETING OF REAL ESTATE SERVICES OF OTHERS (U.S. CLS. 100, 101 AND 102).

FIRST USE 6-23-2005; IN COMMERCE 6-23-2005.

3,234,039. CHORDUS, INC., PELHAM, AL. SN 76-637,609. PUB. 1-24-2006, FILED 5-2-2005.

3,234,014. AMERICAN PHARMACISTS ASSOCIATION, FORMERLY AMERICAN PHARMACEUTICAL ASSOCIATION, WASHINGTON, DC. SN 76-630,480. PUB. 1-31-2006, FILED 2-4-2005.



OWNER OF U.S. REG. NO. 1,893,126. NO CLAIM IS MADE TO THE EXCLUSIVE RIGHT TO USE "OTC" OR "PHARMACY" OR "#1 PHARMACIST RECOMMENDED", APART FROM THE MARK AS SHOWN.

FOR SURVEY SERVICES RENDERED BY APPLICANT, NAMELY, SURVEYING AND EVALUATING PHARMACISTS' PREFERRED OVER-THE-COUNTER REMEDIES TO DETERMINE WHICH PRODUCTS ARE MOST RECOMMENDED BY PHARMACISTS (U.S. CLS. 100, 101 AND 102). FIRST USE 2-1-2006; IN COMMERCE 2-1-2006.

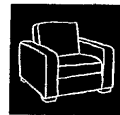

**RoomChoices**  
Your way. Right away.

FOR RETAIL RESIDENTIAL FURNITURE STORE SERVICES (U.S. CLS. 100, 101 AND 102). FIRST USE 5-15-2005; IN COMMERCE 6-30-2005.

3,234,066. HARRIS INTERACTIVE INC., ROCHESTER, NY. SN 76-643,270. PUB. 4-11-2006, FILED 7-20-2005.

# PREFERENCEPOINT

THE MARK CONSISTS OF STANDARD CHARACTERS WITHOUT CLAIM TO ANY PARTICULAR FONT, STYLE, SIZE, OR COLOR.

FOR MARKET RESEARCH SERVICES (U.S. CLS. 100, 101 AND 102). FIRST USE 12-13-2004; IN COMMERCE 12-13-2004.

**CLASS 35—(Continued).**

3,234,106. CAMPUS MEDIA HOLDINGS, INC., BALTIMORE, MD. SN 78-135,043. PUB. 9-23-2003, FILED 6-12-2002.

**AMERICAN COLLEGIATE**

FOR PROMOTING SPORTS COMPETITIONS, ATHLETIC CONTESTS, EXHIBITIONS AND EVENTS IN THE FIELD OF INTRAMURAL SPORTS, NAMELY, FLAG FOOTBALL, SOCCER, VOLLEYBALL, FITNESS AND SOFTBALL (U.S. CLS. 100, 101 AND 102).  
FIRST USE 2-1-2005; IN COMMERCE 2-1-2005.

**CLASS 35—(Continued).**

3,234,213. DIGITAL LIVING NETWORK ALLIANCE, BEAVERTON, OR. SN 78-363,330. PUB. 8-30-2005, FILED 2-5-2004.

**DIGITAL LIVING  
NETWORK  
ALLIANCE**

3,234,178. THOMAS PUBLISHING COMPANY, NEW YORK, NY. SN 78-321,435. PUB. 9-14-2004, FILED 10-31-2003.

**IEN WORLD**

OWNER OF U.S. REG. NO. 2,519,417.  
NO CLAIM IS MADE TO THE EXCLUSIVE RIGHT TO USE "WORLD", APART FROM THE MARK AS SHOWN.  
FOR PROVIDING ONLINE INDUSTRIAL PRODUCT INFORMATION (U.S. CLS. 100, 101 AND 102).  
FIRST USE 12-6-2006; IN COMMERCE 12-6-2006.

THE MARK CONSISTS OF STANDARD CHARACTERS WITHOUT CLAIM TO ANY PARTICULAR FONT, STYLE, SIZE, OR COLOR.

NO CLAIM IS MADE TO THE EXCLUSIVE RIGHT TO USE "NETWORK ALLIANCE", APART FROM THE MARK AS SHOWN.

FOR ASSOCIATION SERVICES, NAMELY, PROMOTING THE INTERESTS OF THE CONSUMER ELECTRONICS INDUSTRY AND STANDARDS FOR NETWORKED DIGITAL CONSUMER ELECTRONICS PRODUCTS AND SERVICES (U.S. CLS. 100, 101 AND 102).

FIRST USE 11-16-2006; IN COMMERCE 11-16-2006.

3,234,221. IRIDESSE, INC., NEW YORK, NY. SN 78-373,297. PUB. 3-22-2005, FILED 2-24-2004.

**IRIDESSE**

3,234,190. KOLE IMPORTS, CARSON, CA. SN 78-332,172. PUB. 1-10-2006, FILED 11-24-2003.

**GENESIS COLLECTION**

THE MARK CONSISTS OF STANDARD CHARACTERS WITHOUT CLAIM TO ANY PARTICULAR FONT, STYLE, SIZE, OR COLOR.

FOR DISTRIBUTORSHIP SERVICES IN THE FIELD OF RELIGIOUS PRODUCTS (U.S. CLS. 100, 101 AND 102).

FIRST USE 11-24-2003; IN COMMERCE 2-1-2004.

THE MARK CONSISTS OF STANDARD CHARACTERS WITHOUT CLAIM TO ANY PARTICULAR FONT, STYLE, SIZE, OR COLOR.

FOR ONLINE RETAIL STORE SERVICES AND MAIL ORDER SERVICES FEATURING PEARL JEWELRY AND NECKLACES, BRACELETS, PENDANTS, RINGS AND EARRINGS ALL MADE OF PEARLS (U.S. CLS. 100, 101 AND 102).

FIRST USE 11-13-2006; IN COMMERCE 11-13-2006.

**CLASS 35—(Continued).**

3,234,241. THE TRUSTEE(S) OF THE SMG TRUST, WASHINGTON, DC. SN 78-382,549. PUB. 9-13-2005, FILED 3-11-2004.

**CLASS 35—(Continued).**

3,234,247. RMSG LLC, PRINCETON, NJ. SN 78-384,187. PUB. 1-11-2005, FILED 3-15-2004.

# WIPE N WIN

THE MARK CONSISTS OF STANDARD CHARACTERS WITHOUT CLAIM TO ANY PARTICULAR FONT, STYLE, SIZE, OR COLOR.

FOR PROMOTING THE SALE OF THE GOODS AND/OR SERVICES OF OTHERS THROUGH THE DISTRIBUTION OF PRINTED MATERIAL AND CONDUCTING A PROMOTIONAL CONTEST IN CONNECTION THEREWITH, NAMELY, PACKAGING PROMOTIONAL GAME PIECES WITH PRODUCTS, WHICH GAME PIECE MAY BE REDEEMED ONLINE FOR PRIZES IN THE NATURE OF OTHER GOODS OR SERVICES (U.S. CLS. 100, 101 AND 102).

FIRST USE 3-11-2004; IN COMMERCE 12-6-2006.

# Personality-Trac

THE MARK CONSISTS OF STANDARD CHARACTERS WITHOUT CLAIM TO ANY PARTICULAR FONT, STYLE, SIZE, OR COLOR.

FOR BUSINESS MANAGEMENT CONSULTATION, NAMELY, PROVIDING DATA, ANALYTICAL TECHNIQUES, OR INSIGHTS TO ENABLE MANAGEMENT TO IMPROVE BUSINESS EFFECTIVENESS (U.S. CLS. 100, 101 AND 102).

FIRST USE 12-4-2006; IN COMMERCE 12-4-2006.

3,234,248. RMSG LLC, PRINCETON, NJ. SN 78-384,203. PUB. 9-27-2005, FILED 3-15-2004.

3,234,246. RMSG LLC, PRINCETON, NJ. SN 78-384,151. PUB. 6-28-2005, FILED 3-15-2004.

# Personality Marketing System

THE MARK CONSISTS OF STANDARD CHARACTERS WITHOUT CLAIM TO ANY PARTICULAR FONT, STYLE, SIZE, OR COLOR.

NO CLAIM IS MADE TO THE EXCLUSIVE RIGHT TO USE "MARKETING SYSTEM", APART FROM THE MARK AS SHOWN.

FOR BUSINESS MANAGEMENT CONSULTATION, NAMELY, PROVIDING DATA, ANALYTICAL TECHNIQUES, OR INSIGHTS TO ENABLE MANAGEMENT TO IMPROVE BUSINESS EFFECTIVENESS (U.S. CLS. 100, 101 AND 102).

FIRST USE 11-30-2006; IN COMMERCE 11-30-2006.

# Personality

THE MARK CONSISTS OF STANDARD CHARACTERS WITHOUT CLAIM TO ANY PARTICULAR FONT, STYLE, SIZE, OR COLOR.

FOR BUSINESS MANAGEMENT CONSULTATION, NAMELY, PROVIDING MARKET SEGMENT DATA, MARKET SEGMENT ANALYTICAL TECHNIQUES, OR MARKET SEGMENT INSIGHTS TO ENABLE MANAGEMENT TO IMPROVE BUSINESS EFFECTIVENESS (U.S. CLS. 100, 101 AND 102).

FIRST USE 12-5-2006; IN COMMERCE 12-5-2006.

**CLASS 35—(Continued).**

3,234,249. RMSG LLC, PRINCETON, NJ. SN 78-384,214. PUB. 8-30-2005, FILED 3-15-2004.

**CLASS 35—(Continued).**

3,234,251. RMSG LLC, PRINCETON, NJ. SN 78-384,243. PUB. 7-5-2005, FILED 3-15-2004.

# Patient Personality

THE MARK CONSISTS OF STANDARD CHARACTERS WITHOUT CLAIM TO ANY PARTICULAR FONT, STYLE, SIZE, OR COLOR.

NO CLAIM IS MADE TO THE EXCLUSIVE RIGHT TO USE PATIENT, APART FROM THE MARK AS SHOWN.

FOR BUSINESS MANAGEMENT CONSULTATION, NAMELY, PROVIDING MARKET SEGMENT DATA, MARKET SEGMENT ANALYTICAL TECHNIQUES, OR MARKET SEGMENT INSIGHTS TO ENABLE MANAGEMENT TO IMPROVE BUSINESS EFFECTIVENESS (U.S. CLS. 100, 101 AND 102).

FIRST USE 12-5-2006; IN COMMERCE 12-5-2006.

# Auto Personality

THE MARK CONSISTS OF STANDARD CHARACTERS WITHOUT CLAIM TO ANY PARTICULAR FONT, STYLE, SIZE, OR COLOR.

FOR BUSINESS MANAGEMENT CONSULTATION, NAMELY, PROVIDING DATA, ANALYTICAL TECHNIQUES, OR INSIGHTS TO ENABLE MANAGEMENT TO IMPROVE BUSINESS EFFECTIVENESS (U.S. CLS. 100, 101 AND 102).

FIRST USE 12-5-2006; IN COMMERCE 12-5-2006.

---

3,234,250. RMSG LLC, PRINCETON, NJ. SN 78-384,229. PUB. 7-5-2005, FILED 3-15-2004.

---

3,234,252. RMSG LLC, PRINCETON, NJ. SN 78-384,247. PUB. 7-5-2005, FILED 3-15-2004.

# E-Personality

THE MARK CONSISTS OF STANDARD CHARACTERS WITHOUT CLAIM TO ANY PARTICULAR FONT, STYLE, SIZE, OR COLOR.

FOR BUSINESS MANAGEMENT CONSULTATION, NAMELY, PROVIDING DATA, ANALYTICAL TECHNIQUES, OR INSIGHTS TO ENABLE MANAGEMENT TO IMPROVE BUSINESS EFFECTIVENESS (U.S. CLS. 100, 101 AND 102).

FIRST USE 12-5-2006; IN COMMERCE 12-5-2006.

# NAB Personality

THE MARK CONSISTS OF STANDARD CHARACTERS WITHOUT CLAIM TO ANY PARTICULAR FONT, STYLE, SIZE, OR COLOR.

FOR BUSINESS MANAGEMENT CONSULTATION, NAMELY, PROVIDING DATA, ANALYTICAL TECHNIQUES, OR INSIGHTS TO ENABLE MANAGEMENT TO IMPROVE BUSINESS EFFECTIVENESS (U.S. CLS. 100, 101 AND 102).

FIRST USE 12-5-2006; IN COMMERCE 12-5-2006.

**CLASS 35—(Continued).**

3,234,254. YASSA, FATHY, SOQUEL, CA. SN 78-385,536. PUB. 2-28-2006, FILED 3-16-2004.

**COCAST**

THE MARK CONSISTS OF STANDARD CHARACTERS WITHOUT CLAIM TO ANY PARTICULAR FONT, STYLE, SIZE, OR COLOR.  
FOR PROMOTING THE GOODS AND SERVICES OF OTHERS BY PROVIDING HYPERTEXT LINKS TO THE WEB SITES OF OTHERS (U.S. CLS. 100, 101 AND 102).  
FIRST USE 11-13-2006; IN COMMERCE 11-13-2006.

3,234,280. GENERAL CABLE TECHNOLOGIES CORPORATION, HIGHLAND HEIGHTS, KY. SN 78-406,882. PUB. 9-13-2005, FILED 4-23-2004.

**OE DOWN TO THE CORE**

THE MARK CONSISTS OF STANDARD CHARACTERS WITHOUT CLAIM TO ANY PARTICULAR FONT, STYLE, SIZE, OR COLOR.  
FOR WHOLESALE DISTRIBUTORSHIP AND ORDERING SERVICES FOR AUTOMOTIVE PRODUCTS FEATURING IGNITION WIRE, BOOSTER CABLES, PRIMARY WIRE, AND BATTERY STARTER CABLES (U.S. CLS. 100, 101 AND 102).  
FIRST USE 6-0-2004; IN COMMERCE 6-0-2004.

3,234,288. LANE, CHERYL A., SAN FRANCISCO, CA. SN 78-410,306. PUB. 6-14-2005, FILED 4-29-2004.



**CLASS 35—(Continued).**

NO CLAIM IS MADE TO THE EXCLUSIVE RIGHT TO USE "GROUP", APART FROM THE MARK AS SHOWN.  
FOR INTERNATIONAL TAX PLANNING AND BUSINESS CONSULTING (U.S. CLS. 100, 101 AND 102).  
FIRST USE 11-1-2004; IN COMMERCE 11-1-2004.

3,234,306. CONSEIL INTERPROFESSIONNEL DES VINS DU LANGUEDOC (C.I.V.L.), NARBONNE CEDEX, FRANCE. SN 78-418,966. PUB. 6-28-2005, FILED 5-14-2004.

**LANGUEDOC  
SENSATIONS**

THE MARK CONSISTS OF STANDARD CHARACTERS WITHOUT CLAIM TO ANY PARTICULAR FONT, STYLE, SIZE, OR COLOR.  
NO CLAIM IS MADE TO THE EXCLUSIVE RIGHT TO USE "LANGUEDOC", APART FROM THE MARK AS SHOWN.  
FOR ASSOCIATION SERVICES, NAMELY, PROMOTING THE INTERESTS OF WINERIES OF LANGUEDOC, FRANCE (U.S. CLS. 100, 101 AND 102).  
FIRST USE 6-26-2006; IN COMMERCE 6-26-2006.

3,234,342. BRIDGEWATER, INC., SALT LAKE CITY, UT. SN 78-445,188. PUB. 11-15-2005, FILED 7-2-2004.

**INTERLINKSUPPLY.  
COM**

THE MARK CONSISTS OF STANDARD CHARACTERS WITHOUT CLAIM TO ANY PARTICULAR FONT, STYLE, SIZE, OR COLOR.  
FOR ADVERTISING SERVICES, NAMELY DISSEMINATING ADVERTISING MATERIALS TO COMMERCIAL CLEANING CUSTOMERS OF APPLICANT'S FRANCHISEES AND DISTRIBUTORSHIP SERVICES IN THE FIELD OF COMMERCIAL CLEANING SUPPLIES AND COMMERCIAL CLEANING EQUIPMENT FOR FRANCHISEES OF APPLICANT (U.S. CLS. 100, 101 AND 102).  
FIRST USE 5-10-2004; IN COMMERCE 5-10-2004.

**CLASS 35—(Continued).**

3,234,350. HOBOKEN WOOD FLOORING CORPORATION, WAYNE, NJ. SN 78-449,080. PUB. 9-13-2005, FILED 7-12-2004.



OWNER OF U.S. REG. NO. 1,116,229.  
FOR RETAIL STORE AND DISTRIBUTORSHIP SERVICES FEATURING HARD-SURFACE FLOORING, NAMELY, HARDWOOD, ENGINEERED, COMPOSITE, CERAMIC, MINERAL AND VINYL FLOORING; AND HARD-SURFACE FLOORING ACCESSORIES, NAMELY, ABRASIVES, WOOD FINISHES, SANDERS, BUFFERS, EDGERS, VACUUM CLEANERS, DUST-COLLECTION APPARATUS, NAILERS, STAPLERS, NAILS, STAPLES, SAWS AND METERS (U.S. CLS. 100, 101 AND 102).  
FIRST USE 7-1-2004; IN COMMERCE 7-1-2004.

---

3,234,351. LATIMARK, IRVING, TX. SN 78-450,018. PUB. 11-1-2005, FILED 7-13-2004.

# Smartractor

THE MARK CONSISTS OF STANDARD CHARACTERS WITHOUT CLAIM TO ANY PARTICULAR FONT, STYLE, SIZE, OR COLOR.

FOR PROVIDING CONSULTATION IN THE FIELD OF MARKETING, TO INCLUDE THE AREAS OF MARKET RESEARCH AND ANALYSIS, PRODUCT LAUNCH AND MARKETING, PUBLIC RELATIONS, ADVERTISING, BRANDING, MARKETING COMMUNICATIONS, CHANNEL MARKETING, PROMOTIONS AND INCENTIVES, AND EVENTS; PROVIDING MARKETING STAFF ON A TEMPORARY, CONTRACT, OR PERMANENT BASIS; PROVIDING CONSULTING SERVICES IN MARKETING AND BUSINESS MANAGEMENT (U.S. CLS. 100, 101 AND 102).

FIRST USE 5-22-2006; IN COMMERCE 5-22-2006.

**CLASS 35—(Continued).**

3,234,356. SHIMANO INC., SAKAI CITY, JAPAN. SN 78-453,079. PUB. 3-14-2006, FILED 7-19-2004.

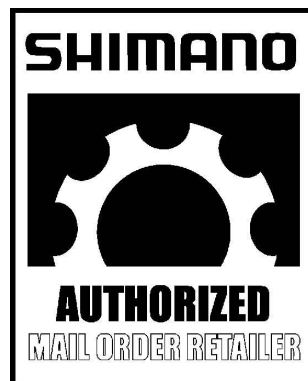

OWNER OF U.S. REG. NOS. 2,493,168, 2,625,926, AND OTHERS.

NO CLAIM IS MADE TO THE EXCLUSIVE RIGHT TO USE "AUTHORIZED MAIL ORDER RETAILER", APART FROM THE MARK AS SHOWN.

FOR MAIL ORDER CATALOG SERVICES FEATURING SPORTING GOODS; MAIL ORDER STORE SERVICES FEATURING SPORTING GOODS; PROMOTING THE SALE OF GOODS AND SERVICES OFFERED BY OTHERS IN THE FIELD OF SPORTING GOODS THROUGH THE DISTRIBUTION OF PRINTED CATALOGS (U.S. CLS. 100, 101 AND 102).

FIRST USE 10-25-2002; IN COMMERCE 10-25-2002.

---

3,234,400. ZING COMMUNICATIONS PTY LTD., SURRY HILLS NEW SOUTH WALES, AUSTRALIA. SN 78-478,588. PUB. 9-27-2005, FILED 9-3-2004.

# zing

FOR MARKETING CONSULTING; BUSINESS PLANNING IN THE FIELD OF BROADCAST MEDIA; PUBLIC RELATIONS; COPYWRITING, NAMELY THE WRITING OF ADVERTISING COPY DESIGNED TO SELL THE PRODUCTS OR SERVICES OF OTHERS; PREPARATION AND REALIZATION OF MEDIA AND ADVERTISING PLANS AND CONCEPTS (U.S. CLS. 100, 101 AND 102).

FIRST USE 9-0-2004; IN COMMERCE 9-0-2004.

**CLASS 35—(Continued).**

3,234,413. HEALTHPLACERS, INC., ALPHARETTA, GA. SN 78-482,929. PUB. 9-6-2005, FILED 9-14-2004.

**HEALTHPLACERS**

THE MARK CONSISTS OF STANDARD CHARACTERS WITHOUT CLAIM TO ANY PARTICULAR FONT, STYLE, SIZE, OR COLOR.

FOR EMPLOYMENT HIRING, RECRUITING, PLACEMENT, STAFFING AND CAREER NETWORKING SERVICES (U.S. CLS. 100, 101 AND 102).

FIRST USE 9-1-2004; IN COMMERCE 9-1-2004.

3,234,432. HEARTS ON FIRE COMPANY LLC, BOSTON, MA. SN 78-490,834. PUB. 9-6-2005, FILED 9-28-2004.

**HEARTS ON FIRE**

THE MARK CONSISTS OF STANDARD CHARACTERS WITHOUT CLAIM TO ANY PARTICULAR FONT, STYLE, SIZE, OR COLOR.

OWNER OF U.S. REG. NOS. 2,119,886 AND 2,686,511. FOR RETAIL STORE SERVICES IN THE FIELD OF DIAMONDS AND JEWELRY (U.S. CLS. 100, 101 AND 102).

FIRST USE 9-30-2002; IN COMMERCE 9-30-2002.

3,234,435. SPANLINK COMMUNICATIONS, INC., MINNEAPOLIS, MN. SN 78-491,007. PUB. 9-13-2005, FILED 9-28-2004.

**MARKETROUTING**

THE MARK CONSISTS OF STANDARD CHARACTERS WITHOUT CLAIM TO ANY PARTICULAR FONT, STYLE, SIZE, OR COLOR.

FOR BUSINESS SERVICES, NAMELY, PROVIDING SERVICES FOR COMMERCIAL CONTACT CENTERS AND OTHER CALL-TAKING ORGANIZATIONS TO PRIORITIZE, ORGANIZE AND RESPOND TO INCOMING COMMUNICATIONS (U.S. CLS. 100, 101 AND 102).

FIRST USE 7-0-2005; IN COMMERCE 7-0-2005.

**CLASS 35—(Continued).**

3,234,440. WHISPER, NEWPORT BEACH, CA. SN 78-493,616. PUB. 9-13-2005, FILED 10-3-2004.

**OWN THE CONVERSATION**

THE MARK CONSISTS OF STANDARD CHARACTERS WITHOUT CLAIM TO ANY PARTICULAR FONT, STYLE, SIZE, OR COLOR.

FOR BUSINESS CONSULTATION SERVICES IN THE FIELD OF MARKETING; CONDUCTING BUSINESS AND MARKETING RESEARCH SURVEYS; DEVELOP AND IMPLEMENTATION OF MARKETING STRATEGIES FOR OTHERS; ADVERTISING AGENCY SERVICES; NAMING AND BRANDING OF PRODUCTS AND SERVICES FOR OTHERS; ADVERTISING SERVICES FOR OTHERS NAMELY CREATING, EVALUATING, AND MANAGING CORPORATE BRAND NAMES, IMAGES, LOGOS AND IDENTITIES; BUSINESS MANAGEMENT AND CONSULTING SERVICES IN THE FIELD OF BRAND NAMES, NAMELY, BRAND EVALUATION, BRAND POSITIONING, BRAND STRATEGY, BRAND, PRODUCTS AND SERVICES PROMOTION AND CONSULTING SERVICES RELATED THERETO; CREATING TRADEMARKS FOR OTHERS (U.S. CLS. 100, 101 AND 102).

FIRST USE 1-0-2006; IN COMMERCE 1-0-2006.

3,234,445. LEVEL 3 COMMUNICATIONS, INC., BROOMFIELD, CO. SN 78-494,782. PUB. 2-14-2006, FILED 10-5-2004.

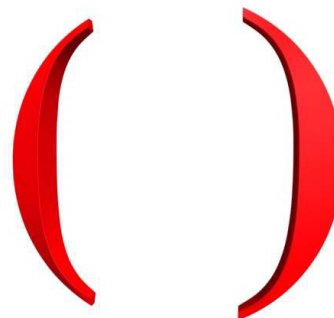

OWNER OF U.S. REG. NO. 2,826,213. THE COLOR(S) RED IS/ARE CLAIMED AS A FEATURE OF THE MARK.

THE MARK CONSISTS OF A PAIR OF THREE-DIMENSIONAL RED BRACKETS OR PARENTHESES.

FOR PROVIDING ONLINE ORDERING OF TELECOMMUNICATIONS GATEWAY SERVICES, TELECOMMUNICATIONS SERVICES, NAMELY, VOICE, VIDEO AND DATA TRANSMISSION SERVICES VIA A GLOBAL COMPUTER INFORMATION NETWORK (U.S. CLS. 100, 101 AND 102).

FIRST USE 5-0-2004; IN COMMERCE 5-0-2004.

**CLASS 35—(Continued).**

3,234,479. A.T. KEARNEY, INC., CHICAGO, IL. SN 78-506,934. PUB. 9-13-2005, FILED 10-27-2004.

**CLASS 35—(Continued).**

3,234,488. PLAYBOY ENTERPRISES INTERNATIONAL, INC., CHICAGO, IL. SN 78-511,512. PUB. 3-14-2006, FILED 11-4-2004.

## IDEAS THAT LAST

THE MARK CONSISTS OF STANDARD CHARACTERS WITHOUT CLAIM TO ANY PARTICULAR FONT, STYLE, SIZE, OR COLOR.

FOR BUSINESS MANAGEMENT CONSULTING SERVICES AND EXECUTIVE JOB SEARCH SERVICES (U.S. CLS. 100, 101 AND 102).

FIRST USE 11-22-2004; IN COMMERCE 11-22-2004.

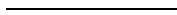

3,234,482. BLUE, INC., PORTLAND, OR. SN 78-508,758. PUB. 5-2-2006, FILED 10-30-2004.



## blue research

THE MARK CONSISTS OF STANDARD CHARACTERS WITHOUT CLAIM TO ANY PARTICULAR FONT, STYLE, SIZE, OR COLOR.

NO CLAIM IS MADE TO THE EXCLUSIVE RIGHT TO USE "RESEARCH", APART FROM THE MARK AS SHOWN.

FOR MARKET RESEARCH SERVICES; MARKET RESEARCH CONSULTATION; BUSINESS MARKETING CONSULTING SERVICES; BUSINESS MANAGEMENT CONSULTATION WITH RELATION TO STRATEGY, MARKETING, RESEARCH AND PRODUCTION (U.S. CLS. 100, 101 AND 102).

FIRST USE 1-27-2005; IN COMMERCE 1-27-2005.

THE MARK CONSISTS OF A THREE DIMENSIONAL BUNNY COSTUME WORN BY A WOMAN. THE COSTUME INCLUDES A CORSETED BODICE, BUNNY EARS WORN ON THE HEAD, A BUNNY TAIL ON THE BACK OF THE BODICE, A NAME TAG ON THE FRONT OF THE BODICE, WRIST CUFFS AND A BOW TIE COLLAR. THE DOTTED OUTLINE OF A WOMAN IS NOT A PART OF THE MARK BUT IS MERELY INTENDED TO SHOW THE POSITION OF THE COSTUME.

FOR RETAIL STORE SERVICES IN THE FIELDS OF CLOTHING, CLOTHING ACCESSORIES, JEWELRY, BOOKS, MAGAZINES, STATIONARY, VIDEOS, CD'S, DVD'S, HOME ACCESSORIES, BED AND BATH ACCESSORIES, SMOKER'S ARTICLES, ELECTRONICS, FOOD AND DRINKS, SPORTING GOODS, TRAVEL ACCESSORIES, COSMETICS, GAME EQUIPMENT (U.S. CLS. 100, 101 AND 102).

FIRST USE 6-30-1999; IN COMMERCE 6-30-1999.



**CLASS 35—(Continued).**

3,234,510. SULLIVAN, NADINE M, SPOKANE, WA. SN 78-515,803. PUB. 9-5-2006, FILED 11-12-2004.



THE COLOR(S) GREEN, BLUE, YELLOW IS/ARE CLAIMED AS A FEATURE OF THE MARK.

THE MARK CONSISTS OF THE WORDING ECO DEPOT IN GREEN LETTERS, A BLUE ARC WITH YELLOW SUNSHINE RAYS PEEKING OUT FROM BEHIND THE ARC UNDERNEATH THE WORDS ECO DEPOT.

THE MARK CONSISTS OF THE WORDING ECO DEPOT IN GREEN LETTERS, A BLUE ARC WITH YELLOW SUNSHINE RAYS PEEKING OUT FROM BEHIND THE ARC UNDERNEATH THE WORDS ECO DEPOT.

FOR RETAIL STORE SERVICES IN THE FIELD OF ENVIRONMENTAL PRODUCTS FOR HOME USE, FEATURING GREEN AND SUSTAINABLE BUILDING AND CONSTRUCTION MATERIALS, WIND AND SOLAR RENEWABLE ENERGY SYSTEMS, WATER TREATMENT SYSTEMS, WASTE OIL HEATERS AND BOILERS (U.S. CLS. 100, 101 AND 102).

FIRST USE 12-1-2003; IN COMMERCE 12-1-2003.

**CLASS 35—(Continued).**

3,234,522. ATC HEALTHCARE SERVICES, INC., LAKE SUCCESS, NY. SN 78-520,181. PUB. 10-18-2005, FILED 11-19-2004.

**ATC ALPHASOURCE**

THE MARK CONSISTS OF STANDARD CHARACTERS WITHOUT CLAIM TO ANY PARTICULAR FONT, STYLE, SIZE, OR COLOR.

OWNER OF U.S. REG. NO. 1,577,053.

FOR MEDICAL EMPLOYMENT PLACEMENT AND STAFFING SERVICES (U.S. CLS. 100, 101 AND 102).

FIRST USE 4-1-2006; IN COMMERCE 4-1-2006.

3,234,558. TRACPOINT SYSTEM, LP, SAN ANTONIO, TX. SN 78-529,275. PUB. 9-27-2005, FILED 12-8-2004.

3,234,517. THE SUPPORTING CAST, INC., NEW YORK, NY. SN 78-518,823. PUB. 3-14-2006, FILED 11-17-2004.



**TRACWHERE**

NO CLAIM IS MADE TO THE EXCLUSIVE RIGHT TO USE "TEAM", APART FROM THE MARK AS SHOWN.

FOR ASSOCIATION SERVICES, NAMELY PROMOTING THE INTERESTS OF INDEPENDENTLY OWNED AND OPERATED EMPLOYMENT AGENCIES, EACH PROVIDING HIRING, COUNSELING, RECRUITING, TEMPORARY AND PERMANENT PLACEMENT, STAFFING AND CAREER NETWORKING SERVICES AND OUTPLACEMENT SERVICES (U.S. CLS. 100, 101 AND 102).

FIRST USE 12-1-2006; IN COMMERCE 12-1-2006.

THE MARK CONSISTS OF STANDARD CHARACTERS WITHOUT CLAIM TO ANY PARTICULAR FONT, STYLE, SIZE, OR COLOR.

FOR LOCATING, TRACKING, TRACING AND MONITORING OF LAND, SEA AND AIR VEHICLES AND CRAFT AND PACKAGES AND CONTAINERS; TRANSPORTATION LOGISTICS SERVICES, NAMELY SHIPMENT PROCESSING, PREPARING SHIPPING DOCUMENTS AND INVOICES, TRACKING DOCUMENTS, PACKAGES, FREIGHT AND INVENTORY OVER COMPUTER NETWORKS, INTRANETS AND INTERNETS (U.S. CLS. 100, 101 AND 102).

FIRST USE 1-15-2005; IN COMMERCE 1-15-2005.

**CLASS 35—(Continued).**

3,234,576. GRIZZARD COMMUNICATIONS GROUP, INC., ATLANTA, GA. SN 78-532,348. PUB. 4-4-2006, FILED 12-14-2004.

GrizzardSignatureGroup

OWNER OF U.S. REG. NOS. 2,684,590 AND 2,722,303.  
NO CLAIM IS MADE TO THE EXCLUSIVE RIGHT TO USE "GROUP", APART FROM THE MARK AS SHOWN.  
THE MARK CONSISTS OF THE WORDS GRIZZARD SIGNATURE GROUP WITH STYLIZED LETTERS.  
FOR DIRECT RESPONSE MARKETING SERVICES PROMOTING NON-PROFIT GROUPS VIA DIRECT MAIL, ELECTRONIC MAIL, PUBLIC COMMUNICATIONS, ALTERNATIVE MEDIA, MAJOR GIFT STRATEGIES, AND DONOR-FOCUSED MARKETING CHANNELS (U.S. CLS. 100, 101 AND 102).  
FIRST USE 4-28-2005; IN COMMERCE 4-28-2005.

---

3,234,587. INVENTION SUBMISSION CORPORATION, PITTSBURGH, PA. SN 78-536,694. PUB. 12-27-2005, FILED 12-21-2004.

INVENTHELP

THE MARK CONSISTS OF STANDARD CHARACTERS WITHOUT CLAIM TO ANY PARTICULAR FONT, STYLE, SIZE, OR COLOR.  
FOR ASSISTING INVENTORS AND OTHERS IN THE PACKAGING AND PRESENTATION OF THEIR IDEAS TO INDUSTRY; PATENT REFERRAL SERVICES, NAMELY REFERRING INVENTORS TO PATENT SERVICES PROVIDERS (U.S. CLS. 100, 101 AND 102).  
FIRST USE 6-3-2003; IN COMMERCE 3-22-2005.

**CLASS 35—(Continued).**

3,234,605. SAUDER WOODWORKING CO., ARCHBOLD, OH. SN 78-543,350. PUB. 9-5-2006, FILED 1-6-2005.

GO FURNITURE

THE MARK CONSISTS OF STANDARD CHARACTERS WITHOUT CLAIM TO ANY PARTICULAR FONT, STYLE, SIZE, OR COLOR.  
NO CLAIM IS MADE TO THE EXCLUSIVE RIGHT TO USE "FURNITURE", APART FROM THE MARK AS SHOWN.  
FOR RETAIL STORE SERVICES FEATURING FURNITURE (U.S. CLS. 100, 101 AND 102).  
FIRST USE 8-0-2004; IN COMMERCE 8-0-2004.

---

3,234,609. J FISHER LLC, NEW YORK, NY. SN 78-544,157. PUB. 12-20-2005, FILED 1-7-2005.

j fisher

NO CLAIM IS MADE TO THE EXCLUSIVE RIGHT TO USE FISHER, APART FROM THE MARK AS SHOWN.  
THE MARK CONSISTS IN PART OF A FISHHOOK DESIGN INCORPORATED INTO THE LETTER "J".  
FOR MAIL ORDER CATALOG SERVICES, AND COMPUTERIZED ON-LINE RETAIL STORE SERVICES, ALL FEATURING FISHING TACKLE, CLOTHING, AND ACCESSORIES (U.S. CLS. 100, 101 AND 102).  
FIRST USE 5-1-2005; IN COMMERCE 5-1-2005.

**CLASS 35—(Continued).**

3,234,624. O HOTEL, INC., SANTA MONICA, CA. SN 78-547,838. PUB. 6-27-2006, FILED 1-14-2005.

O Hotel

THE MARK CONSISTS OF STANDARD CHARACTERS WITHOUT CLAIM TO ANY PARTICULAR FONT, STYLE, SIZE, OR COLOR.

NO CLAIM IS MADE TO THE EXCLUSIVE RIGHT TO USE "HOTEL", APART FROM THE MARK AS SHOWN.

FOR HOTEL MANAGEMENT FOR OTHERS (U.S. CLS. 100, 101 AND 102).

FIRST USE 11-1-2006; IN COMMERCE 11-1-2006.

3,234,635. LIPSON ASSOCIATES, INC., DBA LIPSON-AL-PORT-GLASS & ASSOCIATES, NORTHBROOK, IL. SN 78-555,195. PUB. 11-8-2005, FILED 1-27-2005.

TRI LAB

THE MARK CONSISTS OF STANDARD CHARACTERS WITHOUT CLAIM TO ANY PARTICULAR FONT, STYLE, SIZE, OR COLOR.

OWNER OF U.S. REG. NO. 2,847,367.

FOR ADVERTISING AND MARKETING SERVICES, NAMELY, BRAND CONCEPT EVALUATION STUDIES PROVIDING INTERACTIVE RESEARCH SESSIONS WITH CONSUMER-PARTICIPANTS AND COLLECTING DATA USED AND APPLIED FOR THE PURPOSE OF EVALUATING PACKAGING AND POSITIONING FOR BRAND CONCEPTS (U.S. CLS. 100, 101 AND 102).

FIRST USE 9-15-2004; IN COMMERCE 9-15-2004.

**CLASS 35—(Continued).**

3,234,652. DELAWARE NORTH COMPANIES TRAVEL HOSPITALITY SERVICES, INC., BUFFALO, NY. SN 78-564,278. PUB. 5-23-2006, FILED 2-10-2005.

EVERYTHING ASAP

THE MARK CONSISTS OF STANDARD CHARACTERS WITHOUT CLAIM TO ANY PARTICULAR FONT, STYLE, SIZE, OR COLOR.

FOR RETAIL STORE SERVICES FEATURING HEALTH AND BEAUTY PRODUCTS AND CONVENIENCE STORE ITEMS (U.S. CLS. 100, 101 AND 102).

FIRST USE 11-6-2005; IN COMMERCE 11-6-2005.

3,234,665. REDPEG MARKETING, INC., ALEXANDRIA, VA. SN 78-571,472. PUB. 12-20-2005, FILED 2-21-2005.



FOR ARRANGING AND CONDUCTING MARKETING PROMOTIONAL EVENTS FOR OTHERS, NAMELY, CREATING MASTER ORGANIZATIONAL PLANS, CREATING SCHEDULES AND SITE MAPS, SCREENING AND HIRING STAFF, INVESTIGATING NECESSARY INSURANCE AND CITY AND STATE PERMITS, THEMATICALLY DESIGN AND STRATEGICALLY POSITION PROMOTIONAL MATERIALS, SIGNAGE, EXHIBITS, TENTING, AND BANNERS, DEVELOP AND EXECUTE PUBLIC RELATIONS OPPORTUNITIES, UTILIZE TECHNOLOGY TO CONDUCT REAL TIME AUDITS OF EVENTS, AND CONDUCT POST EVENT EVALUATIONS (U.S. CLS. 100, 101 AND 102).

FIRST USE 11-30-2004; IN COMMERCE 11-30-2004.

**CLASS 35—(Continued).**

3,234,705. GILLEBAARD, HENDRICK D., JR., SAN CLEMENTE, CA. SN 78-586,894. PUB. 1-17-2006, FILED 3-14-2005.

CUSTOMER  
APPRECIATION  
REFERRAL  
ENHANCEMENT (C.A.R.  
E.)

THE MARK CONSISTS OF STANDARD CHARACTERS WITHOUT CLAIM TO ANY PARTICULAR FONT, STYLE, SIZE, OR COLOR.

NO CLAIM IS MADE TO THE EXCLUSIVE RIGHT TO USE CUSTOMER APPRECIATION REFERRAL, APART FROM THE MARK AS SHOWN.

FOR PROMOTING THE GOODS AND SERVICES OF OTHERS THROUGH A CUSTOMER APPRECIATION PROGRAM IN WHICH CUSTOMERS ARE REWARDED WITH DISCOUNTS AND MERCHANDISE (U.S. CLS. 100, 101 AND 102).

FIRST USE 4-20-2006; IN COMMERCE 4-20-2006.

3,234,709. SUPERVALU HOLDINGS, INC., EDEN PRAIRIE, MN. SN 78-588,246. PUB. 4-18-2006, FILED 3-16-2005.



NO CLAIM IS MADE TO THE EXCLUSIVE RIGHT TO USE "PUMP REWARDS", APART FROM THE MARK AS SHOWN.

FOR RETAIL STORE SERVICES FEATURING GROCERIES AND GASOLINE; ADMINISTRATION OF A DISCOUNT PROGRAM FOR ENABLING PARTICIPANTS TO OBTAIN DISCOUNTS ON GASOLINE (U.S. CLS. 100, 101 AND 102).

FIRST USE 11-9-2006; IN COMMERCE 11-9-2006.

**CLASS 35—(Continued).**

3,234,721. ASSOCIATION OF INTERNATIONAL AUTOMOBILE MANUFACTURERS, INC., ARLINGTON, VA. SN 78-593,196. PUB. 3-21-2006, FILED 3-23-2005.



OWNER OF U.S. REG. NO. 1,882,683.  
FOR ASSOCIATION SERVICES, NAMELY PROMOTING THE INTERESTS OF INTERNATIONAL AUTOMOBILE MANUFACTURERS (U.S. CLS. 100, 101 AND 102).  
FIRST USE 3-1-2005; IN COMMERCE 3-1-2005.

3,234,744. AGILEVIEW SOFTWARE, INC., SALEM, NH. SN 78-599,240. PUB. 12-27-2005, FILED 3-31-2005.

ONEBUNDLE

THE MARK CONSISTS OF STANDARD CHARACTERS WITHOUT CLAIM TO ANY PARTICULAR FONT, STYLE, SIZE, OR COLOR.

FOR LICENSING OF COMPUTER SOFTWARE, OUTSOURCING IN THE FIELD OF SALES, AND MARKETING OF COMPUTER SOFTWARE (U.S. CLS. 100, 101 AND 102).

FIRST USE 8-2-2006; IN COMMERCE 8-2-2006.

**CLASS 35—(Continued).**

3,234,760. FLIPSIDEA SOLUTIONS, LLC, CENTENNIAL, CO. SN 78-604,670. PUB. 4-4-2006, FILED 4-8-2005.

flipsidea  
solutions, LLC

THE MARK CONSISTS OF STANDARD CHARACTERS WITHOUT CLAIM TO ANY PARTICULAR FONT, STYLE, SIZE, OR COLOR.

NO CLAIM IS MADE TO THE EXCLUSIVE RIGHT TO USE "SOLUTIONS, LLC", APART FROM THE MARK AS SHOWN.

FOR BUSINESS ORGANIZATION AND MANAGEMENT CONSULTING SERVICES (U.S. CLS. 100, 101 AND 102).

FIRST USE 4-6-2004; IN COMMERCE 12-27-2004.

---

3,234,780. WHITED, AIMEE Y., FAIRBORN, OH. SN 78-613,485. PUB. 7-18-2006, FILED 4-21-2005.

MYHAIRBROKER.COM

THE MARK CONSISTS OF STANDARD CHARACTERS WITHOUT CLAIM TO ANY PARTICULAR FONT, STYLE, SIZE, OR COLOR.

FOR PROMOTING THE GOODS AND SERVICES OF OTHERS BY PROVIDING A WEB SITE AT WHICH USERS CAN LINK TO AND VIEW INFORMATION IN THE FIELDS OF HAIR CARE, HAIR CARE PRODUCTS, HAIR STYLES, SALONS, PROFESSIONAL STYLISTS, SPAS, NAIL CARE; PROMOTING THE SERVICES OF OTHERS VIA A GLOBAL COMPUTER NETWORK, NAMELY, PROVIDING A WEBSITE WHEREBY PROFESSIONAL STYLISTS CAN DISPLAY PHOTOGRAPHS OF THEIR WORK IN PORTFOLIO FORM FOR PROSPECTIVE CLIENTS; PROVIDING REFERRALS FOR PROFESSIONAL STYLISTS AND SALONS; PROMOTING THE PROFESSIONAL HAIR CARE SERVICES OF OTHERS THROUGH THE ON-LINE DISTRIBUTION OF ADVERTISING MATERIALS, COUPONS, AND SPECIAL OFFERS; DISPLAYING BANNER ADVERTISEMENTS FOR OTHERS; PROVIDING SPACE ON A WEB SITE FOR THE ADVERTISEMENT OF THE GOODS AND SERVICES OF OTHERS; PROMOTING THE GOODS AND SERVICES OF OTHERS BY PROVIDING HYPERTEXT LINKS TO THE WEB SITES OF OTHERS; PROVIDING ON-LINE DIRECTORY INFORMATION SERVICES FEATURING INFORMATION AND CONTACT INFORMATION FOR SALONS AND HAIR CARE PROFESSIONALS; AND PROVIDING CAREER NETWORKING SERVICES FOR STYLISTS AND SALON PROFESSIONALS (U.S. CLS. 100, 101 AND 102).

FIRST USE 11-0-2005; IN COMMERCE 11-0-2005.

**CLASS 35—(Continued).**

3,234,791. FVG HOLDINGS, L.C., TAMPA, FL. AND FVG CALIFORNIA PARTNERSHIP, LOS ANGELES, CA. SN 78-617,858. PUB. 1-17-2006, FILED 4-27-2005.

SBV NETWORK

NO CLAIM IS MADE TO THE EXCLUSIVE RIGHT TO USE "NETWORK", APART FROM THE MARK AS SHOWN. THE COLOR(S) BLUE AND RED IS/ARE CLAIMED AS A FEATURE OF THE MARK.

THE LETTERS ARE BLUE AND THE CIRCLES ARE RED. FOR PROGRAM OF BUSINESS CONSULTATION SERVICES DESIGNED TO ASSESS VARIOUS BENCHMARKS IN THE GROWTH AND PRODUCTIVITY OF COMPANIES AND TO ADVISE COMPANIES ON HOW TO IMPROVE PRODUCTIVITY AND ACHIEVE GROWTH (U.S. CLS. 100, 101 AND 102).

FIRST USE 10-1-2005; IN COMMERCE 10-1-2005.

---

3,234,806. PETSURANCE, INC., EAST HAMPTON, NY. SN 78-623,675. PUB. 3-14-2006, FILED 5-5-2005.

PETSURANCE

THE MARK CONSISTS OF STANDARD CHARACTERS WITHOUT CLAIM TO ANY PARTICULAR FONT, STYLE, SIZE, OR COLOR.

OWNER OF U.S. REG. NOS. 2,158,931 AND 2,160,526.

FOR ADVERTISING AND MARKETING SERVICES, NAMELY PROMOTING THE GOODS AND SERVICES OF OTHERS IN THE FIELDS OF PET HEALTH, PET HEALTH INSURANCE, PET ACCIDENT INSURANCE, AND PET ILLNESS INSURANCE (U.S. CLS. 100, 101 AND 102).

FIRST USE 8-12-2005; IN COMMERCE 8-12-2005.

**CLASS 35—(Continued).**

3,234,808. BRAINSTORM USA, LLC, ATLANTA, GA. SN 78-624,016. PUB. 3-28-2006, FILED 5-5-2005.



OWNER OF U.S. REG. NO. 2,754,890.  
NO CLAIM IS MADE TO THE EXCLUSIVE RIGHT TO USE "EDUCATIONAL SYSTEM", APART FROM THE MARK AS SHOWN.

FOR DIRECT MARKETING SERVICES PROVIDED VIA ELECTRONIC COMMUNICATION MEDIA AND WEB SITES RELATING TO EDUCATIONAL PRODUCTS AND EQUIPMENT, NAMELY, SOFTWARE BUNDLES, COMPUTER HARDWARE, EDUCATION WEB SITE REFERRALS, SCHOLARSHIPS, TUTORING PROGRAMS AND PRESENTATIONS, MATERIALS FOR USE BY EDUCATORS AND PARENTS OF STUDENTS (U.S. CLS. 100, 101 AND 102).

FIRST USE 5-24-2005; IN COMMERCE 6-30-2005.

3,234,814. HELENA HOLDING COMPANY, WILMINGTON, DE. SN 78-625,421. PUB. 8-29-2006, FILED 5-9-2005.



FOR PROVIDING A CUSTOMER LOYALTY AND FREQUENT BUYER PROGRAM IN THE CROP PROTECTION AND AGRICULTURAL INDUSTRIES (U.S. CLS. 100, 101 AND 102).

FIRST USE 4-1-2005; IN COMMERCE 4-1-2005.

**CLASS 35—(Continued).**

3,234,827. BASKETT, RAY, MURRIETA, CA. SN 78-628,631. PUB. 2-14-2006, FILED 5-12-2005.

**FANTASY ISLANDS**

THE MARK CONSISTS OF STANDARD CHARACTERS WITHOUT CLAIM TO ANY PARTICULAR FONT, STYLE, SIZE, OR COLOR.

FOR RETAIL AND WHOLESALE STORE SERVICES AND ON-LINE RETAIL AND WHOLESALE STORE SERVICES FEATURING BARBEQUES, COOKING ISLANDS, SPAS, BILLIARD AND POOL TABLES (U.S. CLS. 100, 101 AND 102).

FIRST USE 5-1-2005; IN COMMERCE 12-1-2005.

3,234,846. PIGMOVER.COM, LLC, CARMEL, IN. SN 78-633,475. PUB. 2-21-2006, FILED 5-19-2005.

**PIGMOVER.COM**

THE MARK CONSISTS OF STANDARD CHARACTERS WITHOUT CLAIM TO ANY PARTICULAR FONT, STYLE, SIZE, OR COLOR.

FOR ADVERTISING THE GOODS AND SERVICES OF OTHERS OVER THE INTERNET; PROVIDING AND RENTAL OF ADVERTISING SPACE ON THE INTERNET (U.S. CLS. 100, 101 AND 102).

FIRST USE 5-20-2005; IN COMMERCE 5-20-2005.

**CLASS 35—(Continued).**

3,234,847. BALBONI ASSOCIATES INC., SPRINGFIELD, MA. SN 78-633,482. PUB. 5-23-2006, FILED 5-19-2005.

**EVERYTHING IT TAKES**

THE MARK CONSISTS OF STANDARD CHARACTERS WITHOUT CLAIM TO ANY PARTICULAR FONT, STYLE, SIZE, OR COLOR.

FOR BUSINESS MARKETING SERVICES IN THE FIELDS OF NEW AND USED RENTAL EQUIPMENT INCLUDING HEAVY AND INDUSTRIAL EQUIPMENT NAMELY, PUMPS, GENERATORS, BOOM LIFTS, SCISSOR LIFTS, FORKLIFTS, COMPACTION ROLLERS, BACKHOES, EXCAVATORS, SKID STEERS, AIR COMPRESSORS, TRAILERS, TRUCKS, COMPACTION EQUIPMENT, CRANES, GENERATORS, TRENCHERS, BULLDOZERS, AND CONCRETE FORMING EQUIPMENT, GENERAL TOOLS AND EQUIPMENT, NAMELY HAND TOOLS AND GARDENING AND LANDSCAPING EQUIPMENT, SPECIAL EVENTS EQUIPMENT, NAMELY TENTS, TABLES AND CHAIRS, AND PARTS THEREOF (U.S. CLS. 100, 101 AND 102).

FIRST USE 11-27-2006; IN COMMERCE 11-27-2006.

---

3,234,882. MEDICAL BROADCASTING, LLC, PHILADELPHIA, PA. SN 78-641,142. PUB. 2-28-2006, FILED 6-1-2005.

**THE AGENCY FOR WHAT'S NEXT**

THE MARK CONSISTS OF STANDARD CHARACTERS WITHOUT CLAIM TO ANY PARTICULAR FONT, STYLE, SIZE, OR COLOR.

FOR ADVERTISING AGENCY SERVICES AND ADVERTISING, MARKETING, AND PROMOTION AND RELATED CONSULTING SERVICE FOR MEDICAL, PHARMACEUTICAL, AND HEALTH CARE COMPANIES (U.S. CLS. 100, 101 AND 102).

FIRST USE 6-0-2005; IN COMMERCE 6-0-2005.

**CLASS 35—(Continued).**

3,234,883. MEDICAL BROADCASTING, LLC, PHILADELPHIA, PA. SN 78-641,150. PUB. 2-28-2006, FILED 6-1-2005.

**MEDICAL BROADCASTING  
COMPANY THE AGENCY FOR  
WHAT'S NEXT**

THE MARK CONSISTS OF STANDARD CHARACTERS WITHOUT CLAIM TO ANY PARTICULAR FONT, STYLE, SIZE, OR COLOR.

OWNER OF U.S. REG. NOS. 2,809,828 AND 2,809,829.

NO CLAIM IS MADE TO THE EXCLUSIVE RIGHT TO USE "MEDICAL" AND "COMPANY", APART FROM THE MARK AS SHOWN.

FOR ADVERTISING AGENCY SERVICES AND ADVERTISING, MARKETING, AND PROMOTION AND RELATED CONSULTING SERVICE FOR MEDICAL, PHARMACEUTICAL, AND HEALTH CARE COMPANIES (U.S. CLS. 100, 101 AND 102).

FIRST USE 6-0-2005; IN COMMERCE 6-0-2005.

---

3,234,926. MAKEPEACE, CLAYTON, SARASOTA, FL. SN 78-650,335. PUB. 2-21-2006, FILED 6-14-2005.

**THE PROFIT CENTER**

THE MARK CONSISTS OF STANDARD CHARACTERS WITHOUT CLAIM TO ANY PARTICULAR FONT, STYLE, SIZE, OR COLOR.

FOR BUSINESS MARKETING AND ADVERTISING SERVICES (U.S. CLS. 100, 101 AND 102).

FIRST USE 6-9-2005; IN COMMERCE 6-9-2005.

---

3,234,942. REIMAN MEDIA GROUP, INC., GREENDALE, WI. SN 78-652,053. PUB. 3-7-2006, FILED 6-16-2005.

**Taste of Home Entertaining**

THE MARK CONSISTS OF STANDARD CHARACTERS WITHOUT CLAIM TO ANY PARTICULAR FONT, STYLE, SIZE, OR COLOR.

OWNER OF U.S. REG. NOS. 2,002,133, 2,955,195, AND OTHERS.

FOR RETAIL SERVICES BY DIRECT SOLICITATION BY SALES REPRESENTATIVES IN THE FIELD OF BOOK AND GIFT PRODUCTS RELATING TO KITCHEN, HOME DECOR AND LIFESTYLE (U.S. CLS. 100, 101 AND 102).

FIRST USE 5-1-2006; IN COMMERCE 5-1-2006.

**CLASS 35—(Continued).**

3,234,953. UNIFIED WESTERN GROCERS, INC., COMMERCE, CA. SN 78-653,144. PUB. 8-8-2006, FILED 6-17-2005.

**FRESH OBSESSED**

THE MARK CONSISTS OF STANDARD CHARACTERS WITHOUT CLAIM TO ANY PARTICULAR FONT, STYLE, SIZE, OR COLOR.

NO CLAIM IS MADE TO THE EXCLUSIVE RIGHT TO USE "FRESH", APART FROM THE MARK AS SHOWN.

FOR DISTRIBUTORSHIP AND ONLINE DISTRIBUTORSHIP SERVICES IN THE FIELD OF GROCERIES AND PRODUCE (U.S. CLS. 100, 101 AND 102).

FIRST USE 12-0-2003; IN COMMERCE 12-0-2003.

---

3,234,954. BRANDING RIGHTS, LLC, PHILADELPHIA, PA. SN 78-653,478. PUB. 3-7-2006, FILED 6-17-2005.

**VIRTUAL FINISH LINE**

THE MARK CONSISTS OF STANDARD CHARACTERS WITHOUT CLAIM TO ANY PARTICULAR FONT, STYLE, SIZE, OR COLOR.

FOR BUSINESS MARKETING CONSULTING SERVICES IN THE FIELD OF BRANDING AND BRAND STRATEGY, NAMELY, SPONSORSHIPS, ADVERTISING, AND DEVELOPING AND IMPLEMENTING BRAND IDENTITIES FOR THE GOODS AND SERVICES OF OTHERS (U.S. CLS. 100, 101 AND 102).

FIRST USE 10-20-2005; IN COMMERCE 10-20-2005.

---

3,235,012. LIN, GERARD, LOS GATOS, CA. SN 78-660,683. PUB. 3-21-2006, FILED 6-29-2005.

**NiceMail**

THE MARK CONSISTS OF STANDARD CHARACTERS WITHOUT CLAIM TO ANY PARTICULAR FONT, STYLE, SIZE, OR COLOR.

FOR ADVERTISING SERVICES, NAMELY DISTRIBUTING ELECTRONIC MAILS FOR THE ADVERTISING PURPOSE (U.S. CLS. 100, 101 AND 102).

FIRST USE 11-1-2005; IN COMMERCE 12-1-2006.

**CLASS 35—(Continued).**

3,235,014. ALLCONNECT, INC., ATLANTA, GA. SN 78-660,952. PUB. 5-16-2006, FILED 6-29-2005.

**GETTING YOU PLUGGED IN**

THE MARK CONSISTS OF STANDARD CHARACTERS WITHOUT CLAIM TO ANY PARTICULAR FONT, STYLE, SIZE, OR COLOR.

FOR AGENCY REPRESENTATION OF COMPANIES MARKETING A VARIETY OF SERVICES TO HOME OWNERS AND RENTERS, NAMELY, UTILITY HOOK-UPS, TELECOMMUNICATION SERVICES, HOME SECURITY SERVICES, HOME WARRANTIES, HOME AND YARD MAINTENANCE, FURNITURE AND APPLIANCE RENTAL; CONSULTATION SERVICES IN ASSISTING CONSUMERS WITH THE INITIATION AND TERMINATION OF SERVICES WITH UTILITY AND TELECOMMUNICATION PROVIDERS (U.S. CLS. 100, 101 AND 102).

FIRST USE 2-0-2005; IN COMMERCE 2-0-2005.

---

3,235,020. BARON'S WHOLESALE CLOTHIERS INC., FARMINGTON HILLS, MI. SN 78-661,844. PUB. 4-11-2006, FILED 6-30-2005.

**SUITTOGO**

THE MARK CONSISTS OF STANDARD CHARACTERS WITHOUT CLAIM TO ANY PARTICULAR FONT, STYLE, SIZE, OR COLOR.

FOR ON-LINE RETAIL CLOTHING STORE SERVICES PROVIDED VIA AN ONLINE ELECTRONIC COMMUNICATIONS NETWORK (U.S. CLS. 100, 101 AND 102).

FIRST USE 11-29-2006; IN COMMERCE 11-29-2006.

---

3,235,028. ZELLER, LOUANN, EAST DUNDEE, IL. SN 78-662,582. PUB. 3-14-2006, FILED 7-1-2005.

**Zoomco**

THE MARK CONSISTS OF STANDARD CHARACTERS WITHOUT CLAIM TO ANY PARTICULAR FONT, STYLE, SIZE, OR COLOR.

FOR DIRECT MAIL MARKETING SERVICES; DIRECT MAIL ADVERTISING; BUSINESS MARKETING AND DIRECT MAIL CONSULTING SERVICES (U.S. CLS. 100, 101 AND 102).

FIRST USE 2-1-2006; IN COMMERCE 2-1-2006.



**CLASS 35—(Continued).**

3,235,030. ZELLER, LOUANN, EAST DUNDEE, IL. SN 78-662,600. PUB. 3-14-2006, FILED 7-1-2005.

**CLASS 35—(Continued).**

3,235,032. RMSG LLC, PRINCETON, NJ. SN 78-662,761. PUB. 3-21-2006, FILED 7-1-2005.



**BORROWING PERSONALITY**

THE MARK CONSISTS OF WORD ZOOMCO INSIDE SPEECH BUBBLE.  
FOR DIRECT MAIL MARKETING SERVICES; DIRECT MAIL ADVERTISING; BUSINESS MARKETING AND DIRECT MAIL CONSULTING SERVICES (U.S. CLS. 100, 101 AND 102).  
FIRST USE 2-1-2006; IN COMMERCE 2-1-2006.

THE MARK CONSISTS OF STANDARD CHARACTERS WITHOUT CLAIM TO ANY PARTICULAR FONT, STYLE, SIZE, OR COLOR.  
NO CLAIM IS MADE TO THE EXCLUSIVE RIGHT TO USE "BORROWING", APART FROM THE MARK AS SHOWN.  
FOR BUSINESS MANAGEMENT CONSULTATION, NAMELY, PROVIDING MARKET SEGMENT DATA, ANALYTICAL TECHNIQUES, OR INSIGHTS TO ENABLE MANAGEMENT TO IMPROVE BUSINESS EFFECTIVENESS (U.S. CLS. 100, 101 AND 102).  
FIRST USE 12-5-2006; IN COMMERCE 12-5-2006.

---

3,235,031. RMSG LLC, PRINCETON, NJ. SN 78-662,734. PUB. 3-21-2006, FILED 7-1-2005.

---

3,235,033. RMSG LLC, PRINCETON, NJ. SN 78-662,765. PUB. 3-21-2006, FILED 7-1-2005.

**CREDIT CARD PERSONALITY**

**INVESTMENT PERSONALITY**

THE MARK CONSISTS OF STANDARD CHARACTERS WITHOUT CLAIM TO ANY PARTICULAR FONT, STYLE, SIZE, OR COLOR.  
NO CLAIM IS MADE TO THE EXCLUSIVE RIGHT TO USE "CREDIT CARD", APART FROM THE MARK AS SHOWN.  
FOR BUSINESS MANAGEMENT CONSULTATION, NAMELY, PROVIDING MARKET SEGMENT DATA, ANALYTICAL TECHNIQUES, OR INSIGHTS TO ENABLE MANAGEMENT TO IMPROVE BUSINESS EFFECTIVENESS (U.S. CLS. 100, 101 AND 102).  
FIRST USE 12-5-2006; IN COMMERCE 12-5-2006.

THE MARK CONSISTS OF STANDARD CHARACTERS WITHOUT CLAIM TO ANY PARTICULAR FONT, STYLE, SIZE, OR COLOR.  
NO CLAIM IS MADE TO THE EXCLUSIVE RIGHT TO USE "INVESTMENT", APART FROM THE MARK AS SHOWN.  
FOR BUSINESS MANAGEMENT CONSULTATION, NAMELY, PROVIDING MARKET SEGMENT DATA, ANALYTICAL TECHNIQUES, OR INSIGHTS TO ENABLE MANAGEMENT TO IMPROVE BUSINESS EFFECTIVENESS (U.S. CLS. 100, 101 AND 102).  
FIRST USE 12-5-2006; IN COMMERCE 12-5-2006.

**CLASS 35—(Continued).**

3,235,034. RMSG LLC, PRINCETON, NJ. SN 78-662,772. PUB. 3-21-2006, FILED 7-1-2005.

**CLASS 35—(Continued).**

3,235,036. RMSG LLC, PRINCETON, NJ. SN 78-662,797. PUB. 3-21-2006, FILED 7-1-2005.

**BANKING PERSONALITY**

THE MARK CONSISTS OF STANDARD CHARACTERS WITHOUT CLAIM TO ANY PARTICULAR FONT, STYLE, SIZE, OR COLOR.

NO CLAIM IS MADE TO THE EXCLUSIVE RIGHT TO USE "BANKING", APART FROM THE MARK AS SHOWN.

FOR BUSINESS MANAGEMENT CONSULTATION, NAMELY, PROVIDING MARKET SEGMENT DATA, ANALYTICAL TECHNIQUES, OR INSIGHTS TO ENABLE MANAGEMENT TO IMPROVE BUSINESS EFFECTIVENESS (U.S. CLS. 100, 101 AND 102).

FIRST USE 12-5-2006; IN COMMERCE 12-5-2006.

**MORTGAGE PERSONALITY**

THE MARK CONSISTS OF STANDARD CHARACTERS WITHOUT CLAIM TO ANY PARTICULAR FONT, STYLE, SIZE, OR COLOR.

NO CLAIM IS MADE TO THE EXCLUSIVE RIGHT TO USE "MORTGAGE", APART FROM THE MARK AS SHOWN.

FOR BUSINESS MANAGEMENT CONSULTATION, NAMELY, PROVIDING MARKET SEGMENT DATA, ANALYTICAL TECHNIQUES, OR INSIGHTS TO ENABLE MANAGEMENT TO IMPROVE BUSINESS EFFECTIVENESS (U.S. CLS. 100, 101 AND 102).

FIRST USE 12-5-2006; IN COMMERCE 12-5-2006.

---

3,235,035. RMSG LLC, PRINCETON, NJ. SN 78-662,789. PUB. 3-21-2006, FILED 7-1-2005.

---

3,235,037. RMSG LLC, PRINCETON, NJ. SN 78-662,807. PUB. 3-21-2006, FILED 7-1-2005.

**INSURANCE PERSONALITY**

THE MARK CONSISTS OF STANDARD CHARACTERS WITHOUT CLAIM TO ANY PARTICULAR FONT, STYLE, SIZE, OR COLOR.

NO CLAIM IS MADE TO THE EXCLUSIVE RIGHT TO USE "INSURANCE", APART FROM THE MARK AS SHOWN.

FOR BUSINESS MANAGEMENT CONSULTATION, NAMELY, PROVIDING MARKET SEGMENT DATA, ANALYTICAL TECHNIQUES, OR INSIGHTS TO ENABLE MANAGEMENT TO IMPROVE BUSINESS EFFECTIVENESS (U.S. CLS. 100, 101 AND 102).

FIRST USE 12-5-2006; IN COMMERCE 12-5-2006.

**VACATION PERSONALITY**

THE MARK CONSISTS OF STANDARD CHARACTERS WITHOUT CLAIM TO ANY PARTICULAR FONT, STYLE, SIZE, OR COLOR.

NO CLAIM IS MADE TO THE EXCLUSIVE RIGHT TO USE "VACATION", APART FROM THE MARK AS SHOWN.

FOR BUSINESS MANAGEMENT CONSULTATION, NAMELY, PROVIDING MARKET SEGMENT DATA, ANALYTICAL TECHNIQUES, OR INSIGHTS TO ENABLE MANAGEMENT TO IMPROVE BUSINESS EFFECTIVENESS (U.S. CLS. 100, 101 AND 102).

FIRST USE 12-5-2006; IN COMMERCE 12-5-2006.

**CLASS 35—(Continued).**

3,235,038. RMSG LLC, PRINCETON, NJ. SN 78-662,826. PUB. 3-21-2006, FILED 7-1-2005.

**REAL ESTATE PERSONALITY**

THE MARK CONSISTS OF STANDARD CHARACTERS WITHOUT CLAIM TO ANY PARTICULAR FONT, STYLE, SIZE, OR COLOR.

NO CLAIM IS MADE TO THE EXCLUSIVE RIGHT TO USE "REAL ESTATE", APART FROM THE MARK AS SHOWN.

FOR BUSINESS MANAGEMENT CONSULTATION, NAMELY, PROVIDING MARKET SEGMENT DATA, ANALYTICAL TECHNIQUES, OR INSIGHTS TO ENABLE MANAGEMENT TO IMPROVE BUSINESS EFFECTIVENESS (U.S. CLS. 100, 101 AND 102).

FIRST USE 12-5-2006; IN COMMERCE 12-5-2006.

**CLASS 35—(Continued).**

3,235,077. MATTRESS WAREHOUSE, INC., FREDERICK, MD. SN 78-669,425. PUB. 3-28-2006, FILED 7-13-2005.

**SLEEP BEGINS HERE!**

THE MARK CONSISTS OF STANDARD CHARACTERS WITHOUT CLAIM TO ANY PARTICULAR FONT, STYLE, SIZE, OR COLOR.

FOR RETAIL STORE SERVICES FEATURING BEDS, MATTRESSES, BEDSPRINGS, BED FRAMES AND RELATED ACCESSORIES (U.S. CLS. 100, 101 AND 102).

FIRST USE 12-3-2006; IN COMMERCE 12-3-2006.

3,235,082. LEXTERA GROUP, MINNEAPOLIS, MN. SN 78-669,960. PUB. 3-21-2006, FILED 7-13-2005.

**LEXTERA GROUP**

THE MARK CONSISTS OF STANDARD CHARACTERS WITHOUT CLAIM TO ANY PARTICULAR FONT, STYLE, SIZE, OR COLOR.

NO CLAIM IS MADE TO THE EXCLUSIVE RIGHT TO USE "GROUP", APART FROM THE MARK AS SHOWN.

FOR BUSINESS MANAGEMENT AND CONSULTING SERVICES, NAMELY, PROVIDING ON-SITE PROJECT MANAGEMENT, TEAM LEADERSHIP AND ADVISORY SERVICES (U.S. CLS. 100, 101 AND 102).

FIRST USE 8-30-2005; IN COMMERCE 8-30-2005.

3,235,052. WE PAK 4 U, INC., HUNTINGTON BEACH, CA. SN 78-664,670. PUB. 3-28-2006, FILED 7-6-2005.



3,235,089. SCHURMAN FINE PAPERS, FAIRFIELD, CA. SN 78-671,689. PUB. 4-4-2006, FILED 7-15-2005.

**THE JOY OF EVERYDAY**

THE MARK CONSISTS OF WE PAK 4 U IN BLOCK LETTERS CENTERED IN AN OVAL IN FRONT OF BOX.

FOR ONLINE ORDERING AND MAIL ORDER SERVICES FEATURING PERSONAL CARE PRODUCTS, COSMETICS, SKIN AND HAIR CARE PRODUCTS, FOODS AND BEVERAGES, SUNDRIES, TOILETRIES, APPLIANCES AND PERSONAL ELECTRONICS, MAGAZINES AND OTHER PRINTED MATTER, AND PREPAID MERCHANDISE CARDS (U.S. CLS. 100, 101 AND 102).

FIRST USE 10-1-2004; IN COMMERCE 10-1-2005.

THE MARK CONSISTS OF STANDARD CHARACTERS WITHOUT CLAIM TO ANY PARTICULAR FONT, STYLE, SIZE, OR COLOR.

FOR RETAIL STORE AND ON-LINE RETAIL STORE SERVICES FEATURING A WIDE VARIETY OF GREETING CARDS, PRINTED INVITATIONS, STATIONERY, GIFT WRAP PAPER, AND GIFTWARE (U.S. CLS. 100, 101 AND 102).

FIRST USE 9-0-2005; IN COMMERCE 10-0-2005.

**CLASS 35—(Continued).**

3,235,090. SCHURMAN FINE PAPERS, FAIRFIELD, CA. SN 78-671,703. PUB. 4-4-2006, FILED 7-15-2005.



FOR RETAIL STORE AND ON-LINE RETAIL STORE SERVICES FEATURING A WIDE VARIETY OF GREETING CARDS, PRINTED INVITATIONS, STATIONERY, GIFT WRAP PAPER, AND GIFTWARE (U.S. CLS. 100, 101 AND 102).

FIRST USE 8-0-2005; IN COMMERCE 10-0-2005.

3,235,094. PROMO INK, NEW YORK, NY. SN 78-672,589. PUB. 2-21-2006, FILED 7-18-2005.

**VIP GIFT CHEQUE**

THE MARK CONSISTS OF STANDARD CHARACTERS WITHOUT CLAIM TO ANY PARTICULAR FONT, STYLE, SIZE, OR COLOR.

NO CLAIM IS MADE TO THE EXCLUSIVE RIGHT TO USE "GIFT CHEQUE", APART FROM THE MARK AS SHOWN.

FOR PROMOTING THE GOODS AND SERVICES OF OTHERS THROUGH THE ISSUANCE AND DISTRIBUTION OF GIFT CERTIFICATES (U.S. CLS. 100, 101 AND 102).

FIRST USE 7-18-2005; IN COMMERCE 7-18-2005.

**CLASS 35—(Continued).**

3,235,106. COLORADO OFF-HIGHWAY VEHICLE COALITION, MEAD, CO. SN 78-676,545. PUB. 5-16-2006, FILED 7-22-2005.

**Keep Your Wheels Where They Belong**

THE MARK CONSISTS OF STANDARD CHARACTERS WITHOUT CLAIM TO ANY PARTICULAR FONT, STYLE, SIZE, OR COLOR.

FOR PROMOTING PUBLIC AWARENESS OF THE NEED FOR PEOPLE WHO USE TRAILS AND ROADS TO STAY ON THE TRAIL AND NOT WANDER OFF AND CREATE AN UNAUTHORIZED NETWORK OF PATHS (U.S. CLS. 100, 101 AND 102).

FIRST USE 3-4-2005; IN COMMERCE 3-28-2006.

3,235,113. CUESEE B.V., EDE, NETHERLANDS. SN 78-678,548. PUB. 7-11-2006, FILED 7-26-2005.

**CUESEE**

THE MARK CONSISTS OF STANDARD CHARACTERS WITHOUT CLAIM TO ANY PARTICULAR FONT, STYLE, SIZE, OR COLOR.

PRIORITY CLAIMED UNDER SEC. 44(D) ON ERP N CMNTY TM OFC APPLICATION NO. 004504197, FILED 7-20-2005.

FOR PROVIDING AN ONLINE COMMERCIAL INFORMATION DIRECTORY ON THE INTERNET IN THE FIELD OF PERFORMANCE AND COMPOSITION OF DIAGNOSTIC PRODUCTS (U.S. CLS. 100, 101 AND 102).

FIRST USE 12-6-2001; IN COMMERCE 12-6-2001.

3,235,154. O'HARA, STEPHEN S, NEWPORT BEACH, CA. SN 78-692,017. PUB. 5-2-2006, FILED 8-12-2005.

**SchoolFolks**

THE MARK CONSISTS OF STANDARD CHARACTERS WITHOUT CLAIM TO ANY PARTICULAR FONT, STYLE, SIZE, OR COLOR.

FOR GENERAL BUSINESS NETWORKING REFERRAL SERVICES, NAMELY, PROMOTING THE GOODS AND SERVICES OF OTHERS BY PASSING BUSINESS LEADS AND REFERRALS AMONG GROUP MEMBERS (U.S. CLS. 100, 101 AND 102).

FIRST USE 9-25-2005; IN COMMERCE 9-25-2005.

**CLASS 35—(Continued).**

3,235,157. PROMO INK, NEW YORK, NY. SN 78-693,351.  
PUB. 2-21-2006, FILED 8-16-2005.

**VIP CELEBRATIONS**

THE MARK CONSISTS OF STANDARD CHARACTERS WITHOUT CLAIM TO ANY PARTICULAR FONT, STYLE, SIZE, OR COLOR.

NO CLAIM IS MADE TO THE EXCLUSIVE RIGHT TO USE "CELEBRATIONS", APART FROM THE MARK AS SHOWN.

FOR PROVIDING INFORMATION ABOUT THE GOODS AND SERVICES OF OTHERS VIA THE GLOBAL COMPUTER NETWORK (U.S. CLS. 100, 101 AND 102).  
FIRST USE 7-25-2005; IN COMMERCE 7-25-2005.

**CLASS 35—(Continued).**

3,235,182. BROOKPARK MARKETS, LLC, MINNETONKA, MN. SN 78-702,352. PUB. 8-8-2006, FILED 8-29-2005.

**FRESH SEASONS MARKET**

THE MARK CONSISTS OF STANDARD CHARACTERS WITHOUT CLAIM TO ANY PARTICULAR FONT, STYLE, SIZE, OR COLOR.

NO CLAIM IS MADE TO THE EXCLUSIVE RIGHT TO USE "FRESH" AND "MARKET", APART FROM THE MARK AS SHOWN.

FOR RETAIL GROCERY STORE SERVICES (U.S. CLS. 100, 101 AND 102).  
FIRST USE 11-15-2005; IN COMMERCE 11-15-2005.

3,235,167. M-SCRIBE TECHNOLOGIES, LLC, FRAMINGHAM, MA. SN 78-695,214. PUB. 7-11-2006, FILED 8-18-2005.

**M-SCRIBE**

THE MARK CONSISTS OF STANDARD CHARACTERS WITHOUT CLAIM TO ANY PARTICULAR FONT, STYLE, SIZE, OR COLOR.

FOR TRANSCRIPTION SERVICES, NAMELY, MEDICAL TRANSCRIPTION, MESSAGE TRANSCRIPTION AND STENOGRAPHIC TRANSCRIPTION (U.S. CLS. 100, 101 AND 102).

FIRST USE 11-15-2005; IN COMMERCE 11-15-2005.

3,235,194. HIGHLY GRAPHIC, INC, LOS ANGELES, CA. SN 78-705,783. PUB. 5-16-2006, FILED 9-1-2005.

**ELECTRIC WONDERS**

THE MARK CONSISTS OF STANDARD CHARACTERS WITHOUT CLAIM TO ANY PARTICULAR FONT, STYLE, SIZE, OR COLOR.

NO CLAIM IS MADE TO THE EXCLUSIVE RIGHT TO USE "ELECTRIC", APART FROM THE MARK AS SHOWN. FOR WHOLESALE DISTRIBUTORSHIP SERVICES FEATURING ELECTRICAL AND ELECTRONIC PROMOTIONAL LIGHT AND SOUND PRODUCTS (U.S. CLS. 100, 101 AND 102).

FIRST USE 9-20-2005; IN COMMERCE 9-20-2005.

3,235,180. CORE POTENTIAL, LLC, WOODSTOCK, GA. SN 78-700,954. PUB. 5-23-2006, FILED 8-26-2005.

**CORE POTENTIAL**

THE MARK CONSISTS OF STANDARD CHARACTERS WITHOUT CLAIM TO ANY PARTICULAR FONT, STYLE, SIZE, OR COLOR.

FOR BUSINESS MARKETING CONSULTING SERVICES; BUSINESS MARKETING SERVICES; DEVELOPMENT OF MARKETING STRATEGIES AND CONCEPTS; MARKETING CONSULTING (U.S. CLS. 100, 101 AND 102).

FIRST USE 9-5-2005; IN COMMERCE 9-5-2005.

3,235,219. CHILD DEVELOPMENT CORPORATION, NORWALK, CT. SN 78-718,256. PUB. 8-8-2006, FILED 9-22-2005.

**EBEANSTALK**

THE MARK CONSISTS OF STANDARD CHARACTERS WITHOUT CLAIM TO ANY PARTICULAR FONT, STYLE, SIZE, OR COLOR.

FOR ONLINE RETAIL STORE SERVICES FEATURING DEVELOPMENTAL TOYS, GAMES, PUPPETS, AND PUZZLES, ALL FOR CHILDREN (U.S. CLS. 100, 101 AND 102).

FIRST USE 7-0-2005; IN COMMERCE 8-16-2006.

**CLASS 35—(Continued).**

3,235,230. ISTA ADMINISTRATIVE SERVICES CORPORATION, INDIANAPOLIS, IN. SN 78-724,387. PUB. 8-1-2006, FILED 9-30-2005.



NO CLAIM IS MADE TO THE EXCLUSIVE RIGHT TO USE "HEALTH" AND "PERKS", APART FROM THE MARK AS SHOWN.

THE COLOR(S) BLUE, RED, WHITE, AND GREEN IS/ ARE CLAIMED AS A FEATURE OF THE MARK.

THE MARK CONSISTS OF THE WORDS HEALTH, THE ITALICIZED LETTER "E", AND THE CAPITALIZED WORD PERKS ALL WRITTEN AS ONE WORD. THE "E" IS SHOWN IN THE WHITE NEGATIVE SPACE OF A RED APPLE GRAPHIC WITH A GREEN LEAF WHICH IS INSERTED BETWEEN THE BLUE WORD "HEALTH" AND THE BLUE LETTERS "PERK". THE "S" IN THE WORD PERKS IS GREEN AND IS CUSTOMIZED TO APPEAR AS A DOLLAR SIGN.

FOR CONDUCTING EMPLOYEE INCENTIVE AWARD PROGRAMS TO PROMOTE WELLNESS (U.S. CLS. 100, 101 AND 102).

FIRST USE 1-2-2006; IN COMMERCE 1-2-2006.

3,235,231. FLYTXT LTD., LONDON, UNITED KINGDOM. SN 78-725,069. PUB. 7-18-2006, FILED 10-3-2005.

# FLYTXT

THE MARK CONSISTS OF STANDARD CHARACTERS WITHOUT CLAIM TO ANY PARTICULAR FONT, STYLE, SIZE, OR COLOR.

FOR MARKETING CONSULTING; AND ADVERTISING, MARKETING AND PROMOTION SERVICES (U.S. CLS. 100, 101 AND 102).

FIRST USE 12-31-2000; IN COMMERCE 3-31-2004.

**CLASS 35—(Continued).**

3,235,251. MEDCO HEALTH SOLUTIONS, INC., FRANKLIN LAKES, NJ. SN 78-730,865. PUB. 6-27-2006, FILED 10-11-2005.

MEDCO RX DISCOUNT PROGRAM

THE MARK CONSISTS OF STANDARD CHARACTERS WITHOUT CLAIM TO ANY PARTICULAR FONT, STYLE, SIZE, OR COLOR.

OWNER OF U.S. REG. NOS. 2,744,576, 2,755,838, AND OTHERS.

NO CLAIM IS MADE TO THE EXCLUSIVE RIGHT TO USE "RX DISCOUNT PROGRAM", APART FROM THE MARK AS SHOWN.

FOR ADMINISTRATION OF PRESCRIPTION DISCOUNT DRUG PROGRAM (U.S. CLS. 100, 101 AND 102). FIRST USE 11-30-2005; IN COMMERCE 11-30-2005.

3,235,255. AT WORLD PROPERTIES, LLC, CHICAGO, IL. SN 78-734,779. PUB. 8-8-2006, FILED 10-17-2005.

# @Home Agent

THE MARK CONSISTS OF STANDARD CHARACTERS WITHOUT CLAIM TO ANY PARTICULAR FONT, STYLE, SIZE, OR COLOR.

NO CLAIM IS MADE TO THE EXCLUSIVE RIGHT TO USE "AGENT", APART FROM THE MARK AS SHOWN.

FOR PROVIDING ON-LINE REAL ESTATE ADVERTISING INFORMATION FOR THE PURCHASE AND SALE OF REAL ESTATE, NAMELY NEW HOME INFORMATION AS TO LOCATION, PRICE, SIZE, FLOOR PLANS, EXTERIOR PHOTOGRAPHY AND/OR ARTIST'S RENDERING AND SALES OFFICE CONTACT INFORMATION (U.S. CLS. 100, 101 AND 102).

FIRST USE 9-0-2005; IN COMMERCE 9-0-2005.

3,235,280. ECCA ENTERPRISES, INC., SAN ANTONIO, TX. SN 78-750,710. PUB. 8-1-2006, FILED 11-9-2005.

# CONTACTS MADE EASY

THE MARK CONSISTS OF STANDARD CHARACTERS WITHOUT CLAIM TO ANY PARTICULAR FONT, STYLE, SIZE, OR COLOR.

NO CLAIM IS MADE TO THE EXCLUSIVE RIGHT TO USE "CONTACTS", APART FROM THE MARK AS SHOWN.

FOR RETAIL STORE SERVICES FEATURING OPTICAL GOODS (U.S. CLS. 100, 101 AND 102).

FIRST USE 12-15-2005; IN COMMERCE 12-15-2005.

**CLASS 35—(Continued).**

3,235,295. LEASE PLAN U.S.A., INC., ALPHARETTA, GA. SN 78-757,144. PUB. 8-22-2006, FILED 11-18-2005.

**GREENPLAN**

THE MARK CONSISTS OF STANDARD CHARACTERS WITHOUT CLAIM TO ANY PARTICULAR FONT, STYLE, SIZE, OR COLOR.

OWNER OF U.S. REG. NOS. 2,706,086 AND 2,990,897.  
FOR PROMOTING PUBLIC AWARENESS OF THE NEED FOR ENVIRONMENTALLY FRIENDLY BUSINESS PRACTICES AND LOW CARBON EMISSIONS VEHICLES; BUSINESS MANAGEMENT SERVICES, NAMELY, MANAGEMENT OF FLEET-LEASED VEHICLES, INCLUDING NORMAL AND LOW CARBON EMISSIONS VEHICLES; BUSINESS ADMINISTRATION SERVICES, NAMELY, ADMINISTRATION AND MANAGEMENT OF ENVIRONMENTALLY FRIENDLY BUSINESS PRACTICES FOR OTHERS (U.S. CLS. 100, 101 AND 102).

FIRST USE 8-1-2006; IN COMMERCE 8-1-2006.

---

3,235,320. HUNTER, TAYLOR H., NEWPORT BEACH, CA. SN 78-763,916. PUB. 8-8-2006, FILED 11-30-2005.

**Methodology Selling**

THE MARK CONSISTS OF STANDARD CHARACTERS WITHOUT CLAIM TO ANY PARTICULAR FONT, STYLE, SIZE, OR COLOR.

FOR BUSINESS MANAGEMENT CONSULTING WITH RELATION TO STRATEGY, MARKETING, PRODUCTION, PERSONNEL AND RETAIL SALE MATTERS (U.S. CLS. 100, 101 AND 102).

FIRST USE 1-1-2006; IN COMMERCE 1-1-2006.

---

3,235,360. MITCHELL, JOHN R., WESTPORT, CT. SN 78-781,214. PUB. 8-22-2006, FILED 12-27-2005.

**HUG YOUR HUGGERS**

THE MARK CONSISTS OF STANDARD CHARACTERS WITHOUT CLAIM TO ANY PARTICULAR FONT, STYLE, SIZE, OR COLOR.

OWNER OF U.S. REG. NO. 2,784,389.  
FOR BUSINESS CONSULTING SERVICES (U.S. CLS. 100, 101 AND 102).

FIRST USE 4-20-2006; IN COMMERCE 4-20-2006.

**CLASS 35—(Continued).**

3,235,383. TRILEGIANT CORPORATION, NORWALK, CT. SN 78-809,897. PUB. 7-25-2006, FILED 2-8-2006.

**COOLEXTRAS**

THE MARK CONSISTS OF STANDARD CHARACTERS WITHOUT CLAIM TO ANY PARTICULAR FONT, STYLE, SIZE, OR COLOR.

FOR ADMINISTRATION OF A CONSUMER MEMBERSHIP PROGRAM FOR ENABLING PARTICIPANTS TO OBTAIN DISCOUNTS, SAVINGS AND REBATES ON CONSUMER MERCHANDISE, DINING, CAR RENTAL, TRAVEL AND LODGING, GIFTS, HEALTHCARE SERVICES AND PRODUCTS, FITNESS AND EXERCISE PRODUCTS AND SERVICES, PERSONAL FINANCE PRODUCTS AND SERVICES, HOME IMPROVEMENT PRODUCTS AND SERVICES, AUTOMOTIVE PRODUCTS AND SERVICES, AND MOVIES, RECREATION AND OTHER LEISURE AND ENTERTAINMENT ACTIVITIES, PROVIDING THE FOREGOING SERVICES VIA AN ONLINE WEBSITE; PROVIDING ON-LINE CONSUMER PRODUCT GUIDES AND DIRECTORIES, PROVIDING CONSUMER HOTLINE SERVICES FOR QUESTIONS ABOUT PRODUCTS AND SERVICES (U.S. CLS. 100, 101 AND 102).

FIRST USE 5-11-2006; IN COMMERCE 5-11-2006.

---

3,235,385. BREATHE CALIFORNIA OF SACRAMENTO-EMIGRANT TRAILS, SACRAMENTO, CA. SN 78-825,561. PUB. 8-22-2006, FILED 2-28-2006.

**The Hackademy Awards**

THE MARK CONSISTS OF STANDARD CHARACTERS WITHOUT CLAIM TO ANY PARTICULAR FONT, STYLE, SIZE, OR COLOR.

NO CLAIM IS MADE TO THE EXCLUSIVE RIGHT TO USE "AWARDS", APART FROM THE MARK AS SHOWN.

FOR PROMOTING PUBLIC AWARENESS THROUGH YOUTH ADVOCACY OF THE ISSUE OF TOBACCO GLAMORIZATION IN FILM, USING A PROGRAM MODELLED AFTER A HOLLYWOOD STYLE AWARDS CEREMONY (U.S. CLS. 100, 101 AND 102).

FIRST USE 2-1-1996; IN COMMERCE 1-1-2003.

**CLASS 35—(Continued).**

3,235,407. LANNOM INCORPORATED, PEMBROKE PINES, FL. SN 78-978,037. PUB. 1-10-2006, FILED 3-8-2005.

**PEOPLE  
FIRST**

FOR BUSINESS SERVICES, NAMELY, BUSINESS MANAGEMENT CONSULTATION IN THE FIELD OF EXECUTIVE AND LEADERSHIP DEVELOPMENT (U.S. CLS. 100, 101 AND 102).

FIRST USE 6-1-2005; IN COMMERCE 6-1-2005.

**CLASS 36—INSURANCE AND FINANCIAL**

3,233,800. T & G GROUP LLC., FOUNTAIN VALLEY, CA. SN 76-426,790. PUB. 8-26-2003, FILED 7-1-2002.

**LITTLE MEXICO**

NO CLAIM IS MADE TO THE EXCLUSIVE RIGHT TO USE "MEXICO", APART FROM THE MARK AS SHOWN, FOR SHOPPING CENTER SERVICES (U.S. CLS. 100, 101 AND 102).

FIRST USE 11-14-2006; IN COMMERCE 11-14-2006.

**CLASS 36—(Continued).**

3,233,866. SOLIDUS NETWORKS, INC., SAN FRANCISCO, CA. SN 76-555,361. PUB. 9-21-2004, FILED 10-14-2003.



FOR ELECTRONIC PAYMENT SERVICES, NAMELY, IDENTIFICATION AND TRANSACTION SERVICES FOR MERCHANTS BY MEANS OF ON-LINE DATABASES; ELECTRONIC PROCESSING AND TRANSMISSION OF PAYMENTS TO MERCHANTS; ELECTRONIC PROCESSING AND TRANSMISSION OF PAYMENTS BY MERCHANTS, ELECTRONIC PROCESSING AND TRANSMISSION OF PAYMENT TO MERCHANTS VIA ON-LINE DEBIT, CHECKING, CREDIT CARD, AND LOYALTY/REWARD ACCOUNT PAYMENTS; ELECTRONIC PROCESSING AND TRANSMISSION OF PAYMENTS BY MERCHANTS VIA ON-LINE DEBIT, CHECKING, CREDIT CARD, AND LOYALTY/REWARD ACCOUNT PAYMENTS; PROVIDING A BIOMETRIC AUTHENTICATION AND PAYMENT SYSTEM, NAMELY, PROVIDING ELECTRONIC TRANSMISSION AND PROCESSING OF FINANCIAL TRANSACTIONS BETWEEN CONSUMERS AND MERCHANTS BY MEANS OF BIOMETRIC BASED IDENTITY VERIFICATION AND TRANSACTION AUTHORIZATION, WHERE INDIVIDUAL CONSUMERS ARE IDENTIFIED WITHIN DATABASES THAT LINK AN INDIVIDUAL CONSUMER'S FINANCIAL ACCOUNTS WITH THEIR BIOMETRIC DATA; BIOMETRIC SECURITY SCANNING AND PROCESSING VIA A COMPUTER NETWORK AND AT THE POINT OF SALE FOR THE PURPOSE OF BANKING AND CREDIT ISSUANCE; PROVIDING DATABASES TO MERCHANTS WHEREIN THE DATABASES FACILITATE IDENTIFICATION OF INDIVIDUAL CUSTOMERS BY LINKING CHECKING, CREDIT, DEBIT, OR LOYALTY/REWARD ACCOUNTS WITH BIOMETRIC DATA (U.S. CLS. 100, 101 AND 102).

FIRST USE 6-30-2001; IN COMMERCE 6-30-2001.

3,233,883. CITIZENS FINANCIAL GROUP, INC., PROVIDENCE, RI. SN 76-578,032. PUB. 10-25-2005, FILED 2-23-2004.



NO CLAIM IS MADE TO THE EXCLUSIVE RIGHT TO USE "MONEY MANAGER" AND "GLOBAL PROCESSING", APART FROM THE MARK AS SHOWN.

FOR FINANCIAL SERVICES, NAMELY, ELECTRONIC BANKING SERVICES; PROVIDING BANKING ACCOUNT INFORMATION OVER A COMPUTER NETWORK (U.S. CLS. 100, 101 AND 102).

FIRST USE 9-21-2004; IN COMMERCE 9-21-2004.



**CLASS 36—(Continued).**

3,233,891. MAGNOLIA ENTERPRISES, INC., SPOTSYLVANIA, VA. SN 76-582,913. PUB. 11-22-2005, FILED 3-15-2004.

**TruAdvantage**

THE MARK CONSISTS OF STANDARD CHARACTERS WITHOUT CLAIM TO ANY PARTICULAR FONT, STYLE, SIZE, OR COLOR.

FOR BANKING SERVICES, MORTGAGE BANKING BROKERAGE AND LENDING (U.S. CLS. 100, 101 AND 102).

FIRST USE 7-22-1996; IN COMMERCE 2-10-2006.

3,233,911. GLOBAL ACCESS CORP. PONTE VEDRA BEACH, FL. SN 76-595,419. PUB. 6-20-2006, FILED 5-28-2004.

**ATMs Made Easy!**

THE MARK CONSISTS OF STANDARD CHARACTERS WITHOUT CLAIM TO ANY PARTICULAR FONT, STYLE, SIZE, OR COLOR.

NO CLAIM IS MADE TO THE EXCLUSIVE RIGHT TO USE "ATMS", APART FROM THE MARK AS SHOWN.

FOR AUTOMATED TELLER MACHINE SERVICES FEATURING AUTOMATED TELLER MACHINE ACCOUNT MANAGEMENT IN THE NATURE OF PROCESSING FINANCIAL INFORMATION CONCERNING CUSTOMER ACCOUNT WITHDRAWALS AND DEPOSITS VIA AUTOMATED TELLER MACHINES; AUTOMATED TELLER MACHINE FEE COLLECTION AND PAYMENT SERVICES, NAMELY, PROCESSING ELECTRONIC TRANSACTIONS VIA AUTOMATED TELLER MACHINES; AUTOMATED TELLER MACHINE FINANCIAL INFORMATION PROCESSING SERVICES, NAMELY, PROCESSING FINANCIAL INFORMATION RELATED TO TRANSACTIONS MADE VIA AUTOMATED TELLER MACHINES (U.S. CLS. 100, 101 AND 102).

FIRST USE 9-30-2004; IN COMMERCE 9-30-2004.

3,233,936. EMPYREAN CAPITAL PARTNERS, LP, LOS ANGELES, CA. SN 76-608,092. PUB. 10-25-2005, FILED 8-20-2004.

**EMPYREAN CAPITAL PARTNERS**

THE MARK CONSISTS OF STANDARD CHARACTERS WITHOUT CLAIM TO ANY PARTICULAR FONT, STYLE, SIZE, OR COLOR.

NO CLAIM IS MADE TO THE EXCLUSIVE RIGHT TO USE "CAPITAL PARTNERS", APART FROM THE MARK AS SHOWN.

FOR FINANCIAL SERVICES, NAMELY, INVESTMENT ADVISORY SERVICES, INVESTMENT MANAGEMENT SERVICES AND ASSET MANAGEMENT SERVICES (U.S. CLS. 100, 101 AND 102).

FIRST USE 3-11-2004; IN COMMERCE 7-1-2004.

**CLASS 36—(Continued).**

3,233,937. EMPYREAN CAPITAL FUND, LP, LOS ANGELES, CA. SN 76-608,093. PUB. 10-25-2005, FILED 8-20-2004.

**EMPYREAN CAPITAL FUND**

THE MARK CONSISTS OF STANDARD CHARACTERS WITHOUT CLAIM TO ANY PARTICULAR FONT, STYLE, SIZE, OR COLOR.

NO CLAIM IS MADE TO THE EXCLUSIVE RIGHT TO USE "CAPITAL FUND", APART FROM THE MARK AS SHOWN.

FOR FINANCIAL SERVICES, NAMELY, INVESTMENT ADVISORY SERVICES, INVESTMENT MANAGEMENT SERVICES AND ASSET MANAGEMENT SERVICES (U.S. CLS. 100, 101 AND 102).

FIRST USE 7-1-2004; IN COMMERCE 7-1-2004.

3,233,938. CHINA MERCHANTS BANK CO., LTD., SHENZHEN, CHINA. SN 76-608,355. PUB. 8-2-2005, FILED 8-23-2004.

**CMB**

THE MARK CONSISTS OF STANDARD CHARACTERS WITHOUT CLAIM TO ANY PARTICULAR FONT, STYLE, SIZE, OR COLOR.

FOR BANKING SERVICES (U.S. CLS. 100, 101 AND 102).

FIRST USE 6-15-2006; IN COMMERCE 6-15-2006.

3,233,942. WESTCHESTER MEDICAL CENTER FOUNDATION, VALHALLA, NY. SN 76-609,147. PUB. 9-13-2005, FILED 8-25-2004.

**WESTCAN**

THE MARK CONSISTS OF STANDARD CHARACTERS WITHOUT CLAIM TO ANY PARTICULAR FONT, STYLE, SIZE, OR COLOR.

FOR CHARITABLE FUNDRAISING SERVICES (U.S. CLS. 100, 101 AND 102).

FIRST USE 4-30-2004; IN COMMERCE 4-30-2004.

**CLASS 36—(Continued).**

3,233,960. GLOBAL TRANSITION SOLUTIONS, LLC, NEW YORK, NY. SN 76-613,307. PUB. 9-27-2005, FILED 9-22-2004.

# GTS

THE MARK CONSISTS OF STANDARD CHARACTERS WITHOUT CLAIM TO ANY PARTICULAR FONT, STYLE, SIZE, OR COLOR.

FOR FINANCIAL SERVICES, NAMELY, INSTITUTIONAL INVESTMENT BROKERAGE AND FINANCIAL CONSULTING IN THE FIELD OF INVESTMENTS (U.S. CLS. 100, 101 AND 102).

FIRST USE 11-27-2006; IN COMMERCE 11-27-2006.

3,233,975. PACE GLOBAL ENERGY SERVICES, LLC, FAIRFAX, VA. SN 76-615,630. PUB. 2-7-2006, FILED 10-13-2004.

# Pace RIRP

THE MARK CONSISTS OF STANDARD CHARACTERS WITHOUT CLAIM TO ANY PARTICULAR FONT, STYLE, SIZE, OR COLOR.

FOR RISK MANAGEMENT SERVICES WHICH FACILITATE UTILITIES AND INDUSTRIALS TO MAKE BETTER ENERGY-RELATED INVESTMENT AND RESOURCE PLANNING DECISIONS BY CONSIDERING MARKET VOLATILITY, CREDIT ABROGATION RISK AND OTHER RISKS DIRECTLY IN THE DECISION FRAMEWORK, AND BY EVALUATING ALTERNATIVE PORTFOLIOS ON THE BASIS OF LONG TERM RISK-RETURN METRICS, UTILIZING TOOLS THAT ARE DESIGNED SPECIFICALLY TO HANDLE CORRELATED STOCHASTIC VARIABLES AS INPUTS AND PRESENT RESULTS IN A STOCHASTIC FRAMEWORK (U.S. CLS. 100, 101 AND 102).

FIRST USE 7-6-2005; IN COMMERCE 7-6-2005.

3,234,040. MONTEBELLO SCHOOLS FEDERAL CREDIT UNION, MONTEBELLO, CA. SN 76-637,740. PUB. 8-1-2006, FILED 5-2-2005.



NO CLAIM IS MADE TO THE EXCLUSIVE RIGHT TO USE "FEDERAL CREDIT UNION", APART FROM THE

**CLASS 36—(Continued).**

MARK AS SHOWN.

"THE FOREIGN WORDING IN THE MARK TRANSLATES INTO ENGLISH AS "ROAD" OR "WAY."  
FOR CREDIT UNIONS (U.S. CLS. 100, 101 AND 102).  
FIRST USE 10-1-2005; IN COMMERCE 10-1-2005.

3,234,063. EXCELLUS HEALTH PLAN, INC., ROCHESTER, NY. SN 76-642,107. PUB. 3-14-2006, FILED 7-1-2005.

# GO GETTERS

THE MARK CONSISTS OF STANDARD CHARACTERS WITHOUT CLAIM TO ANY PARTICULAR FONT, STYLE, SIZE, OR COLOR.

FOR HEALTH INSURANCE SERVICES, NAMELY, PROVIDING REIMBURSEMENT FOR PHYSICAL FITNESS ACTIVITY FEES, WEIGHT LOSS PROGRAM FEES, HEALTH CLUB FEES AND DANCE INSTRUCTION FEES (U.S. CLS. 100, 101 AND 102).

FIRST USE 12-21-2005; IN COMMERCE 12-21-2005.

3,234,064. EXCELLUS HEALTH PLAN, INC., ROCHESTER, NY. SN 76-642,108. PUB. 3-14-2006, FILED 7-1-2005.

# ACTIVE ANYTIME

THE MARK CONSISTS OF STANDARD CHARACTERS WITHOUT CLAIM TO ANY PARTICULAR FONT, STYLE, SIZE, OR COLOR.

FOR HEALTH INSURANCE SERVICES, NAMELY, PROVIDING REIMBURSEMENT FOR PHYSICAL FITNESS ACTIVITY FEES, WEIGHT LOSS PROGRAM FEES, HEALTH CLUB FEES AND DANCE INSTRUCTION FEES (U.S. CLS. 100, 101 AND 102).

FIRST USE 12-21-2005; IN COMMERCE 12-21-2005.

3,234,113. EDGAR ONLINE, INC., NORWALK, CT. SN 78-160,270. PUB. 9-2-2003, FILED 9-3-2002.

# EDGAR ANALYST

THE MARK CONSISTS OF STANDARD CHARACTERS WITHOUT CLAIM TO ANY PARTICULAR FONT, STYLE, SIZE, OR COLOR.

FOR FINANCIAL INFORMATION PROVIDED BY ELECTRONIC MEANS (U.S. CLS. 100, 101 AND 102).

FIRST USE 11-21-2006; IN COMMERCE 11-21-2006.

**CLASS 36—(Continued).**

3,234,232. COMPASS BANCSHARES, INC., BIRMINGHAM, AL. SN 78-379,278. PUB. 7-20-2004, FILED 3-5-2004.

**COMPASS CARD**

THE MARK CONSISTS OF STANDARD CHARACTERS WITHOUT CLAIM TO ANY PARTICULAR FONT, STYLE, SIZE, OR COLOR.

OWNER OF U.S. REG. NOS. 1,604,027, 1,876,083, AND OTHERS.

NO CLAIM IS MADE TO THE EXCLUSIVE RIGHT TO USE "CARD", APART FROM THE MARK AS SHOWN.

FOR BANKING SERVICES (U.S. CLS. 100, 101 AND 102).

FIRST USE 11-16-2006; IN COMMERCE 11-16-2006.

**CLASS 36—(Continued).**

3,234,303. HAHN, SIMON S., BRAMBLETON, VA. SN 78-417,942. PUB. 4-19-2005, FILED 5-13-2004.

**Real Estate for  
the Digital Age**

THE MARK CONSISTS OF STANDARD CHARACTERS WITHOUT CLAIM TO ANY PARTICULAR FONT, STYLE, SIZE, OR COLOR.

NO CLAIM IS MADE TO THE EXCLUSIVE RIGHT TO USE "REAL ESTATE", APART FROM THE MARK AS SHOWN.

FOR REAL ESTATE BROKERAGE (U.S. CLS. 100, 101 AND 102).

FIRST USE 4-1-2004; IN COMMERCE 4-1-2004.

3,234,269. HUMANA INC., LOUISVILLE, KY. SN 78-399,273. PUB. 9-6-2005, FILED 4-9-2004.

**DETROIT BENEFITS**

THE MARK CONSISTS OF STANDARD CHARACTERS WITHOUT CLAIM TO ANY PARTICULAR FONT, STYLE, SIZE, OR COLOR.

NO CLAIM IS MADE TO THE EXCLUSIVE RIGHT TO USE "DETROIT", APART FROM THE MARK AS SHOWN.

FOR CHARITABLE FUND-RAISING; FINANCIAL SPONSORSHIP OF CHARITABLE FUND-RAISING SERVICES OF OTHERS (U.S. CLS. 100, 101 AND 102).

FIRST USE 8-4-2004; IN COMMERCE 8-4-2004.

3,234,321. STRATEGIC REAL ESTATE ADVISORS LIMITED, LONDON, UNITED KINGDOM. SN 78-428,775. PUB. 4-12-2005, FILED 6-2-2004.

**THE STRATREAL  
FOUNDATION**

THE MARK CONSISTS OF STANDARD CHARACTERS WITHOUT CLAIM TO ANY PARTICULAR FONT, STYLE, SIZE, OR COLOR.

NO CLAIM IS MADE TO THE EXCLUSIVE RIGHT TO USE FOUNDATION, APART FROM THE MARK AS SHOWN.

FOR CHARITABLE FUND RAISING ACTIVITIES (U.S. CLS. 100, 101 AND 102).

FIRST USE 1-31-2006; IN COMMERCE 1-31-2006.

**CLASS 36—(Continued).**

3,234,374. CANTELLA & CO., INC., BOSTON, MA. SN 78-467,359. PUB. 6-6-2006, FILED 8-13-2004.

the best kept  
secret on Wall  
Street

THE MARK CONSISTS OF STANDARD CHARACTERS WITHOUT CLAIM TO ANY PARTICULAR FONT, STYLE, SIZE, OR COLOR.

NO CLAIM IS MADE TO THE EXCLUSIVE RIGHT TO USE WALL STREET, APART FROM THE MARK AS SHOWN.

FOR BROKERAGE IN THE FIELD OF STOCKS, BONDS, EQUITIES AND INSURANCE (U.S. CLS. 100, 101 AND 102).

FIRST USE 11-1-1996; IN COMMERCE 11-1-1996.

3,234,375. CANTELLA & CO., INC., BOSTON, MA. SN 78-467,364. PUB. 6-6-2006, FILED 8-13-2004.

Professional Pride

THE MARK CONSISTS OF STANDARD CHARACTERS WITHOUT CLAIM TO ANY PARTICULAR FONT, STYLE, SIZE, OR COLOR.

FOR BROKERAGE IN THE FIELD OF STOCKS, BONDS, EQUITIES AND INSURANCE (U.S. CLS. 100, 101 AND 102).

FIRST USE 11-10-2006; IN COMMERCE 11-10-2006.

**CLASS 36—(Continued).**

3,234,382. SIMPLIFI, LLC, WINSTON SALEM, NC. SN 78-470,472. PUB. 3-14-2006, FILED 8-19-2004.

SIMPLIFI

THE MARK CONSISTS OF STANDARD CHARACTERS WITHOUT CLAIM TO ANY PARTICULAR FONT, STYLE, SIZE, OR COLOR.

FOR PROVIDING, VIA THE INTERNET, PERSONAL FINANCIAL ADVISORY SERVICES, NAMELY, PERSONAL FINANCIAL ANALYSIS, BASED ON ONLINE PERSONAL INTERVIEWS; PROVIDING, VIA THE INTERNET, PERSONAL FINANCIAL PLANNING SERVICES BASED ON ONLINE PERSONAL INTERVIEWS (U.S. CLS. 100, 101 AND 102).

FIRST USE 12-4-2006; IN COMMERCE 12-4-2006.

3,234,385. PADCO ADVISORS, INC., ROCKVILLE, MD. SN 78-472,236. PUB. 12-13-2005, FILED 8-24-2004.

ESSENTIAL  
PORTFOLIO THEORY

THE MARK CONSISTS OF STANDARD CHARACTERS WITHOUT CLAIM TO ANY PARTICULAR FONT, STYLE, SIZE, OR COLOR.

NO CLAIM IS MADE TO THE EXCLUSIVE RIGHT TO USE "PORTFOLIO THEORY", APART FROM THE MARK AS SHOWN.

FOR FINANCIAL MANAGEMENT SERVICES, NAMELY, ASSISTING OTHERS WITH BUILDING FINANCIAL PORTFOLIOS AND PROVIDING AN ONLINE FINANCIAL CALCULATOR ON A GLOBAL NETWORK FOR PORTFOLIO ANALYSIS AND RISK ASSESSMENT IN THE FIELD OF INVESTMENTS (U.S. CLS. 100, 101 AND 102).

FIRST USE 6-0-2005; IN COMMERCE 6-0-2005.

**CLASS 36—(Continued).**

3,234,401. HURLBUT, TERRANCE, WOODSTOCK, ONTARIO, CANADA. SN 78-480,003. PUB. 8-23-2005, FILED 9-8-2004.

**CLASS 36—(Continued).**

3,234,446. NATIONAL CASA ASSOCIATION, SEATTLE, WA. SN 78-495,062. PUB. 2-21-2006, FILED 10-5-2004.

**DONATION STATION**

THE MARK CONSISTS OF STANDARD CHARACTERS WITHOUT CLAIM TO ANY PARTICULAR FONT, STYLE, SIZE, OR COLOR.

PRIORITY CLAIMED UNDER SEC. 44(D) ON CANADA APPLICATION NO. 1,227,694, FILED 8-20-2004.

NO CLAIM IS MADE TO THE EXCLUSIVE RIGHT TO USE "DONATION", APART FROM THE MARK AS SHOWN.

FOR CHARITABLE FUND RAISING SERVICES, NAMELY OFFERING PREMIUMS SUCH AS "LONG-DISTANCE PHONE CARDS" IN RETURN FOR FINANCIAL DONATIONS THROUGH AUTOMATED MACHINES (U.S. CLS. 100, 101 AND 102).

FIRST USE 3-0-2006; IN COMMERCE 3-0-2006.

---

3,234,411. SCOTTI, JOHN A., PITTSBURGH, PA. SN 78-482,221. PUB. 9-13-2005, FILED 9-13-2004.



THE NAME "SCOTTI" IDENTIFIES A LIVING INDIVIDUAL WHOSE CONSENT IS OF RECORD.

THE COLOR(S) RED AND BLACK IS/ARE CLAIMED AS A FEATURE OF THE MARK.

THE MARK CONSISTS OF THE FOLLOWING – STITCHING ON THE BASEBALL AND THE LETTER "T" ARE THE COLOR RED AND OUTLINE OF THE BASEBALL AND THE REMAINING WORDING ARE THE COLOR BLACK.

FOR INSURANCE ADMINISTRATION AND BROKERAGE SERVICES (U.S. CLS. 100, 101 AND 102).

FIRST USE 11-20-1999; IN COMMERCE 6-15-2006.

**CASA**

THE MARK CONSISTS OF STANDARD CHARACTERS WITHOUT CLAIM TO ANY PARTICULAR FONT, STYLE, SIZE, OR COLOR.

OWNER OF U.S. REG. NO. 1,839,711.

THE ENGLISH TRANSLATION OF THE WORD CASA IN THE MARK IS HOUSE.

FOR CHARITABLE FUND RAISING; CHARITABLE FUND RAISING ACTIVITIES FOR SPONSORSHIP OF PROGRAMS RELATING TO CHILD WELFARE, CHILDREN INVOLVED IN LEGAL ACTIONS AND VOLUNTEERS ACTING ON BEHALF OF CHILDREN (U.S. CLS. 100, 101 AND 102).

FIRST USE 0-0-1984; IN COMMERCE 0-0-1984.

---

3,234,462. WYNDHAM RESORT DEVELOPMENT CORPORATION, ORLANDO, FL. SN 78-502,063. PUB. 9-27-2005, FILED 10-19-2004.

**TRAVELSHARE**

THE MARK CONSISTS OF STANDARD CHARACTERS WITHOUT CLAIM TO ANY PARTICULAR FONT, STYLE, SIZE, OR COLOR.

FOR VACATION REAL ESTATE TIME-SHARING EXCHANGE SERVICES; VACATION HOME RENTAL SERVICES (U.S. CLS. 100, 101 AND 102).

FIRST USE 11-7-2006; IN COMMERCE 11-7-2006.

**CLASS 36—(Continued).**

3,234,495. DIAGEO NORTH AMERICA, INC., NORWALK, CT. SN 78-511,993. PUB. 9-13-2005, FILED 11-5-2004.

CROWN ROYAL  
CHAMPIONSHIP RACING

THE MARK CONSISTS OF STANDARD CHARACTERS WITHOUT CLAIM TO ANY PARTICULAR FONT, STYLE, SIZE, OR COLOR.

OWNER OF U.S. REG. NOS. 1,724,742, 2,094,877, AND 2,851,028.

NO CLAIM IS MADE TO THE EXCLUSIVE RIGHT TO USE "CHAMPIONSHIP RACING", APART FROM THE MARK AS SHOWN.

FOR FINANCIAL SPONSORSHIP OF SPORTING AND CULTURAL EVENTS (U.S. CLS. 100, 101 AND 102).

FIRST USE 2-0-2005; IN COMMERCE 2-0-2005.

**CLASS 36—(Continued).**

3,234,542. ALLIANZ GLOBAL INVESTORS OF AMERICA L.P., NEWPORT BEACH, CA. SN 78-524,620. PUB. 3-21-2006, FILED 11-30-2004.

PREMIER VIT

THE MARK CONSISTS OF STANDARD CHARACTERS WITHOUT CLAIM TO ANY PARTICULAR FONT, STYLE, SIZE, OR COLOR.

FOR FINANCIAL SERVICES, NAMELY, FINANCIAL PORTFOLIO MANAGEMENT, FINANCIAL ANALYSIS AND CONSULTATION, INVESTMENT MANAGEMENT SERVICES, SECURITIES TRADING FOR OTHERS, MUTUAL FUND INVESTMENT, INVESTMENT ADVICE, FUNDS INVESTMENT, INVESTMENT CONSULTATION AND INVESTMENT OF FUNDS FOR OTHERS; AND LIMITED PARTNERSHIP INVESTMENT AND INVESTMENT ADVICE (U.S. CLS. 100, 101 AND 102).

FIRST USE 5-1-2005; IN COMMERCE 5-1-2005.

3,234,533. AMERICAN INTERNATIONAL GROUP, INC., NEW YORK, NY. SN 78-521,941. PUB. 10-25-2005, FILED 11-23-2004.

WE KNOW INSURANCE

THE MARK CONSISTS OF STANDARD CHARACTERS WITHOUT CLAIM TO ANY PARTICULAR FONT, STYLE, SIZE, OR COLOR.

OWNER OF U.S. REG. NOS. 2,926,449, 2,962,332, AND OTHERS.

NO CLAIM IS MADE TO THE EXCLUSIVE RIGHT TO USE INSURANCE, APART FROM THE MARK AS SHOWN.

FOR UNDERWRITING SERVICES, NAMELY PROPERTY AND CASUALTY, AUTOMOBILE, AIRCRAFT, LIFE, ACCIDENT, HEALTH, TRAVEL, MANAGEMENT, DIRECTOR AND OFFICER LIABILITY, NON-MEDICAL PROFESSIONAL LIABILITY, ENVIRONMENTAL, WORKERS' COMPENSATION, POLITICAL RISK, ERRORS AND OMISSIONS; INSURANCE CLAIMS ADJUSTMENT SERVICES FOR CORPORATE AND OTHER COMMERCIAL CLIENTS; RISK MANAGEMENT SERVICES; INVESTMENT MANAGEMENT (U.S. CLS. 100, 101 AND 102).

FIRST USE 6-1-2005; IN COMMERCE 6-1-2005.

3,234,555. THE PNC FINANCIAL SERVICES GROUP, INC., PITTSBURGH, PA. SN 78-528,831. PUB. 9-13-2005, FILED 12-8-2004.

SELF-RELIANT LOAN

THE MARK CONSISTS OF STANDARD CHARACTERS WITHOUT CLAIM TO ANY PARTICULAR FONT, STYLE, SIZE, OR COLOR.

NO CLAIM IS MADE TO THE EXCLUSIVE RIGHT TO USE LOAN, APART FROM THE MARK AS SHOWN.

FOR FINANCIAL SERVICES, NAMELY, LOANS FOR THE DISABLED FOR ACCESSIBILITY NEEDS (U.S. CLS. 100, 101 AND 102).

FIRST USE 4-20-2005; IN COMMERCE 4-20-2005.

**CLASS 36—(Continued).**

3,234,573. ENCORE BANK, HOUSTON, TX. SN 78-532,220.  
PUB. 12-6-2005, FILED 12-14-2004.

**ENCORE TRUST**

THE MARK CONSISTS OF STANDARD CHARACTERS WITHOUT CLAIM TO ANY PARTICULAR FONT, STYLE, SIZE, OR COLOR.

OWNER OF U.S. REG. NOS. 2,849,150, 2,882,994, AND 2,957,865.

NO CLAIM IS MADE TO THE EXCLUSIVE RIGHT TO USE "TRUST", APART FROM THE MARK AS SHOWN.

FOR TRUST SERVICES, NAMELY, INVESTMENT AND TRUST COMPANY SERVICES; FINANCIAL TRUST OPERATIONS INCLUDING TRUST ADMINISTRATION FOR PERSONAL TRUSTS, EMPLOYEE BENEFIT TRUSTS, CORPORATE TRUSTS, CHARITABLE TRUSTS, AND GUARDIANSHIPS; ESTATE TRUST MANAGEMENT; ESTATE ADMINISTRATION; FINANCIAL AGENCY SERVICES, NAMELY SAFEKEEPING OF ASSETS, INVESTMENT MANAGEMENT, TRANSFER AGENT AND REGISTRAR SERVICES; FINANCIAL SERVICES, NAMELY ASSISTING OTHERS WITH THE COMPLETION OF FINANCIAL TRANSACTIONS FOR STOCKS, BONDS, SECURITIES, AND EQUITIES; AND ESCROW SERVICES, NAMELY MAINTAINING ESCROW ACCOUNTS FOR INDIVIDUALS (U.S. CLS. 100, 101 AND 102).

FIRST USE 4-4-2005; IN COMMERCE 7-11-2005.

3,234,607. THE MCGRAW-HILL COMPANIES, INC., NEW YORK, NY. SN 78-543,442. PUB. 4-25-2006, FILED 1-6-2005.

**STANDARD & POOR'S  
SECURITIES  
DATAMANAGER**

THE MARK CONSISTS OF STANDARD CHARACTERS WITHOUT CLAIM TO ANY PARTICULAR FONT, STYLE, SIZE, OR COLOR.

OWNER OF U.S. REG. NOS. 527,414, 765,131, AND OTHERS.

NO CLAIM IS MADE TO THE EXCLUSIVE RIGHT TO USE "SECURITIES DATA MANAGER", APART FROM THE MARK AS SHOWN.

FOR PROVIDING FINANCIAL INFORMATION ON FINANCIAL SECURITIES THROUGH A GLOBAL COMPUTER NETWORK (U.S. CLS. 100, 101 AND 102).

FIRST USE 1-31-2005; IN COMMERCE 1-31-2005.

**CLASS 36—(Continued).**

3,234,613. HANSON MCCLAIN RETIREMENT NETWORK, LLC, FOLSOM, CA. SN 78-545,771. PUB. 10-4-2005, FILED 1-11-2005.

**HMRN**

THE MARK CONSISTS OF STANDARD CHARACTERS WITHOUT CLAIM TO ANY PARTICULAR FONT, STYLE, SIZE, OR COLOR.

FOR INVESTMENT ADVISORY SERVICES (U.S. CLS. 100, 101 AND 102).

FIRST USE 6-12-2006; IN COMMERCE 6-12-2006.

3,234,636. ENCORE BANK, HOUSTON, TX. SN 78-556,123.  
PUB. 3-21-2006, FILED 1-28-2005.

**ENCORETRUST**

OWNER OF U.S. REG. NOS. 2,849,150, 2,882,994, AND 2,957,865.

THE COLORS BLUE AND BLACK ARE CLAIMED AS FEATURES OF THE MARK.

THE COLOR BLACK APPEARS IN ALL THE LETTERS IN THE MARK, WITH THE EXCEPTION OF THE "O", AND THE COLOR BLUE APPEARS IN A SPHERICAL GEOMETRIC SHAPE WHICH IS SUBSTITUTED FOR THE LETTER "O" IN THE TERM "ENCORETRUST".

THE MARK IS COMPRISED OF THE TERM "ENCORETRUST" WITH A SPHERICAL GEOMETRIC SHAPE SUBSTITUTED FOR THE LETTER "O."

FOR TRUST SERVICES, NAMELY, INVESTMENT AND TRUST COMPANY SERVICES; FINANCIAL TRUST OPERATIONS INCLUDING TRUST ADMINISTRATION FOR PERSONAL TRUSTS, EMPLOYEE BENEFIT TRUSTS, CORPORATE TRUSTS, CHARITABLE TRUSTS, AND GUARDIANSHIPS; ESTATE TRUST MANAGEMENT; ESTATE ADMINISTRATION; FINANCIAL AGENCY SERVICES, NAMELY SAFEKEEPING OF ASSETS, INVESTMENT MANAGEMENT, TRANSFER AGENT AND REGISTRAR SERVICES; FINANCIAL SERVICES, NAMELY ASSISTING OTHERS WITH THE COMPLETION OF FINANCIAL TRANSACTIONS FOR STOCKS, BONDS, SECURITIES, AND EQUITIES; AND ESCROW SERVICES, NAMELY MAINTAINING ESCROW ACCOUNTS FOR INDIVIDUALS (U.S. CLS. 100, 101 AND 102).

FIRST USE 4-4-2005; IN COMMERCE 7-11-2005.

**CLASS 36—(Continued).**

3,234,637. HSBC FINANCE CORPORATION, PROSPECT HEIGHTS, IL. SN 78-557,014. PUB. 4-25-2006, FILED 1-31-2005.

**TRIPLE PLUS**

THE MARK CONSISTS OF STANDARD CHARACTERS WITHOUT CLAIM TO ANY PARTICULAR FONT, STYLE, SIZE, OR COLOR.

FOR FINANCIAL SERVICES IN THE FIELD OF MONEY LENDING; CREDIT CARD SERVICES; AND BANKING SERVICES (U.S. CLS. 100, 101 AND 102).

FIRST USE 3-0-2005; IN COMMERCE 3-0-2005.

3,234,648. INDEPENDENCE BANCSHARES, INC., GREENVILLE, SC. SN 78-563,017. PUB. 3-7-2006, FILED 2-8-2005.

**INDEPENDENCE  
NATIONAL BANK**

NO CLAIM IS MADE TO THE EXCLUSIVE RIGHT TO USE NATIONAL BANK, APART FROM THE MARK AS SHOWN.

FOR BANKING SERVICES; FINANCIAL SERVICES, NAMELY, PROVIDING FINANCIAL ANALYSIS, CONSULTATION, PLANNING AND MANAGEMENT, COMMERCIAL AND CONSUMER LENDING AND LEASING SERVICES, MORTGAGE LENDING, AND LOAN FINANCING; CREDIT CARD SERVICES; DEBIT CARD SERVICES; ELECTRONIC PAYMENT, NAMELY, ELECTRONIC PROCESSING AND TRANSMISSION OF BILL PAYMENT DATA; SECURITY SERVICES, NAMELY, GUARANTEEING LOANS; CASH MANAGEMENT; MORTGAGE BANKING; SAFETY DEPOSIT BOX SERVICES (U.S. CLS. 100, 101 AND 102).

FIRST USE 5-16-2005; IN COMMERCE 5-16-2005.

**CLASS 36—(Continued).**

3,234,656. ASSURANT, INC., NEW YORK, NY. SN 78-565,836. PUB. 3-7-2006, FILED 2-11-2005.

**ASSURANT EMPLOYEE  
BENEFITS**

THE MARK CONSISTS OF STANDARD CHARACTERS WITHOUT CLAIM TO ANY PARTICULAR FONT, STYLE, SIZE, OR COLOR.

OWNER OF U.S. REG. NOS. 2,543,367, 2,946,817, AND OTHERS.

NO CLAIM IS MADE TO THE EXCLUSIVE RIGHT TO USE "EMPLOYEE BENEFITS", APART FROM THE MARK AS SHOWN.

FOR INSURANCE UNDERWRITING SERVICES IN THE FIELDS OF HEALTH, LIFE, DENTAL, DISABILITY, ACCIDENTAL DEATH AND DISMEMBERMENT; CREATION AND ADMINISTRATION OF PREFERRED PROVIDER, PREPAID AND DISCOUNT HEALTHCARE PLANS; ADMINISTRATION OF INSURANCE-BASED SELF-FUNDED GROUP BENEFIT PLANS; AND DISABILITY CLAIM ADMINISTRATION IN THE NATURE OF PROCESSING AND PAYMENT SERVICES (U.S. CLS. 100, 101 AND 102).

FIRST USE 2-5-2004; IN COMMERCE 2-5-2004.

3,234,666. CITIGROUP INC., NEW YORK, NY. SN 78-572,339. PUB. 7-25-2006, FILED 2-22-2005.

**DRIVE REBATES**

THE MARK CONSISTS OF STANDARD CHARACTERS WITHOUT CLAIM TO ANY PARTICULAR FONT, STYLE, SIZE, OR COLOR.

NO CLAIM IS MADE TO THE EXCLUSIVE RIGHT TO USE REBATES, APART FROM THE MARK AS SHOWN.

FOR CREDIT CARD USER LOYALTY AND REWARD PROGRAMS, NAMELY, PROVIDING REBATES AT PARTICIPATING ESTABLISHMENTS AND RETAIL OUTLETS FOR OTHERS THROUGH A USAGE AWARD ACCUMULATION AND REDEMPTION PROGRAM (U.S. CLS. 100, 101 AND 102).

FIRST USE 5-23-2005; IN COMMERCE 5-23-2005.



**CLASS 36—(Continued).**

3,234,707. FIRSTAGAIN LLC, SAN DIEGO, CA. SN 78-586,997. PUB. 12-6-2005, FILED 3-14-2005.

# FirstAgain

THE MARK CONSISTS OF STANDARD CHARACTERS WITHOUT CLAIM TO ANY PARTICULAR FONT, STYLE, SIZE, OR COLOR.

FOR FINANCIAL SERVICES, NAMELY CONSUMER LENDING (U.S. CLS. 100, 101 AND 102).

FIRST USE 10-17-2006; IN COMMERCE 10-17-2006.

---

3,234,716. MORGAN STANLEY, NEW YORK, NY. SN 78-590,185. PUB. 12-20-2005, FILED 3-18-2005.

# VK CAPITAL

THE MARK CONSISTS OF STANDARD CHARACTERS WITHOUT CLAIM TO ANY PARTICULAR FONT, STYLE, SIZE, OR COLOR.

NO CLAIM IS MADE TO THE EXCLUSIVE RIGHT TO USE "CAPITAL", APART FROM THE MARK AS SHOWN.

FOR COMMODITY TRADING ADVISORY SERVICES AND COMMODITY TRADING SERVICES FOR OTHERS (U.S. CLS. 100, 101 AND 102).

FIRST USE 10-0-2005; IN COMMERCE 10-0-2005.

**CLASS 36—(Continued).**

3,234,725. U.T. FEDERAL CREDIT UNION, KNOXVILLE, TN. SN 78-594,833. PUB. 5-23-2006, FILED 3-24-2005.



THE MARK CONSISTS OF A STYLIZED HUMAN WITH ITS ARMS AROUND THREE STARS.

FOR FINANCIAL SERVICES, NAMELY, CREDIT UNION SERVICES FEATURING CONSUMER LOANS, MORTGAGE LOANS, INSTALLMENT LOANS, SAVINGS ACCOUNT SERVICES, CHECKING ACCOUNT SERVICES, MONEY MARKET DEPOSIT ACCOUNT SERVICES, CERTIFICATE OF DEPOSIT ACCOUNT SERVICES, INDIVIDUAL RETIREMENT ACCOUNT SERVICES, CREDIT CARD SERVICES, DEBIT CHECK CARD SERVICES, PROVIDING PERSONAL LINES OF CREDIT, PROPRIETARY AUTOMATED TELLER MACHINES SERVICES, TELEPHONE BANKING, AND INTERNET BANKING (U.S. CLS. 100, 101 AND 102).

FIRST USE 7-25-2005; IN COMMERCE 8-1-2005.

---

3,234,749. WM. PAGE & ASSOCIATES, INC., DBA THE LIFELINE PROGRAM, TUCKER, GA. SN 78-600,890. PUB. 12-27-2005, FILED 4-4-2005.

# A NEW ROAD TO FINANCIAL FREEDOM

THE MARK CONSISTS OF STANDARD CHARACTERS WITHOUT CLAIM TO ANY PARTICULAR FONT, STYLE, SIZE, OR COLOR.

FOR VIATICAL SETTLEMENT SERVICES; AND LIFE INSURANCE POLICY SETTLEMENT SERVICES (U.S. CLS. 100, 101 AND 102).

FIRST USE 4-1-2005; IN COMMERCE 4-1-2005.

**CLASS 36—(Continued).**

3,234,775. PRENTICE CAPITAL MANAGEMENT, LP, NEW YORK, NY. SN 78-611,373. PUB. 2-14-2006, FILED 4-18-2005.

PRENTICE CAPITAL PARTNERS  
QP, LP

THE MARK CONSISTS OF STANDARD CHARACTERS WITHOUT CLAIM TO ANY PARTICULAR FONT, STYLE, SIZE, OR COLOR.

NO CLAIM IS MADE TO THE EXCLUSIVE RIGHT TO USE CAPITAL PARTNERS QP, LP, APART FROM THE MARK AS SHOWN.

FOR FINANCIAL SERVICES, NAMELY, INVESTMENT ADVISORY SERVICES, INVESTMENT MANAGEMENT SERVICES AND ASSET MANAGEMENT SERVICES (U.S. CLS. 100, 101 AND 102).

FIRST USE 5-2-2005; IN COMMERCE 5-2-2005.

3,234,776. CEYUAN MANAGEMENT, LLC, SAN FRANCISCO, CA. SN 78-611,415. PUB. 12-6-2005, FILED 4-18-2005.

CEYUAN

THE MARK CONSISTS OF STANDARD CHARACTERS WITHOUT CLAIM TO ANY PARTICULAR FONT, STYLE, SIZE, OR COLOR.

FOR FINANCIAL SERVICES IN THE NATURE OF VENTURE CAPITAL, PRIVATE EQUITY AND OTHER INVESTMENT SERVICES, NAMELY PROVIDING FINANCING TO COMPANIES AND OTHER ENTERPRISES IN ALL STAGES FOR USE IN THE FORMATION, DEVELOPMENT, OPERATION AND MANAGEMENT OF SUCH ENTERPRISES AND FORMATION OF INVESTMENT FUNDS TO INVEST IN SUCH ENTERPRISES; FINANCIAL INVESTMENT MANAGEMENT AND ADVISORY SERVICES; FINANCIAL CONSULTATION SERVICES (U.S. CLS. 100, 101 AND 102).

FIRST USE 5-1-2005; IN COMMERCE 5-1-2005.

3,234,778. STAUBI, PAUL W., RYE, NY. SN 78-611,882. PUB. 5-9-2006, FILED 4-19-2005.

DIFFERENCE CARD

THE MARK CONSISTS OF STANDARD CHARACTERS WITHOUT CLAIM TO ANY PARTICULAR FONT, STYLE, SIZE, OR COLOR.

NO CLAIM IS MADE TO THE EXCLUSIVE RIGHT TO USE "CARD", APART FROM THE MARK AS SHOWN.

FOR ADMINISTRATION OF HEALTH INSURANCE BENEFIT AND FLEXIBLE SPENDING PLANS (U.S. CLS. 100, 101 AND 102).

FIRST USE 4-1-2005; IN COMMERCE 4-1-2005.

**CLASS 36—(Continued).**

3,234,798. KING, WILLIAM F., BIRMINGHAM, AL. AND MOLINA, ALLAN F., BIRMINGHAM, AL. SN 78-620,605. PUB. 5-9-2006, FILED 5-2-2005.

FLAMINGO RIVIERA

THE MARK CONSISTS OF STANDARD CHARACTERS WITHOUT CLAIM TO ANY PARTICULAR FONT, STYLE, SIZE, OR COLOR.

NO CLAIM IS MADE TO THE EXCLUSIVE RIGHT TO USE "RIVIERA", APART FROM THE MARK AS SHOWN.

FOR REAL ESTATE BROKERAGE (U.S. CLS. 100, 101 AND 102).

FIRST USE 4-0-2005; IN COMMERCE 6-0-2005.

3,234,820. PATHWAY DATA, INC., COSTA MESA, CA. SN 78-626,142. PUB. 2-7-2006, FILED 5-9-2005.

myperfectcredit

THE MARK CONSISTS OF STANDARD CHARACTERS WITHOUT CLAIM TO ANY PARTICULAR FONT, STYLE, SIZE, OR COLOR.

FOR PROVIDING INFORMATION AND FINANCIAL SERVICES, NAMELY, CREDIT RISK ANALYSIS, CREDIT MONITORING, CREDIT MANAGEMENT AND ANALYSIS OVER COMPUTER NETWORKS AND GLOBAL COMMUNICATION NETWORKS (U.S. CLS. 100, 101 AND 102).

FIRST USE 5-1-2003; IN COMMERCE 5-1-2003.

3,234,835. VON BORSTEL, HECTOR, GLENDORA, CA. SN 78-630,724. PUB. 4-18-2006, FILED 5-16-2005.

SIENDO PARTE DE LA SOLUCION

THE MARK CONSISTS OF STANDARD CHARACTERS WITHOUT CLAIM TO ANY PARTICULAR FONT, STYLE, SIZE, OR COLOR.

THE FOREIGN WORDING IN THE MARK TRANSLATES INTO ENGLISH AS BEING A PART OF THE SOLUTION.

FOR MORTGAGE BROKERAGE SERVICES (U.S. CLS. 100, 101 AND 102).

FIRST USE 5-16-2005; IN COMMERCE 5-16-2005.

**CLASS 36—(Continued).**

3,234,858. BEARD MILLER COMPANY LLP, YORK, PA. SN 78-634,965. PUB. 2-14-2006, FILED 5-23-2005.

**CLASS 36—(Continued).**

3,234,907. JACKSON NATIONAL LIFE INSURANCE COMPANY, LANSING, MI. SN 78-646,915. PUB. 2-28-2006, FILED 6-9-2005.

MOVING YOUR VISION FORWARD

THE MARK CONSISTS OF STANDARD CHARACTERS WITHOUT CLAIM TO ANY PARTICULAR FONT, STYLE, SIZE, OR COLOR.

FOR BUSINESS AND FINANCIAL VALUATION SERVICES, ESTATE PLANNING, ESTATE TRUST MANAGEMENT, FINANCIAL ANALYSIS AND CONSULTATION (U.S. CLS. 100, 101 AND 102).

FIRST USE 10-1-2005; IN COMMERCE 10-1-2005.

ELITE CHOICE REWARDS

THE MARK CONSISTS OF STANDARD CHARACTERS WITHOUT CLAIM TO ANY PARTICULAR FONT, STYLE, SIZE, OR COLOR.

OWNER OF U.S. REG. NOS. 2,341,841, 2,400,118, AND 2,809,187.

FOR FINANCIAL SERVICES, NAMELY, UNDERWRITING OF FIXED INDEX ANNUITIES (U.S. CLS. 100, 101 AND 102).

FIRST USE 2-13-2006; IN COMMERCE 2-13-2006.

3,234,872. STATUE OF RESPONSIBILITY FOUNDATION, SALT LAKE CITY, UT. SN 78-638,588. PUB. 2-21-2006, FILED 5-26-2005.

STATUE OF RESPONSIBILITY

THE MARK CONSISTS OF STANDARD CHARACTERS WITHOUT CLAIM TO ANY PARTICULAR FONT, STYLE, SIZE, OR COLOR.

FOR CHARITABLE FUNDRAISING SERVICES (U.S. CLS. 100, 101 AND 102).

FIRST USE 3-0-2005; IN COMMERCE 3-0-2005.

3,234,908. JACKSON NATIONAL LIFE INSURANCE COMPANY, LANSING, MI. SN 78-646,917. PUB. 2-28-2006, FILED 6-9-2005.

ELITE CHOICE

3,234,901. FIRST NATIONAL BANK TEXAS, KILLEEN, TX. SN 78-645,820. PUB. 2-21-2006, FILED 6-7-2005.

REAL HOURS FOR REAL PEOPLE

THE MARK CONSISTS OF STANDARD CHARACTERS WITHOUT CLAIM TO ANY PARTICULAR FONT, STYLE, SIZE, OR COLOR.

FOR FULL SERVICE BANKING (U.S. CLS. 100, 101 AND 102).

FIRST USE 12-31-2005; IN COMMERCE 12-31-2005.

THE MARK CONSISTS OF STANDARD CHARACTERS WITHOUT CLAIM TO ANY PARTICULAR FONT, STYLE, SIZE, OR COLOR.

OWNER OF U.S. REG. NOS. 2,341,841, 2,400,118, AND 2,809,187.

FOR FINANCIAL SERVICES, NAMELY, UNDERWRITING OF FIXED INDEX ANNUITIES (U.S. CLS. 100, 101 AND 102).

FIRST USE 2-13-2006; IN COMMERCE 2-13-2006.

**CLASS 36—(Continued).**

3,234,947. COMMONWEALTH GENERAL CORPORATION, LOUISVILLE, KY. SN 78-652,752. PUB. 3-21-2006, FILED 6-17-2005.

**STONEBRIDGE TRAVEL  
PROTECTION**

THE MARK CONSISTS OF STANDARD CHARACTERS WITHOUT CLAIM TO ANY PARTICULAR FONT, STYLE, SIZE, OR COLOR.

OWNER OF U.S. REG. NOS. 2,830,487, 2,830,488, AND 2,832,578.

NO CLAIM IS MADE TO THE EXCLUSIVE RIGHT TO USE TRAVEL PROTECTION, APART FROM THE MARK AS SHOWN.

FOR INSURANCE SERVICES, NAMELY, BROKERAGE, CLAIMS PROCESSING, CONSULTATION, UNDERWRITING AND ADMINISTRATION OF TRAVEL INSURANCE, TRIP INSURANCE, LOST PROPERTY INSURANCE AND ID THEFT INSURANCE (U.S. CLS. 100, 101 AND 102).

FIRST USE 7-26-2005; IN COMMERCE 7-26-2005.

3,234,971. COMMONWEALTH GENERAL CORPORATION, LOUISVILLE, KY. SN 78-654,903. PUB. 3-21-2006, FILED 6-21-2005.



OWNER OF U.S. REG. NOS. 2,830,487, 2,830,488, AND 2,832,578.

NO CLAIM IS MADE TO THE EXCLUSIVE RIGHT TO USE TRAVEL PROTECTION, APART FROM THE MARK AS SHOWN.

FOR INSURANCE SERVICES, NAMELY, BROKERAGE, CLAIMS PROCESSING, CONSULTATION, UNDERWRITING AND ADMINISTRATION OF TRAVEL INSURANCE, TRIP INSURANCE, LOST PROPERTY INSURANCE AND ID THEFT INSURANCE (U.S. CLS. 100, 101 AND 102).

FIRST USE 7-26-2005; IN COMMERCE 7-26-2005.

**CLASS 36—(Continued).**

3,234,981. GMAC MORTGAGE CORPORATION, HORSHAM, PA. SN 78-656,722. PUB. 3-21-2006, FILED 6-23-2005.

# BUYLINE

THE MARK CONSISTS OF STANDARD CHARACTERS WITHOUT CLAIM TO ANY PARTICULAR FONT, STYLE, SIZE, OR COLOR.

FOR REAL ESTATE MORTGAGE BANKING AND LENDING SERVICES; LOAN ORIGINATION AND FINANCING VIA A GLOBAL COMMUNICATIONS NETWORK (U.S. CLS. 100, 101 AND 102).

FIRST USE 7-15-2004; IN COMMERCE 7-15-2004.

3,234,996. KIWANIS CLUB OF SACRAMENTO SUBURBAN INC., SACRAMENTO, CA. SN 78-658,844. PUB. 6-6-2006, FILED 6-27-2005.

## Town and Country Art Fiesta

THE MARK CONSISTS OF STANDARD CHARACTERS WITHOUT CLAIM TO ANY PARTICULAR FONT, STYLE, SIZE, OR COLOR.

NO CLAIM IS MADE TO THE EXCLUSIVE RIGHT TO USE "ART FIESTA", APART FROM THE MARK AS SHOWN.

FOR RENTAL OF EXHIBITION SPACE FOR ARTISTS TO PROVIDE RETAIL SERVICES TO THE PUBLIC (U.S. CLS. 100, 101 AND 102).

FIRST USE 11-29-2006; IN COMMERCE 11-29-2006.

3,235,067. I4 COMMERCE INC., TIMONIUM, MD. SN 78-668,261. PUB. 5-30-2006, FILED 7-12-2005.

## KNOW HOW AT THE POINT OF SALE

THE MARK CONSISTS OF STANDARD CHARACTERS WITHOUT CLAIM TO ANY PARTICULAR FONT, STYLE, SIZE, OR COLOR.

FOR CREDIT SERVICES, NAMELY, PROVIDING REVOLVING CREDIT ACCOUNT SERVICES AND BILL PAYMENT SERVICES TO OTHERS VIA TELEPHONE AND WORLD WIDE WEB (U.S. CLS. 100, 101 AND 102).

FIRST USE 8-0-2005; IN COMMERCE 8-0-2005.

**CLASS 36—(Continued).**

3,235,111. BANK OF AMERICA CORPORATION, CHARLOTTE, NC. SN 78-678,180. PUB. 8-8-2006, FILED 7-26-2005.

**CLASS 36—(Continued).**

3,235,178. PROESEL, HENRY A. III, CHICAGO, IL. SN 78-699,487. PUB. 6-6-2006, FILED 8-24-2005.

## AQUIFER FUNDING

THE MARK CONSISTS OF STANDARD CHARACTERS WITHOUT CLAIM TO ANY PARTICULAR FONT, STYLE, SIZE, OR COLOR.

NO CLAIM IS MADE TO THE EXCLUSIVE RIGHT TO USE "FUNDING", APART FROM THE MARK AS SHOWN. FOR INVESTMENT SERVICES, NAMELY ASSET FINANCING (U.S. CLS. 100, 101 AND 102).

FIRST USE 10-5-2005; IN COMMERCE 10-5-2005.

## Kor Financial

THE MARK CONSISTS OF STANDARD CHARACTERS WITHOUT CLAIM TO ANY PARTICULAR FONT, STYLE, SIZE, OR COLOR.

NO CLAIM IS MADE TO THE EXCLUSIVE RIGHT TO USE "FINANCIAL", APART FROM THE MARK AS SHOWN.

FOR FINANCIAL PLANNING, ADVISORY AND MANAGEMENT SERVICES IN THE FIELDS OF INVESTMENTS, INSURANCE, ANNUITIES, MORTGAGES, REAL ESTATE, ESTATE PLANNING, FOUNDATION PLANNING, AND PLANNED CHARITABLE GIVING (U.S. CLS. 100, 101 AND 102).

FIRST USE 11-1-2006; IN COMMERCE 11-1-2006.

3,235,130. I4 COMMERCE INC., TIMONIUM, MD. SN 78-682,691. PUB. 5-30-2006, FILED 8-1-2005.

**KNOW HOW AT THE POINT OF SALE.**

FOR CREDIT SERVICES, NAMELY, PROVIDING REVOLVING CREDIT ACCOUNT SERVICES AND BILL PAYMENT SERVICES TO OTHERS VIA TELEPHONE AND WORLD WIDE WEB (U.S. CLS. 100, 101 AND 102).

FIRST USE 8-0-2005; IN COMMERCE 8-0-2005.

3,235,179. ALLIANZ LIFE INSURANCE COMPANY OF NORTH AMERICA, MINNEAPOLIS, MN. SN 78-699,693. PUB. 6-13-2006, FILED 8-24-2005.

## GENDEX-RP

3,235,162. SPRINGBOARD NON-PROFIT CONSUMER CREDIT MANAGEMENT, INC., RIVERSIDE, CA. SN 78-694,585. PUB. 5-2-2006, FILED 8-17-2005.

## BANKRUPTCY RELIST

THE MARK CONSISTS OF STANDARD CHARACTERS WITHOUT CLAIM TO ANY PARTICULAR FONT, STYLE, SIZE, OR COLOR.

NO CLAIM IS MADE TO THE EXCLUSIVE RIGHT TO USE "BANKRUPTCY", APART FROM THE MARK AS SHOWN.

FOR CREDIT CONSULTATION AND CREDIT REPAIR SERVICES (U.S. CLS. 100, 101 AND 102).

FIRST USE 1-1-2004; IN COMMERCE 1-1-2004.

THE MARK CONSISTS OF STANDARD CHARACTERS WITHOUT CLAIM TO ANY PARTICULAR FONT, STYLE, SIZE, OR COLOR.

OWNER OF U.S. REG. NO. 3,051,572.

FOR INSURANCE ADMINISTRATION; INSURANCE ADMINISTRATION IN THE FIELD OF LIFE INSURANCE; INSURANCE BROKERAGE; INSURANCE BROKERAGE IN THE FIELD OF LIFE INSURANCE; INSURANCE CARRIER SERVICES; INSURANCE CLAIMS ADMINISTRATION; INSURANCE CLAIMS PROCESSING; INSURANCE CONSULTATION; INSURANCE UNDERWRITING IN THE FIELD OF LIFE INSURANCE; LIFE INSURANCE BROKERAGE; LIFE INSURANCE UNDERWRITING (U.S. CLS. 100, 101 AND 102).

FIRST USE 12-6-2005; IN COMMERCE 12-6-2005.

**CLASS 36—(Continued).**

3,235,188. PALO ALTO PARTNERS IN EDUCATION, PALO ALTO, CA. SN 78-704,154. PUB. 7-25-2006, FILED 8-31-2005.



PALO ALTO  
PARTNERS  
IN EDUCATION

NO CLAIM IS MADE TO THE EXCLUSIVE RIGHT TO USE "PALO ALTO" AND "EDUCATION", APART FROM THE MARK AS SHOWN.

THE MARK CONSISTS OF A STYLIZED HUMAN FIGURE IN A CIRCLE ABOVE THE WORDS PALO ALTO PARTNERS IN EDUCATION.

FOR CHARITABLE FUND RAISING (U.S. CLS. 100, 101 AND 102).

FIRST USE 8-30-2005; IN COMMERCE 8-30-2005.

3,235,189. FIRSTAGAIN LLC, SAN DIEGO, CA. SN 78-704,342. PUB. 2-28-2006, FILED 8-31-2005.



THE COLOR(S) BLUE, RED AND GRAY IS/ARE CLAIMED AS A FEATURE OF THE MARK.

THE WORDS "FIRST AGAIN" APPEAR IN THE COLOR BLUE, THE STYLIZED ANGLED STAR ICON APPEARS IN THE COLOR RED AND THE SWEEPING TRAILS APPEAR IN THE COLOR GRAY.

FOR CONSUMER LENDING SERVICES; FINANCIAL SERVICES, NAMELY MONEY LENDING (U.S. CLS. 100, 101 AND 102).

FIRST USE 10-17-2006; IN COMMERCE 10-17-2006.

3,235,206. AMERICAN INTERNATIONAL GROUP, INC., NEW YORK, NY. SN 78-711,887. PUB. 7-11-2006, FILED 9-13-2005.

AIG TRIBAL GROWTH

**CLASS 36—(Continued).**

THE MARK CONSISTS OF STANDARD CHARACTERS WITHOUT CLAIM TO ANY PARTICULAR FONT, STYLE, SIZE, OR COLOR.

OWNER OF U.S. REG. NOS. 1,151,229, 1,273,845, AND OTHERS.

NO CLAIM IS MADE TO THE EXCLUSIVE RIGHT TO USE "TRIBAL GROWTH", APART FROM THE MARK AS SHOWN.

FOR FINANCIAL INVESTMENT IN THE FIELD OF ANNUITIES AND INSURANCE PRODUCTS, NAMELY, PROPERTY AND CASUALTY, ACCIDENT AND HEALTH, AND PERSONAL LINES INSURANCE AND INVESTMENT ADVICE (U.S. CLS. 100, 101 AND 102).

FIRST USE 2-1-2006; IN COMMERCE 2-1-2006.

3,235,207. FIFTH THIRD BANCORP, CINCINNATI, OH. SN 78-711,955. PUB. 7-11-2006, FILED 9-13-2005.

**FIFTH THIRD BANKING BASICS**

THE MARK CONSISTS OF STANDARD CHARACTERS WITHOUT CLAIM TO ANY PARTICULAR FONT, STYLE, SIZE, OR COLOR.

OWNER OF U.S. REG. NOS. 1,645,502, 2,366,546, AND OTHERS.

NO CLAIM IS MADE TO THE EXCLUSIVE RIGHT TO USE "BANKING BASICS", APART FROM THE MARK AS SHOWN.

FOR PROVIDING BANKING SERVICES TO PREVIOUSLY UNBANKED INDIVIDUALS (U.S. CLS. 100, 101 AND 102).

FIRST USE 10-1-2005; IN COMMERCE 10-1-2005.

3,235,305. SIMPLE TUITION LLC, NEWTON, MA. SN 78-759,118. PUB. 8-15-2006, FILED 11-22-2005.

**SIMPLETUITION**

THE MARK CONSISTS OF STANDARD CHARACTERS WITHOUT CLAIM TO ANY PARTICULAR FONT, STYLE, SIZE, OR COLOR.

FOR CONSUMER LENDING SERVICES; FINANCING SERVICES FOR THE FINANCING OF EDUCATION (U.S. CLS. 100, 101 AND 102).

FIRST USE 12-1-2005; IN COMMERCE 12-1-2005.

3,235,308. HUSQVARNA AKTIEBOLAG, HUSKVARNA, SWEDEN. SN 78-760,438. PUB. 2-28-2006, FILED 11-23-2005.

HUSQVARNA FINANCIAL  
SERVICES

**CLASS 36—(Continued).**

THE MARK CONSISTS OF STANDARD CHARACTERS WITHOUT CLAIM TO ANY PARTICULAR FONT, STYLE, SIZE, OR COLOR.

OWNER OF U.S. REG. NOS. 1,067,453, 2,878,397, AND OTHERS.

NO CLAIM IS MADE TO THE EXCLUSIVE RIGHT TO USE "FINANCIAL SERVICES", APART FROM THE MARK AS SHOWN.

FOR CREDIT CARD SERVICES AND FLOOR PRODUCT DISPLAY FINANCING (U.S. CLS. 100, 101 AND 102).

FIRST USE 12-1-2005; IN COMMERCE 12-1-2005.

---

3,235,359. SCOTT W. GAD, MADISON, WI. SN 78-780,546. PUB. 8-22-2006, FILED 12-23-2005.

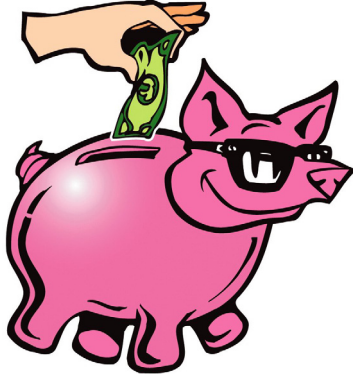

THE APPLICANT CLAIMS COLOR AS A FEATURE OF THE MARK, NAMELY, TAN, GREEN, PINK, BLACK, AND WHITE.

THE MARK CONSISTS OF A BLACK-OUTLINED TAN HAND DROPPING A GREEN DOLLAR BILL INTO THE BLACK SLOT OF A BLACK-OUTLINED PIGGYBANK WITH A PINK BODY, BLACK NOSE, BLACK EARS, BLACK EYEBROW, BLACK MOUTH, AND BLACK AND WHITE SUNGLASSES.

FOR REAL ESTATE BROKERAGE (U.S. CLS. 100, 101 AND 102).

FIRST USE 1-15-2006; IN COMMERCE 1-15-2006.

---

3,235,379. JANUS INTERNATIONAL HOLDING LLC, DENVER, CO. SN 78-804,526. PUB. 9-5-2006, FILED 2-1-2006.

**JANUSINTECH**

THE MARK CONSISTS OF STANDARD CHARACTERS WITHOUT CLAIM TO ANY PARTICULAR FONT, STYLE, SIZE, OR COLOR.

FOR INVESTING THE FUNDS OF OTHERS; MUTUAL FUND INVESTMENT AND INVESTMENT ADVISORY SERVICES (U.S. CLS. 100, 101 AND 102).

FIRST USE 1-1-2006; IN COMMERCE 1-1-2006.

**CLASS 36—(Continued).**

3,235,390. UNIVERSITY OF WASHINGTON, SEATTLE, WA. SN 78-977,772. PUB. 1-10-2006, FILED S.R. 7-28-2003; AM. P.R. 2-5-2007.

**INSTITUTE FOR LEARNING AND BRAIN SCIENCES**

NO CLAIM IS MADE TO THE EXCLUSIVE RIGHT TO USE "LEARNING AND BRAIN SCIENCES", APART FROM THE MARK AS SHOWN.

FOR CHARITABLE FUND RAISING IN THE AREAS OF RESEARCH, STUDY AND EDUCATION IN THE FIELDS OF LEARNING, BEHAVIORAL DEVELOPMENT, COGNITIVE DEVELOPMENT, SOCIAL DEVELOPMENT, EMOTIONAL DEVELOPMENT, LANGUAGE DEVELOPMENT AND BRAIN DEVELOPMENT (U.S. CLS. 100, 101 AND 102).

FIRST USE 9-8-2006; IN COMMERCE 9-8-2006.

**CLASS 37—CONSTRUCTION AND REPAIR**

---

3,234,032. HISTORIC LEMP BREWERY, L.L.C., ST. LOUIS, MO. SN 76-635,134. PUB. 7-11-2006, FILED 4-4-2005.

**LEMP BREWERY**

THE MARK CONSISTS OF STANDARD CHARACTERS WITHOUT CLAIM TO ANY PARTICULAR FONT, STYLE, SIZE, OR COLOR.

FOR REAL ESTATE DEVELOPMENT, HOME AND BUILDING CONSTRUCTION AND RENOVATION (U.S. CLS. 100, 103 AND 106).

FIRST USE 12-17-1996; IN COMMERCE 12-17-1996.

---

3,234,044. PRIDE COMMERCIAL CLEANING CONCEPTS (PC3), LLC, ATLANTA, GA. SN 76-638,486. PUB. 2-7-2006, FILED 5-12-2005.

**TEAMPRIDE COMMERCIAL CLEANING CONCEPTS**

THE MARK CONSISTS OF STANDARD CHARACTERS WITHOUT CLAIM TO ANY PARTICULAR FONT, STYLE, SIZE, OR COLOR.

NO CLAIM IS MADE TO THE EXCLUSIVE RIGHT TO USE "COMMERCIAL CLEANING", APART FROM THE MARK AS SHOWN.

FOR JANITORIAL SERVICES (U.S. CLS. 100, 103 AND 106).

FIRST USE 0-0-2003; IN COMMERCE 0-0-2003.

**CLASS 37—(Continued).**

3,234,120. NERDS ON SITE, INC., LONDON, ONTARIO, CANADA. SN 78-198,568. PUB. 9-16-2003, FILED 12-30-2002.

**NERDS ON WHEELS**

FOR COMPUTER INSTALLATION AND REPAIR SERVICES; MAINTENANCE OF COMPUTER HARDWARE (U.S. CLS. 100, 103 AND 106).

FIRST USE 6-0-2000; IN COMMERCE 6-0-2000.

3,234,238. GGP-BRIDGELAND, LP, CHICAGO, IL. SN 78-381,090. PUB. 1-11-2005, FILED 3-9-2004.

**BRIDGELAND**

THE MARK CONSISTS OF STANDARD CHARACTERS WITHOUT CLAIM TO ANY PARTICULAR FONT, STYLE, SIZE, OR COLOR.

FOR LAND DEVELOPMENT SERVICES, NAMELY PLANNING, LAYING OUT, AND CONSTRUCTION OF A RESIDENTIAL AND COMMERCIAL COMMUNITY (U.S. CLS. 100, 103 AND 106).

FIRST USE 4-1-2004; IN COMMERCE 4-4-2004.

3,234,550. NEW URBAN WORKS DEVELOPMENT, LLC, CORAL GABLES, FL. SN 78-527,440. PUB. 3-14-2006, FILED 12-6-2004.



NO CLAIM IS MADE TO THE EXCLUSIVE RIGHT TO USE "YACHT CLUB", APART FROM THE MARK AS SHOWN.

FOR DEVELOPMENT OF WATERFRONT RESIDENTIAL AND COMMERCIAL REAL ESTATE AND MARINAS (U.S. CLS. 100, 103 AND 106).

FIRST USE 10-0-2006; IN COMMERCE 10-0-2006.

**CLASS 37—(Continued).**

3,234,551. NEW URBAN WORKS DEVELOPMENT, LLC, CORAL GABLES, FL. SN 78-527,664. PUB. 3-14-2006, FILED 12-6-2004.

**MARLIN BAY**

THE MARK CONSISTS OF STANDARD CHARACTERS WITHOUT CLAIM TO ANY PARTICULAR FONT, STYLE, SIZE, OR COLOR.

NO CLAIM IS MADE TO THE EXCLUSIVE RIGHT TO USE "BAY", APART FROM THE MARK AS SHOWN.

FOR DEVELOPMENT OF WATERFRONT RESIDENTIAL AND COMMERCIAL REAL ESTATE AND MARINAS (U.S. CLS. 100, 103 AND 106).

FIRST USE 10-0-2006; IN COMMERCE 10-0-2006.

3,234,617. PACIFIC LAWN SPRINKLERS L.L.C., COLLEGE POINT, NY. SN 78-547,206. PUB. 6-20-2006, FILED 1-13-2005.



NO CLAIM IS MADE TO THE EXCLUSIVE RIGHT TO USE LAWN SPRINKLERS AND IRRIGATION, APART FROM THE MARK AS SHOWN.

FOR INSTALLATION, MAINTENANCE AND REPAIR OF SPRINKLER AND IRRIGATION SYSTEMS (U.S. CLS. 100, 103 AND 106).

FIRST USE 5-31-2005; IN COMMERCE 5-31-2005.

3,234,693. IVAN STEPHAN COLLINS, UPPER MARLBORO, MD. SN 78-581,742. PUB. 5-2-2006, FILED 3-7-2005.

**INNOFACE SYSTEMS**

THE MARK CONSISTS OF STANDARD CHARACTERS WITHOUT CLAIM TO ANY PARTICULAR FONT, STYLE, SIZE, OR COLOR.

NO CLAIM IS MADE TO THE EXCLUSIVE RIGHT TO USE "SYSTEMS", APART FROM THE MARK AS SHOWN.

FOR INSTALLATION OF HIGH-END AUDIO VISUAL SYSTEMS AND CONSULTATION REGARDING THE INSTALLATION OF HIGH-END AUDIO VISUAL SYSTEMS (U.S. CLS. 100, 103 AND 106).

FIRST USE 4-0-2005; IN COMMERCE 8-4-2005.



**CLASS 37—(Continued).**

3,234,728. CITIZENS COMMUNICATIONS COMPANY, STAMFORD, CT. SN 78-595,267. PUB. 2-14-2006, FILED 3-25-2005.

**CLASS 37—(Continued).**

3,234,978. HESSE, CONNIE, IDAHO FALLS, ID. SN 78-656,058. PUB. 3-14-2006, FILED 6-22-2005.

**FRONTIER  
CONNECTIONS**

**Distinguished Images**

THE MARK CONSISTS OF STANDARD CHARACTERS WITHOUT CLAIM TO ANY PARTICULAR FONT, STYLE, SIZE, OR COLOR.

NO CLAIM IS MADE TO THE EXCLUSIVE RIGHT TO USE "CONNECTIONS", APART FROM THE MARK AS SHOWN.

FOR INSTALLATION, MAINTENANCE AND REPAIR SERVICES FOR RESIDENTIAL AND COMMERCIAL SATELLITE RECEIVERS; INSTALLATION, MAINTENANCE AND REPAIR SERVICES FOR TELECOMMUNICATIONS EQUIPMENT (U.S. CLS. 100, 103 AND 106).  
FIRST USE 3-21-2005; IN COMMERCE 3-21-2005.

THE MARK CONSISTS OF STANDARD CHARACTERS WITHOUT CLAIM TO ANY PARTICULAR FONT, STYLE, SIZE, OR COLOR.

FOR CLEANING SERVICES OF COMMERCIAL PREMISES AND RESIDENTIAL HOUSES (U.S. CLS. 100, 103 AND 106).

FIRST USE 7-26-2005; IN COMMERCE 7-26-2005.

3,234,817. CASTLE ROCK INTERNATIONAL, LLC, ROCHESTER, NY. SN 78-625,929. PUB. 2-14-2006, FILED 5-9-2005.

3,235,164. TRUE VALUE COMPANY, CHICAGO, IL. SN 78-694,803. PUB. 5-9-2006, FILED 8-17-2005.

**Castle Rock Maintenance**

**COLOR INSPIRATIONS MADE  
SIMPLE**

THE MARK CONSISTS OF STANDARD CHARACTERS WITHOUT CLAIM TO ANY PARTICULAR FONT, STYLE, SIZE, OR COLOR.

NO CLAIM IS MADE TO THE EXCLUSIVE RIGHT TO USE "MAINTENANCE", APART FROM THE MARK AS SHOWN.

FOR JANITORIAL SERVICES, HANDYMAN SERVICES (U.S. CLS. 100, 103 AND 106).  
FIRST USE 1-1-1997; IN COMMERCE 1-1-1997.

THE MARK CONSISTS OF STANDARD CHARACTERS WITHOUT CLAIM TO ANY PARTICULAR FONT, STYLE, SIZE, OR COLOR.

FOR CUSTOM COLOR MATCHING SERVICES FOR PAINTS, PRIMERS, STAINS AND COATINGS (U.S. CLS. 100, 103 AND 106).

FIRST USE 3-0-2005; IN COMMERCE 3-0-2005.

**CLASS 37—(Continued).**

3,235,225. SECILIA, TONY MARK, ALTADENA, CA. SN 78-721,412. PUB. 7-11-2006, FILED 9-27-2005.

**CLASS 37—(Continued).**

3,235,330. OCEAN WEST INC., LOS ANGELES, CA. SN 78-767,162. PUB. 8-22-2006, FILED 12-6-2005.



NO CLAIM IS MADE TO THE EXCLUSIVE RIGHT TO USE "SECURITY", APART FROM THE MARK AS SHOWN. "THE COLOR(S) BLACK, WHITE AND RED IS/ARE CLAIMED AS A FEATURE OF THE MARK."

THE MARK CONSISTS OF A BLACK AND WHITE GARGOYLE WITH RED EYES; THE GARGOYLE SITS ATOP A BLACK AND WHITE CAMERA ON WHICH THE WORDING "WWW.GARGOYLESECURITY.COM" IN BLACK LETTERS IS LOCATED.

FOR FIRE AND/OR BURGLAR ALARM INSTALLATION AND/OR REPAIR (U.S. CLS. 100, 103 AND 106). FIRST USE 10-3-2006; IN COMMERCE 10-3-2006.



NO CLAIM IS MADE TO THE EXCLUSIVE RIGHT TO USE "COLLISION CENTER" AND "AUTOBODY AND PAINT", APART FROM THE MARK AS SHOWN.

THE COLORS WHITE, GREEN, PURPLE, ORANGE, YELLOW, RED, SILVER, BLACK AND BLUE ARE CLAIMED AS A FEATURE OF THE MARK.

THE COLOR WHITE APPEARS IN THE JOKER'S FACE, THE PLAYING CARDS AND THE WORDING, THE COLOR GREEN APPEARS IN THE JOKER'S HAT AND IN THE BACKGROUND, THE COLOR PURPLE APPEARS ON THE JOKER'S TASSELS, THE COLOR RED APPEARS IN THE JOKER'S GUMS, THE COLOR BLACK APPEARS IN THE JOKER'S FACE, IN THE BACKGROUND, AND ON THE LETTERING OF THE CARDS, THE COLOR YELLOW APPEARS IN THE EYES AND THE BELLS, THE COLOR BLUE APPEARS IN THE JOKER'S HAT, THE COLOR ORANGE APPEARS IN THE EYES, AND THE COLOR SILVER APPEARS IN THE BOTTOM PART OF THE WORDING "BLACK JACK".

FOR AUTOMOTIVE REFINISHING (U.S. CLS. 100, 103 AND 106).

FIRST USE 3-3-1995; IN COMMERCE 1-1-2006.

**CLASS 38—COMMUNICATION**

**CLASS 38—(Continued).**

3,233,810. OPTICAL FUSION, INC., PALO ALTO, CA. SN 76-461,949. PUB. 3-8-2005, FILED 10-25-2002.

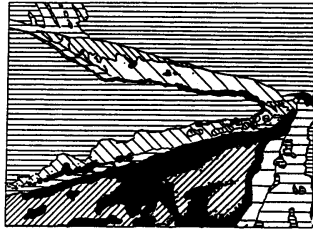

COLOR IS A FEATURE OF THE MARK. THE MARK CONSISTS OF THE DEPICTION OF A NON-GEOMETRIC DESIGN ELEMENT THAT IS WIDER AT THE LEFT AND NARROWS TOWARD THE RIGHT. THE ELEMENT IS THE COLOR DARK BLUE AND THE ELEMENT IS OUTLINED IN GRADED SHADES OF GREEN. THE BOTTOM PORTION OF THE GRADED GREEN OUTLINING IS BORDERED BY A GRADED BROWN SECTION. ABOVE AND TO THE RIGHT OF THE ELEMENT IS A PORTION REPRESENTED IN GRADED BLUE, AND BELOW AND TO THE RIGHT OF THE ELEMENT, IS A PORTION REPRESENTED IN LIGHTER GRADED BLUE.

FOR PROVIDING FACILITIES AND EQUIPMENT FOR VIDEO CONFERENCING FOR WIRED AND WIRELESS TELECOMMUNICATIONS AND VIA THE INTERNET (U.S. CLS. 100, 101 AND 104).  
FIRST USE 8-29-2006; IN COMMERCE 8-29-2006.

---

3,233,981. CITADEL BROADCASTING COMPANY, LAS VEGAS, NV. SN 76-618,925. PUB. 8-22-2006, FILED 11-2-2004.

**DIVA**

THE MARK CONSISTS OF STANDARD CHARACTERS WITHOUT CLAIM TO ANY PARTICULAR FONT, STYLE, SIZE, OR COLOR.  
FOR RADIO BROADCASTING SERVICES (U.S. CLS. 100, 101 AND 104).  
FIRST USE 10-18-2004; IN COMMERCE 10-18-2004.

**CLASS 38—(Continued).**

3,234,015. BRIGHT HOUSE NETWORKS LLC, EAST SYRACUSE, NY. SN 76-630,905. PUB. 4-25-2006, FILED 2-10-2005.

**THE FIBER LEADER**

THE MARK CONSISTS OF STANDARD CHARACTERS WITHOUT CLAIM TO ANY PARTICULAR FONT, STYLE, SIZE, OR COLOR.

NO CLAIM IS MADE TO THE EXCLUSIVE RIGHT TO USE "FIBER", APART FROM THE MARK AS SHOWN.

FOR DIGITAL COMMUNICATION AND TELECOMMUNICATION SERVICES NAMELY DIGITAL TRANSMISSION OF VOICE, DATA, IMAGES, SIGNALS AND MESSAGES; PROVIDING FIBER OPTIC NETWORK SERVICES; PROVIDING HIGH SPEED ACCESS TO THE INTERNET; CABLE TELEVISION BROADCASTING SERVICES (U.S. CLS. 100, 101 AND 104).  
FIRST USE 3-1-2005; IN COMMERCE 3-1-2005.

---

3,234,159. RPOST INTERNATIONAL LIMITED, HAMILTON, BERMUDA. SN 78-293,076. PUB. 8-10-2004, FILED 8-27-2003.

**(C)ONFIDENTIAL**

NO CLAIM IS MADE TO THE EXCLUSIVE RIGHT TO USE CONFIDENTIAL, APART FROM THE MARK AS SHOWN.

FOR ELECTRONIC MESSAGE SERVICES, NAMELY, TRANSMISSION, TRACKING, COMPILATION AND AUTHENTICATION OF ELECTRONIC MAIL ON A CONFIDENTIAL BASIS (U.S. CLS. 100, 101 AND 104).  
FIRST USE 4-15-2002; IN COMMERCE 4-15-2002.

---

3,234,203. BELL SOUTH INTELLECTUAL PROPERTY CORPORATION, WILMINGTON, DE. SN 78-348,325. PUB. 6-28-2005, FILED 1-6-2004.

**PRI ADVANTAGE PLUS**

THE MARK CONSISTS OF STANDARD CHARACTERS WITHOUT CLAIM TO ANY PARTICULAR FONT, STYLE, SIZE, OR COLOR.

NO CLAIM IS MADE TO THE EXCLUSIVE RIGHT TO USE "PRI", APART FROM THE MARK AS SHOWN.

FOR TELECOMMUNICATIONS SERVICES, NAMELY, PROVIDING TRANSMISSION OF VOICE, DATA, FACSIMILE AND VIDEO VIA COMPUTER, TELEVISION AND TELECOMMUNICATIONS NETWORKS (U.S. CLS. 100, 101 AND 104).  
FIRST USE 7-1-2004; IN COMMERCE 10-1-2004.

**CLASS 38—(Continued).**

3,234,383. IBASIS, INC., BURLINGTON, MA. SN 78-470,488.  
PUB. 8-8-2006, FILED 8-19-2004.

**PIN<sub>pass</sub>**

FOR TELECOMMUNICATIONS ACCESS SERVICES THAT FEATURE THE REGISTRATION OF TELEPHONE NUMBERS THAT SERVE AS PERSONAL IDENTIFIERS (U.S. CLS. 100, 101 AND 104).

FIRST USE 9-13-2006; IN COMMERCE 9-13-2006.

3,234,499. BLUE FROG MOBILE, INC., SEATTLE, WA. SN 78-513,936. PUB. 3-14-2006, FILED 11-9-2004.

**RINGTOPIA**

THE MARK CONSISTS OF STANDARD CHARACTERS WITHOUT CLAIM TO ANY PARTICULAR FONT, STYLE, SIZE, OR COLOR.

FOR TELECOMMUNICATION SERVICES, NAMELY WIRELESS TRANSMISSION, UPLOADING AND DOWNLOADING OF CUSTOMIZED AND FEATURED RING TONES, SCREEN SAVERS, AND GAMES TO WIRELESS MOBILE COMMUNICATION DEVICES; PROVIDING ON-LINE AND MOBILE CHAT ROOMS AND MESSAGE BOARDS IN THE FIELD OF GENERAL INTEREST; TRANSMISSION OF NEWS AND INFORMATION VIA WIRELESS MOBILE COMMUNICATION DEVICES (U.S. CLS. 100, 101 AND 104).

FIRST USE 12-17-2004; IN COMMERCE 12-17-2004.

**CLASS 38—(Continued).**

3,234,588. AMERICATEL CORPORATION, MIAMI, FL. SN 78-537,077. PUB. 3-7-2006, FILED 12-22-2004.

**1010123 PREPAID**

THE MARK CONSISTS OF STANDARD CHARACTERS WITHOUT CLAIM TO ANY PARTICULAR FONT, STYLE, SIZE, OR COLOR.

OWNER OF U.S. REG. NO. 2,518,976.

NO CLAIM IS MADE TO THE EXCLUSIVE RIGHT TO USE "PREPAID", APART FROM THE MARK AS SHOWN. SEC. 2(F) AS TO "1010123".

FOR TELECOMMUNICATION SERVICES, NAMELY LOCAL, LONG DISTANCE AND INTERNATIONAL VOICE, TEXT, FACSIMILE, VIDEO, IMAGE, DATA AND WIRELESS TRANSMISSION VIA SATELLITE, TERRESTRIAL AND UNDERSEA COMMUNICATION LINKS; TELEPHONE TELECOMMUNICATIONS SERVICES PROVIDED VIA PREPAID TELEPHONE CALLING CARDS; PROVIDING MULTIPLE USER ACCESS TO A GLOBAL COMPUTER NETWORK (U.S. CLS. 100, 101 AND 104).

FIRST USE 3-8-2005; IN COMMERCE 3-8-2005.

3,234,711. COX RADIO, INC., ATLANTA, GA. SN 78-588,270.  
PUB. 4-18-2006, FILED 3-16-2005.

**COX**  
RADIO, INC. ARC  
ADVERTISER RESOURCE CENTER

NO CLAIM IS MADE TO THE EXCLUSIVE RIGHT TO USE "RADIO, INC." OR "ADVERTISER RESOURCE CENTER", APART FROM THE MARK AS SHOWN.

FOR PROVISION OF ACCESS TO ELECTRONIC SITES, NAMELY, DIRECTORIES, SEARCHABLE DATABASES, INDICES OF INFORMATION AND OTHER RESOURCES FOR ADVERTISERS AND ADVERTISING AGENCIES IN THE FIELD OF SCHEDULING AND TRAFFIC INFORMATION FOR RADIO AND ONLINE ADVERTISING (U.S. CLS. 100, 101 AND 104).

FIRST USE 4-27-2005; IN COMMERCE 4-27-2005.

**CLASS 38—(Continued).**

3,234,718. CITIZENS COMMUNICATIONS COMPANY, STAMFORD, CT. SN 78-591,584. PUB. 2-14-2006, FILED 3-21-2005.

## FRONTIER CONNECTIONS

THE MARK CONSISTS OF STANDARD CHARACTERS WITHOUT CLAIM TO ANY PARTICULAR FONT, STYLE, SIZE, OR COLOR.

NO CLAIM IS MADE TO THE EXCLUSIVE RIGHT TO USE "CONNECTIONS", APART FROM THE MARK AS SHOWN.

FOR COMMUNICATION SERVICES, NAMELY, PROVIDING VIDEO, IMAGE, VOICE, AUDIO, TEXT AND DATA INFORMATION VIA COMMUNICATION SATELLITES; PROVIDING TELEVISION BROADCASTING SERVICES VIA COMMUNICATION SATELLITES; LOCAL AND LONG DISTANCE TELEPHONE SERVICES; WIRELESS TRANSMISSION OF VIDEO, IMAGE, VOICE, AUDIO, TEXT AND DATA INFORMATION VIA TELEPHONES, HANDHELD COMPUTERS AND MOBILE DATA RECEIVERS; VOICE OVER INTERNET PROTOCOL TELECOMMUNICATIONS SERVICES; PROVIDING MULTIPLE USER ACCESS TO A GLOBAL COMPUTER INFORMATION NETWORK (U.S. CLS. 100, 101 AND 104).

FIRST USE 3-21-2005; IN COMMERCE 3-21-2005.

3,235,296. UNO COMMUNICATIONS INC., NEW YORK, NY. SN 78-757,671. PUB. 8-29-2006, FILED 11-19-2005.



NO CLAIM IS MADE TO THE EXCLUSIVE RIGHT TO USE "COMMUNICATIONS", APART FROM THE MARK AS SHOWN.

THE COLOR(S) RED, WHITE, BLUE AND BLACK IS/ARE CLAIMED AS A FEATURE OF THE MARK.

THE COLOR BLUE APPEARS ON THE LETTERING OF "UNO", THE COLOR BLACK APPEARS ON THE LETTERS OF "COMMUNICATIONS" AND THE COLOR RED APPEARS ON THE DESIGN, ALL ON A WHITE BACKGROUND.

FOR COMMUNICATIONS VIA MULTINATIONAL TELECOMMUNICATION NETWORKS; PROVIDING TELECOMMUNICATIONS CONNECTIONS TO A GLOBAL COMPUTER NETWORK; TELECOMMUNICATIONS ROUTING AND JUNCTION SERVICES GATEWAY SERVICES; COMMUNICATIONS BY COMPUTER TERMINALS; COMMUNICATIONS BY TELEPHONE; INTERNATIONAL TELEPHONE SERVICES; VOICE OVER INTERNET PROTOCOL (VOIP) SERVICES (U.S. CLS. 100, 101 AND 104).

FIRST USE 11-25-2006; IN COMMERCE 11-25-2006.

**CLASS 38—(Continued).**

3,235,303. HUGHES NETWORK SYSTEMS LLC, GERMANTOWN, MD. SN 78-758,918. PUB. 8-8-2006, FILED 11-22-2005.

## HUGHESNET

THE MARK CONSISTS OF STANDARD CHARACTERS WITHOUT CLAIM TO ANY PARTICULAR FONT, STYLE, SIZE, OR COLOR.

OWNER OF U.S. REG. NOS. 1,288,713 AND 1,503,201.

FOR TELECOMMUNICATIONS SERVICES, NAMELY THE TRANSMISSION OF VOICE, VIDEO, DATA AND DOCUMENTS VIA SATELLITE, TELEPHONE AND COMPUTER; TELECOMMUNICATIONS GATEWAY SERVICES; PROVIDING TELECOMMUNICATIONS CONNECTIONS TO A GLOBAL COMPUTER NETWORK; BROADCASTING PROGRAMS VIA A GLOBAL COMPUTER NETWORK; ELECTRONIC TRANSMISSION OF MESSAGES AND DATA; VIDEO BROADCASTING AND VIDEO MESSAGING SERVICES; AUDIO BROADCASTING; AND PROVIDING MULTIPLE-USER ACCESS TO A GLOBAL COMPUTER INFORMATION NETWORK; VIDEO-CONFERENCING SERVICES; VIDEO STREAMING SERVICES; VIDEO MESSAGING SERVICES; VIRTUAL NETWORK TELECOMMUNICATIONS SERVICES, NAMELY, PROVIDING AN INTERFACE FOR APPLICATION SHARING, PRESENTATION BROADCASTS, WEB PAGE SHARING, POLLING AND INSTANT MESSAGING; AND PROVIDING A WEB-BASED INTERFACE WHICH TRANSPARENTLY CONVERTS AUDIO AND VIDEO MATERIAL FROM ONE USER APPLICATION TO ANOTHER (U.S. CLS. 100, 101 AND 104).

FIRST USE 3-26-2006; IN COMMERCE 3-26-2006.

**CLASS 39—TRANSPORTATION AND STORAGE**

3,234,281. MSC MEDITERRANEAN SHIPPING COMPANY HOLDING SA, 1206 GENEVA, SWITZERLAND. SN 78-406,983. PUB. 2-8-2005, FILED 4-23-2004.

## MSC ORCHESTRA

THE MARK CONSISTS OF STANDARD CHARACTERS WITHOUT CLAIM TO ANY PARTICULAR FONT, STYLE, SIZE, OR COLOR.

OWNER OF U.S. REG. NOS. 2,685,706, 2,767,950, AND OTHERS.

FOR TRAVEL SERVICES, NAMELY, ARRANGING OF CRUISES AND CRUISE SHIP SERVICES; AND TRANSPORTING PASSENGERS BY LUXURY CRUISE SHIPS (U.S. CLS. 100 AND 105).

FIRST USE 8-0-2006; IN COMMERCE 8-0-2006.

**CLASS 39—(Continued).**

3,234,395. NEW MILLENNIUM TOURS, INC., CHICAGO, IL. SN 78-476,713. PUB. 11-1-2005, FILED 8-31-2004.

**NEW MILLENNIUM TOURS, INC.**

THE MARK CONSISTS OF STANDARD CHARACTERS WITHOUT CLAIM TO ANY PARTICULAR FONT, STYLE, SIZE, OR COLOR.

NO CLAIM IS MADE TO THE EXCLUSIVE RIGHT TO USE "TOURS, INC.", APART FROM THE MARK AS SHOWN.

FOR LEISURE TRAVEL AGENCY SERVICES, NAMELY, MAKING RESERVATIONS AND BOOKINGS FOR TRAVEL IN THE NATURE OF COORDINATING TRAVEL ARRANGEMENTS FOR INDIVIDUALS AND FOR GROUPS; TRAVEL AGENCY SERVICES, NAMELY, MAKING RESERVATIONS AND BOOKINGS FOR TRANSPORTATION; LEISURE TRAVEL AGENCY SERVICES, NAMELY, MAKING RESERVATIONS AND BOOKINGS FOR TRAVEL IN THE NATURE OF PROVIDING TRAVEL AND TOUR INFORMATION SERVICE; LEISURE TRAVEL AGENCY SERVICES, NAMELY, MAKING RESERVATIONS AND BOOKINGS FOR TRAVEL IN THE NATURE OF PROVIDING TRAVEL, EXCURSION AND CRUISE ARRANGEMENT (U.S. CLS. 100 AND 105).

FIRST USE 8-0-2004; IN COMMERCE 8-0-2004.

3,234,472. STREAM GAS AND ELECTRIC, LTD., DALLAS, TX. SN 78-505,610. PUB. 3-7-2006, FILED 10-25-2004.

# IGNITE

THE MARK CONSISTS OF STANDARD CHARACTERS WITHOUT CLAIM TO ANY PARTICULAR FONT, STYLE, SIZE, OR COLOR.

FOR ELECTRICITY AND NATURAL GAS SERVICES, NAMELY, THE LEASING, TRANSMISSION AND DISTRIBUTION OF ELECTRICITY AND GAS (U.S. CLS. 100 AND 105).

FIRST USE 2-0-2005; IN COMMERCE 2-0-2005.

3,234,767. SIERRA ENTERTAINMENT, DAVIS, CA. SN 78-608,151. PUB. 8-29-2006, FILED 4-13-2005.

# RIVERTRAIN

THE MARK CONSISTS OF STANDARD CHARACTERS WITHOUT CLAIM TO ANY PARTICULAR FONT, STYLE, SIZE, OR COLOR.

FOR TRANSPORTATION OF PASSENGERS AND GOODS BY RAIL WITHIN THE STATES OF CALIFORNIA AND NEVADA (U.S. CLS. 100 AND 105).

FIRST USE 12-1-2004; IN COMMERCE 12-1-2004.

**CLASS 39—(Continued).**

3,234,930. INFOQUEST TECHNOLOGIES, INC., HARRISBURG, PA. SN 78-651,014. PUB. 3-28-2006, FILED 6-15-2005.

# Storasphere

THE MARK CONSISTS OF STANDARD CHARACTERS WITHOUT CLAIM TO ANY PARTICULAR FONT, STYLE, SIZE, OR COLOR.

FOR STORAGE SERVICES FOR ARCHIVING DATABASES, IMAGES AND OTHER ELECTRONIC DATA (U.S. CLS. 100 AND 105).

FIRST USE 7-1-2006; IN COMMERCE 7-1-2006.

3,235,005. BIG VALLEY DIVERS, INC., CHICO, CA. SN 78-659,912. PUB. 4-11-2006, FILED 6-28-2005.

**BIG VALLEY DIVERS, INC.**

THE MARK CONSISTS OF STANDARD CHARACTERS WITHOUT CLAIM TO ANY PARTICULAR FONT, STYLE, SIZE, OR COLOR.

NO CLAIM IS MADE TO THE EXCLUSIVE RIGHT TO USE "DIVERS, INC.", APART FROM THE MARK AS SHOWN.

FOR DIVING SERVICES, NAMELY, DIVING AND UNDERWATER SALVAGE (U.S. CLS. 100 AND 105).

FIRST USE 8-0-2006; IN COMMERCE 8-0-2006.

3,235,355. TRAVEL NETWORKS EUROPE LTD., HARLOW, UNITED KINGDOM. SN 78-779,572. PUB. 8-22-2006, FILED 12-22-2005.

# Carjet

THE MARK CONSISTS OF STANDARD CHARACTERS WITHOUT CLAIM TO ANY PARTICULAR FONT, STYLE, SIZE, OR COLOR.

FOR CAR RENTAL SERVICES (U.S. CLS. 100 AND 105).

FIRST USE 11-19-2006; IN COMMERCE 1-19-2006.

**CLASS 40—MATERIAL TREATMENT**

**CLASS 40—(Continued).**

3,233,934. PR POWER CO., ATLANTA, GA. SN 76-607,987.  
PUB. 12-20-2005, FILED 8-12-2004.

# NEOTHERMA

THE MARK CONSISTS OF STANDARD CHARACTERS WITHOUT CLAIM TO ANY PARTICULAR FONT, STYLE, SIZE, OR COLOR.

FOR WASTE RECYCLING, NAMELY, TRANSFORMATION OF WASTE PRODUCTS INTO USEABLE BYPRODUCTS, NAMELY, ENERGY, GASES AND SCRAP MATERIALS (U.S. CLS. 100, 103 AND 106).

FIRST USE 12-1-2005; IN COMMERCE 1-1-2006.

---

3,234,217. MAGNA-LASTIC DEVICES, INC., CARTHAGE, IL.  
SN 78-364,346. PUB. 3-22-2005, FILED 2-7-2004.

# MAGNA-LASTIC DEVICES, INC.

THE MARK CONSISTS OF STANDARD CHARACTERS WITHOUT CLAIM TO ANY PARTICULAR FONT, STYLE, SIZE, OR COLOR.

NO CLAIM IS MADE TO THE EXCLUSIVE RIGHT TO USE "DEVICES, INC.", APART FROM THE MARK AS SHOWN.

FOR MANUFACTURE OF TORQUE, FORCE AND ANGLE SENSORS, TORQUE, FORCE AND ANGLE CONTROLLERS AND TORQUE, FORCE AND ANGLE MEASURING DEVICES TO THE ORDER AND SPECIFICATION OF OTHERS (U.S. CLS. 100, 103 AND 106).

FIRST USE 9-30-2005; IN COMMERCE 9-30-2005.

---

3,235,169. ENVIRONMENTAL POWER CORPORATION,  
PORTSMOUTH, NH. SN 78-695,724. PUB. 5-9-2006, FILED  
8-18-2005.

# BEYOND RENEWABLE

THE MARK CONSISTS OF STANDARD CHARACTERS WITHOUT CLAIM TO ANY PARTICULAR FONT, STYLE, SIZE, OR COLOR.

FOR GENERATION OF ENERGY; PRODUCTION OF ENERGY (U.S. CLS. 100, 103 AND 106).

FIRST USE 8-0-2005; IN COMMERCE 8-0-2005.

**CLASS 40—(Continued).**

3,235,232. STORK TOWNSEND INC., DES MOINES, IA. SN  
78-725,347. PUB. 8-22-2006, FILED 10-3-2005.

# COOK-IN-PACK

THE MARK CONSISTS OF STANDARD CHARACTERS WITHOUT CLAIM TO ANY PARTICULAR FONT, STYLE, SIZE, OR COLOR.

FOR MANUFACTURING OF SAUSAGE MAKING AND MEAT PROCESSING MACHINES FOR OTHERS (U.S. CLS. 100, 103 AND 106).

FIRST USE 10-26-2005; IN COMMERCE 10-26-2005.

---

3,235,237. AZOTIC COATING TECHNOLOGY, INC., ROCHESTER, MN. SN 78-726,759. PUB. 7-4-2006, FILED 10-5-2005.

# ODYSSEY

THE MARK CONSISTS OF STANDARD CHARACTERS WITHOUT CLAIM TO ANY PARTICULAR FONT, STYLE, SIZE, OR COLOR.

FOR APPLICATION OF PROTECTIVE COATINGS TO TRANSPARENT OR TRANSLUCENT SUBSTRATES (U.S. CLS. 100, 103 AND 106).

FIRST USE 5-17-2005; IN COMMERCE 5-17-2005.

---

3,235,238. AZOTIC COATING TECHNOLOGY, INC., ROCHESTER, MN. SN 78-726,761. PUB. 7-4-2006, FILED 10-5-2005.

# SUNSHINE

THE MARK CONSISTS OF STANDARD CHARACTERS WITHOUT CLAIM TO ANY PARTICULAR FONT, STYLE, SIZE, OR COLOR.

FOR APPLICATION OF PROTECTIVE COATINGS TO TRANSPARENT OR TRANSLUCENT SUBSTRATES (U.S. CLS. 100, 103 AND 106).

FIRST USE 8-1-2003; IN COMMERCE 8-1-2003.

**CLASS 40—(Continued).**

3,235,239. AZOTIC COATING TECHNOLOGY, INC., ROCHESTER, MN. SN 78-726,763. PUB. 7-4-2006, FILED 10-5-2005.

**ENCHANTED**

THE MARK CONSISTS OF STANDARD CHARACTERS WITHOUT CLAIM TO ANY PARTICULAR FONT, STYLE, SIZE, OR COLOR.

FOR APPLICATION OF PROTECTIVE COATINGS TO TRANSPARENT OR TRANSLUCENT SUBSTRATES (U.S. CLS. 100, 103 AND 106).

FIRST USE 8-1-2003; IN COMMERCE 8-1-2003.

3,235,274. FRANK MAYBORN ENTERPRISES, INC., TEMPLE, TX. SN 78-745,501. PUB. 7-18-2006, FILED 11-2-2005.

**FME CUSTOM PRINTING**

THE MARK CONSISTS OF STANDARD CHARACTERS WITHOUT CLAIM TO ANY PARTICULAR FONT, STYLE, SIZE, OR COLOR.

NO CLAIM IS MADE TO THE EXCLUSIVE RIGHT TO USE "CUSTOM PRINTING", APART FROM THE MARK AS SHOWN.

FOR PRINTING (U.S. CLS. 100, 103 AND 106).  
FIRST USE 1-1-2006; IN COMMERCE 1-1-2006.

**CLASS 41—EDUCATION AND ENTERTAINMENT**

3,233,764. SWENSON, NORMAN, CHARLOTTE, NC. SN 75-380,585. PUB. 6-7-2005, FILED 10-28-1997.

**CROWN JEWELS OF GOLF**

NO CLAIM IS MADE TO THE EXCLUSIVE RIGHT TO USE "GOLF", APART FROM THE MARK AS SHOWN.

FOR ENTERTAINMENT SERVICES, NAMELY, ORGANIZING AND CONDUCTING EXHIBITIONS FEATURING GOLF EQUIPMENT AND GOLF MEMORABILIA (U.S. CLS. 100, 101 AND 107).

FIRST USE 12-1-2000; IN COMMERCE 12-1-2000.

**CLASS 41—(Continued).**

3,233,811. DOWNTOWN COMMUNITY TELEVISION CENTER, NEW YORK, NY. SN 76-463,098. PUB. 9-9-2003, FILED 10-31-2002.

**CYBERCYCLE**

FOR INTERACTIVE TELEVISION AND INTERNET PRODUCTION FACILITIES VIA A TOURING MOTORCYCLE EQUIPPED WITH A VIDEO SCREEN AND CONTAINING EQUIPMENT FOR TRANSMITTING AND RECEIVING LIVE TELEVISION AND INTERNET SIGNALS AND TO SERVE AS A LOCUS FOR NATION-WIDE INTERNET ACTIVITY (U.S. CLS. 100, 101 AND 107).

FIRST USE 10-31-2006; IN COMMERCE 11-1-2006.

3,233,821. SHAW, SONYA, AGOURA, CA. SN 76-481,433. PUB. 9-2-2003, FILED 1-10-2003.

**JEANA'S GIRL**

FOR MUSIC PUBLISHING SERVICES; PRODUCTION OF TELEVISION PROGRAMS; AND AN ONGOING TELEVISION SERIES IN THE FIELDS OF CHILDREN'S ENTERTAINMENT AND VARIETY (U.S. CLS. 100, 101 AND 107).

FIRST USE 11-21-2006; IN COMMERCE 11-21-2006.

3,233,823. JAMUL INDIAN VILLAGE OF CALIFORNIA, JAMUL, CA. SN 76-483,062. PUB. 3-23-2004, FILED 1-17-2003.

**JAMUL**

FOR EDUCATIONAL AND ENTERTAINMENT SERVICES, NAMELY, CASINO SERVICES, PROVIDING CASINO FACILITIES, NIGHT CLUB ENTERTAINMENT, LIVE PERFORMANCES BY MUSICAL BANDS, MOVIE THEATERS, AMUSEMENT ARCADES, AMUSEMENT PARKS, AMUSEMENT RIDES, AMUSEMENT CENTERS, ANIMAL EXHIBITIONS, CONCERTS, CONCERT BOOKING, ORGANIZING COMMUNITY FESTIVALS FEATURING A VARIETY OF ACTIVITIES, NAMELY SPORTING EVENTS, ART EXHIBITIONS, ETHNIC DANCES, AND THE LIKE, DANCE PERFORMANCES, DOG AND HORSE SHOWS, MAGIC SHOWS, FASHION SHOWS, LIGHT AND LASER SHOWS, FIREWORKS DISPLAYS, ART EXHIBITIONS, AND DEVELOPMENT AND DISSEMINATION OF EDUCATION MATERIALS IN THE FIELD OF TRIBAL AWARENESS FOR OTHERS (U.S. CLS. 100, 101 AND 107).

FIRST USE 7-1-2005; IN COMMERCE 7-1-2005.



**CLASS 41—(Continued).**

3,233,856. FAIRCHILD PUBLICATIONS, INC., NEW YORK, NY. SN 76-534,188. PUB. 9-21-2004, FILED 7-21-2003.

**WWD BEAUTY BIZ AWARDS**

OWNER OF U.S. REG. NOS. 913,731, 1,822,709, AND 2,620,447.

NO CLAIM IS MADE TO THE EXCLUSIVE RIGHT TO USE "BEAUTY" AND "AWARDS", APART FROM THE MARK AS SHOWN.

FOR ENTERTAINMENT SERVICES, NAMELY, CONDUCTING AN AWARDS PROGRAM HONORING DESIGNERS, MODELS AND OTHERS INDIVIDUALS INVOLVED IN THE FASHION INDUSTRY (U.S. CLS. 100, 101 AND 107).

FIRST USE 12-1-2003; IN COMMERCE 12-1-2003.

3,233,872. ARENA FOOTBALL LEAGUE LLC, CHICAGO, IL. SN 76-565,273. PUB. 9-21-2004, FILED 12-15-2003.

**THERE'S A RUMBLE IN THE HOUSE**

FOR ENTERTAINMENT SERVICES, NAMELY ORGANIZING AND PRESENTING FOOTBALL GAMES BEFORE LIVE AUDIENCES AND ON TELEVISION, RADIO, FOR GLOBAL COMPUTER NETWORK DISPLAY AND OTHER MEDIA (U.S. CLS. 100, 101 AND 107).

FIRST USE 1-1-2004; IN COMMERCE 1-1-2004.

3,233,880. PERTH VENTURES, LLC, GAINSVILLE, FL. SN 76-575,510. PUB. 8-8-2006, FILED 2-13-2004.

**FINANCIAL SIGNATURE**

FOR PROVIDING EDUCATIONAL INFORMATION, TRAINING, SEMINARS, AND WORKSHOPS IN THE FIELD OF PSYCHOLOGICAL TESTING AND SCORING (U.S. CLS. 100, 101 AND 107).

FIRST USE 1-31-2003; IN COMMERCE 1-31-2003.

**CLASS 41—(Continued).**

3,233,894. SOCK PUPPET STUDIO, INC., HOFFMAN ESTATES, IL. SN 76-585,434. PUB. 2-14-2006, FILED 4-7-2004.

**SOCK PUPPET STUDIO**

THE MARK CONSISTS OF STANDARD CHARACTERS WITHOUT CLAIM TO ANY PARTICULAR FONT, STYLE, SIZE, OR COLOR.

NO CLAIM IS MADE TO THE EXCLUSIVE RIGHT TO USE STUDIO, APART FROM THE MARK AS SHOWN.

FOR ELECTRONIC PUBLISHING SERVICES, NAMELY, PUBLICATION OF TEXT AND GRAPHIC WORKS OF OTHERS ON DVDS AND CD-ROMS FEATURING GRAPHIC ADVENTURE NOVELS; MULTIMEDIA ENTERTAINMENT SOFTWARE PRODUCTION SERVICES FOR DVDS AND CD-ROMS CONTAINING GRAPHIC ADVENTURE NOVELS (U.S. CLS. 100, 101 AND 107).

FIRST USE 9-0-2003; IN COMMERCE 9-0-2003.

3,233,941. IN2BOOKS, INC., WASHINGTON, DC. SN 76-609,007. PUB. 8-30-2005, FILED 8-27-2004.

**STUDENT PLACE**

OWNER OF U.S. REG. NO. 2,747,042.

NO CLAIM IS MADE TO THE EXCLUSIVE RIGHT TO USE "STUDENT", APART FROM THE MARK AS SHOWN.

FOR PROVIDING EDUCATIONAL SERVICES, NAMELY ORGANIZING AND CONDUCTING EDUCATIONAL PROGRAMS FEATURING PEN PAL, READING, WRITING, RESEARCH AND CRITICAL THINKING PROGRAMS, TEACHER TRAINING AND DEVELOPMENT, LITERACY DEVELOPMENT, STUDENT ASSESSMENT AND PROGRAM ASSESSMENT PROGRAMS VIA CLASSROOM INSTRUCTION AND VIA A GLOBAL COMMUNICATIONS NETWORK (U.S. CLS. 100, 101 AND 107).

FIRST USE 6-30-2004; IN COMMERCE 6-30-2004.

3,233,952. AMATEUR ATHLETIC UNION OF THE UNITED STATES, INC., LAKE BUENA VISTA, FL. SN 76-611,198. PUB. 7-25-2006, FILED 9-14-2004.

**Kentucky AAU**

THE MARK CONSISTS OF STANDARD CHARACTERS WITHOUT CLAIM TO ANY PARTICULAR FONT, STYLE, SIZE, OR COLOR.

OWNER OF U.S. REG. NOS. 791,171, 2,394,924, AND OTHERS.

NO CLAIM IS MADE TO THE EXCLUSIVE RIGHT TO USE "KENTUCKY", APART FROM THE MARK AS SHOWN.

FOR ESTABLISHING AND MAINTAINING BY REGISTRATION A UNIFORM STANDARD OF AMATEUR ATHLETIC STANDING FOR ATHLETES; SANCTIONING, REGULATING AND GOVERNING AMATEUR ATHLETIC PROGRAMS AND ACTIVITIES; REGULATING AMATEUR ATHLETIC CHAMPIONSHIPS (U.S. CLS. 100, 101 AND 107).

FIRST USE 2-27-1939; IN COMMERCE 7-18-2006.

**CLASS 41—(Continued).**

3,233,961. FRIDAY MORNING QUARTERBACK ALBUM REPORT, INC., CHERRY HILL, NJ. SN 76-613,540. PUB. 9-13-2005, FILED 9-24-2004.

**CLASS 41—(Continued).**

3,234,011. EXCELLUS HEALTH PLAN, INC., ROCHESTER, NY. SN 76-629,401. PUB. 3-14-2006, FILED 1-26-2005.

**MUSIC FIRST ALERT**

THE MARK CONSISTS OF STANDARD CHARACTERS WITHOUT CLAIM TO ANY PARTICULAR FONT, STYLE, SIZE, OR COLOR.

NO CLAIM IS MADE TO THE EXCLUSIVE RIGHT TO USE "MUSIC", APART FROM THE MARK AS SHOWN.

FOR ENTERTAINMENT SERVICES, NAMELY, PROVIDING A WEBSITE FEATURING EARLY ACCESS TO NEW MUSIC, ALBUM ARTWORK, MUSIC VIDEOS, TOUR DATES OF MUSICAL ARTISTS AND INTERVIEWS OF MUSICAL PERFORMERS (U.S. CLS. 100, 101 AND 107).

FIRST USE 10-31-2003; IN COMMERCE 10-31-2003.

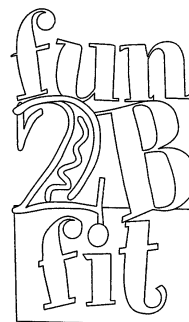

3,233,974. SCHAEFER, DAN, NEW YORK, NY. SN 76-615,359. PUB. 2-7-2006, FILED 10-6-2004.

**CLICK! THE COMPETITIVE EDGE**

THE MARK CONSISTS OF STANDARD CHARACTERS WITHOUT CLAIM TO ANY PARTICULAR FONT, STYLE, SIZE, OR COLOR.

FOR EXECUTIVE MANAGEMENT COACHING, ALSO KNOWN AS TRAINING SERVICES IN THE FIELD OF EXECUTIVE MANAGEMENT, PERSONAL DEVELOPMENT AND MOTIVATION AND SEMINARS ON THE SAME (U.S. CLS. 100, 101 AND 107).

FIRST USE 10-10-2004; IN COMMERCE 10-10-2004.

FOR EDUCATIONAL SERVICES, NAMELY, CONDUCTING HEALTH EDUCATION PROGRAMS FOR CHILDREN AND THEIR FAMILIES WHICH PROMOTE HEALTHY EATING, EXERCISE, AND A HEALTHY LIFESTYLE (U.S. CLS. 100, 101 AND 107).

FIRST USE 1-3-2005; IN COMMERCE 1-3-2005.

3,234,010. SATO, ANDREW M., CHICAGO, IL. SN 76-629,360. PUB. 8-1-2006, FILED 1-25-2005.

**AIKIDO WORLD ALLIANCE**

THE MARK CONSISTS OF STANDARD CHARACTERS WITHOUT CLAIM TO ANY PARTICULAR FONT, STYLE, SIZE, OR COLOR.

NO CLAIM IS MADE TO THE EXCLUSIVE RIGHT TO USE "AIKIDO", APART FROM THE MARK AS SHOWN.

FOR INSTRUCTION IN THE ART OF AIKIDO (U.S. CLS. 100, 101 AND 107).

FIRST USE 4-1-2005; IN COMMERCE 4-1-2005.

3,234,016. ENCYCLOPAEDIA BRITANNICA, INC., CHICAGO, IL. SN 76-631,121. PUB. 2-28-2006, FILED 2-11-2005.

**ENCYCLOVIDEO**

THE MARK CONSISTS OF STANDARD CHARACTERS WITHOUT CLAIM TO ANY PARTICULAR FONT, STYLE, SIZE, OR COLOR.

FOR EDUCATIONAL FILM DISTRIBUTION (U.S. CLS. 100, 101 AND 107).

FIRST USE 2-28-1976; IN COMMERCE 2-28-1976.

**CLASS 41—(Continued).**

3,234,017. DRIVERS ED DIRECT, LLC, CHATSWORTH, CA. SN 76-631,460. PUB. 7-25-2006, FILED 2-16-2005.

**DRIVERS ED DIRECT**

THE MARK CONSISTS OF STANDARD CHARACTERS WITHOUT CLAIM TO ANY PARTICULAR FONT, STYLE, SIZE, OR COLOR.

NO CLAIM IS MADE TO THE EXCLUSIVE RIGHT TO USE "DRIVER'S ED", APART FROM THE MARK AS SHOWN.

FOR PROVIDING DRIVER'S EDUCATION COURSES, PRIMARILY FOR NOVICE DRIVERS, NAMELY, THEORETICAL DRIVER'S SAFETY TRAINING THROUGH INTERACTIVE ONLINE COURSES AND CLASSROOM-BASED INSTRUCTOR-LED PROGRAMS, AND PRACTICAL DRIVER'S SAFETY TRAINING THROUGH THE USE OF IN-VEHICLE INSTRUCTION (U.S. CLS. 100, 101 AND 107).  
FIRST USE 6-22-2005; IN COMMERCE 6-22-2005.

**CLASS 41—(Continued).**

3,234,043. NAMCO BANDAI GAMES INC., TOKYO, JAPAN. SN 76-638,043. PUB. 1-17-2006, FILED 4-25-2005.

**GALAGA**

THE MARK CONSISTS OF STANDARD CHARACTERS WITHOUT CLAIM TO ANY PARTICULAR FONT, STYLE, SIZE, OR COLOR.

OWNER OF U.S. REG. NOS. 1,621,388, 1,746,475, AND 2,145,908.

FOR ENTERTAINMENT, NAMELY PROVIDING COMPUTER GAMES TO MOBILE PHONES AND COMPUTERS; PROVIDING COMPUTER GAMES VIA NETWORK BETWEEN COMMUNICATIONS NETWORKS AND COMPUTERS (U.S. CLS. 100, 101 AND 107).  
FIRST USE 9-20-2004; IN COMMERCE 9-20-2004.

3,234,093. UNIVERSITY OF FLORIDA ALUMNI ASSOCIATION, INC., GAINESVILLE, FL. SN 78-007,522. PUB. 7-25-2006, FILED 5-10-2000.

**GATORNEWS**

FOR COMPUTER SERVICES, NAMELY PROVIDING BROCHURES, NEWSLETTERS, AND MAGAZINES VIA AN ELECTRONIC COMMUNICATION MEANS, INCLUDING E-MAIL AND A GLOBAL COMPUTER NETWORK, REGARDING ACTIVITIES AT THE UNIVERSITY OF FLORIDA AND UNIVERSITY OF FLORIDA ALUMNI ACTIVITIES (U.S. CLS. 100, 101 AND 107).  
FIRST USE 6-1-2000; IN COMMERCE 6-1-2000.

3,234,117. INFORMATION TELEVISION NETWORK, INC., BOCA RATON, FL. SN 78-177,427. PUB. 8-15-2006, FILED 10-23-2002.

3,234,018. DRIVERS ED DIRECT, LLC, CHATSWORTH, CA. SN 76-631,462. PUB. 7-25-2006, FILED 2-16-2005.

**DRIVERSEDDIRECT**

THE MARK CONSISTS OF STANDARD CHARACTERS WITHOUT CLAIM TO ANY PARTICULAR FONT, STYLE, SIZE, OR COLOR.

FOR PROVIDING DRIVER'S EDUCATION COURSES, PRIMARILY FOR NOVICE DRIVERS, NAMELY, THEORETICAL DRIVER'S SAFETY TRAINING THROUGH INTERACTIVE ONLINE COURSES AND CLASSROOM-BASED INSTRUCTOR-LED PROGRAMS, AND PRACTICAL DRIVER'S SAFETY TRAINING THROUGH THE USE OF IN-VEHICLE INSTRUCTION (U.S. CLS. 100, 101 AND 107).  
FIRST USE 6-22-2005; IN COMMERCE 6-22-2005.

**TECHNO  
2100**

FOR PRODUCTION AND SYNDICATION OF TELEVISION PROGRAMMING (U.S. CLS. 100, 101 AND 107).  
FIRST USE 1-1-1996; IN COMMERCE 1-1-1996.

**CLASS 41—(Continued).**

3,234,147. CHOOSE CO LLC, WAITSFIELD, VT. SN 78-269,507. PUB. 10-5-2004, FILED 7-1-2003.

## CHOOSE YOUR OWN ADVENTURE

OWNER OF U.S. REG. NO. 2,807,473.  
FOR PRODUCTION OF TELEVISION PROGRAMS, MOTION PICTURE THEATRICAL FILMS, LIVE-ACTION COMEDY, DRAMA, EVENTS AND/OR ANIMATED FILMS; LIVE THEATRICAL PERFORMANCES; PROVIDING INFORMATION ABOUT MOTION PICTURE FILMS VIA GLOBAL COMPUTER NETWORK; ENTERTAINMENT SERVICES, NAMELY, PROVIDING ON-LINE COMPUTER GAMES, ELECTRONIC GAMES, AND SERIALIZED PUBLICATIONS, NAMELY INTERACTIVE MULTIPLE CHOICE, MULTIPLE ENDING STORIES AND GAMES DELIVERED BY VIDEO ON DEMAND, DIGITAL VIDEO RECORDER, CABLE, TERRESTRIAL, AND SATELLITE TELEVISION; PROVIDING ONLINE BOOKS, GRAPHIC NOVELS AND COMIC BOOKS FEATURING MULTIPLE CHOICE, MULTIPLE ENDING FICTION STORIES PROVIDED ON GLOBAL COMPUTER NETWORKS (U.S. CLS. 100, 101 AND 107).  
FIRST USE 9-15-2006; IN COMMERCE 9-15-2006.

3,234,162. WEINER-DAVIS, MICHELE, BOULDER, CO. SN 78-298,627. PUB. 11-9-2004, FILED 9-10-2003.

## THE SEX-STARVED MARRIAGE

NO CLAIM IS MADE TO THE EXCLUSIVE RIGHT TO USE "MARRIAGE", APART FROM THE MARK AS SHOWN.  
FOR EDUCATIONAL SERVICES, NAMELY PROVIDING SEMINARS AND WORKSHOPS IN THE FIELD OF SEXUAL RELATIONSHIP COUNSELING, MARITAL RELATIONSHIPS AND MARRIAGE COUNSELING (U.S. CLS. 100, 101 AND 107).  
FIRST USE 1-1-2003; IN COMMERCE 1-1-2003.

3,234,165. LEADERSHIP NETWORK, DALLAS, TX. SN 78-303,578. PUB. 8-30-2005, FILED 9-22-2003.

## LEADERSHIP NETWORK INNOVATION SERIES

OWNER OF U.S. REG. NO. 1,887,525.  
NO CLAIM IS MADE TO THE EXCLUSIVE RIGHT TO USE "SERIES", APART FROM THE MARK AS SHOWN.  
SEC. 2(F) AS TO "LEADERSHIP NETWORK".  
FOR EDUCATIONAL SERVICES, NAMELY, CONDUCTING SEMINARS AND TRAINING EVENTS IN THE NATURE OF CONFERENCES, SEMINARS AND WORKSHOPS FOR RELIGIOUS AND PROFESSIONAL LEADERS IN THE FIELDS OF MINISTRY PLANNING, ADMINISTRATION AND MANAGEMENT (U.S. CLS. 100, 101 AND 107).  
FIRST USE 5-0-2003; IN COMMERCE 5-0-2003.

**CLASS 41—(Continued).**

3,234,187. THE COACHES TRAINING INSTITUTE, SAN RAFAEL, CA. SN 78-329,973. PUB. 8-10-2004, FILED 11-19-2003.

THE MARK CONSISTS OF STANDARD CHARACTERS WITHOUT CLAIM TO ANY PARTICULAR FONT, STYLE, SIZE, OR COLOR.

FOR PROFESSIONAL COACH TRAINING (U.S. CLS. 100, 101 AND 107).  
FIRST USE 11-1-2006; IN COMMERCE 11-1-2006.

3,234,214. COURTROOM TELEVISION NETWORK LLC, NEW YORK, NY. SN 78-363,608. PUB. 5-9-2006, FILED 2-6-2004.

## TRACE EVIDENCE

THE MARK CONSISTS OF STANDARD CHARACTERS WITHOUT CLAIM TO ANY PARTICULAR FONT, STYLE, SIZE, OR COLOR.

FOR EDUCATIONAL AND ENTERTAINMENT SERVICES, NAMELY ONGOING CABLE TELEVISION PROGRAMS ON THE SUBJECTS OF CRIME AND CRIMINAL JUSTICE; ENTERTAINMENT SERVICES IN THE NATURE OF A TELEVISION SERIES ON THE SUBJECTS OF CRIME AND CRIMINAL JUSTICE; PROVIDING INFORMATION OVER THE INTERNET ABOUT DRAMATIC TELEVISION PROGRAMS ON THE SUBJECTS OF CRIME AND CRIMINAL JUSTICE; AND PROVIDING INFORMATION ABOUT ENTERTAINMENT PROGRAMMING OVER THE INTERNET ON THE SUBJECTS OF CRIME AND CRIMINAL JUSTICE (U.S. CLS. 100, 101 AND 107).

FIRST USE 6-2-2004; IN COMMERCE 6-2-2004.

**CLASS 41—(Continued).**

3,234,223. TALARICO, JON P, SANTA MONICA, CA. SN 78-375,022. PUB. 1-10-2006, FILED 2-26-2004.



NO CLAIM IS MADE TO THE EXCLUSIVE RIGHT TO USE "AMERICA'S BEST STRIPPER", APART FROM THE MARK AS SHOWN.

THE COLOR(S) RED, BLUE AND WHITE IS/ARE CLAIMED AS A FEATURE OF THE MARK.

THE COLOR RED APPEARS IN THE RECTANGULAR BACKGROUND; THE COLOR BLUE APPEARS IN THE STAR DESIGN AND LETTERING; THE COLOR WHITE APPEARS IN THE SILHOUETTE OF THE WOMEN AND POLE DESIGN.

FOR ENTERTAINMENT SERVICES, NAMELY CONDUCTING CONTESTS ACROSS THE COUNTRY IN SEARCH OF THE BEST FEMALE STRIPPER (U.S. CLS. 100, 101 AND 107).

FIRST USE 9-19-2004; IN COMMERCE 3-15-2006.

**CLASS 41—(Continued).**

3,234,242. SMITH, DANA A., UPPER MARLBORO, MD. SN 78-382,862. PUB. 1-10-2006, FILED 3-11-2004.

## Spiritual Essence Yoga

THE MARK CONSISTS OF STANDARD CHARACTERS WITHOUT CLAIM TO ANY PARTICULAR FONT, STYLE, SIZE, OR COLOR.

NO CLAIM IS MADE TO THE EXCLUSIVE RIGHT TO USE YOGA, APART FROM THE MARK AS SHOWN.

FOR EDUCATIONAL SERVICES, NAMELY, CONDUCTING CLASSES IN THE FIELD OF YOGA TO TEACH THE CALMING AND STRESS RELIEVING EFFECTS THROUGH LESSONS STRUCTURED AROUND JAZZ, CLASSICAL AND RHYTHM AND BLUES MUSIC (U.S. CLS. 100, 101 AND 107).

FIRST USE 12-20-2004; IN COMMERCE 12-20-2004.

3,234,227. MOVIELOT, INC., WOODLAND HILLS, CA. SN 78-377,681. PUB. 1-18-2005, FILED 3-3-2004.

## MOVIELOT

THE MARK CONSISTS OF STANDARD CHARACTERS WITHOUT CLAIM TO ANY PARTICULAR FONT, STYLE, SIZE, OR COLOR.

FOR RENTAL OF VIDEO AND DVDS (U.S. CLS. 100, 101 AND 107).

FIRST USE 6-10-2006; IN COMMERCE 7-5-2006.

3,234,260. VIACOM INTERNATIONAL INC., NEW YORK, NY. SN 78-389,076. PUB. 9-13-2005, FILED 3-23-2004.

## CLUB NOGGIN

THE MARK CONSISTS OF STANDARD CHARACTERS WITHOUT CLAIM TO ANY PARTICULAR FONT, STYLE, SIZE, OR COLOR.

OWNER OF U.S. REG. NOS. 2,349,082 AND 2,451,381.

FOR EDUCATIONAL SERVICES, NAMELY, CONDUCTING AND FACILITATING INTERACTIVE EDUCATIONAL WORKSHOPS IN THE FIELDS OF LANGUAGE, MUSIC, SOCIALIZATION AND COORDINATION FOR CHILDREN AND THEIR PARENTS/CAREGIVERS AT LOCAL SHOPPING MALLS; PROVIDING INFORMATION IN THE FIELD OF ENTERTAINMENT AND EDUCATION VIA THE MEANS OF A GLOBAL COMPUTER NETWORK (U.S. CLS. 100, 101 AND 107).

FIRST USE 8-18-2006; IN COMMERCE 8-18-2006.

**CLASS 41—(Continued).**

3,234,274. JMBO, INC., LOS ANGELES, CA. SN 78-403,550.  
PUB. 9-27-2005, FILED 4-16-2004.

**CLASS 41—(Continued).**

3,234,311. MESSENGER INTERNATIONAL, INC., PALMER  
LAKE, CO. SN 78-425,060. PUB. 9-27-2005, FILED 5-26-2004.

**YOU'RE HIRED**

THE MARK CONSISTS OF STANDARD CHARACTERS WITHOUT CLAIM TO ANY PARTICULAR FONT, STYLE, SIZE, OR COLOR.

FOR ENTERTAINMENT SERVICES IN THE NATURE OF AN ONGOING REALITY-BASED TELEVISION PROGRAM (U.S. CLS. 100, 101 AND 107).

FIRST USE 4-15-2004; IN COMMERCE 4-15-2004.

**Messenger  
International**

THE MARK CONSISTS OF STANDARD CHARACTERS WITHOUT CLAIM TO ANY PARTICULAR FONT, STYLE, SIZE, OR COLOR.

NO CLAIM IS MADE TO THE EXCLUSIVE RIGHT TO USE "INTERNATIONAL", APART FROM THE MARK AS SHOWN.

FOR EDUCATION AND ENTERTAINMENT IN THE NATURE OF ON-GOING RADIO AND TELEVISION PROGRAMS FEATURING TEACHING AND ENCOURAGEMENT IN THE FIELD OF SPIRITUALITY, MORALITY AND CHARACTER DEVELOPMENT (U.S. CLS. 100, 101 AND 107).

FIRST USE 10-9-2006; IN COMMERCE 10-9-2006.

3,234,297. COX RADIO, INC., DBA WAPE, JACKSONVILLE,  
FL. SN 78-412,849. PUB. 4-26-2005, FILED 5-4-2004.

3,234,318. KIDS FOR HEALTH, INC., SPRINGDALE, AR. SN  
78-427,914. PUB. 5-10-2005, FILED 6-1-2004.

**TASTE OF  
JACKSONVILLE**

THE MARK CONSISTS OF STANDARD CHARACTERS WITHOUT CLAIM TO ANY PARTICULAR FONT, STYLE, SIZE, OR COLOR.

NO CLAIM IS MADE TO THE EXCLUSIVE RIGHT TO USE JACKSONVILLE, APART FROM THE MARK AS SHOWN.

FOR ENTERTAINMENT SERVICES, NAMELY, ORGANIZING COMMUNITY FESTIVALS FEATURING LIVE MUSIC AND FOOD (U.S. CLS. 100, 101 AND 107).

FIRST USE 7-17-2006; IN COMMERCE 11-11-2006.

**Be smart, do your  
part**

THE MARK CONSISTS OF STANDARD CHARACTERS WITHOUT CLAIM TO ANY PARTICULAR FONT, STYLE, SIZE, OR COLOR.

FOR EDUCATION SERVICES, NAMELY CONDUCTING CLASSES, SEMINARS, CONFERENCES, AND WORKSHOPS IN THE FIELD OF HEALTH AWARENESS (U.S. CLS. 100, 101 AND 107).

FIRST USE 1-1-2006; IN COMMERCE 1-1-2006.

**CLASS 41—(Continued).**

3,234,319. KIDS FOR HEALTH, INC., SPRINGDALE, AR. SN 78-427,989. PUB. 4-5-2005, FILED 6-1-2004.

**Quack-O Fact-O**

THE MARK CONSISTS OF STANDARD CHARACTERS WITHOUT CLAIM TO ANY PARTICULAR FONT, STYLE, SIZE, OR COLOR.

FOR EDUCATIONAL SERVICES; NAMELY, CONDUCTING CLASSES, SEMINARS, CONFERENCES, AND WORKSHOPS IN THE FIELD OF HEALTH AND PHYSICAL AWARENESS (U.S. CLS. 100, 101 AND 107).

FIRST USE 1-1-2006; IN COMMERCE 1-1-2006.

3,234,326. VIACOM INTERNATIONAL INC., NEW YORK, NY. SN 78-433,706. PUB. 4-19-2005, FILED 6-11-2004.

**NICKELODEON  
UNFABULOUS**

THE MARK CONSISTS OF STANDARD CHARACTERS WITHOUT CLAIM TO ANY PARTICULAR FONT, STYLE, SIZE, OR COLOR.

FOR ENTERTAINMENT SERVICES IN THE NATURE OF AN ON-GOING TELEVISION SHOW FEATURING LIVE ACTION, MUSIC, COMEDY AND DRAMA; PROVIDING ONLINE INFORMATION IN THE FIELD OF ENTERTAINMENT CONCERNING TELEVISION PROGRAMS (U.S. CLS. 100, 101 AND 107).

FIRST USE 9-12-2004; IN COMMERCE 9-12-2004.

**CLASS 41—(Continued).**

3,234,329. TRUMP, DONALD J., NEW YORK, NY. SN 78-435,914. PUB. 10-11-2005, FILED 6-16-2004.

**TRUMPED**

THE MARK CONSISTS OF STANDARD CHARACTERS WITHOUT CLAIM TO ANY PARTICULAR FONT, STYLE, SIZE, OR COLOR.

FOR WEEKLY RADIO PROGRAM IN THE FIELD OF CURRENT EVENTS, POPULAR CULTURE, AND THE LIFE AND BUSINESS OF DONALD J TRUMP (U.S. CLS. 100, 101 AND 107).

FIRST USE 6-15-2004; IN COMMERCE 6-15-2004.

3,234,360. GUIDANCE HELICOPTERS, INC., PRESCOTT, AZ. SN 78-454,594. PUB. 6-21-2005, FILED 7-21-2004.

**Training to a  
higher standard.**

THE MARK CONSISTS OF STANDARD CHARACTERS WITHOUT CLAIM TO ANY PARTICULAR FONT, STYLE, SIZE, OR COLOR.

FOR HELICOPTER FLIGHT TRAINING (U.S. CLS. 100, 101 AND 107).

FIRST USE 11-1-1998; IN COMMERCE 11-1-1998.

3,234,362. MRS UNITED STATES NATIONAL PAGEANT, INC., FAIRPORT, NY. SN 78-457,890. PUB. 5-2-2006, FILED 7-28-2004.

**Miss Junior Teen  
United States**

THE MARK CONSISTS OF STANDARD CHARACTERS WITHOUT CLAIM TO ANY PARTICULAR FONT, STYLE, SIZE, OR COLOR.

OWNER OF U.S. REG. NOS. 1,851,722, 2,824,308, AND OTHERS.

NO CLAIM IS MADE TO THE EXCLUSIVE RIGHT TO USE "TEEN UNITED STATES", APART FROM THE MARK AS SHOWN.

FOR ENTERTAINMENT IN THE NATURE OF BEAUTY PAGEANTS (U.S. CLS. 100, 101 AND 107).

FIRST USE 9-30-2004; IN COMMERCE 9-30-2004.

**CLASS 41—(Continued).**

3,234,363. MRS UNITED STATES NATIONAL PAGEANT, INC., FAIRPORT, NY. SN 78-457,926. PUB. 5-2-2006, FILED 7-28-2004.

Miss Teen United  
States

THE MARK CONSISTS OF STANDARD CHARACTERS WITHOUT CLAIM TO ANY PARTICULAR FONT, STYLE, SIZE, OR COLOR.

OWNER OF U.S. REG. NOS. 1,851,722, 2,824,308, AND OTHERS.

NO CLAIM IS MADE TO THE EXCLUSIVE RIGHT TO USE "TEEN UNITED STATES", APART FROM THE MARK AS SHOWN.

FOR ENTERTAINMENT IN THE NATURE OF BEAUTY PAGEANTS (U.S. CLS. 100, 101 AND 107).

FIRST USE 9-30-2004; IN COMMERCE 9-30-2004.

**CLASS 41—(Continued).**

3,234,393. WINDY CITY WEDDINGS, LLC, CHICAGO, IL. SN 78-476,539. PUB. 7-12-2005, FILED 8-31-2004.

WINDY CITY  
WEDDINGS

THE MARK CONSISTS OF STANDARD CHARACTERS WITHOUT CLAIM TO ANY PARTICULAR FONT, STYLE, SIZE, OR COLOR.

NO CLAIM IS MADE TO THE EXCLUSIVE RIGHT TO USE WEDDINGS, APART FROM THE MARK AS SHOWN.

FOR PROVIDING INFORMATION IN THE FIELD OF WEDDING PLANNING VIA THE INTERNET (U.S. CLS. 100, 101 AND 107).

FIRST USE 10-16-2006; IN COMMERCE 10-16-2006.

3,234,367. GRAND SLAM CLUB/OVIS, BIRMINGHAM, AL. SN 78-462,159. PUB. 6-28-2005, FILED 8-4-2004.

GRAND SLAM OF  
NORTH AMERICAN  
WILD SHEEP

THE MARK CONSISTS OF STANDARD CHARACTERS WITHOUT CLAIM TO ANY PARTICULAR FONT, STYLE, SIZE, OR COLOR.

NO CLAIM IS MADE TO THE EXCLUSIVE RIGHT TO USE NORTH AMERICAN WILD SHEEP, APART FROM THE MARK AS SHOWN.

FOR ARRANGING AND CONDUCTING EDUCATIONAL CONFERENCES; PROVIDING RECOGNITION AND INCENTIVES BY THE WAY OF AWARDS TO DEMONSTRATE EXCELLENCE IN THE FIELD OF WILD SHEEP HUNTING; EDUCATIONAL SERVICES, NAMELY, CONDUCTING CLASSES, SEMINARS, CONFERENCES, AND WORKSHOPS ALL IN THE FIELD OF WILD SHEEP HUNTING (U.S. CLS. 100, 101 AND 107).

FIRST USE 0-0-1967; IN COMMERCE 0-0-1967.

3,234,419. KAROTTKI, SALVADOR K., DBA S.B. RECORDING COMPANY, CHICAGO, IL. SN 78-485,652. PUB. 9-6-2005, FILED 9-17-2004.

SHRED EAGLE

THE MARK CONSISTS OF STANDARD CHARACTERS WITHOUT CLAIM TO ANY PARTICULAR FONT, STYLE, SIZE, OR COLOR.

FOR ENTERTAINMENT SERVICES - NAMELY, MUSICAL ENTERTAINMENT PERFORMANCES RENDERED BY A VOCAL AND INSTRUMENTAL GROUP (U.S. CLS. 100, 101 AND 107).

FIRST USE 3-0-2006; IN COMMERCE 3-0-2006.



**CLASS 41—(Continued).**

3,234,425. JC 23 ENTERTAINMENT, INC., SANTA MONICA, CA. SN 78-487,199. PUB. 9-13-2005, FILED 9-21-2004.

**CLASS 41—(Continued).**

3,234,442. CBS STUDIOS INC., NEW YORK, NY. SN 78-493,964. PUB. 9-13-2005, FILED 10-4-2004.

**JC 23  
ENTERTAINMENT**

**THE STORY FROM  
STAGE 28**

THE MARK CONSISTS OF STANDARD CHARACTERS WITHOUT CLAIM TO ANY PARTICULAR FONT, STYLE, SIZE, OR COLOR.

NO CLAIM IS MADE TO THE EXCLUSIVE RIGHT TO USE "ENTERTAINMENT", APART FROM THE MARK AS SHOWN.

FOR ENTERTAINMENT SERVICES, NAMELY, PRODUCTION OF MOTION PICTURES; DISTRIBUTION OF MOTION PICTURES FOR OTHERS (U.S. CLS. 100, 101 AND 107).

FIRST USE 3-11-2003; IN COMMERCE 12-21-2005.

THE MARK CONSISTS OF STANDARD CHARACTERS WITHOUT CLAIM TO ANY PARTICULAR FONT, STYLE, SIZE, OR COLOR.

FOR TITLE OF A SEGMENT OF A TELEVISION SERIES IN THE NATURE OF AN ENTERTAINMENT NEWS PROGRAM (U.S. CLS. 100, 101 AND 107).

FIRST USE 12-6-2006; IN COMMERCE 12-6-2006.

3,234,429. CBS STUDIOS INC., NEW YORK, NY. SN 78-488,556. PUB. 9-13-2005, FILED 9-23-2004.

3,234,464. VENEVISION INTERNATIONAL PRODUCTIONS LLC, CORAL GABLES, FL. SN 78-503,003. PUB. 9-27-2005, FILED 10-20-2004.

**LIFE ON A STICK**

**TE LLEGO LA SUERTE**

THE MARK CONSISTS OF STANDARD CHARACTERS WITHOUT CLAIM TO ANY PARTICULAR FONT, STYLE, SIZE, OR COLOR.

FOR ENTERTAINMENT SERVICES IN THE NATURE OF A COMEDIC TELEVISION SERIES (U.S. CLS. 100, 101 AND 107).

FIRST USE 3-24-2005; IN COMMERCE 3-24-2005.

THE MARK CONSISTS OF STANDARD CHARACTERS WITHOUT CLAIM TO ANY PARTICULAR FONT, STYLE, SIZE, OR COLOR.

THE ENGLISH TRANSLATION OF THE SPANISH PHRASE TE LLEGO LA SUERTE IS "YOU GOT LUCKY".

FOR ENTERTAINMENT SERVICES, NAMELY PROVIDING AN ONGOING TELEVISION SHOW IN THE FIELD OF PERSONAL RELATIONSHIPS, BEAUTY MAKEOVERS, AND WISH FULFILLMENT (U.S. CLS. 100, 101 AND 107).

FIRST USE 2-0-2005; IN COMMERCE 8-15-2006.

**CLASS 41—(Continued).**

3,234,465. ROCKING HORSE STABLES, LLC, OXFORD, MS.  
SN 78-503,125. PUB. 9-27-2005, FILED 10-20-2004.

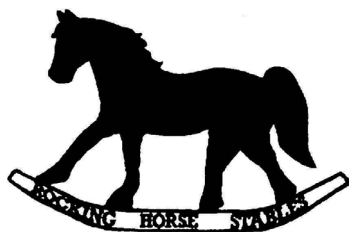

NO CLAIM IS MADE TO THE EXCLUSIVE RIGHT TO USE "STABLES", APART FROM THE MARK AS SHOWN. FOR HORSE TRAINING AND HORSE RIDING INSTRUCTION (U.S. CLS. 100, 101 AND 107). FIRST USE 9-1-2006; IN COMMERCE 9-1-2006.

---

3,234,511. DIXIE STAMPEDE, LLC, PIGEON FORGE, TN. SN 78-516,097. PUB. 9-13-2005, FILED 11-12-2004.

**BRANSON'S #1  
CHOICE FOR THE  
HOLIDAYS**

THE MARK CONSISTS OF STANDARD CHARACTERS WITHOUT CLAIM TO ANY PARTICULAR FONT, STYLE, SIZE, OR COLOR.

FOR CONDUCTING ENTERTAINMENT EXHIBITS IN THE NATURE OF PLAYS, SHOWS AND PAGEANTS (U.S. CLS. 100, 101 AND 107).

FIRST USE 11-1-2006; IN COMMERCE 11-1-2006.

**CLASS 41—(Continued).**

3,234,513. GOSPEL MUSIC CHANNEL, LLC, ATLANTA, GA.  
SN 78-517,844. PUB. 10-11-2005, FILED 11-16-2004.



THE MARK CONSISTS OF A STYLIZED LETTER "G" WITH A PARTIAL HALO.

FOR ENTERTAINMENT SERVICES, NAMELY, PRODUCTION AND DISTRIBUTION OF PROGRAMS CONTAINING MUSIC, MUSICAL PERFORMANCES, BIOGRAPHIES, NEWS, AND GENERAL INTEREST CONTENT, FOR BROADCAST ON TELEVISION, RADIO, AND THE INTERNET; DISTRIBUTION OF TELEVISION PROGRAMMING TO CABLE TELEVISION SYSTEMS (U.S. CLS. 100, 101 AND 107).

FIRST USE 10-30-2004; IN COMMERCE 10-30-2004.

---

3,234,515. METRO-GOLDWYN-MAYER STUDIOS INC., LOS ANGELES, CA. SN 78-518,039. PUB. 3-21-2006, FILED 11-16-2004.

**GIFTSOLVER**

THE MARK CONSISTS OF STANDARD CHARACTERS WITHOUT CLAIM TO ANY PARTICULAR FONT, STYLE, SIZE, OR COLOR.

FOR ENTERTAINMENT SERVICES, NAMELY, PROVIDING INFORMATION IN THE FIELD OF MOTION PICTURES, TELEVISION PROGRAMMING AND MUSIC ALL ON-LINE VIA A GLOBAL COMPUTER NETWORK (U.S. CLS. 100, 101 AND 107).

FIRST USE 11-22-2004; IN COMMERCE 11-22-2004.

**CLASS 41—(Continued).**

3,234,534. FLORIDA ATLANTIC UNIVERSITY, BOCA RATON, FL. SN 78-521,960. PUB. 12-13-2005, FILED 11-23-2004.



NO CLAIM IS MADE TO THE EXCLUSIVE RIGHT TO USE "FLORIDA" AND "UNIVERSITY", APART FROM THE MARK AS SHOWN.

FOR EDUCATION SERVICES AT THE UNIVERSITY LEVEL (U.S. CLS. 100, 101 AND 107).  
FIRST USE 12-3-2004; IN COMMERCE 2-28-2005.

3,234,567. FLORIDA INSTITUTE OF FINANCE, L.L.C., BOCA RATON, FL. SN 78-531,082. PUB. 6-20-2006, FILED 12-12-2004.



Florida  
Institute of  
Finance, LLC

NO CLAIM IS MADE TO THE EXCLUSIVE RIGHT TO USE FLORIDA INSTITUTE OF FINANCE LLC, APART FROM THE MARK AS SHOWN.

THE COLOR(S) BLACK AND GREEN IS/ARE CLAIMED AS A FEATURE OF THE MARK.

THE MARK CONSISTS OF A STYLIZED CAPITAL "F", A LOWER CASE "I" AND ANOTHER CAPITAL "F" ARE PLACED IN A ROW INSIDE A RECTANGLE. THE FIRST TWO LETTERS, "F" AND "I", ARE IN BLACK AND THE THIRD LETTER, "F", IS IN GREEN. THE LETTERS THEMSELVES ARE CONSTRUCTED OF BLOCK SHAPES WITH A SPACE SEPARATING THE LOWER TWO-THIRDS OF THE LETTERS FROM THE TOP THIRD. THE RIGHT-HAND SIDE OF THE RECTANGLE HAS A THICKER DOUBLE LAYER GIVING THE ILLUSION OF DEPTH. THE NAME, "FLORIDA INSTITUTE OF FINANCE, LLC", IS WRITTEN IN BLACK OUTSIDE THE RECTANGLE TO THE RIGHT. THE NAME IS CENTERED AGAINST THE SIDE OF THE RECTANGLE AND IS WRITTEN ON THREE LINES. THE FIRST LINE SPELLS OUT "FLORIDA", THE SECOND LINE SPELLS OUT "INSTITUTE OF" AND THE LAST LINE SPELLS OUT "FINANCE, LLC".

FOR FINANCE EDUCATION TRAINING, NAMELY, PROVIDING FINANCIAL EDUCATION TO BUSINESS PROFESSIONALS (U.S. CLS. 100, 101 AND 107).  
FIRST USE 5-13-2005; IN COMMERCE 5-13-2005.

**CLASS 41—(Continued).**

3,234,569. TURULL, XAVIER, BARCELONA, SPAIN. AND ABAD, MARINA CLARA, BARCELONA, SPAIN. AND GIMENEZ, RAMON, BARCELONA, SPAIN. AND RAMOS, SERGIO, BARCELONA, SPAIN. SN 78-531,217. PUB. 3-14-2006, FILED 12-13-2004.

## Ojos de Brujo

THE MARK CONSISTS OF STANDARD CHARACTERS WITHOUT CLAIM TO ANY PARTICULAR FONT, STYLE, SIZE, OR COLOR.

THE MARK TRANSLATES INTO ENGLISH AS WIZARD EYES.

FOR ENTERTAINMENT IN THE NATURE OF VISUAL AND AUDIO PERFORMANCES, NAMELY, MUSICAL BAND, MUSIC PRODUCTION SERVICES, MUSIC PUBLISHING SERVICES (U.S. CLS. 100, 101 AND 107).

FIRST USE 1-1-1999; IN COMMERCE 6-1-2004.

3,234,592. SENIZERGUES, PIERRE ANDRE, NEWPORT BEACH, CA. SN 78-537,456. PUB. 12-6-2005, FILED 12-22-2004.

## ETNIES GVR CONTEST

THE MARK CONSISTS OF STANDARD CHARACTERS WITHOUT CLAIM TO ANY PARTICULAR FONT, STYLE, SIZE, OR COLOR.

OWNER OF U.S. REG. NOS. 1,644,413, 2,228,611, AND 2,372,422.

NO CLAIM IS MADE TO THE EXCLUSIVE RIGHT TO USE "CONTEST", APART FROM THE MARK AS SHOWN.

FOR ENTERTAINMENT SERVICES, NAMELY ORGANIZING AND CONDUCTING INTERNATIONAL SKATEBOARDING COMPETITIONS (U.S. CLS. 100, 101 AND 107).

FIRST USE 12-31-2004; IN COMMERCE 12-31-2004.

**CLASS 41—(Continued).**

3,234,616. FEATHER ROCK BOOKS, INC., ORONO, MN. SN 78-546,633. PUB. 10-18-2005, FILED 1-12-2005.

**FEATHER ROCK BOOKS**

THE MARK CONSISTS OF STANDARD CHARACTERS WITHOUT CLAIM TO ANY PARTICULAR FONT, STYLE, SIZE, OR COLOR.

NO CLAIM IS MADE TO THE EXCLUSIVE RIGHT TO USE "BOOKS", APART FROM THE MARK AS SHOWN.

FOR BOOK PUBLISHING SERVICES (U.S. CLS. 100, 101 AND 107).

FIRST USE 11-20-2006; IN COMMERCE 11-20-2006.

3,234,640. LEGACY HOCKEY, LLC, PHOENIX, AZ. SN 78-557,726. PUB. 10-18-2005, FILED 2-1-2005.

**PHOENIX ROADRUNNERS**

THE MARK CONSISTS OF STANDARD CHARACTERS WITHOUT CLAIM TO ANY PARTICULAR FONT, STYLE, SIZE, OR COLOR.

NO CLAIM IS MADE TO THE EXCLUSIVE RIGHT TO USE "PHOENIX", APART FROM THE MARK AS SHOWN.

FOR ENTERTAINMENT SERVICES, NAMELY, PROFESSIONAL ICE HOCKEY GAMES, EXHIBITIONS AND COMPETITIONS (U.S. CLS. 100, 101 AND 107).

FIRST USE 2-1-2005; IN COMMERCE 2-1-2005.

3,234,647. COUNTRY MUSIC TELEVISION, INC., NEW YORK, NY. SN 78-563,009. PUB. 11-8-2005, FILED 2-8-2005.

**AMERICAN REVOLUTIONS**

THE MARK CONSISTS OF STANDARD CHARACTERS WITHOUT CLAIM TO ANY PARTICULAR FONT, STYLE, SIZE, OR COLOR.

FOR ENTERTAINMENT SERVICES IN THE NATURE OF AN ON-GOING TELEVISION COUNTRY MUSIC REALITY SERIES FEATURING COMEDY AND DRAMA; PROVIDING INFORMATION IN THE FIELD OF MUSIC BY MEANS OF A GLOBAL COMPUTER NETWORK (U.S. CLS. 100, 101 AND 107).

FIRST USE 11-16-2006; IN COMMERCE 11-16-2006.

**CLASS 41—(Continued).**

3,234,653. STEVENS, GARY M., LONG BEACH, CA. SN 78-564,412. PUB. 11-8-2005, FILED 2-10-2005.

**Planet Bands**

THE MARK CONSISTS OF STANDARD CHARACTERS WITHOUT CLAIM TO ANY PARTICULAR FONT, STYLE, SIZE, OR COLOR.

NO CLAIM IS MADE TO THE EXCLUSIVE RIGHT TO USE "BANDS", APART FROM THE MARK AS SHOWN.

FOR ENTERTAINMENT SERVICES, NAMELY, PROVIDING AN INTERNET WEB SITE WITH LINKS TO PRERECORDED MUSIC, MUSIC AND MOVIE STORE PAY SITES, MUSICAL PERFORMANCES, MUSIC VIDEOS, RELATED FILM CLIPS, PHOTOGRAPHS, INFORMATION IN THE FIELD OF MUSIC AND MOVIES, AND OTHER MULTIMEDIA MATERIALS (U.S. CLS. 100, 101 AND 107).

FIRST USE 7-6-2004; IN COMMERCE 5-19-2006.

3,234,660. WORLD OF BIRDS SHOW, WINTER HAVEN, FL. SN 78-567,281. PUB. 5-2-2006, FILED 2-15-2005.



NO CLAIM IS MADE TO THE EXCLUSIVE RIGHT TO USE "BIRDS SHOW", APART FROM THE MARK AS SHOWN.

THE STIPPLING IS FOR SHADING PURPOSES ONLY.

THE MARK CONSISTS OF GLOBE, BIRD, BLACK & WHITE.

FOR ANIMAL EXHIBITIONS; NAMELY BIRD SHOW PRESENTATIONS FOR EDUCATIONAL AND ENTERTAINMENT PURPOSES; PRODUCTION OF BIRD SHOWS; BIRD TRAINING FOR OTHERS (U.S. CLS. 100, 101 AND 107).

FIRST USE 6-0-1980; IN COMMERCE 6-0-1980.

3,234,690. LEGACY HOCKEY, LLC, PHOENIX, AZ. SN 78-580,087. PUB. 10-18-2005, FILED 3-4-2005.



FOR ENTERTAINMENT SERVICES, NAMELY, PROFESSIONAL ICE HOCKEY GAMES, EXHIBITIONS AND COMPETITIONS (U.S. CLS. 100, 101 AND 107).

FIRST USE 2-1-2005; IN COMMERCE 2-1-2005.

**CLASS 41—(Continued).**

3,234,691. LEGACY HOCKEY, LLC, PHOENIX, AZ. SN 78-580,089. PUB. 10-18-2005, FILED 3-4-2005.



THE COLOR(S) YELLOW, BLUE, BLACK AND WHITE IS/ARE CLAIMED AS A FEATURE OF THE MARK.  
THE COLOR YELLOW APPEARS IN THE LETTERS PH. THE LETTERS ARE OUTLINED IN BLACK. THE COLORS BLUE, BLACK AND WHITE APPEAR AT THE ENDS OF THE HOCKEY STICKS.  
THE MARK CONSISTS OF THE LETTERS PH. THE LETTER X IS COMPRISED OF TWO UPSIDE DOWN HOCKEY STICKS.  
FOR ENTERTAINMENT SERVICES, NAMELY, PROFESSIONAL ICE HOCKEY GAMES, EXHIBITIONS AND COMPETITIONS (U.S. CLS. 100, 101 AND 107).  
FIRST USE 2-1-2005; IN COMMERCE 2-1-2005.

3,234,715. BAGOT, WALTER M., FISHERS, IN. SN 78-589,475. PUB. 12-13-2005, FILED 3-17-2005.

**MADAVENUE**

THE MARK CONSISTS OF STANDARD CHARACTERS WITHOUT CLAIM TO ANY PARTICULAR FONT, STYLE, SIZE, OR COLOR.  
FOR ENTERTAINMENT IN THE NATURE OF THEATRE PRODUCTIONS (U.S. CLS. 100, 101 AND 107).  
FIRST USE 2-1-2004; IN COMMERCE 7-22-2006.

**CLASS 41—(Continued).**

3,234,743. MCDEVITT, SHANNON L., MOUNT PLEASANT, SC. SN 78-599,148. PUB. 2-28-2006, FILED 3-31-2005.



THE COLOR(S) RED, BLACK AND WHITE IS/ARE CLAIMED AS A FEATURE OF THE MARK.  
THE MARK CONSISTS OF A BLACK EXCLAMATION POINT ON A SLIGHT ANGLE WITH THE UPPER PORTION BEING TO THE RIGHT. THE BOTTOM PORTION IS A RED SMILEY FACE WITH BLACK EYES AND A WHITE FACE. THE WORDS JUST HUMOR ME ARE TO THE LEFT OF THE EXCLAMATION POINT IN BLACK AND STACKED WITH EACH WORD BEING ON A SEPARATE LINE.  
FOR ENTERTAINMENT SERVICES AND TRAINING PROGRAMS IN THE NATURE OF PROVIDING LIVE MOTIVATIONAL AND EDUCATIONAL SPEAKERS (U.S. CLS. 100, 101 AND 107).  
FIRST USE 9-0-2001; IN COMMERCE 4-0-2006.

3,234,762. RANGE SYSTEMS BY RENEW RESOURCES, INC., NEW HOPE, MN. SN 78-605,118. PUB. 5-9-2006, FILED 4-8-2005.

**OUTPOST MOBILE SHOOTING RANGE**

THE MARK CONSISTS OF STANDARD CHARACTERS WITHOUT CLAIM TO ANY PARTICULAR FONT, STYLE, SIZE, OR COLOR.  
NO CLAIM IS MADE TO THE EXCLUSIVE RIGHT TO USE "MOBILE SHOOTING RANGE", APART FROM THE MARK AS SHOWN.  
FOR MOBILE GUN FIRING RANGES (U.S. CLS. 100, 101 AND 107).  
FIRST USE 12-0-2004; IN COMMERCE 12-0-2004.

**CLASS 41—(Continued).**

3,234,792. DICK, TIMOTHY ALAN, NORTH HOLLYWOOD, CA. SN 78-619,315. PUB. 3-21-2006, FILED 4-28-2005.



FOR MOBILE MEDIA AND ENTERTAINMENT SERVICES IN THE NATURE OF CONTENT DEVELOPMENT (U.S. CLS. 100, 101 AND 107).  
FIRST USE 9-10-2006; IN COMMERCE 9-10-2006.

---

3,234,822. MINYANVILLE PUBLISHING AND MULTIMEDIA LLC, NEW YORK, NY. SN 78-626,662. PUB. 2-7-2006, FILED 5-10-2005.

**BUZZ & BANTER**

THE MARK CONSISTS OF STANDARD CHARACTERS WITHOUT CLAIM TO ANY PARTICULAR FONT, STYLE, SIZE, OR COLOR.

FOR ENTERTAINMENT SERVICES, NAMELY PROVIDING ON-LINE COMIC STRIPS, CARTOONS AND NEWSLETTER COLUMNS IN THE FIELDS OF STOCK MARKET, FINANCE AND INVESTMENT, VIA GLOBAL COMPUTER NETWORK (U.S. CLS. 100, 101 AND 107).  
FIRST USE 6-0-2006; IN COMMERCE 6-0-2006.

---

3,234,823. TRUMP, DONALD J., NEW YORK, NY. SN 78-627,095. PUB. 1-31-2006, FILED 5-10-2005.

**WE TEACH SUCCESS**

THE MARK CONSISTS OF STANDARD CHARACTERS WITHOUT CLAIM TO ANY PARTICULAR FONT, STYLE, SIZE, OR COLOR.

FOR EDUCATIONAL SERVICES IN THE NATURE OF CONDUCTING ON-LINE COURSES IN THE FIELDS OF BUSINESS AND REAL ESTATE (U.S. CLS. 100, 101 AND 107).

FIRST USE 5-19-2005; IN COMMERCE 5-19-2005.

**CLASS 41—(Continued).**

3,234,842. JUPITER ENTERTAINMENT, INC., KNOXVILLE, TN. SN 78-632,202. PUB. 2-7-2006, FILED 5-18-2005.

**TOOLS OF THE TRADE**

THE MARK CONSISTS OF STANDARD CHARACTERS WITHOUT CLAIM TO ANY PARTICULAR FONT, STYLE, SIZE, OR COLOR.

FOR ENTERTAINMENT IN THE NATURE OF AN ONGOING ADVENTURE, DOCUMENTARY TELEVISION SERIES (U.S. CLS. 100, 101 AND 107).  
FIRST USE 2-0-2005; IN COMMERCE 2-0-2005.

---

3,234,849. GOLD'S GYM LICENSING LLC, IRVING, TX. SN 78-633,757. PUB. 3-14-2006, FILED 5-20-2005.

**SERIOUS FITNESS**

THE MARK CONSISTS OF STANDARD CHARACTERS WITHOUT CLAIM TO ANY PARTICULAR FONT, STYLE, SIZE, OR COLOR.

OWNER OF U.S. REG. NOS. 2,167,409, 2,297,838, AND OTHERS.

FOR GYMNASIUM SERVICES (U.S. CLS. 100, 101 AND 107).

FIRST USE 1-31-2005; IN COMMERCE 1-31-2005.

---

3,234,868. GOODTASTE PITTSBURGH, LLC, PITTSBURGH, PA. SN 78-637,180. PUB. 2-28-2006, FILED 5-25-2005.

**GOODTASTE!**

THE MARK CONSISTS OF STANDARD CHARACTERS WITHOUT CLAIM TO ANY PARTICULAR FONT, STYLE, SIZE, OR COLOR.

FOR ORGANIZING AND CONDUCTING EXHIBITIONS, SHOWS, DEMONSTRATIONS AND WORKSHOPS IN THE FIELD OF FOOD AND COOKING (U.S. CLS. 100, 101 AND 107).

FIRST USE 10-29-2005; IN COMMERCE 10-29-2005.

**CLASS 41—(Continued).**

3,234,870. GOODTASTE PITTSBURGH, LLC, PITTSBURGH, PA. SN 78-637,259. PUB. 2-28-2006, FILED 5-25-2005.



NO CLAIM IS MADE TO THE EXCLUSIVE RIGHT TO USE "PITTSBURGH", APART FROM THE MARK AS SHOWN.

FOR ORGANIZING AND CONDUCTING EXHIBITIONS, SHOWS, DEMONSTRATIONS AND WORKSHOPS IN THE FIELD OF FOOD AND COOKING (U.S. CLS. 100, 101 AND 107).

FIRST USE 10-29-2005; IN COMMERCE 10-29-2005.

**CLASS 41—(Continued).**

3,234,889. METRO-GOLDWYN-MAYER STUDIOS INC., LOS ANGELES, CA. SN 78-642,719. PUB. 3-28-2006, FILED 6-2-2005.

**BARBERSHOP**

THE MARK CONSISTS OF STANDARD CHARACTERS WITHOUT CLAIM TO ANY PARTICULAR FONT, STYLE, SIZE, OR COLOR.

OWNER OF U.S. REG. NO. 3,010,569.

FOR ENTERTAINMENT SERVICES, NAMELY, THE PRODUCTION AND DISTRIBUTION OF A TELEVISION SERIES FEATURING DRAMAS, COMEDIES, ROMANCES, SCIENCE FICTION, ACTION AND ADVENTURES, MYSTERIES AND WESTERNS (U.S. CLS. 100, 101 AND 107).

FIRST USE 8-14-2005; IN COMMERCE 8-14-2005.

3,234,874. DRIVERS ED DIRECT, LLC, CHATSWORTH, CA. SN 78-638,630. PUB. 7-25-2006, FILED 5-26-2005.

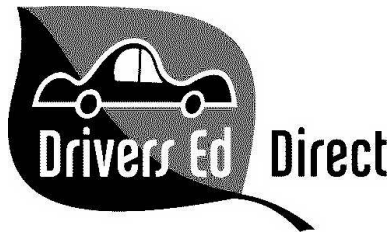

NO CLAIM IS MADE TO THE EXCLUSIVE RIGHT TO USE "DRIVER'S ED", APART FROM THE MARK AS SHOWN.

FOR PROVIDING DRIVER'S EDUCATION COURSES, PRIMARILY FOR NOVICE DRIVERS, NAMELY, THEORETICAL DRIVER'S SAFETY TRAINING THROUGH INTERACTIVE ONLINE COURSES AND CLASSROOM-BASED INSTRUCTOR-LED PROGRAMS, AND PRACTICAL DRIVER'S SAFETY TRAINING THROUGH THE USE OF IN-VEHICLE INSTRUCTION (U.S. CLS. 100, 101 AND 107).

FIRST USE 6-22-2005; IN COMMERCE 6-22-2005.

3,234,894. STONE, JOYCE, DBA BRIARWOOD INTERNATIONAL, PROVO, UT. SN 78-643,473. PUB. 2-21-2006, FILED 6-3-2005.

**BRIARWOOD**

THE MARK CONSISTS OF STANDARD CHARACTERS WITHOUT CLAIM TO ANY PARTICULAR FONT, STYLE, SIZE, OR COLOR.

FOR INFORMATION, ADVISORY AND CONSULTANCY SERVICES RELATING TO EDUCATION, INCLUDING SUCH SERVICES PROVIDED ON LINE VIA THE INTERNET (U.S. CLS. 100, 101 AND 107).

FIRST USE 1-0-1993; IN COMMERCE 1-0-1993.

**CLASS 41—(Continued).**

3,234,896. COLORADO SEMINARY, WHICH OWNS AND OPERATES THE UNIVERSITY OF DENVER, DENVER, CO. SN 78-644,560. PUB. 3-14-2006, FILED 6-6-2005.

**PIONEERING EXCELLENCE**

THE MARK CONSISTS OF STANDARD CHARACTERS WITHOUT CLAIM TO ANY PARTICULAR FONT, STYLE, SIZE, OR COLOR.

FOR EDUCATIONAL SERVICES, NAMELY, CONDUCTING PUBLIC LECTURES, COURSES, WORKSHOPS, SEMINARS, SYMPOSIA, AND CONFERENCES AT THE UNIVERSITY UNDERGRADUATE AND GRADUATE LEVELS; AND ENTERTAINMENT SERVICES; NAMELY, ORGANIZING AND PROVIDING SPORTS EVENTS AND CULTURAL EVENTS, SUCH AS DANCE, THEATER, MUSIC, AND FILM; PROVIDING FACILITIES FOR RECREATIONAL ACTIVITIES (U.S. CLS. 100, 101 AND 107).

FIRST USE 8-30-2005; IN COMMERCE 8-30-2005.

3,234,898. THE ROMAN AUCTION COMPANY, INC., FORT WAYNE, IN. SN 78-645,356. PUB. 2-28-2006, FILED 6-7-2005.

**DANCIOKE**

THE MARK CONSISTS OF STANDARD CHARACTERS WITHOUT CLAIM TO ANY PARTICULAR FONT, STYLE, SIZE, OR COLOR.

FOR ENTERTAINMENT SERVICES, NAMELY, AN INTERACTIVE DANCE CONTEST (U.S. CLS. 100, 101 AND 107).

FIRST USE 4-30-2005; IN COMMERCE 4-30-2005.

3,234,931. FUEL TV, INC., LOS ANGELES, CA. SN 78-651,034. PUB. 3-7-2006, FILED 6-15-2005.

**DAILY HABIT**

THE MARK CONSISTS OF STANDARD CHARACTERS WITHOUT CLAIM TO ANY PARTICULAR FONT, STYLE, SIZE, OR COLOR.

NO CLAIM IS MADE TO THE EXCLUSIVE RIGHT TO USE "DAILY", APART FROM THE MARK AS SHOWN.

FOR ENTERTAINMENT SERVICES IN THE NATURE OF AN ON-GOING TELEVISION PROGRAM FEATURING SPORTS (U.S. CLS. 100, 101 AND 107).

FIRST USE 10-3-2005; IN COMMERCE 10-3-2005.

**CLASS 41—(Continued).**

3,234,939. TRICKED OUT TOONS, INC., TOMBALL, TX. SN 78-651,612. PUB. 3-14-2006, FILED 6-15-2005.

**Tricked Out Toons**

THE MARK CONSISTS OF STANDARD CHARACTERS WITHOUT CLAIM TO ANY PARTICULAR FONT, STYLE, SIZE, OR COLOR.

NO CLAIM IS MADE TO THE EXCLUSIVE RIGHT TO USE TOONS, APART FROM THE MARK AS SHOWN.

FOR ENTERTAINMENT SERVICES IN THE FIELD OF FILM AND TELEVISION, NAMELY, THE CREATION, PRODUCTION AND DISTRIBUTION OF FILMS, ANIMATION, AND COMPUTER GENERATED IMAGES (U.S. CLS. 100, 101 AND 107).

FIRST USE 11-11-2005; IN COMMERCE 12-1-2005.

3,234,988. LIFETOUCH INC., EDEN PRAIRIE, MN. SN 78-657,534. PUB. 3-14-2006, FILED 6-24-2005.

**TRUSTED NATIONALLY  
REPRESENTED LOCALLY**

THE MARK CONSISTS OF STANDARD CHARACTERS WITHOUT CLAIM TO ANY PARTICULAR FONT, STYLE, SIZE, OR COLOR.

FOR PHOTOGRAPHY SERVICES (U.S. CLS. 100, 101 AND 107).

FIRST USE 6-0-2005; IN COMMERCE 6-0-2005.

3,235,007. GREENLEAF, CATHERINE, ANDOVER, NH. SN 78-660,046. PUB. 4-11-2006, FILED 6-28-2005.

**St. Dymphna Press**

THE MARK CONSISTS OF STANDARD CHARACTERS WITHOUT CLAIM TO ANY PARTICULAR FONT, STYLE, SIZE, OR COLOR.

NO CLAIM IS MADE TO THE EXCLUSIVE RIGHT TO USE "PRESS", APART FROM THE MARK AS SHOWN.

FOR PUBLISHING OF BOOKS; PUBLISHING OF GREETING CARDS (U.S. CLS. 100, 101 AND 107).

FIRST USE 7-15-2006; IN COMMERCE 7-15-2006.



**CLASS 41—(Continued).**

3,235,016. GROUP FITNESS USA, LLC, GAITHERSBURG, MD. SN 78-661,543. PUB. 5-23-2006, FILED 6-30-2005.



NO CLAIM IS MADE TO THE EXCLUSIVE RIGHT TO USE "FITNESS", APART FROM THE MARK AS SHOWN.

FOR PHYSICAL FITNESS INSTRUCTION; PHYSICAL FITNESS CONSULTATION; DANCE INSTRUCTION; PHYSICAL FITNESS INSTRUCTION SERVICES FOR THE PURPOSE OF PERSONAL MOTIVATION (U.S. CLS. 100, 101 AND 107).

FIRST USE 6-11-2005; IN COMMERCE 6-11-2005.

3,235,040. ALL-CITY SPORTS MARKETING, INC., NEW YORK, NY. SN 78-662,920. PUB. 3-14-2006, FILED 7-1-2005.



NO CLAIM IS MADE TO THE EXCLUSIVE RIGHT TO USE "3 ON 3 CLASSIC", APART FROM THE MARK AS SHOWN.

FOR ORGANIZING AND CONDUCTING BASKETBALL TOURNAMENTS (U.S. CLS. 100, 101 AND 107).

FIRST USE 8-26-2006; IN COMMERCE 8-26-2006.

**CLASS 41—(Continued).**

3,235,064. TOBACCONIST UNIVERSITY LLC, PRINCETON, NJ. SN 78-666,699. PUB. 8-1-2006, FILED 7-8-2005.

## Tobacconist University

THE MARK CONSISTS OF STANDARD CHARACTERS WITHOUT CLAIM TO ANY PARTICULAR FONT, STYLE, SIZE, OR COLOR.

NO CLAIM IS MADE TO THE EXCLUSIVE RIGHT TO USE "TOBACCONIST", APART FROM THE MARK AS SHOWN.

FOR PROVIDING EDUCATION, NAMELY, ON-LINE PROGRAMS, AS WELL AS SELF-STUDY COURSES IN THE FIELD OF LUXURY TOBACCO PRODUCTS, AND THEIR PRODUCTION, MANUFACTURING, FARMING AND IMPORTING AND EXPORTING (U.S. CLS. 100, 101 AND 107).

FIRST USE 7-0-2005; IN COMMERCE 7-5-2005.

3,235,066. ROOT WHOLE BODY HEALTH, INC., PORTLAND, OR. SN 78-667,887. PUB. 3-21-2006, FILED 7-11-2005.

## ROOT

THE MARK CONSISTS OF STANDARD CHARACTERS WITHOUT CLAIM TO ANY PARTICULAR FONT, STYLE, SIZE, OR COLOR.

FOR HEALTH AND PHYSICAL FITNESS INSTRUCTION; HEALTH CLUB SERVICES, NAMELY PROVIDING INSTRUCTION AND EQUIPMENT IN THE FIELDS OF PHYSICAL EXERCISE, DANCE, MOVEMENT, MEDITATION, RELAXATION TECHNIQUES, MARTIAL ARTS, SPIRITUAL EXERCISE AND NUTRITION (U.S. CLS. 100, 101 AND 107).

FIRST USE 11-11-2005; IN COMMERCE 11-11-2005.

3,235,084. A&E TELEVISION NETWORKS, NEW YORK, NY. SN 78-670,570. PUB. 6-13-2006, FILED 7-14-2005.

## MOVE THIS HOUSE

THE MARK CONSISTS OF STANDARD CHARACTERS WITHOUT CLAIM TO ANY PARTICULAR FONT, STYLE, SIZE, OR COLOR.

FOR ENTERTAINMENT SERVICES, NAMELY, ONGOING SERIES OF CABLE TELEVISION PROGRAMS FEATURING STORIES ABOUT FAMILIES MOVING TO NEW HOMES, AND HOME DECORATING, DESIGN AND RENOVATION (U.S. CLS. 100, 101 AND 107).

FIRST USE 10-2-2005; IN COMMERCE 10-2-2005.

**CLASS 41—(Continued).**

3,235,099. SKEZAS, AMY, PETALUMA, CA. SN 78-673,972. PUB. 4-11-2006, FILED 7-19-2005.

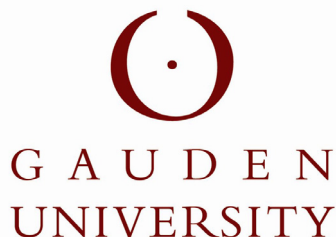

• *Crescere • et • Prodesse •*

NO CLAIM IS MADE TO THE EXCLUSIVE RIGHT TO USE "UNIVERSITY", APART FROM THE MARK AS SHOWN.

THE COLOR RED IS CLAIMED AS A FEATURE OF THE MARK.

THE COLOR RED APPEARS IN THE STYLIZED DESIGN AND LITERAL ELEMENTS OF THE MARK.

THE MARK CONSISTS OF AN OPEN CIRCLE SURROUNDING A CENTRAL DOT, ABOVE THE TERMS GAUDEN UNIVERSITY CRESCERE ET PRODESSE.

THE ENGLISH TRANSLATION OF THE WORDS "CRESCERE ET PRODESSE" IS TO GROW AND TO SERVE.

FOR EDUCATIONAL SERVICES, NAMELY, PROVIDING DOMESTIC, INTERNATIONAL, AND CROSS-CULTURAL PROGRAMS AND INSTRUCTIONAL CLASSES IN THE FIELDS OF METAPHYSICS, SELF-IMPROVEMENT AND HOW TO BE OF SERVICE TO OTHERS (U.S. CLS. 100, 101 AND 107).

FIRST USE 12-4-2006; IN COMMERCE 12-4-2006.

3,235,119. SENECA GAMING CORPORATION, NIAGARA FALLS, NY. SN 78-680,908. PUB. 6-13-2006, FILED 7-28-2005.

**SENECA SELECT CLUB**

THE MARK CONSISTS OF STANDARD CHARACTERS WITHOUT CLAIM TO ANY PARTICULAR FONT, STYLE, SIZE, OR COLOR.

NO CLAIM IS MADE TO THE EXCLUSIVE RIGHT TO USE "SELECT CLUB", APART FROM THE MARK AS SHOWN.

FOR CASINO SERVICES, NAMELY, A CUSTOMER LOYALTY MEMBERSHIP PROGRAM (U.S. CLS. 100, 101 AND 107).

FIRST USE 3-0-2006; IN COMMERCE 6-0-2006.

**CLASS 41—(Continued).**

3,235,127. KOZUBEI, CATHERINE F., NY, NY. AND KOTZUBEI, SAUL F., LOS ANGELES, CA. SN 78-682,258. PUB. 6-27-2006, FILED 7-31-2005.

**BREATHING LIFE**

THE MARK CONSISTS OF STANDARD CHARACTERS WITHOUT CLAIM TO ANY PARTICULAR FONT, STYLE, SIZE, OR COLOR.

NO CLAIM IS MADE TO THE EXCLUSIVE RIGHT TO USE "BREATHING", APART FROM THE MARK AS SHOWN.

FOR CONDUCTING WORKSHOPS AND SEMINARS IN BREATHING (U.S. CLS. 100, 101 AND 107).

FIRST USE 3-1-2005; IN COMMERCE 10-1-2006.

3,235,129. BROKERS' CHOICE OF AMERICA, INC., ENGLEWOOD, CO. SN 78-682,575. PUB. 4-18-2006, FILED 8-1-2005.



NO CLAIM IS MADE TO THE EXCLUSIVE RIGHT TO USE "CONSUMER FINANCIAL AWARENESS WORKSHOP", APART FROM THE MARK AS SHOWN.

FOR EDUCATIONAL SERVICES, NAMELY, CONDUCTING CLASSES, LECTURES, SEMINARS AND WORKSHOPS DIRECTED TO THE SUBJECT OF FINANCIAL INVESTMENT, AND CLASS MATERIALS DISTRIBUTED IN CONNECTION THEREWITH (U.S. CLS. 100, 101 AND 107).

FIRST USE 11-3-2006; IN COMMERCE 11-3-2006.

3,235,158. PROMO INK, NEW YORK, NY. SN 78-694,185. PUB. 2-21-2006, FILED 8-17-2005.

**VIP RECOMMENDATIONS**

**CLASS 41—(Continued).**

THE MARK CONSISTS OF STANDARD CHARACTERS WITHOUT CLAIM TO ANY PARTICULAR FONT, STYLE, SIZE, OR COLOR.

NO CLAIM IS MADE TO THE EXCLUSIVE RIGHT TO USE "RECOMMENDATIONS", APART FROM THE MARK AS SHOWN.

FOR PUBLISHING OF CONSUMER REVIEWS ACCESSIBLE VIA A GLOBAL COMPUTER NETWORK (U.S. CLS. 100, 101 AND 107).

FIRST USE 7-27-2005; IN COMMERCE 7-27-2005.



3,235,159. HARCOURT ASSESSMENT INC., SAN ANTONIO, TX. SN 78-694,426. PUB. 4-25-2006, FILED 8-17-2005.

**VERSANT**

THE MARK CONSISTS OF STANDARD CHARACTERS WITHOUT CLAIM TO ANY PARTICULAR FONT, STYLE, SIZE, OR COLOR.

FOR LANGUAGE PROFICIENCY TESTING SERVICES (U.S. CLS. 100, 101 AND 107).

FIRST USE 4-18-2006; IN COMMERCE 4-18-2006.



3,235,203. FOX 21, INC., LOS ANGELES, CA. SN 78-710,979. PUB. 9-5-2006, FILED 9-12-2005.

**SAVED**

THE MARK CONSISTS OF STANDARD CHARACTERS WITHOUT CLAIM TO ANY PARTICULAR FONT, STYLE, SIZE, OR COLOR.

FOR ENTERTAINMENT SERVICES IN THE NATURE OF A TELEVISION SERIES FEATURING DRAMA (U.S. CLS. 100, 101 AND 107).

FIRST USE 6-12-2006; IN COMMERCE 6-12-2006.

**CLASS 41—(Continued).**

3,235,222. BREATH OF FRESH AIR, LLC, GLEN ALLEN, VA. SN 78-720,676. PUB. 6-6-2006, FILED 9-26-2005.

**Breath of Fresh Air**

THE MARK CONSISTS OF STANDARD CHARACTERS WITHOUT CLAIM TO ANY PARTICULAR FONT, STYLE, SIZE, OR COLOR.

FOR FIRST AID AND CPR TRAINING CLASSES FOR ADULTS AND CHILDREN; BABYSITTER CLASSES; MEDICATION MANAGEMENT TRAINING CLASSES; TRAINING CLASSES FOR INSTRUCTORS IN FIRST AID, CPR, BABYSITTING, AND MEDICATION MANAGEMENT; PET FIRST AID AND CPR TRAINING CLASSES; TRAINING CLASSES FOR INSTRUCTORS IN PET FIRST AID AND CPR (U.S. CLS. 100, 101 AND 107).

FIRST USE 5-1-2002; IN COMMERCE 5-1-2002.



3,235,226. JOE VERDE GROUP, INC., SAN JUAN CAPISTRANO, CA. SN 78-721,944. PUB. 6-6-2006, FILED 9-28-2005.

**THE QUICK AND EASY WAY TO  
BUILD YOUR BUSINESS BY  
PHONE**

THE MARK CONSISTS OF STANDARD CHARACTERS WITHOUT CLAIM TO ANY PARTICULAR FONT, STYLE, SIZE, OR COLOR.

FOR EDUCATIONAL AND TRAINING SERVICES, NAMELY, CONDUCTING SALES AND MANAGEMENT TRAINING SEMINARS AND CLASSES FOR THE AUTOMOTIVE, BOAT AND RECREATIONAL VEHICLE SALES INDUSTRIES (U.S. CLS. 100, 101 AND 107).

FIRST USE 3-2-2002; IN COMMERCE 3-2-2002.



3,235,247. HANSEN, ROBYN E., LOS ANGELES, CA. SN 78-730,328. PUB. 6-27-2006, FILED 10-10-2005.

**Source Therapy**

THE MARK CONSISTS OF STANDARD CHARACTERS WITHOUT CLAIM TO ANY PARTICULAR FONT, STYLE, SIZE, OR COLOR.

NO CLAIM IS MADE TO THE EXCLUSIVE RIGHT TO USE "THERAPY", APART FROM THE MARK AS SHOWN.

FOR PERSONAL COACHING SERVICES IN THE FIELD OF SPIRITUAL GROWTH AND ENLIGHTENMENT (U.S. CLS. 100, 101 AND 107).

FIRST USE 10-1-2005; IN COMMERCE 10-1-2005.

**CLASS 41—(Continued).**

3,235,250. UNITED CHURCH OF GOD, AN INTERNATIONAL ASSOCIATION, MILFORD, OH. SN 78-730,641. PUB. 9-5-2006, FILED 10-11-2005.

**BEYOND  
TODAY**

UNDERSTANDING YOUR FUTURE

THE MARK CONSISTS OF THE STYLIZED VERSION OF THE LITERAL WORDING.

FOR ENTERTAINMENT, NAMELY A CONTINUING RELIGIOUS SHOW BROADCAST OVER TELEVISION, SATELLITE, AUDIO, AND VIDEO MEDIA (U.S. CLS. 100, 101 AND 107).

FIRST USE 12-18-2005; IN COMMERCE 12-18-2005.

3,235,281. WETPAINT.COM, INC., SEATTLE, WA. SN 78-751,220. PUB. 8-1-2006, FILED 11-10-2005.

**WETPAINT**

THE MARK CONSISTS OF STANDARD CHARACTERS WITHOUT CLAIM TO ANY PARTICULAR FONT, STYLE, SIZE, OR COLOR.

FOR EDUCATION AND ENTERTAINMENT SERVICES, NAMELY, PROVIDING REFERENCE LIBRARIES FEATURING ONLINE REFERENCE TOOLS ACCESSIBLE VIA THE INTERNET DIRECTED TOWARD VARIOUS TOPICS OF GENERAL AND SPECIAL INTEREST TO THE PUBLIC; AND ONLINE PUBLISHING OF ARTICLES, EDITORIALS, BLOGS AND WEB SITES OF SPECIAL AND GENERAL INTEREST TO THE PUBLIC (U.S. CLS. 100, 101 AND 107).

FIRST USE 3-9-2006; IN COMMERCE 3-9-2006.

3,235,293. FEEBBII PUBLISHING, L.L.C., TIBURON, CA. SN 78-756,552. PUB. 8-8-2006, FILED 11-17-2005.

**FEEBBII PUBLISHING**

THE MARK CONSISTS OF STANDARD CHARACTERS WITHOUT CLAIM TO ANY PARTICULAR FONT, STYLE, SIZE, OR COLOR.

NO CLAIM IS MADE TO THE EXCLUSIVE RIGHT TO USE "PUBLISHING", APART FROM THE MARK AS SHOWN.

FOR PUBLISHING OF BOOKS AND MAGAZINES (U.S. CLS. 100, 101 AND 107).

FIRST USE 7-1-2006; IN COMMERCE 7-1-2006.

**CLASS 41—(Continued).**

3,235,297. PUTTING ZONE GLOW GOLF ARENA, LLC, GLENWOOD, MD. SN 78-757,770. PUB. 8-1-2006, FILED 11-20-2005.

**PUTTING ZONE**

THE MARK CONSISTS OF STANDARD CHARACTERS WITHOUT CLAIM TO ANY PARTICULAR FONT, STYLE, SIZE, OR COLOR.

NO CLAIM IS MADE TO THE EXCLUSIVE RIGHT TO USE PUTTING, APART FROM THE MARK AS SHOWN.

FOR PROVIDING AMUSEMENT FACILITIES (U.S. CLS. 100, 101 AND 107).

FIRST USE 10-29-2006; IN COMMERCE 10-29-2006.

3,235,298. PUTTING ZONE GLOW GOLF ARENA, LLC, GLENWOOD, MD. SN 78-757,771. PUB. 8-1-2006, FILED 11-20-2005.

**PZONE**

THE MARK CONSISTS OF STANDARD CHARACTERS WITHOUT CLAIM TO ANY PARTICULAR FONT, STYLE, SIZE, OR COLOR.

FOR PROVIDING AMUSEMENT FACILITIES (U.S. CLS. 100, 101 AND 107).

FIRST USE 10-29-2006; IN COMMERCE 10-29-2006.

3,235,299. PUTTING ZONE GLOW GOLF ARENA, LLC, GLENWOOD, MD. SN 78-757,772. PUB. 8-1-2006, FILED 11-20-2005.

**Putting Zone Glow Golf  
Arena**

THE MARK CONSISTS OF STANDARD CHARACTERS WITHOUT CLAIM TO ANY PARTICULAR FONT, STYLE, SIZE, OR COLOR.

NO CLAIM IS MADE TO THE EXCLUSIVE RIGHT TO USE PUTTING AND GLOW GOLF ARENA, APART FROM THE MARK AS SHOWN.

FOR AMUSEMENT CENTERS; PROVIDING AMUSEMENT FACILITIES (U.S. CLS. 100, 101 AND 107).

FIRST USE 10-29-2006; IN COMMERCE 10-29-2006.

**CLASS 41—(Continued).**

3,235,310. SENTURIA, NEIL R., LA JOLLA, CA. SN 78-760,746. PUB. 8-8-2006, FILED 11-24-2005.

**I'M THERE FOR YOU BABY...**

THE MARK CONSISTS OF STANDARD CHARACTERS WITHOUT CLAIM TO ANY PARTICULAR FONT, STYLE, SIZE, OR COLOR.

FOR PRODUCTION OF RADIO AND TELEVISION PROGRAMS (U.S. CLS. 100, 101 AND 107).

FIRST USE 2-28-2006; IN COMMERCE 2-28-2006.

**CLASS 41—(Continued).**

3,235,391. THE COCA-COLA COMPANY, ATLANTA, GA. SN 78-977,854. PUB. 5-9-2006, FILED 8-24-2005.



3,235,315. NATIONAL ASSOCIATION OF STATE BOARDS OF ACCOUNTANCY, INC., NASHVILLE, TN. SN 78-762,603. PUB. 8-22-2006, FILED 11-29-2005.



NO CLAIM IS MADE TO THE EXCLUSIVE RIGHT TO USE "ACCOUNTANCY LICENSING LIBRARY", APART FROM THE MARK AS SHOWN.

FOR ONLINE CPA LICENSING SERVICES, NAMELY, PROVIDING ELECTRONIC LIBRARY SERVICES WHICH FEATURE CPA LICENSURE AND CERTIFICATION REQUIREMENTS, FORMS AND PROCEDURES FOR ACCOUNTANTS IN ALL JURISDICTIONS VIA AN ON-LINE COMPUTER NETWORK (U.S. CLS. 100, 101 AND 107).

FIRST USE 7-14-2006; IN COMMERCE 7-14-2006.

FOR ENTERTAINMENT SERVICES, NAMELY A PUBLIC AQUARIUM; AND EXHIBITION SERVICES, NAMELY THE OPERATION OF A PAVILION WHICH DISPLAYS EXHIBITS AND MEMORABILIA CONCERNING THE COCA-COLA COMPANY, ITS HISTORY AND ITS PRODUCTS FOR PUBLIC VIEWING; AND A RECREATIONAL AND COMMEMORATIVE SITE OPEN TO THE PUBLIC FOR RELAXATION AND CULTURAL, SPORTING, AND ENTERTAINMENT PURPOSES, NAMELY MUSICAL, THEATRICAL AND DANCE EXHIBITIONS, SPORTING EVENTS AND COMPETITIONS, ART EXHIBITS AND CRAFT EXHIBITIONS FOR ENTERTAINMENT PURPOSES (U.S. CLS. 100, 101 AND 107).

FIRST USE 11-9-2005; IN COMMERCE 11-9-2005.

**CLASS 42—SCIENTIFIC, COMPUTER AND LEGAL SERVICES**

3,233,788. ATHENIX CORP., DURHAM, NC. SN 76-392,023. PUB. 8-10-2004, FILED 4-5-2002.

**MIDAS GENE DISCOVERY SYSTEM**

NO CLAIM IS MADE TO THE EXCLUSIVE RIGHT TO USE "GENE DISCOVERY SYSTEM", APART FROM THE MARK AS SHOWN.

FOR RESEARCH AND DEVELOPMENT SERVICE FOR OTHERS IN THE FIELDS OF GENETICS AND BIOTECHNOLOGY, NAMELY, GENETIC ENGINEERING, RECOMBINANT DNA ENGINEERING, BIOCHEMICAL ENGINEERING, AND FERMENTATION ENGINEERING FOR USE IN THE CHEMICAL, ALTERNATIVE ENERGY, BIO-FUEL AND BIOMASS INDUSTRIES; BIOTECHNOLOGY RESEARCH AND DEVELOPMENT SERVICE FOR OTHERS IN THE FIELD OF AGRICULTURE, NAMELY, GENETIC ENGINEERING RELATING TO THE GROWTH AND YIELD OF PLANTS AND CROPS, STRAIN DISCOVERY AND IMPROVEMENT, AND ISOLATING GENES CONFERRING COMMERCIALY USEFUL TRAITS IN PLANTS TO PRODUCE ENHANCED GENETIC CAPABILITIES (U.S. CLS. 100 AND 101).

FIRST USE 12-31-2003; IN COMMERCE 12-31-2003.

3,235,373. NEW YORK RACING ASSOCIATION, INC., THE, JAMAICA, NY. SN 78-797,519. PUB. 9-12-2006, FILED 1-23-2006.

**NYRA REWARDS**

THE MARK CONSISTS OF STANDARD CHARACTERS WITHOUT CLAIM TO ANY PARTICULAR FONT, STYLE, SIZE, OR COLOR.

OWNER OF U.S. REG. NOS. 1,700,816 AND 1,784,538. FOR BETTING SERVICES (U.S. CLS. 100, 101 AND 107).

FIRST USE 5-3-2006; IN COMMERCE 5-3-2006.

**CLASS 42—(Continued).**

3,233,796. FAMILY FIT LIFESTYLE, INC., SCOTTSDALE, AZ. SN 76-404,155. PUB. 8-19-2003, FILED 5-7-2002.

## WORLD'S HEALTHIEST MOM

FOR CONSULTATION SERVICES ON THE SUBJECTS OF FITNESS, EXERCISE, HEALTH, NUTRITION AND COOKING (U.S. CLS. 100 AND 101).  
FIRST USE 10-0-2005; IN COMMERCE 10-0-2005.

3,233,807. EISNER TECHNOLOGY SOLUTIONS, LLC, NEW YORK, NY. SN 76-452,883. PUB. 5-25-2004, FILED 9-20-2002.

## VELOCITY

FOR INFORMATION TECHNOLOGY OUTSOURCING SERVICES, NAMELY, PROVIDING APPLICATION SOFTWARE HOSTING, MANAGEMENT, AND SUPPORT SERVICES IN CONNECTION WITH PAYROLL, HUMAN RESOURCE, ACCOUNTING, AND OTHER BUSINESS SYSTEMS (U.S. CLS. 100 AND 101).  
FIRST USE 10-0-2002; IN COMMERCE 10-0-2002.

3,233,910. KONINKLIJKE PHILIPS ELECTRONICS N.V., EINDHOVEN, NETHERLANDS. SN 76-595,324. PUB. 9-13-2005, FILED 6-1-2004.

## LED CENTRAL

THE MARK CONSISTS OF STANDARD CHARACTERS WITHOUT CLAIM TO ANY PARTICULAR FONT, STYLE, SIZE, OR COLOR.

NO CLAIM IS MADE TO THE EXCLUSIVE RIGHT TO USE "LED", APART FROM THE MARK AS SHOWN.

FOR PROVIDING TECHNICAL INFORMATION VIA THE INTERNET IN THE FIELD OF LIGHT-EMITTING DIODES (LED) (U.S. CLS. 100 AND 101).  
FIRST USE 3-11-2004; IN COMMERCE 6-9-2004.

**CLASS 42—(Continued).**

3,233,940. COORDINATED RESOURCES, INC. OF SAN FRANCISCO, SAN FRANCISCO, CA. SN 76-608,725. PUB. 3-14-2006, FILED 8-26-2004.

## BEST PEOPLE. BEST RESULTS.

THE MARK CONSISTS OF STANDARD CHARACTERS WITHOUT CLAIM TO ANY PARTICULAR FONT, STYLE, SIZE, OR COLOR.

FOR CONSULTING SERVICES IN THE FIELD OF INTERIOR DECORATING, NAMELY, SELECTION OF OFFICE FURNITURE AND FURNISHINGS (U.S. CLS. 100 AND 101).

FIRST USE 1-0-2005; IN COMMERCE 1-0-2005.

3,234,005. ENVIRIAN, LLC, RESTON, VA. SN 76-627,932. PUB. 10-25-2005, FILED 1-14-2005.

## LEAD TERMINAL

THE MARK CONSISTS OF STANDARD CHARACTERS WITHOUT CLAIM TO ANY PARTICULAR FONT, STYLE, SIZE, OR COLOR.

NO CLAIM IS MADE TO THE EXCLUSIVE RIGHT TO USE "TERMINAL", APART FROM THE MARK AS SHOWN.

FOR LEASING ELECTRONIC PERSONAL COMMUNICATION DEVICES AND OPERATING SOFTWARE THEREWITH SO USERS CAN RECEIVE REAL ESTATE INFORMATION IN THE REAL TIME, ON A SUBSCRIPTION BASIS, AND TECHNICAL SUPPORT SERVICES, NAMELY, TROUBLESHOOTING OF COMPUTER HARDWARE AND SOFTWARE PROBLEMS IN CONNECTION WITH THE LEASING OF SAID DEVICES (U.S. CLS. 100 AND 101).

FIRST USE 4-1-2004; IN COMMERCE 1-1-2005.

3,234,125. DEUTSCH CONSULTING & MARKETING, INC., HOLLYWOOD, FL. SN 78-207,990. PUB. 9-9-2003, FILED 1-28-2003.

## GET OFF

FOR LEGAL SERVICES AND PARALEGAL SERVICES (U.S. CLS. 100 AND 101).  
FIRST USE 10-31-2006; IN COMMERCE 10-31-2006.

**CLASS 42—(Continued).**

3,234,126. FINDING OUR ROOTS, L.L.C., LAKE SAINT LOUIS, MO. SN 78-208,055. PUB. 12-30-2003, FILED 1-28-2003.

**FINDING OUR ROOTS**

FOR GENEALOGY RESEARCH VIA AN ON-LINE ELECTRONIC DATABASE ON GLOBAL COMPUTER NETWORKS FEATURING A RESEARCH SITE WITH INFORMATION/SOURCES ON INDIVIDUALS AND THEIR FAMILIES REGARDING THEIR GENETIC INFORMATION, ETHNIC ORIGIN, NATIONALITY, MIGRATION, GENEALOGY, VITAL STATISTICS, CHARACTER TRAITS, LIFE EVENTS, RELIGIOUS BACKGROUND, EDUCATION, OCCUPATION, POLITICS/ELECTED POSITIONS, MILITARY SERVICE, LEGAL INFORMATION/DOCUMENTS, PROPERTY HOLDINGS, CENSUS INFORMATION, PHOTOS, AND DISCUSSION AREAS FOR COMMENTS AND COMMUNICATION ABOUT SAID RESEARCH ISSUES (U.S. CLS. 100 AND 101).

FIRST USE 6-30-2006; IN COMMERCE 6-30-2006.

---

3,234,133. WINTER, ROBERT W., AZUSA, CA. SN 78-233,269. PUB. 5-11-2004, FILED 4-2-2003.

**PINPOINTER**

FOR COMPUTER SERVICES, NAMELY, PROVIDING SEARCH ENGINES FOR OBTAINING DATA CONTENT ON A GLOBAL COMPUTER NETWORK (U.S. CLS. 100 AND 101).

FIRST USE 7-18-2006; IN COMMERCE 7-18-2006.

---

3,234,218. MAGNA-LASTIC DEVICES, INC., CARTHAGE, IL. SN 78-364,350. PUB. 3-22-2005, FILED 2-7-2004.

**MAGNA-LASTIC DEVICES, INC.**

THE MARK CONSISTS OF STANDARD CHARACTERS WITHOUT CLAIM TO ANY PARTICULAR FONT, STYLE, SIZE, OR COLOR.

NO CLAIM IS MADE TO THE EXCLUSIVE RIGHT TO USE "DEVICES, INC"., APART FROM THE MARK AS SHOWN.

FOR RESEARCH AND DEVELOPMENT OF TORQUE, FORCE AND ANGLE SENSORS, TORQUE, FORCE AND ANGLE CONTROLLERS AND TORQUE, FORCE AND ANGLE MEASURING APPARATUS FOR OTHERS (U.S. CLS. 100 AND 101).

FIRST USE 9-30-2005; IN COMMERCE 9-30-2005.

**CLASS 42—(Continued).**

3,234,277. JENSON, HOWARD, MENIFEE, CA. SN 78-404,109. PUB. 3-14-2006, FILED 4-19-2004.

**DATA COMMAND POST**

THE MARK CONSISTS OF STANDARD CHARACTERS WITHOUT CLAIM TO ANY PARTICULAR FONT, STYLE, SIZE, OR COLOR.

NO CLAIM IS MADE TO THE EXCLUSIVE RIGHT TO USE "DATA", APART FROM THE MARK AS SHOWN.

FOR PROVIDING TEMPORARY USE OF A NON-DOWNLOADABLE WEB-BASED COMPUTER SOFTWARE APPLICATION DESIGNED FOR LAW ENFORCEMENT OPERATIONS, NAMELY, FOR DOCUMENT, FILE, DATABASE, OR APPLICATION MANAGEMENT FROM A WEB-BROWSER (U.S. CLS. 100 AND 101).

FIRST USE 7-31-2006; IN COMMERCE 7-31-2006.

---

3,234,291. NANOREX, INC., BLOOMFIELD, MI. SN 78-410,804. PUB. 3-15-2005, FILED 4-29-2004.

**NANOREX**

THE MARK CONSISTS OF STANDARD CHARACTERS WITHOUT CLAIM TO ANY PARTICULAR FONT, STYLE, SIZE, OR COLOR.

FOR COMPUTER SOFTWARE AND HARDWARE CONSULTING SERVICES; INTEGRATION OF COMPUTER SYSTEMS AND NETWORKS; CONSULTING SERVICES IN THE FIELD OF DESIGN, SELECTION, IMPLEMENTATION AND USE OF COMPUTER HARDWARE, ELECTRONIC HARDWARE, AND COMPUTER SOFTWARE ALL IN THE NANOTECHNOLOGY FIELD (U.S. CLS. 100 AND 101).

FIRST USE 7-1-2006; IN COMMERCE 7-1-2006.

**CLASS 42—(Continued).**

3,234,407. BROADLINE MEDIA CORP., INC., SAN FRANCISCO, CA. SN 78-481,231. PUB. 7-12-2005, FILED 9-9-2004.

**LASOO**

THE MARK CONSISTS OF STANDARD CHARACTERS WITHOUT CLAIM TO ANY PARTICULAR FONT, STYLE, SIZE, OR COLOR.

FOR PROVIDING CONSULTING SERVICES IN THE FIELD OF DESIGN, SELECTION, IMPLEMENTATION, AND USE OF COMPUTER HARDWARE AND SOFTWARE SYSTEMS FOR OTHERS TO ENABLE PRIVATE NETWORKS TO BROADCAST AUDIO AND VIDEO CONTENT OVER THE INTERNET, INTRANETS, COMPUTERS, SATELLITE, TELEVISION, AUDIO OR VIDEO MEDIA (U.S. CLS. 100 AND 101).

FIRST USE 8-0-2006; IN COMMERCE 8-0-2006.

3,234,431. VENTRIA BIOSCIENCE, SACRAMENTO, CA. SN 78-490,340. PUB. 10-11-2005, FILED 9-27-2004.

**EXPRESSPRO**

THE MARK CONSISTS OF STANDARD CHARACTERS WITHOUT CLAIM TO ANY PARTICULAR FONT, STYLE, SIZE, OR COLOR.

FOR PROVIDING GENETIC ENGINEERING OF PLANTS AND PLANT CELLS THAT ARE USED TO PRODUCE BIOCHEMICALS, NAMELY, PROTEINS; RESEARCH AND DEVELOPMENT FOR OTHERS IN THE FIELD OF GENETICALLY ENGINEERED PLANTS AND PLANT CELLS FOR PRODUCING BIOCHEMICALS, NAMELY, PROTEINS; RESEARCH AND DEVELOPMENT OF TRANSGENIC CEREAL GRAINS AND CELLS, EXTRACTS OF TRANSGENIC CEREAL GRAIN AND PROTEINS FROM TRANSGENIC CEREAL GRAIN (U.S. CLS. 100 AND 101).

FIRST USE 9-1-2006; IN COMMERCE 9-1-2006.

**CLASS 42—(Continued).**

3,234,457. RIVERCITY SOFTWARE SOLUTIONS, L.L.C., ST. LOUIS, MO. SN 78-500,007. PUB. 2-21-2006, FILED 10-14-2004.

**intraISP**

FOR PROVIDING TEMPORARY USE OF ONLINE, NON-DOWNLOADABLE BUSINESS MANAGEMENT COMPUTER SOFTWARE (U.S. CLS. 100 AND 101).

FIRST USE 10-25-2004; IN COMMERCE 10-25-2004.

3,234,489. CONTROL COMPONENTS, INC., RANCHO SANTA MARGARITA, CA. SN 78-511,640. PUB. 9-6-2005, FILED 11-4-2004.

**TURNING  
ENGINEERING  
KNOWLEDGE INTO  
SOLUTIONS SINCE 1961**

THE MARK CONSISTS OF STANDARD CHARACTERS WITHOUT CLAIM TO ANY PARTICULAR FONT, STYLE, SIZE, OR COLOR.

FOR DESIGN OF CONTROL VALVES, ACTUATORS, SILENCERS AND RESISTORS USED FOR SEVERE SERVICE APPLICATIONS FOR OTHERS (U.S. CLS. 100 AND 101).

FIRST USE 11-1-2004; IN COMMERCE 11-10-2006.



**CLASS 42—(Continued).**

3,234,494. NIPPON DENKI KABUSHIKI KAISHA, DBA NEC CORPORATION, TOKYO, JAPAN. SN 78-511,918. PUB. 3-14-2006, FILED 11-5-2004.

**CLASS 42—(Continued).**

3,234,547. PAN, SHEN Q, WILMINGTON, DE. SN 78-527,150. PUB. 3-14-2006, FILED 12-4-2004.



# UNIVERGE

FOR COSMETICS RESEARCH; COSMETICS RESEARCH FOR OTHERS; DEVELOPMENT OF NEW TECHNOLOGY FOR OTHERS IN THE FIELD OF GENOMICS AND BIOTECHNOLOGY; FOOD RESEARCH; MEDICAL RESEARCH; PHARMACEUTICAL RESEARCH AND DEVELOPMENT; PRODUCT RESEARCH AND DEVELOPMENT; RESEARCH AND DEVELOPMENT OF VACCINES AND MEDICINES; RESEARCH IN THE FIELD OF HAIR CARE; RESEARCH ON FOOD; SCIENTIFIC RESEARCH; SCIENTIFIC RESEARCH IN THE FIELD OF GENETICS AND GENETIC ENGINEERING; TESTING, INSPECTION OR RESEARCH OF PHARMACEUTICALS, COSMETICS OR FOODSTUFF (U.S. CLS. 100 AND 101).

FIRST USE 6-1-2005; IN COMMERCE 6-1-2005.

THE MARK CONSISTS OF STANDARD CHARACTERS WITHOUT CLAIM TO ANY PARTICULAR FONT, STYLE, SIZE, OR COLOR.

FOR TECHNICAL COMPUTER CONSULTING SERVICES AND TECHNICAL CONSULTATION FOR COMPUTER PROGRAMMING AND COMPUTER HARDWARE; DESIGN OF COMPUTER HARDWARE, COMPUTER SOFTWARE, WEB SITES AND COMPUTER NETWORK SYSTEM FOR OTHERS; CUSTOMIZATION OF COMPUTER HARDWARE AND SOFTWARE; INTEGRATION OF COMPUTER SYSTEMS AND NETWORKS; PROVIDING OTHERS WITH INFORMATION IN THE FIELD OF COMPUTER HARDWARE AND COMPUTER SOFTWARE; CONSULTING SERVICES IN THE FIELDS OF COMPUTER NETWORK SUPPORT, THE USE AND OPERATION OF COMPUTER SOFTWARE, SYSTEMS ANALYSIS AND INTEGRATION, INSTALLATION OF COMPUTER NETWORKS, COMPUTER SECURITY AND THE PLANNING, DESIGN, AND OPTIMIZATION OF COMPUTER NETWORK SYSTEMS; MAINTENANCE AND UPDATING OF COMPUTER SOFTWARE AND WEB SITES; COMPUTER NETWORK SYSTEMS ANALYSIS; SERVICES IN THE FIELD OF THE TECHNICAL TECHNOLOGY SUPERVISION AND INSPECTION OF ELECTRONIC APPARATUS AND INSTRUMENTS IN THE NATURE OF ELECTRONIC COMPUTERS; RENTAL SERVICES OF ELECTRIC AND ELECTRONIC APPARATUS, INSTRUMENTS AND IMPLEMENTS, NAMELY, RENTAL OF COMPUTERS AND ELECTRONIC MEASURING APPARATUS; TROUBLESHOOTING OF COMPUTER HARDWARE AND SOFTWARE PROBLEMS VIA TELEPHONE; E-MAIL, IN PERSON AND LOCAL AND GLOBAL COMPUTER INFORMATION NETWORKS; PROVIDING TEMPORARY USE OF NON-DOWNLOADABLE DATABASE MANAGEMENT COMPUTER SOFTWARE PROGRAMS VIA THE GLOBAL INFORMATION NETWORKS (U.S. CLS. 100 AND 101).

FIRST USE 11-30-2004; IN COMMERCE 11-30-2004.

3,234,579. ID ANALYTICS, INC., SAN DIEGO, CA. SN 78-532,609. PUB. 9-13-2005, FILED 12-15-2004.

# ID OPTIMIZER

THE MARK CONSISTS OF STANDARD CHARACTERS WITHOUT CLAIM TO ANY PARTICULAR FONT, STYLE, SIZE, OR COLOR.

NO CLAIM IS MADE TO THE EXCLUSIVE RIGHT TO USE "ID", APART FROM THE MARK AS SHOWN.

FOR APPLICATION SERVICE PROVIDER (ASP) FEATURING SOFTWARE IN THE FIELD OF IDENTITY THEFT AND FRAUD RECOGNITION AND PREVENTION (U.S. CLS. 100 AND 101).

FIRST USE 12-0-2004; IN COMMERCE 12-0-2004.

**CLASS 42—(Continued).**

3,234,641. FEMTOSECOND INC., FAIRFAX, VA. SN 78-558,694. PUB. 11-15-2005, FILED 2-2-2005.

## Femtosecond Inc.

THE MARK CONSISTS OF STANDARD CHARACTERS WITHOUT CLAIM TO ANY PARTICULAR FONT, STYLE, SIZE, OR COLOR.

NO CLAIM IS MADE TO THE EXCLUSIVE RIGHT TO USE INC., APART FROM THE MARK AS SHOWN.

FOR COMPUTER CONSULTATION IN THE FIELD OF COMPUTER SECURITY (U.S. CLS. 100 AND 101).

FIRST USE 1-31-2005; IN COMMERCE 4-25-2005.

---

3,234,729. PICS4IT.COM, INC., RICHMOND, VA. SN 78-595,696. PUB. 6-20-2006, FILED 3-26-2005.

## pics4it

THE MARK CONSISTS OF STANDARD CHARACTERS WITHOUT CLAIM TO ANY PARTICULAR FONT, STYLE, SIZE, OR COLOR.

FOR COMPUTER SERVICES, NAMELY, CREATING, HOSTING AND MAINTAINING WEBSITES FOR OTHERS (U.S. CLS. 100 AND 101).

FIRST USE 1-1-2006; IN COMMERCE 1-1-2006.

---

3,234,733. LOGMEIN, INC., WOBURN, MA. SN 78-596,399. PUB. 1-3-2006, FILED 3-28-2005.

## LOGMEIN IT REACH

THE MARK CONSISTS OF STANDARD CHARACTERS WITHOUT CLAIM TO ANY PARTICULAR FONT, STYLE, SIZE, OR COLOR.

FOR COMPUTER SERVICES, NAMELY REMOTE MANAGEMENT OF APPLICATIONS FOR OTHERS (U.S. CLS. 100 AND 101).

FIRST USE 2-15-2005; IN COMMERCE 2-15-2005.

**CLASS 42—(Continued).**

3,234,750. LANIER WORLDWIDE, INC., ATLANTA, GA. SN 78-600,954. PUB. 1-17-2006, FILED 4-4-2005.

## FORMDIRECTOR

THE MARK CONSISTS OF STANDARD CHARACTERS WITHOUT CLAIM TO ANY PARTICULAR FONT, STYLE, SIZE, OR COLOR.

FOR DESIGN OF ELECTRONIC DOCUMENT DELIVERY AND DOCUMENT MANAGEMENT SYSTEMS FOR OTHERS (U.S. CLS. 100 AND 101).

FIRST USE 2-24-2006; IN COMMERCE 2-24-2006.

---

3,234,768. MEREDITH CORPORATION, DES MOINES, IA. SN 78-608,197. PUB. 2-28-2006, FILED 4-13-2005.



OWNER OF U.S. REG. NOS. 1,366,612 AND 1,897,481. THE COLORS BLACK, RED, AND WHITE ARE CLAIMED AS A FEATURE OF THE MARK.

THE MARK CONSISTS OF THE STYLIZED WORDS "BETTER HOMES AND GARDENS" IN BLACK ABOVE A SQUARE CONTAINING A PLAID OF RED SQUARES, WHITE SQUARES AND SQUARES OF RED AND WHITE COMBINED.

FOR PROVIDING RECIPE DEVELOPMENT; PROVIDING TESTING, RESEARCH AND ANALYSIS OF RECIPES, FOOD PREPARATION, COOKING METHODS AND PROVIDING INFORMATION RELATED TO SUCH TESTING, RESEARCH AND ANALYSIS (U.S. CLS. 100 AND 101).

FIRST USE 8-15-2005; IN COMMERCE 8-15-2005.

**CLASS 42—(Continued).**

3,234,787. TRAPP, GEORGE, WEST CHESTER, PA. SN 78-615,758. PUB. 5-9-2006, FILED 4-25-2005.



NO CLAIM IS MADE TO THE EXCLUSIVE RIGHT TO USE "LLC", APART FROM THE MARK AS SHOWN.  
FOR CONSULTING SERVICES IN THE FIELD OF DESIGN, SELECTION, IMPLEMENTATION AND USE OF COMPUTER HARDWARE AND SOFTWARE SYSTEMS FOR OTHERS (U.S. CLS. 100 AND 101).  
FIRST USE 3-21-2005; IN COMMERCE 3-21-2005.

---

3,234,810. PROGRESS SOFTWARE CORPORATION, BEDFORD, MA. SN 78-624,473. PUB. 2-21-2006, FILED 5-6-2005.

## DATAXTEND

THE MARK CONSISTS OF STANDARD CHARACTERS WITHOUT CLAIM TO ANY PARTICULAR FONT, STYLE, SIZE, OR COLOR.  
FOR COMPUTER SERVICES FOR OTHERS, NAMELY, COMPUTER SOFTWARE DESIGN, DEVELOPMENT, INSTALLATION, AND MAINTENANCE, CONSULTING IN THE FIELD OF COMPUTER SOFTWARE, AND TECHNICAL SUPPORT, NAMELY, TROUBLESHOOTING OF COMPUTER HARDWARE AND SOFTWARE PROBLEMS (U.S. CLS. 100 AND 101).  
FIRST USE 10-17-2005; IN COMMERCE 10-17-2005.

---

3,234,841. VESEY, INC., BOSTON, MA. SN 78-631,709. PUB. 2-21-2006, FILED 5-17-2005.

## GEEK CHOICE

THE MARK CONSISTS OF STANDARD CHARACTERS WITHOUT CLAIM TO ANY PARTICULAR FONT, STYLE, SIZE, OR COLOR.  
FOR TECHNICAL SUPPORT SERVICES, NAMELY, TROUBLESHOOTING OF COMPUTER HARDWARE AND SOFTWARE PROBLEMS VIA TELEPHONE AND REMOTE ACCESS AS WELL AS IN PERSON (U.S. CLS. 100 AND 101).  
FIRST USE 8-16-2006; IN COMMERCE 8-16-2006.

**CLASS 42—(Continued).**

3,234,851. STARR MAP COMPANY, LLC, ANACORTES, WA. SN 78-634,357. PUB. 1-31-2006, FILED 5-20-2005.



OWNER OF U.S. REG. NO. 2,308,880.  
NO CLAIM IS MADE TO THE EXCLUSIVE RIGHT TO USE "MAPS & GUIDES", APART FROM THE MARK AS SHOWN.  
THE MARK CONSISTS OF THE STYLIZED WORDS DESTINATION MAPS & GUIDES WITH A "STAR" ABOVE THE LETTER "I".  
FOR CARTOGRAPHIC SERVICES (U.S. CLS. 100 AND 101).  
FIRST USE 5-0-2005; IN COMMERCE 5-0-2005.

---

3,234,862. BAYNOTE, INC., CUPERTINO, CA. SN 78-636,485. PUB. 2-21-2006, FILED 5-24-2005.

## BAYNOTE

THE MARK CONSISTS OF STANDARD CHARACTERS WITHOUT CLAIM TO ANY PARTICULAR FONT, STYLE, SIZE, OR COLOR.  
FOR COMPUTER SERVICES, NAMELY, ACTING AS AN APPLICATION SERVICE PROVIDER IN THE FIELDS OF INFORMATION DISCOVERY, KNOWLEDGE MANAGEMENT, INFORMATION LOGISTICS AND PRODUCTIVITY MANAGEMENT, TO HOST COMPUTER APPLICATION SOFTWARE FOR SEARCH, NAVIGATION AND ORGANIZATION OF CONTENT AND DATA WITHIN APPLICATIONS, DATABASES, REPOSITORIES AND COMPUTER NETWORKS (U.S. CLS. 100 AND 101).  
FIRST USE 10-0-2004; IN COMMERCE 3-0-2005.

**CLASS 42—(Continued).**

3,234,946. MARKETING ANALYTICS, INC., EVANSTON, IL. SN 78-652,600. PUB. 2-28-2006, FILED 6-16-2005.

# Driver Insights

THE MARK CONSISTS OF THE WORDS "DRIVER INSIGHTS" WITH THE FIRST LETTER OF EACH WORD CAPITALIZED, IN ARIAL FONT FAMILY.

FOR APPLICATION SERVICE PROVIDER (ASP) FEATURING WEB-BASED SOFTWARE IN THE FIELD OF STATISTICAL MODELING TO EXPLAIN WHY RESULTS SUCH AS SALES CHANGED VERSUS PREVIOUS TIME PERIODS DUE TO USER-SELECTED VARIABLES IN THE FIELDS OF MARKETING AND SALES (U.S. CLS. 100 AND 101).

FIRST USE 11-20-2005; IN COMMERCE 10-20-2006.

3,234,979. PRINCIPIA LLC, SAN FRANCISCO, CA. SN 78-656,102. PUB. 3-14-2006, FILED 6-22-2005.

# PRINCIPIA

THE MARK CONSISTS OF STANDARD CHARACTERS WITHOUT CLAIM TO ANY PARTICULAR FONT, STYLE, SIZE, OR COLOR.

FOR CONSULTING SERVICES IN THE FIELD OF ENGINEERING AND FAILURE ANALYSIS; TECHNOLOGY CONSULTING IN THE FIELD OF MECHANICAL ENGINEERING, AEROSPACE ENGINEERING, ELECTRICAL AND ELECTROMECHANICAL ENGINEERING, STRUCTURAL ENGINEERING, AND BIOMEDICAL ENGINEERING; EXPLOSION AND FIRE ANALYSIS SERVICES (U.S. CLS. 100 AND 101).

FIRST USE 6-0-2005; IN COMMERCE 6-0-2005.

**CLASS 42—(Continued).**

3,235,009. SIMWRIGHT, INC., NAVARRE, FL. SN 78-660,279. PUB. 3-28-2006, FILED 6-28-2005.



NO CLAIM IS MADE TO THE EXCLUSIVE RIGHT TO USE "STEREOGIS", APART FROM THE MARK AS SHOWN. THE COLOR(S) RED, BLUE AND WHITE IS/ARE CLAIMED AS A FEATURE OF THE MARK.

THE COLOR RED APPEARS IN THE SQUARE AND ON THE LETTERS "TEREO", THE COLOR WHITE APPEARS ON THE FIDUCIAL WITHIN THE SQUARE AND ON THE LETTER "S", THE COLOR BLUE APPEARS ON THE LETTERS "GIS".

FOR DESIGN, DEVELOPMENT AND IMPLEMENTATION OF SOFTWARE AND THE CONSULTING THEREOF IN THE FIELD OF GEOGRAPHICAL MAPPING AND ANALYSIS (U.S. CLS. 100 AND 101).

FIRST USE 1-1-2004; IN COMMERCE 1-1-2004.

3,235,044. BAKER & HOSTETLER LLP, CLEVELAND, OH. SN 78-663,490. PUB. 3-14-2006, FILED 7-5-2005.

## COUNSEL TO MARKET LEADERS

THE MARK CONSISTS OF STANDARD CHARACTERS WITHOUT CLAIM TO ANY PARTICULAR FONT, STYLE, SIZE, OR COLOR.

NO CLAIM IS MADE TO THE EXCLUSIVE RIGHT TO USE "COUNSEL", APART FROM THE MARK AS SHOWN.

FOR LEGAL SERVICES (U.S. CLS. 100 AND 101).

FIRST USE 1-1-2006; IN COMMERCE 1-1-2006.

3,235,053. AGILETEK LLC, DES PLAINES, IL. SN 78-664,824. PUB. 3-21-2006, FILED 7-6-2005.

## LEAVE NOTHING TO CHANCE

THE MARK CONSISTS OF STANDARD CHARACTERS WITHOUT CLAIM TO ANY PARTICULAR FONT, STYLE, SIZE, OR COLOR.

FOR COMPUTER SOFTWARE DESIGN FOR OTHERS, COMPUTER SOFTWARE CONSULTATION, AND COMPUTER SOFTWARE DEVELOPMENT (U.S. CLS. 100 AND 101).

FIRST USE 8-1-2005; IN COMMERCE 8-1-2005.

**CLASS 42—(Continued).**

3,235,072. BAKER & HOSTETLER LLP, CLEVELAND, OH. SN 78-668,572. PUB. 4-25-2006, FILED 7-12-2005.



OWNER OF U.S. REG. NOS. 1,660,215, 2,141,011, AND OTHERS.

THE NAME "BAKER HOSTETLER" DOES NOT IDENTIFY A LIVING INDIVIDUAL.

THE COLOR(S) BLOOD ORANGE AND WHITE IS/ARE CLAIMED AS A FEATURE OF THE MARK.

THE COLOR WHITE APPEARS AS THE LETTERS AND BLOOD ORANGE IS IN THE BACKGROUND.

FOR LEGAL SERVICES (U.S. CLS. 100 AND 101).  
FIRST USE 1-1-2006; IN COMMERCE 1-1-2006.

---

3,235,092. ROOF EXPRESS, LLC, CENTENNIAL, CO. SN 78-672,378. PUB. 4-25-2006, FILED 7-18-2005.

## ROOF EXPRESS

THE MARK CONSISTS OF STANDARD CHARACTERS WITHOUT CLAIM TO ANY PARTICULAR FONT, STYLE, SIZE, OR COLOR.

NO CLAIM IS MADE TO THE EXCLUSIVE RIGHT TO USE "ROOF", APART FROM THE MARK AS SHOWN.

FOR APPLICATION SERVICE PROVIDER FEATURING SOFTWARE IN THE FIELD OF ROOF INSPECTION FOR USE IN ASSISTING IN THE RECORDING AND REPORTING OF ROOF INSPECTIONS FOR THE INSTALLATION, MAINTENANCE, OR REPAIR OF A ROOF (U.S. CLS. 100 AND 101).

FIRST USE 6-20-2005; IN COMMERCE 6-20-2005.

---

3,235,093. BAKER & HOSTETLER LLP, CLEVELAND, OH. SN 78-672,491. PUB. 4-25-2006, FILED 7-18-2005.

## BAKER & HOSTETLER LLP

THE MARK CONSISTS OF STANDARD CHARACTERS WITHOUT CLAIM TO ANY PARTICULAR FONT, STYLE, SIZE, OR COLOR.

OWNER OF U.S. REG. NOS. 1,660,215, 2,141,011, AND OTHERS.

NO CLAIM IS MADE TO THE EXCLUSIVE RIGHT TO USE "LLP", APART FROM THE MARK AS SHOWN.

"THE NAME(S), PORTRAIT(S), AND/OR SIGNATURE(S) SHOWN IN THE MARK DOES NOT IDENTIFY A PARTICULAR LIVING INDIVIDUAL."

FOR LEGAL SERVICES (U.S. CLS. 100 AND 101).  
FIRST USE 1-1-2006; IN COMMERCE 1-1-2006.

**CLASS 42—(Continued).**

3,235,100. CAPITAL REGION COMPUTERS, INC., DBA ICOM, CLIFTON PARK, NY. SN 78-674,028. PUB. 8-1-2006, FILED 7-20-2005.



NO CLAIM IS MADE TO THE EXCLUSIVE RIGHT TO USE "SERVICES.COM", APART FROM THE MARK AS SHOWN.

THE APPLICANT CLAIMS COLOR AS A FEATURE OF THE MARK, NAMELY, RED, WHITE, BLACK, GRAY. IS/ARE CLAIMED AS A FEATURE OF THE MARK.

THE WORD "HITMAN" IN THE COLOR WHITE WITH "HIT" IN CAPITAL LETTERS AND "MAN" IN NON-CAPITAL LETTERS, OVERLAYING A BLACK BACKGROUND. THE WORD "HITMAN" IS OUTLINED BY THE COLORS BLACK AND GREY. BELOW THE WORD "HITMAN" IS THE WORDING "SERVICES.COM" IN NON-CAPITAL LETTERS IN THE COLOR GRAY. THE WORD "HIT" IS OUTLINED BY A DESIGN SYMBOLIZING A TARGET IN THE COLOR RED. THE DESIGN IS OF AN OUTLINE OF A CIRCLE WITH TWO VERTICAL LINES INTERSECTING THE CIRCLE AT 12 O'CLOCK AND 6 O'CLOCK AND ONE HORIZONTAL LINE INTERSECTING THE CIRCLE AT 9 O'CLOCK.

FOR COMPUTER CONSULTATION; COMPUTER CONSULTATION IN THE FIELD OF COMPUTER SECURITY; COMPUTER DIAGNOSTIC SERVICES; COMPUTER DISASTER RECOVERY PLANNING; COMPUTER GRAPHICS SERVICES; COMPUTER NETWORK DESIGN FOR OTHERS; COMPUTER PROGRAMMING FOR OTHERS; COMPUTER SECURITY SERVICE, NAMELY, RESTRICTING ACCESS TO AND BY COMPUTER NETWORKS TO AND OF UNDESIRED WEB SITES, MEDIA AND INDIVIDUALS AND FACILITIES; COMPUTER SERVICES, NAMELY CREATING INDEXES OF INFORMATION, SITES AND OTHER RESOURCES AVAILABLE ON COMPUTER NETWORKS; COMPUTER SERVICES, NAMELY MONITORING AND REPORTING ON THE PERFORMANCE, AVAILABILITY, AND ERRORS OF WEBSITES OF OTHERS; COMPUTER SERVICES, NAMELY MONITORING, TESTING, ANALYZING, AND REPORTING ON THE INTERNET TRAFFIC CONTROL AND CONTENT CONTROL OF THE WEBSITES OF OTHERS; COMPUTER SERVICES, NAMELY, CREATING AND MAINTAINING WEB SITES FOR OTHERS; COMPUTER SERVICES, NAMELY, DATA RECOVERY SERVICES; COMPUTER SERVICES, NAMELY, DESIGNING AND IMPLEMENTING NETWORK WEB PAGES FOR OTHERS; COMPUTER SERVICES, NAMELY, DESIGNING AND IMPLEMENTING WEB SITES FOR OTHERS; COMPUTER SERVICES, NAMELY, FILTERING OF UNWANTED E-MAILS; COMPUTER SERVICES, NAMELY, MANAGING WEB SITES FOR OTHERS; COMPUTER SERVICES, NAMELY, MONITORING THE WEBSITES OF OTHERS TO IMPROVE SCALABILITY AND PERFORMANCE OF WEBSITES OF OTHERS; COMPUTER SERVICES, NAMELY, REDIRECTING ELECTRONIC MAIL TO CHANGED PERSONAL ELECTRONIC ADDRESS; COMPUTER SOFTWARE CONSULTATION; COMPUTER SOFTWARE DESIGN FOR OTHERS; COMPUTER SOFTWARE DESIGN, COMPUTER PROGRAMMING, OR MAINTENANCE OF COMPUTER SOFTWARE; COMPUTER SOFTWARE DEVELOPMENT; COMPUTER SYSTEMS ANALYSIS; COMPUTER VIRUS PROTECTION SERVICES; CONSULTATION SERVICES IN THE FIELDS OF SELECTION, IMPLEMENTATION AND USE OF COMPUTER HARDWARE AND SOFTWARE SYSTEMS FOR OTHERS; CONSULTING SERVICES IN THE FIELD OF DESIGN, SELECTION, IMPLEMENTATION AND USE OF COMPUTER HARDWARE AND SOFTWARE SYSTEMS FOR OTHERS; DATABASE DEVELOPMENT

**CLASS 42—(Continued).**

SERVICES; DESIGN AND DEVELOPMENT OF ONLINE COMPUTER SOFTWARE SYSTEMS; DESIGN AND MAINTENANCE OF COMPUTER SITES FOR THIRD PARTIES; DESIGN OF HOME PAGES, COMPUTER SOFTWARE AND WEB SITES; DISPLAYING THE WEB SITES AND IMAGES OF OTHERS ON A COMPUTER SERVER; DOCUMENT DATA TRANSFER AND PHYSICAL CONVERSION SERVICES FROM ONE MEDIA TO ANOTHER; GRAPHIC DESIGN SERVICES; GRAPHIC ILLUSTRATION SERVICES FOR OTHERS; HOSTING THE WEB SITES OF OTHERS ON A COMPUTER SERVER FOR A GLOBAL COMPUTER NETWORK; INSTALLATION OF COMPUTER SOFTWARE; INTEGRATION OF COMPUTER SYSTEMS AND NETWORKS; RECOVERY OF COMPUTER DATA; REGISTRATION OF DOMAIN NAMES FOR IDENTIFICATION OF USERS ON A GLOBAL COMPUTER NETWORK; REPAIR OF COMPUTER SOFTWARE; REPAIR OF DAMAGED COMPUTER PROGRAMS; TECHNICAL SUPPORT SERVICES, NAMELY, TROUBLESHOOTING OF COMPUTER HARDWARE AND SOFTWARE PROBLEMS; UP-DATING OF COMPUTER SOFTWARE; UPDATING OF COMPUTER PROGRAMS FOR THIRD PARTIES; UPDATING OF COMPUTER SOFTWARE FOR OTHERS (U.S. CLS. 100 AND 101).

FIRST USE 7-4-2006; IN COMMERCE 7-4-2006.

3,235,109. RALPH R. BERGGREN, SANTA FE, NM. SN 78-676,993. PUB. 4-18-2006, FILED 7-24-2005.

## Odin Optics

THE MARK CONSISTS OF STANDARD CHARACTERS WITHOUT CLAIM TO ANY PARTICULAR FONT, STYLE, SIZE, OR COLOR.

NO CLAIM IS MADE TO THE EXCLUSIVE RIGHT TO USE "OPTICS", APART FROM THE MARK AS SHOWN.

FOR OPTICAL ENGINEERING SERVICES (U.S. CLS. 100 AND 101).

FIRST USE 8-1-2005; IN COMMERCE 8-1-2005.

3,235,218. ARBOR RESEARCH COLLABORATIVE FOR HEALTH, ANN ARBOR, MI. SN 78-718,242. PUB. 7-4-2006, FILED 9-22-2005.

## ARBOR RESEARCH COLLABORATIVE FOR HEALTH

THE MARK CONSISTS OF STANDARD CHARACTERS WITHOUT CLAIM TO ANY PARTICULAR FONT, STYLE, SIZE, OR COLOR.

NO CLAIM IS MADE TO THE EXCLUSIVE RIGHT TO USE "RESEARCH" AND "COLLABORATIVE FOR HEALTH", APART FROM THE MARK AS SHOWN.

FOR MEDICAL AND SCIENTIFIC RESEARCH SERVICES IN THE FIELD OF CHRONIC DISEASES (U.S. CLS. 100 AND 101).

FIRST USE 6-26-2006; IN COMMERCE 6-26-2006.

**CLASS 42—(Continued).**

3,235,228. MEDICAL EDUCATION RESEARCH INSTITUTE ("MERI"), MEMPHIS, TN. SN 78-722,521. PUB. 6-6-2006, FILED 9-28-2005.



THE APPLICANT CLAIMS COLOR AS A FEATURE OF THE MARK, NAMELY, TAN, WHITE AND TEAL.

THE MARK CONSISTS OF A TAN BOX WITH A WHITE BOW AND RIBBON RUNNING HORIZONTALLY AND PARTLY VERTICAL THROUGH THE BOX. ALL THE LETTERS IN THE WORDS WHICH APPEAR BELOW THE TAN BOX ARE TEAL.

FOR MEDICAL RESEARCH; SCIENTIFIC RESEARCH AND DEVELOPMENT (U.S. CLS. 100 AND 101).

FIRST USE 11-3-2005; IN COMMERCE 11-3-2005.

3,235,263. MATTHIAS SCHOLL, HOUSTON, TX. SN 78-738,686. PUB. 8-22-2006, FILED 10-23-2005.

## YOUR IP IS IN GOOD HANDS

THE MARK CONSISTS OF STANDARD CHARACTERS WITHOUT CLAIM TO ANY PARTICULAR FONT, STYLE, SIZE, OR COLOR.

FOR ATTORNEY SERVICES; LEGAL RESEARCH; LEGAL SERVICES; LICENSING OF INTELLECTUAL PROPERTY (U.S. CLS. 100 AND 101).

FIRST USE 8-5-2004; IN COMMERCE 8-5-2004.

**CLASS 42—(Continued).**

3,235,282. WETPAINT.COM, INC., SEATTLE, WA. SN 78-751,221. PUB. 8-1-2006, FILED 11-10-2005.

# WETPAINT

THE MARK CONSISTS OF STANDARD CHARACTERS WITHOUT CLAIM TO ANY PARTICULAR FONT, STYLE, SIZE, OR COLOR.

FOR CREATING AND MAINTAINING WEBSITES OF OTHERS; HOSTING WEBSITES OF OTHERS ON A COMPUTER SERVER; HOSTING OF DIGITAL CONTENT ON THE INTERNET; PROVIDING TEMPORARY USE OF NON-DOWNLOADABLE COMPUTER SOFTWARE FOR COLLABORATIVE WEBSITE AND WEB PAGE CREATION AND EDITING AND WEBSITE AND WEB PAGE MANAGEMENT; PROVIDING TEMPORARY USE OF NON-DOWNLOADABLE COMPUTER SOFTWARE FOR EDITING TEXT, CODE, HTML TEXT AND CODE, IMAGES, SOUND AND VIDEO; COMPUTER AND DATABASE DEVELOPMENT SERVICES, NAMELY, CREATING SEARCHABLE INDEXES OF INFORMATION, INDEXES OF WEB SITES AND INDEXES OF OTHER INFORMATION SOURCES IN CONNECTION WITH GLOBAL COMPUTER NETWORKS; PROVIDING AN INTERACTIVE WEB SITE FEATURING NON-DOWNLOADABLE SOFTWARE THAT ALLOWS USERS TO CREATE AND DEVELOP CUSTOM WEBSITES AND WEB PAGES FOR COLLABORATIVE EDITING; HOSTING THE WEBSITES OF OTHERS ON A COMPUTER SERVER FOR A GLOBAL COMPUTER NETWORK; ELABORATION AND MAINTENANCE OF WEBSITES AND WEB PAGES FOR THIRD PARTIES; CREATING AND MAINTAINING WEBSITES AND WEB PAGES FOR OTHERS (U.S. CLS. 100 AND 101).  
FIRST USE 6-19-2006; IN COMMERCE 6-19-2006.

3,235,287. ARISAPH PHARMACEUTICALS, INC., BOSTON, MA. SN 78-752,478. PUB. 7-25-2006, FILED 11-11-2005.



CREATING SMART MEDICINES

FOR BIOTECHNOLOGY AND PHARMACEUTICAL RESEARCH AND DEVELOPMENT SERVICES (U.S. CLS. 100 AND 101).  
FIRST USE 11-14-2005; IN COMMERCE 11-14-2005.

**CLASS 42—(Continued).**

3,235,291. SAGE HOME INSPECTIONS, LLC, LIVERMORE, CA. SN 78-755,971. PUB. 8-1-2006, FILED 11-17-2005.



NO CLAIM IS MADE TO THE EXCLUSIVE RIGHT TO USE "HOME INSPECTIONS", APART FROM THE MARK AS SHOWN.

FOR HOME INSPECTIONS (U.S. CLS. 100 AND 101).  
FIRST USE 10-18-2005; IN COMMERCE 1-1-2006.

3,235,321. DARRABY, JESSICA L., SANTA MONICA, CA. SN 78-764,510. PUB. 8-22-2006, FILED 12-1-2005.

## The Art of Counsel--Counsel to the Arts

THE MARK CONSISTS OF STANDARD CHARACTERS WITHOUT CLAIM TO ANY PARTICULAR FONT, STYLE, SIZE, OR COLOR.

NO CLAIM IS MADE TO THE EXCLUSIVE RIGHT TO USE COUNSEL TO THE ARTS, APART FROM THE MARK AS SHOWN.

FOR LEGAL SERVICES (U.S. CLS. 100 AND 101).  
FIRST USE 12-1-2005; IN COMMERCE 12-1-2005.

3,235,335. JELLYFISH, INC., MADISON, WI. SN 78-769,534. PUB. 8-15-2006, FILED 12-8-2005.

# JELLYFISH

THE MARK CONSISTS OF STANDARD CHARACTERS WITHOUT CLAIM TO ANY PARTICULAR FONT, STYLE, SIZE, OR COLOR.

FOR PROVIDING A SEARCH ENGINE ON THE INTERNET FOR OBTAINING INFORMATION ON CONSUMER PRODUCTS AND MERCHANTS, AND PRODUCT AND MERCHANT RATINGS (U.S. CLS. 100 AND 101).

FIRST USE 1-5-2006; IN COMMERCE 6-26-2006.

**CLASS 42—(Continued).**

3,235,375. JOSHUA MICHAEL PEROMSIK, WORCESTER, MA. SN 78-798,255. PUB. 9-12-2006, FILED 1-24-2006.

**CLASS 43—(Continued).**

3,234,021. III DREAM WEAVERS, L.L.C., CORPUS CHRISTI, TX. SN 76-632,089. PUB. 5-2-2006, FILED 2-24-2005.

## Dolce Vittoria

THE MARK CONSISTS OF STANDARD CHARACTERS WITHOUT CLAIM TO ANY PARTICULAR FONT, STYLE, SIZE, OR COLOR.

THE ENGLISH TRANSLATION OF DOLCE VITTORIA IS "SWEET VICTORY".

FOR CHARITABLE SERVICES, NAMELY, PROVIDING WEB SITE DESIGN FOR OTHERS; COMMERCIAL ART DESIGN; COMPUTER AIDED DESIGN FOR OTHERS; COMPUTER SERVICES, NAMELY, DESIGNING AND IMPLEMENTING WEB SITES FOR OTHERS; CONSULTING SERVICES IN THE FIELD OF DESIGN, SELECTION, IMPLEMENTATION AND USE OF COMPUTER HARDWARE AND SOFTWARE SYSTEMS FOR OTHERS; DESIGN AND DEVELOPMENT OF MULTIMEDIA PRODUCTS; DESIGNING WEBSITES FOR ADVERTISING PURPOSES; GRAPHIC ART DESIGN; GRAPHIC DESIGN SERVICES (U.S. CLS. 100 AND 101).  
FIRST USE 12-7-2004; IN COMMERCE 1-1-2006.



NO CLAIM IS MADE TO THE EXCLUSIVE RIGHT TO USE COFFEE TRIPLE SHOT, APART FROM THE MARK AS SHOWN.

FOR RESTAURANT SERVICES, NAMELY RESTAURANT SERVICES FOR SERVING COFFEE AND PASTRIES (U.S. CLS. 100 AND 101).

FIRST USE 5-25-2005; IN COMMERCE 5-25-2005.

**CLASS 43—HOTEL AND RESTAURANT SERVICES**

3,233,859. AUSTIN, JOSEPH H. III, MARRERO, LA. SN 76-538,551. PUB. 9-6-2005, FILED 8-4-2003.

3,234,302. PLAYBOY ENTERPRISES INTERNATIONAL, INC., CHICAGO, IL. SN 78-417,492. PUB. 9-13-2005, FILED 5-12-2004.

## PO-BOY ISLAND

NO CLAIM IS MADE TO THE EXCLUSIVE RIGHT TO USE "PO-BOY", APART FROM THE MARK AS SHOWN.

FOR RESTAURANT SERVICES FEATURING NEW ORLEANS STYLE PO-BOY SANDWICHES (U.S. CLS. 100 AND 101).

FIRST USE 11-29-2006; IN COMMERCE 11-29-2006.

## PLAYBOY

3,233,929. BARNARD PROPERTIES LIMITED, CASTRIES, ST. LUCIA, WEST INDIES, BAHAMAS. SN 76-602,507. PUB. 10-25-2005, FILED 7-16-2004.

RENDEZVOUS - THE ESCAPE FOR ROMANTICS

THE MARK CONSISTS OF STANDARD CHARACTERS WITHOUT CLAIM TO ANY PARTICULAR FONT, STYLE, SIZE, OR COLOR.

FOR HOTEL SERVICES (U.S. CLS. 100 AND 101).  
FIRST USE 4-29-1993; IN COMMERCE 4-29-1993.

THE MARK CONSISTS OF STANDARD CHARACTERS WITHOUT CLAIM TO ANY PARTICULAR FONT, STYLE, SIZE, OR COLOR.

FOR RESORT HOTELS, RESTAURANTS, BARS AND COCKTAIL LOUNGES (U.S. CLS. 100 AND 101).  
FIRST USE 10-6-2006; IN COMMERCE 10-6-2006.



**CLASS 43—(Continued).**

3,234,307. TRAVELLER'S INN HOTEL GROUP LTD., VICTORIA, BRITISH COLUMBIA, CANADA. SN 78-419,148. PUB. 9-13-2005, FILED 5-14-2004.

**CLASS 43—(Continued).**

3,234,514. ALBANESE, GRETCHEN C., PERKASIE, PA. SN 78-517,900. PUB. 10-11-2005, FILED 11-16-2004.



**SECRET CHEF**

NO CLAIM IS MADE TO THE EXCLUSIVE RIGHT TO USE "EXTENDED STAY SUITES", APART FROM THE MARK AS SHOWN.

FOR HOTEL, MOTEL AND TOURIST INN SERVICES; RESTAURANT AND COCKTAIL LOUNGE SERVICES; PROVIDING CONVENTION AND CONFERENCE FACILITIES; HOTEL RESERVATION SERVICES (U.S. CLS. 100 AND 101).

FIRST USE 12-6-2006; IN COMMERCE 12-6-2006.

THE MARK CONSISTS OF STANDARD CHARACTERS WITHOUT CLAIM TO ANY PARTICULAR FONT, STYLE, SIZE, OR COLOR.

FOR TAKE-OUT RESTAURANT SERVICES; CATERING FOR THE PROVISION OF FOOD AND BEVERAGES; PREPARATION OF FOOD AND BEVERAGES FOR OTHERS (U.S. CLS. 100 AND 101).

FIRST USE 1-31-2005; IN COMMERCE 4-23-2005.

3,234,433. HEARTS ON FIRE COMPANY LLC, BOSTON, MA. SN 78-490,842. PUB. 9-6-2005, FILED 9-28-2004.

3,234,672. SAM HOUSTON HOTEL, L.P., HOUSTON, TX. SN 78-574,157. PUB. 3-7-2006, FILED 2-24-2005.

**HEARTS ON FIRE**

**ALDEN HOTELS**

THE MARK CONSISTS OF STANDARD CHARACTERS WITHOUT CLAIM TO ANY PARTICULAR FONT, STYLE, SIZE, OR COLOR.

OWNER OF U.S. REG. NOS. 2,119,886 AND 2,686,511. FOR RESTAURANT CAFE SERVICES (U.S. CLS. 100 AND 101).

FIRST USE 8-31-2004; IN COMMERCE 8-31-2004.

THE MARK CONSISTS OF STANDARD CHARACTERS WITHOUT CLAIM TO ANY PARTICULAR FONT, STYLE, SIZE, OR COLOR.

NO CLAIM IS MADE TO THE EXCLUSIVE RIGHT TO USE "HOTELS", APART FROM THE MARK AS SHOWN. FOR HOTEL SERVICES (U.S. CLS. 100 AND 101).

FIRST USE 9-18-2006; IN COMMERCE 9-18-2006.

**CLASS 43—(Continued).**

3,234,681. METROMEDIA STEAKHOUSES COMPANY, L.P., PLANO, TX. SN 78-578,016. PUB. 6-6-2006, FILED 3-2-2005.

**PONDEROSA EXPRESS**

THE MARK CONSISTS OF STANDARD CHARACTERS WITHOUT CLAIM TO ANY PARTICULAR FONT, STYLE, SIZE, OR COLOR.

OWNER OF U.S. REG. NOS. 903,604, 1,677,995, AND OTHERS.

NO CLAIM IS MADE TO THE EXCLUSIVE RIGHT TO USE "EXPRESS", APART FROM THE MARK AS SHOWN.

FOR RESTAURANT SERVICES (U.S. CLS. 100 AND 101).

FIRST USE 4-30-2002; IN COMMERCE 4-30-2002.

3,234,795. JONCO ENTERPRISES, INC., DBA LIL' OLE CABOOSE, DEERFIELD BEACH, FL. SN 78-620,226. PUB. 1-17-2006, FILED 4-29-2005.

**LIL' OLE CABOOSE**

THE MARK CONSISTS OF STANDARD CHARACTERS WITHOUT CLAIM TO ANY PARTICULAR FONT, STYLE, SIZE, OR COLOR.

FOR FAST-FOOD RESTAURANT AND SNACK BAR, SERVING BURGERS, FRENCH FRIES, ONION RINGS, CHICKEN, FISH, AND HOT DOGS (U.S. CLS. 100 AND 101).

FIRST USE 10-0-2006; IN COMMERCE 10-0-2006.

3,234,815. DANNY & CLYDE'S FOOD STORE INC., GRENA, LA. SN 78-625,436. PUB. 3-21-2006, FILED 5-9-2005.



OWNER OF U.S. REG. NOS. 2,968,806 AND 2,974,684. NO CLAIM IS MADE TO THE EXCLUSIVE RIGHT TO USE "NEW ORLEANS' PO-BOYS", APART FROM THE MARK AS SHOWN.

FOR RESTAURANT AND DELICATESSEN SERVICES (U.S. CLS. 100 AND 101).

FIRST USE 11-1-2006; IN COMMERCE 11-1-2006.

**CLASS 43—(Continued).**

3,235,024. WVR, INC., AUSTIN, TX. SN 78-661,950. PUB. 3-28-2006, FILED 6-30-2005.

**Live the Destination**

THE MARK CONSISTS OF STANDARD CHARACTERS WITHOUT CLAIM TO ANY PARTICULAR FONT, STYLE, SIZE, OR COLOR.

FOR PROVIDING TEMPORARY LODGING INFORMATION VIA THE INTERNET (U.S. CLS. 100 AND 101). FIRST USE 1-31-2006; IN COMMERCE 1-31-2006.

3,235,027. AMF BOWLING WORLDWIDE, INC., MECHANICSVILLE, VA. SN 78-662,377. PUB. 3-21-2006, FILED 7-1-2005.



NO CLAIM IS MADE TO THE EXCLUSIVE RIGHT TO USE "PIZZA", APART FROM THE MARK AS SHOWN.

THE MARK CONSISTS OF THE TERM "GIO'S" WHEREIN THE LETTER "O" IS THE DESIGN OF A PIZZA PIE AND THE APOSTROPHE IS A DESIGN OF A SLICE FROM SUCH PIZZA. THE WORD "PIZZA" APPEARS IN CURSIVE THEREUNDER.

FOR RESTAURANT SERVICES (U.S. CLS. 100 AND 101).

FIRST USE 12-31-2005; IN COMMERCE 12-31-2005.

3,235,048. ABICA COFFEE, LLC, ATLANTA, GA. SN 78-664,201. PUB. 3-21-2006, FILED 7-6-2005.



**CLASS 43—(Continued).**

NO CLAIM IS MADE TO THE EXCLUSIVE RIGHT TO USE "COFFEE", APART FROM THE MARK AS SHOWN.

THE COLOR(S) PLUM, LIME GREEN, AND WHITE IS/ARE CLAIMED AS A FEATURE OF THE MARK.

THE MARK CONSISTS OF A LIME GREEN CIRCLE OUTLINED IN PLUM CONTAINING THE WORDS "ABICA" IN WHITE AND "COFFEE" IN PLUM.

FOR COFFEE SHOP (U.S. CLS. 100 AND 101).  
FIRST USE 11-1-2005; IN COMMERCE 11-1-2005.

---

3,235,049. ABICA COFFEE, LLC, ATLANTA, GA. SN 78-664,202. PUB. 3-21-2006, FILED 7-6-2005.

**ABICA COFFEE**

THE MARK CONSISTS OF STANDARD CHARACTERS WITHOUT CLAIM TO ANY PARTICULAR FONT, STYLE, SIZE, OR COLOR.

NO CLAIM IS MADE TO THE EXCLUSIVE RIGHT TO USE "COFFEE", APART FROM THE MARK AS SHOWN.

FOR COFFEE SHOP (U.S. CLS. 100 AND 101).  
FIRST USE 11-1-2005; IN COMMERCE 11-1-2005.

---

3,235,071. DREAM DINNERS, INC., SNOHOMISH, WA. SN 78-668,498. PUB. 4-4-2006, FILED 7-12-2005.

**LIVE THE DREAM**

THE MARK CONSISTS OF STANDARD CHARACTERS WITHOUT CLAIM TO ANY PARTICULAR FONT, STYLE, SIZE, OR COLOR.

FOR PERSONALIZED MENU AND FOOD PREPARATION AND FOOD CATERING FOR THE GENERAL PUBLIC (U.S. CLS. 100 AND 101).

FIRST USE 7-1-2006; IN COMMERCE 7-1-2006.

**CLASS 43—(Continued).**

3,235,242. D IS FOR DOGGY, INC., NEW YORK, NY. SN 78-728,291. PUB. 6-20-2006, FILED 10-6-2005.



FOR DOG DAYCARE AND BOARDING FOR DOGS (U.S. CLS. 100 AND 101).

FIRST USE 12-20-2006; IN COMMERCE 12-20-2006.

---

3,235,307. SALTWATER WILLY'S GRAPEVINE, L.L.C., FLOWER MOUND, TX. SN 78-759,140. PUB. 7-25-2006, FILED 11-22-2005.

**SALTWATER WILLY'S**

THE MARK CONSISTS OF STANDARD CHARACTERS WITHOUT CLAIM TO ANY PARTICULAR FONT, STYLE, SIZE, OR COLOR.

FOR RESTAURANTS (U.S. CLS. 100 AND 101).  
FIRST USE 11-1-2006; IN COMMERCE 11-1-2006.

---

3,235,311. SALTWATER WILLY'S GRAPEVINE, L.L.C., FLOWER MOUND, TX. SN 78-760,973. PUB. 8-8-2006, FILED 11-25-2005.

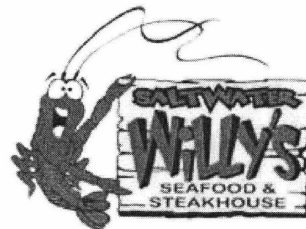

NO CLAIM IS MADE TO THE EXCLUSIVE RIGHT TO USE SEAFOOD & STEAKHOUSE, APART FROM THE MARK AS SHOWN.

FOR RESTAURANTS (U.S. CLS. 100 AND 101).  
FIRST USE 11-1-2006; IN COMMERCE 11-1-2006.

**CLASS 43—(Continued).**

3,235,319. GOLDEN CORRAL CORPORATION, RALEIGH, NC. SN 78-763,706. PUB. 8-1-2006, FILED 11-30-2005.

EVERYONE DESERVES A GOOD  
MEAL, EVERY DAY.

THE MARK CONSISTS OF STANDARD CHARACTERS WITHOUT CLAIM TO ANY PARTICULAR FONT, STYLE, SIZE, OR COLOR.

OWNER OF U.S. REG. NO. 2,900,842.  
FOR RESTAURANT SERVICES (U.S. CLS. 100 AND 101).

FIRST USE 1-2-2006; IN COMMERCE 1-2-2006.

3,235,326. LAVINE, LARRY, DALLAS, TX. SN 78-765,846. PUB. 8-8-2006, FILED 12-2-2005.

**RED'S PATIO GRILL**

THE MARK CONSISTS OF STANDARD CHARACTERS WITHOUT CLAIM TO ANY PARTICULAR FONT, STYLE, SIZE, OR COLOR.

NO CLAIM IS MADE TO THE EXCLUSIVE RIGHT TO USE "PATIO GRILL", APART FROM THE MARK AS SHOWN.

FOR RESTAURANT AND BAR SERVICES; RESTAURANT SERVICES (U.S. CLS. 100 AND 101).

FIRST USE 12-15-2005; IN COMMERCE 12-15-2005.

3,235,340. SIDELINES FRANCHISE GROUP, LLC, MARIETTA, GA. SN 78-770,450. PUB. 9-5-2006, FILED 12-9-2005.

**KAYSONS GRILLE**

THE MARK CONSISTS OF STANDARD CHARACTERS WITHOUT CLAIM TO ANY PARTICULAR FONT, STYLE, SIZE, OR COLOR.

NO CLAIM IS MADE TO THE EXCLUSIVE RIGHT TO USE "GRILLE", APART FROM THE MARK AS SHOWN.

FOR RESTAURANT AND BAR SERVICES (U.S. CLS. 100 AND 101).

FIRST USE 2-0-2006; IN COMMERCE 2-0-2006.

**CLASS 44—MEDICAL, BEAUTY AND AGRICULTURAL SERVICES****CLASS 44—(Continued).**

3,233,797. ST. MARY'S HEALTH CARE SYSTEM, INC., ATHENS, GA. SN 76-410,852. PUB. 9-16-2003, FILED 5-15-2002.



**ST. MARY'S**  
HEALTH CARE SYSTEM

OWNER OF U.S. REG. NOS. 1,880,182, 2,485,445, AND OTHERS.

NO CLAIM IS MADE TO THE EXCLUSIVE RIGHT TO USE "HEALTH CARE SYSTEM", APART FROM THE MARK AS SHOWN.

FOR HEALTH CARE SERVICES, INCLUDING HOSPITAL SERVICES, LONG-TERM CARE FACILITY SERVICES, HOSPICE SERVICES, HOME HEALTH CARE SERVICES, PERSONAL CARE HOMES, AND URGENT CARE CENTERS (U.S. CLS. 100 AND 101).

FIRST USE 5-8-2002; IN COMMERCE 5-8-2002.

3,233,817. LEAKE, H. MILTON, JR., BURBANK, CA. SN 76-476,427. PUB. 8-26-2003, FILED 12-18-2002.

**QUICKEASE**

FOR MASSAGE SERVICES (U.S. CLS. 100 AND 101).  
FIRST USE 5-15-2004; IN COMMERCE 10-19-2005.

3,234,000. MEDICAL SYSTEMS, INCORPORATED, HATTIESBURG, MS. SN 76-626,416. PUB. 11-1-2005, FILED 12-28-2004.

**Camellia**  
HOME HEALTH & HOSPICE

NO CLAIM IS MADE TO THE EXCLUSIVE RIGHT TO USE "HOME HEALTH AND HOSPICE", APART FROM THE MARK AS SHOWN.

THE COLOR(S) GREEN AND RED IS/ARE CLAIMED AS A FEATURE OF THE MARK.

THE MARK CONSISTS OF THE GREEN STYLIZED WORDS CAMELLIA HOME HEALTH & HOSPICE APPEARING WITH A RED FLOWER AT THE TOP RIGHT-HAND CORNER AT THE END OF THE WORD CAMELLIA.

FOR HOME HEALTH CARE AND HOSPICE SERVICES (U.S. CLS. 100 AND 101).

FIRST USE 1-31-2005; IN COMMERCE 1-31-2005.

**CLASS 44—(Continued).**

3,234,060. STEIN, GREG, LOS ANGELES, CA. SN 76-641,562.  
PUB. 3-14-2006, FILED 6-24-2005.

# SPARKY'S

THE MARK CONSISTS OF STANDARD CHARACTERS WITHOUT CLAIM TO ANY PARTICULAR FONT, STYLE, SIZE, OR COLOR.  
FOR PET GROOMING SERVICES (U.S. CLS. 100 AND 101).  
FIRST USE 1-0-2005; IN COMMERCE 1-0-2005.

3,234,067. SONA MEDSPA INTERNATIONAL, INC., FRANKLIN, TN. SN 76-643,396. PUB. 7-25-2006, FILED 7-22-2005.

WHERE MEDICAL TECHNOLOGY MEETS LUXURY SPA

THE MARK CONSISTS OF STANDARD CHARACTERS WITHOUT CLAIM TO ANY PARTICULAR FONT, STYLE, SIZE, OR COLOR.  
FOR MEDICAL SPA SERVICES, NAMELY, LASER HAIR REMOVAL AND OTHER NONINVASIVE COSMETIC PROCEDURES AND TREATMENTS; AESTHETIC AND ANALYSIS SERVICES, NAMELY, LASER- AND LIGHT-BASED TREATMENTS FOR ACNE, ROSACEA, SPIDER VELNS, UNEVEN SKIN TONES, AND REMOVAL OF TATTOOS; HEALTH SPA SERVICES, NAMELY, COSMETIC BODY-CARE SERVICES; AND SKIN REJUVENATION SERVICES, NAMELY, THE INJECTION OF DERMAL FILLERS TO REDUCE THE APPEARANCE OF FACIAL FINE LINES (U.S. CLS. 100 AND 101).  
FIRST USE 11-11-2005; IN COMMERCE 11-11-2005.

3,234,076. LULU & LUIGI, LLC, ST. LOUIS PARK, MN. SN 76-649,171. PUB. 2-14-2006, FILED 10-21-2005.

For Discriminating Pets  
and the People Who Love Them

THE MARK CONSISTS OF STANDARD CHARACTERS WITHOUT CLAIM TO ANY PARTICULAR FONT, STYLE, SIZE, OR COLOR.  
FOR PET GROOMING SERVICES (U.S. CLS. 100 AND 101).  
FIRST USE 11-0-2005; IN COMMERCE 11-0-2005.

3,234,171. CERNER CORPORATION, KANSAS CITY, MO. SN 78-311,127. PUB. 9-7-2004, FILED 10-8-2003.

# HIV INSIGHT

**CLASS 44—(Continued).**

NO CLAIM IS MADE TO THE EXCLUSIVE RIGHT TO USE "HIV", APART FROM THE MARK AS SHOWN.  
FOR PROVIDING MEDICAL INFORMATION IN THE NATURE OF REPORTS WHICH TRACK THE MEDICAL HISTORIES OF PEOPLE WITH ACQUIRED IMMUNIZATION DEFICIENCY SYNDROME, TREATMENTS, AND EFFECTS OF VARIOUS DRUGS UPON THE DISEASE (U.S. CLS. 100 AND 101).  
FIRST USE 11-1-2006; IN COMMERCE 11-1-2006.

3,234,263. BILOW, CATHY, ROANOKE, IL. SN 78-392,345.  
PUB. 8-30-2005, FILED 3-29-2004.



NO CLAIM IS MADE TO THE EXCLUSIVE RIGHT TO USE "KID CONSCIOUS LAWN CARE", APART FROM THE MARK AS SHOWN.  
FOR LAWN CARE (U.S. CLS. 100 AND 101).  
FIRST USE 9-0-2004; IN COMMERCE 9-0-2004.

3,234,586. MAHESH M PATEL MD INC., BEVERLY, MA. SN 78-534,971. PUB. 10-11-2005, FILED 12-17-2004.

# KAYAKALP AESTHETICS

THE MARK CONSISTS OF STANDARD CHARACTERS WITHOUT CLAIM TO ANY PARTICULAR FONT, STYLE, SIZE, OR COLOR.  
NO CLAIM IS MADE TO THE EXCLUSIVE RIGHT TO USE AESTHETICS, APART FROM THE MARK AS SHOWN.  
THE ENGLISH TRANSLATION OF THE SANSKRIT WORD KAYAKALP IN THE MARK IS "BODY REJUVENATION".  
FOR COMPREHENSIVE PLASTIC SURGERY AND MEDICAL SERVICES RELATED TO CARE OF THE SKIN (U.S. CLS. 100 AND 101).  
FIRST USE 1-1-2004; IN COMMERCE 4-15-2004.

3,234,599. JOHN GRAY PUBLICATIONS, INC., MILL VALLEY, CA. SN 78-541,083. PUB. 1-10-2006, FILED 1-3-2005.

# O Spa

**CLASS 44—(Continued).**

THE MARK CONSISTS OF STANDARD CHARACTERS WITHOUT CLAIM TO ANY PARTICULAR FONT, STYLE, SIZE, OR COLOR.

NO CLAIM IS MADE TO THE EXCLUSIVE RIGHT TO USE "SPA", APART FROM THE MARK AS SHOWN.

FOR HEALTH SPA SERVICES, NAMELY, COSMETIC BODY CARE SERVICES (U.S. CLS. 100 AND 101).  
FIRST USE 1-15-2005; IN COMMERCE 1-15-2005.

---

3,234,650. REGIS INTERNATIONAL FRANCHISING S.A.R.L., LUXEMBOURG, LUXEMBOURG. SN 78-564,099. PUB. 5-9-2006, FILED 2-9-2005.



OWNER OF U.S. REG. NOS. 1,823,821, 2,653,360, AND OTHERS.

THE MARK CONSISTS OF A STYLIZED SILHOUETTE OF A WOMAN'S HEAD FEATURING LIPS AND HAIR.

FOR HAIRDRESSING SALON SERVICES (U.S. CLS. 100 AND 101).

FIRST USE 10-7-1992; IN COMMERCE 10-7-1992.

---

3,234,757. DOGCENTRIC, INC., ROCKVILLE, MD. SN 78-603,653. PUB. 5-16-2006, FILED 4-7-2005.

**Our world revolves  
around your pets**

THE MARK CONSISTS OF STANDARD CHARACTERS WITHOUT CLAIM TO ANY PARTICULAR FONT, STYLE, SIZE, OR COLOR.

FOR PET CARE SERVICES NAMELY WALKING, FEEDING AND PLAYING WITH PETS (U.S. CLS. 100 AND 101).

FIRST USE 4-26-2005; IN COMMERCE 4-26-2006.

**CLASS 44—(Continued).**

3,234,766. ROCHE THERAPEUTICS INC., NUTLEY, NJ. SN 78-607,956. PUB. 1-10-2006, FILED 4-13-2005.

**MYBONIVA**

THE MARK CONSISTS OF STANDARD CHARACTERS WITHOUT CLAIM TO ANY PARTICULAR FONT, STYLE, SIZE, OR COLOR.

OWNER OF U.S. REG. NO. 2,931,724.

FOR PATIENT SUPPORT SERVICES, NAMELY, PROVIDING EDUCATIONAL INFORMATION REGARDING A PHARMACEUTICAL PREPARATION FOR THE PREVENTION AND TREATMENT OF BONE DISEASES; PATIENT SUPPORT SERVICES VIA THE INTERNET, NAMELY, PROVIDING EDUCATIONAL INFORMATION REGARDING A PHARMACEUTICAL PREPARATION FOR THE PREVENTION AND TREATMENT OF BONE DISEASES (U.S. CLS. 100 AND 101).

FIRST USE 5-9-2005; IN COMMERCE 5-9-2005.

---

3,234,834. EVA SCRIVO SALON INC., NEW YORK, NY. SN 78-630,679. PUB. 2-14-2006, FILED 5-16-2005.

**THE UNCUT**

THE MARK CONSISTS OF STANDARD CHARACTERS WITHOUT CLAIM TO ANY PARTICULAR FONT, STYLE, SIZE, OR COLOR.

FOR HAIR STYLING SERVICES (U.S. CLS. 100 AND 101).

FIRST USE 8-1-2005; IN COMMERCE 8-1-2005.

---

3,234,852. HAYES, KAREN, HAYDEN LAKE, ID. SN 78-634,444. PUB. 3-21-2006, FILED 5-22-2005.

**The Integral Horse**

THE MARK CONSISTS OF STANDARD CHARACTERS WITHOUT CLAIM TO ANY PARTICULAR FONT, STYLE, SIZE, OR COLOR.

NO CLAIM IS MADE TO THE EXCLUSIVE RIGHT TO USE "HORSE", APART FROM THE MARK AS SHOWN.

FOR PROVIDING INFORMATION VIA A GLOBAL COMPUTER NETWORK IN THE FIELD OF HORSE CARE IN THE FORM OF TEXT, IMAGES, PRERECORDED VIDEO AND/OR AUDIO (U.S. CLS. 100 AND 101).

FIRST USE 4-1-2006; IN COMMERCE 4-1-2006.

**CLASS 44—(Continued).**

3,234,948. CHILDREN'S PSYCHIATRIC HOSPITAL LLC, FARGO, ND. SN 78-652,814. PUB. 3-7-2006, FILED 6-17-2005.

**CLASS 44—(Continued).**

3,235,139. DERMALOUNGE INC., SAN FRANCISCO, CA. SN 78-687,066. PUB. 4-18-2006, FILED 8-5-2005.

**PRAIRIE ST. JOHN'S**

**DERMALOUNGE**

THE MARK CONSISTS OF STANDARD CHARACTERS WITHOUT CLAIM TO ANY PARTICULAR FONT, STYLE, SIZE, OR COLOR.

OWNER OF U.S. REG. NO. 2,754,021.  
FOR HEALTH CARE SERVICES AND HOSPITAL SERVICES, NAMELY, INPATIENT AND OUTPATIENT PSYCHIATRIC CARE (U.S. CLS. 100 AND 101).  
FIRST USE 6-14-2005; IN COMMERCE 6-14-2005.

THE MARK CONSISTS OF STANDARD CHARACTERS WITHOUT CLAIM TO ANY PARTICULAR FONT, STYLE, SIZE, OR COLOR.

FOR HEALTH SPA SERVICES, NAMELY, COSMETIC BODY CARE SERVICES (U.S. CLS. 100 AND 101).  
FIRST USE 12-1-2005; IN COMMERCE 12-1-2005.

3,235,199. SURE THING STABLES, LLC, VERNON HILLS, IL. SN 78-709,674. PUB. 6-6-2006, FILED 9-9-2005.

3,235,074. CHILDREN'S PSYCHIATRIC HOSPITAL, LLC, FARGO, ND. SN 78-668,715. PUB. 3-7-2006, FILED 7-12-2005.

**BRED TO BE A 'SURE THING,'  
RACING TO PROVE IT!**

THE MARK CONSISTS OF STANDARD CHARACTERS WITHOUT CLAIM TO ANY PARTICULAR FONT, STYLE, SIZE, OR COLOR.

FOR HORSE FARMS; HORSE BREEDING AND STUD SERVICES (U.S. CLS. 100 AND 101).  
FIRST USE 12-18-2003; IN COMMERCE 6-23-2005.



**PRAIRIE ST. JOHN'S**

3,235,200. COAST PLAZA DOCTORS HOSPITAL, NORWALK, CA. SN 78-709,765. PUB. 6-13-2006, FILED 9-9-2005.

**COAST PLAZA COSMETIC AND  
RECONSTRUCTIVE SURGERY  
CENTER**

OWNER OF U.S. REG. NO. 2,754,021.  
THE COLOR(S) BLACK, WHITE, DARK BLUE, DARK GRAY, LIGHT GRAY, LIGHT GREEN AND TAN IS/ARE CLAIMED AS A FEATURE OF THE MARK.

THE COLORS BLACK, DARK GRAY, LIGHT GRAY AND TAN APPEAR IN THE RESPECTIVE TRIANGLES OF THE DESIGN ELEMENT. THE COLOR WHITE APPEARS AS THE BACKGROUND FOR THE ABOVE-MENTIONED TRIANGLES. THE COLOR LIGHT GREEN APPEARS IN THE BORDER OF THE CIRCLE THAT CONTAINS THE ABOVE-MENTIONED TRIANGLES AND BACKGROUND. THE COLOR DARK BLUE APPEARS IN THE LITERAL PORTION PRAIRIE ST. JOHN'S, WHICH IS SITUATED TO THE RIGHT OF THE DESIGN ELEMENT.

FOR HEALTH CARE SERVICES AND HOSPITAL SERVICES, NAMELY, INPATIENT AND OUTPATIENT PSYCHIATRIC CARE (U.S. CLS. 100 AND 101).  
FIRST USE 6-14-2005; IN COMMERCE 6-14-2005.

THE MARK CONSISTS OF STANDARD CHARACTERS WITHOUT CLAIM TO ANY PARTICULAR FONT, STYLE, SIZE, OR COLOR.

OWNER OF U.S. REG. NO. 3,074,745.  
NO CLAIM IS MADE TO THE EXCLUSIVE RIGHT TO USE "COSMETIC AND RECONSTRUCTIVE SURGERY CENTER", APART FROM THE MARK AS SHOWN.  
FOR HOSPITAL AND MEDICAL SERVICES (U.S. CLS. 100 AND 101).  
FIRST USE 2-0-2006; IN COMMERCE 2-0-2006.

**CLASS 44—(Continued).**

3,235,259. SCHWARTZ, LISA M., LOS ANGELES, CA. SN 78-736,595. PUB. 8-15-2006, FILED 10-19-2005.

**ETHOS MD**

THE MARK CONSISTS OF STANDARD CHARACTERS WITHOUT CLAIM TO ANY PARTICULAR FONT, STYLE, SIZE, OR COLOR.

NO CLAIM IS MADE TO THE EXCLUSIVE RIGHT TO USE MD, APART FROM THE MARK AS SHOWN.

FOR MEDICAL SERVICES (U.S. CLS. 100 AND 101).  
FIRST USE 10-12-2006; IN COMMERCE 10-12-2006.

---

3,235,309. AFFORDABLE MEDICAL CARE, L.L.C., SAR-GEANT BLUFF, IA. SN 78-760,472. PUB. 8-8-2006, FILED 11-23-2005.

**CURAQUICK CLINIC**

THE MARK CONSISTS OF STANDARD CHARACTERS WITHOUT CLAIM TO ANY PARTICULAR FONT, STYLE, SIZE, OR COLOR.

NO CLAIM IS MADE TO THE EXCLUSIVE RIGHT TO USE "CLINIC", APART FROM THE MARK AS SHOWN.

FOR MEDICAL SERVICES (U.S. CLS. 100 AND 101).  
FIRST USE 3-27-2006; IN COMMERCE 3-27-2006.

---

3,235,357. AFFORDABLE MEDICAL CARE, L.L.C., SAR-GEANT BLUFF, IA. SN 78-780,449. PUB. 8-8-2006, FILED 12-23-2005.



THE MARK CONSISTS OF CURA THAT HAS A CROSS CUTOUT IN THE "R" AND QUICK.

FOR MEDICAL SERVICES (U.S. CLS. 100 AND 101).  
FIRST USE 3-27-2006; IN COMMERCE 3-27-2006.

**CLASS 44—(Continued).**

3,235,361. COMFORCARE HEALTH CARE HOLDINGS, INC., BLOOMFIELD HILLS, MI. SN 78-781,504. PUB. 9-5-2006, FILED 12-28-2005.



NO CLAIM IS MADE TO THE EXCLUSIVE RIGHT TO USE HOME CARE, APART FROM THE MARK AS SHOWN.

THE APPLICANT CLAIMS COLOR AS A FEATURE OF THE MARK, NAMELY, RED AND BLACK.

THE MARK CONSISTS OF A STYLIZED FIGURE OF A PERSON WITH ITS ARMS ENCIRCLING A RED HEART AND THE WORDS AT YOUR SIDE IN RED AND THE WORDS HOME CARE IN BLACK.

FOR HOME HEALTH CARE SERVICES; HOME NURSING AID SERVICES (U.S. CLS. 100 AND 101).  
FIRST USE 2-1-2006; IN COMMERCE 2-1-2006.

---

3,235,388. SATELLITE M.D., L.L.C., ALLONS, TN. SN 78-977,294. PUB. 11-29-2005, FILED 3-2-2005.

**SATELLITE MED**

THE MARK CONSISTS OF STANDARD CHARACTERS WITHOUT CLAIM TO ANY PARTICULAR FONT, STYLE, SIZE, OR COLOR.

NO CLAIM IS MADE TO THE EXCLUSIVE RIGHT TO USE "MED", APART FROM THE MARK AS SHOWN.

FOR MEDICAL SERVICES, NAMELY, PROVIDING NON-URGENT AND SEMI-URGENT MEDICAL CARE TO THE GENERAL PUBLIC (U.S. CLS. 100 AND 101).

FIRST USE 3-1-2006; IN COMMERCE 4-1-2006.

---

**CLASS 45—PERSONAL SERVICES**



**CLASS 45—(Continued).**

3,234,420. WIRELESS EYE, INC., VISALIA, CA. SN 78-485,735.  
PUB. 9-27-2005, FILED 9-17-2004.

**CLASS 45—(Continued).**

3,234,478. MICHAEL, AMERICA S., WOODSIDE, CA. SN 78-506,672. PUB. 2-14-2006, FILED 10-27-2004.

# WIRELESS EYE

# Organizing America One Drawer At A Time!

THE MARK CONSISTS OF STANDARD CHARACTERS WITHOUT CLAIM TO ANY PARTICULAR FONT, STYLE, SIZE, OR COLOR.

NO CLAIM IS MADE TO THE EXCLUSIVE RIGHT TO USE "WIRELESS", APART FROM THE MARK AS SHOWN.

FOR PROVIDING REMOTE SURVEILLANCE MONITORING VIA WIRELESS AND ON-LINE TELECOMMUNICATIONS LINKS FOR PROTECTION AND SAFETY OF PROPERTY (U.S. CLS. 100 AND 101).

FIRST USE 12-31-2004; IN COMMERCE 12-31-2004.

THE MARK CONSISTS OF STANDARD CHARACTERS WITHOUT CLAIM TO ANY PARTICULAR FONT, STYLE, SIZE, OR COLOR.

FOR ORGANIZATIONAL CONSULTING FOR HOMES (U.S. CLS. 100 AND 101).

FIRST USE 2-13-2003; IN COMMERCE 11-4-2006.

3,234,421. WIRELESS EYE, INC., VISALIA, CA. SN 78-485,738.  
PUB. 9-27-2005, FILED 9-17-2004.

3,234,523. SCI MANAGEMENT L.P., HOUSTON, TX. SN 78-520,224. PUB. 10-18-2005, FILED 11-19-2004.

# WSOIP

# "IT'S LIFE! YOU LIVE IT, WE CELEBRATE IT!"

THE MARK CONSISTS OF STANDARD CHARACTERS WITHOUT CLAIM TO ANY PARTICULAR FONT, STYLE, SIZE, OR COLOR.

FOR PROVIDING REMOTE SURVEILLANCE MONITORING VIA WIRELESS AND ON-LINE TELECOMMUNICATIONS LINKS FOR PROTECTION AND SAFETY OF PROPERTY (U.S. CLS. 100 AND 101).

FIRST USE 12-31-2004; IN COMMERCE 12-31-2004.

THE MARK CONSISTS OF STANDARD CHARACTERS WITHOUT CLAIM TO ANY PARTICULAR FONT, STYLE, SIZE, OR COLOR.

FOR CREMATION, FUNERAL HOME, AND CEMETERY SERVICES, NAMELY CONDUCTING AND PROVIDING CREMATION, FUNERAL, AND BURIAL SERVICES; FUNERAL CONCIERGE SERVICES (U.S. CLS. 100 AND 101).

FIRST USE 3-31-2005; IN COMMERCE 3-31-2005.

**CLASS 45—(Continued).**

3,234,813. MATCH PURSUITS LLC, FAIRFAX, VA. SN 78-624,674. PUB. 1-24-2006, FILED 5-6-2005.



FOR ONLINE DATING SERVICE FOR LAWYERS, LAW STUDENTS, AND LEGAL PROFESSIONALS (U.S. CLS. 100 AND 101).  
FIRST USE 2-14-2005; IN COMMERCE 2-14-2005.

3,234,936. WHITE, VICTORIA F., IRVINGTON, NY. SN 78-651,397. PUB. 3-7-2006, FILED 6-15-2005.

The Letter of Your Life

THE MARK CONSISTS OF STANDARD CHARACTERS WITHOUT CLAIM TO ANY PARTICULAR FONT, STYLE, SIZE, OR COLOR.  
FOR PERSONAL LETTER WRITING FOR OTHERS (U.S. CLS. 100 AND 101).  
FIRST USE 6-1-2005; IN COMMERCE 6-1-2005.

3,235,184. KARANICK, PAUL N, SANTA ANA, CA. SN 78-702,991. PUB. 5-23-2006, FILED 8-30-2005.



**CLASS 45—(Continued).**

THE MARK CONSISTS OF STANDARD CHARACTERS WITHOUT CLAIM TO ANY PARTICULAR FONT, STYLE, SIZE, OR COLOR.

FOR MINISTERIAL SERVICES, NAMELY HOLDING SPIRITUAL RETREATS TO ASSIST RELIGIOUS LEADERS, BOTH CLERGY AND LAY, TO DEVELOP AND ENHANCE THEIR SPIRITUAL LIVES (U.S. CLS. 100 AND 101).

FIRST USE 9-22-2006; IN COMMERCE 9-22-2006.

3,235,253. PEACOCK FOUNDATION, THE, NORTH HOLLYWOOD, CA. SN 78-732,614. PUB. 8-15-2006, FILED 10-13-2005.



NO CLAIM IS MADE TO THE EXCLUSIVE RIGHT TO USE "FOUNDATION", APART FROM THE MARK AS SHOWN.

THE COLOR(S) PURPLE, NAVY BLUE, BLUE, YELLOW, GRAY, BLACK, AND WHITE. IS/ARE CLAIMED AS A FEATURE OF THE MARK.

THE MARK CONSISTS OF TWO PEACOCKS, IN PURPLE, BLUE, GRAY, WHITE AND YELLOW, IN THE SHAPE OF A HEART WITH A TEAR DESCENDING FROM THE EYE. IN THE CENTER OF THE MARK ARE THE WORDS "THE PEACOCK FOUNDATION" IN BLACK, WHITE AND GRAY. YELLOW IS USED FOR THE BEAK, NAVY BLUE IS USED FOR THE NECK AND PART OF THE EYE OF THE FEATHERS. GRAY IS USED FOR THE WINGS. BLUE IS USED AS THE OTHER COLOR IN THE EYES OF THE FEATHERS, AND THE TEAR. PURPLE IS USED AS THE PRIMARY COLOR OF THE TAIL FEATHERS.

FOR ORGANIZING AND CONDUCTING SUPPORT GROUPS IN THE FIELD OF GRIEF, LOSS, AND TRAUMA (U.S. CLS. 100 AND 101).

FIRST USE 6-1-2003; IN COMMERCE 6-1-2003.

PRIOR UNITED STATES CLASSIFICATION

APPLICATION IN ONE CLASS

COLLECTIVE MEMBERSHIP MARKS

CLASS 200—COLLECTIVE MEMBERSHIP

3,234,270. NATIONAL ASSOCIATION OF LEGAL SEARCH CONSULTANTS, ATLANTA, GA. SN 78-399,330. PUB. 8-23-2005, FILED 4-9-2004.

**NALSC**

THE CERTIFICATION MARK IS INTENDED TO CERTIFY COMPLIANCE WITH STANDARDS AND SPECIFICATIONS DEVELOPED BY THE CERTIFIER THAT DEFINE REQUIREMENTS TO ENSURE INTEROPERABILITY BETWEEN SMART CARDS AND TERMINALS ON A GLOBAL BASIS.

FOR MAGNETICALLY ENCODED SMART CARDS CONTAINING AN INTEGRATED CIRCUIT CHIP FOR ELECTRONIC CONSUMER AND BUSINESS PAYMENT TRANSACTIONS; MAGNETICALLY ENCODED CHARGE CARDS, BANK CARDS, CREDIT CARDS, DEBIT CARDS AND PAYMENT CARDS, ALL CONTAINING AN INTEGRATED CIRCUIT CHIP FOR CONSUMER AND BUSINESS PAYMENT TRANSACTIONS; MAGNETIC CODED CARD READERS; POINT OF SALE TRANSACTION TERMINALS; ENCRYPTION KEYS AND DIGITAL CERTIFICATES FOR SECURING ELECTRONIC DATA TRANSMISSIONS; COMPUTER HARDWARE AND COMPUTER SECURITY SOFTWARE, NAMELY, ENCRYPTION SOFTWARE; COMPUTER SOFTWARE FOR AUTHENTICATION, ENCRYPTION AND IDENTIFICATION IN FINANCIAL AND SALES TRANSACTIONS; COMPUTER OPERATING SYSTEMS TO INSURE THE SECURITY OF BUSINESSES AND COMPUTER NETWORKS, AND TO PROVIDE SECURITY AND ACCESS CONTROL; COMPUTER OPERATING SYSTEMS FOR FINANCIAL TRANSACTIONS ON COMPUTER NETWORKS (U.S. CL. A).

FIRST USE 3-0-1999; IN COMMERCE 3-0-1999.

---

3,234,197. INTERNATIONAL ASSOCIATION OF PLUMBING AND MECHANICAL OFFICIALS, ONTARIO, CA. SN 78-340,377. PUB. 9-28-2004, FILED 12-12-2003.

NO CLAIM IS MADE TO THE EXCLUSIVE RIGHT TO USE MEMBER, APART FROM THE MARK AS SHOWN, FOR INDICATING MEMBERSHIP OF A(N) LEGAL RECRUITER'S ASSOCIATION (U.S. CL. 200).  
FIRST USE 5-15-2006; IN COMMERCE 5-15-2006.

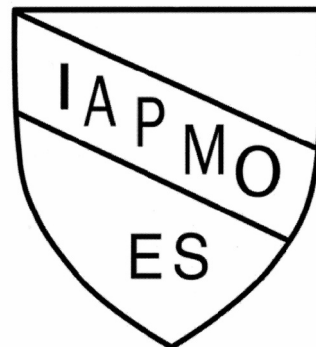

---

CERTIFICATION MARKS

CLASS A—GOODS

3,233,769. EMVCO, LLC, FOSTER CITY, CA. SN 75-746,956. PUB. 9-17-2002, FILED 7-9-1999.

**EMV**

THE CERTIFICATION MARK, AS INTENDED TO BE USED BY AUTHORIZED USERS, IS INTENDED TO CERTIFY THAT MANUFACTURERS AUTHORIZED BY THE CERTIFIER WILL MANUFACTURE THE GOODS IN CONFORMITY WITH THE STANDARDS SET FORTH IN NFPA-5000.

FOR BUILDING, CONSTRUCTION, AND SAFETY MATERIALS AND PRODUCTS (U.S. CL. A).  
FIRST USE 8-0-2005; IN COMMERCE 8-0-2005.

CERTIFICATION MARKS

3,233,993. **COMMISSA, LLC, WOODBRIDGE, CT. SN 76-623,840. PUB. 9-6-2005, FILED 12-9-2004.**

# RCCA

**CLASS B—SERVICES**

THE CERTIFICATION MARK, AS INTENDED TO BE USED BY AUTHORIZED PERSONS, IS INTENDED TO CERTIFY THAT SUCH PERSONS ARE PROFICIENT TO ENGAGE IN THE INSPECTION AND VERIFICATION THAT INFORMATION TECHNOLOGY AND SYSTEMS AND INFRASTRUCTURE ARE DESIGNED, INSTALLED, FUNCTIONALLY TESTED AND CAPABLE OF BEING OPERATED AND MAINTAINED TO PERFORM IN CONFORMITY WITH THE DESIGN INTENT AND INDUSTRY-ACCEPTED STANDARDS.

FOR INSPECTION AND VERIFICATION THAT INFORMATION TECHNOLOGY AND SYSTEMS AND INFRASTRUCTURE ARE DESIGNED, INSTALLED, FUNCTIONALLY TESTED AND CAPABLE OF BEING OPERATED AND MAINTAINED TO PERFORM IN CONFORMITY WITH THE DESIGN INTENT AND INDUSTRY-ACCEPTED STANDARDS (U.S. CL. B).  
FIRST USE 10-1-2006; IN COMMERCE 10-1-2006.

\* \* \* \* \*

# SUPPLEMENTAL REGISTER

These registrations are not subject to opposition.

## SECTION 1.— INTERNATIONAL CLASSIFICATION

The short titles associated below with the international class numbers are terms designed merely for quick identification and are not an official part of the international classification. The full names of international classes are given in section 6.1 of the trademark rules of practice.

The designation "U.S. Cl." appearing in this section refers to the U.S. class in effect prior to Sep. 1, 1973 rather than the international class which applies to applications filed on or after that date. For adoption of international classification see notice in the OFFICIAL GAZETTE of Jun. 26, 1973 (911 O.G. TM 210).

### Application in more than one class

3,235,423. MAVERICK SOUTHERN KITCHENS, INC.,  
CHARLESTON, SC. SN 76-610,493. FILED P.R. 9-8-2004;  
AM. S.R. 2-22-2007.

**CHARLESTON COOKS**

#### CLASS 35—ADVERTISING AND BUSINESS

FOR RETAIL STORE SERVICES IN THE FIELD OF FOOD PREPARATION, FEATURING FOOD PREPARATION RELATED GOODS, NAMELY, PRINTED TEACHING MATERIALS ON COOKING TECHNIQUES, DEMONSTRATIONS, RECIPES, MENU SUGGESTIONS; COOKBOOKS, POSTERS, CALENDARS AND POSTCARDS, SOFTWARE IN THE FIELD OF FOOD PREPARATION, CHEFS HATS, APRONS, BAKEWARE, COOKWARE, DINNERWARE, GLASSWARE, DRINKWARE, STEMWARE, POTS AND PANS; CUTLERY, NAMELY FORKS, SPOONS AND KNIVES; BAKING AND PASTRY TOOLS, MEASURING TOOLS, SERVING UTENSILS, ELECTRIC KITCHEN AND HOUSEHOLD APPLIANCES, COOKING THERMOMETERS, TIMERS, CONTAINERS FOR STORAGE AND SERVING OF FOOD, LINENS, BARBECUE AND GRILLING TOOLS, DECORATIONS AND TOOLS FOR DECORATING FOOD, CONDIMENTS, SPICES, STAPLE FOODS, BEVERAGES, SAUCES, BAKING MIXES, AND DRESSINGS (U.S. CLS. 100, 101 AND 102).

FIRST USE 12-0-2004; IN COMMERCE 12-0-2004.

THE MARK CONSISTS OF STANDARD CHARACTERS WITHOUT CLAIM TO ANY PARTICULAR FONT, STYLE, SIZE, OR COLOR.

#### CLASS 9—ELECTRICAL AND SCIENTIFIC APPARATUS

FOR SOFTWARE IN THE FIELD OF FOOD PREPARATION (U.S. CLS. 21, 23, 26, 36 AND 38).  
FIRST USE 3-0-2006; IN COMMERCE 3-0-2006.

#### CLASS 16—PAPER GOODS AND PRINTED MATTER

FOR PRINTED MATERIALS, NAMELY PRINTED TEACHING MATERIALS ON COOKING TECHNIQUES, DEMONSTRATIONS, RECIPES, MENU SUGGESTIONS; COOKBOOKS, POSTERS, CALENDARS AND POSTCARDS (U.S. CLS. 2, 5, 22, 23, 29, 37, 38 AND 50).  
FIRST USE 2-0-2005; IN COMMERCE 2-0-2005.

#### CLASS 25—CLOTHING

FOR CLOTHING, NAMELY T-SHIRTS, CAPS AND JACKETS, SWEATSHIRTS, AND POLO SHIRTS (U.S. CLS. 22 AND 39).  
FIRST USE 12-0-2004; IN COMMERCE 12-0-2004.

#### CLASS 41—EDUCATION AND ENTERTAINMENT

FOR ENTERTAINMENT AND EDUCATIONAL SERVICES IN THE FIELD OF FOOD PREPARATION, NAMELY, CONDUCTING EXHIBITIONS FEATURING COOKING DEMONSTRATIONS, CLASSES, SEMINARS, WORKSHOPS AND INSTRUCTION OF COOKING TECHNIQUES, RECIPES, AND MENU SUGGESTIONS; AND ORGANIZING, ARRANGING AND CONDUCTING COOKING COMPETITIONS (U.S. CLS. 100, 101 AND 107).

FIRST USE 2-0-2005; IN COMMERCE 2-0-2005.

#### CLASS 43—HOTEL AND RESTAURANT SERVICES

FOR CONSULTATIONS IN THE FIELD OF FOOD PREPARATION, NAMELY, FOOD AND BEVERAGE PREPARATION AND PRESENTATION, AND SERVING, RECIPES AND PREPARATION DEMONSTRATIONS (U.S. CLS. 100 AND 101).

FIRST USE 2-0-2005; IN COMMERCE 2-0-2005.

3,235,424. KUBICKI SOFTWARE, LLC, LINDENHURST, IL. SN 76-624,986. FILED P.R. 12-20-2004; AM. S.R. 12-13-2005.

## KUBICKI SOFTWARE

THE MARK CONSISTS OF STANDARD CHARACTERS WITHOUT CLAIM TO ANY PARTICULAR FONT, STYLE, SIZE, OR COLOR.

NO CLAIM IS MADE TO THE EXCLUSIVE RIGHT TO USE "SOFTWARE", APART FROM THE MARK AS SHOWN.

### CLASS 9—ELECTRICAL AND SCIENTIFIC APPARATUS

FOR COMPUTER AND SYSTEMS SOFTWARE AND FIRMWARE, NAMELY, SOFTWARE APPLICATIONS FOR BUSINESS, PERSONAL, AND TECHNICAL PRODUCTIVITY AND ENTERTAINMENT PURPOSES, NAMELY, APPLICATIONS FOR PRODUCING AND/OR MANIPULATING TEXT DOCUMENTS, BINARY DATA DOCUMENTS, BRIEFING SLIDES, GRAPHICS, PHOTOGRAPHS, AND AUDIOVISUAL MATERIALS IN SOFT-COPY AND HARDCOPY FORM FOR USE AT THE OFFICE, IN INDUSTRY, AT HOME, AND WHILE TRAVELING, APPLICATIONS FOR PLAYING AUDIOVISUAL GAMES AT HOME AND WHILE TRAVELING, DATA AND SYSTEM SECURITY SOFTWARE, DIGITAL RIGHTS MANAGEMENT SOFTWARE, APPLICATIONS AND UTILITIES FOR COMMUNICATING OVER WIDE-AREA NETWORKS, LOCAL-AREA NETWORKS, STRUCTURED WIRELESS NETWORKS, AND DEVICE-TO-DEVICE WIRELESS NETWORKS; SOFTWARE DEVELOPMENT TOOLS AND COMPUTER UTILITY PROGRAMS; COMPUTER OPERATING SYSTEMS; COMPUTER DEVICE DRIVER SOFTWARE; OPERATING SYSTEM CONTROL SOFTWARE AND FIRMWARE; REAL-TIME SOFTWARE FOR THE CONTROL OF SYSTEMS, ELECTRONIC DEVICES, AND EMBEDDED SYSTEMS, NAMELY, WIDE-AREA COMPUTER NETWORKS, LOCAL-AREA COMPUTER NETWORKS, NETWORK STORAGE DEVICES, NETWORK ROUTING AND SWITCHING DEVICES, DESKTOP COMPUTERS, NOTEBOOK COMPUTERS, PORTABLE MINI COMPUTERS, PERSONAL DIGITAL ASSISTANTS, DIGITAL CAMERAS, DIGITAL VIDEO CAMERAS, DEVICES FOR PLAYING CD-ROMS AND DVDS, DEVICES FOR PLAYING AUDIOVISUAL GAMES, DEVICES USED IN COMPUTER-AIDED DESIGN, COMPUTER-AIDED MANUFACTURING, AUTOMOTIVE CONTROL SYSTEMS, AEROSPACE CONTROL SYSTEMS, ELECTROMECHANICAL CONTROL SYSTEMS, POWER GENERATION AND MANAGEMENT CONTROL SYSTEMS, INDUSTRIAL AUTOMATION CONTROL SYSTEMS; EMBEDDED SOFTWARE FOR THE CONTROL OF ELECTRONIC DEVICES, NAMELY, NETWORK STORAGE DEVICES, NETWORK ROUTING AND SWITCHING DEVICES, DESKTOP COMPUTERS, NOTEBOOK COMPUTERS, PORTABLE MINI COMPUTERS, PERSONAL DIGITAL ASSISTANTS, DIGITAL CAMERAS, DIGITAL VIDEO CAMERAS, DEVICES FOR PLAYING CD-ROMS AND DVDS, DEVICES FOR PLAYING AUDIOVISUAL GAMES, DEVICES USED IN COMPUTER-AIDED DESIGN, COMPUTER-AIDED MANUFACTURING, AUTOMOTIVE CONTROL SYSTEMS, AEROSPACE CONTROL SYSTEMS, ELECTROMECHANICAL CONTROL SYSTEMS, POWER GENERATION AND MANAGEMENT CONTROL SYSTEMS, INDUSTRIAL AUTOMATION CONTROL SYSTEMS; ELECTROMECHANICAL MACHINERY, HARDWARE CONTROLLED BY MICROPROCESSORS, HARDWARE CONTROLLED BY MICROCONTROLLERS, HARDWARE CONTROLLED BY FIELD-PROGRAMMABLE GATE ARRAYS, AND HARDWARE CONTROLLED BY DIGITAL SIGNAL PROCESSORS; DATA AND INFORMATION SECURITY SOFTWARE FOR PROTECTION OF PERSONAL

INFORMATION, BUSINESS INFORMATION, AND INTELLECTUAL PROPERTY AND FOR DIGITAL RIGHTS MANAGEMENT; DATA-PROCESSING AND MANIPULATION/MANAGEMENT SOFTWARE, NAMELY, SOFTWARE TO FACILITATE DATA COMPRESSION, DATABASE MANAGEMENT, AND THE STORAGE, PRESENTATION, AND RETRIEVAL OF DATA; COMPUTER SOFTWARE FOR ANALYZING COMPUTER SYSTEMS, NAMELY, DEBUGGERS, PROFILERS, DISASSEMBLERS, DECOMPILERS, AND DUMP UTILITIES AND SOFTWARE USED TO ASSESS THE PERFORMANCE OR ANALYZE THE OPERATION OF COMPUTER, EMBEDDED, AND REAL-TIME SYSTEMS; COMPUTER-GAME AND ELECTRONIC-GAME SOFTWARE; CLIENT/SERVER SOFTWARE FOR THE EXCHANGE OF DATA OVER COMPUTER NETWORKS; SOFTWARE FOR OPERATING LOCAL-AREA NETWORKS, VIRTUAL PRIVATE NETWORKS, AND WIDE-AREA NETWORKS; AND USER MANUALS SOLD THEREWITH AS A UNIT (U.S. CLS. 21, 23, 26, 36 AND 38).

FIRST USE 5-30-2005; IN COMMERCE 5-30-2005.

### CLASS 42—SCIENTIFIC, COMPUTER AND LEGAL SERVICES

FOR DESIGN AND DEVELOPMENT OF COMPUTER SOFTWARE FOR OTHERS; PROFESSIONAL AND TECHNICAL CONSULTING SERVICES IN RELATION TO COMPUTERS, COMPUTER SOFTWARE, SOFTWARE DEVELOPMENT AND DESIGN, SOFTWARE TOOLS AND UTILITY PROGRAMS, OPERATING SYSTEMS, DEVICE DRIVERS, SYSTEM-CONTROL SOFTWARE AND FIRMWARE, REAL-TIME SOFTWARE, EMBEDDED SOFTWARE, SOFTWARE DEVELOPMENT TOOLS, DATA AND INFORMATION SECURITY SOFTWARE, DATA-PROCESSING AND MANIPULATION/MANAGEMENT SOFTWARE, SOFTWARE FOR SYSTEMS ANALYSIS, COMPUTER- AND ELECTRONIC-GAME SOFTWARE, CLIENT/SERVER SOFTWARE, NETWORKING SOFTWARE (U.S. CLS. 100 AND 101).

FIRST USE 5-30-2005; IN COMMERCE 5-30-2005.

---

3,235,452. BYPA, INC., BOSTON, MA. SN 78-706,761. FILED P.R. 9-4-2005; AM. S.R. 9-22-2006.

### BOSTON YOUNG PROFESSIONALS ASSOCIATION

THE MARK CONSISTS OF STANDARD CHARACTERS WITHOUT CLAIM TO ANY PARTICULAR FONT, STYLE, SIZE, OR COLOR.

NO CLAIM IS MADE TO THE EXCLUSIVE RIGHT TO USE "PROFESSIONALS ASSOCIATION", APART FROM THE MARK AS SHOWN.

### CLASS 35—ADVERTISING AND BUSINESS

FOR BUSINESS NETWORKING, NAMELY, ARRANGING AND CONDUCTING SOCIAL EVENTS FOR THE PURPOSE OF FACILITATING NETWORKING OPPORTUNITIES FOR YOUNG PROFESSIONALS (U.S. CLS. 100, 101 AND 102).

FIRST USE 3-1-2003; IN COMMERCE 3-1-2003.

**CLASS 41—EDUCATION AND ENTERTAINMENT**

FOR EDUCATIONAL SERVICES, NAMELY, CONDUCTING, SEMINARS, CONFERENCES, PRESENTATIONS AND WORKSHOPS DIRECTED TO YOUNG PROFESSIONALS FOR THE PURPOSE OF FACILITATING NETWORKING OPPORTUNITIES; ENTERTAINMENT SERVICES, NAMELY, ARRANGING ARID CONDUCTING SOCIAL ACTIVITIES FOR THE PURPOSE OF FACILITATING MEETING OPPORTUNITIES FOR YOUNG PROFESSIONALS (U.S. CLS. 100, 101 AND 107).

FIRST USE 3-1-2003; IN COMMERCE 3-1-2003.

3,235,455. THE NATIONAL MARROW DONOR PROGRAM, MINNEAPOLIS, MN. SN 78-737,381. FILED P.R. 10-20-2005; AM. S.R. 10-4-2006.

**CENTER FOR CORD BLOOD**

THE MARK CONSISTS OF STANDARD CHARACTERS WITHOUT CLAIM TO ANY PARTICULAR FONT, STYLE, SIZE, OR COLOR.

**CLASS 35—ADVERTISING AND BUSINESS**

FOR COORDINATING, MAINTAINING, AND OPERATING A CENTRAL REGISTRY FOR OTHERS FOR USE IN MATCHING CORD BLOOD UNITS WITH PATIENTS NEEDING A TRANSPLANT (U.S. CLS. 100, 101 AND 102).

FIRST USE 11-4-2005; IN COMMERCE 11-4-2005.

**CLASS 42—SCIENTIFIC, COMPUTER AND LEGAL SERVICES**

FOR DEVELOPMENT AND DESIGN OF INFORMATION AND DATABASES USED TO CREATE A CENTRAL REGISTRY FOR OTHERS FOR USE IN MATCHING CORD BLOOD UNITS WITH PATIENTS NEEDING A TRANSPLANT (U.S. CLS. 100 AND 101).

FIRST USE 11-4-2005; IN COMMERCE 11-4-2005.  
3,235,472. LIQUID PLANET, LLC, MISSOULA, MT. SN 78-826,454. FILED P.R. 3-1-2006; AM. S.R. 2-5-2007.

**BEST OF BEVERAGE**

THE MARK CONSISTS OF STANDARD CHARACTERS WITHOUT CLAIM TO ANY PARTICULAR FONT, STYLE, SIZE, OR COLOR.

**CLASS 35—ADVERTISING AND BUSINESS**

FOR ONLINE AND TRADITIONAL RETAIL STORE SERVICES FEATURING WINE, BEER, JUICES, COFFEE, TEAS, CHOCOLATES, GLASSWARE, BARWARE AND BOOKS (U.S. CLS. 100, 101 AND 102).

FIRST USE 1-0-2006; IN COMMERCE 1-0-2006.

**CLASS 43—HOTEL AND RESTAURANT SERVICES**

FOR RESTAURANT AND COFFEE SHOP SERVICES (U.S. CLS. 100 AND 101).

FIRST USE 1-0-2006; IN COMMERCE 1-0-2006.

3,235,475. GIORDANO, KATHLEEN, NEW YORK, NY. SN 78-836,356. FILED P.R. 3-14-2006; AM. S.R. 2-13-2007.

**LADY BARBER**

THE MARK CONSISTS OF STANDARD CHARACTERS WITHOUT CLAIM TO ANY PARTICULAR FONT, STYLE, SIZE, OR COLOR.

NO CLAIM IS MADE TO THE EXCLUSIVE RIGHT TO USE "BARBER", APART FROM THE MARK AS SHOWN.

**CLASS 21—HOUSEWARES AND GLASS**

FOR HAIR COMBS (U.S. CLS. 2, 13, 23, 29, 30, 33, 40 AND 50).

FIRST USE 5-0-2002; IN COMMERCE 5-0-2002.

**CLASS 44—MEDICAL, BEAUTY AND AGRICULTURAL SERVICES**

FOR HAIRDRESSING SERVICES; HAIR CUTTING; HAIR STYLING (U.S. CLS. 100 AND 101).

FIRST USE 3-0-1991; IN COMMERCE 3-0-1991.

3,235,483. COUNCIL ON COMPETITIVENESS, WASHINGTON, DC. SN 78-851,322. FILED P.R. 3-31-2006; AM. S.R. 1-30-2007.

**Council on Competitiveness**

THE MARK CONSISTS OF STANDARD CHARACTERS WITHOUT CLAIM TO ANY PARTICULAR FONT, STYLE, SIZE, OR COLOR.

NO CLAIM IS MADE TO THE EXCLUSIVE RIGHT TO USE "COUNCIL", APART FROM THE MARK AS SHOWN.

**CLASS 16—PAPER GOODS AND PRINTED MATTER**

FOR PUBLICATIONS AND PRINTED EDUCATIONAL MATERIAL, NAMELY NEWSLETTERS, PAPERS, PAMPHLETS, TEXTS AND BOOKS ON ISSUES OF PUBLIC INTEREST, NAMELY, INNOVATION AND NATIONAL ECONOMIC COMPETITIVENESS IN THE FIELDS OF EDUCATION, SCIENCE, ECONOMICS, PETROLEUM, TECHNOLOGY, AUTOMOTIVE, BUSINESS, PRODUCTION, MANUFACTURING, TRADE AND COMMERCE (U.S. CLS. 2, 5, 22, 23, 29, 37, 38 AND 50).

FIRST USE 0-0-1986; IN COMMERCE 0-0-1986.

**CLASS 35—ADVERTISING AND BUSINESS**

3,235,488. SOUTH FLORIDA MEDIA GROUP, LLC, BOCA RATON, FL. SN 78-892,466. FILED P.R. 5-25-2006; AM. S.R. 2-14-2007.

FOR ASSOCIATION SERVICES, NAMELY PROMOTING PUBLIC AWARENESS ON A WIDE RANGE OF TOPICS IMPORTANT TO UNDERSTANDING INNOVATION AND NATIONAL ECONOMIC COMPETITIVENESS IN EDUCATION, SCIENCE, ECONOMICS, PETROLEUM, TECHNOLOGY, AUTOMOTIVE, BUSINESS, PRODUCTION, MANUFACTURING, TRADE AND COMMERCE INDUSTRIES, FOR THE PURPOSE OF RAISING THE STANDARD OF LIVING OF ALL AMERICANS (U.S. CLS. 100, 101 AND 102).  
FIRST USE 0-0-1986; IN COMMERCE 0-0-1986.

**DELRAY BEACH NEWS**

THE MARK CONSISTS OF STANDARD CHARACTERS WITHOUT CLAIM TO ANY PARTICULAR FONT, STYLE, SIZE, OR COLOR.

NO CLAIM IS MADE TO THE EXCLUSIVE RIGHT TO USE "NEWS", APART FROM THE MARK AS SHOWN.

**CLASS 16—PAPER GOODS AND PRINTED MATTER**

FOR NEWSPAPERS (U.S. CLS. 2, 5, 22, 23, 29, 37, 38 AND 50).  
FIRST USE 1-1-2006; IN COMMERCE 1-1-2006.

**CLASS 42—SCIENTIFIC, COMPUTER AND LEGAL SERVICES**

FOR SCIENTIFIC RESEARCH AND RESEARCH SERVICES RELATING TO ANALYSIS AND RESEARCH OF COMPETITIVENESS, INNOVATION AND HIGH PERFORMANCE COMPUTING IN THE FIELDS OF EDUCATION, ECONOMICS, SCIENCE, PETROLEUM, TECHNOLOGY, AUTOMOTIVE, BUSINESS, PRODUCTION, MANUFACTURING, TRADE AND COMMERCE (U.S. CLS. 100 AND 101).  
FIRST USE 0-0-1986; IN COMMERCE 0-0-1986.

**CLASS 41—EDUCATION AND ENTERTAINMENT**

FOR PUBLICATION OF ELECTRONIC NEWSPAPERS ACCESSIBLE VIA A GLOBAL COMPUTER NETWORK (U.S. CLS. 100, 101 AND 107).  
FIRST USE 4-27-2006; IN COMMERCE 4-27-2006.

\* \* \* \* \*



## SECTION 2.— INTERNATIONAL CLASSIFICATION

The short titles associated below with the international class numbers are terms designed merely for quick identification and are not an official part of the international classification. The full names of international classes are given in section 6.1 of the trademark rules of practice.

The designation "U.S. Cl." appearing in this section refers to the U.S. class in effect prior to Sep. 1, 1973 rather than the international class which applies to applications filed on or after that date. For adoption of international classification see notice in the OFFICIAL GAZETTE of Jun. 26, 1973 (911 O.G. TM 210).

### Application in one class

#### CLASS 1—CHEMICALS

3,235,468. HENKEL CONSUMER ADHESIVES, INC., AVON, OH. SN 78-805,344. FILED P.R. 2-2-2006; AM. S.R. 2-7-2007.

## GREEN SERIES

THE MARK CONSISTS OF STANDARD CHARACTERS WITHOUT CLAIM TO ANY PARTICULAR FONT, STYLE, SIZE, OR COLOR.

FOR ADHESIVES FOR USE IN HOME AND BUILDING CONSTRUCTION, RENOVATION, MAINTENANCE AND REPAIR (U.S. CLS. 1, 5, 6, 10, 26 AND 46).

FIRST USE 1-13-2006; IN COMMERCE 1-13-2006.

#### CLASS 3—(Continued).

3,235,446. E.T. BROWNE DRUG CO., INC., ENGLEWOOD CLIFFS, NJ. SN 78-641,039. FILED P.R. 6-1-2005; AM. S.R. 3-2-2007.

## TUMMY BUTTER

THE MARK CONSISTS OF STANDARD CHARACTERS WITHOUT CLAIM TO ANY PARTICULAR FONT, STYLE, SIZE, OR COLOR.

FOR SKIN CARE PRODUCTS, NAMELY, NON-MEDICATED SKIN MOISTURIZING AND CONDITIONING CREAM, STRETCH MARK CREAM (U.S. CLS. 1, 4, 6, 50, 51 AND 52).

FIRST USE 9-30-2005; IN COMMERCE 9-30-2005.

#### CLASS 3—COSMETICS AND CLEANING PREPARATIONS

3,235,427. MARSALESE, GERARD, BIRMINGHAM, MI. SN 76-646,826. FILED P.R. 9-15-2005; AM. S.R. 2-7-2007.

## LA TÊTE

THE MARK CONSISTS OF STANDARD CHARACTERS WITHOUT CLAIM TO ANY PARTICULAR FONT, STYLE, SIZE, OR COLOR.

THE ENGLISH TRANSLATION OF "LA TÊTE" IS "THE HEAD".

FOR HAIR CARE PRODUCTS, NAMELY SHAMPOO, CONDITIONER, HAIR GEL, MOUSSE, VOLUMIZER, STYLING CRÈME AND ANTI-HUMECTANTS (U.S. CLS. 1, 4, 6, 50, 51 AND 52).

FIRST USE 10-1-2003; IN COMMERCE 10-1-2003.

3,235,466. PETER THOMAS ROTH LABS, LLC, NEW YORK, NY. SN 78-797,589. FILED P.R. 1-23-2006; AM. S.R. 1-12-2007.

## UN-WRINKLE

THE MARK CONSISTS OF STANDARD CHARACTERS WITHOUT CLAIM TO ANY PARTICULAR FONT, STYLE, SIZE, OR COLOR.

FOR NON-MEDICATED SKIN CARE SERUMS, GELS, CREAMS AND LOTIONS (U.S. CLS. 1, 4, 6, 50, 51 AND 52).

FIRST USE 12-7-2005; IN COMMERCE 12-7-2005.

**CLASS 3—(Continued).**

3,235,492. SCENTS OF NATURE ENTERPRISES CORP., MIAMI, FL. SN 78-969,424. FILED P.R. 9-7-2006; AM. S.R. 2-1-2007.

---

**HAWAIIAN PLUMERIA**

THE MARK CONSISTS OF STANDARD CHARACTERS WITHOUT CLAIM TO ANY PARTICULAR FONT, STYLE, SIZE, OR COLOR.

NO CLAIM IS MADE TO THE EXCLUSIVE RIGHT TO USE "HAWAIIAN", APART FROM THE MARK AS SHOWN. FOR SCENTED OILS USED TO PRODUCE AROMAS WHEN HEATED (U.S. CLS. 1, 4, 6, 50, 51 AND 52). FIRST USE 1-12-2006; IN COMMERCE 1-12-2006.

**CLASS 5—PHARMACEUTICALS**

3,235,478. GLOBAL LIFE TECHNOLOGIES CORP., CORAL GABLES, FL. SN 78-842,024. FILED P.R. 3-21-2006; AM. S.R. 3-5-2007.

---

**NASAL SANITIZER**

THE MARK CONSISTS OF STANDARD CHARACTERS WITHOUT CLAIM TO ANY PARTICULAR FONT, STYLE, SIZE, OR COLOR.

NO CLAIM IS MADE TO THE EXCLUSIVE RIGHT TO USE "SANITIZER", APART FROM THE MARK AS SHOWN. FOR ANTISEPTIC PREPARATIONS; NASAL SPRAY PREPARATIONS (U.S. CLS. 6, 18, 44, 46, 51 AND 52). FIRST USE 2-15-2006; IN COMMERCE 2-15-2006.

3,235,479. TRIBECA KITCHEN, LLC, NEW YORK, NY. SN 78-842,548. FILED P.R. 3-21-2006; AM. S.R. 2-22-2007.

---

**PLUM ORGANICS**

THE MARK CONSISTS OF STANDARD CHARACTERS WITHOUT CLAIM TO ANY PARTICULAR FONT, STYLE, SIZE, OR COLOR.

NO CLAIM IS MADE TO THE EXCLUSIVE RIGHT TO USE "ORGANICS", APART FROM THE MARK AS SHOWN.

FOR FOOD FOR INFANTS AND BABIES, NAMELY, ORGANIC PREPARED MEALS AND ORGANIC PREPARED SNACKS, NOT CONTAINING PLUM (U.S. CLS. 6, 18, 44, 46, 51 AND 52).

FIRST USE 3-1-2006; IN COMMERCE 3-1-2006.

**CLASS 5—(Continued).**

3,235,491. KESSLER, MICHAEL J, MIAMI BEACH, FL. SN 78-965,901. FILED P.R. 9-1-2006; AM. S.R. 3-15-2007.

---

**OXEGEN AKG**

THE MARK CONSISTS OF STANDARD CHARACTERS WITHOUT CLAIM TO ANY PARTICULAR FONT, STYLE, SIZE, OR COLOR.

NO CLAIM IS MADE TO THE EXCLUSIVE RIGHT TO USE AKG, APART FROM THE MARK AS SHOWN.

FOR INCREASES OXYGEN DELIVERY TO THE CELLS, ENHANCES PHYSICAL ENDURANCE AND SEXUAL STAMINA, SUPPORTS OPTIMUM CIRCULATION AND VASCULAR BLOOD FLOW WHILE PROMOTING THE PRODUCTION OF LEAN MUSCLE MASS AND OXIDIZED FAT BURNING TO IMPROVE HEALTH, VITALITY AND WELL-BEING (U.S. CLS. 6, 18, 44, 46, 51 AND 52).

FIRST USE 2-28-2004; IN COMMERCE 2-28-2004.

**CLASS 6—METAL GOODS**

3,235,430. LEWIS DOLIN INC., KATONAH, NY. SN 76-660,848. FILED P.R. 5-31-2006; AM. S.R. 1-22-2007.

---

**LEVEL HARDWARE**

THE MARK CONSISTS OF STANDARD CHARACTERS WITHOUT CLAIM TO ANY PARTICULAR FONT, STYLE, SIZE, OR COLOR.

NO CLAIM IS MADE TO THE EXCLUSIVE RIGHT TO USE "HARDWARE", APART FROM THE MARK AS SHOWN.

FOR METAL DECORATIVE HARDWARE, NAMELY, DRAWER PULLS, FURNITURE KNOBS, AND CABINET DOOR HANDLES (U.S. CLS. 2, 12, 13, 14, 23, 25 AND 50).

FIRST USE 11-8-2006; IN COMMERCE 11-8-2006.

**CLASS 7—MACHINERY**

**CLASS 7—(Continued).**

3,235,482. CLARKE FIRE PROTECTION PRODUCTS, INC., CINCINNATI, OH. SN 78-850,121. FILED P.R. 3-30-2006; AM. S.R. 2-27-2007.

**CLARKE PUMP SYSTEMS**

THE MARK CONSISTS OF STANDARD CHARACTERS WITHOUT CLAIM TO ANY PARTICULAR FONT, STYLE, SIZE, OR COLOR.

OWNER OF U.S. REG. NO. 2,990,916.  
NO CLAIM IS MADE TO THE EXCLUSIVE RIGHT TO USE "PUMP SYSTEMS", APART FROM THE MARK AS SHOWN.

FOR CONTINUOUS DUTY DUAL CYLINDER PISTON PUMPS FOR USE IN THE TRANSPORTATION AND HANDLING OF HIGHLY VISCOUS AND COARSE GRAINED SLUDGE, GROUT, CONCRETE AND/OR OTHER PASTE TYPE MATERIALS IN THE FIELDS OF BUILDING AND CONSTRUCTION, INDUSTRIAL, AND OIL AND GAS WELL DRILLING APPLICATIONS (U.S. CLS. 13, 19, 21, 23, 31, 34 AND 35).

FIRST USE 0-0-2006; IN COMMERCE 0-0-2006.

**CLASS 9—ELECTRICAL AND SCIENTIFIC APPARATUS**

3,235,432. ELECTRONIC SPECIALTIES, INC., GENOA CITY, WI. SN 77-001,556. FILED P.R. 9-18-2006; AM. S.R. 2-16-2007.

**MAG LEAD**

THE MARK CONSISTS OF STANDARD CHARACTERS WITHOUT CLAIM TO ANY PARTICULAR FONT, STYLE, SIZE, OR COLOR.

NO CLAIM IS MADE TO THE EXCLUSIVE RIGHT TO USE "LEAD", APART FROM THE MARK AS SHOWN.

FOR ELECTRONIC LEADS FOR ELECTRICAL MEASURING INSTRUMENTS HAVING MAGNETIC CONTACTS (U.S. CLS. 21, 23, 26, 36 AND 38).

FIRST USE 9-14-2006; IN COMMERCE 9-14-2006.

**CLASS 9—(Continued).**

3,235,437. WORKSTREAM USA, INC., MAITLAND, FL. SN 78-445,450. FILED P.R. 7-2-2004; AM. S.R. 3-9-2007.

**HEALTH PAGES**

THE MARK CONSISTS OF STANDARD CHARACTERS WITHOUT CLAIM TO ANY PARTICULAR FONT, STYLE, SIZE, OR COLOR.

NO CLAIM IS MADE TO THE EXCLUSIVE RIGHT TO USE "HEALTH", APART FROM THE MARK AS SHOWN.

FOR WEB-BASED SOFTWARE APPLICATIONS CONSISTING OF DATABASES OF HEALTH CARE PROVIDERS, HEALTH CARE PLANS, HEALTH AND WELLNESS INFORMATION, AND RELATED DATA, AND PROGRAMS FOR COMPARING AND ASSESSING SUCH INFORMATION AND DATA (U.S. CLS. 21, 23, 26, 36 AND 38).

FIRST USE 4-0-1998; IN COMMERCE 4-0-1998.

3,235,438. IGG SOFTWARE, LLC, PUTNEY, VT. SN 78-468,954. FILED P.R. 8-17-2004; AM. S.R. 1-29-2007.



THE MARK CONSISTS OF STANDARD CHARACTERS WITHOUT CLAIM TO ANY PARTICULAR FONT, STYLE, SIZE, OR COLOR.

FOR FINANCIAL MANAGEMENT SOFTWARE FOR PERSONAL COMPUTERS (U.S. CLS. 21, 23, 26, 36 AND 38).

FIRST USE 2-1-2003; IN COMMERCE 4-1-2003.

3,235,439. FLEXPLAY TECHNOLOGIES, INC., ATLANTA, GA. SN 78-519,433. FILED P.R. 11-18-2004; AM. S.R. 10-18-2006.

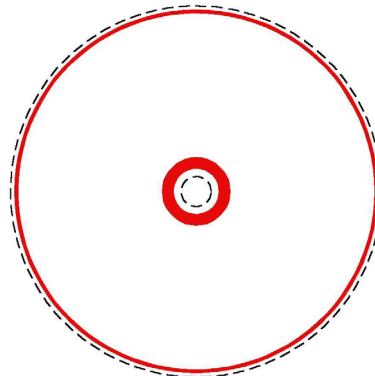

THE COLOR(S) RED IS/ARE CLAIMED AS A FEATURE OF THE MARK.

**CLASS 9—(Continued).**

THE COLOR RED APPEARS IN TWO RED BANDS ON THE NON-INFORMATION SIDE OF THE OPTICAL MEDIA, WITH ONE BAND PLACED AROUND THE CIRCUMFERENCE, AND THE OTHER, WIDER BAND PLACED AROUND THE SPINDLE HOLE.

THE MARK CONSISTS OF TWO CONCENTRIC RED RINGS ON THE NON-INFORMATION SIDE OF THE OPTICAL MEDIA. SPECIFICALLY, A THIN RED BAND IS PLACED AROUND THE CIRCUMFERENCE OF THE OPTICAL MEDIA AND A SECOND, WIDER RED BAND IS PLACED AROUND THE SPINDLE HOLE OF THE OPTICAL MEDIA. THE DOTTED OUTLINE OF THE GOODS IS INTENDED TO SHOW THE POSITION OF THE MARK AND IS NOT A PART OF THE MARK.

FOR LIMITED PLAY OPTICAL MEDIA SOLD BLANK AND WITH PRE-RECORDED DATA FOR EDUCATIONAL, ENTERTAINMENT AND DATA PURPOSES FEATURING MUSIC, MUSICAL SOUND RECORDINGS, MUSICAL VIDEO RECORDINGS, MUSICAL PERFORMANCES, THEATER PERFORMANCES, DANCE PERFORMANCES, ADULT ENTERTAINMENT, COMPUTER GAMES, VIDEO GAMES, JOB TRAINING EDUCATIONAL MATERIALS, COLLEGE LECTURES AND MOVIES IN THE FIELDS OF COMEDY, DRAMA, HORROR, DOCUMENTARY, ACTION, ADVENTURE, SCIENCE FICTION, MYSTERY, ROMANCE, HISTORICAL FICTION AND ANIMATION (U.S. CLS. 21, 23, 26, 36 AND 38).

FIRST USE 8-5-2002; IN COMMERCE 8-5-2002.

---

3,235,448. FIREMEDNET INC, LYNNWOOD, WA. SN 78-668,810. FILED P.R. 7-12-2005; AM. S.R. 2-6-2007.

# WEBFIRS

THE MARK CONSISTS OF STANDARD CHARACTERS WITHOUT CLAIM TO ANY PARTICULAR FONT, STYLE, SIZE, OR COLOR.

FOR SOFTWARE FOR REPORTING AND QUANTIFICATION OF FIRE, MEDICAL, AND RELATED EMERGENCY INCIDENT RESPONSE DATA (U.S. CLS. 21, 23, 26, 36 AND 38).

FIRST USE 11-2-2003; IN COMMERCE 1-28-2004.

---

3,235,450. ANDREA ELECTRONICS CORPORATION, BOHEMIA, NY. SN 78-685,869. FILED P.R. 8-4-2005; AM. S.R. 8-25-2006.

# EHOSTOP

THE MARK CONSISTS OF STANDARD CHARACTERS WITHOUT CLAIM TO ANY PARTICULAR FONT, STYLE, SIZE, OR COLOR.

FOR MICROPHONES INCORPORATING AND FOR USE WITH ACOUSTIC ECHO CANCELLERS (U.S. CLS. 21, 23, 26, 36 AND 38).

FIRST USE 5-12-2005; IN COMMERCE 5-12-2005.

**CLASS 9—(Continued).**

3,235,467. DESIGN CLINICALS LLC, KENT, WA. SN 78-801,816. FILED P.R. 1-29-2006; AM. S.R. 2-27-2007.

# MedsTracker

THE MARK CONSISTS OF STANDARD CHARACTERS WITHOUT CLAIM TO ANY PARTICULAR FONT, STYLE, SIZE, OR COLOR.

FOR MEDICAL SOFTWARE FOR THE RECONCILIATION OF MEDICATIONS (U.S. CLS. 21, 23, 26, 36 AND 38).

FIRST USE 1-20-2006; IN COMMERCE 1-20-2006.

**CLASS 11—ENVIRONMENTAL CONTROL APPARATUS**

3,235,431. CRAFTMADE INTERNATIONAL INC., COPPELL, TX. SN 77-001,499. FILED P.R. 9-18-2006; AM. S.R. 3-5-2007.

# LaTour

THE MARK CONSISTS OF STANDARD CHARACTERS WITHOUT CLAIM TO ANY PARTICULAR FONT, STYLE, SIZE, OR COLOR.

FOR CEILING FANS (U.S. CLS. 13, 21, 23, 31 AND 34).

FIRST USE 2-22-2007; IN COMMERCE 2-22-2007.

**CLASS 11—(Continued).**

3,235,460. BAYCO PRODUCTS, LTD., WYLIE, TX. SN 78-767,374. FILED P.R. 12-6-2005; AM. S.R. 12-22-2006.

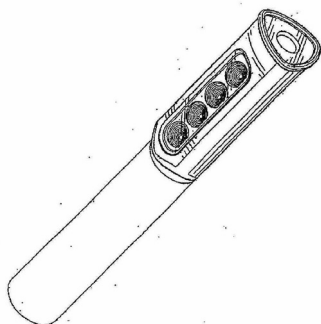

THE MARK CONSISTS OF A CONFIGURATION OF AN ELONGATED LIGHT CASING WITH ONE END FEATURING A THREE-SIDED CONVEX HOUSING HAVING A LIGHT AT THAT END AND AN ARRAY OF LIGHTS ALONG ONE SIDE OF THE CONVEX HOUSING.

FOR PORTABLE LIGHTING EQUIPMENT, NAMELY, FLASHLIGHTS, WORK LIGHTS, DROP LIGHTS AND TASK LIGHTS (U.S. CLS. 13, 21, 23, 31 AND 34).

FIRST USE 12-1-2006; IN COMMERCE 12-1-2006.

**CLASS 14—JEWELRY**

3,235,474. BULOVA CORPORATION, WOODSIDE, NY. SN 78-836,320. FILED P.R. 3-14-2006; AM. S.R. 3-14-2007.

# MASELLA

THE MARK CONSISTS OF STANDARD CHARACTERS WITHOUT CLAIM TO ANY PARTICULAR FONT, STYLE, SIZE, OR COLOR.

FOR WATCHES AND CLOCKS (U.S. CLS. 2, 27, 28 AND 50).

FIRST USE 6-2-2006; IN COMMERCE 6-2-2006.

**CLASS 15—MUSICAL INSTRUMENTS**

3,235,435. MAGNETICS USA INC, MIAMI, FL. SN 77-016,168. FILED P.R. 10-6-2006; AM. S.R. 2-23-2007.

# Rollins

FOR GUITARS (U.S. CLS. 2, 21 AND 36).  
FIRST USE 10-28-2005; IN COMMERCE 10-28-2005.

**CLASS 16—PAPER GOODS AND PRINTED MATTER**

3,235,421. FOUNDATION OF RENEWAL FOR EASTERN NORTH CAROLINA, GREENVILLE, NC. SN 76-570,732. FILED P.R. 1-20-2004; AM. S.R. 2-8-2007.



NO CLAIM IS MADE TO THE EXCLUSIVE RIGHT TO USE INNER BANKS OF EASTERN NORTH CAROLINA, APART FROM THE MARK AS SHOWN.

FOR STICKERS (U.S. CLS. 2, 5, 22, 23, 29, 37, 38 AND 50).

FIRST USE 5-1-2004; IN COMMERCE 5-1-2004.

3,235,445. MOMAGENDA LLC, OLD GREENWICH, CT. SN 78-640,426. FILED P.R. 5-31-2005; AM. S.R. 2-2-2007.

# MOMAGENDA

THE MARK CONSISTS OF STANDARD CHARACTERS WITHOUT CLAIM TO ANY PARTICULAR FONT, STYLE, SIZE, OR COLOR.

FOR DATE BOOKS AND DAYPLANNERS; NOTE PADS (U.S. CLS. 2, 5, 22, 23, 29, 37, 38 AND 50).

FIRST USE 2-0-2005; IN COMMERCE 5-16-2005.

**CLASS 16—(Continued).**

3,235,457. FOX, DEBRA, ROCKLEDGE, FL. SN 78-743,706. FILED P.R. 10-31-2005; AM. S.R. 2-2-2007.



THE COLOR(S) BLACK AND WHITE IS/ARE CLAIMED AS A FEATURE OF THE MARK.

THE COLOR BLACK APPEARS IN THE BACKGROUND ON THE UPPER LEFT-HAND PORTION OF THE BUMPER STICKER AND ALSO IN THE WORDS "SO WHAT— MINE BEAT CANCER. THE COLOR WHITE APPEARS IN THE WORDS "YOUR CHILD'S AN HONOR STUDENT?" AND ALSO IN THE BACKGROUND OF THE REMAINDER OF THE BUMPER STICKER.

FOR PAPER GOODS, NAMELY, BUMPER STICKERS, AND DECALS (U.S. CLS. 2, 5, 22, 23, 29, 37, 38 AND 50). FIRST USE 10-19-2005; IN COMMERCE 10-19-2005.

3,235,459. LIFESTYLE MEDIA, INC., NEW YORK, NY. SN 78-761,600. FILED P.R. 11-28-2005; AM. S.R. 2-16-2007.

**CHEER BIZ NEWS**

THE MARK CONSISTS OF STANDARD CHARACTERS WITHOUT CLAIM TO ANY PARTICULAR FONT, STYLE, SIZE, OR COLOR.

NO CLAIM IS MADE TO THE EXCLUSIVE RIGHT TO USE "NEWS", APART FROM THE MARK AS SHOWN.

FOR PRINTED PERIODICALS PERTAINING TO CHEERLEADING, DIRECTED TO OWNERS OF ATHLETIC FACILITIES CATERING TO CHEERLEADERS AND TO OTHERS INTERESTED IN CHEERLEADING (U.S. CLS. 2, 5, 22, 23, 29, 37, 38 AND 50). FIRST USE 9-3-2004; IN COMMERCE 9-3-2004.

**CLASS 16—(Continued).**

3,235,489. CMP MEDIA LLC, MANHASSET, NY. SN 78-897,388. FILED P.R. 5-31-2006; AM. S.R. 2-14-2007.

**MOBILE BUSINESS EXPO**

THE MARK CONSISTS OF STANDARD CHARACTERS WITHOUT CLAIM TO ANY PARTICULAR FONT, STYLE, SIZE, OR COLOR.

NO CLAIM IS MADE TO THE EXCLUSIVE RIGHT TO USE "EXPO", APART FROM THE MARK AS SHOWN.

FOR PRINTED MATERIALS, NAMELY NEWSLETTERS, REFERENCE MATERIALS, PRESS RELEASES, PAMPHLETS, DIRECTORIES, INFORMATIONAL FLYERS, INFORMATIONAL SHEETS, LEAFLETS, PRODUCT GUIDES, BOOKS, BROCHURES, MAGAZINES, INSTRUCTIONAL MANUALS, WRITTEN PRESENTATIONS AND TEACHING MATERIALS, ALL IN THE FIELDS OF BUSINESS DEVELOPMENT, TECHNICAL BUSINESS MANAGEMENT SERVICES AND INFORMATION TECHNOLOGY; WORKFORCE MANAGEMENT SERVICES (U.S. CLS. 2, 5, 22, 23, 29, 37, 38 AND 50). FIRST USE 10-9-2005; IN COMMERCE 10-9-2005.

**CLASS 18—LEATHER GOODS**

3,235,471. SNOWY RIVER, LLC, MORGAN, UT. SN 78-819,078. FILED P.R. 2-20-2006; AM. S.R. 2-9-2007.

**RUKSAK**

THE MARK CONSISTS OF STANDARD CHARACTERS WITHOUT CLAIM TO ANY PARTICULAR FONT, STYLE, SIZE, OR COLOR.

THE NAME(S), PORTRAIT(S), AND/OR SIGNATURE(S) SHOWN IN THE MARK DOES NOT IDENTIFY A PARTICULAR LIVING INDIVIDUAL.

FOR HIKING BAGS (U.S. CLS. 1, 2, 3, 22 AND 41). FIRST USE 2-8-2006; IN COMMERCE 2-8-2006.

**CLASS 25—CLOTHING**

**CLASS 25—(Continued).**

3,235,422. ASIA UNITED GARMENT MANUFACTURING CO. LTD, TSIM SHA TSUI, HONG KONG. SN 76-588,548. FILED P.R. 4-23-2004; AM. S.R. 2-20-2007.

**CLASS 25—(Continued).**

3,235,425. JONES, CARL D., HUMBLE, TX. SN 76-634,387. FILED P.R. 3-25-2005; AM. S.R. 1-25-2007.



PRIORITY CLAIMED UNDER SEC. 44(D) ON HONG KONG APPLICATION NO. 300100600, FILED 10-27-2003, REG. NO. 300100600, DATED 10-27-2003, EXPIRES 10-27-2013.

THE ENGLISH TRANSLATION OF "TIEN" IS "INDIGO COLOR". THE ENGLISH TRANSLATION OF "AH E" IS "INDIGO COLOR".

THE CHINESE CHARACTER IN THE MARK TRANSLITERATES TO "TIEN" AND "AH E".

FOR CLOTHING, NAMELY, DRESSES, SHIRTS, SKIRTS, SHORTS, TROUSERS, JACKETS, SPORTS JACKETS, SWEATERS, T-SHIRTS, PULLOVERS, CARDIGANS, VESTS, SPORTS SUITS, SUITS, SPORTS CLOTHING, NAMELY, SPORTS SHIRTS, SPORTS PANTS, SWEAT SHIRTS, SWEAT PANTS, PAJAMAS, UNDERWEAR, TIES, GLOVES, SOCKS, STOCKINGS, SCARVES, CLOTHING BELTS, LINGERIE; FOOTWEAR: SHOES, BOOTS, SPORTS SHOES, SLIPPERS, BEACH SHOES, SANDALS; HEADWEAR; HATS, CAPS, SUN VISORS, BERETS, HEADBANDS (U.S. CLS. 22 AND 39).



**PLYUNITZ**  
APPAREL

OWNER OF U.S. REG. NO. 2,885,895.  
NO CLAIM IS MADE TO THE EXCLUSIVE RIGHT TO USE APPAREL, APART FROM THE MARK AS SHOWN.

FOR CLOTHING, NAMELY, PANTS, COATS, SWEAT SUITS, SOCKS, SHOES, TANK TOPS, BASEBALL CAPS, HEADBANDS, POLO KNIT SHIRTS, BUTTON DOWN SHIRTS, ALL TYPES OF HATS, ALL TYPES OF JACKETS, SWEATERS, WRISTBANDS, JERSEYS, JEANS, SHORTS, T-SHIRTS, HOUSE SHOES, SANDALS, SKIRTS, VISORS, BLOUSE, BOXER BRIEFS, BOXER SHORTS, PANTIES AND BRAS (U.S. CLS. 22 AND 39).

FIRST USE 7-15-2003; IN COMMERCE 7-13-2006.

3,235,434. CAMPAGNOLO, STEFANO, SALT LAKE CITY, UT. SN 77-009,120. FILED 9-27-2006.



FOR BELTS; CAPS; DRESS SHIRTS; GLOVES; GOLF SHIRTS; GOLF SHOES; HATS; JACKETS; JEANS; KNIT SHIRTS; OPEN-NECKED SHIRTS; PIQUE SHIRTS; POLO SHIRTS; SANDALS; SHOES; SHORT-SLEEVED AND LONG-SLEEVED T-SHIRTS; SHORTS; SOCKS; SPORT SHIRTS; SWEAT SHIRTS; T-SHIRTS; VISORS (U.S. CLS. 22 AND 39).

FIRST USE 3-1-2006; IN COMMERCE 3-1-2006.

**CLASS 25—(Continued).**

3,235,440. BOYD, RACHEL L., LITHIA SPRINGS, GA. SN 78-543,941. FILED P.R. 1-7-2005; AM. S.R. 2-21-2007.

**1up  
Jesus**

Jesus is always 1up on every situation

FOR CLOTHING FOR MEN, WOMEN AND CHILDREN, NAMELY SHIRTS AND HATS (U.S. CLS. 22 AND 39).

FIRST USE 7-3-2006; IN COMMERCE 7-3-2006.

3,235,441. BROWN, LEROY, JR, MORRISVILLE, NC. SN 78-564,290. FILED P.R. 2-10-2005; AM. S.R. 6-8-2006.

**100% PASSION  
XXL**

NO CLAIM IS MADE TO THE EXCLUSIVE RIGHT TO USE "XXL", APART FROM THE MARK AS SHOWN. FOR T-SHIRTS (U.S. CLS. 22 AND 39).

FIRST USE 10-1-2004; IN COMMERCE 10-1-2004.

3,235,454. AERO DESIGN AND MANUFACTURING COMPANY, INC., DULUTH, MN. SN 78-722,920. FILED P.R. 9-29-2005; AM. S.R. 2-16-2007.

THE ROAD TO ENLIGHTENMENT  
IS MORE FUN ON A BIKE

THE MARK CONSISTS OF STANDARD CHARACTERS WITHOUT CLAIM TO ANY PARTICULAR FONT, STYLE, SIZE, OR COLOR.

FOR CLOTHING, NAMELY, T-SHIRTS (U.S. CLS. 22 AND 39).

FIRST USE 10-19-2005; IN COMMERCE 10-19-2005.

**CLASS 25—(Continued).**

3,235,490. LUCKERSON, KEVIN DEXTER, SAN MARCOS, CA. SN 78-964,506. FILED 8-30-2006.



FOR SHIRTS (U.S. CLS. 22 AND 39).  
FIRST USE 8-30-2006; IN COMMERCE 8-30-2006.

**CLASS 29—MEATS AND PROCESSED FOODS**

3,235,480. ORIENT FISHERIES INC., VERNON, CA. SN 78-844,080. FILED P.R. 3-23-2006; AM. S.R. 2-6-2007.

**ATLANTICWILD**

THE MARK CONSISTS OF STANDARD CHARACTERS WITHOUT CLAIM TO ANY PARTICULAR FONT, STYLE, SIZE, OR COLOR.

FOR SHRIMP (U.S. CL. 46).

FIRST USE 1-9-2006; IN COMMERCE 1-9-2006.

**CLASS 31—NATURAL AGRICULTURAL PRODUCTS**

3,235,476. S&S BRANDS, INC., WILMINGTON, DE. SN 78-836,530. FILED P.R. 3-14-2006; AM. S.R. 2-19-2007.

**SELECT SLICES**

THE MARK CONSISTS OF STANDARD CHARACTERS WITHOUT CLAIM TO ANY PARTICULAR FONT, STYLE, SIZE, OR COLOR.

OWNER OF U.S. REG. NO. 2,778,794.

FOR PET FOOD (U.S. CLS. 1 AND 46).

FIRST USE 1-0-2007; IN COMMERCE 1-0-2007.

**CLASS 32—LIGHT BEVERAGES**



**CLASS 32—(Continued).**

3,235,449. O2 AQUA GROUP, CONCORD, ONTARIO, CANADA. SN 78-680,500. FILED P.R. 7-28-2005; AM. S.R. 1-30-2007.

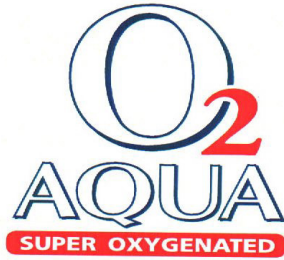

NO CLAIM IS MADE TO THE EXCLUSIVE RIGHT TO USE SUPER OXYGENATED, APART FROM THE MARK AS SHOWN.

THE COLOR(S) BLUE, RED, AND WHITE IS/ARE CLAIMED AS A FEATURE OF THE MARK.

THE MARK CONSISTS OF THE LETTER "O" IS WHITE AND OUTLINED IN BLUE WITH A SUBSCRIPT NUMBER "2" IN RED. THE WORD "AQUA" IS PLACED BELOW THE "O" AND IS WHITE AND OUTLINED IN BLUE. THE WORDS "SUPER OXYGENATED" ARE WHITE SUPERIMPOSED ON A RED BACKGROUND PLACED BELOW THE WORD "AQUA".

FOR DRINKING WATER, NAMELY SUPER OXYGENATED BOTTLED WATER (U.S. CLS. 45, 46 AND 48). FIRST USE 1-31-2003; IN COMMERCE 6-30-2003.

**CLASS 33—WINES AND SPIRITS**

3,235,484. KYSELA PERE ET FILS, LTD., WINCHESTER, VA. SN 78-855,385. FILED P.R. 4-6-2006; AM. S.R. 2-16-2007.

**BELLOT**

THE MARK CONSISTS OF STANDARD CHARACTERS WITHOUT CLAIM TO ANY PARTICULAR FONT, STYLE, SIZE, OR COLOR.

FOR HARD CIDER (U.S. CLS. 47 AND 49). FIRST USE 8-31-2002; IN COMMERCE 8-31-2002.

**SERVICE MARKS**

**CLASS 35—ADVERTISING AND BUSINESS**

**CLASS 35—(Continued).**

3,235,433. HOME BUILDERS ASSOCIATION OF GREATER CHICAGO, ADDISON, IL. SN 77-004,623. FILED P.R. 9-21-2006; AM. S.R. 2-20-2007.

MIDWEST HOME & DESIGN SHOW

THE MARK CONSISTS OF STANDARD CHARACTERS WITHOUT CLAIM TO ANY PARTICULAR FONT, STYLE, SIZE, OR COLOR.

NO CLAIM IS MADE TO THE EXCLUSIVE RIGHT TO USE "HOME & DESIGN SHOW", APART FROM THE MARK AS SHOWN.

FOR ARRANGING AND CONDUCTING TRADE SHOWS IN THE FIELDS OF HOME IMPROVEMENT, OUTDOOR LIVING, DECORATING, RENOVATING, GARDENING AND HOME BUILDING (U.S. CLS. 100, 101 AND 102).

FIRST USE 1-0-2006; IN COMMERCE 1-0-2006.

3,235,436. NEW DISCOVERY MEDIA CORPORATION, NASHVILLE, TN. SN 77-035,315. FILED P.R. 11-2-2006; AM. S.R. 3-14-2007.

THEMONEYEXPERT.COM

THE MARK CONSISTS OF STANDARD CHARACTERS WITHOUT CLAIM TO ANY PARTICULAR FONT, STYLE, SIZE, OR COLOR.

OWNER OF U.S. REG. NO. 3,003,060.

FOR PROMOTING, ADVERTISING, MARKETING GOODS AND SERVICES, INCLUDING ON-LINE WEBSITES, IN THE FIELDS OF FINANCE, BUSINESS, MARKETING, INVESTING, PERSONAL AND PROFESSIONAL DEVELOPMENT, AND EDUCATION (U.S. CLS. 100, 101 AND 102).

FIRST USE 4-5-2005; IN COMMERCE 6-3-2005.

**CLASS 35—(Continued).**

3,235,456. SAMMY Z INC., BEVERLY HILLS, CA. SN 78-737,542. FILED P.R. 10-20-2005; AM. S.R. 2-26-2007.

BEVERLYHILLSPEOPLE.COM

THE MARK CONSISTS OF STANDARD CHARACTERS WITHOUT CLAIM TO ANY PARTICULAR FONT, STYLE, SIZE, OR COLOR.

NO CLAIM IS MADE TO THE EXCLUSIVE RIGHT TO USE "BEVERLY HILLS", APART FROM THE MARK AS SHOWN.

FOR PROMOTING THE GOODS AND SERVICES OF OTHERS BY PREPARING AND PLACING ADVERTISEMENTS IN AN ELECTRONIC MAGAZINE ACCESSED THROUGH A GLOBAL COMPUTER NETWORK (U.S. CLS. 100, 101 AND 102).

FIRST USE 8-20-2005; IN COMMERCE 8-20-2005.

**CLASS 35—(Continued).**

3,235,464. AMERICAN GAITED MOUNTAIN HORSE ASSOCIATION, LLC, CLAY CITY, KY. SN 78-791,686. FILED P.R. 1-13-2006; AM. S.R. 1-8-2007.

### American Spotted Mountain Horse Association

THE MARK CONSISTS OF STANDARD CHARACTERS WITHOUT CLAIM TO ANY PARTICULAR FONT, STYLE, SIZE, OR COLOR.

NO CLAIM IS MADE TO THE EXCLUSIVE RIGHT TO USE ASSOCIATION, APART FROM THE MARK AS SHOWN.

FOR ASSOCIATION SERVICES, NAMELY, PROMOTING THE INTERESTS OF AMERICAN SPOTTED MOUNTAIN HORSE OWNERS AND BREEDERS; PROVIDING AND MAINTAINING A REGISTRY OF CERTIFIED AMERICAN SPOTTED MOUNTAIN HORSES (U.S. CLS. 100, 101 AND 102).

FIRST USE 7-23-2006; IN COMMERCE 1-4-2007.

3,235,486. JOHNSON FRANCHISE CONSULTING, INC., LINCOLN, NE. SN 78-875,512. FILED P.R. 5-3-2006; AM. S.R. 2-19-2007.

### FRANCHISEE APPROVED

THE MARK CONSISTS OF STANDARD CHARACTERS WITHOUT CLAIM TO ANY PARTICULAR FONT, STYLE, SIZE, OR COLOR.

OWNER OF U.S. REG. NO. 2,932,513.

FOR BUSINESS ASSESSMENT SERVICES CONSISTING OF EVALUATION OF FRANCHISE OPPORTUNITIES (U.S. CLS. 100, 101 AND 102).

FIRST USE 11-1-2004; IN COMMERCE 11-1-2004.

3,235,462. AMERICAN GAITED MOUNTAIN HORSE ASSOCIATION, LLC, CLAY CITY, KY. SN 78-791,662. FILED P.R. 1-13-2006; AM. S.R. 1-8-2007.

### American Gaited Spotted Mountain Horse Association

3,235,487. WRIGLEYVILLE SPORTS, INC, BENSENVILLE, IL. SN 78-877,395. FILED P.R. 5-5-2006; AM. S.R. 1-30-2007.

### The Pittsburgh Fan

THE MARK CONSISTS OF STANDARD CHARACTERS WITHOUT CLAIM TO ANY PARTICULAR FONT, STYLE, SIZE, OR COLOR.

NO CLAIM IS MADE TO THE EXCLUSIVE RIGHT TO USE "ASSOCIATION", APART FROM THE MARK AS SHOWN.

FOR ASSOCIATION SERVICES, NAMELY, PROMOTING THE INTERESTS OF AMERICAN GAITED SPOTTED MOUNTAIN HORSE OWNERS AND BREEDERS; PROVIDING AND MAINTAINING A REGISTRY OF CERTIFIED AMERICAN GAITED SPOTTED MOUNTAIN HORSES (U.S. CLS. 100, 101 AND 102).

FIRST USE 3-31-2006; IN COMMERCE 4-11-2006.

THE MARK CONSISTS OF STANDARD CHARACTERS WITHOUT CLAIM TO ANY PARTICULAR FONT, STYLE, SIZE, OR COLOR.

FOR ON-LINE RETAIL STORE SERVICES FEATURING SPORTS TEAMS CLOTHING, MEMORABILIA, AND GENERAL CONSUMER SPORTS MERCHANDISE; RETAIL STORES FEATURING SPORTS TEAMS CLOTHING, MEMORABILIA, AND GENERAL CONSUMER SPORTS MERCHANDISE (U.S. CLS. 100, 101 AND 102).

FIRST USE 9-20-2005; IN COMMERCE 9-20-2005.

**CLASS 35—(Continued).**

3,235,493. MOSCI, FLAVIA MEIRELES, SHERMAN OAKS, CA. SN 78-970,627. FILED P.R. 9-8-2006; AM. S.R. 2-13-2007.

# MOSCI

THE MARK CONSISTS OF STANDARD CHARACTERS WITHOUT CLAIM TO ANY PARTICULAR FONT, STYLE, SIZE, OR COLOR.

FOR RETAIL STORE SERVICES AND ON-LINE RETAIL STORE SERVICES FEATURING CLOTHING, CLOTHING ACCESSORIES, PERSONAL CARE PRODUCTS, HOME PRODUCTS, LUGGAGE AND BAGS (U.S. CLS. 100, 101 AND 102).

FIRST USE 7-0-2005; IN COMMERCE 7-0-2005.

**CLASS 36—INSURANCE AND FINANCIAL**

3,235,426. DIRECTACCESS WORLDWIDE, INC., AMERICAN FORK, UT. SN 76-637,654. FILED P.R. 5-2-2005; AM. S.R. 6-12-2006.

# DIRECTHSA

THE MARK CONSISTS OF STANDARD CHARACTERS WITHOUT CLAIM TO ANY PARTICULAR FONT, STYLE, SIZE, OR COLOR.

FOR SAVINGS ACCOUNT SERVICES IN THE FIELD OF HEALTH SAVINGS ACCOUNTS TO PAY FOR MEDICAL, DENTAL AND HEALTHCARE SERVICES; FINANCIAL MANAGEMENT OF MEDICAL, DENTAL AND HEALTHCARE ACCOUNTS AND BENEFITS (U.S. CLS. 100, 101 AND 102).

FIRST USE 1-30-2004; IN COMMERCE 1-30-2004.

3,235,428. FINANCIAL NETWORK, INC., ST. PAUL, MN. SN 76-652,645. FILED P.R. 12-29-2005; AM. S.R. 7-27-2006.

# FINANCIAL NETWORK-ING

THE MARK CONSISTS OF STANDARD CHARACTERS WITHOUT CLAIM TO ANY PARTICULAR FONT, STYLE, SIZE, OR COLOR.

NO CLAIM IS MADE TO THE EXCLUSIVE RIGHT TO USE FINANCIAL, APART FROM THE MARK AS SHOWN.

FOR FINANCIAL LOAN CONSULTATION SERVICES, NAMELY, CONSULTING REAL ESTATE AGENTS, BROKERS, DEVELOPERS AND LENDERS IN THE PLACEMENT OF INVESTMENT GRADE AND MARGINAL CREDIT COMMERCIAL LOANS; BROKERAGE OF LOAN PORTFOLIOS IN THE SECONDARY MARKET; FINANCING IN THE FIELD OF REAL ESTATE (U.S. CLS. 100, 101 AND 102).

FIRST USE 12-21-2005; IN COMMERCE 12-21-2005.

**CLASS 36—(Continued).**

3,235,442. REALESTATEANDLOAN.COM, INC., DOWNEY, CA. SN 78-570,873. FILED P.R. 2-18-2005; AM. S.R. 12-21-2006.



"THE COLOR(S) BLACK, OLIVE GREEN, AND GRAY IS/ ARE CLAIMED AS A FEATURE OF THE MARK."

THE MARK CONSISTS OF THE COLOR BLACK APPEARING IN THE WORDING LOAN, OLIVE GREEN APPEARING UNDER/OVER-LINES AND IN THE WORDING SYSTEMS, AND GRAY APPEARING IN .COM.

FOR ONLINE MORTGAGE LOAN ORGANIZATION SERVICES, NAMELY, TRACKING LOAN ACTIVITY, PROVIDING LOAN REFERRAL LINKS, AND MANAGEMENT OF LOAN PROGRESS (U.S. CLS. 100, 101 AND 102).

FIRST USE 7-1-2004; IN COMMERCE 7-1-2004.

3,235,458. HISCOX PLC, LONDON, UNITED KINGDOM. SN 78-761,256. FILED P.R. 11-28-2005; AM. S.R. 2-22-2007.

# HISCOX

THE MARK CONSISTS OF STANDARD CHARACTERS WITHOUT CLAIM TO ANY PARTICULAR FONT, STYLE, SIZE, OR COLOR.

FOR INSURANCE UNDERWRITING SERVICES IN THE FIELDS OF THEFT, FIRE, AUTOMOBILE, PROPERTY LOSS, KIDNAP AND RANSOM, FINE ART, MARINE, AVIATION, TRADE AND ASSET RISK, CRIME AND PROFESSIONAL INDEMNITY, PERSONAL ACCIDENT, AEROSPACE, COMPUTER HACKER, AND EQUINE BLOODSTOCK INSURANCE; INSURANCE BROKERAGE; INSURANCE AGENCY SERVICES; INSURANCE CONSULTATION AND INFORMATION SERVICES; REINSURANCE UNDERWRITING SERVICES IN THE FIELDS OF MARINE, AVIATION, AND PROPERTY LOSS INSURANCE; FINANCIAL ADVISORY, CONSULTATION, PLANNING AND INFORMATION SERVICES; ACTUARIAL SERVICES (U.S. CLS. 100, 101 AND 102).

FIRST USE 3-0-2006; IN COMMERCE 3-0-2006.

**CLASS 36—(Continued).**

3,235,469. BANK OF WYOMING, THERMOPOLIS, WY. SN 78-805,610. FILED P.R. 2-2-2006; AM. S.R. 1-26-2007.

**BANK OF WYOMING**

THE MARK CONSISTS OF STANDARD CHARACTERS WITHOUT CLAIM TO ANY PARTICULAR FONT, STYLE, SIZE, OR COLOR.

NO CLAIM IS MADE TO THE EXCLUSIVE RIGHT TO USE "BANK", APART FROM THE MARK AS SHOWN.

FOR BANKING (U.S. CLS. 100, 101 AND 102).  
FIRST USE 1-2-2006; IN COMMERCE 1-2-2006.

3,235,473. AHARONIAN, GREGORY, SAN FRANCISCO, CA. SN 78-829,795. FILED P.R. 3-6-2006; AM. S.R. 2-21-2007.

**Econophysics Trading**

THE MARK CONSISTS OF STANDARD CHARACTERS WITHOUT CLAIM TO ANY PARTICULAR FONT, STYLE, SIZE, OR COLOR.

NO CLAIM IS MADE TO THE EXCLUSIVE RIGHT TO USE "TRADING", APART FROM THE MARK AS SHOWN.

FOR FINANCIAL ANALYSIS AND CONSULTATION; FINANCIAL FORECASTING; FINANCIAL MANAGEMENT; FINANCIAL PORTFOLIO MANAGEMENT; FINANCIAL RESEARCH; FINANCIAL SERVICES, NAMELY ASSISTING OTHERS WITH THE COMPLETION OF FINANCIAL TRANSACTIONS FOR STOCKS, BONDS, SECURITIES AND EQUITIES (U.S. CLS. 100, 101 AND 102).

FIRST USE 2-14-2006; IN COMMERCE 2-14-2006.

**CLASS 39—TRANSPORTATION AND STORAGE**

3,235,485. UNITED AIR LINES, INC., CHICAGO, IL. SN 78-872,046. FILED P.R. 4-28-2006; AM. S.R. 1-29-2007.

**REWARD MILES**

THE MARK CONSISTS OF STANDARD CHARACTERS WITHOUT CLAIM TO ANY PARTICULAR FONT, STYLE, SIZE, OR COLOR.

FOR TRANSPORTATION OF PERSONS, PROPERTY AND MAIL BY AIR; PROVIDING A FREQUENT FLYER BONUS PROGRAM FOR EMPLOYEES AND CUSTOMERS OF OTHERS (U.S. CLS. 100 AND 105).

FIRST USE 11-4-1994; IN COMMERCE 11-4-1994.

**CLASS 41—EDUCATION AND ENTERTAINMENT**

3,235,429. DJ CHEF ENTERTAINMENT CORP., LONG BEACH, NY. SN 76-657,871. FILED P.R. 4-5-2006; AM. S.R. 11-20-2006.

**DJ CHEF**

THE NAME DJ CHEF IDENTIFIES A LIVING INDIVIDUAL WHOSE CONSENT IS OF RECORD.

FOR DISC JOCKEY SERVICES; ENTERTAINMENT SERVICES, NAMELY WINE AND FOOD TASTINGS (U.S. CLS. 100, 101 AND 107).

FIRST USE 1-14-1997; IN COMMERCE 1-14-1997.

3,235,443. THE KENNEDY CENTER FOR REAL ESTATE EDUCATION, INC., ATLANTA, GA. SN 78-603,158. FILED P.R. 4-6-2005; AM. S.R. 5-10-2006.

**ACCREDITED SELLER REPRESENTATIVE**

THE MARK CONSISTS OF STANDARD CHARACTERS WITHOUT CLAIM TO ANY PARTICULAR FONT, STYLE, SIZE, OR COLOR.

NO CLAIM IS MADE TO THE EXCLUSIVE RIGHT TO USE "ACCREDITED", APART FROM THE MARK AS SHOWN.

FOR EDUCATIONAL SERVICES, NAMELY CONDUCTING COURSES, TESTING AND SEMINARS IN REAL ESTATE EDUCATION AND ON REAL ESTATE TOPICS (U.S. CLS. 100, 101 AND 107).

FIRST USE 9-1-2003; IN COMMERCE 9-1-2003.

**CLASS 41—(Continued).**

3,235,447. THE MONEY GAMING CORPORATION LTD., LONDON, UNITED KINGDOM. SN 78-667,376. FILED P.R. 7-11-2005; AM. S.R. 2-13-2007.

**MONEYGAMING.COM**

THE MARK CONSISTS OF STANDARD CHARACTERS WITHOUT CLAIM TO ANY PARTICULAR FONT, STYLE, SIZE, OR COLOR.

FOR PROVIDING GAMBLING AND GAMING SERVICES; ENTERTAINMENT SERVICES, NAMELY, PROVIDING INTERACTIVE ONLINE COMPUTER GAMES VIA LOCAL COMPUTER NETWORKS AND GLOBAL COMMUNICATION NETWORKS; CONDUCTING SPECIAL EVENTS FEATURING GAMBLING AND GAMING CONTESTS AND TOURNAMENTS (U.S. CLS. 100, 101 AND 107).

FIRST USE 5-0-2005; IN COMMERCE 7-15-2005.

3,235,451. NEW HORIZONS EDUCATION CORPORATION, ANAHEIM, CA. SN 78-692,132. FILED P.R. 8-13-2005; AM. S.R. 3-7-2007.

**MENTORED LEARNING**

THE MARK CONSISTS OF STANDARD CHARACTERS WITHOUT CLAIM TO ANY PARTICULAR FONT, STYLE, SIZE, OR COLOR.

FOR EDUCATIONAL SERVICES, NAMELY, CONDUCTING COURSES RELATED TO THE USE OF COMPUTER SOFTWARE AND HARDWARE, NON-TECHNICAL BUSINESS SKILLS AND PROFESSIONAL DEVELOPMENT AND PROVIDING TRAINING IN PROFESSIONAL SKILLS IN THE USE OF COMPUTER SOFTWARE AND HARDWARE AND DISTRIBUTION OF COURSE MATERIALS IN CONNECTION THEREWITH; PROVIDING INTERACTIVE, ON-LINE NEWSLETTERS THAT ARE ACCESSED VIA A GLOBAL COMPUTER NETWORK AND FEATURING INFORMATION ON COMPUTERS (U.S. CLS. 100, 101 AND 107).

FIRST USE 2-0-2005; IN COMMERCE 2-0-2005.

3,235,453. PERAZA, WILLIAM JR., MIAMI, FL. SN 78-712,350. FILED P.R. 9-13-2005; AM. S.R. 2-6-2007.

**CEO Poker Games**

THE MARK CONSISTS OF STANDARD CHARACTERS WITHOUT CLAIM TO ANY PARTICULAR FONT, STYLE,

**CLASS 41—(Continued).**

SIZE, OR COLOR.

NO CLAIM IS MADE TO THE EXCLUSIVE RIGHT TO USE "POKER GAMES", APART FROM THE MARK AS SHOWN.

FOR CONDUCTING ENTERTAINMENT EXHIBITIONS IN THE NATURE OF POKER GAMES CONDUCTED LIVE AND ONLINE; ENTERTAINMENT IN THE NATURE OF VISUAL AND AUDIO PERFORMANCES, AND MUSICAL, VARIETY, NEWS AND COMEDY SHOWS; ENTERTAINMENT NAMELY, PRODUCTION OF LIVE POKER GAMES; ENTERTAINMENT SERVICES, NAMELY, PRODUCTION AND DISTRIBUTION OF A GAME SHOW; ENTERTAINMENT, NAMELY A CONTINUING POKER SHOW BROADCAST OVER TELEVISION, SATELLITE, AUDIO, AND VIDEO MEDIA; PRESENTATION OF LIVE SHOW PERFORMANCES; TELEVISION SHOW PRODUCTION (U.S. CLS. 100, 101 AND 107).

FIRST USE 1-1-2003; IN COMMERCE 1-1-2003.

3,235,470. GUPTA, SANJAY KUMAR, BOSTON, MA. SN 78-806,277. FILED P.R. 2-3-2006; AM. S.R. 1-29-2007.

**Swiss Finance Institute**

THE MARK CONSISTS OF STANDARD CHARACTERS WITHOUT CLAIM TO ANY PARTICULAR FONT, STYLE, SIZE, OR COLOR.

NO CLAIM IS MADE TO THE EXCLUSIVE RIGHT TO USE "INSTITUTE", APART FROM THE MARK AS SHOWN.

FOR PROVIDING TRAINING IN THE FIELD OF INVESTMENT BANKING, WEALTH MANAGEMENT, HEDGE FUNDS AND CORPORATE FINANCE (U.S. CLS. 100, 101 AND 107).

FIRST USE 8-0-2004; IN COMMERCE 8-0-2004.

3,235,477. MAP IMPLANT INSTITUTE, PALM HARBOR, FL. SN 78-836,546. FILED P.R. 3-14-2006; AM. S.R. 2-12-2007.

**DIGITALLY GUIDED BONE AUGMENTATION**

THE MARK CONSISTS OF STANDARD CHARACTERS WITHOUT CLAIM TO ANY PARTICULAR FONT, STYLE, SIZE, OR COLOR.

FOR EDUCATIONAL SERVICES, NAMELY, CONDUCTING SEMINARS, LECTURES, AND WORKSHOPS IN THE FIELD OF BONE AUGMENTATION (U.S. CLS. 100, 101 AND 107).

FIRST USE 1-13-2006; IN COMMERCE 8-19-2006.

**CLASS 44—(Continued).**

3,235,481. AFFINITY DIRECT, LLC, ENGLEWOOD CLIFFS, NJ. SN 78-847,545. FILED P.R. 3-28-2006; AM. S.R. 1-29-2007.

**CLASS 42—(Continued).**

THE MARK CONSISTS OF STANDARD CHARACTERS WITHOUT CLAIM TO ANY PARTICULAR FONT, STYLE, SIZE, OR COLOR.  
FOR LEGAL SERVICES (U.S. CLS. 100 AND 101).  
FIRST USE 7-1-2005; IN COMMERCE 7-1-2005.

GREAT STUDENT LOAN PAYOFF

THE MARK CONSISTS OF STANDARD CHARACTERS WITHOUT CLAIM TO ANY PARTICULAR FONT, STYLE, SIZE, OR COLOR.  
FOR SWEEPSTAKE SERVICES (U.S. CLS. 100, 101 AND 107).  
FIRST USE 7-7-2004; IN COMMERCE 7-7-2004.

**CLASS 44—MEDICAL, BEAUTY AND AGRICULTURAL SERVICES**

3,235,444. BLUE CROSS AND BLUE SHIELD OF RHODE ISLAND, PROVIDENCE, RI. SN 78-608,887. FILED P.R. 4-14-2005; AM. S.R. 3-11-2007.

**CLASS 42—SCIENTIFIC, COMPUTER AND LEGAL SERVICES**

3,235,461. CONNELLY SHEEHAN HARRIS, LLP, CHICAGO, IL. SN 78-780,210. FILED P.R. 12-23-2005; AM. S.R. 1-30-2007.



THE EMPLOYERS' LAWYERS

FOR HEALTH CARE SERVICES, NAMELY ASSISTING INDIVIDUALS TO STOP SMOKING; PROVIDING HEALTH INFORMATION; PROVIDING COUNSELING SERVICES IN THE FIELD OF HEALTH (U.S. CLS. 100 AND 101).  
FIRST USE 1-1-2007; IN COMMERCE 1-1-2007.

\* \* \* \* \*

PRIOR UNITED STATES CLASSIFICATION

APPLICATION IN ONE CLASS

CERTIFICATION MARKS

CLASS A—GOODS

3,235,463. AMERICAN GAITED MOUNTAIN HORSE ASSOCIATION, LLC, CLAY CITY, KY. SN 78-791,675. FILED P.R. 1-13-2006; AM. S.R. 1-8-2007.

American Gaited Spotted  
Mountain Horse

THE MARK CONSISTS OF STANDARD CHARACTERS WITHOUT CLAIM TO ANY PARTICULAR FONT, STYLE, SIZE, OR COLOR.

THE CERTIFICATION MARK AS USED BY AUTHORIZED PERSONS CERTIFIES THAT THE HORSE WITH WHICH THE MARK IS ASSOCIATED MEETS WITH THE CERTIFIER'S STANDARDS FOR THE REGISTRATION OF "AMERICAN GAITED SPOTTED MOUNTAIN HORSES". APPLICANT IS NOT ENGAGED IN THE PRODUCTION OR MARKETING OF ANY GOODS OR SERVICES TO WHICH THE MARK IS APPLIED.

FOR HORSE MUST BE REGISTERED, QUALIFY FOR REGISTRATION, OR AT ONE TIME HAD BEEN REGISTERED, WITH CERTAIN OTHER DESIGNATED REGISTRIES OF GAITED SPOTTED MOUNTAIN HORSES OR BE A FOAL OF A MARE OR SIRE WHERE SUCH MAKE OR SITE IS REGISTERED, QUALIFIES FOR REGISTRATION OR AT ONE TIME WAS REGISTERED WITH CERTAIN DESIGNATED GAITED SPOTTED MOUNTAIN HORSE REGISTRIES (U.S. CL. A).

FIRST USE 3-31-2006; IN COMMERCE 4-11-2006.

3,235,465. AMERICAN GAITED MOUNTAIN HORSE ASSOCIATION, LLC, CLAY CITY, KY. SN 78-791,693. FILED P.R. 1-13-2006; AM. S.R. 1-8-2007.

American Spotted Mountain  
Horse

THE MARK CONSISTS OF STANDARD CHARACTERS WITHOUT CLAIM TO ANY PARTICULAR FONT, STYLE, SIZE, OR COLOR.

THE CERTIFICATION MARK AS USED BY AUTHORIZED PERSONS CERTIFIES THAT THE HORSE WITH WHICH THE MARK IS ASSOCIATED MEETS WITH THE CERTIFIER'S STANDARDS FOR THE REGISTRATION OF "AMERICAN SPOTTED MOUNTAIN HORSES". APPLICANT IS NOT ENGAGED IN THE PRODUCTION OR MARKETING OF ANY GOODS OR SERVICES TO WHICH THE MARK IS APPLIED.

FOR HORSE MUST BE REGISTERED, QUALIFY FOR REGISTRATION OR AT ONE TIME HAD BEEN REGISTERED, WITH CERTAIN OTHER DESIGNATED REGISTRIES OF SPOTTED MOUNTAIN HORSES OR BE A FOAL OF A MARE OR SIRE, WHERE SUCH MARE OR SIRE IS REGISTERED QUALIFIES FOR REGISTRATION OR AT ONE TIME WAS REGISTERED WITH CERTAIN DESIGNATED SPOTTED MOUNTAIN HORSE REGISTRIES (U.S. CL. A).

FIRST USE 7-23-2006; IN COMMERCE 1-4-2007.

\* \* \* \* \*

# TRADEMARK REGISTRATIONS RENEWED

The designation "U.S. Cl." appearing in this section refers to the U.S. class in effect prior to Sep. 1, 1973 rather than the international class which applies to applications filed on or after that date. For adoption of international classification see notice in the OFFICIAL GAZETTE of Jun. 26, 1973 (911 O.G. TM 210).

223,213.	HALF AND HALF (STYLIZED). U.S. CL. 17. (INT. CL. 34). REG. 1-18-1927.	647,040.	MICROWELD. U.S. CL. 21. (INT. CL. 9). REG. 6-18-1957.
224,608.	VOLCK (STYLIZED). U.S. CL. 6. (INT. CL. 5). REG. 3-1-1927.	647,467.	MELITTA (STYLIZED). U.S. CL. 31. (INT. CL. 16). REG. 6-25-1957.
226,182.	MISCELLANEOUS DESIGN. U.S. CL. 37. (INT. CL. 16). REG. 4-5-1927.	652,284.	CEILTILE. U.S. CL. 13. (INT. CL. 6). REG. 10-1-1957.
227,057.	SEALTIGHT (STYLIZED). U.S. CL. 12. (INT. CL. 19). REG. 4-26-1927.	656,476.	BAROID AND DESIGN. U.S. CL. 38. (INT. CL. 16). REG. 12-31-1957.
230,350.	TRAIL (STYLIZED). U.S. CL. 46. (INT. CL. 31). REG. 7-19-1927.	763,778.	FUTURA. U.S. CL. 17. (INT. CL. 34). REG. 1-28-1964.
341,349.	TRIP-O-LINK (STYLIZED). U.S. CL. 21. (INT. CL. 9). REG. 12-8-1936.	810,357.	TITAN. U.S. CL. 13. (INT. CL. 6). REG. 6-28-1966.
342,328.	AQUILA D'ORO (STYLIZED). U.S. CL. 46. (INT. CL. 29). REG. 1-12-1937.	811,233.	CHEMSEAL. U.S. CL. 15. (INT. CL. 4). REG. 7-19-1966.
343,061.	OLIVER. U.S. CL. 23. (INT. CLS. 6, 7, 8, 9, 11, 12, 16, 21 AND 28). REG. 2-9-1937.	812,867.	RIES' THREE STAR MIXTURE AND DESIGN. U.S. CL. 17. (INT. CL. 34). REG. 8-16-1966.
346,426.	GRANT'S. U.S. CL. 49. (INT. CL. 33). REG. 5-25-1937.	816,263.	TOUJOURS MOI. U.S. CL. 51. (INT. CLS. 3 AND 5). REG. 10-4-1966.
347,265.	PORTER. U.S. CL. 46. (INT. CL. 31). REG. 6-22-1937.	818,303.	LILY OF FRANCE (STYLIZED). U.S. CL. 39. (INT. CLS. 10, 25 AND 26). REG. 11-8-1966.
348,517.	REDLANDS FOOTHILL (STYLIZED). U.S. CL. 46. (INT. CL. 31). REG. 7-27-1937.	819,701.	PATHOTEC. U.S. CL. 6. (INT. CL. 1). REG. 12-6-1966.
422,195.	SYROCOSTANDARD CHARACTER MARK U.S. CL. 32. (INT. CL. 20). REG. 7-9-1946.	819,764.	DYVAL (STYLIZED). U.S. CL. 13. (INT. CL. 6). REG. 12-6-1966.
425,768.	OX-O-DECK. U.S. CL. 16. (INT. CL. 2). REG. 12-3-1946.	820,711.	ADDIGEST. U.S. CL. 23. (INT. CL. 11). REG. 12-20-1966.
426,323.	TABU (STYLIZED). U.S. CL. 51. (INT. CL. 3). REG. 12-24-1946.	821,487.	BARTLETT. U.S. CL. 19. (INT. CL. 12). REG. 1-3-1967.
426,932.	AMERSE (STYLIZED). U.S. CL. 6. (INT. CL. 5). REG. 1-21-1947.	821,790.	CORIAN. U.S. CL. 1. (INT. CL. 17). REG. 1-10-1967.
427,106.	AJAX. U.S. CL. 52. (INT. CL. 3). REG. 1-28-1947.	821,791.	DU PONT AND DESIGN. U.S. CL. 1. (INT. CL. 17). REG. 1-10-1967.
427,851.	DEOXO. U.S. CL. 26. (INT. CL. 9). REG. 2-25-1947.	821,799.	STASAFE AND DESIGN. U.S. CLS. 34, 39 AND 50 ONLY. (INT. CLS. 3, 6, 10, 11, 14, 16, 17, 19, 20, 21, 22, 24, 25, 26, 27 AND 28). REG. 1-10-1967.
429,707.	REFRASIL AND DESIGN. U.S. CL. 12. (INT. CL. 17). REG. 5-13-1947.	821,837.	GRANUSIC. U.S. CL. 6. (INT. CL. 1). REG. 1-10-1967.
630,254.	POR-ROK (STYLIZED). U.S. CL. 12. (INT. CL. 19). REG. 7-10-1956.	822,012.	PENROSE. U.S. CL. 46. (INT. CLS. 1, 5, 29, 30, 31 AND 32). REG. 1-10-1967.
638,259.	HERMA (STYLIZED). U.S. CL. 5. (INT. CL. 16). REG. 12-11-1956.	822,981.	ROYAL DUTCH. U.S. CL. 46. (INT. CLS. 29 AND 30). REG. 1-24-1967.
639,275.	DICTAPHONE. U.S. CL. 21. (INT. CLS. 7, 9, 11, 12 AND 15). REG. 1-1-1957.	823,016.	DRIFOND AND DESIGN. U.S. CL. 46. (INT. CL. 30). REG. 1-24-1967.
639,416.	SERA-SHARP (STYLIZED). U.S. CL. 44. (INT. CL. 10). REG. 1-1-1957.	823,043.	TRIPLEMETAL. U.S. CL. 50. (INT. CL. 16). REG. 1-24-1967.
639,885.	DU PONT AND DESIGN. U.S. CL. 6. (INT. CL. 2). REG. 1-15-1957.	823,199.	RILSAN. INT. CL. 1. (U.S. CL. 1). REG. 1-31-1967.
640,179.	GOLDEN STATE BRAND AND DESIGN. U.S. CL. 46. (INT. CL. 30). REG. 1-15-1957.	823,240.	NOVIGANTH. U.S. CL. 6. (INT. CL. 1). REG. 1-31-1967.
640,512.	GEORGIANIER. INT. CL. 1. (U.S. CL. 1). REG. 1-29-1957.	823,257.	DACONIL 2787. U.S. CL. 6. (INT. CL. 5). REG. 1-31-1967.
641,416.	FIRE ENGINEERING (STYLIZED). U.S. CL. 38. (INT. CL. 16). REG. 2-12-1957.	823,290.	RILSAN. U.S. CL. 16. (INT. CL. 2). REG. 1-31-1967.
641,432.	DRAKE. U.S. CL. 39. (INT. CL. 25). REG. 2-12-1957.	823,350.	TEMPO. U.S. CL. 23. (INT. CL. 7). REG. 1-31-1967.
641,610.	MAGIC MARKER. U.S. CL. 11. (INT. CL. 16). REG. 2-19-1957.	823,351.	TEMPO TANKER AND DESIGN. U.S. CL. 23. (INT. CL. 7). REG. 1-31-1967.
641,911.	SEA SNACK (STYLIZED). U.S. CL. 46. (INT. CL. 29). REG. 2-19-1957.	823,396.	APEX. U.S. CL. 35. (INT. CL. 17). REG. 1-31-1967.
642,127.	SWISS COLONY. U.S. CL. 46. (INT. CLS. 29 AND 30). REG. 2-26-1957.	823,397.	OMEGA. U.S. CL. 35. (INT. CL. 17). REG. 1-31-1967.
642,221.	BEL AIR. U.S. CL. 13. (INT. CL. 6). REG. 3-5-1957.	823,586.	LINATONE. U.S. CL. 18. (INT. CL. 5). REG. 2-7-1967.
642,331.	TA' POT AND DESIGN. U.S. CL. 26. (INT. CL. 9). REG. 3-5-1957.	823,870.	BLACK MAGIC. U.S. CL. 11. (INT. CL. 2). REG. 2-14-1967.
642,907.	SI-CHROME. U.S. CL. 23. (INT. CL. 7). REG. 3-19-1957.	824,208.	VIP. U.S. CL. 101. (INT. CL. 35). REG. 2-14-1967.
643,926.	MISCELLANEOUS DESIGN. U.S. CL. 38. (INT. CL. 16). REG. 4-9-1957.	824,390.	VACTOR. U.S. CL. 23. (INT. CL. 7). REG. 2-21-1967.
645,830.	SPERRY. U.S. CL. 46. (INT. CL. 30). REG. 5-21-1957.	824,682.	VENETIAN. U.S. CL. 4. (INT. CL. 3). REG. 2-28-1967.
646,274.	MISCELLANEOUS DESIGN. U.S. CL. 6. (INT. CLS. 1 AND 4). REG. 6-4-1957.	824,710.	DGS. U.S. CL. 6. (INT. CL. 1). REG. 2-28-1967.
		824,711.	K KOLENE (STYLIZED). U.S. CL. 6. (INT. CL. 1). REG. 2-28-1967.
		825,339.	RANDALL'S. U.S. CLS. 39 AND 100. (INT. CLS. 25 AND 42). REG. 3-7-1967.



828,009.	THE ROYAL ORLEANS (STYLIZED). U.S. CL. 100. (INT. CL. 42). REG. 4-25-1967.	1,057,895.	SUNDOWNER. INT. CL. 34. (U.S. CL. 17). REG. 2-1-1977.
829,347.	CARFLEX. U.S. CL. 13. (INT. CL. 20). REG. 5-30-1967.	1,058,037.	VANISHING POINT. INT. CL. 16. (U.S. CL. 37). REG. 2-1-1977.
830,079.	VALCO. U.S. CL. 23 ONLY. (INT. CL. 7). REG. 6-13-1967.	1,058,184.	HEP-LOCK. INT. CL. 5. (U.S. CL. 18). REG. 2-8-1977.
830,161.	SOFTAR (STYLIZED). U.S. CL. 26. (INT. CL. 9). REG. 6-13-1967.	1,058,236.	BERSTORFF. INT. CL. 7. (U.S. CL. 23). REG. 2-8-1977.
830,220.	SANI-PANT. U.S. CL. 39. (INT. CL. 25). REG. 6-13-1967.	1,058,239.	DUOFORMER. INT. CL. 7. (U.S. CLS. 13, 19, 21, 23, 31, 34 AND 35). REG. 2-8-1977.
830,280.	PORTAGEN. U.S. CL. 46. (INT. CL. 5). REG. 6-13-1967.	1,058,334.	GROUND-TITE. INT. CL. 9. (U.S. CL. 21). REG. 2-8-1977.
830,347.	CRC 5-56 AND DESIGN. U.S. CL. 52. (INT. CL. 3). REG. 6-13-1967.	1,058,443.	HOKUSAN (STYLIZED). INT. CL. 19. (U.S. CL. 12). REG. 2-8-1977.
831,047.	S (STYLIZED). U.S. CL. 32. (INT. CL. 20). REG. 6-27-1967.	1,058,684.	DAVIDOFF. INT. CL. 34. (U.S. CLS. 2, 8, 9 AND 17). REG. 2-8-1977.
832,240.	CAVANAGH. U.S. CL. 39. (INT. CL. 25). REG. 7-18-1967.	1,058,700.	ORR AND DESIGN. INT. CL. 35. (U.S. CL. 101). REG. 2-8-1977.
839,835.	HOMASOTE 4-WAY. U.S. CL. 12. (INT. CL. 19). REG. 12-5-1967.	1,058,726.	D AND DESIGN. INT. CL. 37. (U.S. CL. 103). REG. 2-8-1977.
840,323.	HYDERGINE. U.S. CL. 18. (INT. CL. 5). REG. 12-12-1967.	1,058,801.	PIERCE ARROW SOCIETY. U.S. CL. 200. REG. 2-8-1977.
840,920.	BROOKSEASE. U.S. CL. 39. (INT. CL. 25). REG. 12-19-1967.	1,058,901.	MISCELLANEOUS DESIGN. INT. CL. 29. (U.S. CL. 46). REG. 2-15-1977.
841,570.	BASSMAN. U.S. CL. 21. (INT. CL. 9). REG. 1-2-1968.	1,058,905.	BAQUACIL. INT. CL. 5. (U.S. CL. 6). REG. 2-15-1977.
841,905.	SAF-T-STA. U.S. CL. 13. (INT. CL. 6). REG. 1-9-1968.	1,058,955.	TOPY. INT. CL. 6. (U.S. CL. 13). REG. 2-15-1977.
842,590.	CRYSTAL WHITE. U.S. CL. 52. (INT. CL. 3). REG. 1-16-1968.	1,058,984.	ACCU-SCALE. INT. CL. 7. (U.S. CL. 23). REG. 2-15-1977.
1,034,556.	EXTREMITY PUMP. U.S. CL. 44. (INT. CL. 10). REG. 2-24-1976.	1,059,049.	POWER BREAK (STYLIZED). INT. CL. 9. (U.S. CL. 21). REG. 2-15-1977.
1,042,721.	FLUORGLAS. INT. CLS. 7 AND 24 ONLY. (U.S. CLS. 13, 19, 21, 23, 31, 34, 35 AND 42). REG. 7-6-1976.	1,059,199.	BOOK-OF-THE-MONTH. INT. CL. 16. (U.S. CL. 38). REG. 2-15-1977.
1,044,132.	AMSCO. INT. CL. 16. (U.S. CL. 38). REG. 7-20-1976.	1,059,248.	VEKTON. INT. CL. 17. (U.S. CL. 1). REG. 2-15-1977.
1,045,589.	PACKAGE OF PROTECTION. INT. CL. 36. (U.S. CL. 102). REG. 8-3-1976.	1,059,265.	SILTEC. INT. CL. 19. (U.S. CL. 12). REG. 2-15-1977.
1,046,312.	BFG. INT. CL. 12. (U.S. CL. 35). REG. 8-17-1976.	1,059,526.	SKANDINAVIK. INT. CL. 34. (U.S. CL. 17). REG. 2-15-1977.
1,047,993.	STORETTE. INT. CL. 6. (U.S. CL. 32). REG. 9-14-1976.	1,060,502.	JAMES AVERY, CRAFTSMAN. INT. CL. 42. (U.S. CL. 101). REG. 3-1-1977.
1,051,406.	SAVORLAC. INT. CL. 29. (U.S. CL. 46). REG. 10-26-1976.	1,060,755.	TRIXIE BELDEN. INT. CL. 16. (U.S. CL. 38). REG. 3-8-1977.
1,054,904.	MOLLE (STYLIZED). INT. CL. 3. (U.S. CL. 51). REG. 12-28-1976.	1,060,935.	"IF A SEA GULL FLIES OVER THE SEA, WHAT FLIES OVER THE BAY?". INT. CL. 30. (U.S. CL. 46). REG. 3-8-1977.
1,055,293.	JUST US KIDS. INT. CL. 41. (U.S. CL. 107). REG. 12-28-1976.	1,061,404.	FAT BOYS' BAR-B-Q. INT. CL. 42. (U.S. CL. 100). REG. 3-15-1977.
1,055,870.	ALCON. INT. CLS. 3, 5 AND 10 ONLY. (U.S. CLS. 6, 18, 26, 39, 44, 46, 51 AND 52). REG. 1-11-1977.	1,061,545.	PRO HUNTER. INT. CL. 8. (U.S. CL. 23). REG. 3-22-1977.
1,056,059.	GRAY'S. INT. CL. 16. (U.S. CL. 38). REG. 1-11-1977.	1,062,145.	MISCELLANEOUS DESIGN. INT. CL. 9. (U.S. CL. 36). REG. 3-29-1977.
1,056,249.	LORENZO AND DESIGN. INT. CL. 34. (U.S. CL. 8). REG. 1-11-1977.	1,062,511.	KEWPEE (STYLIZED). INT. CL. 42. (U.S. CL. 100). REG. 3-29-1977.
1,056,547.	JETGLAS (STYLIZED). INT. CL. 11. (U.S. CL. 34). REG. 1-18-1977.	1,062,517.	KEWPEE AND DESIGN. INT. CL. 42. (U.S. CL. 100). REG. 3-29-1977.
1,056,586.	CHAMBERS. INT. CL. 16. (U.S. CL. 38). REG. 1-18-1977.	1,062,544.	FICOLL. INT. CL. 1. (U.S. CL. 6). REG. 4-5-1977.
1,056,610.	CLAMP-FINDER. INT. CL. 20. (U.S. CL. 13). REG. 1-18-1977.	1,062,838.	TYEE. INT. CL. 28. (U.S. CL. 22). REG. 4-5-1977.
1,056,856.	G-115. INT. CL. 5. (U.S. CL. 18). REG. 1-25-1977.	1,063,387.	ROCES. INT. CL. 25. (U.S. CL. 39). REG. 4-12-1977.
1,056,872.	WINDOWALLS. INT. CLS. 6 AND 19. (U.S. CLS. 1, 2, 12, 13, 14, 23, 25, 33 AND 50). REG. 1-25-1977.	1,063,441.	CURTIS AND DESIGN. INT. CL. 29. (U.S. CL. 46). REG. 4-12-1977.
1,057,158.	SAUZA HORNITOS. INT. CL. 33. (U.S. CL. 49). REG. 1-25-1977.	1,064,781.	CAPITROL. INT. CL. 3. (U.S. CL. 52). REG. 5-3-1977.
1,057,249.	WALGREENS. INT. CL. 42. (U.S. CL. 100). REG. 1-25-1977.	1,065,661.	TAPER LINE. INT. CL. 6. (U.S. CL. 13). REG. 5-17-1977.
1,057,308.	SUPER SCRUB. INT. CL. 2. (U.S. CL. 16). REG. 2-1-1977.	1,067,128.	RID-O-RUST. INT. CL. 9. (U.S. CL. 26). REG. 6-7-1977.
1,057,340.	KONTROL. INT. CL. 5. (U.S. CL. 6). REG. 2-1-1977.	1,067,155.	FRE-HEATER. INT. CL. 11. (U.S. CL. 34). REG. 6-7-1977.
1,057,371.	WORKMATE. INT. CL. 6. (U.S. CL. 23). REG. 2-1-1977.	1,067,297.	MISCELLANEOUS DESIGN. INT. CL. 28. (U.S. CL. 22). REG. 6-7-1977.
1,057,379.	SETONGUARD. INT. CL. 6. (U.S. CL. 13). REG. 2-1-1977.	1,067,298.	FISCHER AND DESIGN. INT. CL. 28. (U.S. CL. 22). REG. 6-7-1977.
1,057,423.	HAEMONETICS. INT. CLS. 9 AND 10. (U.S. CLS. 26 AND 44). REG. 2-1-1977.	1,067,759.	KARASTAN (STYLIZED). INT. CL. 27. (U.S. CL. 42). REG. 6-14-1977.
1,057,437.	GILFLO. INT. CL. 9. (U.S. CL. 26). REG. 2-1-1977.	1,067,841.	EMPRESS OF TAMPA. INT. CL. 34. (U.S. CL. 17). REG. 6-14-1977.
1,057,609.	THE PULLER. INT. CL. 16. (U.S. CL. 38). REG. 2-1-1977.	1,068,287.	ROADWAY R (STYLIZED). INT. CL. 39. (U.S. CL. 105). REG. 6-21-1977.
1,057,677.	FR-701. INT. CL. 24. (U.S. CL. 42). REG. 2-1-1977.	1,068,871.	TEMA. INT. CL. 6. (U.S. CL. 13). REG. 7-5-1977.
1,057,848.	EARTH GRAINS AND DESIGN. INT. CL. 30. (U.S. CL. 46). REG. 2-1-1977.	1,070,369.	CAVALCADE OF WHEELS. INT. CL. 35. (U.S. CL. 101). REG. 7-26-1977.
1,057,855.	CHOCOLATE SOUP. INT. CL. 30. (U.S. CL. 46). REG. 2-1-1977.	1,071,632.	ELDERHOSTEL. INT. CL. 41. (U.S. CL. 107). REG. 8-16-1977.

- 1,072,802. TRADITION. INT. CL. 28. (U.S. CL. 22). REG. 9-6-1977.
- 1,073,947. ELIZABETH ARDEN. INT. CL. 9. (U.S. CL. 26). REG. 9-27-1977.
- 1,075,142. HEALTH VALLEY. INT. CLS. 29 AND 30. (U.S. CL. 46). REG. 10-11-1977.
- 1,075,260. MISCELLANEOUS DESIGN. INT. CL. 42. (U.S. CL. 100). REG. 10-11-1977.
- 1,075,793. GR-REAT 'N EASY. INT. CL. 3. (U.S. CL. 52). REG. 10-25-1977.
- 1,077,907. JEL-RING. INT. CL. 21. (U.S. CL. 13). REG. 11-22-1977.
- 1,079,644. CREATIVE CURL. INT. CL. 3. (U.S. CL. 51). REG. 12-20-1977.
- 1,081,366. NATIONAL BOARD OF MEDICAL EXAMINERS U.S.A. 1915 AND DESIGN. INT. CL. 42. (U.S. CL. 100). REG. 1-3-1978.
- 1,082,639. HEAVENLY BODIES. INT. CL. 25. (U.S. CL. 39). REG. 1-17-1978.
- 1,298,907. BAN LON AND DESIGN. INT. CL. 25. (U.S. CL. 39). REG. 10-2-1984.
- 1,314,365. SWF AND DESIGN. INT. CLS. 9 AND 12 ONLY. (U.S. CLS. 19 AND 21). REG. 1-15-1985.
- 1,366,524. STEDIM. INT. CL. 10. (U.S. CL. 44). REG. 10-22-1985.
- 1,372,223. OFFSAT COMTECH ANTENNA CORPORATION AND DESIGN. INT. CL. 9. (U.S. CLS. 21, 23, 26, 36 AND 38). REG. 11-26-1985.
- 1,376,364. BUILDING OWNERS AND MANAGERS INSTITUTE INTERNATIONAL. INT. CL. 41. (U.S. CLS. 100, 101 AND 107). REG. 12-17-1985.
- 1,391,567. NURSING ECONOMICS AN ANTHONY J. JANNETTI, INC. PUBLICATION AND DESIGN. INT. CL. 16. (U.S. CL. 38). REG. 4-29-1986.
- 1,397,204. OPERATION CALIFORNIA. INT. CL. 42. (U.S. CLS. 100 AND 101). REG. 6-10-1986.
- 1,400,127. MOLDTRONICS (STYLIZED). INT. CLS. 7 AND 9. (U.S. CLS. 21 AND 23). REG. 7-8-1986.
- 1,401,154. MISCELLANEOUS DESIGN. INT. CL. 16. (U.S. CLS. 2, 5, 22, 23, 29, 37, 38 AND 50). REG. 7-15-1986.
- 1,401,930. ELECTROSTATIC PROXIMITY (STYLIZED). INT. CL. 9. (U.S. CLS. 21 AND 26). REG. 7-22-1986.
- 1,402,635. DLEGAL. INT. CL. 9. (U.S. CL. 38). REG. 7-22-1986.
- 1,402,799. BIOTECHNOLOGY GENERAL. INT. CL. 5. (U.S. CL. 18). REG. 7-29-1986.
- 1,403,759. PEM (STYLIZED). INT. CL. 6. (U.S. CL. 13). REG. 8-5-1986.
- 1,403,897. MISCELLANEOUS DESIGN. INT. CL. 10. (U.S. CL. 44). REG. 8-5-1986.
- 1,404,038. BLACK MAX. INT. CL. 17. (U.S. CLS. 1, 5, 12, 13, 35 AND 50). REG. 8-5-1986.
- 1,404,275. IT TAKES A TOUGH MAN TO MAKE A TENDER CHICKEN. INT. CL. 29. (U.S. CL. 46). REG. 8-5-1986.
- 1,404,635. WISECO AND DESIGN. INT. CL. 7. (U.S. CL. 23). REG. 8-12-1986.
- 1,407,238. MISCELLANEOUS DESIGN. INT. CL. 1. (U.S. CL. 6). REG. 9-2-1986.
- 1,412,432. HIND AND DESIGN. INT. CL. 25. (U.S. CL. 39). REG. 10-7-1986.
- 1,414,414. CANDY'S BIKINI. INT. CL. 30. (U.S. CLS. 46 AND 50). REG. 10-21-1986.
- 1,414,721. GALFAN. INT. CL. 6. (U.S. CLS. 7 AND 14). REG. 10-28-1986.
- 1,415,171. RODIMUS PRIME. INT. CL. 28. (U.S. CL. 22). REG. 10-28-1986.
- 1,417,363. DURACELL. INT. CL. 11. (U.S. CL. 21). REG. 11-18-1986.
- 1,417,539. MISCELLANEOUS DESIGN. INT. CL. 26. (U.S. CL. 40). REG. 11-18-1986.
- 1,418,155. CLEAVER BROOKS AND DESIGN. INT. CLS. 7, 9 AND 11. (U.S. CLS. 13, 21, 23, 26, 31 AND 34). REG. 11-25-1986.
- 1,418,835. PACIFIC. INT. CL. 2. (U.S. CL. 16). REG. 12-2-1986.
- 1,419,912. JOHNSON & JOHNSON. INT. CL. 10. (U.S. CL. 44). REG. 12-9-1986.
- 1,420,400. MISCELLANEOUS DESIGN. INT. CL. 35. (U.S. CL. 101). REG. 12-9-1986.
- 1,421,359. REMUDA. INT. CL. 31. (U.S. CL. 46). REG. 12-16-1986.
- 1,422,088. OATMEAL. INT. CL. 28. (U.S. CL. 22). REG. 12-23-1986.
- 1,422,214. BACARDI. INT. CL. 32. (U.S. CL. 45). REG. 12-23-1986.
- 1,422,403. SELEXSORB. INT. CL. 1. (U.S. CL. 6). REG. 12-30-1986.
- 1,422,653. UNDELETE. INT. CL. 9. (U.S. CL. 38). REG. 12-30-1986.
- 1,423,547. MISCELLANEOUS DESIGN. INT. CL. 4. (U.S. CL. 15). REG. 1-6-1987.
- 1,423,679. RATA BASE. INT. CL. 9. (U.S. CL. 38). REG. 1-6-1987.
- 1,423,714. MISCELLANEOUS DESIGN. INT. CL. 9. (U.S. CLS. 21, 23, 26, 36 AND 38). REG. 1-6-1987.
- 1,424,002. MAD BOMBER AND DESIGN. INT. CL. 25. (U.S. CL. 39). REG. 1-6-1987.
- 1,424,126. TATO SKINS. INT. CL. 29. (U.S. CL. 46). REG. 1-6-1987.
- 1,424,152. MISCELLANEOUS DESIGN. INT. CL. 30. (U.S. CL. 46). REG. 1-6-1987.
- 1,424,175. CHOCOLATES BY MR. ROBERTS PAR EXCELLENCE AND DESIGN. INT. CL. 30. (U.S. CL. 46). REG. 1-6-1987.
- 1,424,176. TRADER JOE'S. INT. CL. 30. (U.S. CL. 46). REG. 1-6-1987.
- 1,424,194. MISCELLANEOUS DESIGN. INT. CL. 32. (U.S. CL. 46). REG. 1-6-1987.
- 1,424,284. SYNCHRONET (STYLIZED). INT. CL. 38. (U.S. CL. 104). REG. 1-6-1987.
- 1,424,435. PETRO STOPPING CENTER. INT. CL. 42. (U.S. CLS. 100 AND 103). REG. 1-6-1987.
- 1,424,470. BIOCONTROL. INT. CL. 1. (U.S. CL. 6). REG. 1-13-1987.
- 1,424,482. THE PROFESSIONAL'S PARTNER. INT. CL. 1. (U.S. CL. 10). REG. 1-13-1987.
- 1,424,483. SAL. INT. CL. 1. (U.S. CL. 6). REG. 1-13-1987.
- 1,424,501. MISCELLANEOUS DESIGN. INT. CL. 3. (U.S. CL. 51). REG. 1-13-1987.
- 1,424,503. VAGISIL. INT. CL. 3. (U.S. CL. 51). REG. 1-13-1987.
- 1,424,521. JUDITH JACKSON. INT. CL. 3. (U.S. CLS. 51 AND 52). REG. 1-13-1987.
- 1,424,588. HYMAC. INT. CL. 7. (U.S. CL. 23). REG. 1-13-1987.
- 1,424,634. PIVOT POINT AND DESIGN. INT. CLS. 9, 16, 18, 21, 25, 26, 41 AND 42. (U.S. CLS. 2, 3, 29, 37, 38, 39, 40, 44, 50, 100 AND 107). REG. 1-13-1987.
- 1,424,655. CAPTURED MOMENTS PHOTOGRAPHY. INT. CL. 16 ONLY. (U.S. CLS. 37 AND 38). REG. 1-13-1987.
- 1,424,713. INTEGRAL. INT. CL. 10. (U.S. CL. 44). REG. 1-13-1987.
- 1,424,719. P-SPLITTER. INT. CL. 10. (U.S. CL. 44). REG. 1-13-1987.
- 1,424,729. DOS-IR. INT. CL. 11. (U.S. CL. 13). REG. 1-13-1987.
- 1,424,797. MONO. INT. CL. 16. (U.S. CL. 37). REG. 1-13-1987.
- 1,425,035. PUREBRED AND DESIGN. INT. CL. 31. (U.S. CL. 46). REG. 1-13-1987.
- 1,425,085. MISCELLANEOUS DESIGN. INT. CL. 35. (U.S. CL. 101). REG. 1-13-1987.
- 1,425,127. MDP MICHIGAN DENTAL PLAN (STYLIZED). INT. CL. 36. (U.S. CL. 102). REG. 1-13-1987.
- 1,425,130. DELTABANK AND DESIGN. INT. CL. 36. (U.S. CL. 102). REG. 1-13-1987.
- 1,425,188. ALFMARK. INT. CL. 39. (U.S. CL. 105). REG. 1-13-1987.
- 1,425,219. MISCELLANEOUS DESIGN. INT. CLS. 41 AND 42. (U.S. CLS. 100 AND 107). REG. 1-13-1987.
- 1,425,382. BIOGENOL. INT. CL. 3. (U.S. CLS. 51 AND 52). REG. 1-20-1987.
- 1,425,386. QUANTUM (STYLIZED). INT. CL. 3. (U.S. CLS. 51 AND 52). REG. 1-20-1987.
- 1,425,398. NATURELLE. INT. CL. 3. (U.S. CL. 51). REG. 1-20-1987.
- 1,425,577. MSD. INT. CL. 9. (U.S. CL. 26). REG. 1-20-1987.
- 1,425,636. SHARPOINT. INT. CL. 10. (U.S. CL. 44). REG. 1-20-1987.
- 1,425,649. AGRITAPE. INT. CL. 11. (U.S. CL. 34). REG. 1-20-1987.
- 1,425,886. YOU CAN TRAVEL THE WORLD OVER AND NEVER FIND A BETTER BEER. INT. CL. 32. (U.S. CL. 48). REG. 1-20-1987.
- 1,425,962. MISCELLANEOUS DESIGN. INT. CL. 37. (U.S. CL. 103). REG. 1-20-1987.
- 1,425,972. WLKF. INT. CL. 38. (U.S. CL. 104). REG. 1-20-1987.
- 1,426,070. CF FOLKS AND DESIGN. INT. CL. 42. (U.S. CL. 100). REG. 1-20-1987.

- 1,426,100. PACIFIC CATARACT AND LASER INSTITUTE. INT. CL. 42. (U.S. CL. 100). REG. 1-20-1987.
- 1,426,110. THE UNITED STATES JUNIOR CHAMBER OF COMMERCE. U.S. CL. 200. REG. 1-20-1987.
- 1,426,115. MULTI-FUNCTION. INT. CL. 6. (U.S. CLS. 13 AND 25). REG. 1-20-1987.
- 1,426,136. PHOTOPROBE. INT. CL. 1. (U.S. CL. 6). REG. 1-27-1987.
- 1,426,172. BOIRON. INT. CLS. 3 AND 5. (U.S. CLS. 1, 4, 6, 18, 44, 50, 51 AND 52). REG. 1-27-1987.
- 1,426,221. INTRASITE. INT. CL. 5. (U.S. CL. 44). REG. 1-27-1987.
- 1,426,226. AMERICAN REGENT. INT. CL. 5. (U.S. CL. 18). REG. 1-27-1987.
- 1,426,249. FLETCHER. INT. CLS. 6, 7 AND 8. (U.S. CLS. 13, 21, 23 AND 26). REG. 1-27-1987.
- 1,426,293. MI-JACK. INT. CL. 7. (U.S. CL. 23). REG. 1-27-1987.
- 1,426,305. SCREWPULL (STYLIZED). INT. CL. 8. (U.S. CL. 23). REG. 1-27-1987.
- 1,426,425. GRADEX. INT. CL. 9. (U.S. CLS. 21 AND 26). REG. 1-27-1987.
- 1,426,427. AION. INT. CL. 9. (U.S. CL. 38). REG. 1-27-1987.
- 1,426,470. \*STAR AND DESIGN. INT. CL. 11. (U.S. CL. 31). REG. 1-27-1987.
- 1,426,505. NITRO. INT. CL. 13. (U.S. CL. 9). REG. 1-27-1987.
- 1,426,563. 3M (STYLIZED). INT. CL. 17. (U.S. CL. 5). REG. 1-27-1987.
- 1,426,605. FRAMEWORK. INT. CL. 20. (U.S. CL. 50). REG. 1-27-1987.
- 1,426,740. TASTE PLEASERS GOURMET. INT. CL. 30. (U.S. CL. 46). REG. 1-27-1987.
- 1,426,788. NOZZOLE. INT. CL. 33. (U.S. CL. 47). REG. 1-27-1987.
- 1,426,789. LA FORRA. INT. CL. 33. (U.S. CL. 47). REG. 1-27-1987.
- 1,426,819. COMPHEALTH. INT. CL. 35. (U.S. CL. 101). REG. 1-27-1987.
- 1,426,877. ESSX. INT. CL. 38. (U.S. CL. 104). REG. 1-27-1987.
- 1,426,894. STAFF CONSULTING SKILLS. INT. CL. 41. (U.S. CL. 107). REG. 1-27-1987.
- 1,427,058. SOARNOL. INT. CL. 1. (U.S. CL. 6). REG. 2-3-1987.
- 1,427,067. RAIN DANCE. INT. CL. 3 ONLY. (U.S. CLS. 1, 4, 6, 50, 51 AND 52 ONLY). REG. 2-3-1987.
- 1,427,074. GONZO. INT. CL. 1. (U.S. CLS. 6 AND 52). REG. 2-3-1987.
- 1,427,105. MITCHUM. INT. CL. 3. (U.S. CL. 51). REG. 2-3-1987.
- 1,427,279. WELD MOLD COMPANY. INT. CL. 9. (U.S. CL. 21). REG. 2-3-1987.
- 1,427,324. SINK-FLOAT. INT. CL. 9. (U.S. CL. 26). REG. 2-3-1987.
- 1,427,355. OMNI-FLOW 4000. INT. CL. 10. (U.S. CL. 44). REG. 2-3-1987.
- 1,427,386. HD AMERICA, INC. AND DESIGN. INT. CL. 12. (U.S. CLS. 19 AND 35). REG. 2-3-1987.
- 1,427,424. CHRISTI PEYE (STYLIZED). INT. CL. 16. (U.S. CL. 38). REG. 2-3-1987.
- 1,427,659. THE ORIGINAL GOURMET CINNAMON ROLL. INT. CL. 30. (U.S. CL. 46). REG. 2-3-1987.
- 1,427,860. DEJA VIEW. INT. CL. 41. (U.S. CLS. 100 AND 107). REG. 2-3-1987.
- 1,427,871. TIME POWER. INT. CL. 41. (U.S. CL. 107). REG. 2-3-1987.
- 1,427,886. FAILURE ANALYSIS ASSOCIATES (STYLIZED). INT. CL. 42. (U.S. CL. 100). REG. 2-3-1987.
- 1,427,974. JANEKE. INT. CLS. 20 AND 21. (U.S. CLS. 29, 32 AND 40). REG. 2-3-1987.
- 1,427,995. DAIRY FOODS. INT. CL. 16. (U.S. CL. 38). REG. 2-3-1987.
- 1,428,078. BONEFOS. INT. CL. 5. (U.S. CL. 18). REG. 2-10-1987.
- 1,428,104. D8S. INT. CL. 6. (U.S. CLS. 13 AND 14). REG. 2-10-1987.
- 1,428,106. MISCELLANEOUS DESIGN. INT. CL. 6. (U.S. CLS. 13 AND 25). REG. 2-10-1987.
- 1,428,162. PROMPT. INT. CL. 9. (U.S. CLS. 6 AND 26). REG. 2-10-1987.
- 1,428,242. REAL ESTATE MATCHUP. INT. CL. 9. (U.S. CL. 38). REG. 2-10-1987.
- 1,428,293. PALISADE. INT. CL. 12. (U.S. CLS. 19 AND 35). REG. 2-10-1987.
- 1,428,295. ABSOLUTE. INT. CL. 12. (U.S. CLS. 19 AND 35). REG. 2-10-1987.
- 1,428,302. BM AND DESIGN. INT. CL. 14. (U.S. CL. 27). REG. 2-10-1987.
- 1,428,381. SAFE-RELEASE. INT. CL. 17. (U.S. CL. 5). REG. 2-10-1987.
- 1,428,413. MECO. INT. CL. 20. (U.S. CL. 32). REG. 2-10-1987.
- 1,428,476. LIFA AND DESIGN. INT. CL. 25. (U.S. CL. 39). REG. 2-10-1987.
- 1,428,557. MISCELLANEOUS DESIGN. INT. CL. 26. (U.S. CL. 40). REG. 2-10-1987.
- 1,428,703. THE HOME TEAM. INT. CL. 36. (U.S. CLS. 101 AND 102). REG. 2-10-1987.
- 1,428,893. VERDICT REVIEWS. INT. CL. 16. (U.S. CL. 38). REG. 2-10-1987.
- 1,428,906. PARTISPHERE. INT. CL. 1. (U.S. CL. 6). REG. 2-17-1987.
- 1,428,957. MICRO. INT. CL. 3. (U.S. CL. 52). REG. 2-17-1987.
- 1,429,226. HATTERAS. INT. CL. 18. (U.S. CL. 3). REG. 2-17-1987.
- 1,429,232. HONMA AND DESIGN. INT. CLS. 18, 25 AND 28. (U.S. CLS. 22, 39 AND 41). REG. 2-17-1987.
- 1,429,451. MIDNIGHT SUN ORNAS HERRGARD AND DESIGN. INT. CL. 29 ONLY. (U.S. CL. 46). REG. 2-17-1987.
- 1,429,636. SCHOOL MATCH. INT. CL. 42. (U.S. CL. 100). REG. 2-17-1987.
- 1,429,687. VENDORS EXCHANGE. INT. CL. 42. (U.S. CL. 101). REG. 2-17-1987.
- 1,429,701. ANAEROCULT. INT. CL. 1. (U.S. CL. 6). REG. 2-24-1987.
- 1,429,844. COLD TRAP. INT. CL. 7. (U.S. CL. 23). REG. 2-24-1987.
- 1,430,260. UNACAST. INT. CL. 19. (U.S. CL. 12). REG. 2-24-1987.
- 1,430,314. SURF OHIO AND DESIGN. INT. CL. 25. (U.S. CL. 39). REG. 2-24-1987.
- 1,430,464. DOMINUS. INT. CL. 33. (U.S. CL. 47). REG. 2-24-1987.
- 1,430,532. FIRSTFED. INT. CL. 36. (U.S. CL. 102). REG. 2-24-1987.
- 1,430,618. A PRAIRIE HOME COMPANION. INT. CL. 41. (U.S. CL. 107). REG. 2-24-1987.
- 1,430,692. ACCENT ON ANIMALS. INT. CL. 42. (U.S. CL. 101). REG. 2-24-1987.
- 1,430,757. DYHARD. INT. CL. 1. (U.S. CL. 6). REG. 3-3-1987.
- 1,431,095. HVACARE. INT. CL. 16. (U.S. CL. 38). REG. 3-3-1987.
- 1,431,205. MISCELLANEOUS DESIGN. INT. CL. 25. (U.S. CL. 39). REG. 3-3-1987.
- 1,431,579. SUBURBAN STEEL. INT. CL. 42. (U.S. CL. 101). REG. 3-3-1987.
- 1,431,637. ENDEX. INT. CL. 1. (U.S. CL. 1). REG. 3-10-1987.
- 1,431,700. ESTROSTEP. INT. CL. 5. (U.S. CL. 18). REG. 3-10-1987.
- 1,431,713. TURBO-C. INT. CL. 6. (U.S. CLS. 13, 31 AND 34). REG. 3-10-1987.
- 1,431,954. TECHNORA. INT. CL. 17. (U.S. CL. 42). REG. 3-10-1987.
- 1,432,310. MISCELLANEOUS DESIGN. INT. CL. 37. (U.S. CL. 103). REG. 3-10-1987.
- 1,432,311. ANTI-PEST CO. INC. (STYLIZED). INT. CL. 37. (U.S. CL. 103). REG. 3-10-1987.
- 1,432,907. ONYX. INT. CL. 16. (U.S. CL. 38). REG. 3-17-1987.
- 1,432,958. AJAX. INT. CL. 19. (U.S. CL. 12). REG. 3-17-1987.
- 1,433,409. CARING JN.3:16 AND DESIGN. INT. CL. 42. (U.S. CL. 100). REG. 3-17-1987.
- 1,434,117. PEMBROOK. INT. CL. 29. (U.S. CL. 46). REG. 3-24-1987.
- 1,434,302. WE'RE THE PROBLEM SOLVERS !. INT. CL. 42. (U.S. CL. 101). REG. 3-24-1987.
- 1,434,596. KOPYKAKE. INT. CL. 9. (U.S. CL. 26). REG. 3-31-1987.
- 1,435,236. BOWLING GREEN. INT. CL. 3. (U.S. CL. 51). REG. 4-7-1987.
- 1,435,243. PARAFFLEX. INT. CL. 4. (U.S. CL. 15). REG. 4-7-1987.
- 1,435,277. MAROXY. INT. CL. 5. (U.S. CL. 6). REG. 4-7-1987.
- 1,435,559. AMIET. INT. CL. 18. (U.S. CL. 3). REG. 4-7-1987.
- 1,435,739. GIORDANA AND DESIGN. INT. CL. 25. (U.S. CL. 39). REG. 4-7-1987.
- 1,436,052. JOHNNY ROCKETS. INT. CL. 42. (U.S. CL. 100). REG. 4-7-1987.

- 1,436,053. JOHNNY ROCKETS THE ORIGINAL HAMBURGER AND DESIGN. INT. CL. 42. (U.S. CL. 100). REG. 4-7-1987.
- 1,436,223. BRONCO. INT. CL. 7. (U.S. CL. 23). REG. 4-14-1987.
- 1,436,569. TRU-COLOR. INT. CL. 29. (U.S. CL. 46). REG. 4-14-1987.
- 1,437,653. BOND-AID. INT. CL. 3. (U.S. CLS. 5, 6 AND 51). REG. 4-28-1987.
- 1,438,236. CAJUN COUNTRY. INT. CL. 30. (U.S. CL. 46). REG. 4-28-1987.
- 1,439,375. FLOUR TORTILLAS TEXAS STYLE FOR FAJITAS AND DESIGN. INT. CL. 30. (U.S. CL. 46). REG. 5-12-1987.
- 1,439,566. SNAPPY TOMATO PIZZA AND DESIGN. INT. CL. 42. (U.S. CL. 100). REG. 5-12-1987.
- 1,439,757. IMMUNAGE. INT. CL. 3. (U.S. CL. 51). REG. 5-19-1987.
- 1,440,276. THE FINE ART OF PRINTING. INT. CL. 42. (U.S. CL. 101). REG. 5-19-1987.
- 1,440,448. RITE-HITE. INT. CL. 7. (U.S. CL. 23). REG. 5-26-1987.
- 1,440,871. MOTHER'S MARKET & KITCHEN AND DESIGN. INT. CL. 42. (U.S. CLS. 100 AND 101). REG. 5-26-1987.
- 1,440,880. LAWPLAN. INT. CL. 42. (U.S. CL. 100). REG. 5-26-1987.
- 1,441,650. MINNESOTA NEWS NETWORK. INT. CL. 41. (U.S. CL. 101). REG. 6-2-1987.
- 1,441,725. SUPRA. INT. CL. 4. (U.S. CL. 15). REG. 6-9-1987.
- 1,442,473. NATIONAL BASEBALL HALL OF FAME AND MUSEUM. INT. CL. 41. (U.S. CL. 107). REG. 6-9-1987.
- 1,442,560. PROGRAM-A-BEAD. INT. CL. 9. (U.S. CL. 26). REG. 6-9-1987.
- 1,442,852. KURRENT-KUTTER. INT. CL. 9. (U.S. CLS. 21 AND 26). REG. 6-16-1987.
- 1,443,709. BUSINESS-FACTS. INT. CL. 35. (U.S. CL. 101). REG. 6-16-1987.
- 1,445,775. RELIABOIL AND DESIGN. INT. CL. 1. (U.S. CL. 6). REG. 7-7-1987.
- 1,446,202. MIDWEST TRADITION. INT. CL. 10. (U.S. CL. 44). REG. 7-7-1987.
- 1,446,233. JAMES R. MODER BEVERLY HILLS-NEW YORK-PARIS-LONDON-TOKYO-VANCOUVER AND DESIGN. INT. CL. 11. (U.S. CL. 21). REG. 7-7-1987.
- 1,446,463. CAROLERS. INT. CL. 21. (U.S. CLS. 5, 30 AND 50). REG. 7-7-1987.
- 1,446,755. MISCELLANEOUS DESIGN. INT. CL. 36. (U.S. CL. 102). REG. 7-7-1987.
- 1,447,107. YUNG FANG (STYLIZED). INT. CL. 6. (U.S. CLS. 13 AND 25). REG. 7-14-1987.
- 1,448,144. SPACEMAKER. INT. CL. 7. (U.S. CL. 23). REG. 7-21-1987.
- 1,448,284. LIGHT RIGHT. INT. CL. 9. (U.S. CL. 26). REG. 7-21-1987.
- 1,448,375. CRUSADER. INT. CL. 12. (U.S. CL. 35). REG. 7-21-1987.
- 1,448,816. SITEL. INT. CL. 35. (U.S. CL. 101). REG. 7-21-1987.
- 1,450,610. PM. INT. CL. 11. (U.S. CLS. 19, 21 AND 50). REG. 8-4-1987.
- 1,451,459. RECORD TOWN (STYLIZED). INT. CL. 42. (U.S. CL. 101). REG. 8-4-1987.
- 1,452,488. PORTLAND BOAT SHOW (STYLIZED). INT. CL. 35. (U.S. CLS. 101 AND 107). REG. 8-11-1987.
- 1,453,856. MAXIVATE. INT. CL. 5. (U.S. CL. 18). REG. 8-25-1987.
- 1,454,830. RECLAIM. INT. CL. 5. (U.S. CL. 6). REG. 9-1-1987.
- 1,454,999. VIAKON. INT. CL. 9. (U.S. CL. 21). REG. 9-1-1987.
- 1,455,038. RADIATION ALERT. INT. CL. 9. (U.S. CL. 26). REG. 9-1-1987.
- 1,455,788. SWEDISH MEDICAL CENTER. INT. CLS. 41 AND 42. (U.S. CLS. 100 AND 107). REG. 9-1-1987.
- 1,456,114. MISCELLANEOUS DESIGN. INT. CL. 6. (U.S. CLS. 13 AND 50). REG. 9-8-1987.
- 1,456,144. MISCELLANEOUS DESIGN. INT. CL. 7. (U.S. CL. 23). REG. 9-8-1987.
- 1,456,574. LONGHORNS. INT. CL. 24. (U.S. CLS. 42 AND 50). REG. 9-8-1987.
- 1,456,575. MISCELLANEOUS DESIGN. INT. CL. 24. (U.S. CLS. 42 AND 50). REG. 9-8-1987.
- 1,456,594. MISCELLANEOUS DESIGN. INT. CL. 25. (U.S. CL. 39). REG. 9-8-1987.
- 1,456,918. YOUTH TO YOUTH. INT. CL. 41. (U.S. CL. 107). REG. 9-8-1987.
- 1,457,280. STEREO TARGETING. INT. CL. 9. (U.S. CL. 21). REG. 9-15-1987.
- 1,457,693. K KEANE AND DESIGN. INT. CL. 35. (U.S. CL. 101). REG. 9-15-1987.
- 1,458,574. TWO-RIFIC. INT. CL. 30. (U.S. CL. 46). REG. 9-22-1987.
- 1,458,704. CRAFTECH CII AND DESIGN. INT. CL. 37. (U.S. CL. 103). REG. 9-22-1987.
- 1,458,787. CRAFTECH CII AND DESIGN. INT. CL. 42. (U.S. CLS. 100 AND 101). REG. 9-22-1987.
- 1,458,854. JOURNEYS. INT. CL. 42. (U.S. CL. 101). REG. 9-22-1987.
- 1,458,890. QUATRISOFT. INT. CL. 1. (U.S. CL. 6). REG. 9-29-1987.
- 1,458,894. WEDGE. INT. CL. 1. (U.S. CLS. 1 AND 10). REG. 9-29-1987.
- 1,459,416. FRUIT-E-O'S. INT. CL. 30. (U.S. CL. 46). REG. 9-29-1987.
- 1,460,410. TEP. INT. CL. 42. (U.S. CL. 100). REG. 10-6-1987.
- 1,460,611. FLOREAT. INT. CL. 6. (U.S. CL. 13). REG. 10-13-1987.
- 1,460,635. BIRO (STYLIZED). INT. CL. 7. (U.S. CL. 23). REG. 10-13-1987.
- 1,460,780. E-Z RAIL. INT. CL. 11. (U.S. CL. 34). REG. 10-13-1987.
- 1,461,462. ILFC. INT. CL. 42. (U.S. CL. 100). REG. 10-13-1987.
- 1,461,847. ARTIS. INT. CL. 16. (U.S. CLS. 2, 37 AND 38). REG. 10-20-1987.
- 1,462,335. WILLIAM ASHLEY AND DESIGN. INT. CL. 42. (U.S. CL. 101). REG. 10-20-1987.
- 1,462,687. ANDERSON MARINE DIVISION. INT. CL. 11. (U.S. CLS. 19 AND 21). REG. 10-27-1987.
- 1,463,137. VAC LAND. INT. CL. 42. (U.S. CL. 101). REG. 10-27-1987.
- 1,463,521. INSULCRETE. INT. CL. 19. (U.S. CLS. 12 AND 16). REG. 11-3-1987.
- 1,464,572. PERM+A+LINING. INT. CL. 17. (U.S. CL. 12). REG. 11-10-1987.
- 1,466,942. MONOPRIL. INT. CL. 5. (U.S. CL. 18). REG. 12-1-1987.
- 1,466,949. DECKMARK. INT. CL. 6. (U.S. CL. 13). REG. 12-1-1987.
- 1,466,958. PERM+A+LOCK. INT. CL. 6. (U.S. CL. 13). REG. 12-1-1987.
- 1,468,003. ULTRA DAMP. INT. CL. 7. (U.S. CL. 23). REG. 12-8-1987.
- 1,468,206. PASSAT. INT. CL. 12. (U.S. CL. 19). REG. 12-8-1987.
- 1,470,232. WHERE THE SIZES ARE. INT. CL. 42. (U.S. CL. 101). REG. 12-22-1987.
- 1,470,435. SEPAC AND DESIGN. INT. CLS. 7 AND 42. (U.S. CLS. 23, 100 AND 101). REG. 12-29-1987.
- 1,471,652. CHRISTIAN BUSINESSCARES FOUNDATION. INT. CL. 36. (U.S. CL. 102). REG. 1-5-1988.
- 1,471,677. WBRU. INT. CL. 38. (U.S. CL. 104). REG. 1-5-1988.
- 1,473,532. KFSN. INT. CL. 38. (U.S. CL. 104). REG. 1-19-1988.
- 1,474,263. SCOTT MC CLINTOCK. INT. CL. 25. (U.S. CL. 39). REG. 1-26-1988.
- 1,876,486. MISCELLANEOUS DESIGN. INT. CL. 11. (U.S. CL. 13). REG. 1-31-1995.
- 1,887,892. MULTIVAULT. INT. CL. 13. (U.S. CLS. 2 AND 9). REG. 4-4-1995.
- 1,911,392. LET ME READ. INT. CL. 16. (U.S. CL. 38). REG. 8-15-1995.
- 1,936,170. PET PERSONALITIES. INT. CL. 28. (U.S. CLS. 22, 23, 38 AND 50). REG. 11-14-1995.
- 1,956,864. ESTEEM. INT. CL. 12. (U.S. CLS. 19, 21, 23, 31, 35 AND 44). REG. 2-13-1996.
- 1,958,952. PEDIGREE PUPPY. INT. CL. 31. (U.S. CLS. 1 AND 46). REG. 2-27-1996.
- 1,962,020. SILENT PARTNER. INT. CL. 9. (U.S. CLS. 21, 23, 26, 36 AND 38). REG. 3-12-1996.
- 1,972,334. MEYER M AND DESIGN. INT. CLS. 7 AND 11. (U.S. CLS. 13, 19, 21, 23, 31, 34 AND 35). REG. 5-7-1996.
- 1,977,720. IMPLICATIONS WHEEL. INT. CLS. 16 AND 41. (U.S. CLS. 2, 5, 22, 23, 29, 37, 38, 50, 100, 101 AND 107). REG. 6-4-1996.
- 1,977,928. SAWA. INT. CL. 10. (U.S. CLS. 26, 39 AND 44). REG. 6-4-1996.
- 1,979,593. CHECKOUT REBATE. INT. CL. 35. (U.S. CLS. 100, 101 AND 102). REG. 6-11-1996.

- 1,980,733. SAD SAM. INT. CL. 28. (U.S. CLS. 22, 23, 38 AND 50). REG. 6-18-1996.
- 1,981,174. STA-MARK. INT. CL. 16. (U.S. CLS. 2, 5, 22, 23, 29, 37, 38 AND 50). REG. 6-18-1996.
- 1,981,817. EVANSVILLE FOOT & ANKLE CENTER. INT. CL. 42. (U.S. CLS. 100 AND 101). REG. 6-18-1996.
- 1,981,929. PROJECT CITY. INT. CL. 41. (U.S. CLS. 100, 101 AND 107). REG. 6-25-1996.
- 1,982,111. REY DEL REY. INT. CL. 34. (U.S. CLS. 2, 8, 9 AND 17). REG. 6-25-1996.
- 1,982,112. REYNITAS. INT. CL. 34. (U.S. CLS. 2, 8, 9 AND 17). REG. 6-25-1996.
- 1,982,797. SIGNATURE. INT. CL. 10. (U.S. CLS. 26, 39 AND 44). REG. 6-25-1996.
- 1,982,800. GREASECUTTER PLUS. INT. CL. 3. (U.S. CLS. 1, 4, 6, 50, 51 AND 52). REG. 6-25-1996.
- 1,982,928. ALUNIT. INT. CL. 1. (U.S. CLS. 1, 5, 6, 10, 26 AND 46). REG. 6-25-1996.
- 1,983,195. DOUBLLOK. INT. CLS. 19 AND 20 ONLY. (U.S. CLS. 1, 2, 12, 13, 22, 25, 32, 33 AND 50). REG. 7-2-1996.
- 1,986,489. ESMALGLASS AND DESIGN. INT. CLS. 1 AND 19. (U.S. CLS. 1, 6, 12, 33 AND 50). REG. 7-16-1996.
- 1,986,548. SEMICOAT (STYLIZED). INT. CL. 1. (U.S. CLS. 1, 5, 6, 10, 26 AND 46). REG. 7-16-1996.
- 1,986,710. THE VIBRATORS. INT. CL. 41. (U.S. CLS. 100, 101 AND 107). REG. 7-16-1996.
- 1,987,100. DIETEC. INT. CL. 42. (U.S. CLS. 100 AND 101). REG. 7-16-1996.
- 1,988,294. PAINTER OF LIGHT. INT. CL. 16. (U.S. CLS. 2, 5, 22, 23, 29, 37, 38 AND 50). REG. 7-23-1996.
- 1,988,838. CARDIOASSIST. INT. CL. 10. (U.S. CLS. 26, 39 AND 44). REG. 7-23-1996.
- 1,989,506. PFALZ. U.S. CL. A. REG. 7-30-1996.
- 1,989,742. CAPITAL ENVIRONMENTAL. INT. CL. 42. (U.S. CLS. 100 AND 101). REG. 7-30-1996.
- 1,990,264. EVERJOY. INT. CL. 21. (U.S. CLS. 2, 13, 23, 29, 30, 33, 40 AND 50). REG. 7-30-1996.
- 1,990,756. KURTIS. INT. CL. 42. (U.S. CLS. 100 AND 101). REG. 8-6-1996.
- 1,990,856. GO KRAZY INC. INT. CL. 41 ONLY. (U.S. CLS. 100, 101 AND 107). REG. 8-6-1996.
- 1,990,927. CLASS AA. U.S. CL. 200. REG. 8-6-1996.
- 1,991,911. WALL FORMS. INT. CL. 11. (U.S. CLS. 13, 21, 23, 31 AND 34). REG. 8-6-1996.
- 1,992,492. KURTIS AND DESIGN. INT. CL. 42. (U.S. CLS. 100 AND 101). REG. 8-13-1996.
- 1,992,643. OSO SWEET WORLD'S PREMIER SWEET ONIONS AND DESIGN. INT. CL. 31. (U.S. CLS. 1 AND 46). REG. 8-13-1996.
- 1,992,969. ASSOCIATION OF CERTIFIED FRAUD EXAMINERS CFE AND DESIGN. INT. CL. 41. (U.S. CLS. 100, 101 AND 107). REG. 8-13-1996.
- 1,993,431. LINX. INT. CL. 20. (U.S. CLS. 2, 13, 22, 25, 32 AND 50). REG. 8-13-1996.
- 1,993,816. GUARDIAN. INT. CL. 5. (U.S. CLS. 6, 18, 44, 46, 51 AND 52). REG. 8-13-1996.
- 1,993,998. RADIO TRICOLOR. INT. CLS. 38 AND 41. (U.S. CLS. 100, 101, 104 AND 107). REG. 8-13-1996.
- 1,994,120. TEACHER'S PAL. INT. CL. 9. (U.S. CLS. 21, 23, 26, 36 AND 38). REG. 8-13-1996.
- 1,995,569. ATT ATTRACTIVE HEADWEAR AND DESIGN. INT. CL. 25. (U.S. CLS. 22 AND 39). REG. 8-20-1996.
- 1,995,840. OPEX. INT. CL. 42. (U.S. CLS. 100 AND 101). REG. 8-20-1996.
- 1,996,708. HAVE A CLEAN DAY. INT. CL. 37. (U.S. CLS. 100, 103 AND 106). REG. 8-27-1996.
- 1,997,600. SCHRADER CLIPHANGER SYSTEM (STYLIZED). INT. CL. 8. (U.S. CLS. 23, 28 AND 44). REG. 8-27-1996.
- 1,997,965. VELUX AND DESIGN. INT. CL. 19. (U.S. CLS. 1, 12, 33 AND 50). REG. 9-3-1996.
- 1,999,466. OPTICOTE. INT. CLS. 5, 9 AND 40. (U.S. CLS. 6, 18, 21, 23, 26, 36, 38, 44, 46, 51, 52, 100, 103 AND 106). REG. 9-10-1996.
- 1,999,659. ACCOUNTOONS! AND DESIGN. INT. CL. 35. (U.S. CLS. 100, 101 AND 102). REG. 9-10-1996.
- 2,001,576. THREE RIVERS. INT. CL. 25. (U.S. CLS. 22 AND 39). REG. 9-17-1996.
- 2,002,622. ON THE GO. INT. CL. 42. (U.S. CLS. 100 AND 101). REG. 9-24-1996.
- 2,002,712. UNCLE BEN'S. INT. CL. 30. (U.S. CL. 46). REG. 9-24-1996.
- 2,003,649. ALTURNAMATS. INT. CL. 17. (U.S. CLS. 1, 5, 12, 13, 35 AND 50). REG. 9-24-1996.
- 2,003,695. HPPI. INT. CL. 35. (U.S. CLS. 100, 101 AND 102). REG. 9-24-1996.
- 2,004,867. SGMA. INT. CL. 42. (U.S. CLS. 100 AND 101). REG. 10-1-1996.
- 2,004,915. NO-OX TUBING (STYLIZED). INT. CL. 17. (U.S. CLS. 1, 5, 12, 13, 35 AND 50). REG. 10-1-1996.
- 2,005,648. TAKE CHARGE AMERICA. INT. CLS. 16 AND 41. (U.S. CLS. 2, 5, 22, 23, 29, 37, 38, 50, 100, 101 AND 107). REG. 10-8-1996.
- 2,006,347. FADO (STYLIZED). INT. CL. 42. (U.S. CLS. 100 AND 101). REG. 10-8-1996.
- 2,006,878. LOCK N' SELL. INT. CL. 36. (U.S. CLS. 100, 101 AND 102). REG. 10-8-1996.
- 2,010,172. FADO (STYLIZED). INT. CL. 25. (U.S. CLS. 22 AND 39). REG. 10-22-1996.
- 2,011,809. LEFT AT ALBUQUERQUE. INT. CL. 42. (U.S. CLS. 100 AND 101). REG. 10-29-1996.
- 2,011,816. MISCELLANEOUS DESIGN. INT. CL. 32. (U.S. CLS. 45, 46 AND 48). REG. 10-29-1996.
- 2,011,817. MISCELLANEOUS DESIGN. INT. CL. 32. (U.S. CLS. 45, 46 AND 48). REG. 10-29-1996.
- 2,012,429. OMNIDRIVE. INT. CL. 9. (U.S. CLS. 21, 23, 26, 36 AND 38). REG. 10-29-1996.
- 2,013,624. ENDURO. INT. CL. 9. (U.S. CLS. 21, 23, 26, 36 AND 38). REG. 11-5-1996.
- 2,014,663. VERSAGAGE. INT. CL. 9. (U.S. CL. 26). REG. 11-12-1996.
- 2,014,922. DEVON AIRE (STYLIZED). INT. CL. 25. (U.S. CLS. 22 AND 39). REG. 11-12-1996.
- 2,016,117. KRINKL. INT. CLS. 6, 17 AND 19. (U.S. CLS. 1, 2, 5, 12, 13, 14, 23, 25, 33, 35 AND 50). REG. 11-12-1996.
- 2,016,545. FLEXO-FEEDER. INT. CL. 21. (U.S. CLS. 2, 13, 23, 29, 30, 33, 40 AND 50). REG. 11-12-1996.
- 2,016,964. BSS. INT. CL. 9. (U.S. CLS. 21, 23, 26, 36 AND 38). REG. 11-19-1996.
- 2,017,404. IMMUSTIM. INT. CL. 5. (U.S. CLS. 6, 18, 44, 46, 51 AND 52). REG. 11-19-1996.
- 2,017,414. THE DIMPLE. INT. CL. 10. (U.S. CLS. 26, 39 AND 44). REG. 11-19-1996.
- 2,018,321. BARREL SEAL. INT. CL. 17. (U.S. CLS. 1, 5, 12, 13, 35 AND 50). REG. 11-19-1996.
- 2,019,165. FADO AND DESIGN. INT. CL. 42. (U.S. CLS. 100 AND 101). REG. 11-26-1996.
- 2,019,252. HEALTH WORLD AND DESIGN. INT. CL. 41. (U.S. CLS. 100, 101 AND 107). REG. 11-26-1996.
- 2,019,809. UBC UNIVERSAL BUSINESS CONSULTANTS PROFESSIONAL REFERRAL NETWORK AND DESIGN. INT. CL. 35. (U.S. CLS. 100, 101 AND 102). REG. 11-26-1996.
- 2,021,084. RX AND DESIGN. INT. CL. 42. (U.S. CLS. 100 AND 101). REG. 12-3-1996.
- 2,021,805. TELECONVERSIONS. INT. CL. 35. (U.S. CLS. 100, 101 AND 102). REG. 12-10-1996.
- 2,021,856. AMTRAK WEST. INT. CL. 39. (U.S. CLS. 100 AND 105). REG. 12-10-1996.
- 2,022,078. TROOP. INT. CL. 25. (U.S. CLS. 22 AND 39). REG. 12-10-1996.
- 2,022,426. OUTSIDE STORE. INT. CL. 42. (U.S. CLS. 100 AND 101). REG. 12-10-1996.
- 2,023,001. CLAYTON AND DESIGN. INT. CLS. 19 AND 42. (U.S. CLS. 1, 12, 33, 50, 100 AND 101). REG. 12-17-1996.
- 2,023,171. BASIC FUN. INT. CL. 28. (U.S. CLS. 22, 23, 38 AND 50). REG. 12-17-1996.
- 2,023,314. NYAC. INT. CLS. 25, 41 AND 42. (U.S. CLS. 22, 39, 100, 101 AND 107). REG. 12-17-1996.
- 2,023,446. THE PORTABLE OF PORTABLES. INT. CL. 28. (U.S. CLS. 22, 23, 38 AND 50). REG. 12-17-1996.
- 2,023,736. FELINS. INT. CL. 7. (U.S. CLS. 13, 19, 21, 23, 31, 34 AND 35). REG. 12-17-1996.
- 2,023,956. FIRST CHECK. INT. CL. 5. (U.S. CLS. 6, 18, 44, 46, 51 AND 52). REG. 12-17-1996.
- 2,024,442. CIRCUIT BAR. INT. CL. 7. (U.S. CLS. 13, 19, 21, 23, 31, 34 AND 35). REG. 12-17-1996.
- 2,024,738. BIOSOLIDS TECHNICAL BULLETIN. INT. CL. 16. (U.S. CLS. 2, 5, 22, 23, 29, 37, 38 AND 50). REG. 12-17-1996.
- 2,024,884. SNOWLINK. INT. CL. 42. (U.S. CLS. 100 AND 101). REG. 12-24-1996.
- 2,024,968. CETACEA AND DESIGN. INT. CL. 28. (U.S. CLS. 22, 23, 38 AND 50). REG. 12-24-1996.

- 2,025,306. KRUNCHIES. INT. CL. 31. (U.S. CLS. 1 AND 46). REG. 12-24-1996.
- 2,025,441. TODD THOMPSON. INT. CL. 25. (U.S. CLS. 22 AND 39). REG. 12-24-1996.
- 2,025,563. SUBMAR. INT. CL. 19. (U.S. CLS. 1, 12, 33 AND 50). REG. 12-24-1996.
- 2,025,684. AOSAFETY. INT. CL. 5. (U.S. CLS. 6, 18, 44, 46, 51 AND 52). REG. 12-24-1996.
- 2,025,689. MISCELLANEOUS DESIGN. INT. CL. 42. (U.S. CLS. 100 AND 101). REG. 12-24-1996.
- 2,025,690. MISCELLANEOUS DESIGN. INT. CL. 42. (U.S. CLS. 100 AND 101). REG. 12-24-1996.
- 2,025,691. MISCELLANEOUS DESIGN. INT. CL. 42. (U.S. CLS. 100 AND 101). REG. 12-24-1996.
- 2,025,692. MISCELLANEOUS DESIGN. INT. CL. 42. (U.S. CLS. 100 AND 101). REG. 12-24-1996.
- 2,025,693. MISCELLANEOUS DESIGN. INT. CL. 42. (U.S. CLS. 100 AND 101). REG. 12-24-1996.
- 2,025,703. GOOD HAIR DAYS. INT. CL. 26. (U.S. CLS. 37, 39, 40, 42 AND 50). REG. 12-24-1996.
- 2,025,980. JUST ENJOY THE GAME. INT. CL. 12. (U.S. CLS. 19, 21, 23, 31, 35 AND 44). REG. 12-24-1996.
- 2,026,056. CONQUEST. INT. CL. 6. (U.S. CLS. 2, 12, 13, 14, 23, 25 AND 50). REG. 12-24-1996.
- 2,026,196. THE WEATHER TEACHER. INT. CL. 42. (U.S. CLS. 100 AND 101). REG. 12-24-1996.
- 2,026,197. THE SKI NETWORK. INT. CL. 42. (U.S. CLS. 100 AND 101). REG. 12-24-1996.
- 2,026,198. THE INTERNATIONAL WEATHER NETWORK. INT. CLS. 9 AND 42. (U.S. CLS. 21, 23, 26, 36, 38, 100 AND 101). REG. 12-24-1996.
- 2,026,199. THE ALLERGY NETWORK. INT. CL. 42. (U.S. CLS. 100 AND 101). REG. 12-24-1996.
- 2,026,200. THE RECREATION NETWORK. INT. CL. 42. (U.S. CLS. 100 AND 101). REG. 12-24-1996.
- 2,026,201. WEATHERMAN. INT. CLS. 9 AND 42. (U.S. CLS. 21, 23, 26, 36, 38, 100 AND 101). REG. 12-24-1996.
- 2,026,202. THE FISHING NETWORK. INT. CL. 42. (U.S. CLS. 100 AND 101). REG. 12-24-1996.
- 2,026,203. SIERRA WEATHER NETWORK. INT. CL. 42. (U.S. CLS. 100 AND 101). REG. 12-24-1996.
- 2,026,438. PERRY BAROMEDICAL AND DESIGN. INT. CLS. 10 AND 42. (U.S. CLS. 26, 39, 44, 100 AND 101). REG. 12-31-1996.
- 2,026,458. V12. INT. CL. 9. (U.S. CLS. 21, 23, 26, 36 AND 38). REG. 12-31-1996.
- 2,026,833. BOATERS VALUE AND DESIGN. INT. CL. 42. (U.S. CLS. 100 AND 101). REG. 12-31-1996.
- 2,027,426. CIRQUE DU SOLEIL AND DESIGN. INT. CL. 16. (U.S. CLS. 2, 5, 22, 23, 29, 37, 38 AND 50). REG. 12-31-1996.
- 2,027,439. MISCELLANEOUS DESIGN. INT. CL. 9. (U.S. CLS. 21, 23, 26, 36 AND 38). REG. 12-31-1996.
- 2,027,819. DOLCE VITA. INT. CL. 3. (U.S. CLS. 1, 4, 6, 50, 51 AND 52). REG. 12-31-1996.
- 2,027,886. EXECUTIVE VOICE. INT. CL. 16. (U.S. CLS. 2, 5, 22, 23, 29, 37, 38 AND 50). REG. 12-31-1996.
- 2,028,046. CALIFORNIA WEATHER NETWORK. INT. CL. 42. (U.S. CLS. 100 AND 101). REG. 12-31-1996.
- 2,028,319. JACOBS FIELD. INT. CL. 41. (U.S. CLS. 100, 101 AND 107). REG. 1-7-1997.
- 2,028,336. PRISCO SAFETYFAX. INT. CL. 42. (U.S. CLS. 100 AND 101). REG. 1-7-1997.
- 2,028,422. THE PACIFIC LUMBER COMPANY. INT. CL. 19. (U.S. CLS. 1, 12, 33 AND 50). REG. 1-7-1997.
- 2,028,506. AIG INSURANCE MANAGEMENT SERVICES. INT. CL. 35. (U.S. CLS. 100, 101 AND 102). REG. 1-7-1997.
- 2,028,519. LRH LIGHTWEIGHT. INT. CL. 28. (U.S. CLS. 22, 23, 38 AND 50). REG. 1-7-1997.
- 2,028,565. THE DEWEY COLOR SYSTEM. INT. CL. 42. (U.S. CLS. 100 AND 101). REG. 1-7-1997.
- 2,028,590. NICKELODEON. INT. CL. 42. (U.S. CLS. 100 AND 101). REG. 1-7-1997.
- 2,028,603. XENTRITE. INT. CL. 1. (U.S. CLS. 1, 5, 6, 10, 26 AND 46). REG. 1-7-1997.
- 2,028,608. MORNING STAR COFFEE. INT. CL. 30. (U.S. CL. 46). REG. 1-7-1997.
- 2,028,625. SCI AND DESIGN. INT. CL. 6. (U.S. CLS. 2, 12, 13, 14, 23, 25 AND 50). REG. 1-7-1997.
- 2,028,669. NORTH CAROLINA TRANSPORTATION MUSEUM. INT. CL. 41. (U.S. CLS. 100, 101 AND 107). REG. 1-7-1997.
- 2,028,679. ARCAT. INT. CL. 42. (U.S. CLS. 100 AND 101). REG. 1-7-1997.
- 2,028,681. OMEGAVIEW II. INT. CL. 9. (U.S. CLS. 21, 23, 26, 36 AND 38). REG. 1-7-1997.
- 2,028,700. NICK AT NITE. INT. CL. 42. (U.S. CLS. 100 AND 101). REG. 1-7-1997.
- 2,029,088. HEP-2000. INT. CLS. 1 AND 5. (U.S. CLS. 1, 5, 6, 10, 18, 26, 44, 46, 51 AND 52). REG. 1-7-1997.
- 2,029,092. SUPERCHARGE. INT. CL. 1. (U.S. CLS. 1, 5, 6, 10, 26 AND 46). REG. 1-7-1997.
- 2,029,260. EVER-LOK. INT. CL. 20. (U.S. CLS. 2, 13, 22, 25, 32 AND 50). REG. 1-7-1997.
- 2,029,284. AROSCI. INT. CL. 3. (U.S. CLS. 1, 4, 6, 50, 51 AND 52). REG. 1-7-1997.
- 2,029,364. BRITISH AMERICAN BUSINESS COUNCIL. INT. CL. 35. (U.S. CLS. 100, 101 AND 102). REG. 1-7-1997.
- 2,029,370. HERZOG. INT. CL. 7. (U.S. CLS. 13, 19, 21, 23, 31, 34 AND 35). REG. 1-7-1997.
- 2,029,453. MOZZARELLA DI BUFALA LUPARA AND DESIGN. INT. CL. 29. (U.S. CL. 46). REG. 1-14-1997.
- 2,029,455. LUISA CEVESE RIEDIZIONI. INT. CLS. 18, 20, 24, 25 AND 27. (U.S. CLS. 1, 2, 3, 13, 19, 20, 22, 25, 32, 37, 39, 41, 42 AND 50). REG. 1-14-1997.
- 2,029,461. CATALYST. INT. CL. 9. (U.S. CLS. 21, 23, 26, 36 AND 38). REG. 1-14-1997.
- 2,029,475. PECORINO ROMANO. U.S. CL. A. REG. 1-14-1997.
- 2,029,526. YARDCARE. INT. CLS. 1, 19 AND 31. (U.S. CLS. 1, 5, 6, 10, 12, 26, 33, 46 AND 50). REG. 1-14-1997.
- 2,029,558. POWERCAST. INT. CL. 5. (U.S. CLS. 6, 18, 44, 46, 51 AND 52). REG. 1-14-1997.
- 2,029,604. OPENMEDIA. INT. CL. 35. (U.S. CLS. 100, 101 AND 102). REG. 1-14-1997.
- 2,029,687. RVI GROUP (STYLIZED). INT. CL. 35. (U.S. CLS. 100, 101 AND 102). REG. 1-14-1997.
- 2,029,714. BRECKENRIDGE. INT. CL. 32. (U.S. CLS. 45, 46 AND 48). REG. 1-14-1997.
- 2,029,756. DIAGNOSTIC SELLING. INT. CL. 16. (U.S. CLS. 2, 5, 22, 23, 29, 37, 38 AND 50). REG. 1-14-1997.
- 2,029,761. MUSTELA. INT. CLS. 3 AND 5. (U.S. CLS. 1, 4, 6, 18, 44, 46, 50, 51 AND 52). REG. 1-14-1997.
- 2,029,838. AMALGAMATED. INT. CL. 25. (U.S. CLS. 22 AND 39). REG. 1-14-1997.
- 2,029,860. FEATHERLITE. INT. CL. 12. (U.S. CLS. 19, 21, 23, 31, 35 AND 44). REG. 1-14-1997.
- 2,029,863. CONNECTPRESS. INT. CL. 16. (U.S. CLS. 2, 5, 22, 23, 29, 37, 38 AND 50). REG. 1-14-1997.
- 2,029,882. PEAK PERFORMANCE AND DESIGN. INT. CL. 42. (U.S. CLS. 100 AND 101). REG. 1-14-1997.
- 2,029,910. X-FILES. INT. CL. 16. (U.S. CLS. 2, 5, 22, 23, 29, 37, 38 AND 50). REG. 1-14-1997.
- 2,029,914. BALANCE SYSTEM. INT. CL. 41. (U.S. CLS. 100, 101 AND 107). REG. 1-14-1997.
- 2,029,963. CONSORZIO (STYLIZED). INT. CLS. 29 AND 30. (U.S. CL. 46). REG. 1-14-1997.
- 2,029,968. COMMUNICATIONS GENERAL. INT. CL. 42. (U.S. CLS. 100 AND 101). REG. 1-14-1997.
- 2,029,998. DON DARIAS. INT. CL. 33. (U.S. CLS. 47 AND 49). REG. 1-14-1997.
- 2,030,083. SONAGE (STYLIZED). INT. CL. 3. (U.S. CLS. 1, 4, 6, 50, 51 AND 52). REG. 1-14-1997.
- 2,030,102. CANTEEN. INT. CL. 1. (U.S. CLS. 1, 5, 6, 10, 26 AND 46). REG. 1-14-1997.
- 2,030,130. MISCELLANEOUS DESIGN. INT. CL. 28. (U.S. CLS. 22, 23, 38 AND 50). REG. 1-14-1997.
- 2,030,210. MISCELLANEOUS DESIGN. INT. CL. 42. (U.S. CLS. 100 AND 101). REG. 1-14-1997.
- 2,030,249. THE BATTLE OF THE SEXES. INT. CL. 41. (U.S. CLS. 100, 101 AND 107). REG. 1-14-1997.
- 2,030,302. MAGNA-FX. INT. CL. 10. (U.S. CLS. 26, 39 AND 44). REG. 1-14-1997.
- 2,030,312. DURUSLIDE. INT. CL. 19. (U.S. CLS. 1, 12, 33 AND 50). REG. 1-14-1997.
- 2,030,354. CREATENET. INT. CL. 41. (U.S. CLS. 100, 101 AND 107). REG. 1-14-1997.
- 2,030,368. DOS COYOTES BORDER CAFE. INT. CL. 42. (U.S. CLS. 100 AND 101). REG. 1-14-1997.
- 2,030,384. E WALK. INT. CL. 36. (U.S. CLS. 100, 101 AND 102). REG. 1-14-1997.
- 2,030,406. MISCELLANEOUS DESIGN. INT. CLS. 3, 18 AND 25. (U.S. CLS. 1, 2, 3, 4, 6, 22, 39, 41, 50, 51 AND 52). REG. 1-14-1997.
- 2,030,461. DATAMATCH. INT. CL. 9. (U.S. CLS. 21, 23, 26, 36 AND 38). REG. 1-14-1997.
- 2,030,497. EDV. INT. CL. 11. (U.S. CLS. 13, 21, 23, 31 AND 34). REG. 1-14-1997.

- 2,030,523. AXSYM EXTEND. INT. CL. 41. (U.S. CLS. 100, 101 AND 107). REG. 1-14-1997.
- 2,030,619. WHALES & FRIENDS. INT. CLS. 16 AND 42. (U.S. CLS. 2, 5, 22, 23, 29, 37, 38, 50, 100 AND 101). REG. 1-14-1997.
- 2,030,625. GLUCONASE. INT. CL. 5. (U.S. CLS. 6, 18, 44, 46, 51 AND 52). REG. 1-14-1997.
- 2,030,643. E-P AND DESIGN. INT. CL. 9. (U.S. CLS. 21, 23, 26, 36 AND 38). REG. 1-14-1997.
- 2,030,687. FLYTHRU. INT. CL. 9. (U.S. CLS. 21, 23, 26, 36 AND 38). REG. 1-14-1997.
- 2,030,766. CLAD PLUS. INT. CL. 19. (U.S. CLS. 1, 12, 33 AND 50). REG. 1-14-1997.
- 2,030,788. SCALAR. INT. CL. 7. (U.S. CLS. 13, 19, 21, 23, 31, 34 AND 35). REG. 1-14-1997.
- 2,030,954. KOOL ALL. INT. CL. 1. (U.S. CLS. 1, 5, 6, 10, 26 AND 46). REG. 1-14-1997.
- 2,031,102. GET WITH THE PROGRAM. INT. CL. 14. (U.S. CLS. 2, 27, 28 AND 50). REG. 1-14-1997.
- 2,031,108. MISCELLANEOUS DESIGN. INT. CL. 9. (U.S. CLS. 21, 23, 26, 36 AND 38). REG. 1-14-1997.
- 2,031,150. NET SUCCESS. INT. CL. 35. (U.S. CLS. 100, 101 AND 102). REG. 1-14-1997.
- 2,031,259. CLASSIC SPORTS NETWORK. INT. CLS. 38, 41 AND 42. (U.S. CLS. 100, 101, 104 AND 107). REG. 1-14-1997.
- 2,031,357. MANHATTAN BAGEL. INT. CL. 42. (U.S. CLS. 100 AND 101). REG. 1-21-1997.
- 2,031,365. JOURDAN (STYLIZED). INT. CLS. 16 AND 18. (U.S. CLS. 1, 2, 3, 5, 22, 23, 29, 37, 38, 41 AND 50). REG. 1-21-1997.
- 2,031,385. ADJUSTA-GROOM. INT. CL. 8. (U.S. CL. 23). REG. 1-21-1997.
- 2,031,397. MULLINER PARK WARD. INT. CL. 37. (U.S. CLS. 100, 103 AND 106). REG. 1-21-1997.
- 2,031,408. CIAO ITALIA. INT. CL. 25 ONLY. (U.S. CLS. 22 AND 39). REG. 1-21-1997.
- 2,031,447. RENOFORM. INT. CL. 4. (U.S. CLS. 1, 6 AND 15). REG. 1-21-1997.
- 2,031,482. STANDING OVATION. INT. CL. 41 ONLY. (U.S. CLS. 100, 101 AND 107). REG. 1-21-1997.
- 2,031,494. MELVIS. INT. CL. 1. (U.S. CLS. 1, 5, 6, 10, 26 AND 46). REG. 1-21-1997.
- 2,031,593. ELITE EIGHT. INT. CL. 41. (U.S. CLS. 100, 101 AND 107). REG. 1-21-1997.
- 2,031,612. LOOSE DEUCE DEUCES WILD. INT. CL. 9. (U.S. CLS. 21, 23, 26, 36 AND 38). REG. 1-21-1997.
- 2,031,692. HOME DAY-TO-DAY CARE REGISTRY, INC. "LIVING AT HOME IS BETTER" AND DESIGN. INT. CL. 42. (U.S. CLS. 100 AND 101). REG. 1-21-1997.
- 2,031,716. THYMUS PMG. INT. CL. 5. (U.S. CLS. 6, 18, 44, 46, 51 AND 52). REG. 1-21-1997.
- 2,031,753. RANGER. INT. CLS. 9 AND 16. (U.S. CLS. 2, 5, 21, 22, 23, 26, 29, 36, 37, 38 AND 50). REG. 1-21-1997.
- 2,031,848. PAESANA. INT. CL. 30. (U.S. CL. 46). REG. 1-21-1997.
- 2,031,857. CARAMEL APPLE WRAP (STYLIZED). INT. CL. 30. (U.S. CL. 46). REG. 1-21-1997.
- 2,031,912. AMAZING COACHELLA AND DESIGN. INT. CL. 31. (U.S. CLS. 1 AND 46). REG. 1-21-1997.
- 2,031,965. THOROUGHbred CHORUS. INT. CL. 41. (U.S. CLS. 100, 101 AND 107). REG. 1-21-1997.
- 2,031,978. ALOE KING AND DESIGN. INT. CL. 31. (U.S. CLS. 1 AND 46). REG. 1-21-1997.
- 2,032,039. PRO 100. INT. CL. 9. (U.S. CLS. 21, 23, 26, 36 AND 38). REG. 1-21-1997.
- 2,032,087. HASTINGS AND DESIGN. INT. CL. 7. (U.S. CLS. 13, 19, 21, 23, 31, 34 AND 35). REG. 1-21-1997.
- 2,032,105. CYBERMETRIX. INT. CL. 42. (U.S. CLS. 100 AND 101). REG. 1-21-1997.
- 2,032,142. TOMAHAWKS AND DESIGN. U.S. CL. 200. REG. 1-21-1997.
- 2,032,180. CRAMARO. INT. CL. 12. (U.S. CLS. 19, 21, 23, 31, 35 AND 44). REG. 1-21-1997.
- 2,032,231. HOT RODS. INT. CL. 15. (U.S. CLS. 2, 21 AND 36). REG. 1-21-1997.
- 2,032,286. NAVY. INT. CL. 3. (U.S. CLS. 1, 4, 6, 50, 51 AND 52). REG. 1-21-1997.
- 2,032,349. SECOND ONLY TO NATURE. INT. CL. 5. (U.S. CLS. 6, 18, 44, 46, 51 AND 52). REG. 1-21-1997.
- 2,032,372. OKATIE CREEK GOLF CLUB AND DESIGN. INT. CL. 41. (U.S. CLS. 100, 101 AND 107). REG. 1-21-1997.
- 2,032,382. RED TAIL ALE. INT. CL. 32. (U.S. CLS. 45, 46 AND 48). REG. 1-21-1997.
- 2,032,389. LEXMARK AND DESIGN. INT. CLS. 9 AND 16. (U.S. CLS. 2, 5, 21, 22, 23, 26, 29, 36, 37, 38 AND 50). REG. 1-21-1997.
- 2,032,400. SIGNATURE FLIGHT SUPPORT. INT. CL. 37. (U.S. CLS. 100, 103 AND 106). REG. 1-21-1997.
- 2,032,443. TELEWASH. INT. CL. 17. (U.S. CLS. 1, 5, 12, 13, 35 AND 50). REG. 1-21-1997.
- 2,032,445. FLEXIRECEIVABLES. INT. CL. 9. (U.S. CLS. 21, 23, 26, 36 AND 38). REG. 1-21-1997.
- 2,032,478. CANADA DIRECT. INT. CL. 38. (U.S. CLS. 100, 101 AND 104). REG. 1-21-1997.
- 2,032,484. PERFECT PRO. INT. CL. 5. (U.S. CLS. 6, 18, 44, 46, 51 AND 52). REG. 1-21-1997.
- 2,032,489. CANADA DIRECT AND DESIGN. INT. CL. 38. (U.S. CLS. 100, 101 AND 104). REG. 1-21-1997.
- 2,032,529. MELOZ. INT. CL. 16. (U.S. CLS. 2, 5, 22, 23, 29, 37, 38 AND 50). REG. 1-21-1997.
- 2,032,573. TALENT ONLINE. INT. CL. 35. (U.S. CLS. 100, 101 AND 102). REG. 1-21-1997.
- 2,032,687. VERSARACK. INT. CL. 12. (U.S. CLS. 19, 21, 23, 31, 35 AND 44). REG. 1-21-1997.
- 2,032,690. ABBOT ALE. INT. CL. 32. (U.S. CLS. 45, 46 AND 48). REG. 1-21-1997.
- 2,032,709. DOLLHOUSE. INT. CL. 25. (U.S. CLS. 22 AND 39). REG. 1-21-1997.
- 2,032,813. THE ORIGINAL ROLLABOARD. INT. CLS. 18 AND 28. (U.S. CLS. 1, 2, 3, 22, 23, 38, 41 AND 50). REG. 1-21-1997.
- 2,032,822. POLESTAR. INT. CL. 11. (U.S. CLS. 13, 21, 23, 31 AND 34). REG. 1-21-1997.
- 2,032,864. D'AC AND DESIGN. INT. CL. 11. (U.S. CLS. 13, 21, 23, 31 AND 34). REG. 1-21-1997.
- 2,032,882. PYREX PORTABLES. INT. CL. 21. (U.S. CLS. 2, 13, 23, 29, 30, 33, 40 AND 50). REG. 1-21-1997.
- 2,032,901. ROLFS. INT. CL. 25. (U.S. CLS. 22 AND 39). REG. 1-21-1997.
- 2,033,180. LOOK OF DIAMONDS. INT. CL. 14. (U.S. CLS. 2, 27, 28 AND 50). REG. 1-21-1997.
- 2,033,317. MISCELLANEOUS DESIGN. INT. CL. 8. (U.S. CLS. 23, 28 AND 44). REG. 1-28-1997.
- 2,033,323. SERIOUS PERFORMANCE. INT. CL. 28. (U.S. CLS. 22, 23, 38 AND 50). REG. 1-28-1997.
- 2,033,350. STEEL TEC AND DESIGN. INT. CL. 8. (U.S. CLS. 23, 28 AND 44). REG. 1-28-1997.
- 2,033,401. AAU USA AND DESIGN. INT. CLS. 25 AND 26. (U.S. CLS. 22, 37, 39, 40, 42 AND 50). REG. 1-28-1997.
- 2,033,408. COMMOLOCO. INT. CL. 36. (U.S. CLS. 100, 101 AND 102). REG. 1-28-1997.
- 2,033,428. CATULIA. INT. CL. 2. (U.S. CLS. 6, 11 AND 16). REG. 1-28-1997.
- 2,033,429. KROLEWSKA AND DESIGN. INT. CLS. 21 AND 33. (U.S. CLS. 2, 13, 23, 29, 30, 33, 40, 47, 49 AND 50). REG. 1-28-1997.
- 2,033,467. MASTERING THE COMPLEX SALE. INT. CLS. 16 AND 41. (U.S. CLS. 2, 5, 22, 23, 29, 37, 38, 50, 100, 101 AND 107). REG. 1-28-1997.
- 2,033,468. PRIME RESOURCE GROUP. INT. CL. 16. (U.S. CLS. 2, 5, 22, 23, 29, 37, 38 AND 50). REG. 1-28-1997.
- 2,033,533. OPERATION RESPOND. INT. CL. 16. (U.S. CLS. 2, 5, 22, 23, 29, 37, 38 AND 50). REG. 1-28-1997.
- 2,033,540. MULTISTAR. INT. CL. 7. (U.S. CLS. 13, 19, 21, 23, 31, 34 AND 35). REG. 1-28-1997.
- 2,033,557. FOX SPORTS. INT. CL. 41. (U.S. CLS. 100, 101 AND 107). REG. 1-28-1997.
- 2,033,581. BFCL R AND DESIGN. INT. CL. 24 ONLY. (U.S. CLS. 42 AND 50). REG. 1-28-1997.
- 2,033,587. THE YELLOW BOX PEOPLE... INT. CL. 42. (U.S. CLS. 100 AND 101). REG. 1-28-1997.
- 2,033,661. GANNON. INT. CL. 16. (U.S. CLS. 2, 5, 22, 23, 29, 37, 38 AND 50). REG. 1-28-1997.
- 2,033,759. TOP OF THE MARK. INT. CL. 42. (U.S. CLS. 100 AND 101). REG. 1-28-1997.
- 2,033,772. VERTEX. INT. CLS. 9 AND 16. (U.S. CLS. 2, 5, 21, 22, 23, 26, 29, 36, 37, 38 AND 50). REG. 1-28-1997.
- 2,033,783. THE LUXURY COLLECTION. INT. CL. 42. (U.S. CLS. 100 AND 101). REG. 1-28-1997.
- 2,033,816. MISCELLANEOUS DESIGN. INT. CLS. 20 AND 42. (U.S. CLS. 2, 13, 22, 25, 32, 50, 100 AND 101). REG. 1-28-1997.
- 2,033,835. GO BAGS (STYLIZED). INT. CL. 16. (U.S. CLS. 2, 5, 22, 23, 29, 37, 38 AND 50). REG. 1-28-1997.

- 2,033,884. FASTBACK AND DESIGN. INT. CL. 7. (U.S. CLS. 13, 19, 21, 23, 31, 34 AND 35). REG. 1-28-1997.
- 2,034,068. IODOFLEX. INT. CL. 5. (U.S. CLS. 6, 18, 44, 46, 51 AND 52). REG. 1-28-1997.
- 2,034,077. GOLD PRO BLADE. INT. CL. 7. (U.S. CLS. 13, 19, 21, 23, 31, 34 AND 35). REG. 1-28-1997.
- 2,034,108. AHEAD. INT. CL. 25. (U.S. CLS. 22 AND 39). REG. 1-28-1997.
- 2,034,146. ADAPTIVE ENGINEERING LAB. INT. CL. 12. (U.S. CLS. 19, 21, 23, 31, 35 AND 44). REG. 1-28-1997.
- 2,034,156. PROFORMA. INT. CL. 10. (U.S. CLS. 26, 39 AND 44). REG. 1-28-1997.
- 2,034,190. ATLAS PRECISION AND DESIGN. INT. CL. 40. (U.S. CLS. 100, 103 AND 106). REG. 1-28-1997.
- 2,034,223. XYBIX. INT. CL. 20. (U.S. CLS. 2, 13, 22, 25, 32 AND 50). REG. 1-28-1997.
- 2,034,247. SMART PACK. INT. CL. 37. (U.S. CLS. 100, 103 AND 106). REG. 1-28-1997.
- 2,034,264. CONTEC AND DESIGN. INT. CL. 9. (U.S. CLS. 21, 23, 26, 36 AND 38). REG. 1-28-1997.
- 2,034,294. FLOJET. INT. CL. 7. (U.S. CLS. 13, 19, 21, 23, 31, 34 AND 35). REG. 1-28-1997.
- 2,034,299. ELITRA. INT. CL. 29. (U.S. CL. 46). REG. 1-28-1997.
- 2,034,347. DOMAINE SANTA BARBARA. INT. CL. 33. (U.S. CLS. 47 AND 49). REG. 1-28-1997.
- 2,034,357. AMBERCARE. INT. CL. 42. (U.S. CLS. 100 AND 101). REG. 1-28-1997.
- 2,034,421. FERROTRON. INT. CL. 5. (U.S. CLS. 6, 18, 44, 46, 51 AND 52). REG. 1-28-1997.
- 2,034,455. WRANGLER. INT. CL. 4. (U.S. CLS. 1, 6 AND 15). REG. 1-28-1997.
- 2,034,553. DACONIL WEATHER STIK. INT. CL. 5. (U.S. CLS. 6, 18, 44, 46, 51 AND 52). REG. 1-28-1997.
- 2,034,621. AMERICA'S CAPO. INT. CL. 15. (U.S. CLS. 2, 21 AND 36). REG. 1-28-1997.
- 2,034,622. AMERICAN PUBLIC COMMUNICATIONS COUNCIL. INT. CLS. 16 AND 41. (U.S. CLS. 2, 5, 22, 23, 29, 37, 38, 50, 100, 101 AND 107). REG. 1-28-1997.
- 2,034,692. HAVA JAVA. INT. CL. 42. (U.S. CL. 100). REG. 2-4-1997.
- 2,034,714. CUPIDO. INT. CL. 31. (U.S. CL. 1). REG. 2-4-1997.
- 2,034,726. VALDERRAMA AND DESIGN. INT. CL. 25. (U.S. CLS. 22 AND 39). REG. 2-4-1997.
- 2,034,772. AISE. INT. CL. 16 ONLY. (U.S. CLS. 2, 5, 22, 23, 29, 37, 38 AND 50). REG. 2-4-1997.
- 2,034,824. THE FLOWER FIELDS AT CARLSBAD RANCH AND DESIGN. INT. CLS. 31 AND 41. (U.S. CLS. 1, 46, 100, 101 AND 107). REG. 2-4-1997.
- 2,034,838. QUALITY CHEF FOODS, INC. (STYLIZED). INT. CLS. 29 AND 30. (U.S. CL. 46). REG. 2-4-1997.
- 2,034,850. TUSCAN OVEN. INT. CL. 42. (U.S. CLS. 100 AND 101). REG. 2-4-1997.
- 2,034,913. KVADRAT. INT. CL. 24. (U.S. CLS. 42 AND 50). REG. 2-4-1997.
- 2,034,997. CUREBEADS. INT. CL. 1. (U.S. CLS. 1, 5, 6, 10, 26 AND 46). REG. 2-4-1997.
- 2,035,005. STARBUCKS COFFEE (STYLIZED). INT. CL. 42. (U.S. CLS. 100 AND 101). REG. 2-4-1997.
- 2,035,040. SH SOFTWARE HORIZONS INC. (STYLIZED). INT. CL. 9. (U.S. CLS. 21, 23, 26, 36 AND 38). REG. 2-4-1997.
- 2,035,076. VOYAGER. INT. CL. 9. (U.S. CLS. 21, 23, 26, 36 AND 38). REG. 2-4-1997.
- 2,035,085. SAFEWAY SELECT. INT. CLS. 29 AND 30. (U.S. CL. 46). REG. 2-4-1997.
- 2,035,094. THE PDR FAMILY GUIDE TO NUTRITION AND HEALTH. INT. CL. 16. (U.S. CLS. 2, 5, 22, 23, 29, 37, 38 AND 50). REG. 2-4-1997.
- 2,035,125. PARTY FAIR. INT. CL. 42. (U.S. CLS. 100 AND 101). REG. 2-4-1997.
- 2,035,162. VICTORIA. INT. CL. 36. (U.S. CLS. 100, 101 AND 102). REG. 2-4-1997.
- 2,035,253. RED'S JAVA HOUSE REDS JAVA HOUSE COFFEE AND DESIGN. INT. CLS. 30 AND 42 ONLY. (U.S. CLS. 46, 100 AND 101). REG. 2-4-1997.
- 2,035,258. ENJOY. (STYLIZED). INT. CL. 9. (U.S. CLS. 21, 23, 26, 36 AND 38). REG. 2-4-1997.
- 2,035,271. MICROCOMPLETE. INT. CL. 37. (U.S. CLS. 100, 103 AND 106). REG. 2-4-1997.
- 2,035,275. PAYASO. INT. CL. 32. (U.S. CLS. 45, 46 AND 48). REG. 2-4-1997.
- 2,035,295. HAMBEENS NAVY BEAN SOUP. INT. CL. 29. (U.S. CL. 46). REG. 2-4-1997.
- 2,035,358. SAFE & SOUND. INT. CL. 9. (U.S. CLS. 21, 23, 26, 36 AND 38). REG. 2-4-1997.
- 2,035,393. HELENA. INT. CL. 25. (U.S. CLS. 22 AND 39). REG. 2-4-1997.
- 2,035,425. DIMAGGIO (STYLIZED). INT. CLS. 14 AND 25. (U.S. CLS. 2, 22, 27, 28, 39 AND 50). REG. 2-4-1997.
- 2,035,442. CRAFTS AT THE CASTLE. INT. CL. 36. (U.S. CLS. 100, 101 AND 102). REG. 2-4-1997.
- 2,035,560. TRENCHFET. INT. CL. 9. (U.S. CLS. 21, 23, 26, 36 AND 38). REG. 2-4-1997.
- 2,035,659. MIGRAGARD. INT. CL. 5. (U.S. CLS. 6, 18, 44, 46, 51 AND 52). REG. 2-4-1997.
- 2,035,697. DIAMALLOY. INT. CL. 1. (U.S. CLS. 1, 5, 6, 10, 26 AND 46). REG. 2-4-1997.
- 2,035,717. PAGEVIEW. INT. CL. 16. (U.S. CLS. 2, 5, 22, 23, 29, 37, 38 AND 50). REG. 2-4-1997.
- 2,035,793. FORENSIC ROOF. INT. CL. 37. (U.S. CLS. 100, 103 AND 106). REG. 2-4-1997.
- 2,035,794. INSPECTION PLUS. INT. CL. 37. (U.S. CLS. 100, 103 AND 106). REG. 2-4-1997.
- 2,035,858. MISCELLANEOUS DESIGN. INT. CLS. 25, 41 AND 42. (U.S. CLS. 22, 39, 100, 101 AND 107). REG. 2-4-1997.
- 2,035,876. PROJECTAVISION. INT. CL. 9. (U.S. CLS. 21, 23, 26, 36 AND 38). REG. 2-4-1997.
- 2,035,878. HEPATASOL. INT. CL. 5. (U.S. CLS. 6, 18, 44, 46, 51 AND 52). REG. 2-4-1997.
- 2,035,902. PECOS (STYLIZED). INT. CLS. 9 AND 42. (U.S. CLS. 21, 23, 26, 36, 38, 100 AND 101). REG. 2-4-1997.
- 2,035,916. SHELL-GUARD. INT. CL. 5. (U.S. CLS. 6, 18, 44, 46, 51 AND 52). REG. 2-4-1997.
- 2,035,944. NVISION (STYLIZED). INT. CL. 35. (U.S. CLS. 100, 101 AND 102). REG. 2-4-1997.
- 2,036,010. ENERGIA. INT. CL. 41. (U.S. CLS. 100, 101 AND 107). REG. 2-4-1997.
- 2,036,012. ENERGIA. INT. CL. 35. (U.S. CLS. 100, 101 AND 102). REG. 2-4-1997.
- 2,036,083. ENERGY SMART. INT. CL. 5. (U.S. CLS. 6, 18, 44, 46, 51 AND 52). REG. 2-4-1997.
- 2,036,101. TRAILBLAZER. INT. CL. 12. (U.S. CLS. 19, 21, 23, 31, 35 AND 44). REG. 2-4-1997.
- 2,036,105. AUTOVAL. INT. CL. 9. (U.S. CLS. 21, 23, 26, 36 AND 38). REG. 2-4-1997.
- 2,036,116. NIRVANA. INT. CL. 27. (U.S. CLS. 19, 20, 37, 42 AND 50). REG. 2-4-1997.
- 2,036,140. INFRATEK. INT. CL. 37. (U.S. CLS. 100, 103 AND 106). REG. 2-4-1997.
- 2,036,183. CENTURION. INT. CL. 9. (U.S. CLS. 21, 23, 26, 36 AND 38). REG. 2-4-1997.
- 2,036,195. MARISA MINICUCCI. INT. CL. 25. (U.S. CLS. 22 AND 39). REG. 2-4-1997.
- 2,036,249. MATHSTART. INT. CL. 16. (U.S. CLS. 2, 5, 22, 23, 29, 37, 38 AND 50). REG. 2-4-1997.
- 2,036,255. MISCELLANEOUS DESIGN. INT. CL. 6. (U.S. CL. 13). REG. 2-4-1997.
- 2,036,260. LUXURY BATH LINERS. INT. CL. 11. (U.S. CLS. 13, 21, 23, 31 AND 34). REG. 2-4-1997.
- 2,036,268. THE PLAYGROUND STORE. INT. CL. 42. (U.S. CLS. 100 AND 101). REG. 2-4-1997.
- 2,036,382. LYNX SERVICES. INT. CLS. 35 AND 36. (U.S. CLS. 100, 101 AND 102). REG. 2-11-1997.
- 2,036,400. MIB 30. INT. CL. 36. (U.S. CLS. 100, 101 AND 102). REG. 2-11-1997.
- 2,036,412. UNITED FURNITURE WAREHOUSE AND DESIGN. INT. CL. 42. (U.S. CLS. 100 AND 101). REG. 2-11-1997.
- 2,036,489. HARRY'S PREMIUM SNACKS AND DESIGN. INT. CLS. 29 AND 30. (U.S. CL. 46). REG. 2-11-1997.
- 2,036,500. DETROIT DIESEL AND DESIGN. INT. CL. 9. (U.S. CLS. 21, 23, 26, 36 AND 38). REG. 2-11-1997.
- 2,036,537. MISCELLANEOUS DESIGN. INT. CL. 9. (U.S. CLS. 21, 23, 26, 36 AND 38). REG. 2-11-1997.
- 2,036,568. NEA ATTIKI. INT. CL. 41. (U.S. CLS. 100, 101 AND 107). REG. 2-11-1997.
- 2,036,609. PS PROVINCE STUDIO AND DESIGN. INT. CL. 16. (U.S. CLS. 2, 5, 22, 23, 29, 37, 38 AND 50). REG. 2-11-1997.
- 2,036,656. ULTREX. INT. CL. 19. (U.S. CLS. 1, 12, 33 AND 50). REG. 2-11-1997.



- 2,036,672. MULTISTEP. INT. CL. 7. (U.S. CLS. 13, 19, 21, 23, 31, 34 AND 35). REG. 2-11-1997.
- 2,036,673. INSULPINK. INT. CL. 17. (U.S. CLS. 1, 5, 12, 13, 35 AND 50). REG. 2-11-1997.
- 2,036,687. SENOLITE. INT. CL. 28. (U.S. CLS. 22, 23, 38 AND 50). REG. 2-11-1997.
- 2,036,688. DOUBLE HORSES BRAND AND DESIGN. INT. CL. 30. (U.S. CL. 46). REG. 2-11-1997.
- 2,036,708. SUPERTOP. INT. CL. 12. (U.S. CLS. 19, 21, 23, 31, 35 AND 44). REG. 2-11-1997.
- 2,036,723. TRANSITION TIGHT. INT. CL. 25. (U.S. CLS. 22 AND 39). REG. 2-11-1997.
- 2,036,776. NAUGHTY DOG. INT. CL. 28. (U.S. CLS. 22, 23, 38 AND 50). REG. 2-11-1997.
- 2,036,816. YEE LAM. INT. CL. 29. (U.S. CL. 46). REG. 2-11-1997.
- 2,036,835. PEARL VALLEY. INT. CL. 29. (U.S. CL. 46). REG. 2-11-1997.
- 2,036,848. MISCELLANEOUS DESIGN. INT. CL. 16. (U.S. CLS. 2, 5, 22, 23, 29, 37, 38 AND 50). REG. 2-11-1997.
- 2,036,849. CLASSIC HEARTH. INT. CL. 30. (U.S. CL. 46). REG. 2-11-1997.
- 2,036,898. BISON AND DESIGN. INT. CL. 31. (U.S. CLS. 1 AND 46). REG. 2-11-1997.
- 2,036,970. FIRST CONSULTING GROUP. INT. CL. 35. (U.S. CLS. 100, 101 AND 102). REG. 2-11-1997.
- 2,036,972. THERAPET. INT. CLS. 3 AND 5. (U.S. CLS. 1, 4, 6, 18, 44, 46, 50, 51 AND 52). REG. 2-11-1997.
- 2,037,096. CAFE MADRID. INT. CL. 42. (U.S. CLS. 100 AND 101). REG. 2-11-1997.
- 2,037,128. CIRCLE SHUTTER. INT. CL. 19. (U.S. CLS. 1, 12, 33 AND 50). REG. 2-11-1997.
- 2,037,212. ARBELLA. INT. CL. 36. (U.S. CLS. 100, 101 AND 102). REG. 2-11-1997.
- 2,037,375. IPEX AND DESIGN. INT. CLS. 11 AND 17. (U.S. CLS. 1, 5, 12, 13, 21, 23, 31, 34, 35 AND 50). REG. 2-11-1997.
- 2,037,415. KEYPER. INT. CL. 20. (U.S. CLS. 2, 13, 22, 25, 32 AND 50). REG. 2-11-1997.
- 2,037,471. DREAMJET. INT. CL. 11. (U.S. CLS. 13, 21, 23, 31 AND 34). REG. 2-11-1997.
- 2,037,499. MISCELLANEOUS DESIGN. INT. CL. 16. (U.S. CLS. 2, 5, 22, 23, 29, 37, 38 AND 50). REG. 2-11-1997.
- 2,037,543. AIGLE. INT. CL. 25. (U.S. CLS. 22 AND 39). REG. 2-11-1997.
- 2,037,570. KLEERTITE AND DESIGN. INT. CL. 6. (U.S. CLS. 2, 12, 13, 14, 23, 25 AND 50). REG. 2-11-1997.
- 2,037,581. TKO. INT. CL. 12. (U.S. CLS. 19, 21, 23, 31, 35 AND 44). REG. 2-11-1997.
- 2,037,583. CASA SOLANA AND DESIGN. INT. CL. 21. (U.S. CLS. 2, 13, 23, 29, 30, 33, 40 AND 50). REG. 2-11-1997.
- 2,037,584. CASA SOLANA. INT. CL. 21. (U.S. CLS. 2, 13, 23, 29, 30, 33, 40 AND 50). REG. 2-11-1997.
- 2,037,610. COTTON PARK COTTAGE. INT. CL. 24. (U.S. CLS. 42 AND 50). REG. 2-11-1997.
- 2,037,648. QUIK-TAP. INT. CL. 9. (U.S. CLS. 21, 23, 26, 36 AND 38). REG. 2-11-1997.
- 2,037,660. DIRT MASTER. INT. CL. 25. (U.S. CLS. 22 AND 39). REG. 2-11-1997.
- 2,037,673. PINGO BINGO (STYLIZED). INT. CL. 28. (U.S. CLS. 22, 23, 38 AND 50). REG. 2-11-1997.
- 2,037,701. ROCKQUEST. INT. CL. 28. (U.S. CLS. 22, 23, 38 AND 50). REG. 2-11-1997.
- 2,037,738. CHALET. INT. CL. 19. (U.S. CLS. 1, 12, 33 AND 50). REG. 2-11-1997.
- 2,037,815. TXT. INT. CL. 12. (U.S. CLS. 19, 21, 23, 31, 35 AND 44). REG. 2-11-1997.
- 2,037,859. UNI-DROP. INT. CL. 11. (U.S. CLS. 13, 21, 23, 31 AND 34). REG. 2-11-1997.
- 2,037,905. OUTRIDER. INT. CL. 7. (U.S. CLS. 13, 19, 21, 23, 31, 34 AND 35). REG. 2-11-1997.
- 2,037,955. INTELLIDERM. INT. CL. 5. (U.S. CLS. 6, 18, 44, 46, 51 AND 52). REG. 2-11-1997.
- 2,037,961. LUXURY BATH SYSTEMS. INT. CL. 11. (U.S. CLS. 13, 21, 23, 31 AND 34). REG. 2-11-1997.
- 2,038,078. VALOR. INT. CL. 30. (U.S. CL. 46). REG. 2-18-1997.
- 2,038,152. CRYSTAL RIVER. INT. CL. 28. (U.S. CLS. 22, 23, 38 AND 50). REG. 2-18-1997.
- 2,038,185. ABS. INT. CL. 41. (U.S. CLS. 100, 101 AND 107). REG. 2-18-1997.
- 2,038,205. AMERICAN SPEECH-LANGUAGE-HEARING ASSOCIATION. INT. CLS. 41 AND 42. (U.S. CLS. 100, 101 AND 107). REG. 2-18-1997.
- 2,038,301. VESPA AND DESIGN. INT. CLS. 6, 14, 16, 26 AND 28. (U.S. CLS. 2, 5, 12, 13, 14, 22, 23, 25, 27, 28, 29, 37, 38, 39, 40, 42 AND 50). REG. 2-18-1997.
- 2,038,342. GREENING AMERICA. INT. CL. 41. (U.S. CLS. 100, 101 AND 107). REG. 2-18-1997.
- 2,038,415. SEPARATE CINEMA. INT. CL. 42. (U.S. CLS. 100 AND 101). REG. 2-18-1997.
- 2,038,544. JETCAL 2000. INT. CL. 9. (U.S. CLS. 21, 23, 26, 36 AND 38). REG. 2-18-1997.
- 2,038,576. THE CENTRE FOR WELL-BEING. INT. CL. 42. (U.S. CLS. 100 AND 101). REG. 2-18-1997.
- 2,038,606. SMART INSIDER. INT. CL. 36. (U.S. CLS. 100, 101 AND 102). REG. 2-18-1997.
- 2,038,806. THE PERFECT RENTAL PACKAGE. INT. CL. 39. (U.S. CLS. 100 AND 105). REG. 2-18-1997.
- 2,038,810. BLACK BODY AND DESIGN. INT. CL. 11. (U.S. CLS. 13, 21, 23, 31 AND 34). REG. 2-18-1997.
- 2,038,890. RFS. INT. CL. 9. (U.S. CLS. 21, 23, 26, 36 AND 38). REG. 2-18-1997.
- 2,038,915. TARCHER. INT. CL. 16. (U.S. CLS. 2, 5, 22, 23, 29, 37, 38 AND 50). REG. 2-18-1997.
- 2,038,936. JAZZY CATS. INT. CL. 12. (U.S. CLS. 19, 21, 23, 31, 35 AND 44). REG. 2-18-1997.
- 2,038,988. LENOX AND DESIGN. INT. CL. 21. (U.S. CLS. 2, 13, 23, 29, 30, 33, 40 AND 50). REG. 2-18-1997.
- 2,038,989. COMFORT PROMISE PURIFIED SENNA AND DESIGN. INT. CL. 5. (U.S. CLS. 6, 18, 44, 46, 51 AND 52). REG. 2-18-1997.
- 2,039,058. I.P. REPORTER INTELLECTUAL PROPERTY AND DESIGN. INT. CL. 16. (U.S. CLS. 2, 5, 22, 23, 29, 37, 38 AND 50). REG. 2-18-1997.
- 2,039,085. ALPHA. INT. CL. 5. (U.S. CLS. 6, 18, 44, 46, 51 AND 52). REG. 2-18-1997.
- 2,039,103. CYCLOMYRAL. INT. CL. 1. (U.S. CLS. 1, 5, 6, 10, 26 AND 46). REG. 2-18-1997.
- 2,039,176. O OHIO STATE (STYLIZED). INT. CL. 24. (U.S. CLS. 42 AND 50). REG. 2-18-1997.
- 2,039,177. O OHIO STATE (STYLIZED). INT. CL. 22. (U.S. CLS. 1, 2, 7, 19, 22, 42 AND 50). REG. 2-18-1997.
- 2,039,178. O OHIO STATE (STYLIZED). INT. CL. 28. (U.S. CLS. 22, 23, 38 AND 50). REG. 2-18-1997.
- 2,039,179. O OHIO STATE AND DESIGN. INT. CL. 15. (U.S. CLS. 2, 21 AND 36). REG. 2-18-1997.
- 2,039,180. O OHIO STATE AND DESIGN. INT. CL. 20. (U.S. CLS. 2, 13, 22, 25, 32 AND 50). REG. 2-18-1997.
- 2,039,181. O OHIO STATE AND DESIGN. INT. CL. 16. (U.S. CLS. 2, 5, 22, 23, 29, 37, 38 AND 50). REG. 2-18-1997.
- 2,039,182. O OHIO STATE AND DESIGN. INT. CL. 11. (U.S. CLS. 13, 21, 23, 31 AND 34). REG. 2-18-1997.
- 2,039,183. O OHIO STATE (STYLIZED). INT. CL. 9. (U.S. CLS. 21, 23, 26, 36 AND 38). REG. 2-18-1997.
- 2,039,184. O OHIO STATE (STYLIZED). INT. CL. 12. (U.S. CLS. 19, 21, 23, 31, 35 AND 44). REG. 2-18-1997.
- 2,039,185. O OHIO STATE (STYLIZED). INT. CL. 6. (U.S. CLS. 2, 12, 13, 14, 23, 25 AND 50). REG. 2-18-1997.
- 2,039,199. MLS AND DESIGN. INT. CLS. 16 AND 25. (U.S. CLS. 2, 5, 22, 23, 29, 37, 38, 39 AND 50). REG. 2-18-1997.
- 2,039,220. COMMITTED TO EXCELLENCE. INT. CLS. 11 AND 17. (U.S. CLS. 1, 5, 12, 13, 21, 23, 31, 34, 35 AND 50). REG. 2-18-1997.
- 2,039,370. RV LIFE. INT. CL. 16. (U.S. CLS. 2, 5, 22, 23, 29, 37, 38 AND 50). REG. 2-18-1997.
- 2,039,564. ADVANCED BIOLOGICS. INT. CL. 42. (U.S. CLS. 100 AND 101). REG. 2-18-1997.
- 2,039,595. MINIVAULT. INT. CL. 13. (U.S. CLS. 2 AND 9). REG. 2-25-1997.
- 2,039,662. BAMBA. INT. CL. 30. (U.S. CL. 46). REG. 2-25-1997.
- 2,039,766. ELS. INT. CLS. 16 AND 41. (U.S. CLS. 2, 5, 22, 23, 29, 37, 38, 50, 100, 101 AND 107). REG. 2-25-1997.
- 2,039,854. DUOSTAT. INT. CL. 1 ONLY. (U.S. CLS. 1, 5, 6, 10, 26 AND 46). REG. 2-25-1997.
- 2,039,874. NORTHFIELD. INT. CL. 7. (U.S. CLS. 13, 19, 21, 23, 31, 34 AND 35). REG. 2-25-1997.
- 2,039,997. CELLSTAR. INT. CL. 29. (U.S. CL. 46). REG. 2-25-1997.
- 2,040,200. VANDAL SHIELD. INT. CL. 17. (U.S. CLS. 1, 5, 12, 13, 35 AND 50). REG. 2-25-1997.
- 2,040,243. CROCODILE ROCKS DUELING PIANOS AND DESIGN. INT. CL. 42. (U.S. CLS. 100 AND 101). REG. 2-25-1997.

- 2,040,278. CLEAR/IMAGE. INT. CL. 36. (U.S. CLS. 100, 101 AND 102). REG. 2-25-1997.
- 2,040,314. TOYO TANSO USA INC.. INT. CL. 1. (U.S. CLS. 1, 5, 6, 10, 26 AND 46). REG. 2-25-1997.
- 2,040,315. TOYO TANSO USA INC. AND DESIGN. INT. CL. 1. (U.S. CLS. 1, 5, 6, 10, 26 AND 46). REG. 2-25-1997.
- 2,040,332. SSGA. INT. CL. 36. (U.S. CLS. 100, 101 AND 102). REG. 2-25-1997.
- 2,040,427. RISKLINK. INT. CL. 9. (U.S. CLS. 21, 23, 26, 36 AND 38). REG. 2-25-1997.
- 2,040,604. TRANNY HONEY. INT. CL. 1. (U.S. CLS. 1, 5, 6, 10, 26 AND 46). REG. 2-25-1997.
- 2,040,606. HONEY MAKER. INT. CL. 9. (U.S. CLS. 21, 23, 26, 36 AND 38). REG. 2-25-1997.
- 2,040,782. O OHIO STATE AND DESIGN. INT. CL. 21. (U.S. CLS. 2, 13, 23, 29, 30, 33, 40 AND 50). REG. 2-25-1997.
- 2,040,783. O OHIO STATE AND DESIGN. INT. CL. 18. (U.S. CLS. 1, 2, 3, 22 AND 41). REG. 2-25-1997.
- 2,040,849. SOILFIX. INT. CL. 1. (U.S. CLS. 1, 5, 6, 10, 26 AND 46). REG. 2-25-1997.
- 2,040,874. LIPOGENOSOME. INT. CL. 5. (U.S. CLS. 6, 18, 44, 46, 51 AND 52). REG. 2-25-1997.
- 2,040,909. ROCKLAND TOOL CO.. INT. CL. 8. (U.S. CLS. 23, 28 AND 44). REG. 2-25-1997.
- 2,041,007. JUMANJI. INT. CL. 28. (U.S. CLS. 22, 23, 38 AND 50). REG. 2-25-1997.
- 2,041,113. TARGA. INT. CL. 12. (U.S. CLS. 19, 21, 23, 31, 35 AND 44). REG. 2-25-1997.
- 2,041,255. LABEL STAR AND DESIGN. INT. CL. 7. (U.S. CLS. 13, 19, 21, 23, 31, 34 AND 35). REG. 2-25-1997.
- 2,041,367. EQUINE JUNIOR. INT. CL. 31. (U.S. CLS. 1 AND 46). REG. 2-25-1997.
- 2,041,431. MILASTIC. INT. CL. 2. (U.S. CLS. 6, 11 AND 16). REG. 2-25-1997.
- 2,041,541. DRAKE. INT. CLS. 25 AND 28. (U.S. CLS. 22, 23, 38, 39 AND 50). REG. 3-4-1997.
- 2,041,548. FLOOD YOUR THIRST! NOAH'S RHINO ROOTBEER AND DESIGN. INT. CL. 32. (U.S. CLS. 45, 46 AND 48). REG. 3-4-1997.
- 2,041,567. DOME VALVE. INT. CL. 9. (U.S. CLS. 21 AND 26). REG. 3-4-1997.
- 2,041,701. PROFESSIONAL'S CHOICE SPORTS MEDICINE PRODUCTS, INC.. INT. CL. 10. (U.S. CLS. 26, 39 AND 44). REG. 3-4-1997.
- 2,041,768. ROCK SHOX AND DESIGN. INT. CL. 25. (U.S. CLS. 22 AND 39). REG. 3-4-1997.
- 2,041,784. MISCELLANEOUS DESIGN. INT. CL. 39. (U.S. CLS. 100 AND 105). REG. 3-4-1997.
- 2,041,819. ROADMAX. INT. CL. 28. (U.S. CLS. 22, 23, 38 AND 50). REG. 3-4-1997.
- 2,041,882. FEATHERLITE. INT. CL. 12. (U.S. CLS. 19, 21, 23, 31, 35 AND 44). REG. 3-4-1997.
- 2,041,903. MAX TRACKER. INT. CL. 20. (U.S. CLS. 2, 13, 22, 25, 32 AND 50). REG. 3-4-1997.
- 2,041,928. CENTER FOR WOMEN'S HEALTH AND DESIGN. INT. CL. 42. (U.S. CLS. 100 AND 101). REG. 3-4-1997.
- 2,041,965. WHATEVER WORKS. INT. CL. 42. (U.S. CLS. 100 AND 101). REG. 3-4-1997.
- 2,041,998. MCG. INT. CL. 14. (U.S. CLS. 2, 27, 28 AND 50). REG. 3-4-1997.
- 2,042,188. AD DETECTOR. INT. CLS. 9 AND 42. (U.S. CLS. 21, 23, 26, 36, 38, 100 AND 101). REG. 3-4-1997.
- 2,042,310. SIDEWALK CHALK. INT. CL. 30. (U.S. CL. 46). REG. 3-4-1997.
- 2,042,389. SOURCEMETER. INT. CL. 9. (U.S. CLS. 21, 23, 26, 36 AND 38). REG. 3-4-1997.
- 2,042,412. THE PRESSURE POSITIVE CO. AND DESIGN. INT. CL. 10. (U.S. CLS. 26, 39 AND 44). REG. 3-4-1997.
- 2,042,447. BLADEGEAR. INT. CL. 28. (U.S. CLS. 22, 23, 38 AND 50). REG. 3-4-1997.
- 2,042,550. U.S. CARGO. INT. CL. 39. (U.S. CLS. 100 AND 105). REG. 3-4-1997.
- 2,042,900. THE NATIONAL DIPPER. INT. CL. 16. (U.S. CLS. 2, 5, 22, 23, 29, 37, 38 AND 50). REG. 3-11-1997.
- 2,043,044. SELECTPAY (STYLIZED). INT. CL. 36. (U.S. CLS. 100, 101 AND 102). REG. 3-11-1997.
- 2,043,193. LLANO. INT. CL. 33. (U.S. CLS. 47 AND 49). REG. 3-11-1997.
- 2,043,194. LLANO ESTACADO. INT. CL. 33. (U.S. CLS. 47 AND 49). REG. 3-11-1997.
- 2,043,230. CRISP 'N CLEAR. INT. CL. 32. (U.S. CLS. 45, 46 AND 48). REG. 3-11-1997.
- 2,043,349. TOYO TANSO USA. INT. CL. 40. (U.S. CLS. 100, 103 AND 106). REG. 3-11-1997.
- 2,043,350. TOYO TANSO USA AND DESIGN. INT. CL. 40. (U.S. CLS. 100, 103 AND 106). REG. 3-11-1997.
- 2,043,668. SPRING HILL NURSERIES STEP-BY-STEP AND DESIGN. INT. CL. 1. (U.S. CLS. 1, 5, 6, 10, 26 AND 46). REG. 3-11-1997.
- 2,043,876. LINEAGE. INT. CL. 25. (U.S. CLS. 22 AND 39). REG. 3-11-1997.
- 2,043,954. ORION. INT. CL. 10. (U.S. CLS. 26, 39 AND 44). REG. 3-11-1997.
- 2,043,966. NBA WESTERN CONFERENCE AND DESIGN. INT. CL. 16. (U.S. CLS. 2, 5, 22, 23, 29, 37, 38 AND 50). REG. 3-11-1997.
- 2,044,118. SOUP EXPRESS. INT. CL. 29. (U.S. CL. 46). REG. 3-11-1997.
- 2,044,216. M PAK. INT. CL. 21. (U.S. CLS. 2, 13, 23, 29, 30, 33, 40 AND 50). REG. 3-11-1997.
- 2,044,362. OXYIR. INT. CL. 5. (U.S. CLS. 6, 18, 44, 46, 51 AND 52). REG. 3-11-1997.
- 2,044,432. TUFF-TEK. INT. CL. 9. (U.S. CLS. 21, 23, 26, 36 AND 38). REG. 3-11-1997.
- 2,044,443. THE MUFFIN "MAM". INT. CL. 30. (U.S. CL. 46). REG. 3-11-1997.
- 2,044,649. SBF AND DESIGN. INT. CL. 30. (U.S. CL. 46). REG. 3-11-1997.
- 2,044,826. SYLVAN BORDER FARM GLUTEN-FREE PRODUCTS AND DESIGN. INT. CL. 30. (U.S. CL. 46). REG. 3-11-1997.
- 2,044,829. WEDGE VENT. INT. CL. 20. (U.S. CLS. 2, 13, 22, 25, 32 AND 50). REG. 3-11-1997.
- 2,044,940. ISO-BLU. INT. CL. 5. (U.S. CLS. 6, 18, 44, 46, 51 AND 52). REG. 3-11-1997.
- 2,045,026. ACD. INT. CL. 5. (U.S. CLS. 6, 18, 44, 46, 51 AND 52). REG. 3-11-1997.
- 2,045,097. LABELSCAPE. INT. CL. 16. (U.S. CLS. 2, 5, 22, 23, 29, 37, 38 AND 50). REG. 3-11-1997.
- 2,045,289. OF3 AND DESIGN. INT. CL. 25. (U.S. CLS. 22 AND 39). REG. 3-18-1997.
- 2,045,296. LIQUINO. INT. CL. 9. (U.S. CL. 26). REG. 3-18-1997.
- 2,045,633. FADO AND DESIGN. INT. CL. 25. (U.S. CLS. 22 AND 39). REG. 3-18-1997.
- 2,045,734. SOFT-ARC. INT. CL. 6. (U.S. CLS. 2, 12, 13, 14, 23, 25 AND 50). REG. 3-18-1997.
- 2,045,807. WHERE THE WOMEN ARE STRONG, THE MEN ARE GOOD LOOKING, AND ALL OF THE CHILDREN ARE ABOVE AVERAGE. INT. CLS. 25 AND 41. (U.S. CLS. 22, 39, 100, 101 AND 107). REG. 3-18-1997.
- 2,045,812. COOL RODS. INT. CL. 15. (U.S. CLS. 2, 21 AND 36). REG. 3-18-1997.
- 2,046,344. GREENE KING. INT. CL. 32. (U.S. CLS. 45, 46 AND 48). REG. 3-18-1997.
- 2,046,518. EXCELLITE. INT. CL. 16. (U.S. CLS. 2, 5, 22, 23, 29, 37, 38 AND 50). REG. 3-18-1997.
- 2,046,604. LA ROMANELLA. INT. CLS. 29 AND 30. (U.S. CL. 46). REG. 3-18-1997.
- 2,046,947. G-STAR. INT. CLS. 18 AND 25 ONLY. (U.S. CLS. 1, 2, 3, 22, 39 AND 41). REG. 3-25-1997.
- 2,047,026. ARMANDA COSTANZA, INC. AND DESIGN. INT. CL. 41. (U.S. CLS. 100, 101 AND 107). REG. 3-25-1997.
- 2,047,351. MYSTERY MIKE'S. INT. CL. 42. (U.S. CLS. 100 AND 101). REG. 3-25-1997.
- 2,047,860. TECH STYLES. INT. CL. 25. (U.S. CLS. 22 AND 39). REG. 3-25-1997.
- 2,048,021. PALLETS MOVE THE WORLD. INT. CL. 42. (U.S. CLS. 100 AND 101). REG. 3-25-1997.
- 2,048,097. AQUACEL. INT. CL. 5. (U.S. CLS. 6, 18, 44, 46, 51 AND 52). REG. 3-25-1997.
- 2,048,220. PLAYER'S OPTION. INT. CL. 28. (U.S. CLS. 22, 23, 38 AND 50). REG. 3-25-1997.
- 2,048,579. RESTORATION HARDWARE. INT. CL. 42. (U.S. CLS. 100 AND 101). REG. 4-1-1997.
- 2,048,917. WORDS WORTH WATCHING. INT. CL. 41. (U.S. CLS. 100, 101 AND 107). REG. 4-1-1997.
- 2,049,025. NO VEJEZ. INT. CL. 3. (U.S. CLS. 1, 4, 6, 50, 51 AND 52). REG. 4-1-1997.
- 2,049,422. WINDOW EXPRESSIONS. INT. CL. 20. (U.S. CLS. 2, 13, 22, 25, 32 AND 50). REG. 4-1-1997.
- 2,049,477. GROUPWISE. INT. CL. 9. (U.S. CLS. 21, 23, 26, 36 AND 38). REG. 4-1-1997.

- 2,049,505. TRUE LOVE ELIZABETH ARDEN AND DESIGN. INT. CL. 3. (U.S. CLS. 1, 4, 6, 50, 51 AND 52). REG. 4-1-1997.
- 2,049,590. SRA AND DESIGN. INT. CL. 28. (U.S. CLS. 22, 23, 38 AND 50). REG. 4-1-1997.
- 2,049,975. GRIFFINS. INT. CL. 41. (U.S. CLS. 100, 101 AND 107). REG. 4-1-1997.
- 2,050,002. BRAIN WARP. INT. CL. 28. (U.S. CLS. 22, 23, 38 AND 50). REG. 4-1-1997.
- 2,050,678. PATTERNS PLUS WINDOW COVERING PATTERNS AND DESIGN. INT. CL. 16. (U.S. CLS. 2, 5, 22, 23, 29, 37, 38 AND 50). REG. 4-8-1997.
- 2,050,703. JAYSON. INT. CL. 33. (U.S. CLS. 47 AND 49). REG. 4-8-1997.
- 2,050,738. BRAZILIAN COURT. INT. CL. 42. (U.S. CLS. 100 AND 101). REG. 4-8-1997.
- 2,051,440. ATA SOIL-SEMENT AND DESIGN. INT. CL. 1. (U.S. CLS. 1, 5, 6, 10, 26 AND 46). REG. 4-8-1997.
- 2,051,477. ULTRA CARE. INT. CL. 31. (U.S. CLS. 1 AND 46). REG. 4-8-1997.
- 2,051,557. DURAEDGE. INT. CL. 10. (U.S. CLS. 26, 39 AND 44). REG. 4-8-1997.
- 2,052,471. PUBLIX PREMIUM. INT. CL. 30. (U.S. CL. 46). REG. 4-15-1997.
- 2,052,717. ROOTBLAST. INT. CL. 1. (U.S. CLS. 1, 5, 6, 10, 26 AND 46). REG. 4-15-1997.
- 2,052,789. ULTREX. INT. CL. 10. (U.S. CLS. 26, 39 AND 44). REG. 4-15-1997.
- 2,052,902. WCYY. INT. CL. 38. (U.S. CLS. 100, 101 AND 104). REG. 4-15-1997.
- 2,053,048. THE MOO FAMILY. INT. CL. 9. (U.S. CLS. 21, 23, 26, 36 AND 38). REG. 4-15-1997.
- 2,053,542. A AND DESIGN. INT. CL. 9. (U.S. CLS. 21, 23, 26, 36 AND 38). REG. 4-15-1997.
- 2,054,038. FOLGER SHAKESPEARE LIBRARY. INT. CLS. 16, 41 AND 42. (U.S. CLS. 2, 5, 22, 23, 29, 37, 38, 50, 100, 101 AND 107). REG. 4-22-1997.
- 2,054,072. MACQUARIUM. INT. CL. 41. (U.S. CLS. 100, 101 AND 107). REG. 4-22-1997.
- 2,054,073. MACQUARIUM AND DESIGN. INT. CL. 41. (U.S. CLS. 100, 101 AND 107). REG. 4-22-1997.
- 2,054,525. MIRAGE. INT. CL. 42. (U.S. CLS. 100 AND 101). REG. 4-22-1997.
- 2,054,598. 1-800-J-R-CIGAR. INT. CL. 42. (U.S. CLS. 100 AND 101). REG. 4-22-1997.
- 2,054,647. ENGINEERED SALES. INT. CL. 42. (U.S. CLS. 100 AND 101). REG. 4-22-1997.
- 2,054,648. HEALTHYFAX AND DESIGN. INT. CL. 29. (U.S. CL. 46). REG. 4-22-1997.
- 2,054,720. PENNY LANE PUBLISHING, INC.. INT. CL. 16. (U.S. CLS. 2, 5, 22, 23, 29, 37, 38 AND 50). REG. 4-22-1997.
- 2,054,742. FREEDOM. INT. CL. 9. (U.S. CLS. 21, 23, 26, 36 AND 38). REG. 4-22-1997.
- 2,055,072. DANCETERIA. INT. CL. 42. (U.S. CLS. 100 AND 101). REG. 4-22-1997.
- 2,055,148. NO FEAR (STYLIZED). INT. CL. 25. (U.S. CLS. 22 AND 39). REG. 4-22-1997.
- 2,055,158. NO FEAR (STYLIZED). INT. CL. 25. (U.S. CLS. 22 AND 39). REG. 4-22-1997.
- 2,055,288. NOMAD. INT. CL. 28. (U.S. CLS. 22, 23, 38 AND 50). REG. 4-22-1997.
- 2,055,430. DEER CANE LIQUID. INT. CL. 5. (U.S. CLS. 6, 18, 44, 46, 51 AND 52). REG. 4-22-1997.
- 2,055,619. AMERICAN PUBLIC COMMUNICATIONS COUNCIL. INT. CL. 35. (U.S. CLS. 100, 101 AND 102). REG. 4-22-1997.
- 2,056,110. MEDICEL (STYLIZED). INT. CL. 10. (U.S. CLS. 26, 39 AND 44). REG. 4-22-1997.
- 2,056,350. POSTURE SPORT. INT. CL. 10. (U.S. CLS. 26, 39 AND 44). REG. 4-22-1997.
- 2,056,729. TAGG. INT. CL. 35. (U.S. CLS. 100, 101 AND 102). REG. 4-29-1997.
- 2,057,254. E-MITTER. INT. CL. 9. (U.S. CLS. 21, 23, 26, 36 AND 38). REG. 4-29-1997.
- 2,057,255. VITALVIEW. INT. CL. 9. (U.S. CLS. 21, 23, 26, 36 AND 38). REG. 4-29-1997.
- 2,057,266. NICE&WARM AND DESIGN. INT. CL. 42. (U.S. CLS. 100 AND 101). REG. 4-29-1997.
- 2,057,409. DEER CO-CAIN. INT. CL. 5. (U.S. CLS. 6, 18, 44, 46, 51 AND 52). REG. 4-29-1997.
- 2,057,459. CHLORCID. INT. CL. 5. (U.S. CLS. 6, 18, 44, 46, 51 AND 52). REG. 4-29-1997.
- 2,057,461. ULTRACID. INT. CL. 5. (U.S. CLS. 6, 18, 44, 46, 51 AND 52). REG. 4-29-1997.
- 2,057,481. NEARLY FAMOUS. INT. CL. 42. (U.S. CLS. 100 AND 101). REG. 4-29-1997.
- 2,057,978. IQ TEN. INT. CL. 9. (U.S. CLS. 21, 23, 26, 36 AND 38). REG. 4-29-1997.
- 2,058,352. NEW STAR. INT. CL. 25. (U.S. CLS. 22 AND 39). REG. 4-29-1997.
- 2,058,379. EQUATE. INT. CL. 28. (U.S. CLS. 22, 23, 38 AND 50). REG. 4-29-1997.
- 2,058,412. SPRAGUELITE. INT. CL. 10. (U.S. CLS. 26, 39 AND 44). REG. 4-29-1997.
- 2,058,550. AMS. U.S. CL. B. REG. 5-6-1997.
- 2,058,908. ABNA. INT. CLS. 1 AND 4. (U.S. CLS. 1, 5, 6, 10, 15, 26 AND 46). REG. 5-6-1997.
- 2,059,200. JT AND DESIGN. INT. CL. 16. (U.S. CLS. 2, 5, 22, 23, 29, 37, 38 AND 50). REG. 5-6-1997.
- 2,059,233. PIANO ADVENTURES. INT. CL. 16. (U.S. CLS. 2, 5, 22, 23, 29, 37, 38 AND 50). REG. 5-6-1997.
- 2,059,423. SERONOSTANDARD CHARACTER MARK INT. CL. 5. (U.S. CLS. 6, 18, 44, 46, 51 AND 52). REG. 5-6-1997.
- 2,059,501. COLDWELL BANKER CB AND DESIGN. INT. CL. 35. (U.S. CLS. 100, 101 AND 102). REG. 5-6-1997.
- 2,059,834. AEL. INT. CL. 12. (U.S. CLS. 19, 21, 23, 31, 35 AND 44). REG. 5-6-1997.
- 2,059,944. BLACK DIAMOND. INT. CL. 27. (U.S. CLS. 19, 20, 37, 42 AND 50). REG. 5-6-1997.
- 2,060,828. STUDIO 35. INT. CLS. 1 AND 9. (U.S. CLS. 1, 5, 6, 10, 21, 23, 26, 36, 38 AND 46). REG. 5-13-1997.
- 2,060,869. GENESIS. INT. CL. 7. (U.S. CLS. 13, 19, 21, 23, 31, 34 AND 35). REG. 5-13-1997.
- 2,061,072. AMCI (STYLIZED). INT. CL. 9. (U.S. CLS. 21, 23, 26, 36 AND 38). REG. 5-13-1997.
- 2,061,132. TRENCOR. INT. CL. 7. (U.S. CLS. 13, 19, 21, 23, 31, 34 AND 35). REG. 5-13-1997.
- 2,061,160. POWERCEPTOR. INT. CL. 9. (U.S. CLS. 21, 23, 26, 36 AND 38). REG. 5-13-1997.
- 2,061,306. BALI-SONG AND DESIGN. INT. CL. 8. (U.S. CLS. 23, 28 AND 44). REG. 5-13-1997.
- 2,061,319. FUNKY FILMS AND DESIGN. INT. CL. 16. (U.S. CLS. 2, 5, 22, 23, 29, 37, 38 AND 50). REG. 5-13-1997.
- 2,061,324. MISCELLANEOUS DESIGN. INT. CL. 42. (U.S. CLS. 100 AND 101). REG. 5-13-1997.
- 2,061,513. @LAW (STYLIZED). INT. CL. 16. (U.S. CLS. 2, 5, 22, 23, 29, 37, 38 AND 50). REG. 5-13-1997.
- 2,061,906. SCUBALOGY. INT. CL. 41. (U.S. CLS. 100, 101 AND 107). REG. 5-13-1997.
- 2,062,205. AURASOL. INT. CL. 5. (U.S. CLS. 6, 18, 44, 46, 51 AND 52). REG. 5-13-1997.
- 2,062,253. SLIP-CATH. INT. CL. 10. (U.S. CLS. 26, 39 AND 44). REG. 5-13-1997.
- 2,062,261. ONE TOUCH. INT. CL. 7. (U.S. CLS. 13, 19, 21, 23, 31, 34 AND 35). REG. 5-13-1997.
- 2,062,392. THE RESTAURANT ISSUE. INT. CL. 16. (U.S. CLS. 2, 5, 22, 23, 29, 37, 38 AND 50). REG. 5-13-1997.
- 2,062,417. ADVENTIST RISK MANAGEMENT. INT. CL. 36. (U.S. CLS. 100, 101 AND 102). REG. 5-13-1997.
- 2,062,560. THE OMNICON GROUP. INT. CL. 42. (U.S. CLS. 100 AND 101). REG. 5-20-1997.
- 2,062,782. SIGMETER. INT. CL. 9. (U.S. CLS. 21, 23, 26, 36 AND 38). REG. 5-20-1997.
- 2,062,847. HART BEAT AND DESIGN. INT. CL. 41. (U.S. CLS. 100, 101 AND 107). REG. 5-20-1997.
- 2,062,930. S-12. INT. CL. 6. (U.S. CLS. 2, 12, 13, 14, 23, 25 AND 50). REG. 5-20-1997.
- 2,063,144. RVT. U.S. CL. B. REG. 5-20-1997.
- 2,063,297. HYPERTECH. INT. CL. 7. (U.S. CLS. 13, 19, 21, 23, 31, 34 AND 35). REG. 5-20-1997.
- 2,063,399. WORLD MINERALS AND DESIGN. INT. CL. 35. (U.S. CLS. 100, 101 AND 102). REG. 5-20-1997.
- 2,063,843. OLL. INT. CL. 30. (U.S. CL. 46). REG. 5-20-1997.
- 2,063,964. HEALTH FORUM WAYNE COUNTY AND DESIGN. INT. CL. 9. (U.S. CLS. 21, 23, 26, 36 AND 38). REG. 5-20-1997.
- 2,064,398. MISCELLANEOUS DESIGN. INT. CLS. 9, 20 AND 28. (U.S. CLS. 2, 13, 21, 22, 23, 25, 26, 32, 36, 38 AND 50). REG. 5-27-1997.
- 2,064,654. TELEQUIP CORPORATION. INT. CL. 9. (U.S. CLS. 21, 23, 26, 36 AND 38). REG. 5-27-1997.
- 2,064,660. MISCELLANEOUS DESIGN. INT. CLS. 39 AND 42. (U.S. CLS. 100, 101 AND 105). REG. 5-27-1997.

- 2,064,914. THE SMART CHOICE. INT. CLS. 9 AND 16. (U.S. CLS. 2, 5, 21, 22, 23, 26, 29, 36, 37, 38 AND 50). REG. 5-27-1997.
- 2,065,518. PERI-MIX. INT. CL. 1. (U.S. CLS. 1, 5, 6, 10, 26 AND 46). REG. 5-27-1997.
- 2,066,072. INSURE EXPRESS. INT. CL. 36. (U.S. CL. 102). REG. 6-3-1997.
- 2,066,163. DURAVAC. INT. CL. 9. (U.S. CLS. 21, 23, 26, 36 AND 38). REG. 6-3-1997.
- 2,066,226. THE BEATLES (STYLIZED). INT. CL. 9. (U.S. CLS. 21, 23, 26, 36 AND 38). REG. 6-3-1997.
- 2,066,230. MIAMI SUBS GRILL AND DESIGN. INT. CL. 42. (U.S. CLS. 100 AND 101). REG. 6-3-1997.
- 2,066,251. FOLGER. INT. CLS. 16, 41 AND 42. (U.S. CLS. 2, 5, 22, 23, 29, 37, 38, 50, 100, 101 AND 107). REG. 6-3-1997.
- 2,066,443. THE GREAT SOLAR SYSTEM RESCUE. INT. CL. 9. (U.S. CLS. 21, 23, 26, 36 AND 38). REG. 6-3-1997.
- 2,066,445. THE GREAT OCEAN RESCUE. INT. CL. 9. (U.S. CLS. 21, 23, 26, 36 AND 38). REG. 6-3-1997.
- 2,066,597. HART BEAT. INT. CL. 41. (U.S. CLS. 100, 101 AND 107). REG. 6-3-1997.
- 2,066,624. SST. INT. CL. 6. (U.S. CLS. 2, 12, 13, 14, 23, 25 AND 50). REG. 6-3-1997.
- 2,066,680. GTD. INT. CL. 7. (U.S. CLS. 13, 19, 21, 23, 31, 34 AND 35). REG. 6-3-1997.
- 2,066,859. MOOSEWOOD. INT. CL. 25. (U.S. CLS. 22 AND 39). REG. 6-3-1997.
- 2,066,860. MOOSEWOOD RESTAURANT. INT. CL. 16. (U.S. CLS. 2, 5, 22, 23, 29, 37, 38 AND 50). REG. 6-3-1997.
- 2,066,934. A RENT A CHEF AND DESIGN. INT. CL. 30. (U.S. CL. 46). REG. 6-3-1997.
- 2,067,002. NATURALLY NUTS. INT. CL. 31. (U.S. CLS. 1 AND 46). REG. 6-3-1997.
- 2,067,498. PERFECTLINK. INT. CL. 20. (U.S. CLS. 2, 13, 22, 25, 32 AND 50). REG. 6-3-1997.
- 2,067,637. FOREVER 21. INT. CL. 42. (U.S. CLS. 100 AND 101). REG. 6-3-1997.
- 2,067,641. AT&T SOLUTIONS. INT. CLS. 35 AND 42. (U.S. CLS. 100, 101 AND 102). REG. 6-3-1997.
- 2,067,921. WINDING CREEK GOLF COURSE. INT. CL. 41. (U.S. CLS. 100, 101 AND 107). REG. 6-3-1997.
- 2,068,262. LAWNET. INT. CL. 35. (U.S. CLS. 100, 101 AND 102). REG. 6-10-1997.
- 2,068,519. SAN FIORENZO. INT. CL. 33. (U.S. CLS. 47 AND 49). REG. 6-10-1997.
- 2,068,592. MISCELLANEOUS DESIGN. INT. CL. 30. (U.S. CL. 46). REG. 6-10-1997.
- 2,068,598. MISCELLANEOUS DESIGN. INT. CL. 19. (U.S. CLS. 1, 12, 33 AND 50). REG. 6-10-1997.
- 2,068,659. BY THE SEA AND DESIGN. INT. CL. 31. (U.S. CLS. 1 AND 46). REG. 6-10-1997.
- 2,068,770. S AND DESIGN. INT. CL. 16. (U.S. CLS. 2, 5, 22, 23, 29, 37, 38 AND 50). REG. 6-10-1997.
- 2,068,838. PRO SHOW. INT. CL. 28. (U.S. CLS. 22, 23, 38 AND 50). REG. 6-10-1997.
- 2,068,867. SHEBOYGAN STYLE HARD ROLLS. INT. CL. 30. (U.S. CL. 46). REG. 6-10-1997.
- 2,069,446. HOLIDAY PANTRY. INT. CL. 32. (U.S. CLS. 45, 46 AND 48). REG. 6-10-1997.
- 2,069,565. ARGENE BIOSOFT DEPARTEMENT AND DESIGN. INT. CL. 1. (U.S. CLS. 1, 5, 6, 10, 26 AND 46). REG. 6-10-1997.
- 2,069,620. ZOOM. INT. CL. 12. (U.S. CLS. 19, 21, 23, 31, 35 AND 44). REG. 6-10-1997.
- 2,070,330. CIENA. INT. CL. 9. (U.S. CLS. 21, 23, 26, 36 AND 38). REG. 6-10-1997.
- 2,070,631. K AND DESIGN. INT. CL. 5. (U.S. CLS. 6, 18, 44, 46, 51 AND 52). REG. 6-10-1997.
- 2,070,677. JACKIE & EDDIE'S. INT. CL. 30. (U.S. CL. 46). REG. 6-10-1997.
- 2,070,785. IMAGINATIONS. INT. CL. 26. (U.S. CLS. 37, 39, 40, 42 AND 50). REG. 6-10-1997.
- 2,071,145. ORDER AND DESIGN. INT. CL. 31. (U.S. CLS. 1 AND 46). REG. 6-17-1997.
- 2,071,486. HEALING MAGAZINE. INT. CL. 16. (U.S. CLS. 2, 5, 22, 23, 29, 37, 38 AND 50). REG. 6-17-1997.
- 2,072,554. BORE-GARD. INT. CL. 17. (U.S. CLS. 1, 5, 12, 13, 35 AND 50). REG. 6-17-1997.
- 2,073,251. FAMOUS DAVE'S BBQ SAUCE. INT. CL. 30. (U.S. CL. 46). REG. 6-24-1997.
- 2,073,258. COACHELLA MAID. INT. CL. 31. (U.S. CLS. 1 AND 46). REG. 6-24-1997.
- 2,073,259. COACHELLA MAID AND DESIGN. INT. CL. 31. (U.S. CLS. 1 AND 46). REG. 6-24-1997.
- 2,073,395. APPLESNAX AND DESIGN. INT. CL. 30. (U.S. CL. 46). REG. 6-24-1997.
- 2,073,698. BARNABAS. INT. CL. 36. (U.S. CLS. 100, 101 AND 102). REG. 6-24-1997.
- 2,073,900. MISCELLANEOUS DESIGN. INT. CL. 37. (U.S. CLS. 100, 103 AND 106). REG. 6-24-1997.
- 2,073,973. WOW!. INT. CL. 5. (U.S. CLS. 6, 18, 44, 46, 51 AND 52). REG. 6-24-1997.
- 2,074,233. ENVIROCARE. INT. CL. 3. (U.S. CLS. 1, 4, 6, 50, 51 AND 52). REG. 6-24-1997.
- 2,075,237. FINANCIAL CLOUT. INT. CL. 36. (U.S. CLS. 100, 101 AND 102). REG. 7-1-1997.
- 2,076,352. AUROUS. INT. CL. 10. (U.S. CLS. 26, 39 AND 44). REG. 7-1-1997.
- 2,076,355. PLATE-DRAPE. INT. CL. 10. (U.S. CLS. 26, 39 AND 44). REG. 7-1-1997.
- 2,076,356. DISC-DRAPE. INT. CL. 10. (U.S. CLS. 26, 39 AND 44). REG. 7-1-1997.
- 2,076,366. ATHLETE'S PLUS. INT. CL. 25. (U.S. CLS. 22 AND 39). REG. 7-1-1997.
- 2,076,530. PRO SERIES. INT. CL. 1. (U.S. CLS. 1, 5, 6, 10, 26 AND 46). REG. 7-1-1997.
- 2,076,819. HY-VEE. INT. CLS. 37, 41 AND 42. (U.S. CLS. 100, 101, 103, 106 AND 107). REG. 7-8-1997.
- 2,076,826. C.K. BEAR. INT. CL. 41. (U.S. CLS. 100, 101 AND 107). REG. 7-8-1997.
- 2,076,892. RICH & SASSY. INT. CL. 30. (U.S. CL. 46). REG. 7-8-1997.
- 2,076,907. AVSAT. INT. CLS. 37 AND 39. (U.S. CLS. 100, 103, 105 AND 106). REG. 7-8-1997.
- 2,076,980. BEACON MORTGAGE A TUALATIN VALLEY FINANCIAL SERVICES, INC. COMPANY AND DESIGN. INT. CL. 36. (U.S. CLS. 100, 101 AND 102). REG. 7-8-1997.
- 2,077,000. ULTRA INTERIOR. INT. CL. 2. (U.S. CLS. 6, 11 AND 16). REG. 7-8-1997.
- 2,077,088. MADHOUSE MUNCHIES. INT. CL. 29 ONLY. (U.S. CL. 46). REG. 7-8-1997.
- 2,077,122. JELTRATE. INT. CL. 5. (U.S. CLS. 6, 18, 44, 46, 51 AND 52). REG. 7-8-1997.
- 2,077,396. ABRADALE. INT. CL. 16. (U.S. CLS. 2, 5, 22, 23, 29, 37, 38 AND 50). REG. 7-8-1997.
- 2,077,418. DIVERS OUTLET. INT. CL. 42. (U.S. CLS. 100 AND 101). REG. 7-8-1997.
- 2,077,558. PROMO-MART. INT. CL. 35. (U.S. CLS. 100, 101 AND 102). REG. 7-8-1997.
- 2,078,036. 1099 PRO. INT. CL. 9. (U.S. CLS. 21, 23, 26, 36 AND 38). REG. 7-8-1997.
- 2,078,483. MISCELLANEOUS DESIGN. INT. CLS. 35 AND 41. (U.S. CLS. 100, 101, 102 AND 107). REG. 7-15-1997.
- 2,078,607. EINSTEIN BROS.. INT. CL. 30. (U.S. CL. 46). REG. 7-15-1997.
- 2,078,794. NABE. INT. CLS. 16 AND 42. (U.S. CLS. 2, 5, 22, 23, 29, 37, 38, 50, 100 AND 101). REG. 7-15-1997.
- 2,078,812. PRIMASOUNDS (STYLIZED). INT. CL. 9. (U.S. CLS. 21, 23, 26, 36 AND 38). REG. 7-15-1997.
- 2,079,330. DOLLAR RENT A CAR AND DESIGN. INT. CL. 39. (U.S. CLS. 100 AND 105). REG. 7-15-1997.
- 2,079,719. WORTHIT FIXED ASSETS. INT. CL. 9 ONLY. (U.S. CLS. 21, 23, 26, 36 AND 38). REG. 7-15-1997.
- 2,079,875. VIEW-X. INT. CL. 6. (U.S. CLS. 2, 12, 13, 14, 23, 25 AND 50). REG. 7-15-1997.
- 2,080,043. THE YARDSTICK. INT. CL. 30. (U.S. CL. 46). REG. 7-15-1997.
- 2,080,115. BIO-OIL HBSL. INT. CL. 1. (U.S. CLS. 1, 5, 6, 10, 26 AND 46). REG. 7-15-1997.
- 2,080,231. PROFACE. INT. CL. 3. (U.S. CLS. 1, 4, 6, 50, 51 AND 52). REG. 7-15-1997.
- 2,080,708. TEPIC AND DESIGN. INT. CL. 31. (U.S. CLS. 1 AND 46). REG. 7-22-1997.
- 2,080,723. ANCHOR LINE AND DESIGN. INT. CL. 36. (U.S. CLS. 100, 101 AND 102). REG. 7-22-1997.
- 2,080,725. ANCHOR BANK AND DESIGN. INT. CL. 36. (U.S. CLS. 100, 101 AND 102). REG. 7-22-1997.
- 2,080,796. NO. 88 SUPER RUBBING COMPOUND. INT. CL. 3. (U.S. CLS. 1, 4, 6, 50, 51 AND 52). REG. 7-22-1997.
- 2,081,106. 9702. INT. CL. 9. (U.S. CLS. 21, 23, 26, 36 AND 38). REG. 7-22-1997.
- 2,081,344. WATERBUG QUIET FLOOR SUCTION AND DESIGN. INT. CL. 10. (U.S. CLS. 26, 39 AND 44). REG. 7-22-1997.

- 2,081,600. ZOOVITE. INT. CL. 5. (U.S. CLS. 6, 18, 44, 46, 51 AND 52). REG. 7-22-1997.
- 2,081,619. SHARPSENTINEL. INT. CL. 10. (U.S. CLS. 26, 39 AND 44). REG. 7-22-1997.
- 2,081,832. BROWNING. INT. CL. 9. (U.S. CLS. 21, 23, 26, 36 AND 38). REG. 7-22-1997.
- 2,082,196. SEA TONE. INT. CL. 31. (U.S. CLS. 1 AND 46). REG. 7-22-1997.
- 2,082,249. SCHOOLWORKS. INT. CLS. 8 AND 16. (U.S. CLS. 2, 5, 22, 23, 28, 29, 37, 38, 44 AND 50). REG. 7-22-1997.
- 2,083,030. VEN-CO AND DESIGN. INT. CL. 31. (U.S. CLS. 1 AND 46). REG. 7-29-1997.
- 2,083,092. ANASTASIA. INT. CLS. 16 AND 42. (U.S. CLS. 2, 5, 22, 23, 29, 37, 38, 50, 100 AND 101). REG. 7-29-1997.
- 2,083,204. AMERICAN INDEPENDENT INSURANCE COMPANY AND DESIGN. INT. CL. 36. (U.S. CLS. 100, 101 AND 102). REG. 7-29-1997.
- 2,083,831. HURRICANE. INT. CL. 11. (U.S. CLS. 13, 21, 23, 31 AND 34). REG. 7-29-1997.
- 2,083,957. 3D. INT. CL. 28. (U.S. CLS. 22, 23, 38 AND 50). REG. 7-29-1997.
- 2,084,146. NICERINK. INT. CL. 17. (U.S. CLS. 1, 5, 12, 13, 35 AND 50). REG. 7-29-1997.
- 2,084,395. AQUASEAL. INT. CL. 17. (U.S. CLS. 1, 5, 12, 13, 35 AND 50). REG. 7-29-1997.
- 2,084,448. BIOGARLIC. INT. CL. 5. (U.S. CLS. 6, 18, 44, 46, 51 AND 52). REG. 7-29-1997.
- 2,084,592. REGUL QUESTA. INT. CL. 12. (U.S. CLS. 19, 21, 23, 31, 35 AND 44). REG. 7-29-1997.
- 2,084,750. CYCLONE XHE. INT. CL. 11. (U.S. CLS. 13, 21, 23, 31 AND 34). REG. 7-29-1997.
- 2,085,246. REFINE SHOUWUCHIH AND DESIGN. INT. CL. 30. (U.S. CL. 46). REG. 8-5-1997.
- 2,085,910. INDILABEL. INT. CL. 16. (U.S. CLS. 2, 5, 22, 23, 29, 37, 38 AND 50). REG. 8-5-1997.
- 2,085,961. SOFTGRIP. INT. CL. 8. (U.S. CLS. 23, 28 AND 44). REG. 8-5-1997.
- 2,086,390. CENTURA. INT. CL. 7. (U.S. CLS. 13, 19, 21, 23, 31, 34 AND 35). REG. 8-5-1997.
- 2,086,724. NATURAL GREEN. INT. CL. 1. (U.S. CLS. 1, 5, 6, 10, 26 AND 46). REG. 8-12-1997.
- 2,087,056. CLAIMS CENTRAL. INT. CL. 36. (U.S. CLS. 100, 101 AND 102). REG. 8-12-1997.
- 2,087,132. HART BEAT. INT. CL. 16. (U.S. CLS. 2, 5, 22, 23, 29, 37, 38 AND 50). REG. 8-12-1997.
- 2,087,177. PAHLMAYER. INT. CL. 33. (U.S. CLS. 47 AND 49). REG. 8-12-1997.
- 2,087,514. MOUNTAIN JACK'S STEAKHOUSE AND DESIGN. INT. CL. 42. (U.S. CLS. 100 AND 101). REG. 8-12-1997.
- 2,087,695. 1-800-ALARM ME. INT. CL. 37. (U.S. CLS. 100, 103 AND 106). REG. 8-12-1997.
- 2,087,696. 1-800-ALARM ME. INT. CL. 42. (U.S. CLS. 100 AND 101). REG. 8-12-1997.
- 2,089,951. WILDWOOD. INT. CLS. 36 AND 41. (U.S. CLS. 100, 101, 102 AND 107). REG. 8-19-1997.
- 2,092,522. EINSTEIN BROS.. INT. CL. 29. (U.S. CL. 46). REG. 9-2-1997.
- 2,092,792. GIRLS INC.. INT. CL. 16. (U.S. CLS. 2, 5, 22, 23, 29, 37, 38 AND 50). REG. 9-2-1997.
- 2,092,793. GIRLS INC.. INT. CL. 21. (U.S. CLS. 2, 13, 23, 29, 30, 33, 40 AND 50). REG. 9-2-1997.
- 2,093,023. EMERGENCY RESPONSE. INT. CL. 39. (U.S. CLS. 100 AND 105). REG. 9-2-1997.
- 2,093,089. PETRA "YOUR ACCESSORY SOURCE" AND DESIGN. INT. CL. 9. (U.S. CLS. 21, 23, 26, 36 AND 38). REG. 9-2-1997.
- 2,093,400. AERO. INT. CL. 12. (U.S. CLS. 19, 21, 23, 31, 35 AND 44). REG. 9-2-1997.
- 2,094,501. GIRLS INC.. INT. CL. 41. (U.S. CLS. 100, 101 AND 107). REG. 9-9-1997.
- 2,094,877. CROWN ROYAL AND DESIGN. INT. CL. 33. (U.S. CLS. 47 AND 49). REG. 9-9-1997.
- 2,094,996. SRA. INT. CL. 9. (U.S. CLS. 21, 23, 26, 36 AND 38). REG. 9-9-1997.
- 2,095,463. ELVIS. INT. CL. 5. (U.S. CLS. 6, 18, 44, 46, 51 AND 52). REG. 9-9-1997.
- 2,096,548. ACOUSTIC NOISE CANCELLING. INT. CL. 9. (U.S. CLS. 21, 23, 26, 36 AND 38). REG. 9-16-1997.
- 2,096,578. INFOSOLUTIONS. INT. CLS. 35 AND 42. (U.S. CLS. 100, 101 AND 102). REG. 9-16-1997.
- 2,097,158. CHATEAUNEUF-DU-PAPE CONTROLE AND DESIGN. INT. CL. 33. (U.S. CLS. 47 AND 49). REG. 9-16-1997.
- 2,097,386. MILLENNIUM. INT. CL. 42. (U.S. CLS. 100 AND 101). REG. 9-16-1997.
- 2,097,455. ALESSI. INT. CLS. 29 AND 30. (U.S. CL. 46). REG. 9-16-1997.
- 2,097,477. ROADEASE RESCUE SQUAD (STYLIZED). INT. CL. 36. (U.S. CLS. 100, 101 AND 102). REG. 9-16-1997.
- 2,099,067. WING HING AND DESIGN. INT. CL. 30. (U.S. CL. 46). REG. 9-23-1997.
- 2,099,864. INAGRO AND DESIGN. INT. CL. 7. (U.S. CLS. 13, 19, 21, 23, 31, 34 AND 35). REG. 9-23-1997.
- 2,100,181. FURNITURE THAT FITS. INT. CL. 20. (U.S. CLS. 2, 13, 22, 25, 32 AND 50). REG. 9-23-1997.
- 2,100,309. VOICE. INT. CL. 16. (U.S. CLS. 2, 5, 22, 23, 29, 37, 38 AND 50). REG. 9-23-1997.
- 2,100,715. ROCKY MOUNTAINEER. INT. CL. 39. (U.S. CLS. 100 AND 105). REG. 9-30-1997.
- 2,101,150. OUTDOOR RESORTS OF AMERICA, INC. AND DESIGN. INT. CL. 42. (U.S. CLS. 100 AND 101). REG. 9-30-1997.
- 2,101,682. MISCELLANEOUS DESIGN. INT. CL. 42. (U.S. CLS. 100 AND 101). REG. 9-30-1997.
- 2,101,823. HYDROGUARD. INT. CL. 1. (U.S. CLS. 1, 5, 6, 10, 26 AND 46). REG. 9-30-1997.
- 2,102,341. VORASURF. INT. CL. 1. (U.S. CLS. 1, 5, 6, 10, 26 AND 46). REG. 9-30-1997.
- 2,102,627. N A W DREF AND DESIGN. INT. CL. 42 ONLY. (U.S. CLS. 100 AND 101). REG. 10-7-1997.
- 2,102,823. BAKER'S PERFECTION INC. PREMIUM GOURMET DESSERTS AND DESIGN. INT. CL. 30. (U.S. CL. 46). REG. 10-7-1997.
- 2,103,244. CHARGE WIZARD. INT. CL. 9. (U.S. CLS. 21, 23, 26, 36 AND 38). REG. 10-7-1997.
- 2,103,245. TCMS. INT. CL. 9. (U.S. CLS. 21, 23, 26, 36 AND 38). REG. 10-7-1997.
- 2,103,367. H AND DESIGN. U.S. CL. 200. REG. 10-7-1997.
- 2,104,211. PEACH. INT. CL. 11. (U.S. CLS. 13, 21, 23, 31 AND 34). REG. 10-7-1997.
- 2,104,284. SPIDERLOCK. INT. CL. 9. (U.S. CLS. 21, 23, 26, 36 AND 38). REG. 10-7-1997.
- 2,104,285. SOUTHERN MOTION. INT. CL. 20. (U.S. CLS. 2, 13, 22, 25, 32 AND 50). REG. 10-7-1997.
- 2,104,452. ESTATE VINEYARD SELECTION. INT. CL. 33. (U.S. CLS. 47 AND 49). REG. 10-7-1997.
- 2,105,015. URBAN MYTH. INT. CL. 41. (U.S. CLS. 100, 101 AND 107). REG. 10-14-1997.
- 2,105,225. SAFETY FIRST A BHS SPONSORED PROGRAM FOR A SUBSTANCE ABUSE FREE ENVIRONMENT AND DESIGN. INT. CL. 42. (U.S. CLS. 100 AND 101). REG. 10-14-1997.
- 2,105,849. DUALOGR. INT. CL. 9. (U.S. CLS. 21, 23, 26, 36 AND 38). REG. 10-14-1997.
- 2,106,102. OMNI. INT. CLS. 39 AND 42. (U.S. CLS. 100, 105 AND 107). REG. 10-21-1997.
- 2,106,617. FUNJET EXPRESS AND DESIGN. INT. CL. 39. (U.S. CLS. 100 AND 105). REG. 10-21-1997.
- 2,107,772. CLEAR PATH. INT. CL. 9. (U.S. CLS. 21, 23, 26, 36 AND 38). REG. 10-21-1997.
- 2,107,950. STX. INT. CL. 10. (U.S. CLS. 26, 39 AND 44). REG. 10-21-1997.
- 2,108,603. HOKANSON. INT. CLS. 9 AND 10. (U.S. CLS. 21, 23, 26, 36, 38, 39 AND 44). REG. 10-28-1997.
- 2,108,847. LIFESTYLE. INT. CL. 9. (U.S. CLS. 21, 23, 26, 36 AND 38). REG. 10-28-1997.
- 2,108,985. BSG. INT. CL. 36. (U.S. CLS. 100, 101 AND 102). REG. 10-28-1997.
- 2,109,001. SHARECARE. INT. CL. 41. (U.S. CLS. 100, 101 AND 107). REG. 10-28-1997.
- 2,109,097. DI (STYLIZED). INT. CL. 7. (U.S. CLS. 13, 19, 21, 23, 31, 34 AND 35). REG. 10-28-1997.
- 2,109,419. THE CHRISTIAN KEY. INT. CL. 14. (U.S. CLS. 2, 27, 28 AND 50). REG. 10-28-1997.
- 2,109,438. RESISTOL. INT. CLS. 25 AND 26. (U.S. CLS. 22, 37, 39, 40, 42 AND 50). REG. 10-28-1997.
- 2,109,692. NATURAL SELECTION FOODS. INT. CL. 31. (U.S. CLS. 1 AND 46). REG. 10-28-1997.
- 2,109,718. AVO FRESCO. INT. CL. 29. (U.S. CL. 46). REG. 10-28-1997.
- 2,109,944. COLOR CATALYST. INT. CL. 3. (U.S. CLS. 1, 4, 6, 50, 51 AND 52). REG. 10-28-1997.
- 2,110,019. DOLLAR RENT A CAR. INT. CL. 39. (U.S. CLS. 100 AND 105). REG. 10-28-1997.

- 2,110,380. THE INCREDIBLE WORLD OF DIC AND DESIGN. INT. CLS. 9, 35 AND 41. (U.S. CLS. 21, 23, 26, 36, 38, 100, 101, 102 AND 107). REG. 11-4-1997.
- 2,110,931. COMMERCENET. INT. CL. 42. (U.S. CLS. 100 AND 101). REG. 11-4-1997.
- 2,111,481. CANDLE LUSTER. INT. CL. 1. (U.S. CLS. 1, 5, 6, 10, 26 AND 46). REG. 11-4-1997.
- 2,111,653. QUOTEPRO. INT. CL. 9. (U.S. CLS. 21, 23, 26, 36 AND 38). REG. 11-11-1997.
- 2,111,785. THE RECORD NEVER FORGETS AND DESIGN. INT. CLS. 35 AND 42. (U.S. CLS. 100, 101 AND 102). REG. 11-11-1997.
- 2,111,831. BIKE DOCTOR AND DESIGN. INT. CL. 42. (U.S. CLS. 100 AND 101). REG. 11-11-1997.
- 2,112,030. AMERICA'S FAMILY COACHES. INT. CL. 41. (U.S. CLS. 100, 101 AND 107). REG. 11-11-1997.
- 2,112,411. RODNEY STRONG. INT. CL. 33. (U.S. CLS. 47 AND 49). REG. 11-11-1997.
- 2,112,569. MAISY. INT. CL. 28. (U.S. CLS. 22, 23, 38 AND 50). REG. 11-11-1997.
- 2,113,372. FLIP AND DESIGN. INT. CL. 9. (U.S. CLS. 21, 23, 26, 36 AND 38). REG. 11-18-1997.
- 2,114,083. CALEA. INT. CL. 42. (U.S. CLS. 100 AND 101). REG. 11-18-1997.
- 2,114,130. 151. INT. CL. 9. (U.S. CLS. 21, 23, 26, 36 AND 38). REG. 11-18-1997.
- 2,114,224. WEIGHTLESS. INT. CL. 5. (U.S. CLS. 6, 18, 44, 46, 51 AND 52). REG. 11-18-1997.
- 2,114,424. INTERIOR EXPRESSIONS. INT. CL. 20 ONLY. (U.S. CLS. 2, 13, 22, 25, 32 AND 50). REG. 11-18-1997.
- 2,114,726. TRADEWINDS. INT. CL. 12. (U.S. CLS. 19, 21, 23, 31, 35 AND 44). REG. 11-18-1997.
- 2,115,004. L/S. INT. CLS. 9 AND 10. (U.S. CLS. 21, 23, 26, 36, 38, 39 AND 44). REG. 11-25-1997.
- 2,115,152. STUD INSIDER. INT. CL. 36. (U.S. CLS. 100, 101 AND 102). REG. 11-25-1997.
- 2,115,230. BIG SHOTS. INT. CL. 13 ONLY. (U.S. CLS. 2 AND 9). REG. 11-25-1997.
- 2,115,357. MIRAGE. INT. CL. 7. (U.S. CLS. 13, 19, 21, 23, 31, 34 AND 35). REG. 11-25-1997.
- 2,115,994. M&C ONLINE. INT. CL. 35. (U.S. CLS. 100, 101 AND 102). REG. 11-25-1997.
- 2,115,995. M&C. INT. CL. 35. (U.S. CLS. 100, 101 AND 102). REG. 11-25-1997.
- 2,116,206. EASY NOW. INT. CL. 5. (U.S. CLS. 6, 18, 44, 46, 51 AND 52). REG. 11-25-1997.
- 2,116,369. WINNINGEST SIGN. INT. CL. 19. (U.S. CLS. 1, 12, 33 AND 50). REG. 11-25-1997.
- 2,116,458. SPINLON. INT. CL. 23. (U.S. CL. 43). REG. 11-25-1997.
- 2,116,570. DANELECTRO. INT. CLS. 9 AND 15. (U.S. CLS. 2, 21, 23, 26, 36 AND 38). REG. 11-25-1997.
- 2,116,800. SPATIALWARE. INT. CL. 9. (U.S. CLS. 21, 23, 26, 36 AND 38). REG. 11-25-1997.
- 2,117,197. VIRGINIA CLE. INT. CL. 41. (U.S. CLS. 100, 101 AND 107). REG. 12-2-1997.
- 2,117,464. RECORDS DEPOSITION SERVICE INCORPORATED (STYLIZED). INT. CLS. 35 AND 42. (U.S. CLS. 100, 101 AND 102). REG. 12-2-1997.
- 2,117,620. DP (STYLIZED). INT. CL. 11. (U.S. CLS. 13, 21, 23, 31 AND 34). REG. 12-2-1997.
- 2,118,525. AUTOFLUSH. INT. CL. 9. (U.S. CLS. 21, 23, 26, 36 AND 38). REG. 12-2-1997.
- 2,118,653. BONZI. INT. CL. 1. (U.S. CLS. 1, 5, 6, 10, 26 AND 46). REG. 12-9-1997.
- 2,118,995. MAKE IT A RULE TO PLAN. INT. CL. 9. (U.S. CLS. 21, 23, 26, 36 AND 38). REG. 12-9-1997.
- 2,119,152. GET A GRIP. INT. CL. 8. (U.S. CLS. 23, 28 AND 44). REG. 12-9-1997.
- 2,119,314. MISCELLANEOUS DESIGN. INT. CLS. 21 AND 25. (U.S. CLS. 2, 13, 22, 23, 29, 30, 33, 39, 40 AND 50). REG. 12-9-1997.
- 2,119,450. GEORGIA BARIATRICES. INT. CL. 42. (U.S. CLS. 100 AND 101). REG. 12-9-1997.
- 2,119,557. DRILCO INDUSTRIAL. INT. CL. 7. (U.S. CLS. 13, 19, 21, 23, 31, 34 AND 35). REG. 12-9-1997.
- 2,120,043. RESTFUL RATES. INT. CL. 42. (U.S. CLS. 100 AND 101). REG. 12-9-1997.
- 2,120,104. RECOVERY. INT. CL. 10. (U.S. CLS. 26, 39 AND 44). REG. 12-9-1997.
- 2,120,108. ADVENTURES IN SCIENCE. INT. CL. 9 ONLY. (U.S. CLS. 21, 23, 26, 36 AND 38). REG. 12-9-1997.
- 2,120,315. ROUGEMONT AND DESIGN. INT. CL. 32. (U.S. CLS. 45, 46 AND 48). REG. 12-9-1997.
- 2,120,484. IF I PLAN TO LEARN, I MUST LEARN TO PLAN. INT. CL. 16. (U.S. CLS. 2, 5, 22, 23, 29, 37, 38 AND 50). REG. 12-9-1997.
- 2,120,485. OLIVIA OWL. INT. CL. 16. (U.S. CLS. 2, 5, 22, 23, 29, 37, 38 AND 50). REG. 12-9-1997.
- 2,120,872. ARIZONA FEDERAL CREDIT UNION. INT. CL. 36. (U.S. CLS. 100, 101 AND 102). REG. 12-16-1997.
- 2,121,344. VOICE OF HOPE. INT. CL. 16. (U.S. CLS. 2, 5, 22, 23, 29, 37, 38 AND 50). REG. 12-16-1997.
- 2,121,428. CARPET MAX (STYLIZED). INT. CL. 35 ONLY. (U.S. CLS. 100, 101 AND 102). REG. 12-16-1997.
- 2,121,429. CUSTARD INSURANCE ADJUSTERS, INC.. INT. CL. 36. (U.S. CLS. 100, 101 AND 102). REG. 12-16-1997.
- 2,121,445. SENIORTV. INT. CL. 9. (U.S. CLS. 21, 23, 26, 36 AND 38). REG. 12-16-1997.
- 2,121,531. ANTIQUE POWER. INT. CL. 16. (U.S. CLS. 2, 5, 22, 23, 29, 37, 38 AND 50). REG. 12-16-1997.
- 2,121,720. BCI. INT. CL. 35. (U.S. CLS. 100, 101 AND 102). REG. 12-16-1997.
- 2,121,837. MARY ENGELBREIT'S HOME COMPANION. INT. CL. 16. (U.S. CLS. 2, 5, 22, 23, 29, 37, 38 AND 50). REG. 12-16-1997.
- 2,122,054. INTERIOR EXPRESSIONS AND DESIGN. INT. CL. 20 ONLY. (U.S. CLS. 2, 13, 22, 25, 32 AND 50). REG. 12-16-1997.
- 2,122,913. LONGLIFE. INT. CLS. 7 AND 9. (U.S. CLS. 13, 19, 21, 23, 26, 31, 34, 35, 36 AND 38). REG. 12-23-1997.
- 2,123,084. MECHANI-PNEUMATIC. INT. CL. 7. (U.S. CLS. 13, 19, 21, 23, 31, 34 AND 35). REG. 12-23-1997.
- 2,123,216. BHS BEHAVIORAL HEALTH SYSTEMS AND DESIGN. INT. CLS. 36 AND 42. (U.S. CLS. 100, 101 AND 102). REG. 12-23-1997.
- 2,123,249. AVATREL. INT. CL. 1. (U.S. CLS. 1, 5, 6, 10, 26 AND 46). REG. 12-23-1997.
- 2,123,553. POINT LIGHTING CORPORATION AND DESIGN. INT. CL. 9. (U.S. CLS. 21, 23, 26, 36 AND 38). REG. 12-23-1997.
- 2,123,573. GOODIE'S GYROS. INT. CL. 42. (U.S. CLS. 100 AND 101). REG. 12-23-1997.
- 2,123,585. GENTLE GIANT MOVING COMPANY (STYLIZED). INT. CL. 39. (U.S. CLS. 100 AND 105). REG. 12-23-1997.
- 2,123,616. KWIK KEY. INT. CL. 6. (U.S. CLS. 2, 12, 13, 14, 23, 25 AND 50). REG. 12-23-1997.
- 2,123,701. MASON DIXON FUNDING, INC AND DESIGN. INT. CL. 36. (U.S. CLS. 100, 101 AND 102). REG. 12-23-1997.
- 2,123,774. ARSENAL MALL. INT. CL. 36. (U.S. CLS. 100, 101 AND 102). REG. 12-23-1997.
- 2,123,789. ROYAL PERSONNEL SERVICES. INT. CL. 35. (U.S. CLS. 100, 101 AND 102). REG. 12-23-1997.
- 2,123,808. PROVIDENCE HOUSE. INT. CL. 42. (U.S. CLS. 100 AND 101). REG. 12-23-1997.
- 2,123,813. ST. INT. CL. 8. (U.S. CLS. 23, 28 AND 44). REG. 12-23-1997.
- 2,123,895. MISCELLANEOUS DESIGN. INT. CL. 29. (U.S. CL. 46). REG. 12-23-1997.
- 2,124,181. NAVIGATOR. INT. CL. 7. (U.S. CLS. 13, 19, 21, 23, 31, 34 AND 35). REG. 12-23-1997.
- 2,124,209. LOADGUIDE. INT. CL. 9. (U.S. CLS. 21, 23, 26, 36 AND 38). REG. 12-23-1997.
- 2,125,062. ALLSTAR STATS. INT. CL. 41. (U.S. CLS. 100, 101 AND 107). REG. 12-30-1997.
- 2,125,383. SENIORTV. INT. CL. 41. (U.S. CLS. 100, 101 AND 107). REG. 12-30-1997.
- 2,125,394. COILCADE. INT. CL. 9. (U.S. CLS. 21, 23, 26, 36 AND 38). REG. 12-30-1997.
- 2,125,780. SWEETUMS. INT. CL. 28. (U.S. CLS. 22, 23, 38 AND 50). REG. 12-30-1997.
- 2,125,967. QUADRASTRETCH. INT. CL. 25. (U.S. CLS. 22 AND 39). REG. 12-30-1997.
- 2,127,314. NEED KNOWS NO SEASON. INT. CL. 42. (U.S. CLS. 100 AND 101). REG. 1-6-1998.
- 2,127,319. CRUISIN'. INT. CL. 16. (U.S. CLS. 2, 5, 22, 23, 29, 37, 38 AND 50). REG. 1-6-1998.
- 2,127,336. PREMIUM CHACHIES SALSA AND DESIGN. INT. CL. 30. (U.S. CL. 46). REG. 1-6-1998.
- 2,128,490. AMERICAN CLEANERS. INT. CL. 37. (U.S. CLS. 100, 103 AND 106). REG. 1-13-1998.
- 2,128,921. YOUR PARTNERS IN INNOVATION. INT. CL. 42. (U.S. CLS. 100 AND 101). REG. 1-13-1998.
- 2,129,528. MW MICHELE AND DESIGN. INT. CL. 14. (U.S. CLS. 2, 27, 28 AND 50). REG. 1-13-1998.

- 2,129,561. TRIHIBIT. INT. CL. 5. (U.S. CLS. 6, 18, 44, 46, 51 AND 52). REG. 1-13-1998.
- 2,129,823. BLUE GEM. INT. CL. 9. (U.S. CLS. 21, 23, 26, 36 AND 38). REG. 1-20-1998.
- 2,129,879. THE QUARTER HOUR. INT. CL. 36. (U.S. CLS. 100, 101 AND 102). REG. 1-20-1998.
- 2,129,881. MISCELLANEOUS DESIGN. INT. CL. 25. (U.S. CLS. 22 AND 39). REG. 1-20-1998.
- 2,130,480. BARAKLEAN. INT. CL. 3. (U.S. CLS. 1, 4, 6, 50, 51 AND 52). REG. 1-20-1998.
- 2,130,815. FULFILL. INT. CL. 5. (U.S. CLS. 6, 18, 44, 46, 51 AND 52). REG. 1-20-1998.
- 2,131,333. ROCK 'N' ROLL MARATHON. INT. CL. 41. (U.S. CLS. 100, 101 AND 107). REG. 1-20-1998.
- 2,132,015. HARDWARE MACHINERY AND DESIGN. INT. CL. 8. (U.S. CLS. 23, 28 AND 44). REG. 1-27-1998.
- 2,132,113. SYNTELLECT AND DESIGN. INT. CLS. 38 AND 42. (U.S. CLS. 100, 101 AND 104). REG. 1-27-1998.
- 2,132,885. KEY WEST MARGARITAVILLE MIX AND DESIGN. INT. CL. 32. (U.S. CLS. 45, 46 AND 48). REG. 1-27-1998.
- 2,132,965. PREMERA. INT. CL. 36. (U.S. CLS. 100, 101 AND 102). REG. 1-27-1998.
- 2,134,860. MR. INT. CL. 12. (U.S. CLS. 19, 21, 23, 31, 35 AND 44). REG. 2-3-1998.

\* \* \* \* \*

# TRADEMARK REGISTRATIONS CANCELED

The designation "U.S. Cl." appearing in this section refers to the U.S. class in effect prior to Sep. 1, 1973 rather than the international class which applies to applications filed on or after that date. For adoption of international classification see notice in the OFFICIAL GAZETTE of Jun. 26, 1973 (911 O.G. TM 210).

## SECTION 7(D)

- 3,027,800. STARR EXCESS INTERNATIONAL AND DESIGN. INT. CL. 36. REG. 12-13-2005.  
3,078,047. MIDLANDS BENEFIT ADMINISTRATORS. INT. CL. 35. REG. 4-11-2006.

## SECTION 8

- 821,799. STASAFE AND DESIGN. U.S. CLS. 2 AND 44 ONLY. REG. 1-10-1967.  
1,314,365. SWF AND DESIGN. INT. CL. 11 ONLY. REG. 1-15-1985.  
1,386,009. HINDSGAUL H (STYLIZED). INT. CL. 20. REG. 3-11-1986.  
1,396,273. WESTERN MAXI-GLOSS. INT. CL. 1. REG. 6-10-1986.  
1,396,274. CROPHEM AND DESIGN. INT. CL. 1. REG. 6-10-1986.  
1,396,275. CARL POOL. INT. CLS. 1 AND 5. REG. 6-10-1986.  
1,396,279. MISCELLANEOUS DESIGN. INT. CL. 1. REG. 6-10-1986.  
1,396,282. EASIGEL. INT. CL. 1. REG. 6-10-1986.  
1,396,299. EKTAPRO. INT. CL. 1. REG. 6-10-1986.  
1,396,301. GLAZD. INT. CL. 1. REG. 6-10-1986.  
1,396,302. HYDRON. INT. CL. 1. REG. 6-10-1986.  
1,396,307. CUNAPSOL-1 WOOD GREEN. INT. CL. 2. REG. 6-10-1986.  
1,396,311. FLEXVAC. INT. CL. 2. REG. 6-10-1986.  
1,396,323. KELLY. INT. CL. 3. REG. 6-10-1986.  
1,396,332. TRU KLEEN. INT. CL. 3. REG. 6-10-1986.  
1,396,335. BEFORE. INT. CL. 3. REG. 6-10-1986.  
1,396,336. BEFORE SOX. INT. CL. 3. REG. 6-10-1986.  
1,396,345. SOLID WAVE. INT. CL. 3. REG. 6-10-1986.  
1,396,351. STAN-PAC. INT. CLS. 3 AND 5. REG. 6-10-1986.  
1,396,354. WIMP. INT. CL. 3. REG. 6-10-1986.  
1,396,355. POLISH BRITE. INT. CL. 3. REG. 6-10-1986.  
1,396,356. ZOTOS LIGHT STROKES (STYLIZED). INT. CL. 3. REG. 6-10-1986.  
1,396,359. NATUDERM. INT. CL. 3. REG. 6-10-1986.  
1,396,360. NATURAL BRILLIANCE. INT. CL. 3. REG. 6-10-1986.  
1,396,362. CHARACTERS. INT. CL. 3. REG. 6-10-1986.  
1,396,374. STEP SAVER. INT. CL. 3. REG. 6-10-1986.  
1,396,377. V CHARACTERS (STYLIZED). INT. CL. 3. REG. 6-10-1986.  
1,396,378. R CHARACTERS (STYLIZED). INT. CL. 3. REG. 6-10-1986.  
1,396,379. B CHARACTERS (STYLIZED). INT. CL. 3. REG. 6-10-1986.  
1,396,380. G CHARACTERS (STYLIZED). INT. CL. 3. REG. 6-10-1986.  
1,396,387. METRODIN. INT. CL. 5. REG. 6-10-1986.  
1,396,392. LOK-PAK. INT. CL. 5. REG. 6-10-1986.  
1,396,401. BIO-MIMETICS. INT. CL. 5. REG. 6-10-1986.  
1,396,402. ARTHROBAN-S. INT. CL. 5. REG. 6-10-1986.  
1,396,404. DECAPEPTYL. INT. CL. 5. REG. 6-10-1986.  
1,396,412. MISCELLANEOUS DESIGN. INT. CL. 5. REG. 6-10-1986.  
1,396,419. SEPTOPOINTES. INT. CL. 5. REG. 6-10-1986.  
1,396,435. SACHS AND DESIGN. INT. CL. 6. REG. 6-10-1986.  
1,396,438. ULTIMATE (STYLIZED). INT. CL. 6. REG. 6-10-1986.  
1,396,440. STRUCTURA (STYLIZED). INT. CL. 6. REG. 6-10-1986.  
1,396,442. VASCOMAX T-250. INT. CL. 6. REG. 6-10-1986.  
1,396,451. THE LONE DRAINER, AND PRONTO!. INT. CL. 7. REG. 6-10-1986.  
1,396,454. SEN (STYLIZED). INT. CLS. 7, 9 AND 11. REG. 6-10-1986.  
1,396,455. ELEPHANT AND DESIGN. INT. CLS. 7 AND 11. REG. 6-10-1986.  
1,396,459. FRAISA AND DESIGN. INT. CLS. 7 AND 8. REG. 6-10-1986.  
1,396,463. Q (STYLIZED). INT. CL. 7. REG. 6-10-1986.  
1,396,466. SNAP-LOK. INT. CL. 7. REG. 6-10-1986.  
1,396,467. CTL AND DESIGN. INT. CL. 7. REG. 6-10-1986.  
1,396,469. POLYTROLLEY. INT. CL. 7. REG. 6-10-1986.  
1,396,471. AVMATIC. INT. CL. 7. REG. 6-10-1986.  
1,396,477. LIFE GARD. INT. CL. 7. REG. 6-10-1986.  
1,396,478. FLOR-COTE. INT. CL. 7. REG. 6-10-1986.  
1,396,479. SERVOTRONIC. INT. CL. 7. REG. 6-10-1986.  
1,396,480. READY AIR. INT. CL. 7. REG. 6-10-1986.  
1,396,481. EAGLE (STYLIZED). INT. CL. 7. REG. 6-10-1986.  
1,396,484. VEND-A-BIT. INT. CL. 7. REG. 6-10-1986.  
1,396,486. D (STYLIZED). INT. CL. 7. REG. 6-10-1986.  
1,396,487. DRESSER. INT. CL. 7. REG. 6-10-1986.  
1,396,490. MISCELLANEOUS DESIGN. INT. CL. 8. REG. 6-10-1986.  
1,396,492. DORMAN PRODUCTS. INT. CL. 8. REG. 6-10-1986.  
1,396,493. FUJI (STYLIZED). INT. CL. 8. REG. 6-10-1986.  
1,396,496. CORONA AND DESIGN. INT. CL. 8. REG. 6-10-1986.  
1,396,498. PAI. INT. CL. 8. REG. 6-10-1986.  
1,396,499. SMITH'S THE SYMBOL OF SHARPENING AND DESIGN. INT. CL. 8. REG. 6-10-1986.  
1,396,507. AI AND DESIGN. INT. CLS. 9 AND 42. REG. 6-10-1986.  
1,396,508. PEOPLE OF DESTINY AND DESIGN. INT. CLS. 9 AND 16. REG. 6-10-1986.  
1,396,509. PEOPLE OF DESTINY. INT. CLS. 9 AND 16. REG. 6-10-1986.  
1,396,511. VINTAGE. INT. CL. 9. REG. 6-10-1986.  
1,396,513. LYDIA FELLOWSHIP AND DESIGN. INT. CLS. 9, 16 AND 42. REG. 6-10-1986.  
1,396,529. POLYTECTOR. INT. CL. 9. REG. 6-10-1986.  
1,396,535. STYLE SETTER. INT. CL. 9. REG. 6-10-1986.  
1,396,539. AGRI-PLAN. INT. CLS. 9 AND 41. REG. 6-10-1986.  
1,396,551. CHEVRON AND DESIGN. INT. CL. 9. REG. 6-10-1986.  
1,396,552. FIELD TRACKER. INT. CL. 9. REG. 6-10-1986.  
1,396,553. PC-WRITE (STYLIZED). INT. CL. 9. REG. 6-10-1986.  
1,396,565. THE INTELLIGENT BODY. INT. CL. 9. REG. 6-10-1986.  
1,396,568. MISCELLANEOUS DESIGN. INT. CL. 9. REG. 6-10-1986.  
1,396,570. ADONNA. INT. CL. 9. REG. 6-10-1986.  
1,396,578. TJLIFE. INT. CL. 9. REG. 6-10-1986.  
1,396,579. AT. INT. CL. 9. REG. 6-10-1986.



- 1,396,585. MISCELLANEOUS DESIGN. INT. CLS. 9 AND 16. REG. 6-10-1986.
- 1,396,588. CLEARLINK. INT. CL. 9. REG. 6-10-1986.
- 1,396,590. REF TEK. INT. CL. 9. REG. 6-10-1986.
- 1,396,592. LIFE LIFTERS AND DESIGN. INT. CL. 9. REG. 6-10-1986.
- 1,396,595. EXPERTLINK. INT. CL. 9. REG. 6-10-1986.
- 1,396,598. CIMLINK. INT. CL. 9. REG. 6-10-1986.
- 1,396,603. MISCELLANEOUS DESIGN. INT. CL. 9. REG. 6-10-1986.
- 1,396,607. SKYLINE AND DESIGN. INT. CL. 9. REG. 6-10-1986.
- 1,396,608. L (STYLIZED). INT. CL. 9. REG. 6-10-1986.
- 1,396,609. IDENTITECH. INT. CL. 9. REG. 6-10-1986.
- 1,396,614. PH PEN. INT. CL. 9. REG. 6-10-1986.
- 1,396,616. GATE STATION. INT. CL. 9. REG. 6-10-1986.
- 1,396,617. TEST STATION. INT. CL. 9. REG. 6-10-1986.
- 1,396,618. RMU. INT. CL. 9. REG. 6-10-1986.
- 1,396,619. RCU. INT. CL. 9. REG. 6-10-1986.
- 1,396,620. DRMU. INT. CL. 9. REG. 6-10-1986.
- 1,396,622. COOLSTAIN. INT. CL. 9. REG. 6-10-1986.
- 1,396,626. SEMIPULSE. INT. CL. 9. REG. 6-10-1986.
- 1,396,627. ROAD RUNNER AND DESIGN. INT. CL. 9. REG. 6-10-1986.
- 1,396,630. HELPLINE. INT. CL. 9. REG. 6-10-1986.
- 1,396,635. STAR AND DESIGN. INT. CL. 10. REG. 6-10-1986.
- 1,396,636. LIFESTYLE. INT. CL. 10. REG. 6-10-1986.
- 1,396,637. VINGMED. INT. CL. 10. REG. 6-10-1986.
- 1,396,638. WET VEST AND DESIGN. INT. CL. 10. REG. 6-10-1986.
- 1,396,640. TRIO. INT. CL. 10. REG. 6-10-1986.
- 1,396,654. MULTI-FLO. INT. CL. 11. REG. 6-10-1986.
- 1,396,655. NOVA. INT. CL. 11. REG. 6-10-1986.
- 1,396,673. SECURITY 1 (STYLIZED). INT. CL. 12. REG. 6-10-1986.
- 1,396,674. MW (STYLIZED). INT. CLS. 12 AND 42. REG. 6-10-1986.
- 1,396,675. PHOENIX. INT. CL. 12. REG. 6-10-1986.
- 1,396,676. TVT (STYLIZED). INT. CL. 12. REG. 6-10-1986.
- 1,396,677. DOUBLE HH QUALITY HITCHPINS AND DESIGN. INT. CL. 12. REG. 6-10-1986.
- 1,396,684. TRU-FIT. INT. CL. 12. REG. 6-10-1986.
- 1,396,689. GOLDLINE. INT. CL. 12. REG. 6-10-1986.
- 1,396,696. JC (STYLIZED). INT. CL. 14. REG. 6-10-1986.
- 1,396,698. BECORA. INT. CL. 14. REG. 6-10-1986.
- 1,396,701. JESUS THE SURFER. INT. CL. 16. REG. 6-10-1986.
- 1,396,703. PREMIER. INT. CL. 16. REG. 6-10-1986.
- 1,396,706. ANNOUNCING IT'S A AND DESIGN. INT. CL. 16. REG. 6-10-1986.
- 1,396,707. SARAH'S ATTIC, "GRANNY'S FAVORITES" AND DESIGN. INT. CLS. 16, 20 AND 28. REG. 6-10-1986.
- 1,396,709. STENOSCRIPT. INT. CLS. 16 AND 41. REG. 6-10-1986.
- 1,396,711. VH-1 VIDEO HITS ONE (STYLIZED). INT. CL. 16. REG. 6-10-1986.
- 1,396,713. PROFESSIONAL ASSOCIATION OF SPORTS EDUCATORS. INT. CL. 16. REG. 6-10-1986.
- 1,396,715. RESTAURANT ROW. INT. CL. 16. REG. 6-10-1986.
- 1,396,726. PREDICASTS. INT. CLS. 16 AND 42. REG. 6-10-1986.
- 1,396,729. THE CREATIVE ORGANIZER AND DESIGN. INT. CL. 16. REG. 6-10-1986.
- 1,396,730. MISCELLANEOUS DESIGN. INT. CL. 16. REG. 6-10-1986.
- 1,396,732. SMITHY (STYLIZED). INT. CLS. 16 AND 18. REG. 6-10-1986.
- 1,396,745. ABC WORLD AIRWAYS GUIDE. INT. CL. 16. REG. 6-10-1986.
- 1,396,751. SOUTHERN GARDENER NEWSLETTER. INT. CL. 16. REG. 6-10-1986.
- 1,396,761. THE QUICK START PLUS PROGRAM. INT. CL. 16. REG. 6-10-1986.
- 1,396,762. PERSONAL CHOICE. INT. CL. 16. REG. 6-10-1986.
- 1,396,764. THE LADY REMEMBERS. INT. CL. 16. REG. 6-10-1986.
- 1,396,770. PRIVILEGED INFORMATION. INT. CL. 16. REG. 6-10-1986.
- 1,396,780. HINDUISM TODAY. INT. CL. 16. REG. 6-10-1986.
- 1,396,787. MISCELLANEOUS DESIGN. INT. CL. 16. REG. 6-10-1986.
- 1,396,791. EARTH TRACKS (STYLIZED). INT. CL. 16. REG. 6-10-1986.
- 1,396,792. USA WEEKEND AND DESIGN. INT. CL. 16. REG. 6-10-1986.
- 1,396,793. MONEY MESSAGES. INT. CL. 16. REG. 6-10-1986.
- 1,396,794. MONEY MEMORY. INT. CL. 16. REG. 6-10-1986.
- 1,396,796. VELSOF. INT. CL. 16. REG. 6-10-1986.
- 1,396,797. LIFETIME. INT. CL. 16. REG. 6-10-1986.
- 1,396,798. PIN LOC. INT. CL. 16. REG. 6-10-1986.
- 1,396,799. SMITH CORONA AND DESIGN. INT. CL. 16. REG. 6-10-1986.
- 1,396,808. FLORIDA TODAY AND DESIGN. INT. CL. 16. REG. 6-10-1986.
- 1,396,809. FLEXI-VIEW. INT. CL. 17. REG. 6-10-1986.
- 1,396,816. BARRA AND DESIGN. INT. CL. 19. REG. 6-10-1986.
- 1,396,823. KENSINGTON. INT. CL. 19. REG. 6-10-1986.
- 1,396,829. SIEGENIA. INT. CL. 20. REG. 6-10-1986.
- 1,396,830. COUNTRY ACCENTS. INT. CL. 20. REG. 6-10-1986.
- 1,396,837. EASTMAN HOUSE. INT. CL. 20. REG. 6-10-1986.
- 1,396,839. ALLISON WINDOW FASHIONS AND DESIGN. INT. CL. 20. REG. 6-10-1986.
- 1,396,840. ALLISON WINDOW FASHIONS. INT. CL. 20. REG. 6-10-1986.
- 1,396,841. FLEXI-STAND. INT. CL. 20. REG. 6-10-1986.
- 1,396,849. MONA PLANT SYSTEM AND DESIGN. INT. CL. 21. REG. 6-10-1986.
- 1,396,861. C.C.F. JUDY MELAMINE AND DESIGN. INT. CL. 21. REG. 6-10-1986.
- 1,396,871. ORMAYVL. INT. CL. 24. REG. 6-10-1986.
- 1,396,873. FAST TRACK AND DESIGN. INT. CL. 25. REG. 6-10-1986.
- 1,396,882. FREEDOM BRA. INT. CL. 25. REG. 6-10-1986.
- 1,396,884. CHRISTYS' LONDON AND DESIGN. INT. CL. 25. REG. 6-10-1986.
- 1,396,888. FAULTLESS. INT. CL. 25. REG. 6-10-1986.
- 1,396,890. REPUBBLICA DI GENOVA AND DESIGN. INT. CL. 25. REG. 6-10-1986.
- 1,396,892. JEAN CHANCEL AND DESIGN. INT. CL. 25. REG. 6-10-1986.
- 1,396,893. BODY LITES. INT. CL. 25. REG. 6-10-1986.
- 1,396,896. THE COMFORT SHIRT AND DESIGN. INT. CL. 25. REG. 6-10-1986.
- 1,396,899. GOOMBAY. INT. CL. 25. REG. 6-10-1986.
- 1,396,901. EASY ON FITTING. INT. CL. 25. REG. 6-10-1986.
- 1,396,902. CHICORY (STYLIZED). INT. CL. 25. REG. 6-10-1986.
- 1,396,903. FAYVA (STYLIZED). INT. CL. 25. REG. 6-10-1986.
- 1,396,913. HY-VITRONIC. INT. CL. 28. REG. 6-10-1986.
- 1,396,917. CONQUEST (STYLIZED). INT. CL. 28. REG. 6-10-1986.
- 1,396,923. IMPORTOYS. INT. CL. 28. REG. 6-10-1986.
- 1,396,925. DATA EAST. INT. CL. 28. REG. 6-10-1986.
- 1,396,940. WINNING WORDS. INT. CL. 28. REG. 6-10-1986.
- 1,396,959. BLOOGLE. INT. CL. 28. REG. 6-10-1986.
- 1,396,963. POLITICAL CHALLENGE. INT. CL. 28. REG. 6-10-1986.
- 1,396,968. DYNACAST. INT. CL. 28. REG. 6-10-1986.
- 1,396,970. SWIMMIN' GRUB. INT. CL. 28. REG. 6-10-1986.
- 1,396,986. ILLUSION IS THE ULTIMATE WEAPON. INT. CL. 28. REG. 6-10-1986.
- 1,396,988. LANDREY'S. INT. CL. 29. REG. 6-10-1986.
- 1,396,991. NAISA BRAND AND DESIGN. INT. CL. 29. REG. 6-10-1986.
- 1,396,997. PISTACHIO PRODUCERS AND DESIGN. INT. CL. 29. REG. 6-10-1986.
- 1,396,999. FISHERMAN AND DESIGN. INT. CL. 29. REG. 6-10-1986.
- 1,397,002. HICKORY TRAIL BRAND AND DESIGN. INT. CL. 29. REG. 6-10-1986.
- 1,397,007. EISKUSSCHEN AND DESIGN. INT. CL. 30. REG. 6-10-1986.
- 1,397,018. TRIVIA FORTUNE COOKIES. INT. CL. 30. REG. 6-10-1986.

- 1,397,022. BEN & JERRY'S ICE CREAM AND DESIGN. INT. CL. 30. REG. 6-10-1986.
- 1,397,024. MOUNTAIN HARVEST. INT. CL. 30. REG. 6-10-1986.
- 1,397,033. MISCELLANEOUS DESIGN. INT. CL. 30. REG. 6-10-1986.
- 1,397,036. I CAN'T MAKE ALL THE CANDY IN THE WORLD, SO I JUST MAKE THE BEST OF IT! AND DESIGN. INT. CL. 30. REG. 6-10-1986.
- 1,397,038. MG AND DESIGN. INT. CL. 30. REG. 6-10-1986.
- 1,397,039. LIBS CANDIES AND DESIGN. INT. CL. 30. REG. 6-10-1986.
- 1,397,041. FLAVOR PRO. INT. CL. 30. REG. 6-10-1986.
- 1,397,042. WILLINGHAM'S WHAM SAUCE WORLD'S CHAMPION FOR THE TABLE AND DESIGN. INT. CL. 30. REG. 6-10-1986.
- 1,397,043. WILLINGHAM'S WHAM SEASONING WORLD'S CHAMPION ALL PURPOSE AND DESIGN. INT. CL. 30. REG. 6-10-1986.
- 1,397,045. MAMA TISH'S GOURMET SORBETTO AND DESIGN. INT. CL. 30. REG. 6-10-1986.
- 1,397,048. VALLEY FORGE. INT. CL. 30. REG. 6-10-1986.
- 1,397,051. RIDGE GROWN. INT. CL. 31. REG. 6-10-1986.
- 1,397,054. M (STYLIZED). INT. CL. 31. REG. 6-10-1986.
- 1,397,057. CALLISONS. INT. CL. 31. REG. 6-10-1986.
- 1,397,062. SQUEEZIT AND DESIGN. INT. CL. 32. REG. 6-10-1986.
- 1,397,066. THE BRITISH GRENADIER AND DESIGN. INT. CL. 33. REG. 6-10-1986.
- 1,397,069. HERE XVII SOUVEREIN. INT. CL. 33. REG. 6-10-1986.
- 1,397,077. COUNTY PRIDE AND DESIGN. INT. CLS. 35 AND 42. REG. 6-10-1986.
- 1,397,080. DEAL DIRECT. INT. CLS. 35 AND 36. REG. 6-10-1986.
- 1,397,088. TALENT-TAP. INT. CL. 35. REG. 6-10-1986.
- 1,397,096. MISCELLANEOUS DESIGN. INT. CL. 36. REG. 6-10-1986.
- 1,397,099. FIRST NATIONAL BANK OF ALABAMA. INT. CL. 36. REG. 6-10-1986.
- 1,397,100. EASY CASH 24. INT. CL. 36. REG. 6-10-1986.
- 1,397,102. MATURE CITIZENS ASSOCIATION. INT. CL. 36. REG. 6-10-1986.
- 1,397,112. PRO + PROTECTION PLUS AND DESIGN. INT. CL. 36. REG. 6-10-1986.
- 1,397,113. THE PENDERGAST-WEYER FOUNDATION. INT. CL. 36. REG. 6-10-1986.
- 1,397,114. KELLY. INT. CL. 36. REG. 6-10-1986.
- 1,397,116. MISCELLANEOUS DESIGN. INT. CL. 37. REG. 6-10-1986.
- 1,397,119. REYNOLDS ALUMINUM RECYCLING PAYS AND DESIGN. INT. CL. 37. REG. 6-10-1986.
- 1,397,120. ASPIRE AND DESIGN. INT. CLS. 37 AND 41. REG. 6-10-1986.
- 1,397,121. REYNOLDS ALUMINUM CAN RECYCLING MACHINE AND DESIGN. INT. CL. 37. REG. 6-10-1986.
- 1,397,132. WNCI. INT. CL. 38. REG. 6-10-1986.
- 1,397,134. KNST. INT. CL. 38. REG. 6-10-1986.
- 1,397,138. KSSN. INT. CL. 38. REG. 6-10-1986.
- 1,397,154. MEGA. INT. CL. 39. REG. 6-10-1986.
- 1,397,162. QMI QUALITY MANAGEMENT INSTITUTE (STYLIZED). INT. CL. 41. REG. 6-10-1986.
- 1,397,168. MR. WEST HOLLYWOOD. INT. CL. 41. REG. 6-10-1986.
- 1,397,173. A CLOSER LOOK. INT. CL. 41. REG. 6-10-1986.
- 1,397,181. CROSS COUNTRY INN. INT. CL. 42. REG. 6-10-1986.
- 1,397,185. DRUG CASTLE. INT. CL. 42. REG. 6-10-1986.
- 1,397,190. MISCELLANEOUS DESIGN. INT. CL. 42. REG. 6-10-1986.
- 1,397,197. CLUB ROOM CR AND DESIGN. INT. CL. 42. REG. 6-10-1986.
- 1,397,201. ZORBA'S. INT. CL. 42. REG. 6-10-1986.
- 1,397,210. MEND AND DESIGN. INT. CL. 42. REG. 6-10-1986.
- 1,397,211. THE BURGER BOYS OF BROOKLYN AND DESIGN. INT. CL. 42. REG. 6-10-1986.
- 1,397,215. HOW-TO STORE OUR OWN AND DESIGN. INT. CL. 42. REG. 6-10-1986.
- 1,397,217. FUTURECOLOR. INT. CL. 42. REG. 6-10-1986.
- 1,397,218. OUR OWN HOW-TO AND DESIGN. INT. CL. 42. REG. 6-10-1986.
- 1,397,223. SEQUOIA PACIFIC. INT. CL. 42. REG. 6-10-1986.
- 1,397,224. THE ARK IN THE PARK AND DESIGN. INT. CL. 42. REG. 6-10-1986.
- 1,397,226. PPC. INT. CL. 42. REG. 6-10-1986.
- 1,397,231. RESTORE. INT. CL. 4. REG. 6-10-1986.
- 1,397,233. AIR-TITE. INT. CL. 6. REG. 6-10-1986.
- 1,397,236. TOTAL SCREEN UPDATE. INT. CL. 9. REG. 6-10-1986.
- 1,397,245. PAIN THERAPY CENTER OF COLUMBIA. INT. CL. 42. REG. 6-10-1986.
- 1,427,067. RAIN DANCE. INT. CL. 1 ONLY. REG. 2-3-1987.
- 1,429,451. MIDNIGHT SUN ORNAS HERRGARD AND DESIGN. INT. CL. 32 ONLY. REG. 2-17-1987.
- 1,448,124. NIBCO AND DESIGN. INT. CL. 7 ONLY. REG. 7-21-1987.
- 1,912,890. MEGA POWER MP REACH FOR THE POWER CAR CARE PRODUCTS AND DESIGN. INT. CL. 1. REG. 8-22-1995.
- 1,979,083. XL AND DESIGN. INT. CL. 16. REG. 6-11-1996.
- 1,979,085. EES AND DESIGN. INT. CL. 9. REG. 6-11-1996.
- 1,979,090. COKTEL VISION AND DESIGN. INT. CLS. 9, 28, 41 AND 42. REG. 6-11-1996.
- 1,979,103. GENERAL MUSIC AND DESIGN. INT. CLS. 9 AND 15. REG. 6-11-1996.
- 1,979,107. RHINO AND DESIGN. INT. CL. 28. REG. 6-11-1996.
- 1,979,114. THE INDIVIDUAL INVESTOR'S GUIDE TO LOW-LOAD MUTUAL FUNDS. INT. CL. 16. REG. 6-11-1996.
- 1,979,117. WASH N' GO. INT. CL. 11. REG. 6-11-1996.
- 1,979,129. CAPSYN. INT. CL. 30. REG. 6-11-1996.
- 1,979,141. VIDEO MUSIC AWARDS. INT. CLS. 16 AND 41. REG. 6-11-1996.
- 1,979,144. THE GAGLIARDI TROPHY. INT. CL. 41. REG. 6-11-1996.
- 1,979,153. MUSO (STYLIZED). INT. CLS. 29 AND 30. REG. 6-11-1996.
- 1,979,154. ANGEL'S DINER BEST AMERICAN DINER AND DESIGN. INT. CL. 42. REG. 6-11-1996.
- 1,979,170. DOC (STYLIZED). INT. CL. 3. REG. 6-11-1996.
- 1,979,175. SMOKING STINKS LIKE CAMEL'S BREATH STU & STELLA STENCH AND DESIGN. INT. CLS. 16, 25 AND 41. REG. 6-11-1996.
- 1,979,190. TIGRE. INT. CL. 12. REG. 6-11-1996.
- 1,979,193. SALCETINO. INT. CL. 33. REG. 6-11-1996.
- 1,979,194. THE ONE INVESTOR ANNUITY. INT. CL. 36. REG. 6-11-1996.
- 1,979,201. BIGHORN AND DESIGN. INT. CL. 12. REG. 6-11-1996.
- 1,979,203. CHRISTIANITY ONLINE AND DESIGN. INT. CLS. 38 AND 42. REG. 6-11-1996.
- 1,979,208. DOLISOS (STYLIZED). INT. CL. 5. REG. 6-11-1996.
- 1,979,209. US-1 AND DESIGN. INT. CL. 42. REG. 6-11-1996.
- 1,979,211. EFAVET. INT. CL. 5. REG. 6-11-1996.
- 1,979,226. CROSSWORD WIZARD. INT. CL. 28. REG. 6-11-1996.
- 1,979,234. BELDEN AND DESIGN. INT. CLS. 8, 9, 16 AND 21. REG. 6-11-1996.
- 1,979,235. HENRI STUDIO. INT. CLS. 11, 19, 20 AND 21. REG. 6-11-1996.
- 1,979,244. MISCELLANEOUS DESIGN. INT. CL. 6. REG. 6-11-1996.
- 1,979,247. PRODEL. INT. CLS. 5, 29, 30 AND 31. REG. 6-11-1996.
- 1,979,255. THE NEW YORKER (STYLIZED). INT. CL. 25. REG. 6-11-1996.
- 1,979,262. TELEFFICIENT AND DESIGN. INT. CLS. 37 AND 42. REG. 6-11-1996.
- 1,979,266. B BLACKWELL SCIENCE (STYLIZED). INT. CL. 16. REG. 6-11-1996.
- 1,979,271. HEUCOROX. INT. CLS. 1 AND 2. REG. 6-11-1996.
- 1,979,275. 128XP. INT. CL. 10. REG. 6-11-1996.

- 1,979,289. DISCOVERY (STYLIZED). INT. CL. 42. REG. 6-11-1996.
- 1,979,303. STARLIGHT INTERNATIONAL AND DESIGN. INT. CL. 5. REG. 6-11-1996.
- 1,979,313. SILVERBACK. INT. CL. 41. REG. 6-11-1996.
- 1,979,323. THE EXPORT YELLOW PAGES. INT. CLS. 16 AND 35. REG. 6-11-1996.
- 1,979,335. SHENPIX. INT. CL. 10. REG. 6-11-1996.
- 1,979,339. TRANSITION MARKETING. INT. CL. 35. REG. 6-11-1996.
- 1,979,343. HEARTSAFE AND DESIGN. INT. CL. 10. REG. 6-11-1996.
- 1,979,347. SIGA-TOPTAC. INT. CLS. 1 AND 17. REG. 6-11-1996.
- 1,979,351. EFAMOL MARINE. INT. CL. 5. REG. 6-11-1996.
- 1,979,357. PLASTOLAN THE POWER OF PROMOTION (STYLIZED). INT. CL. 16. REG. 6-11-1996.
- 1,979,358. MORE THAN MEETS THE EYE. INT. CLS. 35 AND 39. REG. 6-11-1996.
- 1,979,359. TASTETOUR (STYLIZED). INT. CL. 16. REG. 6-11-1996.
- 1,979,361. MEDIA PRO. INT. CL. 9. REG. 6-11-1996.
- 1,979,363. MY FIRST ENCYCLOPEDIA. INT. CL. 9. REG. 6-11-1996.
- 1,979,366. BELLA CERAMICA MICROWAVE SAFE OVEN TO TABLE DISHWASHER SAFE MADE IN CHINA BY TIENSHAN AND DESIGN. INT. CL. 21. REG. 6-11-1996.
- 1,979,370. MISCELLANEOUS DESIGN. INT. CLS. 16 AND 28. REG. 6-11-1996.
- 1,979,376. EARTHLY ELEMENTS AND DESIGN. INT. CL. 3. REG. 6-11-1996.
- 1,979,380. NATIONWIDE CONSUMER TESTING INSTITUTE. INT. CL. 42. REG. 6-11-1996.
- 1,979,390. SUN-FIL. INT. CL. 2. REG. 6-11-1996.
- 1,979,392. SHANG TSUNG. INT. CLS. 16 AND 28. REG. 6-11-1996.
- 1,979,399. KINTARO. INT. CLS. 16 AND 28. REG. 6-11-1996.
- 1,979,402. VECTOR. INT. CL. 35. REG. 6-11-1996.
- 1,979,427. OPTIMOL AND DESIGN. INT. CL. 4. REG. 6-11-1996.
- 1,979,446. FRONTIER COMMUNICATIONS. INT. CL. 16. REG. 6-11-1996.
- 1,979,463. TCAM. INT. CL. 9. REG. 6-11-1996.
- 1,979,468. RED WOLF AND DESIGN. INT. CL. 32. REG. 6-11-1996.
- 1,979,469. ARMADA FUNDS AND DESIGN. INT. CL. 36. REG. 6-11-1996.
- 1,979,470. MISCELLANEOUS DESIGN. INT. CL. 36. REG. 6-11-1996.
- 1,979,473. TRIXIE. INT. CL. 10. REG. 6-11-1996.
- 1,979,474. KAUAI COFFEE AND DESIGN. INT. CL. 30. REG. 6-11-1996.
- 1,979,477. NICOLE MILLER (STYLIZED). INT. CLS. 18 AND 25. REG. 6-11-1996.
- 1,979,483. VISTA WEB GLOBAL TECHNOLOGIES AT YOUR FINGERTIPS AND DESIGN. INT. CL. 36. REG. 6-11-1996.
- 1,979,496. BUSINESS CODE. INT. CL. 25. REG. 6-11-1996.
- 1,979,501. PET COTTAGE. INT. CL. 20. REG. 6-11-1996.
- 1,979,507. GOLF. INT. CL. 34. REG. 6-11-1996.
- 1,979,512. ISA. INT. CL. 42. REG. 6-11-1996.
- 1,979,519. TECHNO WEAR. INT. CL. 25. REG. 6-11-1996.
- 1,979,523. PLANT A SMILE IN YOUR GARDEN. INT. CL. 42. REG. 6-11-1996.
- 1,979,525. FEASIBLE PROPERTIES. INT. CL. 36. REG. 6-11-1996.
- 1,979,538. E L FUDGE AND DESIGN. INT. CL. 30. REG. 6-11-1996.
- 1,979,548. INSULTAB AND DESIGN. INT. CL. 17. REG. 6-11-1996.
- 1,979,560. SPRINT AND DESIGN. INT. CL. 6. REG. 6-11-1996.
- 1,979,563. VANCO EURONET. INT. CL. 38. REG. 6-11-1996.
- 1,979,570. PROVILINK. INT. CL. 5. REG. 6-11-1996.
- 1,979,576. WESTWOOD FARMS. INT. CL. 3. REG. 6-11-1996.
- 1,979,609. BUILD.COM. INT. CL. 35. REG. 6-11-1996.
- 1,979,612. MISCELLANEOUS DESIGN. INT. CL. 6. REG. 6-11-1996.
- 1,979,616. MISCELLANEOUS DESIGN. INT. CL. 36. REG. 6-11-1996.
- 1,979,621. HEALTH SET AND DESIGN. INT. CL. 41. REG. 6-11-1996.
- 1,979,623. THE SKINNY ON FAT AND DESIGN. INT. CL. 42. REG. 6-11-1996.
- 1,979,629. ERGOMAS. INT. CL. 9. REG. 6-11-1996.
- 1,979,630. D&O FORUM. INT. CL. 16. REG. 6-11-1996.
- 1,979,631. THE FUTURIST GOLD AND DESIGN. INT. CL. 36. REG. 6-11-1996.
- 1,979,636. FAX RECALL. INT. CL. 42. REG. 6-11-1996.
- 1,979,645. FINISHING TOUCH. INT. CL. 3. REG. 6-11-1996.
- 1,979,647. ORVILLE. INT. CL. 15. REG. 6-11-1996.
- 1,979,657. COMMON READING. INT. CL. 16. REG. 6-11-1996.
- 1,979,674. ANNIE MOORE'S. INT. CL. 42. REG. 6-11-1996.
- 1,979,675. TENET SOUTH FLORIDA HEALTHSYSTEM. INT. CL. 41. REG. 6-11-1996.
- 1,979,680. PROTECTS IN WAYS OTHER OILS CAN'T. INT. CL. 4. REG. 6-11-1996.
- 1,979,688. LIQUID LOCK-WASHER. INT. CL. 1. REG. 6-11-1996.
- 1,979,713. SOUTHERN COOLER. INT. CL. 11. REG. 6-11-1996.
- 1,979,716. ENVIROCURE (STYLIZED). INT. CL. 1. REG. 6-11-1996.
- 1,979,720. THERA-TURN. INT. CL. 10. REG. 6-11-1996.
- 1,979,726. FORBIDDEN MOMENTS. INT. CL. 25. REG. 6-11-1996.
- 1,979,735. DR. FLAMINGO'S. INT. CL. 3. REG. 6-11-1996.
- 1,979,738. WORSHIP LEADER AND DESIGN. INT. CL. 16. REG. 6-11-1996.
- 1,979,741. T-REX. INT. CL. 31. REG. 6-11-1996.
- 1,979,742. LENS CRAFTERS AND DESIGN. INT. CL. 42. REG. 6-11-1996.
- 1,979,743. GIVE THE GIFT OF SIGHT LENS CRAFTERS AND DESIGN. INT. CL. 42. REG. 6-11-1996.
- 1,979,748. A ADVANTAGE RECEIVABLE SOLUTIONS (STYLIZED). INT. CL. 36. REG. 6-11-1996.
- 1,979,758. THE VIP EDGE. INT. CL. 16. REG. 6-11-1996.
- 1,979,769. MISCELLANEOUS DESIGN. INT. CL. 21. REG. 6-11-1996.
- 1,979,777. BEVERLY OLIVACCE. INT. CL. 25. REG. 6-11-1996.
- 1,979,778. INFILTRATOR. INT. CL. 10. REG. 6-11-1996.
- 1,979,787. G-U-M AND DESIGN. INT. CL. 5. REG. 6-11-1996.
- 1,979,793. RING'NZAP. INT. CL. 9. REG. 6-11-1996.
- 1,979,794. COMMPAGE AND DESIGN. INT. CL. 42. REG. 6-11-1996.
- 1,979,799. HOME BASICS. INT. CL. 5. REG. 6-11-1996.
- 1,979,803. CAFCO. INT. CLS. 1, 2 AND 17. REG. 6-11-1996.
- 1,979,830. GTE. INT. CL. 16. REG. 6-11-1996.
- 1,979,832. T-REX. INT. CL. 5. REG. 6-11-1996.
- 1,979,863. D & B ALERT SERVICES. INT. CL. 35. REG. 6-11-1996.
- 1,979,865. COUNSELING. INT. CL. 16. REG. 6-11-1996.
- 1,979,875. PULSE. INT. CL. 38. REG. 6-11-1996.
- 1,979,886. REAP. INT. CL. 42. REG. 6-11-1996.
- 1,979,889. GIZMO. INT. CL. 16. REG. 6-11-1996.
- 1,979,892. 3M (STYLIZED). INT. CL. 16. REG. 6-11-1996.
- 1,979,896. PLEASER DELI. INT. CL. 42. REG. 6-11-1996.
- 1,979,905. THE GAMESTERS AND DESIGN. INT. CL. 41. REG. 6-11-1996.
- 1,979,927. 800-HGTV-ASK. INT. CLS. 38 AND 42. REG. 6-11-1996.
- 1,979,932. STROPS AND DESIGN. INT. CL. 25. REG. 6-11-1996.
- 1,979,945. DUNGEONS & DRAGONS. INT. CL. 25. REG. 6-11-1996.
- 1,979,949. NOVUS. INT. CLS. 35 AND 36. REG. 6-11-1996.
- 1,979,959. UNICON. INT. CL. 6. REG. 6-11-1996.
- 1,979,960. HEALTHY MEALS IN MINUTES. INT. CL. 16. REG. 6-11-1996.
- 1,979,975. LOCAL MOTION. INT. CL. 28. REG. 6-11-1996.
- 1,979,977. FINDER/DRIVER II. INT. CL. 7. REG. 6-11-1996.

- 1,979,980. PHANTASMAGORIA. INT. CL. 28. REG. 6-11-1996.
- 1,979,981. GRADIENT. INT. CL. 12. REG. 6-11-1996.
- 1,979,990. TABROPS (STYLIZED). INT. CL. 7. REG. 6-11-1996.
- 1,979,995. DOLLAR TOURS. INT. CL. 39. REG. 6-11-1996.
- 1,979,999. THE OZ KIDS. INT. CL. 41. REG. 6-11-1996.
- 1,980,001. A STEP BEYOND JUST WHEELS. INT. CL. 18. REG. 6-11-1996.
- 1,980,005. BRONCO. INT. CL. 6. REG. 6-11-1996.
- 1,980,020. MISCELLANEOUS DESIGN. INT. CL. 21. REG. 6-11-1996.
- 1,980,028. LUCKY STRIKE. INT. CL. 25. REG. 6-11-1996.
- 1,980,046. CAPTIVA. INT. CL. 9. REG. 6-11-1996.
- 1,980,048. ALLURE BY COUNTRY COACH. INT. CL. 12. REG. 6-11-1996.
- 1,980,052. FLANNEL EASE. INT. CL. 25. REG. 6-11-1996.
- 1,980,063. RESUMIX. INT. CL. 9. REG. 6-11-1996.
- 1,980,081. GATORADE AND DESIGN. INT. CLS. 14, 18, 21, 25 AND 28. REG. 6-11-1996.
- 1,980,085. MOTORSPORT SVO AND DESIGN. INT. CL. 14. REG. 6-11-1996.
- 1,980,086. PROBE. INT. CL. 28. REG. 6-11-1996.
- 1,980,090. WARRIOR. INT. CL. 7. REG. 6-11-1996.
- 1,980,104. VISSAN. INT. CL. 19. REG. 6-11-1996.
- 1,980,110. EAR SECRETS. INT. CL. 14. REG. 6-11-1996.
- 1,980,124. AQUA-WALL. INT. CLS. 11 AND 37. REG. 6-11-1996.
- 1,980,134. YK AND DESIGN. INT. CL. 25. REG. 6-11-1996.
- 1,980,137. ADSITE. INT. CL. 9. REG. 6-11-1996.
- 1,980,140. VISION SAN JAMAR AND DESIGN. INT. CL. 21. REG. 6-11-1996.
- 1,980,153. CLEARLY THE RIGHT CHOICE. INT. CLS. 6, 19 AND 40. REG. 6-11-1996.
- 1,980,156. CUTE-N-COZY COTT COTTAGE. INT. CL. 28. REG. 6-11-1996.
- 1,980,159. MAKE MY ROOM. INT. CL. 24. REG. 6-11-1996.
- 1,980,201. THE WATER BUFFALO. INT. CL. 11. REG. 6-11-1996.
- 1,980,204. SAPPHLEX CRYSTAL. INT. CL. 14. REG. 6-11-1996.
- 1,980,205. RANDOMWRAP. INT. CL. 7. REG. 6-11-1996.
- 1,980,210. K-SPIN. INT. CL. 8. REG. 6-11-1996.
- 1,980,213. GARNET. INT. CL. 6. REG. 6-11-1996.
- 1,980,219. TITLETOLS. INT. CL. 9. REG. 6-11-1996.
- 1,980,221. SOFWEAWE. INT. CL. 24. REG. 6-11-1996.
- 1,980,232. BUMP-N-GLIDE. INT. CL. 28. REG. 6-11-1996.
- 1,980,240. WIRE WHIMSY. INT. CL. 26. REG. 6-11-1996.
- 1,980,242. MAXUM BY VACUFLO (STYLIZED). INT. CL. 9. REG. 6-11-1996.
- 1,980,243. SUPER MODELS. INT. CL. 28. REG. 6-11-1996.
- 1,980,255. DAPPLES. INT. CL. 28. REG. 6-11-1996.
- 1,980,257. FORTE (STYLIZED). INT. CL. 18. REG. 6-11-1996.
- 1,980,260. VITANOVA. INT. CL. 25. REG. 6-11-1996.
- 1,980,265. PULL-MAN. INT. CL. 8. REG. 6-11-1996.
- 1,980,268. STORMPROOF. INT. CL. 25. REG. 6-11-1996.
- 1,980,269. BUTTON UP THINGS. INT. CL. 25. REG. 6-11-1996.
- 1,980,276. SILHOUETTE. INT. CL. 8. REG. 6-11-1996.
- 1,980,286. SIMPLE PLEASURES. INT. CL. 26. REG. 6-11-1996.
- 1,980,287. TODAY'S ASAP. INT. CL. 35. REG. 6-11-1996.
- 1,990,856. GO CRAZY INC. INT. CL. 28 ONLY. REG. 8-6-1996.
- 2,031,482. STANDING OVATION. INT. CL. 35 ONLY. REG. 1-21-1997.
- 2,034,772. AISE. INT. CL. 35 ONLY. REG. 2-4-1997.
- 2,039,709. CHRIST. INT. CL. 1 ONLY. REG. 2-25-1997.
- 2,077,088. MADHOUSE MUNCHIES. INT. CL. 30 ONLY. REG. 7-8-1997.
- 2,102,627. N A W DREF AND DESIGN. INT. CL. 41 ONLY. REG. 10-7-1997.
- 2,183,225. LOCAL BRAND. INT. CL. 25. REG. 8-25-1998.
- 2,276,839. HOT DE-ICER. INT. CL. 22. REG. 9-7-1999.
- 2,301,217. PERFORM. INT. CL. 9 ONLY. REG. 12-21-1999.
- 2,354,150. WEIDMANN. INT. CLS. 10, 11 AND 20 ONLY. REG. 5-30-2000.
- 2,356,302. STUDIOHUMMEL A CELEBRATION OF LIFE. INT. CLS. 20 AND 28 ONLY. REG. 6-6-2000.
- 2,356,414. SCHMALBACH-LUBECA AND DESIGN. INT. CLS. 4, 6, 7, 8, 11, 16, 20, 21 AND 28. REG. 6-13-2000.
- 2,356,417. BAGEL & BAGEL. INT. CL. 42. REG. 6-13-2000.
- 2,356,418. DIAL & SAVE AND DESIGN. INT. CL. 38. REG. 6-13-2000.
- 2,356,419. BIOGREEN. INT. CL. 11. REG. 6-13-2000.
- 2,356,420. BRYTAR. INT. CL. 5. REG. 6-13-2000.
- 2,356,428. A AND DESIGN. INT. CL. 39. REG. 6-13-2000.
- 2,356,429. UGOGIRL (STYLIZED). INT. CL. 25. REG. 6-13-2000.
- 2,356,431. RAI'S (STYLIZED). INT. CL. 10. REG. 6-13-2000.
- 2,356,432. EDDYCAT. INT. CL. 16. REG. 6-13-2000.
- 2,356,433. CERTIFIED (STYLIZED). INT. CL. 9. REG. 6-13-2000.
- 2,356,435. M MECCANO AND DESIGN. INT. CL. 28. REG. 6-13-2000.
- 2,356,436. TILT-BODY. INT. CL. 12. REG. 6-13-2000.
- 2,356,437. ALL-AMERICAN SPORTS POSTERS. INT. CL. 16. REG. 6-13-2000.
- 2,356,439. PEPPER PLUS. INT. CL. 30. REG. 6-13-2000.
- 2,356,440. JEAN COLONNA. INT. CL. 9. REG. 6-13-2000.
- 2,356,443. 1 2 3 KIDS. INT. CL. 25. REG. 6-13-2000.
- 2,356,446. OBJECTQ (STYLIZED). INT. CL. 9. REG. 6-13-2000.
- 2,356,448. WIND STAR. INT. CL. 31. REG. 6-13-2000.
- 2,356,449. SS SURE SIGN AND DESIGN. INT. CL. 9. REG. 6-13-2000.
- 2,356,450. THE BEACON GROUP III - FOCUS VALUE FUND. INT. CL. 36. REG. 6-13-2000.
- 2,356,451. PERNIGOTTI AND DESIGN. INT. CL. 30. REG. 6-13-2000.
- 2,356,452. PPI AND DESIGN. INT. CL. 35. REG. 6-13-2000.
- 2,356,457. LANDIS & STAEFA ADVANTAGE AND DESIGN. INT. CLS. 35, 36, 37, 41 AND 42. REG. 6-13-2000.
- 2,356,460. TAX USA AND DESIGN. INT. CL. 42. REG. 6-13-2000.
- 2,356,462. HEALTH PLAN (STYLIZED). INT. CLS. 9, 16 AND 42. REG. 6-13-2000.
- 2,356,464. G'RILLA DOG. INT. CL. 30. REG. 6-13-2000.
- 2,356,465. THE BUSINESS OF OPPORTUNITIES. INT. CLS. 16, 36 AND 42. REG. 6-13-2000.
- 2,356,467. LIVING CONSCIOUSLY (STYLIZED). INT. CLS. 16 AND 41. REG. 6-13-2000.
- 2,356,468. COLLEGE BY CASSETTE. INT. CL. 41. REG. 6-13-2000.
- 2,356,469. RESEARCHWEB. INT. CL. 35. REG. 6-13-2000.
- 2,356,470. RESEARCHWEB AND DESIGN. INT. CL. 35. REG. 6-13-2000.
- 2,356,471. DANCE ZONE. INT. CL. 9. REG. 6-13-2000.
- 2,356,472. IMAGINE FOODS. INT. CLS. 29 AND 30. REG. 6-13-2000.
- 2,356,476. NPC. INT. CL. 9. REG. 6-13-2000.
- 2,356,478. BOTTLED AT THE SOURCE MAUNA LOA VOLCANO HAWAIIAN SPRINGS NATURAL ARTESIAN WATER AND DESIGN. INT. CL. 32. REG. 6-13-2000.
- 2,356,479. GAIANET. INT. CL. 42. REG. 6-13-2000.
- 2,356,480. ASTRA. INT. CLS. 1 AND 31. REG. 6-13-2000.
- 2,356,482. AR AMERICAN RESIDENTIAL INVESTMENT TRUST AND DESIGN. INT. CL. 36. REG. 6-13-2000.
- 2,356,483. OUR GROWING INSTITUTES OF EXCELLENCE AND DESIGN. INT. CL. 42. REG. 6-13-2000.
- 2,356,485. POWER WAVE-SEAL AND DESIGN. INT. CL. 40. REG. 6-13-2000.
- 2,356,487. GREAT LAKES SCIENCE CENTER AND DESIGN. INT. CL. 20. REG. 6-13-2000.
- 2,356,488. GENESIS SERIES AND DESIGN. INT. CL. 31. REG. 6-13-2000.
- 2,356,490. CHAMFER BEAD AND DESIGN. INT. CL. 19. REG. 6-13-2000.
- 2,356,492. INTERADNET. INT. CLS. 35 AND 42. REG. 6-13-2000.

- 2,356,493. MISCELLANEOUS DESIGN. INT. CLS. 41 AND 42. REG. 6-13-2000.
- 2,356,494. COMFORT THAT NEVER QUILTS (STYLIZED). INT. CL. 25. REG. 6-13-2000.
- 2,356,497. MISCELLANEOUS DESIGN. INT. CL. 3. REG. 6-13-2000.
- 2,356,501. ETA. INT. CL. 9. REG. 6-13-2000.
- 2,356,502. MINNESOTA WESTERN. INT. CL. 42. REG. 6-13-2000.
- 2,356,503. DP&L'S RELIABILITY PLUS. INT. CL. 39. REG. 6-13-2000.
- 2,356,504. TUFENKIAN. INT. CL. 35. REG. 6-13-2000.
- 2,356,506. TCM TIME-CAPITAL MANAGEMENT. INT. CL. 41. REG. 6-13-2000.
- 2,356,507. WHAT YOU WANT FROM THE WEB. INT. CL. 35. REG. 6-13-2000.
- 2,356,508. COSTWORKS AND DESIGN. INT. CL. 9. REG. 6-13-2000.
- 2,356,509. PHAT WRAPS AND DESIGN. INT. CL. 42. REG. 6-13-2000.
- 2,356,510. DCOS-2000. INT. CL. 9. REG. 6-13-2000.
- 2,356,514. M ET P HEALTHY AGEING OF MALE AND DESIGN. INT. CL. 5. REG. 6-13-2000.
- 2,356,517. SBA GAP TEAM. INT. CL. 36. REG. 6-13-2000.
- 2,356,518. E\*GAME. INT. CL. 36. REG. 6-13-2000.
- 2,356,522. H B HENRIOT. INT. CL. 21. REG. 6-13-2000.
- 2,356,523. FLICK DERBY. INT. CL. 28. REG. 6-13-2000.
- 2,356,525. WECO FEUERWERK AND DESIGN. INT. CL. 13. REG. 6-13-2000.
- 2,356,526. MISCELLANEOUS DESIGN. INT. CL. 28. REG. 6-13-2000.
- 2,356,531. PLAYLAND RECORDS AND DESIGN. INT. CL. 7. REG. 6-13-2000.
- 2,356,535. JAMES MORTON AND DESIGN. INT. CL. 42. REG. 6-13-2000.
- 2,356,536. F FREEPHONE AND DESIGN. INT. CLS. 9, 35 AND 38. REG. 6-13-2000.
- 2,356,537. AZ COM AND DESIGN. INT. CL. 38. REG. 6-13-2000.
- 2,356,539. GOLDEN WAVES AND DESIGN. INT. CL. 41. REG. 6-13-2000.
- 2,356,540. S & M BICYCLES MADE IN U.S.A. AND DESIGN. INT. CL. 12. REG. 6-13-2000.
- 2,356,542. SMARTFAX. INT. CL. 38. REG. 6-13-2000.
- 2,356,543. CROSLLEY. INT. CL. 9. REG. 6-13-2000.
- 2,356,544. MISCELLANEOUS DESIGN. INT. CLS. 37 AND 42. REG. 6-13-2000.
- 2,356,545. TRINETICS T AND DESIGN. INT. CL. 9. REG. 6-13-2000.
- 2,356,546. MISCELLANEOUS DESIGN. INT. CLS. 9, 38 AND 42. REG. 6-13-2000.
- 2,356,552. THE CELEBRATION HYMNAL. INT. CL. 9. REG. 6-13-2000.
- 2,356,557. WOMENCOMPUTE.COM. INT. CL. 16. REG. 6-13-2000.
- 2,356,562. MISCELLANEOUS DESIGN. INT. CL. 9. REG. 6-13-2000.
- 2,356,563. WCS WILDLIFE CONSERVATION SOCIETY AND DESIGN. INT. CL. 16. REG. 6-13-2000.
- 2,356,564. REALPORT. INT. CL. 9. REG. 6-13-2000.
- 2,356,565. ARGUS OPHTHALMOLOGY'S WORLD NEWS. INT. CL. 16. REG. 6-13-2000.
- 2,356,568. PULSE DIRECT. INT. CL. 35. REG. 6-13-2000.
- 2,356,573. CUSTOM DINING SERVICES AND DESIGN. INT. CL. 42. REG. 6-13-2000.
- 2,356,578. EASYJECT. INT. CL. 10. REG. 6-13-2000.
- 2,356,581. 2 AND DESIGN. INT. CL. 38. REG. 6-13-2000.
- 2,356,589. CRISTAL ET BRONZE. INT. CLS. 11 AND 21. REG. 6-13-2000.
- 2,356,590. JUJU. INT. CL. 18. REG. 6-13-2000.
- 2,356,591. X-TREME. INT. CL. 5. REG. 6-13-2000.
- 2,356,592. COLOR ME COTTON. INT. CL. 35. REG. 6-13-2000.
- 2,356,594. MIGRAWAY. INT. CL. 5. REG. 6-13-2000.
- 2,356,595. EACH ONE REACH ONE. INT. CLS. 16, 25 AND 42. REG. 6-13-2000.
- 2,356,596. STOMP, INC.. INT. CLS. 9 AND 16. REG. 6-13-2000.
- 2,356,598. SPACE BOARD. INT. CL. 19. REG. 6-13-2000.
- 2,356,601. NACIMIENTO. INT. CLS. 9 AND 42. REG. 6-13-2000.
- 2,356,603. DIGITAL ALCHEMY. INT. CL. 35. REG. 6-13-2000.
- 2,356,604. WATCH IT FOR YOUR HEALTH. INT. CLS. 38, 41 AND 42. REG. 6-13-2000.
- 2,356,605. AMAZING BREAST ENHANCER. INT. CL. 10. REG. 6-13-2000.
- 2,356,609. ECE AND DESIGN. INT. CL. 9. REG. 6-13-2000.
- 2,356,610. ACUVOICE. INT. CL. 9. REG. 6-13-2000.
- 2,356,611. MISCELLANEOUS DESIGN. INT. CL. 14. REG. 6-13-2000.
- 2,356,612. BIOX. INT. CL. 40. REG. 6-13-2000.
- 2,356,613. AMERICAN TOWN MAILER. INT. CL. 35. REG. 6-13-2000.
- 2,356,615. VILLAGE TROLLEY CO.. INT. CL. 28. REG. 6-13-2000.
- 2,356,618. REUSABLE LEMAITRE VALVULOTOME. INT. CL. 10. REG. 6-13-2000.
- 2,356,620. UNI-WEST (STYLIZED). INT. CLS. 3 AND 35. REG. 6-13-2000.
- 2,356,626. ECONWEB. INT. CL. 41. REG. 6-13-2000.
- 2,356,627. SNOW ROOF SYSTEMS BASEMENT SEALER. INT. CL. 17. REG. 6-13-2000.
- 2,356,628. KUBA. INT. CL. 9. REG. 6-13-2000.
- 2,356,629. HAVE A BALL WITH ANTENNA TOYS ...POP ONE ON TOP! AND DESIGN. INT. CL. 28. REG. 6-13-2000.
- 2,356,631. AMERICAN WEST WINDMILL. INT. CL. 7. REG. 6-13-2000.
- 2,356,632. DATA TRANSIT INTERNATIONAL AND DESIGN. INT. CL. 42. REG. 6-13-2000.
- 2,356,634. TRI CITRUS. INT. CL. 31. REG. 6-13-2000.
- 2,356,636. TRI-GOLD. INT. CL. 31. REG. 6-13-2000.
- 2,356,637. STARMANAGER. INT. CL. 9. REG. 6-13-2000.
- 2,356,638. BRANDTRAQ. INT. CL. 9. REG. 6-13-2000.
- 2,356,644. MISCELLANEOUS DESIGN. INT. CL. 25. REG. 6-13-2000.
- 2,356,645. MISCELLANEOUS DESIGN. INT. CL. 41. REG. 6-13-2000.
- 2,356,646. CONVERGE WHERE EDUCATION & TECHNOLOGY MEET (STYLIZED). INT. CL. 35. REG. 6-13-2000.
- 2,356,647. CONTROL GURU. INT. CL. 9. REG. 6-13-2000.
- 2,356,650. GENERALI GROUP GENERALI GLOBAL AND DESIGN. INT. CL. 36. REG. 6-13-2000.
- 2,356,652. COMFORTGRIP. INT. CL. 10. REG. 6-13-2000.
- 2,356,655. THE CHERRY CORNER AND DESIGN. INT. CL. 42. REG. 6-13-2000.
- 2,356,656. POINTSOURCE. INT. CL. 36. REG. 6-13-2000.
- 2,356,659. GOTYPE!. INT. CL. 9. REG. 6-13-2000.
- 2,356,660. JSAFE. INT. CL. 9. REG. 6-13-2000.
- 2,356,661. FORMULA VG. INT. CL. 7. REG. 6-13-2000.
- 2,356,662. THE THERESA FOUNDATION. INT. CL. 16. REG. 6-13-2000.
- 2,356,665. OIADB AND DESIGN. INT. CLS. 35 AND 40. REG. 6-13-2000.
- 2,356,666. JOHN BARTLETT. INT. CL. 25. REG. 6-13-2000.
- 2,356,667. QUIDDITY. INT. CL. 9. REG. 6-13-2000.
- 2,356,670. AGCO ALLIS. INT. CL. 12. REG. 6-13-2000.
- 2,356,671. WINTAX 2000. INT. CLS. 9 AND 16. REG. 6-13-2000.
- 2,356,675. MISCELLANEOUS DESIGN. INT. CL. 21. REG. 6-13-2000.
- 2,356,677. GRANDE HARVEST WINES WINE & SPIRITS MERCHANTS AND DESIGN. INT. CL. 35. REG. 6-13-2000.
- 2,356,686. CAPITAL NET. INT. CL. 36. REG. 6-13-2000.
- 2,356,688. THE BRIGHTEST STAR IN WOMEN'S FICTION. INT. CL. 16. REG. 6-13-2000.
- 2,356,689. ESTETX AND DESIGN. INT. CL. 5. REG. 6-13-2000.
- 2,356,694. AMERICAN WILDERNESS EXPERIENCE. INT. CL. 39. REG. 6-13-2000.
- 2,356,702. CHILDREN UPFRONT. INT. CLS. 35, 41 AND 42. REG. 6-13-2000.

- 2,356,707. IRONMAN TRIATHLON. INT. CLS. 12, 18 AND 21. REG. 6-13-2000.
- 2,356,708. DIGIBID.COM. INT. CL. 35. REG. 6-13-2000.
- 2,356,710. OLD HOUSE FAIR. INT. CL. 35. REG. 6-13-2000.
- 2,356,711. MAGIES. INT. CL. 14. REG. 6-13-2000.
- 2,356,712. MFS HERITAGE RESOURCE NETWORK AND DESIGN. INT. CLS. 36 AND 42. REG. 6-13-2000.
- 2,356,714. CHRISTMAS CRAFTS COUNTDOWN. INT. CL. 16. REG. 6-13-2000.
- 2,356,715. POTOMAC YARD. INT. CL. 36. REG. 6-13-2000.
- 2,356,717. U.S. REPROGRAPHICS AND DESIGN. INT. CL. 35. REG. 6-13-2000.
- 2,356,721. ROAD SHOW. INT. CL. 9. REG. 6-13-2000.
- 2,356,722. DIAZINON WATER BASED AND DESIGN. INT. CL. 5. REG. 6-13-2000.
- 2,356,723. MOVING THE COMPUTER INDUSTRY TO THE WEB. INT. CL. 35. REG. 6-13-2000.
- 2,356,724. CARECLAIM (STYLIZED). INT. CL. 36. REG. 6-13-2000.
- 2,356,726. CUAU AND DESIGN. INT. CL. 42. REG. 6-13-2000.
- 2,356,728. ALARM-PRO AND DESIGN. INT. CLS. 37 AND 42. REG. 6-13-2000.
- 2,356,730. GREEN MACHINE. INT. CL. 7. REG. 6-13-2000.
- 2,356,731. SAFEMPS. INT. CL. 35. REG. 6-13-2000.
- 2,356,732. SAFE. INT. CL. 35. REG. 6-13-2000.
- 2,356,733. THE PINE CONE TRAPPER. INT. CL. 8. REG. 6-13-2000.
- 2,356,737. MOTORCARE. INT. CLS. 35 AND 42. REG. 6-13-2000.
- 2,356,739. LONGWAY. INT. CL. 7. REG. 6-13-2000.
- 2,356,740. O ISOKERN (STYLIZED). INT. CLS. 6, 11 AND 19. REG. 6-13-2000.
- 2,356,741. CREATE A KEEPSAKE. INT. CL. 16. REG. 6-13-2000.
- 2,356,742. SABERPRO. INT. CL. 9. REG. 6-13-2000.
- 2,356,747. ISPF AND DESIGN. INT. CL. 35. REG. 6-13-2000.
- 2,356,748. DIGIDELCA. INT. CL. 10. REG. 6-13-2000.
- 2,356,750. INCENTPOWER AND DESIGN. INT. CL. 9. REG. 6-13-2000.
- 2,356,751. GAS 'N' SPLASH. INT. CL. 37. REG. 6-13-2000.
- 2,356,754. INFORM DESIGN. INT. CLS. 12 AND 42. REG. 6-13-2000.
- 2,356,756. CUBANO A MANO AND DESIGN. INT. CL. 34. REG. 6-13-2000.
- 2,356,757. NB AND DESIGN. INT. CL. 14. REG. 6-13-2000.
- 2,356,758. SOCKET AND DESIGN. INT. CL. 35. REG. 6-13-2000.
- 2,356,759. ULTRAPRISE. INT. CL. 9. REG. 6-13-2000.
- 2,356,760. AUTO-911. INT. CLS. 37 AND 39. REG. 6-13-2000.
- 2,356,761. GROUNDWORKS AND DESIGN. INT. CL. 39. REG. 6-13-2000.
- 2,356,762. MISCELLANEOUS DESIGN. INT. CL. 39. REG. 6-13-2000.
- 2,356,768. WORLDNETDAILY.COM. INT. CL. 42. REG. 6-13-2000.
- 2,356,770. POWERED BY. INT. CL. 42. REG. 6-13-2000.
- 2,356,774. MUNEX. INT. CLS. 39 AND 42. REG. 6-13-2000.
- 2,356,776. VERVE. INT. CL. 41. REG. 6-13-2000.
- 2,356,778. TURNING YOUR PROSPECTS INTO SALES. INT. CLS. 35 AND 39. REG. 6-13-2000.
- 2,356,781. ALAZ AND DESIGN. INT. CL. 41. REG. 6-13-2000.
- 2,356,784. CALLMI. INT. CL. 9. REG. 6-13-2000.
- 2,356,786. AMERICA'S MUSIC MACHINES. INT. CL. 9. REG. 6-13-2000.
- 2,356,789. OREGA. INT. CL. 9. REG. 6-13-2000.
- 2,356,791. ENCASE. INT. CLS. 9 AND 41. REG. 6-13-2000.
- 2,356,792. JEANE B.. INT. CL. 42. REG. 6-13-2000.
- 2,356,794. ANIMAL RECORDS LIMITED. INT. CL. 41. REG. 6-13-2000.
- 2,356,795. TRENDMASTER. INT. CL. 35. REG. 6-13-2000.
- 2,356,803. JUST IN TIME PARIS AND DESIGN. INT. CL. 3. REG. 6-13-2000.
- 2,356,804. RECOVROIL. INT. CLS. 1, 40 AND 42. REG. 6-13-2000.
- 2,356,805. D AND DESIGN. INT. CL. 42. REG. 6-13-2000.
- 2,356,807. COMPRAC. INT. CLS. 6 AND 7. REG. 6-13-2000.
- 2,356,808. STERLING DIRECT. INT. CL. 35. REG. 6-13-2000.
- 2,356,810. POWERPRINTER (STYLIZED). INT. CL. 9. REG. 6-13-2000.
- 2,356,814. PARTNERS IN MARKETING. INT. CL. 35. REG. 6-13-2000.
- 2,356,816. LA DE DAH!!!. INT. CL. 14. REG. 6-13-2000.
- 2,356,819. MISCELLANEOUS DESIGN. INT. CL. 9. REG. 6-13-2000.
- 2,356,820. I / O INTELLIOBJECTS AND DESIGN. INT. CL. 42. REG. 6-13-2000.
- 2,356,824. Q LOGISTIC SOLUTIONS. INT. CL. 39. REG. 6-13-2000.
- 2,356,828. WELL MANAGER AND DESIGN. INT. CL. 11. REG. 6-13-2000.
- 2,356,829. DEFENSE IN DEPTH. INT. CL. 9. REG. 6-13-2000.
- 2,356,831. R.E.A.P.. INT. CLS. 9 AND 35. REG. 6-13-2000.
- 2,356,833. ZRIKE. INT. CL. 21. REG. 6-13-2000.
- 2,356,836. ZRIKE. INT. CL. 8. REG. 6-13-2000.
- 2,356,837. 3SP THE MIRACLE FABRIC. INT. CL. 25. REG. 6-13-2000.
- 2,356,842. I AM NUTS ABOUT. INT. CL. 25. REG. 6-13-2000.
- 2,356,844. MEDELEC. INT. CLS. 9 AND 10. REG. 6-13-2000.
- 2,356,845. SEXXXDRIVE. INT. CL. 41. REG. 6-13-2000.
- 2,356,850. BRUSKE RESULTS AND DESIGN. INT. CL. 3. REG. 6-13-2000.
- 2,356,852. CORD COLLAR. INT. CL. 20. REG. 6-13-2000.
- 2,356,853. YAZI. INT. CL. 41. REG. 6-13-2000.
- 2,356,855. TRIPPOWER. INT. CL. 9. REG. 6-13-2000.
- 2,356,857. AMERICAN WATER SYSTEM. INT. CL. 42. REG. 6-13-2000.
- 2,356,858. PLANET EARTH AND DESIGN. INT. CL. 35. REG. 6-13-2000.
- 2,356,860. WINE UNIVERSE. INT. CLS. 36 AND 42. REG. 6-13-2000.
- 2,356,862. THERMOFLUID AND DESIGN. INT. CL. 11. REG. 6-13-2000.
- 2,356,864. ART DISCOVERY. INT. CL. 42. REG. 6-13-2000.
- 2,356,867. AMI AND DESIGN. INT. CL. 20. REG. 6-13-2000.
- 2,356,869. SJ BERWIN & CO. AND DESIGN. INT. CL. 42. REG. 6-13-2000.
- 2,356,872. TURBOPAC. INT. CL. 7. REG. 6-13-2000.
- 2,356,873. CATATONIC RECORDING CORP.. INT. CL. 9. REG. 6-13-2000.
- 2,356,878. STAN WINSTON STUDIO. INT. CL. 41. REG. 6-13-2000.
- 2,356,879. TRAZOM ENTERTAINMENT. INT. CLS. 9 AND 35. REG. 6-13-2000.
- 2,356,881. FAXCOURIER. INT. CL. 38. REG. 6-13-2000.
- 2,356,882. ALTRUA. INT. CLS. 9 AND 36. REG. 6-13-2000.
- 2,356,889. MINNEAPOLIS SPORTS MEDICINE CENTER. INT. CL. 42. REG. 6-13-2000.
- 2,356,892. MISCELLANEOUS DESIGN. INT. CL. 5. REG. 6-13-2000.
- 2,356,893. FOREVER SO REAL. INT. CL. 9. REG. 6-13-2000.
- 2,356,895. ARA MBA MEMBER BUYING ALLIANCE AND DESIGN. INT. CL. 35. REG. 6-13-2000.
- 2,356,897. GRAND MARNIER AND DESIGN. INT. CL. 33. REG. 6-13-2000.
- 2,356,899. COMPLETE BUSINESS SERVICES (STYLIZED). INT. CL. 35. REG. 6-13-2000.
- 2,356,901. OCI (STYLIZED). INT. CL. 25. REG. 6-13-2000.
- 2,356,902. FUTURITY SOLUTIONS. INT. CL. 9. REG. 6-13-2000.
- 2,356,903. MFX. INT. CL. 9. REG. 6-13-2000.
- 2,356,904. FLEXIRAD. INT. CL. 9. REG. 6-13-2000.
- 2,356,905. TOSA. INT. CL. 9. REG. 6-13-2000.
- 2,356,910. MISCELLANEOUS DESIGN. INT. CL. 25. REG. 6-13-2000.
- 2,356,911. INNER CIRCLE M & M'S AND DESIGN. INT. CL. 42. REG. 6-13-2000.
- 2,356,913. CSG CALL CENTER EXPRESS. INT. CLS. 35, 38 AND 42. REG. 6-13-2000.
- 2,356,914. SUNTEK. INT. CL. 3. REG. 6-13-2000.
- 2,356,916. NEWSVIEW (STYLIZED). INT. CL. 9. REG. 6-13-2000.
- 2,356,917. COUNTRY PUMPKIN SPICE. INT. CL. 30. REG. 6-13-2000.
- 2,356,920. COMANSA AND DESIGN. INT. CL. 7. REG. 6-13-2000.

- 2,356,922. KINKONET (STYLIZED). INT. CLS. 35, 38 AND 42. REG. 6-13-2000.
- 2,356,923. THE PRINT MACHINE. INT. CL. 42. REG. 6-13-2000.
- 2,356,924. THE LOCAL CONCIERGE - DESTINATION ORANGE COUNTY. INT. CL. 16. REG. 6-13-2000.
- 2,356,925. THE LOCAL CONCIERGE. INT. CL. 16. REG. 6-13-2000.
- 2,356,927. IPB SG3. INT. CL. 9. REG. 6-13-2000.
- 2,356,928. LIGUORI LIFESPAN AND DESIGN. INT. CL. 16. REG. 6-13-2000.
- 2,356,929. ONBROADBAND.COM. INT. CL. 42. REG. 6-13-2000.
- 2,356,930. NEOESPERANCE. INT. CL. 42. REG. 6-13-2000.
- 2,356,932. ADVENTURE EDITIONS. INT. CL. 39. REG. 6-13-2000.
- 2,356,938. A.C.E.R.I.S. Q.A. DIETARY SUPPLEMENTS QUALITY INGREDIENTS MANUFACTURING LABELING AND DESIGN. U.S. CL. A. REG. 6-13-2000.
- 2,356,939. THE MAGIC WINE TABLE AND DESIGN. INT. CL. 20. REG. 6-13-2000.
- 2,356,940. HEARTALKER. INT. CLS. 10 AND 28. REG. 6-13-2000.
- 2,356,941. LOUI MICHEL. INT. CL. 20. REG. 6-13-2000.
- 2,356,943. ASPIRING HEIGHTS. INT. CLS. 35 AND 41. REG. 6-13-2000.
- 2,356,944. RAG DOG. INT. CL. 25. REG. 6-13-2000.
- 2,356,945. RAG DOG AND DESIGN. INT. CL. 25. REG. 6-13-2000.
- 2,356,946. CONDUCENT. INT. CLS. 35 AND 38. REG. 6-13-2000.
- 2,356,947. CELEBRATING LIFE'S MOST CHERISHED MOMENTS. INT. CL. 16. REG. 6-13-2000.
- 2,356,951. MGEN. INT. CL. 42. REG. 6-13-2000.
- 2,356,952. N:MEDIA PREMIUMS AND DESIGN. INT. CLS. 9, 38 AND 42. REG. 6-13-2000.
- 2,356,953. BEST CHOICE. INT. CL. 36. REG. 6-13-2000.
- 2,356,955. CALCI-COOKIE. INT. CL. 30. REG. 6-13-2000.
- 2,356,956. 989 STUDIOS AND DESIGN. INT. CL. 9. REG. 6-13-2000.
- 2,356,957. VECTORLINK. INT. CL. 9. REG. 6-13-2000.
- 2,356,958. TOTAL RX. INT. CL. 9. REG. 6-13-2000.
- 2,356,959. ASPIRING HEIGHTS AND DESIGN. INT. CLS. 35 AND 41. REG. 6-13-2000.
- 2,356,961. MANUFACTURING CONNECTIVITY. INT. CL. 35. REG. 6-13-2000.
- 2,356,962. MISCELLANEOUS DESIGN. INT. CL. 36. REG. 6-13-2000.
- 2,356,964. THE KANSAS CITY CLUB AND DESIGN. INT. CL. 25. REG. 6-13-2000.
- 2,356,967. XCESS. INT. CL. 9. REG. 6-13-2000.
- 2,356,968. ALLTECH BIOSCIENCE. INT. CL. 35. REG. 6-13-2000.
- 2,356,970. LOVE@WORK AND DESIGN. INT. CL. 9. REG. 6-13-2000.
- 2,356,971. ANCESTORS AND DESIGN. INT. CL. 41. REG. 6-13-2000.
- 2,356,975. LITHOCOAL. INT. CL. 16. REG. 6-13-2000.
- 2,356,976. TOASTY T TOES AND DESIGN. INT. CL. 25. REG. 6-13-2000.
- 2,356,981. MISCELLANEOUS DESIGN. INT. CL. 42. REG. 6-13-2000.
- 2,356,982. TEKWARE. INT. CL. 35. REG. 6-13-2000.
- 2,356,984. LABELS NOW!. INT. CL. 9. REG. 6-13-2000.
- 2,356,985. ALLNET. INT. CL. 42. REG. 6-13-2000.
- 2,356,986. SEAMASTER. INT. CL. 9. REG. 6-13-2000.
- 2,356,991. ASCIA. INT. CLS. 9 AND 42. REG. 6-13-2000.
- 2,356,993. LABOR POWER AND DESIGN. INT. CL. 35. REG. 6-13-2000.
- 2,356,994. TRANZIT XPRESS. INT. CL. 9. REG. 6-13-2000.
- 2,356,998. MINIT AND DESIGN. INT. CLS. 1, 4, 6, 9, 14, 16, 20, 21, 25, 26, 35, 37, 40 AND 42. REG. 6-13-2000.
- 2,356,999. SCALLOP SEAELECTS. INT. CL. 29. REG. 6-13-2000.
- 2,357,002. MIDAMERICA COMPUTER CORP.. INT. CLS. 35 AND 36. REG. 6-13-2000.
- 2,357,004. FLORINA AND DESIGN. INT. CL. 32. REG. 6-13-2000.
- 2,357,005. GOT THE BIKE? GET THE GEAR! (STYLIZED). INT. CL. 25. REG. 6-13-2000.
- 2,357,008. KANE SECURITY ANALYST. INT. CL. 9. REG. 6-13-2000.
- 2,357,010. ABACUS CONTROLS, INC. AND DESIGN. INT. CL. 9. REG. 6-13-2000.
- 2,357,011. WA W/A SYSTEMS INC. AND DESIGN. INT. CLS. 7, 37, 40 AND 42. REG. 6-13-2000.
- 2,357,013. FSBO CENTRAL. INT. CL. 35. REG. 6-13-2000.
- 2,357,014. CARCAREMINDER. INT. CL. 39. REG. 6-13-2000.
- 2,357,017. ITT. INT. CL. 20. REG. 6-13-2000.
- 2,357,018. ITT. INT. CL. 9. REG. 6-13-2000.
- 2,357,019. MERRILL LYNCH ONLINE AND DESIGN. INT. CLS. 9 AND 36. REG. 6-13-2000.
- 2,357,020. TIMCO. INT. CL. 40. REG. 6-13-2000.
- 2,357,023. GOLDEN GEAR AND DESIGN. INT. CL. 7. REG. 6-13-2000.
- 2,357,024. ATPACT. INT. CL. 35. REG. 6-13-2000.
- 2,357,025. MISCELLANEOUS DESIGN. INT. CL. 36. REG. 6-13-2000.
- 2,357,026. ROCKET RESEARCH. INT. CL. 25. REG. 6-13-2000.
- 2,357,028. SIFONE. INT. CL. 3. REG. 6-13-2000.
- 2,357,029. TWINCO DELUX. INT. CL. 21. REG. 6-13-2000.
- 2,357,030. PERFECTLY SAFE FROM PRENATAL THROUGH PRESCHOOL. INT. CL. 35. REG. 6-13-2000.
- 2,357,031. EWANTED. INT. CL. 35. REG. 6-13-2000.
- 2,357,032. TOTAL RX AND DESIGN. INT. CL. 9. REG. 6-13-2000.
- 2,357,033. MORTGAGE RATE MONITOR. INT. CL. 16. REG. 6-13-2000.
- 2,357,038. ETERNITY DE SALONI (STYLIZED). INT. CLS. 19 AND 27. REG. 6-13-2000.
- 2,357,040. TISSUES 'N TLC. INT. CLS. 16 AND 42. REG. 6-13-2000.
- 2,357,044. PRO-TECH BUSINESS SOLUTIONS. INT. CL. 42. REG. 6-13-2000.
- 2,357,046. DON AND SYLVIA SHAW. INT. CL. 42. REG. 6-13-2000.
- 2,357,047. MAILLE LES CAVIARS DE LEGUMES. INT. CL. 29. REG. 6-13-2000.
- 2,357,049. MEDI QUIK. INT. CL. 36. REG. 6-13-2000.
- 2,357,053. SUPERIOR INSTRUMENT CASES SAN FRANCISCO, CALIFORNIA AND DESIGN. INT. CL. 15. REG. 6-13-2000.
- 2,357,055. PPS AND DESIGN. INT. CL. 39. REG. 6-13-2000.
- 2,357,057. CORNETT (STYLIZED). INT. CL. 6. REG. 6-13-2000.
- 2,357,059. BAYLOR YOU (STYLIZED). INT. CLS. 25 AND 41. REG. 6-13-2000.
- 2,357,060. TEMPO DESIGN. INT. CL. 18. REG. 6-13-2000.
- 2,357,061. VASONA SYSTEMS, INC.. INT. CL. 9. REG. 6-13-2000.
- 2,357,062. PHYSIOME SCIENCES. INT. CL. 42. REG. 6-13-2000.
- 2,357,064. RCI. INT. CL. 9. REG. 6-13-2000.
- 2,357,065. SCRATCH TECHNOLOGIES. INT. CL. 9. REG. 6-13-2000.
- 2,357,069. MISCELLANEOUS DESIGN. INT. CL. 5. REG. 6-13-2000.
- 2,357,072. THE HOWARD GROUP, INC. (HGI). INT. CL. 35. REG. 6-13-2000.
- 2,357,073. 7M AND DESIGN. INT. CL. 25. REG. 6-13-2000.
- 2,357,075. SCRATCHTECH. INT. CL. 9. REG. 6-13-2000.
- 2,357,076. I'M SELLING IT MYSELF. INT. CL. 35. REG. 6-13-2000.
- 2,357,078. JUST POINT AND CLOSE. INT. CL. 36. REG. 6-13-2000.
- 2,357,079. OUR BUSINESS MAKES YOUR BUSINESS BETTER. INT. CLS. 35 AND 42. REG. 6-13-2000.
- 2,357,082. EXPERIENCE BASED TRAINING AND DESIGN. INT. CL. 41. REG. 6-13-2000.
- 2,357,083. MEMORY MUMS AND DESIGN. INT. CL. 31. REG. 6-13-2000.
- 2,357,085. ZOOMAIR. INT. CL. 9. REG. 6-13-2000.

- 2,357,086. MEETING RIVERS. INT. CL. 41. REG. 6-13-2000.  
 2,357,088. ZERO24-7. INT. CL. 41. REG. 6-13-2000.  
 2,357,089. ZERO24-7 WEB RADIO WWW.ZERO24-7.ORG AND DESIGN. INT. CL. 41. REG. 6-13-2000.  
 2,357,092. THE TOTAL SHOW AND DESIGN. INT. CLS. 37, 39, 40, 41 AND 42. REG. 6-13-2000.  
 2,357,093. NTH NTH DEGREE AND DESIGN. INT. CL. 41. REG. 6-13-2000.  
 2,357,094. ALL CARIBBEAN. INT. CL. 9. REG. 6-13-2000.  
 2,357,095. BEACH LOVERS AND DESIGN. INT. CL. 20. REG. 6-13-2000.  
 2,357,097. CAFFE DI SCUTARI. INT. CL. 30. REG. 6-13-2000.  
 2,357,100. STRATEQUEST (STYLIZED). INT. CL. 35. REG. 6-13-2000.  
 2,357,101. STUK INDUSTRIES AND DESIGN. INT. CL. 25. REG. 6-13-2000.  
 2,357,102. THE SHOWCATS. INT. CL. 41. REG. 6-13-2000.  
 2,357,103. FROG TOOL. INT. CL. 8. REG. 6-13-2000.  
 2,357,108. MISCELLANEOUS DESIGN. INT. CL. 35. REG. 6-13-2000.  
 2,357,109. CAMP HILL WAREHOUSE SALE. INT. CL. 35. REG. 6-13-2000.  
 2,357,110. RETIREMENT TRACKER. INT. CL. 36. REG. 6-13-2000.  
 2,357,113. PSSECURE. INT. CL. 9. REG. 6-13-2000.  
 2,357,114. PSDETECT. INT. CL. 9. REG. 6-13-2000.  
 2,357,115. PSAUDIT. INT. CL. 9. REG. 6-13-2000.  
 2,357,117. NALANDA. INT. CL. 41. REG. 6-13-2000.  
 2,357,118. AI AND DESIGN. INT. CL. 40. REG. 6-13-2000.  
 2,357,119. LEAGUEWEB. INT. CL. 41. REG. 6-13-2000.  
 2,357,120. ER ON CALL AND DESIGN. INT. CL. 42. REG. 6-13-2000.  
 2,357,121. ER ON CALL. INT. CL. 42. REG. 6-13-2000.  
 2,357,122. BASEBALL COMPUSCORE. INT. CL. 9. REG. 6-13-2000.  
 2,357,123. TRIPP@K ONLINE AND DESIGN. INT. CL. 35. REG. 6-13-2000.  
 2,357,125. THE RUSTY NAILS. INT. CLS. 9 AND 41. REG. 6-13-2000.  
 2,357,127. DON ALEJO. INT. CL. 33. REG. 6-13-2000.  
 2,357,129. AND CALL US, AND WE'LL MAKE YOUR CLIENT CALL YOU (STYLIZED). INT. CL. 42. REG. 6-13-2000.  
 2,357,132. LOTTOSTAKES. INT. CL. 41. REG. 6-13-2000.  
 2,357,135. DYNASTY ONLINE. INT. CLS. 38 AND 42. REG. 6-13-2000.  
 2,357,136. MA MEDICAL ALLIANCE, INC. AND DESIGN. INT. CLS. 35, 37, 41 AND 42. REG. 6-13-2000.  
 2,357,137. ANTIFLAME PROFESSIONAL CLOTHING BY PROF AND DESIGN. INT. CL. 9. REG. 6-13-2000.  
 2,357,139. THE MOST RADICAL THING A WOMAN CAN DO IS REST WHEN SHE IS TIRED!. INT. CL. 41. REG. 6-13-2000.  
 2,357,140. THE KINGWOOD GROUP. INT. CL. 35. REG. 6-13-2000.  
 2,357,141. THE KINGWOOD GROUP AND DESIGN. INT. CL. 35. REG. 6-13-2000.  
 2,357,142. EZ-CLAIM. INT. CL. 9. REG. 6-13-2000.  
 2,357,143. DUAL ACTION. INT. CL. 8. REG. 6-13-2000.  
 2,357,144. SANBIO. INT. CL. 42. REG. 6-13-2000.  
 2,357,145. CREATEOPTS. INT. CL. 42. REG. 6-13-2000.  
 2,357,146. FRISBEE. INT. CL. 9. REG. 6-13-2000.  
 2,357,148. FLORES SILVESTRES AND DESIGN. INT. CL. 31. REG. 6-13-2000.  
 2,357,149. INTERCHARTER. INT. CL. 39. REG. 6-13-2000.  
 2,357,151. FIBERON. INT. CL. 9. REG. 6-13-2000.  
 2,357,152. GALAXY FUNDS AND DESIGN. INT. CL. 36. REG. 6-13-2000.  
 2,357,153. NITELIGHT PLUS. INT. CL. 11. REG. 6-13-2000.  
 2,357,154. PRE-TOUCH. INT. CLS. 15 AND 28. REG. 6-13-2000.  
 2,357,157. SARAH ARIZONA. INT. CL. 25. REG. 6-13-2000.  
 2,357,161. BRACH'S BIG RIVER SUPER PREMIUM TRAIL MIX AND DESIGN. INT. CL. 29. REG. 6-13-2000.  
 2,357,162. BRACH'S BIG RIVER NUT AND BERRY TRAIL MIX AND DESIGN. INT. CL. 29. REG. 6-13-2000.  
 2,357,164. BRACH'S MASTER PRETZEL YOGURT COVERED PRETZEL TWISTS AND DESIGN. INT. CL. 30. REG. 6-13-2000.  
 2,357,165. MISCELLANEOUS DESIGN. INT. CL. 42. REG. 6-13-2000.  
 2,357,166. PPHA AND DESIGN. INT. CL. 42. REG. 6-13-2000.  
 2,357,167. VERIS. INT. CL. 9. REG. 6-13-2000.  
 2,357,170. PARTSTAR. INT. CL. 35. REG. 6-13-2000.  
 2,357,171. DRESDNER BANK LATEINAMERIKA AG AND DESIGN. INT. CL. 36. REG. 6-13-2000.  
 2,357,172. PRINT WIZARD AND DESIGN. INT. CL. 9. REG. 6-13-2000.  
 2,357,173. BROKER FIRST. INT. CL. 36. REG. 6-13-2000.  
 2,357,176. BENGAL TRADERS GOURMET COFFEES AND DESIGN. INT. CL. 30. REG. 6-13-2000.  
 2,357,178. AH WU AND DESIGN. INT. CL. 30. REG. 6-13-2000.  
 2,357,179. TMC THE MUSIC CARTEL AND DESIGN. INT. CL. 9. REG. 6-13-2000.  
 2,357,182. LOWCALL. INT. CL. 16. REG. 6-13-2000.  
 2,357,184. OBB AND DESIGN. INT. CL. 16. REG. 6-13-2000.  
 2,357,186. SALES DIRECTIONS. INT. CL. 35. REG. 6-13-2000.  
 2,357,190. CYBERSWORD. INT. CL. 38. REG. 6-13-2000.  
 2,357,191. MISCELLANEOUS DESIGN. INT. CL. 9. REG. 6-13-2000.  
 2,357,192. I-RING INTERNET (STYLIZED). INT. CL. 9. REG. 6-13-2000.  
 2,357,197. RJOBS.COM. INT. CL. 35. REG. 6-13-2000.  
 2,357,198. PRONTO. INT. CL. 9. REG. 6-13-2000.  
 2,357,199. HELEN HUTCHLEYS. INT. CL. 35. REG. 6-13-2000.  
 2,357,209. DOC'S CARRY-ALL. INT. CL. 18. REG. 6-13-2000.  
 2,357,210. AMS WEBACCESS. INT. CL. 36. REG. 6-13-2000.  
 2,357,213. CUSCATLAN. INT. CL. 31. REG. 6-13-2000.  
 2,357,214. TPI TECHNOLOGY PARTNERS INTERNATIONAL THE SOURCING CONSULTANTS (STYLIZED). INT. CL. 35. REG. 6-13-2000.  
 2,357,216. THE DIAMOND DIET. INT. CL. 41. REG. 6-13-2000.  
 2,357,219. SALSA GARDEN (STYLIZED). INT. CL. 42. REG. 6-13-2000.  
 2,357,220. SALSA GARDEN AND DESIGN. INT. CL. 42. REG. 6-13-2000.  
 2,357,221. SALSA GARDEN. INT. CL. 42. REG. 6-13-2000.  
 2,357,222. EZSURF.COM AND DESIGN. INT. CL. 35. REG. 6-13-2000.  
 2,357,228. CONTRACTOR SPRAY CLUB. INT. CL. 35. REG. 6-13-2000.  
 2,357,230. KUAN SHENG FOOD AND DESIGN. INT. CL. 30. REG. 6-13-2000.  
 2,357,231. FULL HOUSE SPORTS MARKETING. INT. CL. 35. REG. 6-13-2000.  
 2,357,233. PERFECT OMELETTE FILLING MIX AND DESIGN. INT. CLS. 29 AND 30. REG. 6-13-2000.  
 2,357,235. PARADISE. INT. CL. 9. REG. 6-13-2000.  
 2,357,238. COFFEE JAMBI CANDY AND DESIGN. INT. CL. 30. REG. 6-13-2000.  
 2,357,243. 115V/15A AMP SAVER ROD AND DESIGN. INT. CL. 6. REG. 6-13-2000.  
 2,357,244. AUTO STRIKE AND DESIGN. INT. CL. 6. REG. 6-13-2000.  
 2,357,245. HERE'S LOOKING AT YOU. INT. CLS. 9, 16 AND 41. REG. 6-13-2000.  
 2,357,248. THE ORIGINAL SAN FRANCISCO TOY-MAKERS AND DESIGN. INT. CL. 28. REG. 6-13-2000.  
 2,357,249. HOW 'BOUT A BALLOON. INT. CL. 35. REG. 6-13-2000.  
 2,357,252. EXTREME ACHIEVERS. INT. CLS. 35 AND 41. REG. 6-13-2000.  
 2,357,253. "IT'S REALLY ALL ABOUT PEOPLE...!". INT. CL. 35. REG. 6-13-2000.  
 2,357,256. MISCELLANEOUS DESIGN. INT. CLS. 41 AND 42. REG. 6-13-2000.



- 2,357,257. M MERCURYCARE AND DESIGN. INT. CL. 37. REG. 6-13-2000.
- 2,357,258. FIRECREEK AND DESIGN. INT. CL. 12. REG. 6-13-2000.
- 2,357,264. W G (STYLIZED). INT. CL. 21. REG. 6-13-2000.
- 2,357,265. MUD PUPPY. INT. CL. 12. REG. 6-13-2000.
- 2,357,269. WHO YA WIT RECORDS. INT. CL. 9. REG. 6-13-2000.
- 2,357,270. PET-TO-VET-TRANSPORT. INT. CL. 39. REG. 6-13-2000.
- 2,357,271. SIMPLY SIMON SIMPLY THE BEST SHOPPING THERE IS. INT. CL. 35. REG. 6-13-2000.
- 2,357,273. PARTNERSHIPS MAKE A WORLD OF DIFFERENCE. INT. CL. 42. REG. 6-13-2000.
- 2,357,274. M MULTIWAVE TECHNOLOGY AND DESIGN. INT. CL. 35. REG. 6-13-2000.
- 2,357,275. GENUINE RSA ENCRYPTION ENGINE. INT. CL. 9. REG. 6-13-2000.
- 2,357,276. W AND DESIGN. INT. CL. 42. REG. 6-13-2000.
- 2,357,277. WORLD WIDE WEB INSTITUTE AND DESIGN. INT. CLS. 41 AND 42. REG. 6-13-2000.
- 2,357,278. WATER GLO. INT. CL. 21. REG. 6-13-2000.
- 2,357,283. POWERFUL WEB SITES. START TO FINISH.. INT. CL. 42. REG. 6-13-2000.
- 2,357,288. INFLAMER. INT. CL. 12. REG. 6-13-2000.
- 2,357,290. THE CLEAR ALTERNATIVE A PAGE A DAY AND DESIGN. INT. CL. 16. REG. 6-13-2000.
- 2,357,291. FUDGE A LITTLE AND DESIGN. INT. CL. 30. REG. 6-13-2000.
- 2,357,294. WEB STUDIO. INT. CL. 9. REG. 6-13-2000.
- 2,357,296. MYDISCOUNTBROKER.COM. INT. CL. 36. REG. 6-13-2000.
- 2,357,301. ARTHUR LEE AND THE NEXT STEP. INT. CL. 41. REG. 6-13-2000.
- 2,357,302. COMMUNITY'S CC'S GOURMET COFFEE HOUSE AND DESIGN. INT. CL. 30. REG. 6-13-2000.
- 2,357,304. NEW ORLEANS CENTER FOR CREATIVE ARTS. INT. CL. 41. REG. 6-13-2000.
- 2,357,306. A GOLF & COUNTRY CLUB IBIS AND DESIGN. INT. CLS. 37 AND 42. REG. 6-13-2000.
- 2,357,313. LEGGGGGGIE AND DESIGN. INT. CL. 28. REG. 6-13-2000.
- 2,357,316. AMBIENT AND DESIGN. INT. CL. 42. REG. 6-13-2000.
- 2,357,318. ESSENT. INT. CL. 42. REG. 6-13-2000.
- 2,357,319. EMERGENCY SOLUTIONS. INT. CL. 1. REG. 6-13-2000.
- 2,357,321. E.H.C. COMMERCIAL SERVICES. INT. CLS. 37 AND 42. REG. 6-13-2000.
- 2,357,323. LONE WOLF AND CUB. INT. CL. 9. REG. 6-13-2000.
- 2,357,325. FIRSTSENSE AND DESIGN. INT. CL. 9. REG. 6-13-2000.
- 2,357,326. BLUEBIRD. INT. CL. 20. REG. 6-13-2000.
- 2,357,328. THIEF RIVER. INT. CLS. 16 AND 25. REG. 6-13-2000.
- 2,357,331. LORRAINE'S COASTAL CATERING AND DESIGN. INT. CL. 42. REG. 6-13-2000.
- 2,357,332. OUT TO LUNCH. INT. CL. 41. REG. 6-13-2000.
- 2,357,334. INSTALLING THE FUTURE. INT. CL. 37. REG. 6-13-2000.
- 2,357,336. VITAL. INT. CL. 7. REG. 6-13-2000.
- 2,357,338. GRONIMO AND DESIGN. INT. CL. 25. REG. 6-13-2000.
- 2,357,352. SO FAR. SO GOOD.. INT. CLS. 25 AND 32. REG. 6-13-2000.
- 2,357,356. A APPLIANCE (STYLIZED). INT. CL. 7. REG. 6-13-2000.
- 2,357,360. VERTEX COLLECTION. INT. CL. 20. REG. 6-13-2000.
- 2,357,361. ADVANCED KNOWLEDGE AND DESIGN. INT. CL. 35. REG. 6-13-2000.
- 2,357,362. MISCELLANEOUS DESIGN. INT. CL. 33. REG. 6-13-2000.
- 2,357,365. "STRIVE FOR 35". INT. CL. 41. REG. 6-13-2000.
- 2,357,367. ZERO PRODUCTIONS AND DESIGN. INT. CL. 42. REG. 6-13-2000.
- 2,357,368. THE FIGHTER ENTERPRISE AND DESIGN. INT. CL. 42. REG. 6-13-2000.
- 2,357,369. SNAPPYBEAR. INT. CL. 28. REG. 6-13-2000.
- 2,357,370. TURN 4 PIZZA. INT. CLS. 39 AND 42. REG. 6-13-2000.
- 2,357,372. EARTHGRO THE NATURAL CHOICE DECORATIVE HARDWOOD MULCH FOR WELL-GROOMED LANDSCAPES AND DESIGN. INT. CL. 31. REG. 6-13-2000.
- 2,357,373. EARTHGRO THE NATURAL CHOICE RICH, DARK TOP SOIL FOR LANDSCAPES AND GARDENS AND DESIGN. INT. CL. 31. REG. 6-13-2000.
- 2,357,374. NETPREP. INT. CL. 41. REG. 6-13-2000.
- 2,357,375. AROMAGICA AND DESIGN. INT. CL. 3. REG. 6-13-2000.
- 2,357,376. ENABLING IT PARTNERSHIPS. INT. CL. 42. REG. 6-13-2000.
- 2,357,377. QTRPAQ. INT. CL. 7. REG. 6-13-2000.
- 2,357,378. QTRCO. INT. CL. 7. REG. 6-13-2000.
- 2,357,380. SOFTWARESTREET.COM. INT. CL. 35. REG. 6-13-2000.
- 2,357,381. NEWSLINE EXPO. INT. CL. 35. REG. 6-13-2000.
- 2,357,382. MISCELLANEOUS DESIGN. INT. CL. 5. REG. 6-13-2000.
- 2,357,383. POP AND DESIGN. INT. CLS. 9 AND 20. REG. 6-13-2000.
- 2,357,384. TYMETRIX. INT. CL. 35. REG. 6-13-2000.
- 2,357,385. TODAY'S ANSWER TO AFFORDABLE LEGAL SERVICES. INT. CL. 42. REG. 6-13-2000.
- 2,357,386. BEJEANIE. INT. CL. 9. REG. 6-13-2000.
- 2,357,388. .COMERCIS (STYLIZED). INT. CL. 42. REG. 6-13-2000.
- 2,357,390. X-TREME CHALLENGE ADVENTURE RACING. INT. CL. 41. REG. 6-13-2000.
- 2,357,396. WE DELIVER RAIL SAVINGS BY THE TRUCKLOAD. INT. CL. 39. REG. 6-13-2000.
- 2,357,397. FOAMY FLOP AND DESIGN. INT. CL. 20. REG. 6-13-2000.
- 2,357,400. QUICK-FIT. INT. CL. 10. REG. 6-13-2000.
- 2,357,402. TECH2000. INT. CL. 41. REG. 6-13-2000.
- 2,357,404. MISCELLANEOUS DESIGN. INT. CL. 42. REG. 6-13-2000.
- 2,357,405. ADAPT-A-SOCKET. INT. CL. 9. REG. 6-13-2000.
- 2,357,412. SOUND OPTICAL. INT. CLS. 35 AND 42. REG. 6-13-2000.
- 2,357,415. COMPUTERS THAT FIT PEOPLE. INT. CL. 42. REG. 6-13-2000.
- 2,357,417. CHRISTMAS DUST. INT. CL. 28. REG. 6-13-2000.
- 2,357,418. AUTOBUYERS HELPER. INT. CL. 35. REG. 6-13-2000.
- 2,357,419. XCESS HOLLYWOOD. INT. CL. 41. REG. 6-13-2000.
- 2,357,420. GLOBALVISION. INT. CL. 41. REG. 6-13-2000.
- 2,357,421. A O A ER AND DESIGN. INT. CL. 42. REG. 6-13-2000.
- 2,357,424. BROADBANDNOW! AND DESIGN. INT. CL. 38. REG. 6-13-2000.
- 2,357,429. FRATERNAL ORDER OF BORDER AGENTS (STYLIZED). U.S. CL. 200. REG. 6-13-2000.
- 2,357,430. TOFFEE TEASE. INT. CL. 3. REG. 6-13-2000.
- 2,357,431. ORLANDO WILL NEVER BE THE SAME. INT. CL. 41. REG. 6-13-2000.
- 2,357,432. BEYOND LIBATIONS AND DESIGN. INT. CL. 42. REG. 6-13-2000.
- 2,357,435. AMBROTOSE SPORT. INT. CL. 5. REG. 6-13-2000.
- 2,357,437. VPNCARE. INT. CLS. 37 AND 42. REG. 6-13-2000.
- 2,357,438. AMERICANA MEDIA. INT. CL. 35. REG. 6-13-2000.
- 2,357,441. VIRTUADINE. INT. CL. 42. REG. 6-13-2000.
- 2,357,442. CONTROVERSY. INT. CL. 3. REG. 6-13-2000.
- 2,357,444. BROWNANDWILLIAMSON.COM. INT. CL. 42. REG. 6-13-2000.
- 2,357,445. DEMOCRACY OF ENTERTAINMENT. INT. CL. 35. REG. 6-13-2000.
- 2,357,449. PRECISE FELINE SENIOR FORMULA. INT. CL. 31. REG. 6-13-2000.

- 2,357,450. PRECISE FELINE SENIOR FORMULA FOR CATS 9 YEARS OR OLDER NEW FORMULA NATURAL CHICKEN FLAVOR AND DESIGN. INT. CL. 31. REG. 6-13-2000.
- 2,357,451. MITAMMI. INT. CL. 25. REG. 6-13-2000.
- 2,357,454. CMS. INT. CL. 9. REG. 6-13-2000.
- 2,357,455. CYCLONE MELTING SYSTEM. INT. CL. 9. REG. 6-13-2000.
- 2,357,457. MEIOT AND DESIGN. INT. CL. 4. REG. 6-13-2000.
- 2,357,458. NEWSROOM INFORMATION MODEL SOFTWARE - NIM. INT. CL. 9. REG. 6-13-2000.
- 2,357,461. LOCKWOOD & CARLISLE. INT. CL. 7. REG. 6-13-2000.
- 2,357,465. CLOYSES PARTNERS. INT. CL. 35. REG. 6-13-2000.
- 2,357,471. SURVEY INTELLIGENCE. INT. CL. 35. REG. 6-13-2000.
- 2,357,474. KILLER CROW RECORDS AND DESIGN. INT. CL. 9. REG. 6-13-2000.
- 2,357,477. FINANCE IQNET. INT. CL. 41. REG. 6-13-2000.
- 2,357,478. BUSINESS IQNET. INT. CL. 41. REG. 6-13-2000.
- 2,357,479. DANCING BEAR PARTNERS. INT. CL. 36. REG. 6-13-2000.
- 2,357,480. FOXHOUND FUND. INT. CL. 36. REG. 6-13-2000.
- 2,357,481. MARGARET JERROLD (STYLIZED). INT. CL. 25. REG. 6-13-2000.
- 2,357,482. RAPPAHANNOCK AND DESIGN. INT. CL. 31. REG. 6-13-2000.
- 2,357,489. IT'S NOT A PROMISE UNTIL YOU KEEP IT.. INT. CL. 36. REG. 6-13-2000.
- 2,357,492. GEMS SMS SYSTEMS MANAGEMENT SPECIALISTS AND DESIGN. INT. CL. 42. REG. 6-13-2000.
- 2,357,493. THE CYLINDER SOLUTION PEOPLE. INT. CL. 7. REG. 6-13-2000.
- 2,357,496. GARDEN BOBBER. INT. CLS. 24 AND 28. REG. 6-13-2000.
- 2,357,499. BALIAN'S OUTDOOR & NATURE PHOTOGRAPHY. INT. CL. 16. REG. 6-13-2000.
- 2,357,501. THE ORIGINAL SANDBAGS. INT. CL. 18. REG. 6-13-2000.
- 2,357,505. FIDO VITES. INT. CL. 5. REG. 6-13-2000.
- 2,357,508. POLYGARD. INT. CL. 1. REG. 6-13-2000.
- 2,357,509. SEDA SOLUTIONS. INT. CL. 9. REG. 6-13-2000.
- 2,357,510. FLEXPEECH. INT. CL. 9. REG. 6-13-2000.
- 2,357,513. B I C O AND DESIGN. INT. CLS. 7, 8 AND 21. REG. 6-13-2000.
- 2,357,514. HOLA AMIGO (STYLIZED). INT. CLS. 16 AND 38. REG. 6-13-2000.
- 2,357,516. RIVERGLEN TIGERS. INT. CL. 42. REG. 6-13-2000.
- 2,357,517. TRANSPCHAIR AND DESIGN. INT. CL. 12. REG. 6-13-2000.
- 2,357,522. THE WISDOM OF EXPERIENCE. INT. CL. 42. REG. 6-13-2000.
- 2,357,523. WHERE THE HEART OF HEALTHCARE BEATS. INT. CL. 42. REG. 6-13-2000.
- 2,357,526. HIRE-SAFE AND DESIGN. INT. CL. 42. REG. 6-13-2000.
- 2,357,527. VOICELOK. INT. CL. 9. REG. 6-13-2000.
- 2,357,530. ARTBAGS AND DESIGN. INT. CL. 16. REG. 6-13-2000.
- 2,357,533. UGARTE AND DESIGN. INT. CL. 34. REG. 6-13-2000.
- 2,357,535. USAA INVESTMENT ADVISORY SERVICES. INT. CL. 36. REG. 6-13-2000.
- 2,357,537. PREPAIDX.COM. INT. CL. 41. REG. 6-13-2000.
- 2,357,538. WE CARE FOR PEOPLE, NOT JUST EYES.. INT. CL. 42. REG. 6-13-2000.
- 2,357,539. EMOTIONAILS. INT. CL. 3. REG. 6-13-2000.
- 2,357,542. MYPOINTS.COM, INC.. INT. CL. 35. REG. 6-13-2000.
- 2,357,543. DEFENDERS OF THE FREE WORLD. INT. CLS. 35 AND 38. REG. 6-13-2000.
- 2,357,548. BIG H. INT. CL. 30. REG. 6-13-2000.
- 2,357,551. LITENNA. INT. CL. 9. REG. 6-13-2000.
- 2,357,552. HEAVENLYPASTA.COM. INT. CL. 30. REG. 6-13-2000.
- 2,357,553. HSINTEK. INT. CL. 9. REG. 6-13-2000.
- 2,357,554. SMALL BUSINESS STRATEGIES CONFERENCE AND DESIGN. INT. CL. 35. REG. 6-13-2000.
- 2,357,555. WHO'S FIRST. INT. CL. 28. REG. 6-13-2000.
- 2,357,556. INSUR-ENROLL. INT. CL. 36. REG. 6-13-2000.
- 2,357,557. INSUR-FLEX. INT. CL. 36. REG. 6-13-2000.
- 2,357,566. FASTWORLD LEADERSHIP AND DESIGN. INT. CL. 41. REG. 6-13-2000.
- 2,357,567. CYBERSITTER. INT. CL. 9. REG. 6-13-2000.
- 2,357,570. SUNCHASER. INT. CL. 11. REG. 6-13-2000.
- 2,357,574. PROJECT/2. INT. CL. 9. REG. 6-13-2000.
- 2,357,578. THE HUE-MAN EXPERIENCE. INT. CL. 35. REG. 6-13-2000.
- 2,357,579. 2S AND DESIGN. INT. CL. 9. REG. 6-13-2000.
- 2,357,580. MAKING OUR WORLD EASIER TO CONTROL. INT. CL. 42. REG. 6-13-2000.
- 2,357,582. TOPF TECHNIQUE. INT. CL. 41. REG. 6-13-2000.
- 2,357,583. DYNAMIC ANATOMY. INT. CL. 41. REG. 6-13-2000.
- 2,357,584. MAINFRAME FOR YOU. INT. CL. 25. REG. 6-13-2000.
- 2,357,585. MO MOCHI AND DESIGN. INT. CL. 16. REG. 6-13-2000.
- 2,357,586. STICKLET. INT. CL. 42. REG. 6-13-2000.
- 2,357,588. BUD LIGHT PARTY PASSPORT. INT. CL. 32. REG. 6-13-2000.
- 2,357,590. ART OF CARING. INT. CL. 36. REG. 6-13-2000.
- 2,357,591. CHOWBABY.COM AND DESIGN. INT. CL. 35. REG. 6-13-2000.
- 2,357,592. WHAT DO THESE 3 HAVE IN COMMON?. INT. CL. 9. REG. 6-13-2000.
- 2,357,593. LEASE AIR. INT. CL. 36. REG. 6-13-2000.
- 2,357,594. ABOVE & BEYOND. INT. CL. 36. REG. 6-13-2000.
- 2,357,597. A FINER NEIGHBORHOOD DINER. INT. CL. 42. REG. 6-13-2000.
- 2,357,600. MISCELLANEOUS DESIGN. INT. CL. 41. REG. 6-13-2000.
- 2,357,601. CREATING NEW PATHS. EXPANDING THE WORLD.. INT. CL. 41. REG. 6-13-2000.
- 2,357,603. MADISON. INT. CL. 9. REG. 6-13-2000.
- 2,357,604. AUSTIN. INT. CL. 9. REG. 6-13-2000.
- 2,357,605. CYBERLUNCH.COM AND DESIGN. INT. CL. 35. REG. 6-13-2000.
- 2,357,608. ASYMPTOTE. INT. CL. 42. REG. 6-13-2000.
- 2,357,609. "W-R-T 100". INT. CL. 1. REG. 6-13-2000.
- 2,357,610. WHITETAILE BUSINESS BUILDING YOUR BUSINESS WITH AMERICA'S # 1 GAME ANIMAL (STYLIZED). INT. CL. 16. REG. 6-13-2000.
- 2,357,611. SCHRODERS AND DESIGN. INT. CLS. 35 AND 36. REG. 6-13-2000.
- 2,357,624. ST. PADDY'S J. A. M. JUSTICE ARTS MUSIC 2000 AND DESIGN. INT. CL. 41. REG. 6-13-2000.
- 2,357,625. ARTISTS 4 IRELAND NEW YORK DUBLIN AND DESIGN. INT. CL. 41. REG. 6-13-2000.
- 2,357,626. THE UNION BAR. INT. CL. 42. REG. 6-13-2000.
- 2,357,627. PROSPECTOR CS. INT. CL. 9. REG. 6-13-2000.
- 2,357,628. FULL FLEX. INT. CL. 36. REG. 6-13-2000.
- 2,357,630. SOUTH REMESSA INSTANTANEA AND DESIGN. INT. CL. 36. REG. 6-13-2000.
- 2,357,631. SOUTH INSTANT MONEY TRANSFERS AND DESIGN. INT. CL. 36. REG. 6-13-2000.
- 2,357,632. LITTLE TIGER (STYLIZED). INT. CL. 41. REG. 6-13-2000.
- 2,357,637. PRODUCTFACTORY. INT. CL. 9. REG. 6-13-2000.
- 2,357,638. KIDALERT CAPSULE (STYLIZED). INT. CL. 20. REG. 6-13-2000.
- 2,357,642. POSTX EXPRESS. INT. CL. 9. REG. 6-13-2000.
- 2,357,643. JASON. INT. CL. 36. REG. 6-13-2000.
- 2,357,647. CAMBAR. INT. CL. 20. REG. 6-13-2000.
- 2,357,651. RED RETAIL ENVIRONMENT DESIGN AND DESIGN. INT. CLS. 37, 40 AND 42. REG. 6-13-2000.
- 2,357,655. UNION STATION AND DESIGN. INT. CL. 9. REG. 6-13-2000.
- 2,357,656. PATRICE COLLECTION. INT. CL. 35. REG. 6-13-2000.
- 2,357,657. DOXA. INT. CL. 41. REG. 6-13-2000.

- 2,357,658. ACCUCCELL BY MULLER-GERMANY (STYLIZED). INT. CL. 9. REG. 6-13-2000.
- 2,357,660. MAGNIFICA. INT. CL. 26. REG. 6-13-2000.
- 2,357,661. BOW WOW BELONGINGS AND DESIGN. INT. CL. 18. REG. 6-13-2000.
- 2,357,662. BOW WOW BELONGINGS. INT. CL. 18. REG. 6-13-2000.
- 2,357,664. SWAN'S E-Z SPIN. INT. CL. 28. REG. 6-13-2000.
- 2,357,667. CLEAN START. INT. CL. 36. REG. 6-13-2000.
- 2,357,669. CARDMATE. INT. CL. 16. REG. 6-13-2000.
- 2,357,670. MANGO FLAMBE (STYLIZED). INT. CL. 3. REG. 6-13-2000.
- 2,357,672. CLASSIC FLORALS. INT. CL. 3. REG. 6-13-2000.
- 2,357,673. LODGE OUTDOORS SINCE 1896 AND DESIGN. INT. CL. 21. REG. 6-13-2000.
- 2,357,675. PRINTMED/USA. INT. CL. 42. REG. 6-13-2000.
- 2,357,676. NARC. INT. CL. 16. REG. 6-13-2000.
- 2,357,678. FUNKY DIVA AND DESIGN. INT. CLS. 16 AND 18. REG. 6-13-2000.
- 2,357,679. SPORTABOUT. INT. CL. 12. REG. 6-13-2000.
- 2,357,680. REAL DEAL TRAVEL. INT. CL. 39. REG. 6-13-2000.
- 2,357,684. I STAND. INT. CL. 20. REG. 6-13-2000.
- 2,357,685. FUBAR. INT. CL. 28. REG. 6-13-2000.
- 2,357,686. HEALTH CARE PIPELINE NEWS AND DESIGN. INT. CL. 16. REG. 6-13-2000.
- 2,357,691. BABACOO. INT. CL. 25. REG. 6-13-2000.
- 2,357,695. DATACAT. INT. CL. 16. REG. 6-13-2000.
- 2,357,696. MAINFRAME FOR YOU. INT. CL. 35. REG. 6-13-2000.
- 2,357,698. FEATHERSTONE. INT. CL. 35. REG. 6-13-2000.
- 2,357,700. BUFFET BROTHERS. INT. CL. 41. REG. 6-13-2000.
- 2,357,701. READINESS TO COMPETE. INT. CL. 35. REG. 6-13-2000.
- 2,357,702. BASEIT. INT. CL. 42. REG. 6-13-2000.
- 2,357,706. ISLE OF MTV FANTASIES. INT. CL. 41. REG. 6-13-2000.
- 2,357,707. HOT ZONE. INT. CL. 41. REG. 6-13-2000.
- 2,357,708. 3DNA. INT. CLS. 1 AND 5. REG. 6-13-2000.
- 2,357,717. MISCELLANEOUS DESIGN. INT. CL. 30. REG. 6-13-2000.
- 2,357,719. RED SHEEP AND DESIGN. INT. CL. 29. REG. 6-13-2000.
- 2,357,722. J (STYLIZED). INT. CL. 25. REG. 6-13-2000.
- 2,357,723. WHERE HEALTHY HEARTS ARE BORN!. INT. CL. 41. REG. 6-13-2000.
- 2,357,724. ANGELS IN THE WOODLANDS. INT. CL. 36. REG. 6-13-2000.
- 2,357,727. BRAND PARENTING. INT. CL. 35. REG. 6-13-2000.
- 2,357,728. ANGELS IN THE PARK. INT. CL. 36. REG. 6-13-2000.
- 2,357,729. D (STYLIZED). INT. CLS. 9, 37 AND 42. REG. 6-13-2000.
- 2,357,730. LES CIGALES. INT. CL. 29. REG. 6-13-2000.
- 2,357,732. QUAKER TOASTED OATMEAL SQUARES. INT. CL. 30. REG. 6-13-2000.
- 2,357,733. TAKE CONTROL AND DESIGN. INT. CL. 29. REG. 6-13-2000.
- 2,357,736. WHERE SERVICE IS A SURE THING. INT. CL. 37. REG. 6-13-2000.
- 2,357,739. KRILL PLUS. INT. CL. 31. REG. 6-13-2000.
- 2,357,740. DOUBLE POPS. INT. CL. 12. REG. 6-13-2000.
- 2,357,743. WORLDSUBMIT. INT. CL. 35. REG. 6-13-2000.
- 2,357,745. SAFESEAL. INT. CL. 37. REG. 6-13-2000.
- 2,357,746. GLASSMOBILE. INT. CL. 37. REG. 6-13-2000.
- 2,357,747. BABY BELLIES. INT. CL. 24. REG. 6-13-2000.
- 2,357,749. SPIRULINA MAX. INT. CL. 31. REG. 6-13-2000.
- 2,357,753. 1-800-CUT BILLS. INT. CL. 36. REG. 6-13-2000.
- 2,357,754. DELLAND. INT. CL. 41. REG. 6-13-2000.
- 2,357,755. SURFACE PRO. INT. CL. 37. REG. 6-13-2000.
- 2,357,756. LAGAYLES. INT. CL. 30. REG. 6-13-2000.
- 2,357,758. WYLYX (STYLIZED). INT. CL. 38. REG. 6-13-2000.
- 2,357,759. MR. Z'S BEST AND DESIGN. INT. CL. 30. REG. 6-13-2000.
- 2,357,760. IMAGINE. INT. CL. 33. REG. 6-13-2000.
- 2,357,761. JCM AND DESIGN. INT. CL. 31. REG. 6-13-2000.
- 2,357,766. THE BAREFOOT BOYS. INT. CL. 41. REG. 6-13-2000.
- 2,357,767. FORMOST SELECT. INT. CL. 42. REG. 6-13-2000.
- 2,357,768. THE HARDEST WORKING SQUARE FEET IN TOWN AND DESIGN. INT. CL. 39. REG. 6-13-2000.
- 2,357,769. FORMOST. INT. CL. 42. REG. 6-13-2000.
- 2,357,770. FORMOST ONCALL. INT. CL. 42. REG. 6-13-2000.
- 2,357,771. RIO TEJAS NEW TEXAS CUISINE. INT. CL. 42. REG. 6-13-2000.
- 2,357,773. STATE OF DESIGN. INT. CL. 25. REG. 6-13-2000.
- 2,357,774. LUCERNE LABIDOU. INT. CL. 25. REG. 6-13-2000.
- 2,357,775. BECAUSE RISK MATTERS. INT. CL. 36. REG. 6-13-2000.
- 2,357,782. MONSTER CAKES. INT. CL. 30. REG. 6-13-2000.
- 2,357,783. PLAIDBERRY. INT. CL. 29. REG. 6-13-2000.
- 2,357,784. CANS. INT. CL. 42. REG. 6-13-2000.
- 2,357,785. NULLI'S. INT. CLS. 25 AND 42. REG. 6-13-2000.
- 2,357,788. MISCELLANEOUS DESIGN. INT. CL. 29. REG. 6-13-2000.
- 2,357,789. WHAT A STYLE. INT. CL. 42. REG. 6-13-2000.
- 2,357,793. BLENDENIM. INT. CL. 23. REG. 6-13-2000.
- 2,357,795. MISCELLANEOUS DESIGN. INT. CL. 20. REG. 6-13-2000.
- 2,357,797. MISCELLANEOUS DESIGN. INT. CL. 18. REG. 6-13-2000.
- 2,357,798. LISA JENKS. INT. CL. 18. REG. 6-13-2000.
- 2,357,801. JESUS 'N DA HOOD. INT. CL. 25. REG. 6-13-2000.
- 2,357,809. STORE FOR MORE. INT. CL. 35. REG. 6-13-2000.
- 2,357,811. ENZO CARISI. INT. CL. 25. REG. 6-13-2000.
- 2,357,813. MISCELLANEOUS DESIGN. INT. CLS. 14 AND 25. REG. 6-13-2000.
- 2,357,814. UP-TO-DATE BANKING. DOWN-TO-EARTH BANKERS.. INT. CL. 36. REG. 6-13-2000.
- 2,357,818. FREQUENT CALLER. INT. CL. 38. REG. 6-13-2000.
- 2,357,819. MCF. INT. CL. 7. REG. 6-13-2000.
- 2,357,820. COMPOVAC. INT. CLS. 7 AND 11. REG. 6-13-2000.
- 2,357,821. PARTNER PRODUCTS. INT. CL. 9. REG. 6-13-2000.
- 2,357,824. ZD.NET. INT. CLS. 35 AND 41. REG. 6-13-2000.
- 2,357,826. HEADCOACH. INT. CL. 28. REG. 6-13-2000.
- 2,357,829. SOFTDIE. INT. CLS. 16 AND 40. REG. 6-13-2000.
- 2,357,832. AQUADVANTAGE. INT. CL. 29. REG. 6-13-2000.
- 2,357,833. FALCO AND DESIGN. INT. CL. 25. REG. 6-13-2000.
- 2,357,834. SALAD SOLUTIONS. INT. CL. 30. REG. 6-13-2000.
- 2,357,837. WORLD VIEW. INT. CL. 9. REG. 6-13-2000.
- 2,357,838. PRIMALEVE. INT. CL. 3. REG. 6-13-2000.
- 2,357,840. PARKCHIP. INT. CL. 9. REG. 6-13-2000.
- 2,357,841. PNEULEARN. INT. CL. 9. REG. 6-13-2000.
- 2,357,842. IBL. INT. CL. 41. REG. 6-13-2000.
- 2,357,843. STARFIRE. INT. CL. 9. REG. 6-13-2000.
- 2,357,851. PET-SPA. INT. CL. 5. REG. 6-13-2000.
- 2,357,852. MISCELLANEOUS DESIGN. INT. CL. 5. REG. 6-13-2000.
- 2,357,854. SOFT-WALK. INT. CL. 25. REG. 6-13-2000.
- 2,357,855. OUR PREFERRED PILLOW. INT. CL. 20. REG. 6-13-2000.
- 2,357,856. FOREVER CONCEPTS. INT. CL. 16. REG. 6-13-2000.
- 2,357,858. POWERPAK 21. INT. CL. 42. REG. 6-13-2000.
- 2,357,859. LACTI-SHIELDS AND DESIGN. INT. CL. 10. REG. 6-13-2000.
- 2,357,861. OUTTA YOUR MIND. INT. CL. 28. REG. 6-13-2000.
- 2,357,863. THE REPPIES AND DESIGN. INT. CLS. 9, 16, 25, 28 AND 41. REG. 6-13-2000.
- 2,357,864. NETWORK KNOWLEDGE CENTER. INT. CL. 38. REG. 6-13-2000.
- 2,357,865. EDANET. INT. CL. 42. REG. 6-13-2000.
- 2,357,866. QPID AND DESIGN. INT. CL. 10. REG. 6-13-2000.
- 2,357,867. CYBER GRANNIES. INT. CL. 9. REG. 6-13-2000.
- 2,357,868. THRILLOGY. INT. CL. 16. REG. 6-13-2000.
- 2,357,869. THRILLOGY. INT. CL. 30. REG. 6-13-2000.
- 2,357,871. PITTADO. INT. CL. 14. REG. 6-13-2000.
- 2,357,874. INTRAVERSE. INT. CL. 9. REG. 6-13-2000.

- 2,357,875. MOBILE REFERENCE AND DESIGN. INT. CL. 9. REG. 6-13-2000.
- 2,357,876. SYSTEM THINKING. INT. CLS. 17 AND 19. REG. 6-13-2000.
- 2,357,878. ESOX. INT. CL. 9. REG. 6-13-2000.
- 2,357,880. ELIPRINT. INT. CLS. 19, 20 AND 42. REG. 6-13-2000.
- 2,357,884. SOUTHERN TIER IPA. INT. CL. 35. REG. 6-13-2000.
- 2,357,886. SCANDIRECT. INT. CL. 9. REG. 6-13-2000.
- 2,357,888. VISIONARY CHOICE VARIABLE ANNUITY. INT. CL. 36. REG. 6-13-2000.
- 2,357,892. NULINE. INT. CLS. 7 AND 9. REG. 6-13-2000.
- 2,357,895. KINDER GARDEN. INT. CL. 28. REG. 6-13-2000.
- 2,357,897. ELECTRICMINDS AND DESIGN. INT. CL. 42. REG. 6-13-2000.
- 2,357,898. BDI BRYNDANA INTERNATIONAL, LTD. AND DESIGN. INT. CL. 2. REG. 6-13-2000.
- 2,357,899. A CREDIT CARD WITH A DIFFERENCE YOU CANCELRARELY SEE. INT. CL. 9. REG. 6-13-2000.
- 2,357,900. CANINE ELEMENTS. INT. CLS. 3 AND 21. REG. 6-13-2000.
- 2,357,903. THE ARCHITECTS OF INFORMATION. INT. CLS. 9 AND 42. REG. 6-13-2000.
- 2,357,904. ORIGINAL MINT SOURCE (STYLIZED). INT. CL. 3. REG. 6-13-2000.
- 2,357,905. AUDIE MURPHY (STYLIZED). INT. CL. 13. REG. 6-13-2000.
- 2,357,908. SOFRESH AND DESIGN. INT. CL. 29. REG. 6-13-2000.
- 2,357,909. NEOLOGY INFORMATION DESIGN. INT. CL. 42. REG. 6-13-2000.
- 2,357,910. PRO-VANTAGE. INT. CL. 16. REG. 6-13-2000.
- 2,357,911. MCS. INT. CL. 9. REG. 6-13-2000.
- 2,357,915. BLUE TECHNOLOGY FOR THE ABSOLUTE (STYLIZED). INT. CL. 24. REG. 6-13-2000.
- 2,357,916. HAMMER OF THOR. INT. CL. 32. REG. 6-13-2000.
- 2,357,917. GOLDDEN WEAR. INT. CL. 25. REG. 6-13-2000.
- 2,357,919. HEALTH EXPRESS. INT. CL. 41. REG. 6-13-2000.
- 2,357,921. LADYBUG FUN. INT. CL. 28. REG. 6-13-2000.
- 2,357,922. BLAZE. INT. CL. 9. REG. 6-13-2000.
- 2,357,923. EXERCISE EXPRESS. INT. CL. 41. REG. 6-13-2000.
- 2,357,924. YVES SAINT LAURENT POUR HOMME (STYLIZED). INT. CL. 25. REG. 6-13-2000.
- 2,357,925. CATTO'S RARE OLD SCOTTISH HIGHLAND WHISKY 1861 JAMES CATTO PARIS 1873 LONDON 1884 AND DESIGN. INT. CL. 33. REG. 6-13-2000.
- 2,357,927. LB LEFROY BROOKS AND DESIGN. INT. CL. 11. REG. 6-13-2000.
- 2,357,928. POTTER THE OTTER. INT. CL. 16. REG. 6-13-2000.
- 2,357,930. PNM ADVANTAGE (STYLIZED). INT. CLS. 35, 36, 38, 39, 41 AND 42. REG. 6-13-2000.
- 2,357,931. RIGHTSSSTATION. INT. CL. 9. REG. 6-13-2000.
- 2,357,932. COMMERCESTATION. INT. CL. 9. REG. 6-13-2000.
- 2,357,934. TRUSTSTATION. INT. CL. 9. REG. 6-13-2000.
- 2,357,935. CU COPPERNET. INT. CL. 38. REG. 6-13-2000.
- 2,357,937. SCIENCE PARK. INT. CL. 41. REG. 6-13-2000.
- 2,357,938. INTERTRUSTWARE. INT. CL. 9. REG. 6-13-2000.
- 2,357,939. BMI AND DESIGN. INT. CL. 41. REG. 6-13-2000.
- 2,357,941. CYBERVILLAGE, USA. INT. CL. 42. REG. 6-13-2000.
- 2,357,942. TIGEREY. INT. CLS. 9, 11, 12 AND 17. REG. 6-13-2000.
- 2,357,947. CHANGHONG AND DESIGN. INT. CLS. 9 AND 11. REG. 6-13-2000.
- 2,357,949. IRONMAN. INT. CL. 32. REG. 6-13-2000.
- 2,357,955. POWERMOTIVE. INT. CL. 7. REG. 6-13-2000.
- 2,357,956. TIME STATION. INT. CLS. 9 AND 14. REG. 6-13-2000.
- 2,357,957. NEW ZEALAND'S OWN. INT. CL. 5. REG. 6-13-2000.
- 2,357,958. SURELOCK. INT. CL. 9. REG. 6-13-2000.
- 2,357,959. T3 AND DESIGN. INT. CL. 9. REG. 6-13-2000.
- 2,357,961. EPIC TRAVEL. INT. CLS. 39 AND 42. REG. 6-13-2000.
- 2,357,962. CYBEREDGE. INT. CLS. 9 AND 41. REG. 6-13-2000.
- 2,357,965. EDGERUNNER. INT. CLS. 9 AND 16. REG. 6-13-2000.
- 2,357,967. INTUITIVE EDGE. INT. CL. 9. REG. 6-13-2000.
- 2,357,968. OASYS. INT. CL. 9. REG. 6-13-2000.
- 2,357,969. MULL ISLAND. INT. CL. 18. REG. 6-13-2000.
- 2,357,971. LIFECODES. INT. CL. 9. REG. 6-13-2000.
- 2,357,973. LANGUAGES A LA CARTE. INT. CL. 41. REG. 6-13-2000.
- 2,357,975. CTA CENTURY SOLUTIONS 2000 AND DESIGN. INT. CL. 42. REG. 6-13-2000.
- 2,357,977. THE EASY WAY TO A BEAUTIFUL LAWN & GARDEN. INT. CL. 16. REG. 6-13-2000.
- 2,357,979. GALILEO. INT. CL. 9. REG. 6-13-2000.
- 2,357,980. TELLABS SELECT. INT. CLS. 37, 41 AND 42. REG. 6-13-2000.
- 2,357,982. MORGAN'S TROPICAL FOREST. INT. CL. 42. REG. 6-13-2000.
- 2,357,984. PROLIPID. INT. CL. 1. REG. 6-13-2000.
- 2,357,986. KAN SHAKER. INT. CL. 7. REG. 6-13-2000.
- 2,357,991. SALT LAKE 2002. INT. CL. 16. REG. 6-13-2000.
- 2,357,992. I LIKE THE BEAT. INT. CL. 25. REG. 6-13-2000.
- 2,357,999. NEW TRADITIONS. INT. CL. 27. REG. 6-13-2000.
- 2,358,000. LOCAL INSIGHT GLOBAL REACH. INT. CLS. 35 AND 42. REG. 6-13-2000.
- 2,358,002. VARIRATE. INT. CL. 12. REG. 6-13-2000.
- 2,358,003. SALON CONCEPTS. INT. CL. 3. REG. 6-13-2000.
- 2,358,005. CAUZZ. INT. CL. 25. REG. 6-13-2000.
- 2,358,006. SECURREADER. INT. CL. 9. REG. 6-13-2000.
- 2,358,008. U.S. 1 AND DESIGN. INT. CL. 25. REG. 6-13-2000.
- 2,358,009. SILVER CREEK. INT. CL. 16. REG. 6-13-2000.
- 2,358,012. TERALOGIC. INT. CL. 9. REG. 6-13-2000.
- 2,358,014. NBS MEDALLION SERIES. INT. CLS. 7 AND 9. REG. 6-13-2000.
- 2,358,015. GUARDIAN. INT. CL. 9. REG. 6-13-2000.
- 2,358,016. KAN-DO-KID. INT. CL. 16. REG. 6-13-2000.
- 2,358,017. PLUG FOR XG WORKS AND DESIGN. INT. CL. 9. REG. 6-13-2000.
- 2,358,020. LOVE LIFE. INT. CL. 3. REG. 6-13-2000.
- 2,358,021. INTERPOD. INT. CLS. 9 AND 38. REG. 6-13-2000.
- 2,358,023. NEOVOX RECORDINGS. INT. CL. 41. REG. 6-13-2000.
- 2,358,025. H AND DESIGN. INT. CL. 36. REG. 6-13-2000.
- 2,358,026. CALIFORNIA 1 AND DESIGN. INT. CL. 25. REG. 6-13-2000.
- 2,358,027. ARIZONA 89A AND DESIGN. INT. CL. 25. REG. 6-13-2000.
- 2,358,029. SMART RESCUE. INT. CL. 37. REG. 6-13-2000.
- 2,358,031. GAMEFX. INT. CL. 9. REG. 6-13-2000.
- 2,358,034. I CAN. INT. CL. 3. REG. 6-13-2000.
- 2,358,035. QUICKCHANGE. INT. CL. 9. REG. 6-13-2000.
- 2,358,036. PETS-A-POPPIN'. INT. CL. 28. REG. 6-13-2000.
- 2,358,037. CD-COOKER. INT. CL. 9. REG. 6-13-2000.
- 2,358,038. RAYMOND JAMES DIRECT BANKING. INT. CL. 36. REG. 6-13-2000.
- 2,358,039. HEATSEEKER: EXPERT SELLING STRATEGIES. INT. CL. 9. REG. 6-13-2000.
- 2,358,045. WNBA CHAMPIONSHIP AND DESIGN. INT. CL. 41. REG. 6-13-2000.
- 2,358,046. ORIGINAL LIME SOURCE (STYLIZED). INT. CL. 3. REG. 6-13-2000.
- 2,358,047. ORIGINAL ORANGE SOURCE (STYLIZED). INT. CL. 3. REG. 6-13-2000.
- 2,358,050. GREAT RIGS. INT. CL. 39. REG. 6-13-2000.
- 2,358,053. STATBEANS. INT. CL. 9. REG. 6-13-2000.
- 2,358,056. SUNSET HARVEST. INT. CL. 30. REG. 6-13-2000.
- 2,358,057. AROMA AID. INT. CL. 3. REG. 6-13-2000.
- 2,358,059. HAMPTONS AND DESIGN. INT. CL. 36. REG. 6-13-2000.
- 2,358,062. AUTOCYTE QUIC. INT. CL. 9. REG. 6-13-2000.
- 2,358,063. MISCELLANEOUS DESIGN. INT. CL. 9. REG. 6-13-2000.
- 2,358,064. G BENNES GUILLAUME AND DESIGN. INT. CL. 12. REG. 6-13-2000.
- 2,358,066. RGT. INT. CL. 9. REG. 6-13-2000.
- 2,358,068. LORD, SOMETHING'S GOT TO GIVE. INT. CLS. 9 AND 16. REG. 6-13-2000.

- 2,358,074. GIROMY SAMONI AND DESIGN. INT. CL. 18. REG. 6-13-2000.
- 2,358,076. GENTITE-EF. INT. CL. 9. REG. 6-13-2000.
- 2,358,077. BUTTERFLY WINGS. INT. CL. 9. REG. 6-13-2000.
- 2,358,081. MISCELLANEOUS DESIGN. INT. CL. 5. REG. 6-13-2000.
- 2,358,082. NEXTRAN. INT. CL. 36. REG. 6-13-2000.
- 2,358,083. MISCELLANEOUS DESIGN. INT. CL. 5. REG. 6-13-2000.
- 2,358,084. MISCELLANEOUS DESIGN. INT. CL. 5. REG. 6-13-2000.
- 2,358,088. KEBAB KORNER. INT. CLS. 30 AND 42. REG. 6-13-2000.
- 2,358,089. NEODESIC. INT. CL. 9. REG. 6-13-2000.
- 2,358,090. ARE YOU INTO IT?. INT. CL. 25. REG. 6-13-2000.
- 2,358,092. ERGORIGHT. INT. CL. 9. REG. 6-13-2000.
- 2,358,096. KADY BLS. INT. CL. 11. REG. 6-13-2000.
- 2,358,097. NIGHTINGALE OB/GYN EXAMLITE. INT. CL. 11. REG. 6-13-2000.
- 2,358,099. PRESENT (STYLIZED). INT. CL. 21. REG. 6-13-2000.
- 2,358,100. VS VIBRATOR. INT. CL. 7. REG. 6-13-2000.
- 2,358,103. MEET THE MEDIA WITH YOUR AGENDA AND DESIGN. INT. CL. 16. REG. 6-13-2000.
- 2,358,104. THE NUMBERS DON'T SPEAK FOR THEMSELVES (STYLIZED). INT. CL. 16. REG. 6-13-2000.
- 2,358,105. MEET THE MEDIA WITH YOUR AGENDA AND DESIGN. INT. CL. 9. REG. 6-13-2000.
- 2,358,106. EXTREMOTION. INT. CL. 25. REG. 6-13-2000.
- 2,358,107. VIBROFORCE. INT. CL. 37. REG. 6-13-2000.
- 2,358,109. V AND DESIGN. INT. CL. 9. REG. 6-13-2000.
- 2,358,110. THE BEAUTY BOOK. INT. CL. 3. REG. 6-13-2000.
- 2,358,111. RESPONENOW. INT. CL. 9. REG. 6-13-2000.
- 2,358,113. SUMMER GIRL. INT. CL. 25. REG. 6-13-2000.
- 2,358,114. CALIFORNIA 29 AND DESIGN. INT. CL. 25. REG. 6-13-2000.
- 2,358,117. TENDING TURF. INT. CL. 16. REG. 6-13-2000.
- 2,358,118. NILYN. INT. CL. 11. REG. 6-13-2000.
- 2,358,120. POSILAC ISTEP. INT. CL. 5. REG. 6-13-2000.
- 2,358,121. MISCELLANEOUS DESIGN. INT. CL. 3. REG. 6-13-2000.
- 2,358,122. CMTI. INT. CL. 35. REG. 6-13-2000.
- 2,358,123. HOOKED ON SUCTION. INT. CL. 20. REG. 6-13-2000.
- 2,358,126. SAVAGE GRACE. INT. CLS. 9 AND 41. REG. 6-13-2000.
- 2,358,127. DERIVANET. INT. CL. 36. REG. 6-13-2000.
- 2,358,128. GLOMAR. INT. CL. 29. REG. 6-13-2000.
- 2,358,137. AT&T CALLER CONNECTIONS. INT. CL. 38. REG. 6-13-2000.
- 2,358,138. AUTO D. INT. CL. 12. REG. 6-13-2000.
- 2,358,140. BERRY CAKE BEARS. INT. CL. 30. REG. 6-13-2000.
- 2,358,142. METCOAT L.L.C. (STYLIZED). INT. CL. 4. REG. 6-13-2000.
- 2,358,144. THE POWER OF UNDERSTANDING. INT. CL. 16. REG. 6-13-2000.
- 2,358,145. SWAP CLEAR AND DESIGN. INT. CL. 36. REG. 6-13-2000.
- 2,358,146. UNLOCKING THE POWER OF SOUND. INT. CLS. 35 AND 42. REG. 6-13-2000.
- 2,358,149. KID-NOMERS. INT. CL. 16. REG. 6-13-2000.
- 2,358,150. MAX COLOR. INT. CL. 3. REG. 6-13-2000.
- 2,358,152. CREATIVE SIMPLICITY. INT. CL. 41. REG. 6-13-2000.
- 2,358,154. MISCELLANEOUS DESIGN. INT. CL. 42. REG. 6-13-2000.
- 2,358,155. TRING. INT. CL. 17. REG. 6-13-2000.
- 2,358,157. EXTRACTA. INT. CL. 1. REG. 6-13-2000.
- 2,358,158. SMARTFLOW. INT. CL. 9. REG. 6-13-2000.
- 2,358,159. ALTA-LAK. INT. CL. 2. REG. 6-13-2000.
- 2,358,160. KEEP OFF. INT. CL. 2. REG. 6-13-2000.
- 2,358,162. ULTRA PLUS. INT. CL. 19. REG. 6-13-2000.
- 2,358,166. KARNDAN. INT. CL. 19. REG. 6-13-2000.
- 2,358,167. KARNDAN INTERNATIONAL LTD AND DESIGN. INT. CL. 19. REG. 6-13-2000.
- 2,358,168. BABY&YOU. INT. CL. 9. REG. 6-13-2000.
- 2,358,169. POWERPICS. INT. CL. 42. REG. 6-13-2000.
- 2,358,170. PHARAOH'S BLUFF. INT. CL. 28. REG. 6-13-2000.
- 2,358,172. TRIPLE MILEATHON. INT. CL. 35. REG. 6-13-2000.
- 2,358,185. EZUSE (STYLIZED). INT. CL. 11. REG. 6-13-2000.
- 2,358,186. MISCELLANEOUS DESIGN. INT. CL. 35. REG. 6-13-2000.
- 2,358,188. DESERT SWEET. INT. CL. 31. REG. 6-13-2000.
- 2,358,189. MISCELLANEOUS DESIGN. INT. CL. 30. REG. 6-13-2000.
- 2,358,190. LAWMAN. INT. CL. 12. REG. 6-13-2000.
- 2,358,192. THE BUSINESS CHANNEL AND DESIGN. INT. CL. 9. REG. 6-13-2000.
- 2,358,193. CYBORG 3D. INT. CL. 9. REG. 6-13-2000.
- 2,358,197. FLORAL WORKS AND DESIGN. INT. CL. 35. REG. 6-13-2000.
- 2,358,198. EBREEZE. INT. CL. 25. REG. 6-13-2000.
- 2,358,199. PADDLE SCENTS (STYLIZED). INT. CL. 5. REG. 6-13-2000.
- 2,358,200. SUN BATHING. INT. CL. 3. REG. 6-13-2000.
- 2,358,203. WAY-PURE. INT. CL. 4. REG. 6-13-2000.
- 2,358,204. SINCRONISITY. INT. CL. 41. REG. 6-13-2000.
- 2,358,208. REEL SCHOOL. INT. CL. 28. REG. 6-13-2000.
- 2,358,209. STRATEGY SHOPPE. INT. CL. 35. REG. 6-13-2000.
- 2,358,210. GARDEN TRIO. INT. CL. 21. REG. 6-13-2000.
- 2,358,211. SYNTHETIX AND DESIGN. INT. CLS. 9 AND 10. REG. 6-13-2000.
- 2,358,212. INAGRID. INT. CL. 9. REG. 6-13-2000.
- 2,358,213. RAIL TALES. INT. CL. 16. REG. 6-13-2000.
- 2,358,217. HYDRAULICEXPRESS. INT. CL. 9. REG. 6-13-2000.
- 2,358,220. PURINA AND DESIGN. INT. CL. 16. REG. 6-13-2000.
- 2,358,221. WNBA BE ACTIVE AND DESIGN. INT. CL. 16. REG. 6-13-2000.
- 2,358,223. THE GREAT AMERICAN FURNITURE CO AND DESIGN. INT. CL. 20. REG. 6-13-2000.
- 2,358,224. DREAMBOX. INT. CLS. 6, 16, 20, 21 AND 28. REG. 6-13-2000.
- 2,358,226. AVANDIA. INT. CL. 42. REG. 6-13-2000.
- 2,358,227. DB DREAMBOX AND DESIGN. INT. CLS. 6, 16, 20, 21 AND 28. REG. 6-13-2000.
- 2,358,230. EXERLITE. INT. CL. 28. REG. 6-13-2000.
- 2,358,231. PET IQ. INT. CL. 9. REG. 6-13-2000.
- 2,358,236. DUPONTROLLEY AND DESIGN. INT. CL. 12. REG. 6-13-2000.
- 2,358,239. HOO LOOS. INT. CLS. 16 AND 28. REG. 6-13-2000.
- 2,358,241. CANNON. INT. CL. 8. REG. 6-13-2000.
- 2,358,243. SNAPSITE. INT. CL. 9. REG. 6-13-2000.
- 2,358,246. THE X-FILES EXPO. INT. CL. 41. REG. 6-13-2000.
- 2,358,247. ALTIERI POWERHAIR. INT. CL. 8. REG. 6-13-2000.
- 2,358,249. TELWORKS. INT. CL. 38. REG. 6-13-2000.
- 2,358,251. INSTANTCONNECT. INT. CL. 42. REG. 6-13-2000.
- 2,358,252. PTAH. INT. CLS. 36 AND 37. REG. 6-13-2000.
- 2,358,253. MISCELLANEOUS DESIGN. INT. CLS. 36 AND 37. REG. 6-13-2000.
- 2,358,256. RUB-R STUFF AND DESIGN. INT. CLS. 12 AND 28. REG. 6-13-2000.
- 2,358,258. TWINGRADE. INT. CL. 7. REG. 6-13-2000.
- 2,358,261. PROVANT. INT. CL. 16. REG. 6-13-2000.
- 2,358,262. PROVANT. INT. CL. 41. REG. 6-13-2000.
- 2,358,265. PARAFORM. INT. CL. 9. REG. 6-13-2000.
- 2,358,266. XEMOS. INT. CL. 9. REG. 6-13-2000.
- 2,358,268. THE NEW WAY FOR BUSINESS TO CONNECT. INT. CL. 38. REG. 6-13-2000.
- 2,358,269. PHOTOPARADE. INT. CL. 9. REG. 6-13-2000.
- 2,358,271. ALE NINO. INT. CL. 32. REG. 6-13-2000.
- 2,358,272. DIGITAL DESTINATIONS. INT. CLS. 35 AND 41. REG. 6-13-2000.
- 2,358,274. MACHI. INT. CL. 30. REG. 6-13-2000.
- 2,358,276. BEVERLY CARE ALLIANCE (STYLIZED). INT. CL. 42. REG. 6-13-2000.
- 2,358,277. BEVERLY CARE ALLIANCE AND DESIGN. INT. CL. 42. REG. 6-13-2000.
- 2,358,279. RAPIGENE. INT. CL. 42. REG. 6-13-2000.
- 2,358,284. ANGARA. INT. CL. 9. REG. 6-13-2000.
- 2,358,285. BIG LEAGUE. INT. CL. 28. REG. 6-13-2000.

- 2,358,286. AMERICAN PRIDE & THE AMERICAN WAY. INT. CL. 9. REG. 6-13-2000.
- 2,358,289. VERI-SYS. INT. CL. 9. REG. 6-13-2000.
- 2,358,290. POWER BY SYNRAD. INT. CL. 9. REG. 6-13-2000.
- 2,358,291. EMBEDDED SYNTHESIS. INT. CL. 9. REG. 6-13-2000.
- 2,358,292. IMAGESHIELD. INT. CL. 9. REG. 6-13-2000.
- 2,358,294. MELODY. INT. CL. 21. REG. 6-13-2000.
- 2,358,296. U.S. LEARNING INC. AND DESIGN. INT. CL. 41. REG. 6-13-2000.
- 2,358,298. NTC NORTH AMERICAN TREE CONCEPTS AND DESIGN. INT. CL. 28. REG. 6-13-2000.
- 2,358,299. NORTH AMERICAN TREE CONCEPTS. INT. CL. 28. REG. 6-13-2000.
- 2,358,300. PACIFIC HANDLES. INT. CL. 25. REG. 6-13-2000.
- 2,358,303. LEARNING OPTIONS. INT. CL. 41. REG. 6-13-2000.
- 2,358,306. GROWER'S BLEND. INT. CL. 1. REG. 6-13-2000.
- 2,358,307. SARILA (STYLIZED). INT. CL. 20. REG. 6-13-2000.
- 2,358,310. LITIGATEWAY (STYLIZED). INT. CL. 9. REG. 6-13-2000.
- 2,358,311. LIQUID SAND. INT. CL. 24. REG. 6-13-2000.
- 2,358,313. CHIPCO PROXY. INT. CL. 1. REG. 6-13-2000.
- 2,358,315. BARE SKIN. INT. CL. 3. REG. 6-13-2000.
- 2,358,318. TLPLANET. INT. CL. 35. REG. 6-13-2000.
- 2,358,320. REAL MCCOY. INT. CL. 28. REG. 6-13-2000.
- 2,358,321. NASCAR GARAGE (STYLIZED) & DESIGN AND DESIGN. INT. CLS. 16, 25 AND 41. REG. 6-13-2000.
- 2,358,323. LOLA. INT. CL. 30. REG. 6-13-2000.
- 2,358,324. PASTA BON TEMPI. INT. CL. 30. REG. 6-13-2000.
- 2,358,327. 57/ESV. INT. CL. 6. REG. 6-13-2000.
- 2,358,328. RACING SPORT AUTO ACCESSORIES AND DESIGN. INT. CL. 12. REG. 6-13-2000.
- 2,358,330. CHAMPIONSHIP COLLECTION. INT. CL. 35. REG. 6-13-2000.
- 2,358,331. ORBIUM. INT. CL. 9. REG. 6-13-2000.
- 2,358,333. TEDDY 2000. INT. CL. 28. REG. 6-13-2000.
- 2,358,334. EVIL CORE - THE FALLEN CITIES. INT. CL. 9. REG. 6-13-2000.
- 2,358,336. CERAMIDE SOURCE. INT. CL. 3. REG. 6-13-2000.
- 2,358,339. SUNRISE. INT. CL. 9. REG. 6-13-2000.
- 2,358,340. BABY MELODY. INT. CL. 28. REG. 6-13-2000.
- 2,358,341. VICTORIA. INT. CL. 27. REG. 6-13-2000.
- 2,358,342. MSA. INT. CL. 9. REG. 6-13-2000.
- 2,358,344. MOBIDGET. INT. CL. 9. REG. 6-13-2000.
- 2,358,345. LES PARADIS DES ENFANTS. INT. CL. 25. REG. 6-13-2000.
- 2,358,349. BAHIA DON BRAVO AND DESIGN. INT. CL. 42. REG. 6-13-2000.
- 2,358,350. BLUESTAR PLATINUM. INT. CL. 9. REG. 6-13-2000.
- 2,358,353. GATEWAY AND DESIGN. INT. CLS. 9 AND 35. REG. 6-13-2000.
- 2,358,354. EVERY STEP IS AN OPPORTUNITY TO LEARN. INT. CLS. 41 AND 42. REG. 6-13-2000.
- 2,358,357. POLAR CLAW. INT. CL. 8. REG. 6-13-2000.
- 2,358,361. ROUNDUP SOLUGRAN. INT. CL. 5. REG. 6-13-2000.
- 2,358,363. OCD STORM CENTER. INT. CL. 42. REG. 6-13-2000.
- 2,358,365. BASSETTI FARMS. INT. CL. 31. REG. 6-13-2000.
- 2,358,366. PERFORMANCE MATTERS. INT. CL. 28. REG. 6-13-2000.
- 2,358,367. ULENROLL. INT. CL. 35. REG. 6-13-2000.
- 2,358,369. IN ORCHESTRA EXPERIENCE AND DESIGN. INT. CL. 9. REG. 6-13-2000.
- 2,358,371. GALLERY OF GOWNS. INT. CL. 28. REG. 6-13-2000.
- 2,358,373. INLAIDIA. INT. CL. 27. REG. 6-13-2000.
- 2,358,374. 247 FLATBACK. INT. CL. 14. REG. 6-13-2000.
- 2,358,375. KINGS AND DRAGONS AND DESIGN. INT. CL. 28. REG. 6-13-2000.
- 2,358,376. XPD. INT. CL. 25. REG. 6-13-2000.
- 2,358,380. EZ VENT SYSTEMS. INT. CL. 11. REG. 6-13-2000.
- 2,358,381. EVERYDAY CARPETS. INT. CL. 27. REG. 6-13-2000.
- 2,358,382. BRAND BUILDERS AND DESIGN. INT. CL. 35. REG. 6-13-2000.
- 2,358,383. PHYTOFEM. INT. CL. 5. REG. 6-13-2000.
- 2,358,384. INFOLENS. INT. CL. 42. REG. 6-13-2000.
- 2,358,385. MERCY RIDGE AND DESIGN. INT. CL. 42. REG. 6-13-2000.
- 2,358,387. GOLDFIBRE. INT. CL. 30. REG. 6-13-2000.
- 2,358,388. XANTUS. INT. CL. 36. REG. 6-13-2000.
- 2,358,391. UCI. INT. CL. 19. REG. 6-13-2000.
- 2,358,392. WILD WEEKEND AND DESIGN. INT. CL. 25. REG. 6-13-2000.
- 2,358,393. WILD WEEKEND AND DESIGN. INT. CL. 41. REG. 6-13-2000.
- 2,358,394. CELEBRITY INSIDER. INT. CL. 16. REG. 6-13-2000.
- 2,358,400. MONOCELL. INT. CL. 1. REG. 6-13-2000.
- 2,358,401. TREASUREWOOD. INT. CL. 20. REG. 6-13-2000.
- 2,358,402. INFERNO. INT. CL. 5. REG. 6-13-2000.
- 2,358,404. LA BELLE EPOCH. INT. CL. 16. REG. 6-13-2000.
- 2,358,413. WESTAR COMMUNICATIONS. INT. CLS. 9, 37 AND 38. REG. 6-13-2000.
- 2,358,414. SPORTS AT HOME. INT. CL. 41. REG. 6-13-2000.
- 2,358,415. STEDI-STAK. INT. CL. 7. REG. 6-13-2000.
- 2,358,418. BAWDY SURFER. INT. CL. 28. REG. 6-13-2000.
- 2,358,420. GLOBE SHOPPING. INT. CL. 41. REG. 6-13-2000.
- 2,358,421. NET PAY. INT. CL. 41. REG. 6-13-2000.
- 2,358,422. RISE, RALLY, RECLAIM. INT. CLS. 14 AND 36. REG. 6-13-2000.
- 2,358,423. NEOLINEAR AND DESIGN. INT. CL. 9. REG. 6-13-2000.
- 2,358,424. CHOLESTIN. INT. CL. 30. REG. 6-13-2000.
- 2,358,425. AUDITY. INT. CL. 15. REG. 6-13-2000.
- 2,358,426. SUMMERSAVER. INT. CL. 39. REG. 6-13-2000.
- 2,358,427. BEREB. INT. CL. 5. REG. 6-13-2000.
- 2,358,428. B AND DESIGN. INT. CL. 5. REG. 6-13-2000.
- 2,358,429. PROFESSIONAL EXPRESSIONS. INT. CL. 16. REG. 6-13-2000.
- 2,358,431. TITANIUM TWEEZERMAN. INT. CL. 8. REG. 6-13-2000.
- 2,358,432. GARLOCK TECHFLEX. INT. CL. 7. REG. 6-13-2000.
- 2,358,434. VINYLICIOUS. INT. CL. 9. REG. 6-13-2000.
- 2,358,435. ROLL-A-BOPPER. INT. CL. 28. REG. 6-13-2000.
- 2,358,437. EXORI. INT. CL. 28. REG. 6-13-2000.
- 2,358,438. E-Z COVER. INT. CL. 16. REG. 6-13-2000.
- 2,358,442. TOGO. INT. CL. 9. REG. 6-13-2000.
- 2,358,443. OUTDOOR SPIRIT. INT. CL. 20. REG. 6-13-2000.
- 2,358,445. OUTDOOR SPIRIT. INT. CL. 9. REG. 6-13-2000.
- 2,358,446. PLAYERS. INT. CL. 9. REG. 6-13-2000.
- 2,358,447. SPEEDPATH. INT. CL. 42. REG. 6-13-2000.
- 2,358,449. BECOMING FAMILY. INT. CL. 16. REG. 6-13-2000.
- 2,358,450. PHAENNA SURNATURAL AND DESIGN. INT. CL. 3. REG. 6-13-2000.
- 2,358,458. AUTOIC. INT. CL. 9. REG. 6-13-2000.
- 2,358,460. VICTORIA DESIGN. INT. CL. 14. REG. 6-13-2000.
- 2,358,461. MEADOW VALLEY. INT. CL. 29. REG. 6-13-2000.
- 2,358,463. THE JACKAL. INT. CL. 8. REG. 6-13-2000.
- 2,358,464. OPENSHARE. INT. CL. 9. REG. 6-13-2000.
- 2,358,467. VADUS. INT. CL. 10. REG. 6-13-2000.
- 2,358,468. VACFACTS. INT. CL. 16. REG. 6-13-2000.
- 2,358,469. TRAFFICTOWN. INT. CL. 28. REG. 6-13-2000.
- 2,358,471. PLAY PATROL. INT. CL. 28. REG. 6-13-2000.
- 2,358,472. OCCMED. INT. CL. 42. REG. 6-13-2000.
- 2,358,474. WE'VE GOT A LOT TO SHOW YOU. INT. CLS. 38 AND 41. REG. 6-13-2000.
- 2,358,476. M-PREP ACCELERATOR. INT. CL. 9. REG. 6-13-2000.
- 2,358,480. ORNA-MUSIC. INT. CL. 28. REG. 6-13-2000.
- 2,358,483. U.D.O.. INT. CL. 28. REG. 6-13-2000.
- 2,358,485. UNIDENTIFIED DRIVING OBJECT. INT. CL. 28. REG. 6-13-2000.
- 2,358,486. CRUISE SAILS. INT. CL. 39. REG. 6-13-2000.
- 2,358,487. THERM-ALL (STYLIZED). INT. CL. 11. REG. 6-13-2000.
- 2,358,488. FINISH OFF. INT. CL. 3. REG. 6-13-2000.
- 2,358,489. TESTOSTERONE. INT. CL. 25. REG. 6-13-2000.

- 2,358,498. SOCCER CRAZY AND DESIGN. INT. CL. 25. REG. 6-13-2000.
- 2,358,503. LEGENDS OF URAK. INT. CL. 9. REG. 6-13-2000.
- 2,358,504. MINUTE TO MINUTE. INT. CL. 16. REG. 6-13-2000.
- 2,358,505. PINE RIDGE PANTRY. INT. CLS. 29 AND 30. REG. 6-13-2000.
- 2,358,506. HYCURVE. INT. CL. 9. REG. 6-13-2000.
- 2,358,507. ROUND-A-BOUNTS. INT. CL. 30. REG. 6-13-2000.
- 2,358,512. MR. TORT. INT. CL. 42. REG. 6-13-2000.
- 2,358,513. WITH IRON AND DESIGN. INT. CL. 25. REG. 6-13-2000.
- 2,358,514. FIBERVIEWS. INT. CL. 16. REG. 6-13-2000.
- 2,358,515. DIRTY DEMONS. INT. CL. 28. REG. 6-13-2000.
- 2,358,516. BEASTBALLS. INT. CL. 28. REG. 6-13-2000.
- 2,358,518. NORTHWEST ANGLE. INT. CL. 25. REG. 6-13-2000.
- 2,358,519. GIVE YOUR PASTA PIZAZZ. INT. CL. 30. REG. 6-13-2000.
- 2,358,521. SURVEYOR. INT. CL. 9. REG. 6-13-2000.
- 2,358,522. EGGS & MORE AND DESIGN. INT. CL. 29. REG. 6-13-2000.
- 2,358,523. BUG N' ME. INT. CL. 25. REG. 6-13-2000.
- 2,358,524. PNI ACCESS SERVICES. INT. CL. 38. REG. 6-13-2000.
- 2,358,528. PLAY N' TRAY. INT. CL. 21. REG. 6-13-2000.
- 2,358,529. SCIENCE FX. INT. CL. 28. REG. 6-13-2000.
- 2,358,530. JOYPOPPER. INT. CL. 41. REG. 6-13-2000.
- 2,358,531. ICE PALACE. INT. CL. 25. REG. 6-13-2000.
- 2,358,532. LONG ISLAND WEDDINGS OF DISTINCTION. INT. CL. 16. REG. 6-13-2000.
- 2,358,534. WIMBLEDON. INT. CLS. 29 AND 30. REG. 6-13-2000.
- 2,358,536. EXTRALINK. INT. CL. 37. REG. 6-13-2000.
- 2,358,538. WOWZER. INT. CL. 9. REG. 6-13-2000.
- 2,358,539. KITCHEN COUNTER. INT. CL. 35. REG. 6-13-2000.
- 2,358,540. SOJOURNS. INT. CL. 30. REG. 6-13-2000.
- 2,358,541. NEW ADVENTURES IN TEA. INT. CL. 30. REG. 6-13-2000.
- 2,358,544. JAC OUTSIDE AND DESIGN. INT. CL. 25. REG. 6-13-2000.
- 2,358,546. SCORIAE. INT. CL. 28. REG. 6-13-2000.
- 2,358,549. WE TEACH COMPUTERS HOW TO LISTEN. INT. CL. 42. REG. 6-13-2000.
- 2,358,550. FAIRWAY CENTER. INT. CL. 41. REG. 6-13-2000.
- 2,358,551. VITA SPECIAL. INT. CL. 31. REG. 6-13-2000.
- 2,358,553. DR. KATZ'S THERABRITE BRIGHTENING TOOTHPASTE AND DESIGN. INT. CL. 3. REG. 6-13-2000.
- 2,358,554. GABRIEL. INT. CL. 35. REG. 6-13-2000.
- 2,358,555. VITAL INSTINCTS. INT. CL. 41. REG. 6-13-2000.
- 2,358,558. ANTIQUITIES. INT. CL. 16. REG. 6-13-2000.
- 2,358,560. SILVER LININGS. INT. CL. 16. REG. 6-13-2000.
- 2,358,561. SIZZLELEAN. INT. CL. 11. REG. 6-13-2000.
- 2,358,565. CALLEGRA (STYLIZED). INT. CL. 9. REG. 6-13-2000.
- 2,358,567. DLM (STYLIZED). INT. CL. 9. REG. 6-13-2000.
- 2,358,570. MILLIONS OF MEMORIES. INT. CL. 24. REG. 6-13-2000.
- 2,358,571. MATTE MAKER. INT. CL. 3. REG. 6-13-2000.
- 2,358,573. MOSES PECANTE. INT. CL. 30. REG. 6-13-2000.
- 2,358,575. PLUG&SIM. INT. CL. 9. REG. 6-13-2000.
- 2,358,576. DISCOVER THE SOFTNESS EXPERIENCE THE COMFORT. INT. CL. 25. REG. 6-13-2000.
- 2,358,577. INNSIGHTS. INT. CL. 16. REG. 6-13-2000.
- 2,358,579. SUN SHEEN. INT. CL. 3. REG. 6-13-2000.
- 2,358,580. BIRCH FREEZE. INT. CL. 3. REG. 6-13-2000.
- 2,358,581. CALM CHAMOMILE. INT. CL. 3. REG. 6-13-2000.
- 2,358,585. FAST TAKE. INT. CL. 9. REG. 6-13-2000.
- 2,358,587. LITTLE LIONEL AND DESIGN. INT. CL. 28. REG. 6-13-2000.
- 2,358,589. AMAZON. INT. CL. 9. REG. 6-13-2000.
- 2,358,593. ZOOMATE. INT. CL. 9. REG. 6-13-2000.
- 2,358,595. THIRD EYE. INT. CL. 35. REG. 6-13-2000.
- 2,358,599. MYNEXTBOAT.COM. INT. CL. 35. REG. 6-13-2000.
- 2,358,600. GRAD SOLUTION. INT. CL. 36. REG. 6-13-2000.
- 2,358,601. OL' SAN ANTONE. INT. CL. 30. REG. 6-13-2000.
- 2,358,604. PRO YO ACE. INT. CL. 28. REG. 6-13-2000.
- 2,358,606. DANIMALS (STYLIZED). INT. CL. 29. REG. 6-13-2000.
- 2,358,609. TOUCH MATIC. INT. CL. 7. REG. 6-13-2000.
- 2,358,611. TAIMS. INT. CL. 9. REG. 6-13-2000.
- 2,358,612. FACTLOGIC. INT. CL. 9. REG. 6-13-2000.
- 2,358,613. DELL TALK. INT. CL. 38. REG. 6-13-2000.
- 2,358,614. SYSYS. INT. CL. 42. REG. 6-13-2000.
- 2,358,615. OFFICE COURIER. INT. CL. 9. REG. 6-13-2000.
- 2,358,616. O (STYLIZED). INT. CL. 20. REG. 6-13-2000.
- 2,358,618. N'TIME AND DESIGN. INT. CL. 16. REG. 6-13-2000.
- 2,358,620. PREMIUM HARVEST. INT. CL. 32. REG. 6-13-2000.
- 2,358,621. COMMUNITY CARE PARTNERS AND DESIGN. INT. CL. 42. REG. 6-13-2000.
- 2,358,622. 3VH. INT. CL. 12. REG. 6-13-2000.
- 2,358,624. GRIST MILL (STYLIZED). INT. CLS. 29 AND 30. REG. 6-13-2000.
- 2,358,625. ULTRON AND DESIGN. INT. CL. 9. REG. 6-13-2000.
- 2,358,626. VACCESSHEALTH. INT. CL. 42. REG. 6-13-2000.
- 2,358,629. BOOKTROLLER ACCOUNTING. INT. CL. 35. REG. 6-13-2000.
- 2,358,632. MISCELLANEOUS DESIGN. INT. CL. 30. REG. 6-13-2000.
- 2,358,633. NOW YOUR NEWS IS ALWAYS ON. INT. CL. 38. REG. 6-13-2000.
- 2,358,635. MEMOCAST. INT. CL. 9. REG. 6-13-2000.
- 2,358,637. RABBIT ISLAND. INT. CL. 32. REG. 6-13-2000.
- 2,358,638. CARCINEX. INT. CL. 5. REG. 6-13-2000.
- 2,358,639. CARDIOMEGA. INT. CL. 5. REG. 6-13-2000.
- 2,358,640. CRISIS RELIEF TEAM. INT. CL. 36. REG. 6-13-2000.
- 2,358,641. TRIUMPH OVER PAIN. INT. CL. 42. REG. 6-13-2000.
- 2,358,643. YOU BELONG. INT. CL. 38. REG. 6-13-2000.
- 2,358,644. DAIRYTIME. INT. CL. 29. REG. 6-13-2000.
- 2,358,645. QUAKE II NETPACK I: EXTREMITIES. INT. CL. 9. REG. 6-13-2000.
- 2,358,646. CLIMB FOR THE KIDS!. INT. CL. 35. REG. 6-13-2000.
- 2,358,648. RADICAL WAVES. INT. CL. 3. REG. 6-13-2000.
- 2,358,649. HEALTHY LEADERS. INT. CLS. 16 AND 41. REG. 6-13-2000.
- 2,358,651. RARE BIRD. INT. CL. 9. REG. 6-13-2000.
- 2,358,652. MAGIONIC. INT. CL. 5. REG. 6-13-2000.
- 2,358,653. MIXED-UP BERRIES. INT. CLS. 3 AND 4. REG. 6-13-2000.
- 2,358,654. THE USAA EDUCATIONAL FOUNDATION AND DESIGN. INT. CL. 36. REG. 6-13-2000.
- 2,358,658. PERFECT IMPRESSIONS. INT. CL. 16. REG. 6-13-2000.
- 2,358,660. ROMANTIC ESCAPES. INT. CL. 16. REG. 6-13-2000.
- 2,358,661. PLAN& GO AND DESIGN. INT. CL. 16. REG. 6-13-2000.
- 2,358,663. NATURULE. INT. CL. 16. REG. 6-13-2000.
- 2,358,665. LONG LIVE YOUR CLOTHES. INT. CL. 3. REG. 6-13-2000.
- 2,358,666. VOYAGER. INT. CL. 16. REG. 6-13-2000.
- 2,358,667. ALPHA ZOO EXPRESS. INT. CL. 28. REG. 6-13-2000.
- 2,358,668. HYDRA FINISH. INT. CL. 3. REG. 6-13-2000.
- 2,358,672. ESHARP. INT. CL. 41. REG. 6-13-2000.
- 2,358,673. CONSIGNMART. INT. CL. 35. REG. 6-13-2000.
- 2,358,674. CRISTOBAL AND DESIGN. INT. CL. 32. REG. 6-13-2000.
- 2,358,676. WHEY-TEK. INT. CL. 5. REG. 6-13-2000.
- 2,358,677. WINDOW JEWELS. INT. CL. 28. REG. 6-13-2000.
- 2,358,679. THE ONLY WAY TO STAY. INT. CL. 42. REG. 6-13-2000.
- 2,358,680. WE'VE TAKEN THE IDEA OF EXTENDED STAY AND EXTENDED IT. INT. CL. 42. REG. 6-13-2000.
- 2,358,682. MARK'S TENDER CUTS. INT. CL. 29. REG. 6-13-2000.

- 2,358,683. WENDELL'S WORLD AND DESIGN. INT. CL. 16. REG. 6-13-2000.
- 2,358,685. USAA MONEY@EASE AND DESIGN. INT. CL. 16. REG. 6-13-2000.
- 2,358,687. COMFORTGARD. INT. CL. 27. REG. 6-13-2000.
- 2,358,689. H2000 AND DESIGN. INT. CL. 32. REG. 6-13-2000.
- 2,358,690. GALACTIC BERRY. INT. CL. 29. REG. 6-13-2000.
- 2,358,692. TRES RIOS. INT. CL. 33. REG. 6-13-2000.
- 2,358,693. PATE SLATE. INT. CL. 28. REG. 6-13-2000.
- 2,358,694. LABOR HEADQUARTERS. INT. CL. 35. REG. 6-13-2000.
- 2,358,695. ROOMMATES. INT. CL. 16. REG. 6-13-2000.
- 2,358,697. LACTICLEAR. INT. CL. 5. REG. 6-13-2000.
- 2,358,698. MAGIC WHEEL. INT. CL. 16. REG. 6-13-2000.
- 2,358,699. SECRETS OF THE HUNT. INT. CL. 41. REG. 6-13-2000.
- 2,358,706. ONE OF A KIND HELMET PROTECTION FOR YOUR ONE OF A KIND LIFESTYLE. INT. CL. 9. REG. 6-13-2000.
- 2,358,707. ONE OF A KIND HELMET PROTECTION FOR YOUR ONE OF A KIND TODDLER. INT. CL. 9. REG. 6-13-2000.
- 2,358,708. DIFFERENT AND BETTER BECAUSE YOU ARE. INT. CL. 9. REG. 6-13-2000.
- 2,358,716. OLD LONDON COFFEE TOPPERS. INT. CL. 30. REG. 6-13-2000.
- 2,358,717. DEXTER. INT. CL. 32. REG. 6-13-2000.
- 2,358,719. DOLPHIN TECHNOLOGY INC.. INT. CL. 9. REG. 6-13-2000.
- 2,358,720. LODESTAR. INT. CL. 16. REG. 6-13-2000.
- 2,358,722. METREON. INT. CLS. 16, 25, 41 AND 42. REG. 6-13-2000.
- 2,358,730. MISCELLANEOUS DESIGN. INT. CL. 9. REG. 6-13-2000.
- 2,358,737. POKEMON (STYLIZED). INT. CL. 30. REG. 6-13-2000.
- 2,358,742. PRAIRIEWARE. INT. CL. 25. REG. 6-13-2000.
- 2,358,743. LE MONTI. INT. CL. 3. REG. 6-13-2000.
- 2,358,746. ECLIPSE INTERACTIVE OPTICIAN TRAINING AND DESIGN. INT. CL. 9. REG. 6-13-2000.
- 2,358,749. ROBOGUIDE. INT. CLS. 35 AND 42. REG. 6-13-2000.
- 2,358,750. THE PEPTIDE LABORATORY. INT. CL. 1. REG. 6-13-2000.
- 2,358,751. MISCELLANEOUS DESIGN. INT. CL. 18. REG. 6-13-2000.
- 2,358,752. MISCELLANEOUS DESIGN. INT. CL. 8. REG. 6-13-2000.
- 2,358,753. EQUITY LINKED INDEX ANNUITY. INT. CL. 36. REG. 6-13-2000.
- 2,358,754. SANTA FE. INT. CL. 32. REG. 6-13-2000.
- 2,358,755. DR DAP-RUGGET AND DESIGN. INT. CL. 25. REG. 6-13-2000.
- 2,358,756. GRAPHICS MALL. INT. CL. 16. REG. 6-13-2000.
- 2,358,757. MISCELLANEOUS DESIGN. INT. CL. 22. REG. 6-13-2000.
- 2,358,758. MISCELLANEOUS DESIGN. INT. CL. 22. REG. 6-13-2000.
- 2,358,759. US DETOX. INT. CL. 42. REG. 6-13-2000.
- 2,358,763. ENOTIFY (STYLIZED). INT. CL. 42. REG. 6-13-2000.
- 2,358,764. THE CLASSIC CALIFORNIA LIFESTYLE RE-SORT. INT. CLS. 35 AND 42. REG. 6-13-2000.
- 2,358,766. ESTRADA. INT. CL. 11. REG. 6-13-2000.
- 2,358,768. VALVE WIZARD. INT. CL. 9. REG. 6-13-2000.
- 2,358,769. PROFESSIONAL TAEKWONDO FEDERATION. INT. CL. 35. REG. 6-13-2000.
- 2,358,773. THORPE. INT. CL. 28. REG. 6-13-2000.
- 2,358,774. HOLLYWOOD UNDERWATER. INT. CLS. 25, 41 AND 42. REG. 6-13-2000.
- 2,358,775. CONTACT CAPITATION MANAGER. INT. CL. 9. REG. 6-13-2000.
- 2,358,778. YARDLEY COLLECTIONS. INT. CL. 21. REG. 6-13-2000.
- 2,358,784. WALL STREET FINANCIAL. INT. CL. 36. REG. 6-13-2000.
- 2,358,785. WALL STREET FINANCIAL GROUP. INT. CL. 36. REG. 6-13-2000.
- 2,358,786. WALL STREET OFFSHORE. INT. CL. 36. REG. 6-13-2000.
- 2,358,788. CT DEMO FALL. INT. CL. 35. REG. 6-13-2000.
- 2,358,789. SPECIALTY MULTIPURPOSE SOLUTION. INT. CL. 5. REG. 6-13-2000.
- 2,358,790. TEACHERS AND TECHNOLOGY. INT. CL. 41. REG. 6-13-2000.
- 2,358,791. AMERICA'S OUTSOURCE RESOURCE. INT. CLS. 35 AND 42. REG. 6-13-2000.
- 2,358,793. 1-888-CONTRACTOR. INT. CL. 35. REG. 6-13-2000.
- 2,358,794. FLEETCOM (STYLIZED). INT. CL. 38. REG. 6-13-2000.
- 2,358,795. PROFIT CENTER 2000. INT. CL. 9. REG. 6-13-2000.
- 2,358,796. LIFEJOURNAL. INT. CL. 9. REG. 6-13-2000.
- 2,358,797. ISD. INT. CLS. 35 AND 42. REG. 6-13-2000.
- 2,358,801. THE INTERNET STOCK INDEX. INT. CL. 16. REG. 6-13-2000.
- 2,358,802. PROMOTIONAL APPAREL BUSINESS. INT. CL. 16. REG. 6-13-2000.
- 2,358,806. DAQSUIE. INT. CL. 9. REG. 6-13-2000.
- 2,358,808. PC PARTS NET. INT. CL. 35. REG. 6-13-2000.
- 2,358,810. WORLD'S LARGEST ON LINE ART AND FRAMINGSUPER GALLERY. INT. CLS. 35 AND 40. REG. 6-13-2000.
- 2,358,811. WEBCRITERIA. INT. CL. 42. REG. 6-13-2000.
- 2,358,813. THE ULTIMATE IN RELAXATION. INT. CL. 42. REG. 6-13-2000.
- 2,358,814. NEW YORK INTERACTIVE. INT. CL. 42. REG. 6-13-2000.
- 2,358,815. TRAIN AMERICA. INT. CL. 35. REG. 6-13-2000.
- 2,358,817. CANVAS IMAGES (STYLIZED). INT. CL. 16. REG. 6-13-2000.
- 2,358,822. ENVIRONMENTAL ABSORBENT PRODUCTS. INT. CL. 4. REG. 6-13-2000.
- 2,358,823. SALES PERFORMANCE TOOL KIT. INT. CL. 35. REG. 6-13-2000.
- 2,358,824. MARMA FACIAL MASSAGE. INT. CL. 41. REG. 6-13-2000.
- 2,358,825. ENTERPRISE QUALITY SUITE. INT. CL. 42. REG. 6-13-2000.
- 2,358,826. MARMA MASSAGE. INT. CL. 41. REG. 6-13-2000.
- 2,358,829. E-CERTS. INT. CL. 39. REG. 6-13-2000.
- 2,358,830. E-CERT. INT. CL. 39. REG. 6-13-2000.
- 2,358,831. TOOTHJEWELS. INT. CL. 14. REG. 6-13-2000.
- 2,358,832. TOPAL. INT. CL. 7. REG. 6-13-2000.
- 2,358,833. BITCH.COM. INT. CL. 41. REG. 6-13-2000.
- 2,358,834. STONE CENTERS OF AMERICA. INT. CL. 42. REG. 6-13-2000.
- 2,358,835. INTRAPLANT. INT. CLS. 7 AND 9. REG. 6-13-2000.
- 2,358,838. SAFEWATER ANYWHERE. INT. CL. 11. REG. 6-13-2000.
- 2,358,839. BABY.WEB. INT. CL. 42. REG. 6-13-2000.
- 2,358,843. REALESTATEBANKERS. INT. CL. 35. REG. 6-13-2000.
- 2,358,844. TELECOM VENTURE GROUP. INT. CL. 36. REG. 6-13-2000.
- 2,358,846. IN-PLACE PROOFREADER. INT. CL. 9. REG. 6-13-2000.
- 2,358,847. THE CONNECTION COMPANY. INT. CLS. 35, 37, 38 AND 42. REG. 6-13-2000.
- 2,358,848. FULL VALUE PROCUREMENT. INT. CLS. 35 AND 42. REG. 6-13-2000.
- 2,358,851. TANKLESS. INT. CL. 11. REG. 6-13-2000.
- 2,358,853. 1-800-ON HEALTH. INT. CL. 42. REG. 6-13-2000.
- 2,358,855. CAREGIVER NEWS & REPORT. INT. CL. 16. REG. 6-13-2000.
- 2,358,856. NEXT-DAY COMMISSARY SERVICE. INT. CL. 39. REG. 6-13-2000.
- 2,358,857. BRINGING BUYERS AND SELLERS TOGETHER.. INT. CL. 42. REG. 6-13-2000.
- 2,358,859. VERMILLION. INT. CL. 19. REG. 6-13-2000.
- 2,358,860. CROSS OF ERIN. INT. CL. 4. REG. 6-13-2000.
- 2,358,862. 1-800-4-TRADEMARK. INT. CL. 42. REG. 6-13-2000.



- 2,358,863. 4TRADEMARK.COM. INT. CL. 42. REG. 6-13-2000.
- 2,358,867. TRANSMIT. INT. CL. 9. REG. 6-13-2000.
- 2,358,868. PREFERRED PHYSICIANS HEALTHCARE ALLIANCE. INT. CL. 42. REG. 6-13-2000.
- 2,358,869. RUNNINGSKOOL (STYLIZED). INT. CLS. 9 AND 41. REG. 6-13-2000.
- 2,358,870. ASSOCIATION MEMBERS ONLY. INT. CL. 35. REG. 6-13-2000.
- 2,358,872. SAFER FOR YOU AND THE ENVIRONMENT. INT. CL. 3. REG. 6-13-2000.
- 2,358,874. THE ORIGINAL HONEY SAUCE. INT. CL. 30. REG. 6-13-2000.
- 2,358,876. SAVER CARDS. INT. CL. 16. REG. 6-13-2000.
- 2,358,877. PAYMENT METHOD MONITOR. INT. CL. 35. REG. 6-13-2000.
- 2,358,880. SAND & GRAVEL MAGAZINE (STYLIZED). INT. CL. 16. REG. 6-13-2000.
- 2,358,881. CARE CHECK. INT. CL. 42. REG. 6-13-2000.
- 2,358,883. GRAM PRECISION AND DESIGN. INT. CL. 9. REG. 6-13-2000.
- 2,358,885. MAIL UNIVERSITY. INT. CL. 41. REG. 6-13-2000.
- 2,358,886. SELECT BREEDERS CLUB. INT. CL. 35. REG. 6-13-2000.
- 2,358,887. ENHANCED RECRUITMENT ADVERTISING. INT. CL. 35. REG. 6-13-2000.
- 2,358,890. WHAT'S WORKING IN DENTAL PRACTICE BUILDING. INT. CL. 16. REG. 6-13-2000.
- 2,358,891. WHAT'S WORKING IN MEDICAL PRACTICE BUILDING. INT. CL. 16. REG. 6-13-2000.
- 2,358,892. CELEBRITY WEDDINGS. INT. CL. 16. REG. 6-13-2000.
- 2,358,893. SUPERIOR INFORMATION SERVICES. INT. CL. 42. REG. 6-13-2000.
- 2,358,894. WIRE WAGON AND DESIGN. INT. CL. 16. REG. 6-13-2000.
- 2,358,898. TRAIN AMERICA. INT. CL. 28. REG. 6-13-2000.
- 2,358,899. GEORGIA WATERFOWL ASSOCIATION. INT. CL. 36. REG. 6-13-2000.
- 2,358,908. BUSINESS INDEXED INVESTMENT ACCOUNT. INT. CL. 36. REG. 6-13-2000.
- 2,358,911. SMALL BUSINESS LEGAL CENTER. INT. CL. 42. REG. 6-13-2000.
- 2,358,912. 1-800-PAINT-JOB. INT. CL. 35. REG. 6-13-2000.
- 2,358,913. EMARINE. INT. CL. 35. REG. 6-13-2000.
- 2,358,915. FRUIT N' TEA FREEZE. INT. CL. 30. REG. 6-13-2000.
- 2,358,922. PHARMACYNATURELLE.COM. INT. CL. 35. REG. 6-13-2000.
- 2,358,923. SUH. INT. CL. 36. REG. 6-13-2000.
- 2,358,924. VETERINARY OPHTHALMOLOGY. INT. CL. 16. REG. 6-13-2000.
- 2,358,925. REAL ESTATE AUTOMATION. INT. CL. 36. REG. 6-13-2000.
- 2,358,928. VITAMINA 12. INT. CL. 32. REG. 6-13-2000.
- 2,360,471. FIRSTCARE. INT. CL. 42 ONLY. REG. 6-20-2000.
- 2,375,504. THERE IS NO OFF POSITION ON THE GENIUS SWITCH. INT. CL. 25 ONLY. REG. 8-8-2000.
- 2,375,901. MAGIC NUUDLES. INT. CL. 28 ONLY. REG. 8-8-2000.
- 2,377,295. A.M AND DESIGN. INT. CLS. 25 AND 35 ONLY. REG. 8-15-2000.
- 2,380,070. MISCELLANEOUS DESIGN. INT. CLS. 20 AND 21 ONLY. REG. 8-22-2000.
- 2,394,924. AAU USA AND DESIGN. INT. CL. U.S. CLS. 200, 200, 200, 200, 200, 200, 200, 200, 200 AND 200 ONLY. REG. 10-17-2000.
- 2,395,428. SPHEROTENE. INT. CL. 9 ONLY. REG. 10-17-2000.
- 2,407,708. JUDSON COLLEGE WOMEN. FAITH. KNOWLEDGE. AND DESIGN. INT. CLS. 6, 9, 18 AND 24 ONLY. REG. 11-28-2000.
- 2,422,482. DOE. INT. CL. 41 ONLY. REG. 1-23-2001.
- 2,422,759. KAMAX AND DESIGN. INT. CLS. 7 AND 8 ONLY. REG. 1-23-2001.
- 2,423,747. SECURERITE. INT. CL. 35 ONLY. REG. 1-23-2001.
- 2,424,440. TRANSFORMING COMPANIES AND CAREERS. INT. CLS. 37, 41 AND 42 ONLY. REG. 1-30-2001.
- 2,425,020. POSITIVE DIRECTIONS THROUGH DANCE. INT. CL. 36 ONLY. REG. 1-30-2001.
- 2,427,245. PERFECT PAIRS. INT. CL. 16 ONLY. REG. 2-6-2001.
- 2,427,846. DIANORA SALVIATI. INT. CL. 3 ONLY. REG. 2-13-2001.
- 2,427,856. POTATO AND DESIGN. INT. CL. 30 ONLY. REG. 2-13-2001.
- 2,447,954. WUNDERSEARCH. INT. CL. 35 ONLY. REG. 5-1-2001.
- 2,460,543. STOXX. INT. CL. 9 ONLY. REG. 6-12-2001.
- 2,479,489. MICHIGAN RAG CO. AND DESIGN. INT. CL. 18 ONLY. REG. 8-21-2001.
- 2,495,585. JACKSON BLUE MAX. INT. CL. 12 ONLY. REG. 10-9-2001.
- 2,496,403. THEODORE ALEXANDER AND DESIGN. INT. CL. 26 ONLY. REG. 10-30-2001.
- 2,498,823. E AND DESIGN. INT. CL. 18 ONLY. REG. 10-16-2001.
- 2,501,570. INVEST IN LEARNING. INT. CL. 36 ONLY. REG. 10-30-2001.
- 2,502,143. THEODORE ALEXANDER. INT. CL. 26 ONLY. REG. 10-30-2001.
- 2,513,746. PROFESSOR HAMMER. INT. CL. 7 ONLY. REG. 12-4-2001.
- 2,514,642. DRAGONFLOWER. INT. CL. 25 ONLY. REG. 12-4-2001.
- 2,519,235. SONGSELECT. INT. CL. 9 ONLY. REG. 12-18-2001.
- 2,525,985. MOMENTS IN MOTION. INT. CL. 40 ONLY. REG. 1-1-2002.

---

**SECTION 18**

- 925,513. MONTE CRISTO. U.S. CL. 28. REG. 12-14-1971.
- 1,232,452. EYE TREATS (STYLIZED). INT. CL. 3. REG. 3-29-1983.
- 1,413,389. EAGLE STRUCTURAL PATCH. INT. CL. 19. REG. 10-14-1986.
- 2,146,379. PERFECT CREATINE STS. INT. CL. 5. REG. 3-24-1998.
- 2,279,651. BIG GAME. INT. CL. 25. REG. 9-21-1999.
- 2,425,096. RAD RODS (STYLIZED). INT. CL. 28. REG. 1-30-2001.
- 2,520,458. SLIM IMAGE AND DESIGN. INT. CL. 5. REG. 12-18-2001.
- 2,526,573. AIRLUX AND DESIGN. INT. CL. 20. REG. 1-8-2002.
- 2,529,746. TRICK DOG CAFE. INT. CLS. 25 AND 42. REG. 1-15-2002.
- 2,615,571. US INSPECT AND DESIGN. INT. CL. 42. REG. 9-3-2002.
- 2,623,857. MYWEBCAST. INT. CL. 38. REG. 9-24-2002.
- 2,649,590. BIODERM. INT. CL. 42. REG. 11-12-2002.
- 2,749,081. BACCHUS FRENCH PARADOX. INT. CLS. 29, 30, 32, 33 AND 42. REG. 8-12-2003.
- 2,821,871. XCOM (STYLIZED). INT. CLS. 9, 35, 36, 41 AND 42. REG. 3-16-2004.
- 2,885,125. ZONECHEF. INT. CLS. 29, 30 AND 39. REG. 9-14-2004.
- 2,915,645. THE WAITING ROOM. INT. CLS. 16 AND 35. REG. 1-4-2005.
- 3,040,558. ULTRAWALL SYSTEMSTANDARD CHARACTER MARK INT. CLS. 35 AND 37. REG. 1-10-2006.
- 3,054,264. MAHINA HAWAIIAN BBQSTANDARD CHARACTER MARK INT. CL. 43. REG. 1-31-2006.

---

**INADVERTENTLY ISSUED REGISTRATION**

**NUMBERS**

3,166,652. 100% NODSTANDARD CHARACTER MARK  
INT. CL. 20. REG. 10-31-2006. RESTORED TO  
SN 78-645,909.

3,024,872. AVJOBS (STYLIZED). INT. CL. 35. REG. 12-6-2005.  
RESTORED TO SN 78-502,216.

\* \* \* \* \*

# TRADEMARK REGISTRATIONS AMENDED, CORRECTED, ETC.

The designation "U.S. Cl." appearing in this section refers to the U.S. class in effect prior to Sep. 1, 1973 rather than the international class which applies to applications filed on or after that date. For adoption of international classification see notice in the OFFICIAL GAZETTE of Jun. 26, 1973 (911 O.G. TM 210).

Any change to the registration will be indicated at the bottom of each entry under ELEMENTS AMENDED, CORRECTED OR RESTRICTED. With the exception of changes to the goods and services, additions to the registration will appear in asterisks and deletions of the registration will appear in brackets. Elements which are only changed will be listed with no punctuation. As to the goods/services statement, amendments to the goods/services will appear in asterisks and deletions will appear in brackets. In addition if any change to the goods/services occurs, the element "Goods/Services" will be listed under ELEMENTS AMENDED, CORRECTED OR RESTRICTED.

518,709. REG. 12-13-1949. NEW WORLD PASTA COMPANY (DELAWARE CORPORATION) 85 SHANNON ROAD, HARRISBURG, PA. 17112. SN 71-554,610. FILED 4-14-1948. PRINCIPAL REGISTER.

1,426,531. REG. 1-27-1987. PRISM BUSINESS MEDIA INC. (DELAWARE CORPORATION) 249 W. 17TH STREET, 4TH FLOOR, NEW YORK, NY, 10011, SN 73-580,963. FILED 2-3-1986. PRINCIPAL REGISTER.

## RONZONI

THE MARK CONSISTS OF STANDARD CHARACTERS WITHOUT CLAIM TO ANY PARTICULAR FONT, STYLE, SIZE, OR COLOR.

OWNER OF U.S. REG. NOS. 270,229 AND 306,691. SEC. 2(F).

INT. CLS. 5 AND 30/U.S. CL. 46

FOR ALIMENTARY PASTES, SPAGHETTI SAUCE, AND A CEREAL FOOD FOR INFANTS, CHILDREN, OR CONVALESCENTS.

FIRST USE 5-1-1919; IN COMMERCE 5-1-1919.

ELEMENTS AMENDED  
MARK

1,007,801. REG. 4-1-1975. RAPID GRANULATOR AKTIEBOLAG (SWEDEN CORPORATION) INDUSTRIVAGEN 4, S-330 10 BREDARYD, SWEDEN., SN 73-021,054. FILED 5-9-1974. PRINCIPAL REGISTER.



INT. CL. 7/U.S. CLS. 13, 19, 21, 23, 31, 34 AND 35  
FOR MACHINES FOR THE PLASTICS INDUSTRY—NAMESLY, GRANULATORS, CUTTING MACHINES, HOPPERS, AND SUCTION FANS.  
FIRST USE 3-21-1969; IN COMMERCE 4-10-1969.

ELEMENTS AMENDED  
MARK

## MUNICIPAL INDEX

OWNER OF U.S. REG. NO. 668,070.  
NO CLAIM IS MADE TO THE EXCLUSIVE RIGHT TO USE "INDEX", APART FROM THE MARK AS SHOWN. SEC. 2(F).

INT. CL. 16/U.S. CL. 38

FOR ANNUAL DIRECTORY PROVIDING LISTINGS OF PRODUCTS AND SERVICES UTILIZED BY LOCAL GOVERNMENTS IN THE CONDUCT OF DAILY AFFAIRS.

FIRST USE 0-0-1984; IN COMMERCE 0-0-1984.

ELEMENTS AMENDED  
\*ASSIGNMENT/NAME CHANGE\*  
MARK

1,512,284. REG. 11-15-1988. GENERAL MILLS, INC. (DELAWARE CORPORATION) NUMBER ONE GENERAL MILLS BOULEVARD, MINNEAPOLIS, MN, 55426, SN 73-717,883. FILED 3-21-1988. PRINCIPAL REGISTER.



OWNER OF U.S. REG. NOS. 515,266, 1,431,192 AND OTHERS.

THE NAME "BETTY CROCKER" DOES NOT IDENTIFY A PARTICULAR LIVING INDIVIDUAL AND IS INTENDED TO BE FANCIFUL.

INT. CL. 4/U.S. CL. 15

FOR CANDLES.

FIRST USE 3-16-1972; IN COMMERCE 3-16-1972.

INT. CL. 21/U.S. CLS. 2, 13 AND 34

FOR [ PAPER BAKING CUPS, PAPER PLATES, PAPER DRINKING CUPS. ] CAKE DECORATING TIPS, AND CANDLEHOLDERS.

FIRST USE 3-16-1972; IN COMMERCE 3-16-1972.

INT. CL. 30/U.S. CL. 46

FOR ICING, DECORATING GEL, EDIBLE CANDY CAKE DECORATIONS AND EDIBLE CANDY DECORATING DECORS.  
FIRST USE 1-1-1971; IN COMMERCE 1-1-1971.

ELEMENTS AMENDED  
MARK

1,614,424. REG. 9-18-1990. BELK STORES SERVICES, INC. (NORTH CAROLINA CORPORATION) 2801 WEST TYVO LA ROAD, CHARLOTTE, NC. 282174500, SN 73-840,144. FILED 11-15-1989. PRINCIPAL REGISTER.



OWNER OF U.S. REG. NOS. 360,310, 1,040,297 AND OTHERS.  
INT. CL. 42/U.S. CL. 101  
FOR RETAIL DEPARTMENT STORE SERVICES.  
FIRST USE 3-6-1968. FIRST USED IN ANOTHER FORM ON SEPTEMBER 1, 1895; IN COMMERCE 3-6-1968, FIRST USED IN COMMERCE IN ANOTHER FORM ON SEPTEMBER 1, 1895 .

ELEMENTS AMENDED  
MARK

1,802,452. REG. 11-2-1993. JAN SERVICES CORP. (NEW YORK CORPORATION) 412 GREENWICH STREET, NEW YORK, NY, 10013, SN 74-364,795. FILED 3-5-1993. PRINCIPAL REGISTER.

## GOURMET GARAGE

NO CLAIM IS MADE TO THE EXCLUSIVE RIGHT TO USE "GOURMET", APART FROM THE MARK AS SHOWN.  
INT. CL. 42/U.S. CL. 101  
FOR DISTRIBUTORSHIP AND RETAIL FOOD OUTLET SERVICES.  
FIRST USE 11-0-1992; IN COMMERCE 11-0-1992.

ELEMENTS CORRECTED  
OWNER NAME

1,943,094. REG. 12-19-1995. CAMBIASO HERMANOS S.A.C. (CHILE CORPORATION) AV BRAZIL 2492, C.P. 22, CASILLA 1222-1240, VALPARAISO, CHILE., SN 74-354,111. FILED 2-1-1993. PRINCIPAL REGISTER.

## SILVESTRE

INT. CL. 30/U.S. CL. 46  
FOR HERB TEA.  
FIRST USE 4-4-1995; IN COMMERCE 4-4-1995.

ELEMENTS CORRECTED  
OWNER NAME

1,958,406. REG. 2-27-1996. DIGENE CORPORATION (DELAWARE CORPORATION) 1201 CLOPPER ROAD, GAITHERSBURG, MD, 20878, SN 74-551,279. FILED 7-20-1994. PRINCIPAL REGISTER.



INT. CL. 1/U.S. CL. 6  
FOR DIAGNOSTIC REAGENTS FOR SCIENTIFIC OR RESEARCH USE.  
FIRST USE 3-0-1991; IN COMMERCE 3-0-1991.  
INT. CL. 5/U.S. CLS. 6, 18, 44, 46, 51 AND 52  
FOR DIAGNOSTIC REAGENTS FOR MEDICAL OR CLINICAL USE.  
FIRST USE 3-0-1991; IN COMMERCE 3-0-1991.  
INT. CL. 10/U.S. CLS. 26, 39 AND 44  
FOR DNA PROBE BASED DIAGNOSTIC TEST KITS FOR THE DETERMINATION AND MONITORING OF HUMAN DISEASES.  
FIRST USE 3-0-1991; IN COMMERCE 3-0-1991.

ELEMENTS CORRECTED  
\*ASSIGNMENT/NAME CHANGE\*  
CITIZENSHIP

1,958,407. REG. 2-27-1996. DIGENE CORPORATION (DELAWARE CORPORATION) 1201 CLOPPER ROAD, GAITHERSBURG, MD, 20878, SN 74-551,283. FILED 7-20-1994. PRINCIPAL REGISTER.

## DIGENE

INT. CL. 1/U.S. CL. 6  
FOR DIAGNOSTIC REAGENTS FOR SCIENTIFIC OR RESEARCH USE.  
FIRST USE 1-1-1988; IN COMMERCE 1-1-1988.  
INT. CL. 5/U.S. CLS. 6, 18, 44, 46, 51 AND 52  
FOR DIAGNOSTIC REAGENTS FOR MEDICAL OR CLINICAL USE.  
FIRST USE 1-1-1988; IN COMMERCE 1-1-1988.  
INT. CL. 10/U.S. CLS. 26, 39 AND 44  
FOR DNA PROBE BASED DIAGNOSTIC TEST KITS FOR THE DETERMINATION AND MONITORING OF HUMAN DISEASES.  
FIRST USE 1-1-1988; IN COMMERCE 1-1-1988.

ELEMENTS CORRECTED  
\*ASSIGNMENT/NAME CHANGE\*  
CITIZENSHIP

1,986,812. REG. 7-16-1996. BLOCK CORPORATION (DELAWARE CORPORATION) 350 FIFTH AVENUE, SUITE 2512, NEW YORK, NY, 10118, SN 74-649,205. FILED 3-20-1995. PRINCIPAL REGISTER.

2,306,903. REG. 1-11-2000. EDGAR ONLINE, INC. (DELAWARE CORPORATION) 50 WASHINGTON STREET, 9TH FLOOR, NORWALK, CT, 06854, SN 75-388,486. FILED 11-12-1997. PRINCIPAL REGISTER.



THE NAME "BIG DADDY" DOES NOT IDENTIFY A LIVING INDIVIDUAL.

INT. CL. 25/U.S. CLS. 22 AND 39

FOR ACTIVEWEAR, NAMELY TEE SHIRTS, SHORTS, SWEAT SUITS, SWEAT SHIRTS, AND HATS.  
FIRST USE 2-1-1994; IN COMMERCE 2-1-1994.

ELEMENTS AMENDED  
MARK

## EDGAR PRO

INT. CL. 36/U.S. CLS. 100, 101 AND 102

FOR PROVIDING FINANCIAL INFORMATION IN THE FIELDS OF GOVERNMENTAL REGULATORY FINANCIAL FILINGS AND COMPANY FINANCIAL INFORMATION.

FIRST USE 11-1-1997; IN COMMERCE 11-1-1997.

ELEMENTS AMENDED  
MARK

2,413,433. REG. 12-19-2000. PHILD CO., LTD. (JAPAN CORPORATION) 678, TEARAIMIZU-CHO, KARASUMADORI NISHIKIKOJIKADO, NAKAGYO-KU, KYOTO CITY, KYOTO PREF., JAPAN, 604-8152, SN 75-495,203. FILED 6-2-1998. PRINCIPAL REGISTER.

## PHITEN

OWNER OF JAPAN REG. NO. 3276246, DATED 4-11-1997.  
INT. CL. 3/U.S. CLS. 1, 4, 6, 50, 51 AND 52

FOR [ SOAPS, NAMELY, SHAMPOOS FOR PETS, WASHING POWDER, WASHING RICE BRAN, SHAMPOO POWDER FOR HAIR, PREPARATIONS FOR CLEANING GLASSES, POWDERED CLEANSER FOR CLEANING AND POLISHING KITCHEN UNIT AND WARE. ] TOILET SOAPS, [ INDUSTRIAL SOAP FOR WASHING HANDS, DRY CLEANING PREPARATIONS, PETROLIC SYNTHETIC DETERGENTS, PREPARATIONS FOR CLEANING CHAMBER POTS, CLEANING POWDER FOR CLEANING AND POLISHING KITCHEN UNITS AND WARES, LIQUID SOAP FOR WASHING AND CLEANING THE FACE AND HANDS; COSMETICS, NAMELY, POWDERS, NAMELY, PAPER POWDER, CREAM, POWDER, CAKE POWDER, FACE POWDER, LIQUID POWDER, PASTE POWDER, ] TOILET WATERS, NAMELY, SKIN LOTION, GENERAL TOILET WATER, EMULSION, NAMELY, MILKY LOTION FOR SOOTHING AND SOFTENING THE SKIN OF HANDS AND FACE, VISCOUS LOTION FOR SOOTHING AND SOFTENING THE SKIN OF HANDS AND FACE, [SHAVING TOILET WATER, ] HAND LOTION, [ EAU DE COLOGNE; CREAMS, NAMELY, VANISHING CREAM, HYGIENIC CREAM, COLD CREAM, ] CLEANSING CREAM, [ HAND CREAM, SHAVING CREAM, SUNBURN PREVENTIVE CREAM, SUNBURN CREAM, LIP CREAM, BLEACHING CREAM, FOUNDATION CREAM; ROUGES, NAMELY, ROUGE, LIPSTICK, CREAM ROUGE; HAIR TOILETS, NAMELY, COLOR RINSE, HAIR SPRAY, POMADE, ] HAIR OIL, [ HAIR CREAM, HAIR FIXATIVE, HAIR TONIC, SETTING LOTION, HAIR LACQUER, PERMANENT SOLUTION, COLD WAVING SOLUTION, ] HAIR RINSE, [ HAIR DYES, ] HAIR TREATMENT, NAMELY, HAIR CONDITIONER AND HAIR PACK PREPARATIONS, NAMELY, PASTE LIKE SUBSTANCES APPLIED TO HAIR FOR EMOLLIENT PURPOSES; [ PERFUMES, NAMELY, PERFUME, SOLID PERFUME, PASTE PERFUME, POWDERED PERFUME; ANY OTHER COSMETICS, NAMELY, OIL-REMOVING PAPER FOR CLEANSING THE FACE, COLOR-REMOVING PREPARATIONS FOR HAIR, EYE SHADOW, EYEBROW PAINT, MASCARA, NAIL ENAMEL, NAIL ENAMEL REMOVER, TALCUM POWDER, DEPI-LATORY, BATH SALT, BATH OIL, DECOLORANT TOILET SET, NAMELY, FACIAL PACK CONSISTING OF COSMETIC MATERIAL APPLIED TO FACE FOR SOFTENING AND PURIFYING THE SKIN OF THE FACE, BABY POWDER, ] BABY OIL.  
FIRST USE ; IN COMMERCE .

INT. CL. 5/U.S. CLS. 6, 18, 44, 46, 51 AND 52

2,196,870. REG. 10-20-1998. EXPRESS COMMUNICATIONS, INC. (SOUTH DAKOTA CORPORATION) 2900 WEST 10TH STREET, SIOUX FALLS, SD, 57104, SN 75-015,946. FILED 11-7-1995. PRINCIPAL REGISTER.

## DIME TALK

INT. CL. 38/U.S. CLS. 100, 101 AND 104

FOR TELECOMMUNICATIONS SERVICES, NAMELY, PROVIDING LONG DISTANCE CALLING SERVICES.  
FIRST USE 6-5-1995; IN COMMERCE 6-5-1995.

ELEMENTS CORRECTED  
OWNER NAME

2,218,406. REG. 1-19-1999. CARTIERE PAOLO PIGNA S.P.A. (ITALY CORPORATION) ALZANO LOMBARDO, VIA DANIELE PESENTI 1, BERGAMO, ITALY., SN 75-334,534. FILED 8-1-1997. PRINCIPAL REGISTER.

## RILECART

INT. CL. 7/U.S. CLS. 13, 19, 21, 23, 31, 34 AND 35

FOR BINDING MACHINES AND STRUCTURAL PARTS THEREFOR.

FIRST USE 12-0-1961; IN COMMERCE 12-0-1980.

INT. CL. 16/U.S. CLS. 2, 5, 22, 23, 29, 37, 38 AND 50

FOR BOOKBINDING MATERIALS, [ NAMELY, PAPER, CARDBOARD, PLASTICS, ] WIRE [ AND TAPE].

FIRST USE 12-0-1961; IN COMMERCE 12-0-1980.

ELEMENTS AMENDED  
GOODS/SERVICES  
MARK

FOR [ MEDICATED TOILET WATER, MEDICATED SOAP FOR WASHING AND CLEANING THE FACE AND HANDS, MEDICATED HAND AND FACE CREAM ].  
FIRST USE ; IN COMMERCE .

ELEMENTS AMENDED  
GOODS/SERVICES  
MARK

2,424,813. REG. 1-30-2001. KING ISLAND COMPANY LTD., THE (AUSTRALIA COMPANY) SHAMROCK STREET, ABBOTSFOR, VICTORIA 3067, AUSTRALIA., SN 75-788,878. FILED 8-30-1999. PRINCIPAL REGISTER.



NO CLAIM IS MADE TO THE EXCLUSIVE RIGHT TO USE "KING ISLAND DAIRY, PREMIUM QUALITY DAIRY PRODUCE" AND "FARMHOUSE STYLE", APART FROM THE MARK AS SHOWN.

INT. CL. 29/U.S. CL. 46  
FOR CREAM AND CHEESE.  
FIRST USE 0-0-1992; IN COMMERCE 9-0-1998.

ELEMENTS AMENDED  
MARK

2,481,352. REG. 8-28-2001. JAN SERVICES CORP. (NEW YORK COMPANY) 412 GREENWICH STREET, NEW YORK, NY, 10013, SN 75-701,523. FILED 5-10-1999. PRINCIPAL REGISTER.

## SHOP LIKE A CHEF

INT. CL. 35/U.S. CLS. 100, 101 AND 102  
FOR SUPERMARKET SERVICES FEATURING HOME DELIVERY; WHOLESALE AND RETAIL DISTRIBUTORSHIP FEATURING FOOD.

FIRST USE 11-0-1998; IN COMMERCE 11-0-1998.  
INT. CL. 42/U.S. CLS. 100 AND 101  
FOR CATERING SERVICES; RESTAURANT SERVICES.  
FIRST USE 11-0-1998; IN COMMERCE 11-0-1998.

ELEMENTS CORRECTED  
OWNER NAME

2,490,890. REG. 9-18-2001. PAUL REED SMITH GUITARS, LIMITED PARTNERSHIP (MARYLAND LIMITED PARTNERSHIP) 107 LOG CANOE CIRCLE, STEVENSVILLE, MD, 21666, SN 76-173,050. FILED 11-30-2000. PRINCIPAL REGISTER.

## MCCARTY

OWNER OF U.S. REG. NO. 1,919,052.  
SEC. 2(F).  
INT. CL. 15/U.S. CLS. 2, 21 AND 36

FOR MUSICAL INSTRUMENTS, NAMELY GUITARS.  
FIRST USE 1-21-1994; IN COMMERCE 1-21-1994.

ELEMENTS CORRECTED  
OWNER NAME

2,537,401. REG. 2-5-2002. ASSOCIATED WHOLESALE GROCERS, INC. (MISSOURI CORPORATION) 5000 KANSAS AVENUE, KANSAS CITY, KS, 66106, SN 78-025,072. FILED 9-8-2000. PRINCIPAL REGISTER.

## BEST CHOICE GROWER'S CHOICE

OWNER OF U.S. REG. NOS. 1,399,721 AND 1,640,147.  
INT. CL. 32/U.S. CLS. 45, 46 AND 48  
FOR ORANGE JUICE [ AND FRUIT JUICES ].  
FIRST USE 10-8-2001; IN COMMERCE 10-8-2001.

ELEMENTS AMENDED  
MARK

2,586,635. REG. 6-25-2002. REALTY EXECUTIVES INTERNATIONAL, INC. (ARIZONA CORPORATION) 4427 NORTH 36TH STREET, SUITE 100, PHOENIX, AZ, 85018, SN 76-279,995. FILED 7-3-2001. PRINCIPAL REGISTER.

## EXPERIENCE EXCELLENCE

INT. CL. 35/U.S. CLS. 100, 101 AND 102  
FOR FRANCHISING, NAMELY, TECHNICAL ASSISTANCE IN THE ESTABLISHMENT OF REAL ESTATE AGENCIES AND REAL ESTATE RECRUITMENT.  
FIRST USE 12-20-2001; IN COMMERCE 12-20-2001.

ELEMENTS CORRECTED  
OWNER NAME

2,710,978. REG. 4-29-2003. GOTT BROTHERS DEVELOPMENT, L.L.C. (CALIFORNIA LIMITED LIABILITY CORPORATION) 1458 LINCOLN AVENUE, RAILCAR #15, CALISTOGA, CA, 94515, SN 76-378,515. FILED 3-5-2002. PRINCIPAL REGISTER.

## TAYLOR'S AUTOMATIC REFRESHER

INT. CL. 43/U.S. CLS. 100 AND 101  
FOR RESTAURANT SERVICES.  
FIRST USE 9-24-1999; IN COMMERCE 9-24-1999.

ELEMENTS CORRECTED  
OWNER NAME

2,724,499. REG. 6-10-2003. SUZUKI MOTOR CORPORATION (SUZUKI KABUSHIKI KAISHA) (JAPAN CORPORATION) 300 TAKATSUKA-CHO, HAMAMATSU-SHI, SHIZUOKA-KEN, JAPAN., SN 75-531,637. FILED 8-5-1998. PRINCIPAL REGISTER.



NO CLAIM IS MADE TO THE EXCLUSIVE RIGHT TO USE "TEAM", APART FROM THE MARK AS SHOWN. THE STIPPLING IS FOR SHADING PURPOSES AND DOES NOT INDICATE COLOR.

INT. CL. 6/U.S. CLS. 2, 12, 13, 14, 23, 25 AND 50 FOR METAL KEY HOLDERS.

FIRST USE 1-0-1998; IN COMMERCE 8-0-1999.

INT. CL. 16/U.S. CLS. 2, 5, 22, 23, 29, 37, 38 AND 50

FOR [CALENDARS, POSTERS, POSTCARDS, ENVELOPES, PAMPHLETS AND BOOKS FEATURING INFORMATION ABOUT MOTOR LAND VEHICLES,] STICKERS, [AND STATIONERY].

FIRST USE 1-0-1998; IN COMMERCE 8-0-1999.

INT. CL. 18/U.S. CLS. 1, 2, 3, 22 AND 41

FOR BAGS, NAMELY, TRAVELING BAGS, ATHLETIC BAGS, GYM BAGS, LUGGAGE TRUNKS, SUITCASES, BRIEFCASES, KNAPSACKS, WALLETS, KEY CASES, POUCHES, NAMELY, FELT POUCHES, DRAWSTRING POUCHES, AND UMBRELLAS .

FIRST USE 1-0-1998; IN COMMERCE 8-0-1999.

INT. CL. 24/U.S. CLS. 42 AND 50

FOR TOWELS AND HANDKERCHIEFS.

FIRST USE 1-0-1998; IN COMMERCE 8-0-1999.

INT. CL. 25/U.S. CLS. 22 AND 39

FOR CLOTHING, NAMELY, T-SHIRTS, JACKETS, PANTS, SHOES, AND HATS.

FIRST USE 1-0-1998; IN COMMERCE 8-0-1999.

ELEMENTS CORRECTED  
GOODS/SERVICES

2,735,946. REG. 7-15-2003. SHARP PACKAGING SYSTEMS, LLC (WISCONSIN LIMITED LIABILITY CORPORATION) N62 W22632 WILLAGE DRIVE, SUSSEX, WI, 53089, SN 76-301,554. FILED 8-20-2001. PRINCIPAL REGISTER.



NO CLAIM IS MADE TO THE EXCLUSIVE RIGHT TO USE "PACKAGING SYSTEMS, INC.", APART FROM THE MARK AS SHOWN.

THE MARK CONSISTS OF THE TERMS "SHARP PACKAGING SYSTEMS, INC." THE TERM "SHARP" IS STYLIZED AND IS IN BLACK AND BOLD LETTERS. A HAWK WITH ITS WINGS SPREAD OUT COVERS PART OF THE LETTER "S" OF THE TERM "SHARP".

INT. CL. 7/U.S. CLS. 13, 19, 21, 23, 31, 34 AND 35

FOR MACHINES FOR MANUFACTURING AND DISPENSING PLASTIC BAGS FOR PACKAGING.

FIRST USE 11-1-1985; IN COMMERCE 11-1-1985.

INT. CL. 16/U.S. CLS. 2, 5, 22, 23, 29, 37, 38 AND 50

FOR FLEXIBLE PLASTIC BAGS FOR PACKAGING. FIRST USE 11-1-1985; IN COMMERCE 11-1-1985.

ELEMENTS AMENDED

\*OWNER NAME\*

\*OWNER ADDRESS\*

\*CITIZENSHIP\*

\*ENTITY\*

MARK

2,850,844. REG. 6-8-2004. SICC S.P.A. (ITALY CORPORATION) VIA TOSCANA 32, MONSANO, ANCONA, ITALY, 60030. SN 78-224,475. FILED 3-12-2003. PRINCIPAL REGISTER.

**sicc**

PRIORITY CLAIMED UNDER SEC. 44(D) ON ITALY APPLICATION NO. BO2003C00014, FILED 2-12-2003.

INT. CL. 20/U.S. CLS. 2, 13, 22, 25, 32 AND 50

FOR [FURNITURE, MODULAR FURNITURE, ] KITCHEN FURNITURE, \* NAMELY, HOUSEHOLD KITCHEN FURNITURE AND HOUSEHOLD KITCHEN CABINETS \* [ BATHROOM FURNITURE, MODULAR FURNITURE FOR KITCHENS, WARDROBES, COMMODES, NAMELY, WASHSTANDS, BEDSIDE TABLES, BEDSPRINGS, MATTRESSES, MIRRORS ].

FIRST USE 2-1-1978; IN COMMERCE 11-29-2002.

INT. CL. 37/U.S. CLS. 100, 103 AND 106

FOR INSTALLATION, REPAIR AND MAINTENANCE OF FURNITURE AND MODULAR FURNITURE FOR KITCHENS.

FIRST USE 2-1-1978; IN COMMERCE 11-29-2002.

ELEMENTS AMENDED  
GOODS/SERVICES

2,862,506. REG. 7-13-2004. FRITZ SCHAFFER GMBH (FED REP GERMANY CORPORATION) FRITZ-SCHAFFER-STRASSE 20, NEUNKIRCHEN, FED REP GERMANY, 57290, SN 78-162,019. FILED 9-9-2002. PRINCIPAL REGISTER.

**PICKOSOFT**

PRIORITY CLAIMED UNDER SEC. 44(D) ON FED REP GERMANY APPLICATION NO. 30215663142, FILED 3-2-2002, REG. NO. 30215663, DATED 2-11-2003.

INT. CL. 9/U.S. CLS. 21, 23, 26, 36 AND 38

FOR DATA PROCESSING DEVICES, NAMELY ELECTRICAL INDUSTRIAL CONTROLLERS, ELECTRONIC INDUSTRIAL CONTROLS FOR OPERATING HEIGHT-ADJUSTABLE SHELVING SYSTEMS AND INDUSTRIAL PROCESS CONTROL SOFTWARE AND COMPUTERS; DIALOG SYSTEM CONSISTING OF COMPUTERS WITH STORAGE MEDIA, NAMELY HARD DISCS AND NON-ERASABLE MEMORY, PROXIMITY-SENSITIVE INPUT DEVICES, NAMELY TOUCH SCREENS AND OPTICAL SCANNERS AND NETWORK INTERFACES BETWEEN A SECOND OR MORE CONTROL UNITS AND/OR HOST SYSTEMS; CONTROL AND ADMINISTRATION SOFTWARE FOR ONE OR MORE HEIGHT-ADJUSTABLE SHELVING SYSTEMS FOR RECEIVING AND DISPENSING GOODS.

FIRST USE ; IN COMMERCE .  
INT. CL. 42/U.S. CLS. 100 AND 101

FOR PROVIDING TEMPORARY USE OF NON-DOWNLOADABLE CONTROL AND ADMINISTRATION SOFTWARE FOR ONE OR MORE HEIGHT-ADJUSTABLE SHELVING SYSTEMS FOR RECEIVING AND DISPENSING GOODS.

FIRST USE ; IN COMMERCE .

ELEMENTS AMENDED  
FOREIGN REG. NO.  
FOREIGN REG. DATE

2,927,287. REG. 2-22-2005. INNOVATIVE BEVERAGE CONCEPTS, INC. (CALIFORNIA CORPORATION) 27111 ALISO CREEK ROAD, SUITE 175, ALISO VIEJO, CA, 92656, SN 76-516,480. FILED 5-22-2003. PRINCIPAL REGISTER.

## TEA WITHOUT THE BAGGAGE

INT. CL. 30/U.S. CL. 46

FOR TEAS, HERBAL TEAS, ICED TEAS, [ TEA BAGS ], TEA BASED BEVERAGES, [ CANDY BREATH MINTS, AND CHEWING GUM ].

FIRST USE 4-24-2002; IN COMMERCE 4-24-2002.

ELEMENTS AMENDED  
GOODS/SERVICES  
DATE OF FIRST USE  
DATE OF FIRST USE IN COMMERCE  
[INTERNATIONAL CLASS(ES)]

2,933,425. REG. 3-15-2005. GRUPO ANDREA, S.A. DE C.V. (MEXICO CORPORATION) J.A. DE TORRES NO. 106, FRACC. SAN JERONIMO, C.P. 37148, LEON, GUANAJUATO, MEXICO., SN 75-458,555. FILED 3-27-1998. PRINCIPAL REGISTER.



INT. CL. 18/U.S. CLS. 1, 2, 3, 22 AND 41

FOR HANDBAGS, SHOULDERS BAGS, TOTE BAGS, WALLETS, PURSES, AND BOOK BAGS.

FIRST USE 6-19-2004; IN COMMERCE 6-19-2004.

INT. CL. 25/U.S. CLS. 22 AND 39

FOR SHOES, NAMELY, BOOTS, SANDALS, AND SNEAKERS, BELTS AND HOSIERY.

FIRST USE 6-19-2004; IN COMMERCE 6-19-2004.

INT. CL. 35/U.S. CLS. 100, 101 AND 102

FOR RETAIL SHOE STORE SERVICES.  
FIRST USE 6-19-2004; IN COMMERCE 6-19-2004.

ELEMENTS AMENDED  
MARK

2,933,616. REG. 3-15-2005. KONAMI CORPORATION (JAPAN CORPORATION) 2-4-1, MARUNOUCHI, CHIYODA-KU, TOKYO, JAPAN., SN 76-429,948. FILED 7-10-2002. PRINCIPAL REGISTER.

## ARIA OF SORROW

INT. CL. 9/U.S. CLS. 21, 23, 26, 36 AND 38

FOR COMPUTER GAME PROGRAMS; RECORDED VIDEO DISCS AND VIDEO TAPES FEATURING COMPUTER GAMES; VIDEO GAME SOFTWARE; VIDEO GAME PROGRAMS; VIDEO GAME CD-ROMS; VIDEO GAME DIGITAL VERSATILE DISC-ROMS; COMPUTER GAME PROGRAMS; COMPUTER GAME CD-ROMS; COMPUTER GAME DIGITAL VERSATILE DISC-ROMS; ELECTRONIC GAME PROGRAMS; ELECTRONIC GAME CD-ROMS; ELECTRONIC GAME DIGITAL VERSATILE DISC-ROMS; CARTRIDGES AND CASSETTES FOR USE WITH HAND-HELD VIDEO GAME MACHINE; CIRCUIT BOARDS CONTAINING GAME PROGRAMS FOR USE WITH HAND-HELD VIDEO GAME MACHINE; VIDEO OUTPUT GAME MACHINES; DOWNLOADABLE ELECTRONIC GAME SOFTWARE; DOWNLOADABLE COMPUTER GAME SOFTWARE AND DOWNLOADABLE VIDEO GAME SOFTWARE.

FIRST USE 5-6-2003; IN COMMERCE 5-6-2003.

ELEMENTS CORRECTED  
GOODS/SERVICES

2,960,116. REG. 6-7-2005. RINKINC, LLC (DELAWARE LIMITED PARTNERSHIP) 11 WEST 56TH STREET, NEW YORK, NY, 10019, SN 76-405,703. FILED 5-10-2002. PRINCIPAL REGISTER.

## ILOVEOLIVEOIL

INT. CL. 29/U.S. CL. 46

FOR BLENDS OF EDIBLE OIL.

FIRST USE 9-0-2003; IN COMMERCE 9-0-2003.

ELEMENTS CORRECTED  
ASSIGNMENT/NAME CHANGE



3,004,130. REG. 10-4-2005. AWS CONVERGENCE TECHNOLOGIES, INC. (DELAWARE CORPORATION) 12410 MILESTONE CENTER DR, GERMANTOWN, MD, 20876, SN 78-443,772. FILED 6-30-2004. PRINCIPAL REGISTER.

**WEATHERBUG ACHIEVE**

THE MARK CONSISTS OF STANDARD CHARACTERS WITHOUT CLAIM TO ANY PARTICULAR FONT, STYLE, SIZE, OR COLOR.

OWNER OF U.S. REG. NO. 2,620,037.

INT. CL. 41/U.S. CLS. 100, 101 AND 107

FOR PROVIDING AN ON-LINE COMPUTER DATABASE FEATURING EDUCATIONAL LESSON PLANS IN THE FIELD OF WEATHER [CONDITION] \*CONDITIONS\* BY MEANS OF A GLOBAL COMPUTER NETWORK.

FIRST USE 4-0-2004; IN COMMERCE 4-0-2004.

INT. CL. 42/U.S. CLS. 100 AND 101

FOR PROVIDING WEATHER RELATED INFORMATION BY MEANS OF A GLOBAL COMPUTER NETWORK.

FIRST USE 4-0-2004; IN COMMERCE 4-0-2004.

ELEMENTS CORRECTED  
GOODS/SERVICES

3,031,948. REG. 12-20-2005. AOL LLC (DELAWARE LTD LIAB CO) 22000 AOL WAY, DULLES, VA, 20166, SN 78-502,561. FILED 10-20-2004. PRINCIPAL REGISTER.

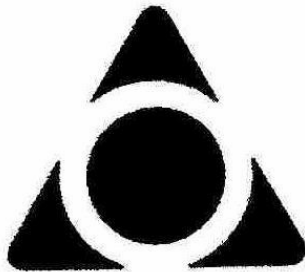

THE MARK CONSISTS OF A TRIANGLE WITH A CIRCLE IN THE MIDDLE.

INT. CL. 42/U.S. CLS. 100 AND 101

FOR PROVIDING INFORMATION IN THE FIELD OF COMPUTERS VIA COMPUTER NETWORKS; COMPUTER SERVICES, NAMELY, PROVIDING SEARCH ENGINES FOR OBTAINING DATA ON A GLOBAL COMPUTER NETWORK; CREATING INDEXES OF INFORMATION, SITES, AND OTHER RESOURCES AVAILABLE ON COMPUTER NETWORKS; FILTERING OF UNWANTED E-MAILS; COMPUTER VIRUS PROTECTION SERVICES; COMPUTER SECURITY SERVICES, NAMELY, RESTRICTING ACCESS TO AND BY COMPUTER NETWORKS TO AND OF UNDESIRED WEBSITES, MEDIA, INDIVIDUALS, AND FACILITIES.

FIRST USE 10-14-2004; IN COMMERCE 10-14-2004.

ELEMENTS AMENDED  
MARK

3,031,949. REG. 12-20-2005. AOL LLC (DELAWARE LTD LIAB CO) 22000 AOL WAY, DULLES, VA, 20166, SN 78-502,562. FILED 10-20-2004. PRINCIPAL REGISTER.

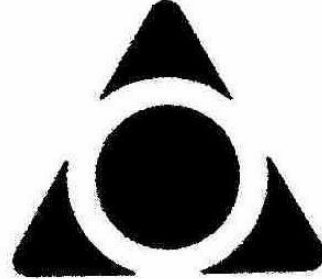

THE MARK CONSISTS OF A TRIANGLE WITH A CIRCLE IN THE MIDDLE.

INT. CL. 38/U.S. CLS. 100, 101 AND 104

FOR TELECOMMUNICATIONS SERVICES, NAMELY, PROVIDING MULTIPLE USER ACCESS TO COMPUTER NETWORKS; ELECTRONIC TRANSMISSION OF DATA, IMAGES, DOCUMENTS, MESSAGES, AND SOUND VIA COMPUTER NETWORKS; PROVIDING ONLINE ELECTRONIC BULLETIN BOARDS AND CHAT ROOMS FOR TRANSMISSION OF MESSAGES AMONG COMPUTER USERS CONCERNING TOPICS OF GENERAL INTEREST; ELECTRONIC MAIL SERVICES; PROVIDING ON-LINE COMPUTER NETWORK FACILITIES FOR REAL TIME INTERACTION AND COMMUNICATION WITH OTHER COMPUTER USERS.

FIRST USE 10-14-2004; IN COMMERCE 10-14-2004.

ELEMENTS AMENDED  
MARK

3,046,756. REG. 1-17-2006. RINKINC, LLC (DELAWARE LIMITED PARTNERSHIP) 11 WEST 56TH STREET, NEW YORK, NY, 10019, SN 78-230,322. FILED 3-26-2003. PRINCIPAL REGISTER.

**BARXV**

INT. CL. 3/U.S. CLS. 1, 4, 6, 50, 51 AND 52

FOR BATH AND SHOWER GEL; NON-MEDICATED BATH SALTS; BEAUTY MASKS; BLUSH; BODY CREAM, MOISTURIZER AND LOTION; BUBBLE BATH, COLD CREAM; HAIR SHAMPOO; HAIR CONDITIONER; COSMETIC PENCILS; EYE CREAM; HAND CREAM, MOISTURIZER, AND LOTION; SHAVING BALM, LOTION, GEL AND CREAM; SKIN CREAM, MOISTURIZER, AND LOTION; FACIAL CREAM, MOISTURIZER, AND LOTION; FOOT CREAM, MOISTURIZER, SCRUB, AND LOTION; PERSONAL DEODORANTS AND ANTIPERSPIRANTS; ESSENTIAL OILS FOR PERSONAL USE; ESSENTIAL OILS FOR USE IN MANUFACTURING COSMETICS; EYE MAKEUP; EYE SHADOW; EYELINERS; FACE POWDER; FACIAL SCRUBS; FACIAL MAKEUP; FOUNDATION MAKEUP; HAIR GEL; SHAVING GEL; SHOWER GEL; LIP GLOSS; HAIR RINSES; NON-MEDICATED LIP BALM; LIPSTICK; EYE MAKEUP REMOVER; MASCARA; NAIL CREAM, MOISTURIZER, AND LOTION; MASSAGE OIL; BATH OIL; PRE-MOISTENED COSMETIC TISSUES, WIPES, AND TOWELETTES; SOAP; SUNTANNING PREPARATIONS; AND WRINKLE REMOVING SKIN CARE PREPARATIONS.

FIRST USE 9-30-2003; IN COMMERCE 9-30-2003.

INT. CL. 29/U.S. CL. 46

FOR OLIVE OIL.

FIRST USE 9-30-2003; IN COMMERCE 9-30-2003.

INT. CL. 30/U.S. CL. 46

FOR TEA, TEA-BASED BEVERAGES, NAMELY, TEA-BASED BEVERAGES WITH FRUIT FLAVORINGS, FLAVORED ICES; HONEY, BISCUITS.

FIRST USE 9-30-2003; IN COMMERCE 9-30-2003.  
INT. CL. 32/U.S. CLS. 45, 46 AND 48

FOR BOTTLED SODA WATER.  
FIRST USE 9-30-2003; IN COMMERCE 9-30-2003.  
INT. CL. 35/U.S. CLS. 100, 101 AND 102

FOR RETAIL STORE SERVICES IN THE FIELDS OF APPAREL, FOOTWEAR, COSMETICS, LOTIONS, BOTTLED WATER, COFFEE, COFFEE BASED BEVERAGES, TEA, TEA-BASED BEVERAGES, PREPARED FOOD, OLIVE OIL.

FIRST USE 9-30-2003; IN COMMERCE 9-30-2003.

ELEMENTS CORRECTED  
ASSIGNMENT/NAME CHANGE

3,073,062. REG. 3-28-2006. UNFILTERED NAPA LLC (CALIFORNIA LTD LIAB CO) 5012 SILVERADO TRAIL, NAPA, CA, 94558, SN 78-521,582. FILED 11-23-2004. PRINCIPAL REGISTER.

# JADEN

THE MARK CONSISTS OF STANDARD CHARACTERS WITHOUT CLAIM TO ANY PARTICULAR FONT, STYLE, SIZE, OR COLOR.

INT. CL. 33/U.S. CLS. 47 AND 49  
FOR WINE.

FIRST USE 8-31-2003; IN COMMERCE 8-31-2003.

ELEMENTS CORRECTED  
ENTITY

3,054,352. REG. 1-31-2006. EVERBANK (UNITED STATES FEDERAL SAVINGS INSTITUTION) LEGA, 8100 NATIONS WAY, JACKSONVILLE, FL. 32256, SN 78-550,216. FILED 1-19-2005. PRINCIPAL REGISTER.

# EVERHOME

3,094,758. REG. 5-23-2006. EMERSON PARTNERS, INC. (TEXAS CORPORATION) 10005 TECHNOLOGY BLVD. W., SUITE 151, DALLAS, TX, 75220, SN 76-627,792. FILED 1-12-2005. PRINCIPAL REGISTER.

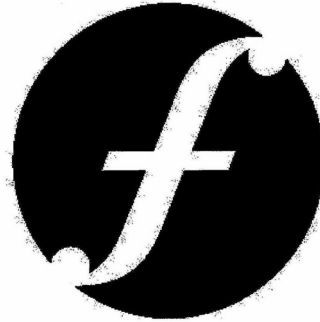

THE MARK CONSISTS OF STANDARD CHARACTERS WITHOUT CLAIM TO ANY PARTICULAR FONT, STYLE, SIZE, OR COLOR.

INT. CL. 36/U.S. CLS. 100, 101 AND 102  
FOR MORTGAGE LENDING SERVICES.  
FIRST USE 1-1-2004; IN COMMERCE 1-1-2004.

ELEMENTS CORRECTED  
ENTITY

INT. CL. 37/U.S. CLS. 100, 103 AND 106  
FOR REAL ESTATE DEVELOPMENT SERVICES.  
FIRST USE 0-0-2002; IN COMMERCE 0-0-2002.

ELEMENTS AMENDED  
MARK

3,107,831. REG. 6-20-2006. HOBOKEN WOOD FLOORING LLC (NEW JERSEY LTD LIAB CO) 70 DEMAREST DRIVE, WAYNE, NJ, 074706702, SN 78-440,127. FILED 6-23-2004. PRINCIPAL REGISTER.

3,122,779. REG. 8-1-2006. FISHER AND PAYKEL HEALTH-CARE LIMITED (NEW ZEALAND COMPANY) 15 MAURICE PAYKEL PLACE, EAST TAMAKI, AUCKLAND, NEW ZEALAND., SN 78-529,397. FILED 12-8-2004. PRINCIPAL REGISTER.

## HOBOKEN FLOORS

## SENSAWAKE

THE MARK CONSISTS OF STANDARD CHARACTERS WITHOUT CLAIM TO ANY PARTICULAR FONT, STYLE, SIZE, OR COLOR.

OWNER OF U.S. REG. NO. 1,116,229.  
NO CLAIM IS MADE TO THE EXCLUSIVE RIGHT TO USE "FLOORS", APART FROM THE MARK AS SHOWN.  
AS TO HOBOKEN.

INT. CL. 35/U.S. CLS. 100, 101 AND 102

FOR RETAIL STORE SERVICES AND DISTRIBUTORSHIP SERVICES IN THE FIELD OF HARD SURFACE FLOORING; NAMELY HARDWOOD FLOORING, ENGINEERED FLOORING, COMPOSITE FLOORING, CERAMIC FLOORING, MINERAL FLOORING, AND SYNTHETIC FLOORING, NAMELY VINYL FLOORING, AND HARD SURFACE FLOORING ACCESSORIES; NAMELY ABRASIVES, WOOD FINISHES, SANDERS, BUFFERS, EDGERS, VACUUMS, DUST COLLECTION SYSTEMS, NAILERS, STAPLERS, NAILS, STAPLES, SAWS, METERS AND ABRASIVES.

FIRST USE 0-0-1989; IN COMMERCE 0-0-1989.

ELEMENTS CORRECTED  
ENTITY  
DISCLAIMER

THE MARK CONSISTS OF STANDARD CHARACTERS WITHOUT CLAIM TO ANY PARTICULAR FONT, STYLE, SIZE, OR COLOR.

PRIORITY CLAIMED UNDER SEC. 44(D) ON NEW ZEALAND APPLICATION NO. 722524, FILED 12-7-2004, REG. NO. 722524, DATED 6-9-2005, EXPIRES 12-7-2014.

INT. CL. 10/U.S. CLS. 26, 39 AND 44

FOR MEDICAL APPARATUS AND INSTRUMENTS, NAMELY, RESPIRATORS AND ARTIFICIAL RESPIRATION APPARATUS; APPARATUS FOR MEDICAL USE, NAMELY, HUMIDIFIERS; MEDICAL APPARATUS, NAMELY, VENTILATION AND NON-INVASIVE VENTILATION APPARATUS AND INSTRUMENTS; MEDICAL APPARATUS AND INSTRUMENTS FOR CONTINUOUS POSITIVE AIRWAY PRESSURE, ALSO KNOWN AS CPAP, AND BI-LEVEL THERAPY; MEDICAL APPARATUS, NAMELY, HUMIDIFIERS AND METERS FOR CONTINUOUS POSITIVE AIRWAY PRESSURE ALSO KNOWN AS CPAP AND BI-LEVEL THERAPY; MEDICAL APPARATUS, NAMELY, SLEEP APNEA MONITORS; MEDICAL APPARATUS, NAMELY, FACIAL MASKS, ORAL MASKS, NASAL MASKS, MOUTHPIECES, NASAL GUARDS, FACIAL GUARDS, AND HEADGEAR FOR USE BY PATIENTS; PARTS AND FITTINGS FOR ALL THE AFOREMENTIONED GOODS.

FIRST USE ; IN COMMERCE .

ELEMENTS CORRECTED  
FOREIGN REG. EXPIRATION DATE

3,116,568. REG. 7-18-2006. NATURE'S THERAPY 101, LLC (ARIZONA LTD LIAB CO) 1731 MESQUITE AVE, #4, LAKE HAVASU CITY, AZ, 86403, SN 78-592,443. FILED 3-22-2005. PRINCIPAL REGISTER.

3,127,708. REG. 8-8-2006. KPL LIMITED (NEW ZEALAND CORPORATION) 625 MT. EDEN ROAD, MT. EDEN, AUCKLAND, NEW ZEALAND., SN 78-425,642. FILED 5-26-2004. PRINCIPAL REGISTER.

## KICK-A-KOLD

## KIWIPROPS

THE MARK CONSISTS OF STANDARD CHARACTERS WITHOUT CLAIM TO ANY PARTICULAR FONT, STYLE, SIZE, OR COLOR.

INT. CL. 5/U.S. CLS. 6, 18, 44, 46, 51 AND 52  
FOR VITAMINS AND HERBAL SUPPLEMENTS TO FIGHT COLDS.

FIRST USE 12-1-2004; IN COMMERCE 12-1-2004.

ELEMENTS AMENDED  
OWNER NAME

THE MARK CONSISTS OF STANDARD CHARACTERS WITHOUT CLAIM TO ANY PARTICULAR FONT, STYLE, SIZE, OR COLOR.

PRIORITY CLAIMED UNDER SEC. 44(D) ON NEW ZEALAND APPLICATION NO. 712583, FILED 5-19-2004, REG. NO. 712583, DATED 5-19-2004, EXPIRES 5-19-2014.  
INT. CL. 12/U.S. CLS. 19, 21, 23, 31, 35 AND 44

FOR BOAT PROPELLERS.  
FIRST USE 10-13-2004; IN COMMERCE 10-13-2004.

ELEMENTS CORRECTED  
FOREIGN REG. EXPIRATION DATE

3,137,493. REG. 9-5-2006. KABUSHIKI KAISHA SONY COMPUTER ENTERTAINMENT (JAPAN CORPORATION), TA SONY COMPUTER ENTERTAINMENT INC., 1-1, AKA-SAKA 7-CHOME, MINATO-KU, TOKYO 107-0052, JAPAN., SN 76-477,501. FILED 12-20-2002. PRINCIPAL REGISTER.

## DNAS-LOCATOR

OWNER OF JAPAN REG. NO. 4747161, DATED 2-13-2004, EXPIRES 2-13-2014.

INT. CL. 9/U.S. CLS. 21, 23, 26, 36 AND 38

FOR MOUSE PADS FOR COMPUTERS; MOUSE FOR COMPUTERS; ELECTRONIC CIRCUITS, MAGNETIC DISCS AND MAGNETIC TAPES FOR ENCODING COMPUTER PROGRAMS FOR ENCRYPTING OR DECRYPTING INFORMATION DATA; ENCRYPTING AND MICRO PROGRAMMING DEVICES FOR INFORMATION PROCESSING MACHINES, NAMELY, ELECTRONIC CIRCUITS; STRAPS FOR CELLULAR PHONES; INSTANT CAMERAS WITH FILMS; COMPUTER E-COMMERCE SOFTWARE TO ALLOW USERS TO PERFORM ELECTRONIC BUSINESS TRANSACTIONS VIA A GLOBAL COMPUTER NETWORK; AMUSEMENT APPARATUS FOR USE WITH TELEVISION RECEIVER ONLY, NAMELY VIDEO OUTPUT GAME MACHINES FOR USE WITH TELEVISIONS; SLOT MACHINES; DOWNLOADABLE COMPUTER GAME PROGRAMS; DOWNLOADABLE ELECTRONIC PUBLICATIONS.[\*] IN THE NATURE OF\*BOOKS, MAGAZINES AND MANUALS FEATURING COMPUTER GAMES AND VIDEO GAMES RECORDED ON COMPUTER MEDIA; DOWNLOADABLE VIDEO GAME SOFTWARE; ELECTRONIC CIRCUITS, MAGNETIC DISCS, MAGNETIC TAPES, OPTICAL DISCS, CD-ROMS, MAGNETIC CARDS, AND OTHER MEMORY MEDIA ENCODING ASSEMBLERS, COMPILERS, AND COMPUTER PROGRAMS FOR SOFTWARE DEVELOPMENT AND COMPUTER PROGRAMMING; ENCRYPTION DEVICES, NAMELY, MODEMS AND ENCODERS, USED FOR SCRAMBLING IN TELECOMMUNICATION; ELECTRONIC CIRCUITS, MAGNETIC DISCS, OPTICAL DISCS, MAGNETIC OPTICAL DISCS, CD-ROMS, MAGNETIC TAPES AND DIGITAL VERSATILE DISC ROMS FOR ENCODING VIDEO GAME PROGRAMS FOR BUSINESS USE; ELECTRICAL CONTROLLERS, JOYSTICKS, MEMORY CARDS, ELECTRIC VOLUME CONTROLLERS; MAGNETIC DISCS, OPTICAL DISCS, MAGNETIC OPTICAL DISCS, CD-ROMS, MAGNETIC TAPES AND DIGITAL VERSATILE DISC ROMS FOR ENCODING MAGAZINES, BOOKS, NEWS PAPERS, MAPS, PICTURES, IMAGES AND OTHER LITERAL INFORMATION; ROTARY CONVERTERS; PHASE MODIFIERS; DRY CELL BATTERIES; WET CELL BATTERIES; ELECTRIC ACCUMULATORS AND BATTERIES; PHOTOVOLTAIC CELLS; ELECTRIC WIRES; ELECTRIC CABLES; PHOTOGRAPHIC APPARATUS AND INSTRUMENTS, NAMELY, TILTING HEADS FOR CAMERAS, CAMERAS, RANGE FINDERS FOR CAMERAS, TRIPDS FOR CAMERAS, SHUTTERS FOR CAMERAS, BELLOWS FOR CAMERAS, SPOOLS FOR CAMERAS, SLIDE PROJECTORS, SELF-TIMERS FOR CAMERAS, PHOTOGRAPHIC FLASH UNITS FOR CAMERAS, FLASH LAMPS FOR CAMERAS, VIEWFINDERS FOR CAMERAS, LENS FILTERS FOR CAMERAS, LENS HOODS FOR CAMERAS, FLASH GUNS FOR CAMERAS, FILM MAGAZINES FOR CAMERAS, SHUTTER RELEASES FOR CAMERAS, LENSES FOR PHOTOGRAPHIC APPARATUS, EXPOSURE METERS; CINEMATOGRAPHIC APPARATUS AND INSTRUMENTS, NAMELY, MOVIE FILM PROJECTORS, MOVIE FILM PROCESSING AND FINISHING APPARATUS, CI-

NEMATOGRAPHIC CAMERAS, PROJECTION SCREENS FOR MOVIE FILMS, MOVIE FILM EDITING MACHINES, SOUND RECORDING APPARATUS FOR MOVIES; TELESCOPES; MICROSCOPES; EYEGGLASSES AND SAFETY GOGGLES; LIFE NETS; LIFE BELTS; LIFE-JACKETS; LIFE-BUOYS; TELEPHONE APPARATUS, NAMELY, INTERCOMS, AUTOMATIC SWITCHING APPARATUS FOR TELECOMMUNICATION, MANUAL SWITCHING APPARATUS FOR TELECOMMUNICATION, TELEPHONE SETS; WIRE COMMUNICATION APPARATUS, NAMELY, TELETYPEWRITERS, AUTOMATIC TELEGRAPH APPARATUS, PHOTO-TELEGRAPHY APPARATUS, MANUAL TELEGRAPH APPARATUS, TRUNK EXCHANGE APPARATUS, FACSIMILE MACHINES; BROADCASTING APPARATUS, NAMELY, TELEVISION RECEIVERS, TELEVISION TRANSMITTERS, RADIO RECEIVERS, RADIO TRANSMITTERS; RADIO COMMUNICATION APPARATUS, NAMELY, PORTABLE RADIO COMMUNICATION TRANSMITTERS, AERONAUTICAL RADIO COMMUNICATION TRANSMITTERS, MULTI CHANNEL RADIO COMMUNICATION TRANSMITTERS FOR FIXED STATIONS, SINGLE-CHANNEL RADIO COMMUNICATION TRANSMITTERS FOR FIXED STATIONS, VEHICULAR RADIO COMMUNICATION TRANSMITTERS, MARINE RADIO COMMUNICATION TRANSMITTERS; AUDIO FREQUENCY APPARATUS, NAMELY, PUBLIC-ADDRESS SYSTEMS, JUKE BOXES, TAPE RECORDERS, ELECTRIC PHONOGRAPHS, RECORD PLAYERS, VIDEOTAPE RECORDERS; VIDEO FREQUENCY APPARATUS, NAMELY, VIDEO CAMERAS, VIDEODISC PLAYERS, VIDEOTAPE RECORDERS; EP RECORDS CONTAINING MUSIC; LP RECORDS CONTAINING MUSIC; METRONOMES; RECORDED COMPACT DISCS CONTAINING MUSIC; COMPUTERS; ELECTRON MICROSCOPES; ELECTRONIC DESK CALCULATORS; WORD PROCESSORS; GLASS TUBES FOR SCIENTIFIC PURPOSES, NAMELY, X-RAY TUBES, PHOTOSENSITIVE TUBES, VACUUM TUBES, RECTIFIER TUBES, DISCHARGE TUBES; CATHODE RAY TUBES; THERMISTORS; DIODES FOR USE IN CIRCUIT BOARDS AND ELECTRONIC CIRCUITRY; TRANSISTORS; ELECTRON TUBES; SEMI-CONDUCTOR DEVICES; INTEGRATED CIRCUITS; LARGE SCALE INTEGRATED CIRCUITS; ELECTRIC FLAT IRONS FOR HOUSEHOLD USE; ELECTRIC HAIR-CURLERS FOR HOUSEHOLD USE; ELECTRIC BUZZERS FOR HOUSEHOLD USE; EXPOSED CINEMATOGRAPHIC FILMS; EXPOSED SLIDE FILMS; PHOTOGRAPHIC SLIDE TRANSPARENCIES; SLIDE FILM MOUNTS; ENCODED VIDEO DISCS AND TAPES FEATURING PICTURES; VENDING MACHINES; VIDEO GAME MACHINES FOR PERSONAL USE FOR USE WITH TELEVISIONS; BROADCAST SATELLITE DOWNLINK TERMINALS; DIGITAL VERSATILE DISC ROM PLAYERS; DIGITAL VERSATILE DISC RECORDERS; DIGITAL VERSATILE DISC VIDEO RECORDERS; DIGITAL VERSATILE DISC PLAYERS; DNA CHIPS; HARD DISC DRIVE RECORDERS; HARD DISC DRIVE VIDEO RECORDERS; TUNERS FOR TELEVISION SET; DIGITAL IDENTITY CERTIFICATION SYSTEM USED ON COMPUTERS.

FIRST USE ; IN COMMERCE .

INT. CL. 35/U.S. CLS. 100, 101 AND 102

FOR DATA PROCESSING SERVICES; COMPUTERIZED TRACKING AND TRACING OF PACKAGES IN TRANSIT; DATA ENTRY SERVICES FOR OTHERS; COMPUTERIZED DATA PROCESSING SERVICES; COMPUTERIZED DATA PROCESSING SERVICES FOR IMAGES; COMPUTERIZED DATA PROCESSING SERVICES FOR INPUTTING DATA INTO MAGNETIC CARDS.

FIRST USE ; IN COMMERCE .

INT. CL. 42/U.S. CLS. 100 AND 101

FOR ENCRYPTION OF INFORMATION AVAILABLE ON A COMPUTER; PLANNING, PRODUCING, AND MAINTAINING COMPUTER SYSTEM PROGRAMS FOR OTHERS FOR DATA SECURITY AVAILABLE ON A COMPUTER; DATA ENCRYPTION SERVICES; PROVIDING ELECTRONIC VERIFICATION OF ON-LINE ORDERS OF DIGITAL CONTENT AND GENERATING ELECTRONIC PERMISSION CODES WHICH THEN ALLOW USERS TO ACCESS SAID DIGITAL CONTENT ONLINE; CONDUCTING COMPUTER SEARCHES FOR OTHERS ABOUT NEWS ARTICLES; COMPUTER AIDED GRAPHICS DESIGN; DESIGNING AND PRODUCING COMPUTER GRAPHICS PROGRAMS FOR OTHERS; ESTABLISHING AND MANAGING INTERNET WEB SITES FOR OTHERS; COMPUTER SERVICES, NAMELY, DESIGNING AND IMPLEMENTING NETWORK WEB

PAGES FOR OTHERS; PROVIDING TEMPORARY USE OF ON-LINE NON-DOWNLOADABLE COMPUTER GAME SOFTWARE AND VIDEO GAME SOFTWARE; PROVIDING TEMPORARY USE OF NON-DOWNLOADABLE COMPUTER SOFTWARE FOR TRACKING DOCUMENTS, PACKAGES, AND FREIGHT OVER COMPUTER NETWORKS, INTRANETS, AND THE INTERNET; PROFESSIONAL CONSULTANCY REGARDING DESIGNING COMPUTER SYSTEMS; DESIGNING COMPUTER SYSTEMS FOR OTHERS; DESIGNING VIDEO GAME SOFTWARE FOR OTHERS; PROCESSING INFORMATION BY A COMPUTER; MAINTENANCE OF COMPUTER SOFTWARE, NAMELY, MAINTENANCE OF ELECTRONIC MAIL SERVERS FOR OTHERS; PROVIDING ELECTRONIC VERIFICATION OF ON-LINE USERS OF ELECTRONIC MAIL AND WEB PAGES AND GENERATING ELECTRONIC PERMISSION CODES WHICH THEN ALLOW USERS TO ACCESS SAID DIGITAL CONTENT; DESIGNING PROGRAMS FOR OTHERS FOR VIDEO GAMES WITH TELEVISION FOR PERSONAL USE; WRITING MANUALS FOR OTHERS FOR PROGRAMS FOR VIDEO GAMES WITH TELEVISION FOR PERSONAL USE; PROVIDING INFORMATION ABOUT COMPUTER PROGRAMS AND COMPUTERS; WRITING MANUALS FOR OTHERS FOR COMPUTER PROGRAMS AND COMPUTERS; COMPUTER CONSULTATION REGARDING THE WORKINGS OF A COMPUTER; DESIGNING AND MAINTAINING INFORMATION PROCESSING SYSTEMS FOR OTHERS BY A COMPUTER; COMPUTER SOFTWARE DEVELOPMENT AND CUSTOMIZATION; AGENCY OF COMPUTER DATA OUTPUT; DESIGNING COMPUTER NETWORKS FOR OTHERS; PROFESSIONAL CONSULTANCY REGARDING DESIGNING AND STUDYING COMPUTER NETWORKS; COMPUTER GRAPHIC SERVICES FOR DESIGNING AND DRAWING MACHINES, APPARATUS AND FACILITIES; INSTALLATION OF COMPUTER SOFTWARE; RENTAL AND LEASING OF MAGNETIC TAPES ENCODING PROGRAMS FOR COMPUTER FOR COMPUTER SYSTEM SECURITY; RENTAL AND LEASING OF MAGNETIC TAPES ENCODING PROGRAMS FOR VIDEO GAMES WITH TELEVISION FOR PERSONAL USE FOR COMPUTER SYSTEM SECURITY; LEASING SERVERS FOR WEB PAGES; RENTAL AND LEASING OF COMPUTERS AND COMPUTER PROGRAMS; PROVIDING ELECTRONIC VERIFICATION OF ON-LINE ORDERS OF DIGITAL CONTENT AND GENERATING ELECTRONIC PERMISSION CODES WHICH THEN ALLOW USERS TO ACCESS SAID DIGITAL CONTENT; HOURLY RENTAL AND LEASING OF COMPUTERS VIA ON-LINE NETWORK; COMPUTER SOFTWARE CONSULTANCY; COMPUTER VIRUS PROTECTION SERVICES; RENTAL OF WEB SERVERS; MONITORING THE COMPUTER SYSTEMS OF OTHERS FOR TECHNICAL PURPOSES AND PROVIDING BACK-UP COMPUTER PROGRAMS AND FACILITIES; COMPUTER SERVICES, NAMELY, DESIGNING, IMPLEMENTING, TESTING, AND ANALYZING SECURITY, AUTHORIZATION, AUTHENTICATION, AND ENCRYPTION SYSTEMS TO PROVIDE SECURE ACCESS TO COMPUTER SOFTWARE, COMPUTER HARDWARE, AND COMPUTER NETWORKS; PROVIDING ELECTRONIC VERIFICATION OF USERS OF DIGITAL CONTENT WHICH THEN ALLOWS USERS TO ACCESS SAID DIGITAL CONTENT.

FIRST USE : IN COMMERCE .

ELEMENTS CORRECTED  
GOODS/SERVICES

3,137,494, REG. 9-5-2006. KABUSHIKI KAISHA SONY COMPUTER ENTERTAINMENT (JAPAN CORPORATION), TA SONY COMPUTER ENTERTAINMENT INC., 1-1, AKA-SAKA 7-CHOME, MINATO-KU, TOKYO 107-0052, JAPAN., SN 76-477,521. FILED 12-20-2002. PRINCIPAL REGISTER.

## DNAS-CHRONO

OWNER OF JAPAN REG. NO. 4747160, DATED 2-13-2004, EXPIRES 2-13-2014.  
INT. CL. 9/U.S. CLS. 21, 23, 26, 36 AND 38

FOR MOUSE PADS FOR COMPUTERS; MOUSE FOR COMPUTERS; ELECTRONIC CIRCUITS, MAGNETIC DISCS AND MAGNETIC TAPES FOR ENCODING COMPUTER PROGRAMS FOR ENCRYPTING OR DECRYPTING INFORMATION DATA; ENCRYPTING AND MICRO PROGRAMMING DEVICES FOR INFORMATION PROCESSING MACHINES, NAMELY, ELECTRONIC CIRCUITS; STRAPS FOR CELLULAR PHONES; INSTANT CAMERAS WITH FILMS; COMPUTER E-COMMERCE SOFTWARE TO ALLOW USERS TO PERFORM ELECTRONIC BUSINESS TRANSACTIONS VIA A GLOBAL COMPUTER NETWORK; AMUSEMENT APPARATUS FOR USE WITH TELEVISION RECEIVER ONLY, NAMELY VIDEO OUTPUT GAME MACHINES FOR USE WITH TELEVISIONS; SLOT MACHINES; DOWNLOADABLE COMPUTER GAME PROGRAMS; DOWNLOADABLE ELECTRONIC PUBLICATIONS [.] \*IN THE NATURE OF\* BOOKS, MAGAZINES AND MANUALS FEATURING COMPUTER GAMES AND VIDEO GAMES RECORDED ON COMPUTER MEDIA; DOWNLOADABLE VIDEO GAME SOFTWARE; ELECTRONIC CIRCUITS, MAGNETIC DISCS, MAGNETIC TAPES, OPTICAL DISCS, CD-ROMS, MAGNETIC CARDS, AND OTHER MEMORY MEDIA ENCODING ASSEMBLERS, COMPILERS, AND COMPUTER PROGRAMS FOR SOFTWARE DEVELOPMENT AND COMPUTER PROGRAMMING; ENCRYPTION DEVICES, NAMELY, MODEMS AND ENCODERS, USED FOR SCRAMBLING IN TELECOMMUNICATION; ELECTRONIC CIRCUITS, MAGNETIC DISCS, OPTICAL DISCS, MAGNETIC OPTICAL DISCS, CD-ROMS, MAGNETIC TAPES AND DIGITAL VERSATILE DISC ROMS FOR ENCODING VIDEO GAME PROGRAMS FOR BUSINESS USE; ELECTRICAL CONTROLLERS, JOYSTICKS, MEMORY CARDS, ELECTRIC VOLUME CONTROLLERS; MAGNETIC DISCS, OPTICAL DISCS, MAGNETIC OPTICAL DISCS, CD-ROMS, MAGNETIC TAPES AND DIGITAL VERSATILE DISC ROMS FOR ENCODING VIDEO GAME PROGRAMS FOR BUSINESS USE; ELECTRICAL CONTROLLERS, JOYSTICKS, MEMORY CARDS, ELECTRIC VOLUME CONTROLLERS; MAGNETIC DISCS, OPTICAL DISCS, MAGNETIC OPTICAL DISCS, CD-ROMS, MAGNETIC TAPES AND DIGITAL VERSATILE DISC ROMS FOR ENCODING MAGAZINES, BOOKS, NEWS PAPERS, MAPS, PICTURES, IMAGES AND OTHER LITERAL INFORMATION; ROTARY CONVERTERS; PHASE MODIFIERS; DRY CELL BATTERIES; WET CELL BATTERIES; ELECTRIC ACCUMULATORS AND BATTERIES; PHOTOVOLTAIC CELLS; ELECTRIC WIRES; ELECTRIC CABLES; PHOTOGRAPHIC APPARATUS AND INSTRUMENTS, NAMELY, TILTING HEADS FOR CAMERAS, CAMERAS, RANGE FINDERS FOR CAMERAS, TRIPODS FOR CAMERAS, SHUTTERS FOR CAMERAS, BELLOWS FOR CAMERAS, SPOOLS FOR CAMERAS, SLIDE PROJECTORS, SELF-TIMERS FOR CAMERAS, PHOTOGRAPHIC FLASH UNITS FOR CAMERAS, FLASH LAMPS FOR CAMERAS, VIEW-FINDERS FOR CAMERAS, LENS FILTERS FOR CAMERAS, LENS HOODS FOR CAMERAS, FLASH GUNS FOR CAMERAS, FILM MAGAZINES FOR CAMERAS, SHUTTER RELEASES FOR CAMERAS, LENSES FOR PHOTOGRAPHIC APPARATUS, EXPOSURE METERS; CINEMATOGRAPHIC APPARATUS AND INSTRUMENTS, NAMELY, MOVIE FILM PROJECTORS, MOVIE FILM PROCESSING AND FINISHING APPARATUS, CINEMATOGRAPHIC CAMERAS, PROJECTION SCREENS FOR MOVIE FILMS, MOVIE FILM EDITING MACHINES, SOUND RECORDING APPARATUS FOR MOVIES; TELESCOPES; MICROSCOPES; EYEGASSES AND SAFETY GOGGLES; LIFE NETS; LIFE BELTS; LIFE-JACKETS; LIFE-BUOYS; TELEPHONE APPARATUS, NAMELY, INTERCOMS, AUTOMATIC SWITCHING APPARATUS FOR TELECOMMUNICATION, MANUAL SWITCHING APPARATUS FOR TELECOMMUNICATION, TELEPHONE SETS; WIRE COMMUNICATION APPARATUS, NAMELY, TELETYPEWRITERS, AUTOMATIC TELEGRAPH APPARATUS, PHOTO-TELEGRAPHY APPARATUS, MANUAL TELEGRAPH APPARATUS, TRUNK EXCHANGE APPARATUS, FACSIMILE MACHINES; BROADCASTING APPARATUS, NAMELY, TELEVISION RECEIVERS, TELEVISION TRANSMITTERS, RADIO RECEIVERS, RADIO TRANSMITTERS; RADIO COMMUNICATION APPARATUS, NAMELY, PORTABLE RADIO COMMUNICATION TRANSMITTERS, AERONAUTICAL RADIO COMMUNICATION TRANSMITTERS, MULTI CHANNEL RADIO COMMUNICATION TRANSMITTERS FOR FIXED STATIONS, SINGLE-CHANNEL RADIO COMMUNICATION TRANSMITTERS FOR FIXED STATIONS, VEHICULAR RADIO COMMUNICATION TRANSMITTERS, MARINE

RADIO COMMUNICATION TRANSMITTERS; AUDIO FREQUENCY APPARATUS, NAMELY, PUBLIC-ADDRESS SYSTEMS, JUKE BOXES, TAPE RECORDERS, ELECTRIC PHONOGRAPHS, RECORD PLAYERS, VIDEOTAPE RECORDERS; VIDEO FREQUENCY APPARATUS, NAMELY, VIDEO CAMERAS, VIDEODISC PLAYERS, VIDEOTAPE RECORDERS; EP RECORDS CONTAINING MUSIC; LP RECORDS CONTAINING MUSIC; METRONOMES; RECORDED COMPACT DISCS CONTAINING MUSIC; COMPUTERS; ELECTRON MICROSCOPES; ELECTRONIC DESK CALCULATORS; WORD PROCESSORS; GLASS TUBES FOR SCIENTIFIC PURPOSES, NAMELY, X-RAY TUBES, PHOTOSENSITIVE TUBES, VACUUM TUBES, RECTIFIER TUBES, DISCHARGE TUBES; CATHODE RAY TUBES; THERMISTORS; DIODES FOR USE IN CIRCUIT BOARDS AND ELECTRONIC CIRCUITRY; TRANSISTORS; ELECTRON TUBES; SEMI-CONDUCTOR DEVICES; INTEGRATED CIRCUITS; LARGE SCALE INTEGRATED CIRCUITS; ELECTRIC FLAT IRONS FOR HOUSEHOLD USE; ELECTRIC HAIR-CURLERS FOR HOUSEHOLD USE; ELECTRIC BUZZERS FOR HOUSEHOLD USE; EXPOSED CINEMATOGRAPHIC FILMS; EXPOSED SLIDE FILMS; PHOTOGRAPHIC SLIDE TRANSPARENCIES; SLIDE FILM MOUNTS; ENCODED VIDEO DISCS AND TAPES FEATURING PICTURES; VENDING MACHINES; VIDEO GAME MACHINES FOR PERSONAL USE FOR USE WITH TELEVISIONS; BROADCAST SATELLITE DOWNLINK TERMINALS; DIGITAL VERSATILE DISC ROM PLAYERS; DIGITAL VERSATILE DISC RECORDERS; DIGITAL VERSATILE DISC VIDEO RECORDERS; DIGITAL VERSATILE DISC PLAYERS; DNA CHIPS; HARD DISC DRIVE RECORDERS; HARD DISC DRIVE VIDEO RECORDERS; TUNERS FOR TELEVISION SET; DIGITAL IDENTITY CERTIFICATION SYSTEM USED ON COMPUTERS.

FIRST USE ; IN COMMERCE .

INT. CL. 35/U.S. CLS. 100, 101 AND 102

FOR DATA PROCESSING SERVICES; COMPUTERIZED TRACKING AND TRACING OF PACKAGES IN TRANSIT; DATA ENTRY SERVICES FOR OTHERS; COMPUTERIZED DATA PROCESSING SERVICES; COMPUTERIZED DATA PROCESSING SERVICES FOR IMAGES; COMPUTERIZED DATA PROCESSING SERVICES FOR INPUTTING DATA INTO MAGNETIC CARDS.

FIRST USE ; IN COMMERCE .

INT. CL. 42/U.S. CLS. 100 AND 101

FOR ENCRYPTION OF INFORMATION AVAILABLE ON A COMPUTER; PLANNING, PRODUCING, AND MAINTAINING COMPUTER SYSTEM PROGRAMS FOR OTHERS FOR DATA SECURITY AVAILABLE ON A COMPUTER; DATA ENCRYPTION SERVICES; PROVIDING ELECTRONIC VERIFICATION OF ON-LINE ORDERS OF DIGITAL CONTENT AND GENERATING ELECTRONIC PERMISSION CODES WHICH THEN ALLOW USERS TO ACCESS SAID DIGITAL CONTENT ONLINE; CONDUCTING COMPUTER SEARCHES FOR OTHERS ABOUT NEWS ARTICLES; COMPUTER AIDED GRAPHICS DESIGN; DESIGNING AND PRODUCING COMPUTER GRAPHICS PROGRAMS FOR OTHERS; ESTABLISHING AND MANAGING INTERNET WEB SITES FOR OTHERS; COMPUTER SERVICES, NAMELY, DESIGNING AND IMPLEMENTING NETWORK WEB PAGES FOR OTHERS; PROVIDING TEMPORARY USE OF ON-LINE NON-DOWNLOADABLE COMPUTER GAME SOFTWARE AND VIDEO GAME SOFTWARE; PROVIDING TEMPORARY USE OF NON-DOWNLOADABLE COMPUTER SOFTWARE FOR TRACKING DOCUMENTS, PACKAGES, AND FREIGHT OVER COMPUTER NETWORKS, INTRANETS, AND THE INTERNET; PROFESSIONAL CONSULTANCY REGARDING DESIGNING COMPUTER SYSTEMS; DESIGNING COMPUTER SYSTEMS FOR OTHERS; DESIGNING VIDEO GAME SOFTWARE FOR OTHERS; PROCESSING INFORMATION BY A COMPUTER; MAINTENANCE OF COMPUTER SOFTWARE, NAMELY, MAINTENANCE OF ELECTRONIC MAIL SERVERS FOR OTHERS; PROVIDING ELECTRONIC VERIFICATION OF ON-LINE USERS OF ELECTRONIC MAIL AND WEB PAGES AND GENERATING ELECTRONIC PERMISSION CODES WHICH THEN ALLOW USERS TO ACCESS SAID DIGITAL CONTENT; DESIGNING PROGRAMS FOR OTHERS FOR VIDEO GAMES WITH TELEVISION FOR PERSONAL USE; WRITING MANUALS FOR OTHERS FOR PROGRAMS FOR VIDEO GAMES WITH TELEVISION FOR PERSONAL USE; PROVIDING INFORMATION ABOUT COMPUTER PROGRAMS AND COMPUTERS; WRITING MANUALS FOR OTHERS FOR COMPUTER

PROGRAMS AND COMPUTERS; COMPUTER CONSULTATION REGARDING THE WORKINGS OF A COMPUTER; DESIGNING AND MAINTAINING INFORMATION PROCESSING SYSTEMS FOR OTHERS BY A COMPUTER; COMPUTER SOFTWARE DEVELOPMENT AND CUSTOMIZATION; AGENCY OF COMPUTER DATA OUTPUT; DESIGNING COMPUTER NETWORKS FOR OTHERS; PROFESSIONAL CONSULTANCY REGARDING DESIGNING AND STUDYING COMPUTER NETWORKS; COMPUTER GRAPHIC SERVICES FOR DESIGNING AND DRAWING MACHINES, APPARATUS AND FACILITIES; INSTALLATION OF COMPUTER SOFTWARE; RENTAL AND LEASING OF MAGNETIC TAPES ENCODING PROGRAMS FOR COMPUTER FOR COMPUTER SYSTEM SECURITY; RENTAL AND LEASING OF MAGNETIC TAPES ENCODING PROGRAMS FOR VIDEO GAMES WITH TELEVISION FOR PERSONAL USE FOR COMPUTER SYSTEM SECURITY; LEASING SERVERS FOR WEB PAGES; RENTAL AND LEASING OF COMPUTERS AND COMPUTER PROGRAMS; PROVIDING ELECTRONIC VERIFICATION OF ON-LINE ORDERS OF DIGITAL CONTENT AND GENERATING ELECTRONIC PERMISSION CODES WHICH THEN ALLOW USERS TO ACCESS SAID DIGITAL CONTENT; HOURLY RENTAL AND LEASING OF COMPUTERS VIA ON-LINE NETWORK; COMPUTER SOFTWARE CONSULTANCY; COMPUTER VIRUS PROTECTION SERVICES; RENTAL OF WEB SERVERS; MONITORING THE COMPUTER SYSTEMS OF OTHERS FOR TECHNICAL PURPOSES AND PROVIDING BACK-UP COMPUTER PROGRAMS AND FACILITIES; COMPUTER SERVICES, NAMELY, DESIGNING, IMPLEMENTING, TESTING, AND ANALYZING SECURITY, AUTHORIZATION, AUTHENTICATION, AND ENCRYPTION SYSTEMS TO PROVIDE SECURE ACCESS TO COMPUTER SOFTWARE, COMPUTER HARDWARE, AND COMPUTER NETWORKS; PROVIDING ELECTRONIC VERIFICATION OF USERS OF DIGITAL CONTENT WHICH THEN ALLOWS USERS TO ACCESS SAID DIGITAL CONTENT.

FIRST USE ; IN COMMERCE .

ELEMENTS CORRECTED  
GOODS/SERVICES

3,137,495. REG. 9-5-2006. KABUSHIKI KAISHA SONY COMPUTER ENTERTAINMENT (JAPAN CORPORATION), TA SONY COMPUTER ENTERTAINMENT INC., 1-1, AKASAKA 7-CHOME, MINATO-KU, TOKYO 107-0052, JAPAN., SN 76-477,522. FILED 12-20-2002. PRINCIPAL REGISTER.

## DNAS-NET

OWNER OF JAPAN REG. NO. 4747158, DATED 2-13-2004, EXPIRES 2-13-2014.

INT. CL. 9/U.S. CLS. 21, 23, 26, 36 AND 38

FOR MOUSE PADS FOR COMPUTERS; MOUSE FOR COMPUTERS; ELECTRONIC CIRCUITS, MAGNETIC DISCS AND MAGNETIC TAPES FOR ENCODING COMPUTER PROGRAMS FOR ENCRYPTING OR DECRYPTING INFORMATION DATA; ENCRYPTING AND MICRO PROGRAMMING DEVICES FOR INFORMATION PROCESSING MACHINES, NAMELY, ELECTRONIC CIRCUITS; STRAPS FOR CELLULAR PHONES; INSTANT CAMERAS WITH FILMS; COMPUTER E-COMMERCE SOFTWARE TO ALLOW USERS TO PERFORM ELECTRONIC BUSINESS TRANSACTIONS VIA A GLOBAL COMPUTER NETWORK; AMUSEMENT APPARATUS FOR USE WITH TELEVISION RECEIVER ONLY, NAMELY VIDEO OUTPUT GAME MACHINES FOR USE WITH TELEVISIONS; SLOT MACHINES; DOWNLOADABLE COMPUTER GAME PROGRAMS; DOWNLOADABLE ELECTRONIC PUBLICATIONS [.] \*IN THE NATURE OF\* BOOKS, MAGAZINES AND MANUALS FEATURING COMPUTER GAMES AND VIDEO GAMES RECORDED ON COMPUTER MEDIA; DOWNLOADABLE VIDEO GAME SOFTWARE; ELECTRONIC CIRCUITS, MAGNETIC DISCS, MAGNETIC TAPES, OPTICAL DISCS, CD-ROMS, MAGNETIC CARDS, AND OTHER MEMORY MEDIA ENCODING ASSEMBLERS, COMPILERS, AND COMPUTER PRO-

GRAMS FOR SOFTWARE DEVELOPMENT AND COMPUTER PROGRAMMING; ENCRYPTION DEVICES, NAMELY, MODEMS AND ENCODERS, USED FOR SCRAMBLING IN TELECOMMUNICATION; ELECTRONIC CIRCUITS, MAGNETIC DISCS, OPTICAL DISCS, MAGNETIC OPTICAL DISCS, CD-ROMS, MAGNETIC TAPES AND DIGITAL VERSATILE DISC ROMS FOR ENCODING VIDEO GAME PROGRAMS FOR PERSONAL USE; ELECTRONIC CIRCUITS, MAGNETIC DISCS, OPTICAL DISCS, MAGNETIC OPTICAL DISCS, CD-ROMS, MAGNETIC TAPES AND DIGITAL VERSATILE DISC ROMS FOR ENCODING VIDEO GAME PROGRAMS FOR BUSINESS USE; ELECTRICAL CONTROLLERS, JOYSTICKS, MEMORY CARDS, ELECTRIC VOLUME CONTROLLERS; MAGNETIC DISCS, OPTICAL DISCS, MAGNETIC OPTICAL DISCS, CD-ROMS, MAGNETIC TAPES AND DIGITAL VERSATILE DISC ROMS FOR ENCODING MAGAZINES, BOOKS, NEWS PAPERS, MAPS, PICTURES, IMAGES AND OTHER LITERAL INFORMATION; ROTARY CONVERTERS; PHASE MODIFIERS; DRY CELL BATTERIES; WET CELL BATTERIES; ELECTRIC ACCUMULATORS AND BATTERIES; PHOTOVOLTAIC CELLS; ELECTRIC WIRES; ELECTRIC CABLES; PHOTOGRAPHIC APPARATUS AND INSTRUMENTS, NAMELY, TILTING HEADS FOR CAMERAS, CAMERAS, RANGE FINDERS FOR CAMERAS, TRIPODS FOR CAMERAS, SHUTTERS FOR CAMERAS, BELLOWS FOR CAMERAS, SPOOLS FOR CAMERAS, SLIDE PROJECTORS, SELF-TIMERS FOR CAMERAS, PHOTOGRAPHIC FLASH UNITS FOR CAMERAS, FLASH LAMPS FOR CAMERAS, VIEW-FINDERS FOR CAMERAS, LENS FILTERS FOR CAMERAS, LENS HOODS FOR CAMERAS, FLASH GUNS FOR CAMERAS, FILM MAGAZINES FOR CAMERAS, SHUTTER RELEASES FOR CAMERAS, LENSES FOR PHOTOGRAPHIC APPARATUS, EXPOSURE METERS; CINEMATOGRAPHIC APPARATUS AND INSTRUMENTS, NAMELY, MOVIE FILM PROJECTORS, MOVIE \*FILM\* PROCESSING AND FINISHING APPARATUS, CINEMATOGRAPHIC CAMERAS, PROJECTION SCREENS FOR MOVIE FILMS, MOVIE FILM EDITING MACHINES, SOUND RECORDING APPARATUS FOR MOVIES; TELESCOPES; MICROSCOPES; EYEGLASSES AND SAFETY GOGGLES; LIFE NETS; LIFE BELTS; LIFE JACKETS; LIFE-BUOYS; TELEPHONE APPARATUS, NAMELY, INTERCOMS, AUTOMATIC SWITCHING APPARATUS FOR TELECOMMUNICATION, MANUAL SWITCHING APPARATUS FOR TELECOMMUNICATION, TELEPHONE SETS; WIRE COMMUNICATION APPARATUS, NAMELY, TELETYPEWRITERS, AUTOMATIC TELEGRAPH APPARATUS, PHOTOTELEGRAPH APPARATUS, MANUAL TELEGRAPH APPARATUS, TRUNK EXCHANGE APPARATUS, FACSIMILE MACHINES; BROADCASTING APPARATUS, NAMELY, TELEVISION RECEIVERS, TELEVISION TRANSMITTERS, RADIO RECEIVERS, RADIO TRANSMITTERS; RADIO COMMUNICATION APPARATUS, NAMELY, PORTABLE RADIO COMMUNICATION TRANSMITTERS, AERONAUTICAL RADIO COMMUNICATION TRANSMITTERS, MULTI CHANNEL RADIO COMMUNICATION TRANSMITTERS FOR FIXED STATIONS, SINGLE-CHANNEL RADIO COMMUNICATION TRANSMITTERS FOR FIXED STATIONS, VEHICULAR RADIO COMMUNICATION TRANSMITTERS, MARINE RADIO COMMUNICATION TRANSMITTERS; AUDIO FREQUENCY APPARATUS, NAMELY, PUBLIC-ADDRESS SYSTEMS, JUKE BOXES, TAPE RECORDERS, ELECTRIC PHONOGRAPHS, RECORD PLAYERS, VIDEOTAPE RECORDERS; VIDEO FREQUENCY APPARATUS, NAMELY, VIDEO CAMERAS, VIDEODISC PLAYERS, VIDEOTAPE RECORDERS; EP RECORDS CONTAINING MUSIC; LP RECORDS CONTAINING MUSIC; METRONOMES; RECORDED COMPACT DISCS CONTAINING MUSIC; COMPUTERS; ELECTRON MICROSCOPES; ELECTRONIC DESK CALCULATORS; WORD PROCESSORS; GLASS TUBES FOR SCIENTIFIC PURPOSES, NAMELY, X-RAY TUBES, PHOTSENSITIVE TUBES, VACUUM TUBES, RECTIFIER TUBES, DISCHARGE TUBES; CATHODE RAY TUBES; THERMISTORS; DIODES FOR USE IN CIRCUIT BOARDS AND ELECTRONIC CIRCUITRY; TRANSISTORS; ELECTRON TUBES; SEMI-CONDUCTOR DEVICES; INTEGRATED CIRCUITS; LARGE SCALE INTEGRATED CIRCUITS; ELECTRIC FLAT IRONS FOR HOUSEHOLD USE; ELECTRIC HAIR-CURLERS FOR HOUSEHOLD USE; ELECTRIC BUZZERS FOR HOUSEHOLD USE; EXPOSED CINEMATOGRAPHIC FILMS; EXPOSED SLIDE FILMS; PHOTOGRAPHIC SLIDE TRANSPARENCIES;

SLIDE FILM MOUNTS; ENCODED VIDEO DISCS AND TAPES FEATURING PICTURES; VENDING MACHINES; VIDEO GAME MACHINES FOR PERSONAL USE FOR USE WITH TELEVISIONS; BROADCAST SATELLITE DOWNLINK TERMINALS; DIGITAL VERSATILE DISC ROM PLAYERS; DIGITAL VERSATILE DISC RECORDERS; DIGITAL VERSATILE DISC VIDEO RECORDERS; DIGITAL VERSATILE DISC PLAYERS; DNA CHIPS; HARD DISC DRIVE RECORDERS; HARD DISC DRIVE VIDEO RECORDERS; TUNERS FOR TELEVISION SET; DIGITAL IDENTITY CERTIFICATION SYSTEM USED ON COMPUTERS.

FIRST USE ; IN COMMERCE .

INT. CL. 35/U.S. CLS. 100, 101 AND 102

FOR DATA PROCESSING SERVICES; COMPUTERIZED TRACKING AND TRACING OF PACKAGES IN TRANSIT; DATA ENTRY SERVICES FOR OTHERS; COMPUTERIZED DATA PROCESSING SERVICES; COMPUTERIZED DATA PROCESSING SERVICES FOR IMAGES; COMPUTERIZED DATA PROCESSING SERVICES FOR INPUTTING DATA INTO MAGNETIC CARDS.

FIRST USE ; IN COMMERCE .

INT. CL. 42/U.S. CLS. 100 AND 101

FOR ENCRYPTION OF INFORMATION AVAILABLE ON A COMPUTER; PLANNING, PRODUCING, AND MAINTAINING COMPUTER SYSTEM PROGRAMS FOR OTHERS FOR DATA SECURITY AVAILABLE ON A COMPUTER; DATA ENCRYPTION SERVICES; PROVIDING ELECTRONIC VERIFICATION OF ON-LINE ORDERS OF DIGITAL CONTENT AND GENERATING ELECTRONIC PERMISSION CODES WHICH THEN ALLOW USERS TO ACCESS SAID DIGITAL CONTENT ONLINE; CONDUCTING COMPUTER SEARCHES FOR OTHERS ABOUT NEWS ARTICLES; COMPUTER AIDED GRAPHICS DESIGN; DESIGNING AND PRODUCING COMPUTER GRAPHICS PROGRAMS FOR OTHERS; ESTABLISHING AND MANAGING INTERNET WEB SITES FOR OTHERS; COMPUTER SERVICES, NAMELY, DESIGNING AND IMPLEMENTING NETWORK WEB PAGES FOR OTHERS; PROVIDING TEMPORARY USE OF ON-LINE NON-DOWNLOADABLE COMPUTER GAME SOFTWARE AND VIDEO GAME SOFTWARE; PROVIDING TEMPORARY USE OF NON-DOWNLOADABLE COMPUTER SOFTWARE FOR TRACKING DOCUMENTS, PACKAGES, AND FREIGHT OVER COMPUTER NETWORKS, INTRANETS, AND THE INTERNET; PROFESSIONAL CONSULTANCY REGARDING DESIGNING COMPUTER SYSTEMS; DESIGNING COMPUTER SYSTEMS FOR OTHERS; DESIGNING VIDEO GAME SOFTWARE FOR OTHERS; PROCESSING INFORMATION BY A COMPUTER; MAINTENANCE OF COMPUTER SOFTWARE, NAMELY, MAINTENANCE OF ELECTRONIC MAIL SERVERS FOR OTHERS; PROVIDING ELECTRONIC VERIFICATION OF ON-LINE USERS OF ELECTRONIC MAIL AND WEB PAGES AND GENERATING ELECTRONIC PERMISSION CODES WHICH THEN ALLOW USERS TO ACCESS SAID DIGITAL CONTENT; DESIGNING PROGRAMS FOR OTHERS FOR VIDEO GAMES WITH TELEVISION FOR PERSONAL USE; WRITING MANUALS FOR OTHERS FOR PROGRAMS FOR VIDEO GAMES WITH TELEVISION FOR PERSONAL USE; PROVIDING INFORMATION ABOUT COMPUTER PROGRAMS AND COMPUTERS; WRITING MANUALS FOR OTHERS FOR COMPUTER PROGRAMS AND COMPUTERS; COMPUTER CONSULTATION REGARDING THE WORKINGS OF A COMPUTER; DESIGNING AND MAINTAINING INFORMATION PROCESSING SYSTEMS FOR OTHERS BY A COMPUTER; COMPUTER SOFTWARE DEVELOPMENT AND CUSTOMIZATION; AGENCY OF COMPUTER DATA OUTPUT; DESIGNING COMPUTER NETWORKS FOR OTHERS; PROFESSIONAL CONSULTANCY REGARDING DESIGNING AND STUDYING COMPUTER NETWORKS; COMPUTER GRAPHIC SERVICES FOR DESIGNING AND DRAWING MACHINES, APPARATUS AND FACILITIES; INSTALLATION OF COMPUTER SOFTWARE; RENTAL AND LEASING OF MAGNETIC TAPES ENCODING PROGRAMS FOR COMPUTER FOR COMPUTER SYSTEM SECURITY; RENTAL AND LEASING OF MAGNETIC TAPES ENCODING PROGRAMS FOR VIDEO GAMES WITH TELEVISION FOR PERSONAL USE FOR COMPUTER SYSTEM SECURITY; LEASING SERVERS FOR WEB PAGES; RENTAL AND LEASING OF COMPUTERS AND COMPUTER PROGRAMS; PROVIDING ELECTRONIC VERIFICATION OF ON-LINE ORDERS OF DIGITAL CONTENT AND GENERATING ELECTRONIC PERMISSION CODES WHICH THEN ALLOW USERS TO

ACCESS [ SAD ] \*SAID\* DIGITAL CONTENT; HOURLY RENTAL AND LEASING OF COMPUTERS VIA ON-LINE NETWORK; COMPUTER SOFTWARE CONSULTANCY; COMPUTER VIRUS PROTECTION SERVICES; RENTAL OF WEB SERVERS; MONITORING THE COMPUTER SYSTEMS OF OTHERS FOR TECHNICAL PURPOSES AND PROVIDING BACK-UP COMPUTER PROGRAMS AND FACILITIES; COMPUTER SERVICES, NAMELY, DESIGNING, IMPLEMENTING, TESTING, AND ANALYZING SECURITY, AUTHORIZATION, AUTHENTICATION, AND ENCRYPTION SYSTEMS TO PROVIDE SECURE ACCESS TO COMPUTER SOFTWARE, COMPUTER HARDWARE, AND COMPUTER NETWORKS; PROVIDING ELECTRONIC VERIFICATION OF USERS OF DIGITAL CONTENT WHICH THEN ALLOWS USERS TO ACCESS SAID DIGITAL CONTENT.  
FIRST USE ; IN COMMERCE .

3,147,371. REG. 9-26-2006. WESTERN ASSISTIVE TECHNOLOGY, LLC (CALIFORNIA LTD LIAB CO) 12062 VALLEY VIEW ST., SUITE 109, GARDEN GROVE, CA, 92845, SN 76-648,866. FILED 10-20-2005. PRINCIPAL REGISTER.



ELEMENTS CORRECTED  
GOODS/SERVICES

3,139,773. REG. 9-5-2006. DISNEY ENTERPRISES, INC. (DELAWARE CORPORATION) 500 SOUTH BUENA VISTA STREET, BURBANK, CA, 91521, SN 78-287,547. FILED 8-14-2003. PRINCIPAL REGISTER.

NO CLAIM IS MADE TO THE EXCLUSIVE RIGHT TO USE "LOW VISION STORE", APART FROM THE MARK AS SHOWN.

INT. CL. 35/U.S. CLS. 100, 101 AND 102

FOR RETAIL STORE SERVICES FEATURING OPTICAL DEVICES TO AID PATIENTS WITH LOW VISION; RETAIL OUTLETS FEATURING OPTICAL DEVICES TO AID PATIENTS WITH LOW VISION; ONLINE RETAIL STORE SERVICES FEATURING OPTICAL DEVICES TO AID PATIENTS WITH LOW VISION.

FIRST USE 3-25-2004; IN COMMERCE 11-11-2004.

**KIM POSSIBLE**

OWNER OF U.S. REG. NO. 2,652,590.  
THE NAME IN THE MARK DOES NOT IDENTIFY A PARTICULAR LIVING INDIVIDUAL.  
INT. CL. 30/U.S. CL. 46  
FOR PASTRY.  
FIRST USE 6-1-2003; IN COMMERCE 6-1-2003.

ELEMENTS CORRECTED  
OWNER NAME

ELEMENTS CORRECTED  
GOODS/SERVICES

3,149,780. REG. 9-26-2006. UNFILTERED NAPA LLC (CALIFORNIA LTD LIAB CO) 5012 SILVERADO TRAIL, NAPA, CA, 94558, SN 78-513,495. FILED 11-8-2004. PRINCIPAL REGISTER.

3,145,776. REG. 9-19-2006. CHUM LIMITED (CANADA CORPORATION) 1331 YONGE STREET, TORONTO, ONTARIO, CANADA, M4T 1Y1, SN 75-463,341. FILED 3-31-1998. PRINCIPAL REGISTER.

**FASHIONTELEVISION CHANNEL**

PRIORITY CLAIMED UNDER SEC. 44(D) ON CANADA APPLICATION NO. 857,738, FILED 10-2-1997, REG. NO. TMA621,572, DATED 10-4-2004, EXPIRES 10-4-2014.

NO CLAIM IS MADE TO THE EXCLUSIVE RIGHT TO USE TELEVISION AND THE CHANNEL, APART FROM THE MARK AS SHOWN.

AS TO FASHION TELEVISION .

INT. CL. 41/U.S. CLS. 100, 101 AND 107

FOR TELEVISION PROGRAMMING AND DISTRIBUTION OF TELEVISION PROGRAMS FOR OTHERS, AND ENTERTAINMENT SERVICES IN THE NATURE OF AN ONGOING SERIES OF SHOWS RELATING TO COMMENTARY, NEWS, ARTS, FASHION, LIFESTYLE, SPORTS, MUSIC, PERFORMANCES, CONVERSATION, ADVICE, AND/OR ARTS THROUGH THE MEDIA OF TELEVISION, SATELLITE, RADIO, AND/OR VIA A GLOBAL COMPUTER NETWORK.  
FIRST USE 3-0-2004; IN COMMERCE 3-0-2004.

**PARCEL 41**

THE MARK CONSISTS OF STANDARD CHARACTERS WITHOUT CLAIM TO ANY PARTICULAR FONT, STYLE, SIZE, OR COLOR.

INT. CL. 33/U.S. CLS. 47 AND 49

FOR WINE.

FIRST USE 3-22-2005; IN COMMERCE 3-24-2005.

ELEMENTS CORRECTED  
MARK  
MARK TYPE

ELEMENTS CORRECTED  
ENTITY



3,152,313. REG. 10-3-2006. COHEN, SHOLMO (ISRAEL INDIVIDUAL) 8C NICE BLVD., NETANYA 42262, ISRAEL., AND GELMAN, PNINA (ISRAEL INDIVIDUAL) 40 USH-SKIN ST., NETANYA 42273, ISRAEL., SN 76-613,103. FILED P.R. 9-28-2004; AM. S.R. 7-28-2006. SUPPLEMENTAL REGISTER.

3,161,287. REG. 10-24-2006. KABUSHIKI KAISHA TANITA (JAPAN CORPORATION) 14-2, 1-CHOME, MAENOCHO, ITABASHI-KU, TOKYO, JAPAN., SN 76-582,626. FILED 3-24-2004. PRINCIPAL REGISTER.

## CutGrade Analyzer

THE MARK CONSISTS OF STANDARD CHARACTERS WITHOUT CLAIM TO ANY PARTICULAR FONT, STYLE, SIZE, OR COLOR.

PRIORITY CLAIMED UNDER SEC. 44(D) ON ISRAEL APPLICATION NO. 171409, FILED 4-1-2004, REG. NO. 171409, DATED 2-28-2005, EXPIRES 4-1-2011.

INT. CL. 9/U.S. CLS. 21, 23, 26, 36 AND 38

FOR COMPUTER SOFTWARE AND PROGRAMS THAT ANALYZE AND QUANTIFY THE MOVEMENT OF LIGHT THROUGH A COMPUTER MODEL OF DIAMONDS AND PRECIOUS STONES; COMPUTER [ SOFTWARE ] \*SOFTWARE\* AND PROGRAMS FOR USE IN DEVELOPING, FORMING, IMAGING, MEASURING, PRODUCING, CUTTING AND POLISHING OF DIAMONDS AND PRECIOUS STONES AND IN ANALYZING THEIR CHARACTERISTICS; DATA PROCESSING EQUIPMENT.

FIRST USE : IN COMMERCE .

ELEMENTS CORRECTED  
GOODS/SERVICES



PRIORITY CLAIMED UNDER SEC. 44(D) ON JAPAN APPLICATION NO. 2003-113741, FILED 12-22-2003, REG. NO. 4826948, DATED 12-17-2004, EXPIRES 12-17-2014.

INT. CL. 9/U.S. CLS. 21, 23, 26, 36 AND 38

FOR ALCOHOL BREATH TESTING UNITS, BREATH ANALYZERS, BODY WEIGHT SCALES WITH BODY FAT ANALYZER, BODY WEIGHT SCALES WITH BODY COMPOSITION ANALYZER, BODY WEIGHT SCALES, BABY SCALES, KITCHEN SCALES, BATH ROOM SCALES, INDUSTRIAL SCALES, SCALES FOR COMMERCIAL USE, PEDOMETERS, WATER QUALITY ANALYZERS, SKIN CONDITION ANALYZERS NOT FOR MEDICAL USE, AIR ANALYZERS, BODY ODORS ANALYZERS, ELECTRONIC COMMUNICATION DEVICES, NAMELY, RECEIVERS AND TRANSMITTERS FOR RECEIVING MEASURING DATA FROM BODY COMPOSITION ANALYZERS, BODY FAT ANALYZERS, SPHYGMOMANOMETERS, AND PEDOMETERS; COMPUTERS, COMPUTER KEYBOARDS, COMPUTER MEMORIES, PRINTERS FOR USE WITH COMPUTERS, MOUSE, MOUSE PADS, ELECTRONIC CIRCUITS, INTEGRATED CIRCUITS, ELECTRONIC CIRCUITS IN WHICH COMPUTER PROGRAMS ARE RECORDED, COMPUTER PROGRAMS FOR MANAGING PERSONAL DATA FOR HEALTH CARE, AND PROVIDING ADVICE BASED ON SAID DATA FOR USE IN ASSOCIATION WITH BODY WEIGHT SCALES WITH BODY FAT ANALYZER AND OTHER AFOREMENTIONED GOODS, ELECTRONIC CIRCUITS AND CD-ROMS IN WHICH COMPUTER GAME PROGRAMS FEATURING TRAVELS OR THE GROWTH OF ANIMALS AND HUMANS ARE RECORDED, PRE-RECORDED VIDEO DISCS AND VIDEOTAPES FEATURING HEALTH, BODY COMPOSITION, WEIGHT LOSS, WEIGHT MANAGEMENT, AIR, ODOR AND BREATH ANALYSIS, BEAUTY, MEDICINE AND NUTRITION, VIDEO GAMES FOR HOME USE, METRONOMES, ELECTRONIC CIRCUITS AND CD-ROMS IN WHICH PROGRAMS FOR PORTABLE GAMES WITH LIQUID CRYSTAL DISPLAYS ARE RECORDED, DOWNLOADABLE ELECTRONIC PUBLICATIONS, NAMELY, BOOKS, MAGAZINES AND MANUALS, AND ELECTRONIC PUBLICATIONS RECORDED ON OPTICAL DISCS, MAGNETIC DISCS AND MAGNETIC TAPES, NAMELY, BOOKS, MAGAZINES AND MANUALS, ALL IN THE FIELD OF HEALTH CARE AND HOW TO LOSE WEIGHT.

INT. CL. 10/U.S. CLS. 26, 39 AND 44

3,153,390. REG. 10-10-2006. MOTOMAN DISTRIBUTING (CALIFORNIA SOLE PROPRIETORSHIP) 8468 LOMA PLACE, UPLAND, CA. 91786, SN 78-666,837. FILED 7-8-2005. PRINCIPAL REGISTER.

## MOTOMAN

THE MARK CONSISTS OF STANDARD CHARACTERS WITHOUT CLAIM TO ANY PARTICULAR FONT, STYLE, SIZE, OR COLOR.

INT. CL. 12/U.S. CLS. 19, 21, 23, 31, 35 AND 44

FOR [ STRUCTURAL ] \* STRUCTURAL \* PARTS FOR MOTORCYCLES.

FIRST USE 1-0-1983; IN COMMERCE 1-0-1983.

ELEMENTS CORRECTED  
GOODS/SERVICES

FOR CONTRACEPTIVES, NAMELY DIAPHRAGMS FOR CONTRACEPTION AND CONDOMS, MEDICAL APPARATUS, NAMELY PULSE RATE MONITOR FOR MEASURING A PERSON'S PULSE, CLINICAL THERMOMETERS FOR MEDICAL USE, BONE DENSITOMETERS AND ULTRASOUND SONOMETERS FOR BONE DENSITY, BODY FAT ANALYZERS FOR MEDICAL USE, BODY COMPOSITION ANALYZERS FOR MEDICAL USE, [ BIOELECTRICAL ] \*BIOELECTRICAL\* IMPEDANCE ANALYZERS FOR MEDICAL USE, SPHYGMOMANOMETER, ELECTRIC MASSAGE DEVICES FOR DOMESTIC USE.  
FIRST USE ; IN COMMERCE .

3,164,465. REG. 10-31-2006. KOLTER HOLDINGS FLORIDA, INC. (DELAWARE CORPORATION) 1601 FORUM PLACE, SUITE 805, WEST PALM BEACH, FL, 33401, SN 76-643,323. FILED 7-21-2005. PRINCIPAL REGISTER.

ELEMENTS CORRECTED  
GOODS/SERVICES

# VERANO

---

3,161,468. REG. 10-24-2006. GREEN HORIZONS, INC. (HAWAII CORPORATION) 91-1030 PUAHALA STREET 24T, EWA BEACH, HI, 96706, SN 76-651,458. FILED 12-2-2005. PRINCIPAL REGISTER.

THE MARK CONSISTS OF STANDARD CHARACTERS WITHOUT CLAIM TO ANY PARTICULAR FONT, STYLE, SIZE, OR COLOR.

THE ENGLISH TRANSLATION FOR THE TERM VERANO IN THE MARK IS "SUMMER."  
INT. CL. 37/U.S. CLS. 100, 103 AND 106

FOR REAL ESTATE DEVELOPMENT SERVICES FEATURING THE DEVELOPMENT OF SINGLE FAMILY HOMES, MULTI-FAMILY HOMES AND RESORT FACILITIES.

FIRST USE 11-9-2005; IN COMMERCE 11-9-2005.

# INFINIFLUID

ELEMENTS CORRECTED  
[AMENDED REGISTER]

THE MARK CONSISTS OF STANDARD CHARACTERS WITHOUT CLAIM TO ANY PARTICULAR FONT, STYLE, SIZE, OR COLOR.

INT. CL. 1/U.S. CLS. 1

FOR BATTERY [ DESULFONATOR ] \* DESULFATOR \* CHEMICAL MIXTURE FOR USE IN LEAD ACID BATTERIES.

FIRST USE 12-27-2004; IN COMMERCE 5-19-2005.

ELEMENTS CORRECTED  
GOODS/SERVICES

---

3,169,723. REG. 11-7-2006. FAMILYMART CO., LTD. (JAPAN CORPORATION) 26-10, HIGASHI-IKEBUKURO 4-CHOME, TOSHIMA-KU, TOKYO, JAPAN., SN 78-536,193. FILED 12-21-2004. PRINCIPAL REGISTER.

3,162,966. REG. 10-24-2006. THE CHAMBELRLAN GROUP, INC. (CONNECTICUT CORPORATION) 845 LARCH AVENUE, ELRMHURST, IL, 60126, SN 76-240,736. FILED 4-13-2001. PRINCIPAL REGISTER.



# SOFTGLO

INT. CL. 35/U.S. CLS. 100, 101 AND 102

FOR RETAIL CONVENIENCE STORES; \* RETAIL GROCERY STORES; RETAIL STORE SERVICES FEATURING A WIDE VARIETY OF CONSUMER GOODS OF OTHERS; \* PROFESSIONAL BUSINESS CONSULTANCY FOR FRANCHISE STORES.

FIRST USE 7-20-2005; IN COMMERCE 7-20-2005.

INT. CL. 9/U.S. CLS. 21, 23, 26, 36 AND 38  
FOR ELECTRIC OPERATORS FOR DOORS, GATES AND SECURITY SYSTEMS.

FIRST USE 11-30-2002; IN COMMERCE 11-30-2002.

ELEMENTS CORRECTED  
MARK

ELEMENTS CORRECTED  
GOODS/SERVICES

3,171,967. REG. 11-14-2006. HBC DISTRIBUTION INCORPORATED (CALIFORNIA CORPORATION) 5560 GOLDEN GATE AVENUE, OAKLAND, CA, 94618, SN 78-167,532. FILED 9-24-2002. PRINCIPAL REGISTER.

## NATURE'S CURE

OWNER OF U.S. REG. NOS. 1,928,558 AND 2,582,852.  
INT. CL. 3/U.S. CLS. 1, 4, 6, 50, 51 AND 52

FOR SKIN CARE AND BEAUTY CARE PREPARATIONS, NAMELY BODY SOAP, BODY WASHES, SKIN CLARIFIERS, SKIN CLEANSING SOAP, SKIN CLEANSING CREAMS, SKIN CLEANSING GELS, COSMETIC ASTRINGENTS, [ DENTIFRICE, DEODORANT, ] EYE CREAM, FACE CREAM, FACIAL LOTION, FACIAL WASHES, [ FACIAL MASKS, MOUTHWASH, SUN BLOCKS, SUNSCREENS ].

FIRST USE 3-31-2004; IN COMMERCE 3-31-2004.  
INT. CL. 5/U.S. CLS. 6, 18, 44, 46, 51 AND 52

FOR ALLOPATHIC AND HOMEOPATHIC TREATMENTS, NAMELY, PREPARATIONS FOR TREATING YEAST INFECTIONS, PREPARATIONS FOR TREATING HYPER PIGMENTATION, \* PREPARATIONS FOR THE TREATMENT OF DRY AND SENSITIVE SKIN\*.

FIRST USE 3-31-2004; IN COMMERCE 3-31-2004.

ELEMENTS AMENDED  
GOODS/SERVICES  
MARK

FOR COIN ALBUMS, COIN HOLDERS, COIN MATS, COIN WRAPPERS; SLEEVES FOR HOLDING AND PROTECTING COINS; COIN CASES; CARDBOARD FLOOR DISPLAY UNITS FOR MERCHANDISING COIN PRODUCTS; BLANK OR PARTIALLY PRINTED POSTCARDS RELATING TO COINS; BUSINESS CARDS RELATING TO COINS; PRINTED AWARD CERTIFICATES RELATING TO COINS; ANNOUNCEMENT CARDS RELATING TO COINS; PAPER ENVELOPES FOR PACKAGING RELATING TO COINS; PAPER IDENTIFICATION TAGS RELATING TO COINS; PAPER GIFT WRAPPING AND RIBBONS RELATING TO COINS; BOOKLETS, PAMPHLETS, AND MAGAZINE SUPPLEMENTS IN THE FIELD OF NUMISMATICS; PRINTED INSTRUCTIONAL, EDUCATIONAL, AND TEACHING MATERIALS IN THE FIELD OF NUMISMATICS; COMPUTER MANUALS FOR NUMISMATICS; EVENTS ALBUMS, MEMORY BOOKS, PHOTOGRAPH ALBUMS, ALL RELATING TO COINS; PICTURE FRAMING MAT BOARDS, PAPER PICTURE MOUNTS, PRINTS IN THE NATURE OF PHOTOGRAPHS, LITHOGRAPHS, AND PICTURES, ALL RELATING TO [ CORNS ] \* COINS \*

FIRST USE 12-20-2004; IN COMMERCE 12-20-2004.

ELEMENTS CORRECTED  
GOODS/SERVICES

3,177,586. REG. 11-28-2006. DIC ENTERTAINMENT CORPORATION (DELAWARE CORPORATION) 4100 WEST ALAMEDA AVENUE, BURBANK, CA, 91505, SN 76-978,152. FILED 9-13-2004. PRINCIPAL REGISTER.

## ONYX VON TROLLENBERG

THE MARK CONSISTS OF STANDARD CHARACTERS WITHOUT CLAIM TO ANY PARTICULAR FONT, STYLE, SIZE, OR COLOR.

THE NAME IN THE MARK DOES NOT IDENTIFY A LIVING INDIVIDUAL.

INT. CL. 28/U.S. CLS. 22, 23, 38 AND 50

FOR DOLLS, DOLL CLOTHING, \* AND \* DOLL ACCESSORIES, [ SWIMMING AIDS, NAMELY, POOL RINGS AND ARM FLOATS FOR RECREATIONAL USE ].

FIRST USE 8-0-2005; IN COMMERCE 9-0-2005.

ELEMENTS AMENDED  
GOODS/SERVICES

3,197,242. REG. 1-9-2007. HOT STUFF FOODS, LLC (SOUTH DAKOTA LIMITED LIABILITY COMPANY) P.O. BOX 85210, SIOUX FALLS, SD, 571185210, SN 78-320,349. FILED 10-29-2003. PRINCIPAL REGISTER.

## HOT STUFF GRILL

3,178,934. REG. 12-5-2006. REIDENBACH, BRYAN L. (UNITED STATES INDIVIDUAL) 26 NORTHERN DRIVE, MILLERSBURG, OH, 44654, SN 76-627,322. FILED 1-7-2005. PRINCIPAL REGISTER.

## HERE'S YOUR PROOF

THE MARK CONSISTS OF STANDARD CHARACTERS WITHOUT CLAIM TO ANY PARTICULAR FONT, STYLE, SIZE, OR COLOR.

INT. CL. 16/U.S. CLS. 2, 5, 22, 23, 29, 37, 38 AND 50

OWNER OF U.S. REG. NOS. 1,273,749, 2,449,152 AND OTHERS.

NO CLAIM IS MADE TO THE EXCLUSIVE RIGHT TO USE "GRILLE", APART FROM THE MARK AS SHOWN.

INT. CL. 35/U.S. CLS. 100, 101 AND 102

FOR FRANCHISING SERVICES IN THE FIELD OF RESTAURANTS AND FOOD KIOSKS.

FIRST USE 7-0-2006; IN COMMERCE 7-0-2006.

ELEMENTS AMENDED  
MARK

3,199,582. REG. 1-16-2007. HOT STUFF FOODS, LLC (SOUTH DAKOTA LTD LIAB CO) P.O. BOX 85210, SIOUX FALLS, SD, 571185210, SN 78-560,971. FILED 2-4-2005. PRINCIPAL REGISTER.

FOR RESTAURANT SERVICES, CARRY-OUT FOOD SHOP SERVICES.  
FIRST USE 6-0-2005; IN COMMERCE 6-0-2005.

ELEMENTS CORRECTED  
GOODS/SERVICES

**HOT STUFF FOODS  
CREATING VALUE...  
EVERY DAY!**

3,205,040. REG. 2-6-2007. SONIA, S.A. (SPAIN CORPORATION) CARRETERA BARCELONA, 35, 56131 BONREPOS, VALENCIA, SPAIN., SN 78-567,093. FILED 2-14-2005. PRINCIPAL REGISTER.

THE MARK CONSISTS OF STANDARD CHARACTERS WITHOUT CLAIM TO ANY PARTICULAR FONT, STYLE, SIZE, OR COLOR.

OWNER OF U.S. REG. NOS. 1,646,945, 2,449,152 AND OTHERS.

NO CLAIM IS MADE TO THE EXCLUSIVE RIGHT TO USE "FOODS", APART FROM THE MARK AS SHOWN.

INT. CL. 29/U.S. CL. 46

FOR FOOD PRODUCTS NAMELY FRUIT-BASED FILLING FOR DONUTS, [ CHEESE; ] REFRIED BEANS; AND SCRAMBLED EGGS.

FIRST USE 2-0-2005; IN COMMERCE 2-0-2005.

INT. CL. 30/U.S. CL. 46

FOR FOOD PRODUCTS, NAMELY CONDIMENT SAUCES NAMELY KETCHUP, MUSTARD, HOT SAUCE, MAYONNAISE AND SALAD DRESSING; BREAD ROLL DOUGH; PIZZA SAUCE; AND SYRUP TOPPINGS.

FIRST USE 5-0-2005; IN COMMERCE 5-0-2005.

INT. CL. 35/U.S. CLS. 100, 101 AND 102

FOR FRANCHISING SERVICES, OFFERING TECHNICAL ASSISTANCE IN THE ESTABLISHMENT AND OPERATION OF RESTAURANTS, CARRY-OUT FOOD SHOPS, FOOD KIOSKS, FOOD MARKETS; FOOD KIOSK SERVICES, FOOD MARKET SERVICES.

FIRST USE 1-0-2005; IN COMMERCE 1-0-2005.

INT. CL. 43/U.S. CLS. 100 AND 101

**TECNO PROJECT**

THE MARK CONSISTS OF STANDARD CHARACTERS WITHOUT CLAIM TO ANY PARTICULAR FONT, STYLE, SIZE, OR COLOR.

OWNER OF ERPN CMNTY TM OFC REG. NO. 3388832, DATED 5-30-2005, EXPIRES 10-3-2013.

INT. CL. 21/U.S. CLS. 2, 13, 23, 29, 30, 33, 40 AND 50

FOR BATHROOM ACCESSORIES, NAMELY, TOILET BRUSHES, TOILET BRUSH HOLDERS, DRINKING GLASSES, BATHROOM GLASS HOLDERS NOT OF PRECIOUS METAL, SOAP DISHES AND BRACKETS, SOAP HOLDERS, TOILET PAPER HOLDERS, TOWEL HOLDERS, TOWEL RACKS, AND TOWEL RINGS.

ELEMENTS CORRECTED  
FOREIGN REG. NO.

\* \* \* \* \*

# TRADEMARK REGISTRATIONS—NEW CERTIFICATES

New Certificates issued under section 7(d) of the Trademark Act of 1946 for the unexpired term of the original registrations.

2,854,530. HEAT TREAT. INT. CL. 10. JOHN WAGNER  
ASSOCIATES, INC., CONCORD, CA. REG. 6-15-2004.  
NEW CERT. SEC. 7(D) TO REGISTRANT.

2,975,831. COMTE AND DESIGN. INT. CL. 25. GLOBAL  
ONE HEADWEAR MANUFACTORY LIMITED, SHATIN,  
NEW TERRITORIES, HONG KONG. REG. 7-26-2005. NEW  
CERT. SEC. 7(D) TO REGISTRANT.

\* \* \* \* \*

This page is intentionally blank

# INDEX OF REGISTRANTS

APRIL 24, 2007

(Registered; Renewed; Canceled; Amended, Corrected, etc.; New Certificates; 12c Publications.)

The designation "U.S. Cl." appearing in this section refers to the U.S. class in effect prior to Sep. 1, 1973 rather than the international class which applies to applications filed on or after that date. For adoption of international classification see notice in the OFFICIAL GAZETTE of Jun. 26, 1973 (911 O.G. TM 210).

- (OSI) EYETECH, INC., NEW YORK, NY:  
3,233,450, PUB. 2-6-2007. MULTIPLE CLASS, INT. CLS. 41 AND 44.
- A & E LIMITED PARTNERSHIP, TIJERAS, NM:  
1,979,735, CANC. INT. CL. 3.
- A & M TECHNOLOGY, FRANCE:  
3,233,695, PUB. 2-6-2007. INT. CL. 8.
- A & V, INC., MILWAUKEE, WI:  
3,232,704, PUB. 2-6-2007. INT. CL. 1.  
3,232,714, PUB. 2-6-2007. INT. CL. 3.
- A. K. DRAFT SEAL LTD., COQUITLAM, B.C. V3K 3V5, CANADA:  
3,232,589, PUB. 2-6-2007. MULTIPLE CLASS, INT. CLS. 6 AND 19.
- A. MOKSEL AG, FED REP GERMANY:  
3,233,522, PUB. 2-6-2007. MULTIPLE CLASS, INT. CLS. 29 AND 30.
- A. O. SMITH CORPORATION, MILWAUKEE, WI:  
2,084,750, REN. 3-16-07. INT. CL. 11.
- A. T. STORRS LTD., VANCOUVER, BRITISH COLUMBIA, CANADA:  
3,235,212, INT. CL. 14.
- A. TUFENKIAN AND SONS, INC., PORTLAND, OR:  
2,356,504, CANC. INT. CL. 35.
- A.B.T.S. INTELLIGENT GROUP, INC., ALTAMONTE SPRINGS, FL:  
2,358,334, CANC. INT. CL. 9.
- A.P. GREEN INDUSTRIES, INC., MOON TOWNSHIP, PA:  
1,430,260, REN. 3-16-07. INT. CL. 19.
- A.T. KEARNEY, INC., CHICAGO, IL:  
3,234,479, INT. CL. 35.
- A&E TELEVISION NETWORKS, NEW YORK, NY:  
3,232,308, PUB. 2-6-2007. MULTIPLE CLASS, INT. CLS. 9 AND 41.  
3,235,084, INT. CL. 41.
- A-Z ENTERTAINMENT, LTD., WHEELING, IL:  
3,232,327, PUB. 10-17-2006. INT. CL. 41.
- AAKANSON TRADING COMP., INC., MIAMI, FL:  
1,396,991, CANC. INT. CL. 29.
- AAMP OF FLORIDA, INC., CLEARWATER, FL:  
2,107,772, REN. 3-20-07. INT. CL. 9.
- AARON INDUSTRIES, INC., CLINTON, SC:  
2,044,940, REN. 3-21-07. INT. CL. 5.
- AARON, LAWRENCE DAVID, LEDGEWOOD, NJ:  
3,234,175, MULTIPLE CLASS, INT. CLS. 35 AND 41.
- AAVEN PRODUCTS INC., FRESH MEADOWS, NY:  
3,235,197, INT. CL. 3.
- AB SERVICES, B.P.24 - 09120 VARILHES, FRANCE:  
2,069,565, REN. 3-16-07. INT. CL. 1.
- ABACUS CONTROLS, INC., CHELMSFORD, MA:  
2,357,010, CANC. INT. CL. 9.
- ABACUS GROUP, L.L.C., THE, KNOXVILLE, TN:  
2,357,025, CANC. INT. CL. 36.
- ABB FLAKT AB, SWEDEN, SWEDEN:  
1,396,626, CANC. INT. CL. 9.
- ABB PARTNERS, LLC, LOCUST VALLEY, NY:  
3,234,990, INT. CL. 33.  
3,234,991, INT. CL. 33.
- ABBEY FOODS, INC., SHERMAN OAKS, CA:  
2,070,677, REN. 3-19-07. INT. CL. 30.
- ABBOTT LABORATORIES, ABBOTT PARK, IL:  
2,030,523, REN. 3-17-07. INT. CL. 41.
- ABBOTT, PAUL J., YORK, PA:  
3,234,229, MULTIPLE CLASS, INT. CLS. 6 AND 9.
- ABC COOKING STUDIO CO., LTD., JAPAN:  
3,233,639, PUB. 2-6-2007. INT. CL. 41.
- ABC, INC., NEW YORK, NY:  
1,473,532, REN. 3-22-07. INT. CL. 38.
- ABDNOR, JOHN, DALLAS, TX:  
1,397,102, CANC. INT. CL. 36.
- ABICA COFFEE, LLC, ATLANTA, GA:  
3,235,048, INT. CL. 43.  
3,235,049, INT. CL. 43.
- ABLE PLANET, INCORPORATED, LAKEWOOD, CO:  
3,232,402, PUB. 2-6-2007. INT. CL. 9.
- ABLEMAN, CORINNE, TUSTIN, CA:  
3,233,394, PUB. 2-6-2007. INT. CL. 3.
- ABN AMRO BANK N.V., 1082 PP AMSTERDAM, NETHERLANDS:  
3,232,369, PUB. 7-4-2006. MULTIPLE CLASS, INT. CLS. 9, 35, 36 AND 41.
- ABNA PRODUCTS, INC., ATLANTA, GA, ABNA PRODUCTS, INC., ATLANTA, GA:  
2,058,908, REN. 3-22-07. MULTIPLE CLASS, INT. CLS. 1 AND 4.
- ABREU, LINDA MIHOS, NORTON, MA:  
2,358,570, CANC. INT. CL. 24.
- ABS GLOBAL, INC., DEFOREST, WI:  
3,233,409, PUB. 2-6-2007. INT. CL. 5.
- ACADEMIC MANAGEMENT SERVICE, CORP., SWANSEA, MA:  
2,357,210, CANC. INT. CL. 36.
- ACADEMY OF CLINICAL, ENVIRONMENTAL, RESEARCH, AND INFORMATIONAL SCIENCIES, SAN FRANCISCO, CA, DBA A.C.E.R.I.S.:  
2,356,938, CANC. U.S. CL. A.
- ACC CAPITAL HOLDINGS CORPORATION, ORANGE, CA:  
3,232,150, PUB. 2-6-2007. INT. CL. 36.
- ACCENT SERVICE COMPANY, INC., OMAHA, NE TO OMNIUM WORLDWIDE, INC., OMAHA, NE:  
1,979,748, CANC. INT. CL. 36.
- ACCIDENT INSURANCE SERVICES, INC., DALLAS, TX:  
3,232,050, PUB. 2-6-2007. INT. CL. 36.
- ACCIDENT SCENE MANAGEMENT, INC., WAUKESHA, WI:  
3,233,053, PUB. 2-6-2007. INT. CL. 41.
- ACE SURGICAL SUPPLY CO, INC., BROCKTON, MA:  
3,232,207, PUB. 2-6-2007. INT. CL. 5.
- ACH FOOD COMPANIES, INC., CORDOVA, TN:  
3,234,352, INT. CL. 29.  
3,234,355, INT. CL. 29.
- ACHENBACH BUSCHHUTTEN GMBH, D-57223 KREUZTAL, FED REP GERMANY:  
2,358,835, CANC. MULTIPLE CLASS, INT. CLS. 7 AND 9.
- ACHIEVEGLOBAL, INC., TAMPA, FL:  
2,358,039, CANC. INT. CL. 9.  
2,358,823, CANC. INT. CL. 35.
- ACHILLES GUARD, INC., DALLAS, TX, DBA CRITICAL WATCH:  
3,232,905, PUB. 2-6-2007. MULTIPLE CLASS, INT. CLS. 9 AND 45.
- ACL SERVICES LTD., VANCOUVER, BRITISH COLUMBIA, CANADA:  
3,234,097, MULTIPLE CLASS, INT. CLS. 9, 16, 38, 41 AND

42.  
ACORN PRODUCTS CO., INC., LEWISTON, ME:  
3,235,336, INT. CL. 25.
- ACROPRINT TIME RECORDER COMPANY, RALEIGH, NC:  
2,357,956, CANC. MULTIPLE CLASS, INT. CLS. 9 AND 14.
- ACS MARKETING, L.P., DALLAS, TX:  
2,357,123, CANC. INT. CL. 35.
- ACTION MEDIA OPERATING, LLC, IRVINE, CA:  
3,234,949, MULTIPLE CLASS, INT. CLS. 35 AND 41.
- ACTON EDUCATIONAL SERVICES, INC., COSTA MESA, CA:  
3,232,786, PUB. 2-6-2007. INT. CL. 41.
- ACUITY BRANDS INC, ATLANTA, GA, HOLOPHANE CORPORATION, NEWARK, OH:  
2,032,822. REN. 3-22-07. INT. CL. 11.
- ACUITY MANAGEMENT, INC., PLYMOUTH, MA, REVERE COPPER AND BRASS INCORPORATED, NEW YORK, NY:  
823,043. REN. 3-17-07. U.S. CL. 50 (INT. CL. 16).
- ACUITY TECHNOLOGY SERVICES, L.L.C., MCLEAN, VA:  
2,357,376, CANC. INT. CL. 42.
- ACUMENT INTELLECTUAL PROPERTIES, LLC, TROY, MI:  
2,066,624. REN. 3-16-07. INT. CL. 6.
- ACUPRINT, INC, CARLSBAD, CA:  
3,234,179, INT. CL. 9.
- ACUSON CORPORATION, MOUNTAIN VIEW, CA:  
1,979,275, CANC. INT. CL. 10.
- ACXIOM CORPORATION, LITTLE ROCK, AR:  
3,232,323, PUB. 2-6-2007. MULTIPLE CLASS, INT. CLS. 35 AND 42.
- ADAMS, JEFF, UPLAND, CA:  
3,233,180, PUB. 2-6-2007. INT. CL. 41.
- ADAMS, MARLENE, SPRINGFIELD GARDENS, NY:  
3,233,898, INT. CL. 25.
- ADAMS, SANDRA LEE, OTHELLO, WA:  
2,037,673. REN. 3-22-07. INT. CL. 28.
- ADAPTIVE ENGINEERING LAB, INC., MILL CREEK, WA:  
2,034,146. REN. 3-17-07. INT. CL. 12.  
2,059,834. REN. 3-17-07. INT. CL. 12.
- ADDITIVE SYSTEMS INC., BROKEN ARROW, OK:  
3,232,545, PUB. 2-6-2007. MULTIPLE CLASS, INT. CLS. 7 AND 37.
- ADJUSTABLE CLAMP COMPANY, CHICAGO, IL:  
3,232,459, PUB. 2-6-2007. INT. CL. 8.
- ADJUSTABLE FIXTURE CO., MILWAUKEE, WI:  
2,358,097, CANC. INT. CL. 11.
- ADOPTION RESOURCES OF WISCONSIN, MILWAUKEE, WI:  
3,233,105, PUB. 2-6-2007. INT. CL. 45.
- ADRENALIN GAMING L.L.C., LADERA RANCH, CA:  
3,233,841, INT. CL. 9.  
3,234,148, INT. CL. 9.  
3,234,167, INT. CL. 9.
- ADRENALIN GAMING LLC, LADERA RANCH, CA:  
3,234,410, INT. CL. 9.  
3,235,208, INT. CL. 9.
- ADRENALIN GAMING, LLC., LADERA RANCH, CA:  
3,234,819, INT. CL. 9.
- ADT SERVICES AG, SCHAFFHAUSEN, SWITZERLAND:  
3,232,337, PUB. 2-6-2007. INT. CL. 45.  
3,232,338, PUB. 2-6-2007. INT. CL. 45.
- ADVANCE MAGAZINE PUBLISHERS INC., NEW YORK, NY:  
1,979,255, CANC. INT. CL. 25.  
2,062,392. REN. 3-22-07. INT. CL. 16.
- ADVANCED BIOLOGICS LLC, NEW HOPE, PA:  
2,039,564. REN. 3-16-07. INT. CL. 42.
- ADVANCED BIONICS CORPORATION, VALENCIA, CA:  
3,232,473, PUB. 2-6-2007. MULTIPLE CLASS, INT. CLS. 9, 10 AND 16.
- ADVANCED BOTANICALS LTD., RICHMOND, BRITISH COLUMBIA, CANADA:  
3,232,325, PUB. 5-23-2006. INT. CL. 5.
- ADVANCED DIGITAL INFORMATION CORPORATION, SAN JOSE, WA:  
2,030,788. REN. 3-22-07. INT. CL. 7.
- ADVANCED FOODS NUTRITION LLC, RAHWAY, NJ:  
3,233,125, PUB. 2-6-2007. INT. CL. 5.
- ADVANCED HAIR STUDIOS (EUROPE) LTD, DUBLIN 2, IRELAND:  
3,234,228, MULTIPLE CLASS, INT. CLS. 16 AND 44.
- ADVANCED INGREDIENTS, INC., CAPITOLA, CA, FRUIT-SOURCE ASSOCIATES, SANTA CRUZ, CA:  
2,036,083. REN. 3-19-07. INT. CL. 5.
- ADVANCED KNOWLEDGE, INC., ENCINO, CA:  
2,357,361, CANC. INT. CL. 35.
- ADVANCED LASER & ANTI-AGING CENTER, INC., SCHAUMBURG, IL:  
3,232,720, PUB. 2-6-2007. INT. CL. 10.  
3,232,721, PUB. 2-6-2007. INT. CL. 10.
- ADVANCED MICRO CONTROLS, INC., TERRYVILLE, CT:  
2,061,072. REN. 3-16-07. INT. CL. 9.
- ADVANCED NUTRITIONAL BIOSYSTEMS, INC., ORLANDO, FL:  
3,235,039, INT. CL. 5.
- ADVANCED SPORTS, INC., PHILADELPHIA, PA:  
1,428,293. REN. 3-16-07. INT. CL. 12.  
1,428,295. REN. 3-16-07. INT. CL. 12.
- ADVANTA CORP., SPRING HOUSE, PA:  
3,232,687, PUB. 2-6-2007. INT. CL. 35.
- ADVANTAGE BUSINESS SOLUTIONS LIMITED, GAINSBOROUGH, UNITED KINGDOM:  
3,233,199, PUB. 2-6-2007. INT. CL. 9.
- ADVENTIST HEALTH SYSTEM/WEST, ROSEVILLE, CA:  
2,087,056. REN. 3-16-07. INT. CL. 36.
- ADVERTAIN ON-LINE CANADA INC., VANCOUVER, BRITISH COLUMBIA, CANADA:  
2,357,445, CANC. INT. CL. 35.
- ADVERTISING UNLIMITED, INC., SLEEPY EYE, MN:  
2,357,698, CANC. INT. CL. 35.
- AEON GAMING LLC, ST. PAUL, MN:  
3,234,345, INT. CL. 9.
- AERO DESIGN AND MANUFACTURING COMPANY, INC., DULUTH, MN:  
3,235,454, INT. CL. 25.
- AERO-MOD INCORPORATED, MANHATTAN, KS:  
3,233,004, PUB. 12-19-2006. INT. CL. 7.
- AEROPOSTALE WEST, INC., WAYNE, NJ:  
3,233,142, PUB. 2-6-2007. INT. CL. 3.
- AEROVIAS DEL CONTINENTE AMERICANO S.A. AVIANCA, BARRANQUILLA, ATLANTICO, COLOMBIA:  
3,232,579, PUB. 2-6-2007. MULTIPLE CLASS, INT. CLS. 35 AND 36.
- AETNA INC., BLUE BELL, PA:  
3,233,117, PUB. 2-6-2007. INT. CL. 36.
- AFFILIATE FUTURE LIMITED, UNITED KINGDOM:  
3,233,651, PUB. 2-6-2007. INT. CL. 35.
- AFFINITY DIRECT, LLC, ENGLEWOOD CLIFFS, NJ:  
3,232,700, PUB. 2-6-2007. INT. CL. 36.  
3,235,481, INT. CL. 41.
- AFFORDABLE MEDICAL CARE, L.L.C., SARGEANT BLUFF, IA:  
3,235,309, INT. CL. 44.  
3,235,357, INT. CL. 44.
- AG-COM PRODUCTIONS LTD., EMERALD PARK, SASKATCHEWAN, CANADA:  
3,232,383, PUB. 2-6-2007. MULTIPLE CLASS, INT. CLS. 9, 25 AND 41.
- AGCO CORPORATION, DULUTH, GA, OLIVER FARM EQUIPMENT COMPANY, CHICAGO, IL:  
343,061. REN. 3-21-07. U.S. CL. 23 (INT. CLS. 6, 7, 8, 9, 11, 12, 16, 21 AND 28).
- AGCO CORPORATION, DULUTH, GA:  
2,356,670, CANC. INT. CL. 12.
- AGENDA FAIRS, INC., TAMPA, FL:  
2,358,661, CANC. INT. CL. 16.
- AGENT SOFTWARE CORPORATION, MOUNTAIN VIEW, CA:  
3,233,813, INT. CL. 9.
- AGILENT TECHNOLOGIES, INC., SANTA CLARA, CA:  
1,425,577. REN. 3-21-07. INT. CL. 9.



AGILETEK LLC, DES PLAINES, IL:  
 3,235,053, INT. CL. 42.  
 AGILEVIEW SOFTWARE, INC., SALEM, NH:  
 3,234,744, INT. CL. 35.  
 AGILIX LABS, INC., OREM, UT:  
 3,234,553, INT. CL. 9.  
 3,234,554, INT. CL. 9.  
 AGRI-MARK, INCORPORATED, LAWRENCE, MA:  
 3,232,662, PUB. 2-6-2007. INT. CL. 29.  
 AGRI-PULSE COMMUNICATIONS, INC., ST. CHARLES, IL:  
 3,234,398, INT. CL. 16.  
 AGRICOLA CASEARIA LUPARA S.R.L., 81050 PASTORANO, CASERTA, ITALY:  
 2,029,453, REN. 3-19-07. INT. CL. 29.  
 AGRIGUARD COMPANY, LLC, CRANFORD, NJ:  
 3,232,361, PUB. 6-14-2005. INT. CL. 5.  
 AGUILA RECORDS INC., WEST CHICAGO, IL:  
 3,235,152, INT. CL. 9.  
 AGWAY INC., SYRACUSE, NY:  
 1,396,539, CANC. MULTIPLE CLASS, INT. CLS. 9 AND 41.  
 AHARONIAN, GREGORY, SAN FRANCISCO, CA:  
 3,235,473, INT. CL. 36.  
 AHAVA FOOD CORP., BROOKLYN, NY:  
 3,233,383, PUB. 2-6-2007. INT. CL. 29.  
 3,233,384, PUB. 2-6-2007. INT. CL. 29.  
 AHEAD, INC., NEW BEDFORD, MA, PRIME HEADGEAR LTD., MATTAPOISETT, MA:  
 2,034,108, REN. 3-19-07. INT. CL. 25.  
 AHK AIR HONG KONG LTD., KOWLOON, HONG KONG:  
 2,356,428, CANC. INT. CL. 39.  
 AHN PARTNERS, L.P., ORLANDO, FL:  
 2,358,853, CANC. INT. CL. 42.  
 AHN/FIT CABLE, LLC, LOS ANGELES, CA:  
 2,356,604, CANC. MULTIPLE CLASS, INT. CLS. 38, 41 AND 42.  
 AIC LIMITED, BURLINGTON, ONTARIO, CANADA:  
 3,232,466, PUB. 9-19-2006. MULTIPLE CLASS, INT. CLS. 35 AND 36.  
 AIDMA ENTERPRISE CO., LTD., TAIPEI HSIEN, TAIWAN:  
 3,235,132, INT. CL. 20.  
 AIGLE INTERNATIONAL S.A., BOULOGNE-BILLAN-COURT, FRANCE, AIGLE S.A., 75116 PARIS, FRANCE:  
 2,037,543, REN. 3-22-07. INT. CL. 25.  
 AIM MANAGEMENT, INC., LAS VEGAS, NV:  
 2,358,538, CANC. INT. CL. 9.  
 AIR TURBINE TECHNOLOGY, INC., BOCA RATON, FL:  
 3,232,427, PUB. 2-6-2007. INT. CL. 7.  
 AIR VENT INC., PEORIA, IL:  
 3,234,789, INT. CL. 19.  
 AIRCRAFTERS, INC., WILMINGTON, DE:  
 3,232,237, PUB. 2-6-2007. MULTIPLE CLASS, INT. CLS. 7, 9 AND 12.  
 AIRLUX AG, CH-8105 REGENSDORF-WATT, SWITZERLAND:  
 2,526,573, CANC. INT. CL. 20.  
 AIRPLACO EQUIPMENT COMPANY, CINCINNATI, OH:  
 3,233,195, PUB. 2-6-2007. INT. CL. 7.  
 AJB SOFTWARE DESIGN INC., TORONTO, ONTARIO, CANADA:  
 3,232,345, PUB. 6-27-2006. MULTIPLE CLASS, INT. CLS. 9 AND 42.  
 AK STEEL CORPORATION, MIDDLETOWN, OH:  
 3,233,851, INT. CL. 6.  
 AK TICKETS, STERLING HEIGHTS, MI:  
 3,233,392, PUB. 2-6-2007. INT. CL. 41.  
 AKC SERVICES, INC., LAKE ELSINORE, CA:  
 3,233,340, PUB. 2-6-2007. INT. CL. 42.  
 AKTIESELSKABET VALDEMAR SKAK DANSK SVINGNINGSTEKNIK, DK-5700 SVENDBORG, DENMARK:  
 2,358,100, CANC. INT. CL. 7.  
 AL SIGL CENTER FOR REHABILITATION AGENCIES, INC., ROCHESTER, NY:  
 3,232,564, PUB. 2-6-2007. INT. CL. 36.  
 ALADEX CORP., GLEN ELLYN, IL:  
 3,233,237, PUB. 2-6-2007. INT. CL. 35.  
 ALAGIO CORP., FARMINGDALE, NY:  
 3,232,121, PUB. 2-6-2007. INT. CL. 3.  
 ALAMO GROUP INC., SEGUIN, TX:  
 2,123,084, REN. 3-22-07. INT. CL. 7.  
 ALAN/ANTHONY, INC., NEW YORK, NY:  
 3,232,696, PUB. 2-6-2007. MULTIPLE CLASS, INT. CLS. 35, 41 AND 42.  
 ALAR, INC., ORLANDO, FL:  
 2,358,813, CANC. INT. CL. 42.  
 ALATI, JOSEPH, UTICA, NY:  
 2,357,417, CANC. INT. CL. 28.  
 ALBANESE, GRETCHEN C., PERKASIE, PA:  
 3,234,514, INT. CL. 43.  
 ALCOA INC., PITTSBURGH, PA:  
 1,397,119, CANC. INT. CL. 37.  
 1,397,121, CANC. INT. CL. 37.  
 ALCON LABORATORIES, INC., FORT WORTH, TX, ALCON LABORATORIES, INC., FORT WORTH, TX:  
 1,055,870, REN. 3-17-07. MULTIPLE CLASS, INT. CLS. 3, 5 AND 10.  
 ALDAZ, ALBERTO MUNARRIZ, 31001 PAMPLONA (NAVARRA), SPAIN:  
 2,356,920, CANC. INT. CL. 7.  
 ALDIVIA S.A., 69 561 SAINT-GENIS-LAVAL CEDEX, FRANCE:  
 3,233,809, INT. CL. 1.  
 ALEN SANDS YORK ASSOCIATES, NEW YORK, NY:  
 3,234,331, INT. CL. 24.  
 ALEXIA FOODS, INC., BROOKLYN, NY:  
 3,235,344, INT. CL. 30.  
 ALFRED A. FIRATO, MORGAN HILL, CA:  
 2,357,526, CANC. INT. CL. 42.  
 ALINA GROUP, INC., HOUSTON, TX:  
 3,234,240, INT. CL. 18.  
 ALIZA'S FOODS PRIVATE LTD., KARACHI, PAKISTAN:  
 3,234,754, MULTIPLE CLASS, INT. CLS. 29, 30 AND 32.  
 ALL AMERICAN PHARMACEUTICAL & NATURAL FOODS CORPORATION, BILLINGS, MT:  
 3,232,280, PUB. 2-6-2007. INT. CL. 5.  
 ALL AMERICAN PHARMACEUTICAL & NATURAL FOODS CORPORATION, BOZEMAN, MT:  
 3,232,281, PUB. 2-6-2007. INT. CL. 5.  
 ALL AXCES, LLC., LOS ANGELES, CA:  
 3,232,539, PUB. 10-24-2006. INT. CL. 25.  
 ALL ENGLAND LAWN TENNIS CLUB (WIMBLEDON) LIMITED, THE, WIMBLEDON, ENGLAND:  
 2,358,534, CANC. MULTIPLE CLASS, INT. CLS. 29 AND 30.  
 ALL NATIONS FULL GOSPEL CHURCH, NORTH YORK, CANADA:  
 3,232,435, PUB. 5-30-2006. INT. CL. 41.  
 ALL NET, INCORPORATED, RSM, CA:  
 2,356,985, CANC. INT. CL. 42.  
 ALL-CITY SPORTS MARKETING, INC., NEW YORK, NY:  
 3,235,040, INT. CL. 41.  
 ALLAN BLOCK CORPORATION, EDINA, MN:  
 3,234,261, INT. CL. 19.  
 ALLCONNECT, INC., ATLANTA, GA:  
 3,234,596, MULTIPLE CLASS, INT. CLS. 35, 38 AND 39.  
 3,235,014, INT. CL. 35.  
 ALLEGIANCE CORPORATION, MCGAW PARK, IL:  
 3,234,893, INT. CL. 5.  
 ALLEN ENTERPRISES OF CENTRAL FL, INC., MIMS, FL:  
 2,357,390, CANC. INT. CL. 41.  
 ALLEN, STEVEN K., MILFORD, OH, DBA ALLEN'S APPLIANCE PARTS AND SERVICE, AND DBA VACLAND DISTRIBUTING CO.:  
 1,463,137, REN. 3-21-07. INT. CL. 42.  
 ALLENDALE LLC, TAMPA, FL:  
 3,234,848, INT. CL. 9.  
 ALLERGY KIDS LLC, LAFAYETTE, CO:  
 3,232,838, PUB. 10-24-2006. INT. CL. 20.  
 ALLIANCE FOODS, INC., COLDWATER, MI:  
 1,396,323, CANC. INT. CL. 3.  
 ALLIANCE OF NEW STAGE ADULTS, LLC, BOULDER, CO:  
 3,233,790, INT. CL. 35.  
 ALLIANCE TRADING, INC., COVINGTON, LA:  
 3,233,200, PUB. 2-6-2007. INT. CL. 35.

- ALLIANCEONE BUSINESS RESOURCES, LLC, NACOGDOCHES, TX:  
2,358,791, CANC. MULTIPLE CLASS, INT. CLS. 35 AND 42.
- ALLIANCES ASSOCIATES, BEDMINSTER, NJ:  
3,232,708, PUB. 2-6-2007. INT. CL. 37.
- ALLIANZ GLOBAL INVESTORS OF AMERICA L.P., NEWPORT BEACH, CA:  
3,234,542, INT. CL. 36.
- ALLIANZ LIFE INSURANCE COMPANY OF NORTH AMERICA, MINNEAPOLIS, MN:  
2,358,367, CANC. INT. CL. 35.  
3,235,179, INT. CL. 36.
- ALLIED DEVELOPMENT CORPORATION, LAKEVILLE, MN:  
3,232,835, PUB. 2-6-2007. MULTIPLE CLASS, INT. CLS. 9 AND 42.
- ALLISON-ERWIN COMPANY, CHARLOTTE, NC:  
1,396,839, CANC. INT. CL. 20.  
1,396,840, CANC. INT. CL. 20.
- ALLOR PROJECT COMPANY, INC., CONCORD, NH:  
1,396,335, CANC. INT. CL. 3.  
1,396,336, CANC. INT. CL. 3.
- ALLOY WHEEL REPAIR SPECIALIST, INC., NORCROSS, GA:  
3,232,248, PUB. 2-6-2007. INT. CL. 37.
- ALLSTAR STATS, INC., SOMERS, NY:  
2,125,062, REN. 3-22-07. INT. CL. 41.
- ALLTECH ASSOCIATES, INC., DEERFIELD, IL:  
2,356,968, CANC. INT. CL. 35.
- ALM PROPERTIES, INC., NEW YORK, NY:  
3,233,102, PUB. 2-6-2007. INT. CL. 41.
- ALMACENES SIMAN, SOCIEDAD ANONIMA DE CAPITAL VARIABLE, COLONIA ESCALON, SAN SALVADOR, EL SALVADOR:  
3,232,115, PUB. 8-1-2006. INT. CL. 35.  
3,232,116, PUB. 8-1-2006. INT. CL. 35.
- ALOHA AIRLINES, INC., HONOLULU, HI:  
3,233,921, MULTIPLE CLASS, INT. CLS. 39, 43 AND 45.
- ALPHA ANALYTICAL, INC., WESTBOROUGH, MA:  
3,232,893, PUB. 2-6-2007. INT. CL. 42.
- ALPHA BID POKER LLC, BAYONNE, NJ:  
3,232,876, PUB. 2-6-2007. INT. CL. 28.
- ALPHA WIRE CORPORATION, ELIZABETH, NJ TO INSULTAB, INC., WOBURN, MA:  
1,979,548, CANC. INT. CL. 17.
- ALPINE ELECTRONICS, INC., TOKYO, JAPAN:  
2,026,458, REN. 3-16-07. INT. CL. 9.
- ALPINE LODGE LLC, PRESTON, WA:  
3,232,910, PUB. 2-6-2007. INT. CL. 43.
- ALPS AUTOMOTIVE, INC., AUBURN HILLS, MI:  
3,235,153, INT. CL. 9.
- ALSONS CORPORATION, HILLSDALE, MI:  
3,234,552, INT. CL. 11.
- ALTA + CAST, L.L.C., HORSHAM, PA:  
2,357,979, CANC. INT. CL. 9.
- ALTIA, INC., COLORADO SPRINGS, CO:  
3,235,267, MULTIPLE CLASS, INT. CLS. 9 AND 42.
- ALTICOR INVESTMENTS INC., BINGHAM FARMS, MI:  
2,357,809, CANC. INT. CL. 35.
- ALTIERI, LAS VEGAS, NV:  
2,358,247, CANC. INT. CL. 8.
- ALTURNAMATS, INC., TITUSVILLE, PA, AARON, JAMES F., FRANKLIN, PA, DBA ALTURNAMATS:  
2,003,649, REN. 3-20-07. INT. CL. 17.
- ALYN-WEISS AND ASSOCIATES, INC., DENVER, CO:  
3,232,644, PUB. 2-6-2007. INT. CL. 35.
- ALZHEIMER'S DISEASE & RELATED DISORDERS ASSOCIATION OF S.D., INC., SAN DIEGO, CA:  
2,357,083, CANC. INT. CL. 31.
- ALZO INTERNATIONAL INC., SAYREVILLE, NJ, DBA BERNEL CHEMICAL COMPANY INC.:  
3,233,196, PUB. 2-6-2007. INT. CL. 1.
- AMATEUR ATHLETIC UNION OF THE UNITED STATES, INC., LAKE BUENA VISTA, FL:  
2,033,401, REN. 3-22-07. MULTIPLE CLASS, INT. CLS. 25 AND 26.  
2,394,924, CANC. MULTIPLE CLASS, U.S. CL. 200 INT.
- CLS. 9, 14, 16, 18, 24, 25, 26, 41 AND 42.  
3,233,952, INT. CL. 41.
- AMAZON TECHNOLOGIES, INC., RENO, NV:  
3,234,643, MULTIPLE CLASS, INT. CLS. 35 AND 39.
- AMBELLA HOME COLLECTION, INC., DALLAS, TX:  
3,232,788, PUB. 2-6-2007. INT. CL. 20.
- AMBERCARE CORPORATION, BELEN, NM:  
2,034,357, REN. 3-22-07. INT. CL. 42.
- AMBIENT LABS, INC., NEW YORK, NY:  
2,357,316, CANC. INT. CL. 42.
- AMERICA'S FAMILY COACHES, INC., DES MOINES, IA:  
2,112,030, REN. 3-16-07. INT. CL. 41.
- AMERICA'S POWERSPORTS, INC., BRENTWOOD, TN:  
3,232,828, PUB. 2-6-2007. INT. CL. 35.
- AMERICAN ACADEMY OF OPHTHALMOLOGY, INC., SAN FRANCISCO, CA:  
2,356,565, CANC. INT. CL. 16.
- AMERICAN ASSOCIATION OF INDIVIDUAL INVESTORS, INC., CHICAGO, IL:  
1,979,114, CANC. INT. CL. 16.
- AMERICAN AUTOMOBILE ASSOCIATION, INC., HEATHROW, FL:  
3,233,408, PUB. 2-6-2007. INT. CL. 16.
- AMERICAN BEEFALO WORLD REGISTRY, ALLEGAN, MI:  
2,357,165, CANC. INT. CL. 42.
- AMERICAN BOARD OF SURGERY, INC., PHILADELPHIA, PA:  
2,038,185, REN. 3-16-07. INT. CL. 41.
- AMERICAN BROADCASTING COMPANIES, INC., NEW YORK, NY:  
2,358,643, CANC. INT. CL. 38.
- AMERICAN CAPITAL FINANCIAL SERVICES, INC., BETHESDA, MD:  
2,358,211, CANC. MULTIPLE CLASS, INT. CLS. 9 AND 10.
- AMERICAN CENTURY SERVICES CORPORATION, KANSAS CITY, MO:  
2,357,110, CANC. INT. CL. 36.
- AMERICAN CLEANERS AND LAUNDRY COMPANY, INC., ST. LOUIS, MO:  
2,128,490, REN. 3-22-07. INT. CL. 37.
- AMERICAN COALITION FOR ETHANOL, SIOUX FALLS, SD:  
3,233,386, PUB. 2-6-2007. INT. CL. 35.
- AMERICAN COLLEGE OF VETERINARY OPHTHALMOLOGISTS, GAINESVILLE, FL:  
2,358,924, CANC. INT. CL. 16.
- AMERICAN COMPUTER GROUP, PHOENIX, AZ:  
2,356,731, CANC. INT. CL. 35.  
2,356,732, CANC. INT. CL. 35.
- AMERICAN DRIVER MEDIA, INC., ADDISON, TX:  
3,233,504, PUB. 2-6-2007. INT. CL. 16.
- AMERICAN ETIQUETTE INSTITUTE, SAN JOSE, CA:  
2,356,432, CANC. INT. CL. 16.
- AMERICAN EXPRESS COMPANY, NEW YORK, NY:  
2,356,855, CANC. INT. CL. 9.  
2,358,600, CANC. INT. CL. 36.
- AMERICAN EXPRESS MARKETING AND DEVELOPMENT CORP., NEW YORK, NY:  
3,234,923, MULTIPLE CLASS, INT. CLS. 36 AND 39.
- AMERICAN FAMILY MUTUAL INSURANCE COMPANY, MADISON, WI:  
2,073,900, REN. 3-21-07. INT. CL. 37.
- AMERICAN GAITED MOUNTAIN HORSE ASSOCIATION, LLC, CLAY CITY, KY:  
3,235,462, INT. CL. 35.  
3,235,463, U.S. CL. A.  
3,235,464, INT. CL. 35.  
3,235,465, U.S. CL. A.
- AMERICAN GIFT CORPORATION, MIAMI, FL:  
2,357,095, CANC. INT. CL. 20.
- AMERICAN GIRL, LLC, EL SEGUNDO, CA:  
3,234,659, INT. CL. 14.
- AMERICAN HEART ASSOCIATION, INC., DALLAS, TX:  
2,356,595, CANC. MULTIPLE CLASS, INT. CLS. 16, 25 AND 42.  
3,234,169, MULTIPLE CLASS, INT. CLS. 9, 16, 35, 36 AND

41.  
 AMERICAN HYDRO SYSTEMS INC, ST PETERSBURG, FL:  
 1,067,128. REN. 3-22-07. INT. CL. 9.  
 AMERICAN IDEAS AND DESIGNS, INC., FALLS CHURCH,  
 VA, DBA GREENING AMERICA:  
 2,038,342. REN. 3-20-07. INT. CL. 41.  
 AMERICAN INDEPENDENT INSURANCE COMPANY,  
 CONSHOHOCKEN, PA:  
 2,083,204. REN. 3-17-07. INT. CL. 36.  
 AMERICAN INTERNATIONAL GROUP, INC., NEW YORK,  
 NY:  
 2,028,506. REN. 3-20-07. INT. CL. 35.  
 AMERICAN INTERNATIONAL GROUP, INC., NEW YORK,  
 NY, AMERICAN GENERAL FINANCE, INC., EVANS-  
 VILLE, IN:  
 2,033,408. REN. 3-20-07. INT. CL. 36.  
 AMERICAN INTERNATIONAL GROUP, INC., NEW YORK,  
 NY:  
 3,027,800, CANC. INT. CL. 36.  
 3,234,533, INT. CL. 36.  
 3,235,206, INT. CL. 36.  
 AMERICAN LAND RESOURCES, LLC, CHICAGO, IL:  
 2,356,962, CANC. INT. CL. 36.  
 AMERICAN MUSIC & SOUND, LLC, PLATTSBURGH, NY:  
 2,357,684, CANC. INT. CL. 20.  
 AMERICAN OF LYNCHBURG, INC., ROANOKE, VA, DBA  
 EMBASSY CARPETS:  
 2,036,116. REN. 3-17-07. INT. CL. 27.  
 AMERICAN OPTICAL IP CORPORATION, SAN DIEGO, CA:  
 2,025,684. REN. 3-22-07. INT. CL. 5.  
 AMERICAN PHARMACISTS ASSOCIATION, WASHING-  
 TON, DC, FORMERLY AMERICAN PHARMACEUTICAL  
 ASSOCIATION:  
 3,234,014, INT. CL. 35.  
 AMERICAN PUBLIC COMMUNICATIONS COUNCIL,  
 ALEXANDRIA, VA:  
 2,034,622. REN. 3-16-07. MULTIPLE CLASS, INT. CLS. 16  
 AND 41.  
 2,055,619. REN. 3-16-07. INT. CL. 35.  
 AMERICAN PUBLIC COMPANY, INC., NEW YORK, NY:  
 1,979,519, CANC. INT. CL. 25.  
 AMERICAN REGISTRY FOR DIAGNOSTIC MEDICAL  
 SONOGRAPHY, INC., ROCKVILLE, MD:  
 2,063,144. REN. 3-19-07. U.S. CL. B.  
 AMERICAN RELIANCE INDUSTRIES, CO., SHIPSHEWA-  
 NA, IN:  
 3,232,476, PUB. 8-29-2006. INT. CL. 12.  
 AMERICAN RENTAL ASSOCIATION, MOLINE, IL:  
 2,356,895, CANC. INT. CL. 35.  
 AMERICAN RESIDENTIAL INVESTMENT TRUST, DEL  
 MAR, CA:  
 2,356,482, CANC. INT. CL. 36.  
 AMERICAN ROLLER COMPANY, LLC, UNION GROVE, IL:  
 1,468,003. REN. 3-16-07. INT. CL. 7.  
 AMERICAN SIGNATURE, INC., COLUMBUS, OH:  
 3,234,964, INT. CL. 20.  
 AMERICAN SOCIETY OF INTERIOR DESIGNERS, INC.,  
 WASHINGTON, DC:  
 3,232,645, PUB. 2-6-2007. INT. CL. 35.  
 AMERICAN SPEECH-LANGUAGE-HEARING ASSOCIA-  
 TION, ROCKVILLE, MD:  
 2,038,205. REN. 3-22-07. MULTIPLE CLASS, INT. CLS. 41  
 AND 42.  
 AMERICAN SPORTS LICENSING, INC., WILMINGTON,  
 DE:  
 3,233,896, INT. CL. 25.  
 AMERICAN STANDARD INTERNATIONAL INC., NEW  
 YORK, NY:  
 3,235,059, INT. CL. 11.  
 AMERICAN SUPERCONDUCTOR CORPORATION, WEST-  
 BOROUGH, MA:  
 3,234,230, INT. CL. 9.  
 AMERICAN SWEETENER CORPORATION, YONKERS, NY,  
 SUCREST CORPORATION, NEW YORK, NY:  
 823,016. REN. 3-16-07. U.S. CL. 46 (INT. CL. 30).  
 AMERICAN TANK GAUGE, INC., CHICKASHA, OK:  
 3,233,899, INT. CL. 9.  
 AMERICAN TELEPHONE AND TELEGRAPH CO.:  
 1,396,588, CANC. INT. CL. 9.  
 AMERICAN TEXTILE COMPANY, DUQUESNE, PA:  
 3,234,086, INT. CL. 20.  
 3,234,087, INT. CL. 20.  
 AMERICAN TIRE DISTRIBUTORS, INC., HUNTERSVILLE,  
 NC, J.H. HEAFNER COMPANY, INC., THE, LINCOLN-  
 TON, NC:  
 2,084,592. REN. 3-22-07. INT. CL. 12.  
 AMERICAN WATER WORKS COMPANY, INC., VOOR-  
 HEES, NJ:  
 2,356,857, CANC. INT. CL. 42.  
 AMERICAN WEAVERS, L.P., CALHOUN, GA TO MOHAWK  
 BRANDS, INC., WILMINGTON, DE:  
 1,980,221, CANC. INT. CL. 24.  
 AMERICANA MEDIA CONSULTING, INC., TALLAHAS-  
 SEE, FL:  
 2,357,438, CANC. INT. CL. 35.  
 AMERICATEL CORPORATION, MIAMI, FL:  
 3,234,588, INT. CL. 38.  
 AMERIGROUP CORPORATION, VIRGINIA BEACH, VA:  
 3,234,864, MULTIPLE CLASS, INT. CLS. 35 AND 44.  
 AMERIMARK BUILDING PRODUCTS, INC., RALEIGH,  
 NC:  
 1,396,438, CANC. INT. CL. 6.  
 AMERITOR REALTY, INC., FORT MYERS, FL:  
 3,233,328, PUB. 2-6-2007. INT. CL. 36.  
 AMERTRON INC., WEST MELBOURNE, FL:  
 2,357,118, CANC. INT. CL. 40.  
 AMES TRUE TEMPER PROPERTIES, INC., WILMINGTON,  
 DE:  
 3,235,378, INT. CL. 17.  
 AMF BOWLING WORLDWIDE, INC., MECHANICSVILLE,  
 VA:  
 3,235,027, INT. CL. 43.  
 AMICK, DARRYL D., ALBANY, OR:  
 3,234,983, INT. CL. 13.  
 AMIET AG, CH-4515 OBERDORF, SWITZERLAND:  
 1,435,559. REN. 3-16-07. INT. CL. 18.  
 AMMO BOX AMPLIFIERS LLC, NEW HAVEN, CT:  
 3,234,802, INT. CL. 9.  
 AMORA MAILLE, 21000 DIJON, FRANCE:  
 2,357,047, CANC. INT. CL. 29.  
 AMOREPACIFIC CORPORATION, SEOUL, REPUBLIC OF  
 KOREA:  
 3,233,852, INT. CL. 3.  
 AMOREPACIFIC CORPORATION, SEOUL 140-777, REPUB-  
 LIC OF KOREA:  
 3,234,854, INT. CL. 3.  
 AMOS PRESS, INC., SIDNEY, OH:  
 2,356,714, CANC. INT. CL. 16.  
 AMRION, INC., BOULDER, CO:  
 2,356,594, CANC. INT. CL. 5.  
 AMS RESEARCH CORPORATION, MINNETONKA, MN,  
 AMERICAN MEDICAL SYSTEMS, INC., MINNETONKA,  
 MN:  
 2,052,789. REN. 3-21-07. INT. CL. 10.  
 AMSCO SCHOOL PUBLICATIONS, INC., NEW YORK, NY:  
 1,044,132. REN. 3-20-07. INT. CL. 16.  
 AMSOUTH BANCORPORATION, BIRMINGHAM, AL:  
 1,397,099, CANC. INT. CL. 36.  
 AMUSE, INC., FOUNTAIN VALLEY, CA:  
 3,233,230, PUB. 2-6-2007. INT. CL. 9.  
 ANABOLIC VIDEO PRODUCTIONS, INC., CHATSWORTH,  
 CA:  
 3,234,272, INT. CL. 9.  
 ANALOGY, INC., BEAVERTON, OR:  
 2,358,217, CANC. INT. CL. 9.  
 ANASTASIA, INTERNATIONAL, INC., BANGOR, ME:  
 2,083,092. REN. 3-17-07. MULTIPLE CLASS, INT. CLS. 16  
 AND 42.  
 ANCHOR BANCORP, INC., WAYZATA, MN:  
 2,080,723. REN. 3-16-07. INT. CL. 36.  
 2,080,725. REN. 3-22-07. INT. CL. 36.  
 ANCHOR HOLDINGS, LLC, WARREN, MI:  
 2,357,076, CANC. INT. CL. 35.

- ANCHOR WALL SYSTEMS, INC., MINNETONKA, MN:  
3,234,438, INT. CL. 7.  
3,235,068, INT. CL. 19.
- ANCIENS ETABLISSEMENTS EDARD, F-77330 OZOIR-LA-FERRIERE, FRANCE:  
3,233,644, PUB. 2-6-2007. MULTIPLE CLASS, INT. CLS. 6 AND 20.
- ANCIENT EGYPT RESEARCH ASSOCIATES INC., CAMBRIDGE, MA:  
2,357,421, CANC. INT. CL. 42.
- AND WHY NOT US, NEW YORK, NY:  
3,232,718, PUB. 2-6-2007. INT. CL. 21.
- ANDALÉ LOS GATOS, SAN FRANCISCO, CA:  
3,232,877, PUB. 2-6-2007. INT. CL. 43.
- ANDERSEN CORPORATION, BAYPORT, MN:  
1,056,872, REN. 3-22-07. MULTIPLE CLASS, INT. CLS. 6 AND 19.
- ANDERSEN STERILIZERS, INC., HAW RIVER, NC:  
3,233,324, PUB. 2-6-2007. INT. CL. 9.
- ANDERSON, RICHARD, BOISE, ID:  
2,356,437, CANC. INT. CL. 16.
- ANDERSON, SHAWN M., GENESEO, IL:  
2,357,657, CANC. INT. CL. 41.
- ANDERSON, TIMOTHY V., VIRGINIA BEACH, VA:  
2,358,512, CANC. INT. CL. 42.
- ANDERSONS, INC., THE, MAUMEE, OH:  
1,424,482, REN. 3-19-07. INT. CL. 1.
- ANDON ENTERPRISE, INC., INDUSTRY, CA, DBA COMM-PAGE TO JUST PCS, INC., CITY OF INDUSTRY, CA:  
1,979,794, CANC. INT. CL. 42.
- ANDRADE, MARY J., SAN JOSE, CA:  
3,233,808, MULTIPLE CLASS, INT. CLS. 16, 25 AND 35.
- ANDREA ELECTRONICS CORPORATION, BOHEMIA, NY:  
3,235,450, INT. CL. 9.
- ANDRAE, JOHN, C, NEWPORT BEACH, CA:  
3,234,098, INT. CL. 25.
- ANDREW JAMES HOSIE, AUSTRALIA:  
3,233,609, PUB. 2-6-2007. MULTIPLE CLASS, INT. CLS. 25, 28 AND 41.
- ANDREW, SINCLAIR M., BROOKLYN, NY:  
3,232,499, PUB. 3-28-2006. INT. CL. 25.
- ANDREWS, JAMES P., LONDON, UNITED KINGDOM:  
3,234,194, INT. CL. 33.
- ANDRITZ LTD., VILLE ST-LARENT, QUEBEC, CANADA, HYMAC LTD., LAVAL, QUEBEC, CANADA:  
1,424,588, REN. 3-17-07. INT. CL. 7.
- ANGARA DATABASE SYSTEMS, INC., SAN JOSE, CA:  
2,358,284, CANC. INT. CL. 9.
- ANGELA MOORE, INC., NEWPORT, RI:  
2,377,295, CANC. MULTIPLE CLASS, INT. CLS. 25 AND 35.
- ANGUS CHEMICAL COMPANY, BUFFALO GROVE, IL:  
2,101,823, REN. 3-19-07. INT. CL. 1.
- ANHEUSER-BUSCH INCORPORATED, ST LOUIS, MO:  
2,357,588, CANC. INT. CL. 32.
- ANHEUSER-BUSCH, INCORPORATED, ST. LOUIS, MO:  
1,979,468, CANC. INT. CL. 32.  
3,233,486, PUB. 2-6-2007. INT. CL. 32.  
3,234,921, INT. CL. 30.  
3,235,220, INT. CL. 32.
- ANIMAL RECORDS LIMITED, ENCINO, CA:  
2,356,794, CANC. INT. CL. 41.
- ANIMEIGO, INC., WILMINGTON, NC:  
2,357,323, CANC. INT. CL. 9.
- ANITECH SYSTEMS, INC., VALENCIA, CA:  
1,979,361, CANC. INT. CL. 9.
- ANOCYSYS AG, CH-6460 ALTDORF, SWITZERLAND:  
3,233,704, PUB. 2-6-2007. MULTIPLE CLASS, INT. CLS. 9 AND 42.
- ANONYMOUS INTERNET SITE INC., CROSS RIVER, NY:  
2,357,537, CANC. INT. CL. 41.
- ANSON COMPUTER, INC., INDUSTRY, CA:  
2,357,274, CANC. INT. CL. 35.
- ANSWERS SYSTEMS INC., OLDSMAR, FL:  
3,233,358, PUB. 2-6-2007. INT. CL. 42.
- ANTENEX, INC., GLENDALE HEIGHTS, IL:  
2,035,076, REN. 3-22-07. INT. CL. 9.
- ANTHONY J. JANNETTI, INC., PITMAN, NJ:  
1,391,567, REN. 3-16-07. INT. CL. 16.
- ANTI-PEST COMPANY, INC., SHREVEPORT, LA:  
1,432,310, REN. 3-22-07. INT. CL. 37.  
1,432,311, REN. 3-22-07. INT. CL. 37.
- ANTICANCER, INC., SAN DIEGO, CA:  
2,040,874, REN. 3-17-07. INT. CL. 5.
- ANTIQUA POWER, INC., YELLOW SPRINGS, OH:  
2,121,531, REN. 3-21-07. INT. CL. 16.
- ANTONIO MERLONI S.P.A., I-60044 FABRIANO (AN), ITALY:  
3,233,710, PUB. 2-6-2007. MULTIPLE CLASS, INT. CLS. 7 AND 11.
- AOL LLC, DULLES, VA:  
3,031,948, AM. INT. CL. 42.  
3,031,949, AM. INT. CL. 38.  
3,232,300, PUB. 2-6-2007. INT. CL. 38.  
3,232,307, PUB. 2-6-2007. INT. CL. 41.
- AON SERVICES GROUP, INC., CHICAGO, IL:  
2,129,879, REN. 3-21-07. INT. CL. 36.
- APCON, INC., WILSONVILLE, OR:  
3,232,701, PUB. 2-6-2007. INT. CL. 9.
- APLICARE, INC., MERIDEN, CT:  
3,233,034, PUB. 2-6-2007. INT. CL. 5.  
3,233,052, PUB. 2-6-2007. INT. CL. 5.
- APOLIS HOLDINGS, LLC, SANTA BARBARA, CA:  
3,233,310, PUB. 2-6-2007. INT. CL. 25.
- APPALACHIAN STATE UNIVERSITY, BOONE, NC:  
3,234,906, INT. CL. 9.
- APPLE & EVE, LLC, PORT WASHINGTON, NY:  
2,358,461, CANC. INT. CL. 29.
- APPLE CORPS LIMITED, LONDON SW3 1LJ, ENGLAND:  
2,036,537, REN. 3-17-07. INT. CL. 9.
- APPLE CORPS LIMITED, LONDON, ENGLAND:  
2,066,226, REN. 3-17-07. INT. CL. 9.
- APPLE HILL HOLDINGS, LLC, BETHESDA, MD:  
3,232,179, PUB. 2-6-2007. INT. CL. 35.
- APPLE INC., CUPERTINO, CA:  
1,401,154, REN. 3-17-07. INT. CL. 16.
- APPLIED INDUSTRIAL TECHNOLOGIES, INC., CLEVELAND, OH, BEARINGS, INC., CLEVELAND, OH:  
2,054,647, REN. 3-16-07. INT. CL. 42.
- APPLICA CONSUMER PRODUCTS, INC., MIRAMAR, FL:  
2,358,561, CANC. INT. CL. 11.
- APPLIED COMPUTER SYSTEMS, INCORPORATED, JOHNSTOWN, OH:  
3,232,486, PUB. 2-6-2007. INT. CL. 9.
- APPLIED ENTERPRISE DYNAMICS, INC., BELMONT, CA:  
3,232,492, PUB. 2-6-2007. INT. CL. 9.
- APPLIED MINDS, INC., GLENDALE, CA:  
3,234,191, MULTIPLE CLASS, INT. CLS. 12 AND 28.
- APPROPRIATE SOLUTIONS PTY LTD, ELTHAM, AUSTRALIA:  
3,232,530, PUB. 2-6-2007. INT. CL. 9.
- APS HEALTHCARE BETHESDA, INC., SILVER SPRING, MD:  
3,232,419, PUB. 2-6-2007. MULTIPLE CLASS, INT. CLS. 16, 41 AND 44.  
3,232,433, PUB. 2-6-2007. MULTIPLE CLASS, INT. CLS. 41 AND 44.
- APSCO, INC., LUBBOCK, TX, DBA AMERICAN WEST WINDMILL CO.:  
2,356,631, CANC. INT. CL. 7.
- APTECH ENGINEERING SERVICES, INC., PALO ALTO, CA:  
1,396,578, CANC. INT. CL. 9.
- AQUA CAL, INC., ST. PETERSBURG, FL:  
1,979,713, CANC. INT. CL. 11.
- AQUA WALL DANMARK A/S, DK-2620 ALBERTSLUND, DENMARK:  
1,980,124, CANC. MULTIPLE CLASS, INT. CLS. 11 AND 37.
- AQUABOUNTY TECHNOLOGIES, INC., WALTHAM, MA:  
2,357,832, CANC. INT. CL. 29.
- AQUINO, EDWIN A., PLEASANTON, CA:  
3,232,430, PUB. 2-6-2007. INT. CL. 42.

ARAMARK EDUCATIONAL RESOURCES, INC., GOLDEN, CO:  
2,358,354, CANC. MULTIPLE CLASS, INT. CLS. 41 AND 42.

ARATO DESIGN ASSOCIATES INC., WILLOWDALE, ONTARIO, M2H 2S5, CANADA:  
1,983,195. REN. 3-20-07. MULTIPLE CLASS, INT. CLS. 19 AND 20.

ARAWAZA EQUIPMENT INC., QUEBEC, CANADA:  
3,233,775, INT. CL. 25.

ARBELLA MUTUAL INSURANCE COMPANY, QUINCY, MA:  
2,037,212. REN. 3-22-07. INT. CL. 36.

ARBOR RESEARCH COLLABORATIVE FOR HEALTH, ANN ARBOR, MI:  
3,235,218, INT. CL. 42.

ARBUS SOFTWARE INC., BURNABY, CANADA:  
3,234,475, MULTIPLE CLASS, INT. CLS. 9 AND 42.

ARBY'S IP HOLDER TRUST, ATLANTA, GA, T.J. CINNAMONS, LTD., KANSAS CITY, MO:  
1,427,659. REN. 3-22-07. INT. CL. 30.

ARCAT, INC., FAIRFIELD, CT, ARCHITECT'S CATALOG, INC., THE, FAIRFIELD, CT:  
2,028,679. REN. 3-17-07. INT. CL. 42.

ARCH PERSONAL CARE PRODUCTS, L. P., SOUTH PLAINFIELD, NJ, BROOKS INDUSTRIES, INC., SOUTH PLAINFIELD, NJ:  
2,080,115. REN. 3-22-07. INT. CL. 1.

ARCH UK BIOCIDES LIMITED, CASTLEFORD, WEST YORKSHIRE WF10 2JT, UNITED KINGDOM:  
1,058,905. REN. 3-19-07. INT. CL. 5.

ARCHER-DANIELS-MIDLAND COMPANY, DECATUR, IL:  
3,234,358, MULTIPLE CLASS, INT. CLS. 29 AND 31.

ARCHIBALD CANDY CORPORATION:  
1,397,036, CANC. INT. CL. 30.

ARCHON PAINTBALL, INC., GREENVILLE, SC:  
3,234,278, INT. CL. 28.

ARCUS MEDICAL, LLC, CHARLOTTE, NC:  
3,234,521, INT. CL. 5.

ARDELL INTERNATIONAL, INC., LOS ANGELES, CA:  
1,232,452, CANC. INT. CL. 3.

ARENA FOOTBALL LEAGUE LLC, CHICAGO, IL:  
3,233,872, INT. CL. 41.

ARES TRADING S.A., CH-1170 AUBONNE, SWITZERLAND:  
2,059,423. REN. 3-22-07. INT. CL. 5.

ARES TRADING S.A., 2028 VAUMARCUS, SWITZERLAND:  
2,356,578, CANC. INT. CL. 10.

ARES TRADING S.A., AUBONNE, SWITZERLAND:  
3,232,929, PUB. 2-6-2007. INT. CL. 5.

ARGENTO, JOHN, NEW YORK, NY:  
2,055,072. REN. 3-17-07. INT. CL. 42.

ARGOS TECHNOLOGIES, INC., EAST DUNDEE, IL:  
3,235,256, INT. CL. 11.

ARGUS PRESSURE GROUTING SERVICES, INC., WARREN, MI:  
2,358,107, CANC. INT. CL. 37.

ARIA CAPITAL ADVISORS, LLC, ST. PETERSBURG, FL:  
3,232,424, PUB. 2-6-2007. MULTIPLE CLASS, INT. CLS. 35 AND 36.

ARIENS COMPANY, BRILLION, WI:  
3,235,292, INT. CL. 7.

ARISAPH PHARMACEUTICALS, INC., BOSTON, MA:  
3,235,287, INT. CL. 42.

ARIZONA FEDERAL CREDIT UNION, PHOENIX, AZ:  
2,120,872. REN. 3-20-07. INT. CL. 36.

ARJO LIMITED, GLOUCESTER GL1 2SL, ENGLAND:  
1,979,473, CANC. INT. CL. 10.

ARKEMA, 92800 PUTEAUX, FRANCE:  
1,396,809, CANC. INT. CL. 17.

ARKEMA FRANCE, PUTEAUX, FRANCE:  
823,199. REN. 3-22-07. U.S. CL. 1 (INT. CL. 1).  
823,290. REN. 3-22-07. U.S. CL. 16 (INT. CL. 2).

ARMAMENT SYSTEMS AND PROCEDURES, INC., APPLETON, WI:  
2,123,616. REN. 3-16-07. INT. CL. 6.  
3,233,814, INT. CL. 11.

ARMANDA COSTANZA, INC., NASHVILLE, TN:  
2,047,026. REN. 3-19-07. INT. CL. 41.

ARMS BUILDING & MAINTENANCE, INC., LONGVIEW, TX:  
3,235,204, INT. CL. 27.

ARNOLD PALMER GOLF COMPANY, THE, OOLTEWAH, TN:  
2,358,773, CANC. INT. CL. 28.

AROMCA S.A, ATTICA, GREECE:  
3,233,058, PUB. 2-6-2007. INT. CL. 3.

ARROW FASTENER CO., INC., SADDLE BROOK, NJ:  
652,284. REN. 3-22-07. U.S. CL. 13 (INT. CL. 6).

ARROW GROUP INDUSTRIES, INC., WAYNE, NJ:  
1,047,993. REN. 3-16-07. INT. CL. 6.

ARROW INTERNATIONAL INVESTMENT CORP., WILMINGTON, DE:  
3,234,222, INT. CL. 10.

ARROWDEAN, LTD., DUBLIN 2, IRELAND:  
2,356,514, CANC. INT. CL. 5.

ART.COM, INC., LAKE FOREST, IL:  
2,358,810, CANC. MULTIPLE CLASS, INT. CLS. 35 AND 40.

ARTHREX, INC., NAPLES, FL:  
3,235,332, INT. CL. 10.

ARTHUR, BROOKS, BEVERLY HILLS, CA:  
2,358,023, CANC. INT. CL. 41.

ARTISTRY IN MOTION, INC., VAN NUYS, CA:  
2,115,230. REN. 3-21-07. INT. CL. 13.

ARUZE CORPORATION, TOKYO, JAPAN:  
3,232,331, PUB. 2-6-2007. INT. CL. 28.

ARVIN RIDE CONTROL PRODUCTS, INC., TORONTO, ONTARIO, CANADA:  
3,233,842, INT. CL. 12.

ASBELL, JOSEPH C., DURHAM, NC:  
3,234,196, INT. CL. 25.

ASCENDER CORPORATION, ELK GROVE VILLAGE, IL:  
3,233,398, PUB. 2-6-2007. INT. CL. 9.

ASHLAND LICENSING AND INTELLECTUAL PROPERTY LLC, DUBLIN, OH, DREW CHEMICAL CORPORATION, BOONTON, NJ:  
2,074,233. REN. 3-21-07. INT. CL. 3.

ASIA UNITED GARMENT MANUFACTURING CO. LTD, TSIM SHA TSUI, HONG KONG:  
3,235,422, INT. CL. 25.

ASIAN DISTRIBUTORS, INC., AGANA, GUAM:  
3,234,811, INT. CL. 25.

ASICS CORPORATION, CHUO-KU, KOBE, JAPAN:  
3,232,189, PUB. 2-6-2007. INT. CL. 25.

ASOCIACION LATINOAMERICANA DE AMBIDEXTROS Y ZURDOS, INC., COVINGTON, LA:  
2,356,781, CANC. INT. CL. 41.

ASPEN PET PRODUCTS, INC., DENVER, CO:  
3,235,080, INT. CL. 18.

ASPIRE, INC., MORRISVILLE, PA:  
1,397,120, CANC. MULTIPLE CLASS, INT. CLS. 37 AND 41.

ASPIRING HEIGHTS, BERKELEY, CA:  
2,356,943, CANC. MULTIPLE CLASS, INT. CLS. 35 AND 41.  
2,356,959, CANC. MULTIPLE CLASS, INT. CLS. 35 AND 41.

ASSICURAZIONI GENERALI S.P.A., 34132 TRIESTE (TS), ITALY:  
2,356,650, CANC. INT. CL. 36.

ASSISTANTGM, LLC, DANVILLE, CA:  
3,232,404, PUB. 12-6-2005. INT. CL. 42.

ASSOCIATED ELECTRIC & GAS INSURANCE SERVICES LIMITED, EAST RUTHERFORD, NJ:  
3,232,811, PUB. 2-6-2007. MULTIPLE CLASS, INT. CLS. 9 AND 41.

ASSOCIATED HEALTHCARE SYSTEMS, INC., AMHERST, NY:  
3,233,083, PUB. 2-6-2007. INT. CL. 44.

ASSOCIATED WHOLESALE GROCERS, INC., KANSAS CITY, KS:  
2,537,401, AM. INT. CL. 32.

ASSOCIATION FOR IRON AND STEEL TECHNOLOGY, WARRENDALE, PA:  
2,034,772. REN. 3-19-07. INT. CL. 16.  
2,034,772, CANC. INT. CL. 35.

- ASSOCIATION FOR POSTAL COMMERCE, ARLINGTON, VA:  
3,232,201, PUB. 2-6-2007. INT. CL. 35.
- ASSOCIATION OF AMERICAN MEDICAL COLLEGES, WASHINGTON, DC:  
3,234,405, MULTIPLE CLASS, INT. CLS. 16, 35, 36, 41 AND 42.
- ASSOCIATION OF CERTIFIED FRAUD EXAMINERS, INC., AUSTIN, TX:  
1,992,969. REN. 3-17-07. INT. CL. 41.
- ASSOCIATION OF INTERNATIONAL AUTOMOBILE MANUFACTURERS, INC., ARLINGTON, VA:  
3,234,721, INT. CL. 35.
- ASSURANT, INC., NEW YORK, NY:  
3,234,656, INT. CL. 36.
- AST EIS- UND SOLARTECHNIK; GMBH & CO KG, A-6600 REUTTE, AUSTRIA:  
3,233,718, PUB. 2-6-2007. INT. CL. 19.
- ASTORINO, CHRISTINE, PITTSBURGH, PA:  
3,232,621, PUB. 2-6-2007. INT. CL. 42.
- ASTRA AKTIEBOLAG, S-151 85 SODERTALJE, SWEDEN:  
2,356,420, CANC. INT. CL. 5.
- ASTRA FOODS, INC., UPPER DARBY, PA:  
3,232,177, PUB. 2-6-2007. INT. CL. 29.
- ASTRA FUTTERMITTELHANDELS-GMBH, 49074 OSNABRUECK, FED REP GERMANY:  
2,356,480, CANC. MULTIPLE CLASS, INT. CLS. 1 AND 31.
- ASTRA TECH AB, SWEDEN:  
3,233,692, PUB. 2-6-2007. MULTIPLE CLASS, INT. CLS. 10 AND 44.
- ASTRA TECH AB, SE-431 21 MÖLNDAL, SWEDEN:  
3,233,745, PUB. 2-6-2007. INT. CL. 10.
- ASUSTEK COMPUTER INCORPORATION, TAIPEI, TAIWAN:  
3,234,150, INT. CL. 9.
- ASYST TECHNOLOGIES, INC., FREMONT, CA:  
2,356,961, CANC. INT. CL. 35.
- AT LAST NATURALS, INC., VALHALLA, NY:  
1,054,904. REN. 3-17-07. INT. CL. 3.
- AT WORLD PROPERTIES, LLC, CHICAGO, IL:  
3,235,255, INT. CL. 35.
- AT&T CORP., NEW YORK, NY:  
2,358,137, CANC. INT. CL. 38.
- AT&T KNOWLEDGE VENTURES II, L.P., RENO, NV:  
2,067,641. REN. 3-19-07. MULTIPLE CLASS, INT. CLS. 35 AND 42.
- ATC HEALTHCARE SERVICES, INC., LAKE SUCCESS, NY:  
3,234,522, INT. CL. 35.
- ATHENA PRODUCTS CORPORATION, DALLAS, TX:  
1,396,275, CANC. MULTIPLE CLASS, INT. CLS. 1 AND 5.
- ATHENIX CORP., DURHAM, NC:  
3,233,788, INT. CL. 42.
- ATHESIA VINI S.R.L., 38063 AVIO (TN), ITALY:  
3,232,717, PUB. 2-6-2007. INT. CL. 33.
- ATHLETICA, INC., GENESEO, NY:  
3,234,758, INT. CL. 25.
- ATICO INTERNATIONAL USA, INC., FT. LAUDERDALE, FL:  
3,234,667, INT. CL. 20.
- ATLANTIC AUTOMOTIVE CORP., BALTIMORE, MD:  
2,357,667, CANC. INT. CL. 36.
- ATLANTIC BOTTLING, LLC, LONG BRANCH, NJ:  
3,234,009, INT. CL. 33.  
3,234,012, INT. CL. 33.
- ATLANTIC CITY COIN & SLOT SERVICE COMPANY, INC., PLEASANTVILLE, NJ:  
3,233,949, INT. CL. 9.
- ATLANTIC COMPANIES, INC., JACKSONVILLE, FL:  
3,232,841, PUB. 2-6-2007. MULTIPLE CLASS, INT. CLS. 9, 37 AND 45.
- ATLANTIC RICHFIELD COMPANY, WARRENVILLE, IL:  
1,425,962. REN. 3-17-07. INT. CL. 37.
- ATLAS BRICK COMPANY LLC, SUGAR LAND, TX:  
3,234,674, INT. CL. 19.
- ATLAS OIL COMPANY, TAYLOR, MI:  
3,232,155, PUB. 2-6-2007. INT. CL. 39.
- ATLAS PRECISION, INC., ARDEN, NC:  
2,034,190. REN. 3-22-07. INT. CL. 40.
- ATLAS ROOFING CORPORATION, MERIDIAN, MS:  
2,037,738. REN. 3-22-07. INT. CL. 19.
- ATLEY PHARMACEUTICALS, INC., ASHLAND, VA:  
3,234,285, INT. CL. 5.
- ATOTECH DEUTSCHLAND GMBH, BERLIN, FED REP GERMANY:  
3,232,176, PUB. 2-6-2007. INT. CL. 1.
- ATRIA SENIOR LIVING GROUP, INC., LOUISVILLE, KY:  
2,357,522, CANC. INT. CL. 42.
- ATRONIC INTERNATIONAL GMBH, 32312 LÜBBECKE, FED REP GERMANY:  
3,232,078, PUB. 5-16-2006. MULTIPLE CLASS, INT. CLS. 9 AND 28.
- ATRONIC INTERNATIONAL GMBH, 32312 LUBBECKE, FED REP GERMANY:  
3,232,350, PUB. 2-7-2006. MULTIPLE CLASS, INT. CLS. 9 AND 28.
- ATT HEADWEAR INC., HOUSTON, TX:  
1,995,569. REN. 3-20-07. INT. CL. 25.
- AU-TOMOTIVE GOLD, INC., TUCSON, AZ:  
3,232,864, PUB. 2-6-2007. MULTIPLE CLASS, INT. CLS. 6, 12 AND 20.
- AUDIO & VIDEO LABS, INC./DISC MAKERS, PENNSAUKEN, NJ:  
3,232,423, PUB. 2-6-2007. INT. CL. 9.
- AUGUSTA PROFESSIONAL BASEBALL LLC, BALTIMORE, MD:  
3,235,294, MULTIPLE CLASS, INT. CLS. 25 AND 41.
- AUSTIN, JOSEPH H. III, MARRERO, LA:  
3,233,859, INT. CL. 43.
- AUTO-GRAPHICS, INC., POMONA, CA:  
2,357,695, CANC. INT. CL. 16.
- AUTO/MATE, INC., CLIFTON PARK, NY:  
3,232,147, PUB. 2-6-2007. INT. CL. 42.
- AUTOBUYERS-HELPER, L.L.C., CORDOVA, TN:  
2,357,418, CANC. INT. CL. 35.
- AUTOMATED PACKAGING SYSTEMS, INC., STREETS-BORO, OH:  
1,058,984. REN. 3-22-07. INT. CL. 7.  
2,033,835. REN. 3-21-07. INT. CL. 16.
- AUTOMATION INTELLIGENCE, INC., ORLANDO, FL:  
1,396,507, CANC. MULTIPLE CLASS, INT. CLS. 9 AND 42.
- AUTOMOTIVE RENTALS, INC., MT. LAUREL, NJ:  
3,232,283, PUB. 2-6-2007. INT. CL. 42.  
3,232,284, PUB. 2-6-2007. INT. CL. 35.
- AUTOMOTIVE.COM, INC., IRVINE, CA:  
3,232,614, PUB. 2-6-2007. INT. CL. 35.
- AUTOTEC, LLC, BIRMINGHAM, AL:  
3,233,399, PUB. 2-6-2007. INT. CL. 35.  
3,233,401, PUB. 2-6-2007. INT. CL. 35.
- AUTOTESTER INC., DALLAS, TX:  
2,358,825, CANC. INT. CL. 42.
- AVA RUHA CORPORATION, COSTA MESA, CA, DBA MOTHER'S MARKET AND KITCHEN:  
1,440,871. REN. 3-22-07. INT. CL. 42.
- AVALON FORTRESS SECURITY CORPORATION, COON RAPIDS, MN:  
3,232,630, PUB. 2-6-2007. MULTIPLE CLASS, INT. CLS. 41 AND 45.
- AVAZ, INC., PHOENIX, AZ:  
3,234,047, INT. CL. 9.
- AVDEL CHERRY TEXTRON INC., STANFIELD, NC:  
1,396,471, CANC. INT. CL. 7.
- AVEDA CORPORATION, MINNEAPOLIS, MN:  
2,109,944. REN. 3-21-07. INT. CL. 3.
- AVENTURA PIZZA, INC., AVENTURA, FL:  
2,357,219, CANC. INT. CL. 42.  
2,357,220, CANC. INT. CL. 42.  
2,357,221, CANC. INT. CL. 42.
- AVENUES IN LEATHER, INC., TINTON FALLS, NJ:  
3,233,481, PUB. 2-6-2007. INT. CL. 9.
- AVERITT EXPRESS, COOKEVILLE, TN:  
3,232,136, PUB. 2-6-2007. INT. CL. 39.
- AVERY DENNISON CORPORATION, PASADENA, CA:  
3,234,234, MULTIPLE CLASS, INT. CLS. 16, 17 AND 20.

EVERETT DENNISON OFFICE PRODUCTS COMPANY, BREA, CA:  
2,356,596, CANC. MULTIPLE CLASS, INT. CLS. 9 AND 16.

AVIATION SALES COMPANY, MIAMI, FL:  
2,357,020, CANC. INT. CL. 40.

AVICENNA LASER TECHNOLOGY, INC., WEST PALM BEACH, FL:  
3,233,046, PUB. 2-6-2007. MULTIPLE CLASS, INT. CLS. 10 AND 44.

AVIOTT DESIGN, INC., DETROIT, MI:  
3,234,265, INT. CL. 28.

AVJOBS, INC., LITTLETON, CO:  
3,024,872, CANC. IIRN. RESTORED TO S.N. 78-502,216.

AVON PRODUCTS, INC., NEW YORK, NY:  
1,396,360, CANC. INT. CL. 3.  
2,358,020, CANC. INT. CL. 3.  
2,358,336, CANC. INT. CL. 3.  
2,358,579, CANC. INT. CL. 3.  
2,358,580, CANC. INT. CL. 3.  
2,358,581, CANC. INT. CL. 3.  
2,358,668, CANC. INT. CL. 3.

AVSAT, INC., BENTON HARBOR, MI:  
2,076,907, REN. 3-20-07. MULTIPLE CLASS, INT. CLS. 37 AND 39.

AWANA CLUBS INTERNATIONAL, STREAMWOOD, IL:  
3,233,485, PUB. 2-6-2007. INT. CL. 41.  
3,233,500, PUB. 2-6-2007. MULTIPLE CLASS, INT. CLS. 9 AND 16.

AWARE PRODUCTS, CHATSWORTH, CA:  
3,232,868, PUB. 2-6-2007. INT. CL. 35.

AWESUMATION, INC., DENVER, CO:  
3,233,378, PUB. 2-6-2007. INT. CL. 42.

AWS CONVERGENCE TECHNOLOGIES, INC., GERMANTOWN, MD:  
3,004,130, COR. MULTIPLE CLASS, INT. CLS. 41 AND 42.

AXIS CLOTHING COMPANY, INC., CULVER CITY, CA:  
1,980,260, CANC. INT. CL. 25.

AYOUB AND ASSOCIATES INC., RALEIGH, NC:  
2,358,092, CANC. INT. CL. 9.

AZ COM PAGING, INC., PHOENIX, AZ:  
2,356,537, CANC. INT. CL. 38.

AZOTIC COATING TECHNOLOGY, INC., ROCHESTER, MN:  
3,234,621, INT. CL. 14.  
3,234,622, INT. CL. 14.  
3,235,237, INT. CL. 40.  
3,235,238, INT. CL. 40.  
3,235,239, INT. CL. 40.

AZTEC PACIFIC, INC., NEWPORT BEACH, CA:  
3,234,480, INT. CL. 9.

B & K INDUSTRIES, INC., ELK GROVE, IL:  
2,036,255, REN. 3-17-07. INT. CL. 6.

B.I.C. ENTERPRISE, INC., LOS ANGELES, CA:  
2,357,513, CANC. MULTIPLE CLASS, INT. CLS. 7, 8 AND 21.

B.J. ALAN COMPANY, YOUNGSTOWN, OH:  
3,235,244, INT. CL. 13.

B.J. VINES, INC., NEW YORK, NY:  
3,232,866, PUB. 2-6-2007. INT. CL. 18.

B.J.D., INC., BELL, CA:  
3,234,019, INT. CL. 25.

BABACOO, BRECKENRIDGE, CO:  
2,357,691, CANC. INT. CL. 25.

BABY GRAZIELLA SRL, ITALY:  
3,233,683, PUB. 2-6-2007. INT. CL. 25.

BACARDI & COMPANY LIMITED, NEW PROVIDENCE, BAHAMAS:  
1,422,214, REN. 3-17-07. INT. CL. 32.  
1,424,194, REN. 3-19-07. INT. CL. 32.

BACCHUS, 33000 BORDEAUX, FRANCE:  
2,749,081, CANC. MULTIPLE CLASS, INT. CLS. 29, 30, 32, 33 AND 42.

BACK TO THE BEACH SOFTWARE, EL CAJON, CA:  
2,357,294, CANC. INT. CL. 9.

BACKERHAUS VEIT LTD., ONTARIO, L4L 7Z4, CANADA:  
2,358,387, CANC. INT. CL. 30.

BACKUPRIGHT, LLC, SAN DIEGO, CA:  
3,232,303, PUB. 2-6-2007. INT. CL. 39.

BAENZIGER, KASPAR, PFEFFINGEN, SWITZERLAND:  
3,234,224, INT. CL. 18.

BAGOT, WALTER M., FISHERS, IN:  
3,234,715, INT. CL. 41.

BAHL, VALERIE WAKEFIELD, SPARKS, NV:  
3,234,748, INT. CL. 16.

BAILEY, KEN, GRAIN VALLEY, MO:  
3,232,930, PUB. 2-6-2007. INT. CL. 9.

BAILEY, ROBERT G., ANCHORAGE, AK AND BAILEY, DELORES F., ANCHORAGE, AK:  
2,357,675, CANC. INT. CL. 42.

BAILLY S.A., 93600 AULNAY SOUS BOIS, FRANCE:  
2,357,730, CANC. INT. CL. 29.

BAINBRIDGE, BONNIE C., TULARE, CA AND LEMONS, COLLEEN, TULARE, CA:  
3,232,792, PUB. 2-6-2007. INT. CL. 35.

BAIRD-NEECE PACKING CORPORATION, PORTERVILLE, CA, SUNFLOWER PACKING CORP., PORTERVILLE, CA:  
347,265, REN. 3-21-07. U.S. CL. 46 (INT. CL. 31).

BAKER & HOSTETLER LLP, CLEVELAND, OH:  
3,235,044, INT. CL. 42.  
3,235,072, INT. CL. 42.  
3,235,093, INT. CL. 42.

BAKER HUGHES INCORPORATED, HOUSTON, TX:  
3,232,623, PUB. 2-6-2007. INT. CL. 42.

BAKER, GEOFFREY B., PASADENA, CA:  
2,358,775, CANC. INT. CL. 9.

BAKER, SUZANNE, CHICAGO, IL:  
3,232,455, PUB. 2-6-2007. INT. CL. 45.

BAKER'S PERFECTION, INC., ROCKAWAY, NJ:  
2,102,823, REN. 3-20-07. INT. CL. 30.

BALBONI ASSOCIATES INC., SPRINGFIELD, MA:  
3,234,847, INT. CL. 35.

BALCOMB, STUART VAIL, VENICE, CA:  
3,233,294, PUB. 2-6-2007. INT. CL. 41.

BALENCIAGA, 75006 PARIS, FRANCE:  
3,233,877, INT. CL. 25.

BALIAN, EDWARD S., ENCINITAS, CA:  
2,357,499, CANC. INT. CL. 16.

BALL HORTICULTURAL COMPANY, WEST CHICAGO, IL:  
2,356,488, CANC. INT. CL. 31.

BALL, BOUNCE AND SPORT INCORPORATED, ASHLAND, OH:  
3,235,175, INT. CL. 12.

BALLANDA CORPORATION, LOS ANGELES, CA:  
1,396,698, CANC. INT. CL. 14.

BALLARINI PAOLO & FIGLI S.P.A., RIVAROLO MANTOVANO, ITALY:  
3,234,917, INT. CL. 21.  
3,234,918, INT. CL. 21.

BALLET MAKERS, INC., TOTOWA, NJ:  
2,036,723, REN. 3-22-07. INT. CL. 25.

BALTIMORE DOMINICANA, C. POR A., SANTIAGO DE LOS CABALLEROS, DOMINICAN REP:  
2,063,843, REN. 3-22-07. INT. CL. 30.

BANANA REPUBLIC (APPAREL), LLC, SAN FRANCISCO, CA:  
3,233,245, PUB. 2-6-2007. INT. CL. 4.  
3,233,246, PUB. 2-6-2007. INT. CL. 4.

BANK OF AMERICA CORPORATION, CHARLOTTE, NC:  
2,357,152, CANC. INT. CL. 36.  
3,235,111, INT. CL. 36.

BANK OF CALIFORNIA, N.A., THE, SAN FRANCISCO, CA:  
2,040,278, REN. 3-21-07. INT. CL. 36.

BANK OF WYOMING, THERMOPOLIS, WY:  
3,235,469, INT. CL. 36.

BAOJI TITANIUM INDUSTRY CO., LTD, BAOJI, SHAANXI, CHINA:  
3,233,739, PUB. 2-6-2007. INT. CL. 6.

BAPTIST MEMORIAL HEALTH CARE CORPORATION, MEMPHIS, TN:  
2,357,590, CANC. INT. CL. 36.  
2,357,594, CANC. INT. CL. 36.  
2,358,649, CANC. MULTIPLE CLASS, INT. CLS. 16 AND 41.

- BARENBRUG USA, INC., TANGENT, OR:  
3,234,459, INT. CL. 31.
- BARKER, JOEL A., ST. PAUL, MN:  
1,977,720. REN. 3-17-07. MULTIPLE CLASS, INT. CLS. 16 AND 41.
- BARNABAS FOUNDATION, TINLEY PARK, IL:  
2,073,698. REN. 3-16-07. INT. CL. 36.
- BARNARD PROPERTIES LIMITED, CASTRIES, ST. LUCIA, WEST INDIES, BAHAMAS:  
3,233,929, INT. CL. 43.
- BARNETTE, S. RONALD, PEMBROKE PINES, FL:  
2,016,117. REN. 3-20-07. MULTIPLE CLASS, INT. CLS. 6, 17 AND 19.
- BARON'S WHOLESALE CLOTHIERS INC., FARMINGTON HILLS, MI:  
3,235,020, INT. CL. 35.
- BARONE, ADRIANA, SAG HARBOR, NY:  
3,232,888, PUB. 2-6-2007. INT. CL. 16.
- BARR, DEBI, HUNTINGTON BEACH, CA:  
3,232,581, PUB. 2-6-2007. MULTIPLE CLASS, INT. CLS. 39 AND 41.
- BARRA CORPORATION OF AMERICA, INC., WEST CALDWELL, NJ:  
1,396,816, CANC. INT. CL. 19.
- BARRAZA, TIMOTHY R., LOS ANGELES, CA AND DETRICK, JOHN CHRISTOPHER, LOS ANGELES, CA:  
3,234,365, MULTIPLE CLASS, INT. CLS. 38 AND 42.
- BARRETT-JACKSON AUCTION COMPANY, LLC, SCOTTSDALE, AZ:  
3,233,336, PUB. 2-6-2007. INT. CL. 35.
- BARRY CALLEBAUT AG, ZURICH, SWITZERLAND:  
2,357,161, CANC. INT. CL. 29.  
2,357,162, CANC. INT. CL. 29.  
2,357,164, CANC. INT. CL. 30.  
2,358,140, CANC. INT. CL. 30.  
2,358,189, CANC. INT. CL. 30.
- BARRY CALLEBAUT NEDERLAND B.V., BUSSUM, NETHERLANDS, CACAO- EN CHOCOLADEFABRIEKEN BENDSDORP N.V., BUSSUM, NETHERLANDS:  
822,981. REN. 3-20-07. U.S. CL. 46 (INT. CLS. 29 AND 30).
- BARTHOLOMEW ENTERPRISES, INC., DES PLAINES, IL:  
1,448,284. REN. 3-17-07. INT. CL. 9.
- BARTLETT HOLDINGS, LLC, NEW YORK, NY:  
2,356,666, CANC. INT. CL. 25.
- BASF CATALYSTS LLC, ISELIN, NJ, BAKER & CO., INC., NEWARK, NJ:  
427,851. REN. 3-20-07. U.S. CL. 26 (INT. CL. 9).
- BASF CATALYSTS LLC, ISELIN, NJ:  
1,422,403. REN. 3-19-07. INT. CL. 1.
- BASF CONSTRUCTION POLYMERS GMBH, TROSTBERG, FED REP GERMANY, SKW TROSTBERG AKTIENGESELLSCHAFT, D-83303 TROSTBERG, FED REP GERMANY:  
2,031,494. REN. 3-16-07. INT. CL. 1.
- BASIC FUN, INC., SOUTHAMPTON, PA:  
2,023,171. REN. 3-21-07. INT. CL. 28.
- BASIC TRADEMARK S.A., L-1150 LUXEMBOURG, LUXEMBOURG:  
3,232,057, PUB. 9-27-2005. INT. CL. 25.
- BASIS TECHNOLOGY CORPORATION, CAMBRIDGE, MA AND GARFINKEL, SIMSON, CAMBRIDGE, MA:  
3,232,830, PUB. 2-6-2007. INT. CL. 9.  
3,232,831, PUB. 2-6-2007. INT. CL. 9.
- BASKETS ON THE RUN, MILWAUKEE, WI:  
3,232,123, PUB. 2-6-2007. INT. CL. 3.
- BASKETT, RAY, MURRIETA, CA:  
3,234,827, INT. CL. 35.
- BASKETVILLE, INC., PUTNEY, VT:  
3,234,458, INT. CL. 21.
- BATEHAM, JOSEPH E., SYLVESTER, GA, DBA BATEHAM MANUFACTURING:  
2,356,733, CANC. INT. CL. 8.
- BATESVILLE SERVICES, INC., BATESVILLE, IN, BATESVILLE CASKET COMPANY, INC., BATESVILLE, IN:  
2,067,498. REN. 3-22-07. INT. CL. 20.
- BATH & BODY WORKS, INC., REYNOLDSBURG, OH:  
3,234,869, INT. CL. 3.  
3,235,402, MULTIPLE CLASS, INT. CLS. 4 AND 35.
- BATH SOLUTIONS, INC., BENSENVILLE, IL:  
3,232,436, PUB. 2-6-2007. INT. CL. 11.
- BATTERY CENTER, INC., THE, NORCROSS, GA:  
2,121,720. REN. 3-22-07. INT. CL. 35.
- BAXTER HEALTHCARE CORPORATION, DEERFIELD, IL, ELKINS-SINN, INC., CHERRY HILL, NJ:  
1,058,184. REN. 3-19-07. INT. CL. 5.
- BAXTER INTERNATIONAL INC., DEERFIELD, IL, CLINTEC NUTRITION COMPANY, DEERFIELD, IL:  
2,035,878. REN. 3-19-07. INT. CL. 5.
- BAYCHAR, INC., EASTPORT, ME:  
3,233,793, INT. CL. 25.
- BAYCO PRODUCTS, LTD., WYLIE, TX:  
3,235,460, INT. CL. 11.
- BAYER ENVIRONMENTAL SCIENCE SA, LYON, FRANCE:  
2,358,313, CANC. INT. CL. 1.
- BAYLOR UNIVERSITY, WACO, TX:  
2,357,059, CANC. MULTIPLE CLASS, INT. CLS. 25 AND 41.
- BAYNOTE, INC., CUPERTINO, CA:  
3,234,862, INT. CL. 42.
- BBC INDUSTRIES, INC., FENTON, MO:  
2,038,810. REN. 3-22-07. INT. CL. 11.
- BBI ACQUISITION CO., DENVER, CO, BRECKENRIDGE BREWERY, INC., BRECKENRIDGE, CO:  
2,029,714. REN. 3-19-07. INT. CL. 32.
- BE A DREAMER PRODUCTIONS, INC., RIVERVIEW, FL:  
3,232,169, PUB. 2-6-2007. INT. CL. 16.
- BE AN ANGEL FUND, INC., HOUSTON, TX:  
2,357,724, CANC. INT. CL. 36.  
2,357,728, CANC. INT. CL. 36.
- BEACH PATROL, INC., CARSON, CA:  
2,358,113, CANC. INT. CL. 25.
- BEACON GROUP, L.L.C., THE, NEW YORK, NY:  
2,356,450, CANC. INT. CL. 36.
- BEACON MEDICAL PRODUCTS LLC, CHARLOTTE, NC:  
3,232,251, PUB. 2-6-2007. INT. CL. 10.
- BEALS, SUSAN C., IRONWOOD, MI, AKA HUOTARI ENTERPRISES:  
2,357,664, CANC. INT. CL. 28.
- BEAR U.S.A., INC., RIDGEFIELD, NJ:  
3,233,762, INT. CL. 25.
- BEARD MILLER COMPANY LLP, YORK, PA:  
3,234,858, INT. CL. 36.
- BEARD, LILLIAN, POTOMAC, MD:  
3,232,277, PUB. 9-13-2005. INT. CL. 44.
- BEAUTY HOLDING COMPANY, INC., HAMILTON, BERMUDA:  
3,235,416, INT. CL. 26.
- BEAUTY ZONE, NORWAY:  
3,233,752, PUB. 2-6-2007. MULTIPLE CLASS, INT. CLS. 20, 24 AND 28.
- BECK/ARNLEY WORLDPARTS CORPORATION, SMYRNA, TN:  
3,235,397, MULTIPLE CLASS, INT. CLS. 6, 7, 9 AND 17.
- BECKER-UNDERWOOD, INC., AMES, IA, TURF HEALTH CARE, L.C., AMES, IA:  
2,030,102. REN. 3-22-07. INT. CL. 1.
- BECKETT, JOSHUA P., PASO ROBLES, CA AND BECKETT, JACOB R., PASO ROBLES, CA:  
3,234,639, INT. CL. 33.
- BECKINGHAM, ROBERT JAMES, LONDON, UNITED KINGDOM:  
3,232,480, PUB. 2-6-2007. INT. CL. 9.
- BEHAVIORAL HEALTH SYSTEMS, INC., BIRMINGHAM, AL:  
2,105,225. REN. 3-21-07. INT. CL. 42.  
2,123,216. REN. 3-21-07. MULTIPLE CLASS, INT. CLS. 36 AND 42.
- BEL-ART PRODUCTS, PEQUANNOCK, NJ:  
3,233,167, PUB. 2-6-2007. INT. CL. 9.
- BELDEN WIRE & CABLE COMPANY, RICHMOND, IN:  
1,979,234, CANC. MULTIPLE CLASS, INT. CLS. 8, 9, 16 AND 21.
- BELK STORES SERVICES, INC., CHARLOTTE, NC:  
1,614,424, AM. INT. CL. 42.



BELLE-RIVE FUNCTIONAL; WATERS PTY LTD, AUSTRALIA:  
3,233,714, PUB. 2-6-2007. INT. CL. 32.

BELLEFAIRE JCB, SHAKER HEIGHTS, OH:  
3,232,102, PUB. 10-10-2006. MULTIPLE CLASS, INT. CLS. 41, 44 AND 45.

BELLMAN & SYMFON AB, GOTHEBORG, SWEDEN:  
2,027,439. REN. 3-21-07. INT. CL. 9.

BELLSOUTH INTELLECTUAL PROPERTY CORPORATION, WILMINGTON, DE:  
1,424,284. REN. 3-17-07. INT. CL. 38.  
1,426,877. REN. 3-21-07. INT. CL. 38.  
3,234,203, INT. CL. 38.

BELO COMPANY, THE, WILMINGTON, DE:  
2,358,633, CANC. INT. CL. 38.

BELTONE ELECTRONICS CORPORATION, CHICAGO, IL:  
1,396,640, CANC. INT. CL. 10.

BELVEDERE, BEAUNE, FRANCE, FRANCE-EURO AGRO, 21420 SAVIGNY LES BEAUNE, FRANCE:  
2,033,429. REN. 3-20-07. MULTIPLE CLASS, INT. CLS. 21 AND 33.

BEMIS MANUFACTURING COMPANY, SHEBOYGAN FALLS, WI:  
2,081,619. REN. 3-19-07. INT. CL. 10.

BEN & JERRY'S HOMEMADE, INC., BURLINGTON, VT:  
1,397,022, CANC. INT. CL. 30.

BEN ABATTI FARMS, LLC, EL CENTRO, CA:  
2,036,898. REN. 3-22-07. INT. CL. 31.

BEN RICKERT CORPORATION, FAIRFIELD, NJ:  
2,357,672, CANC. INT. CL. 3.

BENCHMADE KNIFE COMPANY, INC., OREGON CITY, OR:  
2,061,306. REN. 3-17-07. INT. CL. 8.

BENCHMARK COMMUNICATIONS, INC., CARLISLE, MA:  
2,358,555, CANC. INT. CL. 41.

BENEFIT SERVICES GROUP, INC., THE, PEWAUKEE, WI:  
2,108,985. REN. 3-17-07. INT. CL. 36.

BENGE, DONALD, BURBANK, CA:  
1,396,917, CANC. INT. CL. 28.

BENJAMIN MOORE & CO., MONTVALE, NJ:  
2,357,939, CANC. INT. CL. 41.

BENNETT DESIGN STUDIOS, INC., JACKSONVILLE, FL:  
2,357,656, CANC. INT. CL. 35.

BENON, ARON, ALISO VIEJO, CA:  
3,232,211, PUB. 2-6-2007. INT. CL. 35.

BENSON FINANCIAL CORPORATION, SAN ANTONIO, TX:  
1,397,114, CANC. INT. CL. 36.

BENT KARLSEN TRADING SCANDINAVIA AB, SWEDEN:  
3,233,738, PUB. 2-6-2007. INT. CL. 33.

BENTLEY LINGERIE, INC., JERSEY CITY, NJ:  
1,980,269, CANC. INT. CL. 25.

BENTLEY MOTORS LIMITED, CREWE, CHESHIRE CW1 3PL, GREAT BRITAIN:  
2,031,397. REN. 3-19-07. INT. CL. 37.

BENTOLI, INC., HOMESTEAD, FL:  
3,232,570, PUB. 2-6-2007. INT. CL. 31.

BEPONG LLC, PARKVILLE, MD:  
3,232,965, PUB. 2-6-2007. INT. CL. 28.

BEREB CORPORATION, YORBA LINDA, CA:  
2,358,427, CANC. INT. CL. 5.  
2,358,428, CANC. INT. CL. 5.

BERGLUND, STEPHEN E., FRESNO, CA:  
2,358,881, CANC. INT. CL. 42.

BERKELEY LAW & TECHNOLOGY GROUP, LLC, BEAVERTON, OR:  
3,232,477, PUB. 8-22-2006. INT. CL. 42.

BERNDT, MARGARET S, WOLCOTT, NY:  
3,235,260, INT. CL. 19.

BEROL CORPORATION, ATLANTA, GA:  
3,232,616, PUB. 2-6-2007. INT. CL. 16.

BERRY, TOM D., STILLWATER, OK, DBA BERRY AGENCY, AND AKA TOM D. BERRY AND ASSOCIATES:  
1,425,085. REN. 3-17-07. INT. CL. 35.

BERRYMAN PRODUCTS, INC., ARLINGTON, TX:  
811,233. REN. 3-21-07. U.S. CL. 15 (INT. CL. 4).

BERSTORFF GMBH, HANNOVER, FED REP GERMANY:  
1,058,236. REN. 3-22-07. INT. CL. 7.

BERTHOLD TYPES LIMITED, CHICAGO, IL:  
2,357,603, CANC. INT. CL. 9.  
2,357,604, CANC. INT. CL. 9.

BERTHUME ENTERPRISES, LLC, SIMPSONVILLE, SC:  
3,233,461, PUB. 2-6-2007. INT. CL. 28.

BEST LAB DEALS, INC., LEESBURG, FL:  
3,232,743, PUB. 2-6-2007. MULTIPLE CLASS, INT. CLS. 35 AND 37.

BESTOP, INC., BROOMFIELD, CO:  
2,036,708. REN. 3-21-07. INT. CL. 12.

BETALLIC, INC., ST. LOUIS, MO:  
2,357,249, CANC. INT. CL. 35.

BETAZONE, INC., BRENTWOOD, TN:  
3,232,709, PUB. 2-6-2007. INT. CL. 41.

BEVERLY ENTERPRISES, INC., FORT SMITH, AR:  
2,358,276, CANC. INT. CL. 42.  
2,358,277, CANC. INT. CL. 42.

BEYOND LIBATIONS, KNOXVILLE, TN:  
2,357,432, CANC. INT. CL. 42.

BFS BRANDS, LLC, NASHVILLE, TN:  
3,232,311, PUB. 2-6-2007. INT. CL. 9.

BGO INC., GARDENA, CA:  
3,232,872, PUB. 10-24-2006. MULTIPLE CLASS, INT. CLS. 11 AND 20.

BI PROPERTIES I INC., GREENSBORO, NC:  
2,358,311, CANC. INT. CL. 24.

BIC CORPORATION, MILFORD, CT:  
641,610. REN. 3-22-07. U.S. CL. 11 (INT. CL. 16).

BICO DRILLING TOOLS, INC., HOUSTON, TX:  
3,233,900, INT. CL. 7.

BIG FUN A GO-GO, INC., HOMER, NY, DBA TRIBOND ENTERPRISES:  
2,357,592, CANC. INT. CL. 9.

BIG O TIRES, INC., CENTENNIAL, CO:  
3,233,881, INT. CL. 9.

BIG VALLEY DIVERS, INC., CHICO, CA:  
3,235,005, INT. CL. 39.

BIKE BRITE, INC., MENTOR, OH:  
3,234,074, INT. CL. 3.

BIKE DOCTOR FRANCHISE CORP., ARNOLD, MD:  
2,111,831. REN. 3-21-07. INT. CL. 42.

BILL GOOD MARKETING, DRAPER, UT:  
3,232,310, PUB. 2-6-2007. INT. CL. 9.

BILLARD, CHARLES, SANDWICH, MA:  
3,232,799, PUB. 2-6-2007. INT. CL. 35.

BILOW, CATHY, ROANOKE, IL:  
3,234,263, INT. CL. 44.

BIMBO BAKERIES USA, INC., FORT WORTH, TX:  
2,358,056, CANC. INT. CL. 30.

BIO-BOTANICA, INC., HAUPAUGGE, NY:  
3,234,669, INT. CL. 1.

BIO-LOK INTERNATIONAL, INC., DEERFIELD BEACH, FL:  
3,232,475, PUB. 2-6-2007. INT. CL. 5.

BIO-MIMETICS INC., LEXINGTON, MA:  
1,396,401, CANC. INT. CL. 5.

BIO-TECHNOLOGY GENERAL CORPORATION, NEW YORK, NY:  
1,402,799. REN. 3-20-07. INT. CL. 5.

BIOCONTROL SYSTEMS, INC., BELLEVUE, WA:  
1,424,470. REN. 3-16-07. INT. CL. 1.

BIOFILM, INC., VISTA, CA:  
2,032,349. REN. 3-21-07. INT. CL. 5.

BIOMANAGEMENT SERVICES, INC., TINLEY PARK, IL:  
2,356,612, CANC. INT. CL. 40.

BIOMET MANUFACTURING CORP., WARSAW, IN:  
2,120,104. REN. 3-16-07. INT. CL. 10.

BIOSOUND ESAOTE, INC., INDIANAPOLIS, IN:  
3,232,531, PUB. 2-6-2007. INT. CL. 9.

BIOSYN ARZNEIMITTEL GMBH, 70734 FELLBACH, FED REP GERMANY:  
3,233,771, INT. CL. 5.

BIOSYN INC., PHILADELPHIA, PA:  
2,357,838, CANC. INT. CL. 3.

BIOOTHERM, MONACO, MONACO:  
3,233,906, INT. CL. 3.

BIOTICS, 75006 PARIS, FRANCE:  
2,356,506, CANC. INT. CL. 41.

- BIOTRON LABORATORIES, CENTERVILLE, UT:  
2,034,421. REN. 3-21-07. INT. CL. 5.
- BIOVERIS CORPORATION, GAITHERSBURG, MD:  
3,233,912, INT. CL. 1.  
3,233,913, INT. CL. 1.
- BIRCHER REGLOMAT AG, SWITZERLAND:  
3,233,717, PUB. 2-6-2007. INT. CL. 9.
- BIRO MANUFACTURING COMPANY, THE, MARBLE-  
HEAD, OH:  
1,460,635. REN. 3-17-07. INT. CL. 7.
- BISHOP-WISECARVER CORPORATION, PITTSBURG, CA:  
841,905. REN. 3-21-07. U.S. CL. 13 (INT. CL. 6).
- BITE OF THE APPLE TOURS INC., LAKE HILL, NY:  
3,232,782, PUB. 2-6-2007. INT. CL. 39.
- BIZDEV, LLC, CHEVY CHASE, MD:  
3,234,957, MULTIPLE CLASS, INT. CLS. 9 AND 35.
- BJORN EYEWEAR, INC., SAN FRANCISCO, CA:  
3,232,735, PUB. 2-6-2007. INT. CL. 9.  
3,232,736, PUB. 2-6-2007. INT. CL. 9.
- BLACK & DECKER CORPORATION, THE, TOWSON, MD:  
1,057,371. REN. 3-17-07. INT. CL. 6.
- BLACK DIAMOND GROUP, LLC, ATLANTA, GA:  
3,233,047, PUB. 2-6-2007. INT. CL. 35.
- BLACK DOG CORPORATION, MANCHESTER, CT, DBA  
NULLI'S ITALIA:  
2,357,785, CANC. MULTIPLE CLASS, INT. CLS. 25 AND  
42.
- BLACKHAWK INDUSTRIES PRODUCT GROUP UNLIM-  
ITED LLC, NORFOLK, VA:  
3,232,395, PUB. 2-6-2007. INT. CL. 11.  
3,232,468, PUB. 2-6-2007. INT. CL. 13.  
3,232,469, PUB. 2-6-2007. INT. CL. 18.  
3,232,945, PUB. 2-6-2007. INT. CL. 21.  
3,232,955, PUB. 2-6-2007. INT. CL. 9.
- BLACKWELL SCIENCE, INC., MALDEN, MA:  
1,979,266, CANC. INT. CL. 16.
- BLACKWELL, LISA NICOLE, OAKLAND, CA:  
3,233,221, PUB. 2-6-2007. INT. CL. 36.
- BLINK TWICE LLC, NEW YORK, NY:  
3,235,382, INT. CL. 9.
- BLOCK & ASSOCIATES, SACRAMENTO, CA:  
2,358,911, CANC. INT. CL. 42.
- BLOOM, AKIVAH, BROOKLYN, NY AND DRATEL, JASON  
EVAN, BROOKLYN, NY:  
3,233,962, INT. CL. 25.  
3,233,963, INT. CL. 25.  
3,233,965, INT. CL. 25.  
3,233,966, INT. CL. 25.
- BLUE CHALK CAFE, PLANO, TX:  
2,011,809. REN. 3-19-07. INT. CL. 42.
- BLUE CORAL, INC., CLEVELAND, OH TO BLUE CORAL-  
SLICK 50, LTD., SALT LAKE CITY, UT:  
1,979,645, CANC. INT. CL. 3.
- BLUE CROSS AND BLUE SHIELD OF ALABAMA, BIR-  
MINGHAM, AL:  
2,096,578. REN. 3-16-07. MULTIPLE CLASS, INT. CLS. 35  
AND 42.
- BLUE CROSS AND BLUE SHIELD OF RHODE ISLAND,  
PROVIDENCE, RI:  
3,235,444, INT. CL. 44.
- BLUE FROG MOBILE, INC., SEATTLE, WA:  
3,233,143, PUB. 2-6-2007. INT. CL. 38.  
3,234,499, INT. CL. 38.
- BLUE GEM SUNGLASSES, INC., CARPINTERIA, CA:  
2,129,823. REN. 3-20-07. INT. CL. 9.
- BLUE LINE PRODUCTIONS, INC., SUWANEE, GA:  
3,234,257, INT. CL. 34.  
3,234,258, INT. CL. 24.
- BLUE RIBBON PRODUCTS, INC., INDIANAPOLIS, IN,  
BLUE LUSTRE PRODUCTS, INC., INDIANAPOLIS, IN:  
2,080,796. REN. 3-17-07. INT. CL. 3.
- BLUE RIDGE TALC COMPANY, INC., HENRY, VA:  
2,358,159, CANC. INT. CL. 2.
- BLUE SEAL FEEDS, INC., LONDONDERRY, NH:  
2,025,306. REN. 3-22-07. INT. CL. 31.
- BLUE SQUARE STUDIOS, LLC, SCOTTSDALE, AZ:  
3,232,685, PUB. 2-6-2007. MULTIPLE CLASS, INT. CLS. 35  
AND 42.
- 3,232,688, PUB. 2-6-2007. MULTIPLE CLASS, INT. CLS. 35  
AND 42.
- BLUE, INC., PORTLAND, OR:  
3,234,482, INT. CL. 35.
- BLUESHIFT TECHNOLOGIES, INC., ANDOVER, MA:  
3,234,670, INT. CL. 7.
- BLUESTAR SYSTEMS U.S.A., INC., SURREY, BRITISH  
COLUMBIA, CANADA:  
2,358,350, CANC. INT. CL. 9.
- BLUEWATER MARINE GROUP, INC., NEWBERRY, SC:  
3,233,253, PUB. 2-6-2007. INT. CL. 12.
- BMG MUSIC, NEW YORK, NY:  
3,233,380, PUB. 2-6-2007. INT. CL. 9.
- BND PLASTERING, INC., HENDERSON, NV:  
3,232,529, PUB. 2-6-2007. INT. CL. 19.
- BNP MEDIA II, LLC, TROY, MI:  
1,427,995. REN. 3-22-07. INT. CL. 16.
- BOARD OF REGENTS, THE UNIVERSITY OF TEXAS  
SYSTEM, AUSTIN, TX:  
1,456,114. REN. 3-19-07. INT. CL. 6.  
1,456,574. REN. 3-22-07. INT. CL. 24.  
1,456,575. REN. 3-19-07. INT. CL. 24.  
1,456,594. REN. 3-19-07. INT. CL. 25.
- BOARD OF TRUSTEES OF THE UNIVERSITY OF ARKAN-  
SAS, LITTLE ROCK, AR:  
3,235,353, INT. CL. 28.
- BOARDROOM REPORTS, INC., NEW YORK, NY:  
1,396,770, CANC. INT. CL. 16.
- BOATWRENCH, INC., CASSELBERRY, FL:  
3,232,236, PUB. 2-6-2007. INT. CL. 35.
- BOBCATS BASKETBALL, LLC, CHARLOTTE, NC:  
3,234,137, INT. CL. 28.
- BOBKAT, INC., WINTER PARK, FL:  
2,358,374, CANC. INT. CL. 14.
- BODEGAS ALTO MONCAYO, S.A., ZARAGOZA, SPAIN:  
3,232,440, PUB. 2-6-2007. INT. CL. 33.
- BODEGAS BORDEJE, S.L., 50570, AINZON, SPAIN:  
3,234,717, INT. CL. 33.
- BODEGAS VITORIANAS, S.A., 01320 OYON (ALAVA),  
SPAIN:  
2,029,998. REN. 3-19-07. INT. CL. 33.
- BODY WISE INTERNATIONAL, INC., TUSTIN, CA:  
2,357,505, CANC. INT. CL. 5.
- BODYWISE HEALTH OPTIONS, INC., EVERGREEN, CO:  
3,234,474, INT. CL. 16.
- BODYWORKS BY NICHOLAS SMITH INC., NAPLES, FL:  
3,233,127, PUB. 2-6-2007. INT. CL. 5.
- BOHAN GROUP LLC, SAN FRANCISCO, CA:  
3,232,429, PUB. 2-6-2007. MULTIPLE CLASS, INT. CLS.  
35, 36 AND 42.
- BOIRON, SAINTE FOY LES LYON, FRANCE:  
1,426,172. REN. 3-17-07. MULTIPLE CLASS, INT. CLS. 3  
AND 5.
- BOIS FORTE BAND OF CHIPPEWA INDIANS, NETT LAKE,  
MN:  
3,232,213, PUB. 2-6-2007. INT. CL. 41.
- BOISE CASCADE OFFICE PRODUCTS CORPORATION,  
ITASCA, IL:  
2,358,186, CANC. INT. CL. 35.
- BOLER COMPANY., THE, ITASCA, IL:  
2,358,002, CANC. INT. CL. 12.
- BOLT EXPRESS, LLC, TOLEDO, OH:  
3,233,301, PUB. 2-6-2007. INT. CL. 39.
- BOLTS & NUTS, INC., CHATTANOOGA, TN:  
3,233,402, PUB. 2-6-2007. INT. CL. 6.
- BOMAC LABORATORIES LIMITED, MANUKAU CITY  
AUCKLAND, NEW ZEALAND:  
3,232,669, PUB. 2-6-2007. INT. CL. 5.  
3,232,670, PUB. 2-6-2007. INT. CL. 5.
- BON APPETIT DANISH, INC., VERNON, CA:  
3,232,107, PUB. 2-6-2007. INT. CL. 30.
- BONACCORSI M SHELLY, GAUTHIER J CAMILLE AND  
LEVESQUE A NATALIE, HAMPTON, NH:  
3,234,461, INT. CL. 28.
- BONADUCE INCORPORATED, LOUISVILLE, OH:  
3,233,415, PUB. 2-6-2007. INT. CL. 37.

BONANZA PRESS, INC., WOODINVILLE, WA:  
3,233,079, PUB. 2-6-2007. INT. CL. 28.

BONDIOLI & PAVESI S.P.A., SUZZARA (MANTOVA), ITALY:  
3,232,065, PUB. 2-6-2007. INT. CL. 12.

BONDO CORPORATION, ATLANTA, GA:  
3,234,157, MULTIPLE CLASS, INT. CLS. 2 AND 40.

BONGAERTS MARKETING INC., TORONTO, ONTARIO, CANADA:  
1,396,871, CANC. INT. CL. 24.

BONINA & BONINA, P.C., BROOKLYN, NY:  
3,232,051, PUB. 5-23-2006. INT. CL. 42.

BONITA SOFTWARE, INC., RALEIGH, NC:  
2,358,442, CANC. INT. CL. 9.

BONK DESIGNS, INC., VENICE, CA:  
3,232,408, PUB. 2-6-2007. INT. CL. 10.

BOOK-OF-THE-MONTH CLUB, INC., NEW YORK, NY:  
1,059,199, REN. 3-21-07. INT. CL. 16.  
2,357,109, CANC. INT. CL. 35.

BOOKMASTERS, INC., MANSFIELD, OH:  
3,232,532, PUB. 2-6-2007. INT. CL. 35.

BOOKTER, JAMES M., BATON ROUGE, LA:  
1,986,710, REN. 3-16-07. INT. CL. 41.

BOOSTER JUICE LIMITED PARTNERSHIP, LAKE OSWEGO, OR:  
3,232,653, PUB. 2-6-2007. INT. CL. 32.

BORDEN LADNER GERVAIS, LLP, OTTAWA, ONTARIO, CANADA:  
3,232,620, PUB. 2-6-2007. MULTIPLE CLASS, INT. CLS. 16 AND 42.

BORDEN, INC., COLUMBUS, OH TO PIDILITE USA, INC., JUPITER, FL, DBA CYCLO INDUSTRIES, INC.:  
1,427,067, CANC. INT. CL. 1.

BORKHUIS, DEBORAH ANN, WATERTOWN, SD, DBA OH BABY O'S:  
3,233,139, PUB. 2-6-2007. INT. CL. 43.

BORSA ITALIANA S.P.A., MILAN, ITALY, CONSIGLIO DI BORSA, 20123 MILAN, ITALY:  
2,036,400, REN. 3-17-07. INT. CL. 36.

BOSE CORPORATION, FRAMINGHAM, MA:  
1,457,280, REN. 3-19-07. INT. CL. 9.  
2,081,106, REN. 3-19-07. INT. CL. 9.  
2,096,548, REN. 3-16-07. INT. CL. 9.  
2,108,847, REN. 3-17-07. INT. CL. 9.  
2,114,130, REN. 3-16-07. INT. CL. 9.

BOSTON RED SOX BASEBALL CLUB LIMITED PARTNERSHIP, BOSTON, MA:  
3,234,850, INT. CL. 14.

BOWERS, FREEDA, LONGWOOD, FL, DBA FREEDA BOWERS MINISTRIES:  
2,358,068, CANC. MULTIPLE CLASS, INT. CLS. 9 AND 16.

BOX, JOHN G., ORANGE, CA:  
2,358,005, CANC. INT. CL. 25.

BOYD FLOTATION, INC., MARYLAND HEIGHTS, MO:  
3,234,719, INT. CL. 20.

BOYD GAMING CORPORATION, LAS VEGAS, NV:  
3,233,178, PUB. 2-6-2007. INT. CL. 25.

BOYD, MICHAEL, GLENDALE, CA:  
2,358,498, CANC. INT. CL. 25.

BOYD, RACHEL L., LITHIA SPRINGS, GA:  
3,235,440, INT. CL. 25.

BOYE, BRETT ALEXANDER, WYCKOFF, NJ:  
2,357,125, CANC. MULTIPLE CLASS, INT. CLS. 9 AND 41.

BOYS TOWN OF MISSOURI, ST. JAMES, MO:  
3,232,989, PUB. 2-6-2007. INT. CL. 44.

BRACE INTERNATIONAL, INC., ATLANTA, GA:  
1,977,928, REN. 3-20-07. INT. CL. 10.

BRADFORD-WHITE CORPORATION, AMBLER, PA:  
1,056,547, REN. 3-22-07. INT. CL. 11.

BRADLEY, ANDUJAR, BROOKLYN, NY:  
3,232,547, PUB. 2-6-2007. INT. CL. 35.

BRAEBON MEDICAL CORPORATION, CARP, CANADA:  
3,232,501, PUB. 10-31-2006. INT. CL. 9.

BRAEUNIG, MARTIN C., RAMONA, CA AND ECCKER, DONALD E., RAMONA, CA:  
2,358,300, CANC. INT. CL. 25.

BRAGEL INTERNATIONAL INC., POMONA, CA:  
2,356,605, CANC. INT. CL. 10.

BRAIN WAREHOUSE LLC, SAN DIEGO, CA:  
3,232,493, PUB. 2-6-2007. INT. CL. 36.

BRAINSTORM USA, LLC, ATLANTA, GA:  
3,234,808, INT. CL. 35.

BRAND DESIGN COMPANY, INC., YORKLYN, DE, DBA HOUSE INDUSTRIES:  
3,232,113, PUB. 2-6-2007. INT. CL. 9.  
3,233,502, PUB. 2-6-2007. INT. CL. 25.

BRANDER VINEYARD, INC., THE, LOS OLIVOS, CA, DBA DOMAINE SANTA BARBARA:  
2,034,347, REN. 3-22-07. INT. CL. 33.

BRANDING RIGHTS, LLC, PHILADELPHIA, PA:  
3,234,954, INT. CL. 35.

BRASS KEY, INC., THE, FEDERAL WAY, WA:  
2,358,371, CANC. INT. CL. 28.

BRASSERIE DE TAHITI S.A., PAPEETE, FRENCH POLYNESIA:  
3,234,416, INT. CL. 18.  
3,234,417, INT. CL. 21.

BRAZIL BRONZE INC., NEW YORK, NY:  
3,234,671, INT. CL. 3.

BREAST CANCER FUND, THE, SAN FRANCISCO, CA:  
2,358,422, CANC. MULTIPLE CLASS, INT. CLS. 14 AND 36.

BREATH OF FRESH AIR, LLC, GLEN ALLEN, VA:  
3,235,222, INT. CL. 41.

BREATHE CALIFORNIA OF SACRAMENTO-EMIGRANT TRAILS, SACRAMENTO, CA:  
3,235,385, INT. CL. 35.

BRECKER & MERRYMAN, INC., NEW YORK, NY:  
2,357,701, CANC. INT. CL. 35.

BRENNAN, MICHAEL J., WESTERVILLE, OH:  
2,357,597, CANC. INT. CL. 42.

BREUCKELEN NYC, INC., BROOKLYN, NY:  
3,235,354, INT. CL. 25.  
3,235,363, INT. CL. 25.  
3,235,364, INT. CL. 25.

BREWER, ERNEST W., KNOXVILLE, TN, DBA POLITICAL CHALLENGE:  
1,396,963, CANC. INT. CL. 28.

BREWSTER WALLPAPER CORP., RANDOLPH, MA:  
3,234,998, INT. CL. 27.

BRICKYARD TRADEMARKS, INC., LAS VEGAS, NV:  
3,232,285, PUB. 2-6-2007. INT. CL. 25.

BRIDGESTONE SPORTS CO., LTD., TOKYO, JAPAN:  
3,235,252, INT. CL. 28.

BRIDGESTREET ACCOMMODATIONS, INC., SOLON, OH:  
2,358,679, CANC. INT. CL. 42.  
2,358,680, CANC. INT. CL. 42.

BRIDGEWATER, INC., SALT LAKE CITY, UT:  
3,234,342, INT. CL. 35.

BRIEE, YVES, ORANGE, CA:  
3,233,286, PUB. 2-6-2007. INT. CL. 16.

BRIEN, SIDNEY, MIAMI BEACH, FL:  
3,232,129, PUB. 2-6-2007. INT. CL. 35.

BRIGHAM YOUNG UNIVERSITY, PROVO, UT:  
2,356,971, CANC. INT. CL. 41.

BRIGHT ANGLE, NEW YORK, NY:  
3,234,572, INT. CL. 16.

BRIGHT HOUSE NETWORKS LLC, EAST SYRACUSE, NY:  
3,234,015, INT. CL. 38.

BRITISH AMERICAN BUSINESS COUNCIL, INC., NEW YORK, NY:  
2,029,364, REN. 3-19-07. INT. CL. 35.

BRITISH SKY BROADCASTING GROUP PLC, MIDDLESEX, UNITED KINGDOM:  
3,232,370, PUB. 8-30-2005. INT. CL. 41.

BROADBAND MEDIA CORPORATION, CAX - CANADA BC V8T2C1, BRITISH COLUMBIA:  
3,232,985, PUB. 2-6-2007. INT. CL. 41.

BROADLINE MEDIA CORP., INC., SAN FRANCISCO, CA:  
3,234,407, INT. CL. 42.

BROEN A/S, 5610 ASSENS, DENMARK:  
3,232,456, PUB. 2-6-2007. MULTIPLE CLASS, INT. CLS. 35, 37 AND 40.

- BROKERS' CHOICE OF AMERICA, INC., ENGLEWOOD, CO:  
3,235,129, INT. CL. 41.
- BROOKPARK MARKETS, LLC, MINNETONKA, MN:  
3,235,182, INT. CL. 35.
- BROWN & WILLIAMSON TOBACCO CORPORATION, LOUISVILLE, KY TO R.J. REYNOLDS TOBACCO COMPANY, WINSTON-SALEM, NC:  
1,980,028, CANC. INT. CL. 25.
- BROWN & WILLIAMSON TOBACCO CORPORATION, LOUISVILLE, KY:  
2,357,444, CANC. INT. CL. 42.
- BROWN BROADCASTING SERVICE, INC., PROVIDENCE, RI:  
1,471,677, REN. 3-20-07, INT. CL. 38.
- BROWN-FORMAN CORPORATION, LOUISVILLE, KY:  
3,232,488, PUB. 2-6-2007, INT. CL. 33.
- BROWN, DAN, NEW YORK, NY:  
3,234,180, INT. CL. 28.
- BROWN, LEROY, JR., MORRISVILLE, NC:  
3,235,441, INT. CL. 25.
- BRUDER SPIELWAREN GMBH & CO KG, D-90768 FURTH, FED REP GERMANY:  
2,041,819, REN. 3-21-07, INT. CL. 28.
- BRUML MANAGEMENT, LLC, SAN MATEO, CA:  
2,047,860, REN. 3-16-07, INT. CL. 25.
- BRUNSWICK BOWLING & BILLIARDS CORPORATION, MUSKEGON, MI:  
1,979,107, CANC. INT. CL. 28.
- BRUNSWICK CORPORATION, LAKE FOREST, IL, AMF INCORPORATED, WHITE PLAINS, NY:  
1,429,226, REN. 3-16-07, INT. CL. 18.
- BRUNSWICK CORPORATION, LAKE FOREST, IL:  
2,357,257, CANC. INT. CL. 37.
- BRUSKE ENTERPRISES, INC., TINLEY PARK, IL:  
2,356,850, CANC. INT. CL. 3.
- BRYAN FOSS, BELLEVUE, WA, DBA TRIPLESTEP DANCE PRODUCTIONS:  
3,233,045, PUB. 2-6-2007, INT. CL. 41.
- BRYANT, PAMELA, SPRINGFIELD, MA:  
3,234,944, MULTIPLE CLASS, INT. CLS. 16 AND 25.
- BRYNDANA INTERNATIONAL, LTD., HAVERTOWN, PA:  
2,357,898, CANC. INT. CL. 2.
- BRÜCO SWISS AG, CH-8153 RÜMLANG, SWITZERLAND:  
3,233,625, PUB. 2-6-2007, MULTIPLE CLASS, INT. CLS. 21 AND 35.
- BSH BOSCH UND SIEMENS HAUSGERAETE GMBH, MUNICH, FED REP GERMANY:  
3,232,837, PUB. 2-6-2007, INT. CL. 11.  
3,232,923, PUB. 2-6-2007, INT. CL. 7.
- BSH HOME APPLIANCES CORPORATION, HUNTINGTON BEACH, CA:  
3,234,344, INT. CL. 7.
- BSN MEDICAL GMBH, FED REP GERMANY:  
3,233,570, PUB. 2-6-2007, INT. CL. 5.
- BUBBLES, INC., FALLS CHURCH, VA:  
3,233,871, INT. CL. 3.
- BUCKEYE INTERNATIONAL, INC., MARYLAND HEIGHTS, MO:  
3,234,940, INT. CL. 3.
- BUCKHIESTER MANAGEMENT LIMITED, VANCOUVER, BRITISH COLUMBIA, CANADA:  
3,234,305, MULTIPLE CLASS, INT. CLS. 9, 16, 35 AND 41.
- BUFFALO WILD WINGS, INC., MINNEAPOLIS, MN:  
3,233,454, PUB. 2-6-2007, INT. CL. 29.
- BUGLE BOY INDUSTRIES, INC., SIMI VALLEY, CA:  
2,357,073, CANC. INT. CL. 25.
- BUILD-A-BEAR WORKSHOP, INC., ST. LOUIS, MO:  
3,232,061, PUB. 1-8-2002, INT. CL. 16.
- BUILDING INDUSTRY ASSOCIATION OF SOUTHEASTERN MICHIGAN, FARMINGTON HILLS, MI:  
3,232,321, PUB. 2-6-2007, INT. CL. 35.
- BUILDING OWNERS AND MANAGERS ASSOCIATION INTERNATIONAL, WASHINGTON, DC, BUILDING OWNERS AND MANAGERS INSTITUTE INTERNATIONAL, INC., ARNOLD, MD:  
1,376,364, REN. 3-17-07, INT. CL. 41.
- BULGARI S.P.A, ROME, ITALY:  
2,356,497, CANC. INT. CL. 3.
- BULLDOG CAPITAL MANAGEMENT LIMITED PARTNERSHIP, CLEARWATER, FL:  
2,357,480, CANC. INT. CL. 36.
- BULOVA CORPORATION, WOODSIDE, NY:  
3,235,474, INT. CL. 14.
- BUMPER 2 BUMPER MEDIA INC., MISSISSAUGA, ONTARIO, CANADA:  
3,233,783, MULTIPLE CLASS, INT. CLS. 9 AND 41.
- BUNKY'S ENTERPRISES, INC., WESTBROOK, CT:  
3,234,370, MULTIPLE CLASS, INT. CLS. 16 AND 28.
- BUNNIES, INC., BLOOMINGTON, MN:  
3,234,038, INT. CL. 35.
- BUOB LAURENT, FRANCE:  
3,233,661, PUB. 2-6-2007, MULTIPLE CLASS, INT. CLS. 30, 32 AND 33.
- BURFORD, TIFFANEY L., DORCHESTER, MA:  
3,235,105, INT. CL. 28.
- BURGER BOYS, INC., NEW YORK, NY:  
1,397,211, CANC. INT. CL. 42.
- BURKE INDUSTRIES (DELAWARE), INC., SAN JOSE, CA:  
3,234,504, INT. CL. 19.
- BURKE-WATKINS, VIRGINIA, DALLAS, TX:  
3,232,510, PUB. 2-6-2007, INT. CL. 30.
- BURLINGTON NETWORKS INC., IRVINE, CA:  
2,093,023, REN. 3-16-07, INT. CL. 39.
- BURNARD, THOMAS M., ORANGE, CA:  
2,356,816, CANC. INT. CL. 14.
- BURNS, BONNE MARIE, CHICAGO, IL:  
3,232,513, PUB. 2-6-2007, INT. CL. 42.
- BURSAW, MICHAEL, CARMEL, IN:  
2,047,351, REN. 3-16-07, INT. CL. 42.
- BURTON CORPORATION, THE, BURLINGTON, VT:  
2,083,957, REN. 3-22-07, INT. CL. 28.
- BURTON, THOMAS, CHATSWORTH, CA AND BURTON, CLAUDIA, CHATSWORTH, CA:  
2,053,048, REN. 3-19-07, INT. CL. 9.
- BUSHNELL INC., OVERLAND PARK, KS:  
2,358,651, CANC. INT. CL. 9.
- BUSINESS BROKERS HAWAII, LLC, WAILEA, HI:  
3,233,028, PUB. 2-6-2007, INT. CL. 36.
- BUSINESS DAY, INC., LYNNWOOD, WA:  
2,039,370, REN. 3-17-07, INT. CL. 16.
- BUSINESS SERVICES CORPORATION, LAS VEGAS, NV:  
3,232,560, PUB. 2-6-2007, MULTIPLE CLASS, INT. CLS. 21, 25 AND 41.
- BUSINESSSTONE LLC, NEW YORK, NY:  
641,432, REN. 3-22-07, U.S. CL. 39 (INT. CL. 25).
- BUSINESSSTONE LLC, NEW YORK, NY, FUMAGALLI, MARTINO, PROVINCE OF MILAN, ITALY:  
2,041,541, REN. 3-22-07, MULTIPLE CLASS, INT. CLS. 25 AND 28.
- BUTEN, DAVID, CINCINNATI, OH:  
3,233,179, PUB. 2-6-2007, INT. CL. 41.
- BUTLER PRODUCTS CORPORATION, BUTLER, KY:  
3,232,563, PUB. 2-6-2007, INT. CL. 8.
- BUTLER, NICKY, LOS ANGELES, CA:  
2,356,757, CANC. INT. CL. 14.
- BUTTERFLY VLSI LTD., KFAR-SABA, ISRAEL:  
2,358,077, CANC. INT. CL. 9.
- BUTTONED UP, INC., BEVERLY HILLS, CA:  
3,233,510, PUB. 2-6-2007, MULTIPLE CLASS, INT. CLS. 16 AND 18.
- BWE LIMITED, ASHFORD, KENT, UNITED KINGDOM:  
3,232,886, PUB. 2-6-2007, MULTIPLE CLASS, INT. CLS. 6, 7, 9 AND 40.
- BYCYCLE, INC., PORTLAND, OR:  
2,357,740, CANC. INT. CL. 12.
- BYERS' CHOICE LTD., CHALFONT, PA:  
1,446,463, REN. 3-22-07, INT. CL. 21.
- BYPA, INC., BOSTON, MA:  
3,235,452, MULTIPLE CLASS, INT. CLS. 35 AND 41.
- B2 ENTERTAINMENT, LLC, ATLANTA, GA:  
3,233,260, PUB. 2-6-2007, INT. CL. 41.
- BÜHLER AG, SWITZERLAND:  
3,233,559, PUB. 2-6-2007, MULTIPLE CLASS, INT. CLS. 7,

- 9, 11 AND 42.  
3,233,560, PUB. 2-6-2007. MULTIPLE CLASS, INT. CLS. 7, 9, 11 AND 42.
- C & C ENGINEERING, DANVILLE, CA:  
2,357,386, CANC. INT. CL. 9.
- C & C PRODUCTS, INC., WATKINSVILLE, GA:  
2,357,527, CANC. INT. CL. 9.
- C F FOLKS LTD., WASHINGTON, DC:  
1,426,070, REN. 3-17-07. INT. CL. 42.
- C. H. GUENTHER & SON, INC., SAN ANTONIO, TX, DBA PIONEER FLOUR MILLS:  
1,397,033, CANC. INT. CL. 30.
- C. R. BARD, INC., MURRAY HILL, NJ:  
3,234,642, INT. CL. 10.
- C.A. ZOES MANUFACTURING CO., CHICAGO, IL:  
824,682, REN. 3-19-07. U.S. CL. 4 (INT. CL. 3).
- C.B. FLEET INVESTMENT CORPORATION, WILMINGTON, DE:  
2,357,069, CANC. INT. CL. 5.
- C.COO, LLC, COATESVILLE, PA:  
3,233,886, INT. CL. 11.
- C.O.M. CUSTOM, LLC, MINNEAPOLIS, MN:  
3,232,162, PUB. 2-6-2007. INT. CL. 24.  
3,232,163, PUB. 2-6-2007. INT. CL. 27.
- C.R. BARD, INC., MURRAY HILL, NJ:  
1,982,797, REN. 3-16-07. INT. CL. 10.
- C-MOBILITY ADVERTISING, INC., AVENTURA, FL:  
3,233,073, PUB. 2-6-2007. INT. CL. 35.
- C-THRU RULER COMPANY, THE, BLOOMFIELD, CT:  
2,358,663, CANC. INT. CL. 16.
- CABLE BEACH RESORTS LTD., NASSAU, NEW PROVIDENCE, BAHAMAS:  
3,232,171, PUB. 2-6-2007. INT. CL. 41.
- CABOT SAFETY INTERMEDIATE CORPORATION, NEWARK, DE:  
3,234,309, INT. CL. 9.
- CABRERA, EDWARD, OVIEDO, FL:  
2,357,166, CANC. INT. CL. 42.  
2,358,868, CANC. INT. CL. 42.
- CADATA CORPORATION, INC., THE, OLNEY, MD:  
3,232,462, PUB. 10-24-2006. INT. CL. 37.
- CADE LABORATORIES, LLC, CHICAGO, IL:  
3,232,549, PUB. 2-6-2007. MULTIPLE CLASS, INT. CLS. 3 AND 5.
- CADILLAC JACK, INC., DULUTH, GA:  
3,235,240, INT. CL. 9.
- CAFE MADRID, INC., DALLAS, TX:  
2,037,096, REN. 3-22-07. INT. CL. 42.
- CAFES RICHARD, 92230 GENNEVILLIES, FRANCE:  
3,234,544, INT. CL. 30.
- CAHN, LAWRENCE STEVEN, WALNUT CREEK, CA:  
1,979,525, CANC. INT. CL. 36.
- CAI RU QING, GUANGDONG CN-510000, CHINA:  
3,233,629, PUB. 2-6-2007. INT. CL. 3.
- CAKE BEAUTY INC., TORONTO, ONTARIO, CANADA:  
3,234,497, INT. CL. 3.
- CALABRIA, INC., KIRKLAND, WA:  
2,357,191, CANC. INT. CL. 9.
- CALAVO GROWERS, INC., SANTA PAULA, CA, CALAVO GROWERS OF CALIFORNIA, TUSTIN, CA:  
2,109,718, REN. 3-17-07. INT. CL. 29.
- CALBEE FOODS CO., LTD., TOKYO, JAPAN:  
2,427,856, CANC. INT. CL. 30.
- CALIBRE PRESS, INC., NORTHBROOK, IL:  
2,357,381, CANC. INT. CL. 35.
- CALIFORNIA COSTUME COLLECTIONS, INC., LOS ANGELES, CA:  
3,232,441, PUB. 2-6-2007. MULTIPLE CLASS, INT. CLS. 25 AND 26.
- CALIFORNIA CREATIVE FOODS, INC., OCEANSIDE, CA, CHACHIES FOODS, INC., OCEANSIDE, CA:  
2,127,336, REN. 3-17-07. INT. CL. 30.
- CALIFORNIA OLIVE COMMITTEE, FRESNO, CA:  
1,979,623, CANC. INT. CL. 42.
- CALIFORNIA PRODUCTS CORPORATION, ANDOVER, MA, LEHMAN BROS. CORP., JERSEY CITY, NJ:  
425,768, REN. 3-17-07. U.S. CL. 16 (INT. CL. 2).
- CALIFORNIA PRODUCTS CORPORATION, ANDOVER, MA, GROW CHEMICAL COATINGS CORP., PENNSAUKEN, NJ:  
1,057,308, REN. 3-20-07. INT. CL. 2.
- CALIFORNIA PRODUCTS CORPORATION, ANDOVER, MA, CALIFORNIA PRODUCTS CORPORATION, ANDOVER, MA:  
1,418,835, REN. 3-19-07. INT. CL. 2.
- CALIFORNIA PROFESSIONAL APPRAISAL SERVICES, INC., FAIR OAKS, CA:  
3,232,722, PUB. 2-6-2007. INT. CL. 36.
- CALLAWAY ARTS AND ENTERTAINMENT, NEW YORK, NY:  
3,233,349, PUB. 2-6-2007. INT. CL. 21.
- CALLAWAY GOLF COMPANY, CARLSBAD, CA:  
3,235,246, INT. CL. 28.
- CALLISONS, INC., SEATTLE, WA:  
1,397,057, CANC. INT. CL. 31.
- CALLISTO CORPORATION, NATICK, MA:  
2,358,269, CANC. INT. CL. 9.
- CALLWARE TECHNOLOGIES, INC., SANDY, UT:  
2,358,565, CANC. INT. CL. 9.
- CALORIQUE, LTD., WEST WAREHAM, MA:  
1,425,649, REN. 3-19-07. INT. CL. 11.
- CALUZ, INC., SAN FRANCISCO, CA:  
3,232,857, PUB. 10-24-2006. INT. CL. 43.
- CALVERT HOLDINGS, LLC, BALTIMORE, MD:  
2,358,666, CANC. INT. CL. 16.
- CAMBRO MANUFACTURING COMPANY, HUNTINGTON BEACH, CA:  
2,357,647, CANC. INT. CL. 20.
- CAMP INTERNATIONAL, INC., JACKSON, MI:  
1,396,332, CANC. INT. CL. 3.
- CAMPAGNOLO, STEFANO, SALT LAKE CITY, UT:  
3,235,434, INT. CL. 25.
- CAMPBELL HAUSFELD/SCOTT FETZER COMPANY, HARRISON, OH:  
2,357,243, CANC. INT. CL. 6.  
2,357,244, CANC. INT. CL. 6.
- CAMPBELL, WILLIAM, JR., DALLAS, TX:  
3,232,850, PUB. 2-6-2007. INT. CL. 43.  
3,232,851, PUB. 2-6-2007. INT. CL. 43.
- CAMPUS MANAGEMENT CORPORATION, BOCA RATON, FL:  
3,232,590, PUB. 2-6-2007. INT. CL. 9.  
3,232,591, PUB. 2-6-2007. INT. CL. 9.
- CAMPUS MEDIA HOLDINGS, INC., BALTIMORE, MD:  
3,234,106, INT. CL. 35.
- CANADIAN AIRLINES INTERNATIONAL LTD., CALGARY, ALBERTA, T2P 2W2, CANADA:  
2,357,055, CANC. INT. CL. 39.
- CANADIAN FISH EXPORTERS, INC., WATERTOWN, MA:  
2,358,674, CANC. INT. CL. 32.  
3,233,111, PUB. 2-6-2007. INT. CL. 29.
- CANADIAN STANDARDS ASSOCIATION, REXDALE, ONTARIO, CANADA:  
1,397,162, CANC. INT. CL. 41.
- CANBERRA INDUSTRIES, INC., MERIDEN, CT:  
3,235,058, INT. CL. 9.
- CANNON, RONALD JAY, TAYLORS, SC:  
3,232,777, PUB. 2-6-2007. INT. CL. 35.
- CANON KABUSHIKI KAISHA, TOKYO, JAPAN:  
3,233,917, INT. CL. 9.
- CANOPY, LOS ALTOS, CA:  
3,232,963, PUB. 2-6-2007. INT. CL. 30.
- CANOPY FINANCIAL, INC., CHICAGO, IL:  
3,232,286, PUB. 2-6-2007. INT. CL. 36.
- CANTELLA & CO., INC., BOSTON, MA:  
3,234,374, INT. CL. 36.  
3,234,375, INT. CL. 36.
- CANTEX ENTERPRISES LIMITED, XIAN, CHINA:  
3,234,722, INT. CL. 25.
- CAP AMERICA, INC., FREDERICKTOWN, MO:  
3,234,589, INT. CL. 25.
- CAPCOM CO., LTD., OSAKA, JAPAN:  
3,234,267, INT. CL. 9.  
3,234,415, INT. CL. 9.

- CAPITAL ADVISORS, INC., TULSA, OK:  
3,233,147, PUB. 2-6-2007. INT. CL. 36.
- CAPITAL LEASE FUNDING, INC., NEW YORK, NY:  
3,233,333, PUB. 2-6-2007. INT. CL. 36.
- CAPITAL NET LIMITED, LONDON WC2R 1JA, ENGLAND:  
2,356,686, CANC. INT. CL. 36.
- CAPITAL REGION COMPUTERS, INC., CLIFTON PARK,  
NY, DBA ICOM:  
3,235,100, INT. CL. 42.
- CAPITAL REGION FINANCIAL GROUP, L.L.C., FOLSOM,  
CA:  
3,232,601, PUB. 2-6-2007. INT. CL. 35.
- CAPMATIC LTEE, RIVIERE-DES-PRAIRIES, QUEBEC, CA-  
NADA:  
2,041,255, REN. 3-21-07. INT. CL. 7.
- CAPSTAR RADIO OPERATING COMPANY, SAN ANTO-  
NIO, TX, EVERGREEN MEDIA CORPORATION OF  
DETROIT, DEARBORN, MI:  
2,030,249, REN. 3-19-07. INT. CL. 41.
- CARAN D'ACHE S.A., SWITZERLAND:  
3,233,589, PUB. 2-6-2007. INT. CL. 16.
- CARBIDE PRODUCTS INTERNATIONAL, INC., HENDER-  
SON, KY, DBA DRILLCO INDUSTRIAL:  
2,109,097, REN. 3-22-07. INT. CL. 7.  
2,119,557, REN. 3-17-07. INT. CL. 7.
- CARD TECHNOLOGY CORPORATION, PARAMUS, NJ:  
2,358,014, CANC. MULTIPLE CLASS, INT. CLS. 7 AND 9.
- CARDAVAN CORPORATION, TORONTO M5S 2Z4, CANA-  
DA:  
3,232,334, PUB. 8-22-2006. INT. CL. 45.
- CARDILLO, JOHN P., NAPLES, FL:  
3,233,061, PUB. 2-6-2007. INT. CL. 16.
- CARDINAL LABORATORIES, INC., IRWINDALE, CA:  
1,979,576, CANC. INT. CL. 3.
- CARDIO THEATER HOLDINGS, INC., ATLANTA, GA:  
2,357,919, CANC. INT. CL. 41.  
2,357,923, CANC. INT. CL. 41.
- CARDIO ZONES, INC., TEMPE, AZ:  
2,357,723, CANC. INT. CL. 41.
- CARDONE INDUSTRIES, INC., PHILADELPHIA, PA:  
3,233,923, INT. CL. 35.
- CAREFIRST OF MARYLAND, INC., OWINGS MILLS, MD:  
2,360,471, CANC. INT. CL. 42.
- CARFARO, INC., HAMILTON TOWNSHIP, NJ:  
3,234,042, INT. CL. 6.
- CARGILL, INCORPORATED, WAYZATA, MN:  
2,034,299, REN. 3-21-07. INT. CL. 29.  
3,232,769, PUB. 2-6-2007. INT. CL. 5.
- CARGILLE-SACHER LABORATORIES, INC., CEDAR  
GROVE, NJ:  
1,427,324, REN. 3-21-07. INT. CL. 9.
- CARHARTT INC., DEARBORN, MI:  
3,234,968, INT. CL. 25.
- CARIBBEAN TELECOM, INC., NEW YORK, NY:  
2,357,094, CANC. INT. CL. 9.
- CARING, INC., ATLANTIC CITY, NJ:  
1,433,409, REN. 3-22-07. INT. CL. 42.
- CARL ZEISS AG, 73447 OBERKOCHEN, FED REP GER-  
MANY:  
830,161, REN. 3-22-07. U.S. CL. 26 (INT. CL. 9).
- CARLON COMPANY, THE, CLEVELAND, OH:  
829,347, REN. 3-22-07. U.S. CL. 13 (INT. CL. 20).
- CARLOS BRAVO & JOSE BRAVO, PARTNERSHIP, THE, LA  
JOLLA, CA:  
2,358,349, CANC. INT. CL. 42.
- CARLTON, G. BUCKLEY, KANSAS CITY, MO:  
2,357,328, CANC. MULTIPLE CLASS, INT. CLS. 16 AND  
25.
- CARMEUSE NORTH AMERICA SERVICES, INC., PITTS-  
BURGH, PA:  
3,234,035, INT. CL. 19.
- CARNEY, WINSTON H., VENICE, CA:  
3,232,410, PUB. 4-4-2006. INT. CL. 41.
- CARNIVAL CORPORATION, MIAMI, FL:  
3,235,418, MULTIPLE CLASS, INT. CLS. 9 AND 28.
- CAROLL THOMAS ENTERPRISES, INC., GUILFORD, CT:  
2,030,619, REN. 3-17-07. MULTIPLE CLASS, INT. CLS. 16  
AND 42.
- CARPOINT SYSTEM CO. LTD., EAST MEADOW, NY:  
3,233,113, PUB. 2-6-2007. INT. CL. 9.
- CARRUTH STUDIO, INC., WATERVILLE, OH:  
1,979,523, CANC. INT. CL. 42.
- CARSON PRODUCTS COMPANY, SAVANNAH, GA:  
2,357,430, CANC. INT. CL. 3.
- CARTEL MARKETING, INC., ENCINO, CA:  
2,066,072, REN. 3-22-07. INT. CL. 36.
- CARTER FENCE CO. INC., NORTH HOLLYWOOD, CA:  
3,232,215, PUB. 2-6-2007. MULTIPLE CLASS, INT. CLS. 6  
AND 19.
- CARTER-WALLACE, INC., NEW YORK, NY:  
2,357,029, CANC. INT. CL. 21.
- CARTER-WATERS CORPORATION, THE, KANSAS CITY,  
MO:  
1,979,716, CANC. INT. CL. 1.
- CARTER, JASON, LYNN, MA:  
2,357,813, CANC. MULTIPLE CLASS, INT. CLS. 14 AND  
25.
- CARTIERE PAOLO PIGNA S.P.A., BERGAMO, ITALY:  
2,218,406, AM. MULTIPLE CLASS, INT. CLS. 7 AND 16.
- CASA LARGA VINEYARDS, INC., FAIRPORT, NY:  
3,232,869, PUB. 10-24-2006. INT. CL. 41.
- CASA MARINA OWNER, LLC, NEW YORK, NY:  
3,233,003, PUB. 2-6-2007. MULTIPLE CLASS, INT. CLS.  
41, 43 AND 44.
- CASCADE PROMOTION CORPORATION, SAN CARLOS,  
CA:  
3,232,748, PUB. 2-6-2007. INT. CL. 35.
- CASCIO, KEN, BARNEGAT, NJ:  
3,232,896, PUB. 2-6-2007. INT. CL. 41.
- CASE LOGIC, INC., LONGMONT, CO:  
3,234,630, INT. CL. 9.
- CASEWORKS MANAGEMENT, LLC, WHITE PLAINS, NY:  
2,358,310, CANC. INT. CL. 9.
- CASEY, DALE E., DECATUR, IL:  
3,234,556, INT. CL. 12.
- CASIO KEISANKI KABUSHIKI KAISHA, TOKYO, JAPAN,  
DBA CASIO COMPUTER CO., LTD.:  
3,232,096, PUB. 8-22-2006. INT. CL. 9.
- CASIO KEISANKI KABUSHIKI KAISHA, SHIBUYA-KU,  
TOKYO, JAPAN, DBA CASIO COMPUTER CO., LTD.:  
3,234,524, INT. CL. 16.
- CASITE INTRACO, LLC, TROY, MI, HASTINGS MANU-  
FACTURING CORPORATION, HASTINGS, MI:  
2,040,604, REN. 3-16-07. INT. CL. 1.
- CASSIS HOLDING COMPANY LTD., NEW YORK, NY:  
2,960,116, COR. INT. CL. 29.  
3,046,756, COR. MULTIPLE CLASS, INT. CLS. 3, 29, 30, 32  
AND 35.
- CASTER, FRANCE:  
3,233,616, PUB. 2-6-2007. INT. CL. 3.  
3,233,622, PUB. 2-6-2007. INT. CL. 3.
- CASTLE ROCK INTERNATIONAL, LLC, ROCHESTER, NY:  
3,234,817, INT. CL. 37.
- CASTRO CHEESE COMPANY, INC., HOUSTON, TX:  
2,123,895, REN. 3-16-07. INT. CL. 29.
- CASTROL LIMITED, SWINDON, WILTSHIRE, SN3 1RE,  
UNITED KINGDOM:  
1,979,680, CANC. INT. CL. 4.
- CATALINA MARKETING CORPORATION, ST. PETERS-  
BURG, FL:  
1,979,593, REN. 3-17-07. INT. CL. 35.
- CATANIA SPAGNA CORPORATION, AYER, MA:  
3,233,171, PUB. 2-6-2007. INT. CL. 29.
- CATATONIC RECORDING CORP., N.Y., NY:  
2,356,873, CANC. INT. CL. 9.
- CATHARON PRODUCTIONS, INC., GHENT, NY:  
1,396,568, CANC. INT. CL. 9.
- CATHEDRAL ART METAL CO., INC., PROVIDENCE, RI:  
3,233,282, PUB. 2-6-2007. INT. CL. 14.
- CATHEDRAL CANDLE COMPANY, SYRACUSE, NY:  
2,358,860, CANC. INT. CL. 4.
- CAVALIERS OPERATING COMPANY, LLC, CLEVELAND,  
OH:  
3,232,445, PUB. 2-6-2007. INT. CL. 25.  
3,232,446, PUB. 2-6-2007. INT. CL. 38.  
3,234,134, INT. CL. 28.

CAYMUS VINEYARDS, RUTHERFORD, CA:  
3,234,914, INT. CL. 31.

CB RANCH ENTERPRISES, CARLSBAD, CA:  
2,034,824. REN. 3-19-07. MULTIPLE CLASS, INT. CLS. 11 AND 41.

CB TM CORP., MISSION VIEJO, CA, PIPER & CO., INC., LUTHERVILLE, MD:  
1,428,703. REN. 3-17-07. INT. CL. 36.

CB TM CORP., MISSION VIEJO, CA:  
2,059,501. REN. 3-20-07. INT. CL. 35.

CBIZ BENEFITS & INSURANCE SERVICES, INC., LEAWOOD, KS:  
2,356,882, CANC. MULTIPLE CLASS, INT. CLS. 9 AND 36.

CBS OUTDOOR INC., NEW YORK, NY:  
3,232,650, PUB. 2-6-2007. INT. CL. 35.  
3,233,013, PUB. 2-6-2007. INT. CL. 35.

CBS RADIO LICENSE, INC., NEW YORK, NY:  
2,357,758, CANC. INT. CL. 38.

CBS STUDIOS INC., NEW YORK, NY:  
3,234,429, INT. CL. 41.  
3,234,442, INT. CL. 41.

CCH INCORPORATED, RIVERWOODS, IL:  
2,356,742, CANC. INT. CL. 9.

CCLR INTERNET, LLC, WEST HOLLYWOOD, CA:  
3,232,544, PUB. 2-6-2007. MULTIPLE CLASS, INT. CLS. 16 AND 41.

CCM COMMUNICATIONS, INC., NASHVILLE, TN TO MISSION TOWN PRODUCTIONS LLC, SAN JUAN CAPISTRANO, CA:  
1,979,738, CANC. INT. CL. 16.

CEBRA INC., TORONTO, ONTARIO, M5X 1A1, CANADA:  
2,356,465, CANC. MULTIPLE CLASS, INT. CLS. 16, 36 AND 42.

CEDRIC S. KING, STONE MOUNTAIN, GA:  
2,358,755, CANC. INT. CL. 25.

CELEBRATION HYMNAL, LLC, NASHVILLE, TN:  
2,356,552, CANC. INT. CL. 9.

CELEBRITY INSIDER, INC., NEW YORK, NY:  
2,358,394, CANC. INT. CL. 16.

CELESTRON ACQUISITION, LLC, TORRANCE, CA:  
2,013,624. REN. 3-22-07. INT. CL. 9.

CENES LIMITED, HISTON, CAMBRIDGE CB4 4ZR, UNITED KINGDOM:  
3,233,655, PUB. 2-6-2007. INT. CL. 5.

CENTER FOR CHILD DEVELOPMENT, WEST PALM BEACH, FL:  
3,233,240, PUB. 2-6-2007. INT. CL. 44.

CENTER FOR MARKETING EXCELLENCE, SAN FRANCISCO, CA:  
3,232,598, PUB. 2-6-2007. INT. CL. 41.

CENTERLINE GUITARS, LLC, SAN FRANCISCO, CA:  
3,232,391, PUB. 2-6-2007. INT. CL. 15.

CENTRAL COAST WINE COMPANY, BENICIA, CA, DBA THE HENRY WINE GROUP:  
2,358,109, CANC. INT. CL. 9.

CENTRAL NEW YORK UNIVISION VIDEO SYSTEMS, INC., SYRACUSE, NY:  
3,232,394, PUB. 4-11-2006. MULTIPLE CLASS, INT. CLS. 37 AND 42.

CENTURY INDUSTRIES, LLC, SELLERSBURG, IN:  
3,232,968, PUB. 2-6-2007. INT. CL. 6.  
3,232,969, PUB. 2-6-2007. INT. CL. 6.

CERAMICA SALONI, S.A, 12130 SAN JUAN DE MORO (CASTELLON), SPAIN:  
2,357,038, CANC. MULTIPLE CLASS, INT. CLS. 19 AND 27.

CERIONX, INC., PENNSAUKEN, NJ:  
3,234,604, INT. CL. 7.  
3,234,606, INT. CL. 7.

CERNER CORPORATION, KANSAS CITY, MO:  
3,234,171, INT. CL. 44.

CERT-A-ROOF LLC, ORANGE, CA, WATROUS, LES, ORANGE, CA:  
2,035,793. REN. 3-19-07. INT. CL. 37.

CERT-A-ROOF, LLC, ORANGE, CA, WATROUS, LES, ORANGE, CA:  
2,035,794. REN. 3-17-07. INT. CL. 37.

CERTAINTEED CORPORATION, VALLEY FORGE, PA:  
3,235,115, INT. CL. 19.

CERVECERIA SANTA FE, S.A., CAPITAL FEDERAL, ARGENTINA:  
2,358,754, CANC. INT. CL. 32.

CERWIN VEGA, INC., HOLLYWOOD, FL:  
3,232,290, PUB. 2-6-2007. INT. CL. 9.  
3,232,292, PUB. 2-6-2007. INT. CL. 9.

CESARE FIORUCCI S.P.A., ROME, ITALY:  
3,232,619, PUB. 2-6-2007. INT. CL. 29.

CETACEA CORPORATION, FOSTER CITY, CA:  
2,024,968. REN. 3-21-07. INT. CL. 28.

CEYUAN MANAGEMENT, LLC, SAN FRANCISCO, CA:  
3,234,776, INT. CL. 36.

CGI GROUP INC., MONTREAL, QUEBEC, CANADA:  
1,423,679. REN. 3-21-07. INT. CL. 9.

CGU CORPORATION, BOSTON, MA:  
2,357,489, CANC. INT. CL. 36.

CHADBOURN, DAVID B., MINNEAPOLIS, MS:  
2,357,326, CANC. INT. CL. 20.

CHALK & WIRE PROFESSIONAL DEVELOPMENT CANADA INC., ST. CATHARINES, ONTARIO L2T 3R5, CANADA:  
3,232,128, PUB. 2-6-2007. INT. CL. 9.

CHAMBERS HARRAP LIMITED, EDINBURGH, SCOTLAND:  
1,056,586. REN. 3-22-07. INT. CL. 16.

CHAMNESS RELOCATION SERVICES, INC., CHANDLER, AZ:  
3,232,099, PUB. 2-6-2007. INT. CL. 36.  
3,232,100, PUB. 2-6-2007. INT. CL. 36.

CHANCE ENTERTAINMENT, LLC, DALLAS, TX:  
3,232,665, PUB. 2-6-2007. INT. CL. 35.

CHANEL, INC., NEW YORK, NY:  
3,233,879, INT. CL. 3.  
3,234,899, INT. CL. 3.

CHANG YOUNG CO. LTD., YONGSANKU SEOUL, REPUBLIC OF KOREA:  
2,358,437, CANC. INT. CL. 28.

CHANG'S IMPORTS, INC., NEW YORK, NY:  
2,357,481, CANC. INT. CL. 25.

CHANGHONG MACHINERY FACTORY, MIANYANG, SICHUAN, CHINA:  
2,357,947, CANC. MULTIPLE CLASS, INT. CLS. 9 AND 11.

CHANNELLOCK, INC., MEADVILLE, PA:  
2,119,152. REN. 3-20-07. INT. CL. 8.

CHAPMAN CHEMICAL COMPANY, MEMPHIS, TN:  
1,396,307, CANC. INT. CL. 2.

CHAPMAN, MARK, SANTA BARBARA, CA:  
2,358,418, CANC. INT. CL. 28.

CHARGE CARD SYSTEMS, INC., BOCA RATON, FL:  
3,232,188, PUB. 2-6-2007. MULTIPLE CLASS, INT. CLS. 9 AND 36.

CHARITY FOLKS INC., NEW YORK, NY:  
3,233,006, PUB. 2-6-2007. INT. CL. 36.

CHARLES F. GLASSMAN MD LLC, MAHWAH, NJ:  
3,232,937, PUB. 2-6-2007. INT. CL. 44.

CHARLES-COLLINS, KELLY, N. H., DULUTH, GA:  
3,233,463, PUB. 2-6-2007. INT. CL. 41.  
3,233,470, PUB. 2-6-2007. INT. CL. 41.

CHARTER SCHOOLS DEVELOPMENT CORPORATION, WASHINGTON, DC:  
3,232,711, PUB. 2-6-2007. MULTIPLE CLASS, INT. CLS. 36 AND 37.

CHARTWELL STUDIO, INC., CHICAGO, IL:  
3,233,391, PUB. 2-6-2007. INT. CL. 16.

CHASE INDUSTRIES INC., CINCINNATI, OH:  
2,030,312. REN. 3-22-07. INT. CL. 19.

CHASE MARKETING INTERNATIONAL, MAMARONECK, NY:  
2,357,153, CANC. INT. CL. 11.

CHATEAU MARGAUX, INC., COCOA, FL:  
3,232,058, PUB. 10-31-2000. INT. CL. 42.

CHECK SIX PRODUCTIONS, INC., SHERMAN OAKS, CA:  
3,232,153, PUB. 2-6-2007. INT. CL. 41.

CHEERFORD INTERNATIONAL INC., HOUSTON, TX:  
3,232,411, PUB. 2-6-2007. INT. CL. 6.

- CHELBERG FOOD CORPORATION, OMAHA, NE:  
2,066,934. REN. 3-22-07. INT. CL. 30.
- CHEMINOVA A/S, DENMARK:  
3,233,759. PUB. 2-6-2007. INT. CL. 5.
- CHEMTOOL INC., CRYSTAL LAKE, IL:  
3,234,937. INT. CL. 4.
- CHERNOW COMMUNICATIONS INC., BOULDER, CO:  
2,357,669. CANC. INT. CL. 16.
- CHESAPEAKE BAY PACKING, L.L.C., NEWPORT NEWS, VA:  
2,356,999. CANC. INT. CL. 29.
- CHESAPEAKE WILDLIFE HERITAGE, INC., EASTON, MD:  
3,232,396. PUB. 2-6-2007. MULTIPLE CLASS, INT. CLS. 35 AND 37.
- CHEVRON CORPORATION, SAN RAMON, CA:  
1,396,551. CANC. INT. CL. 9.  
3,234,950. INT. CL. 16.
- CHG MANAGEMENT, INC., SALT LAKE CITY, UT, COMPREHENSIVE HEALTH SYSTEMS, INC., SALT LAKE CITY, UT:  
1,426,819. REN. 3-19-07. INT. CL. 35.
- CHG MANAGEMENT, INC., SALT LAKE CITY, UT:  
3,232,697. PUB. 2-6-2007. INT. CL. 35.
- CHI, YUWEI, VALLEY STREAM, NY:  
3,235,110. INT. CL. 25.
- CHICAGO IMPORTING CO., ELGIN, IL:  
3,234,173. INT. CL. 29.
- CHILD DEVELOPMENT CORPORATION, NORWALK, CT:  
3,235,219. INT. CL. 35.
- CHILDCAREGROUP, DALLAS, TX:  
3,232,656. PUB. 2-6-2007. INT. CL. 41.
- CHILDREN'S MEDICAL CENTER, DAYTON OHIO, THE, DAYTON, OH:  
1,397,190. CANC. INT. CL. 42.
- CHILDREN'S PSYCHIATRIC HOSPITAL LLC, FARGO, ND:  
3,234,948. INT. CL. 44.
- CHILDREN'S PSYCHIATRIC HOSPITAL, LLC, FARGO, ND:  
3,235,074. INT. CL. 44.
- CHILDREN'S WISH FOUNDATION INTERNATIONAL, INC., ATLANTA, GA:  
2,061,324. REN. 3-22-07. INT. CL. 42.
- CHIMERIC, INC., ENGLEWOOD, CO:  
2,356,741. CANC. INT. CL. 16.
- CHINA MERCHANTS BANK CO., LTD., SHENZHEN, CHINA:  
3,233,938. INT. CL. 36.
- CHIP & COOKIE, LLC, KAILUA, HI:  
3,232,261. PUB. 2-6-2007. INT. CL. 30.  
3,232,262. PUB. 2-6-2007. INT. CL. 28.
- CHIQUITA BRANDS L.L.C., CINCINNATI, OH:  
3,234,824. INT. CL. 31.
- CHITTENDEN & EASTMAN COMPANY, BURLINGTON, IA:  
1,396,837. CANC. INT. CL. 20.
- CHOCOLADEFABRIKEN LINDT & SPRUNGLI A.G., KILCHBERG, SWITZERLAND:  
3,234,698. INT. CL. 30.
- CHOCOLATES VALOR, S.A., 03570 VILLAJYOYOSA (ALICANTE), SPAIN:  
2,038,078. REN. 3-21-07. INT. CL. 30.
- CHOCOLATS CLUIZEL, FRANCE:  
3,233,716. PUB. 2-6-2007. MULTIPLE CLASS, INT. CLS. 16, 30 AND 43.
- CHOICE POINT ASSET COMPANY, ALPHARETTA, GA:  
2,358,893. CANC. INT. CL. 42.
- CHOOSE CO LLC, WAITSFIELD, VT:  
3,234,147. INT. CL. 41.
- CHOP'T CREATIVE SALAD COMPANY LLC, NEW YORK, NY:  
3,232,733. PUB. 11-7-2006. INT. CL. 43.
- CHOPRA ENTERPRISES, LLC, CARLSBAD, CA:  
3,235,174. INT. CL. 3.  
3,235,356. INT. CL. 3.  
3,235,358. INT. CL. 5.
- CHORDUS, INC., PELHAM, AL:  
3,234,039. INT. CL. 35.
- CHORUSCALL, INC., MONROEVILLE, PA:  
2,357,818. CANC. INT. CL. 38.
- CHOU, TERRY, TAINAN CITY, TAIWAN, CHINA:  
3,234,077. INT. CL. 9.
- CHRIST PHARMA & LIFE SCIENCE AG, AESCH, SWITZERLAND:  
2,039,709. CANC. INT. CL. 1.
- CHRISTENSEN O'CONNOR JOHNSON KINDNESS PLLC, SEATTLE, CHRISTENSEN O'CONNOR JOHNSON & KINDNESS, SEATTLE, WA:  
2,128,921. REN. 3-22-07. INT. CL. 42.
- CHRISTIAN BUSINESSCARES FOUNDATION, HINCKLEY, OH:  
1,471,652. REN. 3-22-07. INT. CL. 36.
- CHRISTIAN COPYRIGHT LICENSING, INC., PORTLAND, OR:  
2,519,235. CANC. INT. CL. 9.
- CHRISTIANITY TODAY, INC., CAROL STREAM, IL TO CHRISTIANITY TODAY INTERNATIONAL, CAROL STREAM, IL:  
1,979,203. CANC. MULTIPLE CLASS, INT. CLS. 38 AND 42.
- CHRISTY & CO., LIMITED, STOCKPORT, CHESHIRE, GREAT BRITAIN:  
1,396,884. CANC. INT. CL. 25.
- CHRONICLES SOFTWARE COMPANY, SARASOTA, FL:  
2,358,796. CANC. INT. CL. 9.
- CHUCKHOUSE, INC., SANTA ROSA, CA:  
3,232,322. PUB. 2-6-2007. MULTIPLE CLASS, INT. CLS. 37 AND 42.
- CHUM LIMITED, TORONTO, ONTARIO, CANADA:  
3,145,776. COR. INT. CL. 41.
- CHURCH & DWIGHT CO., INC., GREEN RIVER, WY, LAMBERT-KAY, INCORPORATED, LOS ANGELES, CA:  
823,586. REN. 3-21-07. U.S. CL. 18 (INT. CL. 5).
- CHURCHILL, MICHAEL G., OXFORDSHIRE, UNITED KINGDOM AND LYONS, LEO DW., BUCKS, UNITED KINGDOM AND LEE, RICHARD, DERBYSHIRE, UNITED KINGDOM:  
3,233,280. PUB. 2-6-2007. INT. CL. 41.
- CHURNY COMPANY, INC., NORTHFIELD, IL:  
3,235,266. INT. CL. 30.
- CIAO SYSTEMS, INC., ARLINGTON, VA:  
2,357,441. CANC. INT. CL. 42.
- CIBA SPECIALTY CHEMICALS WATER TREATMENTS LIMITED, BRADFORD, WEST YORKSHIRE BD12 OJZ, ENGLAND, ALLIED COLLOIDS LIMITED, WEST YORKSHIRE, BD12 OJZ, ENGLAND:  
2,040,849. REN. 3-22-07. INT. CL. 1.
- CIENA CORPORATION, LINTHICUM, MD:  
2,070,330. REN. 3-21-07. INT. CL. 9.
- CINCH CONNECTORS, INC., LOMBARD, IL:  
3,234,769. INT. CL. 9.
- CINCINNATI BELL TELEPHONE COMPANY LLC, CINCINNATI, OH:  
2,357,864. CANC. INT. CL. 38.
- CINELLISTUDIO S.R.L., ITALY:  
3,233,519. PUB. 2-6-2007. INT. CL. 25.
- CINNOBER FINANCIAL TECHNOLOGY AB (PUBL), SWEDEN:  
3,233,597. PUB. 2-6-2007. MULTIPLE CLASS, INT. CLS. 9, 35, 36, 37, 38 AND 42.
- CINTAS CORPORATION, CINCINNATI, OH:  
1,396,896. CANC. INT. CL. 25.
- CIRCLE OF FRIENDS, LOS ANGELES, CA:  
2,357,117. CANC. INT. CL. 41.
- CISCO TECHNOLOGY, INC., SAN JOSE, CA, CISCO SYSTEMS, INC., MOUNTAIN VIEW, CA:  
2,029,461. REN. 3-16-07. INT. CL. 9.
- CITADEL BROADCASTING COMPANY, LAS VEGAS, NV:  
2,052,902. REN. 3-21-07. INT. CL. 38.  
3,233,981. INT. CL. 38.
- CITIGROUP INC., NEW YORK, NY:  
3,234,666. INT. CL. 36.
- CITIZENS COMMUNICATIONS COMPANY, STAMFORD, CT:  
3,234,718. INT. CL. 38.  
3,234,728. INT. CL. 37.
- CITIZENS FINANCIAL GROUP, INC., PROVIDENCE, RI:  
3,233,883. INT. CL. 36.



CITY OF LEBANON, LEBANON, OR:  
3,232,826, PUB. 2-6-2007. INT. CL. 35.

CITY OF LOS ANGELES, LOS ANGELES, CA:  
3,232,056, PUB. 2-6-2007. INT. CL. 26.

CITY OF THOMASVILLE, THOMASVILLE, NC:  
2,067,921. REN. 3-16-07. INT. CL. 41.

CITY TECHNOLOGY LIMITED, PORTSMOUTH, HANTS,  
ENGLAND:  
2,056,110. REN. 3-20-07. INT. CL. 10.

CKLA, LLC, LOS ANGELES, CA:  
3,232,224, PUB. 2-6-2007. INT. CL. 4.  
3,232,225, PUB. 2-6-2007. INT. CL. 4.

CLAIROL INCORPORATED, NEW YORK, NY:  
1,396,377, CANC. INT. CL. 3.

CLAMP SWING PRICING CO., OAKLAND, CA:  
1,426,605. REN. 3-22-07. INT. CL. 20.

CLARITAS INC, SAN DIEGO, CA:  
2,075,237. REN. 3-19-07. INT. CL. 36.

CLARITAS INC., SAN DIEGO, CA, NDS, INC., ENCINITAS,  
CA:  
1,443,709. REN. 3-17-07. INT. CL. 35.

CLARK BRANDS LLC, NAPERVILLE, IL, CLARK REFIN-  
ING & MARKETING, INC., ST. LOUIS, MO:  
2,002,622. REN. 3-21-07. INT. CL. 42.

CLARK SECURITY PRODUCTS, INC., SAN DIEGO, CA:  
2,423,747, CANC. INT. CL. 35.

CLARK, DAVID PAUL, NEW YORK, NY:  
2,357,624, CANC. INT. CL. 41.  
2,357,625, CANC. INT. CL. 41.

CLARKE AMERICAN CHECKS, INC., SAN ANTONIO, TX:  
2,127,319. REN. 3-19-07. INT. CL. 16.  
3,235,177, INT. CL. 16.

CLARKE FIRE PROTECTION PRODUCTS, INC., CINCIN-  
NATI, OH:  
3,235,482, INT. CL. 7.

CLASSIC TOUCH, INC., THE, NEW BRIGHTON, MN:  
2,356,751, CANC. INT. CL. 37.

CLASSIC-MIDWEST DIE MOLD, INC., CHICAGO, IL, DBA  
CLASSIC M.D.M., INC.:  
3,234,541, INT. CL. 20.

CLAUVERIE S.A., ZAT DU LONDU 61 005 ALENCON,  
FRANCE:  
1,396,892, CANC. INT. CL. 25.

CLAWSON CUSTOM CUES, INC, JACKSONVILLE, FL:  
3,233,445, PUB. 2-6-2007. INT. CL. 28.

CLAWSON CUSTOM CUES, INC, JACKSONVILLE, FL:  
3,233,446, PUB. 2-6-2007. INT. CL. 28.

CLAYTON HOMES, INC., MARYVILLE, TN:  
2,023,001. REN. 3-16-07. MULTIPLE CLASS, INT. CLS. 19  
AND 42.

CLEAN RUN PRODUCTIONS LLC, CHICOPEE, MA:  
3,234,714, INT. CL. 25.

CLEANER'S SUPPLY, INC., CONKLIN, NY:  
3,234,788, MULTIPLE CLASS, INT. CLS. 16 AND 18.

CLEANING SYSTEMS, INC., GREEN BAY, WI:  
3,233,277, PUB. 2-6-2007. INT. CL. 3.

CLEARWATER INTERNATIONAL LLC, HOUSTON, TX,  
CLEARWATER, INC., PITTSBURGH, PA:  
2,028,603. REN. 3-17-07. INT. CL. 1.

CLEAVER-BROOKS, INC., MILWAUKEE, WI:  
1,418,155. REN. 3-20-07. MULTIPLE CLASS, INT. CLS. 7,  
9 AND 11.

CLEVELAND INDIANS BASEBALL COMPANY LIMITED  
PARTNERSHIP, CLEVELAND, OH:  
2,028,319. REN. 3-19-07. INT. CL. 41.

CLEVELAND MUSEUM OF NATURAL HISTORY, THE,  
CLEVELAND, OH:  
1,397,224, CANC. INT. CL. 42.

CLIF BAR & CO., BERKELEY, CA:  
3,232,305, PUB. 2-6-2007. INT. CL. 30.

CLIFF WEIL, INC., MECHANICSVILLE, VA:  
2,358,589, CANC. INT. CL. 9.

CLINICOMP INTERNATIONAL, INC., SAN DIEGO, CA:  
2,357,911, CANC. INT. CL. 9.

CLINTON INDUSTRIES, INC., CARLSTADT, NJ:  
1,396,477, CANC. INT. CL. 7.

CLIPHANGER, LLC, KAYSVILLE, UT:  
3,234,661, INT. CL. 9.

CLIPHANGER, LLC, SAN DIEGO, CA:  
3,234,663, INT. CL. 9.

CLIPPARD, BRIAN C., ROYAL OAK, MI:  
3,234,512, INT. CL. 25.

CLOCKWORK HOME SERVICES, INC., SARASOTA, FL:  
3,232,695, PUB. 2-6-2007. INT. CL. 41.

CLOSE JOINT STOCK COMPANY "ARTYOMOVSK  
WINERY", UKRAINE:  
3,233,722, PUB. 2-6-2007. INT. CL. 33.

CMEMD.COM INC., TORONTO, ONTARIO, CANADA:  
2,915,645, CANC. MULTIPLE CLASS, INT. CLS. 16 AND  
35.

CMP MEDIA LLC, MANHASSET, NY:  
3,235,489, INT. CL. 16.

CMTI INC., LINCOLN PARK, NJ:  
2,358,122, CANC. INT. CL. 35.

CNET NETWORKS, INC., SAN FRANCISCO, CA:  
2,357,824, CANC. MULTIPLE CLASS, INT. CLS. 35 AND  
41.

CNS, INC., EDEN PRAIRIE, MN:  
3,234,132, INT. CL. 10.

CNS, INC., MINNEAPOLIS, MN:  
3,234,972, INT. CL. 20.

COACHMEN AUTO CLUB, INC., MISHAWAKA, IN:  
1,070,369. REN. 3-22-07. INT. CL. 35.

COAST PLAZA DOCTORS HOSPITAL, NORWALK, CA:  
3,235,200, INT. CL. 44.

COASTAL RESEARCH GROUP, GRANITE BAY, CA:  
3,232,538, PUB. 10-24-2006. MULTIPLE CLASS, INT. CLS.  
38 AND 41.

COASTSIDE BIO RESOURCES, STONINGTON, ME:  
3,233,186, PUB. 2-6-2007. INT. CL. 5.

COBY ELECTRONICS CORP., MASPETH, NY:  
3,234,608, INT. CL. 9.

COCHLEAR LIMITED, LANE COVE, NSW 2066, AUSTRA-  
LIA:  
3,234,050, INT. CL. 9.

COCHRAN & ASSOCIATES, INC., DALLAS, TX:  
2,019,809. REN. 3-17-07. INT. CL. 35.

CODIAC STUDIOS LIMITED, EYE, SUFFOLK IP 23 7AJ,  
UNITED KINGDOM:  
3,233,826, INT. CL. 9.

COFFEE KIDS, INC., SANTA FE, NM:  
2,119,314. REN. 3-19-07. MULTIPLE CLASS, INT. CLS. 21  
AND 25.

COGIX CORPORATION, SAN ANSELMO, CA:  
1,979,226, CANC. INT. CL. 28.

COHEN, LORI ADAMS, EAST HILLS, NY:  
3,233,836, INT. CL. 28.

COHEN, SHOLMO, NETANYA 42262, ISRAEL AND GEL-  
MAN, PNINA, NETANYA 42273, ISRAEL:  
3,152,313, COR. INT. CL. 9.

COKTEL VISION (SARL), TORRANCE, CA:  
1,979,090, CANC. MULTIPLE CLASS, INT. CLS. 9, 28, 41  
AND 42.

COLBY MANUFACTURING CORPORATION, TULLY-  
TOWN, PA:  
2,081,344. REN. 3-19-07. INT. CL. 10.

COLD SPRING GRANITE COMPANY, COLD SPRING, MN:  
3,234,688, INT. CL. 20.

COLE-PARMER INSTRUMENT COMPANY, VERNON  
HILLS, IL:  
2,105,849. REN. 3-19-07. INT. CL. 9.  
2,115,004. REN. 3-19-07. MULTIPLE CLASS, INT. CLS. 9  
AND 10.

COLGATE-PALMOLIVE COMPANY, NEW YORK, NY,  
COLGATE-PALMOLIVE-PEET COMPANY, JERSEY  
CITY, NJ:  
427,106. REN. 3-22-07. U.S. CL. 52 (INT. CL. 3).

COLGATE-PALMOLIVE COMPANY, NEW YORK, NY:  
842,590. REN. 3-19-07. U.S. CL. 52 (INT. CL. 3).

COLLECTION CONRAD C INC., MONTRÉAL, QUÉBEC,  
CANADA:  
3,232,106, PUB. 2-6-2007. INT. CL. 25.

COLLECTORS UNIVERSE, INC., NEWPORT BEACH, CA:  
2,356,860, CANC. MULTIPLE CLASS, INT. CLS. 36 AND  
42.

- COLLETTE, JERRY, CARROLLTON, OH:  
3,233,885, INT. CL. 7.
- COLLETTE, JERRY R., CARROLLTON, OH:  
3,234,710, INT. CL. 7.
- COLONNA, JEAN, 75020 PARIS, FRANCE:  
2,356,440, CANC. INT. CL. 9.
- COLOPLAST A/S, DK-3050 HUMLEBAEK, DENMARK:  
2,358,081, CANC. INT. CL. 5.  
2,358,083, CANC. INT. CL. 5.  
2,358,084, CANC. INT. CL. 5.
- COLORADO OFF-HIGHWAY VEHICLE COALITION,  
MEAD, CO:  
3,235,106, INT. CL. 35.
- COLORADO SEMINARY, WHICH OWNS AND OPERATES  
THE UNIVERSITY OF DENVER, DENVER, CO:  
3,234,896, INT. CL. 41.
- COLORADO SKI COUNTRY U.S.A., INC., DENVER, CO:  
3,235,118, MULTIPLE CLASS, INT. CLS. 16, 35 AND 39.
- COLTAM, INC., DAVIS, CA, DBA DOS COYOTES BORDER  
CAFE:  
2,030,368, REN. 3-19-07, INT. CL. 42.
- COLTEC INDUSTRIES INC., CHARLOTTE, NC:  
2,357,493, CANC. INT. CL. 7.
- COLTEC NORTH CAROLINA, INC., CHARLOTTE, NC:  
2,358,432, CANC. INT. CL. 7.
- COLUMBIA SPORTSWEAR NORTH AMERICA, INC.,  
PORTLAND, OR:  
3,234,614, INT. CL. 18.
- COMBE PHARMA LTD., WHITE PLAINS, NY:  
1,424,503, REN. 3-17-07, INT. CL. 3.
- COMBINED INSURANCE COMPANY OF AMERICA, CHI-  
CAGO, IL:  
3,232,983, PUB. 2-6-2007, INT. CL. 36.
- COMCAST CORPORATION, PHILADELPHIA, PA:  
2,356,929, CANC. INT. CL. 42.
- COMEBACK BREWING, INC., SAN ANTONIO, TX:  
2,357,352, CANC. MULTIPLE CLASS, INT. CLS. 25 AND  
32.
- COMERCIALIAZADORA LOS AGAVES S.A. DE C.V., MEX-  
ICO CITY, MEXICO:  
2,357,127, CANC. INT. CL. 33.
- COMERCIS, INC., SOUTHLAKE, TX:  
2,357,388, CANC. INT. CL. 42.
- COMFORCARE HEALTH CARE HOLDINGS, INC.,  
BLOOMFIELD HILLS, MI:  
3,235,361, INT. CL. 44.
- COMMERCE NET CONSORTIUM, PALO ALTO, CA:  
2,110,931, REN. 3-19-07, INT. CL. 42.
- COMMERCIAL PAVING CO., INC., SCARBOROUGH, ME:  
2,276,839, CANC. INT. CL. 22.
- COMMERCIALIZATION FUNDING COACH, INC., THE,  
AUSTIN, TX:  
3,232,654, PUB. 2-6-2007, INT. CL. 35.
- COMMISSA, LLC, WOODBRIDGE, CT:  
3,233,993, U.S. CL. B.
- COMMISSION ON ACCREDITATION FOR LAW ENFOR-  
CEMENT AGENCIES, INC., FAIRFAX, VA:  
2,114,083, REN. 3-16-07, INT. CL. 42.
- COMMONWEALTH ATLANTIC PROPERTIES INC., ALEX-  
ANDRIA, VA:  
2,356,715, CANC. INT. CL. 36.
- COMMONWEALTH BRANDS, INC., BOWLING GREEN,  
KY:  
3,235,088, INT. CL. 34.
- COMMONWEALTH GENERAL CORPORATION, LOUIS-  
VILLE, KY:  
3,234,947, INT. CL. 36.  
3,234,971, INT. CL. 36.
- COMMONWEALTH TOY & NOVELTY CO., INC., NEW  
YORK, NY:  
2,357,313, CANC. INT. CL. 28.
- COMMUNICATION CHANNELS, INC., ATLANTA, GA TO  
PRISM BUSINESS MEDIA INC., NEW YORK, NY:  
1,426,531, AM. INT. CL. 16.
- COMMUNICATIONS GENERAL CORPORATION, FALL-  
BROOK, CA:  
2,029,968, REN. 3-19-07, INT. CL. 42.
- COMMUNITY COFFEE COMPANY, L.L.C., BATON  
ROUGE, LA:  
2,357,302, CANC. INT. CL. 30.
- COMMUNITY UNITED AGAINST VIOLENCE, SAN FRAN-  
CISCO, CA:  
2,356,726, CANC. INT. CL. 42.
- COMPAGNIE GENERALE D'INFORMATIQUE ET DE TEL-  
ECOMMUNICATIONS, FRANCE:  
3,233,590, PUB. 2-6-2007, MULTIPLE CLASS, INT. CLS. 9,  
38 AND 42.
- COMPANIA FRUTERA DEL NORTE, S. A., POVIDENCIA,  
SANTIAGO, CHILE:  
3,232,363, PUB. 2-6-2007, INT. CL. 31.
- COMPASS BANCSHARES, INC., BIRMINGHAM, AL:  
3,234,232, INT. CL. 36.
- COMPASS INTERNATIONAL, FULLERTON, CA:  
1,466,949, REN. 3-16-07, INT. CL. 6.
- COMPDRUG, COLUMBUS, OH:  
1,456,918, REN. 3-17-07, INT. CL. 41.
- COMPETITIVE MEDIA REPORTING LLC, NEW YORK, NY,  
VNU ADVERTISING EXPENDITURE CORP., NEW  
YORK, NY:  
2,042,188, REN. 3-21-07, MULTIPLE CLASS, INT. CLS. 9  
AND 42.
- COMPLETE PETMART, INC., DAYTON, OH:  
2,025,689, REN. 3-19-07, INT. CL. 42.  
2,025,690, REN. 3-19-07, INT. CL. 42.  
2,025,691, REN. 3-19-07, INT. CL. 42.  
2,025,692, REN. 3-19-07, INT. CL. 42.  
2,025,693, REN. 3-19-07, INT. CL. 42.  
2,030,210, REN. 3-16-07, INT. CL. 42.
- COMPREHENSIVE HEALTH EDUCATION FOUNDATION,  
SEATTLE, WA:  
2,357,245, CANC. MULTIPLE CLASS, INT. CLS. 9, 16  
AND 41.
- COMPUMEDICS LIMITED, AUSTRALIA:  
3,233,542, PUB. 2-6-2007, MULTIPLE CLASS, INT. CLS. 9  
AND 10.
- COMPUTER SCIENCES CORPORATION, EL SEGUNDO,  
CA:  
3,235,085, INT. CL. 9.
- COMTECH ANTENNA CORPORATION, ST. CLOUD, FL:  
1,372,223, REN. 3-22-07, INT. CL. 9.
- CON-CISE, LLC, SAN LEANDRO, CA:  
3,234,151, INT. CL. 9.
- CONAGRA FOODS FOOD INGREDIENTS COMPANY,  
INC., OMAHA, NE:  
2,357,717, CANC. INT. CL. 30.
- CONAGRA FOODS PACKAGED FOODS COMPANY, INC.,  
OMAHA, NE:  
2,358,003, CANC. INT. CL. 3.
- CONAGRA FOODS, INC., OMAHA, NE:  
3,234,092, INT. CL. 30.
- CONAIR CORPORATION, STAMFORD, CT:  
3,234,236, MULTIPLE CLASS, INT. CLS. 7 AND 9.  
3,234,454, MULTIPLE CLASS, INT. CLS. 9 AND 11.  
3,234,876, INT. CL. 3.
- CONCEPTUAL MATH MEDIA, INC., SAN FRANCISCO, CA,  
BEAVERS, MARY KAY, SAN FRANCISCO, CA, DBA  
CONCEPTUAL MATH MEDIA:  
2,058,379, REN. 3-21-07, INT. CL. 28.
- CONCESSION 5 CELLARS LIMITED PARTNERSHIP, ST.  
CATHARINES, ONTARIO, CANADA:  
3,232,097, PUB. 2-6-2007, INT. CL. 33.
- CONCORD FOODS, INC., BROCKTON, MA:  
2,031,857, REN. 3-17-07, INT. CL. 30.
- CONDUCTENT TECHNOLOGIES, INC., HARRISBURG, PA:  
2,356,946, CANC. MULTIPLE CLASS, INT. CLS. 35 AND  
38.
- CONLEY, ED, TULSA, OK:  
1,396,607, CANC. INT. CL. 9.
- CONMED ENDOSCOPIC TECHNOLOGIES, INC., BILLER-  
ICA, MA:  
2,034,156, REN. 3-16-07, INT. CL. 10.
- CONNAUGHT TECHNOLOGY CORPORATION, GREEN-  
VILLE, DE:  
2,129,561, REN. 3-20-07, INT. CL. 5.  
2,358,626, CANC. INT. CL. 42.

CONNECTICUT COMPUTER & CONSULTING COMPANY, KENILWORTH, NJ:  
3,235,135, INT. CL. 9.

CONNECTION FUSION TECHNOLOGIES, LLC, GAINESVILLE, TX, T.D. WILLIAMSON, INC., TULSA, OK:  
2,037,905. REN. 3-20-07. INT. CL. 7.

CONNECTPRESS, LTD., SANTA FE, NM:  
2,029,863. REN. 3-22-07. INT. CL. 16.

CONNELLY SHEEHAN HARRIS, LLP, CHICAGO, IL:  
3,235,461, INT. CL. 42.

CONOCOPHILLIPS COMPANY, HOUSTON, TX:  
646,274. REN. 3-19-07. U.S. CL. 6 (INT. CLS. 1 AND 4).

CONOPCO, INC., NEW YORK, NY, DBA PARFUMS INTERNATIONAL LTD.:  
2,358,121, CANC. INT. CL. 3.

CONOPCO, INC., TRUMBULL, CT, DBA UNILEVER:  
3,234,052, INT. CL. 3.

CONSEIL INTERPROFESSIONNEL DES VINS DU LANGUEDOC (C.I.V.L.), NARBONNE CEDEX, FRANCE:  
3,234,306, INT. CL. 35.

CONSERVE-A-NET, INC., INDEPENDENCE, MO:  
2,357,190, CANC. INT. CL. 38.

CONSOLIDATED FOAM INC., NORTHBROOK, IL:  
3,232,076, PUB. 3-30-2004. MULTIPLE CLASS, INT. CLS. 7, 17 AND 21.

CONSOLIDATED GARAGE DOORS, LTD., ADDISON, IL:  
3,232,740, PUB. 2-6-2007. INT. CL. 37.  
3,232,741, PUB. 2-6-2007. INT. CL. 37.  
3,232,742, PUB. 2-6-2007. INT. CL. 37.

CONSORZIO PER LA TUTELA DEL FORMAGGIO PECORINO ROMANO, 08015 MACOMER-NUORO, ITALY:  
2,029,475. REN. 3-22-07. U.S. CL. A.

CONSTELLATION WINES U.S., INC., CANANDAIGUA, NY:  
3,234,114, INT. CL. 33.

CONSTRUCTION DIFFUSION VENTE INTERNATIONALE, F-93500 PANTIN, FRANCE:  
3,233,525, PUB. 2-6-2007. INT. CL. 9.

CONSUMERSEARCH, INC., WASHINGTON, DC:  
3,233,251, PUB. 2-6-2007. INT. CL. 35.

CONTEC CO., LTD., NISHIYODOGAWA-KU, OSAKA 555, JAPAN:  
2,034,264. REN. 3-22-07. INT. CL. 9.

CONTEX, INC., SHERMAN OAKS, CA:  
1,396,355, CANC. INT. CL. 3.

CONTI, KURT G., SOUTH PLAINFIELD, NJ:  
3,233,007, PUB. 2-6-2007. MULTIPLE CLASS, INT. CLS. 39 AND 40.  
3,233,410, PUB. 2-6-2007. MULTIPLE CLASS, INT. CLS. 39 AND 40.

CONTINENTAL MILLS, INC., SEATTLE, WA:  
2,036,849. REN. 3-21-07. INT. CL. 30.

CONTINUUM, INC., WESTERVILLE, OH:  
2,357,024, CANC. INT. CL. 35.

CONTROL COMPONENTS, INC., RANCHO SANTA MARGARITA, CA:  
3,234,489, INT. CL. 42.

CONTROL MODULE INC., ENFIELD, CT:  
2,358,006, CANC. INT. CL. 9.

CONTROLLED CHAOS, INC., ORANGE PARK, FL:  
3,233,773, INT. CL. 25.

CONVENIENT FUEL GROUP, L.L.C., DALLAS, TX:  
2,358,795, CANC. INT. CL. 9.

CONVERGENT TECHNOLOGIES DESIGN GROUP, INC., BALTIMORE, MD:  
3,232,158, PUB. 2-6-2007. INT. CL. 42.

CONVEX SYSTEMS, INCORPORATED, BOULDER, CO:  
2,358,612, CANC. INT. CL. 9.

COOK & LOVE, INC., MEMPHIS, TN:  
1,470,232. REN. 3-16-07. INT. CL. 42.

COOK INCORPORATED, BLOOMINGTON, IN:  
2,062,253. REN. 3-16-07. INT. CL. 10.  
2,076,352. REN. 3-22-07. INT. CL. 10.

COOPER INDUSTRIES, LLC, HOUSTON, TX:  
3,233,765, INT. CL. 9.

COOPER TECHNOLOGIES COMPANY, HOUSTON, TX, JAMES R. KEARNEY CORPORATION, ST. LOUIS, MO:  
341,349. REN. 3-17-07. U.S. CL. 21 (INT. CL. 9).

COOPER TECHNOLOGIES COMPANY, HOUSTON, TX:  
3,234,915, INT. CL. 9.

COOPER, DOUGLAS J., WILLINGTON, CT:  
2,356,647, CANC. INT. CL. 9.

COOPERATING SCHOOL DISTRICTS OF GREATER ST. LOUIS, ST. LOUIS, MO:  
2,356,831, CANC. MULTIPLE CLASS, INT. CLS. 9 AND 35.

COOPERATIVA DE PRODUCTORES DE LECHE DOSPINOS, R.L., ALAJUELA, COSTA RICA:  
3,234,466, MULTIPLE CLASS, INT. CLS. 29, 30 AND 32.  
3,234,469, INT. CL. 29.

COORDINATED RESOURCES, INC. OF SAN FRANCISCO, SAN FRANCISCO, CA:  
3,233,940, INT. CL. 42.

COORS GLOBAL PROPERTIES, INC., GOLDEN, CO:  
3,235,165, INT. CL. 32.

COPAT S.P.A., I-33070 MARON DI BRUGNERA (PORDENONE), ITALY:  
3,233,656, PUB. 2-6-2007. MULTIPLE CLASS, INT. CLS. 11 AND 20.

COPERA, INC., MOUNTAIN VIEW, CA:  
3,234,131, MULTIPLE CLASS, INT. CLS. 9 AND 42.

CORE POTENTIAL, LLC, WOODSTOCK, GA:  
3,235,180, INT. CL. 35.

CORNETT, PAUL R., DENVER, CO:  
2,357,057, CANC. INT. CL. 6.

CORNING INCORPORATED, CORNING, NY, DATA PACKAGING CORPORATION, CAMBRIDGE, MA:  
1,426,470. REN. 3-21-07. INT. CL. 11.

CORNING INCORPORATED, CORNING, NY:  
2,032,882. REN. 3-19-07. INT. CL. 21.

CORPORATION MARKETING ESSENTIALS LIMITED, LAGUNA NIGUEL, CA:  
2,358,066, CANC. INT. CL. 9.

CORTEC CORPORATION, ST. PAUL, MN:  
3,232,610, PUB. 2-6-2007. MULTIPLE CLASS, INT. CLS. 2 AND 3.  
3,233,128, PUB. 2-6-2007. INT. CL. 2.

CORTELCO, INC., CORINTH, MS:  
2,036,183. REN. 3-16-07. INT. CL. 9.

CORUS BAUSYSTEME GMBH, 56070 KOBLENZ, FED REP GERMANY:  
3,233,787, MULTIPLE CLASS, INT. CLS. 6 AND 37.

COSBAR USA, INC., ASPEN, CO:  
3,233,452, PUB. 2-6-2007. INT. CL. 44.

COSMAIR CREATIVE, INC., NEW YORK, NY:  
2,358,571, CANC. INT. CL. 3.

COSMETIC DERMATOLOGY, INC., MIAMI, FL:  
3,234,903, INT. CL. 3.

COUNCIL ON COMPETITIVENESS, WASHINGTON, DC:  
3,235,483, MULTIPLE CLASS, INT. CLS. 16, 35 AND 42.

COUNTRY COACH, INC., JUNCTION CITY, OR TO NATIONAL R.V. HOLDINGS, INC., PERRIS, CA:  
1,980,048, CANC. INT. CL. 12.

COUNTRY LIFE, LLC, HAUPPAUGE, NY:  
2,358,676, CANC. INT. CL. 5.

COUNTRY MUSIC TELEVISION, INC., NEW YORK, NY:  
3,234,647, INT. CL. 41.

COUNTRYWIDE HOME LOANS, INC., CALABASAS, CA:  
2,006,878. REN. 3-21-07. INT. CL. 36.

COUNTY MATERIALS CORPORATION, MARATHON, WI:  
3,232,354, PUB. 2-6-2007. INT. CL. 19.

COUNT5, LLC, ATLANTA, GA:  
3,233,226, PUB. 2-6-2007. INT. CL. 42.

COURTROOM TELEVISION NETWORK LLC, NEW YORK, NY:  
3,234,214, INT. CL. 41.

COUTURE, LISE ANNE, NEW YORK, NY:  
2,357,608, CANC. INT. CL. 42.

COVELL, RON, FREEDOM, CA:  
2,513,746, CANC. INT. CL. 7.

COVENANT PHARMA INC., MARIETTA, GA:  
3,235,289, INT. CL. 5.

COX RADIO, INC., JACKSONVILLE, FL, DBA WAPE:  
3,234,297, INT. CL. 41.

COX RADIO, INC., ATLANTA, GA:  
3,234,711, INT. CL. 38.

- COYNE & DELANY COMPANY, CHARLOTTESVILLE, VA:  
3,232,987, PUB. 2-6-2007. INT. CL. 11.
- COYOTE SYSTEMS INC., SAN FRANCISCO, CA:  
2,358,458, CANC. INT. CL. 9.
- CPM MEDIA LLC, MANHASSET, NY:  
2,357,865, CANC. INT. CL. 42.
- CRAFT-BILT MANUFACTURING COMPANY, SOUDERTON, PA:  
3,234,340, INT. CL. 19.
- CRAFTECH INDUSTRIES, INC., HUDSON, NY:  
1,458,704, REN. 3-19-07. INT. CL. 37.  
1,458,787, REN. 3-19-07. INT. CL. 42.
- CRAFTMADE INTERNATIONAL INC., COPPELL, TX:  
3,235,431, INT. CL. 11.
- CRAMARO TARPAULIN SYSTEMS, INC., NEWARK, DE:  
2,032,180, REN. 3-19-07. INT. CL. 12.
- CRANDALL, CAROLE E., VALENCIA, CA, DBA BOW WOW BELONGINGS:  
2,357,661, CANC. INT. CL. 18.  
2,357,662, CANC. INT. CL. 18.
- CRANE CO., STAMFORD, CT, DOW CHEMICAL COMPANY, THE, MIDLAND, MI:  
2,026,056, REN. 3-16-07. INT. CL. 6.
- CRAWLEY, MICHAEL F., MARYVILLE, TN:  
2,041,567, REN. 3-16-07. INT. CL. 9.
- CRAZY PET, LLC, AZUSA, CA:  
3,232,212, PUB. 2-6-2007. INT. CL. 41.
- CRC INDUSTRIES HOLDINGS, INC., WILMINGTON, DE, C. J. WEBB, INC., JENKINTOWN, PA:  
830,347, REN. 3-16-07. U.S. CL. 52 (INT. CL. 3).
- CREATENET, INC., NEW YORK, NY, CREATENET, INC., CHICAGO, IL:  
2,030,354, REN. 3-16-07. INT. CL. 41.
- CREATIVE COMPUTERS, INC., TORRANCE, CA:  
2,358,756, CANC. INT. CL. 16.
- CREATIVE COOKIE COMPANY, INC., WASHINGTON, DC:  
1,397,018, CANC. INT. CL. 30.
- CREATIVE MEDICAL, INC., FORT LAUDERDALE, FL TO SENTECH ACQUISITION CORP., LOS ANGELES, CA:  
1,979,720, CANC. INT. CL. 10.
- CREATIVE MICROSYSTEMS, INC., ENGLEWOOD, OH:  
3,234,892, INT. CL. 9.
- CREDARIS PORTOFOLIO MANAGEMENT GMBH, 24103 KIEL, FED REP GERMANY:  
3,233,687, PUB. 2-6-2007. INT. CL. 36.
- CREDO TECHNOLOGY CORPORATION, BROADVIEW, IL:  
1,396,484, CANC. INT. CL. 7.  
1,980,090, CANC. INT. CL. 7.
- CREPE "N" TEARIA, INC., FLUSHING, NY:  
3,233,420, PUB. 2-6-2007. INT. CL. 43.
- CRESCENT MANUFACTURING CO., FREMONT, OH:  
2,051,557, REN. 3-19-07. INT. CL. 10.
- CRESTRON ELECTRONICS, INC., ROCKLEIGH, NJ:  
3,235,004, INT. CL. 9.
- CRIDGE, INC., FALLSINGTON, PA:  
2,358,778, CANC. INT. CL. 21.
- CRISTAL ET BRONZE GEO MARTEL USA, INC., VISTA, CA:  
2,356,589, CANC. MULTIPLE CLASS, INT. CLS. 11 AND 21.
- CRITCHFIELD MEATS, INC., LEXINGTON, KY:  
2,358,682, CANC. INT. CL. 29.
- CROPCHAM MANUFACTURING, CO., DECATUR, IL:  
1,396,274, CANC. INT. CL. 1.
- CROPPORTUNITIES, MARSHFIELD, WI:  
3,234,752, INT. CL. 16.
- CROSS COUNTRY INNS, INC., DOUBLIN, OH:  
1,397,181, CANC. INT. CL. 42.
- CROTHALL BUSINESS & INDUSTRY, INC., WAYNE, PA, BAYSTATE MAINTENENACE CORPORATION, NEWBURYPORT, MA:  
2,035,271, REN. 3-21-07. INT. CL. 37.
- CRYSTAL FOUNTAINS INC., CONCORD, ONTARIO, CANADA:  
3,234,581, INT. CL. 11.
- CSC BRAZILIAN, L.P., WEST PALM BEACH, FL:  
2,050,738, REN. 3-22-07. INT. CL. 42.
- CSG SYSTEMS, INC., ENGLEWOOD, CO:  
2,356,913, CANC. MULTIPLE CLASS, INT. CLS. 35, 38 AND 42.
- CSK AUTO, INC., PHOENIX, AZ:  
2,357,170, CANC. INT. CL. 35.
- CTA INCORPORATED, ROCKVILLE, MD:  
2,357,975, CANC. INT. CL. 42.
- CTA, INC., FENTON, MO:  
3,233,005, PUB. 2-6-2007. MULTIPLE CLASS, INT. CLS. 14 AND 16.
- CTM ENTERPRISES, INC., LAS VEGAS, NV:  
3,234,980, INT. CL. 11.
- CUESEE B.V., EDE, NETHERLANDS:  
3,235,113, INT. CL. 35.
- CUETO, OSCAR SOBERON, MÉXICO DISTRITO FEDERAL MÉXICO, MEXICO:  
3,232,495, PUB. 2-6-2007. INT. CL. 42.
- CUISINE POPULAIRE, INC., CHICAGO, IL:  
3,235,419, MULTIPLE CLASS, INT. CLS. 9 AND 43.
- CULLUM SEEDS, LLC, FISHER, AR:  
3,235,065, INT. CL. 31.
- CUMIS INSURANCE SOCIETY, INC., MADISON, WI:  
1,045,589, REN. 3-17-07. INT. CL. 36.
- CURTIS PACKING COMPANY, GREENSBORO, NC:  
1,063,441, REN. 3-22-07. INT. CL. 29.
- CURTIS, H. MANNING, NORTH ANDOVER, MA:  
1,979,343, CANC. INT. CL. 10.
- CURVES INTERNATIONAL, INC., WACO, TX:  
3,234,975, INT. CL. 3.
- CUSTARD INSURANCE ADJUSTERS, INC., NORCROSS, GA:  
2,121,429, REN. 3-16-07. INT. CL. 36.
- CUSTOM PAPER TUBES, INC., CLEVELAND, OH:  
3,234,783, INT. CL. 10.
- CUSTOM SPEECH USA, INC., CROWN POINT, IN:  
2,358,549, CANC. INT. CL. 42.
- CUSTOM TELECONNECT, INC., LAS VEGAS, NV:  
3,232,359, PUB. 4-26-2005. INT. CL. 38.  
3,232,360, PUB. 4-26-2005. INT. CL. 38.
- CUSTOM WOOD DESIGNS, INC., DOYLESTOWN, PA:  
3,232,452, PUB. 2-6-2007. MULTIPLE CLASS, INT. CLS. 40 AND 42.
- CUTBIRTH, CATHERINE, AUSTIN, TX:  
3,234,357, INT. CL. 5.
- CVT PREPAID SOLUTIONS, INC., GREAT NECK, NY:  
3,232,914, PUB. 2-6-2007. MULTIPLE CLASS, INT. CLS. 16, 36 AND 38.  
3,232,916, PUB. 2-6-2007. MULTIPLE CLASS, INT. CLS. 16, 36 AND 38.
- CYBERLINK CORP., SHINDIAN CITY, TAIPEI, TAIWAN:  
3,234,161, INT. CL. 9.
- CYBERMETRIX, INC., COLUMBUS, IN:  
2,032,105, REN. 3-21-07. INT. CL. 42.
- CYBERSCAN TECHNOLOGY, PALO ALTO, CA:  
3,232,279, PUB. 2-6-2007. INT. CL. 9.
- CYBERSITES, INC., NEW YORK, NY:  
2,357,586, CANC. INT. CL. 42.
- CYRUS COMPANY S.R.L., I-21013 GALLARATE (VARESE), ITALY:  
3,233,680, PUB. 2-6-2007. INT. CL. 20.
- C21 TM CORP., MISSION VIEJO, CA:  
2,357,858, CANC. INT. CL. 42.
- D & L MARKETING, INC., MESA, AZ, DBA AMERICAN TOWN MAILER:  
2,356,613, CANC. INT. CL. 35.
- D IS FOR DOGGY, INC., NEW YORK, NY:  
3,235,242, INT. CL. 43.
- D.E. HOKANSON, INCORPORATED, BELLEVUE, WA:  
2,108,603, REN. 3-17-07. MULTIPLE CLASS, INT. CLS. 9 AND 10.
- D.J. BROTHER'S ENTERTAINMENT CO., INC., FOUNTAIN VALLEY, CA:  
3,233,232, PUB. 2-6-2007. INT. CL. 41.
- D'AMORE, KRIS, BROOKLYN, NY:  
2,358,204, CANC. INT. CL. 41.
- D'UVA FINE ARTISTS MATERIALS, INC., ALBUQUERQUE, NM:  
2,356,975, CANC. INT. CL. 16.

- DAD LAB, INC., AUSTIN, TX:  
3,235,003, MULTIPLE CLASS, INT. CLS. 9, 35 AND 41.
- DAH YANG TOY INDUSTRIAL CO., LTD., TAIPEI, TAIWAN:  
2,358,435, CANC. INT. CL. 28.
- DAIMLERCHRYSLER AG, STUTTGART, FED REP GERMANY:  
3,232,796, PUB. 2-6-2007. INT. CL. 12.
- DAISY BRAND, LP, DALLAS, TX:  
3,233,847, INT. CL. 29.
- DAKA DEVELOPMENT LTD., KOWLOON, HONG KONG, CHINA:  
3,233,953, INT. CL. 9.
- DALLAS BASKETBALL LIMITED, DALLAS, TX:  
3,233,878, INT. CL. 25.
- DALPS & LEISURE PRODUCTS SUPPLY CORPORATION, TAIPEI, TAIWAN:  
3,232,254, PUB. 2-6-2007. INT. CL. 28.
- DAMASTE INVESTMENTS LLC, MACON, GA, DBA THE CHERRY CORNER:  
2,356,655, CANC. INT. CL. 42.
- DAME INTERNATIONAL, INC., ELMHURST, NY:  
2,049,025. REN. 3-22-07. INT. CL. 3.
- DANA BRAUN, INC., NEW YORK, NY:  
2,357,157, CANC. INT. CL. 25.
- DANCE INSTITUTE OF WASHINGTON, WASHINGTON, DC:  
2,425,020, CANC. INT. CL. 36.
- DANCING FEET YOGA CENTER, INC., MICHIGAN CITY, IN:  
3,233,477, PUB. 2-6-2007. INT. CL. 41.
- DANISCO A/S, COPENHAGEN K, DENMARK:  
3,232,774, PUB. 2-6-2007. MULTIPLE CLASS, INT. CLS. 1 AND 30.
- DANNEMILLER MEMORIAL EDUCATIONAL FOUNDATION, SAN ANTONIO, TX:  
2,358,641, CANC. INT. CL. 42.
- DANNON COMPANY, INC., THE, TARRYTOWN, NY:  
2,358,606, CANC. INT. CL. 29.
- DANNY & CLYDE'S FOOD STORE INC., GRETN, LA:  
3,234,815, INT. CL. 43.
- DANNY Q. ROBERTSON, PORTLAND, OR, DBA NEW INDUSTRIES:  
3,232,637, PUB. 2-6-2007. INT. CL. 28.
- DANSK ISOKERN A/S, DK-7470 KARUP, DENMARK:  
2,356,740, CANC. MULTIPLE CLASS, INT. CLS. 6, 11 AND 19.
- DAROS HOLDING AB, SE-433 28 PARTILLE, SWEDEN:  
2,357,461, CANC. INT. CL. 7.
- DARRABY, JESSICA L., SANTA MONICA, CA:  
3,235,321, INT. CL. 42.
- DARREL EDWARDS INC., SAN DIEGO, CA:  
3,232,849, PUB. 2-6-2007. INT. CL. 35.
- DART INDUSTRIES INC., ORLANDO, FL, DBA TUPPERWARE HOME PARTIES:  
1,077,907. REN. 3-21-07. INT. CL. 21.
- DASCOM, INC., SANTA CRUZ, CA:  
2,357,874, CANC. INT. CL. 9.
- DATA EAST USA, INC., SANTA CLARA, CA:  
1,396,925, CANC. INT. CL. 28.
- DATA TRANSIT INTERNATIONAL, INC., NORCROSS, GA:  
2,356,632, CANC. INT. CL. 42.
- DATA WEST CORPORATION, BELLEVUE, WA:  
2,356,493, CANC. MULTIPLE CLASS, INT. CLS. 41 AND 42.
- DATABASE BUILDERS, INC., SUMMIT, IL:  
2,357,231, CANC. INT. CL. 35.
- DATACOLOR HOLDING AG, LUZERN, SWITZERLAND:  
3,234,484, INT. CL. 9.
- DATACOLOR HOLDING AG., LUZERN, SWITZERLAND:  
2,030,461. REN. 3-22-07. INT. CL. 9.  
3,234,501, INT. CL. 9.  
3,234,502, INT. CL. 9.  
3,234,505, INT. CL. 9.  
3,234,506, INT. CL. 9.  
3,234,530, INT. CL. 9.  
3,234,535, INT. CL. 9.  
3,234,570, INT. CL. 9.  
3,234,571, INT. CL. 9.
- DATASCOPE TRADEMARK CORP., WILMINGTON, DE:  
2,357,708, CANC. MULTIPLE CLASS, INT. CLS. 1 AND 5.
- DATATRACPLUS, LLC, CHARLOTTE, NC:  
3,233,229, PUB. 2-6-2007. INT. CL. 9.
- DATAVIZ, INC., MILFORD, CT:  
3,234,741, INT. CL. 9.
- DAVID, NARSAI M., KENSINGTON, CA:  
3,234,997, INT. CL. 33.
- DAVIDOFF & CIE SA, 1200 GENEVA, SWITZERLAND:  
1,058,684. REN. 3-22-07. INT. CL. 34.
- DAVIS LEHRMITAGE, LLC, SANTA ROSA, CA:  
3,234,496, INT. CL. 33.
- DAVIS, DONNY, AUBURN, AL:  
2,357,013, CANC. INT. CL. 35.
- DAVIS, J. MARK, BIRMINGHAM, AL:  
2,109,419. REN. 3-21-07. INT. CL. 14.
- DAY-TIMERS, INC., EAST TEXAS, PA:  
1,427,871. REN. 3-16-07. INT. CL. 41.  
2,358,558, CANC. INT. CL. 16.  
2,358,560, CANC. INT. CL. 16.
- DAY, SHARON, LOS ANGELES, CA:  
2,356,944, CANC. INT. CL. 25.  
2,356,945, CANC. INT. CL. 25.
- DAYCO PRODUCTS, INC., DAYTON, OH, DAYCO CORPORATION, DAYTON, OH:  
1,056,610. REN. 3-21-07. INT. CL. 20.
- DAYTON HUDSON BRANDS, INC., MINNEAPOLIS, MN:  
2,358,660, CANC. INT. CL. 16.
- DAYTON POWER AND LIGHT COMPANY, THE, DAYTON, OH:  
2,356,503, CANC. INT. CL. 39.
- DAYTON, MARILYN, COLUMBUS, GA:  
2,358,149, CANC. INT. CL. 16.
- DDI, INC, DUBUQUE, IA:  
3,234,774, INT. CL. 25.
- DE RUITER'S NIEUWE ROZEN B.V., 1424 PL DE KWAKEL, NETHERLANDS:  
2,034,714. REN. 3-17-07. INT. CL. 31.
- DE TAILLAC, MARIE-HÉLÈNE, UNITED KINGDOM:  
3,233,685, PUB. 2-6-2007. MULTIPLE CLASS, INT. CLS. 3, 14, 40 AND 42.
- DE VARONA, JONAS, SEATTLE, WA:  
3,235,301, INT. CL. 25.
- DEAMONE, DANIEL NEAL, HANOVER, ONTARIO:  
3,234,296, INT. CL. 28.
- DEBOURG, PHILIP, HOLLYWOOD, FL AND BERNIER, TROY, MIAMI GARDENS, FL:  
3,234,055, INT. CL. 25.
- DEBT COUNSELORS OF AMERICA, INC., ROCKVILLE, MD:  
2,358,640, CANC. INT. CL. 36.
- DECISION ACADEMIC INC., OTTAWA, CANADA:  
3,232,346, PUB. 2-6-2007. INT. CL. 9.
- DECISION ANALYST, INC., ARLINGTON, TX:  
3,232,924, PUB. 2-6-2007. INT. CL. 9.
- DECEEQ!, MIAMI, FL:  
3,235,083, INT. CL. 20.
- DEER CREEK COMMUNITY CHURCH, APPLE VALLEY, MN:  
3,232,580, PUB. 2-6-2007. INT. CL. 41.
- DEGUSSA AG, TROSTBERG, FED REP GERMANY:  
1,430,757. REN. 3-22-07. INT. CL. 1.
- DEGUSSA CORPORATION, PARSIPPANY, NJ:  
3,233,876, INT. CL. 2.
- DEITSCH, MIRIAM K., WANTAGH, NY AND LACKMANN, KAY F., SYOSSET, NY:  
3,233,815, INT. CL. 16.

- DEKALB GENETICS CORPORATION, ST. LOUIS, MO:  
3,233,021, PUB. 2-6-2007. INT. CL. 31.
- DEL BOCA, ADRIAN, MIAMI, FL:  
3,233,114, PUB. 2-6-2007. INT. CL. 44.
- DEL LABORATORIES, INC., UNIONDALE, NY:  
3,235,386, INT. CL. 3.
- DEL MONTE CORPORATION, SAN FRANCISCO, CA:  
3,233,888, INT. CL. 25.
- DEL WEBB CORPORATION, SCOTTSDALE, AZ:  
2,032,372. REN. 3-17-07. INT. CL. 41.
- DELAWARE CAPITAL FORMATION, INC., WILMINGTON, DE:  
1,404,635. REN. 3-22-07. INT. CL. 7.  
3,233,413, PUB. 2-6-2007. INT. CL. 7.  
3,233,505, PUB. 2-6-2007. INT. CL. 11.
- DELAWARE NORTH COMPANIES TRAVEL HOSPITALITY SERVICES, INC., BUFFALO, NY:  
3,234,652, INT. CL. 35.
- DELAWARE STATE UNIVERSITY, DOVER, DE:  
3,232,588, PUB. 2-6-2007. INT. CL. 25.
- DELIVERY NETWORK, THE, MADISON, IL:  
2,357,768, CANC. INT. CL. 39.
- DELL COMPUTER CORPORATION, ROUND ROCK, TX:  
2,358,613, CANC. INT. CL. 38.
- DELL, JACOB JOSEPH, GONZALES, TX:  
2,357,754, CANC. INT. CL. 41.
- DELLO, CHRIS, HENDERSON, NV:  
2,357,685, CANC. INT. CL. 28.
- DELORME PUBLISHING COMPANY, INC., YARMOUTH, ME:  
3,234,487, MULTIPLE CLASS, INT. CLS. 9 AND 42.
- DELTA INDUSTRIAL SERVICES, INC., MINNEAPOLIS, MN:  
3,232,521, PUB. 2-6-2007. INT. CL. 7.
- DELTA INDUSTRIE INFORMATIK GMBH, 70736 FELLBACH, FED REP GERMANY TO DELMIA GMBH, 70736 FELLBACH, FED REP GERMANY:  
1,979,629, CANC. INT. CL. 9.
- DELTA NATIONAL BANK AND TRUST COMPANY, NEW YORK, NY:  
1,425,130. REN. 3-22-07. INT. CL. 36.
- DELTA S.R.L., I-81030 PARETE (CE), ITALY:  
3,233,591, PUB. 2-6-2007. MULTIPLE CLASS, INT. CLS. 3, 9, 14, 16, 18 AND 25.
- DEMAIOLO, MARY PIPINO, CANFIELD, OH:  
3,234,689, MULTIPLE CLASS, INT. CLS. 41 AND 44.
- DENNING, SUZY C., CORTE MADERA, CA, DBA OPEN DOOR PRODUCTS:  
3,234,836, INT. CL. 16.
- DENTCRAFTER, INC., GIG HARBOR, WA:  
3,233,385, PUB. 2-6-2007. INT. CL. 37.
- DENTSPLY INTERNATIONAL INC., YORK, PA, NALGE COMPANY, ROCHESTER, NY:  
1,446,202. REN. 3-21-07. INT. CL. 10.
- DENTSPLY INTERNATIONAL INC., YORK, PA, DENTSPLY INTERNATIONAL INC., YORK, PA:  
2,077,122. REN. 3-22-07. INT. CL. 5.
- DENTSPLY INTERNATIONAL INC., YORK, PA:  
3,235,056, INT. CL. 5.
- DENVER BOTANIC GARDENS, INC., DENVER, CO AND COLORADO STATE UNIVERSITY, FORT COLLINS, CO:  
3,232,421, PUB. 2-6-2007. INT. CL. 31.
- DERMALOUNGE INC., SAN FRANCISCO, CA:  
3,235,139, INT. CL. 44.
- DERRING, DAVID, VIRGINIA BEACH, VA:  
3,234,338, INT. CL. 25.
- DESA IP, LLC, MIAMI, FL:  
3,233,875, INT. CL. 11.
- DESERT SWEET AMERICA, INC., UNIVERSITY HEIGHTS, OH:  
2,358,188, CANC. INT. CL. 31.
- DESI NETWORK, INC., TUCSON, AZ, AKA DNI:  
3,233,857, INT. CL. 16.
- DESIGN CLINICALS LLC, KENT, WA:  
3,235,467, INT. CL. 9.
- DESIGNED LEARNING INC., WESTFIELD, NJ, BLOCK PETRELLA WEISBORD, PLAINFIELD, NJ:  
1,426,894. REN. 3-21-07. INT. CL. 41.
- DESILVER, 97133, SAINT BARTHELEMY, FRANCE:  
3,232,143, PUB. 2-6-2007. INT. CL. 33.
- DESSALATOR S.A.R.L., ANTIBES, FRANCE:  
3,233,619, PUB. 2-6-2007. MULTIPLE CLASS, INT. CLS. 7, 11 AND 37.
- DESTON THERAPEUTICS, INC., CHAPEL HILL, NC:  
3,235,343, INT. CL. 5.
- DETONICS, USA, LLC, PENDERGRASS, GA:  
3,234,414, INT. CL. 13.
- DETROIT DIESEL CORPORATION, DETROIT, MI:  
2,036,500. REN. 3-16-07. INT. CL. 9.
- DETROIT PLASTICOS E METAIS LTDA, DIADEMA, SAO PAULO, BRAZIL:  
3,233,778, MULTIPLE CLASS, INT. CLS. 6, 7, 11 AND 12.
- DEUTSCH CONSULTING & MARKETING, INC., HOLLYWOOD, FL:  
3,234,125, INT. CL. 42.
- DEUTSCHE TELEKOM AG, BONN, FED REP GERMANY:  
3,232,328, PUB. 9-12-2006. INT. CL. 35.  
3,232,554, PUB. 10-31-2006. INT. CL. 35.  
3,232,555, PUB. 10-24-2006. INT. CL. 38.  
3,232,556, PUB. 10-24-2006. INT. CL. 41.  
3,232,817, PUB. 2-6-2007. INT. CL. 35.  
3,232,818, PUB. 2-6-2007. INT. CL. 42.  
3,232,819, PUB. 2-6-2007. INT. CL. 35.  
3,232,821, PUB. 2-6-2007. INT. CL. 42.  
3,232,822, PUB. 2-6-2007. INT. CL. 35.  
3,232,947, PUB. 2-6-2007. INT. CL. 35.  
3,232,948, PUB. 2-6-2007. INT. CL. 36.  
3,232,949, PUB. 2-6-2007. INT. CL. 37.  
3,232,950, PUB. 2-6-2007. INT. CL. 38.  
3,232,951, PUB. 2-6-2007. INT. CL. 41.
- DEUTSCHER WEINFONDS, 55116 MAINZ, FED REP GERMANY:  
1,989,506. REN. 3-22-07. U.S. CL. A.
- DEVALUT PACKING CO., INC., DEVAULT, PA:  
3,232,479, PUB. 2-28-2006. INT. CL. 29.
- DEVELOPMENTAL STUDIES CENTER, OAKLAND, CA:  
3,234,615, INT. CL. 16.
- DEVON-AIRE, INC., TAMPA, FL:  
2,014,922. REN. 3-22-07. INT. CL. 25.
- DEXTER BEVERAGE COMPANY, HANOVER, VA:  
2,358,717, CANC. INT. CL. 32.
- DI CRESCENZO, TONY, CONCORD, ONTARIO:  
2,356,760, CANC. MULTIPLE CLASS, INT. CLS. 37 AND 39.
- DIAGEO NORTH AMERICA, INC., STAMFORD, CT:  
2,094,877. REN. 3-22-07. INT. CL. 33.
- DIAGEO NORTH AMERICA, INC., NORWALK, CT:  
3,232,422, PUB. 2-6-2007. INT. CL. 33.  
3,234,379, INT. CL. 25.  
3,234,495, INT. CL. 36.  
3,234,612, INT. CL. 33.
- DIAGEO SCOTLAND LIMITED, EDINBURGH, SCOTLAND:  
3,234,322, INT. CL. 33.
- DIAGNOSTIC HYBRIDS INC., ATHENS, OH:  
2,095,463. REN. 3-16-07. INT. CL. 5.
- DIAL BRANDS, INC., SCOTTSDALE, AZ:  
2,358,648, CANC. INT. CL. 3.  
2,358,653, CANC. MULTIPLE CLASS, INT. CLS. 3 AND 4.  
3,235,376, INT. CL. 5.
- DIAMONDSDEAL.COM CORP., MIAMI, FL:  
3,233,090, PUB. 2-6-2007. INT. CL. 14.
- DIANA BITTLE, CENTERVILLE, TN:  
3,233,379, PUB. 2-6-2007. INT. CL. 45.
- DIAZ WHOLESALE AND MANUFACTURING CO., ATLANTA, GA:  
3,232,138, PUB. 2-6-2007. INT. CL. 29.
- DIC ENTERTAINMENT CORPORATION, BURBANK, CA:  
2,110,380. REN. 3-21-07. MULTIPLE CLASS, INT. CLS. 9, 35 AND 41.  
3,177,586, AM. INT. CL. 28.
- DICK CLARK PRODUCTIONS, INC., BURBANK, CA:  
2,357,992, CANC. INT. CL. 25.
- DICK, TIMOTHY ALAN, NORTH HOLLYWOOD, CA:  
3,234,792, INT. CL. 41.

DICKEY INVESTMENTS, LLC, NOBLESVILLE, IN:  
3,233,170, PUB. 2-6-2007. INT. CL. 5.

DICKSON, DENNIS GORDON, VISTA, CA:  
2,357,783, CANC. INT. CL. 29.

DICTAPHONE CORPORATION (U.S.), BURLINGTON, MA,  
DICTAPHONE CORPORATION, BRIDGEPORT, CT:  
639,275. REN. 3-19-07. U.S. CL. 21 (INT. CLS. 7, 9, 11, 12  
AND 15).

DIE BERGKELDER BEPERK, STELLENBOSCH, SOUTH  
AFRICA:  
1,397,069, CANC. INT. CL. 33.

DIE SWARTLANDSE KOOPERATIEWE WYNKELDER  
LIMITED, MALMESBURY 7299, SOUTH AFRICA:  
3,234,712, INT. CL. 33.

DIETZ DESIGNS, HOUSTON, TX:  
3,235,019, INT. CL. 16.

DIEZ, SUSAN, D, MIRAMAR, FL AND MCCLUSKEY,  
DESIREE, PEMBROKE PINES, FL:  
3,232,578, PUB. 2-6-2007. INT. CL. 36.

DIGENE DIAGNOSTICS, INC., SILVER SPRING, MD TO  
DIGENE DIAGNOSTICS, INC., SILVER SPRING, MD:  
1,958,406, COR. MULTIPLE CLASS, INT. CLS. 1, 5 AND  
10.  
1,958,407, COR. MULTIPLE CLASS, INT. CLS. 1, 5 AND  
10.

DIGI INTERNATIONAL INC., MINNETONKA, MN:  
2,356,564, CANC. INT. CL. 9.

DIGITAL BLUE, MARIETTA, GA:  
3,233,022, PUB. 2-6-2007. INT. CL. 9.

DIGITAL EMPLOYEES' FEDERAL CREDIT UNION, MAY-  
NARD, MA:  
1,397,100, CANC. INT. CL. 36.

DIGITAL INNOVATIONS, LLC, ARLINGTON HEIGHTS, IL:  
3,234,895, INT. CL. 9.

DIGITAL LIVING NETWORK ALLIANCE, BEAVERTON,  
OR:  
3,234,213, INT. CL. 35.

DIGITAL SECURITY CONTROLS LTD, DOWNSVIEW, ON-  
TARIO, CANADA:  
2,357,821, CANC. INT. CL. 9.

DIGITOT (PTY) LTD, DURBAN, KWA ZULU, NATAL,  
SOUTH AFRICA:  
3,232,712, PUB. 2-6-2007. INT. CL. 9.

DILLARD'S INC., LITTLE ROCK, AR:  
3,235,223, INT. CL. 9.  
3,235,224, INT. CL. 14.

DILLARD'S, INC., LITTLE ROCK, AR:  
3,234,013, MULTIPLE CLASS, INT. CLS. 21, 24 AND 27.

DILLMAN ENTERPRISES, INC., KISSIMEE, FL:  
2,358,088, CANC. MULTIPLE CLASS, INT. CLS. 30 AND  
42.

DILLON A. DURANDO, ROHNERT PARK, CA:  
3,235,120, INT. CL. 25.

DILLY NORDESTE S.A., CEARA RIO GRANDE DEL SR,  
BRAZIL:  
3,234,110, INT. CL. 25.

DIMAGI INC., CAMBRIDGE, MA:  
3,232,776, PUB. 2-6-2007. INT. CL. 42.

DIMENSIONS, INC., READING, PA TO BANK ONE, N.A.,  
COLUMBUS, OH:  
1,980,240, CANC. INT. CL. 26.  
1,980,286, CANC. INT. CL. 26.

DIMPLEX NORTH AMERICA LIMITED, CAMBRIDGE,  
ONTARIO, CANADA:  
3,234,861, INT. CL. 11.

DIPTYQUE S.A.S., FRANCE:  
3,233,667, PUB. 2-6-2007. INT. CL. 3.

DIRECTACCESS WORLDWIDE, INC., AMERICAN FORK,  
UT:  
3,235,426, INT. CL. 36.

DIS-KARD, INC., VANCOUVER, WA:  
2,357,182, CANC. INT. CL. 16.

DISHER DESIGN & DEVELOPMENT, ZEELAND, MI:  
3,233,070, PUB. 2-6-2007. INT. CL. 41.

DISKEEPER CORPORATION, BURBANK, CA, RINTEL  
COMPUTER SYSTEMS, INC., CAMBRIDGE, MA:  
1,422,653. REN. 3-16-07. INT. CL. 9.

DISCOVERY EDUCATIONAL SYSTEMS, WEST PALM  
BEACH, FL:  
1,979,289, CANC. INT. CL. 42.

DISNEY ENTERPRISES, INC., BURBANK, CA:  
3,139,773, COR. INT. CL. 30.  
3,232,294, PUB. 2-6-2007. INT. CL. 41.  
3,232,295, PUB. 2-6-2007. INT. CL. 43.  
3,233,262, PUB. 2-6-2007. INT. CL. 33.  
3,233,503, PUB. 2-6-2007. INT. CL. 25.  
3,233,508, PUB. 2-6-2007. INT. CL. 14.  
3,233,781, INT. CL. 30.  
3,234,235, INT. CL. 16.  
3,235,413, INT. CL. 9.

DISPLAY INDUSTRIES, LLC, SMYRNA, GA, MEAD COR-  
PORATION, THE, DAYTON, OH:  
2,041,903. REN. 3-21-07. INT. CL. 20.

DISTRIBUCIONES FAJARDO S.L., 41500 SEVILLA, SPAIN:  
3,234,034, INT. CL. 20.

DISTRIBUIDORA CUSCATLAN, INC., WASHINGTON, DC:  
2,357,213, CANC. INT. CL. 31.

DISTRIBUTED BITS, L.L.C., CHICAGO, IL:  
2,358,111, CANC. INT. CL. 9.

DISTRIBUTION AMERICA, INC., CHARLOTTE, NC, LIB-  
ERTY DISTRIBUTORS, INC., DES PLAINES, IL:  
1,434,302. REN. 3-21-07. INT. CL. 42.

DIVERSIFIED BUILDER SUPPLY, INC., CHANDLER, AZ:  
3,235,060, INT. CL. 19.

DIVERSIFIED VENTURES, INC., ARLINGTON HEIGHTS,  
IL:  
2,357,033, CANC. INT. CL. 16.

DIVERSIONES MOY, S.A. DE C.V., 44960, GUADALAJARA,  
JALISCO, MEXICO AND BEMARAS-STRAUSS, ABRA-  
HAM ELIAS, 44670, GUADALAJARA, JALISCO, MEXICO:  
2,356,523, CANC. INT. CL. 28.

DIXIE STAMPEDE, LLC, PIGEON FORGE, TN:  
3,234,511, INT. CL. 41.

DIXON TICONDEROGA COMPANY, HEATHROW, FL,  
JOSEPH DIXON CRUCIBLE COMPANY, THE, JERSEY  
CITY, NJ:  
226,182. REN. 3-16-07. U.S. CL. 37 (INT. CL. 16).

DJ CHEF ENTERTAINMENT CORP., LONG BEACH, NY:  
3,235,429, INT. CL. 41.

DNA DESIGN CORPORATION, NEW YORK, NY:  
2,358,272, CANC. MULTIPLE CLASS, INT. CLS. 35 AND  
41.

DNC PARKS & RESORTS AT YOSEMITE, INC., YOSEMITE,  
CA:  
1,428,557. REN. 3-21-07. INT. CL. 26.  
1,431,205. REN. 3-22-07. INT. CL. 25.

DOALL COMPANY, WHEELING, IL:  
2,030,954. REN. 3-21-07. INT. CL. 1.

DOBOY INC., NEW RICHMOND, WI:  
1,396,479, CANC. INT. CL. 7.

DOBRAWSKY, MICHAEL T., CARDIFF BY THE SEA, CA:  
3,234,890, INT. CL. 21.

DOCALONTI LLC, NEW YORK, NY:  
3,232,698, PUB. 2-6-2007. INT. CL. 36.

DOCTALK, INC., JACKSON, WY:  
3,232,957, PUB. 2-6-2007. INT. CL. 44.

DOGCENTRIC, INC., ROCKVILLE, MD:  
3,234,757, INT. CL. 44.

DOGLOO, INC., CORONA, CA:  
2,358,751, CANC. INT. CL. 18.

DOGMATIC PRODUCTS, INC., BROOKLYN, NY:  
3,232,993, PUB. 2-6-2007. INT. CL. 42.

DOLCE & GABBANA S.R.L., I-20122 MILANO, ITALY:  
3,233,705, PUB. 2-6-2007. INT. CL. 28.

DOLLAR RENT A CAR SYSTEMS, INC., TULSA, OK:  
1,979,995, CANC. INT. CL. 39.  
2,079,330. REN. 3-19-07. INT. CL. 39.  
2,110,019. REN. 3-19-07. INT. CL. 39.

DOLPHIN TECHNOLOGY, INC., SEATTLE, WA:  
2,358,719, CANC. INT. CL. 9.

DOMAINE RESTAURANT GROUP LLC, NEWPORT  
BEACH, CA:  
3,233,181, PUB. 2-6-2007. INT. CL. 43.

- DOMINGO SANDRA, MARIE, ENAGNON, F-69009 LYON, FRANCE:  
3,233,567, PUB. 2-6-2007. MULTIPLE CLASS, INT. CLS. 14, 18 AND 25.
- DOMINION BEARING COMPANY, PORTLAND, OR:  
3,233,897, MULTIPLE CLASS, INT. CLS. 6 AND 7.
- DOMINUS ESTATE CORPORATION, YOUNTVILLE, CA, JOHN DANIEL SOCIETY, YOUNTVILLE, CA:  
1,430,464. REN. 3-21-07. INT. CL. 33.
- DOMNICK HUNTER ADVANCED FILTRATION INC., OXNARD, CA:  
3,232,372, PUB. 2-6-2007. INT. CL. 11.
- DON SHAW, INC., ATLANTA, GA:  
2,357,046, CANC. INT. CL. 42.
- DONALD L. HUTSON, MEMPHIS, TN:  
2,358,296, CANC. INT. CL. 41.
- DONGGUAN QINGXI JINWONIU; INDUSTRIAL CO., LTD., GUANGDONG PROVINCE, CHINA:  
3,233,668, PUB. 2-6-2007. INT. CL. 11.
- DONLEY, CARA L, SUDBURY, MA AND BOCH, JASON A, SUDBURY, MA:  
3,233,152, PUB. 2-6-2007. INT. CL. 44.
- DOTTIKON ES HOLDING AG, SWITZERLAND:  
3,233,735, PUB. 2-6-2007. MULTIPLE CLASS, INT. CLS. 1, 5 AND 42.
- DOUBLE TAKE ARCHERY LLC., LAVERNIA, TX:  
3,232,268, PUB. 2-6-2007. INT. CL. 28.
- DOUGLAS A. MARCHISELLO TRUST, COMPRISING DOUGLAS A. MARCHISELLO, A US CITIZEN, KANSAS CITY, MO:  
3,233,462, PUB. 2-6-2007. INT. CL. 25.
- DOUGLAS EMMETT PROPERTIES, L.P., SANTA MONICA, CA:  
3,233,482, PUB. 2-6-2007. INT. CL. 36.
- DOW AGROSCIENCES LLC, INDIANAPOLIS, IN, DOW CHEMICAL COMPANY, THE, MIDLAND, MI:  
1,454,830. REN. 3-21-07. INT. CL. 5.
- DOW AGROSCIENCES LLC, INDIANAPOLIS, IN:  
2,357,382, CANC. INT. CL. 5.
- DOW CHEMICAL COMPANY, THE, MIDLAND, MI:  
2,102,341. REN. 3-20-07. INT. CL. 1.
- DOWNTOWN COMMUNITY TELEVISION CENTER, NEW YORK, NY:  
3,233,811, INT. CL. 41.
- DP PROPERTY HOLDING, LLC, MIAMI, FL:  
2,357,961, CANC. MULTIPLE CLASS, INT. CLS. 39 AND 42.
- DR. HANS HEUBACH GMBH & CO. KG, 38685 LANGELSHEIM, FED REP GERMANY:  
1,979,271, CANC. MULTIPLE CLASS, INT. CLS. 1 AND 2.
- DR. HELLE & CO. GMBH & CO. KOMMANDITGESELLSCHAFT, KREFELD, FED REP GERMANY:  
1,397,007, CANC. INT. CL. 30.
- DR. JIM SMITH, D.O., INC., WEST CHESTER, OH:  
3,233,393, PUB. 2-6-2007. INT. CL. 5.
- DR. WALTER V. COLLIER & ASSOCIATES, ALEXANDRIA, VA:  
2,357,471, CANC. INT. CL. 35.
- DR. WILLMAR SCHWABE GMBH & CO. KG, D-76227 KARLSRUHE, FED REP GERMANY:  
2,358,157, CANC. INT. CL. 1.
- DRÄGER MEDICAL AG & CO. KG, LÜBECK, FED REP GERMANY:  
3,233,507, PUB. 2-6-2007. INT. CL. 10.
- DRAGON FULL DEVELOPMENTS LIMITED, CAYMAN ISLANDS, BRITISH WEST INDIES, CAYMAN ISLANDS:  
3,234,919, INT. CL. 18.
- DRANETZ TECHNOLOGIES, INC., EDISON, NJ, DBA DRANETZ-BMI:  
3,234,680, INT. CL. 9.
- DREAM DINNERS, INC., SNOHOMISH, WA:  
3,235,071, INT. CL. 43.
- DREAM MERCHANT COMPANY KFT., THE, H-1074 BUDAPEST, HUNGARY, CREATIONS MEANDRES INC., MONTREAL, QUEBEC, CANADA:  
2,027,426. REN. 3-16-07. INT. CL. 16.
- DREAM RANCH INC., TOKYO, JAPAN:  
3,232,431, PUB. 2-6-2007. MULTIPLE CLASS, INT. CLS. 9 AND 28.
- DREAMWELL, LTD., LAS VEGAS, NV:  
3,233,968, INT. CL. 20.
- DRESDNER BANK LATEINAMERIKA AG, MIAMI, FL:  
2,357,171, CANC. INT. CL. 36.
- DRESSED TO THE K-NINES, INC., SOUTH HUNTINGTON, NY:  
3,232,917, PUB. 2-6-2007. INT. CL. 18.
- DRESSER INDUSTRIES, INC., DALLAS, TX:  
1,396,486, CANC. INT. CL. 7.  
1,396,487, CANC. INT. CL. 7.
- DRIVERS ED DIRECT, LLC, CHATSWORTH, CA:  
3,234,017, INT. CL. 41.  
3,234,018, INT. CL. 41.  
3,234,874, INT. CL. 41.
- DRUG CASTLE FRANCHISES, INC., SPRINGFIELD, OH:  
1,397,185, CANC. INT. CL. 42.
- DSA OF AMERICA, INC., FARMINGTON HILLS, MI, TREMEC TRADING COMPANY, FARMINGTON HILLS, MI:  
2,037,581. REN. 3-17-07. INT. CL. 12.
- DSR IMPORTS LLC, GREAT NECK, NY:  
3,234,737, INT. CL. 33.
- DUBEK LTD, PETACH-TIKVA, ISRAEL:  
1,979,507, CANC. INT. CL. 34.
- DUGGER, ANDREA, CARY, NC:  
2,525,985, CANC. INT. CL. 40.
- DULCENEA, INC., COVINA, CA:  
3,233,352, PUB. 2-6-2007. INT. CL. 25.
- DUN & BRADSTREET CORPORATION, THE, MURRAY HILL, NJ:  
1,979,863, CANC. INT. CL. 35.
- DUNAMIS COMMUNICATIONS LLC, CANTON, GA:  
3,233,190, PUB. 2-6-2007. INT. CL. 35.
- DUNLOP AEROSPACE LIMITED, COVENTRY, ENGLAND:  
3,232,692, PUB. 2-6-2007. MULTIPLE CLASS, INT. CLS. 1, 2 AND 12.
- DUPAGE CHILDREN'S MUSEUM, NAPERVILLE, IL:  
3,232,366, PUB. 2-6-2007. MULTIPLE CLASS, INT. CLS. 9 AND 16.
- DUPONT INDUSTRIES INC., QUEBEC, CANADA:  
2,358,236, CANC. INT. CL. 12.
- DUPONT NURSERY, INC., PLAQUEMINE, LA:  
3,233,071, PUB. 2-6-2007. INT. CL. 31.
- DURAND COMMUNICATIONS, INC., SANTA BARBARA, CA TO DURAND COMMUNICATIONS, INC., SANTA BARBARA, CA:  
2,357,897, CANC. INT. CL. 42.
- DUY, ARTHUR H., SALT LAKE CITY, UT:  
3,235,254, INT. CL. 19.
- DW DATA, INCORPORATED, CHICAGO, IL:  
3,232,379, PUB. 7-4-2006. INT. CL. 35.
- DYER, D. ALEXANDRA, NEW YORK, NY:  
3,232,508, PUB. 2-6-2007. INT. CL. 41.
- DYER, RICHARD H. JR., WATERTOWN, CT:  
2,357,209, CANC. INT. CL. 18.
- DYN-O-MAT, INC., LAKE PARK, FL:  
2,358,822, CANC. INT. CL. 4.
- DYNACRAFT BSC, INC., AMERICAN CANYON, CA:  
2,038,936. REN. 3-17-07. INT. CL. 12.
- DYNALOGIC ENGINEERING, INC., WALLED LAKE, MI:  
2,357,729, CANC. MULTIPLE CLASS, INT. CLS. 9, 37 AND 42.
- DYNAMIC AIR, INC., ST. PAUL, MN:  
2,079,875. REN. 3-22-07. INT. CL. 6.
- DYNAMIC GRAPHICS, INC., ALAMEDA, CA:  
3,233,093, PUB. 2-6-2007. INT. CL. 9.
- DYNAMIC PAINT PRODUCTS INC., MISSISSAUGA, ONTARIO, CANADA:  
3,234,337, INT. CL. 16.
- DYNASAUER CORP., ST. LOUIS, MO:  
1,058,726. REN. 3-22-07. INT. CL. 37.
- DYNASTY DESIGNS LLC, ST. LOUIS, MO:  
3,235,277, INT. CL. 21.
- DYNASTY ONLINE, INC., EVANSVILLE, IN:  
2,357,135, CANC. MULTIPLE CLASS, INT. CLS. 38 AND 42.



D2RM CORP., GARDENA, CA:  
3,233,995, INT. CL. 9.

E & H DISTRIBUTING CO., LAS VEGAS, NV:  
2,356,573, CANC. INT. CL. 42.

E & H DISTRIBUTING CO., NORTH LAS VEGAS, NV:  
3,233,150, PUB. 2-6-2007. INT. CL. 35.

E STREET DENIM CO., HIGHLAND PARK, IL:  
3,233,449, PUB. 2-6-2007. INT. CL. 25.

E. I. DU PONT DE NEMOURS AND COMPANY, WILMINGTON, DE:  
639,885. REN. 3-20-07. U.S. CL. 6 (INT. CL. 2).  
821,790. REN. 3-17-07. U.S. CL. 1 (INT. CL. 17).  
821,791. REN. 3-16-07. U.S. CL. 1 (INT. CL. 17).  
3,234,684, INT. CL. 9.

E. REMY MARTIN & C<sup>o</sup>, FRANCE:  
3,233,657, PUB. 1-23-2007. INT. CL. 33.

E. REPUBLIC, INC., SACRAMENTO, CA:  
2,356,646, CANC. INT. CL. 35.

E.R. SQUIBB & SONS, L.L.C., PRINCETON, NJ:  
1,466,942. REN. 3-22-07. INT. CL. 5.  
2,045,026. REN. 3-17-07. INT. CL. 5.

E.R. SQUIBB & SONS, LLC, PRINCETON, NJ, E. R. SQUIBB & SONS, INC., PRINCETON, NJ:  
2,048,097. REN. 3-17-07. INT. CL. 5.

E.T. BROWNE DRUG CO., INC., ENGLEWOOD CLIFFS, NJ:  
3,235,446, INT. CL. 3.

E! ENTERTAINMENT TELEVISION, INC., LOS ANGELES, CA:  
2,357,332, CANC. INT. CL. 41.

E\*TRADE SECURITIES, INC., PALO ALTO, CA:  
2,356,518, CANC. INT. CL. 36.

E-KNOW, INC., ARLINGTON, VA:  
3,233,772, MULTIPLE CLASS, INT. CLS. 35 AND 42.

E-MU SYSTEMS, INC., SCOTTS VALLEY, CA:  
2,358,425, CANC. INT. CL. 15.

E-SALES ADVANTAGE ENTERPRISES, INC., LONG BOAT KEY, FL:  
3,232,880, PUB. 2-6-2007. INT. CL. 35.

E-Z HITCH, LTD., SEBRING, OH:  
3,234,601, INT. CL. 12.

EAGLE PACK PET FOODS, INC., MISHAWAKA, IN:  
3,234,574, INT. CL. 31.

EAGLE ROCK MANUFACTURING, LLC, MIDLAND, TX:  
3,234,526, INT. CL. 7.

EAGLET ENTERPRISE, INC., LEXINGTON, SC:  
2,356,993, CANC. INT. CL. 35.

EARL M. SCHNEIDER, D.D.S., LTD., GLENVIEW, IL:  
3,232,679, PUB. 2-6-2007. INT. CL. 44.

EARTH TRACKS CARTOGRAPHIC SERVICES, INC.:  
1,396,791, CANC. INT. CL. 16.

EARTHGRO, INC., LEBANON, CT:  
2,357,372, CANC. INT. CL. 31.  
2,357,373, CANC. INT. CL. 31.

EARTHWONDERS, LLC, STEVENS POINT, WI:  
3,232,218, PUB. 2-6-2007. INT. CL. 41.

EAST COAST FRESH CUTS COMPANY, JESSUP, MD:  
3,232,081, PUB. 2-6-2007. MULTIPLE CLASS, INT. CLS. 31 AND 35.

EAST COAST OIL CORPORATION, RICHMOND, VA:  
2,358,539, CANC. INT. CL. 35.

EAST TENNESSEE STAFFING, INC., KNOXVILLE, TN:  
2,358,694, CANC. INT. CL. 35.

EASTERN COMPANY, THE, SOLVAY, NY:  
1,428,104. REN. 3-19-07. INT. CL. 6.

EASTERN MOTOR INNS, INC., ROANOKE, VA:  
2,120,043. REN. 3-19-07. INT. CL. 42.

EASTMAN CHEMICAL RESINS, INC., KINGSPORT, TN:  
1,431,637. REN. 3-21-07. INT. CL. 1.

EASTMAN KODAK COMPANY, ROCHESTER, NY:  
1,396,299, CANC. INT. CL. 1.

EASTWAY FAIR COMPANY LIMITED, TORTOLA, BR. VIRGIN ISLANDS:  
3,234,628, INT. CL. 8.

EASYLINK SERVICES USA, INC., PISCATAWAY, NJ:  
2,356,881, CANC. INT. CL. 38.

EATON CORPORATION, CLEVELAND, OH:  
2,358,794, CANC. INT. CL. 38.

EBBEL, ERIKA, CAMBRIDGE, MA:  
3,234,320, MULTIPLE CLASS, INT. CLS. 18 AND 25.

EBIZ GOOD STEPS, INC., TAMPA, FL:  
3,233,848, INT. CL. 35.

EBSCO INDUSTRIES, INC., BIRMINGHAM, AL:  
3,233,491, PUB. 2-6-2007. INT. CL. 35.

ECCA ENTERPRISES, INC., SAN ANTONIO, TX:  
3,235,280, INT. CL. 35.

ECHO MEDIA, INC., KNOXVILLE, TN:  
3,233,326, PUB. 2-6-2007. INT. CL. 38.

ECMD, INC., NORTH WILKESBORO, NC:  
2,030,766. REN. 3-17-07. INT. CL. 19.

ECNARF CORP., PITTSBURGH, PA:  
2,358,469, CANC. INT. CL. 28.

ECOLAB INC., ST. PAUL, MN:  
1,982,800. REN. 3-17-07. INT. CL. 3.

ECONET, INC., LACEY, WA:  
3,234,912, INT. CL. 1.

ECTACO INC., LONG ISLAND CITY, NY:  
3,232,861, PUB. 2-6-2007. INT. CL. 9.

EDEN FOODS, INC., CLINTON, MI:  
1,979,153, CANC. MULTIPLE CLASS, INT. CLS. 29 AND 30.

EDGAR ONLINE, INC., NORWALK, CT:  
2,306,903, AM. INT. CL. 36.  
3,234,113, INT. CL. 36.

EDI TECHNOLOGIES CORPORATION, MILLERSVILLE, MD:  
3,232,625, PUB. 2-6-2007. INT. CL. 35.

EDIBLES ETC., INC., COLLINGSWOOD, NJ:  
1,414,414. REN. 3-16-07. INT. CL. 30.

EDUCATIONAL SOLUTIONS, INC., NASHVILLE, TN:  
2,357,600, CANC. INT. CL. 41.  
2,357,601, CANC. INT. CL. 41.

EFFICIENT EVOLUTIONS LLC, NEWTON, MA:  
3,233,403, PUB. 2-6-2007. INT. CL. 35.

EFIL INSURANCE GROUP, INC., DES PLAINES, IL:  
2,357,173, CANC. INT. CL. 36.

EHB ELECTRONICS GMBH, FED REP GERMANY:  
3,233,544, PUB. 2-6-2007. MULTIPLE CLASS, INT. CLS. 7, 9 AND 12.

EHRET, BERNARD, 67140 BARR, FRANCE:  
2,357,969, CANC. INT. CL. 18.

EINSTEIN AND NOAH CORP., GOLDEN, CO, EINSTEIN BROS. BAGELS, INC., GOLDEN, CO:  
2,078,607. REN. 3-19-07. INT. CL. 30.

EINSTEIN AND NOAH CORP., GOLDEN, CO, EINSTEIN BROS. BAGELS, INC., GOLDEN, CO:  
2,092,522. REN. 3-19-07. INT. CL. 29.

EINSTEIN/NOAH BAGEL CORP., GOLDEN, CO:  
2,356,417, CANC. INT. CL. 42.

EISAI INC., TEANECK, NJ:  
3,235,392, MULTIPLE CLASS, INT. CLS. 16 AND 44.  
3,235,396, MULTIPLE CLASS, INT. CLS. 41 AND 44.

EISNER TECHNOLOGY SOLUTIONS, LLC, NEW YORK, NY:  
3,233,807, INT. CL. 42.

ELA MEDICAL, FRANCE:  
3,233,664, PUB. 2-6-2007. INT. CL. 10.

ELCOM INTERNATIONAL, INC., NORWOOD, MA, ELCOM INTERNATIONAL, INC., NORWOOD, MA:  
2,035,902. REN. 3-20-07. MULTIPLE CLASS, INT. CLS. 9 AND 42.

ELDER, DOYLE, ARAPAH0, OK:  
2,358,894, CANC. INT. CL. 16.

ELDERHOSTEL, INC., BOSTON, MA, UNIVERSITY OF NEW HAMPSHIRE, THE, DURHAM, NH:  
1,071,632. REN. 3-20-07. INT. CL. 41.

ELECT APPAREL INC., GARDEN CITY, NY:  
3,234,697, INT. CL. 25.

ELECTRIC VEHICLE TECHNOLOGIES, INC., SKOKIE, IL:  
3,234,736, INT. CL. 12.

ELECTROLUX HOME PRODUCTS, INC., CLEVELAND, OH:  
3,233,887, INT. CL. 11.  
3,233,976, MULTIPLE CLASS, INT. CLS. 7 AND 11.

ELECTRONIC DESIGN & SALES, INC., DANVILLE, VA:  
2,357,579, CANC. INT. CL. 9.

- ELECTRONIC SPECIALTIES, INC., GENOA CITY, WI:  
3,235,432, INT. CL. 9.
- ELECTROSONIC LIMITED, DARTFORD, KENT, UNITED KINGDOM:  
3,232,458, PUB. 2-6-2007. INT. CL. 9.
- ELITE CUSTOM, SIMPSONVILLE, SC:  
3,233,024, PUB. 2-6-2007. INT. CL. 37.
- ELIZA JENNINGS SENIOR CARE NETWORK, LAKEWOOD, OH:  
3,233,057, PUB. 2-6-2007. INT. CL. 44.
- ELIZABETH ARDEN, INC., MIAMI LAKES, FL:  
1,435,236, REN. 3-19-07. INT. CL. 3.
- ELIZABETH J. CORPENING, MARIETTA, GA:  
3,233,216, PUB. 2-6-2007. INT. CL. 30.
- ELKAY MANUFACTURING COMPANY, OAK BROOK, IL:  
3,234,290, INT. CL. 11.
- ELKIND + SWEET COMMUNICATIONS, INC., SAN FRANCISCO, CA:  
3,233,803, INT. CL. 16.  
3,233,804, INT. CL. 28.
- ELKTON SPARKLER COMPANY, INC., NORTH EAST, MD:  
1,426,505, REN. 3-16-07. INT. CL. 13.
- ELS EDUCATIONAL SERVICES, INC., PRINCETON, NJ:  
2,039,766, REN. 3-21-07. MULTIPLE CLASS, INT. CLS. 16 AND 41.
- EM COMPANY, SAINT PAUL, MN:  
1,428,162, REN. 3-21-07. INT. CL. 9.
- EMARINE.COM, L.L.C., JUPITER, FL:  
2,358,913, CANC. INT. CL. 35.
- EMBO-OPTICS, LLC, BEVERLY, MA:  
3,233,902, INT. CL. 10.
- EMBREY INK, INC, LOS ANGELES, CA:  
3,232,449, PUB. 2-6-2007. INT. CL. 16.
- EMERALD CITY WEB DESIGN, INC., METHUEN, MA:  
3,233,012, PUB. 2-6-2007. MULTIPLE CLASS, INT. CLS. 35 AND 42.
- EMERGENCY FUEL, LLC, BALTIMORE, MD:  
2,357,319, CANC. INT. CL. 1.
- EMERGING DEMOGRAPHICS INC., NEW YORK, NY:  
3,233,442, PUB. 2-6-2007. INT. CL. 35.
- EMERITUS CORPORATION, SEATTLE, WA:  
3,233,248, PUB. 2-6-2007. MULTIPLE CLASS, INT. CLS. 43 AND 44.
- EMERSON ELECTRIC CO., ST. LOUIS, MO:  
1,980,210, CANC. INT. CL. 8.
- EMERSON PARTNERS, INC., DALLAS, TX:  
3,094,758, AM. INT. CL. 37.
- EMHART INC., NEWARK, DE TO EMHART LLC, NEWARK, DE:  
1,980,213, CANC. INT. CL. 6.
- EMILCOTONI S.P.A., ITALY:  
3,233,615, PUB. 2-6-2007. MULTIPLE CLASS, INT. CLS. 23 AND 24.
- EMISSIVE ENERGY CORPORATION, NORTH KINGSTON, RI:  
3,234,335, INT. CL. 11.
- EMPRESS INTERNATIONAL, LTD., PORT WASHINGTON, NY:  
1,396,999, CANC. INT. CL. 29.
- EMPYREAN CAPITAL FUND, LP, LOS ANGELES, CA:  
3,233,937, INT. CL. 36.
- EMPYREAN CAPITAL PARTNERS, LP, LOS ANGELES, CA:  
3,233,936, INT. CL. 36.
- EMULATION TECHNOLOGY INCORPORATED, SANTA CLARA, CA:  
2,357,405, CANC. INT. CL. 9.
- EMVCO, LLC, FOSTER CITY, CA:  
3,233,769, U.S. CL. A.
- ENCANTO NETWORKS, INC., SANTA CLARA, CA:  
2,358,251, CANC. INT. CL. 42.
- ENCOM, INC., EVANSVILLE, IN:  
3,233,465, PUB. 2-6-2007. INT. CL. 1.  
3,233,467, PUB. 2-6-2007. INT. CL. 1.  
3,233,469, PUB. 2-6-2007. INT. CL. 1.
- ENCORE BANK, HOUSTON, TX:  
3,234,573, INT. CL. 36.  
3,234,636, INT. CL. 36.
- ENCORE ETC., INC., ANDOVER, MA:  
3,233,337, PUB. 2-6-2007. INT. CL. 40.  
3,233,339, PUB. 2-6-2007. INT. CL. 40.
- ENCORE GOURMET FOOD CORPORATION, BAIE D'URFE, QUEBEC, CANADA:  
3,232,362, PUB. 2-6-2007. INT. CL. 30.
- ENCYCLOPAEDIA BRITANNICA, INC., CHICAGO, IL:  
3,234,016, INT. CL. 41.
- END THE PAPERCHASE, INC., CAMPBELL, CA:  
2,358,615, CANC. INT. CL. 9.
- ENDOCARE, INC., IRVINE, CA:  
3,234,865, INT. CL. 10.
- ENESCO GROUP, INC., ITASCA, IL:  
1,396,351, CANC. MULTIPLE CLASS, INT. CLS. 3 AND 5.
- ENIVA CORPORATION, MINNEAPOLIS, MN:  
3,234,720, INT. CL. 3.
- ENRICH CORPORATION, THE, OREM, UT:  
1,979,799, CANC. INT. CL. 5.
- ENSCO, INC., FALL CHURCH, VA:  
3,233,864, INT. CL. 9.
- ENSINGER INDUSTRIES, INC., WASHINGTON, PA:  
1,059,248, REN. 3-22-07. INT. CL. 17.
- ENTERPRISE RENT-A-CAR COMPANY, ST. LOUIS, MO:  
2,038,806, REN. 3-22-07. INT. CL. 39.  
2,064,660, REN. 3-22-07. MULTIPLE CLASS, INT. CLS. 39 AND 42.
- ENTRAVISION COMMUNICATIONS CORPORATION, SANTA MONICA, CA:  
1,993,998, REN. 3-22-07. MULTIPLE CLASS, INT. CLS. 38 AND 41.
- ENVIRIAN, LLC, RESTON, VA:  
3,234,005, INT. CL. 42.
- ENVIRONMENTAL APPLIED RESEARCH TECHNOLOGY HOUSE - EARTH (CANADA) CORPORATION MAISON DE RECHERCHE APPLIQUEE ET DE TECHNOLOGIE EN MATIERE ENVIRONNEMENTALE - CORPORATION EARTH (CANADA), ST. LAURENT, QUEBEC, TA EARTH (CANADA) CORPORATION:  
2,356,804, CANC. MULTIPLE CLASS, INT. CLS. 1, 40 AND 42.
- ENVIRONMENTAL POWER CORPORATION, PORTSMOUTH, NH:  
3,235,169, INT. CL. 40.
- ENVIROSAFE CORPORATION, GERMANTOWN, MD:  
3,233,185, PUB. 2-6-2007. INT. CL. 5.
- ENVISION EAST PHOTOGRAPHY, INC., NEW YORK, NY:  
2,035,944, REN. 3-22-07. INT. CL. 35.
- ENZYMATIC THERAPY, INC., GREEN BAY, WI:  
3,235,043, INT. CL. 5.
- EOS SURFACES, LLC, SUFFOLK, VA:  
3,234,568, INT. CL. 20.
- EPIWORKS, INC., CHAMPAIGN, IL:  
3,234,101, INT. CL. 9.  
3,234,102, INT. CL. 9.
- EPM DEVELOPMENT SYSTEMS CORPORATION, MIDLOTHIAN, VA:  
2,356,940, CANC. MULTIPLE CLASS, INT. CLS. 10 AND 28.
- EPSTEIN, GARY, BAYPORT, NY:  
2,358,912, CANC. INT. CL. 35.
- EQAIR, LLC, GRANDVILLE, MI:  
3,235,269, INT. CL. 9.
- EQUIP, INC., MARION, NC:  
3,232,875, PUB. 10-24-2006. INT. CL. 41.
- EQUITYTHINK, LLC, FOUNTAIN HILLS, AZ:  
3,234,389, MULTIPLE CLASS, INT. CLS. 35 AND 43.
- ER ON CALL, INC., SANTA MONICA, CA:  
2,357,120, CANC. INT. CL. 42.  
2,357,121, CANC. INT. CL. 42.
- ERA TM CORP., MISSION VIEJO, CA:  
3,233,314, PUB. 2-6-2007. INT. CL. 36.
- ERAGRAIN, LLC, NAMPA, ID:  
3,234,369, MULTIPLE CLASS, INT. CLS. 30 AND 31.
- ERCO LEUCHTEN GMBH, FED REP GERMANY:  
3,233,730, PUB. 2-6-2007. INT. CL. 11.
- ERGOFLEX SYSTEMS, LITTLETON, CO:  
2,034,223, REN. 3-19-07. INT. CL. 20.

ERICKSON CRAFTERS CO., INC., WEST BLOOMFIELD, MI:  
2,358,241, CANC. INT. CL. 8.

ERIDON CORPORATION, SHOREWOOD, MN:  
3,234,219, MULTIPLE CLASS, INT. CLS. 9 AND 42.

ERWIN PEARL INC, NEW YORK, NY:  
2,033,180. REN. 3-16-07. INT. CL. 14.

ESI CASES & ACCESSORIES, BROOKLYN, NY:  
3,234,696, INT. CL. 9.

ESM TECHNOLOGIES, L.L.C., CARTHAGE, MO:  
3,234,687, INT. CL. 1.

ESMALGLASS, S.A., 12540 VILLARREAL (CASTELLON), SPAIN:  
1,986,489. REN. 3-20-07. MULTIPLE CLASS, INT. CLS. 1 AND 19.

ESPN CLASSIC, INC., BRISTOL, CT, CLASSIC SPORTS PARTNERS, L.P., NEW YORK, NY:  
2,031,259. REN. 3-22-07. MULTIPLE CLASS, INT. CLS. 38, 41 AND 42.

ESPOSITO JEWELRY, INC., PROVIDENCE, RI:  
3,235,367, INT. CL. 14.

ESQUIRE MAGAZINE GROUP, INC., NEW YORK, NY:  
3,232,049, PUB. 11-23-1993. INT. CL. 16.

ESSELTE CORPORATION, MELVILLE, NY:  
3,234,020, INT. CL. 16.

ESSENT CORPORATION, EASTON, PA:  
2,357,318, CANC. INT. CL. 42.

ESTABLISSEMENTS ROULLET FRANSAC, CHERMIGNAC THENAC, FRANCE:  
3,235,026, INT. CL. 33.

ESTEE LAUDER INC., NEW YORK, NY:  
2,358,315, CANC. INT. CL. 3.

ESTEPHANIAN, MARK, DUARTE, CA AND COHEN, MICHAEL, DUARTE, CA:  
3,232,839, PUB. 2-6-2007. INT. CL. 25.

ESTEREL TECHNOLOGIES, MOUNTAIN VIEW, CA:  
3,232,478, PUB. 2-6-2007. INT. CL. 9.

ESTETX INC., CANYON COUNTRY, CA:  
2,356,689, CANC. INT. CL. 5.

ESTRADA FOODS, PUEBLO, CO:  
2,358,601, CANC. INT. CL. 30.

ETHOS COMMUNICATIONS CORP., EDMOND, OK:  
2,358,763, CANC. INT. CL. 42.

ETIENNE AIGNER, INC., NEW YORK, NY:  
2,053,542. REN. 3-17-07. INT. CL. 9.

ETOYS INC., SANTA MONICA, CA:  
2,358,839, CANC. INT. CL. 42.

ETS SCHAEFER CORPORATION, MACEDONIA, OH:  
1,466,958. REN. 3-21-07. INT. CL. 6.

ETUDES ET CONSTRUCTIONS MECANQUES, FRANCE:  
3,233,711, PUB. 2-6-2007. MULTIPLE CLASS, INT. CLS. 11 AND 40.

EUCLID LEASING PARTNERS, L.P., LOS ANGELES, CA:  
2,356,634, CANC. INT. CL. 31.  
2,356,636, CANC. INT. CL. 31.

EUGENE PERMA FRANCE, FRANCE:  
3,233,575, PUB. 2-6-2007. INT. CL. 3.

EURO-APEX B.V., VOORBURG, NETHERLANDS:  
3,233,526, PUB. 2-6-2007. INT. CL. 7.

EUROCOPTER FRANCE, 13725 MARIGNANE CEDEX, FRANCE:  
1,979,190, CANC. INT. CL. 12.

EUROPEAN ELECTRONIC SYSTEMS LIMITED, POOLE, DORSET BH12 5AG, ENGLAND:  
1,979,085, CANC. INT. CL. 9.

EUROTUNGSTENE POUDES, FRANCE:  
3,233,545, PUB. 2-6-2007. INT. CL. 6.

EVA SCRIVO SALON INC., NEW YORK, NY:  
3,234,834, INT. CL. 44.

EVAN J. MCKINNEY, TOLEDO, OH:  
3,234,243, INT. CL. 25.

EVENFLO COMPANY, INC., VANDALIA, OH:  
2,356,652, CANC. INT. CL. 10.

EVENSTAD, KENNETH L., NAPLES, FL:  
3,234,902, INT. CL. 33.

EVERBANK, JACKSONVILLE, FL:  
3,054,352, COR. INT. CL. 36.

EVEREADY BATTERY COMPANY, INC., ST. LOUIS, MO:  
2,123,813. REN. 3-21-07. INT. CL. 8.

EVERGREEN PRODUCTS, SANTA FE SPRINGS, CA:  
1,990,264. REN. 3-20-07. INT. CL. 21.

EVERGREEN WEIGH, INC., LYNNWOOD, WA:  
1,396,627, CANC. INT. CL. 9.

EVERHART, DONCILLA, THOMASVILLE, NC:  
2,357,501, CANC. INT. CL. 18.

EVERT-FRESH CORP., KATY, TX:  
3,234,516, INT. CL. 16.

EVETS CORPORATION, CAMARILLO, CA:  
2,116,570. REN. 3-19-07. MULTIPLE CLASS, INT. CLS. 9 AND 15.

EVIVA COFFEE & TEA COMPANY INC., GREENDALE, WI:  
3,232,606, PUB. 2-6-2007. INT. CL. 30.  
3,232,607, PUB. 2-6-2007. INT. CL. 30.

EVOLUTIONARY STRATEGIC PLANNING, INC., BROOKLYN, NY:  
3,232,613, PUB. 2-6-2007. MULTIPLE CLASS, INT. CLS. 35, 36 AND 41.

EWANTED.COM CORPORATION, LOS ALTOS, CA:  
2,357,031, CANC. INT. CL. 35.

EXCALIBUR BAGEL & BAKERY EQUIPMENT, INC., PARAMUS, NJ:  
3,232,583, PUB. 2-6-2007. MULTIPLE CLASS, INT. CLS. 7 AND 11.

EXCEL TELECOMMUNICATIONS, INC., DALLAS, TX:  
2,358,249, CANC. INT. CL. 38.

EXCEL TRADE GROUP, INC., LUTZ, FL:  
2,357,108, CANC. INT. CL. 35.

EXCELLUS HEALTH PLAN, INC., ROCHESTER, NY:  
3,234,011, INT. CL. 41.  
3,234,063, INT. CL. 36.  
3,234,064, INT. CL. 36.

EXCELSIOR IMPORTS, LLC, ATLANTA, GA:  
3,234,578, INT. CL. 33.

EXCEPTIONAL SOFTWARE STRATEGIES, INC., LINTHICUM, MD:  
3,233,792, MULTIPLE CLASS, INT. CLS. 41 AND 42.

EXECUTIVE HOME CARE, INC., HIAWATHA, IA:  
2,357,321, CANC. MULTIPLE CLASS, INT. CLS. 37 AND 42.

EXECUTOR OF THE JOYCE JILLSON GALLAGHER ESTATE, SHERMAN OAKS, CA:  
3,234,735, INT. CL. 16.

EXODUS WEB, INC., PHOENIX, AZ:  
3,232,288, PUB. 2-6-2007. INT. CL. 9.

EXOMOS FZCO, DUBAI, UNITED ARAB EMIR.:  
3,233,233, PUB. 2-6-2007. INT. CL. 12.

EXOTIC CUSTOM JEWELRY, RICHMOND, CA:  
3,235,137, INT. CL. 14.

EXPERIENCE BASED LEARNING, INC, ROCKFORD, IL:  
2,357,082, CANC. INT. CL. 41.

EXPONENT, INC., MENLO PARK, CA:  
1,427,886. REN. 3-20-07. INT. CL. 42.

EXPRESS COMMUNICATIONS, INC., SIOUX FALLS, SD:  
2,196,870, COR. INT. CL. 38.

EXTREME SPIRITS LTD, HAVERHILL, SUFFOLK, UNITED KINGDOM:  
3,232,453, PUB. 2-6-2007. INT. CL. 33.

EXXON CORPORATION, IRVING, TX:  
2,357,176, CANC. INT. CL. 30.

EYEPRO, L.L.C., NAPERVILLE, IL:  
2,358,384, CANC. INT. CL. 42.

EZ-CAP ENTERPRISES, LLC, JEFFERSON CITY, MO:  
3,234,233, INT. CL. 9.

F & J DESIGNS INC., NEW YORK, NY, DBA FOUR SEASONS DESIGN GROUP:  
2,125,967. REN. 3-20-07. INT. CL. 25.

F. LLI SAGLIO TROMBONE S.R.L., ORNAVASSO (VERBANIA), ITALY:  
3,232,546, PUB. 2-6-2007. INT. CL. 11.

F.LLI CLAUDIO & CARLALBERTO CORNELIANI SPA, MANTOVA, ITALY:  
3,232,425, PUB. 10-31-2006. INT. CL. 25.

FA MANAGEMENT ENTERPRISES, INC., EARTH CITY, MO:  
2,121,428. REN. 3-21-07. INT. CL. 35.

- FABIO MURZI, ITALY:  
3,233,663, PUB. 2-6-2007. MULTIPLE CLASS, INT. CLS. 3, 4 AND 31.
- FABRIC EDITIONS LLC, GREENVILLE, SC, FORMERLY FE ACQUISITION LLC:  
3,234,989, INT. CL. 24.
- FADO PUBS, INC., ATLANTA, GA, IRISH PUB COMPANY LTD., THE, NEW YORK, NY:  
2,006,347, REN. 3-22-07. INT. CL. 42.  
2,010,172, REN. 3-22-07. INT. CL. 25.  
2,019,165, REN. 3-22-07. INT. CL. 42.
- FADO PUBS, INC., ATLANTA, GA:  
2,045,633, REN. 3-22-07. INT. CL. 25.
- FAIRCHILD PUBLICATIONS, INC., NEW YORK, NY:  
3,233,856, INT. CL. 41.
- FAIRCLOTH, ROBERT A., ROSEBORO, NC, DBA FAIRCLOTH WOODWORKING:  
2,037,128, REN. 3-17-07. INT. CL. 19.
- FAIRLINE BOATS PLC, CAMBS PES SPA, GREAT BRITAIN:  
2,041,113, REN. 3-21-07. INT. CL. 12.
- FAIRVIEW HOSPITAL AND HEALTHCARE SERVICES, MINNEAPOLIS, MN:  
2,356,889, CANC. INT. CL. 42.
- FALCON RICE MILL, INC., CROWLEY, LA, VIDRINE, JAMES L., LAFAYETTE, LA:  
1,438,236, REN. 3-21-07. INT. CL. 30.
- FALLIEN COSMECEUTICALS, LTD., NORRISTOWN, PA, DBA FALLENE LTD.:  
3,232,214, PUB. 2-6-2007. INT. CL. 3.
- FAMILY FIT LIFESTYLE, INC., SCOTTSDALE, AZ:  
3,233,796, INT. CL. 42.
- FAMILY SERVICE OF GREATER BOSTON, INC., JAMAICA PLAIN, MA:  
2,035,442, REN. 3-20-07. INT. CL. 36.
- FAMILY VENTURES, L.L.C., CHICAGO, IL:  
2,358,449, CANC. INT. CL. 16.
- FAMILYMART CO., LTD., TOKYO, JAPAN:  
3,169,723, COR. INT. CL. 35.
- FAMOUS DAVE'S OF AMERICA, INC., MINNETONKA, MN, FAMOUS DAVE'S OF AMERICA, INC., MINNETONKA, MN:  
2,073,251, REN. 3-22-07. INT. CL. 30.  
2,076,892, REN. 3-22-07. INT. CL. 30.
- FANCY HOLDINGS, LLC, MEMPHIS, TN:  
3,234,673, INT. CL. 18.
- FANTASY FACTORY, LTD., BUCHANAN, VA:  
2,080,231, REN. 3-20-07. INT. CL. 3.
- FARLEY'S & SATHERS CANDY COMPANY, INC., ROUND LAKE, MN:  
3,235,142, INT. CL. 30.  
3,235,143, INT. CL. 30.
- FARM CREDIT COUNCIL, THE, WASHINGTON, DC, FARM CREDIT CORPORATION OF AMERICA, ENGLEWOOD, CO:  
1,446,755, REN. 3-22-07. INT. CL. 36.
- FARMER'S SUPPLY CO. OF DINUBA, INC., REEDLEY, CA:  
3,232,197, PUB. 2-6-2007. INT. CL. 31.
- FARMERS' RICE COOPERATIVE, SACRAMENTO, CA:  
640,179, REN. 3-16-07. U.S. CL. 46 (INT. CL. 30).
- FARMONT TECHNIK GMBH & CO. KG, 40217 DUSSELDORF, FED REP GERMANY:  
2,357,840, CANC. INT. CL. 9.
- FARVAL LUBRICATION SYSTEMS, INC., KINSTON, NC:  
2,358,609, CANC. INT. CL. 7.
- FASHION ACCENTS CORPORATION, WARWICK, RI:  
1,980,110, CANC. INT. CL. 14.
- FASHION PARK S.R.L., 36016 THIENE, VICENZA, ITALY:  
3,232,103, PUB. 9-5-2006. MULTIPLE CLASS, INT. CLS. 18 AND 25.
- FAST AID FRANCHISE CORPORATION, DIXON, CA:  
3,232,900, PUB. 2-6-2007. INT. CL. 37.
- FASTWELL INDUSTRY CO. LTD, SHANGHAI, CHINA:  
3,235,006, INT. CL. 6.
- FAT BOYS' BAR-B-Q FRANCHISE SYSTEMS, INC., VERO BEACH, FL, KELLERS' FAT BOYS' BAR-B-Q, COCOA, FL:  
1,061,404, REN. 3-16-07. INT. CL. 42.
- FAVEUR, INC., LEXINGTON, SC:  
3,232,397, PUB. 2-6-2007. INT. CL. 25.
- FAX RECALL CORPORATION, ATLANTA, GA:  
1,979,636, CANC. INT. CL. 42.
- FCG INVESTMENTS COMPANY INC, LONG BEACH, CA, FCG ENTERPRISES, INC., LONG BEACH, CA, DBA FIRST CONSULTING GROUP:  
2,036,970, REN. 3-21-07. INT. CL. 35.
- FCM-MTC MEDICAL, LLC, CENTERVILLE, UT:  
3,232,904, PUB. 2-6-2007. MULTIPLE CLASS, INT. CLS. 35 AND 44.  
3,232,911, PUB. 2-6-2007. MULTIPLE CLASS, INT. CLS. 35 AND 44.
- FD MANAGEMENT, INC., STAMFORD, CT, ELI LILLY AND COMPANY, INDIANAPOLIS, IN:  
1,439,757, REN. 3-17-07. INT. CL. 3.
- FD MANAGEMENT, INC., WILMINGTON, DE:  
2,049,505, REN. 3-19-07. INT. CL. 3.
- FE MANAGEMENT, INC., STAMFORD, CT, ELI LILLY AND COMPANY, INDIANAPOLIS, IN:  
1,073,947, REN. 3-17-07. INT. CL. 9.
- FEATHER ROCK BOOKS, INC., ORONO, MN:  
3,234,616, INT. CL. 41.
- FEATHERLITE, INC., CRESCO, IA, FEATHERLITE MFG., INC., CRESCO, IA:  
2,029,860, REN. 3-17-07. INT. CL. 12.
- FEATHERLITE, INC., CRESCO, IA:  
2,041,882, REN. 3-22-07. INT. CL. 12.
- FEDERAL CORPORATION, TAOYUAN, TAIWAN:  
3,234,447, INT. CL. 12.
- FEDERAL EXPRESS CORPORATION, MEMPHIS, TN AND KINKO'S VENTURES, INC., DALLAS, TX:  
3,234,282, MULTIPLE CLASS, INT. CLS. 9 AND 16.
- FEDERAL SCHEDULERS LTD, HOUSTON, TX:  
3,233,130, PUB. 2-6-2007. INT. CL. 35.
- FEDERAL SIGNAL CORPORATION, OAK BROOK, IL:  
3,235,331, INT. CL. 9.
- FEDORA COLLECTION, INC., CHANDLER, AZ:  
3,233,208, PUB. 2-6-2007. INT. CL. 35.
- FEEBBII PUBLISHING, L.L.C., TIBURON, CA:  
3,235,293, INT. CL. 41.
- FELINS U.S.A., INC., MILWAUKEE, WI, FELINS, INC., MILWAUKEE, WI:  
2,023,736, REN. 3-16-07. INT. CL. 7.
- FEMTOSECOND INC., FAIRFAX, VA:  
3,234,641, INT. CL. 42.
- FENDER MUSICAL INSTRUMENTS CORPORATION, SCOTTSDALE, AZ, COLUMBIA BROADCASTING SYSTEM, INC., NEW YORK, NY:  
841,570, REN. 3-16-07. U.S. CL. 21 (INT. CL. 9).
- FENNER DUNLOP AMERICAS, INC., CHARLOTTE, NC:  
3,232,808, PUB. 2-6-2007. INT. CL. 1.
- FERGUSON, BOBBY R., WARREN, AR, DBA LAGAYLES CANDY COMPANY:  
2,357,756, CANC. INT. CL. 30.
- FERRING B.V., 2132 JX HOOFDDORP, NETHERLANDS:  
3,232,088, PUB. 2-6-2007. MULTIPLE CLASS, INT. CLS. 5, 9, 16 AND 41.
- FERRIS, DAVID, CHICAGO, IL:  
3,233,853, INT. CL. 3.
- FERTILITY CENTERS OF ILLINOIS, S.C., GLENVIEW, IL:  
3,233,038, PUB. 2-6-2007. INT. CL. 44.
- FETHERSTON DESIGN GROUP, THE, GLENBROOK, NV:  
3,232,940, PUB. 2-6-2007. INT. CL. 25.
- FHC HEALTH SYSTEMS, INC., NORFOLK, VA:  
3,232,269, PUB. 2-6-2007. INT. CL. 44.
- FIBERGLASS UTILITY SUPPLIES, INC., LIBERTYVILLE, IA:  
1,424,729, REN. 3-16-07. INT. CL. 11.
- FIBERON, INC., ISSAQUAH, WA:  
2,357,151, CANC. INT. CL. 9.
- FIDELITY ASSETS, LLC, LOS ANGELES, CA:  
3,233,244, PUB. 2-6-2007. INT. CL. 35.
- FIELDTURF TARKETT INC., TMR-MONTREAL, QUEBEC, CANADA:  
3,232,731, PUB. 2-6-2007. MULTIPLE CLASS, INT. CLS. 27 AND 37.
- FIFTH THIRD BANCORP, CINCINNATI, OH:  
3,235,207, INT. CL. 36.

- FILTRON TECHNOLOGY CORPORATION, CLINTON, MA:  
1,396,655, CANC. INT. CL. 11.
- FINANCIAL NETWORK, INC., ST. PAUL, MN:  
3,235,428, INT. CL. 36.
- FINANZ ST. HONORE, B.V., HARVEYS LAKE, PA, CONSOLIDATED COSMETICS, CHICAGO, IL:  
426,323, REN. 3-20-07. U.S. CL. 51 (INT. CL. 3).
- FINANZ ST. HONORE, B.V., HARVEYS LAKE, PA, PARFUMS CORDAY INC., HOLLYWOOD, CA:  
816,263, REN. 3-22-07. U.S. CL. 51 (INT. CLS. 3 AND 5).
- FINANZ ST. HONORE, B.V., HARVEYS LAKE, PA:  
2,032,286, REN. 3-22-07. INT. CL. 3.
- FINDING OUR ROOTS, L.L.C., LAKE SAINT LOUIS, MO:  
3,234,126, INT. CL. 42.
- FINDLATER, MACKIE, TODD & CO LIMITED, LONDON WC2B 5BB, ENGLAND, DBA WHITMORE & BAYLEY:  
1,397,066, CANC. INT. CL. 33.
- FINGER LAKES COFFEE ROASTERS, INC., VICTOR, NY:  
3,232,522, PUB. 2-6-2007. MULTIPLE CLASS, INT. CLS. 30 AND 43.
- FINGERHUT CORPORATION, MINNETONKA, MN:  
2,358,443, CANC. INT. CL. 20.  
2,358,445, CANC. INT. CL. 9.
- FINKELSTEIN, ALAN, LOS ANGELES, CA:  
2,357,899, CANC. INT. CL. 9.
- FIRECREEK ACCESSORIES, INC, YAKIMA, WA:  
2,357,258, CANC. INT. CL. 12.
- FIREMEDNET INC, LYNNWOOD, WA:  
3,235,448, INT. CL. 9.
- FIRST CHECK DIAGNOSTICS LLC, LAKE FOREST, CA:  
2,023,956, REN. 3-20-07. INT. CL. 5.
- FIRST DATA MERCHANT SERVICES CORPORATION, SUNRISE, FL:  
2,358,342, CANC. INT. CL. 9.
- FIRST DATA SYSTEMS, INC., NASHVILLE, TN:  
1,980,219, CANC. INT. CL. 9.
- FIRST NATIONAL BANK TEXAS, KILLEEN, TX:  
3,234,901, INT. CL. 36.
- FIRST-CITIZENS BANK AND TRUST COMPANY OF SOUTH CAROLINA, COLUMBIA, SC:  
2,357,814, CANC. INT. CL. 36.
- FIRSTAGAIN LLC, SAN DIEGO, CA:  
3,234,707, INT. CL. 36.  
3,235,189, INT. CL. 36.
- FIRSTFED FINANCIAL CORPORATION, SANTA MONICA, CA:  
1,430,532, REN. 3-22-07. INT. CL. 36.
- FIRSTSENSE SOFTWARE, INC., BURLINGTON, MA:  
2,357,325, CANC. INT. CL. 9.
- FISCHER & WIESER SPECIALTY FOODS, INC., FREDERICKSBURG, TX:  
3,234,967, INT. CL. 30.
- FISCHER GESELLSCHAFT M.B.H., 4910 VIENNA, AUSTRIA:  
1,067,297, REN. 3-16-07. INT. CL. 28.
- FISCHER GESELLSCHAFT M.B.H., 4910 VIENNA, AUSTRIA:  
1,067,298, REN. 3-16-07. INT. CL. 28.
- FISHER AND PAYKEL HEALTHCARE LIMITED, AUCKLAND, NEW ZEALAND:  
3,122,779, COR. INT. CL. 10.  
3,234,364, INT. CL. 10.
- FISHING SCIENCE, INCORPORATED, LITTLETON, CO:  
3,233,263, PUB. 2-6-2007. INT. CL. 28.
- FISKARS BRANDS, INC., MADISON, WI, FISKARS INC., MADISON, WI:  
2,082,249, REN. 3-21-07. MULTIPLE CLASS, INT. CLS. 8 AND 16.  
2,085,961, REN. 3-21-07. INT. CL. 8.
- FISKARS BRANDS, INC., MADISON, WI:  
2,358,210, CANC. INT. CL. 21.
- FIVE STAR FRAGRANCE COMPANY, INC., NEW YORK, NY:  
3,234,875, INT. CL. 3.
- FÉDÉRATION INTERNATIONALE DE FOOTBALL ASSOCIATION (FIFA), SWITZERLAND:  
3,233,520, PUB. 2-6-2007. MULTIPLE CLASS, INT. CLS. 1, 3, 4, 5, 6, 7, 8, 9, 10, 11, 12, 14, 15, 16, 18, 20, 21, 24, 25, 26, 27, 28, 29, 30, 31, 32, 33, 34, 35 AND OTHERS.
- FÉDÉRATION INTERNATIONALE DES INGÉNIEURS-CONSEILS (FIDIC), CH-1215 GENÈVE 15, SWITZERLAND:  
3,233,568, PUB. 2-6-2007. MULTIPLE CLASS, INT. CLS. 35 AND 41.
- FJH MUSIC COMPANY INC., THE, FORT LAUDERDALE, FL:  
2,059,233, REN. 3-20-07. INT. CL. 16.
- FL FOOD LION, INC., SALISBURY, NC:  
3,234,083, INT. CL. 30.
- FLARB LLC, VALENCIA, CA:  
3,233,207, PUB. 2-6-2007. INT. CL. 9.
- FLASH SEATS, LLC, LIVONIA, MI:  
3,232,605, PUB. 2-6-2007. INT. CL. 35.
- FLAX, GARY ERROL, DALLAS, TX:  
3,234,618, INT. CL. 11.
- FLEETWOOD ENTERPRISES, INC., RIVERSIDE, CA:  
3,234,470, INT. CL. 12.
- FLEETWOOD MANUFACTURING, INC., BILLINGS, MT:  
3,234,143, INT. CL. 9.
- FLETCHER-TERRY COMPANY, THE, FARMINGTON, CT:  
1,426,249, REN. 3-19-07. MULTIPLE CLASS, INT. CLS. 6, 7 AND 8.
- FLEXIBLE PRODUCTS COMPANY, MARIETTA, GA:  
3,234,977, INT. CL. 1.
- FLEXIINTERNATIONAL SOFTWARE, INC., SHELTON, CT, FLEXIINTERNATIONAL SOFTWARE, INC., SHELTON, CT:  
2,032,445, REN. 3-22-07. INT. CL. 9.
- FLEXISTAND NORTH AMERICA, LLC, MOUNTAINSIDE, NJ:  
1,396,841, CANC. INT. CL. 20.
- FLEXIWORLD TECHNOLOGIES, INC, PORTLAND, OR:  
3,234,386, INT. CL. 9.
- FLEXPLAY TECHNOLOGIES, INC., ATLANTA, GA:  
3,235,439, INT. CL. 9.
- FLINT INK CORPORATION, ANN ARBOR, MI:  
3,234,531, INT. CL. 2.
- FLINT POOL & PATIO, INC., FENTON, MI, DBA LIFESTYLES SPAS & POOLS:  
3,232,134, PUB. 10-24-2006. INT. CL. 35.
- FLIP RECORDS INCORPORATED, WEST HOLLYWOOD, CA:  
2,113,372, REN. 3-17-07. INT. CL. 9.
- FLIPSIDE 3, INC., MYRTLE BEACH, SC:  
2,040,243, REN. 3-22-07. INT. CL. 42.
- FLIPSIDEA SOLUTIONS, LLC, CENTENNIAL, CO:  
3,234,760, INT. CL. 35.
- FLORA MANUFACTURING & DISTRIBUTING LTD., BURNABY, B.C. V5J 5B9, CANADA:  
2,356,917, CANC. INT. CL. 30.
- FLORES SILVESTRES, S.A., MEDELLIN, COLOMBIA:  
2,357,148, CANC. INT. CL. 31.
- FLORES, IGNACIO, HOUSTON, TX:  
2,357,533, CANC. INT. CL. 34.
- FLOREZ, STAN R., BONNEY LAKE, WA:  
3,235,149, INT. CL. 30.
- FLORIDA ATLANTIC UNIVERSITY, BOCA RATON, FL:  
3,234,534, INT. CL. 41.
- FLORIDA INSTITUTE OF FINANCE, L.L.C., BOCA RATON, FL:  
3,234,567, INT. CL. 41.
- FLORIDA INTERNATIONAL UNIVERSITY - BOARD OF TRUSTEES, MIAMI, FL:  
3,233,145, PUB. 2-6-2007. INT. CL. 41.  
3,233,146, PUB. 2-6-2007. INT. CL. 41.
- FLORINA A. HONEOS S.A., THESSALONIKI 54623, GREECE:  
2,357,004, CANC. INT. CL. 32.
- FLORISTS' TRANSWORLD DELIVERY, INC., DOWNERS GROVE, IL:  
3,232,754, PUB. 2-6-2007. MULTIPLE CLASS, INT. CLS. 35 AND 39.
- FLORKEY'S CONVEYOR SERVICE, INC., WARREN, MI:  
1,396,478, CANC. INT. CL. 7.
- FLORY, MICHELE M., THE WOODLANDS, TX:  
3,233,133, PUB. 2-6-2007. INT. CL. 35.

- FLOSOURCE, INC., MARTINSVILLE, IN:  
3,233,426, PUB. 2-6-2007. INT. CL. 35.
- FLOWERVE MANAGEMENT COMPANY, IRVING, TX:  
3,234,168, MULTIPLE CLASS, INT. CLS. 6, 7, 9, 11, 37 AND 42.
- FLOWVISION, DILLION, CO:  
3,234,537, MULTIPLE CLASS, INT. CLS. 41 AND 42.
- FLYTXT LTD., LONDON, UNITED KINGDOM:  
3,235,231, INT. CL. 35.
- FMC CORPORATION, PHILADELPHIA, PA:  
2,358,117, CANC. INT. CL. 16.  
2,358,118, CANC. INT. CL. 11.
- FMC FOODTECH INC., CHICAGO, IL:  
2,039,874, REN. 3-20-07. INT. CL. 7.
- FMR CORP., BOSTON, MA:  
3,232,540, PUB. 8-22-2006. INT. CL. 36.  
3,232,541, PUB. 8-22-2006. INT. CL. 36.
- FOAMEX CARPET CUSHION, INC., LINWOOD, PA:  
2,358,687, CANC. INT. CL. 27.
- FOAMEX L.P., LINWOOD, PA, GENERAL FELT INDUSTRIES, INC., LINDWOOD, PA:  
2,059,944, REN. 3-17-07. INT. CL. 27.
- FOAMY FLOP, INC., CHICAGO, IL:  
2,357,397, CANC. INT. CL. 20.
- FOBOX AS, NORWAY:  
3,233,531, PUB. 2-6-2007. MULTIPLE CLASS, INT. CLS. 7, 9, 39, 40 AND 44.
- FOLSOM, DREW V., BIRMINGHAM, AL AND GLASS, WILLIAM PAUL, JR., BIRMINGHAM, AL:  
2,358,008, CANC. INT. CL. 25.  
2,358,026, CANC. INT. CL. 25.  
2,358,027, CANC. INT. CL. 25.  
2,358,114, CANC. INT. CL. 25.
- FON WIRELESS LIMITED, LONDON, UNITED KINGDOM:  
3,232,690, PUB. 2-6-2007. INT. CL. 9.  
3,232,691, PUB. 2-6-2007. INT. CL. 38.
- FONIX CORPORATION, SALT LAKE CITY, UT:  
2,356,610, CANC. INT. CL. 9.
- FOOD EQUIPMENT TECHNOLOGIES COMPANY, INC., LAKE ZURICH, IL:  
3,234,772, INT. CL. 21.
- FOOD FASHION DESIGNS, INC., SANTA MONICA, CA:  
3,233,985, INT. CL. 30.
- FOOD QUALITY SENSOR INTERNATIONAL, INC., LEXINGTON, MA:  
3,233,999, INT. CL. 9.
- FOOT LEVELERS, INC., ROANOKE, VA, DBA THERAPEUTIC PRODUCTS:  
1,403,897, REN. 3-20-07. INT. CL. 10.
- FORBES ENTERPRISES, WEST HOLLYWOOD, CA:  
1,397,168, CANC. INT. CL. 41.
- FORCE SERVICES, LTD., JACKSONVILLE, FL:  
1,979,630, CANC. INT. CL. 16.
- FORD MOTOR COMPANY, DEARBORN, MI:  
1,980,005, CANC. INT. CL. 6.  
1,980,020, CANC. INT. CL. 21.  
1,980,085, CANC. INT. CL. 14.  
1,980,086, CANC. INT. CL. 28.
- FORD'S FOODS, RALEIGH, NC:  
2,068,592, REN. 3-20-07. INT. CL. 30.
- FORE SYSTEMS, INC., WARRENDALE, PA:  
2,357,965, CANC. MULTIPLE CLASS, INT. CLS. 9 AND 16.
- FOREIGN CANDY COMPANY, INC., THE, HULL, IA:  
2,080,043, REN. 3-22-07. INT. CL. 30.
- FOREMOST GROUPS, INC., EAST HANOVER, NJ:  
3,234,782, MULTIPLE CLASS, INT. CLS. 4 AND 11.
- FORENSIC INVESTIGATIVE ASSOCIATES (USA) INC., NEW YORK, NY:  
2,358,000, CANC. MULTIPLE CLASS, INT. CLS. 35 AND 42.
- FOREVER 21, INC, LOS ANGELES, CA, FASHION 21, INC., LOS ANGELES, CA:  
2,067,637, REN. 3-16-07. INT. CL. 42.
- FORMABILITIES, INC., ARDMORE, PA:  
2,358,239, CANC. MULTIPLE CLASS, INT. CLS. 16 AND 28.
- FORMFLEX FOUNDATIONS, INC., SADDLE BROOK, NJ:  
1,396,893, CANC. INT. CL. 25.
- FORMOST INC., LAWRENCEVILLE, NJ:  
2,357,769, CANC. INT. CL. 42.
- FORMOST, INC., LAWRENCEVILLE, NJ:  
2,357,767, CANC. INT. CL. 42.  
2,357,770, CANC. INT. CL. 42.
- FORMULATION, FRANCE:  
3,233,614, PUB. 2-6-2007. INT. CL. 9.
- FORT LOCK CORPORATION, RIVER GROVE, IL:  
1,426,115, REN. 3-17-07. INT. CL. 6.
- FORTEC, INC., WAUKESHA, WI:  
1,396,797, CANC. INT. CL. 16.  
1,396,798, CANC. INT. CL. 16.
- FORTH & TOWNE (APPAREL) LLC, SAN FRANCISCO, CA:  
3,235,415, INT. CL. 4.
- FORTITECH INC., SCHENECTADY, NY:  
3,232,418, PUB. 2-6-2007. MULTIPLE CLASS, INT. CLS. 5, 42 AND 44.
- FORTUNE COMMERCIAL CORPORATION, POMONA, CA:  
3,232,142, PUB. 2-6-2007. INT. CL. 35.
- FOSSIL, INC., RICHARDSON, TX:  
2,129,528, REN. 3-22-07. INT. CL. 14.
- FOSTER CORPORATION, PUTNAM, CT:  
3,235,045, INT. CL. 17.  
3,235,046, INT. CL. 17.
- FOSTER, LINDA GRAYSON, THOUSAND OAKS, CA:  
3,234,969, INT. CL. 14.
- FOUNDATION FOR AN INDEPENDENT TOMORROW, LAS VEGAS, NV:  
3,233,300, PUB. 2-6-2007. INT. CL. 36.
- FOUNDATION FOR EARLY LEARNING, SEATTLE, WA:  
3,234,845, MULTIPLE CLASS, INT. CLS. 16, 35, 36 AND 41.
- FOUNDATION OF RENEWAL FOR EASTERN NORTH CAROLINA, GREENVILLE, NC:  
3,235,421, INT. CL. 16.
- FOUR U LU 2, INC, SAYVILLE, NY:  
3,234,443, INT. CL. 30.
- FOURSTAR GROUP, INC., TAIPEI, TAIWAN:  
3,232,912, PUB. 2-6-2007. INT. CL. 9.
- FOX RIVER PAPER COMPANY LLC, APPLETON, WI, MEAD CORPORATION, THE, DAYTON, OH:  
2,100,309, REN. 3-21-07. INT. CL. 16.
- FOX VALLEY SYSTEMS, INC., CARY, IL:  
2,357,986, CANC. INT. CL. 7.
- FOX 21, INC., LOS ANGELES, CA:  
3,235,203, INT. CL. 41.
- FOX, DEBRA, ROCKLEDGE, FL:  
3,235,457, INT. CL. 16.
- FOXCOM WIRELESS (1998) LTD., JERUSALEM, ISRAEL:  
2,357,551, CANC. INT. CL. 9.
- FPI FIREPLACE PRODUCTS INTERNATIONAL LTD., DELTA, BRITISH COLUMBIA, CANADA:  
3,235,393, INT. CL. 11.
- FRAISA HOLDING AG, BELLACH, SWITZERLAND:  
1,396,459, CANC. MULTIPLE CLASS, INT. CLS. 7 AND 8.
- FRAMERICA CORP., YAPHANK, NY:  
3,234,974, INT. CL. 19.
- FRAMES DATA INC., NEW YORK, NY:  
3,233,131, PUB. 2-6-2007. INT. CL. 16.
- FRAMESI S.P.A., PADERNO DUGNANO, PROVINCE OF MILAN, ITALY, FRAMESI DI FRANCHINA R. & C. S.A.S., PADERNO DUGNANO, MILAN, ITALY:  
1,425,382, REN. 3-19-07. INT. CL. 3.
- FRANCE-CHAMPAGNE, 51200 EPERNAY, FRANCE:  
2,357,760, CANC. INT. CL. 33.
- FRANCE, AMY LEA, ORMOND BEACH, FL:  
3,233,865, INT. CL. 16.
- FRANCK MULLER WATCHLAND SA, CH-1294 GENTHOD, SWITZERLAND:  
3,233,732, PUB. 2-6-2007. INT. CL. 14.
- FRANCOLOR PIGMENTS, RIEUX, FRANCE:  
2,033,428, REN. 3-16-07. INT. CL. 2.
- FRANK MARTIN, MIDDLEBURG, FL:  
2,356,460, CANC. INT. CL. 42.
- FRANK MAYBORN ENTERPRISES, INC., TEMPLE, TX:  
3,235,274, INT. CL. 40.

- FRANKLIN COVEY CO., SALT LAKE CITY, UT:  
2,358,144, CANC. INT. CL. 16.
- FRANKLIN RESOURCES, INC., SAN MATEO, CA:  
2,357,775, CANC. INT. CL. 36.
- FRANTZEN CAPITAL MANAGEMENT, INC., TAMPA, FL:  
3,233,062, PUB. 2-6-2007. INT. CL. 36.
- FRATERNAL ORDER OF BORDER AGENTS, INC., GREEN VALLEY, AZ:  
2,357,429, CANC. U.S. CL. 200.
- FRECON, LESLIE A, MINNEAPOLIS, MN:  
3,232,405, PUB. 2-6-2007. INT. CL. 36.
- FREELIFE INTERNATIONAL, LLC, MILFORD, CT:  
3,232,931, PUB. 11-28-2006. INT. CL. 5.
- FREEMAN CAPITAL COMPANY, LAS VEGAS, NV:  
2,357,092, CANC. MULTIPLE CLASS, INT. CLS. 37, 39, 40, 41 AND 42.
- FREEVERSE CORPORATION, NEW YORK, NY:  
3,232,287, PUB. 2-6-2007. INT. CL. 9.
- FREEWING AERIAL ROBOTICS CORPORATION, COLLEGE STATION, TX:  
2,356,436, CANC. INT. CL. 12.
- FRESH INTELLECTUAL PROPERTIES, INC., WILMINGTON, DE:  
2,358,197, CANC. INT. CL. 35.
- FRESHWOOD PRODUKTENTWICKLUNG-UND LIZENZVERWALTUNG-GMBH, DUESSELDORF, FED REP GERMANY:  
1,396,359, CANC. INT. CL. 3.
- FRESNO BASEBALL CLUB, LLC, STONEHAM, MA:  
3,233,359, PUB. 2-6-2007. INT. CL. 41.
- FREUDENBERG-NOK GENERAL PARTNERSHIP, PLYMOUTH, MI:  
3,232,377, PUB. 2-6-2007. INT. CL. 17.
- FRIDAY MORNING QUARTERBACK ALBUM REPORT, INC., CHERRY HILL, NJ:  
3,233,961, INT. CL. 41.
- FRIPP ISLAND COMPANY, LLC, FRIPP ISLAND, SC:  
3,232,941, PUB. 2-6-2007. MULTIPLE CLASS, INT. CLS. 36, 41 AND 43.
- FRITZ SCHAFFER GMBH, NEUNKIRCHEN, FED REP GERMANY:  
2,862,506, AM. MULTIPLE CLASS, INT. CLS. 9 AND 42.
- FRONTIER CORPORATION, ROCHESTER, NY TO CITIZENS COMMUNICATIONS COMPANY, STAMFORD, CT:  
1,979,446, CANC. INT. CL. 16.
- FRONTPAIGE PRODUCTIONS, INC., LEEDS, AL:  
3,233,868, INT. CL. 28.
- FUCHS PETROLUB AG, MANNHEIM, FED REP GERMANY, FUCHS MINERALOELWERKE GMBH, D-68169 MANNHEIM, FED REP GERMANY:  
2,031,447, REN. 3-16-07. INT. CL. 4.
- FUCHS PETROLUB AG, FED REP GERMANY:  
3,233,612, PUB. 2-6-2007. INT. CL. 1.  
3,233,638, PUB. 2-6-2007. MULTIPLE CLASS, INT. CLS. 1, 2, 3 AND 4.  
3,233,672, PUB. 2-6-2007. MULTIPLE CLASS, INT. CLS. 1 AND 4.  
3,233,673, PUB. 2-6-2007. INT. CL. 4.
- FUEL TV, INC., LOS ANGELES, CA:  
3,234,931, INT. CL. 41.
- FUENTE MARKETING LTD., TORTOLA, BR. VIRGIN ISLANDS:  
3,232,515, PUB. 2-6-2007. INT. CL. 40.
- FUJI CHEMICAL INDUSTRY CO., LTD., NAKANIKAWAGUN, TOYAMA-KEN, JAPAN:  
3,233,945, INT. CL. 1.
- FUJI KOGYO CO., LTD., SHIZUOKA-SHI, SHIZUOKA-KEN, JAPAN:  
1,396,493, CANC. INT. CL. 8.
- FUJIAN E&D GROUP, LTD., CHINA:  
3,233,708, PUB. 2-6-2007. INT. CL. 25.
- FUJIKIN INCORPORATED, NISHI-KU, OSAKA, JAPAN:  
3,232,145, PUB. 2-6-2007. MULTIPLE CLASS, INT. CLS. 6, 7 AND 9.
- FULLER, JASON C, LAGO VISTA, TX:  
3,235,008, MULTIPLE CLASS, INT. CLS. 25 AND 41.
- FUND OF THE LYDIA FELLOWSHIP INTERNATIONAL, SAN JOSE, CA, DBA LYDIA FELLOWSHIP:  
1,396,513, CANC. MULTIPLE CLASS, INT. CLS. 9, 16 AND 42.
- FUNDEX GAMES, LTD., INDIANAPOLIS, IN:  
3,235,156, INT. CL. 28.
- FUNKY DIVA INC., HUNTINGTON BCH, CA:  
2,357,678, CANC. MULTIPLE CLASS, INT. CLS. 16 AND 18.
- FUNLINE MERCHANDISE CO., INC., CONCORD, NC:  
2,425,096, CANC. INT. CL. 28.
- FURTH, FREDERICK P., HEALDSBURG, CA, DBA CHALK HILL WINERY:  
2,104,452, REN. 3-19-07. INT. CL. 33.
- FURUTECH (H.K.) COMPANY LIMITED, MONKOK, HONG KONG:  
2,357,878, CANC. INT. CL. 9.
- FVG HOLDINGS, L.C., TAMPA, FL AND FVG CALIFORNIA PARTNERSHIP, LOS ANGELES, CA:  
3,234,791, INT. CL. 35.
- FWTOOLS, INC., FRANKLIN, TN:  
3,232,798, PUB. 2-6-2007. INT. CL. 35.
- G.F. LASSWELL BRUSH COMPANY, INC., HOUSTON, TX:  
3,233,360, PUB. 2-6-2007. INT. CL. 35.
- G-SHOTS B.V., NETHERLANDS:  
3,233,707, PUB. 2-6-2007. INT. CL. 33.
- G-STAR RAW DENIM KFT, BUDAPEST, HUNGARY, AMSTERDAM FASHION CO. LTD., AMSTERDAM, NETHERLANDS:  
2,046,947, REN. 3-17-07. MULTIPLE CLASS, INT. CLS. 18 AND 25.
- GABEL INDUSTRIA TESSILE S.P.A., ROVELLASCA (COMO), ITALY:  
3,233,517, PUB. 2-6-2007. INT. CL. 24.
- GABRIELLA, DONATO MARIA, 21013 GALLARATE VARESE, ITALY, TAGLIABUE MANIFATTURA PIPE, GALLARATE, VARESE, ITALY:  
1,056,249, REN. 3-21-07. INT. CL. 34.
- GABRIELLE STUDIO, INC., NEW YORK, NY:  
3,234,726, INT. CL. 3.
- GABURO, PATRICE, OCEANPORT, NJ:  
2,357,928, CANC. INT. CL. 16.
- GAIANET INFORMATION SERVICES, INC., LOS ANGELES, CA:  
2,356,479, CANC. INT. CL. 42.
- GAMEDAY CENTERS S.E., LLC, ATLANTA, GA:  
3,232,105, PUB. 2-6-2007. INT. CL. 36.
- GAMEFX, INC., ARLINGTON, MA:  
2,358,031, CANC. INT. CL. 9.
- GAMLA ENTERPRISES N.A. INC., NEW YORK, NY:  
3,235,411, INT. CL. 9.
- GAMMA ARREDAMENTI INTERNATIONAL S.P.A., 47100 FORLI (FO), ITALY:  
3,232,318, PUB. 2-6-2007. INT. CL. 20.
- GAMMAL, MICHAEL W, ESSEX JUNCTION, VT AND GAMMAL, MICHELE J., ESSEX JUNCTION, VT:  
2,358,223, CANC. INT. CL. 20.
- GANEM CARL, FRANCE:  
3,233,682, PUB. 2-6-2007. INT. CL. 3.
- GANNETT CO., INC., ARLINGTON, VA:  
1,396,792, CANC. INT. CL. 16.  
1,396,808, CANC. INT. CL. 16.
- GANNON DESIGN & PACKAGING, INC., GLEN ELLYN, IL:  
2,033,661, REN. 3-20-07. INT. CL. 16.
- GANZ, WOODBRIDGE, CANADA:  
2,357,496, CANC. MULTIPLE CLASS, INT. CLS. 24 AND 28.
- GARAGE CONCEPTS, L.L.C., BEDFORD, TX:  
3,232,198, PUB. 2-6-2007. INT. CL. 37.
- GARAN SERVICES CORP., WILMINGTON, DE:  
1,298,907, REN. 3-17-07. INT. CL. 25.
- GARDENS ALIVE, INC., LAWRENCEBURG, IN:  
2,073,973, REN. 3-21-07. INT. CL. 5.
- GARDNER, MERLE F., MEMPHIS, TN:  
3,235,183, INT. CL. 28.
- GARNER, LATARER, JACKSON, MS:  
3,234,724, INT. CL. 25.

- GARRISON, KEILLOR, ST. PAUL, MN:  
2,045,807. REN. 3-16-07. MULTIPLE CLASS, INT. CLS. 25 AND 41.
- GARY J. SCHWARTZBERG, MEDLEY, FL, BIAGELS UNLIMITED INC., BAYSIDE, NY:  
1,060,935. REN. 3-22-07. INT. CL. 30.
- GARZA, RAYNALDO, MONARCH BEACH, CA:  
3,234,853, INT. CL. 25.
- GAS APPLIANCE MANUFACTURERS ASSOCIATION, ARLINGTON, VA:  
2,057,266. REN. 3-22-07. INT. CL. 42.
- GATEWAY, INC., SAN DIEGO, CA:  
2,358,353, CANC. MULTIPLE CLASS, INT. CLS. 9 AND 35.
- GAUGHAN, RICK L., LONGWOOD, FL:  
3,233,039, PUB. 2-6-2007. INT. CL. 8.
- GAY BOWLES SALES, INC., JANESVILLE, WI:  
2,357,660, CANC. INT. CL. 26.
- GB BIOSCIENCES CORPORATION, WILMINGTON, DE, DIAMOND ALKALI COMPANY, CLEVELAND, OH:  
823,257. REN. 3-21-07. U.S. CL. 6 (INT. CL. 5).
- GB BIOSCIENCES CORPORATION, WILMINGTON, DE, ISK BIOSCIENCES CORPORATION, MENTOR, OH:  
2,034,553. REN. 3-21-07. INT. CL. 5.
- GE HEALTHCARE BIO-SCIENCES AB, UPPSALA, SWEDEN, PHARMACIA FINE CHEMICALS, INC., PISCATAWAY, NJ:  
1,062,544. REN. 3-22-07. INT. CL. 1.
- GE TRANSPORTATION SYSTEMS GLOBAL SIGNALING, LLC, GRAIN VALLEY, MO:  
2,358,015, CANC. INT. CL. 9.
- GEBO PUBLISHING AND SOFTWARE, LLC, MISSION VIEJO, CA:  
2,357,122, CANC. INT. CL. 9.
- GECO SYSTEM S.P.A., I-21052 BUSTO ARSIZIO (VA), ITALY:  
3,233,715, PUB. 2-6-2007. MULTIPLE CLASS, INT. CLS. 17 AND 19.
- GEE! TECHNOLOGIES LLC, SANTA CLARA, CA:  
3,232,773, PUB. 2-6-2007. INT. CL. 18.
- GELMAN, TONDRIA, MIAMI, FL, DBA D.B.A. CREATIVE OPTIONS:  
2,357,145, CANC. INT. CL. 42.
- GENCOR INDUSTRIES, INC., ORLANDO, FL:  
3,233,312, PUB. 2-6-2007. MULTIPLE CLASS, INT. CLS. 6, 7, 9 AND 11.
- GENENTECH, INC., SOUTH SAN FRANCISCO, CA:  
3,232,438, PUB. 3-14-2006. INT. CL. 44.  
3,232,439, PUB. 4-18-2006. INT. CL. 44.
- GENERAL CABLE INDUSTRIES, INC., HIGHLAND HEIGHTS, KY:  
2,358,076, CANC. INT. CL. 9.
- GENERAL CABLE TECHNOLOGIES CORPORATION, HIGHLAND HIGHTS, KY:  
3,234,280, INT. CL. 35.
- GENERAL CONFERENCE CORPORATION OF SEVENTH-DAY ADVENTISTS, SILVER SPRING, MD:  
2,062,417. REN. 3-22-07. INT. CL. 36.
- GENERAL ELECTRIC COMPANY, SCHENECTADY, KY:  
1,448,144. REN. 3-22-07. INT. CL. 7.
- GENERAL ELECTRIC COMPANY, SCHENECTADY, NY:  
3,235,011, MULTIPLE CLASS, INT. CLS. 37 AND 40.  
3,235,333, MULTIPLE CLASS, INT. CLS. 37 AND 40.
- GENERAL ELECTRIC COMPANY, THE, SCHENECTADY, NY:  
1,059,049. REN. 3-16-07. INT. CL. 9.
- GENERAL GROWTH PROPERTIES, INC., CHICAGO, IL:  
3,232,182, PUB. 2-6-2007. MULTIPLE CLASS, INT. CLS. 35 AND 36.  
3,232,183, PUB. 2-6-2007. MULTIPLE CLASS, INT. CLS. 35 AND 36.  
3,232,184, PUB. 2-6-2007. MULTIPLE CLASS, INT. CLS. 35 AND 36.  
3,232,185, PUB. 2-6-2007. MULTIPLE CLASS, INT. CLS. 35 AND 36.
- GENERAL HOSPITAL SUPPLY CORPORATION, WILTON, CT:  
3,232,784, PUB. 2-6-2007. INT. CL. 10.
- GENERAL MILLS, INC., MINNEAPOLIS, MI:  
645,830. REN. 3-17-07. U.S. CL. 46 (INT. CL. 30).
- GENERAL MILLS, INC., MINNEAPOLIS, MN:  
1,397,062, CANC. INT. CL. 32.  
1,512,284, AM. MULTIPLE CLASS, INT. CLS. 4, 21 AND 30.  
3,234,880, INT. CL. 16.
- GENERAL MOTORS CORPORATION, DETROIT, MI:  
2,055,288. REN. 3-16-07. INT. CL. 28.  
3,232,460, PUB. 2-6-2007. INT. CL. 25.
- GENERAL NUTRITION INVESTMENT COMPANY, PITTSBURGH, PA:  
2,358,638, CANC. INT. CL. 5.  
2,358,639, CANC. INT. CL. 5.  
2,358,697, CANC. INT. CL. 5.
- GENERALMUSIC S.P.A., SAN GIOVANNI IN MARIIGNANO (RN), ITALY:  
1,979,103, CANC. MULTIPLE CLASS, INT. CLS. 9 AND 15.
- GENERATION TECHNOLOGIES CORPORATION, OVERLAND PARK, KS:  
2,357,458, CANC. INT. CL. 9.
- GENESCO BRANDS INC., WILMINGTON, DE:  
1,458,854. REN. 3-16-07. INT. CL. 42.
- GENESCO INC., NASHVILLE, TN:  
3,232,063, PUB. 8-14-2001. INT. CL. 35.
- GENESIS HEALTH, INC., JACKSONVILLE, FL:  
3,233,330, PUB. 2-6-2007. INT. CL. 44.  
3,233,335, PUB. 2-6-2007. INT. CL. 44.  
3,233,357, PUB. 2-6-2007. INT. CL. 42.
- GENESIS MICROCHIP INC., MARKHAM, ONTARIO, CANADA:  
2,357,958, CANC. INT. CL. 9.
- GENETIC TESTING INSTITUTE, WAUKESHA, WI:  
3,232,678, PUB. 2-6-2007. INT. CL. 5.
- GENIUS APPLICATION DEVELOPERS, LLC, ANNAPOLIS, MD:  
3,234,313, INT. CL. 9.
- GENMAR INDUSTRIES, INC., MINNEAPOLIS, MN:  
3,232,902, PUB. 2-6-2007. INT. CL. 12.
- GENTIVA HEALTH SERVICES, INC., MELVILLE, NY:  
3,233,987, MULTIPLE CLASS, INT. CLS. 16, 35, 41 AND 44.
- GENTLE GIANT MOVING CO., INC., SOMERVILLE, MA:  
2,123,585. REN. 3-17-07. INT. CL. 39.
- GENWORTH FINANCIAL, INC., RICHMOND, VA:  
3,232,977, PUB. 2-6-2007. INT. CL. 36.
- GEOFFREY, INC., WAYNE, NJ:  
3,235,061, INT. CL. 28.
- GEORGE TAUB PRODUCTS AND FUSION CO., INC., JERSEY CITY, NJ:  
3,233,201, PUB. 2-6-2007. INT. CL. 3.  
3,233,202, PUB. 2-6-2007. INT. CL. 3.
- GEORGIA BARIATRICS, P.C., COLUMBUS, GA:  
2,119,450. REN. 3-19-07. INT. CL. 42.
- GEORGIA WATERFOWL ASSOCIATION, THOMSON, GA:  
2,358,899, CANC. INT. CL. 36.
- GERDAU AMERISTEEL US, INC., TAMPA, FL:  
3,234,891, INT. CL. 2.
- GESELLSCHAFT FUR GERATEBAU MBH, DORTMUND, FED REP GERMANY:  
1,396,529, CANC. INT. CL. 9.
- GESSNER, RICHARD J JR., APOPKA, FL:  
3,232,775, PUB. 2-6-2007. INT. CL. 9.
- GETTY PETROLEUM MARKETING INC., EAST MEADOW, NY:  
3,234,784, INT. CL. 4.
- GFI GROUP INC., NEW YORK, NY:  
2,358,127, CANC. INT. CL. 36.
- GFI HOLDINGS, INC., OMAHA, NE, CHERRY-LEVIS FOOD PRODUCTS CORP., PHILADELPHIA, PA:  
822,012. REN. 3-19-07. U.S. CL. 46 (INT. CLS. 1, 5, 29, 30, 31 AND 32).
- GGP-BRIDGELAND, LP, CHICAGO, IL:  
3,234,238, INT. CL. 37.
- GHISLAIN, JUSTIN MARIE MAT, KRUGERSDORP, GAUTENG, SOUTH AFRICA:  
3,234,279, INT. CL. 7.



GIANTMICROBES, INC., STAMFORD, CT:  
3,232,703, PUB. 2-6-2007. INT. CL. 21.

GIBSON GUITAR CORP., NASHVILLE, TN:  
1,979,647, CANC. INT. CL. 15.

GIBSON, JON, NEW YORK, NY:  
2,357,582, CANC. INT. CL. 41.  
2,357,583, CANC. INT. CL. 41.

GIGANTE IMAGE GROUP, TEMECULA, CA:  
3,233,214, PUB. 2-6-2007. INT. CL. 41.

GIGATRONIX LIMITED, PORTSMOUTH, HAMPSHIRE, ENGLAND:  
3,234,563, INT. CL. 9.

GIGLIO, MARK A, OAKLAND, CA:  
3,232,349, PUB. 2-6-2007. INT. CL. 28.

GILBERT, TREVOR, COLCHESTER, ESSEX CO7 6DT, UNITED KINGDOM:  
3,232,082, PUB. 6-27-2006. INT. CL. 35.

GILGAL GOLF, LLC, WAUNAKEE, WI:  
3,234,888, INT. CL. 28.

GILGEN FORDERSYSTEME AG, CH-3171 OBERWANGEN B. BERN, SWITZERLAND:  
2,356,807, CANC. MULTIPLE CLASS, INT. CLS. 6 AND 7.

GILLEBAARD, HENDRICK D., JR., SAN CLEMENTE, CA:  
3,234,705, INT. CL. 35.

GILLETTE COMPANY, THE, BOSTON, MA, DURACELL INC., BETHEL, CT:  
1,417,363. REN. 3-21-07. INT. CL. 11.

GILICK, JERRY, COLORADO SPRINGS, CO:  
2,358,922, CANC. INT. CL. 35.

GILMORE, STEPHEN J., GLENDALE, MO:  
2,356,629, CANC. INT. CL. 28.

GILSON SAS, FRANCE:  
3,233,648, PUB. 2-6-2007. INT. CL. 9.

GILTSPUR SCIENTIFIC LIMITED, BALLYCLARE, COUNTY ANTRIM, NORTHERN IRELAND:  
3,234,477, INT. CL. 10.

GIN, WILLIAM, SAN FRANCISCO, CA:  
2,357,178, CANC. INT. CL. 30.

GIORDANO, KATHLEEN, NEW YORK, NY:  
3,235,475, MULTIPLE CLASS, INT. CLS. 21 AND 44.

GIORGIO JANEKE S.R.L., MILAN, ITALY:  
1,427,974. REN. 3-20-07. MULTIPLE CLASS, INT. CLS. 20 AND 21.

GIRLS INCORPORATED, NEW YORK, NY:  
2,092,792. REN. 3-20-07. INT. CL. 16.  
2,092,793. REN. 3-22-07. INT. CL. 21.  
2,094,501. REN. 3-17-07. INT. CL. 41.

GITA SPORTS, LTD., CHARLOTTE, NC, DBA GITA SPORTING GOODS, LTD.:  
1,435,739. REN. 3-16-07. INT. CL. 25.

GIUGGIO, RALPH P., BARRINGTON, RI:  
2,358,629, CANC. INT. CL. 35.

GIVE THE GIFT OF SIGHT FOUNDATION, MASON, OH:  
1,979,742, CANC. INT. CL. 42.  
1,979,743, CANC. INT. CL. 42.

GLAXO GROUP LIMITED, MIDDLESEX, ENGLAND:  
3,232,535, PUB. 2-6-2007. INT. CL. 5.

GLAXOSMITHKLINE BIOLOGICALS S.A., RIXENSART B-1330, BELGIUM:  
3,232,316, PUB. 12-30-2003. INT. CL. 5.

GLINN-TANNER, DARYL, TUJUNGA, CA:  
3,233,100, PUB. 2-6-2007. INT. CL. 3.

GLOBAL AXCESS CORP, PONTE VEDRA BEACH, FL:  
3,233,911, INT. CL. 36.

GLOBAL BRAND HOLDINGS, LLC, NEW YORK, NY:  
3,234,559, INT. CL. 20.

GLOBAL BRAND MARKETING INC., SANTA BARBARA, CA:  
3,234,703, INT. CL. 25.

GLOBAL BRANDS, INC., UPPER GRANDVIEW, NY:  
3,232,219, PUB. 2-6-2007. INT. CL. 30.

GLOBAL LIFE TECHNOLOGIES CORP., CORAL GABLES, FL:  
3,235,478, INT. CL. 5.

GLOBAL ONE HEADWEAR LIMITED, FOTAN, SHATIN, NEW TERRITORIES, HONG KONG:  
2,975,831 NEW CERT. 4-24-2007. INT. CL. 25.

GLOBAL RESTAURANT EMPLOYMENT SERVICES, L.L.C., TROY, MI:  
2,357,197, CANC. INT. CL. 35.

GLOBAL STANDARDS, LLC, HARTFORD, CT:  
3,232,133, PUB. 2-6-2007. INT. CL. 42.

GLOBAL STORE LTD, HONG KONG, HONG KONG:  
3,234,403, INT. CL. 33.

GLOBAL TRANSITION SOLUTIONS, LLC, NEW YORK, NY:  
3,233,960, INT. CL. 36.

GLOBAL VOLUNTEERS, ST. PAUL, MN:  
3,233,498, PUB. 2-6-2007. INT. CL. 36.

GLOBAL-EZE INCORPORATED, ISLE OF PALMS, SC:  
3,234,184, MULTIPLE CLASS, INT. CLS. 35 AND 41.

GLOBALNET CONSULTING AND SERVICES, INC., APEX, NC:  
2,356,492, CANC. MULTIPLE CLASS, INT. CLS. 35 AND 42.

GLOBE EXPRESS SERVICES, LTD., CHARLOTTE, NC:  
3,232,643, PUB. 2-6-2007. INT. CL. 35.

GM SPA, CASTIGLION FIBOCCHI (AREZZO), ITALY:  
1,396,890, CANC. INT. CL. 25.

GMAC MORTGAGE CORPORATION, HORSHAM, PA:  
3,234,981, INT. CL. 36.

GMFS, LLC, BATON ROUGE, LA:  
3,233,849, MULTIPLE CLASS, INT. CLS. 9, 36 AND 42.

GO KRAZY INC., HOLLYWOOD, FL:  
1,990,856. REN. 3-20-07. INT. CL. 41.  
1,990,856, CANC. INT. CL. 28.

GOLD'S GYM LICENSING LLC, IRVING, TX:  
3,234,849, INT. CL. 41.

GOLDA, INC., BEACHWOOD, OH:  
3,234,057, INT. CL. 10.

GOLDEN AGE TEA COMPANY LLC, FREMONT, CA:  
2,358,540, CANC. INT. CL. 30.  
2,358,541, CANC. INT. CL. 30.

GOLDEN CORRAL CORPORATION, RALEIGH, NC:  
3,235,319, INT. CL. 43.

GOLDEN GAMING, INC., LAS VEGAS, NV:  
3,233,863, INT. CL. 32.

GOLDEN STATE BULB GROWERS, INC., MOSS LANDING, CA:  
3,234,629, INT. CL. 31.

GOLDSTEIN, ROBERT D., SCARSDALE, NY:  
3,233,268, PUB. 2-6-2007. INT. CL. 44.

GOLF EDUCATORS, LLC, ATLANTA, GA:  
3,234,450, INT. CL. 28.

GONZALEZ, MELQUIADES, MIAMI, FL:  
3,233,925, INT. CL. 34.

GONZO CORPORATION, THE, BELLINGHAM, WA, BENDA PRODUCTS, INC., CANTON, MA:  
1,427,074. REN. 3-22-07. INT. CL. 1.

GOOD FOOD GROUP A/S, VEJLE, DENMARK:  
1,429,451. REN. 3-21-07. INT. CL. 29.  
1,429,451, CANC. INT. CL. 32.

GOOD HAIR DAYS, INC., LEOMINSTER, MA:  
2,025,703. REN. 3-21-07. INT. CL. 26.

GOOD HOPE EQUESTRIAN TRAINING CENTER, INC., MIAMI, FL:  
3,232,597, PUB. 2-6-2007. INT. CL. 36.

GOOD SAMARITAN HOSPITAL MEDICAL CENTER, WEST ISLIP, NY:  
2,356,483, CANC. INT. CL. 42.

GOODI'S GYROS, INC., NORTHBROOK, IL:  
2,123,573. REN. 3-22-07. INT. CL. 42.

GOODTASTE PITTSBURGH, LLC, PITTSBURGH, PA:  
3,234,868, INT. CL. 41.  
3,234,870, INT. CL. 41.

GOODWAY TECHNOLOGIES CORPORATION, STAMFORD, CT:  
3,234,079, INT. CL. 7.

GOODWILL INDUSTRIES OF SOUTHEASTERN WISCONSIN AND METROPOLITAN CHICAGO, INC., MILWAUKEE, WI:  
2,356,702, CANC. MULTIPLE CLASS, INT. CLS. 35, 41 AND 42.

GOODWIN, DANIEL L., BOSTON, MA:  
2,358,530, CANC. INT. CL. 41.

- GOODY'S MS, LP, KNOXVILLE, TN:  
2,356,901, CANC. INT. CL. 25.
- GOODYEAR TIRE & RUBBER COMPANY, THE, AKRON, OH:  
3,235,217, INT. CL. 12.  
3,235,279, INT. CL. 7.
- GOOSE RIDGE, LLC, OUTLOOK, WA:  
3,234,925, INT. CL. 33.
- GORDON, PHILLIP V., DURHAM, NC:  
2,357,676, CANC. INT. CL. 16.
- GORNEY, EDEN B., COVINGTON, LA:  
3,232,979, PUB. 2-6-2007. INT. CL. 35.
- GOSPEL MUSIC CHANNEL, LLC, ATLANTA, GA:  
3,234,513, INT. CL. 41.
- GOTHAM LICENSING GROUP, LLC, NEW YORK, NY,  
JOUJOU DESIGNS INC., NEW YORK, NY:  
2,032,709. REN. 3-21-07. INT. CL. 25.
- GOTT BROTHERS DEVELOPMENT, L.L.C., CALISTOGA, CA:  
2,710,978, COR. INT. CL. 43.
- GRACE ENGINEERED PRODUCTS, INC. CORP., DAVENPORT, IA:  
3,235,214, INT. CL. 9.
- GRACE MANUFACTURING INC., RUSSELLVILLE, AR:  
3,232,180, PUB. 2-6-2007. INT. CL. 8.
- GRACELAND COLLEGE CENTER FOR PROFESSIONAL DEVELOPMENT AND LIFE-LONG LEARNING, INC., THE, MISSION, KS:  
2,064,914. REN. 3-22-07. MULTIPLE CLASS, INT. CLS. 9 AND 16.
- GRACO MINNESOTA INC., MINNEAPOLIS, MN:  
3,235,370, INT. CL. 7.
- GRADY, PATRICIA DRUMM, SPRINGFIELD CENTER, NY:  
3,234,508, INT. CL. 30.
- GRAFFITI REMOVAL, INC., LA HABRA HEIGHTS, CA:  
2,040,200. REN. 3-20-07. INT. CL. 17.
- GRAHAM CORPORATION, BATAVIA, NY:  
2,358,468, CANC. INT. CL. 16.
- GRAHAM PACKAGING PET TECHNOLOGIES INC., YORK, PA:  
3,232,245, PUB. 2-6-2007. INT. CL. 17.
- GRAHAM, RICHARD A., HUNTINGTON BEACH, CA:  
3,233,948, MULTIPLE CLASS, INT. CLS. 10 AND 28.
- GRAIN PROCESSING CORPORATION, MUSCATINE, IA:  
3,235,047, INT. CL. 1.
- GRAIN TO GREEN, INC., CARLSBAD, CA:  
2,358,271, CANC. INT. CL. 32.
- GRAJ & GUSTAVSEN, INC., NEW YORK, NY:  
2,029,838. REN. 3-22-07. INT. CL. 25.
- GRANCRETE LLC, MECHANICSVILLE, VA:  
3,234,781, INT. CL. 1.
- GRAND HALL ENTERPRISE CO., LTD., TAIPEI CITY, TAIWAN:  
3,233,001, PUB. 2-6-2007. INT. CL. 11.
- GRAND SLAM CLUB/OVIS, BIRMINGHAM, AL:  
3,234,367, INT. CL. 41.
- GRANDEX INTERNATIONAL CORPORATION, TAIPEI HSIEN, TAIWAN:  
2,357,192, CANC. INT. CL. 9.
- GRANDPATELLME.COM SOFTWARE SYSTEMS, LLC, CHANDLER, AZ:  
3,233,063, PUB. 2-6-2007. INT. CL. 42.
- GRAPHIC ARTS SYSTEMS, INC., CLEVELAND, OH:  
2,061,319. REN. 3-19-07. INT. CL. 16.
- GRAPHLINE, INC., SUNRISE, FL, DBA DUOSTAT COMPANY:  
2,039,854. REN. 3-21-07. INT. CL. 1.
- GRATISTELEFON SVENSKA AB, S-114 57 STOCKHOLM, SWEDEN:  
2,356,536, CANC. MULTIPLE CLASS, INT. CLS. 9, 35 AND 38.
- GRAVES, TODD DONALD, EDMOND, OK:  
3,234,471, INT. CL. 28.
- GRAY TELEVISION GROUP, INC., ATLANTA, GA:  
3,233,261, PUB. 2-6-2007. INT. CL. 41.
- GRAYMARK INTERNATIONAL, INC., TUSTIN, CA:  
2,031,753. REN. 3-22-07. MULTIPLE CLASS, INT. CLS. 9 AND 16.
- GREAT AMERICAN BICYCLE, LLC, SARATOGA SPRINGS, NY:  
3,233,972, INT. CL. 12.
- GREAT AMERICAN TOOL COMPANY, INC., BUFFALO, NY:  
2,357,103, CANC. INT. CL. 8.
- GREAT CANADIAN RAILTOUR COMPANY LTD., VANCOUVER, BRITISH COLUMBIA:  
2,100,715. REN. 3-16-07. INT. CL. 39.
- GREAT LAKES MUSEUM OF SCIENCE, ENVIRONMENT AND TECHNOLOGY, THE, CLEVELAND, OH:  
2,356,487, CANC. INT. CL. 20.
- GREAT LAKES ORTHODONTICS, LTD., TONAWANDA, NY:  
3,232,228, PUB. 2-6-2007. INT. CL. 10.
- GREAT NECK SAW MANUFACTURERS, INC., MINEOLA, NY:  
2,132,015. REN. 3-22-07. INT. CL. 8.
- GREATER RICHMOND CHAMBER OF COMMERCE, RICHMOND, VA:  
3,232,978, PUB. 2-6-2007. INT. CL. 35.
- GREEK ORTHODOC CHURCH OF ST. GEORGE, INC., BETHESDA, MD:  
2,036,568. REN. 3-22-07. INT. CL. 41.
- GREEN BAY PACKERS, INC., GREEN BAY, WI:  
3,234,095, MULTIPLE CLASS, INT. CLS. 24 AND 28.  
3,234,096, MULTIPLE CLASS, INT. CLS. 24 AND 28.
- GREEN DEVELOPMENT S.A., NEUCHATEL, SWITZERLAND:  
1,396,849, CANC. INT. CL. 21.
- GREEN HILLS SOFTWARE, INC., SANTA BARBARA, CA:  
3,234,145, INT. CL. 9.
- GREEN HORIZONS, INC., EWA BEACH, HI:  
3,161,468, COR. INT. CL. 1.
- GREEN RIVER LOG SALES LTD., BRITISH COLUMBIA V2V 4M4, CANADA:  
3,232,257, PUB. 2-6-2007. INT. CL. 19.
- GREEN RIVER LOG SALES LTD., MISSION, BRITISH COLUMBIA V2V 4M4, CANADA:  
3,232,258, PUB. 2-6-2007. INT. CL. 19.
- GREEN RIVER LOG SALES LTD., BRITISH COLUMBIA V2V 4M4, CANADA:  
3,232,259, PUB. 2-6-2007. INT. CL. 19.
- GREEN WHITE CHECKER, LLC, TORRANCE, CA:  
3,234,763, INT. CL. 25.
- GREEN, DAVID G., UPLAND, CA:  
3,232,398, PUB. 2-6-2007. MULTIPLE CLASS, INT. CLS. 41 AND 42.
- GREEN, EMILY, LOS ANGELES, CA:  
3,232,918, PUB. 2-6-2007. INT. CL. 24.
- GREENE KING BREWING & RETAILING LIMITED, SUFFOLK, ENGLAND, GREENE KING PLC., SUFFOLK, IP33 1QT, ENGLAND:  
2,046,344. REN. 3-22-07. INT. CL. 32.
- GREENE KING BREWING AND RETAILING LIMITED, EDMUNDS, SUFFOLK, ENGLAND, GREENE KING PLC., SUFFOLK IP33 1QT, ENGLAND:  
2,032,690. REN. 3-22-07. INT. CL. 32.
- GREENE, TWEED OF DELAWARE, INC., WILMINGTON, DE:  
2,018,321. REN. 3-17-07. INT. CL. 17.
- GREENLEAF, CATHERINE, ANDOVER, NH:  
3,235,007, INT. CL. 41.
- GRETAG-MACBETH HOLDING A.G., CH-815 REGEN-DORF, SWITZERLAND, KOLLMORGEN INSTRUMENTS CORPORATION, NEWBURGH, NY:  
2,037,499. REN. 3-16-07. INT. CL. 16.
- GRIFFIN INDUSTRIES, INC., COLD SPRING, KY:  
2,032,484. REN. 3-16-07. INT. CL. 5.
- GRIFFIN LLC, VALDOSTA, GA:  
2,358,402, CANC. INT. CL. 5.
- GRIZZARD COMMUNICATIONS GROUP, INC., ATLANTA, GA:  
3,234,576, INT. CL. 35.
- GROB-WERKE BURKHART GROB E.K., 87719 MINDELHEIM, FED REP GERMANY:  
3,233,669, PUB. 2-6-2007. MULTIPLE CLASS, INT. CLS. 7

- AND 12.  
GROOMBADABOOM, INC., ROSEMONT, IL:  
3,235,069, INT. CL. 3.
- GROOPE.COM LLC, CAMBRIDGE, MA:  
3,233,889, MULTIPLE CLASS, INT. CLS. 38 AND 42.  
3,233,890, MULTIPLE CLASS, INT. CLS. 38 AND 42.  
3,233,930, MULTIPLE CLASS, INT. CLS. 38 AND 42.
- GROSS, JOHN, WHITEFISH BAY, WI:  
2,356,626, CANC. INT. CL. 41.
- GROUP ESTATE PLANNING, INC., MINNEAPOLIS, MN,  
DBA GROUP ESTATE PLANNING, LTD.:  
1,397,096, CANC. INT. CL. 36.
- GROUP FITNESS USA, LLC, GAITHERSBURG, MD:  
3,235,016, INT. CL. 41.
- GRUBBLE PRODUCTS, LLC, IRVINE, CA:  
3,234,449, INT. CL. 17.
- GRUPO ANDREA, S.A. DE C.V., LEON, GUANAJUANTO,  
MEXICO:  
2,933,425, AM. MULTIPLE CLASS, INT. CLS. 18, 25 AND  
35.
- GRUPO BIMBO, S.A. DE C.V., MEXICO CITY, MEXICO:  
3,233,291, PUB. 2-6-2007. INT. CL. 29.
- GRUSSO, EKUN LOGAN, BURBANK, CA:  
3,234,679, INT. CL. 9.
- GSEG LLC, FARMINGTON, CT:  
1,058,334, REN. 3-22-07. INT. CL. 9.
- GSI COMMERCE SOLUTIONS, INC., KING OF PRUSSIA,  
PA:  
3,233,493, PUB. 2-6-2007. MULTIPLE CLASS, INT. CLS.  
35, 36 AND 42.
- GTE CORPORATION, NEW YORK, NY:  
1,979,830, CANC. INT. CL. 16.
- GUANGDONG WEIYE CERAMICS INDUSTRIAL CO.,  
LTD., GUANGDONG 521031, CHINA:  
3,233,524, PUB. 2-6-2007. INT. CL. 21.
- GUANGZHOU KUNGFU CATERING MANAGEMENT CO.,  
LTD., GUANGZHOU, GUANGDONG, CHINA:  
3,232,756, PUB. 2-6-2007. INT. CL. 43.
- GUARDIAN INDUSTRIES CORP., AUBURN HILLS, MI:  
3,234,777, INT. CL. 19.
- GUERBET, FRANCE:  
3,233,608, PUB. 2-6-2007. MULTIPLE CLASS, INT. CLS. 5  
AND 16.
- GUESS ?, INC., LOS ANGELES, CA:  
3,235,398, INT. CL. 9.
- GUESS ELECTRONICS, INC., BIRMINGHAM, AL:  
2,356,728, CANC. MULTIPLE CLASS, INT. CLS. 37 AND  
42.
- GUIDANCE HELICOPTERS, INC., PRESCOTT, AZ:  
3,234,360, INT. CL. 41.
- GUIDANCE SOFTWARE, INC., PASADENA, CA:  
2,356,791, CANC. MULTIPLE CLASS, INT. CLS. 9 AND  
41.
- GUIDEPOSTS, A CHURCH CORPORATION, CARMEL, NY:  
3,234,324, INT. CL. 16.
- GUILLAUME, BERNARD, 06800 CAGNES SUR MER,  
FRANCE:  
2,358,064, CANC. INT. CL. 12.
- GUILLOTINE, INC., ATLANTA, GA:  
3,233,317, PUB. 2-6-2007. INT. CL. 41.  
3,233,322, PUB. 2-6-2007. INT. CL. 41.
- GUITAR CENTER, INC., WESTLAKE VILLAGE, CA:  
3,234,366, INT. CL. 9.
- GULF COAST GLASS & ERECTION CO., HOUSTON, TX:  
3,233,476, PUB. 2-6-2007. INT. CL. 19.
- GULL WING PRODUCTS, INC., SANTEE, CA:  
2,356,526, CANC. INT. CL. 28.
- GUMULINSKI, DENNIS RICHARD, WARREN, MI:  
2,358,380, CANC. INT. CL. 11.
- GUNVAULT, INC., SAN BERNARDINO, CA, GUNVAULT,  
INC., ALBUQUERQUE, NM:  
1,887,892, REN. 3-17-07. INT. CL. 13.
- GUNVAULT, INC., SAN BERNARDINO, CA, T.L. INDUS-  
TRIES, INC., SCOTTSDALE, AZ:  
2,039,595, REN. 3-22-07. INT. CL. 13.
- GUPTA, SANJAY KUMAR, BOSTON, MA:  
3,235,470, INT. CL. 41.
- GUPTA, SHYAM K., SCOTTSDALE, AZ:  
2,649,590, CANC. INT. CL. 42.
- GURDA GARDENS LTD., GOSHEN, NY:  
3,232,206, PUB. 2-6-2007. INT. CL. 31.
- GUZMAN, ANDRES ATAYDE, BENITO JUAREZ, MEXICO  
AND GUZMAN, ALFREDO ATAYDE, BENITO JUAREZ,  
MEXICO AND GUZMAN, ALBERTO OSCAR ATAYDE,  
BENITO JUAREZ, MEXICO:  
3,232,348, PUB. 2-6-2007. INT. CL. 41.
- H & L TOOTH COMPANY, MONTEBELLO, CA:  
1,396,466, CANC. INT. CL. 7.
- H.H. BROWN SHOE COMPANY, INC., GREENWICH, CT TO  
COLUMBIA INSURANCE COMPANY, OMAHA, NE:  
1,980,268, CANC. INT. CL. 25.
- H-P PRODUCTS, INC., LOUISVILLE, OH:  
1,980,242, CANC. INT. CL. 9.
- H-TECH, INC., WILMINGTON, DE:  
2,124,181, REN. 3-21-07. INT. CL. 7.
- HAARUP MASKINFABRIK A/S, DENMARK:  
3,233,748, PUB. 2-6-2007. INT. CL. 7.
- HABER VISION, LLC, GOLDEN, CO:  
3,234,844, MULTIPLE CLASS, INT. CLS. 9, 18 AND 25.
- HACIENDA LA CAPILLA S.A. DE C.V., CAPILLA DE  
GUADALUPE, MEXICO:  
3,234,897, INT. CL. 33.
- HADLEY POLLET, LLC, CAMBRIDGE, MA:  
3,234,934, INT. CL. 18.  
3,234,935, INT. CL. 25.
- HAEMONETICS CORPORATION, BRAINTREE, MA:  
1,057,423, REN. 3-21-07. MULTIPLE CLASS, INT. CLS. 9  
AND 10.
- HAGEMEYER NORTH AMERICA, INC., ALPHARETTA,  
GA:  
3,233,822, INT. CL. 7.
- HAHN, SIMON S., BRAMBLETON, VA:  
3,234,303, INT. CL. 36.
- HAIN CELESTIAL GROUP, INC., THE UNIONDALE, NY,  
ORIGINAL HAMPTON POTATO CHIP COMPANY, SYOS-  
SET, NY, DBA HARRY'S PREMIUM SNACKS:  
2,036,489, REN. 3-17-07. MULTIPLE CLASS, INT. CLS. 29  
AND 30.
- HAIX-SCHUHE PRODUKTIONS UND VERTIEBS GMBH,  
MAINBURG D-84048, FED REP GERMANY:  
3,232,907, PUB. 2-6-2007. MULTIPLE CLASS, INT. CLS. 9  
AND 25.  
3,232,908, PUB. 2-6-2007. MULTIPLE CLASS, INT. CLS. 9  
AND 25.
- HAKATAI ENTERPRISES, INC., ASHLAND, OR:  
3,232,813, PUB. 2-6-2007. MULTIPLE CLASS, INT. CLS. 19  
AND 42.
- HALL COMMUNICATIONS, INC., LAKELAND, FL, ROOT,  
CHAPMAN S., LAKELAND, FL:  
1,425,972, REN. 3-16-07. INT. CL. 38.
- HALL, MARK H., ARVIN, CA, DBA HALL FARMING:  
1,397,051, CANC. INT. CL. 31.
- HALLIBURTON ENERGY SERVICE, INC., CARROLLTON,  
TX:  
2,115,357, REN. 3-17-07. INT. CL. 7.
- HALLIBURTON ENERGY SERVICES, INC., CARROLL-  
TON, TX, NATIONAL LEAD COMPANY, NEW YORK,  
NY:  
656,476, REN. 3-17-07. U.S. CL. 38 (INT. CL. 16).
- HALLIBURTON ENERGY SERVICES, INC., CARROLL-  
TON, TX:  
2,130,480, REN. 3-17-07. INT. CL. 3.
- HALLMARK REHABILITATION GP, LLC, FOOTHILL  
RANCH, CA:  
3,233,027, PUB. 2-6-2007. INT. CL. 44.
- HAMILTON BEACH/PROCTOR-SILEX, INC., GLEN AL-  
LEN, VA:  
3,233,417, PUB. 2-6-2007. INT. CL. 11.
- HAMPTONS GROUP LIMITED, BRISTOL BS1 4XE, ENG-  
LAND:  
2,358,025, CANC. INT. CL. 36.
- HAMPTONS GROUP LIMITED, BRISTOL BS1 4XE, UNITED  
KINGDOM:  
2,358,059, CANC. INT. CL. 36.

- HANDY & HARMAN, RYE, NY:  
3,232,246, PUB. 2-6-2007. INT. CL. 6.
- HANLEY-WOOD, LLC, WASHINGTON, DC:  
3,233,194, PUB. 2-6-2007. INT. CL. 35.
- HANNA INSTRUMENTS, INC., WOONSOCKET, RI:  
2,357,198, CANC. INT. CL. 9.
- HANNA-BARBERA PRODUCTIONS, INC, BURBANK, CA:  
3,234,797, INT. CL. 31.
- HANOVER, AMBER, LAS VEGAS, NV:  
3,235,221, INT. CL. 16.
- HANSEN, ROBYN E., LOS ANGELES, CA:  
3,235,247, INT. CL. 41.
- HANSON MCCLAIN RETIREMENT NETWORK, LLC, FOLSOM, CA:  
3,234,613, INT. CL. 36.
- HANSSON, INC., SANTA CLARA, CA:  
3,232,526, PUB. 2-6-2004. INT. CL. 28.
- HAQ, NADEEM, ARLINGTON HEIGHTS, IL, DBA IAMUSA INC:  
2,356,842, CANC. INT. CL. 25.
- HARANDI, MEHDI, SPRINGFIELD, VA:  
3,235,151, MULTIPLE CLASS, INT. CLS. 37 AND 42.
- HARBINGER TECHNOLOGIES GROUP, INC., MCLEAN, VA:  
3,232,970, PUB. 2-6-2007. INT. CL. 9.
- HARBISON-WALKER REFRACTORIES COMPANY, MOON TOWNSHIP, PA, DRESSER INDUSTRIES, INC., DALLAS, TX:  
1,059,265. REN. 3-20-07. INT. CL. 19.
- HARBRO, LLC, BRIGHTON, MI:  
3,232,330, PUB. 8-10-2004. INT. CL. 28.
- HARCOURT ASSESSMENT INC., SAN ANTONIO, TX:  
3,235,159, INT. CL. 41.
- HARDWARESTREET.COM, INC., RENO, NV:  
2,357,380, CANC. INT. CL. 35.
- HARDY, TERRIE R., TULSA, OK:  
1,427,424. REN. 3-22-07. INT. CL. 16.
- HARE, SCOTT, BELLEVILLE, WI AND HARE, LISA, BELLEVILLE, WI:  
3,234,664, INT. CL. 29.
- HARLEQUIN ENTERPRISES LIMITED, DON MILLS, ONTARIO M3B 3K9, CANADA:  
2,356,688, CANC. INT. CL. 16.
- HARMAN INTERNATIONAL INDUSTRIES, LIMITED, NORTHRIDGE, CA, BSS AUDIO LIMITED, HERTS EN6 3JB, ENGLAND:  
2,012,429. REN. 3-16-07. INT. CL. 9.
- HARMAN INTERNATIONAL INDUSTRIES, LIMITED, NORTHRIDGE, CA, BSS AUDIO LIMITED, HERTS EN6 3JB, UNITED KINGDOM:  
2,016,964. REN. 3-16-07. INT. CL. 9.
- HARMSCO, INC., NORTH PALM BEACH, FL:  
2,083,831. REN. 3-20-07. INT. CL. 11.
- HARP, TEREZA ANN, REDLANDS, CA:  
3,233,281, PUB. 2-6-2007. INT. CL. 41.
- HARPERCOLLINS PUBLISHERS L.L.C., NEW YORK, NY:  
2,036,249. REN. 3-22-07. INT. CL. 16.  
3,235,018, INT. CL. 16.  
3,235,021, INT. CL. 16.
- HARRAH'S LICENSE COMPANY, LLC, LAS VEGAS, NV:  
3,232,684, PUB. 7-18-2006. MULTIPLE CLASS, INT. CLS. 35 AND 41.
- HARRIS CORPORATION, MELBOURNE, FL:  
2,358,752, CANC. INT. CL. 8.
- HARRIS INTERACTIVE INC., ROCHESTER, NY:  
3,234,066, INT. CL. 35.
- HARRIS MYCFO, INC., CHICAGO, IL FROM MY CFO, INC., MOUNTAIN VIEW, CA:  
3,233,768, MULTIPLE CLASS, INT. CLS. 35 AND 36.
- HARROW PRODUCTS, INC., GRAND RAPIDS, MI:  
1,396,496, CANC. INT. CL. 8.
- HARRY N. ABRAMS, INCORPORATED, NEW YORK, NY:  
2,077,396. REN. 3-17-07. INT. CL. 16.
- HARTFORD FIRE INSURANCE COMPANY, HARTFORD, CT:  
1,979,758, CANC. INT. CL. 16.  
2,062,847. REN. 3-21-07. INT. CL. 41.  
2,066,597. REN. 3-21-07. INT. CL. 41.  
2,087,132. REN. 3-21-07. INT. CL. 16.
- HARTFORD LIFE INSURANCE COMPANY, HARTFORD, CT:  
3,233,501, PUB. 2-6-2007. INT. CL. 36.
- HARTNESS INTERNATIONAL, INC., GREENVILLE, SC:  
3,233,967, INT. CL. 7.
- HARVEY ENTERTAINMENT, INC., NEW YORK, NY:  
3,234,730, INT. CL. 9.  
3,234,731, INT. CL. 25.  
3,234,732, INT. CL. 28.
- HASBRO, INC., PAWTUCKET, RI:  
1,415,171. REN. 3-19-07. INT. CL. 28.
- HASBRO, INC., PAWTUCKET, RI, TIGER ELECTRONICS, INC., VERNON HILLS, IL:  
2,050,002. REN. 3-22-07. INT. CL. 28.
- HASBRO, INC., PAWTUCKET, RI:  
2,358,036, CANC. INT. CL. 28.  
3,234,058, INT. CL. 28.  
3,234,070, INT. CL. 28.
- HASHEM, JARROD, GOLD CANYON, AZ:  
3,233,287, PUB. 2-6-2007. INT. CL. 36.
- HASTINGS MANUFACTURING COMPANY, LLC, HASTINGS, MI:  
2,032,087. REN. 3-20-07. INT. CL. 7.
- HATRIX INCORPORATED, LOUISVILLE, KY:  
2,358,106, CANC. INT. CL. 25.
- HAVA JAVA, INC., PORTLAND, OR:  
2,034,692. REN. 3-21-07. INT. CL. 42.
- HAWAIIAN NATURAL WATER COMPANY, INC., PEARL CITY, HI:  
2,356,478, CANC. INT. CL. 32.
- HAWAIIAN ORGANICS, L.L.C., HONOLULU, HI:  
3,232,988, PUB. 2-6-2007. INT. CL. 3.
- HAWKINS, TOMIKO, OAKLAND, CA:  
3,234,597, MULTIPLE CLASS, INT. CLS. 9 AND 41.
- HAYES, KAREN, HAYDEN LAKE, ID:  
3,234,852, INT. CL. 44.
- HBC DISTRIBUTION INCORPORATED, OAKLAND, CA:  
3,171,967, AM. MULTIPLE CLASS, INT. CLS. 3 AND 5.
- HBD INDUSTRIES, INC., DUBLIN, OH, B.F. GOODRICH COMPANY, THE, AKRON, OH:  
1,404,038. REN. 3-21-07. INT. CL. 17.
- HBI INTERNATIONAL, PHOENIX, AZ:  
3,233,110, PUB. 2-6-2007. INT. CL. 34.
- HCA-HEALTHONE LLC, DENVER, CO, SWEDISH HEALTH SYSTEMS, ENGLEWOOD, CO:  
1,455,788. REN. 3-21-07. MULTIPLE CLASS, INT. CLS. 41 AND 42.
- HCC INC.:  
1,396,552, CANC. INT. CL. 9.
- HD AMERICA, INC., EARTH CITY, MO:  
1,427,386. REN. 3-21-07. INT. CL. 12.
- HD NUTRITION, INC., COSTA MESA, CA:  
3,234,916, INT. CL. 5.
- HEADRICK, KEN, GRASS VALLEY, CA:  
2,356,930, CANC. INT. CL. 42.
- HEADWATERS RESEARCH & DEVELOPMENT, INC., OTTAWA, ONTARIO K1H5L3, CANADA:  
2,358,035, CANC. INT. CL. 9.
- HEALTH & BEAUTY SOLUTIONS LIMITED, LONDON, W1V 2LD, UNITED KINGDOM:  
2,357,904, CANC. INT. CL. 3.  
2,358,046, CANC. INT. CL. 3.  
2,358,047, CANC. INT. CL. 3.
- HEALTH MARKETING, INC., CHICAGO, IL:  
2,357,523, CANC. INT. CL. 42.
- HEALTH S.E.T., DENVER, CO:  
1,979,621, CANC. INT. CL. 41.
- HEALTH VALLEY COMPANY, MELVILLE, NY, HEALTH VALLEY NATURAL FOODS INC., LOS ANGELES, CA:  
1,075,142. REN. 3-17-07. MULTIPLE CLASS, INT. CLS. 29 AND 30.

HEALTH WORLD OF BARRINGTON LTD, BARRINGTON, IL, JOHN F. KENNEDY HEALTH WORLD, LTD., BARRINGTON, IL:  
2,019,252. REN. 3-20-07. INT. CL. 41.

HEALTHCARE PURCHASING PARTNERS INTERNATIONAL, LLC, IRVING, TX, HEALTHCARE PURCHASING PARTNERS, INC., IRVING, TX:  
2,003,695. REN. 3-17-07. INT. CL. 35.

HEALTHPLACERS, INC., ALPHARETTA, GA:  
3,234,413, INT. CL. 35.

HEALTHPOINT, LTD., SAN ANTONIO, TX:  
3,234,519, INT. CL. 3.

HEALTHSTRING, LLC, CHICAGO, IL:  
3,233,137, PUB. 2-6-2007. MULTIPLE CLASS, INT. CLS. 39 AND 44.  
3,233,138, PUB. 2-6-2007. MULTIPLE CLASS, INT. CLS. 39 AND 44.  
3,233,140, PUB. 2-6-2007. MULTIPLE CLASS, INT. CLS. 39 AND 44.

HEALTHY COMPUTING.COM, SAN DIEGO, CA:  
3,232,557, PUB. 2-6-2007. MULTIPLE CLASS, INT. CLS. 16 AND 41.

HEARST COMMUNICATIONS, INC., NEW YORK, NY:  
2,358,341, CANC. INT. CL. 27.

HEARTHSTONE SENIOR SERVICES, L.P., THE WOODLANDS, TX:  
3,234,498, MULTIPLE CLASS, INT. CLS. 35, 43 AND 44.

HEARTLAND BUILDING PRODUCTS, INC., BOONEVILLE, MS:  
3,233,905, INT. CL. 19.

HEARTS ON FIRE COMPANY LLC, BOSTON, MA:  
3,232,317, PUB. 2-1-2005. INT. CL. 35.  
3,234,432, INT. CL. 35.  
3,234,433, INT. CL. 43.  
3,234,913, INT. CL. 14.

HEAVENLY PASTA, LLC, NEW YORK, NY:  
2,357,552, CANC. INT. CL. 30.

HEB GROCERY COMPANY, LP, SAN ANTONIO, TX:  
3,233,795, INT. CL. 30.  
3,233,816, INT. CL. 35.  
3,234,123, INT. CL. 16.

HEIDELBERGER DRUCKMASCHINEN AG, HEIDELBERG, FED REP GERMANY:  
3,232,833, PUB. 2-6-2007. INT. CL. 7.

HEIFER PROJECT INTERNATIONAL, LITTLE ROCK, AR:  
3,232,725, PUB. 2-6-2007. INT. CL. 36.

HEIKE SCHWARZ, FED REP GERMANY AND ANDREAS EICHSTETTER, FED REP GERMANY:  
3,233,572, PUB. 2-6-2007. INT. CL. 28.

HEIMAN, LESLIE B., NORTHBROOK, IL:  
2,077,558. REN. 3-21-07. INT. CL. 35.

HEINRICH, KYLE, MALIBU, CA:  
3,234,205, INT. CL. 25.

HEISEY COLLECTORS OF AMERICA, INC., NEWARK, OH:  
2,103,367. REN. 3-20-07. U.S. CL. 200.

HELEN & PHIL ROSSO WHOLESALE GLASS DEALERS, INC., PORT VUE, PA:  
2,357,264, CANC. INT. CL. 21.

HELEN HUTCHLEY, INC., CANTON, OH:  
2,357,199, CANC. INT. CL. 35.

HELEN OF TROY LIMITED, ST. MICHAEL, BARBADOS:  
3,232,647, PUB. 2-6-2007. INT. CL. 11.  
3,234,004, MULTIPLE CLASS, INT. CLS. 9 AND 11.  
3,235,245, INT. CL. 21.

HELENA HOLDING COMPANY, WILMINGTON, DE:  
3,234,814, INT. CL. 35.

HELIO LLC, LOS ANGELES, CA:  
3,235,406, INT. CL. 9.

HELLY HANSEN ASA, 1599 MOSS, NORWAY:  
1,428,476. REN. 3-22-07. INT. CL. 25.

HELSON, RACHEL, LOUISVILLE, KY, DBA ACTING FOR A CURE:  
3,233,303, PUB. 2-6-2007. INT. CL. 36.

HEMOPHILIA FOUNDATION OF MICHIGAN, YPSILANTI, MI:  
3,233,159, PUB. 2-6-2007. INT. CL. 36.  
3,233,160, PUB. 2-6-2007. INT. CL. 35.  
3,233,161, PUB. 2-6-2007. INT. CL. 41.  
3,233,162, PUB. 2-6-2007. INT. CL. 41.  
3,233,163, PUB. 2-6-2007. INT. CL. 41.  
3,233,164, PUB. 2-6-2007. INT. CL. 16.  
3,233,165, PUB. 2-6-2007. INT. CL. 16.  
3,233,166, PUB. 2-6-2007. INT. CL. 41.

HENKEL CAPITAL, S.A. DE C.V., ECATEPEC DE MORELOS, MEXICO:  
2,358,150, CANC. INT. CL. 3.

HENKEL CONSUMER ADHESIVES, INC., AVON, OH:  
3,235,468, INT. CL. 1.

HENRI STUDIO, LLC, PEORIA, IL:  
1,979,235, CANC. MULTIPLE CLASS, INT. CLS. 11, 19, 20 AND 21.

HENRY, SYLVESTER III, CORONA, CA:  
3,234,831, INT. CL. 25.

HERAEUS ELECTRO-NITE INTERNATIONAL N.V., A B350 HOUTHALEN, BELGIUM, HERAEUS ELECTRO-NITE CO., PHILADELPHIA, PA:  
2,037,648. REN. 3-17-07. INT. CL. 9.

HERBA NATURAL PRODUCTS, INC., BROOKLYN, NY:  
2,085,246. REN. 3-19-07. INT. CL. 30.

HERBACEUTICALS, INC., NAPA, CA:  
3,233,820, INT. CL. 5.

HERBRUCK'S POULTRY RANCH, SARANAC, MI:  
2,358,522, CANC. INT. CL. 29.

HERCULES TIRE & RUBBER COMPANY, THE, FINDLAY, OH:  
2,134,860. REN. 3-22-07. INT. CL. 12.

HERITAGE MINT, LTD, SCOTTSDALE, AZ:  
3,234,075, INT. CL. 21.

HERITAGE MINT, LTD., SCOTTSDALE, AZ:  
1,936,170. REN. 3-19-07. INT. CL. 28.

HERMA GMBH, D-70327 STUTTGART, DENMARK, FIRMA HEINRICH HERMANN, STUTTGART-WANGEN, FED REP GERMANY:  
638,259. REN. 3-21-07. U.S. CL. 5 (INT. CL. 16).

HERMES INTERNATIONAL, FRANCE:  
3,233,557, PUB. 2-6-2007. MULTIPLE CLASS, INT. CLS. 6, 14, 18, 25 AND 26.  
3,233,558, PUB. 2-6-2007. MULTIPLE CLASS, INT. CLS. 6, 14, 18, 25 AND 26.

HERNANDEZ, JORGE DE LA MORA, MEXICO CITY, MEXICO AND HERNANDEZ, PABLO DE LA MORA, MEXICO CITY, MEXICO:  
2,358,567, CANC. INT. CL. 9.

HEROSE GMBH ARMATUREN UND METALLE, FED REP GERMANY:  
3,233,617, PUB. 2-6-2007. MULTIPLE CLASS, INT. CLS. 6, 7, 11, 17, 19 AND 20.

HERRADA, ANTONIO HIPÓLITO PEÑA, MEXICO, D.F., MEXICO:  
3,232,114, PUB. 10-3-2006. INT. CL. 41.

HERSCH AND COMPANY, LOS ANGELES, CA:  
3,234,127, INT. CL. 28.

HERSHEY CHOCOLATE & CONFECTIONERY CORP., WHEAT RIDGE, CO:  
3,235,275, INT. CL. 30.

HERSHEY CHOCOLATE & CONFECTIONERY CORPORATION, WHEAT RIDGE, CO:  
2,357,868, CANC. INT. CL. 16.  
2,358,632, CANC. INT. CL. 30.

HERSHEY FOODS CORPORATION, HERSHEY, PA:  
1,396,706, CANC. INT. CL. 16.

HERWITT, JENNIFER, WEST HOLLYWOOD, CA:  
3,235,138, INT. CL. 14.

HERZOG AG, 9116 WOLFERTSWIL, SWITZERLAND:  
2,029,370. REN. 3-19-07. INT. CL. 7.

HESSE, CONNIE, IDAHO FALLS, ID:  
3,234,978, INT. CL. 37.

HI-TECH COMUNICATIONS, INC., STAMFORD, CT:  
2,357,514, CANC. MULTIPLE CLASS, INT. CLS. 16 AND 38.

- HIBBS, JOSEPH E., MADISONVILLE, KY AND HIBBS, VICKI Y., MADISONVILLE, KY:  
2,358,673, CANC. INT. CL. 35.
- HICKORY SPRINGS MANUFACTURING COMPANY, HICKORY, NC:  
3,234,271, INT. CL. 22.  
3,234,460, MULTIPLE CLASS, INT. CLS. 20 AND 24.
- HID GLOBAL CORPORATION, IRVINE, CA:  
1,401,930, REN. 3-17-07, INT. CL. 9.
- HIGH DEF EXPO, INC., BURBANK, CA:  
3,232,604, PUB. 2-6-2007, MULTIPLE CLASS, INT. CLS. 35 AND 41.
- HIGH GEAR SPECIALTIES, INC., OAKLAND, FL:  
3,233,933, INT. CL. 6.
- HIGH POINT MILLS, INC., HENRIETTA, NY:  
1,396,402, CANC. INT. CL. 5.
- HIGHLY GRAPHIC, INC., LOS ANGELES, CA:  
3,235,194, INT. CL. 35.
- HIGHWATER DESIGNS LIMITED, CHELTENHAM G105, UNITED KINGDOM:  
2,356,449, CANC. INT. CL. 9.
- HILDEBRANDT, WILLIAM K., INMAN, SC:  
3,234,007, INT. CL. 9.
- HILL, JAMES M., EUGENE, OR:  
2,356,837, CANC. INT. CL. 25.
- HILLCREST ESTATE DURBANVILLE (PTY) LIMITED, DURBANVILLE, SOUTH AFRICA:  
3,233,293, PUB. 2-6-2007, INT. CL. 33.
- HILTON HOLLIS DESIGNS, INC., NEW YORK, NY:  
3,232,220, PUB. 2-6-2007, INT. CL. 25.
- HIMALAYAN ACADEMY, SAN FRANCISCO, CA:  
1,396,780, CANC. INT. CL. 16.
- HIMMEL HANDCRAFTS, L.C., WAYNESBORO, VA:  
2,358,401, CANC. INT. CL. 20.
- HINDSGAUL MANNEQUINS A/S, MALOV, DENMARK:  
1,386,009, CANC. INT. CL. 20.
- HINIKER COMPANY, MANKATO, MN:  
3,233,308, PUB. 2-6-2007, INT. CL. 7.
- HINZ, MARTIN C., DULUTH, MN:  
3,233,092, PUB. 2-6-2007, INT. CL. 35.
- HIRAM A. SMITH WHETSTONE COMPANY, INC., HOT SPRINGS, AR:  
1,396,499, CANC. INT. CL. 8.
- HIRES ENTERPRISES, INC., SANDY, UT:  
2,357,548, CANC. INT. CL. 30.
- HIRTH, DARRELL, FT. THOMAS, KY:  
2,358,199, CANC. INT. CL. 5.
- HISCOX PLC, LONDON, UNITED KINGDOM:  
3,235,458, INT. CL. 36.
- HISTORIC LEMP BREWERY, L.L.C., ST. LOUIS, MO:  
3,234,032, INT. CL. 37.
- HITO CARBON COMPOSITES, INC., GARDENA, CA, THOMPSON, HARRY I., LOS ANGELES, CA, DBA THE H. I. THOMPSON CO.:  
429,707, REN. 3-20-07, U.S. CL. 12 (INT. CL. 17).
- HK SYSTEMS, INC., NEW BERLIN, WI:  
2,356,661, CANC. INT. CL. 7.
- HLI CORPORATION, OXNARD, CA:  
2,358,231, CANC. INT. CL. 9.
- HMI INDUSTRIES INC., STRONGSVILLE, OH TO HMI INDUSTRIES INC., STRONGSVILLE, OH:  
1,980,046, CANC. INT. CL. 9.
- HOANG, THANG V., FOUNTAIN VALLEY, CA:  
3,234,887, INT. CL. 9.
- HOBART BROTHERS COMPANY, TROY, OH, HOBART BROTHERS COMPANY, TROY, OH:  
2,045,734, REN. 3-22-07, INT. CL. 6.
- HOBBY TOWN UNLIMITED, INC., LINCOLN, NE:  
3,233,438, PUB. 2-6-2007, MULTIPLE CLASS, INT. CLS. 16 AND 41.
- HOBOKEN WOOD FLOORING CORPORATION, WAYNE, NJ:  
3,234,350, INT. CL. 35.
- HOBOKEN WOOD FLOORING LLC, WAYNE, NJ:  
3,107,831, COR. INT. CL. 35.  
3,235,318, INT. CL. 19.
- HOCK, DAVID, BOWLING GREEN, KY:  
2,356,611, CANC. INT. CL. 14.
- HODGES, HOLLEY, SEFFNER, FL:  
3,234,812, INT. CL. 25.
- HODGES, RONALD W., LONG BEACH, CA, DBA RESTAURANT ROW:  
1,396,715, CANC. INT. CL. 16.
- HODGES, VANNIE KAY, ANN ARBOR, MI:  
3,235,076, INT. CL. 16.
- HOECHST CERAMTEC AG, SELB, FED REP GERMANY:  
1,982,928, REN. 3-21-07, INT. CL. 1.
- HOFFMANN-LA ROCHE INC., NUTLEY, NJ:  
2,070,631, REN. 3-20-07, INT. CL. 5.
- HOFMANN, RICARDA M., FED REP GERMANY:  
3,233,538, PUB. 2-6-2007, MULTIPLE CLASS, INT. CLS. 18, 24 AND 25.
- HOKUSAN, LTD., KOTO-KU, TOKYO, JAPAN:  
1,058,443, REN. 3-22-07, INT. CL. 19.
- HOLIDAY DIVER, INC., DEERFIELD BEACH, FL:  
2,077,418, REN. 3-19-07, INT. CL. 42.
- HOLIDAY STATIONSTORES, INC., MINNEAPOLIS, MN:  
1,441,725, REN. 3-17-07, INT. CL. 4.  
2,069,446, REN. 3-17-07, INT. CL. 32.
- HOLLEY HOWARD AND SARAH TAYLOR PARTNERSHIP, THE, DECATUR, GA:  
2,357,102, CANC. INT. CL. 41.
- HOLLYWOOD UNDERWATER LTD., REDONDO BEACH, CA:  
2,358,774, CANC. MULTIPLE CLASS, INT. CLS. 25, 41 AND 42.
- HOLTZ, DAVID, CLEARWATER, FL:  
3,232,881, PUB. 2-6-2007, INT. CL. 35.
- HOLTZMAN-FELDMAN, DANA, ST. LOUIS, MO:  
2,358,016, CANC. INT. CL. 16.
- HOLZMAN, COPPY, WESTPORT, CT:  
3,232,785, PUB. 2-6-2007, INT. CL. 35.
- HOMASOTE COMPANY, WEST TRENTON, NJ:  
839,835, REN. 3-16-07, U.S. CL. 12 (INT. CL. 19).
- HOME BUILDERS ASSOCIATION OF GREATER CHICAGO, ADDISON, IL:  
3,235,433, INT. CL. 35.
- HOME BUYER'S FAIR, INC., SCOTTSDALE, AZ:  
2,358,672, CANC. INT. CL. 41.
- HOME DAY-TO-DAY CARE REGISTRY, INC., GOODLETTSVILLE, TN:  
2,031,692, REN. 3-17-07, INT. CL. 42.
- HOME SAFEGUARD INDUSTRIES, LLC, VERNON HILLS, IL:  
3,234,170, INT. CL. 9.
- HOMELAND HOUSEWARES, LLC, LOS ANGELES, CA:  
3,233,893, INT. CL. 7.
- HOMER TLC, INC., CLAYMONT, DE:  
3,234,182, INT. CL. 19.
- HOMESTEAD, INC., NEWARK, DE:  
2,357,869, CANC. INT. CL. 30.
- HOMESTREET, INC., SEATTLE, WA:  
3,233,265, PUB. 2-6-2007, INT. CL. 36.  
3,233,511, PUB. 2-6-2007, INT. CL. 36.
- HONEYWELL INC., MINNEAPOLIS, MN:  
2,358,536, CANC. INT. CL. 37.
- HONMA GOLF CO., LTD., TOKYO, JAPAN:  
1,429,232, REN. 3-21-07, MULTIPLE CLASS, INT. CLS. 18, 25 AND 28.
- HONORGENS TOYS LIMITED, KOWLOON, HONG KONG:  
2,357,154, CANC. MULTIPLE CLASS, INT. CLS. 15 AND 28.
- HOPE HAVEN, INC., ROCK VALLEY, IA:  
1,396,677, CANC. INT. CL. 12.
- HORIBA JOBIN YVON SAS, F-91160 LONGJUMEAU, FRANCE:  
3,233,578, PUB. 2-6-2007, INT. CL. 9.  
3,233,579, PUB. 2-6-2007, INT. CL. 9.
- HORIZON PRODUCTS, LLC, UNIVERSITY HEIGHTS, OH:  
3,234,200, INT. CL. 29.
- HORSELAND, LLC, VERNON HILL, IL:  
3,232,666, PUB. 9-19-2006, MULTIPLE CLASS, INT. CLS. 9, 14 AND 16.
- HOSPIRA, INC., LAKE FOREST, IL:  
1,427,355, REN. 3-21-07, INT. CL. 10.

HOT STUFF FOODS, LLC, SIOUX FALLS, SD:  
3,197,242, AM. INT. CL. 35.  
3,199,582, COR. MULTIPLE CLASS, INT. CLS. 29, 30, 35 AND 43.

HOUSATONIC VALLEY MATERIALS LLC, NEW MILFORD, CT:  
3,232,727, PUB. 2-6-2007. INT. CL. 35.

HOUSE OF HARDY LTD., NORTHUMBERLAND, GREAT BRITAIN:  
2,028,519. REN. 3-17-07. INT. CL. 28.

HOUSE OF HARVEST MINISTRIES, FLORISSANT, MO:  
2,357,801, CANC. INT. CL. 25.

HOUSE OF LLOYD, INC., GRANDVIEW, MO:  
2,356,947, CANC. INT. CL. 16.

HOUSTON, MARSHALL S., GREENVILLE, SC:  
3,233,376, PUB. 2-6-2007. INT. CL. 44.

HOWARD GROUP, INC., THE, OVERLAND PARK, KS:  
2,357,072, CANC. INT. CL. 35.

HOWELL INSTRUMENTS, INC., FORT WORTH, TX, HOWELL INSTRUMENT CO., INC., FORT WORTH, TX:  
642,331. REN. 3-21-07. U.S. CL. 26 (INT. CL. 9).

HOWELL INSTRUMENTS, INC., FORT WORTH, TX:  
2,038,544. REN. 3-21-07. INT. CL. 9.

HOWREY LLP, WASHINGTON, DC, HOWREY & SIMON, WASHINGTON, DC:  
1,989,742. REN. 3-22-07. INT. CL. 42.

HRG ASSOCIATES, INC., BOCA RATON, FL:  
1,424,175. REN. 3-19-07. INT. CL. 30.

HS MUNITIONS, INC., STEVENSVILLE, MT:  
3,235,091, INT. CL. 13.

HS TM, INC., NEWARK, DE, HENRY SCHEIN, INC., MELVILLE, NY:  
2,065,518. REN. 3-16-07. INT. CL. 1.

HSBC FINANCE CORPORATION, PROSPECT HEIGHTS, IL:  
3,234,637, INT. CL. 36.

HSINTEK ELECTRONICS INC., YORBA LINDA, CA:  
2,357,553, CANC. INT. CL. 9.

HUA, YANG JIAN, SHENZHEN, GUANGDONG PROVINCE, CHINA:  
3,232,752, PUB. 2-6-2007. INT. CL. 9.

HUANG, ZIWEI, LA JOLLA, CA:  
3,234,317, INT. CL. 5.

HUBBELL INCORPORATED, ORANGE, CT:  
1,991,911. REN. 3-20-07. INT. CL. 11.

HUEY CHIAO INTERNATIONAL CO., LTD., HSINCHUANG CITY, TAIPEI, TAIWAN:  
3,235,276, INT. CL. 9.

HUFFY SPORTS DELAWARE, INC., MIAMISBURG, OH:  
1,072,802. REN. 3-21-07. INT. CL. 28.

HUGHES NETWORK SYSTEMS LLC, GERMANTOWN, MD:  
3,235,303, INT. CL. 38.  
3,235,304, INT. CL. 9.

HUGO BOSS TRADE MARK MANAGEMENT, METZINGEN, FED REP GERMANY:  
3,232,389, PUB. 2-6-2007. INT. CL. 3.

HULL, DENNIS H., KEIZER, OR:  
3,235,042, INT. CL. 28.

HUMAN CAPITAL SOLUTIONS, LLC, DERRY, NH:  
2,357,253, CANC. INT. CL. 35.

HUMANA INC., LOUISVILLE, KY:  
3,234,269, INT. CL. 36.

HUMBOLDT TECHNOLOGIES, INC., MIAMI BEACH, FL:  
2,357,334, CANC. INT. CL. 37.

HUMES & BARRINGTON, LLP, ST. LOUIS, MO:  
3,233,365, PUB. 2-6-2007. INT. CL. 35.

HUNTER BOAT ANCHORS, LLC, NEW PORT RICHEY, FL:  
3,233,101, PUB. 2-6-2007. INT. CL. 6.

HUNTER FAN COMPANY, MEMPHIS, TN:  
2,358,766, CANC. INT. CL. 11.  
3,232,302, PUB. 2-6-2007. INT. CL. 11.

HUNTER, TAYLOR H., NEWPORT BEACH, CA:  
3,235,320, INT. CL. 35.

HURLBUT, TERRANCE, WOODSTOCK, ONTARIO, CANADA:  
3,234,401, INT. CL. 36.

HUSIC VINEYARDS, LLC, SAN FRANCISCO, CA:  
3,235,316, INT. CL. 33.

HUSQVARNA AKTIEBOLAG, HUSKVARNA, SWEDEN:  
3,235,308, INT. CL. 36.

HY CITE CORPORATION, MADISON, WI:  
3,232,913, PUB. 2-6-2007. INT. CL. 21.

HY-VEE, INC., WEST DES MOINES, IA:  
2,076,819. REN. 3-20-07. MULTIPLE CLASS, INT. CLS. 37, 41 AND 42.

HYATT LEGAL PLANS, INC., CLEVELAND, OH, HYATT LEGAL SERVICES, KANSAS CITY, MO:  
1,440,880. REN. 3-16-07. INT. CL. 42.

HYCURVE, INC., SAN FRANCISCO, CA:  
2,358,506, CANC. INT. CL. 9.

HYDE TOOLS, INC., SOUTHBRIDGE, MA:  
3,232,997, PUB. 2-6-2007. INT. CL. 18.

HYDRON TECHNOLOGIES, INC., BOCA RATON, FL:  
1,396,302, CANC. INT. CL. 1.

HYMAN, JEFFREY M., LOS ANGELES, CA:  
1,396,959, CANC. INT. CL. 28.

HYPERION ENTERTAINMENT, INC., GLENDALE, CA:  
1,979,999, CANC. INT. CL. 41.

HYPERPHYSICS RESEARCH, LLC, HELENA, MT:  
3,232,167, PUB. 2-6-2007. INT. CL. 9.  
3,232,168, PUB. 2-6-2007. INT. CL. 9.

HYPERTECH, INC., BARTLETT, TN:  
2,063,297. REN. 3-19-07. INT. CL. 7.

HYPERTHERM, INC., HANOVER, NH:  
2,122,913. REN. 3-20-07. MULTIPLE CLASS, INT. CLS. 7 AND 9.

I & OC OF JAPAN CO., LTD., TOKYO 113-0033, JAPAN:  
3,234,033, INT. CL. 1.

I.T. XCHANGE LLC, OAKVILLE, ONTARIO, CANADA:  
3,232,946, PUB. 2-6-2007. MULTIPLE CLASS, INT. CLS. 37 AND 42.

I-VU USA, INC., VALENCIA, CA:  
3,232,089, PUB. 2-6-2007. MULTIPLE CLASS, INT. CLS. 9, 35 AND 41.

IAMS COMPANY, THE, DAYTON, OH:  
2,358,886, CANC. INT. CL. 35.

IATIA LIMITED, BOX HILL NORTH, AUSTRALIA:  
3,232,755, PUB. 2-6-2007. INT. CL. 9.

IBASIS, INC., BURLINGTON, MA:  
3,234,383, INT. CL. 38.  
3,234,837, INT. CL. 16.

IBIS WEST PALM PARTNERS L.P., WEST PALM BEACH, FL:  
2,357,306, CANC. MULTIPLE CLASS, INT. CLS. 37 AND 42.

IBS, INC., SOUTH HACKENSACK, NJ:  
3,233,236, PUB. 2-6-2007. INT. CL. 25.

ICONTROL NETWORKS, INC., PALO ALTO, CA:  
3,235,408, MULTIPLE CLASS, INT. CLS. 9 AND 42.

ICOS CORPORATION, BOTHELL, WA:  
3,234,686, MULTIPLE CLASS, INT. CLS. 40 AND 42.

ID ANALYTICS, INC., SAN DIEGO, CA:  
3,234,579, INT. CL. 42.

ID SOFTWARE, INC., MESQUITE, TX:  
2,358,645, CANC. INT. CL. 9.

IDEAL PET PRODUCTS, INC., VALENCIA, CA:  
3,235,002, INT. CL. 19.

IDEAS THAT TRAVEL, INC., DALLAS, TX:  
2,357,186, CANC. INT. CL. 35.

IDEASTREAM CONSUMER PRODUCTS LLC, PARMA, OH:  
3,234,089, INT. CL. 9.

IDEASTREAM CONSUMER PRODUCTS, LLC, PARMA, OH:  
3,234,390, INT. CL. 16.

IGG SOFTWARE, LLC, PUTNEY, VT:  
3,235,438, INT. CL. 9.

IGT, RENO, NV:  
2,031,612. REN. 3-16-07. INT. CL. 9.  
3,234,377, INT. CL. 9.  
3,234,560, INT. CL. 9.  
3,234,561, INT. CL. 9.  
3,234,562, INT. CL. 9.  
3,234,583, INT. CL. 9.

IHF/GM HOLDING CORPORATION, LAKEVILLE, MN:  
2,358,624, CANC. MULTIPLE CLASS, INT. CLS. 29 AND 30.

- III DREAM WEAVERS, L.L.C., CORPUS CHRISTI, TX:  
3,234,021, INT. CL. 43.
- IKON OFFICE SOLUTIONS TECHNOLOGY SERVICES,  
INC., PHOENIX, AZ:  
2,357,402, CANC. INT. CL. 41.
- IL ANNUITY AND INSURANCE COMPANY, INDIANAPO-  
LIS, IN:  
2,357,888, CANC. INT. CL. 36.
- ILLINOIS TOOL WORKS INC., GLENVIEW, IL:  
2,062,930, REN. 3-22-07. INT. CL. 6.
- ILM PARTNERS, INC., WILMINGTON, NC:  
3,232,935, PUB. 2-6-2007. INT. CL. 35.
- IMAGENETIX, SAN DIEGO, CA:  
3,233,014, PUB. 2-6-2007. INT. CL. 5.
- IMAGINE FOODS, INC., PALO ALTO, CA:  
2,356,472, CANC. MULTIPLE CLASS, INT. CLS. 29 AND  
30.
- IMALL, INC., PROVO, UT:  
2,356,507, CANC. INT. CL. 35.
- IMATION CORP., OAKDALE, MN, MEMOREX CORPORA-  
TION, SANTA CLARA, CA:  
1,062,145, REN. 3-16-07. INT. CL. 9.
- IME PUBLISHING, INC., OVILLA, TX:  
2,356,845, CANC. INT. CL. 41.
- IMI NORGREN LIMITED, LICHFIELD, STAFFORDSHIRE  
WS13 6SB, ENGLAND:  
2,357,841, CANC. INT. CL. 9.
- IMMUDYNE, INC., MOUNT KISCO, NY:  
2,017,404, REN. 3-21-07. INT. CL. 5.
- IMMUNO CONCEPTS N.A. LTD., DALLAS, TX:  
2,029,088, REN. 3-19-07. MULTIPLE CLASS, INT. CLS. 1  
AND 5.
- IMPACT CONFECTIONS, INC., COLORADO SPRINGS, CO:  
2,042,310, REN. 3-22-07. INT. CL. 30.
- IMPERIAL CHEMICAL INDUSTRIES PLC, LONDON W1U  
3AN, UNITED KINGDOM:  
3,232,073, PUB. 2-6-2007. MULTIPLE CLASS, INT. CLS. 1,  
2, 3, 5, 16, 30, 35, 40 AND 42.
- IMPLUS FOOTCARE, LLC, MORRISVILLE, NC, IMPLUS  
CORPORATION, DURHAM, NC:  
2,076,366, REN. 3-22-07. INT. CL. 25.
- IMPORTOYS, INC., LOS ANGELES, CA:  
1,396,923, CANC. INT. CL. 28.
- IMPRINT ALLIANCE GROUP, L.L.C., MANALAPAN, NJ:  
3,234,992, INT. CL. 25.
- IMR INTERNATIONAL MINERAL RESOURCES B.V.,  
NETHERLANDS:  
3,233,577, PUB. 2-6-2007. MULTIPLE CLASS, INT. CLS. 1,  
6, 7, 37 AND 40.
- IMT ACCESSORIES INC., NEW YORK, NY:  
2,070,785, REN. 3-22-07. INT. CL. 26.
- IMTEC PRODUCTS, INC., SUNNYVALE, CA:  
2,084,395, REN. 3-21-07. INT. CL. 17.
- IN YOUR OWN SKIN SKIN THERAPY CENTER, INC.,  
VIRGINIA BEACH, VA:  
3,232,815, PUB. 2-6-2007. INT. CL. 44.  
3,232,816, PUB. 2-6-2007. MULTIPLE CLASS, INT. CLS. 3  
AND 44.
- IN-PIPE TECHNOLOGY COMPANY, LLC, WHEATON, IL:  
3,235,306, MULTIPLE CLASS, INT. CLS. 1 AND 40.
- IN-TOUCH MARKETING COMPANY, FRANCE:  
3,233,530, PUB. 2-6-2007. MULTIPLE CLASS, INT. CLS.  
35, 38 AND 42.
- INABYTE INC., NOVATO, CA:  
2,358,212, CANC. INT. CL. 9.
- INBEV S.A., 1000 BRUSSELS, BELGIUM:  
3,232,352, PUB. 10-10-2006. INT. CL. 32.
- INCENSOFT, LLC, GAITHERSBURG, MD:  
2,356,750, CANC. INT. CL. 9.
- INCLINE MEDICAL, LLC, LAKE OSWEGO, OR:  
3,235,155, INT. CL. 5.
- INDECO PRODUCTS, INC., SAN MARCOS, TX:  
1,981,174, REN. 3-19-07. INT. CL. 16.
- INDENA S.P.A., ITALY:  
3,233,724, PUB. 2-6-2007. INT. CL. 42.  
3,233,725, PUB. 2-6-2007. INT. CL. 42.
- INDENTITECH CORPORATION, LIVINGSTON, NJ:  
1,396,609, CANC. INT. CL. 9.
- INDEPENDENCE BANCSHARES, INC., GREENVILLE, SC:  
3,234,648, INT. CL. 36.
- INDEPENDENT CYCLE, INC., RAPID CITY, SD:  
3,232,842, PUB. 2-6-2007. INT. CL. 12.
- INDESIT COMPANY SPA, ITALY:  
3,233,628, PUB. 2-6-2007. INT. CL. 11.
- INDESIT COMPANY SPA, I-60044 FABRIANO (AN), ITALY:  
3,233,632, PUB. 2-6-2007. INT. CL. 11.
- INDIANA HEMOPHILIA & THROMBOSIS CENTER, INC.,  
INDIANAPOLIS, IN:  
3,232,636, PUB. 2-6-2007. INT. CL. 44.
- INDILABEL, LLC, INDIANAPOLIS, IN:  
2,085,910, REN. 3-17-07. INT. CL. 16.
- INDOPCO, INC., BRIDGEWATER, NJ, DBA NATIONAL  
STARCH AND CHEMICAL COMPANY:  
3,234,929, MULTIPLE CLASS, INT. CLS. 1 AND 7.
- INDUSTRIAS XIGNUX, S.A. DE C.V., SAN NICOLAS DE  
LOS GARZA, NL 66493, MEXICO, INDUSTRIAS AXA,  
S.A., NUEVO LEON, MEXICO:  
1,454,999, REN. 3-16-07. INT. CL. 9.
- INDUSTRIES LASSONDE INC., ROUGEMONT, QUEBEC,  
CANADA:  
2,120,315, REN. 3-22-07. INT. CL. 32.
- INDUSTRYCLICK CORP., NEW YORK, NY:  
2,356,708, CANC. INT. CL. 35.
- INFANTINO, INC., CHULA VISTA, CA TO INFANTINO,  
LLC, SAN DIEGO, CA:  
1,980,159, CANC. INT. CL. 24.
- INFINITE CONTROL SYSTEMS, INC., CHINO, CA:  
3,233,278, PUB. 2-6-2007. INT. CL. 42.
- INFINITY WATCH CORPORATION, MONTEREY PARK,  
CA:  
2,035,425, REN. 3-19-07. MULTIPLE CLASS, INT. CLS. 14  
AND 25.
- INFO DESIGNS, INC., TIMONIUM, MD:  
3,235,329, INT. CL. 9.
- INFONOW CORPORATION, DENVER, CO:  
2,356,778, CANC. MULTIPLE CLASS, INT. CLS. 35 AND  
39.
- INFOPIA, INC., SALT LAKE CITY, UT:  
3,234,773, MULTIPLE CLASS, INT. CLS. 9 AND 42.
- INFOQUEST TECHNOLOGIES, INC., HARRISBURG, PA:  
3,234,930, INT. CL. 39.
- INFOR GLOBAL SOLUTIONS (MASSACHUSETTS), INC.,  
ATLANTA, GA:  
1,396,595, CANC. INT. CL. 9.
- INFORM DESIGN, LLC., TROY, MI:  
2,356,754, CANC. MULTIPLE CLASS, INT. CLS. 12 AND  
42.
- INFORMATION DESIGN, INC., MADISON, CT:  
2,356,446, CANC. INT. CL. 9.
- INFORMATION MANAGEMENT ASSOCIATES, INC.,  
SHELTON, CT:  
2,357,962, CANC. MULTIPLE CLASS, INT. CLS. 9 AND  
41.
- INFORMATION TELEVISION NETWORK, INC., BOCA  
RATON, FL:  
3,234,117, INT. CL. 41.
- INFORMEDIA PUBLICATIONS, INC., SAN DIEGO, CA:  
3,233,060, PUB. 2-6-2007. INT. CL. 16.
- INFOSQUARE CORPORATION, SANTA CLARA, CA:  
2,358,464, CANC. INT. CL. 9.
- INFRASONICS, INC., SAN DIEGO, CA:  
1,396,635, CANC. INT. CL. 10.
- INGAMIA, INC., DALLAS, TX:  
2,035,393, REN. 3-20-07. INT. CL. 25.
- INGENJORSFIRMAN TEMA AKTIEBOLAG, S-541 06  
SKOVDE, SWEDEN:  
1,068,871, REN. 3-16-07. INT. CL. 6.
- INGERSOLL-ARGENTINA S.A., 2659 MONTE MAIZ - CBA.,  
ARGENTINA:  
2,099,864, REN. 3-21-07. INT. CL. 7.
- INNCREA KIMYA MAKINA YAZILIM ELEKTRONIK SA-  
NAYI VE TICARET LIMITED SIRKETI, BESIKTAS-IS-  
TANBUL, TURKEY:  
3,234,144, MULTIPLE CLASS, INT. CLS. 3 AND 9.
- INNODATA ISOGEN, INC., HACKENSACK, NJ:  
3,232,845, PUB. 2-6-2007. MULTIPLE CLASS, INT. CLS.



- 35, 40, 41 AND 42.  
 3,232,847, PUB. 2-6-2007. MULTIPLE CLASS, INT. CLS. 35, 40, 41 AND 42.  
 3,232,848, PUB. 2-6-2007. MULTIPLE CLASS, INT. CLS. 35, 40, 41 AND 42.
- INNOSOURCE BUSINESS SOLUTIONS, INC., ATLANTA, GA:  
 3,233,074, PUB. 2-6-2007. INT. CL. 42.
- INNOVA CABLE TRAY, INC., PEMBROKE PINES, FL:  
 3,234,771, INT. CL. 9.
- INNOVATA BIOMED LIMITED, ST ALBANS, UNITED KINGDOM:  
 3,232,384, PUB. 2-6-2007. INT. CL. 5.
- INNOVATIVE BEVERAGE CONCEPTS, INC., ALISO VIEJO, CA:  
 2,927,287, AM. INT. CL. 30.
- INNOVATIVE CUSTOM BRANDS INTERNATIONAL INC, NEW YORK, NY, HYOSUNG (AMERICA), INC., NEW YORK, NY:  
 2,022,078, REN. 3-17-07. INT. CL. 25.
- INNOVATIVE HOSPITALITY SOLUTIONS CORPORATION, VANCOUVER, BC V6B 2S2, CANADA:  
 3,232,072, PUB. 2-7-2006. MULTIPLE CLASS, INT. CLS. 35 AND 42.
- INNOVATIVE SOLUTIONS, INC., ST. CHARLES, IL:  
 3,232,994, PUB. 2-6-2007. INT. CL. 9.
- INPHARMATICA LIMITED, LONDON, W1T 2NU, UNITED KINGDOM:  
 3,233,919, MULTIPLE CLASS, INT. CLS. 9 AND 42.
- INSIDE CONTACTLESS, FRANCE:  
 3,233,649, PUB. 1-23-2007. MULTIPLE CLASS, INT. CLS. 9 AND 42.
- INSIGHT IMPORTS, ASHLAND, OR:  
 3,232,293, PUB. 2-6-2007. INT. CL. 4.
- INSPECT USA, INC., FINKSBURG, MD:  
 2,615,571, CANC. INT. CL. 42.
- INSPIRED TECHNOLOGIES, INC., LE SUEUR, MN:  
 3,234,253, INT. CL. 16.
- INSTITUT FRANCAIS DU PÉTROLE, RUEIL-MALMAISON, CEDEX, FRANCE:  
 3,232,412, PUB. 11-15-2005. MULTIPLE CLASS, INT. CLS. 9 AND 42.
- INSTITUTE FOR FACILITIES IMPROVEMENT, INC., CORNELIUS, NC:  
 2,357,686, CANC. INT. CL. 16.
- INSTITUTE OF MANAGEMENT ACCOUNTANTS, MONTVALE, NJ:  
 3,234,031, MULTIPLE CLASS, INT. CLS. 35 AND 41.
- INSTITUTO DE MONOCRISTALES, S.L., CARMONA, SEVILLA, SPAIN:  
 3,234,764, MULTIPLE CLASS, INT. CLS. 14 AND 35.
- INSURANCE DATA EXCHANGE AUTOMATION, INC., MARIETTA, GA:  
 2,357,968, CANC. INT. CL. 9.
- INSURDATA INCORPORATED, IRVING, TX:  
 2,357,556, CANC. INT. CL. 36.  
 2,357,557, CANC. INT. CL. 36.
- INTEGRATED COMMUNICATION CONCEPTS, INC., LAKEWOOD, CO, DBA SPEECHMASTERS:  
 2,358,103, CANC. INT. CL. 16.  
 2,358,104, CANC. INT. CL. 16.  
 2,358,105, CANC. INT. CL. 9.
- INTEGRATED SYSTEMS, INC., SUNNYVALE, CA:  
 2,358,575, CANC. INT. CL. 9.
- INTELACCOUNT, INC., EDINA, MN:  
 3,232,728, PUB. 2-6-2007. INT. CL. 35.  
 3,232,807, PUB. 2-6-2007. INT. CL. 35.
- INTELENT SOFTWARE, INC., SALT LAKE CITY, UT:  
 3,234,790, INT. CL. 9.
- INTELLIGENT DUMB BELLS, INC., OWATONNA, MN:  
 3,235,010, INT. CL. 28.
- INTELLIGENT NUTRIENTS, LLC, MINNEAPOLIS, MN, AVEDA CORPORATION, MINNEAPOLIS, MN, DBA AVEDA CORPORATION:  
 2,037,955, REN. 3-22-07. INT. CL. 5.
- INTELLIGENT REASONING SYSTEMS, INC., AUSTIN, TX:  
 2,358,063, CANC. INT. CL. 9.
- INTELLIGENT TECHNOLOGIES, LLC, SAN DIEGO, CA, HM ELECTRONICS, INC., SAN DIEGO, CA:  
 2,057,978, REN. 3-16-07. INT. CL. 9.
- INTERACTIVE GALLERY, INC., SHERMAN OAKS, CA:  
 2,357,419, CANC. INT. CL. 41.
- INTERART HOLDING CORPORATION, BLOOMINGTON, IN:  
 2,358,429, CANC. INT. CL. 16.
- INTERCHARTER NETWORK, LLC, DURANGO, CO:  
 2,357,149, CANC. INT. CL. 39.
- INTERFACE CORPORATION, HIROSHIMA 732-0828, JAPAN:  
 3,233,697, PUB. 2-6-2007. INT. CL. 35.  
 3,233,698, PUB. 2-6-2007. INT. CL. 35.
- INTERFACE FABRIC, INC., ATLANTA, GA:  
 1,057,677, REN. 3-22-07. INT. CL. 24.
- INTERNATIONAL ACCOUNTING STANDARDS COMMITTEE FOUNDATION, LONDON, UNITED KINGDOM:  
 3,232,164, PUB. 2-6-2007. MULTIPLE CLASS, INT. CLS. 16, 35 AND 41.
- INTERNATIONAL ASSOCIATION OF PLUMBING AND MECHANICAL OFFICIALS, ONTARIO, CA:  
 3,234,197, U.S. CL. A.
- INTERNATIONAL BROTHERHOOD OF BOILERMAKERS, IRON SHIP BUILDERS, BLACKSMITHS, FORGERS & HELPERS, KANSAS CITY, KS:  
 3,233,249, PUB. 2-6-2007. INT. CL. 35.
- INTERNATIONAL BUSINESS MACHINES CORPORATION, ARMONK, NY:  
 1,396,579, CANC. INT. CL. 9.  
 2,028,681, REN. 3-20-07. INT. CL. 9.
- INTERNATIONAL CABLE CHANNELS PARTNERSHIP, LTD., ENGLEWOOD, CO:  
 2,358,474, CANC. MULTIPLE CLASS, INT. CLS. 38 AND 41.
- INTERNATIONAL HEART INSTITUTE INC., MISSISSAUGA, ONTARIO L5K 2N6, CANADA:  
 2,356,462, CANC. MULTIPLE CLASS, INT. CLS. 9, 16 AND 42.
- INTERNATIONAL HOUSE OF BLUES FOUNDATION, INC., HOLLYWOOD, CA:  
 3,234,645, MULTIPLE CLASS, INT. CLS. 36 AND 41.
- INTERNATIONAL LEAD ZINC RESEARCH ORGANIZATION, INC., DURHAM, NC, INTERNATIONAL LEAD ZINC RESEARCH ORGANIZATION, NEW YORK, NY:  
 1,414,721, REN. 3-20-07. INT. CL. 6.
- INTERNATIONAL LUBRICATION AND FUEL CONSULTANTS, INC., RIO RANCHO, NM:  
 1,460,410, REN. 3-21-07. INT. CL. 42.  
 1,461,462, REN. 3-21-07. INT. CL. 42.
- INTERNATIONAL MASTER PUBLISHERS AB, MALMO, SWEDEN:  
 1,979,960, CANC. INT. CL. 16.
- INTERNATIONAL PAPER COMPANY, STAMFORD, CT:  
 2,358,391, CANC. INT. CL. 19.
- INTERNATIONAL PRODUCTS CORPORATION, BURLINGTON, NJ:  
 1,428,957, REN. 3-22-07. INT. CL. 3.
- INTERNATIONAL TECHNIDYNE CORPORATION, EDISON, NJ:  
 2,357,866, CANC. INT. CL. 10.
- INTERNATIONAL TRUCK INTELLECTUAL PROPERTY COMPANY, LLC, WARRENVILLE, IL:  
 3,235,176, INT. CL. 12.
- INTERNATIONAL WEATHER NETWORK, THE, RENO, NV:  
 2,026,196, REN. 3-21-07. INT. CL. 42.  
 2,026,197, REN. 3-19-07. INT. CL. 42.  
 2,026,198, REN. 3-19-07. MULTIPLE CLASS, INT. CLS. 9 AND 42.  
 2,026,199, REN. 3-22-07. INT. CL. 42.  
 2,026,200, REN. 3-22-07. INT. CL. 42.  
 2,026,201, REN. 3-19-07. MULTIPLE CLASS, INT. CLS. 9 AND 42.  
 2,026,202, REN. 3-22-07. INT. CL. 42.  
 2,026,203, REN. 3-19-07. INT. CL. 42.  
 2,028,046, REN. 3-22-07. INT. CL. 42.

- INTERNATIONAL WILDERNESS LEADERSHIP (WILD) FOUNDATION, THE, OJAI, CA:  
2,358,392, CANC. INT. CL. 25.  
2,358,393, CANC. INT. CL. 41.
- INTERNET CONSORTIUM CORPORATION, THE, MINNEAPOLIS, MN:  
2,356,747, CANC. INT. CL. 35.
- INTERNET.COM CORPORATION, WESTPORT, CT:  
2,358,801, CANC. INT. CL. 16.
- INTERSPORT FASHIONS WEST, TUSTIN, CA:  
2,357,005, CANC. INT. CL. 25.
- INTERSTELLAR TECHNOLOGIES CORPORATION, MONROVIA, CA:  
3,234,104, INT. CL. 9.
- INTERSTRAT CORPORATION, SAN FRANCISCO, CA:  
3,232,594, PUB. 2-6-2007. MULTIPLE CLASS, INT. CLS. 35 AND 41.
- INTERTRUST TECHNOLOGIES CORPORATION, SANTA CLARA, CA:  
2,357,931, CANC. INT. CL. 9.
- INTERTRUST TECHNOLOGIES CORPORATION, SUNNYVALE, CA:  
2,357,932, CANC. INT. CL. 9.  
2,357,934, CANC. INT. CL. 9.  
2,357,938, CANC. INT. CL. 9.
- INTERVENTIONAL TECHNOLOGIES, INC., SAN DIEGO, CA:  
1,979,778, CANC. INT. CL. 10.
- INTERWORKS SYSTEMS, INC, MELVILLE, NY:  
2,358,847, CANC. MULTIPLE CLASS, INT. CLS. 35, 37, 38 AND 42.
- INTERWOVEN, INC., SUNNYVALE, CA:  
3,235,000, INT. CL. 9.
- INTIMATE RESOURCES, NEW YORK, NY TO SARAMAX APPAREL GROUP, INC., NEW YORK, NY:  
1,979,726, CANC. INT. CL. 25.
- INTOHOMES MORTGAGE SERVICES, INC., RENO, NV:  
3,233,318, PUB. 2-6-2007. INT. CL. 36.
- INTRAV, INC., ST. LOUIS, MO:  
2,356,932, CANC. INT. CL. 39.
- INTREPID U.S.A., INC., EDINA, MN:  
3,233,259, PUB. 2-6-2007. MULTIPLE CLASS, INT. CLS. 35 AND 44.
- INTUITIVE EDGE CORPORATION, BELLEVUE, WA:  
2,357,967, CANC. INT. CL. 9.
- INVENTION SUBMISSION CORPORATION, PITTSBURGH, PA:  
3,234,587, INT. CL. 35.
- INVESCO INSTITUTIONAL (N.A.), INC., ATLANTA, GA:  
2,357,628, CANC. INT. CL. 36.
- INVICTA WATCH COMPANY OF AMERICA, INC., HOLLYWOOD, FL:  
3,233,996, MULTIPLE CLASS, INT. CLS. 14 AND 18.
- INVISTA NORTH AMERICA S.A.R.L., WILMINGTON, DE:  
3,234,353, INT. CL. 2.
- IN2BOOKS, INC., WASHINGTON, DC:  
3,233,941, INT. CL. 41.
- ION OPTICS, INC., WALTHAM, MA:  
3,234,195, INT. CL. 9.
- IOWA CITY ENTERTAINMENT, INC., IOWA CITY, IA:  
2,357,626, CANC. INT. CL. 42.
- IP INVESTMENT FUND, LLC, LIVINGSTON, NJ:  
3,233,206, PUB. 2-6-2007. INT. CL. 42.
- IP LOGIC, LLC, ALBANY, NY:  
3,232,374, PUB. 8-22-2006. MULTIPLE CLASS, INT. CLS. 42 AND 45.
- IPEX INC., DON MILLS, ONTARIO, CANADA, SCP AND COMPANY LIMITED PARTNERSHIP, DON MILLS, ONTARIO, M3D 2S9, CANADA:  
2,037,375, REN. 3-20-07. MULTIPLE CLASS, INT. CLS. 11 AND 17.  
2,039,220, REN. 3-20-07. MULTIPLE CLASS, INT. CLS. 11 AND 17.
- IPV SBIC MANAGEMENT, LLC, NEWARK, DE:  
3,232,098, PUB. 2-6-2007. MULTIPLE CLASS, INT. CLS. 35 AND 36.
- IPX CORPORATION, EDMONTON, ALBERTA, CANADA:  
3,233,805, INT. CL. 35.
- IQ HONG KONG, LTD, TSUEN WNA N.T., HONG KONG:  
3,232,301, PUB. 2-6-2007. INT. CL. 9.
- IRIDESSE, INC., NEW YORK, NY:  
3,234,221, INT. CL. 35.
- IRIZARRY, JOSEPH, P, NAMPA, ID:  
3,233,009, PUB. 2-6-2007. INT. CL. 9.
- IRON LORE ENTERTAINMENT, LTD., MAYNARD, MA:  
3,233,270, PUB. 2-6-2007. INT. CL. 41.
- IRWIN INDUSTRIAL TOOL COMPANY, ATLANTA, GA, AMERICAN SAW & MFG. COMPANY, EAST LONGMEADOW, MA:  
1,456,144, REN. 3-19-07. INT. CL. 7.
- ISLAND COFFEE COMPANY, INC., HONOLULU, HI:  
1,979,474, CANC. INT. CL. 30.
- ISP INVESTMENTS INC., WILMINGTON, DE:  
2,357,984, CANC. INT. CL. 1.
- ISTA ADMINISTRATIVE SERVICES CORPORATION, INDIANAPOLIS, IN:  
3,235,230, INT. CL. 35.
- ISTAR FINANCIAL INC., NEW YORK, NY:  
3,233,064, PUB. 2-6-2007. INT. CL. 36.
- ISTITUTO GANASSINI S.P.A. DI RICERCHE BIOCHIMICHE, MILANO, ITALY:  
3,234,163, INT. CL. 3.
- ISYMPHONY HOLDINGS ENTERPRISES, VAN NUYS, CA:  
3,234,528, INT. CL. 9.  
3,234,529, INT. CL. 9.
- IT'S ALL ABOUT IMAGE, INC., MAGNOLIA, AR:  
2,520,458, CANC. INT. CL. 5.
- ITO CORPORATION, FUJI-CITY, SHIZUOKA, JAPAN:  
1,423,714, REN. 3-16-07. INT. CL. 9.
- ITOUCHLESS HOUSEWARES & PRODUCTS, INC., FOSTER CITY, CA:  
3,234,209, INT. CL. 11.
- ITRON, INC., SPOKANE, WA:  
3,232,764, PUB. 2-6-2007. INT. CL. 9.
- ITT CORPORATION, WHITE PLAINS, NY:  
2,034,294, REN. 3-16-07. INT. CL. 7.
- ITT INDUSTRIES, INC., WHITE PLAINS, NY:  
2,358,768, CANC. INT. CL. 9.
- ITT SHERATON CORPORATION, BOSTON, MA:  
2,357,017, CANC. INT. CL. 20.  
2,357,018, CANC. INT. CL. 9.
- IVAN STEPHAN COLLINS, UPPER MARLBORO, MD:  
3,234,693, INT. CL. 37.
- IVILLAGE, INC., NEW YORK, NY:  
3,232,959, PUB. 2-6-2007. INT. CL. 41.  
3,232,960, PUB. 2-6-2007. INT. CL. 38.
- IVOCLAR NORTH AMERICA, INC., AMHERST, NY TO IVOCLAR VIVADENT, INC., AMHERST, NY:  
1,979,570, CANC. INT. CL. 5.
- I3S, INC., IRVING, TX:  
2,357,424, CANC. INT. CL. 38.
- 14 COMMERCE INC., TIMONIUM, MD:  
3,235,067, INT. CL. 36.  
3,235,130, INT. CL. 36.
- J & A IMPORTERS INC., VERNON, CA:  
3,234,080, INT. CL. 32.
- J & S KIDSWEAR, INC., PLAINVIEW, NY:  
3,233,169, PUB. 2-6-2007. INT. CL. 25.
- J FISHER LLC, NEW YORK, NY:  
3,234,609, INT. CL. 35.
- J. STRICKLAND & CO., OLIVE BRANCH, MS:  
1,396,345, CANC. INT. CL. 3.
- J. T. DESIGN STUDIO, INC., LOS ANGELES, CA:  
3,234,142, INT. CL. 25.
- J.B. ASSOCIATES, INC., HEWLETT AVENUE, NY:  
1,428,413, REN. 3-22-07. INT. CL. 20.
- J.C.M. INTERNATIONAL CORP., LAKE OSWEGO, OR:  
2,357,761, CANC. INT. CL. 31.
- J.D.M. IMPORT CO., INC., NEW YORK, NY:  
2,031,102, REN. 3-22-07. INT. CL. 14.
- J.H. FLETCHER & CO., INC., HUNTINGTON, WV:  
3,232,802, PUB. 2-6-2007. MULTIPLE CLASS, INT. CLS. 7, 12 AND 37.
- 3,232,803, PUB. 2-6-2007. MULTIPLE CLASS, INT. CLS. 7, 12 AND 37.

J.LYNN COSMETICS, LLC, CHANDLER, AZ:  
3,233,353, PUB. 2-6-2007. INT. CL. 3.

J.R. BRUNO & ASSOCIATES, GLENDORA, CA:  
2,356,517, CANC. INT. CL. 36.

J.R. LANDREY AND SONS, INC., VINCENNES, IN:  
1,396,988, CANC. INT. CL. 29.

J.R. SIMPLOT COMPANY, BOISE, ID:  
3,234,904, INT. CL. 1.

J&A IMPORTERS, INC., VERNON, CA:  
2,036,688, REN. 3-21-07. INT. CL. 30.

JACKSON FAMILY FARMS, LLC, SANTA ROSA, CA:  
3,232,901, PUB. 10-24-2006. INT. CL. 33.

JACKSON NATIONAL LIFE INSURANCE COMPANY,  
LANSING, MI:  
1,397,080, CANC. MULTIPLE CLASS, INT. CLS. 35 AND  
36.  
2,358,753, CANC. INT. CL. 36.  
3,234,907, INT. CL. 36.  
3,234,908, INT. CL. 36.

JACKSON, JANET A., LAYTON, UT:  
3,233,971, INT. CL. 5.

JACKSONVILLE ELECTRIC AUTHORITY, JACKSON-  
VILLE, FL:  
2,356,761, CANC. INT. CL. 39.  
2,356,762, CANC. INT. CL. 39.

JACOB COMPOSITE GMBH, FED REP GERMANY:  
3,233,654, PUB. 2-6-2007. MULTIPLE CLASS, INT. CLS. 1  
AND 17.

JAFRA COSMETICS INTERNATIONAL, INC., WESTLAKE  
VILLAGE, CA:  
3,234,073, INT. CL. 3.

JAKKS PACIFIC, INC., MALIBU, CA:  
3,234,723, INT. CL. 28.  
3,235,124, INT. CL. 16.  
3,235,327, INT. CL. 28.  
3,235,339, INT. CL. 28.

JAKOBER, DAVID, ROBERT, CASTLE ROCK, CO AND  
JAKOBER, AMY, LYNN, CASTLE ROCK, CO:  
3,232,787, PUB. 2-6-2007. INT. CL. 41.

JAL INTERNATIONAL, INC., DALLAS, TX:  
2,358,298, CANC. INT. CL. 28.  
2,358,299, CANC. INT. CL. 28.

JAM INDUSTRIES LTD./LTEE, QUEBEC, CANADA:  
3,233,874, INT. CL. 9.

JAMBI CORPORATION, BERKELEY, CA:  
2,357,238, CANC. INT. CL. 30.

JAMES AND SONS, LTD., ORLAND PARK, IL:  
3,232,154, PUB. 2-6-2007. INT. CL. 35.

JAMES AVERY, CRAFTSMAN, INC., KERRVILLE, TX:  
1,060,502, REN. 3-20-07. INT. CL. 42.

JAMES CATTO & COMPANY LIMITED, AIRDRIE, ML6  
8PL, SCOTLAND:  
2,357,925, CANC. INT. CL. 33.

JAMES MORTON LIMITED, CAMBRIDGE, ONTARIO,  
CANADA:  
2,356,535, CANC. INT. CL. 42.

JAMES MUSTICH, NEW FAIRFIELD, CT:  
1,979,657, CANC. INT. CL. 16.

JAMES R. MODER CRYSTAL CHANDELIER (CANADA)  
LTD., VANCOUVER, CANADA:  
1,446,233, REN. 3-19-07. INT. CL. 11.

JAMUL INDIAN VILLAGE OF CALIFORNIA, JAMUL, CA:  
3,233,823, INT. CL. 41.

JAN SERVICES CORP., NEW YORK, NY:  
1,802,452, COR. INT. CL. 42.  
2,481,352, COR. MULTIPLE CLASS, INT. CLS. 35 AND  
42.

JANTZEN APPAREL, LLC, MIAMI, FL:  
1,980,052, CANC. INT. CL. 25.

JANUS INTERNATIONAL HOLDING LLC, DENVER, CO:  
3,235,379, INT. CL. 36.

JAPAN SCIENCE AND TECHNOLOGY AGENCY, KAWA-  
GUCHI-SHI, JAPAN:  
3,232,373, PUB. 10-24-2006. INT. CL. 42.

JASON INTERNATIONAL OPTICAL, INC., ELIZABETH, NJ:  
1,396,570, CANC. INT. CL. 9.

JAVA CONE LTD., KENTWOOD, MI:  
3,233,187, PUB. 2-6-2007. INT. CL. 43.

JAYBEAM LTD, NORTHANTS, UNITED KINGDOM:  
3,233,598, PUB. 2-6-2007. INT. CL. 9.

JBM LOGIC INC., LONGUEUIL, QUEBEC:  
3,233,779, INT. CL. 9.

JC 23 ENTERTAINMENT, INC., SANTA MONICA, CA:  
3,234,425, INT. CL. 41.

JD-CMC, INC., SUN VALLEY, CA:  
2,356,592, CANC. INT. CL. 35.

JEANE BEITER & ASSOCIATES, INC., MORAGA, CA:  
2,356,792, CANC. INT. CL. 42.

JEDA TECHNOLOGIES, INC., MOUNTAIN VIEW, CA:  
3,234,886, INT. CL. 9.

JEFF COOPER INCORPORATED, CARLE PLACE, NY:  
1,396,696, CANC. INT. CL. 14.

JEFF LAU, MISSION VIEJO, CA:  
3,232,992, PUB. 2-6-2007. INT. CL. 40.

JELLYFISH, INC., MADISON, WI:  
3,235,335, INT. CL. 42.

JENERIC/PENTRON, INC., WALLINGFORD, CT:  
3,235,302, INT. CL. 5.

JENNINGS CHEVROLET, INC., GLENVIEW, IL:  
3,232,781, PUB. 2-6-2007. MULTIPLE CLASS, INT. CLS.  
35, 37 AND 39.

JENNISON, DAVID, CANTON, MI:  
3,233,375, PUB. 2-6-2007. INT. CL. 30.

JENNY PRODUCTS, INCORPORATED, SOMERSET, PA:  
3,232,181, PUB. 10-24-2006. INT. CL. 4.

JENSON, HOWARD, MENIFEE, CA:  
3,234,277, INT. CL. 42.

JERETON ENTERTAINMENT, INC., NEW YORK, NY:  
3,232,230, PUB. 2-6-2007. INT. CL. 43.

JEROME H. ATCHLEY AND SOUTHERN SKIES CORPORA-  
TION, LITTLE ROCK, AR:  
1,397,138, CANC. INT. CL. 38.

JERRY F. HUTCHINS, INC., COVINGTON, GA:  
3,235,147, INT. CL. 16.

JESSE BRIGGS AND BLANCA F. BRIGGS PARTNERSHIP,  
THE, PLANTATION, FL:  
3,232,166, PUB. 2-6-2007. INT. CL. 41.

JESSICA MCCLINTOCK, INC., SAN FRANCISCO, CA:  
1,474,263, REN. 3-17-07. INT. CL. 25.

JET GENERAL INVESTMENT COMPANY, ELK GROVE  
VILLAGE, IL:  
2,033,350, REN. 3-21-07. INT. CL. 8.

JIANGSU SUNING APPLIANCE; COMPANY LIMITED,  
CHINA:  
3,233,700, PUB. 2-6-2007. MULTIPLE CLASS, INT. CLS. 7,  
9, 11, 35 AND 37.  
3,233,703, PUB. 2-6-2007. MULTIPLE CLASS, INT. CLS. 7,  
9, 11, 35 AND 37.

JIEYANG DEFA TOY CO., LTD., JIEDONG, JIEYANG,  
GUANGDONG, CHINA:  
3,232,498, PUB. 9-19-2006. INT. CL. 28.

JIM BOUTON CORPORATION, THE, NORTH EGREMONT,  
MA:  
2,358,285, CANC. INT. CL. 28.

JIM HUFF REALTY, INC., FT. MITCHELL, KY:  
3,233,320, PUB. 2-6-2007. INT. CL. 35.  
3,233,321, PUB. 2-6-2007. INT. CL. 42.

JING LONG ENG. MACHINERY CO., LTD., GUANGZHOU  
CITY, CHINA:  
3,235,210, INT. CL. 7.

JIT FUNDRAISING CORP., COQUITLAM, B.C. V3C 4A5,  
CANADA:  
2,357,132, CANC. INT. CL. 41.

JIVITA LLC, WAILUKU, HI:  
3,232,753, PUB. 2-6-2007. INT. CL. 32.

JJ LIGHTING GROUP, INC., GREENWICH, CT:  
2,032,864, REN. 3-20-07. INT. CL. 11.

JLM UNLIMITED, INC., ELK GROVE VILLAGE, IL:  
2,042,900, REN. 3-16-07. INT. CL. 16.

JM ASSOCIATES, INC., LITTLE ROCK, AR:  
3,232,976, PUB. 2-6-2007. INT. CL. 41.

JMBP, INC., LOS ANGELES, CA:  
3,234,274, INT. CL. 41.

JO-ANN STORES SUPPLY CHAIN MANAGEMENT, INC.,  
HUDSON, OH:  
3,232,052, PUB. 2-6-2007. INT. CL. 35.

- JOALY ENTERPRISE COMPANY, PARAMOUNT, CA:  
2,357,230, CANC. INT. CL. 30.
- JOCKS & JILLS RESTAURANTS, LLC, ATLANTA, GA:  
2,357,771, CANC. INT. CL. 42.
- JOE VERDE GROUP, INC., SAN JUAN CAPISTRANO, CA:  
3,235,226, INT. CL. 41.
- JOH. WILH. VON EICKEN GMBH & CO., 23556 LUBECK,  
FED REP GERMANY, JOH. WILH. VON EICKEN, HAM-  
BURG, FED REP GERMANY:  
1,057,895, REN. 3-20-07, INT. CL. 34.
- JOHANSON DIELECTRICS, INC., SYLMAR, CA:  
3,234,294, INT. CL. 9.
- JOHN ABATE INTERNATIONAL, INC., SCOTTSDALE, AZ:  
2,357,670, CANC. INT. CL. 3.
- JOHN GRAY PUBLICATIONS, INC., MILL VALLEY, CA:  
3,234,599, INT. CL. 44.
- JOHN MEZZALINGUA ASSOCIATES, INC., EAST SYRA-  
CUSE, NY:  
3,233,285, PUB. 2-6-2007, INT. CL. 9.
- JOHN WAGNER ASSOCIATES, INC., ALPINE, UT:  
2,854,530 NEW CERT. 4-24-2007, INT. CL. 10.
- JOHNNY ROCKETS LICENSING CORPORATION, LAKE  
FOREST, CA, JOHNNY ROCKETS LICENSING COR-  
PORATION, LAKE FOREST, CA:  
1,436,052, REN. 3-17-07, INT. CL. 42.  
1,436,053, REN. 3-17-07, INT. CL. 42.
- JOHNS MANVILLE, DENVER, CO:  
3,233,338, PUB. 2-6-2007, INT. CL. 17.
- JOHNSON & JOHNSON, NEW BRUNSWICK, NJ:  
1,419,912, REN. 3-17-07, INT. CL. 10.  
2,356,892, CANC. INT. CL. 5.  
3,233,935, INT. CL. 5.  
3,234,225, INT. CL. 5.
- JOHNSON FRANCHISE CONSULTING, INC., LINCOLN,  
NE:  
3,235,486, INT. CL. 35.
- JOHNSON, ALBERT SIDNEY, MELBOURNE, FL:  
3,232,747, PUB. 2-6-2007, INT. CL. 35.
- JOHNSON, ERIC CLAY, OREGON CITY, OR:  
2,358,880, CANC. INT. CL. 16.
- JOHNSON, GRACE OLIVIA, LA MIRADA, CA:  
2,358,450, CANC. INT. CL. 3.
- JOHNSON, GUSTAVE WALTER THOR, LANTZVILLE,  
BRITISH COLUMBIA, CANADA:  
2,358,375, CANC. INT. CL. 28.
- JOHNSTON BAKERY, INC., SHEBOYGAN, WI:  
2,068,867, REN. 3-16-07, INT. CL. 30.
- JOLENE COMPANY, INC., PROVO, UT:  
2,358,523, CANC. INT. CL. 25.
- JOLLY PIRATE ENTERPRISES, INC., COLUMBUS, OH,  
JOLLY ROGER ENTERPRISES, INC., COLUMBUS, OH:  
1,075,260, REN. 3-21-07, INT. CL. 42.
- JONBIL, INC., NEW YORK, NY:  
1,396,899, CANC. INT. CL. 25.
- JONCO ENTERPRISES, INC., DEERFIELD BEACH, FL, DBA  
LIL' OLE CABOOSE:  
3,234,795, INT. CL. 43.
- JONES INTERNATIONAL, LTD., ENGLEWOOD, CO:  
2,358,790, CANC. INT. CL. 41.
- JONES, CARL D., HUMBLE, TX:  
3,235,425, INT. CL. 25.
- JONES, KIMBER, LA HABRA, CA:  
2,357,680, CANC. INT. CL. 39.
- JONES, ROSETTA L., MOOREVILLE, NC:  
3,234,287, INT. CL. 25.
- JOS VAN HEMERT INKOOOPPUNT B.V., NETHERLANDS:  
3,233,689, PUB. 2-6-2007, MULTIPLE CLASS, INT. CLS. 9  
AND 25.
- JOSE MARIA RUIZ-ALEJOS HERRERO, SPAIN:  
3,233,688, PUB. 2-6-2007, INT. CL. 33.
- JOSE, INC., FAYETTEVILLE, AR:  
3,233,033, PUB. 2-6-2007, INT. CL. 43.
- JOSEPH M. LOSPINUSO AND MARK S. LOSPINUSO  
PARTNERSHIP, THE, NEWTON, NJ:  
3,234,428, INT. CL. 25.
- JOSHUA MICHAEL PEROMSIK, WORCESTER, MA:  
3,235,375, INT. CL. 42.
- JOSTENS LEARNING CORPORATION, SAN DIEGO, CA:  
1,396,585, CANC. MULTIPLE CLASS, INT. CLS. 9 AND  
16.
- JOVE CORPORATION, ANN ARBOR, MI:  
3,233,254, PUB. 2-6-2007, INT. CL. 38.
- JOVY ENTERPRISES LLC, NEW YORK, NY:  
3,235,213, INT. CL. 26.
- JPJ INVESTMENT HOLDING CORP., CARSON CITY, NV:  
3,233,927, INT. CL. 20.
- JPMORGAN CHASE & CO., NEW YORK, NY:  
1,979,194, CANC. INT. CL. 36.
- JRH BIOSCIENCES, INC., LENEXA, KS:  
3,234,109, MULTIPLE CLASS, INT. CLS. 1, 5 AND 40.
- JUDITH JACKSON, INC., GREENWICH, CT:  
1,424,521, REN. 3-16-07, INT. CL. 3.
- JUDSON COLLEGE, MARION, AL:  
2,407,708, CANC. MULTIPLE CLASS, INT. CLS. 6, 9, 18  
AND 24.
- JUGS BY BERT, INC., MOORE, OK:  
3,232,504, PUB. 2-6-2007, INT. CL. 28.
- JUN PACIFIC LLC, HONOLULU, HI AND JUN CORPORA-  
TION, INC., IIDA, JAPAN:  
3,233,405, PUB. 2-6-2007, INT. CL. 19.
- JUNGLE JIMBO'S, INC., CUTLER BAY, FL:  
3,232,874, PUB. 2-6-2007, INT. CL. 41.
- JUNXION, INC., SEATTLE, WA:  
3,232,631, PUB. 2-6-2007, INT. CL. 9.
- JUPITER ENTERTAINMENT, INC., KNOXVILLE, TN:  
3,234,842, INT. CL. 41.
- JUST FOR WRAPS, INC., COMMERCE, CA:  
3,234,388, INT. CL. 25.
- JUST WHEELS & TIRES CO., HUNTINGTON BEACH, CA:  
3,234,045, INT. CL. 12.  
3,234,046, INT. CL. 12.
- J2 GLOBAL COMMUNICATIONS, INC., HOLLYWOOD, CA:  
3,232,401, PUB. 2-6-2007, INT. CL. 38.
- K DIAMOND, INC., ONTARIO, CA:  
2,356,739, CANC. INT. CL. 7.
- K.K. ENDO SEISAKUSHO, JAPAN:  
3,233,757, PUB. 2-6-2007, INT. CL. 28.
- K&G MEN'S COMPANY, INC., ATLANTA, GA, MEN'S  
WEARHOUSE, THE, HOUSTON, TX:  
2,043,876, REN. 3-20-07, INT. CL. 25.
- K&K MANAGEMENT, INC., BEAUFORT, SC:  
2,357,370, CANC. MULTIPLE CLASS, INT. CLS. 39 AND  
42.
- K-SUN CORPORATION, SOMERSET, WI:  
2,045,097, REN. 3-17-07, INT. CL. 16.
- KABUSHIKI KAISHA G-MODE, TOKYO, JAPAN, DBA G-  
MODE CO., LTD.:  
3,234,565, MULTIPLE CLASS, INT. CLS. 9 AND 41.  
3,234,566, MULTIPLE CLASS, INT. CLS. 9 AND 41.
- KABUSHIKI KAISHA HATTORI SEIKO, CHUO-KU, TO-  
KYO, JAPAN, TA SEIKO CORPORATION TO SEIKO  
KABUSHIKI KAISHA, TOKYO, JAPAN, TA SEIKO COR-  
PORATION:  
1,980,204, CANC. INT. CL. 14.
- KABUSHIKI KAISHA HUDSON, TOKYO, JAPAN:  
3,233,516, PUB. 2-6-2007, INT. CL. 9.
- KABUSHIKI KAISHA KATSURA YUMI BRIDAL HOUSE,  
TOKYO, JAPAN:  
1,980,134, CANC. INT. CL. 25.
- KABUSHIKI KAISHA ONSUI, NIIGATA, JAPAN:  
3,235,145, INT. CL. 29.
- KABUSHIKI KAISHA PILOT CORPORATION A/T/A PILOT  
CORPORATION, CHUO-KU, TOKYO, JAPAN, PILOT PEN  
COMPANY, LTD., THE, CHUO-KU, TOKYO, JAPAN:  
1,058,037, REN. 3-17-07, INT. CL. 16.
- KABUSHIKI KAISHA SATO, JAPAN:  
3,233,534, PUB. 2-6-2007, MULTIPLE CLASS, INT. CLS. 7,  
9, 16, 20, 37 AND 42.
- KABUSHIKI KAISHA SONY COMPUTER ENTERTAIN-  
MENT, TOKYO 107-0052, JAPAN, TA SONY COMPUTER  
ENTERTAINMENT INC.:  
3,137,493, COR. MULTIPLE CLASS, INT. CLS. 9, 35 AND  
42.  
3,137,494, COR. MULTIPLE CLASS, INT. CLS. 9, 35 AND

42.  
3,137,495, COR. MULTIPLE CLASS, INT. CLS. 9, 35 AND 42.
- KABUSHIKI KAISHA TANITA, TOKYO, JAPAN:  
3,161,287, COR. MULTIPLE CLASS, INT. CLS. 9 AND 10.
- KABUSHIKI KAISHA TOP, TOKYO, JAPAN:  
3,234,091, INT. CL. 10.
- KABUSHIKI KAISHA TOSHIBA, MINATO-KU, TOKYO, JAPAN, DBA TOSHIBA CORPORATION:  
3,233,998, INT. CL. 9.
- KABUSHIKI KAISHA YAMAMOTOYAMA, CHUO-KU, TOKYO, JAPAN, DBA YAMAMOTOYAMA CO., LTD.:  
1,058,901, REN. 3-22-07, INT. CL. 29.
- KABUSHIKIKAISHA MATSUI SEISAKUSHO, CHUO-KU, OSAKA, JAPAN:  
1,979,990, CANC. INT. CL. 7.
- KADY INTERNATIONAL INC., SCARBOROUGH, ME:  
2,358,096, CANC. INT. CL. 11.
- KAHN, ELI B., BALTIMORE, MD:  
3,233,256, PUB. 2-6-2007, INT. CL. 36.
- KAIDEA INNOVATION INC., BREA, CA:  
3,235,140, INT. CL. 9.  
3,235,141, INT. CL. 9.
- KALAMDARYAN, VARTAN, T, BURBANK, CA:  
3,234,111, INT. CL. 28.
- KALMAR INDUSTRIES USA LLC, OTTAWA, KS, BARTLETT TRAILER CORPORATION, CHICAGO, IL:  
821,487, REN. 3-19-07, U.S. CL. 19 (INT. CL. 12).
- KALSEC, INC., KALAMAZOO, MI:  
1,979,129, CANC. INT. CL. 30.
- KAM CONTROLS INCORPORATED, HOUSTON, TX:  
3,234,048, INT. CL. 9.
- KAMAX-WERKE RUDOLF KELLERMANN GMBH & CO. KG, D-37520 OSTERODE, FED REP GERMANY:  
2,422,759, CANC. MULTIPLE CLASS, INT. CLS. 7 AND 8.
- KAN-DOO ATTITUDE, INC., KELLER, TX:  
3,234,620, INT. CL. 25.
- KANSAS CITY CLUB, THE, KANSAS CITY, MO:  
2,356,964, CANC. INT. CL. 25.
- KANZAWA SEIKO CO., LTD., HYOGO-KEN, JAPAN:  
3,232,586, PUB. 2-6-2007, INT. CL. 8.
- KAO KABUSHIKI KAISHA, CHUO-KU, TOKYO, JAPAN, TA KAO CORPORATION:  
2,357,028, CANC. INT. CL. 3.
- KAPAK COMPANY LLC, ST. LOUIS PARK, MN:  
2,356,485, CANC. INT. CL. 40.
- KAPLAN, RONALD J., DAYTON, OH:  
1,430,314, REN. 3-22-07, INT. CL. 25.
- KARANICK, PAUL N, SANTA ANA, CA:  
3,235,184, INT. CL. 45.
- KAREN ROSSI STUDIOS, MERIDEN, CT:  
3,234,855, INT. CL. 6.
- KARL FUNK GMBH & CO., MASELHEIM-APFINGEN, FED REP GERMANY:  
3,232,329, PUB. 5-9-2006, MULTIPLE CLASS, INT. CLS. 7, 9, 19, 28, 37 AND 41.
- KARL STORZ GMBH & CO. KG, TUTTLINGEN, FED REP GERMANY:  
3,232,836, PUB. 2-6-2007, MULTIPLE CLASS, INT. CLS. 10 AND 16.
- KARMIKEL CORPORATION, CHARLOTTE, NC:  
1,396,873, CANC. INT. CL. 25.
- KARNDEAN INTERNATIONAL, LTD., WORCESTER, WR11 5RT, UNITED KINGDOM:  
2,358,166, CANC. INT. CL. 19.  
2,358,167, CANC. INT. CL. 19.
- KAROTTKI, SALVADOR K., CHICAGO, IL, DBA S.B. RECORDING COMPANY:  
3,234,419, INT. CL. 41.
- KARRASS LTD, BEVERLY HILLS, CA:  
3,233,016, PUB. 2-6-2007, INT. CL. 41.
- KARSTEN MANUFACTURING CORPORATION, PHOENIX, AZ:  
3,234,857, INT. CL. 28.
- KASPUTIS GROUP LLC, CLEVELAND, OH:  
2,357,566, CANC. INT. CL. 41.
- KATZ, HAROLD, LOS ANGELES, CA:  
2,358,553, CANC. INT. CL. 3.
- KAUFMAN, KARIN, POUND RIDGE, NY:  
3,233,824, INT. CL. 1.
- KAUZ, BARBARA, BEDMINISTER, NJ AND KITNICK, ELLEN, BEDMINISTER, NJ:  
2,356,711, CANC. INT. CL. 14.
- KAY CHEMICAL CO., GREENSBORO, NC:  
3,234,593, INT. CL. 21.
- KCI LICENSING, INC., SAN ANTONIO, TX, JOBST INSTITUTE, INC., TOLEDO, OH:  
1,034,556, REN. 3-19-07, U.S. CL. 44 (INT. CL. 10).
- KEALOHA TECHNOLOGIES, INC., HONOLULU, HI:  
3,233,029, PUB. 2-6-2007, INT. CL. 42.
- KEANE, INC., BOSTON, MA:  
1,457,693, REN. 3-20-07, INT. CL. 35.
- KEARNS-TRIBUNE CORPORATION, SALT LAKE CITY, UT:  
2,356,916, CANC. INT. CL. 9.
- KEEBLER COMPANY, ELMHURST, IL TO KELLOGG NORTH AMERICA COMPANY, BATTLE CREEK, MI:  
1,979,538, CANC. INT. CL. 30.
- KEENEY MANUFACTURING COMPANY, THE, NEWINGTON, CT, DURACRAFT PLASTICS, INC., NEWINGTON, CT:  
2,117,620, REN. 3-19-07, INT. CL. 11.
- KEILLOR, GARRISON, ST. PAUL, MN:  
1,430,618, REN. 3-16-07, INT. CL. 41.
- KEIM, KEVIN P., AUSTIN, TX:  
3,233,266, PUB. 2-6-2007, INT. CL. 16.
- KEITHLEY INSTRUMENTS, INC., CLEVELAND, OH:  
2,042,389, REN. 3-21-07, INT. CL. 9.
- KEL & PARTNERS LLC, WESTBOROUGH, MA:  
3,233,211, PUB. 2-6-2007, MULTIPLE CLASS, INT. CLS. 35 AND 41.
- KEL-GAR, INC., DALLAS, TX:  
2,358,528, CANC. INT. CL. 21.
- KELDSEN, RICHARD L., SOUTH SAN FRANCISCO, CA, DBA SAGA MUSICAL INSTRUMENTS:  
2,357,053, CANC. INT. CL. 15.
- KELLOGG NORTH AMERICA COMPANY, BATTLE CREEK, MI:  
2,358,690, CANC. INT. CL. 29.  
3,235,078, INT. CL. 30.
- KELLY, AUSTIN, LOS ANGELES, CA:  
3,232,195, PUB. 2-6-2007, INT. CL. 42.
- KELSEY ASSOCIATES, LLC, LEDGEWOOD, NJ:  
3,234,878, INT. CL. 5.
- KELSEY, MICHAEL V., SR., GLEN DALE, MD:  
3,233,991, INT. CL. 9.
- KEMIRA OYJ, FINLAND:  
3,233,595, PUB. 2-6-2007, MULTIPLE CLASS, INT. CLS. 1, 2, 16 AND 42.
- KENDA RUBBER INDUSTRIAL CO., LTD., YUANLIN JEN, CHANGHUA CHANGHUA, TAIWAN:  
3,233,964, INT. CL. 12.
- KENG'S FIREARMS SPECIALTY, INC., ATLANTA, GA:  
3,232,561, PUB. 2-6-2007, INT. CL. 13.
- KENNAMETAL INC., LATROBE, PA:  
2,357,819, CANC. INT. CL. 7.
- KENNEDY INTERNATIONAL INC., JERSEY CITY, NJ:  
3,233,219, PUB. 2-6-2007, INT. CL. 24.
- KENSEY NASH CORPORATION, EXTON, PA:  
3,235,249, INT. CL. 10.
- KENTNER, BERNICE, ANTIOCH, CA, DBA COLOR ME A SEASON:  
1,424,501, REN. 3-22-07, INT. CL. 3.
- KERK MOTION PRODUCTS, INC., HOLLIS, NH:  
3,233,982, INT. CL. 7.
- KERRY INC., BELOIT, WI:  
2,358,915, CANC. INT. CL. 30.
- KESSLER, MICHAEL J, MIAMI BEACH, FL:  
3,235,491, INT. CL. 5.
- KESTER, INC., DES PLAINES, IL:  
3,234,633, INT. CL. 6.
- KEWPEE, INC., THE, LIMA, OH, KEWPEE HOTELS SYSTEM, INC., TOLEDO, OH:  
1,062,511, REN. 3-19-07, INT. CL. 42.  
1,062,517, REN. 3-19-07, INT. CL. 42.

- KEY DIGITAL SYSTEMS, INC., MOUNT VERNON, NY:  
3,232,981, PUB. 2-6-2007. INT. CL. 9.
- KEYS FITNESS PRODUCTS, INC., DALLAS, TX:  
2,358,230, CANC. INT. CL. 28.
- KEYSTONE AUTOMOTIVE OPERATIONS, INC., EXETER, PA:  
2,357,356, CANC. INT. CL. 7.
- KIDS FOR HEALTH, INC., SPRINGDALE, AR:  
3,234,318, INT. CL. 41.  
3,234,319, INT. CL. 41.
- KIDS STUFF, INC., NORTH CANTON, OH:  
2,357,030, CANC. INT. CL. 35.
- KIDS WITH FOOD ALLERGIES, INC., DOYLESTOWN, PA:  
3,233,144, PUB. 2-6-2007. INT. CL. 9.
- KIDSPEACE CORPORATION, BETHELEHEM, PA:  
2,071,486, REN. 3-16-07. INT. CL. 16.
- KIELLAND, LAURA J., RENTON, WA:  
2,357,859, CANC. INT. CL. 10.
- KIKKERLAND DESIGNS, INC., NEW YORK, NY:  
3,234,408, INT. CL. 21.
- KILLGERM GROUP LIMITED, OSSETT, WEST YORKSHIRE, UNITED KINGDOM:  
3,232,465, PUB. 5-9-2006. INT. CL. 21.
- KIM, YOUNG CHI, MARIETTA, GA:  
2,358,769, CANC. INT. CL. 35.
- KIMBERLI J. BRYAN, PINE, CO:  
3,234,434, INT. CL. 14.
- KIMPEX ACTION INC., QUEBEC J2B 6V4, CANADA TO KIMPEX INC., DRUMMONDVILLE, QUEBEC, CANADA:  
1,979,201, CANC. INT. CL. 12.
- KINDERCARE LEARNING CENTERS, INC., PORTLAND, OR, KINDER-CARE LEARNING CENTERS, INC., MONTGOMERY, AL:  
1,425,219, REN. 3-17-07. MULTIPLE CLASS, INT. CLS. 41 AND 42.
- KINECT SPORTS LLC, LOVELAND, OH:  
3,235,400, INT. CL. 28.
- KINEMED, INC., EMERYVILLE, CA:  
3,234,122, INT. CL. 5.
- KINEMATRICS, INC., PASADENA, CA:  
3,232,297, PUB. 2-6-2007. INT. CL. 9.
- KING GLORY CO, LTD., JAPAN:  
3,233,540, PUB. 2-6-2007. INT. CL. 25.
- KING ISLAND COMPANY LTD., THE, ABBOTSFORD, VICTORIA 3067, AUSTRALIA:  
2,424,813, AM. INT. CL. 29.
- KING RANCH IP, LLC, WILMINGTON, DE:  
2,357,276, CANC. INT. CL. 42.
- KING, ANDREW, EAST BRUNSWICK, NJ:  
3,232,204, PUB. 2-6-2007. INT. CL. 5.
- KING, WILLIAM F., BIRMINGHAM, AL AND MOLINA, ALLAN F., BIRMINGHAM, AL:  
3,234,798, INT. CL. 36.
- KING'S SEAFOOD COMPANY, LLC, COSTA MESA, CA:  
3,233,222, PUB. 2-6-2007. INT. CL. 43.
- KINGDOM GLOBAL MINISTRIES, YOUNGSTOWN, OH:  
3,233,017, PUB. 2-6-2007. INT. CL. 41.
- KINGMAN INTERNATIONAL CORPORATION, BALDWIN PARK, CA:  
3,235,351, INT. CL. 28.  
3,235,352, INT. CL. 28.
- KINGS RESTAURANT GROUP, LLC, LOS ANGELES, CA:  
3,234,873, MULTIPLE CLASS, INT. CLS. 25, 30 AND 43.
- KINGSTON GLOBAL, INC., SACRAMENTO, CA:  
3,233,381, PUB. 2-6-2007. INT. CL. 11.
- KINGWOOD GROUP, INC., THE, KINGWOOD, TX:  
2,357,140, CANC. INT. CL. 35.  
2,357,141, CANC. INT. CL. 35.
- KINKO'S VENTURES, INC., VENTURA, CA:  
2,356,922, CANC. MULTIPLE CLASS, INT. CLS. 35, 38 AND 42.
- KISCH, JOHN, HYDE PARK, NY:  
2,038,415, REN. 3-22-07. INT. CL. 42.
- KISS NAIL PRODUCTS, INC., PORT WASHINGTON, NY:  
3,234,284, INT. CL. 3.
- KITCHEN INVESTMENT GROUP, INC., MADISON, WI, COUNTRY KITCHEN INTERNATIONAL, INC., MINNEAPOLIS, MN:  
2,076,826, REN. 3-22-07. INT. CL. 41.
- KIU HUNG INDUSTRIES LTD., FOTAN, SHATIN, HONG KONG:  
3,232,165, PUB. 2-6-2007. MULTIPLE CLASS, INT. CLS. 20 AND 28.
- KIVA SYSTEMS, INC., WOBURN, MA:  
3,232,390, PUB. 2-6-2007. INT. CL. 9.
- KIWANIS CLUB OF SACRAMENTO SUBURBAN INC., SACRAMENTO, CA:  
3,234,996, INT. CL. 36.
- KLARETTA FOODS, INC., CHICAGO, IL:  
3,232,444, PUB. 2-6-2007. INT. CL. 43.
- KLEIN BICYCLE CORPORATION, CHEHALIS, WA:  
1,979,981, CANC. INT. CL. 12.
- KLEIN FOODS, INC., HEALDSBURG, CA:  
2,112,411, REN. 3-17-07. INT. CL. 33.
- KLINGER ADVANCED AESTHETICS, INC., NORWALK, NJ:  
3,234,959, INT. CL. 3.
- KLINGSPOR AG, FED REP GERMANY:  
3,233,701, PUB. 2-6-2007. MULTIPLE CLASS, INT. CLS. 3, 7 AND 8.
- KLISE MANUFACTURING COMPANY, GRAND RAPIDS, MI:  
3,234,761, MULTIPLE CLASS, INT. CLS. 19, 20 AND 35.
- KLUG, FRANCES MARIE, BREA, CA:  
2,121,344, REN. 3-22-07. INT. CL. 16.
- KMART OF MICHIGAN, INC., HOFFMAN ESTATES, IL:  
3,232,768, PUB. 2-6-2007. INT. CL. 11.  
3,232,805, PUB. 2-6-2007. MULTIPLE CLASS, INT. CLS. 18, 25 AND 28.
- KMC ACQUISITION CORP., LAKEWOOD, CO:  
3,234,295, INT. CL. 28.
- KNJ SOLUTIONS, LLC, WENDELL, NC:  
3,232,883, PUB. 2-6-2007. INT. CL. 35.  
3,232,884, PUB. 2-6-2007. INT. CL. 35.
- KNOLL, INC., EAST GREENVILLE, PA:  
2,358,616, CANC. INT. CL. 20.
- KNOWLEDGE ADVENTURE, INC., TORRANCE, CA:  
1,979,363, CANC. INT. CL. 9.
- KOBRA INTERNATIONAL, LTD., NEW YORK, NY:  
1,979,477, CANC. MULTIPLE CLASS, INT. CLS. 18 AND 25.
- KOCKS TECHNIK GMBH & CO.KG, 40721 HILDEN, FED REP GERMANY:  
3,233,606, PUB. 2-6-2007. MULTIPLE CLASS, INT. CLS. 6, 7, 9, 11 AND 42.
- KOEHLER, KURT E., PONTE VEDRA, FL:  
3,232,380, PUB. 2-6-2007. INT. CL. 45.
- KOENIG SOFTWARE SYSTEMS, LLC, BELLAIRE, TX:  
3,232,253, PUB. 2-6-2007. INT. CL. 42.
- KOHL'S ILLINOIS, INC., AURORA, IL:  
3,235,322, INT. CL. 27.  
3,235,371, INT. CL. 24.  
3,235,372, INT. CL. 20.
- KOLCRAFT ENTERPRISES, INC., CHICAGO, IL:  
2,357,679, CANC. INT. CL. 12.
- KOLE IMPORTS, CARSON, CA:  
3,234,190, INT. CL. 35.
- KOLENE CORPORATION, DETROIT, MI:  
824,710, REN. 3-17-07. U.S. CL. 6 (INT. CL. 1).  
824,711, REN. 3-17-07. U.S. CL. 6 (INT. CL. 1).
- KOLHOWS, INC., KENNETT SQUARE, PA:  
2,356,955, CANC. INT. CL. 30.
- KOLTER HOLDINGS FLORIDA, INC., WEST PALM BEACH, FL:  
3,164,465, COR. INT. CL. 37.
- KOMODO INTERNATIONAL CORP., RANCHO DOMINGUEZ, CA:  
3,234,545, INT. CL. 21.
- KONA RESTAURANT GROUP, INC., AUSTIN, TX:  
3,233,107, PUB. 2-6-2007. INT. CL. 43.
- KONAMI CORPORATION, TOKYO, JAPAN:  
2,933,616, COR. INT. CL. 9.

KONAMI DIGITAL ENTERTAINMENT CO. LTD., TOKYO, JAPAN:  
3,234,244, INT. CL. 9.

KONAMI DIGITAL ENTERTAINMENT CO., LTD., TOKYO, JAPAN:  
3,234,002, INT. CL. 28.  
3,234,003, INT. CL. 28.  
3,234,023, INT. CL. 28.  
3,234,059, INT. CL. 28.

KONDOH INDUSTRIES, LTD., TOKYO, JAPAN:  
3,235,086, MULTIPLE CLASS, INT. CLS. 7 AND 11.

KONINKLIJKE PHILIPS ELECTRONICS N.V., EINDHOVEN, NETHERLANDS:  
3,232,809, PUB. 2-6-2007. INT. CL. 9.

KONINKLIJKE PHILIPS ELECTRONICS N.V., NETHERLANDS:  
3,233,613, PUB. 2-6-2007. INT. CL. 9.  
3,233,643, PUB. 2-6-2007. INT. CL. 9.

KONINKLIJKE PHILIPS ELECTRONICS N.V., EINDHOVEN, NETHERLANDS:  
3,233,910, INT. CL. 42.

KOPTIX, TORRANCE, CA:  
3,234,347, INT. CL. 9.

KOPYKAKE ENTERPRISES, INC., TORRANCE, CA:  
1,434,596, REN. 3-19-07. INT. CL. 9.

KOSE CORPORATION, CHUO-KU, TOKYO, JAPAN:  
3,233,918, INT. CL. 3.

KOZUBEI, CATHERINE F., NY, NY AND KOTZUBEI, SAUL F., LOS ANGELES, CA:  
3,235,127, INT. CL. 41.

KPL LIMITED, AUCKLAND, NEW ZEALAND:  
3,127,708, COR. INT. CL. 12.

KRAFT FOODS HOLDINGS, INC., NORTHFIELD, IL:  
3,234,909, INT. CL. 30.

KRAFT FOODS, INC., NORTHFIELD, IL:  
2,356,864, CANC. INT. CL. 42.

KRAMER LABORATORIES, INC., MIAMI, FL:  
3,233,054, PUB. 2-6-2007. INT. CL. 5.

KRATOCHVIL, GARY, SAN ANTONIO, TX, DBA EXOTIC TROPICALS:  
2,357,739, CANC. INT. CL. 31.  
2,357,749, CANC. INT. CL. 31.

KRAUSE COMPANIES, INC., FLORISSANT, MO:  
3,233,228, PUB. 2-6-2007. INT. CL. 30.

KRAUSE PUBLICATIONS, INC., IOLA, WI:  
2,357,610, CANC. INT. CL. 16.

KREON, NAAMLOZE VENNOOTSCHAP, BELGIUM:  
3,233,521, PUB. 2-6-2007. INT. CL. 11.

KRINEY, JOHN V., SAN DIEGO, CA:  
3,234,262, INT. CL. 12.

KRISTOPHER TODD BUCKNER, LAWNSDALE, CA:  
3,232,385, PUB. 2-6-2007. INT. CL. 45.

KRONE, WILLIAM R. A. III, SAN MATEO, CA, DBA DEJA VIEW VIDEO PRODUCTIONS:  
1,427,860, REN. 3-16-07. INT. CL. 41.

KRUEGER INTERNATIONAL, INC., GREEN BAY, WI:  
3,235,365, INT. CL. 20.

KTM INDUSTRIES, INC., LANSING, MI:  
2,375,901, CANC. INT. CL. 28.

KUBICKI SOFTWARE, LLC, LINDENHURST, IL:  
3,235,424, MULTIPLE CLASS, INT. CLS. 9 AND 42.

KUEHNE, JONAS, SANTA MONICA, CA:  
3,234,756, INT. CL. 10.

KUHLMAN, DAVE, LOMBARD, IL AND LUTZ, STEVE, GLEN ELLYN, IL:  
3,234,430, INT. CL. 25.

KUN SHOULDER REST INC., THE, OTTAWA, ONTARIO, CANADA:  
3,233,791, INT. CL. 15.

KUNZE, JAMES, MILWAUKIE, OR:  
3,233,458, PUB. 2-6-2007. INT. CL. 41.

KURATORIUM FUER TECHNIK UND BAUWESEN IN DER LANDWIRTSCHAFT E.V. (KTBL), DARMSTADT, FED REP GERMANY:  
3,232,086, PUB. 2-6-2007. MULTIPLE CLASS, INT. CLS. 7, 9, 12, 42 AND 44.

KUREHA CORPORATION, TOKYO, JAPAN:  
3,232,758, PUB. 2-6-2007. INT. CL. 1.

KURTIS MANUFACTURING AND DISTRIBUTING CORPORATION, LIVONIA, MI:  
1,990,756, REN. 3-20-07. INT. CL. 42.  
1,992,492, REN. 3-20-07. INT. CL. 42.

KUTNER, RICHARD B., BROOMALL, PA:  
2,358,345, CANC. INT. CL. 25.

KUTOKA INTERACTIVE INC., MONTREAL, QUEBEC H2L 1J2, CANADA:  
2,357,867, CANC. INT. CL. 9.

KVADRAT A/S, DK-8400 EBELTOFT, DENMARK, KVADRAT BOLIGTEXTILER A/S, DK-8400 EBELTOFT, DENMARK:  
2,034,913, REN. 3-22-07. INT. CL. 24.

KWANG DONG PHARMACEUTICAL CO., LTD., REPUBLIC OF KOREA:  
3,233,691, PUB. 2-6-2007. MULTIPLE CLASS, INT. CLS. 29, 30, 32 AND 44.

KWANG HO, YOU, DONG-GU, INCHON CITY, REPUBLIC OF KOREA:  
2,358,438, CANC. INT. CL. 16.

KYOCERA CORPORATION, KYOTO 607, JAPAN:  
2,358,593, CANC. INT. CL. 9.

KYSELA PERE ET FILS, LTD., WINCHESTER, VA:  
3,235,484, INT. CL. 33.

KYSER MUSICAL PRODUCTS, INC., KAUFMAN, TX:  
2,034,621, REN. 3-16-07. INT. CL. 15.

KZCO INCORPORATED, ASHLAND, NE:  
3,234,069, INT. CL. 7.

K2 RECORDINGS, LLC, WASHINGTON, DC:  
2,358,434, CANC. INT. CL. 9.

L & P PROPERTY MANAGEMENT COMPANY, INC., SOUTHGATE, CA:  
2,032,687, REN. 3-22-07. INT. CL. 12.

L D C CORPORATION, SIOUX CITY, IA, RANDALL'S INC., DENVER, CO:  
825,339, REN. 3-22-07. MULTIPLE CLASS, U.S. CLS. 39 (INT. CL. 25) AND 100 (INT. CL. 42).

L. AND S. PACKING CO., INC., E. FARMINGDALE, NY:  
2,031,848, REN. 3-19-07. INT. CL. 30.

L. C. LICENSING, INC., NEW YORK, NY:  
3,232,933, PUB. 2-6-2007. INT. CL. 3.

L. J. HUTCHINS AUTOMOTIVE SUPPLY, INC., NIAGARA FALLS, NY:  
1,396,689, CANC. INT. CL. 12.

L. PERRIGO COMPANY, ALLEGAN, MI:  
3,233,828, INT. CL. 5.  
3,233,829, INT. CL. 5.  
3,233,830, INT. CL. 5.  
3,233,831, INT. CL. 5.  
3,233,832, INT. CL. 5.  
3,233,833, INT. CL. 5.  
3,233,834, INT. CL. 5.

L.C. LICENSING, INC., NEW YORK, NY:  
3,233,785, INT. CL. 25.

L.J. SMITH, INC., BOWERSTON, OH:  
3,233,839, INT. CL. 7.

L.M. MOORE AND COMPANY, EVANS, GA:  
2,358,488, CANC. INT. CL. 3.

L.O.S. CORPORATION, HIALEAH, FL:  
2,357,375, CANC. INT. CL. 3.

L&P SPIRITS IMPORTS, LLC, SAN FRANCISCO, CA:  
3,234,207, INT. CL. 33.

L-VAD TECHNOLOGY, INC., DETROIT, MI:  
1,988,838, REN. 3-22-07. INT. CL. 10.

L'EQUIPEMENT ET LA CONSTRUCTION ELECTRIQUE, 75020 PARIS, FRANCE:  
2,356,609, CANC. INT. CL. 9.

L'OREAL, PARIS, FRANCE:  
3,235,187, INT. CL. 3.

L'OREAL USA CREATIVE, INC., NEW YORK, NY, REDKEN LABORATORIES, INC., VAN NUYS, CA:  
1,079,644, REN. 3-20-07. INT. CL. 3.

L'ORÉAL, PARIS, FRANCE:  
3,233,924, INT. CL. 3.

LA CENA FINE FOODS, LTD., SADDLE BROOK, NJ:  
3,232,661, PUB. 1-23-2007. MULTIPLE CLASS, INT. CLS. 29 AND 30.

- LA DOLCE DIVA, INC., MARIETTA, GA:  
3,235,241, INT. CL. 3.
- LA INVERSORA SOCIEDAD ANONIMA, COMERCIAL, INDUSTRIAL INMOBILIARIA, CONSTRUCTORA, AGROPECUARIA Y FINANCIERA, NEUQUEN, PROVINCIA DE NEUQUEN, ARGENTINA:  
3,234,300, INT. CL. 33.
- LA REINA, INC., LOS ANGELES, CA:  
1,439,375, REN. 3-22-07. INT. CL. 30.
- LA TOURAINE, INC., SAN DIEGO, CA:  
3,233,036, PUB. 2-6-2007. INT. CL. 41.
- LAB SA, LYON, FRANCE:  
2,030,497, REN. 3-16-07. INT. CL. 11.
- LABIDOU, LUCERNE, BROOKLYN, NY:  
2,357,773, CANC. INT. CL. 25.  
2,357,774, CANC. INT. CL. 25.
- LABON, NORTH AMERICA, PETALUMA, CA:  
1,424,719, REN. 3-20-07. INT. CL. 10.
- LABORATOIRES DOLISOS, 92100 BOULOGNE, FRANCE:  
1,979,208, CANC. INT. CL. 5.
- LABORATOIRES EXPANSCIENCE, 92400 COURBEVOIE, FRANCE:  
2,029,761, REN. 3-17-07. MULTIPLE CLASS, INT. CLS. 3 AND 5.
- LACOURSE, ARTHUR D., BIDDEFORD, ME:  
2,358,599, CANC. INT. CL. 35.
- LACY SYMONS, INC., KEY WEST, FL:  
3,232,209, PUB. 2-6-2007. INT. CL. 35.
- LADY REMEMBERS, THE, TACOMA, WA:  
1,396,764, CANC. INT. CL. 16.
- LAERDAL MEDICAL AS, N-4002, STAVANGAR, NORWAY:  
3,232,967, PUB. 2-6-2007. INT. CL. 10.
- LAICA S.P.A., ITALY:  
3,233,536, PUB. 2-6-2007. MULTIPLE CLASS, INT. CLS. 9 AND 21.
- LAIDLAW COMPANY LLC, SCOTTSDALE, AZ:  
3,232,232, PUB. 2-6-2007. INT. CL. 20.  
3,232,273, PUB. 2-6-2007. INT. CL. 20.
- LAITNER BRUSH COMPANY, TRAVERSE CITY, MI:  
3,234,325, INT. CL. 21.
- LAKE GENEVA SPINDUSTRIES, INC., LAKE GENEVA, WI TO COLMAN GROUP, INC., THE, ELKHORN, WI:  
1,980,140, CANC. INT. CL. 21.
- LAKE GENEVA SPINDUSTRIES, INC., LAKE GENEVA, WI:  
2,358,099, CANC. INT. CL. 21.
- LAMSON & SESSIONS CO., THE, CLEVELAND:  
2,072,554, REN. 3-22-07. INT. CL. 17.
- LAMSON OIL COMPANY, ROCKFORD, IL:  
1,445,775, REN. 3-17-07. INT. CL. 1.
- LANCE L. GOBERMAN, M.D., P.C., MERCHANTVILLE, NJ:  
2,358,759, CANC. INT. CL. 42.
- LANCOME PARFUMS ET BEAUTE & CIE, PARIS, FRANCE:  
3,232,562, PUB. 2-6-2007. INT. CL. 3.  
3,235,414, INT. CL. 3.
- LAND 'N' SEA MIDWEST, INC., CHICGO, IL:  
2,026,833, REN. 3-20-07. INT. CL. 42.
- LANDOLL, INC., ASHLAND, OH:  
2,358,683, CANC. INT. CL. 16.
- LANDSBAUM, SCOTT L., BEVERLY HILLS, CA:  
3,234,590, INT. CL. 25.  
3,234,591, INT. CL. 25.
- LANDWARE, INC., ORADELL, NJ:  
2,356,659, CANC. INT. CL. 9.
- LANE, CHERYL A., SAN FRANCISCO, CA:  
3,234,288, INT. CL. 35.
- LANGUAGE LEARNING ENTERPRISES, INC., WASHINGTON, DC:  
2,357,973, CANC. INT. CL. 41.
- LANIER WORLDWIDE, INC., ATLANTA, GA:  
3,234,750, INT. CL. 42.
- LANNOM INCORPORATED, PEMBROKE PINES, FL:  
3,235,407, INT. CL. 35.
- LANTIS EYEWEAR CORPORATION, NEW YORK, NY:  
2,358,446, CANC. INT. CL. 9.
- LARISA BART, STATEN ISLAND, NY:  
3,235,186, INT. CL. 3.
- LARSON, DALE H., SAN FRANCISCO, CA:  
1,396,354, CANC. INT. CL. 3.
- LARUE, MICHAEL B., NORCO, CA:  
1,979,313, CANC. INT. CL. 41.
- LASALLE, REBECCA, CLEVELAND, OH:  
3,233,044, PUB. 2-6-2007. INT. CL. 35.
- LASER SHOT, INC., STAFFORD, TX:  
3,232,694, PUB. 2-6-2007. INT. CL. 9.
- LASERNETWORKS INC, OAKVILLE, ONTARIO, CANADA:  
3,232,990, PUB. 2-6-2007. MULTIPLE CLASS, INT. CLS. 2, 35 AND 37.  
3,232,991, PUB. 2-6-2007. MULTIPLE CLASS, INT. CLS. 35 AND 37.
- LASHYRO, JEFFREY A., CROSBY, MN:  
2,358,817, CANC. INT. CL. 16.
- LATEXCO N.V., BELGIUM:  
3,233,734, PUB. 2-6-2007. MULTIPLE CLASS, INT. CLS. 17 AND 20.
- LATIMARK, IRVING, TX:  
3,234,351, INT. CL. 35.
- LATITUDE SUBROGATION SERVICES LLC, BLOOMFIELD HILLS, MI:  
3,232,355, PUB. 2-6-2007. INT. CL. 36.
- LATITUDE SUBROGATION SERVICES, LLC, BLOOMFIELD HILLS, MI:  
3,232,356, PUB. 2-6-2007. INT. CL. 36.
- LATTICE SEMICONDUCTOR CORPORATION, PORTLAND, OR:  
1,396,608, CANC. INT. CL. 9.
- LAUFEN INTERNATIONAL, INC., TULSA, OK:  
2,068,598, REN. 3-16-07. INT. CL. 19.
- LAUREN, KIM, SCOTTSDALE, AZ:  
3,234,805, INT. CL. 5.
- LAVINE, LARRY, DALLAS, TX:  
3,235,326, INT. CL. 43.
- LAVINIA LOBO, OCEANSIDE, CA, DBA BABY KAED:  
3,232,801, PUB. 2-6-2007. INT. CL. 18.
- LAWRENCE, CLINT E., COSTA MESA, CA:  
3,233,422, PUB. 2-6-2007. INT. CL. 39.
- LAWSON MARDON PACKAGING INC., MISSISSAUGA, ONTARIO, CANADA TO RELIANCE PRODUCTS LIMITED PARTNERSHIP, WINNEPEG, MINITOBA, CANADA:  
1,979,117, CANC. INT. CL. 11.
- LAZIER INDUSTRIES, INC., FENTON, MO:  
3,232,858, PUB. 2-6-2007. INT. CL. 40.
- LDL TECHNOLOGY S.A.S., FRANCE:  
3,233,527, PUB. 2-6-2007. MULTIPLE CLASS, INT. CLS. 9, 12 AND 38.
- LE GRAND IMPORTS EXPORTS PTY LIMITED, CARLTON NSW 2218, AUSTRALIA:  
3,232,368, PUB. 10-31-2006. INT. CL. 33.
- LE MONTI, INC., LINDEN, NJ:  
2,358,743, CANC. INT. CL. 3.
- LEADERSHIP NETWORK, DALLAS, TX:  
3,234,165, INT. CL. 41.
- LEAHY ORCHARDS INC., QUEBEC, CANADA:  
2,054,648, REN. 3-22-07. INT. CL. 29.
- LEAHY ORCHARDS INC., FRANKLIN CENTRE, QUEBEC, CANADA:  
2,073,395, REN. 3-22-07. INT. CL. 30.
- LEAKE, H. MILTON, JR., BURBANK, CA:  
3,233,817, INT. CL. 44.  
3,233,818, INT. CL. 35.
- LEARN THE SKILLS CORPORATION, CAMBRIDGE, MA:  
3,232,750, PUB. 2-6-2007. INT. CL. 9.
- LEARNING DYNAMICS, INC., HARTFORD, CT:  
2,357,384, CANC. INT. CL. 35.
- LEARNING PLUS ASSOCIATES, RANCHO CUCAMONGA, CA:  
3,232,778, PUB. 2-6-2007. INT. CL. 9.  
3,232,779, PUB. 2-6-2007. INT. CL. 9.
- LEARNING RESOURCES, INC., VERNON HILLS, IL:  
3,235,173, INT. CL. 9.
- LEASE PLAN U.S.A., INC., ALPHARETTA, GA:  
3,235,295, INT. CL. 35.
- LEATHERMAN, KATER LYNN, BALTIMORE, MD:  
2,358,152, CANC. INT. CL. 41.



LEATHERWOOD, JAMES M., LINGLEVILLE, TX:  
3,234,598, INT. CL. 9.

LEDALITE ARCHITECTURAL PRODUCTS, LANGLEY,  
BRITISH COLUMBIA, CANADA:  
3,235,261, INT. CL. 11.

LEE KUM LEE COMPANY LIMITED, TAI PO. N.T., HONG  
KONG, LEE MAN TAT AND LEE MAN LOK, ABERD-  
EEN, HONG KONG, TA LEE KUM KEE:  
1,424,152. REN. 3-16-07. INT. CL. 30.

LEE MIN KUNG, CHINA:  
3,233,583, PUB. 2-6-2007. INT. CL. 18.

LEEDS & NORTHRUP COMPANY, NORTH WALES, PA:  
1,396,614, CANC. INT. CL. 9.

LEFROY-BROOKS, CHRISTOPHER ALAN, AMERSHAM  
BUCKINGHAMSHIRE HD6 5EL, GREAT BRITAIN:  
2,357,927, CANC. INT. CL. 11.

LEGACY HOCKEY, LLC, PHOENIX, AZ:  
3,234,640, INT. CL. 41.  
3,234,690, INT. CL. 41.  
3,234,691, INT. CL. 41.

LEGACY MARKETING PARTNERS, L.L.C., CHICAGO, IL:  
3,232,173, PUB. 2-6-2007. INT. CL. 35.  
3,232,174, PUB. 2-6-2007. INT. CL. 35.

LEGACY MINISTRIES INTERNATIONAL, SUN CITY, AZ:  
3,233,389, PUB. 2-6-2007. INT. CL. 41.

LEGACY TECHNICAL GROUP, INC., SALT LAKE CITY,  
UT:  
3,234,490, INT. CL. 9.  
3,234,491, INT. CL. 9.

LEGARIS S.L., E-47316 CURIEL DE DUERO, VALLADOLID,  
SPAIN:  
3,233,650, PUB. 2-6-2007. INT. CL. 33.

LEHMAN BROTHERS INC., NEW YORK, NY:  
3,232,289, PUB. 2-6-2007. INT. CL. 36.  
3,232,324, PUB. 2-6-2007. INT. CL. 36.

LEMANS CORPORATION, JANESVILLE, WI:  
3,232,068, PUB. 2-6-2007. INT. CL. 35.

LEMELSON WINERY LLC, CARLTON, OR:  
3,232,353, PUB. 2-6-2007. INT. CL. 33.

LENIAR, DORIAN, SPRING VALLEY, CA:  
2,357,269, CANC. INT. CL. 9.

LENOX, INCORPORATED, BRISTOL, PA, LENOX, INCOR-  
PORATED, LAWRENCEVILLE, NJ:  
2,038,988. REN. 3-21-07. INT. CL. 21.

LEON TECH CO., LTD., DAI LI CITY, TAICHUNG HSIEN,  
TAIWAN:  
3,232,964, PUB. 2-6-2007. INT. CL. 14.

LES SYSTEMES DE FORMATION ET DE GESTION PER-  
FORM INC., MONTREAL, PROVIDENCE OF QUEBEC,  
CANADA:  
2,301,217, CANC. INT. CL. 9.

LESZYNSKI GROUP, INC., BELLEVUE, WA:  
3,234,603, INT. CL. 9.

LEUPOLD & STEVENS, INC., BEAVERTON, OR:  
3,232,682, PUB. 2-6-2007. INT. CL. 9.  
3,232,683, PUB. 2-6-2007. INT. CL. 9.

LEVEL 3 COMMUNICATIONS, INC., BROOMFIELD, CO:  
3,234,445, INT. CL. 35.

LEVITON MANUFACTURING CO., INC., LITTLE NECK,  
NY:  
3,233,954, INT. CL. 9.

LEVITT, MILLIE JO AND LEVITT, JAMES J., LEE'S  
SUMMIT, MO AND LEVITT, JAMES J., KANSAS CITY,  
MO:  
1,057,855. REN. 3-19-07. INT. CL. 30.

LEVLAD, INCORPORATED, CHATSWORTH, CA:  
3,232,194, PUB. 2-6-2007. INT. CL. 3.

LEWIS DOLIN INC., KATONAH, NY:  
3,235,430, INT. CL. 6.

LEXAR MEDIA, INC., FREMONT, CA:  
3,234,376, INT. CL. 9.

LEXMARK INTERNATIONAL, INC., LEXINGTON, KY,  
IBM INFORMATION PRODUCTS CORPORATION,  
GREENWICH, CT:  
2,032,389. REN. 3-16-07. MULTIPLE CLASS, INT. CLS. 9  
AND 16.

LEXTERA GROUP, MINNEAPOLIS, MN:  
3,235,082, INT. CL. 35.

LI PENG ENTERPRISE CO., LTD., TAIPEI, TAIWAN:  
3,233,903, INT. CL. 25.

LI PENG ENTERPRISE CO.,LTD., TAIPEI, TAIWAN:  
3,233,904, INT. CL. 23.

LI, ALEX, WALNUT, CA:  
3,232,576, PUB. 2-6-2007. INT. CL. 16.

LIBERTY HOUSE COFFEE, INC., NEWBURGH, NY:  
2,357,097, CANC. INT. CL. 30.

LIBERTY UNIFORM MANUFACTURING CO., INC.,  
WOODBURY, NY:  
2,058,352. REN. 3-16-07. INT. CL. 25.

LIBFELD INC., LAKE WORTH, FL:  
3,233,075, PUB. 2-6-2007. INT. CL. 30.

LIBS CANDIES, INC., EVANSVILLE, IN:  
1,397,039, CANC. INT. CL. 30.

LICORERA ZACAPANECA, SOCIEDAD ANÓNIMA, SANTA  
CRUZ RIO HONDO, ZACAPA, GUATEMALA:  
3,232,090, PUB. 1-23-2007. INT. CL. 33.

LIDL STIFTUNG & CO. KG, FED REP GERMANY:  
3,233,574, PUB. 2-6-2007. INT. CL. 3.

LIFE SYSTEMS, INC., ROCKAWAY, NJ:  
3,233,213, PUB. 2-6-2007. INT. CL. 9.  
3,233,215, PUB. 2-6-2007. INT. CL. 9.

LIFECODES INCORPORATED, ASHEVILLE, NC:  
2,357,971, CANC. INT. CL. 9.

LIFELINE FOOD, CO., SAND CITY, CA:  
2,358,644, CANC. INT. CL. 29.

LIFELOCK, INC., CHANDLER, AZ:  
3,232,956, PUB. 2-6-2007. INT. CL. 45.

LIFESPAN BIOSCIENCES, INC., SEATTLE, WA:  
3,234,409, MULTIPLE CLASS, INT. CLS. 9 AND 42.

LIFESTYLE MEDIA, INC., NEW YORK, NY:  
3,235,459, INT. CL. 16.

LIFETIME NUTRITION BOOKS, LLC, ITHACA, NY:  
3,232,403, PUB. 9-5-2006. INT. CL. 41.

LIFETOUCH INC., EDEN PRAIRIE, MN:  
3,234,988, INT. CL. 41.

LIFEWAY CHRISTIAN RESOURCES OF THE SOUTHERN  
BAPTIST CONVENTION, NASHVILLE, TN:  
3,232,275, PUB. 2-6-2007. MULTIPLE CLASS, INT. CLS. 9  
AND 16.

LIGHTHOUSE ACADEMIES, INC., FRAMINGHAM, MA:  
3,232,524, PUB. 2-6-2007. INT. CL. 16.

LIGHTNING BOX GAMES PTY LIMITED, AUSTRALIA:  
3,233,630, PUB. 2-6-2007. MULTIPLE CLASS, INT. CLS. 9  
AND 28.  
3,233,631, PUB. 2-6-2007. MULTIPLE CLASS, INT. CLS. 9  
AND 28.

LIGHTNING ENTERTAINMENT, SANTA MONICA, CA:  
3,232,870, PUB. 2-6-2007. INT. CL. 41.

LIGHTNING ENTERTAINMENT, INC., SANTA MONICA,  
CA:  
3,232,723, PUB. 2-6-2007. INT. CL. 41.

LIGUORI PUBLICATIONS, INC., LIQUORI, MO:  
2,356,928, CANC. INT. CL. 16.

LILY OF FRANCE, INC., LONG ISLAND CITY, NY:  
1,396,882, CANC. INT. CL. 25.

LIN, GERARD, LOS GATOS, CA:  
3,235,012, INT. CL. 35.

LINCOLN BENEFIT LIFE COMPANY, LINCOLN, NE:  
1,979,631, CANC. INT. CL. 36.

LINCOLN GLOBAL, INC., CITY OF INDUSTRY, CA,  
LINCOLN ELECTRIC COMPANY, THE, CLEVELAND,  
OH:  
2,032,039. REN. 3-20-07. INT. CL. 9.

LINCOLN NATIONAL CORPORATION, PHILADELPHIA,  
PA:  
3,232,676, PUB. 2-6-2007. INT. CL. 35.  
3,232,677, PUB. 2-6-2007. INT. CL. 38.

LINDEN OAKS CORPORATION, WILMINGTON, DE:  
3,232,333, PUB. 2-6-2007. MULTIPLE CLASS, INT. CLS. 29  
AND 30.

LINENS LIMITED, LLC, LEXINGTON, KY:  
3,233,298, PUB. 2-6-2007. INT. CL. 24.

LINK,ALDEN, MILTON, NY:  
3,233,495, PUB. 2-6-2007. INT. CL. 7.

LINKME PTY LIMITED, AUSTRALIA:  
3,233,754, PUB. 2-6-2007. MULTIPLE CLASS, INT. CLS. 35

- AND 45.
- LINQUIST, REBECCA, CAMPBELL, CA:  
3,233,235, PUB. 2-6-2007. INT. CL. 41.
- LINSEY FOODS LTD., MARKHAM, ONTARIO L3R 0J3,  
CANADA:  
2,357,834, CANC. INT. CL. 30.
- LINTEX LINENS, INC., NEW YORK, NY:  
2,037,610. REN. 3-22-07. INT. CL. 24.
- LION APPAREL, INC., DAYTON, OH:  
2,054,742. REN. 3-22-07. INT. CL. 9.
- LION NATHAN WINE GROUP AUSTRALIA LIMITED,  
SYDNEY NSW, AUSTRALIA:  
3,234,828, INT. CL. 33.
- LIONEL L.L.C., CHESTERFIELD, MI:  
2,358,213, CANC. INT. CL. 16.  
2,358,587, CANC. INT. CL. 28.
- LIONEL, L.L.C., CHESTERFIELD, MI:  
2,356,615, CANC. INT. CL. 28.
- LIONESZ, JACKSONVILLE, FL:  
3,233,388, PUB. 2-6-2007. INT. CL. 41.
- LIPPNER, ALICEJANE, HIGHLAND PARK, NJ:  
2,358,057, CANC. INT. CL. 3.
- LIPSON ASSOCIATES, INC., NORTHBROOK, IL, DBA  
LIPSON-ALPORT-GLASS & ASSOCIATES:  
3,234,635, INT. CL. 35.
- LIQUID PLANET, LLC, MISSOULA, MT:  
3,235,472, MULTIPLE CLASS, INT. CLS. 35 AND 43.
- LIQUIGUARD TECHNOLOGIES, INC., FT. LAUDERDALE,  
FL:  
3,232,342, PUB. 9-14-2004. INT. CL. 2.
- LISA JENKS LIMITED, NEW YORK, NY:  
2,357,795, CANC. INT. CL. 20.  
2,357,797, CANC. INT. CL. 18.
- LISA JENKS LIMITED, INC., NEW YORK, NY:  
2,357,798, CANC. INT. CL. 18.
- LISA LELEU STUDIOS, INC., DOYLESTOWN, PA:  
3,232,340, PUB. 2-6-2007. INT. CL. 28.
- LITHOS MARMOR GMBH, LAMPERTHEIM, FED REP  
GERMANY:  
1,432,958. REN. 3-20-07. INT. CL. 19.
- LITTLE CHEFS, LTD., SYOSSET, NY:  
3,232,527, PUB. 2-6-2007. INT. CL. 41.  
3,232,528, PUB. 2-6-2007. INT. CL. 41.
- LITTLE RAPIDS CORPORATION, GREEN BAY, WI:  
3,234,341, INT. CL. 10.
- LITTLE SWITZERLAND, INC., BOCA RATON, FL:  
3,233,271, PUB. 2-6-2007. INT. CL. 16.
- LITTLE TIGER, INC., COON RAPIDS, MN:  
2,357,632, CANC. INT. CL. 41.
- LIVINGSTON, DAVID M., TIBURON, CA:  
3,232,577, PUB. 2-6-2007. INT. CL. 41.
- LJL, INC., MINNEAPOLIS, MN:  
3,234,061, INT. CL. 26.
- LLANO ESTACADO WINERY, INC., LUBBOCK, TX:  
2,043,193. REN. 3-21-07. INT. CL. 33.  
2,043,194. REN. 3-20-07. INT. CL. 33.
- LOBSONS INTERNATIONAL, INC., LONG VALLEY, NJ:  
3,235,387, INT. CL. 5.
- LOCAL MOTION, INC., HONOLULU, HI:  
1,979,975, CANC. INT. CL. 28.
- LOCKHEED MARTIN CORPORATION, BETHESDA, MD:  
2,357,273, CANC. INT. CL. 42.  
2,357,368, CANC. INT. CL. 42.  
2,357,404, CANC. INT. CL. 42.
- LOCKWORKS LOCKSMITH COMPANY, LLC, RIDGE-  
LAND, MS:  
3,232,227, PUB. 2-6-2007. INT. CL. 45.
- LODGE MANUFACTURING COMPANY, SOUTH PITTS-  
BURG, TN:  
2,357,673, CANC. INT. CL. 21.
- LOGMEIN, INC., WOBURN, MA:  
3,234,733, INT. CL. 42.
- LOKELANI DESIGNS, LLC, BETHESDA, MD:  
3,233,019, PUB. 2-6-2007. INT. CL. 14.
- LOLA BEVERAGES INC., VAUGHAN, ONTARIO L4K 4M3,  
CANADA:  
2,358,323, CANC. INT. CL. 30.
- LOMBARDO, STEPHEN J., CHICAGO, IL:  
3,232,130, PUB. 2-6-2007. INT. CL. 43.
- LONDON CLEARING HOUSE LIMITED, THE., LONDON  
EC3N 1EA, UNITED KINGDOM:  
2,358,145, CANC. INT. CL. 36.
- LORENZO MURILLO, SANTA CLARITA, CA, DBA CALI-  
FORNIA DIVING COMPANY:  
3,234,245, INT. CL. 18.
- LORRAINE'S LUNCH BASKET, INC., ROCHESTER, NY:  
2,357,331, CANC. INT. CL. 42.
- LOSEY, RALPH C., WINTER PARK, FL, DBA "SCHOOL OF  
WISDOM":  
2,078,812. REN. 3-20-07. INT. CL. 9.
- LOUISVILLE BEDDING COMPANY, LOUISVILLE, KY:  
3,232,306, PUB. 2-6-2007. INT. CL. 20.
- LOUISVILLE CHAPTER, KENTUCKY NO. 1,  
S.P.E.B.S.Q.S.A., INC., LOUISVILLE, KY:  
2,031,965. REN. 3-20-07. INT. CL. 41.
- LOUISVILLE SUN NETWORK, LLC, LOUISVILLE, KY:  
3,232,943, PUB. 2-6-2007. INT. CL. 41.
- LOUNGE22, LLC, GLENDALE, CA:  
3,233,907, MULTIPLE CLASS, INT. CLS. 35, 37 AND 40.  
3,233,908, MULTIPLE CLASS, INT. CLS. 35, 37 AND 40.
- LOVELAND PRODUCTS, INC., GREELEY, CO:  
3,234,509, INT. CL. 5.
- LOW AND INSIDE, LLC, MINNEAPOLIS, MN:  
3,233,901, INT. CL. 9.
- LOWELL MANUFACTURING COMPANY, PACIFIC, MO:  
3,234,359, MULTIPLE CLASS, INT. CLS. 6 AND 9.
- LRP PUBLICATIONS, INC., PALM BEACH GARDENS, FL,  
JURY VERDICT RESEARCH, INC., SOLON, OH:  
1,428,893. REN. 3-19-07. INT. CL. 16.
- LT. GOVERNOR'S OFFICE OF THE STATE OF UTAH, SALT  
LAKE CITY, UT:  
3,233,175, PUB. 2-6-2007. INT. CL. 35.
- LTMA INC., NEW YORK, NY, DBA SONY RETAIL EN-  
TERTAINMENT:  
2,358,722, CANC. MULTIPLE CLASS, INT. CLS. 16, 25, 41  
AND 42.
- LUBIN, BARRY MARK, GARWOOD, NJ:  
3,232,806, PUB. 2-6-2007. INT. CL. 41.
- LUCERO, MARK, T., PITTSBURGH, PA:  
3,234,538, INT. CL. 33.
- LUCKERSON, KEVIN DEXTER, SAN MARCOS, CA:  
3,235,490, INT. CL. 25.
- LUCKY BRAND DUNGAREES, INC., VERNON, CA,  
LUCKY BRAND DUNGAREES, INC., VERNON, CA:  
2,129,881. REN. 3-21-07. INT. CL. 25.
- LUCKY MART, INC., S. EL MONTE, CA:  
3,232,132, PUB. 2-6-2007. INT. CL. 5.
- LUISA CEVESE S.R.L., 20123 MILAN, ITALY:  
2,029,455. REN. 3-16-07. MULTIPLE CLASS, INT. CLS. 18,  
20, 24, 25 AND 27.
- LUITPOLD PHARMACEUTICALS, INC., SHIRLEY, NY:  
1,426,226. REN. 3-19-07. INT. CL. 5.  
3,235,394, INT. CL. 5.
- LULU & LUIGI, LLC, ST. LOUIS PARK, MN:  
3,234,076, INT. CL. 44.
- LUMINETX TECHNOLOGIES CORPORATION, MEMPHIS,  
TN:  
3,233,494, PUB. 2-6-2007. INT. CL. 10.
- LUMINOSO STUDIOS, INC., NEW RIVER, AZ:  
3,233,188, PUB. 2-6-2007. INT. CL. 3.  
3,233,189, PUB. 2-6-2007. INT. CL. 3.
- LUPOS SCHUHFABRIK GMBH, FED REP GERMANY:  
3,233,658, PUB. 2-6-2007. INT. CL. 9.
- LURIE COMPANY, THE, SAN FRANCISCO, CA:  
2,033,759. REN. 3-17-07. INT. CL. 42.
- LUXE JEWELS, LLC, PALO ALTO, CA:  
3,232,387, PUB. 2-6-2007. MULTIPLE CLASS, INT. CLS. 14  
AND 41.
- LUXOTTICA S.P.A, I-32021 AGORDO (BELLUNO), ITALY:  
2,357,959. CANC. INT. CL. 9.
- LUXURY BATH LINERS, INC., GLENDALE HEIGHTS, IL:  
2,036,260. REN. 3-20-07. INT. CL. 11.  
2,037,961. REN. 3-20-07. INT. CL. 11.

- LUXURY GOODS INTERNATIONAL (L.G.I.) S.A., 6814 CADEMPINO, SWITZERLAND:  
2,357,924, CANC. INT. CL. 25.
- LUXURY OPTICAL HOLDINGS CO., LAS VEGAS, NV:  
3,233,296, PUB. 2-6-2007. INT. CL. 35.
- LVE HUNTING DECALS, LLC, WHITESVILLE, KY:  
3,232,144, PUB. 2-6-2007. INT. CL. 16.
- LY BROTHERS CORPORATION, SAN FRANCISCO, CA:  
3,233,990, INT. CL. 30.
- LYNCH, GEORGE M., VALENCIA, CA:  
3,235,366, INT. CL. 9.
- LYNCÉE TEC S.A., SWITZERLAND:  
3,233,610, PUB. 2-6-2007. MULTIPLE CLASS, INT. CLS. 9, 10 AND 42.
- LYNN W. GENTLE TRUST OF 1990, A CALIFORNIA TRUST, THE TRUSTEES COMPRISING LYNN W. GENTLE, A CITIZEN OF THE UNITED STATES, THE, NORTH HOLLYWOOD, CA:  
3,233,089, PUB. 2-6-2007. MULTIPLE CLASS, INT. CLS. 35 AND 41.
- LYNNE ELLEN, INC., CHARLESTON, SC:  
3,234,273, MULTIPLE CLASS, INT. CLS. 16, 25 AND 28.
- LYNX SERVICES, LLC, PITTSBURGH, PA, LYNX SERVICES FROM PPG, LLC, PITTSBURGH, PA:  
2,036,382, REN. 3-22-07. MULTIPLE CLASS, INT. CLS. 35 AND 36.
- LYONS/LAVEY/NICKEL/SWIFT, INC., NEW YORK, NY:  
2,357,727, CANC. INT. CL. 35.
- LYONS, THOMAS B., LA CRESCENT, MN:  
2,356,852, CANC. INT. CL. 20.
- M.J.C. HOMES, INC., MACOMB, MI:  
3,233,109, PUB. 2-6-2007. INT. CL. 37.
- M.R.S. COMPANY LIMITED, MISSISSAUGA, ONTARIO, CANADA:  
2,079,719, REN. 3-19-07. INT. CL. 9.
- M&S FINE FOODS, INC., CHARLOTTESVILLE, VA:  
3,232,093, PUB. 2-6-2007. MULTIPLE CLASS, INT. CLS. 29, 30 AND 35.
- M-REAL ZANDERS GMBH, BERGISCH GLADBACH, FED REP GERMANY:  
3,232,889, PUB. 2-6-2007. INT. CL. 16.
- M-SCRIBE TECHNOLOGIES, LLC, FRAMINGHAM, MA:  
3,235,167, INT. CL. 35.
- M'DEAR, RANCHO CUCAMONGA, CA:  
3,233,347, PUB. 2-6-2007. INT. CL. 35.
- M'DEAR INC, RANCHO CUCAMONGA, CA:  
3,233,348, PUB. 2-6-2007. INT. CL. 35.
- MA, DELIANG, SAN FRANCISCO, CA:  
3,234,301, INT. CL. 25.
- MAACO ENTERPRISES, INC., KING OF PRUSSIA, PA:  
2,034,247, REN. 3-21-07. INT. CL. 37.
- MAC DONALD, GORDON K., STURGEON BAY, WI AND MAC DONALD, DIANE LYNN, STURGEON BAY, WI:  
3,235,341, MULTIPLE CLASS, INT. CLS. 25 AND 39.
- MAC VALVES, INC., WIXOM, MI:  
2,024,442, REN. 3-17-07. INT. CL. 7.
- MACCABEES MUTUAL LIFE INSURANCE COMPANY, SOUTHFIELD, MI:  
1,397,112, CANC. INT. CL. 36.
- MACDONALD PAGE & CO LLC, SOUTH PORTLAND, ME:  
3,235,166, MULTIPLE CLASS, INT. CLS. 35 AND 36.
- MACKENZIE, WILLIAM S., DENVER, CO, DBA CLOYSES PARTNERS:  
2,357,465, CANC. INT. CL. 35.
- MACMASTERS CORPORATION, CHARLOTTE, NC:  
1,980,137, CANC. INT. CL. 9.
- MACQUARIUM, INC., HOUSTON, TX:  
2,054,072, REN. 3-21-07. INT. CL. 41.  
2,054,073, REN. 3-22-07. INT. CL. 41.
- MACRON S.P.A., ITALY:  
3,233,562, PUB. 2-6-2007. MULTIPLE CLASS, INT. CLS. 18, 25 AND 28.  
3,233,563, PUB. 2-6-2007. MULTIPLE CLASS, INT. CLS. 18, 25 AND 28.
- MACROSONIX CORPORATION, RICHMOND, VA:  
2,358,146, CANC. MULTIPLE CLASS, INT. CLS. 35 AND 42.
- MACSTIR, INC., PITTSBURGH, PA:  
2,358,486, CANC. INT. CL. 39.
- MACY'S MERCHANDISING GROUP, INC., NEW YORK, NY:  
1,397,197, CANC. INT. CL. 42.
- MADACY ENTERTAINMENT GROUP INC., MONTREAL, QUEBEC H3R 3L5, CANADA:  
2,358,369, CANC. INT. CL. 9.
- MADHOUSE MUNCHIES, INC., COLCHESTER, VT:  
2,077,088, REN. 3-19-07. INT. CL. 29.  
2,077,088, CANC. INT. CL. 30.
- MADWISH B.V., ROTTERDAM, NETHERLANDS:  
3,233,626, PUB. 2-6-2007. INT. CL. 28.
- MAGA SHOP S.R.L., LIMIDO COMASCO (CO), ITALY:  
3,232,079, PUB. 2-6-2007. INT. CL. 9.
- MAGEE, STEVEN D, LIVINGSTON, LA:  
3,234,518, INT. CL. 25.
- MAGGERT, JEFF A., THE WOODLANDS, TX:  
2,035,858, REN. 3-22-07. MULTIPLE CLASS, INT. CLS. 25, 41 AND 42.
- MAGIC HAT BREWING COMPANY AND PERFORMING ARTS CENTER, INC., SOUTH BURLINGTON, VT:  
3,232,689, PUB. 2-6-2007. INT. CL. 32.
- MAGNA-LASTIC DEVICES, INC., CARTHAGE, IL:  
3,234,217, INT. CL. 40.  
3,234,218, INT. CL. 42.
- MAGNETICS USA INC, MIAMI, FL:  
3,235,435, INT. CL. 15.
- MAGNOLIA ENTERPRISES, INC., SPOTSYLVANIA, VA:  
3,233,891, INT. CL. 36.
- MAGUS GMBH, ZUG, SWITZERLAND:  
1,396,467, CANC. INT. CL. 7.
- MAHESH M PATEL MD INC., BEVERLY, MA:  
3,234,586, INT. CL. 44.
- MAHINA INC., LOS ANGELES, CA:  
3,054,264, CANC. INT. CL. 43.
- MAICO HEARING INSTRUMENTS, INC., MINNEAPOLIS, MN:  
1,396,636, CANC. INT. CL. 10.
- MAIER, CHARLES E. III, CHARLEMONT, MA:  
3,232,519, PUB. 2-6-2007. MULTIPLE CLASS, INT. CLS. 9 AND 41.
- MAIL UNIVERSITY CORPORATION, NORRISTOWN, PA:  
2,358,885, CANC. INT. CL. 41.
- MAISON GINESTET, FRANCE:  
3,233,611, PUB. 2-6-2007. INT. CL. 33.
- MAJOR LEAGUE SOCCER, L.L.C., NEW YORK, NY:  
2,039,199, REN. 3-20-07. MULTIPLE CLASS, INT. CLS. 16 AND 25.
- MAKEPEACE, CLAYTON, SARASOTA, FL:  
3,234,926, INT. CL. 35.
- MAKITA U.S.A., INC., LA MIRADA, CA:  
1,979,977, CANC. INT. CL. 7.  
3,232,739, PUB. 2-6-2007. INT. CL. 7.
- MALCOLM & CO. LLC, NEW YORK, NY:  
3,232,587, PUB. 2-6-2007. INT. CL. 9.
- MALIBU FILM FOUNDATION, SANTA MONICA, CA:  
3,232,074, PUB. 2-6-2007. MULTIPLE CLASS, INT. CLS. 16, 25 AND 41.
- MALLINCKRODT BAKER, INC., PHILLIPSBURG, NJ:  
821,837, REN. 3-16-07. U.S. CL. 6 (INT. CL. 1).
- MALT-O-MEAL COMPANY, MINNEAPOLIS, MN:  
3,235,211, INT. CL. 30.
- MAMATISH'S ITALIAN SPECIALTIES, INC., CHICAGO, IL:  
1,397,045, CANC. INT. CL. 30.
- MANCELLO, JOSEPH, STATEN ISLAND, NY:  
3,232,066, PUB. 2-6-2007. INT. CL. 35.
- MANGIUCA, DANIELA C., ROCHESTER HILLS, MI:  
2,357,129, CANC. INT. CL. 42.
- MANHATTAN BAGEL COMPANY, INC., GOLDEN, CO:  
2,031,357, REN. 3-19-07. INT. CL. 42.
- MANIS, PETER J, MONMOUTH JUNCTION, NJ:  
3,233,031, PUB. 2-6-2007. INT. CL. 35.
- MANN LAKE, LTD., HACKENSACK, MN:  
2,040,606, REN. 3-19-07. INT. CL. 9.  
2,111,481, REN. 3-19-07. INT. CL. 1.

- MANN'S BAIT COMPANY, INC., EUFAULA, AL, DBA MANN'S BAIT COMPANY:  
1,396,970, CANC. INT. CL. 28.
- MANNATECH, INC., COPPELL, TX:  
2,357,435, CANC. INT. CL. 5.
- MAP IMPLANT INSTITUTE, PALM HARBOR, FL:  
3,235,477, INT. CL. 41.
- MAPINFO CORPORATION, TROY, NY, MAPINFO CORPORATION, TROY, NY:  
2,116,800, REN. 3-21-07. INT. CL. 9.
- MARAJ, BAL, FULLERTON, CA:  
3,234,785, INT. CL. 9.
- MARCH MADNESS ATHLETIC ASSOCIATION LLC, BLOOMINGTON, IL:  
3,233,129, PUB. 2-6-2007. INT. CL. 38.
- MARCON INTERNATIONAL, INC., HARRISBURG, NC:  
2,037,415, REN. 3-16-07. INT. CL. 20.
- MARCUS IDEAWORKS, INC., LAKE FOREST, IL:  
2,356,603, CANC. INT. CL. 35.
- MARGARITAVILLE ENTERPRISES, LLC, PALM BEACH, FL:  
2,132,885, REN. 3-19-07. INT. CL. 32.
- MARIAH MEDIA INC., SANTA FE, NM:  
2,022,426, REN. 3-20-07. INT. CL. 42.
- MARILYN ROSE HAZEL MOORE, UNITED KINGDOM:  
3,233,528, PUB. 2-6-2007. INT. CL. 25.
- MARIN MOUNTAIN BIKES, INC., NOVATO, CA:  
2,358,622, CANC. INT. CL. 12.
- MARION FÜRMETZ, FED REP GERMANY:  
3,233,696, PUB. 2-6-2007. MULTIPLE CLASS, INT. CLS. 31 AND 38.
- MARION PEPSI-COLA BOTTLING CO., MARION, IL:  
2,043,230, REN. 3-19-07. INT. CL. 32.
- MARK ANTHONY INTERNATIONAL SRL, ROCKLEY, CHRIST CHURCH, BARBADOS:  
3,232,759, PUB. 6-6-2006. MULTIPLE CLASS, INT. CLS. 18, 25, 32 AND 33.
- MARK FELDSTEIN & ASSOCIATES, INC., MAUMEE, OH:  
3,235,285, INT. CL. 9.
- MARK TRAVEL CORPORATION, THE, MILWAUKEE, WI:  
2,106,617, REN. 3-16-07. INT. CL. 39.
- MARKET AMERICA, INC., GREENSBORO, NC:  
3,232,414, PUB. 2-6-2007. MULTIPLE CLASS, INT. CLS. 9 AND 16.
- MARKET CONTOURS, LLC, MADISON, WI:  
3,233,121, PUB. 2-6-2007. INT. CL. 9.
- MARKETING ANALYTICS, INC., EVANSTON, IL:  
3,234,946, INT. CL. 42.
- MARKETING AND COMMUNICATION STRATEGIES, INC., NE, CEDAR RAPIDS, IA:  
2,358,209, CANC. INT. CL. 35.
- MARKIE, ELIZABETH, LITCHFIELD, IL:  
3,233,106, PUB. 2-6-2007. INT. CL. 35.
- MARKLINE S.A., LUXEMBOURG:  
3,233,746, PUB. 2-6-2007. INT. CL. 3.
- MARKMAN, LEONID, BROOKLYN, NY:  
3,235,087, INT. CL. 3.
- MARMOT MOUNTAIN LLC, SANTA ROSA, CA:  
3,233,922, INT. CL. 20.
- MARRIOTT INTERNATIONAL, INC., BETHESDA, MD:  
3,232,795, PUB. 2-6-2007. INT. CL. 43.
- MARS, INCORPORATED, MCLEAN, VA:  
1,958,952, REN. 3-16-07. INT. CL. 31.  
2,002,712, REN. 3-22-07. INT. CL. 30.  
2,356,911, CANC. INT. CL. 42.  
3,233,255, PUB. 2-6-2007. INT. CL. 30.
- MARS, INCORPORATED, MC LEAN, VA:  
3,234,826, INT. CL. 31.  
3,235,409, MULTIPLE CLASS, INT. CLS. 29, 30 AND 31.  
3,235,410, MULTIPLE CLASS, INT. CLS. 29, 30 AND 31.
- MARSALESE, GERARD, BIRMINGHAM, MI:  
3,235,427, INT. CL. 3.
- MARSHALL CAVENDISH CORPORATION, TARRYTOWN, NY:  
3,235,216, INT. CL. 16.
- MARTHA, J. PAUL, PITTSBURGH, PA:  
2,357,842, CANC. INT. CL. 41.
- MARTIN, CRAIG, TORRANCE, CA:  
3,234,255, MULTIPLE CLASS, INT. CLS. 9 AND 25.
- MARVIN J. PERRY, INC., KENSINGTON, MD:  
3,232,715, PUB. 7-25-2006. INT. CL. 35.
- MARVIN LUMBER AND CEDAR CO., WARROAD, MN:  
2,036,656, REN. 3-21-07. INT. CL. 19.
- MARY ANN ESPOSITO, INC., DURHAM, NH:  
2,031,408, REN. 3-22-07. INT. CL. 25.
- MARY ENGELBREIT ENTERPRISES, INC., ST. LOUIS, MO, DBA ME INK:  
2,121,837, REN. 3-19-07. INT. CL. 16.
- MARY T. RYAN, JACKSON, WY:  
3,233,404, PUB. 2-6-2007. INT. CL. 44.
- MARYLAND CLUB FOODS, INC.:  
1,397,024, CANC. INT. CL. 30.
- MASCHINENFABRIK WIFAG, CH-3001 BERN, SWITZERLAND:  
2,066,680, REN. 3-22-07. INT. CL. 7.
- MASCOT BOOKS, INC., HERNDON, VA:  
3,235,395, MULTIPLE CLASS, INT. CLS. 14 AND 16.
- MASON DIXON FUNDING, INC., ROCKVILLE, MD:  
2,123,701, REN. 3-22-07. INT. CL. 36.
- MASRON BV, NETHERLANDS:  
3,233,751, PUB. 2-6-2007. MULTIPLE CLASS, INT. CLS. 9, 20 AND 21.
- MASSACHUSETTS FINANCIAL SERVICES COMPANY, BOSTON, MA:  
2,356,712, CANC. MULTIPLE CLASS, INT. CLS. 36 AND 42.
- MASTER APPLIANCE CORP., RACINE, WI:  
3,233,015, PUB. 2-6-2007. INT. CL. 7.
- MASTERBLEND INTERNATIONAL, INC., CLEVELAND, OH:  
2,358,306, CANC. INT. CL. 1.
- MASTRION, HELEN, GREENFIELD CENTER, NY:  
3,233,819, INT. CL. 25.
- MATCH PURSUITS LLC, FAIRFAX, VA:  
3,234,813, INT. CL. 45.
- MATSUSHITA ELECTRIC INDUSTRIAL CO., LTD., OSAKA-FU, JAPAN:  
3,233,843, MULTIPLE CLASS, INT. CLS. 7, 8, 9, 10, 11, 16, 21 AND 37.
- MATTEL, INC., EL SEGUNDO, CA:  
2,357,921, CANC. INT. CL. 28.  
2,358,340, CANC. INT. CL. 28.  
3,232,548, PUB. 10-24-2006. INT. CL. 28.  
3,234,237, INT. CL. 28.  
3,234,372, INT. CL. 28.  
3,234,685, INT. CL. 21.  
3,234,694, INT. CL. 28.  
3,234,695, INT. CL. 28.  
3,234,770, INT. CL. 28.
- MATTHIAS H. VAN DOORN, CHANHASSEN, MN:  
3,233,135, PUB. 2-6-2007. INT. CL. 14.
- MATTHIAS SCHOLL, HOUSTON, TX:  
3,235,263, INT. CL. 42.
- MATTRESS WAREHOUSE, INC., FREDERICK, MD:  
3,235,077, INT. CL. 35.
- MAUNA LOA MACADAMIA NUT CORPORATION, HILO, HI:  
2,357,788, CANC. INT. CL. 29.
- MAURICE SPORTINGS GOODS, INC., NORTHBROOK, IL:  
2,038,152, REN. 3-17-07. INT. CL. 28.
- MAVENSPIRE, INC., HANOVER, MD:  
3,233,275, PUB. 2-6-2007. INT. CL. 42.
- MAVERICK DATA SYSTEMS, INC., BENSALEM, PA:  
3,232,461, PUB. 2-6-2007. INT. CL. 9.
- MAVERICK SOUTHERN KITCHENS, INC., CHARLESTON, SC:  
3,235,423, MULTIPLE CLASS, INT. CLS. 9, 16, 25, 35, 41 AND 43.
- MAX ROHR, INC., WILMINGTON, DE:  
812,867, REN. 3-21-07. U.S. CL. 17 (INT. CL. 34).  
3,233,292, PUB. 2-6-2007. INT. CL. 34.
- MAXENS GMBH, D-83308 TROSTBERG, FED REP GERMANY:  
3,233,784, MULTIPLE CLASS, INT. CLS. 1, 30, 32, 35 AND 40.

MAXIFORJA SA FORJARIA METALURIGIA, CANOAS, BRAZIL:  
3,233,242, PUB. 2-6-2007. MULTIPLE CLASS, INT. CLS. 7 AND 12.

MAXPREPS, INC., CAMERON PARK, CA:  
3,233,098, PUB. 2-6-2007. MULTIPLE CLASS, INT. CLS. 35 AND 41.

MAXWELL, JAMES H., DUNCANVILLE, TX:  
2,357,336, CANC. INT. CL. 7.

MAY & SPEH, INC., DOWNERS GROVE, IL:  
2,356,667, CANC. INT. CL. 9.

MAYER-BERKSHIRE CORPORATION, WAYNE, NJ:  
1,396,888, CANC. INT. CL. 25.

MAYRAND, LIONEL E., SAN FRANCISCO, CA:  
2,356,899, CANC. INT. CL. 35.

MAYZO, INC., NORCROSS, GA:  
3,232,996, PUB. 2-6-2007. INT. CL. 1.

MAZDA MOTOR OF AMERICA, INC., IRVINE, CA:  
3,233,176, PUB. 2-6-2007. INT. CL. 41.

MAZEH, ABBAS, WESTMINSTER, CA:  
3,235,144, INT. CL. 25.

MAZELMINTS, INC., ELDERSBURG, MD:  
3,235,374, INT. CL. 6.

MAZZETTA COMPANY, THE, HIGHLAND PARK, IL:  
2,358,128, CANC. INT. CL. 29.

MBI INTERNATIONAL, INC., ROAD TOWN, TORTOLA, BR. VIRGIN ISLANDS:  
3,232,070, PUB. 12-20-2005. INT. CL. 36.

MCAFFEE, INC., SANTA CLARA, CA:  
3,232,954, PUB. 2-6-2007. INT. CL. 9.

MCCALLUM, KENNETH G. SR., WEST MONROE, LA:  
3,234,036, MULTIPLE CLASS, INT. CLS. 20 AND 25.

MCCARNEY, KEVIN T., NO. HOLLYWOOD, CA, DBA POQUITO MAS:  
3,234,539, MULTIPLE CLASS, INT. CLS. 8, 29 AND 30.

MCCARTHY, JAMES, R., TUCSON, AZ:  
3,234,976, INT. CL. 9.

MCCLAIN, JANECE LUND, VENTURA, CA:  
3,232,124, PUB. 2-6-2007. INT. CL. 18.

MCCLIVE & CO., INC., STAMFORD, CT:  
2,357,903, CANC. MULTIPLE CLASS, INT. CLS. 9 AND 42.

MCCONAUGHY, PAUL, COLLINSVILLE, MS, COLLEGE WATERCOLOR GROUP, INC., THE, RINGOES, NJ:  
1,056,059, REN. 3-20-07. INT. CL. 16.

MCCORMICK & COMPANY, INCORPORATED, SPARKS, MD:  
3,232,746, PUB. 2-6-2007. INT. CL. 41.

MCCOY, RONALD T., HARRISONBURG, VA:  
2,357,278, CANC. INT. CL. 21.

MCCRONE RESEARCH INSTITUTE, CHICAGO, IL:  
3,233,472, PUB. 2-6-2007. MULTIPLE CLASS, INT. CLS. 41 AND 42.

MCCULLOUGH-CARNES, YOLANDA, AURORA, IL, DBA N-TIME:  
2,358,618, CANC. INT. CL. 16.

MCDEVITT, SHANNON L., MOUNT PLEASANT, SC:  
3,234,743, INT. CL. 41.

MCDONALD'S CORPORATION, OAK BROOK, IL:  
3,232,844, PUB. 2-6-2007. INT. CL. 30.

MCFADDEN, CHRIS, PALM DESERT, CA:  
3,234,911, INT. CL. 6.

MCGAHA DESIGNS, LLC, DALLAS, TX:  
3,232,243, PUB. 2-6-2007. INT. CL. 42.

MCGIVERN CO., PERRYSBURG, OH:  
2,041,998, REN. 3-21-07. INT. CL. 14.

MCGRATH, MARK, MANALAPAN, NJ:  
3,234,037, INT. CL. 25.

MCGUIGAN ENTERPRISES, FORT MYERS BEACH, CA:  
2,357,982, CANC. INT. CL. 42.

MCINTIRE, RANDY B., LAKE GEORGE, CO:  
2,356,939, CANC. INT. CL. 20.

MCKESSON CORPORATION, SAN FRANCISCO, CA:  
2,356,795, CANC. INT. CL. 35.

MCKINNON 'S LLC, HARTFORD, CT:  
3,232,152, PUB. 2-6-2007. INT. CL. 43.

MCLANE ADVANCED TECHNOLOGIES, TEMPLE, TX:  
3,232,464, PUB. 2-6-2007. INT. CL. 42.

MCNEAL, SANDERS, JACKSON, MS:  
3,233,197, PUB. 2-6-2007. INT. CL. 16.

MCNEELY, FR. MAURICE G., HONOLULU, HI:  
1,396,701, CANC. INT. CL. 16.

MCNISH CORPORATION, AURORA, IL:  
1,396,654, CANC. INT. CL. 11.

MCREPS INC., OCONOMOWOC, WI:  
3,232,882, PUB. 2-6-2007. INT. CL. 35.

MDL FRANCE, FRANCE:  
3,233,693, PUB. 2-6-2007. MULTIPLE CLASS, INT. CLS. 20, 22 AND 24.

MEAD CORPORATION, THE, DAYTON, OH:  
1,979,083, CANC. INT. CL. 16.

MEAD JOHNSON & COMPANY, EVANSVILLE, IN, MEAD JOHNSON & COMPANY, EVANSVILLE, IN:  
830,280, REN. 3-20-07. U.S. CL. 46 (INT. CL. 5).

MEADOWBROOK L.L.C., NORTHBROOK, IL:  
3,166,652, CANC. IIRN. RESTORED TO S.N. 78-645,909.

MEADWESTVACO CORPORATION, STAMFORD, CT:  
3,232,789, PUB. 2-6-2007. INT. CL. 20.  
3,232,909, PUB. 2-6-2007. INT. CL. 16.

MEADWESTVACO CORPORATION, GLEN ALLEN, VA:  
3,235,233, INT. CL. 16.

MEALS, ROY A., LOS ANGELES, CA:  
3,233,154, PUB. 2-6-2007. INT. CL. 41.

MECCANO, CLICHY, FRANCE:  
2,356,435, CANC. INT. CL. 28.

MECCANO S.A., 92100 BOULOGNE BILLANCOURT, FRANCE:  
2,358,529, CANC. INT. CL. 28.

MECHANICAL EQUIPMENT COMPANY, INC., NEW ORLEANS, LA:  
1,980,201, CANC. INT. CL. 11.

MECHANICAL SIMULATION CORPORATION, ANN ARBOR, MI:  
3,233,840, INT. CL. 9.

MED GEN INC., BOCA RATON, FL:  
3,235,112, INT. CL. 5.

MEDBASICS LLC, NEW YORK, NY FROM HERMANN, TARA S., NEW YORK, NY:  
3,234,105, INT. CL. 16.

MEDCO HEALTH SOLUTIONS, INC., FRANKLIN LAKES, NJ:  
3,235,251, INT. CL. 35.

MEDEXUS INC., ONTARIO, CANADA:  
3,234,881, INT. CL. 5.

MEDI GROUP LIMITED, OAK, PA:  
1,962,020, REN. 3-22-07. INT. CL. 9.

MEDIA ARTS GROUP, INC., SAN JOSE, CA, LIGHTPOST PUBLISHING, INC., SAN JOSE, CA:  
1,988,294, REN. 3-22-07. INT. CL. 16.

MEDIA IN MOTION, L.P., SAN FRANCISCO, CA:  
2,358,243, CANC. INT. CL. 9.

MEDIAMOTION EUROPE GMBH, SWITZERLAND:  
3,233,741, PUB. 2-6-2007. INT. CL. 9.

MEDIATRAC, LLC, SAN RAMON, CA:  
3,232,635, PUB. 2-6-2007. MULTIPLE CLASS, INT. CLS. 35 AND 38.

MEDICAL ALLIANCE, INC., IRVING, TX:  
2,357,136, CANC. MULTIPLE CLASS, INT. CLS. 35, 37, 41 AND 42.

MEDICAL BROADCASTING, LLC, PHILADELPHIA, PA:  
3,234,882, INT. CL. 35.  
3,234,883, INT. CL. 35.

MEDICAL EDUCATION RESEARCH INSTITUTE ("MERI"), MEMPHIS, TN:  
3,235,228, INT. CL. 42.

MEDICAL SYSTEMS, INCORPORATED, HATTIESBURG, MS:  
3,234,000, INT. CL. 44.

MEDICAL WORLD BUSINESS PRESS, INC., JAMESBURG, NJ:  
3,235,243, INT. CL. 16.

MEDIIMPACT HEALTHCARE SYSTEMS, INC., SAN DIEGO, CA:  
3,232,533, PUB. 2-6-2007. MULTIPLE CLASS, INT. CLS. 35, 36 AND 42.

- MEDIQUIK SERVICES, INC., HOUSTON, TX:  
2,357,049, CANC. INT. CL. 36.
- MEDLOGIC GLOBAL CORPORATION, COLORADO SPRINGS, CO:  
2,357,852, CANC. INT. CL. 5.
- MEDSTRAT, INC., DOWNERS GROVE, IL:  
3,234,423, INT. CL. 9.  
3,234,424, INT. CL. 9.
- MEDTRONIC, INC., MINNEAPOLIS, MN:  
3,235,288, INT. CL. 10.
- MEETING GROUP S.P.A., ITALY:  
3,233,678, PUB. 2-6-2007. MULTIPLE CLASS, INT. CLS. 18 AND 25.
- MEGA MEDIA HOLDINGS, INC., COCONUT GROVE, FL:  
3,232,238, PUB. 2-6-2007. INT. CL. 41.
- MEGA POWER, INC., OLDSMAR, FL:  
1,912,890, CANC. INT. CL. 1.
- MEIJER, INC., GRAND RAPIDS, MI:  
1,396,902, CANC. INT. CL. 25.
- MEL BERNIE AND COMPANY, INC., BURBANK, CA:  
3,233,323, PUB. 2-6-2007. INT. CL. 14.
- MELITTA HAUSHALTSPRODUKTE GMBH & CO. KG, D-32427 MINDEN, FED REP GERMANY:  
647,467. REN. 3-22-07. U.S. CL. 31 (INT. CL. 16).
- MELIVET PRODUCTS, INC., FOGELSVILLE, PA:  
3,233,939, INT. CL. 10.
- MELLUSO DI BENIAMINO MELLUSO; E C. S.A.S., ITALY:  
3,233,627, PUB. 2-6-2007. INT. CL. 25.
- MELO DEVELOPMENT, INC., MIAMI, FL:  
3,232,812, PUB. 2-6-2007. INT. CL. 37.
- MELODY, TIMOTHY JOSEPH. LAKE FOREST, CA:  
3,234,266, INT. CL. 9.
- MELROSE TECHNOLOGIES, GLENSIDE, PA:  
2,061,160. REN. 3-19-07. INT. CL. 9.
- MEMBERSTRADE LLC, SALT LAKE CITY, UT:  
3,233,091, PUB. 2-6-2007. INT. CL. 36.
- MENDALE HOUSEHOLD TEXTILES CO., LTD, CHANG-SHASHI; HUNAN 410008, CHINA:  
3,233,676, PUB. 2-6-2007. INT. CL. 24.
- MENDOCINO BREWING COMPANY, INC., UKIAH, CA:  
2,011,816. REN. 3-16-07. INT. CL. 32.  
2,011,817. REN. 3-16-07. INT. CL. 32.  
2,032,382. REN. 3-16-07. INT. CL. 32.
- MENDOCINO GLUTEN-FREE PRODUCTS, INC., WILLITS, CA:  
2,044,649. REN. 3-16-07. INT. CL. 30.  
2,044,826. REN. 3-16-07. INT. CL. 30.
- MENDOCINO WINE GROUP, LLC, UKIAH, CA:  
3,234,427, INT. CL. 33.
- MENELAUS B.V., 1183 AT AMSTELVEEN, NETHERLANDS:  
3,232,159, PUB. 2-6-2007. INT. CL. 5.
- MENENDEZ, JORGE SUAREZ, CORAL GABLES, FL:  
3,232,744, PUB. 2-6-2007. MULTIPLE CLASS, INT. CLS. 3 AND 5.
- MENTOR GRAPHICS CORPORATION, BEAVERTON, OR:  
1,396,616, CANC. INT. CL. 9.  
1,396,617, CANC. INT. CL. 9.
- MERCADO LATINO, INC., CITY OF INDUSTRY, CA:  
2,035,275. REN. 3-20-07. INT. CL. 32.
- MERCANTILE BANKSHARES CORPORATION, BALTIMORE, MD:  
3,232,126, PUB. 2-6-2007. INT. CL. 36.
- MERCEDES HOMES, INC., MELBOURNE, FL:  
3,233,315, PUB. 2-6-2007. INT. CL. 37.
- MERCHANDISING INTERNATIONAL S.A., 1208 GENEVA, SWITZERLAND:  
2,356,998, CANC. MULTIPLE CLASS, INT. CLS. 1, 4, 6, 9, 14, 16, 20, 21, 25, 26, 35, 37, 40 AND 42.
- MERCHSOURCE, LLC, FOOTHILL RANCH, CA:  
3,232,652, PUB. 2-6-2007. INT. CL. 35.
- MERCK KGAA, 64293 DARMSTADT, FED REP GERMANY:  
1,429,701. REN. 3-22-07. INT. CL. 1.
- MERCY MEDICAL CENTER, INC., BALTIMORE, MD:  
2,358,385, CANC. INT. CL. 42.
- MEREDITH CORPORATION, DES MOINES, IA:  
3,234,768, INT. CL. 42.
- MERELINDA FARMS L.L.C., WHITMORE LAKE, MI, DBA ALPACA.COM L.L.C.:  
3,232,319, PUB. 2-11-2003. INT. CL. 25.
- MERRICK SYSTEMS, INC., HOUSTON, TX:  
3,233,112, PUB. 2-6-2007. INT. CL. 9.  
3,233,168, PUB. 2-6-2007. INT. CL. 9.
- MERRILL LYNCH & CO., INC., NEW YORK, NY:  
2,357,019, CANC. MULTIPLE CLASS, INT. CLS. 9 AND 36.
- MERRILL, MARCIA, BALTIMORE, MD:  
3,233,346, PUB. 2-6-2007. INT. CL. 41.
- MERZ PHARMACEUTICALS, LLC, GREENSBORO, NC:  
3,233,153, PUB. 2-6-2007. INT. CL. 5.
- MESA CITRUS GROWERS, MESA, AZ, SIERRA MADRE-LAMANDA CITRUS ASSOCIATION, LAMANDA PARK, CA:  
230,350. REN. 3-19-07. U.S. CL. 46 (INT. CL. 31).
- MESSENGER INTERNATIONAL, INC., PALMER LAKE, CO:  
3,234,311, INT. CL. 41.
- METACARTA, INC., CAMBRIDGE, MA:  
3,234,346, MULTIPLE CLASS, INT. CLS. 9 AND 42.
- METALLINE CORPORATION, MEQUON, WI:  
3,232,536, PUB. 2-6-2007. INT. CL. 3.
- METCOAT L.L.C., MOBERLY, MO:  
2,358,142, CANC. INT. CL. 4.
- METL-SPAN I, LTD., LEWISVILLE, DENTON COUNTY, TX:  
3,233,858, INT. CL. 19.
- METO INTERNATIONAL GMBH, D-69434 HIRSCHHORN, FED REP GERMANY:  
2,356,984, CANC. INT. CL. 9.
- METRIX GROUP, INC., SOUTH PLAINFIELD, NJ:  
1,396,674, CANC. MULTIPLE CLASS, INT. CLS. 12 AND 42.
- METRO-GOLDWYN-MAYER STUDIOS INC., LOS ANGELES, CA:  
3,234,515, INT. CL. 41.  
3,234,889, INT. CL. 41.
- METROHM LTD., 9100 HERISAU, SWITZERLAND:  
2,045,296. REN. 3-19-07. INT. CL. 9.
- METROMEDIA STEAKHOUSES COMPANY, L.P., PLANO, TX:  
3,234,681, INT. CL. 43.
- METSO MINERALS (MATAMATA) LIMITED, MATAMATA, NEW ZEALAND:  
3,232,454, PUB. 10-31-2006. INT. CL. 19.
- MEYER INDUSTRIES, INC., SAN ANTONIO, TX:  
1,972,334. REN. 3-16-07. MULTIPLE CLASS, INT. CLS. 7 AND 11.
- MEYNARD DESIGNS, INC., WALTHAM, MA:  
2,498,823, CANC. INT. CL. 18.
- MFX RESEARCH PTY LTD, PYMBLE, NEW SOUTH WALES 2073, AUSTRALIA:  
2,356,903, CANC. INT. CL. 9.
- MGEN, INC., FOXBOROUGH, MA:  
2,356,951, CANC. INT. CL. 42.
- MH WATERS PTY. LTD., WAVERTON, NSW 2060, AUSTRALIA:  
3,234,332, INT. CL. 32.
- MHP MANNESMANN PRÄZISROHR GMBH, FED REP GERMANY:  
3,233,588, PUB. 2-6-2007. INT. CL. 6.
- MI WINDOWS AND DOORS, INC., GRATZ, PA:  
3,233,969, MULTIPLE CLASS, INT. CLS. 6 AND 19.
- MI-JACK PRODUCTS INC., HAZEL CREST, IL:  
1,426,293. REN. 3-22-07. INT. CL. 7.
- MI-JACK PRODUCTS, INC., HAZEL CREST, IL:  
3,233,861, INT. CL. 9.
- MIAMI SUBS OF DELAWARE INC., FORT LAUDERDALE, FL:  
2,066,230. REN. 3-21-07. INT. CL. 42.
- MIBOY, INC., KEARNY, NJ:  
3,232,161, PUB. 2-6-2007. INT. CL. 25.  
3,232,193, PUB. 2-6-2007. INT. CL. 25.
- MICHAEL S. MORRIS, MD, LLC, ROCKVILLE, MD:  
3,235,126, INT. CL. 5.
- MICHAEL, AMERICA S., WOODSIDE, CA:  
3,234,478, INT. CL. 45.

MICHEL PUBLISHING, LTD., NEW CANAAN, CT:  
2,357,530, CANC. INT. CL. 16.

MICHELE DAIGNAULT, WINDSOR, CANADA:  
3,233,276, PUB. 2-6-2007. INT. CL. 18.

MICHELIN NORTH AMERICA, INC, GREENVILLE, SC:  
1,046,312, REN. 3-17-07. INT. CL. 12.

MICHELIN NORTH AMERICA, INC., GREENVILLE, SC:  
2,357,288, CANC. INT. CL. 12.

MICHIGAN DENTAL PLAN, FLINT, MI:  
1,425,127, REN. 3-16-07. INT. CL. 36.

MICHIGAN RAG COMPANY, GRAND HAVEN, MI:  
2,479,489, CANC. INT. CL. 18.

MICRO ABRASIVES CORPORATION, WESTFIELD, MA:  
3,234,186, INT. CL. 3.

MICRO GRAPHIC INFORMATION SERVICES CORPORATION, SADDLE BROOK, NJ:  
3,232,919, PUB. 2-6-2007. MULTIPLE CLASS, INT. CLS. 40 AND 42.

MICRO MEDICAL LIMITED, KENT, ME4 4QY, UNITED KINGDOM:  
3,232,135, PUB. 9-19-2006. INT. CL. 10.

MICRO PRODUCTS CO., BENSENVILLE, IL:  
647,040, REN. 3-22-07. U.S. CL. 21 (INT. CL. 9).

MICROSOFT CORPORATION, REDMOND, WA:  
3,235,107, INT. CL. 9.

MICROSTRAIN, INC., WILLISTON, VT:  
3,233,464, PUB. 2-6-2007. INT. CL. 9.

MICROTRAIN INTERNATIONAL, INC., COMMERCE TOWNSHIP, MI:  
3,233,148, PUB. 2-6-2007. INT. CL. 9.

MICROWORKS, INC., CULLEOKA, TN:  
2,356,508, CANC. INT. CL. 9.

MID-AMERICA COMPUTER CORPORATION, BLAIR, NE:  
2,357,002, CANC. MULTIPLE CLASS, INT. CLS. 35 AND 36.

MID-STATES SERVICES, INC., DALLAS, TX:  
2,358,856, CANC. INT. CL. 39.

MID-WEST NATIONAL LIFE INSURANCE COMPANY OF TENNESSEE, NORTH RICHLAND HILLS, TX:  
3,233,126, PUB. 2-6-2007. INT. CL. 36.

MIDLANDS BENEFIT ADMINISTRATORS, INC., OMAHA, NE:  
3,078,047, CANC. INT. CL. 35.

MIDTECH R&D, INC., FAIRMONT, MN:  
3,235,312, INT. CL. 1.  
3,235,313, INT. CL. 1.  
3,235,314, INT. CL. 1.

MIDWAY AMUSEMENT GAMES, LLC, CHICAGO, IL:  
3,234,943, INT. CL. 9.

MIDWAY MANUFACTURING COMPANY, CHICAGO, IL TO MIDWAY AMUSEMENT GAMES, LLC, CHICAGO, IL:  
1,979,392, CANC. MULTIPLE CLASS, INT. CLS. 16 AND 28.  
1,979,399, CANC. MULTIPLE CLASS, INT. CLS. 16 AND 28.

MIDWEST GRAIN PRODUCTS, INC., ATCHISON, KS:  
1,397,041, CANC. INT. CL. 30.

MIDWEST INDUSTRIAL SUPPLY, INC., CANTON, OH:  
2,051,440, REN. 3-22-07. INT. CL. 1.

MIDWEST REGIONAL MARKETING, INC., BURNSVILLE, MN:  
3,234,371, INT. CL. 20.

MIDWEST VETERINARY SERVICES, INC., OAKLAND, NE:  
3,232,633, PUB. 2-6-2007. INT. CL. 5.  
3,232,634, PUB. 2-6-2007. INT. CL. 35.

MIDWEST WINE EXCHANGE LLC, NOVI, MI:  
3,235,338, INT. CL. 33.

MIGHTY BIDS AUCTIONS INC., ST-LAURENT, QUEBEC, CANADA:  
3,232,719, PUB. 2-6-2007. INT. CL. 35.

MIKRON HOLDING AG, BH-2502 BIEL, SWITZERLAND:  
2,033,540, REN. 3-22-07. INT. CL. 7.

MIKRON HOLDING AG, CH-2501 BIEL, SWITZERLAND:  
2,036,672, REN. 3-22-07. INT. CL. 7.

MILANO MANHATTAN, LLC, NEW YORK, NY:  
3,234,001, INT. CL. 25.

MILBERGER TURF FARM CO., BAY CITY, TX:  
1,397,054, CANC. INT. CL. 31.

MILLENNIUM PHARMACEUTICALS, INC., CAMBRIDGE, MA:  
2,097,386, REN. 3-19-07. INT. CL. 42.

MILLENNIUM2HEALTH, INC., CARSON, CA:  
3,233,307, PUB. 2-6-2007. INT. CL. 5.

MILLER FREEMAN, INC., SAN FRANCISCO, CA:  
2,358,788, CANC. INT. CL. 35.  
2,358,802, CANC. INT. CL. 16.

MILLER PAINT CO., INC., PORTLAND, OR:  
2,041,431, REN. 3-22-07. INT. CL. 2.

MILLER/ZELL, INC., ATLANTA, GA:  
2,358,797, CANC. MULTIPLE CLASS, INT. CLS. 35 AND 42.

MILLER, FRANCIS, PARIS, FRANCE AND BERTAUX, PATRICK, PARIS, FRANCE:  
3,232,502, PUB. 2-6-2007. INT. CL. 3.

MILLER, MARK C., SANTA FE, NM:  
3,233,862, MULTIPLE CLASS, INT. CLS. 16 AND 43.

MILLER, WENTWORTH E., SEWICKLEY, PA:  
3,233,835, INT. CL. 34.

MILLIKEN & COMPANY, NEW YORK, NY:  
3,234,128, INT. CL. 21.

MILLIPORE CORPORATION, BILLERICA, MA:  
3,234,172, INT. CL. 11.  
3,234,786, INT. CL. 11.

MIMEO.COM, INC., NEW YORK, NY:  
3,232,944, PUB. 2-6-2007. MULTIPLE CLASS, INT. CLS. 35, 39 AND 40.

MINDERSOFT, INC., HERNDON, VA:  
2,357,014, CANC. INT. CL. 39.

MINE SAFETY APPLIANCES COMPANY, PITTSBURGH, PA:  
3,232,274, PUB. 2-6-2007. INT. CL. 9.

MINI-MITTER CO., INC., SUNRIVER, OR:  
2,057,254, REN. 3-16-07. INT. CL. 9.  
2,057,255, REN. 3-16-07. INT. CL. 9.

MINICUCCI, MARISA, PROVINCE OF QUEBEC H7M 5K2, CANADA:  
2,036,195, REN. 3-20-07. INT. CL. 25.

MINNESOTA MINING AND MANUFACTURING COMPANY, SAINT PAUL, MN, AKA 3M:  
1,979,892, CANC. INT. CL. 16.

MINNESOTA MUTUAL LIFE INSURANCE COMPANY, ST. PAUL, MN:  
1,396,793, CANC. INT. CL. 16.  
1,396,794, CANC. INT. CL. 16.

MINNESOTA PUBLIC RADIO, ST. PAUL, MN:  
3,232,599, PUB. 2-6-2007. INT. CL. 38.

MINNESOTA WESTERN, BERKELEY, CA:  
2,356,502, CANC. INT. CL. 42.

MINOM, INC., SAN ANTONIO, TX:  
3,234,779, INT. CL. 30.

MINTEQ INTERNATIONAL INC., EASTON, PA, QUIGLEY COMPANY, INC., NEW YORK, NY:  
1,463,521, REN. 3-22-07. INT. CL. 19.

MINTZ, LEEJAY, LOS ANGELES, CA:  
3,234,803, INT. CL. 3.

MINUTE TO MINUTE, INC., ENCINO, CA:  
2,358,504, CANC. INT. CL. 16.

MINUTEMAN INTERNATIONAL, INC., ADDISON, IL:  
3,232,146, PUB. 2-6-2007. INT. CL. 37.

MINYANVILLE PUBLISHING AND MULTIMEDIA LLC, NEW YORK, NY:  
3,234,822, INT. CL. 41.

MINYARD FOOD STORES, INC., COPPELL, TX:  
3,232,490, PUB. 2-6-2007. MULTIPLE CLASS, INT. CLS. 35, 40 AND 43.

MIRAGE RESORTS, INCORPORATED, LAS VEGAS, NV:  
2,054,525, REN. 3-21-07. INT. CL. 42.  
2,358,420, CANC. INT. CL. 41.  
2,358,421, CANC. INT. CL. 41.

MIRALOMA CORPORATION, ANAHEIM, CA:  
3,234,231, INT. CL. 3.

MIRAMA ENTERPRISES INC., SAN DIEGO, CA:  
3,232,125, PUB. 2-6-2007. INT. CL. 11.

MISS ELAINE, INC., ST. LOUIS, MO:  
1,082,639, REN. 3-17-07. INT. CL. 25.

- MISSION FEDERAL CREDIT UNION, SAN DIEGO, CA:  
3,232,489, PUB. 2-7-2006. INT. CL. 36.
- MISSISSIPPI LIME COMPANY, ST. LOUIS, MO:  
3,234,700, INT. CL. 1.
- MISYS HOSPITAL SYSTEMS, INC., RALEIGH, NC:  
2,356,904, CANC. INT. CL. 9.
- MITCHELL, JOHN R., WESTPORT, CT:  
3,235,360, INT. CL. 35.
- MITSUBISHI PENCIL CO., LTD., JAPAN:  
3,233,749, PUB. 2-6-2007. INT. CL. 16.
- MITSUBISHI PENCIL CO., LTD., TOKYO, JAPAN:  
3,235,081, INT. CL. 16.
- MITSUBOSHI CO., LTD., OSAKA, JAPAN:  
3,233,342, PUB. 2-6-2007. INT. CL. 17.
- MIZUNO USA, INC., NORCROSS, GA, MIZUNO SPORTS,  
INC., NORCROSS, GA:  
2,033,323. REN. 3-17-07. INT. CL. 28.
- MJB PIZZA INC., CAREFREE, AZ AND A & D PIZZA INC.,  
CHANDLER, AZ:  
3,232,681, PUB. 12-26-2006. MULTIPLE CLASS, INT. CLS.  
30 AND 43.
- MJJ MULTIMEDIA LLC, NEW YORK, NY:  
2,357,895, CANC. INT. CL. 28.
- MLA SYSTEMS, INC., PLEASANTVILLE, NY:  
2,358,625, CANC. INT. CL. 9.
- MOBICOOL INTERNATIONAL LIMITED, TUEN MUN,  
N.T., HONG KONG:  
3,232,400, PUB. 5-9-2006. INT. CL. 9.
- MOBILAID CORPORATION, BOCA RATON, FL:  
2,357,517, CANC. INT. CL. 12.
- MODERN DISPLAY SERVICES, INC., SALT LAKE CITY,  
UT:  
3,232,463, PUB. 2-6-2007. INT. CL. 35.
- MODERN MARKETING CONCEPTS, INC., LOUISVILLE,  
KY, DBA CROSLEY RADIO:  
2,356,543, CANC. INT. CL. 9.
- MOEN INCORPORATED, NORTH OLMSTED, OH:  
3,234,585, INT. CL. 11.
- MOHAWK BRANDS, INC., CALHOUN, GA, FIELDCREST  
MILLS, INC., EDEN, NC:  
1,067,759. REN. 3-21-07. INT. CL. 27.
- MOLDTRONICS, INC., DOWNERS GROVE, IL:  
1,400,127. REN. 3-21-07. MULTIPLE CLASS, INT. CLS. 7  
AND 9.
- MOLSON CANADA 2005, TORONTO, ONTARIO, CANADA:  
3,232,069, PUB. 7-1-2003. INT. CL. 32.
- MOMAGENDA LLC, OLD GREENWICH, CT:  
3,235,445, INT. CL. 16.
- MONDEX INTERNATIONAL LIMITED, LONDON, UNI-  
TED KINGDOM:  
3,232,426, PUB. 2-6-2007. MULTIPLE CLASS, INT. CLS. 9  
AND 36.
- MONGELLUZZI, FRANK, CLEARWATER, FL:  
3,233,882, INT. CL. 29.
- MONKMAN INTERNATIONAL CONSULTING, LTD., WIL-  
MINGTON, DE:  
1,397,088, CANC. INT. CL. 35.
- MONOGIUDIS, NICK, FLUSHING, NY:  
3,233,302, PUB. 2-6-2007. INT. CL. 35.
- MONORAIL COMPUTER CORPORATION, MARIETTA,  
GA:  
2,356,476, CANC. INT. CL. 9.
- MONSANTO COMPANY, ST. LOUIS, MO:  
2,358,120, CANC. INT. CL. 5.  
2,358,361, CANC. INT. CL. 5.
- MONTEBELLO SCHOOLS FEDERAL CREDIT UNION,  
MONTEBELLO, CA:  
3,234,040, INT. CL. 36.
- MONTESINO INTERNATIONAL CORP., FORT LAUDER-  
DALE, FL:  
3,233,443, PUB. 2-6-2007. INT. CL. 14.
- MOO TECHNOLOGIES, LLC, BATAVIA, OH:  
3,233,023, PUB. 2-6-2007. MULTIPLE CLASS, INT. CLS. 11  
AND 29.
- MOORE LANGEN PRINTING COMPANY, INC., INDIANA-  
POLIS, IN:  
1,440,276. REN. 3-21-07. INT. CL. 42.
- MOOREHEAD MANAGEMENT, INC., RICHMOND, IN,  
DBA ESQX RODS:  
3,232,523, PUB. 2-6-2007. INT. CL. 28.
- MOOSEWOOD, INC., ITHACA, NY, VEGETABLE KING-  
DOM, INC., THE, ITHACA, NY:  
2,066,859. REN. 3-16-07. INT. CL. 25.  
2,066,860. REN. 3-16-07. INT. CL. 16.
- MORAVEC, DANIEL, ROWLAND HEIGHTS, CA:  
3,233,374, PUB. 2-6-2007. INT. CL. 9.
- MORELL, ERNESTO, MIAMI, FL:  
3,235,073, INT. CL. 16.
- MORGAN STANLEY, NEW YORK, NY:  
3,234,716, INT. CL. 36.
- MORGAN STANLEY SENIOR FUNDING, INC., AS THE  
ADMINISTRATIVE AGENT, NEW YORK, NY:  
3,232,186, PUB. 2-6-2007. INT. CL. 11.
- MORNING STAR COFFEE, INC., WEST CHESTER, PA:  
2,028,608. REN. 3-16-07. INT. CL. 30.
- MORRIS ROTHENBERG & SON, INC., RONKONKOMA,  
NY:  
3,232,938, PUB. 2-6-2007. INT. CL. 25.
- MORRIS, RICHARD L. JR., MIAMI BEACH, FL:  
2,358,862, CANC. INT. CL. 42.  
2,358,863, CANC. INT. CL. 42.
- MORSE SHOE, INC., MAHWAH, NJ:  
1,396,903, CANC. INT. CL. 25.
- MORTGAGEIT, INC., NEW YORK, NY:  
2,357,078, CANC. INT. CL. 36.
- MOSCI, FLAVIA MEIRELES, SHERMAN OAKS, CA:  
3,235,493, INT. CL. 35.
- MOSES, HORACE A., KATY, TX:  
2,358,573, CANC. INT. CL. 30.
- MOTHERS EMBRACING NUCLEAR DISARMAMENT  
FOUNDATION, LA JOLLA, CA:  
1,397,210, CANC. INT. CL. 42.
- MOTION PICTURE ASSOCIATION OF AMERICA, INC.,  
ENCINO, CA:  
3,233,914, MULTIPLE CLASS, INT. CLS. 35 AND 41.  
3,233,915, INT. CL. 35.
- MOTOMAN DISTRIBUTING, UPLAND, CA:  
3,153,390, COR. INT. CL. 12.
- MOTORCARE SERVICES INTERNATIONAL, B.V., 1077 ZX  
AMSTERDAM, NETHERLANDS:  
2,356,737, CANC. MULTIPLE CLASS, INT. CLS. 35 AND  
42.
- MOTOROLA, INC., SCHAUMBURG, IL:  
2,030,643. REN. 3-19-07. INT. CL. 9.
- MOTRAX MOTORCYCLE ACCESSORIES LIMITED, HIGH-  
AM FERRERS, NORTHAMPTONSHIRE, UNITED KING-  
DOM:  
3,234,108, MULTIPLE CLASS, INT. CLS. 6, 9 AND 12.
- MOTSENBOCKER, GREGG A, SAN DIEGO, CA:  
2,358,160, CANC. INT. CL. 2.
- MOULTON, RAYMOND A., BROCKTON, MA:  
2,357,833, CANC. INT. CL. 25.
- MOUNTAIN WEST, L.L.C., REXBURG, ID, MOUNTAIN  
WEST PRODUCTS, INC., REXBURG, ID:  
2,029,526. REN. 3-16-07. MULTIPLE CLASS, INT. CLS. 1,  
19 AND 31.
- MOVA, LLC, SAN FRANCISCO, CA:  
3,235,412, INT. CL. 25.
- MOVIELOT, INC., WOODLAND HILLS, CA:  
3,234,227, INT. CL. 41.
- MOVING TRADITIONS, FORT WASHINGTON, PA:  
3,233,406, PUB. 2-6-2007. INT. CL. 41.  
3,233,407, PUB. 2-6-2007. INT. CL. 41.
- MP AUTOMOTIVE SERVICES, INC., DULUTH, MN:  
2,358,050, CANC. INT. CL. 39.
- MPHASE TECHNOLOGIES, INC., LITTLE FALLS, NJ:  
3,233,191, PUB. 2-6-2007. INT. CL. 9.
- MR. SQUEEKY CAR WASH, INC., MIAMI, FL:  
3,232,942, PUB. 2-6-2007. INT. CL. 37.
- MRG ENTERTAINMENT, INC., SANTA MONICA, CA:  
3,232,867, PUB. 2-6-2007. INT. CL. 41.
- MRS UNITED STATES NATIONAL PAGEANT, INC., FAIR-  
PORT, NY:  
3,234,362, INT. CL. 41.  
3,234,363, INT. CL. 41.



- MRSI (MARKETING RESEARCH SERVICES, INC.), CINCINNATI, OH:  
3,232,995, PUB. 2-6-2007. INT. CL. 35.
- MSC MEDITERRANEAN SHIPPING COMPANY HOLDING SA, 1206 GENEVA, SWITZERLAND:  
3,234,281, INT. CL. 39.
- MSC SERVICES CORP., PLAINVIEW, NY:  
2,357,892, CANC. MULTIPLE CLASS, INT. CLS. 7 AND 9.
- MUFFIN MAM, INC., THE, GREENVILLE, SC:  
2,044,443, REN. 3-20-07. INT. CL. 30.
- MUIR, GLEN BECK, REXBURG, ID:  
3,235,079, MULTIPLE CLASS, INT. CLS. 14 AND 25.
- MULLER, MANFRED M., 73630 REMSHALDEN-GRUNBACH, FED REP GERMANY:  
2,357,658, CANC. INT. CL. 9.
- MULVIHILL, HENRY N., JR., DALLAS, TX:  
2,357,643, CANC. INT. CL. 36.
- MUNCHKIN, INC., NORTH HILLS, CA:  
3,234,118, INT. CL. 21.
- MUNEX, INC., ITHACA, NY:  
2,356,774, CANC. MULTIPLE CLASS, INT. CLS. 39 AND 42.
- MURPHY, TERRY MICHAEL, SANTA CLARITA, CA:  
2,357,905, CANC. INT. CL. 13.
- MURRAY, BARBARA J., MINNETONKA, MN:  
3,234,830, INT. CL. 20.
- MUSES LEGAL PRODUCTS, INC., PROSPECT, KY:  
3,234,675, INT. CL. 9.  
3,234,676, INT. CL. 9.
- MUSIC CARTEL, INC., THE, NEW YORK, NY:  
2,357,179, CANC. INT. CL. 9.
- MUZZA INSIDER CONSULTING SERVICES, LLC, STAMFORD, CT:  
2,038,606, REN. 3-16-07. INT. CL. 36.  
2,115,152, REN. 3-16-07. INT. CL. 36.
- MYCA GROUP, INC., CINCINNATI, OH:  
2,357,941, CANC. INT. CL. 42.
- MYEASYWEBSITE LLC, AUSTIN, TX:  
3,232,140, PUB. 2-6-2007. INT. CL. 42.
- MYEXTENT, DRAPER, UT:  
3,233,390, PUB. 2-6-2007. INT. CL. 42.
- MYPOINTS.COM, INC., SAN FRANCISCO, CA:  
2,357,542, CANC. INT. CL. 35.
- MYRO, INC., MILWAUKEE, WI TO SCOTTAL, LLC, BEACHWOOD, OH:  
1,979,688, CANC. INT. CL. 1.
- MYWEBCAST.NET, INC., OKLAHOMA CITY, OK:  
2,623,857, CANC. INT. CL. 38.
- M7 AEROSPACE LP, SAN ANTONIO, TX:  
3,234,348, INT. CL. 12.  
3,234,349, INT. CL. 12.
- MÜLHENS GMBH & CO. KG, FED REP GERMANY:  
3,233,753, PUB. 2-6-2007. INT. CL. 3.  
3,233,758, PUB. 2-6-2007. INT. CL. 3.
- N & H BAKER AND SANDWICH MAKER, LLC, SHERMAN OAKS, CA:  
3,232,584, PUB. 2-6-2007. INT. CL. 30.
- N.K. HURST COMPANY, INC., INDIANAPOLIS, IN:  
2,035,295, REN. 3-22-07. INT. CL. 29.
- N, LLC, NANTUCKET, MA:  
3,232,574, PUB. 2-6-2007. INT. CL. 16.
- N:MEDIA DATAPOLYSYSTEMS GMBH, 40217 DUSSELDORF, FED REP GERMANY:  
2,356,952, CANC. MULTIPLE CLASS, INT. CLS. 9, 38 AND 42.
- NA, SEHTI, NEW YORK, NY:  
3,232,409, PUB. 2-6-2007. INT. CL. 14.
- NACIMIENTO SOFTWARE CORPORATION, AUSTIN, TX:  
2,356,601, CANC. MULTIPLE CLASS, INT. CLS. 9 AND 42.
- NAKAYAMA, TOSHIRO, RANCHO PALOS VERDES, CA:  
3,233,884, INT. CL. 8.
- NALCO COMPANY, NAPERVILLE, IL:  
3,233,136, PUB. 2-6-2007. INT. CL. 1.  
3,233,506, PUB. 2-6-2007. INT. CL. 42.
- NALS, INC., TULSA, OK:  
3,233,097, PUB. 1-23-2007. U.S. CL. B.
- NAMASTE LABORATORIES, L.L.C., BLUE ISLAND, IL:  
3,235,401, INT. CL. 3.
- NAMCO BANDAI GAMES AMERICA INC., SANTA CLARA, CA:  
3,234,536, INT. CL. 9.
- NAMCO BANDAI GAMES INC., TOKYO, JAPAN:  
3,234,043, INT. CL. 41.
- NAME RITE, L.L.C., TEMECULA, CA:  
2,427,245, CANC. INT. CL. 16.
- NANHALL MANUFACTURING CO., INC., MOBILE, AL:  
3,232,506, PUB. 2-6-2007. INT. CL. 31.
- NANOREX, INC., BLOOMFIELD, MI:  
3,234,291, INT. CL. 42.
- NAPA VALLEY KITCHENS, NAPA, CA:  
2,029,963, REN. 3-22-07. MULTIPLE CLASS, INT. CLS. 29 AND 30.
- NAPA VALLEY VINTNERS ASSOCIATION, ST. HELENA, CA:  
3,232,326, PUB. 2-6-2007. U.S. CL. A.
- NAPRO, INC, FAIRPORT HARBOR, OH:  
2,016,545, REN. 3-22-07. INT. CL. 21.
- NATERRA INTERNATIONAL, INC., DALLAS, TX:  
3,235,095, INT. CL. 3.
- NATIONAL ASSOCIATION FOR BUSINESS ECONOMICS, THE, WASHINGTON, DC:  
2,078,794, REN. 3-19-07. MULTIPLE CLASS, INT. CLS. 16 AND 42.
- NATIONAL ASSOCIATION FOR STOCK CAR AUTO RACING, INC., DAYTONA BEACH, FL:  
2,358,321, CANC. MULTIPLE CLASS, INT. CLS. 16, 25 AND 41.
- NATIONAL ASSOCIATION OF CHILD CARE RESOURCE AND REFERRAL AGENCIES, WASHINGTON, DC:  
2,358,303, CANC. INT. CL. 41.
- NATIONAL ASSOCIATION OF LEGAL SEARCH CONSULTANTS, ATLANTA, GA:  
3,234,270, U.S. CL. 200.
- NATIONAL ASSOCIATION OF PROFESSIONAL BASEBALL LEAGUES, INC., ST. PETERSBURG, FL:  
1,990,927, REN. 3-17-07. U.S. CL. 200.
- NATIONAL ASSOCIATION OF REALTORS, CHICAGO, IL:  
3,235,104, INT. CL. 16.
- NATIONAL ASSOCIATION OF STATE BOARDS OF ACCOUNTANCY, INC., NASHVILLE, TN:  
3,235,315, INT. CL. 41.
- NATIONAL ASSOCIATION OF WHOLESALE-DISTRIBUTORS, WASHINGTON, DC:  
2,102,627, REN. 3-16-07. INT. CL. 42.  
2,102,627, CANC. INT. CL. 41.
- NATIONAL ASSOCIATION OF LEGAL SECRETARIES, TULSA, OK:  
2,061,513, REN. 3-22-07. INT. CL. 16.
- NATIONAL BASEBALL HALL OF FAME AND MUSEUM, INC., COOPERSTOWN, NY:  
1,442,473, REN. 3-17-07. INT. CL. 41.
- NATIONAL BOARD OF MEDICAL EXAMINERS, PHILADELPHIA, PA:  
1,081,366, REN. 3-21-07. INT. CL. 42.
- NATIONAL CABLE AND TELECOMMUNICATIONS ASSOCIATION, INC., WASHINGTON, D.C., DC:  
3,233,331, PUB. 2-6-2007. INT. CL. 35.
- NATIONAL CABLE AND TELECOMMUNICATIONS ASSOCIATION, INC., WASHINGTON, DC:  
3,233,332, PUB. 2-6-2007. INT. CL. 35.
- NATIONAL CAPTIONING INSTITUTE, INC., VIENNA, VA:  
2,048,917, REN. 3-22-07. INT. CL. 41.
- NATIONAL CASA ASSOCIATION, SEATTLE, WA:  
3,234,446, INT. CL. 36.
- NATIONAL CHILDREN'S ALLIANCE, WASHINGTON, DC:  
3,232,800, PUB. 2-6-2007. U.S. CL. 200.
- NATIONAL CITY CORPORATION, CLEVELAND, OH:  
2,358,908, CANC. INT. CL. 36.  
3,232,820, PUB. 2-6-2007. INT. CL. 36.
- NATIONAL COLLEGIATE ATHLETIC ASSOCIATION, THE, INDIANAPOLIS, IN:  
2,031,593, REN. 3-17-07. INT. CL. 41.
- NATIONAL CONEY ISLAND, INC., ROSEVILLE, MI:  
3,232,611, PUB. 2-6-2007. INT. CL. 43.

- NATIONAL DAIRY HOLDINGS, LP, DALLAS, TX:  
3,234,008, INT. CL. 32.
- NATIONAL ENZYME COMPANY, FORSYTH, MO:  
3,234,840, INT. CL. 5.
- NATIONAL HEALTH INFORMATION NETWORK, INC.,  
FORT WORTH, TX:  
2,356,958, CANC. INT. CL. 9.  
2,357,032, CANC. INT. CL. 9.
- NATIONAL LEAGUE FOR NURSING, NEW YORK, NY:  
3,232,615, PUB. 2-6-2007. MULTIPLE CLASS, INT. CLS. 35  
AND 41.
- NATIONAL MODEL RAILROAD ASSOCIATION, INC.,  
CHATTANOOGA, TN:  
3,234,129, INT. CL. 16.
- NATIONAL RAILROAD PASSENGER CORPORATION,  
WASHINGTON, DC:  
2,021,856, REN. 3-19-07. INT. CL. 39.
- NATIONAL RESTAURANT ASSOCIATION, WASHING-  
TON, DC:  
3,232,474, PUB. 2-6-2007. INT. CL. 36.
- NATIONAL TECHNOLOGY UNIVERSITY CORPORATION,  
ALPHARETTA, GA:  
2,358,192, CANC. INT. CL. 9.
- NATIONAL TRACTOR PULLERS ASSOCIATION, INC.,  
COLUMBUS, OH:  
1,057,609, REN. 3-22-07. INT. CL. 16.
- NATIONAL TRADE PRODUCTIONS, INC., ALEXANDRIA,  
VA:  
3,232,980, PUB. 2-6-2007. INT. CL. 35.
- NATIONAL TRUST FOR HISTORIC PRESERVATION IN  
THE UNITED STATES, WASHINGTON, DC:  
3,232,332, PUB. 7-5-2005. MULTIPLE CLASS, INT. CLS. 35  
AND 37.
- NATIONAL WOODEN PALLET AND CONTAINER ASSO-  
CIATION, ALEXANDRIA, VA:  
2,048,021, REN. 3-20-07. INT. CL. 42.
- NATIONAL 4-H COUNCIL, CHEVY CHASE, MD:  
2,358,090, CANC. INT. CL. 25.
- NATIONWIDE COMMUNICATIONS INC., COLUMBUS,  
OH:  
1,397,132, CANC. INT. CL. 38.  
1,397,134, CANC. INT. CL. 38.
- NATURAL DIETARY PRODUCTS, INC., MONTEREY, CA:  
1,979,303, CANC. INT. CL. 5.
- NATURAL SELECTION FOODS, LLC, SAN JUAN BAUTIS-  
TA, CA:  
2,109,692, REN. 3-20-07. INT. CL. 31.
- NATURAL VET LLC, THE, UNICOI, TN:  
3,234,941, INT. CL. 5.
- NATURE'S BEST INC., HAUPPAUGE, NY:  
2,146,379, CANC. INT. CL. 5.
- NATURE'S THERAPY 101, LLC, LAKE HAVASU CITY, AZ:  
3,116,568, AM. INT. CL. 5.
- NATURE'S WAY PRODUCTS, INC., SPRINGVILLE, UT:  
2,039,085, REN. 3-19-07. INT. CL. 5.
- NAUGHTY DOG, INC., SANTA MONICA, CA, NAUGHTY  
DOG, INC., MCLEAN, VA:  
2,036,776, REN. 3-21-07. INT. CL. 28.
- NAUTICA APPAREL, INC., NEW YORK, NY:  
3,232,827, PUB. 2-6-2007. INT. CL. 18.  
3,232,846, PUB. 2-6-2007. INT. CL. 35.  
3,233,030, PUB. 2-6-2007. INT. CL. 14.  
3,233,513, PUB. 2-6-2007. INT. CL. 25.
- NAVREN LLC, FORT WORTH, TX, DBA HEMINGWAY  
AND HALE:  
3,234,922, INT. CL. 33.
- NBA PROPERTIES, INC., NEW YORK, NY:  
2,043,966, REN. 3-17-07. INT. CL. 16.  
3,234,520, INT. CL. 28.
- NBC UNIVERSAL, INC., NEW YORK, NY:  
3,232,734, PUB. 2-6-2007. MULTIPLE CLASS, INT. CLS. 41  
AND 42.
- NBS TRUCKING LTD., CUSTER CITY, PA:  
3,234,632, INT. CL. 25.
- NBTY, INC., BOHEMIA, NY TO NBTY, INC., BOHEMIA,  
NY:  
1,979,376, CANC. INT. CL. 3.
- NCC FUNDS, CLEVELAND, OH TO ARMADA FUNDS,  
CLEVELAND, OH:  
1,979,469, CANC. INT. CL. 36.
- NCC FUNDS, CLEVELAND, OH:  
1,979,470, CANC. INT. CL. 36.
- NEARLY FAMOUS DELI, LLC, SPRINGFIELD, MO:  
2,057,481, REN. 3-20-07. INT. CL. 42.
- NEAT-O FLEET WASHING SERVICES, INC., ST. LOUIS,  
MO:  
3,233,487, PUB. 2-6-2007. INT. CL. 37.  
3,233,488, PUB. 2-6-2007. INT. CL. 37.
- NEIL BASSETTI FARMS, GREENFIELD, CA:  
2,358,365, CANC. INT. CL. 31.
- NEJAD, MATTHEW, FRESNO, CA:  
3,234,582, INT. CL. 25.
- NEMSCHOFF CHAIRS, INC., SHEBOYGAN, WI:  
3,235,248, INT. CL. 20.
- NEO LINEAR, INC., PITTSBURGH, PA:  
2,358,423, CANC. INT. CL. 9.
- NEODESIC CORPORATION, EVANSTON, IL:  
2,358,089, CANC. INT. CL. 9.
- NERDS ON SITE, INC., LONDON, ONTARIO, CANADA:  
3,234,120, INT. CL. 37.
- NET NET, INC., MIDDLETOWN, NY:  
1,979,609, CANC. INT. CL. 35.
- NETBURNER, SAN DIEGO, CA:  
3,233,343, PUB. 2-6-2007. MULTIPLE CLASS, INT. CLS. 9  
AND 42.
- NETCONCEPTS, MADISON, WI:  
3,234,626, MULTIPLE CLASS, INT. CLS. 35 AND 42.
- NETDRAFTER, LLC, ASHBURN, VA:  
3,232,939, PUB. 2-6-2007. INT. CL. 42.
- NETEXPRESSUSA INC., FORT MYERS, FL:  
3,232,482, PUB. 2-6-2007. INT. CL. 16.
- NETROSOFT, INC., MIAMI, FL:  
3,233,400, PUB. 2-6-2007. INT. CL. 42.
- NETSUCCESS, INC., DALLAS, TX:  
2,031,150, REN. 3-22-07. INT. CL. 35.
- NETWORK ACCESS SOLUTIONS CORPORATION, STER-  
LING, VA:  
2,357,935, CANC. INT. CL. 38.
- NETWORK SOLUTIONS, LLC, HERNDON, VA:  
3,232,149, PUB. 2-6-2007. INT. CL. 42.
- NETZERO, INC., WESTLAKE VILLAGE, CA:  
2,357,543, CANC. MULTIPLE CLASS, INT. CLS. 35 AND  
38.
- NET2PHONE, INC., HACKENSACK, NJ:  
2,357,222, CANC. INT. CL. 35.
- NEUF, FRANCE:  
3,233,633, PUB. 2-6-2007. MULTIPLE CLASS, INT. CLS. 14  
AND 25.  
3,233,634, PUB. 2-6-2007. MULTIPLE CLASS, INT. CLS. 14  
AND 18.
- NEVIS BLUFF WINES LIMITED, CROMWELL, NEW ZEAL-  
AND:  
3,232,568, PUB. 2-6-2007. INT. CL. 33.
- NEW BALANCE ATHLETIC SHOE, INC., BOSTON, MA:  
3,233,994, INT. CL. 25.
- NEW CHAPTER, INC., BRATTLEBORO, VT:  
3,233,018, PUB. 2-6-2007. INT. CL. 5.
- NEW DISCOVERY MEDIA CORPORATION, NASHVILLE,  
TN:  
3,235,436, INT. CL. 35.
- NEW HORIZONS EDUCATION CORPORATION, ANA-  
HEIM, CA:  
3,235,451, INT. CL. 41.
- NEW JERSEY MACHINE INC., LEBANON, NH, DOBOY  
PACKAGING MACHINERY, INC., NEW RICHMOND, WI:  
1,436,223, REN. 3-22-07. INT. CL. 7.
- NEW MILLENNIUM TOURS, INC., CHICAGO, IL:  
3,234,395, INT. CL. 39.
- NEW ORLEANS BAPTIST THEOLOGICAL SEMINARY,  
NEW ORLEANS, LA:  
2,123,808, REN. 3-20-07. INT. CL. 42.
- NEW TAN, INC., LOS ANGELES, CA:  
3,235,161, INT. CL. 16.

- NEW URBAN WORKS DEVELOPMENT, LLC, CORAL GABLES, FL:  
3,234,550, INT. CL. 37.  
3,234,551, INT. CL. 37.
- NEW VENTURE HOLDINGS, LLC, STERLING HEIGHTS, MI:  
1,979,886, CANC. INT. CL. 42.
- NEW VISION INTERNATIONAL, INC., TEMPE, AZ:  
2,357,420, CANC. INT. CL. 41.
- NEW WORLD PASTA COMPANY, HARRISBURG, PA:  
518,709, AM. U.S. CL. 46.
- NEW YORK ATHLETIC CLUB, THE, NEW YORK, NY:  
2,023,314, REN. 3-16-07. MULTIPLE CLASS, INT. CLS. 25, 41 AND 42.
- NEW YORK INTERACTIVE, INC., NEW YORK, NY:  
2,358,814, CANC. INT. CL. 42.
- NEW YORK RACING ASSOCIATION, INC., THE, JAMAICA, NY:  
3,235,373, INT. CL. 41.
- NEW ZEALAND DAIRY BOARD, AUCKLAND, NEW ZEALAND, WESTERN DAIRY PRODUCTS DIVISION OF CHELSEA INDUSTRIES, INC., SAN FRANCISCO, CA:  
1,051,406, REN. 3-20-07. INT. CL. 29.
- NEWCOMER SUPPLY, INC., MIDDLETON, WI:  
3,235,054, INT. CL. 1.
- NEWELL INTERNATIONAL, INC., SALT LAKE CITY, UT:  
3,232,137, PUB. 2-6-2007. MULTIPLE CLASS, INT. CLS. 8, 9 AND 18.
- NEWELL OPERATING COMPANY, ATLANTA, GA:  
3,234,188, INT. CL. 16.  
3,234,189, INT. CL. 16.
- NEWFIRST BANK, EL CAMPO, TX:  
3,232,272, PUB. 2-6-2007. INT. CL. 36.  
3,233,329, PUB. 2-6-2007. INT. CL. 36.
- NEWFREY LLC, NEWARK, DE, KWIKSET LOCKS, INC., ANAHEIM, CA:  
642,221, REN. 3-17-07. U.S. CL. 13 (INT. CL. 6).
- NEWLIFE RESEARCH LIMITED, AUSTRALIA:  
3,233,736, PUB. 2-6-2007. INT. CL. 5.
- NEWMAN, CANDACE J., CHIMNEY ROCK, CO:  
3,233,311, PUB. 2-6-2007. INT. CL. 44.
- NEWMAN, MATTHEW, NEW ROADS, LA:  
2,055,430, REN. 3-17-07. INT. CL. 5.  
2,057,409, REN. 3-17-07. INT. CL. 5.
- NEWSDAY, INC., MELVILLE, NY:  
2,358,532, CANC. INT. CL. 16.
- NEXAGEN USA, LLC, AKRON, OH:  
3,232,376, PUB. 2-21-2006. INT. CL. 5.
- NEXTRIDGE, INC., MENANDS, NY:  
3,232,953, PUB. 2-6-2007. MULTIPLE CLASS, INT. CLS. 35 AND 36.
- NEYRA, EDWARD J., CINCINNATI, OH, DBA ROCK-QUEST COMPANY:  
2,037,701, REN. 3-22-07. INT. CL. 28.
- NIBCO INC., ELKHART, IN:  
1,448,124, CANC. INT. CL. 7.
- NICE DAY INDUSTRIAL (U.S.A.) INC, SOUTH EL MONTE, CA:  
2,357,722, CANC. INT. CL. 25.
- NICHOLAS FOUNDATION, ALISO VIEJO, CA:  
3,233,099, PUB. 2-6-2007. INT. CL. 36.
- NICHOLS INSTITUTE DIAGNOSTICS, SAN JUAN, CAPISTRANO, CA:  
2,358,476, CANC. INT. CL. 9.
- NICOLES, INC., CHICAGO, IL:  
3,233,453, PUB. 2-6-2007. MULTIPLE CLASS, INT. CLS. 5 AND 30.
- NIELSEN MEDIA RESEARCH, INC., NEW YORK, NY, A.C. NIELSEN COMPANY, CHICAGO, IL:  
824,208, REN. 3-19-07. U.S. CL. 101 (INT. CL. 35).
- NIELSEN, ROBERT, LAKE HAVASU CITY, AZ:  
3,233,419, PUB. 2-6-2007. INT. CL. 30.
- NIELSEN, ROGER B., MERIDIAN, ID AND NIELSEN, KARLA S., MERIDIAN, ID:  
2,358,155, CANC. INT. CL. 17.
- NIER GROUP, THE, MAYFIELD, PA:  
2,356,994, CANC. INT. CL. 9.
- NIGURA METZLER OPTICS INTERNATIONAL GMBH, DUSSELDORF, FED REP GERMANY:  
2,035,258, REN. 3-22-07. INT. CL. 9.
- NIHON YAKUHIN KENKYUJYO; KABUSHIKI KAISHA, JAPAN:  
3,233,743, PUB. 2-6-2007. INT. CL. 2.
- NILFISK-ADVANCE, INC., MINNEAPOLIS, MN, WHITE CONSOLIDATED INDUSTRIES, INC., CLEVELAND, OH:  
2,066,163, REN. 3-16-07. INT. CL. 9.
- NILFISK-ADVANCE, INC., PLYMOUTH, MN:  
3,234,381, INT. CL. 21.
- NINAPHARM, ANNECY, FRANCE:  
3,232,343, PUB. 2-6-2007. INT. CL. 5.
- NINE WEST DEVELOPMENT CORPORATION, WILMINGTON, DE:  
2,358,198, CANC. INT. CL. 25.
- NINGBO YUNHUAN ELECTRONIC; GROUP CO. LTD., YUYAO CITY, ZHEJIANG 315472, CHINA:  
3,233,740, PUB. 2-6-2007. INT. CL. 9.
- NINTENDO OF AMERICA INC., REDMOND, WA:  
2,358,737, CANC. INT. CL. 30.  
3,234,966, INT. CL. 28.
- NIOXIN RESEARCH LABORATORIES, INC., LITHIA SPRINGS, GA:  
3,234,755, INT. CL. 3.
- NIPPON DENKI KABUSHIKI KAISHA, TOKYO, JAPAN, DBA NEC CORPORATION:  
2,358,344, CANC. INT. CL. 9.  
3,234,494, INT. CL. 42.
- NIPPON SYNTHETIC CHEMICAL INDUSTRY CO., LTD., THE, OSAKA-FU, JAPAN:  
1,427,058, REN. 3-22-07. INT. CL. 1.
- NISHIMOTO TRADING CO., LTD., SANTA FE SPRINGS, CA:  
3,233,396, PUB. 2-6-2007. INT. CL. 30.
- NIX, GRETCHEN, WEST HOLLYWOOD, CA:  
3,234,838, INT. CL. 32.
- NO FEAR, INC., CARLSBAD, CA:  
2,055,148, REN. 3-22-07. INT. CL. 25.  
2,055,158, REN. 3-22-07. INT. CL. 25.
- NOBONZ, INC., AUSTIN, TX, DBA THE outhouse:  
2,356,429, CANC. INT. CL. 25.
- NOMIS, L.P., SAN DIEGO, CA:  
3,233,274, PUB. 2-6-2007. MULTIPLE CLASS, INT. CLS. 35 AND 41.
- NONIN MEDICAL, INC., PLYMOUTH, MN:  
3,235,029, INT. CL. 10.
- NOORDHOFF GROUP, INC., THE, DALLAS, TX:  
2,357,747, CANC. INT. CL. 24.
- NORDICA S.P.A., TREVIGNANO (TV), ITALY:  
2,042,447, REN. 3-21-07. INT. CL. 28.
- NORFLEET PRODUCTS, INC., FREDERICKSBURG, VA:  
2,357,482, CANC. INT. CL. 31.
- NORPAC FOODS, INC., LAKE OSWEGO, OR:  
2,044,118, REN. 3-21-07. INT. CL. 29.
- NORTH AMERICAN BEAR CO., INC., CHICAGO, IL:  
1,422,088, REN. 3-17-07. INT. CL. 28.
- NORTH CAROLINA TRANSPORATION MUSEUM FOUNDATION, SPENCER, NC:  
2,028,669, REN. 3-19-07. INT. CL. 41.
- NORTH FORK DAVIDOFF OF COLUMBUS CIRCLE LLC, WELLESLEY, MA:  
3,234,198, INT. CL. 34.
- NORTH PACIFIC GROUP, INC., PORTLAND, OR:  
2,358,859, CANC. INT. CL. 19.
- NORTH STAR DENTAL PRODUCTS INC., FRAMINGHAM, MA:  
2,357,400, CANC. INT. CL. 10.
- NORTHEAST NEBRASKA REGIONAL PHYSICIAN/HOSPITAL ORGANIZATION, NORFOLK, NE:  
2,358,621, CANC. INT. CL. 42.
- NORTHERN COMMUNICATIONS, INC., BIRDSBORO, PA:  
1,979,875, CANC. INT. CL. 38.
- NORTHERN MANUFACTURING CO., INC., OAK HARBOR, OH:  
2,014,663, REN. 3-16-07. INT. CL. 9.
- NORTHPOLE LIMITED, KOWLOON, HONG KONG:  
3,234,138, INT. CL. 22.

- NORTHSATR TRAVEL MEDIA, LLC, SECAUCUS, NJ:  
2,115,994. REN. 3-19-07. INT. CL. 35.
- NORTHSTAR TRAVEL MEDIA, LLC, SECAUCUS, NJ:  
2,115,995. REN. 3-19-07. INT. CL. 35.
- NORTHWEST AIRLINES, INC., ST. PAUL, MN:  
2,358,829, CANC. INT. CL. 39.  
2,358,830, CANC. INT. CL. 39.
- NORWALK FURNITURE CORPORATION, NORWALK, OH:  
2,033,816. REN. 3-22-07. MULTIPLE CLASS, INT. CLS. 20 AND 42.
- NOVAPTUS SYSTEMS, INCORPORATED, CHESAPEAKE, VA:  
3,232,926, PUB. 2-6-2007. INT. CL. 39.
- NOVARTIS AG, BASEL, SWITZERLAND, SANDOZ, INC., HANOVER, NJ:  
840,323. REN. 3-21-07. U.S. CL. 18 (INT. CL. 5).
- NOVARTIS AG, 4002 BASEL, SWITZERLAND:  
2,356,722, CANC. INT. CL. 5.
- NOVARTIS AG, BASEL, SWITZERLAND:  
3,233,231, PUB. 2-6-2007. INT. CL. 5.
- NOVARTIS AG, SWITZERLAND:  
3,233,721, PUB. 2-6-2007. INT. CL. 5.
- NOVARTIS AG, BASEL, SWITZERLAND:  
3,234,177, INT. CL. 16.
- NOVELL, INC., PROVO, UT:  
2,049,477. REN. 3-17-07. INT. CL. 9.
- NOVEX SYSTEMS INTERNATIONAL, INC., BRONXVILLE, NY, HALLEMITE MANUFACTURING COMPANY, THE, CLEVELAND, OH:  
630,254. REN. 3-19-07. U.S. CL. 12 (INT. CL. 19).
- NOVOGRADAC & COMPANY LLP, SAN FRANCISCO, CA:  
3,232,925, PUB. 2-6-2007. INT. CL. 35.
- NOVOZYMES A/S, BAGSVAERD, DENMARK:  
3,233,684, PUB. 2-6-2007. MULTIPLE CLASS, INT. CLS. 1, 41 AND 42.  
3,234,119, INT. CL. 5.
- NOVUS CREDIT SERVICES INC., RIVERWOODS, IL:  
1,979,949, CANC. MULTIPLE CLASS, INT. CLS. 35 AND 36.
- NOXELL CORPORATION, THE, HUNT VALLEY, MD:  
3,234,456, INT. CL. 3.
- NPD GROUP, INC., THE, PORT WASHINGTON, NY:  
2,358,877, CANC. INT. CL. 35.
- NTH DEGREE, MARSHVILLE, NC:  
2,357,093, CANC. INT. CL. 41.
- NTT AMERICA, INC., NEW YORK, NY:  
2,358,021, CANC. MULTIPLE CLASS, INT. CLS. 9 AND 38.
- NTY INTERNATIONAL CORP., PISCATAWAY, NJ:  
2,049,422. REN. 3-17-07. INT. CL. 20.
- NUFARM AMERICAS INC., BURR RIDGE, IL:  
3,233,850, INT. CL. 5.
- NUFOLD, INC., MIAMI, FL:  
3,232,859, PUB. 10-24-2006. INT. CL. 18.
- NURCRAFT FURNITURE COMPANY, COMSTOCK PARK, MI:  
2,357,360, CANC. INT. CL. 20.
- NUTRACEUTICAL RESEARCH LABS, INC., FLORAL PARK, NY, NUTRACEUTICAL RESEARCH LABS, INC., FLORAL PARK, NY:  
2,030,625. REN. 3-16-07. INT. CL. 5.
- NVIDIA CORPORATION, SANTA CLARA, CA:  
3,234,493, INT. CL. 9.
- NYLINT CORPORATION, ROCKFORD, IL:  
2,358,320, CANC. INT. CL. 28.
- NYNKE FENNEMA, NETHERLANDS:  
3,233,585, PUB. 2-6-2007. MULTIPLE CLASS, INT. CLS. 18 AND 25.
- NYP HOLDINGS, INC., NEW YORK, NY:  
3,235,317, INT. CL. 16.
- O HOTEL, INC., SANTA MONICA, CA:  
3,234,624, INT. CL. 35.
- O.C. TANNER COMPANY, SALT LAKE CITY, UT:  
3,234,668, MULTIPLE CLASS, INT. CLS. 9, 16 AND 41.
- O.R. SOLUTIONS, INC., CHANTILLY, VA:  
2,076,355. REN. 3-17-07. INT. CL. 10.  
2,076,356. REN. 3-17-07. INT. CL. 10.
- O'CONNOR, MICHAEL, SPRINGFIELD, MA:  
3,232,443, PUB. 10-31-2006. INT. CL. 20.
- O'HARA, STEPHEN S, NEWPORT BEACH, CA:  
3,235,154, INT. CL. 35.
- O'KEEFE, DANIEL J, LISLE, IL:  
3,234,646, INT. CL. 20.
- O'LENICK, ANTHONY J., DACULA, GA:  
3,233,115, PUB. 2-6-2007. INT. CL. 42.
- O'NEILL, ROSALINDA, CALABASAS, CA:  
3,232,512, PUB. 2-6-2007. MULTIPLE CLASS, INT. CLS. 35 AND 41.
- O'REILLY OFFICE SUPPLY CO., INC., FORT WAYNE, IN, DBA ASSOCIATION MEMBERS ONLY:  
2,358,870, CANC. INT. CL. 35.
- O'SULLIVAN INDUSTRIES, INC., LAMAR, MO:  
3,235,234, INT. CL. 6.  
3,235,235, INT. CL. 20.  
3,235,236, INT. CL. 6.
- OATES & COMPANY, LLC, GREENSBORO, NC:  
3,233,267, PUB. 2-6-2007. INT. CL. 41.
- OBJECTSOFT CORP., HACKENSACK, NJ:  
2,358,585, CANC. INT. CL. 9.
- OBSHESTVO S OGRANICHENNOY OTVETSTVENNOSTJU "ASKANELI", RUSSIAN FED.:  
3,233,561, PUB. 2-6-2007. MULTIPLE CLASS, INT. CLS. 33, 35 AND 43.
- OBSHCESTVO S OGRANICHENNOY OTVETSTVENNOSTYU "KONTSEPT", RUSSIAN FED.:  
3,233,737, PUB. 2-6-2007. MULTIPLE CLASS, INT. CLS. 3 AND 21.
- OCCUPATIONAL MEDICAL PARTNERS, INC., LONG BEACH, CA:  
2,358,472, CANC. INT. CL. 42.
- OCEAN DUKE CORPORATION, TORRANCE, CA:  
2,036,816. REN. 3-17-07. INT. CL. 29.  
2,039,997. REN. 3-17-07. INT. CL. 29.
- OCEAN FUTURES SOCIETY, INC., SANTA BARBARA, CA:  
2,356,645, CANC. INT. CL. 41.
- OCEAN INTERNATIONAL HOLDINGS LIMITED, SINGAPORE 048424, SINGAPORE:  
3,233,666, PUB. 2-6-2007. INT. CL. 29.
- OCEAN KING INFLATABLE PRODUCTS LTD., CHAI WAN, HONG KONG:  
2,358,256, CANC. MULTIPLE CLASS, INT. CLS. 12 AND 28.
- OCEAN NUTRITION CORPORATION, NATIONAL CITY, CA TO T-REX PRODUCTS INCORPORATED, CHULA VISTA, CA:  
1,979,741, CANC. INT. CL. 31.  
1,979,832, CANC. INT. CL. 5.
- OCEAN STATE JOBBERS, INC., NORTH KINGSTOWN, RI:  
2,040,909. REN. 3-22-07. INT. CL. 8.
- OCEAN WEST INC., LOS ANGELES, CA:  
3,235,330, INT. CL. 37.
- OCSA OFFICINE DI CROCETTA S.P.A., ITALY:  
3,233,635, PUB. 2-6-2007. INT. CL. 6.
- OCTOBIA LLC, BOSTON, MA:  
3,232,618, PUB. 2-6-2007. INT. CL. 14.
- ODONATA INCORPORATED, SEATTLE, WA:  
3,232,108, PUB. 2-6-2007. INT. CL. 37.
- OFF SHORE GLOBAL LICENSING CORP., PAITILLA, PANAMA, DBA OFF SHORE OF CALIFORNIA, INC.:  
3,232,375, PUB. 2-6-2007. MULTIPLE CLASS, INT. CLS. 3, 9, 18, 24 AND 28.
- OFFICE IMAGES, INC., NATICK, MA:  
2,357,555, CANC. INT. CL. 28.
- OFFICIAL PILLOWTEX LLC, COLUMBUS, OH:  
3,234,081, INT. CL. 24.
- OFFICINE MECCANICHE GALLETTI O.M.G. SRL, ITALY:  
3,233,607, PUB. 2-6-2007. INT. CL. 7.
- OFIELD, ANDREW FRANK, OADBYP, GREAT BRITAIN:  
3,232,737, PUB. 2-6-2007. INT. CL. 9.
- OGIHARA CORPORATION, GUNMA, JAPAN:  
3,233,040, PUB. 2-6-2007. MULTIPLE CLASS, INT. CLS. 7 AND 12.
- OHIO ART COMPANY, THE, BRYAN, OH:  
2,064,398. REN. 3-21-07. MULTIPLE CLASS, INT. CLS. 9, 20 AND 28.

OHIO STATE UNIVERSITY, THE, COLUMBUS, OH:  
 2,039,176. REN. 3-22-07. INT. CL. 24.  
 2,039,177. REN. 3-22-07. INT. CL. 22.  
 2,039,178. REN. 3-22-07. INT. CL. 28.  
 2,039,179. REN. 3-22-07. INT. CL. 15.  
 2,039,180. REN. 3-22-07. INT. CL. 20.

OHIO STATE UNIVERSITY, THE, COLUMBUS, OH:  
 2,039,181. REN. 3-22-07. INT. CL. 16.

OHIO STATE UNIVERSITY, THE, COLUMBUS, OH:  
 2,039,182. REN. 3-22-07. INT. CL. 11.  
 2,039,183. REN. 3-22-07. INT. CL. 9.  
 2,039,184. REN. 3-22-07. INT. CL. 12.  
 2,039,185. REN. 3-22-07. INT. CL. 6.  
 2,040,782. REN. 3-22-07. INT. CL. 21.  
 2,040,783. REN. 3-22-07. INT. CL. 18.

OK-1 MANUFACTURING COMPANY, ALTUS, OK:  
 3,232,496, PUB. 2-6-2007. INT. CL. 28.

OLD LONDON FOODS, INC., BRONX, NY:  
 2,358,716, CANC. INT. CL. 30.

OLD ROAD SOFTWARE, INC, ELMSFORD, NY:  
 3,232,503, PUB. 2-6-2007. INT. CL. 42.

OLDELFT B.V., 2624 BD DELFT, NETHERLANDS:  
 2,356,748, CANC. INT. CL. 10.

OLIVACCE, BEVERLEY ANN, QUTTENBERY, NJ:  
 1,979,777, CANC. INT. CL. 25.

OLSEN, JUDITH K., RACINE, WI:  
 3,233,350, PUB. 2-6-2007. INT. CL. 14.

OLYMPIC COMMITTEE, UNITED STATES, COLORADO SPRINGS, CO:  
 2,357,991, CANC. INT. CL. 16.

OLYMPUS CORPORATION, TOKYO, JAPAN:  
 3,234,192, INT. CL. 9.

OMEGA TECH LABS, LLC, BOISE, ID:  
 3,232,862, PUB. 2-6-2007. INT. CL. 5.

OMNATION CORPORATION, WINDERMERE, FL:  
 3,233,272, PUB. 2-6-2007. INT. CL. 35.

OMNI HOTELS MANAGEMENT CORPORATION, IRVINE, TX, HOTEL CORPORATION OF AMERICA, BOSTON, MA:  
 828,009. REN. 3-20-07. U.S. CL. 100 (INT. CL. 42).

OMNI HOTELS MANAGEMENT CORPORATION, IRVING, TX:  
 2,106,102. REN. 3-16-07. MULTIPLE CLASS, INT. CLS. 39 AND 42.

OMNICON GROUP INC., THE, HAUPPAUGE, NY:  
 2,062,560. REN. 3-19-07. INT. CL. 42.

OMNILAW LEGAL PLANS, INC., NEW YORK, NY:  
 2,357,385, CANC. INT. CL. 42.

OMNISYS, INC., GREENVILLE, TX:  
 2,356,724, CANC. INT. CL. 36.

OMRON HEALTHCARE CO., LTD., JAPAN:  
 3,233,731, PUB. 2-6-2007. INT. CL. 10.  
 3,233,733, PUB. 2-6-2007. INT. CL. 10.

OMS INVESTMENTS, INC., LOS ANGELES, CA, CALIFORNIA SPRAY-CHEMICAL COMPANY, WATSONVILLE, CA:  
 224,608. REN. 3-20-07. U.S. CL. 6 (INT. CL. 5).

OMS INVESTMENTS, INC., LOS ANGELES, CA:  
 3,233,837, INT. CL. 1.

ON RITE CO., INC., FORT LAUDERDALE, FL:  
 3,232,790, PUB. 2-6-2007. INT. CL. 44.

ON TRACK POWER WINDOW REPAIR, MOUNT WASHINGTON, KY:  
 3,233,356, PUB. 2-6-2007. INT. CL. 37.

ONE STEP PAPERS, L.L.C., MIAMI, FL:  
 3,232,595, PUB. 2-6-2007. INT. CL. 16.

ONE TOUCH GMBH CO. KG, CELLE, FED REP GERMANY:  
 3,233,514, PUB. 2-6-2007. MULTIPLE CLASS, INT. CLS. 9, 14, 18, 23, 25 AND 26.

ONE WORLD SPORTS INC., MALVERN, PA TO BLOCK CORPORATION, NEW YORK, NY:  
 1,986,812, AM. INT. CL. 25.

OPEN BUSINESS CLUB AG, FED REP GERMANY:  
 3,233,565, PUB. 2-6-2007. MULTIPLE CLASS, INT. CLS. 9, 35, 38 AND 42.

OPEN SOFTWARE TECHNOLOGIES, INC., ALTAMONTE SPRINGS, FL:  
 2,358,635, CANC. INT. CL. 9.

OPENMEDIA, INC., OSSINING, NY:  
 2,029,604. REN. 3-16-07. INT. CL. 35.

OPERA S.R.L., ITALY:  
 3,233,618, PUB. 2-6-2007. INT. CL. 24.

OPERATION CALIFORNIA, INC., CULVER CITY, CA:  
 1,397,204. REN. 3-19-07. INT. CL. 42.

OPERATION RESPOND INSTITUTE, INC., WASHINGTON, DC:  
 2,033,533. REN. 3-22-07. INT. CL. 16.

OPI PRODUCTS, INC., NORTH HOLLYWOOD, CA:  
 1,437,653. REN. 3-17-07. INT. CL. 3.

OPICI IMPORT CO. INC., GLEN ROCK, NJ:  
 3,235,215, INT. CL. 33.

OPTICAL FUSION, INC., PALO ALTO, CA:  
 3,233,810, INT. CL. 38.

OPTICAL RESOURCES GROUP, INC., HUNTERSVILLE, NC:  
 2,357,412, CANC. MULTIPLE CLASS, INT. CLS. 35 AND 42.

OPTICHRON, INC., FREMONT, CA:  
 3,234,863, INT. CL. 9.

OPTICOTE, INC., FRANKLIN PARK, IL:  
 1,999,466. REN. 3-20-07. MULTIPLE CLASS, INT. CLS. 5, 9 AND 40.

OPTIMOL OLWERKE INDUSTRIE GMBH, D-8000 MUNCHEN 80, FED REP GERMANY:  
 1,979,427, CANC. INT. CL. 4.

OPTIMOX CORPORATION, TORRANCE, CA:  
 2,062,205. REN. 3-22-07. INT. CL. 5.

OPTOPO, INC., DURHAM, NC, DBA CENTICE CORPORATION:  
 3,232,972, PUB. 2-6-2007. INT. CL. 9.  
 3,232,973, PUB. 2-6-2007. INT. CL. 9.

ORANGE COVE-SANGER CITRUS ASSOCIATION, ORANGE COVE, CA:  
 2,071,145. REN. 3-22-07. INT. CL. 31.

ORATEC CORPORATION, MANASSAS, VA:  
 3,232,810, PUB. 2-6-2007. MULTIPLE CLASS, INT. CLS. 3 AND 10.

ORB ENTERPRISES, INC., SCOTT, LA:  
 2,358,874, CANC. INT. CL. 30.

ORBITZ AWAY LLC, CHICAGO, IL:  
 2,356,694, CANC. INT. CL. 39.

ORBUM LTDA., SAO PAULO SP, BRAZIL:  
 2,358,331, CANC. INT. CL. 9.

OREGON ASSOCIATION CHIEFS OF POLICE, SALEM, OR:  
 3,233,440, PUB. 2-6-2007. INT. CL. 44.

OREXIS, LLC, HOBOKEN, NJ:  
 3,232,347, PUB. 2-6-2007. INT. CL. 5.

ORFEVRERIE CHRISTOFLE, FRANCE:  
 3,233,554, PUB. 2-6-2007. MULTIPLE CLASS, INT. CLS. 8, 14 AND 21.

ORGANISATION SYSTEME PRODUCTIVITE, PUTEAUX, FRANCE:  
 3,233,535, PUB. 2-6-2007. MULTIPLE CLASS, INT. CLS. 9, 16, 35, 38, 41 AND 42.

ORGANISATION SYSTEME PRODUCTIVITE, FRANCE:  
 3,233,539, PUB. 2-6-2007. MULTIPLE CLASS, INT. CLS. 9, 16, 35, 41 AND 42.

ORGANON INC., WEST ORANGE, NJ:  
 1,396,404, CANC. INT. CL. 5.

ORIENT FISHERIES INC., VERNON, CA:  
 3,235,480, INT. CL. 29.

ORIGINAL SAN FRANCISCO TOYMAKERS, THE, SOUTH SAN FRANCISCO, CA:  
 2,357,248, CANC. INT. CL. 28.

ORLANDO SCIENCE CENTER, INC., ORLANDO, FL:  
 2,357,937, CANC. INT. CL. 41.

ORLEANS PARISH SCHOOL BOARD, NEW ORLEANS, LA:  
 2,357,304, CANC. INT. CL. 41.

ORR CORPORATION, LOUISVILLE, KY, ORR SAFETY EQUIPMENT COMPANY, INC., LOUISVILLE, KY:  
 1,058,700. REN. 3-22-07. INT. CL. 35.

ORVAR S.A. DE C.V., MÉXICO, MÉXICO, D.F., MEXICO:  
 3,232,520, PUB. 2-6-2007. MULTIPLE CLASS, INT. CLS. 9, 25 AND 28.

OSBORN, N. JASON, CHERRY HILL, NJ:  
 3,233,273, PUB. 2-6-2007. INT. CL. 30.

- OSEM FOOD INDUSTRIES LTD., PETACH TIKVA, ISRAEL:  
2,039,662. REN. 3-21-07. INT. CL. 30.
- OSRAM; GESELLSCHAFT MIT BESCHRÄNKTER HAF-  
TUNG, 81543 MÜNCHEN, FED REP GERMANY:  
3,233,742, PUB. 2-6-2007. INT. CL. 11.
- OTA ASSET MANAGEMENT LLC, PURCHASE, NY:  
3,233,295, PUB. 2-6-2007. INT. CL. 36.
- OTSUKA PHARMACEUTICAL FACTORY INC., TOKUSH-  
IMA-KEN, JAPAN:  
3,232,491, PUB. 8-1-2006. INT. CL. 5.
- OTTO BOCK HEALTHCARE GMBH, FED REP GERMANY:  
3,233,719, PUB. 2-6-2007. INT. CL. 12.
- OTTO BOCK SCHAUMSTOFFWERKE GMBH, 37115 DU-  
DERSTADT, FED REP GERMANY:  
3,233,604, PUB. 2-6-2007. INT. CL. 10.
- OUR OWN HARDWARE COMPANY, BURNSVILLE, MN:  
1,397,215, CANC. INT. CL. 42.  
1,397,218, CANC. INT. CL. 42.
- OUTDOOR RESORTS OF AMERICA, INC., BERMUDA  
DUNES, CA, OUTDOOR RESORTS OF AMERICA, INC.,  
NASHVILLE, TN:  
2,101,150. REN. 3-21-07. INT. CL. 42.
- OUTPUT EXPLORATION, LLC, STAFFORD, TX, OUTPUT  
EXPLORATION COMPANY, INC., STAFFORD, TX:  
1,995,840. REN. 3-17-07. INT. CL. 42.
- OUTRIGGER, INC., CHAPPAQUA, NY:  
1,980,001, CANC. INT. CL. 18.
- OUTSOURCEONE, INC., MINNEAPOLIS, MN:  
3,232,250, PUB. 2-6-2007. INT. CL. 36.
- OVERFINCH HOLDINGS LIMITED, HORSELL, WOKING,  
SURREY, UNITED KINGDOM:  
3,232,381, PUB. 2-6-2007. MULTIPLE CLASS, INT. CLS. 9,  
12, 35 AND 40.
- OWEN EUGENE DELL, SANTA BARBARA, CA, DBA  
COUNTY LANDSCAPE & DESIGN:  
3,233,184, PUB. 2-6-2007. MULTIPLE CLASS, INT. CLS. 42  
AND 44.
- OWENS-CORNING FIBERGLAS TECHNOLOGY INC.,  
SUMMIT, IL:  
2,036,673. REN. 3-21-07. INT. CL. 17.  
2,357,876, CANC. MULTIPLE CLASS, INT. CLS. 17 AND  
19.
- OWENS, CALEB R., VENICE, CA AND PARROTT,  
GEORGE, MIAMI, FL:  
3,234,543, MULTIPLE CLASS, INT. CLS. 9 AND 25.
- OXFORD INSTRUMENTS AMERICA, INC., CONCORD,  
MA:  
3,235,227, MULTIPLE CLASS, INT. CLS. 35, 37 AND 41.
- OIDB, INC., SKANEATELES, NY:  
2,356,665, CANC. MULTIPLE CLASS, INT. CLS. 35 AND  
40.
- O2 AQUA GROUP, CONCORD, ONTARIO, CANADA:  
3,235,449, INT. CL. 32.
- O2 HOLDINGS, LLC, NEW YORK, NY:  
3,233,483, PUB. 2-6-2007. INT. CL. 38.  
3,233,484, PUB. 2-6-2007. INT. CL. 41.
- P.A.N.G. ITHALAT IHRACAT GIDA INSAAT TURIZM  
TICARET VE SANAYI LIMITED SIRKETI, TURKEY:  
3,233,549, PUB. 2-6-2007. MULTIPLE CLASS, INT. CLS.  
39, 40, 41 AND 43.
- P.P.C., INC.:  
1,397,226, CANC. INT. CL. 42.
- PACCAR FINANCIAL CORP., BELLEVUE, WA, DBA PAC-  
CAR LEASING COMPANY:  
3,232,891, PUB. 2-6-2007. INT. CL. 35.
- PACE GLOBAL ENERGY SERVICES, LLC, FAIRFAX, VA:  
3,233,975, INT. CL. 36.
- PACIFIC ART GROUP LLC, EMERYVILLE, CA:  
3,233,421, PUB. 2-6-2007. INT. CL. 35.
- PACIFIC CATARACT AND LASER INSTITUTE, INC.,  
CHEHALIS, WA:  
1,426,100. REN. 3-21-07. INT. CL. 42.
- PACIFIC CATTLE CORPORATION, DALLAS, TX:  
1,979,616, CANC. INT. CL. 36.
- PACIFIC CHOICE SPECIALTY FOODS, INC., FRESNO, CA:  
3,232,609, PUB. 2-6-2007. INT. CL. 29.
- PACIFIC COAST FEATHER COMPANY, SEATTLE, WA:  
2,357,855, CANC. INT. CL. 20.
- PACIFIC CYCLE, LLC, MADISON, WI, ROADMASTER  
CORPORATION, OLNEY, IL:  
2,036,101. REN. 3-19-07. INT. CL. 12.
- PACIFIC LAWN SPRINKLERS L.L.C., COLLEGE POINT,  
NY:  
3,234,617, INT. CL. 37.
- PACIFIC LUMBER COMPANY, THE, SCOTIA, CA:  
2,028,422. REN. 3-21-07. INT. CL. 19.
- PACIFIC OUTDOOR PRODUCTS, INC., MAPLE VALLEY,  
WA, PLAYSYSTEMS, INC., MAPLE VALLEY, WA:  
2,036,268. REN. 3-19-07. INT. CL. 42.
- PACIFIC RESEARCH LABORATORIES, INC., EL CAJON,  
CA:  
2,081,600. REN. 3-19-07. INT. CL. 5.
- PACIFIC TOMATO GROWERS, LTD., PALMETTO, FL:  
3,232,055, PUB. 2-6-2007. INT. CL. 31.
- PACKAGE SERVICE COMPANY, KANSAS CITY, MO:  
2,357,829, CANC. MULTIPLE CLASS, INT. CLS. 16 AND  
40.
- PACKAGING CONCEPTS ASSOC. INC., BOYNTON BEACH,  
FL:  
2,044,216. REN. 3-17-07. INT. CL. 21.
- PACON CORPORATION, APPLETON, WI:  
3,234,982, INT. CL. 16.
- PADCO ADVISORS, INC., ROCKVILLE, MD:  
3,234,385, INT. CL. 36.
- PADILLA, ELIZABETH R., LOS ANGELES, CA:  
3,232,906, PUB. 2-6-2007. INT. CL. 41.
- PAHLMMEYER, JAYSON L., NAPA, CA, DBA PAHLMMEYER  
WINERY:  
2,050,703. REN. 3-22-07. INT. CL. 33.
- PAHLMMEYER, JAYSON L., NAPA, CA:  
2,087,177. REN. 3-22-07. INT. CL. 33.
- PAIN THERAPY CENTERS, P.A., GREENVILLE, SC TO  
GREENVILLE HEALTH CORPORATION:  
1,397,245, CANC. INT. CL. 42.
- PAK INTERNATIONAL, INC., LOS ANGELES, CA:  
3,234,078, INT. CL. 25.
- PALMER, A RAYMOND, GOODYEAR, AZ:  
3,234,602, MULTIPLE CLASS, INT. CLS. 16 AND 25.
- PALO ALTO PARTNERS IN EDUCATION, PALO ALTO, CA:  
3,235,188, INT. CL. 36.
- PALOTAS, MARIE, STOCKTON, NJ, DBA COUNTRY AC-  
CENTS AT SPINDELTOP FARM AND PALOTAS, JAMES,  
STOCKTON, NJ, DBA COUNTRY ACCENTS AT SPIN-  
DLETOP FARM:  
1,396,830, CANC. INT. CL. 20.
- PAN OCEANIC EYEWEAR, LTD., NEW YORK, NY:  
3,234,759, INT. CL. 9.
- PAN-MASSACHUSETTS CHALLENGE, INC., NEEDHAM,  
MA:  
3,232,853, PUB. 2-6-2007. INT. CL. 36.  
3,232,854, PUB. 2-6-2007. INT. CL. 36.
- PAN, SHEN Q, WILMINGTON, DE:  
3,234,547, INT. CL. 42.
- PANASONIC CORPORATION OF NORTH AMERICA, SE-  
CAUCUS, NJ:  
2,356,721, CANC. INT. CL. 9.
- PANDESIC LLC, SUNNYVALE, CA:  
2,358,154, CANC. INT. CL. 42.
- PANIC INC, PORTLAND, OR:  
2,358,867, CANC. INT. CL. 9.
- PAOLIN, JOHN R., DELRAN, NJ:  
3,233,319, PUB. 2-6-2007. INT. CL. 41.
- PAPER DAISY, L.L.C., CYPRESS, TX:  
3,232,928, PUB. 2-6-2007. MULTIPLE CLASS, INT. CLS. 16  
AND 35.
- PAPER MAGIC GROUP, INC., THE, WILMINGTON, DE,  
PAPER MAGIC GROUP, INC., THE, SCRANTON, PA:  
1,461,847. REN. 3-20-07. INT. CL. 16.
- PARADIGM SPORTS, INC., LAWRENCE, MA:  
2,025,980. REN. 3-19-07. INT. CL. 12.
- PARADISE INNOVATIONS, INC., FREMONT, CA:  
2,357,235, CANC. INT. CL. 9.
- PARADISE USA, LLC, VENTURA, CA:  
3,232,823, PUB. 2-6-2007. INT. CL. 30.
- PARAFORM, INC., SAN JOSE, CA:  
2,358,265, CANC. INT. CL. 9.

- PARAGON OF MICHIGAN, INC., SAN DIEGO, CA:  
2,087,514. REN. 3-20-07. INT. CL. 42.
- PARAGON TECHNOLOGIE GMBH; SYSTEMPROGRAM-  
MIERUNG, 79426 BUGGINGEN, FED REP GERMANY:  
3,233,747. PUB. 2-6-2007. INT. CL. 9.
- PARAMOUNT PICTURES CORPORATION, HOLLYWOOD,  
CA:  
3,233,439. PUB. 2-6-2007. INT. CL. 43.
- PARETOLOGIC INC., VICTORIA, BRITISH COLUMBIA,  
CANADA:  
3,232,365. PUB. 2-6-2007. INT. CL. 9.
- PARFUMS CHRISTIAN DIOR, S.A., 75008 PARIS, FRANCE,  
PARFUMS CHRISTIAN DIOR U.S. CORP., NEW YORK,  
NY:  
2,027,819. REN. 3-21-07. INT. CL. 3.
- PARFUMS CARON, 75008 PARIS, FRANCE:  
3,233,010. PUB. 2-6-2007. INT. CL. 3.
- PARFUMS CHRISTIAN DIOR, 75008 PARIS, FRANCE:  
3,234,993. INT. CL. 3.  
3,234,994. INT. CL. 3.
- PARK CITY ENTERTAINMENT, INC., PARK CITY, UT:  
3,233,327. PUB. 2-6-2007. INT. CL. 28.
- PARK, JEFF HAE CHAN, NEW YORK, NY:  
2,358,513. CANC. INT. CL. 25.
- PARKER INTAGIBLES LLC, CLEVELAND, OH:  
819,764. REN. 3-19-07. U.S. CL. 13 (INT. CL. 6).
- PARKER, YVONNE, PELHAM, NY AND TAYLOR, RO-  
BERT B., PELHAM, NY:  
3,232,407. PUB. 2-6-2007. INT. CL. 43.
- PARMALAT FOOD INC., ETOBICOKE ONTARIO, CANA-  
DA:  
1,979,247. CANC. MULTIPLE CLASS, INT. CLS. 5, 29, 30  
AND 31.
- PARMELEE INDUSTRIES, INC., LENEXA, KS:  
2,357,922. CANC. INT. CL. 9.
- PARSENN-PRODUKTE AG, SWITZERLAND:  
3,233,690. PUB. 2-6-2007. INT. CL. 5.
- PARTNERS IN MARKETING, INC., WORTHINGTON, OH:  
2,356,814. CANC. INT. CL. 35.
- PARTS ASSOCIATES INC., CLEVELAND, OH:  
1,396,498. CANC. INT. CL. 8.
- PARTS INTERNATIONAL INC., NEW YORK, NY:  
3,232,233. PUB. 2-6-2007. INT. CL. 25.
- PARTY FAIR FRANCHISING CO. OF AMERICA II, FREE-  
HOLD, NJ, PARTY FAIR FRANCHISING CO. OF AMER-  
ICA INC., FREEHOLD, NJ:  
2,035,125. REN. 3-17-07. INT. CL. 42.
- PARVUS CORPORATION, THE, SALT LAKE CITY, UT:  
2,357,580. CANC. INT. CL. 42.
- PASQUINI OLIVIER, NEW YORK, NY:  
3,233,489. PUB. 2-6-2007. INT. CL. 33.
- PASSPORT ASIA ASSOCIATES, LOS ANGELES, CA:  
2,099,067. REN. 3-19-07. INT. CL. 30.
- PAST BREWING COMPANY, MILL VALLEY, CA:  
1,425,886. REN. 3-22-07. INT. CL. 32.
- PASTA MONTANA L.L.C., GREAT FALLS, MT:  
2,358,324. CANC. INT. CL. 30.
- PASTA POMODORO, INC., SAN FRANCISCO, CA:  
3,233,041. PUB. 2-6-2007. INT. CL. 43.
- PATCH PRODUCTS, INC., BELOIT, WI:  
2,356,628. CANC. INT. CL. 9.
- PATE SLATE, L.L.C., SPRINGFIELD, LA:  
2,358,693. CANC. INT. CL. 28.
- PATHWAY DATA, INC., COSTA MESA, CA:  
3,234,820. INT. CL. 36.
- PATLER, LOUIS, MILL VALLEY, CA, DBA B.I.T. GROUP:  
3,233,414. PUB. 2-6-2007. INT. CL. 41.
- PATRIC, JOHANSSON, S-429 S-429 30 KULLAVIK, SWEDEN:  
2,357,916. CANC. INT. CL. 32.
- PATRIOT PLASTICS, INC., WOBURN, MA:  
2,356,452. CANC. INT. CL. 35.
- PATRIOT SIGNAGE INCORPORATED, DAYTON, KY:  
2,116,369. REN. 3-21-07. INT. CL. 19.
- PATTERSON, TIM ALLYN, COLORADO SPRINGS, CO:  
2,358,489. CANC. INT. CL. 25.
- PAUL MUELLER COMPANY, SPRINGFIELD, MO:  
1,067,155. REN. 3-22-07. INT. CL. 11.
- PAUL REED SMITH GUITARS, LIMITED PARTNERSHIP,  
STEVENSVILLE, MD:  
2,490,890. COR. INT. CL. 15.
- PAULA DEEN ENTERPRISES, LLC, SAVANAH, GA:  
3,232,278. PUB. 2-6-2007. INT. CL. 16.
- PAUTZKE BAIT CO., INC., ELLENSBURG, WA:  
1,062,838. REN. 3-17-07. INT. CL. 28.
- PAVONETTI, OROFRIO F., SCARSDALE, NY:  
2,023,446. REN. 3-21-07. INT. CL. 28.
- PAXAR AMERICAS, INC., MIAMISBURG, OH:  
3,232,226. PUB. 2-6-2007. INT. CL. 7.
- PAYDAY SPORTS, INC., WILMINGTON, DE:  
3,232,974. PUB. 2-6-2007. INT. CL. 41.  
3,232,975. PUB. 2-6-2007. INT. CL. 41.
- PAYNE, PATRICK, WASHINGTON, DC:  
2,357,338. CANC. INT. CL. 25.
- PC FARM, NEWINGTON, CT:  
3,234,154. MULTIPLE CLASS, INT. CLS. 9 AND 37.
- PC SERVICE SOURCE, INC., DALLAS, TX:  
2,356,982. CANC. INT. CL. 35.  
2,358,808. CANC. INT. CL. 35.
- PCI OF AMERICA, INC., ROCKVILLE, MD:  
3,233,000. PUB. 2-6-2007. INT. CL. 3.
- PCJ FRANCHISING COMPANY LLC, WILMINGTON, NC:  
3,233,909. MULTIPLE CLASS, INT. CLS. 30 AND 43.
- PCORDER.COM, AUSTIN, TX:  
2,356,723. CANC. INT. CL. 35.
- PCS DIGITAL, L.L.C., SCOTTSDALE, AZ:  
3,234,402. INT. CL. 9.
- PEACHTREE CREEK CONSULTING GROUP, INC.,  
ATLANTA, GA:  
2,357,383. CANC. MULTIPLE CLASS, INT. CLS. 9 AND  
20.
- PEACHTREE INTERNATIONAL LIMITED, HAMILTON  
HM, BERMUDA MX, BERMUDA:  
3,233,766. INT. CL. 27.
- PEACOCK FOUNDATION, THE, NORTH HOLLYWOOD,  
CA:  
3,235,253. INT. CL. 45.
- PEAK PERFORMANCE PRODUCTION AB, SWEDEN:  
3,233,621. PUB. 2-6-2007. INT. CL. 35.
- PEARL VALLEY CHEESE, INC., FRESNO, OH:  
2,036,835. REN. 3-21-07. INT. CL. 29.
- PEARSON EDUCATION, INC., UPPER SADDLE RIVER, NJ,  
HARPERCOLLINS EDUCATIONAL PUBLISHERS INC.,  
NEW YORK, NY:  
1,911,392. REN. 3-20-07. INT. CL. 16.
- PEBBLE BEACH COMPANY, PEBBLE BEACH, CA:  
3,233,988. INT. CL. 25.
- PECONIC DEVELOPMENT CORP., CLINTONDALE, NY:  
3,234,354. INT. CL. 32.
- PELICAN SOAP CO., LTD., TOKYO, JAPAN:  
3,233,210. PUB. 2-6-2007. INT. CL. 3.
- PELLE PELLE INC., ROCHESTER HILLS, MI:  
3,232,686. PUB. 2-6-2007. INT. CL. 25.
- PELLE PELLE, INC., ROCHESTER HILLS, MI:  
3,232,890. PUB. 2-6-2007. MULTIPLE CLASS, INT. CLS. 18  
AND 25.
- PELLERIN, BURLEY J., II, LAFAYETTE, LA:  
3,233,051. PUB. 2-6-2007. INT. CL. 40.
- PEM MANAGEMENT, INC., WILMINGTON, DE:  
1,403,759. REN. 3-21-07. INT. CL. 6.
- PENCE, CAIN M., MINNEAPOLIS, MN:  
3,232,210. PUB. 2-6-2007. INT. CL. 35.
- PENDERGAST-WEYER FOUNDATION, THE, MARSHALL,  
MO:  
1,397,113. CANC. INT. CL. 36.
- PENGUIN GROUP (USA) INC., NEW YORK, NY, NAL  
PENGUIN INC., NEW YORK, NY:  
1,432,907. REN. 3-20-07. INT. CL. 16.
- PENGUIN GROUP (USA) INC., NEW YORK, NY, JEREMY  
P. TARCHER, INC., LOS ANGELES, CA:  
2,038,915. REN. 3-20-07. INT. CL. 16.  
2,059,200. REN. 3-20-07. INT. CL. 16.
- PENNINGTON SEED, INC. OF NEBRASKA, SIDNEY, NE:  
2,356,448. CANC. INT. CL. 31.

- PENNWELL CORPORATION, TULSA, OK, REUBEN H. DONNELLEY CORPORATION, THE, CHICAGO, IL: 641,416. REN. 3-21-07. U.S. CL. 38 (INT. CL. 16).
- PENNWELL CORPORATION, TULSA, OK: 3,234,084, MULTIPLE CLASS, INT. CLS. 16 AND 36.
- PENNY LANE PUBLISHING, INC., NEW CARLISLE, OH: 2,054,720. REN. 3-20-07. INT. CL. 16.
- PENOBSCOT SHOE COMPANY, OLD TOWN, ME: 2,357,854, CANC. INT. CL. 25.
- PENTASAFE, INCORPORATED, HOUSTON, TX: 2,357,113, CANC. INT. CL. 9.  
2,357,114, CANC. INT. CL. 9.  
2,357,115, CANC. INT. CL. 9.
- PENTE OF AMERICA, LTD., TORRANCE, CA: 1,979,889, CANC. INT. CL. 16.
- PEOPLE OF DESTINY INTERNATIONAL, INC., GAITHERSBURG, MD: 1,396,508, CANC. MULTIPLE CLASS, INT. CLS. 9 AND 16.  
1,396,509, CANC. MULTIPLE CLASS, INT. CLS. 9 AND 16.
- PEOPLEMARK, INC., MEMPHIS, TN: 1,420,400. REN. 3-19-07. INT. CL. 35.
- PEOPLES EDUCATION, INC., THE, SADDLE BROOK, NJ: 3,233,289, PUB. 2-6-2007. MULTIPLE CLASS, INT. CLS. 16 AND 41.  
3,233,290, PUB. 2-6-2007. MULTIPLE CLASS, INT. CLS. 16 AND 41.
- PEPPER PLUS! FOODS, INC., LAUGHLIN, NV: 2,356,439, CANC. INT. CL. 30.
- PEPSICO, INC., PURCHASE, NY: 3,232,309, PUB. 2-6-2007. INT. CL. 16.  
3,233,497, PUB. 2-6-2007. INT. CL. 36.
- PERAZA, WILLIAM JR., MIAMI, FL: 3,235,453, INT. CL. 41.
- PERCEPTUM, INC., BEDMINSTER, NJ: 2,356,902, CANC. INT. CL. 9.
- PERCHEM LIMITED, GILLINGHAM, KENT, ENGLAND: 1,396,282, CANC. INT. CL. 1.
- PERDUE HOLDINGS, INC., WILMINGTON, DE, PERDUE FARMS INCORPORATED, SALISBURY, MD: 1,404,275. REN. 3-20-07. INT. CL. 29.
- PERDUE HOLDINGS, INC., WILMINGTON, DE: 3,234,426, INT. CL. 29.
- PERFECT OPTICS, LLC, VISTA, CA: 3,232,840, PUB. 2-6-2007. INT. CL. 40.
- PERFECT SMILE CORPORATION, WESTLAKE, OH: 3,234,437, MULTIPLE CLASS, INT. CLS. 3 AND 5.
- PERFECTION HY-TEST COMPANY, TIMMONSVILLE, SC: 2,069,620. REN. 3-21-07. INT. CL. 12.
- PERFECTION PAINTING COMPANY, LONGMONT, CO: 3,233,116, PUB. 2-6-2007. INT. CL. 37.
- PERFORMANCE MOTION DEVICES, INC., LINCOLN, MA: 3,234,866, INT. CL. 9.  
3,234,867, INT. CL. 9.
- PERGADIA, PRATIKSHA, FOREST HILLS, NY: 3,233,072, PUB. 2-6-2007. INT. CL. 35.
- PERMA-CHINK SYSTEMS, INC., REDMOND, WA: 1,993,816. REN. 3-21-07. INT. CL. 5.  
2,035,916. REN. 3-21-07. INT. CL. 5.
- PERNIGOTTI S.P.A., PROVINCE OF ALESSANDRIA, ITALY: 2,356,451, CANC. INT. CL. 30.
- PERNOD RICARD MEXICO S.A. DE C.V., MEXICO DF, MEXICO: 3,235,198, INT. CL. 33.
- PERRY BAROMEDICAL CORPORATION, RIVIERA BEACH, FL: 2,026,438. REN. 3-16-07. MULTIPLE CLASS, INT. CLS. 10 AND 42.
- PERRY EQUIPMENT CORPORATION, MINERAL WELLS, TX: 2,104,211. REN. 3-17-07. INT. CL. 11.
- PERRY IP GROUP A LAW CORPORATION, GREENBRAE, CA: 3,233,423, PUB. 2-6-2007. INT. CL. 42.  
3,233,424, PUB. 2-6-2007. INT. CL. 42.
- PERSEVERANCE MILLS LIMITED, LANCASHIRE, BB12 7DY, ENGLAND: 2,357,915, CANC. INT. CL. 24.
- PERTH VENTURES, LLC, GAINSVILLE, FL: 3,233,880, INT. CL. 41.
- PESTBUSTERS, INC., SIOUX CITY, IA: 3,233,313, PUB. 2-6-2007. INT. CL. 37.  
3,233,474, PUB. 2-6-2007. INT. CL. 37.
- PET APPEAL, INC., CLACKAMAS, OR: 3,233,094, PUB. 2-6-2007. INT. CL. 28.  
3,233,095, PUB. 2-6-2007. INT. CL. 31.
- PET-TO-VET-TRANSPORT, LLC, FAIRFIELD, CT: 2,357,270, CANC. INT. CL. 39.
- PETCO ANIMAL SUPPLIES, INC., SAN DIEGO, CA: 3,234,116, INT. CL. 21.
- PETER BREHM, FED REP GERMANY: 3,233,686, PUB. 2-6-2007. INT. CL. 10.
- PETER FUNK INC., PRINCETON, NJ: 1,396,940, CANC. INT. CL. 28.
- PETER MACCALLUM CANCER INSTITUTE, EAST MELEBOURNE VIC 3002, AUSTRALIA: 3,233,670, PUB. 2-6-2007. INT. CL. 42.
- PETER RABBIT FARMS, COACHELLA, CA: 2,031,912. REN. 3-16-07. INT. CL. 31.
- PETER STOKKEBYE TOBAKSFABRIK A/S, DENMARK, SKANDINAVISK TOBAKSKOMPAGNI A/S, SOBORG, DENMARK: 1,059,526. REN. 3-16-07. INT. CL. 34.
- PETER THOMAS ROTH LABS, LLC, NEW YORK, NY: 3,235,466, INT. CL. 3.
- PETERS, ANDREW, GOSHEN, IN: 3,234,149, INT. CL. 28.
- PETERSON MANUFACTURING COMPANY, GRANDVIEW, MO: 1,450,610. REN. 3-21-07. INT. CL. 11.  
1,462,687. REN. 3-21-07. INT. CL. 11.
- PETERSON PACIFIC CORP., EUGENE, OR: 3,234,174, MULTIPLE CLASS, INT. CLS. 7 AND 12.
- PETESKI PRODUCTIONS, INC., IRVING, TX: 3,233,806, INT. CL. 16.
- PETITE MENAGERIE, INC., ATLANTA, GA: 3,234,995, MULTIPLE CLASS, INT. CLS. 3, 4, 25 AND 30.
- PETRA INDUSTRIES, INC., EDMOND, OK: 2,093,089. REN. 3-20-07. INT. CL. 9.
- PETRO STOPPING CENTERS, L.P., EL PASO, TX: 1,424,435. REN. 3-19-07. INT. CL. 42.
- PETRO-LUBE, INC., WHITMORE LAKE, MI: 2,358,203, CANC. INT. CL. 4.
- PETROQUIP ENERGY SERVICES, HOUSTON, TX: 3,233,264, PUB. 2-6-2007. INT. CL. 9.
- PETSMART, INC., PHOENIX, AZ: 2,357,900, CANC. MULTIPLE CLASS, INT. CLS. 3 AND 21.
- PETSUNITED, LLC, HAZLETON, PA: 2,036,972. REN. 3-21-07. MULTIPLE CLASS, INT. CLS. 3 AND 5.
- PETSURANCE, INC., EAST HAMPTON, NY: 3,234,806, INT. CL. 35.
- PF BRANDS, INC., NEWARK, DE: 2,358,519, CANC. INT. CL. 30.  
3,235,290, INT. CL. 30.
- PFIZER INC., NEW YORK, NY: 3,233,867, MULTIPLE CLASS, INT. CLS. 5 AND 10.
- PFLEIDERER WATER SYSTEMS GMBH, NEUMARKT, FED REP GERMANY: 3,232,505, PUB. 12-26-2006. INT. CL. 11.
- PFW AROMA CHEMICALS B.V., BARNEVALD, NETHERLANDS, HERCULES INCORPORATED, WILMINGTON, DE: 2,039,103. REN. 3-22-07. INT. CL. 1.
- PHANTOM GOURMET, INC., BOSTON, MA: 3,232,760, PUB. 2-6-2007. MULTIPLE CLASS, INT. CLS. 41 AND 43.
- PHARMACIA & UPJOHN COMPANY LLC, PEAPACK, NJ: 3,235,057, MULTIPLE CLASS, INT. CLS. 5, 10 AND 11.
- PHARMACY DEVELOPMENT SERVICES, BOYNTON BEACH, FL: 3,235,128, INT. CL. 9.



PHARMANEX LLC, PROVO, UT:  
3,234,152, INT. CL. 5.

PHARMANEX, LLC, PROVO, UT:  
2,358,424, CANC. INT. CL. 30.

PHARMATON S.A., CH-6934 BIOGGIO, SWITZERLAND,  
DBA PHARMATON LTD. AND DBA PHARMATON AG:  
1,056,856. REN. 3-22-07. INT. CL. 5.

PHAT FASHIONS LLC, NEW YORK, NY:  
3,233,844, INT. CL. 9.

PHAT WRAPS, L.L.C., CHATTANOOGA, TN:  
2,356,509, CANC. INT. CL. 42.

PHILD CO., LTD., KYOTO CITY, KYOTO PREF., JAPAN:  
2,413,433, AM. MULTIPLE CLASS, INT. CLS. 3 AND 5.

PHILIP ALLAN POTTER, AUSTRALIA:  
3,233,702, PUB. 2-6-2007. INT. CL. 10.

PHILIP L. GOOCH, HOUSTON, TX TO GETAGADGET,  
INC., AUSTIN, TX:  
1,979,769, CANC. INT. CL. 21.

PHILIPPS, IGOR JOHN, BRAMPTON, ONTARIO, CANADA:  
3,232,497, PUB. 2-6-2007. MULTIPLE CLASS, INT. CLS. 12  
AND 22.

PHILLIES FLORIDA LLC, CLEARWATER, FL:  
3,234,183, INT. CL. 16.

PHILLIPS & TEMRO INDUSTRIES INC., EDEN PRAIRIE,  
MN:  
3,232,667, PUB. 2-6-2007. INT. CL. 9.

PHILOSOPHY, INC., PHOENIX, AZ:  
2,358,034, CANC. INT. CL. 3.  
2,358,110, CANC. INT. CL. 3.  
2,358,200, CANC. INT. CL. 3.  
3,234,202, INT. CL. 3.  
3,235,185, INT. CL. 3.

PHOENIX HEALTHCARE CORPORATION, NASHVILLE,  
TN:  
2,358,388, CANC. INT. CL. 36.

PHOENIX INTAGIBLES HOLDING COMPANY, GREEN-  
VILLE, DE, KONICA PHOTO SERVICE U.S.A., INC., EAST  
HARTFORD, CT:  
2,076,530. REN. 3-20-07. INT. CL. 1.

PHOENIX MARINE ENTERPRISES, INC., HIALEAH, FL:  
1,396,675, CANC. INT. CL. 12.

PHONAK HOLDING AG, CH-8712 STAEFA, SWITZER-  
LAND:  
3,233,973, MULTIPLE CLASS, INT. CLS. 9 AND 10.

PHOTODISC, INC., SEATTLE, WA:  
2,358,169, CANC. INT. CL. 42.

PHYSICIANS FORMULA, INC., AZUSA, CA:  
3,235,191, INT. CL. 3.  
3,235,257, INT. CL. 3.

PHYSIOME SCIENCES, INC., PRINCETON, NJ:  
2,357,062, CANC. INT. CL. 42.

PIAGGIO & C. S.P.A., PISA, ITALY, PIAGGIO VEICOLI  
EUROPEI S.P.A., 56025 PONTEDERA (PI), ITALY:  
2,038,301. REN. 3-21-07. MULTIPLE CLASS, INT. CLS. 6,  
14, 16, 26 AND 28.

PICSEL (RESEARCH) LIMITED, GLASGOW, G51 4BP, UNI-  
TED KINGDOM:  
3,233,569, PUB. 2-6-2007. MULTIPLE CLASS, INT. CLS. 9  
AND 42.

PICS4IT.COM, INC., RICHMOND, VA:  
3,234,729, INT. CL. 42.

PIDILITE USA, INC., JUPITER, FL, DBA CYCLO INDUS-  
TRIES, INC., BORDEN, INC., COLUMBUS, OH:  
1,427,067. REN. 3-19-07. INT. CL. 3.

PIERCE ARROW SOCIETY, THE, ATLANTA, GA:  
1,058,801. REN. 3-16-07. U.S. CL. 200.

PIERCE ATWOOD LLP, PORTLAND, ME:  
2,039,058. REN. 3-22-07. INT. CL. 16.

PIERRE FABRE DERMO-COSMETIQUE, FRANCE:  
3,233,623, PUB. 2-6-2007. INT. CL. 5.

PIERRE, DANIEL, BUHL-LORRAINE, FRANCE:  
3,234,181, INT. CL. 30.

PIGMOVER.COM, LLC, CARMEL, IN:  
3,234,846, INT. CL. 35.

PII LIMITED, CRAMLINGTON, NORTHUMBERLAND,  
UNITED KINGDOM:  
3,234,312, INT. CL. 9.

PILOT AIR FREIGHT CORP., LIMA, PA:  
1,979,358, CANC. MULTIPLE CLASS, INT. CLS. 35 AND  
39.

PIN-AMAX, BLOOMFIELD HILLS, MI:  
2,358,483, CANC. INT. CL. 28.  
2,358,485, CANC. INT. CL. 28.

PINPOINT SYSTEMS INTERNATIONAL, L.L.C.,  
WESTHAMPTON BEACH, NY:  
2,356,986, CANC. INT. CL. 9.

PIONEER LICENSING SERVICES, INC., LAS VEGAS, NV:  
3,233,512, PUB. 2-6-2007. INT. CL. 36.

PIONEERING TECHNOLOGY INC., MISSISSAUGA, ON-  
TARIO:  
3,233,980, INT. CL. 9.

PISTACHIO PRODUCERS OF CALIFORNIA, MADERA, CA:  
1,396,997, CANC. INT. CL. 29.

PITCHER, BRIAN, EASTON, PA:  
3,232,626, PUB. 2-6-2007. INT. CL. 35.

PIVOT POINT INTERNATIONAL, INC., EVANSTON, IL:  
1,424,634. REN. 3-19-07. MULTIPLE CLASS, INT. CLS. 9,  
16, 18, 21, 25, 26, 41 AND 42.

PIZZA HUT, INC., DALLAS, TX:  
3,234,654, INT. CL. 16.

PIZZERIA UNO CORPORATION, WILMINGTON, DE:  
3,235,209, INT. CL. 29.

PLANET EARTH, INC., GRANGER, IN:  
2,356,858, CANC. INT. CL. 35.

PLANET SMOOTHIE FRANCHISES, LLC, ATLANTA, GA:  
2,358,507, CANC. INT. CL. 30.

PLANT SCIENCES, INC., WATSONVILLE, CA:  
3,234,185, INT. CL. 31.

PLANTE, JOSEPH M., AMESBURY, MA AND PLANTE,  
CHRISTOPHER L., AMESBURY, MA AND DROUIN,  
DAVID, AMESBURY, MA AND KANE, KELLY, AMES-  
BURY, MA:  
3,234,314, MULTIPLE CLASS, INT. CLS. 9 AND 41.

PLANTRONICS, INC., SANTA CRUZ, CA:  
3,234,928, INT. CL. 9.

PLANVIEW, INC., AUSTIN, TX:  
3,232,899, PUB. 10-24-2006. INT. CL. 9.  
3,233,492, PUB. 10-31-2006. INT. CL. 35.

PLASMA INDUSTRIES INC, GILBERT, AZ:  
3,233,382, PUB. 2-6-2007. INT. CL. 11.

PLASMATRONICS, LLC, CENTER MORICHES, NY:  
3,234,933, MULTIPLE CLASS, INT. CLS. 7 AND 9.

PLASTOLAN KLAUS LANGENBACH GMBH & CO. KG,  
59557 LIPPSTADT, FED REP GERMANY TO PLASTOLAN  
GMBH, LIPPSTADT 59557, FED REP GERMANY:  
1,979,357, CANC. INT. CL. 16.

PLATELOCK LLC, LEHIGH ACRES, FL:  
3,232,222, PUB. 2-6-2007. INT. CL. 12.

PLATINUM TECHNOLOGY, INC., ISLANDIA, NY, AION  
CORPORATION, PALO ALTO, CA:  
1,426,427. REN. 3-21-07. INT. CL. 9.

PLATTE RIVER ART SERVICES, INC., DENVER, CO:  
3,232,192, PUB. 2-6-2007. INT. CL. 20.

PLAYBOY ENTERPRISES INTERNATIONAL, INC., CHICA-  
GO, IL, HMH PUBLISHING CO., INC., CHICAGO, IL:  
643,926. REN. 3-17-07. U.S. CL. 38 (INT. CL. 16).

PLAYBOY ENTERPRISES INTERNATIONAL, INC., CHICA-  
GO, IL:  
3,234,302, INT. CL. 43.  
3,234,488, INT. CL. 35.

PLAYCORE WISCONSIN, INC., CHATTANOOGA, TN:  
3,234,463, INT. CL. 28.

PLAYFIRST, INC., SAN FRANCISCO, CA:  
3,235,323, INT. CL. 9.

PLAYMAXX, INC., TUCSON, AZ:  
2,358,604, CANC. INT. CL. 28.

PLEXON INCORPORATED, DALLAS, TX:  
3,232,672, PUB. 2-6-2007. INT. CL. 9.

PLEXTRON CORP., TORONTO, ONTARIO, CANADA:  
3,233,827, MULTIPLE CLASS, INT. CLS. 40 AND 42.

PLOWSHARES, LTD., WOODSTOCK, IL:  
3,234,738, MULTIPLE CLASS, INT. CLS. 25 AND 28.

PLUM POINT OYSTERS, LLC, NORTH KINGSTOWN, RI:  
3,235,324, INT. CL. 31.

- PM CO. L.L.C., CINCINNATI, OH:  
2,358,658, CANC. INT. CL. 16.
- PM KNIGHTS, INC., CASSELBERRY, FL:  
3,232,751, PUB. 2-6-2007. INT. CL. 44.
- PNP PETRO-N-PROVISIONS, INC., CEDAR RAPIDS, IA:  
1,979,896, CANC. INT. CL. 42.
- PODSHOW, INC., SAN FRANCISCO, CA:  
3,232,852, PUB. 2-6-2007. INT. CL. 38.
- POINT LIGHTING CORPORATION, BLOOMFIELD, CT:  
2,123,553, REN. 3-21-07. INT. CL. 9.
- POINT-TO-POINT MARKETING, INC., FORT COLLINS, CO:  
2,021,805, REN. 3-19-07. INT. CL. 35.
- POKER LIFE MAGAZINE, LLC, NEW YORK, NY:  
3,232,205, PUB. 2-6-2007. INT. CL. 16.
- POLAK, ALICIA DANIELLE, CINNAMINSON, NJ:  
3,233,172, PUB. 2-6-2007. INT. CL. 30.
- POLHEMUS, NEIL W., PRINCETON, NJ:  
2,358,053, CANC. INT. CL. 9.
- POLIMASTER LTD., MINSK, BELARUS:  
3,234,476, MULTIPLE CLASS, INT. CLS. 9 AND 42.
- POLLACK, RONALD J., CLEARWATER, FL:  
2,357,479, CANC. INT. CL. 36.
- POLYGON COMPANY, WALKERTON, IN:  
3,235,146, INT. CL. 10.
- POLYONE CORPORATION, AVON LAKE, OH:  
3,234,158, INT. CL. 1.
- POMFRET, STEVE, WABASSO, FL:  
3,232,585, PUB. 2-6-2007. INT. CL. 35.
- POORE BROTHERS-BLUEFTON, LLC, BLUFFTON, IN:  
1,424,126, REN. 3-19-07. INT. CL. 29.
- POPULAR HOLDINGS LIMITED, SINGAPORE:  
3,233,550, PUB. 2-6-2007. MULTIPLE CLASS, INT. CLS. 9, 16, 41 AND 42.
- PORCELAIN-PLUS DENTAL SYSTEMS, INC, CRANFORD, NJ:  
3,234,486, INT. CL. 5.
- PORPIGLIA, BARBARA MANSON, CORNWALL ON THE HUDSON, NY:  
2,358,404, CANC. INT. CL. 16.
- PORTAL PUBLICATIONS, LTD., NOVATO, CA:  
3,234,961, INT. CL. 16.  
3,234,962, INT. CL. 16.
- PORTER ATHLETIC, INC., BROADVIEW, IL:  
3,234,958, INT. CL. 27.  
3,234,960, INT. CL. 27.  
3,234,963, INT. CL. 27.
- PORTWELL, INC., TAIPEI, TAIWAN:  
3,232,603, PUB. 2-6-2007. INT. CL. 9.
- POST UNIVERSITY, INC, WATERBURY, CT:  
3,232,312, PUB. 2-6-2007. INT. CL. 41.  
3,232,313, PUB. 2-6-2007. INT. CL. 41.  
3,232,314, PUB. 2-6-2007. INT. CL. 41.
- POSTX CORPORATION, CUPERTINO, CA:  
2,357,642, CANC. INT. CL. 9.
- POTLATCH CORPORATION, SPOKANE, WA:  
3,235,193, INT. CL. 16.
- POTLATCH FOREST PRODUCTS CORPORATION, SPOKANE, WA:  
3,235,325, INT. CL. 16.
- POTPOURRI GROUP, INC., CHELMSFORD, MA:  
2,041,965, REN. 3-20-07. INT. CL. 42.
- POWELL, CARLTON L., OAK PARK, CA:  
3,233,471, PUB. 2-6-2007. INT. CL. 35.
- POWER PLUS IGNITOR, LLC, TULSA, OK:  
3,233,451, PUB. 2-6-2007. INT. CL. 20.
- POWERMOTIVE, INC., QUEBEC, CANADA:  
2,357,955, CANC. INT. CL. 7.
- POWERQUEST CORPORATION, OREM, UT:  
2,358,292, CANC. INT. CL. 9.
- POWERS, MARK A., SHAWNEE, KS:  
3,232,596, PUB. 2-6-2007. MULTIPLE CLASS, INT. CLS. 9 AND 41.
- POWER3 MEDICAL PRODUCTS, INC., THE WOODLANDS, TX:  
3,233,932, INT. CL. 5.
- POZDEREC, SUSANNE, PARIS, FRANCE:  
3,232,745, PUB. 2-6-2007. INT. CL. 34.
- PPM ENERGY, INC., PORTLAND, OR:  
3,234,121, MULTIPLE CLASS, INT. CLS. 35, 36, 37, 39, 40 AND 42.
- PR POWER CO., ATLANTA, GA:  
3,233,934, INT. CL. 40.
- PRACTICE BUILDER ORGANIZATION, INC., IRVINE, CA:  
2,358,890, CANC. INT. CL. 16.  
2,358,891, CANC. INT. CL. 16.
- PRACTISING LAW INSTITUTE, NEW YORK, NY, CLE GROUP, MENLO PARK, CA:  
2,031,108, REN. 3-22-07. INT. CL. 9.
- PRAIRIE PACKAGING, INC., BEDFORD PARK, IL:  
2,358,742, CANC. INT. CL. 25.
- PRATS, CARLOS ROYO, CASTELLON, SPAIN:  
3,234,166, INT. CL. 24.
- PRATT, NATHAN D., SOMIS, CA:  
3,233,957, INT. CL. 25.  
3,233,958, INT. CL. 28.  
3,233,959, INT. CL. 28.
- PRECISION LINE INDUSTRIES, INC., PLYMOUTH, MN:  
2,358,518, CANC. INT. CL. 25.
- PRECO ELECTRONICS, INC., BOISE, ID:  
3,233,873, INT. CL. 35.
- PREFERRED NETWORKS, INC., NORCROSS, GA:  
2,358,524, CANC. INT. CL. 38.
- PREFIX CORPORATION, ROCHESTER HILLS, MI:  
3,234,204, MULTIPLE CLASS, INT. CLS. 11, 12, 28, 37 AND 42.
- PREMERA, SEATTLE, WA:  
2,132,965, REN. 3-19-07. INT. CL. 36.
- PREMIER AGENDAS, INC., BELLINGHAM, WA:  
2,118,995, REN. 3-16-07. INT. CL. 9.  
2,120,484, REN. 3-16-07. INT. CL. 16.  
2,120,485, REN. 3-16-07. INT. CL. 16.
- PREMIERE RADIO NETWORKS, INC., SHERMAN OAKS, CA:  
2,357,256, CANC. MULTIPLE CLASS, INT. CLS. 41 AND 42.
- PRENOVA, INC., MARIETTA, GA:  
3,233,368, PUB. 2-6-2007. INT. CL. 35.
- PRENTICE CAPITAL MANAGEMENT, LP, NEW YORK, NY:  
3,234,775, INT. CL. 36.
- PRENTISS DOUTHIT, LLC, BIRMINGHAM, AL:  
3,234,396, INT. CL. 16.
- PRESBYTERIAN CHURCH (USA) FOUNDATION, JEFFERSONVILLE, IN:  
3,232,962, PUB. 2-6-2007. MULTIPLE CLASS, INT. CLS. 35 AND 36.
- PRESERVATION ALLIANCE FOR GREATER PHILADELPHIA, THE, PHILADELPHIA, PA:  
2,356,710, CANC. INT. CL. 35.
- PRESONUS AUDIO ELECTRONIC, INC., BATON ROUGE, LA:  
3,235,346, INT. CL. 9.
- PRESSURE POSITIVE COMPANY, THE, GILBERTSVILLE, PA:  
2,042,412, REN. 3-22-07. INT. CL. 10.
- PRESTIGE S.A. PARIS, 75017 PARIS, FRANCE:  
2,356,803, CANC. INT. CL. 3.
- PRESTO GALAXY SUCTION CUPS, INC., GREENPOINT, NY:  
2,358,123, CANC. INT. CL. 20.
- PRESTONE PRODUCTS CORPORATION, DANBURY, CT:  
2,358,357, CANC. INT. CL. 8.
- PREVERCO INC., SAINT-AUGUSTIN-DE-DESMAURES, QUEBEC, CANADA:  
3,232,420, PUB. 2-6-2007. INT. CL. 19.
- PREVIEW SYSTEMS, INC., CUPERTINO, CA:  
2,356,819, CANC. INT. CL. 9.
- PRICEGEMS, LLC, SUISUN CITY, CA:  
3,232,873, PUB. 2-6-2007. INT. CL. 14.
- PRICewaterhouseCOOPERS LLP, NEW YORK, NY:  
2,358,848, CANC. MULTIPLE CLASS, INT. CLS. 35 AND 42.
- PRICHARD'S DISTILLERY, INC., KELSO, TN:  
3,232,252, PUB. 2-6-2007. INT. CL. 33.

- PRIDE COMMERCIAL CLEANING CONCEPTS (PC3), LLC,  
ATLANTA, GA:  
3,234,044, INT. CL. 37.
- PRIME RESOURCE GROUP INC., MINNEAPOLIS, MN,  
P.R.G., INC., MINNEAPOLIS, MN:  
2,033,468. REN. 3-19-07. INT. CL. 16.
- PRIME RESOURCE GROUP INC., MINNEAPOLIS, MN,  
P.R.G., INC., MINNEAPOLIS, MN:  
2,029,756. REN. 3-19-07. INT. CL. 16.  
2,033,467. REN. 3-17-07. MULTIPLE CLASS, INT. CLS. 16  
AND 41.
- PRIME TIME SOLUTIONS, INC., TORRINGTON, CT:  
3,235,265, INT. CL. 8.
- PRIMECHECK, INC., DULUTH, GA:  
2,358,082, CANC. INT. CL. 36.
- PRIMERATURF, INC., NORTH RIDGEVILLE, OH:  
2,086,724. REN. 3-22-07. INT. CL. 1.
- PRIMESOURCE HEALTHCARE, INC., TUCSON, AZ:  
3,234,549, MULTIPLE CLASS, INT. CLS. 35 AND 40.
- PRIMUS PHARMACEUTICALS, INC., SCOTTSDALE, AZ:  
3,234,821, INT. CL. 5.
- PRINCIPIA LLC, SAN FRANCISCO, CA:  
3,234,979, INT. CL. 42.
- PRINT MACHINE, INC., THE, GREENVILLE, SC:  
2,356,923, CANC. INT. CL. 42.
- PRINTERS' SERVICE, INC., NEWARK, NJ:  
2,028,336. REN. 3-17-07. INT. CL. 42.
- PRINTMARK INDUSTRIES, INC., HAZLETON, PA:  
2,044,432. REN. 3-21-07. INT. CL. 9.  
2,046,518. REN. 3-21-07. INT. CL. 16.
- PRIONICS AG, SWITZERLAND:  
3,233,547, PUB. 2-6-2007. INT. CL. 10.
- PRIORITY HEALTH, GRAND RAPIDS, MI:  
3,232,558, PUB. 2-6-2007. MULTIPLE CLASS, INT. CLS. 41  
AND 44.
- PRIORITY RECORDS, LLC, HOLLYWOOD, CA:  
2,356,531, CANC. INT. CL. 7.
- PRISM BUSINESS MEDIA INC., NEW YORK, NY:  
2,358,208, CANC. INT. CL. 28.
- PRISM MORTGAGE COMPANY, CHICAGO, IL:  
2,356,656, CANC. INT. CL. 36.
- PRIVATE DUTY SOLUTIONS, INC., LEOLA, PA:  
2,357,040, CANC. MULTIPLE CLASS, INT. CLS. 16 AND  
42.
- PRL USA HOLDINGS, INC., WILMINGTON, DE:  
3,234,164, MULTIPLE CLASS, INT. CLS. 41, 44 AND 45.
- PRO ALUMINUM, INC., SACRAMENTO, CA:  
3,233,997, INT. CL. 12.
- PRO CITRUS NETWORK, VISALIA, CA:  
3,232,793, PUB. 2-6-2007. INT. CL. 31.
- PRO-ACTIVITY ASSOCIATES, LLC, ANNANDALE, NJ:  
3,233,234, PUB. 2-6-2007. INT. CL. 44.
- PRO-AD SPORTS, INC., CHATTANOOGA, TN:  
2,358,695, CANC. INT. CL. 16.
- PRO-MARK CORPORATION, HOUSTON, TX:  
2,032,231. REN. 3-16-07. INT. CL. 15.  
2,045,812. REN. 3-16-07. INT. CL. 15.
- PRO-TECH BUSINESS SOLUTIONS INC., EDMONTON,  
ALBERTA, CANADA:  
2,357,044, CANC. INT. CL. 42.
- PROBIOHEALTH, LLC, BEVERLY HILLS, CA:  
3,234,136, INT. CL. 5.
- PROCTER & GAMBLE COMPANY, THE, CINCINNATI, OH:  
1,396,362, CANC. INT. CL. 3.  
1,396,378, CANC. INT. CL. 3.  
1,396,379, CANC. INT. CL. 3.  
1,396,380, CANC. INT. CL. 3.  
2,358,665, CANC. INT. CL. 3.
- PRODUCT DESIGN, LLC, DELAWARE, OH:  
3,235,342, INT. CL. 19.
- PRODUCT PARTNERS, LLC, BEVERLY HILLS, CA:  
3,234,804, MULTIPLE CLASS, INT. CLS. 9 AND 16.
- PRODUCT VISIONAIRES GMBH, 10245 BERLIN, FED REP  
GERMANY:  
3,232,336, PUB. 8-29-2006. INT. CL. 42.
- PRODUCTIVITY SOFTWARE INTERNATIONAL, INC.,  
NEW YORK, NY:  
1,396,709, CANC. MULTIPLE CLASS, INT. CLS. 16 AND  
41.
- PRODUCTIVITY SOLUTIONS, INC., DUBLIN, CA:  
3,233,123, PUB. 2-6-2007. INT. CL. 9.
- PRODUCTORA DE TEQUILA GEMINIS, S.A. DE C.V.,  
MEXICO CITY, MEXICO:  
3,233,032, PUB. 2-6-2007. INT. CL. 33.
- PROESEL, HENRY A. III, CHICAGO, IL:  
3,235,178, INT. CL. 36.
- PROF CANADA LTD., EDMONTON, ALBERTA, CANADA:  
2,357,137, CANC. INT. CL. 9.
- PROFESSIONAL ASSOCIATION OF SPORTS EDUCATORS,  
SANTA ANA, CA:  
1,396,713, CANC. INT. CL. 16.
- PROFESSIONAL'S CHOICE SPORTS MEDICINE PRO-  
DUCTS, INC., EL CAJON, CA:  
2,041,701. REN. 3-17-07. INT. CL. 10.
- PROFESSORS WORLD PEACE ACADEMY, THE, NEW  
YORK, NY:  
1,396,730, CANC. INT. CL. 16.
- PROGRESS SOFTWARE CORPORATION, BEDFORD, MA:  
3,234,809, INT. CL. 9.  
3,234,810, INT. CL. 42.
- PROGRESSIVE APPLIANCE CORPORATION, TYNGS-  
BORO, MA:  
3,232,958, PUB. 2-6-2007. INT. CL. 10.
- PROGRESSIVE DYNAMICS, INC., MARSHALL, MI:  
2,103,244. REN. 3-16-07. INT. CL. 9.  
2,103,245. REN. 3-16-07. INT. CL. 9.
- PROGRESSIVE GAMING INTERNATIONAL CORPORA-  
TION, LAS VEGAS, NV:  
3,234,065, INT. CL. 9.
- PROJECT OXYGEN, LTD., HAMILTON HM AX, BERMU-  
DA:  
2,356,581, CANC. INT. CL. 38.
- PROJECT SOFTWARE & DEVELOPMENT, INC, BEDFORD,  
MA:  
2,357,574, CANC. INT. CL. 9.
- PROKSCH, CARSTEN, 73527 SCHWABISCH GMUND, FED  
REP GERMANY:  
3,232,525, PUB. 2-6-2007. MULTIPLE CLASS, INT. CLS.  
38, 42 AND 45.
- PROMARK BRANDS INC., MERIDIAN, ID FROM PRO-  
MARK INTERNATIONAL, INC., BOISE, ID:  
3,233,799, INT. CL. 21.
- PROMERUS LLC, BRECKSVILLE, OH:  
2,123,249. REN. 3-21-07. INT. CL. 1.
- PROMETHEAN GROUP, LLC, OLATHE, KS:  
3,234,920, MULTIPLE CLASS, INT. CLS. 41 AND 44.
- PROMO INK, NEW YORK, NY:  
3,235,094, INT. CL. 35.  
3,235,157, INT. CL. 35.  
3,235,158, INT. CL. 41.
- PROPACK DATA GMBH, 76131 KARLSRUHE, FED REP  
GERMANY:  
3,233,789, INT. CL. 9.
- PROPPER MANUFACTURING COMPANY, INC., LONG  
ISLAND CITY, NY:  
639,416. REN. 3-21-07. U.S. CL. 44 (INT. CL. 10).
- PROQUEST INFORMATION AND LEARNING COMPANY,  
ANN ARBOR, MI:  
3,232,260, PUB. 2-6-2007. INT. CL. 41.
- PROSPERITY TIEH ENTERPRISE CO., LTD., KAO-HSIUNG  
HSIEN, TAIWAN:  
1,979,612, CANC. INT. CL. 6.
- PROTECTIVE COATING COMPANY, ALLENTOWN, PA:  
3,233,916, INT. CL. 2.
- PROVACON INC., RESERVE, LA:  
2,358,327, CANC. INT. CL. 6.
- PROVANT, INC., BOSTON, MA:  
2,358,261, CANC. INT. CL. 16.  
2,358,262, CANC. INT. CL. 41.
- PROVINE, CLARENCE T. AND PROVINCE, VICKI L.,  
BERRIEN SPRINGS, MI, DBA PROVINCE STUDIO AND  
PROVINCE, VICKI L., BERRIEN SPRINGS, MI, DBA  
PROVINCE STUDIO:  
2,036,609. REN. 3-22-07. INT. CL. 16.

- PRYM CONSUMER USA INC., SPARTANBURG, SC:  
2,114,424, REN. 3-19-07. INT. CL. 20.  
2,122,054, REN. 3-19-07. INT. CL. 20.
- PTAH INCORPORATED, SAN DIEGO, CA:  
2,358,252, CANC. MULTIPLE CLASS, INT. CLS. 36 AND 37.  
2,358,253, CANC. MULTIPLE CLASS, INT. CLS. 36 AND 37.
- PUBLIC BROADCASTING SERVICE, ALEXANDRIA, VA:  
2,356,468, CANC. INT. CL. 41.
- PUBLIC PRIORITY SYSTEMS, INC., WESTERVILLE, OH,  
PUBLIC PRIORITY SYSTEMS, WEST MILTON, OH:  
1,429,636, REN. 3-21-07. INT. CL. 42.
- PUBLIC SERVICE COMPANY OF NEW MEXICO, ALBUQUERQUE, NM:  
2,357,930, CANC. MULTIPLE CLASS, INT. CLS. 35, 36, 38, 39, 41 AND 42.
- PUBLIX ASSET MANAGEMENT COMPANY, LAKELAND, FL,  
PUBLIX SUPER MARKETS, INC., LAKELAND, FL:  
2,052,471, REN. 3-22-07. INT. CL. 30.
- PULSAFEEDER, INC., ROCHESTER, NY:  
3,235,015, INT. CL. 9.
- PULSE DIRECT, INC., LOCKPORT, IL:  
2,356,568, CANC. INT. CL. 35.
- PULSE-LINK, INC., CARLSBAD, CA:  
3,234,644, INT. CL. 9.
- PURCELL, SHERRI M., PHILADELPHIA, PA:  
3,232,249, PUB. 2-6-2007. INT. CL. 41.
- PURDUE PHARMA L.P., STAMFORD, CT:  
2,044,362, REN. 3-20-07. INT. CL. 5.
- PURDUE PRODUCTS L.P., STAMFORD, CT:  
2,038,989, REN. 3-20-07. INT. CL. 5.  
3,234,619, INT. CL. 16.
- PURE POWER! INCORPORATED, HUNTINGTON BEACH, CA:  
3,234,692, INT. CL. 4.
- PUREBRED COMPANY, INC., AURORA, CO:  
1,425,035, REN. 3-19-07. INT. CL. 31.
- PURINA MILLS, LLC, ST. LOUIS, MO, PURINA MILLS, INC., ST. LOUIS, MO:  
2,041,367, REN. 3-22-07. INT. CL. 31.
- PURNIA MILLS, LLC, ST. LOUIS, MO, PURINA MILLS, INC., ST. LOUIS, MO:  
2,051,477, REN. 3-16-07. INT. CL. 31.
- PURPLE WINE COMPANY LLC, GRATON, CA:  
3,234,905, INT. CL. 33.
- PURSELL INDUSTRIES, INC., SYLACAUGA, AL:  
2,357,977, CANC. INT. CL. 16.
- PUSH BUTTON MEMORIES, LLC, MINNEAPOLIS, MN:  
3,232,451, PUB. 2-6-2007. INT. CL. 16.
- PUTTING ZONE GLOW GOLF ARENA, LLC, GLENWOOD, MD:  
3,235,297, INT. CL. 41.  
3,235,298, INT. CL. 41.  
3,235,299, INT. CL. 41.
- PWE PRODUCTIONS, LLC, SANTA CLARITA, CA:  
3,232,111, PUB. 2-6-2007. INT. CL. 41.
- PYRO STUDIOS, S.L., 28036 MADRID, SPAIN:  
3,232,060, PUB. 10-24-2006. MULTIPLE CLASS, INT. CLS. 6, 9, 14, 16, 18, 25, 28, 34, 41 AND 42.
- PYROBAN GROUP LIMITED, SUSSEX BN43 6QG, UNITED KINGDOM:  
3,232,388, PUB. 8-22-2006. INT. CL. 7.
- PYXIS MOBILE, INC., WALTHAM, MA:  
3,232,357, PUB. 2-6-2007. INT. CL. 9.
- P38 MEDIA LLC, DENVER, CO:  
3,234,584, INT. CL. 33.
- Q LOGISTIC SOLUTIONS, INC., ATLANTA, GA:  
2,356,824, CANC. INT. CL. 39.
- Q&X LTD., UNITED KINGDOM:  
3,233,729, PUB. 2-6-2007. INT. CL. 25.
- QC PROPERTIES COMPANY, LLC, CHICAGO, IL:  
3,233,928, INT. CL. 30.
- QIAN, SONG, LA VERNE, CA:  
3,233,088, PUB. 2-6-2007. INT. CL. 11.
- QTRCO, INC., TOMBALL, TX:  
2,357,377, CANC. INT. CL. 7.  
2,357,378, CANC. INT. CL. 7.
- QUADION CORPORATION, MINNEAPOLIS, MN:  
1,396,463, CANC. INT. CL. 7.
- QUAKER OATS COMPANY, THE, CHICAGO, IL:  
2,357,732, CANC. INT. CL. 30.
- QUALITY CUBE, LLC, APOPKA, FL:  
3,233,468, PUB. 2-6-2007. INT. CL. 9.
- QUALITY PACIFIC MANUFACTURING, INC., NOVATO, CA:  
2,356,867, CANC. INT. CL. 20.
- QUATECH, INC., AKRON, OH:  
2,358,806, CANC. INT. CL. 9.
- QUEST ENGINEERING CONSULTANTS INC., TROY, MI:  
3,233,223, PUB. 2-6-2007. INT. CL. 35.
- QUESTEX MEDIA GROUP, INC., NEWTON, MA:  
3,234,436, INT. CL. 16.
- QUICKIE MANUFACTURING CORPORATION, CINNAMINSON, NJ:  
3,234,387, INT. CL. 21.
- QUICKSOFT, INC., SEATTLE, WA:  
1,396,553, CANC. INT. CL. 9.
- QUIKEY MANUFACTURING CO., INC., AKRON, OH:  
3,234,062, INT. CL. 20.
- QUIKRETE INTERNATIONAL, INC., ATLANTA, GA:  
1,413,389, CANC. INT. CL. 19.
- QUINCE MEDIA, LLC, VAN ALSTYNE, TX:  
3,235,131, INT. CL. 16.
- QUOTEPRO, INC., CHICAGO, IL:  
2,111,653, REN. 3-21-07. INT. CL. 9.
- R. H. PETERSON CO., CITY OF INDUSTRY, CA:  
1,423,547, REN. 3-16-07. INT. CL. 4.
- R.M. WADE & CO., PORTLAND, OR:  
3,234,701, INT. CL. 7.
- R.V.I. GUARANTY CO., LTD., PEBROKE HM8, BERMUDA:  
2,029,687, REN. 3-17-07. INT. CL. 35.
- R-DENTAL DENTALERZEUGNISSE GMBH, 22085 HAMBURG, FED REP GERMANY:  
3,232,582, PUB. 2-6-2007. INT. CL. 5.
- R/D TECH INSTRUMENTS INC., WALTHAM, MA:  
3,234,473, INT. CL. 9.
- R'CLUB CHILD CARE, INC, ST PETERSBURG, FL:  
3,232,083, PUB. 6-22-2004. MULTIPLE CLASS, INT. CLS. 41 AND 43.
- RABBIT ISLAND, INC., EUFAULA, AL:  
2,358,637, CANC. INT. CL. 32.
- RACKSPACE, LTD., SAN ANTONIO, TX:  
3,232,710, PUB. 10-31-2006. MULTIPLE CLASS, INT. CLS. 35 AND 38.
- RADIANT AVIATION SERVICES, INC., NIAGARA FALLS, NY:  
2,036,140, REN. 3-21-07. INT. CL. 37.
- RADIANT SOFTWARE, INC., CLEARWATER, FL:  
3,232,208, PUB. 2-6-2007. INT. CL. 9.
- RADICA GAMES LTD., HAMILTON, BERMUDA:  
3,234,206, INT. CL. 9.
- RADIO FREQUENCY SYSTEMS INC, MERIDEN, CT:  
2,038,890, REN. 3-22-07. INT. CL. 9.
- RADIO ITALIA S.P.A., ITALY:  
3,233,674, PUB. 1-23-2007. MULTIPLE CLASS, INT. CLS. 38 AND 41.
- RADIO LAZLOW, INC., LONG BEACH, NY:  
3,232,553, PUB. 2-6-2007. INT. CL. 41.
- RADIO TRAINING NETWORK, INC., GREENVILLE, SC:  
3,232,406, PUB. 2-6-2007. INT. CL. 38.
- RAFATI, HAROON, SAN ANTONIO, TX:  
3,235,284, INT. CL. 28.
- RAIL UNLIMITED, INC., OKLAHOMA CITY, OK:  
2,041,784, REN. 3-16-07. INT. CL. 39.
- RAINBOW PLAY SYSTEMS, INC., PRIOR LAKE, MN:  
1,980,156, CANC. INT. CL. 28.
- RALF HÜTTER, FED REP GERMANY AND FLORIAN SCHNEIDER, FED REP GERMANY:  
3,233,744, PUB. 2-6-2007. MULTIPLE CLASS, INT. CLS. 9, 18 AND 41.
- RALINK TECHNOLOGY CORPORATION, CUPERTINO, CA:  
3,234,702, INT. CL. 9.
- RALPH H. DOUGHERTY, P.A., CHARLOTTE, NC:  
2,356,805, CANC. INT. CL. 42.

RALPH R. BERGGREN, SANTA FE, NM:  
3,235,109, INT. CL. 42.

RALSTON PURINA COMPANY, ST. LOUIS, MO:  
2,358,220, CANC. INT. CL. 16.

RAMLINE MOBILE COMPUTERS, INC., HOFFMAN ESTATES, IL:  
2,357,146, CANC. INT. CL. 9.

RANA, SHRISHAIL, JAIPUR, INDIA:  
3,232,565, PUB. 2-6-2007. INT. CL. 9.

RANDOM HOUSE, INC., NEW YORK, NY, WESTERN PUBLISHING COMPANY, INC., RACINE, WI:  
1,060,755. REN. 3-16-07. INT. CL. 16.

RANDOM HOUSE, INC., NEW YORK, NY, SCHOCKEN BOOKS, INC., NEW YORK, NY:  
2,068,770. REN. 3-16-07. INT. CL. 16.

RANGE SYSTEMS BY RENEW RESOURCES, INC., NEW HOPE, MN:  
3,234,762, INT. CL. 41.

RAPID GRANULATOR AKTIEBOLAG, S-330 10 BREDARYD, SWEDEN:  
1,007,801, AM. INT. CL. 7.

RAPID LEGAL, MONTEREY PARK, CA:  
3,233,241, PUB. 2-6-2007. INT. CL. 42.  
3,233,341, PUB. 2-6-2007. INT. CL. 42.

RAPIGENE, INC., BOTHELL, WA:  
2,358,279, CANC. INT. CL. 42.

RARITAN ENGINEERING COMPANY, INC., MILLVILLE, NJ:  
3,234,871, INT. CL. 11.

RARITY, INC., NEW YORK, NY:  
3,234,580, INT. CL. 24.

RASCOR SPEZIALBAU GMBH, FED REP GERMANY:  
3,233,541, PUB. 2-6-2007. MULTIPLE CLASS, INT. CLS. 1, 7, 17, 19, 37 AND 42.

RASHMAN CORPORATION, NORTHRIDGE, CA, PRES-TIGE MEDICAL CORPORATION, NORTHRIDGE, CA:  
2,058,412. REN. 3-21-07. INT. CL. 10.

RAUTARUUKKI OYJ, FINLAND:  
3,233,646, PUB. 2-6-2007. INT. CL. 6.

RAVAN, REBECCA HEKMAT, BEVERLY HILLS, CA:  
3,235,196, INT. CL. 25.

RAVEN PUBLICATIONS, INC., COSTA MESA, CA:  
2,356,924, CANC. INT. CL. 16.  
2,356,925, CANC. INT. CL. 16.

RAYMOND JAMES BANK, FSD, ST. PETERSBURG, FL:  
2,358,038, CANC. INT. CL. 36.

RAYMOND JAMES FINANCIAL, INC., ST. PETERSBURG, FL:  
3,233,767, MULTIPLE CLASS, INT. CLS. 9, 16 AND 25.

RAYONIER TRS HOLDINGS INC., JACKSONVILLE, FL, RAYONIER INCORPORATED, NEW YORK, NY:  
640,512. REN. 3-21-07. U.S. CL. 1 (INT. CL. 1).

READER'S DIGEST ASSOCIATION, INC., THE, PLEASANTVILLE, NY:  
2,358,698, CANC. INT. CL. 16.

REAL ESTATE AUTOMATION, INC., IRVING, TX:  
2,358,925, CANC. INT. CL. 36.

REAL ESTATE BANKERS, INC, BOCA RATON, FL:  
2,358,843, CANC. INT. CL. 35.

REALESTATEANDLOAN.COM, INC., DOWNEY, CA:  
3,235,442, INT. CL. 36.

REALSOFTWARE SOLUTIONS, LLC, BRADENTON, FL:  
3,235,328, INT. CL. 9.

REALTY EXECUTIVES INTERNATIONAL, INC., PHOENIX, AZ:  
2,586,635, COR. INT. CL. 35.

REBATH LLC, MESA, AZ, AMERICAN BATHTUB LINERS, INC., MESA, AZ:  
1,876,486. REN. 3-20-07. INT. CL. 11.

RECORDS DEPOSITION SERVICE INCORPORATED, SOUTHFIELD, MI:  
2,111,785. REN. 3-21-07. MULTIPLE CLASS, INT. CLS. 35 AND 42.  
2,117,464. REN. 3-21-07. MULTIPLE CLASS, INT. CLS. 35 AND 42.

RECORE SYSTEMS B.V., ENSCHEDE, NETHERLANDS:  
3,232,825, PUB. 2-6-2007. INT. CL. 9.

RECTOR, STEPHANIE, PHOENIX, AZ:  
3,232,892, PUB. 2-6-2007. INT. CL. 25.

RED BULL GMBH, AUSTRIA:  
3,233,533, PUB. 6-27-2006. INT. CL. 32.

RED CHAMBER CO., VERNON, CA:  
3,233,103, PUB. 2-6-2007. INT. CL. 29.

RED WING SHOE COMPANY, INC., RED WING, MN:  
2,356,494, CANC. INT. CL. 25.

RED X HOLDINGS, LLC, RENO, NV:  
3,232,120, PUB. 2-6-2007. MULTIPLE CLASS, INT. CLS. 35 AND 41.

RED-BAN COMMUNICATIONS, LLC, SANDY, UT:  
3,234,053, MULTIPLE CLASS, INT. CLS. 9 AND 38.

REDCATS USA, L.P., INDIANAPOLIS, IN:  
3,234,264, INT. CL. 25.

REDDY ICE CORPORATION, DALLAS, TX:  
3,234,275, INT. CL. 30.  
3,234,276, INT. CL. 30.

REDIKER, TIM, LAS VEGAS, NV:  
3,234,557, INT. CL. 25.

REDLANDS FOOTHILL GROVES, REDLANDS, CA:  
348,517. REN. 3-19-07. U.S. CL. 46 (INT. CL. 31).

REDPEG MARKETING, INC., ALEXANDRIA, VA:  
3,234,665, INT. CL. 35.

REEBOK INTERNATIONAL LIMITED, LANCASTER LA1 1GF, UNITED KINGDOM:  
3,234,100, MULTIPLE CLASS, INT. CLS. 9, 18, 28, 35 AND 36.

REED TELEPUBLISHING LIMITED, DUNSTABLE, BEDS, LUS 4HB, ENGLAND:  
1,396,745, CANC. INT. CL. 16.

REES-ROHRBACHER, DARHON E, ALBANY, NY, DBA DRAGONFLOWER:  
2,514,642, CANC. INT. CL. 25.

REEVES INTERNATIONAL, INC., PEQUANNOCK, NJ:  
1,980,255, CANC. INT. CL. 28.

REEVES, BRIAN, LADERA RANCH, CA:  
3,232,642, PUB. 2-6-2007. INT. CL. 24.

REFRACTION TECHNOLOGY, INC., DALLAS, TX:  
1,396,590, CANC. INT. CL. 9.

REGAL MARINE INDUSTRIES, INC., ORLANDO, FL:  
3,234,751, INT. CL. 12.

REGENT ASSET MANAGEMENT GROUP, LLC, SACRAMENTO, CA:  
3,233,008, PUB. 2-6-2007. INT. CL. 37.

REGIONAL MARKETING GROUP, INC., LUTZ, FL:  
2,358,646, CANC. INT. CL. 35.

REGIS INTERNATIONAL FRANCHISING S.A.R.L., LUXEMBOURG, LUXEMBOURG:  
3,234,650, INT. CL. 44.

REHAB TRAINING NETWORK, INC., PITTSBURGH, PA:  
2,358,855, CANC. INT. CL. 16.

REID, JOHN A., RINGOES, NJ:  
2,356,828, CANC. INT. CL. 11.

REIDENBACH, BRYAN L., MILLERSBURG, OH:  
3,178,934, COR. INT. CL. 16.

REILLY, STEVEN, MILL VALLEY, CA, DBA RED'S JAVA HOUSE:  
2,035,253. REN. 3-22-07. MULTIPLE CLASS, INT. CLS. 30 AND 42.

REIMAN MEDIA GROUP, INC., GREENDALE, WI:  
3,234,942, INT. CL. 35.

RELIABILITY MAGAZINE, LLC, KNOXVILLE, TN:  
3,232,470, PUB. 2-6-2007. INT. CL. 16.

REMA FOODS, INC., ENGLEWOOD CLIFFS, NJ:  
3,235,350, INT. CL. 29.

REMEL, INC., LENEXA, KS, WARNER-LAMBERT PHARMACEUTICAL COMPANY, MORRIS PLAINS, NJ:  
819,701. REN. 3-21-07. U.S. CL. 6 (INT. CL. 1).

RENEC, INC., YARMOUTH, ME:  
1,979,932, CANC. INT. CL. 25.

RENT COM, INC., SCHILLER PARK, IL:  
2,078,483. REN. 3-22-07. MULTIPLE CLASS, INT. CLS. 35 AND 41.

REPPIES ENTERTAINMENT INVESTORS, L.L.C., ATLANTA, GA:  
2,357,863, CANC. MULTIPLE CLASS, INT. CLS. 9, 16, 25, 28 AND 41.

- RESEARCH & DIAGNOSTIC ANTIBODIES, RICHMOND, CA:  
2,358,750, CANC. INT. CL. 1.
- RESEARCH ENGINEERING & MANUFACTURING INC., MIDDLETOWN, RI:  
2,037,570, REN. 3-22-07. INT. CL. 6.
- RESEARCH TRIANGLE SOFTWARE, INC., CARY, NC:  
3,235,300, INT. CL. 9.
- RESMED LIMITED, BELLA VISTA, NSW, AUSTRALIA:  
3,233,011, PUB. 2-6-2007. INT. CL. 10.
- RESOURCE CORPORATION OF AMERICA & RECOVERY OF TEXAS, INC., CLEAR LAKE SHORES, TX:  
3,233,065, PUB. 2-6-2007. INT. CL. 35.
- RESPECT, INC., SAN FRANCISCO, CA:  
2,357,539, CANC. INT. CL. 3.
- RESTAURANT BRODARD, INC., GARDEN GROVE, CA:  
3,233,825, INT. CL. 29.
- RESTEK CORPORATION, BELLEFONTE, PA:  
3,235,075, INT. CL. 9.
- RESTORATION HARDWARE, CORTE MADERA, CA:  
2,048,579, REN. 3-22-07. INT. CL. 42.
- RESTORE INC., FORT LAUDERDALE, FL:  
1,397,231, CANC. INT. CL. 4.
- RESTORGANIZE, LLC., HOUSTON, TX:  
3,232,202, PUB. 2-6-2007. INT. CL. 39.
- RESUMIX, INC., SUNNYVALE, CA:  
1,980,063, CANC. INT. CL. 9.
- RETAIL BRAND ALLIANCE, INC., ENFIELD, CT, JULIUS GARFINCKEL & CO., INCORPORATED, WASHINGTON, DC:  
840,920, REN. 3-17-07. U.S. CL. 39 (INT. CL. 25).
- REUBEN, CATHERINE E., SOMERVILLE, MA:  
2,105,015, REN. 3-17-07. INT. CL. 41.
- REVA SYSTEMS CORPORATION, CHELMSFORD, MA:  
3,234,051, INT. CL. 9.
- REVLON CONSUMER PRODUCTS CORPORATION, NEW YORK, NY:  
1,427,105, REN. 3-22-07. INT. CL. 3.  
3,235,384, INT. CL. 3.
- REYNOLDS, R. BRENT, SPRINGFIELD, VA, DBA MAD BOMBER:  
1,424,002, REN. 3-17-07. INT. CL. 25.
- RGM PRODUCTS, INC., FRESNO, CA:  
3,234,049, INT. CL. 19.
- RHE HATCO, INC., GARLAND, TX, HAT CORPORATION OF AMERICA, NEW YORK, NY:  
832,240, REN. 3-16-07. U.S. CL. 39 (INT. CL. 25).
- RHE HATCO, INC., GARLAND, TX, HAT BRANDS, INC., GARLAND, TX:  
2,109,438, REN. 3-20-07. MULTIPLE CLASS, INT. CLS. 25 AND 26.
- RHEIN CHEMIE CORPORATION, CHARDON, OH, ELAS-TOCHEM, INC., CHARDON, OH:  
2,034,997, REN. 3-22-07. INT. CL. 1.
- RHEODYNE, LLC, ROHNERT PARK, CA:  
2,004,915, REN. 3-17-07. INT. CL. 17.
- RHINO INTERNATIONAL CORP., WOODBRIDGE, ONTARIO, CANADA:  
2,358,162, CANC. INT. CL. 19.
- RHODE ISLAND TEXTILE COMPANY, PAWTUCKET, RI:  
3,232,668, PUB. 2-6-2007. INT. CL. 18.
- RICHARD C. HALPERN AND KRICKETT JONES HALPERN PARTNERSHIP, THE, ENCINO, CA:  
3,234,753, INT. CL. 25.
- RICHARD LEEDS INTERNATIONAL, INC., NEW YORK, NY:  
3,234,380, INT. CL. 25.
- RICHARD SCIENTIFIC, NOVATO, CA:  
2,358,400, CANC. INT. CL. 1.
- RICHARDSON, LINDA, LIVERMORE, CA:  
2,357,369, CANC. INT. CL. 28.
- RICHEMONT INTERNATIONAL SA, VILLARS-SUR-GLANE, SWITZERLAND, DAVID G. STEVEN, INC., NEW YORK, NY:  
1,428,302, REN. 3-22-07. INT. CL. 14.
- RIDDELL & ASSOCIATES, INC., JACKSONVILLE, FL:  
3,233,361, PUB. 2-6-2007. INT. CL. 5.
- RIFOCS CORPORATION, CAMARILLO, CA:  
2,358,514, CANC. INT. CL. 16.
- RIO GRANDE FOOD PRODUCTS, INC., BELTSVILLE, MD:  
3,232,566, PUB. 2-6-2007. INT. CL. 32.
- RISK MANAGEMENT SOLUTIONS, INC., NEWARK, CA:  
2,040,427, REN. 3-22-07. INT. CL. 9.
- RIT TECHNOLOGIES, LTD., TEL AVIV, ISRAEL:  
3,232,726, PUB. 2-6-2007. INT. CL. 9.
- RITE-HITE CORPORATION, MILWAUKEE, WI:  
1,440,448, REN. 3-22-07. INT. CL. 7.
- RITTAL GMBH & CO. KG, 35745 HERBORN, FED REP GERMANY:  
3,233,642, PUB. 2-6-2007. MULTIPLE CLASS, INT. CLS. 6, 9, 11 AND 20.
- RIVERCITY SOFTWARE SOLUTIONS, L.L.C., ST. LOUIS, MO:  
3,234,457, INT. CL. 42.
- RMSG LLC, PRINCETON, NJ:  
3,234,246, INT. CL. 35.  
3,234,247, INT. CL. 35.  
3,234,248, INT. CL. 35.  
3,234,249, INT. CL. 35.  
3,234,250, INT. CL. 35.  
3,234,251, INT. CL. 35.  
3,234,252, INT. CL. 35.  
3,235,031, INT. CL. 35.  
3,235,032, INT. CL. 35.  
3,235,033, INT. CL. 35.  
3,235,034, INT. CL. 35.  
3,235,035, INT. CL. 35.  
3,235,036, INT. CL. 35.  
3,235,037, INT. CL. 35.  
3,235,038, INT. CL. 35.
- ROAD RESCUE INCORPORATED, SAN MATEO, CA:  
2,358,029, CANC. INT. CL. 37.
- ROB-GOF, LLC, LOUISVILLE, KY:  
1,996,708, REN. 3-21-07. INT. CL. 37.
- ROBERT MAYER CORPORATION, THE, NEWPORT BEACH, CA:  
2,358,764, CANC. MULTIPLE CLASS, INT. CLS. 35 AND 42.
- ROBERTS, ELIOT, CHATSWORTH, CA:  
3,232,573, PUB. 2-6-2007. INT. CL. 25.
- ROBINSON & ROBINSON INC., SAN DIEGO, CA:  
3,234,130, INT. CL. 20.
- ROBINSON, JACKIE, MORENO VALLEY, CA:  
2,279,651, CANC. INT. CL. 25.
- ROBITAILLE, LUC, LOS ANGELES, CA:  
3,233,334, PUB. 2-6-2007. INT. CL. 28.
- ROBOCAST INC., NEW YORK, NY:  
2,358,749, CANC. MULTIPLE CLASS, INT. CLS. 35 AND 42.
- ROBROY INDUSTRIES, INC., VERONA, PA:  
3,233,134, PUB. 2-6-2007. INT. CL. 9.
- ROCAWEAR LICENSING LLC, NEW YORK, NY:  
3,233,986, INT. CL. 12.
- ROCES - S.R.L., MONTEBELLUNA (TREVISO), ITALY, CALZATURIFICIO ROCES S.N.C. DI CAVASIN OTTORINO & FIGLI, TREVISO, ITALY:  
1,063,387, REN. 3-19-07. INT. CL. 25.
- ROCHE THERAPEUTICS INC., NUTLEY, NJ:  
3,234,766, INT. CL. 44.
- ROCK 'N' ROLL MARATHON, INC., SAN DIEGO, CA:  
2,131,333, REN. 3-19-07. INT. CL. 41.
- ROCK RIVER ARMS, INC., COLONA, IL:  
3,232,814, PUB. 2-6-2007. INT. CL. 13.
- ROCKET GAMING SYSTEMS, LLC, LAS VEGAS, NV:  
3,234,984, INT. CL. 9.  
3,234,985, INT. CL. 9.  
3,234,986, INT. CL. 9.  
3,235,116, INT. CL. 9.  
3,235,117, INT. CL. 9.
- ROCKET RESEARCH, SAN DIEGO, CA:  
2,357,026, CANC. INT. CL. 25.
- ROCKET USA, INC, FOREST PARK, IL:  
3,232,386, PUB. 2-6-2007. INT. CL. 28.
- ROCKING HORSE STABLES, LLC, OXFORD, MS:  
3,234,465, INT. CL. 41.

RODAN & FIELDS INC., NEW YORK, NY:  
 3,234,397, MULTIPLE CLASS, INT. CLS. 3 AND 5.  
 RODGERS, JODY, STRATHAM, NH:  
 3,233,457, PUB. 2-6-2007. INT. CL. 31.  
 RODMAN, MICHAEL W., BELMONT, CA:  
 1,397,217, CANC. INT. CL. 42.  
 ROETMAN, BARBARA, LAKE PLACID, NY AND ROET-  
 MAN, EDWARD, LAKE PLACID, NY:  
 3,233,158, PUB. 2-6-2007. INT. CL. 25.  
 ROGERS, DEBORAH M., PARKMAN, OH:  
 3,232,494, PUB. 2-6-2007. INT. CL. 19.  
 ROHM AND HAAS COMPANY, PHILADELPHIA, PA:  
 1,424,483, REN. 3-19-07. INT. CL. 1.  
 3,234,155, INT. CL. 11.  
 ROHRMOSER, ALOIS, SALZBURG, AUSTRIA, DBA SKI-  
 FABRIK ALOIS ROHRMOSER:  
 1,396,913, CANC. INT. CL. 28.  
 ROLLAX GMBH & CO. KG, 33607 BIELEFELD, FED REP  
 GERMANY:  
 3,233,551, PUB. 2-6-2007. INT. CL. 10.  
 ROLO DEVELOPMENT, LLC, SCOTTSDALE, AZ:  
 3,232,887, PUB. 2-6-2007. INT. CL. 35.  
 ROMAN SANDAL, INC., THE, PASSAIC, NJ:  
 2,357,811, CANC. INT. CL. 25.  
 ROMPF, CAROL L., LEXINGTON, KY, DBA CAPTURED  
 MOMENTS PHOTOGRAPHY:  
 1,424,655, REN. 3-20-07. INT. CL. 16.  
 RONALD A. FRAGEN M.D., A MEDICAL CORPORATION,  
 PALM SPRINGS, CA:  
 3,232,794, PUB. 12-5-2006. INT. CL. 44.  
 RONIN, LLC, LAKE MILLS, WI:  
 3,235,102, INT. CL. 32.  
 3,235,103, INT. CL. 32.  
 RONK ELECTRICAL INDUSTRIES, INC., NOKOMIS, IL:  
 1,442,852, REN. 3-16-07. INT. CL. 9.  
 ROOF EXPRESS, LLC, CENTENNIAL, CO:  
 3,235,092, INT. CL. 42.  
 ROOSTER PRODUCTS INTERNATIONAL, INC., SAN AN-  
 TONIO, TX:  
 3,232,315, PUB. 2-6-2007. INT. CL. 18.  
 ROOT WHOLE BODY HEALTH, INC., PORTLAND, OR:  
 3,235,066, INT. CL. 41.  
 ROOTBLAST INTERNATIONAL, INC., CANTON, OH,  
 FRESH START MARKETING, MASSILLON, OH:  
 2,052,717, REN. 3-22-07. INT. CL. 1.  
 ROOTS CANADA LTD., TORONTO, ONTARIO, CANADA:  
 3,233,776, INT. CL. 3.  
 3,233,777, INT. CL. 3.  
 ROPAK CORPORATION, FOUNTAIN VALLEY, CA:  
 3,234,094, INT. CL. 20.  
 ROPPE CORPORATION, FOSTORIA, OH:  
 3,232,865, PUB. 2-6-2007. INT. CL. 19.  
 ROSE CREEK FARMS, INC., CHEYENNE, WY:  
 3,232,511, PUB. 2-6-2007. INT. CL. 35.  
 ROSE, ALYCIA M., LOS ANGELES, CA:  
 2,358,168, CANC. INT. CL. 9.  
 ROSEANNE GULLO, PLANO, TX:  
 3,234,595, INT. CL. 30.  
 ROSELON INDUSTRIES, INC., QUAKERTOWN, PA:  
 2,116,458, REN. 3-22-07. INT. CL. 23.  
 ROSENMUND, INC., NORTH CAROLINA, NC:  
 2,357,820, CANC. MULTIPLE CLASS, INT. CLS. 7 AND  
 11.  
 ROSES FOREVER APS, DK-5600 FAABORG, DENMARK:  
 3,234,747, INT. CL. 31.  
 ROSEVINE ENTERPRISES, LLC, MARIETTA, GA:  
 3,234,392, INT. CL. 33.  
 ROSIVARA, S.L., ELCHE (ALICANTE), SPAIN:  
 3,235,023, INT. CL. 25.  
 ROSSIGNOL SKI COMPANY, INC., PARK CITY, UT:  
 3,234,022, MULTIPLE CLASS, INT. CLS. 9, 18, 25 AND 28.  
 ROSY BLUE, N.V., 2018 ANTWERP, BELGIUM:  
 3,234,220, INT. CL. 14.  
 ROTEX, INC., CINCINNATI, OH:  
 1,426,425, REN. 3-17-07. INT. CL. 9.  
 ROTH, CHRISTIAN, MONACO, MONACO:  
 3,233,220, PUB. 2-6-2007. INT. CL. 9.  
 ROUX LABORATORIES, INC., JACKSONVILLE, FL, RE-  
 VLON CONSUMER PRODUCTS CORPORATION, NEW  
 YORK, NY:  
 2,029,284, REN. 3-19-07. INT. CL. 3.  
 ROVCAL, INC., MADISON, WI:  
 1,396,535, CANC. INT. CL. 9.  
 2,357,143, CANC. INT. CL. 8.  
 ROYAL PERSONNEL SERVICES, INC., SCOTTSDALE, AZ:  
 2,123,789, REN. 3-16-07. INT. CL. 35.  
 ROYAL PRECISION, INC., TORRINGTON, CT:  
 2,358,366, CANC. INT. CL. 28.  
 ROYAL-PEDIC MATTRESS MANUFACTURING, LLC, BEV-  
 ERLY HILLS, CA:  
 3,234,422, INT. CL. 20.  
 ROYCE, STANTON, ALBUQUERQUE, NM:  
 2,357,252, CANC. MULTIPLE CLASS, INT. CLS. 35 AND  
 41.  
 RPOST INTERNATIONAL LIMITED, HAMILTON, BERMU-  
 DA:  
 3,234,159, INT. CL. 38.  
 RSA DATA SECURITY, INC., SAN MATEO, CA:  
 2,356,660, CANC. INT. CL. 9.  
 2,357,275, CANC. INT. CL. 9.  
 RSH PROTECTION, INC., MOORESVILLE, NC:  
 3,232,783, PUB. 2-6-2007. INT. CL. 9.  
 RUAN LOGISTICS CORPORATION, DES MOINES, IA:  
 1,397,154, CANC. INT. CL. 39.  
 RUDOLF WILD OF AMERICA, INC., SALT LAKE CITY, UT:  
 2,358,928, CANC. INT. CL. 32.  
 RUNCO, L.L.C., UNION CITY, CA, PROJECTAVISION, INC.,  
 NEW YORK, NY:  
 2,035,876, REN. 3-16-07. INT. CL. 9.  
 RUNNING GAMES AS, N-1256 OSLO, NORWAY, NORWAY:  
 3,233,723, PUB. 2-6-2007. MULTIPLE CLASS, INT. CLS. 9  
 AND 41.  
 RUNNINGSKOOL, LLC, SAN DIEGO, CA:  
 2,358,869, CANC. MULTIPLE CLASS, INT. CLS. 9 AND  
 41.  
 RUSSELL CORPORATION, ATLANTA, GA, A&C INTER-  
 NATIONAL, INC., VIDALIA, GA:  
 2,001,576, REN. 3-21-07. INT. CL. 25.  
 RUSSELL CORPORATION, ATLANTA, GA:  
 3,234,839, INT. CL. 28.  
 RUSSELL ENTERPRISES, INC., MILFORD, CT:  
 3,235,172, MULTIPLE CLASS, INT. CLS. 35 AND 41.  
 RUSSELL-NEWMAN, LTD., DENTON, TX:  
 3,233,478, PUB. 2-6-2007. INT. CL. 25.  
 RUX, R. DAVID, LITTLETON, CO:  
 3,235,377, INT. CL. 12.  
 RXCROSSROADS, LLC, LOUISVILLE, KY:  
 3,232,071, PUB. 2-6-2007. INT. CL. 35.  
 RYAN SEACREST PRODUCTIONS, INC., LOS ANGELES,  
 CA:  
 3,234,453, INT. CL. 25.  
 RYDER, TRACEY, OJAI, CA AND TOPALIAN, CAROLE,  
 OJAI, CA:  
 3,234,727, INT. CL. 16.  
 RYLEN, INC., BURBANK, CA:  
 3,232,569, PUB. 2-6-2007. INT. CL. 25.  
 RÖHM GMBH & CO. KG, FED REP GERMANY:  
 3,233,699, PUB. 2-6-2007. INT. CL. 35.  
 S & J ADVERTISING, INC., VACAVILLE, CA:  
 3,233,395, PUB. 2-6-2007. INT. CL. 16.  
 S. C. JOHNSON & SON, INC., RACINE, WI:  
 1,396,374, CANC. INT. CL. 3.  
 S.A. SOCIETE NOUVELLE DES FAIENCERIES DE QUIM-  
 PER, CEDEX, FRANCE:  
 2,356,522, CANC. INT. CL. 21.  
 S.D.R. BIOTEC; VERFAHRENSTECHNIK GMBH, FED REP  
 GERMANY:  
 3,233,637, PUB. 2-6-2007. MULTIPLE CLASS, INT. CLS. 21  
 AND 23.  
 S.E. INTERNATIONAL, INC., SUMMERTOWN, TN:  
 1,455,038, REN. 3-20-07. INT. CL. 9.  
 S.M. TENIMENTI PILE E LAMOLE E VISTARENNI S.R.L.,  
 SIENA, ITALY:  
 1,979,193, CANC. INT. CL. 33.

- S.T. EAST 43RD ST. CORP., NEW YORK, NY:  
1,979,674, CANC. INT. CL. 42.
- S&G HOLDINGS, INC., NASHVILLE, TN:  
2,358,699, CANC. INT. CL. 41.
- S&K FAMOUS BRANDS, INC., GLEN ALLEN, VA:  
1,979,496, CANC. INT. CL. 25.
- S&M BIKES, INC., SANTA ANA, CA:  
2,356,540, CANC. INT. CL. 12.
- S&S BRANDS, INC., WILMINGTON, DE:  
3,235,476, INT. CL. 31.
- S/G/P SYSTEMS CORPORATION, HERMITAGE, PA:  
1,402,635, REN. 3-21-07. INT. CL. 9.
- SABLE MARCO INC., PONT-ROUGE, QUEBEC, CANADA:  
3,234,304, INT. CL. 19.
- SAC ACQUISITION LLC, STAMFORD, CT:  
3,234,481, INT. CL. 17.
- SACHS COMMUNICATIONS INC., CHAMPLAIN, NY:  
1,396,435, CANC. INT. CL. 6.
- SACK FOUNDATION, YORBA LINDA, CA:  
3,232,804, PUB. 2-6-2007. INT. CL. 35.
- SACKS, LAUREN P., KATY, TX:  
3,233,869, INT. CL. 16.
- SADKA, DEWEY, MARIETTA, GA:  
2,028,565, REN. 3-22-07. INT. CL. 42.
- SADKA, DEWEY, ATLANTA, GA:  
2,036,010, REN. 3-17-07. INT. CL. 41.  
2,036,012, REN. 3-17-07. INT. CL. 35.
- SAF-T-SCREENS, INC., COMFORT, TX:  
3,234,259, INT. CL. 17.
- SAFARI PROGRAMS, INC., MIAMI, FL, DBA SAFARI LIMITED:  
2,358,667, CANC. INT. CL. 28.
- SAFE SONG USA, L.L.C., ROYAL PALM BEACH, FL:  
3,232,235, PUB. 2-6-2007. INT. CL. 35.
- SAFELITE GROUP, INC., COLUMBUS, OH:  
2,357,745, CANC. INT. CL. 37.  
2,357,746, CANC. INT. CL. 37.
- SAFENET CONSULTING, INC., MINNETONKA, MN:  
3,233,078, PUB. 2-6-2007. INT. CL. 38.
- SAFETYWATCH, LLC, PALM HARBOR, FL:  
3,233,205, PUB. 2-6-2007. INT. CL. 45.
- SAFewater ANYWHERE, LLC, DURANGO, CO:  
2,358,838, CANC. INT. CL. 11.
- SAFeway INC., PLEASANTON, CA:  
2,035,085, REN. 3-21-07. MULTIPLE CLASS, INT. CLS. 29 AND 30.  
3,232,053, PUB. 10-31-2006. INT. CL. 30.  
3,232,276, PUB. 2-6-2007. INT. CL. 29.
- SAGA RADIO NETWORKS, LLC, GROSSE POINT FARMS, MI:  
1,441,650, REN. 3-21-07. INT. CL. 41.
- SAGE HOME INSPECTIONS, LLC, LIVERMORE, CA:  
3,235,291, INT. CL. 42.
- SAGEE USA GROUP INC., ROWLAND HTS., CA:  
3,234,072, INT. CL. 30.
- SAGINAW PRODUCTS CORPORATION, SAGINAW, MI:  
1,396,469, CANC. INT. CL. 7.
- SAINT GABRIEL PARTNERS, LLC, SULPHUR, LA:  
3,235,205, INT. CL. 3.
- SAINT JOHN'S UNIVERSITY, COLLEGEVILLE, MN:  
1,979,144, CANC. INT. CL. 41.
- SAINT-GOBAIN PERFORMANCE PLASTICS CORPORATION, AURORA, OH:  
1,042,721, REN. 3-19-07. MULTIPLE CLASS, INT. CLS. 7 AND 24.  
3,234,153, MULTIPLE CLASS, INT. CLS. 10 AND 20.
- SAITEK LTD., KWUN TONG, KOWLOON, HONG KONG:  
2,358,193, CANC. INT. CL. 9.
- SALARTI ENTERPRISES, INC., PUTNAM VALLEY, NY:  
3,233,081, PUB. 2-6-2007. INT. CL. 25.  
3,233,082, PUB. 2-6-2007. MULTIPLE CLASS, INT. CLS. 6, 18 AND 25.
- SALENTEIN ARGENTINA B.V., C1001AAD BUENOS AIRES C.F., ARGENTINA:  
3,232,101, PUB. 2-6-2007. INT. CL. 31.
- SALK, INC., BOSTON, MA, MURRAY SALK, INC., BRIGHTON, MA:  
830,220, REN. 3-16-07. U.S. CL. 39 (INT. CL. 25).
- SALTWATER WILLY'S GRAPEVINE, L.L.C., FLOWER MOUND, TX:  
3,235,307, INT. CL. 43.  
3,235,311, INT. CL. 43.
- SALVATION ARMY, THE, WEST NYACK, NY:  
2,127,314, REN. 3-17-07. INT. CL. 42.
- SALVIATI, DIANORA, 56010 PISA, ITALY:  
2,427,846, CANC. INT. CL. 3.
- SAM HOUSTON HOTEL, L.P., HOUSTON, TX:  
3,234,672, INT. CL. 43.
- SAMARITAN HOSPICE, MARLTON, NJ:  
2,357,784, CANC. INT. CL. 42.
- SAMMY Z INC., BEVERLY HILLS, CA:  
3,235,456, INT. CL. 35.
- SAMSON GOLF CORPORATION:  
1,396,968, CANC. INT. CL. 28.
- SAMSONITE CORPORATION, DENVER, CO:  
3,234,327, INT. CL. 9.
- SAMSUNG ELECTRONICS CO., LTD., KYUNGKI-DO, REPUBLIC OF KOREA:  
3,233,780, INT. CL. 9.
- SAMTEE INTERNATIONAL, INC, NEW YORK, NY:  
2,358,074, CANC. INT. CL. 18.
- SAN FRANCIS IMPORTS, GLENDALE, CA:  
3,232,364, PUB. 2-6-2007. INT. CL. 16.
- SAN MIGUEL CORPORATION, METRO MANILA, PHILIPPINES:  
3,232,640, PUB. 2-6-2007. INT. CL. 32.  
3,232,641, PUB. 2-6-2007. INT. CL. 32.
- SANCHEZ, EDAN C., LEESBURG, VA:  
3,234,216, INT. CL. 9.
- SANDERS, LINDA, GASTONIA, NC:  
2,357,291, CANC. INT. CL. 30.
- SANDERS, MARY E., RENO, NV:  
2,356,539, CANC. INT. CL. 41.
- SANDVIK INTELLECTUAL PROPERTY AB, SE-811 81 SANDVIKEN, SWEDEN:  
2,358,258, CANC. INT. CL. 7.
- SANFORD, L.P., OAK BROOK, IL, HIGGINS INK CO., INC., BROOKLYN, NY:  
823,870, REN. 3-22-07. U.S. CL. 11 (INT. CL. 2).
- SANFORD, L.P., FREEPORT, IL:  
3,232,550, PUB. 2-6-2007. INT. CL. 16.  
3,232,551, PUB. 2-6-2007. INT. CL. 16.
- SANJEL LIMITED PARTNERSHIP, CALGARY, CANADA:  
3,232,472, PUB. 10-10-2006. MULTIPLE CLASS, INT. CLS. 37 AND 40.
- SANOFI-AVENTIS, FRANCE:  
3,233,761, PUB. 2-6-2007. INT. CL. 5.
- SANRIO COMPANY, LTD., TOKYO 141, JAPAN:  
3,234,085, INT. CL. 32.
- SANSOUCY, RYAN, WOODSTOCK, CT:  
3,233,304, PUB. 2-6-2007. INT. CL. 35.
- SANSUI ELECTRIC CO., LTD., SUGINAMI-KU, TOKYO, JAPAN:  
1,396,511, CANC. INT. CL. 9.
- SANT, TAMRA REED, ST. LOUIS, MO:  
2,358,471, CANC. INT. CL. 28.
- SANTA CLARA, WHIPPANY, NJ, CIGARS BY SANTA CLARA N.A. INC., STATESVILLE, NC:  
1,982,111, REN. 3-19-07. INT. CL. 34.
- SANTA CLARA, INC., WHIPPANY, NJ, CIGARS BY SANTA CLARA N.A. INC., STATESVILLE, NC:  
1,982,112, REN. 3-19-07. INT. CL. 34.
- SANTA FE DINING, INC., SANTA FE, NM:  
3,233,978, INT. CL. 32.
- SANTANNA NATURAL GAS CORPORATION, AUSTIN, TX:  
3,233,515, PUB. 2-6-2007. INT. CL. 39.
- SANTINI ANNA LUISA, ITALY:  
3,233,706, PUB. 2-6-2007. MULTIPLE CLASS, INT. CLS. 24 AND 25.
- SARA LEE BAKERY GROUP, INC., DOWNERS GROVE, IL, CAMPBELL TAGGART, INC., DALLAS, TX:  
1,057,848, REN. 3-17-07. INT. CL. 30.
- SARA LEE/DE N.V., NETHERLANDS:  
3,233,755, PUB. 2-6-2007. INT. CL. 11.
- SARAH'S ATTIC, INC., CHESANING, MI:  
1,396,707, CANC. MULTIPLE CLASS, INT. CLS. 16, 20



- AND 28.  
 SARAMAR, L.L.C., CHICAGO, IL:  
 3,234,112, INT. CL. 11.  
 SARILA ITALIA S.R.L. (RIMINI), ITALY:  
 2,358,307, CANC. INT. CL. 20.  
 SARTORIUS AG, D-37075 GOTTINGEN, FED REP GER-  
 MANY:  
 3,234,006, INT. CL. 9.  
 SATELLITE M.D., L.L.C., ALLONS, TN:  
 3,235,388, INT. CL. 44.  
 SATHIS, FRANCE:  
 3,233,596, PUB. 2-6-2007. INT. CL. 27.  
 SATICOY LEMON ASSOCIATION, VENTURA, CA:  
 2,080,708. REN. 3-19-07. INT. CL. 31.  
 2,082,196. REN. 3-19-07. INT. CL. 31.  
 SATO, ANDREW M., CHICAGO, IL:  
 3,234,010, INT. CL. 41.  
 SAUCONY, INC., LEXINGTON, MA, HIND-WELLS, INC.,  
 SAN LUIS OBISPO, CA:  
 1,412,432. REN. 3-20-07. INT. CL. 25.  
 SAUCONY, INC., PEABODY, MA:  
 3,234,634, INT. CL. 25.  
 SAUDER WOODWORKING CO., ARCHBOLD, OH:  
 3,234,605, INT. CL. 35.  
 SAUNDERS GROUP, INC., THE, CHASKA, MN:  
 2,056,350. REN. 3-20-07. INT. CL. 10.  
 2,107,950. REN. 3-20-07. INT. CL. 10.  
 SAVEN CORPORATION, CHARLESTON, WV:  
 1,992,643. REN. 3-16-07. INT. CL. 31.  
 SAVION, TIFFANY, SHERMAN OAKS, CA:  
 3,232,927, PUB. 2-6-2007. INT. CL. 41.  
 SAZERAC COMPANY, INC., NEW ORLEANS, LA:  
 3,233,043, PUB. 2-6-2007. INT. CL. 33.  
 SB OPERATINGCO, INC.:  
*See— SB OPERATINGCO, LLC.*  
 SB OPERATINGCO, LLC, SAN DIEGO, CA FROM SB  
 OPERATINGCO, INC., SAN DIEGO, CA:  
 3,232,320, PUB. 12-30-2003. INT. CL. 40.  
 SB PHARMCO PUERTO RICO INC., 254 MUNOZ RIVERA  
 AVE., PUERTO RICO:  
 2,358,226, CANC. INT. CL. 42.  
 SBC KNOWLEDGE VENTURES, L.P., AUSTIN, TX:  
 2,358,447, CANC. INT. CL. 42.  
 SCAN/PLAN, INC., SANTA MONICA, CA:  
 1,396,729, CANC. INT. CL. 16.  
 SCANBUY, INC., NEW YORK, NY:  
 3,234,800, INT. CL. 9.  
 SCANDIA DOWN, LLC, WEEHAWKEN, NJ:  
 3,233,209, PUB. 2-6-2007. INT. CL. 35.  
 SCANSOFT INC., PEABODY, MA:  
 2,358,846, CANC. INT. CL. 9.  
 SCANSOFT, INC., PEABODY, MA:  
 2,357,886, CANC. INT. CL. 9.  
 SCARAB CREATIONS INC., NORTH VANCOUVER, BRIT-  
 ISH COLUMBIA, CANADA:  
 2,358,170, CANC. INT. CL. 28.  
 SCENTS OF NATURE ENTERPRISES CORP., MIAMI, FL:  
 3,235,492, INT. CL. 3.  
 SCENTSATIONAL TECHNOLOGIES, JENKINTOWN, PA:  
 3,232,104, PUB. 2-6-2007. INT. CL. 21.  
 SCHAEFER BROTHERS INC., CLEVELAND, OH:  
 1,464,572. REN. 3-17-07. INT. CL. 17.  
 SCHAEFER, DAN, NEW YORK, NY:  
 3,233,974, INT. CL. 41.  
 SCHECHTER, PAUL L., BEVERLY HILLS, CA:  
 2,356,970, CANC. INT. CL. 9.  
 SCHENKEL, LESLIE J., BEVERLY HILLS, CA:  
 3,234,140, INT. CL. 14.  
 SCHERING A.G., BERLIN 65, FED REP GERMANY:  
 823,240. REN. 3-16-07. U.S. CL. 6 (INT. CL. 1).  
 SCHERING OY, FIN-20210 TURKU, FINLAND:  
 1,428,078. REN. 3-20-07. INT. CL. 5.  
 SCHERING-PLOUGH ANIMAL HEALTH CORPORATION,  
 SUMMIT, NJ:  
 1,396,412, CANC. INT. CL. 5.  
 SCHERING-PLOUGH HEALTHCARE PRODUCTS, INC.,  
 MEMPHIS, TN:  
 3,234,927, INT. CL. 25.  
 SCHILLER, HENRI, PARIS, FRANCE:  
 1,396,419, CANC. INT. CL. 5.  
 SCHLUMBERGER TECHNOLOGY CORPORATION, SU-  
 GAR LAND, TX:  
 2,125,394. REN. 3-21-07. INT. CL. 9.  
 SCHMALBACH-LUBECA A.G., D-W-3300 BRAUNSCH-  
 WEIG, FED REP GERMANY:  
 2,356,414, CANC. MULTIPLE CLASS, INT. CLS. 4, 6, 7, 8,  
 11, 16, 20, 21 AND 28.  
 SCHMIT, DAVID, MINNEAPOLIS, MN:  
 2,357,086, CANC. INT. CL. 41.  
 SCHNITZELKÖNIG HOTEL-; UND GASTRONOMIE  
 GES.M.B.H., AUSTRIA:  
 3,233,659, PUB. 2-6-2007. MULTIPLE CLASS, INT. CLS. 41  
 AND 44.  
 SCHOLASTIC INC., NEW YORK, NY:  
 3,233,418, PUB. 2-6-2007. INT. CL. 9.  
 SCHRODERS PLC, LONDON, UNITED KINGDOM:  
 2,357,611, CANC. MULTIPLE CLASS, INT. CLS. 35 AND  
 36.  
 SCHUMACHER PAINTING INC., YAKIMA, WA:  
 3,232,415, PUB. 2-6-2007. INT. CL. 39.  
 SCHURMAN FINE PAPERS, FAIRFIELD, CA:  
 3,235,089, INT. CL. 35.  
 3,235,090, INT. CL. 35.  
 SCHWAN'S IP, LLC, MARSHALL, MN:  
 3,235,345, INT. CL. 30.  
 SCHWARTZ, LISA M., LOS ANGELES, CA:  
 3,235,259, INT. CL. 44.  
 SCHWARZ PHARMA AG, MONHEIM, FED REP GER-  
 MANY:  
 3,232,648, PUB. 10-24-2006. INT. CL. 5.  
 SCHWARZ PHARMA AG, D-40789 MONHEIM, FED REP  
 GERMANY:  
 3,232,765, PUB. 10-24-2006. INT. CL. 5.  
 3,232,766, PUB. 10-24-2006. INT. CL. 5.  
 3,232,767, PUB. 10-24-2006. INT. CL. 5.  
 SCHWARZ PHARMA AKTIENGESELLSCHAFT, FED REP  
 GERMANY:  
 3,233,720, PUB. 2-6-2007. INT. CL. 5.  
 SCI MANAGEMENT L.P., HOUSTON, TX:  
 3,234,523, INT. CL. 45.  
 SCIELE PHARMA, INC., ATLANTA, GA:  
 3,234,816, INT. CL. 5.  
 SCIOMETRIC INSTRUMENTS INC., OTTAWA, ONTARIO,  
 CANADA:  
 2,062,782. REN. 3-17-07. INT. CL. 9.  
 SCIENCE OF SKINCARE, LLC, GLENDALE, CA:  
 3,234,099, INT. CL. 3.  
 SCIENTIFIC TOYS LTD., TSIM SHA TSUI EAST, KOW-  
 LOON, HONG KONG:  
 3,234,193, INT. CL. 28.  
 SCIENTIFIC-ATLANTA EUROPE NV, KORTRIJK, BEL-  
 GIUM:  
 3,232,763, PUB. 8-29-2006. INT. CL. 9.  
 SCOPETIME GMBH, 20537 HAMBURG, FED REP GER-  
 MANY:  
 3,233,571, PUB. 2-6-2007. INT. CL. 14.  
 SCOTIA HOLDINGS PLC, GUILDFORD, SURREY GUI  
 1BA, ENGLAND:  
 1,979,351, CANC. INT. CL. 5.  
 SCOTIA HOLDINGS PLC., GUILDFORD, SURREY, GUI  
 1BA, ENGLAND:  
 1,979,211, CANC. INT. CL. 5.  
 SCOTSMAN PUBLISHING, INC., BOTHELL, WA:  
 3,232,118, PUB. 2-6-2007. MULTIPLE CLASS, INT. CLS. 9  
 AND 16.  
 SCOTT FETZER COMPANY, THE, WESTLAKE, OH:  
 3,232,234, PUB. 2-6-2007. INT. CL. 7.  
 3,232,267, PUB. 2-6-2007. INT. CL. 21.  
 SCOTT W. GAD, MADISON, WI:  
 3,235,359, INT. CL. 36.  
 SCOTT, WILLIAM H, ROCHESTER, NH:  
 1,979,175, CANC. MULTIPLE CLASS, INT. CLS. 16, 25  
 AND 41.  
 SCOTTI, JOHN A., PITTSBURGH, PA:  
 3,234,411, INT. CL. 36.

- SCOTTISH & NEWCASTLE PLC, EDINBURGH EH12 6HX, SCOTLAND:  
3,233,802, INT. CL. 32.
- SCRATCH TECHNOLOGIES LLC, REDWOOD CITY, CA:  
2,357,065, CANC. INT. CL. 9.  
2,357,075, CANC. INT. CL. 9.
- SCRATCH-ART COMPANY, INC., AVON, MA:  
2,358,677, CANC. INT. CL. 28.
- SCRIPPS HOWARD BROADCASTING COMPANY, KNOXVILLE, TN, DBA HOME & GARDEN TELEVISION TO SCRIPPS NETWORKS, INC., KNOXVILLE, TN:  
1,979,927, CANC. MULTIPLE CLASS, INT. CLS. 38 AND 42.
- SDI OPERATING PARTNERS, L.P., PHILADELPHIA, PA:  
1,396,492, CANC. INT. CL. 8.
- SEA SNACK FOODS, INC., LOS ANGELES, CA, SEA SNACK COMPANY, PHILADELPHIA, PA:  
641,911. REN. 3-21-07. U.S. CL. 46 (INT. CL. 29).
- SEALANT EQUIPMENT & ENGINEERING, INC., PLYMOUTH, MI:  
1,442,560. REN. 3-20-07. INT. CL. 9.
- SEALED AIR CORPORATION (US), ELMWOOD PARK, NJ:  
3,235,268, INT. CL. 7.
- SEARS, ROEBUCK AND CO., HOFFMAN ESTATES, IL:  
2,357,584, CANC. INT. CL. 25.  
2,357,696, CANC. INT. CL. 35.  
2,357,999, CANC. INT. CL. 27.  
2,358,576, CANC. INT. CL. 25.
- SEASOURCE, INC., MORRISTOWN, NJ:  
3,234,678, INT. CL. 29.
- SEATTLE'S BEST COFFEE, LLC, SEATTLE, WA:  
3,234,391, INT. CL. 30.
- SEAWAY FOOD TOWN, INC., MAUMEE, OH:  
2,357,638, CANC. INT. CL. 20.
- SEBAGO USA, LLC, ROCKFORD, MI:  
3,234,299, INT. CL. 25.
- SEBASTIAN INTERNATIONAL, INC., WOODLAND HILLS, CA:  
3,234,651, INT. CL. 3.
- SECILIA, TONY MARK, ALTADENA, CA:  
3,235,225, INT. CL. 37.
- SECRETS OF THE SOUTH MEDIA, INC., SAVANNAH, GA:  
3,233,425, PUB. 2-6-2007. INT. CL. 35.
- SECURITY DYNAMICS TECHNOLOGIES, INC., BEDFORD, MA:  
2,357,008, CANC. INT. CL. 9.
- SECURITY 1, INC., LINDEN, NJ:  
1,396,673, CANC. INT. CL. 12.
- SEDA SOLUTIONS CORPORATION, SAN FRANCISCO, CA:  
2,357,509, CANC. INT. CL. 9.  
2,357,510, CANC. INT. CL. 9.
- SEEBOARD PRODUCTS LLC, POINT LOOKOUT, NY:  
3,234,796, INT. CL. 12.
- SEEGWAY, INC., BEDFORD, NH:  
3,233,798, INT. CL. 35.
- SEGUTRONIC INTERNATIONAL, INC., MIAMI, FL:  
3,232,075, PUB. 8-29-2006. INT. CL. 9.
- SEIBEL, RAINER, 76351 LINKENHEIM-HOCHSTETTEN, FED REP GERMANY:  
2,356,431, CANC. INT. CL. 10.
- SEIKO EPSON KABUSHIKI KAISHA, TOKYO, JAPAN, DBA SEIKO EPSON CORPORATION:  
3,234,594, INT. CL. 9.
- SEIKO INSTRUMENTS KABUSHIKI KAISHA, CHIBA 261-8507, JAPAN, TA SEIKO INSTRUMENTS INC.:  
3,233,838, INT. CL. 9.
- SEITZ ENZINGER NOLL MASCHINENBAU AG, MANNHEIM, FED REP GERMANY:  
1,396,454, CANC. MULTIPLE CLASS, INT. CLS. 7, 9 AND 11.
- SELBACH, HANS D., BONN, FED REP GERMANY:  
3,234,540, INT. CL. 25.
- SELECTIVE INSURANCE GROUP, INC., BRANCHVILLE, NJ:  
2,043,044. REN. 3-17-07. INT. CL. 36.
- SELFWORX.COM LLC, SCARBOROUGH, ME, DBA PREVAL:  
3,235,283, INT. CL. 5.
- SELL, ARNOLD J., BALTIMORE, MD:  
3,232,770, PUB. 2-6-2007. MULTIPLE CLASS, INT. CLS. 44 AND 45.
- SELLARS ABSORBENT MATERIALS, INC., MILWAUKEE, WI:  
3,234,708, INT. CL. 16.
- SELLE ROYAL S.P.A., ITALY:  
3,233,599, PUB. 2-6-2007. MULTIPLE CLASS, INT. CLS. 12 AND 25.
- SEMINIS VEGETABLE SEEDS, INC., SATICOY, CA:  
2,357,508, CANC. INT. CL. 1.
- SENA, MIYUKI, TORRANCE, CA:  
3,233,794, INT. CL. 16.
- SENECA GAMING CORPORATION, NIAGARA FALLS, NY:  
3,235,119, INT. CL. 41.
- SENIOR FITNESS PRODUCTIONS, INC., PENFIELD, NY:  
2,029,914. REN. 3-20-07. INT. CL. 41.
- SENZERGUES, PIERRE ANDRE, NEWPORT BEACH, CA:  
3,234,592, INT. CL. 41.
- SENNHEISER ELECTRONIC GMBH & CO. KG, 30900 WEDEMARK, FED REP GERMANY:  
3,232,339, PUB. 3-7-2006. INT. CL. 9.
- SENOH KABUSHIKI KAISHA, TOKYO, JAPAN:  
2,036,687. REN. 3-16-07. INT. CL. 28.
- SENSIBLY ORGANIZED INC., MACUNGIE, PA:  
3,232,863, PUB. 10-31-2006. INT. CL. 35.
- SENSIS CORPORATION, EAST SYRACUSE, NY:  
3,234,843, INT. CL. 9.
- SENTRYL SOFTWARE CORPORATION, SAN MATEO, CA:  
2,356,637, CANC. INT. CL. 9.
- SENTURIA, NEIL R., LA JOLLA, CA:  
3,235,310, INT. CL. 41.
- SEPAC, INC., ELMIRA, NY:  
1,470,435. REN. 3-22-07. MULTIPLE CLASS, INT. CLS. 7 AND 42.
- SEQUOIA PACIFIC SYSTEMS CORPORATION, EXETER, CA:  
1,396,603, CANC. INT. CL. 9.  
1,397,223, CANC. INT. CL. 42.
- SER INTERNATIONAL, INC., LAKEVILLE, CT:  
2,357,917, CANC. INT. CL. 25.
- SERONO, INC., ROCKLAND, MA:  
1,396,387, CANC. INT. CL. 5.
- SERV-A-LITE, EAST MOLINE, IL:  
2,033,587. REN. 3-22-07. INT. CL. 42.
- SERVERON CORPORATION, HILLSBORO, OR, MICROMONITORS, INC., SISTERS, OR:  
2,124,209. REN. 3-16-07. INT. CL. 9.
- SERVOTRONICS, INC., BUFFALO, NY:  
823,396. REN. 3-21-07. U.S. CL. 35 (INT. CL. 17).  
823,397. REN. 3-20-07. U.S. CL. 35 (INT. CL. 17).
- SEVENTH GENERATION, INC., BURLINGTON, VT:  
2,358,872, CANC. INT. CL. 3.
- SEXTANT IN-FLIGHT SYSTEMS, LLC, IRVINE, CA:  
2,357,837, CANC. INT. CL. 9.
- SEYCHELLE ENVIRONMENTAL TECHNOLOGIES, INC., SAN JUAN CAPISTRANO, CA:  
3,234,938, INT. CL. 11.
- SHAKESPEARE COMPANY, LLC, COLUMBIA, SC:  
3,235,337, INT. CL. 28.
- SHAKLEE CORPORATION, SAN FRANCISCO, CA:  
2,358,383, CANC. INT. CL. 5.
- SHANDONG DONGYUE CHEMICAL CO., LTD., ZIBO, SHANDONG 256401, CHINA:  
3,233,679, PUB. 2-6-2007. INT. CL. 1.
- SHANDONG DOUBLE LINK BRAKE MATERIAL CO., LTD., RUSHAN CITY, SHANDONG, CHINA:  
3,232,517, PUB. 2-6-2007. INT. CL. 12.
- SHANGHAI FORTUNE CERAMIC CO., LTD., CHINA:  
3,233,665, PUB. 2-6-2007. INT. CL. 19.
- SHANGHAI MACHINERY IMPORT & EXPORT (GROUP) CORP., LTD, SHANGHAI 200041, CHINA:  
2,357,023, CANC. INT. CL. 7.
- SHANGHAI MINGYUE OPTICAL; GLASSES CO., LTD, CHINA:  
3,233,750, PUB. 2-6-2007. INT. CL. 9.
- SHANKLIN CORPORATION, SADDLE BROOK, NJ:  
1,980,205, CANC. INT. CL. 7.

SHARON W. CHIANG, PASADENA, CA:  
3,234,970, INT. CL. 18.

SHARON Z. ZADANOFF, DC, P.A., NORTH MIAMI BEACH, FL:  
2,029,882, REN. 3-16-07. INT. CL. 42.

SHARP PACKAGING SYSTEMS, LLC, SUSSEX, WI:  
2,735,946, AM. MULTIPLE CLASS, INT. CLS. 7 AND 16.

SHAW, SONYA, AGOURA, CA:  
3,233,821, INT. CL. 41.

SHAWNEE MILLING COMPANY, SHAWNEE, OK:  
1,421,359, REN. 3-16-07. INT. CL. 31.

SHE-MOTO, INC, HOLLAND, MI:  
3,234,082, INT. CL. 9.

SHEEHAN, BRIAN, MARLTON, NJ AND SHEEHAN, CHRISTOPHER, MARLTON, NJ:  
2,358,381, CANC. INT. CL. 27.

SHEET METAL CONNECTORS, INC., MINNEAPOLIS, MN:  
1,460,780, REN. 3-22-07. INT. CL. 11.

SHEFFER, RONIYA, SAN FRANCISCO, CA:  
2,356,590, CANC. INT. CL. 18.

SHEFFIELD NOLAN, INC., MILPITAS, CA:  
2,357,743, CANC. INT. CL. 35.

SHELBY YARN CO., SHELBY, NC:  
2,357,793, CANC. INT. CL. 23.

SHELTERED WINGS, INC., MIDDLETOWN, WI:  
3,233,466, PUB. 2-6-2007. INT. CL. 9.

SHELTON, MICHAEL DARRELL, FOREST PARK, GA:  
2,357,789, CANC. INT. CL. 42.

SHENPIX CO., LTD., GUNMA, JAPAN:  
1,979,335, CANC. INT. CL. 10.

SHERATON LLC, THE, WHITE PLAINS, NY, ITT SHERATON CORPORATION, BOSTON, MA:  
2,033,783, REN. 3-22-07. INT. CL. 42.

SHERIDAN ROSS P.C., DENVER, CO:  
3,233,239, PUB. 2-6-2007. INT. CL. 42.

SHEVOKAS, WAYNE R., JOLIET, IL:  
3,232,229, PUB. 2-6-2007. INT. CL. 33.

SHIH SANYO ENTERPRISE CO., LTD., TAICHUNG, TAIWAN:  
3,232,915, PUB. 2-6-2007. INT. CL. 11.

SHIMANO INC., SAKAI OSAKA 590-77, JAPAN:  
2,358,138, CANC. INT. CL. 12.

SHIMANO INC., SAKAI CITY, JAPAN:  
3,234,356, INT. CL. 35.

SHIN NIHON KOSAN, INC., PASADENA, CA:  
3,232,190, PUB. 2-6-2007. INT. CL. 43.

SHIN-ETSU CHEMICAL CO., LTD., TOKYO, JAPAN:  
1,986,548, REN. 3-20-07. INT. CL. 1.

SHINER ROOFING, INC., FAIRFAX, VA:  
3,233,173, PUB. 2-6-2007. INT. CL. 37.  
3,233,174, PUB. 2-6-2007. INT. CL. 37.

SHISEIDO CO., LTD., TOKYO, JAPAN:  
1,396,356, CANC. INT. CL. 3.

SHONEY'S NORTH AMERICA CORPORATION, ATLANTA, GA:  
3,235,171, INT. CL. 30.

SHONEY'S, LLC, NASHVILLE, TN:  
3,235,170, INT. CL. 30.

SHOOT THE MOON PRODUCTS II, LLC, PLEASANTON, CA:  
3,234,739, INT. CL. 28.

SHOPKO STORES OPERATING CO., LLC, GREEN BAY, WI:  
2,358,746, CANC. INT. CL. 9.

SHOPPING SECRETS PTY. LTD., MELBOURNE, AUSTRALIA:  
3,232,393, PUB. 2-6-2007. INT. CL. 16.

SHORN INDUSTRIES, LLC, PENNINGTON, NJ:  
3,233,066, PUB. 2-6-2007. INT. CL. 41.

SHOWCASE REALTY, LAS VEGAS, NV:  
3,232,843, PUB. 2-6-2007. INT. CL. 35.

SHUFFLE MASTER, INC., LAS VEGAS, NV, WEBB, DEREK J., LITTLEOVER DERBY, GREAT BRITAIN:  
2,036,848, REN. 3-21-07. INT. CL. 16.

SICC S.P.A., MONSANO, ANCONA, ITALY:  
2,850,844, AM. MULTIPLE CLASS, INT. CLS. 20 AND 37.

SIDELINES FRANCHISE GROUP, LLC, MARIETTA, GA:  
3,235,340, INT. CL. 43.

SIDELLA, LOUIS J, REDONDO BEACH, CA:  
3,232,062, PUB. 2-6-2007. INT. CL. 41.

SIEGEL & GALE LLC, NEW YORK, NY, SIEGEL & GALE, NEW YORK, NY:  
2,027,886, REN. 3-17-07. INT. CL. 16.

SIEGENIA-FRANK KG, SIEGEN, FED REP GERMANY:  
1,396,829, CANC. INT. CL. 20.

SIEMENS AKTIENGESELLSCHAFT, MUNICH, FED REP GERMANY:  
2,356,991, CANC. MULTIPLE CLASS, INT. CLS. 9 AND 42.

SIEMENS AKTIENGESELLSCHAFT, FED REP GERMANY:  
3,233,653, PUB. 2-6-2007. INT. CL. 7.

SIEMENS AKTIENGESELLSCHAFT, 80333 MÜNCHEN, FED REP GERMANY:  
3,233,694, PUB. 2-6-2007. MULTIPLE CLASS, INT. CLS. 9 AND 16.

SIEMENS AUDIOLOGISCHE TECHNIK GMBH, FED REP GERMANY:  
3,233,594, PUB. 2-6-2007. INT. CL. 10.

SIEMENS BUILDING TECHNOLOGIES AG, ZURICH, SWITZERLAND:  
2,356,457, CANC. MULTIPLE CLASS, INT. CLS. 35, 36, 37, 41 AND 42.

SIERRA ENTERTAINMENT, DAVIS, CA:  
3,234,767, INT. CL. 39.

SIERRA ON-LINE, INC., BELLEVUE, WA:  
1,979,980, CANC. INT. CL. 28.  
2,358,503, CANC. INT. CL. 9.

SIGA SIEBER-GADIANT AG, 6105 SCHACHEN, SWITZERLAND TO SIGA COVER AG, CH-6105 SCHACHEN, SWITZERLAND:  
1,979,347, CANC. MULTIPLE CLASS, INT. CLS. 1 AND 17.

SIGMA ALPHA OMEGA CHRISTIAN SORORITY, INC., RALEIGH, NC:  
3,232,638, PUB. 2-6-2007. U.S. CL. 200.

SIGMA-ALDRICH BIOTECHNOLOGY L.P., SAINT LOUIS, MO:  
3,234,734, INT. CL. 1.

SIGNATURE APPRAISALS, UNDERWRITING AND LOSS CONTROL, INC., FORT MYERS, FL:  
3,232,514, PUB. 2-6-2007. INT. CL. 36.

SIGNATURE FLIGHT SUPPORT CORPORATION, ORLANDO, FL:  
2,032,400, REN. 3-17-07. INT. CL. 37.

SIGNET SOLUTIONS, INC., CLEVELAND, OH:  
3,233,122, PUB. 2-6-2007. INT. CL. 35.

SIGNUS MEDIZINTECHNIK GMBH, 63755 ALZENAU, FED REP GERMANY:  
3,232,170, PUB. 2-6-2007. INT. CL. 10.

SIGSBEE REHABILITATION CORPORATION, ERIE, PA:  
3,232,749, PUB. 8-22-2006. INT. CL. 44.

SIKKING, ARTHUR LEE, III, GLENVIEW, IL:  
2,357,301, CANC. INT. CL. 41.

SILICON VALLEY BANK, SANTA CLARA, CA:  
2,358,062, CANC. INT. CL. 9.  
3,235,190, MULTIPLE CLASS, INT. CLS. 38 AND 42.

SILICONIX INCORPORATED, SANTA CLARA, CA:  
2,035,560, REN. 3-16-07. INT. CL. 9.

SILVER CREEK GRAPHICS INC., TORONTO, ONTARIO M4Y 1N3, CANADA:  
2,358,009, CANC. INT. CL. 16.

SILVER FERN, INCORPORATED, SHAWNEE MISSION, KS:  
2,357,957, CANC. INT. CL. 5.

SILVER IMPRESSIONS, INC., GAINESVILLE, FL:  
3,233,459, PUB. 2-6-2007. INT. CL. 25.

SILVER JOE'S CORPORATION, FORT SMITH, AR, DBA SILVER JOE'S COFFEE COMPANY:  
3,234,441, INT. CL. 30.

SIMON PROPERTY GROUP, L.P., INDIANAPOLIS, IN:  
2,357,271, CANC. INT. CL. 35.

SIMONDS INDUSTRIES INC., FITCHBURG, MA, SIMONDS SAW AND STEEL COMPANY, FITCHBURG, MA:  
642,907, REN. 3-21-07. U.S. CL. 23 (INT. CL. 7).

SIMONI RACING SRL, 44043 MIRABELLO (FERRARA), ITALY:  
2,358,328, CANC. INT. CL. 12.

- SIMONSSVOSS TECHNOLOGIES AG, 85774 UNTERFOHRING, FED REP GERMANY:  
3,232,966, PUB. 2-6-2007. MULTIPLE CLASS, INT. CLS. 9, 16 AND 42.
- SIMPLE TUITION LLC, NEWTON, MA:  
3,235,305, INT. CL. 36.
- SIMPLICITY MANUFACTURING, INC., PORT WASHINGTON, WI:  
3,234,316, INT. CL. 12.
- SIMPLIFI, LLC, WINSTON SALEM, NC:  
3,234,382, INT. CL. 36.
- SIMPSON DOOR COMPANY, TACOMA, WA:  
3,234,662, INT. CL. 19.
- SIMWRIGHT, INC., NAVARRE, FL:  
3,235,009, INT. CL. 42.
- SINGER, MICHAEL G., HARRISVILLE, MI:  
3,234,799, INT. CL. 9.
- SINTECH SOFTWARE, LLC, CHICAGO, IL:  
2,357,627, CANC. INT. CL. 9.
- SIRECH & CO S.A.S., FRANCE:  
3,233,566, PUB. 2-6-2007. INT. CL. 33.
- SISSLE INC., SUMAS, WA:  
3,232,450, PUB. 2-6-2007. INT. CL. 28.
- SITEL CORPORATION, OMAHA, NE:  
1,448,816, REN. 3-20-07. INT. CL. 35.
- SIX DISCIPLINES CORPORATION, FINDLAY, OH:  
3,234,373, INT. CL. 9.
- SIX SIGMA ACADEMY INTERNATIONAL, LLC, SCOTTSDALE, AZ:  
3,233,141, PUB. 2-6-2007. INT. CL. 35.
- SJ BERWIN & CO., LONDON WC1X 8HB, ENGLAND:  
2,356,869, CANC. INT. CL. 42.
- SJI WHOLESALE, INC., KNOXVILLE, TN:  
2,356,756, CANC. INT. CL. 34.
- SKAGIT BEVERAGE LLC, TENINO, WA:  
3,232,627, PUB. 2-6-2007. INT. CL. 33.
- SKATE RANGER, BROOKLYN, NY:  
3,234,713, MULTIPLE CLASS, INT. CLS. 25 AND 28.
- SKATEBOARD WORLD INDUSTRIES INC, UNITED STATES:  
3,233,660, PUB. 2-6-2007. MULTIPLE CLASS, INT. CLS. 18, 25 AND 28.
- SKEZAS, AMY, PETALUMA, CA:  
3,235,099, INT. CL. 41.
- SKF GLOBAL, INC., HACKENSACK, NJ:  
3,233,305, PUB. 2-6-2007. INT. CL. 21.
- SKIS DYNASTAR, INC., PARK CITY, UT:  
3,233,984, INT. CL. 28.
- SKYLINE CORPORATION, ELKHART, IN:  
1,396,823, CANC. INT. CL. 19.
- SKYWAY LUGGAGE COMPANY, SEATTLE, WA:  
1,980,257, CANC. INT. CL. 18.
- SLOMIN'S INC., HICKSVILLE, NY:  
2,087,696, REN. 3-16-07. INT. CL. 42.
- SLOMIN'S, INC., HICKSVILLE, NY:  
2,087,695, REN. 3-16-07. INT. CL. 37.
- SMALLTOWN, INC., FOSTER CITY, CA:  
3,234,631, MULTIPLE CLASS, INT. CLS. 38 AND 42.
- SMART & FINAL STORES CORPORATION, COMMERCE, CA:  
2,046,604, REN. 3-16-07. MULTIPLE CLASS, INT. CLS. 29 AND 30.
- SMART SOLUTIONS LTD., 54030 GIVAT SHMUEL, ISRAEL:  
2,358,158, CANC. INT. CL. 9.
- SMARTCO, FRANCE:  
3,233,537, PUB. 2-6-2007. MULTIPLE CLASS, INT. CLS. 38 AND 42.
- SMG STRATEGIC MANAGEMENT GROUP, INC., PHILADELPHIA, PA:  
2,357,477, CANC. INT. CL. 41.  
2,357,478, CANC. INT. CL. 41.
- SMG, INC., NEWPORT NEWS, VA, RATH PACKING COMPANY, THE, WATERLOO, IA:  
342,328, REN. 3-22-07. U.S. CL. 46 (INT. CL. 29).
- SMITH & LOVELESS, INC., LENEXA, KS, UNION TANK CAR COMPANY, CHICAGO, IL:  
820,711, REN. 3-16-07. U.S. CL. 23 (INT. CL. 11).
- SMITH & NEPHEW, INC., ITASCA, IL:  
1,396,392, CANC. INT. CL. 5.
- SMITH CORONA CORPORATION, NEW CANAAN, CT:  
1,396,799, CANC. INT. CL. 16.
- SMITH-COOPER INTERNATIONAL, INC., MONTEBELLO, CA:  
2,028,625, REN. 3-19-07. INT. CL. 6.
- SMITH, BUCKLIN & ASSOCIATES, INC., CHICAGO, IL:  
2,357,909, CANC. INT. CL. 42.
- SMITH, CAMERON, DALLAS, TX:  
3,232,191, PUB. 2-6-2007. INT. CL. 41.
- SMITH, CRAIG, GLEN HEAD, NY:  
2,356,591, CANC. INT. CL. 5.
- SMITH, DANA A., UPPER MARLBORO, MD:  
3,234,242, INT. CL. 41.
- SMITH, FRANK R., WICHITA, KS:  
3,232,112, PUB. 2-6-2007. INT. CL. 44.
- SMITH, MELANIE, WASHINGTON CROSSING, PA:  
3,234,451, INT. CL. 25.
- SMITHERS-OASIS COMPANY, CUYAHOGA FALLS, OH:  
1,458,894, REN. 3-22-07. INT. CL. 1.
- SMITHKLINE BEECHAM CORPORATION, PHILADELPHIA, PA:  
2,358,363, CANC. INT. CL. 42.
- SMITHY ACCESSORIES, NEW YORK, NY:  
1,396,732, CANC. MULTIPLE CLASS, INT. CLS. 16 AND 18.
- SMSC EUROPE GMBH, KARLSRUHE, FED REP GERMANY:  
3,232,087, PUB. 8-15-2006. MULTIPLE CLASS, INT. CLS. 9, 41 AND 42.
- SMYTH ADVERTISING, INC., PELHAM, AL:  
2,358,286, CANC. INT. CL. 9.
- SNAP-TITE, INC., UNION CITY, PA:  
1,397,233, CANC. INT. CL. 6.
- SNAPPLE BEVERAGE CORP., RYE BROOK, NY:  
3,233,387, PUB. 2-6-2007. INT. CL. 3.
- SNAPPY TOMATO PIZZA, INC., FLORENCE, KY:  
1,439,566, REN. 3-20-07. INT. CL. 42.
- SNAPTON FOODS, INC., LOS ANGELES, CA:  
2,357,233, CANC. MULTIPLE CLASS, INT. CLS. 29 AND 30.
- SNOWSPORTS INDUSTRIES AMERICA, INCORPORATED, MCLEAN, VA, SKI INDUSTRIES AMERICA, MCLEAN, VA:  
2,024,884, REN. 3-22-07. INT. CL. 42.
- SNOWY RIVER, LLC, MORGAN, UT:  
3,235,471, INT. CL. 18.
- SOAVE ENTERPRISES L.L.C., DETROIT, MI:  
3,233,217, PUB. 2-6-2007. MULTIPLE CLASS, INT. CLS. 35, 36, 37, 39, 40 AND 43.  
3,233,441, PUB. 2-6-2007. MULTIPLE CLASS, INT. CLS. 35, 36, 37, 39, 40 AND 43.
- SOCIETA' AGRICOLA SAN FELICE S.P.A., MILAN, ITALY:  
2,068,519, REN. 3-22-07. INT. CL. 33.
- SOCIETE CIVILE DE BREVETS MATIERE, FRANCE:  
3,233,548, PUB. 2-6-2007. MULTIPLE CLASS, INT. CLS. 6 AND 19.
- SOCIETE DES PRODUITS MARNIER-LAPOSTOLLE, 75008 PARIS, FRANCE:  
2,356,897, CANC. INT. CL. 33.
- SOCIETE DES PRODUITS NESTLE S.A., VEVEY, SWITZERLAND:  
3,232,291, PUB. 2-6-2007. INT. CL. 31.  
3,233,297, PUB. 2-6-2007. INT. CL. 31.
- SOCIETE DES PRODUITS NESTLE S.A., 1800 VEVEY, SWITZERLAND:  
3,234,139, MULTIPLE CLASS, INT. CLS. 11, 30 AND 43.  
3,234,378, INT. CL. 11.  
3,235,389, INT. CL. 30.
- SOCIETE FRANCAISE DU RADIOTELEPHONE-SFR, PARIS, FRANCE:  
2,356,546, CANC. MULTIPLE CLASS, INT. CLS. 9, 38 AND 42.
- SOCIETY OF ACCREDITED MARINE SURVEYORS, INCORPORATED, JACKSONVILLE, FL:  
2,058,550, REN. 3-22-07. U.S. CL. B.

- SOCIÉTÉ DE CONSEILS DE RECHERCHES ET D'APPLICATIONS SCIENTIFIQUES (S.C.R.A.S.), FRANCE:  
3,233,529, PUB. 2-6-2007. MULTIPLE CLASS, INT. CLS. 5, 16, 38, 41, 42 AND 44.
- SOCK PUPPET STUDIO, INC., HOFFMAN ESTATES, IL:  
3,233,894, INT. CL. 41.
- SODEXHO OPERATIONS, LLC, GAITHERSBURG, MD:  
3,232,382, PUB. 2-6-2007. INT. CL. 36.
- SOFTTEL-USA, NORWALK, CT:  
3,232,895, PUB. 2-6-2007. INT. CL. 9.
- SOFTWARE HORIZONS INC, N BILLERICA, MA:  
2,035,040. REN. 3-21-07. INT. CL. 9.
- SOFTWARE NUGGETS, INC., PONTE VEDRA BEACH, FL:  
3,232,448, PUB. 2-6-2007. INT. CL. 16.
- SOGESPROM SA, FRANCE:  
3,233,712, PUB. 2-6-2007. MULTIPLE CLASS, INT. CLS. 14, 16 AND 18.
- SOHMER, SHARON, WESTMINSTER, CA:  
3,232,263, PUB. 2-6-2007. INT. CL. 41.
- SOLARAY, INC., PARK CITY, UT:  
2,035,659. REN. 3-21-07. INT. CL. 5.
- SOLAS SCIENCE & ENGINEERING CO., LTD., TAICHUNG, TAIWAN:  
3,234,503, INT. CL. 12.
- SOLID OAK SOFTWARE, INC., SANTA BARBARA, CA:  
2,357,567, CANC. INT. CL. 9.
- SOLIDUS NETWORKS, INC., SAN FRANCISCO, CA:  
3,233,866, INT. CL. 36.
- SOLINTIX, INC., ENCINO, CA:  
3,232,772, PUB. 2-6-2007. INT. CL. 42.
- SOLTON, MIKE, NEWPORT BEACH, CA:  
2,357,591, CANC. INT. CL. 35.  
2,357,605, CANC. INT. CL. 35.
- SOLVE IT, LLP, LAKEWOOD, CO:  
3,232,148, PUB. 2-6-2007. INT. CL. 42.
- SOMA BEVERAGE COMPANY, LLC, SAN FRANCISCO, CA:  
3,233,056, PUB. 2-6-2007. INT. CL. 32.
- SOMALIFE INTERNATIONAL, INC., TUMWATER, WA:  
3,232,999, PUB. 2-6-2007. INT. CL. 3.
- SOMFY SAS, FRANCE:  
3,233,760, PUB. 2-6-2007. INT. CL. 9.
- SONA MEDSPA INTERNATIONAL, INC., FRANKLIN, TN:  
3,232,255, PUB. 2-6-2007. INT. CL. 44.  
3,232,256, PUB. 2-6-2007. INT. CL. 44.  
3,234,067, INT. CL. 44.
- SONAGE, INC., CHATSWORTH, CA:  
2,030,083. REN. 3-17-07. INT. CL. 3.
- SONESTA INTERNATIONAL HOTELS CORPORATION, BOSTON, MA:  
1,055,293. REN. 3-19-07. INT. CL. 41.
- SONIA, S.A., 56131 BONREPOS, VALENCIA, SPAIN:  
3,205,040, COR. INT. CL. 21.
- SONNENTOR KRÄUTERHANDELS GESELLSCHAFT M.B.H., AUSTRIA:  
3,233,518, PUB. 10-18-2005. INT. CL. 30.
- SONNIER, NATHANIEL GERARD, LADERA RANCH, CA:  
3,234,103, MULTIPLE CLASS, INT. CLS. 25 AND 35.
- SONTGERATH, MELINDA, VASHON, WA:  
3,232,936, PUB. 2-6-2007. INT. CL. 43.
- SONY COMPUTER ENTERTAINMENT AMERICA INC., FOSTER CITY, CA:  
2,356,956, CANC. INT. CL. 9.
- SONY KABUSHIKI KAISHA, TOKYO, JAPAN, TA SONY CORPORATION:  
3,233,983, INT. CL. 9.  
3,235,121, INT. CL. 9.
- SOPHIS INC, NEW YORK, NY:  
3,234,283, INT. CL. 9.
- SOTAS, INC., GAITHERSBURG, MD:  
1,979,793, CANC. INT. CL. 9.
- SOURCEFINDER, INC., SAN DIEGO, CA:  
2,356,542, CANC. INT. CL. 38.
- SOURCINGPARTNER, INC., MCKINNEY, TX:  
3,233,812, INT. CL. 16.
- SOUTH EXCHANGE, INC., MIAMI, FL, DBA SOUTH REMESSA INSTANTANEA:  
2,357,630, CANC. INT. CL. 36.
- SOUTH EXCHANGE, INC., MIAMI, FL:  
2,357,631, CANC. INT. CL. 36.
- SOUTH FLORIDA MEDIA GROUP, LLC, BOCA RATON, FL:  
3,235,488, MULTIPLE CLASS, INT. CLS. 16 AND 41.
- SOUTHEAST BEDDING COMPANY, COLUMBUS, GA:  
3,233,870, INT. CL. 20.
- SOUTHERN AGRICULTURAL INSECTICIDES INC., PALMETTO, FL:  
3,234,879, INT. CL. 5.
- SOUTHERN BLOOMER, MFG. CO., BRISTOL, TN:  
3,232,156, PUB. 2-6-2007. MULTIPLE CLASS, INT. CLS. 21 AND 25.
- SOUTHERN CALIFORNIA FOAM, INC., BREA, CA, DBA LAZY PET PRODUCTS:  
1,979,501, CANC. INT. CL. 20.
- SOUTHERN CALIFORNIA GAS COMPANY, LOS ANGELES, CA:  
2,358,426, CANC. INT. CL. 39.
- SOUTHERN DIGITAL SERVICES, INC., FRANKLIN, TN:  
2,358,611, CANC. INT. CL. 9.
- SOUTHERN FIELDS ALOE INC., MERCEDES, TX:  
2,031,978. REN. 3-22-07. INT. CL. 31.
- SOUTHERN FRESH PRODUCE LIMITED, PUKEKOHE, NEW ZEALAND:  
2,357,908, CANC. INT. CL. 29.
- SOUTHERN FRIED ICE CREAM, LLC, HOMOSASSA, FL:  
3,234,745, INT. CL. 30.
- SOUTHERN GOSPEL MUSIC ASSOCIATION, BOONE, NC:  
2,004,867. REN. 3-20-07. INT. CL. 42.
- SOUTHERN GROUP ENTERPRISES, LLC, MIAMI, FL:  
3,234,054, INT. CL. 5.
- SOUTHERN LIVING, INC., BIRMINGHAM, AL:  
1,396,751, CANC. INT. CL. 16.
- SOUTHERN MOTION, INC., TUPELO, MS:  
2,104,285. REN. 3-16-07. INT. CL. 20.
- SOUTHERN TIER IPA, INC., OLEAN, NY:  
2,357,884, CANC. INT. CL. 35.
- SOUTHWEST FEED PRODUCTS, INC., JULESBURG, CO:  
2,357,609, CANC. INT. CL. 1.
- SOUTHWEST FIREBIRD, INC., SCOTTSDALE, AZ:  
3,232,221, PUB. 2-6-2007. INT. CL. 11.
- SOUTHWEST ONCOLOGY GROUP, ANN ARBOR, MI:  
3,233,460, PUB. 2-6-2007. INT. CL. 42.
- SOUTHWEST SECURITIES GROUP, INC., DALLAS, TX:  
2,357,296, CANC. INT. CL. 36.
- SOUTHWESTERN FIREARMS, INC., RED OAK, TX:  
3,233,198, PUB. 2-6-2007. INT. CL. 9.
- SPACE BEACH CLUB, S.A., SPAIN:  
3,233,552, PUB. 1-23-2007. INT. CL. 41.
- SPACEAGE SYNTHETICS, INC., WAHPETON, ND:  
2,356,598, CANC. INT. CL. 19.
- SPANGLER, GREGORY D., CORONA, CA:  
3,233,946, INT. CL. 25.
- SPANLINK COMMUNICATIONS, INC., MINNEAPOLIS, MN:  
3,234,435, INT. CL. 35.
- SPANSET, INC., SANFORD, NC:  
2,358,757, CANC. INT. CL. 22.  
2,358,758, CANC. INT. CL. 22.
- SPARTAN TOOL, L.L.C., DOWNERS GROVE, IL:  
3,233,269, PUB. 2-6-2007. INT. CL. 41.
- SPATIAL TECHNOLOGY, INC., BOULDER, CO:  
2,356,981, CANC. INT. CL. 42.
- SPCA INTERNATIONAL, INC., WILMINGTON, DE:  
3,233,155, PUB. 2-6-2007. INT. CL. 36.
- SPCN, INC., COSTA MESA, CA:  
3,234,334, INT. CL. 12.
- SPEAKER ACQUISITION SUB, A CAYMAN ISLAND CORPORATION, SANTA FE SPRINGS, CA:  
2,357,875, CANC. INT. CL. 9.
- SPECIAL SPRINGS S.R.L., ITALY:  
3,233,647, PUB. 2-6-2007. MULTIPLE CLASS, INT. CLS. 6 AND 7.
- SPECIALTY CONSTRUCTION BRANDS, INC., SAINT PAUL, MN:  
3,233,149, PUB. 2-6-2007. INT. CL. 2.

- SPECIALTY LOOSE LEAF, INC., HOLYOKE, MA:  
2,357,856, CANC. INT. CL. 16.
- SPECIALTY PRODUCTS OF GREENWOOD, MISSOURI  
INC. GREENWOOD, MO, SPECIALTY PRODUCTS OF  
GREENWOOD, MISSOURI, INC., GREENWOOD, MO:  
2,032,443. REN. 3-21-07. INT. CL. 17.
- SPECIALTY ULTRAVISION, INC., CAMPBELL, CA:  
2,358,789, CANC. INT. CL. 5.
- SPECTRUM SURGICAL INSTRUMENTS CORP., STOW, OH:  
3,233,854, INT. CL. 21.
- SPEEDRACK PRODUCTS GROUP, LTD., SPARTA, MI:  
831,047. REN. 3-17-07. U.S. CL. 32 (INT. CL. 20).
- SPENCER, COLLIN C, NEW YORK, NY:  
3,235,270, INT. CL. 25.
- SPER CHEMICAL CORPORATION, CLEARWATER, FL:  
3,232,879, PUB. 2-6-2007. INT. CL. 1.
- SPERBER, JOSHUA D., BERKELEY, CA AND MANDEL,  
LEV L., BERKELEY, CA:  
3,235,264, INT. CL. 25.
- SPG ARSENAL, LP, INDIANAPOLIS, IN, WATERTOWN  
ARSENAL ASSOCIATES, L.P., NEWTON, MA:  
2,123,774. REN. 3-22-07. INT. CL. 36.
- SPIN MASTER LTD., TORONTO, ONTARIO, CANADA:  
3,232,572, PUB. 2-6-2007. INT. CL. 31.  
3,232,600, PUB. 2-6-2007. INT. CL. 28.
- SPINETRONICS LLC, PARKLAND, FL:  
3,235,272, INT. CL. 10.
- SPIRAX-SARCO, LTD., GLOUCESTERSHIRE, GREAT  
BRITAIN, GERVAISE INSTRUMENTS LIMITED, CRAN-  
LEIGH, SURREY, ENGLAND:  
1,057,437. REN. 3-21-07. INT. CL. 9.
- SPIRUS MEDICAL INC., STOUGHTON, MA:  
3,234,829, INT. CL. 10.
- SPLICED NETWORKS LLC, ATHENS, OH:  
3,232,559, PUB. 2-6-2007. INT. CL. 9.
- SPOELSTRA, DUANE, LANCASTER, CA:  
3,233,860, INT. CL. 25.
- SPOLETO FRANCHISING LTDA., RIO DE JANEIRO, BRA-  
ZIL:  
3,232,092, PUB. 1-17-2006. INT. CL. 43.
- SPOMO INC., ALTOONA, IA, DBA KIN FOLKS TEXAS BBQ:  
3,233,252, PUB. 2-6-2007. INT. CL. 43.
- SPORTS SOURCE, INC., TORRANCE, CA:  
3,234,885, MULTIPLE CLASS, INT. CLS. 9, 25 AND 28.
- SPORTS@HOME, L.L.C, EVANSTON, IL:  
2,358,414, CANC. INT. CL. 41.
- SPORTSCOPE, INC., CHICAGO, IL:  
2,358,706, CANC. INT. CL. 9.  
2,358,707, CANC. INT. CL. 9.  
2,358,708, CANC. INT. CL. 9.
- SPP PUMPS LIMITED, READING BERKSHIRE RG31 7SP,  
UNITED KINGDOM:  
3,234,444, INT. CL. 7.
- SPPC PARIS BLEU, PARIS, FRANCE:  
3,235,229, INT. CL. 3.
- SPREAD MAGAZINE, NEW YORK, NY:  
3,233,351, PUB. 2-6-2007. INT. CL. 16.
- SPRING HILL NURSERIES LLC, GUILFORD, IN, SPRING  
HILL NURSERIES COMPANY, PEORIA, IL:  
2,043,668. REN. 3-17-07. INT. CL. 1.
- SPRINGBOARD NON-PROFIT CONSUMER CREDIT MAN-  
AGEMENT, INC., RIVERSIDE, CA:  
3,235,162, INT. CL. 36.
- SPRINGER-VERLAG GMBH, FED REP GERMANY:  
3,233,543, PUB. 2-6-2007. MULTIPLE CLASS, INT. CLS. 9,  
16 AND 41.
- SPRINT COMMUNICATIONS COMPANY L.P., KANSAS  
CITY, MO:  
1,979,560, CANC. INT. CL. 6.
- SPYDER ACTIVE SPORTS, INC., BOULDER, CO:  
3,233,490, PUB. 2-6-2007. INT. CL. 25.
- SPYDERCO, INC., GOLDEN, CO:  
2,033,317. REN. 3-22-07. INT. CL. 8.
- SQUILLACE PRODUCTION STUDIOS LLC, BURBANK, CA:  
3,234,485, INT. CL. 9.
- SRA INTERNATIONAL, INC., FAIRFAX, VA:  
2,094,996. REN. 3-21-07. INT. CL. 9.
- SRAM CORPORATION, CHICAGO, IL:  
2,041,768. REN. 3-19-07. INT. CL. 25.
- SSI VENTURE LLC, DENVER, CO:  
3,233,042, PUB. 2-6-2007. MULTIPLE CLASS, INT. CLS. 35  
AND 41.
- SSPC: THE SOCIETY FOR PROTECTIVE COATINGS, PITTS-  
BURGH, PA:  
3,232,705, PUB. 2-6-2007. INT. CL. 41.
- ST ANDREWS LINKS LIMITED, FIFE KY16 9SF, UNITED  
KINGDOM:  
3,233,846, INT. CL. 33.
- ST. MARY'S HEALTH CARE SYSTEM, INC., ATHENS, GA:  
3,233,797, INT. CL. 44.
- STA TRAVEL, INC., LOS ANGELES, CA:  
3,232,878, PUB. 2-6-2007. MULTIPLE CLASS, INT. CLS. 39  
AND 43.
- STA-RITE INDUSTRIES, LLC, DELAVAN, WI:  
3,233,499, PUB. 2-6-2007. INT. CL. 7.
- STAATLICHES HOFBRAUHAUS IN MÜNCHEN, 81829  
MÜNCHEN, FED REP GERMANY:  
3,233,677, PUB. 2-6-2007. MULTIPLE CLASS, INT. CLS. 9,  
14, 16, 18, 21, 24, 25, 28, 32, 42 AND 43.
- STAHL INTERNATIONAL B.V., NL-5145 PE WAALWIJK,  
NETHERLANDS:  
3,233,681, PUB. 2-6-2007. INT. CL. 1.
- STAN WINSTON STUDIO, INC., VAN NUYS, CA:  
2,356,878, CANC. INT. CL. 41.
- STANDARD HOMEOPATHIC COMPANY, LOS ANGELES,  
CA:  
3,234,210, INT. CL. 5.
- STANDARD PROCESS INC., PALMYRA, WI:  
2,031,716. REN. 3-20-07. INT. CL. 5.
- STANDARD SAFETY EQUIPMENT COMPANY,  
MCHENRY, IL:  
821,799. REN. 3-17-07. MULTIPLE CLASS, U.S. CLS. 34  
(INT. CL. 11), 39 (INT. CLS. 10, 25 AND 26) AND 50  
(INT. CLS. 3, 6, 14, 16, 17, 19, 20, 21, 22, 24, 26, 27 AND  
28).  
821,799, CANC. MULTIPLE CLASS, U.S. CLS. 2 AND 44.
- STAR BEVERAGES PTY LIMITED, SILVERDALE, AUS-  
TRALIA:  
3,234,527, INT. CL. 33.
- STARBUCKS U.S. BRANDS, LLC, MINDEN, NV, STAR-  
BUCKS CORPORATION, SEATTLE, WA, DBA STAR-  
BUCKS COFFEE COMPANY:  
2,035,005. REN. 3-20-07. INT. CL. 42.
- STARENT NETWORKS CORP., TEWKSBURY, MA:  
3,232,829, PUB. 2-6-2007. INT. CL. 9.
- STARGLOW PRODUCTIONS INC., WOODLAND HILLS,  
CA:  
3,233,801, MULTIPLE CLASS, INT. CLS. 9 AND 16.
- STARMARK INTERNATIONAL, INC., DANIA, FL:  
3,234,404, MULTIPLE CLASS, INT. CLS. 9 AND 35.
- STARR MAP COMPANY, LLC, ANACORTES, WA:  
3,234,851, INT. CL. 42.
- STARZ CLUB LTD., OAK BROOK, IL:  
2,357,782, CANC. INT. CL. 30.
- STATE INDUSTRIAL PRODUCTS CORPORATION, CLEVE-  
LAND, OH:  
1,057,340. REN. 3-21-07. INT. CL. 5.
- STATE STREET CORPORATION, BOSTON, MA, STATE  
STREET BOSTON CORPORATION, BOSTON, MA:  
2,040,332. REN. 3-22-07. INT. CL. 36.
- STATECRAFT INTERNATIONAL INC., PORT VILA, VA-  
NUATU:  
2,496,403, CANC. INT. CL. 26.  
2,502,143, CANC. INT. CL. 26.
- STATUE OF RESPONSIBILITY FOUNDATION, SALT LAKE  
CITY, UT:  
3,234,872, INT. CL. 36.
- STAUBI, PAUL W., RYE, NY:  
3,234,778, INT. CL. 36.
- STE. MICHELLE WINE ESTATES LTD., WOODINVILLE,  
WA:  
3,233,225, PUB. 2-6-2007. INT. CL. 33.
- STEDIM S.A., AUBAGNE, FRANCE:  
1,366,524. REN. 3-16-07. INT. CL. 10.

- STEFAN EBELING, FED REP GERMANY:  
3,233,523, PUB. 2-6-2007. MULTIPLE CLASS, INT. CLS. 3, 14, 18 AND 25.
- STEFANO, A TASTE OF ITALY, INC., PITTSBURGH, PA:  
2,358,274, CANC. INT. CL. 30.
- STEGER DESIGNS, INC., ELY, MN:  
3,234,683, INT. CL. 25.
- STEIN, GREG, LOS ANGELES, CA:  
3,234,060, INT. CL. 44.
- STEIN, RONALD B., BOCA RATON, FL:  
3,235,420, INT. CL. 3.
- STEINEL GMBH, D-4836 HERZEBROCK 1, FED REP GERMANY:  
3,234,026, INT. CL. 7.
- STEINEL GMBH, D 4836 HERZEBROCK I, FED REP GERMANY:  
3,234,027, INT. CL. 11.
- STELLAR PRIVATE CABLE SYSTEMS, INC., AKRON, OH:  
2,121,445, REN. 3-19-07. INT. CL. 9.  
2,125,383, REN. 3-19-07. INT. CL. 41.
- STEPS DELAWARE LIMITED, NEW YORK, NY:  
3,233,177, PUB. 2-6-2007. INT. CL. 25.  
3,233,203, PUB. 2-6-2007. INT. CL. 25.
- STERIS INC., TEMECULA, CA, VESTAL CHEMICAL COMPANY, ST. LOUIS, MO:  
426,932, REN. 3-22-07. U.S. CL. 6 (INT. CL. 5).
- STERLING DIRECT, INC., EARTH CITY, MO:  
2,356,808, CANC. INT. CL. 35.
- STERLING GIFTWARE, INC., WHITE PLAINS, NY:  
2,358,480, CANC. INT. CL. 28.
- STERLING PUBLISHING CO., INC., NEW YORK, NY:  
3,234,740, INT. CL. 16.  
3,234,746, INT. CL. 16.
- STEVE M. WILSON, O.D., P.C., VALDOSTA, GA:  
2,357,538, CANC. INT. CL. 42.
- STEVENS, GARY M., LONG BEACH, CA:  
3,234,653, INT. CL. 41.
- STEWART TITLE GUARANTY COMPANY, HOUSTON, TX:  
3,232,432, PUB. 2-6-2007. MULTIPLE CLASS, INT. CLS. 9 AND 36.
- STILLWATER DESIGNS & AUDIO, INC., STILLWATER, OK:  
2,356,786, CANC. INT. CL. 9.
- STO-COTE PRODUCTS, INC., GENOA CITY, WI:  
2,084,146, REN. 3-21-07. INT. CL. 17.
- STOKELY-VAN CAMP, INC., CHICAGO, IL:  
1,980,081, CANC. MULTIPLE CLASS, INT. CLS. 14, 18, 21, 25 AND 28.  
3,235,334, INT. CL. 32.
- STOLOSKI, DANIEL, SACRAMENTO, CA AND PHILLIPS, JOSH, SACRAMENTO, CA:  
3,234,343, INT. CL. 25.
- STONE MOUNTAIN CARPET MILLS, INC., EARTH CITY, MO:  
3,232,961, PUB. 2-6-2007. INT. CL. 35.
- STONE, JOYCE, PROVO, UT, DBA BRIARWOOD INTERNATIONAL:  
3,234,894, INT. CL. 41.
- STOORZA, ZIEGAUS & METZGER, INC., SAN DIEGO, CA:  
2,358,595, CANC. INT. CL. 35.
- STORK TOWNSEND INC., DES MOINES, IA:  
3,235,232, INT. CL. 40.
- STORM DEPOT OF AMERICA, INC., MELBOURNE, FL, DBA STORM-BUSTERS:  
3,232,216, PUB. 2-6-2007. INT. CL. 6.
- STOUT, ARTHUR RICHARD, JR., PENNINGTON, NJ:  
2,357,766, CANC. INT. CL. 41.
- STOXX LIMITED, 8001 ZURICH, SWITZERLAND:  
2,460,543, CANC. INT. CL. 9.
- STRASBURGER ENTERPRISES, INC., TEMPLE, TX:  
2,356,464, CANC. INT. CL. 30.
- STRATAGENE CALIFORNIA, LA JOLLA, CA:  
3,234,956, INT. CL. 1.
- STRATEGIC DIAGNOSTICS INC., NEWARK, DE:  
3,232,612, PUB. 2-6-2007. MULTIPLE CLASS, INT. CLS. 40 AND 42.
- STRATEGIC DISTRIBUTION INC., GREENWICH, CT:  
1,979,512, CANC. INT. CL. 42.
- STRATEGIC REAL ESTATE ADVISORS LIMITED, LONDON, UNITED KINGDOM:  
3,234,321, INT. CL. 36.
- STRATEGY GOLF, LTD., DENTON, NC:  
2,358,550, CANC. INT. CL. 41.
- STREAM GAS AND ELECTRIC, LTD., DALLAS, TX:  
3,234,472, INT. CL. 39.
- STUCK, JAY, PALM BEACH, FL:  
3,233,238, PUB. 2-6-2007. INT. CL. 35.
- STUDIO EL NINO, INC., NEW YORK, NY:  
3,234,507, INT. CL. 28.
- STUDIO INTERACTIVE, INC., HOLLYWOOD, CA:  
2,357,861, CANC. INT. CL. 28.
- STULLER, INC., LAFAYETTE, LA:  
3,234,029, INT. CL. 14.  
3,234,030, INT. CL. 14.
- STYLAIR, LLC, MANHASSET, NY:  
3,234,090, MULTIPLE CLASS, INT. CLS. 6, 14, 16 AND 26.
- STYLE AGENT, SANTA FE, NM:  
3,232,593, PUB. 2-6-2007. INT. CL. 42.
- SUBMAR, INC., HOUMA, LA:  
2,025,563, REN. 3-21-07. INT. CL. 19.
- SUBURBAN BAKING COMPANY, INC., ELK GROVE VILLAGE, IL:  
2,357,759, CANC. INT. CL. 30.
- SUBURBAN STEEL CORPORATION, HIGHLAND HEIGHTS, OH:  
1,431,579, REN. 3-20-07. INT. CL. 42.
- SUGAR CREEK PACKING CO., WASHINGTON COURT HOUSE, OH:  
3,233,397, PUB. 2-6-2007. INT. CL. 29.
- SUGAR SUGAR, INC., LAKE MARY, FL:  
3,233,473, PUB. 2-6-2007. INT. CL. 35.
- SUH, INC., HOUSTON, TX:  
2,358,923, CANC. INT. CL. 36.
- SUIMON ENGINEERING CANADA LTD., VANCOUVER, BRITISH COLUMBIA, CANADA:  
2,356,419, CANC. INT. CL. 11.
- SULESKE, CHRISTOPHER A., MECHANICSVILLE, VA:  
3,233,306, PUB. 2-6-2007. INT. CL. 42.
- SULLIVAN, NADINE M, SPOKANE, WA:  
3,234,510, INT. CL. 35.
- SULLIVANT, WAYNE A., UPPER MONTCLAIR, NJ:  
3,232,671, PUB. 2-6-2007. MULTIPLE CLASS, INT. CLS. 35 AND 41.
- SULZER METCO (US) INC., WESTBURY, NY:  
2,035,697, REN. 3-22-07. INT. CL. 1.
- SUMMIT ADVISORS, LLC, BEVERLY FARMS, MA:  
2,356,953, CANC. INT. CL. 36.
- SUN CHEMICAL CORPORATION, NEW YORK, NY:  
1,396,311, CANC. INT. CL. 2.
- SUN LLC, WINTER PARK, FL:  
3,232,724, PUB. 2-6-2007. INT. CL. 43.
- SUN MICROSYSTEMS, INC., MOUNTAIN VIEW, CA:  
2,357,843, CANC. INT. CL. 9.
- SUN RIVER BERRIES, LLC, YAKIMA, WA:  
3,234,965, INT. CL. 31.
- SUN VALLEY GROUP, INC., THE, ARCATA, CA:  
3,233,943, INT. CL. 31.
- SUNBEAM CORPORATION, BOCA RATON, FL:  
2,031,385, REN. 3-19-07. INT. CL. 8.
- SUNBELT COATINGS, INC., PICAYUNE, MS TO VALSPAR REFINISH, INC., PICAYUNE, MS:  
1,979,390, CANC. INT. CL. 2.
- SUNRISE MEDIA LLC, NEW YORK, NY:  
3,232,629, PUB. 2-6-2007. INT. CL. 9.
- SUNRISE MEDICAL, INC., CARLSBAD, CA:  
2,358,339, CANC. INT. CL. 9.
- SUNRISE SKINCARE, LLC, CORRALES, NM:  
3,232,483, PUB. 2-6-2007. INT. CL. 3.
- SUNSTAR AMERICAS, INC., CHICAGO, IL:  
1,979,787, CANC. INT. CL. 5.
- SUNTIGER, INC., CALABASAS, CA:  
3,232,434, PUB. 2-6-2007. INT. CL. 9.
- SUPER ALLOY (USA) CO., LTD., LOS ANGELES, CA, DBA SKM ENTERPRISES, INC.:  
2,358,333, CANC. INT. CL. 28.

- SUPERMAX, INC., AURORA, IL:  
3,233,926, INT. CL. 10.
- SUPERTREND INTERNATIONAL INC., TAIPEI, TAIWAN:  
3,235,271, INT. CL. 20.
- SUPERVALU HOLDINGS, INC., EDEN PRAIRIE, MN:  
3,234,709, INT. CL. 35.
- SUPREME ASSEMBLY, INTERNATIONAL ORDER OF THE RAINBOW FOR GIRLS, INCORPORATED, MCALESTER, OK:  
2,033,581, REN. 3-20-07, INT. CL. 24.
- SUPREME OIL COMPANY, ENGLEWOOD, NJ:  
3,234,807, INT. CL. 29.
- SURATI SWEET MART LIMITED, TORONTO, ONTARIO, CANADA:  
3,234,468, MULTIPLE CLASS, INT. CLS. 29, 30 AND 32.
- SURE THING STABLES, LLC, VERNON HILLS, IL:  
3,235,199, INT. CL. 44.
- SURFACE COMBUSTION, INC., MAUMEE, OH:  
2,037,859, REN. 3-22-07, INT. CL. 11.
- SURFACE PRO, INC., SPARTA, TN:  
2,357,755, CANC. INT. CL. 37.
- SURFACE PROTECTION INDUSTRIES, INC., LOS ANGELES, CA:  
2,357,228, CANC. INT. CL. 35.
- SURGICAL SPECIALTIES CORPORATION, READING, PA, SHARPOINT INC., READING, PA:  
1,425,636, REN. 3-21-07, INT. CL. 10.
- SURRY LICENSING LLC, KEENE, NH:  
1,397,077, CANC. MULTIPLE CLASS, INT. CLS. 35 AND 42.
- SURVEYOR CORP., SAN LUIS OBISPO, CA:  
2,358,521, CANC. INT. CL. 9.
- SUZUKI MOTOR CORPORATION, SHIZUOKA-KEN, JAPAN:  
1,956,864, REN. 3-17-07, INT. CL. 12.
- SUZUKI MOTOR CORPORATION (SUZUKI KABUSHIKI KAISHA), SHIZUOKA-KEN, JAPAN:  
2,724,499, COR. MULTIPLE CLASS, INT. CLS. 6, 16, 18, 24 AND 25.
- SVEHLA, ERNEST JAMES, COLUMBIA, MD:  
2,356,820, CANC. INT. CL. 42.
- SVEJKOVSKY, PAUL A., MARQUEZ, TX:  
2,033,884, REN. 3-20-07, INT. CL. 7.
- SWAROVSKI AKTIENGESELLSCHAFT, LIECHTENSTEIN:  
3,233,546, PUB. 2-6-2007, MULTIPLE CLASS, INT. CLS. 3, 14, 16, 18, 21, 25 AND 41.
- SWARTZ, RUTH, ST. PAUL, MN:  
2,357,139, CANC. INT. CL. 41.
- SWEDISH MATCH UNITED BRANDS AB, STOCKHOLM, SWEDEN, AMERICAN TOBACCO COMPANY, THE, NEW YORK, NY:  
223,213, REN. 3-16-07, U.S. CL. 17 (INT. CL. 34).
- SWEET CANDY COMPANY, SALT LAKE CITY, UT:  
3,235,001, INT. CL. 30.
- SWEET, JOANNE, NEW BRAUNFELS, TX:  
3,233,118, PUB. 2-6-2007, INT. CL. 16.
- SWENSON, NORMAN, CHARLOTTE, NC:  
3,233,764, INT. CL. 41.
- SWIMC, INC., WILMINGTON, DE:  
1,396,273, CANC. INT. CL. 1.
- SWIMC, INC., WILMINGTON, DE, SWIMC, INC., WILMINGTON, DE:  
2,077,000, REN. 3-22-07, INT. CL. 2.
- SWIMC, INC., WILMINGTON, DE:  
2,356,627, CANC. INT. CL. 17.  
3,232,971, PUB. 2-6-2007, INT. CL. 2.
- SWIMC, NIC., WILMINGTON, DE:  
2,357,910, CANC. INT. CL. 16.
- SWINGER INTERNATIONAL S.P.A., ITALY:  
3,233,709, PUB. 2-6-2007, INT. CL. 43.
- SWISHER INTERNATIONAL, INC., JACKSONVILLE, FL:  
763,778, REN. 3-16-07, U.S. CL. 17 (INT. CL. 34).
- SWISS COLONY, INC., THE, MONROE, WI, DBA THE SWISS COLONY:  
642,127, REN. 3-22-07, U.S. CL. 46 (INT. CLS. 29 AND 30).
- SYLVANIA EXPORT CORPORATION N.V., CURACAO, NETHERLD ANTILLES, DBA SYLVANIA LIGHTING INTERNATIONAL:  
2,356,433, CANC. INT. CL. 9.
- SYNDERA CORPORATION, REDWOOD CITY, CA:  
3,234,832, INT. CL. 9.
- SYNDICAT DES PROPRIETAIRES VITICULTEURS DE CHATEAUNEUF-DU-PAPE, 84230 CHATEAUNEUF-DU-PAPE, FRANCE:  
2,097,158, REN. 3-21-07, INT. CL. 33.
- SYNERGENCE, FRANCE:  
3,233,662, PUB. 2-6-2007, MULTIPLE CLASS, INT. CLS. 35, 36, 41 AND 42.
- SYNERGIS TECHNOLOGIES GROUP CORPORATION, GRAND RAPIDS, MI:  
3,233,224, PUB. 2-6-2007, INT. CL. 40.  
3,233,456, PUB. 2-6-2007, INT. CL. 40.
- SYNGENTA CROP PROTECTION, INC., GREENSBORO, NC, ZENECA INC., WILMINGTON, DE:  
2,029,092, REN. 3-17-07, INT. CL. 1.
- SYNGENTA INVESTMENT CORPORATION, GREENSBORO, NC, CIBA-GEIGY CORPORATION, ARDSLEY, NY:  
2,130,815, REN. 3-17-07, INT. CL. 5.
- SYNGENTA LIMITED, BRACKNELL BERKSHIRE, UNITED KINGDOM:  
2,118,653, REN. 3-17-07, INT. CL. 1.
- SYNPLICITY, INC., SUNNYVALE, CA:  
2,358,291, CANC. INT. CL. 9.
- SYNRAD, INC., MUKILTEO, WA:  
2,358,290, CANC. INT. CL. 9.
- SYNTECH PRODUCTS CORPORATION, TOLEDO, OH:  
1,979,170, CANC. INT. CL. 3.
- SYNTELLECT, INC., PHOENIX, AZ:  
2,132,113, REN. 3-22-07, MULTIPLE CLASS, INT. CLS. 38 AND 42.
- SYRATECH CORPORATION, EAST BOSTON, MA:  
925,513, CANC. U.S. CL. 28.
- SYROCO, INC., BALDWINVILLE, NY:  
422,195, REN. 3-16-07, U.S. CL. 32 (INT. CL. 20).
- SYSCO CORPORATION, HOUSTON, TX:  
1,425,188, REN. 3-20-07, INT. CL. 39.  
2,037,583, REN. 3-17-07, INT. CL. 21.  
2,037,584, REN. 3-17-07, INT. CL. 21.
- SYSTEM DEVELOPMENT, INC, HOUSTON, TX:  
2,357,172, CANC. INT. CL. 9.
- SYSTEMS MANAGEMENT SPECIALISTS, INC., SANTA ANA, CA:  
2,357,492, CANC. INT. CL. 42.
- SYSYS CORPORATION, LAKEWOOD, CO:  
2,358,614, CANC. INT. CL. 42.
- SZABO DESIGN COMPANY, INC., LIVINGSTON, NJ:  
1,396,490, CANC. INT. CL. 8.
- T & G GROUP LLC., FOUNTAIN VALLEY, CA:  
3,233,800, INT. CL. 36.
- T.F.H. PUBLICATIONS, INC., NEPTUNE CITY, NJ:  
3,234,877, INT. CL. 31.  
3,235,017, INT. CL. 28.
- T.J. SMITH AND NEPHEW, LIMITED, HULL, ENGLAND:  
1,426,221, REN. 3-22-07, INT. CL. 5.
- TADIM GIDA MADDELERI SANAYI VE TICARET A.S, ISTANBUL, TURKEY:  
3,232,762, PUB. 2-6-2007, MULTIPLE CLASS, INT. CLS. 29 AND 30.
- TAEKWONDO FITNESS CENTER OF DELAWARE INC., BEAR, DE:  
3,233,119, PUB. 2-6-2007, INT. CL. 41.
- TAG TRACK & ID, FRANCE:  
3,233,640, PUB. 2-6-2007, MULTIPLE CLASS, INT. CLS. 9, 38, 39 AND 42.
- TAIWAN GREEN DEVICE CO., LTD., TAIPEI, TAIWAN:  
3,232,199, PUB. 1-23-2007, INT. CL. 2.
- TAIWAN TOBACCO & LIQUOR CORPORATION, TAIPEI, TAIWAN:  
3,233,931, INT. CL. 33.
- TAIZHOU YINGZIDA PLASTICS INDUSTRY CO., LTD, CHINA:  
3,233,586, PUB. 2-6-2007, INT. CL. 24.



- TAIZHOU ZHEDONG MACHINE TOOL ACCESSORY FACTORY CO., LTD, CHINA:  
3,233,592, PUB. 2-6-2007. INT. CL. 7.
- TAK'ASIC S.A., 78284 GUYANCOURT CEDEX, FRANCE:  
2,356,927, CANC. INT. CL. 9.
- TAKE CHARGE AMERICA, INC., PHOENIX, AZ:  
2,005,648. REN. 3-17-07. MULTIPLE CLASS, INT. CLS. 16 AND 41.
- TALARICO, JON P, SANTA MONICA, CA:  
3,234,223, INT. CL. 41.
- TALENT PLUS, INC., LINCOLN, NE, DBA TALENT+, TALENT ONLINE, INC., LINCOLN, NE:  
2,032,573. REN. 3-21-07. INT. CL. 35.
- TALENT PLUS, INC., LINCOLN, NE, DBA TALENT+:  
3,232,094, PUB. 2-6-2007. INT. CL. 35.
- TALLY HO DESIGNS, LTD., NEW YORK, NY:  
3,232,575, PUB. 2-6-2007. MULTIPLE CLASS, INT. CLS. 18 AND 25.
- TANKLESS, INC., SARASOTA, FL:  
2,358,851, CANC. INT. CL. 11.
- TANTALUS CELLARS, INC., SONOMA, CA:  
2,357,362, CANC. INT. CL. 33.
- TAPCO INTERNATIONAL CORPORATION, WIXOM, MI:  
3,234,945, INT. CL. 19.
- TAPER LINE, INC., WARREN, MI:  
1,065,661. REN. 3-21-07. INT. CL. 6.
- TARA'S DREAM LTD., GRAND CAYMAN, CAYMAN ISLANDS:  
3,234,548, INT. CL. 3.
- TARGET BRANDS, INC., MINNEAPOLIS, MN:  
3,233,049, PUB. 2-6-2007. INT. CL. 36.
- TARGETTI SANKEY S.P.A., FIRENZE, ITALY:  
1,396,440, CANC. INT. CL. 6.
- TARHEEL MASONRY INC., SHELBY, NC:  
2,358,689, CANC. INT. CL. 32.
- TARKETT INC., FARNHAM, QUEBEC:  
2,358,373, CANC. INT. CL. 27.
- TASTEBUD ENTERTAINMENT, INC., NEWPORT COAST, CA:  
3,232,371, PUB. 2-6-2007. MULTIPLE CLASS, INT. CLS. 29 AND 30.
- TATIANA AND COMPANY, INC., TINTON FALLS, NJ:  
3,233,479, PUB. 2-6-2007. MULTIPLE CLASS, INT. CLS. 24 AND 25.
- TAYLOR BRANDS, LLC, KINGSPORT, TN:  
1,061,545. REN. 3-22-07. INT. CL. 8.  
1,980,276, CANC. INT. CL. 8.  
1,997,600. REN. 3-22-07. INT. CL. 8.  
3,234,657, INT. CL. 9.
- TAYLOR, DICKIE D., HOUSTON, TX:  
2,357,700, CANC. INT. CL. 41.
- TAYMARK, INC., NORTH MANKATO, MN:  
3,233,193, PUB. 2-6-2007. INT. CL. 35.
- TBAC INVESTMENT TRUST, ARLINGTON, VA, AMITY LEATHER PRODUCTS CO., WEST BEND, WI:  
2,032,901. REN. 3-16-07. INT. CL. 25.
- TBAC INVESTMENT TRUST, ARLINGTON, TX:  
2,357,060, CANC. INT. CL. 18.
- TCAM TECHNOLOGIES, INC., MENTOR, OH:  
1,979,463, CANC. INT. CL. 9.
- TC3 HEALTH, LLC., COSTA MESA, CA:  
3,233,355, PUB. 2-6-2007. MULTIPLE CLASS, INT. CLS. 35, 42 AND 45.
- TEAC CORPORATION, MUSASHINO-SHI, TOKYO, JAPAN:  
2,358,037, CANC. INT. CL. 9.
- TEACHER CREATED RESOURCES, INC., WESTMINSTER, CA:  
3,234,298, INT. CL. 16.
- TEACHER'S PAL, INC., PHOENIX, AZ:  
1,994,120. REN. 3-21-07. INT. CL. 9.
- TEAM RESOURCES, INC., ATLANTA, GA:  
3,234,999, MULTIPLE CLASS, INT. CLS. 16 AND 35.
- TEARDROP GOLF CO., MORTON GROVE, IL:  
2,358,546, CANC. INT. CL. 28.
- TEC WELL SERVICE, INC., LONGVIEW, TX:  
3,232,351, PUB. 2-6-2007. INT. CL. 37.
- TECH S2, INC., LANSING, NY:  
3,232,534, PUB. 2-6-2007. INT. CL. 35.
- TECHNICA CORPORATION, DULLES, VA:  
2,357,437, CANC. MULTIPLE CLASS, INT. CLS. 37 AND 42.
- TECHNICAL CONCEPTS, LLC, MUNDELEIN, IL:  
2,118,525. REN. 3-22-07. INT. CL. 9.
- TECHNICON INSTRUMENTS CORPORATION, TARRY-TOWN, NY:  
1,396,279, CANC. INT. CL. 1.
- TECHNOGENIA, 74410 SAINT JORIOZ, FRANCE:  
2,395,428, CANC. INT. CL. 9.
- TECHNOLOGY PARTNERS INTERNATIONAL INC., HOUSTON, TX:  
2,357,214, CANC. INT. CL. 35.
- TECHSOLVE, INC., CINCINNATI, OH:  
3,233,192, PUB. 2-6-2007. INT. CL. 42.
- TECHSONIC INDUSTRIES, INC., EUFAULA, AL:  
1,397,236, CANC. INT. CL. 9.
- TECUMSEH PRODUCTS COMPANY, TECUMSEH, MI:  
2,086,390. REN. 3-16-07. INT. CL. 7.
- TEDESCHI, BRUCE, SAN DIEGO, CA:  
2,357,144, CANC. INT. CL. 42.
- TEFAL S.A., 74150 RUMILLY, FRANCE:  
2,356,675, CANC. INT. CL. 21.
- TEIHO TECHNO PRODUCTS LIMITED, CHUO-KU, OSAKA, JAPAN:  
1,431,954. REN. 3-16-07. INT. CL. 17.
- TEL CONTROL, INC., HUNTSVILLE, AL:  
3,235,348, INT. CL. 9.
- TELCO COMMUNICATIONS GROUP, INC., CHANTILLY, VA:  
2,356,418, CANC. INT. CL. 38.
- TELCORDIA TECHNOLOGIES, INC., MORRISTOWN, NJ:  
2,356,510, CANC. INT. CL. 9.
- TELECOM VENTURE GROUP LIMITED, CENTRAL, HONG KONG:  
2,358,844, CANC. INT. CL. 36.
- TELEDYNE INDUSTRIES, INC., LOS ANGELES, CA:  
1,396,442, CANC. INT. CL. 6.
- TELEFFICIENT CORPORATION, COUNTRYSIDE, IL, DBA THE PHONE PLACE:  
1,979,262, CANC. MULTIPLE CLASS, INT. CLS. 37 AND 42.
- TELEFONICA MULTIMEDIA S.A.C., LIMA, PERU:  
3,232,500, PUB. 10-3-2006. MULTIPLE CLASS, INT. CLS. 38 AND 41.
- TELEGLOBE BERMUDA LTD, HAMILTON, BERMUDA:  
2,032,478. REN. 3-21-07. INT. CL. 38.
- TELEGLOBE BERMUDA LTD, HAMILTON, BERMUDA, TELEGLOBE CANADA INC., MONTREAL (QUEBEC), CANADA:  
2,032,489. REN. 3-22-07. INT. CL. 38.
- TELEQUIP CORPORATION, SALEM, NH:  
2,064,654. REN. 3-22-07. INT. CL. 9.
- TELEVISA SA. DE C.V., COLONIA ZEDEC SANTA FE, MEXICO, D.F., MEXICO:  
3,234,336, INT. CL. 9.
- TELIGENCE (CANADA), INC., VANCOUVER, CANADA:  
3,232,651, PUB. 2-6-2007. INT. CL. 38.
- TELLABS OPERATIONS, INC., LISLE, IL:  
2,357,980, CANC. MULTIPLE CLASS, INT. CLS. 37, 41 AND 42.
- TELSERVE, INC., CLEVELAND, OH:  
2,358,887, CANC. INT. CL. 35.
- TEMERLIN MCCLAIN LP, IRVING, TX:  
2,356,758, CANC. INT. CL. 35.
- TEMPLE UNIVERSITY - OF THE COMMONWEALTH SYSTEM OF HIGHER EDUCATION, PHILADELPHIA, PA:  
3,234,742, MULTIPLE CLASS, INT. CLS. 16, 25 AND 41.
- TEMPO PRODUCTS CO INC, SOLON, OH, TEMPO PRODUCTS COMPANY, CLEVELAND, OH:  
2,035,358. REN. 3-22-07. INT. CL. 9.
- TEMPO PRODUCTS COMPANY, CLEVELAND, OH:  
823,350. REN. 3-22-07. U.S. CL. 23 (INT. CL. 7).
- TEMPO PRODUCTS COMPANY, CLEVELAND, OH, TEMPO PRODUCTS COMPANY, CLEVELAND, OH:  
823,351. REN. 3-22-07. U.S. CL. 23 (INT. CL. 7).

- TEMPORARY ACCOUNTING PERSONNEL OF COLORADO, INC., DENVER, CO:  
1,999,659. REN. 3-19-07. INT. CL. 35.
- TENDAIRE INDUSTRIES, INC., BERESFORD, SD:  
3,235,347. INT. CL. 12.
- TENET HEALTHCARE CORPORATION, SANTA BARBARA, CA TO TENET HEALTHCARE CORPORATION, SANTA BARBARA, CA:  
1,979,675. CANC. INT. CL. 41.
- TENG DA TRADING USA INC., NEW YORK, NY:  
3,235,192. INT. CL. 18.
- TENIMENTI AGRICOLA VALDIGREVE S.A.S, DI COMOTTI GIACOMO MINO & C., BRESCIA, ITALY:  
1,426,788. REN. 3-22-07. INT. CL. 33.  
1,426,789. REN. 3-22-07. INT. CL. 33.
- TEODOMIRO DAL NEGRO - FABBRICA CARTE DA GIOCO - S.P.A., ZONA INDUSTRIALE, ITALY:  
1,979,370. CANC. MULTIPLE CLASS, INT. CLS. 16 AND 28.
- TEPER, RICHARD J., MUNDELEIN, IL:  
2,061,906. REN. 3-22-07. INT. CL. 41.
- TEQUILA SAUZA S.A. DE C.V., ZAPOPAN, JALISCO C.P. 45010, MEXICO, TEQUILA SAUZA S.A., JALISCO, MEXICO:  
1,057,158. REN. 3-17-07. INT. CL. 33.
- TERADYNE, INC., BOSTON, MA:  
1,396,618. CANC. INT. CL. 9.  
1,396,619. CANC. INT. CL. 9.  
1,396,620. CANC. INT. CL. 9.
- TERALOGIC, INC., MOUNTAIN VIEW, CA:  
2,358,012. CANC. INT. CL. 9.
- TERRACYCLE, INC., TRENTON, NJ:  
3,234,293. INT. CL. 1.
- TESA ENTRY SYSTEMS, S.L., GUIPUZCOA, SPAIN:  
3,234,107. MULTIPLE CLASS, INT. CLS. 6, 9, 37 AND 42.
- TEXAS CHEERLEADING ASSOCIATION, INC., BACLIFF, TX, DBA TCA CORPORATION:  
3,232,282. PUB. 2-6-2007. INT. CL. 41.
- TEXAS FARM PRODUCTS COMPANY, NACOGDOCHES, TX:  
2,357,449. CANC. INT. CL. 31.  
2,357,450. CANC. INT. CL. 31.
- TEXSTEAM INC., HOUSTON, TX:  
1,396,481. CANC. INT. CL. 7.
- TEXTRON FASTENING SYSTEMS LIMITED, WELWYN GARDEN CITY, GREAT BRITAIN:  
2,060,869. REN. 3-21-07. INT. CL. 7.
- TEXTRON INNOVATIONS INC., PROVIDENCE, RI:  
2,037,815. REN. 3-22-07. INT. CL. 12.
- TEXVA, INC., PLANO, TX:  
2,356,914. CANC. INT. CL. 3.
- TGI ACQUISITIONS CORPORATION, CHICAGO, IL:  
2,357,880. CANC. MULTIPLE CLASS, INT. CLS. 19, 20 AND 42.
- TH&M ADVERTISING, INC., TUSTIN, CA:  
2,358,382. CANC. INT. CL. 35.
- THADANI, MOHAN J., MISSISSAUGA, ONTARIO L5N 6P2, CANADA:  
2,358,883. CANC. INT. CL. 9.
- THATCHER, MARK, FLAGSTAFF, AZ:  
2,358,376. CANC. INT. CL. 25.
- THE ALLEGHENY COUNTY BAR ASSOCIATION, PITTSBURGH, PA:  
3,235,349. INT. CL. 16.
- THE AMERICAN BREAST CANCER FOUNDATION, INC., BALTIMORE, MD:  
3,232,518. PUB. 2-6-2007. INT. CL. 36.
- THE ASSOCIATED PRESS, NEW YORK, NY:  
3,232,716. PUB. 2-6-2007. MULTIPLE CLASS, INT. CLS. 38 AND 41.
- THE BANDANA CO., INC., LOUISVILLE, KY:  
3,234,973. MULTIPLE CLASS, INT. CLS. 6, 9 AND 16.
- THE BARKING DOG, LTD., HOOKSETT, NH:  
3,233,444. PUB. 2-6-2007. INT. CL. 44.  
3,233,447. PUB. 2-6-2007. INT. CL. 41.
- THE BOEING MANAGEMENT COMPANY, SEAL BEACH, CA, BOEING COMPANY, THE, SEATTLE, WA:  
2,030,687. REN. 3-16-07. INT. CL. 9.
- THE BURTON CORPORATION, BURLINGTON, VT:  
3,232,894. PUB. 2-6-2007. MULTIPLE CLASS, INT. CLS. 9, 25 AND 28.
- THE CAPITAL GOLD GROUP, SHERMAN OAKS, CA:  
3,232,920. PUB. 2-6-2007. MULTIPLE CLASS, INT. CLS. 14 AND 36.  
3,232,921. PUB. 2-6-2007. MULTIPLE CLASS, INT. CLS. 14 AND 36.  
3,232,922. PUB. 2-6-2007. MULTIPLE CLASS, INT. CLS. 14 AND 36.
- THE CHAMBELRLAN GROUP, INC., ELRMHURST, IL:  
3,162,966. COR. INT. CL. 9.
- THE CHEN FAMILY LIMITED PARTNERSHIP, HENDERSON, NV:  
3,234,330. MULTIPLE CLASS, INT. CLS. 6, 20, 21 AND 28.
- THE CINCINNATI INSURANCE COMPANY, CINCINNATI, OH:  
3,232,271. PUB. 2-6-2007. INT. CL. 36.
- THE COACHES TRAINING INSTITUTE, SAN RAFAEL, CA:  
3,234,187. INT. CL. 41.
- THE COCA-COLA COMPANY, ATLANTA, GA:  
3,232,602. PUB. 2-6-2007. INT. CL. 32.  
3,235,391. INT. CL. 41.
- THE COSMONAUT CORP., ISLINGTON, ONTARIO, CANADA:  
3,232,064. PUB. 2-15-2005. INT. CL. 25.
- THE CRUCIBLE GROUP, INC., PITMAN, NJ:  
3,233,480. PUB. 2-6-2007. INT. CL. 9.
- THE CULTURED CUP, INC., DALLAS, TX:  
3,232,187. PUB. 2-6-2007. INT. CL. 30.
- THE DEAL, LLC, NEW YORK, NY:  
3,232,932. PUB. 2-6-2007. INT. CL. 16.
- THE DOW CHEMICAL COMPANY, MIDLAND, MI:  
3,235,278. INT. CL. 5.
- THE ELDRED CORPORATION, MILAN, IL, DBA FOLDA-TANK COMPANY:  
3,232,141. PUB. 2-6-2007. INT. CL. 20.
- THE FEDERATED GROUP, INC., ARLINGTON HEIGHTS, IL:  
3,235,101. INT. CL. 29.
- THE FORCE, INC., HUNTSVILLE, AL:  
3,233,448. PUB. 2-6-2007. INT. CL. 9.  
3,233,455. PUB. 2-6-2007. MULTIPLE CLASS, INT. CLS. 9 AND 41.
- THE GILLETTE COMPANY, BOSTON, MA:  
3,235,013. INT. CL. 9.
- THE GIRAFFE PROJECT, INC., LANGLEY, WA:  
3,234,239. INT. CL. 9.
- THE HOMER LAUGHLIN CHINA COMPANY, NEWELL, WV:  
3,235,380. INT. CL. 21.
- THE HUMPHREYS GROUP, SAN FRANCISCO, CA:  
3,232,571. PUB. 2-6-2007. INT. CL. 36.
- THE INSTITUTE FOR WEALTH MANAGMENT, LLC, DENVER, CO:  
3,232,265. PUB. 2-6-2007. INT. CL. 36.
- THE INSTITUTE OF CULINARY EDUCATION, INC., NEW YORK, NY:  
3,233,055. PUB. 2-6-2007. MULTIPLE CLASS, INT. CLS. 41 AND 43.
- THE INTERNATIONAL GROUP, INC., WAYNE, PA, BOLER PETROLEUM COMPANY, WAYNE, PA:  
1,435,243. REN. 3-22-07. INT. CL. 4.
- THE KAHLUA COMPANY, WILMINGTON, DE:  
3,234,124. INT. CL. 30.
- THE KENNEDY CENTER FOR REAL ESTATE EDUCATION, INC., ATLANTA, GA:  
3,235,443. INT. CL. 41.
- THE KILLION CORPORATION, INDIANAPOLIS, IN:  
3,235,286. INT. CL. 20.
- THE KROGER CO. OF MICHIGAN, LIVONIA, MI:  
3,234,765. INT. CL. 30.
- THE LAMPO GROUP, INC., BRENTWOOD, TN:  
3,233,048. PUB. 2-6-2007. INT. CL. 41.
- THE LARYNGEAL MASK COMPANY LIMITED, VICTORIA, MAHE, SEYCHELLES:  
3,234,339. INT. CL. 10.

- THE MAJOR AUTOMOTIVE COMPANIES, INC., LONG ISLAND CITY, NY:  
3,233,283, PUB. 2-6-2007. INT. CL. 35.  
3,233,288, PUB. 2-6-2007. INT. CL. 35.
- THE MAKERY, DENVER, CO:  
3,235,108, MULTIPLE CLASS, INT. CLS. 30 AND 35.
- THE MALISH CORPORATION, WILLOUGHBY, OH:  
3,232,244, PUB. 2-6-2007. INT. CL. 21.
- THE MCGRAW-HILL COMPANIES, INC., NEW YORK, NY, MCGRAW-HILL, INC., NEW YORK, NY:  
2,049,590. REN. 3-22-07. INT. CL. 28.
- THE MCGRAW-HILL COMPANIES, INC., NEW YORK, NY:  
3,234,607, INT. CL. 36.
- THE MCLEAN HOSPITAL CORPORATION, BELMONT, MA:  
3,234,564, INT. CL. 16.
- THE MISS AMERICA ORGANIZATION, ATLANTIC CITY, NJ:  
3,232,344, PUB. 2-6-2007. MULTIPLE CLASS, INT. CLS. 36 AND 41.
- THE MOBILE PRESS REGISTER, INC., MOBILE, AL:  
3,232,231, PUB. 2-6-2007. INT. CL. 16.
- THE MONEY GAMING CORPORATION LTD., LONDON, UNITED KINGDOM:  
3,235,447, INT. CL. 41.
- THE MUHLER COMPANY, INC., NORTH CHARLESTON, SC:  
3,232,707, PUB. 2-6-2007. INT. CL. 37.
- THE NATIONAL MARROW DONOR PROGRAM, MINNEAPOLIS, MN:  
3,235,455, MULTIPLE CLASS, INT. CLS. 35 AND 42.
- THE NATIONAL TEACHERS HALL OF FAME, INC., EMPORIA, KS:  
3,232,832, PUB. 2-6-2007. INT. CL. 16.
- THE NEW YORK RACING ASSOCIATION INC., JAMAICA, NY:  
3,233,362, PUB. 2-6-2007. INT. CL. 41.  
3,233,363, PUB. 2-6-2007. INT. CL. 41.  
3,233,364, PUB. 2-6-2007. INT. CL. 41.  
3,233,366, PUB. 2-6-2007. INT. CL. 41.  
3,233,367, PUB. 2-6-2007. INT. CL. 41.  
3,233,369, PUB. 2-6-2007. INT. CL. 41.  
3,233,370, PUB. 2-6-2007. INT. CL. 41.  
3,233,371, PUB. 2-6-2007. INT. CL. 41.  
3,233,372, PUB. 2-6-2007. INT. CL. 41.  
3,233,373, PUB. 2-6-2007. INT. CL. 41.  
3,233,377, PUB. 2-6-2007. INT. CL. 41.  
3,233,427, PUB. 2-6-2007. INT. CL. 41.  
3,233,428, PUB. 2-6-2007. INT. CL. 41.  
3,233,429, PUB. 2-6-2007. INT. CL. 41.  
3,233,430, PUB. 2-6-2007. INT. CL. 41.  
3,233,431, PUB. 2-6-2007. INT. CL. 41.  
3,233,432, PUB. 2-6-2007. INT. CL. 41.  
3,233,433, PUB. 2-6-2007. INT. CL. 41.  
3,233,434, PUB. 2-6-2007. INT. CL. 41.  
3,233,435, PUB. 2-6-2007. INT. CL. 41.  
3,233,436, PUB. 2-6-2007. INT. CL. 41.
- THE NORTH FACE APPAREL CORP., WILMINGTON, DE:  
3,232,358, PUB. 5-17-2005. INT. CL. 12.
- THE OFFICER DOWN MEMORIAL PAGE, INC., FAIRFAX, VA:  
3,233,475, PUB. 2-6-2007. INT. CL. 16.
- THE PASADENA TOURNAMENT OF ROSES ASSOCIATION, INC., PASADENA, CA:  
3,235,150, INT. CL. 25.
- THE PILLSBURY COMPANY, MINNEAPOLIS, MN:  
3,232,663, PUB. 2-6-2007. INT. CL. 30.
- THE PNC FINANCIAL SERVICES GROUP, INC., PITTSBURGH, PA:  
3,234,555, INT. CL. 36.
- THE PROCTER & GAMBLE COMPANY, CINCINNATI, OH:  
3,234,146, INT. CL. 3.  
3,234,215, INT. CL. 5.  
3,234,525, INT. CL. 5.
- THE QUEENS BOROUGH PUBLIC LIBRARY, JAMAICA, NY:  
3,232,247, PUB. 2-6-2007. INT. CL. 41.
- THE READER'S DIGEST ASSOCIATION, INC., PLEASANTVILLE, NY:  
3,234,910, INT. CL. 9.
- THE RETROFIT COMPANIES, INC., OWATONNA, MN:  
3,232,509, PUB. 2-6-2007. MULTIPLE CLASS, INT. CLS. 35, 37 AND 40.
- THE ROMAN AUCTION COMPANY, INC., FORT WAYNE, IN:  
3,234,898, INT. CL. 41.
- THE SASSY SANDWICH, INC., TRAVERSE CITY, MI:  
3,233,151, PUB. 2-6-2007. INT. CL. 43.
- THE SECOND RENAISSANCE S.R.L., ITALY:  
3,233,576, PUB. 10-31-2006. MULTIPLE CLASS, INT. CLS. 36 AND 38.
- THE SHAVE, INC., BEVERLY HILLS, CA:  
3,232,437, PUB. 2-6-2007. MULTIPLE CLASS, INT. CLS. 25, 35 AND 44.
- THE SHERATON LLC, WHITE PLAINS, NY, SHERATON PHOENICIAN CORPORATION, SCOTTSDALE, AZ:  
2,038,576. REN. 3-22-07. INT. CL. 42.
- THE SOAP STORY N.V., ANTWERPEN, BELGIUM:  
3,232,467, PUB. 10-31-2006. MULTIPLE CLASS, INT. CLS. 3 AND 35.
- THE STARLIGHT STARBRIGHT CHILDREN'S FOUNDATION, LOS ANGELES, CA:  
3,235,399, MULTIPLE CLASS, INT. CLS. 9, 14, 28, 35, 36, 38, 41, 42 AND 44.  
3,235,404, MULTIPLE CLASS, INT. CLS. 9, 14, 28, 35, 36, 38, 41, 42 AND 44.
- THE SUPPORTING CAST, INC., NEW YORK, NY:  
3,234,517, INT. CL. 35.
- THE SUSAN G. KOMEN BREAST CANCER FOUNDATION, INC., DALLAS, TX:  
3,232,299, PUB. 2-6-2007. INT. CL. 35.
- THE SYSTEMS BIOLOGY INSTITUTE, SHIBUYA-KU, TOKYO, JAPAN:  
3,233,845, MULTIPLE CLASS, INT. CLS. 9 AND 42.
- THE TAX CAFE INC., YONKERS, NY:  
3,233,212, PUB. 2-6-2007. MULTIPLE CLASS, INT. CLS. 35 AND 43.
- THE TC LANE FOUNDATION, SAPULPA, OK:  
3,235,160, INT. CL. 14.
- THE TRUSTEE(S) OF THE SMG TRUST, WASHINGTON, DC:  
3,234,241, INT. CL. 35.
- THE TRUSTEES OF SALISH TRUST, ANACORTES, WA:  
3,234,199, INT. CL. 13.
- THE TRUSTEES OF THE MELVIN LOYD CHILCOAT FAMILY TRUST, STILLWATER, OK:  
3,233,218, PUB. 2-6-2007. INT. CL. 7.
- THE TRUSTEES OF THE UNIVERSITY OF PENNSYLVANIA, PHILADELPHIA, PA:  
3,234,041, MULTIPLE CLASS, INT. CLS. 16 AND 44.
- THE UNITED METHODIST PUBLISHING HOUSE, NASHVILLE, TN:  
3,232,196, PUB. 2-6-2007. MULTIPLE CLASS, INT. CLS. 9, 16 AND 35.
- THE UNIVERSITY OF AKRON, AKRON, OH:  
3,232,757, PUB. 2-6-2007. MULTIPLE CLASS, INT. CLS. 25 AND 41.
- THE UNLIMITED "INC." WELL, LLC, RENO, NV:  
3,234,794, INT. CL. 9.
- THE WHISTLER GROUP, INC., CHELMSFORD, MA:  
3,234,638, INT. CL. 9.
- THE ZIG ZIGLAR CORPORATION, ADDISON, TX:  
3,232,157, PUB. 2-6-2007. INT. CL. 41.
- THELADDERS.COM, INC., NEW YORK, NY:  
3,233,309, PUB. 2-6-2007. MULTIPLE CLASS, INT. CLS. 35 AND 41.
- THERESA ALESSANDRA RUSSO FOUNDATION, THE, LIDO BEACH, NY:  
2,356,662, CANC. INT. CL. 16.
- THEROLD INDUSTRIES, INC., HOLTVILLE, CA:  
1,396,480, CANC. INT. CL. 7.
- THINKAGE, LLC, ATLANTA, GA:  
3,234,655, MULTIPLE CLASS, INT. CLS. 9 AND 35.
- THOMAS A. GORDY GROUP, INC., THE, NEWNAN, GA:  
2,056,729. REN. 3-17-07. INT. CL. 35.

- THOMAS JOSEPH LENTINI, LOS ANGELES, CA:  
3,234,025, INT. CL. 9.
- THOMAS NELSON, INC., NASHVILLE, TN:  
2,358,554, CANC. INT. CL. 35.
- THOMAS PUBLISHING COMPANY, NEW YORK, NY:  
3,234,178, INT. CL. 35.
- THOMPSON AND COMPANY OF TAMPA, INC., TAMPA, FL:  
1,067,841, REN. 3-21-07. INT. CL. 34.
- THOMSON HEALTHCARE INC., MONTVALE, NJ, ME LICENSING CORPORATION, WILMINGTON, DE:  
2,035,094, REN. 3-22-07. INT. CL. 16.
- THOMSON PROFESSIONAL & REGULATORY INC., CARROLLTON, TX:  
3,233,509, PUB. 2-6-2007. INT. CL. 9.
- THOMSON S.A., 75008 PARIS, FRANCE:  
2,356,789, CANC. INT. CL. 9.
- THOR TECH, INC., SAGINAW, MI:  
2,093,400, REN. 3-16-07. INT. CL. 12.
- THORNBURG, GARRETT H., SANTA FE, NM:  
3,233,037, PUB. 2-6-2007. INT. CL. 36.
- THORNBURG, H. GARRETT, SANTA FE, NM:  
3,232,639, PUB. 2-6-2007. INT. CL. 36.
- THOSE CHARACTERS FROM CLEVELAND, INC., CLEVELAND, OH:  
3,234,825, INT. CL. 28.  
3,234,952, INT. CL. 28.
- THOT TECHNOLOGIES, CAMPBELL, CA:  
3,232,139, PUB. 2-6-2007. INT. CL. 9.
- THOUSAND ISLANDS WINERY, LLC, ALEXANDRIA BAY, NY:  
3,232,855, PUB. 2-6-2007. INT. CL. 33.
- THQ WIRELESS INC., AGOURA HILLS, CA:  
3,233,979, INT. CL. 9.
- THRIVE ENTERTAINMENT, LLC, WEST TOLUCA LAKE, CA:  
2,356,879, CANC. MULTIPLE CLASS, INT. CLS. 9 AND 35.
- THWT SOFTWARE, INC., MARIETTA, GA:  
2,357,119, CANC. INT. CL. 41.
- TICKETMASTER CORPORATION, WEST HOLLYWOOD, CA:  
3,235,403, MULTIPLE CLASS, INT. CLS. 35 AND 42.
- TIENSHAN, INC., SOUTH NORWALK, CT:  
1,979,366, CANC. INT. CL. 21.
- TIERNEY, MELISSA H., EVANSTON, IL:  
3,235,201, INT. CL. 25.
- TILLEY, KERI, ESCONDIDO, CA:  
3,235,262, INT. CL. 25.
- TILTON, THOMAS & MORGAN, INC, ST. JOSEPH, MO:  
3,232,898, PUB. 2-6-2007. INT. CL. 36.
- TIMBERLINE FARMS CO., LLC, ALPINE, UT:  
2,358,505, CANC. MULTIPLE CLASS, INT. CLS. 29 AND 30.
- TIME INC., NEW YORK, NY:  
2,358,892, CANC. INT. CL. 16.
- TIME-O-MATIC, INC., DANVILLE, IL:  
3,232,119, PUB. 2-6-2007. INT. CL. 9.
- TIMEDOMAIN CORPORATION, IKOMA-SHI, NARA-KEN 630-0101, JAPAN:  
3,233,581, PUB. 2-6-2007. MULTIPLE CLASS, INT. CLS. 9 AND 16.  
3,233,582, PUB. 2-6-2007. INT. CL. 9.
- TIMES MIRROR COMPANY, THE, LOS ANGELES, CA, DBA LOS ANGELES TIMES:  
2,357,554, CANC. INT. CL. 35.
- TISHCON CORP, WESTBURY, NY:  
2,358,652, CANC. INT. CL. 5.
- TITAN UMREIFUNGSTECHNIK GMBH & CO. KG., SCHWELM, FED REP GERMANY, TITAN EISENWARENFABRIK GESELLSCHAFT MIT BESCHRANKTER HAFTUNG, SCHWELM, WESTPHALIA, FED REP GERMANY:  
810,357, REN. 3-19-07. U.S. CL. 13 (INT. CL. 6).
- TITLE2LAND LLC, BATON ROUGE, LA:  
3,232,442, PUB. 2-6-2007. MULTIPLE CLASS, INT. CLS. 36 AND 42.
- TJ SMITH & NEPHEW LIMITED, HULL, ENGLAND, PERSTORP AB, S-284 80 PERSTORP, SWEDEN:  
2,034,068, REN. 3-22-07. INT. CL. 5.
- TJC, INCORPORATED, WALNUT, CA:  
2,031,365, REN. 3-21-07. MULTIPLE CLASS, INT. CLS. 16 AND 18.
- TKP, INC., SAN FRANCISCO, CA:  
2,358,824, CANC. INT. CL. 41.  
2,358,826, CANC. INT. CL. 41.
- TLAQUEPAQUE DISTILLERS COMPANY, LLC, NORWOOD, NJ:  
2,358,692, CANC. INT. CL. 33.
- TLB HOLDINGS, INC., MEDINA, MN:  
3,234,024, INT. CL. 25.
- TLP INC., DALLAS, TX:  
2,358,318, CANC. INT. CL. 35.
- TO-RO ENTERPRISES, INC., PORTLAND, OR:  
1,452,488, REN. 3-20-07. INT. CL. 35.
- TOADEGRIP PARTNERS, LLP, UNIVERSAL CITY, TX:  
3,235,258, INT. CL. 24.
- TOASTY TOES, L.L.C., ORANGE PARK, FL:  
2,356,976, CANC. INT. CL. 25.
- TOBACCO IMPORTS INTERNATIONAL, INC., RANDOLPH, NJ:  
3,234,115, INT. CL. 34.
- TOBACCONIST UNIVERSITY LLC, PRINCETON, NJ:  
3,235,064, INT. CL. 41.
- TODAYS TEMPORARY, INC., DALLAS, TX TO YELLOW CANYON CORPORATION, WILMINGTON, DE:  
1,980,287, CANC. INT. CL. 35.
- TODD THOMPSON, INC., LOS ANGELES, CA:  
2,025,441, REN. 3-17-07. INT. CL. 25.
- TODDLER U, INC., WESTPORT, CT:  
1,396,901, CANC. INT. CL. 25.
- TOKIS CORPORATION, SAN RAFAEL, CA:  
2,356,784, CANC. INT. CL. 9.
- TOLEDO HOSPITAL, THE, TOLEDO, OH:  
2,041,928, REN. 3-21-07. INT. CL. 42.
- TOM SNYDER PRODUCTIONS INC, NEW YORK, NY, TOM SNYDER PRODUCTIONS INC, WATERTOWN, MA:  
2,066,445, REN. 3-16-07. INT. CL. 9.
- TOM SNYDER PRODUCTIONS, INC., WATERTOWN, MA:  
2,066,443, REN. 3-16-07. INT. CL. 9.
- TOMA'S, LLC, OKLAHOMA CITY, OK:  
3,233,944, INT. CL. 3.
- TOMAHAWK BROTHERHOOD, THE, NEW ALBANY, IN:  
2,032,142, REN. 3-17-07. U.S. CL. 200.
- TOMBOW PENCIL CO., LTD., TOKYO 114, JAPAN, AMERICAN TOMBOW, INC., WESTLAKE VILLAGE, CA:  
1,424,797, REN. 3-16-07. INT. CL. 16.
- TOMCANY, BRIAN, STRONGSVILLE, OH:  
3,233,920, INT. CL. 10.
- TOMKE, TIM BRUCE, BURBANK, CA:  
2,357,474, CANC. INT. CL. 9.
- TOMMY HILFIGER LICENSING LLC, NEW YORK, NY, TOMMY HILFIGER, INC., NEW YORK, NY:  
2,030,406, REN. 3-19-07. MULTIPLE CLASS, INT. CLS. 3, 18 AND 25.
- TOMMY HILFIGER LICENSING LLC, NEW YORK, NY:  
2,380,070, CANC. MULTIPLE CLASS, INT. CLS. 20 AND 21.
- TONALSOFT, INC., RENO, NV:  
3,235,122, INT. CL. 9.
- TONG CONG TY BIA-RUOU-NUOC GIAI KHAT HA NOI, BA DINH DISTRICT, HANOI, VIETNAM, AKA HANOI BEER-ALCOHOL BEVERAGE CORPORATION:  
3,233,892, INT. CL. 32.
- TONKA CORPORATION, PAWTUCKET, RI:  
1,396,986, CANC. INT. CL. 28.
- TONY TIME PRODUCTS, LLC, AURORA, CO:  
3,234,818, INT. CL. 9.
- TOO FACED COSMETICS, INC., IRVINE, CA:  
3,235,114, INT. CL. 3.
- TOOLS THAT ROCK, LLC, WEST BEND, WI:  
3,234,328, MULTIPLE CLASS, INT. CLS. 6, 8 AND 25.
- TOOLZ, LTD., MONGKOK, KOWLOON, HONG KONG:  
3,233,770, INT. CL. 9.

TOOTHART, INC., KANSAS CITY, MO:  
2,358,831, CANC. INT. CL. 14.

TOP TIER SOFTWARE, INC., SAN JOSE, CA:  
2,356,562, CANC. INT. CL. 9.

TOPAL INDUSTRIES, 69800 SAINT PRIEST, FRANCE:  
2,358,832, CANC. INT. CL. 7.

TOPY KOGYO KABUSHIKI KAISHA, TOKYO, JAPAN:  
1,058,955, REN. 3-22-07, INT. CL. 6.

TORRA RAVES, MIGUEL, BARCELONA, SPAIN:  
2,045,289, REN. 3-20-07, INT. CL. 25.

TOSA INTERNATIONAL INC., TAIPEI, TAIWAN:  
2,356,905, CANC. INT. CL. 9.

TOSCHI VIGNOLA S.R.L., I-41056 SAVIGNANO SUL PA-  
NARO (MODENA), ITALY:  
3,233,675, PUB. 2-6-2007, INT. CL. 30.

TOTAL ADMINISTRATIVE BENEFIT SYSTEMS, INC.,  
JACKSONVILLE, FL:  
3,232,054, PUB. 2-6-2007, MULTIPLE CLASS, INT. CLS.  
16, 41 AND 42.

TOTAL LIVING INTERNATIONAL, INCORPORATED,  
AURORA, IL, DBA CHRISTIAN COMMUNICATIONS  
OF CHICAGOLAND, INC.:  
1,397,173, CANC. INT. CL. 41.

TOTAL MARKETING COMPANY, INC., PLEASANT HILL,  
CA:  
1,396,796, CANC. INT. CL. 16.

TOTAL SEAL, INC., PHOENIX, AZ:  
3,233,947, INT. CL. 12.

TOTAL WELLNESS SYSTEMS, INC., CHICAGO, IL:  
3,232,706, PUB. 2-6-2007, INT. CL. 41.

TOTORA SURFBOARDS, INC., HOBE SOUND, FL:  
3,232,824, PUB. 2-6-2007, MULTIPLE CLASS, INT. CLS. 25  
AND 28.

TOWN MONEY SAVER, INC., LUCAS, OH:  
3,234,500, INT. CL. 16.

TOWNHOUSE TIMES LLC, WAYNE, NJ:  
3,232,200, PUB. 2-6-2007, INT. CL. 36.

TOY POLLOI PTY LTD, CLAYTON VICTORIA 3168, AUS-  
TRALIA AND P FALK & CO PTY LTD, CLAYTON  
VICTORIA 3168, AUSTRALIA:  
3,233,600, PUB. 10-24-2006, MULTIPLE CLASS, INT. CLS.  
16 AND 28.

TOYO TANSO USA, INC., TROUTDALE, OR:  
2,040,314, REN. 3-22-07, INT. CL. 1.  
2,040,315, REN. 3-22-07, INT. CL. 1.  
2,043,349, REN. 3-22-07, INT. CL. 40.  
2,043,350, REN. 3-22-07, INT. CL. 40.

TOYOTA JIDOSHA KABUSHIKI KAISHA, TOYOTA-SHI,  
AICHI-KEN, JAPAN, TA TOYOTA MOTOR CORPORA-  
TION:  
3,234,201, INT. CL. 12.

TRACE DIGITAL, LLC, SAN JOSE, CA:  
2,356,810, CANC. INT. CL. 9.

TRACPOINT SYSTEM, LP, SAN ANTONIO, TX:  
3,234,558, INT. CL. 35.

TRADEFINDERS LTD., T.S.T. EAST, KOWLOON, HONG  
KONG:  
2,358,224, CANC. MULTIPLE CLASS, INT. CLS. 6, 16, 20,  
21 AND 28.  
2,358,227, CANC. MULTIPLE CLASS, INT. CLS. 6, 16, 20,  
21 AND 28.

TRADEMARK MANAGEMENT COMPANY, MERIDIAN,  
ID:  
1,426,740, REN. 3-19-07, INT. CL. 30.

TRADEMARK MANAGEMENT COMPANY, MERIDIAN,  
ID, QUALITY CHEF FOODS, INC., CEDAR RAPIDS, IA:  
2,034,838, REN. 3-21-07, MULTIPLE CLASS, INT. CLS. 29  
AND 30.

TRADER JOE'S COMPANY, MONROVIA, CA:  
1,424,176, REN. 3-19-07, INT. CL. 30.

TRADITIONAL MEDICINALS, INC., SEBASTOPOL, CA TO  
TRADITIONAL MEDICINALS, INC., SEBASTOPOL, CA:  
1,943,094, COR. INT. CL. 30.

TRADITIONAL MEDICINALS, INC., SEBASTOPOL, CA:  
2,114,224, REN. 3-21-07, INT. CL. 5.  
2,116,206, REN. 3-19-07, INT. CL. 5.

TRAIN AMERICA CORP., CANFIELD, OH:  
2,358,815, CANC. INT. CL. 35.  
2,358,898, CANC. INT. CL. 28.

TRANQUIL SPACE, LLC, WASHINGTON, DC:  
3,232,122, PUB. 2-6-2007, INT. CL. 25.

TRANS WORLD NEW YORK, LLC, ALBANY, NY:  
1,451,459, REN. 3-20-07, INT. CL. 42.

TRANSFLO CORPORATION, JACKSONVILLE, FL:  
2,357,396, CANC. INT. CL. 39.

TRANSOLUTIONS, INC., SCOTTSDALE, AZ:  
2,357,142, CANC. INT. CL. 9.

TRANSWORLD AQUATIC ENTERPRISES INCORPO-  
RATED, INGLEWOOD, CA:  
3,232,780, PUB. 2-6-2007, INT. CL. 9.

TRANSWORLD DIVERSIFIED SERVICES, INC., TAMPA,  
FL:  
2,424,440, CANC. MULTIPLE CLASS, INT. CLS. 37, 41  
AND 42.

TRANTER, INC., WICHITA FALLS, TX:  
2,356,862, CANC. INT. CL. 11.

TRAPP, GEORGE, WEST CHESTER, PA:  
3,234,787, INT. CL. 42.

TRAVEL NETWORKS EUROPE LTD., HARLOW, UNITED  
KINGDOM:  
3,235,355, INT. CL. 39.

TRAVEL PLANNERS, INC., NEW YORK, NY:  
3,232,239, PUB. 2-6-2007, INT. CL. 43.  
3,232,240, PUB. 2-6-2007, INT. CL. 43.  
3,232,241, PUB. 2-6-2007, INT. CL. 43.  
3,232,242, PUB. 2-6-2007, INT. CL. 43.

TRAVELHOST, INC., DALLAS, TX:  
3,233,416, PUB. 2-6-2007, INT. CL. 16.

TRAVELLER'S INN HOTEL GROUP LTD., VICTORIA,  
BRITISH COLUMBIA, CANADA:  
3,234,307, INT. CL. 43.

TRAVELPRO INTERNATIONAL, INC., BOCA RATON, FL,  
EIFFEL DESIGN, INC., DEERFIELD BEACH, FL:  
2,032,813, REN. 3-17-07, MULTIPLE CLASS, INT. CLS. 18  
AND 28.

TRAVIS INDUSTRIES, INC., MUKILTEO, WA:  
3,234,418, INT. CL. 11.

TRAVIS LEE WEEDMAN, PORTLAND, OR:  
3,232,860, PUB. 2-6-2007, INT. CL. 20.

TREADWAYS CORPORATION, EAST NORITON, PA,  
COOPER TIRE AND RUBBER COMPANY, FINDLAY,  
OH:  
1,448,375, REN. 3-19-07, INT. CL. 12.

TREK BICYCLE CORPORATION, WATERLOO, WI:  
2,357,265, CANC. INT. CL. 12.

TRENCOR, INC., LOUDON, TN:  
2,061,132, REN. 3-20-07, INT. CL. 7.

TRENDMASTERS, INC., ST. LOUIS, MO:  
2,358,515, CANC. INT. CL. 28.  
2,358,516, CANC. INT. CL. 28.

TRENT, SCOTT, RICHARDSON, TX:  
2,357,184, CANC. INT. CL. 16.

TRENTZ MUSIC, INC., TINTON FALLS, NJ:  
3,233,299, PUB. 2-6-2007, INT. CL. 41.

TRI-STATE ACQUISITIONS, INC., SADDLE BROOK, NJ:  
3,040,558, CANC. MULTIPLE CLASS, INT. CLS. 35 AND  
37.

TRI-STATE FOOT & ANKLE SPECIALISTS, LLC, EVANS-  
VILLE, IN:  
1,981,817, REN. 3-22-07, INT. CL. 42.

TRIBECA KITCHEN, LLC, NEW YORK, NY:  
3,235,479, INT. CL. 5.

TRICERAT, INC., COLUMBIA, MD:  
3,232,699, PUB. 10-31-2006, INT. CL. 9.  
3,232,761, PUB. 2-6-2007, INT. CL. 9.

TRICKED OUT TOONS, INC., TOMBALL, TX:  
3,234,939, INT. CL. 41.

TRICOR DIRECT, INC., BRANFORD, CT:  
1,057,379, REN. 3-16-07, INT. CL. 6.

TRIJAY TECHNOLOGIES INTERNATIONAL CORPORA-  
TION, NEWPORT BEACH, CA:  
2,358,289, CANC. INT. CL. 9.

TRILEGIANT CORPORATION, NORWALK, CT:  
3,235,383, INT. CL. 35.

- TRILINE MEDICAL LLC, VAN NUYS, CA:  
3,232,622, PUB. 2-6-2007. INT. CL. 10.
- TRIM-TEX, INC., LINCOLNWOOD, IL:  
2,356,490, CANC. INT. CL. 19.
- TRIMACO, LLC, DURHAM, NC:  
3,235,405, MULTIPLE CLASS, INT. CLS. 9, 16, 17, 21, 22,  
24 AND 25.
- TRINETICS, INC., MISHAWAKA, IN:  
2,356,545, CANC. INT. CL. 9.
- TRINITY TECHNOLOGIES CORPORATION, WELLESLEY  
HILLS, MA:  
3,232,608, PUB. 2-6-2007. INT. CL. 9.
- TRIPLETS, MOMS, AND MORE, INC. BURLINGTON, MA:  
2,357,365, CANC. INT. CL. 41.
- TRIPP BAKERS, INC., WHEELING, IL:  
1,397,048, CANC. INT. CL. 30.
- TRIPP, FRED, PAIGE, TX:  
2,357,100, CANC. INT. CL. 35.
- TRIPWIRE SECURITY SYSTEMS, INC., PORTLAND, OR:  
2,356,829, CANC. INT. CL. 9.
- TRISTAR CORPORATION, SAN ANTONIO, TX:  
2,357,442, CANC. INT. CL. 3.
- TRISTAR PICTURES, INC., CULVER CITY, CA:  
2,041,007, REN. 3-16-07. INT. CL. 28.
- TRITAUER, LLC, HOUSTON, TX:  
3,233,437, PUB. 2-6-2007. INT. CL. 42.
- TRIVIUM CAPITAL MANAGEMENT LLC, NEW YORK,  
NY:  
3,233,279, PUB. 2-6-2007. INT. CL. 36.
- TROPICANA PRODUCTS, INC., BRADENTON, FL:  
3,234,658, INT. CL. 29.
- TROXEL PRODUCTS, LLC, WEST POINT, MS:  
1,980,232, CANC. INT. CL. 28.
- TRS QUALITY, INC., FORT WORTH, TX:  
3,234,627, INT. CL. 9.
- TRUCK-LITE CO., INC., FALCONER, NY:  
2,357,942, CANC. MULTIPLE CLASS, INT. CLS. 9, 11, 12  
AND 17.
- TRUE TEMPER HARDWARE PROPERTIES INC., CAMP  
HILL, PA TO AMES TRUE TEMPER PROPERTIES, INC.,  
WILMINGTON, DE:  
2,495,585, CANC. INT. CL. 12.
- TRUE VALUE COMPANY, CHICAGO, IL:  
3,235,123, INT. CL. 17.  
3,235,125, INT. CL. 21.  
3,235,163, INT. CL. 9.  
3,235,164, INT. CL. 37.
- TRUGREEN LANDCARE L.L.C., MEMPHIS, TN:  
2,356,544, CANC. MULTIPLE CLASS, INT. CLS. 37 AND  
42.
- TRUITT BROS., INC., SALEM, OR:  
1,434,117, REN. 3-21-07. INT. CL. 29.  
1,436,569, REN. 3-21-07. INT. CL. 29.
- TRUMP, DONALD J., NEW YORK, NY:  
3,234,329, INT. CL. 41.  
3,234,823, INT. CL. 41.  
3,235,051, MULTIPLE CLASS, INT. CLS. 36 AND 37.
- TRUMPET AWARDS FOUNDATION, INC., ATLANTA, GA:  
3,233,227, PUB. 2-6-2007. INT. CL. 41.
- TRUST INTEGRATION SERVICES B.V., NETHERLANDS:  
3,233,555, PUB. 2-6-2007. MULTIPLE CLASS, INT. CLS. 9,  
38 AND 42.
- TRUSTEES OF AMHERST COLLEGE, THE, WASHINGTON,  
DC, DBA THE FOLGER SHAKESPEARE LIBRARY:  
2,054,038, REN. 3-19-07. MULTIPLE CLASS, INT. CLS. 16,  
41 AND 42.  
2,066,251, REN. 3-19-07. MULTIPLE CLASS, INT. CLS. 16,  
41 AND 42.
- TRUTEC LLC, RALEIGH, NC:  
3,232,175, PUB. 2-6-2007. INT. CL. 10.
- TRYLON COMMUNICATIONS, INC., NEW YORK, NY:  
3,232,986, PUB. 2-6-2007. INT. CL. 35.
- TSINGTAO BREWERY COMPANY LIMITED, QINGDAO  
266071, CHINA:  
3,233,067, PUB. 2-6-2007. INT. CL. 32.  
3,233,068, PUB. 2-6-2007. INT. CL. 32.  
3,233,069, PUB. 2-6-2007. INT. CL. 32.
- TSR, INC., LAKE GENEVA, WI TO WIZARDS OF THE  
COAST, THE, RENTON, WA:  
1,979,945, CANC. INT. CL. 25.
- TSUKIBOSHI MFG. CO. LTD., KAGA CITY ISHIKAWA,  
PREF. 922, JAPAN:  
3,234,056, INT. CL. 7.
- TSUKIHOSHI KASEI KABUSHIKI KAISHA, KURUME-SHI,  
KUKUOKA-KEN, JAPAN:  
3,233,955, INT. CL. 25.
- TSUNAMI INVESTMENTS, LLC, WILMINGTON, DE:  
3,232,738, PUB. 2-6-2007. INT. CL. 42.
- TSUNG, KUO HSUNG, CHEJIANG PROVINCE, CHINA:  
2,358,185, CANC. INT. CL. 11.
- TUALATIN VALLEY FINANCIAL SERVICES INC., PORT-  
LAND, OR, DBA BEACON MORTGAGE:  
2,076,980, REN. 3-19-07. INT. CL. 36.
- TUCAN COFFEE ESTATES AND ROASTERS, LTD., PALI-  
SADE, CO:  
3,232,392, PUB. 1-10-2006. INT. CL. 30.
- TUDC LP, NEW YORK, NY, TISHMAN URBAN DEVELOP-  
MENT CORPORATION, NEW YORK, NY:  
2,030,384, REN. 3-16-07. INT. CL. 36.
- TULIPANI, VICTOR, SAN RAFAEL, CA:  
3,234,955, INT. CL. 28.
- TUMI, INC., SOUTH PLAINFIELD, NJ:  
3,234,649, INT. CL. 18.
- TUNGSTEN STRATEGIC LLC, FORT COLLINS, CO:  
3,235,022, INT. CL. 9.
- TURBODYNE SYSTEMS, INC., CARPINTERIA, CA:  
2,356,872, CANC. INT. CL. 7.
- TURNER COMMUNICATIONS CORP., FT. LAUDERDALE,  
FL:  
3,234,860, INT. CL. 25.
- TURNER, RENITA S, EPWORTH, GA:  
3,232,567, PUB. 2-6-2007. INT. CL. 32.
- TURNER, WOODROW WILSON, III, LOS ANGELES, CA:  
3,232,160, PUB. 2-6-2007. INT. CL. 40.
- TURNPIKE CORPORATION, SAN DIEGO, CA, TURNPIKE  
CORPORATION, SAN DIEGO, CA:  
2,068,262, REN. 3-21-07. INT. CL. 35.
- TURULL, XAVIER, BARCELONA, SPAIN AND ABAD,  
MARINA CLARA, BARCELONA, SPAIN AND GIMENEZ,  
RAMON, BARCELONA, SPAIN AND RAMOS, SERGIO,  
BARCELONA, SPAIN:  
3,234,569, INT. CL. 41.
- TUSCAN OVEN, INC., THE, NORWALK, CT:  
2,034,850, REN. 3-22-07. INT. CL. 42.
- TUSKER TRAIL & SAFARI CO., INCLINE VILLAGE, NV:  
3,232,998, PUB. 2-6-2007. INT. CL. 39.
- TUWINER, MARC, ANNAPOLIS, MD:  
2,183,225, CANC. INT. CL. 25.
- TVT COMPOSITE:  
1,396,676, CANC. INT. CL. 12.
- TWEEZERMAN INTERNATIONAL, INC., PORT WASHING-  
TON, NY:  
2,358,431, CANC. INT. CL. 8.
- TWENTIETH CENTURY FOX FILM CORPORATION, LOS  
ANGELES, CA:  
2,029,910, REN. 3-19-07. INT. CL. 16.  
2,033,557, REN. 3-20-07. INT. CL. 41.  
2,358,246, CANC. INT. CL. 41.
- TWIN TOGS CREATIONS, INC., NEW YORK, NY:  
2,356,443, CANC. INT. CL. 25.
- TWISTED FIBER, INC., TUSTIN, CA:  
3,232,552, PUB. 2-6-2007. INT. CL. 25.
- TWO-CAN ENTERPRISES, INC., BEVERLY HILLS, CA:  
2,358,730, CANC. INT. CL. 9.
- TXU ENERGY RETAIL COMPANY LP, DALLAS, TX:  
3,232,624, PUB. 2-6-2007. INT. CL. 35.
- TY INC., WESTMONT, IL:  
3,232,298, PUB. 2-6-2007. INT. CL. 42.  
3,234,532, INT. CL. 28.
- TYPEFI SYSTEMS PTY LTD, QUEENSLAND, AUSTRALIA:  
3,234,176, MULTIPLE CLASS, INT. CLS. 9 AND 40.
- TYSON REFRIGERATED PROCESSED MEATS, INC.,  
SPRINGDALE, AR:  
1,397,002, CANC. INT. CL. 29.

- U S WEST MARKETING RESOURCES GROUP, INC., ENGLEWOOD, CO TO INTERNATIONAL TRADE ADMINISTRATION, US DEPARTMENT OF COMMERCE, WASHINGTON, DC:  
1,979,323, CANC. MULTIPLE CLASS, INT. CLS. 16 AND 35.
- U. S. A. GEORGE ELEVATOR, INC., CHICAGO, IL:  
3,234,211, INT. CL. 7.
- U.S. DEPARTMENT OF ENERGY, WASHINGTON, DC:  
2,422,482, CANC. INT. CL. 41.
- U.S. FOODS & PHARMACEUTICALS, INC., MADISON, WI:  
3,232,084, PUB. 2-6-2007. INT. CL. 5.
- U.S. GAMES SYSTEMS, INC., STAMFORD, CT:  
3,232,399, PUB. 2-6-2007. INT. CL. 16.
- U.S. GRAPHIC ARTS, INC., TEMPE, AZ:  
3,235,133, INT. CL. 9.
- U.S. MILLS, LLC, NEEDHAM, MA, NEOPC, INC., LEOMINSTER, MA:  
1,459,416. REN. 3-17-07. INT. CL. 30.
- U.S. TACTICAL SUPPLY, INC., ALBANY, OR:  
3,232,264, PUB. 2-6-2007. INT. CL. 16.
- U.T. FEDERAL CREDIT UNION, KNOXVILLE, TN:  
3,234,725, INT. CL. 36.
- U-BLOX AG, SWITZERLAND:  
3,233,636, PUB. 2-6-2007. MULTIPLE CLASS, INT. CLS. 9, 16, 38 AND 42.
- UBIMED L.L.C., MIAMI, FL:  
3,235,195, INT. CL. 10.
- UCB, SOCIÉTÉ ANONYME, BELGIUM:  
3,233,556, PUB. 2-6-2007. MULTIPLE CLASS, INT. CLS. 5, 16, 41, 42 AND 44.
- UHDE GMBH, FED REP GERMANY:  
3,233,584, PUB. 2-6-2007. MULTIPLE CLASS, INT. CLS. 1, 7, 37 AND 42.
- ULRICH GMBH & CO. KG, 89081 ULM, FED REP GERMANY:  
3,233,553, PUB. 2-6-2007. MULTIPLE CLASS, INT. CLS. 10 AND 44.
- ULTAN F. FEIGHERY, ASHLAND, MA:  
3,232,897, PUB. 2-6-2007. INT. CL. 35.
- ULTIMATE WIREFORMS, INC., BRISTOL, CT:  
2,017,414. REN. 3-22-07. INT. CL. 10.
- ULTRA PET CO., INC., ANDERSON, SC:  
3,233,895, MULTIPLE CLASS, INT. CLS. 18 AND 28.
- ULTRA-KOOL, INC., GILBERTSVILLE, PA:  
1,429,844. REN. 3-20-07. INT. CL. 7.
- ULTRADENT PRODUCTS, INC., SOUTH JORDAN, UT:  
2,057,459. REN. 3-16-07. INT. CL. 5.  
2,057,461. REN. 3-16-07. INT. CL. 5.
- ULTRA ECHO, LTD., ROCHESTER, MN:  
3,232,417, PUB. 2-6-2007. INT. CL. 41.
- ULTRALINGUA, INC., MINNEAPOLIS, MN:  
3,232,982, PUB. 2-6-2007. INT. CL. 9.
- ULTRAPRISE CORPORATION, SHEPHARDSTOWN, WV:  
2,356,759, CANC. INT. CL. 9.
- UMEKEN USA, INC., LOS ANGELES, CA:  
3,233,059, PUB. 2-6-2007. INT. CL. 5.
- UNBEATEN PATH INTERNATIONAL LTD., RACINE, WI:  
2,031,482. REN. 3-20-07. INT. CL. 41.  
2,031,482, CANC. INT. CL. 35.
- UNBREAKABLE LOCK COMPANY, BERWYN, PA:  
2,358,190, CANC. INT. CL. 12.
- UNEEDA DOLL CO., LTD., NEW YORK, NY:  
2,125,780. REN. 3-20-07. INT. CL. 28.
- UNEEDA DOLL COMPANY, LTD., NEW YORK, NY:  
3,233,257, PUB. 2-6-2007. INT. CL. 28.
- UNFILTERED NAPA LLC, NAPA, CA:  
3,073,062, COR. INT. CL. 33.  
3,149,780, COR. INT. CL. 33.
- UNIFIED WESTERN GROCERS, INC., COMMERCE, CA:  
3,234,953, INT. CL. 35.
- UNILEVER SUPPLY CHAIN, INC., CLINTON, CT:  
2,357,733, CANC. INT. CL. 29.  
3,232,270, PUB. 1-23-2007. INT. CL. 30.  
3,235,168, INT. CL. 30.
- UNION BANK & TRUST COMPANY, LINCOLN, NE:  
2,357,655, CANC. INT. CL. 9.
- UNION CARBIDE CHEMICALS & PLASTICS TECHNOLOGY CORPORATION, AMERCHOL CORPORATION, EDISON, NJ:  
1,458,890. REN. 3-20-07. INT. CL. 1.
- UNION ESPANOLA DE EXPLOSIVOS-MINING SERVICES INTERNATIONAL S.A., SALT LAKE CITY, UT:  
3,233,050, PUB. 2-6-2007. INT. CL. 13.
- UNION TELECOM, INC., CHICAGO, IL:  
3,232,617, PUB. 1-23-2007. INT. CL. 16.
- UNION WINE COMPANY, NEWBERG, OR:  
3,233,182, PUB. 2-6-2007. INT. CL. 40.  
3,233,183, PUB. 2-6-2007. INT. CL. 40.
- UNISANTIS HOLDING COMPANY PTE, LTD., THE, #34-04A. THE CONCOURSE, SINGAPORE:  
3,232,067, PUB. 2-6-2007. MULTIPLE CLASS, INT. CLS. 9 AND 10.
- UNISYS CORPORATION, BLUE BELL, PA:  
2,357,702, CANC. INT. CL. 42.
- UNITE HERE, NEW YORK, NY:  
3,232,223, PUB. 2-6-2007. U.S. CL. A.
- UNITED AIR LINES, INC., CHICAGO, IL:  
3,235,485, INT. CL. 39.
- UNITED BEVERAGE GROUP, LLC, ATLANTA, GA:  
3,234,932, INT. CL. 32.
- UNITED CHEMICAL CORPORATION, PIRU, CA:  
3,233,411, PUB. 2-6-2007. INT. CL. 1.  
3,233,412, PUB. 2-6-2007. INT. CL. 1.
- UNITED CHINA ELECTRONICS (HONG KONG) COMPANY LIMITED, NEW TERRITORIES, HONG KONG:  
3,234,068, INT. CL. 9.
- UNITED CHURCH OF GOD, AN INTERNATIONAL ASSOCIATION, MILFORD, OH:  
3,235,250, INT. CL. 41.
- UNITED COMMUNICATIONS GROUP LIMITED PARTNERSHIP, ROCKVILLE, MD:  
3,235,050, MULTIPLE CLASS, INT. CLS. 16, 35 AND 41.
- UNITED CUTLERY CORPORATION, SEVIERVILLE, TN:  
2,358,463, CANC. INT. CL. 8.
- UNITED FURNITURE WAREHOUSE [2005] INC., SURREY, BRITISH COLUMBIA V3W 5A1, CANADA:  
2,036,412. REN. 3-22-07. INT. CL. 42.
- UNITED NATURAL FOODS, INC., DAYVILLE, CT:  
3,233,763, INT. CL. 29.
- UNITED PENTEK, INC., INDIANAPOLIS, IN:  
2,358,415, CANC. INT. CL. 7.
- UNITED SERVICES AUTOMOBILE ASSOCIATION, SAN ANTONIO, TX:  
2,357,535, CANC. INT. CL. 36.  
2,358,654, CANC. INT. CL. 36.  
2,358,685, CANC. INT. CL. 16.
- UNITED STATES CARGO SERVICES CORP., COLUMBUS, OH:  
2,042,550. REN. 3-19-07. INT. CL. 39.
- UNITED STATES ENVIROFUELS, LLC, BRANDON, FL:  
3,232,110, PUB. 2-6-2007. INT. CL. 35.
- UNITED STATES JUDO, INC., COLORADO SPRINGS, CO:  
3,232,856, PUB. 10-17-2006. MULTIPLE CLASS, INT. CLS. 25, 35 AND 41.
- UNITED STATES JUNIOR CHAMBER OF COMMERCE, THE, TULSA, UNITED STATES JAYCEES, THE, TULSA, OK, AKA THE UNITED STATES JUNIOR CHAMBER OF COMMERCE:  
1,426,110. REN. 3-21-07. U.S. CL. 200.
- UNITED STATES MINERAL PRODUCTS COMPANY, STANHOPE, NJ, DBA ISOLATEK INTERNATIONAL:  
1,979,803, CANC. MULTIPLE CLASS, INT. CLS. 1, 2 AND 17.
- UNITED STATES PLAYING CARD COMPANY, THE, CINCINNATI, OH:  
1,396,787, CANC. INT. CL. 16.
- UNITED STATES POSTAL SERVICE, WASHINGTON, DC:  
2,358,876, CANC. INT. CL. 16.  
3,234,924, MULTIPLE CLASS, INT. CLS. 35 AND 39.
- UNITED STATES SAILING ASSOCIATION, INC., NEWPORT, RI:  
3,232,729, PUB. 2-6-2007. INT. CL. 41.  
3,232,730, PUB. 2-6-2007. U.S. CL. 200.

- UNITED STATES TESTING COMPANY, INC., HOBOKEN, NJ TO SGS U.S. TESTING COMPANY, INC., FAIRFIELD, NJ:  
1,979,380, CANC. INT. CL. 42.
- UNITED STATIONERS SUPPLY COMPANY, DEERFIELD, IL:  
3,234,856, INT. CL. 20.
- UNITED WESTERN SUPPLY COMPANIES, INC, SEATTLE, WA:  
2,356,620, CANC. MULTIPLE CLASS, INT. CLS. 3 AND 35.
- UNITEDHEALTH GROUP INCORPORATED, GOLDEN VALLEY, MN:  
3,234,268, MULTIPLE CLASS, INT. CLS. 35, 38, 41, 42 AND 44.
- UNITERS S.P.A., VICENZA, ITALY:  
3,233,786, MULTIPLE CLASS, INT. CLS. 2 AND 3.
- UNITY CLOTHING INC., EL MONTE, CA:  
2,357,451, CANC. INT. CL. 25.
- UNIVERSAL BLUE C.V., CH-8038 ZURICH, SWITZERLAND:  
3,233,956, INT. CL. 25.
- UNIVERSAL CITY STUDIOS, INC., UNIVERSAL CITY, CA:  
2,357,431, CANC. INT. CL. 41.
- UNIVERSAL INSTRUMENTS CORPORATION, BINGHAMTON, NY:  
1,396,598, CANC. INT. CL. 9.
- UNIVERSAL SECURITY INSTRUMENTS, INC., OWINGS MILLS, MD:  
1,396,630, CANC. INT. CL. 9.
- UNIVERSAL VALVE CO., INC., ELIZABETH, NJ:  
1,979,244, CANC. INT. CL. 6.
- UNIVERSAL, ESPERANZA, RANCHO SANTA FE, CA:  
3,232,791, PUB. 2-6-2007. INT. CL. 41.
- UNIVERSITY ATHLETIC ASSOCIATION, GAINESVILLE, FL:  
3,232,658, PUB. 2-6-2007. INT. CL. 25.
- UNIVERSITY ATHLETIC ASSOCIATION INC, GAINESVILLE, FL:  
3,232,732, PUB. 2-6-2007. MULTIPLE CLASS, INT. CLS. 25 AND 41.
- UNIVERSITY OF FLORIDA ALUMNI ASSOCIATION, INC., GAINESVILLE, FL:  
3,234,093, INT. CL. 41.
- UNIVERSITY OF NEW MEXICO, THE, ALBUQUERQUE, NM:  
2,358,720, CANC. INT. CL. 16.
- UNIVERSITY OF PITTSBURGH - OF THE COMMONWEALTH SYSTEM OF HIGHER EDUCATION, PITTSBURGH, PA:  
3,232,178, PUB. 2-6-2007. INT. CL. 24.
- UNIVERSITY OF WASHINGTON, SEATTLE, WA:  
3,235,390, INT. CL. 36.
- UNO COMMUNICATIONS INC., NEW YORK, NY:  
3,235,296, INT. CL. 38.
- UPGRADEBASE.COM, NEWPORT BEACH, CA:  
2,358,857, CANC. INT. CL. 42.
- URBAN, KEITH, NASHVILLE, TN:  
3,232,834, PUB. 2-6-2007. INT. CL. 25.
- UROLOGICAL STONE SURGEONS, INC., PARK RIDGE, IL:  
2,358,834, CANC. INT. CL. 42.
- US ALTERNATIVE MEDICINE, INC., CRANFORD, NJ:  
2,357,290, CANC. INT. CL. 16.
- US-1 AUTO PARTS FRANCHISE CORP., NEW HYDE PARK, NY:  
1,979,209, CANC. INT. CL. 42.
- USA FINANCIAL MARKETING CORPORATION, ADA, MI:  
3,234,226, MULTIPLE CLASS, INT. CLS. 16, 35, 36 AND 41.
- USA-1 INTERIORS, BLACKWOOD, NJ:  
1,396,684, CANC. INT. CL. 12.
- USW, INC., LOS ANGELES, CA:  
2,357,585, CANC. INT. CL. 16.
- UTAX CO., LTD., HYOGO, JAPAN:  
3,232,649, PUB. 2-6-2007. MULTIPLE CLASS, INT. CLS. 24 AND 26.
- UTICA MUTUAL INSURANCE COMPANY, NEW HARTFORD, NY, DBA UTICA NATIONAL INSURANCE GROUP:  
2,097,477, REN. 3-19-07. INT. CL. 36.
- V.E.C. CORPORATION OF DELAWARE, HACKENSACK, NJ:  
2,357,593, CANC. INT. CL. 36.
- V.E.W., LTD., NEW YORK, NY:  
3,234,315, INT. CL. 16.
- V, INC., COSTA MESA, CA:  
3,235,417, INT. CL. 9.
- VACCARO, JOHN, CALABASAS, CA:  
3,234,028, MULTIPLE CLASS, INT. CLS. 18 AND 25.
- VACTOR MANUFACTURING, INC., STREATOR, IL, MYERS-SHERMAN COMPANY, THE, STREATOR, IL:  
824,390, REN. 3-21-07. U.S. CL. 23 (INT. CL. 7).
- VADUS, INC., ANN ARBOR, MI:  
2,358,467, CANC. INT. CL. 10.
- VAHLE'S PET STUFF, INC., PHILADELPHIA, PA:  
1,430,692, REN. 3-20-07. INT. CL. 42.
- VALCO CINCINNATI, INC., CINCINNATI, OH, VALCO INC., CINCINNATI, OH:  
830,079, REN. 3-22-07. U.S. CL. 23 (INT. CL. 7).
- VALDERRAMA ESTATES, S.A., SAN ROQUE, SPAIN, VALDERRAMA, S.A., 11360 SAN ROQUE (CADIZ), SPAIN:  
2,034,726, REN. 3-22-07. INT. CL. 25.
- VALENTINE, KEITH W., LOS ANGELES, CA, DBA YUMMY BARTENDERS:  
3,232,952, PUB. 2-6-2007. INT. CL. 43.
- VALENTINO, GEORGE, GARDEN CITY, NY:  
1,980,733, REN. 3-21-07. INT. CL. 28.
- VALENZUELA, JERRY, TUCSON, AZ:  
3,233,345, PUB. 2-6-2007. INT. CL. 36.
- VALEO WISCHERSYSTEME GMBH, BIETIGHEIM-BISSINGEN, GERMAN DEM REP:  
1,314,365, REN. 3-17-07. MULTIPLE CLASS, INT. CLS. 9 AND 12.
- 1,314,365, CANC. INT. CL. 11.
- VALID8.COM, INC., WOBURN, MA:  
3,233,250, PUB. 2-6-2007. INT. CL. 9.
- VALLEY-DYNAMO LLC, LAKE FOREST, IL, TORNADO TABLE SOCCER, INC., FORT WORTH, TX:  
2,030,130, REN. 3-22-07. INT. CL. 28.
- VALOIS SAS, 27110 LE NEUBOURG, FRANCE:  
3,234,575, MULTIPLE CLASS, INT. CLS. 8 AND 21.
- VALPAK DIRECT MARKETING SYSTEMS, INC., LARGO, FL:  
2,356,644, CANC. INT. CL. 25.
- VALUE MARKETING, INC., CEDARHURST, NY:  
3,234,625, INT. CL. 5.
- VAN HORN, PETER, TERRE HAUTE, IN:  
3,234,682, INT. CL. 20.
- VAN NOTEN ANDRIES,; NAAMLOZE VENNOOTSCHAP, BELGIUM:  
3,233,728, PUB. 2-6-2007. MULTIPLE CLASS, INT. CLS. 14, 18, 25 AND 35.
- VANCE, REBECCA, WILKESBORO, NC:  
3,234,492, INT. CL. 21.
- VANCE'S FOODS, INC., SACRAMENTO, CA:  
3,233,243, PUB. 2-6-2007. INT. CL. 29.
- VANCO GROUP LIMITED, ISLEWORTH, MIDDLESEX, UNITED KINGDOM:  
1,979,563, CANC. INT. CL. 38.
- VANI USA, INC., NEW YORK, NY:  
3,233,950, MULTIPLE CLASS, INT. CLS. 9 AND 25.
- VANILLA GORILLA, L.P., LOS ANGELES, CA:  
3,232,628, PUB. 2-6-2007. INT. CL. 25.
- 3,234,088, INT. CL. 16.
- 3,234,900, INT. CL. 28.
- VANITY FAIR, INC., WILMINGTON, DE, LILY OF FRANCE, INC., NEW HAVEN, CT:  
818,303, REN. 3-22-07. U.S. CL. 39 (INT. CLS. 10, 25 AND 26).
- VANITY FAIR, INC., WILMINGTON, DE:  
3,234,452, INT. CL. 25.
- VANITY SHOP OF GRAND FORKS, INC., FARGO, ND:  
3,232,934, PUB. 2-6-2007. INT. CL. 35.



VANITY 800, INC., BROOKLYN, NY:  
2,357,753, CANC. INT. CL. 36.

VARASTEH, STEVE, SCOTTSDALE, AZ:  
2,358,531, CANC. INT. CL. 25.

VARDI STONEHOUSE INC., NEW YORK, NY:  
2,357,871, CANC. INT. CL. 14.

VARLEPIC PARTICIPATIONS, F-75018 PARIS, FRANCE:  
3,233,624, PUB. 2-6-2007. MULTIPLE CLASS, INT. CLS. 15 AND 41.  
3,233,726, PUB. 2-6-2007. INT. CL. 15.  
3,233,727, PUB. 2-6-2007. INT. CL. 15.

VARNI BROTHERS CORPORATION, MODESTO, CA:  
2,041,548, REN. 3-22-07. INT. CL. 32.

VARSITY GROUP, INC., WASHINGTON, DC:  
3,232,378, PUB. 2-6-2007. MULTIPLE CLASS, INT. CLS. 35, 38 AND 41.

VASCUTECH, INC., BURLINGTON, MA:  
2,356,618, CANC. INT. CL. 10.

VASONA SYSTEMS, INC., CAMPBELL, CA:  
2,357,061, CANC. INT. CL. 9.

VECTOR HEALTHSYSTEMS, INC., PROVIDENCE, RI:  
1,979,402, CANC. INT. CL. 35.

VECTOR LABORATORIES, INC., BURLINGAME, CA:  
1,426,136, REN. 3-16-07. INT. CL. 1.

VECTORLINK, INC., FREMONT, CA:  
2,356,957, CANC. INT. CL. 9.

VEDROS BIOSCIENCE LABORATORIES, SAN LEANDRO, CA:  
2,357,851, CANC. INT. CL. 5.

VEGA RIBAS, CARINA, MIAMI, FL:  
3,232,416, PUB. 2-6-2007. INT. CL. 35.

VEGETABLE JUICES, INC., BEDFORD PARK, IL:  
3,234,546, MULTIPLE CLASS, INT. CLS. 29 AND 32.

VENDORS EXCHANGE INTERNATIONAL, INC., CLEVELAND, OH:  
1,429,687, REN. 3-22-07. INT. CL. 42.

VENEVISION INTERNATIONAL PRODUCTIONS LLC, CORAL GABLES, FL:  
3,234,464, INT. CL. 41.

VENTRIA BIOSCIENCE, SACRAMENTO, CA:  
3,234,431, INT. CL. 42.

VENTURA COUNTY LEMON COOPERATIVE, OXNARD, CA, DBA VENTURA PACIFIC CO.:  
2,068,659, REN. 3-21-07. INT. CL. 31.

VENTURA COUNTY LEMON COOPERATIVE, MONTALVO, CA, DBA VENTURA PACIFIC CO.:  
2,073,258, REN. 3-20-07. INT. CL. 31.

VENTURA COUNTY LEMON COOPERATIVE, OXNARD, CA, DBA VENTURA PACIFIC CO.:  
2,073,259, REN. 3-20-07. INT. CL. 31.  
2,083,030, REN. 3-19-07. INT. CL. 31.

VENTURE PRODUCTS, LLC, FAIRFIELD, NJ:  
3,234,399, INT. CL. 19.

VENTURE RESEARCH, INC., PLANO, TX:  
3,235,273, MULTIPLE CLASS, INT. CLS. 9 AND 42.

VENVEST, INCORPORATED, SARASOTA, FL:  
3,232,080, PUB. 10-12-2004. INT. CL. 36.

VERBAND DER EUROPÄISCHEN BETTFEDERN- UND BETTWARENINDUSTRIE E.V., MAINZ, FED REP GERMANY:  
3,232,543, PUB. 2-6-2007. MULTIPLE CLASS, INT. CLS. 20 AND 24.

VERDE YAG BESIN MADDELERI SANAYII VE TICARET ANONIM SIRKETI, IZMIR, TURKEY:  
3,234,801, INT. CL. 29.

VERILUX, INC., STAMFORD, CT:  
3,235,062, INT. CL. 11.

VERIS INDUSTRIES LLC, PORTLAND, OR:  
2,357,167, CANC. INT. CL. 9.

VERSATILE HOUSEWARES & GARDENING SYSTEMS, INC., CAMBRIDGE, WI:  
3,233,284, PUB. 2-6-2007. INT. CL. 8.

VERTEX, INC., BERWYN, PA:  
2,033,772, REN. 3-20-07. MULTIPLE CLASS, INT. CLS. 9 AND 16.

VERTIS, INC., BALTIMORE, MD:  
3,232,903, PUB. 2-6-2007. MULTIPLE CLASS, INT. CLS. 35, 40, 41 AND 42.

VERYFINE PRODUCTS, INC., WESTFORD, MA:  
2,358,620, CANC. INT. CL. 32.

VESEY, INC., BOSTON, MA:  
3,234,841, INT. CL. 42.

VESTAS CONTROL SYSTEMS A/S, DENMARK:  
3,233,580, PUB. 2-6-2007. MULTIPLE CLASS, INT. CLS. 7, 9 AND 42.

VETERANS ENERGY TECHNOLOGIES, INC., MOUND HOUSE, NV:  
3,232,871, PUB. 2-6-2007. MULTIPLE CLASS, INT. CLS. 7 AND 9.

VIÑAS DEL MONTSANT, SL, MARÇA, SPAIN:  
3,232,457, PUB. 2-6-2007. INT. CL. 33.

VIA, INC., NORTHFIELD, MN:  
2,357,415, CANC. INT. CL. 42.

VIACOM INTERNATIONAL INC., NEW YORK, NY:  
1,396,711, CANC. INT. CL. 16.  
2,028,590, REN. 3-19-07. INT. CL. 42.  
2,028,700, REN. 3-19-07. INT. CL. 42.  
2,357,706, CANC. INT. CL. 41.  
2,357,707, CANC. INT. CL. 41.  
3,234,260, INT. CL. 41.  
3,234,326, INT. CL. 41.

VIACOM INTERNATIONAL, INC., NEW YORK, NY TO VIACOM INTERNATIONAL INC., NEW YORK, NY:  
1,979,141, CANC. MULTIPLE CLASS, INT. CLS. 16 AND 41.

VIAD CORP, PHOENIX, AZ:  
2,357,651, CANC. MULTIPLE CLASS, INT. CLS. 37, 40 AND 42.

VIASYS HOLDINGS INC., CONSHOHOCKEN, PA:  
2,356,844, CANC. MULTIPLE CLASS, INT. CLS. 9 AND 10.

VIATOR SA, SWITZERLAND:  
3,233,564, PUB. 2-6-2007. MULTIPLE CLASS, INT. CLS. 14, 16 AND 18.

VIBRADERM, INC., GRAND PRAIRIE, TX:  
3,232,507, PUB. 2-6-2007. INT. CL. 10.

VICKERY, EUGENE, EASLEY, SC, DBA VICKERY OFFICE:  
1,428,242, REN. 3-16-07. INT. CL. 9.

VICORP RESTAURANTS, INC., DENVER, CO:  
1,979,154, CANC. INT. CL. 42.

VICTORIA + CO LTD., WARWICK, RI:  
2,358,460, CANC. INT. CL. 14.

VICTORIA FINANCIAL CORPORATION, CLEVELAND, OH:  
2,035,162, REN. 3-19-07. INT. CL. 36.

VICTORY LANE QUICK OIL CHANGE, INC., ANN ARBOR, MI:  
2,357,736, CANC. INT. CL. 37.

VICTORY MACHINES, LLC, GRANDVIEW, MO:  
3,232,516, PUB. 2-6-2007. INT. CL. 7.

VIGO IMPORTING COMPANY, TAMPA, FL:  
2,097,455, REN. 3-19-07. MULTIPLE CLASS, INT. CLS. 29 AND 30.

VIKING INDUSTRIES, INC., PORTLAND, OR:  
1,980,153, CANC. MULTIPLE CLASS, INT. CLS. 6, 19 AND 40.

VIKING RIVER CRUISES, INC., WOODLAND HILLS, CA:  
3,232,655, PUB. 2-6-2007. INT. CL. 39.

VIKOMA INTERNATIONAL LIMITED, ISLE OF WIGHT P031 7AD, ENGLAND:  
1,979,959, CANC. INT. CL. 6.

VILLAROSA, CLARA, DENVER, CO:  
2,357,578, CANC. INT. CL. 35.

VILLEROY & BOCH AG, METTLACH, FED REP GERMANY:  
3,233,601, PUB. 2-6-2007. INT. CL. 21.

VINGMED SOUND, INC., SALT LAKE CITY, UT:  
1,396,637, CANC. INT. CL. 10.

VINTACO, INC., NEW YORK, NY:  
2,356,677, CANC. INT. CL. 35.

VINTAGE SPORTS CARD INC., CONROE, TX:  
2,358,330, CANC. INT. CL. 35.

VINTEK, INC., PHILADELPHIA, PA:  
2,036,105, REN. 3-21-07. INT. CL. 9.

VINTIMILLA ABAD, MARCELO, CUENCA, ECUADOR:  
3,235,202, INT. CL. 31.

- VIRBAC CORPORATION, FORT WORTH, TX:  
1,435,277. REN. 3-16-07. INT. CL. 5.
- VIRCO MGMT. CORPORATION, TORRANCE, CA:  
2,100,181. REN. 3-21-07. INT. CL. 20.
- VIRGINIA LAW FOUNDATION, CHARLOTTESVILLE, VA:  
2,117,197. REN. 3-22-07. INT. CL. 41.
- VIRGO PUBLISHING, INC., PHOENIX, AZ:  
2,358,577. CANC. INT. CL. 16.
- VIRTUAL DATES, INC., BOYNTON BEACH, FL:  
2,358,833. CANC. INT. CL. 41.
- VIRTUAL INFORMATION SYSTEMS, INC., STROUDSBURG, PA:  
2,356,671. CANC. MULTIPLE CLASS, INT. CLS. 9 AND 16.
- VIRTUALCAST, LLC, ALBUQUERQUE, NM:  
3,232,296. PUB. 2-6-2007. INT. CL. 9.
- VISCOTEK CORPORATION, HOUSTON, TX:  
2,356,501. CANC. INT. CL. 9.
- VISIONCOR, INC., CHARLOTTE, NC:  
2,357,079. CANC. MULTIPLE CLASS, INT. CLS. 35 AND 42.
- VISSAN DESIGNS LIMITED, RENFREW, ONTARIO K7V 3N6, CANADA TO CFM CORPORATION, MISSISSAUGA, ONTARIO, CANADA:  
1,980,104. CANC. INT. CL. 19.
- VISSER SOFTWARE SERVICES, INC., NEW YORK, NY:  
3,233,080. PUB. 2-6-2007. INT. CL. 9.
- VISTANT HOLDINGS, INC., DUBLIN, OH:  
3,234,292. INT. CL. 9.
- VISTAWEB.COM, POINT PLEASANT, NJ:  
1,979,483. CANC. INT. CL. 36.
- VISUAL RISK SOLUTIONS, INC., DUBLIN, OH:  
3,232,632. PUB. 2-6-2007. INT. CL. 42.  
3,232,657. PUB. 2-6-2007. INT. CL. 42.  
3,232,659. PUB. 2-6-2007. INT. CL. 42.  
3,232,660. PUB. 2-6-2007. INT. CL. 42.  
3,232,664. PUB. 2-6-2007. INT. CL. 36.
- VISUAL SERVICES, INCORPORATED, CHESAPEAKE, VA:  
3,233,354. PUB. 2-6-2007. INT. CL. 42.
- VISUALSONICS INC., TORONTO, ONTARIO, M4N 3A9, CANADA:  
3,232,085. PUB. 11-8-2005. MULTIPLE CLASS, INT. CLS. 9 AND 10.
- VITAKRAFT-WERKE WUHRMANN & SOHN, 28307 BREMEN, FED REP GERMANY:  
2,358,551. CANC. INT. CL. 31.
- VITAL PHARMACEUTICALS, INC., DAVIE, FL:  
1,987,100. REN. 3-17-07. INT. CL. 42.  
3,232,447. PUB. 6-13-2006. INT. CL. 5.
- VIVA LIFE SCIENCE, INC., COSTA MESA, CA:  
2,084,448. REN. 3-17-07. INT. CL. 5.
- VIVA VISION, INC., SAN DIEGO, CA:  
3,233,325. PUB. 2-6-2007. INT. CL. 9.  
3,233,496. PUB. 2-6-2007. INT. CL. 9.
- VKR HOLDING A/S, DK-2860 SOBOG, DENMARK, V. KANN RASMUSSEN INDUSTRI A/S, DK-2860 SOBORG, DENMARK:  
1,997,965. REN. 3-16-07. INT. CL. 19.
- VKR HOLDING A/S, DK-2860 SOBORG, DENMARK:  
3,232,471. PUB. 2-6-2007. INT. CL. 19.
- VLISCO B.V., NETHERLANDS:  
3,233,713. PUB. 2-6-2007. INT. CL. 24.
- VNU ADVERTISING EXPENDITURE CORP., NEW YORK, NY:  
2,356,638. CANC. INT. CL. 9.
- VOCA LIMITED, HERTFORDSHIRE, UNITED KINGDOM:  
3,232,095. PUB. 8-15-2006. MULTIPLE CLASS, INT. CLS. 9, 36, 42 AND 45.
- VOICEIT TECHNOLOGIES, LLC, MINNEAPOLIS, MN:  
3,232,771. PUB. 8-22-2006. INT. CL. 9.
- VOIP SERVICES, INC, MIAMI, FL:  
3,233,025. PUB. 2-6-2007. INT. CL. 16.  
3,233,026. PUB. 2-6-2007. INT. CL. 16.  
3,233,077. PUB. 2-6-2007. INT. CL. 16.  
3,233,084. PUB. 2-6-2007. INT. CL. 16.  
3,233,085. PUB. 2-6-2007. INT. CL. 16.  
3,233,086. PUB. 2-6-2007. INT. CL. 16.  
3,233,087. PUB. 2-6-2007. INT. CL. 16.
- VOITH PATENT GMBH, HEIDENHEIM, FED REP GERMANY:  
1,058,239. REN. 3-17-07. INT. CL. 7.
- VOLCOM, INC., COSTA MESA, CA:  
3,234,394. INT. CL. 25.
- VOLKSWAGEN ATKIENGESELLSCHAFT, WOLFSBURG, FED REP GERMANY:  
1,468,206. REN. 3-18-07. INT. CL. 12.
- VOLLRATH COMPANY, L.L.C., THE, SHEBOYGAN, WI:  
2,358,294. CANC. INT. CL. 21.
- VOLUNTARY INTERINDUSTRY COMMERCE STANDARDS ASSOC., LAWRENCEVILLE, NJ:  
3,233,316. PUB. 2-6-2007. INT. CL. 42.
- VOLUNTEER FLORIDA FOUNDATION, INC., TALLAHASSEE, FL:  
3,233,096. PUB. 2-6-2007. MULTIPLE CLASS, INT. CLS. 42 AND 43.
- VON BORSTEL, HECTOR, GLENDORA, CA:  
3,234,835. INT. CL. 36.
- VORTEC CORPORATION, COLLEGEVILLE, PA:  
2,357,454. CANC. INT. CL. 9.  
2,357,455. CANC. INT. CL. 9.
- VOSS OF NORWAY ASA, OSLO, NORWAY:  
3,233,035. PUB. 2-6-2007. INT. CL. 32.
- VULCAN MATERIAL COMPANY, BIRMINGHAM, AL:  
1,396,301. CANC. INT. CL. 1.
- VUONG'S TAE KWON DO CENTER, LTD., CROFTON, MD:  
3,232,680. PUB. 2-6-2007. INT. CL. 41.
- VZ CORPORATION, WILMINGTON, DE, HALLEN COMPANY, HOUSTON, TX:  
1,426,305. REN. 3-22-07. INT. CL. 8.
- W W WOOD, INC., PLEASANTON, TX:  
2,034,455. REN. 3-22-07. INT. CL. 4.
- W. GOEBEL PORZELLANFABRIK GMBH & CO. KG, 96472 RODENTAL, FED REP GERMANY:  
2,356,302. CANC. MULTIPLE CLASS, INT. CLS. 20 AND 28.
- W. R. MEADOWS, INC., HAMPSHIRE, IL, W. R. MEADOWS, INC., ELGIN, IL:  
227,057. REN. 3-16-07. U.S. CL. 12 (INT. CL. 19).
- W.A. KRAPF, INC., MACEDON, NY, KRAPF BUSINESS SYSTEMS, INC., MACEDON, NY:  
2,035,717. REN. 3-21-07. INT. CL. 16.
- W.C. HERAEUS GMBH, D-63450 HANAU, FED REP GERMANY:  
3,232,131. PUB. 10-31-2006. INT. CL. 6.
- W.H. SMITH PAPER CORPORATION, ALBANY, NY:  
1,396,703. CANC. INT. CL. 16.
- W.M. BARR AND COMPANY INC., MEMPHIS, TN:  
3,232,675. PUB. 2-6-2007. INT. CL. 3.
- W-S ASSOCIATES, INC., SALISBURY, MD:  
2,021,084. REN. 3-20-07. INT. CL. 42.
- W/A SYSTEMS, INC., WIXOM, MI:  
2,357,011. CANC. MULTIPLE CLASS, INT. CLS. 7, 37, 40 AND 42.
- WADSWORTH, JENNIFER, MARIETTA, GA:  
3,235,368. INT. CL. 3.
- WAGMAN METAL PRODUCTS, INC., YORK, PA:  
2,034,077. REN. 3-19-07. INT. CL. 7.
- WAINER, JESSE ILAN, SANTA MONICA, CA:  
3,234,310. INT. CL. 29.
- WAKE FOREST UNIVERSITY, WINSTON-SALEM, NC:  
3,232,487. PUB. 2-6-2007. INT. CL. 44.
- WAKEFERN FOOD CORP., ELIZABETH, NJ:  
3,233,951. MULTIPLE CLASS, INT. CLS. 35 AND 36.
- WAL-MART STORES, INC., BENTONVILLE, AR:  
3,233,992. INT. CL. 35.
- WALGREEN CO., DEERFIELD, IL:  
1,057,249. REN. 3-19-07. INT. CL. 42.  
2,060,828. REN. 3-22-07. MULTIPLE CLASS, INT. CLS. 1 AND 9.  
3,232,266. PUB. 2-6-2007. INT. CL. 5.
- WALKER BOOKS LIMITED, LONDON, ENGLAND:  
2,112,569. REN. 3-16-07. INT. CL. 28.

WALL STREET FINANCIAL GROUP, INC., ROCHESTER, NY:  
 2,358,784, CANC. INT. CL. 36.  
 2,358,785, CANC. INT. CL. 36.  
 2,358,786, CANC. INT. CL. 36.  
 WALLCOAT, INC., WINTER PARK, FL:  
 3,234,704, INT. CL. 2.  
 WALLIS, JAMES W., OKLAHOMA CITY, OK:  
 3,234,406, INT. CL. 6.  
 WALSCH, TARA-JENELLE C., ASHLAND, OR:  
 3,234,289, INT. CL. 16.  
 WALT'S PIZZA, INC., MARION, IL, WALT'S PIZZA, INC., MARION, IL:  
 1,458,574, REN. 3-22-07. INT. CL. 30.  
 WANCHESE POTTERY, INC., MANTEO, NC:  
 3,233,108, PUB. 2-6-2007. INT. CL. 14.  
 WANDREY, HOWARD L. JR., CORONA, CA:  
 3,234,141, INT. CL. 3.  
 WARNER BROS. ENTERTAINMENT INC., BURBANK, CA:  
 3,235,148, INT. CL. 16.  
 WARNER CHILCOTT COMPANY, INC., FAJARDO, PUERTO RICO:  
 1,431,700, REN. 3-19-07. INT. CL. 5.  
 3,234,156, INT. CL. 5.  
 WARSAW ORTHOPEDIC, INC., WARSAW, IN, DANEK MEDICAL, INC., MEMPHIS, TN:  
 2,043,954, REN. 3-17-07. INT. CL. 10.  
 WARWICK BAKER O'NEILL INC., NEW YORK, NY:  
 2,356,469, CANC. INT. CL. 35.  
 2,356,470, CANC. INT. CL. 35.  
 WATER ENVIRONMENT FEDERATION, ALEXANDRIA, VA:  
 2,024,738, REN. 3-16-07. INT. CL. 16.  
 WATER GIRL, U.S.A., LLC, VENTURA, CA:  
 2,356,910, CANC. INT. CL. 25.  
 WATKINS MANUFACTURING CORPORATION, VISTA, CA:  
 2,037,471, REN. 3-22-07. INT. CL. 11.  
 WAYNE COUNTY LOCAL HEALTH DEPARTMENT, RICHMOND, IN:  
 2,063,964, REN. 3-16-07. INT. CL. 9.  
 WAYNE FARMS, LLC, OAKWOOD, GA:  
 3,232,646, PUB. 2-6-2007. INT. CL. 42.  
 WCJ HOLDINGS CO., LTD., KOWLOON, HONG KONG:  
 3,232,367, PUB. 2-6-2007. INT. CL. 14.  
 WE PAK 4 U, INC., HUNTINGTON BEACH, CA:  
 3,235,052, INT. CL. 35.  
 WEALTHBRIDGE PARTNERS LLC, WASHINGTON, DC:  
 3,233,120, PUB. 2-6-2007. MULTIPLE CLASS, INT. CLS. 36 AND 41.  
 WEATHER UNDERGROUND, INC., THE, ANN ARBOR, MI:  
 2,447,954, CANC. INT. CL. 35.  
 WEATHERNEWS AMERICAS INC., SAN FRANCISCO, CA:  
 3,232,413, PUB. 2-6-2007. INT. CL. 9.  
 WEB DESIGN GROUP, INC., CHICAGO, IL:  
 2,357,283, CANC. INT. CL. 42.  
 WEBCRITERIA, INC., PORTLAND, OR:  
 2,358,811, CANC. INT. CL. 42.  
 WEBER, LUTZ, 81541 MUNICH, FED REP GERMANY:  
 3,232,693, PUB. 2-6-2007. MULTIPLE CLASS, INT. CLS. 1, 5 AND 42.  
 WEBGENERAL.COM INC., VOORHEES, NJ:  
 2,356,770, CANC. INT. CL. 42.  
 WECHEM INC, HARAHAN, LA:  
 3,232,984, PUB. 2-6-2007. INT. CL. 3.  
 WECO PYROTECHNISCHE FABRIK GMBH, D-53783 EITORT, FED REP GERMANY:  
 2,356,525, CANC. INT. CL. 13.  
 WEDGE VENT LLC, HIGHLAND BEACH, FL:  
 2,044,829, REN. 3-22-07. INT. CL. 20.  
 WEDGEWOOD COMMUNICATIONS, INC., GREENBROOK, NJ:  
 1,979,865, CANC. INT. CL. 16.  
 WEIGHT WATCHERS INTERNATIONAL, INC., MANHASSET, NY:  
 1,396,761, CANC. INT. CL. 16.  
 1,396,762, CANC. INT. CL. 16.  
 WEILAND SLIDING DOORS AND WINDOWS, INC., OCEANSIDE, CA:  
 3,232,702, PUB. 2-6-2007. INT. CL. 40.  
 WEIMAN PRODUCTS, LLC, GURNEE, IL, FIBERGLASS CLEANING PRODUCTS, INC., NEWPORT BEACH, CA:  
 1,075,793, REN. 3-22-07. INT. CL. 3.  
 WEINER-DAVIS, MICHELE, BOULDER, CO:  
 3,234,162, INT. CL. 41.  
 WEISS, MARISA M.D., WYNNEWOOD, PA:  
 2,356,776, CANC. INT. CL. 41.  
 WELCH, GARY L., EDMOND, OK:  
 2,081,832, REN. 3-21-07. INT. CL. 9.  
 WELD MOLD COMPANY, BRIGHTON, MI:  
 1,396,622, CANC. INT. CL. 9.  
 1,427,279, REN. 3-21-07. INT. CL. 9.  
 WELLNESS RESOURCES, INC., EDINA, MN:  
 3,234,384, MULTIPLE CLASS, INT. CLS. 9 AND 16.  
 WELLQUEST INTERNATIONAL INC., NEW YORK, NY:  
 3,235,025, MULTIPLE CLASS, INT. CLS. 3, 10 AND 21.  
 WELLS FARGO BANK, NATIONAL ASSOCIATION, ATLANTA, GA:  
 2,114,726, REN. 3-19-07. INT. CL. 12.  
 WELLSRING LIVING, INC., PEACHTREE CITY, GA:  
 3,232,797, PUB. 2-6-2007. MULTIPLE CLASS, INT. CLS. 41 AND 45.  
 WENGO, FRANCE:  
 3,233,605, PUB. 2-6-2007. MULTIPLE CLASS, INT. CLS. 9, 35 AND 38.  
 WENGO, F-92100 BOULOGNE BILLANCOURT, FRANCE:  
 3,233,620, PUB. 2-6-2007. MULTIPLE CLASS, INT. CLS. 35, 38 AND 42.  
 WENNIHAN, JEFF, BAKERSFIELD, CA AND TORALBA, JOSEPH M., BAKERSFIELD, CA:  
 2,357,101, CANC. INT. CL. 25.  
 WEST MICHIGAN HOCKEY, INC., GRAND RAPIDS, MI:  
 2,049,975, REN. 3-21-07. INT. CL. 41.  
 WESTAR CAPITAL, INC., TOPEKA, KS:  
 2,358,413, CANC. MULTIPLE CLASS, INT. CLS. 9, 37 AND 38.  
 WESTBROOK, WILLIAM JR., IRVINGTON, VA:  
 2,529,746, CANC. MULTIPLE CLASS, INT. CLS. 25 AND 42.  
 WESTCHESTER MEDICAL CENTER FOUNDATION, VALHALLA, NY:  
 3,233,942, INT. CL. 36.  
 WESTERFIELD, JAMES, SWANSEA, IL:  
 3,232,127, PUB. 2-6-2007. INT. CL. 31.  
 WESTERN ASSISTIVE TECHNOLOGY, LLC, GARDEN GROVE, CA:  
 3,147,371, COR. INT. CL. 35.  
 WESTERN BLUE PRINT COMPANY, L.L.C., KANSAS CITY, MO:  
 2,356,717, CANC. INT. CL. 35.  
 WESTERN BUILDERS SUPPLY, INC., BILLINGS, MT:  
 3,235,055, INT. CL. 6.  
 WESTERN HOLDINGS, LLC, CHEYENNE, WY:  
 3,234,160, INT. CL. 5.  
 3,234,448, INT. CL. 5.  
 WESTERN JOURNALISM CENTER, FAIR OAKS, CA:  
 2,356,768, CANC. INT. CL. 42.  
 WESTERN RECREATIONAL VEHICLES, INC., YAKIMA, WA:  
 3,234,706, INT. CL. 12.  
 WESTERN STATES LEARNING CORPORATION, CHEYENNE, WY:  
 2,501,570, CANC. INT. CL. 36.  
 WESTERN STATES WHOLESALE, INC., ONTARIO, CA:  
 3,234,610, INT. CL. 6.  
 3,234,611, INT. CL. 19.  
 WESTFALIASURGE, INC., NAPERVILLE, IL, BABSON BROS. CO., NAPERVILLE, IL:  
 2,062,261, REN. 3-21-07. INT. CL. 7.  
 WESTIN HOTEL COMPANY, SEATTLE, WA:  
 2,358,172, CANC. INT. CL. 35.  
 WESTLB AG, FED REP GERMANY:  
 3,233,532, PUB. 2-6-2007. INT. CL. 36.  
 WESTRIDGE LABORATORIES, INC., LAKE FOREST, CA:  
 3,232,341, PUB. 2-6-2007. INT. CL. 5.

- WESTWOOD-SQUIBB PHARMACEUTICALS, INC., BUFFALO, NY, WESTWOOD PHARMACEUTICALS, INC., BUFFALO, NY:  
1,064,781. REN. 3-17-07. INT. CL. 3.
- WESTWOOD-SQUIBB PHARMACEUTICALS, INC., BUFFALO, NY, WESTWOOD PHARMACEUTICALS INC., BUFFALO, NY:  
1,453,856. REN. 3-17-07. INT. CL. 5.
- WET VEST, L.L.C., EUGENE, OR:  
1,396,638. CANC. INT. CL. 10.
- WETHERILL INVESTMENT LLC, WESTWOOD HILLS, KS:  
3,233,247. PUB. 2-6-2007. INT. CL. 42.
- WETPAINT.COM, INC., SEATTLE, WA:  
3,235,281. INT. CL. 41.  
3,235,282. INT. CL. 42.
- WEYERHAEUSER COMPANY, FEDERAL WAY, WA:  
3,234,323. MULTIPLE CLASS, INT. CLS. 35, 39, 40 AND 42.  
3,234,361. INT. CL. 9.
- WGBH EDUCATIONAL FOUNDATION, BOSTON, MA:  
2,120,108. REN. 3-21-07. INT. CL. 9.
- WHATMAN, INC., FLORHAM PARK, NJ, WHATMAN INTERNATIONAL LIMITED, KENT, ENGLAND:  
1,428,906. REN. 3-22-07. INT. CL. 1.
- WHEAT, CLEVELAND E., RESTON, VA:  
3,234,677. INT. CL. 28.
- WHG TM CORP., LAS VEGAS, NV:  
3,232,172. PUB. 1-23-2007. INT. CL. 43.
- WHIP MIX CORPORATION, LOUISVILLE, KY:  
2,029,558. REN. 3-19-07. INT. CL. 5.
- WHISH BODY PRODUCTS, L.L.C., SCOTTSDALE, AZ:  
3,235,134. INT. CL. 3.
- WHISPER, NEWPORT BEACH, CA:  
3,234,440. INT. CL. 35.
- WHITE CONSOLIDATED INDUSTRIES, INC., CLEVELAND, OH:  
2,357,570. CANC. INT. CL. 11.
- WHITE, VICTORIA F., IRVINGTON, NY:  
3,234,936. INT. CL. 45.
- WHITED, AIMEE Y., FAIRBORN, OH:  
3,234,780. INT. CL. 35.
- WHITFORD WORLDWIDE COMPANY, WILMINGTON, DE:  
3,234,412. INT. CL. 16.
- WHOLE FOODS MARKET IP, L.P., AUSTIN, TX:  
3,233,970. INT. CL. 31.
- WHOLISTIC PLANET, LLC, PICKERINGTON, OH:  
3,232,537. PUB. 2-6-2007. INT. CL. 35.
- WICOR HOLDING AG, CH-8640 RAPPERSWIL, SWITZERLAND:  
2,354,150. CANC. MULTIPLE CLASS, INT. CLS. 10, 11 AND 20.
- WIDE-EYED DESIGNS, LLC, ST. LOUIS, MO:  
3,233,989. INT. CL. 14.
- WIEGAND AND BOBLITT FAMILY LIMITED PARTNERSHIP, NAPA, CA:  
1,979,359. CANC. INT. CL. 16.
- WILBERT, INC., PORTAGE, WI, TRIENDA CORPORATION, PORTAGE, WI:  
2,029,260. REN. 3-19-07. INT. CL. 20.
- WILBUR ELLIS COMPANY, SAN FRANCISCO, CA, BRAYTON CHEMICALS, INC., WEST BURLINGTON, IA:  
1,407,238. REN. 3-19-07. INT. CL. 1.
- WILCOX AND ASSOCIATES, INC., NEW YORK, NY TO DMW, LLC, WAYNE, PA:  
1,979,339. CANC. INT. CL. 35.
- WILD BIRDS UNLIMITED, INC., CARMEL, IN:  
2,067,002. REN. 3-19-07. INT. CL. 31.
- WILD HORSEFEATHERS LLC, PORTSMOUTH, RI:  
3,232,109. PUB. 2-6-2007. INT. CL. 35.
- WILD PLANET ENTERTAINMENT, INC., SAN FRANCISCO, CA:  
3,235,041. INT. CL. 28.
- WILDLIFE CONSERVATION SOCIETY, BRONX, NY:  
2,356,563. CANC. INT. CL. 16.
- WILDMAN, FRANK, PH.D., BERKELEY, CA:  
1,396,565. CANC. INT. CL. 9.
- WILDWOOD FINANCIAL GROUP, LTD., WILDWOOD, MO:  
2,089,951. REN. 3-21-07. MULTIPLE CLASS, INT. CLS. 36 AND 41.
- WILL, JEFFREY A., MAPLE GROVE, MN:  
3,234,600. INT. CL. 9.
- WILLETT, RICHARD E., EAST HAMPTON, NY:  
3,234,212. INT. CL. 18.
- WILLIAM ASHLEY LTD., TORONTO, ONTARIO, CANADA:  
1,462,335. REN. 3-17-07. INT. CL. 42.
- WILLIAM C HANCOCK & DALE G HANCOCK, ALEXANDRIA, VA:  
3,232,117. PUB. 2-6-2007. INT. CL. 9.
- WILLIAM GRANT & SONS LIMITED, DUFFTOWN, BANFFSHIRE, SCOTLAND, WILLIAM GRANT & SONS LIMITED, SCOTLAND, SCOTLAND:  
346,426. REN. 3-22-07. U.S. CL. 49 (INT. CL. 33).
- WILLIAMS-SONOMA, INC., SAN FRANCISCO, CA:  
3,233,782. INT. CL. 3.
- WILLIAMS, JOSEPH G, MILWAUKEE, WI:  
3,234,699. INT. CL. 18.
- WILLIAMS, LEONARD M, BENDIGO, AUSTRALIA:  
3,233,204. PUB. 2-6-2007. INT. CL. 6.
- WILLIAMS, TOMMY, NEW ORLEANS, LA:  
2,356,893. CANC. INT. CL. 9.
- WILLINGHAM, JOHN H., COLLIERVILLE, TN, DBA WILLINGHAM'S WORLD CHAMPION BAR-B-QUE:  
1,397,042. CANC. INT. CL. 30.  
1,397,043. CANC. INT. CL. 30.
- WILLIS NORTH AMERICA INC., NASHVILLE, TN:  
3,232,304. PUB. 2-6-2007. INT. CL. 36.
- WILLIS, JOAN, NORTH FORT MEYERS, FL, DBA PATTERNS PLUS:  
2,050,678. REN. 3-17-07. INT. CL. 16.
- WILLY BOGNER GMBH & CO.; KOMMANDITGESELLSCHAFT AUF AKTIEN, FED REP GERMANY:  
3,233,641. PUB. 2-6-2007. MULTIPLE CLASS, INT. CLS. 9, 18, 25 AND 28.  
3,233,645. PUB. 2-6-2007. MULTIPLE CLASS, INT. CLS. 9, 18 AND 25.
- WILSON AUDIO SPECIALTIES, INC., PROVO, UT:  
3,234,577. INT. CL. 9.
- WILSON SPORTING GOODS CO., CHICAGO, IL:  
2,037,660. REN. 3-19-07. INT. CL. 25.
- WILSON, DEREK J, IRVINE, CA:  
3,232,335. PUB. 2-6-2007. MULTIPLE CLASS, INT. CLS. 9, 18, 25 AND 28.
- WIN-HOLT EQUIPMENT CORPORATION, GARDEN CITY, NY:  
2,358,487. CANC. INT. CL. 11.
- WINBROOK COMMUNICATIONS, INC., BILLERICA, MA:  
3,232,151. PUB. 2-6-2007. INT. CL. 35.
- WINDSHIELD SERVICE COMPANY, INC., OWENSBORO, KY:  
1,397,116. CANC. INT. CL. 37.
- WINDY CITY WEDDINGS, LLC, CHICAGO, IL:  
3,234,393. INT. CL. 41.
- WINEGARD COMPANY, BURLINGTON, IA:  
3,233,157. PUB. 2-6-2007. INT. CL. 9.
- WINFREY, WALTER L., CALUMET PARK, IL:  
1,981,929. REN. 3-19-07. INT. CL. 41.
- WINGING YOUR WAY LLC, CHANTILLY, VA:  
3,234,833. MULTIPLE CLASS, INT. CLS. 28 AND 35.
- WINGS RESEARCH & DEVELOPMENT S.R.L., PIANORO (BO), ITALY:  
3,234,135. MULTIPLE CLASS, INT. CLS. 18 AND 25.
- WINN INCORPORATED, HUNTINGTON BEACH, CA:  
3,234,467. INT. CL. 28.
- WINTER, ROBERT W., AZUSA, CA:  
3,234,133. INT. CL. 42.
- WIRELESS EYE, INC., VISALIA, CA:  
3,234,420. INT. CL. 45.  
3,234,421. INT. CL. 45.
- WIREMOLD COMPANY, THE, WEST HARTFORD, CT:  
2,357,064. CANC. INT. CL. 9.
- WISCON CORPORATION, LAKE FOREST, IL:  
2,357,719. CANC. INT. CL. 29.

- WISCONSIN DELLS VISITOR AND CONVENTION BUREAU, INC., WISCONSIN DELLS, WI:  
3,232,481, PUB. 2-6-2007. MULTIPLE CLASS, INT. CLS. 35, 39, 41 AND 43.
- WISCONSIN SHEEP DAIRY COOPERATIVE, SPOONER, WI:  
3,233,258, PUB. 2-6-2007. INT. CL. 29.
- WISNER, GAYLE S., SAND LAKE, MI:  
2,356,467, CANC. MULTIPLE CLASS, INT. CLS. 16 AND 41.
- WITKIN, ROBERT L., FREEHOLD, NJ:  
1,980,243, CANC. INT. CL. 28.
- WITT INDUSTRIES, INC., CINCINNATI, OH:  
3,234,368, MULTIPLE CLASS, INT. CLS. 20 AND 21.
- WIZARDS OF THE COAST, INC., PAWTUCKET, RI:  
2,048,220, REN. 3-22-07. INT. CL. 28.  
3,234,071, INT. CL. 28.
- WM. PAGE & ASSOCIATES, INC., TUCKER, GA, DBA THE LIFELINE PROGRAM:  
3,234,749, INT. CL. 36.
- WM. WRIGHT CO., WEST WARREN, MA, NEWELL CO, FREEPORT, IL, DBA BOYE NEEDLE COMPANY:  
1,417,539, REN. 3-21-07. INT. CL. 26.
- WM. WRIGLEY JR. COMPANY, CHICAGO, IL:  
3,234,951, INT. CL. 30.
- WMS GAMING INC., WAUKEGAN, IL:  
3,234,859, INT. CL. 9.
- WN PHARMACEUTICALS LTD., BURNABY, BRITISH COLUMBIA, CANADA:  
3,233,774, INT. CL. 5.
- WNBA ENTERPRISES, LLC, SECAUCUS, NJ:  
2,358,045, CANC. INT. CL. 41.  
2,358,221, CANC. INT. CL. 16.
- WOLSEY LIMITED, LEICESTER LE4 9JD, UNITED KINGDOM:  
3,233,602, PUB. 2-6-2007. INT. CL. 25.  
3,233,603, PUB. 2-6-2007. INT. CL. 25.
- WOLVERINE TUBE, INC., HUNTSVILLE, AL:  
1,431,713, REN. 3-22-07. INT. CL. 6.
- WOMENCOMPUTE, INC., BOULDER, CO:  
2,356,557, CANC. INT. CL. 16.
- WOODS & ZIMMERMAN, RANCHO PALOS VERDES, CA:  
3,234,208, INT. CL. 20.
- WOOL FELT PRODUCTS, INC., ROANOKE, VA:  
3,232,485, PUB. 2-6-2007. MULTIPLE CLASS, INT. CLS. 24 AND 40.
- WOOSTER BRUSH COMPANY, THE, WOOSTER, OH:  
1,980,265, CANC. INT. CL. 8.
- WORD, INCORPORATED, WACO, TX:  
1,396,592, CANC. INT. CL. 9.
- WORKFORCE ORGANIZATIONS FOR REGIONAL COLLABORATION, WASHINGTON, DC:  
3,233,002, PUB. 2-6-2007. INT. CL. 35.
- WORKGROUP TECHNOLOGY CORPORATION, LEXINGTON, MA:  
2,357,637, CANC. INT. CL. 9.
- WORKSTREAM USA, INC., MAITLAND, FL:  
3,235,437, INT. CL. 9.
- WORKSTREAM, INC., FAIRFIELD, OH:  
3,233,076, PUB. 2-6-2007. INT. CL. 20.
- WORLD BAZAARS, INC., COMMERCE, CA:  
2,356,941, CANC. INT. CL. 20.
- WORLD KITCHEN, LLC, RESTON, VA:  
3,233,132, PUB. 2-6-2007. INT. CL. 21.
- WORLD MINERALS INC., SANTA BARBARA, CA:  
2,063,399, REN. 3-22-07. INT. CL. 35.
- WORLD OF BIRDS SHOW, WINTER HAVEN, FL:  
3,234,660, INT. CL. 41.
- WORLD TRIATHLON CORPORATION, TARPON SPRINGS, FL:  
2,356,707, CANC. MULTIPLE CLASS, INT. CLS. 12, 18 AND 21.  
2,357,949, CANC. INT. CL. 32.
- WORLD VIDEO & SUPPLY, INC., SO. SAN FRANCISCO, CA:  
3,232,091, PUB. 2-6-2007. MULTIPLE CLASS, INT. CLS. 9, 35 AND 41.
- WORLD WIDE IMPORTS ENTERPRISES, INC., FT. LAUDERDALE, FL:  
3,233,977, INT. CL. 1.
- WORLD WIDE NEST LLC, LAKE OSWEGO, OR:  
3,233,156, PUB. 2-6-2007. INT. CL. 42.
- WORLD WIDE WEB INSTITUTE, INC., FORT LAUDERDALE, FL:  
2,357,277, CANC. MULTIPLE CLASS, INT. CLS. 41 AND 42.
- WORLD WRESTLING ENTERTAINMENT, INC., STAMFORD, CT:  
3,234,256, INT. CL. 16.
- WORLDWIDE PANTS INCORPORATED, LOS ANGELES, CA:  
2,375,504, CANC. INT. CL. 25.
- WPP PROPERTIES, SAN FRANCISCO, CA:  
3,232,673, PUB. 2-6-2007. INT. CL. 35.  
3,232,674, PUB. 2-6-2007. INT. CL. 35.
- WPT ENTERPRISES, INC., LOS ANGELES, CA:  
3,234,308, INT. CL. 9.  
3,235,063, INT. CL. 25.
- WRIGHT LINE LLC, WORCESTER, MA, WRIGHT LINE INC., WORCESTER, MA:  
1,993,431, REN. 3-19-07. INT. CL. 20.
- WRIGLEYVILLE SPORTS, INC, BENSENVILLE, IL:  
3,235,487, INT. CL. 35.
- WVR, INC., AUSTIN, TX:  
3,235,024, INT. CL. 43.
- WYETH HOLDINGS CORPORATION, MADISON, NJ:  
3,235,070, INT. CL. 5.  
3,235,136, INT. CL. 5.
- WYNDHAM RESORT DEVELOPMENT CORPORATION, ORLANDO, FL:  
3,234,462, INT. CL. 36.
- XCESS TECHNOLOGY, CORP., CITY OF INDUSTRY, CA:  
2,356,967, CANC. INT. CL. 9.
- XCOM AG, 63225 LANGEN, FED REP GERMANY:  
2,821,871, CANC. MULTIPLE CLASS, INT. CLS. 9, 35, 36, 41 AND 42.
- XEMOD INCORPORATED, SUNNYVALE, CA:  
2,358,266, CANC. INT. CL. 9.
- XIANFA MENG, FLUSHING, NY:  
2,357,457, CANC. INT. CL. 4.
- XL REAL ESTATE LLC, SILVER SPRING, MD:  
3,232,885, PUB. 2-6-2007. INT. CL. 36.
- XO COMMUNICATIONS, LLC, RESTON, VA:  
2,358,268, CANC. INT. CL. 38.
- Y.Z.Y. INC, MIAMI, FL:  
3,235,381, INT. CL. 3.
- YA-YA BRAND INCORPORATED, LOS ANGELES, CA:  
3,232,077, PUB. 2-6-2007. INT. CL. 25.
- YAHOO! INC., SUNNYVALE, CA:  
3,234,884, INT. CL. 9.
- YALE-NEW HAVEN HEALTH SERVICES CORP., NEW HAVEN, CT:  
2,101,682, REN. 3-22-07. INT. CL. 42.
- YAMAHA CORPORATION, SHIZUOKA, JAPAN:  
2,358,017, CANC. INT. CL. 9.
- YAMAHA HATSUDOKI KABUSHIKI KAISHA, IWATA-SHI, SHIZUOKA-KEN, JAPAN:  
3,234,286, INT. CL. 12.
- YAMATO CO., LTD., EHIME, JAPAN:  
3,232,428, PUB. 8-8-2006. INT. CL. 25.
- YASSA, FATHY, SOQUEL, CA:  
3,234,254, INT. CL. 35.
- YAZI COMPANY, L.L.C., CASTLE ROCK, CO:  
2,356,853, CANC. INT. CL. 41.
- YERETSKAYA, YEVGENIYA, MIAMI, FL:  
3,233,855, INT. CL. 16.
- YOAS, CHAD, DALLAS, TX:  
3,233,104, PUB. 2-6-2007. INT. CL. 29.
- YONEHAMA, AKIHIDE, TENAFLY, NJ:  
3,232,713, PUB. 2-6-2007. INT. CL. 43.
- YONG HWA INDUSTRY CO., KYEONGKI-DO, REPUBLIC OF KOREA:  
1,396,861, CANC. INT. CL. 21.
- YONI DISTRIBUTORS, INC., LOS ANGELES, CA:  
3,232,203, PUB. 2-6-2007. INT. CL. 9.

- YORK BARBELL COMPANY, INC., YORK, PA:  
2,357,826, CANC. INT. CL. 28.
- YORK INTERNATIONAL CORP., YORK, PA:  
1,431,095, REN. 3-22-07. INT. CL. 16.
- YOUNG, ANTHONY LORICK, WAKE FOREST, NC:  
3,233,124, PUB. 2-6-2007. MULTIPLE CLASS, INT. CLS. 18 AND 35.
- YOUNG, BETTY JO, WESTFORK, AR, DBA RIVERGLEN TIGERS:  
2,357,516, CANC. INT. CL. 42.
- YRC WORLDWIDE, INC., OVERLAND PARK, KS:  
1,068,287, REN. 3-20-07. INT. CL. 39.
- YUDOF, SETH, HOLLYWOOD, CA AND LEFEROVICH, DOUGLAS, HOLLYWOOD, CA:  
1,979,905, CANC. INT. CL. 41.
- YUNG FANG STEEL CHAINS & HARDWARES WORKS CO., LTD., TAINAN, TAIWAN:  
1,428,106, REN. 3-20-07. INT. CL. 6.  
1,447,107, REN. 3-20-07. INT. CL. 6.
- YVONNE LOW, SUNNYVALE, CA:  
3,234,987, MULTIPLE CLASS, INT. CLS. 16 AND 25.
- Z.U.R.I.O MUSIC CORPORATION, GOLDEN, CO, MUSIC MENTOR CORPORATION, GOLDEN, CO:  
2,032,529, REN. 3-19-07. INT. CL. 16.
- Z-AXIS LTD., SAN MATEO, CA:  
2,356,471, CANC. INT. CL. 9.
- ZAKRYTOE AKTSIONERNOE OBSHCHESTVO; "RUSS-KAYA MEDNAYA KOMPANIA", RU-620075 EKATERINBURG, RUSSIAN FED.:  
3,233,652, PUB. 2-6-2007. MULTIPLE CLASS, INT. CLS. 1, 6 AND 14.
- ZATARAIN'S PARTNERSHIP, L.P., GRETN, LA:  
3,235,369, INT. CL. 30.
- ZAVATA, INC., ATLANTA, GA:  
3,235,362, MULTIPLE CLASS, INT. CLS. 35 AND 41.
- ZEFER OPERATIONS, INC., FAIRFIELD, PA:  
2,356,730, CANC. INT. CL. 7.
- ZEIS EXCELSA SPA, ITALY:  
3,233,587, PUB. 2-6-2007. MULTIPLE CLASS, INT. CLS. 18 AND 25.
- ZELLER + GMELIN GMBH & CO, 73054 EISLINGEN, FED REP GERMANY:  
3,233,573, PUB. 2-6-2007. INT. CL. 4.
- ZELLER, LOUANN, EAST DUNDEE, IL:  
3,235,028, INT. CL. 35.  
3,235,030, INT. CL. 35.
- ZERO POPULATION GROWTH, WASHINGTON, DC:  
2,357,088, CANC. INT. CL. 41.  
2,357,089, CANC. INT. CL. 41.
- ZERO PRODUCTIONS, INC, AUSTIN, TX:  
2,357,367, CANC. INT. CL. 42.
- ZETA ESPACIAL S.A., 08830 SANT BOI DEL LLOBREGAT, SPAIN:  
1,397,038, CANC. INT. CL. 30.
- ZHENGZHOU HI-TECH ABRASIVES; COMPANY LTD., CHINA:  
3,233,756, PUB. 2-6-2007. INT. CL. 7.
- ZHOU, WANGJIAN, FLUSHING, NY:  
3,232,217, PUB. 2-6-2007. INT. CL. 18.
- ZIABICKI IMPORT COMPANY, INC., RACINE, WI:  
1,460,611, REN. 3-16-07. INT. CL. 6.
- ZIDISIUS, INC., HOUSTON, TX:  
3,234,483, MULTIPLE CLASS, INT. CLS. 25, 41 AND 43.
- ZIFF COMMUNICATIONS COMPANY, NEW YORK, NY:  
1,396,726, CANC. MULTIPLE CLASS, INT. CLS. 16 AND 42.
- ZIGZAG ASIA CO., LTD., SHIBUYA, JAPAN:  
3,232,592, PUB. 2-6-2007. INT. CL. 41.
- ZIMMER DENTAL INC., CARLSBAD, CA, CALCITEK, INC., SAN DIEGO, CA:  
1,424,713, REN. 3-16-07. INT. CL. 10.
- ZIMMER TECHNOLOGY, INC., WARSAW, IN, ZIMMER, INC., WARSAW, IN:  
2,030,302, REN. 3-16-07. INT. CL. 10.
- ZING COMMUNICATIONS PTY LTD., SURRY HILLS NEW SOUTH WALES, AUSTRALIA:  
3,234,400, INT. CL. 35.
- ZINGERLE METAL SPA, I-39040 NAZ/SCIAVES (BZ), ITALY:  
3,233,593, PUB. 2-6-2007. MULTIPLE CLASS, INT. CLS. 6, 19 AND 22.
- ZMD AMERICA INC., MELVILLE, NY:  
3,235,097, INT. CL. 9.  
3,235,098, INT. CL. 9.
- ZOCKOLL GROUP LIMITED, THE, SURBITON, SURREY, ENGLAND:  
1,396,451, CANC. INT. CL. 7.
- ZODIAC U.S. CORPORATION, WILMINGTON, DE:  
3,232,542, PUB. 2-6-2007. INT. CL. 9.
- ZOJIRUSHI CORPORATION, KITA-KU, OSAKA, JAPAN:  
1,396,455, CANC. MULTIPLE CLASS, INT. CLS. 7 AND 11.
- ZONECHEF, BROOKLYN, NY:  
2,885,125, CANC. MULTIPLE CLASS, INT. CLS. 29, 30 AND 39.
- ZOOM EYEWORKS, INC., BERKELEY, CA:  
3,234,623, INT. CL. 9.
- ZOOM TELEPHONICS, INC., BOSTON, MA:  
2,357,085, CANC. INT. CL. 9.
- ZORBA'S PIZZARIA, BRADENTON, FL:  
1,397,201, CANC. INT. CL. 42.
- ZOTOS INTERNATIONAL, INC., DARIEN, CT:  
1,425,386, REN. 3-22-07. INT. CL. 3.  
1,425,398, REN. 3-20-07. INT. CL. 3.
- ZRIKE COMPANY, INC., THE, POMPTON PLAINS, NJ:  
2,356,833, CANC. INT. CL. 21.  
2,356,836, CANC. INT. CL. 8.
- ZUCRUM FOODS, L.L.C., RIO RICO, AZ:  
3,233,344, PUB. 2-6-2007. INT. CL. 30.
- ZUMWALT, CHARLES L., SANTEE, CA:  
2,358,544, CANC. INT. CL. 25.
- ZURN INDUSTRIES, INC., ERIE, PA:  
3,235,181, INT. CL. 11.
- ZUTRON MEDICAL, L.L.C., KANSAS CITY, MO:  
3,234,793, MULTIPLE CLASS, INT. CLS. 3, 9 AND 10.
- 01 DB-METRAVIB, FRANCE:  
3,233,671, PUB. 2-6-2007. INT. CL. 9.
- 1-800 CONTRACTOR, INC., SOLANA BEACH, CA:  
2,358,793, CANC. INT. CL. 35.
- 1% FOR THE PLANET, INC., NEWBURYPORT, MA:  
3,233,020, PUB. 2-6-2007. U.S. CL. 200.
- 1099 PRO, CALABASAS, CA:  
2,078,036, REN. 3-22-07. INT. CL. 9.
- 26 INTERNATIONAL, INC., LOS ANGELES, CA:  
3,232,059, PUB. 2-6-2007. INT. CL. 25.
- 3COM CORPORATION, SANTA CLARA, CA:  
2,357,374, CANC. INT. CL. 41.
- 3M COMPANY, ST. PAUL, MN:  
1,426,563, REN. 3-17-07. INT. CL. 17.  
1,428,381, REN. 3-22-07. INT. CL. 17.
- 3VR SECURITY, INC., SAN FRANCISCO, CA:  
3,234,333, INT. CL. 9.
- 33 1/3 RECORDS, INC., ANN ARBOR, MI:  
2,358,126, CANC. MULTIPLE CLASS, INT. CLS. 9 AND 41.
- 4TH DAY ENTERPRISES, LLC, BANGOR, ME:  
3,234,439, INT. CL. 9.
- 4U BAYOU, LLC, VERONA, NJ:  
2,357,216, CANC. INT. CL. 41.
- 496268 NEW YORK, INC., NORTH BOSTON, NY, DBA FARGO TRADING:  
2,068,838, REN. 3-22-07. INT. CL. 28.
- 579732 B.C. LTD., SCOTCHCREEK, CANADA, DBA ROSS CHOCOLATES:  
3,232,484, PUB. 2-6-2007. INT. CL. 30.
- 7-ELEVEN, INC., DALLAS, TX:  
3,234,455, INT. CL. 30.
- 800 JR CIGAR, INC., WHIPPANY, NJ, J.R. TOBACCO OF AMERICA, INC., FAIRFIELD, NJ:  
2,054,598, REN. 3-16-07. INT. CL. 42.
- 88 INTERNATIONAL, INC., ALHAMBRA, CA:  
3,235,096, INT. CL. 25.

APRIL 24, 2007

U.S. PATENT AND TRADEMARK OFFICE

TMI 97

9001-6262 QUEBEC INC., ST-AUGUSTIN-DE-DESMARES,  
QUEBEC, CANADA:  
2,104,284. REN. 3-16-07. INT. CL. 9.

\* \* \* \* \*